

DEPARTMENT OF THE ARMY TECHNICAL MANUAL

TM 11-5805-201-12

DEPARTMENT OF THE AIR FORCE TECHNICAL ORDER

TO 31 W1-2PT-291

Operator's and Unit
Maintenance Manual

TELEPHONE SETS

TA-312/PT

(NSN 5805-00-543-0012)

AND

TA-312A/PT

(NSN 5805-01-217-7310)

Distribution authorized to the Department of Defense and DOD contractors only for official use or for administrative or operational purposes. This determination was made on 15 April 1990. Other requests for this document will be referred to Commander, US Army Communications-Electronics Command and Fort Monmouth, ATTN: AMSEL-LC-ME-P, Fort Monmouth, NJ 07703-5000.

DESTRUCTION NOTICE - Destroy by any method that will prevent disclosure of contents or reconstruction of the document.

DEPARTMENTS OF THE ARMY AND THE AIR FORCE

1 AUGUST 1990

CONDENSED OPERATING INSTRUCTIONS

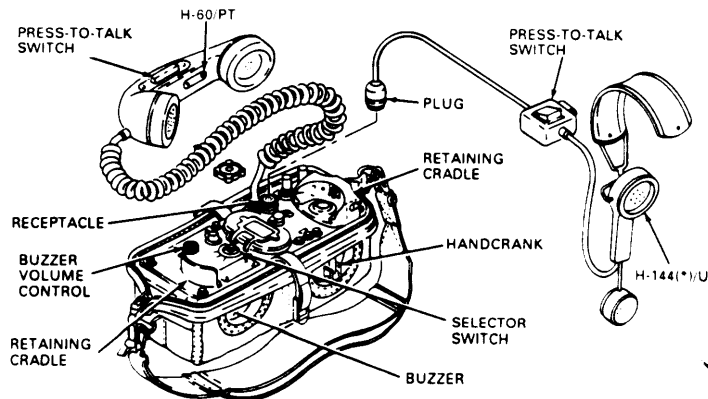

USING HANDSET H-60/PT (**EXT-INT**) SWITCH AT **INT**

PLACING CALL (LB OPERATION)

1. WITH H-60/PT IN CRADLE, TURN HANDCRANK.
2. REMOVE H-60/PT LISTEN FOR CALLED PARTY.

PLACING CALL (CB OR CBS OPERATION)

3. REMOVE H-60/PT AND LISTEN FOR OPERATOR.

CONVERSING (LB AND CBS OPERATION)

4. PUSH PRESS-TO-TALK SWITCH TO TALK; RELEASE TO LISTEN

CONVERSING (CB OPERATION)

5. DO NOT OPERATE PRESS-TO-TALK SWITCH)

(CONTINUED ON INSIDE OF BACK COVER)



5

SAFETY STEPS TO FOLLOW IF SOMEONE IS THE VICTIM OF ELECTRICAL SHOCK

1

DO NOT TRY TO PULL OR GRAB THE INDIVIDUAL

2

IF POSSIBLE, TURN OFF THE ELECTRICAL POWER

3

IF YOU CANNOT TURN OFF THE ELECTRICAL POWER, PULL, PUSH, OR LIFT THE PERSON TO SAFETY USING A DRY WOODEN POLE OR A DRY ROPE OR SOME OTHER INSULATING MATERIAL

4

SEND FOR HELP AS SOON AS POSSIBLE

5

AFTER THE INJURED PERSON IS FREE OF CONTACT WITH THE SOURCE OF ELECTRICAL SHOCK, MOVE THE PERSON A SHORT DISTANCE AWAY AND IMMEDIATELY START ARTIFICIAL RESUSCITATION

WARNING

**SEVERE SHOCK OR DEATH MAY
RESULT FROM CONTACT BETWEEN
FIELD WIRE AND POWER LINES**

Do not lay, place, or throw field wire on or near power lines or transformers. Dangerous high voltages exist at these structures. Follow the five emergency steps for electric shock. Be careful when using the TA-312/PT during storms. Lightning may pose a shock hazard.

WARNING

**HIGH VOLTAGE MAY BE PRESENT
IN THIS EQUIPMENT**

90 to 100 volts AC may be present on the field wire terminals of the TA-312/PT. Don't take chances.

WARNING

**TRICHLOROTRIFLUOROETHANE
IS HAZARDOUS**

and prolonged breathing of the vapor should be avoided. Adequate ventilation should be provided while using TRICHLOROTRIFLUOROETHANE. The solvent should not be used near heat or open flame; the products of decomposition are toxic and irritating. Since TRICHLOROTRIFLUOROETHANE dissolves natural oils, prolonged contact with skin should be avoided. When necessary use gloves that the solvent cannot penetrate. If solvent is taken internally, consult a physician immediately.

B

TECHNICAL MANUAL
No. 11-5805-201-12

TECHNICAL ORDER
No. 31 W1-2PT-291 1

DEPARTMENTS OF
THE ARMY AND
THE AIR FORCE
WASHINGTON, DC
1 August 1990

Operator's and Unit Maintenance Manual

TELEPHONE SETS
TA-312/PT
(NSN 5805-00-543-0012)
AND
TA-312A/PT
(NSN 5805-01-217-7310)

REPORTING ERRORS AND RECOMMENDING IMPROVEMENTS

You can help improve this manual. If you find any mistakes or if you know of a way to improve the procedures, please let us know. Mail your letter, DA Form 2028 (Recommended Changes to Publications and Blank Forms), or DA Form 2028-2 located in back of this manual direct to: Commander, US Army Communications- Electronics Command and Fort Monmouth, ATTN: AMSEL-LC-ME-PS, Fort Monmouth, New Jersey 07703-5000.

For Air Force, submit AFTO Form 22 (Technical Order System Publication Improvement Report and Reply) in accordance with paragraph 6-5, Section VI, T.O. 00-5-1. Forward direct to prime ALC/MST.

* This manual supersedes TM 11-5805-201-12/TO31 W1-2 PT-291, 22 June 1967

	Paragraph	Page
CHAPTER 1. INTRODUCTION		
Section 1. General		
scope	1-1	1-1
Consolidated Index of Army Publications and Blank Forms	1-2	1-1
Maintenance Forms, Records, and Reports	1-3	1-2
Reporting equipment improvement recommendations (EIR)	1-4	1-2
Administrative Storage	1-5	1-2
Destruction of Army Electronics Materiel	1-6	1-2
II. Description and data		
Purpose and use	1-7	1-3
Technical characteristics	1-8	1-3
Items comprising an operable equipment	1-9	1-4
Description	1-10	1-4
Additional Equipment Required	1-11	1-4
Differences Between Models	1-12	1-4
CHAPTER 2. INSTALLATION		
Unpacking	2-1	2-1
Checking	2-2	2-3
Installing	2-3	2-3
Installing off-hook lamp assembly . .	2-4	2-7
Adjusting Buzzer BZ-23/PT	2-5	2-9
Connecting Handset-Headset H-144(*)/U	2-6	2-9
CHAPTER 3. OPERATION		
Controls and indicators	3-1	3-1
Initiating calls	3-2	3-3
Answering calls	3-3	3-5
Operation under unusual conditions	3-4	3-6
CHAPTER 4. MAINTENANCE		
Scope of maintenance	4-1	4-1
Operator/crew preventive maintenance checks and services (PMCS)	4-2	4-3
Unit maintenance	4-3	4-7

	Paragraph	Page
CHAPTER 5. SHIPMENT AND LIMITED STORAGE		
Disassembly	5-1	5-1
Repacking for shipment or limited storage	5-2	5-1
APPENDIX A. REFERENCES		A-1
APPENDIX B. MAINTENANCE ALLOCATION		
Section I. Introduction		B-1
II. Maintenance allocation chart		B-5
III. Tools and test equipment requirements		B-6
IV. Remarks		B-7
APPENDIX C. COMPONENTS OF END ITEM (COEIL) AND BASIC ISSUE ITEMS LIST (BIIL)		
Section I. Introduction		C-1
II. Basic issue items list		C-3
III. Items troop installed or authorized list (not applicable)		C-4
APPENDIX D. ADDITIONAL AUTHORIZATION LIST		
Section I. Introduction		D-1
II. Additional authorization list		D-2
APPENDIX E. EXPENDABLE/DURABLE SUPPLIES		
Section I. Introduction		E-1
II. Expendable/Durable supplies		E-2

LIST OF ILLUSTRATIONS

Figure Number	Title	Page
1-1	Telephone Set TA-312/PT Case Open, and Handset H-60/PT Removed from Cradle.	1-0
1-2	Telephone Set TA-312/PT, Case Closed	1-5
2-1	Telephone Set TA-312/PT, Packaging Diagram	2-2
2-2	Telephone Set TA-312/PT, Batteries Installed	2-6
2-3	Installation of Off-Hook Lamp Assembly	2-8
3-1	Telephone Set TA-312/PT, Controls and Indicators	3-2

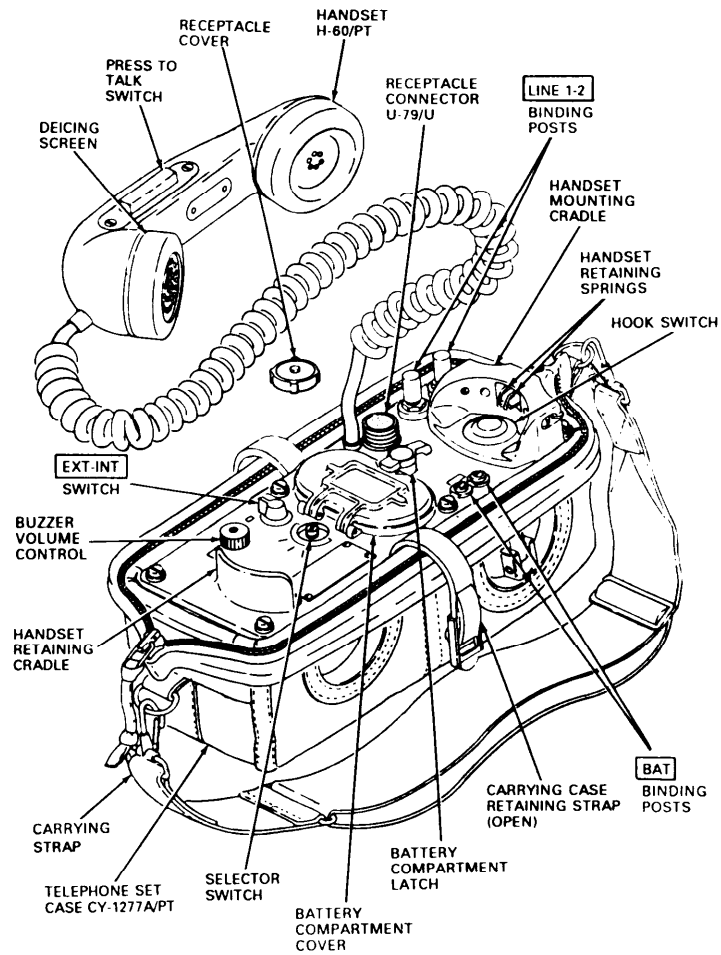

Figure 1-1. Telephone Set TA-312/PT Case Open, and Handset H-60/PT, Removed From Cradle.

(v blank)/1-0

CHAPTER 1 INTRODUCTION

Section I. GENERAL.

1-1. Scope

a. This manual describes Telephone Sets TA-312/PT and TA-312A/PT and covers their installation, operation, and unit maintenance. It includes operation under usual and unusual conditions, cleaning and inspection of the equipment, and replacement of authorized parts for unit maintenance personnel. Unless otherwise indicated, wherever a reference to TA-312/PT appears, the information also applies to the TA-312A/PT.

b. Official nomenclature followed by (*) is used to indicate all models of the equipment item covered in this manual. Therefore, Case, Telephone Set CY-1277(*)/PT represents Cases, Telephone Set CY-1277A/PT and CY-1277B/PT.

1-2. Consolidated index of Army Publications and Blank Forms.

Refer to the latest issue of DA Pam 25-30 to determine whether there are new editions, changes or additional publications pertaining to the equipment.

1-3. Maintenance Forms, Records, and Reports

a. *Reports of Maintenance and Unsatisfactory Equipment.* Department of the Army forms and procedures used for equipment maintenance will be those prescribed by DA Pam 738-750 as contained in Maintenance Management Update. Air Force personnel will use AFR 66-1 for maintenance reporting and TO-00-35D54 for unsatisfactory equipment reporting.

b. Reporting of Item and Packaging Discrepancies. Fill out and forward SF 364 (Report of Discrepancy (ROD)) as prescribed in AR 735-11 -2/DLAR 4140.55/SECNAVINST 4355.18/AFR 400-54/MCO 4430.3J.

c. Transportation Discrepancy Report (TDR) (SF361). Fill out and forward Transportation Discrepancy Report (TDR) (SF361) as . prescribed in AR 55-38/NAVSUPINST4610.33C/AFR-75-18/MCO P4610.19D/DLAR4500.15.

1-4. Reporting Equipment improvement Recommendations “ (EIR)

a. Army. If your TA -312/PT needs improvement, let us know. You, the user, are the only one who can tell us what you don't like about your equipment. Let us know why you don't like the design or performance. Put it on an SF 368 (Product Quality Deficiency Report). Mail it to Commander, US Army Communications–Electronics Command and Fort Monmouth, ATTN: AMSEL–PA– MA–D, Fort Monmouth, New Jersey 07703–5000. We'll send you a reply.

b. Air Force. Air Force personnel are encouraged to submit EIR's in accordance with AFR 900-4.

1-5. Administrative Storage

Administrative Storage of Equipment issued to and used by Army activities will have preventive maintenance performed in accordance with the PMCS charts before storing. When removing the equipment from administrative storage the PMCS should be performed to assure operational readiness. Disassembly and repacking of equipment for shipment or limited storage are covered in paragraphs 5-1 and 5-2.

1-6. Destruction of Army Electronics Materiel

Destruction of Army electronics material to prevent enemy use shall be in accordance with TM 750-244-2.

Section II. DESCRIPTION AND DATA

1-7. Purpose and Use

The TA-312/PT is a two wire, battery-operated field telephone. It may be used in a simple point-to-point voice frequency (vf) wire communication link or in any two-wire ringdown subscriber position of a telephone communications system.

1-8. Technical Characteristics

- a. Voltage requirements 3 volts dc.
- b. Frequency range 300 to 3,200 Hz.
- c. Signaling:
 - Frequency 20 Hz.
 - Voltage 90 to 100 volts.
- d. *Station-to-station distance.*

Wire description and type or gauge	Maximum distance (miles)	
	Wet	Dry
Wire, Cable, Telephone WD-1/TT (field wire).	14	22
Wire, Cable, Telephone WD-14/TT (field wire).	14	22
	Loaded	Not Loaded
Cable Assembly, Telephone CX-1065/G (spiral-four)	29	50
Cable Assembly, Telephone CX-162/G (five-pair cable).		23
Lead-covered cable, 19-gauge		30
Lead-covered cable, 22-gauge		20
Lead-covered cable, 24-gauge		
Open-wire lines, W-2 #1 4 AWG copper.		230
Open-wire lines, W-74 #1 2 AWG copper.		520

1-9. Items Comprising an Operable Equipment

NSN	QTY	Nomenclature, part No., and mfr code
-----	-----	--------------------------------------

NOTE

The part number is followed by the applicable five digit Federal supply code for manufacturers or distributor or Government agency, etc, which is identified in SB 708-41/42.

5805-00-503-1469		Generator, Ringing, Hand G-42A/PT
5965-00-669-9145		Handset H-60/PT

1-10. Description (figs. 1-1 and 1-2)

All connections and operating controls of the TA-312/PT are located on the panel assembly and housing. The handcrank (part of Generator, Ringing, Hand G-42A/PT) for generating the ringdown signal is located on the side of the housing. Connector, Receptacle U-79/U allows connection of Handset-Headset H-182/U for use in place of the H-60/PT.

1-11. Additional Equipment Required

Two Batteries BA-30 or an external 3-volt direct current (dc) source are required. The external source must be connected to the BAT binding posts.

1-12. Differences Between Models

The TA-312/PT and TA-312A/PT are identical functionally and in appearance. The TA-312/PT has a metal case. The case of the TA-312A/PT is molded plastic and requires no painting.

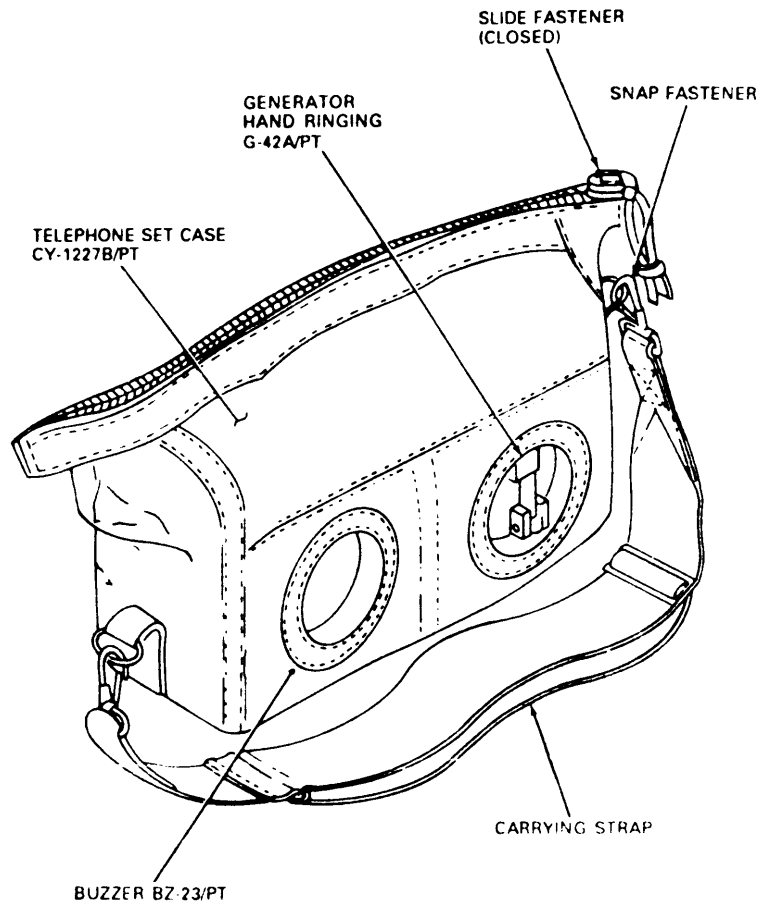

Figure 1-2. Telephone Set TA-312/PT, Case Closed.

1-5/(1-6blank)

**CHAPTER 2
INSTALLATION**

2-1. Unpacking (fig. 2-1)

a. Packaging Data. When packaged for shipment, the TA-312/PT is placed in a cardboard carton. For domestic shipment, six cardboard cartons are placed in a cardboard box. For export shipment, 15 cardboard cartons are packed in a waterproof barrier in a wooden box. The dimensions, volume, and weight are as follows:

Package	Approximate dimensions (in.)			Volume (Cu ft)	Weight (lb)
	Length	Height	Width		
Carton	15	7 3/4	5	.34	9 3/4
Cardboard box	31	8 1/2	15 3/4	2.4	62
Wooden box	28 1/2	17	24 1/2	6.86	194

b. Removing Contents.

(1) *Cardboard box.*

(a) Cut or tear the sealing tape, and fold back the top flaps of the cardboard box.

(b) Remove the cardboard cartons.

(2) *Wooden box.*

(a) Cut and fold back the metal straps.

CAUTION

Do not attempt to pry off the wooden cover. Prying may damage the equipment in the wooden box.

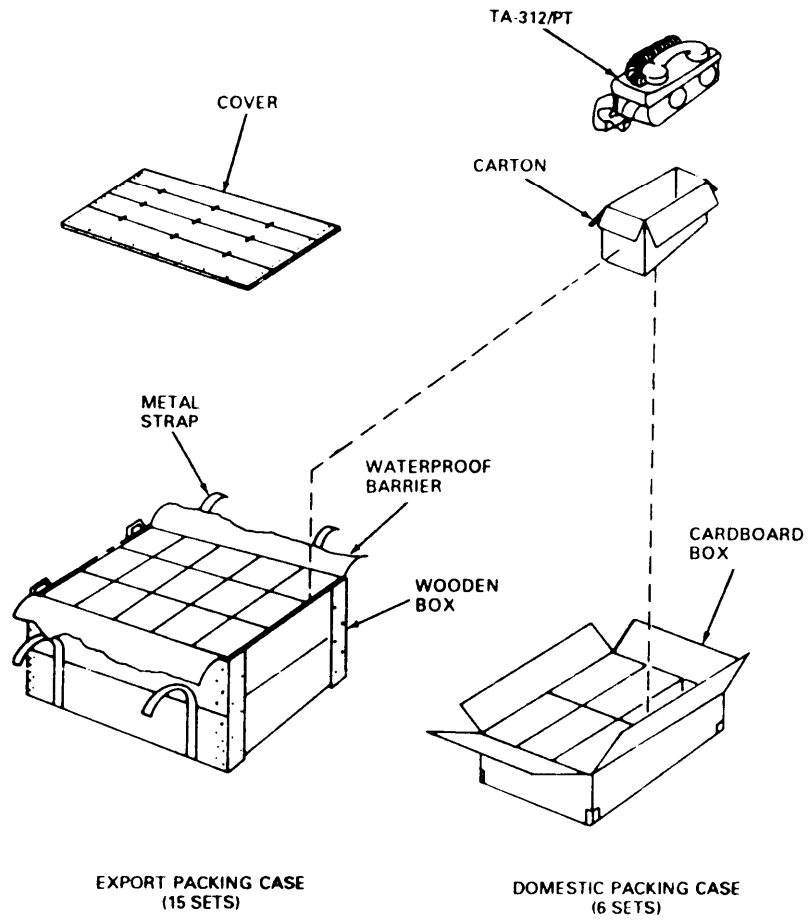

Figure 2-1. Telephone Set TA-312/PT, Packaging Diagram.

- (b) Remove the nails from the cover with a nail puller, and remove the cover.
- (c) Cut or tear open the waterproof barrier.
- (d) Remove the cardboard cartons.

(3) *Cardboard cartons.*

- (a) Cut or tear the sealing tape, and fold back the top flaps of the cardboard carton.
- (b) Open the slide fastener, and remove the corrugated paper.

2-2. Checking

a. inspect the equipment for damage. If a TA-312/PT has been damaged, fill out and forward SF 364 (para. I-3b).

b. Check to see that the equipment is complete as listed on the packing slip. If a packing slip is not available, check the equipment against the basic issue items list (appendix B). Report all discrepancies in accordance with DA Pam 738-750.

c. if the equipment has been reconditioned, ascertain if it has been modified. if the equipment has been modified, the modification work order (MWO) number will appear on the front panel near the nomenclature plate. Check to see whether appropriate notations concerning modifications have been written in to the manual on the equipment.

NOTE

Current MWO's applicable to the equipment are listed in DA Pam 25-30.

2-3. Installing

The TA-312/PT may be used as a desk phone, mounted vertically on a tree, pole, or other support.

a. *Use of TA-312/PT as a Desk Set.* Unbuckle the carrying case retaining strap (fig. 1-1), and remove the panel and housing assembly from the carrying case. Store the carrying case for later use. Place the panel and housing assembly in a convenient location on the desk.

b. *Installation of TA-312/PT on a Tree or Pole.*

1. Unhook the end of the carrying strap on the Buzzer BZ-23/PT end of the carrying case.
2. Adjust the carrying strap to a length equal to the circumference of the support. For a thin support adjust it to twice the circumference to wrap it around twice.
3. Place the TA-312/PT against the support with the LINE 1-2 binding posts (fig. 1-1) at the top.
4. Wrap the carrying strap around the support, and secure the free end to the upper ring on the carrying case.
5. Wrap a length of field wire around the support and through the lower loop of the carrying case, and tie it securely in place.

c. *Setting Selector Switch.* Use a screwdriver to set the selector switch to the proper position for the service being used.

d. *Connecting the Line.*

- (1). Strip approximately 1 inch of insulation from the ends of the two wires in the line to be connected. Scrape the stripped ends clear.
- (2). Fold back the stripped wires about one-half inch from the end.
- (3). Push down one of the LINE 1-2 binding posts. Insert the bare end of one wire into the binding post slot, and release the post. Check to see that the wire is securely clamped. Repeat the procedure with the other wire, in the other post.

e. Connecting External Batteries.

- (1) Remove the BA-30's from the battery compartment.

Connect a 3-volt battery source to the BAT binding posts on the panel.

f. Install Batteries BA30 (fig. 2-2).

- (1) Remove the H-60/PT from the retaining cradle, and open the carrying case retaining strap.
- (2) Rotate the battery compartment cover latch clockwise until the cover is released. Lift the cover to expose the battery compartment.
- (3) Insert two Batteries BA-30 in the battery compartment, one with the positive terminal up, and the other with the positive terminal down.
- (4) Close the cover, and turn the cover latch counterclockwise to lock the cover closed.
- (5) Refasten the carrying case retaining strap over the battery compartment, if the TA-312/PT is to be kept in the carrying cases.

g. Installing and Removing Deicing Screen (fig. 1-1).

- (1) In cold climates, install the deicing screen to prevent the operator's breath from freezing on the transmitter.
 - (a) Place the screen in position over the front of the transmitter cap.

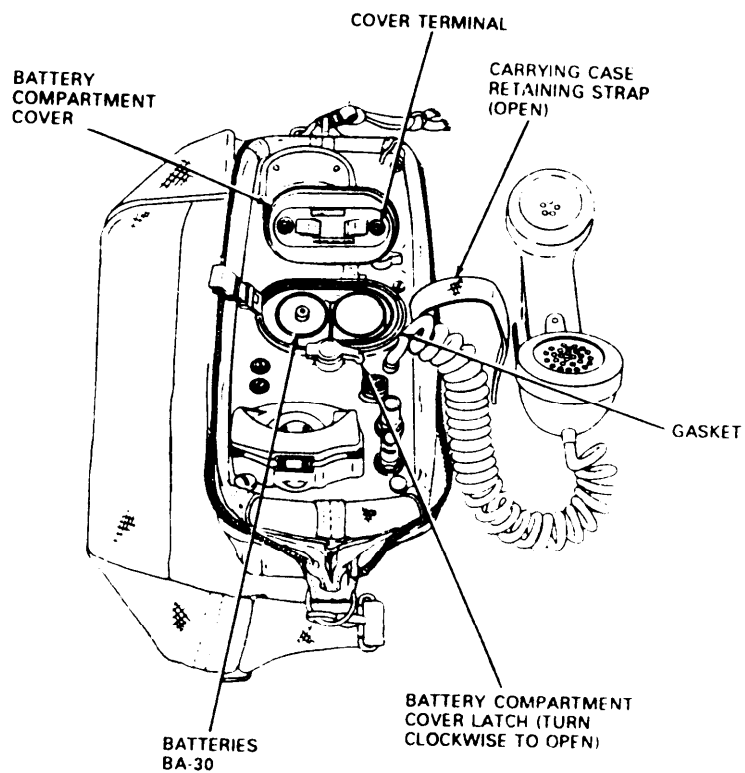

Figure 2-2. Telephone Set TA-312/PT, Batteries Installed.

- (b) Use your finger or the blade of a screwdriver to press evenly around the rim of the screen and seat it firmly in the slot around the face of the transmitter cap.
- (2) Remove the deicing screen by inserting the blade of a screwdriver in the slot in the transmitter cap. Pry up the screen with a twisting motion.
- (3) When the screen is not in use, store it between the carrying case and the side of the housing assembly opposite the BZ-23/PT.
- (4) If used only seasonally, deicing screens maybe stored in a central location until needed.

2-4. Installing Off-Hook Lamp Assembly (fig. 2-3).

NOTE

The security lamp is to alert personnel that Handset H-60/PT is not seated properly in its retaining brackets leaving the line open. The lamp is for use only in sensitive areas; it is not to be installed on every telephone set in the field.

- (a) Remove the panel screw nearest the LINE binding posts.
- (b) Secure the off-hook lamp assembly to the panel with this screw, keeping the lamp portion of the attachment snugged near the telephone cradle.
- (c) Run the lead of the off-hook lamp assembly around the handset retaining bracket and connect its two terminals to the BAT binding posts on the panel.

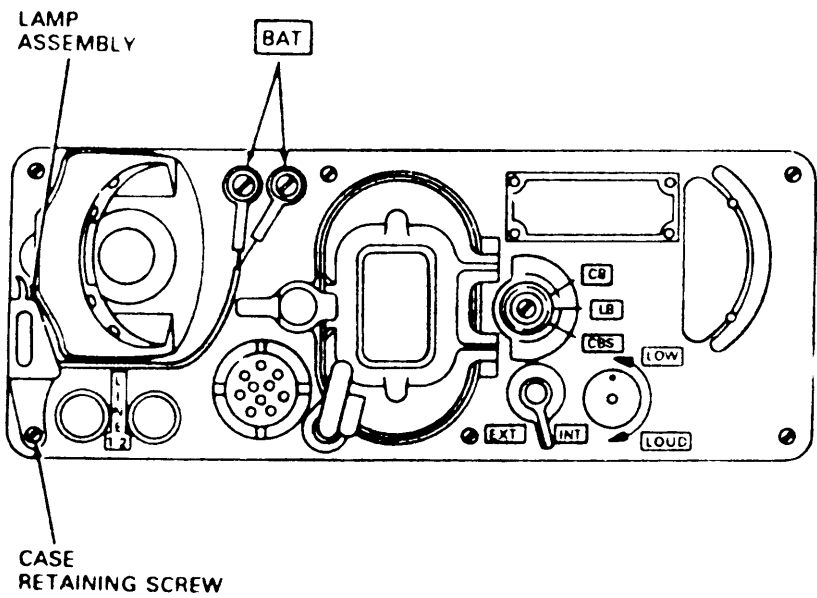

Figure 2-3. Installation of Off-hook Lamp Assembly.

2-5. Adjusting Buzzer BZ-23/PT Volume

Contact a distant party or switchboard, and ask them to ring on the line. Adjust the LOUD-LOW control to the desired volume. The fully clockwise position of the control is the maximum loud position.

2-6. Connecting Handset-Headset H-182/U

Connect Handset-Headset H-182/U to the TA-312/PT by connecting connector, Plug U-77/U on the H-182U cord to connector, Receptacle U-79/U on the panel of the TA-312/PT. Leave the H-60/PT in the retaining cradle while the H-182/U connected.

2-7. Connecting Visual Ring Indicator.

NOTE

A visual ring indicator (U-184/GT, step a or Glow Lamp, step b) may be installed if your situation warrants it.

- a. Remove wires from TA-312 binding posts. Strip away an extra inch of insulation. Slip the wires through U-184/GT Adapter and back to the posts.
- b. Attach leads from Glow Lamp M15098/1 -001 or M15098/1-003 across TA-312 binding posts with the incoming phone line.

**CHAPTER 3
OPERATION**

3-1. Controls and Indicators (figures 3-1 and 1-2)

The following chart describes the controls and indicators of Telephone Set TA-312/PT and the function of each.

Control or indicator	Function								
Hook switch	Connects H-60PT to line during operation. Switch is operated when H-60/PT is removed from retaining cradle and is open when H-60PT is in retaining cradle.								
Selector switch	Connects internal circuits of TA-312/PT for particular type of service to be used: <table border="0" data-bbox="711 705 1190 863"> <thead> <tr> <th data-bbox="711 705 813 730">Position</th> <th data-bbox="954 705 1057 730">Function</th> </tr> </thead> <tbody> <tr> <td data-bbox="711 758 764 783">C B</td> <td data-bbox="841 758 1149 783">Common battery operation.</td> </tr> <tr> <td data-bbox="711 783 764 808">L B</td> <td data-bbox="841 783 1105 808">Local battery operation.</td> </tr> <tr> <td data-bbox="711 808 764 833">CBS</td> <td data-bbox="841 808 1198 863">Common battery signaling (local battery for voice).</td> </tr> </tbody> </table>	Position	Function	C B	Common battery operation.	L B	Local battery operation.	CBS	Common battery signaling (local battery for voice).
Position	Function								
C B	Common battery operation.								
L B	Local battery operation.								
CBS	Common battery signaling (local battery for voice).								
EXT-INT switch	Permits selection of H-144(*)/U in place of H-60/PT: <table border="0" data-bbox="711 968 1166 1073"> <tbody> <tr> <td data-bbox="711 968 764 993">EXT</td> <td data-bbox="841 968 1166 1022">Selects H-144(*)/U (H-60/PT inoperative).</td> </tr> <tr> <td data-bbox="711 1022 764 1047">INT</td> <td data-bbox="841 1022 1166 1077">Selects H-60/PT (H-144(*)/U inoperative).</td> </tr> </tbody> </table>	EXT	Selects H-144(*)/U (H-60/PT inoperative).	INT	Selects H-60/PT (H-144(*)/U inoperative).				
EXT	Selects H-144(*)/U (H-60/PT inoperative).								
INT	Selects H-60/PT (H-144(*)/U inoperative).								
LOW-LOUD control	Adjusts BZ-23/PT volume.								
HandCrank (part of G-4WPT)	When turned, operates G-42A/PT for signaling in LB operation.								
BZ-23/PT	Provides audible indication of incoming call or disconnect.								

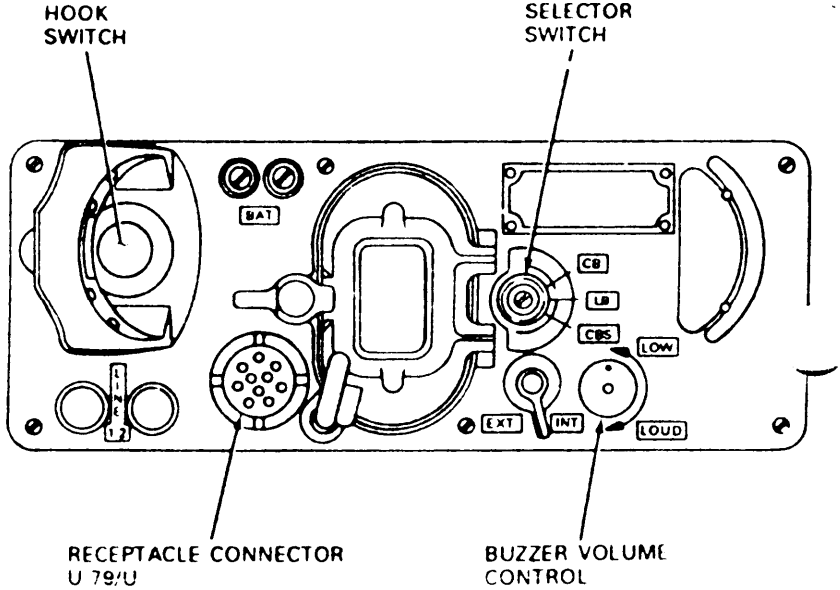

Figure 3-1. Telephone Set TA-312/P~ Controls and Indicators.

3-2. Initiating Calls

CAUTION

Always perform the appropriate disconnect procedure when the call is terminated. If the proper procedure is not followed, the buzzer may not operate on the next incoming call.

NOTE

Ensure that batteries are removed if the telephone set is to be used in a Common Battery (CB) system.

a. CB and CBS Operation Using H-60/PT.

- (1) Operate the INT-EXT switch to INT.
- (2) Remove the H-60/PT from its retaining cradle, and wait for the switchboard operator to answer.
- (3) For CBS operation, operate the press-to-talk switch (fig. 1-1) to talk and release it when listening.
- (4) For CB operation, do not use the press-to-talk switch.
- (5) When the call is terminated, replace the H-60/PT in its retaining cradle.

b. CB and CBS Operation Using H-182/U

- (1) Make sure that the H-60/PT is seated firmly in the retaining cradle.
- (2) Operate the INT-EXT switch to EXT, and wait for the operator to answer.
- (3) For CBS operation, press the press-to-talk switch to talk and release it to listen.

- (4) For CB operation, the press-to-talk switch is not used.
- (5) When the call is terminated, operate the INT-EXT switch to INT.

c. *LB Operation Using H-60/PT.*

- (1) Operate the INT-EXT switch to INT.
- (2) Make sure that the H-60/PT is seated firmly in the retaining cradle.
- (3) Turn the handcrank rapidly a few turns.
- (4) Remove the H-60/PT from the retaining cradle, and wait for the operator or called party to answer.
- (5) Operate the press-to-talk switch to talk and release it to listen.
- (6) When the call is terminated, replace the H-60/PT in the retaining cradle and turn the handcrank rapidly a few turns. This will signal the switchboard that the call has been completed.

d. *LB Operation Using H-182/U.*

- (1) Make sure that the H-60/PT is firmly seated in the retaining cradle.
- (2) Operate the INT-EXI switch to EXT, and turn the handcrank rapidly for a few turns.
- (3) Wait for the called party or the switchboard to answer.
- (4) Press the press-to-talk switch to talk, and release it to listen.
- (5) When the call is terminated, release the press-to-talk switch and turn the handcrank rapidly a few turns. This will signal the switchboard that the call has been completed.

3-3. Answering Calls

a. Using H-60/PT.

- (1) When the BZ-23/PT sounds, remove the H-60/PT from the retaining cradle.
- (2) For LB or CBS operation, press the press-to-talk switch to talk and release it to listen. For CB operation, it is not necessary to operate the press-to-talk switch to talk.
- (3) When the call is terminated, replace the H-60/PT in the retaining cradle. After LB operation, turn the handcrank rapidly a few turns to signal the switchboard that the call has been completed.

b. Using H-182/U.

- (1) Make sure that the H-60/PT is seated firmly in the retaining cradle.
- (2) When the BZ-23/PT sounds, operate the INT-EXT switch to EXT.
- (3) For LB or CBS operation, press the press-to-talk switch to answer, release it to listen. For CB operation it is not necessary to operate the press-to-talk switch to answer.
- (4) When the call is terminated, release the press-to-talk switch. After CB or CBS operation, operate the INT-EXT switch to INT. After LB operation, turn the handcrank rapidly a few turns to signal the switchboard that the call is completed.

3-4. Operation Under Unusual Conditions

a. Cold Climates. Extreme cold reduces battery voltage, decreases the efficiency of the transmitter and receiver, and makes the H-60/PT and H-182/U cords and other rubber pads stiff and brittle.

- (1) Protect the TA-312/PT as much as possible. If the TA-312/PT must be kept outdoors in the extreme cold, install Batteries BA-3030 in place of Batteries BA-30, or keep an extra set of Batteries BA-30 in your pocket to keep them warm. The extra batteries may be used to replace batteries affected by the cold.
- (2) Install the deicing screen with the metal ring facing downward and the dot on the screen aligned with the notch in the transmitter cover of the H-60/PT.

NOTE

If no deicing screen is available, carefully remove ice or moisture from the transmitter and cover it with a dry, clean cloth.

- (3) Handle the TA-312/PT carefully to avoid breaking or cracking the rubber parts.

b. Hot, Dry Climates. Hot, dry climates expose the TA-312/PT to damage from dirt, dust, and the effects of strong sunlight.

- (1) Protect the TA-312/PT from sand, dust, and strong sunlight. Clean and dust the equipment frequently.
- (2) When the TA-312/PT is not in use, close the slide fastener to keep out dust and other dirt.

c. Warm Damp Climates. Warm, damp climates expose the TA-312/PT to damage from moisture and fungus. Wipe all fungus and moisture from the exterior with a clean, lint-free cloth.

d. Noisy Areas.

- (1) Speak directly into the transmitter in a loud, clear voice.
- (2) For LB or CBS operation, release the press-to-talk switch when listening. For CB operation, cover the transmitter with one hand while listening.
- (3) Shield the transmitter from the noise source with the hand or body while talking.

e. Long Telephone Loops. The LB and CBS circuits provide better transmission than the CB circuit overlong distances. When the TA-312/PT is used on a long CB circuit and transmission is noticeably affected, operate the selector switch to the CBS position and install batteries.

f. Emergency Sound Power Operation. If no battery supply is available, it is possible to transmit for approximately 4 miles by using the receiver element as a sound-powered transmitter element.

- (1) Signal by turning the handcrank rapidly a few turns.
- (2) Speak directly into the receiver element, then listen while the distant party is transmitting.

**CHAPTER 4
MAINTENANCE**

4-1. Scope of Maintenance

a. General.

- (1) To be sure that your Telephone Set TA-312/PT is always ready for your mission, you must do scheduled PREVENTIVE MAINTENANCE CHECKS AND SERVICES (PMCS).
- (2) When you are doing any PMCS or routine checks, keep in mind the warnings and cautions.
- (3) BEFORE OPERATION, perform your (B) PMCS to be sure that your equipment is ready to go.
- (4) DURING OPERATION, perform your (D) PMCS. This should help you spot small troubles before they become big problems.
- (5) AFTER OPERATION, perform your (A) PMCS. This should keep your equipment in top shape.
- (6) MONTHLY (M) PMCS are important checks you make to keep serious problems from suddenly happening.
- (7) ROUTINE CHECKS LIKE: CLEANING, DUSTING, WASHING, CHECKING FOR FRAYED CABLES, STOWING ITEMS NOT IN USE, COVERING UNUSED RECEPTACLES AND CHECKING FOR LOOSE NUTS AND BOLTS are not listed as PMCS checks. They are things that you should do anytime you see they must be done.

- (8) Defective items that cannot be corrected must be reported to higher category maintenance personnel. Records and reports of repairs and preventive maintenance must be made in accordance with procedures given in DA Pam 738-750.
- (9) Operator/Crew PMCS are provided in paragraph 4-2.

NOTE

Use the ITEM NO column in your PMCS table as a source of numbers for the TM ITEM NO. column on DA Form 2404 (Equipment Inspection and Maintenance Worksheet) in recording results of PMCS.

The PROCEDURES column in your PMCS Chart instructs you to "CHECK AND HAVE REPAIRED OR ADJUSTED AS NECESSARY". Carefully follow these instructions and if tools are needed or the chart instructions tell you, get unit maintenance to do the necessary work.

b. Cleaning.

NOTE

**TRICHLOROTRIFLUOROETHANE IS
HAZARDOUS**

and prolonged breathing of the vapor should be avoided. Adequate ventilation should be provided while using TRICHLOROTRIFLUOROETHANE, The solvent should not be used near heat or open flame; the products of decomposition are toxic and irritating. Since TRICHLOROTRIFLUOROETHANE dissolves natural oils, prolonged contact with skin should be avoided. When necessary, use gloves that the solvent cannot penetrate. If solvent is taken internally, consult a physician immediately.

- (1) Remove dust or loose dirt with a clean soft cloth or brush. Use cloth, Item 1, Appendix E.
- (2) Remove grease, fungus, and ground in dirt with a clean cloth dampened (not wet) with TRICHLOROTRI-FLUOROETHANE. Use cleaning compound, Item 2, Appendix E.

4-2. Operator/Crew Preventive Maintenance Checks and Services (PMCS)

NOTE

If the equipment must be kept in continuous operation, check only those items that can be checked and serviced without disturbing operation. Make the complete checks and services when the equipment can be shut down.

Within designated interval, these checks are to be performed in the order listed.

TM11-5805-201-12/T031W1-2PT-291

B – Before

D – During

A – After

M – Monthly

Item no.	Interval				Item to be Inspected	Procedures	For readiness reporting equipment is not ready/ available if:
	B	D	A	M			
1				•	Batteries	Inspect for foreign matter and corrosion.	Corrosion prohibits operation
2	•				Binding Posts	Check binding posts to assure that they will securely hold WD-ITT wire and their rubber boots are serviceable	
3			•		Battery Compartment	Remove batteries if telephone set will not be used again within one week. If lid is hard to open, put one drop of oil on hinge pins.	

4-3. Unit Maintenance

NOTE

DD Form 314 is not to be filled out as scheduled unit maintenance is not required.

a. General. Unit maintenance includes those procedures listed in the maintenance allocation chart (Appendix C) of this manual.

b. Repairing H-60/PT Cord Assembly. If the outer jacket of the cord is frayed, cut, broken, or cracked, repair with electrical tape provided there is no evidence of damage to any of the internal conductors. If such damage is suspected, refer cord assembly to next higher category of maintenance for repair or replacement as required.

**CHAPTER 5
SHIPMENT AND LIMITED STORAGE**

5-1. Disassembly

- a. Remove the line wires from the LINE 1-2 binding posts.
- b. Open the battery compartment, and remove the batteries.
- c. Clean all moisture, fungus, or corrosion from the battery compartment.
- d. Clean and dry the battery compartment gasket with a clean cloth, and secure the battery compartment cover.
- e. Remove all dirt and moisture from the TA-312/PT and its carrying case.
- f. Install the deicing screen in the transmitter cap of the H-60/PT.

5-2. Repackaging for Shipment or Limited Storage

Repackaging of the TA-312/PT should conform as closely as possible to the original packaging (fig. 2-1). Follow the general procedures outlined below:

- a. Mount the H-60/PT in the retaining cradle. Place enough cushioning material around the H-60/PT to prevent it from shifting in transit.
- b. Fold the handcrank into the wheel on the hand generator.
- c. Close the carrying case cover, and close the slide fastener.
- d. Replace the TA-312/PT in the carton; use the original carton or a suitable substitute.

5-1/(5/2 blank)

**APPENDIX A
REFERENCES**

DA PAM 25-30	Consolidated Index of Army Publications and Blank Forms.
DA PAM 738-750	The Army Maintenance Management System (TAMMS).
SB 11-6	FSC Class 6135; Primary Battery Supply Data.
TM 11-5965-206-14P	Operator's, Organizational, Direct Support, and General Support Maintenance Repair Parts and Special Tools Lists (Including Depot Maintenance Repair Parts and Special Tools: Headset-Microphone H-91A/U (NSN 5965-00-669-6871); Handset-Headset H-144/U, H-144A/U, H-144B/U, and H-144C/U (NSN 5965-00-682-2769) and Headset-Microphone H-210/G (NSN 5965-00-892-1 068).
TM 750-244-2	Procedures for Destruction of Electronics Materiel to Prevent Enemy Use (Electronics Command).

APPENDIX B MAINTENANCE ALLOCATION

B-1. General

This appendix provides a summary of the maintenance operations for the TA-312/PT. It authorities categories of maintenance for specific maintenance functions on repairable items and components and the tools and equipment required to perform each function. This appendix may be used as an aid in planning maintenance operations.

B-2. Maintenance Function

Maintenance functions will be limited to and defined as follows:

a. Inspect. To determine the serviceability of an item by comparing its physical, mechanical, and/or electrical characteristics with established standards through examination.

b. Test. To verify service ability and to detect incipient failure by measuring the mechanical or electric characteristics of an item and comparing those characteristics with prescribed standards.

c. Service. Operations required periodically to keep an item in proper operation condition, i.e., to clean (decontaminate), preserve, drain, paint, or to replenish fuel, lubricants, hydraulic fluids or compressed air supplies.

d Adjust. Maintain within prescribed limits by bringing into proper or exact position, or by setting the operating characteristics to the specified parameters.

e. Align. To adjust specified variable elements of an item to bring about optimum or desired performance.

f. Calibrate. To determine and cause corrections to be made or to be adjusted on instruments or test measuring and diagnostic equipment used in precision measurement. Consists of the comparison of two instruments, one of which is a certified standard of known accuracy, to detect and adjust any discrepancy in the accuracy of the instrument being compared.

g. Install. The act of emplacing, seating, or fixing into positional item, part, module (component or assembly) in a manner to allow the proper functioning of the equipment or systems.

h. Replace. The act of substituting a serviceable like-type part, subassembly, or module (component or assembly) for an unserviceable counterpart.

i. Repair. The application of maintenance services (inspect, test, service, adjust, align, calibrate, replace) or other maintenance actions (welding, grinding, riveting, straightening, facing, remachining, or resurfacing) to restore serviceability to an item by correcting specific damage, fault, malfunction, or failure in a part, subassembly module (component or assembly), end item, or system.

j. Overhaul. That maintenance effort (service/action) necessary to restore an item to a completely serviceable/operational condition as prescribed by maintenance standards (i.e., DMWR) in appropriate technical publications. Overhaul is normally the highest degree of maintenance performed by the Army. Overhaul does not normally return an item to like-new condition.

k. Rebuild. Consists of those services/actions necessary for the restoration of unserviceable equipment to a like-new condition in accordance with original manufacturing standards. Rebuild is the highest degree of materiel maintenance applied to Army equipment. The rebuild operation includes the act of returning to zero those age measurements (hours, miles, etc.) considered in classifying Army equipment/components.

B-3. Column Entries

a. *Column 1, Group Number.* Column 1 lists group numbers, the purpose of which is to identify components, assemblies, subassemblies, and modules with the next higher assembly.

b. *Column 2, Component/Assembly.* Column 2 contains the noun names of components, assemblies, subassemblies, and modules for which maintenance is authorized.

c. *Column 3, Maintenance Functions.* Column 3 lists the functions to be performed on the item listed in column 2. When items are listed without maintenance functions, it is solely for the purpose of having the group numbers in the MAC and RPSTL coincide.

d. *Column 4, Maintenance Category.* Column 4 specifies, by the listing of a "worktime" figure in the appropriate subcolumn(s), the lowest level of maintenance authorized to perform the functions listed in column 3. This figure represents the active time required to perform the maintenance function at the indicated category of maintenance. If the number or complexity of the tasks within the listed maintenance function vary at different maintenance categories, appropriate "worktime" figures will be shown for each category. The number of task-hours specified by the "worktime" figure represents the average time required to restore an item (assembly, subassembly, component, module, end item, or system) to a serviceable condition under typical field operating conditions. This time includes preparation time, troubleshooting time, and quality assurance/quality control time in addition to the time required to perform the specific tasks identified for the maintenance functions authorized in the maintenance allocation chart. Subcolumns of column 4 are as follows:

- C - Operator/Crew
- O - Unit
- F - Direct Support
- H - General Support
- D - Depot

TM11-5805-201-12/TO31W1-2PT-291

e. Column 5, Tools and Equipment. Column 5 specifies by code, those common tool sets (not individual tools) and special tools, test, and support equipment required to perform the desired function.

f. Column 6, Remarks. Column 6 contains an alphabetic code which leads to the remark in section IV, Remarks, which is pertinent to the item opposite the particular code.

B-4. Tools and Test Equipment Requirements (Section III)

a. Tool or Test Equipment Reference Codes. The numbers in this column coincide with the numbers used in the tools and equipment column of the MAC. The numbers indicate the applicable tool or test equipment for the maintenance functions.

b. Maintenance Category. The code in this column indicate the maintenance category allocated to the tool or test equipment.

c. Nomenclature. This column lists the noun name and nomenclature of the tools and test equipment required to perform the maintenance functions.

d. National/NATO Stock Number. This column lists the National/NATO stock number of the specific tool or test equipment.

e. Tool Number. This column lists the manufacturer's part number of the tool followed by the Federal Supply Code for manufacturers (5-digit) in parentheses.

B-5. Remarks (Section IV)

a. Reference Code. This code refers to the appropriate item in section 11, column 6.

b. Remarks. This column provides the required explanatory information necessary to clarify items appearing in section II.

Section II. MAINTENANCE ALLOCATION CHART FOR TELEPHONE SET TA-312/PT

(1) Group Number	(2) Component/Assembly	(3) Maintenance Function	(4) Maintenance Category					(5) Tools and Eqpt.	(6) Remarks
			c	O	F	H	D		
00	Telephone Set TA-312/PT	Inspect	0.5	0.2					A
		Service	0.5	0.2				4	B
		Test			0.5			1,3	C
		Replace		0.6				1,3	D
		Adjust Repair		0.4		1.5		1,2,3,4	E
01	Case, Telephone Set	Service		0.4				1,3	B
		Replace			1.0			1,3	F
02	Telephone Set	Service		0.5				4	B
		Replace			1.5			1,3	G
		Repair			1.5			1,2,3,4	H
		Adjust			1.5			1,3	I
03	Handset H-60/PT							J	

Section III. TOOL AND TEST EQUIPMENT REQUIREMENTS FOR TELEPHONE SET TA-312/PT

Tool or Test Equipment Ref Code	Maintenance Category	Nomenclature	National/Nato Stock Number	Tool Number
1	F	Multimeter, 3 1/2 Digit AN/PSM-45 Alternate Multimeter TS-352D/U	6625-01-139-2512 6625-00-242-5023	
2	F	Test Set, Telephone TS-716/U	6625-00-965-1433	
3	F	Tool Equipment, Telephone Electricians TE-49	5180-00-408-1863	
4	O	Tool Equipment TE-33	5180-00-408-1859	

Section IV. REMARKS FOR TELEPHONE SET TA-312/PT

Reference Code	Remarks
A	External.
B	Preventive maintenance.
c	Test external controls, battery, and handset elements.
D	Replace external control knob, battery, fuse.
E	Adjust external controls.
F	Replace ringing generator assembly, water proof air valves.
G	Replace hookswitch, receptacle connector, panel gasket,
	terminal board, buzzer and impedance matching network.
H	Repair in accordance with component MAC.
I	Adjust hookswitch assembly and buzzer.
J	Handset is an expendable item.

APPENDIX C
COMPONENTS OF END ITEM (COEIL) AND BASIC ISSUE
ITEMS LIST (BIIL)

Section I. INTRODUCTION

C-1. Scope

This appendix lists only basic issue items crew/operator for installation, operation, and Telephone Set TA-312/PT.

C-2. General

This Basic Issue Items List is a list, in alphabetical sequence, of items which are furnished with, and which must be turned in with the end item.

C-3. Explanation of Columns

The following provides an explanation of columns found in the tabular listings:

a. *Illustration*. This column is divided as follows:

(1) *Figure number*. Indicates the figure number of the illustration in which the item is shown.

(2) *Item Number*. Not applicable

b. *Federal Stock Number*. Indicates the Federal stock number assigned to the item and will be used for requisitioning purposes.

c. *Part Number*. Indicates the primary number used by the manufacturer (individual, company, firm, corporation, or Government activity), which controls the design and characteristics of the item by means of its engineering drawings, specifications standards, and inspection requirements to identify an item or range of items.

d. Federal Supply Code for Manufacturer (FSCM). The FSCM is a 5-digit numeric code used to identify the manufacturer, distributor, or Government agency, etc., and is identified in SB 708-42.

e. Description. Indicates the Federal item name and a minimum description required to identify the item.

f. Unit of Measure (U/M). Indicates the standard of basic quantity of the listed item as used in performing the actual maintenance function. This measure is expressed by a two-character alphabetical abbreviation, (e.g., ea, in., pr, etc). When the unit of measure differs from the unit of issue, the lowest unit of issue that will satisfy the required units of measure will be requisitioned.

g. Quantity Furnished with Equipment (Basic issue Items Only). Indicates the quantity of the basic issue item furnished with the equipment.

Section II. BASIC ISSUE ITEMS LIST

(1) Illustration		(2)	(3)	(4)	(5)	(6)	(7)
(a) Fig. No.	(b) Item No.	National Stock Number	Part Number	FSCM	Description Usable On Code	Unit of Meas	Qty Furn With Equip
1-2		5805-00-752-6166	SC-D-140783	80063	Case, Telephone CY-1277BIPT	Ea	1
1-2		8465-00-269-0682	MIL-S-1698	81349	Sling, Carrying, Bag and Case	Ea	1

NOTE: CY-1277B/PT is one-way interchangeable with all previous models.

C-3/(C-4 blank)

**APPENDIX D
ADDITIONAL AUTHORIZATION LIST**

Section 1. INTRODUCTION

D-1. Scope

This appendix lists additional items you are authorized for the support of the TA-312/PT.

D-2. General

This list identifies items that do not have to accompany the TA-312/PT and that do not have to be turned in with it. These items are authorized to you by CTA, MTOE, TDA, or JTA.

D-3. Explanation of Listing

National stock numbers, descriptions, and quantities are provided to help you identify and request the additional items you require to support this equipment. The items are listed in alphabetical sequence by item name under the type document (i.e., CTA, MTOE, TDA, or JTA) which authorizes the item(s) to you.

Section II. ADDITIONAL AUTHORIZATION LIST

(1) National Stock Number	(2) Description FSCM & Part Number Usable on Code	(3) U/M	(4) Qty Auth
	CTA Authorized Items		
5805-00-782-210	Lamp Assembly	Ea	1
5970-00-29-6263	Boot, Binding Post	Ea	2
9905-00-226-1742	Plate, Designation	Ea	1
5808-00-392-7628	Screen, Deicing	Ea	1
5805-00-708-2203	U-184/GT Connector Adapter	Ea	1
6240-00-577-8456	Glow Lamp M15098/1-001	Ea	1
6240-00428-6737	Glow Lamp M15098/1-003	Ea	1

APPENDIX E
EXPENDABLE/DURABLE SUPPLIES

Section I. INTRODUCTION

E-1. Scope

This appendix lists expendable/durable supplies you will need to operate and maintain the TA-312/PT. These items are authorized to you by CTA50-970, Expendable Items (Except Medical, Class V, Repair Parts, and Heraldic Items).

E-2. Explanation of Columns

a. Column 1 – Item Number. This number is assigned to the entry in the listing and is referenced in the narrative instructions to identify the material (e.g., “Use cleaning compound, item 5, App. D”).

b. Column 2– Level. This column identifies the lowest level of maintenance that requires the listed item.

- C – Operator/Crew
- O – Unit Maintenance
- F – Direct Support Maintenance
- H – General Support Maintenance

c. Column 3 – National Stock Number. This is the National stock number assigned to the item; use it to request or requisition the item.

d Column 4- Description. Indicates the Federal item name, and if, required, a description to identify the item. The last line for each item indicates the part number followed by the Federal Supply Code for Manufacturer (FSCM) in parentheses, if applicable.

e. Column 5 – Unit of Measure (U/M). Indicates the measure used in performing the actual maintenance function. This measure is expressed by a two-character alphabetical abbreviation (e.g., ea, in, pr). If the unit of measure differs from the unit of issue, requisition the lowest unit of issue that will satisfy your requirements.

Section II. EXPENDABLES/DURABLE SUPPLIES

(1) Item No.	(2) Level	(3) National Stock Number	(4) Description Part No. and FSCM	(5) Unit of Meas
1	C	8305-00-205-3496	Cloth, Cotton, Lint-free (81348) CCCC44	Pg
2	C	6180-00-105-3084	Trichlorotriiuroethane (80244) (16 Oz Can)	Oz
3	C	6135-00-120-1020	Battery, Dry (80063) BA-30	Ea

RECOMMENDED CHANGES TO EQUIPMENT TECHNICAL PUBLICATIONS

SOMETHING WRONG WITH THIS PUBLICATION?



THEN JOT DOWN THE DOPE ABOUT IT ON THIS FORM. CAREFULLY TEAR IT OUT, FOLD IT AND DROP IT IN THE MAIL.

FROM (PRINT YOUR UNIT'S COMPLETE ADDRESS)
 Commander
 Stateside Army Depot
 ATTN: AMSTA-US
 Stateside, N.J. 07703-5007

DATE SENT
 10 July 1975

PUBLICATION NUMBER TM 11-5840-340-12	PUBLICATION DATE 23 Jan 74	PUBLICATION TITLE Radar Set AN/PRC-76
---	-------------------------------	--

BE EXACT		PIN-POINT WHERE IT IS		IN THIS SPACE TELL WHAT IS WRONG AND WHAT SHOULD BE DONE ABOUT IT:
PAGE NO	PARA GRAPH	FIGURE NO	TABLE NO	
2-25	2-28			<p>Recommend that the installation antenna alignment procedure be changed throughout to specify a 2° IFF antenna lag rather than 1°.</p> <p>REASON: Experience has shown that with only a 1° lag, the antenna servo system is too sensitive to wind gusting in excess of 25 knots, and has a tendency to rapidly accelerate and decelerate as it hunts, causing strain to the drive train. Hunting is minimized by adjusting the lag to 2° without degradation of operation.</p>
3-10	3-3		3-1	<p>Item 5, Function column. Change "2 db" to "3db."</p> <p>REASON: The adjustment procedure for the TRANS POWER FAULT indicator calls for a 3 db (500 watts) adjustment to light the TRANS POWER FAULT indicator.</p>
5-6	5-8			<p>Add new step f.1 to read, "Replace cover plate removed in step e.1, above."</p> <p>REASON: To replace the cover plate.</p> <p>Zone C 3. On J1-2, change "+24 VDC to "+5 VDC."</p> <p>REASON: This is the output line of the 5 VDC power supply. +24 VDC is the input voltage.</p>

PRINTED NAME GRADE OR TITLE AND TELEPHONE NUMBER SSG I. M. DeSpirito 999-1776	SIGN HERE 
--	---

FILL IN YOUR
UNIT'S ADDRESS

FOLD BACK

DEPARTMENT OF THE ARMY

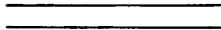

OFFICIAL BUSINESS

TEAR ALONG PERFORATED LINE

Commander
US Army Communications-Electronics Command
and Fort Monmouth
ATTN: AMSEL-LC-ME-PS
Fort Monmouth, New Jersey 07703-9908

SAMPLE



FOLD BACK

RECOMMENDED CHANGES TO EQUIPMENT TECHNICAL PUBLICATIONS



SOMETHING WRONG WITH THIS PUBLICATION?

THEN...JOT DOWN THE DOPE ABOUT IT ON THIS FORM. CAREFULLY TEAR IT OUT. FOLD IT AND DROP IT IN THE MAIL.

FROM: (PRINT YOUR UNIT'S COMPLETE ADDRESS)

DATE SENT

PUBLICATION NUMBER	PUBLICATION DATE	PUBLICATION TITLE
TM 11-5805-201-12	1 August 1990	Telephone Sets TA-312/PT

PAGE NO	PARA. GRAPH	FIGURE NO	TABLE NO	IN THIS SPACE TELL WHAT IS WRONG AND WHAT SHOULD BE DONE ABOUT IT:

PRINTED NAME GRADE OR TITLE AND TELEPHONE NUMBER

SIGN HERE

TEAR ALONG PERFORATED LINE

DA FORM 1 JUL 79 2028-2

PREVIOUS EDITIONS ARE OBSOLETE

P.S. -- IF YOUR OUTFIT WANTS TO KNOW ABOUT YOUR RECOMMENDATION MAKE A CARBON COPY OF THIS AND GIVE IT TO YOUR HEADQUARTERS

FILL IN YOUR
UNIT'S ADDRESS

FOLD BACK

DEPARTMENT OF THE ARMY



OFFICIAL BUSINESS

Commander
US Army Communications Electronics Command
and Fort Monmouth
ATTN: AMSSEL LC ME PS
Fort Monmouth, New Jersey 07703-9988



FOLD BACK

TEAR ALONG PERFORATED LINE

RECOMMENDED CHANGES TO EQUIPMENT TECHNICAL PUBLICATIONS

 <p>THEN...JOT DOWN THE DOPE ABOUT IT ON THIS FORM. CAREFULLY TEAR IT OUT. FOLD IT AND DROP IT IN THE MAIL.</p>		<p>SOMETHING WRONG WITH THIS PUBLICATION?</p>	
		<p>FROM (PRINT YOUR UNIT'S COMPLETE ADDRESS)</p>	
		<p>DATE SENT</p>	
<p>PUBLICATION NUMBER</p> <p>TM 11-5805-201-12</p>		<p>PUBLICATION DATE</p> <p>1 August 1990</p>	<p>PUBLICATION TITLE</p> <p>Telephone Sets TA-312/PT</p>
<p>BE EXACT PIN-POINT WHERE IT IS</p>			
<p>PAGE NO</p>	<p>PARA. GRAPH</p>	<p>FIGURE NO</p>	<p>TABLE NO</p>
<p>IN THIS SPACE TELL WHAT IS WRONG AND WHAT SHOULD BE DONE ABOUT IT:</p>			
<p>PRINTED NAME GRADE OR TITLE AND TELEPHONE NUMBER</p>			<p>SIGN HERE</p>

IT IS ACTION-ORIENTED

DA FORM 2028-2
1 JUL 79

PREVIOUS EDITIONS ARE OBSOLETE

P.S.—IF YOUR OUTFIT WANTS TO KNOW ABOUT YOUR RECOMMENDATION MAKE A CARBON COPY OF THIS AND GIVE IT TO YOUR HEADQUARTERS

FILL IN YOUR
UNIT'S ADDRESS

FOLD BACK

DEPARTMENT OF THE ARMY



OFFICIAL BUSINESS

Commander
US Army Communications Electronics Command
and Fort Monmouth
ATTN: AMSEL LC ME PS
Fort Monmouth, New Jersey 07703-9988



FOLD BACK

TAB ALONG PERFORATED LINE

RECOMMENDED CHANGES TO EQUIPMENT TECHNICAL PUBLICATIONS



THEN...JOT DOWN THE DOPE ABOUT IT ON THIS FORM. CAREFULLY TEAR IT OUT. FOLD IT AND DROP IT IN THE MAIL.

SOMETHING WRONG WITH THIS PUBLICATION?

FROM (PRINT YOUR UNIT'S COMPLETE ADDRESS)

DATE SENT

PUBLICATION NUMBER

TM 11-5805-201-12

PUBLICATION DATE

1 August 1990

PUBLICATION TITLE

Telephone Sets TA-312/PT

BE EXACT		PIN-POINT WHERE IT IS		IN THIS SPACE TELL WHAT IS WRONG AND WHAT SHOULD BE DONE ABOUT IT:
PAGE NO	PARA-GRAPH	FIGURE NO	TABLE NO	

PRINTED NAME GRADE OR TITLE AND TELEPHONE NUMBER

SIGN HERE

DA FORM 2028-2
1 JUL 79

PREVIOUS EDITIONS
ARE OBSOLETE

P.S.—IF YOUR OUTFIT WANTS TO KNOW ABOUT YOUR RECOMMENDATION MAKE A CARBON COPY OF THIS AND GIVE IT TO YOUR HEADQUARTERS

FILL IN YOUR
UNIT'S ADDRESS

FOLD BACK

DEPARTMENT OF THE ARMY



OFFICIAL BUSINESS

Commander
US Army Communications Electronics Command
and Fort Monmouth
ATTN: AMSEL LC ME PS
Fort Monmouth, New Jersey 07703 9988



FOLD BACK

TEAR ALONG PERFORATED LINE

By Order of the Secretary of the Army:

CARL E. VUONO
General, United States Army
Chief of Staff

Official:

THOMAS F. SIKORA
Brigadier General, United States Army
The Adjutant General

By Order of the Secretary of the Air Force:

LARRY D. WELSH
General, United States Air Force
Chief of Staff

Official:

CHARLES C. McDONALD
General, United States Air Force
Commander, Air Force
Logistics Command

DISTRIBUTION:

To be distributed in accordance with DA Form 12-36-E,
block 6954, Operator and Unit Maintenance requirements
for TM 11-5805-201-12.

▣ U.S. GOVERNMENT PRINTING OFFICE: 1991 0 - 281-486 (42704)

(CONTINUED FROM INSIDE FRONT COVER)

CONDENSED OPERATING INSTRUCTIONS

ADJUSTING BUZZER VOLUME

6. REQUEST DISTANT PARTY TO SIGNAL AND REPLACE H-60/PT.
7. WHEN SIGNAL IS RECEIVED, ADJUST BUZZER VOLUME CONTROL, COMPLETING CALL
8. REPLACE H-60/PT.
9. IF CONNECTED THROUGH LB SWITCHBOARD, "RING OFF" BY TURNING HANDCRANK.

USING HANDSET-HEADSET H-144(*)/U (HANDSET H-60/PT IN MOUNTING)

PLACING CALL (LB OPERATION)

1. OPERATE **[EXT-INT]** SWITCH TO **[EXT]**.
2. TURN HANDCRANK; LISTEN FOR CALLED PARTY.

PLACING CALL (CB OR CBS OPERATION)

3. OPERATE **[EXT-INT]** SWITCH TO **[EXT]**; LISTEN FOR OPERATOR TO ANSWER.
4. DO NOT LEAVE **[EXT-INT]** SWITCH AT **[EXT]** WHEN NOT IN USE.

CONVERSING (LB AND CBS OPERATION)

5. PRESS PUSH-TO-TALK SWITCH TO TALK; RELEASE TO LISTEN.

CONVERSING (CB OPERATION)

6. DO NOT OPERATE PRESS-TO-TALK SWITCH.

ADJUSTING BUZZER VOLUME

7. REQUEST DISTANT PARTY TO SIGNAL AND THEN OPERATE **[EXT-INT]** SWITCH TO **[INT]**.
8. WHEN SIGNAL IS RECEIVED, ADJUST BUZZER VOLUME CONTROL.

COMPLETING CALL

9. OPERATE **[EXT-INT]** SWITCH TO **[INT]**.
10. IF CONNECTED THROUGH LB SWITCHBOARD, "RING OFF" BY TURNING HANDCRANK.

PIN:028544-000