

DEPARTMENT OF THE ARMY TECHNICAL MANUAL

TM 11-5820-222-35

DEPARTMENT OF THE AIR FORCE TECHNICAL ORDER

TO 31R2-2TRC68-22

---

**FIELD AND DEPOT  
MAINTENANCE MANUAL**

**RADIO SETS AN/VRC-24  
AND AN/TRC-68**

This copy is a reprint which includes current  
pages from Changes 1 through 6.

---

*DEPARTMENTS OF THE ARMY AND THE AIR FORCE*

*1 JUNE 1961*

## **WARNING**

**DANGEROUS VOLTAGES EXIST AT THE ANTENNAS AND IN  
RECEIVER-TRANSMITTER GROUPS**

**OA-2648/VRC-24 AND OA-2649/TRC-68**

**Be careful when working around the antenna or the antenna connectors, as high radiofrequency voltages exist at these points. Be careful when working on the 300-volt, 125-volt plate and power supply circuits, or on the ac line connections (115 or 230 volts).**

**DON'T TAKE CHANCES!**

CHANGE }  
No. 6 }

HEADQUARTERS  
DEPARTMENT OF THE ARMY  
WASHINGTON, DC 2 January 1979

**DIRECT SUPPORT, GENERAL SUPPORT,  
AND DEPOT MAINTENANCE MANUAL  
RADIO SETS AN/VRC-24 (NSN 5820-00-402-2264)  
AN/VRC-24A (NSN 5820-00-223-7413),  
AN/TRC-68 (NSN 5820-00-682-2718), AND  
AN/TRC-68A (NSN 5820-00-682-2718)**

TM 11-5820-222-35, 1 June 1961, is changed as follows:

The title of this manual is changed as indicated above.

Page 2. Paragraph 1.2 is superseded as follows:

**1.2. Forms and Records**

a. *Reports of Maintenance and Unsatisfactory Equipment.* Maintenance forms, records, and reports which are to be used by maintenance personnel at all maintenance levels are listed in and prescribed by TM 38-750.

b. *Report of Packaging and Handling Deficiencies.* Fill out and forward DD Form 6 (Packaging Improvement Report) as prescribed in AR 700-58/NAVSUPINST 4030.29/AFR 71-13/MCO P4030.29A, and DLAR 4145.8.

c. *Discrepancy in Shipment Report (DISREP) (SF 361).* Fill out and forward Discrepancy in Shipment Report (DISREP) (SF 361) as prescribed in AR 55-38 /NAVSUPINST 4610.33B/AFR 75-18/MCO P4610.19C and DLAR 4500.15.

**1.2-1. Reporting of Equipment Publication Improvements**

The reporting of errors, omissions, and recommendations for improving this publication by

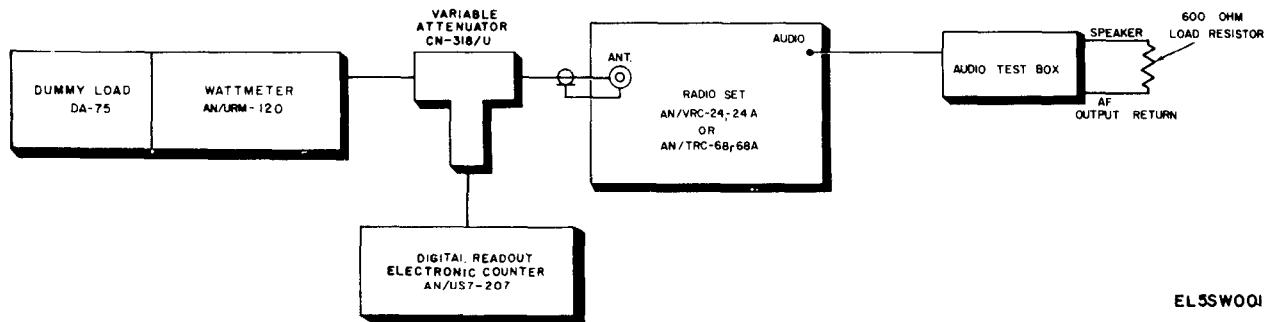
the individual user is encouraged. Reports should be submitted on DA Form 2028 (Recommended Changes to Publications and Blank Forms) and forwarded direct to Commander, US Army Communications and Electronics Materiel Readiness Command, ATTN: DRSEL-ME-MQ, Fort Monmouth, NJ 07703.

**1.2-2. Reporting Equipment Improvement Recommendations (EIR)**

EIR's will be prepared using Standard Form 368 (Quality Deficiency Report). Instructions for preparing EIR's are provided in TM 38-750 (The Army Maintenance Management System). EIR's should be mailed direct to Commander, US Army Communications and Electronics Materiel Readiness Command, ATTN: DRSEL-ME-MQ, Fort Monmouth, NJ 07703. A reply will be furnished direct to you.

Page 185. Paragraph 149. Change the title of subparagraph 149a to read "Transmitter RF Output and Frequency Stability Test (fig. 119.2)." Add the following to subparagraph a(3). "The actual operating frequency will be  $\pm 11$  kHz of the channel frequency."

Page 192. Delete figure 119.2 and substitute new figure 119.2.



EL55W001

Figure 119.2. Transmitter of power and frequency stability tests.

## APPENDIX REFERENCES

---

DA Pam 310-4	Index of Technical Publications: Technical Manuals, Technical Bulletins, Supply Manuals (Types 7, 8, and 9), Supply Bulletins, and Lubrication Orders.
DA Pam 310-7	US Army Equipment Index of Modification Work Orders.
TB SIG 355-1	Depot Inspection Standard for Repaired Signal Equipment.
TB SIG 355-2	Depot Inspection Standard for Refinishing Repaired Signal Equipment.
TB SIG 355-3	Depot Inspection Standard for Moisture and Fungus Resistant Treatment.
TM 11-284	Radio Sets AN/GRC-3, -4, -5, -6, -7, and -8.
TM 11-5030	Signal Generator TS-497A/URR.
TM 11-5038	Control Group AN/GRA-6.
TM 11-5094	Frequency Meter AN/URM-79.
TM 11-5095	Frequency Meter AN/URM-80 (NSN 6625-00-649-4286).
TM 11-5096	Frequency Meter AN/URM-81.
TM 11-5120	Frequency Meters AN/URM-32 and AN/URM-32A and Power Supply PP-1243/U.
TM 11-5129	Oscilloscopes AN/USM-50A, B, and C.
TM 11-5551D	R. F. Signal Generator Set AN/URM-25D.
TM 11-5820-222-10	Operator's Manual: Radio Sets AN/VRC-24, AN/VRC-24A, AN/TRC-68, and AN/TRC-68A.
TM 11-5820-222-20	Organizational Maintenance Manual: Radio Sets AN/VRC-24, AN/VRC-24A, AN/TRC-68, and AN/TRC-68A.
TM 11-6625-200-15	Operator's, Organizational, DS, GS, and Depot Maintenance Manual Multimeters ME-26A/U, ME-26B/U, ME-26C/U, and ME-26D/U.
TM 11-6625-446-15	Operator's, Organizational, DS, GS, and Depot Maintenance Manual: Wattmeter AN/URM-120.
TM 11-6625-493-15	Operator's, Organizational, Direct Support, General Support, and Depot Maintenance Manual: Frequency Comparator CM-77A/USM (NSN 6625-00-080-7204).
TM 11-6625-508-10	Operator's Manual: Signal Generators AN/USM-44 and AN/USM-44A.
TM 11-6625-665-15	Operator's, Organizational, DS, GS, and Depot Maintenance Manual: Generator, Signal AN/USM-205.
TM 11-6625-683-15	Operator's, Organizational, Direct Support, General Support, and Depot Maintenance Manual: Signal Generator AN/URM-127 (NSN 6625-00-783-5965).
TM 11-6625-700-10	Operator's Manual: Digital Readout, Electronic Counter AN/USM-207 (NSN 6625-00-911-6368).
TM11-6625-1703-15	Operator, Organizational, Direct Support, General Support and Depot Maintenance Manual Including Repair Parts and Special Tool Lists: Oscilloscope AN/USM-281A.
TM 38-750	The Army Maintenance Management System (TAMMS).



By Order of the Secretary of the Army:

BERNARD W. ROGERS  
*General, United States Army*  
*Chief of Staff*

Official:

J. C. PENNINGTON  
*Brigadier General, United States Army*  
*The Adjutant General*

Distribution:

To be distributed in accordance with DA Form 12-51, Direct and General Support maintenance requirements for AN/VRC-24, 24A, AN/TRC-68.



CHANGE }  
No. 5 }

HEADQUARTERS  
DEPARTMENT OF THE ARMY  
Washington, D.C., 3 July 1972

**Direct Support, General Support,  
and Depot Maintenance Manual  
RADIO SETS AN/VRC-24, AN/VRC-24A, AN/TRC-68, AND AN/TRC-68A**

TM 11-5820-222-35, 1 June 1961, is changed as follows:  
Change title as indicated above.

Page 2, paragraph 1-1. Delete paragraph 1-1 and substitute the following:

**1.1. Indexes of Publications**

a. *DA Pam 310-4.* Refer to the latest issue of DA Pam 310-4 to determine whether there are new editions, changes, or additional publications pertaining to the equipment.

b. *DA Pam 310-7.* Refer to the latest issue of DA Pam 310-7 to determine whether there are notification work orders (MWO's) pertaining to the equipment.

Paragraph 1-2. Delete paragraph 1-2 and substitute the following:

**1.2. Maintenance Forms and Records**

a. *Forms and Records.* Use equipment forms and records in accordance with instructions given in TM 38-750.

b. *Equipment Serviceability Criteria.* The equipment serviceability criteria (ESC) for Radio Sets AN/VRC-24, AN/VRC-24A, and Radio Sets AN/TRC-68, AN/TRC-68A are contained in TM 11-5820-222-ESC/1, and TM 11-5820-222-ESC/2 respectively.

c. *Administrative Storage.* For procedures, forms and records, and inspections required during administrative storage of this equipment refer to TM 740-90-1.

d. *Reporting of Equipment Publication Improvements.* The reporting of errors, omissions, and recommendations for improving this publication by the individual user is encouraged. Reports should be submitted on DA Form 2028 (Recommended Changes to Publications) and forwarded

direct to Commanding General, U. S. Army Electronics Command, ATTN: AMSEL-MA-CR, Fort Monmouth, NJ 07703.

Page 181. Paragraph 141.9. Make the following changes: Delete the following subparagraphs from the performance standard column of the chart: a, c, g, h, and i, and substitute the following:

a. Not less than 280 volts dc.

c. Not less than 118 volts dc.

g. The ripple voltage shall not exceed 2% of the measured dc voltage.

h. The ripple voltage shall not exceed 2% of the measured dc voltage.

i. The ripple voltage shall not exceed 2% of the measured dc voltage.

Paragraph 141.12. Make the following changes to Step 1 of the chart. Delete subparagraphs e and f in both the test procedure and the performance standard columns.

Step 2 of the Chart. Make the following changes: Delete subparagraphs d, through h, in the test procedure and the performance standard columns.

Step 4 of the Chart. Delete Step 4 in its entirety. Paragraph 141.17. Make the following changes: Delete subparagraph b and substitute:

b. *DY-151/U Voltage and Ripple.*

	<i>Voltage</i>	<i>Ripple</i>
300 VDC	Not less than 280	Not more than 2% of measured dc voltage.
125 VDC	Not less than 118	Not more than 2% of measured dc voltage.
-30VDC	-30 $\pm$ 3	Not more than 2% of measured dc voltage.

Subparagraph *c.* Make the following changes to lines 10 and 11.

Delete: "250." from line 10, and "100 cps and" from line 11.

Subparagraph *d.* Make the following changes to line 12:

Delete: "-8db -100 cps"

Page 182, paragraph 144. Add the following to the chart:

Audio Oscillator TS-421/U ..... TM 11-6625-355-12 ..... 1  
Paragraph 148. Delete *a* (8) and substitute:

(8) Perform (1) through (7) above for the following test frequencies.

Frequency (MHz)

311.1

225.0

Subparagraph *b.* Delete (4), (5) and (6) and substitute the following:

(4) Turn the SQUELCH control fully clockwise (minimum sensitivity). SQUELCH must deactivate with an input signal that is *not less than* 25 microvolts without readjustment of the SQUELCH control.

(5) Repeat the test at 309.0 and 225.0 MHz by following the instructions in (3) and (4) above.

(6) Perform (3), (4), and (5) above with supply voltages of 103 (or 207) and 127 (or 253) volts ac (AN/TRC-68 or AN/TRC-68A), or at 23.4 and 29.4 volts dc (AN/VRC-24 or AN/VRC-24A) (fig. 114). The input signal required to deactivate the squelch *must be between* 0.5 and 17 microvolts for maximum sensitivity, and greater than 17 microvolts for minimum sensitivity.

Subparagraph *d.* Delete subparagraph *d.*, and substitute the following:

*d. Bandwidth Selectivity Test (fig. 117).*

(1) Operate the radio set for normal receive. Set CHAN SEL switch to MANUAL and the TENTH selector switch to .5.

(2) Set Signal Generator AN/USM-205 for a maximum indication on Multimeter ME-26/U (approx. 3.5 MHz) and adjust the output level of the generator to obtain a 1.0 volt indication on the ME-26/U.

(3) Increase the AN/USM-205 output level to 6 db above the level set in (2) above.

(4) Record the frequencies above and below the previous setting of the signal generator ((2) above as indicated on AN/USM-207) which will provide 1.0 volt on the ME-26/U. The difference between these two frequencies (6 db bandwidth) *must not be less than* 80 kHz. The center frequency

should be determined by using the following formula:

$$\frac{(\text{upper freq. reading} - \text{low freq. reading})}{2}$$

+ lower freq. reading = 6 db center freq. and should be 3500  $\pm$  4.5 kHz

#### NOTE

Center frequency is defined as that frequency midway between the two points on the attenuation (or response) curve at which the output is 6 db below its maximum level.

(5) Increase the AN/USM-205 output level (at the center frequency) to 60 db above the level set in (2) above.

(6) Record the frequencies above and below center frequency (as indicated on the AN/USM-207) which will provide 1.0 volt on the ME-26/U. The difference between these two frequencies (60 db bandwidth) *must not be greater than* 150 kHz.

#### NOTE

Always subtract the smaller deviation from the larger.

(7) Determine the 60 db half-bandwidth difference percentages by using the following formula:  
$$\frac{\text{deviation (plus)} - \text{deviation (minus)} \times 100}{\text{average deviation}}$$

half-bandwidth difference percentage where: deviation (plus) is the frequency difference in megahertz (6) above) above the center frequency; deviation (minus) is the frequency difference in MHz (6) above) below the center frequency. Average deviation is the bandwidth in megahertz (determined in (6) above) divided by 2.

*Example:* If the two recorded frequencies ((6) above) are 3.565635 and 3.441647 MHz, the deviation (plus) equals 0.065635 MHz, the deviation (minus) equals 0.058353 MHz, and the total bandwidth equals 0.123988 MHz. The half bandwidth is 0.123988 divided by 2 or 0.061994. Therefore: half bandwidth difference percentage of 60 db =  $\frac{0.065635 - 0.058353 \times 100}{0.061994}$

= 11.8 percent.

(8) The half-bandwidth difference percentages at 60 db shall not exceed 25 percent.

Subparagraph *e.* Delete subparagraph *e.* and substitute the following:

*e. Receiver Audio Output and Audio Level Adjustment Test (fig. 118).*

(1) Tune the receiver-transmitter and AN/

GPO 807-889-1

USM-44 to any convenient frequency. Adjust the AN/USM-44 for an rf signal modulated 30 percent with a 1,000 Hz audio signal.

(2) Set the (radio set) METER switch to S-METER and adjust the AN/USM-44 rf signal output level for a maximum S-METER indication.

(3) Connect ME-30B/U to the radio set as directed below. Reading obtained shall not be less than the values given in the chart below.

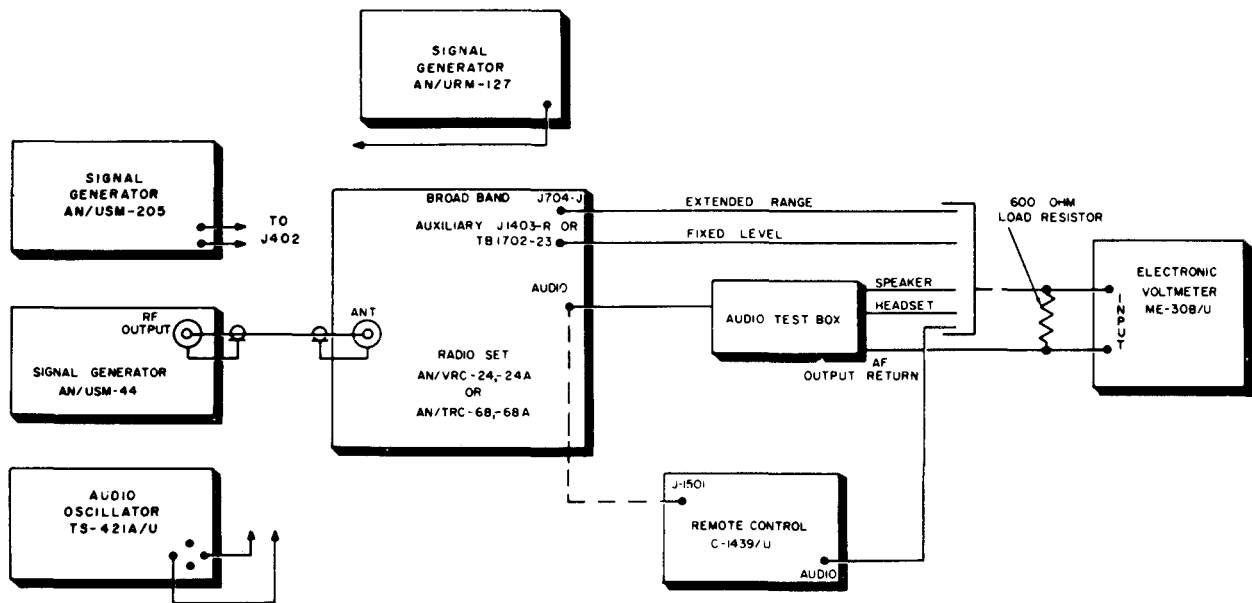
(4) To perform the test, make one set of measurements with normal input voltage applied to the receiver-transmitter unit and a second set of measurements with the input voltage reduced to 103 (or 207) volts ac (AN/TRC-68 and AN/TRC-68A) or 23.4 volts dc (AN/VRC-24 and AN/VRC-24A).

#### NOTE

Terminate speaker output with a 600 ohm resistor for all tests in this subparagraph.

(5) Check the front panel VOLUME control audio level adjustment range. VOLUME control should provide loudspeaker and headset output level adjustment of at least 25 db. The setting of the VOLUME control must not affect the output level of the extended range audio circuits by more than  $\pm 2$  db, or the fixed level and remote audio circuits by more than  $\pm 3$  db.

(6) Audio output will be not less than that indicated in the chart below. Delete figure 118 and substitute new figure 118. Make the following changes to the chart.



TM5820-222-35-C5-5

Figure 118. Receiver audio output and audio level adjustment test.

Add the following to the *Audio output with normal input voltage*, and the *Audio output with reduced input voltage* column headings: (Not less than)

Subparagraph *f*. Delete subparagraphs *f*(1), (2), (4), and (10) and substitute the following:

(1) Repeat the procedure in *e*(1) above.

(2) Set the METER switch to S-METER and adjust the AN/USM-44 rf signal output level for a maximum S-METER indication.

(4) Set Signal Generator AN/URM-127 output signal to frequencies of 300, 3,000, 5,000, and 10,000 Hz. Without further adjustment of the receiver-transmitter controls, measure and record the db indication of the ME-30B/U. At 300 and 3,000 Hz, the audio output level *must be* within  $\pm 3$  db of the indication in (3) above. Audio output levels at 5,000 and 10,000 Hz should not be less than -5 db, -15 db, respectively, from the indications in (3) above.

(10) Measure and record the audio output voltage at modulation frequencies of 300, 1,000, 4,000, 10,000, 15,000, 20,000, and 25,000 Hz. The db indications of the ME-30B/U from 300 to 10,000 Hz *should be within  $\pm 3$  db* of the indication at 1,000 Hz. The db indications at 15,000, 20,000, and 25,000 Hz *should not be more than -5, -6, and -7 db* respectively from the db indication at 1,000 Hz. Turn S801 NOR-BB switch to NOR. Subparagraph *g*. Delete subparagraphs *g*(1), (2), and (3), and substitute the following:

- (1) Repeat procedure in *e*(1) above.
- (2) Adjust the AN/USM-44 rf signal output

level to that level necessary to accomplish (3) below.

(3) Set the front panel METER switch to S-METER and adjust the AN/USM-44 rf signal output level for a maximum S-METER indication. Delete figure 119 and substitute new figure 119. Subparagraph *h*. Delete subparagraphs *h*(2) and (3) and substitute the following:

(2) Set the front panel METER switch to S-METER.

(3) Adjust the AN/USM-44 rf signal output level (rf signal modulated 30% by a 1000 Hz signal) to that level necessary for a maximum S-METER indication.

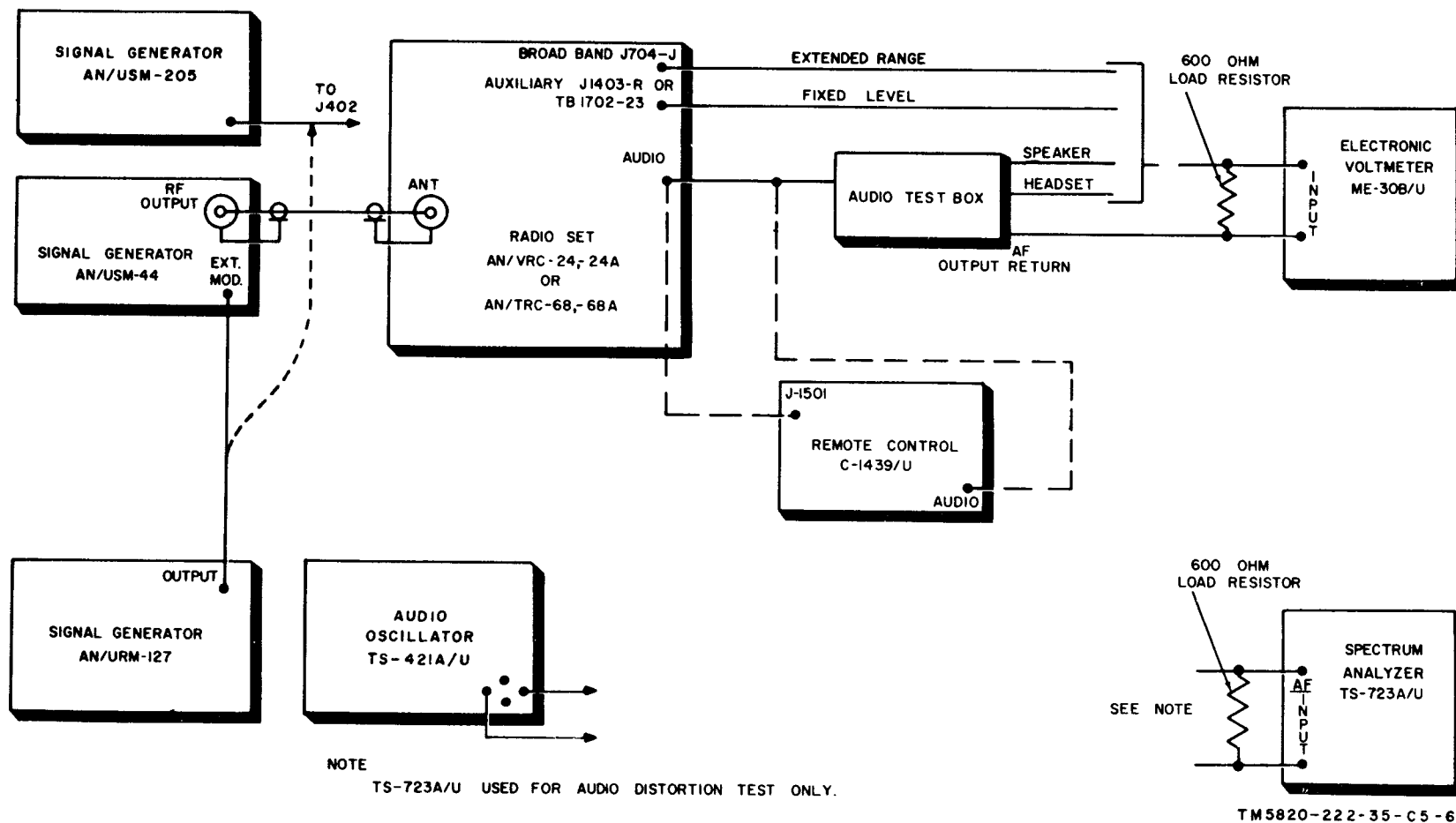


Figure 119. Audio frequency response characteristics and distortion measurements tests.

Subparagraph *i*. Delete subparagraphs *i*(2) and (3) and substitute the following:

(2) Set the front panel METER switch to S-METER.

(3) Adjust the AN/USM-44 rf signal output level (rf signal modulated 30% by a 1000 Hz signal) to that level necessary for a maximum S-METER indication.

Paragraph 149. Delete the last sentence of subparagraph *a*(1) and substitute the following:

Allow a five minute warmup period. Delete the last sentence of subparagraph *a*(3) and substitute the following:

This power output *must not be less than* 16 watts at any channel frequency from 225.0 to 399.9 MHz.

Subparagraph *b*(2) (*a*) and (*f*). Delete subparagraph *b*(2)(*a*) and (*f*) and substitute the following:

(*a*) Set the AN/URM-127 for an 1,000 Hz output and feed signal through dummy microphone. Set the signal level for 0.2 volt on the ME-30B/U, across 150 ohm resistor in dummy mic circuit.

(*f*) The modulation percentage *must be* between 65 and 100 percent.

Subparagraph *b*(3). Delete subparagraph *b*(3) in its entirety and substitute the following:

(3) *Broadband audio test procedure.*

**NOTE**

Refer to TM 11-5820-222-20 for procedure

and location of S801.

(*a*) Remove receiver-transmitter unit from its case and set switch S801 NOR-BB to BB, and then return it to its case.

(*b*) Make equipment connection changes as follows:

1. Disconnect the dummy microphone and connect the matching pad for external range to terminal B of BROADBAND jack J704 (or J704-E on AN/VRC-24A, or AN/TRC-68A). Connect the ME-30B/U across the output of the matching pad.

2. Connect the TS-421A/U between the input of matching pad terminal B of BROADBAND jack J704 (or J704-E on AN/VRC-24A and AN/TRC-68A), and the AF INPUT RETURN terminal of the audio test box.

(*c*) Perform the preliminary adjustments given in (1) above.

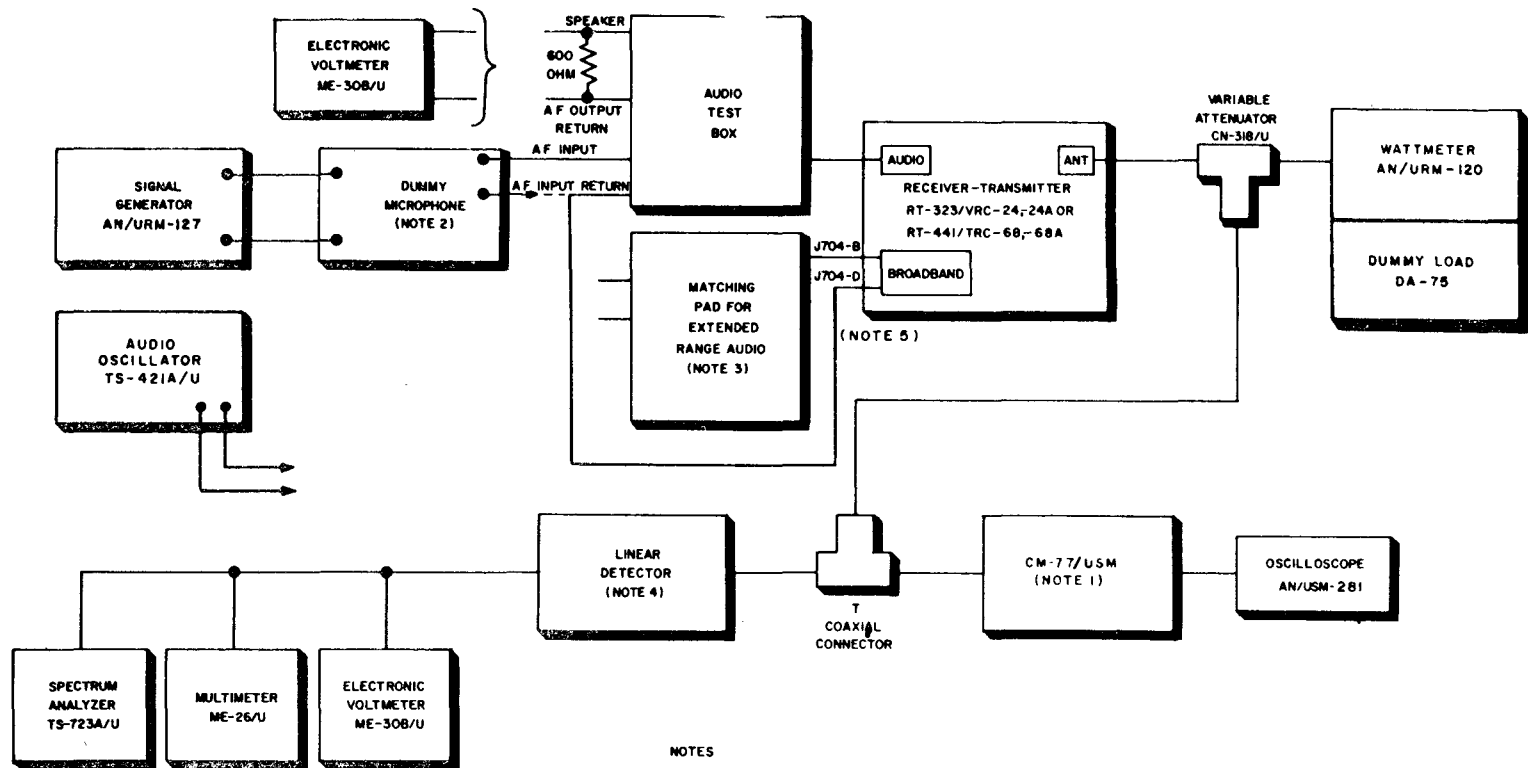
(*d*) Set the TS-421A/U for an 1,000 Hz output. Set the signal level to an amplitude (approximately 8 volts as indicated on the ME-30B/U sufficient to just begin waveform clipping (as viewed on the AN/USM-281).

(*e*) Record the wave form amplitudes and calculate the modulation percentages as described in (2) (*c*), (*d*), and (*e*) above.

(*f*) Modulation percentages must be between 65 and 100 percent.

Figure 119.3. Delete old figure 119.3 and substitute new figure 119.3.

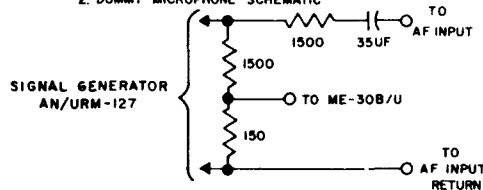




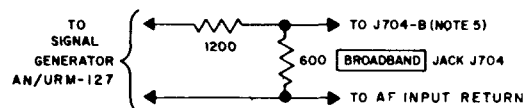
NOTES

1. IF FREQUENCY COMPARATOR CM-77/USM OR EQUIVALENT IS NOT AVAILABLE, CONNECT VERTICAL PLATES OF OSCILLOSCOPE AN/USM-281 DIRECTLY TO VARIABLE ATTENUATOR CN-318/U.

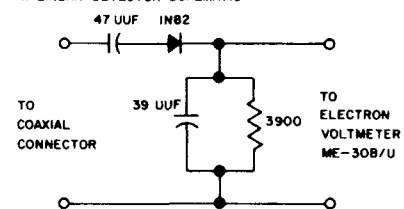
2. DUMMY MICROPHONE SCHEMATIC



3. MATCHING PAD FOR EXTENDED RANGE AUDIO



4. LINEAR DETECTOR SCHEMATIC



(OR GENERAL RADIO, MODEL GR874VR MAY BE USED IN LIEU OF FABRICATED LINEAR DETECTOR.)

5. J704-B AND J704-D ARE E AND AF INPUT RETURN ON AN/VRC-24A AND AN/TRC-68A.

Figure 119.3. Transmitter final test setup.

Subparagraph *c*. Delete subparagraph *c*(2) and substitute the following:

(2) Set the AN/URM-127 for an 1,000 Hz output at a level of 0.2 volt measured across 150 ohm resistor in the dummy microphone circuit.

Subparagraph *d*. Delete subparagraph *d*(1)(*g*) and substitute the following:

(*g*) The ME-30B/U indications at 300 and 6,000 Hz must be within  $\pm 3$  db of that obtained in (*d*) above. The indication at 3,000 Hz must be within  $\pm 2$  db of that in (*d*) above.

Delete subparagraph *d*(2) (*b*), (*c*), and (*f*) and substitute the following:

(*b*) Make the connections given in (1) above, *except* omit the dummy microphone, and connect the matching pad for extended range to terminals B and D of BROAD BAND jack J704 (or J704-E and -F on AN/VRC-24A and AN/TRC-68A).

(*c*) Connect the AN/URM-127 to the input of the matching pad and set for an 1,000-Hz output. Connect the ME-30B/U to terminals B and D of BROAD BAND jack J704 and adjust the AN/URM-127 for a signal level for 4.0 volts on the ME-30B/U. Record the AN/URM-127 output level meter indication.

(*f*) The ME-30B/U indications at 3,000, 6,000, 10,000, 15,000, and 25,000 Hz *must be within*  $\pm 2$  db of that obtained in (*d*) above. The 300 Hz indication is not down more than 3 db from the

reference frequency (*d*) above.

Subparagraph *e*. Delete line 2 of subparagraph *e*(1) and substitute the following: output signal of 0.2 volt at 1,000 Hz at

Subparagraph *g*. Delete subparagraph *g* in its entirety and substitute the following:

*g. Side Tone Test (fig. 119.4).*

(1) Connect the AN/USM-44 to the receiver antenna input and set for an output of 100 microvolts at 399.9 MHz modulated at 30 percent with a 1,000 Hz assigned.

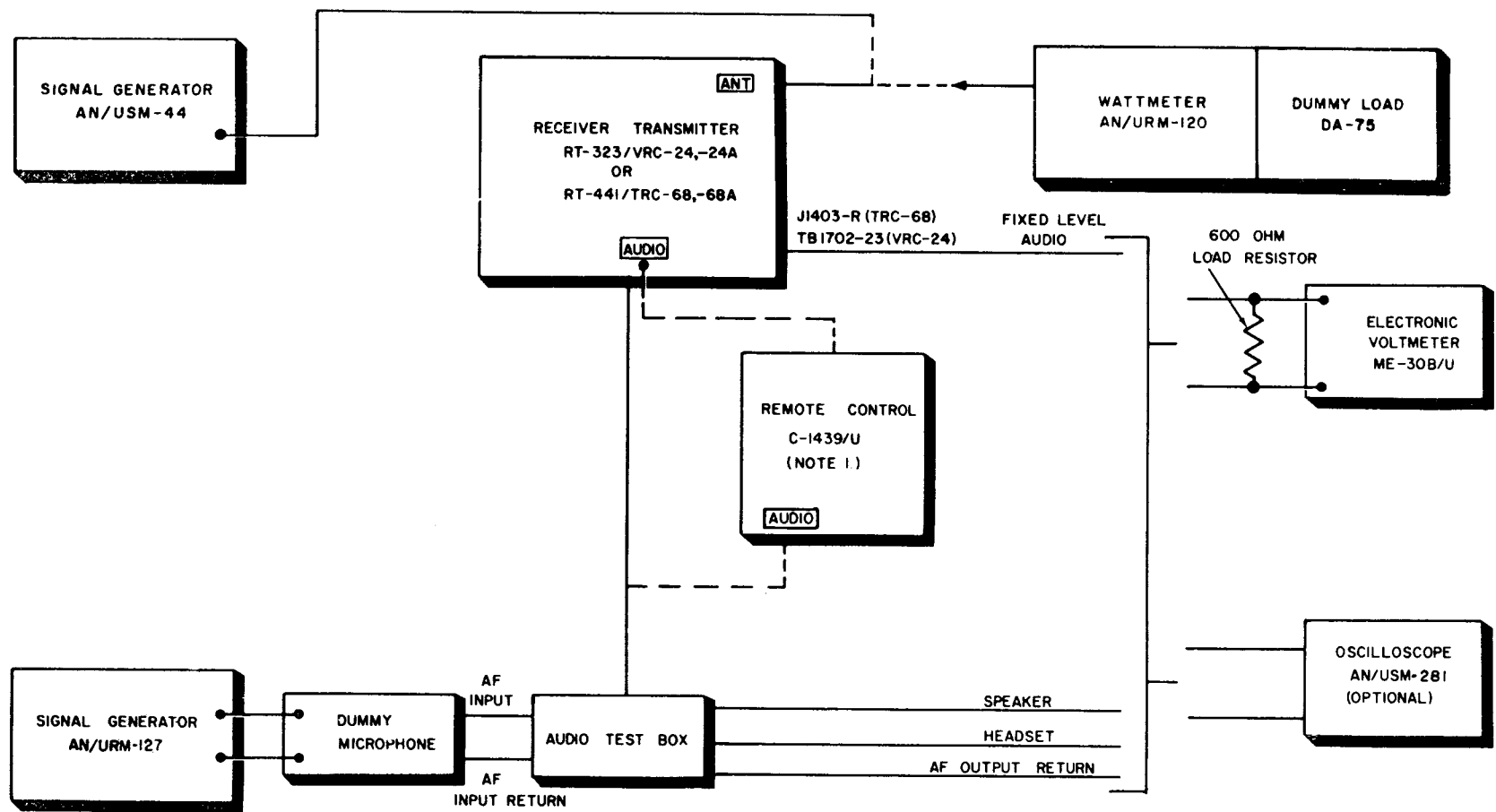
(2) Tune the radio set to 399.9 MHz and with the volume control fully clockwise obtain voltage readings with the ME-30B/U across the speaker headset, remote audio, and fixed level outputs.

(3) Disconnect the AN/USM-44 and replace with the AN/URM-120 and DA-75.

(4) Key the transmitter by connecting the RADIO CONT LINE AND CONT LINE RETURN terminals on the audio test box. Measure the voltage across the speaker, headset, remote audio, and fixed level with the ME-30B/U.

(5) Compare the voltages obtained in (4) with the reference voltages obtained in (2) and determine the db changes. The changes should be in accordance with the following requirements:

Figure 119.4. Delete old figure 119.4 and substitute new figure 119.4.



NOTES:

- I. CONNECT AUDIO TEST BOX TO EITHER **AUDIO** JACK ON RADIO SET CONTROL C-1439 TO MEASURE REMOTE AUDIO OUTPUT AT HEADSET TERMINAL.

TM5820-222-35-C5-10

Figure 119.4. Sidetone test.



LIBRARY FILE COPY  
Must be Returned To

TM 11-5820-222-35

C 4

CHANGE

No. 4



USAAGPC St. Louis, Mo.

HEADQUARTERS  
DEPARTMENT OF THE ARMY  
WASHINGTON, D. C., 28 August 1970

**DS, GS, and Depot Maintenance Manual**

**RADIO SETS AN/VRC-24, AN/VRC-24A, AN/TRC-68, AND AN/TRC-68A**

TM 11-5820-222-35, 1 June 1961, is changed as follows:

*Page 181*, paragraph 141.9. Make the following changes to subparagraph c, "Performance standard" column.

Delete *g*, *h*, and *i* and substitute:

*g*. Less than 1 percent of source voltage.

*h*. Less than 1 percent of source voltage.

*i*. Less than 1 percent of source voltage.

*Page 182*. Delete chapter 7 and insert new chapter 7.

---

**CHAPTER 7**

**DEPOT OVERHAUL STANDARDS**

**FOR**

**RECEIVER-TRANSMITTERS RT-441/TRC-68, RT-441/TRC-68A,**

**RT-323/VRC-24, AND RT-323/VRC-24A**

**142. Applicability of Depot Overhaul Standards**

The tests outlined in this chapter are designed to measure the performance capability of repaired Receiver-Transmitters RT-441/TRC-68, RT-441/TRC-68A, RT-323/VRC-24, and RT-323/VRC-24A. Units that are to be returned to stock must meet the standards given in these tests.

**143. Applicable References**

*a. Repair Standards.* Applicable pro-

cedures of the depot performing these tests and the general standards for repaired electronic equipment given in TB SIG 355-1, TB SIG 355-2, and TB SIG 355-3 form a part of the requirements for testing these equipments.

*b. Technical Publications.* The technical publications applicable to the equipment are contained in the appendix.

*c. Modification Work Orders.* Perform all modification work orders applicable to this equipment before making the test speci-

fied. DA Pam 310-7 lists all applicable MWO's.

**NOTE**

These depot overhaul standards rescind all previous interim Depot Overhaul Standards and Signal Corps Repair Standards applicable to this equipment.

**144. Test Equipment Required**

The test equipment required is listed in the chart below. Refer to paragraph 128c and figure 112 for audio test box fabrication instructions.

<i>Item</i>	<i>Technical manual</i>	<i>Quantity</i>
Spectrum Analyzer TS-723A/U .....	TM 11-5097 .....	1
Multimeter ME-26B/U .....	TM 11-6625-200-15 .....	1
Electronic Voltmeter ME-30B/U .....	TM 11-6625-320-12 .....	1
Wattmeter AN/URM-120 and Dummy Load DA-75 .....	TM 11-6625-446-15 .....	1
Frequency Comparator CM-77A/USM .....	TM 11-6625-493-15 .....	1
Signal Generator AN/USM-44A .....	TM 11-6625-508-10 .....	1
Signal Generator AN/USM-205 .....	TM 11-6625-665-15 .....	1
Signal Generator AN/URM-127 .....	TM 11-6625-683-15 .....	1
Digital Readout, Electronic Counter AN/USM-207 .....	TM 11-6625-700-10 .....	1
Oscilloscope AN/USM-281 .....	TM 11-6625-1703-15 .....	1
Power Transformer (Variable) CN-16/U, FSN 5950-235-2086 .....		1
Variable Attenuator CN-318/U .....		1
Audio test box .....		1

**145. General Test Conditions**

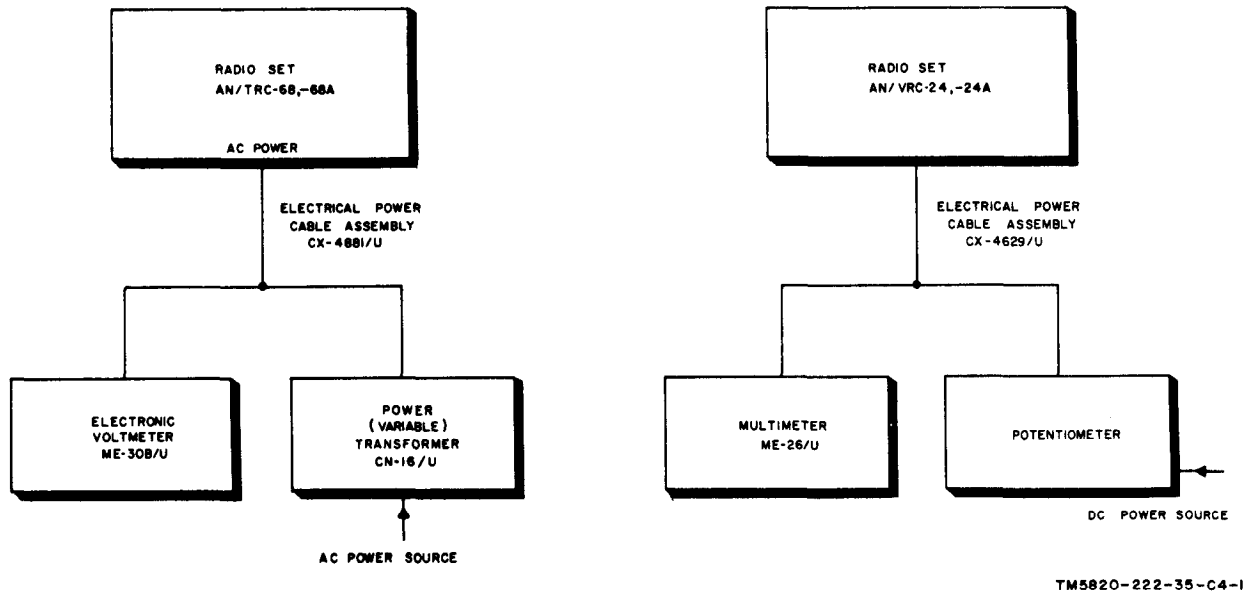
When a repaired radio set is being tested, perform tests in sequence and comply with preparatory instructions.

*a. Scope of Tests.* The following tests will be performed to determine the acceptability of repaired radio sets for return to stock:

- (1) Physical tests and inspection.
- (2) Electrical circuit tests.

*b. Initial Conditions.*

- (1) Perform all tests at room temperature.
- (2) Properly ground all equipment before making power connections.
- (3) Connect appropriate power source as shown in figure 114.
- (4) Allow an equipment warmup time of 5 minutes.



TM5820-222-35-C4-1

Figure 114. Supply voltage test setup block diagram.

#### 146. Physical Test and Inspection

The equipment shall meet the mechanical and visual requirements specified in Repair Standards TB SIG 355-1, TB SIG 355-2, and TB SIG 355-3.

#### 147. Electrical Circuit Tests

The electrical circuit tests are in two sections, paragraph 148 for the receiver section and paragraph 149 for the transmitter section for RT-323/VRC-24, RT-323/VRC-24A, RT-441/TRC-68, and RT-441/TRC-68A.

#### 148. Receiver Tests

The tests in this paragraph are designed to measure the performance capability of the receiver.

##### a. Receiver Sensitivity Test (fig. 115).

Set the equipment controls as follows:

- (1) Set the AN/USM-44 to 399.9 MHz.
- (2) Set the METER switch to S-METER and the MICROVOLTS control setting to 6 microvolts.
- (3) Modulate the AN/USM-44 output signal at 30 percent with a 1,000-Hz signal.
- (4) Tune the radio set to 399.9 MHz and turn the VOLUME control until the ME-30B/U indicates 12.25 volts across the 600-ohm load.
- (5) Record the db reading on the ME-30B/U that corresponds to 12.25 volts.
- (6) Turn the AN/USM-44 modulation to off.
- (7) The ME-30B/U indication must be at least 10 db below the value recorded in (5) above.

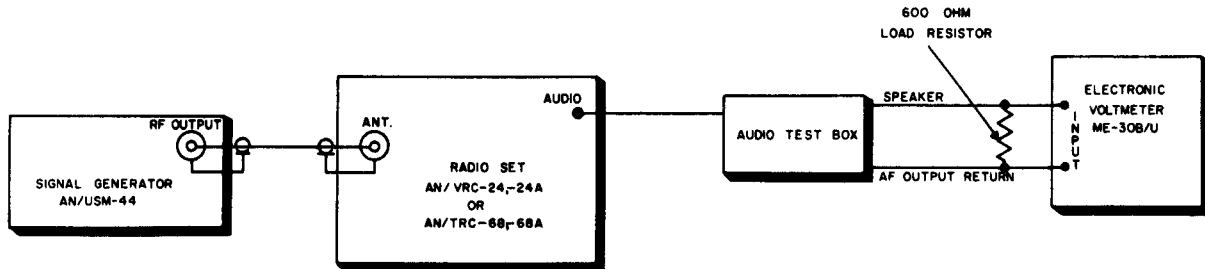
(8) Perform (1) through (7) above for the following test frequencies.

*Frequency (MHz)*

399.9

311.1

225.0



TM5820-222-35-C4-2

Figure 115. Receiver sensitivity and agc characteristics test.

*b. Receiver Squelch Test (fig. 116).*

(1) Set Receiver-transmitter controls as follows:

(a) Tune the radio set to 399.9 MHz.

(b) Turn SQUELCH control clockwise with no signal in until call light goes out.

(c) Set METER switch to S-METER.

(2) Set the AN/USM-44 to 399.9 MHz and tune for a maximum S-METER indication.

(3) Increase the signal level of the AN/USM-44 for the *minimum* setting of the OUTPUT attenuator control that will deactivate the squelch (as indicated by the lighting of the CALL LIGHT lamp). The OUTPUT attenuator control setting on the AN/USM-44 *must not exceed* 3 microvolts.

(4) Turn the SQUELCH control fully clockwise (minimum sensitivity). SQUELCH must deactivate with an input signal that is *not less than* 25 microvolts nor *more than* 75 microvolts without readjustment of the SQUELCH control.

(5) Perform (3) and (4) above at test frequencies of 309.0 and 225.0 MHz. Sig-

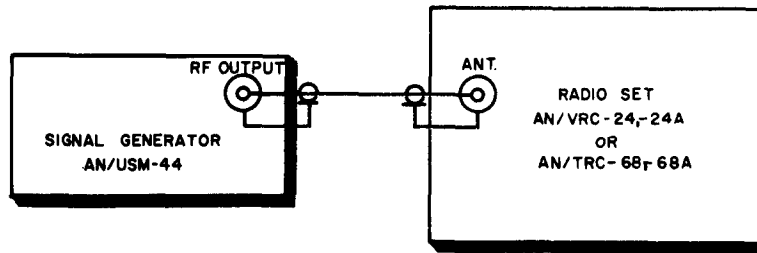
nal input required to deactivate the squelch *must not exceed* 3 microvolts for *maximum* sensitivity, and be *between* 12.5 and 100 microvolts for minimum sensitivity.

(6) Perform (3), (4), and (5) above with supply voltages of 103 (or 207) and 127 (or 253) volts ac (AN/TRC-68 or AN/TRC-68A), or at 23.4 and 29.4 volts dc (AN/VRC-24 or AN/VRC-24A) (fig. 114). The input signal required to deactivate the squelch *must be between* 0.5 and 17 microvolts for maximum sensitivity, and between 4.5 and 280 microvolts for minimum sensitivity.

(7) Tune the receiver-transmitter to 399.9 MHz. Set the AN/USM-44 at the same frequency. Readjust the AN/USM-44 for a maximum S-METER indication.

(8) Turn OUTPUT attenuator control on the AN/USM-44 to 6. Adjust SQUELCH control on unit under test for the minimum setting that will deactivate the squelch. Turn the OUTPUT attenuator control on the AN/USM-44 to the minimum setting that will operate the squelch. Signal input voltage ratio between unsquelched and squelched conditions *must not exceed* 2 to 1.





TM5820-222-35-C4-3

Figure 116. Receiver squelch test.

**c. Receiver Agc Characteristics Test (fig. 115).**

(1) Tune the receiver-transmitter and the AN/USM-44 to any convenient frequency.

(2) Set the METER switch to S-METER and adjust the AN/USM-44 output frequency for a maximum S-METER indication.

(3) Modulate the AN/USM-44 output frequency at 30 percent with the 1,000-Hz audiofrequency.

(4) Adjust the AN/USM-44 OUTPUT attenuator control for 100-microvolt output.

(5) Adjust the receiver-transmitter VOLUME control (note position of control) for a 12.25-volt rms indication on the ME-30B/U. Record this indication on the corresponding db scale.

(6) Adjust the AN/USM-44 OUTPUT attenuator control for 0.5-volt output.

(7) With the unit VOLUME control in the position specified in (5) above, note the audio level on the ME-30B/U. This audio level should not change *more than*  $\pm 5$  db from the level recorded in (5) above.

(8) Adjust the OUTPUT attenuator control on the AN/USM-44 for 6-microvolt output.

(9) With the unit VOLUME control in the position specified in (5) above, note the audio level on the ME-30B/U. Audio level should not decrease *more than* 6 db from the level recorded in (5) above.

**d. Bandwidth/Selectivity Test (fig. 117).**

(1) Operate the radio set for normal receive.

(2) Set Signal Generator AN/USM-205 to 3.5 MC and adjust the output level for a -1.0-volt indication on the Multimeter ME-26/U.

(3) Increase the AN/USM-205 output level to 6 db above the level set in (2) above.

(4) Record the frequencies above and below 3.5 MHz (as indicated on Digital Readout, Electronic Counter AN/USM-207) which will provide -1.0 volt on the ME-26/U. The difference between these two frequencies (6-db bandwidth) *must not be less than* 80 kHz.

(5) Increase the AN/USM-205 output level (at 3.5 MHz) to 60 db above the level set in (3) above.

(6) Record the frequencies above and below 3.5 MHz (as indicated on the AN/USM-207) which will provide -1.0 volt on the ME-26/U. The difference between these two frequencies (60-db bandwidth) *must not be greater than* 150 kHz.

(7) Determine the 6-db and 60-db half-bandwidth difference percentages by using the following formula:

$$\frac{\text{deviation (plus)} - \text{deviation (minus)} \times 100}{\text{average deviation}} =$$

half-bandwidth difference percentage where: deviation (plus) is the frequency difference in megahertz, above 3.5 MHz ((4) or (6) above); deviation (minus) is the frequency difference in megahertz below 3.5 MHz ((4) or (6) above). Average deviation is the bandwidth in megahertz (determined in (4) or (6) above) divided by 2.

**NOTE**

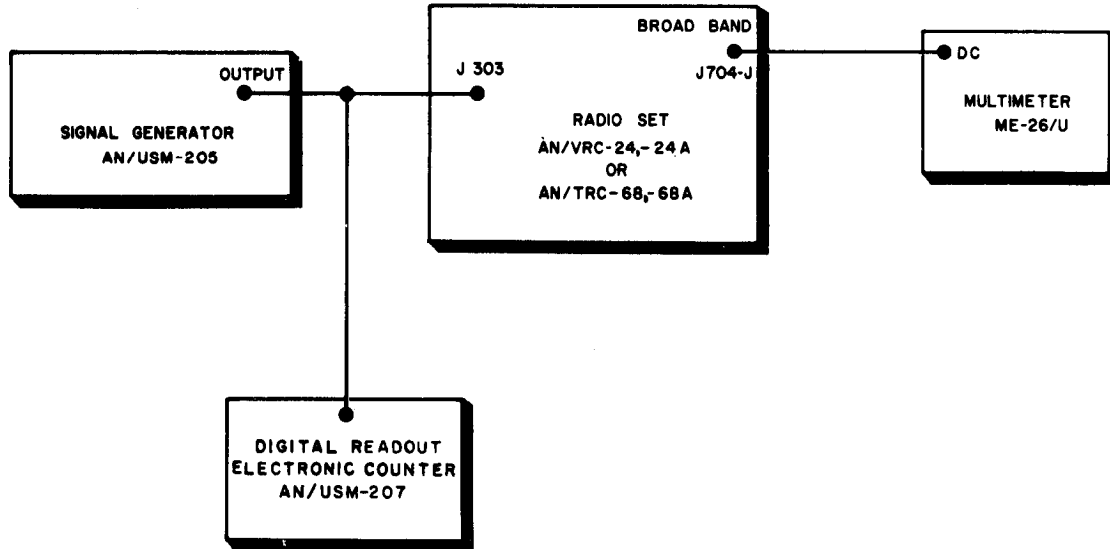
Always subtract the smaller deviation from the larger.

*Example:* If the two recorded frequencies ((4) above) are 3.538635 and 3.456647 MHz, the deviation (plus) equals 0.038635 MHz, the deviation (minus) equals 0.043353, and the total bandwidth equals 0.081988 MHz. The half bandwidth is 0.081988 divided by 2 or 0.040994. There-

$$\begin{aligned} \text{fore: half-bandwidth difference percentage} \\ \text{of 6 db} &= \frac{.043353 - 0.038635 \times 100}{.040994} = \end{aligned}$$

11.5 percent.

(8) The half-bandwidth difference percentages at 6 db shall not exceed 15 percent, and at 60 db shall not exceed 25 percent.



TM5820-222-35-C4-4

Figure 117. Bandwidth/selectivity test.

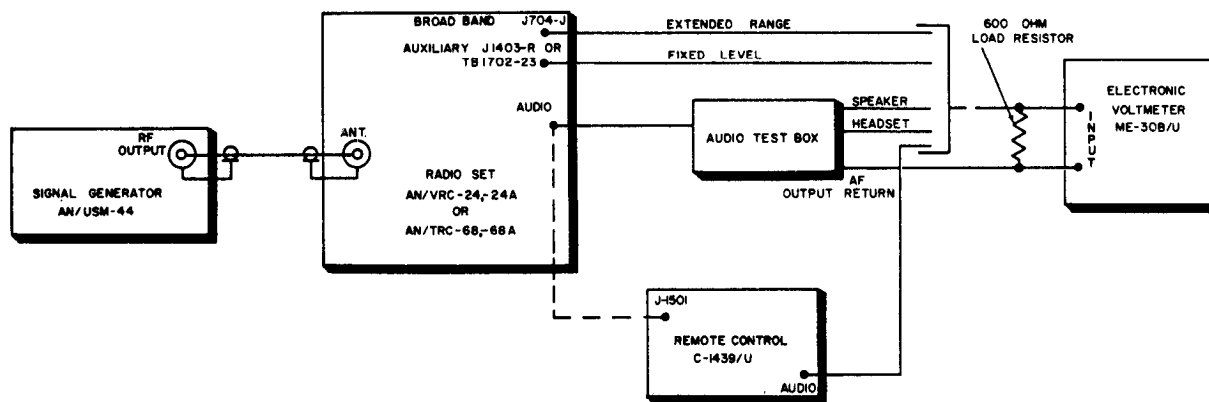
*e. Receiver Audio Output and Audio Level Adjustment Test (fig. 118).*

- (1) Tune the receiver-transmitter and AN/USM-44 to any convenient frequency.
- (2) Set the METER switch to S-METER and adjust the AN/USM-44 output frequency for a maximum S-METER indication.
- (3) Connect ME-30B/U to the radio set as directed below. Readings obtained shall be as indicated in chart below.
- (4) Adjust the AN/USM-44 for a 3.5 = MHz, 100-microvolt rf signal modulated 30 percent with a 1,000-Hz audio signal, and inject at receiver 3rd mixer grid.
- (5) To perform the test, make one set of measurements with normal input voltage

applied to the receiver-transmitter unit and a second set of measurements with the input voltage reduced to 103 (or 207) volts ac (AN/TRC-68 and AN/TRC-68A) or 23.4 volts dc (AN/VRC-24 and AN/VRC-24A).

(6) Check the front panel VOLUME control audio level adjustment range. VOLUME control should provide loud-speaker and headset output level adjustment of at least 25 db. The setting of the VOLUME control must not affect the output level of the extended range audio circuits by more than ±2 db, or the fixed level and remote audio circuits by more than ±3 db.

(7) Audio output will be not less than that indicated in the chart below.



TM5820-222-35-C4-5

Figure 118. Receiver audio output and audio level adjustment test.

Audio level measured	Test equipment connections	Audio output with normal input voltage	Audio output with reduced input voltage
Speaker .....	Connect ME-30B/U between SPEAKER and AF OUTPUT RETURN on audio test box.	24.5 .....	17.3
Headset .....	Connect ME-30B/U between HEADSET and AF OUTPUT RETURN on audio test box.	12.25 .....	8.6
Remote audio .....	Turn VOLUME control fully clockwise. Remove 10-pin audio connector from front panel AUDIO jack and connect it to one of AUDIO jacks on the C-1439/U. Connect ME-30B/U between HEADSET and AF OUTPUT RETURN on audio test box.	19.0 .....	13.3
Extended range .....	Connect ME-30B/U between terminals E and D of front panel BROAD BAND jack J704 (or J704-A and -F for AN/VRC-24A and AN/TRC-68A).	0.78 .....	0.55
Fixed level .....	Turn the VOLUME control fully clockwise. Connect ME-30B/U between AUXILIARY jack J1403-R (AN/TRC-68), or terminal board TB1702-23 (AN/VRC-24) and chassis ground.	5.5 .....	3.9

*f. Audiofrequency Response Characteristics Test (fig. 119).*

- (1) Repeat the procedure in e(4) above.
- (2) Set the METER switch to S-METER and adjust the AN/USM-44 frequency for a maximum S-METER indication.
- (3) Connect the ME-30B/U and 600-ohm load across the SPEAKER and AF OUTPUT RETURN terminals of the audio

test box and adjust the front panel VOLUME control for 1 watt of audio output power (24.5 volts rms across the 600-ohm load). Record the corresponding db indication of the ME-30/B.

- (4) Set Signal Generator AN/URM-127 output signal to frequencies of 300, 3,000, 5,000, and 10,000 Hz. Without further adjustment of the receiver-transmitter controls, measure and record the db indication

of the ME-30B/U. At 300 and 3,000 Hz, the audio output level *must be* within  $\pm 3$  db of the indication in (3) above. Audio output levels at 5,000 and 10,000 Hz should not be less than -5 db, -20 db, respectively, from the indications in (3) above.

(5) Connect the 600-ohm load and ME-30B/U between the HEADSET and AF OUTPUT RETURN terminals of the audio test box.

(6) Repeat the audio response measurements made in (4) above. *Do not* change the setting of the front panel VOLUME control. Record the db indications. The db relationships *must be the same* as in (4) above.

(7) Connect the 600-ohm load and ME-30B/U between AUXILIARY jack J1403-R (AN/TRC-68) or terminal board TB1702-23 (AN/VRC-24) and chassis ground. Repeat the measurements made in (4) above. Record the db indications. These db relationships *must be the same* as in (4) above.

(8) Disconnect the audio test box from the AUDIO jack and connect it to either of the remote control C-1439/U AUDIO jacks. Connect the 600-ohm load and the ME-30B/U between the HEADSET and AF OUTPUT RETURN terminals of the audio test box, and repeat the measurements made in (4) above. Record the db indications. These db relationships *must be the same* as in (4) above.

(9) Connect the 600-ohm load and ME-30B/U between terminals D and E of BROAD BAND jack J704 (for J104-F and -A on AN/VRC-24A and AN/TRC-68A). Turn the S801 NOR-BB switch (rear of chassis) to BB.

(10) Measure and record the audio output voltage at modulation frequencies of 300, 1,000, 4,000, 10,000, 15,000, 20,000, and 25,000 Hz. The db indications of the ME-30B/U from 300 to 10,000 Hz *should be within*  $\pm 3$  db of the indication at 1,000

Hz. The db indications at 15,000, 20,000, and 25,000 Hz *should not be more than* -7 db from the db indication at 1,000 Hz. Turn S801 NOR-BB switch to NOR.

*g. Audio Distortion Measurements* (fig. 119).

(1) Repeat procedure in *e*(4) above.

(2) Adjust the AN/USM-44 for a 1,000-microvolt output signal at 1,000 Hz modulated 30 percent.

(3) Set the front panel METER switch to S-METER and adjust the AN/USM-44 for a maximum S-METER indication.

(4) Connect Spectrum Analyzer TS-723A/U and the 600-ohm load between audio test box terminals SPEAKER and AF OUTPUT RETURN.

#### NOTE

To perform the harmonic distortion measurements in this procedure; refer to TM 11-5097.

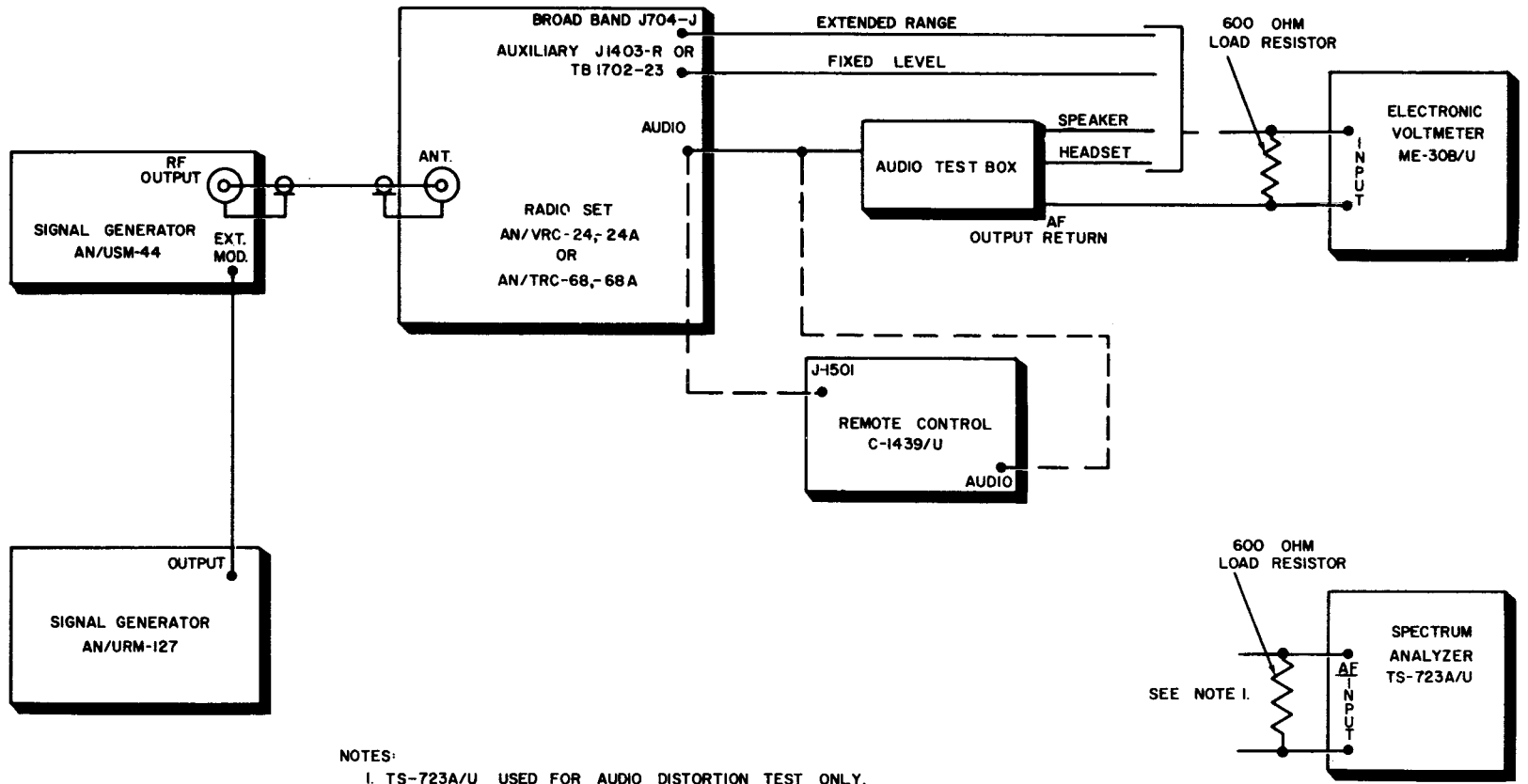
(5) Set the AN/URM-127 output frequency to 300 cycles and measure and record the percentage of harmonic distortion with the TS-723A/U. Repeat this procedure for modulating frequencies of 500, 1,000, 2,000, and 3,000 Hz. The percentage of harmonic distortion for these measurements *must not exceed* 10 percent.

(6) Repeat the procedure detailed in (5) above with the TS-723A/U and the 600-ohm load connected between the terminals listed below:

(a) HEADSET and AF OUTPUT RETURN on the test box (test box is connected to the C-1439/U AUDIO jack *for this test only*).

(b) AUXILIARY jack J1403-R (AN/TRC-68) or terminal board TB1702-23 (AN/VRC-24) and chassis ground.

(c) Terminals D and E or BROAD BAND jack J704 (or J704-F and -A on AN/VRC-24A and AN/TRC-68A).



NOTES:  
 I. TS-723A/U USED FOR AUDIO DISTORTION TEST ONLY.

TMS820-222-35-C4-6

Figure 119. Audiofrequency response characteristics and distortion measurements tests.

*h. Receiver Noise Rejection Test (fig. 119.1).*

(1) Tune the receiver-transmitter and AN/USM-44 to any convenient frequency.

(2) Adjust the AN/USM-44 for an 10,000-microvolt output signal at 1,000 Hz modulated 30 percent.

(3) Set the front panel METER switch to S-METER and adjust the AN/USM-44 frequency for a maximum S-METER indication.

(4) Connect the ME-30B/U and 600-ohm load across the SPEAKER and AF OUTPUT RETURN terminals of the audio test box. Adjust the front panel VOLUME control for 1 watt of audio output (24.5 volts rms across the 600-ohm load). Remove the ME-30B/U and connect Oscilloscope AN/USM-281 in its place.

(5) Adjust the percentage of modulation on the AN/USM-44 until clipping *just begins* to appear on the AN/USM-281 pattern. Record the percentage of modulation.

Modulation level at which the noise limiter starts to clip (as observed on the AN/USM-128) should be not more than 55 percent nor less than 35 percent.

*i. Signal Plus Noise-to-Noise Ratio (fig. 119.1).*

(1) Tune the receiver-transmitter and AN/USM-44 to any convenient frequency.

(2) Adjust the AN/USM-44 for a 1,000-microvolt output signal at 1,000 Hz modulated 30 percent.

(3) Set the front panel METER switch to S-METER and adjust the AN/USM-44 for a maximum S-METER indication.

(4) Adjust the receiver-transmitter VOLUME control for a 24.5-volt rms indication on the ME-30B/U. Record the indication observed on the corresponding db scale.

(5) Turn the modulator switch on the AN/USM-44 to OFF. The decrease in db (as indicated on the ME-30B/U) *must not be less than 35 db*.

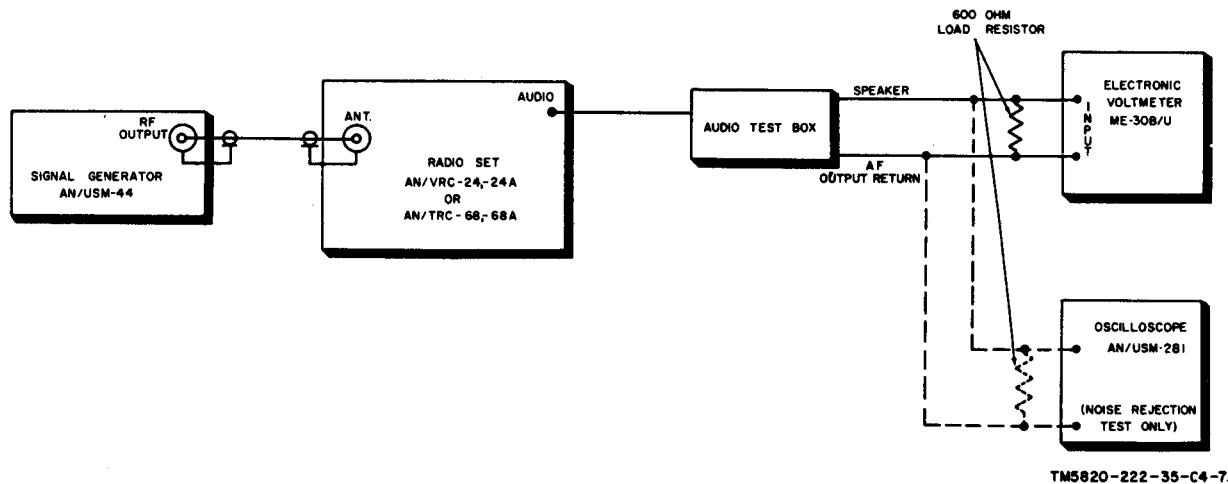


Figure 119.1. Receive noise rejection and signal plus noise-to-noise tests.

## 149. Transmitter Tests

The tests in this paragraph are designed to measure the performance capability of the transmitter.

### a. Transmitter Rf Power Output Test (fig. 119.2).

(1) Set Power Transformer (Variable) CN-16/U for 115 (or 230) volts ac (AN/TRC-68 and AN/TRC-68A) or the potentiometer for 26.4 volts dc (AN/VRC-24 and AN/VRC-24A) as indicated on the ME-26/U (fig. 114). Allow a 2-hour warmup period.

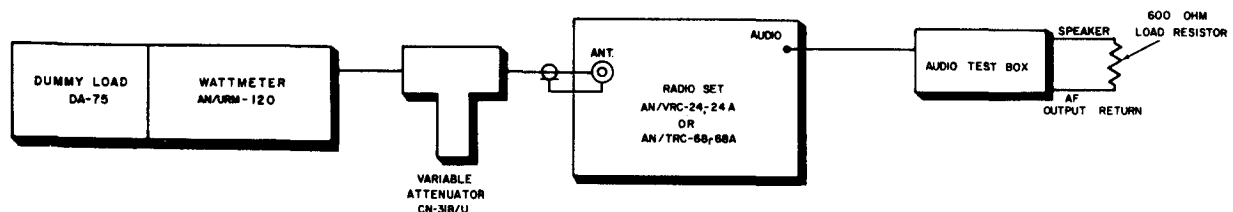
(2) Key the transmitter by connecting a lead between the RADIO CONT LINE

and CONT LINE RETURN terminals on the audio test box. Readjust the input voltage control to maintain the voltage established in (1) above.

(3) Note the transmitter radiofrequency power output indicated on wattmeter AN/URM-120. This power output *must not be less than 16 watts* at any channel frequency from 225.0 to 300.9 MHz.

(4) Reduce the input voltage to 103 (207) volts ac (AN/TRC-68 and AN/TRC-68A) or 23.4 volts dc (AN/VRC-24 and AN/VRC-24A) with the transmitter keyed.

(5) Repeat the procedure given in (3) above. Power output *must not be less than 4 watts*.



TM5820-222-35-C4-8

Figure 119.2. Transmitter rf power test.

### b. Modulation Capability Test (fig. 119.3).

#### (1) Preliminary adjustments.

(a) Tune the receiver-transmitter to 399.9 MHz.

(b) Key the transmitter by connecting a lead between the RADIO CONTLINE and CONT LINE RETURN terminals on the audio test box.

(c) Set Variable Attenuator CN-318/U for minimum attenuation.

(d) Set the AN/USM-281 MULTIPLIER switch to 1, the VERTICAL GAIN control to midrange, and the SWEEP TIME control to 1,000 microseconds.

(e) Tune Frequency Comparator CM-77A/USM for maximum pattern height on the AN/USM-281. Adjust the appropriate control for vertical gain on the AN/USM-281

to maintain the pattern height within the cathode-ray tube face.

(f) Adjust the CN-318/U so that a 6-db increase (twice the rf input) or decrease (half the rf input) in the radiofrequency input to the CM-77A/USM causes a 6-db change (twice or half the height) of the pattern on the AN/USM-281.

#### (2) Normal audio test procedure.

(a) Set the AN/URM-127 for an 1,000 Hz output feed signal through dummy microphone. Set the signal level for 0.1 volt on the ME-30B/U.

(b) Adjust the appropriate control for fine sweep time and sync control on the AN/USM-281 to hold the pattern reasonably steady on the cathode-ray tube face.

(c) Record the height of the pattern

from peak-to-peak and from valley-to-valley.

(d) Repeat (b) and (c) above for channel settings of 300.0 MHz and 225.0 MHz.

(e) Calculate modulation percentage as follows:

$$\text{Modulation percentage} = \frac{(\text{peak-to-peak}) - (\text{valley-to-valley})}{(\text{peak-to-peak}) + (\text{valley-to-valley})} \times 100$$

(f) The modulation percentage *must be* between 70 and 100 percent.

(3) *Broadband audio test procedure.*

**NOTE**

Refer to TM 11-5820-222-20 for procedure and location of S801.

(a) Remove the receiver-transmitter unit from its case and set switch S801 NOR-BB to BB, and then return it to its case.

(b) Make equipment connection

changes as follows:

1. Disconnect the dummy microphone.

2. Connect the AN/USM-127 and ME-30B/U between terminal B of BROAD BAND jack J704 (or J704-E on AN/VRC-24A and AN/TRC-68A) and the AF INPUT RETURN terminal of the audio test box.

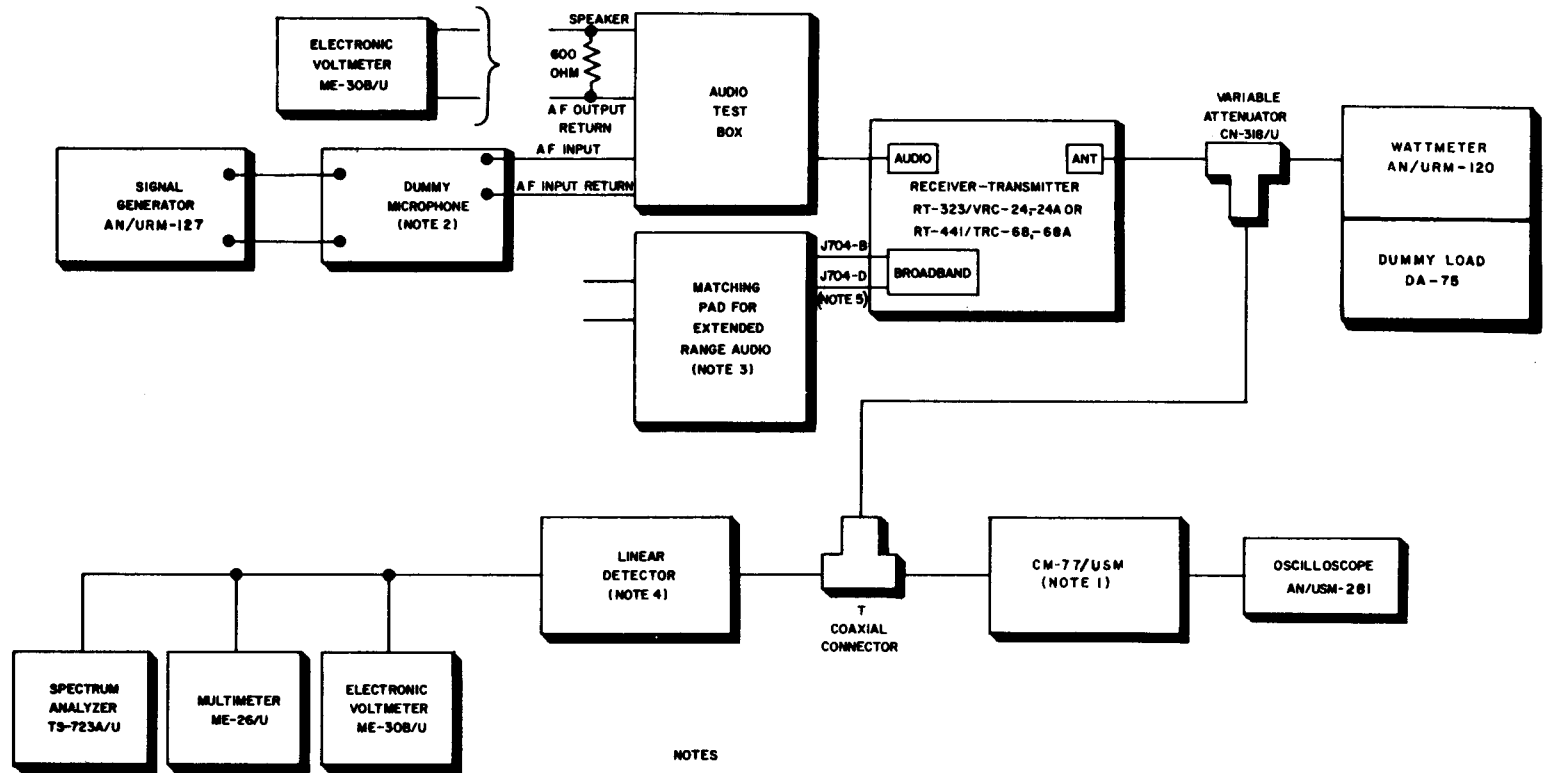
(c) Perform the preliminary adjustments given in (1) above.

(d) Set the AN/USM-127 for an 1,000-Hz output. Set the signal level to an amplitude (approximately 8 volts as indicated on the ME-30B/U) sufficient to just begin waveform clipping (as viewed on the AN/USM-281).

(e) Record the waveform amplitudes and calculate the modulation percentages as described in (2)(c), (d), and (e) above.

(f) Modulation percentages *must be* between 70 and 100 percent.

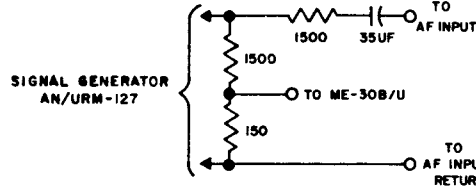




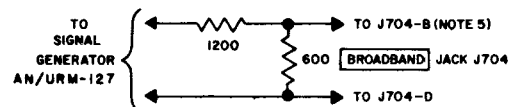
NOTES

1. IF FREQUENCY COMPARATOR CM-77/USM OR EQUIVALENT IS NOT AVAILABLE, CONNECT VERTICAL PLATES OF OSCILLOSCOPE AN/USM-281 DIRECTLY TO VARIABLE ATTENUATOR CN-318/U.

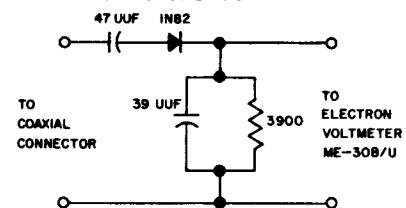
2. DUMMY MICROPHONE SCHEMATIC



3. MATCHING PAD FOR EXTENDED RANGE AUDIO



4. LINEAR DETECTOR SCHEMATIC



(OR GENERAL RADIO, MODEL 6R874VR MAY BE USED IN LIEU OF FABRICATED LINEAR DETECTOR.)

5. J704-B AND J704-D ARE E AND F ON AN/VRC-24A AND AN/TRC-68A

Figure 119.3. Transmitter final test setup.

c. *Automatic Modulation Limiter Test* (fig. 19.3).

(.) Key the transmitter by connecting a lead between the RADIO CONT LINE and CONT LINE RETURN terminals on the audio test box.

(2) Set the AN/URM-127 for an 1,000-Hz output at a level of 0.1 volt.

(3) Connect the ME-30B/U between the SPEAKER and AF OUTPUT RETURN terminals on the audio test box. Measure and record the output signal level.

(4) Reduce the input signal level to 0.05 volt and measure the output signal level. The output signal level *must be at least 3 db* below the level measured in (3) above.

(5) Increase the input signal level to 0.4 volt and measure the output signal level. The output signal level *must not be more than 2 db* above the level measured in (3) above.

d. *Audiofrequency Response Test* (fig. 119.3).

(1) *Normal audio test procedure.*

(a) Key the transmitter by connecting a lead between the RADIO CONT LINE and CONT LINE RETURN terminals on the audio test box.

(b) Disconnect CN-318/U from CM-77A/USM and adjust the CN-318/U for 0.5 volt dc on the ME-26/U.

(c) Set the AN/URM-127 for an 1,000-Hz output. Connect the ME-30B/U across the 150-ohm resistor in the dummy microphone and adjust the AN/URM-127 signal level for 0.05 volt. Record the AN/URM-127 output level meter indication.

(d) Connect the ME-30B/U to the output of the linear detector. Record the level of the demodulated output signal (in db).

#### NOTE

Maintain a *constant signal level* from the AN/URM-127 at the frequencies below by maintaining the AN/URM-127 output-level-meter indication obtained in (c) above.

(e) Set the AN/URM-127 to 300, 3,000, 6,000 and 10,000 Hz, and record the ME-30B/U indication (in db) at the linear detector output for each frequency.

(f) The ME-30B/U indications at 10,000 Hz *must be at least 3 db lower than* obtained in (d) above.

(g) The ME-30B/U indications at 300 and 6,000 Hz *must be within ±3 db* of that obtained in (d) above. The indication at 3,000 Hz *must be within ±3 db* of that obtained in (d) above. The indication at 3,000 Hz *must be within ±2 db* of that in (d) above.

(2) *Broadband audio test procedure.*

(a) Remove the receiver-transmitter unit from its case and set switch S801 to BB, and then return it to its case.

(b) Make the connections given in (1) above, *except* omit the dummy microphone, and connect the AN/URM-127 to terminals B and D of BROAD BAND jack J704 (or J704-E and -F on AN/VRC-24A and AN/TRC-68A).

(c) Set the AN/URM-127 for an 1,000-Hz output. Connect the ME-30B/U to terminals B and D of BROAD BAND jack J704 and adjust the AN/URM-127 for a signal level for 4.0 volts on the ME-30B/U. Record the AN/URM-127 output level meter indication.

(d) Connect the ME-30B/U to the output of the linear detector. Record the level of the demodulated output signal (in db).

(e) Set the AN/URM-127 to 300, 3,000, 6,000, 10,000, 15,000, and 25,000 Hz and record the ME-30B/U indication (in db) at the linear detector for each frequency.

#### NOTE

Maintain a constant signal level from the AN/URM-127 at the above frequencies by maintaining the AN/URM-127 output level meter indication obtained in (c) above.

(f) The ME-30B/U indications at 300, 3,000, 6,000, 10,000, 15,000, and 25,000 Hz *must be within ±2 db* of that

obtained in (d) above.

*e. Carrier Noise Level Test (fig. 119.3).*

(1) Adjust the AN/URM-127 for an output signal of 0.1 volt at 1,000 Hz at AF INPUT and AF INPUT RETURN terminals on the audio test box.

(2) Tune the receiver-transmitter to 399.9 MHz and key it by shorting the RADIO CONT LINE terminal to the CONT LINE RETURN terminal on the audio test box.

(3) Record the demodulated audio output at the linear detector (in db) observed on the ME-30B/U.

(4) Remove the 1,000-Hz signal input and note the db reading on the ME-30B/U. The db reading should be at least 35 db below the reading obtained in (3) above.

*f. Overall Distortion Test (fig. 119.3).*

(1) Adjust the AN/URM-127 for an output signal of 0.1 volt at 1,000 Hz across the 150-ohm resistor in the dummy microphone.

(2) Using the TS-723A/U, measure the harmonic distortion of the 1,000-Hz signal

at the output of the linear detector. Harmonic distortion *must not exceed* 10 percent.

(3) Set the AN/URM-127 frequency to 300, 500, 3,000, and 6,000 Hz at 0.1 volt. Repeat the distortion measurement for each frequency. Harmonic distortion *must not exceed* 10 percent.

(4) Repeat the procedures in (2) and (3) above for receiver-transmitter frequencies of 310.0 MHz and 255.0 MHz.

(5) Increase the audio signal input to 0.4 volt rms and repeat the procedures in (2), (3), and (4) above. Distortion at this input level *must not exceed* 20 percent.

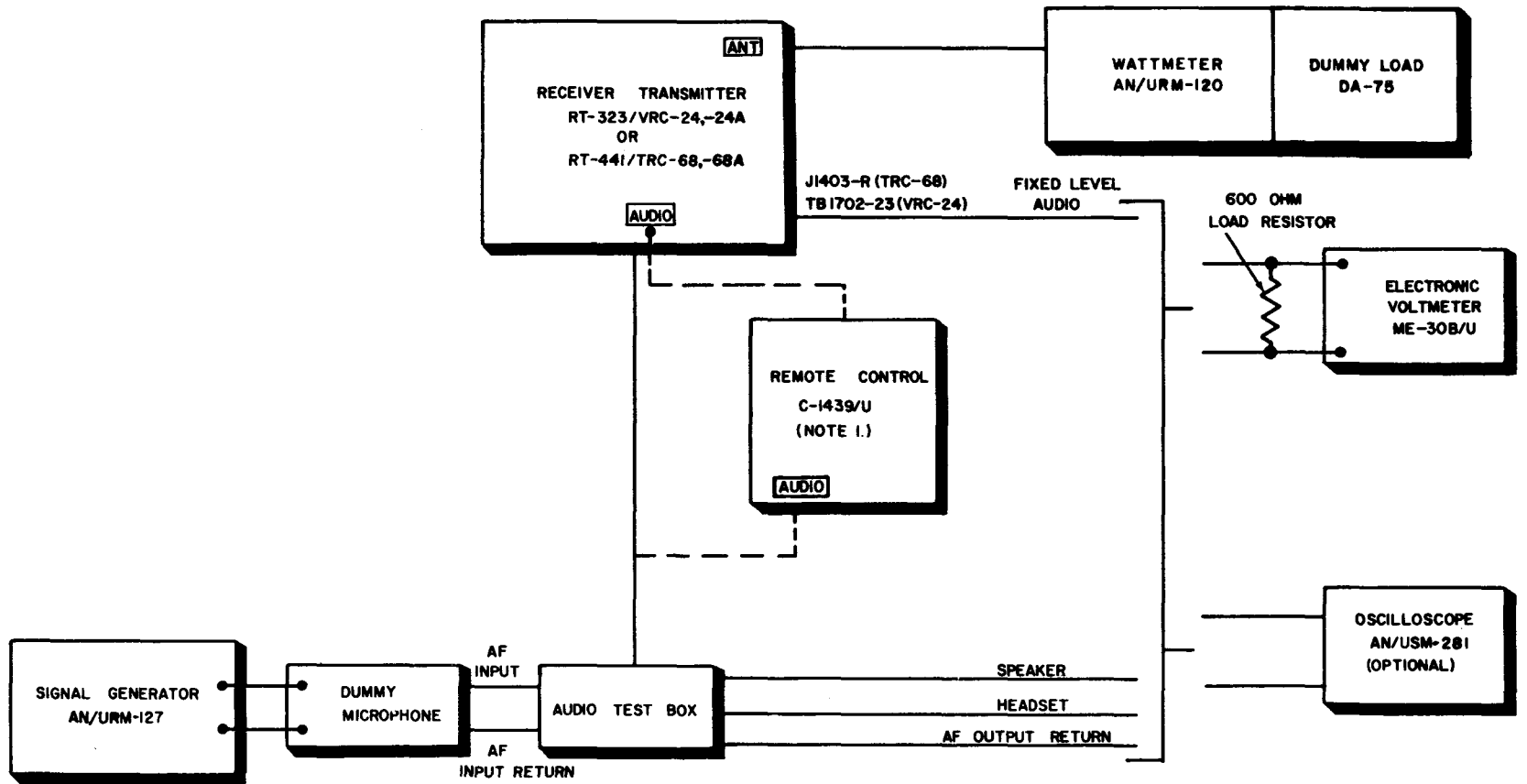
*g. Side Tone Test (fig. 119.4).*

(1) Adjust the AN/URM-127 for an output signal of 0.1 volt at 1,000 Hz across the 150-ohm resistor in the dummy microphone.

(2) Key the receiver-transmitter by connecting the RADIO CONT LINE and CONT LINE RETURN terminals on the audio test box.

(3) Perform the following to obtain the readings indicated:

<i>Audio level measured</i>	<i>Test equipment connections</i>	<i>Limits</i>
Speaker .....	Connect 600-ohm load and ME-30B/4 between SPEAKER and AF OUTPUT RETURN on audio test box.	More than 20 db down from received signal.
Headset .....	Connect test equipment between HEADSET and AF OUTPUT RETURN on audio test box.	From 0 to 6 db below received signal.
Remote audio .....	Turn VOLUME CONTROL fully clockwise. Remove 10-pin audio connector from front panel AUDIO jack and connect it to one of AUDIO jacks on the C-1439/U. Connect test equipment between HEADSET and AF OUTPUT RETURN on audio test box.	From 0 to 6 db below received signal.
Fixed level .....	Turn the VOLUME control fully clockwise. Connect test equipment between AUXILIARY jack J1403-R (AN/TRC-68), or terminal board TB1702-23 (AN/VRC-24), and chassis ground.	From 0 to 6 db below received signal.



NOTES:

- I. CONNECT AUDIO TEST BOX TO EITHER **AUDIO** JACK ON RADIO SET CONTROL C-1439 TO MEASURE REMOTE AUDIO OUTPUT AT HEADSET TERMINAL.

TM5820-222-35-C4-10

Figure 119.4. Sidetone test.

**150. Summary of Test Data**

*a. Receiver.*

Sensitivity .....	6 microvolts for 10-db signal to noise.
Squelch .....	2-to-1 ratio of input voltage between squelch and unsquelched conditions.
Agc characteristics .....	± 5 db for 100 mv to 0.5-volt input signal.
Bandwidth/selectivity .....	6 db: More than 80 kHz. 60 db: Less than 150 kHz.
Audio output (with normal input voltage).	Speaker: 24.5 volts. Headset: 12.25 volts. Broadband: 0.78 volt. Remote: 19.0 volts. Auxiliary: 5.5 volts.
Frequency response .....	± 3 db, -100 Hz. -5 db, -5,000 Hz. -20 db, -10,000 Hz.
Distortion .....	Less than 10 percent.
Noise rejection .....	35 to 55 percent of modulation.

Signal plus noise-to-noise ratio. 35 db.

*b. Transmitter*

Rf power output .....	Reduced voltage, not less than 6 watts. Normal voltage, not less than 16 watts.
Modulation .....	70 to 100 percent.
Limiting .....	0.4 volt produces not more than 2-db increase in modulating audio.
Frequency response .....	± 2 db -300, 6,000 Hz. -3 db, -10,000 Hz. -2 db, -3,000 Hz.
Carrier noise level .....	-35 db.
Distortion .....	Less than 10 percent at 0.1 volt; less than 20 percent at 0.4 volt.
Sidetone .....	Speaker: -20 db. Handset: 0 to -6 db. Remote: 0 to -6 db. Auxiliary: 0 to -6 db.

*Page 208, appendix. Add the following to the appendix:*

DA Pam 310-7	U.S. Army Equipment Index of Modification Work Orders.
TB SIG 355-1	Depot Inspection Standard for Repaired Signal Equipment.
TB SIG 355-2	Depot Inspection Standard for Refinishing Repaired Signal Equipment.
TB-SIG 355-3	Depot Inspection Standard for Moisture and Fungus Resistant Treatment.
TM 11-6625-446-15	Operator, Organizational, Field and Depot Maintenance Manual: Wattmeter AN/URM-120.
TM 11-6625-493-15	Operator, Organizational, DS, GS, and Depot Maintenance Manual: Frequency Comparator CM-77A/USM.
TM 11-6625-508-10	Operator's Manual: Signal Generators AN/USM-44 and AN/USM-44A.
TM 11-6625-665-15	Organizational, DS, GS, and Depot Maintenance Manual: Generator, Signal AN/USM-205.
TM 11-6625-683-15	Operator, Organizational, DS, GS, and Depot Maintenance Manual: Signal Generator AN/URM-127.
TM 11-6625-700-10	Operator's Manual: Digital Readout, Electronic Counter AN/USM-207.
TM 11-6625-1703-15	Operator, Organizational, DS, GS, and Depot Maintenance Manual Including Repair Parts and Special Tool Lists: Oscilloscope AN/USM-281.

By Order of the Secretary of the Army:

W. C. WESTMORELAND,  
General, United States Army,  
Chief of Staff.

Official:

KENNETH G. WICKHAM,  
Major General, United States Army,  
The Adjutant General.

Distribution:

To be distributed in accordance with DA Form 12-51, Direct and General Support maintenance requirements for AN/TRC-68 and AN/VRC-24 radio.

CHANGE }  
No. 3 }

HEADQUARTERS  
DEPARTMENT OF THE ARMY  
WASHINGTON, D.C., 7 August 1967

**DS, GS and Depot Maintenance Manual**

**RADIO SETS AN/VRC-24, AN/VRC-24A, AN/TRC-68, AND AN/TRC-68A**

TM 11-5820-222-35, 1 June 1961, is changed as indicated so that the manual also applies to the following equipment:

<i>Nomenclature</i>	<i>Order No.</i>	<i>Serial No.</i>
Radio Set AN/TRC-68A.....	FR 36-039-D-6-31865(E).....	1 through 224

*Note.* The parenthetical reference to previous changes (example: page 1 of C 1) indicates that pertinent material was published in that change.

Add the following caution (as added by C 2, 14 Dec 64) in the places listed below:

**Caution: When operating the CHAN SEL switch, or CHANNEL selector switch, allow a minimum of 10 seconds between channel re-selections.**

Page 82, paragraph 99e, below the heading of subparagraph e.

Page 88, paragraph 99f, below the heading of subparagraph f.

Page 195, paragraph 161, below the paragraph heading.

Add the following note (as added by C 2, 14 Dec 64) to the figures listed below:

**NOTE:**

ON ORDERS NO. 32626-PC-63 AND FR 36-039-D-6-31865(E), ELECTRON TUBE 6J4WA HAS BEEN REPLACED BY 6J4WB.

Page 15, figure 7. Change the word "NOTE" to NOTES. Number the existing note 1. Add as note 2.

Page 34, figure 18. Change the word "NOTE" to NOTES. Number the existing note 1. Add as note 2.

Page 47, figure 23. Add as note 7.

Page 122, figure 85. Add as note 8.

Page 123, figure 86. Add as note 7.

Page 207, figure 128(2). Add to note 18.

Page 2, paragraph 1.1 (As added by C 1, 10 Oct 63). Delete paragraph 1-1 and substitute:

**1-1. Index of Publications**

Refer to the latest issue of DA Pam 310-4 to determine whether there are new additions, changes, or additional publications pertaining to the equipment.

Paragraph 1-2 (as changed by C 2, 14 Dec 64). Delete paragraph 1-2 and substitute:

**1-2. Forms and Records**

a. *Reports of Maintenance and Unsatisfactory Equipment.* Use equipment forms and records in accordance with instructions given in TM 38-750.

\*This change supersedes C 2, 14 December 1964.

*b. Report of Packaging and Handling Deficiencies.* Fill out and forward DD Form 6 (Report of Packaging and Handling Deficiencies) as prescribed in AR 700-58 (Army), NAVSUP Publication 378 (Navy), AFR 71-4 (Air Force), and MCO P4610 (Marine Corps).

*c. Discrepancy in Shipment Report (DISREP) (SF361).* Fill out and forward Discrepancy in Shipment Report (DISREP) (SF361) as prescribed in AR 55-38 (Army), NAVSUP Pub 459 (Navy), AFM 75-34 (Air Force), and MCO P4610.19 (Marine Corps).

*d. Reporting of Equipment Manual Improvements.* Reporting of errors, omissions, and recommendations for improving this manual by the individual user is encouraged. Reports should be submitted on DA Form 2028 (Recommended Changes to DA Publications) and forwarded direct

to Commanding General, U. S. Army Electronics Command, ATTN: AMSEL-ME-NMP-AD, Fort Monmouth, N. J. 07703.

Paragraph 1.3 (page 1 of C 1). Add paragraph 1.4 after paragraph 1.3.

#### 1.4. Differences in Models

Centrifugal Fan HD-390A/U (fig. 42.1), as furnished in Radio Set AN/TRC-68A on order FR 36-039-D-6-31865(E), is interchangeable with Centrifugal Fan HD-390/U (fig. 42) but differs internally in that the spur gear drive assembly for operating the impeller has been replaced by a ball bearing speed increaser and the rubber shaft coupling has been eliminated (fig. 111.1). Information in this manual applies to both models unless otherwise specified.

Page 92. Add figure 42.1 after figure 42.

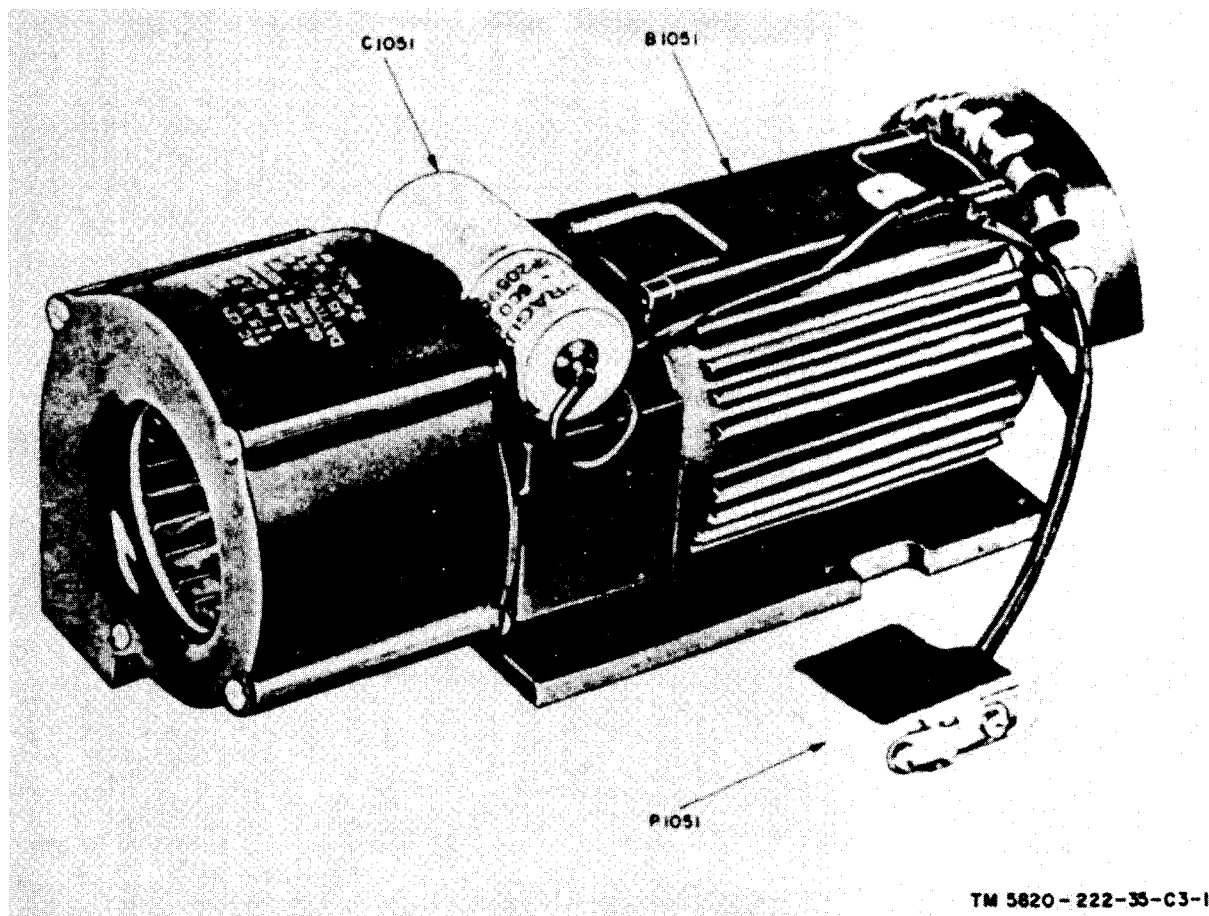


Figure 42.1 Centrifugal Fan HD-390A/U, side view.



Page 163, paragraph 127h(3). Add the following after subparagraph h(3):

- (4) Check the speed increaser assembly in Centrifugal Fan HD-390A/U after every 2,000 hours of operation (fig. 111.1). To disassemble, remove capacitor C1051 from the speed increaser housing. Remove the base plate to allow access to the screws that secure the impeller cover. Remove the impeller cover, loosen the socket screw, and remove the impeller. Loosen the three retaining screws that

secure the speed increaser housing to the motor and separate the two units. Replace the ball bearing and helical spring as required. Align the speed increaser, helical spring, and ball bearing retainer, and tighten the three retaining screws. Reassemble the impeller, impeller cover, base plate, and capacitor C1051 by replacing all screws removed during disassembly.

Page 169. Add figure 111.1 after figure 111:

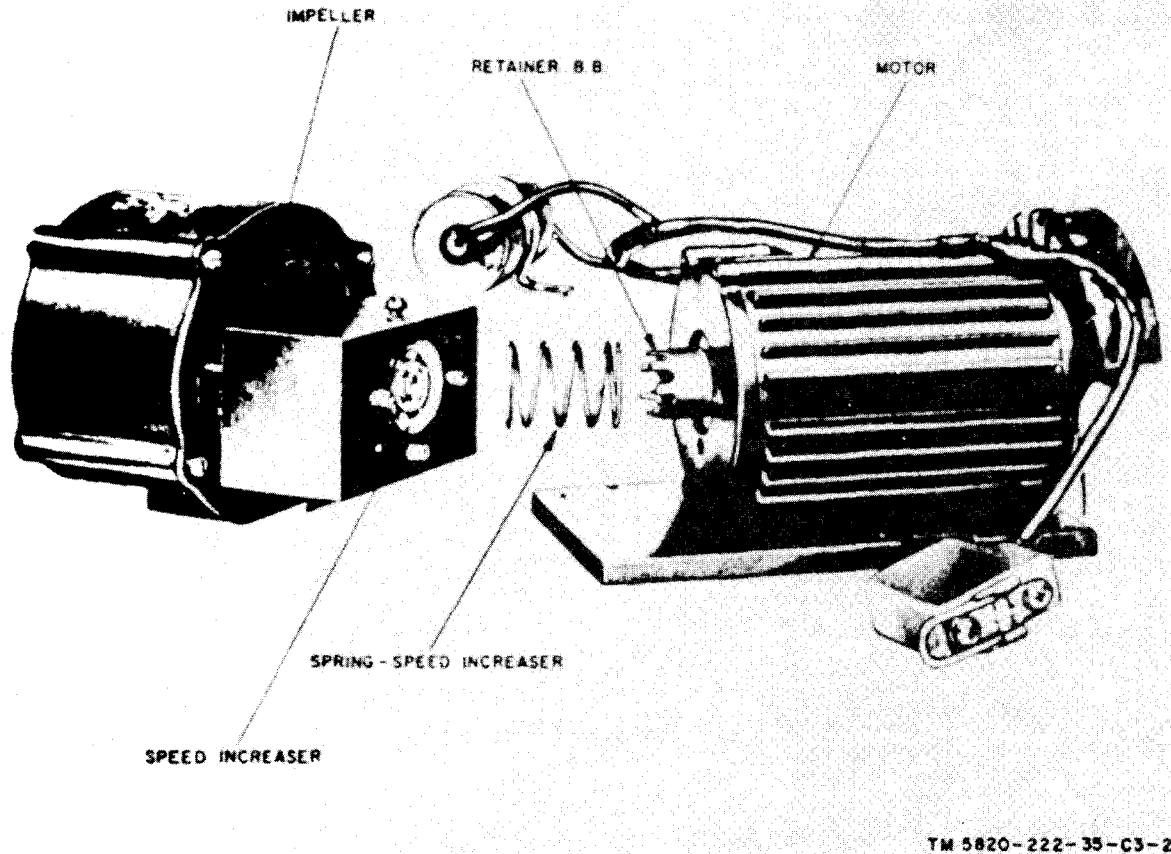


Figure 111.1 Centrifugal Fan HD-390A/U, partially disassembled.

By Order of the Secretary of the Army:

Official:

KENNETH G. WICKHAM,  
Major General, United States Army,  
The Adjutant General.

HAROLD K. JOHNSON,  
General, United States Army,  
Chief of Staff.

**Distribution:**

**Active Army:**

USASA (2)  
CNGB (1)  
CC-E (7)  
Dir of Trans (1)  
CofEngrs (1)  
TSG (1)  
CofSptS (1)  
Bd (5)  
USACDCEC (10)  
USACDC Agcy (1)  
USAMC (5)  
USCONARC (5)  
ARADCOM (5)  
ARADCOM Rgn (2)  
OS Maj Comd (4)  
LOGCOMD (2)  
USAMICOM (4)  
USASTRATCOM (4)  
USAESC (70)  
MDW (1)  
Armies (5)  
Corps (2)  
USAC (3)  
Instl (2) except  
    Ft Gordon (10)  
    Ft Huachuca (10)  
    Ft Carson (21)  
    Ft. Knox (12)  
    YPG (5)  
    WSMR (5)  
    USAEPG (5)  
USMA (5)  
Svc Colleges (2)  
Br Svc Sch (8)  
USATC Armor (2)  
USATCFLW (2)  
USATC Inf (2)  
USASTC (2)  
Army Dep (2) except  
    LBAD (14)

SAAD (30)  
TOAD (14)  
ATAD (10)  
Gen Dep (2)  
Sig Sec, Gen Dep (5)  
Sig Dep (12)  
AMS (1)  
MAAG (2)  
AAF (5)  
USARMIS (2)  
WRAMC (1)  
USAATC (5)  
Army Pic (2)  
TPMG  
Pine Bluff Arsenal (5)  
USAERDAA (2)  
USAERDAW (13)  
USACRREL (2)  
Sig FLDMS (2)

Units org under fol TOE: — 2 ea. UNOINDC

11-7  
11-35  
11-57  
11-95  
11-96  
11-97  
11-98  
11-99  
11-117  
11-127  
11-155  
11-157  
11-158  
11-217  
11-225  
11-500(AA-AC)  
11-587  
11-592  
11-597

**NG:** State AG (3); units — same as active Army except allowance is one (1) copy each.

**USAR:** None.

For explanation of abbreviations used, see AR 320-50.

**Field and Depot Maintenance Manual**  
**RADIO SETS AN/VRC-24, AN/VRC-24A, AN/TRC-68, AND AN/TRC-68A**

CHANGE }  
No. 1 }

HEADQUARTERS,  
DEPARTMENT OF THE ARMY  
WASHINGTON, D.C., 10 October 1963

TM 11-5820-222-35, 1 June 1961, is changed as indicated so that the manual also applies to the following equipment:

Nomenclature	Order No.	Serial No.
Radio Set AN/VRC-24A	4295-PP-61-A1-51	1 through 527
Radio Set AN/TRC-68A	4295-PP-61-A1-51	1 through 129

Change the title of the manual to: Field and Depot Maintenance Manual, RADIO SETS AN/VRC-24, AN/VRC-24A, AN/TRC-68, AND AN/TRC-68A.

Page 2, chapter 1, below the title. Add:

Note. Radio Sets AN/VRC-24A and AN/TRC-68A are similar to Radio Sets AN/VRC-24 and AN/TRC-68. Information in this manual applies to all sets unless otherwise specified.

Paragraph 1. Delete subparagraph *c* and *d*.

Add paragraphs 1.1, 1.2, and 1.3.

**1.1. Index of Publications**

Refer to the latest issue of DA Pam 310-4 to determine whether there are new editions, changes, or additional publications pertaining to your equipment. DA Pam 310-4 is an index of current technical manuals, technical bulletins, supply bulletins, lubrication orders, and modification work orders that are available through publications supply channels. The index lists the individual parts (-10, -20, -35P, etc.) and the latest changes and revisions of each equipment publication.

**1.2. Forms and Records**

*a. Report of Maintenance and Unsatisfactory Equipment.* Use equipment forms and records in accordance with instructions in TM 38-750.

*b. Report of Damaged or Improper Shipment.* Fill out and forward DD Form 6 (Report of Damaged or Improper Shipment) as prescribed in AR 700-58 (Army), NAVSANDA Publication 378 (Navy), and AFR 71-4 (Air Force).

*c. Reporting of Equipment Manual Improvements.* The direct reporting by the individual user of errors, omissions, and recommendations for improving this manual is authorized and encouraged. DA Form 2028 (Recommended Changes to DA Technical Manual Parts Lists or Supply Manual 7, 8, or 9) will be used for reporting these improvements. This form will be completed in triplicate using pencil, pen, or typewriter. The original and one copy will be forwarded direct to: Commanding Officer, U.S. Army Electronics Materiel Support Agency, ATTN: SELMS-MP, Fort Monmouth, N. J., 07703. One information copy will be furnished to the individual's immediate supervisor (officer, noncommissioned officer, supervisor, etc).

**1.3. Internal Differences in Models**

Internal differences are listed in the chart below. For external differences see TM 11-5820-222-10.

(1) Item	Unlettered models			(5) A Models
	Order numbers			
	(2) 14276-PC-58	(3) 14476-PC-58	(4) 19275-PC-60	
BROADBAND jack J704.	12 pins.....	12 pins.....	12 pins.....	10 pins.
Capacitor in FL711.....	2,500 $\mu\text{mf}$ .....	2,500 $\mu\text{mf}$ .....	2,500 $\mu\text{mf}$ .....	1,000 $\mu\text{mf}$ .
FL712.....	Used.....	Used.....	Used.....	Not used.
NOR-BB switch S801.....	Wired per fig. 128.....	Wired per fig. 128.....	Wired per fig. 128.....	Wiring changed per fig. 2.2.
R106.....	100 ohms.....	Under serial No. 548 100 ohms. Serial No. 548 and above, 390 ohms.	390 ohms.....	390 ohms.

(1) Item	Unlettered models			(5) A Models
	Order numbers			
	(2) 14276-PC-58	(3) 14476-PC-58	(4) 19275-PC-60	
Z203, Z205, and Z207	Under serial No. 201, Used.  Serial No. 201 and above replaced by 100 ohm resistors R215, R216, and R207 respectively.	All equipments same as Serial No. 201 and above in column 2.	Same as column 3	Same as column 3.
L316 through L319	Serial Nos. under 101, not used. Serial No. 101 and above, used.	Used	Used	Used.
R526	Serial Nos. under 400, 100 ohms. Serial No. 400 and above, 390 ohms.	Serial Nos. under 400, 100 ohms. Serial No. 400 and above, 390 ohms.	390 ohms	390 ohms.
R719 (100 ohms)	Not used	Not used	Serial Nos. under 41, not used.  Serial No. 41 and above, connected between terminal 1 of I701 and terminal R of J703.	All equipments same as Serial No. 41 and above in column 4.
V106	4X150D	4X150D	Serial Nos. under 41, 4X150D. Serial No. 41 and above, 7609. Replaced by L803, 0.47 $\mu$ h.	7609.
R850	Serial Nos. below 101, used. Serial Nos. 101 and above, replaced by L803, 0.47 $\mu$ h.	Serial Nos. below 200, used. Serial No. 200 and above, replaced by L803, 0.47 $\mu$ h.	Replaced by L803, 0.47 $\mu$ h.	Same as column 4.
C820 (470 $\mu$ f)	Serial Nos. below 101, not used. Serial No. 101 and above connected in parallel with C817.	Serial Nos. below 200, not used. Serial No. 200 and above connected in parallel with C817.	Connected in parallel with C817.	Same as column 4.
R818	Serial Nos. below 101, 10K ohms. Serial Nos. 101 and higher, 6,800 ohms.	Serial Nos. below 200, 10K ohms. Serial Nos. 200 and higher, 6,800 ohms.	6,800 ohms	6,800 ohms.
C603, C604, and C605	Serial Nos. below 450, 25 $\mu$ f. Serial Nos. 450 and higher, 40 $\mu$ f.	Serial Nos. below 450, 25 $\mu$ f. Serial Nos. 450 and higher, 40 $\mu$ f.	40 $\mu$ f	40 $\mu$ f.
R717	Serial Nos. below 37, not used. Serial Nos. 37 and higher, 47K.	Serial Nos. below 38, not used. Serial No. 38 and higher, 47K.	47K. <i>Note.</i> In some units, R717 is 22K.	47K.
R124 (0.56 ohms)	Not used	Not used	Used in serial No. 41 and higher. Connected in series with the end of C143 not connected to L117.	Same as serial No. 41 and higher in column 3.

(1) Item	Unlettered models			(5) A Models
	Order numbers			
	(2) 14276-PC-58	(3) 14476-PC-58	(4) 19275-PC-60	
R718 (0.56 ohms).....	Not used.....	Not used.....	Used in serial No. 41 and higher. Connected in series between junction of I702 and I703 and F703.	Same as serial No. 4 and higher in column 4.
C348.....	Serial Nos. below 101, not used.	Used.....	Used.....	Used.

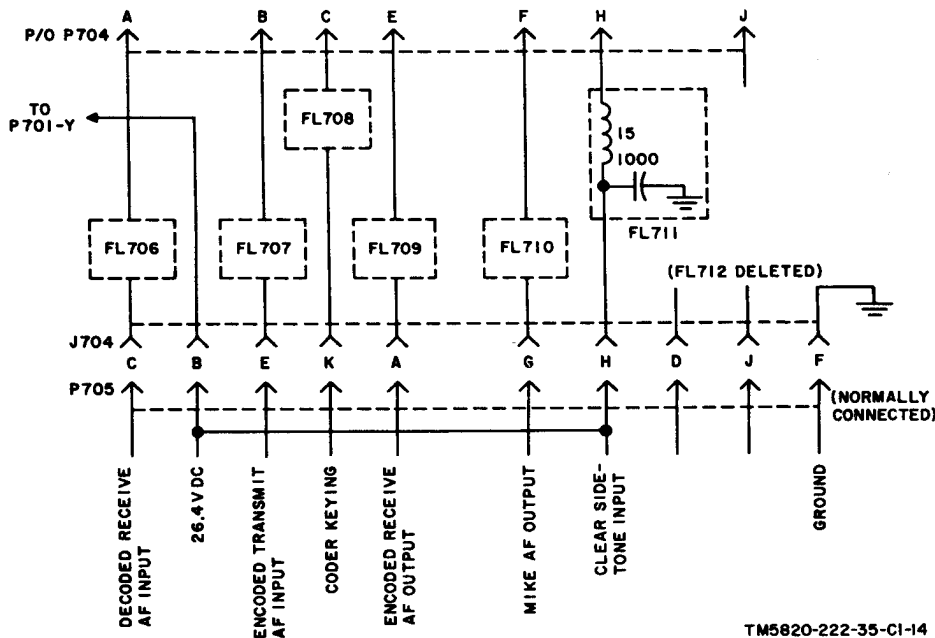


Figure 2.1. Broadband filler circuit for Radio Sets AN/VRC-24A and AN/TRC-68A.

Page 17, figure 8. Delete note 2.

Page 18, figure 9. Change the value of "R313" to: 15K.

Page 24, figure 12. Right side of figure. After "AND BROADBAND Jack J704-J," add: (ON AN/VRC-24 AND AN/TRC-68).

Page 26, figure 13. Make the following changes: Near "I701". Change "J703" to: P703.

Insert resistor R719, 100 ohms, in place of the wire that connects terminal 1 of "I701" to terminal R of P703.

Page 27, paragraph 45a(1), right-hand column, line 9. After "T802," add: (or through S801B, contacts 10 and 12, on AN/VRC-24A and AN/TRC-68A).

Page 28, paragraph 45b(1), right-hand column, line 2. After "K802," add: (or S801B contacts 12 and 10 in AN/VRC-24A and AN/TRC-68A).

Page 29, figure 15, left side. At "K802-11," add: (NOTE 4). Add the following to the notes:

- ON RADIO SETS AN/VRC-24A AND AN/TRC-68A, LEAD FROM K802-11 ROUTES THROUGH S801B, CONTACTS 10 AND 12, TO T802-8.

Page 39, figure 20. Make the following changes: At left of "K802", contacts 4 and 5, add: (NOTE 4).

Add the following note:

- ON RADIO SETS AN/VRC-24A AND AN/TRC-68A, RECEPTACLE J704 PINS -A, -B, -C, AND -F ARE

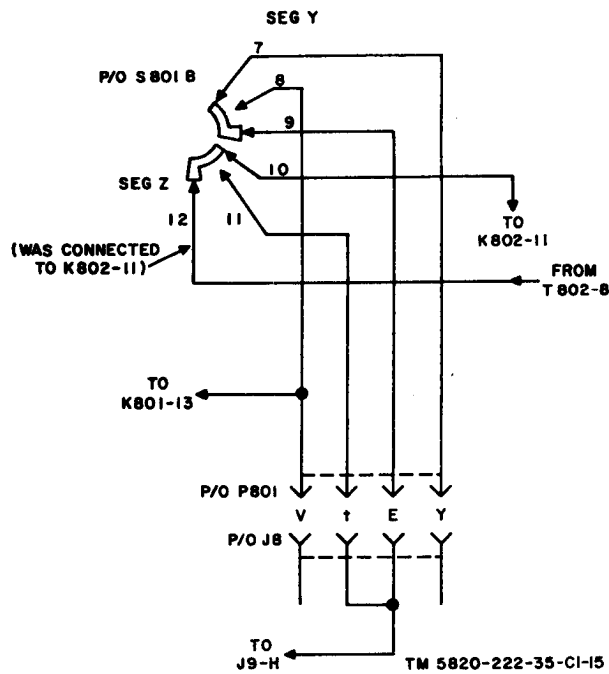


Figure 2.2. Changes to circuit of NOR-BB switch S801 in Radio Sets AN/VRC-24A and AN/TRC-68A.

RESPECTIVELY -C, -E, -K, AND -G.

Insert capacitor C820, 470  $\mu\text{f}$ , in parallel with "C817".

Page 40, paragraph 63b, line 12. Make the following changes:

Change "b" to: d.

Last line. Add: (or J704-A on AN/VRC-24A and AN/TRC-68A).

Page 41, figure 21, right side. After "AF OUTPUT" add:

(J704-A ON RADIO SETS AN/VRC-24A AND AN/TRC-68A).

Page 47, figure 23. Make the following changes: Change the value of "R717" to: 47K.

Disconnect "R609" from "P603-J" and connect "R609" to "P603-K".

Disconnect "R608" from "P603-K" and connect "R608" to ground.

Page 51, paragraph 82. Make the following changes:

Subparagraph a. Add the following to subparagraph a:

This voltage is obtained on NOR position in AN/VRC-24A and AN/TRC-68A. On these sets, a jumper connector to J704, normally used when the broadband encoder is not connected, supplies the 26.4 volts dc.

Subparagraph b(1). Add to the first sentence: (or BB position on AN/VRC-24A and AN/TRC-68A).

Page 53, figure 26. Make the following changes: At "S801B," contacts "8" and "9", add: (NOTE 4).

At "J704" terminal "C," add: (NOTE 4).

Add the following note:

4. ON RADIO SETS AN/VRC-24A AND AN/TRC-68A; WIRES TO S801B, CONTACTS 8 AND 9, ARE REVERSED AND J704-C is -K (ENCODER KEYING OCCURS ON J704-K).

Page 67, figure 32. Change the voltage value at terminal "K" of "P1001" to: +125V.

Page 70, paragraph 93b. Before subparagraph b(1), add the following caution:

**Caution:** Check to see that the rectangular rubber airhose near P1 is in place after replacement of any components involving the airhose connection, otherwise serious damage might result.

Page 72, paragraph 96b. Make the following changes:

Add the following note before the chart:

*Note.* Where reference is made to J704 terminals on AN/VRC-24A and AN/TRC-68A, the chained connector must be connected for the equipment to operate.

Make the following changes to the chart: "Indication" column, item 1, add: (or J704-A on AN/VRC-24A and AN/TRC-68A).

Item 2, add: (or J704-C on AN/VRC-24A and AN/TRC-68A).

Add to the "Probable trouble" column, item 3, add: (AN/VRC-24 and AN/TRC-68).

Page 73, paragraph 96b. Make the following changes in the "Indication column:"

Item 4. Add: (or J704-G on AN/VRC-24A and AN/TRC-68A).

Item 5. Add: (or J704-E on AN/VRC-24A and AN/TRC-68A).

Item 6. Add: (or J704-K on AN/VRC-24A and AN/TRC-68A).

Page 74, figure 35, right side. At "S801" under "(NOTE 5)," add: (NOTE 6).

Add the following note:

6. WIRES TO S801, CONTACTS 8 AND 9, ARE REVERSED ON AN/VRC-24A AND AN/TRC-68A.

Page 75, figure 36. Make the following changes: Above "J704" add: (NOTE 4).

Below "S801" add: (NOTE 4).

Add the following note:

- ON AN/VRC-24A AND AN/TRC-68A, J704 CONTACTS A, B, C, E, F, AND D are C, E; K, A, G, AND F RESPECTIVELY, AND H CARRIES CLEAR SIDETONE INPUT. WIRES TO S801, CONTACTS 8 AND 9, ARE REVERSED.

Page 79, figure 37. Make the following changes:  
Delete NOTE 4.

Delete "(NOTE 4)" from below "L118".

Insert resistor R124, 0.56 ohms, in series with the end of "C143" that is not connected to "L117".

Relocate fuse "F703" so that it is across terminals K and R of "P701". Insert resistor R718, 0.56 ohms, between the junction of "F703" and "P701-R" and lamps "I702" and "I703".

Page 108. Delete figure 64 and substitute new figure 64.

Page 110. Delete figure 67 and substitute new figure 67.

Page 115. Delete figure 75 and substitute new figure 75.

Page 121, figure 84. Make the following changes:  
Delete the following from the caption: "tube socket".

At pins "7" and "2" of "V504", add: (NOTE 8).

Add the following note:

- IN UNITS BEARING SERIAL NUMBERS 400 AND ABOVE ON ORDERS NO. 14276-PC-58 AND 14476-PC-58, AND ALL UNITS ON ORDER NO. 19275-PC-60, THE RESISTANCE AT PIN 7 AND PIN 2 OF V504 IS 390 OHMS.

Page 122, figure 85. Delete the following from the caption:  
"tube socket".

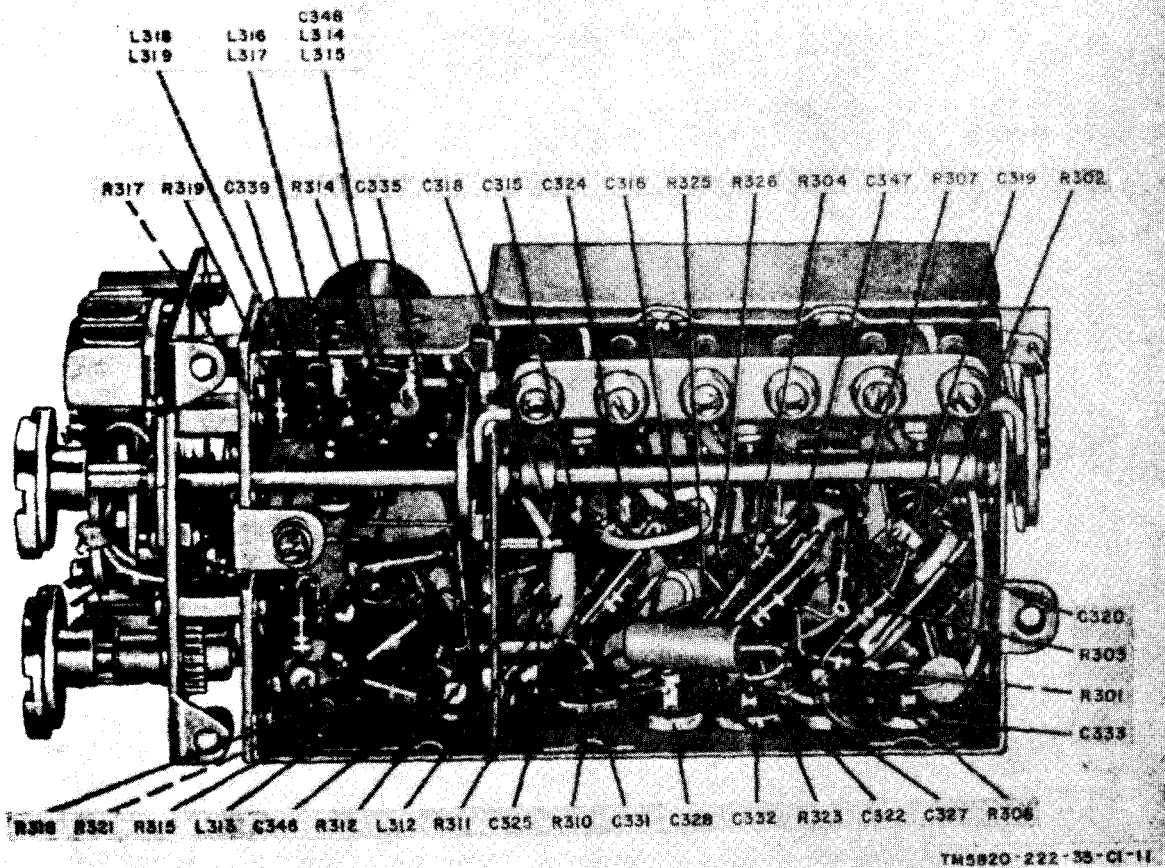
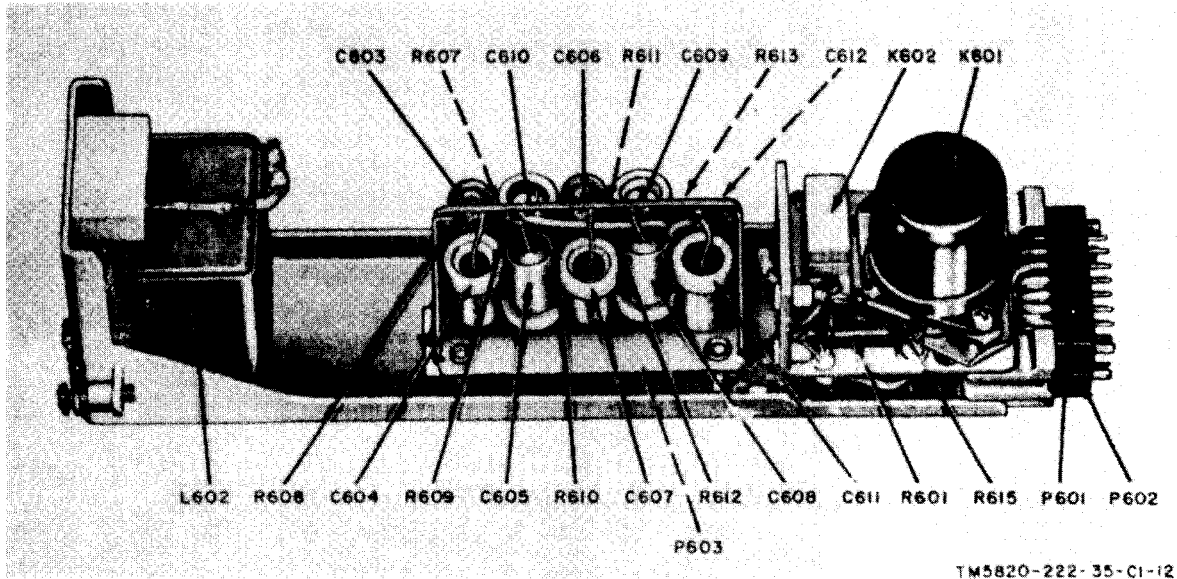
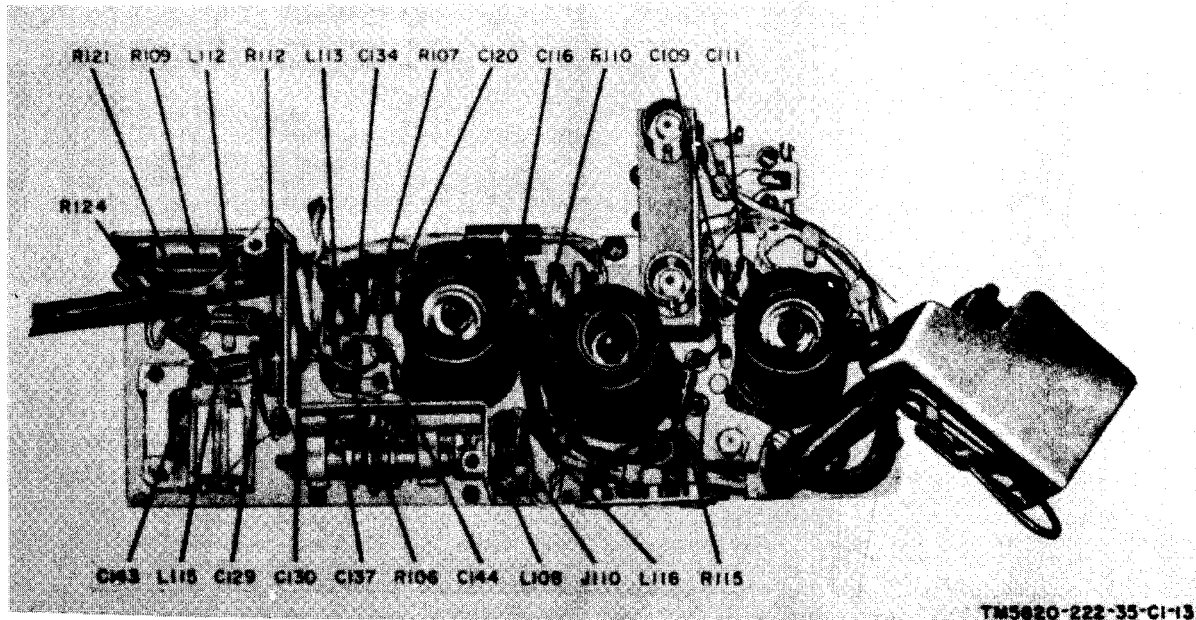


Figure 64. First IF amplifier subunit, bottom and left side view.



TM5820-222-35-C1-12

Figure 67. Relay subunit, top view.



TM5820-222-35-C1-13

Figure 75. RF and power amplifier subunit tube chassis, top view, relay deck removed.



*Page 123*, figure 86. Delete the following from the caption:

“tube socket”.

*Page 126*, figure 89. Change “100K” at pin “6” of “V305” to: 113K.

*Page 127*, paragraph 100, chart, “Test point” column. Add the following after the last item:

(or J704-C on AN/VRC-24A and AN/TRC-68A).

*Page 131*, paragraph 106. Insert the following before subparagraph *b*:

**Caution:** Check to see that the rectangular rubber air hose near P1 is properly in place after replacement of any components involving the air hose connection, otherwise serious damage can result.

## CHAPTER 6.1

### FOURTH ECHELON TESTING PROCEDURES

#### 141.1. General

a. Testing procedures are prepared for use by Signal Field Maintenance Shops and Signal Service Organizations responsible for fourth echelon maintenance to determine the acceptability of repaired signal equipment. These procedures set forth specific requirements that repaired signal equipment *must* meet before it is returned to the using organization. The testing procedures may also be used as a guide for testing equipment repaired at third echelon if the proper tools and test equipment are available. A summary of the performance standards is given in paragraph 141.17.

b. Each test depends on the preceding one for certain operating procedures and, where applicable, for test equipment calibrations. Comply with the instructions preceding each chart before proceeding to the chart. Perform each test in sequence. *Do not vary the sequence.* For each step, perform all the

actions required in the *Control settings* columns; then perform each specific test procedure and verify it against its performance standard.

#### 141.2. Test Equipment and Other Equipment Required

All test equipment and other equipment required to perform the testing procedures given in this section are listed in the following charts and are authorized under TA 11-17 (Signal Field Maintenance Shops) and TA 11-100 (11-17) (Allowances of Signal Corps Expendable Supplies for Signal Field Maintenance Shops, Continental United States) or TOE 158D (Signal Depot Company) and TA 11-101 (11-158) (Allowances of Signal Corps Expendable Supplies for Signal Depot Company), or are repair part items of the subject equipment authorized for stockage at fourth echelon levels.

##### a. Test Equipment.

Nomenclature	Federal stock No.	Technical reference
Multimeter TS-352(*)/U <sup>a</sup> .....	6625-242-5023	TM 11-5527
Voltmeter, Electronic ME-30(*)/U <sup>b</sup> .....	6625-669-0742	TM 11-6625-320-12
Audio Oscillator TS-382(*)/U <sup>c</sup> .....	6625-192-5094	TM 11-6625-261-12 or TM 11-2684
Radio Frequency Wattmeter AN/URM-43(*) <sup>d</sup> .....	6625-535-9186	TM 11-5133
Spectrum Analyzer TS-723(*)/U <sup>e</sup> .....	6625-668-9418	TM 11-5097
Output Meter TS-585(*)/U <sup>f</sup> .....	6625-244-0501	TM 11-5017
Comparator, Frequency CM-77/USM.....	None.....	HP-540A or HP-540B (Hewlett-Packard)
Converter, Frequency AN/USA-5.....	None.....	HP-525B (Hewlett-Packard)
Frequency Meter AN/USM-26.....	6625-692-6553	TM 11-5057
Signal Generator AN/USM-44(*) <sup>g</sup> .....	6625-669-4031	TO 33A1-8-119-1 (USAF)
Multimeter ME-26(*)/U <sup>h</sup> .....	6625-542-6407	TM 11-6625-200-12

<sup>a</sup> Indicates TS-352/U, TS-352A/U, and TS-352B/U.

<sup>b</sup> Indicates ME-30B/U, ME-30C/U, and Voltmeter, Meter ME-30A/U.

<sup>c</sup> Indicates TS-382/U, TS-382A/U, TS-382B/U, TS-382D/U, TS-382E/U, and TS-382F/U.

<sup>d</sup> Indicates AN/URM-43A and AN/URM-43C.

<sup>e</sup> Indicates TS-723A/U, TS-723B/U, and TS-723C/U.

<sup>f</sup> Indicates TS-585A/U, TS-585B/U, TS-585C/U, and TS-585D/U.

<sup>g</sup> Indicates AN/USM-44 and AN-USM-44A.

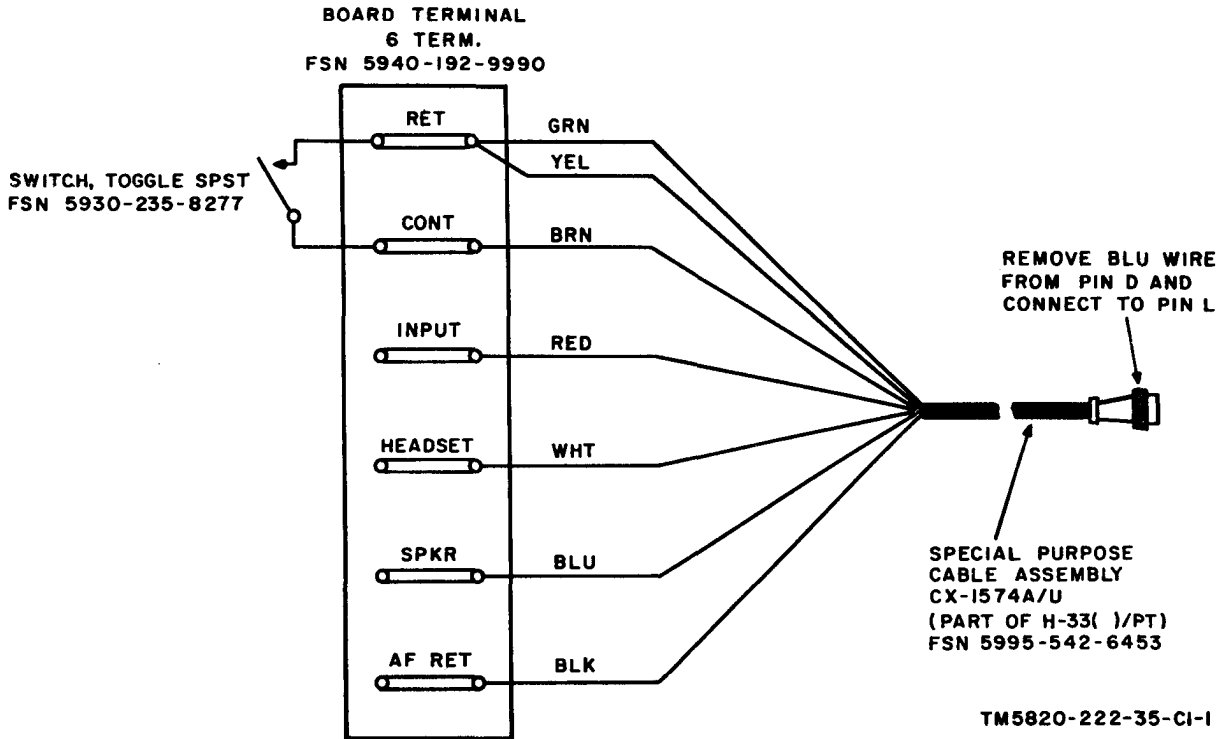
<sup>h</sup> Indicates ME-26/U and ME-26B/U.

**b. Other Equipment.**

Nomenclature	Federal stock No.	Technical reference
Transformer CN-16/U.....	5950-235-2086	None
Power Supply PP-1104A/G.....	6130-542-6385	TM 11-5126
Radio Assembly, Radio Frequency CG-409E/U.....	5995-501-4417	None
Three-way plug (cube tap).....	None	
Adapter UG-201A/U (2 ea).....	5935-201-3096	None
Adapter, Connector UG-565A/U.....	5935-665-6543	None
Connector, Adapter UG-1034A/U.....	5935-204-5098	None
Adapter, Connector UG-491/U.....	5935-280-1454	None
Adapter UG-274/U.....	5935-201-2411	None
Board, terminal, 6 term.....	5940-192-9990	None
Switch, toggle, SPST.....	5930-235-8277	None
Special purpose.....	5995-542-6453	None
Cable Assembly CX-1574A/U <sup>a</sup> .....	None	None
Radio Receiving Set AN/URR-35(*) <sup>b</sup> .....	5820-665-0099	TM 11-527-15
Headset HS-30-U.....	5965-164-7259	None
Cord CD-605 (used w/HS-30/U).....	6625-170-9608	None

<sup>a</sup> Indicates repair part item of unit under test.

<sup>b</sup> Indicates AN/URR-35, AN/URR-35A, AN/URR-35B, and AN/URR-35C.



*Figure 113.1. Special test cable fabrication.*

### 141.3. Special Requirements

a. The RF-IF switch on Spectrum Analyzers TS-723/U and TS-723A/U does not exist on the TS-723B/U. These tests are not affected by the omission of the RF-IF switch on the TS-723B/U. The signal input control is panel marked INPUT on the TS-723A/U and AF INPUT on the TS-723B/U and TS-723C/U.

b. The labeling of certain controls differs on Audio Oscillator TS-382A/U. References to controls in the charts apply to the TS-382B/U, TS-382D/U, TS-382E/U and TS-382F/U. If the TS-382A/U is used to perform these tests, use the control that corresponds to that given in the test procedure.

c. Comparator, Frequency CM-77/USM has commercial nomenclature, Hewlett-Packard, HP-540A or HP-540B. Converter, Frequency AN/USA-5 has commercial nomenclature, Hewlett-Packard, HP-525B. If these items are not available, Frequency Meter AN/URM-81 (TM 11-5096) may be substituted, using the operating instructions contained in the calibration book attached to the meter.

d. Any variable power supply delivering 30 volts dc at 15 amperes and capable of withstanding a 50-ampere surge may be used as the primary source for tests on Radio Set AN/VRC-24(\*).

e. Any radio receiver capable of receiving amplitude-modulated signals and having the proper frequency range may be used as the test receiver for the tests in paragraph 141.16.

### 141.4. Modification Work Orders

There were no modification work orders in effect for these equipments as of the date of this change. MWO's pertaining to these equipments that may have been published since the date of this publication will be listed in DA PAM 310-4 and changes thereto. Nonapplication of MWO's other than

those classed URGENT should not be reason for rejection.

### 141.5. Special Test Facilities

Fabricate a special test cable as shown in figure 113.1. Label the terminal board contacts as shown in the illustration.

### 141.6. Presetting Equipment Under Test

Follow the procedure on the back of the RT-323/VRC-24(\*) or RT-441/TRC-68(\*) memory drum cover and preset channels 1 through 19 to the following frequencies:

Channel	Frequency
1.....	225.0
2.....	233.3
3.....	244.4
4.....	255.5
5.....	266.6
6.....	277.7
7.....	288.8
8.....	299.9
9.....	301.0
10.....	311.1
11.....	322.2
12.....	333.3
13.....	344.4
14.....	355.5
15.....	366.6
16.....	377.7
17.....	388.8
18.....	395.0
19.....	399.9

### 141.7. Physical Tests and Inspections

a. *Test Equipment and Materials.* None.

b. *Test Connections and Conditions.* Do not make any connections to the equipment during these tests. Remove the RT-323/VRC-24(\*) or the RT-441/TRC-68(\*) from its case before performing this procedure.

c. *Test Procedure.*

Control settings		Test procedure	Performance standard
Test equipment	Equipment under test		
N/A.....	Controls may be in any position.	<p>a. Inspect all controls and mechanical assemblies for evidence of physical damage or loose or missing parts.</p> <p>b. Check front panel switches and controls for proper operation.</p>	<p>a. Equipment is complete and undamaged.</p> <p>b. All switches and controls operate smoothly without evidence of binding or scraping.</p>

Control settings		Test procedure	Performance standard
Test equipment	Equipment under test		
		<p>c. Inspect all metal surfaces for condition of finish.</p> <p><i>Note.</i> Touchup painting is recommended in lieu of refinishing whenever practicable.</p> <p>d. Inspect plug and connector contacts for bent or missing pins.</p> <p>e. Inspect all subunit dust covers for evidence of physical damage and missing screws.</p> <p>f. Remove and check all fuses for proper type and rating.</p> <p><i>Note.</i> Ratings of all fuses are panel marked.</p> <p>g. Check all vacuum-tube shields and tubes for proper seating.</p> <p>h. Check the equipment for applicable MWO's and note any MWO's not performed.</p>	<p>c. No bare metal shows on metal surfaces intended to be painted.</p> <p>d. All plugs and connectors are complete and undamaged.</p> <p>e. Dust covers are securely mounted and free from dents.</p> <p>f. Fuses are of proper type and rating.</p> <p>g. Tubes and shields are firmly seated in sockets.</p> <p>h. See paragraph 141.4.</p>

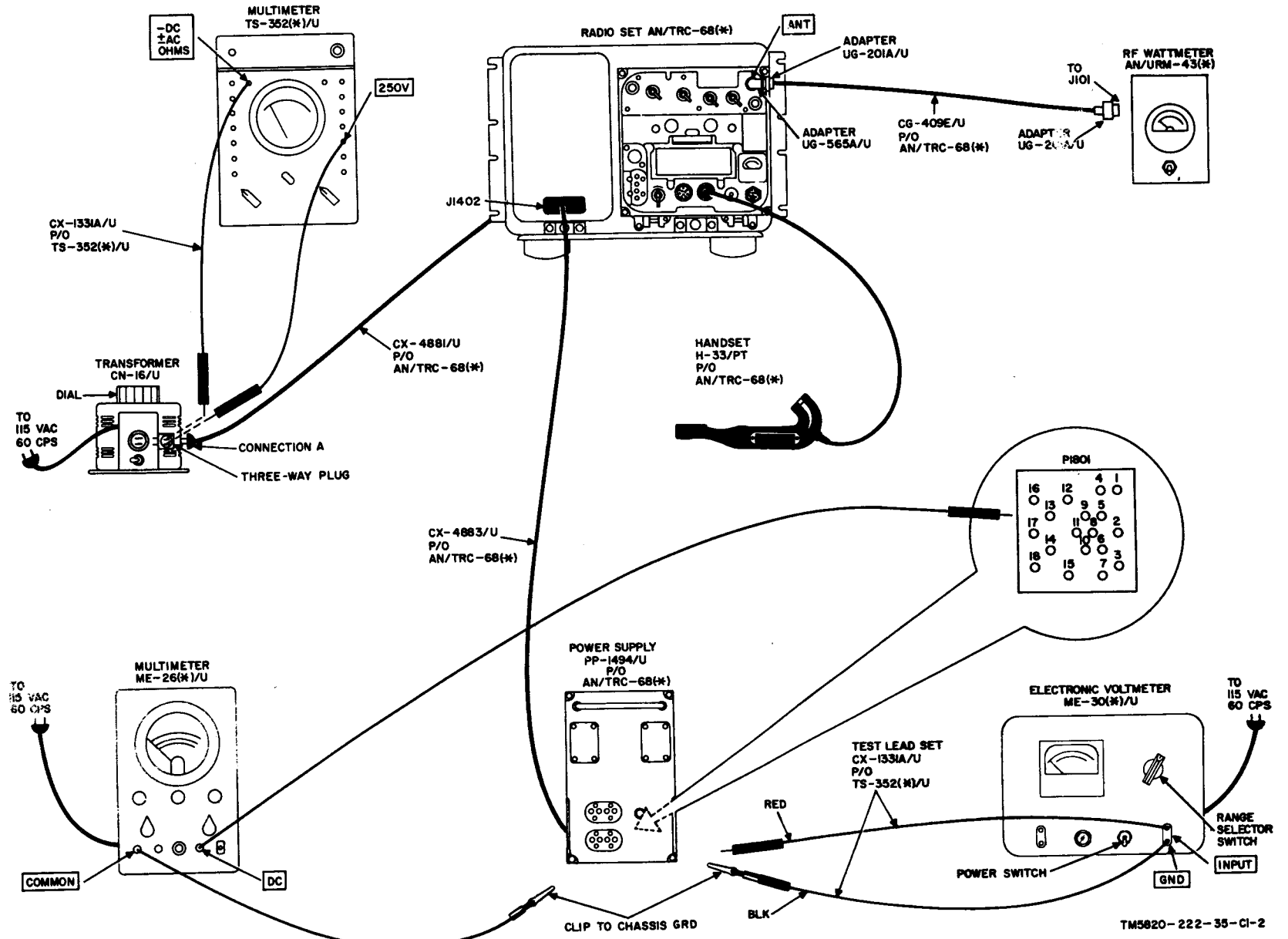


Figure 113.2. Power Supply PP-1494/U voltage and ripple tests, test setup.

**141.9. Dynamotor DY-151/U Voltage and Ripple Tests***a. Test Equipment and Materials.*

Power Supply PP-1104A/G

Multimeter ME-26(\*)/U

Voltmeter, Electronic ME-30(\*)/U

Radio Frequency Wattmeter AN/URM-43(\*)

Cable Assembly, Radio Frequency CG-409E/U

Adapter UG-201A/U (2 each)

Adapter, Connector UG-565A/U

*b. Test Connections and Conditions.* Connect the equipment as shown in figure 113.3. Use needle-pointed probes to make all measurements.*c. Test Procedure.*

Test equipment control settings	Equipment under test control settings	Test procedure	Performance standard
<p><i>PP-1104A/G</i></p> <p>Circuit breaker: ON</p> <p>INCREASE VOLTAGE: For 26.4 volts on dc voltmeter</p> <p><i>ME-26(*)/U</i></p> <p>FUNCTION: +</p> <p>RANGE: 1000V</p> <p>ZERO ADJ: For meter zero with COMMON and DC probes shorted</p> <p>OHMS ADJ: Any position</p> <p>AC ZERO: Any position</p> <p><i>ME-30(*)/U</i></p> <p>Range selector: .3 VOLTS</p> <p>Power: ON</p> <p><i>AN/URM-43(*)</i></p> <p>15W-60W: 60W</p> <p><i>OA-2648/VRC-24</i></p> <p>POWER: Operate to ON and release</p> <p>CHAN SEL: 9</p> <p>MANUAL FREQUENCY switches:</p> <p>TENS: 30</p> <p>UNITS: 5</p> <p>TENTHS: .5</p> <p>SQUELCH: Midposition</p> <p>VOLUME: Midposition</p> <p>METER: LINE V</p>	N/A-----	<p><i>a.</i> Depress H-33/PT switch, connect ME-26(*)/U DC probe to J10, pin F, and note the ME-26(*)/U indication.</p> <p><i>b.</i> Release H-33/PT switch-----</p> <p><i>c.</i> Operate ME-26(*)/U RANGE switch to 300V and connect DC probe to J10, pin K. Note ME-26(*)/U indication.</p> <p><i>d.</i> Operate ME-26(*)/U RANGE switch to 100V and FUNCTION switch to -.</p> <p><i>e.</i> Connect DC probe to J10, pin M, and note ME-26(*)/U indication.</p> <p><i>f.</i> Clip ME-30(*)/U black test lead to RT-323/VRC-24 chassis ground.</p> <p><i>g.</i> Connect ME-30(*)/U red test lead to J10, pin F, and note ME-30(*)/U indication.</p> <p><i>h.</i> Operate ME-30(*)/U range selector switch to .1 VOLTS and connect red lead to J10, pin K. Note ME-30(*)/U indication.</p> <p><i>i.</i> Connect ME-30(*)/U red lead to J10, pin M, and note ME-30(*)/U indication.</p>	<p><i>a.</i> 300 volts <math>\pm 20</math> (0.28 to 0.32 on top scale).</p> <p><i>b.</i> None.</p> <p><i>c.</i> 125 volts <math>\pm 7</math> (1.18 to 1.32 on lower row of top scale).</p> <p><i>d.</i> None.</p> <p><i>e.</i> -30 volts <math>\pm 3</math> (0.27 to 0.33 on top scale).</p> <p><i>f.</i> None.</p> <p><i>g.</i> Less than 0.3 volt (less than 3 on center scale).</p> <p><i>h.</i> Less than 0.1 volt (less than 1.0 on top scale).</p> <p><i>i.</i> Less than 0.1 volt (less than 1.0 on top scale).</p>

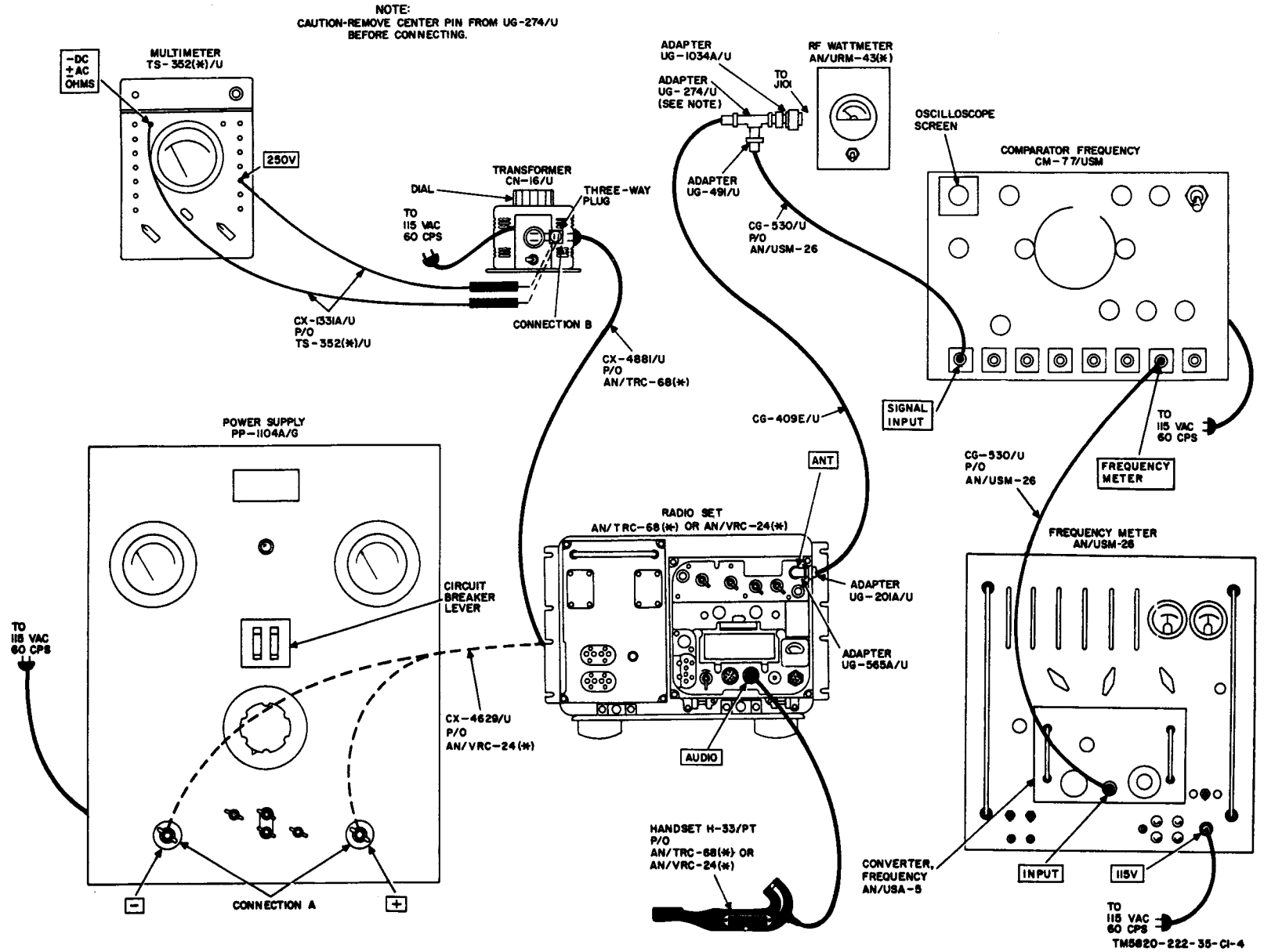


Figure 113.4. RT-323/VRC-24 or RT-441/TRC-68 transmit frequency stability, metering, and power output tests, test setup.



## 141.17. Summary of Test Data

### a. PP-1494/U Voltage and Ripple

	Voltage	Ripple
300 VDC.....	300 ±15V	Less than 0.3 VAC
125 VDC.....	125 ±7V	Less than 0.1 VAC
26.4 VDC.....	26.4 ±3V	-----
-30 VDC.....	-30 ±3V	Less than 0.1 VAC
26.4 VAC.....	26.4 ±3V	-----
18.9 VAC.....	18.9 ±2V	-----
12.6 VAC.....	12.6 ±.6V	-----
6.3 VAC.....	6.3 ±3V	-----

### b. DY-151/U Voltage and Ripple

	Voltage	Ripple
300 VDC.....	300 ±20	Less than 0.3 VAC
125 VDC.....	125 ±7	Less than 0.1 VAC
+30 VDC.....	-30 ±3	Less than 0.1 VAC

### c. RT-323/VRC-24(\*) or RT-441/TRC-68(\*)

#### Transmit

Frequency Stability.....	±2 kc
Power Output.....	16 watts minimum
Metering.....	±20%
Modulation.....	0.1 volt for 85 ±10%
Limiting.....	0.4 volt produces not more than 2 db increase in modulating audio
Frequency Response.....	±2 db 250 - 6,000 cps -6 db 100 cps and 10 kc
Carrier Noise Level.....	-35 db
Distortion.....	Less than 10%

### d. RT-323/VRC-24(\*) or RT-441/TRC-68(\*)

#### Receive

Sensitivity.....	6 microvolts for 10-db signal to noise
Resettability.....	±2 db
Audio Output.....	Speaker..... 1 watt Headset..... 0.3 watt Broadband... 2 milliwatts
Signal Plus Noise-to-Noise.....	35 db
Squelch Sensitivity.....	3 microvolts
Frequency Response.....	±2 db -300 -3000 cps -8 db -100 cps -20 db -10 kc
Distortion.....	Less than 10%
Selectivity.....	6 db... More than 80 kc 60 db... Less than 150 kc
Symmetry.....	±20 kc

### e. C-1439/U

Channel Switch.....	Preset channel dial must correspond to switch position
Squelch.....	Not more than 50% of full rotation
Transmit.....	Must key and modulate transmitter without hum, noise, or buzz
Audio.....	Reception must be intelligible and free from hum, noise, or buzz

Page 186, paragraph 150, chart, "Test equipment

and connections" column, line 4. Add: (or J704-A and -F on AN/VRC-24A and AN/TRC-68A).

Page 187, figure 116. At "J704-J," add: (OR J504 ON AN/VRC-24A AND AN/TRC-68A). At "J704-E," add: (OR -A ON AN/VRC-24A AND AN/TRC-68A).

Page 188, paragraph 151. Add the following to the first sentence of subparagraph j: (or J704-F and -A on AN/VRC-24A and AN/TRC-68A).

Paragraph 152f. Add the following to subparagraph (3): (or J704-F and -A on AN/VRC-24A and AN/TRC-68A).

Page 189, figure 117. At "J704-J," add: (J504 ON AN/VRC-24A AND AN/TRC-68A).

Page 191, paragraph 155d(2), line 6. After "J704", add: (or J704-E on AN/VRC-24A and AN/TRC-68A).

Page 192, figure 119. Above "J704-B" and below "J704-D", add: (NOTE 5).

Add the following to the notes:

5. J704-B AND -D ARE -E AND -F ON AN/VRC-24A AND AN/TRC-68A.

Page 194, paragraph 157c(2). Add to subparagraph (2): (or J704-E and -F on AN/VRC-24A and AN/TRC-68A).

Page 206, figure 128ⓐ. Make the following changes:

At "R313" delete "(NOTE 22)" and change the value to: 15K.

At "R122" delete "(NOTE 21)".

At "L118" delete "(NOTE 19)".

At "R717", "L317" and "L318" delete "(NOTE 18)".

Insert resistor R719, 100 ohms, in place of the wire that connects terminal "1" of "I701" to terminal "R" of "P703".

Change the value of "R717" to: 47K.

Disconnect "R609" from "P603-J" and connect "R609" to "P603-K".

Disconnect "R608" from "P603-K" and connect "R608" to ground.

Insert resistor "R124", 0.56 ohms, between "L117" and the heater of V105.

Relocate fuse "F703" so it is across terminals "K" and "R" of "P701". Insert resistor R718, 0.56 ohms, between the junction of "F703" and "P701-R" and lamps "I702" and "I703".

Page 207, figure 128ⓑ. Make the following changes:

Add "P603" above "C610" and "J601" below "L602".

Delete notes 17 through 22 and substitute:

17. DURING PRODUCTION, CERTAIN CHANGES WERE MADE. REFER TO PARAGRAPH 1.3. At "R850", delete "(NOTE 18)". At "Z203", "Z205", and "Z207" delete "(NOTE 17)".

Page 208, appendix. Add the following in proper sequence:

TM 11-527-15 Radio Receiving Set AN/URR-35C

By Order of the Secretary of the Army:

Official:

J. C. LAMBERT,  
Major General, United States Army,  
The Adjutant General.

Distribution:

*Active Army:*

DASA (6)  
USASA (2)  
CNGB (1)  
CofEngrs (1)  
TSG (1)  
CSigO (7)  
CofT (1)  
CofSptS (1)  
USA CD Agcy (1)  
USCONARC (5)  
USAMC (5)  
ARADCOM (2)  
ARADCOM Rgn (2)  
OS Maj Comd (3)  
OS Base Comd (2)  
LOGCOMD (2)  
USAECOM (5)  
USAMICOM (4)  
USASCC (4)  
MDW (1)  
Armies (2)  
Corps (2)  
USA Corps (3)  
USATC AD (2)  
USATC Engr (2)  
USATC Inf (2)

USATC Armor (2)  
USASTC (5)  
Instl (2) except  
Ft Monmouth (65)  
Svc Colleges (2)  
Br Svc Sch (2) except  
GENDEP (OS) (2)  
Sig Dep (OS) (12)  
Sig Sec, GENDEP (5)  
Army Dep (2) except  
Ft Worth (8)  
Lexington (12)  
Sacramento (28)  
Tobyhanna (12)  
USA Trans Tml Comd (1)  
Army Tml (1)  
USAOSA (1)  
POE (1)  
USMA (5)  
WSMR (5)  
WRAMC (1)  
AMS (1)  
AFIP (1)  
Army Pic Cen (2)  
USA Mbl Spt Cen (1)  
USA Elct Mat Agcy (12)

Chicago Proc Dist (1)  
USA Elct RD Actv, White Sands (13)  
USA Elct RD Actv, Ft Huachuca (2)  
USARSOUTHCOM Sig Agcy (1)  
Sig Fld Maint Shop (3)  
Units org under fol TOE's  
(2 copies each except as indicated):  
11-5  
11-7  
11-16  
11-57  
11-95  
11-96  
11-98  
11-99  
11-117  
11-155  
11-157  
11-500 (AA-AE, RM-RT) (4)  
11-557  
11-587  
11-592  
11-597  
29-56

NG: State AG (3); units—same as active Army except allowance is one copy to each unit.

USAR: None.

For explanation of abbreviations used, see AR 320-50.

TM 11-5017

Output Meters TS-585A/U, TS-585B/U, TS-585C/U, and TS-585D/U

TM 11-5126

Power Supplies PP-1104A/G and PP-1104B/G

TM 11-6325-261-12

Operator's and Organizational Maintenance Manual, Audio Oscillators TS-382A/U, TS-382B/U, TS-382D/U, TS-382E/U and TS-382F/U

EARLE G. WHEELER,  
General, United States Army,  
Chief of Staff.

Technical Manual  
 No. 11-5820-222-35  
 Technical Order  
 No. 31R2-2TRC68-22



**DEPARTMENTS OF THE ARMY  
 AND THE AIR FORCE  
 WASHINGTON 25, D. C., 1 June 1961**

**RADIO SETS AN/VRC-24 AND AN/TRC-68**

C H A P T E R 1 .	BLOCK DIAGRAM THEORY		
Section I.	General . . . . .	1, 2	2
Section II.	Block diagram of radio sets . . . . .	3-7	2
C H A P T E R 2 .	RECEIVER THEORY		2-4
Section I.	Receiving signal path . . . . .	8, 9	5
Section II.	Directional coupler and rf input stages . . . . .	10-16	5-7
Section III.	Uhf injection subunit . . . . .	17-24	8-11
Section IV.	First if. stages, second receiver mixer and second oscillator . . . . .	25-28	12-15
Section V.	Third receiver mixer and third oscillator section . . . . .	29-33	16-18
Section VI.	Audio amplifier subunit and 500-kc if . . . . .	34-41	19,20
Section VII.	Squelch and audio output section . . . . .	42-45	20-24
C H A P T E R 3 .	TRANSMITTER THEORY		25-29
Section I.	Transmitter signal path . . . . .	46, 47	30
Section II.	Low-level stages . . . . .	48-54	30-34
Section III.	High-level rf and modulator stages . . . . .	55-61	32-35
C H A P T E R 4 .	THEORY OF BROADBAND, CONTROL METERING, POWER DISTRIBUTION, AND FREQUENCY SELECTION STAGES		35-39 40
Section I.	Broadband reception and transmission . . . . .	62-65	40,41
Section II.	Metering circuits . . . . .	66-76	41-45
Section III.	B+ and bias distribution . . . . .	77-79	46-48
Section IV.	Power control circuits . . . . .	80, 81	48-51
Section V.	Control and frequency selection circuits. . . . .	82-86	51-60
Section VI.	Power supplies and minor components . . . . .	87-91	60-69
C H A P T E R 5 .	TROUBLESHOOTING		70
Section I.	General troubleshooting procedures . . . . .	92-94	70,71
Section II.	System application troubleshooting . . . . .	95, 96	71-75
Section III.	Unit troubleshooting . . . . .	97-105	75-130
C H A P T E R 6 .	REPAIRS AND ALIGNMENT		131
Section I.	Removal and replacement of subunits . . . . .	106-120	131-136
Section II.	Repairs . . . . .	121-127	136-169
Section III.	Alignment . . . . .	128-137	170-179
Section IV.	Adjustments . . . . .	138-141	179-181
C H A P T E R 7 .	FINAL TESTING		182
Section I.	Introduction . . . . .	142,143	182
Section II.	Tests . . . . .	144-161	181-207
A P P E N D I X	REFERENCES . . . . .		208
I N D E X . . . . .			209

# CHAPTER 1

## BLOCK DIAGRAM THEORY

---

### Section I. GENERAL

#### 1. Scope

a. This manual covers field and depot maintenance for Radio Sets AN/VRC-24 and AN/TRC-68. It includes instructions appropriate to third, fourth, and fifth echelons for troubleshooting, testing, aligning, and repairing the equipment, replacing maintenance parts, and repairing specified maintenance parts. The manual also lists tools, materials, and test equipment for third, fourth, and fifth echelon maintenance. Detailed functions of the components are covered in the theory chapter.

b. The complete set of technical manuals for this equipment includes TM 11-5820-222-10, TM 11-5820-222-20, TM 11-5820-222-20P, and TM 11-5820-222-35P.

c. Forward comments concerning this manual direct to the Commanding Officer, U.S. Army Signal Materiel Support Agency, ATTN: SIGMS-PA2d, Fort Monmouth, N.J.

d. For applicable forms and records, see paragraph 2, TM 11-5820-222-10.

#### 2. System Applications

a. *Retransmission Communications System.* Radio Set AN/VRC-24 can be used with Radio Sets AN/GRC-3 through -8 as a retransmission device. In this system, amplitude-modulated (am.) signals within

the 225.0 to 399.9-megacycles (mc) frequency range are received by Receiver-Transmitter RT-323/VRC-24 and retransmitted as frequency-modulated (fm) signals in the frequency range of 20 to 55 mc by Radio Set AN/GRC-3 through -8. Fm signals are received by Radio Sets AN/GRC-3 through -8 and retransmitted as am. signals by Receiver-Transmitter RT-323/VRC-24. Figure 3, in TM 11-5820-222-10 illustrates the necessary cable connections for system operation. Installation details are provided in paragraph 5 of TM 11-5820-222-20.

b. *Broadband Applications.* Both Radio Set AN/VRC-24 and AN/TRC-68 can be used with broadband encoding and decoding equipment to transmit and receive encoded am. radiotelephone signals. The radio sets can be connected to the broadband equipment through the BROADBAND jack on the front panel of either Receiver-Transmitter RT-323/VRC-24 or RT-441/TRC-68. When the broadband encoding equipment is used, audio is coupled from the radio set to the broadband equipment, encoded, and returned to the radio set for transmission. Received encoded signals are detected by the radio set, coupled to the broadband equipment, decoded, and returned to the radio set audio output circuits.

### Section II. BLOCK DIAGRAM OF RADIO SETS

#### 3. General

The receiving and transmitting signal paths and automatic frequency selection circuits of Receiver-Transmitter Groups OA-2648/VRC-24 and OA-2649/TRC-68 are identical. The different power supplies, fuses, and blowers used with each receiver-transmitter group comprise the basic electrical differences between

Receiver-Transmitter Group OA-2648/VRC-24 and Receiver-Transmitter Group OA-2649/TRC-68.

#### 4. Simplified Receiving Signal Path (fig. 1)

Receiver-Transmitters RT-323/VRC-24 and RT-441/TRC-68 (referred throughout as the rt units) receive am. signals in

the frequency range of 225.0 to 399.9 mc. The input signals are heterodyned with the 200- to 370-mc signal supplied by the ultrahigh frequency (uhf) injection subunit to produce a 20.0 to 29.9-mc first intermediate frequency (if.) signal. The 20.0 to 29.9-mc if. signal is amplified and heterodyned with a 17.0 to 26.0-mc signal in the first if. amplifier subunit to produce a 3.0 to 3.9-mc if. signal. The 3.0- 3.9-mc if. signal is heterodyned again to produce a 500-kilocycle (kc) if. signal. The 500-kc signal is amplified by the 500-kc if. amplifiers and demodulated. The audio signals are amplified in the 500-kc if. amplifier and audio amplifier and modulator subunits and applied to the local, remote, and fixed level outputs or to the broadband equipment. Decoded signals from the broadband equipment are returned to the audio amplifier and modulator for amplification before being applied to local, remote, or fixed level audio outputs.

## 5. Simplified Transmitting Signal Path (fig. 2)

The rt units transmit am. radiofrequency (rf) signals in the frequency range of 225.0 to 399.9 mc. During transmission, the first and the 3.0- to 3.9-mc if. amplifier subunits function as signal generators. The 3.0- to 3.9-mc signal is heterodyned with a 17.0- to 26.0-mc signal from the first if. amplifier subunit to produce a 20.0- to 29.9-mc signal. This signal is heterodyned with a 200- to 370-mc signal from the uhf injection subunit to produce an rf carrier that can be varied from 225.0 to 399.9 mc. The rf carrier signal is amplitude modulated by audiofrequencies from the audio amplifier and modulator subunit and coupled to the uhf antenna.

## 6. Frequency Selector System

*a. General.* The frequency range of the rt units is covered by 1,750 crystal-controlled channel frequencies in 0.1-mc steps. Nineteen channels can be preset for automatic selection from the front panel or from the radio set control. A manual system permits selection of any channel frequency within the 225.0- to 399.9-mc

range without disturbing the preset channels.

### *b. Frequency Selection.*

- (1) The frequency selector subunit includes four automatic positioners: a 20-position channel selector; an 18-position, 10-mc selector; a 10-position, 1.0-mc selector; and a 10-position, 0.1-mc selector. The 20-position, channel selector automatic positioner, controlled by the setting of the CHAN SEL selector switch on the front panel to the CHANNEL selector switch on the radio set control, positions a channel selector memory drum to select the desired channel.
- (2) The 10.0-, 1.0-, and 0.1-mc automatic positioners drive seeking switches which select the frequencies preset on the memory drum or on the MANUAL FREQUENCY controls. The 10.0 -,1.0-, and 0.1-mc automatic positioners also drive five tuning shafts through a series of gear trains.
- (3) The frequency selector shafts are coupled to the tuning shafts within the rf and power amplifier, the uhf injection subunit, and the first and 3.0- to 3.9-mc if. amplifier subunits.
- (4) When each seeking switch reaches its proper position, the corresponding automatic positioner stops. When all automatic positioners have stopped, the rt unit is ready for operation on the selected channel frequency.

## 7. Power Supplies

*a. Radio Set AN/VRC-24 Power Supply.* The internal power supply of Radio Set AN/VRC-24 consists of Dynamotor DY-151/U and appropriate filters which provide the +125-, +300-, and -30-volt direct current (dc) operating voltages. Dynamotor DY-151/U operates on an input voltage of 26.4-volt dc. Relay and filament voltages are supplied directly from the input voltage.

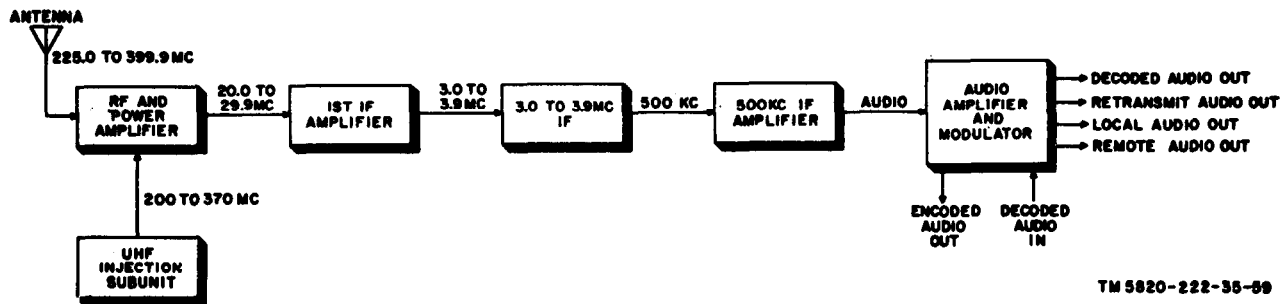


Figure 1. Receiving signal path, simplified block diagram.

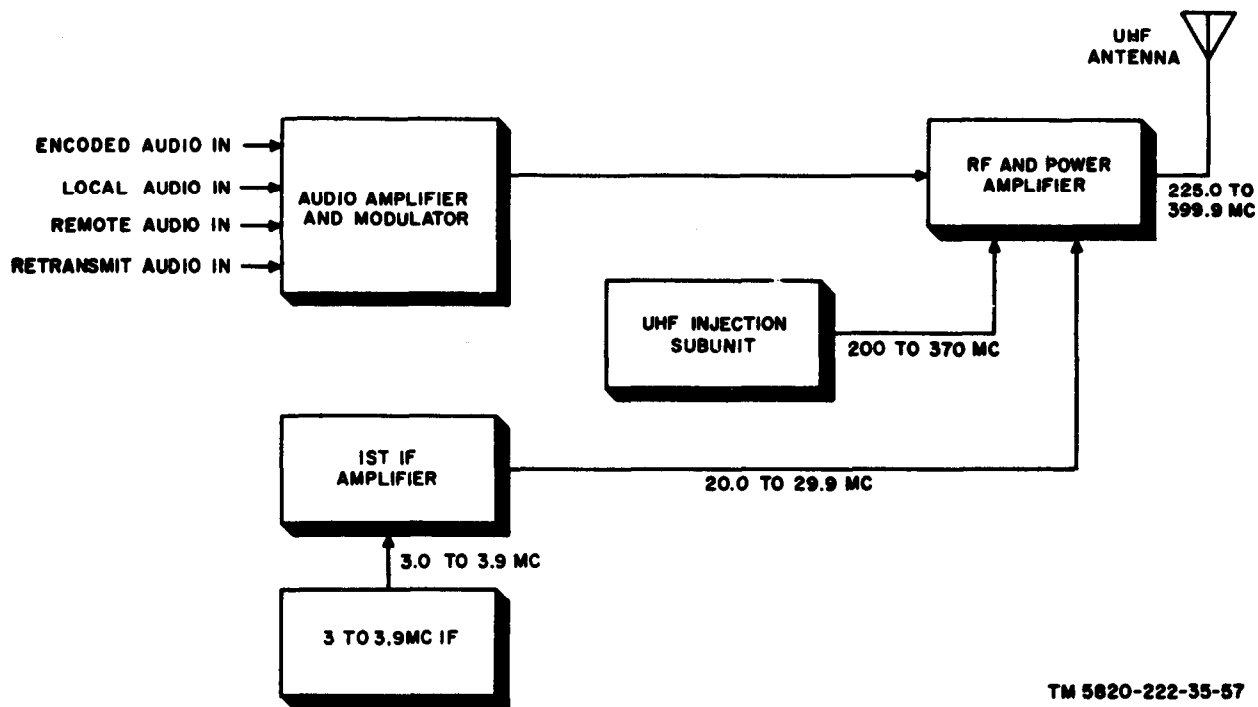


Figure 2. Transmitting signal path, simplified block diagram.

*b. Radio Set AN/TRC-68 Power Supply.*  
The internal power supply of Radio Set AN/TRC-68 consists of Power Supply PP-1494/U. Power Supply PP-1494/U operates with either external 115- or 230-volt

alternating current (ac), 50/60 cycles per second (cps) input voltages, and supplies +125-volt dc, +300-volt dc and -30-volt dc to the rt unit.

## CHAPTER 2

### RECEIVER THEORY

---

#### Section I. RECEIVING SIGNAL PATH

#### 8. Receiver Rf Sections (fig. 3)

The signal path for the receive function of the rt unit is shown in block diagram form in figure 3. The block diagram also shows the positions of transmit-receive (tr) relay contacts in the signal path.

*a. General.* The rf unit operates as a receiver at all times when in the standby condition. On receive, the tr relays are deenergized because the push-to-talk switch on the transmitter microphone is not operated.

*b. Rf Section.* The 225.0- to 399.9-mc input rf signal feeds from the uhf antenna through the directional coupler and through antenna relay K101 to first rf amplifier V102. The rf signal is amplified by first and second rf amplifiers V102 and V103. The rf signal is coupled from the second rf amplifier to first receiver mixer V104. The uhf injection subunit provides the heterodyning frequency to the first receiver mixer through injection relay K102.

*c. Uhf Injection.*

(1) The uhf injection system consists of first oscillator V201, frequency tripler V202, and first, second, and third uhf injection amplifiers V203, V204, and V205. The first oscillator V201 provides 18 crystal-controlled output frequencies. Frequency tripler V202 selects the third harmonic of these frequencies to produce 18 frequencies which cover the 200- to 370-mc range in 10-mc steps.

(2) The output of V202 is amplified by three rf amplifiers, V203 through V205. The output of V205 is applied to the first receiver mixer V104 through injection relay K102.

*d. If. Section.*

(1) The uhf injection frequency and the received rf are heterodyned in first

receiver mixer V104 to produce the 20.0- to 29.9-mc first if. After amplification by first and second if. amplifiers V301 and V302, the first if. signal is coupled to second receiver mixer V303, where it is heterodyned with the signal from second oscillator V305 to produce the 3.0- to 3.9-mc if. signal.

(2) The second oscillator uses 10 crystals covering the 17.0- to 26.0-mc range in 1.0-mc steps. The output of V303 is the difference frequency of the two inputs and is in the 3.0- to 3.9-mc frequency range.

(3) The 3.0- to 3.9-mc triple-tuned bandpass filter, consisting of filters Z401, Z402, and Z403, passes the 3.0- to 3.9-mc if. signal and applies it to third receiver mixer V401A. The 3.0- to 3.9-mc signal is heterodyned with the output of third oscillator V401B to produce the 500-kc if. signal.

(4) The third oscillator is controlled by 10 crystals covering the 3.0- to 3.9-mc range in 0.1-mc steps. The third oscillator output is 0.5 mc higher than the if. when the if. is between 3.0 to 3.4 mc. The third oscillator output is 0.5 mc lower than the if. when the if. is between 3.5 and 3.9 mc. Thus, the output of third receiver mixer V401A is always 0.5 mc (500 kc). The 500-kc if. is passed by 500-kc if. filter FL901 and is amplified by three 500-kc if. amplifiers V501, V502, and V503.

#### 9. Receiver Audio Section (fig. 3)

*a. Audio Input Section.*

(1) The output of V503 is applied to

output transformer T501. Detector diode CR501 is connected across the secondary of output transformer T501. When encoding equipment is used, the incoming encoded signals are demodulated and applied to broadband cathode follower V802A. Tube V802A couples the encoded broadband signal to the broadband decoding equipment.

- (2) Detector diode CR501 demodulates the 500-kc if. signal and applies the audio signal to series noise limiter diode CR503. Detector CR501 also develops automatic volume control (avc) voltage. Avc voltages are applied to the first and second rf amplifiers through rf avc gate CR505. If. amplifiers V301 and V302, and the first and second 500-kc if. amplifiers V501 and V502, are controlled by avc voltage through if. avc gate CR504.
- (3) Series noise limiter diode CR503 clips noise peaks from the audio signal. First audio amplifier V504 amplifies the audio output of the series noise limiter.
- (4) The decoded audio output of the broadband equipment is applied to audio preamplifier V903 through relays K801 and K802, and NOR BB switch S801, when the NOR BB

switch S801, is in the BB position. The decoded signals are amplified by V803 and coupled to second receiver audio amplifier V804.

*b. Audio Output Section.*

- (1) When NOR-BB switch S801 is in the NOR position, audio signals from first audio amplifier V504 are coupled to the second receiver audio amplifier V804 through squelch relay K801. Second receiver audio amplifier V804 amplifies the audio signals to drive amplifiers V805, V806, V807, and V808.
- (2) The output of the amplifiers is applied to audio output transformer T802. Audio is tapped off the secondary and applied to the local and remote headsets and speakers and to the fixed level audio terminal.

*c. Squelch Circuit.* The carrier squelch is controlled by the dc voltage developed across the detector diode CR501 load. When no signal is being received, squelch relay K801 is deenergized and the input circuits to the second audio amplifier V804 are opened. When a signal of sufficient strength (determined by the setting of the SQUELCH control) is received, the relay is energized and the circuits to the second audio amplifier are closed.





## Section II. DIRECTIONAL COUPLER AND RF INPUT STAGES

### 10. Directional Coupler (fig. 4)

#### a. General.

- (1) Transmitted and received rf signals travel to and from the antenna on the transmission line through the directional coupler subunit. The directional coupler subunit consists of two directional coupler circuits, which use short transmission lines for coupling elements. The directional coupler circuit which includes coupling element A is arranged to sample the incident waves of transmitter power (traveling toward the antenna) and provide a front panel meter indication of output power (PWR).
- (2) The directional coupler circuit which includes coupling element B is arranged to sample the reflected waves of transmitter power (traveling toward the rf and power amplifier subunit) and provide a front panel meter indication of the reflected power (SWR). The metering circuits are shown in figure 22.

#### b. Directional Coupler Theory.

- (1) Directional coupler circuits A and B are identical except for reference symbols, and they operate on the same principle. Only directional coupler circuit A is discussed in detail. The transmission line is coupled to directional coupler A by mutual inductance and capacitive coupling. Assume that the incident waves induce a current to coupling element A which flows toward diode CR1301. Because of capacitive coupling between the transmission line and coupling element A, the incident waves will cause two equal capacitive currents to flow in opposite directions in coupling element A; one toward diode CR1301 and one toward resistor R1306.
- (2) The inductive and capacitive coupling between coupling element A

and the transmission line is arranged so that the effect of capacitively coupled current flowing toward resistor R1306 is cancelled by the inductively coupled current flowing in the opposite direction. However, the capacitively coupled current flowing in the direction of CR1301 tends to reinforce the inductively coupled current flowing in that direction. Thus, the incident waves induce a resultant current in coupling element A, which flows toward diode CR1301.

- (3) Reflected waves, traveling along the transmission line from the antenna, also induce a resultant current flow in coupling element A because of the inductive and capacitive coupling between coupling element A and the transmission line. Because of the polarity reversal of reflected waves, the resultant current flow induced in coupling element A is in the opposite direction.
- (4) The resultant current flow is absorbed by resistor R1306, which terminates coupling element A in its characteristic impedance (51.1 ohms). Thus, incident waves on the transmission line induce a resultant current flow in coupling element A which is not affected by reflected waves on the transmission line. Diode CR1301 rectifies the resultant rf current induced in coupling element A. Capacitor C1301 filters the output of diode CR1301; resistor R1302 is the diode load resistor
- (5) The magnitude of the resultant current is determined by the inductive and capacitive coupling between coupling element A and the transmission line, which is, in turn, determined by the operating frequency of the radio set. Therefore, the other end of coupling element A is terminated by capacitor

C1302. When the operating frequency is lowered and the coupling decreases, the impedance of capacitor C1302 increases to compensate for the decreased current flowing through the diode load. Thus, capacitor C1302 provides a constant meter current for any given transmitter output power over the frequency range from 225.0 to 399.9 mc.

- (6) The voltage drop developed across resistor R1302 by the rectified rf current is coupled to the meter circuit through calibrating resistor R1301. The value of resistor R1301 is selected to obtain a PWR meter indication 60 percent of full scale for 16 watts output power at 319.9 mc.

*c. Directional Coupler B.*

- (1) The directional coupler circuit which includes coupling element B operates on the same principles described above. The circuit components associated with coupling element B are located physically opposite to those associated with coupling element A. Thus, the resultant rf current induced in coupling element B by the reflected wave is rectified by diode CR1302 and metered to indicate reflected power (SWR). The rf current induced by the incident wave is absorbed by resistor R1303.
- (2) Capacitors C1303 and C1304 and resistors R1307 and R1308 perform the same circuit functions as the corresponding components in the directional coupler circuit which includes coupling element A. Resistor R1308 has the same value as resistor R1301.

**11. Rf Section on Receive**  
(fig. 5)

On receive, antenna relay K101 is deenergized and first and second rf amplifiers V102 and V103 amplify the received rf signal. First receiver mixer V104 heterodynes the rf signal with the uhf injection frequency to obtain the first if.

**12. Input Circuit**

Received rf signals are fed to antenna relay K101 from the antenna through the directional coupler (fig. 4). Antenna relay K101 is deenergized on receive, contacts 2 and 3 of relay K101 are closed, and the rf signal is coupled to parallel-tuned tank circuit Z101 through coupling capacitors C106 and C108. Resistor R117 provides a dc path to ground for static charges developed on the antenna. The parallel-tuned tank circuit consisting of Z101 and C107 provides a high impedance to rf signals in the 225.0- to 399.9-mc range.

**13. First Rf Amplifier V102**  
(fig. 5)

*a.* Capacitor C110 couples the signal voltage developed across Z101 and C107 to the cathode of grounded grid first rf amplifier V102. The cathode circuit consists of a Z102, a parallel-tuned circuit, and cathode bias resistor R122. The tuned circuit is resonant in the 225.0 to 399.9-mc range and provides a high impedance for the rf signal. Capacitor C112 grounds rf at the grid of V102. Resistor R104 connects the grid of V102 to the rf avc bus and with capacitor C109, isolates the rf signal from the rf avc bus.

*b.* The +125-volt dc plate voltage is supplied to the plate of V102 through plate load L105 and plate voltage dropping resistor R116. Capacitor C113 bypasses rf signals from the +125-volt dc supply. The rf signal is amplified by V102 and coupled by capacitor C114 to the parallel-tuned tank circuit Z103 and variable capacitor C115. The parallel-tuned tank circuit serves as a high coupling impedance for the rf signal.

**14. Second Rf Amplifier V103**  
(fig. 5)

*a.* Coupling capacitor C117 couples the rf signal voltage developed across Z103 to the cathode of the second rf amplifier V103, a grounded grid amplifier. The cathode circuit consists of Z104, a parallel-tuned circuit which is resonant in the 225.0- to 399.9-mc range and cathode bias

resistor R123. Tuned circuit Z104 provides a high coupling impedance for the rf signal.

b. Capacitor C119 grounds rf at the grid of V103. The +125-volt dc plate voltage is supplied to V103 through rf choke L107. Capacitor C120 bypasses rf signals from the +125-volt dc supply. Resistors R105 and R110 return the grid of V103 to the rf avc bus. Capacitor C116 bypasses rf signals to ground. The rf signal is amplified by V103 and coupled by capacitor C121 to parallel-tuned tank circuit Z105 and variable capacitor C122. Jack J105 is a test point for measuring rf avc voltage.

### 15. First Receiver Mixer V104

(fig. 5)

a. The rf signal voltage developed across Z105 is coupled to the cathode of first receiver mixer V104 by C123. Resistor R111 provides cathode bias for V104 through rf choke L110. Capacitor C125 is a cathode bias bypass capacitor. Capacitors C137 and C144 ground rf at the grid of V104, and resistors R106 and R107 provide grid leak bias. (On transmit, R107 is short-circuited by contacts 9 and 17 of tr relay K601.)

b. A 200- to 370-mc signal is also applied to the cathode of V104 from the uhf

injection subunit (sect. III) through injection contacts 6 and 7 of relay K102 (closed on receive), jack J112, and capacitor C135. The uhf injection signal heterodynes with the received rf signal to produce the 20.0 to 29.9-mc difference frequency, which is coupled directly to output jack J102 through injection relay K102, contacts 3 and 5. Jack J106 is a test point for checking the first receiver mixer injection.

c. The first receiver mixer V104, receives plate voltage from the +125-volt supply through plate load rf chokes L109 and L113. Choke L113 and bypass capacitors C134 and C136 decouple rf signals from the +125-volt dc supply.

### 16. Tuning

(fig. 5)

When tank circuits Z101, Z103 and Z105 are tuned by the frequency selector, both capacitance and inductance are varied; this improves the selectivity by maintaining the proper inductance-capacitance (LC) ratio. Trimmer capacitors C107, C115, and C122 set the minimum capacity points of the tank circuits. The 1,800-position shaft of the frequency selector tunes the three tank circuits through the 225.0- to 399.9-mc frequency range.

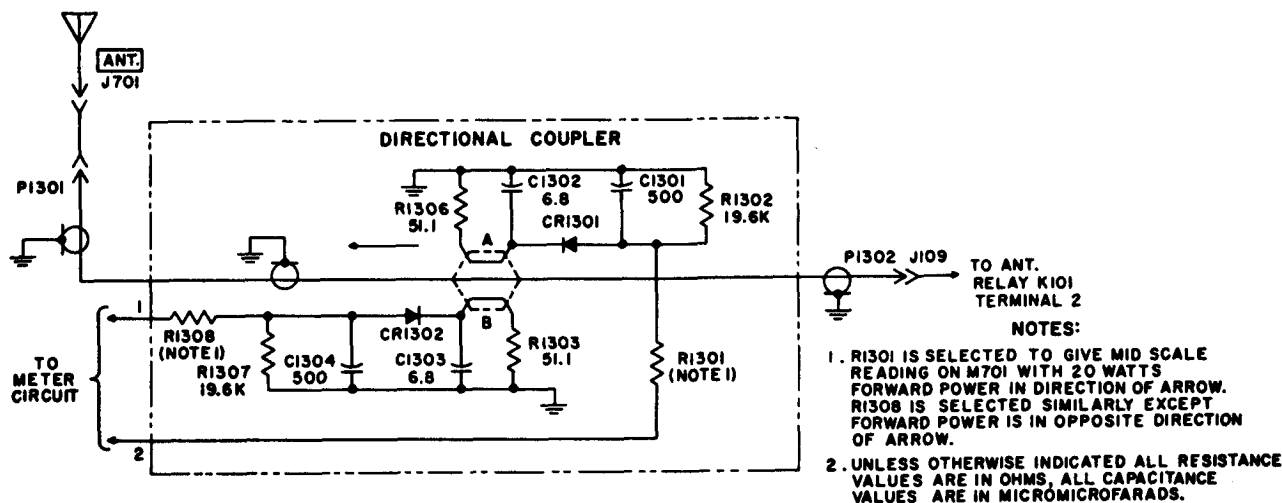


Figure 4. Directional coupler, schematic diagram.

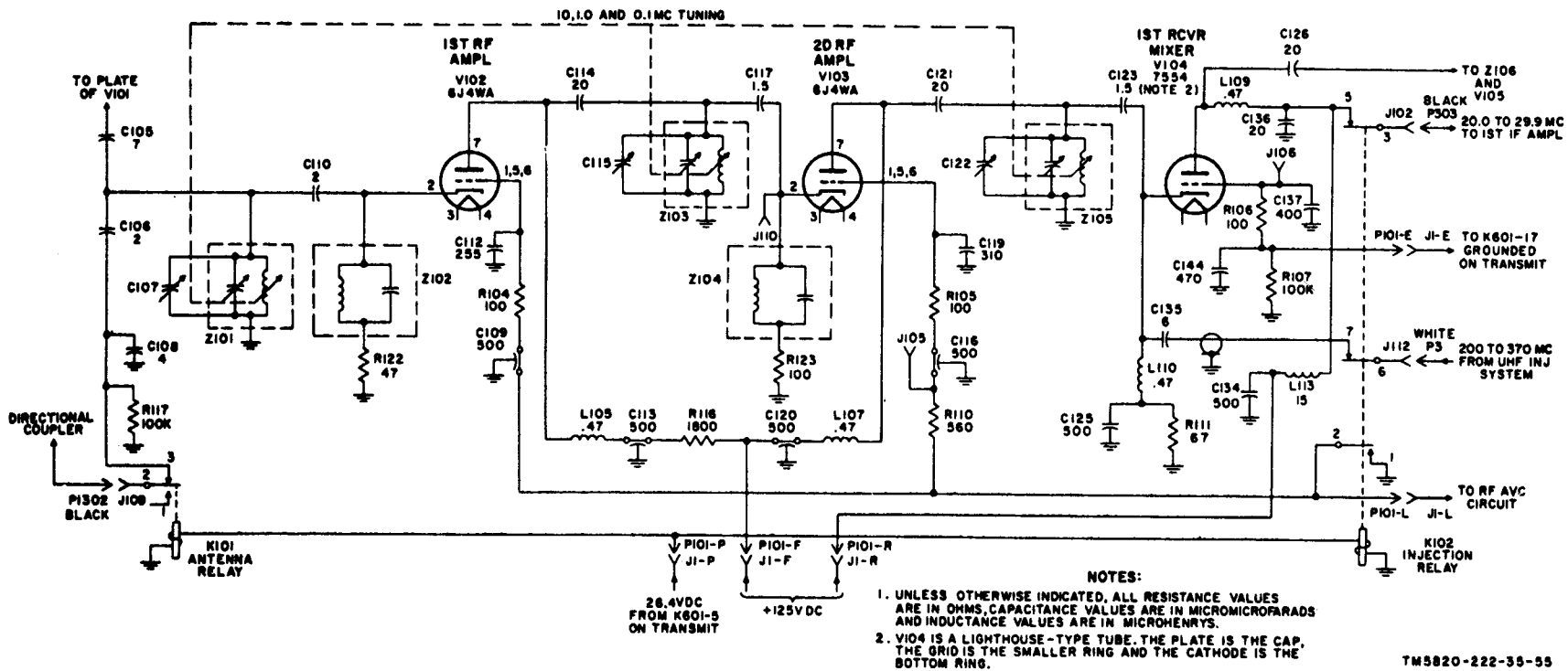


Figure 5. First rf amplifier V102, second rf amplifier V103, and first receiver mixer V104, schematic diagram.

### Section III. UHF INJECTION SUBUNIT

#### 17. Uhf Injection on Receive and Transmit

The uhf injection system, which consists of stages V201 through V205 (fig. 6 and 7), provides 18 crystal-controlled frequencies that cover the 200- to 370-mc range in 10-mc steps. On receive, the output is heterodyned with the received rf to produce the first if. On transmit, the output is heterodyned with the first if. to produce the rf carrier frequency.

#### 18. Crystal-Selection

(fig. 6)

a. First oscillator V201 is controlled by 1 of 15 crystals Y202, Y204, and Y206 through Y218 (fig. 56). These crystals can be selected by switch S202 to provide a total of 18 oscillator output frequencies are available. Switch S201, operated with switch S202, selects the correct plate trimmer coil (L201 through L218) for V201A.

b. Blocking capacitor C201 prevents dc plate voltage on pin 4 of V201 from being grounded through the coil. Rf chokes L219 and L220 resonate the crystal case and socket capacities and cancel their effect on the operation of the circuit.

#### 19. First Oscillator V201

(fig. 6)

a. Tube V201 functions as a cathode-coupled crystal oscillator. Triode section V201A is connected as a grounded grid amplifier. (Parasitic suppressor R202 effectively grounds the control grid.) The selected crystal in the cathode circuit of V201A controls plate current through this tube section. The signal voltage is developed across plate load L221 which is shunted by the selected coil (L201 through L218) and temperature-compensating capacitor C236. The voltage across L221 is coupled through C207, developed across grid resistor R205, and applied to the control grid of V201B. To sustain oscillation, feedback current is coupled from the cathode of V201B through C203; through the selected crystal, which functions as a series-tuned resonant circuit; and through C204 to the cathode of V201A.

b. The signal applied to the grid of V201B is amplified and developed across plate load Z201. Resistor R206 is a parasitic oscillation suppressor and C208 is a trimmer for Z201. Coil L222 is an additional trimmer adjustment for tuned circuit Z201. The voltage developed across Z201 is coupled through C210 to frequency tripler V202.

c. Resistors R203 and R204 provide cathode bias for the two triode sections of V201. Resistor R201 and C202 provide plate decoupling for V201A. The filter network, which consists of C239 and FL203, decouples V201B from the +125-Volt supply.

#### 20. Multiplier Network Z201

(fig. 6)

a. Tuned circuit Z201 is tuned to the second harmonic of the crystal frequency when the radio set operates in the 220.0 to 299.9-mc range. When the radio set operates in the 300.0 to 399.9-mc range, Z201 is tuned to the third harmonic of the crystal frequency. Thus the frequency developed across Z201 is either two or three times the crystal frequency, depending upon the frequency of operation selected.

b. Capacitor C210 couples the output signal from Z201 to the control grid of frequency tripler V202. Capacitor C208 and coil L222 are variable and insure proper tracking for Z201.

#### 21. Frequency Tripler V202

(fig. 6)

a. Frequency tripler V202 is a tuned rf voltage amplifier. Resistors R207 and R208 and capacitor C210 are the grid leak bias circuit. Capacitor C211 bypasses rf signals to ground to prevent rf from interfering with dc bias measurements at test jack J201. Screen grid voltage is supplied to V202 through plate voltage dropping resistor R213 and screen voltage dropping resistor R209. Capacitor C212 provides the screen grid with rf ground.

b. Plate voltage for V202 is supplied through resistor R213 and rf choke L224.

Choke L224 and capacitor C213, decouple rf from the +125-volt supply. Blocking capacitor C214 prevents the V202 plate voltage from being grounded through 2202 and couples the rf output of V202 to Z202. Parallel-tuned tank circuit 2202 is tuned to the third harmonic (200 to 370 mc) of the rf signal applied to the grid of V202. Trimmer capacitor C215 sets the minimum capacity point of tank circuit 2202.

## 22. First Uhf Injection Amplifier V203 (fig. 7)

a. *Coupling* capacitor C216 couples the rf uhf injection signal from 2202 to the cathode of first uhf injection amplifier V203. Cathode circuit 2203 consists of a parallel-tuned circuit, resonant in the 200- to 370-mc range, and a 100-ohm resistor. The parallel-tuned circuit presents a high coupling impedance for the input signal, and the resistor provides cathode bias. Jack J202 is available for measuring uhf signals at the cathode of V203.

b. Plate voltage for V203 is supplied from the +125-volt supply through voltage dropping resistor R210 and rf choke L226. Choke L226 and capacitor C219, decouple

rf from the +125-volt supply. Capacitor C220 couples the amplified 200- to 370-mc signal from the plate of V203 to Z204. Parallel-tuned tank circuit 2204, similar to 2202, is tuned to the 200- to 370-mc third harmonic of the V201 output frequency. Capacitor C222 couples the uhf signal from the plate of V203 to the cathode of V204.

## 23. Second and Third Uhf Injection Amplifiers V204 and V205 (fig. 7)

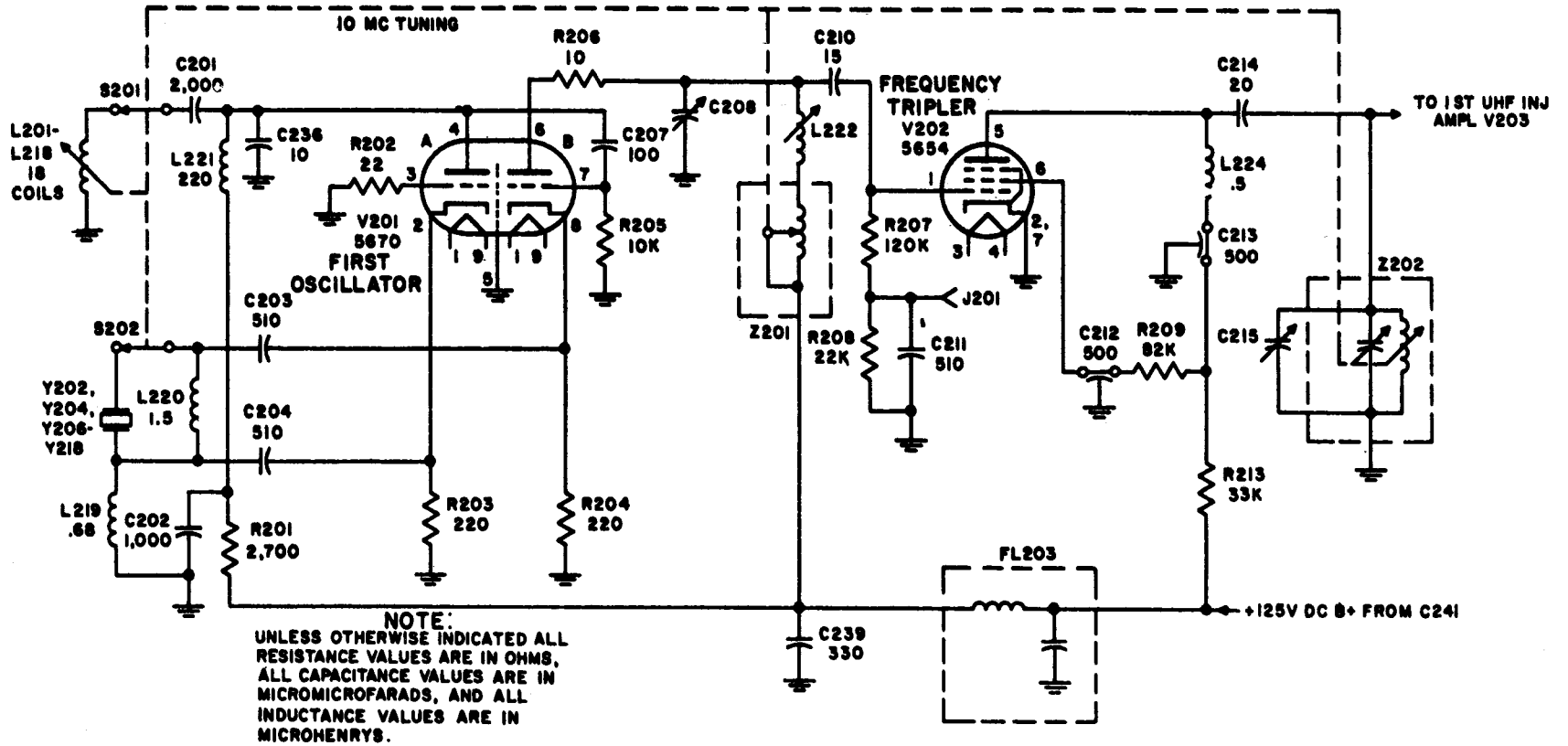
Second and third uhf injection amplifiers V204 and V205 provide two additional stages of uhf amplification. Except for part numbers, the stages are identical with the first uhf injection amplifier described in paragraph 22. Capacitors C234 and C235 form an ac voltage divider from which the uhf signal output of V205 is applied to contact 6 of injection relay K102 (fig. 5).

## 24. Receiving Frequency Conversion Scheme

The following chart correlates the dial settings with the oscillator and mixer circuit frequencies. The chart applies to the receive function.

Channel Frequency (0.1-mc steps)	Uhf Injection output frequency (10-mc steps)	1st receiver mixer output frequency (0.1-mc steps)	2d oscillator frequency (1.0-mc steps)	2d receiver mixer output frequency (0.1-mc steps)	3d oscillator frequency (0.1-mc steps)
225.0 to 225.9	200	25.0 to 25.9	22.0	3.0 to 3.9	3.5 to 3.9 then 3.0 to 3.4
226.0 to 226.9	200	26.0 to 26.9	23.0	3.0 to 3.9	3.5 to 3.9 then 3.0 to 3.4
227.0 to 227.9	200	27.0 to 27.9	24.0	3.0 to 3.9	3.5 to 3.9 then 3.0 to 3.4
228.0 to 228.9	200	28.0 to 28.9	25.0	3.0 to 3.9	3.5 to 3.9 then 3.0 to 3.4
229.0 to 229.9	200	29.0 to 29.9	26.0	3.0 to 3.9	3.5 to 3.9 then 3.0 to 3.4
230.0 to 239.9	210	20.0 to 29.9	17.0 to 26.0	3.0 to 3.9	3.5 to 3.9 then 3.0 to 3.4
240.0 to 249.9	220	20.0 to 29.9	17.0 to 26.0	3.0 to 3.9	3.5 to 3.9 then 3.0 to 3.4
250.0 to 259.9	230	20.0 to 29.9	17.0 to 26.0	3.0 to 3.9	3.5 to 3.9 then 3.0 to 3.4
260.0 to 269.9	240	20.0 to 29.9	17.0 to 26.0	3.0 to 3.9	3.5 to 3.9 then 3.0 to 3.4
270.0 to 279.9	250	20.0 to 29.9	17.0 to 26.0	3.0 to 3.9	3.5 to 3.9 then 3.0 to 3.4
280.0 to 289.9	260	20.0 to 29.9	17.0 to 26.0	3.0 to 3.9	3.5 to 3.9 then 3.0 to 3.4
290.0 to 299.9	270	20.0 to 29.9	17.0 to 26.0	3.0 to 3.9	3.5 to 3.9 then 3.0 to 3.4
300.0 to 309.9	280	20.0 to 29.9	17.0 to 26.0	3.0 to 3.9	3.5 to 3.9 then 3.0 to 3.4
310.0 to 319.9	290	20.0 to 29.9	17.0 to 26.0	3.0 to 3.9	3.5 to 3.9 then 3.0 to 3.4
320.0 to 329.9	300	20.0 to 29.9	17.0 to 26.0	3.0 to 3.9	3.5 to 3.9 then 3.0 to 3.4
330.0 to 339.9	310	20.0 to 29.9	17.0 to 26.0	3.0 to 3.9	3.5 to 3.9 then 3.0 to 3.4
340.0 to 349.9	320	20.0 to 29.9	17.0 to 26.0	3.0 to 3.9	3.5 to 3.9 then 3.0 to 3.4
350.0 to 359.9	330	20.0 to 29.9	17.0 to 26.0	3.0 to 3.9	3.5 to 3.9 then 3.0 to 3.4
360.0 to 369.9	340	20.0 to 29.9	17.0 to 26.0	3.0 to 3.9	3.5 to 3.9 then 3.0 to 3.4
370.0 to 379.9	350	20.0 to 29.9	17.0 to 26.0	3.0 to 3.9	3.5 to 3.9 then 3.0 to 3.4
380.0 to 389.9	360	20.0 to 29.9	17.0 to 26.0	3.0 to 3.9	3.5 to 3.9 then 3.0 to 3.4
390.0 to 399.9	370	20.0 to 29.9	17.0 to 26.0	3.0 to 3.9	3.5 to 3.9 then 3.0 to 3.4

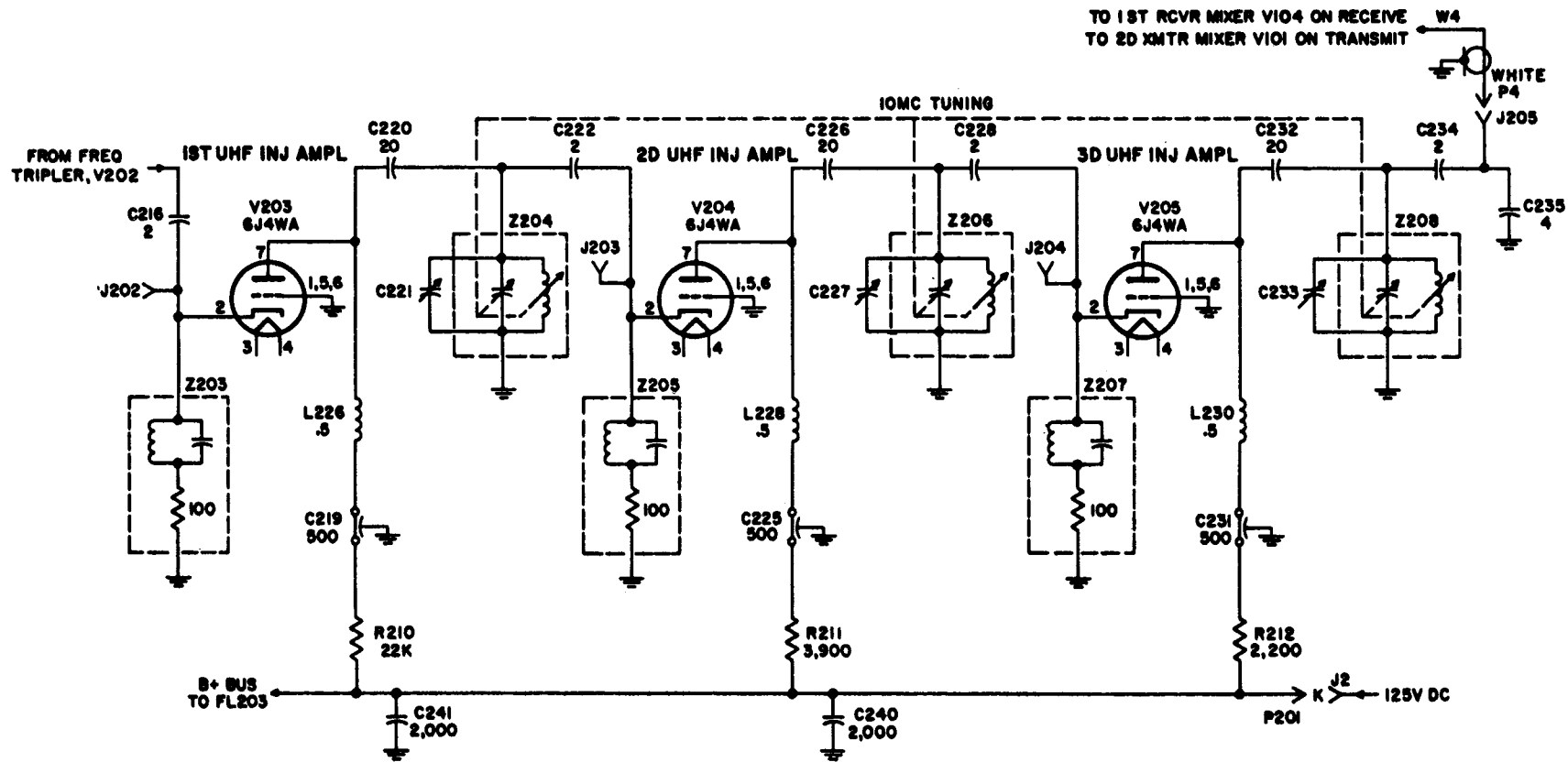
*Note.* The output of the third receiver oscillator mixes with the output of the second receiver mixer in the third receiver mixer. The output of the third receiver mixer is always 500 kc.



TM5820-222-35-48

Figure 6. First oscillator V801 and frequency tripler V802, schematic diagram.





TO 1ST RCVR MIXER V104 ON RECEIVE  
TO 2D XMTR MIXER V101 ON TRANSMIT

10MC TUNING

B+ BUS  
TO FL203

125V DC  
P201

**NOTE**

UNLESS OTHERWISE INDICATED ALL RESISTANCE VALUES ARE IN OHMS, ALL CAPACITANCE VALUES ARE IN MICROMICROFARADS, AND, ALL INDUCTANCE VALUES ARE IN MICROHENRYS.

TM5620-222-35-44

Figure 7. First, second, and third uhf injection amplifiers V203, V204, and V205, schematic diagram.

### 25. First If. Amplifier V301 (fig. 8)

*a.* On receive, first and second if. amplifiers V301 and V302 amplify the 20.0- to 29.9-mc first if. The amplified first if. is heterodyned in V303 with the 17.0- to 26.0-mc output of second oscillator V305 (fig. 9) to produce the 3.0- to 3.9-mc if.

*b.* The 20.0- to 29.9-mc if. signal from first receiver mixer V104 (para 15) is coupled from plug P303 through coupling capacitor C301 to parallel-tuned circuit Z301. Coupling capacitor C303 couples the if. signal to parallel-tuned circuit Z302. Avc blocking capacitor C305 couples the if. signal to the control grid of first if. amplifier V301 through parasitic-suppressor resistor R324. Inductors L316 and L317 are harmonic suppressors. Jack J301 is a test point for measuring avc voltage at the control grid of V301. Resistor R301 and bypass capacitor C326 decouple the if. signal from the avc bus. Resistor R302 provides cathode bias for V301 and bypass capacitor C319 grounds the cathode for if.

*c.* Series resistors R303, R304, and R305 form a voltage divider which provides proper plate and screen voltages to V301. Resistor R304 is connected to the +125-volt supply through terminal K of plug P301, and R303 is grounded through terminal M of plug P301 by tr relay K601 and contacts 2 and 13 (fig. 23). (On transmit, relay contacts 2 and 13 of K601 open the ground return for R303 and raise the screen grid voltage to V301.) Resistor R304 and capacitor C321 decouple if. signals from the +125-volt supply. Capacitor C320 grounds if. signals at the screen grid of V301. Parallel-tuned circuit Z303 is the plate load for V301. Coupling capacitor C308 couples the if. signal developed across Z303 to parallel-tuned circuit Z304.

### 26. Second If. Amplifier V302 (fig. 8)

*a.* Second if. amplifier V302 provides additional amplification to the 20.0- to 29.9-mc signal. Avc blocking capacitor

C311 couples the signal to the control grid of V302 through parasitic-suppressor resistor R307. Resistor R306 decouples the if. signal from the avc source. The cathode bias for V302 is provided by resistors R323 and R308. The dc voltage developed across R308 is applied to the S-METER circuit through plug B of P301 to indicate the Input signal strength. Capacitors C322 and C323 ground the cathode for if. signals. Jack J302 is a test point for measuring avc voltage on the grid of V302.

*b.* Series resistors R309, R325, and R326 form a voltage divider which provides proper plate and screen voltages to V302. Resistor R309 and capacitors C324 and C328 decouple if. signals from the +125-volt supply. Capacitor C347 grounds the screen of V302 for if. signal. A coupling network Z305, C314, Z306, and C316 couple the amplified if. signal from the plate of V302 to the control grid of second receiver mixer V303.

### 27. Second Receiver Mixer V303 (fig. 8)

*a.* The 17.0- to 26.0-mc signal produced by second oscillator V305 (para 28) is coupled to the cathode of second receiver mixer V303 through coupling capacitor C325. The 17.0- to 26.0-mc signal is heterodyned with the 20.0- to 29.9-mc if. signal from V302 to produce the 3.0- to 3.9-mc difference frequency. Jack J303 is a test point for measuring the bias voltage developed on the grid of V303.

*b.* Plate voltage is applied to V303 from the +125-volt dc supply through plug P304. Inductor L312 is the plate load for V303. Screen grid voltage is received from the +125-volt dc source through voltage dropping resistor R312. Capacitor C318 grounds the screen grid for rf signals. Resistor R311 provides cathode bias for V303. The 3.0- to 3.9-mc output of V303 is applied to the 3.0- to 3.9-mc if. subunit through harmonic trap L312 and plug P304. Inductors L319 and L320 and capacitor C339 form a harmonic suppressor network.

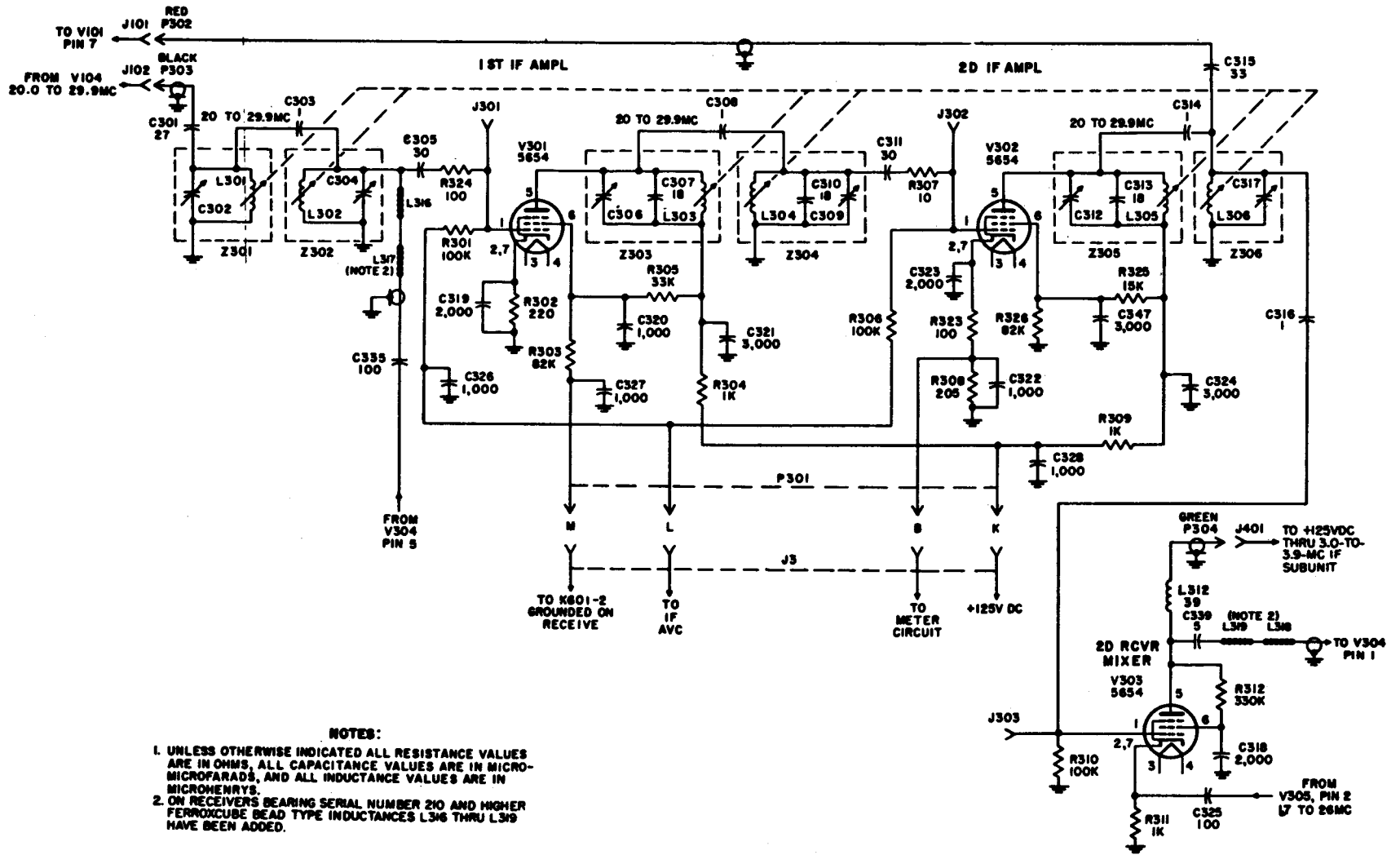


Figure 8. First and second if. amplifiers V301 and V302, and second receiver mixer V303, schematic diagram.

**28. Second Oscillator V305**  
(fig. 9)

a. Second oscillator V305 is a cathode-coupled, crystal-controlled oscillator. The grounded grid amplifier section (pins 6, 7, and 8) develops an output voltage across parallel-tuned circuit 2307 which functions as the plate load for V305A. Capacitor C343 couples the output from the plate of V305A to the control grid of V305B.

b. One of 10 crystals in the 17.0- to 26.0-mc range, selected by crystal switches S301 and S302, couples the signal developed on the cathode of V305B to the cathode of V305A. The crystal functions at series resonance and provides low-impedance coupling to the oscillator frequency. Parallel-tuned circuit 2307 is gang-tuned with the crystal switches and driven by the 10-position, 1.0-mc shaft of the frequency selector. Thus, the second oscillator produces any of 10 frequencies in the 17.0- to 26.0-mc range in 1.0-megacycle steps.

c. The output frequency of the oscillator is coupled from the cathode of V305B to the cathode of second receiver mixer V303 (para 27), through a harmonic trap network that consists of coil L313, capacitor C346, and coupling capacitor C325. Rf choke L311 neutralizes the crystal socket capacity. Resistors R321 and R322 provide the coupling impedance at the cathodes of V305 and provide cathode bias for the two sections. Resistor R320 is the grid leak to ground circuit for V302B. Resistor R318 isolates jack J305 from the control grid of the cathode follower and prevents loading of the grid circuit by test instruments. Jack J305 is a test point for measuring the dc bias developed across resistor R320.

d. Plate voltage is applied to V305B through resistor R315. Resistor R315 and capacitors C329 and C330 decouple rf from the +125-volt dc supply. Plate voltage is applied to V305A through plate load Z307 and resistor R313. Resistor R313 and capacitor C329 decouple rf from the +125-Volt supply.

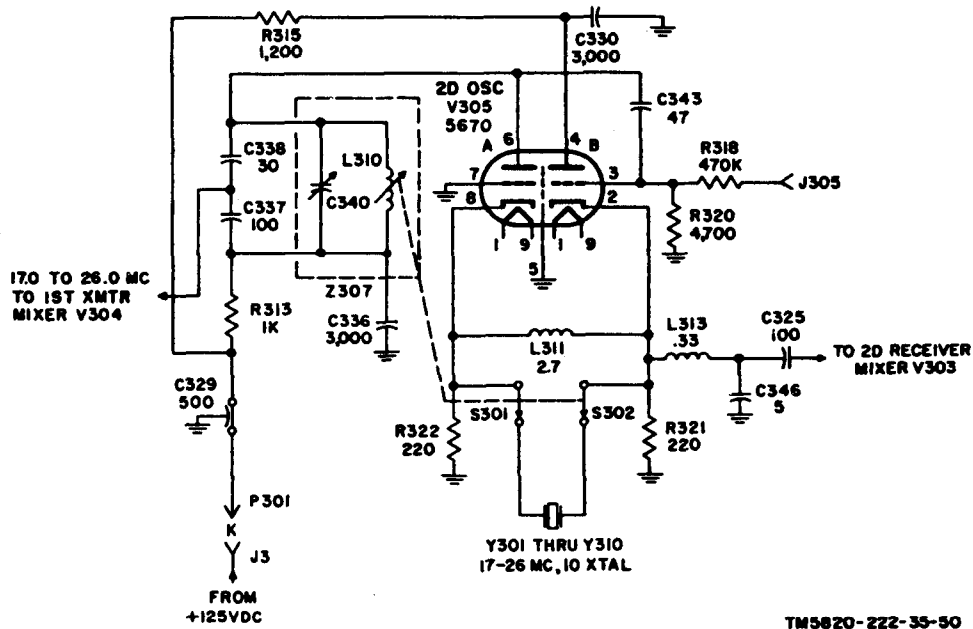


Figure 9. Second oscillator V305, schematic diagram.

## Section V. THIRD RECEIVER MIXER AND THIRD OSCILLATOR SECTION

### 29. Filters Z401 Through Z403, 3.0 to 3.9 Mc (fig. 10)

a. The 3.0- to 3.9-mc if. from second receiver mixer V303 (para 27) is applied through jack J401 to tuned circuit Z401, which is the plate load for second receiver mixer V303 (fig. 8). Capacitor C403 couples the signal developed across Z401 to Z402, and C407 couples the signal from Z402 to Z403.

b. Filter networks Z401, Z402, and Z403 are bandpass filters that are tuned by the 10-position, 0.1-mc shaft of the frequency selector. The shaft positions the powdered iron cores in the tuning coils of L401, L403, and L405. Trimmer coils L402, L404, and L406 adjust the LC ratio for proper tracking. Resistor R401 and capacitor C406 decouple rf from the +125-volt supply which provides plate and screen voltage to V303 through Z401. Capacitor C411 couples the 3.0- to 3.9-mc signal to the cathode (pin 2) of third receiver mixer V401A.

### 30. Crystal Selection

(fig. 10)

a. Two signals are applied to V401A. One signal is the 3.0- to 3.9-mc output rf filter networks Z401 through Z403; the other signal is the voltage generated by selected crystal Y401 through Y410. The crystal frequency is always 500-kc higher or lower than the 3.0- to 3.9-mc if. Third oscillator V401B is crystal-controlled by one of 10 crystals. On receive, relay K401 is deenergized and relay contacts 1 and 2 of K401 connect crystal selector switch S401 to the control grid of third oscillator V401B.

b. Switch S401 is driven by the 10-position, 0.1-mc shaft of the frequency selector and selects crystals so that there is a 500-kc difference between the oscillator frequency and the 3.0- to 3.9-mc if. For example, assume that the rt unit is tuned to receive 286.9 mc. The if. is then 3.9 mc. Selector switches S401 and S402 are positioned by the 0.1-mc tuning shaft so that the rotor of S401 is in contact with terminal

4 (fig. 10). When switch S401 is in this position, and when relay K401 is deenergized, 3.4-mc crystal Y405 is connected to the grid circuit of third oscillator V401B.

### 31. Third Oscillator V401B

(fig. 10)

a. Third oscillator V401B operates at the frequency of the crystal switched into the grid circuit. The voltage divider action of capacitors C412 and C413 controls the feedback in the oscillator circuit. The values of these capacitors are such that oscillation is maintained at the fundamental frequency of the crystal. Resistor R402 isolates jack J404 from the control grid and prevents bias measurements at jack J404 from loading the oscillator grid circuit. Resistor R404 develops cathode bias to protect V401B in case oscillation stops. Rf choke L407 isolates bias resistor R404 from the crystal circuit.

b. Oscillator V401B receives plate voltage through plate voltage dropping resistor R407. Capacitor C416, resistor R407, and filter FL404 decouple rf from the + 125-volt supply. Capacitor C418 provides rf ground at the junction of resistors R408, R409, and R410. Resistor R408 is a voltage dropping resistor for V401A. Coupling capacitor C417 couples the signal from the cathode of V401B to the control grid of third receiver mixer V401A.

### 32. Third Receiver Mixer V401A

(fig. 10)

The 3.0- to 3.9-mc signal from Z403 and the third oscillator output mix in the third receiver mixer V401A to produce the 500-kc difference frequency. The 500-kc signal is coupled to filter FL901 through blocking capacitor C410. The third receiver mixer receives plate voltage from voltage divider resistors R409 and R410 through resistor R408. Resistor R406 is the grid-return circuit to ground. Resistor R405 provides cathode bias and the coupling impedance for the 3.0- to 3.9-mc second if. signal

from bandpass filters Z401, Z402, and Z403. Jack J402 is a test point for measuring the dc bias and rf voltage on the grid of V401A.

### 33. 500-Kc If. Filter FL901

(fig. 10)

The 500-kc if. filter consists of nine

parallel-tuned circuits in cascade and capacitively coupled. Only three of the tuned circuits are shown in figure 10. The 500-kc if signal is coupled from third receiver mixer V401A through FL901 to first 500-kc if. amplifier V501 (para 34).

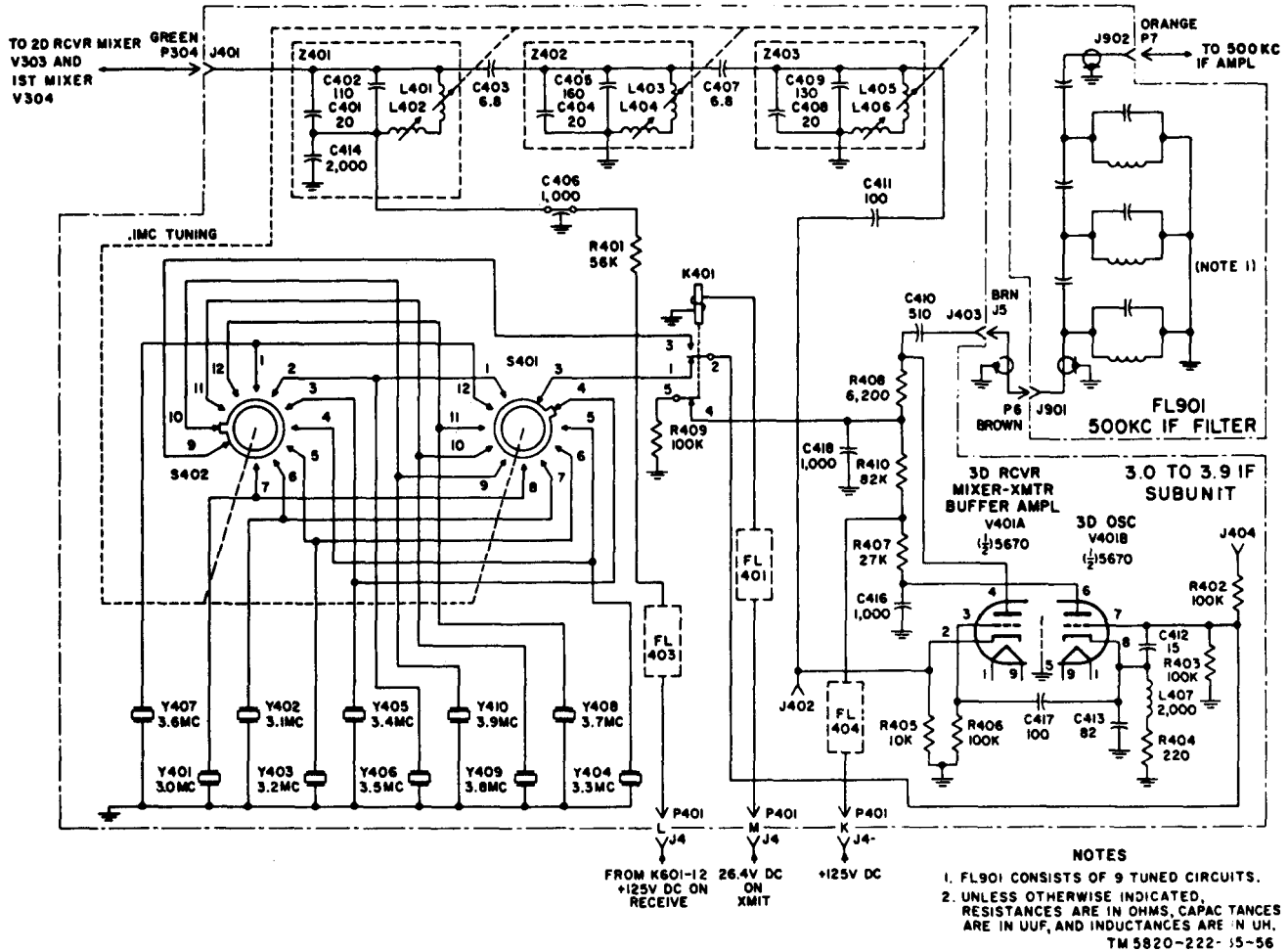


Figure 10. Third receiver mixer and third oscillator V401, schematic diagram.

## Section VI. 500-KC IF. AND AUDIO AMPLIFIER SUBUNIT

### 34. First 500-KC If. Amplifier V501

(fig. 11)

a. First 500-kc amplifier V501 is the first of three if. amplifiers that amplify the 500-kc output of V401A (para 32). When this equipment is used for receiving, the 500-kc third if. is fed from 500-kc if. filter FL901 (fig. 10) through plug P8 and jack J502 to the control grid V501. Jack

J503 is provided for injecting a test signal for troubleshooting. The control grid is connected to the if. avc bus through isolating resistor R501. Resistor R502 provides cathode bias for V501 and capacitor C507 is a bypass capacitor to ground. Capacitor C504 provides a low-impedance path for rf signals from the screen grid to the cathode.

b. Plate voltage is supplied from the

+125-volt dc supply through the plate load which consists of rf choke L501 and resistor R504. Screen grid voltage is supplied through a voltage divider network that consists of resistors R503 and R507. Capacitor C519 decouples rf from the +125-Volt dc supply. The output of V501 is coupled through capacitor C502 to the grid of V502.

### **35. Second 500-Kc If. Amplifier V502** (fig. 11)

The second 500-kc if. amplifier stage is identical (except for reference symbols) to first 500-if. amplifier V501 (para 34), and provides a second stage of amplification to the 500-kc signal. The output is coupled through C503 to the control grid of V503.

### **36. Third 500-Kc If. Amplifier V503** (fig. 11)

The third 500-kc if. amplifier is similar to the two previous stages (para 34 and 35). Jack J505 is provided for injecting test signals for troubleshooting. Resistor R510 provides cathode bias for V503, and capacitor C509 is a bypass capacitor for rf. Capacitor C506 is a low-impedance path for rf signals between the screen grid and cathode. Plate voltage is supplied through resistor R512 and the primary of output transformer T501. Screen voltage is supplied through voltage dropping resistor R511. Capacitors C527 and C510 and resistor R512 decouple rf from the +125-volt dc supply. The output of V503 is developed across the primary of output transformer T501.

### **37. Detector CR501** (fig. 12)

*a.* The secondary of transformer T501 is connected across detector diode CR501 through rf filter capacitor C520. Resistor R539 is connected across the secondary of T501 to improve the frequency response of the transformer.

*b.* Detector CR501 demodulates the 500-kc input and produces an audio signal across detector load resistors R516, R517,

and R518. The audio signal is coupled from the junction of resistors R518 and R517 through resistor R538, diode CR503, and capacitor C522 to the grid circuit of first audio amplifier V504. Capacitor C524 grounds the cathode of detector CR501 for audio and rf voltages. Resistor R538 and capacitor C521 filter rf components from the audio signal. Jack J508 is a test point for measuring avc delay bias plus dc bias developed by detector CR501 across resistors R516, R517, and R518. Resistor R532 prevents test equipment from loading the detector circuit.

*c.* The audio and dc voltage developed across the diode load (R516, R517, and R518) is also applied through resistor R515 to the control grid of squelch amplifier V801 (para 42) and to the control grid of broadband cathode follower V802A (para 63). The series circuit that consists of capacitor C528 and L503 is resonant at 500 kc and provides a low-impedance path for the 500-kc if. components to ground.

### **38. Series Noise Limiter CR503** (fig. 12)

*a.* The audio signal applied to the anode of diode CR503 is a varying dc negative with respect to the cathode of detector CR501. The applied signal is approximately 63 percent of the total audio signal across the diode detector load (resistors R516, R517, and R518). The negative end of the diode detector load (junction of resistors R515, R516, R519, R529, and R532) is connected through a filter that consists of capacitor C523, resistor R519, and series noise limiter diode load resistor R520 to the cathode of diode CR503.

*b.* The long time-constant of resistor R519 and capacitor C523 causes a negative bias voltage at the cathode of diode CR503 that is fairly constant. This cathode voltage is more negative than the varying negative dc applied to the anode of CR503; the diode conducts and produces a voltage drop across load resistor R520 which reproduces the varying audio signal. Sharp negative peaks of noise, which drive the anode instantaneously more negative than

the cathode of CR503, cut off the diode, thereby clipping the peaks.

39. If. AVC  
(fig. 12)

a. During reception, approximately +5.6 volts is applied to the cathode of detector CR501. This voltage obtained from the power supply, is applied through terminal 4 of P509 and J509, and provides the delay action for application of avc voltage to the if. amplifiers.

b. The cathode of if. avc gate diode CR504 is returned to the negative end of the diode detector load (R516, R517, and R518). Diode CR504 cannot conduct until the algebraical sum of the +5.6 volts and the negative voltage across the diode detector load results in a net negative voltage at the cathode of CR504. When the input signal amplitude causes the voltage across R516, R517, and R518 to exceed -5.6 volts, the cathode of if. avc gate diode CR504 becomes negative, the diode conducts and develops a voltage across R531 that is used as avc voltage for if. amplifiers V301, V302, V501, and V502.

c. The exact voltage that causes CR504 to conduct can be varied by the application of a negative voltage to the anode of CR504 through R531. This voltage is obtained from the squelch circuit (para 42) and is also applied to the control grids of the if. amplifiers and controls the gain of these stages.

d. The if. avc voltage is applied through if. avc gate load resistor R531 and an audio and rf filter consisting of resistor R530 and capacitor C515. The if. avc bus is decoupled from the diode load by resistor R529 and capacitor C514.

40. Rf AVC  
(fig. 12)

Rf avc gate CR505 functions the same as the if. avc gate, except that the cathode is connected through resistor R537 to a more positive point on the detector load (junction of resistors R517 and R516). Thus, the voltage that appears at the cathode of CR505 is always less negative than the voltage at the cathode of CR504. This allows more delay for the rf avc bias and improves the low-level signal sensitivity of first and second rf amplifiers V102 and V103. Resistor R537 and capacitor C526 filter rf and audio signals from the rf avc line. Resistor R533 is the rf avc load resistor.

41. First Audio Amplifier V504  
(fig. 12)

The audio signals developed across series noise limiter load resistor R520 are coupled to the grid of first audio amplifier V504 through coupling capacitor C522. Resistors R514 and R525 form a voltage divider which decreases the amplitude of the input signals to decrease distortion. Cathode resistor R526 is unby-passed. This introduces degeneration in the stage and reduces distortion that may be generated in the stage. Capacitor C516 is a low-impedance path to ground for audio signals on the screen grid. On receive, plate and screen voltages are supplied from the +125-volt dc supply through relay contacts 12 and 20 of K601 (fig. 23), plate load resistor R527, and screen dropping resistor R528. The audio output is developed across R527 and coupled to the grid of second receiver audio amplifier V804 (para 43) through capacitor C517.



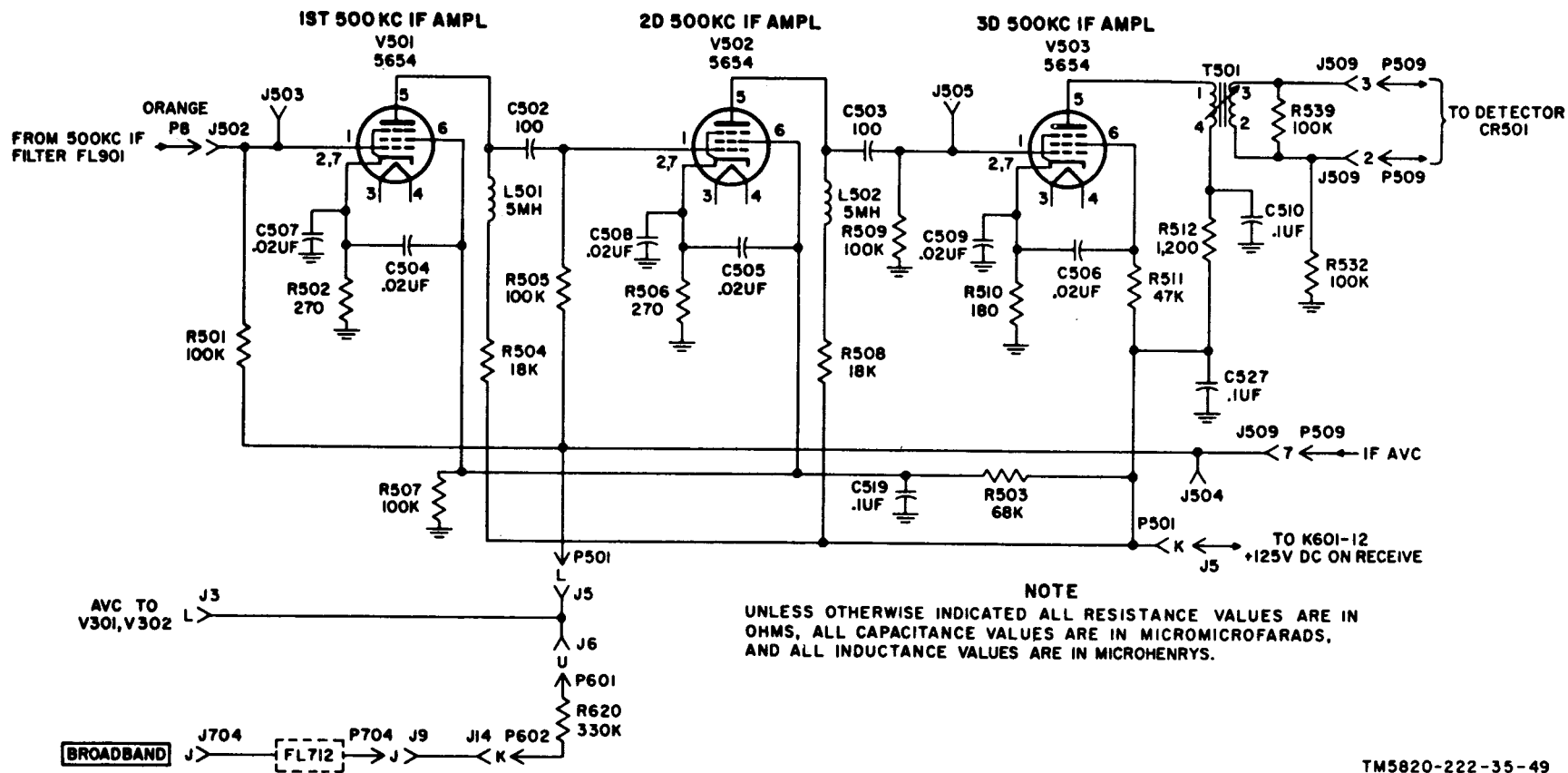


Figure 11. First, second, and third 500-kc if. amplifiers V501, V502, and V503, schematic diagram.

TM5820-222-35-49

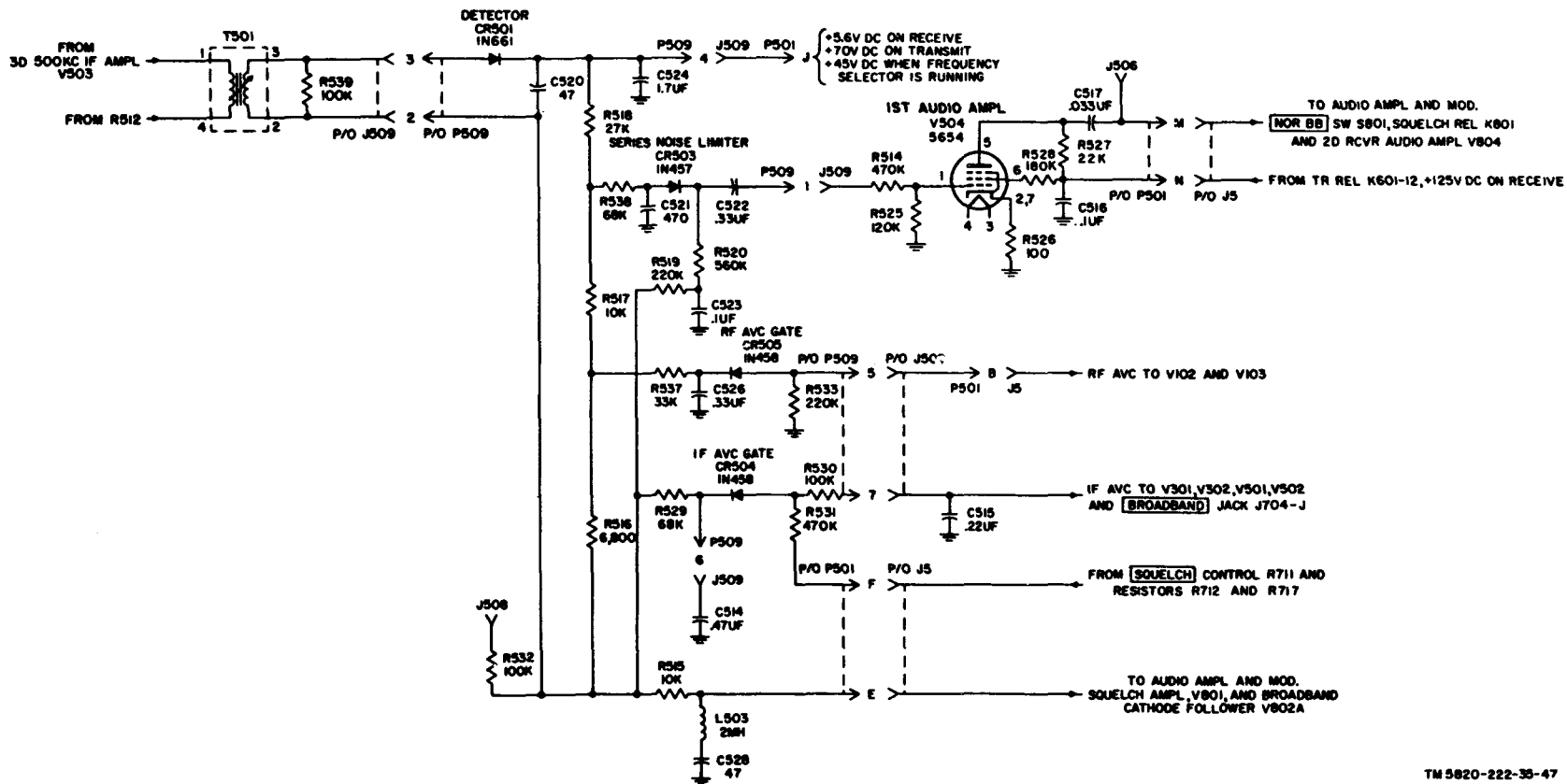


Figure 12. Detector, avc and noise limiter circuits, and first audio amplifier V504, schematic diagram.

## Section VII. SQUELCH AND AUDIO OUTPUT SECTION

### 42. Squelch Amplifier V801

(fig. 13)

*a.* The squelch relay circuit deenergizes the audio stages when no signal is being received or when the input signal falls below the threshold level of the squelch circuit. The SQUELCH control, on the front panel, determines what input signal amplitude will deactivate the squelch circuit.

*b.* SQUELCH control R711 (fig. 23) controls the gain of the receiver by applying a negative voltage to the if. avc line. As the control is turned clockwise, more negative bias is applied and the receiver gain is decreased further. The control grid of V801A is connected to the diode load (fig. 12) through resistor R803 (fig. 13). When no rf signal or noise is present at output transformer T501 (fig. 12), the dc voltage on pin 3 of V801A is approximately +5.6 volts (fig. 13).

*c.* When a small rf or noise signal appears at transformer T501, the voltage on pin 3 of V801A will be less positive by an amount equal to the +5.6 avc delay voltage less the dc voltage developed across the diode load by rectification of the rf or noise by detector CR501 (fig. 12). The voltage on pin 3 of V801 with no signal is approximately +5.6 volts dc, and, with signal or noise, the voltage is some value less positive than +5.6 dc, depending on the signal strength.

*d.* When received signals are of sufficient magnitude to produce if. avc threshold bias (para 39), the grid voltage on pin 3 of V801 is zero. When signals of greater magnitude are received, the grid voltage on pin 3 goes negative. When no signals (or weak signals) are received, the voltage on pin 3 is positive or zero, and V801A conducts. Plate current flows through resistors R809, R812, and R811. The voltage drop across resistor R812 produced by this plate current biases V801B to cutoff. There is no ground return from terminal 10 of squelch relay K801 through V801B, and the squelch relay is deenergized.

*e.* When stronger rf signals are present at transformer T501 (fig. 12), the voltage

on the control grid of V801A becomes negative. Tube V801A is cut off and plate current no longer flows through resistor R812; thus the cutoff bias on V801B is removed. Tube V801B conducts and the dc path from terminal 10 of relay K801 to ground is completed, and causes squelch relay K801 to energize.

*f.* When squelch relay K801 is energized, the following occurs:

- (1) Contacts 6-13 K801 close.
- (2) A dc path from CALL LIGHT 1701 through terminal P of J8 and P801 and through relay contacts 6 and 13 to +26.4 volts is completed.
- (3) If Radio Control C-1439/U is used, a dc path from CALL LIGHT I1501 to +26.4 volts is completed through terminal *h* of J1501 and P1601, terminal *h* of J1401 (for AN/TRC-68) or J1701 (for AN/VRC-24), terminal *h* of P1, terminal P of J8 and P801, and through closed contacts 6-13 of K801.
- (4) If auxiliary equipment is used, 26.4 volts is applied through R184, terminal R of P801 and J8, and terminal C of P1.

*g.* The SQUELCH control is normally adjusted for threshold at the frequency of minimum received signal strength. Weak signals or noise may cause squelch relay K801 to operate intermittently (the CALL LIGHT lamps flicker on and off). To determine whether noise or signals are causing the lamps to flicker, SQUELCH DISABLE PUSH switch S703 should be pressed. This switch provides a ground return for squelch relay K801 through resistor R713, thereby energizing K801. The audio output will permit identification of the input signal.

*h.* When the rt unit is controlled from Radio Set Control C-1439/U, microswitch S705E is operated and transfers control of the squelch amplifier to Radio Set Control C-1439/U squelch control circuit. SQUELCH switch S1502 and SQUELCH DISABLE PUSH switch S1501 perform similar functions to those described for local operation.

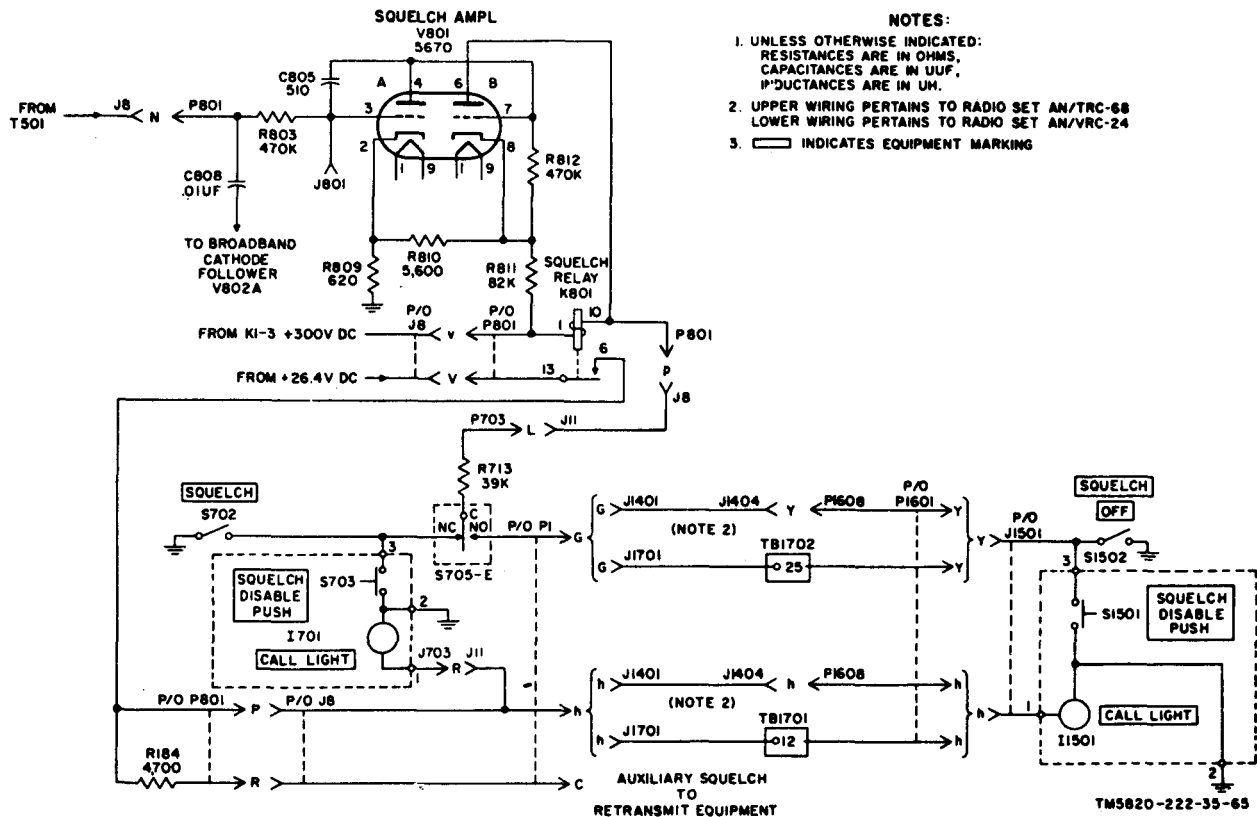


Figure 13. Squelch amplifier V801 and squelch control circuits, schematic diagram.

#### 43. Second Receiver Audio Amplifier V804 (fig. 14)

a. Tube V804, a type 5670, is a parallel-connected dual triode that amplifies the output of first audio amplifier V504 (para 41) and drives the receiver audio output stage. When the rt unit is used in the transmit function, this state functions as a modulation driver. When this equipment is used for broadband operation, V803 (para 64) is a preamplifier for V804.

b. When the NOR-BB switch S801 is set to NOR, the input signal is coupled through contacts 6-4 of S801B, through low-pass filter L801, C806, and C807; contacts 1-3 of S801A, input adjustment resistor R826, isolating resistor R825, contacts 8-14 of K801, and through parasitic suppressors R844 and R845 to both control grids of V804. Jack J802 is a test point for measuring or injecting audio signals at the control grids of V804. Resistor R802 is an input matching resistor for the low-pass filter, and resistors R808 and R826 pro-

vide proper termination impedance for the filter network. Contacts 11-3 of K801 supply ground through contact S of P801 to the retransmit equipment.

c. The input signal is developed across grid resistor R822, amplified by V804, and applied to the primary of T801. Cathode bias is provided by R827 which is bypassed for audio frequencies by C814. Plate voltage for V804 is supplied through the primary of T801.

#### 44. Output Amplifiers V805, V806, V807, and V808 (fig. 14)

a. The receiver audio output stage is a class AB<sub>2</sub> push-pull-parallel power amplifier that consists of tubes V805, V806, V807, and V808. Tube V805 is parallel with V807 and tube V806 is parallel with V808. The secondary winding of transformer T801 supplies equal excitation signals, 180° out of phase, to the control grids of the two parallel combinations. The amplified outputs of the parallel combinations

are combined across the center-tapped primary of output transformer T802.

b. Plate voltage is supplied from the +300-volt dc supply through the center tap (terminal 4) of the primary winding. On receive, the voltage is dropped to approximately +270 volts dc. Screen grid voltage is supplied from the +125-volt dc supply. Resistors R845, R846, R847, and R848 are parasitic suppressors in the screen grid

circuit. The cathodes of V805, V806, V807, and V808 are returned to ground through meter shunt resistor R828. The voltage drop across resistor R828, caused by cathode current drawn by the tubes, is applied to the meter circuit (para 72) to indicate the percentage of modulation (% MOD) on transmit. The voltage across the tapped secondary winding of T802 is applied to the audio output circuits (para 45).

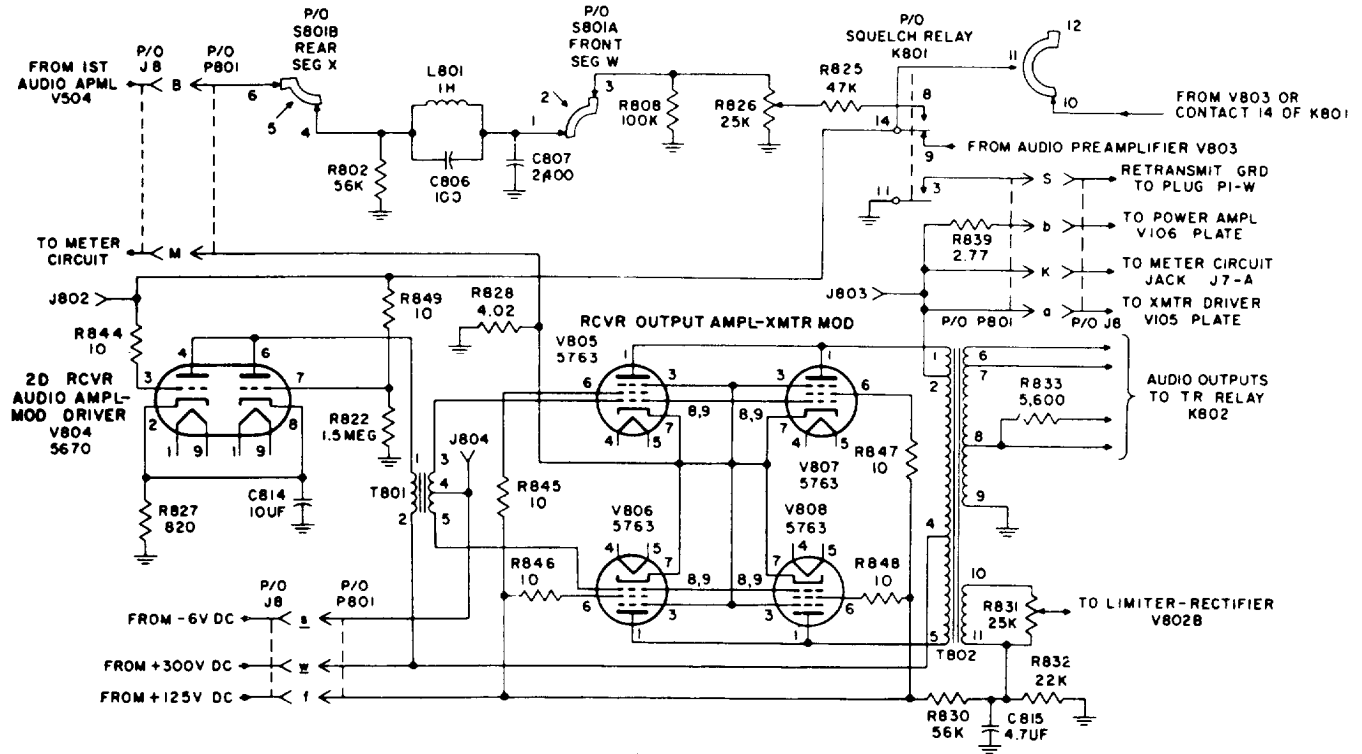


Figure 14. Second receiver audio amplifier V804 and receiver output amplifiers V805, V806, V807, and V808, schematic diagram.

#### 45. Audio Output Circuits (fig. 15)

The audio output circuits supply received audio signals to the speaker and headset terminals of the front panel and to Radio Set Control C-1439/U AUDIO jacks. When Radio Set AN/GRC-3 through -8 is used for retransmission purposes, fixed-level audio can be applied through P1.

##### a. Speaker Audio.

(1) On receive, speaker audio is tapped

off terminal 6 of the secondary of output transformer T802 and applied to the speaker circuits through contacts 8 and 17 of relay K802 to the speaker circuits. On transmit, contacts 9 and 17, and 11 and 19 of relay K802 close. Speaker audio is tapped off terminal 8 of T802. Resistor R833 decreases the speaker sidetone audio level approximately 20 decibels (db) with respect to the audio level on receive.

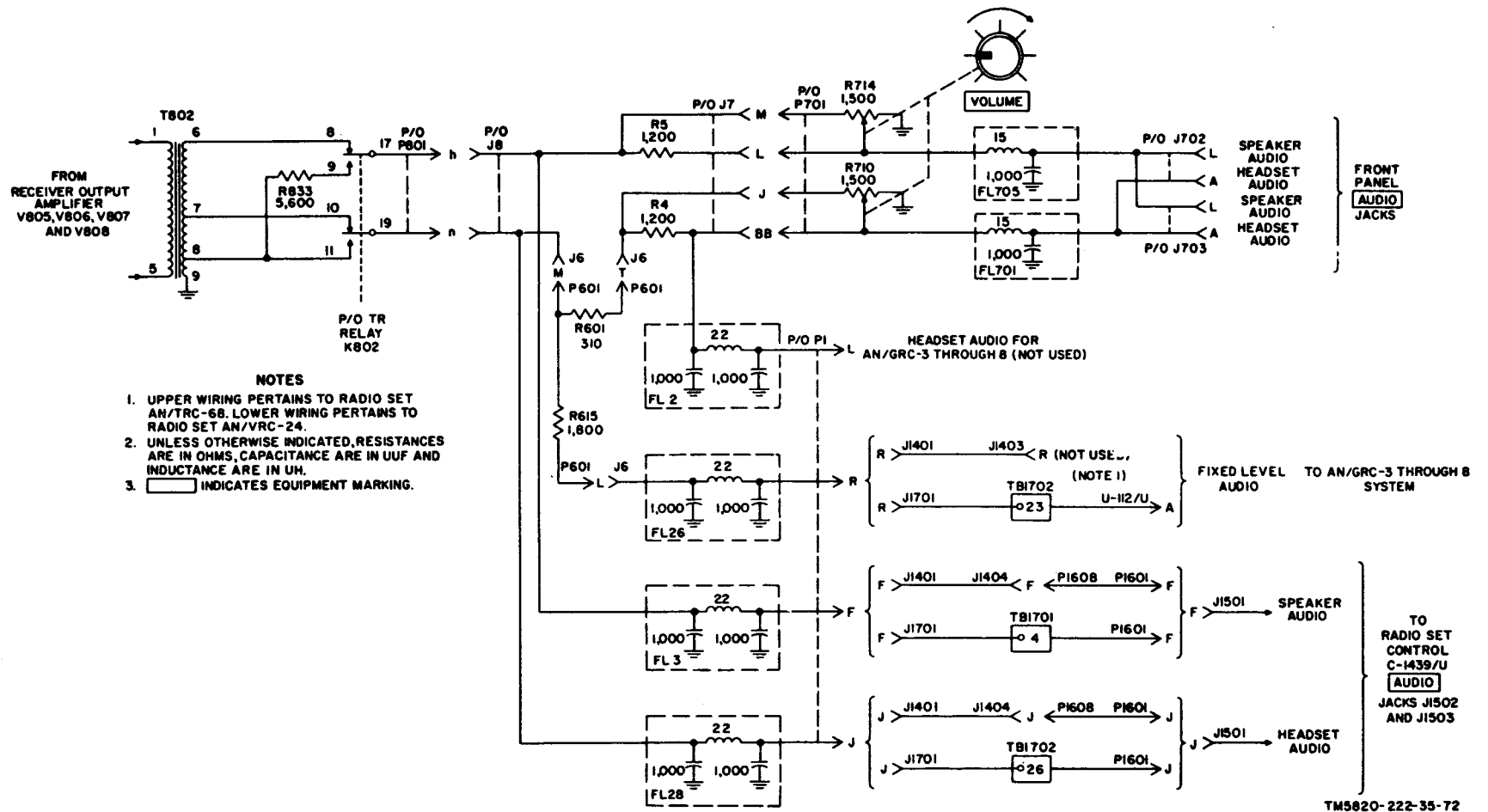
(2) Speaker audio is applied to the front panel AUDIO jacks through a volume control that consists of fixed resistor R5, variable resistor R714 (the front section of the VOLUME control), and rf filter FL705. Speaker audio is applied to Radio Set Control C-1439/U through filter FL3 and terminal F of plug P1. Interunit audio output connections are shown for both Radio Set AN/VRC-24 and AN/TRC-68. Radio Set Control C-1439/U audio circuits are described in paragraph 88.

*b. Headset Audio.*

(1) On receive, headset audio is tapped off terminal 7 of the secondary of output transformer T802 and applied to the headset and fixed-level

audio circuits through contacts 10 and 19 of relay K802. On transmit, headset audio for sidetone at a reduced level is tapped off terminal 8 of T802 through contacts 11 and 19 of relay K802. Resistor R615 attenuates the audio applied to the AN/GRC-3 through -8 communications equipment to a fixed level of approximately 50 milliwatts (mw). The fixed-level audio is applied through rf filter FL26 and plug P1.

(2) Resistor R601 attenuates the headset audio applied to the front panel AUDIO jacks. Front panel headset audio level is controlled by fixed resistor R4 and variable resistor R710 (ganged to R714). Front panel headset audio is applied to terminals A of J702 and J703, in parallel, through rf filter FL701.



TM5820-222-35-72

Figure 16. Audio output circuits, schematic diagram.

# CHAPTER 3

## TRANSMITTER THEORY

---

### Section I. TRANSMITTER SIGNAL PATH

#### 46. Common Purpose Stages

Several stages in this equipment are used in both the receive and transmit functions. Where the circuit remains identical (except for some switch position), reference is made to the illustrations in the receiver section of this manual. Refer to figure 16, the transmitting path block diagram, which shows the order in which the stages are discussed in this chapter.

#### 47. Transmitter Block Diagram (fig. 16)

*a. General.* The signal path for the transmit function of the rt unit is shown in the block diagram and is discussed in *b* through *e* below. The block diagram shows the positions of the relays in the signal path. When the rt unit is turned on and the handset or microphone push-to-talk switch is operated, the relays energize and the rt unit operates as a transmitter.

##### *b. Signal Generating Section.*

- (1) On transmit, third oscillator V401B generates a signal from 3.0 to 3.9 mc that is coupled to transmitter buffer amplifier V401A. The amplified output of V401A is applied through bandpass filters Z403, Z402, and Z401 to first transmitter mixer V304.
- (2) The 3.0- to 3.9-mc signal is heterodyned with the 17.0- to 26.0-mc signal from second oscillator V305 in first transmitter mixer V304. The *sum* frequency, 20.0 to 29.9 mc, is amplified by first and second if. amplifiers V301 and V302. The amplified 20.0- to 29.9-mc if. signal is coupled to second transmitter mixer V101 and heterodyned with the 200- to 370-mc signal from the uhf injection subunit.
- (3) The uhf injection system operates

as described in paragraph 8 *c*, except that when injection relay K102 is energized, the uhf injection unit output is applied to second transmitter mixer V101 instead of first receiver mixer V104.

##### *c. Rf Amplifier Section.*

- (1) The 20.0 to 29.9-if. signal and the 200- to 370-mc uhf injection signal are heterodyned by second transmitter mixer V101 to produce an rf carrier which can be varied from 220.0 to 399.9 mc. (The first 5-mc band is not considered to be within the useful range of the rt unit.) First and second rf amplifiers V102 and V103 and third transmitter rf amplifier V104 provide three stages of rf amplification.
- (2) The output of V104 is applied to transmitter driver V105. The output of V105 drives transmitter power amplifier V106. The B+ supplied to both transmitter driver V105 and transmitter power amplifier V106 is modulated by audio signals from audio output transformer T802.

*d. Audio Amplifier Section.* Audio preamplifier V803 receives audio signals from the local or remote microphone, or from the external retransmit equipment. The audio input is applied to audio preamplifier V803 when squelch relay K801 is deenergized and the NOR-BB switch is set on NOR. Audio signals are amplified and coupled to modulator driver V804. Encoded broadband signals are applied to audio preamplifier V803 when the broadband switch is set for broadband operation.

##### *e. Modulator and Output Stages.*

- (1) Modulator driver V804 amplifies the audio signals to drive transmitter modulator stages V805,



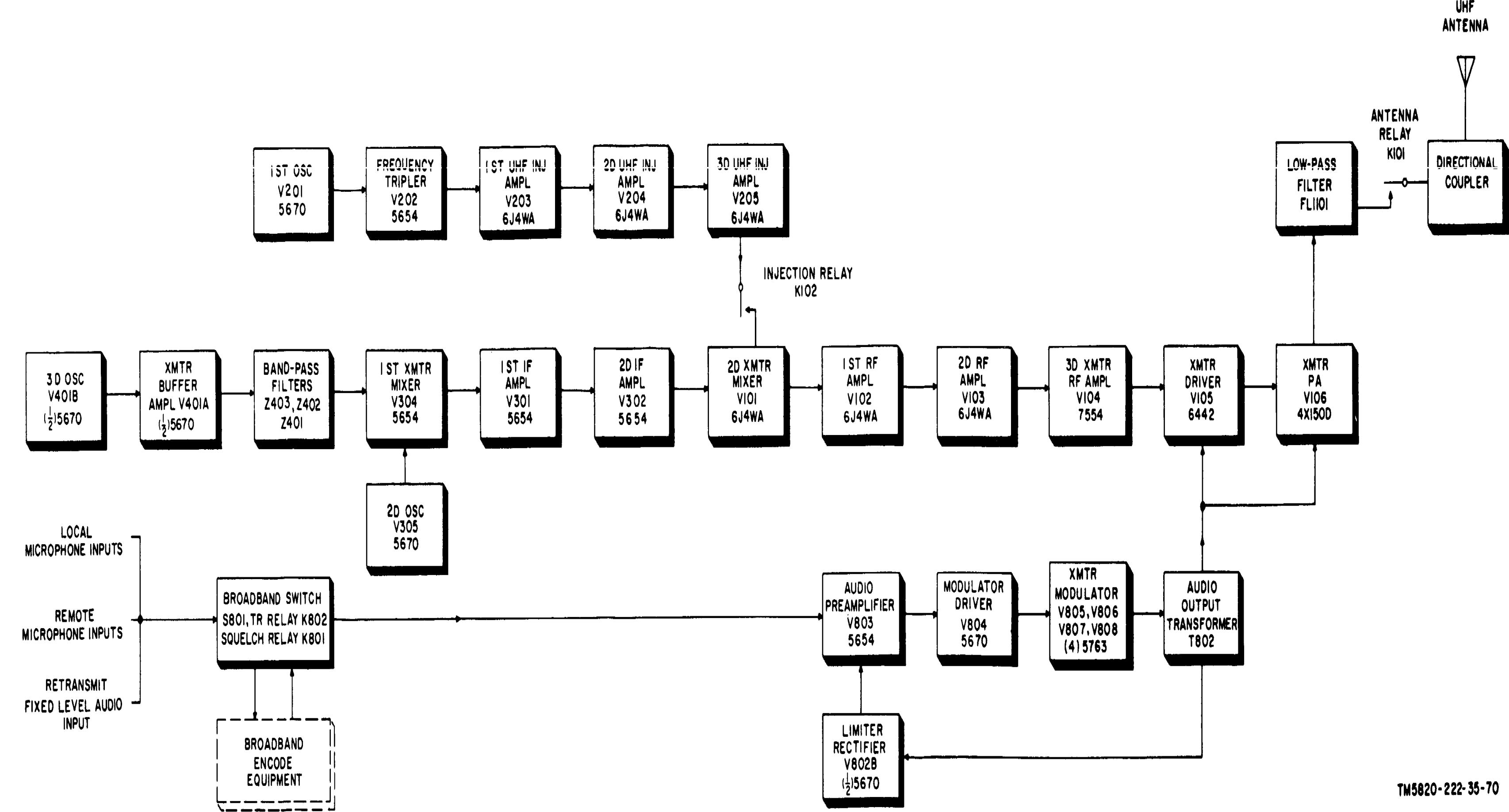


Figure 16. Rt unit, transmitting signal path, block diagram.



V806, V807, and V808. The transmitter modulator amplifies the signal and modulates the plate voltage supply to the transmitter driver and power amplifier stages V105, and V106, and the V106 screen grid supply.

- (2) The modulated rf output signal of the transmitter power amplifier is

fed through low-pass filter FL1101, energized antenna relay K101, and the directional coupler to the antenna. Filter FM1101 minimizes radiation of undesired harmonics, and directional coupler provides an indication of the power input to the antenna and the standing wave ratio on the transmission line.

## Section II. LOW-LEVEL STAGES

### 48. Third Oscillator V401B On Transmit (fig. 10)

a. On transmit, third oscillator V401B functions as the initial frequency source. Switch S402, driven by the 10-position, 0.1-mc shaft, selects a crystal that corresponds to the frequency to which the filter network consisting of Z401, Z402, and Z403 is tuned. For example, if the rt unit is tuned to a frequency, the last digit of which is 0.9 mc, 3.9-mc crystal Y410 is connected between ground and the grid of V401B through contacts 9 and 10 of switch S402 and contacts 3 and 2 of relay K401 (energized on transmit).

b. The 3.9-mc output of V401B is coupled through C417 into the cathode circuit of V401A. The remaining components within this oscillator circuit operate as described for the receive function (para 31).

### 49. Transmitter Buffer Amplifier V401A (fig. 10)

a. On transmit, V401A functions as a buffer and amplifies the output of oscillator V401B. Resistor R409 is disconnected from the plate circuit by relay K401. This increases the plate voltage applied to V401A, which, in turn, raises the plate current through V401A and the level of the output signal developed across cathode resistor R405.

b. The input signal is applied across grid resistor R406. The output voltage is taken off cathode resistor R405, coupled through C411, filter Z403, Z402, and Z401, and applied to first transmitter mixer V304. The

remaining components in this circuit operate as described for the receive function (para 32).

### 50. First Transmitter Mixer V304 (fig. 17)

a. On transmit, first transmitter mixer V304 heterodynes the 3.0- to 3.9- mc signal from V401A (para 49) with the 17.0- to 26.0-mc output of second oscillator V305, to produce the 20.0 to 29.9 first if. The operation of second oscillator V305 is identical in both the receive and transmit functions. Refer to paragraph 28 for circuit component details.

b. The 3.0- to 3.9-mc signal is coupled to the control grid of V304 through plug P304, choke L312, and coupling capacitor C339. The 17.0- to 26.0-mc output of second oscillator V305 (para 28) is coupled to the cathode of V304 and developed across R317. Inductors L314, L315, and C348 form a harmonic suppression network. The 3.0- to 3.9-mc signal mixes with the 17.0 to 26.0 signal in V304 to produce the 20.0- to 29.9-mc sum frequency. Resistor R319 is the grid leak to ground circuit for V304. Resistor R317 provides cathode bias for V304 and provides coupling resistance for the 17.0- to 26.0-mc signal from the second oscillator.

c. Plate voltage for V304 is supplied from the +125-volt supply through J3, P301, feedthrough capacitor C334, resistor R314, and choke L309. Screen grid voltage is supplied through voltage dropping resistor R316. Capacitors C342

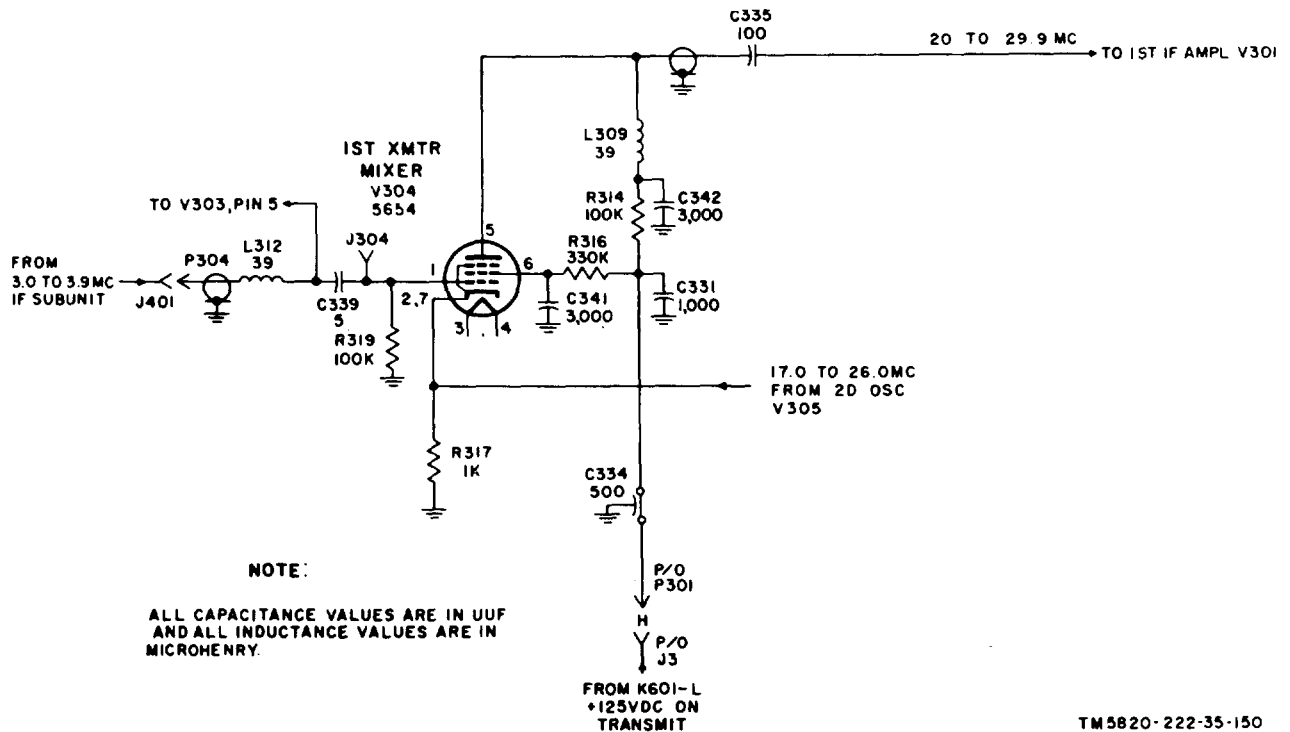


Figure 17. First transmitter mixer, V304, schematic diagram.

C341, C334, and C331 provide a low-impedance path to ground for rf signals. The range of frequencies produced by V304 is coupled from the plate of V304 to the parallel-tuned circuit of Z302 (fig. 8) through coupling capacitor C335. Parallel-tuned circuit Z302 selects the desired if. signal in the 20.0- to 29.9-mc range.

### 51. First and Second If. Amplifiers V301 and V302 (fig. 8)

The 20.0- to 29.9-mc signals from mixer V304 (para 50) is coupled to the control grid of first if. amplifier V301 through C335, harmonic suppressors L316 and L317, C305, and parasitic suppressor R324. First and second if. amplifiers V301 and V302, provide two stages of amplification as on receive except that avc lines are grounded by contacts 3 and 13 of relay K601 (fig. 26). The output of second if. amplifier V302 is coupled to second transmitter mixer V101 (para 52) through coupling capacitor C315 and plug P302. On transmit, the ground at the junction of capacitor C327

and resistor R303 is removed, raising the screen, grid voltage of V301.

### 52. Second Transmitter Mixer V101 (fig. 18)

a. Tube V101 functions as a mixer stage that heterodynes the 20.0- to 29.9-mc signal from second if. amplifier V302 (para 51) with the output frequency (200 to 370 mc) of the uhf injection stages to produce the final carrier frequency between 220 to 399.9 mc. The uhf system operates in the same manner for both the receive and transmit functions of the rt unit. For detailed circuit analysis of the uhf system, refer to section III, chapter 2.

b. The 200- to 370-mc uhf injection frequency is applied to the cathode of V101 through W4, P3, J112, contacts 6-8 (closed on transmit) of injection relay K102, J113, P103, P107, and J107. The 20.0- to 29.9-mc first if. is applied to the plate of V101 through jack J101 and uhf choke L102. Plate voltage for V101 is supplied by the +125-volt dc supply through plate voltage dropping resistor R115 and chokes L103

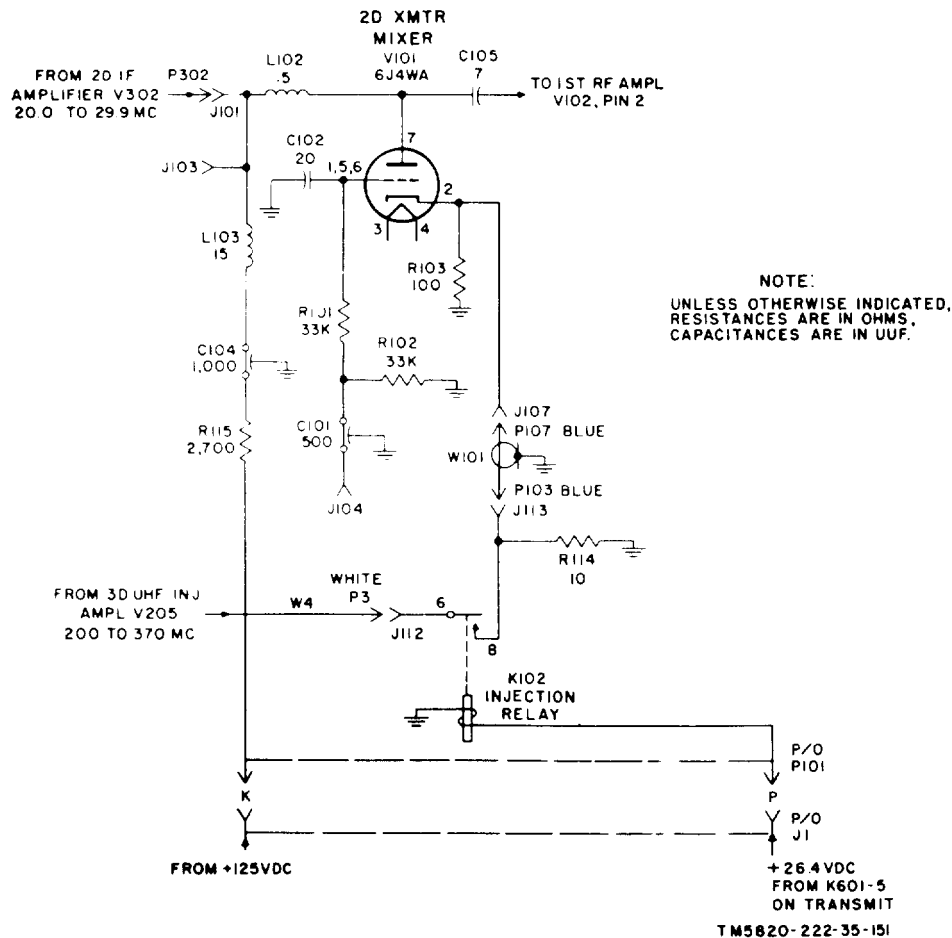


Figure 18. Second transmitter mixer, V101, schematic diagram.

and L102. J103 is a test point for measuring the plate voltage or the 20.0- to 29.9-mc signal applied to the plate of V101. Rf choke L103 and bypass capacitor C104 decouple rf from the +125-volt dc supply. Capacitor C102 grounds rf at the grid of V101. Resistors R101 and R102 are the grid-leak circuit to ground. Jack J104 is a test point for measuring grid bias on V101. Bypass capacitor C101 provides a low-impedance path to ground for rf signals. Resistors R103 and R114 provide the correct termination for injection cables W101 and W4. On transmit, the +26 vdc from K601 energizes R102.

c. The 200- to 370-mc uhf injection frequency and the 20.0- to 29.0-mc first if. are heterodyned in V101 to produce an output rf within the 225.0- to 399.9-mc range. (The band of frequencies between 220-225 mc is not used.) Blocking capacitor C105

prevents the dc plate voltage on V101 from being grounded through Z101 (fig. 5) and couples the 225.0- to 399.9-mc from the plate of V101 to first rf amplifier V102.

### 53. First, Second, and Third Rf Amplifiers V102, V103, and V104 on Transmit (fig. 5)

Coupling capacitors C105 and C110 couple the rf signal to the cathode of V102. The rf signal receives three stages of rf amplification and is applied to transmitter driver V105 (para 55). The rf amplifiers function as described in paragraphs 13 through 15 with the following exceptions:

a. Antenna relay K101 energizes (contacts 2-3 open) to remove the directional coupler from the input circuit of first rf amplifier V102.

b. Injection relay K102 energizes to operate the following circuits:

- (1) Contacts 1-2 close grounding the rf avc line.
- (2) Contacts 6-7 open. This action prevents the 200-370-mc uhf signal from being applied to the cathode of V104. On transmit, only the rf signal from second rf amplifier V103 is applied to the cathode of V104. Tube V104 functions as an rf amplifier when the rt unit is used for transmission.

(3) Contacts 3-5 open and prevent any signal from being fed from the plate of V104 to first if. amplifier V301.

c. The output of V104 is coupled through C126 and Z106 to V105 (para 55).

#### 54. Transmitting Frequency Conversion Scheme

The following chart correlates the dial settings with the oscillator and mixer circuit frequencies used in the low-level stages of the rt unit. This chart applies only to the transmit function.

3d oscillator frequency (0.1-mc steps)	2d oscillator frequency (1.0-mc steps)	1st transmitter mixer output frequency (10-mc steps)	Uhf injection out- put frequency (0.1 -mc steps)	2d transmitter mixer output and channel frequency (0.1-mc steps)
3.0 to 3.9	22	25.0 to 25.9	200.0	225.0 to 225.9
3.0 to 3.9	23	26.0 to 26.9	200.0	226.0 to 226.9
3.0 to 3.9	24	27.0 to 27.9	200.0	227.0 to 227.9
3.0 to 3.9	25	28.0 to 28.9	200.0	228.0 to 228.9
3.0 to 3.9	26	29.0 to 29.9	200.0	229.0 to 229.9
3.0 to 3.9	17.0 to 26.0	20.0 to 29.9	210.0	230.0 to 239.9
3.0 to 3.9	17.0 to 26.0	20.0 to 29.9	220.0	240.0 to 249.9
3.0 to 3.9	17.0 to 26.0	20.0 to 29.9	230.0	250.0 to 259.9
3.0 to 3.9	17.0 to 26.0	20.0 to 29.9	240.0	260.0 to 269.9
3.0 to 3.9	17.0 to 26.0	20.0 to 29.9	250.0	270.0 to 279.9
3.0 to 3.9	17.0 to 26.0	20.0 to 29.9	260.0	280.0 to 289.9
3.0 to 3.9	17.0 to 26.0	20.0 to 29.9	270.0	290.0 to 299.9
3.0 to 3.9	17.0 to 26.0	20.0 to 29.9	280.0	300.0 to 309.9
3.0 to 3.9	17.0 to 26.0	20.0 to 29.9	290.0	310.0 to 319.9
3.0 to 3.9	17.0 to 26.0	20.0 to 29.9	300.0	320.0 to 329.9
3.0 to 3.9	17.0 to 26.0	20.0 to 29.9	310.0	330.0 to 339.9
3.0 to 3.9	17.0 to 26.0	20.0 to 29.9	320.0	340.0 to 349.9
3.0 to 3.9	17.0 to 26.0	20.0 to 29.9	330.0	350.0 to 359.9
3.0 to 3.9	17.0 to 26.0	20.0 to 29.9	340.0	360.0 to 369.9
3.0 to 3.9	17.0 to 26.0	20.0 to 29.9	350.0	370.0 to 379.9
3.0 to 3.9	17.0 to 26.0	20.0 to 29.9	360.0	380.0 to 389.9
3.0 to 3.9	17.0 to 26.0	20.0 to 29.9	370.0	390.0 to 399.9

### Section III. HIGH-LEVEL RF AND MODULATOR STAGES

#### 55. Transmitter Driver V105

(fig. 19)

a. The amplified rf output of V104 is coupled to parallel-tuned circuit Z106 by capacitor C126. The tuned circuit provides a high-impedance to the 225.0- to 399.9-mc frequencies. Capacitor C127 is a trimmer for Z106. The signal voltage developed across the tuned circuit is coupled through capacitor C139 to the cathode of transmitter driver V105, which functions as a

grounded grid amplifier. Coil L115 provides the cathode impedance for the input signal and resistor R112 provides cathode bias for V105. Capacitor C129 is a cathode bypass capacitor. Capacitor C140 provides rf ground for the grid of V105 and resistor R120 is the grid-return circuit to ground. Jack J114 is a test point for measuring grid bias on V105 developed by the rf signal. Transmitter driver V105 receives modulated plate voltage from the +300-volt

supply through terminal V of plug P101 resistor R121, rf choke L119, and parallel-tuned circuit Z107.

b. The amplified output of V105 is developed across tuned circuit Z107. Tuned circuit Z107, in parallel with capacitor C145 and trimmer capacitor C141, is tuned to present a high impedance to rf signals in the 225.0- to 399.9-mc range. Choke L119 and capacitor C142 form a plate decoupling network for V105. Resistor R121 is a meter shunt for M701 (fig. 22) when S704 is placed in the DVR  $I_p$  position.

#### 56. Transmitter Power Amplifier V106 (fig. 19)

a. The output of transmitter driver V105 is developed across Z107 and is coupled by C128 to the grid of V106. Rf choke L114 provides a high impedance for the rf driving signal. Resistor R108 and capacitor C146 provide grid-leak bias for V106. Resistor R109 is a meter shunt for M701 (fig. 22) when switch S704 is placed in the PA  $I_g$  position. Fixed-protective bias is supplied through terminal T of P101. Jack J111 is a test point for measuring the fixed and grid-leak bias.

b. The screen grid of V106 receives modulated dc voltage through terminal N of plug P101. Capacitor C138 and inductor L121 are a screen grid rf decoupling network. Power amplifier V106 receives modulated plate voltage through an insulated conductor passing through the inner conductor of coaxial cavity Z108, through feedthrough capacitor C133, and terminal M of plug P101. Capacitor C133 bypasses rf signals from the +300-volt supply.

#### 57. Power Amplifier Output Circuit (fig. 19)

The power amplifier output is developed across plate tank Z108. The tuned circuit is a coaxial cavity and an integral tuning capacitor that is ganged with the rf amplifier tank circuits and is tuned by the 1,750-position shaft of the frequency selector. Blocking capacitor C131 prevents the dc plate voltage on V106 from being grounded through Z108 and couples the rf energy from the plate of V106 to Z108. Trimmer

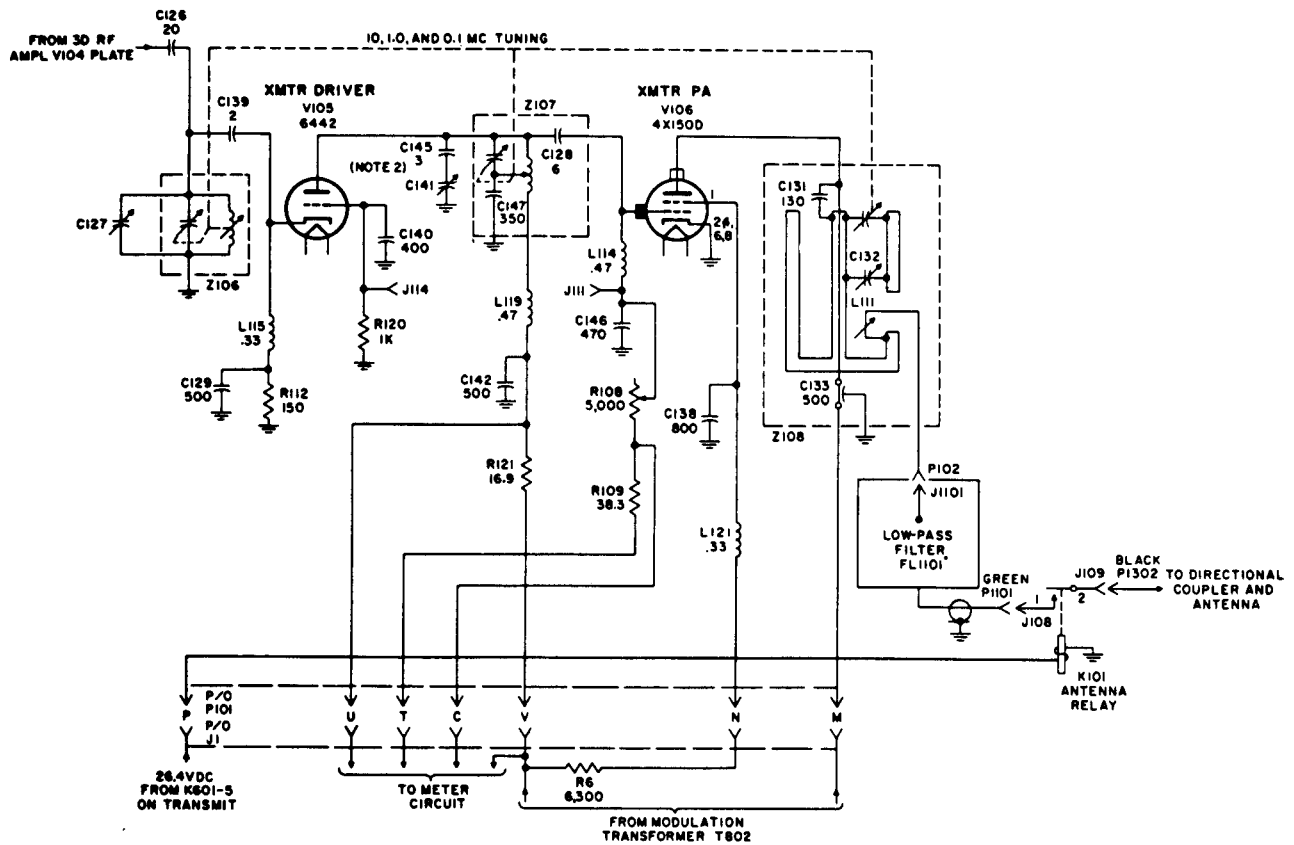
capacitor C132 sets the minimum capacity point of Z108. Coupling loop L111 couples the rf energy from Z108 and low-pass filter FL1101 to the antenna through contacts 1 and 2 of antenna relay K101 and the directional coupler (para 10). The screen grid voltage of V106 is reduced by resistor R6. Rf decoupling is provided by C138 and L121. Low pass filter FL1101 attenuates all frequencies above 400 mc to reduce harmonic output.

#### 58. Audio Input Circuits (fig. 20)

Figure 20 shows the interunit audio input circuits for both Radio Set AN/VRC-24 and AN/TRC-68. For normal transmission (NOR BB switch set to NOR), microphone audio signals from AUDIO jacks J702-C and J703-C are coupled through rf filter FL702 to the audio amplifier and modulator subunit through terminal F of P801. Audio signals from Radio Set Control C-1439/U or from the retransmit equipment are coupled through rf filter FL19 to the same input terminal. Microphone current for the carbon microphone is supplied from the -30-volt supply through terminal M of plug P801 and the filter network that consists of capacitors C816 and C819 and resistor R817.

#### 59. Audio Preamplifier V803 (fig. 20)

a. Audio input signals are amplified by audio preamplifier V803 and applied to modulation driver stage V804. Microphone signals from terminal F of P801 are coupled through switch contacts 7 and 9 of S801A, coupling capacitor C809, resistor R818, and R850 to the control grid of V803. Resistors R820 and R819 are the grid-return bias circuit for V803. Bypass capacitor C817 limits the high-frequency response of the preamplifier stage. Resistor R821 and capacitor C811 provide cathode bias for V803. Screen grid voltage for V803 is supplied from the +125-volt dc supply through voltage dropping resistor R823. Capacitor C812 provides a low-impedance path to ground for audio signals on



- NOTES:
1. UNLESS OTHERWISE INDICATED ALL RESISTANCE VALUES ARE IN OHMS, ALL CAPACITANCE VALUES ARE IN MICROMICROFARADS, AND ALL INDUCTANCE VALUES ARE IN MICROHENRYS.
  2. V105 IS A PENCIL TRIODE-TYPE TUBE. THE PLATE IS THE CAP, THE GRID IS THE SMALLER RING AND THE CATHODE IS THE BOTTOM RING. THE FILAMENT HAS AN ADAPTER CAP.

TM5820-222-35-51

Figure 19. Transmitter driver V105 and transmitter power amplifier V106, schematic diagram.

the screen grid. Plate voltage is supplied to V803 through plate load resistor R824.

Note. In some rt units, L803 has been substituted for R850.

b. The audio output signals developed across load resistor R824 are coupled through C813, potentiometer R843, contacts 1 and 20 of tr relay K802 (energized on transmit), contacts 9 and 14 of squelch relay K801 (deenergized on transmit) to the control grid of modulation driver stage V804 (fig. 14).

#### 60. Modulator Driver V804 and Transmitter Modulator V804 through V808 (fig. 14)

a. Tube V804 performs a dual purpose as the second receiver audio amplifier and the

modulator driver. Tubes V805, V806, V807, and V808 perform a dual purpose as the receiver output amplifier and the transmitter modulator. On transmit, each stage functions as described in paragraphs 43 and 44. However, the plate voltage supplied to the stages is approximately 300 volts dc on transmit and the drive level is increased. Thus, the output power of these stages is higher on transmit than on receive.

b. The modulated B+ supplied to the plates of transmitter driver V105 (para 55) and the screen grid and plate of transmitter power amplifier V106 (para 56) is tapped off the primary winding (terminal 2) of output transformer T802. Jack J803 is a test point for measuring the modulated B+. The metering circuit connected across



resistor R839 meters the voltage drop across that resistor to indicate transmitter power amplifier plate current when the METER switch is placed in the PA  $I_b$  position. The metering circuit is shown in figure 22, Sidetone audio is tapped off secondary winding terminals 8-9, through R833 and applied to Radio Set Control C-1439/U and front panel AUDIO jacks as described in paragraph 45b.

#### **61. Limiter Rectifier V802B (fig. 14 and 20)**

a. Limiter rectifier V802B monitors the modulation voltage developed across modulation transformer T802 and limits the modulator output to a predetermined value. When the voltage across secondary terminals 10-11 exceeds the predetermined value, a negative voltage is developed by limiter rectifier V802B. This negative voltage is applied as bias to audio preamplifier V803 and reduces the gain of V803; thereby, limiting the maximum voltage that can be developed across modulation transformer T802.

b. Voltage divider resistors R830 and R832 (fig. 14) bias the cathode of V802B (fig. 20) positive with respect to the plate cutting off the tube. Potentiometer R831, connected across secondary winding 10-11, of output transformer T802, controls the amplitude of the audio applied to the cathode of V802B.

c. When the amplitude of audio signals on the secondary winding increases so that the peak audio voltage exceeds the R830 and R831 voltage divider bias, the negative half cycles of audio signals cause the cathode of limiter-rectifier V802B to go negative with respect to the plate. This causes V802B to conduct. Tube V802B plate current through resistors R841 and R819 develops a voltage drop which applies a negative bias voltage to the control grid of V803. Capacitor C810 maintains the negative bias on the grid of V803 while V802B is cutoff during positive half cycles of audio voltage. The negative bias applied to the control grid of audio preamplifier V803 lowers the gain of the stage. Thus, the modulator output is automatically limited.

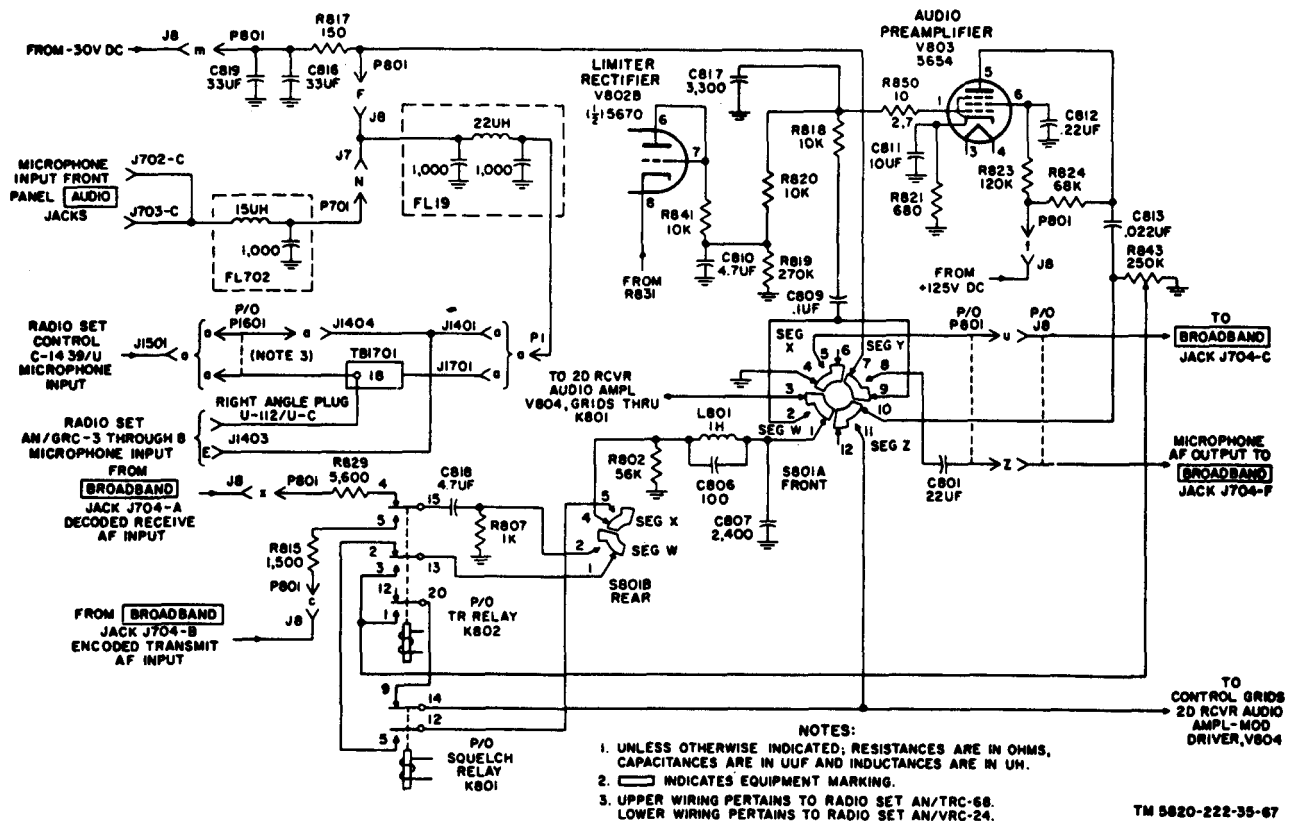


Figure 20. Audio preamplifier V803, limiter rectifier V802B, and audio input circuits, schematic diagram.

# CHAPTER 4

## THEORY OF BROADBAND, CONTROL, METERING, POWER, DISTRIBUTION, AND FREQUENCY SELECTION STAGES

---

### Section I. BROADBAND RECEPTION AND TRANSMISSION

#### 62. Audio Amplifier and Modulator on Broadband Receive

When NOR-BB switch S801 (fig. 20) is placed in the BB position (broadband), encoded received signals from transformer T501 (fig. 12) are coupled through cathode follower V802A to the decoding equipment (not part of this radio set). Decoded signals are returned from the decoding equipment to audio preamplifier V803 (fig. 20) where the signals are amplified and applied to audio output stages V805 through V808.

#### 63. Cathode Follower V802A (fig. 21)

a. Detected coded audio signals are coupled from the detector stage through terminal N of plug P801 and coupling capacitor C808 to the control grid of V802A. A portion of the detected signal is applied to squelch amplifier V801 (para 42). When squelch relay K801 operates, relay contacts 2 and 11 open and remove the ground on the control grid of V802A. Tube V802A functions as an impedance-matching transformer and couples the signal from the high-impedance detector circuit to the low-impedance transmission line to the decoding equipment.

b. Resistor R806 is the high grid input resistance, and resistors R805 and R804 provide the low output resistance load. Plate voltage is supplied from the +300-volt dc (approximately 270 volts on receive) supply through contacts 6 and 16 of tr relay K802. The output of the broadband cathode follower is coupled to the decoding equipment through coupling capacitor C802, and a 500-kc if. filter that consists of C804 and L802, and terminal *b* of plug P801, and J8 to broadband jack J704-E.

#### 64. Decoded Broadband Audio (fig. 20)

a. Decoded broadband audio is returned from the decoding equipment to the audio preamplifier through terminal X of plug P801. Contacts 4 and 15 of tr relay K802 are closed on receive. Voltage-divider resistors R829 and R807 attenuate the returned audio signal to the proper level. Capacitor C818 provides dc isolation between the audio amplifier and modulator and the broadband decoding equipment. The path of the decoded received signal is through contacts 1 and 2 of NOR-BB switch S801B, contacts 2 and 13 of K802, contacts 5 and 12 of K801, and contacts 4 and 5 of S801B to the low-pass filter that consists of R802, C806, C807, and L801.

b. The output of the low-pass filter is connected through contacts 1 and 2 of switch S801A and coupling capacitor C809 and R818 to the grid circuit of audio preamplifier V803. The output of V803, developed across R824 and R843, is coupled through contacts 10 and 11 of switch S801A to the control grids of the second receiver audio amplifier V804. The remaining path of the received broadband signals is the same as described for normal audio circuits in paragraphs 43 and 44.

#### 65. Audio Amplifier and Modulator Circuits on Broadband Transmit (fig. 20)

a. Microphone audio is normally coupled from the front panel or from Radio Set Control C-1429/U AUDIO jacks from terminal F of plug P801 to audio preamplifier V803 through contacts 7 and 9 of S801A, capacitor C809, and resistor R818. When NOR-BB switch S801 is set to BB, the audio input from the microphone or Radio

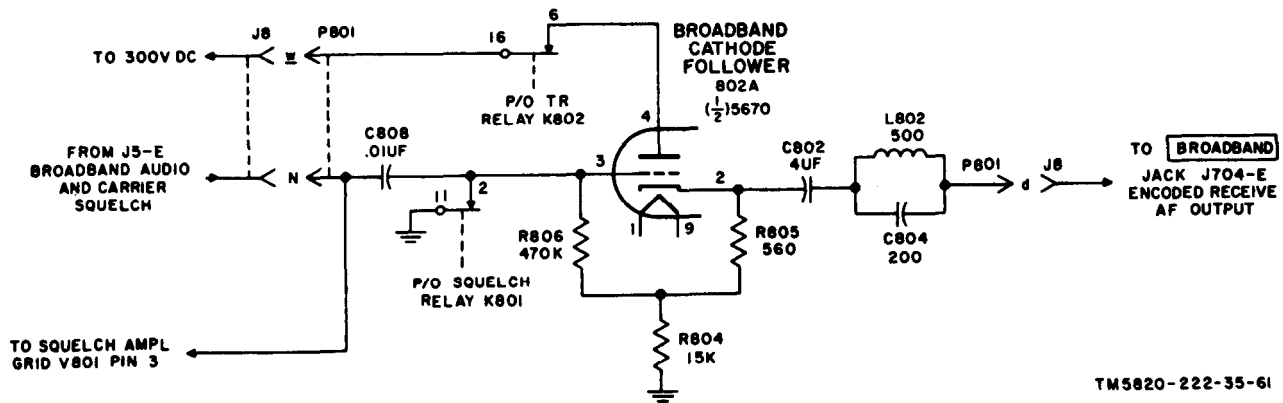


Figure 21. Broadband cathode follower V802A, schematic diagram.

Set Control C-1439/U is routed through contacts 7 and 8 of switch S801A, capacitor C801, and terminal Z of plug P801 to the broadband encoding equipment. The encoding equipment returns coded audio signal through terminal c of P801, resistor R815, contacts 5 and 15 of tr relay K802 (energized on transmit), capacitor C818 (loaded by R807) contacts 2 and 1 of S801B, contacts 13 and 3, and 1 and 20 of K802, contacts 9 and 14 of squelch relay K801

(deenergized on transmit) to the control grids of V804 (fig. 14).

b. Resistors R815 and R807 form a voltage divider that attenuates the input signal to the proper level. Capacitor C818 blocks the flow of dc current between the encoding equipment and the audio amplifier and modulator subunit. The transmitted broadband signals are amplified and used to modulate transmitter driver V105 and transmitter power amplifier V106 (para 55 and 56).

## Section II. METERING CIRCUITS

### 66. Meter M701 and METER switch S704 (fig. 22)

Meter M701, together with S704, permits measurements of all critical current and voltage levels throughout the rt unit and the power supplies associated with Radio Set AN/VRC-24 or Radio Set AN/TRC-68. The various switch positions and the associated circuit components are covered in paragraphs 67 through 76.

### 67. SWR Position (fig. 22)

a. When METER switch S704 is in the SWR position, Meter M701 indicates reflected power on the transmission line from the antenna. The rectified voltage drop across resistor R1307 is proportional to the reflected power on the antenna. Refer to paragraph 10 for a detailed discussion of the directional coupler.

b. The voltage drop across R1307 causes a current to flow through M701 through the following path:

- (1) From R1307 through calibrating resistor R1308.
- (2) Terminal S of J7 and P701.
- (3) Contacts 11 and 12 of S704A.
- (4) Meter M701 and current-limiting resistor R701.
- (5) Contacts 12 and 11 of S704B to ground.

### 68. PWR Position (fig. 22)

a. When METER switch S704 is in the PWR position, meter M701 indicates incident power delivered to the antenna. Under normal operating conditions, the meter will read upscale on the PWR position and nearly zero on the SWR position. When a mismatch is introduced, such as an open-circuited or short-circuited coaxial cable,

the meter will indicate nearly equal on both PWR and SWR positions. In this way, the PWR and SWR meter positions provide a convenient means of determining the degree of match or mismatch presented by the load.

b. The voltage drop across R1302, which is proportional to the transmitter power output, causes a current to flow through meter M701 through the following path:

- (1) Resistor R1302 and resistor R1301.
- (2) Terminal T of J7 and P701.
- (3) Contacts 10 and 12 of S704A.
- (4) Meter M701 and current-limiting resistor R701.
- (5) Contacts 12 and 10 of S704B to ground.

#### 69. PA $I_b$ Position (fig. 22)

a. When METER switch S704 is in the PA  $I_b$  position, meter M701 indicates power amplifier V106 plate current. METER switch S704 connects METER M701 across resistor R839. Power amplifier plate current flows through resistor R839 and develops a voltage drop proportional to the plate current through the tube.

b. When switch S704 is placed in the PA  $I_b$  position, resistor R839 shunts the meter through the following terminals and switch contacts:

- (1) Terminal *b* of P801 and J8.
- (2) Terminal U of J7 and P701.
- (3) Contacts 9 and 12 of S704A.
- (4) Meter M701 and series current-limiting resistor R701.
- (5) Contacts 12 and 9 of S704B.
- (6) Terminal A of P701 and J7.
- (7) Terminal K of J8 and P801.

#### 70. PA $I_g$ Position (fig. 22)

a. When METER switch S704 is in the PA  $I_g$  position, meter M701 indicates power amplifier grid current. METER switch 704 connects meter M701 across resistor R109, which is in series with the grid-leak circuit for power amplifier V106. The voltage drop across resistor R109 is proportional to the power amplifier grid current.

b. When switch S704 is placed in the PA  $I_g$  position, resistor R109 shunts the meter through the following terminals and switch contacts:

- (1) Terminal C of P101 and J1.
- (2) Terminal V of J7 and P701.
- (3) Contacts 8 and 12 of S704A.
- (4) Meter M701 and R701.
- (5) Contacts 12 and 8 of S704B.
- (6) Terminal DD of P701 and J7.
- (7) Terminal T of J1 and P101.

#### 71. DVR $I_b$ Position (fig. 22)

a. When METER switch S704 is in the DVR  $I_b$  position, meter M701 indicates transmitter driver V105 plate current. METER switch S704 connects meter M701 across resistor R121. The voltage drop across resistor R121 is proportional to the flow of plate current through V105.

b. When switch S704 is placed in the DVR  $I_b$  position, resistor R121 shunts the meter through the following terminals and switch contacts:

- (1) Resistor R121 to terminal U of P101 and J1.
- (2) Terminal W of J7 and P701.
- (3) Contacts 7 and 12 of S704A.
- (4) Meter M701 and R701.
- (5) Contacts 12 and 7 of S704B.
- (6) Terminal Z of P701 and J7.
- (7) Terminal V of J1 and P101 to R121.

#### 72. % MOD Position (fig. 22)

a. When METER switch S704 is in the % MOD position, meter M701 indicates the percentage of modulation imposed on transmitter driver V105 and transmitter power amplifier V106. METER switch S704 connects meter M701 across resistor R828. Transmitter modulator cathode current flowing through tubes V805, V806, V807, and V808 develops a voltage drop across resistor R828 that is proportional to the cathode current. The meter reading provides an indication of transmitter modulator output because it is proportional to the voltage drop across R828.

b. When switch S704 is in the % MOD position, resistor R828 shunts the meter

through the following terminals and switch contacts:

- (1) Grounded contact 6 to 12 of S704A.
- (2) Meter M701 and R701.
- (3) Contacts 12 and 6 of S704B.
- (4) Terminal B of P701 and J7.
- (5) Terminal M of J8 and P801.

### 73. LINE V Position

(fig. 22)

a. When METER switch S704 is in the LINE V position on the front panel of Receiver Transmitter RT-323/VRC-24 meter M701 measures the 26.4-volt dc line supplying power to Radio Set AN/VRC-24. When METER switch S704 is in the LINE V position on the front panel of Receiver-Transmitter RT-441/TRC-68, meter M701 measures the 26.4 volts dc supplied to the POWER lamp on Power Supply PP-1494/U and the front panel dial lamps and tr relays in Receiver-Transmitter RT-441/TRC-68. A midscale meter reading corresponds to 26.4 volts dc on both rt units.

b. When switch S704 is in the LINE V position, resistor R703 is connected in series with the meter circuit. The meter circuit shunts the 26.4 source through the following terminals and switch contacts:

- (1) Grounded contact 5 to 12 of S704A.
- (2) Meter M701 and R701.
- (3) Contacts 12 and 5 of S704B.
- (4) Resistor R703 and terminal Y of P701 and J7.
- (5) For Radio Set AN/TRC-68, the path to 26.4 volts is completed through terminal E of P1.
- (6) For Radio Set AN/VRC-24, the path to 26.4 volts is completed through terminal J of J10.

c. Resistor R704 and R716 function as a meter shunt when S704 is in the LINE V position.

### 74. LOW B+ Position

(fig. 22)

a. When METER switch S704 is in the LOW B+ position, meter M701 measures the +125 volts dc supplied by either the dynamotor (part of AN/VRC-24) or the power supply (part of the AN/TRC-68). METER switch S704 connects meter M701

across resistor R708. Resistors R708 and R706 are a voltage divider connected in series with the +125 volts dc line to ground. A portion of the +125 volts dc is dropped across resistor R708 and is used for measurement. A midscale meter reading corresponds to +125 volts dc.

b. When switch S704 is in the LOW B+ position, resistor R708 shunts M701 through contacts 4-12 of S704A and contacts 12-4 of S704B.

c. In Radio Set AN/TRC-68, the voltage divider (R706 and R708) is returned to +125 volts through terminal K of P701 and J7, and through terminal P of J15, terminal K and R of P2, E of J15, and P of P1.

d. In Radio Set AN/VRC-24, the voltage divider (R706 and R708) is returned to +125 volts through terminal K of P701 and J7, and through terminal P of J15 and P2, terminal T of P2 and J15, and terminal H of J14.

### 75. HIGH B+ Position

(fig.22)

a. When METER switch S704 is in the HIGH B+ position, Meter M701 measures the +300 volts dc supplied by either the dynamotor (part of AN/VRC-24) or the power supply (part of AN/TRC-68). METER switch S704 connects meter M701 across resistor R707. Resistors R707 and R705 form a voltage divider which is connected in series from the +300 volts dc line to ground. A portion of the +300 volts dc is dropped across R707 and is used for measurement. A midscale meter reading corresponds to +300 volts dc.

b. When switch S704 is in the HIGH B+ position, resistor R707 shunts M701 through contacts 3-12 of S704A and contacts 12-3 of S704B.

c. In Radio Set AN/TRC-68, the voltage divider (R707 and R705) is returned to +300 volts through fuse F701, terminal C of P701 and J7, and terminal N of P1. When Radio Set AN/VRC-24 is used, the voltage divider path to +300 volts is similar, except that it is routed through terminal V of J15, terminals V and X of P2, terminal X of J15, and F of J10.

## 76. S-METER Position (fig. 22)

When METER switch S704 is in the S-METER position, meter M701 indicates the strength of the received signal. METER switch S704A connects the negative side of meter M701 to resistor R308, which is a part of the cathode bias circuit for the second if. amplifier V302. METER switch S704B connects the positive side of meter

M701 to the junction of voltage divider resistors R704 and R716. When no received signal, the voltage across R716 cancels the effect of the voltage drop across resistor R308 and M701 indicates no input. When a signal is received, avc action reduces the current through the second if. amplifier V302. This reduces the voltage drop across resistor R308 and results in a meter reading that is proportional to the amplitude of the received signal.

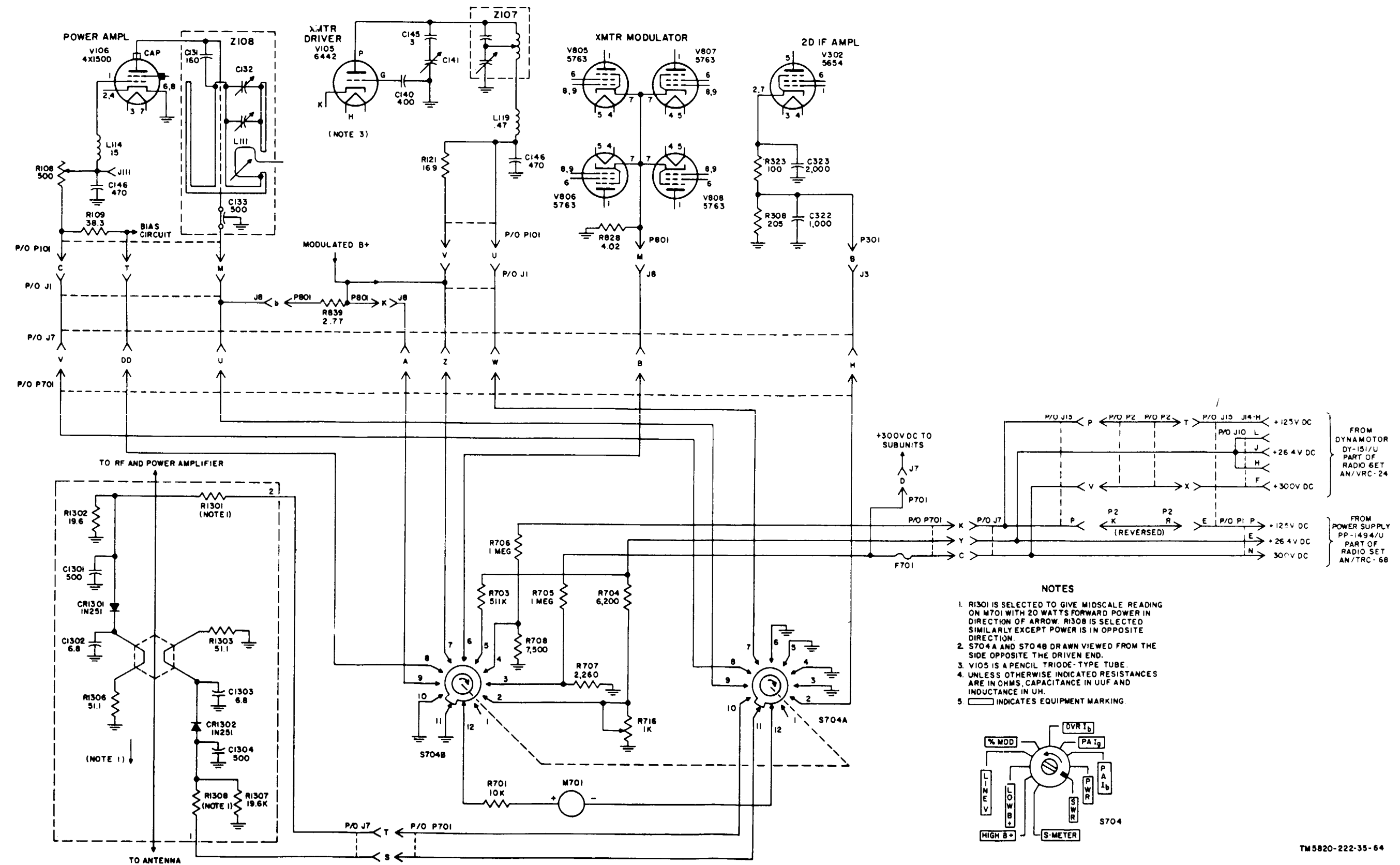


Figure 22. Metering circuits, schematic diagram.



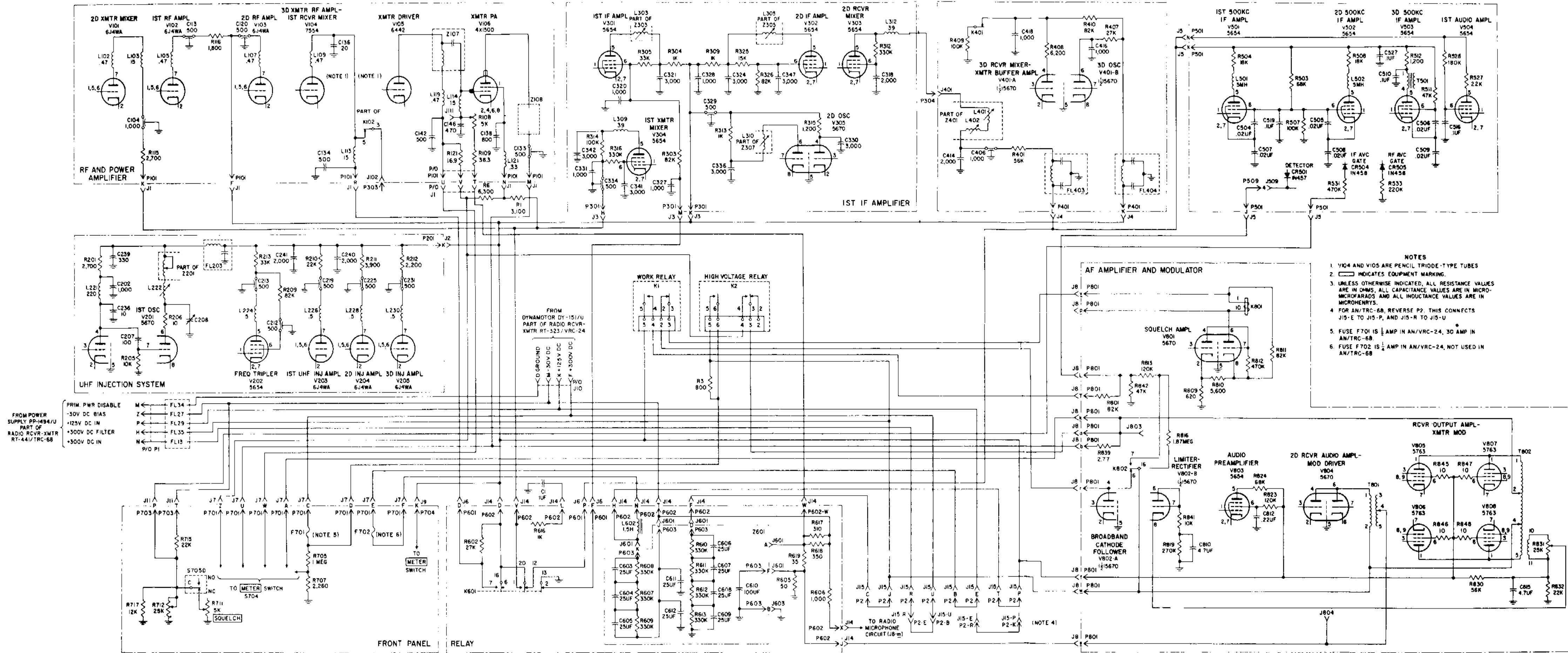


Figure 83. Bias and B+ distribution, schematic diagram.



## Section III. B+ AND BIAS DISTRIBUTION

### 77. +300-Volt Distribution (fig. 23)

Receiver-Transmitter RT-323/VRC-24 is supplied with +300 volts dc from Dynamotor DY-151/U through terminal F of jack J10. The +300-volt dc filter circuit is contained within the relay subunit. Receiver-Transmitter RT-441/TRC-68 is supplied with +300 volts dc by Power Supply PP-1494/U through terminal N of rear plug P1. The +300-volt dc filter circuit is contained within the power supply. These are the only differences in the +300-volt distribution circuits. The +300-volt distribution circuits on receive and on transmit are described in *a* and *b* below.

#### *a. Receive.*

- (1) Both +300-volt dc inputs are connected through +300-volt fuse F701 to high-voltage relay K2. In Receiver-Transmitter RT-441/TRC-68, the +300-volt supply is applied through P1-N, FL13, J15-R, through plug P2, and returned to J15-U, J7-C, P701-C, to fuse F701. Fuse F701 is a 30-ampere fuse in this set and is used only to complete the circuit. The protective fuse (F1806) is located in Power Supply PP-1494/U (fig. 29). In Receiver-Transmitter RT-323/VRC-24, the +300-volt input is applied through J10-F, J7-C, P701-C to fuse F701, a 1/2-ampere fuse.
- (2) On receive, relay K2 is deenergized, contacts 5 and 6 are open, and the +300-volt input is dropped to approximately +270 volts dc by resistor R3. The +270 volts dc is applied to the plates of broadband cathode follower V802A, second receiver audio amplifier V804, and receiver output amplifier tubes V805, V806, V807, and V808. Modulated B+ is supplied to the plate of power amplifier V106. Screen voltage to V106 is removed on receive. The 270 volts dc is also supplied to plate pin 6 of V801 through

the coil of squelch relay K801, contacts 2-3 of K1, and contacts 6-16 of K802.

*b. Transmit.* On transmit, high-voltage relay K2 is energized, closing contacts 5 and 6. Resistor R3 is shorted out and +300 volts is supplied to the plates of tubes V804 through V808. Contacts 3 and 4 of high-voltage relay close, and the modulated B+ tapped off the primary of T802 (terminal 2) is applied to the plate of transmitter driver V105 and the screen grid of power amplifier V106. Plate voltage is removed from the broadband cathode follower V802A when contacts 6 and 16 of relay K802 open.

### 78. Low B+ Distribution (fig. 23)

Receiver-Transmitter RT-323/VRC-24 is supplied with +125 volts dc from Dynamotor DY-151/U through terminal K of jack J10. The +125 volts is routed through fuse F702 and the filter subunit and applied to terminal P of J15 for distribution. Receiver-Transmitter RT-441/TRC-68 is supplied +125 volts from Power Supply PP-1494/U through rear terminal P of plug P1 and FL29. This voltage is already filtered and is applied directly to terminal P of jack J15 when plug P2 is reversed.

*a. Receive.* On receive, the following stages receive plate and/or screen voltage from the +125-volt dc supply.

- (1) First and second rf amplifiers V102 and V103, and first receiver mixer V104.
- (2) All stages of the uhf injection system subunit, V201 through V205.
- (3) First and second if. amplifiers V301 and V302, second receiver mixer V303, and second oscillator V305.
- (4) Third receiver mixer V401A and third oscillator V401B.
- (5) 500-kc amplifiers V501 through V504.
- (6) Audio preamplifier V803 and the screen grids of receiver output amplifier V805, V806, B807, and V808.



b. *Transmit.* On transmit, tr relay K601 operates (para 82b) and contacts 12-20 of relay K601 open. This removes the +125-volt dc supply to the 500-kc if. amplifier stages, V501 through V503, first audio amplifier V504, and second receiver mixer V303. Contacts 1 and 20 of relay K601 close and supply +125 volts dc to first transmitter mixer V304, second transmitter mixer V101, and the screen grid of transmitter power amplifier V106. Resistor R616 and capacitor C1 lengthen the decay time for the low B+, which reduces the transient produced by the change in current through transformer T801 when the rt unit is switched from transmit to receive. Tr relay contacts 7 and 16 of relay K601 close and short-circuit resistor R602, which raises the plate voltage supplied to third rf amplifier V104.

#### 79. Bias Voltage Distribution (fig. 23)

a. Receiver-Transmitter RT-323/VRC-24 is supplied -30 volts dc from Dynamotor DY-151/U through terminal M of jack J10. Receiver-Transmitter RT-441/

TRC-68 is supplied -30 volts dc from Power Supply PP-1494/U through terminal Z of plug P1 and FL27. A negative voltage is tapped off the parallel combination of resistors R711, R712, and R717 in series with R715 and applied to the if. avc gate CR504. Resistor R711 controls the squelch threshold adjustment.

b. Approximately 6 volts negative bias is tapped off voltage divider resistors R605, R619, R617, and R618, at the junction of resistors R605 and R619, and applied to the control grids of V805, V806, V807, and V808 through the secondary of T801 (fig. 14). The -30-volt bias supply also supplies energizing voltage to the carbon microphones. The cathode of detector diode CR 501 is biased with +5.6 volts dc on receive, +70 volts dc on transmit, and +45 volts dc when the frequency selector is running. Transmitter power amplifier V106 is protected by a fixed bias applied to the control grid through relay subunit terminal W of plug P602, jack terminal W of J14, terminal T of jack J1, terminal T of plug P101, resistors R109, R108, and coil L114.

### Section IV. POWER CONTROL CIRCUITS

#### 80. Radio Set AN/VRC-24, Power Control (fig. 24)

Radio Set AN/VRC-24 is powered by a 26.4-volt dc vehicle battery connected to the positive and negative terminals of terminal board TB1703. The 26.4-volt dc input is applied to Dynamotor DY-151/U, which supplies the operating voltages to the radio set and to the filament circuits, through power relay K3.

##### a. *POWER ON Control.*

- (1) The negative terminal of terminal board TB1703 is grounded. The positive terminal is connected through terminal 35 of TB1702 and fuse F704 to contacts 1 and through silicon rectifier CR1 to terminal 6 of relay K3. Silicon rectifier CR1 protects the equipment in case the battery polarity is reversed; since

it will not conduct when a negative voltage is applied to the anode, the equipment cannot be turned on when the polarity of the battery voltage is reversed.

- (2) When the POWER control (S701) on the rt unit or POWER control (S1505) on the Radio Set Control C-1439/U is momentarily turned to the ON position, contact 5 of power relay K3 is grounded and power relay K3 is energized. Holding contacts 2 and 3 of K3 close and complete a groundpath through resistor R2 to contact 5 of K3, so that when the POWER control is released, relay K3 remains energized. Relay contacts 1 and 4 of K3 close to apply the +26.4 volts dc to the dynamotor, the filament circuits, the dc case blower, the pilot

lamp on Radio Set Control C-1439/U, and the dial lamps on the front panel.

*b. POWER OFF Control.* When the POWER control (S701) on the rt unit or POWER control (S1505) on Radio Set Control C-1439/U is momentarily turned to the OFF position, the positive terminal of TB1703 is connected to both sides of the power relay K3 coil (contacts 5 and 6). The equal voltage across the coil reduces the current flow to zero and the relay is deenergized. Relay contacts 1 and 4 open and remove the +26.4-volt dc supplied to the dynamotor, dc case blower, filament and the light circuits. Relay contacts 2-3 open to break the ground return for K3. Resistor R2 prevents a direct short circuit across the vehicle battery.

#### 81. Radio Set AN/TRC-68 Power Control (fig. 25)

Radio Set AN/TRC-68 is powered by a 115- or 230-volt, 50-60 cps, ac source, applied to the primary windings of transformers T1801, T1802, and T1803 (fig. 29). Transformer T1803 is energized whenever the equipment is connected to the primary power source. A full-wave rectifier consisting of CR1813, CR1814, CR1815, and CR1816, across the secondary of transformer T1803, produces +26.4 volts dc.

*a. POWER ON Control.* When the front panel or the C-1439/U POWER control,

S701 or S1505, is momentarily turned to the ON position, contact X1 of power relay K1801 is grounded and the relay is energized. Contacts A1 and A2, B1 and B2, and D1 and D2 of K1801 close and connect the 115/230-volt ac source to the transformer T1801 and T1802 primary windings (fig. 29). In addition, holding contacts C1 and C2 complete a path to ground for relay coil X1 through resistor R1803 so that when the POWER control is released, relay K1801 remains energized. The holding ground circuit is routed through the ac case blower plugs H and F of P1401 and the Centrifugal Fan HD-390/U plugs P1051-D and P1051-A so that the radio set will not operate unless these blowers are connected.

*b. POWER OFF Control.* When the front panel or the C-1439/U POWER control, S701 or S1505, is momentarily turned to the OFF position, the +26.4 volts dc applied to contact X2 of relay K1801 is also applied to contact X1. The relay coil is short-circuited and relay K1801 is deenergized. All the relay contacts open and remove the 115/230 volts ac input from the primary windings of transformers T1801 and T1802. Resistor R1803 prevents a direct short circuit across the bridge rectifier circuit on the secondary of transformer T1803 until relay contacts C1 and C2 release. The primary of transformer T1803 is connected through fuse F1801 and terminals 13 and 14 of P1801 (fig. 29) to the ac power input at all times.

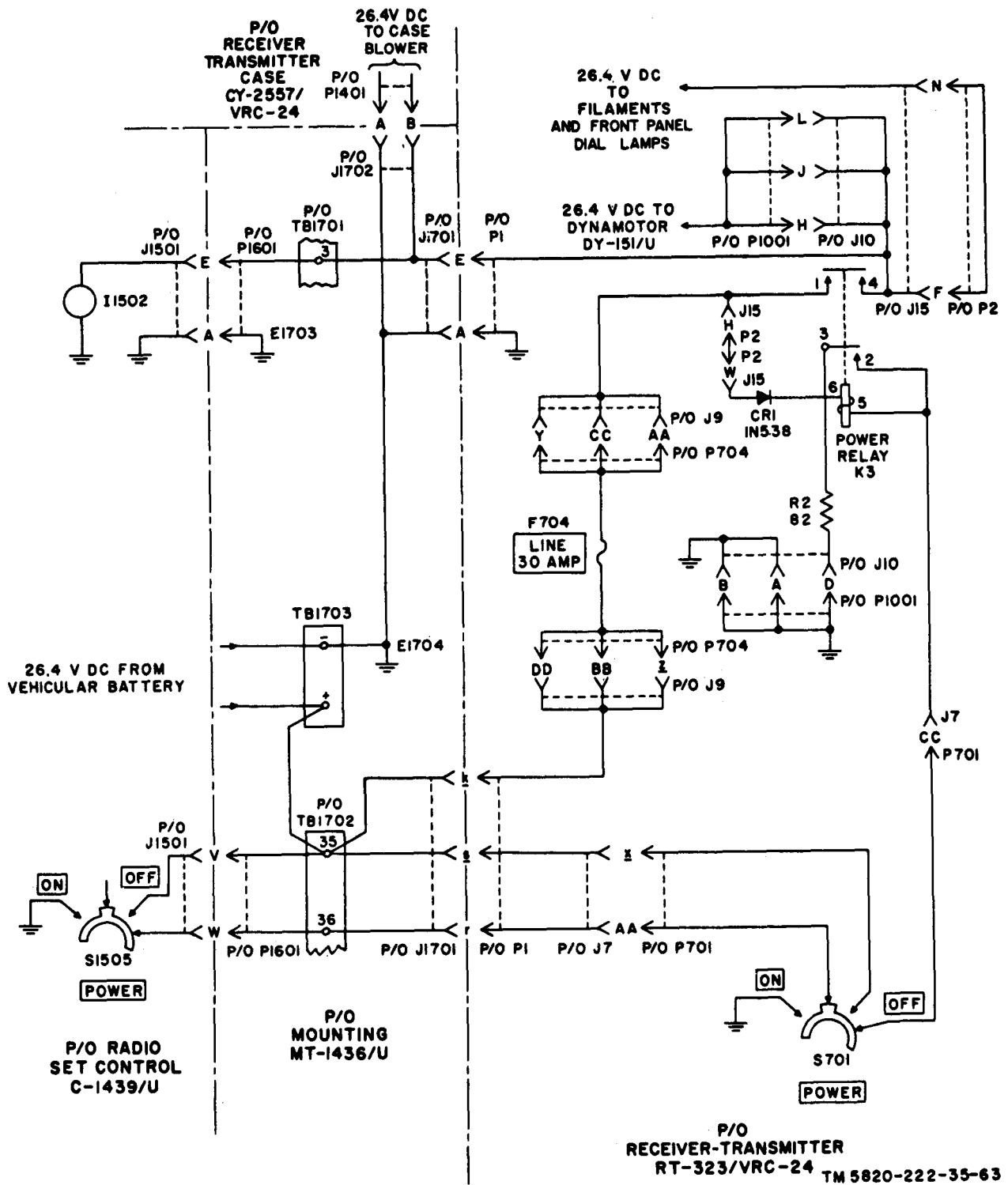
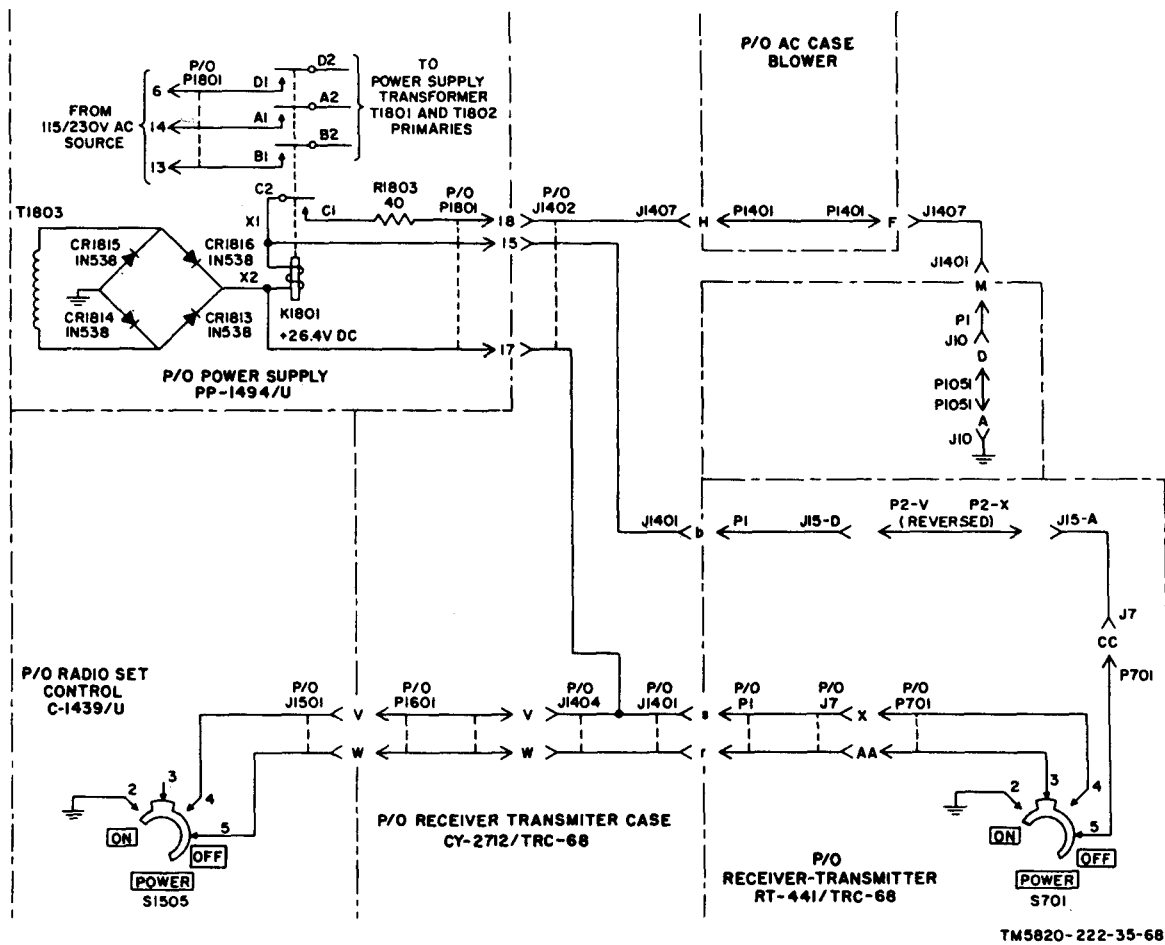


Figure 24. Radio Set AN/VRC-24, power control, schematic diagram.



TM5820-222-35-68

Figure 25. Radio Set AN/TRC-68, power control, schematic diagram.

## Section V. CONTROL AND FREQUENCY SELECTION CIRCUITS

### 82. Push-to-Talk Circuit (fig. 26)

a. *General.* The rt unit functions as a receiver in standby operation. When the push-to-talk switch of Microphone M-29A/U (RT-323/VRC-24) or Handset H-33/PT (RT-441/TRC-68) is pressed, or when a retransmit ground is supplied from the AN/GRC-3 through -8 equipment, the rt unit functions as a transmitter. The push-to-talk circuit receives 26.4 volts dc from the broadband encoder supply when NOR-BB switch S801 is on the BB position.

### b. Energizing Tr Relays.

- (1) Tr relay K601 is energized by 26.4 volts from Dynamotor DY-151/U (AN/VRC-24) or PP-1494 (AN/TRC-68) when NOR-BB switch S801 is in the NOR position. The push-to-talk switch completes the ground circuit to relay K6-1 and the relay operates.
- (2) Tr relay K601 can be operated from Radio Set Control C-1439/U only when radio-interphone switch S1504 is on the RAD or RAD-INT





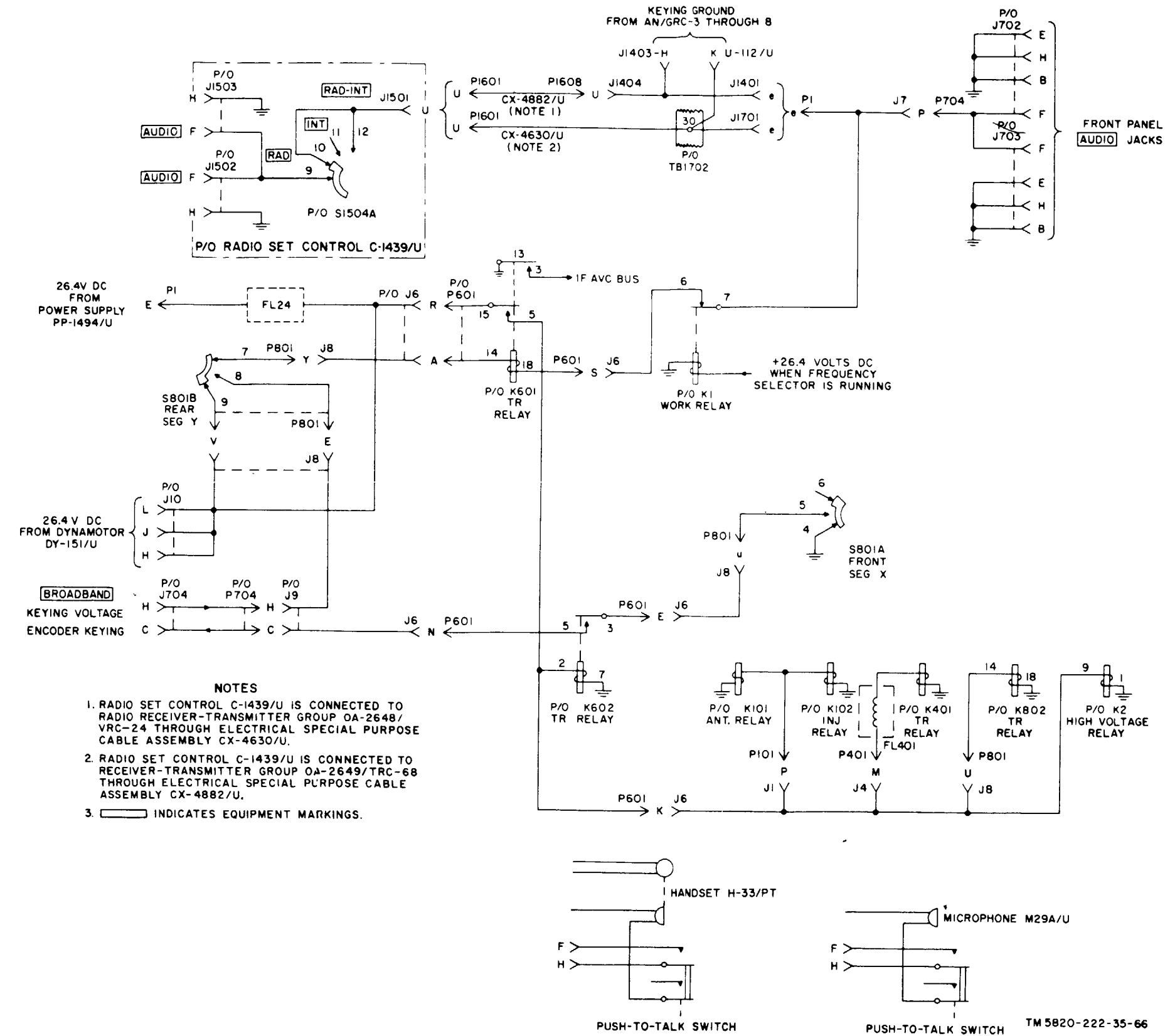


Figure 26. Push-to-talk circuit, schematic diagram.



position. While the frequency selector is running, K601 cannot be operated from any position because relay K1204 (fig. 27) supplies +26.4 volts dc to energize relay K1. Work relay K1 energizes and opens contacts 6 and 7 of K1, thereby interrupting the ground return for relay K601. Relay K1 prevents transmission while the rt unit is channeling from one frequency to another.

- (3) When relay K601 operates, contacts 5-15 and 3-13 of relay K601 close. Contacts 5-15 complete the 26.4 volts dc circuit to relay K602, antenna relay K101, injection relay K102, tr relay K401, tr relay K802, and high-voltage relay K2. Contacts 3 and 13 of K601 ground the if. avc bus.
- (4) When NOR-BB switch S801 is in the BB position and the tr relays are energized, contacts 3 and 5 of relay K602 close and supply an encoder keying ground to the broadband encoder from contacts 4 and 5 of NOR-BB switch S801A.

### 83. Local Channel Selection (fig. 27)

a. *Channel Selection Function.* Any one of 19 preset channels can be selected from the front panel of the rt unit by turning CHAN SEL selector switch S705 to the desired channel. When the CHAN SEL switch is turned, terminal 2 of channel selector automatic position relay K1204 is grounded through contacts 1 and 2 of S705C, local-seeking switch S1205, and switch S705B. (In figure 27, local-seeking switch S1205 is shown in the position to which it will be advanced after the channel selection sequence (*b* below) is completed. Just before switch S1205 was advanced to this position, the ground return path for K1204 was through contacts 8 and 5 of S1205 front, and 5 and 7 of S705B). When relay K1204 is energized, the following sequence occurs:

- (1) Contacts 3 and 5 of K1204 open. This action removes the 26.4 volts dc supply from 10.0-, 1.0-, and

0.1-mc automatic positioner relays K1201, K1202, and K1203.

- (2) Contacts 3 and 4 of K1204 close. This action applies +26.4 volts dc to tuning motor B1201. The pawl lifts from the detent wheel associated with B1201, permitting it to run.
- (3) Motor B1201 drives the channel indicator wheel, the preset channel memory drum, and the local and remote switches S1205 and S1206. Although motor B1201 is physically connected to the 10-mc, 1.0-mc, and 0.1-mc detent wheels through a slip-clutch arrangement, these wheels do not turn at this time because they are locked by pawls that slip into the detent wheels whenever the associated relay is deenergized.
- (4) Local-seeking switch S1205, ganged to the preset channel memory drum, turns until the rotor finds the one position that opens the ground path to terminal 2 of relay K1204. When S1205 reaches this position, relay K1204 deenergizes and drops the pawl into the detent wheel which prevents further rotation of the preset channel memory drum and the local- and remote-seeking switches S1205, and S1206.
- (5) When relay K1204 deenergizes, contacts 3 and 5 of K1204 close and the +26.4 volts dc supply is removed from tuning motor B1201 and applied to the coils of the 10.0-mc, 1.0-mc and 0.1-mc relays K1201, K1202, and K1203.

b. *Operation of 10-Mc Automatic Positioner.* Assume that the preset frequency for channel 19 is 376.3 mc. The left pin (first pin counting from the left (TM 11-5820-222-10) of the preset channel memory drum selects the first digit of the preset channel frequency. This pin opens one of the two normally closed contacts of switch S1210A. The left-center pin (second pin from the left) of the preset channel memory drum selects the second digit of the preset channel frequency. This pin opens one of the 10 normally closed contacts of switch S1210B. These two switches

control the selection of the first two digits as follows:

- (1) The 10.0-mc automatic positioner relay, K1201, is controlled by the settings of switches S1210A and S1210B. These switch settings are, in turn, controlled by the pin settings on the preset channel memory drum. In this case, channel 19 is preset to 376.3 mc and the 10.0-mc seeking switch (fig. 27) is shown at rest in the 370.0-mc position. If this switch is in any other position at the time channel 19 is selected, the ground circuit to relay K1201 is completed and relay K1201 energizes.
- (2) When relay K1201 energizes, contacts 3 and 4 close; this applies +26.4 volts to tuning motor B1201. Relay K1201 also lifts the pawl from the detent wheel, which allows tuning motor B1201 to drive the 10.0-mc automatic positioner through a slip-clutch arrangement. The tuning motor B1201 continues to drive the automatic positioner until the rotor contact of S1201 makes with ungrounded contact 37. Relay K1201 deenergizes, releases the pawl which falls into a detent on the 10-mc wheel, and thus prevents further rotation of the positioning wheel.
- (3) Note that several switch positions of the 10-mc seeking switch S1201 are tied together; for example, switch contacts 22 and 32, 23 and 33, 24 and 34, etc. In the example shown in figure 27, neither contact 27 nor 37 is grounded through switch S1210B. To prevent switch S1201 from stopping at contact 27 when 37 is selected, phasing switch S1202 rear returns terminal 2 of K1201 to ground when seeking switch S1201 arrives at contact 27.
- (4) The action of phasing switch S1202 rear is controlled by switch S1210A. When 370.0 mc is selected S1210 can select either a 2 or a 3 for the first digit. In this case, the left pin opens the switch that cor-

responds to a 3. Switch S1202 rotates at one-half the speed of S1201 because of a 2:1 gear reduction. At the time that the rotor contact on S1201 makes contact with ungrounded contact 27, the rotor contact of S1202 makes contact with switch contact 2 which is returned to ground through S1210A. This action grounds terminal 2 of K1201, which keeps the relay energized, and switch S1201 continues to be driven by B1201 until the rotor contact of S1201 lines up with contact 37, which is ungrounded. Similarly, if 270.0 mc was the selected frequency, switch S1202 rear would provide a ground return (through contacts 4 and 17) for K1201 when switch S1201 made contact with ungrounded contact 37.

- (5) Switch S1202 front is a blanking switch that grounds terminal 2 of K1201 when the uhf tuning elements are tuned below 225.0 mc. During the blanked alternation of the tuning cycle, the tuning elements are returned to the 399.9-mc position.

*c. Operation of 1-Mc Automatic Positioner.*

- (1) The right center pin (third pin, counting from the left; (TM 11-5820-222-10) ) of the preset channel memory drum closes one of the 10 normally open contacts of switch S1210C. The closed contact represents the third digit of the preset channel frequency. In the example shown in figure 27, the channel 19 preset frequency is 376.3 and contact 6 of S1201C is closed by the right center pin of the preset channel memory drum. If the 1.0-mc automatic positioner is not in the 6-mc position, contact 6 of switch S1210C completes the ground circuit to relay K1202 through 1.0-mc seeking-switch contacts S1203 and wiper contact A.
- (2) When relay K1202 energizes, +26.4 volts dc is supplied to tuning motor

B1201 through closed contacts 3 and 4 of relay K1202. The relay also lifts the pawl from the detent wheel, which allows the tuning motor to drive the 1.0-mc automatic positioner through a slip clutch. The 1.0-mc seeking switch, S1203, ganged to the 1.0-mc automatic positioner, rotates until the detent reaches position 6. The ground circuit to relay K1202 is then opened, and the relay deenergizes and drops the pawl into the detent wheel, which prevents further rotation of the indicator, detent wheels, and the 1.0-mc seeking switch.

- (3) If the 1.0-mc seeking switch has previously been set to a position lower than 6, it rotates counterclockwise through positions 0 and 9 to reach position 6. At this instant, the detent on the rear wafer of S1203 momentarily grounds the 10.0-mc automatic positioner relay K1201 through switch contact B of S1203 rear. This allows time for the 10.0-mc automatic positioner to recycle to tune the uhf tuning elements to the higher frequency setting:

*d. Operation of 0.1-MC Positions.* The right pin of the preset channel memory drum closes one of the 10 normally open contacts of switch S1210D to control the selection of the fourth digit of the preset channel frequency. Selection of this digit is similar to the selection of the third digit ( *c* above).

*Note.* Once the preset channel memory drum reaches the selected channel and the +26.4 volts is supplied to the 10.0-, the 1.0-, and the 0.1-mc automatic positioner relays K1201, K1202, and K1203, selection of the individual digits of the preset channel occurs simultaneously. Tuning motor B1201 drives the automatic positioner systems through slip clutches that permit the motor to run when any or all of the automatic positioners are at rest.

#### **84. Remote Channel Selection** (fig. 27)

- a. When CHAN SEL selector switch S705 is on the REMOTE PRESET position, con-

tacts 2 and 3 of S705C are closed by a cam, and contacts 1 and 2 of S705C are opened. Thus, control of the frequency selector system is transferred from the CHAN SEL selector switch on the front panel to the CHANNEL selector switch, S1503, located on Radio Set Control C-1439/U.

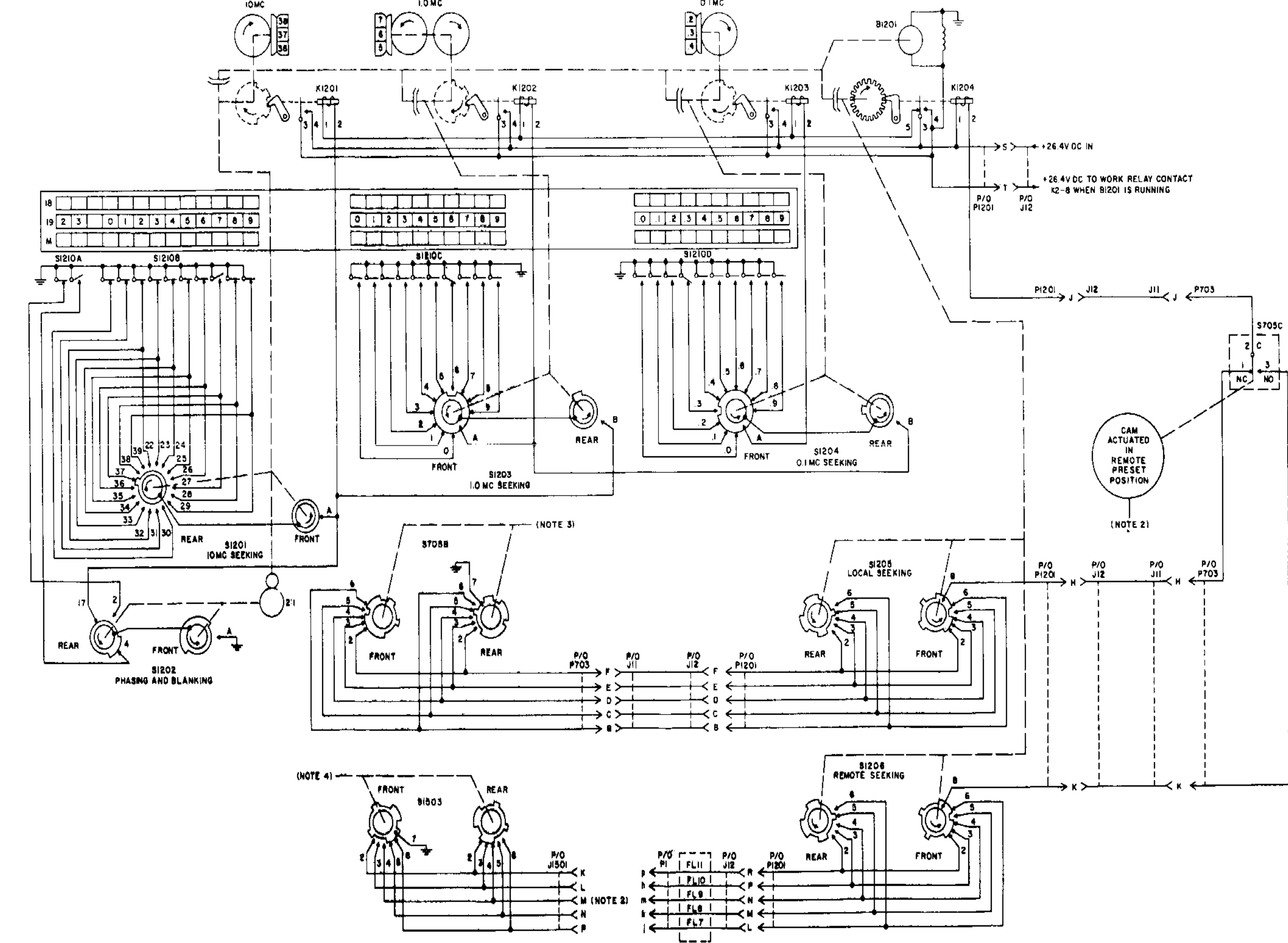
- b. The ground circuit to channel selector automatic positioner relay K1204 is completed through contacts 6 and 8 of remote-seeking switch S1206 and contacts 6 and 7 of CHANNEL selector switch S1503 front. This causes tuning motor B1201 to drive the preset channel memory drum and remote-seeking switch S1206 until there-remote-seeking switch reaches the channel position selected by the CHANNEL switch that opens the ground circuit to relay K1204. Channel frequency selection is accomplished from the remote position in the same manner as described for local channel selection (para 83).

#### **85. Manual Frequency Selection** (fig. 28)

When CHAN SEL switch S705 is turned to the MANUAL position, any one of the 1,750 channel frequencies can be selected by physically positioning the MANUAL FREQUENCY TENS, UNITS and TENTHS controls S706, S707, and S708.

- a. When S705 is turned to MANUAL, the preset channel memory drum rotates to position M. In this position, a nylon bar opens all contacts on switches S1210A and S1210B (fig. 27). Switch contacts on switches S1210C and S1210D are normally open (fig. 27). Switch S705A is operated by a cam to connect TENS switch S706 to 10.0-mc seeking switch S1201 in place of switches S1210A and S1210B. The wafers of the TENS, UNITS and TENTHS switches, S706, S707 and S708, are grounded through switch contacts S705A-20, -21, -24, and -26.

*Note.* Figure 28 shows only the wiring required to manually select frequencies of 220.0, 238.6, 320.0 and 338.6 mc. The controls and switches are shown in the 220.0-mc position. For this example, assume that the MANUAL FREQUENCY controls are changed from 220.0 mc to 238.6 mc.



- NOTES:
- ALL SWITCHES ARE VIEWED FROM OPPOSITE THE KNOB OR DRIVEN END EXCEPT S1201, S1205, AND S1206, WHICH ARE VIEWED FROM FRONT.
  - RADIO SET CONTROL C-1439/U IS CONNECTED TO RECEIVER-TRANSMITTER GROUP OA-2648/VRC-24 THROUGH ELECTRICAL SPECIAL PURPOSE CABLE ASSEMBLY CX-4630/U. RADIO SET CONTROL C-1439/U IS CONNECTED TO RECEIVER-TRANSMITTER GROUP OA-2649/TRC-68 THROUGH ELECTRICAL SPECIAL PURPOSE CABLE ASSEMBLY CX-4882/U.

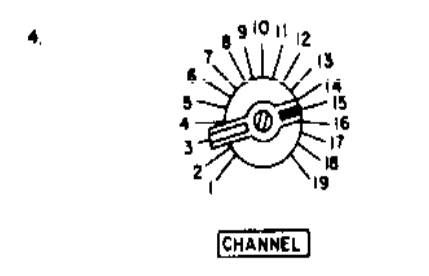
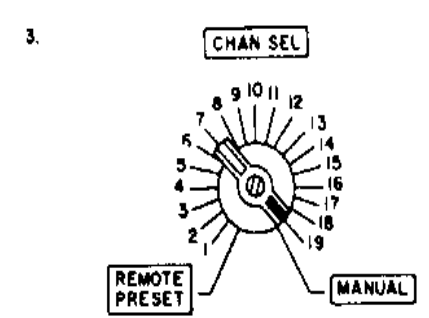


Figure 27. Channel selector circuits, schematic diagram.





b. When the MANUAL FREQUENCY TENS control is turned from 22 to 23, the following sequence occurs:

- (1) The ground circuit to the 10.0-mc automatic positioner relay K1201 is completed through contacts A and 22 of the 10.0-mc seeking switch contacts S1201, contacts 9 and 10 of CHAN SEL selector switch contacts S705A, contacts 22, 32, and F of TENS switch S706, and contacts 20 and 21 of CHAN SEL selector switch S705A. All other contacts of S1201, except contacts 23 and 33, are also grounded through similar circuits not shown on the simplified schematic.
- (2) Relay K1201 energizes and causes the 10.0-mc automatic positioner to operate as described in paragraph 83 b. Switch S1201, ganged to the 10.0-mc automatic positioner, rotates counterclockwise until the rotor contact reaches contact 23. Although contact 33 (180° from contact 23) is also ungrounded, relay K1201 is kept energized during that phase of the cycle by the ground circuit through phasing and blanking switch contacts 7 and 17 of S1202 and contacts C and F of the TENS switch. Similarly, if the TENS control S706 were set to 33, the 10.0-mc seeking-switch detent would not stop at position 23. During that phase of the 10.0-mc seeking-switch cycle, the ground circuit to relay K1201 would be completed through contacts 2 and 17 of S1202 and contacts G and F of S706 front.

c. When UNITS switch S707 is turned to 8, the sequence described in (1) and (2) below occurs :

- (1) The ground circuit to the 1.0-mc automatic positioner relay K1202 is completed through contacts A and 8 of S1203 and 8 and 12 of S707.
- (2) Switch S1203 is ganged to the 1.0-mc automatic positioner and rotates until the detent reached position 8 and opens the ground circuit.

As the rear wafer of S1203 rotates from 0 to 9, the front wafer detent supplies a momentary ground to relay K1201 through contact B of S1203, which causes the 10.0-mc automatic positioner to recycle.

- (3) TENTHS switch S708 controls the .1-mc automatic positioner in the same manner as the UNITS switch controls the 1.0-mc automatic positioner. Relay K1203 is kept energized by the ground circuit through contacts A and .6 of switch S1204 and contacts .6 and 12 of S708 until the .1-mc seeking switch detent reached the .6 position.

#### 86. Automatic Positioner Functions

a. The 18-position, 10.0-mc automatic positioner controls the rotation of the tuning shaft within the uhf injection system subunit. When the tuning shaft turns, it changes the positions of the crystal and coil switches, S201 and S202 (fig. 6), the variable capacitors and the tuning coils to tune the radio set to the selected frequency. The 10.0-mc automatic positioner tunes the uhf injection system from 200 to 370 mc in 10.0-mc steps.

b. The 10-position, 1.0-mc automatic positioner controls the rotation of one of the tuning shafts within the first if. amplifier subunit. This tuning shaft is coupled to second oscillator crystal switches S301 and S302 and tuning coil L310 (fig. 9). When it turns, the tuning shaft changes the positions of the crystal switches and the tuning coil to tune the output of the second oscillator from 17.0 to 26.0 mc in 1.0-mc steps.

c. The 10-position, 0.1-mc automatic positioner controls the rotation of the tuning shaft within the second if. subunit. This tuning shaft is coupled to third oscillator crystal selector switches S401 and S402 (fig. 10), and the tuning coils within bandpass filters Z401, Z402, and Z403 (fig. 10). When the shaft turns, the output of the third oscillator, V401B, and the bandpass filters Z401, Z402, and Z403 is changed from 3.0 to 3.9 mc in 0.1-mc steps.

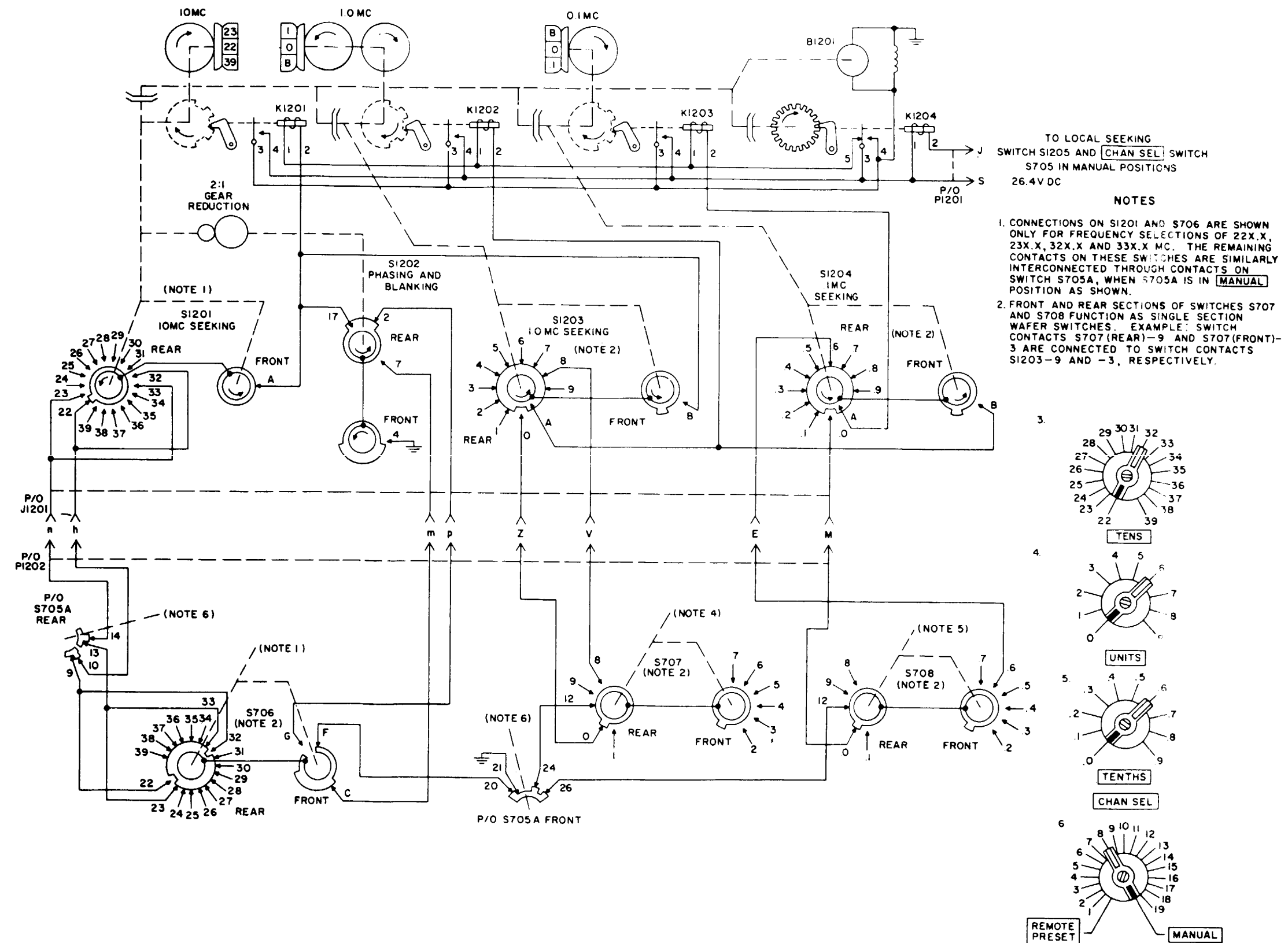


Figure 28. Manual frequency selector circuits, schematic diagram.



d. The outputs of the 10-position, 1.0-mc and 0.1-mc automatic positioners are combined through a gear train to control the rotation of a second tuning shaft within the first if. amplifier. This shaft is coupled to the tuning coils of if. coil assemblies 2301 through 2306 (fig. 8). Because the .1-mc automatic positioner turns 10 times for each revolution of the 1.0-mc automatic positioner, the turning shaft can be accurately turned to 100 positions in increments of 0.1-mc, which enables the tuning

coils to be tuned from 20.0 to 29.9 mc. 0.1-mc steps.

e. The outputs of all three automatic positioners are combined by a gear train to control the rotation of the tuning shaft within the rf and power amplifier subunit. Parallel-tuned tank circuits Z101, Z103, Z105, Z106, and Z107 and cavity resonator Z108 (fig. 5 and 19) are tuned from 399.9 to 225.0 mc, in 0.1-mc steps, by the rotation of the 1,800-position tuning shaft.

## Section VI. POWER SUPPLIES AND MINOR COMPONENTS

### 87. Power Supply PP-1494/U (fig. 29)

Power Supply PP-1494/U operates on 115/230 volts ac, 50/60 cps, and supplies operating voltages for Receiver-Transmitter RT-441/TRC-68.

a. Ac power is applied to power supply input terminals 13 and 14 of plug 1801. When the ac power source voltage is 115 volts switch S1803 is positioned as shown, and 115 volts ac is applied across the primary windings (1-2 and 3-4) of transformer T1803 in parallel. When S1803 switch is in the 230-volt position, the primary windings are in series and 115 volts ac is applied across each winding. Switches S1801 and S1802 perform the same function for T1801 and T1802. The primary of T1803 is connected to the ac power cord at all times.

b. Fuse F1801 is either 3- or 5-ampere, depending on whether the source voltage is 230 or 115 volts ac. Fuse F1804 protects the primary winding of transformer T1803. A full-wave rectifier circuit, which consists of diodes CR1813, CR1814, CR1815, and CR1816, rectifies the output of transformer T1803 and applies +26.7 volts across relay K1081. When relay K1801 is energized (para 81), contacts B1 and B2 and A1 and A2 close and the ac power source is applied to the primary windings of transformers T1801 and T1802. Contacts D1 and D2 of K1801 close and complete the ac circuit to the case

blower. Fuse F1802 protects the primary windings of transformer T1801; it is either a 1-1/2- or 3-ampere fuse, depending on whether the operating voltage is 230 or 115 volts ac. Fuse F1803 protects the primary windings of transformer T1802 and is either a 3/4- or a 1-1/2-ampere fuse.

c. A full-wave rectifier, which consists of diodes CR1801, CR1802, CR1803 and CR1804, is connected across secondary winding terminals 5 and 6 of transformer T1801. This circuit provides +300 volts dc for the transmitter tubes and is protected by fuse F1806. Filtering is provided by reactors L1801 and L1802 and capacitor C1801. Capacitor C1802 is an additional filter in the +300-volt line. Diode CR1817, connected across L1802, is a transient suppressor, and resistors R1801, R1802, R1804, and R1805 are bleeder resistors to ground.

d. A full-wave rectifier, which consists of diodes CR1805, CR1806, CR1807, and CR1808, is connected across secondary terminals 7 and 8 of transformer T1801. This circuit provides +26.4 volts dc for the RT-441/TRC-68 and is protected by fuse F1805. When this voltage is supplied, POWER indicator lamp I1801 lights.

e. Ac filament voltage is supplied to the RT-441/TRC-68 from secondary taps 8, 9, 10, and 11 of transformer T1802. Full wave rectifier, CR1809, CR1810, CR1811 and CR1812, is connected across transformer T1802 secondary terminals 5 and 6. This circuit provides 115 volts dc across

bleeder resistor R1806 and terminals 10 and 12 of P1801. Resistive networks within the RT-441/TRC-68 form a voltage divider circuit that provides +125 volts from terminal 10 of P1801 to ground and -30 volts from terminal 12 of P1801 to ground. This circuit is protected by fuse F1807. Filtering is provided by reactors L1803 and L1804 and capacitors C1804 and C1805. Capacitor C1803 and coil L1803, connected in parallel, present a high impedance to the 120-cps components of the full-wave rectifier output, for improved filtering action.

#### 88. Radio Set Control C-1439/U

(fig. 30)

Radio Set Control C-1439/U permits remote control and operation of Receiver-Transmitter Group OA-2648/VRC-24 or OA-2649/TRC-68. The push-to-talk circuits of associated communication equipment such as Radio Set AN/GRC-3 through -8 can also be controlled from this unit.

a. The C-1439/U contains controls that duplicate the function of similar controls on the front panel of the rt unit. The function of CHANNEL selector switch, S1503 is covered in paragraph 84. The functions of SQUELCH control R1501, SQUELCH DISABLE PUSH switch S1501, SQUELCH OFF switch S1502, and CALL LIGHT lamp I1501, are covered in paragraph 42. The function of POWER control S1505 is covered in paragraphs 80 and 81. The PHONE VOLUME and the SPEAKER VOLUME controls, which consist of resistors R1502 and R1506, and resistors R1503 and R1504, control the headset and speaker audio levels at terminals A and L, respectively, of AUDIO jacks J1502 and J1503. Both volume control circuits are similar to the front panel volume control circuits (para 45).

b. When the C-1439/U is used with Receiver-Transmitter Group OA-2648/VRC-24, a pilot lamp I1502 is connected as shown in figure 24. When the C-1439/U is used with Receiver-Transmitter Group OA-2649/TRC-68, the pilot lamp is connected through rt case wiring to POWER indicator lamp I1801 (fig. 29).

c. When control C-1439/U is used as

part of a communication system that consists of Receiver-Transmitter Group OA-2648/VRC-24 and Radio Set AN/GRC-5, radio interphone switch S1504 functions as follows:

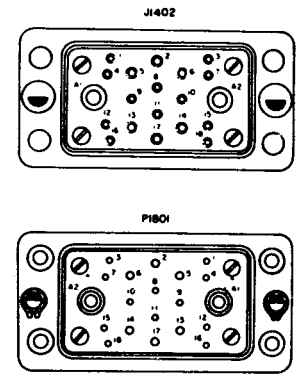
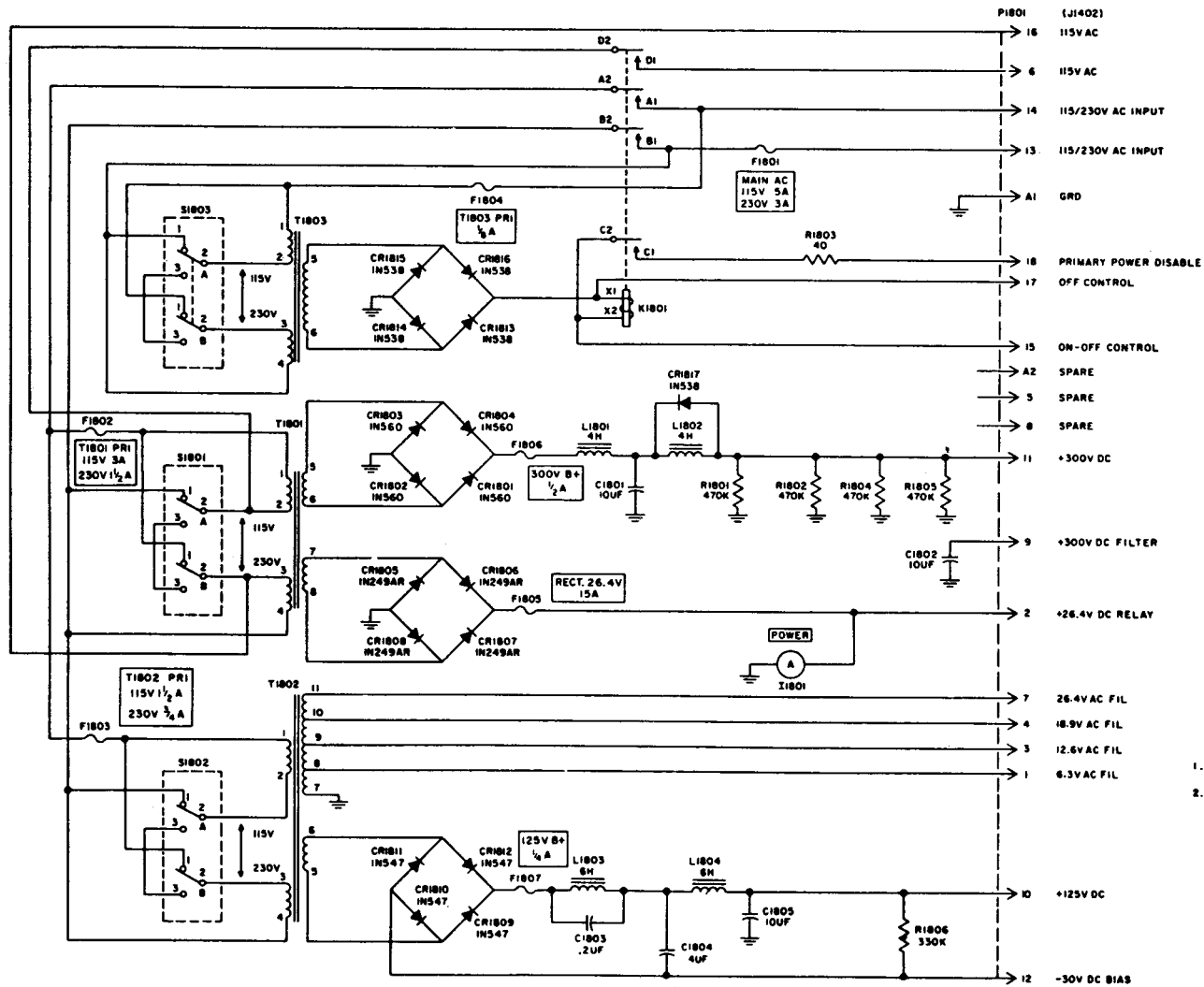
(1) On the RAD INT position, the radio interphone switch connects AN/VRC-24 and AN/GRC-5 headset (through contacts 4 and 1 of S1504B rear) and speaker (through contacts 8 and 5 of S1504B rear) audio to terminal A and L on AUDIO jacks J1502 and J1503. In this position, push-to-talk transmission is permitted on Radio Set AN/VRC-24 and the AF Amplifier AM-65/GRC (part of the AN/GRC3-8 series) interphone amplifier through contacts 9 and 12 of S1504B rear and contacts 4 and 1 of S1504A.

(2) On the INT position, switch S1504 applies RT-323/VRC-24 and AN/GRC-5 headset and speaker audio to AUDIO jacks J1502 and J1503 in the manner described in (1) above (except that contacts 3, 7, and 11 of S1504B rear make contact). In this position, the switch permits push-to-talk transmission on Radio Set AN/GRC-5 interphone only.

(3) In the RAD position, switch S1504 applies only RT-323/VRC-24 audio output to AUDIO jacks J1502 and J1503. The headset and speaker audio input terminals to the rt unit are terminals J and F of J1501. Microphone audio and push-to-talk control circuits are switched to output terminals a and U of J1501, and transmission on Radio Set AN/VRC-24 only is permitted.

d. When the C-1439/U is used with Receiver-Transmitter Group OA-2649/TRC-68, or when the retransmit cable used with Radio Set AN/VRC-24, Special Purpose Cable Assembly CX-4498/U, is not connected to the AN/GRC-5 equipment, radio interphone switch S1504 functions as follows:

(1) On the RAD INT position, radio interphone switch S1504 switches the headset and speaker output



NOTES:  
 1. UNLESS OTHERWISE INDICATED, ALL RESISTANCE VALUES ARE IN OHMS, CAPACITANCE VALUES ARE IN MICROMICROFARADS.  
 2. □ INDICATES EQUIPMENT MARKING.

Figure 29. Power Supply PP-1494/U, schematic diagram.

terminals A and L of AUDIO jacks J1502 and J1503 to input terminal T of J1501. Because this terminal is connected only to terminal L of AUXILIARY jack J1403 (fig. 34), no audio is available. However, this switch position permits push-to-talk transmission on Receiver-Transmitter RT-323/VRC-24 or RT-441/TRC-68.

- (2) On the INT position, radio inter-phone switch S1504 prevents transmission or reception at control C-1439/U. All audio circuits are connected through terminals R, S, and T on jack J1501 to AUXILIARY jack J1403, terminals B, K and L, (fig. 34) or terminals TB1701-16 and -17 and terminal TB1702-20 (fig. 46).
- (3) On the RAD position, radio inter-phone switch S1504 functions as described in c (3) above.

#### 89. Centrifugal Fan HD-390/U (fig. 31)

Centrifugal Fan HD-390/U (part of the AN/TRC-68) consists of three blowers that provide forced air cooling for the modulator and transmitter power amplifier stages and circulate cooling air through the rt unit chassis. The blowers are driven by a single-phase ac induction motor, B1051, which operates on 115 volts ac, 50/65 cps. Capacitor C1051 provides starting torque for the motor. Input power is supplied through terminals C and E of plug P1051. Plug terminals A and D are jumpered to provide a ground circuit to power supply relay K1801 (fig. 25). Thus, the rt unit will not remain on when POWER control switch S701 is released, unless plug P1051 is properly connected to jack J10 of the RT-441/TRC-68.

#### 90. Dynamotor DY-151/U (fig. 32)

a. Dynamotor DY-151/U provides dc plate, screen grid, and bias voltages for Receiver-Transmitter RT-323/VRC-24. The low-voltage commutator is driven from a 26.4-volt storage battery source.

The low-voltage commutator drives two high-voltage commutators which provide operating voltages to the rt unit. The output of the +300-volt commutator is applied to terminal F of plug P1001. The electrical noise from the 300-volt commutator is filtered by capacitor C1003 and filter FL1003.

b. The output of the 170-volt commutator is applied to terminals M and K of plug P1001. The load across terminals M and K functions as a voltage divider to ground. The voltage from terminal K to ground is +140 volts dc and the voltage from terminal M to ground is -30 volts dc. The electrical noise from the 170-volt commutator is filtered by capacitor C1002 and filters FL1001 and FL1002. The voltage on terminal K is filtered in the relay subunit (fig. 23). Under operating conditions, the output voltage at terminal K drops to +125 volts dc.

c. Dynamotor DY-151/U also includes transmitter modulator blower B1003, dynamotor and radio set blower B10002, and transmitter power amplifier blower B1001. These blowers supply forced air cooling to the rt unit. Terminals A, B, and D of plug P1001 are grounded and are in the holding ground circuit to power relay K3 (fig. 24). The rt unit will not remain on when POWER control switch S701 is released, unless dynamotor plug P1001 is properly connected to jack J10.

#### 91. Case Blowers

a. *Receiver-Transmitter Case CY-2557 VRC-24 and Blower B1401* (fig. 33). This case contains a blower that circulates cooling air through the ducts between the inner and outer walls of the case. The blower is driven by series-wound dc motor B1401, which operates from the storage battery source, 26.4 volts dc. Input power is supplied through terminals A and B of plug P1401, which mate with jack terminals A and B of jack J1702 on Mounting MT-1436/U. Filter FL1401 isolates electrical noise from blower motor B1401 from the main dc input supply.

b. *Receiver-Transmitter Case CY-2712/TRC-68 and Blower* (fig. 34). This case contains a blower that circulates





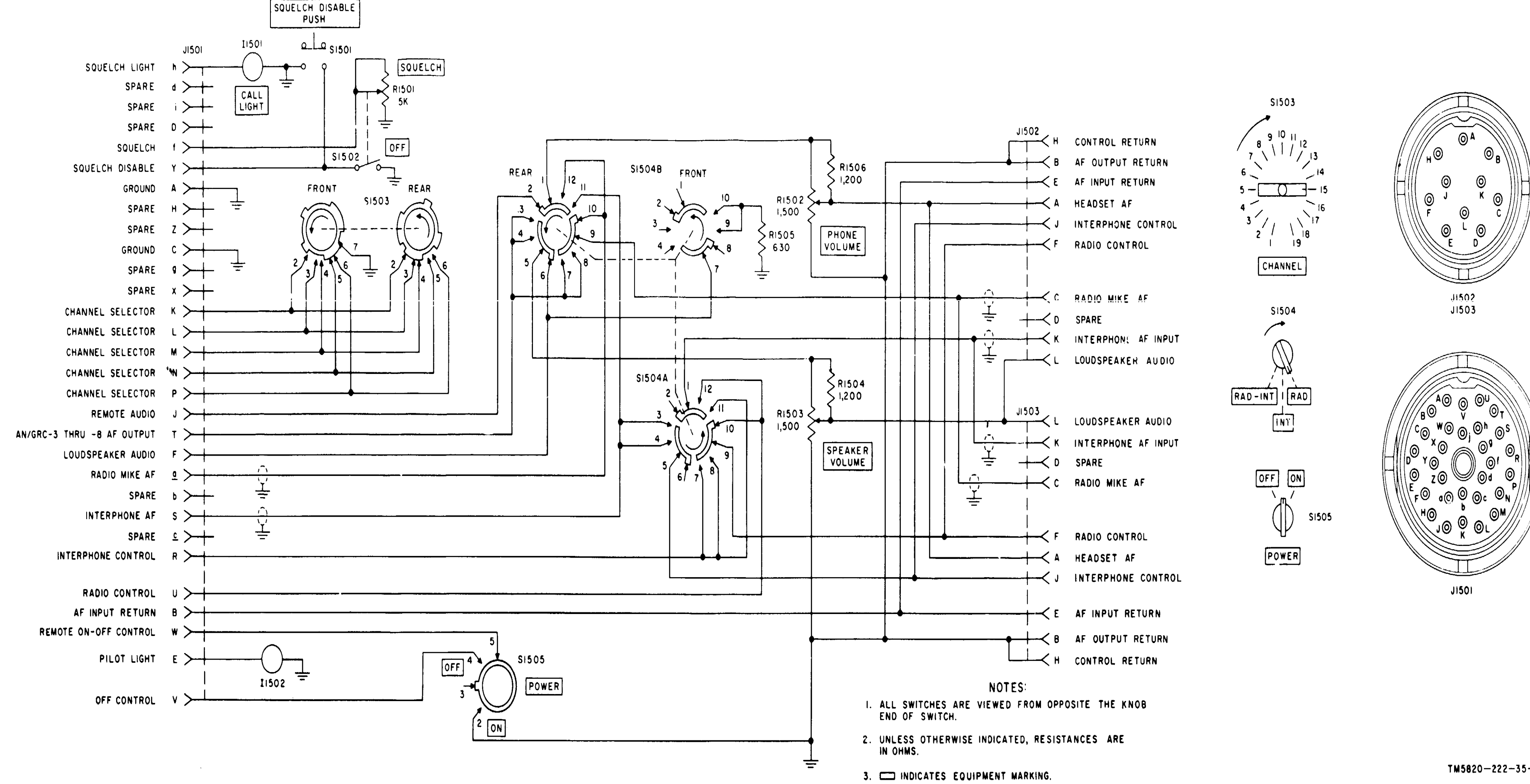


Figure 30. Radio Set Control C-1439/U, schematic diagram.





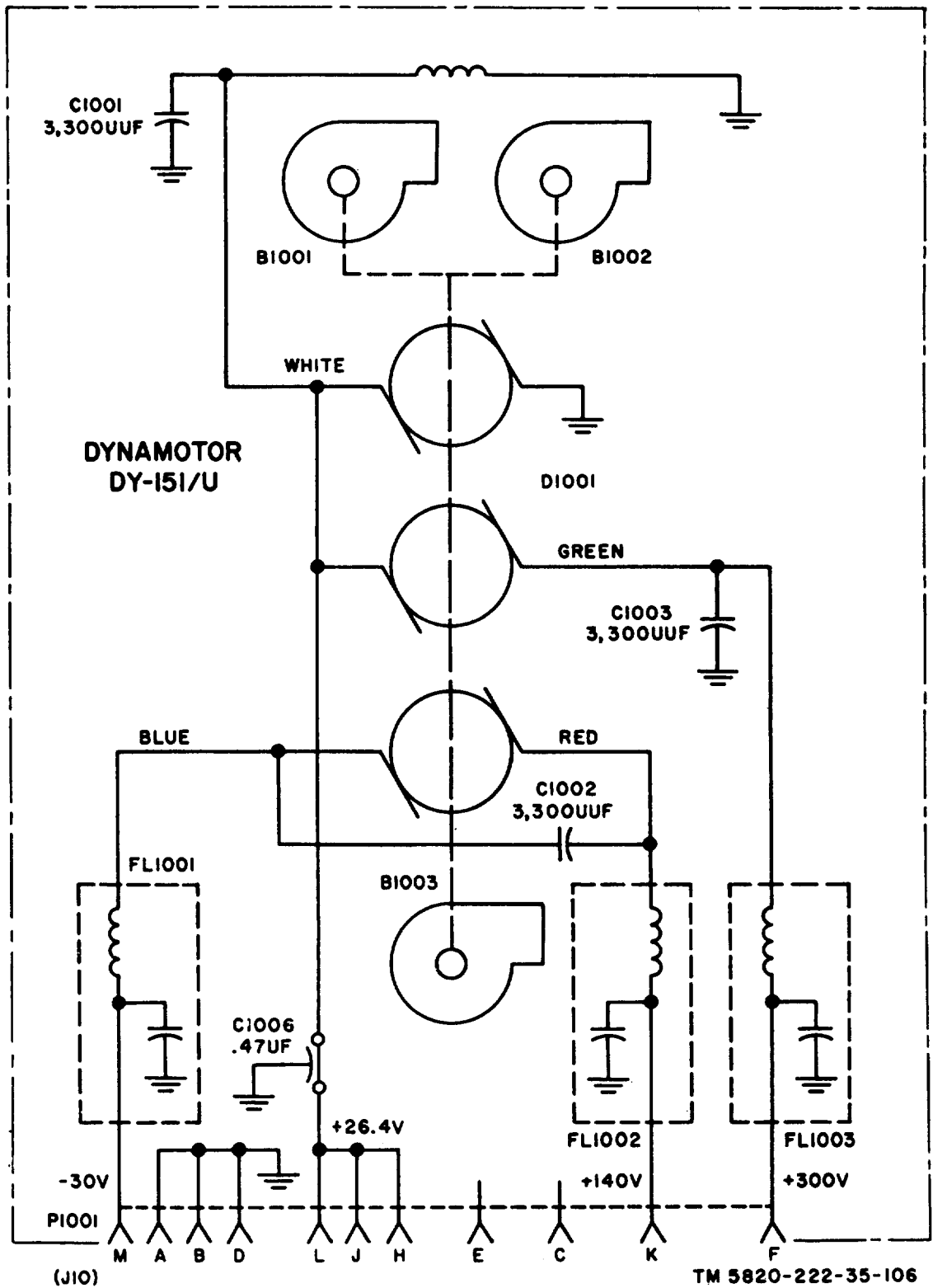


Figure 32. Dynamotor DY-151/U, schematic diagram.

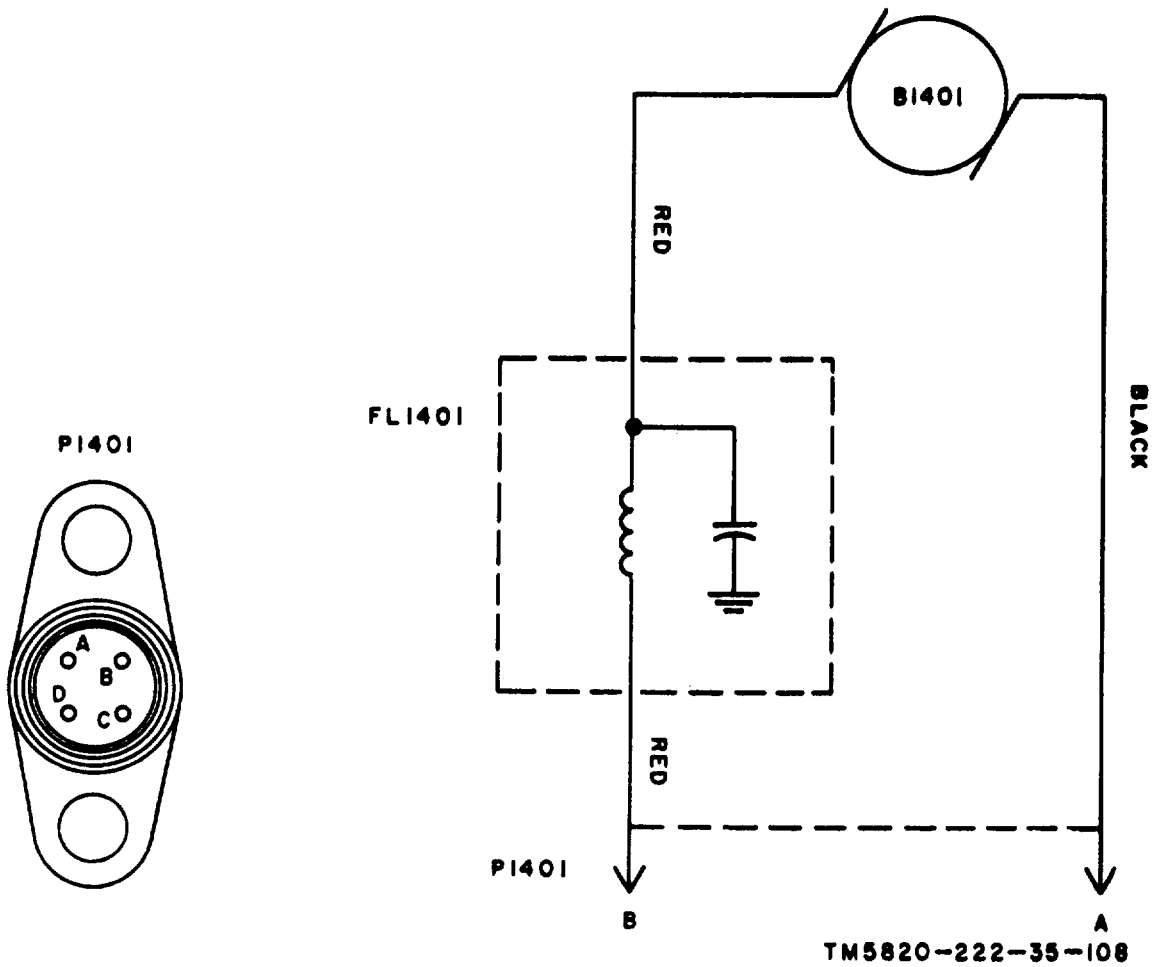


Figure 33. Receiver-Transmitter Case CY-2557/VRC-24, schematic diagram.

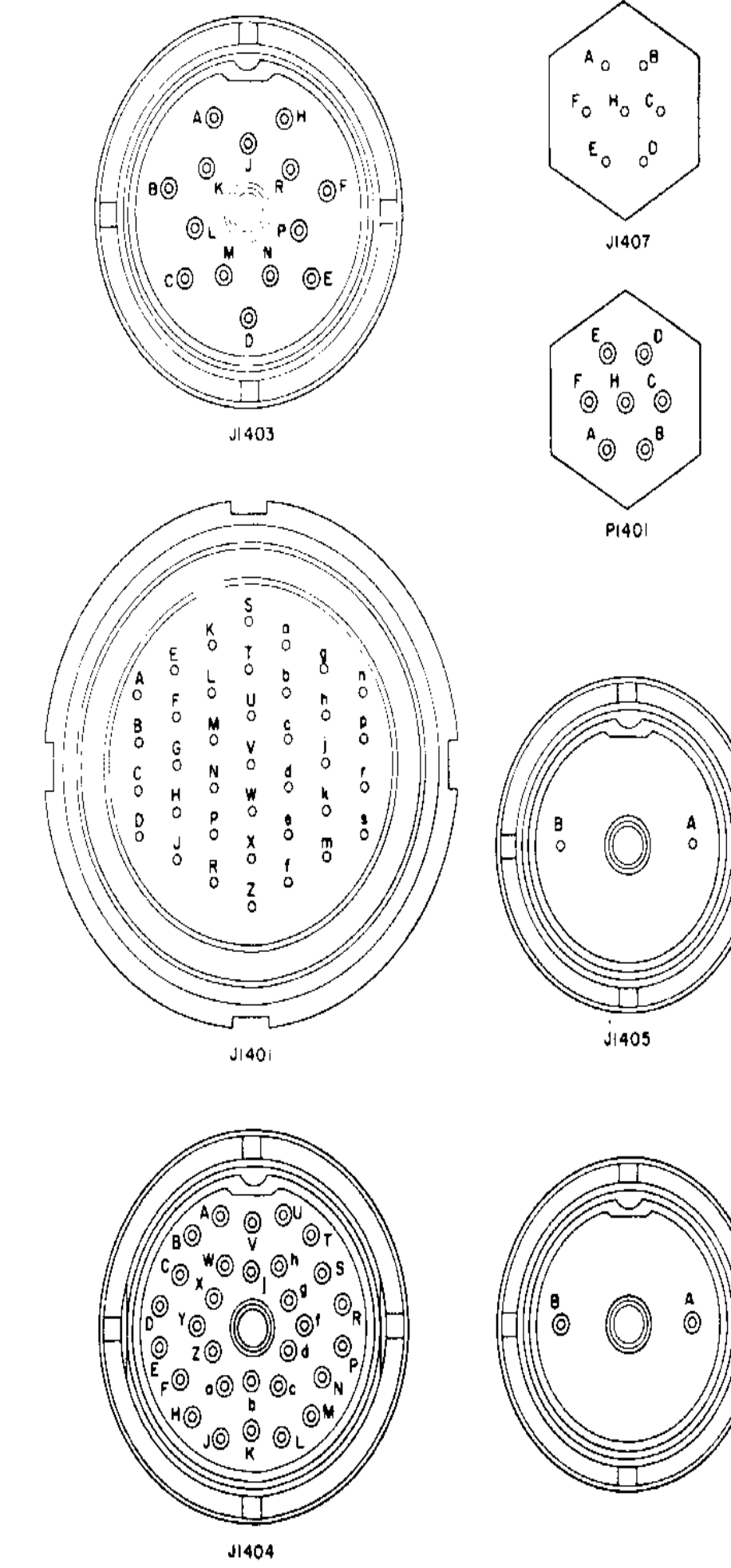
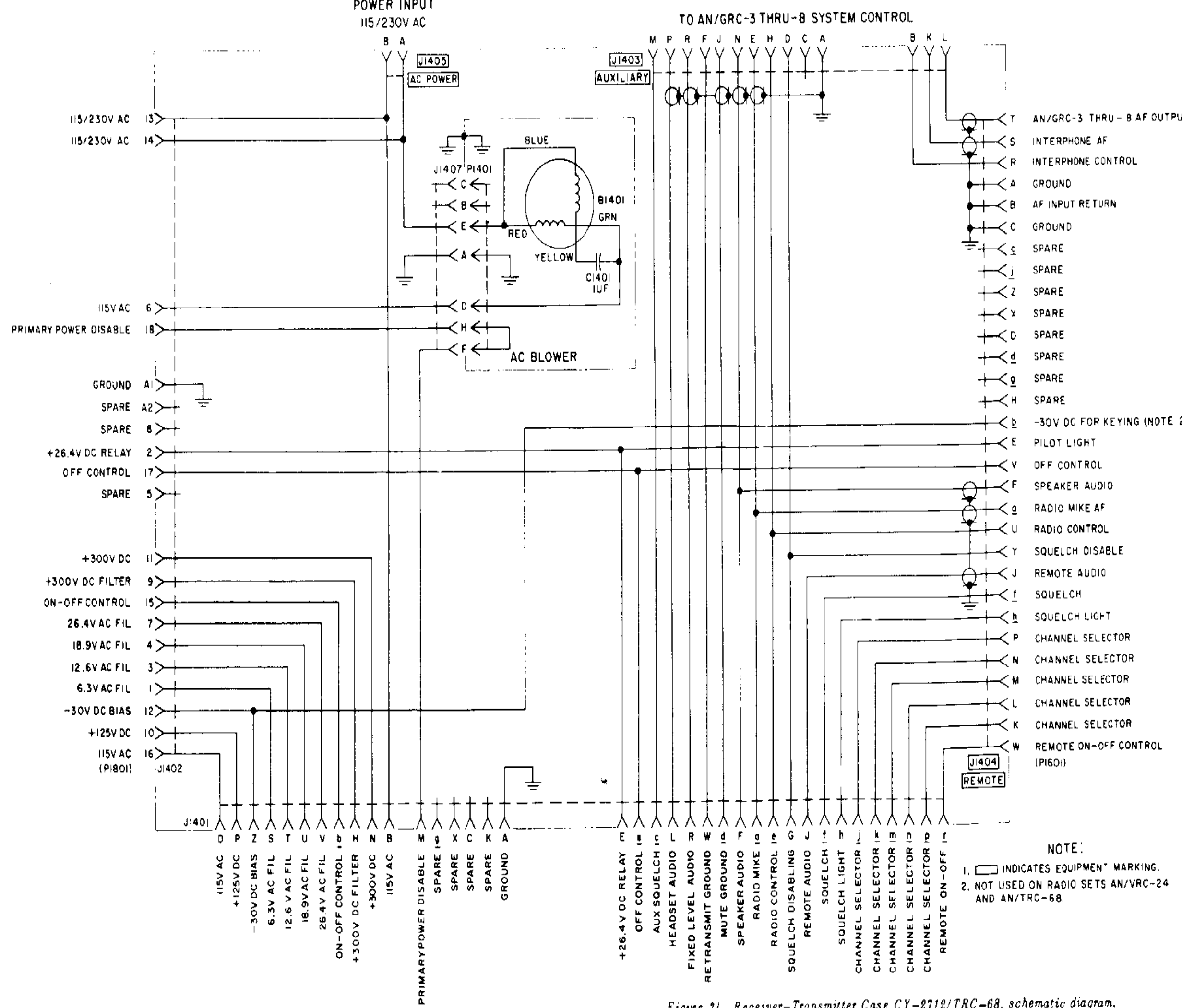


Figure 34. Receiver-Transmitter Case CY-2712/TRC-68, schematic diagram.



# CHAPTER 5

## TROUBLESHOOTING

*Note. Troubleshooting in this chapter is performed at 3rd echelon unless otherwise noted.*

---

### Section I. GENERAL TROUBLESHOOTING PROCEDURES

#### 92. General

The field and depot maintenance procedures in this manual supplement the procedures described in the organizational maintenance manual. The systematic troubleshooting procedure, which begins with the operational and sectionalization checks that can be performed at an organizational level, is carried to a higher level in this portion of the manual. Section II of this chapter provides information for troubleshooting when the radio set is used for retransmission purposes or with the broadband equipment. Section III provides information for troubleshooting the rt unit and the radio set control.

#### 93. Organization of Troubleshooting Procedures

*a. General.* The first step in servicing a defective radio set is to sectionalize the fault. Sectionalization means tracing the fault to a subunit, the main frame, or the radio set control. The second step is to localize the fault. Localization means tracing the fault to a stage or area within a subunit or the main frame. The third step is to isolate the trouble to the defective part or parts. Some faults, such as burned-out resistors, arcing, cold solder joints, unsoldered joints, broken wires, and shorted transformers can often be located by sight, smell, and hearing. The majority of faults must be isolated by checking voltages and resistances.

*b. Sectionalization.* Listed below is a group of tests arranged to aid in troubleshooting a defective radio set. Radio Set AN/VRC-24 consists of the rt unit, RT-323/VRC-24 case, Radio Set Control C-1439/U, Mounting MT-1436/U, and interconnecting cables. Radio Set AN/TRC-68 consists of the rt unit, Radio Set Control

C-1439/U, AN/TRC-68 case, power supply, and interconnecting cables. Spare subunits (when available) may be substituted for subunits which are suspected of having defects.

(1) *Visual inspection.* The purpose of visual inspection is to locate faults without testing or measuring circuits. All meter readings, or other visual signs, such as broken or burned-out electron tubes, plugs, relays, resistors, or capacitors should be observed and an attempt made to sectionalize the fault to a particular subunit or to the main frame.

(2) *Operational tests.* Operational tests frequently indicate the general location of trouble. In many instances, the tests will help in determining the exact nature of the fault. Use the equipment performance checklist (TM 11-5820-222-20). Additional operational tests are given in paragraphs 95 and 96.

*c. Localization.* The tests listed below will aid in localizing the trouble. Use the following methods for localizing trouble.

(1) *Troubleshooting charts.* The trouble symptoms listed in the charts (para 95, 96, 97, and 99) will aid in sectionalizing and localizing trouble to a subunit, the main frame, interconnecting cables, or Radio Set Control C-1439/U.

(2) *Sensitivity checks.* The sensitivity checks given in paragraph 103 enable the repairman to localize a trouble quickly to a stage. A signal generator, audio oscillator, and oscilloscope are used in signal substitution procedures



- (3) *Intermittent troubles.* If intermittent troubles are present, they may often be made to appear by tapping or jarring the equipment. Check the wiring and connections to the sub-units of the radio set.

*d. Voltage and Resistance Measurements.* Voltage and resistance measurement tests can be made by the use of adapter sockets for all vacuum tubes except V104, V105, and V106. Remove the screws (1) (fig. 68); remove the cover plates to gain access to V104, V105, and V106 (fig. 70). Figure 83 shows the sub-unit locations. Use the voltage and resistance diagrams (fig. 84 through 89) to find the normal readings for the rt unit, and compare them with the readings taken.

#### 94. Test Equipment Required

The following chart lists the test equipment required for troubleshooting Radio Sets AN/VRC-24 and AN/TRC-68. The

associated technical manuals are also listed.

Test equipment	Technical manual
Multimeter TS-352/U . . . . .	TM 11-5527
Electron Tube Test Set TV-7/U . . .	TM 11-6625-274-12
Electron Tube Test Set TV-2/U . . .	TM-2661
Audio Oscillator TS-382A/U . . . . .	TM 11-2684A
Signal Generator TS-497A/URR . . .	TM 11-5030
Frequency Meter AN/URM-79 . . . . .	TM 11-5094
Frequency Meter AN/URM-80 . . . . .	TM 11-5095
Frequency Meter AN/URM-81 . . . . .	TM 11-5096
Analyzer, Spectrum TS-723A/U . . .	TM 11-5097
Frequency Meter AN/URM-32 . . . . .	TM 11-5120
Oscilloscope AN/USM-50 . . . . .	TM 11-5129
Radio Frequency Wattmeter AN/URM-43A.	TM 11-5133
R.F. Signal Generator Set AN/URM-25D.	TM 11-5551-D
Electronic Voltmeter ME-30B/U . .	TM 11-6625-320-12
Frequency Meter AN/USM-26 . . . . .	TM 11-5057
Attenuator, Variable CN-318/U.	
Linear Detector, Hewlett Packard Model 420A or equivalent.	
Multimeter ME-26 B/U . . . . .	TM 11-6625-200-12

## Section II. SYSTEM APPLICATION TROUBLESHOOTING

### 95. Defective Retransmission Operation With Radio Sets AN/GRC-3 Through AN/GRC-8

*a. General.* When Radio Set AN/VRC-24 operates normally on transmit and receive for local and remote positions (and the AN/GRC-3 through AN/GRC-8 operates normally as a separate radio set), failure to retransmit may be caused by a faulty CX-4498/U, faulty rt unit, faulty MT-1436/U, Radio Set Control C-1439/U,

or remote cable. Use figure 35 as a guide in troubleshooting the retransmission circuits.

*b. Conditions for Tests.* With the equipment connected for normal operation as shown in TM 11-5820-222-10, perform all checks outlined in the following chart to sectionalize trouble to the faulty unit.

*c. Retransmission Troubleshooting Chart (fig. 35).*

Item	Indication	Probable trouble	Procedure
1	Signal received on the AN/VRC-24 (VRC-24 CALL LIGHT on and signal heard in headset or speaker), but RT-66/GRC, RT-67/GRC, or RT-68/GRC transmitter not keyed.	Faulty wire in, or connector on, CX-4498/U. Faulty wiring in the MT-1436/U, rt unit main frame, or audio amplifier modulator, or faulty R814.	Remove rear cover on MT-1436/U (fig. 46) and check continuity. Make resistance and continuity measurements to isolate trouble in faulty audio amplifier modulator subunit. Check resistance and continuity in main frame or Mounting MT-1436/U (fig. 35, 126).
2	AN/GRC-5 transmitter does not modulate on retransmit function. (No AN/VRC-24 fixed level audio output present.)	Defective wiring in MT-1436/U, main frame, or relay unit; defective R615 or FL26.	Remove rear cover on MT-1436/U (fig. 46) and check continuity. Make resistance and continuity measurements to isolate trouble in relay subunit (fig. 66 and 67 and para 113).

Item	Indication	Probable trouble	Procedure
3	No AM-65/GRC interphone control from C-1439/U.	Faulty C-1439/U wiring; remote cable; MT-1436/U wiring; CX-4498/U.	Make resistance and continuity checks to isolate trouble in main frame (fig. 127). Check C-1439/U for proper position of controls. Make resistance and continuity measurements to isolate trouble to faulty wiring in C-1439/U (fig. 30 and 35). Check continuity and resistance from remote cable connector through MT-1436/U and CX-4498/U to isolate faulty wiring.
4	No AM-65/GRC interphone audio at C-1439/U.	Refer to item 3 . . . . .	Refer to item 3.
5	No interphone input from AM-65/GRC amplifier when speaking into microphone at C-1439/U.	Refer to item 3. . . . .	Refer to item 3.
6	AN/VRC-24 does not key on retransmit.	Faulty wiring in MT-1436/U or CX-4498/U.	Check resistance and continuity (fig. 126).
7	AN/VRC-24 does not modulate on retransmit.	Refer to item 6 . . . . .	Refer to item 6.

**96. Defective Broadband Operation**

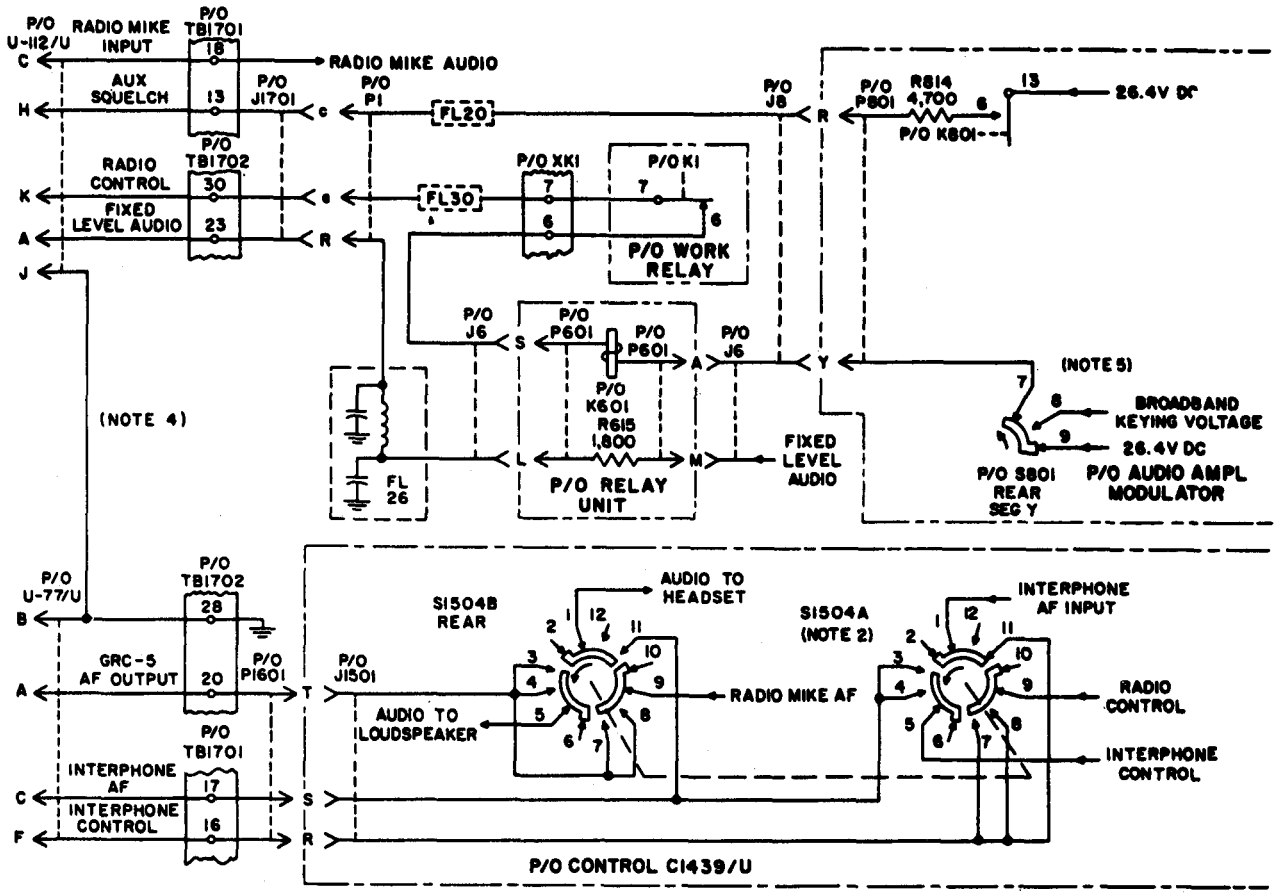
*a. General.* With the rt unit operating normally with the broadband switch at NOR, subunits in the rt unit that may be faulty, causing defective broadband operation, are the audio amplifier and modula-

tor, 500-kc if. amplifier, front panel, or relay subunit. Faulty main frame wiring can also be the trouble. Use figure 36 as a guide in troubleshooting the broadband circuits.

*b. Broadband Operation Troubleshooting Chart* (fig. 36).

Item	Indication	Probable trouble	Procedure
1	No audio output at BROAD BAND connector terminal E of J704 (encoded receive).	Faulty V802 or associated circuit components, or 500-kc if. subunit extended range output circuit components. Faulty main frame or front panel wiring.	Isolate trouble to audio amplifier modulator or 500-kc if. subunit by resistance and continuity measurements (or replace V802) to isolate trouble (fig. 88). Remove front panel (para 117) and make continuity and resistance measurements to isolate faulty wiring.
2	No speaker or headset output when decoded signal is coupled to BROAD BAND connector terminal A of J704 (decoded receive af input).	Faulty audio amplifier modulator wiring or associated component.  Refer to last paragraph of item 1.	Check V803 and circuit components by stage gain measurements (para 100). Make resistance and continuity measurements to isolate fault in defective subunit. Refer to last paragraph of item 1.
3	AN/VRC-24 will not key . . . .	No relay voltage at BROAD BAND connector terminal H of J704 (broadband keying voltage). Faulty wiring in audio amplifier modulator subunit. Faulty front panel or main frame wiring.	Check voltage from external source and correct abnormal condition.  Check subunit by continuity and resistance measurement (fig. 88). Remove front panel (para 117) and make continuity and resistance measurements to isolate faulty wiring (fig. 127).

Item	Indication	Probable trouble	Procedure
4	No microphone audio at coder (no audio output at BROAD BAND connector terminal F of J704, microphone af output).	Refer to last two probable troubles in item 3.	Refer to item 3.
5	No modulation of carrier when encoded signal is present at BROAD BAND connector terminal B or J704 (encoded transmitter af input).	Refer to last two probable troubles in item 3.	Refer to item 3.
6	Coder keying line not grounded (terminal C of J704 BROAD BAND connector, coder keying).	Faulty wiring or relay K602 in relay subunit. Refer to item 4 . . . . .	Check by relay subunit continuity measurements (fig. 36). Refer to item 3.



- NOTES:**
1. UNLESS OTHERWISE INDICATED, RESISTANCES ARE IN OHMS, CAPACITANCES ARE IN UUF, INDUCTANCES ARE IN UH.
  2. S1504
- 
3. INDICATES EQUIPMENT MARKING.
  4. ELECTRICAL SPECIAL PURPOSE CABLE ASSEMBLY CX-4498/U CONSISTS OF PLUGS U-112/U AND U-77/U PLUS WIRES SHOWN.
  5. 

NOR
 BB

TM5820-222-35-76

Figure 35. Retransmission circuits, schematic diagram.

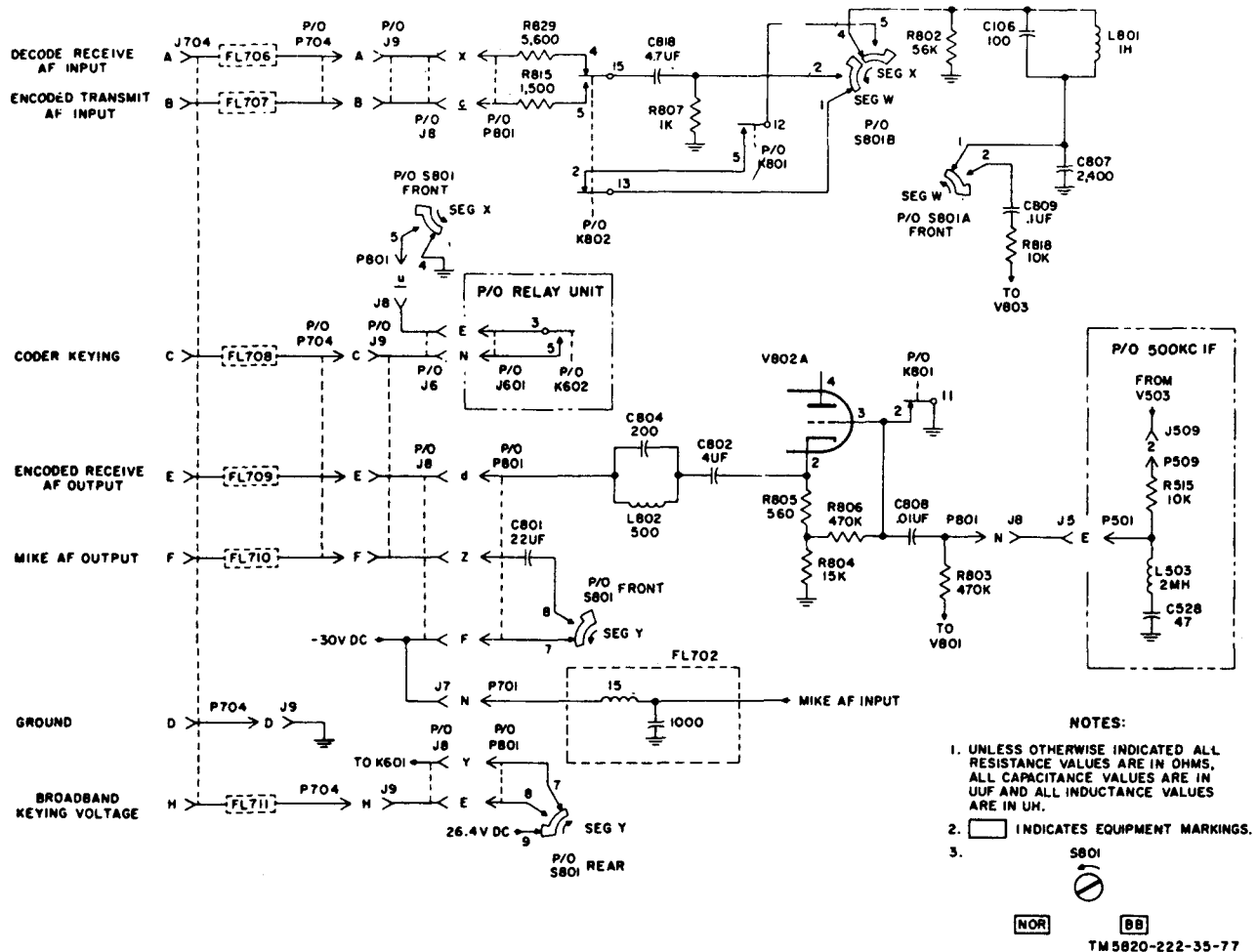


Figure 36. Broadband operation, schematic diagram.

### Section III. UNIT TROUBLESHOOTING

#### 97. Checking Filament B+, and Bias Circuits for Short Circuits

a. *When to Check.* When any of the following conditions apply, check for short circuits and clear the troubles before applying power.

- (1) When the rt unit is being serviced apart from other units of Radio Set / AN/VRC-24 or AN/TRC-68 and the defect is unknown.
- (2) When blown fuses are reported from the operational tests.

b. *Conditions for Tests.* Prepare for short-circuit tests as follows:

- (1) Remove the rt unit from its case

(TM 11-5820-222-20).

- (2) For the B+ or bias short-circuit tests, disconnect P1001 (AN/VRC-24) or P1051 (AN/TRC-68) (fig. 83).
  - (3) For filament short circuit tests:
    - (a) Disconnect plugs P1201, P101, P301, P201, P401, P501, P801, and P1001 for the AN/VRC-24, or P1051 for the AN/TRC-68 (fig. 83).
    - (b) Remove the dial lamps.
    - (c) Turn the SQUELCH control to OFF.
    - (d) Remove all tubes except V106.
- c. *Measurements.* Make the resistance

measurements indicated in the following charts in the *Point of measurement* column. If abnormal results are obtained, as

indicated in the *Normal indication* column, make the additional checks outlined under *Isolating procedure*.

Point of measurement	Normal Indication	Isolating procedure
Filament abort-circuit tests (fig. 37)		
Terminal E of P1 to ground . . .	Approximately 6,000 ohms . . . . .	Disconnect P2, front panel (para 117), wires from rear plug filters, or wires from tie points E1 through E5 as necessary to isolate trouble to faulty circuit (fig. 47).  <i>Note.</i> To reach rear plug filters FL22 through FL25 and FL15, remove rear cover on filters (fig. 48). The filter locations are silk-screened on the cover.  Make continuity checks to isolate trouble for each item listed in this chart.
Terminal S of P1 to ground . . . .	Infinite resistance . . . . .	
Terminal T of P1 to ground . . . .	Infinite resistance . . . . .	
Terminal U of P1 to ground . . . .	Infinite resistance . . . . .	
Terminal D of J1 to ground . . . .	Infinite resistance . . . . .	
Terminal J of J1 to ground . . . .	Infinite resistance . . . . .	
Terminal H of J8 to ground . . . .	Infinite resistance . . . . .	
Terminal K of J8 to ground . . . .	Infinite resistance . . . . .	
Terminal J of J8 to ground . . . .	Infinite resistance . . . . .	
P401 (3.0-3.9 mc if. subunit), pin F or C to ground.	Infinite resistance . . . . .	
P501 (500-kc if. subunit), pins C, D, and H to ground.	Infinite resistance . . . . .	
P301 (first if.), pins C, D, E, and J to ground.	Infinite resistance . . . . .	
P201 (uhf injection subunit), pins C, D, and F to ground.	Infinite resistance . . . . .	
P801 (audio amplifier and modulator subunit), pins C, D, H, J, and K to ground.	Infinite resistance . . . . .	
P101 (rf end power amplifier subunit), pin J to ground.	Infinite resistance . . . . .	
Pin B to ground . . . . .	Approximately 5 ohms . . . . .	

Point of measurement	Normal indications	Isolating procedure
300V B+ short-circuit test (fig. 23)		
Terminal H of P1 . . . . .	30K ohms . . . . .	If resistance is lower than 30K ohms, proceed with 300V B+ short-circuit tests. If resistance is now 30K ohms, remove 500-kc if. amplifier subunit (para 111) and check plate and screen grid circuit components (fig. 59, 60, and 61). If resistance is now 570K ohms, remove audio amplifier and modulator subunit (para 112) and check plate and screen grid circuit components (fig. 76, 77, and 78). If resistance is now 570K ohms, remove rf and power amplifier subunit (para 107) and check C133 (fig. 69), Z108 (fig. 74), the plate circuit of V106, plate circuit components of V105 (fig. 70). If resistance is now 1 megohm, check relay subunit capacitors C606 through C609 (fig. 67). If resistance is now infinite, check front panel resistors R705 and R707 (fig. 49). If resistance is not infinite, check FL13, FL35 (fig. 48), and associated main frame wiring (fig. 127).
Terminal H of P1 with P501 disconnected . .	30K ohms . . . . .	
Terminal H of P1 with P501 and P801 disconnected.	570K ohms . . . . .	
Terminal H of P1 with P501, P801, and P101 disconnected.	570K ohms . . . . .	
Terminal H of P1 with P501, P801, P101, and relay subunit removed.	1 megohm . . . . .	
Terminal H of P1 with P501, P801, P101, disconnected and relay subunit and front panel removed.	Infinite resistance . . . . .	

Point of measurement	Normal indications	Isolating procedure
----------------------	--------------------	---------------------

125V B+ short-circuit test (fig. 23)

Terminal P of P1 (fig. 48). . . . .	22K ohms . . . . .	If resistance is less than 22K ohms, proceed with 125V B+ short-circuit tests.
Terminal P of P1 with P101 disconnected (fig. 83, right side view).	22K ohms . . . . .	If resistance is now 22K ohms, remove rf and power amplifier subunit (para 107) and check plate circuit components of V101, V102, and V103 (68 through 75).
Terminal P of P1 with P101, and P201 disconnected (fig. 83, left side view).	22K ohms . . . . .	If resistance is now 22K ohms, remove uhf injection subunit (para 108) and check plate circuit components of V201 through V205 (fig. 53, 54, and 55).
Terminal P of P1 with P101, P201, and P501 disconnected (fig. 83, bottom view).	25K ohms . . . . .	If resistance is now 25K ohms, remove 500-kc if. amplifier (subunit (para 111)) and check plate and screen circuits of V501 through V504 (fig. 59, 60, and 61).
Terminal P of P1 with P101, P201, P501, and P304 disconnected (fig. 83, right side view).	25K ohms. . . . .	If resistance is now 25K ohms, the fault is in the plate or screen circuit of V303 in the first if. amplifier subunit (fig. 62, 63, and 64).
Terminal P of P1 with P101, P201, P501, P304, and P401 disconnected (fig. 83, right side view).	30K ohms . . . . .	If resistance is now 30K ohms, remove 3.0- to 3.9 if. subunit (para 110) and check plate circuit components of V401 (fig. 56, 57, and 58).
Terminal P of P1 with P101, P201, P501, P304, P401, and P801 disconnected (fig. 83, left side view).	50K ohms . . . . .	If resistance is now 50K ohms, remove audio amplifier and modulator subunit (para 112) and check plate and screen components of V803, V805, V806, V807, and V808 (fig. 76, 77, and 78).
Terminal P of P1 with P101, P201, P501, P304, P401, P801, and P301 disconnected (fig. 83, right side view).	500K ohms. . . . .	If resistance is now 500K ohms, remove first if. amplifier subunit (para 109) and check plate and screen circuit components of V301, V302, V304, and plate circuit components of V305. If removal of first if. amplifier subunit does not cause an increase to 500K ohms, remove relay subunit (para 113) and check associated circuit component. If resistance still does not increase to 500K ohms, remove front panel (para 117), check F702 fuseholder (fig. 49), and main frame wiring (fig. 127).

Bias short-circuit test (fig. 23)

Terminal Z of P1 . . . . .	239 ohms. . . . .	If resistance is lower than 239 ohms, proceed with bias short-circuit tests.
Terminal Z of P1 with P101 disconnected . .	239 ohms. . . . .	If resistance is now 239 ohms, remove rf and power amplifier subunit (para 107) and check R109, R108, C146, and L114 (fig. 68 through 75).
Terminal Z of P1 with P101, and P801 disconnected,	239 ohms . . . . .	If resistance is now 239 ohms, remove audio amplifier and modulator subunit (para 112) and check T801 and grid circuit wiring of V805 through V808 (fig. 76, 77, and 78).
Terminal Z of P1 with P101, and P801 disconnected and relay subunit removed (para 113).	22K ohms . . . . .	If resistance is now 22K ohms, check C610, C611, C612, and associated bias circuit components in relay subunit (fig. 67).
Terminal Z of P1 with P101, P801, and P501 disconnected and relay subunit removed.	22K ohms . . . . .	If resistance is now 22K ohms, remove 500-kc amplifier and check R531 and associated circuit component (fig. 59, 60, and 61).

Point of measurement	Normal indications	Isolating procedure
Bias short-circuit test (fig. 23)-Continued		
Terminal Z of P1 with P101, P801, and P501 disconnected and relay subunit and front panel removed (para 113, 117).	Infinite resistance	If the resistance is now infinite, check R711, R712, R715, and R717, and front panel circuit components. If resistance is not infinite, check FL27 (fig. 48) and main frame wiring (fig. 127).



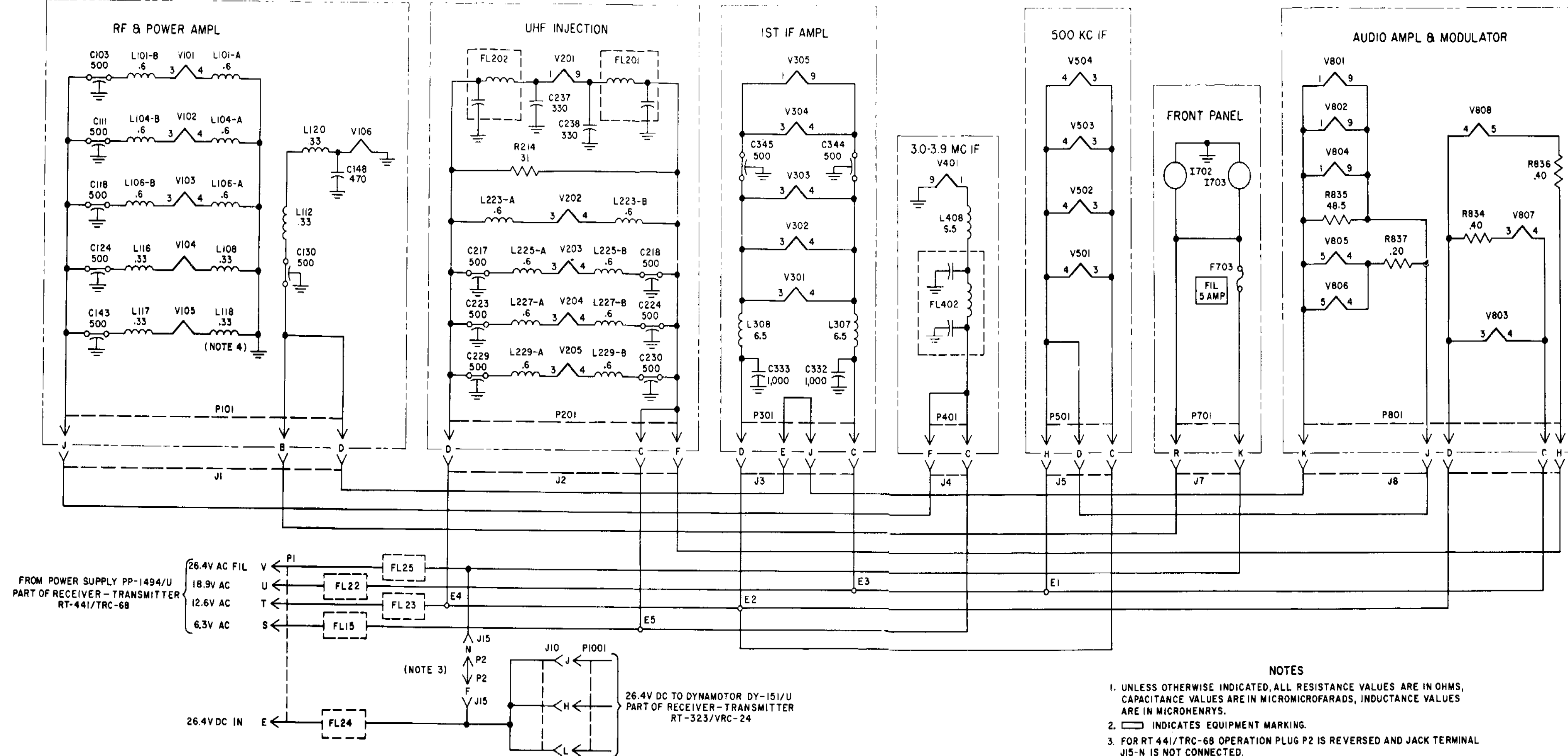


Figure 37. Receiver-Transmitter RT-323/VRC-24 and RT-441/TRC-68 filament circuits, schematic diagram.



**98. Test Setup**  
(fig. 38)

Bench tests of Radio Sets AN/VRC-24 and AN/TRC-68 require connections to an external power source and to various test equipments.

*a. Power Source Required.* The external power source must be connected to the rt unit for all dynamic-servicing procedures. Measure and adjust the input voltage to obtain a value as close as possible to the input voltage specified for normal operation of the radio set.

- (1) Radio Set AN/VRC-24 requires a 26.4-volt dc source capable of providing 300 watts.
- (2) Radio Set AN/TRC-68 requires a 115- or 230-volt, 50/60-cps, 1-phase ac source capable of providing 300 watts.

*b. Test Equipment Connections.* Test equipment connections vary for each of the troubleshooting tests and are described in the paragraph covering each test. Receiver-Transmitters RT-323/VRC-24 and RT-441/TRC-68 can be removed from their respective cases for testing under operating conditions (TM 11-5820-222-20). After removing the rt unit, connect Electrical Special Purpose Cable Assembly CX-4884/U between rear plug P1 and the mating connector (jack J1701 on Mounting MT-1436/U or Jack J1401 on Receiver-Transmitter Case CY-2712/TRC-68). Connect an audio test box, described in paragraph 128c, to either of the front panel AUDIO jacks to aid in making audio output measurements.

**Caution:** Before performing any test procedures requiring transmitter operation, be sure Signal Generator TS-497/URR is disconnected from the ANT jack

and Radio Frequency Wattmeter AN/URM-43A or the antenna is connected to the ANT jack.

**99. Troubleshooting Radio Sets AN/VRC-24 and AN/TRC-68**

*a. General.* The troubleshooting chart below is divided as follows:

- (1) Subparagraph *c* is for the power supply and power circuits, OA-2649/TRC-68.
- (2) Subparagraph *d* is for the power supply and power circuits, OA-2648/VRC-24.
- (3) Subparagraph *e* is for the rt unit of both radio sets.
- (4) Subparagraph *f* is for Radio Set Control C-1439/U.

*b. Use of Troubleshooting Chart.* This chart is designed to supplement the tests detailed in the equipment performance checklist (TM 11-5820-222-20). If previous tests have resulted in a symptom that indicates the use of a particular subparagraph (a above), go directly to that subparagraph. When using the AN/TRC-68 with Radio Set Control C-1439/U, and location of trouble is unknown, disconnect the CX-4882/U from the remote receptacle at the rear of the AN/TRC-68 case. If the radio set now operates normally, go directly to subparagraph *f* of the troubleshooting chart.

**Caution:** If operational symptoms are not known, or they indicate the possibility of short circuits within the radio set, make the short-circuit tests (para 97) before applying power to the radio set.

*c. Troubleshooting Chart for OA-2649/TRC-68, Power Supply and Power Circuits* (fig. 39-43).

Item	Indication	Probable trouble	Procedure
1	AN/TRC-68 will not turn on.	Faulty circuit wiring in power supply, AN/TRC-68 case CY-2712/TRC-68, main frame, or front panel. Faulty K1801, CR1813, CR1814, CR1815, CR1816, T1803, S1803, or S701.	Remove Power Supply PP-1494/U and rt unit (TM 11-5820-222-20). Check circuit resistance and continuity to isolate trouble (fig. 25 and 29). If necessary, remove front panel (para 117).

Item	Indication	Probable trouble	Procedure
2	AN/TRC-68 turns on but does not stay on when POWER switch is released. <b>Caution:</b> Do not hold switch at ON to operate the AN/TRC-68.	Faulty holding circuit wiring, R1803, or holding contacts on K1801.	Check holding circuit continuity from J1401 (case) through to J10 (rt unit main frame). Isolate trouble to case or frame (fig. 25). Check circuit resistance and continuity in the power supply and isolate trouble to wiring or R1803 (fig. 25). Check condition of holding contacts on K1801 (fig. 25) for excess pitting, corrosion, or heat damage. Clean contacts or replace relay.
3	AN/TRC-68 will not turn off.	Faulty power switch, main frame, case, power supply wiring, or relay K1801.	Unplug from power source to turn AN/TRC-68 off. Then isolate trouble by resistance and continuity measurements (fig. 25).
4	CALL LIGHT out, no noise in headset.	Defective power supply wiring or component.	Make voltage, resistance, and continuity measurements to isolate trouble in defective power supply (fig. 29). Check 300-volt B+ circuit continuity and resistance from case through front panel and main frame to isolate trouble. Remove front panel (para 117) to isolate trouble (fig. 23).
5	POWER (I1801) and CALL LIGHT lamps out.	Faulty power supply .....	Check voltage, resistance, and continuity measurements in power supply to isolate trouble (fig. 29).
6	POWER light out .....	Faulty power supply .....	Check voltage, resistance, and continuity measurements in power supply to isolate trouble (fig. 29).
7	No noise in headset .....	Faulty T1802 secondary CR1809, CR1810, CR1811, CR1812, filter components, or power supply wiring.	Check voltage, resistance, and continuity measurement to isolate trouble (fig. 29).

d. Troubleshooting Chart for OA-2648/VRC-24, Power Supply and Power Circuits (fig. 24).

Item	Indication	Probable trouble	Procedure
1	AN/VRC-24 will not turn on.	Wrong supply voltage polarity, or no supply voltage. No voltage at power relay K3 ..  Faulty wiring in Mounting MT-1436/U. Relay K3 not being energized, caused by defective power switch, defective front panel, or main frame wiring, connector(s) or defective power relay K3.	Check magnitude and polarity of supply voltage (22-30 volts dc). Check for 22-30 volts dc at contacts 1 and 2 of K3. If no voltage is present, disconnect the rt unit from the extension cable and check for continuity from P1 to relay K3. Isolate trouble to front panel or main frame wiring or to CR1 by removing front panel (para 117) and checking circuit continuity. Check circuit continuity in Mounting MT-1436/U (fig. 126). Note whether K3 energizes when power switch is turned on. If K3 does not energize, disconnect the rt unit from the extension cable and check continuity of ON-OFF circuit components. Isolate trouble to front panel wiring or connector, POWER switch S701, main frame, or power relay K3.

Item	Indication	Probable trouble	Procedure
2	<p>AN/VRC-24 turns on but does not stay on when POWER switch S701 is released.</p> <p><b>Caution:</b> Do not hold switch at ON in an attempt to operate AN/VRC-24.</p>	<p>Low line voltage . . . . .</p> <p>Excessive current drain during start.</p> <p>Holding circuit malfunction due to defective dynamotor plug P1001.</p> <p>Defective holding contacts on K3.</p> <p>Defective main frame wiring or resistor R2.</p> <p>Defective relay coil K3 . . . . .</p>	<p>Check line voltage (22-30 volts dc). Connect the TS-352/U from contact 2 of K3 to ground. Turn POWER switch to ON and hold for approximately 5 seconds. The voltmeter should read at least 18 volts at the end of 5 seconds. If not, check adequacy of power source.</p> <p><i>Note.</i> The AN/VRC-24 requires a source capable of maintaining 18 volts during an initial surge of approximately 50 amperes. The current demand decreases to less than 10 amperes at the end of approximately 3 to 4 seconds. If power source is adequate and the voltage measured at contact 2 of K3 is less than 18 volts after 5 seconds, replace Dynamotor DY-151/U (para 114).</p> <p>Make resistance measurements (fig. 32).</p> <p>Remove P1001 from J10 (fig. 47) and check for continuity between pins A, B, and D of P1001 and ground. Check for ground on J10A and J10B (fig. 32).</p> <p>Connect the TS-352/U from contact 3 of K3 (fig. 47) to ground. Turn POWER switch to ON and note whether voltage is the same as line voltage. If not, examine contacts 2 and 3 for proper pressure, pitting, corrosion, or dirt.</p> <p>Clean contacts after disconnecting the AN/VRC-24 from power source, or replace relay.</p> <p>Isolate holding circuit fault by making resistance measurements.</p> <p>Measure resistance of relay coil K3 (para 105). Replace if out of tolerance.</p>

e. Troubleshooting Chart for Rt Unit.

(1) RT unit (fig. 128).

Item	Indication	Probable trouble	Procedure
1	<p>Frequency selector motor runs continuously and PRESET and FREQ indicator dials rotate continuously when CHANNEL and/or MANUAL FREQUENCY switches are turned to one or more positions.</p>	<p>Faulty wiring or switch in front panel, frequency selector, or faulty main frame wiring.</p>	<p><b>Caution:</b> Turn radio set off to avoid damage to relays, motor, or gears. Make resistance and continuity measurements to isolate trouble, removing front panel (para 117) if necessary to completely check out frequency selection circuit components (fig. 27, 28).</p>
2	<p>One or more frequency indicator dials do not rotate as motor runs continuously.</p>	<p>Mechanical interference present in one or more of following subunits: uhf injection system, rf and power amplifier, first if. or 3.0-3.9 mc if.</p>	<p>Turn radio set off. Decouple one subunit at a time checking shaft(s) for excess friction. Turn radio set on each time a subunit is removed to see if condition still exists. All shafts should turn freely.</p>

Item	Indication	Probable trouble	Procedure
3	Indications in <b>FREQ</b> windows do not agree with manual selections, or preset channel frequency.	Mechanical interference in frequency selector.  Refer to item 1 . . . . . Improper adjustment of frequency selector.	<i>Note.</i> If frequency selector <b>TENTHS</b> switch is not set at .9, it may be necessary to remove front panel and frequency selector subunits in order to remove second lf. subunit. Do not try to force this subunit out of main frame.  Refer to paragraph 126 for disassembly and repair of frequency selector (4th echelon). Refer to item 1. Refer to paragraph 126 for adjustment of frequency selector.

(2) Receiver (fig. 128).

Item	Indication	Probable trouble	Procedure
1	Dial lamps out, no noise heard in headsets, <b>CALL LIGHT</b> on or off.	Defective wiring in front panel..	Isolate fault by making continuity measurements (fig. 13).
2	Dial light(s) out, <b>CALL LIGHT</b> on with squelch control set to <b>OFF</b> , noise heard in headset.	Defective wiring in front panel..	Isolate trouble in front panel by inspection and/or continuity measurements (fig. 13). Replace defective lampholder(s). Press <b>SQUELCH DISABLE</b> <b>PUSH</b> switch on front panel. If <b>CALL LIGHT</b> lights, there is a defective ground return from switch <b>S703</b> and lamp <b>I701</b> assembly (fig. 49). Isolate trouble by continuity measurements. (fig. 13).
3	<b>CALL LIGHT</b> out, noise heard in speaker, and squelch control set to <b>OFF</b> .	Defective <b>SQUELCH DISABLE</b> <b>PUSH</b> switch and lamp assembly or ground return.  Defective <b>CALL LIGHT</b> circuit wiring or relay <b>K801</b> .	Isolate trouble to audio amplifier and modulator, front panel, or main frame subunits by checking circuit continuity (fig. 13).
4	<b>CALL LIGHT</b> out and no noise in speaker with <b>SQUELCH</b> control set at <b>OFF</b> .	Defective front panel wiring or squelch circuit components.  Defective audio amplifier and modulator subunit wiring or squelch relay <b>K801</b> .	Switch <b>CHAN SEL</b> switch to <b>REMOTE PRESET</b> . Turn remote <b>SQUELCH</b> to <b>OFF</b> if <b>CALL LIGHT</b> lights and noise is heard in speaker, check associated front panel circuit components (fig. 13). If <b>CALL LIGHT</b> does not light and noise is not heard with the above conditions, return the <b>CHAN SEL</b> switch to any channel or <b>MANUAL</b> position. Check by substituting audio amplifier and modulator subunit (para 112). Isolate trouble in faulty subunit by continuity and resistance checks (fig. 13, 14, 88).
5	No noise in speaker, but all lights are on.	Defective main frame wiring, relay <b>K1</b> , or resistor <b>R3</b> .  Defective front panel wiring, or <b>R713</b> , <b>S702</b> , or <b>S705E</b> . Faulty control <b>C-1439/U</b> . . . . .  Defective audio amplifier modulator subunit.	Remove plug <b>P703</b> from jack <b>J11</b> (fig. 47) and check continuity of squelch relay circuit components (fig. 13). Check front panel squelch circuit continuity (fig. 13). Check by disconnecting control <b>C-1439/U</b> . Localize trouble by stage gain measurements (para 100).

Item	Indication	Probable trouble	Procedure
6	All lights are on, noise is heard in speaker, but the level of noise cannot be controlled by front panel VOLUME control.	<p>Defective 500-kc, 3.0-3.9, first if, or 500-kc filter subunits.</p> <p>Defective main frame or front panel wiring, R4, R5, connector(s) J8, J7, J9, P1; or defective front panel volume control (R710, R714); connector(s) J702, J703, P701, P704.</p> <p>Faulty volume control.....</p>	<p>Check the subunits by signal substitution (para 101) in the following sequence: 500-mc if.; 3.0-3.9 mc if.; first if.; 500-kc filter.</p> <p>Use sensitivity checks to localize trouble to a stage (para 103) (except in 500-kc filter).</p> <p>Check audio output circuit continuity from J8 to the front panel audio connectors (fig. 15).</p> <p>Turn POWER switch to OFF.</p> <p>Remove P801 from J8 (fig. 47) and check resistance to ground of pins (headset and speaker) on J702 and J703 (front panel AUDIO jacks) (fig. 15).</p>
7	No indication with panel METER switch on S-METER (no rf signal is applied to receiver ANT). Satisfactory operation of meter is verified by NORMAL readings on HIGH B+, LOW B+, and LINE V positions.	<p>Defective 500-kc if., first if., or 3.0-3.9 mc if., subunits K601, relay and filter unit wiring, main frame wiring, front panel wiring, R704, R716, S704, or 500-kc filter.</p> <p><i>Caution:</i> When checking continuity of front panel meter circuit, make sure that ohmmeter is not applied to front panel meter, as damage might result.</p>	<p>Check for defective if. subunits by signal substitution (para 101) in the following sequence; 500-kc if.; first if., 3.0-3.9 mc if.</p> <p>Localize trouble to a stage by sensitivity checks (para 103).</p> <p>Check relay subunit to isolate trouble by continuity and resistance measurements (fig. 23).</p> <p>Check 500-kc filter by substitution (para 116).</p> <p>Check main frame and front panel circuit continuity and resistances for faulty wiring or components (fig. 23).</p>
8	Meter reads below zero with METER switch at S-METER.	<p>Improper adjustment of R716 or malfunction on first if. subunit.</p> <p>Faulty S-METER circuit wiring on front panel.</p>	<p>Check adjustment of the S-METER (para 140). Check first if. subunit by signal substitution (para 101). Isolate trouble in faulty first if. subunit by voltage and resistance measurements (fig. 83, 89).</p> <p>Remove front panel (para 117) and check continuity and resistance of metering circuits (fig. 22).</p>
9	Low sensitivity (poor signal reception; low signal-plus-noise to noise ratio with a given rf signal).	<p>Poor alignment, defective stage or stages in one or more of the following: rf and power amplifier subunit, uhf injection system subunit, first if., 3.0-3.9 mc if., 500-kc if. or defective 500-kc filter.</p>	<p>Localize difficulty by sensitivity checks (para 103).</p> <p>Check oscillator bias on subunits containing oscillators (uhf injection system, first if. and 3.0-3.9 mc if. subunits), when gain at first, second, or third receive mixers is low (para 101).</p> <p>Localize and isolate trouble to stage and circuit component.</p>
10	Low audio output.....	<p>Low B+ or supply voltage.....</p> <p>High voltage below normal in audio amplifier modulator subunit.</p>	<p>Check HIGH B+, LOW B+, and LINE V positions on front panel meter with METER switch. If one or more of the above read below NORMAL, check supply voltage.</p> <p>Replace dynamotor for AN/VRC-24 (power supply for AN/TRC-68).</p> <p>Check resistance of 125 volts B+ circuit (fig. 23).</p> <p>Measure voltage at J803 (fig. 88) (approximately 260 volts dc). If below normal, replace audio amplifier and modulator subunit (para 112).</p>

Item	Indication	Probable trouble	Procedure
11	Distorted audio output.....	<p>Low gain in audio amplifier modulator subunit.</p> <p>Faulty bias circuit .....</p> <p>Defective detector, noise limiter, audio amplifier stages in 500-kc if. subunit or defective stages in audio amplifier and modulator subunit.</p> <p>Faulty bias circuit.....</p>	<p>Check resistance measurements on faulty subunit to isolate trouble (fig. 88).</p> <p>Check to see whether receiver af control R826 is adjusted properly (para 139).</p> <p>Check stage gain measurements to localize trouble to a stage (para 100).</p> <p>Measure bias at J804 (fig. 88) (approximately -6 volts). Check bias circuit continuity (fig. 23).</p> <p>Check by stage gain (para 100).</p> <p>Measure distortion in output as signal is applied to the various inputs (4th echelon, para 152).</p>
12	Speaker output present, no headset output or vice versa.	<p>Open tap on T802, faulty contacts on K802, faulty wiring in audio amplifier modulator, main frame, or front panel subunits, or volume control R710, R714, or associated connectors.</p> <p>For no headset output; defective relay subunit wiring, R601 or R615.</p>	<p>Measure bias at J804 (approximately -6 volts) (fig. 88).</p> <p>Check bias circuit continuity (fig. 23).</p> <p>Check audio amplifier modulator subunit by substitution (para 112).</p> <p>Isolate trouble in subunit by resistance and continuity measurements (fig. 88).</p> <p>Check remainder of audio output circuit by continuity and resistance measurements to locate faulty component or circuit (fig. 15).</p>
13	CALL LIGHT does not go out and nearly the same noise level is heard in speaker when SQUELCH control is rotated fully clockwise.	<p>R712 improperly adjusted.....</p> <p>Faulty main frame, front panel, or relay subunit wiring. Components possibly faulty are R712, R715, K601.</p> <p>Faulty wiring or avc circuit components in 500-kc if., first if., or rf and power amplifier subunits.</p>	<p>Refer to paragraph 141 for adjustment of R712.</p> <p>Check by making continuity and resistance measurements in squelch threshold circuit (fig. 13).</p> <p>Localize trouble to one of the faulty subunits.</p> <p>Check subunits by signal substitution in the following sequence: 500-kc if., first if., rf and power amplifier (para 101).</p> <p>Isolate trouble in subunit by continuity and resistance measurements (fig. 84, 89, and 85).</p>
14	Noise in speaker decreases as SQUELCH control is turned clockwise, but CALL LIGHT is on.	<p>Faulty squelch circuit which includes V801, K801, associated components, or wiring.</p>	<p>Replace V801 (fig. 76).</p> <p>Remove audio amplifier modulator subunit (para 112) and make continuity and resistance measurements in squelch circuit (fig. 13 and 88).</p> <p>Replace K801 (fig. 76).</p>
15	CALL LIGHT off and no noise heard in speaker when SQUELCH DISABLE PUSH switch is pressed with SQUELCH control adjusted to normally turn CALL LIGHT off.	<p>Refer to item 13.....</p> <p>Faulty wiring in audio amplifier modulator, main frame or front panel subunits; or faulty SQUELCH DISABLE PUSH switch and lamp assembly.</p>	<p>Refer to item 13.</p> <p>Check audio amplifier modulator subunit by substitution.</p> <p>Isolate trouble in subunit by resistance and continuity measurements (fig. 13).</p> <p>Remove front panel (para 117) and check resistance and circuit continuity on both front panel and main frame (squelch disable circuits) (fig. 13).</p>



(3) Transmitter (fig. 128).

Item	Indication	Probable trouble	Procedure
1	<p>Transmitter will not key. Indications are: the CALL LIGHT remains on, and there is no indication on panel meter with METER switch at PAL<sub>b</sub>, PAL<sub>g</sub>, DVRI<sub>b</sub>, or PWR.</p> <p><i>Note.</i> With rt unit out of the case, the transmit-receive relays can be heard energizing when the transmitter is keyed.</p>	<p>Faulty AUDIO connector on front panel.</p> <p>Faulty push-to-talk switch on microphone.</p> <p>BB-NOR switch S801 in BB position (TM 11-5820-222-20).</p> <p>Faulty audio amplifier modulator-subunit wiring, K801, or S801.</p> <p>Faulty relay subunit wiring or K601.</p> <p>Faulty work relay K1 . . . . .</p> <p>Faulty main frame or front panel wiring.</p>	<p>Check by plugging microphone into other AUDIO connector.</p> <p>Check by substitution of microphone.</p> <p>Check position of switch S801.</p> <p>Check subunit by substitution (para 112).</p> <p>Isolate trouble in faulty subunit (fig. 13 and 26).</p> <p>Check subunit by substitution.</p> <p>Isolate trouble in faulty subunit (fig. 26) by resistance measurements.</p> <p>Check by substitution (fig. 48).</p> <p>Check circuit continuity (fig. 26).</p>
2	<p>No power output with the METER switch at PWR and the following meter readings:</p> <p>SWR = 0 - 10%</p> <p>PAL<sub>b</sub> = 0</p> <p>PAL<sub>g</sub> = NORMAL</p> <p>DVRI<sub>b</sub> = NORMAL</p> <p>No power output indicated on wattmeter.</p>	<p>Defective T802 or R839 in audio amplifier modulator subunit.</p>	<p>Check subunit (para 112) by substitution.</p> <p>Isolate trouble in subunit (fig. 14).</p> <p>Turn radio set off and remove rear top cover rf and power amplifier subunit. Connect the TS-352/U to the plate of V106 (fig. 70). Turn radio set on and measure voltage.</p> <p><i>Caution:</i> With the radio set on, the potential at the point being measured is from 270 to 300 volts.</p> <p>If voltage is approximately 300 volts, replace V106.</p> <p>Align the radio set after replacing V106 (para 137).</p> <p>If no voltage is present on the plate of V106, turn the radio set off and check the B+ circuit to sectionalize the trouble to the rf and power amplifier subunit or main frame wiring (fig. 23).</p>
3	<p>Front panel meter reads as follows:</p> <p>PWR = 0</p> <p>PAL<sub>b</sub> = NORMAL</p> <p>DVRI<sub>b</sub> = NORMAL</p> <p>SWR = 0 - 10%</p> <p>No power output indicated on wattmeter.</p>	<p>Rotor plate(s) in power amplifier cavity shorted to stator plates or plates arcing due to presence of foreign matter.</p> <p>Open or short-circuited coaxial cable between rf and power amplifier subunit and directional coupler. Defective low pass filter FL1101, antenna changeover relay K101, link and output cable assembly, or tuned circuit in power amplifier cavity.</p>	<p>Turn off radio set, remove rear top cover of rf and power amplifier subunit (para 125) and inspect. If plates are shorted, bend shorting rotor plate slightly to remove short. Realign the rf and power amplifier (para 137).</p> <p>Remove P102 from J1101 (fig. 69) and measure for continuity between J1101 and ground for possible short circuits, and between J1101 and P1101 for continuity of FL1101 (fig. 79).</p> <p>Check between ANT and ground for short. Remove P1302 from J109 and check between ANT and P1302 for continuity (fig. 81).</p> <p><i>Caution:</i> Make sure P102 and P1101 are disconnected, before keying transmitter.</p> <p>To measure continuity through relay K101, momentarily key transmitter and check continuity.</p>

Item	Indication	Probable trouble	Procedure
4	Front panel meter reads as follows: PWR = 0 or below NORMAL PAI <sub>b</sub> = NORMAL or above PAI <sub>g</sub> = 0 or very low DVRI <sub>b</sub> = NORMAL or above SWR = 0 -10%	No or low excitation to V106, open or short circuit in grid of V106, faulty coupling capacitor C128, faulty main frame or relay and filter subunit wiring. Defective first if., or 3.0-3.9 mc if. subunits, relay K102, W4 or W101 coaxial cables. Rotor plates shorted to stator intuned circuit Z101, Z103, Z105, Z106, Z107, or Z108 (fig. 74). Misalignment ..... Defective relay K401 ..... Defective relay K1, main frame, or audio amplifier modulator submit B+ wiring.	Refer to transmitter signal tracing (para 102) and measure appropriate voltages to localize trouble to a stage within a subunit, main frame, or relay unit. If signal tracing indicates cable difficulties, check cables W4 and W101 by continuity checks (fig. 113 and 70) and/or substitution. Inspect and correct. <b>Warning: Z107 and Z108 are at high potential.</b> Check alignment of Z101, Z103, Z105, Z107 trimmer, with tuning wand (para 137); if mistuned on transmit but tuned on receive, substitute relay K401 (fig. 56). Check relay K401 by substitution. Check relay K1 (fig. 48) by replacement. Check circuit continuity in audio amplifier modulator and main frame (fig. 23).
5	Front panel meter reads as follows: PWR = low or zero PAI <sub>b</sub> = low PAI <sub>g</sub> = low DVRI <sub>b</sub> = low SWR = 0 -10%	Faulty directional coupler metering circuit. Misalignment ..... Faulty V106 ..... Frequency selector improperly synchronized. R108 improperly adjusted ....	Check power output with AN/URM-43A (4th echelon, para 154). If power output is 16 watts or more, meter circuit is defective. If power output is less than 16 watts, a malfunction exists in power amplifier output stage. Refer to alignment procedure (para 137). Replace V106 (TM 11-5820-222-20) and align (para 137). Refer to paragraph 126 to synchronize frequency selector. Turn METER switch to PAI <sub>b</sub> and adjust R108 (fig. 72) for a mid-scale front panel meter indication.
6	Front panel meter reads as follows: PWR = Below NORMAL PAI <sub>b</sub> = NORMAL PAI <sub>g</sub> = NORMAL DVRI <sub>b</sub> = NORMAL SWR = 0 -10%	Faulty V106 ..... Frequency selector improperly synchronized. R108 improperly adjusted ....	Check by V106 substitution (TM 11-5820-222-20). Check by microphone substitution. Reverse speaker and microphone in AUDIO jacks. If sidetone is heard and % MOD is indicated, remove front panel (para 117) and repair faulty AUDIO jack. Check by signal substitution. Refer to signal tracing procedures (para 102) to localize trouble to a stage. Make continuity checks to isolate trouble (fig. 22). Refer to paragraph 138 for adjustment.
7	Low PWR low PAI <sub>b</sub> .....	Faulty V106 .....	Turn METER switch to PAI <sub>b</sub> and adjust R108 (fig. 72) for a mid-scale front panel meter indication.
8	No indication on front panel meter when METER switch is at % MOD, and no sidetone heard when microphone is spoken into.	Faulty microphone ..... Faulty front panel AUDIO jack. Faulty audio amplifier and modulator subunit.	Check by V106 substitution (TM 11-5820-222-20). Check by microphone substitution. Reverse speaker and microphone in AUDIO jacks. If sidetone is heard and % MOD is indicated, remove front panel (para 117) and repair faulty AUDIO jack. Check by signal substitution. Refer to signal tracing procedures (para 102) to localize trouble to a stage. Make continuity checks to isolate trouble (fig. 22). Refer to paragraph 138 for adjustment.
9	Indication on front panel meter below NORMAL with METER switch at % MOD.	Faulty front panel or main frame meter circuit wiring. XMIT AF control (R843) and/or COMP control (R831) improperly adjusted (fig. 76). Faulty audio amplifier modulator subunit.	Refer to paragraph 138 for adjustment. See item 8, last procedure
10	No sidetone in speaker but meter reading for % MOD is NORMAL.	Defective K802 ..... Faulty wiring or R833 in audio amplifier modulator subunit.	Replace to check (fig. 76). Make continuity and resistance measurements to isolate trouble (fig. 13, 14, and 15).

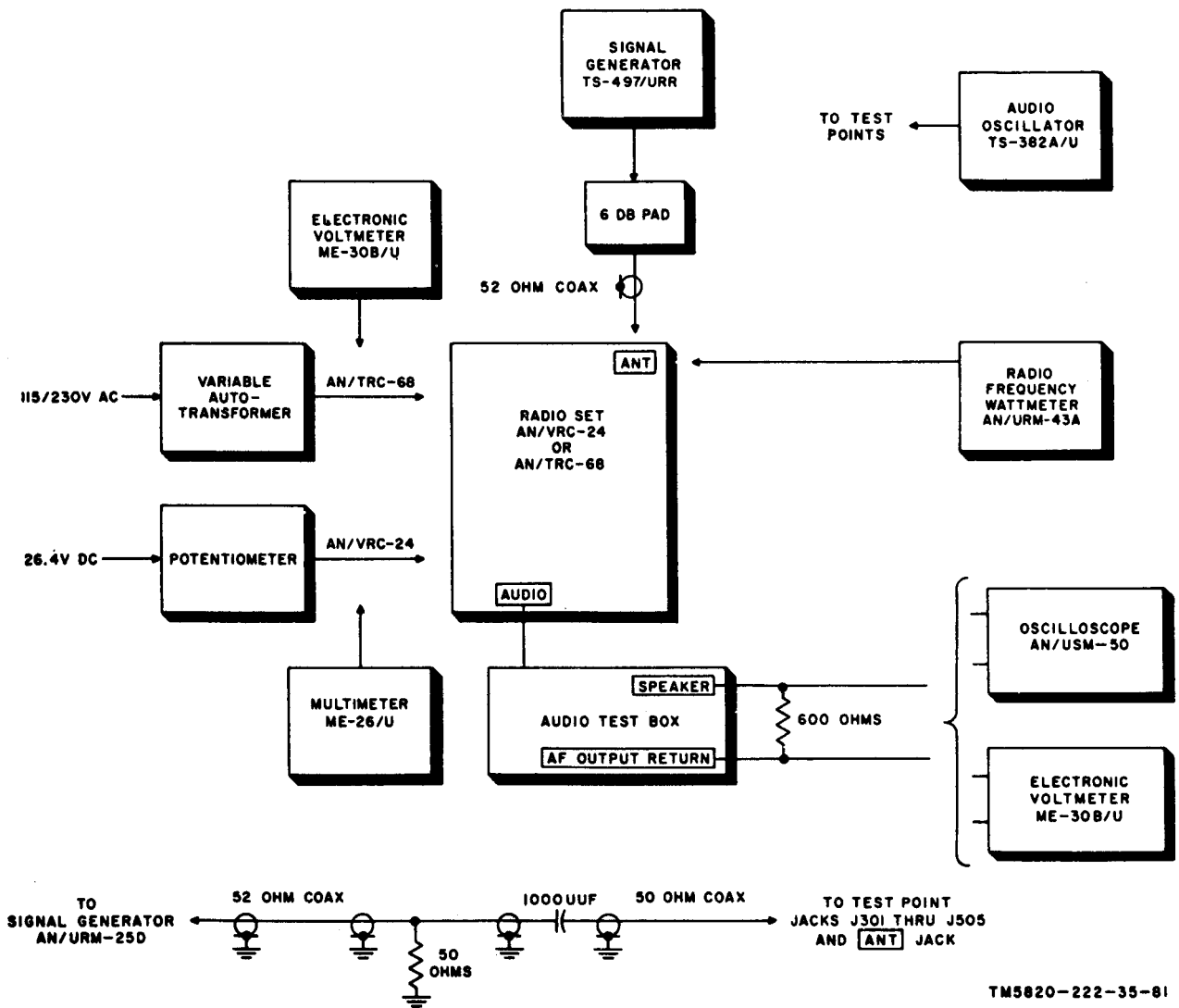
Item	Indication	Probable trouble.	Procedure
11	High distortion in modulation (as evidenced by reports by other operators, and the monitoring of sidetone).	Improper adjustment of modulator controls R831 (COMP) and/or R843 (XMIT AF). Faulty audio amplifier modulator subunit. Improper adjustment of V106 plate current. Faulty V105 or V106 . . . . .	Refer to paragraph 138 for proper adjustments of R831 and R843.  See item 8, last procedure.  Refer to procedure for item 7 above. Check V105 and V106.
12	Front panel meter reads low on METER switch positions PWR, PAI <sub>b</sub> , PAI <sub>g</sub> , DVRI <sub>b</sub> , LOW B+, and HIGH B+.	Low line or supply voltage . . . .  Faulty dynamotor (AN/VRC-24)  Faulty main frame wiring . . . .  Excess voltage drop between contacts 1 and 4 of K3 (AN/VRC-24).	Check LINE V position on METER switch. If LINE V position gives a NORMAL reading, check dynamotor by substitution (para 114). Check primary input wiring in frame for excess voltage drop (fig. 24 for AN/VRC-24, fig. 25 for AN/TRC-68). Check condition of contacts of K3 for excess pitting, corrosion, or heat damage (para 105). Repair or replace relay K3 (fig. 47).

f. Troubleshooting Chart Using Radio Set Control C-1439/U (fig. 30).

Note: Use the information in this subparagraph only when it is known that operation of the rt unit from the local position is normal.

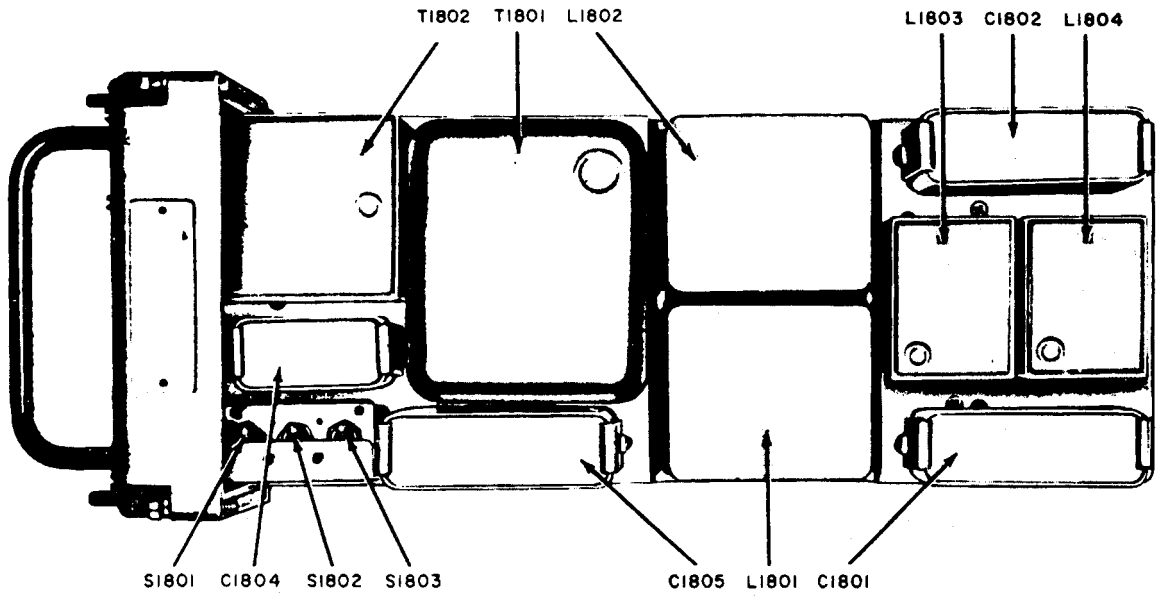
Item	Indication	Probable trouble	Procedure
1	Operating the CHANNEL switch does not operate frequency selector.	Faulty wiring in Radio Set Control C-1439/U, remote cable CX-4630/U, or Mounting MT-1436/U for AN/VRC-24, remote cable CX-4882/U or Case CY-2712/TRC-68 for AN/TRC-68, main frame, front panel, or frequency selector. Faulty S705C, S1206, P1201, J11, J12, or P703.	Isolate trouble to C-1439/U by substitution. Check resistance and continuity in faulty unit (fig. 30 and 82). Check circuit continuity and resistance from remote connector to frequency selector, removing front panel (para 117) if necessary to isolate fault (fig. 27).
2	Selecting channel with CHANNEL switch causes frequency selector motor to run continuously as evidenced by frequency indicator dials rotating continuously, or dials set up on wrong frequency.	Refer to item 1 . . . . .	Refer to item 1.
3	AN/VRC-24 will not turn on.	Faulty remote cable connector or J1501. Faulty switch or wiring in C-1439/U. Faulty CX-4630/U, wiring in, or connections to, Mounting MT-1436/U or J1701 for AN/VRC-24. Faulty CY-2712/TRC-68 connections or CX-4882/U for AN/TRC-68. Faulty main frame wiring. . . . .	Check connector for damage (fig. 82). Check resistance and continuity in faulty unit (fig. 30). Check continuity in circuit (fig. 122 and 126).  Check continuity in circuit (fig. 123).
4	POWER light does not light.	Faulty lamp . . . . . Faulty lampholder . . . . .	Check continuity in circuit and associated components. Check lamp. Check by substituting C-1439/U. Check circuit continuity in faulty unit.

Item	Indication	Probable trouble	Procedure
5	CALL LIGHT is not on .....	Defective lamp ..... Faulty remote cable connector. Defective wiring or lamp switch assembly in C-1439/U.  Faulty CX-4630/U, wiring in or connections to Mounting MT-1436/U (for AN/VRC-24). Faulty CX-4882/U, REMOTE receptacle or wiring in case CY-2712/TRC-68 (for AN/TRC-68).	<i>Note.</i> Check mounting and main frame for faulty wiring (fig. 24, 30, and 125 for AN/VRC-24 or fig. 25 and 30 for AN/TRC-68).  Check lamp. Examine each connector for damage. Isolate trouble to C-1439/U by substitution. Check resistance and continuity of faulty unit circuits (fig. 30). Check resistance and continuity of units to isolate trouble (fig. 122 and 126 for AN/VRC-24). Check resistance and continuity of wiring in case or main frame (fig. 13, 34 for AN/TRC-68).
.6	No noise in headset or no control of volume.	Faulty AUDIO connector on C-1439/U. Radio interphone control at INT or faulty in either RAD or RAD-INT position.  Faulty remote cable connector or J1501 (fig. 82). Faulty wiring or volume control(s) in C-1439/U.	Switch headset cable to other AUDIO jack. Check switch position and switch to either RAD or RAD-INT, depending on initial position. If audio is heard, repair C-1439/U. Examine each connector for damage.  Isolate trouble to C-1439/U by substituting units. Check resistance and continuity in faulty unit (fig. 30).
7	CALL LIGHT goes out and noise disappears when CHANNEL switch is turned to REMOTE PRESET. (SQUELCH control on C-1439/U is turned to OFF.)	Poor ground connections in SQUELCH control.  Faulty remote cable connector or J1501 (fig. 82). Faulty main frame, front panel wiring, or switch S705E.	Press SQUELCH DISABLE PUSH switch. If CALL LIGHT lights and noise is heard, remove C-1439/U and repair faulty ground (fig. 30). Examine connector for damage.  Unplug P703 (fig. 83, leftside view) from J11 and check front panel and main frame continuity and resistance to isolate trouble (fig. 13).
8	Noise is not reduced as SQUELCH control is turned clockwise.	Faulty remote cable connectors.  Faulty SQUELCH control or wiring in C-1439/U.	Check connectors. Make continuity checks to isolate trouble (fig. 13). Substitute C-1439/U to isolate trouble to the unit. Check resistance and continuity in faulty unit (fig. 30).
9	Transmitter will not key or modulate.	Refer to last trouble in item 7. Faulty connection in AUDIO jack J1502 or J1503.  Faulty microphone ..... Refer to item 3 .....	Refer to item 7. Plug microphone in other AUDIO jack. If transmitter keys, remove C-1439/U and isolate bad connection in jack (fig. 30). Check by substitution. Refer to item 3.



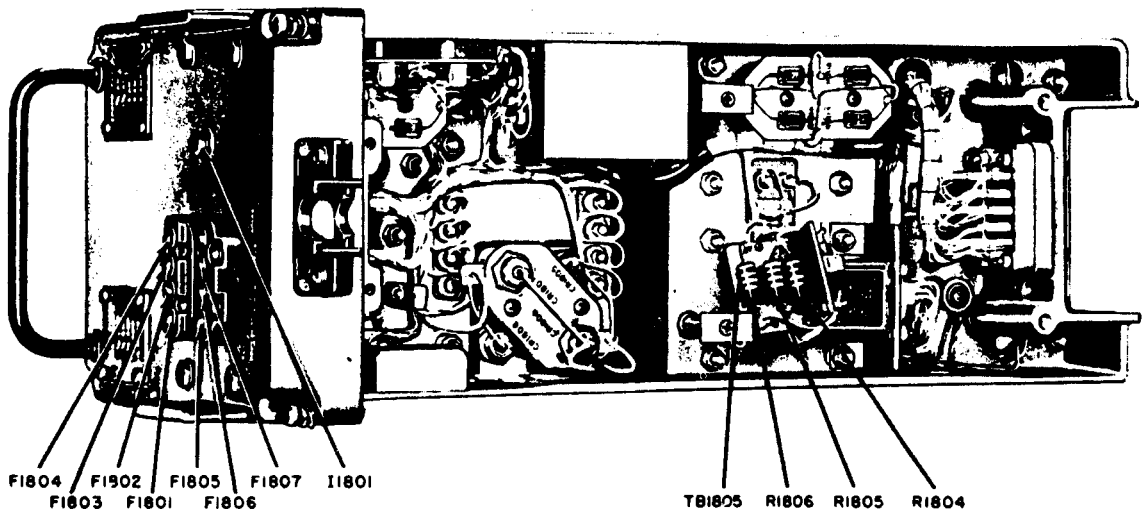
TM5820-222-35-81

Figure 38. Troubleshooting test setup.



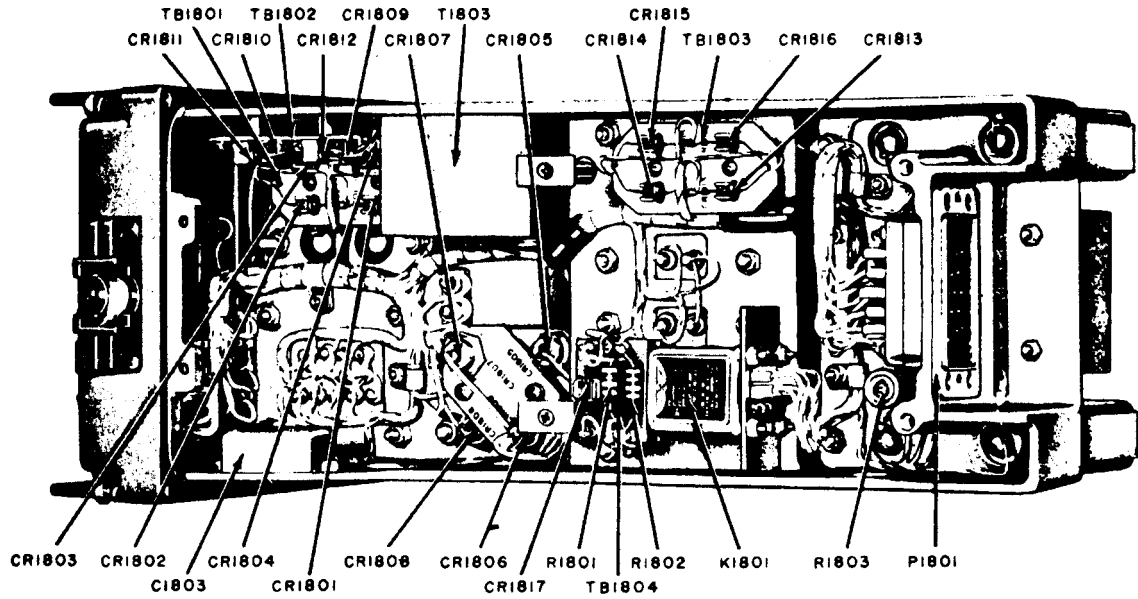
TM 5820-222-35-37

Figure 39. Power Supply PP-1494/U, top view.



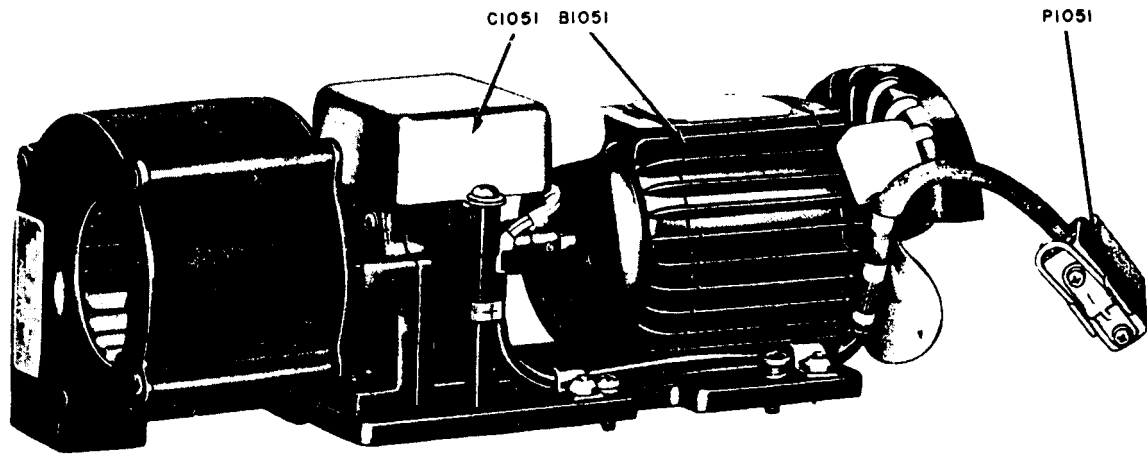
TM5820-222-35-38

Figure 40. Power Supply PP-1494/U, bottom and front view.



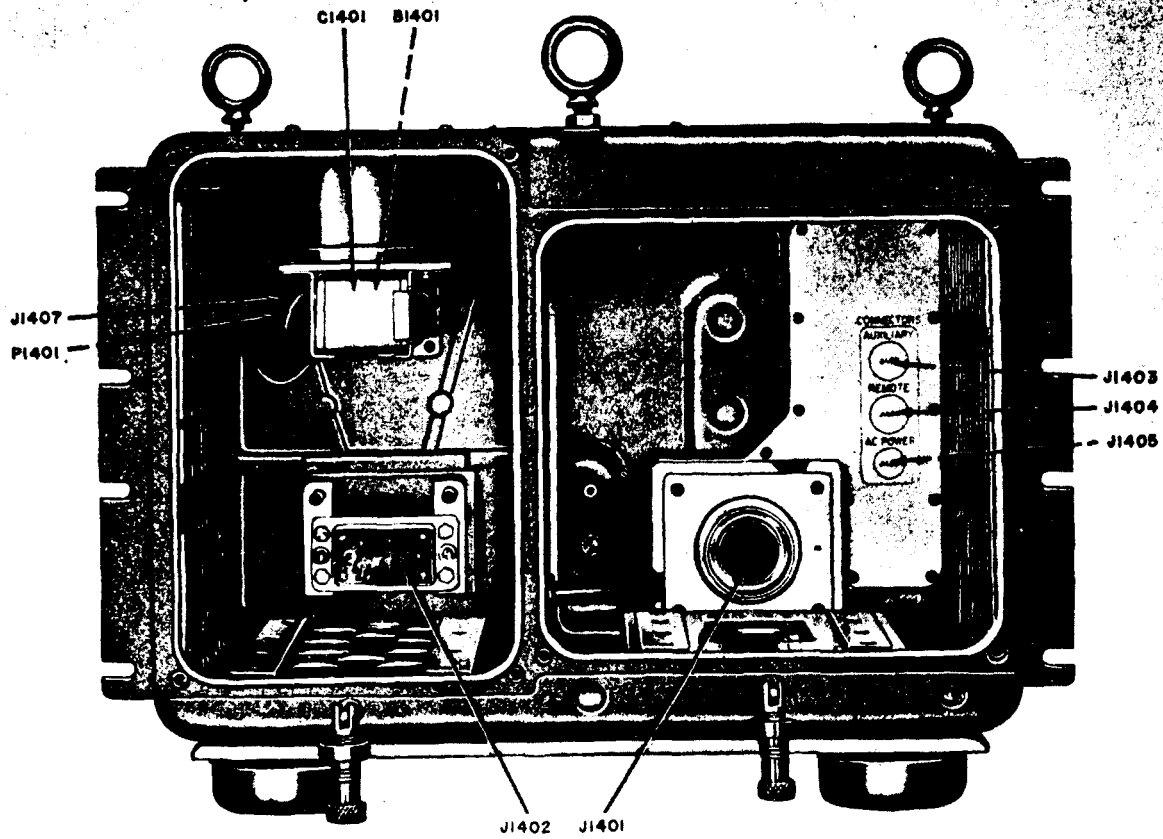
TM 5820-222-35-39

Figure 41. Power Supply PP-1494/U, bottom view.



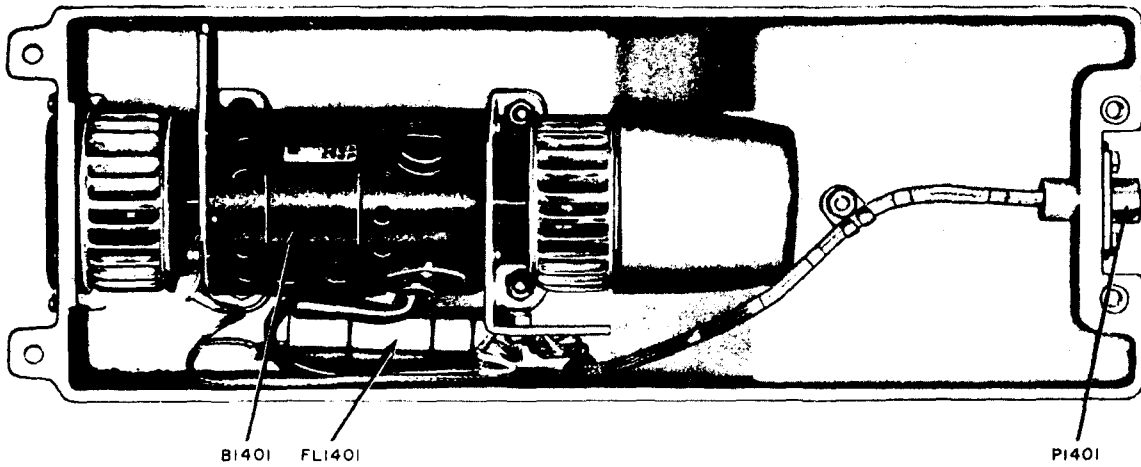
TM5820-222-35-8

Figure 42. Centrifugal Fan HD-390/U, side view.



TM5820-222-35-2

Figure 43. Receiver-Transmitter Case CY-2712/TRC-68, front view, ac case blower connected.



TM5820-222-35-53

Figure 44. Receiver-Transmitter Case CY-2557/VRC-24 blower, bottom view.



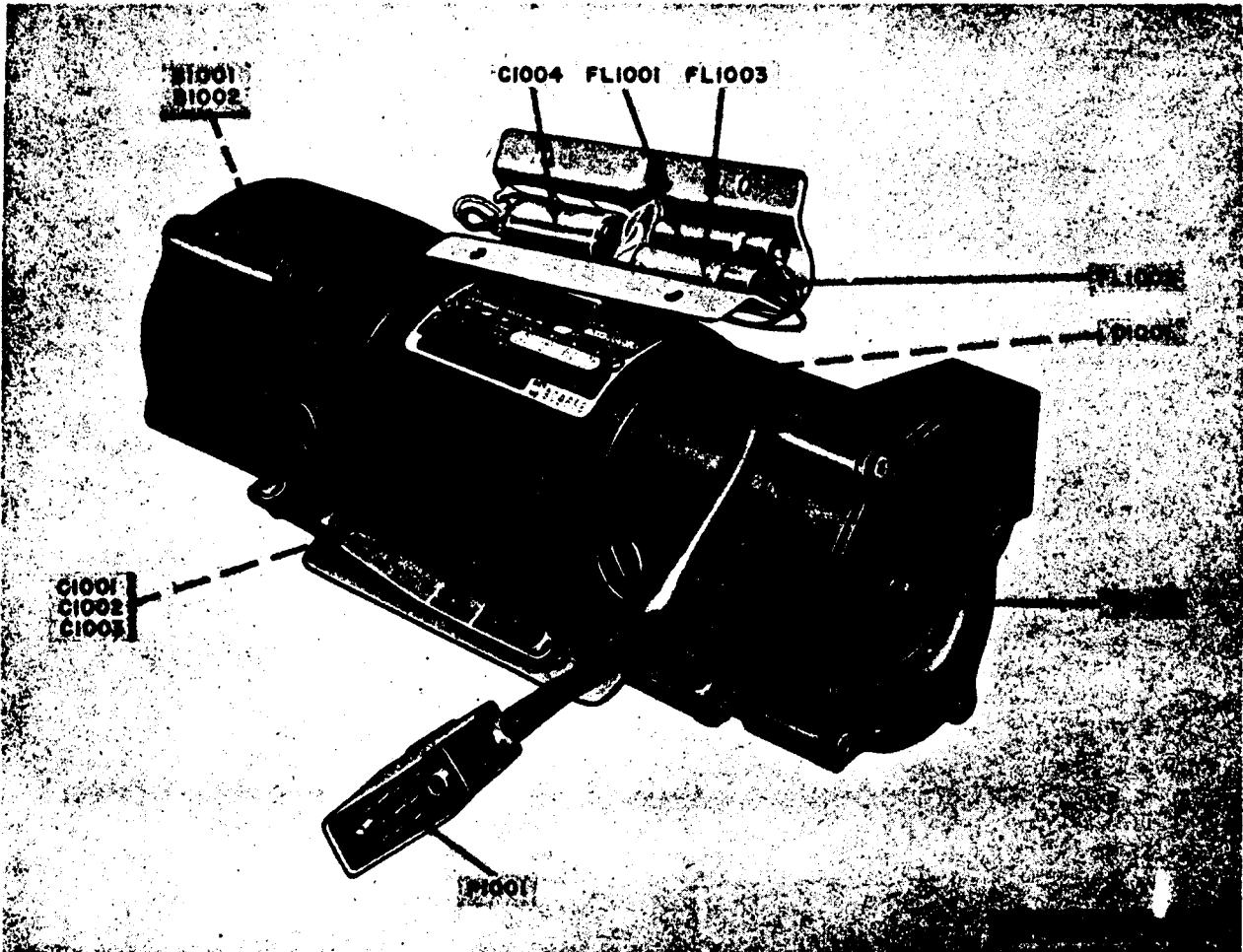
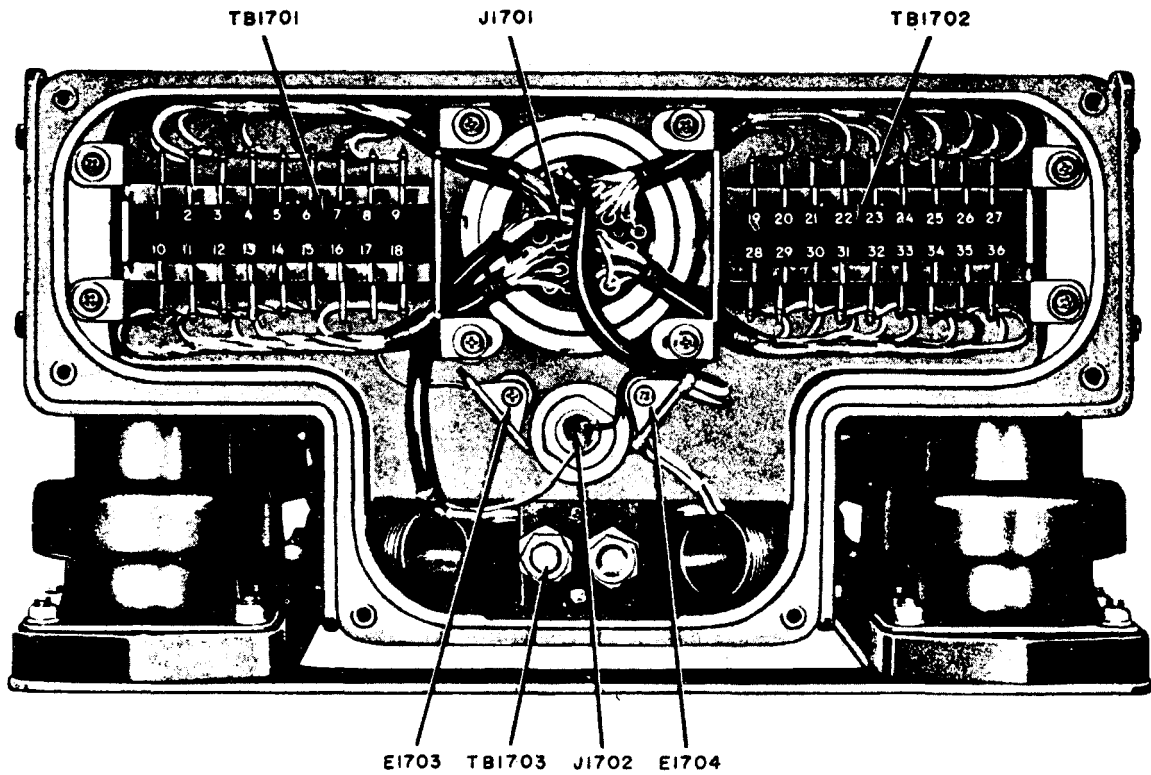
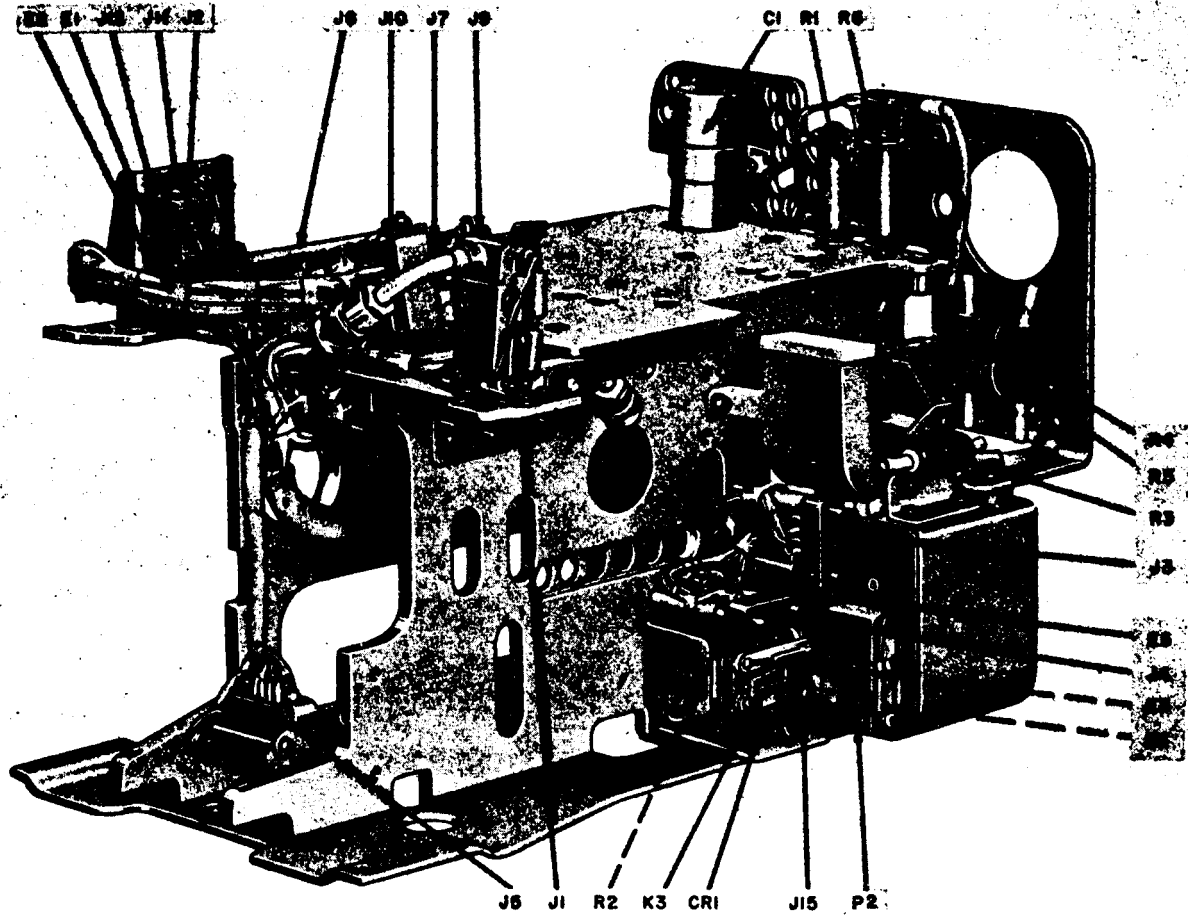


Figure 45. Dynamotor DY-151/U, side view.



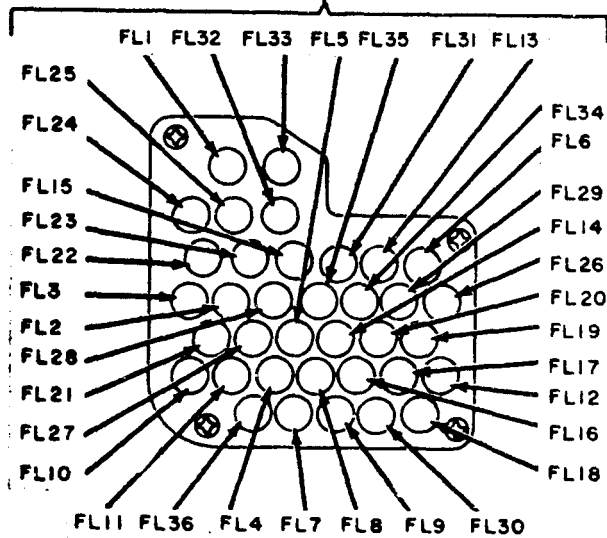
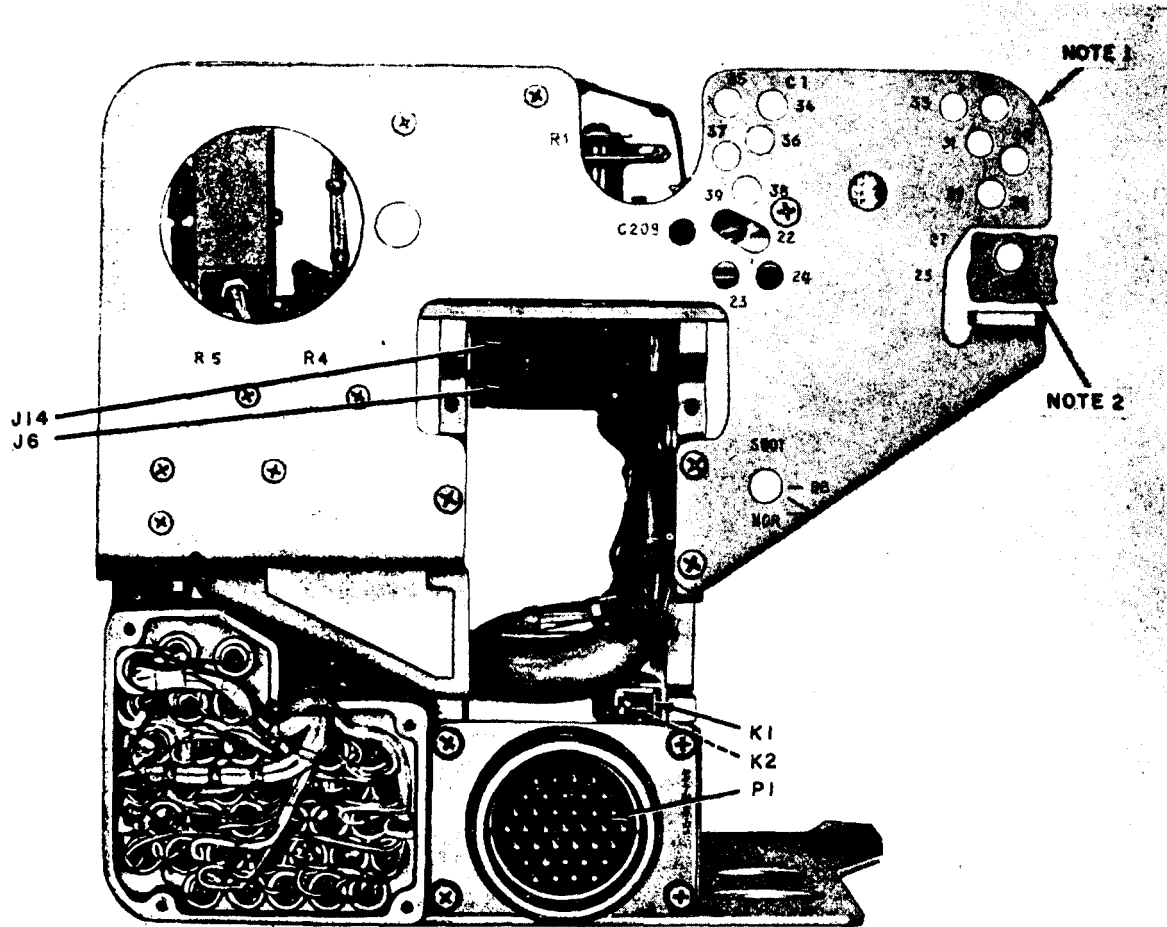
TM5820-222-35-4

Figure 46. Mounting MT-1436/U, rear view, terminal box, cover removed.



TM5620-222-39-46

Figure 47. Main frame, right side view.



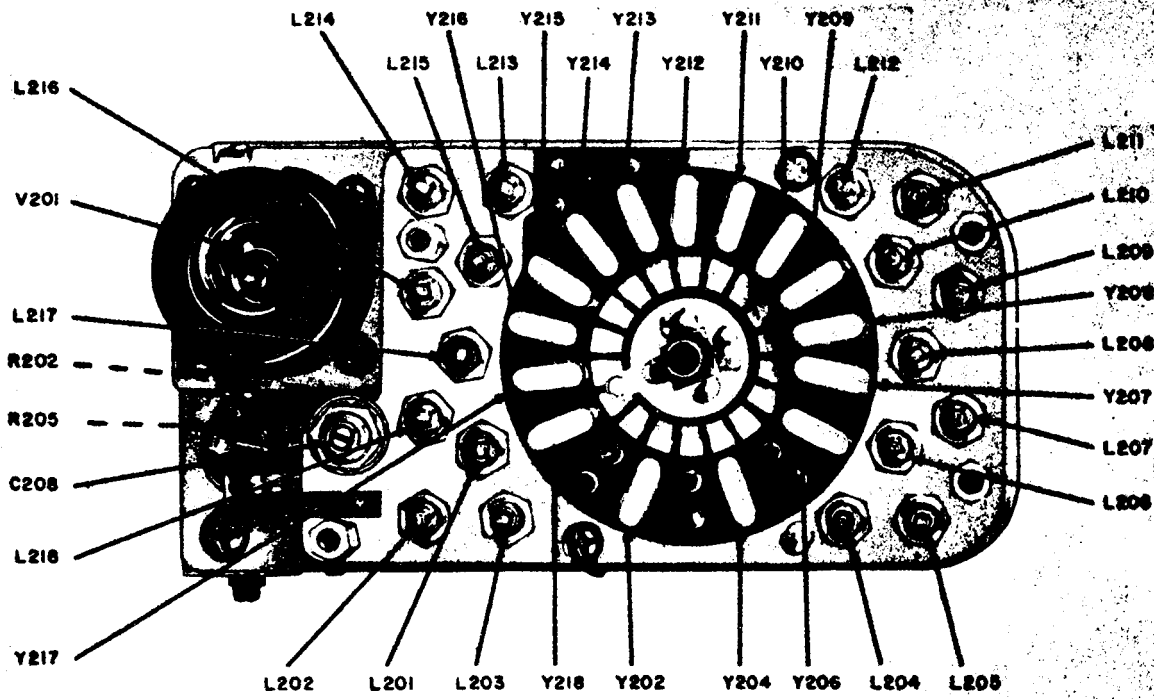
- NOTES:
1. HOLES NUMBERED 22 THRU 39 ARE ACCESS HOLES FOR TUNING FIRST OSCILLATOR V201.
  2. ACCESS HOLE 26 IS ON REAR PLATE OF FIRST OSCILLATOR ASSEMBLY AND IS VISIBLE FROM THE REAR OF THE RT UNIT.

TM5820-222-35-43

Figure 48. Main frame, rear view.

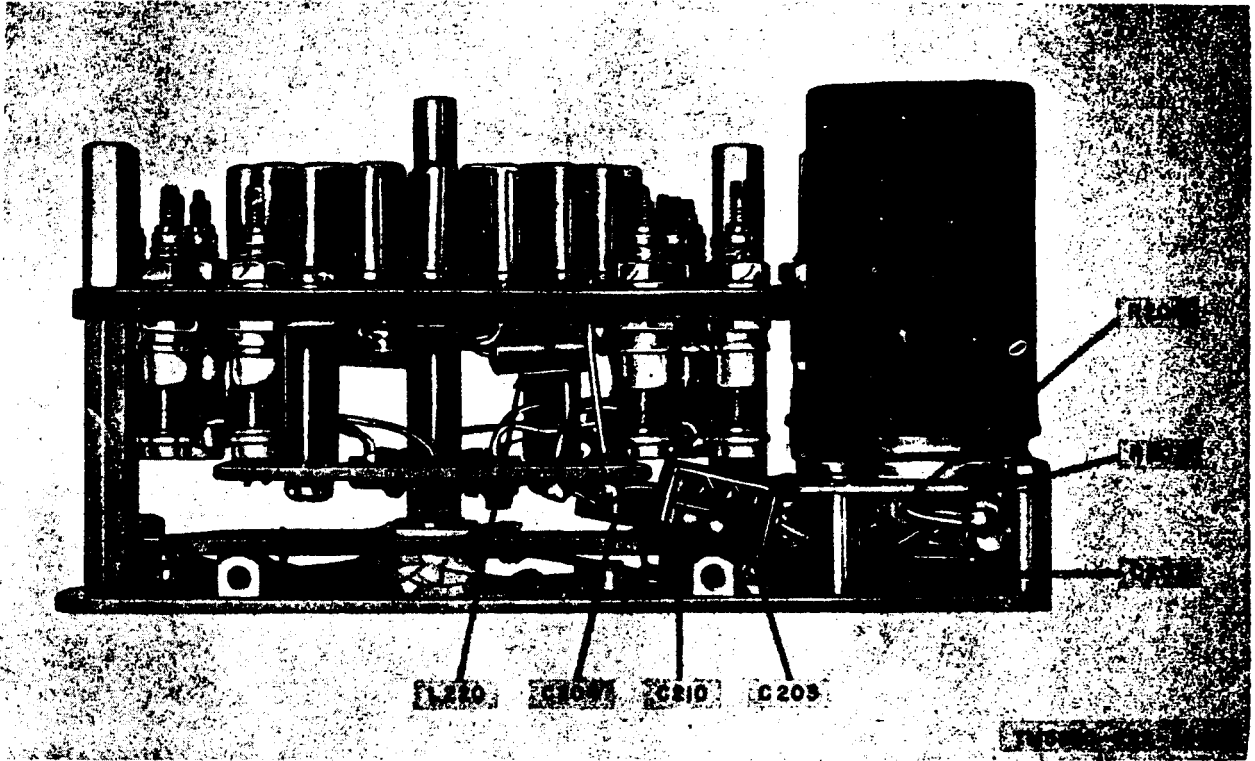


Figure 49. Receiver-transmitter unit front panel, rear view.

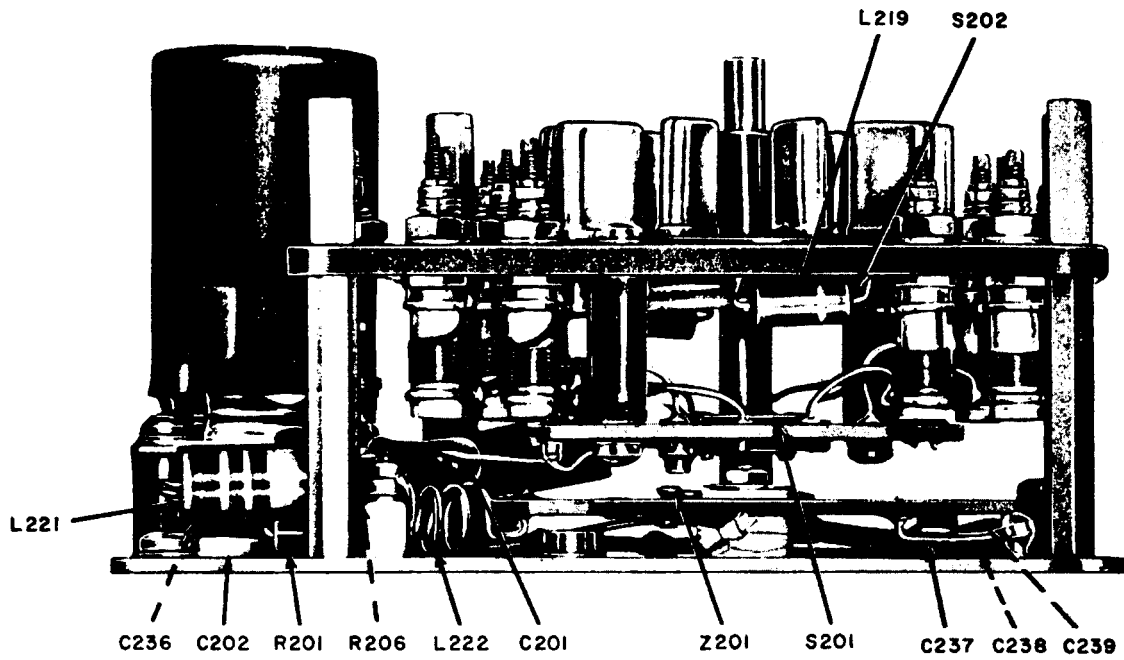


TM5820-222-75-6

Figure 50. First oscillator, crystal cover removed.

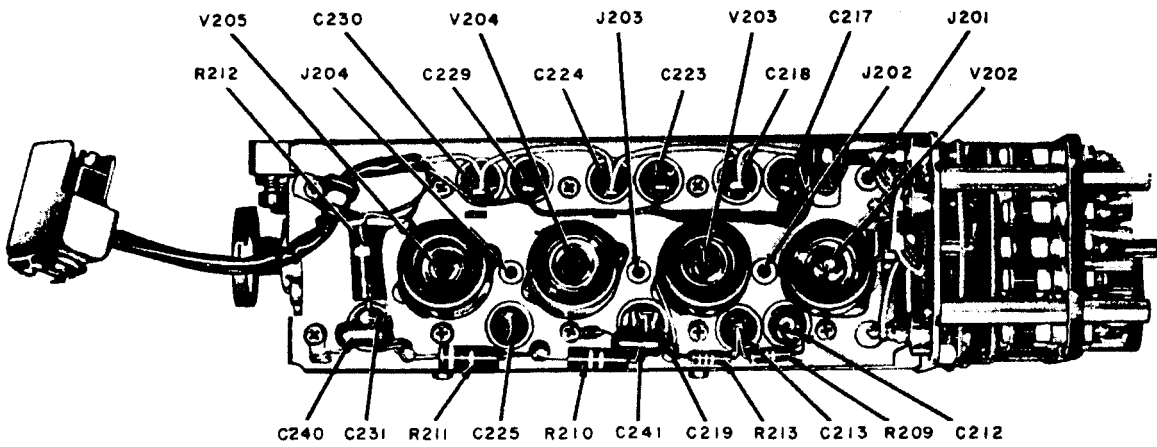


*Figure 51. First oscillator, left side view.*



TM5820-222-35-11

Figure 52. First oscillator, right side view.



TM5820-222-35-28

Figure 53. Uhf injection subunit, top view.



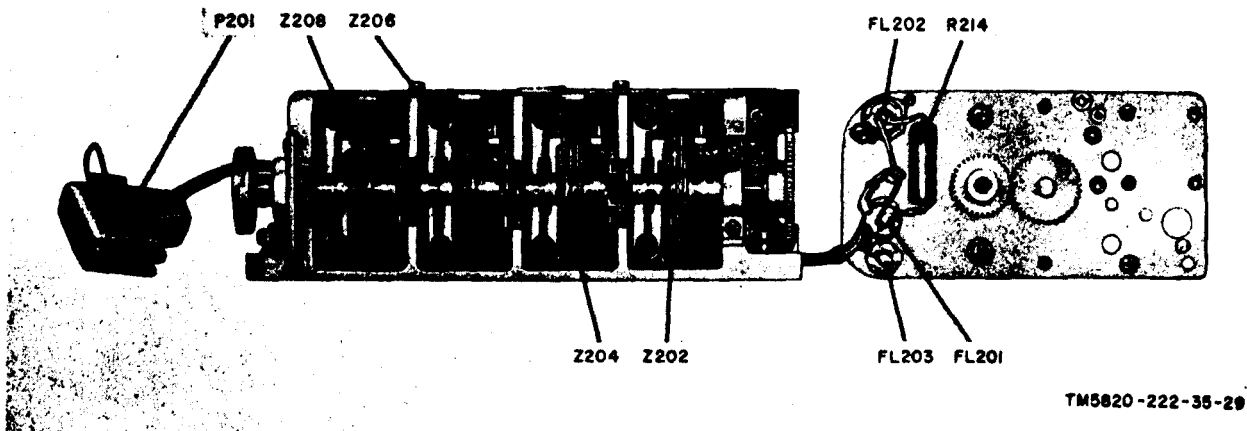


Figure 54. Uhf injection subunit, bottom view, first oscillator assembly folded out.

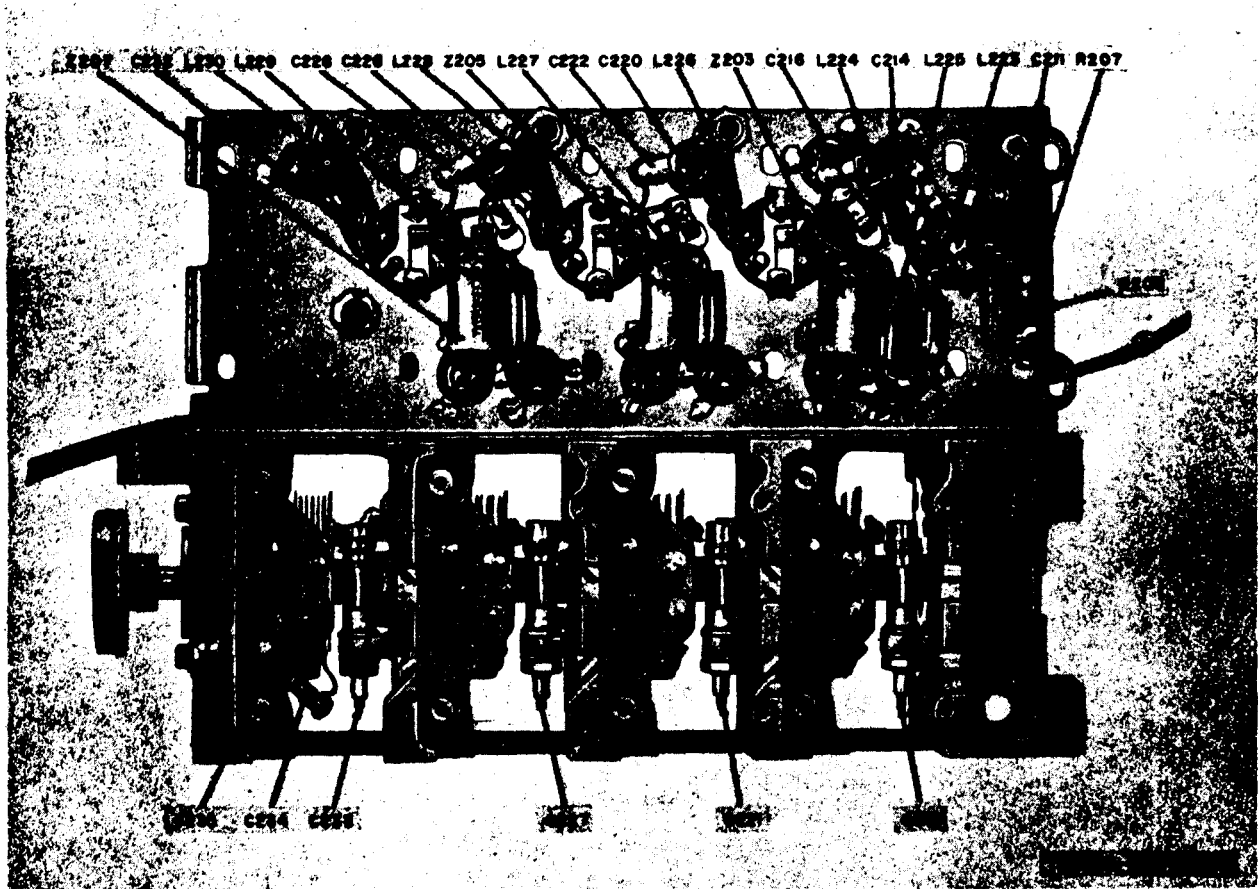


Figure 55. Uhf injection subunit, left side view, tube chassis folded out.

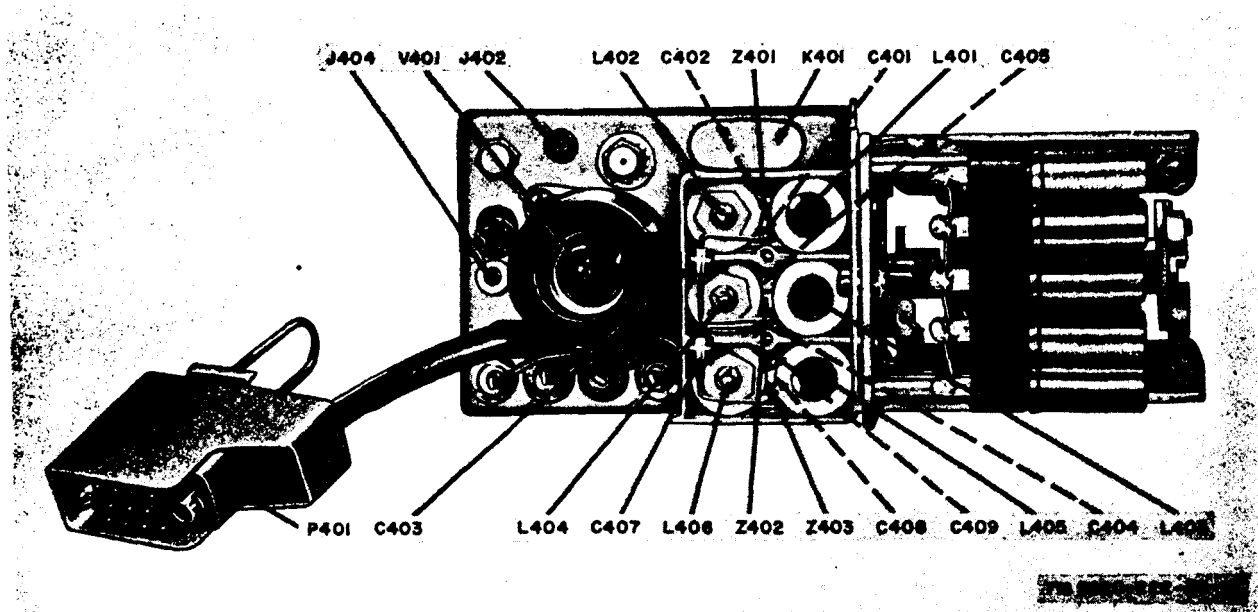


Figure 56. 3.0- to 3.9 mc if. subunit, topview, crystal cover removed.

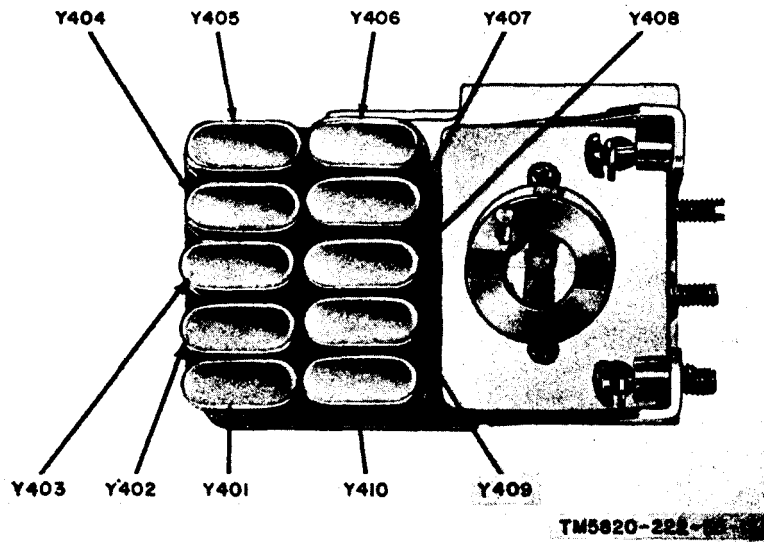
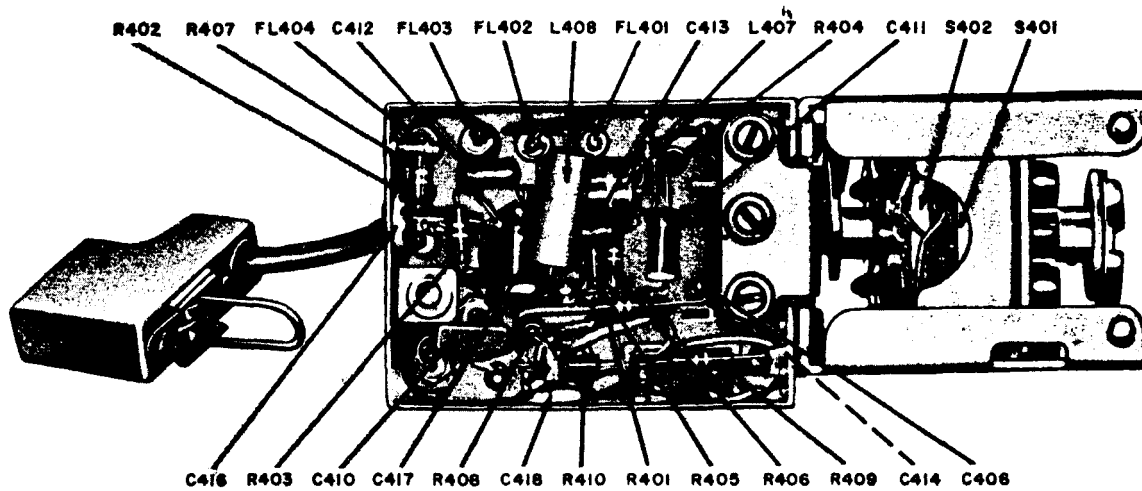


Figure 57. 3.0- to 3.9 mc if. subunit, front view, crystal cover removed.



TM5820-222-35-14

Figure 58. 3.0 to 3.9 mc if. subunit, bottom view.

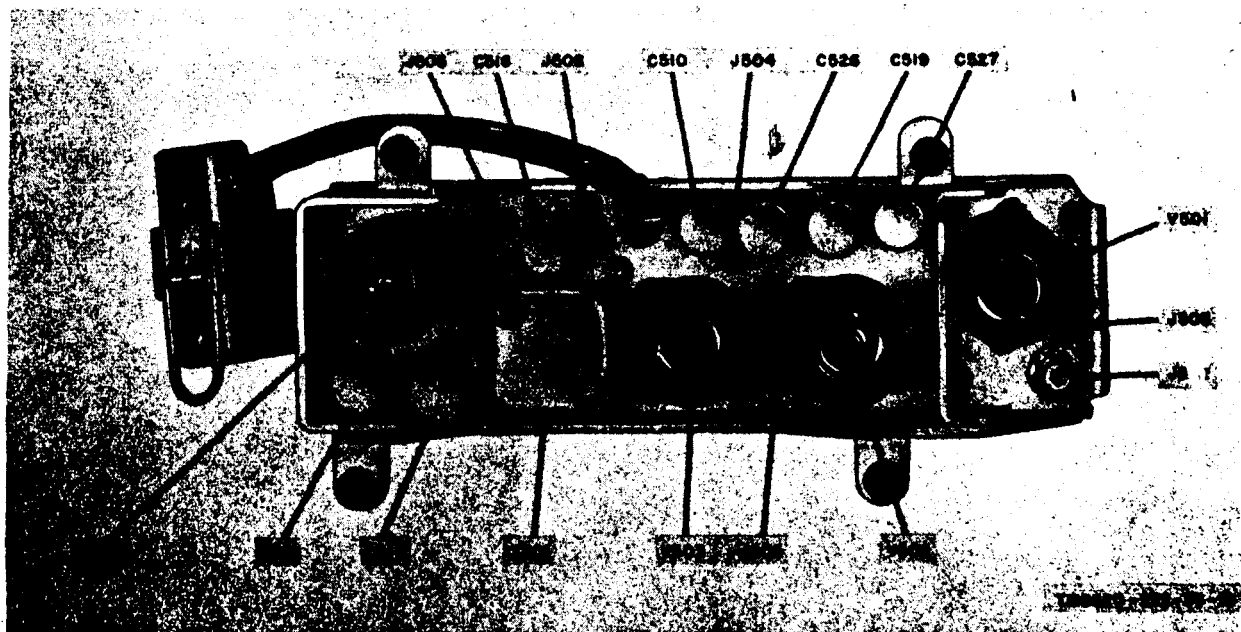


Figure 59. 500-kc if. subunit, top view.

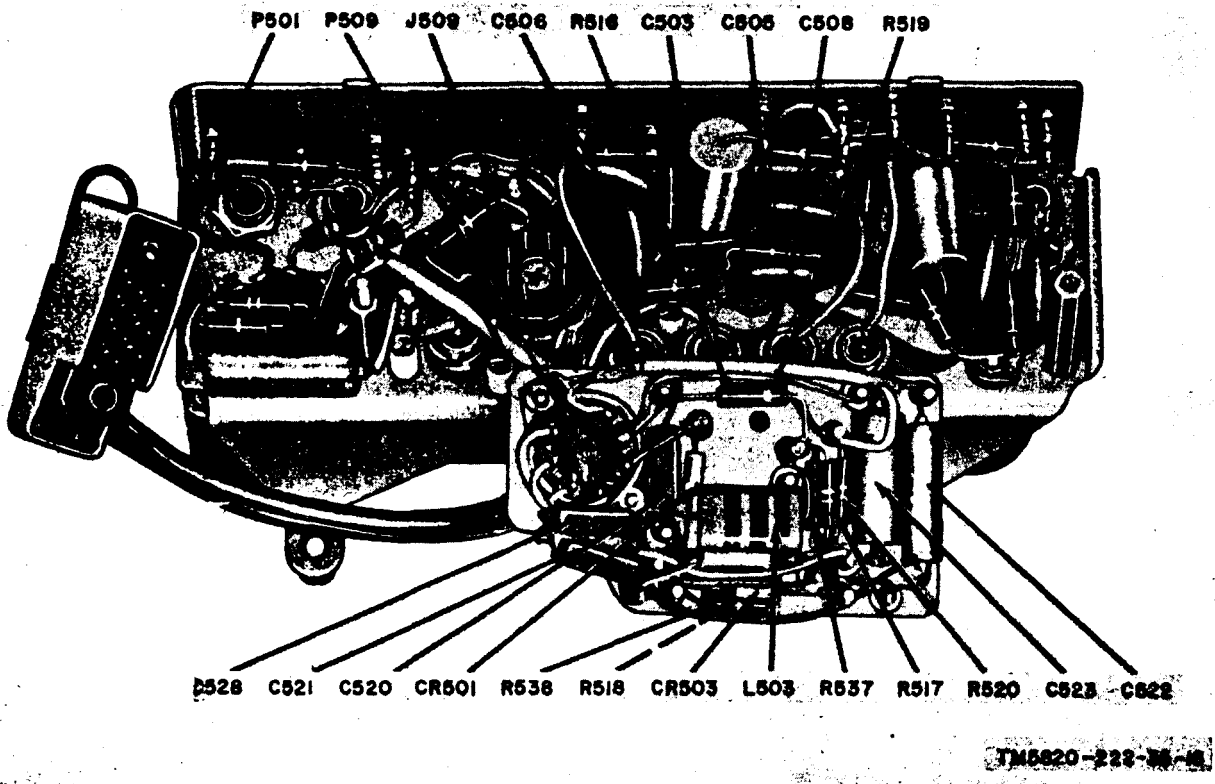
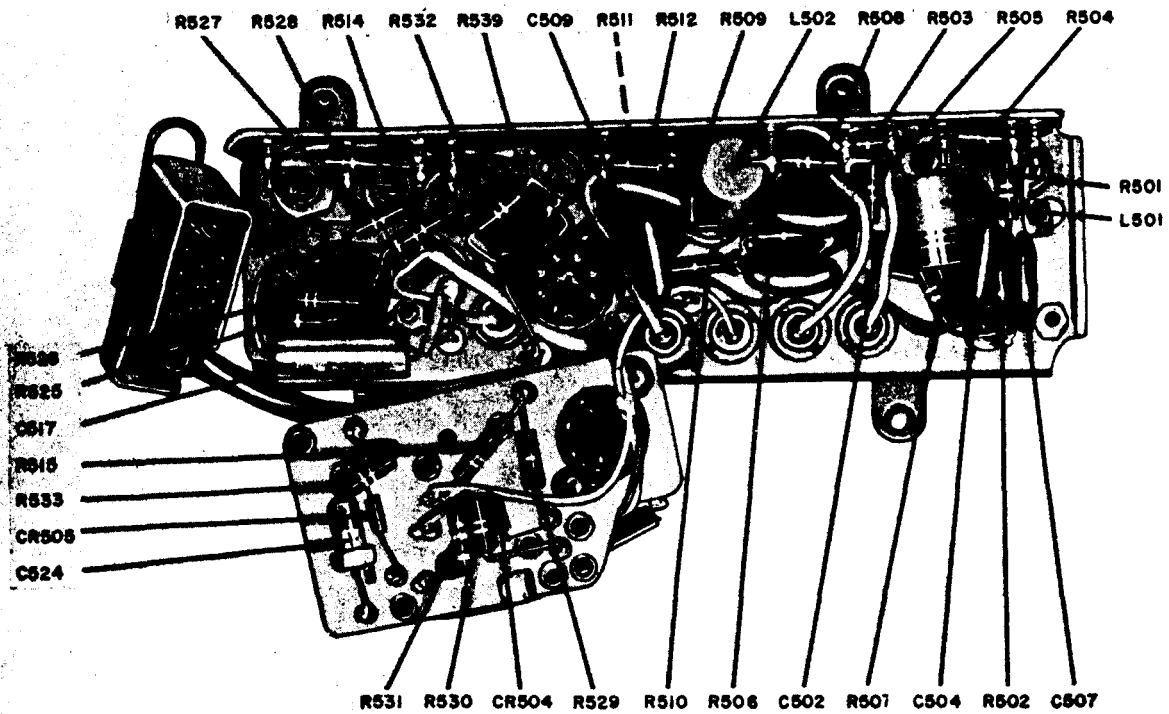


Figure 60. 500-kc if. amplifier subunit, bottom view, outer side of detector plate.



TM5820-222-35-17

Figure 61. 500-kc if. amplifier subunit, bottom view, inner side of detector plate.

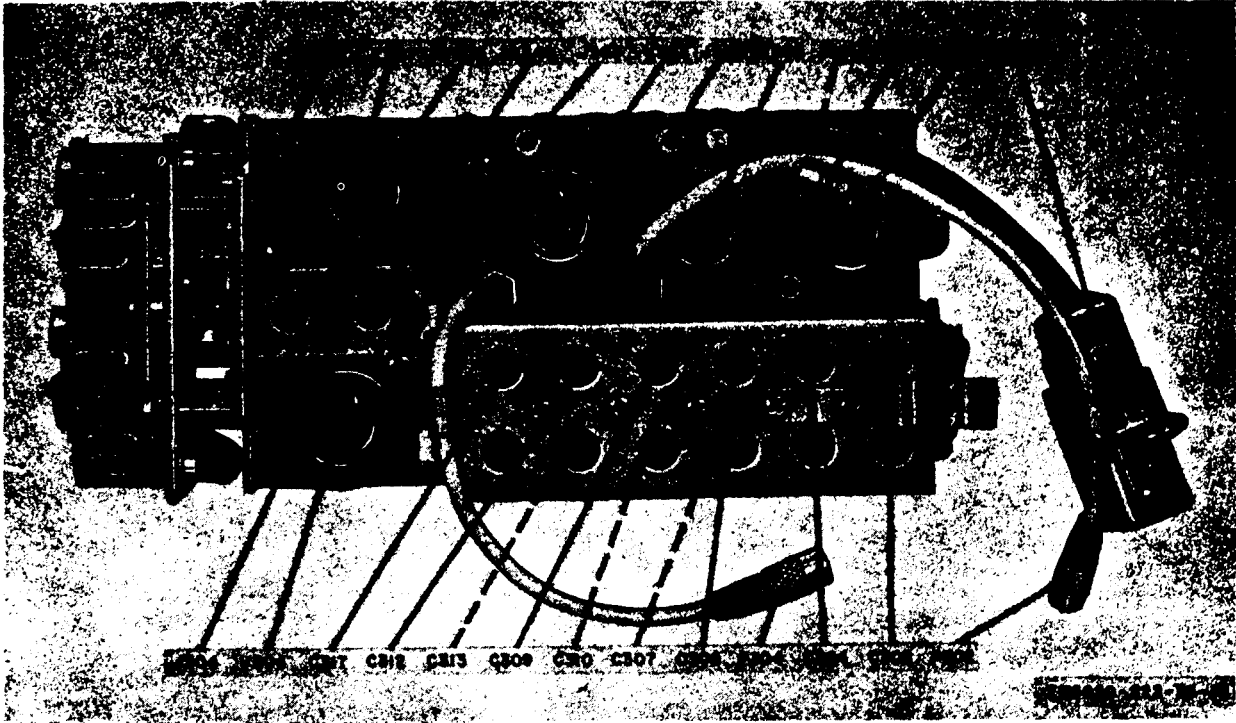


Figure 62. First if. amplifier subunit, top view.

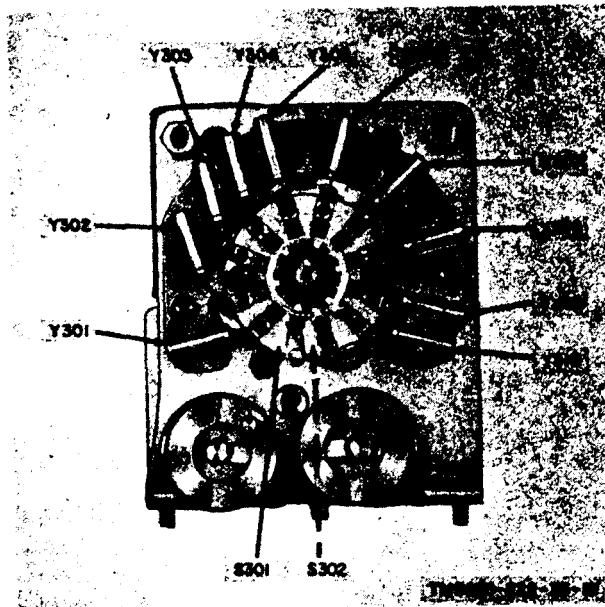


Figure 63. First if. amplifier subunit, front view, crystal cover removed.

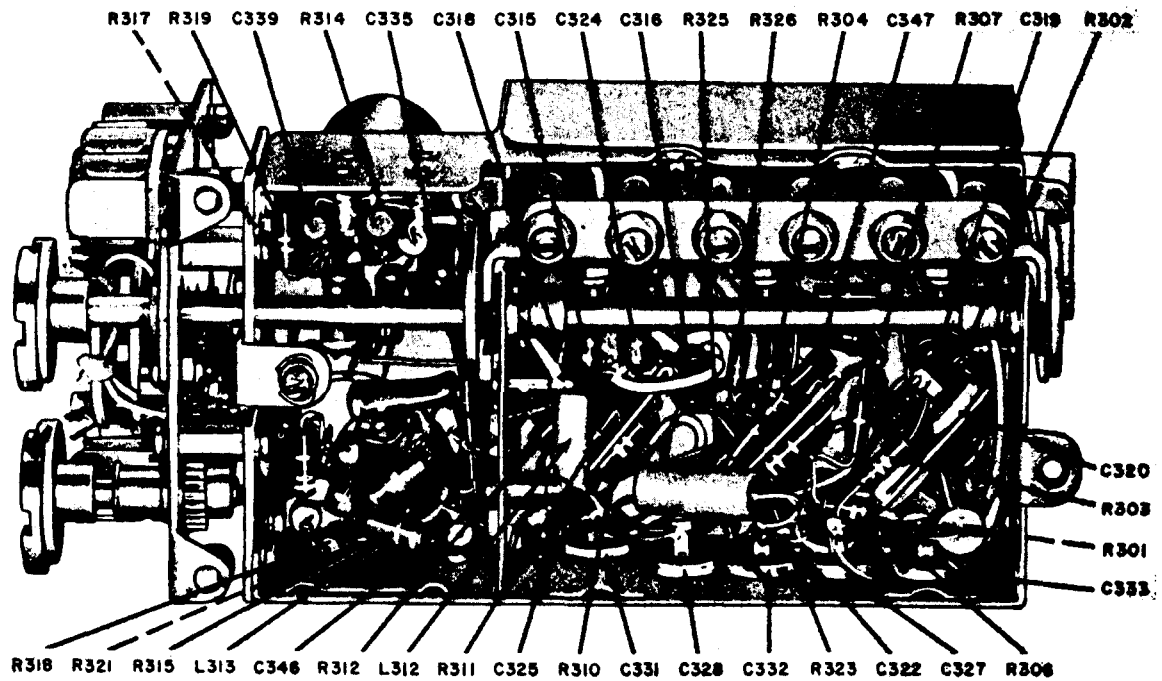


Figure 64. First if. amplifier subunit, bottom and left side view

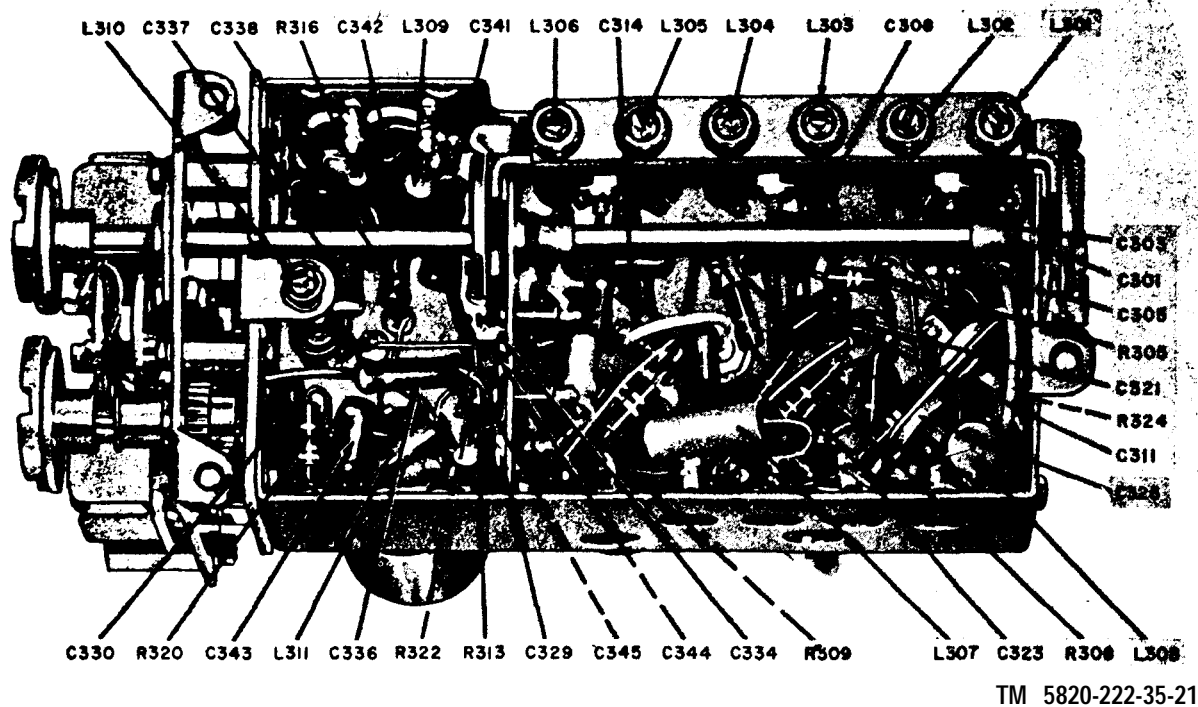


Figure 65. First if. amplifier subunit, bottom view.

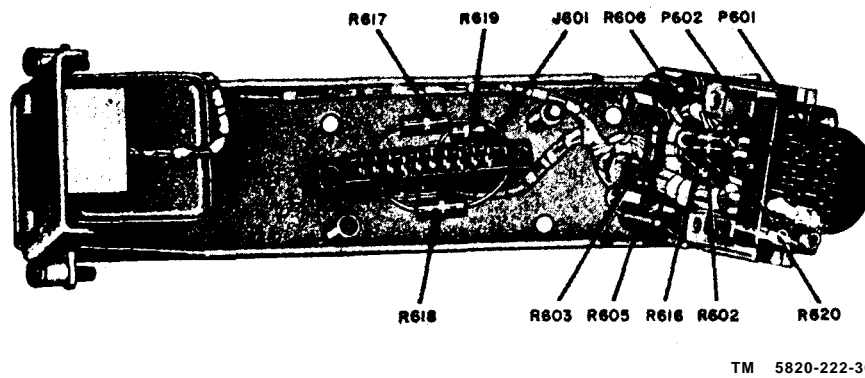
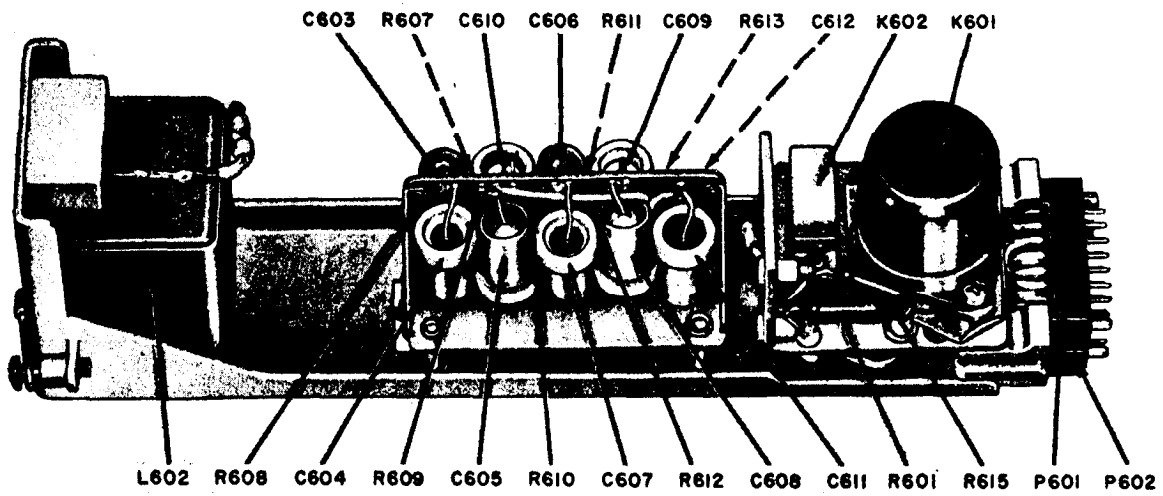


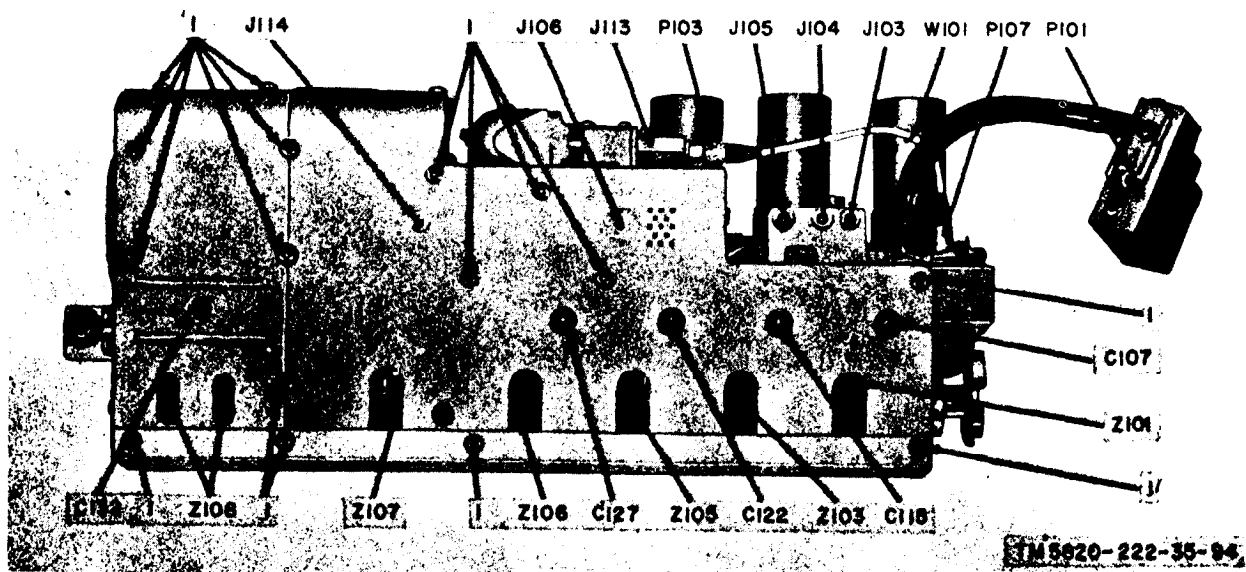
Figure 66. Relay and subunit, top view, relay terminal board exposed, Z601 removed.





TM5820-222-35-23

Figure 67. Relay subunit, top view.



TM5820-222-35-94

Figure 68. Rf and power amplifier subunit, left side view.

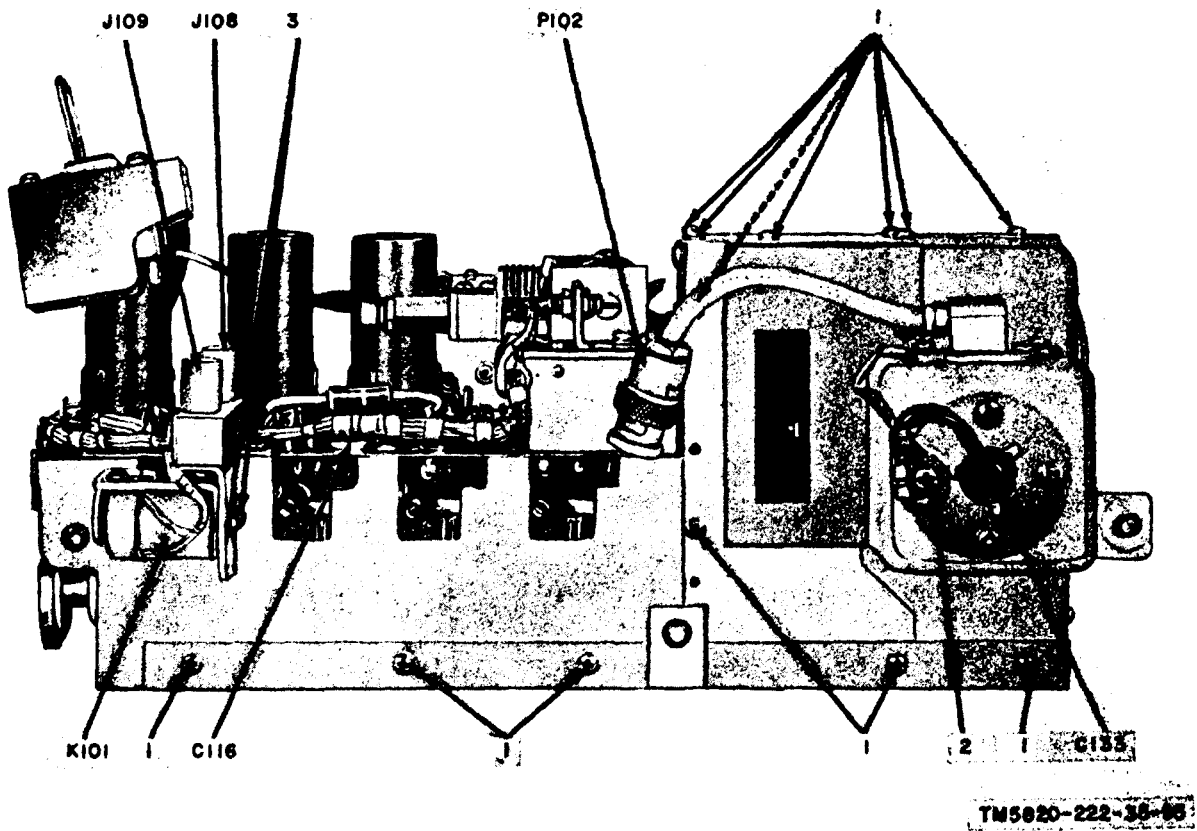
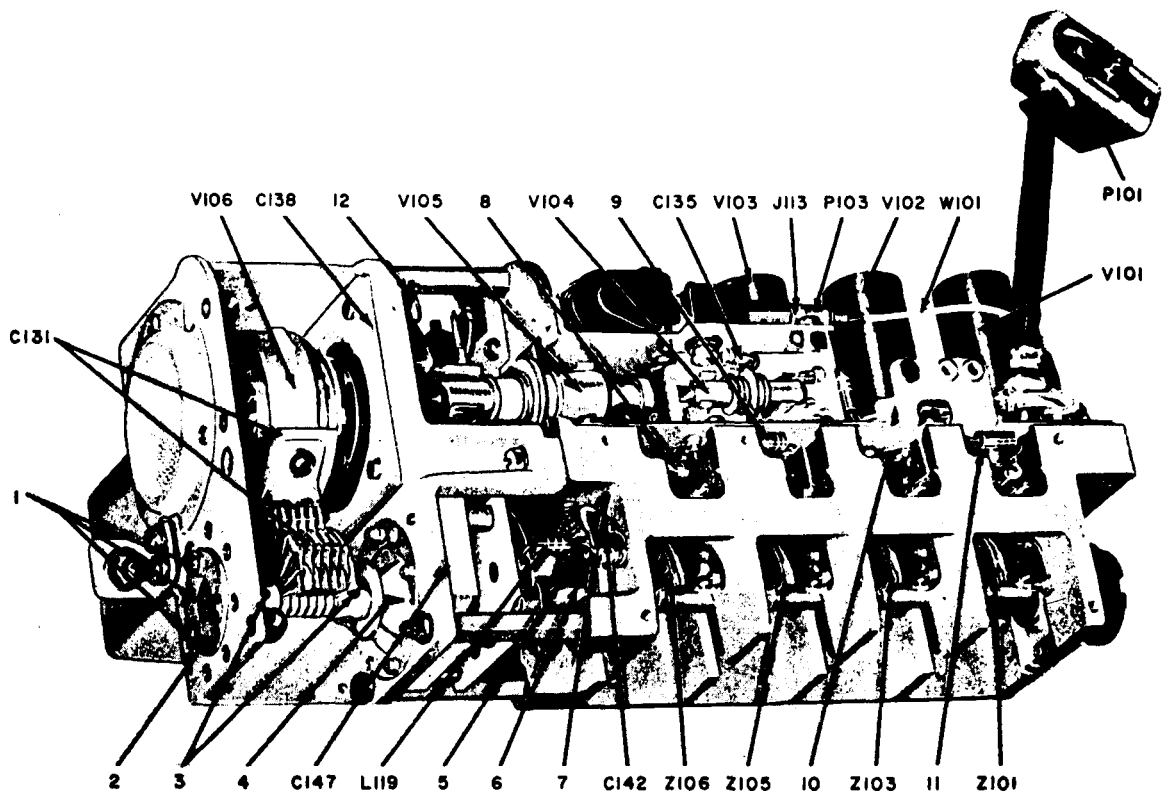
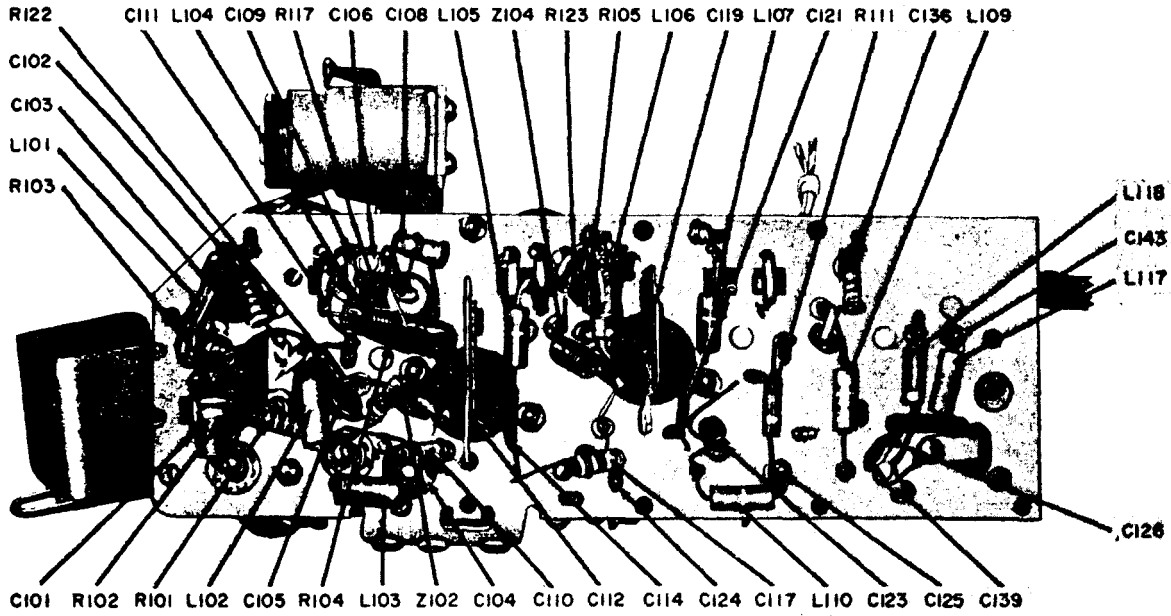


Figure 69. Rf and power amplifier subunit, right side view.



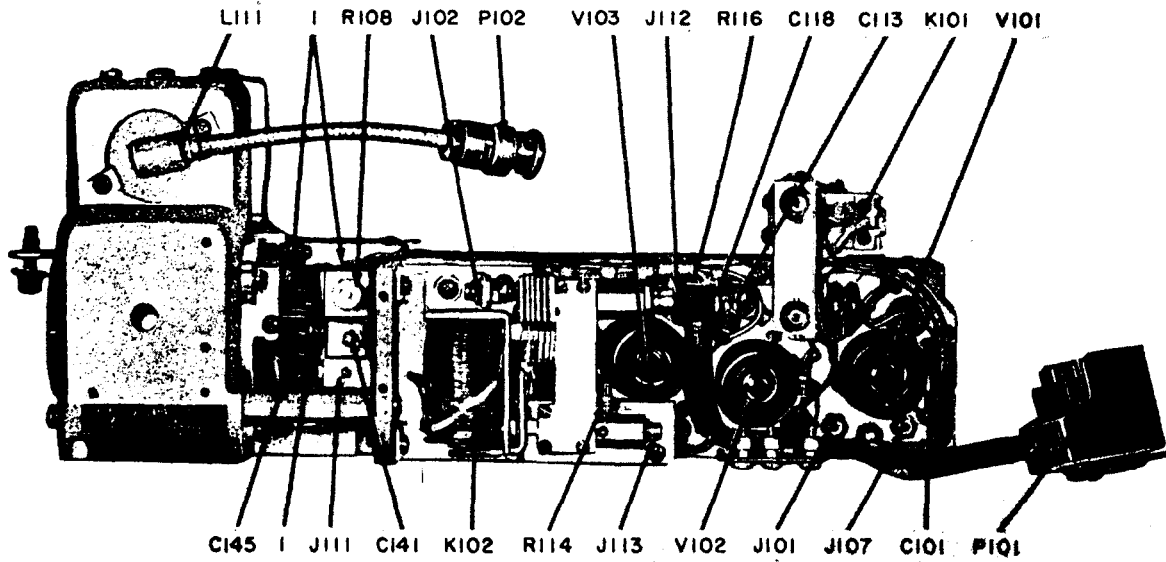
TM5820-222-35-96

Figure 70. Rf and power amplifier subunit, covers removed.



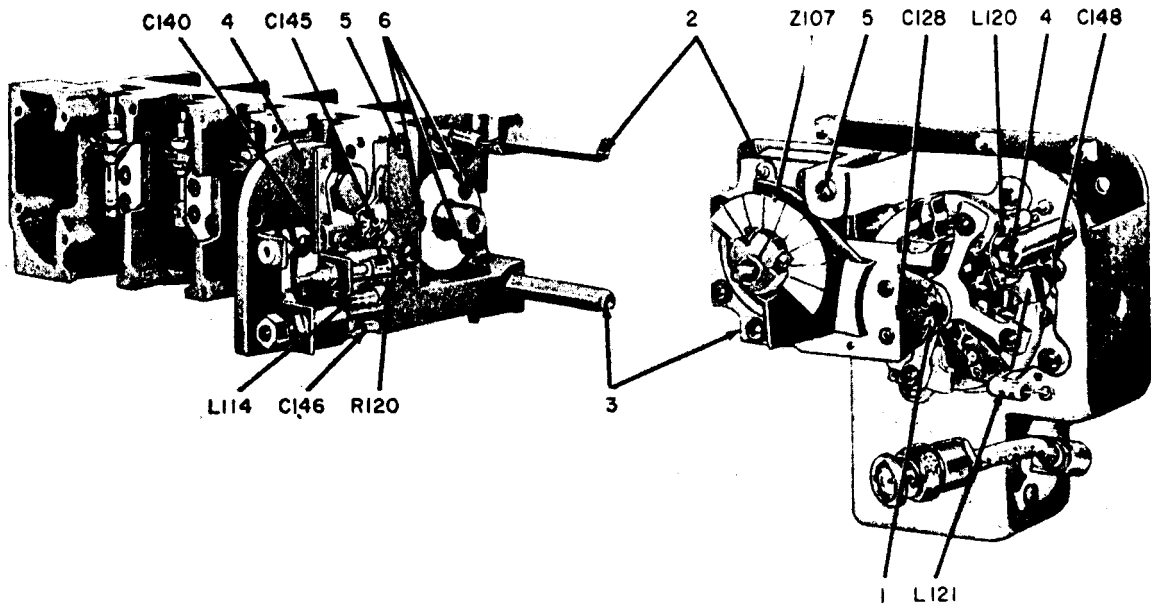
TM 5820-222-35-97

Figure 71. Rf and power amplifier subunit, tube chassis, bottom view.



TM 5820-222-35-98

Figure 72. Rf and power amplifier subunit, top view.



TM 5820-222-35-99

Figure 73. Rf and power amplifier subunit, tube chassis removed, power amplifier folded out.

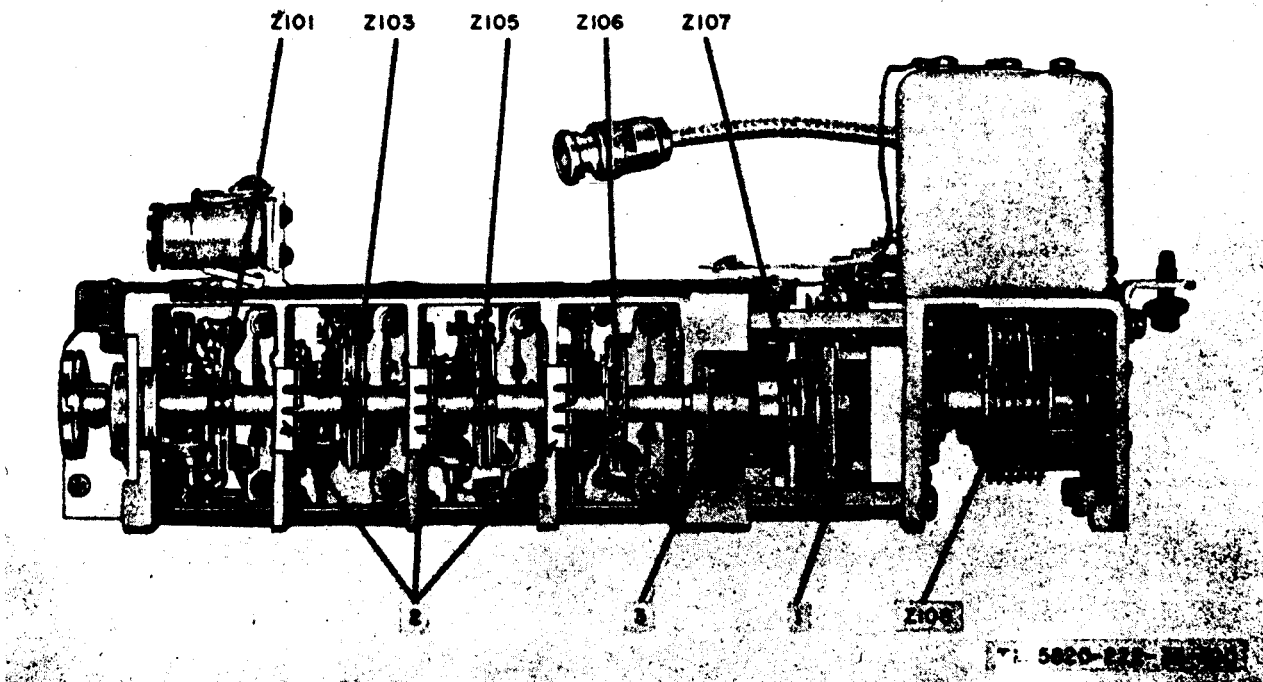


Figure 74. Rf and power amplifier subunit, bottom view cover plates removed.

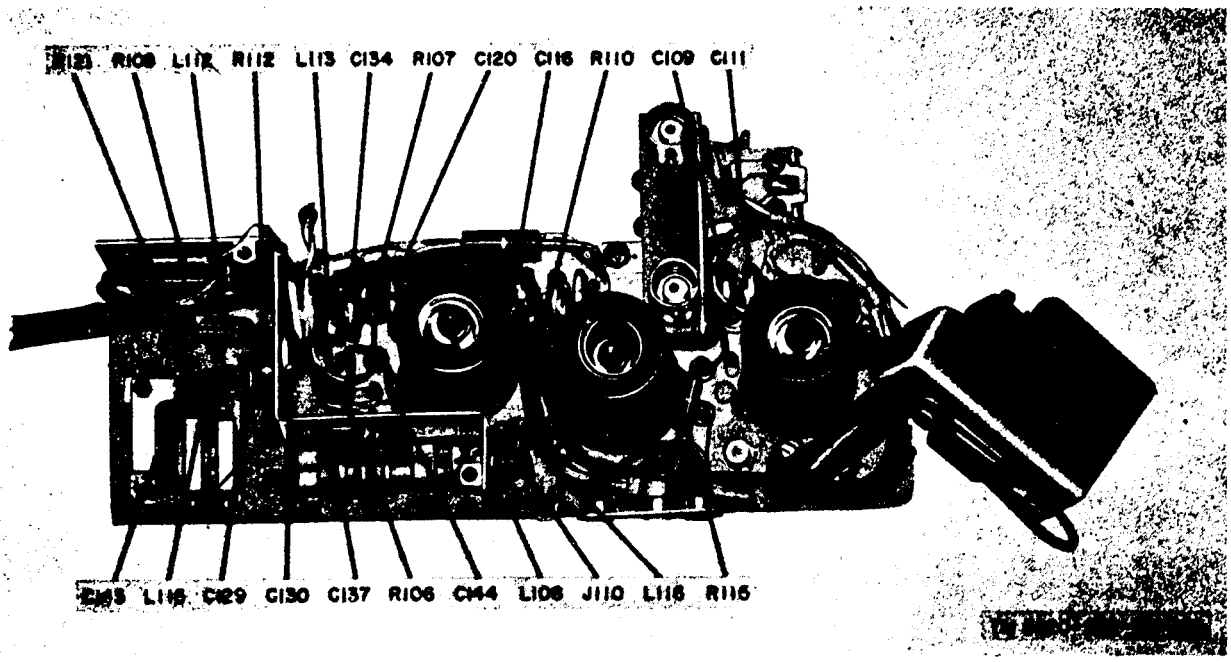


Figure 75. Rf and power amplifier subunit, tube chassis removed, power amplifier folded out.

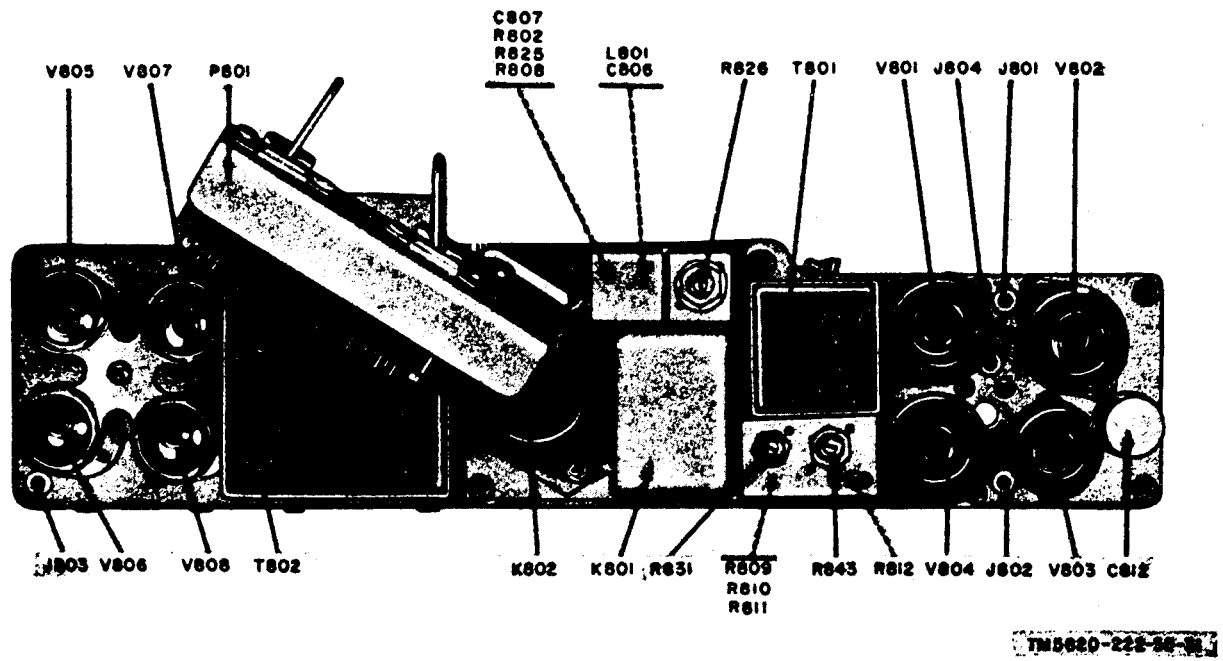
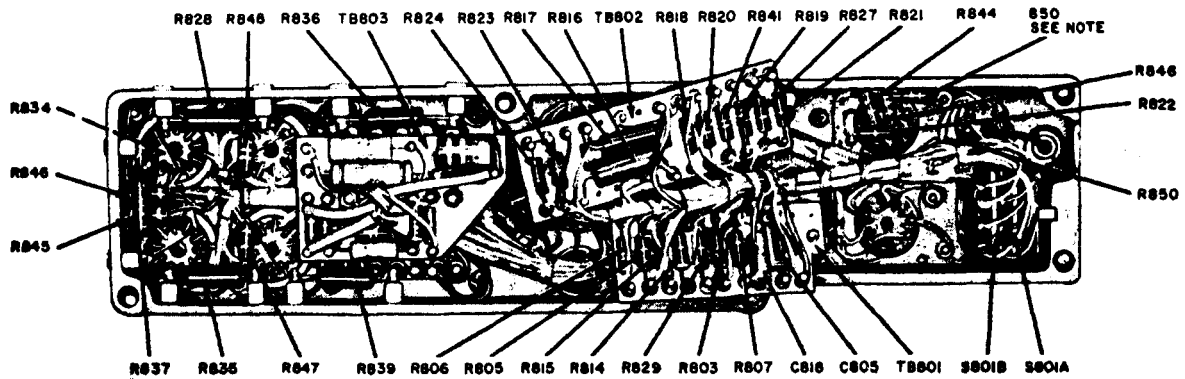


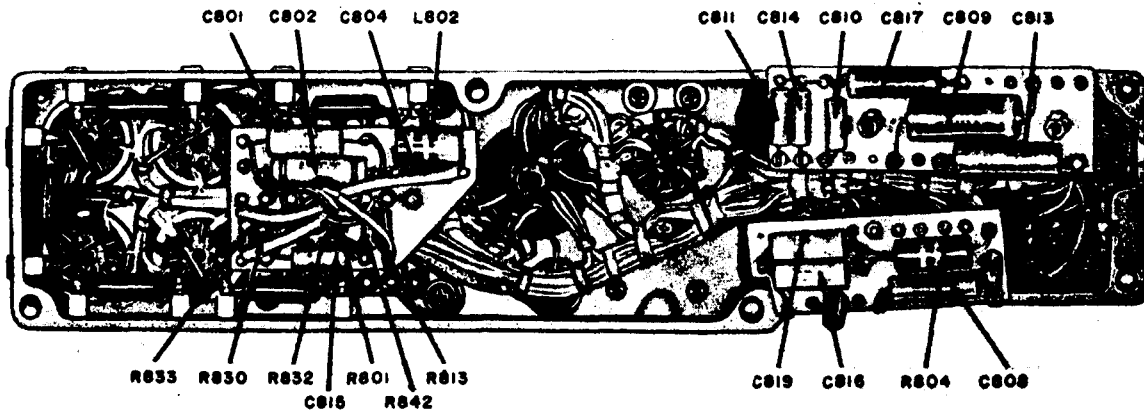
Figure 76. Audio amplifier and modulator subunit, top view.



**NOTE:**  
ON UNITS BEARING SERIAL NUMBER 210 AND  
HIGHER 100-ΩHM RESISTOR R850 HAS BEEN  
REPLACED BY 0.47 MH COIL L603.

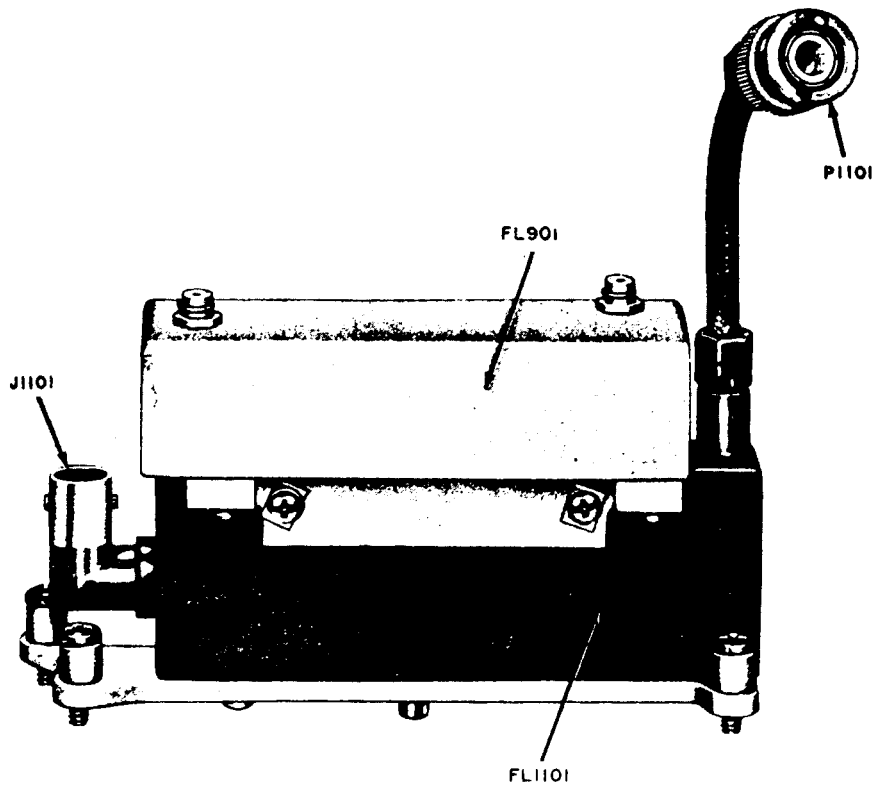
TM5820-222-36-88

Figure 77. Audio amplifier and modulator subunit, bottom view, inner sides of terminal boards.



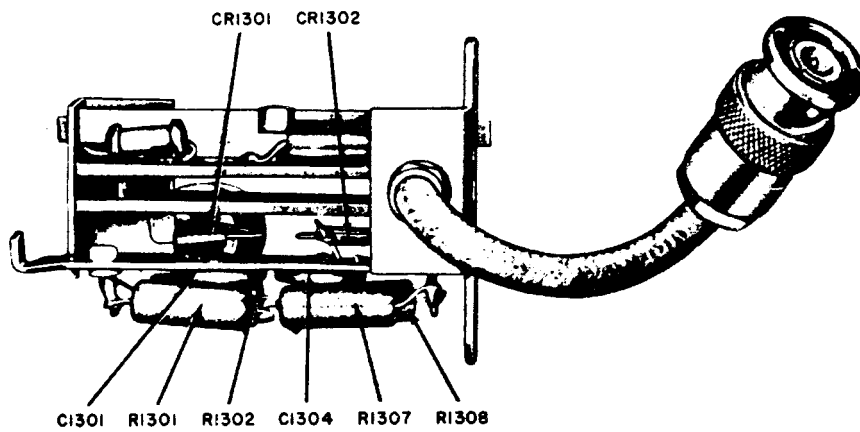
TM5820-222-36-88

Figure 78. Audio amplifier and modulator subunit, bottom view, outer sides of terminal boards.



TM5820-222-35-34

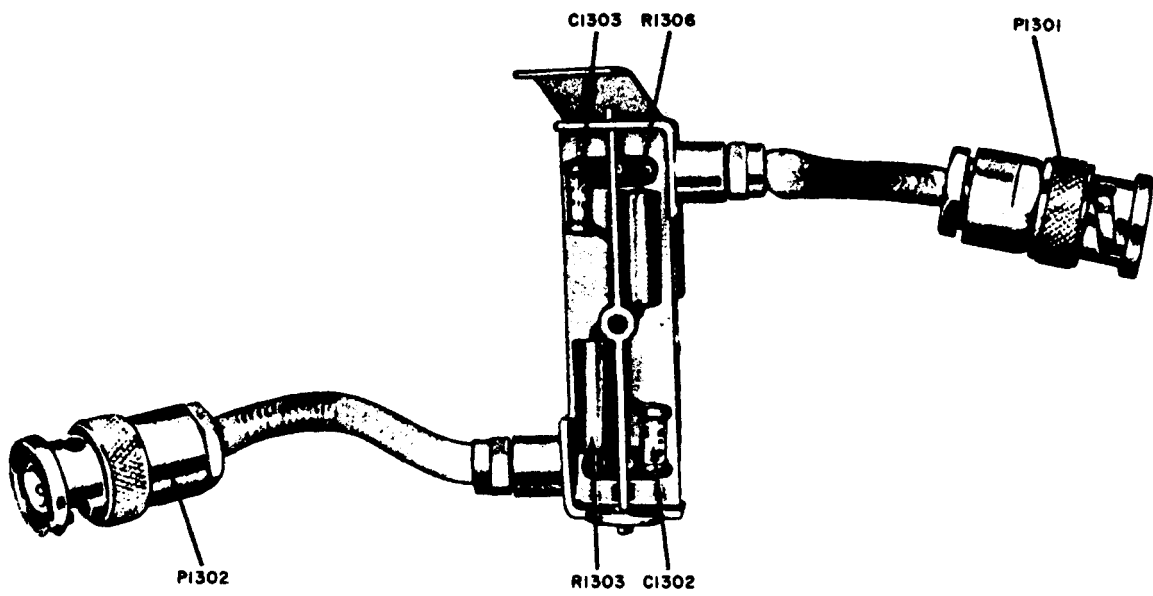
Figure 79. 500-kc if. filter and low pass filter, side view.



TM5820-222-35-35

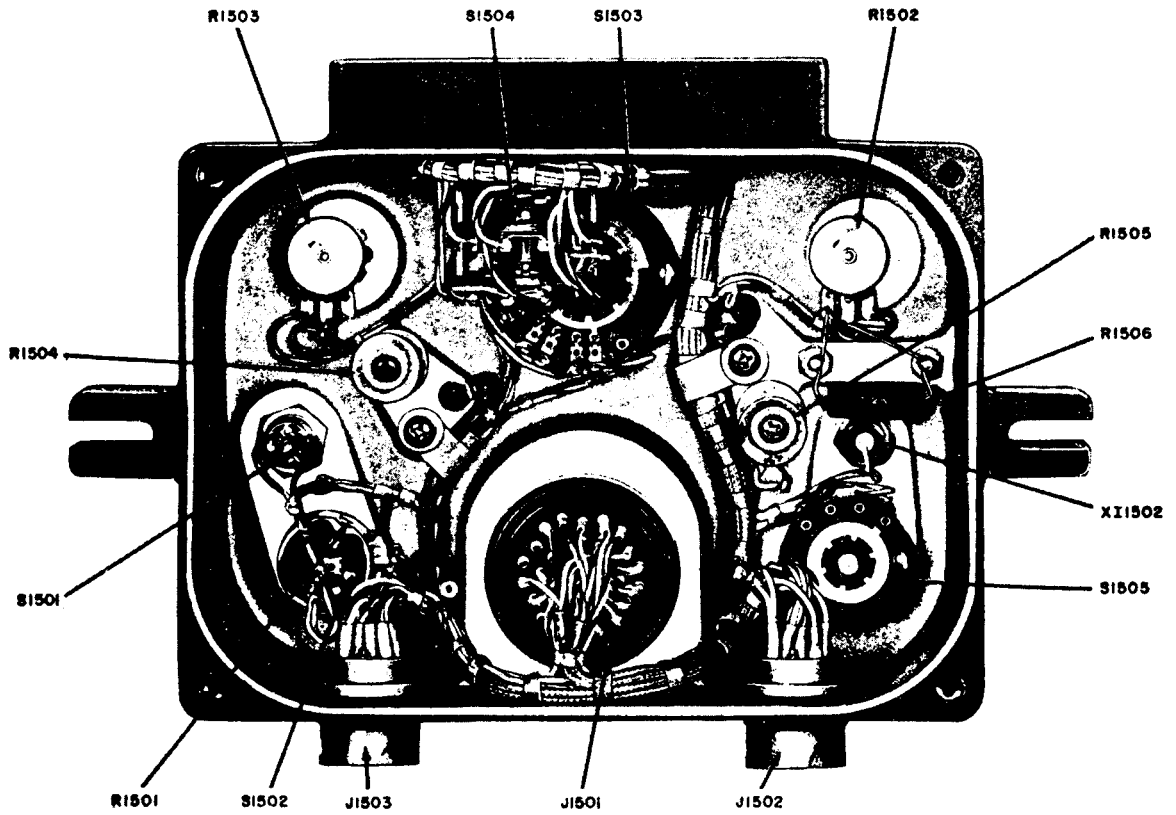
Figure 80. Directional coupler, side view.





TM 5820-222-35-36

Figure 81. Directional coupler, rear view.



TM 5820-222-35-1

Figure 82. Radio Set Control C-1439/U, rear view, cover removed.

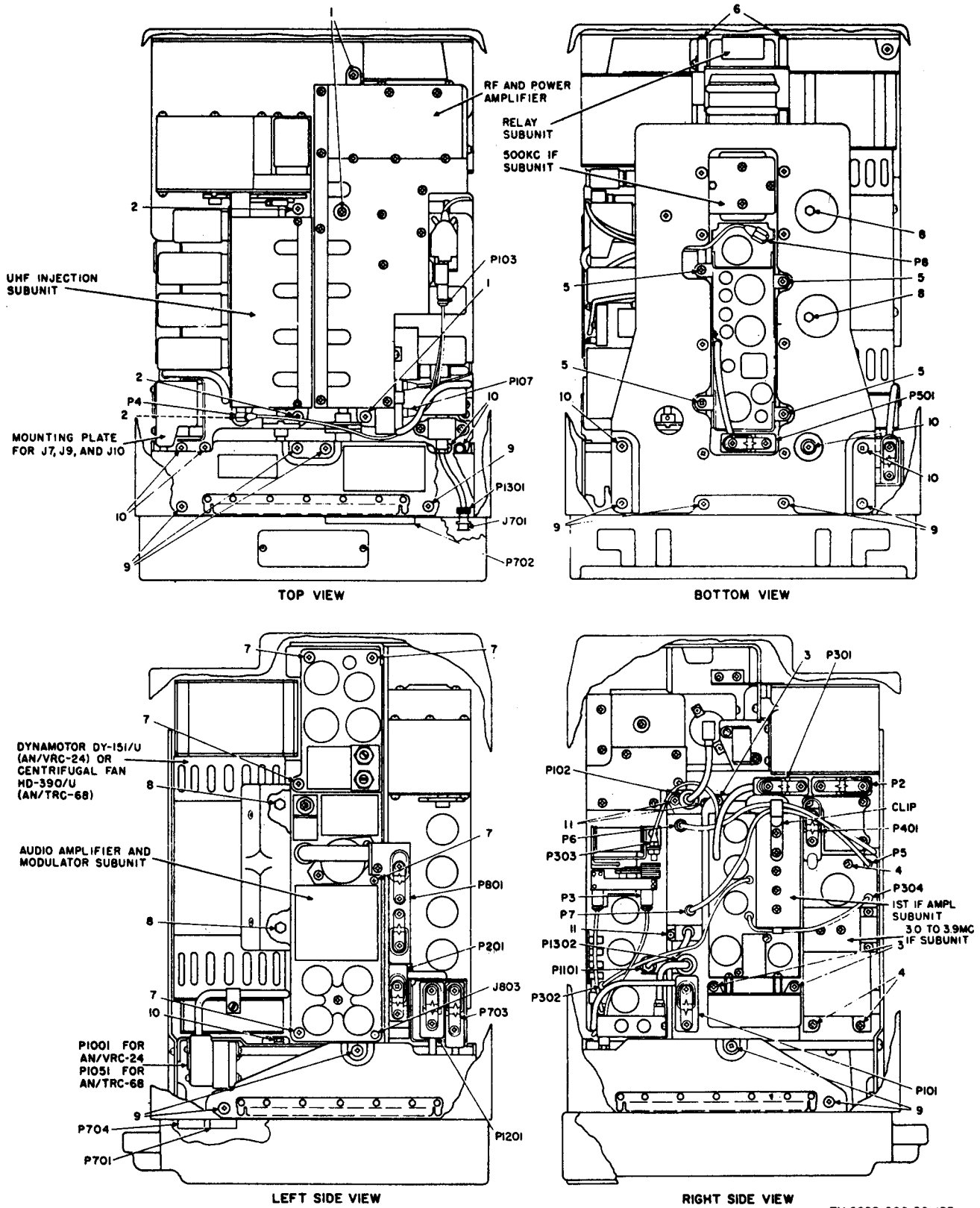
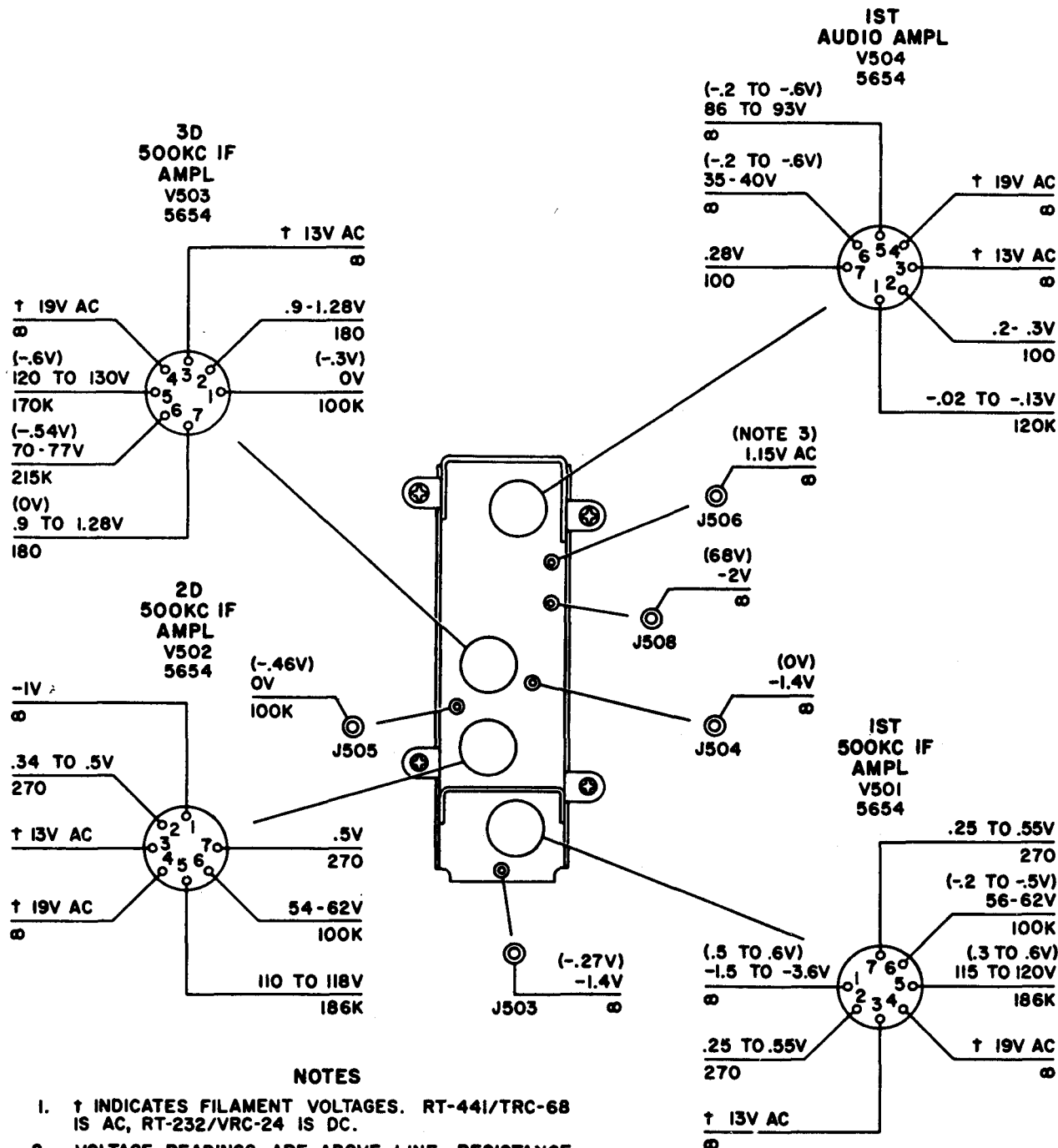


Figure 83. Location chart for subunits, subunit connectors, and subunit retaining hardware.



**NOTES**

1. † INDICATES FILAMENT VOLTAGES. RT-441/TRC-68 IS AC, RT-232/VRC-24 IS DC.
2. VOLTAGE READINGS ARE ABOVE LINE, RESISTANCE READINGS ARE BELOW.
3. MEASURED WITH 399.9MC 100UV, 30% MOD, 1,000 CPS SIGNAL APPLIED TO ANTENNA.
4. TEST JACK VOLTAGES MEASURED AT 399.9MC.
5. VOLTAGE READINGS IN PARENTHESES MEASURED DURING UNMODULATED TRANSMIT, ALL OTHERS MEASURED ON RECEIVE, TUBES AND SUBUNIT CONNECTED.
6. RESISTANCE MEASUREMENTS MADE WITH TUBES REMOVED AND SUBUNIT DISCONNECTED.
7. VOLTAGE AND RESISTANCE MEASUREMENTS MADE TO GROUND WITH MULTIMETER ME-26/U.

TM-5820-222-35-104

Figure 84. 600-kc if. amplifier subunit tube socket voltage-resistance diagram.

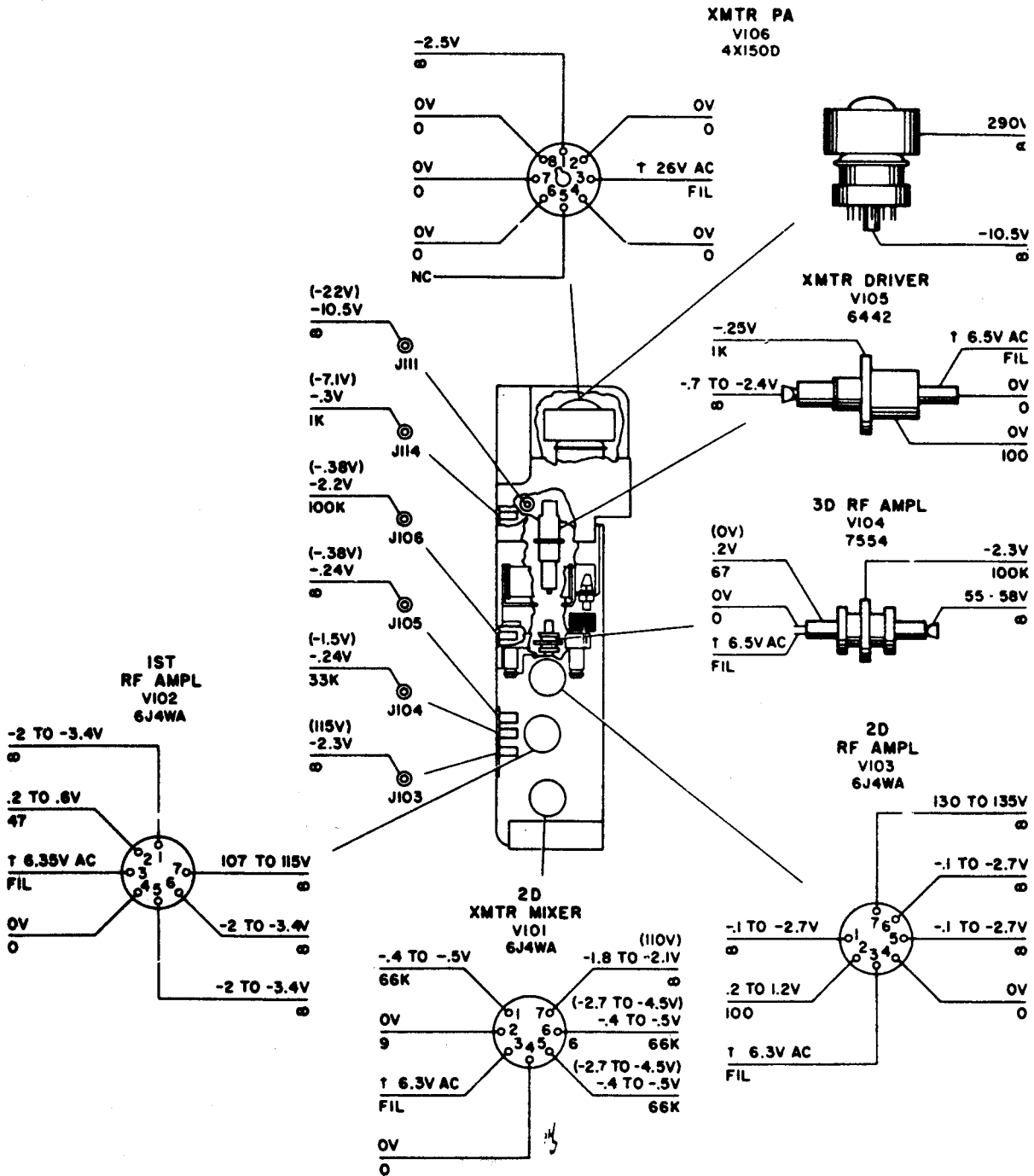


Figure 86. Rf and power amplifier subunit, tube socket voltage-resistance diagram.

**NOTES**

1. VOLTAGE READINGS ABOVE LINE, RESISTANCE READINGS BELOW LINE.
2. † INDICATES FILAMENT VOLTAGE. RT-441/TRC-68 IS AC, RT-323/VRC-24 IS DC.
3. TEST JACK MEASUREMENTS MADE AT 399.9MC.
4. RESISTANCES AND VOLTAGES ARE MEASURED TO GROUND WITH MULTIMETER ME-26/U.
5. VOLTAGES IN PARENTHESES MEASURED DURING UNMODULATED TRANSMISSION.
6. VOLTAGE MEASUREMENTS ON VIO4, VIO5 AND VIO6 WERE TAKEN ON RECEIVE ONLY. ALL VOLTAGE MEASUREMENTS MADE WITH TUBES IN AND SUBUNIT CONNECTED.
7. RESISTANCE MEASUREMENTS ARE MADE WITH TUBES REMOVED AND SUBUNIT DISCONNECTED.

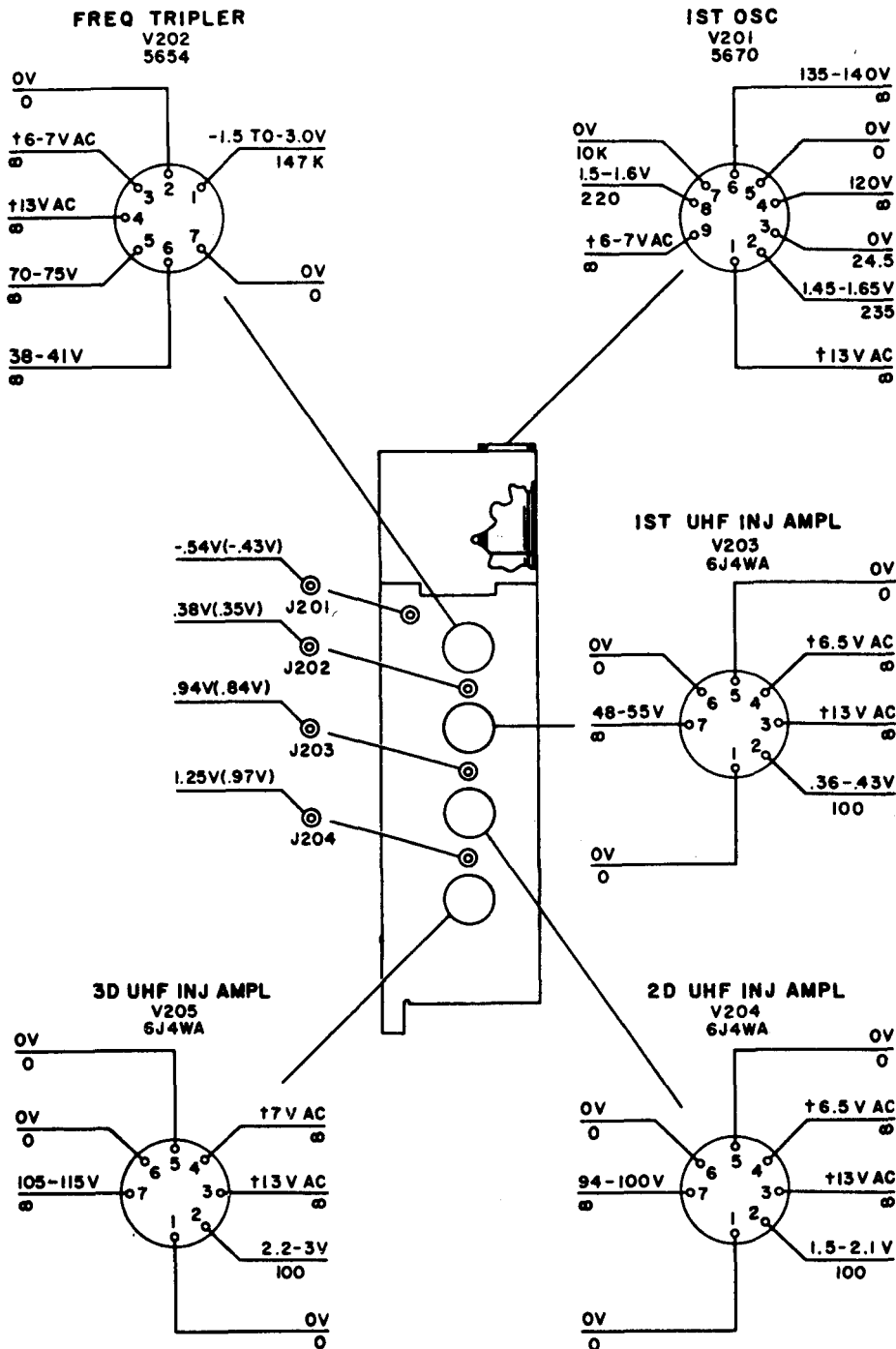


Figure 86. Uhf injection subunit, tube socket voltage-resistance diagram.

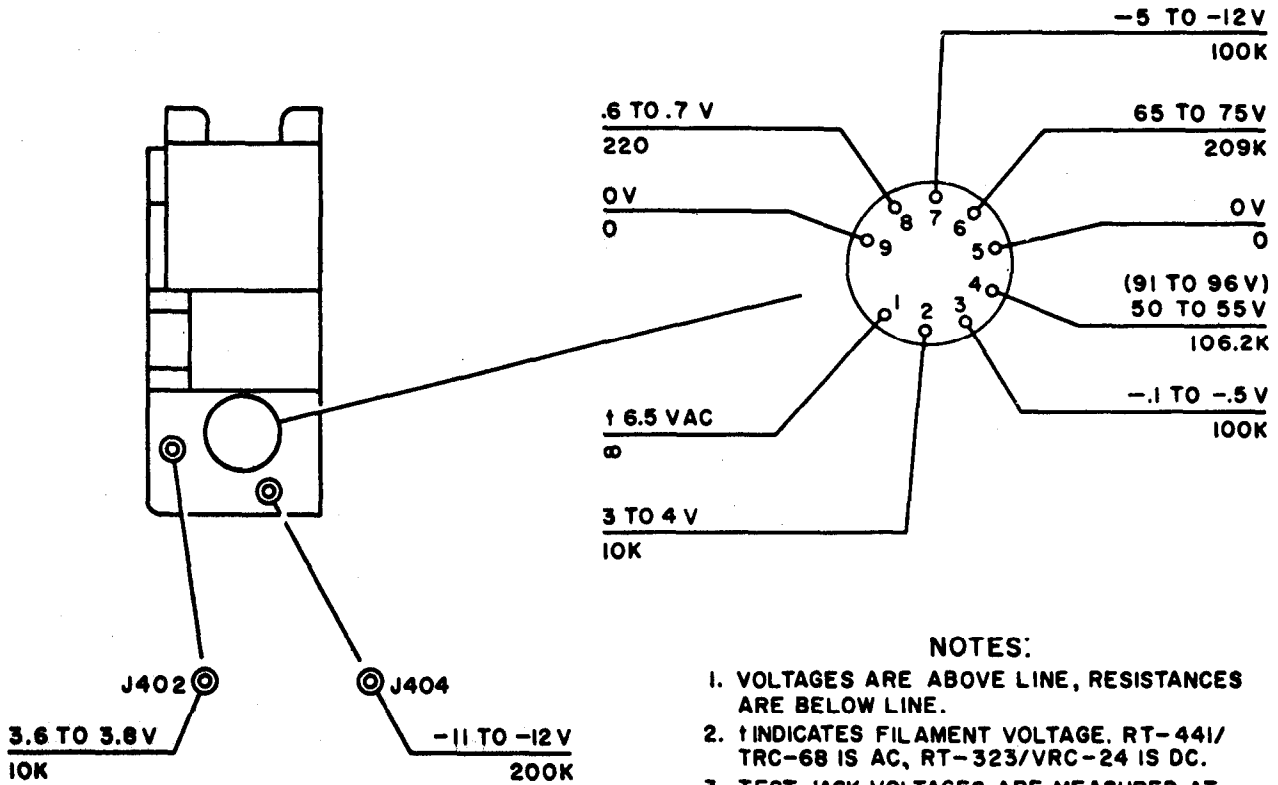
**NOTES:**

1. † INDICATES FILAMENT VOLTAGE, RT-441/TRC-68 IS AC, RT-323/VRC-24 IS DC.
2. VOLTAGE READINGS ARE ABOVE LINE, RESISTANCE READINGS ARE BELOW LINE.
3. TEST JACK VOLTAGES MEASURED AT 399.9 MC.
4. VOLTAGE READINGS IN PARENTHESES WERE MEASURED DURING UNMODULATED TRANSMISSION, ALL OTHER VOLTAGES MEASURED ON RECEIVE, TUBES IN AND SUBUNIT CONNECTED.
5. VOLTAGES AND RESISTANCES ARE MEASURED TO GROUND WITH MULTIMETER ME-26/U.
6. RESISTANCE MEASUREMENTS ARE MADE WITH TUBES REMOVED AND SUBUNIT DISCONNECTED. TUBES NEED NOT BE REMOVED FOR FILAMENT RESISTANCE MEASUREMENTS.

TM 5620-222-35-114

**3D RCVR MIXER-  
XMTR BUFFER AMPL**  
V401A  
( $\frac{1}{2}$ ) 5670

**3D OSC**  
V401B  
( $\frac{1}{2}$ ) 5670

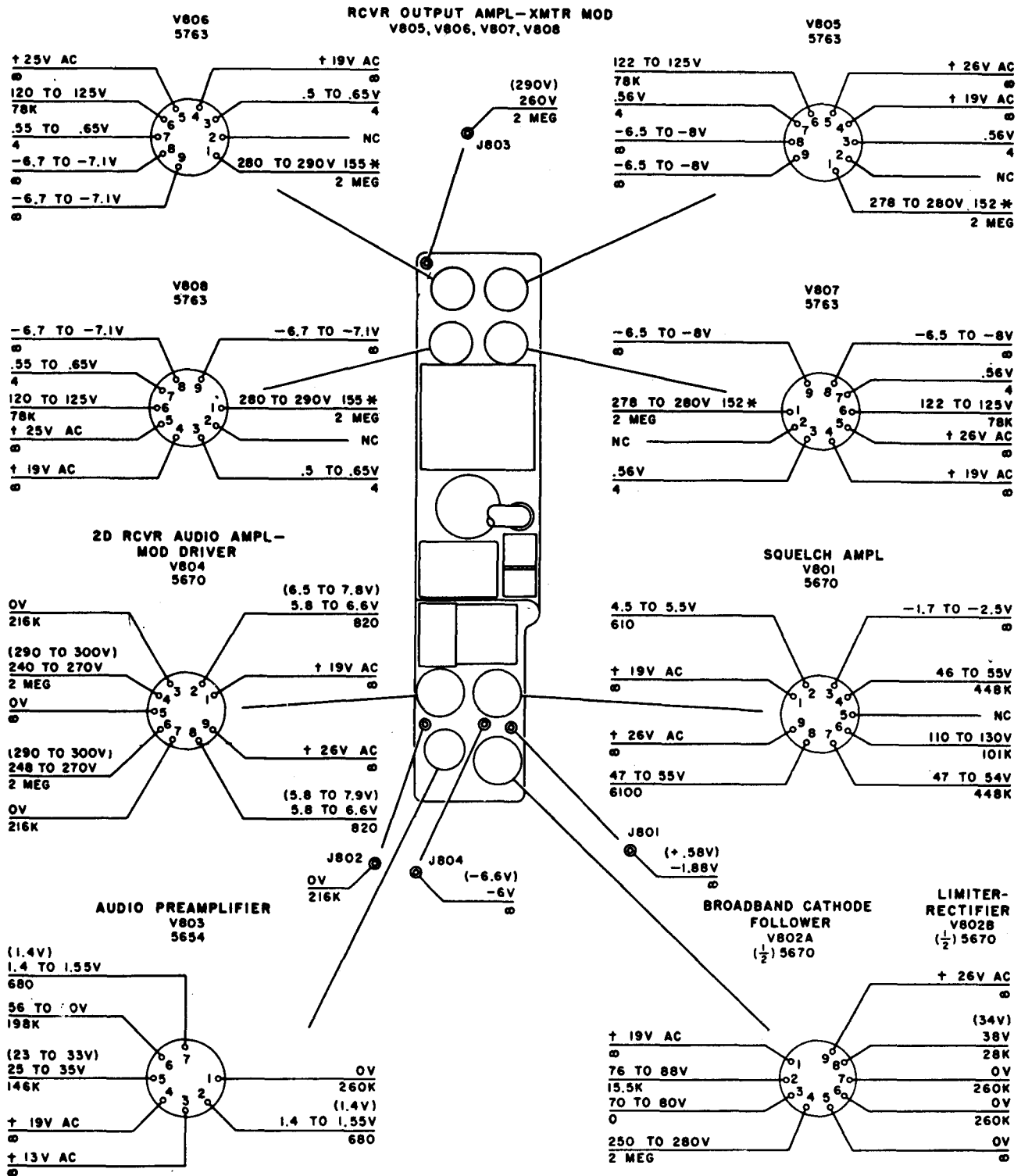


**NOTES:**

1. VOLTAGES ARE ABOVE LINE, RESISTANCES ARE BELOW LINE.
2. 1 INDICATES FILAMENT VOLTAGE. RT-441/TRC-68 IS AC, RT-323/VRC-24 IS DC.
3. TEST JACK VOLTAGES ARE MEASURED AT 399.9 MC.
4. VOLTAGES IN PARENTHESES ARE MEASURED DURING UNMODULATED TRANSMISSION, ALL OTHER VOLTAGES MEASURED ON RECEIVE, TUBE AND SUBUNIT CONNECTED.
5. VOLTAGE AND RESISTANCE MEASUREMENTS MADE TO GROUND WITH MULTIMETER ME-26/U.
6. RESISTANCE MEASUREMENTS MADE WITH TUBE REMOVED AND SUBUNIT DISCONNECTED.

TM 5820-222-35-115

Figure 87. 3.0- to 3.9 mc if. subunit, tube socket voltage-resistance diagram.



**NOTES:**

1. † INDICATES FILAMENT VOLTAGE. RT-441/TRC-68 IS AC. RT-323/VRC-24 IS DC.
2. NC INDICATES NO CONNECTION.
3. VOLTAGE READINGS ARE ABOVE LINE. RESISTANCE READINGS ARE BELOW LINE.
4. TEST JACK MEASUREMENTS MADE AT 399.9 MC. VOLTAGES AND RESISTANCES ARE MEASURED TO GROUND WITH MULTIMETER ME-26/U. RESISTANCE MEASUREMENTS ARE MADE WITH TUBES REMOVED AND SUBUNIT DISCONNECTED. TUBES NEED NOT BE REMOVED FOR FILAMENT RESISTANCES. VOLTAGE MEASUREMENTS MADE WITH ALL TUBES IN AND SUBUNIT CONNECTED.
5. VOLTAGES IN PARENTHESES MEASURED ON UNMODULATED TRANSMIT.
6. V801 MEASUREMENTS TAKEN WITH SQUELCH CONTROL IN OFF POSITION.
7. \* INDICATES AUDIO VOLTAGES.

TM 5820-222-35-116

Figure 88. Audio amplifier and modulator subunit, tube socket voltage-resistance diagram.



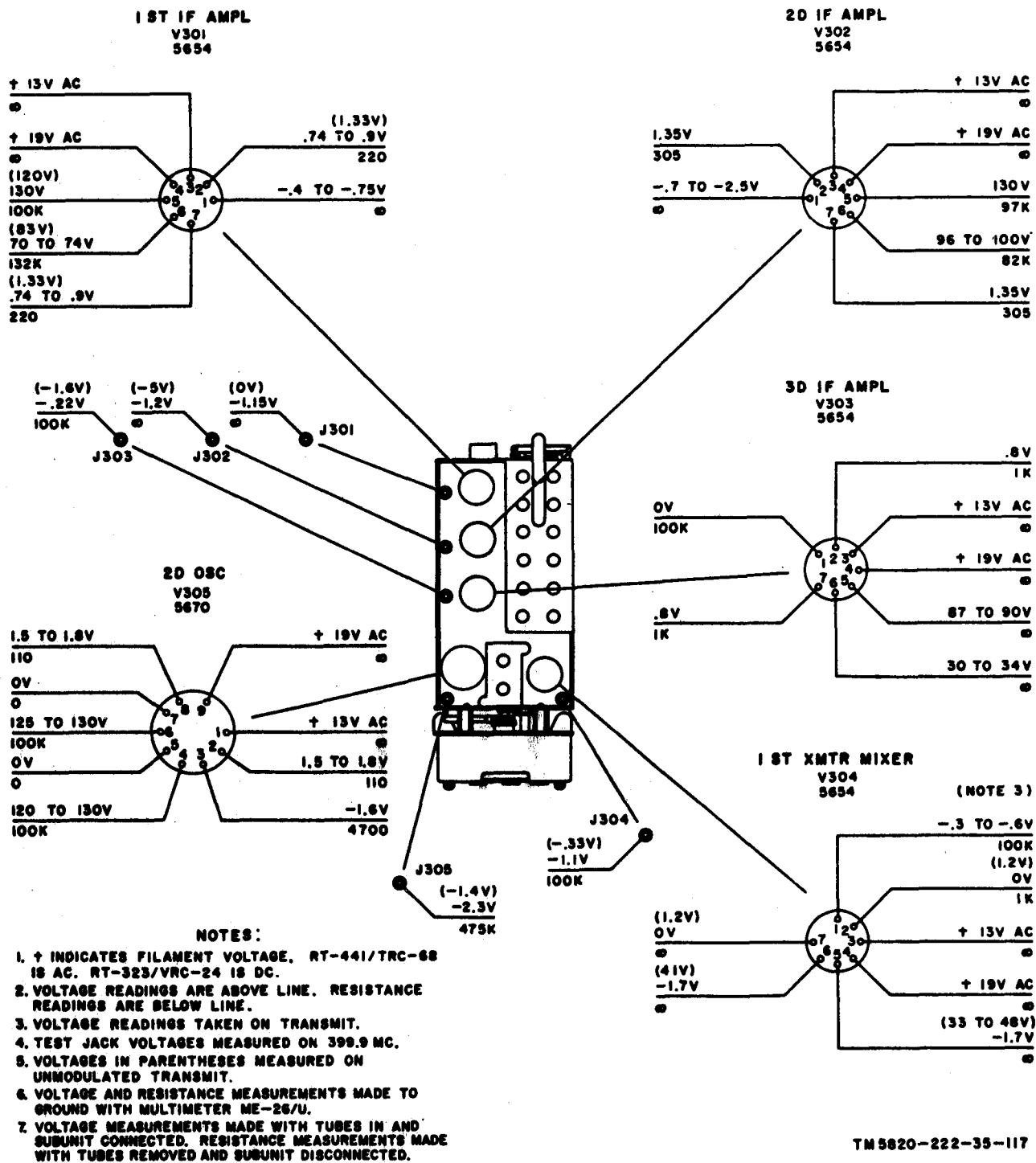


Figure 89. First if. amplifier subunit, tube socket voltage-resistance diagram.

## 100. Audio Stage Gain on Receive

The voltage measurements listed in the following chart will aid in locating a faulty stage or circuit component in the audio amplifier and modulator subunit. Operate Radio Set AN/VRC-24 or AN/TRC-68 on normal receive. Turn the SQUELCH control on the front panel to OFF. Use a variable autotransformer and the ME-30/U to obtain 115 (or 230) volts ac input to Radio Set AN/TRC-68, or use a potentiometer and Multimeter ME-26/U to obtain 26.4 volts dc input to Radio Set AN/VRC-24; then, connect the audio test box (para 128) and the ME-30/U to either front panel AUDIO jack (fig. 38). Connect the voltmeter leads and a 600-ohm load across the SPEAKER and AF OUTPUT RETURN terminals. (Connect oscilloscope AN/USM-50 across these terminals to check for spurious noise voltages.) Use Audio Oscillator TS-382/U and inject a 1,000-cps signal to the test points indicated in the following chart. Adjust the audio voltage level of the audio oscillator to obtain a 24.5-volt ac indication on the ME-30/U. If the audio oscillator TS-382/U input required to obtain a 24.5 volt ac reading is greater than the input indicated in the following chart, check the circuits and components indicated.

Test point	Audio voltage level (volts dc)	Check
J802 (fig. 76).	0.93	Audio output circuits, including V804, T801, V805, V806, V807, V808, and T802 (fig. 14).
BROADBAND jack J704-A (NOR BB switch S801 in BB position) (TM 11-5820-222-10).	0.042	Audio input circuits to V803 and associated circuit components (fig. 20).
J506 (fig. 59).	2.3	Audio input circuits to V804, including S801 and K801.

## 101. Receiver Signal Tracing (fig. 128)

The voltage measurements listed in the following chart will aid in locating a malfunctioning stage or circuit component in the uhf injection subunit, the first if. am-

plifier, or the 3.0-3.9-mc if. subunits. Operate Radio Set AN/VRC-24 or AN/TRC-68 on normal receive. Check for proper input voltages (para 100). Use Multimeter ME-26/U to measure the voltages at the test points listed. Voltages listed are for frequencies in the range of 225.0 to 399.9 mc.

Test point	Voltage (volts dc)	Check
J201 (fig. 53)	-0.8 to -1.7	V201 and associated circuit components.
J202 (fig. 53)	+0.38 to 0.43	V202 and associated circuit components.
J203 (fig. 53)	+0.8 to 1.1	V203 and associated circuit components.
J204 (fig. 53)	+1.1 to 2.1	V204 and associated circuit components.  <i>Note.</i> If reading is 1.1 volts at J203 and J204, trouble is indicated in V204.
J106 (fig. 68)	-0.94 to -3.8	V205 and associated circuit components, or coaxial cable W4.
J305 (fig. 62)	-2.0 to -2.6	V305 and associated circuit components.
J404 (fig. 56)	-7.0 to -12.0	V401 and associated circuit components.

## 102. Transmitter Signal Tracing (fig. 128)

Use the following chart to locate defective circuits or stages while the radio set is operating on transmit. Before keying the transmitter, connect *Radio Frequency Wattmeter AN/URM-43A to the ANT. jack on the front panel.* Before measuring voltages at the test points indicated, check the input voltage to the radio set (para 100). Use Multimeter ME-26/U to measure voltages. Voltages listed in the chart are for the frequency range from 225.0 to 399.9 mc.

Test point	Voltage (volts dc)	Check
J404 (fig. 56)	-6 to -12	V401 and third oscillator circuit components.
J402 (fig. 56)	3 to 3.8	V401 or buffer amplifier circuit components.
J304 (fig. 62)	-0.3 to -0.98	Z403, Z402, and Z401 (fig. 56).
J305 (fig. 62)	-1.4 to -2.6	V305 or associated circuit components.
J301 (fig. 62)	-1 to -1.5	V304 or associated circuit components.

Test point	Voltage (volts dc)	Check
<b>J302 (fig. 62)</b>	<b>-5 to -1.1</b>	V301 or associated circuit components.
J104 (fig. 74)	-0.6 to -2.6	V302 or associated circuit components.
J201 (fig. 53)	-0.9 to -1.4	V201 or associated circuit components.
J105 (fig. 68)	0 to -0.38	V101, V102, or associated circuit components.
J106 (fig. 68)	-0.23 to -1.2	V103 or associated circuit components.
J114 (fig. 68)	-4 to -7	V104 or associated circuit components.
J111 (fig. 72)	-22 to -40	V105 or associated circuit components.

### 103. Sensitivity Checks (fig. 38 and 83 through 90)

a. Perform the sensitivity checks as follows:

- (1) Set up the rt unit for normal receive (SQUELCH control at OFF) on 399.9 mc. Do not change the frequency setting during the sensitivity checks.
- (2) Check for proper input voltage as described in paragraph 100.
- (3) Connect the audio test box (para 128) to either front panel AUDIO jack and connect Electronic Voltmeter ME - 30B/U, Oscilloscope AN/USM-50, and a 600-ohm load between the SPEAKER and AF OUTPUT RETURN terminals of the audio test box.
- (4) Connect the AN/URM-25D to the test jack indicated in the chart below. Adjust the signal generator

to the frequency indicated in the chart. To perform the sensitivity checks at the ANT. jack, connect the TS-497/URR to the ANT. jack through the 6-db pad supplied with the TS-497/URR.

- (5) Modulate the input frequency 30 percent at 1,000 cps and adjust the input level to the maximum input microvolt setting listed in the chart.
- (6) Note the rt unit audio output level (in db) as indicated on the ME-30B/U, and note the AN/URM-25D or TS-497/URR output in microvolt.
- (7) Remove the 1,000 -cps, 30-percent modulation from the signal generator output frequency and note the decrease in rt unit audio output level (in db). The decrease must be at least 10 db.

b. The following chart indicates the normal ranges of signal generator output voltage required to obtain a 10-db signal plus noise-to-noise ratio at each test point. The input voltage required at each test jack will vary slightly with each unit. Because of the difference in power supplies, separate ranges are listed for the RT-441/TRC-68 and the RT-323/VRC-24. The input microvolt ranges listed were determined by measurements made on typical receiver-transmitter units. When abnormally high or low input voltages are required to obtain a 10-db signal plus noise-to-noise ratio, perform the isolating procedure indicated in the chart to locate the cause of trouble.

Test point	Frequency (mc)	Input microvolts		Isolating procedure
		RT-323/VRC-24	RT-441/TRC-68	
J505 (fig. 59)	0.5	10,000-32,000	10,000-18,000	Check V503 and V504 and make voltage-resistance checks in these stages, or check detector and noise limiter circuits to isolate trouble. Check V501 and V502, and make voltage resistance measurements to isolate trouble. Check 500-kc filter. Check V401 and make voltage-resistance measurement to isolate trouble.
J503 (fig. 59)	0.5	10-55	10-30	
J402 (fig. 56)	0.5	35-80	35-60	

Test point	Frequency (mc)	Input microvolts		Isolating procedure
		RT-323/VRC-24	RT-441/TRC-68	
J402 (fig. 56)	3.9	35-80	35-60	Check V401 and make voltage-resistance measurements to isolate trouble.
J303 (fig. 62)	3.9	35-100	35-70	Check V303 and make voltage-resistance measurements to isolate trouble.
J303 (fig. 62)	29.9	40-85	38-76	Check V305 and make resistance-voltage measurements to isolate trouble.
J302 (fig. 62)	29.9	20-45	20-38	Check V302 and make voltage-resistance measurements to isolate trouble.
J301 (fig. 62)	29.9	4.5-10	4-8	Check V301 and make voltage-resistance measurements to isolate trouble.
ANT. jack (front panel) (use TS-497/U)	399.9	2.5-4.5 (typical) 6 maximum	2.5-4.5 (typical) 6 maximum	Check bias at J106 (fig. 68 and 85). If normal, go to transmit operation and check tuning of rf amplifiers (para 137). Then check V102 and V103 by substitution. If tubes are good, plug in test socket adapter and make voltage-resistance measurements. If bias at J106 is abnormal, go to transmit operation and check bias at J104 (para 97). If signal is abnormal, trace the uhf injection subunit (para 97) to isolate trouble. If bias at J104 is normal, go to transmit operation. Check tuning of rf amplifier and the rf amplifier stages V102, V103 and V104 (para 137).

#### 104. Isolating Trouble Within a Stage

When trouble has been localized to a stage, use the following techniques to isolate the defective part.

a. Test the tube involved either in Tube Tester TV-7/U or by substituting a similar type tube which is known to be operating normally.

b. Take voltage measurements at the tube sockets (fig. 83 through 89) to isolate open and short circuits.

c. If voltage readings are abnormal, take resistance readings (fig. 83 through 89) to isolate open and short circuits. Refer also to the dc resistances of transformers

and relay coils in paragraph 105.

d. If signals are weak and all checks fail to indicate a defective part, check the alignment (para 128 through 141).

e. Use the partial schematic diagrams to circuit-trace and isolate the faulty component.

#### 105. Dc Resistances of Transformers and Relay Coils

The dc resistances of the transformer windings and the relay coils in the receiver-transmitter are listed below. Relay resistances must be measured with the relays disconnected.

Transformer or relay coil	Terminals	Do resistance (ohms)
T501	1-4	82
	3-2	45
T801	1-2	2,000
	3-4	45
	4-5	47
T802	1-4	46
	4-5	160
	6-7	45
	7-9	23
	10-11	60
K1	1,9	237
K2	1,9	237
K3		300 ± 30%, 25° C
K 1 0 1 <sup>a</sup>		275
K 1 0 2 <sup>a</sup>		100
K401		525
K601		675
K602	1,5	200
K801	1,10	14,000
K802	14,18	200
K1201, K1202, K1203, and K1204		20

<sup>a</sup>K101 and K102 are wired in parallel. The resistance of the two relays in parallel is approximately 80 ohms.

# CHAPTER 6

## REPAIRS AND ALIGNMENT

*Note.* Procedures in this chapter are performed at 3rd echelon unless, otherwise noted.

---

### Section I. REMOVAL AND REPLACEMENT OF SUBUNITS

#### 106. General Instructions

a. When equipment failure occurs, use the troubleshooting procedures in chapter 5 to localize the trouble. Check applicable cables and connectors before attempting to replace any subunit. *Before removing any subunit, channel the rt unit to 399.9 mc.* At this frequency setting, the frequency selector tuning shaft couplers are positioned for easy removal and replacement.

*Warning:* Turn the POWER control to OFF before attempting any removal procedures.

b. To gain access to the subunits, refer to TM 11-5820-222-20 for removal of the rt unit from the radio set. The subunits can be removed from the rt unit without the use of special tools. The retaining hardware on the subunits is painted green for easy location. When replacing a subunit, align all retaining screws with their respective holes before tightening the screws.

c. All single-connector plugs are color coded. The color of the plug sleeve matches the colored dot alongside the mating jack. After replacing the subunit, be sure that all the jack and plug colors match before applying power. When disconnecting cable connectors, do not twist or bend; pull the plug connectors straight out of the mating jacks.

#### 107. Removal and Replacement of Rf and Power Amplifier Subunit (fig. 83)

##### a. Removal

- (1) Place the rt unit top side up on the bench.

- (2) Disconnect plugs P3, P101, P102, P302, P303, P1101, and P1302 (right-side view).
- (3) Loosen the three green-headed captive screws (1) on the top of the subunit (top view). Remove the captive screw, which is about two-thirds of the distance from the front of the subunit, by inserting the screwdriver into the circular cutout in the shield.
- (4) Lift the rf and power amplifier subunit from the main frame.

##### b. Replacement.

- (1) Set the coupler on the rf and power amplifier so that, when viewed from the front of the subunit, the slot in the coupler is vertical and the guide pin is in the upper-right corner.
- (2) Seat the subunit on the chassis, align the captive screws with the holes, and arrange the subunit coupler to mesh with the frequency selector coupler.
- (3) Tighten the three captive screws (1) on the top of the subunit (top view).
- (4) Connect plugs P3, P101, P102, P302, P303, P1101, and P1302 (right-side view).

#### 108. Removal and Replacement of Uhf Injection Subunit (fig. 83)

##### a. Removal

- (1) Place the rt unit top side up on the bench.
- (2) Disconnect plug P4 (top view).
- (3) Disconnect plug P201 (left-side view); insert a screwdriver under

the handle to pull the plug straight out.

- (4) Loosen the two captive screws (2) at the front end of the subunit, and the single captive screw (2) at the rear (top view).
- (5) Lift up to remove the subunit.

**b. Replacement.**

- (1) Align the slot on the subunit coupler vertically with the guide pin in the upper right corner, to mesh with the coupler on the frequency selector.
- (2) Hold plug P201 clear and seat the subunit on the main frame so that the captive screws are aligned with the holes.
- (3) Tighten the three captive screws (2) (top view).
- (4) Connect plug P4 (top view) and plug P201 (left-side view).

**109. Removal and Replacement of First If. Amplifier Subunit**  
(fig. 83)

**a. Removal.**

- (1) Set the rt unit on its left side on the bench.
- (2) Disconnect plugs P302 and P303 (right-side view).
- (3) Disconnect plug P304 (right-side view).
- (4) Disconnect plug P301 (right-side view).
- (5) For convenience, disconnect plugs P6 and P7, and slide the cables out from under the clip (right-side view).
- (6) Loosen the two captive screws (3) at the front of the subunit, and the single captive screw (3) at the rear (right-side view).
- (7) Lift the subunit up to remove it.

**b. Replacement.**

- (1) Align the slots on the subunit couplers vertically, with the guide pins in the upper right quadrant when the subunit is viewed from the front, to mesh with the frequency selector couplers.

- (2) Seat the subunit on the main chassis and align the captive screws with the holes.
- (3) Tighten the three captive screws (3) (right-side view).
- (4) Connect plugs P301, P302, P303, and P304 (right-side view).
- (5) Connect plugs P6 and P7 and slide the cables under the clip (right-side view).

**110. Removal and Replacement of 3.0- to 3.9-Mc If. Subunit**  
(fig. 83)

**a. Removal**

- (1) Set the rt unit on its left side on the bench.
- (2) Disconnect plugs P5, P304, and P401 (right-side view).
- (3) Loosen two captive screws (4) at the front of the subunit and one captive screw at the rear (right-side view).
- (4) Lift the subunit up to remove it.

**b. Replacement.**

- (1) Align the slot on the subunit coupler vertically, with the guide pin in the upper right quadrant when the subunit is viewed from the front, to mesh with the frequency selector coupler.
- (2) Seat the subunit on the chassis so that the captive screws are aligned with the holes.
- (3) Tighten the three captive screws (4) (right-side view).
- (4) Connect plugs P5, P304, and P401 (right-side view).

**111. Removal and Replacement of 500-Kc If. Amplifier Subunit**  
(fig. 83)

**a. Removal**

- (1) Set the rt unit bottom side up on the bench.
- (2) Disconnect plugs P8 and P501 (bottom view).
- (3) Loosen the four captive screws (5) (bottom view).
- (4) Lift the subunit up to remove it.

*b. Replacement.*

- (1) Seat the subunit on the chassis so that the captive screws are aligned with the holes.
- (2) Tighten the four captive screws (5) (bottom view).
- (3) Connect plugs P8 and P501 (bottom view).
- (4) Dress the cable to plug P501 close to the chassis.

**112. Removal and Replacement of Audio Amplifier and Modulator Subunit (fig. 83)**

*a. Removal.*

- (1) Set the rt unit on its right side on the bench.
- (2) Disconnect plug P801 by placing a screwdriver under both handles and pulling straight up (left-side view).
- (3) Loosen one captive screw (7) at the front end of the subunit, one captive screw (7) adjacent to P801, one captive screw (7) slightly to the rear of center of the subunit, and two captive screws at the rear of the subunit (7) (left-side view).
- (4) Lift the subunit up to remove it.

*b. Replacement*

- (1) Seat the subunit on the chassis, rear end first, and align the captive screws with the holes.
- (2) Tighten the five captive screws (7) (left-side view).
- (3) Connect plug P801 (left-side view).

**113. Removal and Replacement of Relay Subunit (fig. 83)**

*a. Removal.*

- (1) Set the rt unit top side up on the bench.
- (2) Remove the two green roundhead screws (6) and the lockwashers at the rear of the main frame, which fasten the relay subunit to the chassis (bottom view).
- (3) Slip a screwdriver between the subunit and the blower hose so that

the bottom of the subunit clears the blower hose.

- (4) Grasp the subunit handle and pull the subunit out of the main frame.

*b. Replacement.*

- (1) Push the blower hose downward and slide the subunit into the chassis.
- (2) Replace the two roundhead screws (6) and lockwashers and tighten them (bottom view).
- (3) Be sure that the blower hose is properly connected between the blower outlet and the air duct to the rf and power amplifier subunit.

**114. Removal and Replacement of Dynamotor DY-151/U (AN/VRC-24 Only) (fig. 83)**

*a. Removal.*

- (1) Remove the audio amplifier and modulator subunit (para 112) before removing the dynamotor.
- (2) Set the rt unit on its right side on the bench.
- (3) Disconnect plug P1001 (left-side view).
- (4) Remove two hexagonal-head screws (8) from the left side of the rt unit (left-side view).
- (5) Remove the two remaining hexagonal-head screws (8) on the bottom of the chassis (bottom view).
- (6) Lift the dynamotor off the chassis. The blower hose can be slid off the air duct if necessary.

*b. Replacement.*

- (1) Replace the blower hose on the air duct.
- (2) Insert the blower outlet into the blower hose as the dynamotor is seated on the chassis. Align the hexagonal-head screws (8) with the holes.
- (3) Tighten the two hexagonal-head screws (8) on the left side (left-side view), and the two hexagonal-head screws (8) on the bottom (bottom view) of the main frame.
- (4) Correct plug P1001 (left-side view).



### 115. Removal and Replacement of Centrifugal Fan HD-390/U (AN/TRC-68 Only) (4th Echelon)

The instructions for the removal and replacement of the dynamotor (para 114) also apply to Centrifugal Fan HD-390/U, which is included in Receiver-Transmitter Group OA-2649/TRC-68, except that plug P1051 is substituted for plug P1001.

### 116. Removal and Replacement of 500-Kc and Low-Pass Filter Assembly (fig. 83)

#### a. Removal.

- (1) Set the rt unit on its left side on the bench.
- (2) Disconnect plugs P6, P7, P102, and P1101 (right-side view).
- (3) Loosen one captive screw (11) on the front end of the assembly and two captive screws (11) on the rear end of the assembly (right-side view).
- (4) Lift the filter assembly out of the chassis. The 500-kc and low-pass filters can be separated for individual replacement by removal of the four screws that fasten the filters together.

#### b. Replacement.

- (1) Replace and tighten the four screws that fasten the filters together (if disassembled).
- (2) Seat the filter assembly on the chassis and align the captive screws with the holes.
- (3) Tighten the three captive screws (11) (right-side view).
- (4) Connect plugs P6, P7, P102, and P1101 (right-side view).

### 117. Removal and Replacement of Front Panel (fig. 83)

#### a. Removal.

- (1) Set the rt unit top side up on the bench.
- (2) Disconnect plug P703 (left-side view).

- (3) Remove the two flathead screws (9) and the two roundhead screws (9) and lockwashers from the top of the shroud (top view).
- (4) Remove one flathead screw (9) and one roundhead screw (9) and lockwasher from each side of the shroud (left- and right-side views).
- (5) Lift the shroud straight up and off the chassis.
- (6) Loosen coaxial connector P1301 in the lower right corner (top view).
- (7) Turn the rt unit over and remove the four roundhead screws (9) and lockwashers on the bottom of the chassis (bottom view).
- (8) Tilt the rt unit upward so that it rests on the rear of the mainframe. Work the front panel carefully to loosen plugs P701, P702, and P704 (top- and left-side view). These plugs are mounted on the front panel and disengage from their mating jacks when the panel is removed. Pull the front panel straight up from the chassis.

#### b. Replacement.

- (1) Center the front panel on the chassis; make certain that jacks J7, J1201, and J9, and ANT. jack J701 mate properly with plugs P701, P702, P704, and P1301 (top- and left-side views).
- (2) Tighten plug P1301 (top view).
- (3) Replace the four roundhead screws (9) and lockwashers on the bottom of the chassis (bottom view). Do not tighten.
- (4) Connect plug P703 (left-side view).
- (5) Slide the shroud into place from the top of the chassis.
- (6) Replace the flathead screw and the roundhead screw (9) and lockwashers on each side of the shroud (left- and right-side view). Do not tighten.
- (7) Replace the two flathead screws and the two roundhead screws (9) and lockwashers in the top of the shroud (top view).
- (8) Tighten all screws around the shroud.

**118. Removal and Replacement of Frequency Selector**  
(fig. 83)

*a. Removal.*

- (1) Before attempting to remove the frequency selector, remove the dynamotor or Centrifugal Fan HD-390/U (para 114 or 115), the audio amplifier and modulator subunit (para 112), and the front panel (para 117).
- (2) Set the rt unit on its right side on the bench.
- (3) Remove the two roundhead screws and lockwashers that fasten the mounting plate (top view) to the frequency selector frame.
- (4) Remove the three roundhead screws (10) and lockwashers on the bottom of the main frame (bottom view).
- (5) Loosen the hexagonal-head screw (10, left-side view) on the rear of the frequency selector.
- (6) Disconnect plug P1201 (left-side view).
- (7) Pull the mounting plate for jacks J7, J9, and J10 (top view) out of the clamp.
- (8) Remove the two roundhead screws and lockwashers (10) on the lower-left corner (top view).
- (9) Remove the roundhead and the hexagonal-head screw (10) adjacent to the directional coupler in the lower right corner (top view).
- (10) Tilt the rt unit upward so that it rests on the rear of the mainframe. Remove the two roundhead screws and lockwashers directly below and behind the memory drum.
- (11) Carefully slide the frequency selector off the main chassis.

*b. Replacement.*

- (1) Carefully center the frequency selector on the main chassis and replace two roundhead screws (10) and lockwashers in the upper left corner, and two roundhead screws and lockwashers directly below and behind the memory drum. *Do not tighten.*

- (2) If the shaft couplers have been disturbed, align the five subunit tuning shaft couplers with the frequency selector couplers.
- (3) Replace the roundhead and the hexagonal-head screws (10) next to the directional coupler in the lower right corner (top view). Do not tighten.
- (4) Replace the hexagonal-head screw (10, left-side view) on the rear of the frequency selector.
- (5) Replace the mounting plate for jacks J7, J9, and J10, and fasten it with two roundhead screws and lockwashers (top view).
- (6) Replace the three roundhead screws (10) on the bottom of the main frame (bottom view).
- (7) Tighten all of the replaced screws.
- (8) Replace the dynamotor or Centrifugal Fan HD-390/U (para 114 or 115), the audio amplifier and modulator (para 112), and the front panel (para 117).

**119. Removal and Replacement of Ac Case Blower Part of Receiver-Transmitter Case CY-2712/TRC-68 (4th Echelon)**

*a. Removal.*

- (1) Remove the power supply as directed in TM 11-5820-222-20.
- (2) Disconnect plug P1401 from jack J1407 (fig. 43).
- (3) Remove the four Phillips-head retaining screws and lockwashers on top of the case.
- (4) Remove the ac case blower from the AN/TRC-68 case.

*b. Replacement.*

- (1) Insert the ac case blower into the power supply section of the AN/TRC-68 case with the mounting plate up, and align the mounting plate with the four mounting holes.
- (2) Replace the four Phillips-head retaining screws and washers through the mounting holes on the top of the AN/TRC-68 case, and tighten them securely.

- (3) Connect plug P1401 to jack JL407 (fig. 43).
- (4) Replace the power supply as directed in TM 11-5820-222-20.

#### 120. Removal and Replacement of the Dc Case Blower, Part of Receiver-Transmitter Case CY-2557/VRC-24

##### *a. Removal.*

- (1) Remove the RT-323/VRC-24 and its case from mounting MT-1436/U as described in TM 11-5820-222-20.
- (2) Turn the rt unit and case upside

down and remove the four Phillips-head screws and lockwashers that fasten the dc case blower (fig. 44) to the case.

##### *b. Replacement.*

- (1) Align the dc case blower (fig. 44) with the four mounting holes on the bottom of Receiver-Transmitter Case CY-2557/VRC-24.
- (2) Insert and tighten the four screws and lockwashers in the mounting holes.
- (3) Replace the RT-323/VRC-24 and its case as described in TM 11-5820-222-20.

## Section II. REPAIRS

#### 121. General Parts Replacement Techniques

Most of the parts in Radio Sets AN/VRC-24 and AN/TRC-68 can be easily reached and replaced. However, careless replacement of parts can cause new troubles. Observe the following precautions when replacing parts:

*a.* Whenever a faulty part, such as a resistor, a capacitor, or a coil is to be removed, note the exact position of the part before removing it. Replace the part with an identical new part, placed in the same position. This precaution is particularly important for replacement of parts in stages that operate at high and ultrahigh frequencies.

*b.* Whenever faulty parts with multiple contacts, such as wafer switches and transformers, are removed for replacement, mark or tag each contact for identification.

*c.* When soldering a replacement part within a subunit, use the lowest wattage soldering iron that will do the job. When soldering a replacement part (such as a variable glass capacitor), grasp the lead between the part and the connection with a pair of pliers before applying heat. This will prevent the soldering iron heat from damaging the part.

#### 122. Removal and Replacement of First Oscillator Assembly

##### *a. Removal.*

*Caution:* Index the capacitor tuning shaft and crystal switching gears shown in figure 90 so that they can be easily synchronized before replacement. Mark the relative positions of the gears with a light pencil mark.

- (1) Remove the uhf injection subunit from the rt unit main frame (para 108 *a*).
- (2) Remove the six Phillips-head screws and lockwashers marked 1 (fig. 92) and slide the cover plate off the rear of the first oscillator assembly.
- (3) Unsolder the junction marked 1 (fig. 90).
- (4) Unsolder the red, brown, and green leads to the junctions shown in figure 93.
- (5) Remove the screw marked 3 (fig. 90) and the two screws marked 1 (fig. 91). Pull the first oscillator assembly away from the frequency multiplier-amplifier subchassis.

##### *b. Replacement.*

- (1) Mesh the first oscillator and frequency multiplier-amplifier assemblies so that the capacitor

tuning shaft and crystal switching gears are mechanically synchronized.

- (2) Replace the retaining screw marked 3 (fig. 90) and the two retaining screws marked 1 (fig. 91).
- (3) Refit the cover plate over the first oscillator assembly and replace the six Phillips-head screws marked 1 (fig. 92).
- (4) Resolder the red, brown, and green leads to the junctions as shown in figure 93.
- (5) Resolder the lead to the junction (1, fig. 90).
- (6) Replace the uhf injection subunit in the rt unit mainframe (para 108 b).

### 123. Removal and Replacement of Frequency Multiplier-Amplifier Assembly

#### a. Removal.

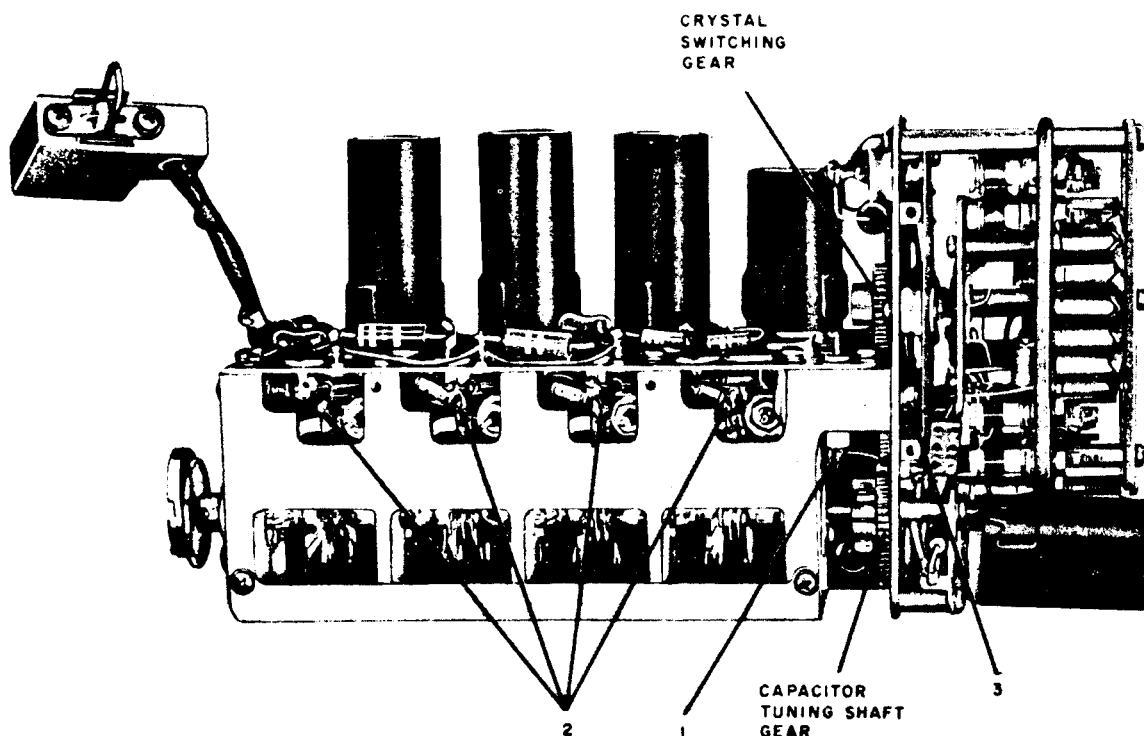
- (1) Remove the uhf injection subunit

from the rt unit main frame (para 108a).

- (2) Remove the cover plate by loosening the two screws (2) and removing the two screws (3, fig. 92).
- (3) Carefully heat the four junctions (2, fig. 90); withdraw the wire lead of the fixed capacitor and the ribbon lead of the ceramic capacitor from each joint.

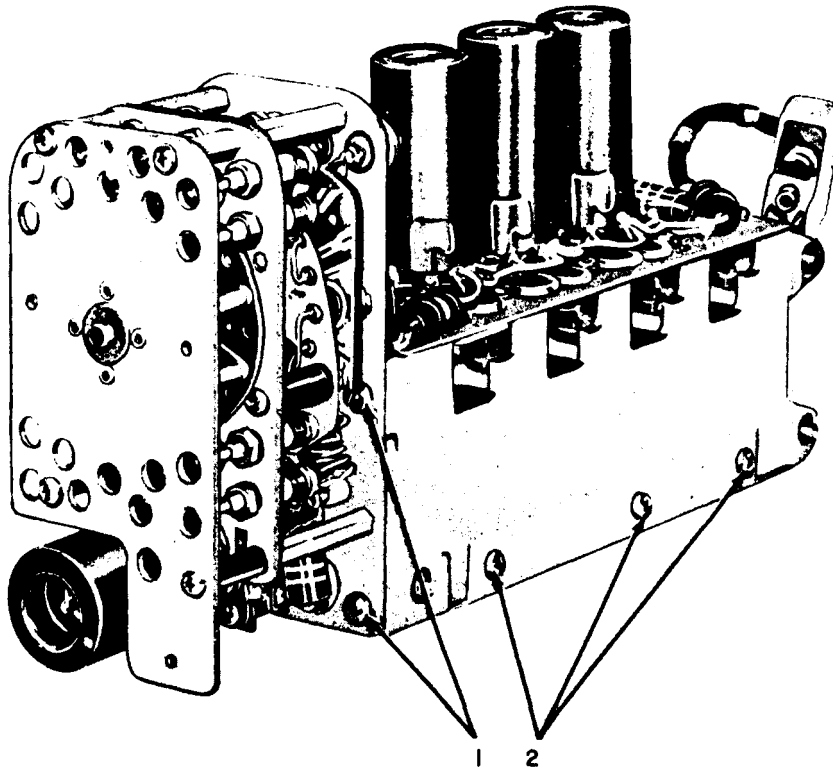
*Caution:* Do not place any strain on the ribbon lead of the ceramic capacitor, or the capacitor will be damaged. Avoid overheating the junctions.

- (4) Unsolder and disconnect the lead from the junction (1) (fig. 90).
- (5) Remove the 12 retaining screws (1, fig. 93) and pull the frequency multiplier-amplifier assembly off the main casting of the uhf injection subunit.



TM5820-222-35-89

Figure 90. Uhf injection subunit, left-side view, cover plates removed.



TM5820-222-35-92

Figure 91. Uhf injection system, right-rear view, first oscillator cover plate removed.

*b. Replacement.*

- (1) Reseat the frequency multiplier-amplifier assembly on the uhf injection subunit and align the screw holes. Replace the 12 retaining screws (1, fig. 93).
- (2) Resolder the capacitor leads to the junctions marked 2 (fig. 90).

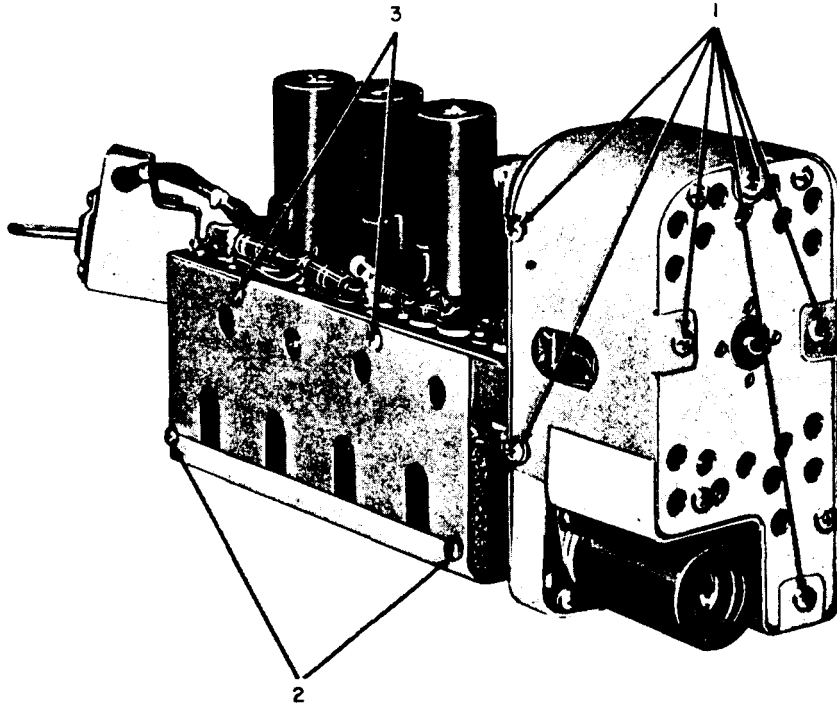
*Caution:* Do not place any strain on the variable capacitor tabs. Solder carefully; do not overheat.

- (3) Connect and resolder the lead to the junction (1, fig. 90).
- (4) Replace the cover plate and replace the retaining screws marked 3; tighten the two screws (2, fig. 92).
- (5) Replace the uhf injection subunit in the rt unit mainframe (para 108b).

**124. Removal and Replacement of Uhf Capacitor Tuning Shaft**

*a. Removal.*

- (1) Remove the uhf injection subunit from the rt unit main frame (para 108a).
- (2) Index the tuning capacitor shaft and crystal switching gears (para 122a).
- (3) Remove the five retaining screws and flat washers (2, fig. 92 and 91). Slip the cover plate off the chassis.
- (4) Remove the two spring-retaining screws (1, fig. 94). Remove the spring.
- (5) Slide the three grounding fingers (2, fig. 94) off the casting.
- (6) Remove the three screws (2, fig.



TM5820-222-35-91

Figure 92. Uhf injection subunit, left-rear view.

- 93). Slide the bearing retainer and grounding fingers off the casting.
- (7) Pull the uhf capacitor tuning shaft out of the casting.
- b. *Replacement.*
- (1) Replace the uhf capacitor tuning shaft and align the rotors of the capacitors so that the gear at the rear of the tuning shaft is mechanically synchronized with the drive gear on the crystal switch (fig. 94).
  - (2) Insert the bearing retainer in the front slot of the casting. Align the screw holes and replace the three retaining screws marked 2 (fig. 93).
  - (3) Slide the three grounding fingers (2, fig. 94) back in place.
  - (4) Replace the spring at the rear of the tuning shaft and fasten it with the two retaining screws (1, fig. 94).

- (5) Replace the cover plate and replace the five screws and flat washers (2, fig. 91 and 92).
- (6) Replace the uhf injection subunit in the rt unit mainframe (para 108 b).

#### 125. Removal and Replacement of Rf and Power Amplifier Subassemblies

a. *Removal of Tube Chassis.* Before removing the tube chassis, remove the rf and power amplifier subunit from the rt unit main frame (para 108 a).

- (1) Remove the side, bottom, and manifold covers by removing the retaining screws and lockwashers (1, fig. 68 and 69).
- (2) Remove the transmitter driver tube, V105 (TM 11-5820-222-20).
- (3) Carefully heat the junctions of capacitors C105 and C110 (fig. 71) and withdraw the wire and ribbon

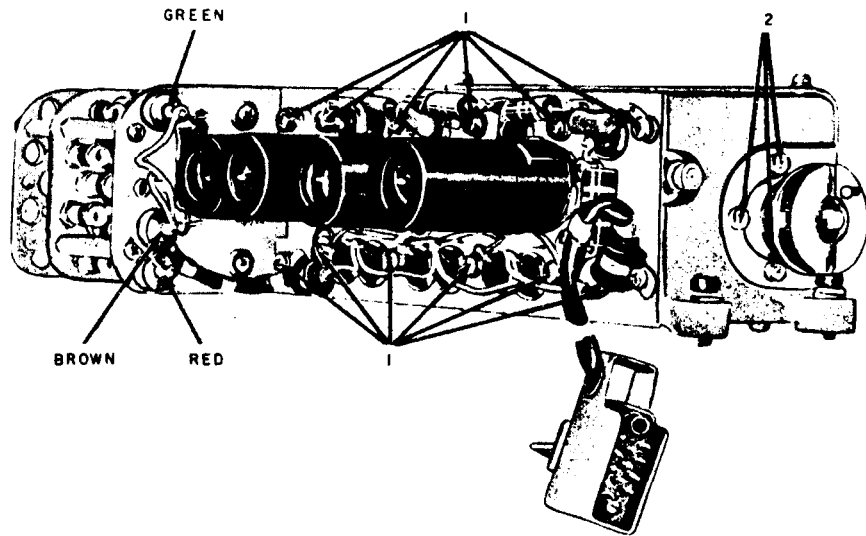
leads of the fixed capacitors from the junctions. Separate the ribbon lead of the ceramic capacitor from the Z101 terminal (fig. 74). Insert the soldering iron tip through the space marked 11 (fig. 70).

*Caution:* Do not place any strain on the ribbon lead of the ceramic capacitor, or the capacitor will become damaged. Avoid overheating the junction.

- (4) Repeat the operation outlined in (3) above to separate capacitors C114

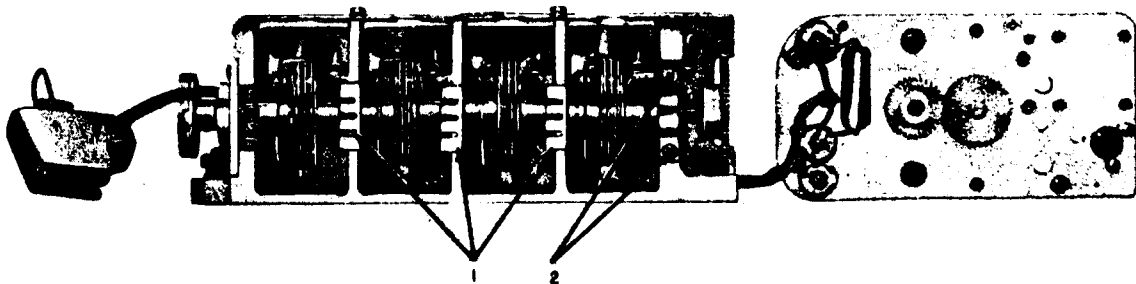
and C117 (fig. 71) from the Z103 terminal. Insert the soldering iron tip through the space 10 (fig. 70).

- (5) Repeat the operation outlined in (3) above to separate capacitors C121 and C123 (fig. 71) from the Z105 terminal. Insert the soldering iron tip through the space 9 (fig. 70).
- (6) Repeat the operation outlined in (3) above to separate capacitors C 126 and C139 (fig. 71) from the Z106 terminal. Insert the soldering iron tip through the space 8 (fig. 70).
- (7) Remove the two retaining screws



TM5820-222-35-90

Figure 93. Uhf injection subunit, upper-front view, first oscillator cover plate removed.



TM5820-222-35-93

Figure 94. Uhf injection subunit, bottom view, cover plate removed, first oscillator folded out.

and lockwashers marked (3, fig. 69) and pull relay K101 away from the tube chassis. Do not misplace the small relay push rod.

- (8) With relay K101 pulled away from the chassis, unsolder capacitor C106 (fig. 71) from the Z101 (fig. 74) terminal.
- (9) Unsolder the purple lead 7 (7, fig. 70).
- (10) Unsolder the green, brown, orange, and red leads (1, fig. 72).
- (11) Remove the ground terminal (2, fig. 69).
- (12) Unsolder coil L114 from the lug (1, fig. 73).
- (13) Unsolder capacitor C145 (fig. 73) from the V105 plate clips (fig. 70).
- (14) Remove the four retaining screws (2, 3, 4, and 5, fig. 73), which fasten the tube chassis to the power amplifier chassis.
- (15) Loosen the setscrew (5, fig. 70) and pull the castings of the two sub-assemblies apart.

#### *b. Removal of Power Amplifier Rotor Assembly*

*Note.* The power amplifier, the driver, and the rf tuning rotor assemblies must be removed in the order listed.

- (1) If the tube chassis and power amplifier chassis have not been removed, loosen the setscrews (5, fig. 70).
- (2) Remove the three screws (1, fig. 70) and remove the bearing housing (2, fig. 70) from the power amplifier chassis.
- (3) Loosen the setscrew (4, fig. 70).
- (4) Loosen the four setscrews on the power amplifier rotor (3, fig. 70).
- (5) Pull the power amplifier shaft out through the rear of the casting and slide the power amplifier rotor assembly out of the chassis.

#### *c. Removal of Driver Rotor Assembly.*

- (1) Loosen the coupler clamp screw on Z107 (fig. 73).
- (2) Push the driver rotor shaft out of the rotor assembly through the power amplifier rotor assembly space.

- (3) Remove the driver rotor and the grounding spring marked 1 (1, fig. 74) from the power amplifier chassis. If necessary, turn the rotor slightly to disengage the stator.

#### *d. Removal of Rf Tuning Rotor Assembly.*

- (1) Loosen the setscrew (6, fig. 70) and remove the coupler (3, fig. 74) from the tuning shaft.
- (2) Remove the three bearing retainer screws at the front of the tube chassis casting (fig. 95).
- (3) Slide the partition grounding fingers (2, fig. 74) off the tube chassis casting.
- (4) Remove the three screws in the rear bearing retainer, marked 6 (fig. 73).
- (5) Slide the rear bearing retainer to the rear and lift the rf tuning rotor assembly out through the slots in the tube chassis casting.

#### *e. Replacement of Rf Tuning Rotor Assembly.*

- (1) Slip the rf tuning rotor assembly into the slots in the tube chassis casting.
- (2) Replace the three screws in the rear bearing retainer (6, fig. 73).
- (3) Replace the three screws in the front bearing retainer (fig. 95).
- (4) Slide the three partition grounding fingers (2, fig. 74) back on the tube chassis casting.
- (5) Replace the coupler (3, fig. 74) on the rf tuning shaft and tighten the setscrew (6, fig. 70).

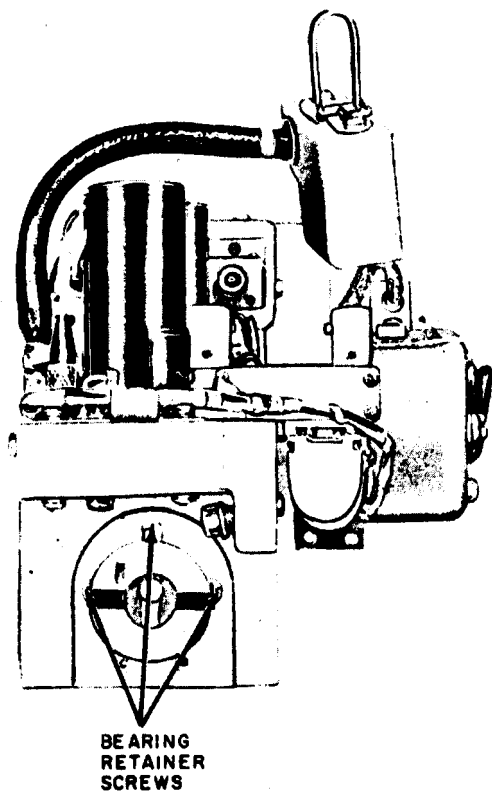
#### *f. Replacement of Driver Rotor Assembly.*

- (1) Replace the grounding spring (1, fig. 74). Line the spring up with the key on the stator block.
- (2) Mount the driver rotor assembly, inserting the insulator cylinder in the grounding spring.
- (3) Slip the driver rotor shaft through the center of the rotor assembly. Do not tighten any setscrews.

#### *g. Replacement of Power Amplifier Rotor Assembly.*

- (1) Place the power amplifier rotor assembly in position to insert the





TM5820-222-35-101

Figure 95. Rf and power amplifier subunit, front view.

- power amplifier rotor shaft from the rear of the chassis.
- (2) Replace the bearing housing (2, fig. 70) and align the two pins with the holes in the bearing retainer.
  - (3) Replace the three screws (1, fig. 70) that fasten the bearing retainer to the housing.
  - (4) Align the screw holes in the tube chassis with the standoffs on the power amplifier chassis, and replace the four retaining screws that fasten the two chassis together (2, 3, 4, and 5, fig. 73).
  - (5) Push the driver rotor shaft up against the rf tuning rotor shaft. Align the flats of both shafts and tighten the setscrew (5 and 6, fig. 70) that engages each shaft.
  - (6) Align the flat of the power amplifier rotor shaft with the setscrew on the

driver rotor shaft (3, fig. 74). Tighten the setscrew.

- (7) Center the capacitor rotors axially on the rf tuning, the driver, and the power amplifier rotor assemblies so that the rotor plates are centered between the stator plates.
  - (8) Rotate the rotors of the tuning capacitors to the right until the trailing edges of the rotors of Z101, Z103, Z105, Z106, Z107, and Z108 (fig. 74) are lined up with the stator plates of each tuning capacitor.
  - (9) Tighten the setscrews (4 and 6, fig. 70).
- h. Replacement of Tube Chassis.*
- (1) Align points 2, 3, 4, and 5 (fig. 73) and replace the four retaining screws that fasten the tube chassis to the power amplifier.
  - (2) Tighten the setscrew (5, fig. 70).
  - (3) Solder capacitor C145 (fig. 73) to the plate clip of V105 (fig. 70).
  - (4) Solder coil L114 to the terminal lug (1, fig. 73).
  - (5) Replace the ground terminal to 2 (fig. 69).
  - (6) Solder the green, brown, orange, and red leads to the points 1 (fig. 72).
  - (7) Solder the purple lead to 7 (fig. 70).
  - (8) Solder capacitor C106 (fig. 71) to the Z101 (fig. 74) terminal.
  - (9) Align relay K101 with the holes in the relay mounting plate, insert the relay push rod, and replace the two retaining screws (3, fig. 69).
  - (10) Connect the wire and ribbon leads of capacitors C105 and C110 (fig. 71) to the Z101 terminal (fig. 74).
- Caution:* Do not place any strain on the ribbon lead of the ceramic capacitor, or the capacitor will be damaged.
- (11) Repeat the operations outlined in (10) above to solder capacitors C114 and C117 (fig. 71) to the Z103 terminal through the space marked 10 (fig. 70).
  - (12) Repeat the operations outlined in (10) and (11) above to solder capacitors C121 and C123 (fig. 71)



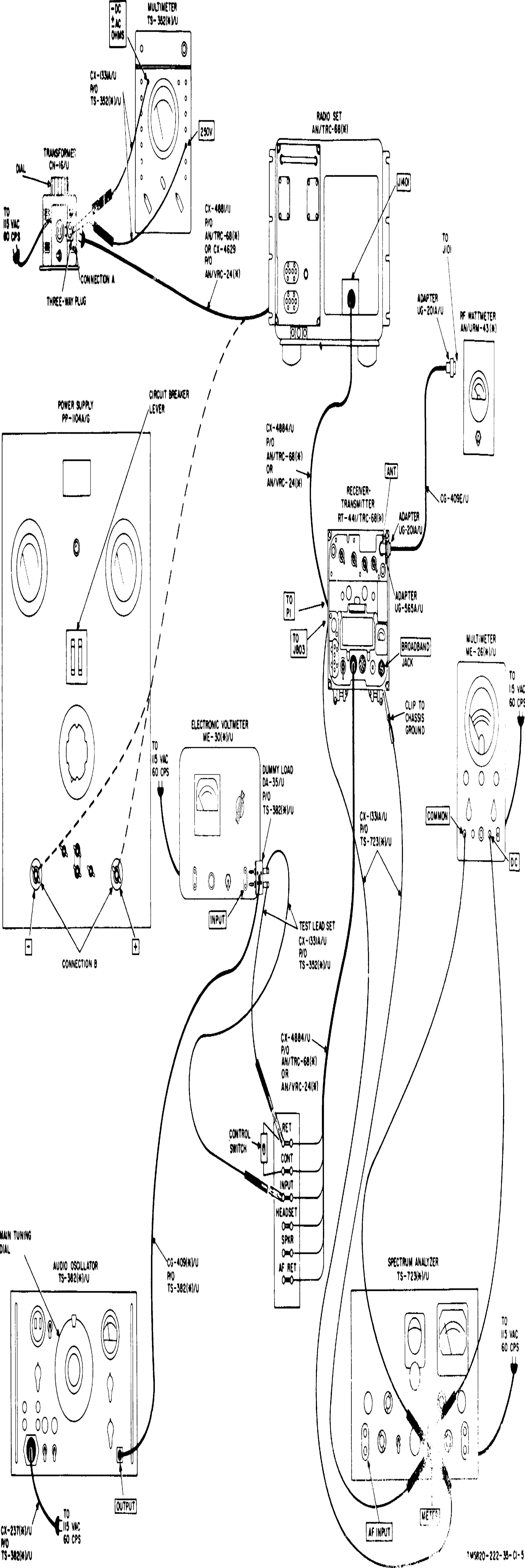


Figure 113.5. RT-323/VRC-24(\*) or RT-441/TRC-68(\*) modulation and modulation limiting tests, test setup.

**141.11. RT-323/VRC-24(\*) or RT-441/TRC-68(\*) Modulation Limiting Tests**

*a. Test Equipment and Materials.*

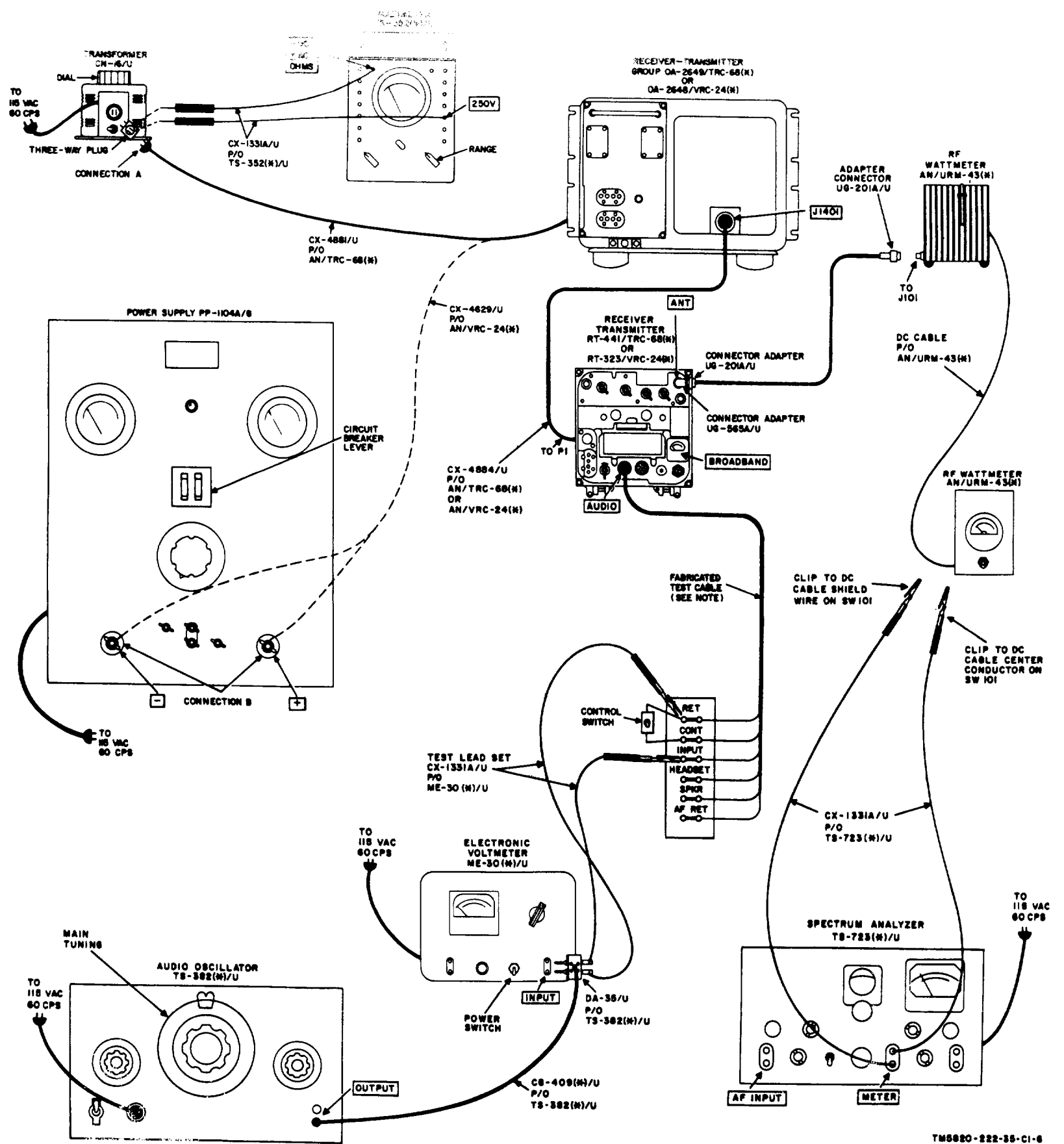
Transformer CN-16/U or  
Power Supply PP-1104A/G  
Multimeter TS-352(\*)/U  
Audio Oscillator TS-382(\*)/U  
Voltmeter, Electronic ME-30(\*)/U  
Radio Frequency Wattmeter AN/URM-43(\*)  
Multimeter ME-26(\*)/U  
Spectrum Analyzer TS-723(\*)/U

Cable Assembly, Radio Frequency CG-409E/U  
Adapter UG-201A/U (2 each)  
Adapter, Connector UG-565A/U  
Fabricated test cable (fig. 113.1)

*b. Test Connections and Conditions.* Connect the equipment as shown in figure 113.5. For the RT-323/VRC-24(\*), connect the PP-1104A/G as shown in *Connection E* and disregard all references to the CN-16/U and TS-352(\*)/U. For the RT-441/TRC-68(\*), connect the CN-16/U and TS-352(\*)/U as shown in *Connection A* and disregard references to the PP-1104A/G.

*c. Test Procedure.*

Step	Control settings		Test procedure	Performance standard
	Test equipment	Equipment under test		
1	<p>CN-16/U Dial: 115 ON-OFF: ON or PP-1104A/G Circuit breaker: ON INCREASE VOLTAGE: For 26.4 volts on dc voltmeter TS-352(*)/U FUNCTION AC VOLTS Range: Any position OHMS ZERO ADJ.: Any position ME-30(*)/U Range selector switch: 3 VOLTS Power switch: ON TS-382(*)/U OUTPUT LEVEL: Fully counterclockwise ATTENUATOR: 1 THERMOSTAT: Fully clockwise OSC.: ON HEATER: ON RANGE: X10 FREQ. METER: OFF Main tuning dial: 100 AN/URM-43(*) 15W-60W: 60W ME-26(*)/U FUNCTION: + RANGE: 1000V ZERO ADJ: For meter zero with COMMON and DC probes shorted OHMS ADJ: Any position AC ZERO: Any position TS-723(*)/U Function: METER Meter range: R.M.S. VOLTS 300 <i>Note.</i> Remaining controls may be in any position.</p>	<p>RT-441/TRC-68(*) or RT-323/VRC-24(*) POWER: Operate to ON and release CHAN SEL: 19 MANUAL FREQUENCY switches: TENS: 30 UNITS: 5 TENTHS: 5 SQUELCH: Midposition VOLUME: Fully counterclockwise METER: % MOD NOR-BB switch (rear of chassis): NOR</p>	<p>a. Plug TS-352(*)/U test leads into three-way plug and adjust CN-16/U dial until TS-352(*)/U indicates 115 volts (1.15 on the 0 to 2.5 AC scale). b. Allow 30-minute warmup period before proceeding. c. Operate control switch to on and rotate TS-382(*)/U OUTPUT LEVEL control clockwise until ME-30(*)/U indicates 1 on 0 to 3 scale. d. Note and record indications of ME-26(*)/U (0 to 1 upper scale) and TS-723(*)/U (0 to 3 scale). Operate control switch to OFF. e. Compute percentage modulation as follows: Percent modulation = <math>141.4 \times \text{TS-723(*)/U indication (d above)} \times \text{ME-26(*)/U indication (d above)}</math> f. Operate ME-30(*)/U range selector switch to 1 VOLTS. g. Operate control switch to on and rotate TS-382(*)/U OUTPUT LEVEL control counterclockwise until ME-30(*)/U indicates 0.5 on 0 to 1.0 scale. h. Note and record TS-723(*)/U indication on 0 to 3 scale. Operate control switch to off. i. Subtract TS-723(*)/U indication noted in h above from TS-723(*)/U indication noted in d above. j. Operate ME-30(*)/U range selector switch to 1 VOLTS. k. Operate control switch to on and rotate TS-382(*)/U OUTPUT LEVEL control clockwise until ME-30(*)/U indicates 0.4 volt on 0 to 1.0 scale. l. Note and record TS-723(*)/U indication. Operate control switch to off. m. Subtract TS-723(*)/U indication noted in d above from TS-723(*)/U indication noted in l above. n. Disconnect test lead from INPUT terminal of fabricated test cable and clip to terminal B of BROAD BAND jack of unit under test.</p>	<p>a. None. b. None. c. None. d. None. e. Computed modulation is 85% ±10. f. None. g. None. h. None. i. Difference does not exceed 65 volts. j. None. k. None. l. None. m. Difference does not exceed 45 volts. n. None.</p>
2	<p>As last set in test procedure, except: TS-382(*)/U OUTPUT LEVEL: Fully counterclockwise ATTENUATOR: 10 RANGE: X1 ME-30(*)/U Range selector switch 10 VOLTS</p>	<p>As last set in test procedure, except: RT-441/TRC-68 or RT-323/VRC-24 NOR-BB switch (rear of chassis): BB</p>	<p>a. Operate control switch to on and rotate TS-382(*)/U OUTPUT LEVEL control clockwise until ME-30(*)/U indicates 8 volts on 0 to 1.0 scale. b. Repeat step 1d and e above.</p>	<p>a. None. b. Computed modulation is 85% ±10.</p>



TM6880-222-35-C1-6

Figure 113.6 RT-323/VRC-24 or RT-441/TRC-68 transmit frequency response, carrier noise, and distortion tests, test setup.

**141 12. RT-323/VRC-24(\*) or RT-441/TRC-68(\*) Transmit Frequency Response, Carrier Noise, and Distortion Tests**

Adapter UG-201A/U (2 each)  
Adapter, Connector UG-565A/U  
Fabricated test cable (fig. 113.1)

**a. Test Equipment and Materials.**

Transformer CN-16/U or  
Power Supply PP-1104A/G  
Multimeter TS-352(\*)/U  
Audio Oscillator TS-382(\*)/U  
Voltmeter, Electronic ME-30(\*)/U  
Radio Frequency Wattmeter AN/URM-43(\*)  
Spectrum Analyzer TS-723(\*)/U  
Cable Assembly, Radio Frequency CG-409E/U

**b. Test Connections and Conditions.** Connect the equipment as shown in figure 113.6. For the OA-2648/VRC-24, connect the PP-1104A/G as shown in *Connection B* and disregard all references to the CN-16/U and TS-352(\*)/U. For the OA-2649/TRC-68, connect the CN-16/U and TS-352(\*)/U as shown in *Connection A* and disregard references to the PP-1104A/G.

**c. Test Procedure.**

Step	Control settings	Test equipment	Equipment under test	Test procedure	Performance standard
1		<p>Test equipment</p> <p><i>CN-16/U</i> Dial: 115 ON-OFF: ON or <i>PP-1104A/G</i> Circuit breaker: ON INCREASE VOLTAGE: For 26.4 volts on dc voltmeter <i>TS-352(*)/U</i> FUNCTION: AC VOLTS Range: Any position RMS ZERO ADJ.: Any position <i>ME-30(*)/U</i> Range selector switch: 1 VOLTS Power switch: ON <i>TS-382(*)/U</i> OUTPUT LEVEL: Fully counterclockwise ATTENUATOR: 1 THERMOSTAT: Fully clockwise OSC.: ON HEATER: ON RANGE: X10 FREQ. METER: OFF Main tuning dial: 100 AN/URM-43(*) 15W-60W: 60W <i>TS-723(*)/U</i> Function: METER Meter range: R.M.S. VOLTS 3.0 Power: ON Note. Remaining controls may be in any position.</p>	<p>Equipment under test</p> <p><i>RT-441/TRC-68(*)</i> or <i>RT-323/VRC-24(*)</i> POWER: Operate to ON and release FRANSEL 1 MANUAL FREQUENCY RANGE: 1 TENS: 30 UNITS: 5 SQUELCH: Midposition VOLUME: Fully counterclockwise NOR-BB switch (rear of chassis): NOR</p>	<p>a. Plug TS-352(*)/U test leads into three-way plug and adjust CN-16/U dial until TS-352(*)/U indicates 115 volts (1.15 on 0 to 2.5 AC scale). b. Allow 30-minute warmup period before proceeding. c. Operate control switch to on and rotate TS-382(*)/U OUTPUT LEVEL control clockwise until ME-30(*)/U indicates 0 on 0 to 1.0 scale. d. Note and record TS-723(*)/U indication on DECIBELS (bottom) scale. e. Operate TS-382(*)/U RANGE switch to X1 and adjust OUTPUT LEVEL control for ME-30(*)/U indication of .1 on 0 to 1.0 scale. f. Note TS-723(*)/U indication on DECIBELS (bottom) scale. g. Rotate TS-382(*)/U main tuning dial to 25 and operate RANGE switch to X10. h. Adjust TS-382(*)/U OUTPUT LEVEL control for ME-30(*)/U indication of .1 on 0 to 1.0 scale. i. Note TS-723(*)/U indication on DECIBELS (bottom) scale. j. Rotate TS-382(*)/U main tuning dial to 30 and operate RANGE switch to X100. k. Adjust TS-382(*)/U OUTPUT LEVEL control for ME-30(*)/U indication of .1 on 0 to 1.0 scale. l. Note TS-723(*)/U indication on DECIBELS (bottom) scale. m. Rotate TS-382(*)/U main tuning dial to 60 and adjust OUTPUT LEVEL control for ME-30(*)/U indication of .1 on 0 to 1.0 scale. n. Note TS-723(*)/U indication on DECIBELS (bottom) scale. o. Rotate TS-382(*)/U main tuning dial to 100 and adjust OUTPUT LEVEL control for ME-30(*)/U indication of .1 on 0 to 1.0 scale. p. Note TS-723(*)/U indication on DECIBELS (bottom) scale and operate control switch to off.</p>	<p>a. None. b. None. c. None. d. None. e. None. f. At least 3 db less (to the left) than indication noted in d above. g. None. h. None. i. Within <math>\pm 2</math> db of indication noted in d above. j. None. k. None. l. Within <math>\pm 2</math> db of indication noted in d above. m. None. n. Within <math>\pm 2</math> db of indication noted in d above. o. None. p. At least 3 db less (to the left) than indication noted in d above.</p>
2		<p>As last set in test procedure, except: <i>TS-382(*)/U</i> OUTPUT LEVEL: Fully counterclockwise RANGE: X10</p>	<p>As last set in test procedure, except: <i>RT-441/TRC-68(*)</i> or <i>RT-323/VRC-24(*)</i> NOR-BB switch (rear of chassis): BB</p>	<p>a. Remove test lead from INPUT terminal of fabricated test cable and clip to terminal B of BROAD BAND jack of unit under test. b. Operate control switch to on and rotate TS-382(*)/U OUTPUT LEVEL control clockwise until ME-30(*)/U indicates .1 on 0 to 1.0 scale. c. Note TS-723(*)/U indication on DECIBELS (bottom) scale. d. Operate TS-382(*)/U RANGE switch to X1 and adjust OUTPUT LEVEL control for ME-30(*)/U indication of .1 on 0 to 1.0 scale. e. Note TS-723(*)/U indication on DECIBELS (bottom) scale. f. Rotate TS-382(*)/U main tuning dial to 25 and operate RANGE switch to X10. g. Adjust TS-382(*)/U OUTPUT LEVEL control for ME-30(*)/U indication of .1 on 0 to 1.0 scale. h. Note TS-723(*)/U indication on DECIBELS (bottom) scale. i. Rotate TS-382(*)/U main tuning dial to 60 and operate RANGE switch to X100. j. Adjust TS-382(*)/U OUTPUT LEVEL control for ME-30(*)/U indication of .1 on 0 to 1.0 scale. k. Note TS-723(*)/U indication on DECIBELS (bottom) scale. l. Rotate TS-382(*)/U main tuning dial to 25 and operate RANGE switch to X1000. m. Adjust TS-382(*)/U OUTPUT LEVEL control for ME-30(*)/U indication of .1 on 0 to 1.0 scale. n. Note TS-723(*)/U indication on DECIBELS (bottom) scale. o. Remove test lead from terminal B of BROAD BAND jack of unit under test. p. Operate TS-723(*)/U meter range switch to R.M.S. VOLTS -20 and note meter indication. q. Operate control switch to off and connect test lead (removed in o above) to INPUT terminal of fabricated test cable.</p>	<p>a. None. b. None. c. None. d. None. e. Within -5 db (to the left) indication noted in c above. f. None. g. None. h. Within <math>\pm 2</math> db of indication noted in c above. i. None. j. None. k. Within <math>\pm 2</math> db of indication noted in c above. l. None. m. None. n. Within <math>\pm 2</math> db of indication noted in c above. o. None. p. Meter must indicate at least 35 db less (to the left) indication noted in c above. q. None.</p>
3		<p>As last set in test procedure, except: <i>TS-382(*)/U</i> OUTPUT LEVEL: Fully counterclockwise RANGE: X10 Main tuning dial: 100 <i>TS-723(*)/U</i> AF-RF: AF INPUT: MIN RANGE: X10 Function: SET LEVEL Meter range: DB +10 BALANCE: Fully clockwise Coarse FREQUENCY: 100</p>	<p>As last set in test procedure, except: <i>RT-441/TRC-68(*)</i> or <i>RT-323/VRC-24(*)</i> NOR-BB switch (rear of chassis): NOR</p>	<p>a. Disconnect test leads from METER terminals and connect to AF INPUT terminals of TS-723(*)/U. b. Operate control switch to on and rotate TS-382(*)/U OUTPUT LEVEL control clockwise until ME-30(*)/U indicates 1 on 0 to 1.0 scale. c. Measure the distortion of unit under test as follows:  (1) Slowly rotate TS-723(*)/U INPUT control clockwise until meter indicates 1.0 on 0 to 1.0 scale. (2) Operate function switch to DISTORTION. (3) Adjust coarse FREQUENCY control until sharp dip is indicated on meter. (4) Adjust fine FREQUENCY control for minimum meter indication. Note. As adjustment progresses, decrease setting (counterclockwise) of meter range switch to maintain midscale meter deflections. (5) Adjust the BALANCE control for minimum meter indication. (6) Repeat (4) and (5) above until no further reduction in meter indication can be obtained. (7) Rotate meter range switch to DB +10 and note distortion as indicated on TS-723(*)/U. d. Operate control switch to off.</p>	<p>a. None. b. None. c. Less than 1.0 on 0 to 1.0 (top) scale (less than 10% distortion). d. None.</p>
4		<p>As last set in test procedure, except: <i>TS-382(*)/U</i> OUTPUT LEVEL: Fully counterclockwise Main tuning dial: 25 <i>TS-723(*)/U</i> INPUT: MIN Function: SET LEVEL Meter range: DB +10 BALANCE: Fully clockwise Coarse FREQUENCY: 25</p>	<p>As last set in test procedure.</p>	<p>Repeat step 3b, c, d above.</p>	<p>Same as 3c above.</p>
5		<p>As last set in test procedure, except: <i>TS-382(*)/U</i> OUTPUT LEVEL: Fully counterclockwise RANGE: X100 Main tuning dial: 60 <i>TS-723(*)/U</i> INPUT: MIN Function: SET LEVEL Meter range: DB +10 BALANCE: Fully clockwise Coarse FREQUENCY: 60 RANGE: X100</p>	<p>As last set in test procedure.</p>	<p>Repeat step 3b, c, and d above.</p>	<p>Same as 3c above.</p>

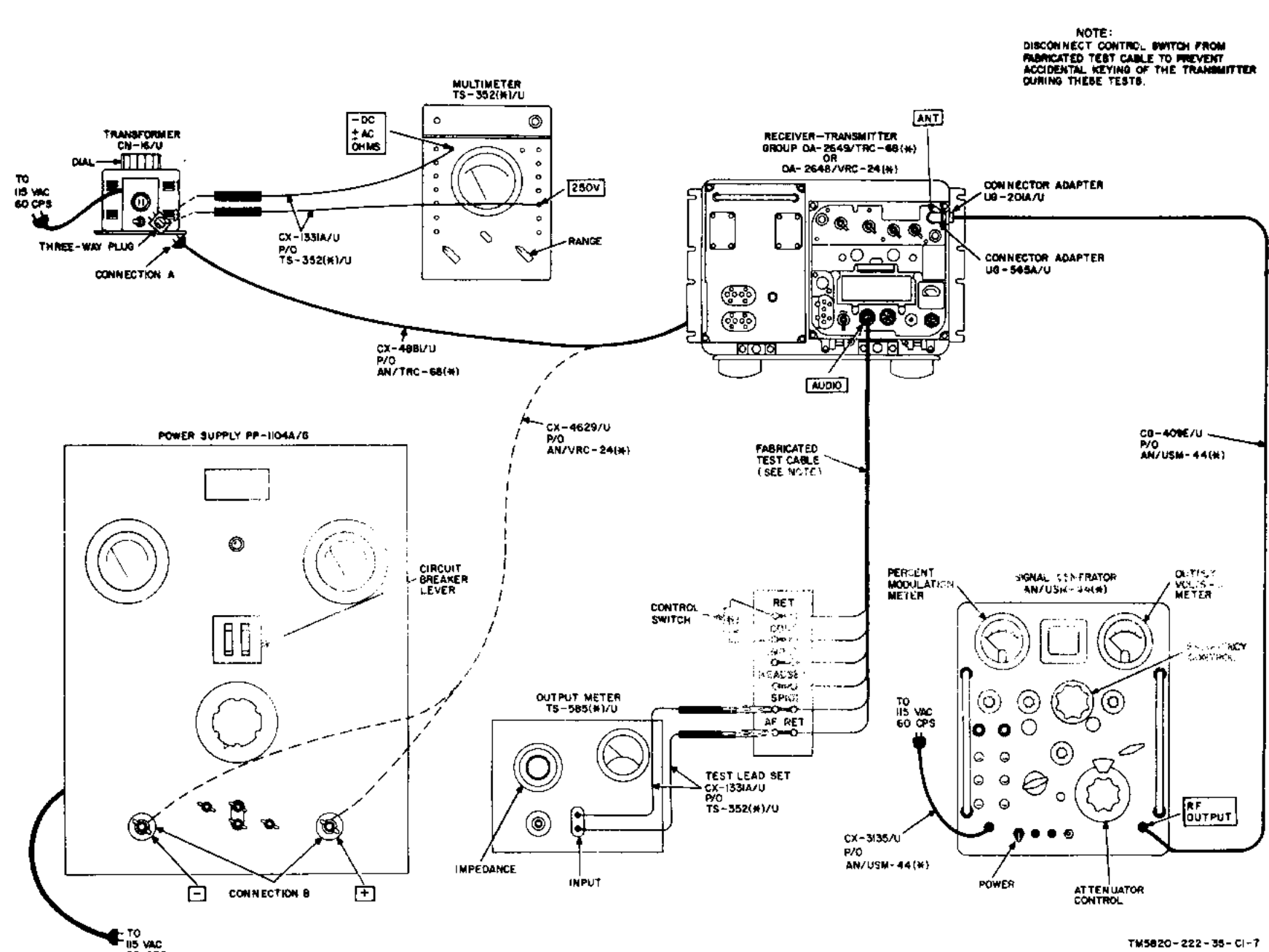


Figure 115.7. RT-383/VRC-24(\*) or RT-441/TRC-68(\*) receiver sensitivity, resetability, audio output, signal plus noise-to-noise, and squelch tests, test setup.



**14.13. RT-323/VRC-24(\*) or RT-441/TRC-68(\*) Receiver Sensitivity, Resettability, Audio Output, Signal Plus Noise-to-Noise, and Squelch Tests**

Adapter, Connector UG-565A/U  
Fabricated test cable (fig. 113.1)

**a. Test Equipment and Materials.**

Transformer CN-16/U or  
Power Supply PP-1104A/G  
Multimeter TS-352(\*)/U  
Signal Generator AN/USM-44(\*)  
Output Meter TS-585(\*)/U  
Adapter UG-201A/U

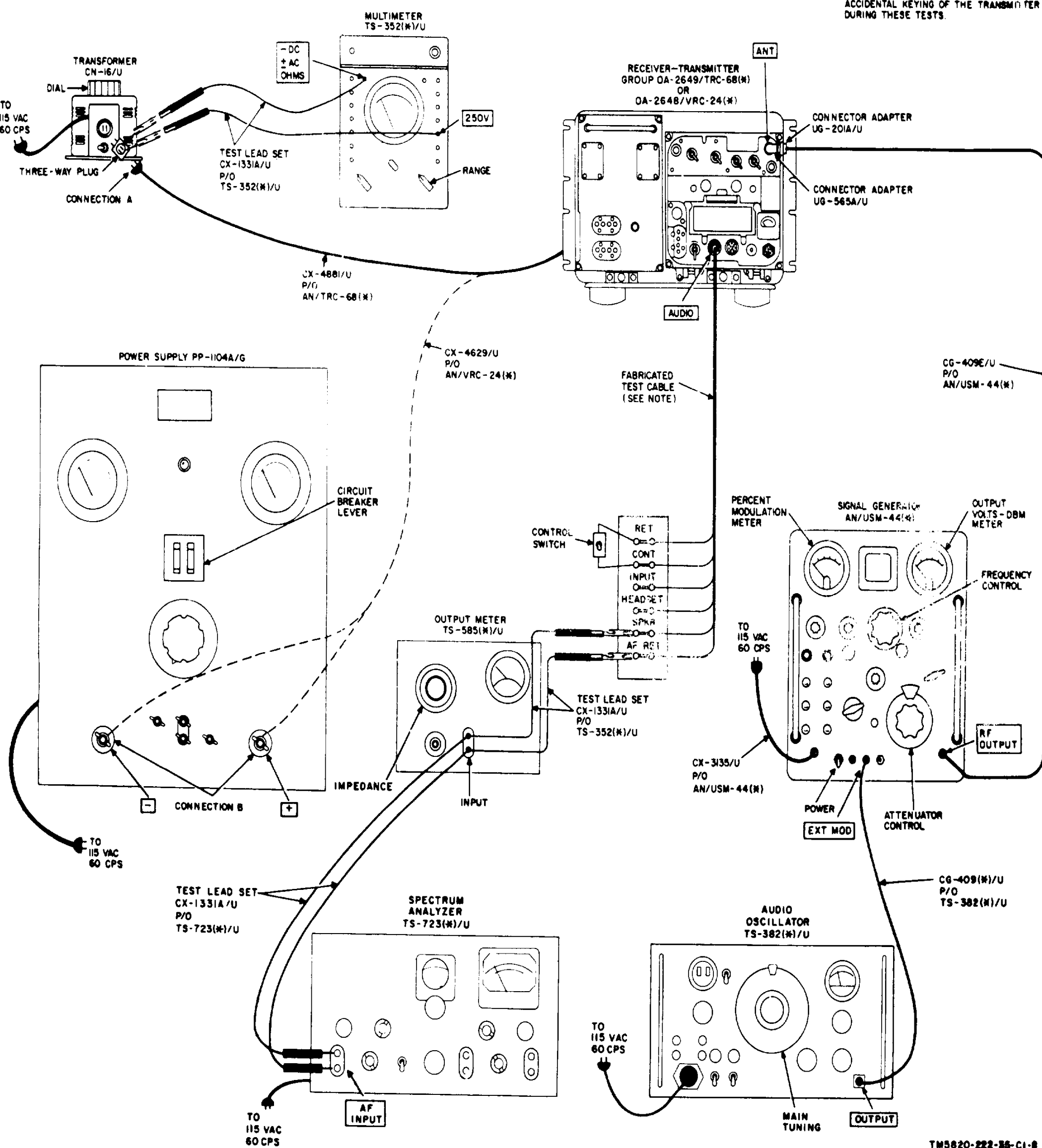
**b. Test Connections and Conditions.** Connect the equipment as shown in figure 113.7. For the OA-2648/VRC-24, connect the PP-1104A/G as shown in *Connection B* and disregard all references to the CN-16/U and TS-352(\*)/U. For the OA-2649/TRC-68, connect the CN-16/U and TS-352(\*)/U as shown in *Connection A* and disregard all references to the PP-1104A/G.

**c. Test Procedure.**

Step	Control settings		Test procedure	Performance standard																																				
	Test equipment	Equipment under test																																						
1	<p>Test equipment</p> <p>CN-16/U Dial: 115 ON-OFF: ON or PP-1104A/G Circuit breaker: ON INCREASE VOLTAGE: For 26.4 volts on dc voltmeter TS-585(*)/U FUNCTION: AC VOLTS Range: Any position OHMS ZERO ADJ.: Any position. TS-585(*)/U Meter multiplier: +10 Impedance: 60 in. X10 bracket AN/USM-44(*) FREQUENCY RANGE: E Frequency control: 225 FINE FREQ. ADJUST: To index marker MOD. SELECTOR: CW MOD. LEVEL: Fully counterclockwise Output attenuator: 5 MICROVOLTS 1MC-OFF-5MC: OFF XTAL CAL. GAIN: Fully counterclockwise OUTPUT LEVEL: 75% of full clockwise rotation AMP. TRIMMER: Any position Power: ON</p>	<p>Equipment under test</p> <p>OA-2649/TRC-68 or OA-2648/VRC-24 POWER: operate to ON and release CHAN SEL: 1 MANUAL FREQUENCY switches: TENS: 30 UNITS: 5 TENTHS: 5 SQUELCH: OFF VOLUME: Fully clockwise METER: S METER NOR-BB switch (rear of chassis): NOR</p>	<p>a. Plug TS-352(*)/U test leads into three way plug and adjust CN-16/U dial for a TS-352(*)/U indication of 115 volts (1.15 on 0 to 2.5 volt scale). b. Prepare AN/USM-44(*) for operation as follows: (1) Adjust AMP. TRIMMER control for maximum indication on OUTPUT VOLTS meter. (2) Adjust OUTPUT LEVEL control until OUTPUT VOLTS meter indicates SET LEVEL. (3) Operate MOD. SELECTOR switch to 1000. (4) Rotate MOD. LEVEL control clockwise until PERCENT MODULATION meter indicates 30%. c. Carefully adjust AN/USM-44(*) frequency control for maximum meter indication on unit under test. d. Adjust AN/USM-44(*) output attenuator control until TS-585(*)/U indicates 14 on DECIBELS (top) scale. e. Note AN/USM-44(*) ATTENUATOR setting. f. Operate AN/USM-44(*) MOD. SELECTOR switch to CW and note TS-585(*)/U indication on DECIBELS (top) scale. g. Operate AN/USM-44(*) MOD. SELECTOR switch to 1000. h. Operate CHAN SEL switch on unit under test to 19 and wait for unit to retune. i. Operate CHAN SEL switch to 1 and wait for unit to retune. j. Note TS-585(*)/U indication on DECIBELS (top) scale.</p>	<p>a. None. b. None. c. None. d. None. e. Less than 2 MICROVOLTS. f. Less than 10 to the left of 4. g. None. h. None. i. None. j. 14 ±2.</p>																																				
2	<p>As last set in test procedure, except: AN/USM-44(*) MOD. SELECTOR: CW MOD. LEVEL: Fully counterclockwise Frequency control: 301</p>	<p>As last set in test procedure, except: CHAN SEL: 9</p>	<p>a. Repeat step 1b, c, d, and e. b. Repeat step 1b. c. Repeat step 1g and h above. d. Operate CHAN SEL switch on unit under test to 9 and wait for unit to retune. e. Note TS-585(*)/U indication on the DECIBELS (top) scale.</p>	<p>a. Same as 1e. b. Same as 1f. c. None. d. None. e. 14 ±2.</p>																																				
3	<p>As last set in test procedure, except: AN/USM-44(*) MOD. SELECTOR: CW MOD. LEVEL: Fully counterclockwise Frequency control: 309.9</p>	<p>As last set in test procedure, except: CHAN SEL: 19</p>	<p>a. Repeat step 1b, c, d, and e above. b. Repeat step 1f. c. Repeat step 1g. d. Operate CHAN SEL switch on unit under test to 1 and wait for the unit to retune. e. Repeat step 1h and j.</p>	<p>a. Same as 1e. b. Same as 1f. c. None. d. None. e. Same as 1j.</p>																																				
4	<p>As last set in test procedure, except: AN/USM-44(*) MOD. SELECTOR: CW MOD. LEVEL: Fully counterclockwise</p>	<p>As last set in test procedure.</p>	<p>Repeat step 1b, c, d, e, and f for each of the following CHAN SEL switch positions on unit under test and AN/USM-44(*) frequency control settings: Note. Operate the AN/USM-44(*) MOD. SELECTOR switch to CW and MOD LEVEL control fully counterclockwise before proceeding with step 1b.</p> <table border="1"> <thead> <tr> <th>AN/USM-44(*) Frequency Control</th> <th>CHAN SEL</th> </tr> </thead> <tbody> <tr><td>395.0</td><td>18</td></tr> <tr><td>388.8</td><td>17</td></tr> <tr><td>377.7</td><td>16</td></tr> <tr><td>366.6</td><td>15</td></tr> <tr><td>355.5</td><td>14</td></tr> <tr><td>344.4</td><td>13</td></tr> <tr><td>333.3</td><td>12</td></tr> <tr><td>322.2</td><td>11</td></tr> <tr><td>311.1</td><td>10</td></tr> <tr><td>305.5</td><td>MANUAL</td></tr> <tr><td>299.9</td><td>8</td></tr> <tr><td>288.8</td><td>7</td></tr> <tr><td>277.7</td><td>6</td></tr> <tr><td>266.6</td><td>5</td></tr> <tr><td>255.5</td><td>4</td></tr> <tr><td>244.5</td><td>3</td></tr> <tr><td>233.3</td><td>2</td></tr> </tbody> </table>	AN/USM-44(*) Frequency Control	CHAN SEL	395.0	18	388.8	17	377.7	16	366.6	15	355.5	14	344.4	13	333.3	12	322.2	11	311.1	10	305.5	MANUAL	299.9	8	288.8	7	277.7	6	266.6	5	255.5	4	244.5	3	233.3	2	<p>Same as 1e and j.</p>
AN/USM-44(*) Frequency Control	CHAN SEL																																							
395.0	18																																							
388.8	17																																							
377.7	16																																							
366.6	15																																							
355.5	14																																							
344.4	13																																							
333.3	12																																							
322.2	11																																							
311.1	10																																							
305.5	MANUAL																																							
299.9	8																																							
288.8	7																																							
277.7	6																																							
266.6	5																																							
255.5	4																																							
244.5	3																																							
233.3	2																																							
5	<p>As last set in test procedure, except: TS-585(*)/U Meter multiplier: +20 AN/USM-44(*) ATTEN: 100 MICROVOLTS</p>	<p>As last set in test procedure.</p>	<p>a. Note TS-585(*)/U indication on DECIBELS (top) scale. b. Remove test lead from SPKR terminal and connect to HEADSET terminal of fabricated test cable. c. Operate TS-585(*)/U meter multiplier switch to +10 and note indication on DECIBELS (top) scale. d. Remove test lead from HEADSET terminal of fabricated test cable and connect to terminal E of BROAD BAND jack on unit under test. e. Operate TS-585(*)/U meter multiplier switch to -10 and note indication on DECIBELS (top) scale.</p>	<p>a. Not less than 10. b. None. c. Not less than 14. d. None. e. Not less than 13.</p>																																				
6	<p>As last set in test procedure, except: TS-585(*)/U Meter multiplier: +20 AN/USM-44(*) Output attenuator: 10 MILLIVOLTS</p>	<p>As last set in test procedure.</p>	<p>a. Remove test lead from BROAD BAND jack on unit under test and connect to SPKR terminal on fabricated test cable. b. Adjust VOLUME control on unit under test until TS-585(*)/U indicates 10 on the DECIBELS (top) scale. c. Operate AN/USM-44(*) MOD. SELECTOR switch to CW. d. Operate TS-585(*)/U meter multiplier switch to -10 and note indication on DECIBELS (top) scale.</p>	<p>a. None. b. None. c. None. d. Less than 5.</p>																																				
7	<p>As last set in test procedure, except: TS-585(*)/U Meter multiplier: +10 AN/USM-44(*) MOD. LEVEL: Fully counterclockwise Frequency control: 309.9 Output attenuator: 5 MICROVOLTS</p>	<p>As last set in test procedure, except: CHAN SEL: 19 SQUELCH: Fully counterclockwise (not OFF)</p>	<p>a. Repeat step 1b and c above. b. Rotate AN/USM-44(*) output attenuator control fully counterclockwise. c. Slowly rotate AN/USM-44(*) output attenuator control clockwise until TS-585(*)/U indicates a sudden upscale deflection and CALL LIGHT on unit under test lights. d. Note setting of AN/USM-44(*) output attenuator control. e. Rotate SQUELCH control on unit under test fully clockwise. f. Repeat c above and note setting of AN/USM-44(*) output attenuator control. g. Set AN/USM-44 output attenuator control to 6 MICROVOLTS. h. Rotate SQUELCH control counterclockwise until CALL LIGHT lights and clockwise until light is again extinguished. i. Rotate AN/USM-44(*) output attenuator control clockwise until CALL LIGHT lights. j. Note AN/USM-44(*) ATTEN setting.</p>	<p>a. None. b. None. c. None. d. 3 MICROVOLTS or less. e. None. f. Not less than 25 nor more than 50 MICROVOLTS. g. None. h. None. i. None. j. Less than 12 MICROVOLTS.</p>																																				
8	<p>As last set in test procedure, except: AN/USM-44(*) MOD. SELECTOR: CW MOD. LEVEL: Fully counterclockwise Frequency control: 233.3 Output attenuator: 5 MICROVOLTS</p>	<p>As last set in test procedure, except: CHAN SEL: 2 SQUELCH: Fully counterclockwise (not OFF)</p>	<p>a. Repeat step 1b and c. b. Repeat step 7b, c, and d. c. Repeat step 7e and c.</p>	<p>a. None. b. Not less than 1.5 nor more than 6 MICROVOLTS. c. Not less than 12.5 nor more than 100 MICROVOLTS.</p>																																				
9	<p>As last set in test procedure, except: TS-585(*)/U Meter multiplier: +20 AN/USM-44(*) Output attenuator: 100 MICROVOLTS</p>	<p>As last set in test procedure, except: OA-2649/TRC-68 or OA-2648/VRC-24 VOLUME: Fully clockwise SQUELCH: OFF</p>	<p>a. Adjust CN-16/U dial until TS-352(*)/U indicates 103 volts (1.03 on the 0 to 2.5 AC scale). b. Adjust PP-1104A/G INCREASE VOLTAGE control until the dc voltmeter indicates 22 volts. c. Note TS-585(*)/U indication on the DECIBELS (top) scale. d. Repeat step 5b and c above. e. Operate SQUELCH control on unit under test fully counterclockwise (not OFF). f. Repeat step 7b, c, and d. g. Repeat step 7e and c.</p>	<p>a. None. b. Not less than 7. c. Not less than 11. d. Not less than 9. e. None. f. Less than 17 MICROVOLTS. g. Less than 270 MICROVOLTS.</p>																																				



NOTE:  
DISCONNECT CONTROL SWITCH FROM  
FABRICATED TEST CABLE TO PREVENT  
ACCIDENTAL KEYING OF THE TRANSMITTER  
DURING THESE TESTS.



TM5620-222-55-C1-8

Figure 115.8. RT-323/VRC-24(\*) or RT-441/TRC-65(\*) receive frequency response and distortion tests, test setup.

**141.14. RT-323/VRC-24(\*) or RT-441/TRC-68(\*) Receive Frequency Response and Distortion Tests**

Adapter UG-201A/U  
Adapter, Connector UG-565A/U  
Fabricated test cable (fig. 113.1)

**a. Test Equipment and Materials.**

Transformer CN-16/U or  
Power Supply PP-1104A/G  
Multimeter TS-352(\*)/U  
Signal Generator AN/USM-44(\*)  
Audio Oscillator TS-382(\*)/U  
Output Meter TS-585(\*)/U  
Spectrum Analyzer TS-723(\*)/U

**b. Test Connections and Conditions.** Connect the equipment as shown in figure 113.8. For the RT-323/VRC-24(\*), connect the PP-1104A/G as shown in *Connection B* and disregard all references to the CN-16/U and TS-352(\*)/U. For the RT-441/TRC-68(\*), connect the CN-16/U and TS-352(\*)/U as shown in *Connection A* and disregard all references to the PP-1104A/G.

**c. Test Procedure.**

Step No.	Test equipment control settings	Equipment under test control settings	Test procedure	Performance standard
1	<p><i>CN-16/U</i> Dial: 115 ON-OFF: ON or <i>PP-1104A/G</i> Circuit breaker: ON INCREASE VOLTAGE: for 26.4 volts on dc voltmeter <i>TS-368(*)/U</i> FUNCTION: AC VOLTS Range: Any position OHMS ZERO ADJ: any position <i>TS-858(*)/U</i> Meter multiplier: +20 Impedance: 60 in X10 bracket <i>TS-783(*)/U</i> AF-RF: AF INPUT: MIN RANGE: X10 Function: SET LEVEL Meter range: DB 100% BALANCE: Fully clockwise Coarse FREQUENCY: 30 Power: ON <i>AN/USM-44(*)</i> FREQUENCY RANGE: E Frequency control: 225 FINE FREQ. ADJUST: To index marker MOD. SELECTOR: CW MOD. LEVEL: Fully counterclockwise Output attenuator: 1 MILLI-VOLT IMC-OFF-5MC: OFF XTAL CAL. GAIN: Fully counterclockwise OUTPUT LEVEL: 75% of full clockwise rotation AMP. TRIMMER: Any position Power: ON <i>TS-585(*)/U</i> OUTPUT LEVEL: Fully clockwise. ATTENUATOR: 10 THERMOSTAT: Fully clockwise OSC.: ON HEATER: ON RANGE: X1 FREQ. METER: OFF Main tuning dial: 100</p>	<p><i>OA-8649/TRC-68</i> or <i>OA-8648/VRC-84</i> POWER: operate to ON and release. CHAN SEL: 1 MANUAL FREQUENCY switches: TENS: 30 UNITS: 5 TENTHS: 5 SQUELCH: OFF VOLUME: Midposition METER: S-METER</p>	<p>a. Plug TS-352(*)/U test leads into three-way plug and adjust CN-16/U dial until TS-352(*)/U indicates 115 volts (1.15 on 0 to 2.5 AC scale). b. Allow a 30-minute warmup period before proceeding. c. Prepare AN/USM-44(*) for operation as follows: (1) Adjust AMP. TRIMMER control for maximum indication on OUTPUT VOLTS meter. (2) Adjust OUTPUT LEVEL control until OUTPUT VOLTS meter indicates SET LEVEL. (3) Operate MOD. SELECTOR switch to 1000~. (4) Rotate MOD. LEVEL control clockwise until PERCENT MODULATION meter indicates 30%. d. Carefully adjust AN/USM-44(*) Frequency control for maximum meter indication on unit under test. e. Adjust VOLUME control on unit under test until TS-585(*)/U indicates 10 on the DECIBELS (top) scale. f. Rotate AN/USM-44(*) MOD. LEVEL control fully counterclockwise and set MOD. SELECTOR switch to EXT. MOD. g. Rotate MOD. LEVEL control clockwise until PERCENT MODULATION meter indicates 30%. h. Operate TS-585(*)/U meter multiplier switch to +10 and note indication on the DECIBELS (top) scale. i. Operate TS-382(*)/U RANGE switch to X10 and rotate main tuning dial to 100. j. Adjust AN/USM-44(*) MOD. LEVEL control until PERCENT MODULATION meter indicates 30%. k. Operate TS-585(*)/U meter multiplier switch to +20 and note the indication on DECIBELS (top) scale. l. Operate TS-382(*)/U RANGE switch to X100. m. Adjust AN/USM-44(*) MOD. LEVEL control until PERCENT MODULATION meter indicates 30%. n. Note TS-585(*)/U indication on DECIBELS (top) scale. o. Rotate TS-382(*)/U main tuning dial to 50. p. Adjust AN/USM-44(*) MOD. LEVEL control until PERCENT MODULATION meter indicates 30%. q. Note TS-585(*)/U indication on DECIBELS (top) scale. r. Rotate TS-382(*)/U main tuning dial to 100. s. Adjust AN/USM-44(*) MOD. LEVEL control until PERCENT MODULATION meter indicates 30%. t. Operate TS-585(*)/U meter multiplier switch to 0 and note meter indication. u. Momentarily operate POWER switch of unit under test to OFF and release. v. Remove unit under test from its case. w. Operate NOR-BB switch on unit under test (rear of chassis) to BB. x. Reinstall the unit under test in its case. y. Momentarily operate POWER switch of unit under test to ON and release. z. Remove test lead from SPKR terminal of fabricated test cable and connect to terminal E of BROAD BAND jack on unit under test.</p>	<p>a. None. b. Nope. c. None. d. None. e. None. f. None. g. None. h. Less than 12. i. None. j. None. k. 10 ±2. l. None. m. None. n. 10 ±2. o. None. p. None. q. Less than 5. r. None. s. None. t. Less than 10. u. None. v. None. w. None. x. None. y. None. z. None.</p>
2	<p>As last set in test procedure, except: <i>AN/USM-44(*)</i> MOD. SELECTOR: 1000~ <i>TS-686(*)/U</i> Meter multiplier: -10 <i>TS-585(*)/U</i> RANGE: X1</p>	As last set in test procedure	<p>a. Adjust AN/USM-44(*) MOD. LEVEL control until PERCENT MODULATION meter indicates 30%. b. Note and record TS-585(*)/U indication on the DECIBELS (top) scale. c. Repeat step 1f and g. d. Note TS-585(*)/U indication on DECIBELS (top) scale. e. Repeat step 1i and j. f. Note TS-585(*)/U indication. g. Repeat step 1l, m, and n. h. Repeat step 1o, p, and q above. i. Repeat step 1r and s. j. Note TS-585(*)/U indication on DECIBELS (top) scale. k. Rotate TS-382(*)/U main tuning dial to 180. l. Adjust AN/USM-44(*) MOD. LEVEL control until PERCENT MODULATION meter indicates 30%. m. Note and record TS-585(*)/U indication on DECIBELS (top) scale. n. Subtract value noted in m above from value noted in b above. o. Operate TS-382(*)/U RANGE switch to X1000 and rotate main tuning dial to 25. p. Adjust AN/USM-44(*) MOD. LEVEL control until PERCENT MODULATION meter indicates 30%. q. Note and record TS-585(*)/U indication on DECIBELS (top) scale. r. Subtract value recorded in q above from value recorded in b above.</p>	<p>a. None. b. None. c. None. d. Within ±3 of the indication recorded in b above. e. None. f. Within ±3 of the indication recorded in b above. g. Within ±3 of the indication recorded in b above. h. Within ±3 of the indication recorded in b above. i. None. j. Within ±3 of the indication recorded in b above. k. None. l. None. m. None. n. Difference must not be greater than 7. o. None. p. None. q. None. r. Difference must not be greater than 7.</p>
3	<p>As last set in test procedure, except: <i>TS-585(*)/U</i> RANGE: X10 Main tuning dial: 30 <i>TS-783(*)/U</i> INPUT: MIN Function: SET LEVEL RANGE: X10 Coarse FREQUENCY: 30</p>	As last set in test procedure.	<p>a. Adjust AN/USM-44(*) MOD. LEVEL control until PERCENT MODULATION meter indicates 30%. b. Measure distortion of unit under test as follows: (1) Slowly rotate TS-723(*)/U INPUT control clockwise until OUTPUT VOLTS meter indicates 1.0 on 0 to 1.0 scale. (2) Operate function switch to DISTORTION. (3) Adjust coarse FREQUENCY control until sharp dip is indicated on OUTPUT VOLTS meter. (4) Adjust fine FREQUENCY control for minimum OUTPUT VOLTS meter indication. <i>Note:</i> As adjustment progresses, decrease setting of (counterclockwise) R.N.S. VOLTS meter range switch to maintain midscale deflections. (5) Adjust BALANCE control for minimum OUTPUT VOLTS meter indication. (6) Repeat (4) and (5) above until no further reduction in OUTPUT VOLTS meter indication can be obtained. (7) Set meter range switch to 10%, and note distortion as indicated on OUTPUT VOLTS meter.</p>	<p>a. None. b. Less than 1.0 on 0 to 1.0 (top) scale (less than 10% distortion).</p>
4	<p>As last set in test procedure, except: <i>AN/USM-44(*)</i> MOD. SELECTOR: 1000~ <i>TS-783(*)/U</i> INPUT: MIN Function: SET LEVEL Meter range: 100% Coarse FREQUENCY: 100</p>	As last set in test procedure.	<p>a. Repeat step 3a and b.</p>	<p>a. Same as 3b.</p>
5	<p>As last set in test procedure, except: <i>AN/USM-44(*)</i> MOD. SELECTOR: EXT. MOD <i>TS-585(*)/U</i> RANGE: X100 <i>TS-783(*)/U</i> INPUT: MIN Function: SET LEVEL Meter range: 100% RANGE: X100 Coarse FREQUENCY: 30 <i>TS-585(*)/U</i> Meter multiplier: +20</p>	As last set in test procedure.	<p>a. Repeat step 3a and b. b. Momentarily operate POWER switch on unit under test to OFF and release. c. Remove unit under test from its case. d. Operate NOR-BB switch (rear of chassis) to NOR. e. Reinstall unit under test in its case. f. Remove test lead from BROAD BAND jack of unit under test and connect to SPKR terminal of fabricated test cable. g. Momentarily operate POWER switch to ON and release. h. Repeat step 3. i. Repeat step 4. j. Reset AN/USM-44(*)/U, and TS-723(*)/U controls as indicated in test equipment control settings column for this step and repeat step 3a and b.</p>	<p>a. Same as 3b. b. None. c. None. d. None. e. None. f. None. g. None. h. Same as 3b. i. Same as 3b. j. Same as 3b.</p>

NOTE:  
DISCONNECT CONTROL SWITCH FROM  
FABRICATED TEST CABLE TO PREVENT  
ACCIDENTAL KEYING OF THE TRANSMITTER  
DURING THESE TESTS.

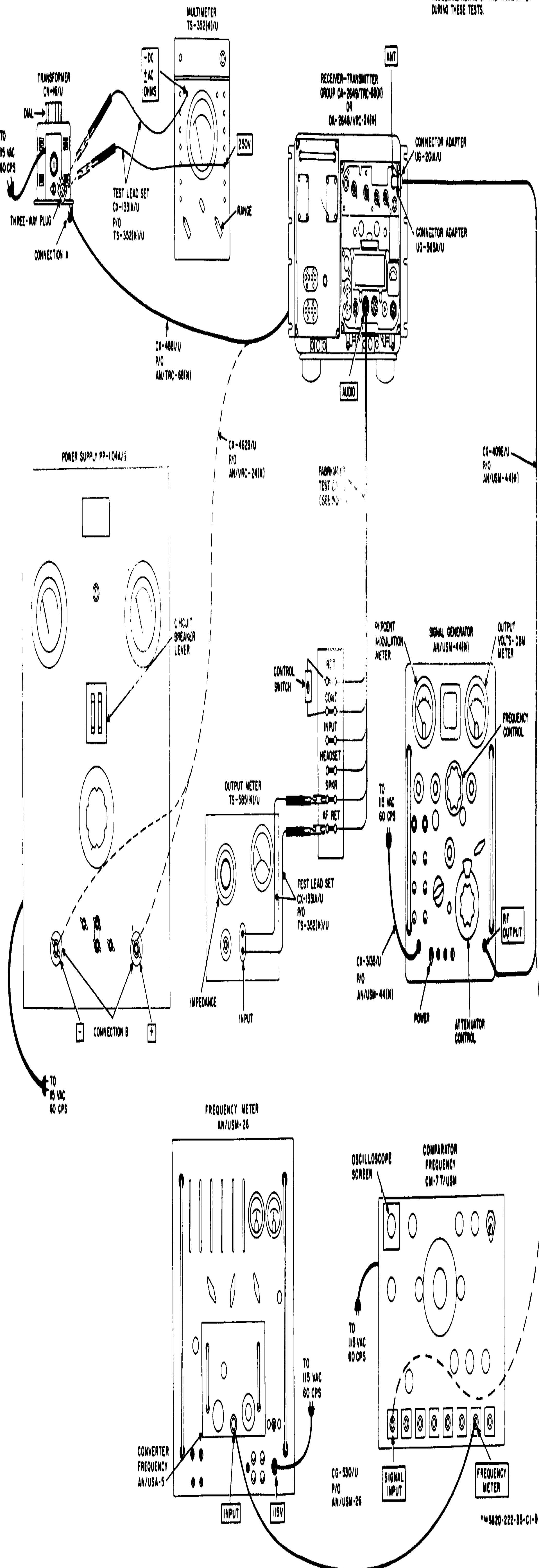


Figure 113.9. RT-323/VRC-24(\*) or RT-441/TRC-65(\*) selectivity and symmetry tests, test setup.

**141.15. RT-323/VRC-24(\*) or RT-441/TRC-68(\*) Selectivity and Symmetry Tests**

*a. Test Equipment and Materials.*

Transformer CN-16/U or  
Power Supply PP-1104A/G  
Multimeter TS-352(\*)/U  
Output Meter TS-585(\*)/U  
Signal Generator AN/USM-44(\*)  
Comparator, Frequency CM-77/USM  
Frequency Meter AN/USM-26  
Converter, Frequency AN/USA-5

Adapter UG-201A/U  
Adapter, Connector UG-565A/U  
Fabricated Test Cable (fig. 113.1)

*b. Test Connections and Conditions.* Connect the equipment as shown in figure 113.9. For the RT-323/VRC-24(\*), connect the PP-1104A/G as shown in *Connection B* and disregard all references to the CN-16/U and TS-352(\*)/U. For the RT-441/TRC-68(\*), connect the CN-16/U and TS-352(\*)/U as shown in *Connection A* and disregard all references to the PP-1104A/G.

*c. Test Procedure.*

Step No.	Test equipment control settings	Equipment under test control settings	Test procedure	Performance standard
1	<p>CN-16/U Dial: 115 ON-OFF: ON or PP-1104A/G Circuit breaker: ON INCREASE VOLTAGE: For 26.4 volts on dc voltmeter TS-352(*)/U FUNCTION: AC VOLTS Range: Any position OHMS ZERO ADJ: any position TS-585(*)/U Meter multiplier: +20 Impedance: 60 in bracket X10 AN/USM-44(*) FREQUENCY RANGE: E Frequency control: 225 FINE FREQ. ADJUST: To index marker MOD. SELECTOR: CW MOD. LEVEL: Fully counterclockwise Output attenuator: 5 MICROVOLTS 1MC-OFF-5MC: OFF XTAL CAL. GAIN: Fully counterclockwise OUTPUT LEVEL: 75% of fully clockwise rotation AMP. TRIMMER: Any position Power: ON CM-77/USM POWER: ON FOCUS INTENSITY: Midposition HORIZ GAIN: Midposition COARSE VERNIER: Adjust for 113 on MEGACYCLES dial <i>Note.</i> The remaining controls may be in any position. AN/USM-26 Power: ON MANUAL GATE: CLOSED 100 KC STANDARD: EXT. STD. FREQ. COUNTED: 10-MC FUNCTION SELECTOR: FREQUENCY STD. GATE TIME~ SEC.: 1 DISPLAY TIME: Inf AN/USA-5 FUNCTION: WAVEMETER WAVEMETER DIAL: 110 MIXING FREQUENCY: 110</p>	<p>OA-2649/TRC-68 or OA-2648/VRC-24 POWER: Operate to ON and release CHAN SEL: 1 MANUAL FREQUENCY switches: TENS: 30 UNITS: 5 TENTHS: 5 SQUELCH: OFF VOLUME: Midposition METER: S-METER</p>	<p>a. Plug TS-352(*)/U test leads into three-way plug and adjust CN-16/U dial until TS-352(*)/U indicates 115 volts (1.15 on 0 to 2.5 AC scale). b. Allow a 30-minute warmup period before proceeding. c. Prepare AN/USM-44(*) for operation as follows: (1) Adjust AMP. TRIMMER control for maximum indication on OUTPUT VOLTS meter. (2) Adjust OUTPUT LEVEL control until OUTPUT VOLTS meter indicates SET LEVEL. (3) Operate MOD. SELECTOR switch to 1000~. (4) Rotate MOD. LEVEL control clockwise until PERCENT MODULATION meter indicates 30%. d. Carefully adjust AN/USM-44(*) frequency control for maximum indication on TS-585(*)/U. e. Adjust VOLUME control on unit under test until TS-585(*)/U indicates 10 on DECIBELS (top) scale. f. Set AN/USM-44(*) output attenuator control to 10 MICROVOLTS. g. Slowly rotate AN/USM-44(*) frequency control clockwise until TS-585(*)/U again indicates 10 on DECIBELS (top) scale. h. Remove AN/USM-44(*) RF OUTPUT cable from UG-201A/U at ANT. connector of unit under test and connect to CM-77/USM MIXER INPUT B connector. i. Measure frequency of AN/USM-44(*) as follows: (1) Rotate AN/USM-44(*) output attenuator control to 10 MILLIVOLTS. (2) Carefully adjust CM-77/USM COARSE VERNIER control until pattern is observed on oscilloscope screen. (3) Carefully adjust FINE VERNIER control until oscilloscope pattern is reduced to a straight horizontal line. <i>Note.</i> It is not necessary to maintain the straight line display. After the straight line has been obtained, the adjustment is considered accurate. (4) Carefully adjust AN/USA-5 WAVEMETER DIAL for closure of tuning eye. (5) Operate AN/USA-5 FUNCTION switch to MIXER. j. Operate AN/USM-26 100 KC STANDARD switch to INT. and record AN/USM-26 indication. k. Rotate AN/USM-44(*) output attenuator control to 10 MICROVOLTS. l. Remove RF OUTPUT cable from CM-77/USM MIXER INPUT B connector and connect to UG-201A/U at ANT. connector on unit under test. m. Rotate AN/USM-44(*) frequency control counterclockwise until TS-585(*)/U again indicates 10 on DECIBELS (top) scale. n. Repeat h, i, and j above. o. Subtract indication recorded in n above from indication recorded in j above. p. Add indications recorded in j and n above and divide sum by 2.</p>	<p>a. None. b. None. c. None. d. None. e. None. f. None. g. None. h. None. i. None. j. None. k. None. l. None. m. None. n. None. o. Difference must be not less than 40 KC (80 KC, 6-db bandwidth). p. Result must not be less than 02495.000 nor more than 02505.000.</p>
2	<p>As last set in test procedure, except: AN/USM-44(*) Output attenuator: 5 MILLIVOLTS</p>	<p>As last set in test procedure.</p>	<p>a. Repeat step 1i above. b. Repeat steps 1g, h, i, and j above. c. Reset AN/USM-44(*) output attenuator control to 5 millivolts. d. Repeat steps 1m, h, i, and j. e. Subtract indication recorded in b above from indication record in d above.</p>	<p>a. None. b. None. c. None. d. None. e. Difference must not be more than 75 kc (150 kc, 60-db bandwidth).</p>

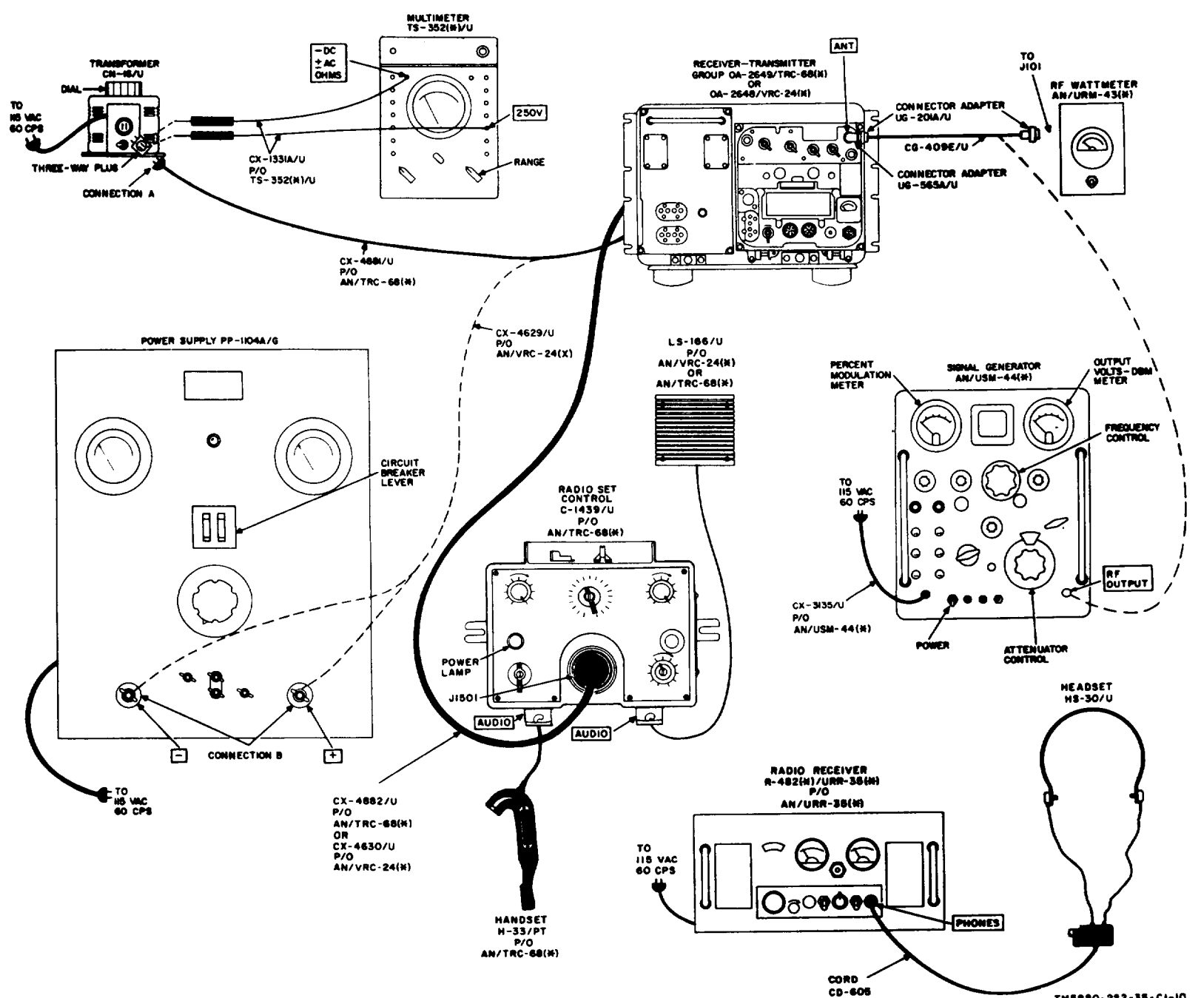


Figure 115.10. Radio Set Control C-1439/U tests and overall operation test, tests setup.

**141.16. Radio Set Control C-1439/U Tests and Overall Operation Test**

*a. Test Equipment and Materials.*

Transformer CN-16/U or  
Power Supply PP-1104A/G  
Multimeter TS-352(\*)/U  
Radio Frequency Wattmeter AN/URM-43(\*)  
Signal Generator AN/USM-44(\*)  
Radio Receiving Set AN/URR-35(\*)  
Headset HS-30-U

Cord CD-605 (used W/HS-30-U)  
Adapter UG-201A/U  
Adapter, Connector UG-565A/U

*b. Test Connections and Conditions.* Connect the equipment as shown in figure 113.10. For the OA-2648/VRC-24, connect the PP-1104A/G as shown in *Connection B* and disregard all references to the CN-16/U and TS-352(\*)/U. For the OA-2649/TRC-68 connect the CN-16/U and TS-352(\*)/U as shown in *Connection A* and disregard references to the PP-1104A/G.

*c. Test Procedure.*

Step No.	Test equipment control settings	Equipment under test control settings	Test procedure	Performance standard
1	<p><i>CN-16/U</i> Dial: 115 ON-OFF: ON <i>or</i> <i>PP-1104A/G</i> Circuit breaker: ON INCREASE VOLTAGE: For 26.4 volts on dc voltmeter <i>AN/URM-43(*)</i> 15W-60W: 60W <i>AN/USM-44(*)</i> FREQUENCY RANGE: E Frequency control: 225 FINE FREQ. ADJUST: To index marker MOD. SELECTOR: CW MOD. LEVEL: Fully counterclockwise Output attenuator: 100 MICROVOLTS OUTPUT LEVEL: 75% of full clockwise rotation XTAL CAL. GAIN: Fully counterclockwise AMP. TRIMMER: Any position 1-MC-OFF-5MC: OFF Power: ON <i>RT-441/TRC-68(*)</i> <i>or</i> <i>RT-523/VRC-24(*)</i> CHAN SEL: REMOTE PRESET SQUELCH: VOLUME: METER: S-METER POWER: Vertical (do not operate to ON) <i>TS-352(*)/U</i> FUNCTION: AC VOLTS Range: Any position OHMS ZERO ADJ: Any position <i>R-482(*)/URR-35(*)</i> ALIGN-REC: REC OSC: MANUAL LOCK: Fully counterclockwise Tuning: For 225 on MEGACYCLES dial DIMMER: Any position SILENCER: OUT PHONES: 8 POWER: ON N.L. IN-OUT: OUT</p>	<p><i>C-1439/U</i> SPEAKER VOLUME: Mid-position PHONE VOLUME: Midposition CHANNEL: 1 SQUELCH: OFF RAD-INT—INT—RAD: RAD POWER: Vertical (do not operate to ON)</p>	<p>a. Plug TS-352(*)/U test leads into three-way plug and adjust CN-16/U dial until TS-352(*)/U indicates 115 volts (1.15 on the 0 to 2.5 AC scale.) b. Operate C-1439/U POWER switch to ON and release. c. Note PRESET CHANNEL dial on unit under test. d. Operate C-1439/U CHANNEL switch to positions 2 through 19 and note PRESET CHANNEL dial indication of unit under test. e. Operate C-1439/U CHANNEL switch to position 1. f. Slowly rotate C-1439/U SQUELCH control clockwise until CALL LIGHT is extinguished. g. Depress SQUELCH DISABLE PUSH switch..... h. Release SQUELCH DISABLE PUSH switch..... i. Depress H-33/PT switch and speak in a normal tone into microphone of H-33/PT. Have an assistant adjust R-482(*)/URR-35(*) tuning control for maximum audio in HS-30-U and observe quality of voice reproduction. Release H-33/PT switch. j. Operate C-1439/U RAD-INT—INT—RAD switch to RAD-INT and lock in position. k. Depress H-33/PT switch and speak in normal tone into microphone of H-33/PT. Have an assistant observe quality of voice reproduction in HS-30-U. Release H-33/PT switch. l. Operate C-1439/U RAD-INT—INT—RAD switch to INT. m. Depress H-33/PT switch and note AN/URM-43(*) indication. Release H-33/PT switch. n. Operate C-1439/U RAD-INT—INT—RAD switch to RAD. o. Interchange H-33/PT and LS-166/U connections to C-1439/U. p. Repeat j through o above..... q. Remove CG-409E/U from UG-201A/U at AN/URM-43(*) and connect to AN/USM-44(*) RF OUTPUT connector.</p>	<p>a. None. b. C-1439/U power lamp lights. c. Dial indicates 1. c. PRESET CHANNEL dial indication corresponds to CHANNEL switch position. e. CALL LIGHT is on. f. CALL LIGHT goes out in less than 50% of full rotation. g. CALL LIGHT lights. h. CALL LIGHT goes out. i. Voice reproduction is intelligible and free from hum, noise, or buzz. j. None. k. Voice reproduction must be intelligible and free from hum, noise, or buzz. l. None. m. AN/URM-43(*) does not indicate (transmitter not keyed). n. None. o. None. p. Same as j through n above. q. None.</p>
2	As last set in test procedure.	As last set in test procedure.	<p>a. Prepare AN/USM-44(*) for operation as follows: (1) Adjust AMP. TRIMMER control for maximum indication on OUTPUT VOLTS meter. (2) Adjust OUTPUT LEVEL control until OUTPUT VOLTS meter indicates SET LEVEL. (3) Operate MOD. SELECTOR switch to 1000~. (4) Rotate MOD. LEVEL control clockwise until PERCENT MODULATION meter indicates 30%. b. Carefully adjust AN/USM-44(*) frequency control for maximum indication on panel meter of unit under test. c. Observe quality of 1,000~ tone in H-33/PT receiver and loudspeaker. d. Listen to tone in H-33/PT and rotate PHONE VOLUME control fully counterclockwise and fully clockwise. Adjust for normal listening level. e. Listen to tone in loudspeaker and rotate SPEAKER VOLUME control fully counterclockwise and fully clockwise. Adjust for normal listening level. f. Interchange H-33/PT and LS-166/U connections to C-1439/U. g. Observe quality of 1,000~ tone in H-33/PT and LS-166/U. h. Turn off all power and disconnect all equipment..</p>	<p>a. None. b. None. c. Tone must be clear and free from hum, noise, or buzz. d. Tone decreases and increases in volume and is free of interruptions, noise, or scratching. e. Tone decreases and increases in volume and is free from interruptions, noise, or scratching. f. None. g. Tone must be clear and free from hum, noise, or buzz. h. None.</p>

to the Z105 terminal (9, fig. 70).

- (13) Repeat the operations outlined in (10) above to solder capacitors C126 and C139 (fig. 71) to the Z106 terminal (8, fig. 70).

*i. Replacement of Rf and Power Amplifier Subunit.* After performing the desired removal and replacement procedures above, replace the rf and power amplifier subunit in the rt unit main frame (para 108 b).

## 126. Disassembly and Reassembly of Frequency Selector (4th Echelon)

### *a. General Instructions.*

- (1) The following paragraphs contain instructions for the complete disassembly and reassembly of the frequency selector. Usually, repair of the frequency selector requires the repair or replacement of only a single part or assembly, and complete disassembly is not required. When the fault is located and corrected, go directly to the corresponding reassembly instructions and proceed to reassemble the subunit.
- (2) The frequency selector cabling can be removed intact and the subunit can be disassembled without unsoldering or disconnecting any wires. When wires are disconnected for parts repair or replacement, tag each wire for identification. Before removing a wired part, make a sketch of the wiring to aid in rewiring the replacement part. Tag and remove as many wires as possible from the switch wafers before removing the switch.

### *b. Special Tools and Materials Required.*

The special tools and materials required for disassembly and reassembly of the frequency selector are listed below.

- (1) Waldes Truarc pliers, No. 212, or equivalent.
- (2) Torque meter, Torqometer TQ-12A, Snap-On Tool Corp., or equivalent. This tool requires an extension (fig. 104) that will fit hexagonal-head nuts (6), (15), (24),

and (33), and will fit over shaft assemblies (2), (11), (20), and (29) (fig. 97).

- (3) Torque meter, Collins part No. 110 6610 00, or equivalent. This tool can be fitted with an adapter shaft assembly (fig. 105), Collins part number 558 1377 002, which mates with coupler (62, fig. 98).
  - (4) Gear-loading rod (fig. 106).
  - (5) Lubrication materials (para 127b).
- c. Memory Drum Disassembly* (fig. 96).
- (1) Remove three screws (1) and washers (2) from the mounting (3).
  - (2) Remove three screws (1) and washers (2) from the drum drive assembly (4), and remove the scale (5) and the switch assembly (6) and spacers (7).
  - (3) Remove four screws (8) and washers (9).
  - (4) Use a Bristo screwdriver to loosen the two setscrews on the hub (10). Move the gear shaft to disengage the shaft of the drum drive assembly (4).
  - (5) Loosen the clamp (11) and remove the drum drive assembly (4) from the bearing on the front plate (13).
  - (6) Remove gear (12), clamp (11), and hub (10).
  - (7) Slide the mounting (3) off the end of the shaft of the drum drive assembly (4).
  - (8) Loosen and remove nut (14) with a socket wrench and slide hub (15), memory drum (16), and dial hub (17) off the shaft of the drum drive assembly (4).

### *d. Memory Drum Reassembly* (fig. 96).

- (1) Place a thin coating of low-temperature oil (para 127b) on the bronze bearings on the drum drive assembly (4) and the rear plate.
- (2) Slide the flatted shaft of the drum drive assembly (4) through hole E in the front plate (13).
- (3) Assemble clamp (11) on gear (12) and mount on the flatted shaft of drum drive assembly (4). Rotate the shaft until it engages the rotors of wafer switches S1206 (85) and S1205 (83). Position the rotors so



that the smallest detent is in contact with clip No. 2 (white, black, and orange lead).

- (4) Mount hub (10) on the flatted shaft of drum drive assembly (4).
- (5) Mount dial hub (17), memory drum (16), and hub (15) on the shaft of drum drive assembly (4). Locate the, manual tuning bar next to the letter M on the dial hub (17).
- (6) Replace and tighten nut (14) with a socket wrench.
- (7) Mount the drum drive assembly (4) on the front plate (13) and secure with two screws (8) and washers (9). Do not tighten the screws.
- (8) Slide mounting (3) on the shaft of drum drive assembly (4) and secure to front plate (13) with two screws (8) and washers (9). Do not tighten the screws.
- (9) Position the drum drive assembly (4) to prevent the shafts from binding, and tighten all four screws (8). Position the shaft of the drum drive assembly (4) so that the flat side faces the bottom edge of the frequency selector.
- (10) Raise the shaft of the drum drive assembly (4) that engages switches S1206 (85) and S1205 (83) to obtain optimum gear mesh of the miter gears between the two shafts on the drum drive assembly (4). Tighten the setscrews on the hub (10) with a Bristo screwdriver.
- (11) Place a thin coating of light-consistency grease (para 127b ) on the gear (12) on the shaft of the drum drive assembly (4); then position gear (12) one-sixteenth of an inch from the front plate (13), and tighten clamp (11).
- (12) Mount the switch assembly (6) on the drum drive assembly (4) and mounting (3). Use spacers (7) to position the switch assembly so that the switch contacts line up with the pins on the memory drum (16). Secure with one screw (1) and was her (2) on each side of the switch assembly.
- (13) Mount the scale (5) on the drum

drive assembly (4) and mounting (3) and secure with two screws (1) and two washers (2).

*e. Disassembly of Front Plate Components (fig. 96).*

*Note.* Components mounted on the front plate need not be disassembled in the following order. Disassemble components as required for replacement or repair.

- (1) *Removal of relay K1201.*
  - (a) Remove two screws (18) and washers (19) and one screw (20), washer (21), and spacer (22) to remove relay K1201 (23) from front plate (13).
  - (b) Separate relay K1201 (23) from bracket (24) by removing four screws (25) and washers (26).
- (2) *Removal of relay K1202.*
  - (a) Remove two screws (18) and washers (19) and one screw (25) and washer (26) to remove relay K1202 (28) from front plate (13).
  - (b) Separate bracket (29) from relay K1202 (28) by removing four screws (25) and washers (26).
  - (c) Remove plate (27) from front plate (13) by removing roundhead screw (31) and flathead screw (30).
- (3) *Removal of relay K1203.*
  - (a) Remove two screws (18) and washers (19), and one screw (20), washer (21), and spacer (22) to remove relay K1203 (33) from the front plate.
  - (b) Separate bracket (34) from relay K1203 (33) by removing four screws (25) and washers (26) and cable clamp (35).
- (4) *Removal of relay K1204.*
  - (a) Remove two screws (18) and washers (19), and one screw (20), washer (21), and spacer (22) to remove relay K1204 (36) from front plate (13).
  - (b) Separate relay K1204 (36) from bracket (37) by removing four screws (25) and washers (26).
- (5) *Removal of dial assemblies, switch S1202, and jack J1201.*
  - (a) Remove the four retaining rings



- (32) and the four relay pawls (38), (39), (40), and (41).
- (b) Remove the two retaining screws (42) and washers (43) on each dial assembly, and remove dial assemblies (44), (45), (46), and (47). Remove washer (49) and cable clamp (48) from dial assembly (47).
- (c) Remove two screws (50), two washers (51), and two washers (52), and remove wafer switch S1202 (54) and two spacers (53).
- (d) Remove two screws (55) and washers (56) and remove connector plate (57) from the front plate. Disassemble connector J1201 (58) by removing two screws (59).
- (e) Remove the screw that fastens the ground lug to the front plate immediately above the 10.0-mc dial assembly (45).
- (f) Remove two screws (63), washers (64) and (65), and remove the two cable clamps (66) along the left edge of the front plate (13).

*f. Reassembly of Front Plate Components (fig. 96).*

- (1) *Replacement of dial assemblies, switch S1202, and jack J1201.*
  - (a) Position the front plate cable assembly as shown in figure 101. Replace the cable clamps (66), washers (65) and (64), and screws (63) to secure the cable assembly along the left edge of the front plate (13).
  - (b) Replace the ground lug above the 10.0-mc dial assembly (45).
  - (c) Reassemble connector J1201 (58), springs (60), and plate (62), and secure to connector plate (57) with screws (59) and posts (61).
  - (d) Secure the assembled connector to the front plate with two screws (55) and washers (56).
  - (e) Replace wafer switch S1202 (54) and two spacers (53), and secure to the front plate with two screws (50) and washers (51) and (52).

- (f) Secure each dial assembly (44), (45), (46), and (47) to the front plate with two retaining screws (42) and washers (43). Replace washer (49) and cable clamp (48) before securing dial assembly (47).
- (g) Replace relay pawls (38), (39), (40), and (41) and secure them with retaining rings (32).
- (2) *Replacement of relay K1204.*
  - (a) Reassemble relay K1204 (36) and bracket (37), and secure them with four screws (25) and washers (26).
  - (b) Replace relay K1204 on the front plate (13) and secure it with two screws (18) and washers (19) and one screw (20), washer (21), and spacer (22). Be sure that pawl (38) is between the lever arm and the spring of relay K1204.
- (3) *Replacement of relay K1203.*
  - (a) Reassemble relay K1203 (33), bracket (34), and cable clamp (35), and secure with four screws (25) and washers (26).
  - (b) Fasten relay K1203 (33) to front plate (13) with two screws (18) and washers (19) and one screw (20), washer (21), and spacer (22).
- (4) *Replacement of relay K1202.*
  - (a) Secure plate (27) to front plate (13) with one roundhead screw (31) and one flathead screw (30). Be sure that flathead screw (30) is one-fourth-inch long so that it will not contact the cam on the opposite side of the front plate.
  - (b) Reassemble relay K1202 (28) and bracket (29) with four screws (25) and washers (26).
  - (c) Secure relay K1202 (28) to front plate (13) with two screws (18) and washers (19) and one screw (25) and washer (26).
- (5) *Replacement of relay K1201.*
  - (a) Reassemble relay K1201 (23) and bracket (24) and secure them with four screws (25) and washers (26).

- (b) Fasten relay K1201 (23) to front plate (13) with two screws (18) and washers (19) and one screw (20), washer (21), and spacer (22).

*g. Separation of Front and Rear Plates (fig. 96).*

- (1) Remove the memory drum (c above).
- (2) Remove retaining ring (107) from the shaft on the rear of the rear plate (102) and withdraw the shaft assembly (67) from the front of the rear plate (102); then remove washer (68).
- (3) Remove two screws (69) and washers (70) and (71) from the two posts (72), and remove wafer switch S1201 (73) from the posts.
- (4) Remove two screws (104) and washers (103) from the rear of the rear plate, and remove the two posts (72) from the rear plate.
- (5) Remove two screws (74) and washers (75) to remove wafer switch S1203 (76) and two spacers (77).
- (6) Remove two screws (78) and washers (79) to remove wafer switch S1204 (80) and spacers (81).
- (7) Remove two screws (82) from two posts (88) to remove wafer switches S1205 (83) and S1206 (85).
- (8) Remove two nuts (86) to separate switches S1205 (83) and S1206 (85).
- (9) Remove one screw (55) and washer (56) and pivot connector J1201 to locate one flathead screw (89). Remove all three flathead screws (89) on the front of the front plate.
- (10) Remove one screw (25), washer (26), and cable clamp (35) that secure bracket (34) to relay K1203 (33). Position the cable assembly to locate and remove screw (91) and washer (90) from front plate (13).
- (11) Remove, similar screw (91) and washer (90) from the opposite side of front plate (13).
- (12) Remove three screws (100) and washers (101), and remove motor (99) from rear plate (102).

- (13) Carefully pull apart the front and rear plates (13) and (102).
- (14) Remove gear (92) from the gear bearing on the rear plate.
- (15) Remove washers (93), (94), (95), (96), (97), and (98).

*h. Reassembly of Front and Rear Plates (fig. 96).*

- (1) Place washers (93) and (98) on the shafts of front plate shaft assemblies (20) and (29) (fig. 97).
- (2) Place washers (94), (95), (96), and (97) on the shafts of the rear plate shaft assemblies.
- (3) Apply Grease, aircraft and instrument (9150-272-3370) (light consistency) to the working surfaces of all gears and cams mounted on the front and rear plates (fig. 97 and 98).
- (4) Place gear (92) on the rear plate to mesh with the 36-tooth gear (78, fig. 98) and the 36-tooth gear (24, fig. 98).
- (5) Place front plate (13) on rear plate (102). Carefully mesh the matching gears as the two plates are fitted together. Align posts A, B, C, and D on the rear plate with corresponding holes A, B, C, and D on the front plates.
- (6) Secure the two plates (13) and (102) with three flathead screws (89). Insert the three screws through front plate holes A and B and the counter-sunk hole directly above dial assembly (46).
- (7) Replace screw (91) and washer (90) by inserting them through front plate hole C, and secure them to post C on rear plate.
- (8) Replace screw (91) and washer (90) by inserting them through front plate hole D and securing them to post D on rear plate.
- (9) Replace screw (25), washer (26), and cable clamp (35) on bracket (34) and relay K1203 (33).
- (10) Pivot connector J1201 into place and secure it with screw (55) and washer (56).
- (11) Lubricate all the wafer switches on both sides of the wafers with low-

temperature grease and form the cable assembly on the front plate as shown in figure 101 to mount the switches.

- (12) Mount motor (99) on the rear plate and secure with three screws (100) and three washers (101).
- (13) Mount switch S1203 (76) on the gear plate (10, fig. 98) and secure with two screws (74), flat washers (75), and spacers (77).
- (14) Mount switch S1204 (80) on the gear plate (10, fig. 98) and secure with two screws (78), washers (79), and spacers (81).
- (15) Mount the posts (72) on the rear plate (102) and secure with screws (104) and washers (103).
- (16) Mount switch S1201 (73) on the two posts (72) and secure with two screws (69) and washers (70) and (71).
- (17) Place a thin coating of Lubricating oil, general purpose (OGP) on the bronze bearing; insert shaft assembly (67) through switch S1201 (73) and washer (68), and secure from the rear of plate (102) with retaining ring (107). Place a thin coating of Grease, aircraft (MIL-G-7421) on the teeth of shaft assembly (67).
- (18) Assemble switches S1205 (83) and S1206 (85), washers (87), spacers (84), and posts (88), and secure with nuts (86). Align the switches with the holes in the switchplate (74, fig. 98) and secure with two nuts (82).

*i. Disassembly of Front Plate (fig. 97).*

- (1) Remove the memory drum and separate the front and rear plates as in *c* and *g* above.
- (2) Remove retaining ring (62), washer (61), spring (60), washer (59), retaining ring (58), washer (57), cam arm assembly (56), and washer (55) from the post on the front plate (1).
- (3) Remove retaining ring (54), washer (53), and the 60-tooth gear (52) from the post on the front plate.
- (4) Remove retaining ring (51), washer (50), and the 29-tooth gear (49)

from the gear assembly post on the front plate.

- (5) Remove two retaining rings (48) and the 72-tooth gear (47) from the shaft assembly (29).
- (6) Remove retaining ring (46), clamp (45), the 57-tooth gear (44), retaining ring (43), and the 72-tooth gear (42) from shaft assembly (20).
- (7) Remove retaining ring (41) and the 72-tooth gear (40) from the shaft assembly (11).
- (8) Remove retaining ring (39) and the 48-tooth gear (38) from the assembly shaft (2).

*Note.* The remaining front plate disassembly procedures consist of disassembling the four automatic positioner clutch assemblies. These clutch assemblies are secured by the four hexagonal-head nuts (6), (15), (24), and (33), which are tightened to the proper torque at the factory and are sealed with Loctite. The clutch assemblies require little maintenance other than cleaning, which can be performed when the clutches (8), (17), (26), and (35) are removed from the clutch drums. Therefore, do not remove the hexagonal-head nuts that secure the clutch assemblies unless a part obviously requires replacement.

- (9) Remove retaining ring (10) and remove the clutch (8) and three springs (9) from inside the clutch drum (4).
- (10) Loosen and remove the hexagonal-head nut (6) and remove the clutch spacer (7), clutch flange (5), clutch drum (4), and washer (3) from the shaft (2).
- (11) Remove retaining ring (19) and remove the clutch (17) and three springs (18) from inside the clutch drum (13).
- (12) Loosen and remove hexagonal-head nut (15) and remove the clutch spacer (16), clutch flange (14), clutch drum (13), and washer (12) from the shaft assembly (11).
- (13) Remove retaining ring (28) and remove the clutch (26) and three springs (27) from inside the clutch drum (22).
- (14) Loosen and remove the hexagonal-head nut (24) and remove the clutch

- spacer (25), clutch flange (23), clutch drum (22), and the 90-tooth gear (21) from the shaft assembly (20).
- (15) Remove retaining ring (37) and remove clutch (35) and three springs (36) from inside the clutch drum (31).
  - (16) Loosen and remove the hexagonal-head nut (33) and remove clutch spacer (34), clutch flange (32), clutch drum (31), and the 86-tooth gear (30) from the shaft assembly (29).
  - (17) Remove shaft assemblies (2), (11), (20), and (29) from the front plate.
  - (18) Remove retaining ring (64) and remove the gear assembly (63) from the hub on the front plate.
- j. Reassembly of Front Plate* (fig. 97).
- (1) Lightly oil the hub on front plate mount gear assembly (63) on the hub and secure with retaining ring (64).
  - (2) Lightly oil the bronze bearing with oil (OGP) and insert shaft assembly (2) through the front plate (1).
  - (3) Place washer (3), clutch drum (4), and clutch flange (5) on shaft assembly (2), and secure with hexagonal-head nut (6). Tighten the hexagonal-head nut (6) with 50 inch-pounds of torque and check to see if clutch assembly turns freely. If the clutch assembly does not turn freely, washer (3) is scored and is acting as a brake. Replace washer (3). Use the torque meter and extension listed in *b* above.
  - (4) Apply a thin coating of Grease, Ordnance, extreme pressure (9150-209-8014) (pressure grease) to the threads of the hexagonal-head nut (6).
  - (5) Mount clutch spacer (7) inside clutch drum (4).
  - (6) Mount clutch (8) inside clutch drum (4); position the top edge of the clutch flush with the clutch drum.
  - (7) Mount the three springs (9) inside of clutch drum (4) and place retaining ring (10) on shaft assembly (2).
  - (8) Lightly oil the bronze bearing on the front plate (1) with oil (OGP) and insert shaft assembly (11) through the front plate.
  - (9) Place washer (12), clutch drum (13), and clutch flange (14) on shaft assembly (11) and secure with the hexagonal-head nut (15). Use the same procedure to tighten the hexagonal-head nut (15) as described in (3) above.
  - (10) Apply a thin coating of pressure grease to the threads of the hexagonal-head nut (15).
  - (11) Mount clutch spacer (16) and clutch (17) inside clutch drum (13).
  - (12) Mount three springs (18) inside of clutch drum (13) and place retaining ring (19) on shaft assembly (11).
  - (13) Lightly oil the porous bronze bearing on the front plate (1) with low-temperature oil and insert shaft assembly (20) through the front plate.
  - (14) Place the 90-tooth gear (21), clutch drum (22), and clutch flange (23) on shaft assembly (20) and secure with the hexagonal-head nut (24). Tighten the hexagonal-head nut (24) with 50 inch-pounds of torque.
  - (15) Apply a thin coating of pressure grease to the threads of the hexagonal-head nut (24).
  - (16) Mount clutch spacer (25) and clutch (26) inside the clutch drum (22).
  - (17) Mount the three springs (27) inside the clutch drum (22) and place retaining ring (28) on shaft assembly (20).
  - (18) Lightly oil the bronze bearing on the front plate (1) with oil (OGP) and insert shaft assembly (29) through the front plate.
  - (19) Place the 86-tooth gear (30), clutch drum (31), and clutch flange (32) on shaft assembly (29) and secure with the hexagonal-head nut (33). Tighten the hexagonal-head nut (33) with 50 inch-pounds of torque.
  - (20) Apply a coating of pressure grease to the threads of the hexagonal-head nut (33).

2	Screw, No. 4-40 NC 2A x 1/4		57	Connector plate	A1216
	Washer, No. 4, 0.212 in. OD, 0.115 in. ID		58	Connector	J1201
3	Mounting	A1212	59	Screw	p/o J1201
4	Drum drive assembly	01299.32	60	Spring	01299.35
5	Scale	A1214	61	Post	H1256
6	Switch assembly	S1210	62	Plate	A1215
7	Spacers	A1215	63	Screw, No. 6-32 NC-2A x 1/4	
8	Screw, No. 6-32 NC-2A x 1-1/8		64	Washer, flat No. 6, 0.375 in. OD, 0.147 in. ID	
9	Washer, No. 6, 0.253 in. OD, 0.141 in. ID		65	Washer, flat No. 6, 0.253 in. OD, 0.141 in. ID	
10	Hub	01299.33	66	Cable clamp	H1228
11	Clamp	01239	67	Shaft assembly	01299.23
12	Gear (86 teeth)	01271	68	Washer	H1204
13	Front plate	A1205	69	Screw, No. 4-40 NC-2A x 5/16	
14	Nut	H1203	70	Washer, No. 4, 0.212 in. OD, 0.115 in. ID	
15	Hub	01299.30	71	Washer, round, flat, 0.187 in. OD, 0.116 in. ID	
16	Memory drum	01299.29	72	Post	H1206
17	Dial hub	01299.28	73	Switch	S1201
18	Screw, No. 4-40 NC-2A x 1/4		74	Screw, No. 4-40 NC-2A x 1/2	
19	Washer, No. 4, 0.212 in. OD, 0.115 in. ID		75	Washer, round, flat, 0.187 in. OD, 0.116 in. ID	
20	Screw, No. 4-40 NC-2A x 5/16		76	Switch	S1203
21	Washer, No. 4, 0.212 in. OD, 0.115 in. ID		77	Spacer	H1216
22	Spacer	H1254	78	Screw, No. 4-40 NC-2A x 3/8	
23	Relay	K1201	79	Washer, round, flat, 0.187 in. OD, 0.116 in. ID	
24	Bracket	A1208	80	Switch	S1204
25	Screw, No. 4-40 NC-2A x 5/16		81	Spacer	H1217
26	Washer, No. 4, 0.212 in. OD, 0.115 in. ID		82	Screw, No. 8-32 NC-2A x 3/16	
27	Plate	A1211	83	Switch	S1205
28	Relay	K1202	84	Spacer	H1265
29	Bracket	A1213	85	Switch	S1206
30	Screw, flathead, No. 4-40 NC-2A x 1/4		86	Nut	p/o S1205, S1206
31	Screw, roundhead, No. 4-40 NC-2A x 1/4		87	Nut	p/o S1205, S1206
32	Retaining ring	H1223	88	Post	H1206
33	Relay	K1203	89	Screw, flathead, No. 8-32 NC-2A x 3/8	
34	Bracket	A1213	90	Washer	H1202
35	Cable clamp	H1228	91	Screw, flathead, No. 8-32 NC-2A x 3/8	
36	Relay	K1204	92	Gear (72 teeth)	01258
37	Bracket	A1207	93	Washer	H1202
38	Pawl	01229	94	Washer	H1204
39	Pawl	01230	95	Washer	H1202
40	Pawl	01231	96	Washer	H1202
41	Pawl	01232	97	Washer	H1204
42	Screw, retaining, No. 4-40 NC-2A x 5/16		98	Washer, 0.5 in. OD, 0.191 in. ID	
43	Washer, No. 4, 0.212 in. OD, 0.115 in. ID		99	Motor	B1201
44	Dial assembly	H1204	100	Screw, No. 6-32 NC-2A x 3/8	
45	Dial assembly	H1201	101	Washer, No. 6, 0.253 in. OD, 0.141 in. ID	
46	Dial assembly	H1202	102	Rear plate	A1203
47	Dial assembly	H1203	103	Washer, No. 4, 0.212 in. OD, 0.115 in. ID	
48	Cable clamp	H1228	104	Screw, No. 4-40 NC-2A x 3/8	
49	Washer, flat No. 6, 0.375 in. OD, 0.147 in. ID		105	Clamp	01243
50	Screw, No. 4-40 NC-2A x 3/8		106	Clamp	01244
51	Washer, No. 4, 0.212 in. OD, 0.115 in. ID		107	Retaining ring	H1220
52	Washer, round, flat, 0.187 in. OD, 0.116 in. ID				
53	Spacer	H1218			
54	Switch	S1202			
55	Screw, No. 8-32 NC-2A x 3/16				
56	Washer, No. 4, 0.212 in. OD, 0.115 in. ID				

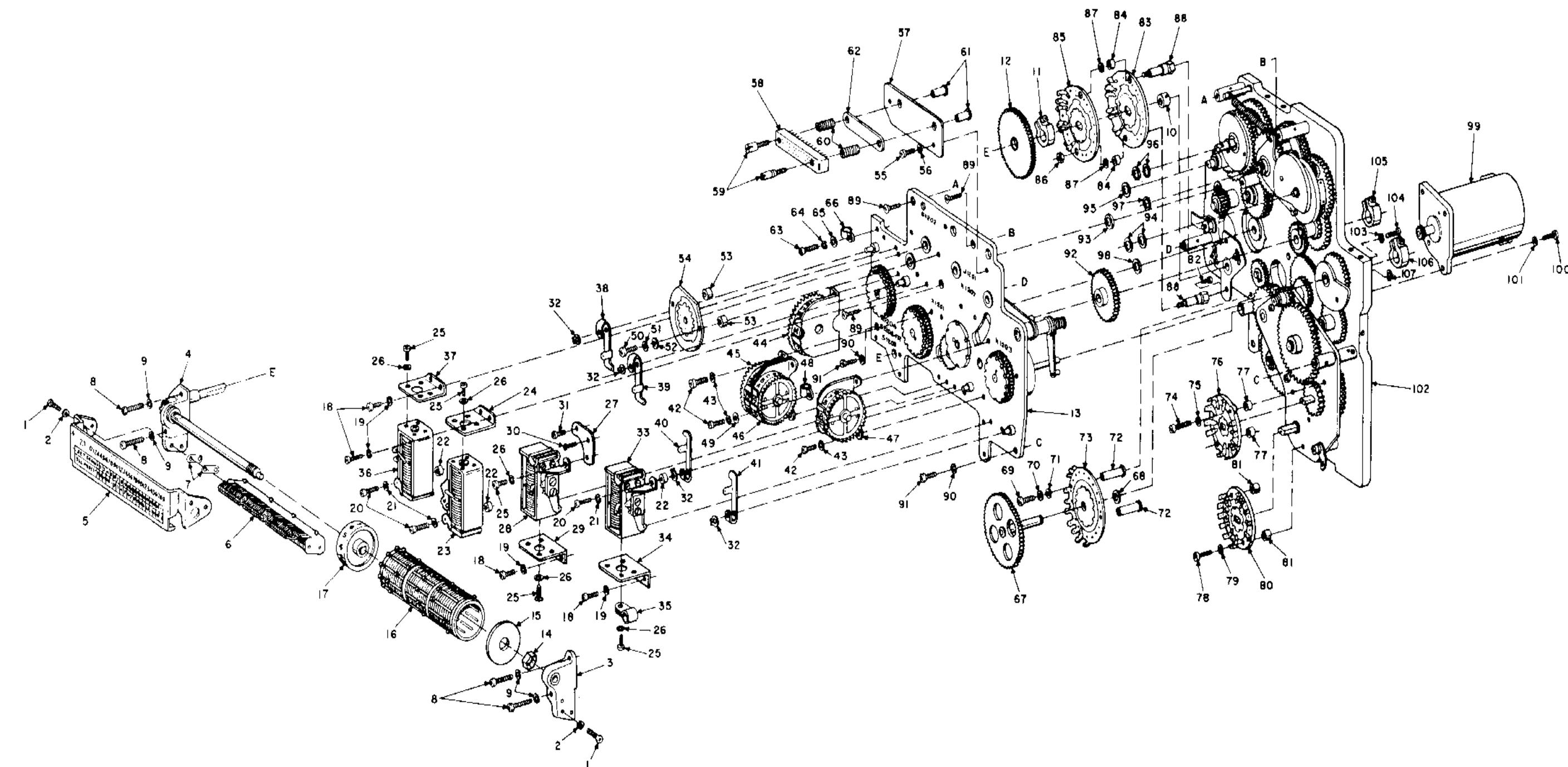


Figure 96. Frequency selector assembly, exploded view.

- (21) Mount clutch spacer (34) and clutch (35) inside of clutch drum (31).
  - (22) Mount springs (36) inside of clutch drum (31) and place retaining ring (37) on shaft assembly (29).
  - (23) Lightly oil the hub of the 48-tooth gear (38) and place the gear on shaft assembly (2) and secure with retaining ring (39).
  - (24) Lightly oil the hub of the 72-tooth gear (40), place the gear on shaft assembly (11) and secure with retaining ring (41).
  - (25) Lightly oil the hub of the 29-tooth gear (49), place the gear and washer (50) on gear assembly post on the back of the front plate (1), and secure with retaining ring (51).
  - (26) Lightly oil the hub of the 60-tooth gear (52), place the gear and washer (53) on shaft (flush side of gear nearest retaining ring), and secure with retaining ring (54).
  - (27) Lightly oil the hub of the 72-tooth gear (42), place the gear on shaft assembly (20), and secure with retaining ring (43). Lightly oil the hub of the 57-tooth gear (44) and place the gear on shaft assembly (20). Mount the clamp (45) on the gear and secure with retaining ring (46). Do not tighten clamp (45). Position the clamp so that the screw faces the left side of the front plate (viewing from the front).
  - (28) Lightly oil the hub of the 72-tooth gear (47) and place the gear on shaft assembly (29), and secure with the two retaining rings (48).
  - (29) Place washer (55) on cam follower shaft. Lightly oil the hub of the cam arm assembly (56) and place the cam arm assembly and washer (57) on cam follower shaft, and secure with retaining ring (58).
  - (30) Mount washer (59) and spring (60) on cam follower shaft, and fasten spring (60) to the notch on the cam arm assembly (56). Place washer (61) on shaft and secure with retaining ring (62).
- (1) Separate the front and rear plates (*g* above).
  - (2) Remove coupler (1) and clamp (2); use a Bristo driver.
  - (3) Remove coupler (3) and clamp (4); use a Bristo driver.
  - (4) Remove four screws (5) and washers (6) from rear of the rear plate (7).
  - (5) Remove retaining ring (8) and gear (9) from shaft on gear plate (10).
  - (6) Remove retaining ring (11) and gear (12) from gear shaft (25).
  - (7) Remove three screws (13), three washers (14), lug (15), two spacers (16), and spacer (19) from gear plate (10).
  - (8) Remove spacers (17) and (18) from gear plate (10).
  - (9) Remove retaining ring (20) and washer (21), and remove gear assembly (22) from gear plate (10).
  - (10) Remove washer (23) and the 36-tooth gear (24) from gear shaft (25).
  - (11) Remove washer (29) and retaining ring (30) from shaft (27).
  - (12) Remove clamp (28) and gear assembly (26) from shaft (27).
  - (13) Remove washer (31), gear shaft assembly (32), and washer (33) from rear plate (7).
  - (14) Remove retaining ring (34), washer (35), and the 96-tooth gear (36) from rear plate (7).
  - (15) Remove retaining ring (37), washer (38), and the 54-tooth gear (39) from rear plate (7).
  - (16) Remove gear assembly (40) and washer (41) from rear plate (7).
  - (17) Remove retaining ring (44), washer (45), and the gear set (46) from rear plate (7).
  - (18) Remove retaining ring (47), washer (50), and the 57-tooth gear (51) from rear plate (7).
  - (19) Remove gear set (42) and washer (43) from rear plate (7).
  - (20) Loosen clamp (49) on rear of rear plate and remove cam (48).
  - (21) Remove coupler (53) and clamp (52) from gear shaft (25).
  - (22) Remove spring (54) between the anchor shaft (55) and the hole in

*k. Disassembly of Rear Plate (fig. 98).*

- the cam arm (84).
- (23) Remove three screws (56) and washers (57), and remove the three posts (58).
  - (24) Remove two retaining rings (59) from anchor shaft (55) and remove anchor shaft from rear plate (7).
  - (25) Loosen and remove clamps (60), (61), (64), and (65), and couplers (62) and (63).
  - (26) Remove screw (66), washer (67), and clamp assembly (68).
  - (27) Remove screw (69), washer (70), and post (72).
  - (28) Remove two screws (71) from two self-locking nuts (73) and remove switchplate (74).
  - (29) Remove the 36-tooth gear (75) from rear plate (7).
  - (30) Remove retaining ring (76), washer (77), and the 36-tooth gear (78) and the 72-tooth gear (79) from rear plate (7).
  - (31) Remove cam shaft (80), the 36-tooth gear (81), gear frame assembly (82), and the 36-tooth gear (83) from rear plate (7).
  - (32) Remove cam arm (84), gear frame assembly (85), gear set (86), and washer (87) from rear plate (7).
  - (33) Remove retaining ring (88), washer (89), and the 29-tooth gear (90) from rear plate (7).
  - (34) Remove retaining rings (95) and (96) from the shaft of drive shaft (101).
  - (35) Slide the 84-tooth gear (97) and the 76-tooth gear (100) apart and remove the loop of the spring (99) from the post on the 84-tooth gear (97).
  - (36) Remove retaining ring (98) from the post on the 76-tooth gear (100) and remove the loop of the spring (99).
  - (37) Remove drive shaft (101) from rear plate (7) and remove washer (105), gear set (104) and the 76-tooth gear (103) and spring (102).
  - (38) Remove retaining ring (91), washer (92), and the two 57-tooth gears (93) and (94) from rear plate (7).
  - (39) Remove retaining ring (106), idler

gear shaft (107), and washer (108) from rear plate (7).

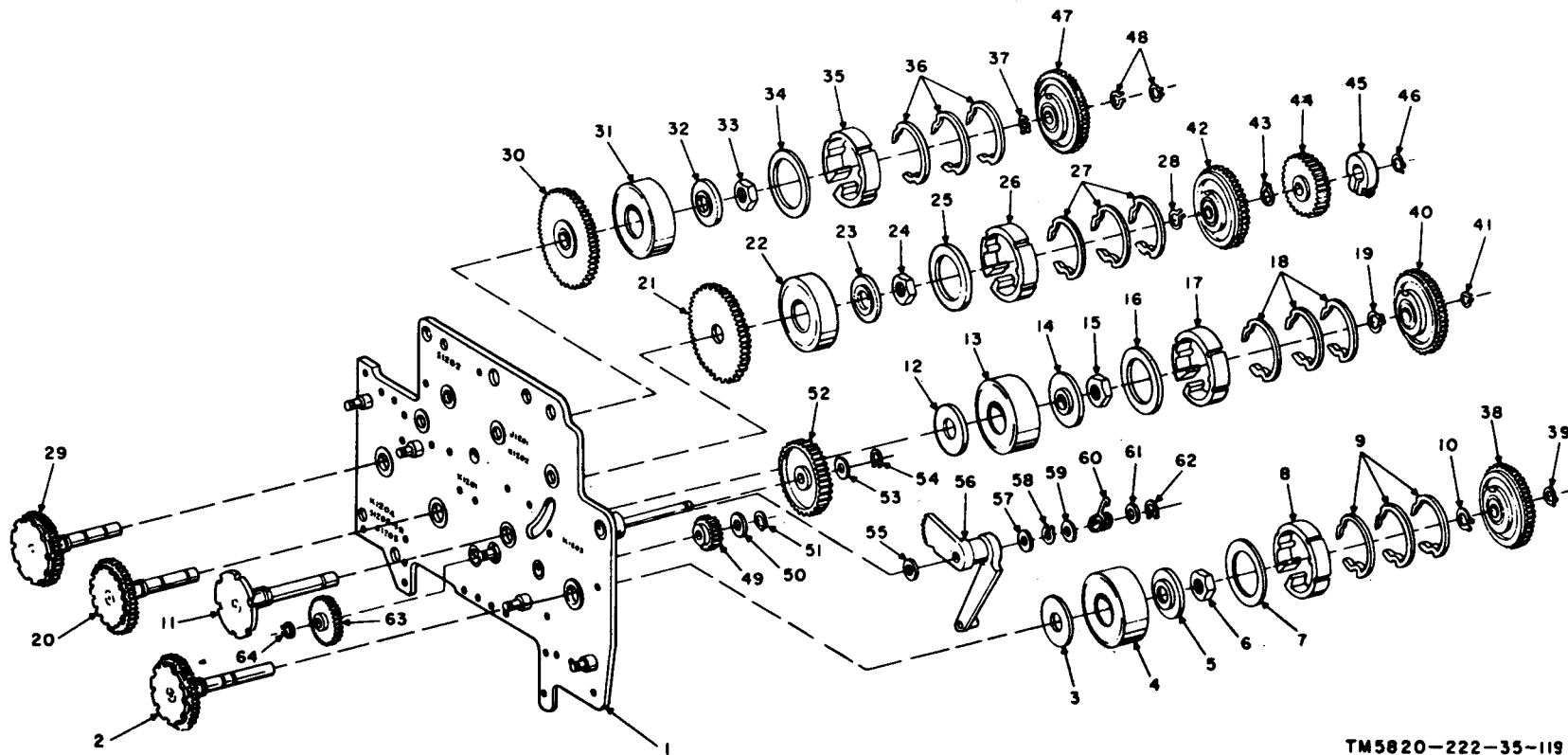
#### *1. Reassembly of Rear Plate (fig. 98).*

*Note.* In this procedure, use only light-consistency grease.

- (1) Pack the 57-tooth gear (51) with grease, place the gear on the rear plate (7) post, and secure with the washer (50) and retaining ring (47).
- (2) Pack the gear set (46) with grease and mount on shaft on rear plate. Place washer (45) on shaft and secure with retaining ring (44).
- (3) Pack gear set (42) with grease, place washer (43) on base of gear, and slide the gear set (42) into position under the 57-tooth gear (51) and the gear set (46).
- (4) Place washer (41) on gear assembly (40) and carefully slide the gear into the center of the gear set (42). Check for proper gear mesh.
- (5) Lightly oil the hub of the 29-tooth gear (90), mount on shaft of rear plate, place washer (89) on shaft, and secure with retaining ring (88).
- (6) Lightly oil the hubs of the 72-tooth gear (79) and the 36-tooth gear (78) and mount on the shaft on the rear plate. Place washer (77) on the shaft and secure with retaining ring (76).
- (7) Lightly oil hub of the 96-tooth gear (36), place gear and washer (35) on shaft, and secure with retaining ring (34).
- (8) Lightly oil hub of the 54-tooth gear (39), place gear and washer (38) on shaft, and secure with retaining ring (37).
- (9) Place clamp (28) upon base of gear assembly (26), slide the gear assembly into position on shaft (27), mount retaining ring (30), washer (29), and tighten clamp (28). Place a thin coating of low-temperature oil on the bronze bearing and insert the shaft (27) through the rear plate. Secure the shaft (27) with clamp (2) and coupler (1).
- (10) Place retaining ring (59) on the centermost slot of anchor shaft

- (55), insert the anchor shaft through hole in rear plate, and secure with second retaining ring (59).
- (11) Mount clamp assembly (68) on rear plate; position and secure with washer (67) and screw (66).
  - (12) Mount switchplate (74) on rear plate and secure with self-locking nuts (73) and screws (71).
  - (13) Mount post (72) under clamp assembly (68) and secure with washer (70) and screw (69).
  - (14) Place a thin coating of oil (OGP) on the bronze bearing and place washer (105) and gear set (104) imposition on the bearing.
  - (15) Place washer (108) on idler gear shaft (107). Place a thin coating of oil (OGP) on the bronze bearing and slide idler shaft (107) into bearing on rear plate and secure with retaining ring (106).
  - (16) Lightly oil the hub of the 57-tooth gear (94) and mount on the shaft. Lightly oil the hub of the 57-tooth gear (93) and mount on the 57-tooth gear (94). Place washer (92) on the shaft and secure with retaining ring (91).
  - (17) Mount spring (102) on the gear of drive shaft (101), place the 76-tooth gear (103) on drive shaft (101), and insert opposite end of spring (102) in the 76-tooth gear (103). Rotate drive shaft (101) and the 76-tooth gear (103) to close the spring. Insert the gear loading rod ( *b* above) in the holes provided to maintain the loading until the front and rear plates are reassembled.
  - (18) Insert the drive shaft (101) through the hub of the gear set (104) and the bronze bearing, and carefully mesh the 76-tooth gear (103) with gear set (104) and idler gear shaft (107). Secure with clamp (60) and coupler (63) on rear of rear plate.
  - (19) Mount spring (99) upon the small post of the 76-tooth gear (100) and secure the spring with retaining ring (98).
  - (20) Mount the 76-tooth gear (100) on drive shaft (101).
  - (21) Mount the 84-tooth gear (97) on drive shaft (101), grasp the loop of spring (99) with pliers, and mount on post of gear (97). Slide gears (100) and (97) together on drive shaft (101) and secure with retaining rings (95) and (96).
- Note.* Spring (99) is wound to a specified torque of 2 inch-pounds by turning gear (97) counterclockwise, as viewed from the front of the rear plate. The torque loading is read at coupler (62), using torque meter and adapter shaft assembly listed in *b* above. If the loading is not correct, remove retaining ring (95), disengage the 84-tooth gear (97) from gear frame assembly (85), tighten or loosen spring loading by rotating the 84-tooth gear (97) counterclockwise or clockwise, engage gear (97) with gear frame assembly (85), and replace retaining ring (95). Recheck for 2 inch-pounds of torque on coupler (62).
- (22) Mount the three posts (58) on the holes in the rear plate (7) and secure with washers (57) and screws (56).
  - (23) Place washer (33) on gear shaft assembly (32), lightly oil the bronze bearing in the rear plate with low-temperature oil, and insert the shaft assembly (32) through the rear plate. Replace washer (31). Secure with clamp (4) and coupler (3).
  - (24) Lightly oil hub of the 36-tooth gear (24) and place on gear shaft (25). Place washer (23) on gear shaft (25), oil bronze bearing on gear plate (10) with oil (OGP) and insert gear shaft through bearing. Secure gear shaft (25) with clamp (52) and coupler (53).
  - (25) Mount gear (12) on gear plate (10) and secure with retaining ring (11).
  - (26) Lightly oil bronze bearing with oil (OGP), insert cam (48) through rear plate, and secure with clamp (49).
  - (27) Lightly oil the bronze bearing with oil (OGP), insert the shaft of the 36-tooth gear (75) through the rear plate, and secure clamp (65).



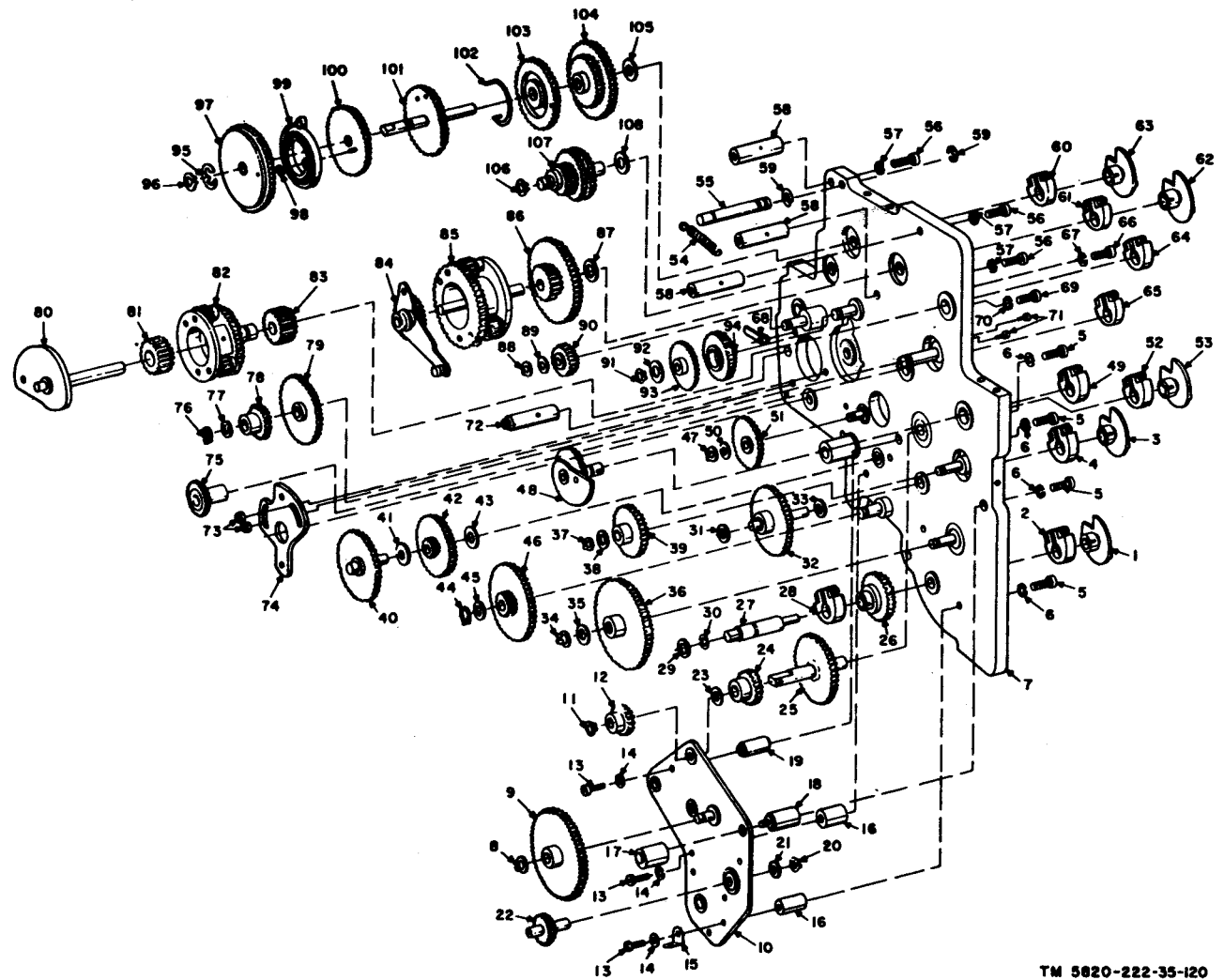


TM5820-222-35-119

Figure 97. Frequency selector front plate, exploded view.

<i>Index No.</i>	<i>Description</i>	<i>Symbol No.</i>			
1	Front plate	A1205	30	Gear (86 teeth)	01270
2	Shaft assembly	01298	31	Clutch drum	01204
3	Washer	01247	32	Clutch flange	01228
4	Clutch drum	01203	33	Nut, hexagonal- head	H1227
5	Clutch flange	01227	34	Clutch spacer	01208
6	Nut, hexagonal- head	H1227	35	Clutch	01212
7	Clutch spacer	01207	36	Spring	01222, 01223, 01224
8	Clutch	01211	37	Retaining ring	H1222
9	Spring	01219, 01220, 01221	38	Gear (48 teeth)	01297
10	Retaining ring	H1222	39	Retaining ring	H1222
11	Shaft assembly	01299	40	Gear (72 teeth)	01234
12	Washer	01246	41	Retaining ring	H1222
13	Clutch drum	01202	42	Gear (72 teeth)	01233
14	Clutch flange	01226	43	Retaining ring	H1222
15	Nut, hexagonal- head	H1227	44	Gear (57 teeth)	01267
16	Clutch spacer	01206	45	Clamp	01237
17	Clutch	01210	46	Retaining ring	H1222
18	Spring	01216, 01217, 01218	47	Gear (72 teeth)	01236
19	Retaining ring	H1222	48	Retaining ring	H1222
20	Shaft assembly	01299.1	49	Gear (29 teeth)	01278
21	Gear (90 teeth)	01268	50	Washer	H1204
22	Clutch drum	01201	51	Retaining ring	H1220
23	Clutch flange	01225	52	Gear (60 teeth)	01274
24	Nut, hexagonal- head	H1227	53	Washer	H1204
25	Clutch spacer	01205	54	Retaining ring	H1220
26	Clutch	01209	55	Washer	H1204
27	Spring	01213, 01214, 01215	56	Cam arm assembly	01299.9
28	Retaining ring	H1222	57	Washer	H1204
29	Shaft assembly	01299.34	58	Retaining ring	H1220
			59	Washer	H1204
			60	Spring	01248
			61	Washer	H1204
			62	Retaining ring	H1220
			63	Gear assembly	01228
			64	Retaining ring	H1221

*Figure 97—Continued.*



TM 5820-222-35-120

Figure 98. Frequency selector rear plate, exploded view.

<i>Index No.</i>	<i>Description</i>	<i>Symbol No.</i>						
			36	Gear (96 teeth)	01261	71	Screw, No. 8-32 NC-	
			37	Retaining ring	H1220		2A x 3/16	
			38	Washer	H1204	72	Post	H1208
1	Coupler	01295	39	Gear (54 teeth)	01260	73	Nut, self-locking	
2	Clamp	0.1245.2	40	Gear assembly	01290	74	Switchplate	A1201
3	Coupler	01294	41	Washer	H1219	75	Gear (36 teeth)	01259
4	Clamp	01245.1	42	Gear set (68 and 18 teeth)	01284	76	Retaining ring	H1220
5	Screw, No. 8-32 NC-2A x 3/8		43	Washer	H1219	77	Washer	H1204
6	Washer, 0.296-in. OD, 0.168-in. ID		44	Retaining ring	H1220	78	Gear (36 teeth)	01256
7	Rear plate	A1203	45	Washer	H1204	79	Gear (72 teeth)	01255
8	Retaining ring	H1220	46	Gear set (98 and 24 teeth)	01277	80	Cam shaft	01299.26
9	Gear	01299.11	47	Retaining ring	H1220	81	Gear (36 teeth)	0.1252
10	Gear plate	A1204	48	Cam	01297	82	Gear frame assembly	01299.13
11	Retaining ring	H1222	49	Clamp	01244	83	Gear (36 teeth)	01254
12	Gear	01253	50	Washer	H1219	84	Cam arm	01299.4
13	Screw, No. 6-32 NC-2A x 5/16		51	Gear (57 teeth)	01282	85	Gear frame assembly	01299.5
14	Washer, No: 6, 0.253-in. OD, 0.141-in. ID		52	Clamp	01245	86	Gear set (42 teeth)	01289
15	Lug	E1202	53	Coupler	01293	87	Washer, 0.375-in. OD, 0.191-in. ID	
16	Spacer	H1209	54	Spring	01299.31	88	Retaining ring	H1220
17	Spacer	H1212	55	Anchor shaft	01269	89	Washer	H1204
18	Spacer	H1211	56	Screw, No. 8-32 NC-2A x 3/8		90	Gear (29 teeth)	01279
19	Spacer	H1210	57	Washer, 0.296-in. OD, 0.168 in. ID		91	Retaining ring	H1220
20	Retaining ring	H1220	58	Post	H1207	92	Washer	H1205
21	Washer	H1204	59	Retaining ring	H1224	93	Gear (57 teeth)	01265
22	Gear assembly	01299.12	60	Clamp	01240	94	Gear (57 teeth)	01266
23	Washer	H1204	61	Clamp	01241	95	Retaining ring	H1225
24	Gear (36 teeth)	01257	62	Coupler	01292	96	Retaining ring	H1222
25	Gear shaft	01299.22	63	Coupler	01291	97	Gear (84 teeth)	01299.24
26	Gear assembly	01263	64	Clamp	01242	98	Retaining ring	H1226
27	Shaft	01262	65	Clamp	01243	99	Spring	01251
28	Clamp	01238	66	Screw, No. 8-32 NC-2A x 1/2		100	Gear (76 teeth)	01299.25
29	Washer	H1202	67	Washer, 0.296-in. OD, 0.168-in. ID		101	Drive shaft	01296
30	Retaining ring	H1222	68	Clamp assembly	H1213	102	Spring	01250
31	Washer	H1204	69	Screw, No. 8-32 NC-2A x 1/2		103	Gear (76 teeth)	01273
32	Gear shaft assembly (72 teeth)	01299.7	70	Washer, 0.296-in. OD, 0.168-in. ID		104	Gear set (57 and 84 teeth)	0.1299.8
33	Washer	H1204				105	Washer	H1204
34	Retaining ring	H1220				106	Retaining ring	H1222
35	Washer	H1204				107	Idler gear shaft	01299.6
						108	Washer, 0.437-in. OD, 0.252-in. ID	

Figure 98—Continued.

- (28) Place the 36-tooth gear (81), gear frame assembly (82), and the 36-tooth gear (83) on cam shaft (80), lightly oil bronze bearing on the rear plate with low-temperature oil, insert the cam shaft (80), and secure with clamp (64).
- (29) Assemble cam arm (84) and gear set (86) on gear frame assembly (85).
- (30) Lightly oil the bronze bearing in the rear plate (7) with low-temperature oil, place washer (87) on bearing insert gear frame assembly (85) shaft through bearing, and secure with clamp (61) and coupler (62).
- (31) Insert spacer (18) through hole in gear plate (10), and mount spacer (17) on spacer (18).
- (32) Place washer (14) on screw (13); insert through gear plate (10), and mount spacer (19).
- (33) Place washer (14) and lug (15) on screw (13); insert through hole in gear plate (10), and mount spacer (16).
- (34) Grease gear (9), mount on gear plate shaft, and secure with retaining ring (8).
- (35) Grease gear assembly (22), lightly oil bronze bearing, insert gear assembly through bearing, place washer (21) on shaft, and secure with retaining ring (20).
- (36) Grease the gears on the rear plate; oil the two bronze bearings on the rear plate (7). Lightly oil the two bronze bearings on the gear plate (10), and mount the gear plate (10) on the rear plate (7). Secure the gear plate to the rear plate with screws (5) and washers (6).
- (37) Mount spring (54) through anchor shaft (55) and the hole in the cam arm (84).

*m. Adjustment and Synchronization of Frequency Selector.*

(1) *Relay adjustment.*

- (a) Adjust relays K1201, K1202, K1203, and K1204 (fig. 101) to make contact when the pawl is on the periphery of the stop wheel.

Manually operate the armature of each relay to position the pawl and, while operating the armature, bend the stationary, normally open contact to make contact with the movable contact.

- (b) Reseat the relay pawls in the stop wheels and check for slight play in the mechanical movement of the armature. Loosen the relay mounting screws and adjust the position of the relay on the front plate to obtain the slight play required. Tighten the relay mounting screws.
  - (c) Bend the normally open stationary relay contact to obtain 0.030-inch minimum contact gap when the relay pawl is fully seated in the stop-wheel notch.
- (2) *Synchronization of 0.1-mc automatic positioner at .0.*
    - (a) Loosen clamp 01237 (1) (fig. 100).
    - (b) Position cam 01297 so that the cam follower on arm assembly 01299.9 is opposite the index mark on the cam (fig. 99).
    - (c) Tighten clamp 01237 (1) (fig. 100).
    - (d) Loosen clamp 01237 (fig. 99).
    - (e) Center the notch in the rotor of switch S1204 over the contact connected to the black wire (first, contact to the left of the switch wafer-securing screw) (fig. 101).
    - (f) Tighten clamp 01237 (fig. 99).
  - (3) *Synchronization of 1.0-mc automatic positioner at 0.0.*
    - (a) Loosen clamp 01237 (2) (fig. 100).
    - (b) Position cam shaft 01299.26 (fig. 99) so that the cam follower of cam arm 01299.4 is opposite the index mark on the cam shaft 01299.26. When properly positioned, the index mark and the cam follower can be seen through the curved slot in the front plate above the 0.1-mc dial assembly, I1203 (fig. 100).
    - (c) Tighten clamp 01237 (2) (fig. 100).

- (d) Loosen clamp 01237 (3) (fig. 100).
  - (e) Center the notch of the rotor of switch S1203 (fig. 101) over the clip connected to the black wire.
  - (f) Tighten the clamp 01237 (3) (fig. 100).
- (4) *Synchronization of 10.0-mc automatic positioner at 220.0.*
- (a) Remove retaining ring H1220 (fig. 100).
  - (b) Unmesh gear 01299.23 from gear 01258 (fig. 102).
  - (c) Position the rotor of switch S1201 (fig. 102) so that the detent is in contact with the contact connected to the rod wires at the bottom of the switch.
  - (d) Remesh gears 01299.23 and 01258 (fig. 102).
  - (e) Replace the retaining ring H1220 (fig. 100).
- (5) *Synchronization of blanking and phasing switch S1202.*
- (a) Remove cable guide H1213 to reach and loosen clamp 01237 (fig. 103).
  - (b) Position the rotor of switch S1202 (fig. 101) so that any further counterclockwise rotation of the rotor will cause contact with the clip connected to the black wire.
  - (c) Check to be sure that backlash or looseness of the rotor within the stator does not cause contact with the clip connected to the black wire.
  - (d) Tighten clamp 01237 and replace cable guide H1213 (fig. 103).
- (6) *Synchronization of preset channel automatic positioner.*
- (a) Loosen the hub 01299.33 (fig. 102) and unmesh the miter gears that drive the memory drum 01299.29 (fig. 101).
  - (b) Loosen the clamp 01239 on the hub of gear 01271 (fig. 102).
  - (c) Be sure that the rotors of switches S1205 and S1206 (fig. 102) are positioned so that the smallest detent is in contact with clip No. 2, which is connected to

the white, black, and orange wire. The switches are on the same shaft and can be positioned simultaneously. Make sure that the relative positions of the switch rotors are not positioned 180° apart.

- (d) Rotate the memory drum 01299.29 so that the pins in the preset channel-5 slots are centered over the curved portion of the actuating fingers of switches S1210A, S1210B, S1210C, and S1210D (fig. 101).
  - (e) Carefully remesh the miter gears (fig. 101) and hub 01299.33 and clamp 01239 on gear 01271 (fig. 102).
  - (f) Loosen the two screws that hold each of the four dial assemblies 11201, 11202, 11203, and 11204 in place on the front plate (fig. 101).
  - (g) Set dial assembly 11204 to 5 and tighten the mounting screws.
  - (h) Set dial assembly 11201 to 22 and tighten the mounting screws.
  - (i) Set dial assembly 11202 to 0 and tighten the mounting screws.
  - (j) Set dial assembly 11203 to .0 and tighten the mounting screws.
- (7) *Coupler adjustment.*
- (a) Set the frequency selector subunit to 399.9 mc.

*Note.* Unless a frequency selector final inspection test fixture is available, the frequency selector and front panel must be replaced on the rt unit main frame (para 117b and 118b) to channel the frequency selector to 399.9 mc.

- (b) Remove the frequency selector from the rt unit main frame and loosen clamps 01237 (4) through 01237 (8) (fig. 100).
- (c) Position couplers 01291 through 01295 as shown in figure 100. A guide post is located on the rear plate adjacent to each coupler. Use the posts to align each coupler properly by placing a straightedge tangent to the guide post and parallel to the bar on each coupler.

(d) Tighten clamps 01237 (4) through 01237 (8) (fig. 100).

(8) *Reassembly check.* After reassembly and synchronization of the frequency selector, refer to paragraph 161 for complete frequency selector checking procedures.

## 127. Lubrication

*a. General.* Lubricate the subunit mechanical and electrical parts listed in the following charts after every 1,000 hours of operation. If the radio set is operated 8 hours a day, the 1,000-hour interval is approximately equal to 4 months operation. When a subunit is removed for repair, lubricate the parts as indicated before replacing the subunit. Clean the parts with a

dry, lint-free cloth before applying new lubricant. Apply oil with a thin brush. Rotate movable parts to apply lubricant to the entire contact surface.

*Caution:* Do not mix natural-base lubricants such as MIL-L-7870 and MIL-G-7421 with synthetic lubricants such as MIL-L-6085 and MIL-G-3278. Mixing a natural and a synthetic oil or grease often destroys the lubricating properties of both lubricants.

*b. Lubricant Chart.* The chart below lists the nomenclature and federal stock number and common name of the lubricants used for this radio set. Only the common name will be listed in the lubrication charts.

Lubricant	Specification	Federal stock No.	Common name
Grease, Aircraft and Instruments Lubricating oil, instrument (OAI) Lubricating Oil, General Purpose Aircraft, Low-Temperature (OGP)	MIL-G-7421 MIL-L-6085 MIL-L-7870	9150-190-0883 9150-223-4129 9150-273-2398	Grease Oil (OAI) Oil (OGP)
Grease, Aircraft and Instruments Grease, General Purpose, Low-Temperature		9150-272-3370 9150-291-9088	Light-consistency grease Low-temperature grease
Grease, Ordnance, Extreme Pressure		9150-209-8014	Pressure grease

*c. Rf and Power Amplifier Subunit Lubrication* (fig. 107). Remove the rf and power amplifier subunit (para 107). Remove the cover plates from the bottom of the subunit and lubricate the mechanical and electrical parts listed in the chart below. Apply a thin film of grease to the shaft bearings. Apply a minimum amount to the parts requiring oil. Visible amounts of oil on these parts is not desirable.

Part	Lubricant	Interval
Front tuning shaft bearing	Grease (MIL-G-7421)	Lubricate all parts after 1,000 hours of operation or every 4 months.
Rear tuning shaft bearing	Light consistency grease	
Power amplifier rotor shaft bearing	Grease (MIL-G-7421)	
Grounding finger contact surfaces	Oil (OAI)	

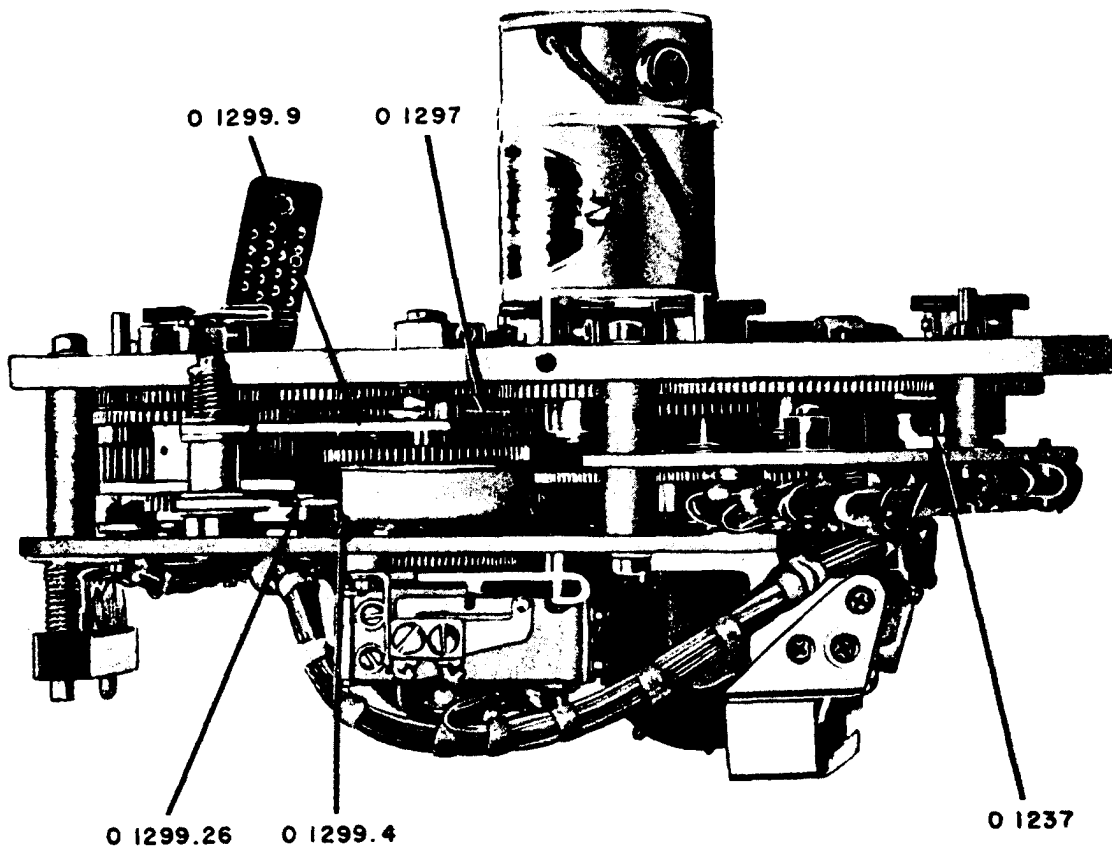
Part	Lubricant	Interval
Induction ring assemblies, both sides of each assembly	Oil (OAI)	
Power amplifier rotor contact surfaces, both ends	Oil (OAI)	
Driver rotor contact surfaces	Oil (OAI)	

*d. Uhf Injection Subunit Lubrication* (fig. 108). Remove the uhf injection system subunit (para 108a). Remove the cover plate from the first oscillator assembly (para 122a(2)) and remove the cover plate from the bottom of the frequency multiplier-amplifier tube chassis (para 124a(3)). Lubricate the mechanical and electrical parts listed in the chart below. Apply a thin film of grease to the shaft bearings. Apply three

to six drops of oil to the capacitor tuning shaft gear and the crystal switch gear. Apply one drop of oil to the bore of the idler gear located between the capacitor tuning

shaft and the crystal switch gears. Apply only a minimum amount of oil to the parts. Visible lubrication of these parts is undesirable.

Part	Lubricant	Interval
Front tuning shaft bearing	Grease (MIL-G-7421)	Lubricate all parts after 1,000 hours of operation or every 4 months
Rear tuning shaft bearing	Grease (MIL-G-7421)	
Tank circuit induction rings, 4 rings, both sides	Oil (OAI)	
Grounding finger contact surfaces	Oil (OAI)	
Capacitor tuning shaft coupler	Oil (OAI)	
Capacitor tuning shaft gear	Oil (OGP)	
Crystal switch gear	Oil (OGP)	
Idler gear bore	Oil (OGP)	



TM5820-222-35-111

Figure 99. Frequency selector, right-side view.



e. *First If. Amplifier Subunit Lubrication* (fig. 109). Remove the first if. amplifier subunit (para 109). Lubricate the mechanical parts listed in the chart below. Apply only one or two drops of oil to the cam surfaces and shaft bearings. Apply one drop of oil to the tuning table guides.

Part	Lubricant	Interval
Cam surfaces (2)	Oil (OGP) Low-temperature oil	Lubricate all parts after 1,000 hours of operation or every 4 months
Bearings (7) Tuning table guides (7)	Oil (OGP) Oil (OGP)	

f. *3.0- to 3.9-Mc If. Subunit Lubrication* (fig. 110). Remove the 3.0- to 3.9-mc if. subunit as described in paragraph 110 and lubricate the mechanical parts listed in the chart below. Apply one or two drops of oil to the cam surface. Apply a minimum amount of oil to the shaft bearings.

Part	Lubricant	Amount	Interval
All bronze bearings	Oil (OGP)	One drop	Lubricate all parts after every 1,000 hours of operation or every 4 months.
Bores of gear frame assemblies 0.1299.13 and 01299.5 (fig. 103)	Oil (OGP)	One drop	
Relay pawl pivot studs of relays K1201, K1202, K1203, and K1204 (fig. 101)	Oil (OGP)	One drop	
Switch S1202 wafer (fig. 101)	Oil (OGP)	Thin film to both sides of wafer	
Cam follower on cam arm 01299.4 (fig. 99)	Grease (MIL-G-7421)	Thin film	
Roller on arm assembly 01299.9 (fig. 99)	Oil (OGP)	One drop	
Memory drum pins on memory drum 01299.29 (fig. 101)	Low-temperature grease	Thin film to pins.	

h. *Dynamotor, Centrifugal Fan HD-390/U, and Case Blower Lubrication and Maintenance* (fig. 111).

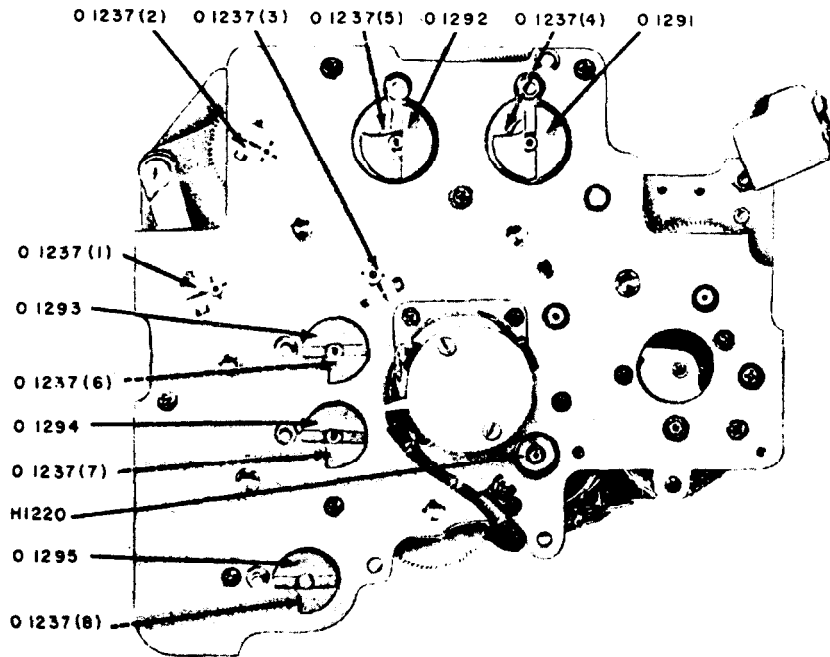
- (1) Check the Receiver-Transmitter Group OA-2648/VRC-24 dynamotor and dc case blower or the Receiver-Transmitter Group OA-2649/TRC-68 centrifugal fan and

Part	Lubricant	Interval
Cam surface	Oil (OGP)	Lubricate all parts after 1,000 hours of operation or every 4 months.
Front and rear shaft bearings	Oil (OGP)	

g. *Frequency Selector Lubrication*. Complete frequency selector lubrication procedures are included in the reassembly instructions (para 126). The following general lubrication instructions apply to mechanical parts that can be easily reached without disassembly of the frequency selector. Lubricate the parts indicated in the chart below after every 1,000 hours of operation unless the frequency selector has already been completely disassembled and reassembled during that period of time.

*Caution:* Do not permit grease or oil to get into the automatic positioner clutch assemblies. Oil or grease on the clutch faces will cause malfunction of the frequency selector.

ac case blower after every 1,000 hours of operation. When any of these subunits are operating noisily or vibrating excessively, replace the sealed bearings on the subunit. Figure 111 shows the general location of one dynamotor sealed bearing.

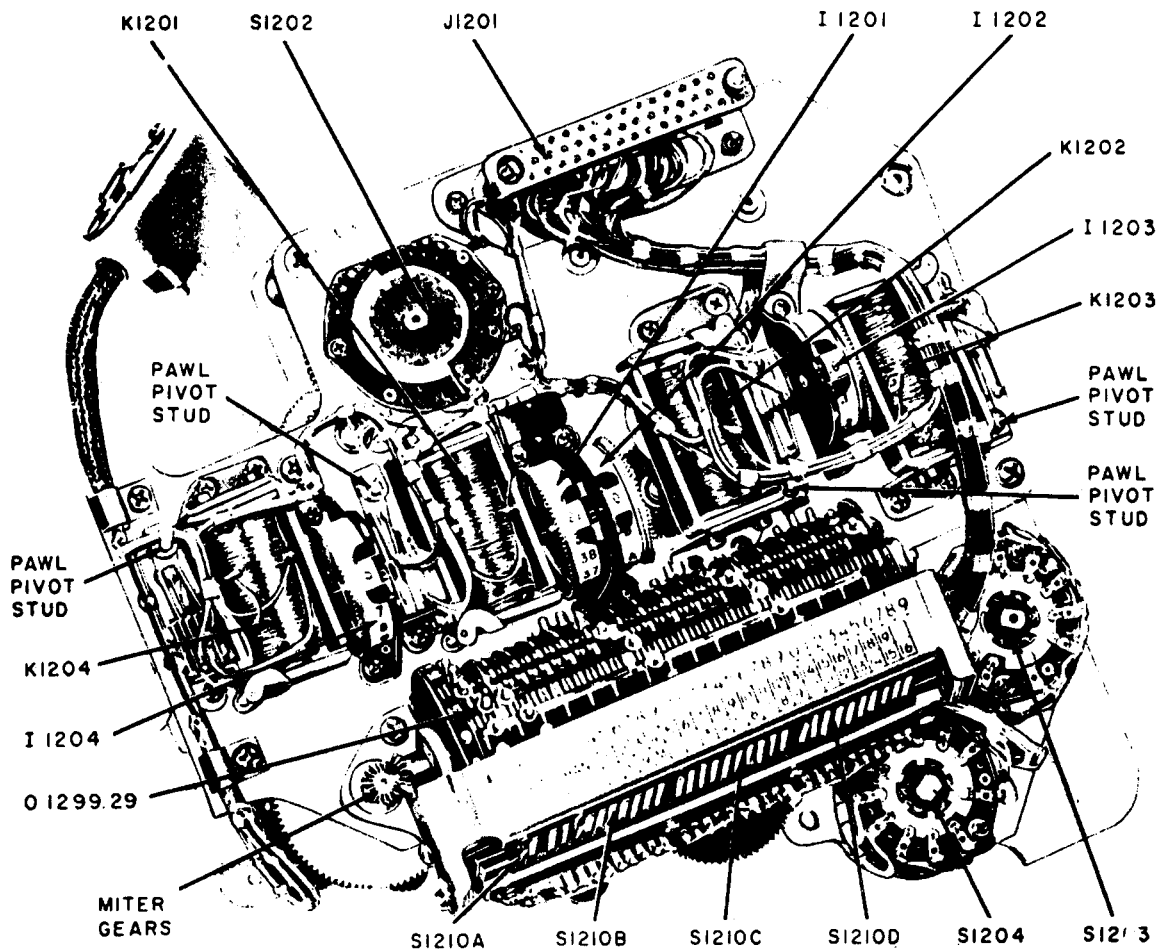


TM5820-222-35-110

Figure 100. Frequency selector, rear view.

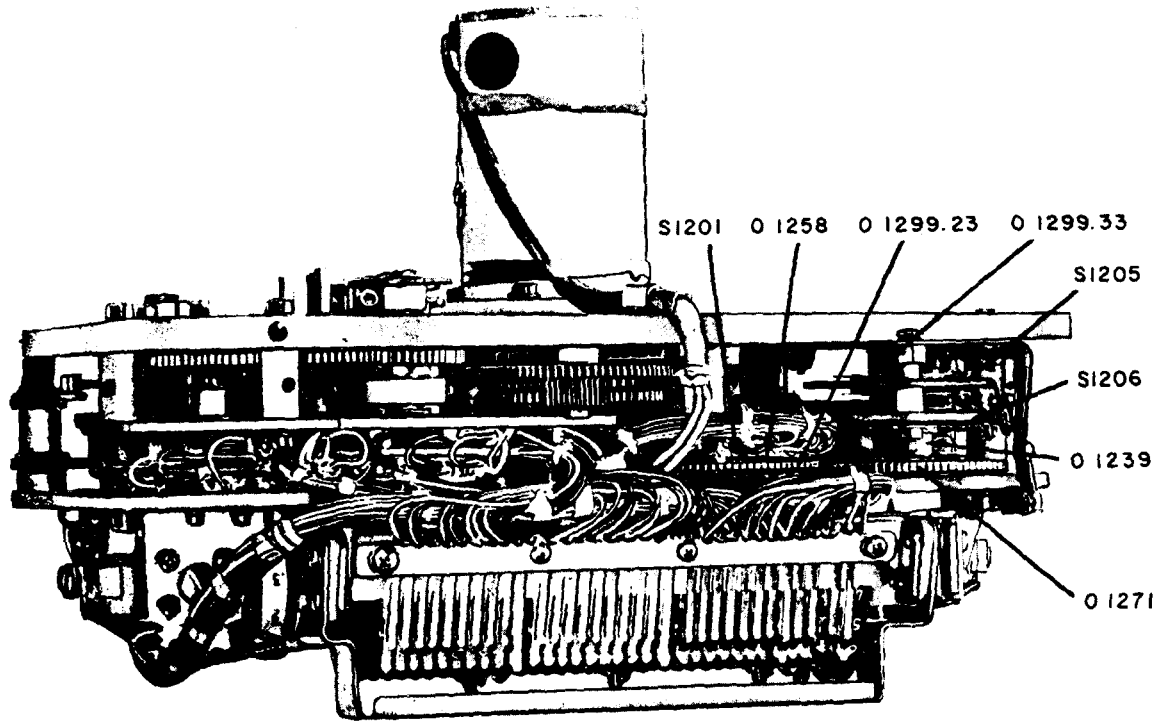
- (2) During the 1,000-hour lubrication check of the Receiver-Transmitter Group OA-2648/VRC-24 dynamotor and dc case blower, check the condition of the electrical brushes by unscrewing the brush holder caps and removing the brushes. Replace the brushes as required.
- (3) The rubber coupling on the shaft of Centrifugal Fan HD-390/U fatigues rapidly after 1,000 hours of operation. During the 1,000-hour lubrication check of this subunit, replace the rubber coupling. Re-

move the rubber coupling by loosening the four small setscrews that secure the rubber coupling to the two shafts, remove the four retaining screws that fasten the motor to the mounting base, and pull the motor and centrifugal fan shafts apart. Align the replacement rubber coupling with the flats of both shafts, slide the shafts together, tighten the four setscrews, and replace the retaining screws and washers that fasten the motor to the mounting base.



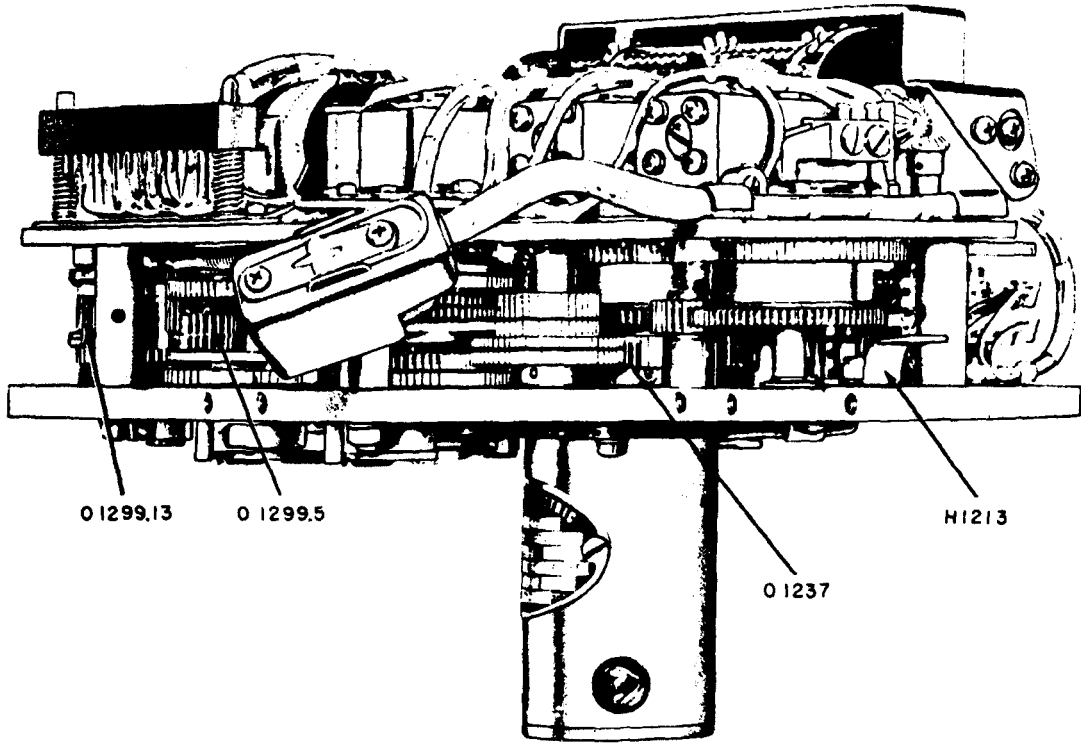
TM5820-222-35-109

Figure 101. Frequency selector, front view.



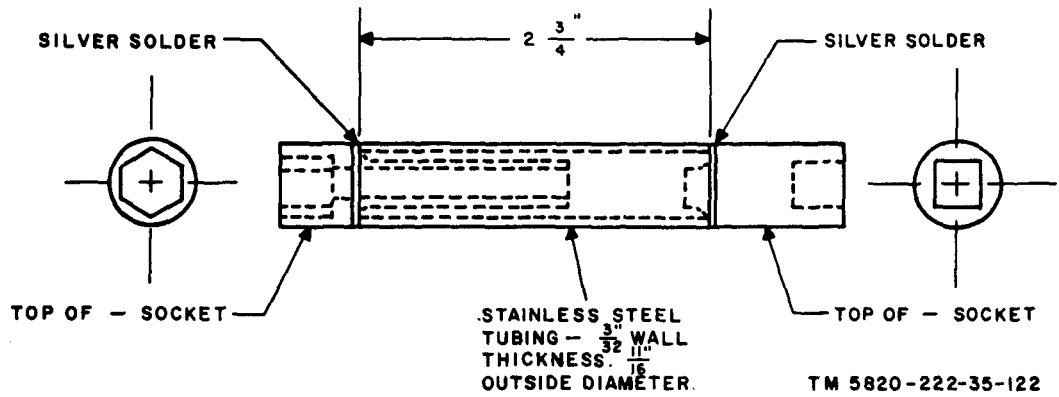
TM5820-222-35-112

Figure 102. Frequency selector, bottom view.



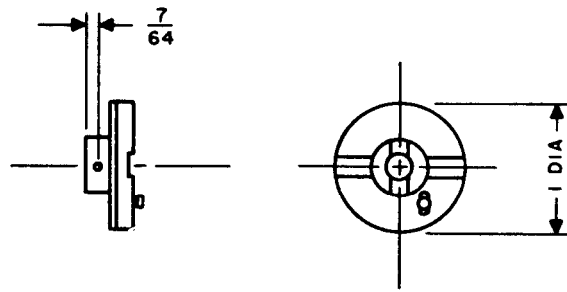
TM5820-222-35-126

Figure 103. Frequency selector, left side view.



TM 5820-222-35-122

Figure 104. Torque wrench extension.



TM5820-222-35-123

Figure 105. Torque meter adapter.

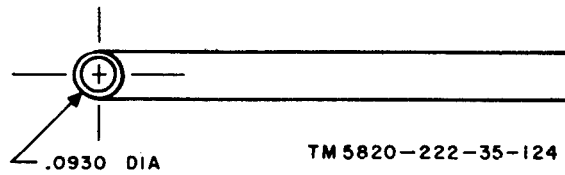
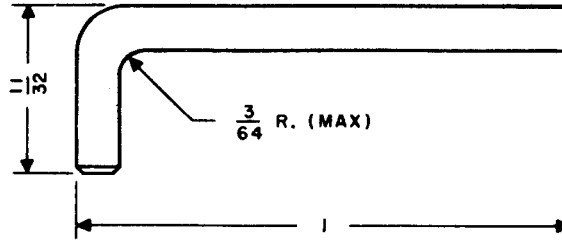
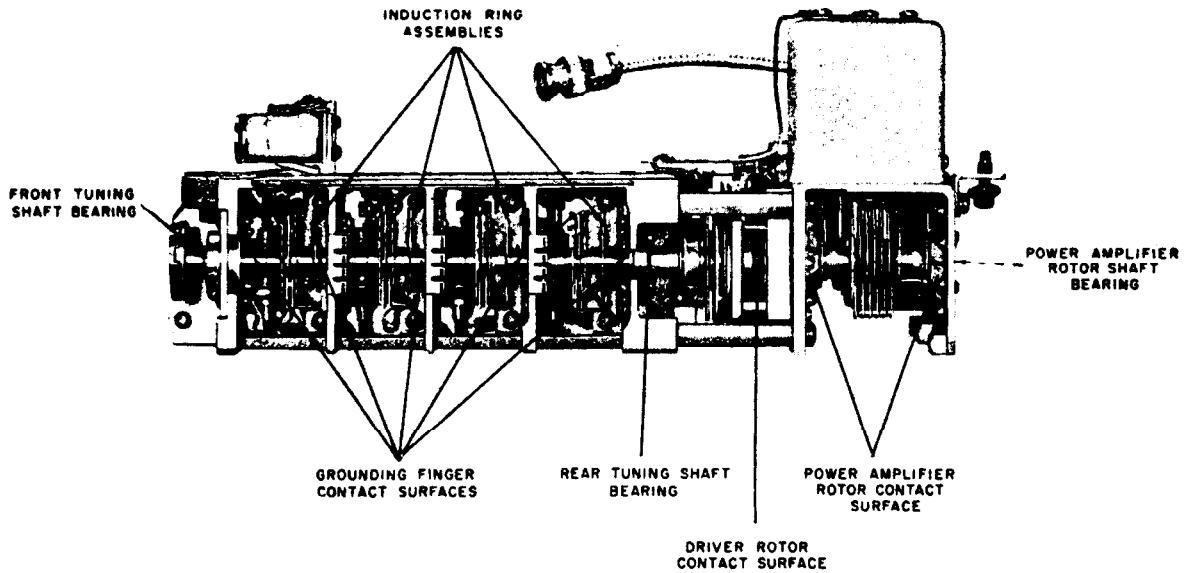
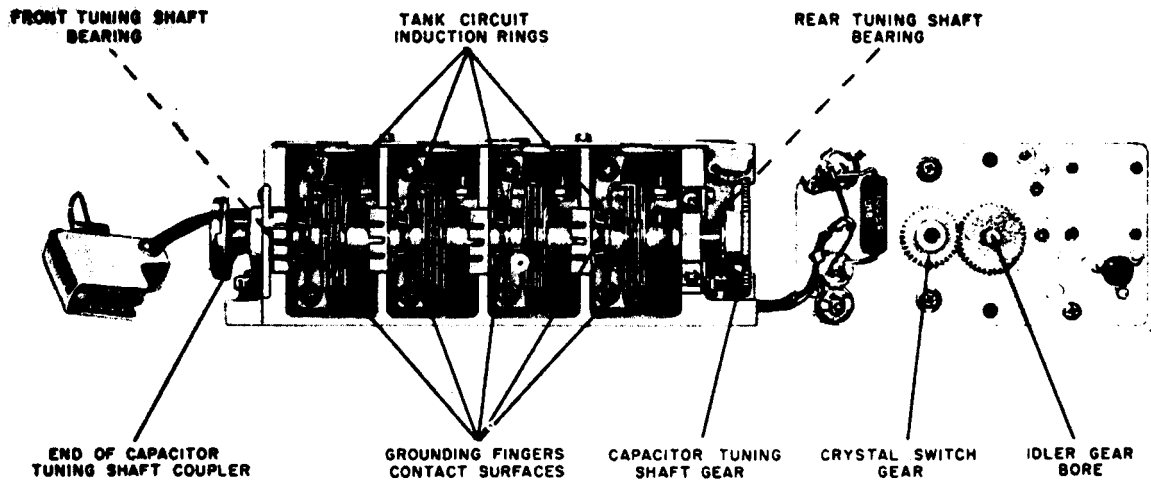


Figure 106. Gear-loading rod.



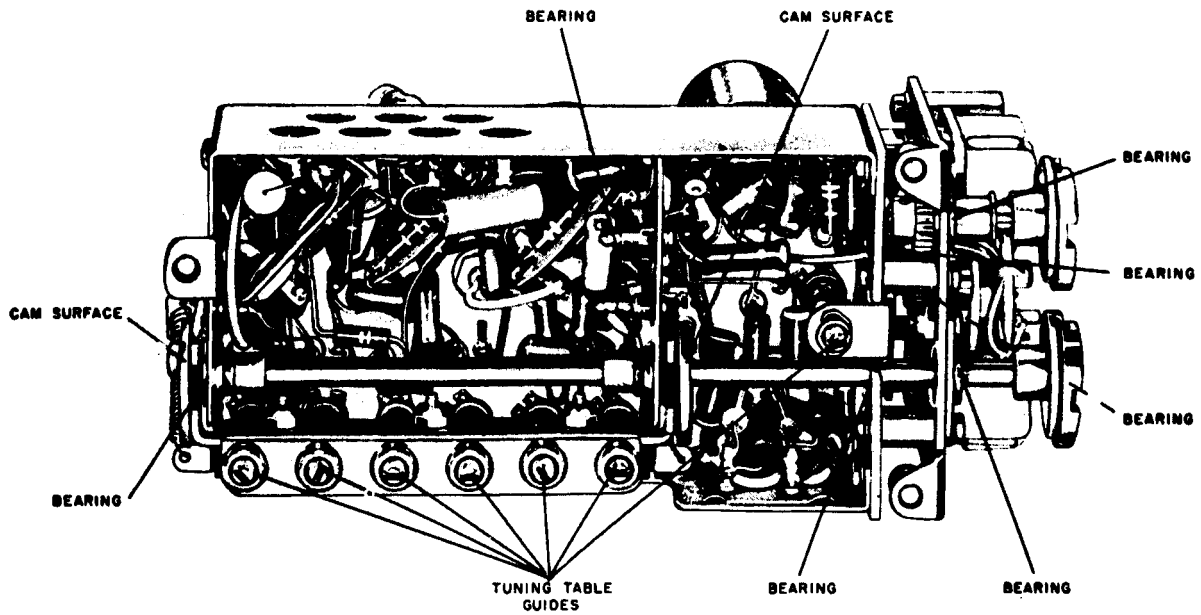
TM5820-222-35-127

Figure 107. Rf and power amplifier subunit, lubrication points.



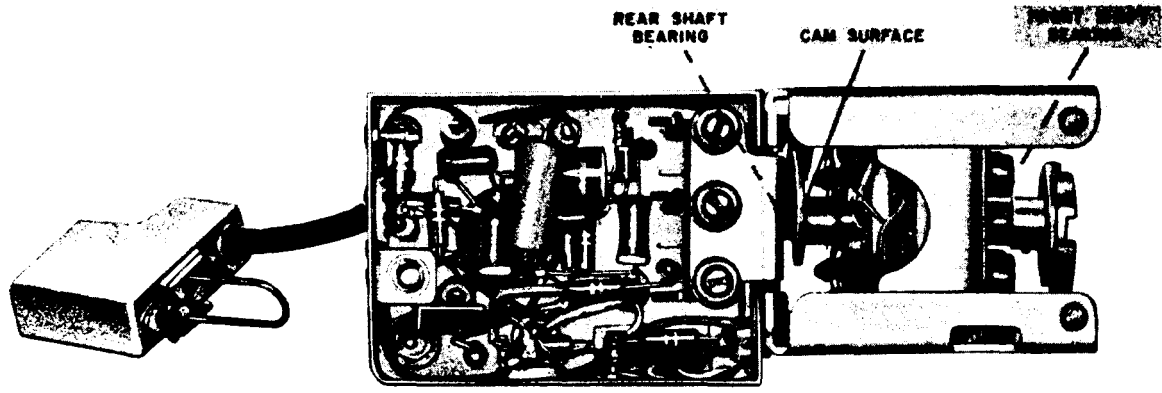
TM5820-222-35-128

Figure 108. Uhf injection subunit, lubrication points.



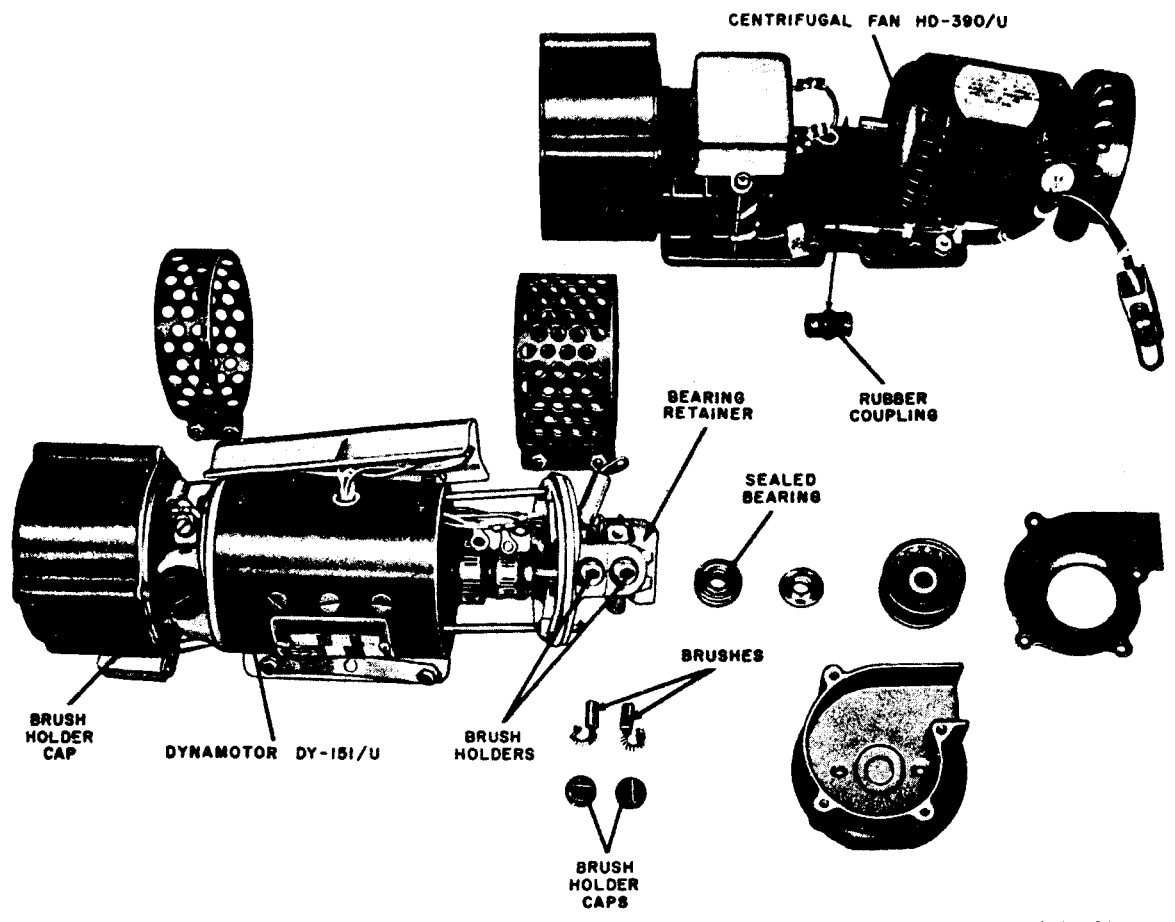
TM5820-222-35-129

Figure 109. First if. amplifier subunit, lubrication points.



TM5820-222-35-156

Figure 110. 3.0- to 3.9-mc if. subunit, lubrication points.



TM5820-222-35-155

Figure 111. Centrifugal Fan HD-390/U and Dynamotor DY-151/U, partially disassembled.



### Section III. ALIGNMENT

#### 128. Test Equipment and Special Tools Required

*a. Test Equipment.* The following test equipment is required for alignment of Radio Sets AN/VRC-24 and AN/TRC-68.

Item	Technical manual
Radio Frequency Wattmeter AN/URM-43A	TM 11-5133
Multimeter ME-26/U	
Audio Oscillator TS-382/U	TM 11-2684A
Signal Generator SG-213/U <sup>a</sup>	
Signal Generator TS-497/URR <sup>a</sup>	TM 11-5030
Rf Signal Generator Set AN/URM-25D	TM 11-5551-D
Oscilloscope AN/USM-50	TM 11-5129
Voltmeter, Meter ME-30/U	TM 11-5132

<sup>a</sup>Signal Generator TS-497/URR is to be replaced by Signal Generator SG-213/U when it becomes available.

*b. Special Tools.* The following special tools are required for alignment.

- (1) Alignment tool. This tool (Federal stock No. 5120-690-7403) is a phenolic, lucite, or nylon rod 3/16 inch in diameter, with a screwdriver blade on one end and a slot on the other end. It is used for coil slug and trimmer capacitor adjustments.
- (2) *Tab-bending tool.* This tool is a lucite rod with a pointed end. It is used to bend the tabs on the tuning capacitors.
- (3) *Tuning wand.* The tuning wand (Federal stock No. 5120-521-8775) is a phenolic, lucite, or nylon rod with a 3/16-inch diameter brass slug on one end and a 3/16-inch diameter powdered iron slug on the other end. It is used to check the alignment of tuning coils. When the brass slug is inserted into a coil, the inductance is decreased and the resonant frequency of the tuned circuit is raised. When the powdered iron slug is inserted into a coil, the inductance is increased and the resonant frequency of the tuned circuit is lowered.

*c. Audio Test Box* (fig. 112). To facilitate the connection of test equipment such as voltmeters and signal generators to the 10-pin AUDIO jacks, prepare an audio test box. The materials required are a small metal or wooden chassis, a spare 10-pin audio connector, six test terminals or jacks, six 2-foot lengths of No. 22 copper wire, and a 2-foot length of No. 22 or No. 26 shielded wire. Mount the test terminals on the chassis. Connect, solder, and label the test terminals to the 10-pin audio connector as follows:

- (1) Connect one end of a length of the No. 22 copper wire to pin L of the 10-pin audio connector, and label the other end SPEAKER.
- (2) Connect one end of a length of the No. 22 copper wire to pin B of the 10-pin audio connector, and label the other end AF OUTPUT RETURN.
- (3) Connect one end of a length of the No. 22 copper wire to pin E of the 10-pin audio connector, and label the other end AF INPUT RETURN.
- (4) Connect one end of a length of the No. 22 copper wire to pin H of the 10-pin audio connector, and label the other end CONT LINE RETURN.
- (5) Connect one end of a length of the No. 22 copper wire to pin A of the 10-pin audio connector, and label the other end HEADSET.
- (6) Connect one end of the shielded wire to pin C of the 10-pin audio connector, and label the other end AF INPUT. Ground the shield to pin B of the 10-pin audio connector.
- (7) Connect one end of a length of the No. 22 copper wire to pin F of the 10-pin audio connector, and label the other end RADIO CONT LINE.

#### 129. Alignment Test Setup

*a. General.* The following paragraphs contain alignment and adjustment procedures necessary to obtain optimum

equipment performance. When performing overall alignment of the equipment, perform the procedures in the order in which they are listed. When only one alignment procedure is performed, it is assumed that all other subunits are properly aligned. Before attempting alignment, read the complete alignment procedure carefully to become familiar with the steps involved. *Do not attempt alignment of the equipment as a substitute for troubleshooting. Attempt alignment only after troubleshooting procedures indicate the need for alignment.*

*b. Preliminary Test Setup.*

- (1) Remove the rt unit from its case (TM 11-5820-222-20).
- (2) Connect Electrical Special Purpose Cable Assembly CX-4884/U (extension cable) between P1 of the rt unit and the mating jack in the case.
- (3) Connect the audio test box (para 128) to either AUDIO jack J702

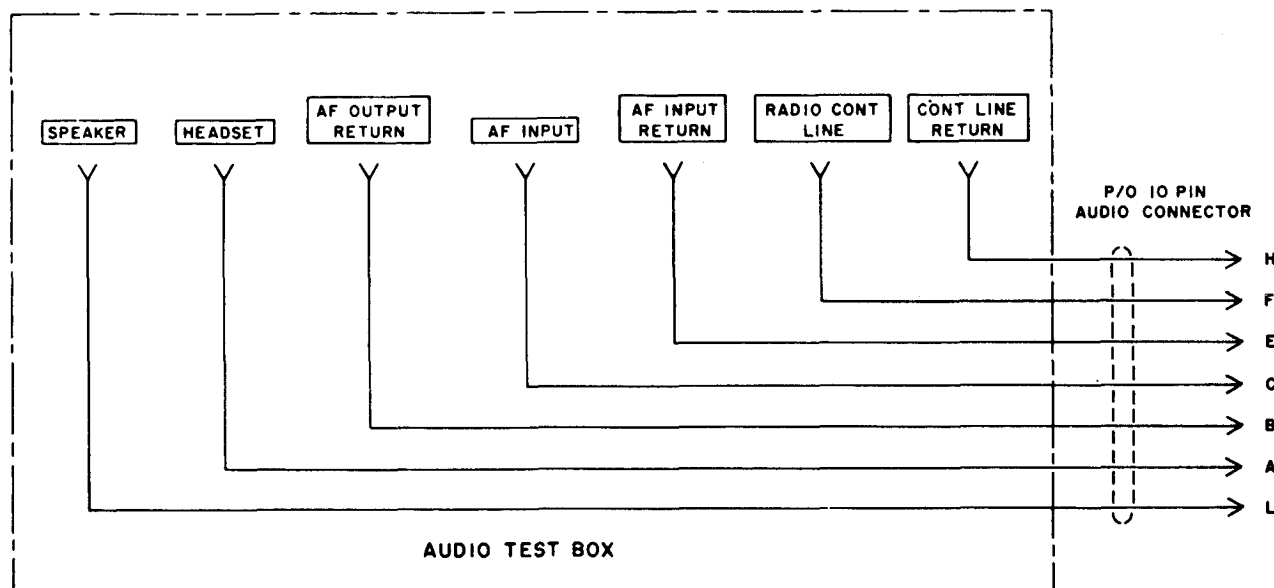
or J703 on the front panel of the rt unit.

- (4) Connect the 600-ohm, 2-watt resistor between the SPEAKER and the AF OUTPUT RETURN terminals of the audio test box.
- (5) Connect the radio set to the external power source and monitor the input voltage with the ME-26/U. Be sure that the input voltage is within the operating range of the radio set (Radio Set AN/VRC-24, -22 to -30 volts dc; Radio Set AN/TRC-68, 103 to 127, or 207 to 253 volts ac).

*c. Control Settings.*

**Warning: Voltages dangerous to life (+125 volts, +300 volts dc) are present in Receiver-Transmitters RT-323/VRC-24 and RT-441/TRC-68.**

- (1) The preliminary control settings for Receiver-Transmitter RT-323/VRC-24 or RT-441/TRC-68



NOTE  
 IO PIN AUDIO CONNECTOR TO MATE WITH **AUDIO**  
 J702 OR J703 ON FRONT PANEL.

TM5820-222-35-88

Figure 112. Audio test box schematic.

are the same. Set the front-panel controls as follows:

Control	Setting
CHAN SEL	MANUAL
SQUELCH	OFF
VOLUME	Fully to the right
POWER	Turn to ON, momentarily

(2) Set the controls of Radio Set Control C-1439/U as follows:

Control	Setting
SQUELCH	OFF
PHONE VOLUME and SPEAKER VOLUME	Fully to the right
Radio-interphone	RAD

*Caution:* Do not key the transmitter unless the ANT. jack is terminated in a proper load (either the antenna or Radio Frequency Wattmeter AN/URM-43A). Do not key the transmitter with a signal generator connected to the ANT. jack. Failure to observe these precautions will result in damage to the rt unit and to the test equipment.

*Note.* Allow at least 5 minutes for the radio set to warm up before performing any alignment procedures.

### 130. Third Oscillator Check

Perform the following procedure before aligning the if. amplifier subunits. If the third oscillator does not meet the specifications below, check V401B and make voltage and resistance measurements to isolate the trouble (fig. 87).

*a. Test Equipment Required.* Multimeter ME-26/U.

*b. Test Setup.*

- (1) Perform the alignment test setup (para 129).
- (2) Set the ME-26/U to the -10-volt dc range and connect the dc probe to test point J404 (fig. 56).

*c. Procedure.* Operate MANUAL FREQUENCY TENTHS control from 0.0 to 0.9. At each position, check the Multimeter ME-26/U indication on receive and transmit. The meter indication should be between 5 and 12 volts dc on both transmit and receive.

### 131. Alignment of Second Oscillator

*a. Test Equipment and Tool Required.*

- (1) Multimeter ME-26/U.
- (2) Alignment tool.

*b. Test Setup.*

- (1) Perform the alignment test setup (para 129).
- (2) Set Multimeter ME-26/U to the -3 volt dc range and connect the dc probe to test point J305 (fig. 62).

*c. Procedure.*

- (1) Set MANUAL FREQUENCY UNITS control to 9.

**Warning:** The capacitor C340 trimmer shaft is at B+ potential. Avoid direct contact with shaft. Do not short shaft to ground.

*Note.* Perform procedures (2) and (3) below only when this subunit has been severely misaligned.

- (2) Turn trimmer capacitor C340 (fig. 62) clockwise to its stop; then tune it counterclockwise seven complete turns.
- (3) Adjust the slug of L310 (fig. 113) so that the top of the slug is approximately 1 inch from the top of the tank compartment cover.
- (4) Set the MANUAL FREQUENCY UNITS control to 0.
- (5) Tune L310 for a maximum indication on the ME-26/U.
- (6) Set the MANUAL FREQUENCY UNITS control to 9.
- (7) Tune C340 for a maximum indication on the ME-26/U.
- (8) Set the MANUAL FREQUENCY UNITS control to 0.
- (9) Tune L310 for a maximum indication on the ME-26/U.
- (10) Repeat procedures (6) through (9) above until no further increase in the voltage indication on the ME-26/U can be obtained.
- (11) Set the MANUAL FREQUENCY UNITS control to positions 0 through 9 and see that the voltage at test point J305 is not less than 1.0 volt for each position.

### 132. Alignment of 3.0- to 3.9-Mc If. Subunit

#### a. Test Equipment Required.

- (1) Rf Signal Generator Set AN/URM-25D.
- (2) Multimeter ME-26/U.
- (3) Alignment tool.
- (4) Tuning wand.

#### b. Test Setup.

- (1) Perform the alignment test setup (para 129).
- (2) Connect the output of the AN/URM-25D to test point J303 (fig. 62).
- (3) Set ME-26/U to the -3-volt dc range and connect the dc probe to test point J504 (fig. 59).

#### c. Procedure.

- (1) Set the MANUAL FREQUENCY TENTHS control to .9.

*Note.* Perform procedures (2) and (3) below only when this subunit has been severely misaligned.

- (2) Adjust the slugs of L402, L404, and L406 (fig. 56) counterclockwise to their stops; then turn three complete turns clockwise.
- (3) Adjust slugs of L401, L403, and L405 (fig. 56) so that the tops of the slugs are 1-3/32 inches from the top of the cover.
- (4) Set the MANUAL FREQUENCY TENTHS control to .0.
- (5) Set the AN/URM-25D frequency to 3.0 mc unmodulated and adjust the output level for a readable indication on the ME-26/U.

*Note.* In the following procedure, adjust the AN/URM-25D output level as necessary to keep the ME-26/U indication between -1 and -2 volts dc. This will prevent the avc voltage from affecting alignment.

- (6) Check L401, L403, and L405 with the tuning wand ((7) below).
- (7) If the meter indication shows a decrease when either the brass or the iron tip of the tuning wand is inserted into the coil form, the tuned circuit requires no further adjustment. However, if the indication increases when the iron tip is in-

serted, the circuit is tuned above resonance and requires adjustment. If the indication increases when the brass tip is inserted, the tuned circuit is below resonance and requires adjustment.

- (8) Tune L401, L403, and L405, if necessary, for a maximum indication of the ME-26/U.
- (9) Set the MANUAL FREQUENCY TENTHS control to .9. Set the AN/URM-25D frequency to 3.9 mc.
- (10) Check L401, L403, and L405 with the tuning wand ((7) above).
- (11) Tune L402, L404, and L406, if necessary, for a maximum indication of the ME-26/U.
- (12) Repeat (4) through (11) above until no further increase in the ME-26/U voltage indication can be obtained.
- (13) Operate the MANUAL FREQUENCY TENTHS control from .9 to .0 and tune the AN/URM-25D in corresponding 0.1-mc decrements from 3.9 to 3.0 mc. Check the tuning of L401, L403, and L405 with the tuning wand. Only slight detuning (if any) should be noted in the middle of the .9- to .0-mc range. If considerable detuning is noted, check the tuning slugs for proper travel. The slugs should move linearly for given increments of rotation. Replace any worn or broken parts, or replace coil L401, L403, or L405 (para 110).

### 133. Alignment of First If. Amplifier Subunit

#### a. Test Equipment and Tools Required.

- (1) Rf Signal Generator Set AN/URM-25D.
- (2) Signal Generator TS-497/URR.
- (3) Multimeter ME-26/U.
- (4) Alignment tool.
- (5) Tuning wand.

#### b. Test Setup.

- (1) Perform the alignment test setup (para 129).
- (2) Set the ME-26/U to -3-volt dc range and connect the dc probe to test point J504 (fig. 59).

- (3) Connect the output of AN/URM-25D to test point J301 (fig. 62).

c. *Procedure.*

**Warning: Avoid direct contact with the trimmer shafts of capacitors C306 and C312. The shafts are at B+ potential; do not short them to ground.**

- (1) Set the MANUAL FREQUENCY UNITS control to 9. Set the MANUAL FREQUENCY TENTHS control to .9.

*Note.* In the following procedure, adjust the AN/URM-25D output level as necessary to maintain the ME-26/U indication between -1 and -2 volts dc.

- (2) Turn trimmer capacitors C302, C304, C306, C309, C312, and C317 (fig. 62) to the right, to their stops.
- (3) Adjust slugs of L301 through L306 (fig. 113) so that the tops of the slugs are 1 inch from the top of the cover.
- (4) Set the AN/URM-25D frequency to 29.9 mc unmodulated and adjust the output level to obtain a readable indication on the ME-26/U.

*Note.* Perform (2) and (3) below only when this subunit has been severely misaligned.

- (5) If necessary, check L306, L305, L304, and L303 with the tuning wand (para 132c(7)) for maximum voltage on ME-26/U.
- (6) Set the MANUAL FREQUENCY UNITS control to 0. Set the MANUAL FREQUENCY TENTHS control of .0. Set the AN/URM-25D frequency to 20.0 mc unmodulated.
- (7) Check L306, L305, L304, and L303 with the tuning wand (para 132c(7)).
- (8) If necessary, tune L306, L305, L304, and L303 for maximum voltage on ME-26/U.
- (9) Set the MANUAL FREQUENCY UNITS control to 9. Set the MANUAL FREQUENCY TENTHS control to .9. Set the AN/URM-25D frequency to 29.9 mc unmodulated.
- (10) Check L306, L305, L304, and L303 (fig. 113) with the tuning wand.

- (11) If procedure (10) above indicates the necessity, tune C317, C312, C309, and C306 for maximum voltage on the ME-26/U (fig. 62).
- (12) Repeat procedure (6) through (11) above until no further increase in voltage can be obtained on the ME-26/U.
- (13) Operate the MANUAL FREQUENCY UNITS control from 9 to 0 and tune the AN/URM-25D from 29.9 to 20.9 mc in corresponding 1.0-mc decrements. At each control position, check the tuning of L303, L304, L305, and L306 with the tuning wand. Only slight detuning (if any) should be noted in the middle of the 9 to 0 range. If considerable detuning is noted, check the tuning slugs for proper travel. The slugs should move linearly for given increments of rotation. Replace any worn or broken parts or replace L303, L304, L305, or L306.
- (14) Remove the AN/URM-25D and connect the TS-497/URR to the ANT. jack through the 6-db attenuator (supplied with the TS-497/URR).
- (15) Set the MANUAL FREQUENCY UNITS and the TENTHS controls to 9 and .9, respectively. Set the MANUAL FREQUENCY TENS control to 29 or 39. Set the TS-497/URR to the same frequency indicated by the MANUAL FREQUENCY controls (299.9 or 399.9 mc).

*Note.* In the procedures outlined in (16) through (22) below, slightly readjust the TS-497/URR for a maximum ME-26/U indication each time the frequency of the TS-497/URR is changed.

- (16) Adjust the output level of the TS-497/URR to obtain a readable indication on the ME-26/U (between -1 and -2 volts dc).
- (17) Check L302 and L301 (fig. 113) with the tuning wand and adjust, if necessary.
- (18) Adjust C302 and C304 (fig. 62) for maximum indication on the ME-26/U.

- (19) Set the MANUAL FREQUENCY UNITS and the TENTHS controls to 0 and .0, respectively. Set the TS-497/URR to the frequency indicated by the MANUAL FREQUENCY controls.
- (20) Check L301 and L302 with the tuning wand and, if necessary, tune L301 and L302 for a maximum indication of the ME-26/U.
- (21) Repeat procedures (15) through (20) above until no further increase in voltage can be obtained on the ME-26/U.
- (22) Operate the MANUAL FREQUENCY controls from 299.9 to 290.0 mc in .1-mc steps and tune the TS-497/URR frequency to corresponding frequencies. At each control position, check the tuning of

L301 and L302 with the tuning wand. Only slight detuning (if any) should be noted in the middle of the 299.9- to 290 .0-mc range. If considerable detuning is noted, check the tuning slugs for proper travel. The slugs should move linearly for given increments of rotation. Replace any worn or broken parts or replace L301 or L302.

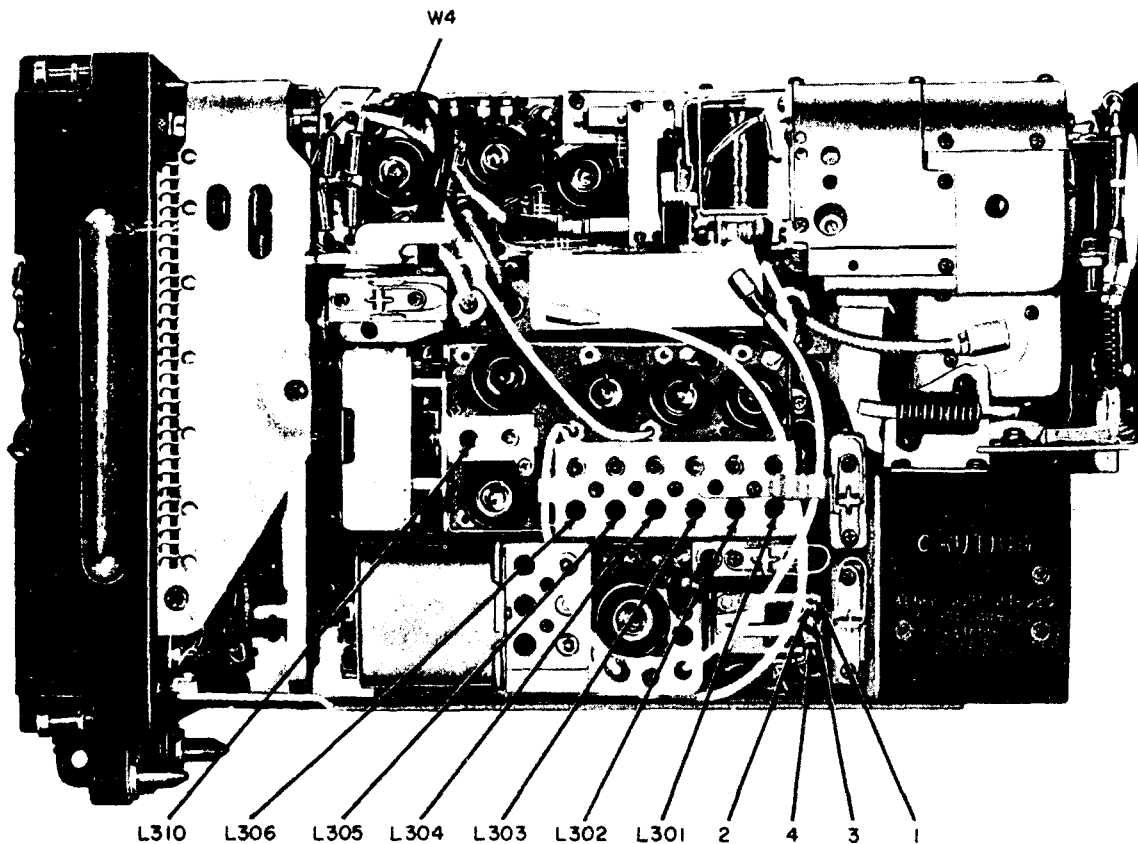
#### 134. Alignment of First Oscillator

##### a. Test Equipment Required.

- (1) Multimeter ME-26/U.
- (2) Alignment tool.

##### b. Test Setup.

- (1) Perform the alignment test setup (para 129).



TM 5820-222-35-118

Figure 113. Rt unit, right-side view.

- (2) Set the ME-26/U to -3-volt dc range and connect the dc probe to test point J201 (fig. 53).

*c. Procedure.*

*Note.* Access holes (fig. 48) are numbered from 22 to 39 and correspond to the numbers on the MANUAL FREQUENCY TENS control.

- (1) Set the MANUAL FREQUENCY TENS control to 39.
- (2) Tune trimmer inductance L218 (fig. 50) through the access hole marked 39 on the first oscillator rear plate (fig. 48) for maximum voltage on the ME-26/U.
- (3) Set the MANUAL FREQUENCY TENS control to 38 and tune trimmer inductance L217 (fig. 50) through the hole marked 38 (fig. 48) for maximum voltage on the ME-26/U.
- (4) Continue through the frequency range of the MANUAL FREQUENCY TENS control and, at each position, tune the corresponding trimmer inductance (fig. 48) for maximum voltage on the ME-26/U.

### 135. Alignment of Uhf Injection Subunit Step Tuner

*a. Test Equipment Required.*

- (1) Multimeter ME-26/U.
- (2) Alignment tool.

*b. Test Setup.*

- (1) Perform the alignment test setup (para 129).
- (2) Set the ME-26/U to the -3-volt dc range and connect the dc probe to test point J201 (fig. 53).

*Note.* The voltage at J201 will be approximately twice the amplitude between 225.0 and 299.9 mc that it is between 300.0 and 399.9 mc.

*c. Procedure.*

- (1) Set the MANUAL FREQUENCY TENS control to 39.
- (2) Rotate trimmer capacitor C208 (fig. 48) through the hole in the first oscillator rear plate counterclockwise to its stop.
- (3) Adjust L222 through the hole in the bottom of the first oscillator cover (fig. 52) by spreading or squeezing

the turns of L222 for a maximum voltage on ME-26/U.

*Note.* To gain access to L222, loosen the three retaining screws on the uhf injection subunit and remove the subunit from the main frame (para 108). Do not disconnect plug P4 or plug P201. Be careful not to ground the exposed terminal of C1 which is directly behind the uhf subunit. Capacitor C1 is connected to the 300-volt supply.

- (4) Set the MANUAL FREQUENCY TENS control to 22.
- (5) Tune C208 (fig. 48) for maximum voltage on the ME-26/U.
- (6) Set the MANUAL FREQUENCY TENS control to 39.
- (7) Repeat procedures (3) through (6) above, until no increase in voltage on the ME-26/U is obtained at positions 22 and 39 of the MANUAL FREQUENCY TENS control.

### 136. Alignment of Uhf Injection Subunit Frequency Tripler and Amplifier

*a. Test Equipment Required.*

- (1) Multimeter ME-26/U.
- (2) Radio Frequency Wattmeter AN/USM-43A.
- (3) Alignment tool.
- (4) Tab-bending tool.

*b. Tab Identification Chart.*

Frequency (mc)	Tab color
399.9	Black
389.9	White
379.9	Yellow
369.9	Orange
359.9	Blue
349.9	Brown
339.9	Green
329.9	Red
319.9	White
309.9	Blue
299.9	Red
289.9	Brown
279.9	Green
269.9	Yellow
259.9	White
249.9	Orange
239.9	Black
229.9	Yellow
225.0	Red

*c. Test Setup.*

- (1) Perform the alignment test setup (para 129).

- (2) Connect the AN/URM-43A to the ANT. jack on the front panel. Set the AN/URM-43A to the 60-watt range.
  - (3) Set the ME-26/U to the 3-volt .ac range and connect rf probe to the junction of R114 and J113 (fig. 72).
- d. *Procedure.*
- (1) Turn trimmer capacitors C215, C221, C227, and C233 (fig. 55) counterclockwise to their stops (minimum capacity).
  - (2) Set the MANUAL FREQUENCY TENS control to 39.
  - (3) Key the transmitter by connecting a lead between the RADIO CONT LINE and the CONT LINE RETURN terminals on the audio test box.
  - (4) Turn C215, C221, C227, and C233 clockwise to the first voltage peak indicated on the ME-26/U.
  - (5) Unkey the transmitter by removing the lead in procedure (3) above.
  - (6) Set the ME-26/U to -3 volts dc range and connect the dc probe to test point J106 (fig. 68).
  - (7) Make slight adjustments on C233, C227, C221, and C215 to obtain maximum voltage on the ME-26/U. This voltage is approximately 1.8 to 2.75 volts.
  - (8) Track the frequency tripler-amplifier section of the uhf injection system over the upper half of the radio set frequency range (399.9 to 309.9 mc) by bending the tabs on the main tuning capacitor rotors of Z208, Z206, Z204, and Z202 (fig. 54). For example, when the radio set is tuned to 399.9 mc, the tabs with black tips will be half-meshed with the stators on Z208, Z206, Z204, and Z202. Do not adjust any other tabs at this frequency. Tune for maximum voltage on the ME-26/U. Operate the MANUAL FREQUENCY TENS control from 39 to 30 and, at each position, bend only the tabs that are half-meshed with the stators. Start with Z208; then tune Z206, Z204, and Z202. The chart in *b* above shows the tab frequencies and tab color code.

**Caution: Do not bend the tabs beyond 30° from parallel to the stator plates. Bending beyond this point produces little change in capacitance and will weaken the tab.**

- (9) Connect the dc probe of the ME-26/U to test point J104 (fig. 68).
- (10) Key the transmitter as in (3) above.
- (11) Operate the MANUAL FREQUENCY TENS control from 29 through 22 and, at each position, bend the tab that is half-meshed with the stator for a maximum voltage indication on the ME-26/U. Start with Z208, and then tune Z206, Z204, and Z202. The voltage at J104 should vary from -1 to -3 volts.
- (12) Unkey the transmitter by removing the lead in (3) above.

**Caution: To prevent damage to V104, V105, and V106, do not operate the rf unit as a transmitter for longer than 3 minutes at one time when the rf amplifiers are misaligned.**

### 137. Alignment of Rf and Power Amplifier Subunit

- a. *Test Equipment and Tools Required.*
- (1) Multimeter ME-26/U.
  - (2) Radio Frequency Wattmeter AN/URM-43A.
  - (3) Alignment tool.
  - (4) Tuning wand.
- b. *Test Setup.*
- (1) Perform the alignment test setup (para 129).
  - (2) Set the AN/URM-43A to the 60-watt range and connect it to the ANT. jack on the front panel.
- c. *Procedure.*
- (1) Set the MANUAL FREQUENCY controls to 399.9 mc.
  - (2) Check the mechanical synchronization of Z101, Z103, Z105, Z106, and Z108 (fig. 68); the small tab on the rotor should be in full-mesh with the stator, and the tab (black tip) opposite should be in half-mesh. On the Z107 (fig. 68), the first rotor tab leading edge on both



sides should be lined up with the stator. Refer to paragraph 125 for mechanical synchronization.

- (3) Set the R108 (fig. 72) fully clockwise (maximum resistance) and rotate trimmer capacitors C107, C115, C122, C127, C141, and C132 counterclockwise to their stops (fig. 68 and 72).
- (4) Key the transmitter by connecting a lead between the RADIO CONT LINE and the CONT LINE RETURN terminals on the audio test box.

*Note.* The following procedures are performed with the radio set keyed to transmit. If the tuning indications at test points J105 and J106 are masked by saturation (tuning a capacitor over a wide range produces only a slight change in the voltage reading at a test point), decrease the if. voltage to V101 by inserting a tuning wand into one of the if. tuning coils L303, L303, L304, L305, or L306 (fig. 113).

- (5) Set the ME-26/U to the -1-volt dc range and connect the dc probe to test point J105 (fig. 68).
- (6) Adjust C107 and C115 (fig. 68) for maximum voltage indication on the ME-26/U.
- (7) Set the ME-26/U to the -3-volt dc range and connect the dc probe to test point J106 (fig. 68).
- (8) Adjust C122 (fig. 68) for maximum voltage indication on the ME-26/U.
- (9) Set the ME-26/U to -10-volt dc range and connect the dc probe to test point J114 (fig. 68).
- (10) Adjust C127 (fig. 68) for a maximum voltage indication on the ME -26/U.
- (11) Set the ME-26/U to the -100-volt dc range and connect the dc probe to test point J111 (fig. 72).
- (12) Adjust C141 (fig. 72) for a maximum voltage indication on the ME -26/U. The meter should read -25 to -30 volts dc.
- (13) Adjust C132 (fig. 68) for a maximum output reading on the AN/URM-43A.
- (14) Perform procedures (5) through (13) above in reverse order.

- (15) Adjust L111 (fig. 72) for a maximum power output indication on AN/URM-43A. To adjust coupling loop L111, loosen the two holding screws and rotate the rf connector.
- (16) Readjust C132 as described in (13) above.
- (17) Rotate the front panel METER switch to PA I<sub>a</sub> and adjust R108 (fig. 72) for a midscale indication on the front-panel meter. Recheck C132 and C141 as described in (13) and (12) above.
- (18) Track Z108 (fig. 68) by bending the tabs on the rotors of the main tuning capacitor part (part of Z108). Start at 399.9 mc and decrease the setting of the MANUAL FREQUENCY TENS control in 10-mc steps to 229.9, then decrease the frequency to 225.0 mc. At each frequency, bend the tab that is half-meshed with the stator for maximum power output on the AN/URM-43A. The chart in paragraph 136b shows the tab frequencies and the color code of the tabs.

*Note.* At 229.9 mc, the yellow tab should be fully meshed with the stator.

- (19) Track Z107 (fig. 68) by bending the tabs on the rotors of the main tuning capacitor (part of Z107). Start at 375.0 mc and decrease the setting of the MANUAL FREQUENCY controls in 20-mc steps to 235.0; then decrease the frequency to 225.0 mc. At each frequency, bend the tabs on each side for a maximum voltage indication on ME -26/U.
- (20) Set the ME-26/U to the -10 volts dc range and connect the dc probe to test point J114 (fig. 68).
- (21) Track Z106 by bending the tabs on the rotors of the main tuning capacitor (part of Z106) (fig. 68) for a maximum voltage indication on the ME-26/U. Start at 399.9 mc and decrease the frequency in 10-mc steps to 229.9 mc; then decrease the frequency to 225.0 mc. At each frequency setting, bend the

half-meshed tabs on each side for a maximum voltage indication on the ME-26/U. Refer to the tab color chart in paragraph 136 b.

- (22) Set the ME-26/U to the -3 volts dc range and connect the dc probe to test point J106 (fig. 68).
- (23) Track Z105 by bending the tabs on the rotor of the main tuning capacitor (part of Z105) (fig. 68) for a maximum voltage on the ME -26/U. Start at 399.9 mc and decrease the frequency in 10-mc steps to 229.9 mc; then decrease the frequency to 225.0 mc. Refer to the chart in paragraph 136b.
- (24) Set the ME-26/U to the -1 volt dc range and connect the dc probe to test point J105 (fig. 68).

- (25) Track Z103 and Z101 (fig. 68) by bending the tabs on the rotors of the main tuning capacitors for a maximum voltage at the ME -26/U. Start at 399.9 mc and decrease the the frequency in 10-mc steps to 229.9 mc; then decrease the frequency to 225.0 mc. Refer to the chart in paragraph 136b.

*Note.* When the tank circuits are completely misaligned, it may be impossible to track each tank circuit individually from 399.9 mc to 225.0 mc because of lack of excitation. If this happens, bend the tabs on the appropriate tanks at each frequency. For example, at 389.9 mc, bend the tabs on Z108, Z106, Z105, Z103, and Z101; then bend the tabs on Z107. Start with 375.0 mc and decrease the MANUAL FREQUENCY control in 20-mc steps to 235 mc; then decrease to 225 mc.

#### Section IV. ADJUSTMENTS

##### 138. Transmit Audio Level Adjustments

###### a. Test Equipment Required.

- (1) Audio Oscillator TS-382/U.
- (2) Oscilloscope AN/USM-50.
- (3) Radio Frequency Wattmeter AN/URM-43A.
- (4) Multimeter ME-26/U.
- (5) Electronic Voltmeter ME-30B/U.
- (6) Audio test box.

###### b. Test Setup.

- (1) Perform alignment test setup (para 129).
- (2) Connect the AN/URM-43A to the ANT. jack on the front panel.

**Warning: Be extremely careful when making the following connections because +300 volts dc is present at test point J803.**

- (3) Connect the AN/USM-50 to test point J803 (fig. 76).
- (4) Set the ME-26/U to 300 volts ac. Connect the ac probe to test point J803. Ground the other ME-26/U test lead.
- (5) Set the ME-30B/U to the 0.3-volt ac scale and connect the test leads

between the audio test box terminals labeled AF INPUT and AF INPUT RETURN (10-pin audio connector terminals C and E).

- (6) Connect the TS-382/U between the audio test box terminals labeled AF INPUT and AF INPUT RETURN.
- (7) Turn control R831 (fig. 76) fully counterclockwise (zero resistance.)
- (8) Set NOR BB switch S801 (rear of main frame, fig. 48) to NOR.

###### c. Procedure.

- (1) Key the transmitter by connecting a lead between the RADIO CONT LINE and the CONT LINE RETURN terminals on the audio test box.
- (2) Set the TS-382/U audio output to 1,000 cps and adjust it to produce a 0.1-volt ac indication on the ME-30B/U.
- (3) Adjust control R843 (fig. 76) until clipping of the sine wave is barely perceptible on the oscilloscope. The ME-26/U indication should be approximately 150 volts ac or more.

- (4) Rotate R831 clockwise until a slight decrease in voltage at test point J803 is noted on the ME-26/U and the AN/USM-50.
- (5) Decrease the TS-382/U output to 0.05 volt ac as indicated on the ME-30B/U. The decrease in output at test point J803 should be at least 3 db (approximately a 45-volt drop if the output voltage was 150 volts).
- (6) If the decrease is more than 3 db, repeat the procedures in (2) and (4) above, adjust control R831 slightly further clockwise, and repeat (5) above until a 3-db decrease is noted in the procedure for (5) above.
- (7) If the decrease indicated in procedure (5) above is less than 3 db, repeat procedure (2) above, adjust control R831 slightly counterclockwise, and repeat the procedures in (5) above. Continue this procedure until exactly 3-db decrease is noted in procedure (5) above.
- (8) Increase the TS-382/U output to 0.4 volts ac, as indicated on ME-30B/U. Note that the output at test point J803 does not increase more than 2 db from the output at a 0.1-volt ac input (approximately 40-volt rise if the output voltage was 150 volts).

### 139. Receiver Audio Level Adjustments

- a. *Test Equipment Required.*
  - (1) Signal Generator TS-497/URR.
  - (2) Electronic Voltmeter ME-30B/U.
  - (3) Audio test box.
  - (4) Six-db attenuator pad (supplied with the TS-497/URR).
- b. *Test Setup.*
  - (1) Perform the alignment test setup (para 129).
  - (2) Connect the TS-497/URR through the 6 db pad to the ANT. jack on the front panel.
  - (3) Connect the ME-30B/U between the audio test box terminals labeled SPEAKER and AF OUTPUT RE-

TURN (10-pin audio connector terminals L and B).

- (4) Set the ME-30B/U to the 30-volt ac scale.
- c. *Procedure.*
  - (1) Set the TS-497/URR and the rt unit to the same frequency.
  - (2) Adjust the TS-497/URR for a 100-microvolt output, modulated 30 percent, with a 1,000-cps signal.
  - (3) Adjust R826 (fig. 76) for a 24.5-volt ac indication on the ME-30B/U.

### 140. S-METER Adjustment

- a. *Test Equipment Required.*
  - (1) Signal Generator TS-497/URR.
  - (2) 6-db attenuator pad (supplied with the TS-497/URR).
- b. *Test Setup.*
  - (1) Perform the alignment test setup (para 129).
  - (2) Operate the rt unit on normal receive.
  - (3) Set the MANUAL FREQUENCY control to 399.9 mc.
  - (4) Set the METER switch to S-METER.
  - (5) Connect the TS-497/URR through the 6-db pad to the ANT. jack on the rt unit front panel.
- c. *Procedure.*
  - (1) Adjust the TS-497/URR for a 6-microvolt rf output at 399.9 mc. Slightly readjust the frequency of the TS-497/URR for a maximum indication on the rt unit front panel meter.
  - (2) Adjust resistor R716 so that the meter pointer is at the left border of the area marked NORMAL on the front panel meter.

### 141. Squelch Adjustment

- a. *Test Equipment Required.*
  - (1) Signal Generator TS-497/URR.
  - (2) Six-db attenuator pad (supplied with the TS-497/URR).
- b. *Test Setup.*
  - (1) Perform the alignment test setup (para 129).
  - (2) Set the METER switch to S-METER.

- (3) With no signal input, operate the MANUAL FREQUENCY TENS controls from 22 to 39 and set the control to the position at which the highest S-METER reading can be obtained.
- (4) Connect the TS-497/URR to the ANT. jack on the front panel through the 6-db attenuator pad.
- (5) Set the TS-497/URR to the same frequency as indicated by the MANUAL FREQUENCY controls. Readjust the TS-497/URR frequency slightly for a maximum reading on the S-METER.
- (6) Set the TS-497/URR output at 50 microvolt.

*c. Procedure.*

- (1) Rotate the SQUELCH control fully clockwise.
- (2) Adjust control R712 (fig. 49) until the CALL LIGHT lamp lights.
- (3) Decrease the TS-497/URR output signal level until the CALL LIGHT lamp goes off.
- (4) Increase the TS-497/URR output signal level until the CALL LIGHT lamp lights, and check for a 50-microvolt setting on the TS-497/URR.
- (5) If the CALL LIGHT lamp lights at a signal level lower or higher than 50 microvolt, repeat the procedures in (2), (3), and (4) above.

# CHAPTER 7

## FINAL TESTING

### Section I. INTRODUCTION

#### 142. Purpose of Final Testing

The tests outlined in this section are designed to measure the performance capability of a repaired Radio Set AN/VRC-24 or AN/TRC-68. Equipment that meets the requirements stated in the tests will provide satisfactory operation equivalent to that of new equipment.

#### 143. Test Equipment Required for Final Testing

In addition to the test equipment and

audio test box listed in paragraph 128 the following items are required for final testing:

Item	Technical manual
Frequency Meter AN/USM-26 . . . . .	11-5057
Spectrum Analyzer TS-723A/U . . . . .	11-5097
Frequency Meter AN/URM-81 . . . . .	11-5096
Variable Attenuator CN-318/U . . . . .	
Transfer Oscillator CM-77/USM . . . . .	
Variable Autotransformer CN-16A/U . . . . .	
Dc potentiometer, rated at 15 amperes, 0.5 to 1.0 ohms.	

### Section II. TESTS

#### 144. Frequency Stability Versus Supply Voltage

Connect Radio Set AN/VRC-24 or AN/TRC-68 and the test equipment as shown in figure 114.

##### *a. Test Procedure, Radio Set AN/VRC-24.*

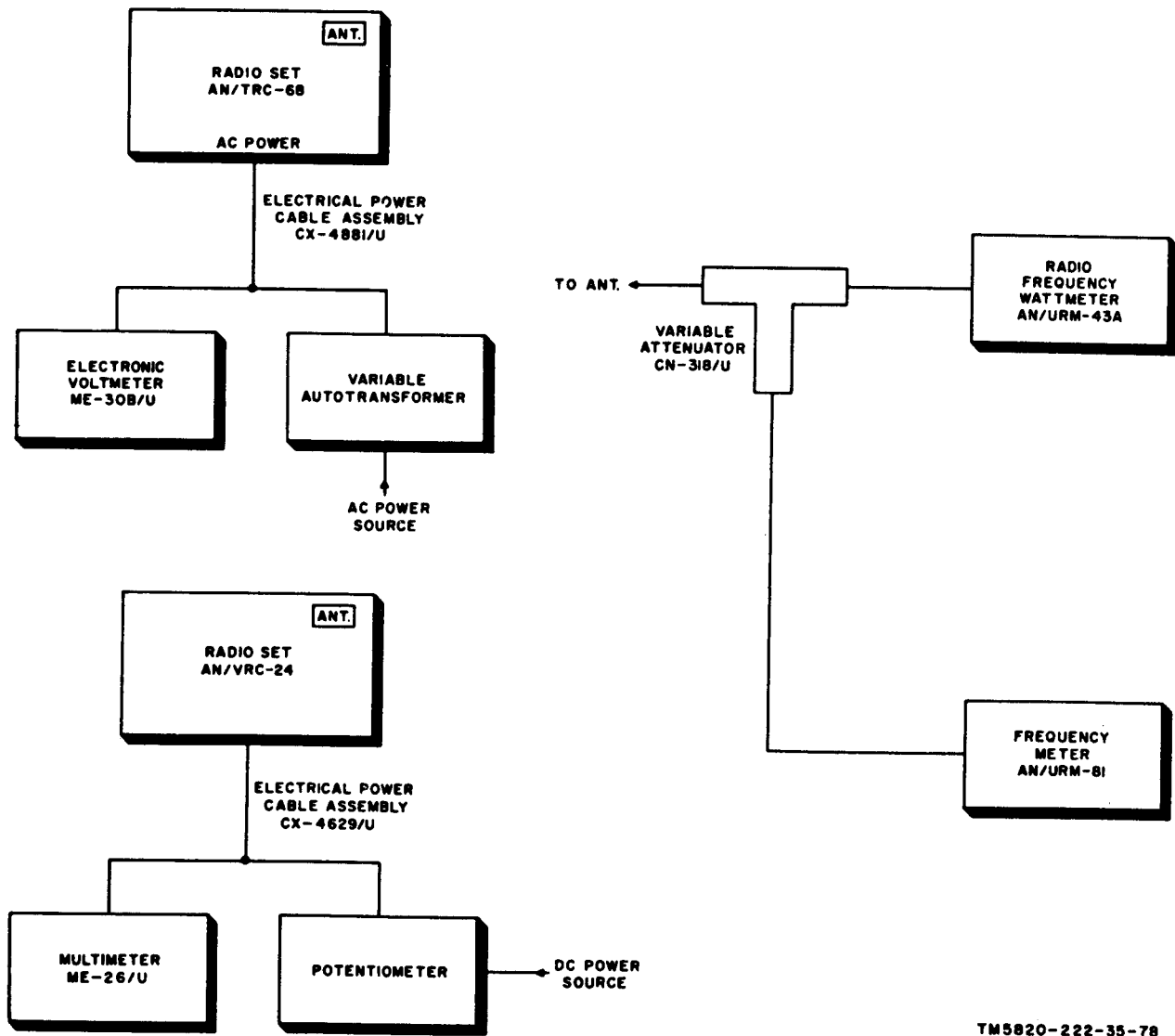
- (1) Adjust the input voltage to 26.4 volts dc with the AN/VRC-24 operating on transmit. Use the ME-26/U to measure the dc input voltage.
- (2) Set the frequency to 399.9 mc.
- (3) After a 30-minute warmup, measure and record the transmitter output frequency.
- (4) Adjust the input voltage to 22 volts dc and, after 5 minutes, repeat the frequency measurement. The frequency must be within  $\pm 2$  kc of 399.9 mc.
- (5) Adjust the input voltage to 30 volts dc and, after 5 minutes, repeat the frequency measurement. The frequency must be within  $\pm 2$  kc of 399.9 mc.

##### *b. Test Procedure, Radio Set AN/TRC-68.*

- (1) Adjust the input voltage to 115 (or 230) volts ac with the AN/TRC-68 operating on transmit.
- (2) Set the frequency to 399.9 mc.
- (3) After a 30-minute warmup, measure and record the transmitter output frequency.
- (4) Adjust the input voltage to 103 (or 207) volts ac and, after 5 minutes, repeat the frequency measurement. The frequency must be within  $\pm 2$  kc of 399.9 kc.
- (5) Adjust the input voltage to 127 (or 253) volts ac and, after 5 minutes, repeat the frequency measurement. The frequency must be within  $\pm 2$  kc of 399.9 kc.

#### 145. Front Panel Meter

Connect the AN/VRC-24 or AN/TRC-68 for normal operation. Check LINE V, LOW B+, HIGH B+, and S-METER on receive. Operate the push-to-talk switch and check LOW B+, HIGH B+, DVR I<sub>b</sub>, PA I<sub>g</sub>, PA I<sub>b</sub>,



TM5820-222-35-78

Figure 114. Frequency stability vs supply voltage test setup, block diagram.

SWR and PWR on transmit. Check % MOD while speaking into the microphone. The following chart lists normal indications.

METER switch position	Meter indication
LINE V	Midscale $\pm 20$ percent
LOW B+	Midscale $\pm 20$ percent
HIGH B+	Midscale $\pm 20$ percent
S-METER	Zero, no signal (SQUELCH control at OFF)
% MOD	Midscale $\pm 20$ percent
DVR $I_b$	Midscale $\pm 20$ percent
PA $I_g$	Midscale $\pm 20$ percent
PA $I_b$	Midscale $\pm 20$ percent
PWR	80 to 100 percent
SWR	0

#### 146. Receiver Sensitivity Test

Connect the AN/VRC-24 or AN/TRC-68 and the test equipment as shown in figure 115.

a. Tune the radio set to 399.9 mc and turn the VOLUME control fully clockwise.

b. Set the TS-497/URR to 399.9 mc. Set the METER switch to S-METER and tune the TS-497/URR for a maximum indication on the meter.

c. Modulate the TS-497/URR output signal at 30 percent with a 1,000-cycle audio-frequency.

d. Adjust the MICROVOLTS control on

the TS-497/URR until the ME-30B/U indicates 12.25 volts across the 600-ohm load (the MICROVOLTS control setting must not exceed 6).

e. Record the db reading on the ME-30B/U that corresponds to 12.25 volts.

f. Turn the TS-497/URR modulator switch to OFF.

g. The ME-30B/U indication must be at least 10 db below the value recorded in e above.

h. Perform steps a through g above for the following test frequencies:

Frequency (mc)	Frequency (mc)	Frequency (mc)
399.9	333.3	277.7
388.8	322.2	266.6
377.7	311.1	255.5
366.6	300.0	244.4
355.5	299.9	233.3
344.4	288.8	225.0

## 147. Resettability Tests

### a. Rf Power Output Resettability.

- (1) Connect the AN/URM-43A to the rt unit ANT. jack.
- (2) Place the rt unit in its case. Place the AN/VRC-24 on Mounting MT-1436/U.
- (3) Apply 115 (or 230) volts ac to the AN/TRC-68 or 26.4 volts dc to the AN/VRC-24.
- (4) Tune the rt unit to a test frequency of 225.0 mc.
- (5) Allow 2 hours for warmup.
- (6) Key the rt unit. The unmodulated

rf power output should be not less than 16 watts.

- (7) Recycle the rt unit to 399.9 mc and then back to the test frequency. Key the rt unit and measure the unmodulated power output. The power output should be within 5 percent of 16 watts.
- (8) Repeat step (7) above for test frequencies of 300 and 235 mc.

### b. Transmitter Frequency Resettability.

- (1) Connect the equipment as shown in figure 114.
- (2) Apply 115 (or 230) volts ac (AN/TRC-68) or 26.4 volts dc (AN/VRC-24) to the rt unit.
- (3) Tune the rt unit to a test frequency of 225.0 mc and allow a 30-minute warmup period.
- (4) Key the rt unit and measure the output frequency. The output frequency should be within  $\pm 2$  kc of 225.0 mc.
- (5) Recycle the rt unit to 399.9 mc and then back to the test frequency. Key the rt unit and measure the output frequency. The output frequency should be within  $\pm 2$  kc of the test frequency.
- (6) Repeat (5) above for test frequencies of 300 and 235 mc.

### c. Receiver Sensitivity Resettability.

- (1) Connect the equipment as shown in figure 115.
- (2) Apply 115 (or 230) volts ac (AN/TRC-68) or 26.4 volts dc (AN/VRC-24) to the rt unit.

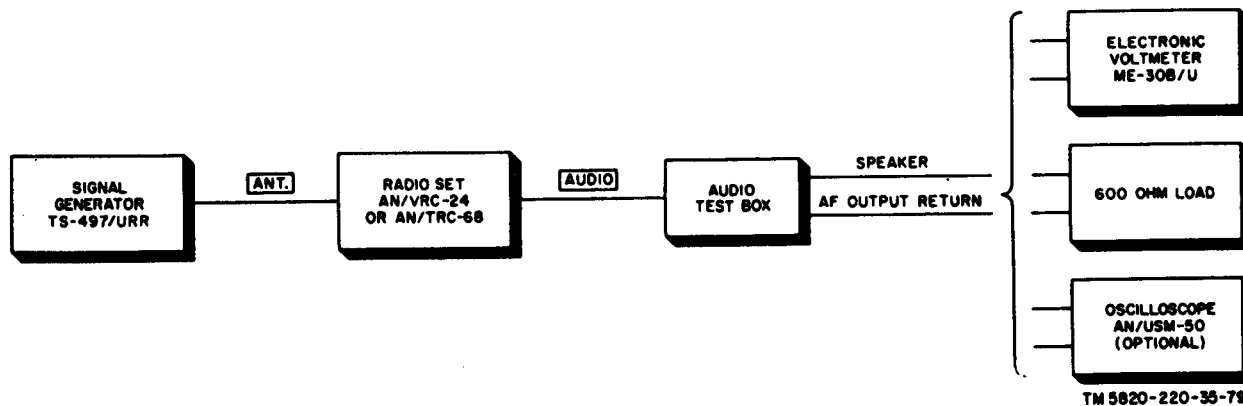


Figure 115. Receiver sensitivity test setup, block diagram.

- (3) Tune the rt unit to 225.0 mc.
- (4) Set the TS-497/URR to a test frequency of 225.0 mc. Set the METER switch to S-METER and tune the TS-497/URR for a maximum indication on the meter.
- (5) Modulate the TS-497/URR output signal at 30 percent with a 1,000-cycle audiofrequency.
- (6) Adjust the MICROVOLTS control on the TS-497/URR until the ME-30B/U indicates 12.25 volts across 600-ohm load.
- (7) Recycle the rt unit to 399.9-mc and then back to the test frequency. The ME-30B/U indication should be within 10 percent of 12.25 volts.
- (8) Repeat (7) above for test frequencies of 300 and 235 mc.

#### 148. Squelch Test

Connect the equipment as shown in figure 115. Connect the ME-30B/U and variable autotransformer or the ME-26/U and potentiometer as shown in figure 114.

*a.* Tune the rt unit to 399.9 mc.

*b.* Set the SQUELCH control to the maximum sensitivity position (fully counterclockwise to the stop but not to OFF).

*c.* Turn the METER switch to S-METER and tune the TS-497/URR for a maximum indication of the S-METER.

*d.* Adjust the TS-497/URR for the minimum setting of the MICROVOLTS control that will deactivate the squelch (as indicated by the lighting of the CALL LIGHT lamp). The MICROVOLTS SETTING must not exceed 3 microvolt.

*e.* Turn the SQUELCH control fully clockwise (minimum sensitivity). The squelch must deactivate with an input signal of not less than 25 microvolts nor more than 50 microvolt without readjustment of the SQUELCH control.

*f.* Perform *b* through *e* above at test frequencies of 309.9 and 225.0 mc. The signal input required to deactivate the squelch must be between 1.5 and 6 microvolt for maximum sensitivity, and between 12.5 and 100 microvolt for minimum sensitivity.

*g.* Perform *b* through *f* above with supply voltages of 103 (or 207) and 127 (or

253) volts ac (AN/TRC-68), or at 22 and 30 volts dc (AN/VRC-24). The input signal required to deactivate the squelch must be between 0.5 and 17 microvolt for maximum sensitivity, and between 4.5 and 280 microvolt for minimum sensitivity.

*h.* Tune the rt unit to 399.9 mc. Set the TS-497/URR at the same frequency. Turn the METER switch to S-METER and readjust the TS-497/URR for a maximum S-METER indication. Turn the MICROVOLTS dial to 6. Adjust the SQUELCH control for the minimum setting that will deactivate the squelch. Turn the MICROVOLTS dial to the minimum setting that will operate the squelch. The signal input voltage ratio between the unsquelched and the squelched condition must not exceed 2 to 1.

#### 149. Signal Plus Noise-to-Noise Ratio

Connect the AN/VRC-24 or AN/TRC-68 to the test equipment as shown in figure 115.

*a.* Set the TS-497/URR to the same frequency as the rt unit and tune the TS-497/URR for a maximum indication on the S-METER.

*b.* Adjust the TS-497/URR for a 10,000-microvolt output modulated 30 percent with a 1,000-cycle audio signal.

*c.* Adjust the rt unit VOLUME control for a 24.5-volt root-mean-square (rms) indication on the ME-30B/U. Record the indication on the corresponding db scale.

*d.* Turn the modulator switch on the TS-497/URR to OFF. The decrease in db as indicated on the ME-30B/U must be not less than 35 db.

#### 150. Receiver Audio Output Test

Connect the test equipment to the AN/VRC-24 or AN/TRC-68 as shown in figure 116. Do not connect the ME-26/U, the AN/USM-50, the TS-723A/U, or the AN/URM-25D.

*a.* Tune the rt unit and the TS-497/URR to any convenient frequency.

*b.* Set the METER switch to S-METER and adjust the TS-497/URR frequency for a maximum S-METER indication.

*c.* Adjust the TS-497/URR for a 100-microvolt rf signal modulated 30 percent



with a 1,000-cycle audio signal.

d. To perform the test in the chart below, make one set of measurements with normal input voltage applied to the rt unit and

the second set of measurements with the input voltage reduced to 103 (or 207) volts ac (AN/TRC-68) or 22 volts dc (AN/VRC-24).

Audio level being measured	Test equipment* and connections	Audio output with normal input voltage	Audio output with reduced input voltage
Speaker .....	Connect the test equipment between the SPEAKER and AF OUTPUT RETURN on the audio test box.	24.5	17.3
Headset .....	Connect the test equipment between the HEADSET and AF OUTPUT RETURN on the audio test box.	12.25	8.6
Remote audio ....	Turn the VOLUME control fully clockwise. Remove the 10-pin audio connector from the front panel AUDIO jack and connect it to one of the AUDIO jacks on the C-1439/U. Connect the test equipment between the HEADSET and AF OUTPUT RETURN on the audio test box.	19.0	13.3
Extended range ...	Connect the test equipment between terminals E and D of front panel BROAD BAND jack J704.	1.1	0.7
Fixed level.....	Turn the VOLUME control fully clockwise. Connect the test equipment between AUXILIARY jack J1403-R (AN/TRC-68), or terminal board TB1702-23 (AN/VRC-24), and chassis ground.	5.5	3.9

\*The test equipment in this test is the ME-30B/U and the 600-ohm load (fig. 116). Connect these items in parallel between the points indicated in the *Test equipment and connections* column.

### 151. Audiofrequency Response Characteristics

Connect the AN/VRC-24 or the AN/TRC-68 to the test equipment as shown in figure 116. Connect the TS-382A/U to the EXT MOD jack of the TS-497/URR to provide external modulating frequencies from 100 to 25,000 cps. Do not connect the TS-723A/U or the AN/URM-25D.

a. Tune the rt unit and TS-497/URR to any convenient frequency.

b. Adjust the TS-497/URR for a 1,000-microvolt signal modulated 30 percent with a 1,000-cycle audio signal.

c. Set the front panel METER switch to S-METER and adjust the TS-497/URR frequency for a maximum S-METER indication.

d. Connect the ME-30B/U and 600-ohm load across the SPEAKER and AF OUTPUT RETURN terminals of the audio test box and adjust the front panel VOLUME control for 1 watt of audio output power (24.5 volts rms across the 600-ohm load). Record the corresponding db indication of the ME-30B/U.

e. Set the TS-382A/U modulation signal to frequencies of 100, 300, 3,000, 5,000,

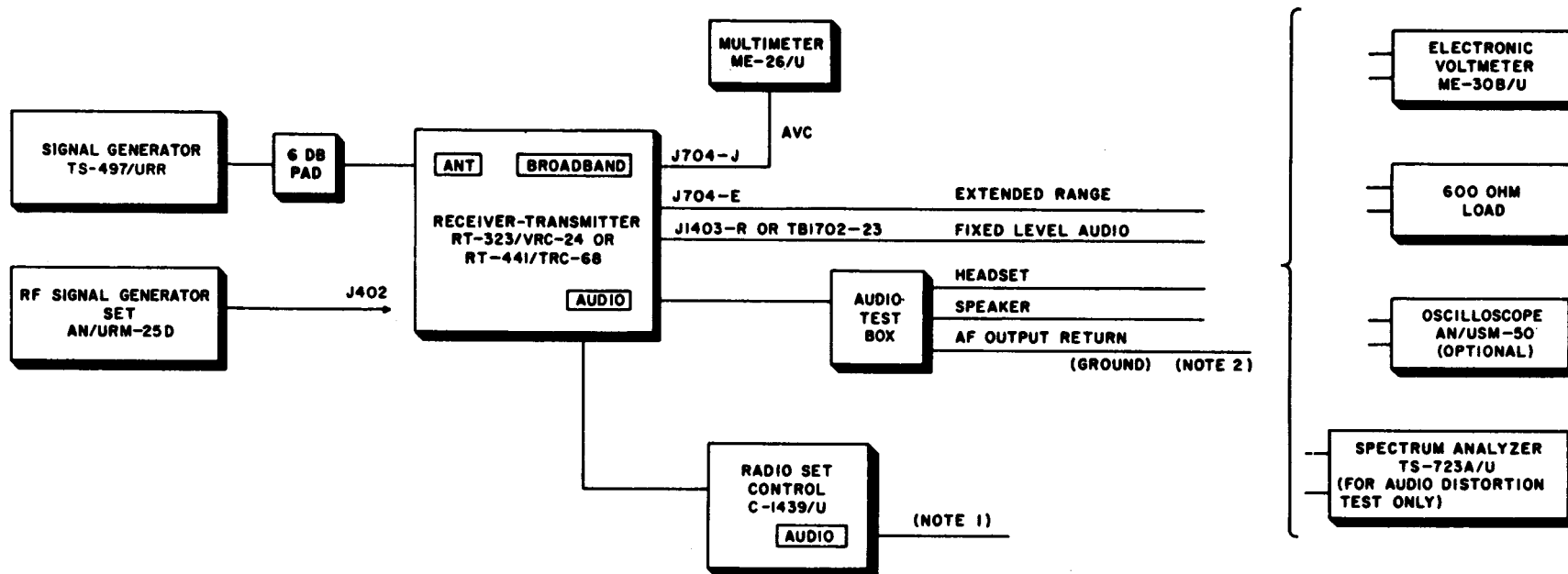
and 10,000 cps and, without further adjustment of the rt unit controls, measure and record the db indication of the ME-30B/U. At 300 and 3,000 cps, the audio output level must be within  $\pm 2$  db of the indication in *d* above. The audio output level at 100, 5,000, and 10,000 cps should be at least -8 db, -5 db, and -20 db respectively from the indication in *d* above.

f. Connect the 600-ohm load and ME-30B/U between the HEADSET and AF OUTPUT RETURN terminals of the audio test box.

g. Repeat the audio response measurements made in *e* above. Do not change the setting of the front panel VOLUME control. Record the db indications. The db relationships must be the same as in *e* above.

h. Connect the 600-ohm load and ME-30B/U between AUXILIARY jack J1403-R (AN/TRC-68) or terminal board TB1702-23 (AN/VRC-24), and chassis ground, and repeat the measurements made in *e* above. Record the db indications. The db relationships must be the same as in *e* above.

i. Disconnect the audio test box from the front panel AUDIO jack and connect it to either of the C-1439/U AUDIO jacks. Connect the 600-ohm load and the ME-30B/U



**NOTES:**

1. CONNECT AUDIO TEST BOX TO **AUDIO** JACK ON RADIO SET CONTROL C-1439/U TO MEASURE REMOTE AUDIO OUTPUT AT HEADSET TERMINAL.
2. CONNECT TEST EQUIPMENT AND 600 OHM LOAD TO THE INDIVIDUAL AUDIO OUTPUT AND AF OUTPUT RETURN TERMINALS FOR EACH SUCCESSIVE TEST.

TM5620-222-35-103

Figure 116. Receiver audio output, frequency response and distortion test setup, block diagram.

between the HEADSET and AF OUTPUT RETURN terminals of the audio test box and repeat the measurements made in *e* above. Record the db indications. The db relationships should be the same as in *e* above.

*j.* Connect the 600-ohm load and ME-30B/U between terminals D and E of BROAD BAND jack J704. Turn the NOR-BB switch (TM 11-5820-222-20) to BB.

*k.* Measure and record the audio output voltage at modulation frequencies of 100, 250, 400, 1,000, 4,000, 10,000, 15,000, 20,000, and 25,000 cps. The db indications of the ME-30B/U from 100 to 10,000 cps should be within  $\pm 3$  db of the indication at 1,000 cps. The db indications at 15,000, 20,000, and 25,000 cps should be not more than -7 db from the db indication at 1,000 cps.

### 152. Audio Distortion Measurements

Connect the AN/VRC-24 or AN/TRC-68 as shown in figure 116. The AN/URM-25D, the ME-26/U, and the AN/USM-50 are not used in this test. Connect the TS-382/U to the EXT MOD jack on the TS-497/URR to provide external modulating frequencies.

*a.* Tune the rt unit and TS-497/URR to any convenient frequency.

*b.* Adjust the TS-497/URR for a 1,000-microvolt signal modulated 30 percent with a 1,000-cycle audio signal.

*c.* Set the front panel METER switch to S-METER and adjust the TS-497/URR for a maximum S-METER indication.

*d.* Connect the TS-723A/U and the 600-ohm load between audio test box terminals SPEAKER and AF OUTPUT RETURN.

*Note.* To perform the harmonic distortion measurements in this procedure, refer to TM 11-5097.

*e.* Set the TS-382A/U modulating frequency to 300 cycles and measure the harmonic distortion with the TS-723A/U. Record the percentage of harmonic distortion. Repeat this procedure for modulating frequencies of 500, 1,000, 2,000, and 3,000 cps. The percentage of harmonic distortion for these measurements must not exceed 10 percent.

*f.* Repeat the procedure detailed in *e* above with the TS-723A/U and the 600-ohm

load connected between the terminals listed below:

- (1) HEADSET and AF OUTPUT RETURN on the test box (the test box is connected to the C-1439/U AUDIO jack for this test only).
- (2) AUXILIARY jack J1403-R (AN/TRC-68) or terminal board TB1702-23 (AN/VRC-24) and chassis ground.
- (3) Terminals D and E of BROAD BAND jack J704.

### 153. If. Bandwidth

Connect Radio Set AN/VRC-24 or AN/TRC-68 and the test equipment as shown in figure 117. Operate the radio set for normal receive.

*a.* Set the AN/URM-25D to 3.5 mc.

*b.* Adjust the AN/URM-25D output level for -1.0 volt on the ME-26/U.

*c.* Increase the AN/URM-25D output level to 6 db above (twice) the level set in *b* above.

*d.* Set and record the frequency above and the frequency below 3.5 mc (indicated on the AN/USM-26) which provide -1.0 volt on the ME-26/U. The difference between the two frequencies (6-db bandwidth) must be not less than 80 kc.

*e.* Increase the AN/URM-25D output level (at 3.5 mc) to 60 db above (1,000 times) the level set in *b* above.

*f.* Set and record the frequency above and the frequency below 3.5 mc (indicated on the AN/USM-26) which provide -1.0 volt on the ME-26/U. The difference between the two frequencies (60-db bandwidth) must be not greater than 150 kc.

*g.* Determine the 6-db and 60-db half-bandwidth difference percentages by using the following formula:

$$\frac{\text{deviation (plus)} - \text{deviation (minus)}}{\text{average deviation}} \times 100 =$$

Half-bandwidth difference percentage where: *deviation (plus)* is the frequency difference (in megacycles) above 3.5 mc (*d* or *f* above).

*deviation (minus)* is the frequency difference (in megacycles) below 3.5 mc (*d* or *f* above).

average deviation is the bandwidth in megacycles (determined in d or e above) divided by 2.

Note. Always subtract the smaller deviation from the larger deviation.

**Example:** If the two recorded frequencies (d above) are 3.538635 and 3.456647 mc, the deviation (plus) equals 0.038635 mc, the deviation (minus) equals 0.043353, and the total bandwidth equals 0.081988 mc. The half bandwidth is 0.081988-2 or 0.040994. Therefore: half bandwidth difference percentage at 6 db =

$$\frac{(.043353 - .038635) \times 100}{.040994} = 11.5 \text{ percent}$$

h. The half-bandwidth difference percentages (6 or 60 db) must not exceed 15 percent.

#### 154. Transmitter Rf Power Output

a. Make the following connections. Use fig. 118 as a guide.

- (1) Connect the input voltage control (variable autotransformer (AN/TRC-68) or potentiometer (AN/VRC-24)) and Multimeter ME-26/U to the radio set input line.
- (2) Connect the audio test box 10-pin connector to either AUDIO receptacle on the rt unit front panel.
- (3) Connect the 600-ohm load between the SPEAKER and AF OUTPUT RETURN terminals on the audio test box.

- (4) Connect Radio Frequency Wattmeter AN/URM-43A to the rt unit ANT. jack with a 10-foot length of RG-8/U coaxial cable.

b. Turn the radio set on and set the variable autotransformer for 115 (or 230) volts ac (AN/TRC-68) or the potentiometer for 26.4 volts dc (AN/VRC-24) as indicated on the ME-26/U. Allow a 2-hour warmup time.

c. Key the transmitter by connecting a lead between the RADIO CONT LINE and CONT LINE RETURN terminals on the audio test box. Readjust the input voltage control to maintain the voltage in b above.

d. Note the transmitter rf power output indicated on the AN/URM-43A for the frequency settings listed in the chart in paragraph 146h. The rf power output must be not less than 16 watts at any test frequency.

e. Reduce the input voltage to 103 (207) volts ac (AN/TRC-68) or 22 volts dc (AN/VRC-24) with the transmitter keyed.

f. Repeat the procedure given in d above. The rf power output must be not less than 4 watts.

#### 155. Modulation Capability

a. Connections for Normal Audio Test (fig. 119).

- (1) Connect Audio Oscillator TS-382/U to the dummy microphone input. Connect Electronic Voltmeter ME-30B/U across the 150-ohm resistor in the dummy microphone (fig. 119, note 2).
- (2) Connect the dummy microphone

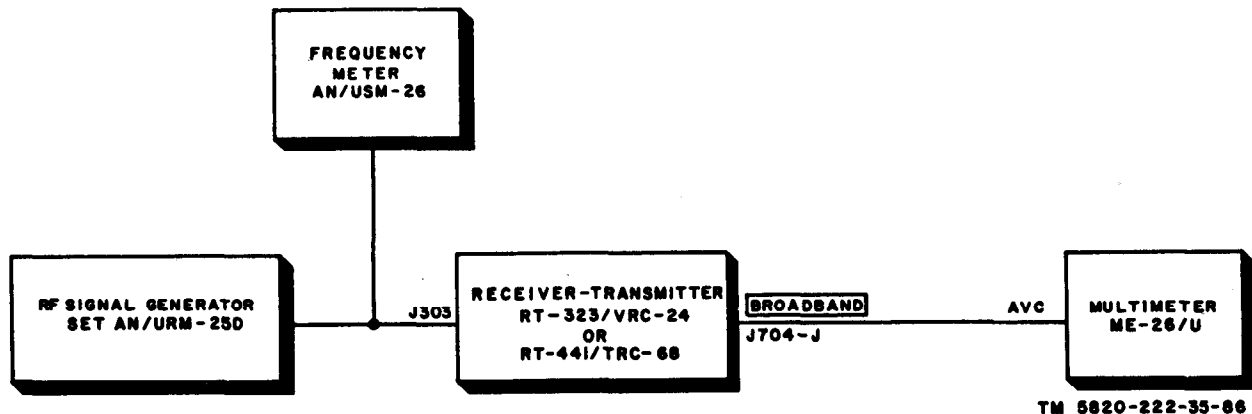
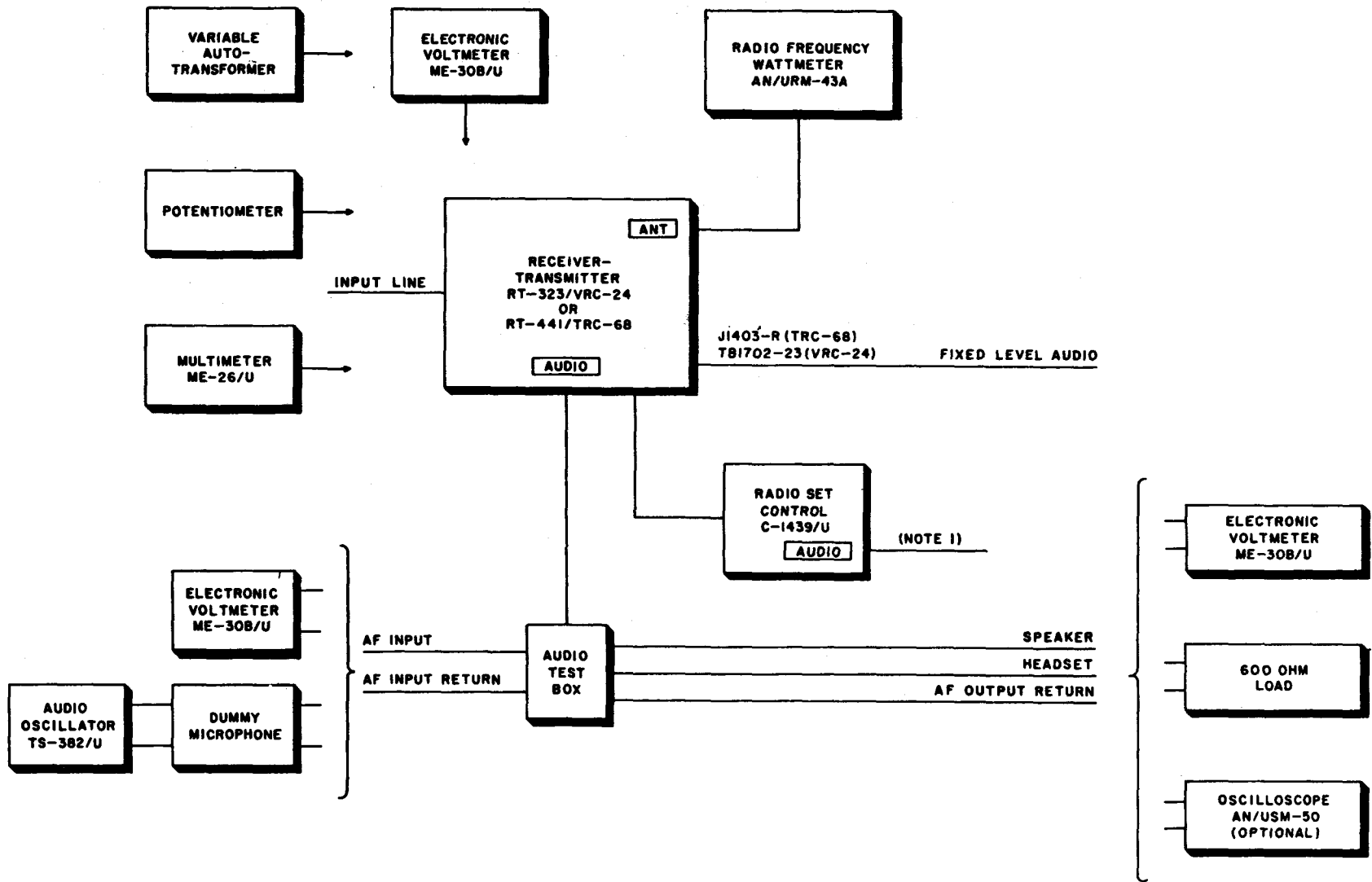


Figure 117. If. bandwidth test setup, block diagram.



NOTE

CONNECT AUDIO TEST BOX TO EITHER [AUDIO] JACK ON RADIO SET CONTROL C-1439/U TO MEASURE REMOTE AUDIO OUTPUT AT HEADSET TERMINAL.

TM5820-222-35-105

Figure 118. Rf power output, test setup, block diagram.

output to the AF INPUT and AF INPUT RETURN terminals on the audio test box.

- (3) Connect the audio test box 10-pin connector to either AUDIO receptacle on the rt unit front panel.
- (4) Connect a 600-ohm load between the SPEAKER and AF OUTPUT RETURN terminals on the audio test box.
- (5) Connect the feedthrough crossarm of Variable Attenuator CN-318/U between the ANT. jack on the rt unit and Radio Frequency Wattmeter AN/URM-43A.
- (6) Connect the variable adjustment leg of the CN-318/U directly to the input of Transfer Oscillator CM-77/USM.
- (7) Connect Oscilloscope AN/USM-50 to the output of the CM-77/USM.

*b. Preliminary Adjustments.*

- (1) Tune the rt unit to 399.9 mc.
- (2) Key the transmitter by connecting a lead between the RADIO CONT LINE and CONT LINE RETURN terminals on the audio test box.
- (3) Set the CN-318/U for minimum attenuation.
- (4) Set the AN/USM-50 MULTIPLIER switch to 1, the VERTICAL GAIN control to midrange, and the SWEEP TIME control to 1,000 microseconds.
- (5) Tune the CM-77/USM for maximum pattern height on the AN/USM-50. Adjust the AN/USM-50 VERTICAL GAIN control to maintain the pattern height within the cathode-ray tube face.
- (6) Adjust the CN-318/U so that a 6-db increase (twice the rf input) or decrease (half the rf input) in the rf input to the CM-77/USM causes a 6-db change (twice or half the height) of the pattern on the AN/USM-50.

*c. Normal Audio Test Procedure.*

- (1) Set the TS-382/U to 1,000 cps; set the signal level for 0.1 volt on the ME-30B/U.
- (2) Adjust the AN/USM-50 SWEEP TIME FINE and SYNC controls to

maintain the pattern reasonably steady on the cathode-ray tube face.

- (3) Record the height of the pattern from peak to peak and from valley to valley.
- (4) Repeat procedures (2) and (3) above for channel settings of 300.0 mc and 225.0 mc.
- (5) Calculate the modulation percentage as follows:

$$\text{Modulation percentage} = \frac{(\text{peak-to-peak}) - (\text{valley-to-valley})}{(\text{peak-to-peak}) + (\text{valley-to-valley})} \times 100$$

- (6) The modulation percentage must be between 70 and 100 percent.

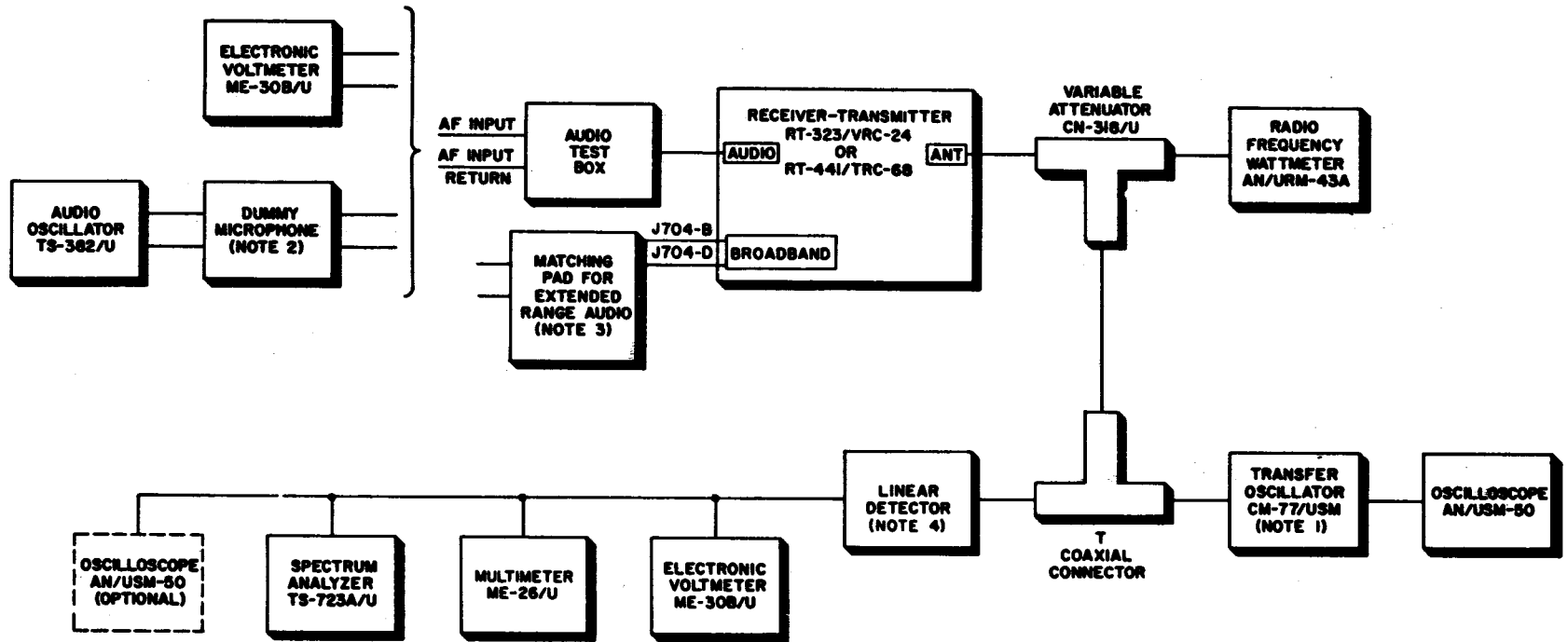
*d. Broadband Audio Test Procedure.*

- (1) Remove the rt unit from its case and set switch S801 to BB. Replace the rt unit in its case. (Refer to TM 11-5820-222-20 for procedure and location of S801.)
- (2) Make the connections given in *a* above, except omit the dummy microphone and connect the TS-382/U and the ME-30B/U between terminal B of BROADBAND jack J704 and the AF INPUT RETURN terminal of the audio test box.
- (3) Perform the preliminary adjustments given in *b* above.
- (4) Set the TS-382/U to 1,000 cps; set the signal level to an amplitude (approximately 8 volts as indicated on the ME-30B/U) sufficient to begin wave from clipping (as viewed on the AN/USM-50).
- (5) Record the waveform amplitudes and calculate the modulation percentages as described in *c* (3), (4), and (5) above.
- (6) The modulation percentages must be between 70 and 100 percent.

## 156. Automatic Modulation Limiter

*a. Connections.* Use figure 119 as a guide.

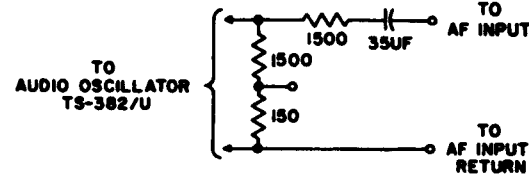
- (1) Connect Audio Oscillator TS-382/U to the dummy microphone input.
- (2) Connect the dummy microphone output to the AF INPUT and AF



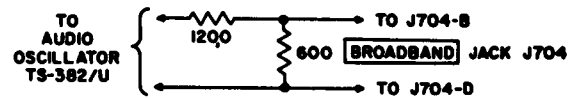
NOTES

1. IF TRANSFER OSCILLATOR CM-77/USM OR EQUIVALENT IS NOT AVAILABLE, CONNECT VERTICAL PLATES OF OSCILLOSCOPE AN/USM-50 DIRECTLY TO VARIABLE ATTENUATOR CN-318/U.

2. DUMMY MICROPHONE SCHEMATIC



3. MATCHING PAD FOR EXTENDED RANGE AUDIO



4. LINEAR DETECTOR SCHEMATIC

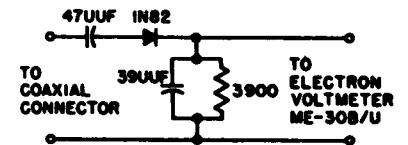


Figure 119. Transmitter final test setup, block diagram.

INPUT RETURN terminals on the audio test box.

- (3) Connect a 600-ohm load between the SPEAKER and AF OUTPUT RETURN terminals on the audio test box.
- (4) Connect Electronic Voltmeter ME-30 B/U across the 150-ohm resistor in the dummy microphone (fig. 119, note 2) for input signal *voltage* measurements.
- (5) Connect the ME-30B/U between the SPEAKER and AF OUTPUT RETURN terminals on the audio test box for output signal *decibel* measurements.
- (6) Connect the audio test box 10-pin connector to either AUDIO receptacle on the rt unit front panel.
- (7) Connect Radio Frequency Wattmeter AN/URM-43A to the ANT. jack on the rt unit front panel.

*b. Procedure.*

- (1) Key the transmitter by connecting a lead between the RADIO CONT LINE and CONT LINE RETURN terminals on the audio test box.
- (2) Set the TS-382/U to 1,000 cps; set the input signal level for 0.1 volt on the ME-30B/U (a(4) above).
- (3) Record the output signal level (a(5) above).
- (4) Reduce the input signal level to 0.05 volt (a(4) above).
- (5) Record the output signal level (a(5) above). The output signal level must be at least 3 db below the level given in (3) above.
- (6) Increase the input signal level to 0.4 volt (a(4) above).
- (7) Record the output signal level (a(5) above). The output signal level must be not more than 2 db above the level given in (3) above.

### 157. Transmitter Audiofrequency Response

*a. Connections for Normal Audio Test.*  
Use figure 119 as a guide.

- (1) Connect Audio Oscillator TS-382/U to the dummy microphone input.
- (2) Connect the dummy microphone output to the AF INPUT and AF IN-

PUT RETURN terminals on the audio test box.

- (3) Connect a 600-ohm load between the SPEAKER and AF OUTPUT RETURN terminals on the audio test box.
- (4) Connect Electronic Voltmeter ME-30B/U as required in the procedures below.
- (5) Connect the audio test box 10-pin connector to either AUDIO receptacle on the rt unit front panel.
- (6) Connect the feedthrough crossarm of Variable Attenuator CN-318/U between the ANT. jack on the rt unit and Radio Frequency Wattmeter AN/URM-43A.
- (7) Connect the variable adjustment leg of the CN-318/U directly to the input of the linear detector.
- (8) Connect Multimeter ME-26/U to the output of the linear detector.

*b. Normal Audio Test Procedure.*

- (1) Key the transmitter by connecting a lead between the RADIO CONT LINE and CONT LINE RETURN terminals on the audio test box.
- (2) Adjust the CN-318/U for 0.5 volt dc on the ME-26/U.
- (3) Set the TS-382/U to 1,000 cps. Connect the ME-30B/U across the 150-ohm resistor in the dummy microphone (fig. 119, note 2), and adjust the TS-382/U signal level for 0.05 volt on the ME-30B/U. *Record the TS-382/U output level meter indication.*
- (4) Connect the ME-30B/U to the output of the linear detector. Record the level of the demodulated output signal, in decibels, indicated on the ME-30B/U.
- (5) Set the TS-382/U to 100, 250, 3,000, 6,000 and 10,000 cps and record the ME-30B/U indication (in db) at the linear detector output for each frequency.

*Note.* Maintain a constant signal level from the TS-382/U at the above frequencies by maintaining the TS-382/U output level meter indication recorded in (3) above.

- (6) The ME-30B/U indications at 100



and 10,000 cps must be at least 6 db lower than that in (4) above.

- (7) The ME-30B/U indications at 250, 3,000, and 6,000 cps must be within  $\pm 2$  db of that in (4) above.

*c. Broadband Audio Test Procedure.*

- (1) Remove the rt unit from its case and set switch S801 to BB. Replace the rt unit in its case. (Refer to TM 11-5820-222-20 for procedure and location of S801.)
- (2) Make the connections given in *a* above, except omit the dummy microphone and connect the TS-382/U, through the matching pad (fig. 119, note 3), to terminals B and D of BROAD BAND jack J704.
- (3) Set the TS-382/U to 1,000 cps. Connect the ME-30B/U across the 600-ohm resistor in the matching pad (fig. 119, note 3), and adjust the TS-382/U signal level for 0.1 volt on the ME-30B/U. *Record the TS-382/U output level meter indication.*
- (4) Connect the ME-30B/U to the output of the linear detector. Record the level of the demodulated output signal, in decibels, indicated on the ME-30B/U.
- (5) Set the TS-382/U to 100,250,3,000, 6,000, 10,000, 15,000, and 25,000 cps and record the ME-30B/U indication (in db) at the linear detector for each frequency.

*Note.* Maintain a constant signal level from the TS-382/U at the above frequencies by maintaining the TS-382/U output level meter indication recorded in (3) above.

- (6) The ME-30B/U indications at 100 cps must be not more than 5 db below that in (4) above.
- (7) The ME-30B/U indications at 250, 3,000, 6,000, 10,000, 15,000, and 25,000 cps must be within  $\pm 2$  db of that in (4) above.

### 158. Carrier Noise Level

*a.* Make the following connections to the rt unit. Use figure 119 as a guide.

- (1) Connect the TS-382/U through the dummy microphone to the AF IN-

PUT and AF INPUT RETURN terminals on the audio test box. Connect the 10-pin connector on the test box to the AUDIO jack on the rt unit.

- (2) Connect Variable Attenuator CN-318/U, the AN/URM-43A, the T-coaxial connector, the linear detector, and the ME-30B/U.

*b.* Adjust the TS-382/U to produce a test signal of 0.1 volt at 1,000 cps across the 150-ohm resistor in the dummy microphone.

*c.* Tune the rt unit to 399.9 mc and key it by shorting the RADIO CONT LINE terminal to the CONT LINE RETURN terminal on the audio test box.

*d.* Note the demodulated audio output at the linear detector, as indicated in db on the ME-30B/U.

*e.* Remove the 1,000-cps signal input and note the db reading on the ME-30B/U. The db reading should be at least 35 db below the reading obtained in *d* above.

### 159. Overall Distortion Test

*a.* Make the following connections to the rt unit. Use figure 119 as a guide.

- (1) Connect the TS-382/U through the dummy microphone to the AF INPUT and AF INPUT RETURN terminals on the audio test box. Connect the 10-pin connector on the audio test box to the AUDIO jack on the rt unit.
- (2) Connect Variable Attenuator CN-318/U, the AN/URM-43A, the T-coaxial connector, and the linear detector.
- (3) Connect the TS-723A/U across the output of the linear detector.

*b.* Adjust the TS-382/U to produce a test signal of 0.1 volt at 1,000 cps across the 150-ohm resistor in the dummy microphone.

*c.* Using the TS-723A/U, measure the harmonic distortion of the 1,000-cps signal at the output of the linear detector. The harmonic distortion must not exceed 10 percent.

*Note.* Do not change the input signal level.

*d.* Set the TS-382/U frequency to 250,

500, 3,000, and 6,000 cps and repeat the distortion measurement for each frequency. The harmonic distortion must not exceed 10 percent.

*e.* Repeat the procedures in *c* and *d* above for rt unit frequencies of 310.0 mc and 255.0 mc.

*f.* Increase the audio signal input to 0.4 volts rms and repeat the procedures in *c*, *d*, and *e* above. The distortion for this input level must not exceed 20 percent.

#### 160. Sidetone Test

*a.* Make the following connections. Use figure 118 as a guide.

- (1) Connect the TS-382/U and the dummy microphone to the AF INPUT and AF INPUT RETURN terminals on the audio test box.
- (2) Connect the audio test box 10-pin connector to the AUDIO receptacle on the rt unit front panel.
- (3) Connect the AN/URM-43A to the ANT. terminal on the rt unit.

*b.* Adjust the TS-382/U to apply an input signal (0.1 volt rms at 1,000 cps) across the 150-ohm resistor in the dummy microphone.

*c.* Connect the 600-ohm load and the ME-30B/U between the audio test SPEAKER and AF OUTPUT RETURN terminals.

*d.* Key the rt unit by connecting the RADIO CONT LINE and CONT LINE RETURN terminals on the audio test box. The speaker sidetone levels as indicated on the DB scale of the ME-30B/U, must not exceed +10 db.

*e.* Connect the 600-ohm load and the ME-30B/U across the audio test box AF OUTPUT RETURN and HEADSET terminals. Repeat the procedure in *d* above. The headset sidetone level, as indicated on the ME-30B/U, must be within 1.5 of 24 db.

*f.* Remove the 10-pin connector from the AUDIO receptacle on the rt unit and connect it to either AUDIO jack on the C-1439/U. Repeat the procedure in *d* above. The remote sidetone audio, as indicated on the ME-30B/U, must be within 1.5 of 27 db.

*g.* Connect the 600-ohm load and the ME-30B/U between the fixed level audio terminal (AUXILIARY jack J1403-R, AN/

TRC-68, or terminal board TB1702-23, AN/VRC-24) and chassis ground. Repeat the procedure in *d* above. The fixed level audio signal, as indicated on the ME-30B/U, must be within 1.5 of 17 db.

#### 161. Frequency Selection (fig. 101)

*a.* Perform the final test procedures listed in *a*, *b*, and *c* below after repair and reassembly of the frequency selector. Note the pattern of any troubles which may occur during these tests. Analysis of these patterns will aid in locating the cause of the troubles.

##### *a. Manual Frequency Selection.*

- (1) Turn the CHAN SEL control to MANUAL and turn the MANUAL FREQUENCY TENTHS control to position .0 through .9 and, at each position, check for a corresponding indication on dial assembly I1203.
- (2) Turn the MANUAL FREQUENCY UNITS control to positions 0 through 9 and, at each position, check for a corresponding indication on dial assembly I1202.
- (3) Turn the MANUAL FREQUENCY TENS control to positions 22 through 39 and, at each position, check for a corresponding indication on dial assembly I1201.

##### *b. Remote Channel Selection.*

- (1) Preset the channels on the memory drum (TM 11-5820-222-10) as indicated in the following chart.

Channel	Preset frequency (mc)
1	399.9
2	388.8
3	377.7
4	366.6
5	355.5
6	344.4
7	333.3
8	322.2
9	311.1
10	300.0
11	299.9
12	288.8
13	277.7
14	266.6
15	255.5
16	244.4

<b>Channel</b>	<b>Preset frequency (mc)</b>
<b>17</b>	<b>233.3</b>
<b>18</b>	<b>222.2</b>
<b>19</b>	<b>211.1</b>

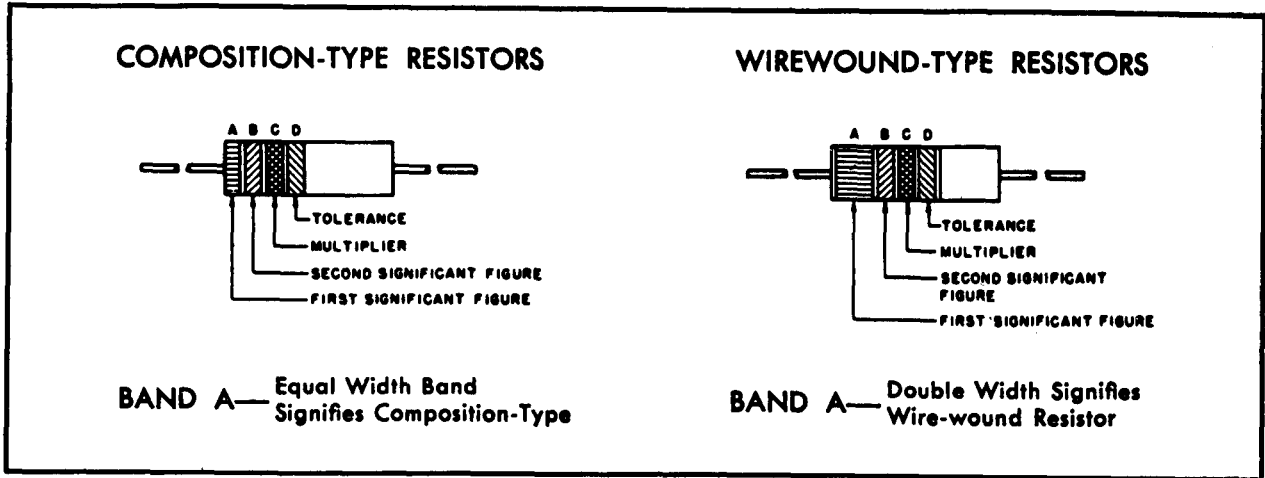
- (2) Set the CHAN SEL control to REMOTE PRESET and position the C-1439/U CHANNEL selector to positions 1 through 19.
- (3) At each position, note that the PRESET CHANNEL dial assembly (I1204) indication corresponds to the CHANNEL selector position.

Make sure the MANUAL FREQUENCY dial assembly (I1203, I1202, and I1201) indications agree with the preset frequency.

*c. Local Channel Selection.*

- (1) Set the CHAN SEL control to positions 1 through 19.
- (2) At each position, note that the PRESET CHANNEL dial assembly (I1204) indication agrees with the CHAN SEL control position. See that the MANUAL FREQUENCY dial assembly (I1203, I1202, and I1201) indications agree with the preset channel frequencies.

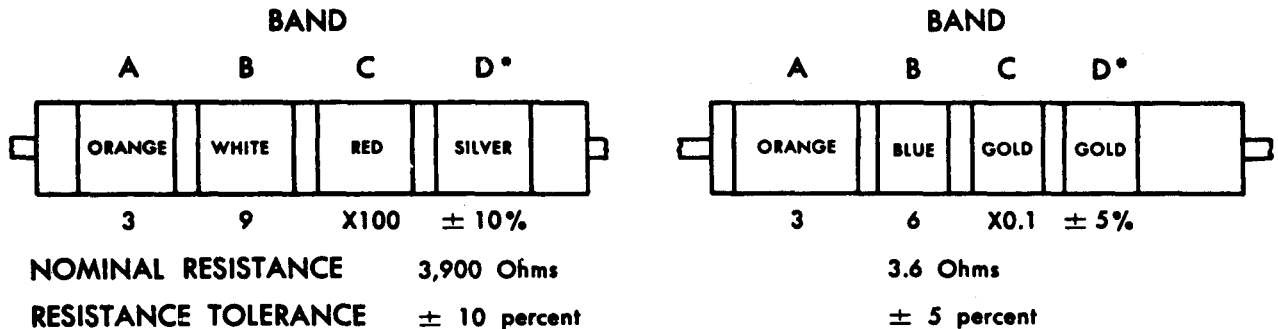
## COLOR CODE MARKING FOR MILITARY STANDARD RESISTORS



### COLOR CODE TABLE

BAND A		BAND B		BAND C		BAND D*	
COLOR	FIRST SIGNIFICANT FIGURE	COLOR	SECOND SIGNIFICANT FIGURE	COLOR	MULTIPLIER	COLOR	RESISTANCE TOLERANCE (PERCENT)
BLACK	0	BLACK	0	BLACK	1		
BROWN	1	BROWN	1	BROWN	10		
RED	2	RED	2	RED	100		
ORANGE	3	ORANGE	3	ORANGE	1,000		
YELLOW	4	YELLOW	4	YELLOW	10,000	SILVER	± 10
GREEN	5	GREEN	5	GREEN	100,000	GOLD	± 5
BLUE	6	BLUE	6	BLUE	1,000,000		
PURPLE (VIOLET)	7	PURPLE (VIOLET)	7				
GRAY	8	GRAY	8	SILVER	0.01		
WHITE	9	WHITE	9	GOLD	0.1		

### EXAMPLES OF COLOR CODING



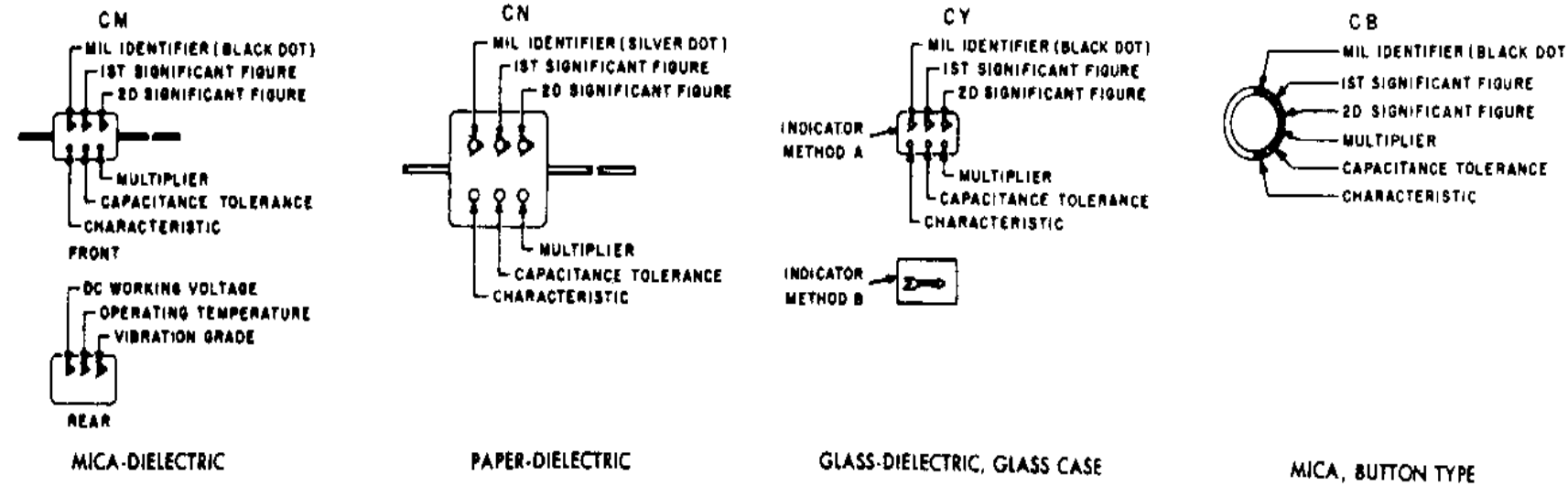
\*If Band D is omitted, the resistor tolerance is ± 20%, and the resistor is not Mil-Std.

STD-R2

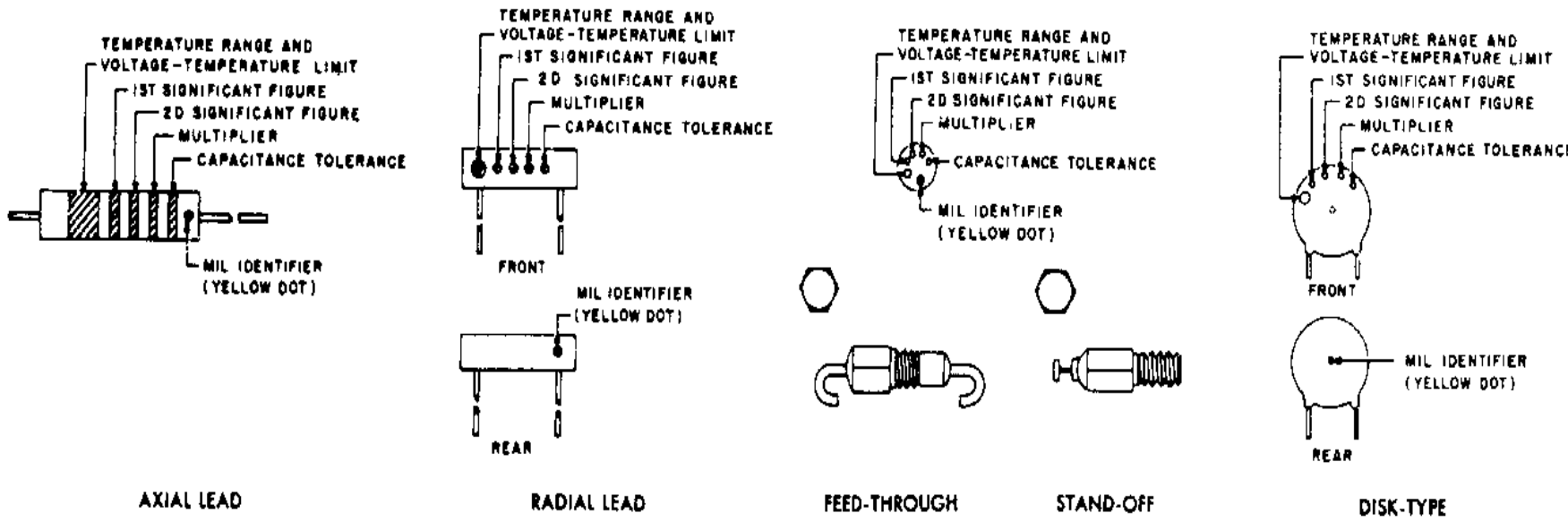
*Figure 120. Color code marking for military standard resistors.*



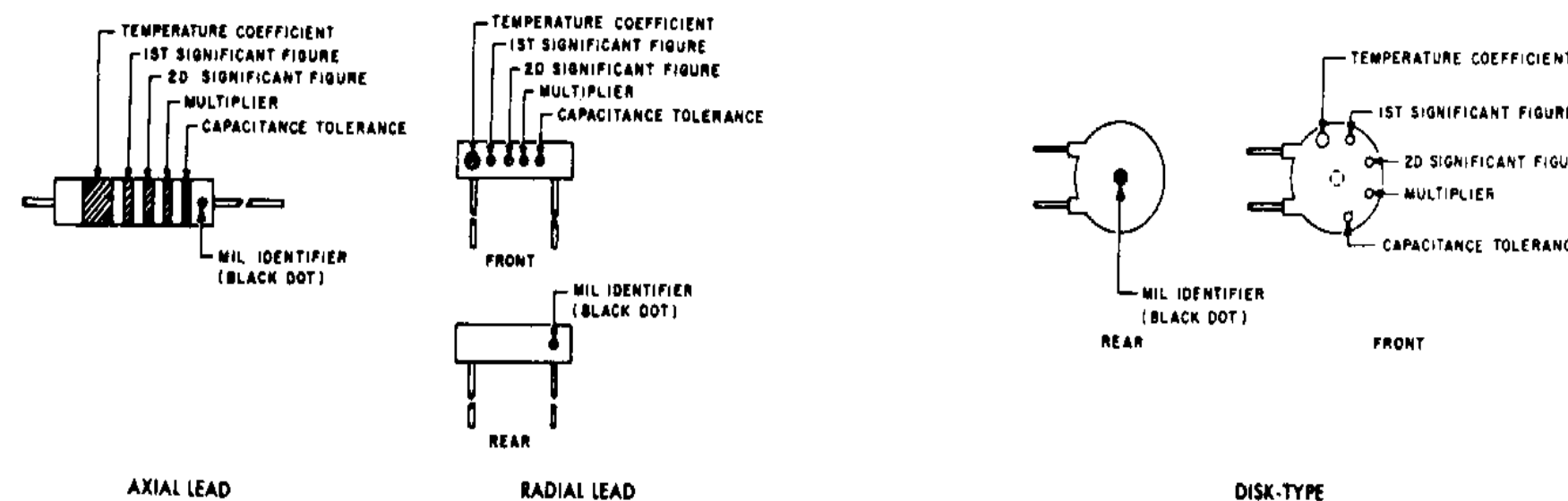
GROUP I Capacitors, Fixed, Various-Dielectrics, Styles CM, CN, CY, and CB



GROUP II Capacitors, Fixed Ceramic-Dielectric (General Purpose) Style CK



GROUP III Capacitors, Fixed, Ceramic-Dielectric (Temperature Compensating) Style CC



COLOR CODE TABLES

TABLE I - For use with Group I, Styles CM, CN, CY and CB

COLOR	MIL ID	1st SIG FIG	2nd SIG FIG	MULTIPLIER <sup>1</sup>	CAPACITANCE TOLERANCE				CHARACTERISTIC <sup>2</sup>				DC WORKING VOLTAGE		OPERATING TEMP. RANGE		VIBRATION GRADE
					CM	CN	CY	CB	CM	CN	CY	CB	CM	CM	CM		
BLACK	CM, CY, CB	0	0	1			± 20%	± 20%		A					-55° to +70°C	10-55 cps	
BROWN		1	1	10					B	E		B			-55° to +85°C		
RED		2	2	100	± 2%		+ 2%	± 2%	C		C				-55° to +125°C		
ORANGE		3	3	1,000		+ 30%			D			D	300			10-2,000 cps	
YELLOW		4	4	10,000					E				300		-55° to +125°C		
GREEN		5	5		± 5%				F								
BLUE		6	6												-55° to +150°C		
PURPLE (VIOLET)		7	7														
GREY		8	8														
WHITE		9	9														
GOLD				0.1			± 5%	± 5%									
SILVER	CN				± 10%	± 10%	± 10%	+ 10%									

TABLE II - For use with Group II, General Purpose, Style CK

COLOR	TEMP. RANGE AND VOLTAGE - TEMP. LIMITS <sup>3</sup>	1st SIG FIG	2nd SIG FIG	MULTIPLIER <sup>1</sup>	CAPACITANCE TOLERANCE	MIL ID
BROWN	AW	1	1	10	± 10%	
RED	AX	2	2	100		
ORANGE	BX	3	3	1,000		
YELLOW	AY	4	4	10,000		CK
GREEN	CZ	5	5			
BLUE	BY	6	6			
PURPLE (VIOLET)		7	7			
GREY		8	8			
WHITE		9	9			
GOLD						
SILVER						

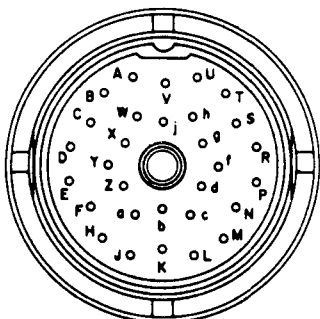
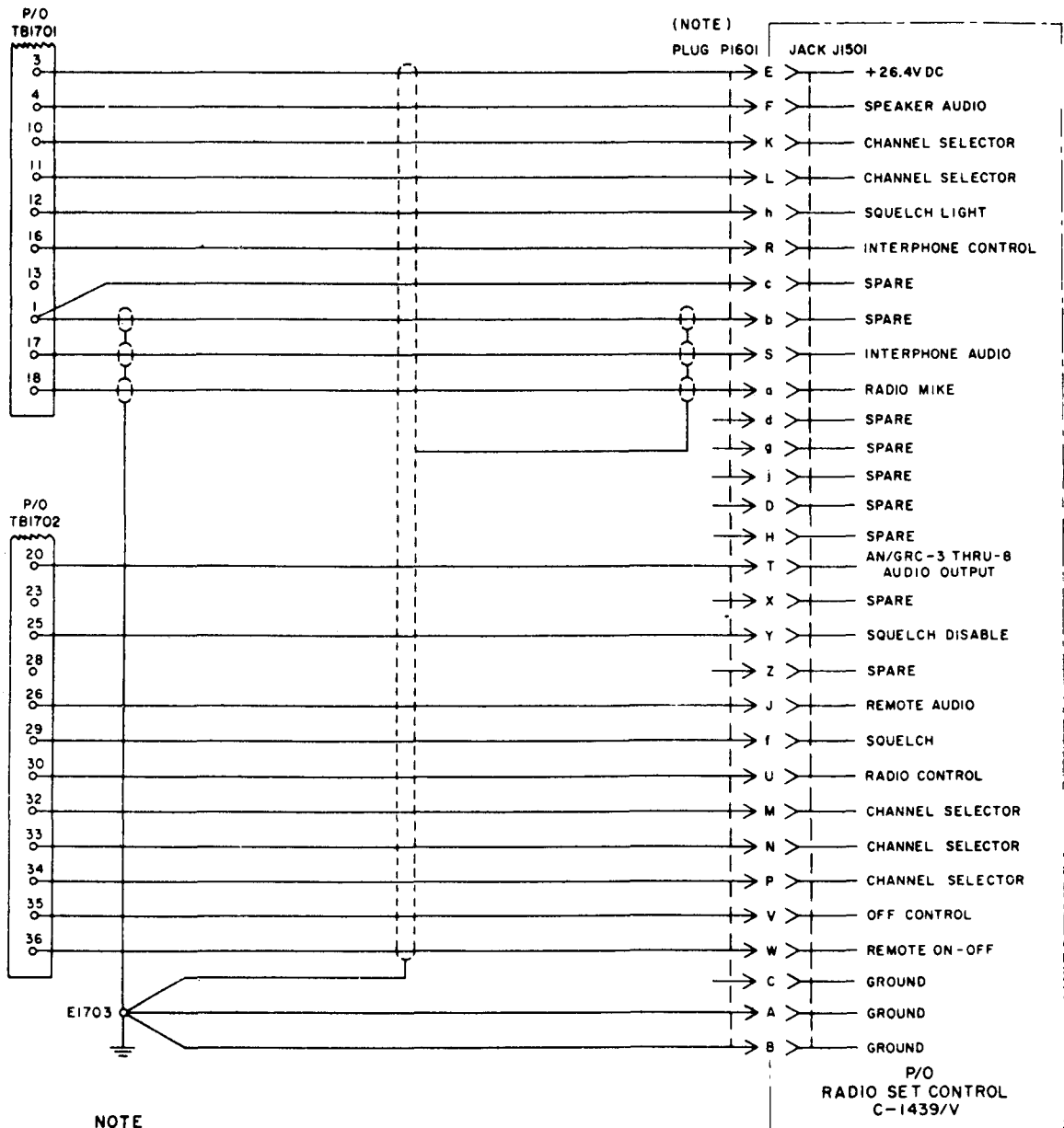
TABLE III - For use with Group III, Temperature Compensating, Style CC

COLOR	TEMPERATURE COEFFICIENT <sup>4</sup>	1st SIG FIG	2nd SIG FIG	MULTIPLIER <sup>1</sup>	CAPACITANCE TOLERANCE		MIL ID
					Capacitances over 10uuf	Capacitances 10uuf or less	
BLACK	0	0	0	1		± 2.0uuf	CC
BROWN	-30	1	1	10	± 1%		
RED	-80	2	2	100	± 2%	± 0.25uuf	
ORANGE	-150	3	3	1,000			
YELLOW	-220	4	4				
GREEN	330	5	5		± 5%	± 0.3uuf	
BLUE	-470	6	6				
PURPLE (VIOLET)	-750	7	7				
GREY		8	8	0.01			
WHITE		9	9	0.1	± 10%		
GOLD	+100					± 1.0uuf	
SILVER							

1. The multiplier is the number by which the two significant (SIG) figures are multiplied to obtain the capacitance in uuf.
2. Letters indicate the Characteristics designated in applicable specifications: MIL-C-5, MIL-C-91, MIL-C-11272, and MIL-C-10950 respectively.
3. Letters indicate the temperature range and voltage-temperature limits designated in MIL-C-11015.
4. Temperature coefficient in parts per million per degree centigrade.

Figure 121. Color code marking for military standard capacitors.



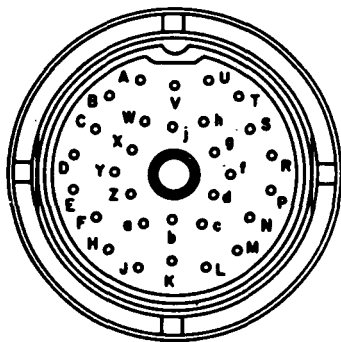
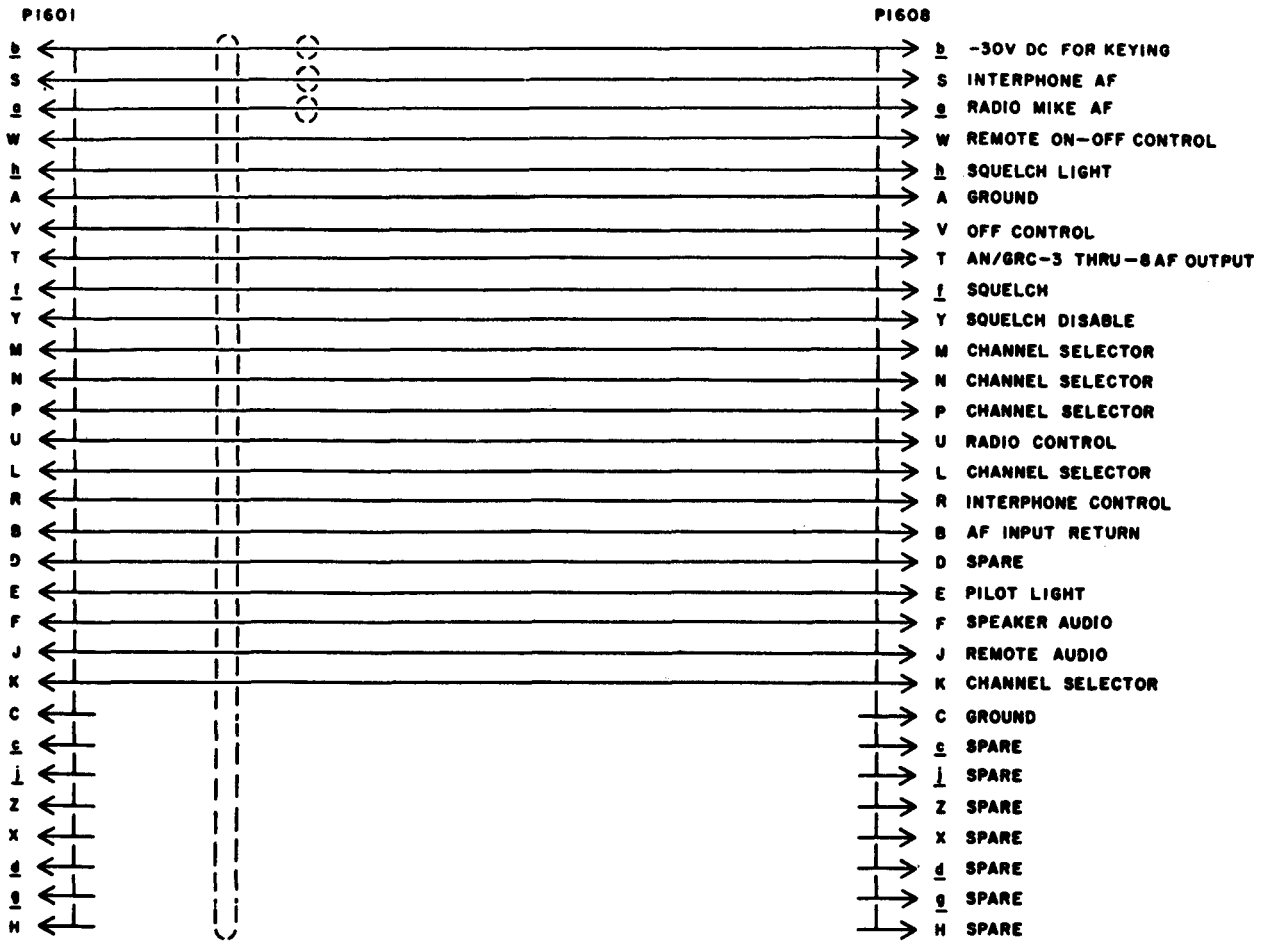


P1601

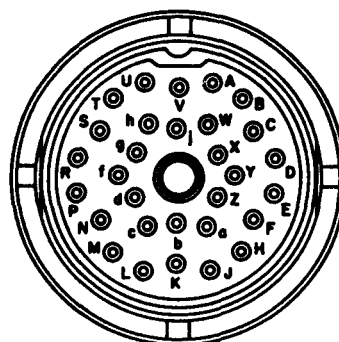
TM5820-222-35-75

Figure 122. Electrical Special Purpose Cable Assembly CX-4630/U, schematic diagram.





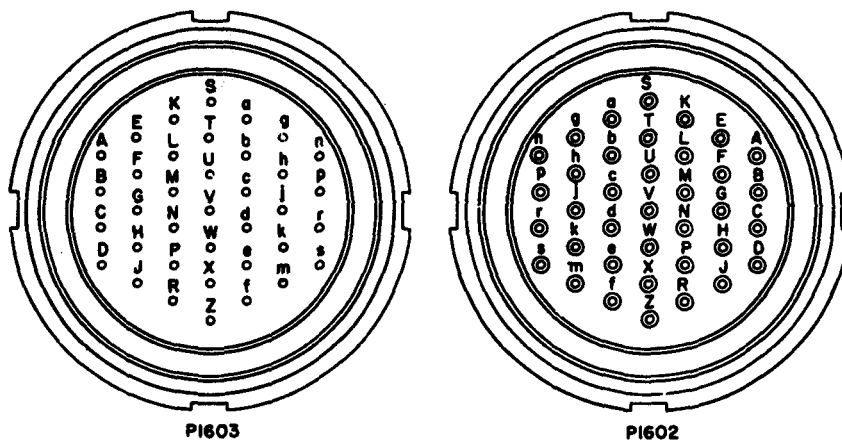
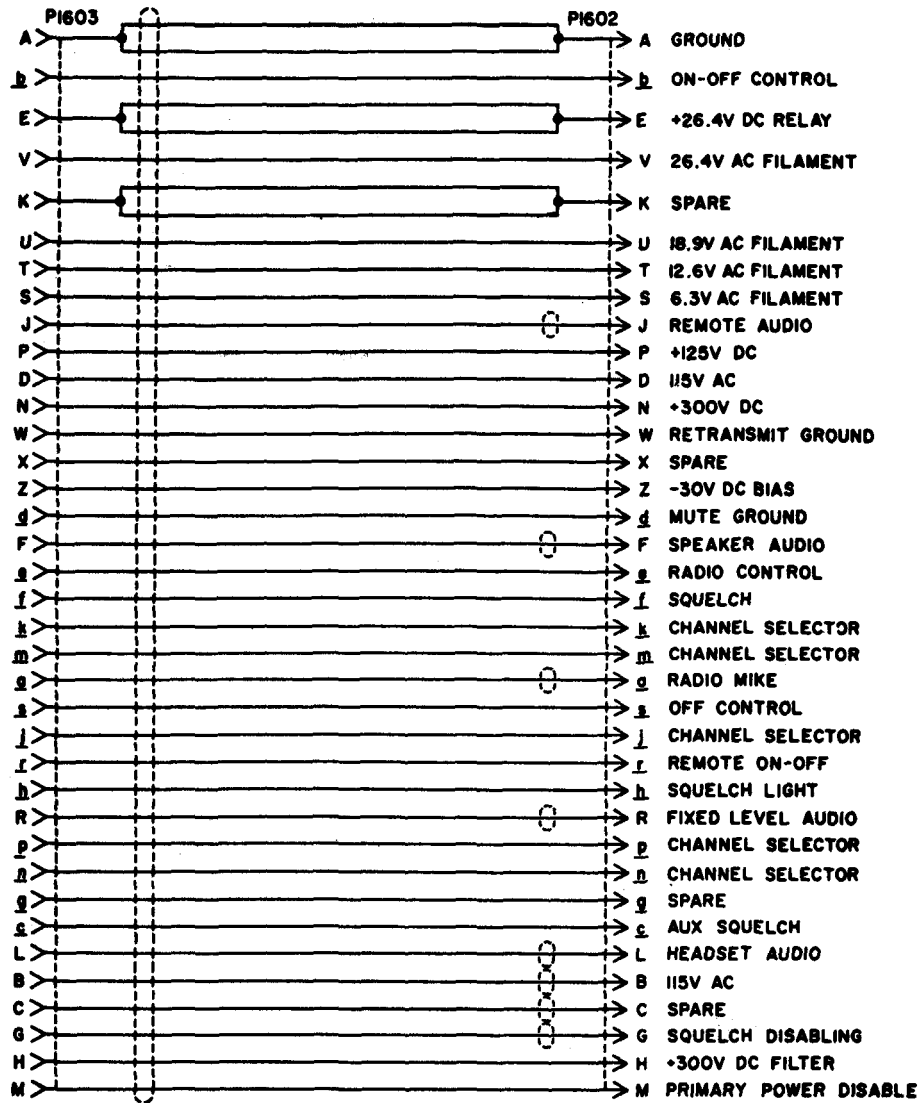
P1601



P1608

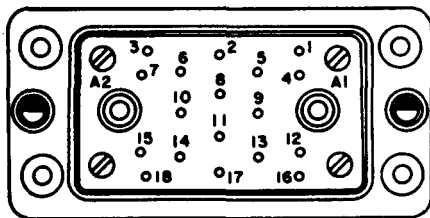
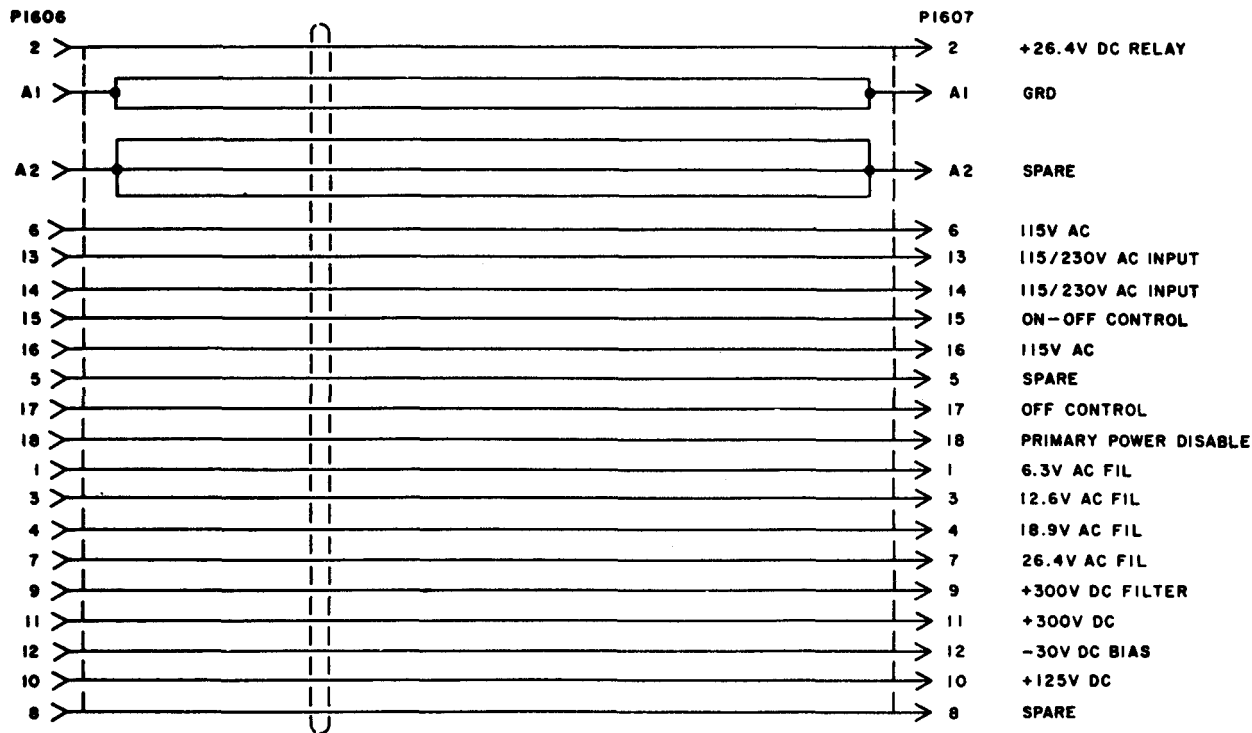
TM5620-222-35-85

Figure 123. Electrical Special Purpose Cable Assembly CX-4882/U, schematic diagram.

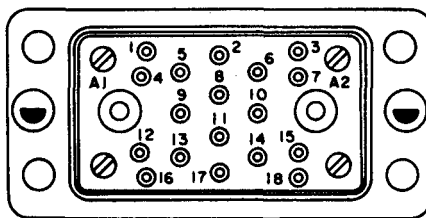


TM 5820-222-35-84

Figure 124. Electrical Special Purpose Cable Assembly CX-4884/U, schematic diagram.



P1606



P1607

TM5820-222-35-83

Figure 125. Electrical Special Purpose Cable Assembly CX-4883/U, schematic diagram.

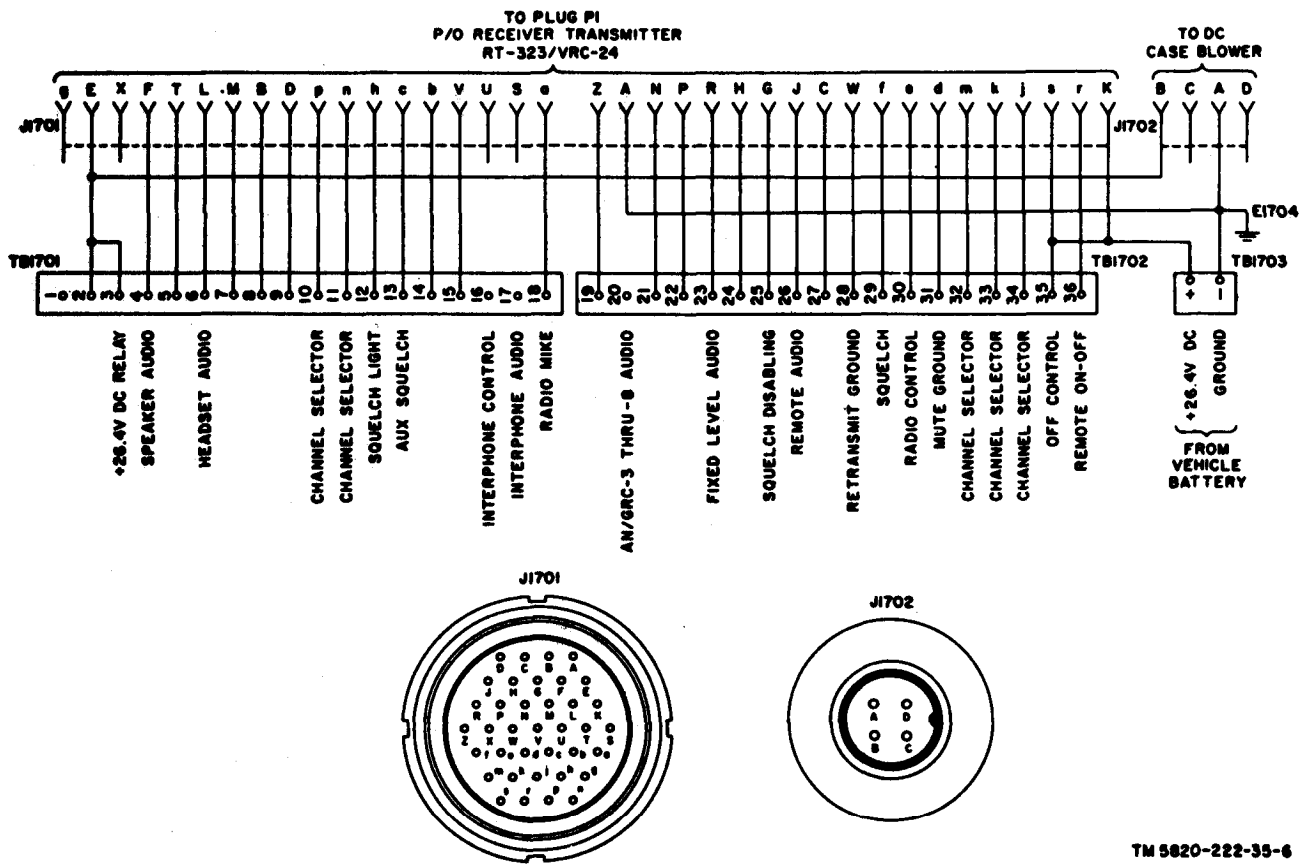


Figure 126. Mounting MT-1436/U, schematic diagram.

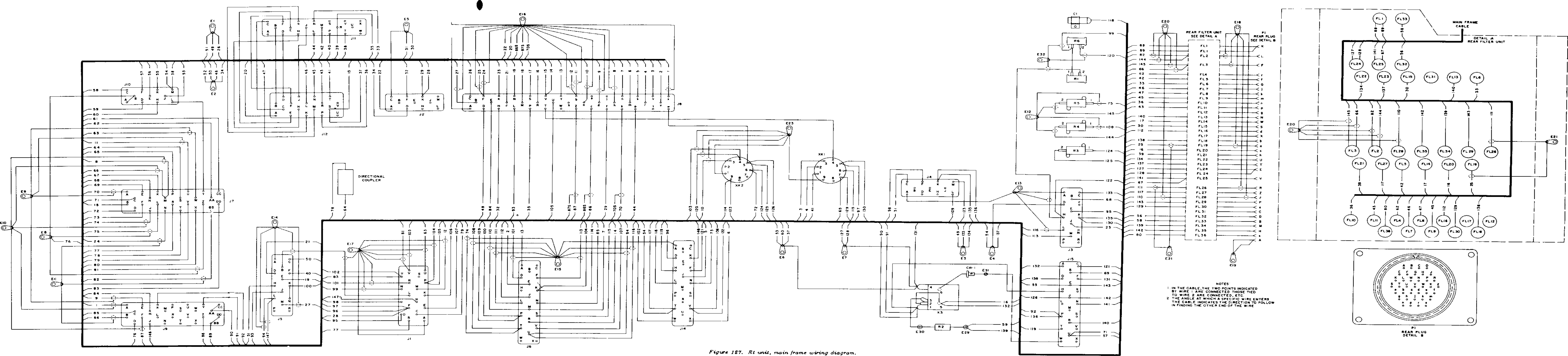


Figure 127. Rt unit, main frame wiring diagram.

NOTES:  
 1. IN THE CABLE, THE TWO POINTS INDICATED BY WIRE 1 AND WIRE 2 ARE CONNECTED, ETC.  
 2. THE ANGLE AT WHICH A SPECIFIC WIRE ENTERS THE CABLE INDICATES THE DIRECTION TO FOLLOW IN FINDING THE OTHER END OF THE WIRE.

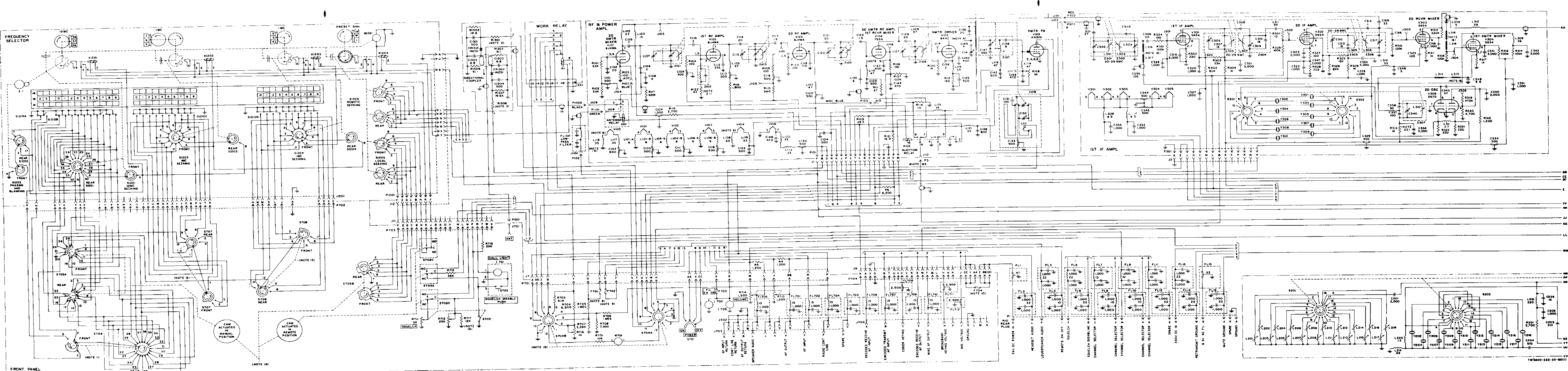


Figure 188 (1). Receiver-Transmitter RT-383/VRC-24 or RT-441/TRC-68, main schematic diagram (part 1 of 2).









## APPENDIX

### REFERENCES

---

DA PAM 108-1	Index of Army Motion Pictures, Film Strips, Slides and Phono-Recordings
DA PAM 310-4	Index of Technical Manuals, Technical Bulletins, Supply Bulletins, Lubrication Orders, and Modification Work Orders
FM 21-5	Military Training
FM 21-6	Techniques of Military Instruction
FM 21-30	Military symbols
AR 320-5	Dictionary of United States Army Terms
AR 320-50	Authorized Abbreviations and Brevity Codes
TM 11-284	Radio Sets AN/GRC-3, -4, -5, -6, -7, and -8
TM 11-2661	Electron Tube Test Sets TV-2/U, TV-2A/U, and TV-2B/U
TM 11-2684A	Audio Oscillators TS-382A/U, TS-382B/U, TS-382D/U, and TS-382 E/U
TM 11-5030	Signal Generator TS-497/URR
TM 11-5038	Control Group AN/GRA-6
TM 11-5057	Frequency Meter AN/USM-26
TM 11-5094	Frequency Meters AN/URM-79 and AN/URM-82
TM 11-5095	Frequency Meter AN/URM-80
TM 11-5096	Frequency Meter AN/URM-81
TM 11-5097	Spectrum Analyzers TS-723A/U and TS-723/U
TM 11-5120	Frequency Meters AN/URM-32 and AN/URM-32A
TM 11-5129	Oscilloscopes AN/USM-50, B, and C
TM 11-5132	Voltmeter, Meter ME-30A/U and Voltmeters, Electronic ME-30B/U and ME-30C/U
TM 11-5133	Radio Frequency Wattmeter AN/URM-43A
TM 11-5527	Multimeters TS-352/U, TS-352A/U, and TS-352B/U
TM 11-5551-D	R.F. Signal Generator Set AN/URM-25D
TM 11-5820-222-10	Operator's Manual: Radio Sets AN/VRC-24 and AN/TRC-68
TM 11-5820-222-20	Organizational Maintenance Manual: Radio Sets AN/VRC-24 and AN/TRC-68
TM 11-6625-200-12	Operation and Organizational Maintenance: Multimeter ME-26B/U
TM 11-6625-274-12	Operator's and Organizational Maintenance Manual: Test Sets, Electron Tube TV-7/U, TV-7A/U, TV-7B/U, and TV-7D/U
TM 11-6625-320-12	Operator's and Organizational Maintenance Manual: Voltmeter, Meter ME-30A/U and Voltmeters, Electronic ME-30B/U and ME-30C/U

## INDEX

	Paragraph	Page		Paragraph	Page
Ac case blower -----	119	135	Receiver output, final test -----	150	185
Adjustments:			Speaker, fig. 15 -----	45	27
And synchronization of frequency selector-----	126	143	Stage gain on receive -----	100	127
Receiver audio level -----	139	180	Test box, fig. 112 -----	128	170
S-METER -----	140	180	Audio amplifier:		
Squelch -----	141	180	And modulator on broadband		
Transit audio level -----	138	179	receive, fig. 20 -----	62	40
Alignment:			And modulator subunit, removal		
First if. amplifier subunit -----	133	173	and replacement, fig. 83 -----	112	133
First oscillator -----	134	175	Circuits on broadband transmit ---	65	40
Rf and power amplifier-----	137	177	First, V504, fig. 12 -----	41	22
Second oscillator -----	131	172	Second V804, fig. 14 -----	43	26
Test setup -----	129	170	Automatic:		
3.0- to 3.9-mc if. subunit -----	132	173	Modulation limiter, final test ----	156	191
Uhf injection subunit:			Modulation limiter, V802B -----	61	38
Frequency tripler and amplifier --	136	176	Positioner functions -----	86	58
Step tuner -----	135	176	Volume control (avc) if., fig. 12 ---	39	22
Amplifiers:			Volume control (avc) rf, fig. 12 ---	40	22
Audio:			Bandpass filter, triple tuned, fig. 3 ---	8	5
Broadband receive -----	62	40	Bandwidth; if., final test -----	153	188
Circuits on broadband			Bias:		
transmit, fig. 20 -----	65	40	Short-circuit test chart -----	97	75
First, V504, fig. 12 -----	41	22	Voltage distribution -----	79	48
Output, V805 through V808,			Block diagrams:		
fig. 14 -----	44	26	Rt unit on receive, fig. 1 -----	4	2
Second receiver, fig. 14 -----	43	26	Rt unit on transmit, fig. 16 -----	47	30
Squelch, fig. 13 -----	42	25	Blower, case: -----	91	63
Transmitter section, fig. 16 ---	47	30	Ac, removal and replacement ----	119	135
If:			Dc, removal and replacement ----	120	136
First, V301, fig. 8 -----	25	16	Lubrication and maintenance,		
First and second on transmit,			fig. 111 -----	127	160
V301 and V302, fig. 8 -----	51	33	B+ short circuit:		
500-kc:			125-volt and 300-volt test charts,		
First, V501, fig. 11 -----	34	20	fig. 23 -----	97	75
Second, V502, fig. 11 -----	35	21	B+ voltage distribution, fig. 23 -----	77	46
Third, V503, fig. 11 -----	36	21	Broadband:		
Second, V302, fig. 8 -----	26	16	Applications -----	2	2
Rf:			Audio decoded, fig. 20 -----	64	40
On receive:			Cathode follower (fig. 21) -----	63	40
First, V102, fig. 5 -----	13	9	Operation, defective -----	96	72
Second, V103, fig. 5 -----	14	9	Receive, audio amplifier and		
On transmit, fig. 5 -----	53	34	modulator, fig. 20 -----	62	40
Power output circuit -----	57	36	Transmit, audio amplifier -----	?	?
Transmitter:			Buffer amplifier -----	49	32
Buffer, V401A fig. 10 -----	49	32	Call light, fig. 13 -----	42	25
Power, V106, fig. 19 -----	56	36	Carrier noise level, final test -----	158	194
Section, fig. 16 -----	47	30	Case blowers -----	91	63
Uhf injection, fig. 7 -----	22,23	13	Ac, removal and replacement ----	119	135
Applications, system -----	2	2	Dc, removal and replacement ----	120	136
Audio:			Lubrication and maintenance,		
Distortion, final test -----	152	88	fig. 111 -----	127	160
Frequency response:			Centrifugal Fan HD-390/U:		
Characteristics, final test -----	151	86	Lubrication and maintenance,		
Transmitter, final test -----	157	193	fig. 111 -----	127	160
Headset, fig. 15 -----	45	27	Removal and replacement -----	115	134
Input circuits, fig. 20 -----	58	36	Theory, fig. 31 -----	89	63
Input section, fig. 3 -----	9	5	Channel selection:		
Level adjustments:			Local, fig. 27 -----	83	54
Receive -----	139	180	Remote, fig. 27 -----	84	56
Transmit -----	138	179	Characteristics, audiofrequency		
Output:			response, final test -----	151	186
Amplifiers, V805 through V808,			Charts:		
fig. 14 -----	44	26	Audio stage gain on receive -----	100	127
Circuits, fig. 15 -----	45	27	Alignment test equipment -----	128	170
Section -----	9	5	Frequency conversion scheme:		
Preampfier, V803, fig. 20 -----	59	39	Receiving -----	24	13

	Paragraph	Page
Transmitting -----	54	35
Final test:		
If., bandwidth-----	153	188
Channel selection -----	161	195
Front panel meter indication --	145	182
Receiver audio output -----	150	185
Test equipment -----	143	182
Test frequencies -----	146	183
Receiver signal tracing -----	101	127
Sensitivity checks -----	103	128
Short-circuit tests-----	97	75
Transmitter signal tracing, fig. 128 -----	102	127
Troubleshooting:		
Broadband operation, fig. 42 --	96	72
Measurements -----	97	75
Retransmission, fig. 41 -----	95	71
Rt unit, fig. 128 -----	99	80
Use -----	99	80
Checks, sensitivity: -----	93	70
Circuit, squelch, fig. 13-----	9	5
Comments -----	1	2
Common purpose stages -----	46	30
Conversion scheme, frequency:		
Receiving -----	24	13
Transmitting-----	54	35
Coupler, directional, theory, fig. 4 --	10	8
Crystal selection, oscillator:		
First, fig. 6 -----	17	12
Second, fig. 9 -----	28	18
Third, fig. 10 -----	30	19
Dc case blower:		
Lubrication and maintenance ----	127	170
Removal and replacement -----	120	136
Dc resistances of transformers and relay coils -----	105	129
Decoded broadband audio, fig. 20 ----	64	40
Defective broadband operation -----	96	72
Defective retransmission-----	95	71
Directional coupler, theory -----	10	8
Disassembly and reassembly of frequency selector -----	126	143
Distortion:		
Audio -----	152	188
Overall, final test -----	159	194
Distribution, voltage:		
Bias, fig. 23 -----	79	48
B+ 125-volt, fig. 23 -----	78	46
B+ 300-volt, fig. 23 -----	77	46
Driver:		
Modulator V804, fig. 14 -----	60	37
Rotor assembly, removal and replacement -----	125	139
Transmitter, fig. 19 -----	55	35
DVRI <sub>1</sub> , meter position, theory -----	71	42
Dynamotor:		
Lubrication and maintenance ----	127	170
Removal and replacement, fig. 83 -----	114	133
Theory, fig. 32 -----	90	63
Energizing transmitter relays, fig. 26 -----	82	51
Fan, Centrifugal HD-390/U:		
Lubrication and maintenance ----	127	170
Removal and replacement -----	115	134
Theory, fig. 31 -----	89	63
Filament short-circuit test -----	97	75

	Paragraph	Page
Filter, 500-kc if., fig 11 -----	33	20
Filters 3.0 to 3.9 mc, fig. 10 -----	29	19
Final testing		
Audio frequency response		
characteristics -----	151	186
Carrier noise level -----	158	194
Distortion:		
Audio -----	152	188
Overall-----	159	194
Frequency:		
Selection, channels -----	161	195
Stability versus supply voltage -	144	182
Front panel meter -----	145	182
If. bandwidth-----	153	188
Modulation:		
Automatic limiter -----	156	191
Capability-----	155	189
Receiver:		
Audio output -----	150	185
Sensitivity -----	146	183
Resettability-----	147	184
Sidetone-----	160	195
Signal plus noise-to-noise ratio ---	149	185
Squelch -----	148	185
Test equipment -----	143	182
Transmitter:		
Audio frequency response ----	157	193
Transmitter:		
Purpose -----	142	182
Rf power output -----	154	189
Squelch -----	146	185
First audio amplifier V504, fig. 12 ---	41	22
First 500-kc if. amplifier V501, fig. 11 -----	34	20
First if. amplifier V301, fig. 6 ----	25	16
First if. amplifier on transmit ----	51	33
First if. amplifier subunit:		
Alignment -----	133	173
Lubrication, fig. 109 -----	127	160
Removal and replacement, fig. 83 -----	109	132
First oscillator:		
Alignment -----	134	175
Removal and replacement, fig. 83 -----	122	136
Theory, fig. 6 -----	19	12
First receiver mixer, theory, fig. 5 --	15	10
First rf amplifier V102, theory:		
On receive, fig. 5 -----	13	9
On transmit, fig. 5 -----	53	34
First transmitter mixer, V304, fig. 17 -----	50	32
First uhf injection amplifier V203, fig. 7 -----	22	13
500-kc if. amplifier:		
Assembly, and filter assembly, re- moval and replacement, fig. 83--	116	134
Filter FL901, fig. 11 -----	33	20
First, V501, fig. 11 -----	34	20
Second, V502, fig. 11 -----	35	21
Subunit, removal and replacement -	111	132
Theory -----	8	5
Third, V503, fig. 11 -----	36	22
Follower V802, cathode, fig. 21 ----	63	40
Frequency conversion scheme:		
Receiving -----	24	13
Transmitting -----	54	35
Frequency multiplier amplifier as- sembly, removal and replacement --	123	137

	Paragraph	Page
Frequency multiplier network, fig. 6--	20	12
Frequency selection theory:		
Local channel, fig. 27-----	83	54
Manual, fig. 28 -----	85	56
Remote channel, fig. 27 -----	84	56
Frequency selector:		
Adjustment and synchronization ---	126	143
Disassembly and reassembly:		
Front and rear plate		
components -----	126	143
Lubrication -----	127	160
Removal and replacement -----	118	135
System -----	6	3
Frequency tripler V202, fig. 6 -----	21	12
Frequency tripler and amplifier,		
alignment -----	136	176
Front panel, removal and replacement -	117	134
General troubleshooting procedures --	92	70
Generating section, signal, fig. 16---	47	30
Headset audio, fig. 15 -----	45	27
High B+ position, meter, theory,		
fig. 22 -----	75	43
Isolating trouble within stage -----	104	129
If.:		
Amplifiers:		
First, V301, fig. 8 -----	25	16
First and second 500-kc V501		
and V502, fig. 11 -----	35	21
Receiving signal path -----	8	5
Second, V302, fig. 8 -----	26	16
Third 500-kc, V503, fig. 11 -----	36	21
Automatic volume control, fig. 12 -	39	22
Bandwidth, final test -----	153	188
Filter FL901, 500-kc, fig. 11 ----	33	20
Injection, uhf, theory on receive and		
transmit, fig. 6 and 7-----	17	12
Input circuits, audio, fig. 20-----	58	36
Input section, audio-----	9	5
Intermittent troubles-----	93	70
Light, call, fig. 13 -----	42	25
Limiter:		
Modulation, automatic, final test --	156	191
Rectifier V802B, fig. 14 and 20 ---	61	38
Series noise, fig. 12-----	38	21
Line V position, meter, theory, fig. 22-	73	43
Local channel selection, fig. 27-----	83	54
Local channel selection, final test ----	161	195
Low B+:		
Distribution, fig. 23-----	78	46
Position, meter, theory, fig. 22 ---	74	43
Low-pass filter assembly, removal		
and replacement-----	116	134
Lubricant chart -----	126	143
Lubrication and maintenance, fig. 111 -	127	160
Manual frequency:		
Selection, fig. 28-----	85	56
Selection, final test -----	161	195
Memory drum, disassembly and		
reassembly-----	126	143
Meter, M701, fig. 22-----	66	41
Meter position, theory, fig. 22:		
DRVI <sub>b</sub> -----	71	42
HIGH B+ -----	75	43
LINE V -----	73	43
LOW B+-----	74	43
PWR -----	68	41
PAI <sub>b</sub> -----	69	42

	Paragraph	Page
PAI <sub>g</sub> -----	70	42
% MOD -----	72	42
SWR -----	67	41
S-METER -----	76	44
Mixer:		
First receiver V104 (fig. 5) - - - - -	15	10
First transmitter V304 (fig. 17) ---	50	32
Second receiver V303 (fig. 8) ----	27	16
Second transmitter V101 (fig. 18) --	52	33
Third receiver V401A (fig. 10) ---	32	19
Modulation capability, final test ----	155	189
Modulation limiter, automatic,		
final test -----	156	191
Modulator:		
And audio amplifier subunit, re-		
moval and replacement (fig. 83) -	112	133
And output stages (fig. 16) - - - - -	47	30
Driver (fig. 14)-----	60	37
On broadband receive (fig. 20) ----	62	40
V805 through V808 (fig. 14) -----	60	37
Multiplier network, frequency (fig. 6) -	20	12
Noise level, carrier, final test -----	158	194
Noise limiter, series (fig. 12) - - - - -	38	21
Organization of troubleshooting		
procedures -----	93	70
Oscillator:		
First, V201 (fig. 6) - - - - -	19	12
First, alignment -----	134	175
Second, V305 (fig. 9) -----	28	18
Second, alignment -----	131	172
Third, V401B (fig. 10) - - - - -	31	19
Third, check-----	130	172
Third, on transmit (fig. 10) -----	48	32
Third, theory -----	8	5
Output:		
Audio amplifiers, V805 through		
V808 (fig. 14)-----	44	26
Circuit, audio (fig. 15) -----	45	27
Circuit, power amplifier (fig. 19) --	57	39
Section, audio -----	9	5
Stages, and modulator (fig. 16) --	47	30
Overall distortion-----	159	194
PAI <sub>i</sub> position, meter, theory (fig. 22) -	69	42
PAI <sub>o</sub> position, meter, theory (fig. 22) -	70	42
Parts replacement techniques,		
general -----	121	136
Percentage of modulation (fig. 22) ----	72	42
Positioner functions, automatic - - - - -	86	58
Power amplifier:		
Alignment -----	137	177
Output circuit (fig. 19) -----	57	36
Rotor assembly, removal and		
replacement -----	125	139
Transmitter, V106 (fig. 19) -----	56	36
Power control:		
Radio Set AN/TRC-68 (fig. 25) ---	81	49
Radio Set AN/VRC-24 (fig. 24) ---	80	48
Troubleshooting chart,		
AN/VRC-24 -----	99	80
Power supply:		
PP-1494/U (fig. 29)-----	87	60
Radio Sets AN/TRC-68 and		
AN/VRC-24 -----	7	3
Troubleshooting chart -----	99	80
Preamplifier V803, audio (fig. 20) ---	59	36
Preset channel, automatic positioner,		
synchronization -----	126	143
Push-to-talk circuit (fig. 26)-----	82	51

	Paragraph	Page		Paragraph	Page
PWR position, meter, theory (fig. 22) -	68	41	Defective -----	95	71
Radio Set AN/TRC-68:			Troubleshooting chart (fig. 41) ---	95	71
Power control (fig. 25) -----	81	49	Rf amplifiers:		
Power supply -----	7	3	On receive:		
Radio Set AN/VRC-24:			First, V102 (fig. 5) -----	13	9
Power control (fig. 24) -----	80	48	Second, V103 (fig. 5) -----	14	9
Power supply -----	7	3	On transmit -----	53	34
Radio Set Control:			Rf and power amplifier subunit:		
C-1439/U (fig. 30) -----	88	61	Alignment -----	137	177
Troubleshooting chart (fig. 30) ---	99	80	Lubrication (fig. 107) -----	127	160
Receiver audio:			Removal and replacement (fig. 83) -	107	131
Level adjustments -----	139	180	Tube chassis, removal and		
Output, final test -----	150	185	replacement (fig. 83) -----	125	139
Section -----	9	5	Rf automatic volume control (fig. 12) --	40	22
Receiver mixer:			Rf power output, transmitter, final		
First, V104 (fig. 5) -----	15	10	test -----	154	189
Second, V303 (fig. 8) -----	27	16	Rf section:		
Third, 401A (fig. 10) -----	32	19	On receive:		
Receiver rf section (fig. 3) -----	8	5	Signal path (fig. 3) -----	8	5
Receiver sensitivity:			Theory -----	11	9
Final test -----	146	183	On transmit -----	47	30
Resettability -----	147	184	Rotor assembly -----	125	139
Receiver signal tracing (fig. 128) ---	101	127	Scope -----	1	2
Receiver troubleshooting chart -----	99	80	Second and third uhf injection		
Receiving frequency conversion			amplifiers V204 and V205 -----	23	13
scheme -----	24	13	Second 500-kc if. amplifier V502		
Receiving signal path (fig. 3) -----	8	5	(fig. 11) -----	35	21
Receiving signal path, simplified			Second if. amplifier V302:		
(fig. 1) -----	4	2	On receive (fig. 8) -----	26	16
Rectifier V802B, limiter			On transmit (fig. 8) -----	51	33
(fig. 14 and 20) -----	61	38	Second oscillator:		
Relay:			Alignment -----	131	172
Coils, dc resistance -----	105	129	Receiving signal path (fig. 3) ----	8	5
Squelch (fig. 13) -----	42	25	Theory -----	28	18
Subunit, removal and replacement			Second receiver:		
(fig. 83) -----	113	133	Audio amplifier, V804 (fig. 14) ---	43	26
Transmitter (fig. 26) -----	82	51	Mixer, V303 (fig. 8) -----	27	16
Rf and power amplifier subassemblies -	125	139	Rf amplifier (fig. 5) -----	14	9
Remote channel:			Second rf amplifier V103, on transmit		
Selection (fig. 27) -----	84	56	(fig. 5) -----	53	34
Selection, final test -----	161	195	Second transmitter mixer (fig. 18) ----	52	33
Removal and replacement:			Sectionalization of troubleshooting		
Assemblies:			procedures -----	93	70
First oscillator -----	122	136	Selection, crystal, first oscillator		
500-kc and low-Pass filter ----	116	134	(fig. 6) -----	17	12
Frequency multiplier-			Selection, frequency:		
amplifier -----	123	137	Final test -----	161	195
Case blowers:			Local channel (fig. 27) -----	83	54
Ac -----	119	135	Manual (fig. 28) -----	85	56
Dc -----	120	136	Remote channel (fig. 27) -----	84	56
Centrifugal fan -----	115	134	Selector system, frequency -----	6	3
Dynamotor -----	114	133	Sensitivity:		
Frequency selector -----	118	135	Checks -----	103	128
Front panel -----	117	134	Checks, general -----	70	
Subunits :			Receiver, final test -----	183	
Audio amplifier and modulator -	112	133	Series noise limiter (fig. 12) -----	38	21
First if. amplifier -----	109	132	Short-circuit tests -----	97	75
500-kc if. amplifier -----	111	132	Sidetone, final test -----	160	195
General instructions -----	106	131	Signal generating section (fig. 16) ----	47	30
Relay -----	113	133	Signal path:		
Rf and power amplifier ----	107	131	On receive (fig. 3) -----	8	5
3.0 to 3.9 mc if -----	110	132	On receive, simplified (fig. 1) ----	4	2
Uhf injection subunit -----	108	131	On transmit (fig. 16) -----	47	30
Uhf capacitor tuning shaft ----	124	138	On transmit, simplified -----	5	3
Replacement techniques, parts,			Signal plus noise-to-noise ratio ----	149	185
general -----	121	136	Signal tracing:		
Resettability, final test -----	147	184	On receive (fig. 128) -----	101	127
Retransmission:			On transmit (fig. 128) -----	102	127
Communications system -----	2	2	Speaker audio (fig. 15) -----	45	27

	Paragraph	Page		Paragraph	Page
Squelch:					
Adjustment-----	141	180	Second V305 (fig. 9) -----	28	18
Amplifier, V801 (fig. 13)-----	42	25	Third, V401B (fig. 10) ----	31	19
Circuit -----	9	5	Power supplies -----	7	3
Control (fig. 23) -----	42	25	Rf amplifiers, fig. 5:		
Final test -----	148	185	First V102 -----	13	9
Relay (fig. 13)-----	42	25	Second V103 -----	14	9
SQUELCH DISABLE PUSH switch			Resection -----	11	9
(fig. 13) -----	42	25	Series noise limiter -----	38	21
Stability, frequency versus supply			Simplified receiving path		
voltage-----	144	182	(fig. 1) -----	4	2
Stage gain on receive, audio -----	100	127	Squelch amplifier V801		
Stages, common purpose -----	46	30	(fig. 13) -----	42	25
Stages, modulator and output (fig. 16) -	47	30	System applications -----	2	2
Step tuner, uhf injection, alignment ---	135	176	Tuning (fig. 5) -----	16	10
S-METER:			Uhf injection:		
Adjustment-----	140	180	Amplifiers:		
Theory (fig. 22)-----	76	44	First V203 (fig. 7) ----	22	13
Supplies, power -----	7	3	Second V204; third V205		
Switch, squelch disable push (fig. 13) --	42	25	(fig. 7) -----	23	13
Switch S704, meter -----	66	41	Crystal selection (fig. 6) --	18	12
SWR position, meter, theory (fig. 22) --	67	41	First oscillator V201		
Synchronization -----	126	143	(fig. 6) -----	19	12
System applications -----	2	2	Frequency tripler V202		
Test box, audio (fig. 110) -----	128	170	(fig. 6) -----	21	12
Test equipment:			Multiplier network (fig. 6) -	20	12
Final testing-----	143	182	Transmitter:		
Special tools -----	128	170	Audio:		
Troubleshooting -----	94	71	Input circuits (fig. 20) ----	58	36
Testing, final, purpose of-----	142	182	Preamplifier, V803		
Test setup:			(fig. 20)-----	59	36
Alignment -----	129	170	Buffer amplifier V401A		
Troubleshooting (fig. 38)-----	98	80	(fig. 10) -----	49	32
Theory:			Common purpose stages ----	46	30
Receiver:			Driver, V105 (fig. 19) -----	55	35
Audio amplifiers:			Frequency conversion scheme -	54	35
First V504 (fig. 12) -----	41	22	If. amplifiers, first and second,		
(Output V805 through V808			V301 and V302 (fig. 8)-----	51	33
(fig. 14) -----	44	26	Limiter rectifier, V802B		
Second V804 (fig. 14) ----	43	26	(fig. 14 and 20) -----	61	38
Audio output circuits (fig. 15) --	45	27	Mixer:		
Audio section (fig. 3)-----	9	5	First, V304 (fig. 17)-----	50	32
Automatic volume control			Second, V101 (fig. 18) ----	52	33
(fig.12) -----	39	22	Modulator driver and output		
Broadband applications -----	2	2	tubes (fig. 14) -----	60	37
Crystal selection:			Power amplifier, V106		
3.0 to 3.9 mc (fig. 10) ----	30	19	(fig. 19) -----	56	36
Uhf injection-----	18	12	Power amplifier output circuit		
Dectector CR501 (fig. 12) ----	37	21	(fig. 19) -----	57	36
Directional coupler-----	10	8	Rf amplifiers, first, second,		
Filters 3.0 to -3.9 mc (fig. 10) -	29	19	and third V102, V103, and		
500-kc filter (fig. 11) -----	33	20	V104 (fig. 5) -----	53	34
500-kc if. amplifier, fig. 11:			Signal path, block diagram		
General -----	3	2	(fig. 16) -----	47	30
First-----	34	20	Signal path, simplified, block		
Second -----	35	21	diagram (fig. 2) -----	5	3
Third -----	36	21	Third oscillator, V401B		
Frequency conversion scheme -	24	13	(fig. 10) -----	48	32
Frequency selector system ---	6	3	Uhf injection:		
If. amplifier, fig. 8:			Amplifiers:		
First V301 -----	25	16	First, V203 (fig. 7) ----	22	13
Second V302 -----	26	16	Second, V204 and third		
Input circuit -----	12	9	V205 (fig. 7) -----	23	13
Mixers:			Crystal selection (fig. 6) --	18	12
First V104 (fig. 5) -----	15	10	First oscillator, V201		
Second V303 (fig. 8) -----	27	16	(fig. 6) -----	19	12
Third V401A (fig. 10) ----	32	19	Frequency tripler, V202		
Oscillators:			(fig. 6) -----	21	12
First V201 (fig. 6) -----	19	12	Multiplier network (fig. 6) -	20	12
			Third 500-kc if. amplifier V503		

	Paragraph	Page		Paragraph	Page
(fig. 11) -----	36	21	Lubrication (fig. 108) -----	127	160
Third oscillator:			Removal and replacement	108	131
Check -----	130	172	(fig. 83) -----	135	176
Crystal selection (fig. 10) -----	30	19	Step tuner alignment -----	17	12
Signal path (fig. 10) -----	48	32	Theory on receive and transmit ---		
Theory (fig. 10) -----	31	19	Visual inspection -----	93	70
Third receiver mixer V401 (fig. 10) --	32	19	Voltage and resistance measurements -	93	70
Third rf amplifier V104 (fig. 5) -----	53	34	V101 second transmitter mixer		
Third uhf injection amplifier V205 ---	23	13	(fig. 18) -----	52	33
3.0- to -3.9-mc if. subunit:			V102 first rf amplifier on receive		
Alignment -----	132	173	(fig. 5) -----	13	9
Filters (fig. 10) -----	29	19	V102, V103, and V104 first, second,		
Lubrication (fig. 110) -----	127	160	and third rf amplifiers on transmit		
Removal and replacement -----	110	132	(f i g . 5 ) -----	53	34
Transformers, dc resistance -----	105	129	V103 second rf amplifier on receive		
Transmitter:			(fig. 5) -----	14	9
Audio:			V104 first receiver mixer (fig. 5) ----	15	10
Amplifier section (fig. 16) ----	47	30	V105 transmitter driver (fig. 19) ----	55	35
Frequency response, final test -	157	193	V106 transmitter power amplifier		
Level adjustments -----	138	179	(fig. 19) -----	56	36
Buffer amplifier V401A (fig. 10) --	49	32	V201 first oscillator (fig. 6) -----	19	12
Driver V105 (fig. 19) -----	55	35	V202 frequency tripler (fig. 6) -----	21	12
Frequency conversion scheme ----	54	35	V203 first uhf injection amplifier		
Frequency resettability -----	147	184	(f i g . 7 ) -----	22	13
Mixers:			V204 second and V205 third uhf		
First, V104 (fig. 17) -----	50	32	injection amplifier (fig. 7) -----	23	13
Second V101 (fig. 18) -----	52	33	V301 first if. amplifier (fig. 8) ----	25	16
Modulator output stage (fig. 14) ---	60	37	V301 and V302 first and second if.		
Power amplifier, V106 (fig. 19) ---	56	36	amplifiers on transmit (fig. 8) ----	51	33
Power output resettability -----	147	184	V302 second if. amplifier (fig. 8) ----	26	16
Relay, energizing -----	82	51	V303 second receiver mixer (fig. 8) --	27	16
Rf amplifier section (fig. 16) ----	47	30	V304 first transmitter mixer (fig. 17) -	50	32
Rf power output, final test -----	154	189	V305 second oscillator (fig. 9) -----	28	18
Signal path, block diagram			V401A third receiver mixer (fig. 10) --	32	19
(fig. 16) -----	47	30	V401B third oscillator (fig. 10) -----	31	19
Signal path simplified, block			V401B third oscillator on transmit		
diagram (fig. 2) -----	5	2	(fig. 10) -----	48	32
Signal tracing (fig. 128) -----	102	127	V501 first and V502 second 500-kc if.		
Third oscillator (fig. 10) -----	48	32	amplifier (fig. 11) -----	35	21
Triple tuned bandpass filter (fig. 3) ---	8	5	V503 third 500-kc if. amplifier		
Tripler V202, frequency (fig. 6) ----	21	12	(fig. 11) -----	36	21
Troubleshooting charts -----	99	80	V504 first audio amplifier (fig. 12) ---	41	22
Tube chassis, hf and power amplifier,			V801 squelch amplifier (fig. 13) ----	42	25
removal and replacement -----	125	139	V802A broadband cathode follower		
Tuning, rf (fig. 5) -----	16	10	(fig. 21) -----	63	40
Uhf injection:			V802A limiter rectifier		
Amplifiers:			(fig. 14 and 20) -----	61	38
First, V203 (fig. 7) -----	22	13	V803 audio preamplifier (fig. 20) ----	59	36
Second, V204 and third, V205 --	23	13	V804 as second receiver audio		
Capacitor tuning shaft, removal			amplifier (fig. 14) -----	43	26
and replacement -----	124	138	V804 as modulator driver (fig. 14) ---	60	37
Signal path (fig. 3) -----	8	5	V805 through V808 as audio output		
Subunit:			amplifiers (fig. 14) -----	44	26
Frequency tripler and amplifier			V805 through V808 as transmitter		
alignment -----	136	176	modulators (fig. 14) -----	60	37

BY ORDER OF THE SECRETARIES OF THE ARMY AND THE AIR FORCE:

G.H. DECKER,  
*General, United States Army,  
Chief of Staff.*

OFFICIAL:

R. V. LEE,  
*Major General, United States Army,  
The Adjutant General.*

THOMAS D. WHITE,  
*Chief of Staff, United States Air Force.*

OFFICIAL:

J. L. TARR,  
*Colonel, United States Air Force,  
Director of Administrative Services.*

Distribution:

*Active Army:*

To be distributed in accordance with DA Form 12-7 requirements for TM 11 Series (Unclas) Plus the following:

USASA (2)	11-57
CNGB (1)	11-95
DASA (5)	11-96
Tech Stf, DA (1) except	11-98
CSigO (18)	11-99
ARADCOM (2)	11-117
ARADCOM Rgn (2)	11-155
MDW (1)	11-500 (TMS AA-AE) (4)
Seventh, USA (2)	11-557
EUSA (2)	11-587
Units org under fol TOE(2 cy ea UNOINDC)	11-592
11-7	11-597
11-16	29-56

NG: State AG(3); Units-Same as Active Army except allowance is one copy to each unit.

USAR: None.

For explanation of abbreviations used, see AR 320-50.





FILL IN YOUR  
UNITS ADDRESS



FOLD BACK

DEPARTMENT OF THE ARMY

---

---

CUT ALONG THIS LINE

Commander  
U.S. Army Missile Command  
ATTN: AMSMI-MMC-LS-LP  
Redstone Arsenal, AL 35898-5238





