

TM 5-6115-423-25P

DEPARTMENT OF THE ARMY TECHNICAL MANUAL

ORGANIZATIONAL, DIRECT AND GENERAL SUPPORT,
AND DEPOT MAINTENANCE REPAIR PARTS
AND SPECIAL TOOLS LISTS

LOAD BANK 0-30KW, AC, PORTABLE, SKID MOUNTED

(SUN ELECTRIC CORP MODEL GPT-3D-1)

FSN 6115-964-1091 AND (MODEL GPT-3D)

FSN 6115-903-8174



HEADQUARTERS, DEPARTMENT OF THE ARMY

JANUARY 1968

**Organizational, Direct and General Support, and Depot
Maintenance Repair Parts and Special Tools Lists
LOAD BANK, 0-30KW, AC, PORTABLE, SKID MOUNTED
(SUN ELECTRIC CORP MODEL GPT-3D-1) FSN 6115-964-1091
AND (MODEL GPT-3D) FSN, 6115-903-8174**

This manual is current as of 6 October 1967

	Paragraph	Page
SECTION I. INTRODUCTION		
Scope	1	iv
General	2	iv
Explanation of columns	3	iv
Special information	4	vi
How to locate repair parts	5	vii
Abbreviations	6	vii
Federal Supply Codes for Manufacturers	7	vii
Recommendations for Maintenance Manual Improvements	8	vii
II. PRESCRIBED LOAD ALLOWANCE		viii
III. SPECIAL TOOLS, TESTAND SUPPORT EQUIPMENT FOR ORGANIZATIONAL MAINTENANCE (Nonapplicable)		
IV. REPAIR PARTS FOR ORGANIZATIONAL MAINTENANCE		
Part I.		
Group 18. Body, Cab, Hood and Hull		
1808 Lock paddle		1
22. Body Chassis or Hull, and Accessory Items		
2210 Data plates		2
40. Electric Motors and Generators		
4004 Ventilating system		3
4012 Switches		3
42. Electrical Equipment		
4201 Transformer, power line or distribution		3
4202 Electrical controls		3
4203 Circuit breakers, cutout devices, fuse and fuse holders		4
4204 Voltage and current regulators		4
4211 Power receptacles		4
4214 Radio interference suppression		5
Part II.		
Group 15. Frame		
1501 Frame assembly		7
18. Body, Cab, Hood and Hull		
1808 Lock paddle		7

	Page
Group 22. Body Chassis or Hull, and Accessory Items	
2210 Data plates-----	7
42. Electrical Equipment	
4202 Electrical controls -----	8
4208 Circuit breakers, cutout devices, fuse and fuse holders -----	8
Part III.	
Group 15. Frame	
1501 Frame assembly -----	9
18. Body, Cab, Hood and Hull	
1808 Lock paddle -----	9
22. Body Chassis or Hull and Accessory Items	
2210 Data plates -----	9
42. Electrical Equipment	
4202 Electrical controls -----	10
4205 Control resistances -----	10
SECTION V. REPAIR PARTS FOR DS, GS, AND DEPOT MAINTENANCE	
Part I.	
Group 18. Body, Cab, Hood and Hull	
1808 Lock paddle -----	11
22. Body Chassis or Hull, and Accessory Items	
2210 Data plates -----	11
40. Electric Motors and Generators	
4000 Motor assembly -----	13
4004 Ventilating system -----	13
4012 Switches -----	13
42. Electrical Equipment	
4201 Transformer, power line or distribution -----	14
4202 Electrical controls -----	15
4203 Circuit breakers, cutout devices, fuse and fuse holders -----	17
4204 Voltage and current regulators -----	17
4211 Power receptacles -----	18
4214 Radio interference suppression -----	18
Part II.	
Group 15. Frame	
1501 Frame assembly -----	20
18. Body, Cab, Hood and Hull	
1808 Lack paddle -----	21
22. Body Chassis or Hull, and Accessory Items	
2210 Data plates -----	21
40. Electric Motors and Generators	
4000 Motor assembly -----	22
42. Electrical Equipment	
4201 Transformer, power line or distribution -----	22
4202 Electrical controls -----	23
4203 Circuit breakers, cutout devices, fuse and fuse holders -----	24
4205 Control resistances -----	24
Part III.	
Group 15. Frame	
1501 Frame assembly -----	26

	Page
Group 18. Body, Cab, Hood and Hull	
1808 Lock paddle	27
22. Body chassis or Hull and Accessory Items	
2210 Data plates	27
40. Electric Motors and Generators	
4000 Motor assembly	27
42. Electrical Equipment	
4201 Transformer, powerline or distribution	28
4202 Electrical controls	28
4203 Circuit breakers, cutout devices, fuse and fuse holders	29
4205 Control resistances	30

SECTION VI. SPECIAL TOOLS, TEST AND SUPPORT EQUIPMENT FOR
DS, GS, AND DEPOT MAINTENANCE (NOT APPLICABLE)

VII. FEDERAL STOCK NUMBER AND REFERENCE NUMBER INDEX

SECTION I
INTRODUCTION

1. Scope

This manual lists repair parts required for the performance of organizational, direct support, general support, and depot maintenance of the Load Bank.

2. General

a. The repair parts list is arranged as follows:

- (1) Individual parts and major assemblies are listed alphabetically by item name within the numbered functional groups.
- (2) Assembly components and subassemblies are indented and listed alphabetically by item name under major assemblies.

b. This Repair Parts and Special Tools List is divided into the following sections:

- (1) Prescribed Load Allowance (PLA)-section II, is consolidated listing of repair parts quantitatively allocated for initial stockage at the organizational level. *This is a mandatory minimum stockage allowance.*
- (2) Special Tools, Test and Support Equipment-Section III, is a list of special tools, test and support equipment authorized for the performance of maintenance at the organizational level. "Not applicable".
- (3) Repair Parts-Section IV, is a list of repair parts authorized for the performance of maintenance at the organizational level.
- (4) Repair Parts-Section V, is a list of repair parts authorized for the performance of maintenance at the direct support, general support, and depot level.

- (5) Special Tools, Test and Support Equipment-Section VI, is a list of special tools, test and support equipment authorized for the performance of maintenance at the direct support, general support, and depot level. "Not applicable".
- (6) Federal Stock Number and Reference Number Index-Section VII, is a list of Federal stock numbers followed by reference numbers, appearing in all the listings, in ascending alphanumeric sequence cross-referenced to index number.

3. Explanation of Columns

The following provides an explanation of columns in the tabular lists in sections II through VI.

a. *Source, Maintenance, and Recoverability Codes (SMR).*

- (1) Source Code. Indicates the selection status and source for the listed item. Source codes used are:

Code	Explanation
P	Applied to repair parts which are stocked in or supplied from DSA/GSA or Army supply system, and authorized for use at indicated maintenance categories.
M	Applied to repair parts which are not procured or stocked but are to be manufactured at indicated maintenance categories.
A	Applied to assemblies which are not procured or stocked as such but made up of two or more units, each of which carry individual stock numbers and descriptions and are procured and stocked and can be assembled by units at indicated maintenance categories.
X	Applied to parts and assemblies which are not procured or stocked, the mortality of which is normally below that

Code	Explanation
	of the applicable end item, and the failure of which should result in retirement of the end item from the supply system.
X1	Applied to repair parts which are not procured or stocked, the requirement for which will be supplied by use of the next higher assembly or components.
X2	Applied to repair parts which are not stocked. The indicated maintenance category requiring such repair parts will attempt to obtain them through cannibalization; if not obtainable through cannibalization, such repair parts will be requisitioned with supporting justification through normal supply channels.
C	Applied to repair parts authorized for local procurements. If not obtainable from local procurement, such repair parts will be requisitioned through normal supply channels with a supporting statement of non-availability from local procurement
G	Applied to major assemblies that are procured with PEMA (Procurement Equipment Missile Army) funds for initial issue only to be used as exchange assemblies at DSU and GSU maintenance level. These assemblies will not be stocked above DSU and GSU level or returned to depot supply level.

Note. Source code and level of maintenance are not shown on common hardware items known to be readily available in Army supply channels and through local procurement.

- (2) **Maintenance Code.** Indicates the lowest category of maintenance authorized to install the listed item. The maintenance level codes are:

Code	Explanation
O	Organizational maintenance
F	Direct support maintenance
H	General support maintenance
D	Depot maintenance

- (3) **Recoverability Code.** Indicates whether unserviceable items should be returned for recovery or salvage. Items not coded are expendable. Recoverability codes are:

Code	Explanation
R	Applied to repair parts and assemblies which are economically repairable at DSU and GSU activities and normally are furnished by supply on an exchange basis.

Code	Explanation
T	Applied to high dollar value recoverable repair parts which are subject to special handling and are issued on an exchange basis. Such repair parts normally are repaired or overhauled at depot maintenance activities.
U	Applied to repair parts specifically selected for salvage by reclamation units because of precious metal content, critical materials, high dollar value reusable castings or castings.

- (4) This column also lists, below the SMR code, an index number for each item in ascending numerical sequence, which is used to locate items in the publication when the Federal stock number and/or reference number is known.

b. Federal Stock Number. Indicates the Federal stock number for the item.

c. Description. Indicates the Federal item name and any additional description of the item required. A part number or other reference number is followed by the applicable five-digit Federal supply code for manufacturers in parentheses.

d. Unit of Issue. Indicates the unit used as a basis for issue, e.g., ea, pr, ft, yd, etc.

e. Quantity Incorporated in Unit Pack. Indicates the actual quantity contained in the unit pack.

f. Quantity Incorporated in Unit. Indicates the quantity of the item used in the functional group.

g. Fifteen-Day Organizational Maintenance Allowances.

- (1) The allowance columns are divided into four subcolumns. Indicated in each subcolumn opposite the first appearance of each item is the total quantity of items authorized for the number of equipments supported. Subsequent appearances of the same item will have no entry in the allowance columns but will have in the description column a reference to the first appearance of the item. Items authorized for use as required but not for initial stockage are identified with an asterisk in the allowance column.

- (2) The quantitative allowances for organizational level of maintenance represents one initial prescribed load for a 15-day period for the number of equipments supported. Units and organizations authorized additional prescribed loads will multiply the number of prescribed loads authorized by the quantity of repair parts reflected in the appropriate density column to obtain the total quantity of repair parts authorized.
- (3) Organizational units providing maintenance for more than 100 of these equipments shall determine the total quantity of parts required by converting the equipment quantity to a decimal factor by placing a decimal point before the next to last digit of the number to indicate hundredths, and multiplying the decimal factor by the parts quantity authorized in the 51-100 allowance column. Example, authorized allowance for 51-100 equipments is 12; for 140 equipments multiply 12 by 1.40 or 16.80 rounded off to 17 parts required.
- (4) Subsequent changes to allowances will be limited as follows: No change in the range of items is authorized. If additional items are considered necessary, recommendation should be forwarded to U. S. Army Mobility Equipment Command for exception or revision to the allowance list. Revisions to the range of items authorized will be made by this Command based upon engineering experience, demand data, or TAERS information,

h. Thirty-Day DS/GS Maintenance Allowance.

- (1) The allowance columns are divided into three subcolumns. Indicated in each subcolumn, opposite the first appearance of each item, is the total quantity of items authorized for the number of equipments supported. Subsequent appearances of the same item will have no entry in the allowance column, but will have in the description column a reference to the

first appearance of the item. Items authorized for use as required but not for initial stockage are identified with an asterisk in the allowance column.

- (2) The quantitative allowances for DS/GS levels of maintenance will represent initial stockage for a 30-day period for the number of equipments supported.
- (3) Determination of the total quantity of parts required for maintenance of more than 100 of these equipments can be accomplished by converting the equipment quantity to a decimal factor by placing a decimal point before the next to last digit of the number to indicate hundredths, and multiplying the decimal factor by the parts quantity authorized in the 51-100 allowance column. Example, authorized allowance for 51-100 equipments is 40; for 150 equipments multiply 40 by 1.50 or 60 parts required.

i. One-Year Allowances Per 100 Equipments/Contingency Planning Purposes. Indicates opposite the first appearance of each item the total quantity required for distribution and contingency planning purposes. The range of items indicates total quantities of all authorized items required to provide for adequate support of 100 equipments for one year.

j. Depot Maintenance Allowance Per 100 Equipments. Indicates opposite the first appearance of each item the total quantity authorized for depot maintenance of 100 equipments. Subsequent appearances of the same item will have no entry in this column, but will have in the description column a reference to the first appearance of the item. Items authorized for use but not for initial stockage are identified with an asterisk in the allowance column.

k. Illustration.

- (1) *Figure Number.* Indicates the figure number of the illustration in which the item is shown.
- (2) *Item Number.* Indicates the callout number used to reference the item in the illustration.

4. Special Information

a. Repair parts applicable to specific models covered in this publication are as follows:

- (1) Part I applies to repair parts applicable to all models covered in this manual.
- (2) Part II applies to repair parts applicable to model GPT-3D-1 only.
- (3) Part III applies to repair parts applicable to model GPT-3D only.

b. Repair parts mortality has been based on 1000 hours of operation per year.

c. Parts which require manufacture or assembly at a category higher than that authorized for installation will indicate in the source column the higher category.

d. The following publications pertain to The Load Bank and its components:

TM 5-6115- 423-15	Operator, Organizational, DS, GS, and Depot Maintenance Manual.
----------------------	---

5. How to locate Repair Parts

a. When Federal stock number or reference number is unknown:

- (1) *First.* Using the table of contents, determine the functional group within which the repair part belongs.
- (2) *Second.* Find the illustration covering the functional group to which the repair part belongs.
- (3) *Third.* Identify the repair part on the illustration, and note the illustration figure and item number of the repair part.
- (4) *Fourth.* Using the Repair Parts Listing, find the functional group to which the repair part belongs and locate the illustration figure and item number noted on the illustration.

b. When Federal stock number or reference number is known:

- (1) *First.* Using the Index of Federal Stock Numbers and Reference Num-

bers, find the pertinent Federal stock number or reference number. This index is in ascending alphanumeric sequence cross-referenced to an index number.

- (2) *Second.* Using the Repair Part Listing, find the index number referenced in the Index of Federal Stock Numbers and Reference Numbers.

6. Abbreviations

ac ----- alternating current
 amp ----- ampere(s)
 dc ----- direct current
 ea ----- each
 kw ----- kilowatt(s)
 pdt ----- pole double throw
 mtg ----- mounting(s)

7. Index of Federal Supply Codes

Code	Manufacturer
09922__ _	Burndy Corporation
60399 __ _	Torrington Manufacturing Co.
62119 __ _	Universal Electric Co..
71400__ _	Bussman Fuse Div. of McGraw-Edison Co.
71468__ _	ITT Cannon Electric, Inc.
72962__ _	Elastic Stop Nut Corp of America
74063 __ _	Hartman Electric Mfg Co.
75915 __ _	Littlefuse, Inc.
82386__ _	Sun Electric Corporation
88044__ _	Aeronautical Standards Group
95019__ _	Spicer Manufacturing Div. of Dana Corp
96906__ _	Military Standards Promulgated by Standardization Div Directorate of Logistic Services (DSA)

8. Recommendations for Maintenance Manual Improvements

Report of errors, omissions, and recommendations for improving this publication by the individual user is encouraged. Reports should be submitted on a DA Form 2028 (Recommended Changes to DA Publications) and forwarded direct to the Commanding General, U, S. Army Mobility Equipment Command, ATTN: AMSME-MPP, 4300 Goodfellow Blvd., St. Louis Mo 63120.

SECTION II

PRESCRIBED LOAD ALLOWANCE

(1) FEDERAL STOCK NUMBER	(2) DESCRIPTION	(3) QTY INC IN UNIT PACK	(4) 15-DAY ORG MAINT. ALW	(A) 1-5	(B) 6-20	(C) 21-50	(D) 51-100
	PART 1 4012-SWITCHES						
5930-782-7215	SWITCH, TOGGLE (82386) 689-231		*	*	*		2
	4203-CIRCUIT BREAKERS, CUTOFF DEVICES, FUSE AND FUSEHOLDERS						
5920-518-1793	FUSE, CARTRIDGE (75915) F03A25V3AS		*	2	2		4
	4204-VOLTAGE AND CURRENT REGULATORS						
5910-194-8758	CAPACITOR, FILTER (82386) 679-341		*	*	*		2
	4214-RADIO INTERFERENCE SUPPRESSION						
4935-863-5082	BRUSH, RADIO: MOTOR, DIRECT CURRENT (82386) 5743A		*	*	*		2

(1) SMR CODE INDEX NO.	(2) FEDERAL STOCK NUMBER	(3) DESCRIPTION REFERENCE NO. & MFR. CODE USABLE ON CODE	(4) UNIT OF ISSUE	(5) QTY INC IN UNIT PACK	(6) QTY INC IN UNIT	(7) 15-DAY ORGANIZATIONAL MAINTENANCE ALW (A) (B) (C) (D)				(8) ILLUS- TRATION (A) (B) FIG ITEM NO. NO.	
						1-5	6-20	21-50	51-100		
00001		SECTION IV - REPAIR PARTS FOR ORGANIZATIONAL MAINTENANCE PART 1									
00001A		GROUP 18 - BODY, CAB, HOOD AND HULL									
00001B		1808 - LOCK PADDLE									
X20 00002		BUMPER,RUBBER: AIR EXHAUST DOOR 1489-2 (82386)	EA		1					1	12
X20 00003		COVER, HANDBOOK COMPARTMENT 8056-006 (82386)	EA		1					1	2
X20 00004		DOOR, AIR EXHAUST C455-1602 (82386)	EA		1					1	14
X20 00005		DOOR, CONTROL PANEL C455-1600 (82386)	EA		1					1	8
P O 00006	4940-920-1150	LOCK,PADDLE 455-1601 (82386)	EA		2	*	*	*	*	1	7
X20 00007		NUT,SELF-LOCKING, HEXAGON: BUMPER MTG AN365-832 (88044)	EA		1					1	10
X20 00008		PANEL, ACCESS C455-1625 (82386)	EA		1					1	6
X20 00009		RIVET, BLIND: BUMPER SUPPORT MTG 608-311 (82386)	EA		2					1	1
X20 00010		RIVET, BLIND: BUMPER SUPPORT MTG 608-310 (82386)	EA		2					1	1
X20 00011		RIVET, BLIND: HANDBOOK COMPARTMENT AND LOCK PADDLE 608-310 (82386)	EA		20					1	1
X20 00012		RIVET, BLIND: HANDBOOK COMPARTMENT AND LOCK PADDLE 608-311 (82386)	EA		20					1	1
X20 00013		SCREW, MACHINE: ACCESS PANEL MTG 615-8 (82386)	EA		18					1	5
X20 00015		SCREW, MACHINE: AIR EXHAUST DOOR MTG 615-12 (82386)	EA		7					1	15

(1) SMR CODE INDEX NO.	(2) FEDERAL STOCK NUMBER	(3) DESCRIPTION REFERENCE NO. & MFR. CODE USABLE ON CODE	(4) UNIT OF ISSUE	(5) QTY INC IN UNIT PACK	(6) QTY INC IN UNIT	(7) 15-DAY ORGANIZATIONAL MAINTENANCE ALW (A) (B) (C) (D)	(8) ILLUS- TRATION (A) (B) FIG ITEM NO. NO.
00016	5305-576-7579	SCREW, MACHINE: BUMPER MTG MS3522346 (96906)	EA		1	1-5 6-20 21-50 51-100	1 13
X20 00017		SUPPORT, BUMPER C455-1609 (82386)	EA		1		1 11
00018	5310-809-8544	WASHER, FLAT: CONTROL PANEL MS27183-7 (96906)	EA		5		1 9
X20 00019		WRAPPER, HANDBOOK COMPARTMENT 8056-007 (82386)	EA		1		1 3
00020		GROUP 22 - BODY CHASSIS OR HULL, AND ACCESSORY ITEMS					
00020A		2210 - DATA PLATES					
X20 00021		PLATE, DESIGNATION: GROUND 4060-015 (82386)	EA		1		
X20 00022		PLATE, DESIGNATION: LOAD SWITCHES C455-1402 (82386)	EA		1		
X20 00023		PLATE, DESIGNATION: MASTER SWITCH C455-1403 (82386)	EA		1		
X20 00024		PLATE, DESIGNATION: OPERATING INSTRUCTIONS CH455-1011 (82386)	EA		1		
X20 00025		PLATE, DESIGNATION: SCHEMATIC AND WIRING C455-1010 (82386)	EA		1		
X20 00026		PLATE DESIGNATION: VARIABLE LOAD 4059-162 (82386)	EA		1		
X20 00027		PLATE, IDENTIFICATION C455-1012 (82386)	EA		1		
X20 00028		PLATE IDENTIFICATION 4062-016 (82386)	EA		1		
X20 00029		PLATE IDENTIFICATION 4062-017 (82386)	EA		1		
X20 00030		PLATE INDENTIFICATION 4062-018 (82386)	EA		1		

(1) SMR CODE INDEX NO.	(2) FEDERAL STOCK NUMBER	(3) DESCRIPTION REFERENCE NO. & MFR. CODE USABLE ON CODE	(4) UNIT OF ISSUE	(5) QTY INC IN UNIT PACK	(6) QTY INC IN UNIT	(7) 15-DAY ORGANIZATIONAL MAINTENANCE ALW (A) (B) (C) (D) 1-5 6-20 21-50 51-100				(8) ILLUS- TRATION (A) (B) FIG ITEM NO. NO.	
X20 00031		RIVET, BLIND: PLATE MTG 608-204 (82386)	EA		21						
X20 00032		RIVET, BLIND: PLATE MTG 608-205 (82386)	EA		4						
00033		GROUP 40 - ELECTRIC MOTORS AND GENERATORS									
00035		4004 - VENTILATING SYSTEM									
P O 00037		IMPELLAR, FAN AXIAL E823-4 (60399)	EA		3	*	*	*	*		6 1
00039		4012 - SWITCHES									
X20 00040		SCREW, MACHINE: TOGGLE SWITCH MTG 615-015 (82386)	EA		12						4
P O 00042	5930-782-7215	SWITCH, TOGGLE 689-231 (82386)	EA		6	*	*	*	2		4 38
00043		GROUP 42 - ELECTRICAL EQUIPMENT									
00044		4201 - TRANSFORMER, POWER LINE OR DISTRIBUTION									
P O 00046	5355-928-8848	KNOB: VARIABLE TRANSFORMER 758-135 (82386)	EA		1	*	*	*	*		4 37
0 00049	5310-515-8052	NUT, SELF-LOCKING, HEXAGON: TRANSFORMER MTG MS20365-428 (96906)	EA		6						2 11
00063		4202 - ELECTRICAL CONTROLS									
X20 00066		GROMMET, RUBBER: WIRING 501-047 (82386)	EA		1						5 21
P O 00067		LINK, SHORTING 5719 (82386)	EA		2	*	*	*	*		5 34

(1) SMR CODE INDEX NO.	(2) FEDERAL STOCK NUMBER	(3) DESCRIPTION REFERENCE NO. & MFR. CODE USABLE ON CODE	(4) UNIT OF ISSUE	(5) QTY INC IN UNIT PACK	(6) QTY INC IN UNIT	(7) 15-DAY ORGANIZATIONAL MAINTENANCE ALW (A) (B) (C) (D) 1-5 6-20 21-50 51-100				(8) ILLUS- TRATION (A) (B) FIG ITEM NO. NO.	
X20 00069		NUT, SELF-LOCKING, HEXAGON: TERMIANL BOARD MTG 22NM-40 (72962)	EA		2					5	16
X20 00071		NUT, WING: LINK MTG MS35425-14 (96906)	EA		1					5	33
P O 00078	5355-668-5898	KNOB: TERMINAL PANEL 1901-4 (82386)	EA		4	*	*	*	*	5	28
X20 00084 00088		TUBING, INSULATION: WIRING, BAFFLE ASSEMBLY 669-186 (82386) 4203 - CIRCUIT BREAKERS, CUTOOT DEVICES, FUSE AND FUSE HOLDERS	EA		1					5	32
P O 00090	5920-518-1793	FUSE, CARTRIDGE F03A25V3AS (75915)	EA		3	*	2	2	4		
P O 00091 000910	5920-780-2903	FUSEHOLDER HKP-L (71640) 4204 - VOLTAGE AND CURRENT REGULATORS	EA		3	*	*	*	*	4	34
X20 00092		CHOKE ASSEMBLY C455-1700 (82386)	EA		1					4	
P O 00093	5910-194-8758	CAPACITOR, FILTER 679-341 (82386)	EA		2	*	*	*	2	4	9
X20 00094 00095 00098	5310-596-7691	SCREW, CAP, HEXAGON HEAD: CAPACITOR MTG 615-12 (82386) WASHER, LOCK: CAPACITOR MTG MS35335-32 (96906) 4211 - POWER RECEPTACLES	EA		4					4	8
			EA		2					4	7
X20 00099	5935-224-8150	CLAMP, CABLE AN3057-24 (88044)	EA		1					5	38
P O R 00100	5935-518-9479	CONNECTOR PLUG, ELECTRICAL CA3106A36-10S (71468)	EA		1	*	*	*	*	5	29

(1) SMR CODE INDEX NO.	(2) FEDERAL STOCK NUMBER	(3) DESCRIPTION REFERENCE NO. & MFR. CODE USABLE ON CODE	(4) UNIT OF ISSUE	(5) QTY INC IN UNIT PACK	(6) QTY INC IN UNIT	(7) 15-DAY ORGANIZATIONAL MAINTENANCE ALW (A) (B) (C) (D) 1-5 6-20 21-50 51-100				(8) ILLUS- TRATION (A) (B) FIG ITEM NO. NO.	
P O R 00101	5935-847-4234	CONNECTOR RECEPTACLE ELECTRICAL CA3102A36-01P (71468)	EA		1	*	*	*	*	5	4
P O R 00102	5935-836-7770	CONNECTOR, RECEPTACLE ELECTRICAL: BAFFLE ASSEMBLY MS3102A36-01P (96906)	EA		1	*	*	*	*	5	4
P O 00103	5935-577-8646	COVER, CONNECTOR MS25043-36C (96906)	EA		1	*	*	*	*	5	30
X20 00104		NUT, SELF-LOCKING, HEXAGON: CONNECTOR MTG AN365-832 (88044)	EA		8					5	2
X20 00105	5935-847-4234	SCREW, MACHINE: CONNECTOR MTG MS35223-45 (96906)	EA		8					5	12
00106	5305-638-3358	SCREW, MACHINE: COVER MTG MS35223-45 (96906)	EA		1					5	31
00107		4214 - RADIO INTERFERENCE SUPPRESSION									
P O 00108	4935-863-5082	BRUSH, RADIO: MOTOR, DIRECT CURRENT 5743A (82386)	EA		3	*	*	*	2	6	2
00109	5310-655-6933	NUT, PLAIN, HEXAGON: BONDING STRAP MTG MS35650-105 (96906)	EA		2					4	40
00110	5310-497-3882	NUT, SELF-LOCKING, HEXAGON: BONDING STRAP MTG AN365-518 (88044)	EA		1					4	43
0 00111	5305-558-4047	SCREW, MACHINE: BONDING STRAP MTG MS35230-67 (96906)	EA		1					4	45
X20 00112		STRAP, BONDING: GROUND MS25083-2BD10 (96906)	EA		1					4	42
X20 00113		WASHER, FLAT: BONDING STRAP MTG 400-11 (82386)	EA		2					4	5
X20 00114		WASHER, FLAT: BONDING STRAP MTG 400-22 (82386)	EA		4					4	41
00115	5310-209-0786	WASHER, LOCK: BONDING STRAP MTG MS35335-32 (96906)	EA		4					4	44

(1) SMR CODE INDEX NO.	(2) FEDERAL STOCK NUMBER	(3) DESCRIPTION REFERENCE NO. & MFR. CODE USABLE ON CODE	(4) UNIT OF ISSUE	(5) QTY INC IN UNIT PACK	(6) QTY INC IN UNIT	(7) 15-DAY ORGANIZATIONAL MAINTENANCE ALW (A) (B) (C) (D) 1-5 6-20 21-50 51-100	(8) ILLUS- TRATION (A) (B) FIG ITEM NO. NO.
X20 00116		WASHER, LOCK: BONDING STRAP MTG 603-7 (82386)	EA		2		4 6
X20 00117		WASHER, LOCK: BONDING STRAP MTG 604-55 (82386)	EA		2		4 39

(1) SMR CODE INDEX NO.	(2) FEDERAL STOCK NUMBER	(3) DESCRIPTION REFERENCE NO. & MFR. CODE USABLE ON CODE	(4) UNIT OF ISSUE	(5) QTY INC IN UNIT PACK	(6) QTY INC IN UNIT	(7) 15-DAY ORGANIZATIONAL MAINTENANCE ALW (A) (B) (C) (D)	(8) ILLUS- TRATION (A) (B) FIG ITEM NO. NO.
00117A		PART II					
00118		GROUP 15 - FRAME					
00118A		1501 - FRAME ASSEMBLY					
00124	5310-208-1919	NUT, SELF-LOCKING, HEXAGON: CORNER BRACE MTG AN365-420 (88044)	EA	4			
X20 00125		NUT, SELF-LOCKING, HEXAGON: CORNER BRACE MTG MS90726-6 (96906)	EA	4			
X20 00126		SCREW, CAP, HEXAGON: CORNER BRACE MTG 615-019 (82386)	EA	4			
X20 00127		WASHER, FLAT: CORNER BRACE MTG 400-200 (82386)	EA	12			
00136		GROUP 18 - BODY, CAB, HOOD AND HULL					
00136A		1808 - LOCK PADDLE					
X20 00137		COVER, TOP PANEL C533-0735 (82386)	EA	1			1 4
X20 00138		SCREW, MACHINE: COVER TOP PANEL 615-013 (82386)	EA	6			1 5
00139		GROUP 22 - BODY CHASSIS OR HULL AND ACCESSORY ITEMS					
00139A		2210 - DATA PLATES					
X20 00140		PLATE IDENTIFICATION: EQUIPMENT DATA 4055-119 (82386)	EA	1			
X20 00141		PLATE IDENTIFICATION: MANUFACTURER DATA 4055-120 (82386)	EA	1			
X20 00142		RIVET, BLIND: PLATE IDENTIFICATION 608-204 (82386)	EA	8			

(1) SMR CODE INDEX NO.	(2) FEDERAL STOCK NUMBER	(3) DESCRIPTION REFERENCE NO. & MFR. CODE USABLE ON CODE	(4) UNIT OF ISSUE	(5) QTY INC IN UNIT PACK	(6) QTY INC IN UNIT	(7) 15-DAY ORGANIZATIONAL MAINTENANCE ALW (A) (B) (C) (D)	(8) ILLUS- TRATION (A) (B) FIG ITEM NO. NO.
						1-5 6-20 21-50 51-100	
00147		GROUP 42 - ELECTRICAL EQUIPMENT					
00156		4202 - ELECTRICAL CONTROLS					
X20 00163		STRAP, JUMPER: CONTROL PANEL 5372-4 (82386)	EA		6		4
X20 00167		SCREW, MACHINE: CONTROL PANEL ASSEMBLY MTG 615-8 (82386)	EA		6		4 36
00171		4203 - CIRCUIT BREAKERS, CUTOUT DEVICES, FUSE AND FUSE HOLDERS					
00172	5310-282-0512	NUT, SELF-LOCKING, HEXAGON: RELAY BRACKET MTG AN365-1032 (88044)	EA		2		5 6
X20 00173		NUT, SELF-LOCKING HEXAGON: RELAY TUBE SOCKET MTG MS26365-632 (96906)	EA		2		
00178	5305-207-0763	SCREW, MACHINE: RELAY TUBE SOCKET MTG MS35223-28 (96906)	EA		2		
00180	5310-082-1404	WASHER, FLAT: RELAY TUBE SOCKET MTG MS27183-6 (96906)	EA		2		

(1) SMR CODE INDEX NO.	(2) FEDERAL STOCK NUMBER	(3) DESCRIPTION REFERENCE NO. & MFR. CODE USABLE ON CODE	(4) UNIT OF ISSUE	(5) QTY INC IN UNIT PACK	(6) QTY INC IN UNIT	(7) 15-DAY ORGANIZATIONAL MAINTENANCE ALW (A) (B) (C) (D) 1-5 6-20 21-50 51-100	(8) ILLUS- TRATION (A) (B) FIG ITEM NO. NO.
00192		PART III					
00193		GROUP 15 - FRAME					
00194		1501 - FRAME ASSEMBLY					
00200	5310-207-9071	NUT, SELF-LOCKING, HEXAGON: CORNER BRACE MTG AN365-420 (88044)	EA		4		
00201	5310-061-7325	NUT, SELF-LOCKING, HEXAGON: CORNER BRACE MTG MS20365-428 (96906)	EA		4		
00202	5305-068-0506	SCREW, CAP, HEXAGON HEAD: CORNER BRACE MTG MS90726-6 (96906)	EA		4		
X20 00203		WASHER, FLAT: CORNER BRACE MTG 400-200 (82386)	EA		12		
0 00205	5305-225-8499	SCREW, CAP, HEXAGON HEAD: FRAME TO HOUSING MTG MS90725-34 (96906)	EA		1		4 4
00210		GROUP 18 - BODY, CAB, HOOD AND HULL					
00210A		1808-LOCK PADDLE					
X20 00211		COVER, TOP PANEL 4-735A2 (82386)	EA		1		1 4
X20 00212		SCREW, MACHINE: COVER, TOP PANEL MTG 615-12 (82386)	EA		4		1 5
00213		GROUP 22 - BODY CHASSIS OR HULL AND ACCESSORY ITEMS					
00213A		2210 - DATA PLATE					
X20 00214		PLATE IDENTIFICATION: EQUIPMENT DATA 4055-113 (82386)	EA		1		

(1) SMR CODE INDEX NO.	(2) FEDERAL STOCK NUMBER	(3) DESCRIPTION REFERENCE NO. & MFR. CODE USABLE ON CODE	(4) UNIT OF ISSUE	(5) QTY INC IN UNIT PACK	(6) QTY INC IN UNIT	(7) 15-DAY ORGANIZATIONAL MAINTENANCE ALW (A) (B) (C) (D) 1-5 6-20 21-50 51-100	(8) ILLUS- TRATION (A) (B) FIG ITEM NO. NO.
X20 00215		PLATE IDENTIFICATION: MANUFACTURER DATA 4055-114 (82386)	EA		8		
X20 00216		RIVET, BLIND 608-205 (82386)	EA		8		
00222		GROUP 42 - ELECTRICAL EQUIPMENT					
00230		4202 - ELECTRICAL CONTROLS					
X20 00241		SCREW, MACHINE: CONTROL PANEL ASSEMBY MTG 615-8 (82386)	EA		6		4 36
X20 00242		WASHER, FLAT: TRANSFORMER WIRING CLAMP MTG 400-238 (82386)	EA		1		3 4
00249		4205 - CONTROL RESISTANCES					
X20 00254		CLAMP, LOOP 718-307 (82386)	EA		1		3 5
X20 00255		CLAMP, LOOP 718-308 (82386)	EA		1		3 7
X20 00257		SCREW, MACHINE: ABSORBER AND CLAMP MTG 615-018 (82386)	EA		4		3 3
X20 00258		SCREW, MACHINE: CLAMP MTG 615-12 (82386)	EA		6		3 3
X20 00260		WASHER, FLAT: CLAMP MTG 400-238 (82386)	EA		4		3 4
X20 00261		WASHER LOCK: CLAMP MTG 603-30 (82386)	EA		2		3 6

(1) SMR CODE INDEX NO.	(2) FEDERAL STOCK NUMBER	(3) DESCRIPTION REFERENCE NO. & MFR. CODE	(4) USABLE ON CODE	(5) QTY INC IN UNIT PACK	(6) QTY INC IN UNIT	(7) 30-DAY DS MAINT ALLOWANCE (A) (B) (C)	(8) 30-DAY GS MAINT ALLOWANCE (A) (B) (C)	(9) 1-YR ALW PER EQUIP CNTGCTY	(10) DEPOT MAINT ALW- PER EQUIP	(11) ILLUS- TRATION (A) (B) FIG ITEM NO. NO.	
0001		SECTION V- REPAIR PARTS FOR DS, GS, AND DEPOT MAINTENACE PART 1									
00001A		GROUP 18 - BODY, CAB, HOOD AND HULL									
00001B		1808 - LOCK PADDLE									
X20 00002		BUMPER, RUBBER: AIR EXHAUST DOOR 1489-2- (82386)	EA		1					1 12	
X20 00003		COVER, HANDBOOK COMPARTMENT 8056-006 (82386)	EA		1					1 2	
X20 00004		DOOR, AIR EXHAUST C455-1602 (82386)	EA		1					1 14	
X20 00005		DOOR, CONTROL PANEL C455-1600 (82386)	EA		1					1 8	
P O 00006	4940-920-1150	LOCK, PADDLE 455-1601- (82386)	EA		2	*	*	*	*	*	5 5 1 7
X20 00007		NUT, SELF,-LOCKING, HEXAGON: BUMPER MTG AN365-832 (88044)	EA		1					1 10	
X20 00008		PANEL, ACCESS C455-1625 (82386)	EA		1					1 6	
X20 00009		RIVET, BLIND: BUMPER SUPPORT MTG 608-311 (82386)	EA		2					1 1	
X20 00010		RIVET, BLIND: BUMPER SUPPORT MTG 608-310 (82386)	EA		2					1 1	
X20 00011		RIVET, BLIND: HANDBOOK COMPARTMENT AND LOCK PADDLE 608-310 (82386)	EA		20					1 1	
X20 00012		RIVET, BLIND: HANDBOOK COMPARTMENT AND LOCK PADDLE 608-311 (82386)	EA		20					1 1	
X20 00013		SCREW, MACHINE: ACCESS PANEL MTG 615-8 (82386)	EA		18					1 5	
X20 00015		SCREW, MACHINE: AIR EXHAUST DOOR MTG 615-12 (82386)	EA		7					1 15	

(1) SMR CODE INDEX NO.	(2) FEDERAL STOCK NUMBER	(3) DESCRIPTION REFERENCE NO. & MFR. CODE	(4) USABLE ON CODE	(5) QTY INC IN UNIT PACK	(6) QTY INC IN UNIT	(7) 30-DAY DS MAINT ALLOWANCE IN (A) (B) (C)	(8) 30-DAY GS MAINT ALLOWANCE IN (A) (B) (C)	(9) 1-YR ALW PER EQUIP CNIGCY	(10) DEPOT MAINT ALW- PER EQUIP	(11) ILLUS- TRATION (A) (B) FIG ITEM NO. NO.
00016	5305-576-7579	SCREW, MACHINE: BUMPER MTG MS3522346 (96906)	EA	1		1-20 21-50 51-100	1-20 21-50 51-100			1 13
X20 00017		SUPPORT, BUMPER C455-1609 (82386)	EA	1						1 11
00018	5310-809-8544	WASHER, FLAT: CONTROL PANEL MS27183-7 (96906)	EA	5						1 9
X20 00019		WRAPPER, HANDBOOK COMPARTMENT 8056-007 (82386)	EA	1						1 3
00020		GROUP 22 - BODY CHASSIS OR HULL, AND ACCESSORY ITEMS								
00020A		2210 - DATA PLATES								
X20 00021		PLATE, DESIGNATION: GROUND 4060-015 (82386)	EA	1						
X20 00022		PLATE, DESIGNATION: LOAD SWITCHES C455-1402 (82386)	EA	1						
X20 00023		PLATE, DESIGNATION: MASTER SWITCH C455-1403 (82386)	EA	1						
X20 00024		PLATE, DESIGNATION: OPERATING INSTRUCTIONS CH455-1011 (82386)	EA	1						
X20 00025		PLATE, DESIGNATION: SCHEMATIC AND WIRING C455-1010 (82386)	EA	1						
X20 00026		PLATE DESIGNATION: VARIABLE LOAD 4059-162 (82386)	EA	1						
X20 00027		PLATE, IDENTIFICATION C455-1012 (82386)	EA	1						
X20 00028		PLATE IDENTIFICATION 4062-016 (82386)	EA	1						
X20 00029		PLATE IDENTIFICATION 4062-017 (82386)	EA	1						

(1) SMR CODE INDEX NO.	(2) FEDERAL STOCK NUMBER	(3) DESCRIPTION REFERENCE NO. & MFR. CODE	(4) USABLE ON CODE UNIT OF ISSUE	(5) QTY INC IN UNIT PACK	(6) 30-DAY QTY INC IN UNIT	(7) DS MAINT ALLOWANCE (A) (B) (C)	(8) 30-DAY GS MAINT ALLOWANCE (A) (B) (C)	(9) 1-YR ALW PER EQUIP CNTGCTY	(10) DEPOT MAINT ALW- PER EQUIP	(11) ILLUS- TRATION (A) (B)	FIG NO.	ITEM NO.
X20 00030		PLATE IDENTIFICATION 4062-018 (82386)	EA	1								
X20 00031		RIVET, BLIND: PLATE MTG 608-204- (82386)	EA	21								
X20 00032		RIVET, BLIND: PLATE MTG 608-205 (82386)	EA	4								
00033		GRUOUP 40 - ELECTRIC MOTORS AND GENERATORS										
00033A		400 - MOTOR ASSEMBLY										
P F 00034	6105-827-3833	MOTOR DIRECT CURRENT 54-018 (62119)	EA	3	*	2	2	*2	2	15	15	6 3
00035		4004 - VENTILATING SYSTEM										
X2F 00036		GUARD ASSEMBLY C455-1575 (82386)	EA	1								4 47
P O 00037		IMPELLAR, FAN AXIAL E823-4 (60399)	EA	3	*	*	*	*	*	*	5	5 6 1
X2F 00038		SCREW, MACHINE: GUARD ASSEMBLY, FAN 615-019 (82386)	EA	6								4 1
00039		4012 - SWITCHES										
X20 00040		SCREW, MACHINE: TOGGLE SWITCH MTG 615-015 (82386)	EA	12								4
P F 00041	4920-861-9266	SWITCH, AIR FLOW 8002-001 (82386)	EA	3	*2	2	*	2	2	15	10	6 5
P O 00042	5930-782-7215	SWITCH, TOGGLE 689-231 (82386)	EA	6	*	2	2	*	2	2	18	15 4 38

(1) SMR CODE INDEX NO.	(2) FEDERAL STOCK NUMBER	(3) DESCRIPTION REFERENCE NO. & MFR. CODE	(4) USABLE ON CODE	(5) UNIT OF ISSUE	(6) QTY INC IN UNIT PACK	(7) 30-DAY DS MAINT ALLOWANCE IN UNIT PACK	(8) 30-DAY GS MAINT ALLOWANCE IN UNIT PACK	(9) 1-YR ALW PER 100 EQUIP CNTGCTY	(10) DEPOT MAINT ALW- PER 100 EQUIP	(11) ILLUS- TRATION ALW- PER 100 EQUIP NO.	(11) ITEM NO.				
00043		GROUP 42 - ELECTRICAL EQUIPMENT													
00044		4201 - TRANSFORMER, POWER LINE OR DISTRIBUTION													
X2F 00044A		CLAMP, LOOP: TRANSFORMER WIRING HP-12N (09922)		EA	1					4	29				
X2F 00045		CLAMP, LOOP: TRANSFORMER WIRING HP-7N (09922)		EA	1					4	26				
P O 00046	5355-928-8848	KNOB: VAERIALBE TRAFORMER 758-135 (82386)		EA	1	*	*	*	*	5	5	4	37		
00047	5310-282-0512	NUT, SELF-LOCKING, HEXAGON: CLAMP TO TRANSFORMER MTG MS20365-1032 (96906)		EA	14							4	25		
00048	5310-550-3397	NUT, SELF-LOCKING, HEXAGON: TRANSFORMER MTG AN365-420 (88044)		EA	4							4	19		
0 00049	5310-515-8052	NUT,SELF-LOCKING, HEXAGON: TRANSFORMER MTG MS20365-428 (96906)		EA	6							2	11		
P F 00050		RECTIFIER, METALLIC 774-416 (82386)		EA	6	*	2	2	*	2	2	15	15	4	31
X2F 00051		SCREW, MACHINE: TRASFORMER AND RECTIFIER MTG 615-020 (82386)		EA	20							4	23		
X2F 00052		SCREW, MACHINE: TRANFORMER CHANNEL MTG 615-017 (82386)		EA	6										
00053	5305-068-0506	SCREW, MACHINE: TRASFORMER MTG MS90726-6 (96906)		EA	6							2	6		
00054	5305-660-2869	SCREW, MACHINE: TRASFORMER WIRING CLAMP MTG MS35224-70 (96906)		EA	2							4	30		
X2F 00055		SPACER, SLEEVE: CLAMP MTG 401-210 (82386)		EA	2							4	27		
P F 00056		TRANSFORMER 778-301 (82386)		EA	3	*	2	2	*	2	2	15	15	4	24

(1)	(2)	(3)	(4)	(5)	(6)	(7)	-8			(9)	(10)	(11)			
SMR		DESCRIPTION		QTY	30-DAY	30-DAY	30-DAY			1-YR	DEPOT	ILLUS-			
CODE	FEDERAL			INC	QTY	DS MAINT	GS MAINT			ALW	MAINT	TRATION			
INDEX	STOCK			IN	INC	ALLOWANCE	ALLOWANCE			PER	ALW-	(A) (B)			
NO.	NUMBER	REFERENCE NO. & MFR. CODE	USABLE ON CODE	UNIT	IN	(A)	(B)	(C)	(A)	(B)	(C)	100	PER	FIG	ITEM
				PACK	UNIT	1-20	21-50	51-100	20-Jan	21-50	51-100	EQUIP	100	NO.	NO.
												CNTGCTY	EQUIP		
P F		TRANSFORMER, AUTO		EA	3	*	2	2	*	2	2	15	15	4	18
00057		778-300 (82386)													
P F	4940-920-1190	TRANSFORMER MODULE		EA	1	*	*	*	*	*	*	5	5	4	
00058		C455-1350 (82386)													
P F		TRANSFORMER, VARIABLE		EA	1	*	*	*	*	*	*	5	5	2	5
00059		9T9Y961 (95018)													
	5310-809-4058	WASHER, FLAT: TRANSFORMER MTG		EA	12									2	7
00060		MS27183-10 (96906)													
X2F		WASHER, FLAT: TRANSFORMER MTG		EA	4									4	20
00061		400-20 (82386)													
X2F		WASHER, FLAT: TRANSFORMER, RECTIFIER AND CLAMP MTG		EA	10									4	22
00062		MS271836-8 (96906)													
00063		4202 - ELECTRICAL CONTROLS													
X2F	5940-623-7228	BAR, BUS		EA	1									5	17
00064		MS25226-2-5 (96906)													
P F		BOARD, TERMINAL		EA	1	*	*	*	*	*	*	5	5	5	14
00065		MS25123-1-5 (96906)													
X20		GROMMET, RUBBER: WIRING		EA	1									5	21
00066		501-047 (82386)													
P O		LINK, SHORTING		EA	2	*	*	*	*	*	*	5	5	5	34
00067		5719 (82386)													
	5310-274-8884	NUT, SELF-LOCKING, HEXAGON: BUS BAR MTG		EA	5									5	18
00068		MS20365-632 (96906)													
X20		NUT, SELF-LOCKING, HEXAGON: TERMINAL BOARD MTG		EA	2									5	16
00069		22MN-40 (72962)													
	5310-061-7325	NUT, SELF-LOCKING, HEXAGON: TERMINAL PANEL MTG		EA	6									5	23
00070		MS20365-428 (96906)													
X20		NUT, WING: LINK MTG		EA	1									5	33
00071		MS35425-14 (96906)													

(1)	(2)	(3)	(4)	(5)	(6)	(7)	(8)	(9)	(10)	(11)	
SMR	FEDERAL	DESCRIPTION		QTY	30-DAY	30-DAY	1-YR	DEPOT	ILLUS-		
CODE	STOCK			INC	QTY	DS MAINT	GS MAINT	ALW	MAINT	TRATION	
INDEX	NUMBER			IN	INC	ALLOWANCE	ALLOWANCE	PER	ALW-	(A) (B)	
NO.		REFERENCE NO. & MFR. CODE	USABLE ON CODE	UNIT	IN	(A) (B) (C)	(A) (B) (C)	100	PER	FIG	ITEM
				PACK	UNIT	1-20 21-50 51-100	1-20 21-50 51-100	EQUIP	EQUIP	NO.	NO.
X2F 00072		SCREW, MACHINE: TERIMINAL BOARD MTG MS35233-14 (96906)		EA	2					5	5
00073	5305-276-1450	SCREW, MACHINE: TERMINAL PANEL MTG MS35240-91 (96906)		EA	6					5	27
X2F 00074		STRIP, MARKER 1037-405 (82386)		EA	1					5	20
X2F 00075	5970-803-6091	STRIP, NUT, INSULATING MS25227-1 (96906)		EA	2					5	15
X2F 00076		TERMINAL PANEL ASSEMBLY 6502-018 (82386)		EA	1					5	
X2F 00077		INSULATOR, TERMINAL 2088-010 (82386)		EA	2					5	
P O 00078	5355-668-5898	KNOB: TERMINAL PANEL 1901-4 (82386)		EA	4	* * *	* * *	5	5	5	28
X2F 00079		NUT, PLAIN, HEXAGON: TERMINAL PANEL MS35690-631 (96906)		EA	12					5	35
X2F 00080		PANEL, TERMINAL 6508-032 (82386)		EA	1					5	26
X2F 00081		STUD, TERMINAL: TERMINAL PANEL 2179-033 (82386)		EA	4					5	24
X2F 00082		WASHER, FLAT: TERMINAL PANEL 400-165 (82386)		EA	8					5	37
X2F 00083		WASHER, LOCK: TERMINAL PANEL 604-18 (82386)		EA	8					5	36
X20 00084		TUBING, ISULATION: WIRING, BAFFLE ASSEMBLY 669-186 (82386)		EA	1					5	32
00085	5310-082-1404	WASHER, FLAT: BUS BAR MTG MS27183-6 (96906)		EA	5					5	9
X2F 00086		WASHER, FLAT: TERMINAL PANEL MTG 400-20 (82386)		EA	6					5	22

(1) SMR CODE INDEX NO.	(2) FEDERAL STOCK NUMBER	(3) DESCRIPTION REFERENCE NO. & MFR. CODE	(4) USABLE ON CODE	(5) UNIT OF ISSUE	(6) QTY INC IN UNIT PACK	(7) 30-DAY DS MAINT ALLOWANCE IN UNIT PACK	(8) 30-DAY GS MAINT ALLOWANCE IN UNIT PACK	(9) 1-YR ALW PER 100 EQUIP CNTGCTY	(10) DEPOT MAINT ALW- PER 100 EQUIP	(11) ILLUS- TRATION ALW- PER 100 EQUIP	(12) FIG NO.	(13) ITEM NO.			
X2F 00087		WASHER, LOCK: BUS BAR MTG 604-6 (82386)		EA	5						5	19			
00088		4203 - CIRCUIT BREAKERS, CUTOUT DEVICES, FUSE AND FUSE HOLDERS													
X2F 00089		BRACKET, RELAY C455-1451 (82386)		EA	1						5	10			
P O 00090	5920-518-1793	FUSE, CARTRIDGE F03A25V3AS (75915)		EA	3	2	2	8	2	4	8	90	90		
P O 00091	5920-780-2903	FUSEHOLDER HKP-L (71640)		EA	3	*	*	2	*	*	2	10	6	4	34
00091A	5305-622-1509	SCREW, MACHINE: RELAY BRACKET MTG MS35224-63 (96906)		EA	2									5	13
00091B	5310-809-8546	WASHER, FLAT: RELAY BRACKET MTG MS27183-8 (96906)		EA	2									5	8
000910		4204 - VOLTAGE AND CURRENT REGULATORS													
X20 00092		CHOKE ASSEMBLY C455-1700 (82386)		EA	1										4
P O 00093	5910-194-8758	CAPACITOR, FILTER 679-341 (82386)		EA	2	*	*	2	*	*	12	12		4	9
X20 00094		SCREW, CAP, HEXAGON HEAD: CAPACITOR MTG 615-12 (82386)		EA	4									4	8
00095	5310-596-7691	WASHER, LOCK: CAPACITOR MTG MS35335-32 (96906)		EA	2									4	7
P F 00096	5945-00-982-7123	CONTACTOR: 200 AMP BA 104AA (74063)		EA	1	*	*	*	*	*	*	5	5	2	3
X2F 00097		SCREW, MACHINE: CONTACTOR MTG 615-12 (82386)		EA	4									2	2

(1) SMR CODE INDEX NO.	(2) FEDERAL STOCK NUMBER	(3) DESCRIPTION REFERENCE NO. & MFR. CODE	(4) USABLE ON CODE	(5) QTY INC IN UNIT PACK	(6) QTY INC IN UNIT	(7) 30-DAY DS MAINT ALLOWANCE (A) (B) (C)	(8) 30-DAY GS MAINT ALLOWANCE (A) (B) (C)	(9) 1-YR ALW PER 100 EQUIP CNTGNCY	(10) DEPOT MAINT ALW- PER 100 EQUIP	(11) ILLUS- TRATION (A) (B) FIG ITEM NO. NO.
00098		4211 - PWER RECEPTACLES								
X20 00099	5935-224-8150	CLAMP, CABLE AN3057-24 (88044)	EA	1						5 38
P O R 00100	5935-518-9479	CONNECTOR PLUG, ELECTRICAL CA3106A36-105 (71468)	EA	1	*	*	*	*	3	3 5 29
P O R 00101	5935-847-4234	CONNECTOR RECEPTACLE ELECTRICAL CA3102A36-10P (71468)	EA	1	*	*	*	*	3	3 5 4
P O R 00102	5935-836-7770	CONNECTOR, RECEPTACLE ELECTRICAL: BAFFLE ASSEMBLY MS3102A36-10P (96906)	EA	1	*	*	*	*	3	3 5 3
P O 00103	5935-577-8646	COVER, CONNECTOR MS25043-36C (96906)	EA	1	*	*	*	*	5	5 5 30
X20 00104		NUT, SELF-LOCKING, HEXAGON: CONNECTOR MTG AN356-832 (88044)	EA	8						5 2
X20 00105	5935-847-4234	SCREW, MACHINE: CONNECTOR MTG MS35223-45 (96906)	EA	8						5 12
00106	5305-638-3358	SCREW, MACHINE: COVER MTG MS35223-45 (96906)	EA	1						5 31
00107		4214 - RADIO INTERFERENCE SUPPRESSION								
P O 00108	4935-863-5082	BRUSH, RADIO: MOTOR, DIRECT CURRENT 5743A (82386)	EA	3	2	2	2	2	2	15 15 6 2
00109	5310-655-6933	NUT, PLAIN, HEXAGON: BONDING STRAP MTG MS35650-105 (96906)	EA	2						4 40
00110	5310-497-3882	NUT, SELF-LOCKING, HAXAGON: BONDING STRAP MTG AN365-518 (88044)	EA	1						4 43
0 00111	5305-558-4047	SCREW, MACHINE: BONDING STRAP MTG MS35230-67 (96906)	EA	1						4 45
X20 00112		STRAP, BONDING: GROUND MS25083-2BD10 (96906)	EA	1						4 42

(1) SMR CODE INDEX NO.	(2) FEDERAL STOCK NUMBER	(3) DESCRIPTION REFERENCE NO. & MFR. CODE	(4) USABLE ON CODE UNIT OF ISSUE	(5) QTY INC IN UNIT PACK	(6) QTY INC IN UNIT	(7) 30-DAY DS MAINT ALLOWANCE 1-20 21-50 51-100	(8) 30-DAY GS MAINT ALLOWANCE 1-20 21-50 51-100	(9) 1-YR ALW PER EQUIP CNTGCTY	(10) DEPOT MAINT ALW- PER EQUIP	(11) ILLUS- TRATION (A) (B) FIG ITEM NO. NO.
X20 00113		WASHER, FLAT: BONDING STRAP MTG 400-11 (82386)	EA	2						4 5
X20 00114		WASHER, FLAT: BONDING STRAP MTG 400-22 (82386)	EA	4						4 41
	5310-209-0786	WASHER, LOCK: BONDING STRAP MTG MS35335-32 (96906)	EA	1						4 44
X20 00116		WASHER, LOCK: BONDING STRAP MTG 603-7 (82386)	EA	2						4 6
X20 00117		WASHER, LOCK: BONDING STRAP MTG 604-55 (82386)	EA	2						4 39

(1)	(2)	(3)	(4)	(5)	(6)	(7)	(8)	(9)	(10)	(11)
SMR				QTY		30-DAY	30-DAY	1-YR	DEPOT	ILLUS-
CODE	FEDERAL	DESCRIPTION		INC	QTY	DS MAINT	GS MAINT	ALW	MAINT	TRATION
INDEX	STOCK			IN	INC	ALLOWANCE	ALLOWANCE	PER	ALW-	(A) (B)
NO.	NUMBER	REFERENCE NO. & MFR. CODE	USABLE ON CODE	UNIT	IN	(A) (B) (C)	(A) (B) (C)	100	PER	FIG
				PACK	UNIT	1-20 21-50 51-100	1-20 21-50 51-100	EQUIP	EQUIP	NO. NO.
00117A		PART II								
00118		GROUP 15 - FRAME								
00118A		1501 - FRAME ASSEMBLY								
X2F 00119		ANGLE, SUPPORT C533-1303 (82386)		EA		1				4 12
X2F 00120		FRAME AND TRANSFORMER ASSEMBLY C533-1051 (82386)		EA		1				4
X2F 00121		BRACE, CORNER: HOUSING C455-1150 (82386)		EA		2				4 48
X2F 00122		CHANNEL, SUPPORT C455-1301 (82386)		EA		2				4 21
X2F 00123		HOUSING C533-1100 (82386)		EA		1				4 46
00124	5310-208-1919	NUT, SELF-LOCKING, HEXAGON: CORNER BRACE MTG AN365-420 (88044)		EA		4				
X20 00125		NUT, SELF-LOCKING, HEXAGON: CORNER BRACE MTG MS90726-6 (96906)		EA		4				
X20 00126		SCREW, CAP, HEXAGON HEAD: CORNER BRACE MTG 615-019 (82386)		EA		4				
X20 00127		WASHER, FLAT: CORNER BRACE MTG 400-200 (82386)		EA		12				
X2F 00128		FRAME, CENTER C533-1201 (82386)		EA		1				2 4
0 00129	5310-266-4463	NUT, SELF-LOCKING, HEXAGON: ANGLE MTG AN365-1032 (88044)		EA		3				4 10
X2F 00130		NUT, SELF-LOCKING, HEXAGON: TRANSFORMER CHANNEL MTG AN365-518 (88044)		EA		4				4 28
00131	5305-225-8499	SCREW, CAP, HEXAGON HEAD: FRAME TO HOUSING MTG MS90725-36 (96906)		EA		1				4 4

(1) SMR CODE INDEX NO.	(2) FEDERAL STOCK NUMBER	(3) DESCRIPTION REFERENCE NO. & MFR. CODE	(4) USABLE ON CODE UNIT OF ISSUE	(5) QTY INC IN UNIT PACK	(6) QTY INC IN UNIT	(7) 30-DAY DS MAINT ALLOWANCE 1-20 21-50 51-100	(8) 30-DAY GS MAINT ALLOWANCE 1-20 21-50 51-100	(9) 1-YR ALW PER EQUIP CNTGCTY	(10) DEPOT MAINT ALW- PER EQUIP	(11) ILLUS- TRATION (A) (B) FIG ITEM NO. NO.
00132	5305-638-6494	SCREW, MACHINE: TRANSFORMER TO SUPPORT MTG MS35224-65 (96906)	EA	3						4 17
00133	5310-809-8546	WASHER, FLAT: ANGLE MTG MS27183-8 (96906)	EA	6						4 11
X2F 00134		WASHER, FLAT: FRAME TO HOUSING MTG TRANSFORMER CHANNEL MTG 400-11 (82386)	EA	6						4 5
X2F 00135		WASHER, LOCK: FRAME TO HOUSING MTG 603-7 (82386)	EA	1						4 6
00136		GROUP 18 - BODY, CAB, HOOD AND HULL								
00136A		1808 - LOCK PADDLE								
X20 00137		COVER, TOP PANEL C533-0735 (82386)	EA	1						1 4
X20 00138		SCREW, MACHINE: COVER TOP PANEL 615-013 (82386)	EA	6						1 5
00139		GROUP 22 - BODY CHASSIS OR HULL AND ACCESSORY ITEMS								
00139A		2210 - DATA PLATES								
X20 00140		PLATE IDENTIFICATION: EQUIPMENT DATA 4055-119 (82386)	EA	1						
X20 00141		PLATE IDENTIFICATION: MANUFACTURE DATA 4055-120 (82386)	EA	1						
X20 00142		RIVET, BLIND: PLATE IDENTIFICATION 608-204 (82386)	EA	8						

(1)	(2)	(3)	(4)	(5)	(6)	(7)	(8)	(9)	(10)	(11)
SMR				QTY		30-DAY	30-DAY	1-YR	DEPOT	ILLUS-
CODE	FEDERAL	DESCRIPTION		INC	QTY	DS MAINT	GS MAINT	ALW	MAINT	TRATION
INDEX	STOCK			IN	INC	ALLOWANCE	ALLOWANCE	PER	ALW-	(A) (B)
NO.	NUMBER	REFERENCE NO. & MFR. CODE	USABLE ON CODE	UNIT	IN	(A) (B) (C)	(A) (B) (C)	100	PER	PER
				PACK	UNIT	1-20 21-50 51-100	1-20 21-50 51-100	EQUIP	100	FIG ITEM
								CNTGCT	EQUIP	NO. NO.
00143		GROUP 40 - ELECTRIC MOTORS AND GENERATORS								
00144		4000 - MOTOR ASSEMBLY								
X2F 00144		BRACKET, MOUNTING MOTOR C455-1250 (82386)		EA		3				6 4
00145	5310-282-0512	NUT, SELF-LOCKING: MOTOR DIERCT CURRENT AN365-1032 (88044)		EA		15				
X2F 00146		WASHER, FLAT: MOTOR, DIRECT CURRENT 400-216 (82386)		EA		15				
00147		GROUP 42 - ELECTRICAL EQUIPMENT								
00147A		4201 - TRANSFORMER, POWER LINE OR DISTRIBUTION								
X2F 00148		AUTO TRANSFORMER MODULE C533-1300 (82386)		EA		1				4
X2F 00149		CHANNEL, TRANSFORMER MODULE C455-1352 (82386)		EA		1				4 33
X2F 00150		CHANNEL, TRANSFORMER MODULE C455-1351 (82386)		EA		1				4 32
00151	5310-655-6933	NUT, PALIN, HEXAGON: TRANSFORMER CHANNEL MTG MS35650-0102 (969006)		EA		6				4 40
00152	5310-515-8052	NUT, SELF-LOCKING, HEXAGON: TRANSFORMER SUPPORT MTG MS20365-428 (96906)		EA		2				4 14
00153	5305-068-0506	SCREW, MACHINE: TRANSFORMER SUPPORT MTG MS90726-6 (969006)		EA		2				4 16
X2F 00154		WASHER, FLAT: TRANSFORMER CHANNEL MTG 400-22 (96906)		EA		6				4 41
X2F 00155		WASHER, FLAT: TRANSFORMER SUPPORT MTG 400-20 (82386)		EA		4				4 15

(1) SMR CODE INDEX NO.	(2) FEDERAL STOCK NUMBER	(3) DESCRIPTION REFERENCE NO. & MFR. CODE	(4) USABLE ON CODE	(5) QTY INC IN UNIT PACK	(6) QTY INC IN UNIT	(7) 30-DAY DS MAINT ALLOWANCE IN UNIT	(8) 30-DAY GS MAINT ALLOWANCE IN UNIT	(9) 1-YR ALW PER EQUIP CNTGCV	(10) DEPOT MAINT ALW- PER EQUIP	(11) ILLUS- TRATION (A) (B) FIG ITEM NO. NO.
00156		4202 - ELECTRICAL CONTROLS								
X2F 00157		BAFFLE ASSEMBLY C533-1509 (82386)	EA		1					2 19
X2F 00158		BAFFLE, LOAD DUCT C533-1510 (82386)	EA		1					5 1
X2F 00159		CLAMP LOOP: TRANSFORMER WIRING HP 11N (09922)	EA		1					2 10
X2F 00160		COMPONENTS ASSEMBLY C533-1049 (82386)	EA		1					4 3
X2F 00161		CONTROL PANEL ASSEMBLY C533-1400 (82386)	EA		1					4
X2F 00161A		BUS BAR C455-1302 (82386)	EA		1					4 13
X2F 00162		PANEL CONTROL C455-1401 (82386)	EA		1					4 35
X20 00163		STRAP, JUMPER: CONTROL PANEL 5372-4 (82386)	EA		6					4
X2F 00164		NUT, SELF-LOCKING, HEXAGON: COMPONENTS ASSEMBLY MTG AN365-518 (88044)	EA		6					4 40
00165	5305-068-9176	SCREW, CAP, HEXAGON HEAD: VOMONENTS ASSEMBLY MTG MS90725-23 (96906)	EA		6					4 2
X2F 00166		SCREW, MACHINE: BAFFLE ASSEMBLY MTG 615-8 (82386)	EA		6					2 18
X20 00167		SCREW, MACHINE: CONTROL PANEL ASSEMBLY MTG 615-8 (82386)	EA		6					4 36
X2F 00168		SCREW, MAVHINE: TRANSFORMER WIRING CLAMP AND BAFFLE ASSEMBLY MTG 615-12 (82386)	EA		1					2 8
00169	5310-809-8546	WASHER, FLAT: TRANSFORMER WIRING CLAMP MS27183-8 (96906)	EA		1					2 9

(1) SMR CODE INDEX NO.	(2) FEDERAL STOCK NUMBER	(3) DESCRIPTION REFERENCE NO. & MFR. CODE	(4) USABLE ON CODE	(5) QTY INC IN UNIT PACK	(6) QTY INC IN UNIT	(7) 30-DAY DS MAINT ALLOWANCE (A) (B) (C)	(8) 30-DAY GS MAINT ALLOWANCE (A) (B) (C)	(9) 1-YR ALW PER 100 EQUIP CNTG	(10) DEPOT MAINT ALW- PER 100 EQUIP	(11) ILLUS- TRATION ALW- (A) (B) PER FIG ITEM NO. NO.	
00171		4203 - CIRCUIT BRAKERS, CUTOOT DEVICES, FUSE AND FUSE HOLDERS									
00172	5310-282-0512	NUT, SELF-LOCKING HEXAGON: RELAY BRACKET MTG AN365-1032 (88044)	EA	2						5 6	
X20 00173		NUT, SELF-LOCKING HEXAGON: RELAY TUBE SOCKET MTG MS26365-632 (96906)	EA	2							
X2F 00174		RELAY, ASSEMBLY C533-1450 (82386)	EA	1						5	
00175	5310-282-0572	NUT, SELF-LOCKING HEXAGON: RELAY MTG MS20365-632 (96906)	EA	3						5 7	
P F 00176		RELAY: 3 POT 783-257 (82386)	EA	1	*	*	2	*	*	2 10 10 5 11	
00177	5310-082-1404	WASHER, FLAT: RELAY MTG MS27183-6 (96906)	EA	3						5 9	
00178	5305-207-0763	SCREW, MACHINE: RELAY TUBE SOCKET MTG MS35223-28 (96906)	EA	2							
P F 00179	5935-056-2475	SOCKET, TUBE: RELAY TO BRACKET MTG 203-62-14-001 (82386)	EA	1	*	*	*	*	*	5 5	
00180	5310-082-1404	WASHER, FLAT: RELAY TUBE SOCKET MTG MS27183-6 (96906)	EA	2							
00183		4205 - CONTROL RESISTANCES									
P F T 00184	4940-920-1155	ABSORBER, ELECTRICAL POWER 8001-023 (82386)	EA	2	*	*2	*	*2	10	10	2 17
P F T 00185	4940-920-1156	ABSORBER, ELECTRICAL POWER 8001-022 (82386)	EA	1	*	*	2	*	*	2 10 10 2 1	
X2F 00186		CLAMP, LOOP: LOAD ABSORBER WIRING 718-307 (82386)	EA	1						2 12	

(1) SMR CODE INDEX NO.	(2) FEDERAL STOCK NUMBER	(3) DESCRIPTION REFERENCE NO. & MFR. CODE	(4) USABLE ON CODE UNIT OF ISSUE	-5 QTY INC IN UNIT PACK	(6) QTY INC IN UNIT	(7) 30-DAY DS MAINT ALLOWANCE (A) (B) (C)	-8 30-DAY GS MAINT ALLOWANCE (A) (B) (C)	(9) 1-YR ALW PER EQUIP CNTG	(10) DEPOT MAINT ALW- PER EQUIP	(11) ILLUS- TRATION (A) (B) FIG ITEM NO. NO.
00187	5310-282-0512	NUT, SELF-LOCKIN, HEXAGON: ABSORBER MTG AN365-1032 (88044)	EA	4						2 15
X2F 00188		SCREW, MACHINE: ABSORBER AND BAFFLE MTG 615-12 (82386)	EA	6						2 8
00189	5305-543-5743	SCREW, MACHINE: ABSORBER MTG MS35224-65 (96906)	EA	1						2 13
00190	5305-579-5025	SCREW, MACHINE: LOAD ABSORBER MTG MS35224-64 (96906)	EA	5						2 16
00191	5310-809-8546	WASHER, FLAT: ABSORBER AND CLAMP MTG MS27183-8 (96906)	EA	4						2 14

(1) SMR CODE INDEX NO.	(2) FEDERAL STOCK NUMBER	(3) DESCRIPTION REFERENCE NO. & MFR. CODE	(4) USABLE ON CODE UNIT OF ISSUE	(5) QTY INC IN UNIT PACK	(6) QTY INC IN UNIT	(7) 30-DAY DS MAINT ALLOWANCE (A) (B) (C)	(8) 30-DAY GS MAINT ALLOWANCE (A) (B) (C)	(9) 1-YR ALW PER EQUIP CNTG	(10) DEPOT MAINT ALW- PER EQUIP	(11) ILLUS- TRATION (A) (B)	FIG NO.	ITEM NO.
00192		PART III										
00193		GROUP 15 - FRAME										
00194		1501 - FRAME ASSEMBLY										
X2F 00194A		ANGLE SUPPORT C455-1303 (82386)	EA		1						4	12
X2F 00195		FRAME AND TRANSFORMER ASSEMBLY C455-1051 (82386)	EA		1						4	
X2F 00196		FRAME, CENTER C455-1201 (82386)	EA		1						3	2
X2F 00197		HOUSING C455-1100 (82386)	EA		1						4	46
X2F 00198		BRACE, CORNER: HOUSING C455-1150 (82386)	EA		2						4	48
X2F 00199		CHANNEL, SUPPORT C455-1301 (82386)	EA		2						4	21
00200	5310-207-9071	NUT, SELF-LOCKING HEXAGON: CORNER BRACE MTG AN365-420 (80044)	EA		4							
00201	5310-061-7325	NUT, SELF-LOCKING: HEXAGON CORNER BRACE MTG MS20365-428 (96906)	EA		4							
00202	5305-068-0506	SCREW, CAP, HEXAGON HEAD: CORNER BRACE MTG MS90726-6 (96906)	EA		4							
X20 00203		WASHER, FLAT: CORNER BRACE MTG 400-200 (82386)	EA		12							
00204	5310-282-0512	NUT, SELF-LOCKING HEXAGON: ANGLE MTG MS20365-1032 (82386)	EA		3						4	10
0 00205	5305-225-8499	SCREW, CAP, HEXAGON: FRAME TO HOUSING MTG MS90725-34 (96906)	EA		1						4	4
X2F 00206		SCREW, MACHINE: TRANSFORMER TO SUPPORT MTG 410-78 (82386)	EA		3						4	17

(1) SMR CODE INDEX NO.	(2) FEDERAL STOCK NUMBER	(3) DESCRIPTION REFERENCE NO. & MFR. CODE	(4) USABLE ON CODE UNIT OF ISSUE	(5) QTY INC IN UNIT PACK	(6) QTY INC IN UNIT	(7) 30-DAY DS MAINT ALLOWANCE (A) (B) (C)	(8) 30-DAY GS MAINT ALLOWANCE (A) (B) (C)	(9) 1-YR ALW PER EQUIP CNTGCV	(10) DEPOT MAINT ALW- PER EQUIP	(11) ILLUS- TRATION (A) (B) FIG ITEM NO. NO.
X2F 00207		WASHER, FLAT: ANGLE MTG 400-238 (82386)	EA	6		1-20 21-50 51-100	1-20 21-50 51-100			4 11
X2F 00208		WASHER, FLAT: FRAME TO HOUSING MTG AND TRANSFORMER CHANNEL MTG 400-11 (82386)	EA	2						4 5
X2F 00209		WASHER, LOCK: FRAME TO HOUSING MTG 603-7 (82386)	EA	1						4 6
00210		GROUP 18 - BDY, CAB, HOOD AND HULL								
00210A		1808 - LOCK PADDLE								
X20 00211		COVER, TOP PANEL 4-735A2 (82386)	EA	1						1 4
X20 00212		SCREW, MACHINE: COVER, TOP PANEL MTG 615-12 (82386)	EA	4						1 5
00213		GROUP 22 - BODY CHASSIS OR HULL AND ACCESSORY ITEMS								
00213A		2210 - DATA PLATE								
X20 00214		PLATE IDENTIFICATION: EQUIPMENT DATA 4055-113 (82386)	EA	1						
X20 00215		PLATE IDENTIFICATION: MANUFACTURER DATA 4055-114 (82386)	EA	1						
X20 00216		RIVET, BLIND 608-205 (82386)	EA	8						
00217		GROUP 40 - ELECTRIC MOTORS AND GENERATORS								
00217A		400 - MOTOR ASSEMBLY								
X2F 00218		BRACKET, MOUNTING, MOTOR 5199-501 (82386)	EA	1						6 4

(1) SMR CODE INDEX NO.	(2) FEDERAL STOCK NUMBER	(3) DESCRIPTION REFERENCE NO. & MFR. CODE	(4) USABLE ON CODE UNIT OF ISSUE	(5) QTY INC IN UNIT PACK	(6) QTY INC IN UNIT	(7) 30-DAY DS MAINT ALLOWANCE (A) (B) (C)	(8) 30-DAY GS MAINT ALLOWANCE (A) (B) (C)	(9) 1-YR ALW PER EQUIP CNTGCT	(10) DEPOT MAINT ALW- PER EQUIP	(11) ILLUS- TRATION ALW- PER EQUIP NO. NO.
00219	5310-582-6046	NUT, SELF-LOCKING: MOTOR DIRECT CURRENT MS20365-1032 (96906)	EA	5						
X2F 00220		WASHER, FLAT 400-66 (82386)	EA	4						
00221	5310-809-8546	WASHER, FLAT: MOTOR, DIRECT CURRENT MS27183-8 (96906)	EA	4						
00222		GROUP 42 - ELECTRICAL EQUIPMENT								
00222A		4201 - TRANSFORMER, POWERLINE OR DISTRIBUTION								
X2F 00223		AUTO, TRANSFORMER MODULE C455-1300 (82386)	EA	1						4
X2F 00224		CHANNEL, TRANSFORMER MODULE C455-1351 (82386)	EA	1						4 32
X2F 00225		CHANNEL, TRANSFORMER MODULE C455-1352 (82386)	EA	1						4 33
X2F 00226		SCREW, MACHINE: AUTO TRANSFORMER MODULE MTG 615-017 (82386)	EA	4						
X2F 00227		SCREW, MACHINE: AUTO TRANSFORMER MODULE MTG 615-019 (82386)	EA	2						4 16
X2F 00228		WASHER, FLAT: AUTO TRANSFORMER MODULE 400-11 (82386)	EA	4						4 41
X2F 00229		WASHER, FLAT: TRANSFORMER XHANNEL MTG 400-22 (82386)	EA	6						4 41
00230		4202 - ELECTRICAL CONTROLS								
X2F 00231		BAFFLE ASSEMBLY C455-1509 (82386)	EA	1						3 12

(1) SMR CODE INDEX NO.	(2) FEDERAL STOCK NUMBER	(3) DESCRIPTION REFERENCE NO. & MFR. CODE	(4) USABLE ON CODE UNIT OF ISSUE	(5) QTY INC IN UNIT PACK	(6) QTY INC IN UNIT	(7) 30-DAY DS MAINT ALLOWANCE (A) (B) (C)	(8) 30-DAY GS MAINT ALLOWANCE (A) (B) (C)	(9) 1-YR ALW PER EQUIP CNTGNCY	(10) DEPOT MAINT ALW- PER EQUIP	(11) ILLUS- TRATION (A) (B)	ITEM NO.
X2F 00232		BAFFLE, LOAD DUCT C455-1510 (82386)	EA		1						5 1
X2F 00233		CLAMP LOOP: TRANSFORMER WIRING HP11N (09922)	EA		1						3 9
X2F 00234		COMPONENTS ASSEMBLY C455-1049 (82386)	EA		1						4 3
X2F 00235		CONTROL PANEL ASSEMBLY C455-1400 (82386)	EA		1						4
X2F 00236		PANEL, CONTROL C455-1401 (82386)	EA		1						4 35
X2F 00237		NUT, SELF-LOCKING, HEXAGON: COMPONENTS ASSEMBLY MTG AN365-518 (88044)	EA		3						4 40
00238	5310-282-0512	NUT, SELF-LOCKING HEXAGON: TRANSFORMER, WIRING CLAMP MTG MS20365-1032M (82386)	EA		1						3 8
00239	5305-068-9176	SCREW, CAP, HEXAGON HEAD: COMPONENTS ASSEMBLY MTG MS90725-23 (96906)	EA		3						4 2
X2F 00240		SCREW, MACHINE: BAFFLE ASSEMBLY MTG 615-8 (82386)	EA		6						3 11
X20 00241		SCREW, MACHINE: CONTROLS PANEL ASSEMBLY MTG 615-8 (82386)	EA		6						4 36
X20 00242		WASHER, FLAT: TRANSFORMER WIRING CLAMP MTG 400-238 (82386)	EA		1						3 4
00243		4203 - CIRCUIT BREAKERS, CUTOUT DEVICES, FUSE AND FUSE HOLDERS									
F 00243A	5310-282-0512	NUT, SELF-LOCKING, HEXAGON: RELAY BRACKET MTG AN365-1032 (88044)	EA		2						5 6
X2F 00244		RELAY ASSEMBLY C455-1450 (82386)	EA		1						5

(1) SMR CODE INDEX NO.	(2) FEDERAL STOCK NUMBER	(3) DESCRIPTION REFERENCE NO. & MFR. CODE	(4) USABLE ON CODE UNIT OF ISSUE	(5) QTY INC IN UNIT PACK	(6) QTY INC IN UNIT	(7) 30-DAY DS MAINT ALLOWANCE (A) (B) (C)	(8) 30-DAY GS MAINT ALLOWANCE (A) (B) (C)	(9) 1-YR ALW PER 100 EQUIP CNTGCTY	(10) DEPOT MAINT ALW- PER 100 EQUIP	(11) ILLUS- TRATION (A) (B) FIG ITEM NO. NO.
F 00245	5310-282-0512	NUT, SELF-LOCKING HEXAGON: RELAY MTG MS20365-632 (96906)	EA	3						5 7
P F 00246		RELAY: 3 POT 783-243 (82386)	EA	1	*	*	2	*	*	2 10 10 5 11
F 00247	5310-082-1404	WASHER, FLAT: RELAY MTG MS27183-6 (96906)	EA	3						5 9
	00249	4205 - CONTROL RESISTANCES								
P F T 00252	4940-920-1157	ABSORBER, ELECTRICAL POWER 8001-017 (82386)	EA	1	*	*	2	*	*	2 10 10 3 1
P F T 00253	4940-920-1168	ABSORBER, ELECTRICAL POWER 8001-018 (82386)	EA	2	*	*	2	**	2 10 10 3 10	
X20 00254		CLAMP, LOOP 718-307 (82386)	EA	1						3 5
X20 00255		CLAMP, LOOP 718-308 (82386)	EA	1						3 7
X2F 00256		SCREW, MACHINE: ASORBER AND BAFFLE MTG 615-12 (82386)	EA	4						3 11
X20 00257		SCREW, MACHINE: ABSORBER AND CLAMP MTG 615-018 (82386)	EA	4						3 3
X20 00258		SCREW, MACHINE: CLAMP MTG 615-12 (82386)	EA	6						3 3
X2F 00259		WASHER, FLAT: ABSORBER MTG 400-238 (82386)	EA	4						3 4
X20 00260		WASHER, FLAT: CLAMP MTG 400-238 (82386)	EA	4						3 4
X20 00261		WASHER, LOCK: CLAMP MTG 603-30 (82386)	EA	2						3 6

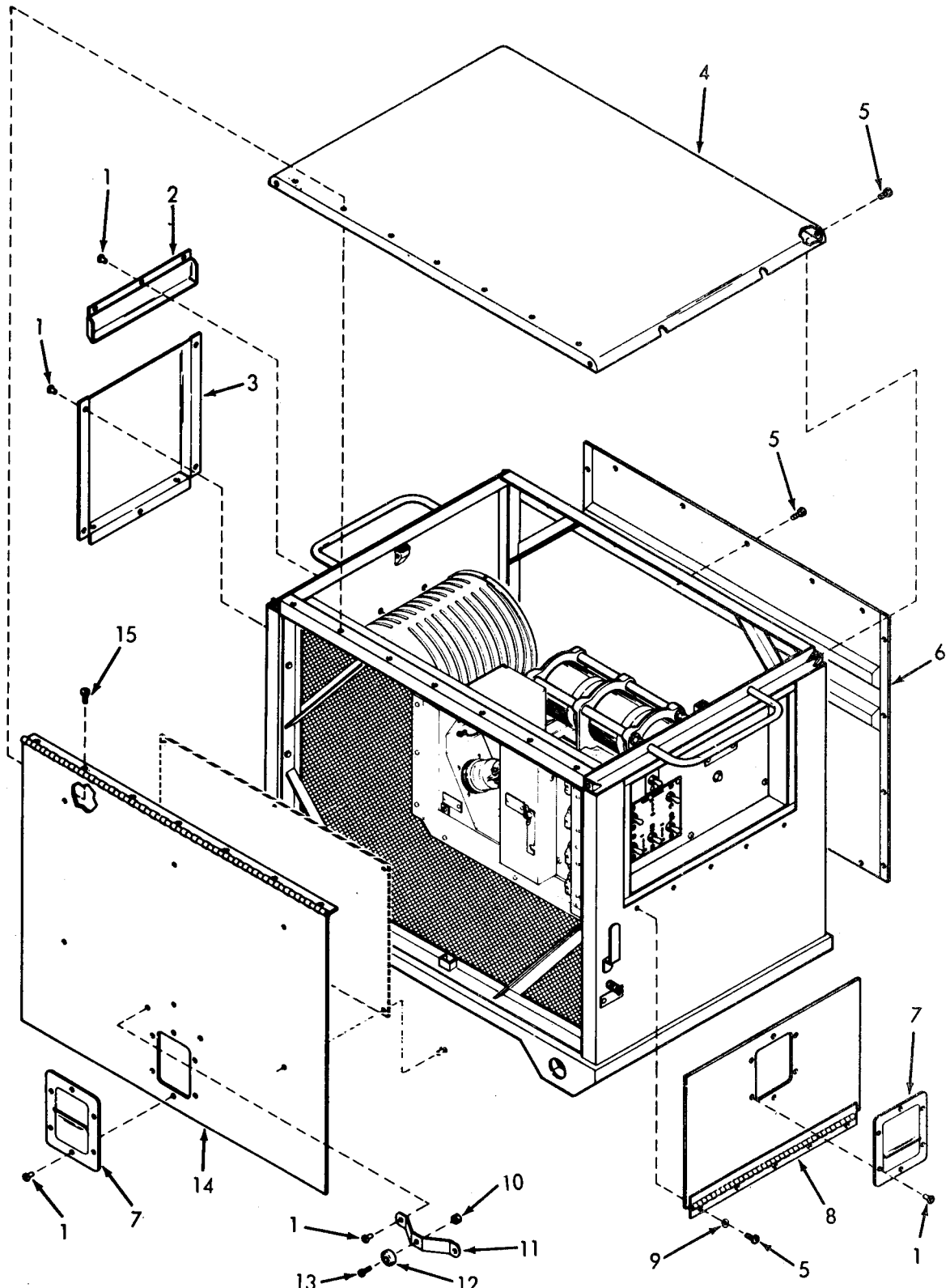

FIGURE NO. 1 DOORS AND PANELS

MEC 6115-423-25P/1

LEGEND TO PARTS, FIGURE 1

ITEM NO.	FUNCT GROUP	APPL PARTS	ITEM NAME
1	1808	1	RI VET
2	1808	1	COVER
3	1808	1	WRAPPER
4	1808	2, 3	COVER
5	1808	2, 3	SCREW
6	1808	1	PANEL
7	1808	1	LOCK
8	1808	1	DOOR
9	1808	1	WASHER
10	1808	1	NUT
11	1808	1	SUPPORT
12	1808	1	BUMPER
13	1808	1	SCREW
14	1808	1	DOOR
15	1808	1	SCREW

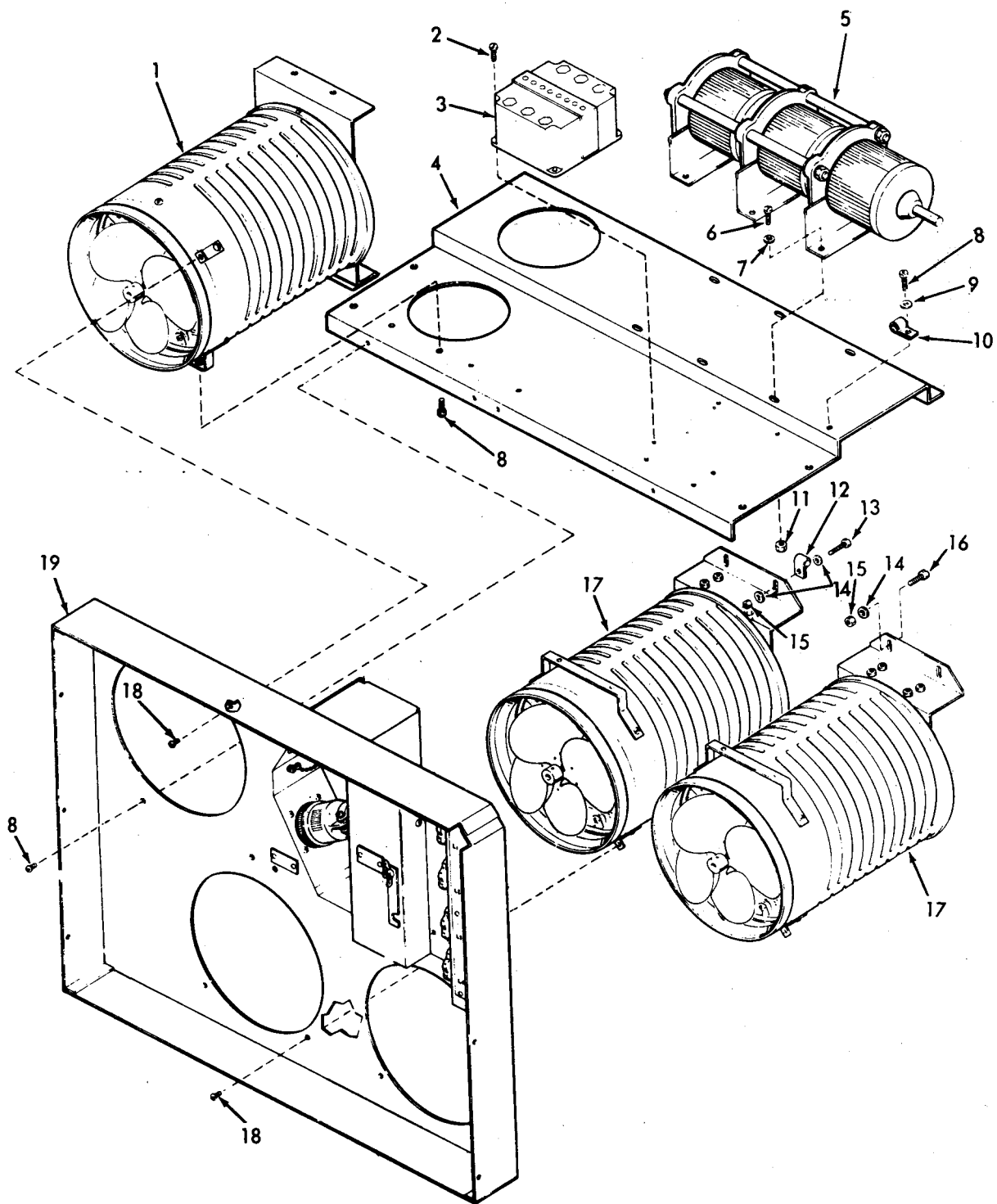
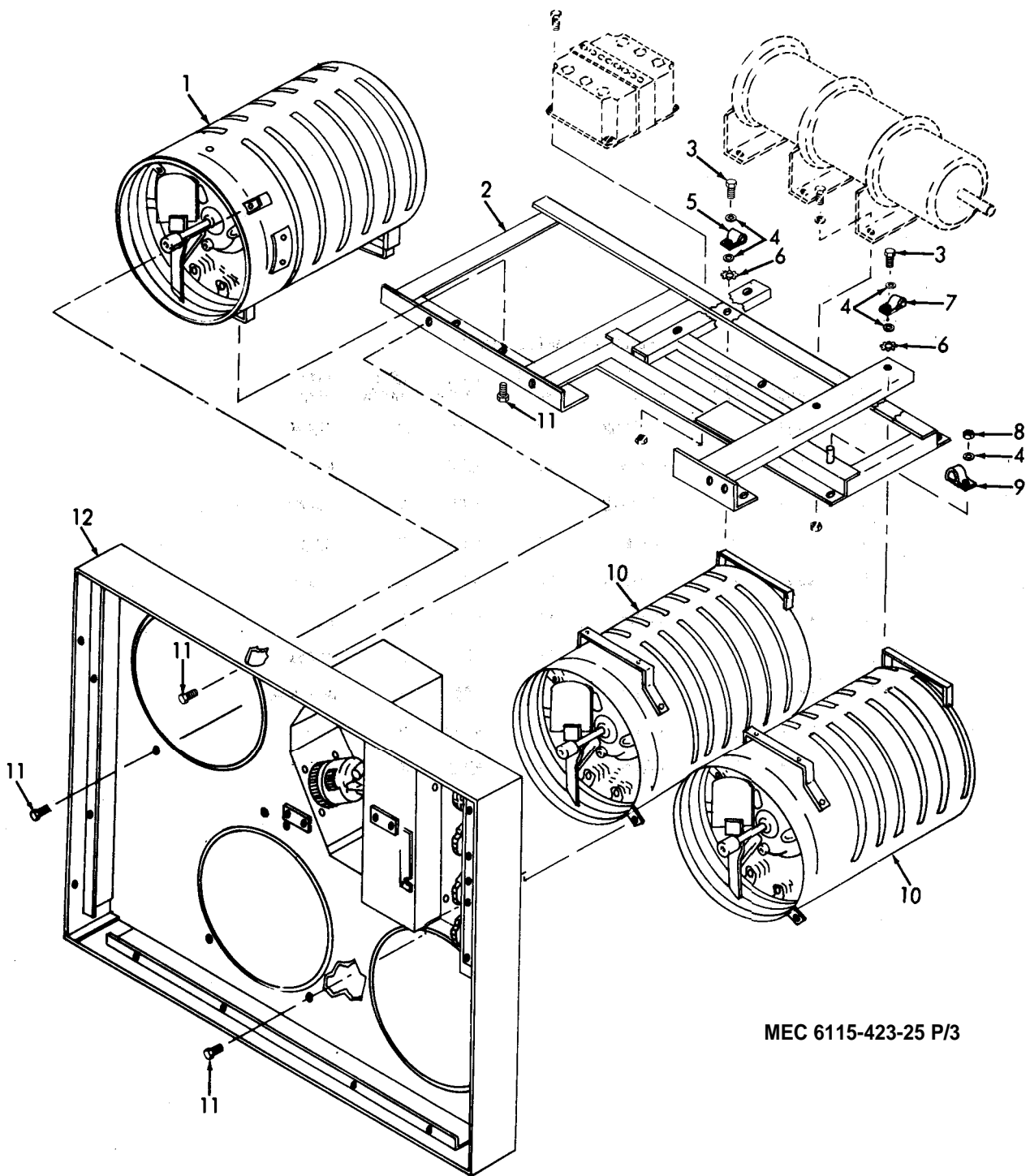

FIGURE NO. 2 ABSORBER , BAFFLE AND FRAME

MEC 6115-423-25P/2

LEGEND TO PARTS, FIGURE 2

ITEM NO.	FUNCT GROUP	APPL PARTS	ITEM NAME	ITEM NO.	FUNCT GROUP	APPL PARTS	ITEM NAME
1	4205	2	ABSORBR	10	4202	2	CLAMP
2	4204	1	SCREW	11	4201	1	NUT
3	4204	1	CNTACTR	12	4205	2	CLAMP
4	1501	2	FRAME	13	4205	2	SCREW
5	4201	1	TRNSFMR	14	4205	2	WASHER
6	4201	1	SCREW	15	4205	2	NUT
7	4201	1	WASHER	16	4205	2	SCREW
8	4202	2	SCREW	17	4205	2	ARSORBR
8	4205	2	SCREW	18	4202	2	SCREW
9	4202	2	WASHER	19	4202	2	BFFLEAY



MEC 6115-423-25 P/3

FIGURE NO. 3 ABSORBER, BAFFLE AND FRAME

LEGEND TO PARTS, FIGURE 3

ITEM NO.	FUNCT GROUP	APPL PARTS	ITEM NAME
1	4205	3	ABSORBR
2	1501	3	FRAME
3	4205	3	SCREW
4	4202	3	WASHER
4	4205	3	WASHER
5	4205	3	CLAMP
6	4205	3	WASHER
7	4205	3	CLAMP
8	4202	3	NUT
9	4202	3	CLAMP
10	4205	3	ABSORBR
11	4202	3	SCREW
11	4205	3	SCREW
12	4202	3	BFFLEAY

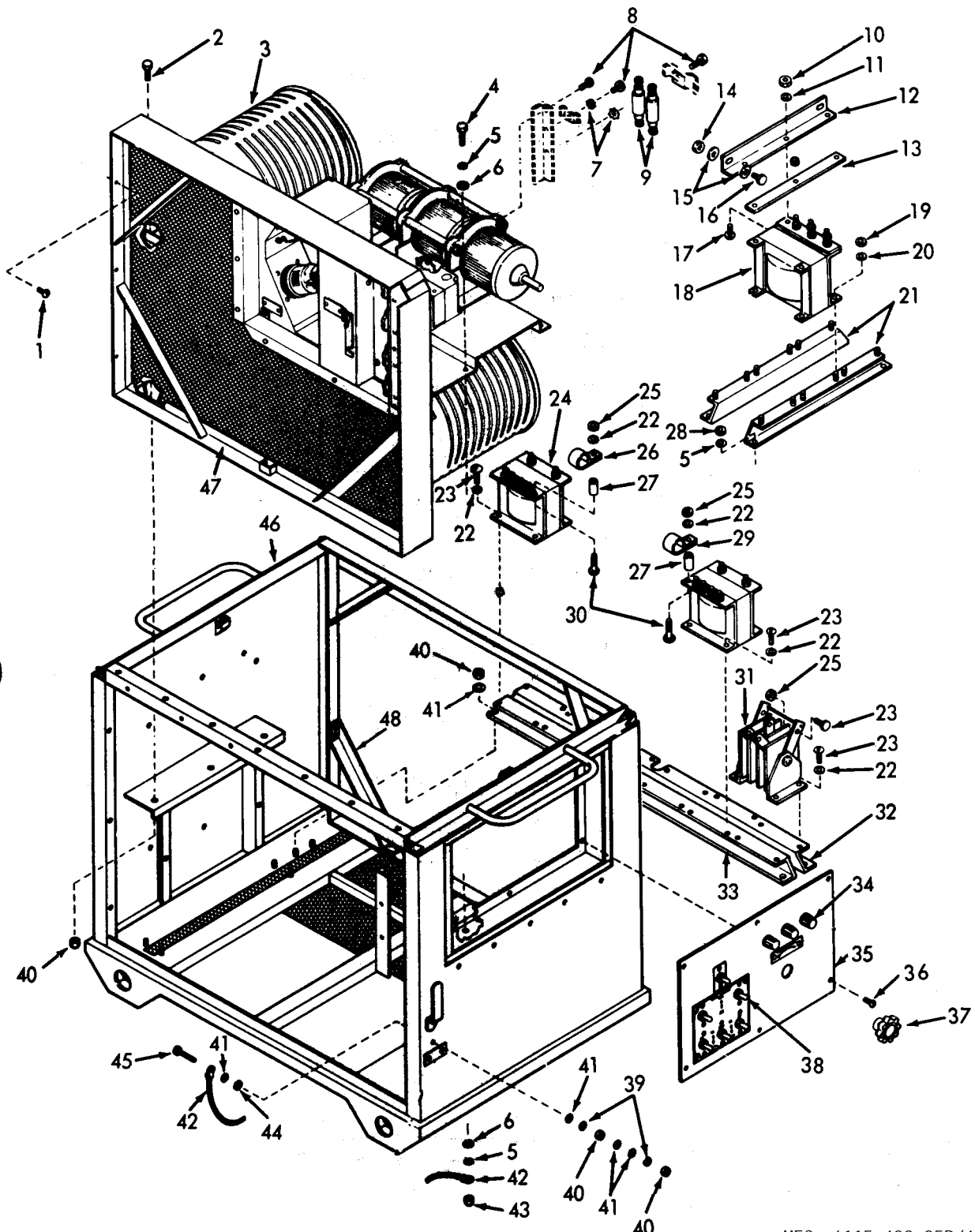

FIGURE NO. 4 COMPONENTS, TRANSFORMERS AND RELATED PARTS

MEC 6115-423-25P/4

LEGEND TO PARTS, FIGURE 4

ITEM NO.	FUNCT GROUP	APPL PARTS	ITEM NAME	ITEM NO.	FUNCT GROUP	APPL PARTS	ITEM NAME
1	4004		SCREW	26	4201	1	CLAMP
2	4202	2, 3	SCREW	27	4201	1	SPACER
3	4202	2, 3	CMPNTAY	28	1501	2	NUT
4	1501	2, 3	SCREW	29	4201	1	CLAMP
5	4214	1	WASHER	30	4201	1	SCREW
5	1501	2, 3	WASHER	31	4201		RCTFLER
6	4214	1	WASHER	32	4201	2, 3	CHANNEL
6	1501	2, 3	WASHER	33	4201	2, 3	CHANNEL
7	4204	1	WASHER	34	4203	1	FUSEHDR
8	4204	1	SCREW	35	4202	2, 3	PANEL
9	4204	1	CPACI TR	36	4202	2, 3	SCREW
10	1501	2, 3	NUT	37	4201	1	KNOB
11	1501	2, 3	WASHER	38	4012	1	SWITCH
12	1501	2, 3	ANGLE	39	4214	1	WASHER
13	4202	2	BUS BAR	40	4214	1	NUT
14	4201	2	NUT	40	4201	2	NUT
15	4201	2	WASHER	40	4202	2, 3	NUT
16	4201	2, 3	SCREW	41	4214	1	WASHER
17	1501	2, 3	SCREW	41	4201	2, 3	WASHER
18	4201	1	TRNSFMR	42	4214	1	STRAP
19	4201	1	NUT	43	4214	1	NUT
20	4201	1	WASHER	44	4214	1	WASHER
21	1501	2, 3	CHANNEL	45	4214	1	SCREW
22	4201	1	WASHER	46	1501	2, 3	HOUSING
23	4201	1	SCREW	47	4004	1	GUARDAY
24	4201	1	TRNSFMR	48	1501	2, 3	BRACE
25	4201	1	NUT				

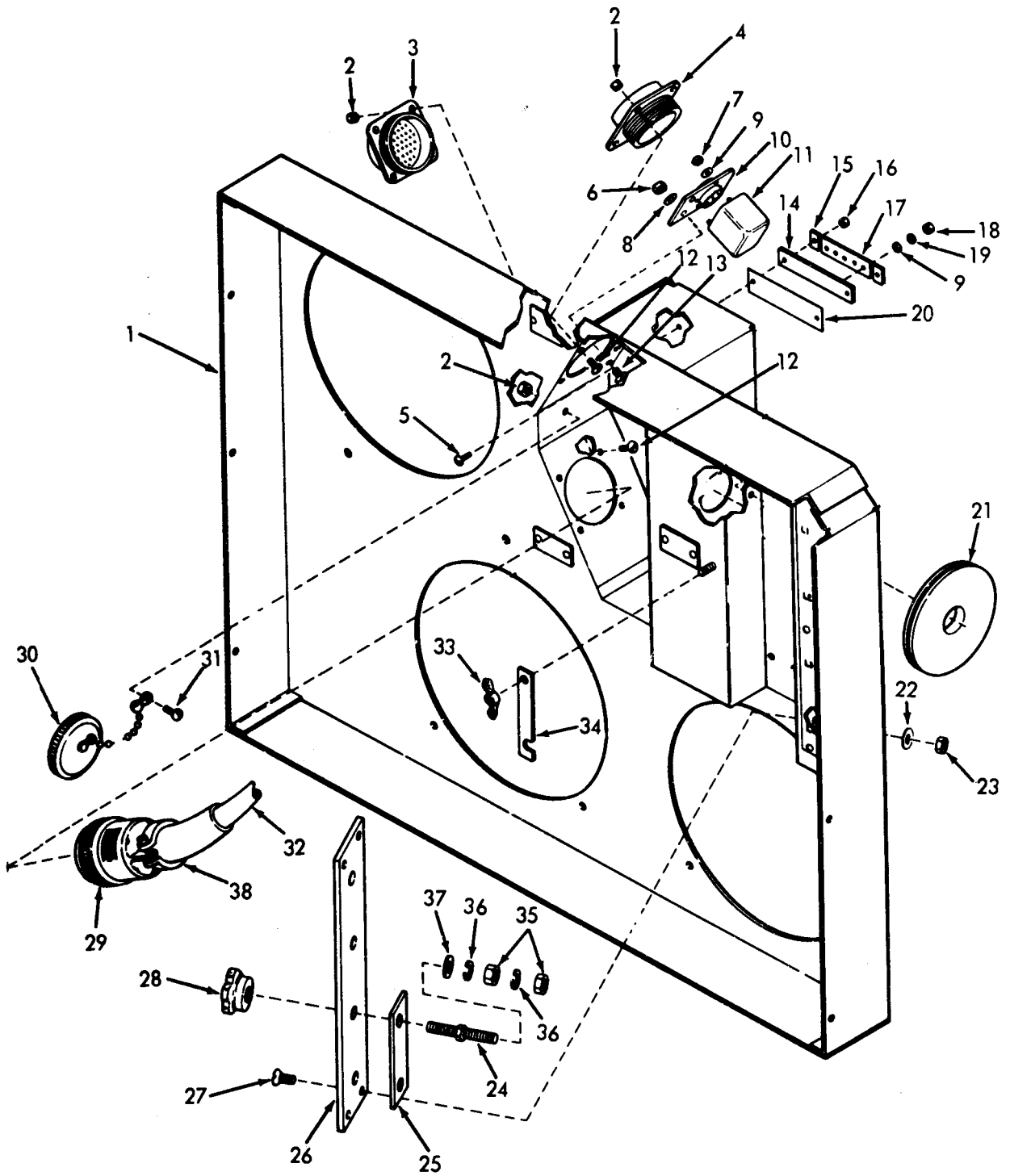

FIGURE NO. 5 BAFFLE

MEC 6115-423-25P/5

LEGEND TO PARTS, FIGURE 5

ITEM NO.	FUNCT GROUP	APPL PARTS	ITEM NAME	ITEM NO.	FUNCT GROUP	APPL PARTS	ITEM NAME
1	4202	2, 3	BAFFLE	20	4202	1	STRIP
2	4211	1	NUT	21	4202	1	GROMMET
3	4211	1	CONNCTR	22	4202	1	WASHER
4	4211	1	CONNCTR	23	4202	1	NUT
5	4202	1	SCREW	24	4202	1	STUD
6	4203	2, 3	NUT	25	4202	1	INSULATR
7	4203	2, 3	NUT	26	4202	1	PANEL
8	4203	1	WASHER	27	4202	1	SCREW
9	4202	1	WASHER	28	4202	1	KNOB
9	4203	2, 3	WASHER	29	4211	1	CONNCTR
10	4203	1	BRACKET	30	4211	1	COVER
11	4203	2, 3	RELAY	31	4211	1	SCREW
12	4211	1	SCREW	32	4202	1	TUBING
13	4203	1	SCREW	33	4202	1	NUT
14	4202	1	BOARD	34	4202	1	LINK
15	4202	1	STRIP	35	4202	1	NUT
16	4202	1	NUT	36	4202	1	WASHER
17	4202	1	EAR	37	4202	1	WASHER
18	4202	1	NUT	38	4211	1	CLAMP
19	4202	1	WASHER				

LEGEND TO PARTS, FIGURE 6

ITEM NO.	FUNCT GROUP	APPL PARTS	ITEM NAME
1	4004	1	IMPELLR
2	4214	1	BRUSH
3	4000	1	MOTOR
4	4000	2,3	BRACKET
5	4012	1	SWITCH

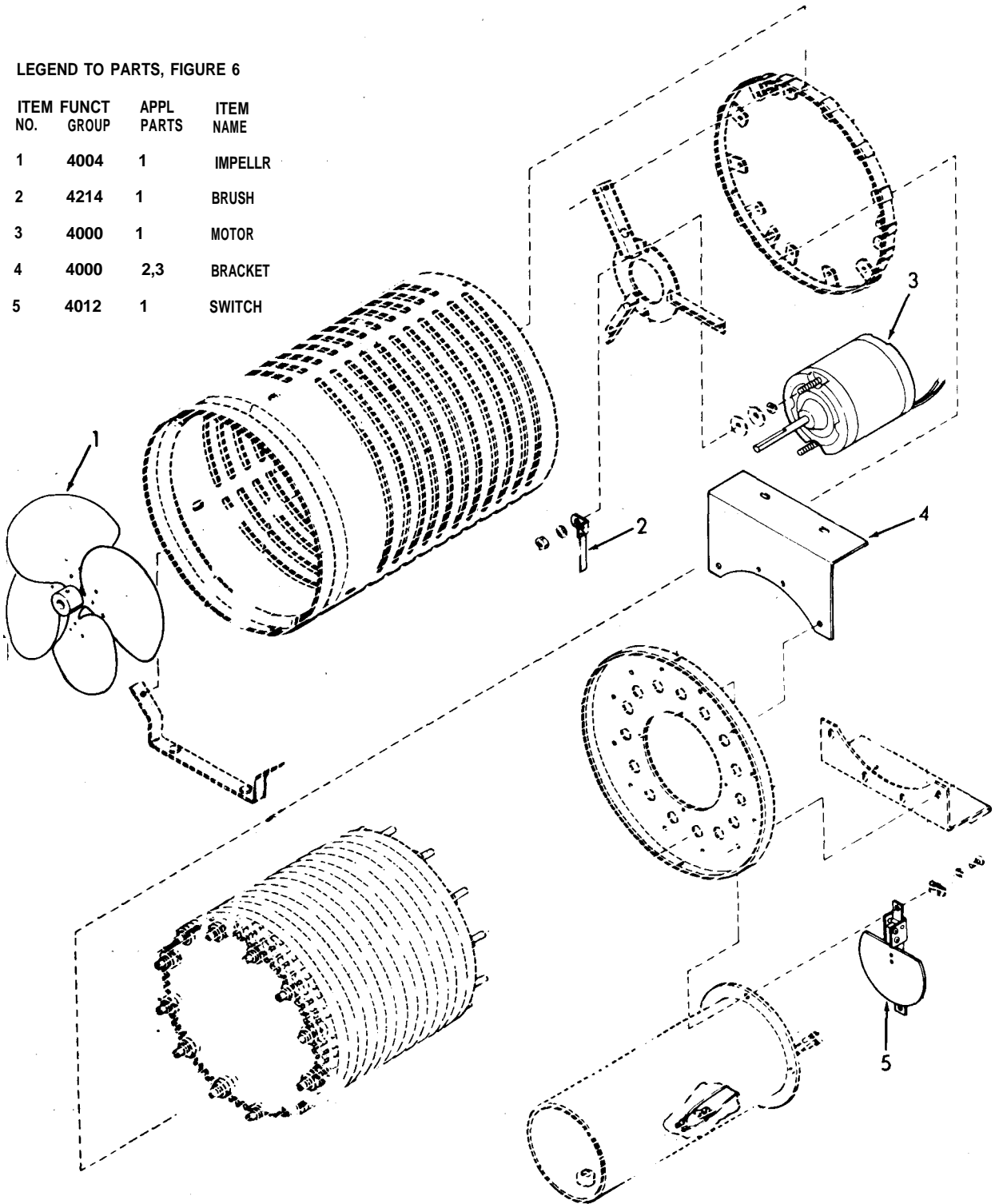

FIGURE NO. 6 MOTOR, IMPELLER AND SWITCH

MEC 6115-423-25P/6

SECTION VII. INDEX-FEDERAL STOCK NUMBER AND REFERENCE NUMBER
 CROSS-REFERENCE TO INDEX NUMBER

STOCK NUMBER	INDEX NUMBER
4920-861-9266	00041
4935-863-5082	00108
4940-920-1150	00006
4940-920-1155	00184
4940-920-1156	00185
4940-920-1157	00252
4940-920-1168	00253
4940-920-1190	00058
5305-068-0506	00053
	00153
	00202
5305-068-9176	00165
	00239
5305-207-0763	00178
5305-225-8499	00131
	00205
5305-276-1450	00073
5305-543-5743	00189
5305-558-4047	00111
5305-576-7579	00016
5305-579-5025	00190
5305-622-1509	00091
5305-638-3358	00106
5305-638-6494	00132
5305-660-2869	00054
5310-061-7325	00070
	00201
5310-082-1404	00085
	00177
	00180
	00247
5310-207-9071	00200
5310-208-1919	00124
5310-209-0786	00115
5310-266-4463	00129
5310-274-8884	00068
5310-282-0512	00047
	00145
	00172
	00187
	00204
	00238
	00243
	00245
5310-282-0572	00175
5310-497-3882	00110
5310-515-8052	00049
	00152
5310-550-3397	00048
5310-582-6046	00219
5310-596-7691	00095
5310-655-6933	00109
	00151
5310-809-4058	00060
5310-809-8544	00018
5310-809-8546	00091
	00133
	00169
	00191
	00221
5355-668-5898	00078
5355-928-8848	00046
5910-194-8758	00093
5920-518-1793	00090
5920-780-2903	00091
5930-782-7215	00042
5935-056-2475	00179
5935-224-8150	00099
5935-518-9479	00100
5935-577-8646	00103
5935-836-7770	00102
5935-847-4234	00101
	00105
5940-623-7228	00064
5945-890-0017	00096
5970-803-6091	00075
6105-827-3833	00034

SECTION VII. INDEX-FEDERAL STOCK NUMBER AND REFERENCE NUMBER
 CROSS-REFERENCE TO INDEX NUMBER

REFERENCE NO.	MFG CODE	INDEX NO.	REFERENCE NO.	MFG CODE	INDEX NO.
AN3057-24	88044	00099	MS27183-10	96906	00060
AN365-1032	88044	00172	MS27183-6	96906	00085
		00187			00177
	88044	00145		96906	00180
		00243			00247
AN365-420	88044	00048	MS27183-7	96906	00018
		00124	MS27183-8	96906	00062
		00200			00091
AN365-518	88044	00237			00133
	88044	00110			00169
		00130			00191
		00164			00221
AN365-832	88044	00104	MS3102A36-10P	96906	00102
	88044	00007	MS35223-28	96906	00178
BA104AA	74063	00096	MS35223-45	96906	00106
CA3102A36-10P	71468	00101		96906	00105
CA3106A36-10S	71468	00100	MS35223-46	96906	00016
CH455-1011	82386	00024	MS35224-64	96906	00190
C455-1010	82386	00025	MS35224-65	96906	00132
C455-1012	82386	00027			00189
C455-1049	82386	00234	MS35224-70	96906	00054
C455-1051	82386	00195	MS35230-67	96906	00111
C455-1100	82386	00197	MS35233-14	96906	00072
C455-1150	82386	00121	MS35240-91	96906	00073
		00198	MS35335-32	96906	00095
C455-1201	82386	00196			00115
C455-1250	82386	00144	MS35425-14	96906	00071
C455-1300	82386	00223	MS35650-105	96906	00151
C455-1301	82386	00199		96906	00109
C455-1302	82386	00161	MS35690-631	96906	00079
C455-1303	82386	00194	MS90725-23	96906	00165
C455-1350	82386	00058		96906	00239
C455-1351	82386	00224	MS90725-34	96906	00131
C455-1352	82386	00225		96906	00205
	82386	00149	MS90726-6	96906	00125
C455-1401	82386	00162			00153
		00236			00202
C455-1402	82386	00022		96906	00053
C455-1403	82386	00023	1037-405	82386	00074
C455-1451	82386	00089	1489-2	82386	00002
C455-1509	82386	00231	1901-4	82386	00078
C455-1510	82386	00232	2088-010	82386	00077
C455-1575	82386	00036	2179-033	82386	00081
C455-1600	82386	00005	22NM-40	72962	00069
C455-1602	82386	00004	4-735A2	82386	00211
C455-1609	82386	00017	400-11	82386	00134
C455-1625	82386	00008			00208
C455-1700	82386	00092		82386	00113
C533-1049	82386	00160			00228
C533-1051	82386	00120	400-165	82386	00082
C533-1100	82386	00123	400-20	82386	00061
C533-1201	82386	00128		82386	00086
C533-1300	82386	00148			00155
C533-1303	82386	00119	400-200	82386	00127
C533-1400	82386	00161			00203
C533-1450	82386	00174	400-216	82386	00146
C533-1509	82386	00157	400-22	82386	00114
C533-1510	82386	00158			00229
E823-4	60399	00037		96906	00154
F03A25V3AS	75915	00090	400-238	82386	00207
HKP-L	71640	00091			00259
HP-12N	09922	00044			00260
HP-7N	09922	00045		82386	00242
HP-11N	09922	00159	401-210	82386	00055
		00233	4055-113	82386	00214
MS20365-1032	82386	00204	4055-114	82386	00215
		00238	4055-120	82386	00141
	96906	00047	4059-162	82386	00026
		00219	4060-015	82386	00021
MS20365-428	96906	00049	4062-016	82386	00028
		00152	4062-017	82386	00029
	96906	00070	4062-018	82386	00030
	96906	00201	410-78	82386	00206
MS20365-632	96906	00068	455-1601	82386	00006
		00175	501-047	82386	00066
		00245	5199-501	82386	00218
MS25043-36C	96906	00103	5372-4	82386	00163
MS25083-2BD10	96906	00112	54-018	62119	00034
MS25123-1-5	96906	00065	5719	82386	00067
MS25226-2-5	96906	00064	5743A	82386	00108
MS25227-1	96906	00075	603-30	82386	00261
MS26365-632	96906	00173	603-7	82386	00116

REFERENCE NO.	MFG CODE	INDEX NO
603-7	82386	00135
		00209
604-18	82386	00083
604-55	82386	00117
604-6	82386	00087
608-204	82386	00031
		00142
608-205	82386	00032
		00216
608-310	82386	00010
	82386	00011
608-311	82386	00012
615-015	82386	00040
615-017	82386	00052
		00226
615-018	82386	00257
615-019	82386	00126
		00227
615-020	82386	00051
615-12	82386	00015
		00212
		00258
	82386	00094
		00097
		00168
		00256
615-8	82386	00166
		00167
		00241
	82386	00013
		00240
6502-018	82386	00076
6508-032	82386	00080
669-186	82386	00084
679-341	82386	00093
689-231	82386	00042
718-307	82386	00186
		00254
718-308	82386	00255
758-135	82386	00046
778-300	82386	00057
778-301	82386	00056
783-243	82386	00246
783-257	82386	00176
8001-018	82386	00253
8001-022	82386	00185
8001-023	82386	00184
8056-006	82386	00003
8056-007	82386	00019
9T92Y1961	95018	00059

By Order of the Secretary of the Army:

HAROLD K. JOHNSON,
General, United States Army,
Chief of Staff.

Official:

KENNETH G. WICKHAM,
Major General, United States Army,
The Adjutant General.

Distribution:

Active Army:

USASA (2)
 ACSI (1)
 DCSLOG (1)
 CNGB (1)
 TSG (1)
 CofEngrs (3)
 ACSC-E (1)
 Dir of Trans (1)
 CofSpts (1)
 USAMB (1)
 USAARTYBD (2)
 USAARENBD (2)
 USAIB (2)
 USARADB (2)
 USAAESWBD (2)
 USAAVNTBD (2)
 USCONARC (3)
 OS Maj Cored (5) except
 USASETAF (2)
 USARJ (1)
 USAMC (1)
 USAMECOM (46)
 MDW (1)
 Armies (2)
 Corps (2)
 Div (2)
 Engr Bde (1)
 Svc Colleges (2)
 Br Svc Sch (2)
 USMA (2)
 USACDCEC (10)
 Cen Dep (10)
 Engr Dep (10)

Army Dep (2) except
 TOAD (3)
 EAMTMTS (2)
 WAMTMTS (2)
 MOTBA (1)
 MOTBY (1)
 MOTKI (1)
 MOTSU (1)
 Div Engr (2)
 Engr Dist (2)
 USA Mbl Equip R&D Cen (3)
 Engr Cen (5)
 USAREUR Engr Proc Cen (2)
 USAREUR Engr Sup Con Agcy (10).
 Engr FLDMS (2)
 Ft Knox FLDMS (10)
 Fld Comd, DASA (8)
 AMS (3)
 USACOMZEUR (2)
 USAC (1)
 MAAG (1)
 JBUSMC (1)
 USARMA (1)
 USARMIS (1)
 Units org under fol TOE:
 5-48 (2)
 5-237 (5)
 5-262 (5)
 5-267 (1)
 5-278 (5)
 5-279 (2)
 39-61 (2)

NG: State AG (3).

USAR: Same as Active Army except allowance is one (1) copy for each unit.

For explanation of abbreviations used see AR 320-50.

TM 5-6115-423-25P-LOAD BANK, 0-30KW, AC, PORTABLE, SKID MOUNTED-1968