

TECHNICAL MANUAL UNIT, DIRECT SUPPORT AND GENERAL SUPPORT MAINTENANCE MANUAL

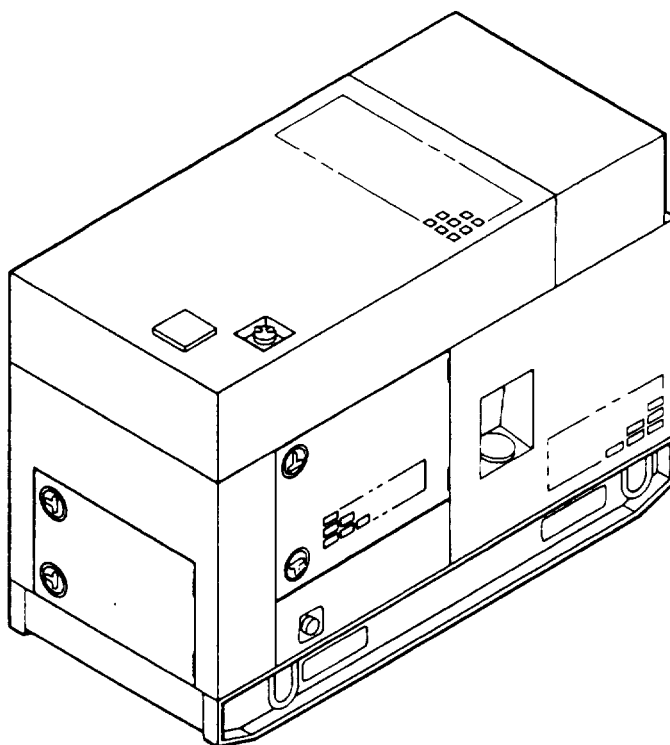

GENERATOR SET, SKID MOUNTED, TACTICAL QUIET

15 KW, 50/60 AND 400 Hz
MEP-804A (50/60 Hz) 6115-01-274-7388
MEP-814A (400 Hz) 6115-01-274-7393

DISTRIBUTION STATEMENT A: Approved for public release; distribution is unlimited.

HEADQUARTERS, DEPARTMENTS OF THE ARMY AND
THE AIR FORCE
1 SEPTEMBER 1993

WARNING

High voltage is produced when this generator set is in operation. Improper operation could result in personal injury or death.

WARNING

Battery acid can cause burns to unprotected skin. Wear protective clothing including rubber gloves and eye protection when servicing the batteries. Failure to observe this warning could result in severe injury or death.

WARNING

Batteries give off a flammable gas. Do not smoke or use open flame when performing maintenance. Flames and explosion could result in severe personal injury or death.

WARNING

Exhaust discharge contains deadly gases. Do not operate generator sets in enclosed areas unless exhaust discharge is properly vented outside. Severe personal injury or death due to carbon monoxide poisoning could result.

WARNING

The fuels used in this generator set are highly explosive. Do not smoke or use open flames when performing maintenance. Fire or explosion could cause serious injury or death.

WARNING

When filling the fuel tank, maintain metal-to-metal contact between filler nozzle and fuel tank opening. Failure to observe this warning could result in explosion, injury, and death.

WARNING

Diesel fuel is flammable and toxic to eyes, skin, and respiratory tract. Skin/eye protection required. Avoid repeated/prolonged contact. Good general ventilation is normally adequate.

WARNING

Liquids under pressure are generated as a result of operation of the generator set. High pressure leaks could cause severe personal injury or death.

WARNING

The cooling system operates at high temperatures. Personal injury or death from burns or scalding could result from high pressure steam.

WARNING

With any access door open, the noise level of this generator set when operating could cause hearing damage. Hearing protection must be worn when operating or working near the generator set while running.

WARNING

Never attempt to start the generator set if it is not properly grounded. Failure to observe this warning could result in serious injury or death by electrocution.

WARNING

Hot refueling of generator set while operating, presents a safety hazard and should not be attempted. Hot engine surfaces and sparks from the engine and generator circuitry are possible sources of ignition. Severe injury or death could result.

WARNING

Prior to making any connections for parallel operation or moving a generator set which has been operating in parallel, ensure that there is no input to the load and that the generator sets are shut down. Failure to observe this warning may result in personal injury or death by electrocution.

WARNING

Dry cleaning solvent inflammable and toxic to eyes, skin, and respiratory tract. Skin/eye protection required. Avoid repeated/prolonged contact. Good general ventilation is normally adequate.

WARNING

Remove metal jewelry when working on electrical system or components. Failure to observe this warning could result in severe personal injury or death by electrocution.

WARNING

Wear a protective mask and gloves when sanding CARC painted surfaces. CARC paint dust is a health hazard and could cause personal injury if warning is not followed.

FOR FIRST AID REFER TO FM 21-11

CHANGE
NO. 4

HEADQUARTERS, DEPARTMENTS OF
THE ARMY AND THE AIR FORCE
WASHINGTON, D.C., 30 October 1996

Unit, Direct Support and General Support
Maintenance Manual

**GENERATOR SET, SKID MOUNTED, TACTICAL QUIET
15kW, 50/60 AND 400Hz
MEP-804A (50/60Hz), 6115-01-274-7388
MEP-814A (400 Hz), 6115-01-274-7393**

DISTRIBUTION STATEMENT A: Approved for public release; distribution is unlimited

TM 9-6115-643-24/TO 35C2-3-445-22,1 September 1993, is changed as follows:

1. Remove and insert pages as indicated below. New or changed text material is indicated by a vertical bar in the margin. An illustration change is indicated by a miniature pointing hand.

Remove pages	Insert pages
i through iv	i through iv
2-9 through 2-12	2-9 through 2-12
2-23 and 2-24	2-23 and 2-24
2-27 and 2-28	2-27 and 2-28
2-31 and 2-32	2-31 and 2-32
2-35 through 2-38	2-35 through 2-38
2-57 through 2-64	2-57 through 2-64
2-77 and 2-78	2-77 and 2-78
- - -	2-78.1/ (2-78.2 blank)
2-81 and 2-82	2-81 and 2-82
2-99 and 2-100	2-99 and 2-100
2-103 and 2-104	2-103 and 2-104
2-111 through 2-114	2-111 through 2-114
2-119 through 2-126	2-119 through 2-126
2-149 and 2-150	2-149 and 2-150
2-153 and 2-154	2-153 and 2-154
3-11 through 3-14	3-11 through 3-14
3-27 and 3-28	3-27 and 3-28
4-31 through 4-34	4-31 through 4-34

2. Retain this sheet in front of manual for reference purposes

ARMY TM 9-6115-643-24
AIR FORCE TO 35c2-3-445-22
C 4

By Order of the Secretaries of the Army and Air Force:

Official:

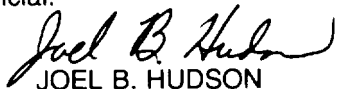
JOEL B. HUDSON
Administrative Assistant to the
Secretary of the Army
02930

DENNIS J. REIMER
General, *United States Army*
Chief of Staff

RONALD R. FOGELMAN
General, *USAF*
Chief of Staff

HENRY VICCELLIO, JR.
General, *USAF*
Commander, Air Force Materiel Command

DISTRIBUTION:

To be distributed in accordance with DA Form 12-25-E, block no. 5266, requirements for
TM 9-6115-643-10.

CHANGE
NO. 3

HEADQUARTERSDEPARTMENTS OF
THE ARMY AND THE AIR FORCE
WASHINGTON, D.C., 15 November 1995

**UNIT, DIRECT SUPPORT AND GENERAL SUPPORT
MAINTENANCE MANUAL**

**GENERATOR SET, SKID MOUNTED, TACTICAL QUIET
15 KW, 50/60 AND 400 Hz
MEP-804A (50/60 Hz) 6115-01-274-7388
MEP-814A (400 Hz) 6115-01-274-7393**

DISTRIBUTION STATEMENT A: Approved for public release; distribution is unlimited

TM 9-6115-643-24/TO 35C2-3-445-22, 1 September 1993, is changed as follows:

1. Remove and insert pages as indicated below. New or changed text material is indicated by a vertical bar in the margin. An illustration change is indicated by a miniature pointing hand.

Remove pages
1-21 and 1-22
2-55 and 2-56
2-59 and 2-60
2-75 and 2-76
2-83 and 2-84

Insert pages
1-21 and 1-22
2-55 and 2-56
2-59 and 2-60
2-75 and 2-76
2-83 and 2-84

2. Retain this sheet in front of manual for reference purposes.

ARMY TM9-6115-643-24
AIR FORCE TO 35C2-3-445-22
C3

By Order of the Secretaries of the Army and Air Force:

Official:

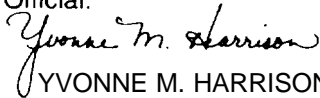

YVONNE M. HARRISON
Administrative Assistant to the
Secretary of the Army
01190

DENNIS J. REIMER
General, United States Army
Chief of Staff

RONALD R. FOGELMAN
General, USAF
Chief of Staff

HENRY VICCELLIO, JR.
General, USAF
Commander, Air Force Materiel Command

DISTRIBUTION:

To be distributed in accordance with DA Form 12-25-E, block no. 5266, requirements for TM 9-6115-643-24.

CHANGE

NO. 2

HEADQUARTERS, DEPARTMENTS OF
THE ARMY AND THE AIR FORCE
WASHINGTON, D.C., 30 APRIL 1995

**Unit, Direct Support and
General Support Maintenance Manual**

**GENERATOR SET,
SKID MOUNTED, TACTICAL QUIET**

**15KW, 50/60 AND 400 Hz
MEP-804A (50/60Hz) 6115-01-274-7388
MEP-814A (400Hz) 6115-01-274-7393**

DISTRIBUTION STATEMENT A: Approved for public release; distribution is unlimited

TM 9-6115-643-24/TO 35C2-3-445-22, 1 September 1993, is changed as follows:

1. Remove and insert pages as indicated below. New or changed text material is indicated by a vertical bar in the margin. An illustration change is indicated by a miniature pointing hand.

Remove pages

1-15 and 1-16
2-95 through 2-98
2-119 and 2-120

Insert pages

1-15 and 1-16
2-95 through 2-98
2-119 and 2-120

2. Retain this sheet in front of manual for reference purposes.

ARMY TM 9-6115-643-24
AIR FORCE TO 35C2-3-445-22
C 2

By Order of the Secretaries of the Army, and the Air Force:

Official:



JOEL B. HUDSON

Acting Administrative Assistant to the
Secretary of the Army
00102

GORDON R. SULLIVAN
General, United States Army
Chief of Staff

MERRILL A. McPEAK
General, USAF
Chief of Staff

Official:

RONALD W. YATES

General, USAF
Commander, Air Force Materiel Command

DISTRIBUTION:

To be distributed in accordance with DA Form 12-25-E, block no. 5266, requirements for
TM 9-6115-643-24.

C1

CHANGE
NO. 1

HEADQUARTERS
DEPARTMENTS OF THE ARMY AND AIR FORCE
WASHINGTON, D.C., 15 DECEMBER 1993

TECHNICAL MANUAL

UNIT, DIRECT SUPPORT AND GENERAL SUPPORT
MAINTENANCE MANUAL
GENERATOR SET, SKID MOUNTED, TACTICAL QUIET
15 KW, 50/60 AND 400 HZ, MEP-804A (50/60 Hz) 6115-01-274-7388
MEP-814A (400 Hz) 6115-01-274-7393

DISTRIBUTION STATEMENT A: Approved for public release; distribution is unlimited.

TM 9-6115-643-24/TO 35C2-3-445-22, 1 SEPTEMBER 1993 is changed as follows:

1. Remove and insert pages as indicated below. New or changed text material is indicated by a vertical bar in the margin. An illustration change is indicated by a miniature pointing hand.

Remove pages

1-13 and 1-14
2-11 and 2-12
2-15 and 2-16
2-19 and 2-20
2-127 and 2-128
2-131 through 2-136
4-27 and 4-28
B-7 and B-8
C-1 and C-2

Insert pages

1-13 and 1-14
2-11 and 2-12
2-15 and 2-16
2-19 and 2-20
2-127 and 2-128
2-131 through 2-136
4-27 and 4-28
B-7 and B-8
C-1 and C-2

2. Retain this sheet in front of manual for reference purposes.

By Order of the Secretaries of the Army, and Air Force:

Official:

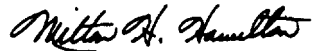

MILTON H. HAMILTON
*Administrative Assistant to the
Secretary of the Army*
05860

GORDON R. SULLIVAN
*General, United States Army
Chief of Staff*

MERRILL A. McPEAK
*General, USAF
Chief of Staff*

Official:

RONALD W. YATES
*General, USAF
Commander Air Force Materiel Command*

DISTRIBUTION:

To be distributed in accordance with DA Form 12-25-E, block no. 5266, requirements for TM 9-6115-643-24.

TECHNICAL MANUAL
NO. 9-6115-643-24

HEADQUARTERS
DEPARTMENTS OF THE ARMY AND THE AIR FORCE
WASHINGTON, D.C., 1 September 1993

Unit, Direct Support and General Support Maintenance Manual

GENERATOR SET, SKID MOUNTED, TACTICAL QUIET
15 KW, 50/60 AND 400 Hz
MEP-804A (50/60 Hz) 6115-01-274-7388
MEP-814A (400 Hz) 6115-01-274-7393

REPORTING OF ERRORS AND RECOMMENDING IMPROVEMENTS

You can help improve this manual. If you find any mistakes or if you know of a way to improve the procedures, please let us know.

(A): Mail your letter or DA Form 2028 (Recommended Changes to Publications and Blank Forms), or DA Form 2028-2 located in the back of this manual directly to: Commander, US Army Aviation and Troop Command, ATTN: AMSAT-I-MP, 4300 Goodfellow Blvd., St. Louis, MO 63120-1798. You may also submit your recommended changes by E-mail directly to <mpmt%avma28@st-louis-emh7.army.mil>. Instructions for sending an electronic 2028 may be found at the back of this publication immediately preceding the hard copy 2028.

(F): Air Force - AFTO Form 22 directly to: Commander, Sacramento Air Logistics Center, ATTN: TILBA, McClellan AFB, CA 95652-5990.

A reply will be furnished directly to you.

DISTRIBUTION STATEMENT A: Approved for public release; distribution is unlimited.

TABLE OF CONTENTS

		Page
	How to Use This Manual	VII
Chapter 1	Introduction	
Section	I. General Information	1-1
Section	II. Equipment Description and Data	1-4
Section	III. Principles of Operation	1-10
Chapter 2	Unit Maintenance Instructions	
Section	I. Service Upon Receipt of Equipment	2-1
Section	II. Repair Parts; Special Tools; Test, Measurement, and Diagnostic Equipment (TMDE); and Special Support Equipment	2-9
Section	III. Special Lubrication Instructions	2-9
Section	IV. Preventive Maintenance Checks and Services (PMCS)	2-9
Section	V. Troubleshooting	2-12
Section	VI. Radio Interference Suppression	2-25
Section	VII. Special Instructions	2-25
Section	VIII. Maintenance of DC Electrical System	2-26
Section	IX. Maintenance of Housing	2-33
Section	X. Maintenance of Control Box Assembly	2-47
Section	XI. Maintenance of Air Intake and Exhaust System	2-105
Section	XII. Maintenance of Coolant System	2-111
Section	XIII. Maintenance of Fuel System	2-126
Section	XIV. Maintenance of Output Box Assembly	2-137
Section	xv. Maintenance of Engine Accessories	2-146
Section	XVI. Maintenance of Lubrication System	2-157
Section	XVII. Preparation for Shipment and Storage	2-159
Chapter 3	General Maintenance Instructions	
Section	I. Repair Parts; Tools; Test, Measurement, and Diagnostic Equipment (TMDE); and Special Support Equipment	3-1
Section	II. Troubleshooting	3-2
Section	III. Removal and Installation of Major Components	3-11
Chapter 4	Direct Support Maintenance Instructions	
Section	I. Maintenance of Control Box Assembly	4-1
Section	II. Maintenance of Coolant System	4-12
Section	III. Maintenance of Fuel System	4-12
Section	IV. Maintenance of Output Box Assembly	4-14
Section	V. Maintenance of Engine Accessories	4-25
Section	VI. Maintenance of Generator Assembly	4-28
Section	VII. Maintenance of Skid Base	4-57
Appendix A	References	A-1
Appendix B	Maintenance Allocation Chart	B-1
Appendix C	Expendable/Durable Supplies and Materials List	C-1
Appendix D	Fabrication/Assembly of Parts	D-1

LIST OF ILLUSTRATIONS

NUMBER	TITLE	PAGE
1-1.	Generator Set, 15 kW, Tactical Quiet	1-2
1-2.	Fault System	1-11
1-3.	Generator Set Fuel System	1-13
1-4.	Generator Set Cooling System	1-15
1-5.	Engine Cooling System	1-16
1-6.	Engine Lubrication System	1-18
1-7.	Engine Air Intake and Exhaust System	1-19
1-8.	Output Supply System	1-21
1-9.	Engine Starting System	1-22
1-10.	Governor Control System	1-25
1-11.	Voltage Regulation System	1-26
1-12.	Generator Set Components	1-30
2-1.	Base Mounting Measurements	2-5
2-2.	Minimum Enclosure Clearance Measurements	2-6
2-3.	Batteries and Cables	2-28
2-4.	NATO Slave Receptacle and Cables	2-32
2-5.	Generator Set Access Doors	2-35
2-6.	Control Box Top Panel	2-37
2-7.	Generator Set Top Housing Section	2-39
2-8.	Generator Set Front Housing Section	2-43
2-9.	Generator Set Rear Housing Section	2-46
2-10.	Control Box Assembly	2-49
2-11.	Control Panel Lights	2-51
2-12.	Control Panel Indicators	2-58
2-13.	Control Panel Switches	2-68
2-13.1	In-Line Fuse Installation	2-78
2-14.	Control Box Components	2-82
2-15.	Permissive Paralleling Relay Test Set-Up	2-89
2-16.	Reverse Power Relay Test Set-Up	2-91
2-17.	Diagnostic Connector Pin Positions	2-95
2-18.	Diode Identification	2-99
2-19.	Control Box Panels	2-103
2-20.	Muffler and Exhaust Pipe	2-106
2-21.	Air Cleaner Assembly	2-109
2-22.	Radiator Cap	2-113
2-23.	Coolant System	2-114
2-24.	Fan Guards	2-117
2-25.	Fan Belt	2-123
2-26.	Coolant Recovery System	2-125
2-27.	Fuel Tank Filler Neck and Low Pressure Fuel System	2-128
2-28.	Fuel Filter/Water Separator	2-135
2-29.	Output Box Assembly	2-138
2-30.	Load Terminal Board Assembly	2-144
2-31.	Engine Switches and Senders, Right Side	2-149
2-32.	Engie Switches and Senders, Left Side	2-152
2-33.	Oil Drain Line	2-158
3-1.	Engine and Generator Assembly Removal	3-13
3-2.	Generator Set Top Housing Panel	3-15
3-3.	Filler Hose and Panel Assembly	3-15
3-4.	Overflow Bottle Assembly	3-17

LIST OF ILLUSTRATIONS - Continued

NUMBER	TITLE	PAGE
3-5.	Top Housing Assembly	3-17
3-6.	Radiator Assembly, Shroud and Fan	3-18
3-7.	Rear Housing Panel	3-18
3-8.	Fuel Filler Panel Assembly	3-19
3-9.	NATO Slave Receptacle	3-20
3-10.	Left Side Housing Panels	3-20
3-11.	Air Cleaner Assembly	3-21
3-12.	Oil Drain Line	3-21
3-13.	Right Side Engine Components.	3-22
3-14.	Left Side Engine Components	3-23
3-15.	Load Output Terminal Board	3-23
3-16.	Engine Components	3-28
4-1.	Control Box Components	4-9
4-2.	Fuel Tank	4-13
4-3.	Output Box Assembly	4-15
4-4.	Testing Current Transformer	4-19
4-5.	Testing Droop Current Transformer	4-21
4-6.	Governor Actuator Assembly	4-26
4-7.	Brushless Generator Schematic	4-28
4-8.	Generator Assembly Removal	4-31
4-9.	Rectifier Assembly (MEP-804A)	4-33
4-10.	Generator Assembly (MEP-804A)	4-35
4-11.	Generator Housing Rib Locations	4-38
4-12.	Rotor Assembly Lifting Device (Typical)	4-42
4-13.	Rectifier Assembly (MEP-814A)	4-47
4-14.	End Bell Removal (MEP-814A)	4-48
4-15.	Generator Assembly (MEP-814A)	4-50
4-16.	SkidBase	4-58
D-1.	Cable Assembly, AC Power (P/Ns: 88-22126-1 through 88-22126-7)	D-1
D-2.	Cable Assembly, Battery (P/N: 88-22123)	D-2
D-3.	Cable Assembly, Battery (P/N: 88-22179)	D-3
D-4.	Cable Assembly, Battery (P/N: 88-22309)	D-5
D-5.	Cable Assembly, Battery (P/N: 88-22310)	D-5
D-4.	Cable Assembly, Battery (P/N: 88-22311)	D-6
D-7.	Capacitor Assembly. EMI (P/N: 88-22758)	D-7
D-8.	Cord, Load Wrench (P/N: 88-22469)	D-8
D-9.	Diode Assembly (P/N: 88-22418-2)	D-9
D-10.	Holder, Control Panel (P/N: 88-22120)	D-10
D-11.	Insulation, Baffle (P/N: 88-22594)	D-11
D-12.	Insulation, Front Housing (P/N: 88-22595)	D-12
D-13.	Pump Assembly, Fuel (P/N: 88-22546)	D-13
D-14.	Resistor Assembly (P/Ns: 122-3066-1 and 122-3066-2)	D-14
D-15.	Resistor Assembly, Volt (P/N: 88-22631)	D-15

LIST OF ILLUSTRATIONS - Continued

NUMBER	TITLE	PAGE
D-1 6.	Resistor-Diode Assembly (P/N:88-22106).....	D-16
D-1 7.	Switch Assembly, Fuel Level (P/N: 88-22547).....	D-17
D-1 8.	Transducer Assembly (P/N:88-22550).....	D-18
D-19.	Wire, Varistor (P/Ns:88-20305-1 through 88-20305-3, and 88-20305-5).....	D-19
FO-1.	Electrical Schematic.....	FP-1 (FP-2 Blank)
FO-2.	Wiring Diagram.....	FP-3 (FP-4 Blank)

LIST OF TABLES

NUMBER	TITLE	PAGE
1-1.	Tabulated Data	1-4
1-2.	Performance Characteristics.	1-8
2-1.	Coolant	2-2
2-2.	Fuel	2-3
2-3.	Lubricating Oil	2-3
2-4.	Fabricated/Assembled Parts	2-8
2-5.	Unit Preventive Maintenance Checks and Services	2-10
2-6.	Unit Troubleshooting	2-14
2-7.	State Of Charge With Specific Gravity Corrected To 80°F (27°C)	2-30
2-8.	Specific Gravity Temperature Corrections	2-30
2-9.	Diagnostic Connector Connection Points	2-97
3-1.	Direct Support Troubleshooting.	3-4
4-1.	Voltage Adjustment Range (MEP-804A)	4-1
4-2.	Voltage Adjustment Range (MEP-814A)	4-3
4-3.	Generator Resistance Values At 25°C (77°F)	4-40
D-1.	Inches To Metric Conversion..	D-20

HOW TO USE THIS MANUAL

In this manual, (TM 9-6115-643-24), paragraphs are underlined and the sections and chapters appear in capital letters. The location of additional material that must be referenced is clearly marked. Illustrations in this text are located as close as possible to their references.

Chapter 1 – INTRODUCTION. Contains general information, equipment description and data, and principles of operation for the generator set.

Chapter 2 – UNIT MAINTENANCE INSTRUCTIONS. Contains information on servicing the generator set and components upon receipt, Unit level Preventive Maintenance Checks and Services (PMCS), troubleshooting procedures used to recognize and correct generator set malfunctions, and all maintenance procedures authorized at Unit level.

Chapter 3 – GENERAL MAINTENANCE INSTRUCTIONS. Contains Direct Support level troubleshooting procedures used to recognize and correct generator set malfunctions, and procedures for the removal and installation of major components.

Chapter 4 – DIRECT SUPPORT MAINTENANCE INSTRUCTIONS. Contains all maintenance procedures authorized to be performed on the generator set at the Direct Support level.

APPENDICES.

Appendix A is a list of publications referenced in this manual and should be used in conjunction with this manual.

Appendix B is the Maintenance Allocation Chart (MAC) which designates all maintenance and repair functions authorized to be performed at the different maintenance levels.

Appendix C is the Expendable/Durable Supplies and Materials List (EDSML) which lists all expendable/durable supplies and materials required in performing the maintenance procedures presented in this manual.

Appendix D lists all parts that require fabrication or assembly for the maintenance of the generator set. Materials and procedures required are included.

Index. The index contains key technical manual subjects arranged in alphabetical order. If you require information on a specific subject (i.e., Time Meter), but you are not sure where to look, use the index to locate specific paragraph.

CHAPTER 1 INTRODUCTION

Section I. GENERAL INFORMATION

1.1 SCOPE.

This manual contains Unit, Direct Support and General Support maintenance instructions for the Tactical Quiet (TQ), 15 kW 50/60 and 400 Hz Generator Sets (FIGURE 1-1), herein referred to as generator sets. Included are descriptions of major components and their functions in relation to other components.

<u>Model Number</u>	<u>Equipment Name</u>
MEP-804A	Generator Set, Skid Mounted, Tactical Quiet 15 kW 50/60 Hz
MEP-814A	Generator Set, Skid Mounted, Tactical Quiet 15 kW 400 Hz

The generator set provides tactical quiet AC power. The generator set is easily transported, operated, and maintained.

1.2 LIMITED APPLICABILITY.

Some portions of this publication are not applicable to all services. These portions are prefixed to indicate the service(s) to which they pertain: (A) for Army, (F) for Air Force, and (N) for Navy.

1.3 MAINTENANCE FORMS AND RECORDS.

1.3.1 (A) Department of the Army forms and procedures used for equipment maintenance will be those prescribed by DA PAM 738-750, The Army Maintenance Management System (TAMMS).

1.3.2 (F) Maintenance Forms and Records maintained by the Air Force are prescribed in AFR 66-1 and the applicable TO 00-20 Series Technical Orders.

1.3.3 (N) Navy users should refer to their service peculiar directives to determine the applicable maintenance forms and records to be used.

1.4 REPORTING OF ERRORS.

Reporting of errors, omissions, and recommendations for improvement of this publication by the individual user is encouraged. Reports should be submitted as follows:

1.4.1 (A) Mail your letter, DA Form 2028 (Recommended Changes to Publications and Blank Forms), or DA Form 2028-2 located in back of this manual direct to:

Commander
U.S. Army Aviation and Troop Support Command
Attn: AMSAT-I-MP
4300 Goodfellow Blvd.
St. Louis, MO 63120-1798

1.4.2 (F) Air Force - AFTO Form 22 directly to:

Commander
Sacramento Air Logistics Center (AFMC)
Attn: TILBA
McClellan AFB, CA 95652-5990

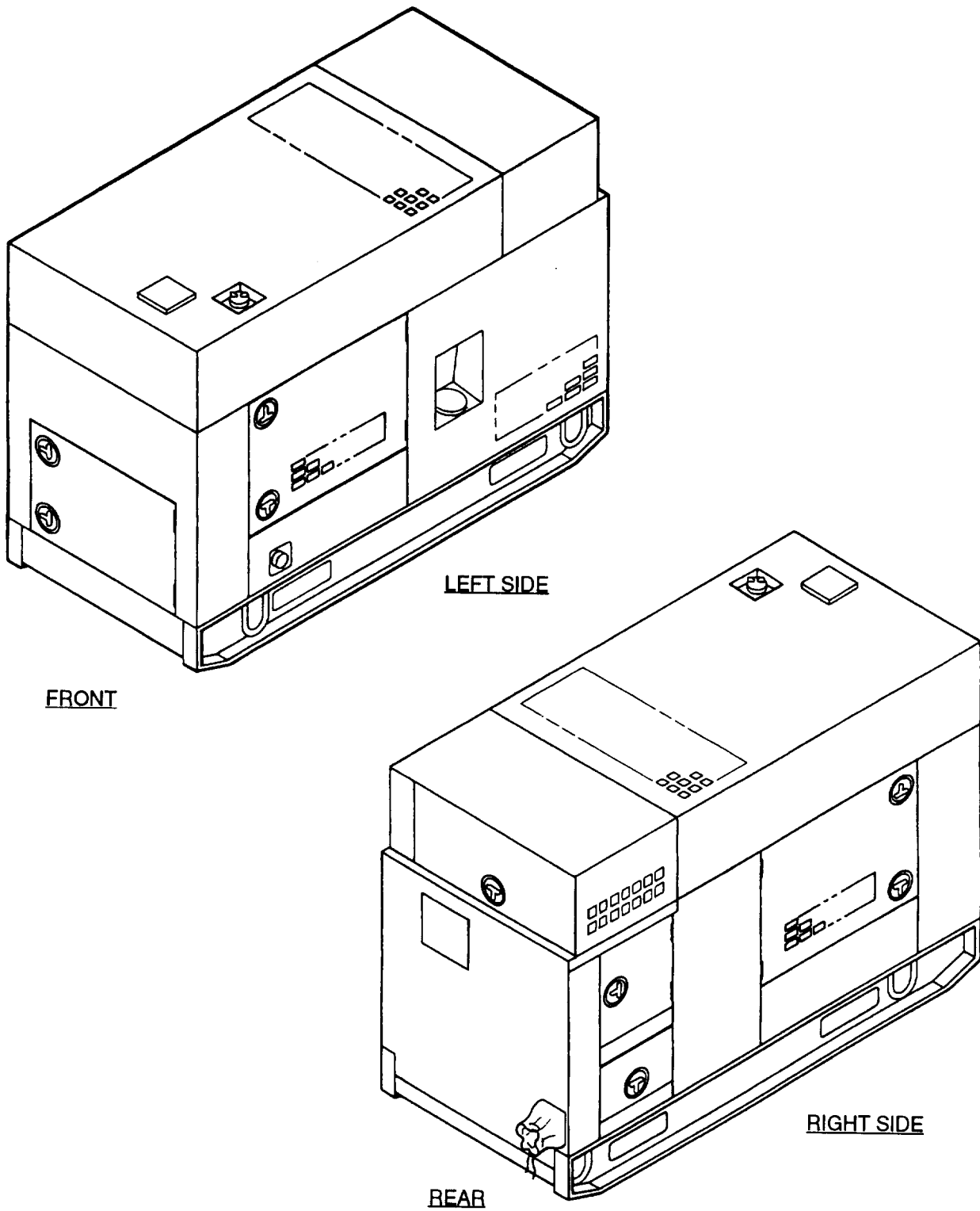

FIGURE 1-1. Generator Set, 15 kw, Tactical Quiet

1.4.3 (N) Navy - by letter directly to:

Commander
US. Navy Ships Parts Control Center
Attn: Code 783
Mechanicsburg, PA 17055

1.5 EQUIPMENT IMPROVEMENT RECOMMENDATIONS (EIRs).

1.5.1 If your generator set needs improvement, let us know. Send us an EIR. You, the user, are the only one who can tell us what you don't like about your equipment. Let us know why you don't like the design or performance. We will send you a reply.

1.5.2 (A) Put it on an SF 368 (Product Quality Deficiency Report). EIRs should be mailed directly to:

Commander
U.S. Army Aviation and Troop Command
Attn: AMSTR-MOF
4300 Goodfellow Blvd.
St. Louis, MO 63120-1798

1.5.3 (N) Put it on applicable Navy form and mail it directly to:

Naval Construction Battalion Center
Attn: Code 157 Civil Engineer
Support Office (CESO)
Port Hueneme, CA 93043-5000

1.5.4 (F) Send QDR/MDR by electric message to:

SM-ALC
McClellan AFB CA//TILE//

For technical assistance notify:

SM-ALC/LIEAE
Attn: Equipment Specialist, TQG
McClellan AFB. CA 95652-5990

1.6 LEVELS OF MAINTENANCE.

1.6.1 (A) Army users shall refer to the Maintenance Allocation Chart (MAC) for tasks and levels of maintenance to be performed.

1.6.2 (F) Refer to the Source Maintenance Recoverability (SMR) Codes for maintenance to be performed.

1.6.3 (N) Navy users shall determine their maintenance levels in accordance with their service directives.

1.7 DESTRUCTION OF MATERIAL TO PREVENT ENEMY USE.

1.7.1 (A) Destruction of the generator set to prevent enemy use shall be in accordance with TM 750-244-3.

1.7.2 (F) (N) Air Force and Navy users shall refer to their service directives to obtain procedures for destruction of material to prevent enemy use.

Section II. EQUIPMENT DESCRIPTION AND DATA

1.8 GENERAL.

The generator sets, models MEP-804A and MEP-814A, (FIGURE 1-1) are fully enclosed, self-contained, skid-mounted, portable units. They are equipped with controls, instruments, and accessories necessary for operation as single units or in parallel with another unit of the same class and mode. The generator sets consist of a diesel engine, brushless generator, excitation system, speed governing system, fuel system, 24 VDC starting system, control system, and fault system.

1.9 TABULATED/ILLUSTRATED DATA.

For a list of Tabulated Data refer to TABLE 1-1.

TABLE 1-1. Tabulated Data

	MEP-804A	MEP-814A
1. Generator Set:		
a. National Stock Number	6115-01-274-7388	6115-01-274-7393
b. Overall Length	69.7 in. (177.2 cm)	69.7 in. (177.2 cm)
c. Overall Width	35.7 in. (90.8 cm)	35.7 in. (90.8 cm)
d. Overall Height	55 in. (139.7 cm)	55 in. (139.7 cm)
e. Dry Weight (leas Basic Issue Items List)	1885 lb. (855 kg)	2015 lb. (911.2 kg)
f. Wet Weight	2140 lb. (970.8 kg)	2250 lb. (1022.7 kg)
2. Engine:		
a. Manufacturer	Isuzu	Isuzu
b. Model	C240	C240
c. Type	Four cylinder, four cycle, naturally aspirated diesel	Four cylinder, four cycle, naturally aspirated diesel
2. Engine - Continued:		
d. Displacement	145 cu. in. (2.4 liters)	145 cu. in. (2.4 liters)
e. Altitude Degradation, 4000 ft. (1220 m) to 8000 ft. (2440 m)	3.5% per 1000 ft. (305 m)	3.5% per 1000 ft. (305 m)
f. Firing Order	1,3,4,2	1,3,4,2
g. Cold Weather Starting Aid System Use	40°F (4°C) or below	40F (4°C) or below

TABLE 1-1. Tabulated Data - Continued

	MEP-804A	MEP-814A
h. Valve Tappet Clearance Adjustment:		
Hot or Cold (Intake)	0.018 in. (0.45 mm)	0.018 in. (0.45 mm)
Hot or Cold (Exhaust)	0.018 in. (0.45 mm)	0.018 in. (0.45 mm)
3. Cooling System:		
a. Type	Pressurized radiator and pump	Pressurized radiator and pump
b. Capacity	13.5 qts. (12.8 liters)	13.5 qts. (12.8 liters)
c. Normal Operating Temperature	170-200°F (77-93°C)	170-200°F (77-93°C)
d. Temperature Indicating System Voltage Rating	24 VDC	24 VDC
4. Lubricating System:		
a. Type	Full flow, circulating pressure	Full flow, circulating pressure
b. Oil Pump Type	Positive displacement gear	Positive displacement gear
c. Normal Operating Pressure	25-60 psi (172-414 kPa)	25-60 psi (172-414 kPa)
d. Oil Filter Type	Full flow, spin-on replaceable element	Full flow, spin-on replaceable element
e. Capacity	6 qts. (5.7 liters)	6 qts. (5.7 liters)
f. Pressure Indicating System Voltage Rating	24 VDC	24 VDC
5. Fuel System:		
a. Type of Fuel	DF-1, DF-2, DF-A, JP4, JP5, JP8	DF-1, DF-2, DF-A, JP4, JP5, JP8
b. Fuel Tank Capacity	14 gal. (53 liters)	14 gal. (53 liters)
c. Fuel Consumption Rate	1.50 gal. (5.7 liters) per hour	1.75 gal. (6.6 liters) per hour

TABLE 1-1. Tabulated Data - Continued

	MEP-804A	MEP-814A
5. Fuel System - Continued:		
d. Auxiliary Fuel Pump:		
(1) Voltage Rating	24 VDC	24 VDC
(2) Delivery Pressure	5.0-6.5 psi 34.5-65.5 kPa)	5.0-6.5 psi (34.5-65.5 kPa) (max)
e. Fuel Level Switch:		
(1) Type	Float	Float
(2) Current	0.6 amps (rein) at 24 VDC	0.6 amps (min) at 24 VDC
6. Engine Starting System:		
a. Batteries	Two 12 volt, connected in series	Two 12 volt, connected in series
b. Starter:		
(1) Manufacturer	Hitachi	Hitachi
(2) Model	S25-121	S25-121
(3) Voltage Rating	24 VDC	24 VDC
(4) Drive Type	Gear reduction	Gear reduction
c. Battery Charging Alternator:		
(1) Manufacturer	Hitachi	Hitachi
(2) Model	LR220-24	LR220-24
(3) Rating	20 amps at 24 VDC	20 amps at 24 VDC
(4) Protective Fuse	30 amps	30 amps
7. AC Generator:		
a. Manufacturer	Marathon Electric	Marathon Electric
b. Type	Rotating field, synchronous	Rotating field, synchronous
c. Load Capacity	15KW	15 KW
d. Current Ratings:		
(1) 120/208 volt connection	60 Hz: 52 amps 50 Hz: 43 amps	52 amps
(2) 240/416 volt connection	60 Hz: 26 amps 50 Hz: 21 amps	26 amps

TABLE 1-1. Tabulated Data - Continued

	MEP-804A	MEP-814A
7. AC Generator - Continued:		
e. Power Factor	0.8	0.8
f. Cooling	Fan Cooled	Fan Cooled
g. Drive Type	Direct Coupling	Direct Coupling
h. Duty Classification	Continuous	Continuous
8. Governing System:		
a. Load Measuring Unit:		
(1) Manufacturer	Technology Research	Technology Research
(2) Model	19310	19310
b. Governor Control Unit:		
(1) Manufacturer	Barber-Colman	Barber-Colman
(2) Model	DYNA 10502-001-0-2	DYNA 10502-001-0-2
9. Protection Devices:		
a. Low Oil Pressure Switch:		
(1) Trip Pressure	15 ± 3 psi (103.4 ± 20.7 kPa)	15 ± 3 psi (103.4 ± 20.7 kPa)
(2) Voltage Rating	24 VDC	24 VDC
(3) Current Rating	7 amps	7 amps
b. Coolant High Temperature Switch:		
(1) Trip Temperature	220 ± 3.5°F (104 ± 2°C)	220 ± 3.5°F (104 ± 2°C)
(2) Voltage Rating	24 VDC	24 VDC
(3) Current Rating	7 amps	7 amps
c. Overspeed Switch:		
(1) Element Trip and Reset	2200 ± 40 RPM	2200 ± 40 RPM
(2) Voltage Rating	28 VDC	28 VDC
(3) Current Rating	1 amp	1 amp
d. Overvoltage Relay:		
(1) Trip Point Conditions	153 ± 3 VAC for no less than 200 milliseconds (120 VAC coil winding)	153 ± 3 VAC for no less than 200 milliseconds (120 VAC coil winding)
(2) Trip Point	No more than 1.25 seconds after trip conditions exist	No more than 1.25 seconds after trip conditions exist

1.10 DIFFERENCES BETWEEN MODELS.

1.10.1 The differences between models of the generator sets covered in this manual areas follows:

- a. Model MEP-804A is equipped with a 50/60 Hz generator, 50/60 Hz frequency meter, and frequency selector switch.
- b. Model MEP-814A is equipped with a 400 Hz generator and 400 Hz frequency meter.

1.10.2 Performance characteristics for the two models are shown in TABLE 1-2.

TABLE 1-2. Performance Characteristics

	MEP-804A	MEP-814A
1. Voltage:		
(a) Voltage waveform deviation factor:	5% (max)	5% (max)
Single voltage harmonics:	2% (max)	2% (max)
(b) Voltage unbalance	5% of rated voltage (max)	5% of rated voltage (max)
(c) Phase balance voltage	1% of rated voltage (max)	1% of rated voltage (max)
(d) Voltage modulation	2% (max)	2% (max)
(e) Voltage regulation	1% (max)	1% (max)
(f) Short-term stability (30 seconds)	1% of rated voltage	1% of rated voltage
(g) Long-term stability (4 hours)	2% of rated voltage	2% of rated voltage
(h) Voltage drift (60°F (16°C) in 8-hour period)	±1% (max)	±1% (max)
(i) Dip and rise for rated load	15% of rated voltage (max)	12% of rated voltage (max)
Recovery time	0.5 seconds	0.5 seconds
(j) Dip for low power factor load	30% of no-load voltage (max)	25% of no-load voltage (max)
Recovery time	0.7 seconds 95% of no-load voltage	0.7 seconds 95% of no-load voltage
(k) Adjustment range VAC		
120/208V connection	50 Hz 190-213V	400 Hz 197-229V
240/416V connection	380-426V 60 Hz 197-240V	395-458V
120/208V connection		
240/416V connection	395-480V	

TABLE 1-2. Performance Characteristics - Continued

	MEP-804A	MEP-814A
2. Frequency:		
(a) Regulation	0.25% of rated frequency	0.25% of rated frequency
(b) Short-term steady-state stability (30 seconds)	0.5% of rated frequency	0.5% of rated frequency
(c) Long-term steady-state stability (4 hours)	1% of rated frequency	1% of rated frequency
(d) Frequency drift (60°F (16°C) in 8 hour period)	0.5% (rmax)	0.5% (max)
(e) Undershoot with application of load	4% of rated frequency (max)	1.5% of rated frequency (max)
Recovery time	2 seconds	1 second
(f) Overshoot with application of load	4% of rated frequency (max)	1.5% of rated frequency (max)
Recovery time	2 seconds	1 second
(g) Adjustment range	48-52 Hz, not below 45 Hz for 50 Hz operation 58-62 Hz, not above 65 Hz for 60 Hz operation	390-420 Hz, not below 370 Hz or above 430 Hz

Section III. PRINCIPLES OF OPERATION

1.11 INTRODUCTION.

This section contains functional descriptions of the generator set and explains how the controls and indicators interact with the systems, and the location and description of major components.

1.12 PRINCIPLES OF OPERATION.

1.12.1 Fault System.

1.12.1.1 The Fault System (FIGURE 1-2) protects the generator set and any connected load against the potential faults described below and provides an indication of any incurred fault. The following summary of the Fault System will assist in understanding the operation of the other generator set systems. Additional details relating to specific protection devices are also provided in the descriptions of the respective systems.

1.12.1.2 The Fault System consists of the malfunction indicator, low fuel level float switch, fuel float switch module, fuel level relay, low oil pressure switch, coolant high temperature switch, overvoltage relay, overload/short circuit relay, overspeed switch, overspeed relay, OVERSPEED RESET switch, undervoltage relay, reverse power relay, engine fault relay, electrical fault relay, and BATTLE SHORT switch. In addition to the fault indicator lamps, the malfunction indicator includes the PUSH TEST & RESET LAMPS switch which when depressed, illuminates all the lamps and resets any fault indication.

1.12.1.3 Activation of any one of the following protection devices will cause three events to occur. The AC circuit interrupter relay will open; the generator set engine will be shut down; and a fault indicator lamp will be illuminated to show which malfunction occurred.

1.12.1.3.1 Coolant High Temperature Switch. This device will activate when the engine coolant leaving the engine exceeds $220 \pm 3.5^{\circ}\text{F}$ ($104 \pm 2^{\circ}\text{C}$).

1.12.1.3.2 Low Oil Pressure Switch. This device activates when the engine lubrication oil pressure falls below 15 ± 3 psi (103.4 ± 20.7 kPa).

1.12.1.3.3 Low Fuel Level Float Switch. This device will activate when the fuel level falls to a point at which the operating time of the set at rated load is four minutes.

1.12.1.3.4 Overvoltage Relay. This device will activate when the 120-volt generator coil winding has risen to and remained at any value greater than 153 ± 3 volts.

1.12.1.3.5 Overspeed Relay. This device will activate when the engine speed exceeds 2200 ± 40 RPM.

1.12.1.4 Fuel Float Switch Module. This device prevents inadvertent engine shutdown by providing a one second delay after actuation of the low fuel level float switch.

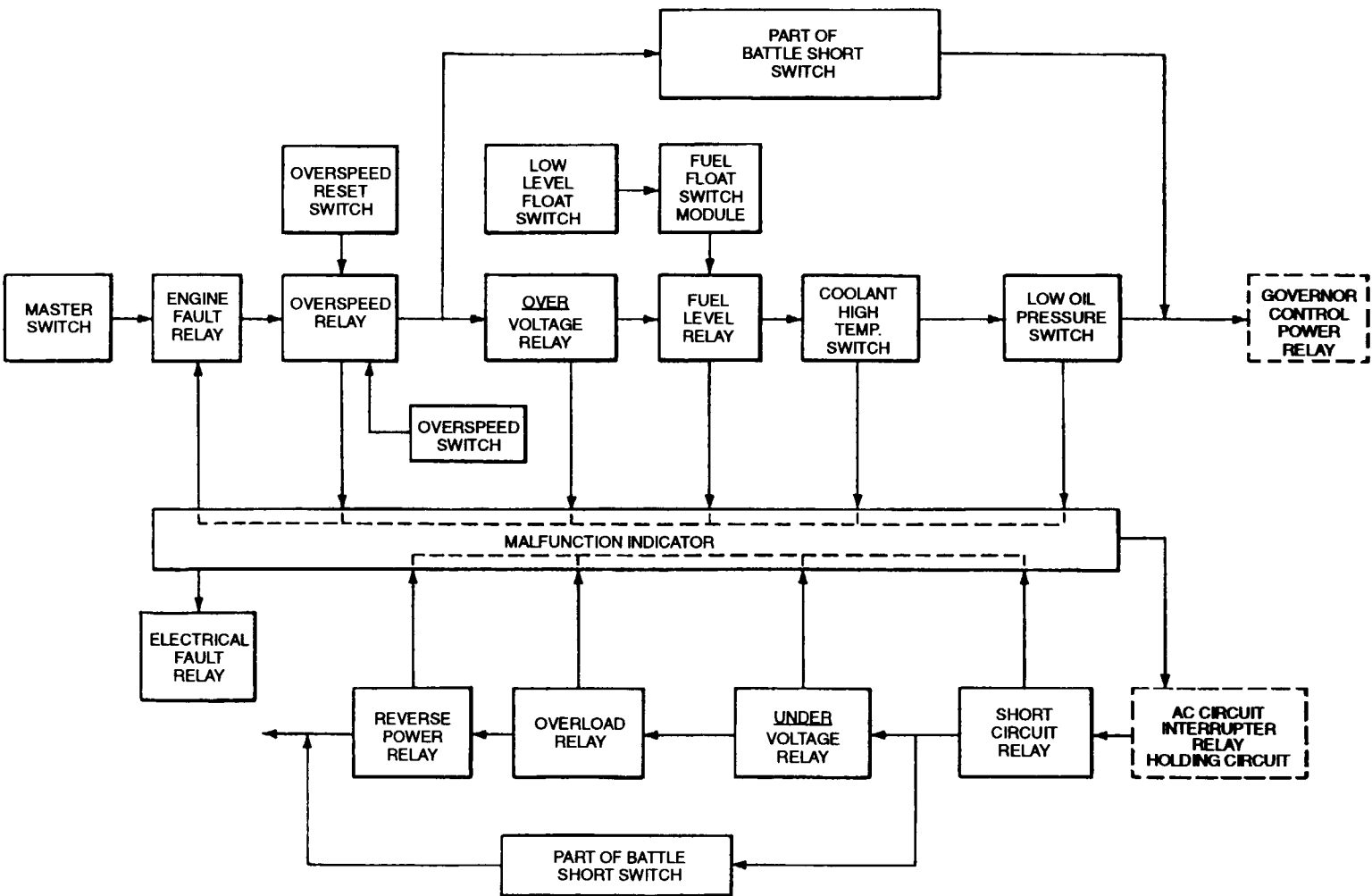

FIGURE 1-2. Fault System

1.12.1.5 Electrical protection devices will cause two events to occur. The AC circuit interrupter relay will open, and a fault indicator lamp will illuminate to indicate which fault occurred.

1.12.1.5.1 Short Circuit Relay. This device will activate when the set output current in any phase exceeds 425 percent of the rated value.

1.12.1.5.2 Overload Relay. This device will operate when the load current in any phase exceeds 110 percent of rated value.

1.12.1.5.3 Undervoltage Relay. This device will activate instantaneously when the 120 volt generator coil winding has dropped to 48 volts and will trip after time delay when the coil voltage drops below 99 volts.

1.12.1.5.4 Reverse Power Relay. This device will operate if power flow into the generator set exceeds 20 percent of rated value.

1.12.1.6 Although it is possible for more than one fault to occur at one time during operation, only the first fault to occur will be displayed by the malfunction indicator. The activated indicator lamp circuit remains illuminated until the malfunction indicator is reset. The lamp will be off with the MASTER SWITCH in the OFF position and will be reilluminated when the MASTER SWITCH is turned to one of the RUN positions. Resetting a fault indication is done in two steps. First push the PUSH TEST & RESET LAMPS switch located on the malfunction indicator. Then move the MASTER SWITCH to the OFF position. After a shutdown due to engine overspeed, the OVERSPEED RESET switch must be actuated to reset the engine electrical control circuit before the engine can be restarted.

1.12.1.7 After the generator set engine has been started, the BATTLE SHORT switch can be used to override all of the potential faults except engine overspeed and short circuit.

1.12.2 Fuel System.

1.12.2.1 The Fuel System (FIGURE 1-3) includes a primary subsystem and an auxiliary subsystem.

1.12.2.2 The primary subsystem consists of fuel lines, fittings, fuel tank, low fuel level float switch, fuel float switch module, fuel level sender, FUEL LEVEL indicator, transfer pump, fuel filter/water separator, injection pump, and injectors.

1.12.2.3 The injection pump output is controlled by the electronic governor control and governor actuator. When the electronic governor control is deenergized, electrical power is removed from the governor actuator which is spring loaded to the fuel shutoff position. The electronic governor control is energized by turning the MASTER SWITCH to the START position or either of the two RUN positions. With the engine cranking or running, fuel is drawn from the fuel tank by the transfer pump. After reaching the transfer pump, fuel passes through a fuel filter/water separator where water and small impurities are removed. The fuel then goes to the injection pump. With the governor system energized, the fuel is metered, pressurized, and pushed through the injectors by the injection pump. Fuel is sprayed by the injectors into the diesel engine combustion chambers where it is mixed with air and ignited. The fuel that is not used by the injectors is returned to the fuel tank by an excess fuel return line. power is removed from the electronic governor control, and the fuel is shut off whenever the MASTER SWITCH is turned to the OFF position. The electronic governor control is also deenergized by the Fault System (refer to Paragraph 1.12.1 .3). The FUEL LEVEL indicator displays the fuel level of the fuel tank from E (empty) to F (full) in quarter tank increments.

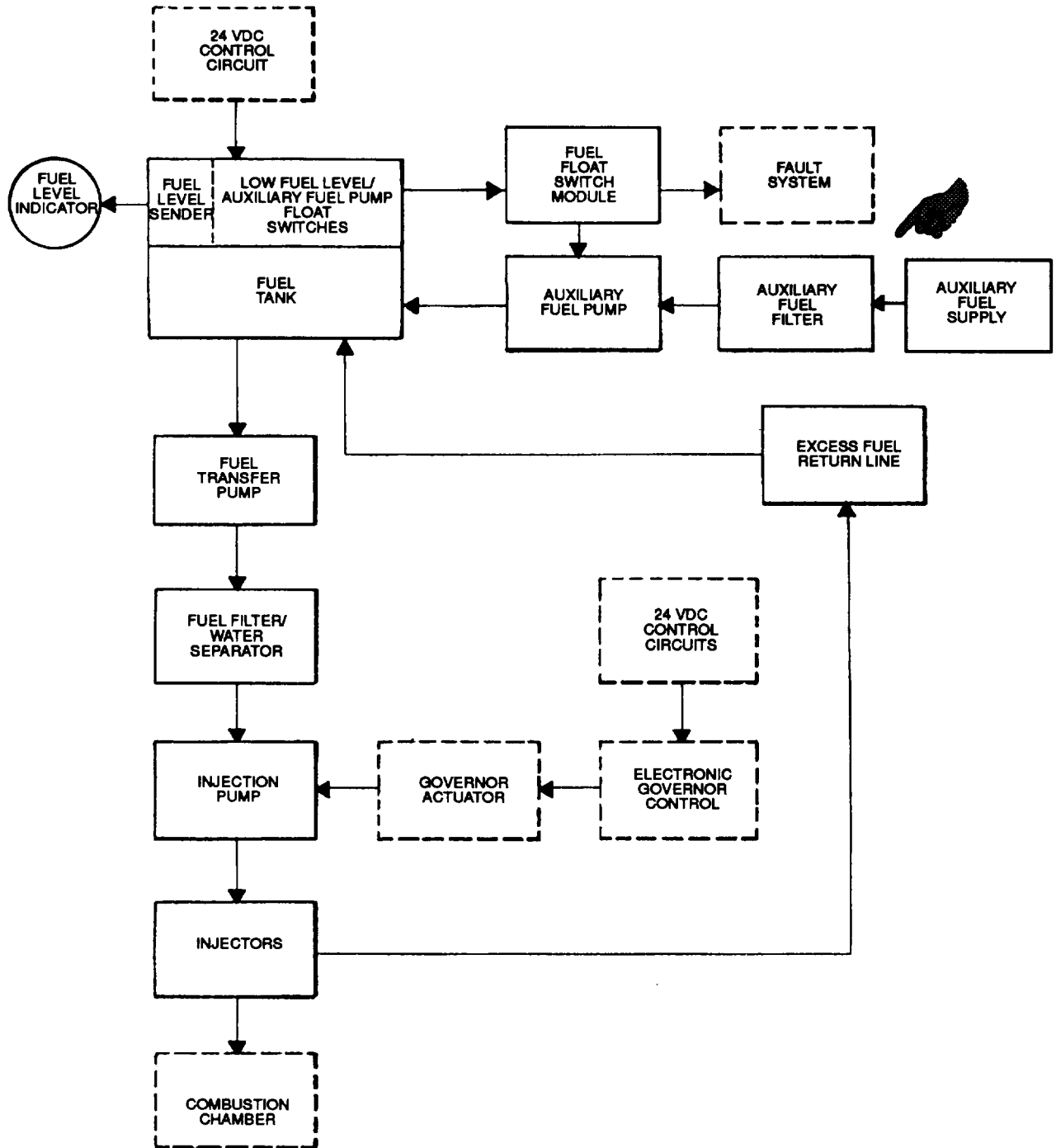

FIGURE 1-3. Generator Set Fuel System

1.12.2.4 The auxiliary subsystem consists of an auxiliary fuel supply, fuel lines, fittings, auxiliary fuel filter, auxiliary fuel pump, and auxiliary fuel pump float switch located in the fuel tank, and a fuel float switch module.

1.12.2.5 When the MASTER switch is set on PRIME & RUN AUX FUEL, it actuates the auxiliary fuel pump and transfers fuel from the auxiliary fuel supply to the fuel tank. The auxiliary fuel pump float switch shuts off the auxiliary fuel pump when the fuel tank is full and reactivates the pump as the level drops. The fuel float switch module allows the current used by the auxiliary fuel pump to bypass the float switch.

1.12.2.6 The 24 VDC control circuits provide control and power for indicators, float switches, fault system, governor system, and auxiliary fuel pump.

1.12.3 Generator Set Cooling System.

1.12.3.1 The Generator Set Cooling System (FIGURE 1 -4) includes air intake and exhaust grilles, baffles and ducting within the generator set housing and the engine driven radiator cooling fan. The air intake grilles are located in panels on both sides of the generator set housing. The air exhaust grille is located in the housing top panel.

1.12.3.2 Air is drawn in through the air intake grilles and forced through the engine coolant radiator and out of the generator set through the exhaust grille by the radiator cooling fan. Most of the cooling airflows externally past the generator assembly and engine. Some cooling air is circulated internally through the generator assembly by a generator fan which is an integral part of the AC generator assembly. Baffles, ducting, and sound absorbing material are used to control the air flow through the generator set and to reduce sound transmission through the grilles.

1.12.4 Engine Cooling System.

1.12.4.1 The Engine Cooling System (FIGURE 1-5) consists of a radiator, hoses, thermostat, temperature sender, coolant high temperature switch, COOLANT TEMP indicator, water pump, a belt driven fan, and cooling jackets (part of engine).

1.12.4.2 The water pump forces coolant through passages (cooling jackets) in the engine block and cylinder head where the coolant absorbs heat from the engine. When the engine reaches normal operating temperature, the thermostat opens and the heated coolant flows through the upper radiator hose assembly into the radiator. The cooling fan circulates air through the radiator where the coolant temperature is reduced.

1.12.4.3 A coolant high temperature switch in conjunction with the fault system provides automatic shutdown in the event that coolant temperature exceeds $220 \pm 3.5^{\circ}\text{F}$ ($104 \pm 2^{\circ}\text{C}$). The COOLANT TEMP indicator indicates the engine coolant temperature, from 120°F to 240°F (48°C to 115°C).

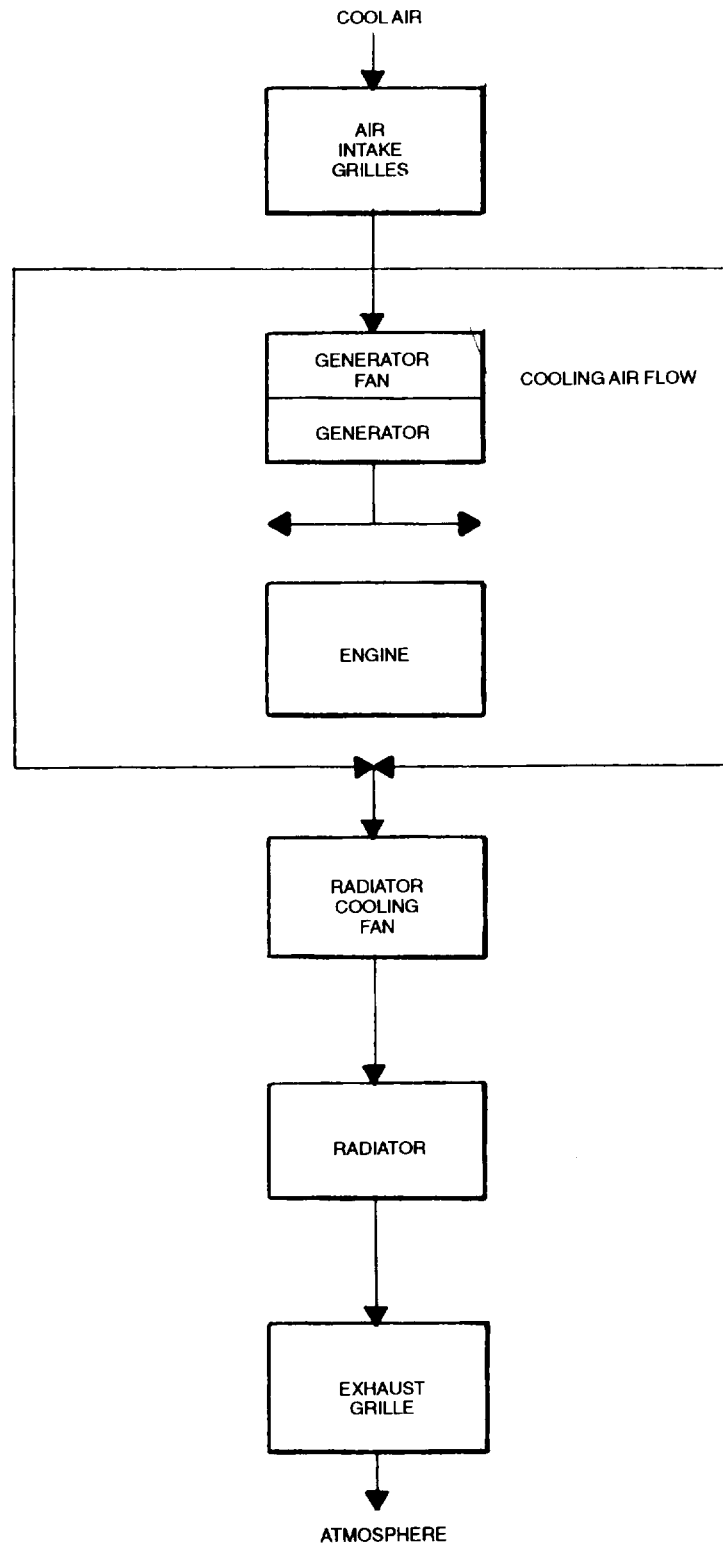

FIGURE 1-4. Generator Set Cooling System

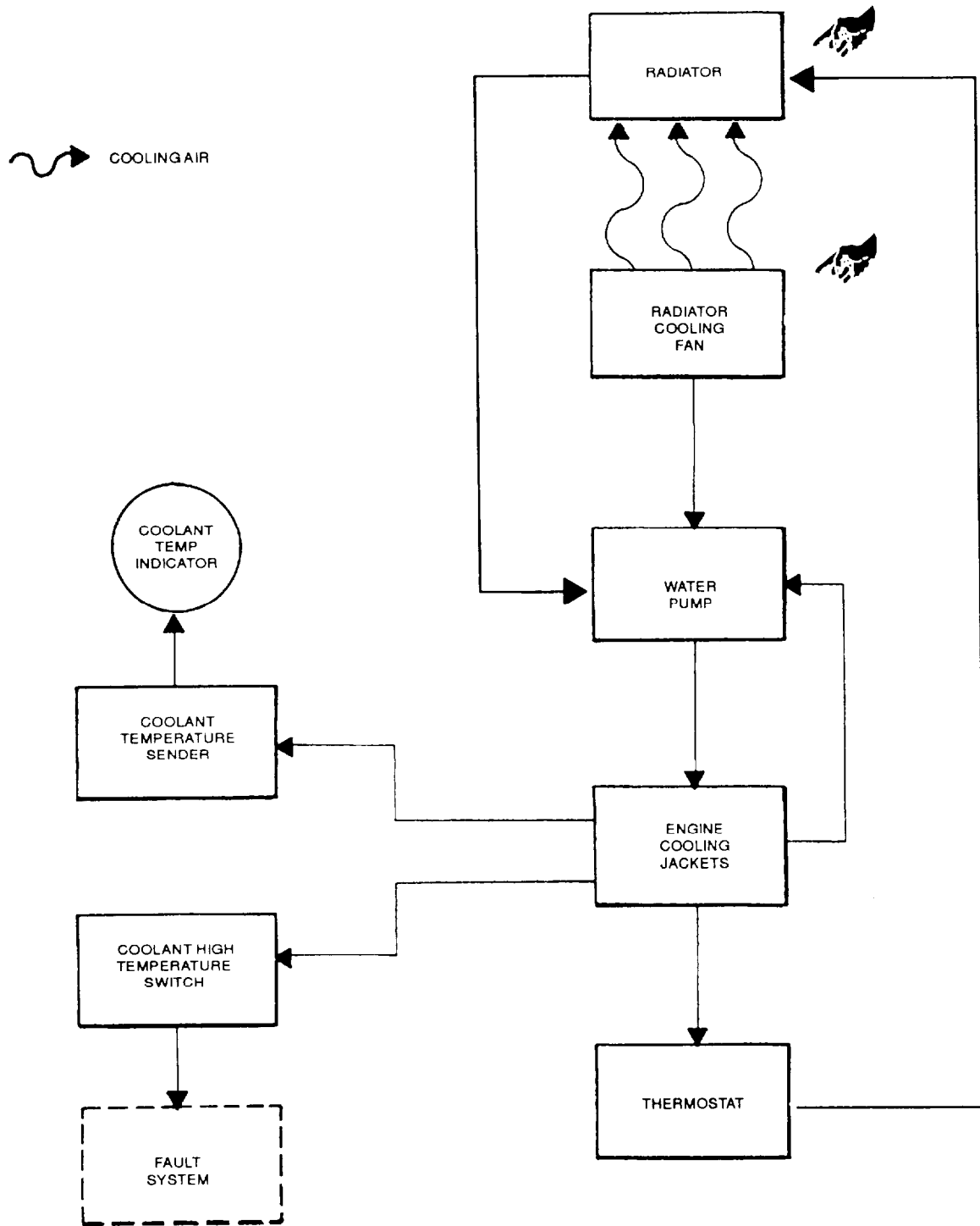

FIGURE 1-5. Engine Cooling System

1.12.5 Engine Lubrication System.

1.12.5.1 The Engine Lubrication System (FIGURE 1-6) consists of an oil pan, dipstick, pump, oil sample valve, oil pressure sender, OIL PRESSURE indicator, low oil pressure switch, and filter.

1.12.5.2 The oil pan is a reservoir for engine lubricating oil. The dipstick indicates oil level in the pan. The oil level can be checked during engine operation. One side of the dipstick is used for checking oil level while the engine is running and the other side is used while the engine is shutdown. The pump draws oil from the oil pan through a screen removing large impurities. The oil then passes through a spin-on type filter where small impurities are removed. From the filter, oil is distributed to the engine's internal moving parts and then returns to the oil pan. The oil pressure sender located in the engine block senses oil pressure. The oil pressure is displayed on the OIL PRESSURE indicator. An Army Oil Analysis Program (AOAP) sample valve located in the block allows oil samples to be taken while the engine is operating. The low oil pressure switch, also located in the engine block, functions with the generator set fault system. The engine is automatically shut off if the oil pressure drops below 15 ± 3 psi (103.4 ± 20.7 kPa).

1.12.6 Engine Air Intake and Exhaust System.

1.12.6.1 The Engine Air Intake and Exhaust System (FIGURE 1-7) consists of an air cleaner assembly, intake manifold, four glow plugs, glow plug contactor, positive crankcase ventilation (PCV) valve, exhaust manifold, and muffler. The air cleaner assembly includes a dust collector, filter element, dust evacuator valve, and a restriction indicator.

1.12.6.2 Air is drawn into the dust collector and passes through the filter element. Airborne dirt is removed and trapped in the dust collector and filter element. Some dust can be removed from the dust collector by pinching the evacuator valve. The restriction indicator indicates when the filter should be serviced. Filtered air is drawn out of the filter through air intake tubes to the intake manifold where it passes into the engine.

1.12.6.3 The engine exhaust gases are expelled into the exhaust manifold. The exhaust manifold channels the gases into the muffler that deadens the sound of the exhaust gases. The gases pass from the muffler through the muffler outlet and are vented upward from the generator set housing. A cover, which is held open by the pressure of the exhaust gases during operation, closes over the exhaust port to prevent rain, water, or other foreign matter from entering the exhaust port when the set is not in use. The cover is easily removed for connection of an exhaust pipe for indoor operation.

1.12.6.4 The PCV valve and associated tubing allow gases which buildup in the crankcase to be recycled through the intake manifold. The PCV valve closes to retain vapors within the engine after the engine is shut down.

1.12.6.5 To improve engine starting when ambient temperature is below 40°F (4°C), a glow plug is located in the engine head for each cylinder. The glow plugs are energized through the glow plug contactor when the MASTER SWITCH is held in the PREHEAT position.

1.12.7 Output Supply System.

1.12.7.1 The Output Supply System (FIGURE 1-8) consists of the AC generator, GROUND FAULT CIRCUIT INTERRUPTER (GFCI), CONVENIENCE RECEPTACLE, current transformer, AC circuit interrupter relay, output terminals, AC CIRCUIT INTERRUPTER switch, kilowatt transducer, kilowattmeter (PERCENT POWER), AM-VM transfer switch, AC voltmeter (VOLTS AC), and ammeter (PERCENT RATED POWER).

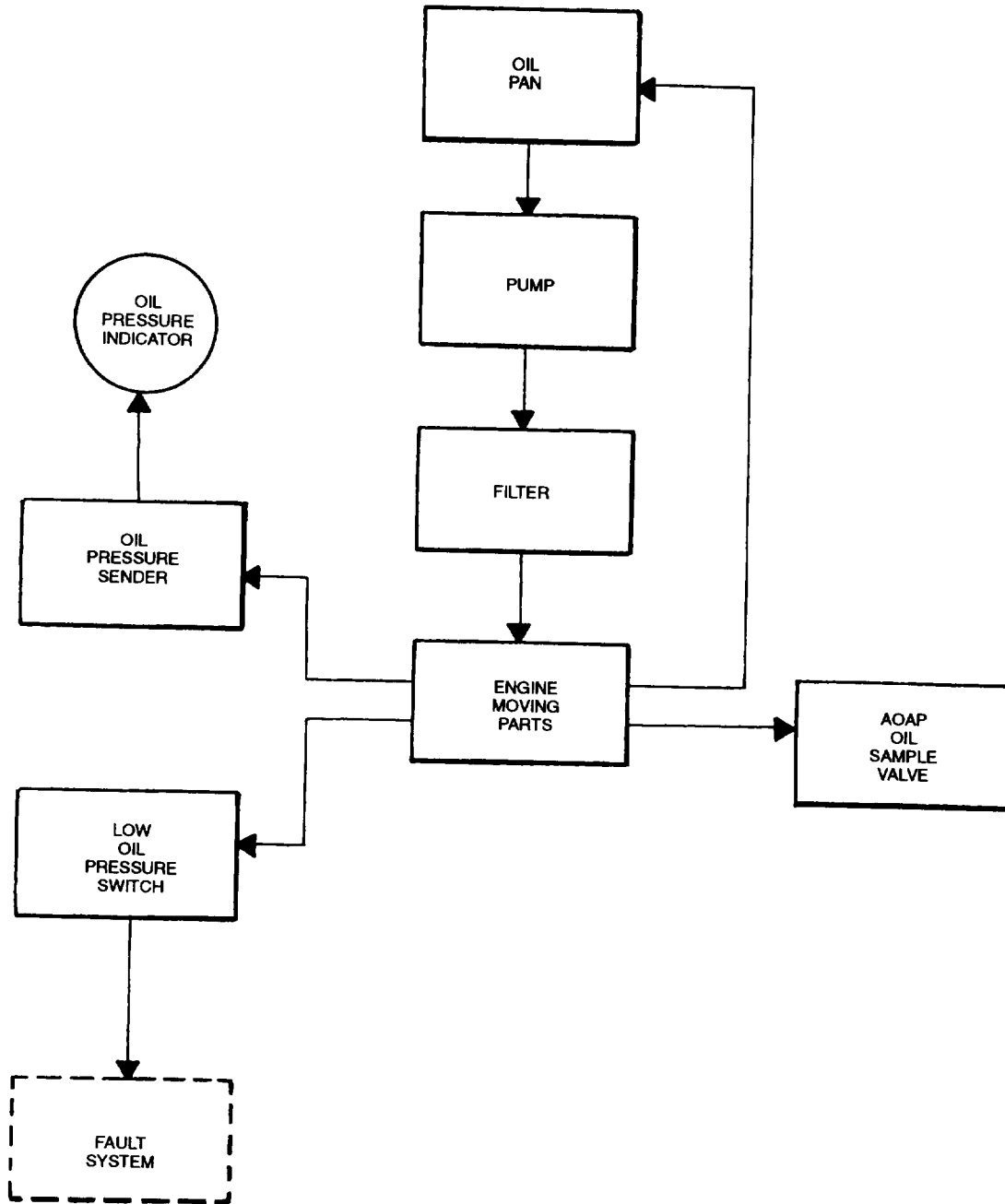

FIGURE 1-6. Engine Lubrication System

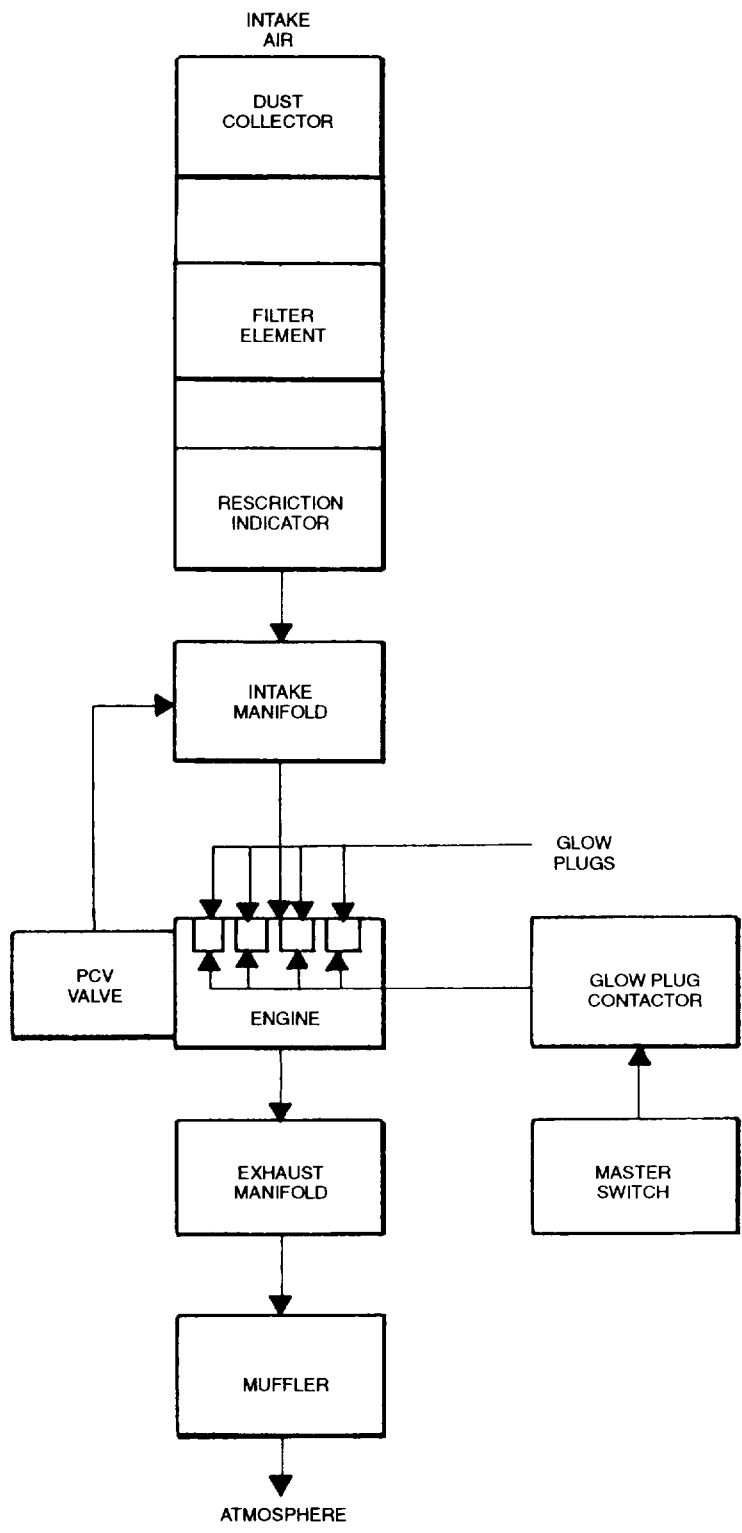

FIGURE 1-7. Engine Air Intake and Exhaust System

1.12.7.2 Power created by the generator is supplied through the current transformer, AC voltage reconnection board, and AC circuit interrupter relay to the output terminals. The AC voltage reconnection board allows configuration of the generator set for 120/208 volt connections or 240/416 volt connections. The AC CIRCUIT INTERRUPTER switch closes and opens the AC circuit interrupter relay. This enables or interrupts the power flow between the voltage reconnection board and the output terminals. The voltage regulation system (refer to paragraph 1.12.10) senses generator output voltage and provides a control signal to the generator exciter to maintain the desired generator output voltage. Generator output frequency is controlled by the governor control system (refer to paragraph 1.12.9) and is read on the FREQUENCY meter (HERTZ). The current transformer provides a reduced current signal to the kilowatt transducer and ammeter (PERCENT RATED CURRENT). The kilowatt transducer and kilowattmeter (PERCENT POWER) provide an indication of the power being used by the load. The ammeter (PERCENT RATED CURRENT) indicates the percent of rated current being supplied to the load. The position of the AM-VM transfer switch selects the output terminals from which current and voltage is measured. The AC circuit interrupter relay will open and disconnect the load whenever any of the following faults occur: reverse power, undervoltage, overload, or short circuit.

1.12.7.3 The AC generator also provides 120 VAC power to the CONVENIENCE RECEPTACLE through the GROUND FAULT CIRCUIT INTERRUPTER.

1.12.8 Generator Set Controls.

1.12.8.1 Engine Starting System.

1.12.8.1.1 Engine starting is accomplished primarily with two 12-volt batteries, connected in series to provide 24 VDC power, and a starter (FIGURE 1-9). The starter includes a cranking motor and a solenoid. To permit engine starting, the DC CONTROL POWER circuit breaker must be pushed in, the DEAD CRANK switch must be in the NORMAL position, and the BATTLE SHORT switch must be in the OFF position. In addition, any ENGINE SHUTDOWN fault previously registered on the malfunction indicator panel must have been corrected and the malfunction indicator panel must have been reset. When the MASTER SWITCH is then placed in the START position, the starting circuits supply 24 VDC power to the starter. As the engine accelerates to approximately 900 rpm, the starting circuits disconnect power from the starter.

1.12.8.1.2 When the MASTER SWITCH is first moved to the START position, the various instrument and control circuits are energized. The Engine Starting System includes two control circuits. One starting control circuit energizes the start relay through closed switch contacts of the engine fault relay and the BATTLE SHORT switch. The other starting control circuit energizes the cranking relay coil through closed contacts of the crank disconnect switch and the start relay. (The crank disconnect switch is an integral part of the electronic governor control.)

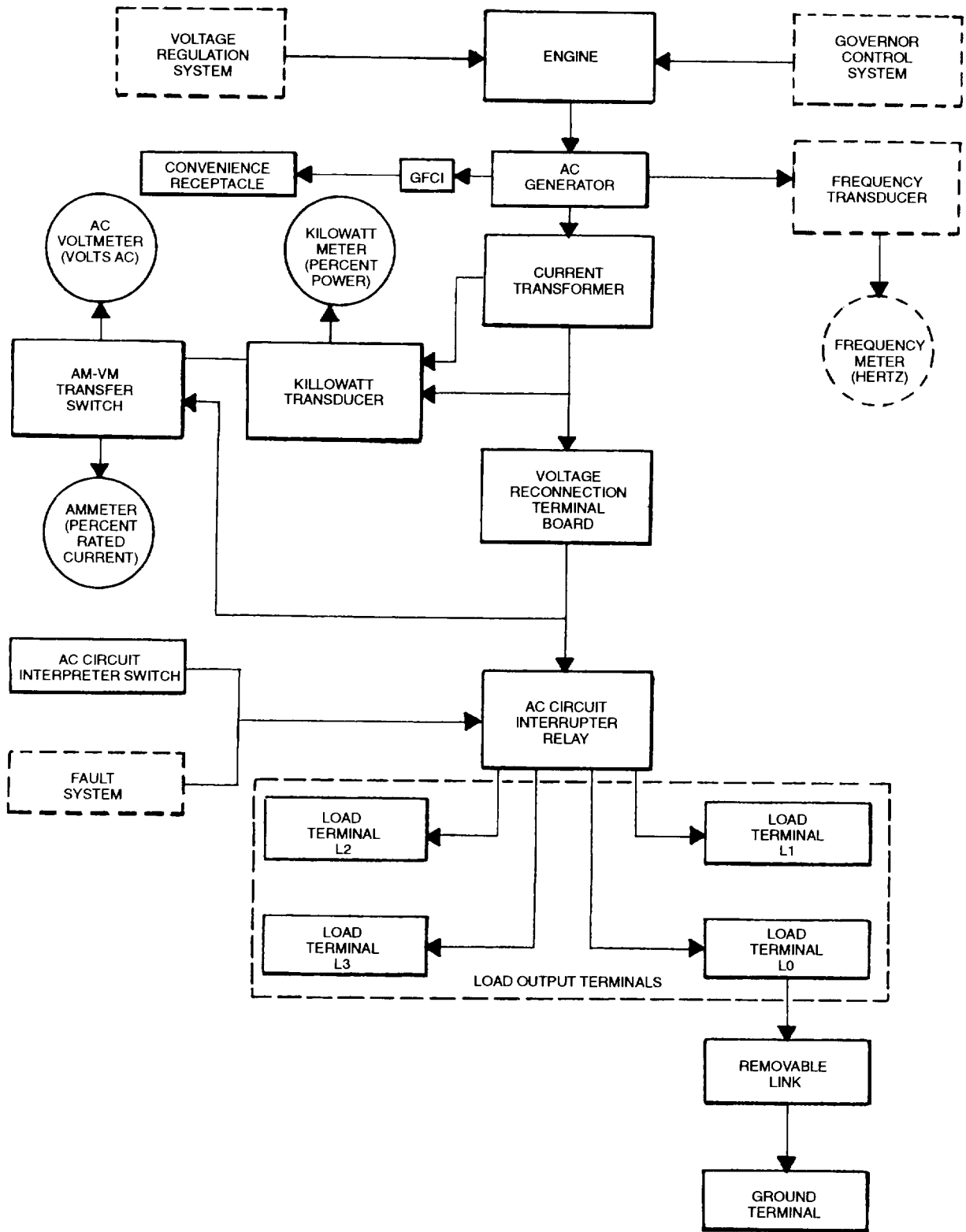

FIGURE 1-8. Output Supply System

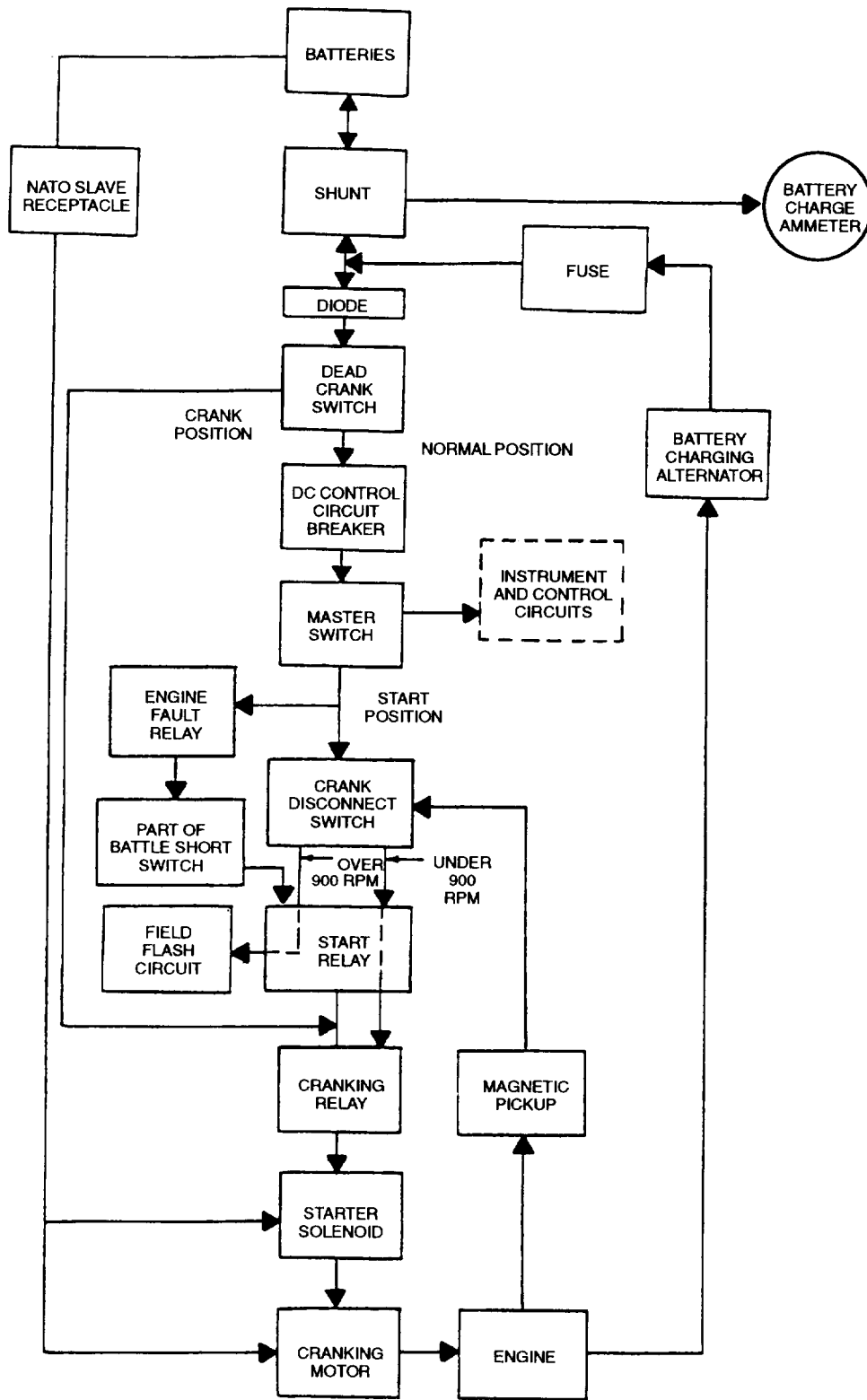

FIGURE 1-9. Engine Starting System

With the cranking relay energized, power passes from the batteries through closed contacts of the cranking relay to energize the starter solenoid. With the starter solenoid energized, power passes from the starter solenoid to the cranking motor. The cranking motor then cranks the engine. Engine speed is sensed by the magnetic pickup which sends a signal to the electronic governor control. As the engine accelerates to approximately 900 rpm, the signal from the magnetic pickup causes the crank disconnect switch to open one set of contacts and close another set of contacts. The open contacts break the circuit to the cranking relay and stop engine cranking. The closed contacts cause the field flash relay to be energized. When the MASTER SWITCH is moved to one of the two RUN positions, both starting control circuits are deenergized. The other generator set control and instrument circuits remain energized.

1.12.8.1.3 The engine may be cranked without starting by use of the DEAD CRANK switch. With the DEAD CRANK switch in the CRANK position, the cranking relay coil is energized to initiate engine cranking without energizing any other starting or control functions.

1.12.8.1.4 The generator set can be started without batteries by connecting an external 24 VDC power source to the NATO SLAVE RECEPTACLE. The generator set can also supply starting power to another set through the NATO SLAVE RECEPTACLE.

1.12.8.1.5 The batteries are charged by the battery charging alternator that is belt driven by the engine. The BATTERY CHARGE ammeter indicates the charge/discharge rate of the batteries, from -10 Amps to +20 Amps. A shunt provides a DC voltage signal, which is directly proportional to the actual battery current flow, to the BATTERY CHARGE ammeter. Normal operating indication on the BATTERY CHARGE ammeter depends on the state of the charge in the batteries. A low charge, which may exist immediately after engine starting, will cause a high reading (needle moves toward CHARGE area). When the charge in the batteries has been restored, the indicator moves near zero (0). The battery charging system is protected from reverse polarity in the battery connections by a fuse and diode.

1.12.8.2 Field Flash. When the engine reaches sufficient speed (900 rpm), the magnetic pickup causes a set of contacts in the crank disconnect switch to close and energize the field flash relay. This circuit provides current to the exciter field windings which sets up an electromagnetic field. The field current is necessary for the set to generate sufficient voltage for the voltage regulator (FIGURE 1-11) to begin controlling the output voltage of the generator set. The field flash circuit is maintained until the MASTER SWITCH is released from the START position.

1.12.8.3 Operation. Placing the MASTER SWITCH in the PRIME& RUN or PRIME & RUN AUX FUEL positions keeps the electronic governor control (FIGURE 1-10) energized, and fuel will be supplied to the fuel injection pump as long as no fault condition exists. During operation, the operator should periodically check the set's instruments to ensure they are reading in the normal operating ranges. The VOLTAGE and FREQUENCY potentiometers are adjusted as required to maintain desired frequency and voltage output.

1.12.8.4 Applying the Load. The load is applied by placing the AC CIRCUIT INTERRUPTER switch in the CLOSED position. This is a momentary contact switch that returns to the neutral, or center position. The AC circuit interrupter relay is energized by this momentary contact and a holding circuit keeps it closed, bringing the load on line.

1.12.8.5 Shutdown.

1.12.8.5.1 The AC circuit interrupter relay is disengaged by placing the AC CIRCUIT INTERRUPTER switch in the OPEN position. This is a momentary contact switch which will break the AC circuit interrupter relay holding circuit and then return to the neutral, or center position, disconnecting the load from the line.

1.12.8.5.2 When the MASTER SWITCH is placed in the OFF position all power is removed from the control circuit and the engine will stop.

1.12.8.5.3 The EMERGENCY STOP switch will remove power from the control circuit by energizing the engine fault relay. This will cause the engine to shut down. The EMERGENCY STOP switch is not to be used as an alternative for routine shutdown procedures. When the generator set is stopped using the EMERGENCY STOP switch, some circuits remain energized causing a drain on the batteries until the MASTER SWITCH is placed in the OFF position.

1.12.8.6 Paralleling.

1.12.8.6.1 The generator set is capable of being operated in parallel with one other set of the same model number. This capability is provided by the PARALLELING RECEPTACLE, paralleling cable, the LOAD SHARING ADJUST and REACTIVE CURRENT ADJUST rheostats, two SYNCHRONIZATION LIGHTS, the UNIT-PARALLEL switch, reverse power relay, voltage sensing relay, droop current transformer, and the permissive paralleling relay.

1.12.8.6.2 The paralleling cable is used to interconnect the governor and voltage regulator paralleling circuits of the two sets. The UNIT-PARALLEL switch is used to select parallel operation. Voltage and frequency of the two generator sets are synchronized by adjusting each set's VOLTAGE and FREQUENCY controls. Phase synchronization is indicated by the SYNCHRONIZATION LIGHTS. The reverse power relay serves as a safety device by detecting any excessive out-of-phase condition and interrupting power to the AC circuit interrupter relay holding coil when that condition occurs. The permissive paralleling relay monitors the voltage phase relationship and prevents the AC circuit interrupter relay from closing when the units are not properly synchronized.

1.12.9 Governor Control System.

1.12.9.1 The Governor Control System (FIGURE 1 -10) includes the electronic governor control, governor actuator, magnetic pickup, load measuring unit, frequency transducer, FREQUENCY meter (HERTZ), kilowatt transducer, fuel injection pump, FREQUENCY SELECT switch, and FREQUENCY adjust potentiometer.

1.12.9.2 The governor actuator is a linear electromechanical actuator which controls the output of the fuel injection pump in response to the electrical input from the electronic governor control. The FREQUENCY adjust potentiometer, located on the control panel and adjusted by the operator, provides a signal representing the desired engine speed/generator frequency to the electronic governor

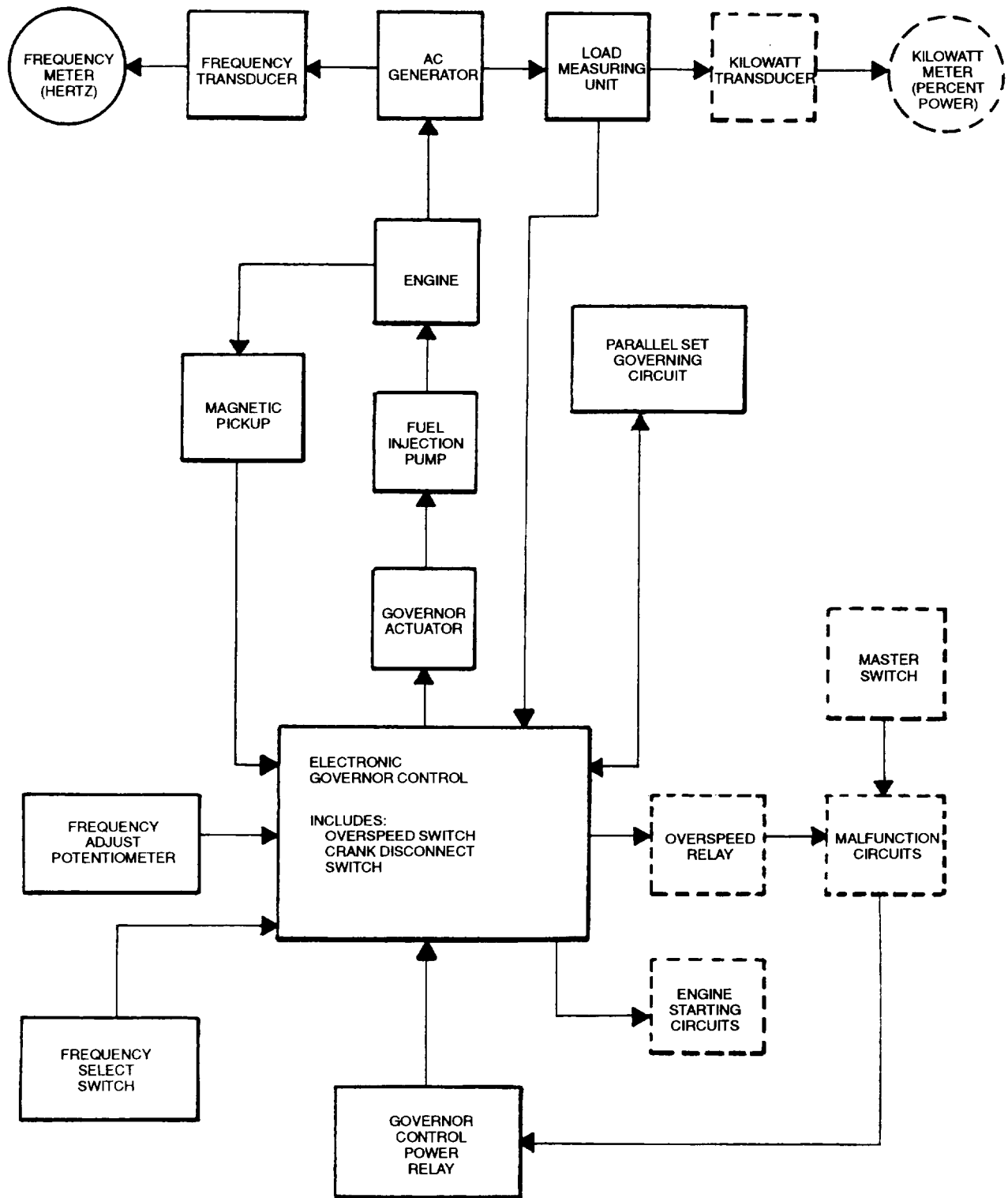

FIGURE 1-10. Governor Control System

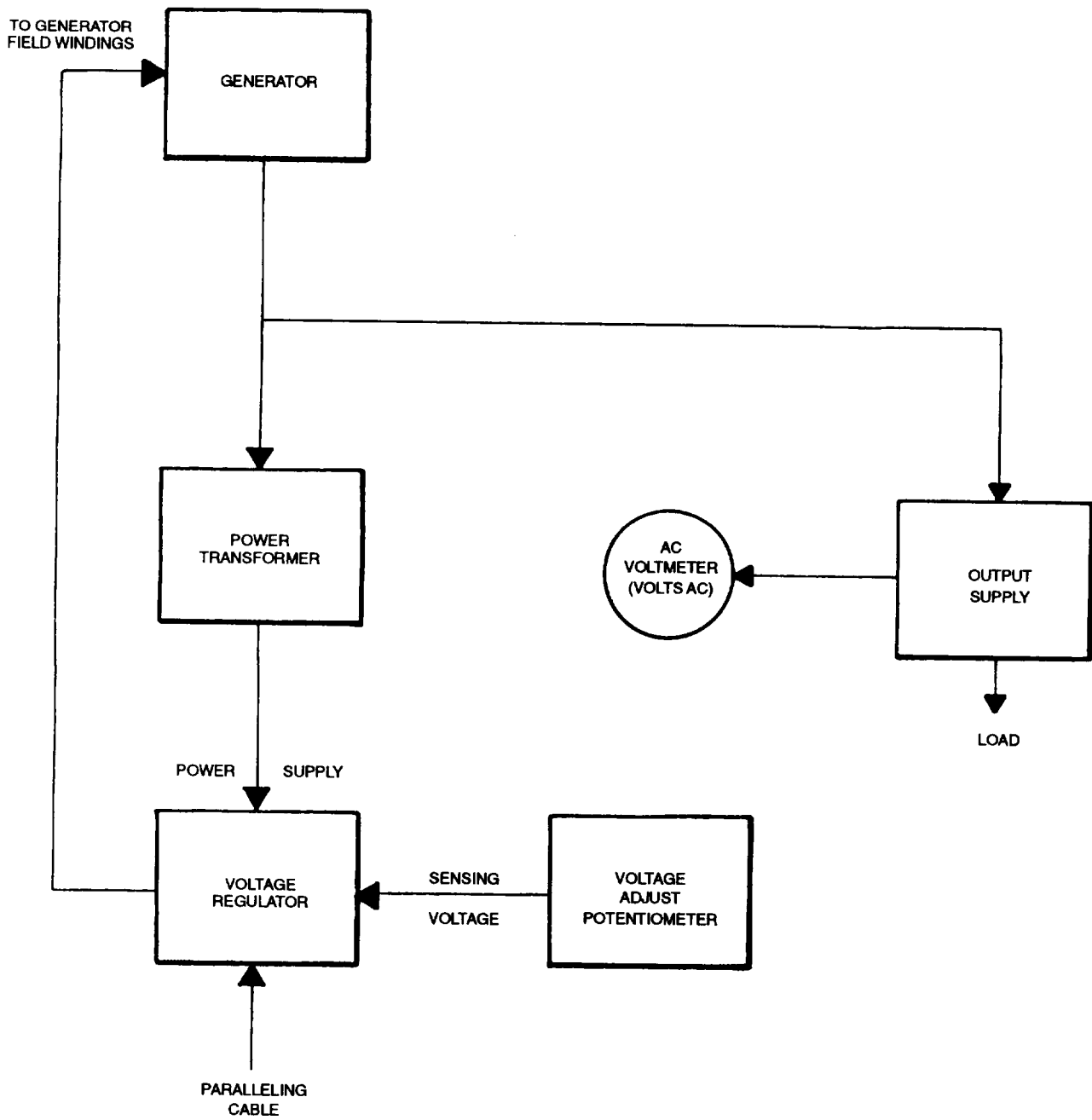

FIGURE 1-11. Voltage Regulation System

control. A signal representative of the actual engine speed/generator frequency is sent to the electronic governor control by the magnetic pickup. Any change in engine speed from that selected by the operator, as sensed by the magnetic pickup, causes the electronic governor control to increase or decrease the fuel pump output to maintain the desired speed. The load measuring unit senses changes in external load demand and provides a change signal to the electronic governor control allowing the control to start its response prior to any actual change in engine speed. The generator set frequency and power output are indicated by the FREQUENCY meter (HERTZ) and the kilowattmeter (PERCENT POWER) on the control panel. The FREQUENCY SELECT switch is used to set the generator for 50 hertz or 60 hertz operating frequencies (50 hertz/60 hertz sets only).

1.12.9.3 The electronic governor control also contains the engine overspeed switch (Fault System) and the crank disconnect switch (Engine Starting System). These switches function as a result of input from the magnetic pickup.

1.12.9.4 Twenty-four VDC power is supplied to the electronic governor control through the governor control power relay. The governor control relay is controlled by the fault system. The electronic governor controls of two generator sets operating in parallel are interconnected by the paralleling cable.

1.12.10 Voltage Regulation System.

The Voltage Regulation System (FIGURE 1 -11) consists of the voltage regulator, VOLTAGE adjust potentiometer, and power transformer. The voltage regulator senses and controls the generator output voltage which is operator adjustable within the design limits by use of the VOLTAGE adjust potentiometer. The power transformer provides operating power to the voltage regulator. The output voltage is indicated by the AC voltmeter (VOLTS AC) on the control panel.

1.13 LOCATION AND DESCRIPTION OF MAJOR COMPONENTS.

NOTE

All locations (FIGURE 1-12) referenced herein are given facing the control box side (rear) of the generator set.

1.13.1 Malfunction Indicator Panel (1). The malfunction indicator panel is located to the left of the control panel. It indicates malfunctions of the generator set components.

1.13.2 Control Panel Assembly (2). The generator set control panel is located at the rear of the generator set and contains controls and instruments for operating the engine and the generator.

1.13.3 Muffler (3). The muffler and exhaust tubing are connected to the exhaust manifold on the engine. The exhaust exits from the top of the generator set housing. Gases are exhausted upward.

1.13.4 Skid Base (4). The skid base supports the generator set. It has fork lift access openings and cross members for short distance movement. The skid base has provisions in the bottom for installation of the generator set on a trailer.

1.13.5 Fuel Filter/Water Separator (5). The fuel filter/water separator is located in the engine compartment on the right side. The element removes impurities and water from the diesel fuel.

1.13.6 DEAD CRANK Switch (6). The DEAD CRANK switch is located in the engine compartment on the right side. The switch allows the engine to be turned over without starting for maintenance purposes.

1.13.7 Oil Fitter (7). The oil filter is located in the engine compartment on the right side. The filter removes impurities from the engine lube oil.

1.13.8 Voltage Reconnection Terminal Board (8). The voltage reconnection terminal board is located on the right side (rear) of the generator set. The board allows reconfiguration from 120/208 to 240/416 VAC output.

1.13.9 Load Output Terminal Board (9). The load output terminal board is located on the right side (rear) of the generator set. Four AC output terminals are located on the board. They are marked L1, L2, L3, and L0. A fifth terminal, marked GND, is located next to the output terminals and serves as equipment ground for the generator set. A removable, solid copper bar is connected between the L0 and GND terminals.

1.13.10 CONVENIENCE RECEPTACLE (10).

The CONVENIENCE RECEPTACLE is a 120 VAC receptacle used to operate small plug in type equipment.

1.13.11 PARALLELING RECEPTACLE (11). The PARALLELING RECEPTACLE is used to connect the paralleling cable between two generator sets of the same size and mode to operate in parallel.

1.13.12 Diagnostic Connector (12). The diagnostic connector is a multi-pin plug that is wired to specific points in the generator set electrical system to enable monitoring and troubleshooting of the generator set operation at a single location.

1.13.13 Air Cleaner Assembly (13). The air cleaner assembly is located on the left side behind the air cleaner access door. It consists of a drytype, disposable paper filter and canister. The air cleaner assembly features a dust collector which traps large dust particles. The air cleaner assembly has a restriction indicator which will pop up during operation when the air cleaner requires servicing.

1.13.14 AC Generator (14). The AC generator is a single bearing, drip-proof, synchronous, brushless, three phase, air-cooled generator. The generator is coupled directly to the rear of the diesel engine.

1.13.15 Starter (15). The starter is located on the left side of the engine. The electric cranking motor mechanically engages the engine flywheel in order to start the diesel engine.

1.13.16 Dipstick (16). The dipstick is located in the engine compartment on the left side. The gauge shows the lube oil level in the engine crankcase.

1.13.17 Engine (17). The generator is powered by a four cylinder, four cycle, fuel injected, naturally-aspirated, liquid-cooled diesel engine which occupies the front half of the generator set. The engine is also equipped with a fuel filter/water separator, oil filter, and an air cleaner assembly. Protection devices automatically stop the engine during conditions of high coolant temperature, low oil pressure, no fuel, overspeed or overvoltage.

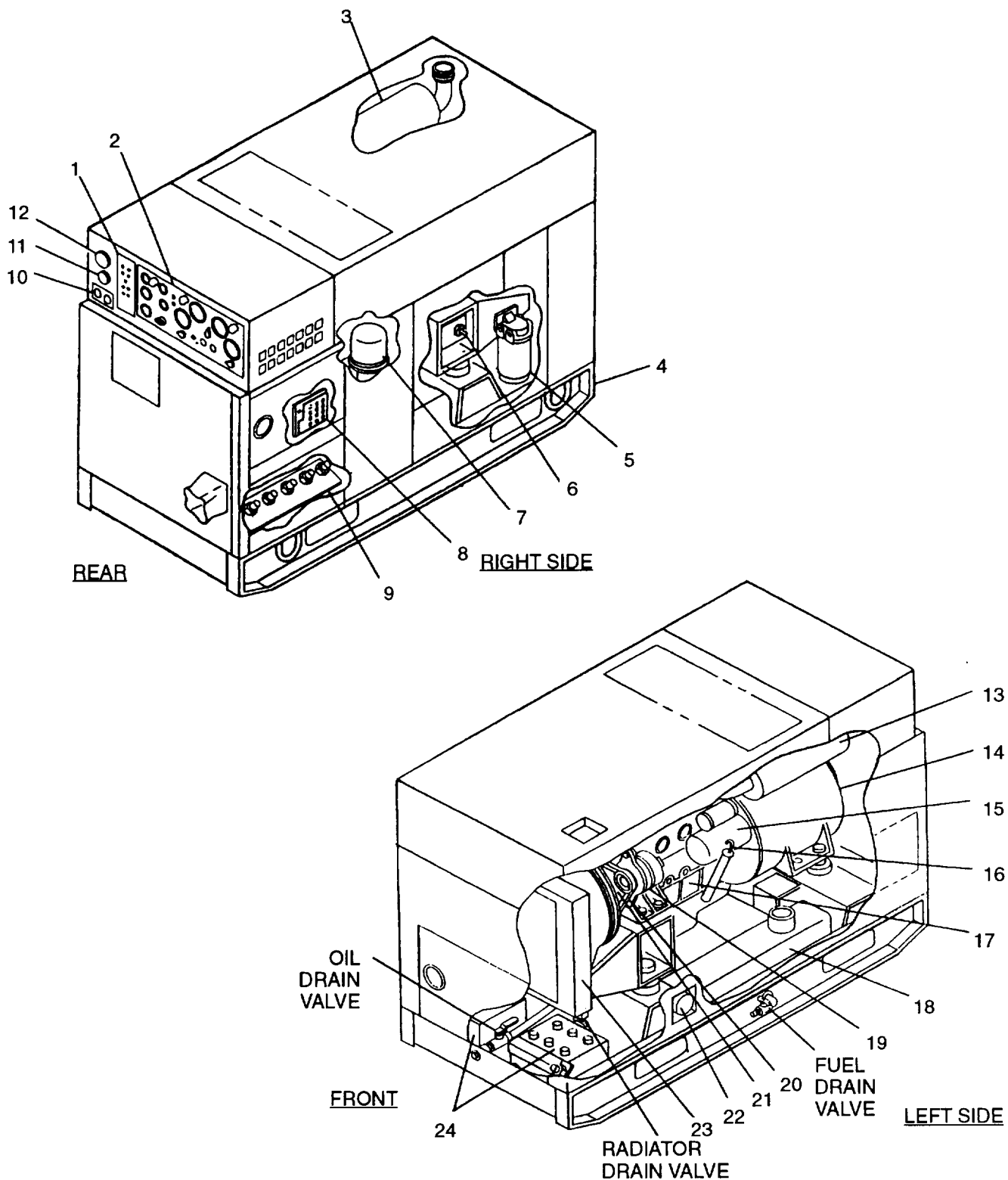

FIGURE 1-12. Generator Set Components

1.13.18 Fuel Tank (18). The 14 gallon (53 liters) fuel tank is located in the front of the generator set below the engine and between the skid base side members. The fuel tank is a fuel reservoir and has sufficient capacity to enable the generator set to operate for at least 8 hours without refueling.

1.13.19 Battery Charging Alternator (19). The battery charging alternator is located on the left side of the engine. It is capable of maintaining the batteries in a state of full charge in addition to providing the required 24 VDC control power.

1.13.20 Fan Belt (20). The fan belt is located in the engine compartment on the front of the engine. The belt drives the fan, water pump, and the battery charging alternator.

1.13.21 Water Pump (21). The water pump is located in the engine compartment on the front of the engine. The pump circulates the engine coolant through the engine block and the radiator.

1.13.22 NATO SLAVE RECEPTACLE (22). The NATO SLAVE RECEPTACLE is located on the left side of the generator set under engine compartment access door. It is a NATO receptacle used for remote battery connection.

1.13.23 Radiator (23). The radiator is located at the front of the generator set. It acts as a heat exchanger for the engine coolant.

1.13.24 Batteries (24). Two batteries are located at front of the generator set. The batteries are electrolyte serviceable, lead acid, 12 volt type. After starting, the generator set is capable of operating with batteries removed. A diode, located behind the control panel, protects the generator set if the batteries are incorrectly connected.

CHAPTER 2 UNIT MAINTENANCE INSTRUCTIONS

Section I. SERVICE UPON RECEIPT OF EQUIPMENT

2.1 INSPECTING AND SERVICING THE EQUIPMENT.

This section provides information and guidance for inspecting, servicing, and installing the generator set under normal conditions.

2.1.1 Inspection.

- a. Unpack and inventory all end item components for serviceability.
- b. Check that all packing materials have been removed.
- c. Check generator set identification plate for proper identification.
- d. Inspect generator set exterior for shipping damage.
- e. Open battery compartment access door and inspect batteries for damage.
- f. Check battery cables for proper polarity connection, damage, and loose connections.
- g. Open control panel access door and check panel for damage.
- h. Lower control panel and check electrical components for damage or loose connections.
- i. Raise control panel and secure fasteners.
- j. Check air cleaner assembly for external damage and exhaust opening for obstruction.
- k. Check fan belt for looseness and ensure it is not frayed or cracked.
- l. Inspect generator set for loose or missing mounting hardware or damaged or missing parts.

NOTE

Dipstick is marked indicating that oil level can be checked and oil added when engine is running or stopped. Make sure the correct side of dipstick is checked.

- m. Check oil level. As required, drain preservative from engine and fill with proper lubricating oil, refer to paragraph 2.1.2.4.
- n. Unpack grounding rod from inside left engine access door, parallel cable, and auxiliary fuel hose from storage box. Inspect each item for damage and accountability.

2.1.2. Service.

2.1.2.1. Batteries. For servicing batteries, refer to TM9-6140-200-14

2.1.2.2. Radiator.

WARNING

Do not operate generator set while servicing radiator. Damage to equipment or personal injuries may result.

- a. Remove radiator cap.
- b. Check that radiator drain valve is closed, refer to FIGURE 1-12.
- c. Fill radiator with proper coolant/antifreeze in accordance with TABLE 2-1. Fill radiator to a level two inches below fill opening.

- d. Remove overflow bottle cap.
- e. Fill overflow bottle to “COLD” level.

TABLE 2-1. Coolant

AMBIENT TEMPERATURE	RADIATOR COOLANT	RATIO
+40°F TO +120°F (4°C TO 49°C)	WATER: MIL-A-53009 INHIBITOR, CORROSION	35:1
-25°F TO +120°F (-32°C TO 49°C)	WATER: MIL-A-46153 ANTIFREEZE	1:1
-25°F TO +120°F (-32°C TO 49°C)	MIL-A-11755 ANTIFREEZE	N/A

- f. Install overflow bottle and radiator caps.
- g. After 30 minutes of operation check coolant/antifreeze level at overflow bottle. Add coolant/antifreeze as required to overflow bottle.

2.1.2.3. Fuel Tank.

WARNING

Maintain metal-to-metal contact between fuel tank filler neck and fuel nozzle to prevent sparks from static electricity. Do not smoke or use open flame in area of fueling operation. Failure to follow this warning could result in explosion, severe personal injury, or death.

- a. Check that fuel drain valve is closed, refer to FIGURE 1-12.

WARNING

Hot refueling of generators while they are operating presents a safety hazard and should not be attempted. Hot engine surfaces and sparks produced from the engine and generator circuitry are possible sources of ignition. Failure to observe this warning could result in severe personal injury or death.

- b. Remove fuel tank filler cap.
- c. Fill fuel tank with fuel type in accordance with TABLE 2-2. Fuel tank capacity is 14 gallons (53 liters).
- d. Install fuel tank filler cap.

2.1.2.4. Lubricating Oil.

- a. Place suitable container under oil drain plug and remove plug.
- b. Open battery access door, and open oil drain valve (FIGURE 1-12) and drain oil.
- c. Close oil drain valve and remove oil fill cap.

NOTE

Dipstick is marked indicating that oil level can be checked and oil added when engine is running or stopped. Make sure the correct side of dipstick is checked.

- d. Fill engine with proper engine lubricating oil in accordance with TABLE 2-3 to FULL mark on dipstick. Lubrication system capacity is 6 quarts (5.7 liters).
- e. Install oil fill cap.
- f. Close battery access door.

TABLE 2-2. Fuel

AMBIENT TEMPERATURE	DIESEL FUEL
+20°F TO +120°F (-6°C TO 49°C)	VV-F-800 GRADE DF-2, JP4, JP5, OR JP8
0°F TO +20°F (-17°C TO -6°C)	VV-F-800 GRADE DF-1, JP4, JP5, OR JP8
-25°F TO 0°F (-32°C TO -17°C)	VV-F-800 GRADE DF-1
-25°F TO 0°F (-32°C TO -17°C)	VV-F-800 GRADE DF-A

TABLE 2-3. Lubricating Oil

AMBIENT TEMPERATURE	LUBRICATING OIL
+20°F TO +120°F (-6°C TO 49°C)	MIL-L-2104 OE HDO-30 or OE HDO-15/40
0°F TO +20°F (-17°C TO 6°C)	MIL-L-2104 OE HDO-10
-25°F TO 0°F (-32°C TO -17°C)	MIL-L-46167

2.2. GENERATOR SET INSTALLATION.

2.2.1. General

WARNING

Do not operate generator set in an enclosed area unless exhaust fumes are piped outside the enclosure. Exhaust gases contain noxious and deadly fumes. Failure to observe this warning could result in severe personal injury or death.

- a. Ensure that installation site is as level as possible.
- b. Provide adequate ventilation to prevent recirculation of hot air exhausted from generator set.
- c. Refer to FIGURE 2-1 for base mounting measurements.

2.2.2. Outdoor Installation.

- a. Make use of natural protective barriers.
- b. Allow space on all sides for service and maintenance. Refer to FIGURE 2-2 for minimum clearance measurements.
- c. Ensure that site soil is firm and well drained.
- d. Use planks or other material for support in areas where soil will not support the generator set.

2.2.3. Indoor Installation.

WARNING

Do not operate generator set in an enclosed area unless exhaust fumes are piped outside the enclosure. Exhaust gases contain noxious and deadly fumes. Failure to observe this warning could result in severe personal injury or death.

CAUTION

Never position generator set with the air inlets near a wall or other object that interferes with cooling air circulation, damage to equipment could occur.

- a. Provide ducts and vents to outside of building if good supply of cooling air is not available.
- b. Make air intake and outlet openings in building same size or larger as those on the generator set.
- c. Install a gas tight metal pipe from exhaust pipe of generator set to outside of building.

NOTE

Make exhaust pipe extension as short and straight as possible with only one 90 degree bend, if needed.

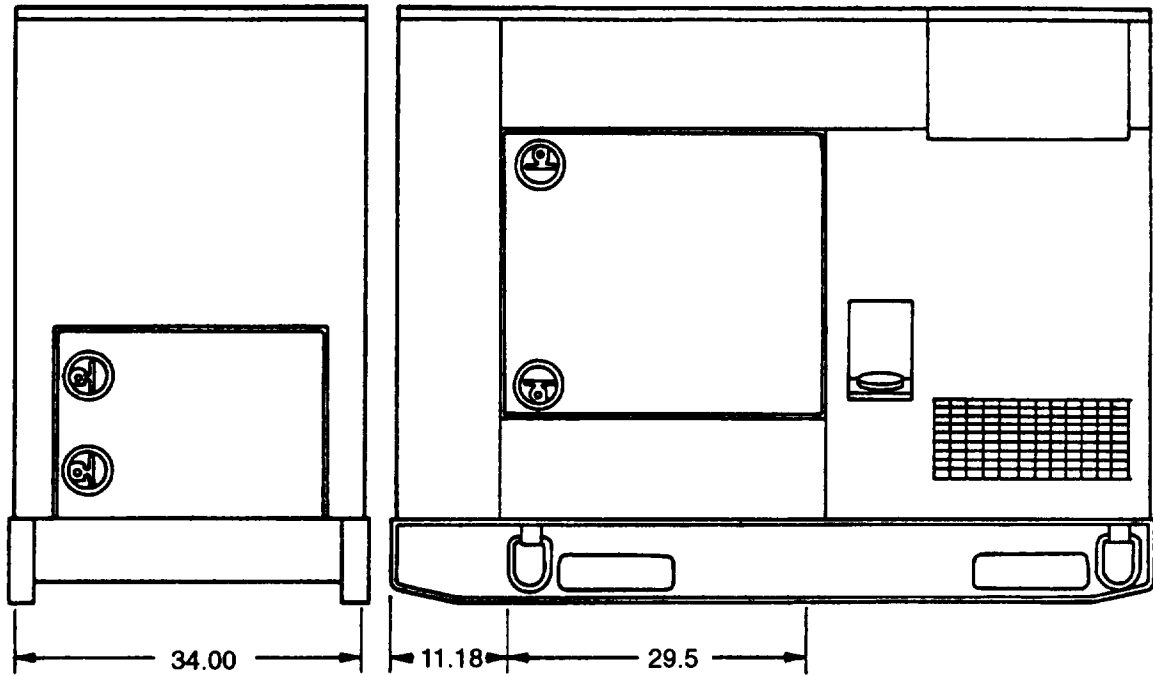

FIGURE 2-1. Base Mounting Measurements

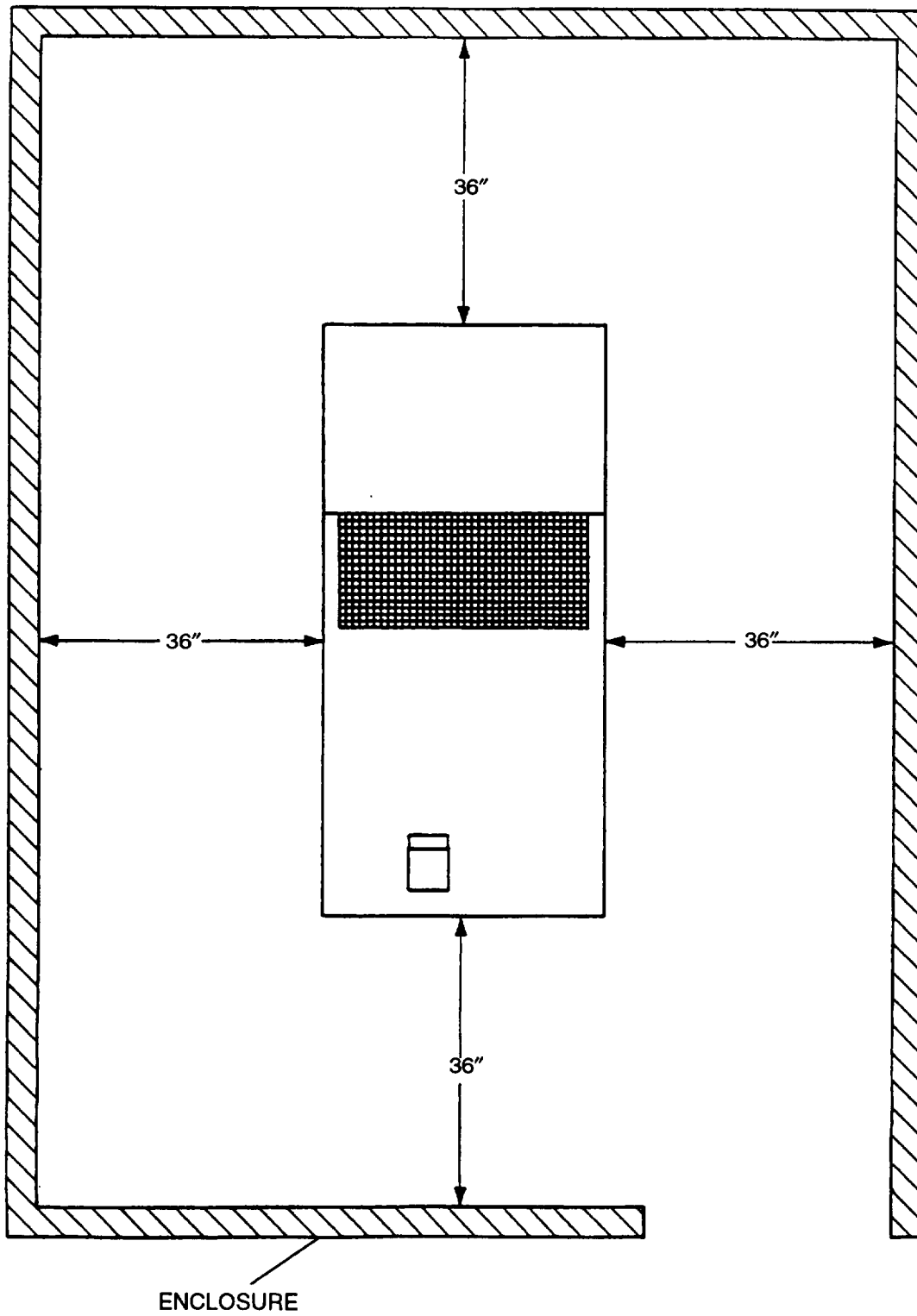

FIGURE 2-2. Minimum Enclosure Clearance Measurements

- d. Ensure that inside diameter of exhaust pipe extension is as large or larger than generator exhaust pipe.

WARNING

Hot exhaust gases can ignite flammable materials. Failure to observe this warning could result in severe personal injury or death.

- e. Provide for harmless discharge of hot gases and sparks. Do not direct exhaust into area containing flammable materials.

WARNING

If not shielded, hot exhaust pipe can ignite flammable wall materials. Failure to observe this warning could result in severe personal injury or death.

- f. Shield exhaust pipe with fireproof material at point where it passes through a flammable wall.

WARNING

An unwrapped exhaust pipe can cause injury if touched,

- g. Wrap exhaust pipe in protective material.

- h. Allow space on all sides for service and maintenance. Refer to FIGURE 2-2 for minimum clearance measurements.

2.3. FABRICATION/ASSEMBLY OF PARTS.

TABLE 2-4 is a list of generator set parts that require fabrication or assembly when replacing. See Appendix D for fabrication and assembly instructions.

TABLE 2-4. Fabricated/Assembled Parts

NAME	PART NUMBER
Cable Assembly, AC Power	88-22126-1
Cable Assembly, AC Power	88-22126-2
Cable Assembly, AC Power	88-22126-3
Cable Assembly, AC Power	88-22126-4
Cable Assembly, AC Power	88-22126-5
Cable Assembly, AC Power	88-221264
Cable Assembly, AC Power	88-22126-7
Cable Assembly, Battery	88-22123
Cable Assembly, Battery	88-22179
Cable Assembly, Battery	88-22309
Cable Assembly, Battery	88-22310
Cable Assembly, Battery	88-22311
Capacitor Assembly, EMI	88-22758
Cord, Load Wrench	88-22469
Diode Assembly	88-22418-2
Holder, Control Panel	88-22120
Insulation, Baffle	88-22594
Insulation, Front Housing	88-22595
Pump Assembly, Fuel	88-22546
Resistor Assembly	122-3066-1
Resistor Assembly	122-3066-2
Resistor Assembly, Volt	88-22631
Resistor-Diode Assembly	88-22106
Switch Assembly, Fuel Level	88-22547
Transducer Assembly	88-22550
Wire, Varistor (L0)	88-20305-5
Wire, Varistor (L1)	88-20305-1
Wire, Varistor (L2)	88-20305-2
Wire, Varistor (L3)	88-20305-3

Section II. REPAIR PARTS; SPECIAL TOOLS; TEST, MEASUREMENT, AND DIAGNOSTIC EQUIPMENT (TMDE); AND SPECIAL SUPPORT EQUIPMENT

2.4. REPAIR PARTS AND SPECIAL TOOLS LIST (RPSTL).

2.4.1. Tools and Equipment. There are no special tools or support equipment required to perform unit level of maintenance on the generator set. A list of recommended tools and support equipment required to maintain the generator set is contained in Appendix B, Section III.

2.4.2. Maintenance Repair Parts. Repair parts and equipment are listed and illustrated in the Repair Parts and Special Tools List (RPSTL) manual TM 9-6115-643-24P.

Section III. SPECIAL LUBRICATION INSTRUCTIONS

NOTE

There are no special lubrication instructions. Refer to LO 9-6115-643-12 for generator set lubrication requirements.

Section IV. PREVENTIVE MAINTENANCE CHECKS AND SERVICES (PMCS)

2.5. PMCS PROCEDURES.

2.5.1. General. To ensure that the generator set is ready for operation at all times, it must be inspected so that defects can be discovered and corrected before they result in serious damage or failure.

2.5.2. Purpose of PMCS Table. Your Preventive Maintenance Checks and Services table lists the inspections and care of your equipment required to keep it in good operating condition.

2.5.3. Purpose of Service Intervals. The interval column of your PMCS table tells you when to do a certain check or service.

2.5.4. Procedures Column. The procedures column of your PMCS table tells you how to do the required checks and services. Carefully follow these instructions.

2.5.5. The "Equipment Is Not Ready/Available If". This column tells you when and why the generator set cannot be used.

NOTE

The terms ready/available and mission capable refer to the same status: Generator set is on hand and is able to perform its combat missions (see DA Pam 738-750).

2.5.6. Reporting and Correcting Deficiencies. If your generator set does not perform as required, refer to Troubleshooting section for possible problems. Report any malfunctions or failures on DA Form 2404, or refer to DA Pam 738-750.

TABLE 2-5. Unit Preventive Maintenance Checks and Services

M-Monthly Q-Quarterly S-Semi-annually A-Annually B-Bi-annually H-Hours

Item No.	Interval						Item to be Inspected	Procedures Check for and have repaired or adjusted as necessary	Equipment is not Ready/ Available if
	M	Q	S	A	B	H			
1			•			300	Engine Lube Oil	NOTE. Oil filter should be changed with lube oil change. Refer to TM 9-2815-254-24 Drain engine lube oil. Add proper lube oil per LO 9-6115-643-12	
2				•		300	Fuel Filter/Water Separator	Change fuel filter/water separator Refer to paragraph 2.93.	
3					•	1500	Cooling System	Drain coolant and flush cooling system Add proper coolant Refer to paragraph 2.75.2.	
4				•			Radiator Cap	Inspect radiator cap for corrosion, torn or deteriorated seal, and obvious damage.	Radiator cap or seal is damaged
5				•		300	Batteries	Remove batteries. Refer to paragraph 2.12.2 Clean batteries, cable terminals, and battery posts Test batteries for state of charge. Refer to paragraph 2.12.1.	Batteries will not hold charge.
6				•		300	Air Cleaner Assembly	Inspect air cleaner assembly and mounting bracket for cracks, dents, and other damage. Inspect element for clogs and damage. Clean or replace as necessary Clean housing with cleaning cloth	
7				•		750	Air Cleaner Tubing and Breather	Remove, clean, and Inspect tubing and breather. Refer to paragraph 2.74.	
8				•		300	Hardware and sound Insulation	Inspect for loose, damaged, or missing hardware and sound insulation Tighten loose hardware Repair or replace damaged or missing hardware and insulation	Loose, missing, or damaged hardware or insulation

TABLE 2-5. Unit Preventive Maintenance Checks and Services - Continued

M-Monthly Q-Quarterly S-Semi-annually A-Annually B-Biannually H-Hours

Item No.	Interval						Item to be Inspected	Procedures Check for and have repaired or adjusted as necessary	Equipment is not Ready/ Available if:
	M	Q	S	A	B	H			
9				•		1500	Radiator and Interior of Generator set	Clean radiator exterior surfaces. Refer to paragraph 2.76. Clean engine compartment.	
10				•		1500	Magnetic Pickup	Remove, inspect and dean magnetic pickup. Refer to paragraph 2.106.	Magnetic pickup is damaged.
11				•			wiring Harnesses	Inspect wiring harnesses for break and loose connections. Repair and tighten wiring harnesses as necessary.	Wiring harnesses are damaged or connections are loose.
12				•		3000	Muffler	Check muffler for leaks, restriction, and accumulation of carbon. Replace or dean as required.	Muffler leaks, is restricted, or has excessive carbon accumulation.
NOTE									
If the auxiliary fuel system is used as the primary fuel source, then the auxiliary fuel filter must be replaced semi-annually.									
13				•		300	Auxiliary Fuel Filter	Check for proper operation using the auxiliary fuel system as primary source.	

Section V. TROUBLESHOOTING

2.6 UNIT TROUBLESHOOTING PROCEDURES.

2.6.1. Purpose of Troubleshooting Table. This section contains troubleshooting information for locating and correcting operating troubles which may develop in the generator set. Each malfunction for an individual component, unit, or system is followed by a list of tests or inspections which will help you to determine probable causes and corrective actions to take. You should perform the tests/inspections and corrective actions in the order listed.

This table cannot list all malfunctions that can occur, nor all tests or inspections and corrective actions. If a malfunction is not listed or cannot be corrected by listed corrective actions, notify your supervisor.

NOTE

Before you use this table, be sure you have performed your PMCS.

NOTE

Before using this table, ensure that operator level troubleshooting steps have been performed.

NOTE

Refer to the Diagnostic Connector Table 2-9, Electrical Schematic FO-1 and Wiring Diagram FO-2 as troubleshooting aids.

SYMPTOM INDEX
GENERATOR SET

	Troubleshooting Procedure Page
COOLING SYSTEM	
Engine overheating	2-19
Engine coolant temperature too low	2-20
ELECTRICAL SYSTEM	
BATTERY CHARGE ammeter	
Shows no charge when batteries are low or discharged	2-22
Shows excessive charging after prolonged operation	2-22
AC voltmeter (VOLTS AC) Does not indicate voltage	2-23
Indicates voltage but FREQUENCY meter (HERTZ) is off scale	2-23
Voltage fluctuates	2-23
FREQUENCY meter (HERTZ) Frequency fluctuates	2-24
ENGINE	
Fails to crank	2-14
Cranks but fails to start	2-15
Stops suddenly	2-16
Runs erratically or stalls frequently	2-16
Misfiring	2-17
Does not develop full power	2-17
Abnormal Engine Noise	2-17
Excessive fuel consumption	2-20
Coolant in crankcase or oil in coolant	2-20
Vibrating	2-21
Fails to start in cold weather	2-21
EXHAUST SYSTEM	
Black or grey smoke in exhaust	2-18
Blue or white exhaust smoke	2-18
LUBRICATION SYSTEM	
High oil consumption	2-18
Low oil pressure	2-19
High oil pressure	2-19

TABLE 2-6. UNIT TROUBLESHOOTING

MALFUNCTION	TEST OR INSPECTION	CORRECTIVE ACTION
1. ENGINE FAILS TO CRANK.		
Step 1.	Test for defective DEAD CRANK switch, paragraph 2.109.1.	a. If DEAD CRANK switch is not defective, do step 5. b. If defective, replace DEAD CRANK Switch, paragraph 2.109.
Step 2.	Check for loose or corroded battery cable terminals or battery posts.	a. If terminals are tight and posts are clean, do step 3. b. If not clean and tight, clean and tighten battery cable terminals and posts, paragraph 2.14.4.
Step 3.	Check that batteries are installed correctly, paragraph 2.12.5.	a. If batteries are installed correctly, do step 4. b. If not properly installed, install batteries correctly, paragraph 2.12.5.
Step 4.	Test for low or no battery charge, paragraph 2.12.1.	a. If fully charged, do step 5. b. If not fully charged, replace batteries, paragraph 2.12.
Step 5.	Test for defective DC CONTROL POWER circuit breaker, paragraph 2.49.2.	a. If DC CONTROL POWER circuit breaker is not defective, do step 6. b. If defective, replace DC CONTROL POWER circuit breaker, paragraph 2.49.
Step 6.	Test for battery voltage at input of MASTER SWITCH.	a. If battery voltage is present, do step 7. b. If battery voltage is not present, do step 8.
Step 7.	Test MASTER SWITCH output voltage in START position.	a. If battery voltage is present at MASTER SWITCH output terminal (7) and GND, do step 11. b. If battery voltage is not present at output terminal, test MASTER SWITCH, paragraph 2.32.3.
Step 8.	Test for defective battery charging ammeter shunt, paragraph 2.53.2.	a. If not defective, do step 9. b. If defective, replace battery charging ammeter shunt, paragraph 2.53.
Step 9.	Test for defective reverse battery diode (CRI), paragraph 2.65.2.	a. If not defective, do step 10. b. If defective, replace reverse battery diode, paragraph 2.65.
Step 10.	Test for defective EMERGENCY STOP switch, paragraph 2.40.2.	a. If not defective, do step 11. b. If defective, replace EMERGENCY STOP switch, paragraph 2.40.

TABLE 2-6. UNIT TROUBLESHOOTING - Continued

MALFUNCTION	TEST OR INSPECTION	CORRECTIVE ACTION
Step 11.	Test for defective start relay (K15), paragraph 2.59.2.	a. If not defective, do step 12. b. If defective, replace start relay, paragraph 2.59.
Step 12.	Test for defective cranking relay (K2), paragraph 2.100.2.	a. If cranking relay is not defective, do step 13. b. If defective, replace cranking relay, paragraph 2.100.
Step 13.	Test for defective crank disconnect relay (K16), paragraph 2.59.2.	a. If crank disconnect relay is not defective, do step 14. b. If defective, replace crank disconnect relay, paragraph 2.59.
Step 14.	Check starting circuit for breaks or loose connections.	a. If starting circuit has no breaks and connections are tight, do step 5. b. If defective, repair or replace defective wires or connections.
Step 15.	Test for defective starter solenoid, refer to TM 9-2815-254-24.	a. If starter solenoid is not defective, do step 16. b. If defective, replace starter solenoid in accordance with TM 9-2815-254-24.
Step 16.	Test for defective starting motor, refer to TM 9-2815-254-24.	a. If defective, replace starting motor in accordance with TM 9-2815-254-24. b. If starting motor is not defective, notify next higher level of maintenance.
<u>2. ENGINE CRANKS BUT FAILS TO START</u>		
Step 1.	Test for low battery output, paragraph 2.12.1.	a. If batteries are fully charged, do step 2. b. If not fully charged, replace batteries, paragraph 2.12.
Step 2.	Check for dogged or defective fuel filter/water separator.	a. If fuel filter/water separator is not dogged or defective, do step 3. b. If clogged or defective, service fuel filter/water separator, paragraph 2.93.2.
Step 3.	Check for blocked fuel line(s) and/or components.	a. If fuel lines are not blocked, do step 4. b. If blocked, unblock or replace fuel line(s) and/or components, paragraph 2.85 and/or paragraph 2.86.
Step 4.	Check for air in fuel lines.	a. If air in fuel lines, bleed fuel lines in accordance with TM 9-2815-254-24. b. If no air in fuel lines, do step 5.

TABLE 2-6. UNIT TROUBLESHOOTING - Continued

MALFUNCTION	TEST OR INSPECTION	CORRECTIVE ACTION
Step 5.	Check for contaminated or incorrect grade of fuel.	<ul style="list-style-type: none"> a. If fuel is not contaminated and is correct grade, do step 6. b. If contaminated or incorrect grade, drain engine fuel system and service fuel filter/ water separator, paragraph 2.93.2. Drain generator set tank. Service generator set fuel tank with dean fuel of a proper grade (TABLE 2-2). Prime engine fuel system in accordance With TM 9-2815-254-24.
Step 6.	Check for defective fuel feed pump, refer to TM 9-2815-254-24.	<ul style="list-style-type: none"> a. If defective, replace fuel feed pump in accordance with TM 9-2815-254-24. b. If fuel feed pump is not defective, notify next higher level of maintenance.
3. ENGINE STOPS SUDDENLY.		
Step 1.	Check for tripped protective devices.	<ul style="list-style-type: none"> a. If no malfunction indicator lights are lit, do step 2. b. If lit, comet fault indicated.
Step 2.	Check for air lock in fuel supply line.	<ul style="list-style-type: none"> a. If no air lock in fuel line, do step NO TAG. b. If air in line, bleed fuel lines in accordance with TM 9-2815-254-24.
Step 3.	Check for blocked fuel line(s) and/or components, starting at injection pump inlet line.	<ul style="list-style-type: none"> a. If blocked, unblock or replace fuel line(s) and/or components, paragraph 2.85 and/or paragraph 2.86. b. If fuel lines are not blocked, notify next higher level of maintenance.
4. ENGINE RUNS ERRATICALLY OR STALLS FREQUENTLY.		
Step 1.	Check for obstruction in fuel line(s).	<ul style="list-style-type: none"> a. If fuel lines are not obstructed, do step 2. b. If obstructed, unblock or replace fuel line(s), paragraph 2.85.
step 2.	Check for blocked exhaust pipe or muffler.	<ul style="list-style-type: none"> a. If exhaust pipe and muffler are not blocked, do step 3. b. If blocked, unblock or replace muffler, paragraph 2.70.
Step 3.	Check for contaminated or incorrect grade of fuel.	<ul style="list-style-type: none"> a. If contaminated or incorrect grade, drain engine fuel system and service fuel filter/water separator, paragraph 2.83.2. Drain generator set tank. Service generator set fuel tank with dean fuel of a proper grade (TABLE 2-2). Prime engine fuel system in accordance with TM 9-2815-254-24. b. If fuel is not contaminated or incorrect grade, notify next higher level of maintenance.

TABLE 2-6. UNIT TROUBLESHOOTING - Continued

MALFUNCTION	TEST OR INSPECTION	CORRECTIVE ACTION
5. <u>ENGINE MISFIRING.</u>		
Step 1.	Check for contaminated or incorrect grade of fuel.	<ul style="list-style-type: none"> a. If fuel is not contaminated and is correct grade, do step 2. b. If contaminated or incorrect grade, drain engine fuel system and service fuel filter/ water separator, paragraph 2.93.2. Drain generator set tank. Service generator set tank with clean fuel of a proper grade (TABLE 2-2). Prime engine fuel system in accordance with TM 9-2815-254-24.
Step 2.	Check for air in fuel lines.	<ul style="list-style-type: none"> a. If air in lines, bleed fuel lines in accordance with TM 9-2815-254-24. b. If no air in fuel lines, notify next higher level of maintenance.
6. <u>ENGINE DOES NOT DEVELOP FULL POWER.</u>		
Step 1.	Check for restricted fuel filter/water separator.	<ul style="list-style-type: none"> a. If fuel filter/water separator is not restricted, do step 2. b. If restricted, service fuel filter/water separator, paragraph 2.93.2.
Step 2.	Check for contaminated or incorrect grade of fuel.	<ul style="list-style-type: none"> a. If fuel is not contaminated and is correct grade, do step 3. b. If contaminated or incorrect grade, drain engine fuel system and service fuel filter/ water separator, paragraph 2.93.2. Drain generator set tank. Service generator set tank with clean fuel of proper grade (TABLE 2-2). Prime engine fuel system in accordance with TM 9-2815-254-24.
Step 3.	Check for blocked air intake system.	<ul style="list-style-type: none"> a. If air intake system is not blocked, do step 4. b. If blocked, unblock or replace air intake system components as required.
Step 4.	Check blocked exhaust pipe or muffler.	<ul style="list-style-type: none"> a. If blocked, unblock or replace muffler, paragraph 2.70. b. If exhaust pipe and muffler are not blocked, notify next higher level of maintenance.
7. <u>ABNORMAL ENGINE NOISE.</u>		
Step 1.	Check for contaminated or incorrect grade of fuel.	<ul style="list-style-type: none"> a. If contaminated or incorrect grade, drain engine fuel system and service fuel filter/ water separator, paragraph 2.93.2. Drain generator set tank. Service generator set fuel tank with clean fuel of a proper grade (TABLE 2-2). Prime engine fuel system in accordance with TM 9-2815-254-24. b. If fuel is not contaminated and is correct grade, notify next higher level of maintenance.

TABLE 2-6. UNIT TROUBLESHOOTING - Continued

MALFUNCTION	TEST OR INSPECTION	CORRECTIVE ACTION
8.	<u>BLACK OR GREY SMOKE IN EXHAUST</u>	<p>Step 1. Check for improper grade of fuel.</p> <p>a. If improper grade of fuel, drain engine fuel system. Drain generator set tank. Service generator set fuel tank with clean fuel of a proper grade (TABLE 2-2). Prime engine fuel system in accordance with TM 9-2815-254-24.</p> <p>b. If proper grade of fuel, notify next higher level of maintenance.</p>
9.	<u>BLUE OR WHITE EXHAUST SMOKE.</u>	<p>Step 1. Check for excessive engine oil level.</p> <p>a. If oil level is proper, do step 2.</p> <p>b. If oil level is excessive, drain to proper level, paragraph d.</p> <p>Step 2. Check for improper grade of fuel.</p> <p>a. If proper grade of fuel, do step 3.</p> <p>b. If improper grade, drain engine fuel system and generator set tank. Service generator set fuel tank with clean fuel of a proper grade (TABLE 2-2). Prime engine fuel system in accordance with TM 9-2815-254-24.</p> <p>Step 3. Check for defective thermostat, refer to TM 9-2815-254-24.</p> <p>a. If defective, replace thermostat in accordance with TM 9-2815-254-24.</p> <p>b. If thermostat is not defective, notify next higher level of maintenance.</p>
10.	<u>HIGH OIL CONSUMPTION.</u>	<p>Step 1. Check for blocked air intake system.</p> <p>a. If air intake system is not blocked, do step 2.</p> <p>b. If blocked, unblock or replace air intake system components as required, paragraph 2.72.</p> <p>Step 2. Check for improper lube oil type.</p> <p>a. If improper, and paragraph 2.109.10 drain oil and refill with proper lube oil type (TABLE 2-3). Replace oil filter in accordance with TM 9-2815-254-24.</p> <p>b. If proper lube oil type, notify next higher level of maintenance.</p>

TABLE 2-6. UNIT TROUBLESHOOTING - Continued

MALFUNCTION	TEST OR INSPECTION	CORRECTIVE ACTION
1.	<u>LOW OIL PRESSURE.</u>	<p>Step 1. Check for improper lube oil type.</p> <ul style="list-style-type: none"> a. If proper lube oil type, do step 2. b. If improper, drain oil and refill with proper lube oil type (TABLE 2-3) and paragraph 2.111.2. Replace oil filter in accordance with TM 9-2815-254-24. <p>Step 2. Test for defective OIL PRESSURE indicator, paragraph 2.25.2.</p> <ul style="list-style-type: none"> a. If OIL PRESSURE indicator is not defective, do step 3. b. If defective, replace OIL PRESSURE indicator, paragraph 2.25. <p>step 3. Test for defective oil pressure sender, paragraph 2.105.1.</p> <ul style="list-style-type: none"> a. If defective, replace oil pressure sender, paragraph 2.105. b. If oil pressure sender is not defective, notify next higher level of maintenance.
2.	<u>HIGH OIL PRESSURE.</u>	<p>Step 1. Check for improper lube oil type.</p> <ul style="list-style-type: none"> a. If proper lube oil type, do step 2. b. If improper, drain oil and refill with proper lube oil type (TABLE 2-3) and paragraph 2.111.2. Replace oil filter in accordance with TM 9-2815-254-24. <p>Step 2. Test for defective OIL PRESSURE indicator, paragraph 2.25.2.</p> <ul style="list-style-type: none"> a. If OIL PRESSURE indicator is not defective, do step 3. b. If defective, replace OIL PRESSURE indicator, paragraph 2.25. <p>Step 3. Test for defective oil pressure sender, paragraph 2.105.1.</p> <ul style="list-style-type: none"> a. If defective, replace oil pressure sender, paragraph 2.105. b. If oil pressure sender is not defective, notify next higher level of maintenance.
13.	<u>ENGINE OVERHEATING.</u>	<p>Step 1. Check for broken or loose fan belt, paragraph 2.83.1.</p> <ul style="list-style-type: none"> a. If fan belt are not broken and tension is correct, do step 2. b. If worn or broken, replace fan belt, paragraph 2.83. If loose, adjust fan belt, paragraph 2.83.2. <p>step 2. Check for defective Radiator Cap, paragraph 2.75.1.</p> <ul style="list-style-type: none"> a. If radiator cap is not defective, do step 3. b. If defective, replace radiator cap, paragraph 2.76. <p>Step 3. Check for defective coolant hose(s).</p> <ul style="list-style-type: none"> a. If coolant hoses are not leaking or collapsed, do step 4. b. If defective, replace coolant hose(s), paragraphs 2.76 through 2.80.

TABLE 2-6. UNIT TROUBLESHOOTING - Continued

MALFUNCTION	TEST OR INSPECTION	CORRECTIVE ACTION
Step 4.	Check for defective thermostat, refer to TM 9-2815-254-24.	a. If thermostat is not defective, do step 5. b. If defective, replace thermostat in accordance with TM 9-2815-254-24.
Step 5.	Check for dogged radiator, paragraph 2.75.2.	a. If radiator is not clogged, do step 6. b. If dogged, remove obstruction or replace radiator, paragraph 2.81.
Step 6.	Check for defective water pump, refer to TM 9-2815-254-24.	a. If defective, replace water pump in accordance with TM 9-2815-254-24. b. If water pump is not defective, notify next higher level of maintenance.
14.	<u>ENGINE COOLANT TEMPERATURE TOO LOW.</u>	
Step 1.	Check for defective thermostat, refer to TM 9-2815-254-24.	a. If thermostat is operating correctly, do step 2. b. If defective, replace thermostat in accordance with TM 9-2815-254-24.
Step 2.	Test for defective temperature sender, paragraph 2.106.1.	a. If temperature sender is not defective, do step 3. b. If defective, replace temperature sender, paragraph 2.106.
Step 3.	Test for defective COOLANT TEMP. indicator, paragraph 2.24.2.	a. If defective, replace COOLANT TEMP. indicator, paragraph 2.24. b. If COOLANT TEMP. indicator is not defective, notify next higher level of maintenance.
15.	<u>EXCESSIVE FUEL CONSUMPTION.</u>	
Step 1.	Check for blocked air intake system.	a. If air intake system is not blocked, do step 2. b. If blocked, unblock or replace air intake system components as required, paragraph 2.72.
Step 2.	Check for leaks in fuel system.	a. If no leaks in fuel system, do step 3. b. If leaks found, repair fuel system as required.
Step 3.	Check for contaminated oil.	a. If oil is contaminated change oil, paragraph 2.1.2.4. b. If oil is not contaminated or trouble persists, notify next higher level of maintenance.
16.	<u>COOLANT IN CRANKCASE OR OIL IN COOLANT.</u>	
	Check for coolant or oil contamination. If contaminated, notify next higher level of maintenance.	

TABLE 2-6. UNIT TROUBLESHOOTING - Continued

MALFUNCTION	TEST OR INSPECTION	CORRECTIVE ACTION
17.	<u>ENGINE VIBRATING</u>	
Step 1.	Check for bent or broken cooling fan blades.	
	a. If fan blades are not damaged, do step 2.	
	b. If damaged, replace cooling fan, paragraph 2.82.	
Step 2.	Check for loose or defective engine mounts.	
	a. Tighten loose mounting bolts.	
	b. If bolts are tight or problem persists, notify next higher level of maintenance.	
18.	<u>ENGINE FAILS TO START IN COLD WEATHER.</u>	
Step 1.	Test for low or no battery charge, paragraph 2.12.1.	
	a. If batteries are fully charged, do step 2.	
	b. If not fully charged, replace batteries, paragraph 2.12.	
Step 2.	Check for improper lube oil type.	
	a. If proper lube oil type, do step 3.	
	b. If improper, drain oil and refill with proper lube oil type (TABLE 2-3). Replace oil filter in accordance with TM 9-2815-254-24.	
Step 3.	Check for improper grade of fuel.	
	a. If proper grade of fuel, do step 4.	
	b. If improper, drain engine fuel system. Drain generator set tank. Service generator set fuel tank with clean fuel of a proper grade (TABLE 2-2) and paragraph 2.109.10. Prime engine fuel system in accordance with TM 9-2815-254-24.	
Step 4.	Check for defective glow plug DC contactor, paragraph 2.109.6.	
	a. If glow plug contactor is not defective, do step 5.	
	b. If defective, replace glow plug contactor, paragraph 2.109.4.	
Step 5.	Check for defective glow plug(s) in accordance with TM 9-2815-254-24.	
	a. If glow plug(s) is not defective, do step 6.	
	b. If defective, replace glow plug(s) in accordance with TM 9-2815-254-24.	
Step 6.	Test for defective MASTER SWITCH, paragraph 2.32.3.	
	a. If defective, replace MASTER SWITCH, paragraph 2.32.	
	b. If MASTER SWITCH is not defective and problem persists, notify next higher level of maintenance.	

TABLE 2-6. UNIT TROUBLESHOOTING - Continued

MALFUNCTION	TEST OR INSPECTION	CORRECTIVE ACTION
19.	<u>BATTERY CHARGE AMMETER SHOWS NO CHARGE WHEN BATTERIES ARE LOW OR DISCHARGED.</u>	<p>Step 1. Check for broken or loose fan belt, paragraph 2.83.1.</p> <ul style="list-style-type: none"> a. If fan belt is not broken and tension is correct, do step 2. b. If worn or broken, replace fan belt, paragraph 2.83. If loose, adjust fan belt, paragraph 2.83.2. <p>Step 2. Check for defective BATTERY CHARGER FUSE.</p> <ul style="list-style-type: none"> a. If BATTERY CHARGER FUSE is not blown, do step 3. b. If defective, replace BATTERY CHARGER FUSE, paragraph 2.48. <p>Step 3. Test for defective battery charging ammeter shunt (MT4) paragraph 2.53.2.</p> <ul style="list-style-type: none"> a. If battery charging ammeter shunt is not defective, do step 4. b. If defective replace battery charging ammeter, shunt paragraph 2.53.4. <p>Step 4. Test for defective battery charging alternator, refer to TM 9-2815-254-24.</p> <ul style="list-style-type: none"> a. If battery charging alternator is not defective, do step 5. b. If defective, replace battery charging alternator in accordance with TM 9-2815-254-24. <p>Step 5. Test for defective BATTERY CHARGE AMMETER, paragraph 2.27.2.</p> <ul style="list-style-type: none"> a. If BATTERY CHARGE AMMETER is not defective, do step 4. b. If defective, replace Battery Charge Ammeter, paragraph 2.27. <p>Step 6. Check for breaks or loose connections in charging circuit.</p> <p>If breaks or loose connections are found, repair charging circuit, refer to Electrical Schematic FO-1.</p>
20.	<u>BATTERY CHARGE AMMETER SHOWS EXCESSIVE CHARGING AFTER PROLONGED OPERATION.</u>	<p>Step 1. Test for defective batteries, paragraph 2.12.1.</p> <ul style="list-style-type: none"> a. If batteries are not defective, do step 2. b. If defective, replace batteries, paragraph 2.12. <p>Step 2. Test for defective BATTERY CHARGE ammeter, paragraph 2.27.2.</p> <ul style="list-style-type: none"> a. If BATTERY CHARGE ammeter is not defective, do step 3. b. If defective, replace BATTERY CHARGE ammeter, paragraph 2.27. <p>Step 3. Test for defective battery charging alternator, refer to TM 9-2815-254-24.</p> <ul style="list-style-type: none"> a. If battery charging alternator is not defective, do step 4. b. If defective, replace battery charging alternator in accordance with TM 9-2815-254-24. <p>Step 4. Check for short in charging circuit. If shorted, repair charging circuit, refer to Electrical Schematic FO-1.</p>

TABLE 2-6. UNIT TROUBLESHOOTING - Continued

MALFUNCTION	TEST OR INSPECTION	CORRECTIVE ACTION
21.	<u>AC VOLTMETER (VOLTS AC) DOES NOT INDICATE VOLTAGE.</u>	<p>Step 1. Test for defective AC Voltmeter (VOLTS AC), paragraph 2.31.2.</p> <ul style="list-style-type: none"> a. If AC Voltmeter (VOLTS AC) is not defective, do step 2. b. If defective, replace AC Voltmeter (VOLTS AC), paragraph 2.31 <p>Step 2. Test for defective VOLTAGE adjust potentiometer, paragraph 2.33.3.</p> <ul style="list-style-type: none"> a. If VOLTAGE adjust potentiometer is not defective, do step 3. b. If defective, replace VOLTAGE adjust potentiometer, paragraph 2.33. <p>Step 3. Test for defective AM-VM transfer switch, paragraph 2.38.3.</p> <ul style="list-style-type: none"> a. If defective, replace AM-VM transfer switch, paragraph 2.38. b. If AM-VM transfer switch is not defective, notify next higher level of maintenance
22.	<u>AC VOLTMETER (VOLTS AC) INDICATES VOLTAGE, BUT FREQUENCY METER (HERTZ) IS OFF SCALE.</u>	<p>Step 1. Test for defective frequency transducer, paragraphs 2.51.2 and 2.51.3.</p> <ul style="list-style-type: none"> a. If frequency transducer is not defective, do step 2. b. If defective, replace frequency transducer, paragraph 2.51. <p>Step 2. Test for defective FREQUENCY meter (HERTZ), paragraphs 2.28.2 and 2.28.3.</p> <ul style="list-style-type: none"> a. If defective, replace FREQUENCY meter (HERTZ), paragraph 2.28. b. If FREQUENCY meter (HERTZ) is not defective, notify next higher level of maintenance
23.	<u>AC VOLTMETER (VOLTS AC) VOLTAGE FLUCTUATES.</u>	<p>Step 1. Check for loose electrical connections, refer to Electrical Schematic FO-1</p> <ul style="list-style-type: none"> a. If no loose connections, do step 2. b. If loose, tighten electrical connections. <p>Step 2. Test for defective AC Voltmeter (VOLTS AC), paragraph 2.31.2.</p> <ul style="list-style-type: none"> a. If AC Voltmeter (VOLTS AC) is not defective, do step 3. b. If defective, replace AC Voltmeter (VOLTS AC), paragraph 2.31. <p>Step 3. Test for defective VOLTAGE adjust potentiometer, paragraph 2.33.3.</p> <ul style="list-style-type: none"> a. If VOLTAGE adjust potentiometer is not defective, do step 4. b. If defective, replace voltage adjust potentiometer, paragraph 2.33. <p>Step 4. Test for defective AM-VM transfer switch, paragraph 2.38.3.</p> <ul style="list-style-type: none"> a. If AM-VM transfer switch is not defective, notify next higher level of maintenance b. If defective, replace AM-VM transfer switch, paragraph 2.38

TABLE 2-6. UNIT TROUBLESHOOTING - Continued.

MALFUNCTION
TEST OR INSPECTION
CORRECTIVE ACTION
<p>Step 5. Check for defective load measuring unit, paragraph 2.64.1.</p> <ul style="list-style-type: none">a. If load measuring unit is not defective, and trouble persists, notify next higher level of maintenance.b. If defective, replace load measuring unit, paragraph 2.64.3.
<p>24. <u>FREQUENCY METER (HERTZ) FREQUENCY FLUCTUATES.</u></p>
<p>Step 1. Check for erratic engine operation. Refer to Malfunction 4 "Engine Runs Erratically or Stalls Frequently." If engine is operating properly, do Step 2.</p> <p>Step 2. Test for defective frequency transducer, paragraphs 2-51-2 or 2-51-3.</p> <ul style="list-style-type: none">a. If frequency transducer is not defective, do Step 3.b. If defective, replace frequency transducer, paragraph 2-51. <p>Step 2. Test for defective FREQUENCY meter (HERTZ), paragraphs 2-28-2 or 2-28-3.</p> <p>If defective, replace FREQUENCY meter (HERTZ), paragraph 2-28.</p>
<p>25. <u>NO VOLTAGE AT CONVENIENCE RECEPTACLE.</u></p>
<p>Step 1. Open control panel and inspect circuit interrupter on side of Ground Fault Circuit Interrupter device.</p> <ul style="list-style-type: none">a. If devices is tripped, reset device for generator sets, contract number DAAK01-94-b. For generator sets, contract number DAAK01-88-D-082, check in-line fuse on black lead of Ground Fault Circuit Interrupter.c. If device is not tripped, do Step 2. <p>Step 2. Check Ground Fault Circuit Interrupter.</p> <ul style="list-style-type: none">a. If indicator is tripped, reset by pressing RESET button.b. If Indicator is not tripped, do Step 3 <p>Step 3 Check voltage across convenience receptacle.</p> <ul style="list-style-type: none">a. If voltage is present, replace convenience receptacle.b. If voltage is not present, do Step 4. <p>Step 4. Check voltage across Terminals 4 and 6 no TB-5.</p> <ul style="list-style-type: none">a. If voltage is present, replace Ground Fault Circuit Interrupter.b. If voltage IS not present, search for loose or broken wires or loose pin in connectors.

Section VI. RADIO INTERFERENCE SUPPRESSION

2.7. GENERAL METHODS USED TO ATTAIN PROPER SUPPRESSION.

Suppression is attained by providing a low resistance path to ground for stray currents. The methods used include shielding the ignition and high-frequency wires, grounding the frame with bonding straps, and using filtering systems.

2.8. INTERFERENCE SUPPRESSION COMPONENTS.

2.8.1. Primary Suppression Components. Primary suppression components are those whose primary function is to suppress electromagnetic interference.

The primary suppression components on this generator set are the output box access door EMI seal (outer seal), paragraph 2.18, the load output terminal board EMI fitters, paragraph 2.101, and the voltage reconnection terminal board capacitors, paragraph 2.94.

2.8.2. Secondary Suppression Components. Secondary suppression components have electromagnetic interference suppression functions which are incidental or secondary to their primary function. The only secondary suppression component for the generator set is the housing, refer to Section IX, Maintenance of Housing for removal and installation procedures.

Section VII. SPECIAL INSTRUCTIONS

2.9. NUCLEAR, BIOLOGICAL, CHEMICAL CONTAMINATION. The generator set is capable of being operated by personnel wearing nuclear, biological, or chemical (NBC) protective clothing without special tools or support equipment. Refer to FM 3-5, NBC Decontamination for information on decontamination procedures. Specific procedures for the generator set are the following:

2.9.1. Control panel indicators sealing gaskets, rubber sleeves, rope draw cords at output terminal access ports, control panel door gaskets, access door gaskets, rubber tubing and belts within the engine compartment, coverings for electrical conduits, external water drain tubing, and retaining cords for slave receptacle covers will absorb and retain chemical agents. Replacement of these items is the recommended method of decontamination.

2.9.2. Lubricants, fuel, coolant, or battery fluid may be present on the external surfaces of the generator set or components due to leaks or normal operation. These fluids will absorb NBC agents. The preferred method of decontamination is removal of these fluids using conventional decontamination methods in accordance with FM 3-5.

2.9.3. Continued decontamination of external generator set surfaces with supertropical bleach (STB)/decontaminating solution number 2 (DS2) will degrade clear plastic indicator coverings to a point where reading indicators will become impossible. This problem will become more evident for soldiers wearing protective masks. Therefore, the use of STB or DS2 decontaminants in these areas should be minimized. Indicators should be decontaminated with warm soapy water.

2.9.4. External surfaces of the control panel assembly that are marked with painted or stamped lettering will not withstand repeated decontamination with STB or DS2 without degradation of this lettering. The recommended method of decontamination for these areas is warm soapy water.

2.9.5. Areas that will entrap contaminants, making efficient decontamination extremely difficult, include the following: space behind knobs and switches on the control panel, exposed heads of screws, areas adjacent to and behind exposed wiring conduits, hinged areas of access doors, spaces behind externally mounted equipment specification data plates, areas around external oil drain valve, retaining chains for external receptacle covers, areas behind external receptacle covers, access door locking mechanisms, recessed wells for access de-or handles, fuel caps, load output terminal board access door, slave receptacles, frequency adjustment controls, areas around tie-down/lifting rings, crevices around access doors, external screens covering ventilation areas, and areas adjacent to the external fuel drain valve. Replacement of these items, if available, is the preferred method of decontamination. Conventional decontamination methods should be used on these areas, while stressing the importance of thoroughness and the probability of some degree of continuing contact and vapor hazard.

2.9.6. In an NBC contaminated environment, the generator set should be operated with all access doors closed to reduce the effects of contamination.

2.9.7. The use of overhead shelters or chemical protective covers is recommended as an additional means of protection against contamination in accordance with FM 3-5. When using covers, care should be taken to provide adequate space for air flow and exhaust.

2.9.8. For additional NBC information refer to FM 3-3 and 3-4. Other services use applicable publications for NBC.

Section VIII. MAINTENANCE OF DC ELECTRICAL SYSTEM

2.10. INTRODUCTION.

This section contains unit maintenance procedures for the DC Electrical System. Deficiencies noted during inspection/repair which are beyond the scope of unit maintenance shall be reported to the next higher level of maintenance.

NOTE

Refer to TM 9-6115-643-10 for all operator procedures.

2.11. BATTERY AND SLAVE RECEPTACLE CABLES.

WARNING

Batteries give off a flammable gas. Do not smoke or use open flame when performing maintenance. Flames and explosion could result in severe personal injury or death.

WARNING

Remove metal jewelry when working on electrical system/components. Failure to observe this warning could result in severe personal injury or death by electrocution.

NOTE

This procedure is typical for the positive, negative, and interconnect battery cables, and the positive and negative NATO slave receptacle cables.

2.11.1 Inspection.

- a. Shut down generator set.
- b. Open battery access door and left side engine access door.
- c. Inspect battery/slave receptacle cables for security; cracked insulation; broken, burned, or corroded terminals; missing parts; or other damage.
- d. Close access doors.

2.11.2. Removal.

- a. Shut down generator set.
- b. Open battery access door and left side engine access door.

NOTE

Tag all cables before removal.

- c. Disconnect negative battery cable terminal lug (1, FIGURE 2-3) from battery.
- d. Disconnect and remove applicable cable assembly as shown in FIGURE 2-3 or FIGURE 2-4.

2.11.3. Cleaning.

- a. Remove terminal cover(s) (2, FIGURE 2-3) from battery post(s), if applicable.
- b. Clean battery post(s) and cable terminals with battery terminal cleaner.

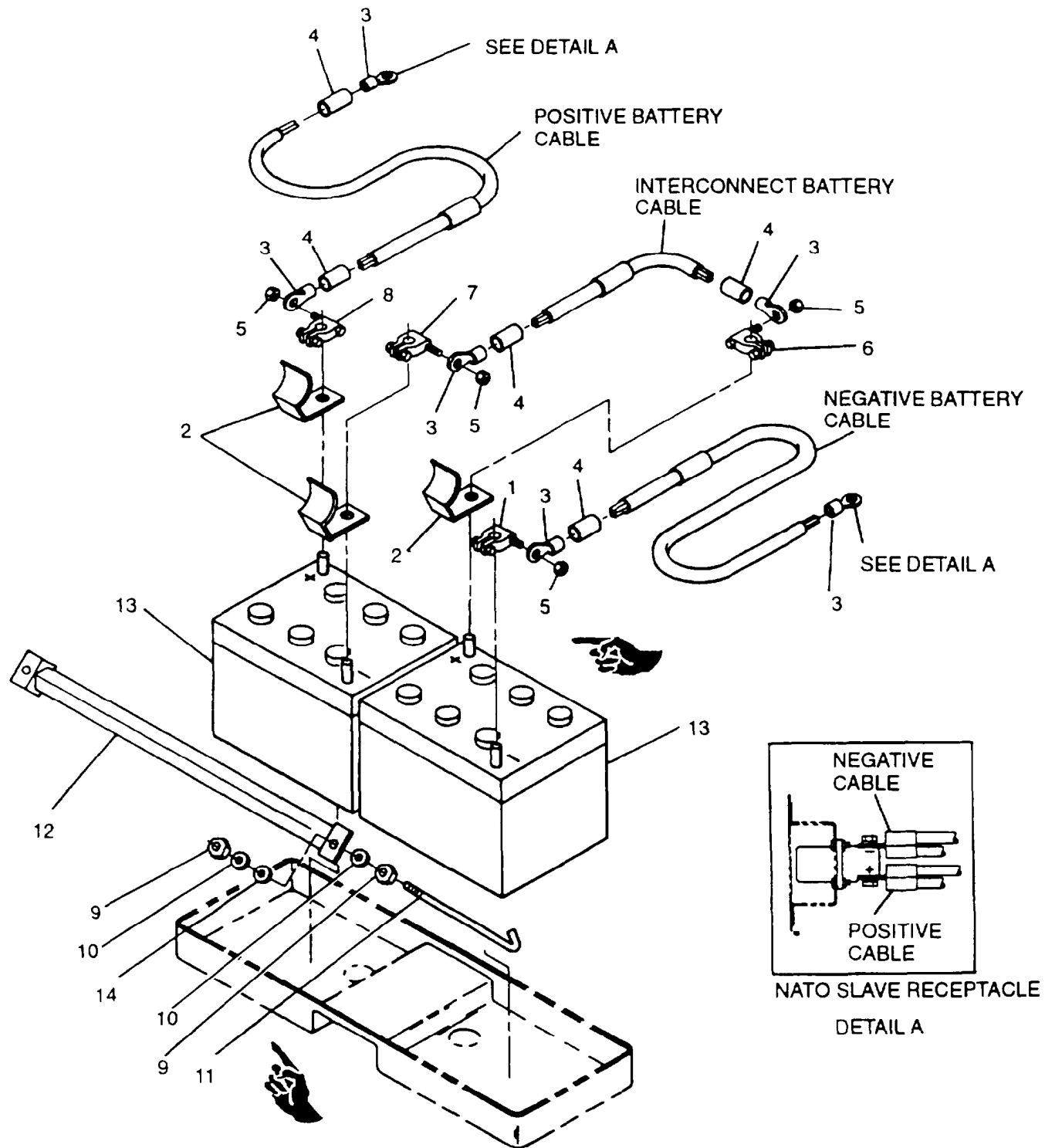

FIGURE 2-3. Batteries and Cables

- c. Install terminal cover(s) (2), if removed.

2.11.4. Repair.

NOTE

If cable cannot be repaired, refer to Appendix D.

- a. Remove nut(s) (5, FIGURE 2-3) and battery cable terminal lug(s), as necessary.
- b. Remove broken or damaged terminal (3, FIGURE 2-3 or 2-4) from cable assembly.
- c. Slide new shrinkable tubing (4, FIGURE 2-3 OR 2-4) OVER CABLE END.
- d. Install terminal (3) to cable end as described in Appendix D.
- e. Heat shrinkable tubing (4) with heat gun until secure.
- f. Install battery cable terminal lug(s) with nuts(s) (5, FIGURE 2-3), as necessary.
- a. Connect negative battery cable terminal lug (1, FIGURE 2-3) to battery.
- b. Close access doors.

2.12. BATTERIES.

2.12.1 Testing.

2.12.2

WARNING

Batteries give off a flammable gas. Do not smoke or use open flame when performing maintenance. Flames and explosion could result in severe personal injury or death.

- a. Shut down generator set.
- b. Open battery access door and disconnect negative battery cable.
- c. Remove battery vent caps.
- d. Test specific gravity of electrolyte in each battery cell with a hydrometer. Refer to TABLE 2-7 for state of charge with specific gravity corrected to 80°F (27°C). Refer to TABLE 2-8 for specific gravity temperature corrections.
- e. Recharge or replace batteries as necessary. Retest batteries per above instructions.
- f. Install battery vent caps.
- g. Connect negative battery cable. Close battery access door.

2.12.2 Removal.

- a. Shut down generator set.
- b. Open battery compartment access door.
- c. Disconnect negative battery cable terminal lug (1, FIGURE 2-3).

TABLE 2-7. STATE OF CHARGE WITH SPECIFIC GRAVITY CORRECT TO 80°F (27°C)

Specific Gravity	Percent Charge
1.280	100
1.250	75
1.220	50
1.190	25
1.160	Little useful
1.130	capacity.
	Discharged

TABLE 2-8. SPECIFIC GRAVITY TEMPERATURE CORRECTIONS

Temperature °F	Correction Factor
+120°F (49°C)	+0.016
+115°F (46°C)	+0.014
+110°F (43°C)	+0.012
+105°F (41°C)	+0.010
+100°F (38°C)	+0.008
+95°F (35°C)	+0.006
+90°F (32°C)	+0.004
+85°F (29°C)	+0.002
+80°F (27°C)	0
+75°F (24°C)	-0.002
+70°F (21°C)	-0.004
+65°F (19°C)	-0.006
+60°F (16°C)	-0.008
+55°F (13°C)	-0.010
+50°F (10°C)	-0.012
+45°F (7°C)	-0.014
+40°F (5°C)	-0.016
+35°F (2°C)	-0.018
+30°F (-1°C)	-0.020
+25°F (-4°C)	-0.022
+20°F (-7°C)	-0.024
+15°F (-9°C)	-0.026
+10°F (-12°C)	-0.028
+5°F (-15°C)	-0.030
0°F (-18°C)	-0.032
-5°F (-20°C)	-0.034
-10°F (-23°C)	-0.036
-15°F (-26°C)	-0.038
-20°F (-29°C)	-0.040

- d. Disconnect interconnect battery cable terminals (6) and (7) and remove interconnect battery cable assembly.
- e. Disconnect positive battery cable terminal lug (8).

WARNING

Ensure proper lifting techniques are used when lifting batteries. Failure to observe this warning could result in personal injury.

- f. Remove nuts (9) washers (IO), lockwashers (14), hook bolts (II), and retaining bar (12).
- g. Remove batteries (13).

2-12-3. Inspection.

- a. Remove batteries.
- b. Inspect batteries for cracked cases, broken, burned or corroded posts, missing parts, and other damage.
- c. Install batteries.

2-12-4. Service.

- a. Remove terminal covers (2, FIGURE 2-3).
- b. Clean cable terminal lugs and battery posts
- c. Install terminal covers (2) on batteries (13)

2-12-5. Installation.

- a. Position batteries (13, FIGURE 2-3) in generator set. Ensure that batteries are serviced and fully charged.
- b. Apply general purpose grease (Item 9, Appendix C) to battery posts and cable terminal lugs (1), (6), (7), and (8).
- c. Install hook bolts (11) and retaining bar (12) with lockwashers (14) washers (IO), and nuts (9).

WARNING

Connect negative battery terminal (1) last when installing battery cables. Failure to follow this procedure could result in sparks which can ignite volatile battery gases.

- d. Connect positive cable terminal lug (8).
- e. Position interconnect battery cable connect terminals (6) and (7).
- f. Connect negative battery cable terminal lug (1) and close battery compartment access door.

2-13. NATO SLAVE RECEPTACLE.

2-13.1. Inspection.

- a. Shut down generator set.
- b. Open left side engine access door.
- c. Inspect NATO slave receptacle for security, corrosion, missing hardware, and other damage
- d. Close access door.

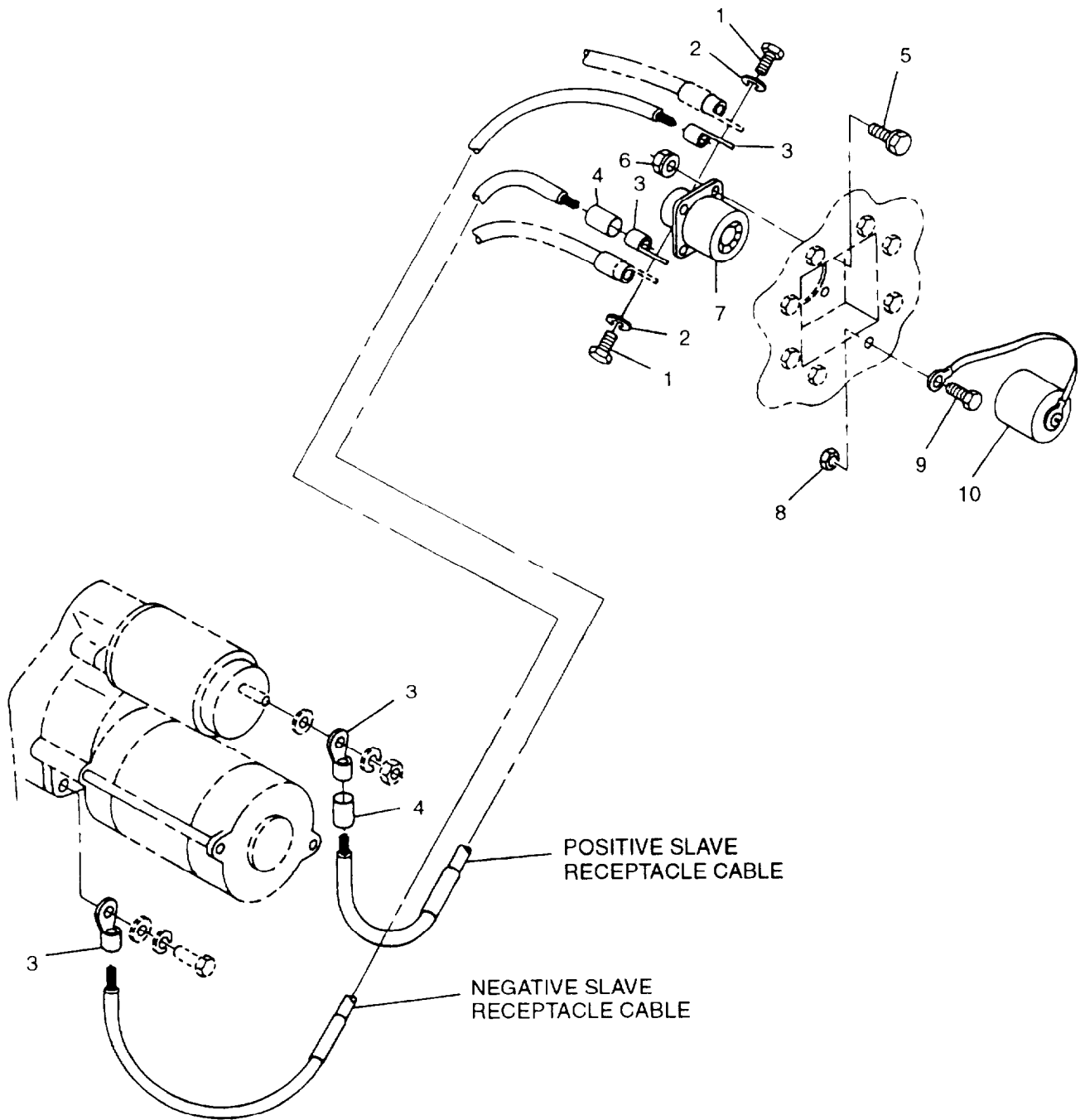

FIGURE 2-4. NATO Slave Receptacle and Cables

2.13.2. Removal.

- a. Shut down generator set.
- b. Open battery access door and disconnect negative battery cable.
- c. Open left side engine access door and tag and disconnect battery and slave receptacle cables from slave receptacle (7, FIGURE 2-4) by removing bolts(1) and lockwashers (2).
- d. Remove bolts (5), nuts (6), and NATO slave receptacle (7) from generator set housing.
- e. Remove nut (8), bolt (9), and cover (10) from generator set.

2.13.3. Installation.

- a. Insert NATO slave receptacle (7, FIGURE 2-4) into left side lower door sill.
- b. Secure receptacle (7) with bolts (5) and nuts (6).
- c. Connect slave receptacle and battery cables to slave receptacle (7) with bolts (1) and lockwashers (2). Remove tags.
- d. Install cover (10) on generator set with bolt (9) and nut (8).
- e. Connect negative battery cable. Close battery access door and engine access door.

Section IX. MAINTENANCE OF HOUSING

2.14. ACCESS DOORS.

NOTE

This procedure is written for the left engine access door, but is typical for all access doors, hinges, latches, and data plates.

NOTE

When removing and installing battery access door, note position of spacers for door hold open mechanism.

2.14.1. Removal.

- a. Shut down generator set.
- b. Open left side engine access door.
- c. Remove nuts (1, FIGURE 2-5), lockwashers (2), bolts (3), washers (4), and hinges (5).
- d. Remove left side engine access door (6) from generator set.
- e. Remove assembled nuts (7), bolts (8), and document box (9).
- f. Remove assembled nuts (10), bolts (11), upper air baffle (12), and lower air baffle (13) from engine access door (6).
- g. Remove assembled nuts (14) and bolts (15) to separate air baffles(12) and (13).
- h. Remove assembled nuts (16), bolts (17), bracket (18), and holding rod (19) from engine access door (6).

- i. Remove assembled nuts (20), bolts (21), and bracket (22) from engine access door (6).
- j. Remove assembled nuts (23), screws (24), and latches (25) from engine access door (6).
- k. Drill out rivets (26), and remove fuel system diagram plate (27) from document box (9).

2,14.2. Inspection.

- a. Shut down generator set.
- b. Inspect access doors, hinges, latches, and baffles for loose and missing hardware, cracks, dents, loose paint, and corrosion.
- c. Inspect data plates for readability, and loose or missing rivets.

2.14.3. Repair

WARNING

Wear a protective mask and gloves when sanding CARC painted surfaces. CARC paint dust is a health hazard and could cause personal injury if warning is not followed.

- a. Repair all dents and cracks, and remove loose paint.
- b. Remove light corrosion with fine grit abrasive paper (Item 15, Appendix C).
- c. Repaint surfaces in accordance with TM 43-0139. (F) Use applicable directives.

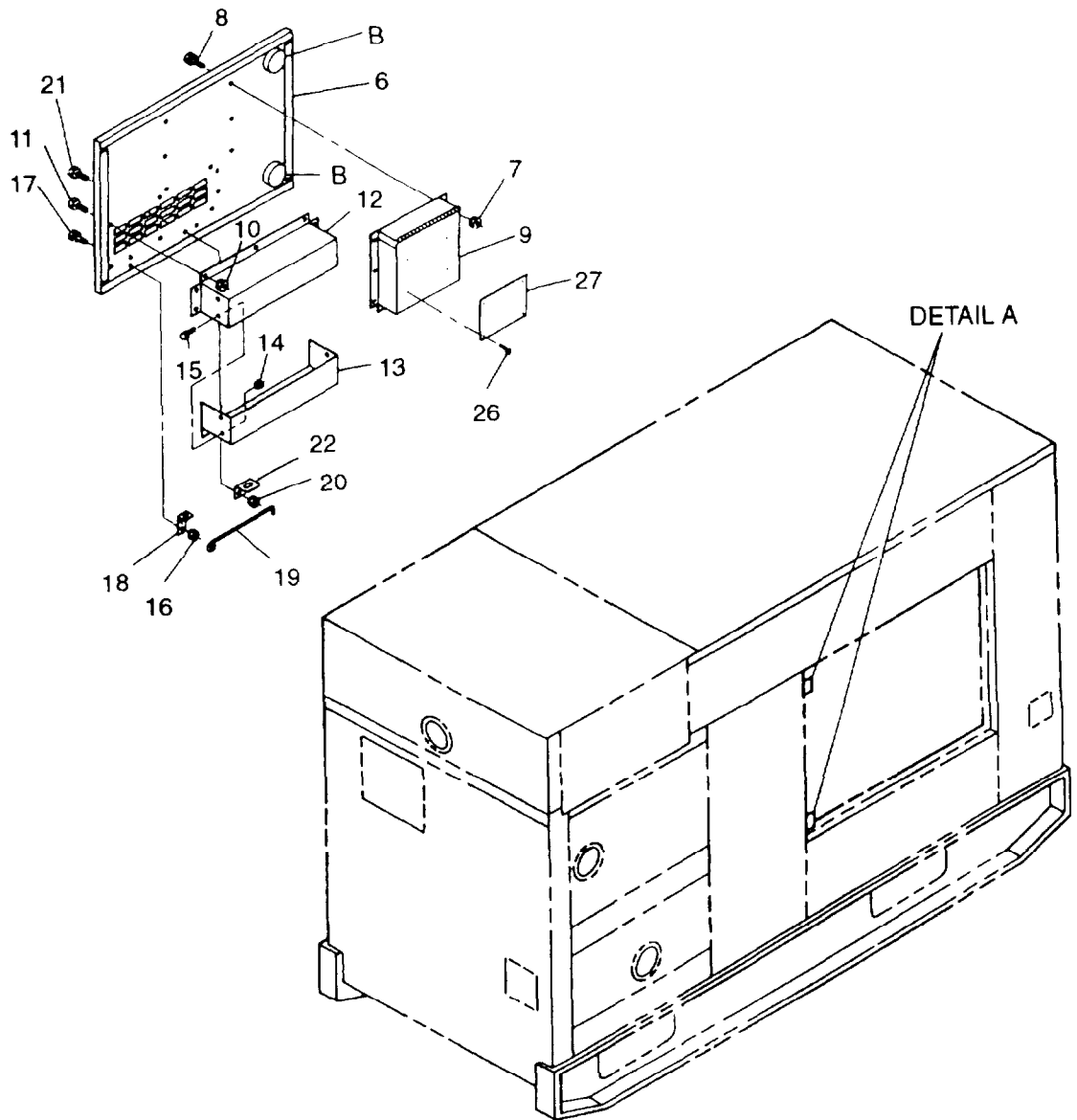
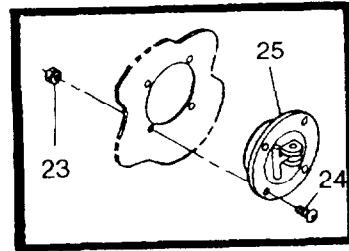
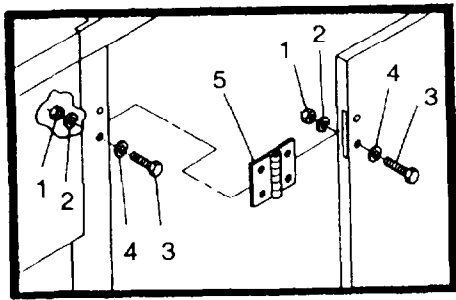

FIGURE 2-5. Generator Set Access Doors

- d Replace unreadable data plates.
- e. Replace loose or missing rivets,

2.14.4. Installation

- a. Install latches (25, FIGURE 2-5) in left side engine access door (6) with screws (24) and assembled nuts (23).
- b. Install bracket (22) on engine access door (6) with bolts (21) and assembled nuts (20).
- c. Install bracket (18) and holding rod (19) on engine access door (6) with bolts (17) and assembled nuts (16).
- d Assemble top air baffle (12) to bottom air baffle (13) with assembled nuts (14) and bolts (15).
- e Install air baffles (12) and (13) on engine access door (6) with bolts (11) and assembled nuts (10)
- f. Install fuel system diagram plate (27) on document box (9) with rivets (26).
- g Install document box (9) with bolts (8) and assembled nuts (7).
- h Install right side engine access door (6) and hinges (5) on generator set with bolts (3), washers (4), lockwashers (2), and nuts (1).
- i. Close left side engine access door

2.15. CONTROL BOX TOP PANEL

2.15.1. Removal

- a Shut down generator set
- b Open battery access door and disconnect negative battery cable
- c Remove control panel access door, paragraph 2.14.1.
- d. Lower control panel and remove bolts (1, FIGURE 2-6), flatwashers (2), lockwashers (3), and assembled nuts (4) from top panel (5).

CAUTION

The control box top panel is attached to the generator set with a silicone sealant to prevent water from entering the control box. Care must be taken not to bend or scratch the control box top panel when separating.

- e Separate and remove control box top panel (5) by prying to break loose sealant
- f If damaged, remove gasket (15).
- g. Remove bolts (6), washers (7), lockwashers (8) nuts (9), and stiffener (10) from control box assembly.
- h Remove bolts (11), assembled nuts (12), bracket (13), and ring (14) from control box top panel (5).

2.15.2. Inspection

- a Shut down generator set.
- b Open battery access door and disconnect negative battery cable

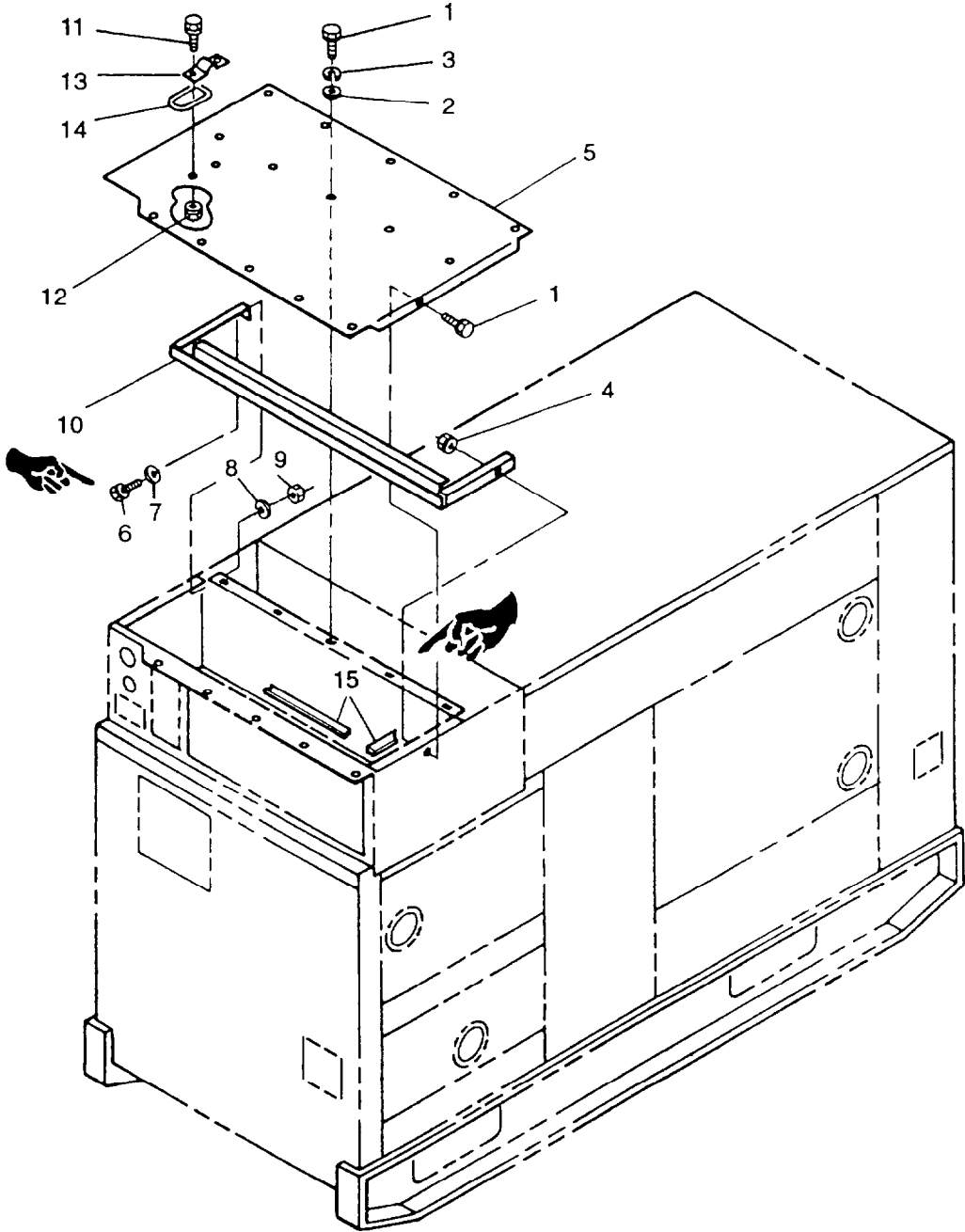

FIGURE 2-6. Control Box Top Panel

- c Inspect control box top panel (5 FIGURE 2-6) for dents, cracks, loose paint, and corrosion

2.15.3. Repair.

WARNING

Wear a protective mask and gloves when sanding CARC painted surfaces. CARC paint dust is a health hazard and could cause personal injury if warning is not followed.

- a Repair all dents and cracks, and remove all loose paint.
- b Remove light corrosion with fine grit abrasive paper (Item 15, Appendix C).
- c Repaint surfaces in accordance with TM 43-0139. (F) Refer to applicable directives.

2.15.4 Installation.

- a Install ring (14, FIGURE 2-6) and bracket (13) on control box top panel (5) with bolts (11) and assembled nuts (12).
- b Install stiffener (10) in control box assembly with bolts (6), washers (7), lockwashers (8), and nuts (9).

NOTE

When replacing old sealant with new gasket, ensure all old sealant residue is completely removed.

- c If gasket (15) was removed, install new gasket (15).
- d Immediately install top panel (5) with bolts (1), flat washers (2), lockwashers (3), and assembled nuts (4).
- e Install control panel access door, paragraph 2-14.4.
- f Connect negative battery cable. Close battery access door.

2.16. TOP HOUSING SECTION.

2.16.1 Removal.

- a Shut down generator set.
- b Remove control box assembly, paragraph 2.19.2.

WARNING

Top housing panels can get very hot. Allow panels to cool down before performing maintenance. Failure to observe this warning could result in severe burns.

- c Remove bolts (1, FIGURE 2-7), flatwashers (3), lockwashers (2), mount (4), and exhaust cover (5) from top housing panel (6).
- d Remove bolts (7 and 10), flatwashers (9 and 12) lockwashers (8 and 11), and top housing panel (6) from generator set.
- e Disconnect radiator fill hose and overflow hose from radiator fill panel (13) and remove radiator fill panel (13) from generator set
- f Remove bolts (14), flatwashers (16), lockwashers (15), and frame (17) from generator set.
- g Remove muffler, paragraph 2.70.2.
- h Remove bolts (18), assembled nuts (19), and air duct channels (20 and 21).

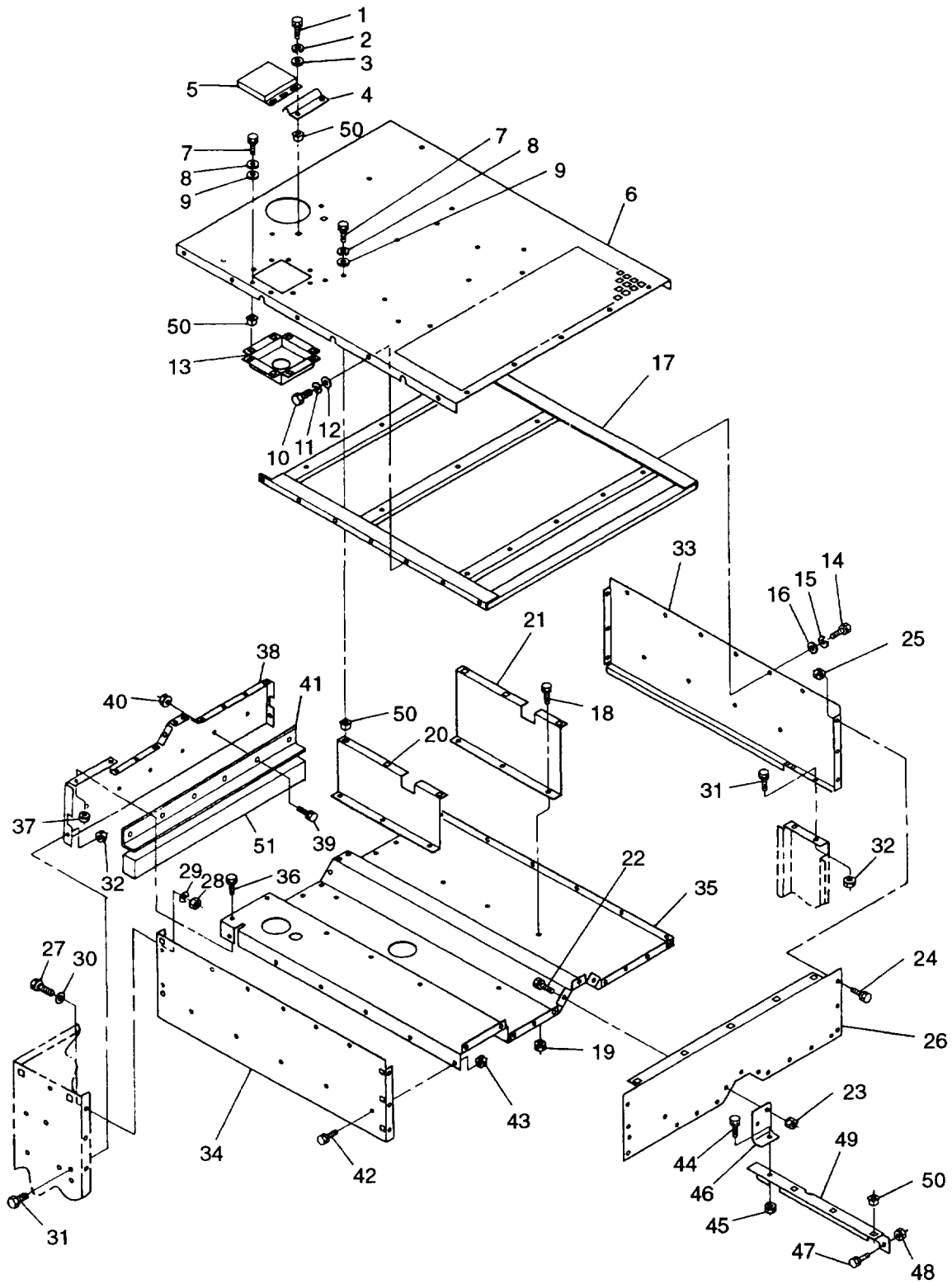

FIGURE 2-7. Generator Set Top Housing Section

- i. Remove bolts (22) and (24), assembled nuts (23) and (25), and panel (26).
- j. Remove bolts (27) and (31), flatwashers (30), lockwashers (29), nuts (28), assembled nuts (32), and top side panels (33) and (34) with top section floor panel (35).
- k. Remove bolts (36), assembled nuts (37), and panel (38) from floor panel (35).
- l. Remove bolts (39), assembled nuts (40), and support (41) from panel (38).
- m. Remove bolts (42), assembled nuts (43), and side panels (34) and (33) from floor panel (35)
- n. Remove bolt (44), assembled nut (45), and bracket (46) from angle (49).

NOTE

Open output box access door to reach assembled nuts (48).

- o. Remove bolts (47), assembled nuts (48), and angle (49) from generator set.

2.16.2. Inspection.

- a. Shut down generator set.
- b. Inspect all top housing section panels for dents, cracks, loose paint, and corrosion.
- c. Inspect all cage nuts (50, FIGURE 2-7) for cracking or stripped threads.
- d. Inspect seal (51) for tears, looseness, and deterioration.

2.16.3. Repair.

WARNING

Wear a protective mask and gloves when sanding CARC painted surfaces. CARC paint dust is a health hazard and could cause personal injury if warning is not followed.

- a. Repair all dents and cracks, and remove all loose paint.
- b. Remove light corrosion with fine grit abrasive paper (Item 15, Appendix C).
- c. Repaint surfaces in accordance with TM 43-0139. (F) Refer to applicable directives.
- d. Replace any cage nuts (50, FIGURE 2-7) that are stripped or cracked.
- e. Replace loose or damaged seal (51).

2.16.4. Installation.

- a. Install angle (49, FIGURE 2-7) in generator set with bolts (47) and assembled nuts (48).
- b. Install bracket (46) to angle (49) with bolt (44) and assembled nut (45).
- c. Install top side panels (34) and (33) on top section floor panel (35) with bolts (42) and assembled nuts (43).
- d. Install support (41) on panel (38) with bolts (39) and assembled nuts (40).
- e. Install panel (38) on top section floor panel (35) with bolts (36) and assembled nuts (37).
- f. Position top section floor panel (35), with side and front panels attached, in generator set and secure with bolts (27) and (31), flatwashers (30), lockwashers (29), nuts (28), and assembled nuts (32).
- g. Install panel (26) with bolts (22) and (24), and assembled nuts (23) and (25).
- h. Install air duct channels (20) and (21) with bolts (18), and assembled nuts (19).

- i. Install muffler, paragraph 2.70.3.
- j. Install frame (17) with bolts (14), flatwashers (16), and lockwashers (15).
- k. Install radiator fill panel (13) in generator set and connect radiator fill hose and overflow hose to panel (13).
- l. Install top housing panel (6) with bolts (7) and (10), flatwashers (9) and (12), and lockwashers (8) and (11).
- m. Install mount (4) and exhaust cover (5) with bolts (1), flatwashers (3), and lockwashers (2).
- n. Install control box assembly, paragraph 2.19.4.

2.17. FRONT HOUSING SECTION.

2.17.1. Removal.

- a. Shut down generator set.
- b. Remove battery box access door, paragraph 2.14.1.
- c. Remove engine access doors, paragraph 2.14.1.
- d. Remove top housing section, paragraph 2.16.1.
- e. Remove batteries, paragraph 2.12.2 and slave receptacle, paragraph 2.13.2.
- f. Remove bolts (1, FIGURE 2–8) and ground rods (2) from brackets (54).
- g. Remove bolts (3), (6), and (10); flatwashers (5), (7), and (11); lockwashers (4), (8), and (12); nuts (9) and (13); and front panel (14) from generator set.
- h. Remove bolts (15) and (18), flatwashers (17) and (19), lockwashers(16) and (20), nuts (21), and side panels (22) and (23) from generator set.
- i. Remove clip halves (24) and insulation (25) from front panel (14).
- j. Remove bolts (26) and (29), washers (28), lockwashers (27), assembled nuts (30), and air deflector (31) from front panel (14).
- k. Remove bolts (32), lockwashers (33), washers (34), and panels (35) and (36) from front panel (14).
- l. Remove bolts (37), assembled nuts (38), and supports (39) and (40) from panels (35) and (36).
- m. Remove bolts (41) and panel (42) from front panel (14).
- n. Remove bolts (43), assembled nuts (44), and support (45) from panel (42).
- o. Remove bolts (46), assembled nuts (47), and support channel (48) from front panel (14).
- p. Remove bolts (49), assembled nuts (50), and slave receptacle box (51) from side panel (22).
- q. Remove bolts (52), assembled nuts (53), and brackets (54) from panels (14) and (22).
- r. If necessary, drill out rivets (55), (56), and (57); remove identification plates (58), (59), and (60).

2.17.2. Inspection.

- a. Shut down generator set.
- b. Inspect all front housing section panels for dents, cracks, loose paint, corrosion, and other damage.
- c. Inspect all cage nuts (61, FIGURE 2–8) for cracking or stripped threads.
- d. Inspect insulation for damage and missing clip halves (24).
- e. Inspect seals (62) and (63) for tears, looseness, and deterioration.

2.17.3. Repair.

WARNING

Wear a protective mask and gloves when sanding CARC painted surfaces. CARC paint dust is a health hazard and could cause personal injury if warning is not followed.

- a. Repair all dents and cracks, and remove all loose paint.
- b. Remove light corrosion with fine grit abrasive paper (Item 15, Appendix C).
- c. Repaint surfaces in accordance with TM 43-0139. (F) Refer to applicable directives.
- d. Replace any cracked or stripped cage nuts (61, FIGURE 2-8).
- e. Replace damaged insulation and missing clip halves (24). Refer to Appendix D for fabrication of insulation.
- f. Replace loose or damaged seals (62) and (63).

2.17.4. Installation.

- a. If removed, install identification plates (58, 59, and 60, FIGURE 2-8) on front panel (14) and side panel (22) with rivets (55), (56), and (57).
- b. Install brackets (54) on panels (14) and (22) with bolts (52) and assembled nuts (53).
- c. Install slave receptacle box (51) on side panel (22) with bolts (49) and assembled nuts (50).
- d. Install side panels (22) and (23) on generator set with bolts (15) and (18), flatwashers (17) and (19), lockwashers (16) and (20), and nuts (21).
- e. Install support channel (48) on front panel (14) with bolts (46) and assembled nuts (47).

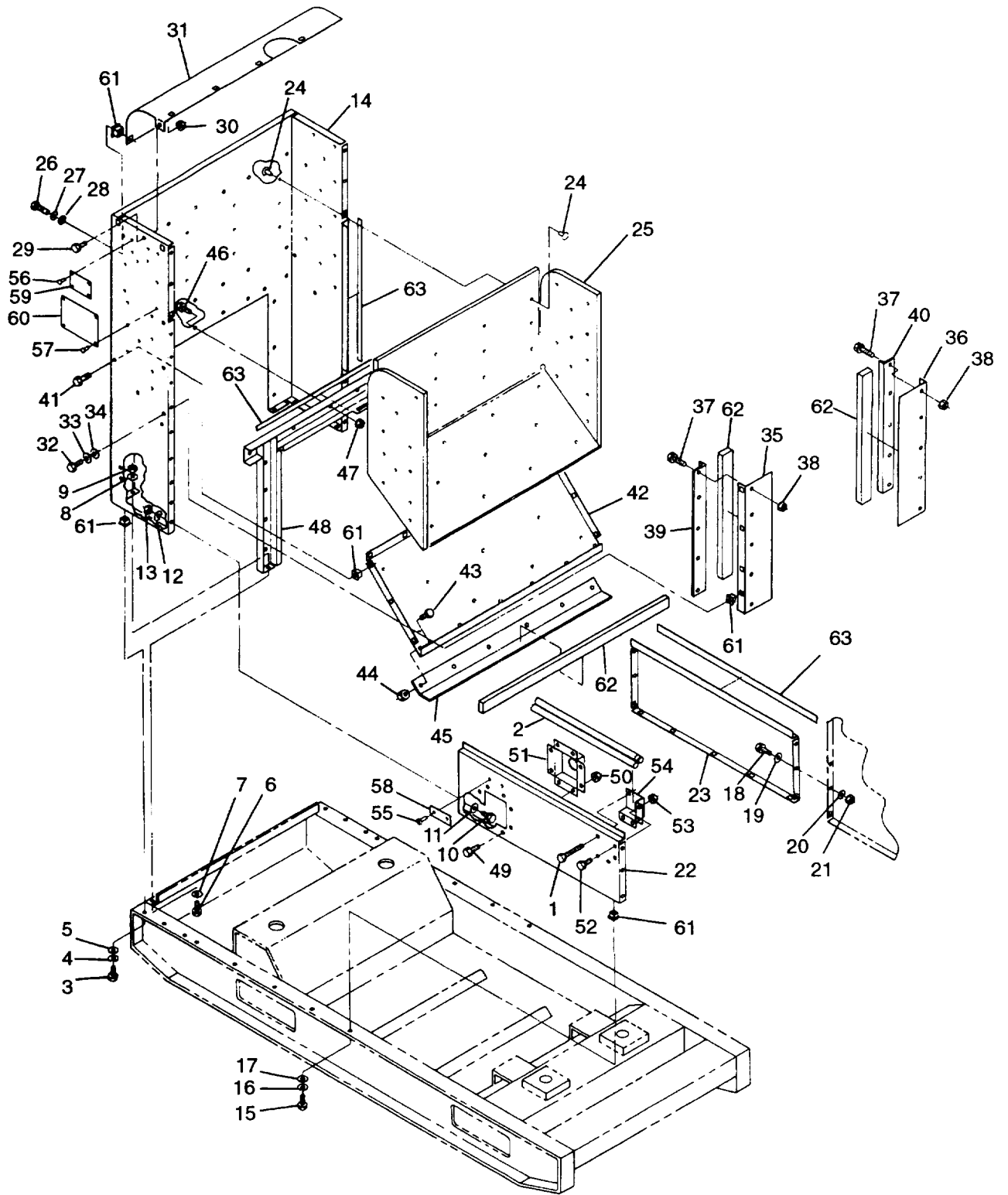

FIGURE 2-8. Generator Set front Housing Section

- f. Install support (45) on panel (42) with bolts (43) and assembled nuts (44).
- g. Install panel (42) on front panel (14) with bolts (41).
- h. Install supports (39) and (40) on panels (35) and (36) with bolts (37) and assembled nuts (38).
- i. Install panels (35) and (36) on front panel(14) with bolts (32), lockwashers (33), and washers (34).
- j. Install air deflector (31) on front panel(14) with bolts (26) and (29), washers (28), lockwashers (27), and assembled nuts (30).
- k. Install insulation (25) on front panel(14) with clip halves (24).
- l. Install front housing panel(14) on generator set with bolts (3), (6), and (10); flatwashers (5), (7), and (11); lockwashers (4) (8), and (12); and nuts (9) and (13).
- m. Install slave receptacle, paragraph 2.13.3 and batteries, paragraph 2.12.5.
- n. Install battery box access door and engine access doors, paragraph 2.14.4.
- o. Install top housing section, paragraph 2.16.4.
- p. Install ground rods (2) in brackets (54) and secure with bolts (1). Close all access doors.

2.18. REAR HOUSING SECTION.

2.18.1. Removal.

- a. Shut down generator set.
- b. Remove control box assembly, paragraph 2.19.2,
- c. Remove air cleaner assembly, paragraph 2.72.3.
- d. Remove output box access door and load terminal board access door, paragraph 2.14.1.
- e. Remove engine access doors and air cleaner access door, paragraph 2.14.1.
- f. Remove fuel filler neck, paragraph 2.87.1.
- g. Remove auxiliary fuel pump, paragraph 2.86.3.
- h. Remove fuel float module, paragraph 2.92.3.
- i. Remove top housing panel, paragraph 2.16.1, step d.
- j. Remove bolts (1 and 4, FIGURE 2-9), flatwashers (3) and (5), lockwashers (2) and (6), nuts (7), and rear panel (8) from generator set.
- k. Remove bolts (9), assembled nuts (1 O), and load cable entrance box (11) from rear panel (8).
- l. Remove bolts (12) and (16), flatwashers (13) and (18), lockwashers (14) and (17), nuts (15), and left side rear panel (19) from generator set.
- m. Remove bolts (20), assembled nuts (21), and baffle (22) from left side rear panel (19).

- n. Remove clip halves (23) and insulation (24) from baffle (22).
- o. Remove bolts (25), assembled nuts (26), and fuel filler neck panel (27) from left side rear panel (19).

NOTE

Ensure output box assembly is secured prior to removal of corner post and door sills.

- p. Remove bolts (28), (32), and (34); flatwashers (29); lockwashers (30); nuts (31); assembled nuts (33) and (35); corner post (36); and door sills (37) and (38) from generator set.
- q. Remove bolts (39), (43), (47), and (49); flatwashers (40) and (44); lockwashers (41) and (45); nuts (42) and (46); assembled nuts (48) and (50); and right side panel (51) from generator set.
- r. If necessary, drill out rivets (52) and remove plate (53) from left side rear panel (19).
- s. If necessary, drill out rivets (54) and remove plate (55) from fuel filler neck panel (27).
- t. If necessary, remove output box EMI seals (56) from door sill (37), corner post (36), and right side panel (51).

2.18.2. Inspection.

- a. Shut down generator set.
- b. Inspect rear housing section panels for dents, cracks, loose paint, corrosion, and other damage.
- c. Inspect all cage nuts (57, FIGURE 2-9) for cracking or stripped threads.
- d. Inspect all insulation for damage and missing clip halves.
- e. Inspect EMI seals (56) for tears, looseness, and deterioration.
- f. Inspect door seals (58) for tears, looseness, and deterioration.

2.18.3. Repair.

WARNING

Wear a protective mask and gloves when sanding CARC painted surfaces. CARC paint dust is a health hazard and could cause personal injury if warning is not followed.

- a. Repair all dents and cracks, and remove all loose paint.
- b. Remove light corrosion with fine grit abrasive paper (Item 15, Appendix C).
- c. Repaint surfaces in accordance with TM 43-0139. (F) Use applicable directives.
- d. Replace all cracked or stripped cage nuts (57, FIGURE 2-9).
- e. Replace damaged insulation and missing clip halves (23). Refer to Appendix D for fabrication of insulation.
- f. Replace EMI seals (56) that are loose or show any evidence of damage.
- g. Replace damaged door seals (58).

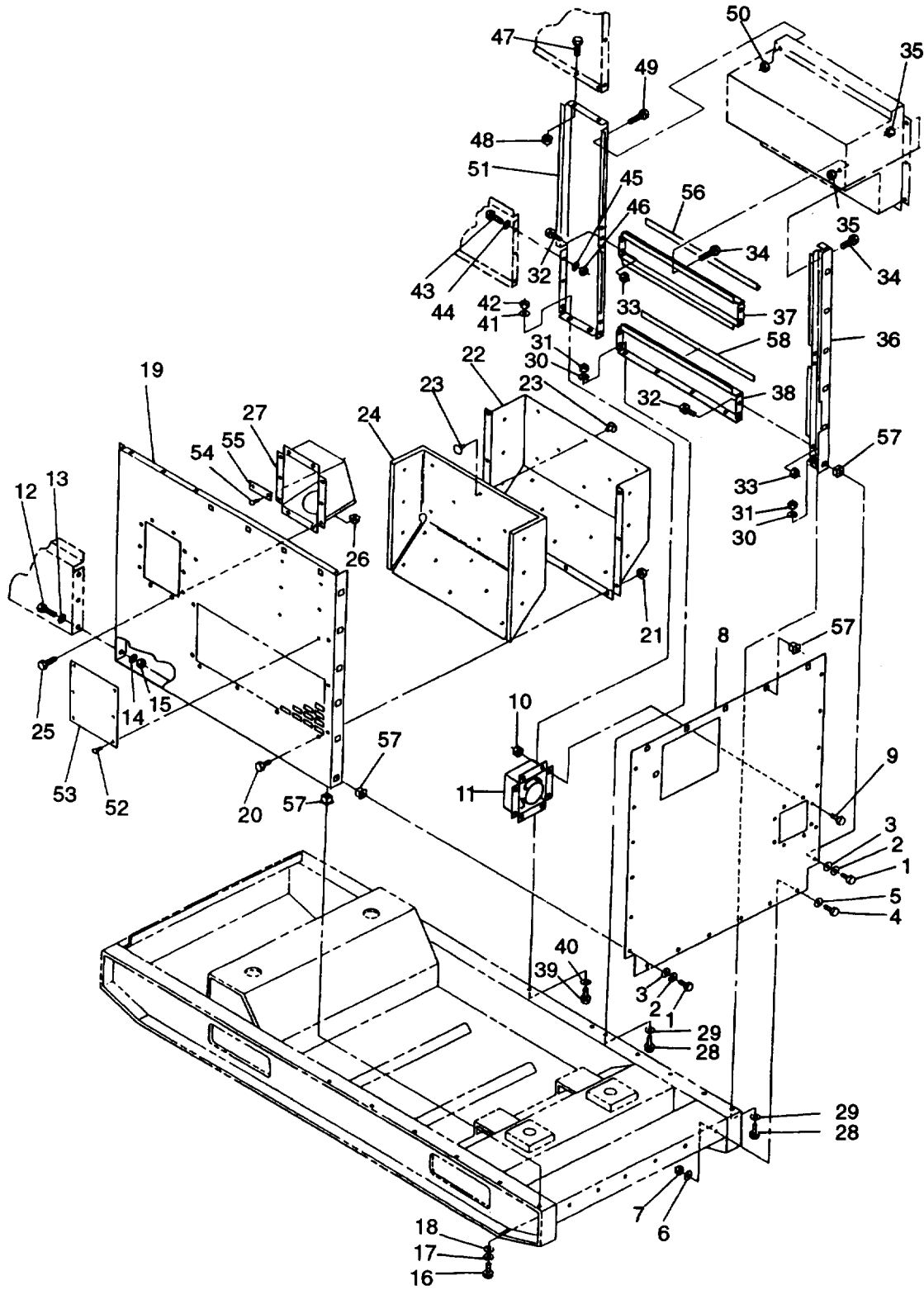

FIGURE 2-9. Generator Set Rear Housing Section

2.18.4. Installation.

- a. If removed, install plate (55, FIGURE 2–9) on fuel filler neck panel (27) with rivets (54).
- b. If removed, install plate (53) on left side rear panel (19) with rivets (52).
- c. Install right side panel (51) on generator set with bolts (39), (43), (47), and (49); flat washers (40) and (44); lockwashers (41) and (45); nuts (42) and (46); and assembled nuts (48) and (50).
- d. Install door sills (37) and (38), and corner post (36) on generator set with bolts (28), (32), and (34); flatwashers (29); lockwashers (30); nuts (31); and assembled nuts (33) and (35).
- e. Install fuel filler neck panel (27) on left side rear panel (19) with bolts (25) and assembled nuts (26).
- f. Install insulation (24) on baffle (22) with clip halves (23).
- g. Install baffle (22) on left side rear panel (19) with bolts (20) and assembled nuts (21).
- h. Install left side rear panel (19) on generator set with bolts (12) and (16), flatwashers (13) and (18), lockwashers (14) and (17), and nuts (15).
- i. Install load entrance box (11) on rear panel (8) with bolts (9) and assembled nuts (10).
- j. Install rear panel (8) on generator set with bolts (1) and (4), flatwashers (3) and (5), lockwashers (2) and (6), and nuts (7).
- k. If removed, install output box EMI seals (56) on door sill (37), corner post (36), and right side panel (51) with adhesive (Item 1, Appendix C). Ensure closed side of seal faces outward.
- l. Install top housing panel, paragraph 2.16.4, step 1.
- m. Install fuel float module, paragraph 2.92.4,
- n. Install auxiliary fuel pump, paragraph 2.86.4.
- o. Install fuel filler neck, paragraph 2.87.3.
- p. Install air cleaner access door and engine access doors, paragraph 2.14.4.
- q. Install load terminal board access door and output box access door, paragraph 2.14.4.

NOTE

Output box EMI seals are primary suppression components. Ensure that a complete seal is made between output box door and generator set.

- r. Install air cleaner assembly, paragraph 2.72.4.
- s. Install control box assembly, paragraph 2.19.4.

Section X. MAINTENANCE OF CONTROL BOX ASSEMBLY

2.19. CONTROL BOX ASSEMBLY.

2.19.1 Inspection.

- a. Shut down generator set.
- b. Inspect control box assembly for cracks, breaks, corrosion, loose paint, and missing parts.

2.19.2. Removal.

- a. Shut down generator set.
- b. Open battery access door and disconnect negative battery cable.
- c. Remove control box top panel, paragraph 2.15.1.
- d. Open output box access door and disconnect two control box harness connectors.
- e. Remove bolts (1 and 5, FIGURE 2-10), lockwashers (2), flatwashers (3), nuts (4), and control box assembly (6) from generator set.

2.19.3. Repair

Repair control box assembly by replacing damaged terminals, damaged or missing hardware, and damaged or defective components.

2.19.4. Installation.

- a. Install control box assembly (6, FIGURE 2-10) on generator set with bolts (1) and (5), flatwashers (3), lockwashers (2), and nuts (4).
- b. Connect two control box harness connectors.
- c. Install control box top panel, paragraph 2.15.4.
- d. Connect negative battery cable. Close battery access door.

2.20. PANEL LIGHTS.

2.20.1. Inspection.

Inspect panel light holder and directional cap for cracks, corrosion, stripped threads, and other damage.

2.20.2. Removal.

- a. Shut down generator set.
- b. Open battery access door and disconnect negative battery cable.
- c. Release control panel by turning two fasteners and lower control panel slowly.
- d. Tag and disconnect panel light (1, FIGURE 2-11) electrical leads.
- e. Remove nut (2) and washer (3).
- f. Remove panel light (1) from control panel

2.20.3. Disassembly.

- a. Remove panel light directional cap (4, FIGURE 2-11) from panel light housing (1).
- b. Remove panel light bulb (5).

2.20.4. Assembly.

- a. Install panel light bulb (5, FIGURE 2-11) into panel light housing (1).
- b. Install panel light directional cap (4).

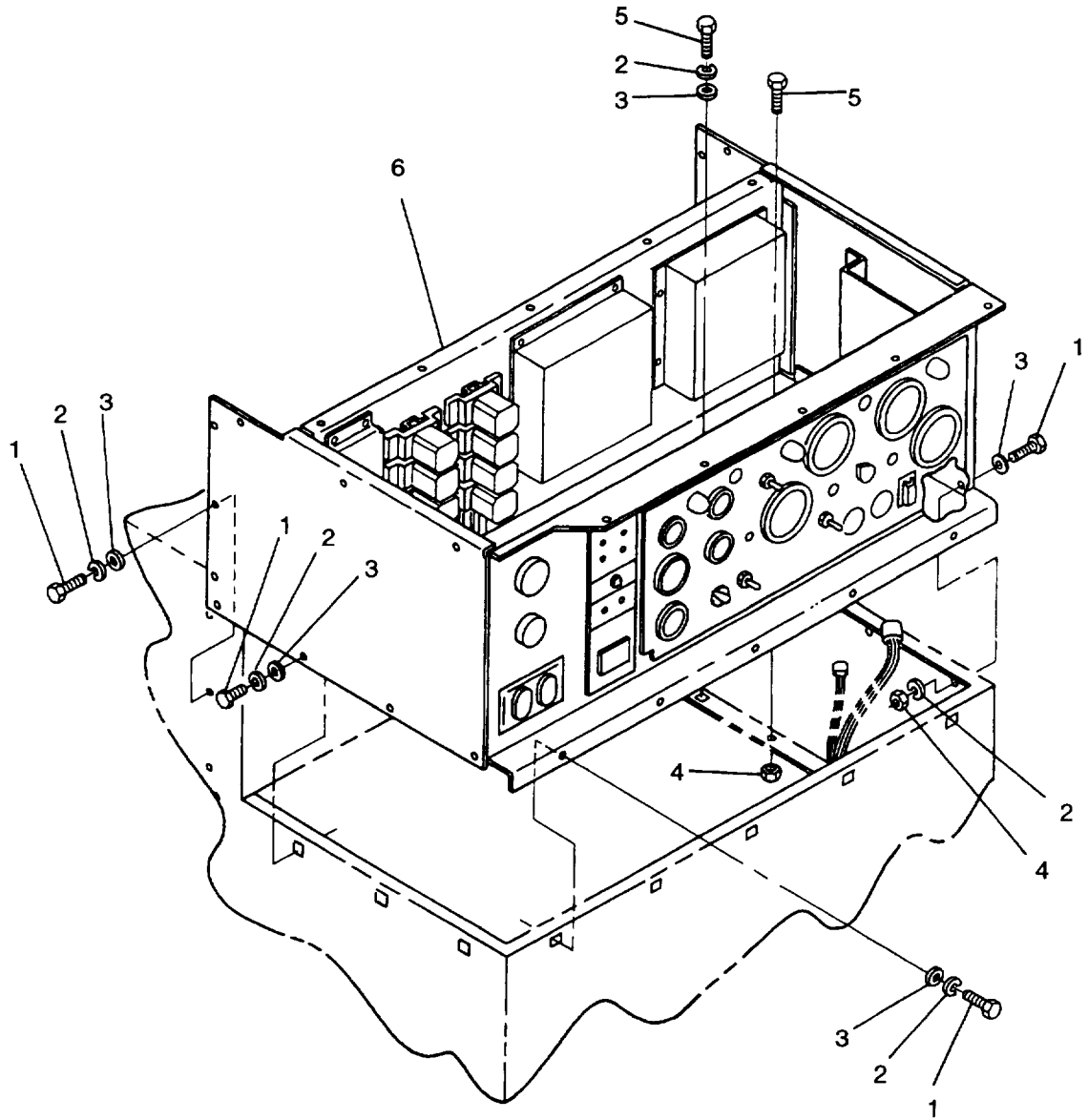

FIGURE 2-10. Control Box Assembly

2.20.5. Installation.

- a. Insert panel light (1, FIGURE 2-11) into control panel.
- b. Install washer (3) and nut (2).
- c. Connect panel light electrical leads and remove tags.
- d. Raise and secure control panel.
- e. Connect negative battery cable. Close battery access door.

2.21. PRESS TO TEST LIGHTS.

2.21.1. Inspection.

- a. Inspect lights for cracks, corrosion, evidence of shorting, and other damage.
- b. Replace or repair lights as necessary.

2.21.2. Testing.

- a. Place MASTER SWITCH in either PRIME & RUN position.
- b. Press in lamp holders (6, FIGURE 2-11) and check that lamps are lit.
- c. If lamp (7) fails to light perform steps d through g.
- d. Release control panel by turning two fasteners and lower control panel slowly.
- e. Set multimeter for DC volts and check for voltage at terminals 1 and 3 on receptacle (10).
- f. If voltage is present, replace press to test light assembly.
- g. Raise and secure control panel.

2.21.3. Removal.

- a. Shut down generator set.
- b. Open battery access door and disconnect negative battery cable.
- c. Release control panel by turning two fasteners and lower control panel slowly.
- d. Tag and disconnect electrical leads to light receptacles (10, FIGURE 2-11).
- e. Remove lamp holders (6), nuts (8), lockwashers (9), and receptacles (10) from control panel.
- f. If necessary, remove lamps (7) from lamp holders (6).

2.21.4. Installation.

- a. Install press to test light receptacles (10, FIGURE 2-11) in control panel with lockwashers (9) and nuts (8).
- b. If removed, install lamps (7) in lamp holders (6).
- c. Install lamp holders (6) on receptacles (10).
- d. Connect electrical leads and remove tags.
- e. Raise and secure control panel.
- f. Connect negative battery cable and close battery access door.

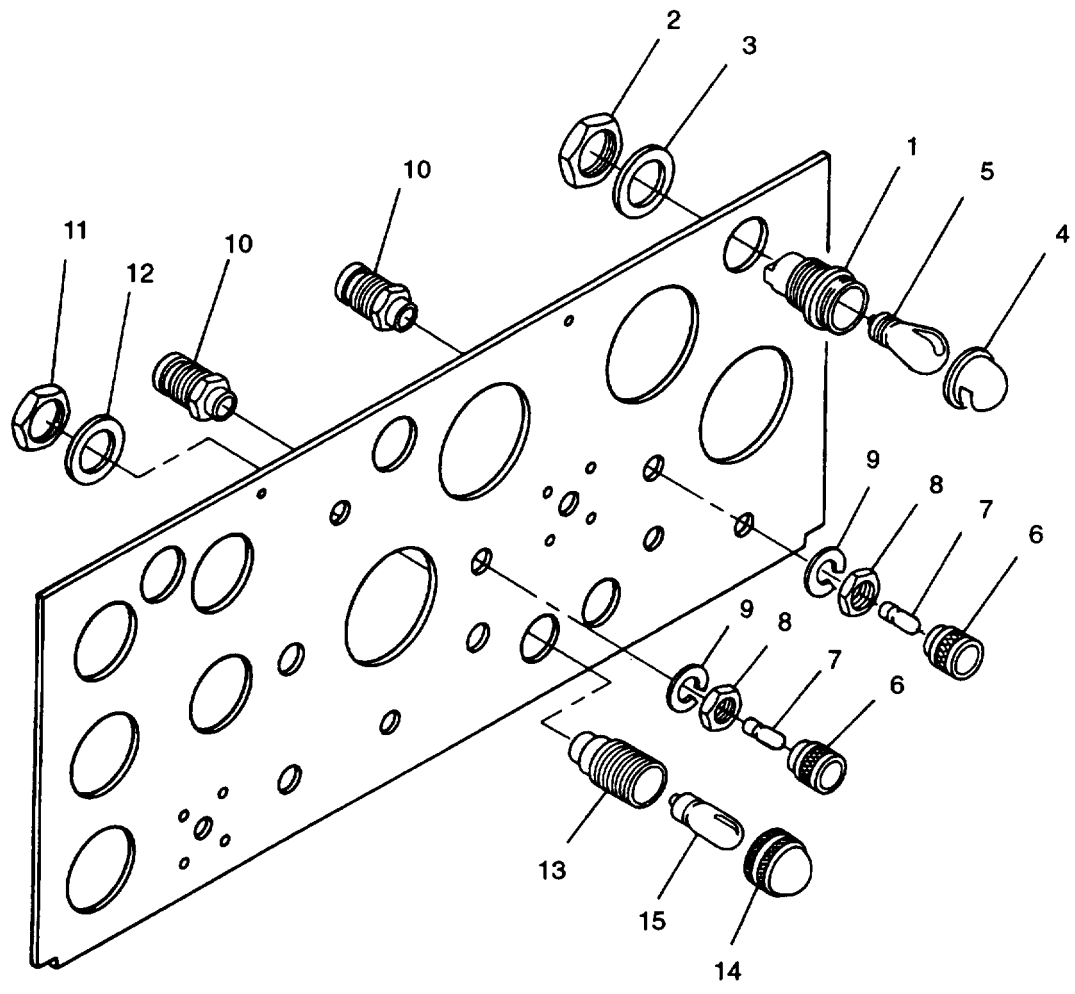

FIGURE 2-11. Control Panel Lights

2.22. SYNCHRONIZING LIGHTS.

2.22.1. Inspection.

Inspect synchronizing lights for cracks, corrosion, evidence of shorting, and other damage.

2.22.2. Removal.

- a. Shut down generator set.
- b. Open battery access door and disconnect negative battery cable.
- c. Release control panel by turning two fasteners and lower control panel slowly.
- d. Tag and disconnect synchronizing lights (13, FIGURE 2-11) electrical connections.
- e. Remove nuts (11) and washers (12).
- f. Remove synchronizing lights (13) from control panel.
- g. Unscrew lenses (14) and remove lamps(15) from light receptacles (13).

2.22.3. Installation.

- a. Insert synchronizing lights (13, FIGURE 2-11) into control panel.
- b. Install washers (12) and nuts (11).
- c. Connect electrical leads and remove tags.
- d. Raise and secure control panel.
- e. Install lamps (15) and screw lenses (14) on light receptacles (13).
- f. Connect negative battery cable. Close battery access door.

2.23. FUEL LEVEL INDICATOR.

2.23.1. Inspection.

- a. Shut down generator set.
- b. Inspect indicator for broken lens, cracked housing, and other damage.

2.23.2. Testing.

- a. Shut down generator set.
- b. Open battery access door and disconnect negative battery cable.
- c. Release control panel by turning two fasteners and lower control panel slowly.

NOTE

On MEP-804A, ensure frequency selector switch is in 50 Hz position.

- d. Isolate generator set VOLTAGE adjust potentiometer by disconnecting wire 137A from voltage regulator, terminal 5, and wire 107G from kilowatt transducer, terminal VI.
- e. Disconnect and isolate electrical lead from terminal S of FUEL LEVEL indicator.
- f. Connect jumper wire between disconnected wire 137A and terminal S of FUEL LEVEL indicator.
- g. Connect jumper wire between disconnected wire 107G and terminal G of FUEL LEVEL indicator.

- h. Set multimeter for ohms and connect between wires 137A and 107G.
- i. Adjust potentiometer until multimeter indicates between 216 and 264 ohms resistance.
- j. Remove multimeter, but do not disturb potentiometer adjustment.
- k. Connect negative battery cable and move generator set MASTER SWITCH to PRIME & RUN position.
- l. FUEL LEVEL indicator should indicate EMPTY ($\pm 1/8$ inch).
- m. Move MASTER SWITCH to OFF position and disconnect negative battery cable.
- n. Repeat steps h through j, setting potentiometer to between 29.7 and 36.3 ohms.
- o. Connect negative battery cable and move MASTER SWITCH to PRIME& RUN position.
- p. FUEL LEVEL indicator should indicate FULL ($\pm 1/8$ inch).
- q. Move MASTER SWITCH to OFF position and disconnect negative battery cable.
- r. Replace FUEL LEVEL indicator if it fails to function properly.
- s. Remove jumper wires and connect electrical leads to FUEL LEVEL indicator, voltage regulator and kilowatt transducer.
- t. Raise and secure control panel.
- u. Connect negative battery cable and close access doors.

2.23.3. Removal.

- a. Shut down generator set.
- b. Open battery access door and disconnect negative battery cable.
- c. Release control panel by turning two fasteners and lower control panel slowly.
- d. Tag and disconnect FUEL LEVEL indicator (4, FIGURE 2-12) electrical leads.
- e. Remove nuts(1), washers (2), and clamp (3).
- f. Remove FUEL LEVEL indicator (4) from control panel.

2.23.4. Installation.

- a. Insert FUEL LEVEL indicator (4, FIGURE 2-12) into control panel.
- b. Install clamp (3), washers (2), and nuts (1).
- c. Connect electrical leads and remove tags.
- d. Raise and secure control panel.
- e. Connect negative battery cable. Close battery access door.

2.24. COOLANT TEMP. INDICATOR.

2.24.1. Inspection.

- a. Shut down generator set.
- b. Inspect indicator for broken lens, cracked housing, or other damage.

2.24.2. Testing.

- a. Shut down generator set.

- b. Open battery access door and disconnect negative battery cable.
- c. Release control panel by turning two fasteners and lower control panel slowly.

NOTE

On MEP-804A, ensure frequency selector switch is in 50 Hz position.

- d. Isolate generator set VOLTAGE adjust potentiometer by disconnecting wire 137A from voltage regulator, terminal 5, and wire 107G from kilowatt transducer, terminal V1.
- e. Disconnect and isolate electrical lead from terminal S of COOLANT TEMP. indicator.
- f. Connect jumper wire between disconnected wire 137A and terminal S of COOLANT TEMP. indicator.
- g. Connect jumper wire between disconnected wire 107G and terminal G of COOLANT TEMP. indicator.
- h. Set multimeter for ohms and connect between wires 137A and 107G.
- i. Adjust potentiometer until multi meter indicates between 117 and 143 ohms resistance.
- j. Disconnect multimeter but do not disturb potentiometer setting.
- k. Connect negative battery cable and move generator set MASTER SWITCH to PRIME & RUN position.
- l. COOLANT TEMP. indicator should indicate between 116 and 164°F.
- m. Move MASTER SWITCH to OFF position and disconnect negative battery cable.
- n. Repeat steps h through j, setting potentiometer to between 58.5 and 71.5 ohms.
- o. Connect negative battery cable and move MASTER SWITCH to PRIME & RUN position.
- p. COOLANT TEMP. indicator should indicate between 156 and 204°F.
- q. Move MASTER SWITCH to OFF position and disconnect negative battery cable.
- r. Replace COOLANT TEMP. indicator if indications are other than above.
- s. Remove jumper wires and connect electrical leads to COOLANT TEMP. indicator, voltage regulator, and kilowatt transducer.
- t. Raise and secure control panel.
- u. Connect negative battery cable and close access doors.

2.24.3. Removal.

- a. Shut down generator set.
- b. Open battery access door and disconnect negative battery cable.
- c. Release control panel by turning two fasteners and lower control panel slowly.
- d. Tag and disconnect COOLANT TEMP. indicator (8, FIGURE 2-12) electrical leads.
- e. Remove nuts (5), washers (6), and clamp (7).

- f. Remove COOLANT TEMP. indicator (8) from control panel.

2.24.4. Installation.

- a. Insert COOLANT TEMP. indicator (8, FIGURE 2-12) in control panel.
- b. Install damp (7), washers (6), and nuts (5).
- c. Connect electrical leads and remove tags.
- d. Raise and secure control panel.
- e. Connect negative battery cable. Close battery access door.

2.25. OIL PRESSURE INDICATOR.

2.25.1. Inspection.

- a. Shut down generator set.
- b. Inspect indicator for broken lens, cracked housing, or other damage.

2.25.2. Testing.

- a. Shut down generator set.
- b. Open battery access door and disconnect negative battery cable.
- c. Release control panel by turning two fasteners and lower control panel slowly.

NOTE

On MEP-804A, ensure frequency selector switch is in 50 Hz position.

- d. Isolate generator set VOLTAGE adjust potentiometer by disconnecting wire 137A from voltage regulator, terminal 5, and wire 107G from kilowatt transducer, terminal VI.
- e. Disconnect and isolate electrical lead from terminal S of OIL PRESSURE indicator.
- f. Connect jumper wire between disconnected wire 137A and terminal S of OIL PRESSURE indicator.
- g. Connect jumper wire between disconnected wire 107G and terminal G of OIL PRESSURE indicator.
- h. Set multimeter for ohms and connect between wires 137A and 107G.
- i. Adjust potentiometer until multimeter indicates between 92.7 and 113.3 ohms resistance.
- j. Disconnect multimeter, but do not disturb potentiometer adjustment.
- k. Connect negative battery cable and move MASTER SWITCH to PRIME & RUN position.
- l. OIL PRESSURE indicator should indicate between 32 and 48 PSI.
- m. Move MASTER SWITCH to OFF position and disconnect negative battery cable.
- n. Repeat steps h through j, setting potentiometer to between 30.15 and 36.85 ohms.
- o. Connect negative battery cable and move MASTER SWITCH to PRIME & RUN position.
- p. OIL PRESSURE indicator should indicate between 72 and 80 PSI.

- q. Move MASTER SWITCH to OFF position and disconnect negative battery cable.
- r. Replace OIL PRESSURE indicator if it does not function properly.
- s. Remove jumper wires and connect electrical leads to OIL PRESSURE indicator, voltage regulator, and kilowatt transducer.
- t. Raise and secure control panel.
- u. Connect negative battery cable, raise control panel and close access doors.

2.25.3. Removal.

- a. Shut down generator set.
- b. Open battery access door and disconnect negative battery cable.
- c. Release control panel by turning two fasteners and lower control panel slowly.
- d. Tag and disconnect OIL PRESSURE indicator (12, FIGURE 2-12) electrical leads.
- e. Remove nuts (9), washers (10), clamp (11), and ground wire.
- f. Remove OIL PRESSURE indicator (12) from control panel.

2.25.4. Installation.

- a. Insert OIL PRESSURE indicator (12, FIGURE 2-12) into control panel.
- b. Install clamp (11), washers (10), and nuts (9).
- c. Connect electrical leads and remove tags.
- d. Raise and secure control panel.
- e. Connect negative battery cable. Close battery access door.

2.26. TIME METER (TOTAL HOURS).

2.26.1. Inspection.

- a. Shut down generator set.
- b. Inspect meter for broken lens, cracked housing, and other damage.

2.26.2. Testing.

- a. Release control panel by turning two fasteners and lower control panel slowly.
- b. Turn MASTER SWITCH to PRIME & RUN position.
- c. Crank engine momentarily to energize time meter relay.
- d. Set multimeter for DC volts and connect across terminals 1 and 2 of time meter (TOTAL HOURS).
- e. If 24 VDC is present, wait approximately 6 minutes. Time meter (TOTAL HOURS) should move 1/10 of an hour.
- f. If time meter (TOTAL HOURS) does not operate properly, meter is defective and must be replaced.
- g. Raise and secure control panel.

2.26.3. Removal.

- a. Shut down generator set.
- b. Open battery access door and disconnect negative battery cable.

- c. Release control panel by turning two fasteners and lower control panel slowly
- d. Tag and disconnect time meter (TOTAL HOURS) (15, FIGURE 2-12) electrical leads.
- e. Remove screws (14), washers (34), and nuts (13)
- f. Remove time meter (TOTAL HOURS) (15) from control panel

2.26.4. Installation

- a. Insert time meter (TOTAL HOURS) (15, FIGURE 2-12) into control panel
- b. Install screws (14), washers (34), and nuts (13)
- c. Connect electrical leads and remove tags.
- d. Raise and secure control panel
- e. Connect negative battery cable. Close battery access door

2.27. BATTERY CHARGE AMMETER

2.27.1. Inspection

- a. Shut down generator set
- a. Inspect ammeter for broken lens, cracked housing and other damage.

2.27.2. Testing

- a. Start and operate generator set at rated voltage and frequency.
- b. Release control panel by turning two fasteners and lower control panel slowly.
- c. Set multimeter for DC volts and connect across BATTERY CHARGE ammeter terminals. Connect positive lead to positive terminal and negative lead to negative terminal if you observe or think battery is charging. Multimeter should indicate up to 50 mv (25 mv equals +10 amps on BATTERY CHARGE ammeter).
- d. Reverse multimeter leads if you observe or think battery is discharging. Multimeter should indicate up to 25 mv (25 mv equals -10 amps on BATTERY CHARGE ammeter).
- e. If multimeter indicates millivolt reading and battery charge is not within $\pm 10\%$ of equal ampere reading, or ammeter is not indicating, replace BATTERY CHARGE ammeter
- f. Raise and secure control panel

2.27.3. Removal

- a. Shut down generator set.
- b. Open battery access door and disconnect negative battery cable
- c. Release control panel by turning two fasteners and lower control panel slowly
- d. Tag and disconnect BATTERY CHARGE ammeter (18, FIGURE 2-12) electrical leads
- e. Remove nuts (16), washers (32, 33), and screws (17)
- f. Remove BATTERY CHARGE ammeter (18)

2.27.4. Installation

- a. Insert BATTERY CHARGE ammeter (18, FIGURE 2-12) into control panel

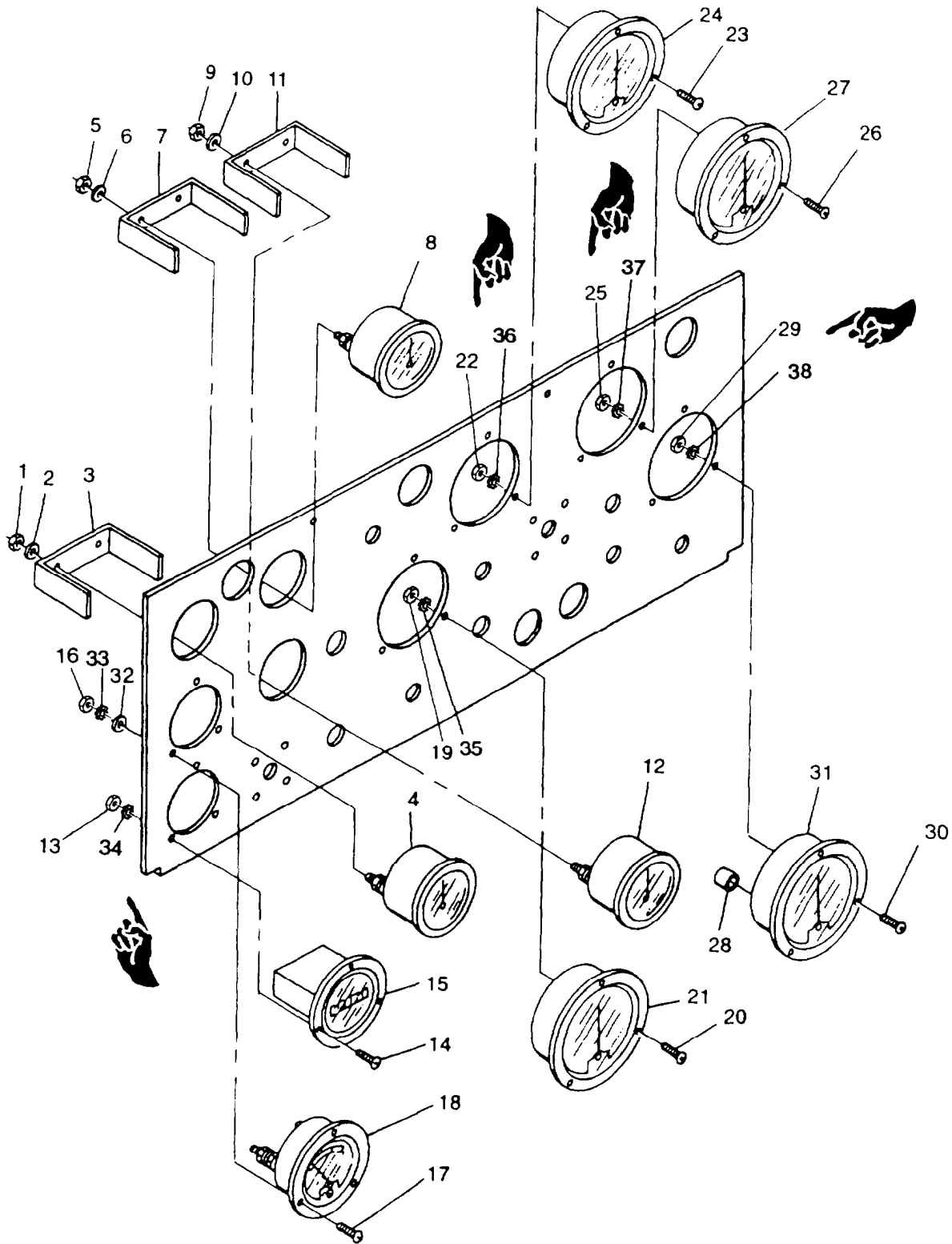

FIGURE 2-12. Control Panel Indicators

- b. Install screws (17), washers (32. 33), and nuts (16)
- c. Connect electrical leads and remove tags.
- d. Raise and secure control panel.
- e. Connect negative battery cable. Close battery access door.

2.28. FREQUENCY METER (HERTZ).

2.28.1. Inspection.

- a. Shut down generator set.
- b. Inspect meter for broken lens, cracked housing, and other damage.

2.28.2. Testing (50/60 Hz).

NOTE

Test frequency transducer in accordance with paragraph 251.2 or 2.51.3 prior to testing FREQUENCY meter (HERTZ).

- a. Shut down generator set.
- b. Open battery access door and disconnect negative battery cable.
- c. Release control panel by turning two fasteners and lower control panel slowly.
- d. Disconnect wire 181 A from positive (+) terminal of FREQUENCY meter (HERTZ).
- e. Set multimeter for DC milliamps and connect negative lead to positive (+) terminal of FREQUENCY meter (HERTZ) and positive lead to wire 181 A.
- f. Position FREQUENCY SELECT switch to 60 Hz.
- g. Connect negative battery cable, start and operate generator set at rated voltage and adjust frequency to 60 Hz.
- h. Multimeter indication should be between 0.781 and 0.923 DC milliamps.
- i. Position FREQUENCY SELECT switch to 50 Hz and adjust frequency to 50 Hz.
- j. Multimeter indication should be between 0.071 and 0.213 DC milliamps.
- k. Replace FREQUENCY meter (HERTZ) if meter readings are not as stated above.
- l. Raise and secure control panel

2.28.3. Testing (400 Hz).

- a. Shut down generator set.
- b. Open battery access door and disconnect negative battery cable.
- c. Release control panel by turning two fasteners and lower control panel slowly.
- d. Disconnect wire 181 A from positive (+) terminal of FREQUENCY meter (HERTZ).
- e. Set multimeter for DC milliamps and connect negative lead to positive (+) terminal of FREQUENCY meter (HERTZ) and positive lead to wire 181A.
- f. Connect negative battery cable, start and operate generator set at rated voltage and adjust frequency to 400 Hz.

- g. Multimeter indication should be between 0.240 and 0.260 DC milliamps.
- h. Replace FREQUENCY meter (HERTZ) if multimeter readings are not as stated above.
- i. Raise and secure control panel.

2.28.4. Removal.

- a. Shut down generator set.
- b. Open battery access door and disconnect negative battery cable.
- c. Release control panel by turning two fasteners and lower control panel slowly.
- d. Tag and disconnect FREQUENCY meter (HERTZ) (21, FIGURE 2-12) electrical leads.
- e. Remove nuts (19), washers (35), and screws (20).
- f. Remove FREQUENCY meter (HERTZ) (21) from control panel.

2.28.5. Installation.

- a. Insert FREQUENCY meter (HERTZ) (21, FIGURE 2-12) into control panel.
- b. Install screws (20), washers (35), and nuts (19).
- c. Connect electrical leads and remove tags.
- d. Raise and secure control panel.
- e. Connect negative battery cable. Close battery access door.

2.29. AMMETER (PERCENT RATED CURRENT).

2.29.1. Inspection.

- a. Shut down generator set.
- b. Inspect ammeter for broken lens, cracked housing, and other damage.

2.29.2. Testing.

- a. Shut down generator set.
- b. Open battery access and disconnect negative battery cable.
- c. Release control panel by turning two fasteners and lower control panel slowly.
- d. Tag and disconnect wire 183A from terminal 1 of ammeter (PERCENT RATED CURRENT).
- e. Set multimeter for AC amperes and conned between disconnected wire 183A and terminal 1 of ammeter (PERCENT RATED CURRENT).
- f. Connect negative battery cable, start and operate generator set at rated voltage and frequency. Appiy some load to generator set.
- g. Observe and note indications on multimeter and ammeter (PERCENT RATED CURRENT).
- h. Shut down generator set.
- i. Calculate the percent of current from the multimeter indication using the following formula:

Percent of current -

$$\frac{100 \times \text{Multimeter Indication}}{0.75 \text{ amperes}}$$

- j. Compare calculated percent of current to ammeter (PERCENT RATED CURRENT) indication noted during operation. If difference is greater than 10%, replace ammeter.
- k. Disconnect negative battery cable.
- l. Remove multimeter, connect wire 183A to ammeter (PERCENT RATED CURRENT).
- m. Raise and secure control panel.
- n. Connect negative battery cable and close battery access door.

2.29.3. Removal.

- a. Shut down generator set.
- b. Open battery access door and disconnect negative **battery** cable.
- c. Release control panel by turning two fasteners and lower control panel slowly.
- d. Tag and disconnect ammeter (PERCENT RATED CURRENT) (24, FIGURE 2-12) electrical leads.
- e. Remove nuts (22), washers (36), and screws (23).
- f. Remove ammeter (PERCENT RATED CURRENT) (24) from control panel.

2.29.4. Installation.

- a. Insert ammeter (PERCENT RATED CURRENT) (24, FIGURE 2-12) into control panel
- b. Install screws (23), washers (36) and nuts (22).
- c. Connect electrical leads and remove tags.
- d. Raise and secure control panel
- e. Connect negative battery cable. Close battery access door.

2.30. KILOWATTMETER (PERCENT POWER).

2.30.1. Inspection.

- a. Shut down generator set.
- b. Inspect meter for broken lens, cracked housing, **and other damage.**

2.30.2. Testing.

- a. Shut down generator set.
- b. Open battery access door and disconnect negative battery cable.
- c. Release control panel by turning two fasteners and lower control panel slowly.
- d. Tag and disconnect wire 120A from positive terminal of kilowattmeter (PERCENT POWER).
- e. Set multimeter for milliamperes and connect between disconnected wire 120A and positive terminal of kilowattmeter.
- f. Connect negative battery cable, start and operate generator set at rated voltage and frequency. Apply some load to generator set.
- g. Observe and note indications on multimeter and kilowattmeter.
- h. Shut down generator set.

- i. Calculate the percent of power from multimeter indication using the following formula:

Percent of power =

$$\frac{133 \times \text{Multimeter indication}}{1.2 \text{ Ma.}}$$

- j. Compare calculated percent of power to kilowattmeter indication noted during operation. If difference is greater than 13%, replace kilowattmeter (PERCENT POWER).
- k. Disconnect negative battery cable.
- l. Remove multimeter and connect wire 120A to kilowattmeter (PERCENT POWER).
- m. Raise and secure control panel.
- n. Connect negative battery cable and close battery access door.

2.30.3. Removal.

- a. Shut down generator set.
- b. Open battery access door and disconnect negative battery cable.
- c. Release control panel by turning two fasteners and lower control panel slowly.
- d. Tag and disconnect kilowattmeter (PERCENT POWER) (27, FIGURE 2-12) electrical leads.
- e. Remove nuts (25), washers (37), and screws (26)
- f. Remove kilowattmeter (PERCENT POWER) (27) from control panel.

2.30.4. Installation.

- a. Insert kilowattmeter (PERCENT POWER) (27, FIGURE 2-12) into control panel
- b. Install screws (26), washers (37), and nuts (25).
- c. Connect electrical leads and remove tags.
- d. Raise and secure control panel.
- e. Connect negative battery cable. Close battery access door.

2.31. AC VOLTMETER (VOLTS AC).

2.31.1. Inspection.

- a. Shut down generator set.
- b. Inspect AC Voltmeter (VOLTS AC) for broken lens, cracked housing, and other damage

2.31.2. Testing.

- a. Shut down generator set.
- b. Release control panel by turning two fasteners and lower control panel slowly.
- c. Set multimeter for AC volts and connect to AC Voltmeter (VOLTS AC) terminals.
- d. Move voltage reconnection board to 120/208 position.
- e. Start and operate generator set at rated voltage and frequency
- f. Move AM/VM transfer switch to L3-L1 position. Note indications on multimeter and AC Voltmeter (VOLTS AC).

- g. Move AM/VM transfer switch to L3-L0 position. Note indications on multimeter and AC Voltmeter (VOLTS AC)
- h. Shut down generator set.
- i. Move voltage reconnection board to 240/416 position.
- j. Start and operate generator set at rated voltage and frequency.
- k. Repeat steps e and f.
- l. Shut down generator set.
- m. Compare AC Voltmeter (VOLTS AC) readings to multimeter in each position.
- n. Replace AC Voltmeter (VOLTS AC) if readings differ more than ± 5 VAC between 115-125 VAC or ± 10 VAC between 200-250 VAC.
- o. Remove multimeter.
- p. Raise and secure control panel.

2.31.3. Removal.

- a. Shut down generator set.
- b. Open battery access door and disconnect negative battery cable.
- c. Release control panel by turning two fasteners and lower control panel slowly.
- d. Tag and disconnect AC Voltmeter (VOLTS AC) (31, FIGURE 2-12) electrical leads and remove sleeves (28).
- e. Remove nuts (29), washers (38), and screws (30).
- f. Remove AC Voltmeter (VOLTS AC) (31) from control panel.

2.31.4. Installation.

- a. Insert AC Voltmeter (VOLTS AC) (31, FIGURE 2-12) into control panel.
- b. Install screws (30) washers (38), and nuts (29).
- c. Connect electrical leads, remove tags, and install sleeves (28) over terminals.
- d. Raise and secure control panel.
- e. Connect negative battery cable. Close battery access door

2.32. MASTER SWITCH.

2.32.1. Inspection.

- a. Shut down generator set.
- b. Inspect switch for loose connections and mounting, and other damage.

2.32.2. Removal.

- a. Shut down generator set.
- b. Open battery access door and disconnect negative battery cable.
- c. Release control panel by turning two fasteners and lower control panel slowly.
- d. Loosen set screw (1, FIGURE 2-13) and remove knob (2) from MASTER SWITCH (5)

- e. Remove nuts (3) and screws (4)
- f. Remove MASTER SWITCH (5) from control panel

NOTE

Ensure the diode is properly tagged so the polarity is not reversed during installation

- g. Tag and disconnect MASTER SWITCH (5) electrical leads.

2.32.3. Testing

- a. Shut down generator set.
- b. Open battery access door and disconnect negative battery cable.
- c. Release control panel by turning two fasteners and lower control panel **slowly**.
- d. Tag and disconnect MASTER SWITCH (5, FIGURE 2-13) electrical leads
- e. Set multimeter for ohms and check switch for continuity. Refer to Electrical Schematic FO-1 (5-1 Circuit Schedule) to determine circuits made to corresponding switch positions.
- f. Check continuity until all five positions have been checked.
- g. If open circuit is noted in any switch position, switch is unserviceable and must be replaced.
- h. Connect electrical leads to MASTER SWITCH (5) and remove tags
- i. Raise and secure control panel.
- j. Connect negative battery cable and close battery access door.

2.32.4. Installation.

- a. Connect electrical leads to MASTER SWITCH (5, FIGURE 2-13) and remove tags.
- b. Insert MASTER SWITCH (5) into control panel
- c. Install screws (4) and nuts (5)
- d. Install knob (2) and tighten set screw (1).
- e. Raise and secure control panel.
- f. Connect negative battery cable. Close battery access door

2.33 VOLTAGE ADJUST POTENTIOMETER.

2.33.1. Inspection.

- a. Shut down generator set.
- b. Inspect potentiometer for loose connections and mounting, and other damage

2.33.2. Removal.

- a. Shut down generator set.
- b. Open battery access door and disconnect negative battery cable
- c. Release control panel by turning two fasteners and lower control panel slowly
- d. Tag and disconnect VOLTAGE adjust potentiometer (10, FIGURE 2-13) rheostat electrical leads using soldering gun. Remove shrinkable tubing

- e. Remove set screws (6) and knob (7).
- f. Remove nut (8) and washer (9).
- g. Remove VOLTAGE adjust potentiometer (10) from control panel.

2.33.3. Testing.

NOTE

Refer to TM 9-6115-643-24P to verify voltage regulator being tested.

- a. Remove VOLTAGE adjust potentiometer, paragraph 2.33.2.
- b. Set multimeter for ohms and connect across two outer terminals of potentiometer (1 O, FIGURE 2-1 3). Indication shall be:
 - 10,000 ohms (Part number RV4NAYSD103A installed).
 - 20,000 ohms (Part number RV4NAYSD203A installed).
- c. Rotate potentiometer shaft counterclockwise as far as it will go.
- d. Connect multimeter between center terminal and either outer terminal.
- e. Slowly, at an even rate, rotate potentiometer shaft clockwise as far as it will go while observing multimeter.
- f. Multimeter indication shall increase, at an even rate, as follows:
 - 0 to 10,000 ohms (Part number RV4NAYSD103A installed).
 - 0 to 20,000 ohms (Part number RV4NAYSD203A installed).
- g. If multimeter indication changes erratically or is not at maximum ohms when rotation is complete, the potentiometer is defective and must be replaced.
- h. Install VOLTAGE adjust potentiometer, paragraph 2.33.4.

2.33.4. Inspection.

- a. Insert VOLTAGE adjust potentiometer (10, FIGURE 2-13) into control panel.
- b. install washer (9) and nut (8).
- c. Install knob (7) and set screws (6).
- d. Install new shrinkable tubing and connect electrical leads using soldering gun. Remove tags.
- e. Raise and secure control panel.
- f. Connect negative battery cable. Close battery access door.

2.34. FREQUENCY ADJUST POTENTIOMETER

2.34.1. Inspection.

- a. Shut down generator set.
- b. Inspect potentiometer for loose connections and mounting, and other damage.

2.34.2. Removal.

- a. Shut down generator set.
- b. Open battery access door and disconnect negative battery cable.

- c. Release control panel by turning two fasteners and lower control panel slowly.
- d. Tag and disconnect FREQUENCY adjust potentiometer (15, FIGURE 2-13) electrical leads using soldering gun. Remove shrinkable tubing.
- e. Remove set screws (11) and knob (12).
- f. Remove nut (13) and washer (14).
- g. Remove FREQUENCY adjust potentiometer (15) from control panel.

2.34.3. Testing.

- a. Remove FREQUENCY adjust potentiometer, paragraph 2.34.2.
- b. Set multimeter for ohms and connect across outer terminals of potentiometer (15, FIGURE 2-13). Multimeter should indicate between 4500 and 5500 ohms resistance.
- c. Rotate potentiometer shaft counterclockwise as far as it will go.
- d. Connect multimeter between center terminal and either outer terminal. Multimeter should indicate zero ohms resistance.
- e. Slowly, at an even rate, rotate the potentiometer shaft clockwise as far as it will go. Multimeter should increase at an even rate from 0 to 5000 ohms.
- f. If multimeter indication changes erratically or is not between 4500 and 5500 ohms when the rotation is completed, the potentiometer is defective and must be replaced.
- g. Install FREQUENCY adjust potentiometer, paragraph 2.34.4.

2.34.4. Installation.

- a. Insert FREQUENCY adjust potentiometer (15, FIGURE 2-13) into control panel.
- b. Install washer (14) and nut (13).
- c. Install knob (12) and set screws (11).
- d. Install new shrinkable tubing, solder leads, and remove tags.
- e. Raise and secure control panel.
- f. Connect negative battery cable. Close battery access door.

2.35. BATTLE SHORT SWITCH.

2.35.1. Inspection.

- a. Shut down generator set.
- b. Inspect switch for loose connections and mounting, and other damage.

2.35.2. Removal.

- a. Shut down generator set.
- b. Open battery access door and disconnect negative battery cable.
- c. Release control panel by turning two fasteners and lower control panel slowly.
- d. Tag and disconnect BATTLE SHORT switch (19, FIGURE 2-13) electrical leads.

- e. Remove nut (16), washer (17), and protective cover (18).
- f. Remove BATTLE SHORT switch (19) from control panel and tab washer (20) from switch stem.

2.35.3. Testing.

- a. Shut down generator set.
- b. Open battery access door and disconnect negative battery cable.
- c. Release control panel by turning two fasteners and lower control panel slowly.
- d. Tag and disconnect BATTLE SHORT switch (19, FIGURE 2-13) electrical leads.
- e. Place switch in ON position.

NOTE

Refer to Wiring Diagram FO-2 for terminal positions.

- f. Set multimeter for ohms and check for continuity between terminals 2 and 3, 5 and 6, 8 and 9, and 11 and 12.
- g. Place switch in OFF position.
- h. Check for continuity between terminals 1 and 2, 4 and 5, 7 and 8, and 10 and 11.
- i. Replace switch if any open circuit is indicated.
- j. Connect electrical leads to switch (19) and remove tags.
- k. Raise and secure control panel.
- l. Connect negative battery cable and close battery access door.

2.35.4. Installation.

- a. Install tab washer (20, FIGURE 2-13) and insert BATTLE SHORT switch (19) into control panel,
- b. Install protective cover (18), washer (17), and nut (16).
- c. Connect electrical leads and remove tags.
- d. Raise and secure control panel.
- e. Connect negative battery cable. Close battery access door.

2.36. AC CIRCUIT INTERRUPTER SWITCH.

2.36.1. Inspection.

- a. Shut down generator set.
- b. Inspect switch for loose connections and mounting, and other damage.

2.36.2. Removal.

- a. Shut down generator set.
- b. Open battery access door and disconnect negative battery cable.
- c. Release control panel by turning two fasteners and lower control panel slowly.
- d. Tag and disconnect AC CIRCUIT INTERRUPTER switch (23, FIGURE 2-13) electrical leads.

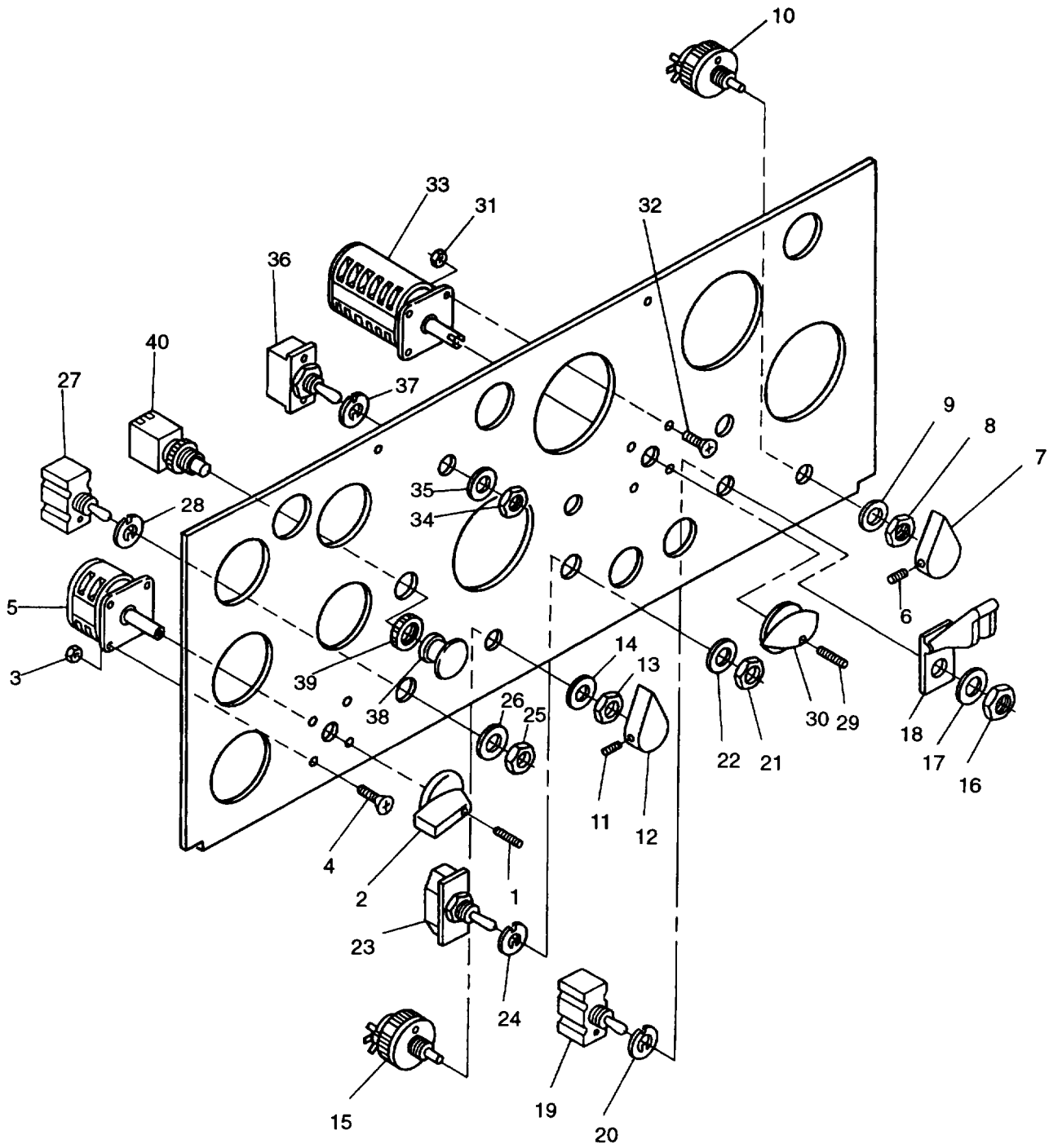

FIGURE 2-13. Control Panel Switches

- e. Remove nut (21) and washer (22).
- f. Remove AC CIRCUIT INTERRUPTER switch (23) from control panel and tab washer (24) from switch stem.

2.36.3. Testing.

- a. Shut down generator set.
- b. Open battery access door and disconnect negative battery cable.
- c. Release control panel by turning two fasteners and lower control panel slowly.
- d. Tag and disconnect AC CIRCUIT INTERRUPTER switch (23, FIGURE 2-13) electrical leads.

NOTE

Refer to Wiring Diagram FO-2 for terminal positions.

- e. Set multimeter for ohms and check for continuity between terminals 5 and 4, and terminals 2 and 3.
- f. Check for open circuits between terminals 5 and 6, and terminals 1 and 2.
- g. Place and hold AC CIRCUIT INTERRUPTER switch in CLOSED position.
- h. Check for continuity between terminals 5 and 6, and terminals 2 and 3.
- i. Check for open circuits between terminals 5 and 4, and terminals 2 and 1.
- j. Place and hold AC CIRCUIT INTERRUPTER switch in OPEN position.
- k. Check for continuity between terminals 5 and 4, and terminals 1 and 2.
- l. Check for open circuits between terminals 5 and 6, and terminals 3 and 1.
- m. Replace switch if any continuity check is other than indicated above.
- n. Connect electrical leads to switch (23) and remove tags.
- o. Raise and secure control panel.
- p. Connect negative battery cable and close battery access door.

2.36.4. Installation.

- a. Install tab washer (24, FIGURE 2-13) and insert AC CIRCUIT INTERRUPTER switch (23) into control panel.
- b. Install washer (22) and nut (21).
- c. Connect electrical leads and remove tags.
- d. Raise and secure control panel.
- e. Connect negative battery cable. Close battery access door.

2.37. PARALLEL-UNIT SWITCH.

2.37.1. Inspection.

- a. Shut down generator set.
- b. Inspect switch for loose connections and mounting, and other damage.

2.37.2. Removal.

- a. Shut down generator set.

- b. Open battery access door and disconnect negative battery cable.
- c. Release control panel by turning two fasteners and lower control panel slowly.
- d. Tag and disconnect PARALLEL-UNIT switch (27, FIGURE 2-13) electrical leads.
- e. Remove nut (25) and washer (26).
- f. Remove PARALLEL-UNIT switch (27) from control panel and tab washer (28) from switch stem.

2.37.3. Testing.

- a. Shut down generator set.
- b. Open battery access door and disconnect negative battery cable.
- c. Release control panel by turning two fasteners and lower control panel slowly.
- d. Tag and disconnect PARALLEL-UNIT switch (27, FIGURE 2-13) electrical leads.

NOTE

Refer to Wiring Diagram FO-2 for terminal positions.

- e. Place switch in PARALLEL position.
- f. Set multimeter for ohms and check for continuity between terminals 1 and 2, 4 and 5, 7 and 8, and 10 and 11.
- g. Place switch in UNIT position.
- h. Check for continuity between terminals: 2 and 3, 5 and 6, 8 and 9, and 11 and 12.
- i. Replace switch if any open circuit is indicated.
- j. Connect electrical leads to switch (27) and remove tags.
- k. Raise and secure control panel.
- l. Connect negative battery cable and close battery access door.

2.37.4. Installation.

- a. Install tab washer (28, FIGURE 2-13) and insert PARALLEL-UNIT switch (27) into control panel.
- b. Install washer (26) and nut (25).
- c. Connect electrical leads and remove tags.
- d. Raise and secure control panel.
- e. Connect negative battery cable. Close battery access door.

2.38. AM-VM TRANSFER SWITCH.

2.38.1. Inspection.

- a. Shut down generator set.
- b. Inspect switch for loose connections and mounting, and other damage.

2.38.2. Removal.

- a. Shut down generator set.
- b. Open battery access door and disconnect negative battery cable.

- c. Release control panel by turning two fasteners and lower control panel slowly.
- d. Remove set screw (29, FIGURE 2-13) and knob (30).
- e. Remove nuts (31) and screws (32).
- f. Remove AM-VM transfer switch (33) from control panel.
- g. Tag and disconnect AM-VM transfer switch (33) electrical leads.

2.38.3. Testing.

- a. Shut down generator set.
- b. Remove AM-VM transfer switch, paragraph 2.38.2.
- c. Set multimeter for ohms and check AM-VM transfer switch for continuity. Refer to Electrical Schematic FO-1 (S-6 Circuit Schedule) to determine circuits made to corresponding switch positions.
- d. Check continuity in all six switch positions.
- e. If open circuit is noted in any switch position, AM-VM transfer switch is unserviceable and must be replaced.
- f. Install AM-VM switch, paragraph 2.38.4.

2.38.4. Installation.

- a. Connect electrical leads to AM-VM transfer switch (33, FIGURE 2-13) and remove tags.
- b. Insert AM-VM transfer switch (33) into control panel.
- c. Install screws (32) and nuts (31).
- d. Install knob (30) and set screw (29).
- e. Raise and secure control panel.
- f. Connect negative battery cable. Close battery access door.

2.39. PANEL LIGHTS SWITCH

2.39.1. Inspection.

- a. Shut down generator set.
- b. Inspect switch for loose connections and mounting, and other damage.

2.39.2. Removal.

- a. Shut down generator set.
- b. Open battery access door and disconnect negative battery cable.
- c. Release control panel by turning two fasteners and lower control panel slowly.
- d. Tag and disconnect PANEL LIGHTS switch (36, FIGURE 2-13) electrical leads.
- e. Remove nut (34) and washer (35).
- f. Remove PANEL LIGHTS switch (36) from control panel and tab washer (37) from switch stem.

2.39.3. Testing.

- a. Shut down generator set.
- b. Open battery access door and disconnect negative battery cable.
- c. Release control panel by turning two fasteners and lower control panel slowly.
- d. Tag and disconnect PANEL LIGHTS switch (36, FIGURE 2-13) electrical leads.
- e. Set multimeter for ohms and connect across switch terminals.
- f. Place switch in ON position. Multimeter should indicate continuity.
- g. Place switch in OFF position. Multimeter should indicate open circuit.
- h. Replace PANEL LIGHTS switch if readings are not as above.
- i. Connect electrical leads to switch (36) and remove tags.
- j. Raise and secure control panel.
- k. Connect negative battery cable and close battery access door.

2.39.4. Installation.

- a. Install tab washer (37, FIGURE 2-13) and insert PANEL LIGHTS switch (36) into control panel
- b. Install washer (35) and nut (34).
- c. Install electrical leads and remove tags.
- d. Raise and secure control panel.
- e. Connect negative battery cable. Close battery access door.

2.40. EMERGENCY STOP SWITCH.

2.40.1. Inspection.

- a. Shut down generator set.
- b. Inspect switch for loose connections and mounting, and other damage.

2.40.2. Testing.

- a. Shut down generator set.
- b. Open battery access door and disconnect negative battery cable.
- c. Release control panel by turning two fasteners and lower control panel slowly.
- d. Tag and disconnect EMERGENCY STOP switch (40, FIGURE 2-13) electrical leads.
- e. With switch in normal (out) position, set multimeter for ohms and check circuit between switch terminals. If no continuity is indicated, EMERGENCY STOP switch is defective.
- f. Push EMERGENCY STOP switch to the in position.
- g. Check for continuity between switch terminals. Replace switch if continuity is indicated.
- h. Connect electrical leads to switch (40) and remove tags.
- i. Raise and secure control panel
- j. Connect negative battery cable and close battery access door.

2.40.3. Removal.

- a. Shut down generator set.
- b. Open battery access door and disconnect negative battery cable.
- c. Release control panel by turning two fasteners and lower control panel slowly.
- d. Tag and disconnect EMERGENCY STOP switch (40, FIGURE 2-13) electrical leads.
- e. Remove knob (38) and nut (39).
- f. Remove EMERGENCY STOP switch (40) from control panel.

2.40.4. Installation.

- a. Insert EMERGENCY STOP switch (40, FIGURE 2-13) into control panel.
- b. Install nut (39) and knob (38).
- c. Connect electrical leads and remove tags.
- d. Raise and secure control panel.
- e. Connect negative battery cable and close battery access door.

2.41. REACTIVE CURRENT ADJUST RHEOSTAT.

2.41.1. Inspection.

- a. Shut down generator set.
- b. Inspect rheostat for loose connections and mounting, and other damage.

2.41.2. Testing.

- a. Shut down generator set.
- b. Open battery access door and disconnect negative battery cable.
- c. Remove control box top panel, paragraph 2.15.1.
- d. Disconnect wires 143C from TB4 terminal 21, 142A from TB6 terminal 12, and 135B from TB5 terminal 4.
- e. Mark reading of REACTIVE CURRENT ADJUST rheostat to reposition at conclusion of testing steps.
- f. Set multimeter for ohms and connect to wires 135B and 142A. Multimeter reading should be between 4.5 and 5.5 ohms.
- g. Connect multimeter to wires 135B and 143C, and turn REACTIVE CURRENT ADJUST rheostat to full clockwise position. Multimeter reading should be approximately 0 ohms. Turn REACTIVE CURRENT ADJUST rheostat slowly to full counterclockwise position and observe multimeter. Multimeter reading should evenly increase to between 4.5 and 5.5 ohms.
- h. Connect multimeter to wires 142A and 143C, and turn REACTIVE CURRENT ADJUST rheostat to full clockwise position. Multimeter reading should be between 4.5 and 5.5 ohms. Turn REACTIVE CURRENT ADJUST rheostat slowly to full counterclockwise position and observe multimeter. Multimeter reading should evenly decrease to approximately 0 ohms.
- i. Replace REACTIVE CURRENT ADJUST rheostat if multimeter readings are other than above.
- j. Reposition REACTIVE CURRENT ADJUST rheostat as marked in step g.
- k. Connect electrical wires as tagged.

- l. Install control box top panel, paragraph 2.15.4.
- m. Connect negative battery cable and close battery access door.

2.41.3. Removal.

- a. Shut down generator set.
- b. Open battery access door and disconnect negative battery cable.
- c. Remove control box top panel, paragraph 2.15.1.
- d. Tag and disconnect REACTIVE CURRENT ADJUST rheostat (3, FIGURE 2-14) electrical leads by unsoldering and remove shrinkable tubing.
- e. Remove nuts (1) and (2), and rheostat (3).

2.41.4. Installation.

- a. Install rheostat (3, FIGURE 2-14) in mounting bracket.
- b. Install nuts (1) and (2).
- c. Install new shrinkable tubing, solder electrical leads, and remove tags.
- d. Install control box top panel, paragraph 2.15.4.
- e. Connect negative battery cable. Close battery access door.

2.42. LOAD SHARING ADJUST RHEOSTAT.

2.42.1. Inspection.

- a. Shut down generator set.
- b. Inspect rheostat for loose connections and mounting, and other damage.

2.42.2. Testing.

- a. Shut down generator set.
- b. Open battery access door and disconnect negative battery cable.
- c. Remove control box top panel, paragraph 2.15.1.
- d. Tag and disconnect wire 161 B from reverse power relay, terminal 2. Insulate end of wire.
- e. Disconnect wire 159A from governor control unit, terminal 11.
- f. Set multimeter for ohms and connect positive lead to wire 159A and negative lead of multimeter to terminal 12 of governor control unit. Record reading of rheostat.
- g. Turn LOAD SHARING ADJUST rheostat to full counterclockwise position. Multimeter reading should be between 4500 and 5500 ohms.
- h. Turn LOAD SHARING ADJUST rheostat to full clockwise position. Multimeter reading should be approximately 0 ohms.
- i. Replace LOAD SHARING ADJUST rheostat if multimeter readings are other than above.
- j. If readings are within tolerance, return rheostat to reading recorded in step f.
- k. Connect electrical wires as tagged.
- l. Install control box top panel, paragraph 2.15.4.

m. Connect negative battery cable and close battery access door.

2.42.3. Removal.

- a. Shut down generator set.
- b. Open battery access door and disconnect negative battery cable.
- c. Remove control box top panel, paragraph 2.15.1.
- d. Tag and disconnect LOAD SHARING ADJUST rheostat (7, FIGURE 2-14) electrical leads.
- e. Remove nuts (4) and (5), lockwasher (6), and rheostat (7).

2.42.4. Installation.

- a. Install LOAD SHARING ADJUST rheostat (7, FIGURE 2-14) in mounting bracket.
- b. Install lockwasher (6) and nuts (5) and (4).
- c. Connect electrical leads and remove tags.
- d. Install control box top panel, paragraph 2.15.4.
- e. Connect negative battery cable. Close battery access door.

2.43. OVERSPEED RESET SWITCH.

2.43.1. Inspection.

- a. Shut down generator set.
- b. Inspect switch for loose connections and mounting, and other damage.

2.43.2. Testing.

- a. Shut down generator set.
- b. Open battery access door and disconnect negative battery cable.
- c. Remove control box top panel, paragraph 2.15.1.
- d. Tag and disconnect OVERSPEED RESET switch (10, FIGURE 2-14) electrical leads.
- e. Set multimeter for ohms and connect across switch terminals. Multimeter should indicate continuity.
- f. Position and hold switch in the up position. Multimeter should indicate open circuit.
- g. OVERSPEED RESET switch is defective and must be replaced, if indications are other than above.
- h. Connect electrical leads to switch (10) and remove tags.
- i. Install control box top panel, paragraph 2.15.4.
- j. Connect negative battery cable and close battery access door.

2.43.3. Removal.

- a. Shut down generator set.
- b. Open battery access door and disconnect negative battery cable.
- c. Remove control box top panel, paragraph 2.15.1.
- d. Tag and disconnect OVERSPEED RESET switch (10, FIGURE 2-14) electrical leads.
- e. Remove nut (8), lockwasher (9), and switch (10).

2.43.4. Installation.

- a. Install OVERSPEED RESET switch (10, FIGURE 2-14) in mounting bracket.
- b. Install lockwasher (9) and nut (8).
- c. Connect electrical leads and remove tags.
- d. Install control box top panel, paragraph 2.15.4.
- e. Connect negative battery cable. Close battery access door.

2.44. FREQUENCY SELECT SWITCH.

NOTE

Applicable to MEP-804A only.

2.44.1. Inspection.

- a. Shut down generator set.
- b. Inspect switch for loose connections and mounting, and other damage.

2.44.2. Testing.

- a. Shut down generator set.
- b. Open battery access door and disconnect negative battery cable.
- c. Remove control box top panel, paragraph 2.15.1.
- d. Tag and disconnect FREQUENCY SELECT switch (14, FIGURE 2-14) electrical leads.
- e. Set multimeter for ohms and connect across switch terminals.
- f. Place switch in the up (60 Hz) position. Multimeter should indicate continuity.
- g. Place switch in down (50 Hz) position. Multimeter should indicate open.
- h. FREQUENCY SELECT switch is defective and must be replaced, if indications are other than above.
- i. Connect electrical leads to switch (14) and remove tags.
- j. Install control box top panel, paragraph 2.15.4.
- k. Connect negative battery cable and close battery access door.

2.44.3. Removal.

- a. Shut down generator set.
- b. Open battery access door and disconnect negative battery cable.
- c. Remove control box top panel, paragraph 2.15.1.
- d. Tag and disconnect electrical leads from FREQUENCY SELECT switch (14, FIGURE 2-14).
- e. Tag and remove resistor (11) from FREQUENCY SELECT switch (14).
- f. Remove nut (12), lockwasher (13) and FREQUENCY SELECT switch (14).

2.44.4. Installation.

- a. Position FREQUENCY SELECT switch (14, FIGURE 2-14) in mounting bracket
- b. Install lockwasher (13) and nut (12).
- c. Install resistor (11) on FREQUENCY SELECT switch (14) **and remove tags.**
- d. Connect electrical leads and remove tags.
- e. Install control box top panel, paragraph 2.15.4.
- f. Connect negative battery cable and close battery access door.

2.45. CONVENIENCE RECEPTACLE.

2.45.1. Inspection.

- a. Shut down generator set.
- b. Inspect CONVENIENCE RECEPTACLE for cracks, breaks, corrosion, bent terminals, or other indications of damage.
- c. Inspect cover for cracks, corrosion, or damaged springs.
- d. Replace defective pans.

2.45.2. Testing.

- a. Shut down generator set.
- b. Remove control box top panel, paragraph 2.15.1.
- c. Tag and disconnect CONVENIENCE RECEPTACLE (20, FIGURE 2-14) electrical leads.
- d. Set multimeter for ohms and check for continuity between upper side terminals and lower side terminals of each plug outlet.
- e. Replace CONVENIENCE RECEPTACLE if continuity is indicated between terminals.
- f. Connect electrical leads to receptacle (20) and remove tags.
- g. Install control box top panel, paragraph 2.15.4.

2.45.3. Removal.

- a. Shut down generator set.
- b. Open battery access door and disconnect negative battery cable.
- c. Remove control box top panel, paragraph 2.15.1.
- d. Remove screws (15, FIGURE 2-14) and nuts (16).
- e. Remove CONVENIENCE RECEPTACLE cover (17).
- f. Remove machine screws (18), nuts (19), and CONVENIENCE RECEPTACLE (20).
- g. Tag and disconnect CONVENIENCE RECEPTACLE (20) electrical leads.

2.45.4. Installation.

- a. Connect electrical leads to CONVENIENCE RECEPTACLE (20, FIGURE 2-14) and remove tags.
- b. Install CONVENIENCE RECEPTACLE (20) into panel cutout with machine screws (18) and nuts (19).

- c. Install CONVENIENCE RECEPTACLE cover (17) with screws (15) and nuts (16).
- d. Install control box top panel, paragraph 2.15.4.
- e. Connect negative battery cable. Close **access** door.

2.46. GROUND FAULT CIRCUIT INTERRUPTER.

2.46.1. Inspection.

- a. Shut down generator set.
- b. Inspect GROUND FAULT CIRCUIT INTERRUPTER for cracks, corrosion, frayed wires, and other damage.

2.46.2. Testing.

- a. Start and operate generator set at rated voltage and frequency.
- b. Set multimeter for AC volts, press TEST button and check for zero voltage at CONVENIENCE RECEPTACLE.
- c. Press RESET button on GROUND FAULT CIRCUIT INTERRUPTER and use multimeter to check for 120 VAC at CONVENIENCE RECEPTACLE.
- d. If indications are other than above, replace GROUND FAULT CIRCUIT INTERRUPTER.

2.46.3. Removal.

- a. Shut down generator set.
- b. Open battery access door and disconnect negative battery cable.
- c. Tag and disconnect GROUND FAULT CIRCUIT INTERRUPTER (23, FIGURE 2-14) electrical leads from TB4 and KS, and convenience receptacle (20).
- d. Remove screws (21) and nuts (22).
- e. Remove GROUND FAULT CIRCUIT INTERRUPTER (23) from malfunction indicator panel.

2.46.3.1. In-Line Fuse Installation.

NOTE

The following procedure applies to generator sets under contract number DAAK01-88-D-D082.

- a. Shut down generator set.
- b. Open left side engine access door and disconnect negative battery cable.
- c. Remove malfunction indicator panel screws (24, FIGURE 2-14), washers (29), and nuts (26). Lay malfunction indicator panel to the side.
- d. Cut black wire on load side of GROUND FAULT CIRCUIT INTERRUPTER (23).

- e. Strip wires on in-line fuse holder (2, FIGURE 2-13.1) and install butt splices (3) at each end. Connect ends of black wire to in-line fuse holder butt splices (3).
- f. Install fuse (1) in fuse holder (2)
- g. Secure excess wire to wiring harness using tie wrap
- h. Install malfunction indicator panel (27, FIGURE 2-14), screws (24), washers (25), and nuts (26)
- i. Reconnect negative battery cable and close battery access door

NOTE

When replacing GROUND FAULT CIRCUIT INTERRUPTER, use new GROUND FAULT CIRCUIT INTERRUPTER with integral circuit breaker Refer to TM 9-6115-643-24P for new part number.

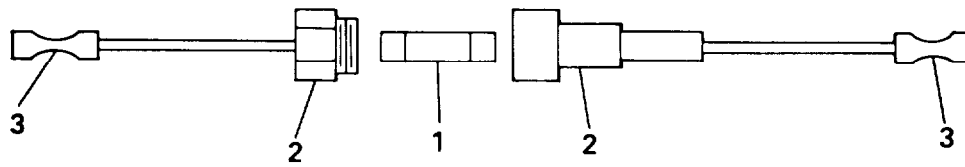

FIGURE 2-13.1. In-Line Fuse Installation

2.46.4. Installation.

- a. Install GROUND FAULT CIRCUIT INTERRUPTER (23, FIGURE 2-14) in malfunction indicator panel with screws (21) and nuts (22).
- b. Connect electrical leads to TB4 and KS, and convenience receptacle (20). Remove tags.
- c. Connect negative battery cable. Close battery access door.

2.47. MALFUNCTION INDICATOR PANEL.

2.47.1. Inspection.

- a. Shut down generator set.
- b. Inspect malfunction indicator panel for broken indicator lights, cracked housing, corrosion, and other damage.

2.47.2. Testing.

- a. Depress TEST/RESET button and check that all indicators are lit.
- b. Replace malfunction indicator panel if one or more indicators do not light.

2.47.3. Removal.

- a. Shut off generator set.
- b. Open battery access door and disconnect negative battery cable.
- c. Remove control box top panel, paragraph 2.15.1.
- d. Remove GROUND FAULT CIRCUIT INTERRUPTER, paragraph 2.46.3 (Do not disconnect electrical leads).
- e. Disconnect multi-pin connector at rear of malfunction indicator panel (27, FIGURE 2-14).
- f. Remove bolts (24), washers (25), and nuts (26).
- g. Remove malfunction indicator panel (27) from control panel.

2.47.4. Installation.

- a. Install malfunction indicator panel (27, FIGURE 2-14) in control panel with bolts (24), washers (25), and nuts (26).
- b. Install multi-pin connector at rear of panel.
- c. Install GROUND FAULT CIRCUIT INTERRUPTER, paragraph, 2.46.4.
- d. Install control box top panel, paragraph 2.15.4.
- e. Connect negative battery cable. Close battery access door.

2.48. BATTERY CHARGER FUSE.

2.48.1. Inspection.

- a. Shut down generator set.
- b. Inspect for blown fuse.
- c. Inspect fuse, fuse holder, and cap for cracks, corrosion, and obvious damage.
- d. Replace defective parts.

2.48.2. Removal.

- a. Shut down generator set.
- b. Open battery access door and disconnect negative battery cable.
- c. Remove control box top panel, paragraph 2.15.1.
- d. Remove cap (28, FIGURE 2-14) and fuse (29) from fuse holder (32)
- e. Tag and unsolder electrical leads from fuse holder (32).
- f. Remove nut (30), lockwasher (31), and fuse holder (32).

2.48.3. Installation.

- a. Install fuse holder (32, FIGURE 2-1 4) and secure with lockwasher (31) and nut (30).
- b. Solder electrical leads to fuse holder (32) and remove tags.
- c. Install fuse (29) and cap (28).
- d. Install control box top panel, paragraph 2.15.4.
- e. Connect negative battery cable. Close battery access door.

2.49. DC CONTROL POWER CIRCUIT BREAKER.

2.49.1. Inspection.

- a. Shut down generator set.
- b. Inspect circuit breaker for loose connections and mounting, cracked housing, and other damage.

2.49.2. Testing.

- a. Shut down generator set.
- b. Open battery access door and disconnect negative battery cable.
- c. Remove control box top panel, paragraph 2.15.1.
- d. Tag and disconnect DC CONTROL POWER circuit breaker (35, FIGUFtE 2-14) electrical leads.
- e. Place circuit breaker in OPEN position.
- f. Set multimeter for ohms and connect across circuit breaker terminals. Multimeter should indicate open circuit.
- g. Place circuit breaker in the CLOSED position. Multimeter should indicate continuity.
- h. Replace circuit breaker if indications are not as above.
- i. Connect electrical leads to circuit breaker (35) and remove tags.
- j. Install control box top panel, paragraph 2.15.4.
- k. Connect negative battery cable and close battery access door.

2.49.3. Removal.

- a. Shut down generator set.
- b. Open battery access door and disconnect negative battery cable.
- c. Remove control box top panel, paragraph 2.15.1.
- d. Remove nut (33, FIGURE 2-14) and flatwasher (34).
- e. Remove DC CONTROL POWER circuit breaker (35) from mounting bracket.
- f. Tag and disconnect DC CONTROL POWER circuit breaker (35) electrical leads.

2.49.4. Installation.

- a. Connect electrical leads and remove tags.
- b. Insert DC CONTROL POWER circuit breaker (35, FIGURE 2-14) into mounting bracket.
- c. Install flatwasher (34) and nut (33).
- d. Install control box top panel, paragraph 2.15.4.
- e. Connect negative battery cable. Close battery access door.

2.50. AC VOLTAGE REGULATOR.

Inspection.

Inspect AC voltage regulator (36, FIGURE 2-14) for cracked case, broken wires, security, and other damage.

2.51. FREQUENCY TRANSDUCER

2.51.1. Inspection.

- a. Shut down generator set.
- b. Inspect transducer for cracked casing, burned or broken terminals, and other damage.

2.51.2. Testing (MEP 804A)

- a. Shut down generator set.
- b. Open battery access door and disconnect negative battery cable
- c. Remove control box top panel, paragraph 2.15.1,
- d. Release control panel by turning two fasteners and lower control panel slowly.
- e. Disconnect wire 181A from positive (+) terminal of FREQUENCY meter (HERTZ).
- f. Set multimeter for DC milliamperes (0 to 2 Ma range) and connect positive lead to disconnected wire 181A. and negative lead to vacant terminal of FREQUENCY meter (HERTZ).

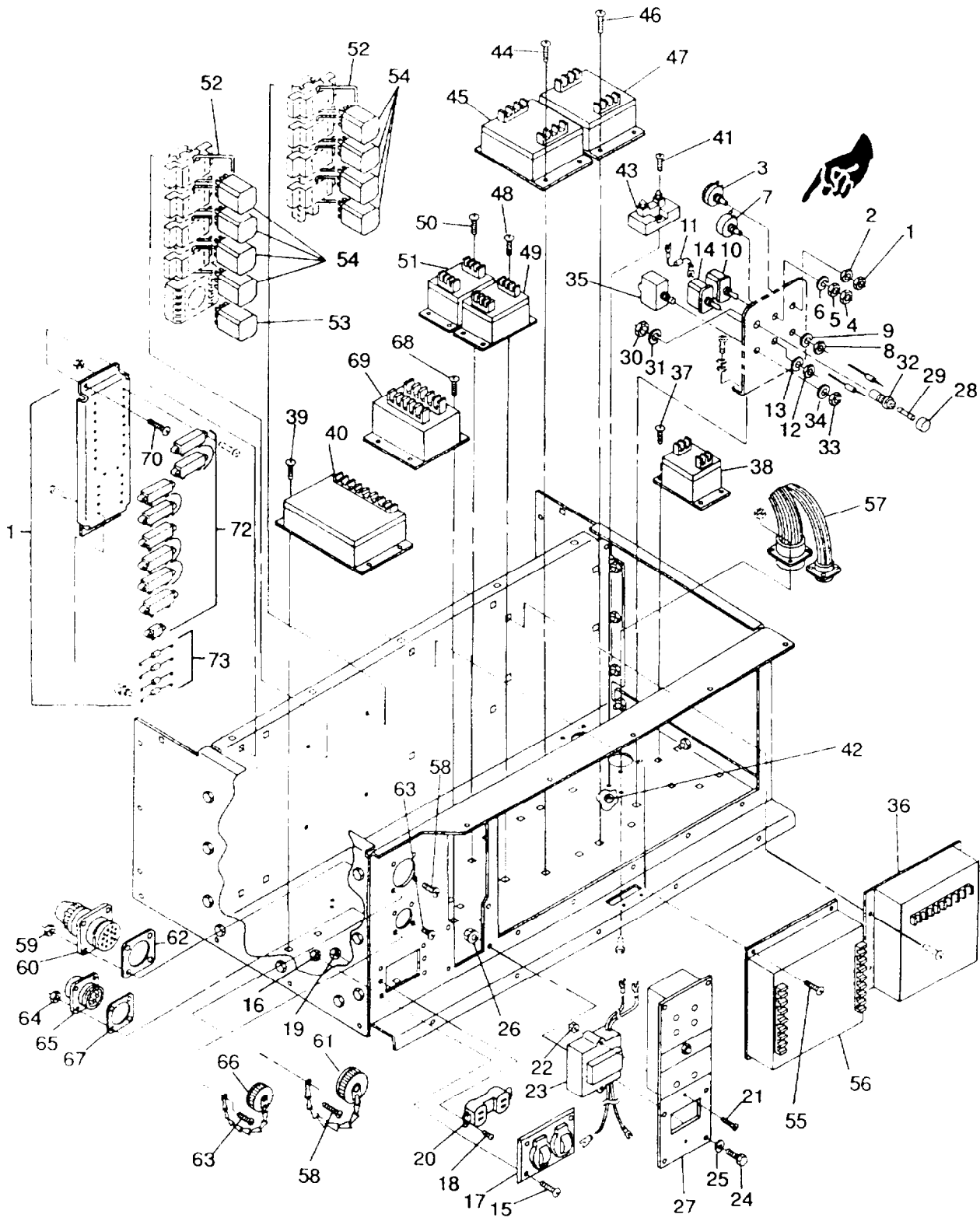

FIGURE 2-14. Control Box Components

- g. Move FREQUENCY SELECT switch to 60 Hz position.
- h. Connect negative battery cable.
- i. Start generator set and adjust frequency to 60 Hz.
- j. Multimeter indication should be between 0.781 and 0.923 Ma.
- k. Adjust frequency to 62 Hz and multimeter indication should be between 0.923 and 1.071 Ma.
- l. Move FREQUENCY SELECT switch to 50 Hz position.
- m. Adjust frequency to 50 Hz and multimeter indication should be between 0.071 and 0.213 Ma.
- n. Adjust frequency to 52 Hz and multimeter indication should be between 0.213 and 0.355 Ma.
- o. Shut down generator set.
- p. Replace frequency transducer if readings are other than above.
- q. If no repair is needed, remove multimeter and connect wire 181 A to positive (+) terminal of FREQUENCY meter (HERTZ).
- r. Raise and secure control panel.
- s. Install control box top panel, paragraph 2.15.4.

2.51.3. Testing (MEP 814A).

- a. Shut down generator set.
- b. Open battery access door and disconnect negative battery cable.
- c. Release control panel by turning two fasteners and lower control panel slowly.
- d. Disconnect wire 181A from positive terminal (+) of FREQUENCY meter (HERTZ).
- e. Set multimeter for DC milliamperes (0 to 2 Ma range) and connect positive lead to free end of wire 181A and connect negative lead to positive terminal (+) of FREQUENCY meter (HERTZ).
- f. Connect negative battery cable.
- g. Start and operate generator set at rated voltage and adjust frequency to 400 Hz.
- h. Multimeter indication should be between 0.229 and 0.271 Ma.
- i. Adjust frequency to 412 Hz. Multimeter indication should be between 0.479 and 0.521 Ma.
- j. Shut down generator set.
- k. Replace frequency transducer if readings are other than above.
- l. If no repair is needed, remove multimeter and connect wire 181A to positive terminal (+) of FREQUENCY meter (HERTZ).
- m. Raise and secure control panel.

2.51.4. Removal.

- a. Shut down generator set.
- b. Open battery access door and disconnect negative battery cable.

- c. Release control panel by turning two fasteners and lower control panel slowly.
- d. Tag and disconnect frequency transducer (38, FIGURE 2-14) electrical leads.
- e. Remove screws (37) and frequency transducer (38).

2.51.5. Installation.

- a. Install frequency transducer (38, FIGURE 2-14) with screws (37).
- b. Connect all electrical leads and remove tags.
- c. Raise and secure control panel.
- d. Connect negative battery cable. Close battery access door.

2.52. KILOWATT TRANSDUCER.

2.52.1. Inspection.

- a. Shut down generator set.
- b. Inspect transducer for cracked casing, burned or broken terminals, and other damage.

2.52.2. Testing.

- a. Start and operate generator set at rated voltage and frequency.
- b. Apply some load to generator set.
- c. Release control panel by turning two fasteners and lower control panel slowly.
- d. Set multimeter for AC volts and take readings between terminals V1 and N1, V2 and N2, and V3 and N3. Multimeter indication should be 120 VAC between each set of terminals.
- e. Take readings between terminals S1 and -, S2 and -, S3 and -, L1 and -, L2 and -, and L3 and-. Multimeter indication should be 0.1 to 3 VAC (reading will vary depending on amount of load applied to generator set).
- f. Change multimeter setting to DC millivolts and take reading between terminals + and -. Multimeter indication should be 0.1 to 50 mv (dependent on amount of load applied to generator set).
- g. Shut down generator set.
- h. Replace kilowatt transducer if multimeter indications are within ranges stated in steps d and e, but not within range stated in step f.
- i. If no repair is needed, raise and secure control panel.

2.52.3. Removal.

- a. Shut down generator set.
- b. Open battery access door and disconnect negative battery cable.
- c. Remove control box top panel, paragraph 2.15.1.
- d. Tag and disconnect kilowatt transducer (40, FIGURE 2-14) electrical leads.
- e. Remove screws (39) and kilowatt transducer (40).

2.52.4. Installation.

- a. Install kilowatt transducer (40, FIGURE 2-14) with screws (39).
- b. Connect electrical leads and remove tags.
- c. Install control box top panel, paragraph 2.15.4.
- d. Connect negative battery cable. Close battery access door.

2.53. SHUNT.

2.53.1. Inspection.

- a. Shut down generator set.
- b. Inspect shunt for cracked casing, burned or broken terminals, and other damage.

2.53.2. Testing.

- a. Shut down generator set.
- b. Remove control box top panel, paragraph 2.15.1.
- c. Tag and disconnect shunt (43, FIGURE 2-14) electrical leads.
- d. Set multimeter for ohms and connect to shunt terminals 1 and 4. Multimeter should indicate less than 0.5 ohms.
- e. Replace shunt if multimeter indication is greater than above.
- f. If no repair is needed, connect electrical leads to shunt (43) and remove tags.
- g. Install control box top panel, paragraph 2.15.4.

2.53.3. Removal.

- a. Shut down generator set.
- b. Open battery access door and disconnect negative battery cable.
- c. Remove control box top panel, paragraph 2.15.1.
- d. Remove control box assembly, paragraph 2.19.2.
- e. Tag and disconnect shunt (43, FIGURE 2-14) electrical leads.
- f. Open output box access door and remove screws (41), nuts (42), and shunt (43).

2.53.4. Installation.

- a. Install shunt (43, FIGURE 2-14) and secure with screws (41) and nuts (42).
- b. Close output box access door.
- c. Connect all electrical leads and remove tags.
- d. Install control box assembly, paragraph 2.19.4.
- e. Install control box top panel, paragraph 2.15.4.
- f. Connect negative battery cable. Close battery access door.

2.54. OVER/UNDER VOLTAGE RELAY.

2.54.1. Inspection.

- a. Shut down generator set.
- b. Inspect relay for cracked casing, burned or broken terminals, and other damage.

2.54.2. Testing.

- a. Shut down generator set.
- b. Open battery access door and disconnect negative battery cable.
- c. Release control panel by turning two fasteners and lower control panel slowly.

CAUTION

The following procedure disables voltage regulator and allows generator to reach an overvoltage condition. Do not allow generator set to operate for an extended period of time in an extreme overvoltage condition.

- d. Disconnect wire 137A from AC voltage regulator, terminal 5, and insulate wire end.
- e. Connect negative battery cable.
- f. Start generator set. As generator accelerates to rated speed, it should instantly shutdown and the OVERVOLTAGE lamp on malfunction indicator panel should light. If this does not occur immediately shut down generator set.
- g. Reconnect wire 137A and disconnect wire 141A from AC voltage regulator, terminal 1. Insulate wire end.
- h. Start generator set. As generator accelerates to rated speed, the UNDER VOLTAGE lamp on malfunction indicator should light. Move AC CIRCUIT INTERRUPTER switch to CLOSED position. AC circuit interrupter relay should not close.
- i. Shut down generator set.
- j. Replace over/under voltage relay if generator set does not operate as above.
- k. If no repair is needed, reconnect wire 141A at AC voltage regulator.
1. Raise and secure control panel

2.54.3. Removal.

- a. Shut down generator set.
- b. Open battery access door and disconnect negative battery cable
- c. Remove control box top panel, paragraph 2.15.1.
- d. Tag and disconnect over/under voltage relay (45, FIGURE 2-14) electrical leads.
- e. Remove screws (44) and over/under voltage relay (45).

2.54.4. Installation.

- a. Install over/under voltage relay (45, FIGURE 2-14) with screws (44).
- b. Connect electrical leads and remove tags.
- c. Install control box top panel, paragraph 2.15.4.
- d. Connect negative battery cable. Close battery access door.

2.55. SHORT CIRCUIT/OVERLOAD RELAY.

2.55.1. Inspection.

- a. Shut down generator set.
- b. Inspect relay for cracked casing, burned or broken terminals, and other damage

2.55.2. Testing.

- a. Shut down generator set.
- b. Open battery access door and disconnect negative battery cable.
- c. Release control panel by turning two fasteners and lower control panel slowly.
- d. Tag, disconnect, and insulate the following wires from short circuit/overload relay:
 - Wires 111B and 111C from terminal 1.
 - Wires 113B and 113C from terminal 2.
 - Wires 115B and 115C from terminal 3.
 - Wires 184B and 184C from terminal 4.
- e. Tag and disconnect wire 141A from terminal 1 on AC voltage regulator.

NOTE

Disconnecting wire 141A at voltage regulator terminal 1, disables voltage regulator and allows generator to develop very low AC output voltage.

- f. Tag, disconnect, and isolate wire 217A from terminal 8 of overfunded voltage relay.
- g. Connect a jumper wire from terminal 4 of short circuit/overload relay to terminal LO of load output terminal board.
- h. Place voltage reconnection terminal board in 120/208 connection.
- i. Connect negative battery cable.
- j. Start generator set and operate at rated frequency.
- k. Close AC CIRCUIT INTERRUPTER switch. After approximately one minute, AC circuit interrupter relay should open and OVERLOAD lamp should illuminate on malfunction indicator panel.
- l. Shut down generator set.
- m. Disconnect jumper wire from terminal 1 of short circuit/overload relay and connect it to terminal 2.
- n. Repeat steps j and k.
- o. Shut down generator set.
- p. Disconnect jumper wire from terminal 2 of short circuit/overload relay and connect it to terminal 3.
- q. Repeat steps j and k.
- r. Shut down generator set.
- s. Disconnect jumper wire from terminal LO of load output terminal board and connect it to L2.
- t. Start generator set and operate at rated frequency.
- u. Close AC CIRCUIT INTERRUPTER switch. AC circuit interrupter relay should open immediately and SHORT CIRCUIT lamp should illuminate on the malfunction indicator panel.

- v. Shut down generator set.
- w. Disconnect jumper wire from terminal 3 of short circuit/overload relay and connect it to terminal 2.
- x. Repeat steps t and u.
- y. Shut down generator set.
- z. Disconnect jumper wire from terminal 2 of short circuit/overload relay and connect it to terminal 1.
- aa. Repeat steps t and u.
- ab. Shut down generator set.
- ac. Replace short circuit/overload relay if any test is not as above.
- ad. If no repair is needed, remove jumper wires and connect wires to short circuit/overload relay, over/under voltage relay and AC voltage regulator as tagged. Remove tags.
- ae. Raise and secure control panel.

2.55.3. Removal.

- a. Shut down generator set.
- b. Open battery access door and disconnect negative battery cable.
- c. Remove control box top panel, paragraph 2.15.1.
- d. Tag and disconnect short circuit/overload relay (47, FIGURE 2-14) electrical leads.
- e. Remove screws (46) and short circuit/overload relay (47).

2.55.4. Installation.

- a. Install short circuit/overload relay (47, FIGURE 2-14) with screws (46).
- b. Connect electrical leads and remove tags.
- c. Install control box top panel, paragraph 2.15.4.
- d. Connect negative battery cable. Close battery access door.

2.56. PERMISSIVE PARALLELING RELAY.

2.56.1. Inspection.

- a. Shut down generator set.
- b. Inspect relay for cracked casing, burned or broken terminals, and other damage.

2.56.2. Testing.

- a. Shut down generator set.
- b. Open battery access door and disconnect negative battery cable.
- c. Release control panel by turning two fasteners and slowly lower control panel.
- d. Disconnect and insulate wires 102D from terminal 1, and 196A and 196B from terminal 2 of permissive paralleling relay.
- e. Mark a 10,000 ohm potentiometer as follows:
 - Center terminal = C
 - Two outside terminals = L and R

- f. Set up a test circuit as shown in FIGURE 2-15. Connect 120 VAC source (can be obtained from convenience receptacle) to terminals L and R of potentiometer. Connect a wire from terminal C of potentiometer to terminal 1 of permissive paralleling relay. Connect a second wire from terminal R of potentiometer to terminal 2 of permissive paralleling relay. Set multimeter for AC volts and connect to terminals 1 and 2 of permissive paralleling relay.
- g. Adjust 10,000 ohm potentiometer to full counterclockwise position.
- h. Connect negative battery cable.
- i. Start and operate generator set at rated frequency and voltage. Multimeter indication should be 0 volts.

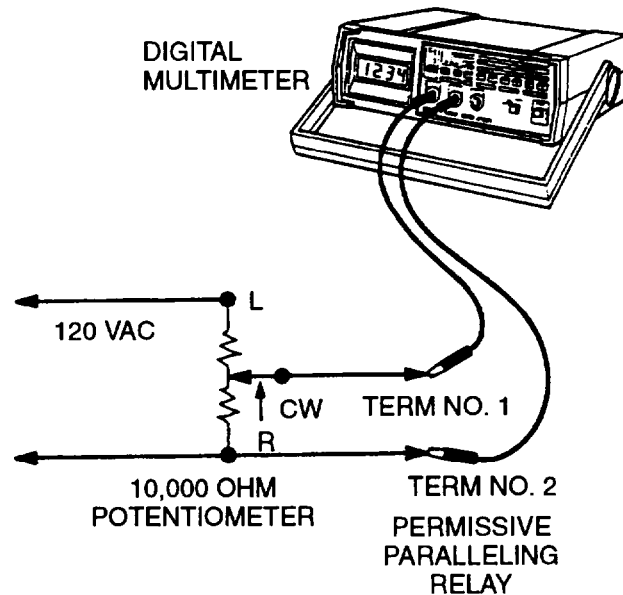

FIGURE 2-15. Permissive Paralleling Relay Test Set-up

- j. Move AC CIRCUIT INTERRUPTER switch to CLOSED position and AC circuit interrupter relay should close. Move AC CIRCUIT INTERRUPTER switch to OPEN position and AC circuit interrupter relay should open. Observe AC CIRCUIT INTERRUPTER light for actuation of relay.
 - k. Adjust 10,000 ohm potentiometer clockwise until multimeter indicates 10 VAC.
 - l. Move AC CIRCUIT INTERRUPTER switch to CLOSED position. The AC circuit interrupter relay should not close (AC CIRCUIT INTERRUPTER light should remain dark).
 - m. Shut down generator set.
 - n. Disconnect negative battery cable.
 - o. Replace permissive paralleling relay if operation is not as above.
 - p. If no repair is needed, remove multimeter and test circuit wires. Reconnect wires 102D, 196A and 196B to permissive paralleling relay.
 - q. Raise and secure control panel.
 - r. Connect negative battery cable and close battery access door.
- 2.56.3. Removal.
- a. Shut down generator set.

- b. Open battery access door and disconnect negative battery cable.
- c. Release control panel by turning two fasteners and lower control panel slowly.
- d. Tag and disconnect permissive paralleling relay (49, FIGURE 2-14) electrical leads.
- e. Remove screws (48) and permissive paralleling relay (49).

2.56.4. Installation.

- a. Install permissive paralleling relay (49, FIGURE 2-14) with screws (48).
- b. Connect all electrical leads and remove tags.
- c. Raise and secure control panel.
- d. Connect negative battery cable. Close battery access door.

2.57. REVERSE POWER RELAY.

2.57.1. Inspection.

- a. Shut down generator set.
- b. Inspect relay for cracked casing, burned or broken terminals, and other damage.

2.57.2. Testing.

- a. Shut down generator set.
- b. Open battery access door and disconnect negative battery cable.
- c. Release control panel by turning two fasteners and lower control panel slowly.
- d. Disconnect and insulate wires 158B and 158C from terminal 1, and 161A and 161B from terminal 2 of reverse power relay.
- e. Mark a 5,000 ohm potentiometer as follows:
 - Center terminal. C
 - Two outside terminals = L and R

CAUTION

Voltage polarity is very important to prevent damage to generator set.

- f. Set up a test circuit as shown in FIGURE 2-16. Connect 24 VDC source to terminals L and R of potentiometer. Connect a wire between terminal C of potentiometer and terminal 1 of reverse power relay. Connect a second wire between terminal R of potentiometer and terminal 2 of reverse power relay. Set multi-meter for DC volts and connect positive lead of multimeter to terminal 1 and negative lead to terminal 2 of reverse power relay.

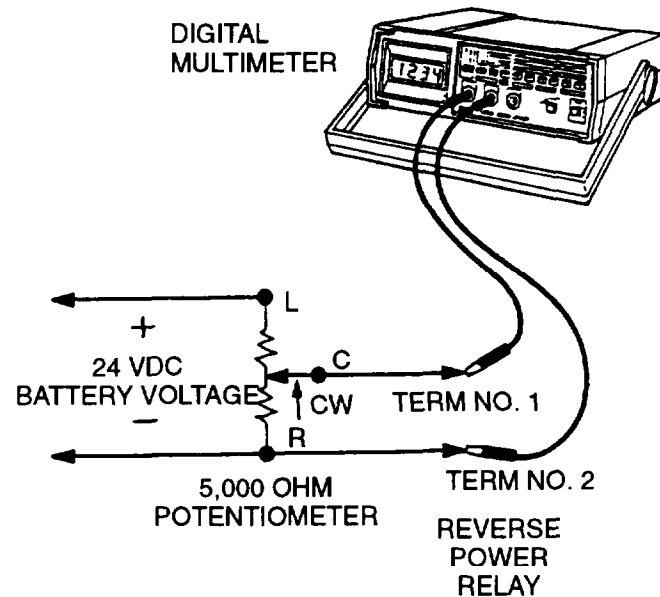

**FIGURE 2-16. Reverse Power Relay
Test Set-up**

- g. Adjust 5,000 ohm potentiometer to full counterclockwise position. Multimeter should indicate 0 volts.
- h. Connect negative battery cable.
- i. Start and operate generator set at rated frequency and voltage.
- j. Move AC CIRCUIT INTERRUPTER switch to CLOSED position. AC CIRCUIT INTERRUPTER light should light.
- k. Adjust 5,000 ohm potentiometer clockwise and at the same time observe multimeter and AC CIRCUIT INTERRUPTER light. AC CIRCUIT INTERRUPTER light should go out at between 1.7 and 2.3 VDC indicating that AC circuit interrupter relay is open.
- l. Shut down generator set.
- m. Disconnect negative battery cable.
- n. Replace reverse power relay if operation is not as above.
- o. Remove multi meter and test circuit wires. Reconnect wires 158B, 158C, 161A and 161B at reverse power relay.
- p. Raise and secure control panel.
- q. Connect negative battery cable and close battery access door.

2.57.3. Removal.

- a. Shut down generator set.
- b. Open battery access door and disconnect negative battery cable.
- c. Release control panel by turning two fasteners and lower control panel slowly.

- d. Tag and disconnect reverse power relay (51, FIGURE 2-14) electrical leads.
- e. Remove screws (50) and reverse power relay (51).

2.57.4. Installation.

- a. Install reverse power relay (51, FIGURE 2-14) with screws (50).
- b. Connect electrical leads and remove tags.
- c. Raise and secure control panel.
- d. Connect negative battery cable. Close battery access door.

2.58. VOLTAGE SENSING RELAY.

2.58.1. Inspection.

- a. Shut down generator set.
- b. Inspect relay for cracks, loose mounting, and other damage.

2.58.2 Testing.

- a. Shut down generator set.
- b. Remove voltage sensing relay, paragraph 2.58.3.
- c. Set multimeter for ohms and check for open circuits between terminals 1 and 3, and terminals 8 and 6 of voltage sensing relay.
- d. Check for continuity between terminals 1 and 4, and terminals 8 and 5.
- e. Connect multimeter between terminals 2 and 7 of relay and check for between 1260 and 1890 ohms.
- f. Depress reset button and check for open circuits between terminals 1 and 4, and terminals 8 and 5.
- g. With reset button still depressed, check for continuity between terminals 1 and 3, and terminals 8 and 6.
- h. Replace voltage sensing relay if indications are not as above.
- i. If no repair is needed, install voltage sensing relay, paragraph 2.58.4.

2.58.3. Removal.

- a. Shut down generator set.
- b. Open battery access door and disconnect negative battery cable.
- c. Release control panel by turning two fasteners and lower control panel slowly.
- d. Release wire clip (52, FIGURE 2-14) and remove voltage sensing relay (53) by gently pulling from socket.

2.58.4 Installation.

- a. Install voltage sensing relay (53, FIGURE 2-14) in socket and secure by snapping wire clip (52) over relay.
- b. Raise and secure control panel.
- c. Connect negative battery cable and close battery access door.

2.59. RELAYS.

2.59.1. Inspection.

- a. Shut down generator set.
- b. Inspect relays for cracks, loose mounting, and other damage.

2.59.2. Testing.

- a. Shut down generator set.
- b. Remove applicable relay, paragraph 2.59.3.
- c. Set multimeter for ohms and check for open circuits between terminals 7 and 4, 8 and 5, and 9 and 6. Check for closed circuits between terminals 7 and 1, 8 and 2, and 9 and 3.
- d. Connect multimeter between terminals A and B, and check for between 427.5 and 522.5 ohms. Using multimeter, check for closed circuits between terminals 7 and 1, 8 and 2, and 9 and 3. Check for open circuits between terminals 7 and 4, 8 and 5, and 9 and 6.
- e. If indications are other than above, relay is defective and must be replaced.
- f. If no repair is needed, install relay, paragraph 2.59.4.

2.59.3. Removal.

- a. Shut down generator set.
- b. Open battery access door and disconnect negative battery cable.
- c. Release control panel by turning two fasteners and lower control panel slowly.
- d. Locate suspected defective relay (54, FIGURE 2-14), release wire clip (52), and remove relay by gently pulling from socket.

2.59.4. Installation.

- a. Install relay (54, FIGURE 2-14) in socket and secure by snapping wire clip (52) over relay.
- b. Raise and secure control panel.
- c. Connect negative battery cable. Close battery access door.

2.60. GOVERNOR CONTROL UNIT.

2.60.1. Inspection.

- a. Shut down generator set.
- b. Inspect governor control unit for loose connections and mounting, and other damage.

2.60.2. Removal.

- a. Shut down generator set.
- b. Open battery access door and disconnect negative battery cable.
- c. Remove control box top panel, paragraph 2.15.1.
- d. Tag and disconnect governor control unit (56, FIGURE 2-14) electrical leads.
- e. Remove screws (55) and governor control unit (56).

2.60.3. Installation.

- a. Install governor control unit (56, FIGURE 2-14) with screws (55).
- b. Connect electrical leads and remove tags.
- c. Install control box top panel, paragraph 2.15.4.
- d. Connect negative battery cable. Close battery access door.

2.61. CONTROL BOX HARNESS.

2.61.1. Inspection.

- a. Shut down generator set.
- b. Inspect control box harness (57, FIGURE 2-14) wiring for breaks, damaged insulation, and loose or damaged terminals.

2.61.2. Testing.

- a. Shut down generator set.
- b. Open battery access door and disconnect negative battery cable.
- c. Remove control box top panel, paragraph 2.15.1.
- d. Set multimeter for ohms, and using Wiring Diagram FO-2 as a guide, check wires for continuity.
- e. If no repair is needed, install control box top panel, paragraph 2.15.4, connect negative battery cable, and close battery access door.

2.61.3 Repair.

- a. Replace individual wires, damaged terminal ends, clamps, and tie wraps.
- b. Ensure proper connection of wires not indicating continuity.

2.62. DIAGNOSTIC CONNECTOR.

NOTE

The diagnostic connector can be used as an aid in troubleshooting. Refer to FIGURE 2-17 and TABLE 2-9.

NOTE

Diagnostic connector is a component of the control box harness assembly, but can be removed and installed separately as follows.

2.62.1. Inspection.

- a. Shut down generator set.
- b. Open battery access door and disconnect negative battery cable.
- c. Inspect diagnostic connector for cracks, breaks, corrosion, bent terminals, burns, or other indications of damage.
- d. Inspect cap for cracks, corrosion, or broken chain.
- e. Inspect gasket for tears and deterioration.
- f. Replace any defective part.
- g. If no repair is needed, connect negative battery cable and close battery access door.

2.62.2. Removal.

- a. Shut down generator set.
- b. Open battery access door and disconnect negative battery cable.
- c. Remove control box top panel, paragraph 2.15.1.
- d. Loosen rear outer ring and plastic insert from diagnostic connector (60, FIGURE 2-14).
- e. Tag and disconnect electrical leads to diagnostic connector (60) by inserting removal tool into pins of connector.
- f. Remove screws (58) and nuts (59).
- g. Remove diagnostic connector cap (61) diagnostic connector (60) and gasket (62).

2.62.3. Installation.

- a. Install diagnostic connector (60, FIGURE 2-14) gasket (62) and cap (61) with screws (58) and nuts (59).
- b. Connect electrical leads to diagnostic connector (60) by using insert tool and remove tags,
- c. Install plastic insert and tighten rear outer ring on connector.

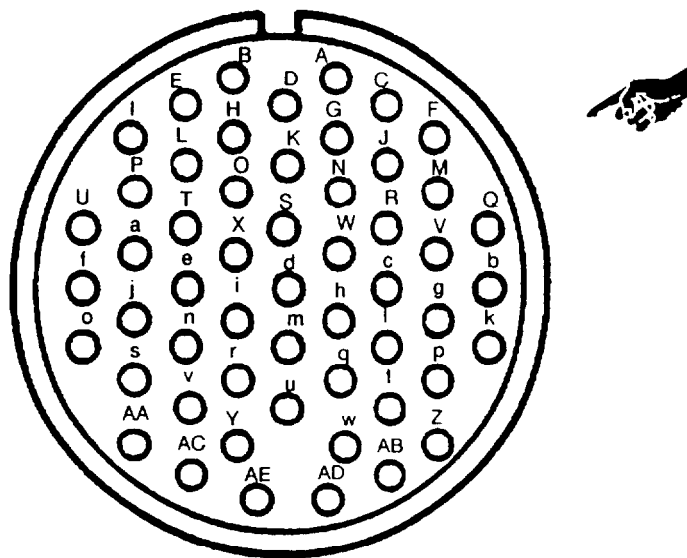

FIGURE 2-17. Diagnostic Connector
Pin Positions

- d. Install control box top panel, paragraph 2.15.4.
- e. Connect negative battery cable. Close battery access door.

2.63. PARALLEL CONNECTOR.

NOTE

Parallel connector is a component of control box harness assembly, but can be removed and installed separately as follows.

2.63.1. Inspection.

- a. Shut down generator set.
- b. Inspect parallel connector for cracks, corrosion, stripped or damaged threads, evidence of shorting, or other damage.
- c. Inspect cap for cracks, corrosion, and broken chain.
- d. Inspect gasket for tears and deterioration.
- e. Replace defective parts.

2.63.2. Removal.

- a. Shut down generator set.
- b. Open battery access door and disconnect negative battery cable.
- c. Remove control box top panel, paragraph 2.15.1.
- d. Tag and disconnect parallel connector (65, FIGURE 2-14) electrical leads by inserting removal tool into pins of connector.
- e. Remove screws (63), nuts (64), and cap (66).
- f. Remove parallel connector (65) and gasket (67).

2.63.3. Inspection.

- a. Install parallel connector (65, FIGURE 2-14), gasket (67), and cap (66) with screws (63) and nuts (64).
- b. Connect electrical leads using insert tool and remove tags.
- c. Install control box top panel, paragraph 2.15.4.
- d. Connect negative battery cable. Close battery access door.

2.64. LOAD MEASURING UNIT.

2.64.1. Inspection.

- a. Shut down generator set.
- b. Inspect load measuring unit for damaged case, cracked or broken terminal lugs, and loose or missing hardware.

2.64.2. Removal.

- a. Shut down generator set.
- b. Open battery access door and disconnect negative battery cable.
- c. Remove control box top panel, paragraph 2.15.1.

TABLE 2-9. Diagnostic Connector Connection Points

NOTE

The Diagnostic Connector can be used as a troubleshooting tool. Refer to FIGURE 2-17 for pin positions.

PIN	DESCRIPTION	EXPECTED OUTPUT*
B	Chassis ground (GND)	Continuity 0 volts
C	DC paralleling voltage for governor synchronization	0-20 VDC (*,5)
D	Chassis ground (GND)	Continuity 0 volts
E	Paralleling voltage for voltage regulator	0-20 VAC set freq. (*,5)
F	DC exciter field voltage (positive)	0-60 VDC (*,6)
G	DC paralleling voltage for governor synchronization	0-20 VDC (*,5)
H	Paralleling voltage for voltage regulator	0-20 VAC set freq.
J	DC exciter field voltage (negative)	0-60 VDC (*,7)
M	DC voltage input to governor	24 VDC(*)
N	DC starter motor solenoid coil	24 VDC (2 or 3)
O	DC voltage across fuel pump (Aux)	24 VDC (1)
P	DC voltage S1, terminal 7	24 VDC (2)
S	DC voltage across engine fuel solenoid coil	24 VDC (*)
T	DC voltage across starter crank relay coil	24 VDC (2 or 3)
U	DC voltage (output of DC circuit breaker)	24 VDC
V	DC voltage across output circuit interrupter coil	24 VDC (*)
X	DC starter motor (motor side of solenoid contacts)	24 VDC (2 or 3)
Z	DC voltage across fuel level contacts	24 VDC (4)
a	DC voltage across low oil pressure switch	0 volts (*)
b	DC voltage across low oil pressure switch	24 VDC (4)
d	DC battery charging voltage	24-27.6 VDC
x	Input frequency sensing voltage to governor	2-6 volts, 0-4000 Hz (3,8)
y	Input frequency sensing voltage to governor	2-6 volts, 0-4000 Hz (3,8)
*	With generator set operating	
(1)	Auxiliary fuel pump in operation (note fuel level), MASTER SWITCH in PRIME & RUN AUX FUEL position	
(2)	During engine starting	
(3)	Use DEAD CRANK switch	
(4)	MASTER SWITCH in PRIME & RUN position	
(5)	AC Circuit Interrupter dosed	
(6)	Read between pins F and J	
(7)	Read between pins J and F	
(8)	Read between pins X and Y	

- d. Release control panel by turning two fasteners and lower control panel slowly.
- e. Tag and disconnect load measuring unit (69, FIGURE 2-14) electrical leads.
- f. Remove screws (68) and load measuring unit (69).

2.64.3. Installation.

- a. Install load measuring unit (69, FIGURE 2-14) with screws (68).
- b. Connect all electrical leads and remove tags.
- c. Install control box top panel, paragraph 2.15.4.
- d. Raise and secure control panel.
- e. Connect negative battery cable. Close battery access door.

2.65. RESISTOR-DIODE ASSEMBLY.

2.65.1. Inspection.

- a. Shut down generator set.
- b. Inspect resistor-diode assembly for cracks, breaks, corrosion, bent terminals, and other damage.

2.65.2. Testing.

- a. Shut down generator set.
- b. Open battery access door and disconnect negative battery cable.
- c. Remove control box top panel, paragraph 2.15.1.
- d. Release control panel by turning two fasteners and lower control panel slowly.

NOTE

Isolate component before testing

- e. Set multi meter for ohms and measure resistance across resistors R10, R11, and R12. Multimeter indication should be between 7.125 and 7.875 ohms for each resistor.
- f. Using multi meter, measure resistance across resistor R14. Multimeter indication should be between 61.75 and 68.25 ohms for MEP-804A generator set, and between 38 and 42 ohms for MEP814A generator set.
- g. Using multimeter, measure resistance across resistor R15. Multimeter indication should be between 1235 and 1365 ohms.
- h. Using multimeter, measure resistance across resistors R6 and R8. Multimeter indication should be between 4750 and 5250 ohms.
- i. Using multimeter, measure resistance across resistors R7 and R9. Multimeter indication should be between 2850 and 3150 ohms.
- j. Connect positive lead of multimeter to cathode side and negative lead to anode side of each diode CR1, CR2, CR3, and CR4. Refer to FIGURE 2-18. Note ohms indication on multi meter for each diode.
- k. Reverse multimeter leads so positive lead is connected to anode side and negative lead is connected to cathode side of each diode CR1, CR2, CR3, and CR4. Note ohms indication on multimeter for each diode.
- l. Multimeter indications should be 1:10 ratio or greater.

m. If any indications are other than above, replace defective component.

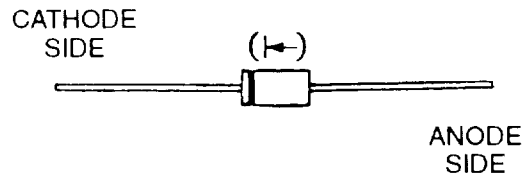

FIGURE 2-18. Diode Identification

- n. If no repair is needed, install control box top panel, paragraph 2.15.4.
- o. Raise and secure control panel.
- p. Connect negative battery cable and close battery access door.

2.65.3. Removal.

- a. Shut down generator set.
- b. Open battery access door and disconnect negative battery cable.
- c. Remove control box top panel, paragraph 2.15.1,
- d. Tag and disconnect resistor-diode assembly (71, FIGURE 2-14) electrical leads.
- e. Remove screws (70) and resistor-diode assembly (71).

2.65.4. Repair.

Repair resistor-diode assembly (71, FIGURE 2-14) by replacing resistors (72) and diodes (73).

2.65.5. Installation.

- a. Install resistor-diode assembly (71, FIGURE 2-14) and secure with screws (70)
- b. Connect electrical leads and remove tags.
- c. Install control box top panel, paragraph 2.15.4.
- d. Connect negative battery cable. Close battery access door.

2.66. CONTROL PANEL.

2.66.1. Inspection.

Inspect control panel (10, FIGURE 2-19) for dents, cracks, loose paint, and corrosion

2.66.2. Removal.

- a. Shut down generator set.
- b. Open battery access door and disconnect negative battery cable.
- c. Remove press to test lights from control panel (do not unsolder wires), paragraph 2.21.3.
- d. Remove VOLTAGE adjust potentiometer from control panel (do not remove wires), paragraph 2.33.2.
- e. Remove FREQUENCY adjust potentiometer from control panel (do not remove wires), paragraph 2.34.2.
- f. Tag and disconnect all electrical leads to remaining indicators and switches on control panel (10, FIGURE 2-19).
- g. Remove screw (1). nuts (2). and strap (3).

- h. Remove bolts (4) and (6), nuts (5) and (7), bracket (9), clamp (8), and control panel (10) from control box assembly.
- i. Remove bolts (11), nuts (12), and hinge (13) from control box assembly.

2.66.3 Repair.

WARNING

Wear a protective mask and gloves when sanding CARC painted surfaces. CARC paint dust is a health hazard and could cause personal injury if warning is not followed.

- a. Repair all dents, cracks, and remove all loose paint
- b. Remove light corrosion with fine grit abrasive paper (Item 15, Appendix C).
- c. Repaint surface in accordance with TM 43-0139. (F) Refer to applicable directives.

2.66.4 Installation.

- a. Install hinge (13, FIGURE 2-19) on control box assembly with bolts (11) and nuts (12)
- b. Install control panel (10), clamp (8), and bracket (9) on control box assembly with bolts (4) and (6). and nuts (5) and (7).
- c. Install strap (3) on control panel (10) with screw (1) and nuts (2)
- d. Connect all electrical wires to indicators and switches as tagged. Remove tags.
- e. Install press to test lights paragraph 2.21.4
- f. Install VOLTAGE adjust potentiometer, paragraph 2.33.4.
- g. Install FREQUENCY adjust potentiometer, paragraph 2.34.4.
- h. Connect negative battery cable. Close battery access door

2.67. CONTROL PANEL FRAME

2.67.1. Inspection.

Inspect control panel frame (19, FIGURE 2-19) for dents, cracks, loose paint, and corrosion.

2.67.2. Removal.

- a. Shut down generator set
- b. Open battery access door and disconnect negative battery cable
- c. Remove control box assembly, paragraph 2.19.2.
- d. Remove control panel, paragraph 2.66.1.
- e. Remove diagnostic connector, paragraph 2.62.2 (do not remove wires)
- f. Remove parallel connector, paragraph 2.63.2 (do not remove wires)
- g. Remove CONVENIENCE RECEPTACLE, paragraph 2.45.3; GROUND FAULT CIRCUIT INTERRUPTER, paragraph 2.46.3; and malfunction indicator panel, paragraph 2.47.3.
- h. Remove bolts (14 and 16, FIGURE 2-19), nuts (15) and (17), clamp (18), and control panel frame (19) from control box assembly.

- i. If necessary, drill out rivets (20), (22), and (24) and remove identification plates (21), (23), and (25).

2.67.3. Repair.

WARNING

Wear a protective mask and gloves when sanding CARC painted surfaces. CARC paint dust is a health hazard and could cause personal injury if warning is not followed.

- j. Repair all dents and cracks, and remove all loose paint.
- k. Remove light corrosion with fine grit abrasive paper (Item 15, Appendix C).
- l. Repaint surface in accordance with TM 43-0139. (F) Refer to applicable directives.

2.67.4. Installation.

- a. Install control panel frame (19, FIGURE 2-19) and clamp (18) to control box assembly with bolts (14) and (16) and nuts (15) and (17).
- b. If removed, install identification plates (21), (23), and (25) on rear panel (19) with rivets (20), (22), and (24).
- c. Install malfunction indicator panel, paragraph 2.47.4; GROUND FAULT CIRCUIT INTERRUPTER, paragraph 2.46.4; CONVENIENCE RECEPTACLE, paragraph 2.45.4; parallel connector, paragraph 2.63.3; and diagnostic connector, paragraph 2.62.3.
- d. Install control panel, paragraph 2.66.4.
- e. Install control box assembly, paragraph 2.19.4.
- f. Connect negative battery cable and close battery access door.

2.68. CONTROL BOX SIDE PANELS.

2.68.1. Inspection.

- a. Inspect side panels (29 and 30, FIGURE 2-19) and air deflector (33) for dents, cracks, loose paint, and corrosion.
- b. Inspect for missing or damaged cage nuts (43).

2.68.2. Removal.

- a. Shut down generator set.
- b. Open battery access door and disconnect negative battery cable.
- c. Remove control box top panel, paragraph 2.15.1.
- d. Remove bolts (16, 26, and 28, FIGURE 2-19), nuts (17) and (27), and control box side panels (29) and (30) from generator set.
- e. Remove bolts (31), nuts (32), and air deflector (33) from side panel (30).

2.68.3. Repair.

WARNING

Wear a protective mask and gloves when sanding CARC painted surfaces. CARC paint dust is a health hazard and could cause personal injury if warning is not followed.

- a. Repair all dents and cracks, and remove all loose paint.
- b. Remove light corrosion with fine grit abrasive paper (Item 15, Appendix C).
- c. Repaint surface in accordance with TM 43-0139. (F) Refer to applicable directives.
- d. Replace missing or damaged cage nuts.

2.68.4. Installation.

- a. Apply a light coat of sealant (Item 16, Appendix C) to flanges of air deflector (33 FIGURE 2-19).
- b. Install air deflector (33) on control box side panel (30) with bolts (31) and nuts (32).
- c. Install control box side panels (29 and 30, FIGURE 2-19) on generator set with bolts (16), (26), and (28) and nuts (17) and (27). Ensure center bolt (16) and nut (17) on left side panel secures clamp (18).
- d. Install control box top panel, paragraph 2.15.4.
- e. Connect negative battery cable. Close battery access door.

2.69. CONTROL BOX BOTTOM.

2.69.1. Inspection.

- f. Inspect control box bottom (42, FIGURE 2-19) for dents, cracks, loose paint, and corrosion.
- g. Inspect for missing or damaged cage nuts (43).

2.69.2. Removal.

- a. Shut down generator set.
- b. Open battery access door and disconnect negative battery cable.
- c. Remove control box assembly, paragraph 2.19.2.
- d. Remove control panel frame, paragraph 2.67.1.
- e. Remove control box side panels, paragraph 2.68.1.
- f. Remove control box components, paragraphs 2.41 through 2.49, 2.51 through 2.60, 2.64, and 2.65.
- g. Contact Direct Support Maintenance to remove AC voltage regulator and control box harness.
- h. Remove screws (34, FIGURE 2-19) and bracket (35) from control box bottom (42).
- i. Remove screws (36), nuts (37), and relay tracks (38) from control box bottom (42).
- j. Remove screws (39), nuts (40), and latch plate (41) from control box bottom (42).

2.69.3 Removal.

WARNING

Wear a protective mask and gloves when sanding CARC painted surfaces. CARC paint dust is a health hazard and could cause personal injury if warning is not followed.

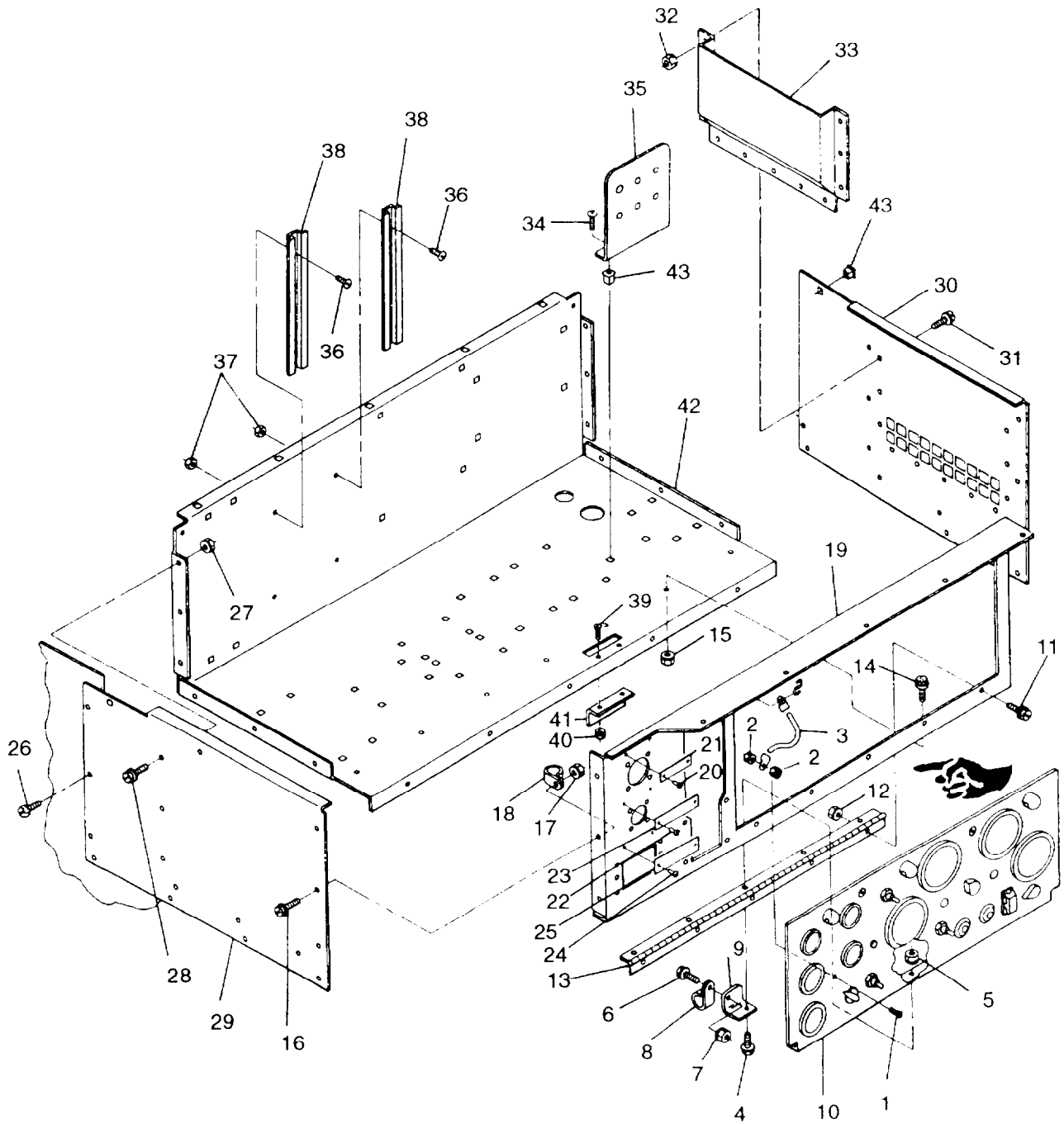

FIGURE 2-19. Control Box Panels

- a. Repair all dents and cracks, and remove all loose paint.
- b. Remove light corrosion with fine grit abrasive paper (Item 15, Appendix C).
- c. Repaint surface in accordance with TM 43-0139. (F) Refer to applicable directives.
- d. Replace missing or damaged cage nuts.

2.69.4. Installation.

- a. Install latch plate (41, FIGURE 2-19) on control box bottom (42) with screws (39) and nuts (40).
- b. Install relay tracks (38) on control box bottom (42) with screws (36) and nuts (37).
- c. Install bracket (35) on control box bottom (42) with screws (34).
- d. Contact Direct Support Maintenance to install control box harness and AC voltage regulator.
- e. Install control box components, paragraphs 2.41 through 2.49, 2.51 through 2.60, 2.64, and 2.65.
- f. Install control box side panels, paragraph 2.68.4.
- g. Install control panel frame, paragraph 2.67.4.
- h. Install control box assembly, paragraph 2.19.4.
- i. Connect negative battery cable and close battery access door.

Section XI. MAINTENANCE OF AIR INTAKE AND EXHAUST SYSTEM

2.70. MUFFLER AND EXHAUST PIPE.

2.70.1. Inspection.

- a. Shut down generator set.
- b. Remove top housing panel and top housing frame, paragraph 2.16.1.
- c. Open engine access doors.
- d. Inspect muffler and pipe for cracks, excessive corrosion, clogging, and other damage.
- e. Replace damaged parts.
- f. Install top housing frame and top housing panel, paragraph 2.16.4.

2.70.2. Removal.

- a. Shut down generator set.
- b. Remove top housing panel and top housing frame, paragraph 2.16.1 and open engine access doors.

WARNING

The exhaust system can get very hot. Allow system to cool before performing maintenance. Failure to follow these instructions could result in severe burns and injuries.

- c. Loosen nuts and remove clamp (1, FIGURE 2-20).
- d. Open bands (2) and separate muffler (3) and exhaust and adapter (12). Remove muffler (3) from generator set.
- e. Remove nuts (4), lockwashers (5), bolts (6), washers (7), and muffler supports (8).
- f. Remove nuts (9), lockwashers (10), washers (11), exhaust adapter (12), and gasket (13).

2.70.3. Installation.

- a. Install muffler supports (8, FIGURE 2-20) with bolts (6), nuts (4), lockwashers (5), and washers (7).
- b. Install exhaust adapter (12) and gasket (13) and secure with nuts (9), lockwashers (10), and washers (11).
- c. Couple muffler (3) to exhaust adapter (12) with clamp (1). Do not tighten clamp (1).
- d. Secure muffler (3) to supports (8) with bands (2).
- e. Tighten clamp (1).
- f. Install top housing frame and top housing panel, paragraph 2.16.4. Close engine access doors.

2.71. AIR RESTRICTION INDICATOR.

2.71.1. Inspection.

- a. Shut down generator set.
- b. Open left side engine access door.
- c. Inspect air restriction indicator (1, FIGURE 2-21) for cracks, stripped threads, or other obvious damage.
- d. Close engine access door.

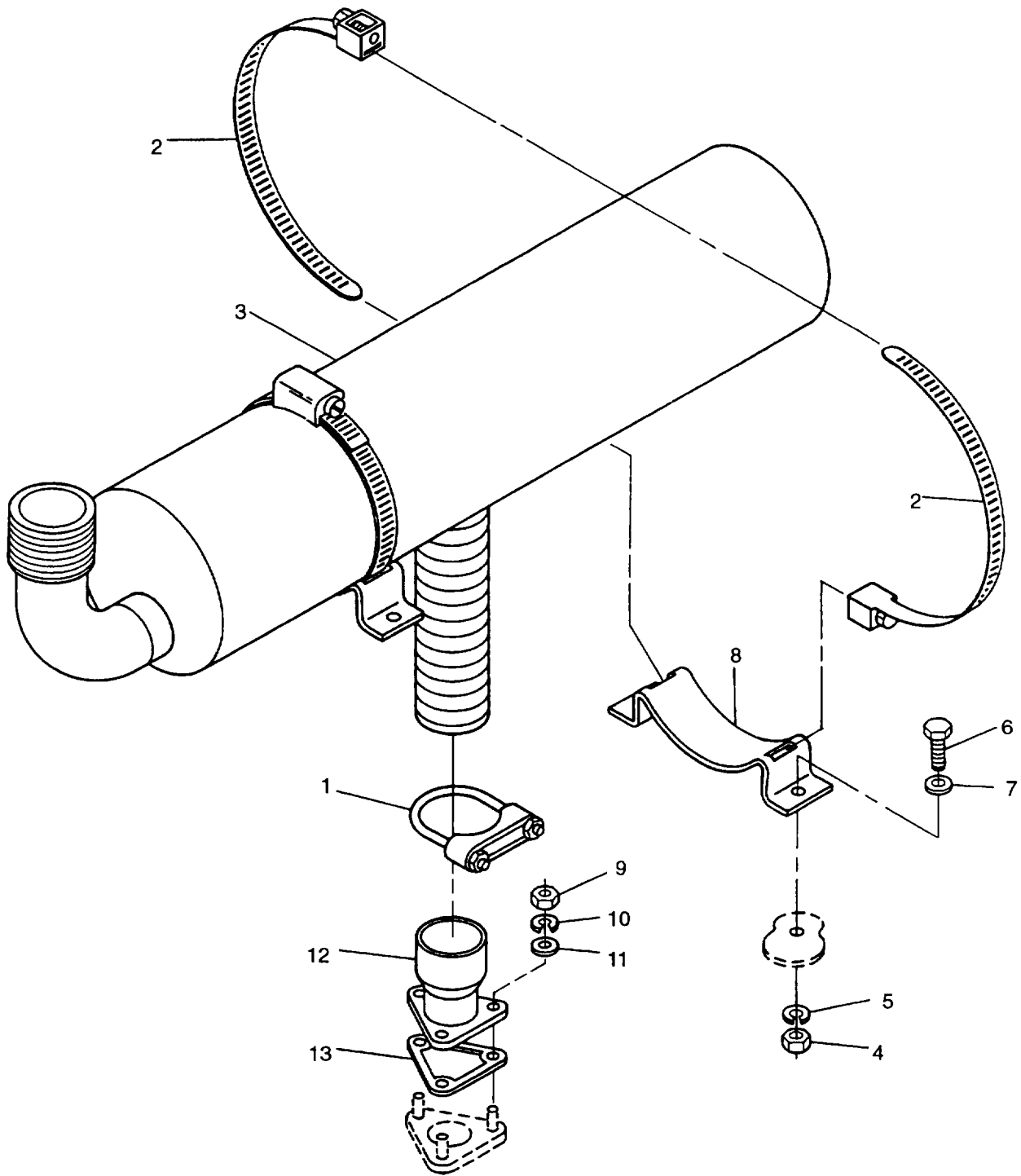

FIGURE 2-20. Muffler and Exhaust Pipe

2.71.2. Removal.

- a. Shut down generator set.
- b. Open left side engine access door.
- c. Unscrew air restriction indicator (1, FIGURE 2–21) from air cleaner housing (7).

2.71.3. Installation.

- a. Install air restriction indicator (1, FIGURE 2–21) on air cleaner housing (7). Tighten hand tight only.
- b. Close left side engine access door.

2.72. AIR CLEANER ASSEMBLY.

2.72.1. Inspection

- a. Shut down generator set.
- b. Open battery access door and disconnect negative battery cable.
- c. Remove control box assembly, paragraph 2.19.2.
- d. Inspect air cleaner assembly and mounting bracket for cracks, dents, and other damage.
- e. Install control box assembly, paragraph 2.19.4.
- f. Connect negative battery cable. Close battery access door.

2.72.2. Service.

- a. Remove air cleaner element, paragraph 2.73.1.
- b. Wipe inside of air cleaner housing with cleaning cloth (Item 7, Appendix C).
- c. Install new air cleaner element, paragraph 2.73.3.

2.72.3. Removal.

- a. Shut down generator set.
- b. Open battery access door and disconnect negative battery cable.
- c. Remove control box assembly, paragraph 2.19.2.
- d. Loosen clamp (2, FIGURE 2-21) and remove hose (18) from air cleaner housing (7).
- e. Remove bolts (3), washers (4), lockwashers (5), nuts (6), mounting bracket (12), and air cleaner assembly from generator set,
- f. Remove bolts (8), washers (9), nuts (10), lockwashers (11), and mounting bracket (12) from air cleaner assembly.
- g. If replacing air cleaner, remove and retain clamps (13).

2.72.4. Installation.

- a. If removed, install clamps(13, FIGURE 2-21) on air cleaner housing (7).
- b. Install mounting bracket (12) on air cleaner assembly with bolts (8), washers (9), lockwashers(11), and nuts (10).
- c. Install air cleaner assembly and mounting bracket (12) on generator set with bolts (3), washers (4), lockwashers (5), and nuts (6).
- d. Install hose (18) and clamp (2) on air cleaner housing (7). Tighten clamp (2).

- e. Install control box assembly, paragraph 2.19.4.
- f. Connect negative battery cable. Close battery access door.

2.73. AIR FILTER ELEMENT.

2.73.1. Removal.

- a. Shut down generator set.
- b. Open air cleaner access door.
- c. Loosen clamp (14, FIGURE 2-21) and remove cover(15) from air cleaner housing (7).
- d. Remove wing nut (16) and filter element(17) from air cleaner housing (7).

2.73.2. Inspection.

- a. Shut down generator set.
- b. Remove air cleaner element, paragraph 2.73.1.
- c. Inspect element (17, FIGURE 2-21) for debris and damage, replace as necessary.
- d. Wipe inside of air cleaner housing (7) with cleaning cloth (Item 7, Appendix C).
- e. Install air cleaner element, paragraph 2.73.3,

2.73.3. Installation.

- a. Install filter element (17, FIGURE 2-21) in air cleaner housing (7) and tighten wing nut (16).
- b. Install cover(15) on air cleaner housing (7), tighten clamp (14).
- c. Close air cleaner access door.

2.74. AIR CLEANER TUBING.

2.74.1. Inspection.

- a. Shut down generator set.
- b. Open engine access doors.
- c. Inspect all tubing for cracks, tears, and holes.
- d. Inspect clamps for cracks.
- e. Replace parts as necessary.
- f. Close engine access doors.

2.74.2. Removal.

- a. Shut down generator set.
- b. Open engine access doors.

NOTE

Due to space restrictions, air cleaner tubing must be removed as an assembly.

- c. Loosen clamps (2 and 19, FIGURE 2-21).

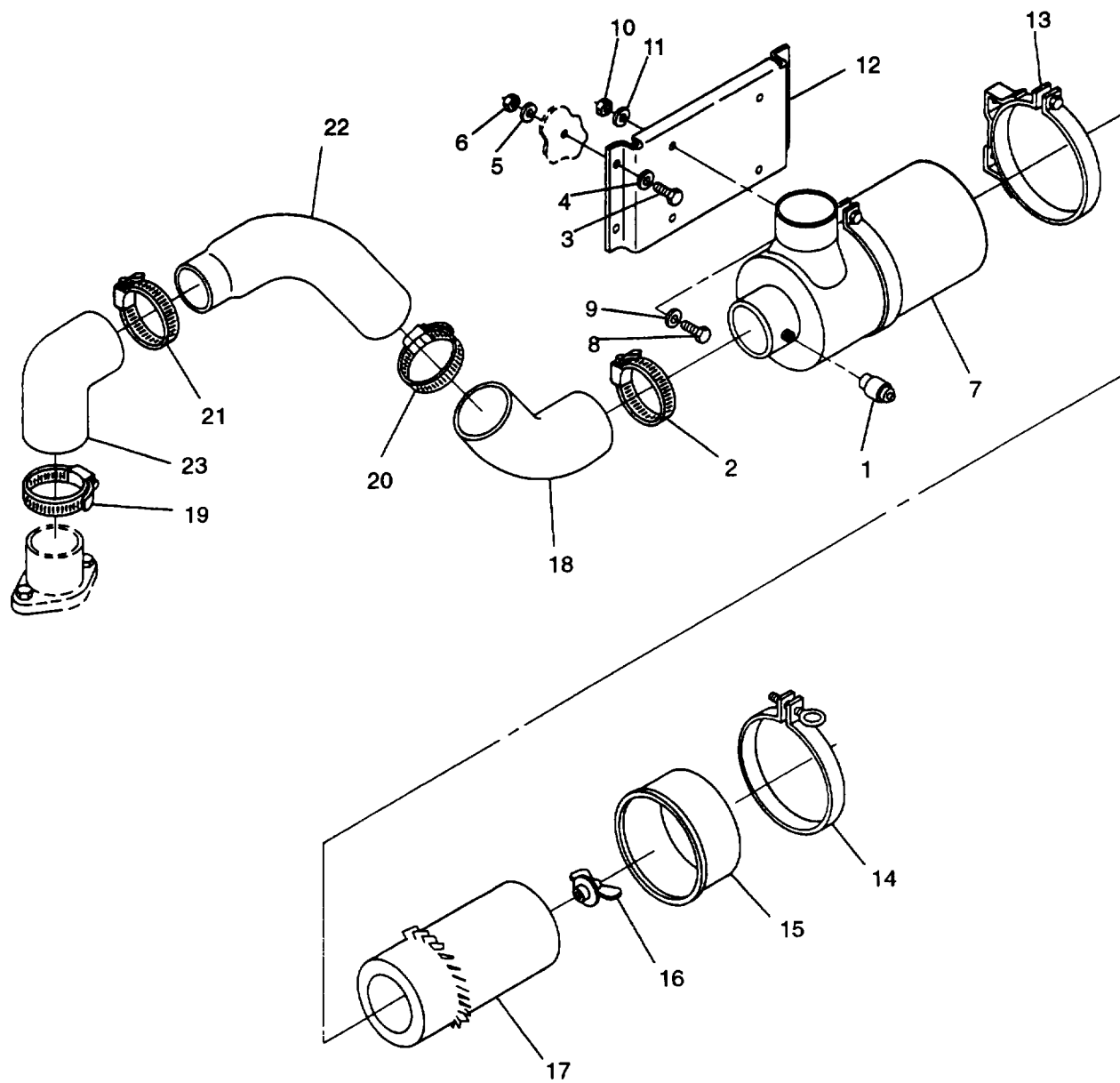

FIGURE 2-21. Air Cleaner Assembly

- d. Remove hoses (18), (22), and (23).
- e. Loosen clamps (20) and (21) and separate hoses (18), (22), and (23).

2.74.3. Installation.

- a. Connect hoses (18 and 22, FIGURE 2-21) with clamp (20). Do not tighten clamp.
- b. Connect hose (22) to hose (23) with clamp (21). Do not tighten clamp.
- c. Install hoses (18), (22), and (23), and secure with clamps (19) and (2).

- d. Tighten clamps (2), (19), (20), and (21).
- e. Close engine access doors.

Section XII. MAINTENANCE OF COOLANT SYSTEM

2.75. COOLANT SYSTEM

2.75.1. Testing.

- a. Shut down generator set

WARNING

Coolant can get very hot, Allow system to cool down before performing maintenance. Failure to follow these instructions could result in severe burns and injuries.

WARNING

Always remove radiator cap slowly to permit any pressure to escape. Failure to observe this warning could result in severe injury.

- b. Slowly remove radiator cap (1, FIGURE 2-23).
- c. Install coolant system pressure tester (ST255) in radiator neck.
- d. Open engine access doors.
- e. Pump pressure tester until 8 psi is indicated, check coolant system for leaks.
- f. Pump pressure tester until 7 psi (\pm 1) is indicated and ensure radiator cap releases.
- g. Release pressure from pressure tester and remove from radiator neck.
- h. Install radiator cap (1).
- i. Close engine access doors.

2.75.2. Service.

- a. Shut down generator set.
- b. Open left side engine access door.
- c. Flush or drain coolant system in accordance with TM 750-254.
- d. Close left side engine access door

2.76. RADIATOR FILLER HOSE AND PANEL.

2.76.1. Removal

- a. Shut down generator set
- b. Open engine access doors.
- c. Remove generator housing top panel, paragraph 2.16.1.

WARNING

Coolant can get very hot, Allow system to cool down before performing maintenance. Failure to follow these instructions could result in severe burns and injuries.

WARNING

Always remove radiator cap slowly to permit any pressure to escape
Failure to observe this warning could result in severe injury.

- d. Slowly remove radiator cap (1, FIGURE 2-23)
- e. Open radiator drain valve (34) and drain coolant/antifreeze into suitable container to a level below radiator filler hose (3) connection at radiator.
- f. Loosen clamps (2) Remove radiator filler hose (3) and clamps (2).
- g. Loosen clamp (4) and disconnect overflow hose (5) from radiator filler neck (9)
- h. Remove radiator fill panel (6) and filler neck (9) from generator set.
- i. Remove bolts (7), nuts (8), cap (1), and radiator filler neck (9) from radiator fill panel (6)

2.76.2. Inspection and Cleaning.

- a. Shut down generator set.
- b. Remove radiator filler hose and panel, paragraph 2.76.1
- c. Inspect radiator filler hose (3, FIGURE 2-23) for cracks, holes, and dry rot.
- d. Inspect filler panel (6), filler neck (9), and cap (1) for cracks, excessive corrosion, and other damage.
- e. Clean light corrosion from filler hose attaching points with fine grit abrasive paper (Item 15, Appendix C)
- f. Replace damaged parts
- g. Install radiator filler hose and panel, paragraph 2.76.3

2.76.3. Installation.

- a. Install radiator filler neck (9, FIGURE 2-23) and cap (1) on radiator fill panel (6) with bolts (7) and nuts (8).
- b. Position radiator fill panel (6) and filler neck (9) in generator set and attach overflow hose (5) with clamp (4)
- c. Install radiator filler hose (3) on filler neck (9) and radiator (32) with clamps (2).
- d. Install generator housing top panel, paragraph 2.16.4.
- e. Close radiator drain valve (34) and add coolant/antifreeze to proper level, paragraph b.

NOTE

If replacing radiator cap solder tab to radiator cap as shown in
FIGURE 2-22 Hook chain to tab.

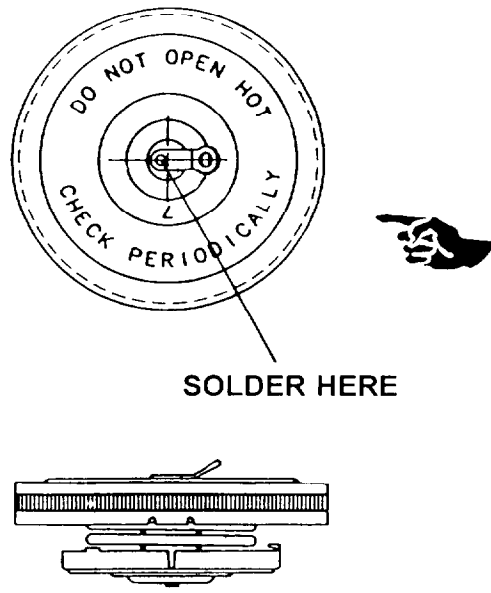

SOLDER HERE

FIGURE 2-22. Radiator Cap

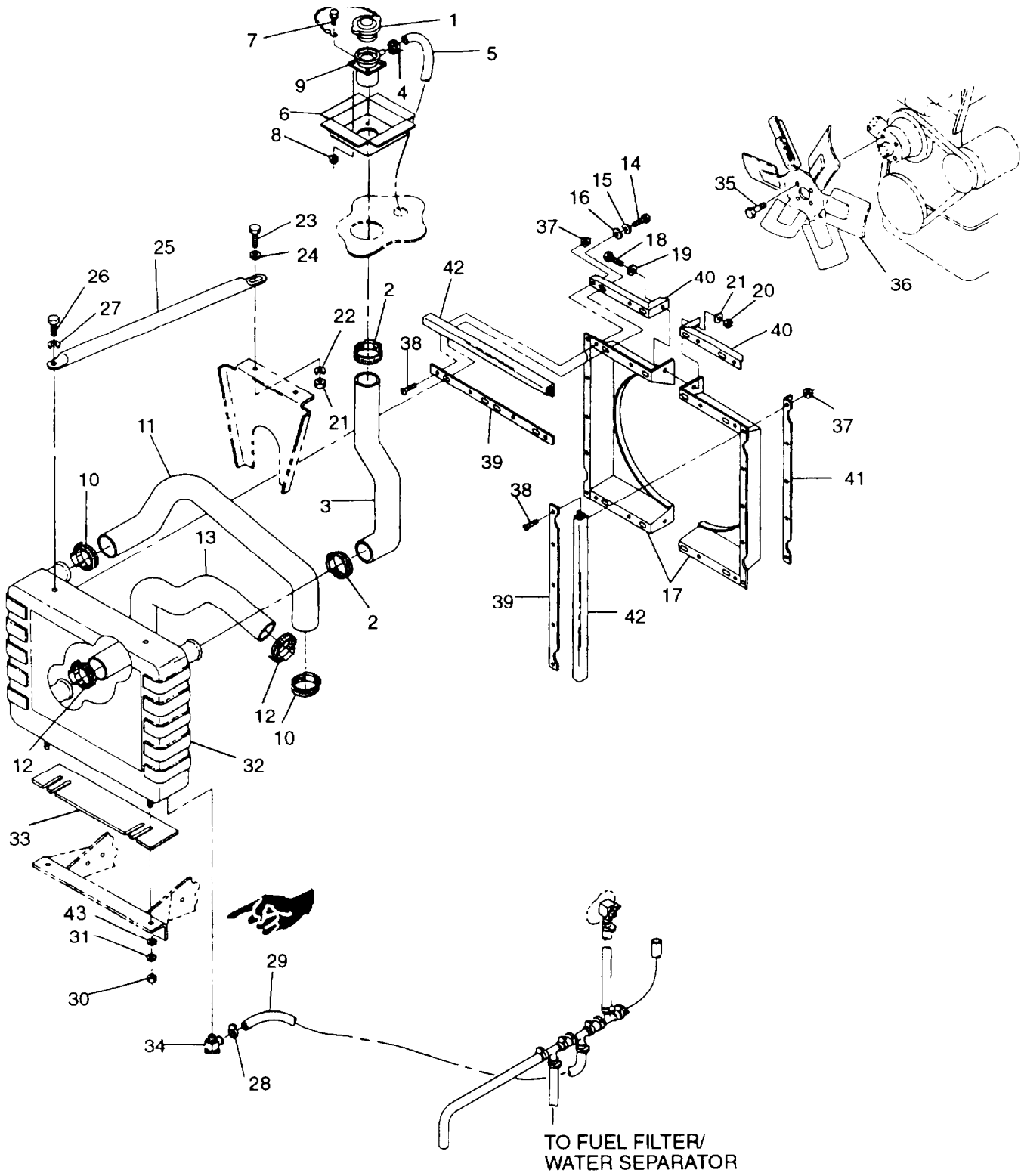

FIGURE 2-23. Coolant System

- f. Install radiator cap (1).
- g. Start generator set. Allow unit to reach operating temperature and check for leaks.
- h. Add coolant/antifreeze to overflow bottle as required.
- i. Close engine access doors.

2.77. FAN GUARDS.

2.77.1. Inspection.

- a. Shut down generator set.
- b. Open both side engine access doors.
- c. Inspect fan guards, brackets, and attaching hardware for damage, corrosion, and loose or missing hardware.
- d. Replace all damaged and missing components. Tighten all loose attaching hardware.
- e. Close engine access doors.

2.77.2. Removal.

- a. Shut down generator set.
- b. Open battery access door and disconnect negative battery cable.
- c. Open both side engine access doors.
- d. Remove bolts (1 and 5, FIGURE 2-24), washers (2) and (6), nuts (3) and (7), and lockwashers (4) and (8) securing fans guards (9) and (10).
- e. If necessary, remove belts (11) and (15), lockwashers (12) and (16) and washers (17) securing brackets (13), (14), and (18).

2.77.3. Installation.

- a. If removed, install bolts(11 and 15, FIGURE 2-24),lockwashers(12) and (16), and washers (17) securing brackets (13), (14), and (18).

NOTE

If damaged or if replacing fan guards (9 and 10), install protective edging (19), cut to fit.

- b. Install bolts(1) and (5), washers (2) and (6), nuts (3) and (7), and lockwashers (4) and (8) securing fan guards (9) and (10).
- c. Close both side engine access doors.
- d. Connect negative battery cable and close battery access door.

2.78. UPPER COOLANT HOSE.

2.78.1. Removal.

- a. Shut down generator set.
- b. Open battery access door and disconnect negative battery cable.
- c. Open engine access doors.

WARNING

Coolant can get very hot. Allow system to cool down before performing maintenance. Failure to follow these instructions could result in severe burns and injuries.

WARNING

Always remove radiator cap slowly to permit pressure to escape. Failure to observe this warning could result in severe injury.

- d. Slowly remove radiator cap (1, FIGURE 2-23).
- e. Remove fan guards, paragraph 2.77.2.
- f. Open radiator drain valve (34) and drain coolant/antifreeze into suitable container.
- g. Loosen clamps (10). Remove upper coolant hose (11) and clamps (10).

2.78.2. Inspection and Cleaning.

- a. Shut down generator set.
- b. Remove upper coolant hose, paragraph 2.78.1.
- c. Inspect upper coolant hose (11, FIGURE 2-23) for cracks, holes, and dry rot.
- d. Clean light corrosion from upper coolant hose attaching points with fine grit abrasive paper (Item 15, Appendix C).
- e. Install upper coolant hose, paragraph 2.78.3.

2.78.3. Installation.

- a. Install upper coolant hose (11, FIGURE 2-23) on thermostat housing opening and radiator (32) with clamps (10).
- b. Close radiator drain valve (34) and add coolant/antifreeze to proper level, paragraph b.
- c. Install fan guards, paragraph 2.77.3.
- d. Install radiator cap (1).
- e. Connect negative battery cable and close battery access door.
- f. Start generator set. Allow unit to reach operating temperature and check for leaks.
- g. Add coolant/antifreeze to overflow bottle as required.
- h. Close engine access doors.

2.79. LOWER COOLANT HOSE.

2.79.1. Removal.

- a. Shut down generator set.
- b. Open battery access door and disconnect negative battery cable.
- c. Open engine access doors.

WARNING

Coolant can get very hot. Allow system to cool down before performing maintenance. Failure to follow these instructions could result in severe burns and injuries.

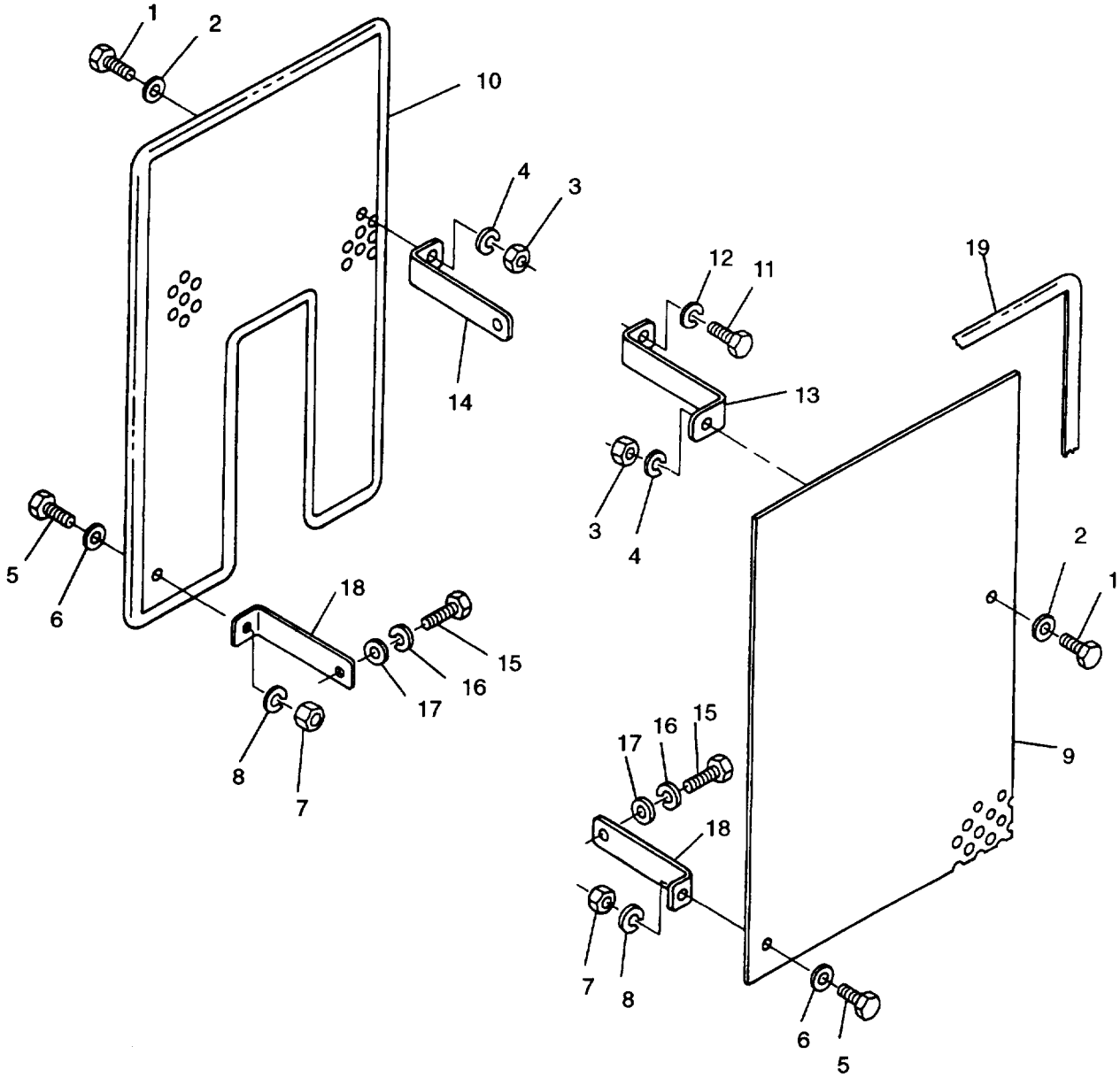

FIGURE 2-24. Fan Guards

WARNING

Always remove radiator cap slowly to permit pressure to escape. Failure to observe this warning could result in severe injury.

- d. Slowly remove radiator cap (1, FIGURE 2-23).
- e. Remove fan guards, paragraph 2.77.2.
- f. Open radiator drain valve (34) and drain coolant into suitable container.
- g. Loosen clamps (12) and remove lower coolant hose (13).

2.79.2. Inspection and Cleaning.

- a. Shut down generator set.
- b. Remove lower coolant hose, paragraph 2.79.1.
- c. Inspect lower coolant hose (13, FIGURE 2-23) for cracks, holes, and dry rot.
- d. Clean lower coolant hose attaching points with fine grit abrasive paper (Item 15, Appendix C).
- e. Install lower coolant hose, paragraph 2.79.3.

2.79.3. Installation.

- a. Install lower coolant hose(13, FIGURE 2-23) on radiator outlet opening and water pump opening with clamps (1 2).
- b. Close radiator drain valve (34) and add coolant/antifreeze to proper level, paragraph b.
- c. Install fan guards, paragraph 2.77.3.
- d. Install radiator cap(1).
- e. Connect negative battery cable and close battery access door.
- f. Start generator set. Allow unit to reach operating temperature and check for leaks.
- g. Add coolant/antifreeze to overflow bottle as required.
- h. Close engine access doors.

2.80. COOLANT OVERFLOW AND DRAIN HOSES.

2.80.1. Inspection.

- a. Shut down generator set.
- b. Open engine access doors.
- c. Inspect hoses for cracks, holes, and dry rot.
- d. Close engine access doors.

2.80.2. Removal.

- a. Shut down generator set.
- b. Open battery access door and disconnect negative battery cable.
- c. Open engine access doors.
- d. Locate overflow or drain hose to be removed, as shown on FIGURE 2-23.
- e. Disconnect hose at both ends and remove from generator set.

2.80.3 Installation

- a Install overflow or drain hose in generator set as removed
- b. Close engine access doors.
- c Connect negative battery cable and close battery access door

2.81. RADIATOR

2.81.1. Removal

- a Shut down generator set
- b. Open engine access doors.
- c Remove generator set top housing section, paragraph 2.16.1,

WARNING

Coolant can get very hot. Allow system to cool down before performing maintenance. Failure to follow these instructions could result in severe burns and injuries.

WARNING

Always remove radiator cap slowly to permit pressure to escape. Failure to follow this warning could result in severe injury.

- d. Slowly remove radiator cap (1, FIGURE 2-23)
- e. Remove fan guards, paragraph 2.772
- f. Open radiator drain valve (34) and drain coolant/antifreeze into suitable container.
- g. Remove radiator filler hose assembly, paragraph 2.76.1,
- h. Remove upper coolant hose, paragraph 2.78.1.
- i. Remove lower coolant hose, paragraph 2.79.1,
- j. Remove bolts (14), lockwashers (15), and flatwashers (16) and allow shroud (17) to rest on fan.
- k. Remove bolts (18), washers (19), nuts (20), and lockwashers (21) securing shroud halves (17). Remove shroud halves (17).
- l. Remove nuts (21), lockwashers (22), bolts (23), and washers (24) securing support rods (25) to bracket on engine.
- m. Remove bolts (26), lockwashers (27), and support rods (25) from radiator (32).
- n. Loosen clamp (28) and disconnect radiator drain hose (29) from radiator drain valve (34).
- o. Remove nuts (30) and washers (31, 43) from radiator mounting points.
- p. Lift radiator (32) up and out of generator set housing and remove shim(s) (33).
- q Remove radiator drain valve (34) from radiator (32).

2.81.2 Inspection and Cleaning

- a. Shut down generator set.
- b. Remove radiator, paragraph 2.81.1
- c Inspect radiator for excessive corrosion, cracks, or bent cooling fins

- d. Check inside of radiator for corrosion and scale

WARNING

Use clean, low pressure air, 30 psi maximum. Wear protective glasses when using compressed air. Failure to follow these instructions could result in eye injury.

WARNING

Dry cleaning solvent is flammable and toxic to eyes, skin, and respiratory tract. Skin/eye protection required. Avoid repeated/prolonged contact. Good general ventilation is normally adequate.

- e. Clean dirt particles from radiator core air passages using filtered, compressed air.
- f. Clean exterior surface of radiator with dry cleaning solvent (Item 18. Appendix C).
- g. Install radiator, paragraph 2.81.4.

2.81.3 Repair.

Repair radiator by straightening bent radiator fins and soldering minor leaks.

2.81.4. Installation.

- a. Install drain valve (34, FIGURE 2-23) in radiator (32).
- b. Assemble shroud halves (17) with nuts (20), lockwashers (21), bolts (18), and washers (19).
- c. Position radiator (32) on radiator mount, and install shroud (17) on radiator with bolts (14), lockwashers (15), and flatwashers (16)
- d. Insert shim(s) (33) under radiator (32) as necessary to obtain equal clearance between fan (36) and top and bottom of shroud (17). Secure shim(s) and radiator (32) to radiator mounting bracket with nuts (30) and washers (31, 43).
- e. Connect radiator drain hose (29) on radiator drain valve (34) with clamp (28).
- f. Connect support rods (25) to radiator (32) with lockwashers (27) and bolts (26).
- g. Attach support rods (25) to bracket on engine with bolts (23), washers (24), lockwashers (22), and nuts (21).
- h. Install lower coolant hose, paragraph 2.79.3.
- i. Install upper coolant hose, paragraph 2.78.3.
- j. Install radiator filler hose and panel assembly, paragraph 2.76.3.
- k. Install fan guards, paragraph 2.77.3.
- l. Install generator set top housing section, paragraph 2.16.4.
- m. Ensure radiator drain valve (34) is closed and add coolant/antifreeze, to proper level, paragraph b.
- n. Install radiator cap (1).
- o. Start generator set. Allow unit to reach operating temperature and check for leakage.
- p. Add coolant to overflow bottle as required
- q. Close engine access doors

2.82. GENERATOR SET COOLING FAN.

2.82.1. Removal.

- a. Shut down generator set.
- b. Open battery access door and disconnect negative battery cable.
- c. Open engine access doors.
- d. Remove fan guards, paragraph 2.77.2.
- e. Remove bolts (14) washers (16), and lockwashers (15) and allow shroud (17) to rest on fan (36).
- f. Remove bolts (18), washers (19), nuts (20) and lockwashers (21). Separate shroud halves (17) and remove at least one half.
- g. Remove bolts (35) and fan (36).
- h. Remove nuts (37), screws (38), stiffeners (39) and (40), supports (41) and seals (42) from each side of shroud (17).

2.82.2. Inspection.

- a. Shut down generator set.
- b. Remove cooling fan, paragraph 2.82.1.
- c. Inspect fan (36, FIGURE 2-23) and blades for cracks, bends, loose rivets, or other damage.
- d. Inspect seals (42), supports (41), and stiffeners (39 and 40) for damage.
- e. Replace damaged parts.
- f. Install cooling fan, paragraph a.

2.82.3. Installation.

- a. Install seals (42, FIGURE 2-23), supports (41), and stiffeners (39) and (40) on each side of shroud (17) with screws (38) and nuts (37).
- b. Position fan (36) and secure with bolts (35). Torque bolts to 72 in-lbs (8.0 Nm).
- c. Install fan shroud halves (17) with nuts (20), lockwashers (21), bolts (18), and washers (19). Attach to radiator with bolts (14), lockwashers (15), and washers (16).
- d. Install fan guards, paragraph 2.77.3.
- e. Close engine access doors.
- f. Connect negative battery cable and close battery access door.

2.83. FAN BELT.

2.83.1. Inspection.

- a. Shut down generator set.
- b. Open battery access door and disconnect negative battery cable,
- c. Open engine access doors.
- d. Remove left side fan guard.
- e. Inspect fan belt (6, FIGURE 2-25) for frays, cracks, oil soaking, and other damage

- f. Replace fan belt that shows any of above or cannot be adjusted for proper tension
- g. Replace fan guard
- h. Close engine access doors
- i. Connect negative battery cable and close battery access door.

2.83.2. Test and Adjustment

NOTE

Run engine for 5 minutes if belt is cold. If belt is hot, let cool for 10 to 15 minutes.

- a. Shut down generator set.
- b. Open battery access door and disconnect negative battery cable
- c. Open engine access doors.
- d. Check fan belt (6, FIGURE 1-25) for proper tension using a suitable belt tension gauge. Belt tension shall be 70 pounds.
- e. If fan belt needs adjustment, loosen alternator mounting bolt (1) and nut (2).

CAUTION

Do not pry against alternator rear frame. Damage to alternator or mounting brackets could occur.

- f. Apply outward pressure to alternator front frame until belt tension is correct
- g. Tighten alternator mounting bolt (1) and nut (2).
- h. Close engine access doors.
- i. Connect negative battery cable and close battery access door.

2.83.3. Removal.

- a. Shut down generator set.
- b. Open battery access door and disconnect negative battery cable.
- c. Open engine access doors.
- d. Remove fan guards, paragraph 2.77.2.
- e. Loosen alternator mounting bolt (1, FIGURE 2-25) and nut (2).
- f. Pivot alternator to relieve tension on fan belt (6). and remove belt (6) from alternator pulley (3), fan pulley (4), and crankshaft pulley (5).
- g. Slip belt (6) over fan (36, FIGURE 2-23) and remove belt from generator set

2.83.4. Installation.

- a. Slip fan belt (6, FIGURE 2-25) over fan (36, FIGURE 2-23).
- b. Install belt (6, FIGURE 2-25) onto alternator pulley (3), fan pulley (4), and crankshaft pulley (5)
- c. Adjust tension on fan belt (6). paragraph 2.83.2.
- d. Install fan guards, paragraph 2.77.3

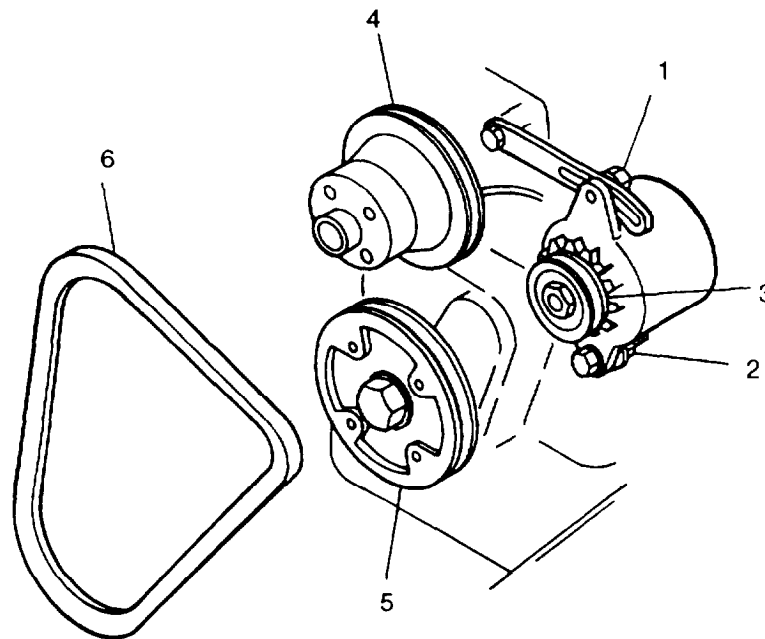

FIGURE 2-25. Fan Belt

- e. Close engine access doors.
- f. Connect negative battery cable and close battery access door.

2.84. COOLANT RECOVERY SYSTEM.

2.84.1. Inspection.

- a. Shut down generator set.
- b. Open left side engine access door.
- c. Inspect coolant recovery system components for cracks, holes, or other damage
- d. Close left side engine access door.

2.84.2. Removal.

- a. Shut down generator set.
- b. Open left side engine access door.

WARNING

Coolant can get very hot. Allow system to cool down before performing maintenance. Failure to follow these instructions could result in severe burns and injuries.

- c. Loosen clamp (1, FIGURE 2-26) and disconnect hose (2) from overflow bottle (5) and drain coolant into suitable container.
- d. Loosen clamp (3) and disconnect hose (4) from overflow bottle (5).

- e Remove overflow bottle (5) from wire holder (10).
- f. Remove bolts (6), nuts (7), lockwashers (8), and wire holder (10) from mount (14).
- g Remove bolts (11), nuts (12), lockwashers (13), and mount (14) from engine.

2.84.3 Installation

- a Install mount (14, FIGURE 2-26) on engine with bolts (11), nuts (12), and lockwashers (13)
- b. Install wire holder (10) on mount (14) with bolts (6), lockwashers (8), and nuts (7).
- c Install coolant overflow bottle (5) in holder (10) and connect hoses (2) and (4) with clamps (1) and (3)
- d Remove cap (15).
- e. Fill overflow bottle (5) with coolant to the COLD level. Refer to TABLE 2-1 for proper coolant.
- f. Install cap (15)
- g. Start generator set, check for leaks, and run until normal operating temperature is reached.
- h. Remove cap (15).
- i. Add coolant to HOT level of overflow bottle (5).
- j. Install cap (15) and close left side engine access door.

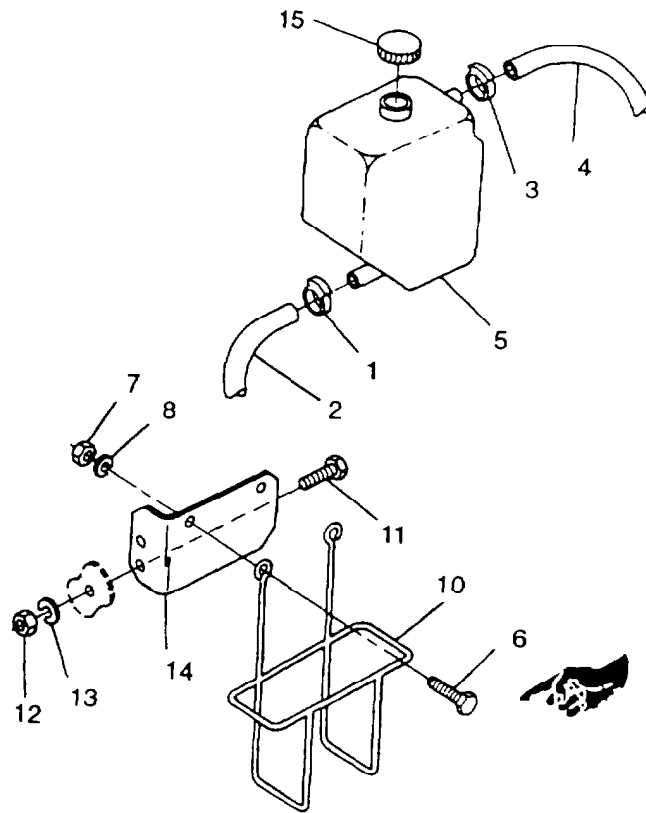

FIGURE 2-26. Coolant Recovery System

Section XIII. MAINTENANCE OF FUEL SYSTEM

2.85. LOW PRESSURE FUEL LINES AND FITTINGS.

2.85.1. Removal

- a. Shut down generator set.
- b. Open battery access door and disconnect negative battery cable.
- c. Identify fuel line or fitting that is damaged or leaking and must be removed as shown in FIGURE 2-27
- d. Disconnect fuel line at both ends and remove any clamps.
- e. Remove fuel line or fitting from generator set
- f. Cover or cap all openings.

2.85.2. Installation.

- a. Remove any caps and position fuel line or fitting in generator set.
- b. Install any clamps as removed and connect fuel line at both ends.
- c. Connect negative battery cable and close battery access door
- d. Start generator set and check for fuel leaks.
- e. Shut down generator set and close all access doors

2.86. AUXILIARY FUEL PUMP.

2.86.1. Inspection

- a. Shut down generator set.
- b. Inspect auxiliary fuel pump (8, FIGURE 2-27) for leaks, cracks, missing hardware, loose connections, and other damage.

2.86.2. Testing.

- a. Shut down generator set.
- b. Connect generator set to auxiliary fuel supply (ensure auxiliary fuel supply is no more than 6 feet (1.83 m) below generator set).
- c. Open left side engine access door.
- d. Disconnect auxiliary fuel pump outlet line (13, FIGURE 2-27) at fuel tank fitting and place disconnected end in measuring container.
- e. Move generator set MASTER SWITCH to PRIME & RUN AUX FUEL position for 1 minute and return MASTER SWITCH to OFF position.
- f. Measuring container should have collected at least 36 ounces (1.06 liters) of fuel.
- g. Replace auxiliary fuel pump if delivery amount is other than above.
- h. Connect auxiliary fuel pump outlet line (13) at fuel tank fitting.
- i. Disconnect generator set from auxiliary fuel supply
- j. Close left side engine access door

2.86.3. Removal.

- a. Shut down generator set.
- b. Open battery access door and disconnect negative battery cable.
- c. Open left side engine access door.
- d. Tag and disconnect auxiliary fuel pump (8, FIGURE 2-27) electrical connector.
- e. Loosen damps (1a). Disconnect fitter (10) and remove adapter fitting (1b) from filler neck panel fitting (12). Remove adapter fitting (1b) from fuel inlet hose (1). Remove fitter (10) from auxiliary fuel pump (8). Cap fuel inlet hose.
- f. Disconnect auxiliary fuel outlet line (2) from auxiliary fuel pump (8).
- g. Remove nuts (3), lockwashers (4), bolts(5), washers(6), cap and chain assembly(7), and auxiliary fuel pump (8).
- h. Remove fitting (9) from auxiliary fuel pump (8).
- i. If necessary, remove nut (11) and fitting (12) from fuel filler panel.

2.86.4. Installation.

- a. If removed, install fitting (12, FIGURE 2-27) and nut (11) in fuel filler panel.
- b. Install fitting (9) on auxiliary fuel pump (8).
- c. Install auxiliary fuel pump (8) and cap and chain assembly(7) in generator set with bolts (5), washers (6), lockwashers (4), and nuts (3).
- d. Connect auxiliary fuel outlet line (2) to auxiliary fuel pump (8).
- e. Remove caps from fuel inlet hose (1). Install filter (10) on auxiliary fuel pump (8). Install adapter fitting (1b) on fuel inlet hose (1) and connect adapter fitting (1b) to filler neck panel fitting (12). Connect other end of fuel inlet hose to filter (10). Tighten damps (1A).
- f. Connect auxiliary fuel pump electrical connector and remove tag.
- g. Connect negative battery cable. Close battery access door.
- h. Move generator set MASTER SWITCH to PRIME AND RUN AUX FUEL position and check for fuel leaks.
- i. Return MASTER SWITCH to OFF position and close engine access door.

2.87. FUEL TANK FILLER NECK.

2.87.1. Removal.

- a. Shutdown generator set.
- b. Open battery access door and disconnect negative battery cable.

WARNING

Diesel fuel is flammable and toxic to eyes, skin, and respiratory tract. Skin/eye protection required. Avoid repeated/prolonged contact. Good general ventilation is normally adequate.

- c. Remove cap (27, FIGURE 2-27), open fuel drain valve (29) and drain fuel into suitable container.
- d. Open left side engine access door.

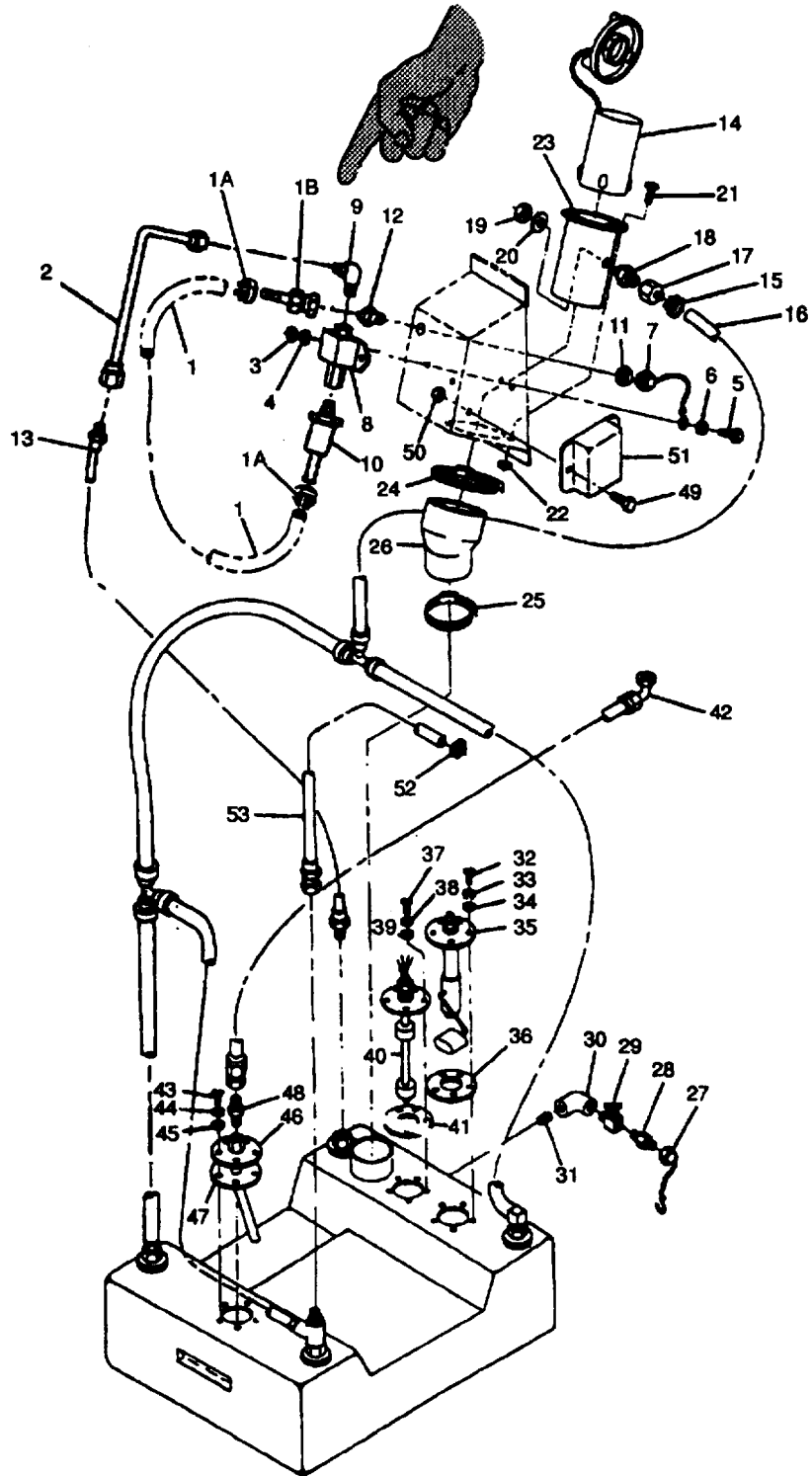

FIGURE 2-27. Fuel Tank Filler Neck and Low Pressure Fuel System

- e. Remove filler neck cap and tube assembly (14).
- f. Loosen clamp (15) and disconnect hose (16) from adapter (17).
- g. Remove adapter (17) from fitting (18).
- h. Remove nut (19), washer (20), and fitting (18) from side of filler neck (23).
- i. Remove bolts (21) and nuts (22) securing filler neck (23) to generator set housing.
- j. Remove clamps (24) and (25), hose (26), and filler neck (23) from fuel tank opening. Cover fuel tank opening.

2.87.2. Inspection.

- a. Shut down generator set.
- b. Remove fuel tank filler neck, paragraph 2.87.1.
- c. Inspect hose (26, FIGURE 2-27) for cracking, wear, or other damage.
- d. Inspect filler neck (23) for corrosion, cracking, or other damage.
- e. Inspect filler neck cap and tube assembly (14) for damage.
- f. Install fuel tank filler neck, paragraph 2.87.3.

2.87.3. Installation.

- a. Position hose (26, FIGURE 2-27), clamps (24) and (25), and filler neck (23) on fuel tank.
- b. Install bolts (21) and nuts (22) securing filler neck (23) to generator set housing.
- c. Tighten clamps (24) and (25).
- d. Install fitting (18), washer (20), and nut(19) inside of filler neck (23).
- e. Install adapter (17) on fitting (18) and connect hose (16) to adapter (17) with clamp (15).
- f. Install filler neck cap and tube assembly (14).
- g. Close fuel drain valve (29), install cap (27), and service fuel tank. Refer to TABLE 2-2 for proper fuel.
- h. Connect negative battery cable. Close battery access door and engine access door.

2.88. FUEL DRAIN VALVE.

2.88.1. Removal.

- a. Shut down generator set.
- b. Open battery access door and disconnect negative battery cable.
- c. Open left side engine access door.
- d. Remove cap and chain assembly (27, FIGURE 2-27) from adapter (28).

WARNING

Diesel fuel is flammable and toxic to eyes, skin, and respiratory tract. Skin/eye protection required. Avoid repeated/prolonged contact. Good general ventilation is normally adequate.

- e. Open drain valve (29) and drain fuel into suitable container.
- f. Remove drain valve (29) and adapter (28) from elbow (30).
- g. Remove adapter (28) from drain valve (29).
- h. If necessary, remove elbow (30) and adapter (31) from fuel tank fitting.

2.88.2. Installation.

- a. If removed, install adapter (31, FIGURE 2-27) and elbow (30) in fuel tank fitting.
- b. Install fuel drain valve (29) into elbow (30).
- c. Install adapter (28) into drain valve (29), and cap and chain assembly (27) on adapter (28).
- d. Ensure fuel drain valve (29) is closed and service fuel tank. Refer to TABLE 2-2 for proper fuel.
- e. Check fuel drain valve and fittings for leakage.
- f. Close left side engine access door.
- g. Connect negative battery cable and close battery access door.

2.89. FUEL LEVEL SENDER.

2.89.1. Inspection.

- a. Shut down generator set.
- b. Open left side engine access door.
- c. Inspect fuel level sender (35, FIGURE 2-27) for loose connections and mounting, and other damage.
- d. Close left side engine access door.

2.89.2. Removal.

- a. Shut down generator set.
- b. Open battery access door and disconnect negative battery cable.
- c. Open left side engine access doors and disconnect fuel level sender (35, FIGURE 2-27) electrical lead.

NOTE

Mark position of float when removing sender. Float must be in same position when installing to ensure clearance with fuel tank.

- d. Remove screws (32), lockwashers (33), flatwashers (34), fuel level sender (35), and gasket (36) from generator set fuel tank.
- e. Cover opening in fuel tank.

2.89.3. Testing.

- a. Shut down generator set.
- b. Remove fuel level sender, paragraph 2.89.2.
- c. Position fuel level sender in vertical position, similar to position as installed in fuel tank.
- d. Set multimeter for ohms and connect positive lead to fuel level sender terminal, and negative lead to sender ground.

- e. With fuel level sender arm resting freely in what would be an empty position, multimeter should indicate between 216 and 264 ohms.
- f. Move fuel level sender arm up to what would be a full position and multimeter should indicate between 29.7 and 36.3 ohms.
- g. Replace fuel level sender if indications are not as above.
- h. Install fuel level sender, paragraph 2.89.4.

2.89.4. Installation.

- a. Remove cover in fuel tank opening.
- b. Clean, make flat and smooth mating surfaces to gasket (36, FIGURE 2-27) ensuring no foreign material enters fuel tank. Apply sealant (item 19, Appendix C) to both sides of gasket (36).
- c. Insert fuel level sender (35) and gasket (36) into fuel tank. Ensure float is in same position as removed.
- d. Install screws (32), Washers (33), and flatwashers (34).
- e. Connect electrical lead, remove tag, and close left side engine access door.
- f. Connect negative battery cable. Close battery access door.

2.90. LOW LEVEL/AUXILIARY FUEL PUMP FLOAT SWITCH.

2.90.1. Inspection.

- a. Shutdown generator set.
- b. Open left side engine access door.
- c. Inspect low fuel level/auxiliary fuel pump float switch (40, FIGURE 2-27) for loose connections and mounting, and other damage.
- d. Close left side engine access door.

2-90-2. Removal.

- a. Shutdown generator set.
- b. Open battery access door and disconnect negative battery cable.
- c. Open left side engine access door, tag and disconnect low fuel level/auxiliary fuel pump float switch (40, FIGURE 2-27) electrical connector.
- d. Remove screws (37), lockwashers (38), flatwashers (39), float switch (40), and gasket (41) from fuel tank.
- e. Cover opening in fuel tank

2.90.3. Testing.

- a. Shutdown generator set.
- b. Remove low fuel level/auxiliary fuel pump float switch, paragraph 2.90.2.
- c. Position float switch in vertical position, similar to position as installed in fuel tank
- d. For the top float, set multimeter for ohms and connect positive lead to pin 2 and negative lead to pin 1 of float switch electrical connector.
- e. With upper or lower float moving toward the down position, the multimeter should indicate continuity 1/4 inch before float reaches the down position.

- f. Move upper float to the full up position, multimeter should indicate open circuit.
- g. Disconnect multimeter leads from pins 1 and 2. To check the lower float connect the positive lead to pin 3 and the negative lead to pin 4 of electrical connector.
- h. Repeat steps e and f, except with lower float.
- i. Replace low fuel level/auxiliary fuel pump float switch if indications are other than above.
- j. Install low fuel level/auxiliary fuel pump float switch, paragraph 2.90.4.

2.90.4. Installation.

- a. Loosen float switch plate adjusting nut.
- b. Remove cover in fuel tank opening.
- c. Clean, make flat and smooth mating surfaces to gasket (41, FIGURE 2-27) ensuring no foreign material enters fuel tank Apply sealant (item 19, Appendix C) to both sides of gasket (41).
- d. Position gasket (41) and float switch (40) in fuel tank.
- e. Install screws (37), lockwashers (36), and flatwashers (39).
- f. Set float switch stem 1/16 inoh from bottom of fuel tank and tighten float switch plate adjusting nut.
- g. Connect electrical connector, remove tag, and close left side engine access door.
- h. Connect negative battery cable. Close battery access door.

2.91. FUEL PICKUP.

2.91.1. Removal.

- a. Shut down generator set.
- b. Open battery access door and disconnect negative battery cable.
- c. Open right side engine access door and disconnect fuel line (42, FIGURE 2-27) from fitting (46).

NOTE

Mark position of fuel pickup before removing.

- d. Remove screws (43), lockwashers (44), flatwashers (45), fuel pickup (46), and gasket (47) from fuel tank.
- e. Remove fitting (46) from fuel pickup (46).
- f. Cover opening in fuel tank.

2.91.2. Inspection.

- a. Shutdown generator set.
- b. Remove fuel pickup, paragraph 2.91.1.
- c. Inspect fuel pickup and fitting for dogs, stripped threads, and other damage.
- d. Replace damaged parts.
- e. Install fuel pickup, paragraph 2.91.3.

2.91.3 Installation.

NOTE

Ensure fuel pickup is in same position as marked on removal.

- a. Remove cover in fuel tank opening.
- b. Clean, make flat and smooth matting surfaces to gasket (47, FIGURE 2-27) ensuring no foreign material enters fuel tank. Apply sealant (item 19, Appendix C) to both sides of gasket (47).
- c. Install gasket (47) and fuel pickup (46) in fuel tank with screws (43), lockwashers (44), and flatwashers (45).
- d. Install fitting (46) in fuel pickup (46).
- e. Connect fuel line (42) to fitting (46) and dose right side engine access door.
- f. Connect negative battery cable and dose battery access door.

2.92. FUEL FLOAT MODULE.

2.92.1. Inspection.

- a. Shutdown generator set.
- b. Open left side engine access door.
- c. Inspect fuel float module (51, FIGURE 2-27) for cracked housing, broken or damaged connectors and wiring, and other damage.
- d. Close left side engine access door.

2.92.2. Testing.

- a. Shut down generator set.
- b. Open left side engine access door.
- c. Disconnect fuel float module (51, FIGURE 2-27) electrical connector (J12) from fuel float switch connector (P12).
- d. Connect pins 1 and 2 of fuel float module electrical connector (J12) together with a jumper wire.
- e. Move MASTER SWITCH to PRIME & RUN AUX FUEL position and auxiliary fuel pump should start operating. Remove jumper wire and auxiliary fuel pump should stop operating.
- f. Start and operate generator set at rated voltage and frequency.
- g. Using jumper wire, make connection between pins 3 and 4 of fuel float module electrical connector (J12). Generator set should shut down after approximately 2 seconds and NO FUEL lamp on malfunction indicator panel should light.
- h. Replace fuel float module if operation is other than above.
- i. Close left side engine access door.

2.92.3. Removal.

- a. Shutdown generator set.
- b. Open battery access door and disconnect negative battery cable.
- c. Open left side engine access door, tag and disconnect electrical connectors from fuel float module (51, FIGURE 2-27).
- d. Remove bolts (49), nuts (50), and fuel float module (51) from generator set.

2.92.4. Installation.

- a. Install fuel float module (51, FIGURE 2-27) in generator set with bolts (49) and nuts (50).
- b. Connect electrical connectors, remove tags, and dose left side engine access door.
- c. Connect negative battery cable and dose battery access door.

2.93. FUEL FILTER/WATER SEPARATOR ELEMENT.

2.93.1. Inspection.

- a. Shutdown generator set.
- b. Open right side engine access door.
- c. Inspect fuel filter/water separator, fuel lines, and fittings for loose connections, damage, and evidence of fuel leaks.
- d. Close right side engine access door.

2.93.2. Service.

- a. Shut down generator set.
- b. Open battery access door and disconnect negative battery cable.
- c. Open water drain valve (1, FIGURE 2-28) and drain all water from fuel filter/water separator.
- d. Loosen damp (3) and disconnect drain tine (4).

WARNING

Diesel fuel is flammable and toxic to eyes, skin, and respiratory tract. Skin/eye protection required. Avoid repeated/prolonged contact. Good general ventilation is normally adequate.

NOTE

Catch fuel in suitable container.

- e. Remove fuel filter/water separator element (2).
- f. Wipe fuel filter/water separator head (11) with cleaning cloth (item 7, Appendix C).
- g. Check petcock valve operation for being only hand tight on fuel filter/water separator element (2) and apply a film of engine oil (item 11, appendix C) to the sealing surface of the fuel filter/water separator (2).
- h. Fill new fuel filter/water separator element (2) with dean diesel fuel.
- i. Install fuel filter/water separator element (2), hand tight. Do not overtighten.
- j. Connect drain tine (4) and install damp (3).
- k. Connect negative battery cable.
- l. Bleed air from fuel system, refer to TM 9-2815-254-24.
- m. Start engine and check for fuel leak.
- n. Close all access doors.

2.93.3. Removal.

- a. Shutdown generator set.
- b. Open battery access door and disconnect negative battery cable.

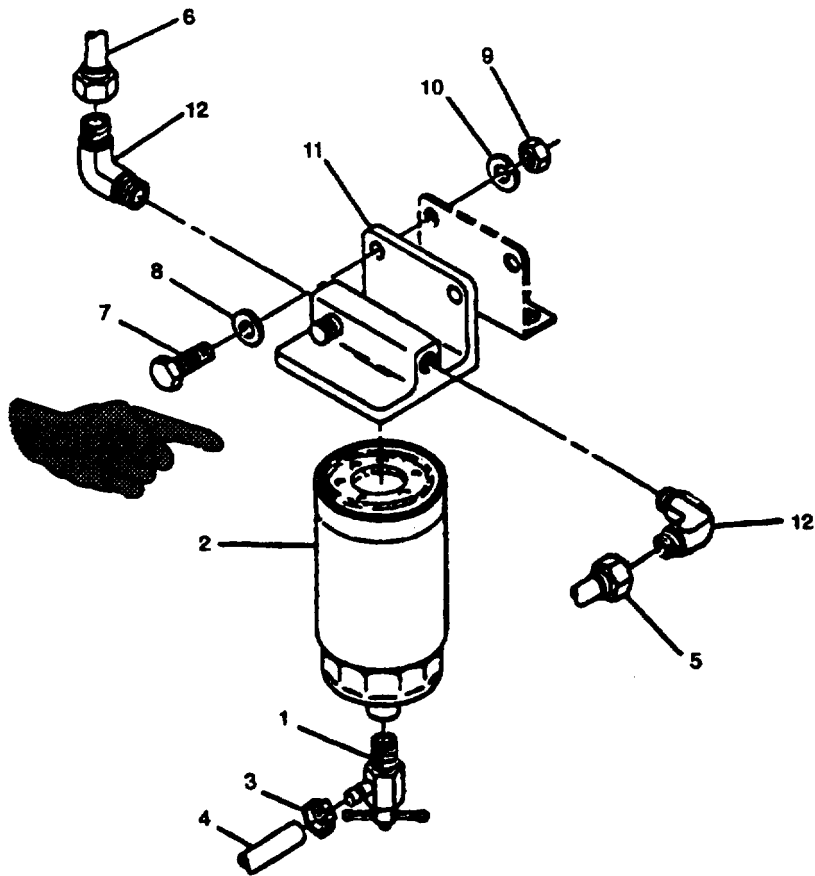

FIGURE 2-28. Fuel Filter/Water Separator

- c. Open right side engine access door.
- d. Loosen damp (3, FIGURE 2-28) and disconnect water drain line (4) from fuel filter/water separator.
- e. Disconnect fuel lines (5) and (6).
- f. Remove bolts (7), flatwashers (8), nuts (9), lockwashers (10), and fuel filter/water separator head (11) with element (2).
- g. Cap all openings.

2.93.4. Repair.

- a. Shut down generator set.
- b. Open battery access door and disconnect negative battery cable.
- c. Remove fuel filter/water separator, paragraph 2.93.3.
- d. If damaged or if replacing fuel filter/water separator, remove and retain elbows (12, FIGURE 2-28) from head (11).
- e. Install elbows (12).
- f. Install fuel filter/water separator, paragraph 2.93.5.

2.93.5. Installation.

- a. Remove caps.
- b. Install fuel filter/water separator head(11, FIGURE 2-28) with nuts (9), lockwashers (10), bolts (7), and flatwashers (8).
- c. Install fuel lines (5) and (6).
- d. Connect negative battery cable. Close battery access door.
- e. Bleed air from fuel system, refer to TM 9-2815-254-24.
- f. Start generator set and check for fuel leaks.
- g. Close right side engine access door.

Section XIV. MAINTENANCE OF OUTPUT BOX ASSEMBLY

2.94. VOLTAGE RECONNECTION TERMINAL BOARD.

2.94.1. Inspection.

- a. Shut down generator set.
- b. Open output box access door.
- c. Inspect protective cover (3, FIGURE 2-29) and moveable terminal board (5) for cracks, breaks, corrosion, and other damage.
- d. Replace damaged parts.
- e. Close output box access door.

2.94.2. Removal.

- a. Shut down generator set.
- b. Open battery access door and disconnect negative battery cable.
- c. Open output box access door.
- d. Remove nuts (1, FIGURE 2-29), washers (2), and protective cover (3) from voltage reconnection terminal board assembly.
- e. Remove nuts (4) and moveable terminal board (5) from voltage reconnection terminal board assembly.

2.94.3. Installation.

- a. Install moveable terminal board (5, FIGURE 2-29) on voltage reconnection terminal board assembly with nuts (4).
- b. Install protective cover (3) on voltage reconnection terminal board assembly with washers (2) and nuts (1).
- c. Close output box access door.
- d. Connect negative battery cable and close battery access door.

2.95. OUTPUT BOX HARNESS.

2.95.1. Inspection.

- a. Shut down generator set.
- b. Inspect wiring harness (6, FIGURE 2-29) for burned, bent, corroded, and broken terminals.
- c. Inspect connectors for cracks, corrosion, stripped threads, bent or broken pins, and obvious damage.
- d. Inspect wire insulation for bumps, deterioration, and chafing.

2.95.2. Testing.

- a. Shut down generator set.
- b. Open battery access door and disconnect negative battery cable.
- c. Open output box and engine access doors.
- d. Set multimeter for ohms, and test individual wires for continuity. Refer to Wiring Diagram FO-2 for wire identification.
- e. Close output box and engine access doors.
- f. Connect negative battery cable and close battery access door.

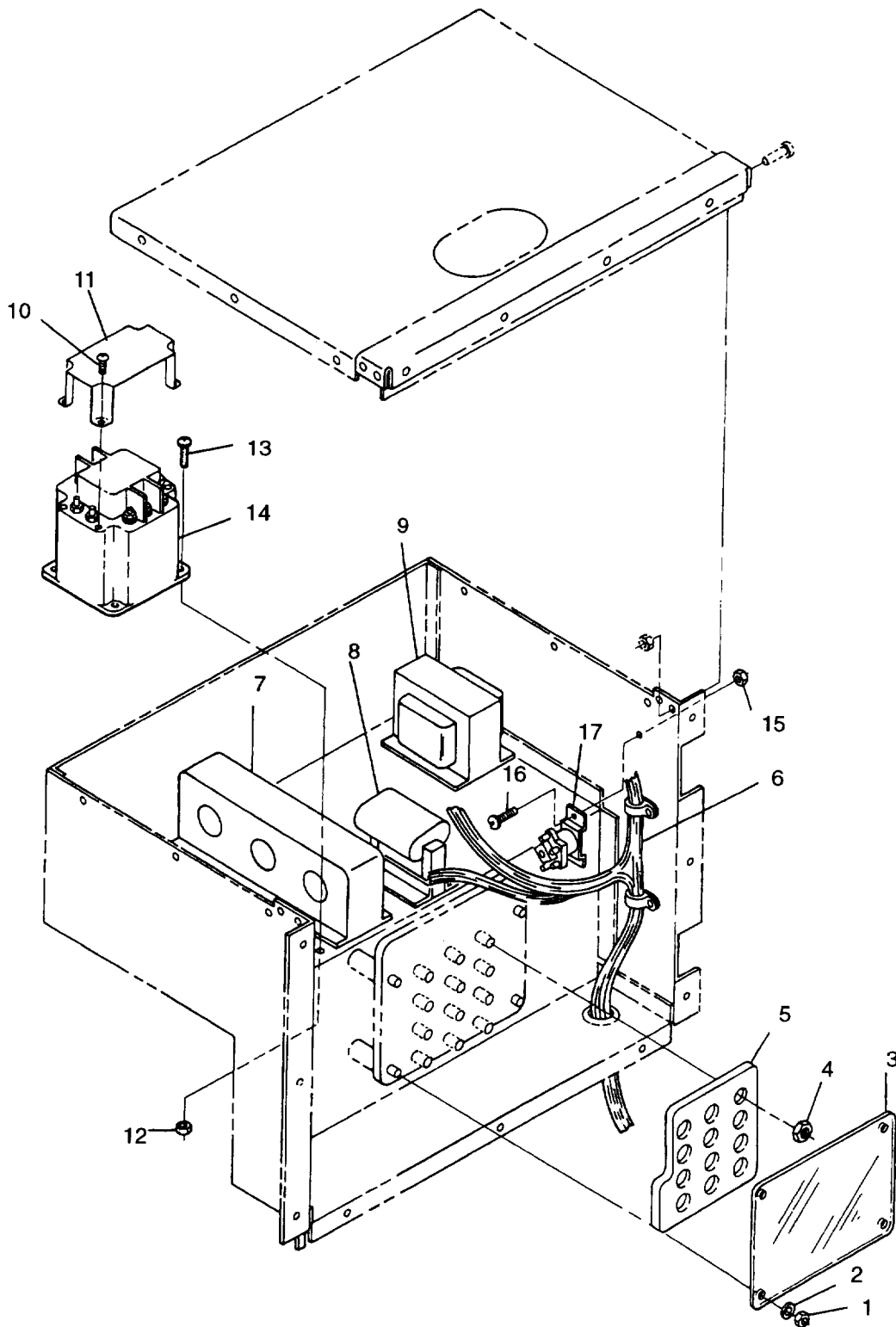

FIGURE 2-29. Output Box Assembly

2.95.3. Repair.

- a. Shut down generator set.
- b. Open battery access door and disconnect negative battery cable.
- c. Open applicable access doors.
- d. Replace damaged terminals and securing hardware.
- e. Connect negative battery cable and close all access doors.

2.96. CURRENT TRANSFORMER.

2.96.1 Inspection.

- a. Shut down generator set.
- b. Open output box access door.
- c. Inspect current transformer (7, FIGURE 2-29) for security, cracked housing, broken or stripped terminals, and loose or missing hardware.
- d. Close output box access door.

2.96.2. Testing.

- a. Shut down generator set.
- b. Open battery access door and disconnect negative battery cable.
- c. Open output box access door.
- d. Tag and disconnect electrical leads from current transformer (7, FIGURE 2-29) secondary terminals.
- e. Set multimeter for ohms and check for continuity between secondary terminals A1 and A2, B1 and B2, and C1 and C2.
- f. If continuity is not present, current transformer is defective. Notify next higher level of maintenance.
- g. If continuity is present, connect electrical leads to secondary terminals and remove tags.
- h. Close output box access door.
- i. Connect negative battery cable and close battery access door.

2.97. DROOP CURRENT TRANSFORMER.

Inspection.

- a. Shut down generator set.
- b. Open output box access door.
- c. Inspect droop current transformer (8, FIGURE 2-29) for cracked housing, security, broken wire terminals, loose or missing hardware, and other damage.
- d. Close output box access door.

2.98. POWER POTENTIAL TRANSFORMER.

Inspection.

- a. Shut down generator set.
- b. Open output box access door.
- c. Inspect power potential transformer (9, FIGURE 2-29) for security, cracked housing, broken wire terminals, loose or missing hardware, and other damage.
- d. Close output box access door.

2.99. AC CIRCUIT INTERRUPTER RELAY.

2.99.1. Inspection.

- a. Shut down generator set.
- b. Open output box access door.
- c. Inspect AC circuit interrupter relay (14, FIGURE 2-29) for security, cracked housing, broken wire terminals, and other damage.
- d. Close output box access door.

2.99.2. Testing.

- a. Shut down generator set.
- b. Open battery access door and disconnect negative battery cable.
- c. Open output box access door.
- d. Set multimeter for ohms and check for open circuits between terminals A1 and A2, B1 and B2, C1 and C2, and 11 and 12.
- e. Connect jumper wire from cranking relay terminal AI to AC circuit interrupter relay terminal X.
- f. Connect negative battery cable.
- g. Check for closed circuits (continuity) between terminals A1 and A2, B1 and B2, C1 and C2, and 11 and 12.
- h. Disconnect negative battery cable.
- i. Replace AC circuit interrupter relay if indications are other than above.
- j. If replacement is not needed, remove jumper wire.
- k. Close output box access door.
- l. Connect negative battery cable and close battery access door.

2.99.3. Removal.

- a. Shut down generator set.
- b. Open battery access door and disconnect negative battery cable.
- c. Open output box access door.
- d. Remove screws (10, FIGURE 2-29) and cover (11) from AC circuit interrupter relay (14).
- e. Tag and disconnect AC circuit interrupter relay (14) electrical leads.
- f. Remove screws (13), nuts (12), and AC circuit interrupter relay (14) from output box.

2.99.4. Installation.

- a. Install AC circuit interrupter relay (14, FIGURE 2-29) in output box with screws (13) and nuts (12).
- b. Connect electrical leads and remove tags.
- c. Install cover (11) on AC circuit interrupter relay (14) with screws (10).
- d. Close output box access door.
- e. Connect negative battery cable. Close battery access door.

2.100. CRANKING RELAY.

2.100.1. Inspection.

- a. Shut down generator set.
- b. Open output box and right side engine access doors.
- c. Inspect cranking relay (17, FIGURE 2-29) for security, cracked housing, broken wire terminals, and other damage.
- d. Close access doors.

2.100.2. Testing.

- a. Shut down generator set.
- b. Open battery access door and disconnect negative battery cable.
- c. Open output box access door.
- d. Tag and disconnect wires from terminals X1, X2, and A2 of cranking relay (17, FIGURE 2-29).
- e. Connect a jumper wire between terminals A1 and X1 of cranking relay.
- f. Connect negative battery cable.
- g. Connect X2 wire disconnected in step d to cranking relay and listen for audible actuation.
- h. Set multimeter for ohms and check for continuity between terminals A1 and A2 of cranking relay. If no continuity is indicated, cranking relay is defective and must be replaced
- i. If replacement is not needed, disconnect negative battery cable.
- j. Remove jumper wire and connect remaining wires to cranking relay as tagged.
- k. Close output box access door.
- l. Connect negative battery cable and close battery access door.

2.100.3. Removal.

- a. Shut down generator set.
- b. Open battery access door and disconnect negative battery cable.
- c. Open output box and right side engine access doors.
- d. Tag and disconnect cranking relay (17, FIGURE 2-29) electrical leads.
- e. Remove screws (16), nuts (15), and cranking relay (17) from output box.

2.100.4. Installation.

- a. Install cranking relay (17, FIGURE 2-29) with screws (16) and nuts (15).
- b. Connect electrical leads and remove tags.
- c. Close output box and right side engine access doors.
- d. Connect negative battery cable. Close battery access door.

2.101. LOAD OUTPUT TERMINAL BOARD.

2.101.1. Removal.

- a. Shut down generator set.
- b. Open battery access door and disconnect negative battery cable.
- c. Open load terminal board access door and disconnect load output cables L1, L2, L3, and L0 from load output terminal board.
- d. Remove generator set housing rear panel, paragraph 2.18.1.
- e. Remove bolt (1, FIGURE 2-30), nut (2), flatwasher (3), and lockwasher (4) securing ground strap (15) to skid base.
- f. Remove bolts (5), lockwashers (6), and washers (7) securing terminal board assembly(12) to supports.
- g. Remove nuts (8) and washers (9), tag and disconnect all main power leads (10) and varistor leads (11) from load terminals (23).
- h. Remove terminal board assembly (12) from generator set.
- i. Remove load output terminals, paragraph 2.102.1.
- j. Remove EMI filter (24) positioned between L0 and GND terminals (23).
- k. Remove varistor leads (11) from varistors (27).
- l. Remove varistors, paragraph 2.103.1.
- m. Remove EMI filters (28) positioned between load terminals (23) and varistors (27).
- n. Remove nuts (13), washers (14), ground strap (15), studs (16), bus bars (17) and (22), and ground plane bar (29) from terminal board (12).
- o. Remove nuts (18) and washers (19) from studs (16).
- p. Remove bolts (30), nuts (31), and load output terminal board supports (32) and (33) from generator set.
- q. Remove nuts (34), bolts (35), cord (36), wrench (37), and bracket (38) from support (33).

2.101.2. Inspection.

- a. Shut down generator set.
- b. Open load terminal board access door.
- c. Inspect load output terminal board for cracks, corrosion, and obvious damage.
- d. Inspect threaded components for stripped threads.
- e. Inspect varistor electrical leads for damaged insulation and loose terminals.
- f. Replace damaged and defective parts.
- g. Close load terminal board access door.

2.101.3. Repair.

Repair load output terminal board assembly by replacing damaged or defective wires, load terminals, EMI filters, and varistors.

2.101.4. Installation.

- a. Install load output terminal board supports (32 and 33), FIGURE 2-30) in generator set with bolts (30) and nuts (31).
- b. Install ground plane bar (29), bus bars (17) and (22), and ground strap (15) on terminal board (12) with studs (16), washers (14) and (19), and nuts (13) and (18).
- c. Position EMI filters (28) between varistors (27) and L1, L2, and L3 load terminals (23) mounting holes.
- d. Install varistors, paragraph 2-103-3.
- e. Position EMI filter (24) between L0 and GND terminals (23) mounting holes.
- f. Install load terminals, paragraph 2.102.3.
- g. Connect leads (11) to varistors (27).
- h. Position load output terminal board assembly in generator set, and connect varistor leads (11) and main power leads (10) to load terminals (23) with washers (9) and nuts (8). Remove tags.
- i. Secure terminal board assembly to supports with washers (7), lockwashers (6), and bolts (5).
- j. Apply a thin coat of antiseize compound (Item 6, Appendix C) to skid at ground strap (15) attaching point.
- k. Install bolt (1), flatwasher (3), lockwasher (4), and nut (2) securing ground strap (15) to skid base.
- l. Install bracket (38), wrench (37), and cord (36) on support (33) with bolts (35) and nuts (34).
- m. Install generator set housing rear panel, paragraph 2.18.4.
- n. Connect load output cables L1, L2, L3, and L0 at load output terminal board and close load terminal access door.
- o. Connect negative battery cable. Close battery access door.

2.102. LOAD OUTPUT TERMINALS.

2.102.1. Removal.

- a. Shut down generator set.
- b. Open battery access door and disconnect negative battery cable.
- c. Open load terminal board access door and disconnect load cables.
- d. Remove load output terminal board assembly from generator set, paragraph 2.101.1.
- e. Remove nuts (20, FIGURE 2-30), copper washers (21), and load terminals (23) from terminal board assembly (12).

2.102.2. Inspection.

- a. Shut down generator set.
- b. Open load terminal board access door.
- c. Inspect load terminals for stripped threads or other obvious damage.
- d. Replace damaged load terminals as necessary.
- e. Close load terminal board access door.

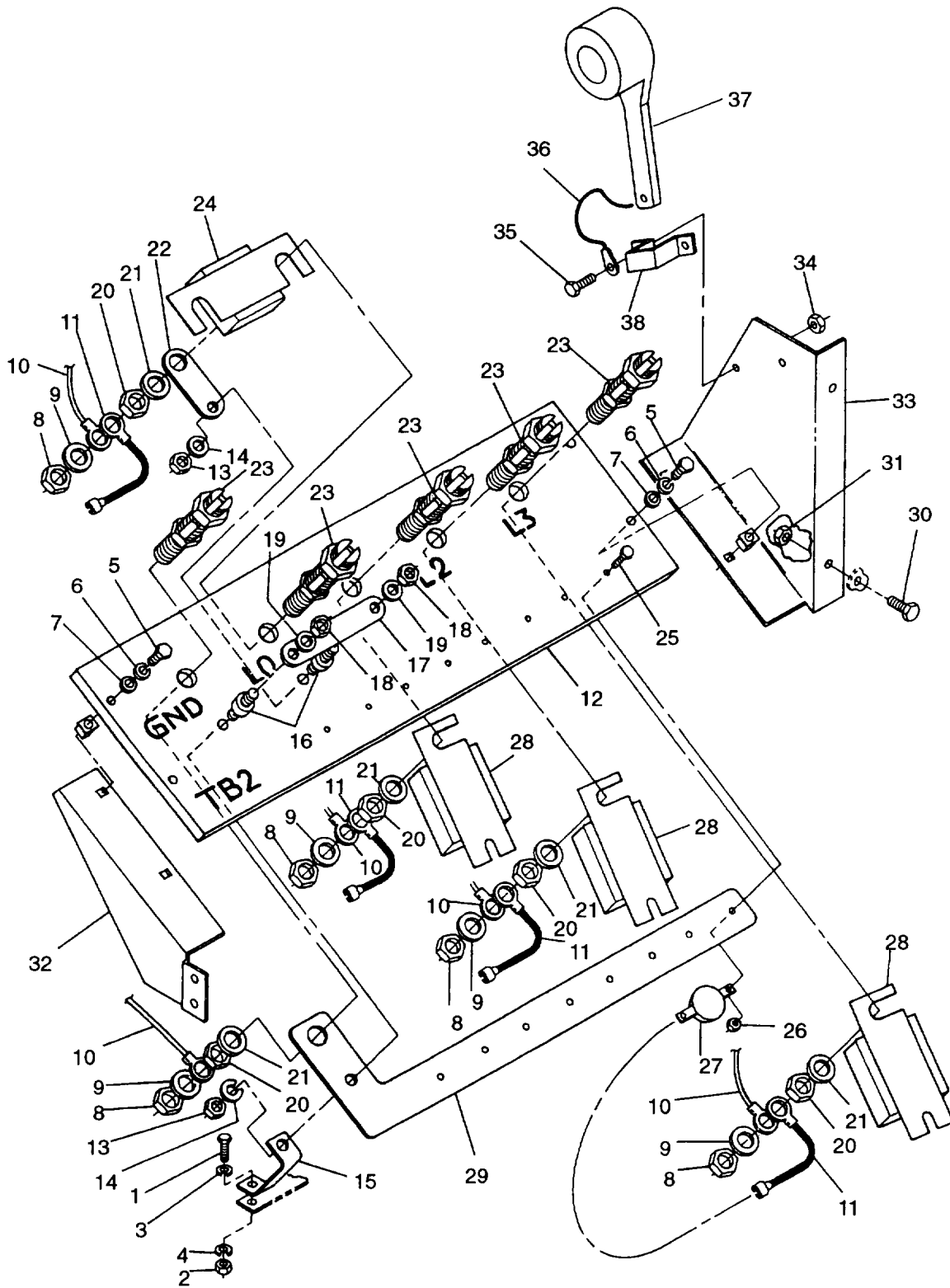

FIGURE 2-30. Load Terminal Board Assembly

2.102.3. Installation.

- a. Install load output terminals (23, FIGURE 2-30) on load output terminal board assembly (12) with copper washers (21) and nuts (20).
- b. Install load output terminal board assembly in generator set, paragraph 2.101.4.

NOTE

Ensure GND load terminal passes through ground plane bracket (29) and L0 load terminal passes through bus bar (22).

- c. Connect load cables and close load terminal board access door.
- d. Connect negative battery cable and close battery access door.

2.103. VARISTORS.

2.103.1. Removal.

- a. Shut down generator set.
- b. Open battery access door and disconnect negative battery cable.
- c. Remove load output terminal board assembly from generator set, paragraph 2.101.1.
- d. Tag and disconnect varistor leads, (11, FIGURE 2-30) from varistors (27).
- e. Remove nuts (26), bolts (25), and varistors (27) from load terminal board assembly (12).

2.103.2. Inspection and Testing.

- a. Shut down generator set.
- b. Remove varistors, paragraph 2.103.1.
- c. Inspect varistors for obvious external damage.
- d. Set multimeter for ohms and test each varistor by connecting multimeter to varistor terminals 1 and 2. Note multimeter indication.
- e. Reverse multimeter leads and note multimeter indication.
- f. Multimeter indications should be infinite ohms in both directions.
- g. Varistors are defective and must be replaced if indications are other than above.
- h. Install varistors, paragraph 2.103.3.

2.103.3. Installation.

- a. Install varistors (27, FIGURE 2-30), on load output terminal board assembly (12) with bolts (25) and nuts (26).
- b. Connect varistor leads (11) to varistors (27) and remove tags.
- c. Install load output terminal board assembly in generator set, paragraph 2.101.4.
- d. Connect negative battery cable and close battery access door.

Section XV. MAINTENANCE OF ENGINE ACCESSORIES

2.104. LOW OIL PRESSURE SWITCH.

2.104.1. Testing.

- a. Shut down generator set.
- b. Open battery access door and disconnect negative battery cable.
- c. Open right side engine access door.
- d. Tag and disconnect electrical leads from low oil pressure switch (1, FIGURE 2-31).
- e. Set multimeter for ohms and connect across switch connector pins C and NO. Multimeter shall indicate open circuit.
- f. Connect multimeter across switch connector pins C and NC. Multimeter shall indicate continuity.
- g. Connect negative battery cable.
- h. Start the generator set. Place BATTLE SHORT switch in the ON position before releasing MASTER SWITCH from START position.
- i. Connect multimeter to switch connector pins C and NC. Multimeter shall indicate open circuit.
- j. Connect multimeter across switch connector pins C and NO. Multimeter shall indicate continuity.
- k. Shut down generator set. Return BATTLE SHORT switch to OFF position.
- l. Disconnect negative battery cable.
- m. If switch fails to meet continuity requirements, replace low oil pressure switch.
- n. If replacement is not needed, connect electrical leads to low oil pressure switch and remove tags.
- o. Close right side engine access door.
- p. Connect negative battery cable and close battery access door.

2.104.2. Removal.

- a. Shut down generator set.
- b. Open battery access door and disconnect negative battery cable.
- c. Open right side engine access door, tag and disconnect low oil pressure switch (1, FIGURE 2-31) electrical leads.
- d. Unscrew low oil pressure switch (1) from oil sample valve assembly.

2.104.3. Cleaning and Inspection.

- a. Shut down generator set.
- b. Remove low oil pressure switch, paragraph 2.104.2.

WARNING

Dry cleaning solvent is flammable and toxic to eyes, skin, and respiratory tract. Skin/eye protection required. Avoid repeated/prolonged contact. Good general ventilation is normally adequate.

WARNING

Use low pressure air, 15 psi maximum. Wear protective glasses when using compressed air. Failure to follow this warning could result in severe personal injury.

- c. Clean low oil pressure switch with dry, filtered compressed air and wipe with a cleaning cloth (Item 7, Appendix C) lightly moistened with dry cleaning solvent (Item 18, Appendix C).
- d. Inspect low oil pressure switch for cracked casing, stripped or damaged threads, corrosion, or other damage.
- e. If no repair is needed, install low oil pressure switch, paragraph 2.104.4.

2.104.4. Installation.

- a. Install low oil pressure switch (1, FIGURE 2-31) into oil sample valve assembly.
- b. Connect electrical leads, remove tags and close right side engine access door.
- c. Connect negative battery cable and close battery access door.

2.105. OIL PRESSURE SENDER.

2.105.1. Testing.

- a. Shut down generator set.
- b. Open battery access door and disconnect negative battery cable.
- c. Open right side engine access door.
- d. Disconnect electrical lead to oil pressure sender (2, FIGURE 2-31).
- e. Set multimeter for ohms and connect between sender terminal and casing.
- f. Multimeter indication shall be between 216 and 264 ohms.
- g. Connect negative battery cable.
- h. Start generator set.
- i. As engine is cranking and accelerates to rated speed, observe multimeter. Indication shall decrease to between 100 and 33 ohms.
- j. Shut down generator set and disconnect negative battery cable.
- k. Replace oil pressure sender if indications are not as above.
- l. If replacement is not needed, connect electrical lead to oil pressure sender.
- m. Close right side engine access door.

n. Connect negative battery cable and close battery access door.

2.105.2. Removal.

- a. Shut down generator set.
- b. Open battery access door and disconnect negative battery cable.
- c. Open right side engine access door and disconnect oil pressure sender (2, FIGURE 2-31) electrical lead.
- d. Unscrew oil pressure sender (2) from engine block.

2.105.3. Cleaning and Inspection.

- a. Shut down generator set.
- b. Remove oil pressure sender, paragraph 2.105.2.

WARNING

Dry cleaning solvent inflammable and toxic to eyes, skin, and respiratory tract. Skin/eye protection required. Avoid repeated/prolonged contact. Good general ventilation is normally adequate.

WARNING

Use low pressure air, 15 psi maximum. Wear protective glasses when using compressed air. Failure to follow this warning could result in severe personal injury.

- c. Clean oil pressure sender with dry, filtered compressed air and wipe with a cleaning cloth (Item 7, Appendix C) lightly moistened with dry cleaning solvent (Item 18, Appendix C).
- d. Inspect oil pressure sender for cracked casing, stripped or damaged threads, corrosion, or other visible damage.
- e. If no repair is needed, install oil pressure sender, paragraph 2.105.4.

2.105.4. Installation.

- a. Screw oil pressure sender (2, FIGURE 2-31) into engine block.
- b. Connect electrical lead and close right side engine access door.
- c. Connect negative battery cable and close battery access door.

2.106. COOLANT TEMPERATURE SENDER.

2.106.1. Testing.

- a. Shut down generator set.
- b. Open battery access door and disconnect negative battery cable.
- c. Open right side engine access door.
- d. Disconnect electrical lead from coolant temperature sender (3, FIGURE 2-31).
- e. Set multimeter for ohms and connect positive lead to temperature sender terminal and negative lead to case. Multimeter indication shall be greater than 300 ohms.
- f. Connect negative battery cable and start generator set.

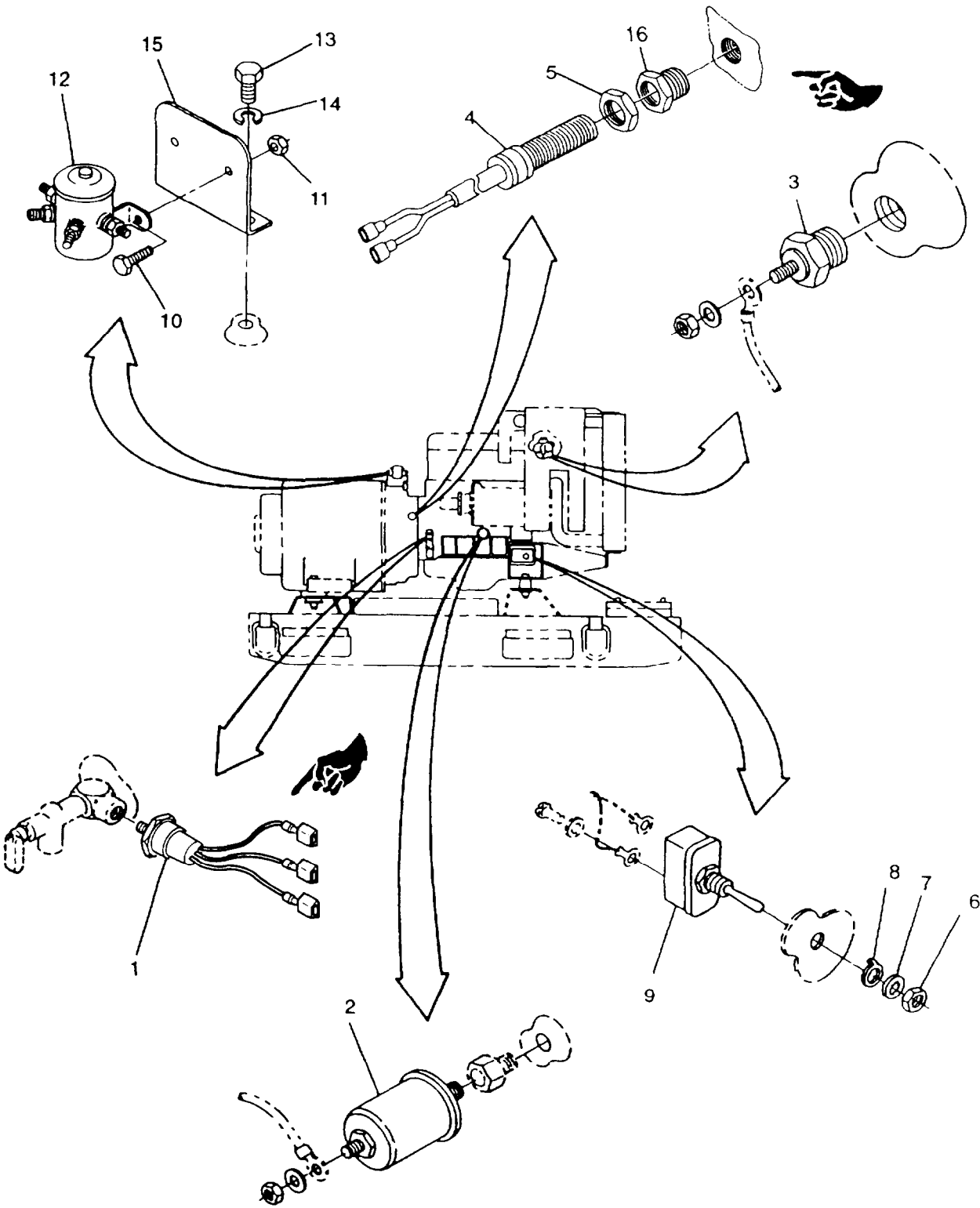

FIGURE 2-31. Engine Switches and Senders, Right Side

- g. Allow the engine to operate while observing multimeter.
- h. Ohms indication should decrease as temperature rises.
- i. Shut down generator set and disconnect negative battery cable
- j. Replace coolant temperature sender if indications are not as above
- k. If replacement is not needed, connect electrical lead to sender.
- l. Close right side engine access door.
- m. Connect negative battery cable and close battery access door.

2.106.2. Removal.

- a. Shut down generator set.
- b. Open battery access door and disconnect negative battery cable

WARNING

Coolant can get very hot. Allow system to cool down before performing maintenance. Failure to follow this warning could result in severe burns and injuries.

WARNING

Always remove radiator cap slowly to permit pressure to escape. Failure to follow this warning could result in severe personal injury.

- c. Slowly remove radiator cap (1, FIGURE 2-23).
- d. Open left side engine access door and open engine block drain valve (1, FIGURE 2-32) and drain coolant into suitable container. Close drain valve.
- e. Open right side engine access door and disconnect coolant temperature sender (3, FIGURE 2-31) electrical lead.
- f. Unscrew temperature sender (3) from engine head.

2.106.3. Cleaning and Inspection.

- a. Shut down generator set.
- b. Remove coolant temperature sender, paragraph 2.106.2.

WARNING

Dry cleaning solvent is flammable and toxic to eyes, skin, and respiratory tract. Skin/eye protection required. Avoid repeated/prolonged contact. Good general ventilation is normally adequate.

WARNING

Use low pressure air, 15 psi maximum. Wear protective glasses when using compressed air. Failure to follow this warning could result in severe personal injury.

- c. Clean temperature sender with dry, filtered compressed air and cleaning cloth (Item 7, Appendix C) lightly moistened with dry cleaning solvent (Item 18, Appendix C).

- d. Inspect temperature sender for cracked casing, corrosion, and damaged threads and connector.
- e. If no repair is needed, install coolant temperature sender, paragraph 2.106.4.

2.106.4. Installation.

- a. Install coolant temperature sender (3, FIGURE 2-31) in engine head.
- b. Connect electrical lead and close right and left side engine access doors.
- c. Add coolant to overflow bottle (5, FIGURE 2-26), as necessary, to replace drained coolant.
- d. Connect negative battery cable and close battery access door.

2.107. COOLANT HIGH TEMPERATURE SWITCH.

2.107 .1. Testing.

- a. Shut down generator set.
- b. Remove coolant high temperature switch, paragraph 2.107.2.
- c. Suspend high temperature switch in a container of 50/50 mixture of antifreeze and water so that sensing element is completely immersed but not touching sides or bottom of container.
- d. Suspend a reliable thermometer in container. Do not allow end of thermometer to rest on bottom of container.
- e. Set multimeter for ohms and check for continuity between switch terminals. Switch operates under open conditions.
- f. Gradually heat antifreeze/water mixture, stirring so that heat will be evenly distributed and observe thermometer and multimeter.
- g. At between 216.5 and 223.5°F (102.5 and 106°C) multimeter should indicate continuity.
- h. Replace high temperature switch if it fails to operate as above.
- i. If replacement is not needed, install coolant high temperature switch, paragraph 2.107.4.

2.107 .2. Removal.

- a. Shut down generator set.
- b. Open battery access door and disconnect negative battery cable.

WARNING

Coolant can get very hot. Allow system to cool down before performing maintenance. Failure to follow this warning could result in severe burns and injuries.

WARNING

Always remove radiator cap slowly to permit pressure to escape. Failure to follow this warning could result in severe personal injury.

- c. Slowly remove radiator cap (1, FIGURE 2-23).

- d. Open left side engine access door. Open engine block drain valve (1, FIGURE 2-32) and drain coolant into suitable container. Close drain valve.
- e. Remove left side fan guard, paragraph 2.77.2.
- f. Tag and disconnect coolant high temperature switch (2) electrical leads.
- g. Unscrew high temperature switch (2) from lower thermostat housing.

2.107.3. Cleaning and Inspection.

- a. Shut down generator set.
- b. Remove coolant high temperature switch, paragraph 2.107.2.

WARNING

Dry cleaning solvent inflammable and toxic to eyes, skin, and respiratory tract. Skin/eye protection required. Avoid repeated/prolonged contact. Good general ventilation is normally adequate.

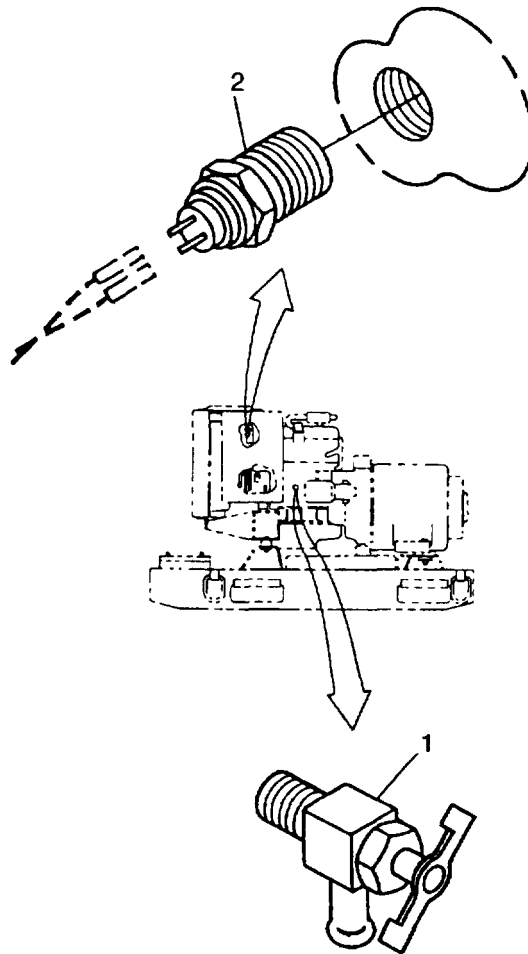

FIGURE 2-32. Engine Switches and Senders, Left Side

WARNING

Use low pressure air, 15 psi maximum, Wear protective glasses when using compressed air. Failure to follow this warning could result in severe personal injury.

- c. Clean high temperature switch with dry, filtered compressed air and cleaning cloth (Item 7, Appendix C) lightly moistened with dry cleaning solvent (Item 18, Appendix C).
- d. Inspect high temperature switch for cracked casing, corrosion, stripped or damaged threads, and bent or broken connector pins.
- e. If no repair is needed, install coolant high temperature switch, paragraph 2.107.4

2.107.4. Installation.

- a. Install coolant high temperature switch (2, FIGURE 2-32) in lower thermostat housing.
- b. Connect electrical leads and remove tags.
- c. Add coolant to overflow bottle (5, FIGURE 2-26), as necessary, to replace drained coolant
- d. Install left side fan guard, paragraph 2.77.3.
- e. Close left side engine access door
- f. Connect negative battery cable and close battery access door.

2.108. MAGNETIC PICKUP.

2.108.1. Removal

- a. Shut down generator set.
- b. Open battery access door and disconnect negative battery cable.
- c. Open right side engine access door, tag and disconnect magnetic pickup (4, FIGURE 2-31) electrical leads.
- d. Loosen lock nut (5) and remove magnetic pickup (4) from flywheel housing. Remove bushing (16).

2.108.2. Cleaning and Inspection.

- a. Shut down generator set
- b. Remove magnetic pickup, paragraph 2.108.1.

WARNING

Dry cleaning solvent is flammable and toxic to eyes, skin, and respiratory tract. Skin/eye protection required. Avoid repeated/prolonged contact. Good general ventilation is normally adequate.

WARNING

Use low pressure air, 15 psi maximum. Wear protective glasses when using compressed air. Failure to follow this warning could result in severe personal injury.

- c. Clean magnetic pickup with dry, filtered compressed air and wipe with a cleaning cloth (Item 7, Appendix C) lightly moistened with dry cleaning solvent (Item 18, Appendix C).
- d. Inspect magnetic pickup for cracked casing, stripped or damaged threads, corrosion, or other visible damage.
- e. If no repair is needed, install magnetic pickup, paragraph 2.108.3.

2.108.3. Installation.

- a. Install bushing (16, FIGURE 2-31) into flywheel housing.
- b. Screw magnetic pickup (4) into flywheel housing until pickup bottoms out on top surface of gear tooth on flywheel. Back magnetic pickup out 1 turn and tighten lock nut (5).
- c. Connect electrical leads and remove tags.
- d. Connect negative battery cable. Close battery access door.
- e. Adjust magnetic pickup in accordance with paragraph 2.108.4.
- f. Close right side access door.

2.108.4. Adjustment.

- a. Release control panel by turning two fasteners and lower control panel slowly.
- b. Disconnect wire 147C from terminal 16 and wire 148C from terminal 17 of governor control Unit.
- c. Set multimeter for ohms and connect to ends of disconnected wires 147C and 148C. Multimeter should indicate between 800 and 900 ohms.
- d. Leave multimeter connected to wires 147C and 148C and set multimeter for AC volts.
- e. Crank engine with DEAD CRANK switch and observe multimeter. Multimeter indication should be between 2.0 and 3.0 VAC.

CAUTION

Do not adjust magnetic pickup inward more than one eighth turn each time, or damage to magnetic pickup may result.

- f. To adjust output voltage in step e, loosen jam nut and turn magnetic pickup in no more than one-eighth turn at a time to increase output voltage, and out no more than one-eighth turn at a time to decrease output voltage. Tighten jam nut.
- g. Repeat steps e and f until proper output voltage is achieved
- h. Remove multimeter, connect wires to governor control unit.
- i. Raise and secure control panel.

2.109. DEAD CRANK SWITCH.

2.109.1. Testing

- a. Shut down generator set
- b. Open battery access door and disconnect negative battery cable.
- c. Open right side engine access door.

- d. Tag and disconnect electrical leads from DEAD CRANK switch (9, FIGURE 2-31).
- e. Set multimeter for ohms and with switch in NORMAL position, check for continuity between contacts 2 and 3.
- f. Move switch to CRANK position and check for continuity between contacts 1 and 2.
- g. If DEAD CRANK switch fails continuity checks, replace switch.
- h. If replacement is not needed, connect electrical leads to switch and remove tags.
- i. Close right side engine access door.
- j. Connect negative battery cable and close battery access door.

2.109.2. Removal.

- a. Shutdown generator set.
- b. Open battery access door and disconnect negative battery cable.
- c. Open right side engine access door and remove nut (6, FIGURE 2-31), lockwasher (7), and tab washer (8).
- d. Remove DEAD CRANK switch (9).
- e. Tag and disconnect DEAD CRANK switch electrical leads.

2.109.3. Installation.

- a. Connect electrical leads to DEAD CRANK switch (9, FIGURE 2-31) and remove tags.
- b. Install DEAD CRANK switch (9) with tab washer (8), lockwasher (7), and nut (6).
- c. Connect negative battery cable. Close battery access door and right side engine access door.

2.110. GLOW PLUGS DC CONTACTOR.

2.110.1. Removal.

- a. Shutdown generator set.
- b. Open battery access door and disconnect negative battery cable.
- c. Open right side engine access door.
- d. Tag and disconnect glow plugs DC contactor (12, FIGURE 2-31) electrical leads.
- e. Remove bolts (10), nuts (11), and contactor (12).
- f. If necessary, remove bolts (13), lockwashers (14), and mounting bracket (15) from flywheel housing.

2.110.2. Testing.

CAUTION

Remove contactor before testing, otherwise damage could occur to the multimeter.

- a. Set multimeter for ohms and check for open circuit between 5/16-inch stud terminals (larger studs at front and rear of contractor).
- b. Apply 24 VDC to 10-32 stud size terminals (smaller studs protruding at 45° angle from contractor).
- c. Listen for audible actuation of contactor and check for closed circuit between 5/16-inch stud terminals.

d. Replace glow plugs DC contactor if indications are other than above.

2.110.3. Installation.

- a. If removed, install mounting bracket (15, FIGURE 2-31) on flywheel housing with bolts (13) and lockwashers (14).
- b. Install glow plugs DC contactor (12) on mounting bracket (15) with bolts (10) and nuts (11).
- c. Connect electrical leads, remove tags, and close right side engine access door.
- d. Connect negative battery cable and close battery access door.

Section XVI. MAINTENANCE OF LUBRICATION SYSTEM

2.111. OIL DRAIN LINE.

2.111.1. Inspection.

- a. Shut down generator set.
- b. Open battery and right side engine access doors.
- c. Inspect oil drain line for cracks, holes, loose or missing hardware, and other damage.
- d. Close battery and right side engine access doors.

2.111.2. Removal.

- a. Shut down generator set.
- b. Open battery access door and disconnect negative battery cable.
- c. Open right side engine access door.
- d. Remove plug (1, FIGURE 2-33), open drain valve (2) and drain engine oil into suitable container.
- e. Remove dampers (3) and drain hose (4) from oil pan fittings and adapter (5).
- f. Remove drain valve (2) from skid fitting.
- g. Remove adapter (5) and pipe fitting (6) from oil drain valve (2).

2.111.3. Installation.

- a. Install adapter (5, FIGURE 2-33) and pipe fitting (6) in oil drain valve (2).
- b. Install drain valve (2) on skid fitting.
- c. Install drain hose (4) on oil pan fittings and adapter (5). Secure with dampers (3).
- d. Ensure drain valve (2) is closed, install plug(1) and service engine oil, paragraph 2.1.2.4.
- e. Check engine oil drain line and valve for leakage.
- f. Connect negative battery cable. Close battery and right side engine access doors.

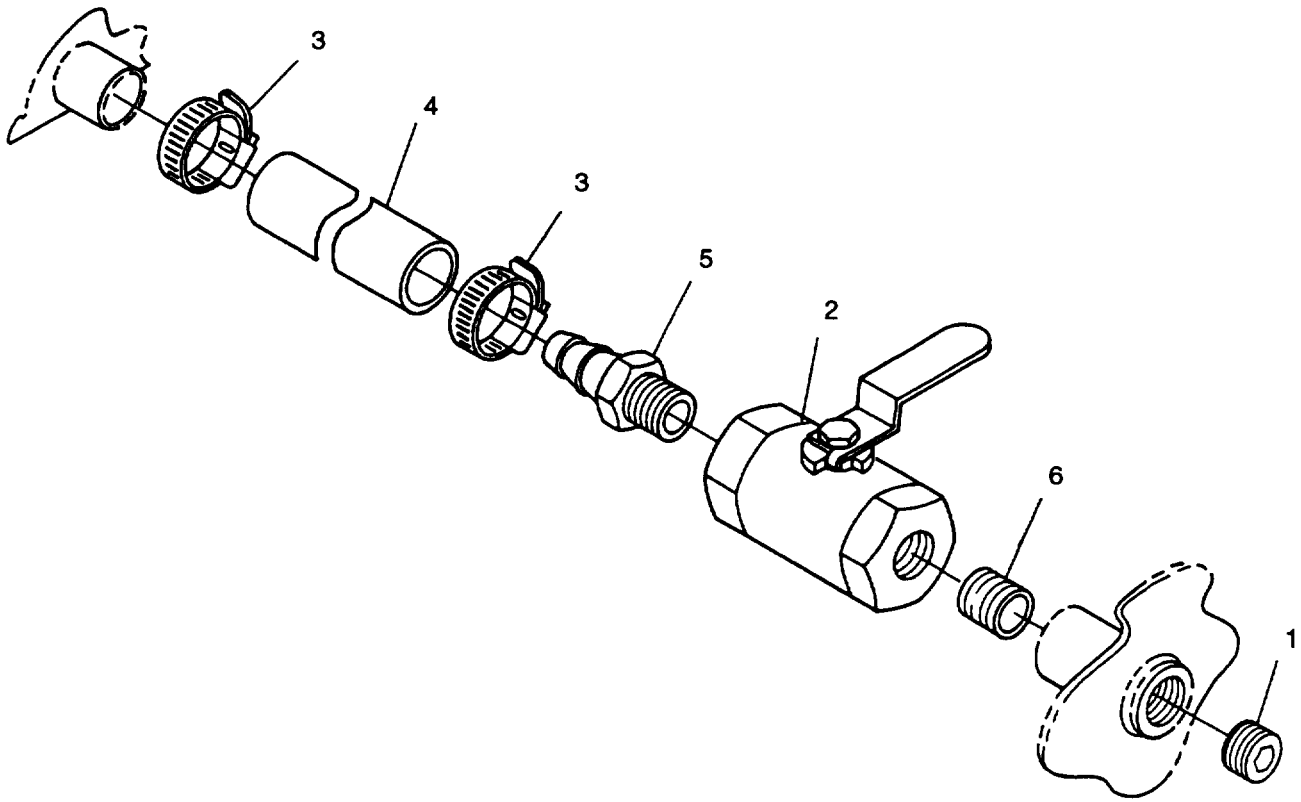

FIGURE 2-33. Oil Drain Line

Section XVII. PREPARATION FOR SHIPMENT AND STORAGE

2.112. PRESERVATION.

Preserve generator sets in accordance with levels A, B, or C of MIL-G-28554.

Preserve generator set cooling systems in accordance with method II of MIL-G-28554 or the antifreeze and water procedure of MIL-E-10062.

2.113. PACKING.

Pack generator sets in accordance with levels A, B, or C of MIL-G-28554.

2.114. MARKING.

Mark for shipment or storage in accordance with MIL-STD-129.

2.115. USE OF CORROSION-PREVENTIVE COMPOUNDS, MOISTURE BARRIERS, AND DESICANT MATERIALS.

(A) Refer to Corrosion and Corrosion Prevention/Metal, MIL-HDBK-729.

2.116. STORAGE.

(A) For storage information refer to TB 740-97-2. (F) Refer to TO 38-1-5.

**CHAPTER 3
GENERAL MAINTENANCE INSTRUCTIONS**

**Section I. REPAIR PARTS; TOOLS; TEST, MEASUREMENT, AND DIAGNOSTIC
EQUIPMENT (TMDE); AND SPECIAL SUPPORT EQUIPMENT**

3.1 MAINTENANCE REPAIR PARTS.

Repair parts and equipment are listed and illustrated in the repair parts and special tools list manual TM 9-6115-643-24P.

3.2 TOOLS AND EQUIPMENT.

There are no special tools or support equipment required to perform any level of maintenance on the generator set. A list of recommended tools and support equipment required to maintain the generator set is contained in Appendix B, Section III.

3.3 FABRICATION OF TOOLS AND EQUIPMENT

No requirement exists for fabrication of tools and equipment for maintenance of the generator set.

Section II. TROUBLESHOOTING

3.4 DIRECT SUPPORT TROUBLESHOOTING PROCEDURES.

3.4.1 Purpose of Troubleshooting Table. This section contains troubleshooting information for locating and correcting operating troubles which may develop in the generator set. Each malfunction for an individual component, unit, or system is followed by a list of tests or inspections which will help you to determine probable causes and corrective actions to take. You should perform the tests/inspections and corrective actions in the order listed.

This table cannot list all malfunctions that can occur, nor all test or inspections and corrective actions. If a malfunction is not listed or cannot be corrected by listed corrective actions, notify your supervisor.

NOTE

Before you use this table, be sure you have performed your PMCS.

NOTE

Before you use this table, be sure unit level troubleshooting steps have been performed.

NOTE

Refer to the Electrical Schematic FO-1 and Wiring Diagram FO-2 as troubleshooting aids.

SYMPTOM INDEX GENERATOR SET

Troubleshooting
Procedure
Page

ENGINE

Cranks but failsto start	3-4
Runs erratically or stalls frequently	3-4
Misfiring	3-5
Does not develop full power...	3-7
Coolant in crankcase or oil in coolant	3-11
Abnormal noise	3-11

EXHAUST SYSTEM

Black or grey smoke in exhaust.	3-8
Blue or white exhaust smoke...	3-9

GENERATOR SET

Fails to generate power	3-14
Fails to generate sufficient voltage	3-15
Output fluctuates	3-15
Overheats	3-16
Noisy when running	3-16

LUBRICATION SYSTEM

Low oil pressure	3-10
High oil pressure	3-11

TABLE 3-1. DIRECT SUPPORT TROUBLESHOOTING

MALFUNCTION	TEST OR INSPECTION	CORRECTIVE ACTION
1.	<u>ENGINE FAILS TO START</u>	
	Step 1.	Check for defective fuel pump, refer to TM 9-2815-254-24. a. If fuel pump is not defective, do step 2. b. If defective, replace fuel feed pump in accordance with TM 9-2815-254-24.
	Step 2.	Test fuel injection pump timing, refer to TM 9-2815-254-24. a. If injection pump timing is correct, do step 3. b. If not correctly timed, time fuel injection pump in accordance with TM 9-2815-254-24.
	Step 3.	Test for defective governor activator, paragraph 4.14.1. a. If governor actuator is not defective, do step 4. b. If defective, replace governor activator, paragraph 4.14.3.
	Step 4.	Test for defective fuel injection pump, refer to TM 9-2815-254-24. a. If fuel injection pump is not defective, do step 5. b. If defective, repair or replace fuel injection pump in accordance with TM 9-2815-254-24.
	Step 5.	Test for defective governor control unit, paragraph 4.2.1. If defective, replace governor control unit, paragraph 4.2.3.
2.	<u>ENGINE RUNS ERRATICALLY OR STALLS FREQUENTLY.</u>	
	Step 1.	Test fuel injection pump timing, refer to TM 9-2815-254-24. a. If fuel injection pump timing is correct, do step 2. b. If not correctly timed, time fuel injection pump in accordance with TM 9-2815-254-24.
	Step 2.	Test for defective fuel injection pump, refer to TM 9-2815-254-24. a. If fuel injection pump is not defective, do step 3. b. If defective, repair or replace fuel injector pump in accordance with TM 9-2815-254-24.
	Step 3.	Check for valve adjustment, refer to TM 9-2815-254-24 a. If valves are properly adjusted, do step 4. b. If improperly adjusted, adjust valves in accordance with TM 9-2815-254-24.
	Step 4.	Check cylinder head gasket for leaks, refer to TM 9-2815-254-24. a. If cylinder head gasket is not leaking, do step 5, b. If leaking, repair or replace cylinder head gasket in accordance with TM 9-2815-254-24.
	Step 5.	Check for stuck or burnt valves, refer to TM 9-2815-254-24. a. If valves are not stuck or burnt, do step 6. b. If stuck or burnt, replace valves in accordance with TM 9-2815-254-24.

TABLE 3-1. DIRECT SUPPORT TROUBLESHOOTING - Continued

MALFUNCTION TEST OR	INSPECTION CORRECTIVE ACTION
<p>Step 6.</p> <p>Step 7.</p>	<p>Test for defective governor control unit, paragraph 4.2.1.</p> <p>a. If governor control unit is not defective, do step 7.</p> <p>b. If defective, replace governor control unit, para 4,2.3.</p> <p>Check for low engine compression, refer to TM 9-2815-254-24.</p> <p>If compression is low, repair or replace engine in accordance with TM 9-2815-254-24.</p>
3.	<p><u>ENGINE MISFIRNG.</u></p> <p>Step 1. Check for dirty fuel injector.</p> <p>a. Remove and inspect fuel injector in accordance with TM 9-2815-254-24. If not dirty, do step 2.</p> <p>b. If dirty, clean fuel injector or if defective, replace in accordance with TM 9-2815-254-24.</p> <p>Step 2. Test for defective governor, refer to paragraph 4.14.1.</p> <p>a. If governor is not defective, do step 3.</p> <p>b. If defective, replace governor in accordance with paragraph 4.14.2.</p> <p>Step 3. Test fuel injection pump timing, refer to TM 9-2815-254-24.</p> <p>a. If fuel injection pump timing is correct, do step 4.</p> <p>b. If timing is not correct, time fuel injection pump in accordance with TM 9-2815-254-24.</p> <p>Step 4. Test for defective fuel injection pump, refer to TM 9-2815-254-24.</p> <p>a. If fuel injection pump is not defective, do step 5.</p> <p>b. If defective, repair or replace fuel injector pump in accordance with TM 9-2815-254-24.</p> <p>Step 5. Check valve adjustment, refer to TM 9-2815-254-24.</p> <p>a. If valves are properly adjusted, do step 6.</p> <p>b. If improperly adjusted, adjust valves in accordance with TM 9-2815-254-24.</p> <p>Step 6. Check for weak valve springs, refer to TM 9-2815-254-24.</p> <p>a. If valve springs are not weak, do step 7.</p> <p>b. If weak, replace valve springs in accordance with TM 9-2815-254-24.</p> <p>Step 7. Check for stuck or burnt valves, refer to TM 9-2815-254-24.</p> <p>a. If valves are not stuck or burnt, do step 8.</p> <p>b. If stuck or burnt, replace valves in accordance with TM 9-2815-254-24.</p> <p>Step 8. Test for low engine compression, refer to TM 9-2815-254-24.</p> <p>If compression is low, repair or replace engine in accordance with TM 9-2815-254-24.</p>

TABLE 3-1. DIRECT SUPPORT TROUBLESHOOTING - Continued

MALFUNCTION	TEST OR INSPECTION	CORRECTIVE ACTION
4. ENGINE DOES NOT DEVELOP FULL POWER.		
Step 1.	Check for dirty fuel injectors.	a. Remove and inspect fuel injectors in accordance with TM 9-2815-254-24. If not dirty, do step 2.
Step 2.	Test for defective governor, refer to paragraph 4.14.1.	a. If governor is not defective, do step 3. b. If defective, replace governor in accordance with paragraph 4.14.2.
Step 3.	Test for defective governor control unit, paragraph 4.2.1.	a. If governor control unit is not defective, do step 4. b. If defective, replace governor control unit, para 4.2.3.
Step 4.	Test fuel injection pump timing, refer to TM 9-2815-254-24.	a. If fuel injection pump timing is correct, do step 5. b. If timing is not correct, time fuel injection pump in accordance with TM 9-2815-254-24.
Step 5.	Check valve adjustment, refer to TM 9-2815-254-24.	a. If valves are properly adjusted, do step 6. b. If improperly adjusted, adjust valves in accordance with TM 9-2815-254-24.
Step 6.	Check for weak valve springs, refer to TM 9-2815-254-24.	a. If valve springs are not weak, do step 7. b. If weak, replace valve springs in accordance with TM 9-2815-254-24.
Step 7.	Check for stuck or burnt valves, refer to TM 9-2815-254-24.	a. If valves are not stuck or burnt, do step 8. b. If stuck or burnt, replace valves in accordance with TM 9-2815-254-24.
Step 8.	Test for defective cylinder head gasket, refer to TM 9-2815-254-24.	a. If cylinder head gasket is not defective, do step 9. b. If defective, replace cylinder head gasket in accordance with TM 9-2815-254-24.
Step 9.	Test for low engine compression, refer to TM 9-2815-254-24.	If compression is low, repair or replace engine in accordance with TM 9-2815-254-24.
5 . BLACK OR GRAY SMOKE IN EXHAUST.		
Step 1.	Check for defective fuel injectors.	a. Remove and inspect fuel injectors in accordance with TM 9-2815-254-24. If not dirty, do step 2. b. If dirty, clean fuel injectors or if defective, replace in accordance with TM 9-2815-254-24.
Step 2.	Test fuel injection pump timing, refer to TM 9-2815-254-24.	If timing is not correct, time fuel injection pump in accordance with TM 9-2815-254-24.

TABLE 3-1. DIRECT SUPPORT TROUBLESHOOTING - Continued

MALFUNCTION	TEST OR INSPECTION	CORRECTIVE ACTION
6.	<u>BLUE OR WHITE EXHAUST SMOKE.</u>	<p>Test fuel injection pump timing, refer to TM 9-2815-254-24.</p> <p>If timing is not correct, time fuel injection pump in accordance with TM 9-2815-254-24.</p>
7.	<u>LOW OIL PRESSURE.</u>	<p>Step 1. Check oil relief valve for proper operation, refer to TM 9-2815-254-24.</p> <p>a. If oil relief valve is operating properly, notify next higher level of maintenance.</p> <p>b. If not operating properly, replace oil relief valve in accordance with TM 9-2815-254-24.</p>
8.	<u>HIGH OIL PRESSURE.</u>	<p>Test for defective oil relief valve, refer to TM 9-2815-254-24.</p> <p>If defective, replace oil relief valve in accordance with TM 9-2815-254-24.</p>
9.	<u>COOLANT IN CRANKCASE OR OIL IN COOLANT.</u>	<p>Step 1. Check for cracked cylinder head, refer to TM 9-2815-254-24.</p> <p>a. If cylinder head is not cracked, do step 2.</p> <p>b. If cracked, replace cylinder head in accordance with TM 9-2815-254-24.</p> <p>Step 2. Check for defective cylinder head gasket, refer to TM 9-2815-254-24.</p> <p>a. If defective, replace cylinder head gasket in accordance with TM 9-2815-254-24.</p> <p>b. If not defective and problem persists, replace engine, refer to TM 9-2815-254-24.</p>
10.	<u>ABNORMAL ENGINE NOISE.</u>	<p>Step 1. Check for defective engine mounts.</p> <p>a. If engine mounts are not defective, do step 2.</p> <p>b. If engine mounts are defective, replace mounts, paragraph 3.6.2.</p> <p>Step 2. Check for dirty fuel injectors.</p> <p>a. Remove and inspect fuel injectors in accordance with TM 9-2815-254-24. If not dirty, do step 3.</p> <p>b. If dirty, clean fuel injectors, or if defective, replace in accordance with TM 9-2815-254-24.</p> <p>Step 3. Check for worn rocker arm shaft, refer to TM 9-2815-254-24.</p> <p>a. If rocker arm shaft is not worn, do step 4.</p> <p>b. If worn, replace shaft and/or rocker arms in accordance with TM 9-2815-254-24.</p>

TABLE 3-1. DIRECT SUPPORT TROUBLESHOOTING - Continued

MALFUNCTION	TEST OR INSPECTION	CORRECTIVE ACTION
Step 4.	Check for bent push rods, refer to TM 9-2815-254-24.	a. If push rods are not bent, do step 5. b. If bent, replace push rods in accordance with TM 9-2815-254-24.
Step 5.	Check for worn idler gears, refer to TM 9-2815-254-24.	a. If idler gears are not worn, do step 6. b. If worn, replace idler gears in accordance with TM 9-2815-254-24.
Step 6.	Test fuel injection pump timing, refer to TM 9-2815-254-24.	a. If fuel injection pump timing is correct, do step 7. b. If timing is not correct, time fuel injection pump in accordance with TM 9-2815-254-24.
Step 7.	Check for foreign material in combustion chambers, refer to TM 9-2815-254-24.	a. If foreign material is found, clean combustion chamber(s) in accordance with TM 9-2815-254-24. b. If no foreign matter is found, and problem persists, refer to TM 9-2815-254-24.
11.	<u>GENERATOR SET FAILS TO GENERATE POWER.</u>	
Step 1.	Test for defective governor control unit, paragraph 4.2.1.	a. If a governor control unit is not defective, do step 2. b. If defective, replace governor control unit, paragraph 4.2.3.
Step 2.	Test for defective AC voltage Regulator, paragraph 4.1.	a. If voltage regulator is not defective, do step 3. b. If defective replace voltage regulator, paragraph 4.1.5.
Step 3.	Test for defective generator exciter stator, paragraph 4.20.1 (MEP-804A) or paragraph 4.28.2 (MEP-814A).	a. If exciter stator is not defective, do step 4. b. If defective, replace exciter stator, paragraph 4.20 (MEP804A) or paragraph 4.28 (MEP-814A).
Step 4.	Test for defective generator stator, paragraph 4.23.1 (MEP-804A) or paragraph 4.31.2 (MEP-814A).	a. If generator stator is not defective, do step 5. b. If defective, replace generator stator and housing assembly, paragraph 4,23 (MEP-804A) or paragraph 4.31 (MEP-81 4A).
Step 5.	Test for defective diode(s) in generator rotating rectifier, paragraph 4.17.1 (MEP-804A) or paragraph 4.25.2 (MEP-814A).	a. If diodes are not defective, do step 6. b. If defective, replace diode(s), paragraph 4.17 (MEP-804A) or paragraph 4.25 (MEP-814A).

TABLE 3-1. DIRECT SUPPORT TROUBLESHOOTING - Continued

MALFUNCTION	TEST OR INSPECTION	CORRECTIVE ACTION
Step 6.	Test for defective generator rotor, paragraph 4.22.1 (MEP-804A) or paragraph 4.30.2 (MEP-814A).	<ul style="list-style-type: none"> a. If generator rotor is not defective, do step 7. b. If defective, replace generator rotor assembly, paragraph 4.22 (MEP-804A) or paragraph 4.30 (MEP-814A).
Step 7.	Test for defective generator exciter rotor, paragraph 4.21.1 (MEP-804A) or paragraph 4.29.2 (MEP-814A).	If defective, replace generator exciter rotor, paragraph 4.21 (MEP-804A) or paragraph 4.29 (MEP-814A).
12.	<u>GENERATOR SET FAILS TO GENERATE SUFFICIENT VOLTAGE.</u>	
Step 1.	Check for low engine speed, refer to TM 9-2815-254-24.	
	<ul style="list-style-type: none"> a. If engine is operating correctly, do step 2. b. If engine is not operating correctly, repair in accordance with TM 9-2815-254-24. 	
Step 2.	Check for defective fuel injection nozzles, TM 9-2815-254-24.	
	<ul style="list-style-type: none"> a. If fuel injection nozzles are not defective, do step 3. b. If defective, repair or replace fuel injection nozzles. 	
Step 3.	Test for defective generator stator, paragraph 4.23.1 (MEP-804A) or paragraph 4.31.2 (MEP-814A).	
	If defective, replace generator stator and housing assembly, paragraph 4.23 (MEP-804A) or paragraph 4.31 (MEP-81 4A).	
13.	<u>GENERATOR SET OUTPUT FLUCTUATES.</u>	
Step 1.	Check for irregular engine speed, refer to TM 9-2815-254-24.	
	<ul style="list-style-type: none"> a. If engine is operating correctly, do step 2. b. If engine is not operating correctly, repair in accordance with TM 9-2815-254-24. 	
Step 2.	Check for loose terminations, refer to FO-1.	
	<ul style="list-style-type: none"> a. If terminations are tight, do step 3. b. If loose, tighten terminals. 	
Step 3.	Check voltage regulator for incorrect output, paragraph 4.1.1.	
	<ul style="list-style-type: none"> a. If voltage regulator is operating properly, do step 4. b. If voltage regulator is inoperative, replace voltage regulator, paragraph 4.1.5. 	
Step 4.	Test for intermediate short in generator exciter field, paragraph 4.20.1 (MEP-804A) or paragraph 4.28.2 (MEP-814A).	
	If shorted, replace exciter stator, paragraph 4.20 (MEP-804A) or paragraph 4.28 (MEP-814A).	

TABLE 3-1. DIRECT SUPPORT TROUBLESHOOTING - Continued

MALFUNCTION	TEST OR INSPECTION	CORRECTIVE ACTION
14.	<u>GENERATOR OVERHEATS.</u>	<p>Step 1. Check for clogged air intake screens.</p> <ul style="list-style-type: none"> a. If air intake screens are not clogged, do step 2. b. If clogged, clean air intake screens. <p>Step 2. Check for defective fan, paragraph 2.83.1.</p> <ul style="list-style-type: none"> a. If fan is not defective, do step 3. b. If defective, replace fan, paragraph 4.21.3 (MEP-804A) and paragraph 4.30.1 (MEP-814A). <p>Step 3. Check for dry generator main bearing, paragraph 4.18 (MEP-804A) or paragraph 4.26 (MEP-814A).</p> <p>If dry, replace main bearing, paragraph 4.18 (MEP-804A) or paragraph 4.26 (MEP-814A)</p>
15.	<u>GENERATOR NOISY WHEN RUNNING.</u>	<p>Step 1. Check for defective generator main bearing, paragraph 4.18 (MEP-804A) or paragraph 4.26 (MEP-814A).</p> <ul style="list-style-type: none"> a. If generator main bearing is not defective, do step 2. b. If defective, replace main bearing, paragraph 4.18 (MEP804A) or paragraph 4.26 (MEP-814A). <p>Step 2. Check for loose engine/generator coupling, paragraph 3.7.2, step j</p> <ul style="list-style-type: none"> a. If engine/generator coupling is not loose, do step 3. b. If loose, tighten engine/generator coupling bolts, paragraph 3.7.2 step j. <p>Step 3. Test for defective generator.</p> <p>If defective, replace generator, paragraph 4.16.</p>

Section III. REMOVAL AND INSTALLATION OF MAJOR COMPONENTS

3.5 GENERAL.

The engine and generator are bolted together at the engine flywheel and flywheel housing adapter. The engine and generator may be removed as an assembly or separately. The engine and generator assembly is mounted on the skid base at four points. There are also brackets installed on both sides of the engine to support rear of engine when removing generator separately.

3.6 ENGINE AND GENERATOR ASSEMBLY.

3.6.1 Removal.

- a. Shut down generator set.
- b. Open battery access door and disconnect negative battery cable
- c. Remove generator set housing, paragraphs 2.16.1, 2.17.1 and 2.18.1.
- d. Remove radiator, paragraph 2.81.1.
- e. Drain engine oil and disconnect oil drain line at oil pan, paragraph 2.11.1.2.
- f. Disconnect fuel line at fuel transfer pump from fuel pickup, paragraph 2.85.1.
- g. Disconnect engine excess fuel return line at tank fitting and fuel filter/water separator fuel lines at engine fittings, paragraph 2.85.1.
- h. Disconnect coolant overflow hose from overflow bottle, paragraph 2.80.1.
- i. Disconnect block coolant drain line at engine fitting, paragraph 2.80.1

NOTE

On 400Hz generator set, attaching parts mount from underside of generator

- j. Remove nuts (1, FIGURE 3-1) washers (2), snubbing washers (3), and bolts (4) from engine mounts (5).
- k. Remove rear forklift guide from generator set, paragraph 4.33.1
- l. Remove nuts (6), washers (7), snubbing washers (8), bolts (9), and Belleville washers (10) from generator mounts.
- m. Tie wrap generator power leads and secure out of the way.

CAUTION

Rated capacity of overhead hoist should be at least 2000 lbs (907 Kg). Arrange lifting device so that it supports both engine and generator to avoid undue stress on the engine-generator coupling.

- n. Attach lifting harness to engine and generator lifting points. Raise engine and generator assembly from skid base.

- o. Move engine and generator assembly to maintenance work area. Support assembly on maintenance stand or fixture.
- p. Remove engine shock mounts (14) from skid base by removing nuts (11), washers (12), and bolts (13).
- q. Remove shock mounts (15) from generator mounting points on skid base.
- r. Remove engine support bracket (5) by removing nuts (16), washers (17), and bolts (18).
- s. Remove engine support brackets (22) by removing bolts (19), lockwashers (20), and washers (21).
- t. Remove generator mount angles (29), plates (28), nuts (23) and (27), washers (24) and (26), and bolts (25) from generator.
- u. Remove bolts (30), lockwashers (31), washers (32), nuts (33), and bracket (34) from engine.
- v. Remove bolts (35) and bracket (36) from engine.

3.6.2 Installation.

- a. Install bracket (36, FIGURE 3-1) on engine with bolts (35).
- b. Install bracket (34) on engine with bolts (30), lockwashers (31), washers (32), and nuts (33).
- c. Install engine shock mounts (14) on skid base with bolts (13), washers (12), and nuts (11).
- d. Position generator shock mounts (15) in skid base.
- e. Install engine support bracket (5) on engine with bolts (18), washers (17), and nuts (16). Torque nuts (16) to 31 ft-lbs (42 Nm).
- f. Install engine support brackets (22) on engine with bolts (19), lockwashers (20), and washers (21).
- g. Install generator mount angles (29) and plate: (28) on generator with bolts (25), washers (24) and (26), and nuts (23) and (27).

CAUTION

Rated capacity of overhead hoist should be at least 2000 lbs (907 Kg).
Arrange lifting device so that it supports both engine and generator to avoid undue stress on the engine and generator coupling.

- h. Attach lifting harness to engine and generator lifting points. Raise engine and generator assembly from maintenance stand or fixture.
- i. Position engine and generator assembly on skid base aligning mounting holes and brackets.
- j. Install bolts (9), Belleville washers (10), snubbing washers (8), washers (7), and nuts (6) to secure generator to skid base Torque bolts (9) to 210 ft-lbs (285 Nm).

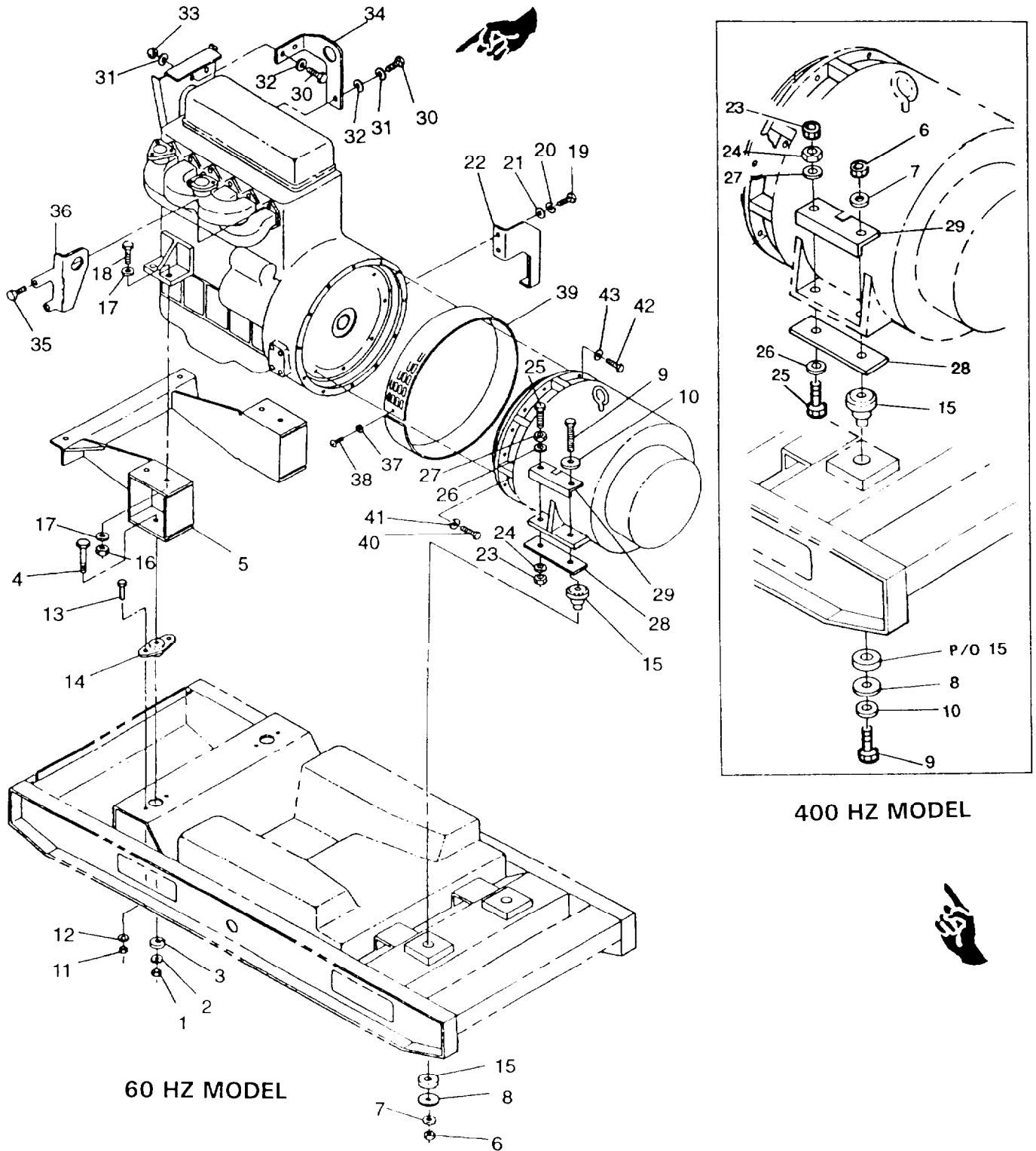

FIGURE 3-1. Engine and Generator Assembly

- k. Adjust nuts (23) and (27) to obtain 0.5 in. minimum clearance between ends of bolts (25) and skid base.
- l. Install bolts (4), snubbing washers (3), washers (2), and nuts (1) to secure engine to skid base Torque bolts (4) to 75 ft-lbs (102 Nm).
- m. Install rear forklift guide in skid base, paragraph 4.33.3.
- n. Connect oil drain line to oil pan, paragraph 2.109.11.
- o. Connect coolant overflow hose to overflow bottle, paragraph 2.80.3.
- p. Connect block coolant drain line at engine fitting, paragraph 2.80.3.
- q. Install radiator, paragraph 2.81.4.
- r. Connect fuel line to fuel transfer pump from fuel pickup, paragraph 2.85.2.
- s. Connect engine excess fuel return line at tank fitting and fuel filter/water separator fuel lines at engine fittings, paragraph 2.85.2.
- t. Install generator set housing, paragraphs 2.16.4, 2.17.4 and 2.18.4.
- u. Service engine lubrication system, paragraph d.
- v. Service coolant system, paragraph b.
- w. Connect negative battery cable. Close battery access door
- x. Start generator set. Perform operational checks and check for leaks.

3.7 ENGINE ASSEMBLY.

3.7.1 Removal.

- a. Shut down generator set.
- b. Open battery access door and disconnect negative battery cable.
- c. Using a suitable container, drain engine oil.

WARNING

Allow system to cool down. Remove radiator cap slowly to permit pressure to escape. Failure to follow these instructions could result in severe burns and injuries.

- d. Using a suitable container, drain engine coolant from radiator and engine block.
- e. Remove control box assembly, paragraph 2.19.2.
- f. Remove bolts (1 and 4, FIGURE 3-2), lockwashers (2) and (5), washers (3) and (6), and top housing panel (7) from generator set.
- g. Loosen clamp (1, FIGURE 3-3) at radiator (2), and disconnect filler hose and panel assembly (5) from radiator.
- h. Loosen clamp (3) and disconnect overflow hose (4) from filler hose and panel assembly (5).

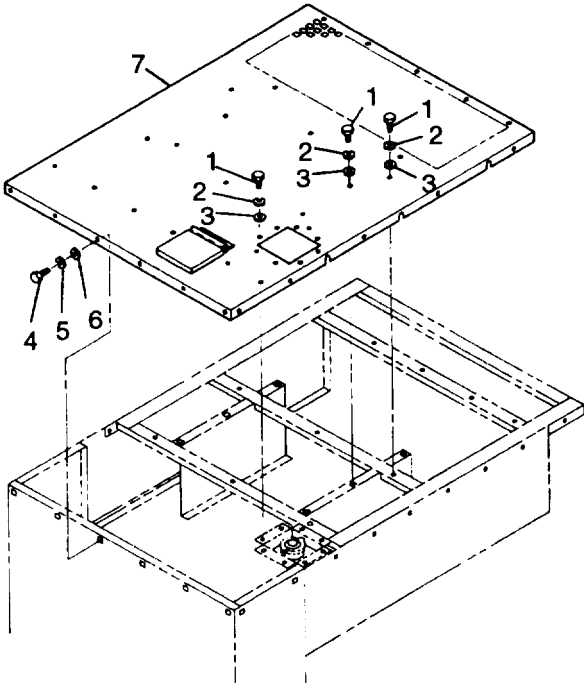

FIGURE 3-2. Generator Set Top Housing Panel

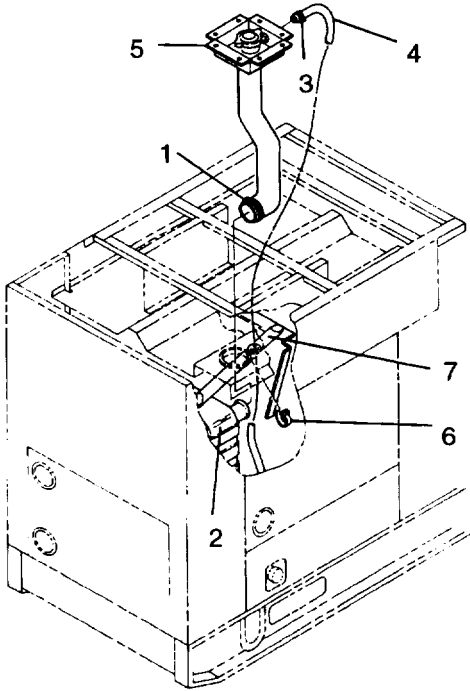

FIGURE 3-3. Filler Hose and Panel Assembly

- i. Remove filler hose and panel assembly (5) from generator set.
- j. Cut wire ties (6) supporting overflow hose (4) to upper radiator supports (7).
- k. Remove clamp (1, FIGURE 3-4) and disconnect hose (2) from overflow bottle assembly (6).
- l. Remove bolts (3), nuts (4), lockwashers (5), and overflow bottle assembly (6) from left side of engine.
- m. Remove exhaust pipe clamp (1, FIGURE 3-5) at exhaust manifold adapter (2).
- n. Remove nuts (3), lockwashers (4), washers(6), and bolts (5) securing top housing assembly (11) to front housing.
- o. Remove assembled nuts (7) and bolts (8) securing top housing assembly (11) to rear side panels.
- p. Remove assembled nut (9) and bolt (10) securing top housing assembly (11) to output box angle.
- q. Using a lifting device, remove top housing assembly (11).
- r. Remove fan guards and mounting brackets, paragraph 2.77.2.
- s. Remove nuts (1, FIGURE 3-6), lockwashers (2) and (6), bolts (3) and (5), washers (4), and support rods (7) from engine lifting bracket and radiator assembly (27).
- t. Remove bolts (10) and (12), washers(11) and (14), lockwashers (9) and (13), nuts (8), and shroud halves(15) from radiator assembly (27).
- u. Remove bolts (16) and fan (17) from water pump.
- v. Loosen clamp (18) at thermostat housing and disconnect hose (1 9).
- w. Loosen clamp (20) at water pump and disconnect hose (21).
- x. Remove clamp (22) at radiator drain valve (24) and disconnect hose (23).
- y. Remove nuts (25) and washers (26) securing radiator assembly (27). With the aid of an assistant, remove radiator assembly (27) and shims (28).
- z. Remove bolts (1 and 4, FIGURE 3-7), washers (3) and (5), lockwashers (2) and (6), nuts (7), and rear housing panel (8) from generator set.
- aa. Loosen clamp (1, FIGURE 3-8) securing fuel filler panel assembly (6) to fuel tank. Cap openings.
- ab. Loosen clamp (2) and disconnect hose (3) from fuel filler panel assembly (6). Cap openings.
- ac. Disconnect fuel hose (4) from fuel line (5). Cap openings.
- ad. Tag and disconnect auxiliary fuel pump (7) and fuel float module (8) electrical connectors.

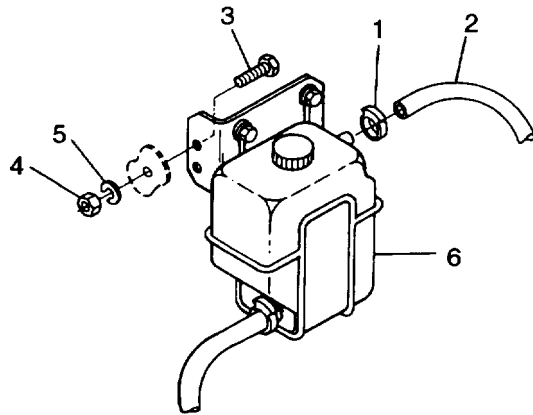

FIGURE 3-4. Overflow Bottle Assembly

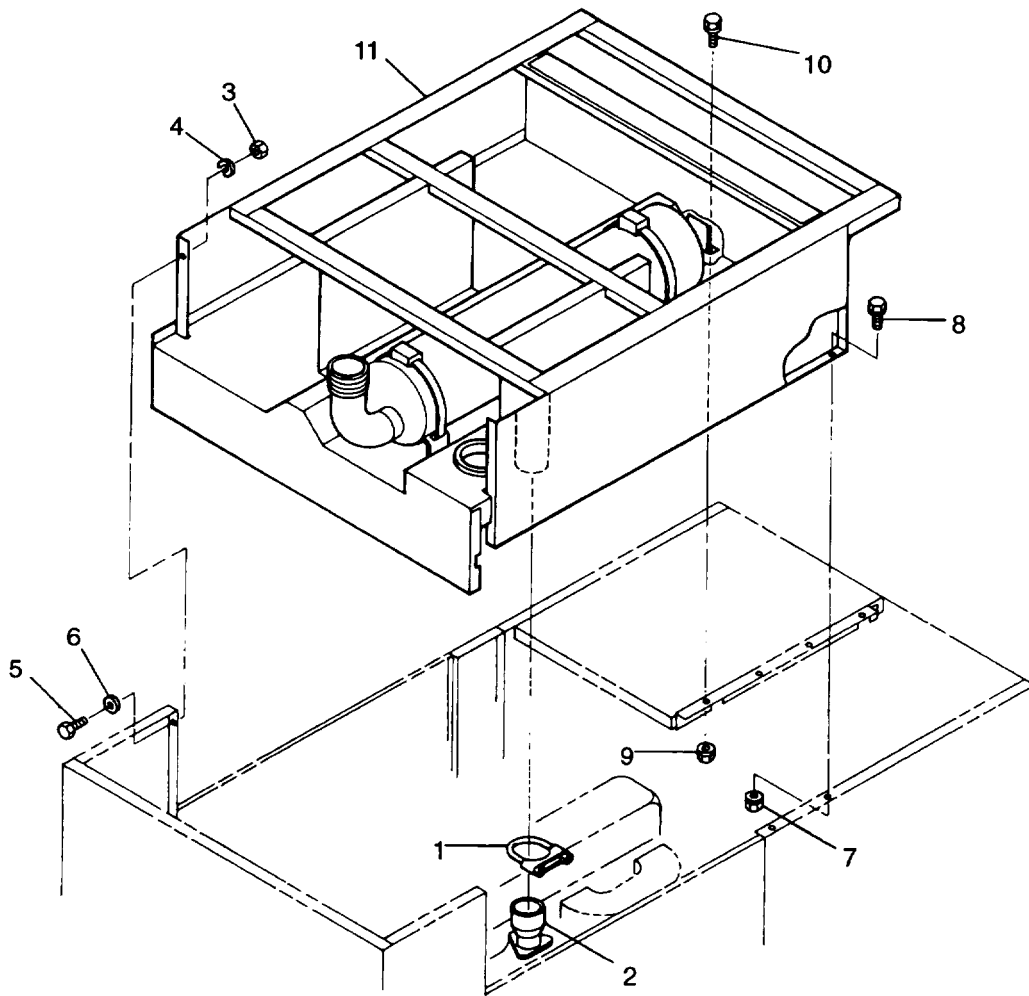

FIGURE 3-5. Top Housing Assembly

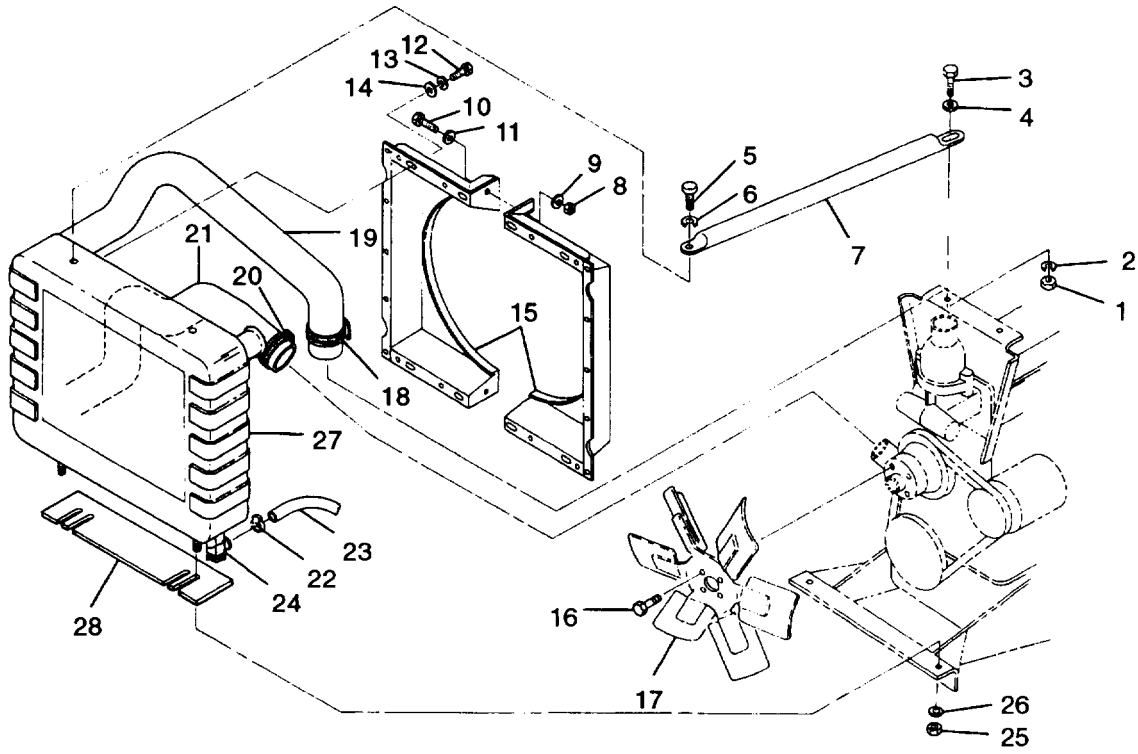

FIGURE 3-8. Radiator Assembly, Shroud and Fan

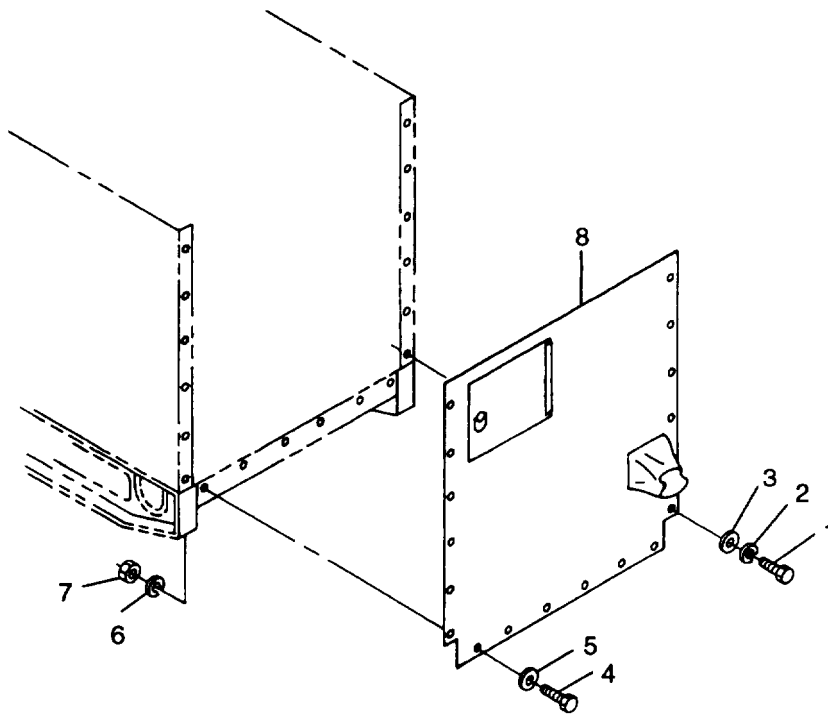

FIGURE 3-7. Rear Housing Panel

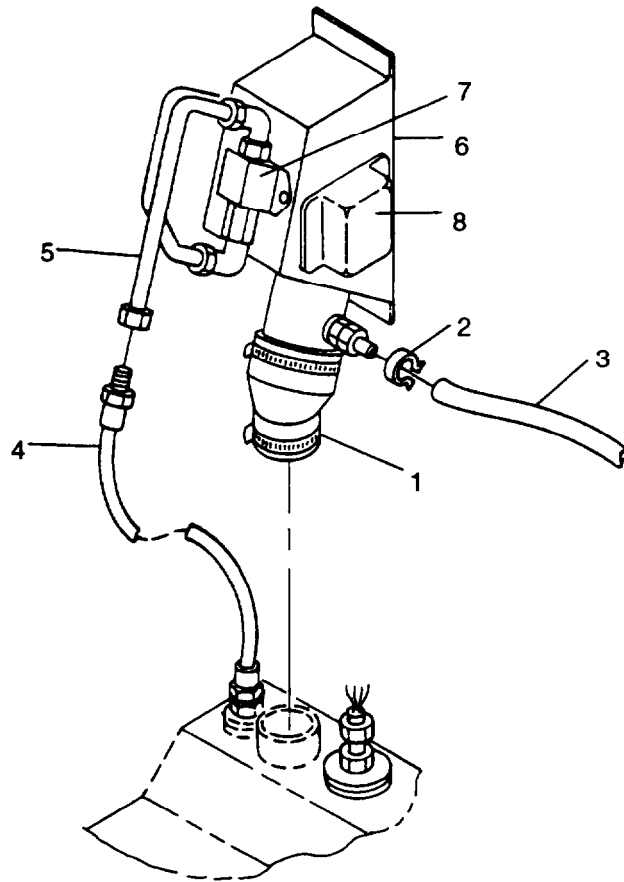

FIGURE 3-8. Fuel Filler Panel Assembly

- ae. Remove bolts (1, FIGURE 3-9), lockwashers (2), battery cables (3), and slave cables (4) from NATO slave receptacle (5).
- af. Remove bolts (1, FIGURE 3-10), lockwashers (2), and washers (3) securing left rear side panel (4) to skid base.
- ag. Remove nuts (8), lockwashers (6) and (9), washers (7) and (11), and bolts (5) and (10) securing lower left side panel (12) to front housing and skid base.
- ah. With aid of an assistant, remove left rear side panel (4) and lower left side panel (12) as an assembly.
- ai. Loosen clamps (1, FIGURE 3-11) and remove air intake hoses (2), (3), and (4) as an assembly.
- aj. Loosen clamp (1, FIGURE 3-1 2) and disconnect oil drain hose (2) from engine oil pan.
- ak. On right side of engine, tag and disconnect electrical leads from glow plug contactor (1, FIGURE 3-13), low oil pressure switch (2), oil pressure sender (3), coolant temperature sender (4), magnetic pickup (5), DEAD CRANK switch (6), and fuel injection pump governor actuator (7).

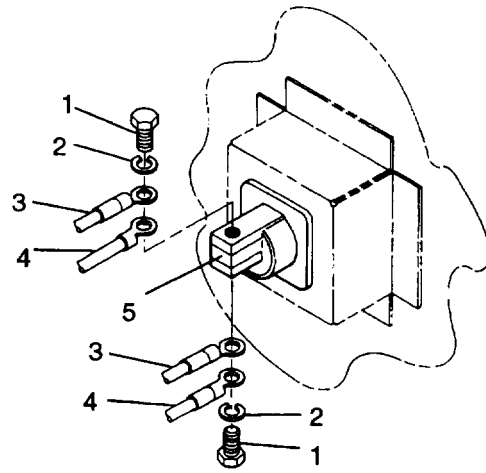

FIGURE 3-9. NATO Slave Receptacle

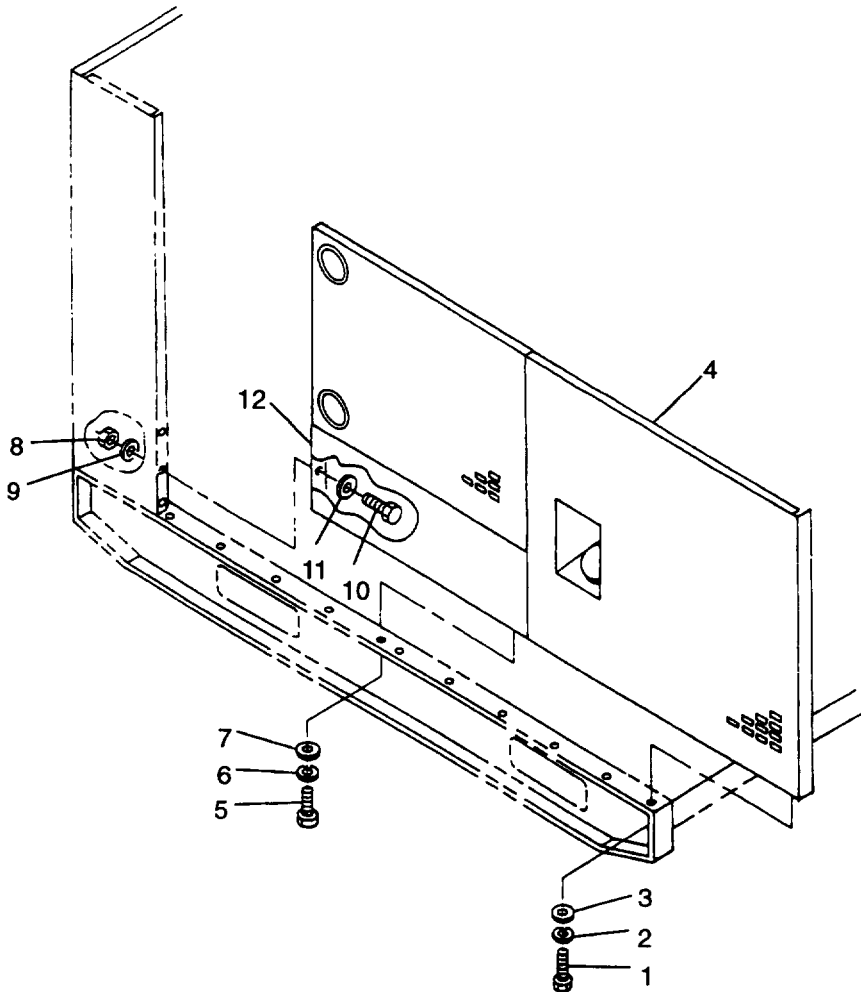

FIGURE 3-10. Left Side Housing Panels

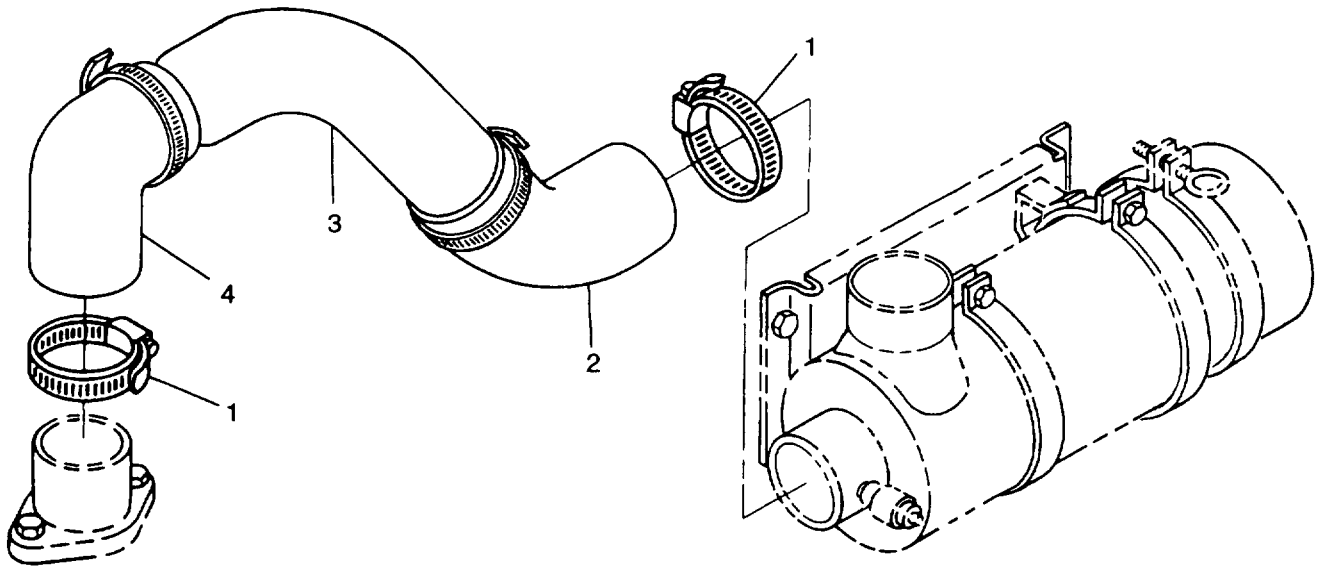

FIGURE 3-11. Air Cleaner Assembly

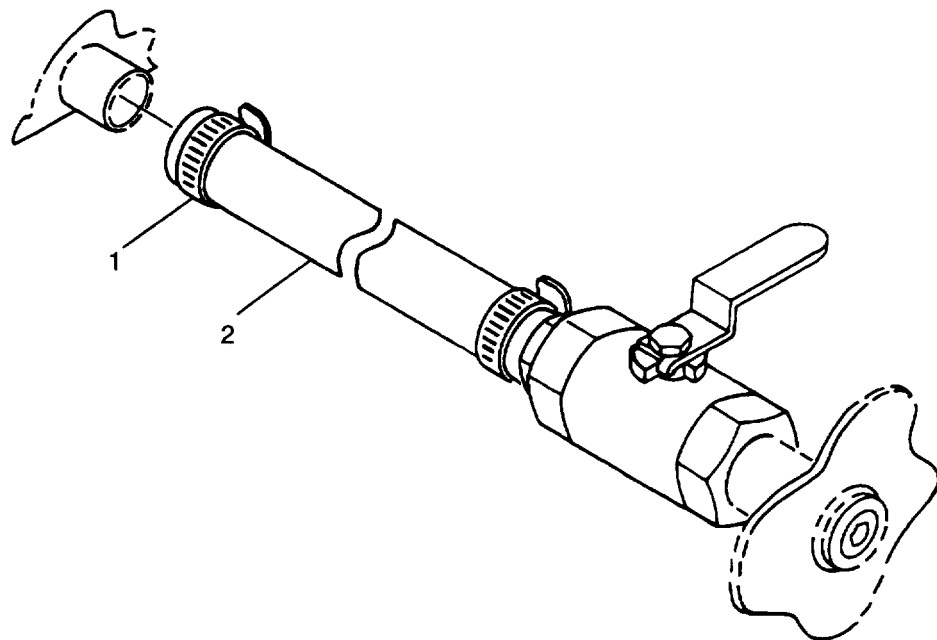

FIGURE 3-12. Oil Drain Line

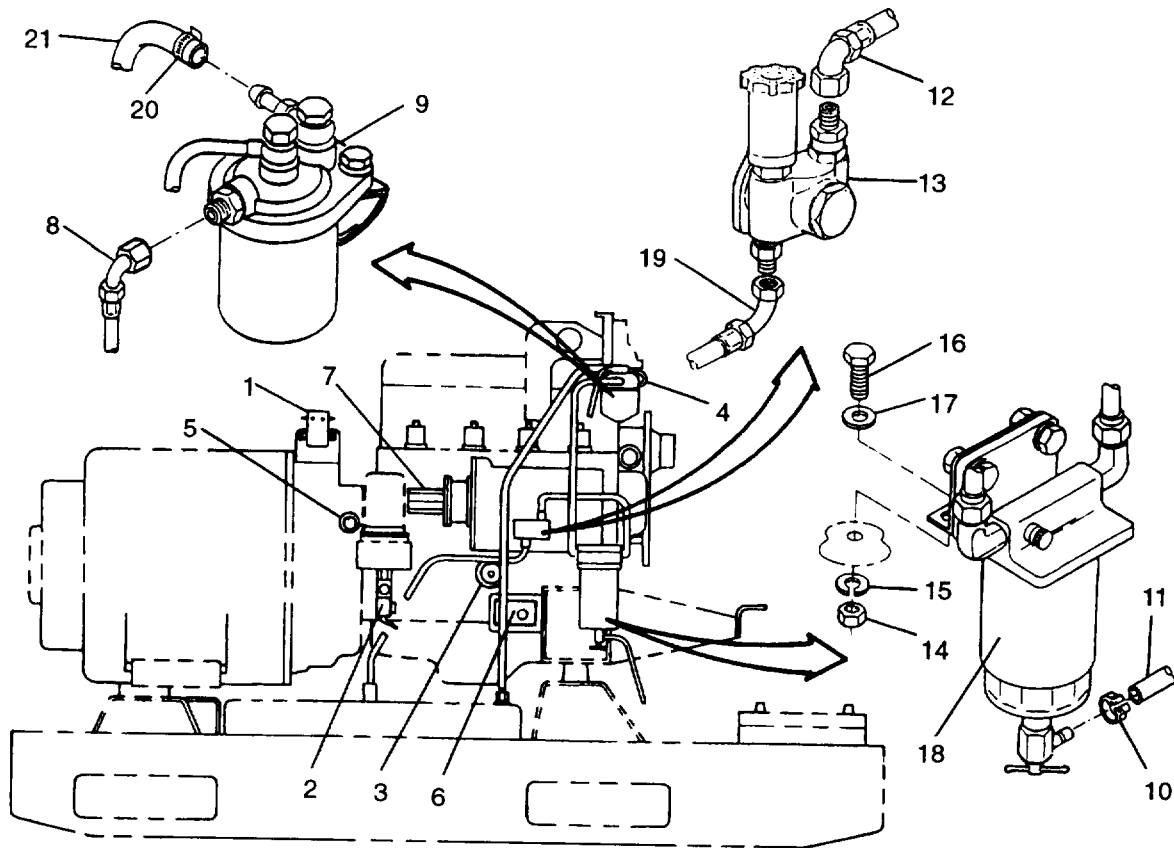

FIGURE 3-13. Right Side Engine Components

- al. Disconnect fuel line (8) from engine fuel filter (9). Cap openings.
- am. Remove clamp (10) and disconnect hose (11) from fuel filter/water separator assembly (18). Cap openings.
- an. Disconnect fuel line (12) from fuel transfer pump (13). Cap openings.
- ao. Remove nuts (14), lockwashers (15), bolts (16), washers (17), and fuel filter/water separator assembly(18) from engine.
- ap. Disconnect fuel line (19) from fuel transfer pump (13). Cap openings.
- aq. Loosen clamp (20) and remove fuel return line (21) from engine fuel filter (9). Cap openings.
- ar. On left side of engine, tag and disconnect electrical leads from battery charging alternator (1, FIGURE 3-14), starter solenoid (2), starter motor (3), and coolant high temperature switch (4). Move engine electrical harness to rear of generator set and clear of engine.
- as. Loosen clamp (5) and disconnect coolant drain hose (6) from engine block coolant drain valve (7).
- at. Remove nut (1, FIGURE 3-15), lockwashers (2), and bolt (3) securing ground strap (4) to skid base.

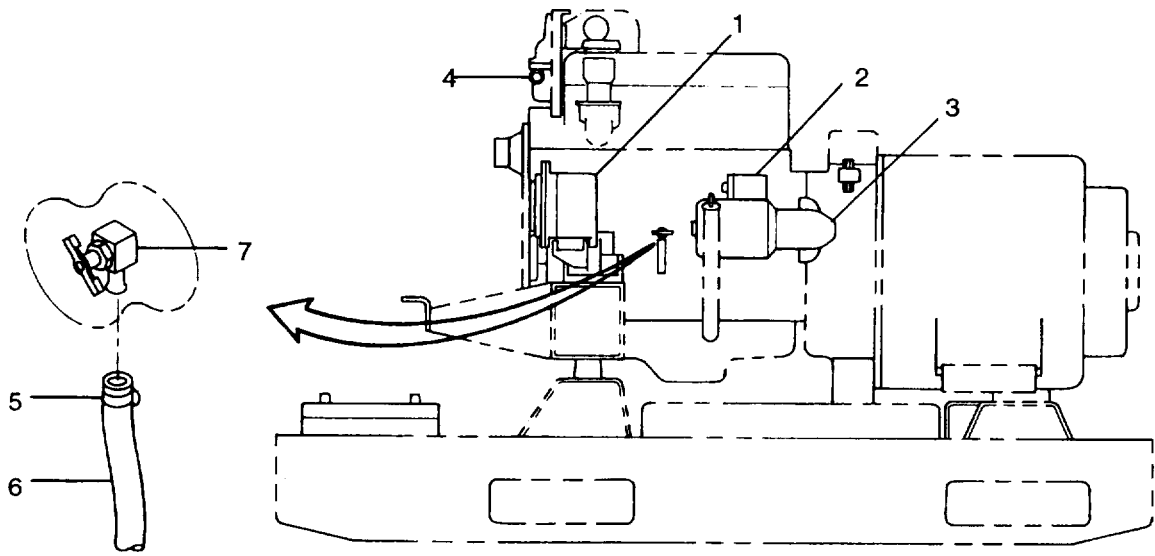

FIGURE 3-14. Left Side Engine Components

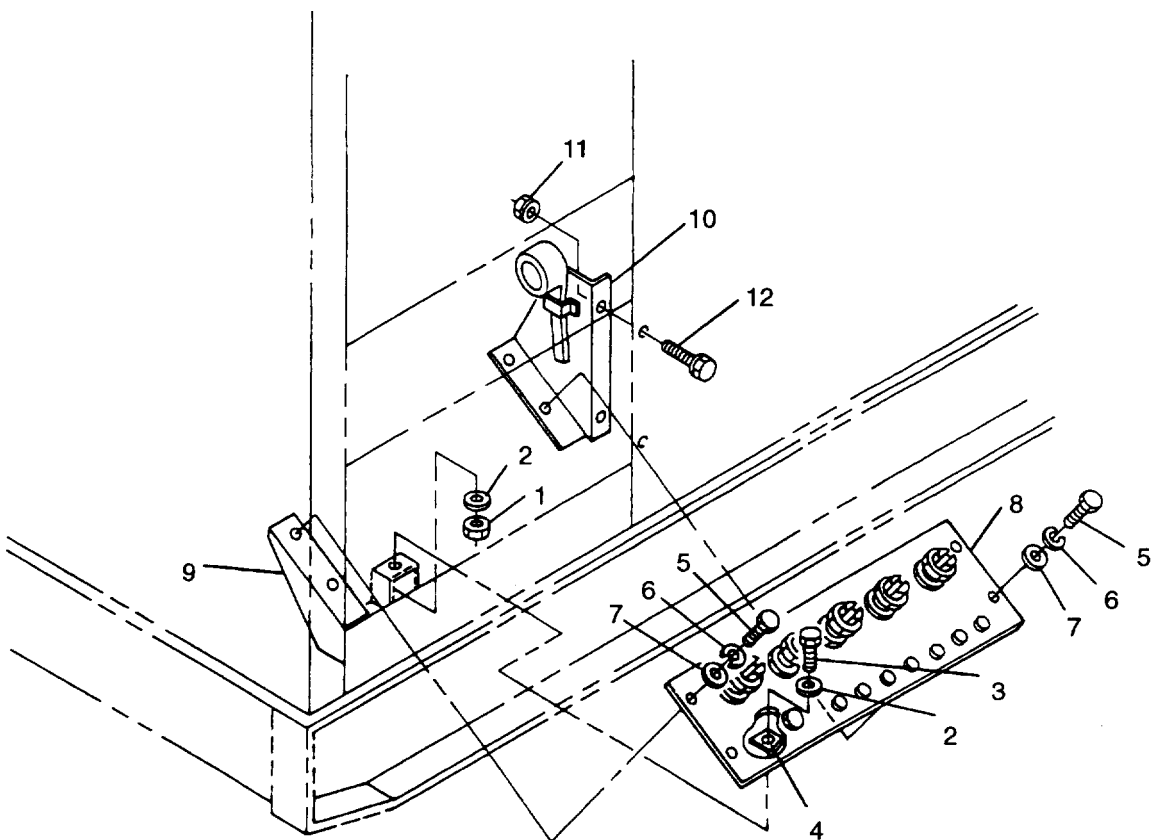

FIGURE 3-15. Load Output Terminal Board

- au. Remove bolts (5), washers (7), and lockwashers (6) securing load output terminal board assembly (8) to supports (9) and (10). Pull load output terminal board assembly out through access door.
- av. Remove assembled nuts (11), bolts (12), and support (10) from right side panel.
- aw. Loosen nuts (23 and 27, FIGURE 3-1), turn bolts (25) to contact skid base and tighten nuts (23) and (27).
- ax. Remove screws (38), washers (37), and screen/over (39) from generator case.
- ay. Scribe mark on generator drive disc and engine flywheel for alignment of bolts during installation.
- az. Remove bolts (40) and lockwashers (41) securing generator drive disc to engine flywheel.

WARNING

Rated capacity of overhead hoist should be at least 1,500 lbs (680 kg). Using a hoist with less capacity could result in equipment damage, personal injury, or death.

- ba. Attach lifting harness to engine and overhead hoist. Take up slack.
- bb. Remove bolts (42) and lockwashers (43) securing generator to flywheel housing.
- bc. Remove nuts (1), washers (2), snubbing washers (3), and bolts (4) securing support bracket (5) to skid base.

WARNING

Keep hands and feet from underside of engine while using lifting device to remove the engine from the generator. Failure to observe this warning could result in serious personal injury and/or death.

- bd. With aid of an assistant, slowly lift engine assembly from skid base, ensuring that engine flywheel housing separates smoothly from generator without binding. Remove engine from generator set housing and place on engine stand.
- be. Remove nuts (11), lockwashers (12), bolts (13), and shock mounts (14) from skid base.
- bf. Remove nuts (16), washers (17), bolts (18), and support frame (5) from engine.
- bg. Remove bolts (19), lockwashers (20), washers (21), and rear support brackets (22) from engine block.
- bh. Remove bolts (30), lockwashers (31), washers (32), nuts (33), and front engine lifting bracket (34) from engine assembly.
- bi. Remove bolts (35) and rear engine lifting bracket (36) from engine assembly.

3.7.2 Installation.

- a. Install rear engine lifting bracket (36, FIGURE 3-1) on engine assembly with bolts (35).
- b. Install front engine lifting bracket (34) on engine assembly with bolts (30), lockwashers (31), washers (32), and nuts (33).
- c. Install rear support brackets (22) on engine block with bolts (19), lockwashers (20), and washers (21).
- d. Install shock mounts (14) on skid base with bolts (1 3), lockwashers (1 2), and nuts (11).
- e. Install support frame (5) on engine with bolts (1 8), washers (1 7), and nuts (16). Torque nuts (16) to 31 ft-lbs (42 Nm).

WARNING

Rated capacity of overhead hoist should be at least 1,500 lbs (680 kg). Using a hoist with less capacity could result in equipment damage, personal injury, or death.

- f. Attach lifting harness to engine and overhead hoist. Take up slack.
- g. With aid of an assistant, lift engine from engine stand and position engine on skid base, aligning mounting holes, brackets and generator to flywheel housing.
- h. Install bolts (42) and lockwashers (43), tightening bolts (42) slowly to ensure even and proper seating of generator housing lip to flywheel housing. Torque bolts (42) to 31 ft-lbs (42 Nm).
- i. Secure engine support bracket (5) to skid base with bolts (4), snubbing washers (3), washers (2), and nuts(1). Torque bolts (4) to 75ft-lbs(102 Nm).
- j. Align scribe mark on generator drive disc and engine flywheel, and install bolts (40) and lockwashers (41) securing generator drive disc to engine flywheel. Torque bolts (40) to 35 ft-lbs (47 Nm).
- k. Install screen/cover (39) on generator case with screw (38) and washer (37).
- l. Loosen nuts (23) and (27), adjust bolts (25) to obtain 0.5 inch (1 2.7 mm) minimum clearance with skid base. Torque nuts (23) and (27) to 150 ft-lbs (204 Nm).
- m. Install support (10, FIGURE 3-15) on right side panel with bolts (12) and assembled nuts (11).
- n. Install load output terminal board assembly (8) on supports (9) and (10) with bolts (5), lockwashers (6), and washers (7).
- o. Secure ground strap (4) to skid base with bolt (3), lockwashers (2) and nut (1).
- p. Position engine electrical harness and connect electrical leads to battery charging alternator (1, FIGURE 3-14), starter solenoid (2), starter motor (3), and coolant high temperature switch (4) on left side of engine. Remove tags.
- q. Connect coolant drain hose (6) at engine block drain valve (7) and tighten clamp (5).
- r. Remove caps and connect fuel line (19, FIGURE 3-13) to fuel transfer pump (13).
- s. Remove caps, connect fuel return line (21) and tighten clamp (20) at engine fuel filter (9).
- t. Install fuel filter/water separator assembly(18) on engine with bolts (16), washers (17), lockwashers (15), and nuts (14).
- u. Remove caps and connect fuel line(12) to fuel transfer pump (13).
- v. Remove caps, connect hose (11) and install clamp (10) at fuel filter/water separator assembly (18).
- w. Remove caps and connect fuel line (8) to engine fuel filter (9).
- x. Connect electrical leads to fuel injection pump governor actuator (7), DEAD CRANK switch (6), magnetic pickup (5), coolant temperature sender (4), oil pressure sender (3), low oil pressure switch (2), and glow plug contactor (1). Remove tags.
- y. Connect oil drain hose (2, FIGURE 3-12) to engine oil pan and tighten clamp(1).
- z. Position air intake hoses (2, 3, and 4, FIGURE 3-11) in generator set and tighten clamps (1).
- aa. With aid of an assistant, position left rear side housing panel (4, FIGURE 3-10) and lower side panel (1 2) on generator set.
- ab. Secure left rear side panel (4) to skid base with bolts (1), lockwashers (2), and washers (3).
- ac. Secure lower left side panel (12) to front housing and skid base with bolts (5) and (10), washers (7) and (11), lockwashers (6) and (9), and nuts (8).
- ad. Connect battery cables (3, FIGURE 3-9) and slave cables (4) to NATO slave receptacle (5) with bolts(1) and lockwashers (2).
- ae. Connect auxiliary fuel pump (7, FIGURE 3-8) and fuel float module (8) electrical connectors and remove tags.
- af. Remove caps and connect fuel hose (4) to fuel line (5).
- ag. Remove caps and connect hose (3) to fuel filler panel assembly (6) and tighten clamp (2).
- ah. Remove caps and connect fuel filler panel assembly (6) to fuel tank and tighten clamp (1).

- ai. Install rear housing panel (8, FIGURE 3-7) on generator set with bolts (1) and (4), washers (3) and (5), lockwashers (2) and (6), and nuts (7).
 - aj. With aid of an assistant, position radiator assembly (27, FIGURE 3-6) and shims (28) in generator set, and secure with nuts (25) and washers (26).
 - ak. Connect hose (21) to water pump and tighten clamp (20).
 - al. Connect hose (19) at thermostat housing and tighten clamp (18).
 - am. Connect hose (23) at radiator drain valve (24) and install clamp (22).
 - an. Install fan (17) on water pump with bolts (16). Torque bolts(16) to 24 ft-lbs (33 Nm).
 - ao. Install shroud halves (15) on radiator assembly (27) with bolts(10)and(12), washers(11) and (14), lockwashers (9) and (13), and nuts (8).
 - ap. Install support rods (7) to radiator assembly (27) and front engine lifting bracket with bolts (3) and (5), washers (4), lockwashers (2) and (6), and nuts (1).
 - aq. Install fan guards and mounting brackets, paragraph 2.77.3.
 - ar. Using lifting device, position top housing assembly (11, FIGURE 3-5) on generator set.
 - as. Secure top housing assembly (11) to output box angle with bolt (10) and assembled nut (9).
 - at. Secure top housing assembly (11) to rear side panels with bolts (8) and assembled nuts (7).
 - au. Secure top housing assembly (11) to front housing with bolts (5), washers (6), lockwashers (4), and nuts (3).
 - av. Connect exhaust pipe to exhaust manifold adapter (2) and install clamp (1).
 - aw. Install overflow bottle assembly (6, FIGURE 3-4) on left side of engine with bolts (3), lockwashers (5), and nuts (4).
 - ax. Connect hose (2) on overflow bottle assembly (6) and install clamp (l).
 - ay. Position filler hose and panel assembly (5, FIGURE 3-3) in generator set, connect to radiator (2) and tighten clamp (1).
 - az. Connect overflow hose (4) to filler hose and panel assembly (5) and tighten clamp (3).
 - ba. Install new ties (6) on radiator supports (7) to secure overflow hose (4).
 - bb. Install top housing panel (7, FIGURE 3-2) with bolts (1) and (4), lockwashers (2) and (5), and washers (3) and (6).
 - bc. Service coolant system, paragraph b.
 - bd. Service lubrication system, paragraph d.
 - be. Install control box assembly, paragraph 2.19.4.
 - bf. Connect negative battery cable and close battery access door.
 - bg. Close all access doors.
 - bh. Start generator set, check for leaks and proper operation.
 - bi. Shut down generator set and service fluid levels as necessary.
- 3.7.3 Replacement.
- a. Remove old engine assembly from generator set, paragraph 3.7.1.
 - b. Remove the following components that come with new engine and return with old engine:
 - (1) Fan belt.

- (2) Mechanical governor on rear of fuel Injection pump
 - (3) Filter element for engine mounted fuel filter.
- c. Remove the following from old engine and install on new engine:
- (1) Oil sample valve, low oil pressure switch, and fitting assembly (1, FIGURE 3-16).
 - (2) Loop clamp (2, FIGURE 3-16) Use hardware from old engine.
 - (3) Fuel filter fitting (3, FIGURE 3-16).
 - (4) Fuel transfer pump fittings (4, FIGURE 3-16).
 - (5) Oil pressure sender and fitting assembly (5, FIGURE 3-16).
 - (6) Radiator support bracket (6, FIGURE 3-16). Use hardware from old engine.
 - (7) Glow plug contactor (12, FIGURE 2-13) and mounting bracket (15). Use hardware from old engine
 - (8) Exhaust adapter (12, FIGURE 2-20) and gasket (13). Use hardware from old engine.
 - (9) Governor actuator and fuel Injection pump interface plate, paragraph 4.14.2.
 - (10) Coolant drain valve (1, FIGURE 2-32).
 - (11) Coolant temperature sender (3, FIGURE 2-31).
 - (12) Coolant high temperature switch (2, FIGURE 2-32).
 - (13) Magnetic pickup (4, FIGURE 2-31). Screw into flywheel housing until magnetic pickup bottoms out, back out 1-1/2 turns and tighten jam nut.
 - (14) Fan belt (6, FIGURE 2-25).
 - (15) Lower starter mounting bolt Bolt replaces stud in new engine.
- d. Install new engine in generator set, paragraph 3.7.2.
- e. Check and adjust magnetic pickup as necessary, paragraph 2.108.4.
- f. Check and adjust fan belt as necessary, paragraph 2.83.2.
- g. Start generator set, check for leaks and proper operation.

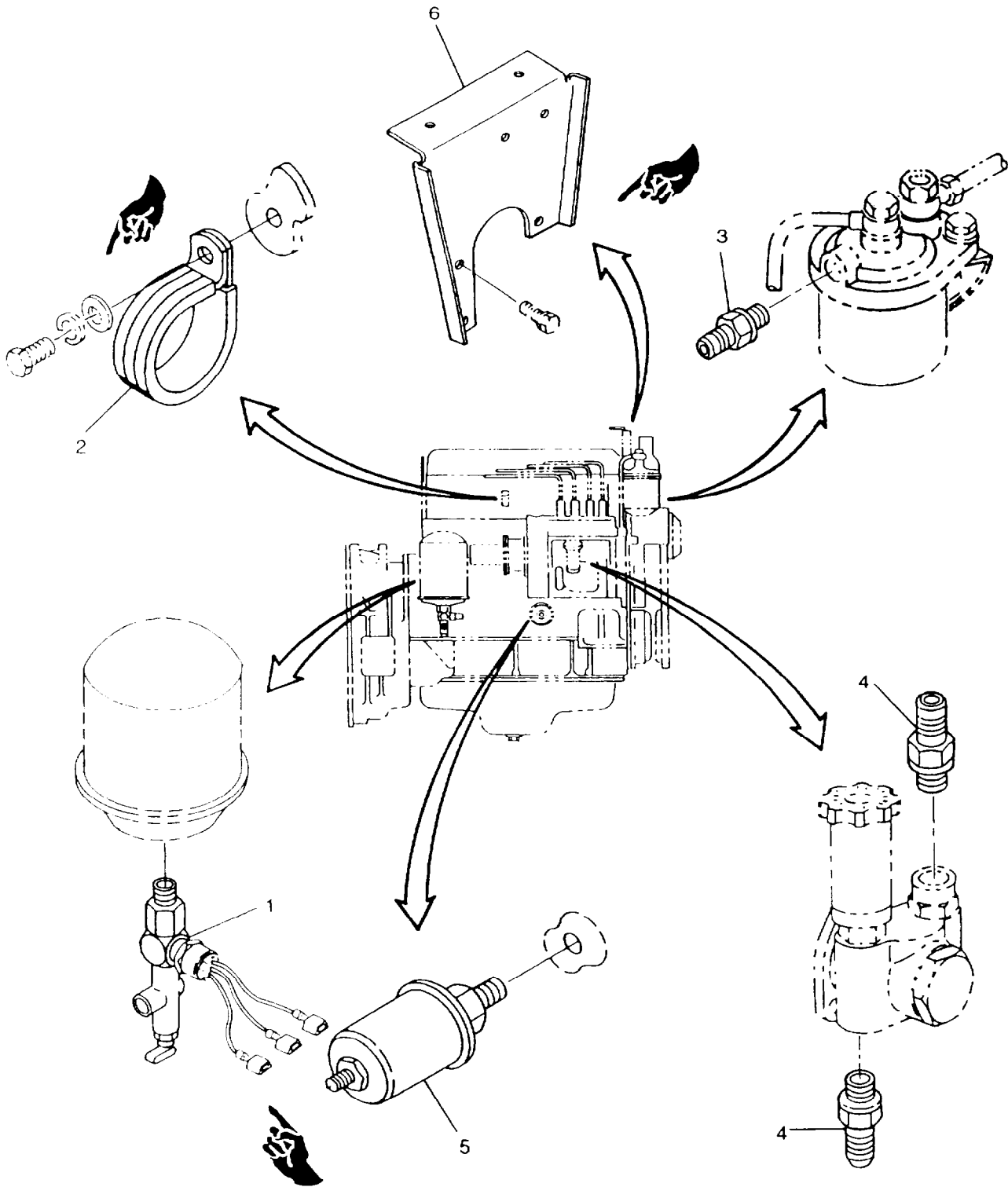

FIGURE 3-16. Engine Components

CHAPTER 4
DIRECT SUPPORT MAINTENANCE INSTRUCTIONS

Section I. MAINTENANCE OF CONTROL BOX ASSEMBLY

4.1 AC VOLTAGE REGULATOR.

WARNING

High voltage is produced when this generator set is in operation. Improper operation could result in personal injury or death.

4.1.1 Testing. (Regulator, P/N: 122-3054 For MEP-804A Generator Set).

- a. Shut down generator set.
- b. Open output box access door.
- c. Note position of voltage reconnection terminal board and set FREQUENCY SELECT switch to 60 Hz position.
- d. Start generator set and turn VOLTAGE adjust potentiometer to ensure the adjustment ranges on TABLE 4-1 are met, depending on position of voltage reconnection terminal board.
- e. Shut down generator set.
- f. If no voltage or low voltage was indicated, or voltage adjustment range could not be achieved, perform the following steps. Otherwise, AC voltage regulator (2, FIGURE 4-1) is serviceable.
- g. Disconnect wire 141 A from terminal 1 of AC voltage regulator.
- h. Set multimeter for DC volts and connect positive lead to wire 141A. Connect negative lead of multimeter to terminal 3 of AC voltage regulator. Start generator set and operate at rated frequency. Move and hold MASTER SWITCH in START position. Multimeter should indicate between 4 and 12 VDC.
- i. Shut down generator set. Isolate wire 141A.
- j. Set multimeter for AC volts and connect to terminals 10 and 11 of AC voltage regulator. Start generator set and operate at rated frequency. Move and hold MASTER SWITCH in START position. Multimeter should indicate 210 to 280 VAC.
- k. Shut down generator set.
- l. Disconnect wire 137A from terminal 5 of AC voltage regulator. Set multimeter for ohms and connect positive lead to wire 137A and negative lead to terminal 4 of AC voltage regulator. Move VOLTAGE adjust potentiometer to full counterclockwise position. Multimeter should indicate approximately 3,000 ohms with FREQUENCY

TABLE 4-1. Voltage Adjustment Range (MEP-804A)

Voltage Reconnection Terminal Board Position	Adjustment Range
120/208	197-240 volts
240/416	395-480 volts

SELECT switch in 60 Hz position, and approximately 0 ohms with FREQUENCY SELECT switch in 50 Hz position. Move VOLTAGE adjust potentiometer clockwise slowly while observing multimeter. Multimeter should increase smoothly to approximately 10,000 ohms.

- m. If steps h, j, and l are as indicated above, AC voltage regulator is defective and must be replaced.
- n. Connect all wires previously disconnected.
- o. Close output box access door.

4.1.2 Testing. (Regulator. PIN: 19870 For MEP-804A Generator Set).

- a. Shut down generator set.
- b. Open output box access door.
- c. Note position of voltage reconnection terminal board and set FREQUENCY SELECT switch to 60 Hz position.
- d. Start generator set and turn VOLTAGE adjust potentiometer to ensure the adjustment ranges on TABLE 4-1 are met, depending on position of voltage reconnection terminal board.
- e. Shut down generator set.
- f. If no voltage or low voltage was indicated, or voltage adjustment range could not be achieved, perform the following steps. Otherwise, AC voltage regulator (2, FIGURE 4-1) is serviceable.
- g. Disconnect wire 141 A from terminal 1 of AC voltage regulator.
- h. Set multimeter for DC volts and connect positive lead to wire 141A. Connect negative lead of multimeter to terminal 3 of AC voltage regulator. Start generator set and operate at rated frequency. Move and hold MASTER SWITCH in START position. Multi meter should indicate between 4 and 12 VDC.
- i. Shut down generator set. Isolate wire 141A.
- j. Set multimeter for AC volts and connect to terminals 10 and 11 of AC voltage regulator. Start generator set and operate at rated frequency. Move and hold MASTER SWITCH in START position. Multimeter should indicate 110 to 160 VAC.
- k. Shut down generator set.
- l. Disconnect wire 137A from terminal 5 of AC voltage regulator. Set multimeter for ohms and connect positive lead to wire 137A and negative lead to terminal 4 of AC voltage regulator. Move VOLTAGE adjust potentiometer to full counterclockwise position. Multimeter should indicate no more than 2 ohms with FREQUENCY SELECT switch in 60 Hz position or 50 Hz position. Move VOLTAGE adjust potentiometer clockwise slowly while observing multimeter. Multimeter should increase smoothly to approximately 20,000 ohms.
- m. If steps h, j, and l are as indicated above, AC voltage regulator is defective and must be replaced.
- n. Connect all wires previously disconnected.
- o. Close output box access door.

4.1.3 Testing. (Reaulator. P/N: 19890-001 ForMEP-814A Generator Set).

- a. Shut down generator set.
- b. Open output box access door.
- c. Note position of voltage reconnection terminal board.
- d. Start generator set and turn VOLTAGE adjust potentiometer to ensure the adjustment ranges on TABLE 4-2 are met, depending on position of voltage reconnection terminal board.
- e. Shut down generator set.
- f. If no voltage or low voltage was indicated, or voltage adjustment range could not be achieved, perform the following steps. Otherwise, AC voltage regulator (2, FIGURE 4-1) is serviceable.
- g. Disconnect wire 141 A from terminal 1 of AC voltage regulator.
- h. Set multimeter for DC volts and connect positive lead to wire 141A. Connect negative lead of multimeter to terminal 3 of AC voltage regulator. Start generator set and operate at rated frequency. Move and hold MASTER SWITCH in START position. Multimeter should indicate between 4 and 12 VDC.
- i. Shut down generator set. Isolate wire 141A.

- j. Set multimeter for AC volts and connect to terminals 10 and 11 of AC voltage regulator. Start generator set and operate at rated frequency. Move and hold MASTER SWITCH in START position. Multimeter should indicate 110 to 160 VAC.
- k. Shut down generator set.
- l. Disconnect wire 137A from terminal 5 of AC voltage regulator. Set multimeter for ohms and connect positive lead to wire 137A and negative lead to terminal 4 of AC voltage regulator. Move VOLTAGE adjust potentiometer to full counterclockwise position. Multimeter should indicate approximately 0 ohms. Move VOLTAGE adjust potentiometer clockwise slowly while observing multimeter. Multimeter should increase smoothly to approximately 20,000 ohms.

TABLE 4-2. Voltage Adjustment Range (MEP-814A)

Voltage Reconnection Terminal Board Position	Adjustment Range
120/208	197-229 volts
240/416	395-458 volts

- m. If steps h, j, and l are as indicated above. AC voltage regulator is defective and must be replaced.
- n. Connect all wires previously disconnected.
- o. Close output box access door.

4.1.4 Removal.

- a. Shut down generator set.
- b. Open battery access door and disconnect negative battery cable.
- c. Release control panel by turning two fasteners and lower control panel slowly.
- d. Tag and disconnect AC voltage regulator (2, FIGURE 4-1) electrical leads.
- e. Remove screws (1) and AC voltage regulator (2).

4.1.5 Installation.

CAUTION

The components of the AC voltage regulator kit are not interchangeable. Ensure the part number of the component to be installed is the same as the removed component. Failure to observe this caution will result in equipment damage.

- a. Install AC voltage regulator (2, FIGURE 4-1) with screws(1).
- b. Connect electrical leads and remove tags.
- c. Raise and secure control panel.
- d. Connect negative battery cable. Close battery access door.

— 4.2 GOVERNOR CONTROL UNIT.

WARNING

High voltage is produced when this generator set is in operation. Improper operation could result in personal injury or death.

4.2.1 Internal Crank Relay Test.

- a. While holding the Master Switch (S-1) in the "START" position, check the for voltage from pin positions 1,3,5 on the GCU (A-5) Ground. The readings should be battery voltage. If there is no voltage between any of the connections, the GCU (A-5) is not receiving the proper voltage and the wiring harness should be checked, refer to FO-1.

NOTE

With the generator running the voltage will read zero.

- b. Place master switch in OFF position. Connect multimeter leads to terminals 19 and 20 on the governor control unit (A-5), then move master switch to START position, reading should be battery voltage when generator does not crank. If there is no voltage between terminals positions, the GCU (A-5) is not functioning properly and should be replaced.

NOTE

With the generator running there will be battery voltage.

- c. Place master switch in OFF position. Connect multimeter leads to terminals 19 and 18 on the governor control unit (A-5), then move master switch to START position, reading should be ZERO voltage when generator does not crank. If there is voltage between the terminal positions, the GCU (A-5) is not functioning properly and should be replaced.

4.2.2 Testing.

- a. Shut down generator set.
- b. Open output box access door. Remove protective cover and attach voltage and frequency recorder to terminals 9 and 12 of voltage reconnection terminal board.
- c. Open load terminal board access door and attach load bank to generator set (4 wire connection).

NOTE

Ensure load bank and generator set voltage reconnection are set for same configuration (i.e., 120/208 or 240/416 VAC).

- d. Start and operate generator set at rated voltage and frequency.
- e. Turn on voltage and frequency recorder and operate at minimum chart speed of 5 mm/sec (chart resolution of 0.2 mm/sec). Adjust recorder voltage amplifier for a minimum chart resolution of 1.0 volt/mm, and frequency deviation amplifier for a minimum resolution of 0.2 Hz/mm.
- f. Set load bank for a load equal to 75% of generator set rated load.
- g. Apply and remove the 75% load to the generator set at 40 second intervals three times.
- h. Repeat steps f and g at 50 percent rated load.
- i. Repeat steps f and g at 25 percent rated load.
- j. Repeat steps f and g at 100 percent rated load.
- k. Shut down generator set.
- l. Turn off voltage and frequency recorder.

- m. Examine voltage and frequency recorder chart. Generator set should meet the following performance criteria:
 - (1) Frequency regulation shall not exceed 1/4 of 1 percent of rated frequency.
 - (2) Frequency short-term stability (30 seconds), frequency will remain constant within a band width equal to 1/2 of 1 percent rated frequency, without repetitive frequency variations, commonly called "hunting".
 - (3) The generator set will reestablish stable engine operating conditions within 2 seconds of a sudden load change (within 1 second for 400 Hz unit). The maximum transient frequency change above or below (overshoot or undershoot) the new steady state frequency shall not be more than 4 percent of rated frequency (not more than 1-1/2 percent for 400 Hz unit).
- n. If the above criteria is not met, adjust the governor control unit (3, FIGURE 4-1) in accordance with paragraph 4.2.2.
- o. If the above criteria cannot be met by adjustment, the governor control unit must be replaced.
- p. Disconnect load bank and close load terminal board access door.
- q. Disconnect voltage and frequency recorder, install voltage reconnection terminal board protective cover and close output box access door.

4.2.3 Adjustment.

- a. Shut down generator set.
- b. Open output box access door, remove cover from voltage reconnection terminal board and attach voltage and frequency recorder to terminals 9 and 12 of voltage reconnection terminal board.

NOTE

The following procedures require monitoring frequency, voltage, current, and power. All readings except for frequencies will utilize the generator set control panel gages. However, since the designed overspeed trip frequency is greater than the range of the control panel FREQUENCY meter (HERTZ), a frequency counter will be required.

- c. Attach frequency counter to voltage reconnection terminal board terminals 9 and 12.
- d. Open load terminal board access door and attach load bank to generator set (four wire connection).

NOTE

Ensure load bank and generator set voltage reconnection are set for same configuration (i.e., 120/208 or 240/416 VAC).

- e. Check for proper adjustment of governor actuator, paragraph 4.14.3. Adjust as necessary.
- f. Check for proper adjustment of magnetic pickup, paragraph 2.108.4. Adjust as necessary.
- g. Lower generator set control panel and turn INTEG, GOV GAIN, and LOAD PULSE potentiometer on governor control unit to their full counterclockwise positions.
- h. Start generator set and operate at rated voltage and frequency.
- i. Observing frequency counter, slowly increase operating frequency of generator set by turning governor control unit FREQ range potentiometer clockwise until frequency counter indicates between 65.94 and 66.06 Hz (MEP-804A) or between 436 and 444Hz(MEP814A). At this point generator set has reached overspeed trip frequency and generator set should shut down.

NOTE

Perform steps j and k if generator set does not shut down within limits noted in step i. Otherwise, proceed to step 1.

- j. If generator set has not shut down at upper limit of frequency noted in step i, proceed as follows:
 - (1) Turn FREQ range potentiometer counterclockwise until frequency counter indicates midrange of overspeed trip frequency (Example: 66 Hz for MEP804A).
 - (2) Turn OVERSPD control potentiometer on governor control unit counterclockwise until generator set shuts down.
 - (3) Activate OVERSPD RESET switch.
 - (4) Repeat steps h and i.
- k. If generator set shuts down prior to reaching lower limit of frequency noted in step i, proceed as follows:
 - (1) Turn OVERSPD control potentiometer clockwise one turn for each hertz generator set shut down prior to lower frequency limit.
 - (2) Activate OVERSPD RESET switch.
 - (3) Repeat steps h and i.
- l. Actuate OVERSPD RESET switch.
- m. Turn FREQ range potentiometer on governor control unit two turns, counterclockwise.
- n. Start and operate generator set at rated voltage and turn FREQUENCY adjust potentiometer on control panel to midrange.
- o. Turn FREQ range potentiometer until rated frequency (50,60 or 400 Hz) is indicated on control panel FREQUENCY meter (HERTZ).
- p. Set load bank for generator set rated load and apply load. Observe generator set instruments and adjust load as needed to ensure rated load is applied.
- q. Set multimeter for DC volts and connect to terminals 11 and 12 of governor control unit (3, FIGURE 4-1).
- r. Adjust LOAD SHARING ADJUST rheostat until multimeter indicates 6 VDC. Disconnect multimeter.
- s. Remove load.
- t. Turn on voltage and frequency recorder and operate at minimum chart speed of 5 mm/sec (chart resolution of 0.2 mm/sec). Adjust recorder voltage amplifier for minimum chart resolution of 1.0 volt/mm and frequency deviation of 0.2 Hz/mm.
- u. Adjust GOV GAIN potentiometer on governor control unit as follows:
 - (1) Turn GOV GAIN potentiometer to its full clockwise position.
 - (2) Momentarily actuate and turn off LOAD switch on control panel.
 - (3) Observe strip chart on recorder for frequency oscillation (hunting). If required, slowly turn GOV GAIN counterclockwise until frequency oscillation disappears.
- v. Apply and remove rated load to generator set at 40-second intervals. Repeat this step two more times.
- w. Shut down generator set and turn off recorder.

x. Examine voltage and frequency strip chart for the following performance criteria:

- (1) Frequency regulation shall not exceed 1/4 of one percent of rated frequency.
- (2) Frequency short-term stability (30 seconds), frequency will remain constant within a band width equal to 1/2 of 1 percent rated frequency, without repetitive frequency variations (hunting).
- (3) The generator set will reestablish stable engine operation within two seconds of a sudden load change (i.e., from a load to no-load condition) (within one second for 400 Hz units). The maximum transient frequency change above (overshoot) and below (undershoot) the new steady state frequency shall not be more than 4 percent of rated frequency (not more than 1 -1/2 percent for 400 Hz units).

NOTE

All required INTEG and LOAD PULSE potentiometer adjustments will be in 10 percent increments.

y. Adjust INTEG potentiometer on governor control unit clockwise to decrease recovery time of load transients.

z. Adjust LOAD PULSE potentiometer on governor control unit clockwise to decrease frequency overshoot and undershoot and to decrease recovery time of overshoot/undershoot transients.

aa. Start generator set.

NOTE

Steps u(1) and u(2) are not required when doing step ab.

ab. Repeat steps t through v until generator set meets performance requirements stated in step x.

ac. Apply and remove 75 percent rated load to generator set at 40-second intervals. Repeat this step two more times.

ad. Apply and remove 50 percent rated load to generator set at 40-second intervals. Repeat this step two more times.

ae. Apply and remove 25 percent rated load to generator set at 40-second intervals. Repeat this step two more times.

af. Shut down generator set and turn off strip chart recorder.

ag. Examine voltage and frequency strip chart for the following performance criteria:

- (1) Frequency regulation shall not exceed 1/4 of one percent of rated frequency.
- (2) Frequency short-term stability (30 seconds), frequency will remain constant within a band width equal to 1/2 of 1 percent rated frequency, without repetitive frequency variations (hunting).
- (3) The generator set will reestablish stable engine operation within two seconds of a sudden load change (i.e., from a load to no-load condition) (within one second for 400 Hz units). The maximum transient frequency change above (overshoot) and below (undershoot) the new steady state frequency shall not be more than four percent of rated frequency (not more than 1-1/2 percent for 400 Hz units).

ah. Disconnect load bank and close load terminal board access door.

ai. Disconnect frequency counter, and voltage and frequency recorder from voltage reconnection terminal board.

aj. Install voltage reconnection terminal board cover and close output box access door.

4.2.4 Replacement.

a. Remove governor control unit, paragraph 2.60.2.

b. Install new governor control unit, paragraph 2.60.3.

c. Perform adjustment of governor control unit, paragraph 4.2.2.

4.3 CONTROL BOX HARNESS.

4.3.1 Removal.

- a. Shut down generator set.
- b. Open battery access door and disconnect negative battery cable.
- c. Remove control box assembly, paragraph 2.19.2.
- d. Remove voltage sensing relay, paragraph 2.58.3.
- e. Remove relays, paragraph 2.59.3.
- f. Remove screws (4, FIGURE 4-1), washers (5), insulators (6), and clips (7).
- g. Tag and remove sockets (8) from tracks (9).
- h. Remove screws (10) and nuts (11) to free terminal boards (12).
- i. Tag and disconnect electrical leads from AC voltage regulator (2) and governor control unit (3).
- j. Tag and disconnect electrical leads from shunt (43, FIGURE 2-14), BATTERY CHARGER FUSE assembly (32), DC CONTROL POWER circuit breaker (35), REACTIVE CURRENT ADJUST rheostat (3), LOAD SHARING ADJUST rheostat (7), FREQUENCY SELECT switch (14), OVERSPEED RESET switch (10), over/under voltage relay (45), frequency transducer (38), short circuit/overload relay (47), permissive paralleling relay (51), reverse power relay (49), load measuring unit (69), watt transducer (40), and resistor-diode assembly (71).

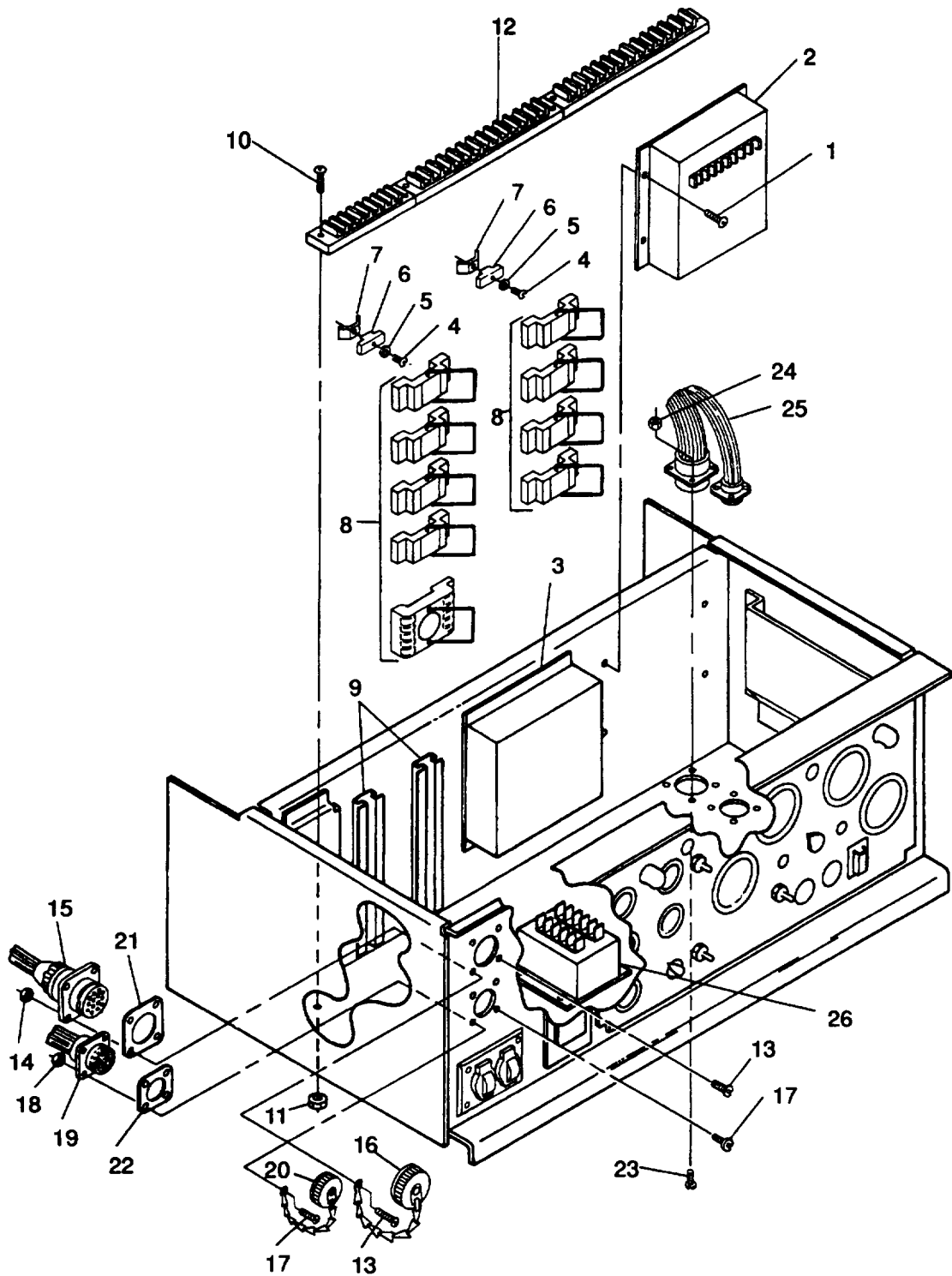

FIGURE 4-1. Control Box Components

- k. Tag and disconnect electrical leads to CONVENIENCE RECEPTACLE (20), GROUND FAULT CIRCUIT INTERRUPTER (23), and connector to malfunction indicator panel (27).
- l. Tag and disconnect electrical leads to all indicators, switches, and lights on control panel.
- m. Remove screws (13 and 17, FIGURE 4-1), nuts (14) and (18), caps (16) and (20), diagnostic connector (15), parallel connector (19), and gaskets (21) and (22) from control box panel.
- n. Remove screws (23) and nuts (24) from harness connectors and remove harness assembly (25) from control box.

4.3.2 Inspection.

- a. Inspect control box harness wiring for breaks, damaged insulation, and loose or damaged terminals.
- b. Inspect harness connectors, sockets and terminal boards for cracks, corrosion, stripped threads, broken pins, and other visible damage.

4.3.3 Testing.

- a. Set multimeter for ohms.
- b. Check individual wires, connectors, and terminal boards for continuity. Refer to Wiring Diagram FO-2 for wire identification.

4.3.4 Repair.

- a. Replace damaged cable assemblies, terminals, connectors, sockets, and terminal boards.
- b. Replace or ensure proper connection of all wires not indicating continuity.

4.3.5 Installation.

- a. Position control box wiring harness assembly (25, FIGURE 4-1) in control box.
- b. Secure harness connectors to control box with screws (23) and nuts (24).
- c. Install gaskets (21) and (22), diagnostic connector (15), parallel connector (19), and caps (16) and (20) in control box panel with screws (13) and (17), and nuts (14) and (18).
- d. Connect all electrical leads to control panel indicators, switches, and lights as tagged on removal. Remove tags.
- e. Connect electrical connector to malfunction indicator panel (27, FIGURE 2-14) and electrical leads to CONVENIENCE RECEPTACLE (20) and GROUND FAULT CIRCUIT INTERRUPTER (23).
- f. Connect electrical leads, as tagged during removal, to watt transducer (40), load measuring unit (69), reverse power relay (49), permissive paralleling relay (51), resistor-diode assembly (71), short circuit/overload relay (47), frequency transducer (38), over/under voltage relay (45), DC CONTROL POWER circuit breaker (35), BATTERY CHARGER FUSE assembly (32), OVERSPEED RESET switch (10), FREQUENCY SELECT switch (14), REACTIVE CURRENT ADJUST rheostat (3), LOAD SHARING ADJUST rheostat (7), and shunt (43). Remove tags.
- g. Connect electrical leads to AC voltage regulator (2, FIGURE 4-1) and governor control unit (3). Remove tags.
- h. Secure terminal boards (12) to control box with screws (10) and nuts (11).
- i. Position sockets (8) on tracks (9) as tagged on removal.
- j. Secure sockets (8) to tracks (9) with clips (7), insulators (6), washers (5), and screws (4). Remove tags.
- k. Install relays, paragraph 2.59.4.
- l. Install voltage sensing relay, paragraph 2.58.4.
- m. Install control box assembly, paragraph 2.19.4.
- n. Connect negative battery cable and close battery access door.

4.4 LOAD MEASURING UNIT.

WARNING

High voltage is produced when this generator set is in operation. Improper operation could result in personal injury or death.

4.4.1 Testing.

- a. Start and operate generator set at rated frequency and voltage.
- b. Apply a load to generator set.
- c. Note reading on kilowattmeter (PERCENT POWER).
- d. Determine DC voltage (calculated value) from the kilowattmeter reading using the following formula:

$$\frac{10.8 \times (\text{kilowattmeter reading})}{100}$$

- e. Release control panel by turning two fasteners and lower control panel slowly.
 - f. Set multimeter for DC volts and connect positive lead to terminal 11 of load measuring unit (26, FIGURE 4-1) and negative lead to terminal 12.
 - g. Compare DC voltage (calculated value) to multimeter reading.
 - h. Load measuring unit must be replaced if difference is more than ± 1.2 VDC.
 - i. Shut down generator set.
 - j. Remove multimeter from load measuring unit terminals.
 - k. Raise and secure control panel.
- ##### 4.4.2 Replacement.
- a. Remove load measuring unit, paragraph 2.64.2.
 - b. Install new load measuring unit, paragraph 2.64.3.

Section II. MAINTENANCE OF COOLANT SYSTEM

4.5 RADIATOR REPAIR.

Repair radiator in accordance with TM 750-254.

Section III. MAINTENANCE OF FUEL SYSTEM

4.6 FUEL TANK.

4.6.1 Inspection.

- a. Shut down generator set.
- b. Remove fuel tank, paragraph 4.6.2.
- c. Inspect fuel tank (6, FIGURE 4-2) for leaks, cracks, missing hardware, and other damage.
- d. If no damage is found, install fuel tank, paragraph 4.6.3.

4.6.2 Removal.

- a. Shut down generator set.
- b. Open battery access door and disconnect negative battery cable.

WARNING

Diesel fuel is flammable and toxic to eyes, skin, and respiratory tract. Skin/eye protection required. Avoid repeated/prolonged contact. Good general ventilation is normally adequate.

- c. Drain fuel tank.
 - d. Remove engine and generator assembly, paragraph 3.6.1.
 - e. Remove fuel tank drain valve, paragraph 2.88.1.
 - f. Remove nuts (1, FIGURE 4-2), lockwashers (2), washers (3), bolts (4), and plates (5) securing fuel tank to skid base.
 - g. Remove fuel tank (6) from skid base.
 - h. Remove low fuel level/auxiliary fuel pump float switch, paragraph 2.90.2.
 - i. Remove fuel level sender, paragraph 2.89.2.
 - j. Remove fuel pickup, paragraph 2.91.1.
 - k. Remove fittings (7) from excess fuel studs (9) on right side of tank.
 - l. Remove fitting (8) from excess fuel stud (9) on left side of tank.
 - m. Remove studs (9), washers (10), and bushings(11) from fuel tank.
 - n. Cover all openings.
- #### 4.6.3 Installation.
- a. Remove covers placed over openings.
 - b. Install bushings (11, FIGURE 4-2), washers (10), and studs (9) in fuel tank (6).
 - c. Install fitting (8) in excess fuel stud (9) on left side of fuel tank.

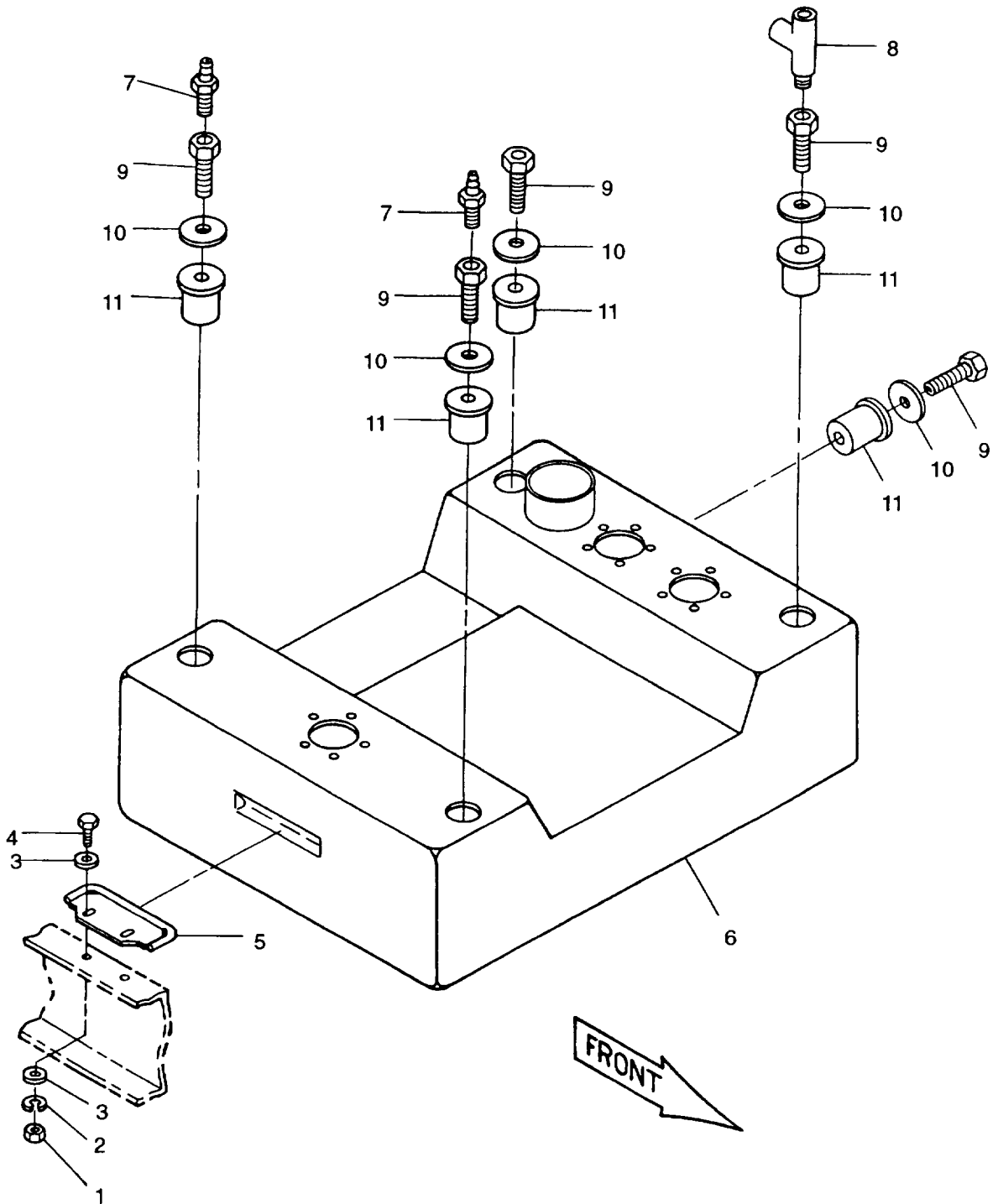

FIGURE 4-2. Fuel Tank

- d. Install fittings (7) in excess fuel studs (9) on right side of fuel tank.
- e. Install low fuel level/auxiliary fuel pump float switch, paragraph 2.90.4.
- f. Install fuel level sender, paragraph 2.89.4.
- g. Install fuel pickup, paragraph 2.91.3.
- h. Install fuel tank (6) in skid and secure with plates (5), bolts (4), washers (3), lockwashers (2), and nuts(1).
- i. Install engine and generator assembly, paragraph 3.6.2.
- j. Install fuel tank drain valve, paragraph 2.88.2.
- k. Service fuel tank. Refer to TABLE 2-2 for proper fuel.
- l. Connect negative battery cable. Close battery access door.

Section IV. MAINTENANCE Of OUTPUT BOX ASSEMBLY

4.7 OUTPUT BOX ASSEMBLY.

4.7.1 Removal.

- a. Shut down generator set.
- b. Open battery access door and disconnect negative battery cable.
- c. Remove control box assembly, paragraph 2.19.2.
- d. Remove air cleaner assembly, paragraph 2.72.3.
- e. Remove output box access door, paragraph 2.14.1.
- f. Remove rear housing panel, paragraph 2.18.1.
- g. Open left side engine access door, tag and disconnect electrical leads from battery charging alternator, starter solenoid, starter motor, coolant high temperature switch, fuel level sender, fuel float module, and auxiliary fuel pump.
- h. Open right side engine access door, tag and disconnect electrical leads from glow plugs contactor, DEAD CRANK switch, low oil pressure switch, oil pressure sender, governor actuator, fuel injection pump, coolant temperature sender, and magnetic pickup.
- i. Note locations and remove loop clamps securing output box harness to engine.
- j. Remove voltage reconnection terminal board, paragraph 4.8.1.
- k. Remove nuts (1, FIGURE 4-3), bolts (2), and output box top panel (3) from output box assembly.

NOTE

Record number and direction of wraps when removing main generator cables from transformers to aid installation.

- l. Unwrap main generator cables from droop current transformer (34) and current transformer (31).
- m. Remove screws (4) and cover (5) from AC circuit interrupter relay (40).
- n. Tag and disconnect output cables from terminals A2, B2, and C2 of AC circuit interrupter relay (40).
- o. Tag and disconnect exciter leads F1 and F2 from terminals 1 and 2 of terminal board (26).
- p. Remove bolts (45, FIGURE 2-7) and nuts (46) securing output box assembly to angle (47).
- q. Remove nuts (6, FIGURE 4-3), bolts (7), and output box assembly from generator set.

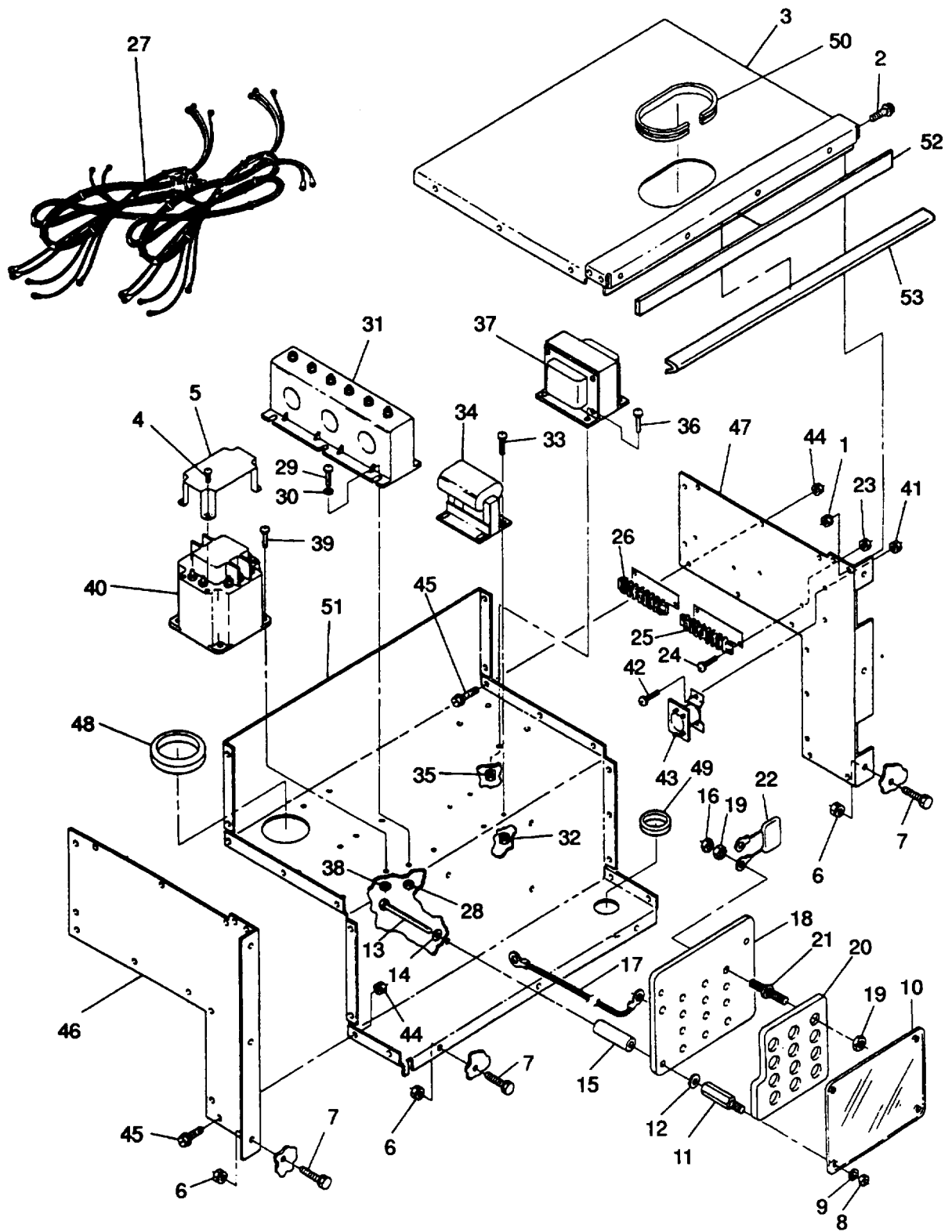

FIGURE 4-3. Output Box Assembly

4.7.2 Installation

- a. Install output box assembly in generator set with bolts (7, FIGURE 4-3) and nuts (6).
- b. Install bolts (45, FIGURE 2-7) and nuts (44) securing rear of output box assembly to angle (47).
- c. Connect exciter leads F1 and F2 to terminals 1 and 2 of terminal board (26, FIGURE 4-3), and remove tags.
- d. Connect output cables to terminals A2, B2, and C2 of AC circuit interrupter relay (40), and remove tags.
- e. Install cover (5) on AC circuit interrupter (40) with screws (4).
- f. Install main generator cables onto current transformer (31) and droop current transformer (34) the same number of wraps recorded during removal.
- g. Install voltage reconnection terminal board, paragraph 4.8.2.
- h. On right side of engine connect electrical leads to magnetic pickup, coolant temperature sender, governor actuator, fuel injection pump, oil pressure sender, low oil pressure switch, DEAD CRANK switch, and glow plugs contactor. Remove tags.
- i. On left side of engine connect electrical leads to starter motor, starter solenoid, battery charging alternator, coolant high temperature switch, fuel level sender, fuel float module, and auxiliary fuel pump. Remove tags.
- j. Install loop clamps securing output box harness to engine as noted during removal. Close engine access doors.
- k. Install output box top panel (3) with bolts (2) and nuts (1).
- l. Install air cleaner assembly, paragraph 2.72.4.
- m. Install rear housing panel, paragraph 2.18.4.
- n. Install control box assembly, paragraph 2.19.4.
- o. Install output box access door, paragraph 2.14.4.
- p. Connect negative battery cable and close battery access door.

4.8 **VOLTAGE RECONNECTION TERMINAL BOARD.**

4.8.1 Removal.

- a. Shut down generator set.
- b. Open battery access door and disconnect negative battery cable.
- c. Open output box access door and load terminal board access door.
- d. Remove nuts (8, FIGURE 4-3), washers (9), and cover (10) from voltage reconnection board (18).
- e. Unscrew standoffs (11) and remove washers (12), bolts (13), washers (14), and mounts (15).
- f. Remove nuts (16), tag and disconnect electrical cables (17) and main generator cables from voltage reconnection board (18).
- g. Remove voltage reconnection board (18) and moveable terminal board (20) from generator set as assembly.
- h. Tag position of capacitors (22) on voltage reconnection board (18).
- i. Remove nuts (19), movable terminal board (20), studs (21), and capacitors (22) from voltage reconnection board (18).

4.8.2 Installation

- a. Insert studs (21, FIGURE 4-3) in voltage reconnection board (18). Position capacitors (22) as tagged, align moveable terminal board (20) with voltage reconnection board (18) and install nuts (19). Remove tags.
- b. Position voltage reconnection board (18) and moveable terminal board (20) in generator set.
- c. Connect electrical cables (17) and main generator cables to voltage reconnection board (18) with nuts(16) and remove tags.
- d. Secure voltage reconnection board(18) to generator set with bolts (13), washers (14), mounts (15), washers (12), and standoffs (11).
- e. Install cover (10) with washers (9) and nuts (8).
- f. Close output box and load terminal board access doors.
- g. Connect negative battery cable and close battery access door.

4.9 OUTPUT BOX HARNESS.

4.9.1 Inspection.

- a. Remove output box harness, paragraph 4.9.2.
- b. Inspect wiring harness for burned, bent, corroded, and broken terminals.
- c. Inspect connectors for cracks, corrosion, stripped threads, bent or broken pins, and obvious damage.
- d. Inspect wire insulation for burns, deterioration, and chafing.
- e. Install output box harness, paragraph 4.9.5.

4.9.2 Removal.

- a. Shut down generator set.
- b. Open battery access door and disconnect negative battery cable.
- c. Remove control box assembly, paragraph 2.19.2.
- d. Remove output box top panel, paragraph 4.7.1, step k.
- e. Open left side engine access door, tag and disconnect electrical leads from battery charging alternator, starter solenoid, starter motor, coolant high temperature switch, fuel level sender, fuel float module, and auxiliary fuel pump.
- f. Open right side engine access door, tag and disconnect electrical leads from glow plugs contactor, DEAD CRANK switch, low oil pressure switch, oil pressure sender, governor actuator, fuel injection pump, coolant temperature sender, and magnetic pickup.
- g. Open output box access door. Remove screws (4, FIGURE 4-3) and cover (5) from AC circuit interrupter relay (40). Tag and disconnect electrical leads from cranking relay (43), current transformer (31), AC circuit interrupter relay (40), power potential transformer (37), and voltage reconnection board (18).

- h. Tag and disconnect electrical leads for droop current transformer (34) from terminal board (25).
- i. Remove screws (24) and nuts (23) securing terminal boards (25) and (26) in output box.
- j. Remove all clamps securing output box harness to generator set.
- k. Remove output box harness (27) from output box and generator set.

4.9.3 Testing.

- a. Set multimeter for ohms.
- b. Check individual wires, connectors, and terminal boards for continuity. Refer to Wiring Diagram FO-2 for wire identification.

4.9.4 Repair.

- a. Replace damaged cable assemblies, terminals, connectors, sockets, and terminal boards.
- b. Replace wires with damaged insulation and those that do not indicate continuity.

4.9.5 Installation

- a. Position output box harness (27, FIGURE 4-3) in output box and generator set.
- b. Install all clamps, as removed, securing output box harness in generator set.
- c. Secure terminal boards (25) and (26) in output box with screws (24) and nuts (23).
- d. Connect electrical leads for droop current transformer (34) to terminal board (25) and remove tags.
- e. Connect electrical leads to AC circuit interrupter relay (40), current transformer (31), cranking relay (43), power potential transformer (37), and voltage reconnection board (18). Install cover (5) with screws (4) on AC circuit interrupter relay (40). Remove tags and close output box access door.
- f. On right side of engine connect electrical leads to magnetic pickup, coolant temperature sender, governor actuator, fuel injection pump, oil pressure sender, low oil pressure switch, DEAD CRANK switch, and glow plugs contactor. Remove tags and close right side engine access door.
- g. On left side of engine connect electrical leads to starter motor, starter solenoid, battery charging alternator, coolant high temperature switch, fuel level sender, fuel float module, and auxiliary fuel pump. Remove tags and close left side engine access door.
- h. Install output box top panel, paragraph 4.7.2, step k.
- i. Install control box assembly, paragraph 2.19.4.
- j. Connect negative battery cable and close battery access door.

4.10 CURRENT TRANSFORMER.

4.10.1 Removal.

- a. Shut down generator set.

- b. Open battery access door and disconnect negative battery cable.
- c. Remove control box assembly, paragraph 2.19.2.
- d. Remove output box top panel, paragraph 4.7.1, step k.
- e. Open output box and right side engine access doors.
- f. Tag and disconnect current transformer (31, FIGURE 4-3) electrical leads.
- g. Tag and disconnect main generator cables T2 and T8 from voltage reconnection board (18).
- h. Unwrap main generator cables from droop current transformer (34) and current transformer (31). Note number and direction of wraps.
- i. Remove screws (29), flatwashers (30), nuts (28), and current transformer (31) from output box.

4.10.2 Testing.

- a. Remove current transformer, paragraph 4.10.1.
- b. Set multimeter for ohms and check for continuity between secondary terminals A1 and A2, B1 and B2, and C1 and C2.
- c. If continuity is present, continue with test. If continuity is not present, current transformer is defective and must be replaced.
- d. Set up a test circuit using 10 gauge wire as shown in FIGURE 4-4. Make ten passes with wire through phase A window.

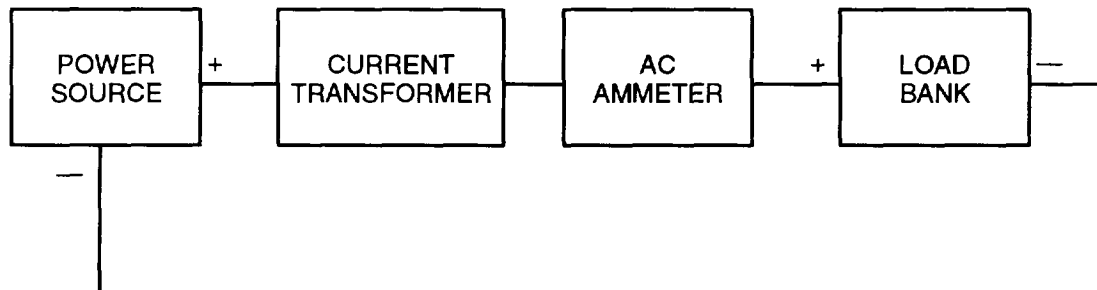

FIGURE 4-4. Testing Current Transformer

- e. Turn on power source and load bank. Adjust load bank until 27.7 amps is indicated on ammeter.
- f. Set multimeter for amperes, and connect to secondary terminals A1 and A2. Multimeter indication must be 0.9 to 1.1 amps.
- g. Repeat steps d, e, and f using phase window B and secondary terminals B1 and B2.
- h. Repeat steps d, e, and f using phase C window and secondary terminals C1 and C2.
- i. Replace current transformer if multimeter indication in any phase is other than stated in step f.
- j. Remove current transformer from test circuit.
- k. Install current transformer, paragraph 4.10.3.

4.10.3 Installation.

- a. Install current transformer (31, FIGURE 4-3) with screws (29), flatwashers (30), and nuts (28).
- b. Wrap main generator cables around current transformer (31) and droop current transformer (34) using same number of wraps noted during removal.
- c. Connect main generator cables to voltage reconnection board(18) and remove tags.
- d. Connect electrical leads to current transformer (31) and remove tags.
- e. Close output box and right side engine access doors.
- f. Install output box top panel, paragraph 4.7.2, step k.
- g. Install control box assembly, paragraph 2.19.4.
- h. Connect negative battery cable. Close battery access door.

4.11 DROOP CURRENT TRANSFORMER.

4.11.1 Removal.

- a. Shut down generator set.
- b. Open battery access door and disconnect negative battery cable.
- c. Open output box and right side engine access doors.
- d. Tag and disconnect main generator cables T2 and T8 from voltage reconnection board(18, FIGURE 4-3).
- e. Unwrap main generator cables T2 and T8 from droop current transformer (34). Note number and direction of wraps.
- f. Tag and disconnect droop current transformer (34) electrical leads from terminal board (25).
- g. Remove screws (33), nuts (32), and droop current transformer (34) from output box.

4.11.2 Testing.

- a. Remove droop current transformer, paragraph 4.11.1.
- b. Set multimeter for ohms and check for continuity between secondary leads 1 and 2.

- c. If continuity is present, continue with test. If continuity is not present, droop current transformer is defective and must be replaced.
- d. Set up a test circuit using 10 gauge wire as shown in FIGURE 4-5. Make ten passes with wire through window of droop current transformer.
- e. Turn on power supply and load bank. Adjust load bank until 20.8 amps is indicated on AC ammeter.
- f. Set multimeter for AC amperes and connect to secondary leads 1 and 2. Multimeter indication must be between 0.9 and 1.1 amps.
- g. Replace droop current transformer if multimeter indication is other than above.
- h. Remove droop current transformer from test circuit.
- i. Install droop current transformer, paragraph 4.11.3.

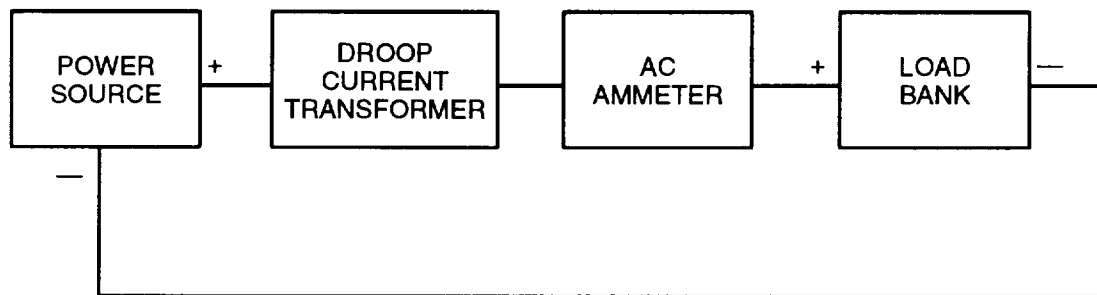

FIGURE 4-5. Testing Droop Current Transformer

4.11.3 Installation

- a. Install droop current transformer (34, FIGURE 4-3) in output box with screws (33) and nuts (34).
- b. Wrap main generator cables around droop current transformer (34) using the same number of wraps noted during removal.
- c. Connect main generator cables to voltage reconnection board (18) and remove tags.
- d. Connect droop current transformer (34) electrical leads to terminal board (25) and remove tags.
- e. Close output box and engine access doors.
- f. Connect negative battery cable and close battery access door.

4.12 POWER POTENTIAL TRANSFORMER.

4.12.1 Removal.

- a. Shut down generator set.
- b. Open battery access door and disconnect negative battery cable.
- c. Remove control box assembly, paragraph 2.19.2.
- d. Remove output box top panel, paragraph 4.7.1, step k.
- e. Tag and disconnect power potential transformer (37, FIGURE 4-3) electrical leads.
- f. Remove screws (36), nuts (35), and power potential transformer (37) from output box.

4.12.2 Testing (P/N: 17910).

- a. Remove power potential transformer, paragraph 4.12.1.
- b. Connect terminals 1 and 2 of power potential transformer to an AC power source (polarity is not important).
- c. Set power supply for 208 VAC, 60 Hz. Turn on power supply.
- d. Set multimeter for AC volts and take readings between the following terminals and compare to voltages shown:
Terminals 3 and 7 = 144-176 VAC
Terminals 4 and 6 = 27-33 VAC
- e. Replace power potential transformer if readings are not as voltages above.
- f. Install power potential transformer, paragraph 4.12.4.

4.12.3 Testing (P/N: A1497B).

NOTE

Used on MEP-804A only.

- a. Remove power potential transformer, paragraph 4.12.1.
- b. Connect terminals 1 and 2 of power potential transformer to an AC power source (polarity is not important).
- c. Set power supply at 208 VAC, 60 Hz. Turn on power supply.
- d. Set multimeter for AC volts and take readings between the following terminals and compare to voltages shown:
Terminals 5 and 6 = 54-66 VAC
Terminals 5 and 4 = 54-66 VAC

Terminals 5 and 3 = 126-154 VAC
Terminals 5 and 7=126-154 VAC

- e. Replace power potential transformer if readings are not as above.
- f. Install power potential transformer, paragraph 4.12.4.

4.12.4 Installation.

- a. Install power potential transformer (37, FIGURE 4-3) with screws (36) and nuts (35).
- b. Connect electrical leads and remove tags.
- c. Install output box top panel, paragraph 4.7.2, step k.
- d. Install control box assembly, paragraph 2.19.4.
- e. Connect negative battery cable. Close battery access door.

4.13 OUTPUT BOX PANELS.

4.13.1 Inspection.

- a. Inspect output box panels (3, 46, 47, and 51, FIGURE 4-3) for cracks, dents, loose paint, corrosion, and other damage.
- b. Inspect grommets (48), (49), and (50); door seal (52); and EMI seal (53) for looseness, tears, deterioration, and other damage.

4.13.2 Removal.

- a. Shut down generator set.
- b. Open battery access door and disconnect negative battery cable.
- c. Remove control box assembly, paragraph 2.19.2.
- d. Remove generator housing rear panel, paragraph 2.18.1.
- e. Remove output box access door, paragraph 2.14.1.
- f. Remove air cleaner assembly, paragraph 2.72.2.
- g. Remove bolts (2, FIGURE 4-3), nuts (1), and output box top panel (3).
- h. Remove voltage reconnection terminal board, paragraph 4.8.1.
- i. Remove droop current transformer, paragraph 4.11.1.
- j. Remove power potential transformer, paragraph 4.12.1.
- k. Remove current transformer, paragraph 4.10.1.
- l. Remove output box harness, paragraph 4.9.2.
- m. Remove nuts (38), screws (39), and AC circuit interrupter relay (40).
- n. Remove nuts (41), screws (42), and cranking relay (43).
- o. Remove nuts (6), bolts (7), and output box panels from generator set.
- p. Remove bolts (45), nuts (44), and output box side panels (46) and (47) from output box bottom panel (51).
- q. Remove grommets (48), (49), and (50) from output box panels (3) and (51).
- r. If necessary, remove door seal (52) and EMI seal (53) from output box top panel (3).

4.13.3 Repair.

WARNING

Wear protective mask and gloves when sanding CARC painted surfaces. CARC paint dust is a health hazard and could cause personal injury if warning is not followed.

- a. Repair all dents and cracks, and remove all loose paint.
- b. Remove light corrosion with fine grit abrasive paper (Item 15, Appendix C).
- c. Replace damaged seals and grommets.
- d. Repaint surfaces in accordance with TM 43-0139. (F) Refer to applicable directives.

4.13.4 Installation.

- a. Install grommets (48, 49, and 50, FIGURE 4-3) in output box panels (3) and (51).
- b. Install output box side panels (46) and (47) on output box bottom panel (51) with bolts (45) and nuts (44).
- c. Install output box panels in generator set with bolts (7) and nuts (6).
- d. Install cranking relay (43) with screws (42) and nuts (41).
- e. Install AC circuit interrupter relay (40) with screws (39) and nuts (38).
- f. Install current transformer, paragraph 4.10.3.
- g. Install power potential transformer, paragraph 4.12.4.
- h. Install droop current transformer, paragraph 4.11.3.
- i. Install voltage reconnection terminal board, paragraph 4.8.2.
- j. Install output box harness, paragraph 4.9.5.
- k. Install air cleaner assembly, paragraph 2.72.4.
- l. Install output box top panel (3) with bolts (2) and nuts(1).
- m. If removed, install self- adhesive door seal (52) and EMI seal (53) with adhesive (Item 1, Appendix C) on output box top panel (3).
- n. Install output box access door, paragraph 2.14.4.
- o. Install generator housing rear panel, paragraph 2.18.4.
- p. Install control box assembly, paragraph 2.19.4.
- q. Connect negative battery cable and close battery access door.

Section V. MAINTENANCE OF ENGINE ACCESSORIES

4.14 GOVERNOR ACTUATOR.

4.14.1 Testing.

- a. Shut down generator set.
- b. Open battery access door and disconnect negative battery cable.
- c. Open right side engine access door and disconnect P10 connector (FIGURE 4-6) from engine electrical harness.
- d. Remove rear fuel injection pump access plug located on top of injection pump housing.
- e. Connect 5 ohm, 25 watt resistor in series with pin 2 of P10 connector and ground.
- f. Connect jumper wire from pin 1 of P10 connector to battery positive terminal (24 VDC).
- g. While looking through rear fuel injection pump access plug hole, connect negative battery cable. Governor actuator shaft should extend to full fuel position.
- h. Disconnect negative battery cable. Governor actuator shaft should retract to no fuel position.
- i. Replace governor actuator if it does not function as above.
- j. Remove resistor and jumper wire from governor actuator.
- k. Install rear fuel injection pump access plug.
- l. Connect P10 connector to engine electrical harness and close right side engine access door.
- m. Connect negative battery cable and close battery access door.

4.14.2 Removal.

- a. Shut down generator set.
- b. Open battery access door and disconnect negative battery cable.
- c. Open right side engine access door.
- d. Tag and disconnect P10 connector from electrical harness.
- e. Remove rear fuel injection pump access plug located on top of fuel injection pump housing.
- f. Remove allen head screws (1, FIGURE 4-6) and lockwashers (2) securing governor actuator (3) to mounting plate (10).
- g. While looking through rear fuel injection pump access plug hole, tilt governor actuator (3) down so that clevis (6) clears stud (19) of injection pump rack linkage, and remove governor actuator(3) and gasket (4) from fuel injection pump.
- h. Loosen nut (5) and unscrew clevis (6) and retention spring (7) from governor actuator shaft.

NOTE

Hold suitable container under fuel injection pump to catch oil that will drain from pump housing when mounting plate (10) is removed.

- i. Remove bolts (8), lockwashers (9), mounting plate (10), and gasket (11) from fuel injection pump.
- j. Remove nut (12), lockwasher (13), bolt (14), bracket (15), spring retainer (16), and spring (17) from injection pump rack lever (inside pump).

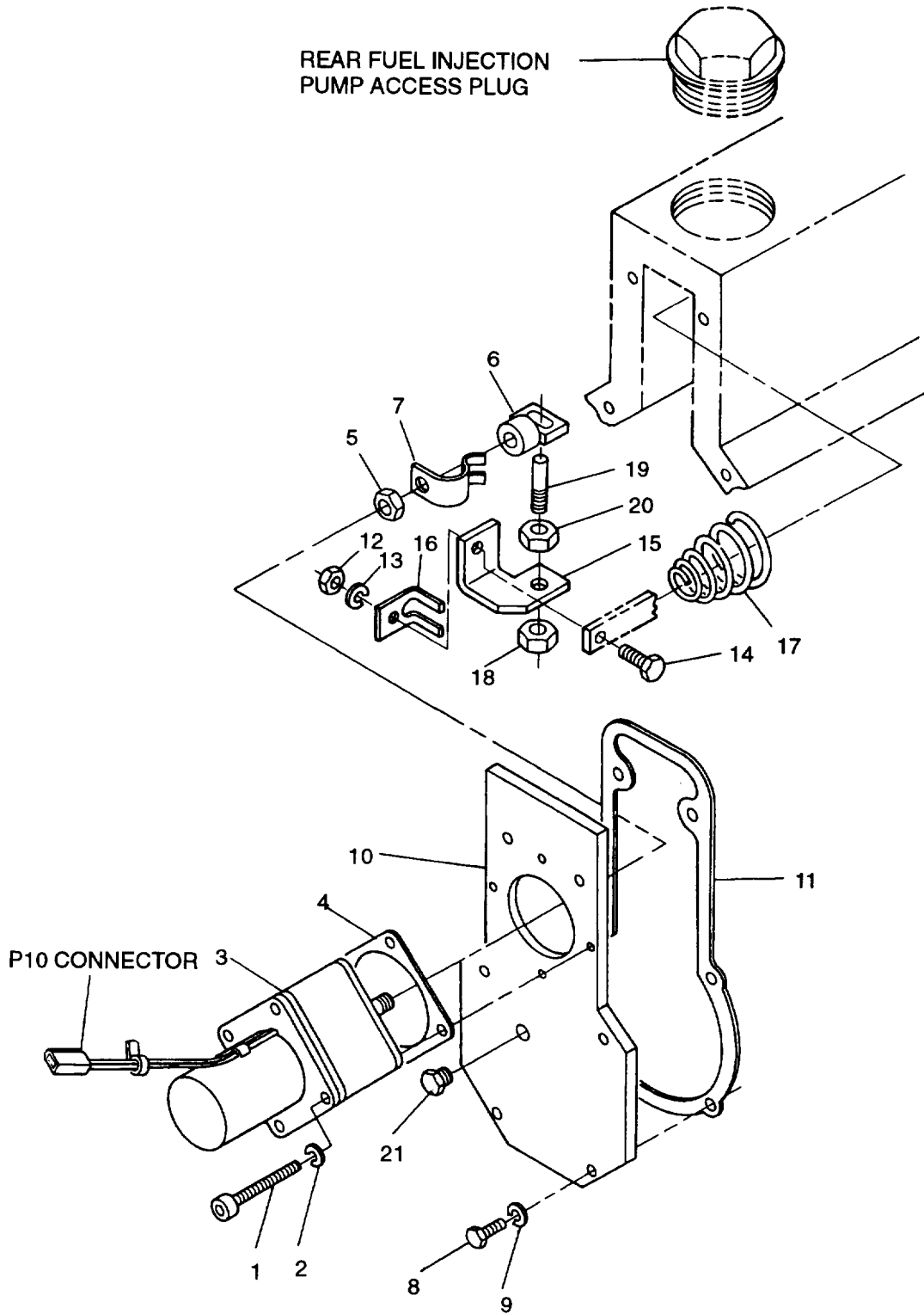

- k. Remove nuts (18) and (20), and stud (19) from bracket (15).
- l. Remove bolt (21) from mounting plate (10).

4.14.3 Installation and Adjustment

- a. Install nut (20, FIGURE 4-6) onto stud (19) until only two or three threads are left exposed on stud shaft.
- b. Install stud (19) and nut (20) in bracket(15) and secure with nut (18).
- c. Install spring (17), spring retainer (16), and bracket (15) on injection pump rack lever (inside pump) with bolt (14), lockwasher (13), and nut (12). Torque nut (12) to 48 in-lbs (5.4 Nm).
- d. Apply sealant (tem 20, appendix C) to both sides of gasket (11), install gasket (11) and mounting plate (10) on injection pump with bolts (8) (threads coated with sealant (item 20, appendix C)) and lockwashers (9). Torque bolts (8) to 100 in ilbs (11.3 Nm).
- e. Position clevis (6) within retention spring(7). Slotted flat end of clevis (6) is to be positioned between the two fingers of spring (7).
- f. Turn clevis and retention spring assembly onto shaft of actuator (3) so that side of hole (slot) in clevis (6) (closest to the actuator face) is between 0.96 to 1.00 in. (2.43 to 2,54 cm) from face of actuator (3). Tighten nut (5) against clevis (6).
- g. Apply sealant (item 20, appendix C) to both sides of gasket (4) and position gasket (4) on actuator base with one bolt (1) and one lockwasher (2) in upper hole of actuator.

NOTE

Polarity of power to the actuator is not important.

- h. Connect 5 ohm, 25 watt resistor in series with one pin of P10 connector and ground. Connect a jumper wire from other pin of P10 connector to positive battery terminal.
- i. Connect negative battery cable to energize and extend actuator shaft.
- j. Insert medium size screwdriver through access hole at top of injection pump housing and hold injection pump rack fully toward rear of engine.
- k. With actuator(3) energized insert actuator shaft through hole in mounting plate (10) at a slight upward angle. Move shaft inward until lower finger of retention spring (7) compresses sufficiently allowing top of stud (19) to align itself under slot of clevis (6).
- l. Use tip of screwdriver that held fuel pump rack to compress upper finger of retention spring (7) so that clevis (6) can drop down on stud (19).
- m. Deenergize actuator (3).
- n. Secure actuator (3) to mounting plate (10) with allen head screws (1) (threads coated with sealant (item 20, appendix C)) and lockwashers (2). Torque to 100 in lbs (11.3 Nm).
- o. While looking through rear injection pump access plug hole, energize and reenergize actuator a few times to insure there is no binding. Lubricate actuator shaft with oil (item 11, appendix C).
- p. Using rear injection pump access hole, fill pump housing with engine oil (TABLE 2-3) to a level even with bottom of hole for bolt (21).
- q. Install rear injection pump access plug in top of injection pump and bolt (21) in mounting plate (10).
- r. Remove jumper wires and connect P10 connector to engine harness.
- s. Connect battery cable. Close access doors.

Section VI. MAINTENANCE OF GENERATOR ASSEMBLY

4.15 TECHINCAL DESCRIPTION.

4.15.1 General. Revolving field type generators have a DC field revolving within a stationary AC winding called the stator. AC power is distribution from the generator through leads connected to the stator windings. There are no sliding contacts between the AC winding and the load, therefore, great amounts of power maybe drawn from this generator.

NOTE

Refer to FIGURE 4-7 as needed.

To energize the field, DC excitation must be applied to the generator field coils. The excitation current is supplied from a brushless exciter mounted on the generator shaft.

The brushless exciter is actually an AC generator with its output rectified through a full wave bridge circuit. This type of brushless exciter will provide the necessary excitation current. The generator set field flash circuit, activated during each engine start, applies voltage to the exciter stator to begin the voltage build-up process to enegize the generator field.

The generator output voltage is controlled by controlling the alternating field current. This is accomplished by regulating the exciter field coil voltage. The exciter field coil voltage is regulated with a solidstate-type voltage regulator.

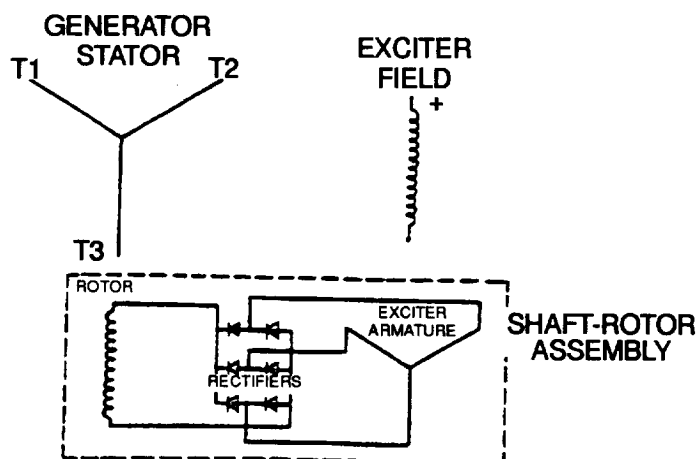

FIGURE 4-7. Brushless Generator Schematic

4.15.2 Damper Bars. Damper bars are inserted through the field laminations and welded at the end to a solid copper plate. The damper windings provide stable parallel operation, reduce damping current losses, and limit the increase of third harmonic voltage with increase in load.

4.15.3 Brushless Exciter. The brushless exciter consists of an armature with a three-phase AC winding and rotating rectifier assembly within a stationary field.

The stationary exciter field assembly is mounted in the main generator frame. The exciter armature is press fit and keyed onto the shaft assembly. The rotating rectifier assembly slides over the bearing end of the generator rotor shaft and is secured with bolts and washers to an adapter hub which is shrunk on the generator shaft.

4.15.4 Rotating Rectifier Bridge. The rotating rectifier bridge consists of rectifying diodes mounted on a brass heat sink which is in turn mounted on an insulating ring. The entire assembly bolts to the adapter on the generator shaft. Therefore, the rotating rectifier assembly will rotate with the exciter armature eliminating the need for any sliding contacts between the exciter output and the alternator field.

4.15.5 Exciter Field. The exciter field on the high frequency exciter consists of laminated segments of high carbon steel which are fitted together to make up the field poles. The field coils are placed into the slots of the field poles.

4.15.6 Exciter Field Coil Voltage Source. Field coil DC voltage is obtained by rectifying the voltage from a phase to neutral line of the generator output, or other appropriate terminal to provide the needed voltage reference.

The rectifier bridge is an integral part of the static regulator. The static regulator senses a change in the generator output and automatically regulates current flow in the exciter field coil circuit to increase or decrease the exciter field strength. An external adjust rheostat sized to be compatible with the regulator is used to provide adjustment to the regulator sensing circuit.

4.15.7 Balance. The rotor assembly is precision balanced to a high degree of static and dynamic balance. Balance is achieved with the balance lugs on the field pole tips. The balance will remain dynamically stable at speed in excess of the design frequencies.

4.15.8 Bearing. The generator rotor assembly is suspended on shielded, factory lubricated ball bearings. They are greased for life and do not require lubrication.

4.15.9 Stator Assembly. The stator assembly consists of laminations of steel mounted in a rolled steel frame. Random wound stator coils are fitted into the insulated slots.

WARNING

Make sure unit is completely shut down and free of any power source before attempting any repair or maintenance on the unit. Failure to follow this procedure could result in injury or death by electrocution.

4.16 GENERATOR ASSEMBLY

4.16.1 Removal.

- a. Shut down generator set
- b. Open battery access door and disconnect negative battery cable.
- c. Remove generator set rear housing section, paragraph 2.18.1.
- d. Loosen bolts(19, FIGURE 3-1) and lower engine support brackets (22) to rest on skid base. Tighten bolts (19). If necessary, place wooden shims under brackets to ensure contact with skid base.

CAUTION

Rated capacity of overhead hoist should be at least 1,000 lbs (454 kg).

- e. Attach lifting harness to overhead hoist and generator lifting eye, and take up slack.
- f. Remove screw (1, FIGURE 4-8), washer (2), and screen/cover (3) from generator case.
- g. Remove bolts (4) and lockwashers (5) securing generator drive disc to engine flywheel.
- h. Remove bolts (6) and lockwashers (7) securing generator to engine flywheel housing.
- i. Remove nuts (8), washers (9), snubbing washers (10), bolts (11), and Belleville washers(12) securing generator to skid base.

- j. Lift generator slowly from skid base, ensuring that engine flywheel housing and generator separate smoothly avoiding any undue stress.
- k. Remove shock mounts (13) from skid base.
- l. Remove nuts (14), washers (15), bolts (16), angles (17), and plates (18) from generator.

4.16.2 Installation.

- a. Position generator shock mounts (13, FIGURE 4-8) in skid base.
- b. Install angles (17) and plates (18) on generator with bolts (16), washers (15), and nuts (14).

CAUTION

Rated capacity of overhead hoist should be at least 1,000 lbs (454 kg),

- c. Attach lifting harness to overhead hoist and generator lifting eye.
- d. Position generator on skid base aligning mounting holes with mounts and engine flywheel housing.
- e. Install bolts (4) and lockwashers (5) securing generator drive disc to engine flywheel. Torque bolts (4) to 35 ft-lbs (47 Nm).
- f. Install bolts (6) and lockwashers (7) securing generator to flywheel housing. Tighten bolts (6) slowly to ensure proper seating of generator case lip in engine flywheel housing. Torque bolts (6) to 31 ft-lbs (42 Nm).
- g. Install bolts (11), Belleville washers (12), snubbing washers (10), washers (9), and nuts (8) securing generator assembly to skid base. Torque bolts (11) to 210 ft-lbs (285 Nm).
- h. Install screen/cover (3) on generator case with screw (1), and washer (2).

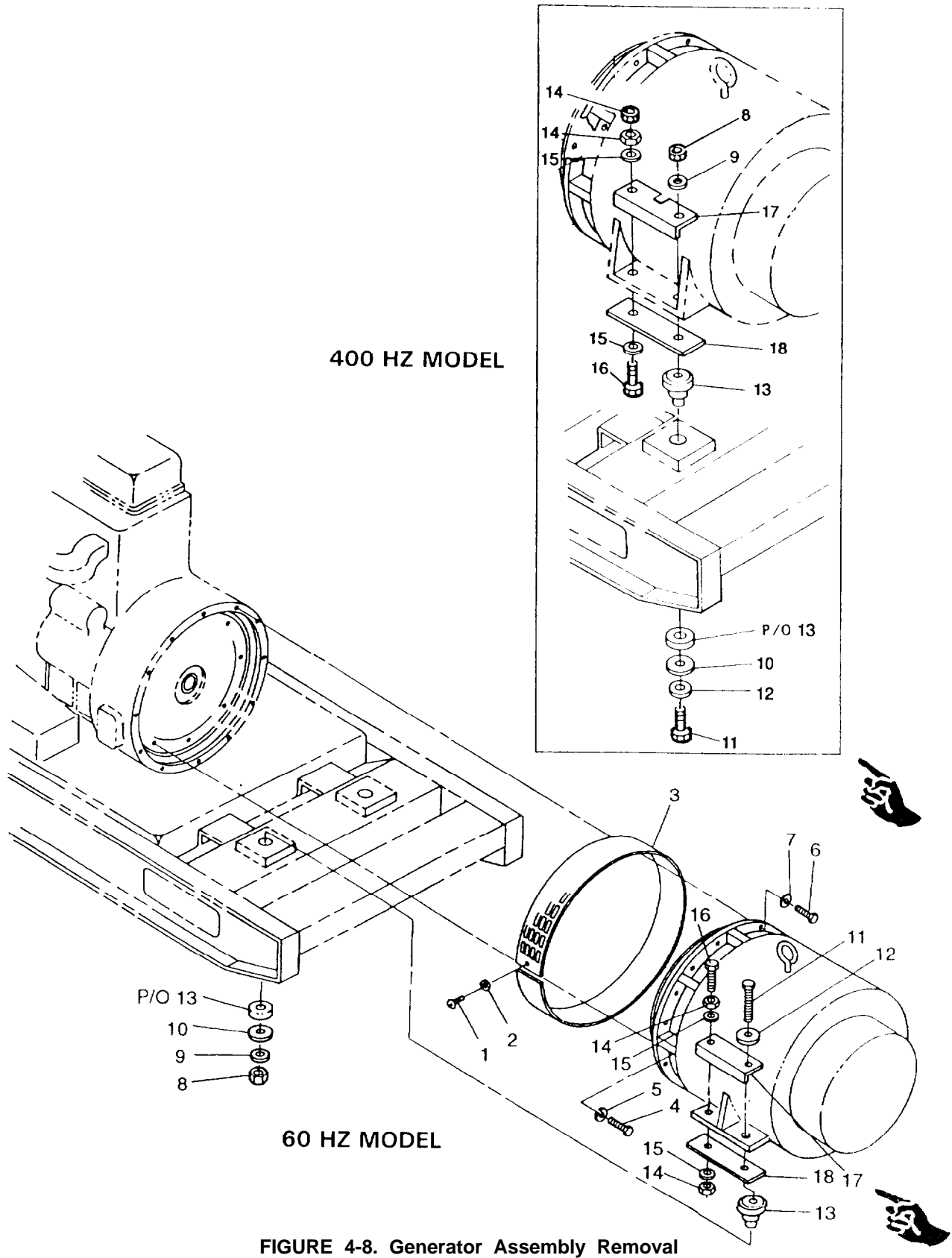

FIGURE 4-8. Generator Assembly Removal

- i. Adjust nuts (14) to obtain 0.5 in. minimum clearance between ends of bolts (16) and skid base.
- j. Loosen bolts (19, FIGURE 3-1) and raise lower engine support brackets (22) to uppermost position. Tighten bolts (19). Remove wooden shims if used.
- k. Install generator set rear housing section, paragraph 2.18.4.
- l. Connect negative battery cable and close battery access door.
- m. Start generator set and check for proper operation.

4.17 ROTATING RECTIFIER DIODES (MEP-804A).

4.17.1 Testing.

- a. Shut down generator set. Allow generator to cool to ambient temperature.
- b. Open battery access door and disconnect negative battery cable.
- c. Remove generator set housing rear panel, paragraph 2.18.1.
- d. Remove generator end bell paragraph 4.18.1.
- e. Tag main rotor leads (2, FIGURE 4-9). Remove screws (1) and main rotor leads (2) from diode mounting plate assembly (5).
- f. Tag exciter rotor leads (4). Remove screws (3) and exciter rotor leads (4) from diode mounting plate assembly (5).
- g. Set multimeter for ohms and connect positive lead to one side and negative lead to other side of each diode (7). Record multimeter reading for each diode.
- h. Repeat step g, with multimeter leads reversed.
- i. Resistance (ohms) readings should be front to back ratio of 1:10 or greater. If any reading is less than 1:10, diode is defective and must be replaced.
- j. Install exciter leads (4) and main rotor leads (2) to diode mounting plate assembly (5) with screws (1) and (3). Remove tags.
- k. Install generator end bell, paragraph 4-18-2.
- l. Install generator set housing rear panel, paragraph 2.18.4.
- m. Connect negative battery cable and close battery access door.

4.17.2 Removal.

- a. Shut down generator set
- b. Open battery access door and disconnect negative battery cable
- c. Remove generator set housing rear panel, paragraph 2.18.1.
- d. Remove generator end bell, paragraph 4-18-1.
- e. Remove rotating rectifier, paragraph 4-19-1.

- f. Unsolder electrical lead (6, FIGURE 4-9) from diode (7) being removed.
- g. Press diode (7) from diode mounting plate assembly (5).

4.17.3 Installation.

- a. Run bead of thermal-electric compound (Item 8, Appendix C) around base of diode (7, FIGURE 4-9) prior to installing.
- b. Press diode (7) into diode mounting plate assembly (5).
- c. Using solder (Item 17, Appendix C) and soldering iron, solder electrical lead (6) to diode (7).
- d. Install rotating rectifier, paragraph 4.19.2.
- e. Install generator end bell, paragraph 4.18.2.
- f. Install generator set housing rear panel, paragraph 2.18.4.
- g. Connect negative battery cable and close battery access door.

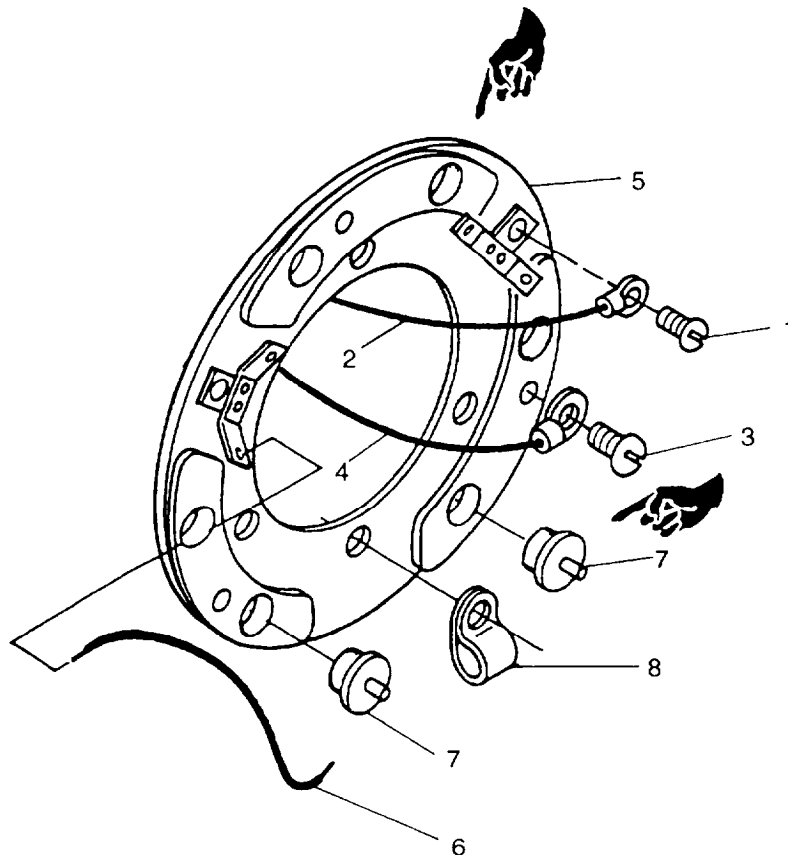

FIGURE 4-9. Rectifier Assembly (MEP-804A)

4.18 END BELL AND MAIN BEARING (MEP-804A).

4.18.1 Removal.

- a. Shut down generator set.
- b. Open battery access door and disconnect negative battery cable.
- c. Remove generator set housing rear panel, paragraph 2.18.1.
- d. Remove bolts (1, FIGURE 4-10), lockwashers (2), and end bell (3) from generator assembly.
- e. If necessary, remove plug (4) and packing (5) from end bell (3).

CAUTION

If bearing needs to be removed for any reason, always install new bearing. Main bearing is easily damaged when removed from rotor shaft. Damage to equipment could result.

- f. Using bearing puller, remove bearing (6) from main rotor assembly (23) shaft and discard bearing
- g. If necessary remove retaining ring (7) from main rotor assembly (23) shaft.

4.18.2 Installation.

- a. If removed, install retaining ring (7, FIGURE 4-10) on main rotor assembly (23) shaft.

CAUTION

If bearing needs to be removed for any reason, always install new bearing. Main bearing is easily damaged when removed from rotor shaft. Damage to equipment could result

- b. Install bearing (6) on main rotor assembly (23) shaft. Ensure that bearing is seated squarely against retaining ring (7) by applying pressure to inner race only.
- c. If removed, install packing (5) and plug (4) in end bell (3).
- d. Position end bell (3) on bearing (6).
- e. Install end bell (3) on generator assembly with bolts (1) and lockwashers (2).
- f. Install generator set housing rear panel, paragraph 2.18.4.
- g. Connect negative battery cable. Close battery access door.

4.19 ROTATING RECTIFIER (MEP-804A).

4.19.1 Removal.

- a. Shut down generator set.
- b. Open battery access door and disconnect negative battery cable
- c. Remove generator set housing rear panel, paragraph 2.18.1.
- d. Remove generator end bell and main bearing, paragraph 4.18.1.

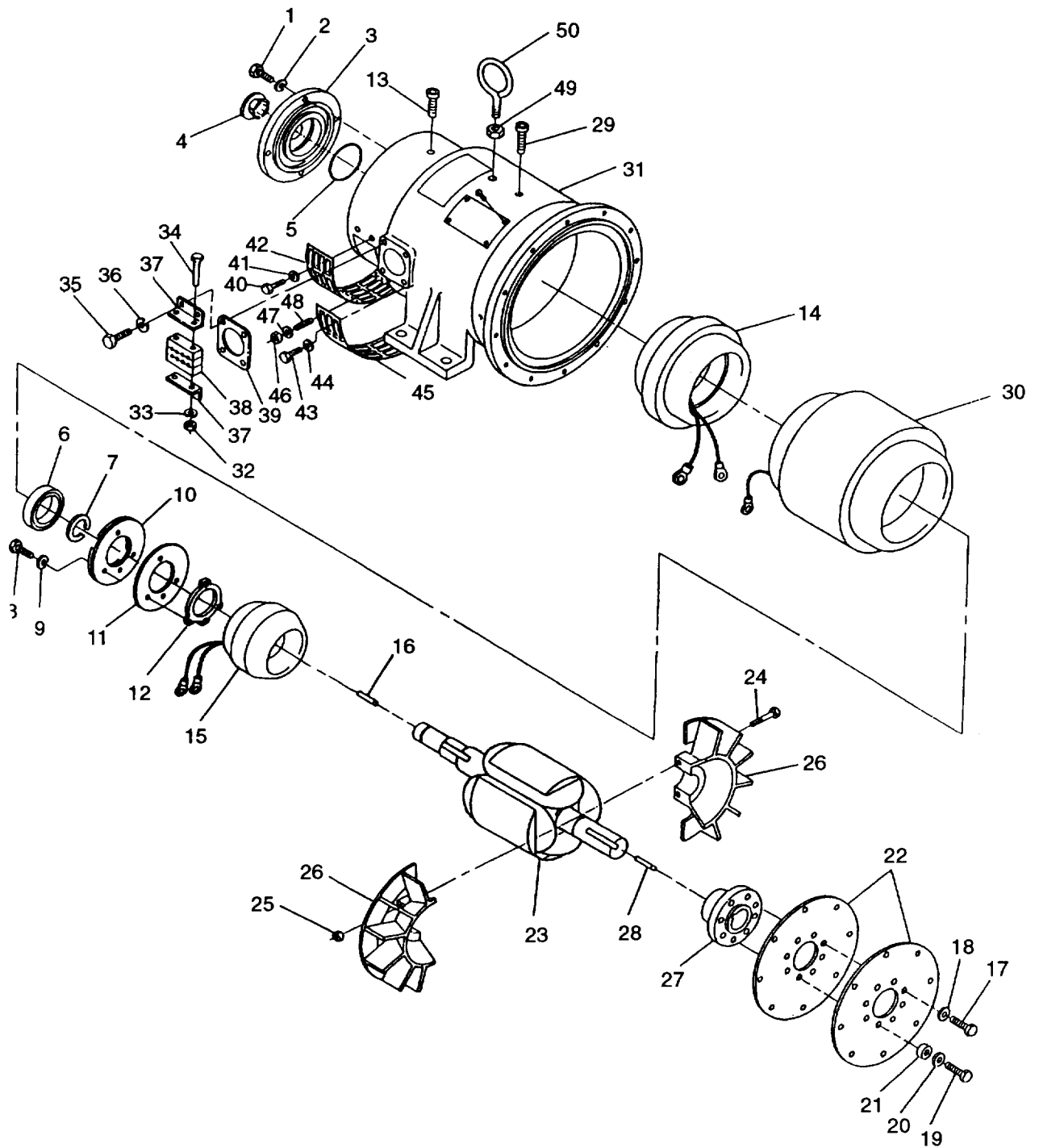

FIGURE 4-10. Generator Assembly (MEP-804A)

- e. Remove screws (3, FIGURE 4-9) securing exciter rotor leads (3 places) to rotating rectifier. Tag and remove exciter rotor leads.
- f. Remove screws (1), tag and remove main rotor leads (2) from rotating rectifier (2 places).
- g. Remove bolts (8, FIGURE 4-10), lockwashers (9), rotating rectifier (10), and insulating plate (11) from rectifier hub (12).
- h. If necessary, remove clamp (8, FIGURE 4-9) from diode mounting plate assembly (5).

4.19.2 Installation.

- a. If removed, install clamp (8, FIGURE 4-9) on diode mounting plate assembly (5).
- b. Install rotating rectifier (10, FIGURE 4-10) and insulating plate (11) on rectifier hub (12) with bolts (8) and lockwashers (9).
- c. Connect two main rotor leads (2, FIGURE 4-9) to rotating rectifier with screws (1). Remove tags.
- d. Connect three exciter rotor leads (4) to rotating rectifier with screws (3). Remove tags.
- e. Install main bearing and generator end bell, paragraph 4.18.2.
- f. Install generator set housing rear panel, paragraph 2.18.4.
- g. Connect negative battery cable. Close battery access door.

4.20 EXCITER STATOR (MEP-804A).

4.20.1 Testing.

- a. Shut down generator set. Allow generator to cool to ambient temperature.
- b. Open battery access door and disconnect negative battery cable.
- c. Open output box access door and disconnect exciter field leads F1 and F2 from terminals 1 and 2 of TB8.
- d. Set multimeter for ohms and connect between disconnected exciter field leads. Multimeter reading should be as shown in TABLE 4-3.
- e. Multimeter reading other than in TABLE 4-3, indicates open or shorted windings and exciter stator must be replaced.
- f. Connect multimeter between each exciter field lead and generator frame in turn.
- g. Multimeter reading of less than infinity indicates defective ground insulation and exciter stator must be replaced.
- h. Connect exciter field leads to terminals 1 and 2 of TB8 and close output box access door.
- i. Connect negative battery cable and close battery access door.

4.20.2 Removal.

- a. Shut down generator set.
- b. Open battery access door and disconnect negative battery cable.

- c. Remove generator set housing rear panel, paragraph 2.18.1.
- d. Remove generator assembly from generator set, paragraph 4.16.1.
- e. Remove generator end bell, paragraph 4.18.1.
- f. Remove main rotor assembly, paragraph 4.22.2.
- g. Remove main stator, paragraph 4.23.2.
- h. Remove setscrews(13, FIGURE 4-10) from generator housing (31).

WARNING

Hot metal surfaces can cause burns to skin. Wear protective gloves and eye protection when applying heat to the generator housing. Failure to observe this warning could result in severe personal injury.

CAUTION

Ensure wires are not touching generator housing and are away from open flame when heat is applied. Be sure to distribute heat evenly to prevent damage to the housing.

- i. Apply heat evenly to ribs of generator housing (31) at end bell section using an acetylene torch with a rose bud tip, refer to FIGURE 4-11 for location of ribs. Heat ribs until exciter stator (14) drops down and lift off housing (31).

4.20.3 Installation.

- a. Stand generator housing (31, FIGURE 4-10) on end with end bell opening in a downward position.
- b. Position exciter stator (14) in generator housing (31). Ensure exciter stator wires are pointing upward and are in alignment with wiring port on side of generator housing (31).

WARNING

Hot metal surfaces can cause burns to skin. Wear protective gloves and eye protection when applying heat to generator housing. Failure to observe this warning could result in severe personal injury.

CAUTION

Ensure wires are not touching generator housing and are away from open flame when heat is applied. Be sure to distribute heat evenly to prevent damage to housing.

- c. Apply heat evenly to ribs of generator housing (31) at end bell section using an acetylene torch with a rose bud tip, refer to FIGURE 4-11 for rib locations. Heat ribs until exciter stator (14) drops into position.
- d. Install setscrews (13) in generator housing (31).

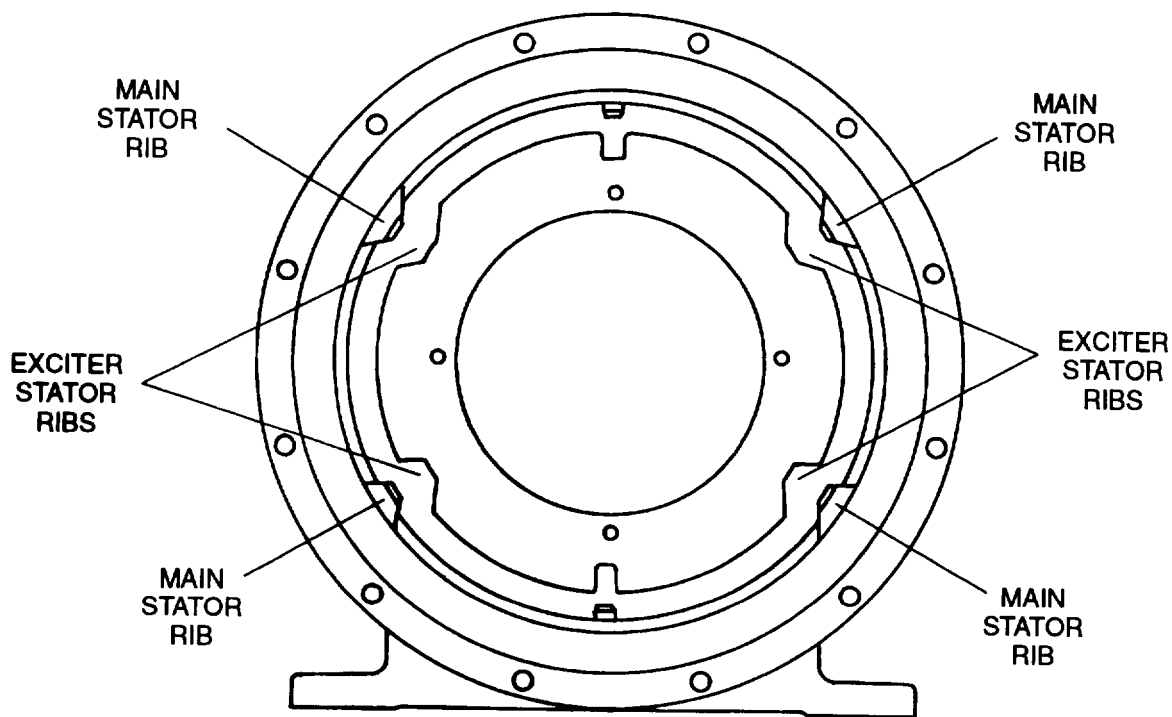

FIGURE 4-11. Generator Housing Rib Locations

CAUTION

Special care must be taken when feeding wires to prevent damaging or breaking off wires.

- e. Feed exciter stator (14) wires through wiring port on side of generator housing (31).
- f. Retest exciter stator to ensure stator was not damaged during installation, paragraph 4.20.1.

- g. Install main stator, paragraph 4.23.3.
- h. Install generator assembly, paragraph 4.16.2.

4.21 EXCITER ROTOR MEP-804A).

4.21.1 Testing.

- a. Shut down generator set. Allow generator to cool to ambient temperature.
- b. Open battery access door and disconnect negative battery cable.
- c. Remove generator set housing rear panel, paragraph 2.18.1.
- d. Remove generator end bell, paragraph 4.18.1.
- e. Tag and disconnect exciter rotor leads (3 places) from rotating rectifier by removing screws (3, FIGURE 4-9).
- f. Connect resistance bridge, between two exciter rotor leads and note resistance reading. Continue this procedure until readings are noted for each combination of leads (i.e., 1 and 2, 1 and 3, and 2 and 3).
- g. Resistance readings should be as shown in TABLE 4-3 for each combination of leads. Readings other than in TABLE 4-3, indicate open or shorted windings and exciter rotor must be replaced.
- h. Set multimeter for ohms and connect between each exciter rotor lead and generator housing in turn.
- i. Multimeter reading of less than infinity indicates defective ground insulation and exciter rotor must be replaced.
- j. Connect exciter rotor leads to rotating rectifier with screws (3, FIGURE 4-9) and remove tags.
- k. Install end bell, paragraph 4.18.2.
- l. Install generator set housing rear panel, paragraph 2.18.4.
- m. Connect negative battery cable and close battery access door.

4.21.2 Removal.

- a. Shut down generator set.
- b. Open battery access door and disconnect negative battery cable.
- c. Remove generator set housing rear panel, paragraph 2.18.1.
- d. Remove generator end bell and main bearing, paragraph 4.18.1.
- e. Remove rotating rectifier, paragraph 4.19.1.

WARNING

Use protective gloves when handling heated rectifier hub (12) to prevent personal injury.

NOTE

Rectifier hub (12) is heat shrunk onto rotor assembly (23) shaft and will require the use of heat to remove.

TABLE 4-3. Generator Resistance Values At 25°C (77°F)

Component	Resistance	
	MEP-804A	MEP-814A
Exciter Stator	Between 28.657 & 38.771 ohms	Between 25.0335 & 33.8715 ohms
Exciter Rotor	Between 0.709 & 0.959 ohms	Between 0.2025 & 0.2739 ohms
Generator Rotor	Between 1.247 & 2.073 ohms	Between 1.2688 & 1.7166 ohms
Generator Stator	Between 0.146 & 0.198 ohms	Between 0.0717 & 0.0971 ohms

NOTE

Ambient temperature must be expressed in °C.
 To convert °F to °C use: °F = °C x 9 + 5 +32

- (1) To determine the resistance values at current ambient temperature, use the following formula:

$$R_1 = R_{25} [1 + 0.00385 (T-25)]$$

Where:

- R₁ = Unknown resistance
- R₂₅ = Known resistance at 25°C (77°F)
- T = Current ambient temperature

- (2) Example for exciter stator leads at 5°C (41 °F) (MEP-804A):

$$R_1 = 33.714 [1 + 0.00385 (5-25)]$$

$$R_1 = 33.714 [1 + 0.00385 (-20)]$$

$$R_1 = 33.714 [1 + -0.077]$$

$$R_1 = 33.714 [0.923]$$

$$R_1 = 31.118 \pm 15\% \text{ ohms}$$

- f. Using bearing puller, remove rectifier hub (12, FIGURE 4-10) from rotor assembly (23) shaft.
- g. Pull two main rotor leads out of holes in exciter rotor (15).
- h. Attach hub puller to two lead holes and remove exciter rotor (15) from rotor assembly (23) shaft.
- i. Remove key (16) from rotor assembly (23) shaft.

4.21.3 Installation.

- a. Install key (16, FIGURE 4-10) on main rotor assembly (23) shaft.
- b. Press exciter rotor (15) onto shaft, over key (16) and against shoulder of rotor assembly (23) shaft.

WARNING

Use protective gloves when handling heated rectifier hub (12) to prevent personal injury.

- c. Heat rectifier hub (12) until it slides into place on rotor assembly (23) shaft with slight pressure.
- d. Once rectifier hub (12) has cooled, pull two main rotor leads through holes in exciter rotor (15) and position for attachment to rotating rectifier (10).

- e. Install rotating rectifier, paragraph 4.19.2.
- f. Install main bearing and generator end bell, paragraph 4.18.2.
- g. Install generator set housing rear panel, paragraph 2.18.4.
- h. Connect negative battery cable and close battery access door.

4.22 GENERATOR ROTOR ASSEMBLY (MEP-804A).

4.22.1 Testing.

- a. Shut down generator set. Allow generator to cool to ambient temperature.
- b. Open battery access door and disconnect negative battery cable.
- c. Remove generator set housing rear panel, paragraph 2.18.1.
- d. Remove generator end bell, paragraph 4.18.1.
- e. Tag and disconnect main rotor leads (2 places) from rotating rectifier by removing screws (1, FIGURE 4-9).
- f. Set multimeter for ohms and connect between disconnected main rotor leads. Multimeter reading should be as shown in TABLE 4-3.
- g. Reading other than in TABLE 4-3, indicates shorted or open windings and main rotor must be replaced.
- h. Connect multimeter between each main rotor lead and generator housing in turn.
- i. Multimeter reading of less than infinity indicates defective ground insulation and main rotor must be replaced.
- j. Connect main rotor leads to rotating rectifier with screws (1, FIGURE 4-9).
- k. Install generator end bell, paragraph 4.18.2.
- l. Install generator set housing rear panel, paragraph 2.18.4.
- m. Connect negative battery cable and close battery access door.

4.22.2 Removal.

- a. Shut down generator set.
- b. Remove generator assembly from generator set, paragraph 4.16.1.

NOTE

Mark location of spacers (21), washers (20), and bolts (19) to ensure correct positioning during installation.

- c. Remove bolts (17 and 19, FIGURE 4-10), washers (18) and (20), spacers (21), and drive discs (22) from drive hub (27).
- d. Attach a suitable rotor lifting device to drive hub (27) and overhead hoist as shown in FIGURE 4-12.
- e. Remove generator end bell, paragraph 4.18.1.

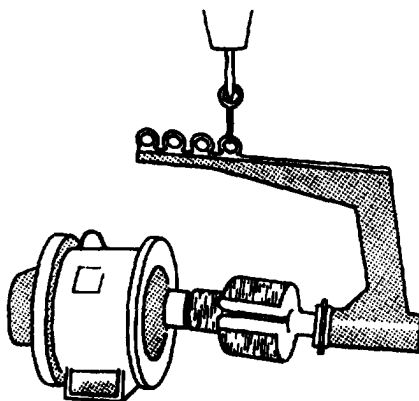

FIGURE 4-12. Rotor Assembly Lifting Device (Typical)

CAUTION

Special care should be taken when removing rotor assembly, winding damage could result if rotor is allowed to hit main stator.

- f. Carefully remove rotor assembly (23) and attached components from generator housing (31).
- g. Remove main bearing, paragraph 4.18.1.
- h. Remove rotating rectifier, paragraph 4.19.1.
- i. Remove exciter rotor, paragraph 4.21.2.
- j. Remove bolts (24), nuts (25), and fan halves (26) from rotor assembly (23).
- k. Using bearing puller, remove drive hub (27) and key (28) from rotor assembly (23),

4.22.3 Installation.

- a. Place key (28, FIGURE 4-10) on rotor assembly (23) and install drive hub (27) over key (28) and onto main rotor assembly (23),

NOTE

Ensure gap between fan halves (26) are equal from side to side.

- b. Install fan halves (26) on rotor assembly (23) with bolts (24) and nuts (25).
- c. Install exciter rotor, paragraph 4.21.3.
- d. Install rotating rectifier, paragraph 4.19.2.
- e. Install main bearing, paragraph 4.18.2.

CAUTION

Special care must be taken installing rotor assembly, winding damage could result if rotor is allowed to hit main stator.

- f. Attach a suitable rotor lifting device to drive hub (31) and overhead hoist as shown in FIGURE 4-12.
- g. Carefully install rotor assembly (23) and attached components into generator housing (31).
- h. Install generator end bell, paragraph 4.18.2 and remove rotor lifting device.

NOTE

Ensure correct positioning of spacers (21), washers (20), and bolts (19) as marked on removal.

- i. Install drive discs (22) on drive hub (27) with spacers (21), washers(18) and (20), and bolts (17) and (19). Torque bolts (17) to 28 ft-lbs (38 Nm) and bolts (19) to 35 ft-lbs (47 Nm).
- j. Install generator assembly in generator set, paragraph 4.16.2.

4.23 GENERATOR MAIN STATOR (MEP-804A).

4.23.1 Testing.

- a. Shut down generator set. Allow generator to cool to ambient temperature.
- b. Open battery access door and disconnect negative battery cable.
- c. Remove protective cover and moveable terminal board from voltage reconnection terminal board, paragraph 2.94.2.
- d. Disconnect two electrical connectors from bottom of control box assembly.
- e. Tag and disconnect wires 107C and 109J from terminals 1 and 2 of power potential transformer (37, FIGURE).
- f. Connect resistance bridge and note readings between terminals T1 and T4, T2 and T5, T3 and T6, T7 and T0, T8 and T0, and T9 and T0 of voltage reconnection terminal board.
- g. All resistance readings should be as shown in TABLE 4-3.
- h. If resistance is low, there are shorted windings, if resistance is high, stator windings are open. In either case, stator must be replaced.
- i. Disconnect removable grounding link on load output terminal board (17, FIGURE 2-30).
- j. Set multimeter for ohms and connect between each coil lead and ground, in turn.
- k. If multimeter indicates resistance on any connection, stator windings are grounded and stator must be replaced.
- l. Connect removable grounding link on load output terminal board.
- m. Connect wires 107C and 109J to terminals 1 and 2 of power potential transformer. Remove tags.
- n. Connect two electrical connectors to bottom of control box assembly.
- o. Install moveable terminal board and protective cover on voltage reconnection terminal board, paragraph 2.94.3.
- p. Connect negative battery cable and close battery access door.

4.23.2 Removal.

- a. Shut down generator set.
- b. Remove generator assembly from generator set, paragraph 4.16.1.
- c. Remove generator rotor assembly, paragraph 4.22.2.
- d. Remove nuts (32, FIGURE 4-10), lockwashers (33), bolts (34), and lead clamp assembly (38) from brackets (37).
- e. Remove main stator setscrews (29) from housing (31).
- f. Set generator housing (31) on end with end bell opening in the upright position.

C A U T I O N

Special care must be taken when feeding wires to prevent damaging or breaking off wires.

- g. Feed main stator (30) and exciter stator (14) wires through generator housing (31) and up through end bell opening.

WARNING

Hot metal surfaces can cause burns to skin. Wear protective gloves and eye protection when applying heat to generator housing. Failure to observe this warning could result in severe personal injury.

CAUTION

Ensure wires are not touching generator housing and are away from open flame when heat is applied. Be sure to distribute heat evenly to prevent damage to housing.

- h. Apply heat evenly to ribs of generator housing (31) at the main stator (30) end using an acetylene torch with a rose bud tip, refer to FIGURE 4-11 for rib locations. Heat ribs until main stator (30) drops down and liftoff housing (31).

4.23.3 Installation.

- a. Stand generator housing (31, FIGURE 4-10) on end with end bell opening in a downward position.
- b. Position main stator (30) in generator housing (31). Ensure stator wires are pointing downward and in alignment with wiring port on side of generator housing (31).

WARNING

Hot metal surfaces can cause burns to skin. Wear protective gloves and eye protection when applying heat to generator housing. Failure to observe this warning could result in severe personal injury.

CAUTION

Ensure wires are not touching generator housing and are away from open flame when heat is applied. Be sure to distribute heat evenly to prevent damage to housing.

- c. Apply heat evenly to ribs of generator housing (31) at main stator (30) end using an acetylene torch with a rose bud tip, refer to FIGURE 4-11 for rib locations. Heat generator housing (31) ribs until main stator (30) drops into position.
- d. Install setscrews (29) in generator housing (31).

CAUTION

Special care must be taken when feeding wires to prevent damaging or breaking off wires.

- e. Feed main stator (30) and exciter stator (14) wires through wiring port on side of generator housing (31).
- f. Retest main stator to ensure stator was not damaged during installation, paragraph 4.23.1.
- g. Position exciter stator (14) and main stator (30) leads in lead clamp assembly (38).
- h. Install lead clamp assembly (38) in brackets (37) with bolts (34), lockwashers (33), and nuts (32).
- i. Install rotor assembly, paragraph 4.22.3.
- j. Install generator assembly, paragraph 4.16.2.

4.24 GENERATOR HOUSING (MEP-804A).

4.24.1 Removal.

- a. Shut down generator set.
- b. Remove generator assembly from generator set, paragraph 4.16.1.
- c. Remove rotor assembly, paragraph 4.22.2.
- d. Remove exciter stator, paragraph 4.20.2.
- e. Remove main stator, paragraph 4.23.2.
- f. Remove bolts (35, FIGURE 4-10), lockwashers (36), brackets (37), and gasket (39) from housing assembly (31).
- g. Remove bolts (40), washers (41), and screen (42) from housing (31).
- h. Remove bolts (43), washers (44), and screen (45) from housing (31).
- i. Remove nut (46), washer (47), and ground stud (48) from housing (31).
- j. Loosen nut (49) and unscrew lifting eye (50) from housing (31).

4.24.2 Installation.

- a. Install lifting eye (50, FIGURE 4-10) in generator housing (31) and tighten nut (49).
- b. Install ground stud (48), washer (47), and nut (46) in housing (31).
- c. Install screen (45) on housing (31) with bolts (43) and washers (44).
- d. Install screen (42) on housing (31) with bolts (40) and washers (41).
- e. Install gasket (39) and brackets (37) on housing assembly (31) with bolts (35) and lockwashers (36)
- f. Install exciter stator, paragraph 4.20.3.
- g. Install main stator, paragraph 4.23.3.
- h. Install rotor assembly, paragraph 4.22.3.
- i. Install generator assembly in generator set, paragraph 4.16.2.

4.25 ROTATING RECTIFIER DIODES (MEP-814A).

4.25.1 Removal.

- a. Shut down generator set.
- b. Open battery access door and disconnect negative battery cable.
- c. Remove generator housing rear panel, paragraph 2.18.1.
- d. Remove end bell plates and screens, paragraph 4.26.1, step d.

NOTE

It will be necessary to bar (turn) engine in order to position a specific area of the rotating rectifier at one of the end bell access holes.

- e. Unsolder electrical lead from diode (6, FIGURE 4-13) being removed.

NOTE

Mark polarity of diodes to ensure correct positioning during installation.

- f. Remove nut (7), lockwasher (8), and diode (6) from rotating rectifier through access hole in end bell.

4.25.2 Testing.

- a. Shut down generator set. Allow generator to cool to ambient temperature.
- b. Open battery access door and disconnect negative battery cable.
- c. Remove generator set housing rear panel, paragraph 2.18.1.
- d. Remove generator end bell plates and screens, paragraph 4.26.1, step d.

NOTE

It will be necessary to bar (turn) engine in order to position a specific area of the rotating rectifier at one of the end bell access holes.

- e. Remove nuts (1, FIGURE 4-13) and lockwashers (2) from rotating rectifier terminals.
- f. Tag and remove main rotor and diode leads from rotating rectifier terminals.
- g. Tag exciter rotor leads and remove bolts (3), washers (4), and exciter rotor leads from rectifier mounting plate assemblies.
- h. Set multimeter for ohms and connect positive lead to one side and negative lead to other side of diode. Repeat procedure for each diode. Record multimeter reading for each diode.
- i. Repeat step h, except with multimeter leads reversed.
- j. Resistance (ohms) readings should be low in one direction and high in reversed direction. If any reading is high or low in both directions, diode is defective and must be replaced.
- k. Install diode and main rotor leads to rotating rectifier terminals with lockwashers (2) and nuts (1). Remove tags.
- l. Install exciter rotor leads to rectifier mounting plate assemblies with washers (4) and bolts (3). Remove tags.
- m. Install generator end bell plates and screens, paragraph 4.26.2, step e.
- n. Install generator set housing rear panel, paragraph 2.18.4.
- o. Connect negative battery cable and close battery access door.

4.25.3 Installation.

- a. Run bead of thermo compound (Item 8, Appendix C) around base of diode (6, FIGURE 4-13) prior to installing. Do not coat threads.

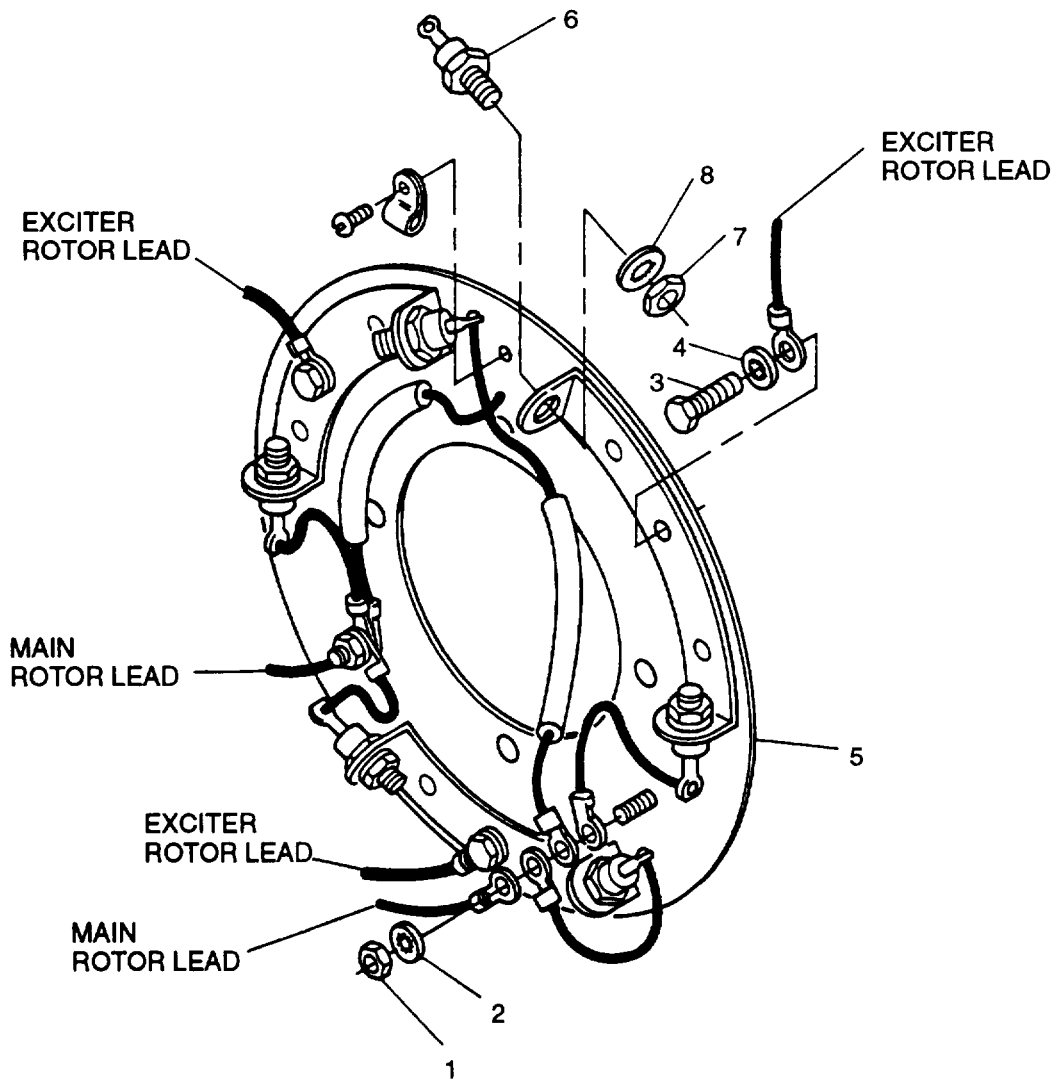

FIGURE 4-13. Rectifier Assembly (MEP-814A)

- b. Insert diode (6) through generator end bell access hole, and install on rotating rectifier plate with lockwasher (8) and nut (7) as marked during removal, Torque nut (7) 28 to 30 in-lbs (3.2 to 3.4 Nm).
- c. Using solder (Item 17, Appendix C) and soldering iron, solder electrical lead to diode (6).
- d. Install generator end bell plates and screens, paragraph 4.26.2, step e.
- e. Install generator set housing rear panel, paragraph 2.18.4.
- f. Connect negative battery cable and close battery access door.

4.26 END BELL AND MAIN BEARING (MEP814A).

4.26.1 Removal.

- a. Shut down generator set.
- b. Open battery access door and disconnect negative battery cable.
- c. Remove generator set housing rear panel, paragraph 2.18.1.
- d. Remove bolts (1, FIGURE 4-15), lockwashers (2), plates (3), and screens (4) from end bell (5).

CAUTION

The end bell supports the main rotor, thus the rotor will drop on the stator once the end bell is removed. Prior to proceeding, turn engine until two main rotor poles are vertical in generator stator. Having the rotor in this position will limit the amount of drop.

- e. Remove bolts (6) and lockwashers (7) from end bell (5).
- f. Install two bolts (6) in "back-out" holes in end bell flange, refer to FIGURE 4-14.

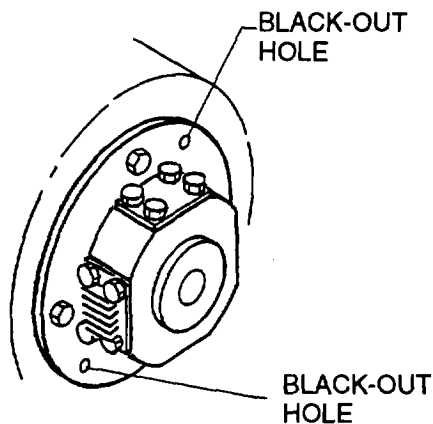

FIGURE 4-14. End Bell Removal (MEP-814A)

- g. Loosen lead clamp assembly (37, FIGURE 4-15) clamping generator leads at side of generator housing. Ensure that wires F1 and F2 are free to slide in and out of generator housing.
- h. Remove end bell (5), with exciter stator (17) attached, by tightening bolts (6) evenly into "back-out" holes.

CAUTION

If bearing needs to be removed for any reason, always install new bearing. Main bearing is easily damaged when removed from rotor shaft, Damage to equipment could result.

- i. Using bearing puller, remove bearing (8) from main rotor shaft (9).

4.26.2 Installation.

CAUTION

If bearing needs to be removed for any reason, always install new bearing. Main bearing is easily damaged when removed from rotor shaft. Damage to equipment could result.

- a. Install bearing (8, FIGURE 4-15). Ensure that bearing is seated squarely against shaft (9) shoulder by applying pressure to inner race only.
- b. Position bearing (8) in end bell (5).

NOTE

It may be necessary to use a lifting device to raise and align end bell (5) with generator housing (10).

- c. Position end bell (5), with exciter stator (17) attached, on generator housing (10) while pulling slack of wires F1 and F2 through side of generator housing. Secure end bell (5) with bolts (6) and lockwashers (7). Torque bolts (6) 59 to 61 in-lbs (6.7 to 7 Nm).
- d. Tighten lead clamp assembly (37) at side of generator housing ensuring that generator leads are clamped securely.
- e. Install screens (4) and plates (3) on end bell (5) with bolts (1) and lockwashers (2).
- f. Install generator set housing rear panel, paragraph 2.18.4.
- g. Connect negative battery cable. Close battery access door.

4.27 ROTATING RECTIFIER (MEP-814A).

4.27.1 Removal.

- a. Shut down generator set.
- b. Open battery access door and disconnect negative battery cable.
- c. Remove generator set housing rear panel, paragraph 2.18.1.
- d. Remove generator end bell and main bearing, paragraph 4.26.1.

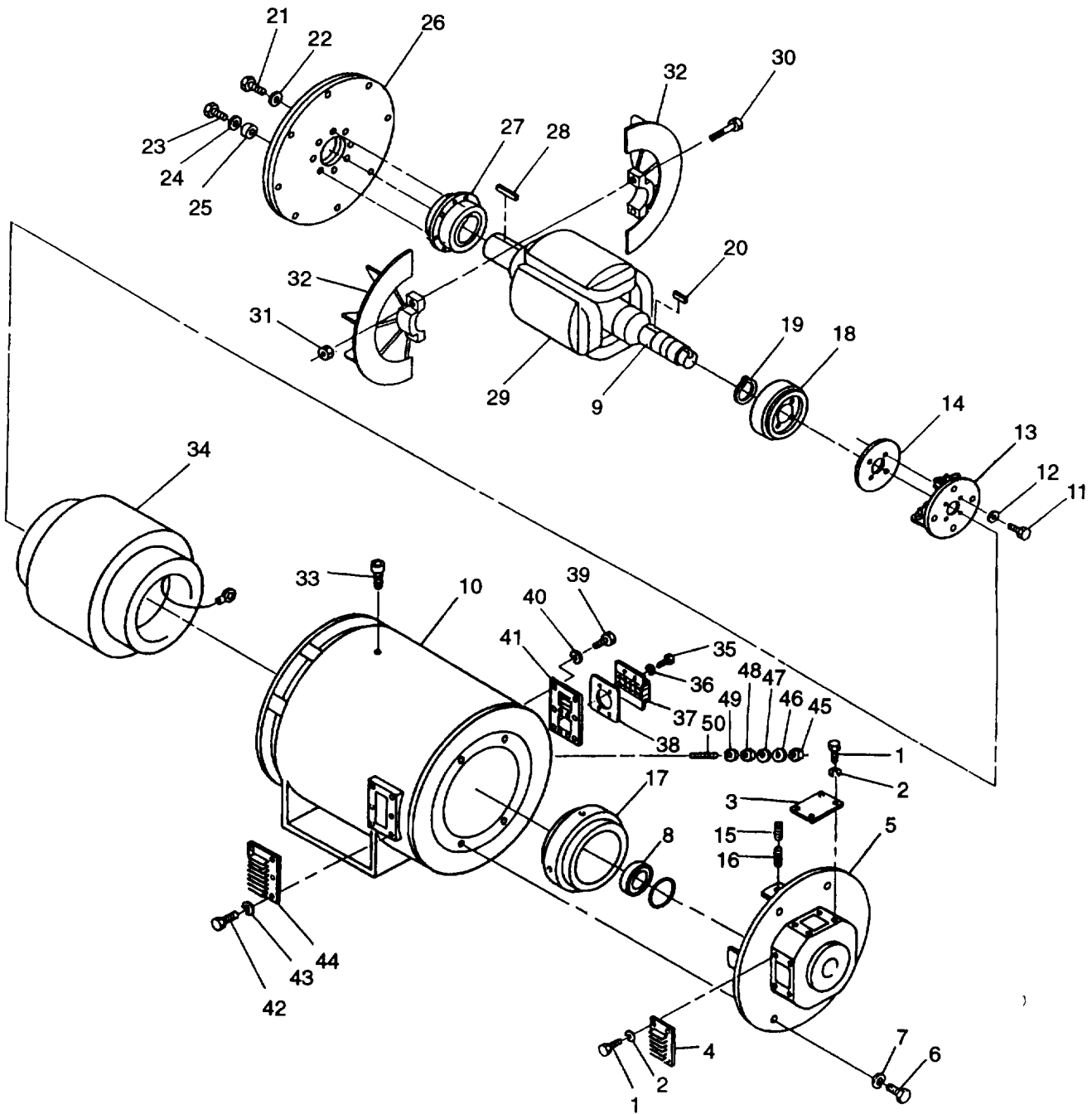

FIGURE 4-15. Generator Assembly (MEP-814A)

- e. Remove bolts (3, FIGURE 4-13) and lockwashers (4) securing exciter rotor leads (3 places) to rotating rectifier. Tag and remove exciter rotor leads.
- f. Remove nuts(1) and lockwashers (2) securing generator rotor leads (2 places) to rotating rectifier. Tag and remove generator rotor leads.
- g. Remove bolts(11, FIGURE 4-15), lockwashers(12) and rotating rectifier(13) from rectifier hub (14).

4.27.2 Installation.

- a. Install rotating rectifier(13, FIGURE 4-15) on rectifier hub (14) with bolts (11) and lockwashers (12).
- b. Connect two generator rotor leads to rotating rectifier with nuts (1, FIGURE 4-13) and lockwashers (2). Remove tags.
- c. Connect three exciter rotor leads to rotating rectifier with bolts (3) and lockwashers (4).
- d. Install main bearing and generator end bell, paragraph 4.26.2.
- e. Install generator set housing rear panel, paragraph 2.18.4.
- f. Connect negative battery cable. Close battery access door.

4.28 EXCITER STATOR (MEP-814A).

4.28.1 Removal.

- a. Shut down generator set.
- b. Open battery access door and disconnect negative battery cable.
- c. Remove generator set housing rear panel, paragraph 2.18.1.
- d. Remove generator end bell, paragraph 4.26.1.
- e. Open output box access door and remove exciter field leads F1 and F2 from terminals 1 and 2 of TB8.
- f. Attach "fish wires" to disconnected F1 and F2 leads to aid in installation process.
- g. Remove setscrews(15 and 16, FIGURE 4-15) and exciter stator (17) from end bell (5).
- h. Detach "fish wires" once F1 and F2 leads clear generator housing (10).

4.28.2 Testing.

- a. Shut down generator set. Allow generator to cool to ambient temperature.
- b. Open battery access door and disconnect negative battery cable.
- c. Open output box access door and disconnect exciter field leads F1 and F2 from terminals 1 and 2 of TB 8.
- d. Set multimeter for ohms and connect between disconnected exciter field leads. Multimeter reading should be as shown in TABLE 4-3.
- e. Multimeter reading other than in TABLE 4-3, indicates open or shorted windings and exciter stator must be replaced.
- f. Connect multimeter between each exciter field lead and generator frame in turn.
- g. Multimeter reading of less than infinity indicates defective ground insulation and exciter stator must be replaced.
- h. Connect exciter field leads to terminals 1 and 2 of TB 8 and close output box access door.
- i. Connect negative battery cable and close battery access door.

4.28.3 Installation.

- a. Attach "fish wires" to F1 and F2 leads of exciter stator (17, FIGURE 4-15).
- b. Gently pull on "fish wires" to pull F1 and F2 leads back through generator housing. Disconnect "fish wires" and position F1 and F2 leads in output box.
- c. Position exciter stator (17) in end bell (5) and secure in place with setscrews(15) and (16).
- d. Install generator end bell, paragraph 4.26.2.
- e. Install generator set housing rear panel, paragraph 2.18.4.
- f. Connect exciter field leads F1 and F2 to terminals 1 and 2 of TB 8 and close output box access door.
- g. Connect negative battery cable and close battery access door.

4.29 EXCITER ROTOR (MEP-814A).

4.29.1 Removal.

- a. Shut down generator set.
- b. Open battery access door and disconnect negative battery cable.
- c. Remove generator set housing rear panel, paragraph 2.18.1.
- d. Remove generator end bell and main bearing, paragraph 4.26.1.
- e. Remove rotating rectifier, paragraph 4.27.1.

WARNING

Use protective gloves when handling heated rectifier hub (14) to prevent personal injury.

NOTE

Rectifier hub (14) is heat shrunk onto shaft (9) and will require the use of heat to remove.

- f. Using bearing puller, remove rectifier hub (14, FIGURE 4-15) from main rotor shaft (9).
- g. Pull two main rotor leads out of holes in exciter rotor (18).
- h. Attach hub puller to two lead holes and remove exciter rotor (18) from shaft (9).
- i. Remove key (20) and retaining ring (19) from shaft (9).

4.29.2 Testing.

- a. Shut down generator set. Allow generator to cool to ambient temperature.
- b. Open battery access door and disconnect negative battery cable.
- c. Remove generator set housing rear panel, paragraph 2.18.1.
- d. Remove generator end bell plates and screens, paragraph 4.26.1, step d.

NOTE

It will be necessary to bar (turn) the engine in order to position a specific area of the rotating rectifier at one of the end bell access holes.

- e. Tag and disconnect exciter rotor leads (3 places) from rotating rectifier by removing bolts (3, FIGURE 4-13) and lockwashers (4).
- f. Connect resistance bridge between two exciter rotor leads and note resistance reading. Continue this procedure until readings are noted for each combination of leads (ie: 1 and 2, 1 and 3, and 2 and 3).
- g. Resistance readings should be as shown in TABLE 4-3 for each combination of leads. Readings other than in TABLE 4-3, indicates open or shorted windings and exciter rotor must be replaced.
- h. Set multimeter for ohms and connect between each exciter rotor lead and exciter stator mounting bolt in turn.
- i. Multimeter reading of less than infinity indicates defective ground insulation and exciter rotor must be replaced.
- j. Connect exciter rotor leads to rotating rectifier with lockwashers (4, FIGURE 4-13) and bolts (3). Remove tags.
- k. Install end bell screens and plates, paragraph 4.26.2, step e.
- l. Install generator set housing rear panel, paragraph 2.18.4.
- m. Connect negative battery cable and close battery access door.

4.29.3 Installation.

- a. Install retaining ring (19, FIGURE 4-15) and key (20) on main rotor shaft (9).
- b. Press exciter rotor(18) onto shaft (9), over key (20) and against retaining ring (19).

WARNING

Use protective gloves when handling heated rectifier hub (14) to prevent personal injury.

- c. Heat rectifier hub (14) until it slides into place on shaft (9) with slight pressure.
- d. Once rectifier hub (14) has cooled, pull two main rotor leads through holes in exciter rotor (1 8).
- e. Install rotating rectifier, paragraph 4.27.2.
- f. Install main bearing and generator end bell, paragraph 4.26.2.
- g. Install generator set housing rear panel, paragraph 2.18.4.
- h. Connect negative battery cable and close battery access door.

4.30 GENERATOR MAIN ROTOR (MEP-814A).

4.30.1 Removal.

- a. Shut down generator set
- b. Remove generator assembly from generator set, paragraph 4.16.1.
- c. Remove bolts (21 and 23, FIGURE 4-15), washers (22) and (24), spacers (25), and drive disc (26) from drive hub (27).

NOTE

Mark location of two spacers (25), washers (24), and bolts (23) to ensure correct positioning during installation procedures.

- d. Attach a suitable rotor lifting fixture to drive hub (27) and overhead hoist, refer to FIGURE 4-12
- e. Remove generator end bell, paragraph 4.26.1.

CAUTION

Special care should be taken when removing main rotor, winding damage could result if rotor is allowed to hit main stator.

- f. Carefully remove main rotor (29) and attached components from generator housing (10).
- g. Remove main bearing, paragraph 4.26.1.
- h. Remove rotating rectifier, paragraph 4.27.1.
- i. Remove exciter rotor, paragraph 4.29.1.
- j. Using bearing puller, remove drive hub (27) and key (28) from main rotor shaft (9).
- k. Remove bolts (30), nuts (31), and fan halves (32) from main rotor shaft (9).

4.30.2 Testing.

- a. Shut down generator set. Allow generator to cool to ambient temperature.
- b. Open battery access door and disconnect negative battery cable.
- c. Remove generator set housing rear panel, paragraph 2.18.1.
- d. Remove generator end bell plates and screens, paragraph 4.26.1, step d.

NOTE

It will be necessary to bar (turn) engine in order to position a specific area of the rotating rectifier at one of the end bell access holes.

- e. Tag and disconnect main rotor leads (2 places) from rotating rectifier by removing screws (1, FIGURE 4-13) and lockwashers (2).
- f. Set multimeter for ohms and connect, between disconnected main rotor leads. Multimeter reading should be as shown in TABLE 4-3.
- g. Reading other than in TABLE 4-3, indicates shorted or open windings and main rotor must be replaced.
- h. Connect multimeter between each main rotor lead and exciter stator mounting bolt in turn.
- i. Multimeter reading of less than infinity indicates defective ground insulation and main rotor must be replaced.
- j. Connect main rotor leads to rotating rectifier with lockwashers (2, FIGURE 4-13) and nuts (1).
- k. Install generator end bell plates and screens, paragraph 4.26.2, step e.
- l. Install generator set housing rear panel, paragraph 2.18.4.
- m. Connect negative battery cable and close battery access door.

4.30.3 Installation.

- a. Place key (28, FIGURE 4-1 5) on main rotor shaft (9) and press drive hub (27) over key (28) and onto shaft (9).

NOTE

Insure gap between fan halves (32) are equal from side-to-side.

- b. Install fan halves (32) onto shaft (9) with bolts (30) and nuts (31).
- c. Install exciter rotor, paragraph 4.29.3.
- d. Install rotating rectifier, paragraph 4.27.2.
- e. Install main bearing, paragraph 4.26.2.

CAUTION

Special care must be taken installing main rotor, winding damage could result if rotor is allowed to hit main stator.

- f. Attach a suitable rotor lifting figure to drive hub (27) and overhead hoist, refer to FIGURE 4-12.
- g. Carefully install rotor (29) and attached components into generator housing (10).
- h. Install generator end bell, paragraph 4.26.2 and remove rotor lifting figure.

NOTE

Ensure correct positioning of spacers (25), washers (24), and bolts (23) as marked on removal.

- i. Install drive disc (26) on drive hub (27) with spacers (25), washers (22) and (24), and bolts (21) and (24). Torque bolts (21) to 28 ft-lbs (38 Nm) and bolts (23) to 35 ft-lbs (47 Nm).
- j. Install generator assembly in generator set, paragraph 4.26.2.

4.31 GENERATOR MAIN STATOR (MEP-814A).

4.31.1 Removal.

- a. Shut down generator set.
- b. Remove generator assembly from generator set, paragraph 4.26.1.
- c. Remove main rotor and attached rotating components, paragraph 4.30.1.
- d. Remove bolts (35, FIGURE 4-15), lockwashers (36), lead clamp assembly (37), and gasket (38) from generator housing (10).
- e. Remove setscrews (33) and main stator (34) from housing assembly (10).

4.31.2 Testing.

- a. Shut down generator set. Allow generator to cool to ambient temperature.
- b. Open battery access door and disconnect negative battery cable.
- c. Remove protective cover and moveable terminal board from voltage reconnection board, paragraph 2.94.2.
- d. Disconnect two electrical connectors from bottom of control box assembly.
- e. Tag and disconnect wires 107C and 109J from terminals 1 and 2 of power potential transformer.
- f. Connect resistance bridge between terminals T1 and T4, T2 and T5, T3 and T6, T7 and T0, T8 and T0, and T9 and T0 of voltage reconnection board.
- g. All resistance readings should be as shown in TABLE 4-3.
- h. If resistance is low, there are shorted windings, if resistance is high, stator windings are open. In either case, stator must be replaced.
- i. Disconnect removable grounding link on output load terminal board.
- j. Set multimeter for ohms and connect between each coil lead and ground, in turn.
- k. If multimeter indicates resistance on any connection, stator windings are grounded and stator must be replaced.
- l. Connect removable grounding link on output load terminal board.
- m. Connect wires 107C and 109J to terminals 1 and 2 of power potential transformer. Remove tags.
- n. Connect two electrical connectors to bottom of control box assembly.
- o. Install moveable terminal board and protective cover on voltage reconnection board, paragraph 2.94.3.
- p. Connect negative battery cable and close battery access door.

4.31.3 Installation.

- a. Install main stator (34, FIGURE 4-15) in housing assembly (10) with setscrews (33).
- b. Pull main stator (34) leads through side of housing (10).
- c. Position exciter stator (17) leads and main stator (34) leads through gasket (38) and in lead clamp assembly (37).
- d. Install gasket (38) and lead clamp assembly (37) on housing (10) with bolts (35) and lockwashers (36).
- e. Install main rotor and attached rotating components, paragraph 4.30.3.
- f. Install generator assembly in generator set, paragraph 4.16.2.

4.32 GENERATOR HOUSING (MEP-814A).

4.32.1 Removal.

- a. Shut down generator set.
- b. Remove generator assembly from generator set, paragraph 4.16.1.
- c. Remove main rotor and attached rotating components, paragraph 4.30.1.
- d. Remove exciter stator, paragraph 4.28.1.
- e. Remove main stator, paragraph 4.31.1.
- f. Remove bolts (39, FIGURE 4-15), lockwashers (40), and plate (41) from housing assembly (10).
- g. Remove bolts (42), lockwashers (43), and screen (44) from housing (10).
- h. Remove nuts (45) and (48), washer (46), lockwashers (47) and (49), and grounding stud (50) from housing (10).

4.32.2 Installation.

- a. Install grounding stud (50, FIGURE 4-15), lockwashers (47) and (49), washer (46), and nuts (45) and (48) on housing (10).
- b. Install screen (44) on housing (10) with bolts (42) and lockwashers (44).
- c. Install plate (41) on housing assembly (10) with screws (39) and lockwashers (40).
- d. Install exciter stator, paragraph 4.28.3.
- e. Install main stator, paragraph 4.31.3.
- f. Install main rotor and attached rotating components, paragraph 4.30.3.
- g. Install generator assembly in generator set, paragraph 4.16.2.

Section VII. MAINTENANCE OF SKID BASE

4.33 SKID BASE.

4.33.1 Removal.

- a. Shut down generator set.
- b. Remove engine and generator assembly, paragraph 3.6.1.
- c. Remove fuel tank, paragraph 4.6.2.
- d. Remove nuts (1, FIGURE 4-16), lockwashers (2), bolts (3), washers (4), and forklift guides (5) from skid base.

4.33.2 Repair. Repair of the skid base will be limited to corrosion control and spot welding minor cracks. If major structural damage to the skid base has occurred, replace the skid base.

4.33.3 Installation.

- a. Install forklift guides (5, FIGURE 4-16) in skid base with bolts (3), washers (4), lockwashers (2), and nuts (1).
- b. Install fuel tank, paragraph 4.6.3.
- c. Install engine and generator assembly, paragraph 3.6.2.

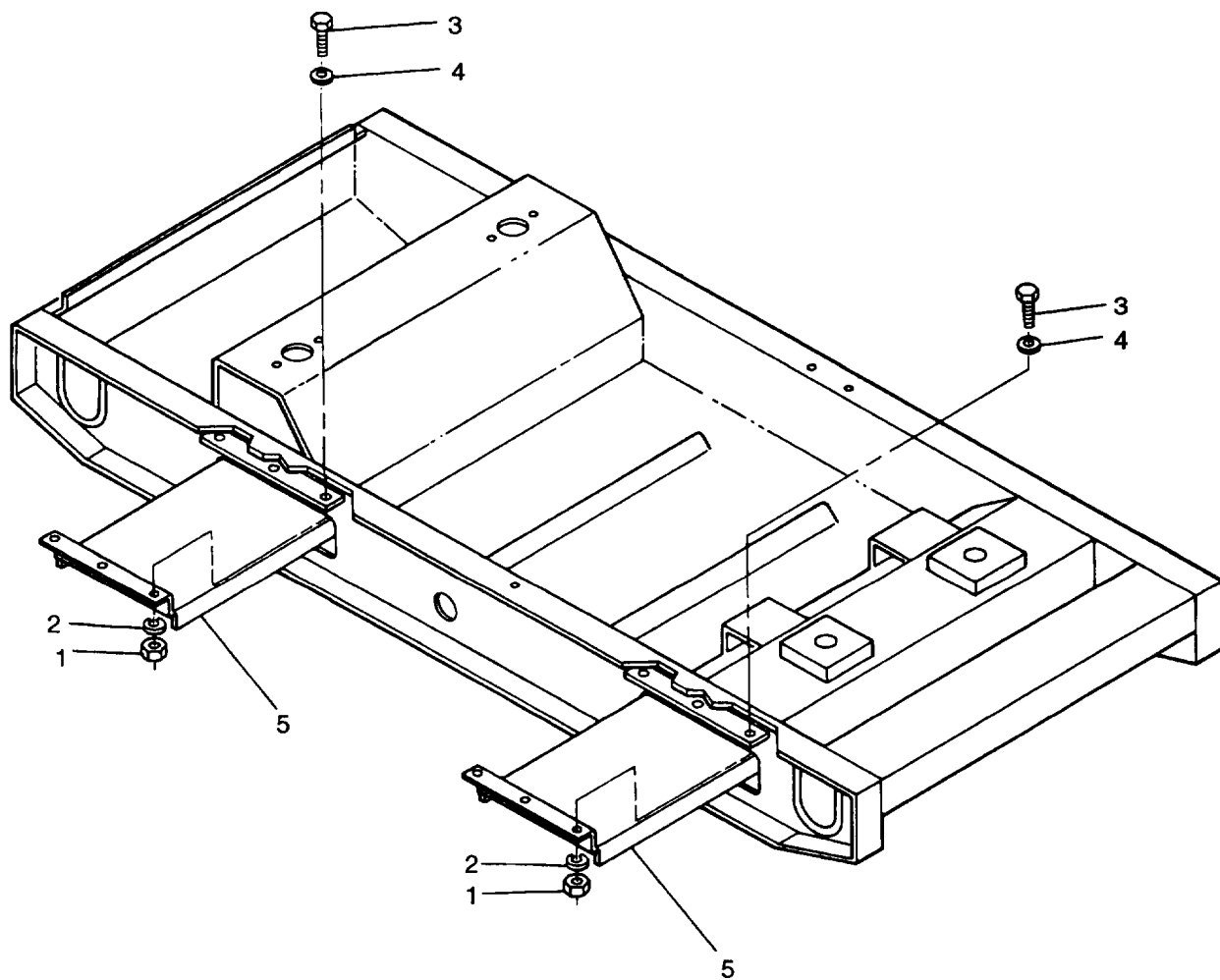

FIGURE 4-16. Skid Base

APPENDIX A REFERENCES

A-1 SCOPE.

This appendix lists all forms, field manuals, technical manuals, and miscellaneous publications referenced in this manual.

A-2 FORMS.

Air Force Reporting of Errors Form	AFTO Form 22
Equipment inspection and Maintenance Work Sheet	DA Form 2404
Product Quality Deficiency Report	SF368
Recommended Changes to Publications and Blank Forms	DA Form 2028
Recommended Changes to DA Publications	DA Form 2028-2

A-3 FIELD MANUALS.

First Aid for Soldiers	FM 21-11
NBC Decontamination	FM3-5
NBC Contamination Avoidance	FM3-3
NBC Protection	FM3-4

A-4 TECHNICAL MANUALS.

Cooling Systems: Tactical Vehicles	TM 750-254
Destruction of Material	TM 750-244-3
Operator's Manual: Generator Set, Tactical Quiet, 15kW,50/60 and 400 Hz	TM 9-6115-643-10
Painting instructions for Army Material	TM 43-0139

APPENDIX A
REFERENCES - Continued

A-4 TECHNICAL MANUALS. - Continued

Repair Parts and Special Tools List: Generator Set,
Tactical Quiet. 15kW, 50/60 and 400 Hz TM9-6115-643-24P

Unit, Direct Support Maintenance Manual:
Engine, Diesel TM 9-2815 -254-24

Operator's Unit, Direct Support & General Support Maintenance
Manual For Lead Storage Batteries. TM 9-6140-200-14

A-5 MISCELLANEOUS PUBLICATIONS.

Maintenance Management Policy (MMP) AFR-66-1

Corrosion and Corrosion Prevention Metals MIL-HDBK-729

Lubrication Order: Generator Set, Tactical Quiet,
15 kW, 50/60 and 400 Hz LO 9-6115-643-12

Marking For Shipment and Storage MIL-STD-129

Packaging of Generator Set, Mobile Power, and Supplemental Equipment MIL-G-28554

Preparation For Shipment and Storage of Engines MIL-E-10062

Preservation of USAMECOM Mechanical Equipment
for Shipment and Storage TB 740-97-2

Processing and Inspection of Nonmounted, Nonaircraft Gasoline and
Diesel Engines for Storage and Shipment TO 38-1-5

The Army Maintenance Management System (TAMMS) DA PAM 738-750

APPENDIX B MAINTENANCE ALLOCATION CHART

SECTION I. INTRODUCTION

B-1 General.

- a. This section provides a general explanation of all maintenance and repair functions authorized at various maintenance categories.
- b. The Maintenance Allocation Chart (MAC) in section II designates overall authority and responsibility for the performance of maintenance functions on the T.Q. Generator Sets and its components. The application of the maintenance functions to the generator sets or components will be consistent with the capacities and capabilities of the designated maintenance categories.
- c. Section III lists the tools and test equipment (both special tools and common tool sets) required for each maintenance function as referenced from section II.
- d. Section IV contains supplemental instructions and explanatory notes for particular maintenance functions.

B-2 Maintenance Functions. Maintenance functions will be limited to and defined as follows:

- a. Inspect. To determine the serviceability of an item by comparing its physical, mechanical, and/or electrical characteristics with established standards through examination (e.g., by sight, sound, or feel).
- b. Test. To verify serviceability by measuring the mechanical, pneumatic, or electrical characteristics of an item and comparing those characteristics with prescribed standards.
- c. Service. Operations required periodically to keep an item in proper operating condition, i.e., to clean (include decontaminate, when required), to preserve, to drain, to paint, or to replenish fuel, lubricants, chemical fluids, or gases.
- d. Adjust. To maintain or regulate, within prescribed limits, by bringing into proper or exact position, or by setting the operating characteristics to specified parameters.
- e. Aline. To adjust specified variable elements of an item to bring about optimum or desired performance.

- f. Calibrate. To determine and cause corrections to be made or to be adjusted on instruments or Test, Measuring, and Diagnostic Equipment (TMDE) used in precision measurement. Consists of comparisons of two instruments, one of which is a certified standard of known accuracy, to detect and adjust any discrepancy in the accuracy of the instrument being compared.
- g. Remove/Install. To remove and install the same item when required to perform service or other maintenance functions. Install may be the act of emplacing, seating, or fixing into position a spare, repair part, or module (component or assembly) in a manner to allow the proper functioning of an equipment or system.
- h. Replace. To remove an unserviceable item and install a serviceable counterpart in its place. "Replace" is authorized by the MAC and is shown as the 3rd position code of the SMR code.
- i. Repair. The application of maintenance services, including fault location/troubleshooting, removal/installation and disassembly/assembly procedures, and maintenance actions to identify troubles and restore serviceability to an item by correcting specific damage, fault, malfunction, or failure in a part, subassembly, module (component or assembly), end item, or system.
- j. Overhaul. That maintenance effort (service/action) prescribed to restore an item to a completely serviceable/operational condition as required by maintenance standards in appropriate technical publications (i.e., DMWR). Overhaul is normally the highest degree of maintenance performed by the Army. Overhaul does not normally return an item to like new condition.
- k. Rebuild. Consists of those services/actions necessary for the restoration of unserviceable equipment to a like new condition in accordance with original manufacturing standards. Rebuild is the highest degree of material maintenance applied to Army equipment. The rebuild operation includes the act of returning to zero those age measurements (hours/miles, etc.) considered in classifying Army equipment/components.

B-3 Explanation of Columns in the MAC. Section II

- a. Column 1, Group Number. Column 1 lists functional group code numbers, the purpose of which are to identify maintenance significant components, assemblies, subassemblies, and modules with the next higher assembly. End item group number shall be "00".
- b. Column 2, Component/Assembly. Column 2 contains the names of components, assemblies, subassemblies, and modules for which maintenance is authorized.
- c. Column 3, Maintenance Function. Column 3 lists the function to be performed on the item listed in column 2. (For detailed explanation of these functions, see paragraph B-2).

- d. Column 4, Maintenance Category. Column 4 specifies, by the listing of a work time figure in the appropriate subcolumn(s), the category of maintenance authorized to perform the function listed in column 3. This figure represents the active time required to perform that maintenance function at the indicated category of maintenance. If the number or complexity of the tasks within the listed maintenance function vary at different maintenance categories, appropriate work time figures will be shown for each category. The work time figure represents the average time required to restore an item (assembly, subassembly, component, module, end item, or system) to a serviceable condition under typical field operating conditions. This time includes preparation time (including any necessary disassembly/assembly time), troubleshooting/fault location time, and quality assurance/quality control time in addition to the time required to perform the specific tasks identified for the maintenance functions authorized in the Maintenance Allocation Chart. The symbol designations for the various maintenance categories are as follows:

- C..... Operator or crew
- O..... Organization Maintenance
- F..... Direct Support Maintenance
- H..... General Support Maintenance
- D..... Depot Maintenance

- e. Column 5, Tools and Equipment. Column 5 specifies, by code, those common tool sets (not individual tools) and special tools, TMDE, and support equipment required to perform the designated function.
- f. Column 6, Remarks. This column shall, when applicable, contain a letter code, in alphabetical order, which shall be keyed to the remarks contained in Section IV.

B-4 Explanation of Columns in Tool and Test Equipment Requirements. Section III

- a. Column 1, Reference Code. The tool and test equipment reference code correlates with a code used in the MAC, Section II, Column 5.
- b. Column 2, Maintenance Category. The lowest category of maintenance authorized to use the tool or test equipment.
- c. Column 3, Nomenclature. Name or identification of the tool or test equipment.
- d. Column 4, National Stock Number. The National Stock Number of the tool or test equipment.
- e. Column 5, Tool Number. The manufacturer's part number of the tool or test equipment.

B-5 Explanation of Columns in Remarks, Section IV

- a. Column 1, Reference Code. The code recorded in column 6, Section II.
- b. Column 2, Remarks. This column lists information pertinent to the maintenance function being performed as indicated in the MAC, Section II.

**SECTION II. MAINTENANCE ALLOCATION CHART
 FOR
 MEP-804A AND MEP-814A**

(1) GROUP NUMBER	(2) COMPONENT/ASSEMBLY	(3) MAINTENANCE FUNCTION	(4) MAINTENANCE CATEGORY					(5) TOOLS AND EQUIP.	(6) REMARKS
			C	O	F	H	D		
00	GENERATOR SET 15KW (LESS ENGINE)	INSPECT	.2	.5				1,2,3,4 4 1,2,4 1,3,3,4	
		TEST		1.0	1.0				
		SERVICE	.3	.3					
		ADJUST REPAIR		.3 2.5	1.0 3.5				
01	D.C. ELECTRICAL SYSTEM	INSPECT	.1	.1			1,4 1,4		
		TEST		.2					
		REPAIR		.3					
0101	BATTERY ADO SLAVE RECEPTACLE CABLES	INSPECT	.1	.1			1,4 4 1,4		
		REPAIR		.3					
		REM/INST REPLACE		.2 .3					
0102	BATTERIES	INSPECT	.1	.1			1,4 4 4 4	B	
		TEST		.1					
		SERVICE	.1	.1					
		REM/INST REPLACE		.2 .2					
0103	SLAVE RECEPTACLE	INSPECT	.1	.1			4 4 4	B	
		REM/INST		.1					
		REPLACE		.1					
02	HOUSING	INSPECT	.2	.3			4 4		
		REPAIR		1.0					
		REM/INST		2.0					
0201	ACCESS DOORS	INSPECT	.1	.1			4 4 4	B	
		REPAIR		.5					
		REM/INST		.5					
		REPLACE		.5					
0202	TOP HOUSING SECTION	INSPECT	.1	.2			4 4 4	B	
		REPAIR		1.0					
		REM/INST		1.0					
		REPLACE		1.0					
0203	FRONT HOUSING SECTION	INSPECT	.1	.2			4 4 4	B	
		REPAIR		1.0					
		REM/INST		.6					
		REPLACE		.6					
0204	REAR HOUSING SECTION	INSPECT	.1	.2			4 4 4	B	
		REPAIR		1.0					
		REM/INST		1.0					
		REPLACE		1.0					

SECTION II. MAINTENANCE ALLOCATION CHART - Continued
FOR
MEP-804A AND MEP-814A

(1) GROUP NUMBER	(2) COMPONENT/ASSEMBLY	(3) MAINTENANCE FUNCTION	(4) MAINTENANCE CATEGORY					(5) TOOLS AND EQUIP.	(6) REMARKS
			C	O	F	H	D		
0205	DECALS AND PLATES	INSPECT	.1	.1					
		REM/INST		.3				1,5	
		REPLACE		.3				1,5	B
03	CONTROL BOX ASSEMBLY	INSPECT	.1	.2					
		TEST		1.0	.5			1,2,3,4, 6,7	
		REPAIR		1.0	2.0			1,3,4	
		REM/INST		.2				4	
		REPLACE			.2			4	B
0301	PANEL LIGHTS	INSPECT	.1	.1					
		REM/INST		.3				4	
		REPLACE		.3				4	B
		REPAIR		.2					C
0302	INDICATORS	INSPECT	.1	.1					
		TEST		.3				1,4	
		REM/INST		.2				4	
		REPLACE		.2				4	
0303	SWITCHES	INSPECT	.1	.1					
		TEST		.2				1,4	
		REM/INST		.2				1,4	
		REPLACE		.2				1.4	
0304	CONVENIENCE RECEPTACLE	INSPECT	.1	.1					
		TEST		.2				1,4	
		REM/INST		.5				4	
		REPLACE		.5				4	B
0305	GROUND FAULT INTERRUPTER	INSPECT	.1	.1					
		TEST	.1	.1				1,4	
		REM/INST		.5				4	
		REPLACE		.5				4	B
0306	MALFUNCTION INDICATOR PANEL	INSPECT	.1	.1					
		TEST	.1	.1					
		REN/INST		.5				4	
		REPLACE		.5				4	
0307	FUSE AND CIRCUIT BREAKER	INSPECT	.1	.1					
		TEST		.2				1,4	
		REM/INST		.5				1,4	
		REPLACE		.5				1,4	

**SECTION II. MAINTENANCE ALLOCATION CHART - Continued
 FOR
 MEP-804A AND MEP-814A**

(1) GROUP NUMBER	(2) COMPONENT/ASSEMBLY	(3) MAINTENANCE FUNCTION	(4) MAINTENANCE CATEGORY					(5) TOOLS AND EQUIP.	(6) REMARKS
			C	O	F	H	D		
0308	VOLTAGE REGULATOR	INSPECT TEST REM/INST REPLACE		.1	.5 .5 .5			1,4 4 4	B
0309	RELAYS AND TRANSDUCERS	INSPECT TEST REM/INST REPLACE		.1 .3 .4 .4				1,4,6,7 4 4	
0310	GOVERNOR CONTROL UNIT	INSPECT TEST ADJUST REM/INST REPLACE	.1	.1	1.0 1.0			2,4 2,4 4 4	
0311	CONTROL BOX HANNESS	INSPECT TEST REPAIR REM/INST REPLACE	.1	.2 1.0 .5	.2 1.0 1.0 1.5 1.5			1,3,4 1,3,4 1,4 3,4	
0312	LOAD MEASURING UNIT	INSPECT TEST REM/INST REPLACE	.1	.1 .5	.5 .5			3,4 4 4	B
0313	RESISTOR-DIODE ASSEMBLY	INSPECT TEST REPAIR REM/INST REPLACE	.1	.1 .5 1.0 1.0 1.0				1,4 1,4 1,4 1,4	B
0314	CONTROL BOX PANELS	INSPECT REPAIR REM/INST REPLACE	.1	.1 .2 3.0 3.0				4 4 4	B
0315	DECALS AND PLATES	INSPECT REM/INST REPLACE	.1	.1 .3 .3				1,5 1,5	B
04	AIR INTAKE/ EXHAUST SYSTEM	INSPECT REPAIR	.2	.2 1.5				4	

**SECTION II. MAINTENANCE ALLOCATION CHART - Continued
FOR
MEP-804A AND MEP-814A**

(1) GROUP NUMBER	(2) COMPONENT/ASSEMBLY	(3) MAINTENANCE FUNCTION	(4) MAINTENANCE CATEGORY					(5) TOOLS AND EQUIP.	(6) REMARKS
			C	O	F	H	D		
0401	MUFFLER AND PIPES	INSPECT	.1	.5					
		REM/INST		.7				4	
		REPLACE		.7				4	B
0402	AIR CLEANER ASSEMBLY	INSPECT	.1	.2					
		SERVICE	.2	.2					
		REPAIR		.5				4	
		REM/INST		.5				4	
		REPLACE		.5				4	B
05	COOLANT SYSTEM	INSPECT	.1	.2					
		TEST		.2				1,8	
		SERVICE	.1	.5				4	
		REPAIR		1.0	2.0			1,3,4	B
0501	COOLANT HOSES	INSPECT	.1	.1					
		REM/INST		.5				4	
		REPLACE		.5				4	B
0502	RADIATOR	INSPECT	.1	.2					
		REPAIR		1.0	2.0			1,3,4	
		REM/INST		1.0				4	
		REPLACE		1.0				4	
0503	COOLING FAN	INSPECT	.1	.1				4	
		REM/INST		.8				4	
		REPLACE		.8				4	
0504	FAN BELT	INSPECT	.1	.1					
		TEST		.1					
		ADJUST		.5				4	
		REM/INST		.5				4	
		REPLACE		.5				4	B
0505	COOLANT RECOVERY SYSTEM	INSPECT	.1	.1					
		REM/INST		.5				4	
		REPLACE		.5				4	
06	FUEL SYSTEM	INSPECT	.1	.2					
		REPAIR		1.0	1.5			4	
0601	LOW PRESSURE FUEL LINES	INSPECT	.1	.2					
		REM/INST		.5				4	
		REPLACE		.5				4	
0602	AUX. FUEL PUMP	INSPECT		.1					
		TEST		.5				4	
		REPAIR		.5				4	
		REM/INST		.5				4	
		REPLACE		.5				1,4	

**SECTION II. MAINTENANCE ALLOCATION CHART - Continued
 FOR
 MEP-804A AND MEP-814A**

(1) GROUP NUMBER	(2) COMPONENT/ASSEMBLY	(3) MAINTENANCE FUNCTION	(4) MAINTENANCE CATEGORY					(5) TOOLS AND EQUIP.	(6) REMARKS
			C	O	F	H	D		
0603	FUEL TANK	INSPECT		.2					
		SERVICE	.3						
		REM/INST REPLACE			2.5 2.5			4 4	
0604	FUEL TANK FLOATS AND SWITCHES	INSPECT		.2					
		TEST		.3				1,4	
		REM/INST REPLACE		.5 .5				4 4	
0605	FUEL FILTER/ WATER SEPARATOR	INSPECT	.1	.2					
		SERVICE	.1	.4				4	
		REPAIR		.5				4	
		REM/INST REPLACE		1.0 1.0				4 4	B
0606	AUXILIARY FUEL FILTER	INSPECT	.1						
		REM/INST		.2				4	
		REPLACE		.2				4	
07	OUTPUT BOX ASSEMBLY	INSPECT	.2						
		TEST	1.0	2.0				1,3,4	
		REPAIR	2.0	3.0				1,3,4	
		REM/INST		2.0				4	
		REPLACE		2.0				4	B
0701	VOLTAGE RECONNECTION BOARD	INSPECT		.2					
		REM/INST REPLACE			.4 .4			4 4	B
0702	OUTPUT BOX HARAESS AND CABLES	INSPECT	.1	.2					
		TEST		.6				1,2,4	
		REPAIR		.5	1.0			1,3,4	
		REM/INST REPLACE			2.0 2.0			4 4	B
0703	TRANSFORMERS	INSPECT	.1	.2					
		TEST			1.0			2,4	
		REM/INST REPLACE			1.3 1.3			4 4	B
0704	A.C. CIRCUIT INTERRUPTER	INSPECT		.2					
		TEST		.5				1,4	
		REM/INST REPLACE		.5 .5				4 4	B
0705	START RELAY	INSPECT		.2					
		TEST		.5				1,4	
		REM/INST REPLACE		.5 .5				4 4	B

SECTION II. MAINTENANCE ALLOCATION CHART - Continued
 FOR
 MEP-804A AND MEP-814A

(1) GROUP NUMBER	(2) COMPONENT/ASSEMBLY	(3) MAINTENANCE FUNCTION	(4) MAINTENANCE CATEGORY					(5) TOOLS AND EQUIP.	(6) REMARKS
			C	O	F	H	D		
0706	OUTPUT BOX PANELS	INSPECT	.1	.1					
		REPAIR		.2	1.0			4	
		REM/INST			2.0			4	
		REPLACE			2.0			4	B
08	OUTPUT LOAD TERMINAL BOARD ASSEMBLY	INSPECT	.1	.1					
		TEST		.5				1	
		REPAIR		1.0				4	
		REM/INST		1.5				4	
		REPLACE		1.5				4	
0801	LOAD TERMINALS	INSPECT		.1					
		REPAIR		.5				4	
		REM/INST		.5				4	
		REPLACE		.5				4	
0802	VARISTORS	INSPECT		1.0					
		TEST		1.1				1,4	
		REM/INST		1.0				4	
		REPLACE		1.0				4	B
0803	LOAD TERMINAL BOARD	INSPECT	.1	.1					
		REM/INST		1.5				4	
		REPLACE		1.5				4	B
09	ENGINE ACCESSORIES	INSPECT	.1	.1					
		TEST		.5				1,4	
		REPAIR		.5				4	
0901	SENDERS AND SWITCHES	INSPECT	.1	.1					
		TEST		.5				1,4	
		REPAIR		.5				4	
		REM/INST		.5				4	
		REPLACE		.5				4	B
0902	DEAD CRANK SWITCH	INSPECT	.1	.1					
		TEST		.5				1,4	
		REM/INST		.5				4	
		REPLACE		.5				4	B
0903	GOVENOR ACTUATOR	INSPECT	.1	.1					
		TEST			.3			4	
		ADJUST			.3			4	
		REPAIR		.5	.5			1,4	
		REM/INST			.5			4	
		REPLACE			.5			4	B

SECTION II. MAINTENANCE ALLOCATION CHART - Continued
 FOR
 MEP-804A AND MEP-814A

(1) GROUP NUMBER	(2) COMPONENT/ASSEMBLY	(3) MAINTENANCE FUNCTION	(4) MAINTENANCE CATEGORY					(5) TOOLS AND EQUIP.	(6) REMARKS
			C	O	F	H	D		
0904	DECALS AND PLATES	INSPECT	.1	.1					
		REM/INST		.3				1.5	
		REPLACE		.3				1.5	B
10	LUBRICATION SYSTEM	INSPECT	.1	.2					
		SERVICE	.2						A
		REPAIR		.5				4	A
1001	OIL DRAIN LINE	INSPECT	.1	.2					
		REPAIR		.5				4	
		REM/INST		.5				4	
		REPLACE		.5				4	B
11	GENERATOR ASSEMBLY	INSPECT		.1	.1				
		TEST		1.0	1.0			1,2,3,4	
		REPAIR			4.0			4	
		REM/INST			4.0			1,3,4	
		REPLACE			4.0			1, 3, 4	B
12	ENGINE ASSEMBLY	INSPECT	.2						A
		SERVICE							A
		ADJUST							A
		REPAIR							A
		REM/INST			4.0			1, 3, 4	
		REPLACE			4.0			1, 3, 4	
13	SKID BASE	INSPECT	.1	.1					
		REPAIR			1.0			4	
		REM/INST			3.0			4	
		REPLACE			3.0			4	B

**SECTION III. TOOL AND TEST EQUIPMENT REQUIREMENTS
 FOR
 MEP-804A AND MEP-814A**

TOOL OR TEST EQUIPMENT REF CODE	MAINTENANCE CATEGORY	NOMENCLATURE	NATIONAL/ NATO STOCK NUMBER	TOOL NUMBER
1	O	SHOP EQUIPMENT, AUTOMOTIVE MAINT AND REPAIR	4910-00-754-0654	SC4910-95-CL-A74
2	F	SHOP EQUIPMENT, ELECTRICAL REPAIR	4910-01-096-4475	SC4940-95-CL-B05
3	F	SHOP EQUIPMENT, AUTOMOTIVE MAINT AND REPAIR, FIELD	4910-00-348-7696	SC4910-95-CL-A02
4	O,F	TOOL KIT, GENERAL MECHANIC	5180-00-177-7033	SC5180-90-CL-N26
5	O	POP RIVET GUN	5120-00-508-1588	GGG-R-00395
6	O	POTENTIOMETER, 5,000 OHMS	--	
7	O	POTENTIOMETER, 10,000 OHMS	--	
8	F	RESISTOR, FIXED 5 OHM, 25 WATT		

SECTION IV. REMARKS
FOR
MEP-804A AND MEP-814A

REFERENCE CODE	REMARKS
A	Refer to TM 9-2815-254-24.
B	Replace function identical to removal/install function.
C	Repair is limited to replacement of bulb.

APPENDIX C
EXPENDABLE/DURABLE SUPPLIES AND MATERIALS LIST

SECTION I. INTRODUCTION

C-1. SCOPE.

This appendix lists expendable supplies and materials you will need to operate and maintain the generator set: These items are authorized to you by CTA 50-970, Expendable Items (Except Medical, Class V, Repair Parts, and Heraldic Items).

C-2 EXPLANATION OF COLUMNS.

- a. Column (1) - Item Number. This number is assigned to the entry in the listing and is referenced in the narrative instructions to identify the material (e.g., "Use cleaning compound, Item 5, Appendix C").
- b. Column (2) - Level. This column identifies the lowest level of maintenance that requires the listed item.
- c. Column (3) - National Stock Number. This is the National Stock Number assigned to the item; use it to request or requisition the item.
- d. Column (4) - Description. Indicates the Federal item name and, if required, a description to identify the item. The last line for each item indicates the Commercial and Government Entity (CAGE) code in parentheses followed by the part number.
- e. Column (5) - Unit of Measure (U/M). Indicates the measure used in performing the actual maintenance function. This measure is expressed by a two-character alphabetical abbreviation (e.g., ea, in, pr). If the unit of measure differs from the unit of issue, requisition the lowest unit of issue that will satisfy your requirements.

SECTION II. TABULAR LIST

(1) Item No.	(2) Level	(3) National Stock Number	(4) Description	(5) U/M
1	O, F	8040-00-380-7959	Adhesive, Seal, EC847	QT
2	O, F	6650-00-181-7929	Antifreeze, MIL-A-46153,1 Gal. Can	GL
3	O, F	6650-00-181-7933	Antifreeze, MIL-A-46153, 5 Gal. Can	GL
4	O, F	6850-00-181-7940	Antifreeze, MIL-A-46153,55 Gal. Drum	GL
5	O, F	6650-00-174-1806	Antifreeze, MIL-A-11755,1 Gal. Can	GL
6	O, F	8030-01-234-2782	Antiseize, Compound, CP-8, 1/2 Lb. Can	OZ
7	O, F	7920-01-338-3329	Cloth, Cleaning, TX-1250	EA
8	F	8030-00-056-8673	Compound, Them, Pentrox A	OZ
9	O, F	9150-00-663-1770	Grease, General Purpose, 630AA, 6 Lb. Can	LB
10	O, F	6850-01-160-3866	Inhibitor, Corrosion, MIL-A-53009	QT
11	O, F	9150-00-152-4117	Lubricating Oil, Engine, MIL-L-2104, 15/40W	QT
12	O, F	9150-00-189-6727	Lubrication Oil, Engine, BRAYC0421C, 10W	QT
13	O, F	9150-00-186-6681	Lubricating Oil, Engine, ALIEDC030, 30W	QT
14	O, F	9150-00-402-2372	Lubricating Oil, Engine, MIL-L-46167, OEA	QT
15	O, F	5330-00-543-3600	Paper, Abrasive, ALOXGRIT 80	SH
16	O, F	8040-00-643-0802	Seal ant, RTV 108	OZ
17	O, F	3439-00-974-1873	Solder, Tin Alloy, SN60WRAP2, 1 Lb. Spool	OZ
18	O, F	6850-00-264-8036	Solvent, Dry Cleaning, P-D-660, 5 Gal. Can	GL
19	O,F	6030-00-84\$0071	Sealing Compound, FORM GASKET 2	TU
20	O,F	8030-01-014-5669	Sealing Compound, LOCKTITE 242	OZ

*U.S. GOVERNMENT PRINTING: 1994-555-028/08673

APPENDIX D
FABRICATION/ASSEMBLY OF PARTS

D-1 INTRODUCTION.

This appendix includes complete instructions for fabricating or assembling parts as required on this generator set.

NOTE

All dimensions are expressed in inches, refer to TABLE D-1 for inches to metric conversions.

D-2 ILLUSTRATIONS.

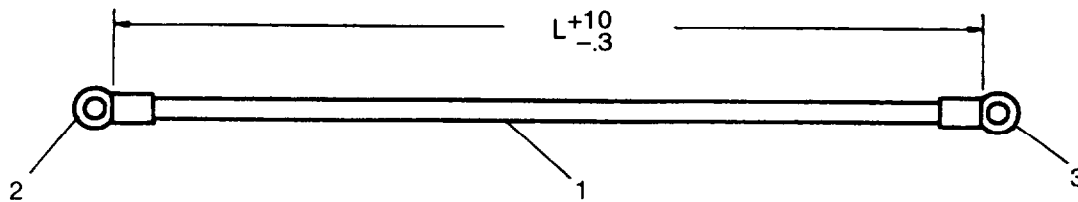

NOTES:

1. Dimensions shown are in inches.
2. Refer to TM 9-6115-643-24P for materials required and length (L) of wire.

PROCEDURES:

1. Cut wire (1) to length indicated.
2. Strip 0.75 inch of insulation from each end of wire (1).
3. Crimp terminal (2) on one end of wire (1) and terminal (3) on other end.

FIGURE D-1. Cable Assembly, AC Power (P/Ns: 88-22126-1 through 88-22126-7)

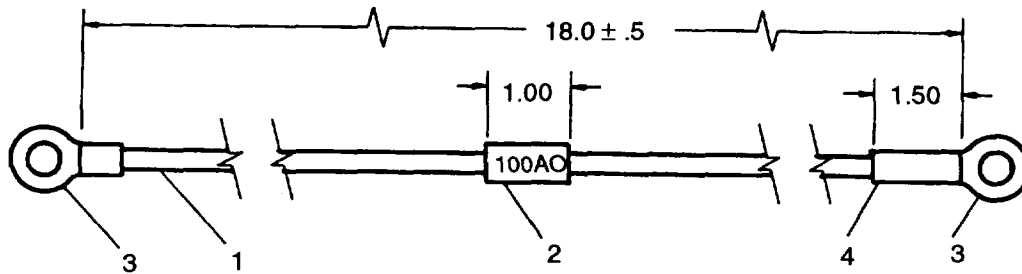

NOTES:

1. Dimensions shown are in inches.
2. Refer to TM 9-6115-643-24P for materials required.

PROCEDURES:

1. Cut wire (1) to length indicated.
2. Strip 0.75 inch of insulation from each end of wire (1).
3. Position insulation sleeving (2) on center of wire, mark with wire number "100AO" and shrink to fit.
4. Mark insulation sleeving (4) with "NEGATIVE" and slide over one end of wire (1).
5. Crimp terminal (3) on each end of wire (1).
6. Position insulation sleeving (4) as shown and shrink to fit.

FIGURE D-2. Cable Assembly, Battery (P/N: 88-22123)

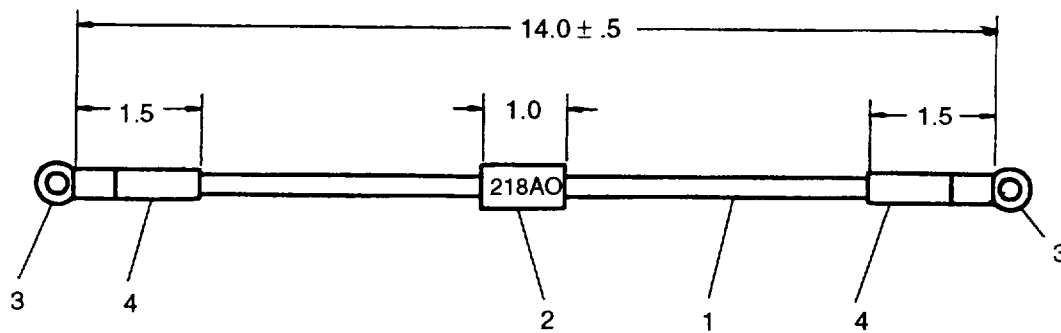

NOTES:

1. Dimensions shown are in inches.
2. Refer to TM 9-6115-643-24P for materials required.

PROCEDURES:

1. Cut wire (1) to length indicated.
2. Strip 0.75 inch of insulation from each end of wire (1).
3. Mark insulation sleeving (2) with wire number "218AO", position on center of wire and shrink to fit.
4. Mark one insulation sleeving (4) with "NEGATIVE", the other with "POSITIVE" and slide over each end of wire (1).
5. Crimp terminal (3) on each end of wire (1).
6. Position insulation sleeving (4) as shown and shrink to fit.

FIGURE D-3. Cable Assembly, Battery (P/N: 88-22179)

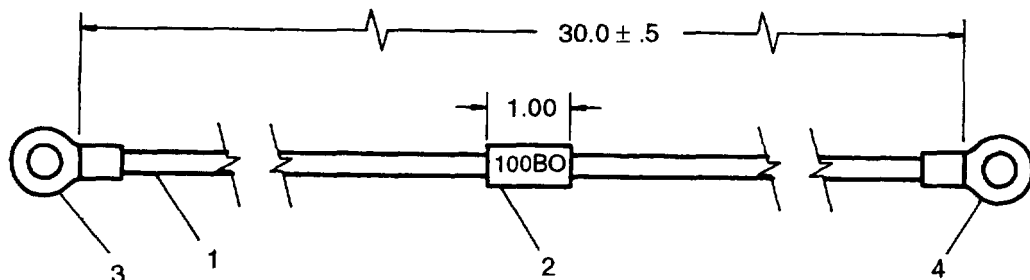

NOTES:

1. Dimensions shown are in inches.
2. Refer to TM 9-6115-643-24P for materials required.

PROCEDURES:

1. Cut wire (1) to length indicated.
2. Strip 0.75 inch of insulation from each end of wire (1).
3. Position insulation sleeving (2) on center of wire, mark with wire number "100BO" and shrink to fit.
4. Crimp terminal (3) on one end of wire (1) and terminal (4) on other end.

FIGURE D-4. Cable Assembly, Battery (P/N: 88-22309)

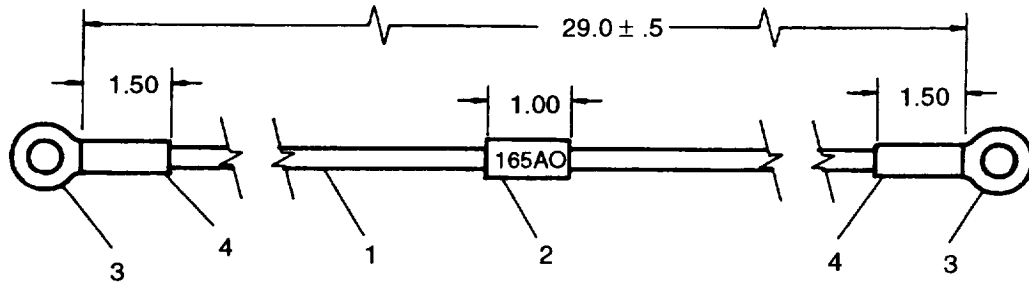

NOTES:

1. Dimensions shown are in inches.
2. Refer to TM 9-6115-643-24P for materials required.

PROCEDURES:

1. Cut wire (1) to length indicated.
2. Strip 0.75 inch of insulation sleeving from each end of wire (1).
3. Mark insulation sleeving (2) with wire number "165AO", position on center of wire and shrink to fit.
4. Mark insulation sleeving (4) with "POSITIVE" and slide over each end of wire (1).
5. Crimp terminal (3) on each end of wire (1).
6. Position insulation sleeving (4) as shown and shrink to fit.

FIGURE D-5. Cable Assembly, Battery (P/N: 88-22310)

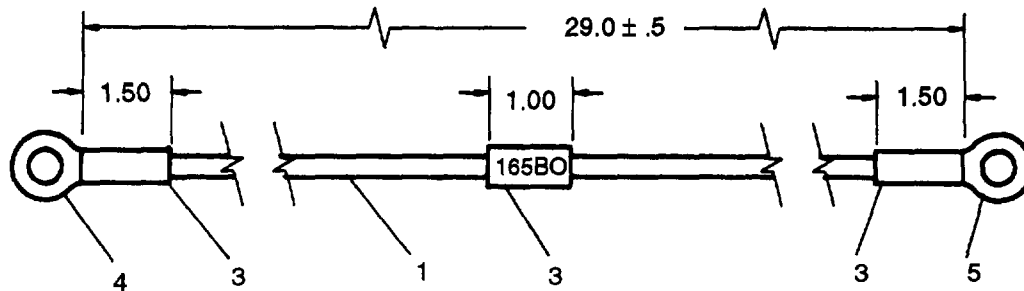

NOTES:

1. Dimensions shown are in inches.
2. Refer to TM 9-6115-643-24P for materials required.

PROCEDURES:

1. Cut wire (1) to length indicated.
2. Strip 0.75 inch of insulation sleeving from each end of wire (1).
3. Mark insulation sleeving (3) with wire number "165BO", position on center of wire and shrink to fit.
4. Mark insulation sleeving (3) with "POSITIVE" and slide over each end of wire (1).
5. Crimp terminal (4) on one end of wire (1) and terminal (5) on other end.
6. Position insulation sleeving (3) as shown and shrink to fit.

FIGURE D-6. Cable Assembly, Battery (P/N: 88-22311)

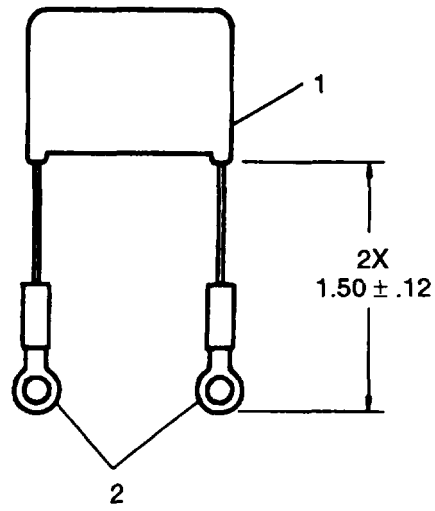

NOTES:

1. Dimensions shown are in inches.
2. Refer to TM 9-6115-643-24P for terminals required.

PROCEDURES:

1. Cut each lead of capacitor (1) to obtain dimension shown with terminals (2) installed.
2. Strip 0.25 inch from each lead of capacitor (1).
3. Crimp and solder terminals (2) on end of each lead.

FIGURE D-7. Capacitor Assembly, EMI (P/N: 88-22758)

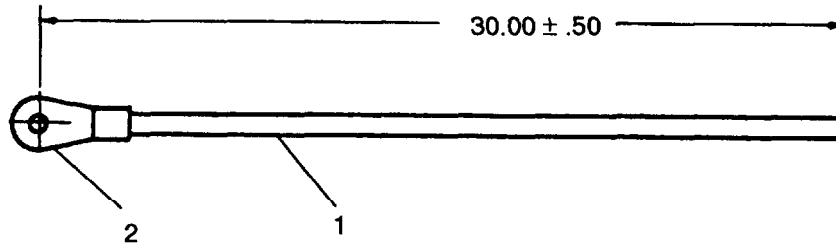

NOTES:

1. Dimensions shown are in inches.
2. Refer to TM 9-6115-643-24P for materials required.

PROCEDURES:

1. Cut rope (1) to length indicated.
2. Crimp terminal (2) on one end of rope (1).

FIGURE D-8. Cord, Load Wrench (P/N: 88-22469)

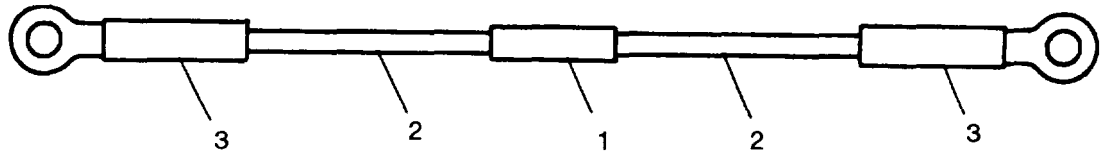

NOTES:

1. Refer to TM 9-6115-643-24P for materials required.

PROCEDURES:

1. Position 0.75 inch of insulation sleeving (2) on each lead of diode (1), leaving 0.25 inch of bare wire on each lead. Shrink sleeving to fit.
2. Crimp and solder terminals (3) on end of each diode (1) lead.

FIGURE D-9. Diode Assembly (P/N: 88-22418-2)

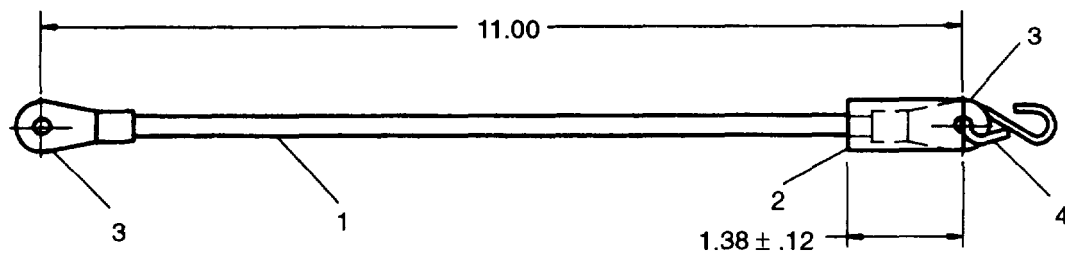

NOTES:

1. Dimensions shown are in inches.
2. Refer to TM 9-6115-643-24P for materials required.

PROCEDURES:

1. Cut rope (1) to length indicated.
2. Slide insulation sleeving (2) over one end of rope (1).
3. Crimp terminal (3) on each end of rope (1).
4. Install hook (4) in one terminal (3) and close hook end securing it to terminal.
5. Position insulation sleeving (2) as shown and shrink to fit.

FIGURE D-10. Holder, Control Panel (P/N: 88-22120)

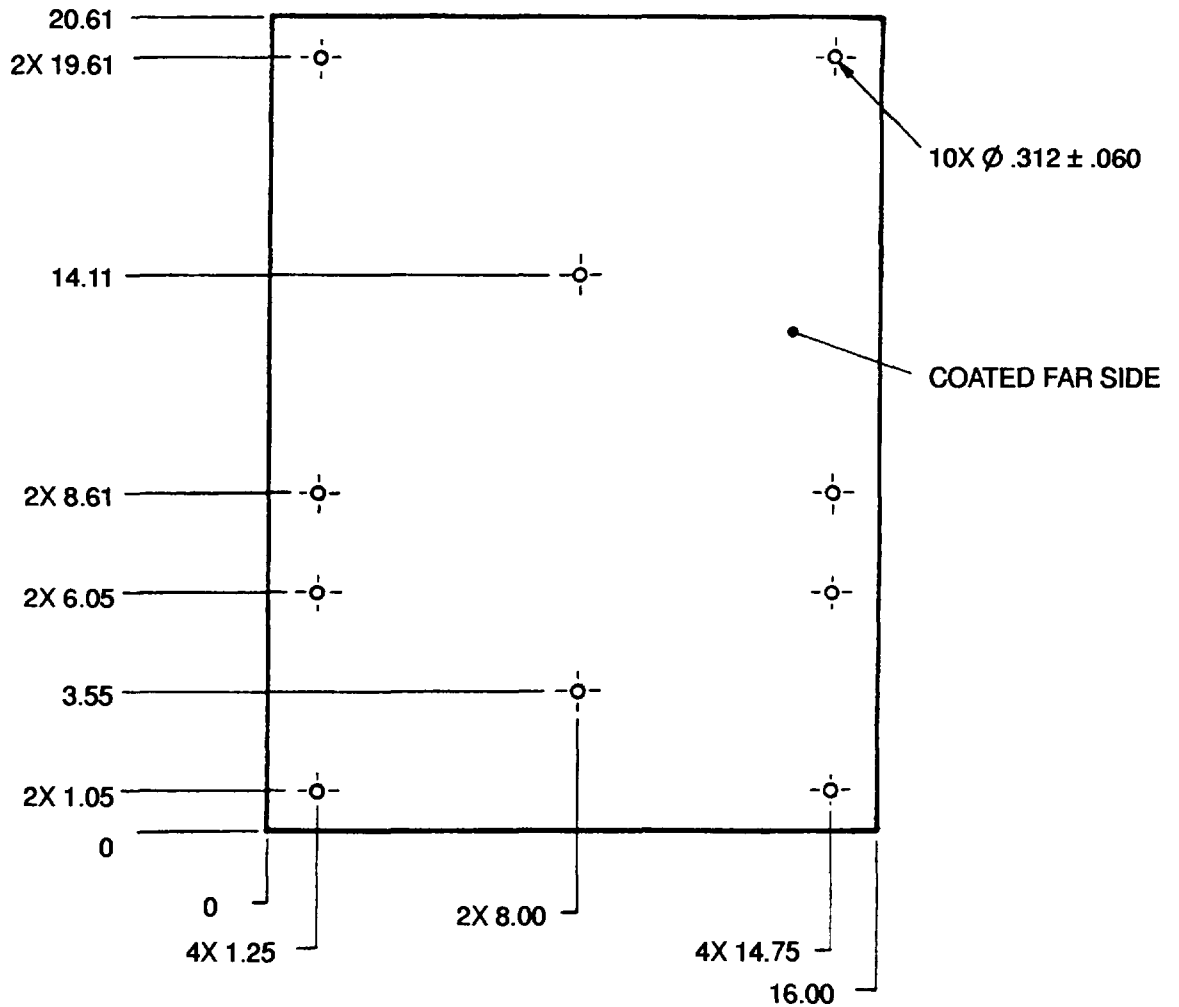

MATERIALS	
Description	Part Number
Foam, Sound Absorbing	FF40JM02

NOTES:

1. Dimensions shown are in inches.
2. Tolerances are 0.1 inch unless otherwise stated.

PROCEDURES:

1. Cut foam to dimensions shown.
2. Drill holes as shown.

FIGURE D-11. Insulation, Baffle (P/N: 88-22594)

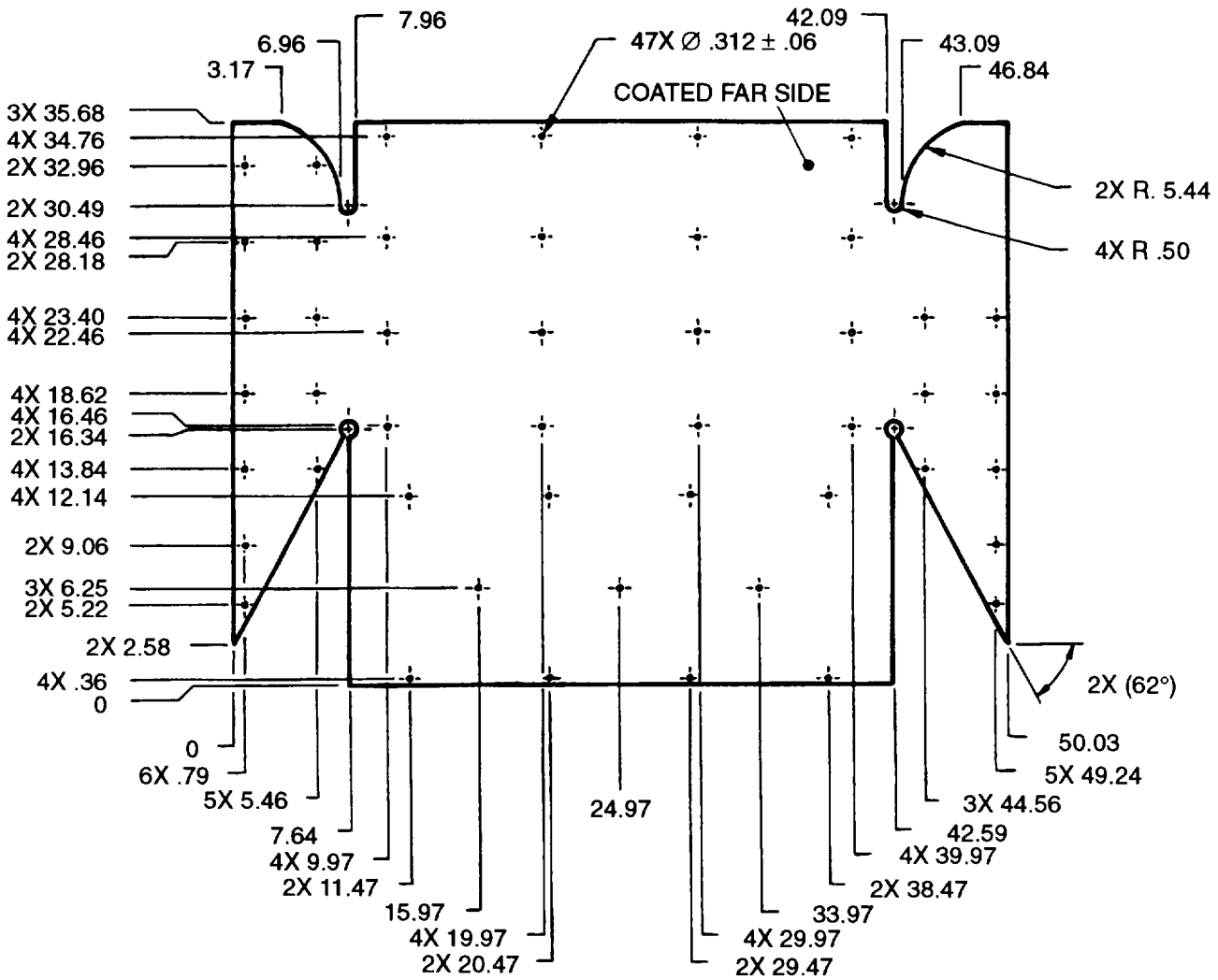

MATERIALS	
Description	Part Number
Foam, Sound Absorbing	FF40JM02

NOTES:

1. Dimensions shown are in inches.
2. Tolerances are 0.1 inch unless otherwise stated.

PROCEDURES:

1. Cut foam to dimensions shown.
2. Drill holes as shown.

FIGURE D-12. Insulation, Front Housing (P/N: 88-22595)

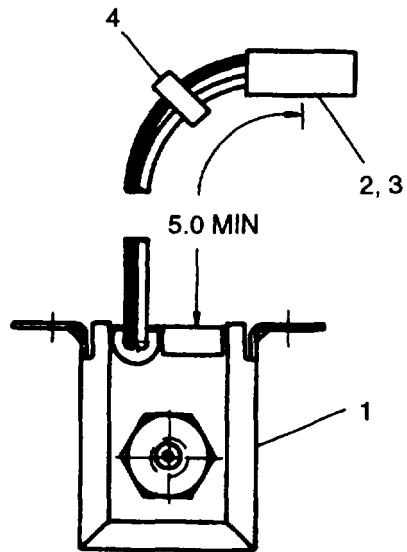

NOTES:

1. Dimensions shown are in inches.
2. Refer to TM 9-6115-643-24P for materials required.

PROCEDURES:

1. Remove and discard terminals supplied with fuel pump (1).
2. Strip 0.125 inch of insulation from end of each pump (1) lead.
3. Crimp pin (2) on end of each lead.
4. Insert pins (2) into housing (3) with red wire in position 1 and black wire in position 2.
5. Mark strap (4) with "P11" and install in position shown.

FIGURE D-13. Pump Assembly, Fuel (P/N: 88-22546)

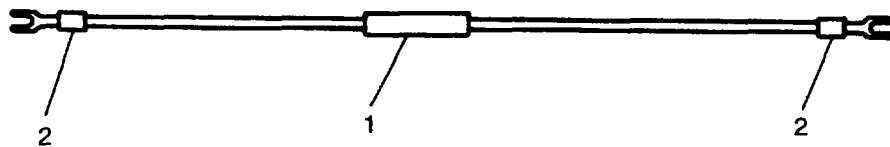

NOTES:

1. Refer to TM 9-6115-643-24P for materials required.
2. Resistors (1) are different depending on dash number being assembled.

PROCEDURES:

1. Crimp terminal (2) on end of each resistor (1) lead.

FIGURE D-14. Resistor Assembly (P/Ns: 122-3066-1 and 122-3066-2)

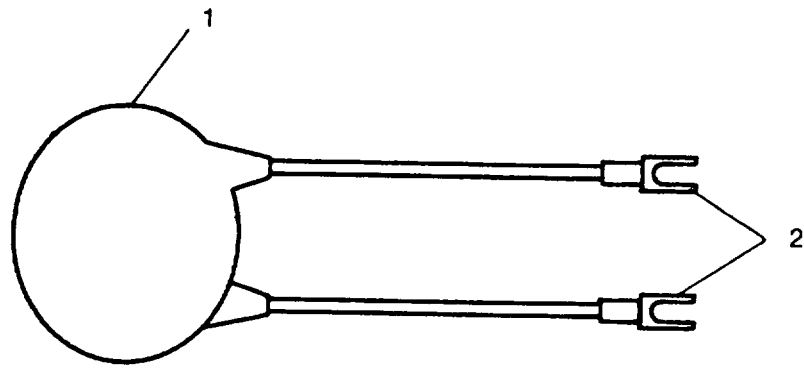

NOTES:

1. Refer to TM 9-6115-643-24P for materials required.

PROCEDURES:

2. Crimp and solder terminals (2) on end of each resistor (1) lead.

FIGURE D-15. Resistor Assembly, Volt (P/N: 88-22631)

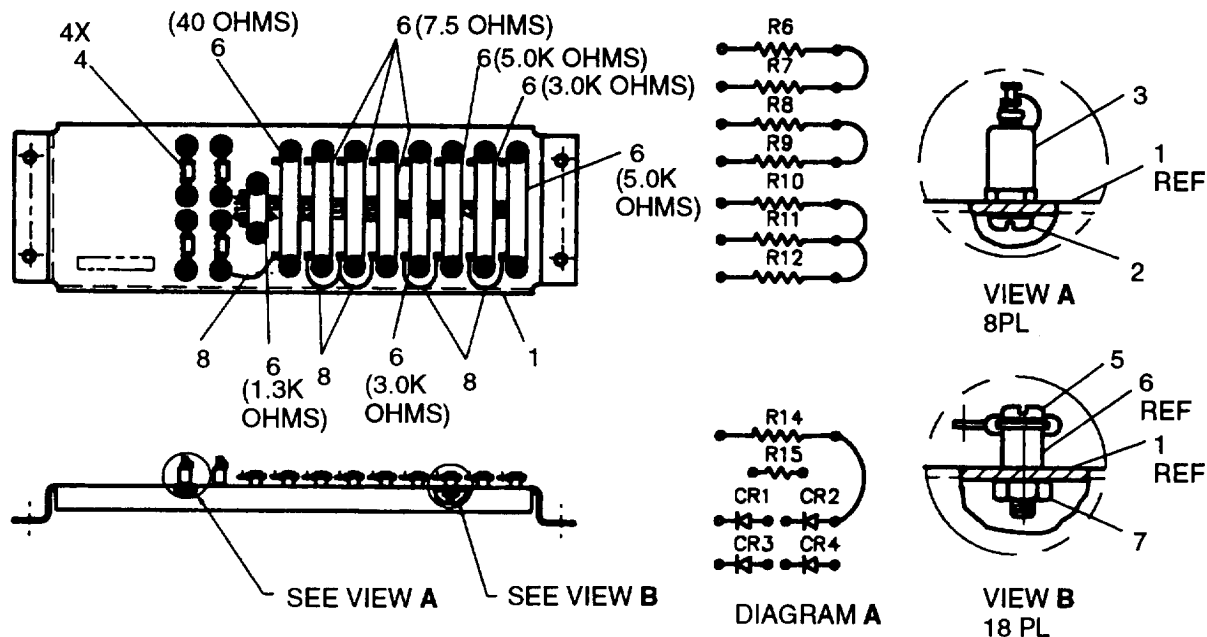

NOTES:

1. Refer to TM 9-6115-643-24P for materials required and positioning of resistors by ohm rating.

PROCEDURES:

1. Install screws (2) and insulated terminals (3) on bracket (1) as shown.
2. Solder diodes (4) to insulated terminals (3) as shown.
3. Install screws (5) resistors (6) and nuts (7) on bracket (1) as shown.
4. Position wires (8) and solder connections as shown.

FIGURE D-16. Resistor-Diode Assembly (P/N: 88-22106)

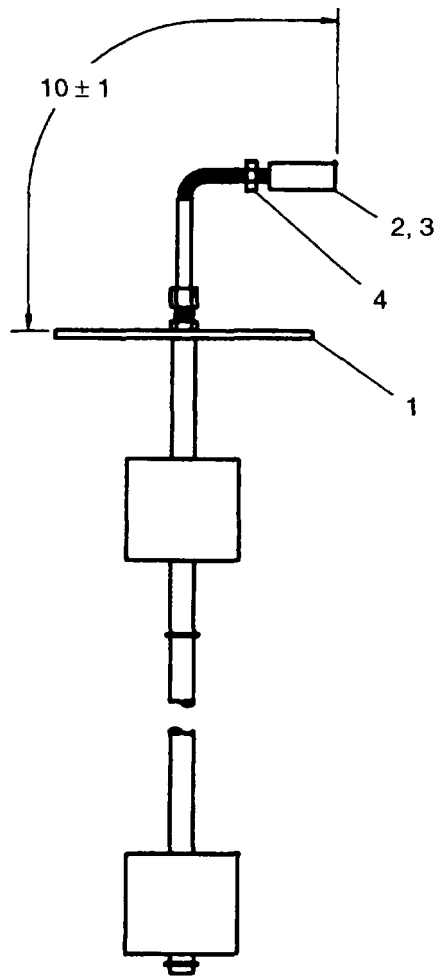

NOTES:

1. Dimensions shown are in inches.
2. Refer to TM 9-6115-643-24P for materials required.

PROCEDURES:

1. Strip 0.125 inch of insulation from end of each switch (1) lead.
2. Crimp pin (2) on end of each lead.
3. Insert pins into housing (3) with lead A in position 1, lead B in position 2, lead C in position 3, and lead D in position 4.
4. Mark "P12" on strap (4) and install in position shown.

FIGURE D-17. Switch Assembly, Fuel Level (P/N: 88-22547)

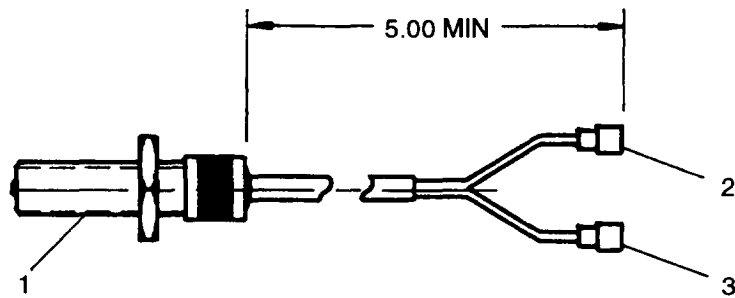

NOTES:

1. Dimensions shown are in inches.
2. Refer to TM 9-6115-643-24P for materials required.

PROCEDURES:

1. Strip 0.25 inch of insulation from end of each transducer (1) lead.
2. Crimp male terminal (2) on red wire and female terminal (3) on black wire.

FIGURE D-18. Transducer Assembly (P/N: 88-22550)

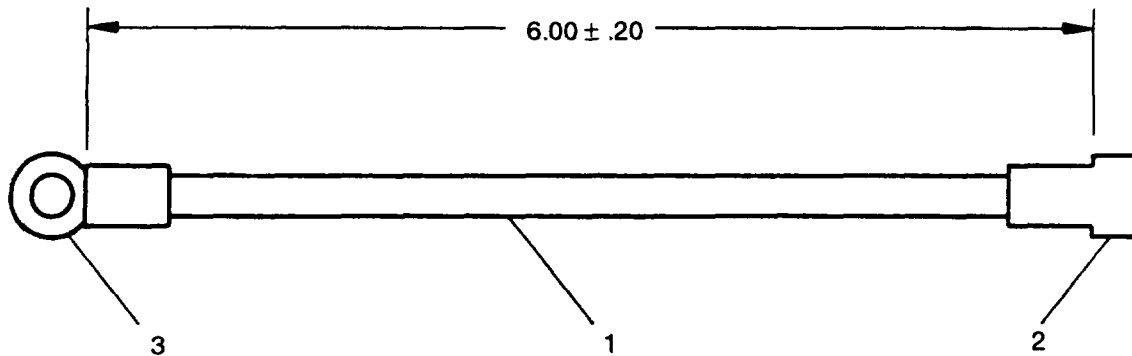

NOTES:

1. Dimensions shown are in inches.
2. Refer to TM 9-6115-643-24P for materials required.

PROCEDURES:

1. Cut wire (1) to length indicated.
2. Strip 0.25 inch from each end of wire (1).
3. Crimp terminal (2) on one end of wire (1) and terminal (3) on other end.

FIGURE D-19. Wire, Varistor (P/Ns: 88-20305-1 through 88-20305-3, and 88-20305-5)

TABLE D-1. INCHES TO METRIC CONVERSION

PART 1. Fractional Equivalent

Fractional Inches	Decimal Inches	mm
1/16	.0625	1.587
1/8	.1250	3.175
3/16	.1875	4.762
1/4	.2500	6.350
5/16	.3125	7.937
3/8	.3750	9.525
7/16	.4375	11.112
1/2	.5000	12.700
9/16	.5625	14.287
5/8	.6250	15.875
11/16	.6875	17.462
3/4	.7500	19.050
13/16	.8125	20.637
7/8	.8750	22.225
15/16	.9375	23.812
1	1	25.400

PART II. Inches to Centimeters

Inches	cm
1	2.540
2	5.080
3	7.620
4	10.16
5	12.70
6	15.24
7	17.78
8	20.32
9	22.86
10	25.40
20	50.80
30	76.20
40	101.6
50	127.0
60	152.4
70	177.8
80	203.2
90	228.6
100	254.0

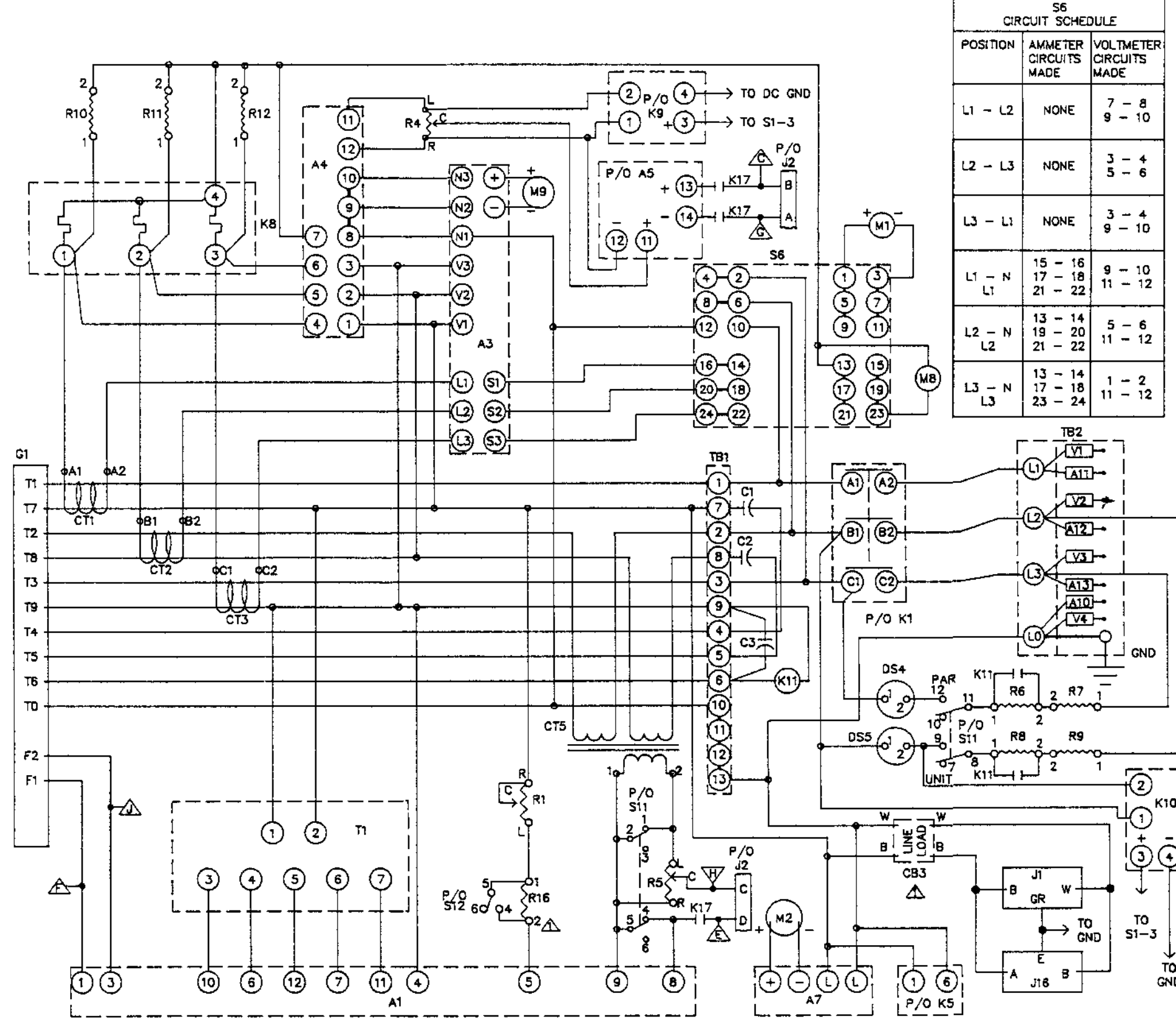
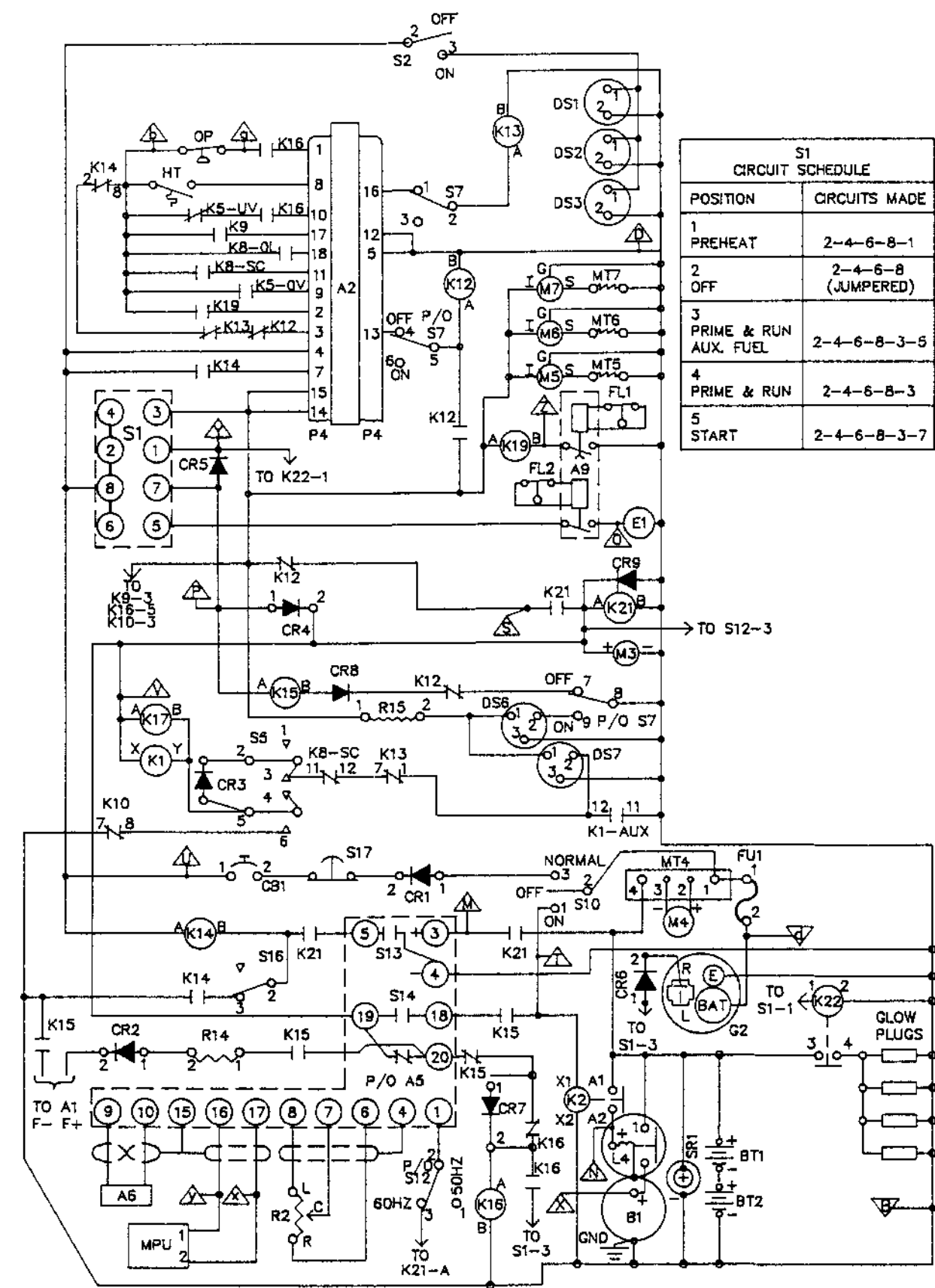

- A1 AC VOLTAGE REGULATOR
- A2 MALFUNCTION INDICATOR
- A3 KILOWATT TRANSOUCEUR
- A4 LOAD MEASURING UNIT
- A5 ELECTRONIC GOVERNOR CONTROL
- A6 ELECTRONIC GOVERNOR ACTUATOR
- A7 FREQUENCY TRANSDUCER
- A8 RESISTOR ASSEMBLY
- A9 FLOAT SWITCH MODULE
- A10-A13 EMI FILTER
- B1 CRANKING MOTOR
- BT1 BATTERY 12V
- BT2 BATTERY 12V
- C1-C3 EMI CAPACITOR
- CB1 DC CONTROL POWER CIRCUIT BREAKER
- CB3 GROUND FAULT CIRCUIT INTERRUPTER
- CBGND CONTROL BOX GROUND
- CPGND CONTROL PANEL GROUND
- CR1 DIODE REVERSE BATTERY
- CR2 DIODE FIELD FLASH
- CR3-9 DIODE BLOCKING
- CT1 CURRENT TRANSFORMER
- CT2 CURRENT TRANSFORMER
- CT3 CURRENT TRANSFORMER
- CT5 DROOP CURRENT TRANSFORMER
- DS1 PANEL LIGHT
- DS2 PANEL LIGHT
- DS3 PANEL LIGHT
- DS4 SYNCHRONIZATION LIGHT
- DS5 SYNCHRONIZATION LIGHT
- DS6 BATTLE SHORT LIGHT
- DS7 AC CIRCUIT INTERRUPTER LIGHT
- E1 AUXILIARY FUEL PUMP
- FL1 LOW FUEL LEVEL FLOAT SWITCH
- FL2 AUXILIARY FUEL PUMP FLOAT SWITCH
- FU1 FUSE
- G1 AC GENERATOR
- G2 BATTERY CHARGING ALTERNATOR
- GND GROUND
- HT COOLANT HIGH TEMPERATURE SWITCH
- J1 CONVENIENCE RECEPTACLE
- J2 PARALLEL RECEPTACLE
- J3 DIAGNOSTIC RECEPTACLE
- J16 SWITCH BOX RECEPTACLE
- K1 AC CIRCUIT INTERRUPTER
- K2 CRANKING RELAY
- K5 OVER / UNDER VOLTAGE RELAY
- K8 OVERLOAD / SHORT CIRCUIT RELAY
- K9 REVERSE POWER RELAY
- K10 PERMISSIVE PARALLELING RELAY
- K11 VOLTAGE SENSING RELAY
- K12 ENGINE FAULT RELAY
- K13 ELECTRICAL FAULT RELAY
- K14 OVERSPEED RELAY
- K15 START RELAY
- K16 CRANK DISCONNECT RELAY
- K17 K1 AUXILIARY RELAY
- K19 FUEL LEVEL RELAY
- K21 GOVERNOR CONTROL POWER
- K22 GLOW PLUGS CONTACTOR
- L0- L3 OUTPUT TERMINAL
- L1 OUTPUT TERMINAL
- L2 OUTPUT TERMINAL
- L3 OUTPUT TERMINAL
- L4 STARTER SOLENOID
- M1 AC VOLTMETER
- M2 FREQUENCY METER
- M3 TIME METER
- M4 BATTERY CHARGING AMMETER
- M5 FUEL LEVEL INDICATOR
- M6 COOLANT TEMPERATURE INDICATOR
- M7 OIL PRESSURE INDICATOR
- M8 AC AMMETER
- M9 KILOWATT METER
- MPU MAGNETIC PICKUP
- MT4 BATTERY CHARGING AMMETER SHUNT
- MT5 FUEL LEVEL SENDER
- MT6 COOLANT TEMPERATURE SENDER
- MT7 OIL PRESSURE SENDER
- OP LOW OIL PRESSURE SWITCH
- P4 PLUG MALFUNCTION INDICATOR
- R1 VOLTAGE ADJUST POTENTIOMETER
- R2 FREQUENCY ADJUST POTENTIOMETER
- R4 LOAD SHARING RHEOSTAT
- R5 KYA SHARING RHEOSTAT
- R6 SYNC LIGHTS DROPPING RESISTOR
- R7 SYNC LIGHTS DROPPING RESISTOR
- R8 SYNC LIGHTS DROPPING RESISTOR
- R9 SYNC LIGHTS DROPPING RESISTOR
- R10 BURDEN RESISTOR
- R11 BURDEN RESISTOR
- R12 BURDEN RESISTOR
- R14 FIELD FLASH RESISTOR
- R15 LED RESISTOR
- R16 VOLTAGE ADJUST RESISTOR
- S1 MASTER SWITCH
- S2 PANEL LIGHT SWITCH
- S3 AC CIRCUIT INTERRUPTER SWITCH
- S5 AM / VM TRANSFER SWITCH
- S6 BATTLE SHORT SWITCH
- S7 DEAD CRANK SWITCH
- S10 UNIT-PARALLEL SWITCH
- S11 FREQUENCY SELECTOR SWITCH
- S13 OVERSPEED SWITCH
- S14 CRANK DISCONNECT SWITCH
- S16 OVERSPEED RESET SWITCH
- S17 EMERGENCY STOP SWITCH
- SR1 SLAVE RECEPTACLE
- T1 POTENTIAL TRANSFORMER
- T8 TERMINAL BOARD (S)
- TB1 VOLTAGE RECONNECTION TERMINAL BOARD
- TB2 LOAD OUTPUT TERMINAL BOARD
- V1-V4 VARIATOR AC LOAD LINES

INDICATES PIN ON DIAGNOSTIC RECEPTACLE (J3)

NOTE S12 AND R16 ARE NOT INCLUDED ON 400 HZ SETS

• LETTER DESIGNATION

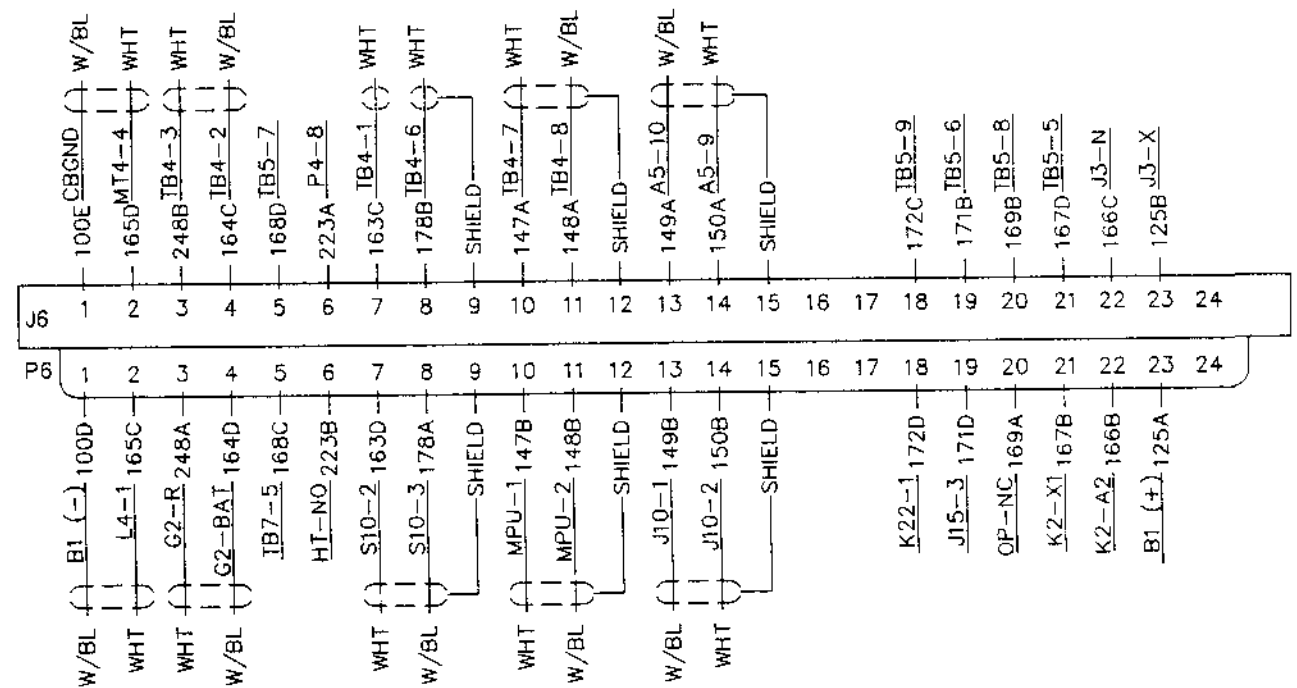
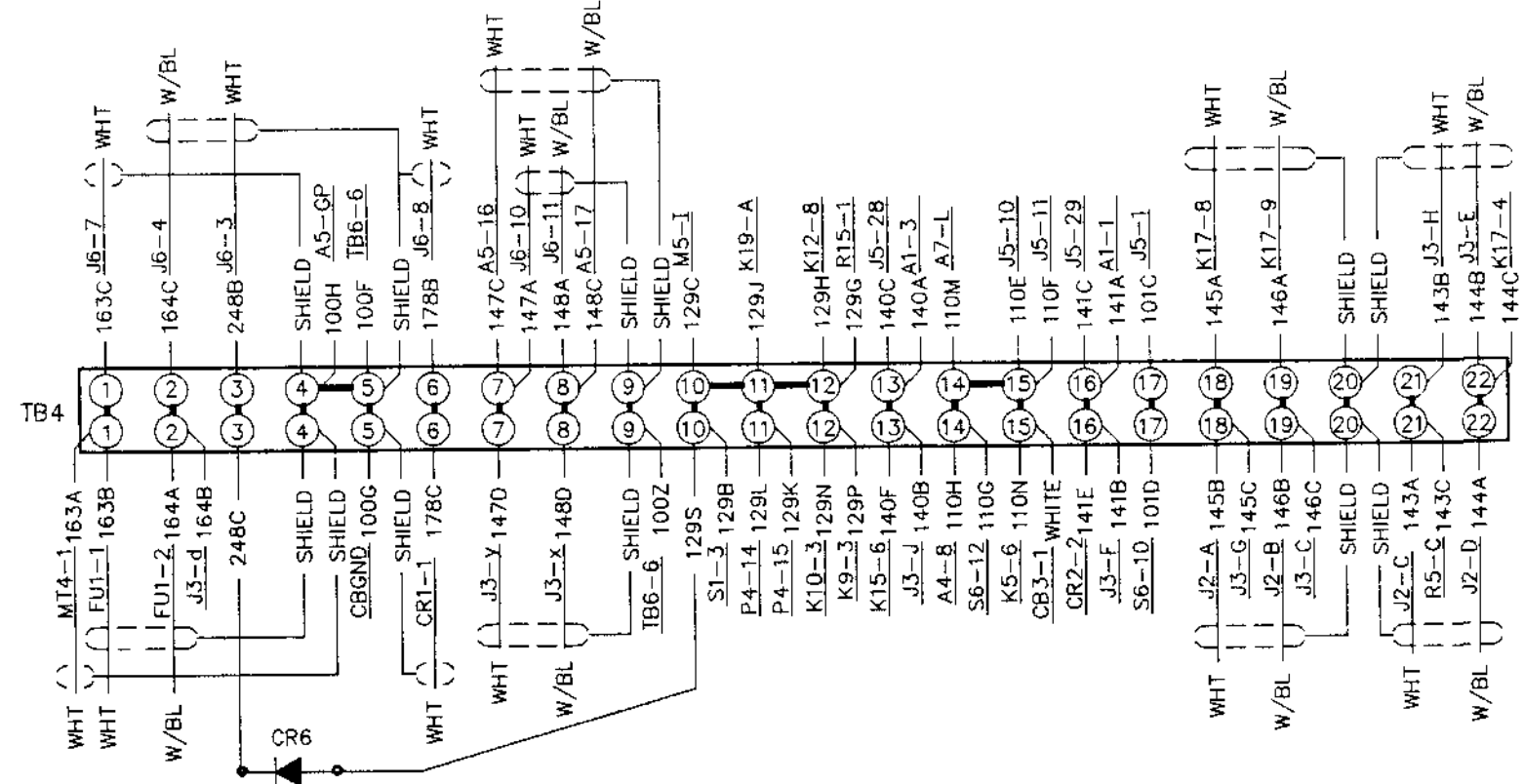
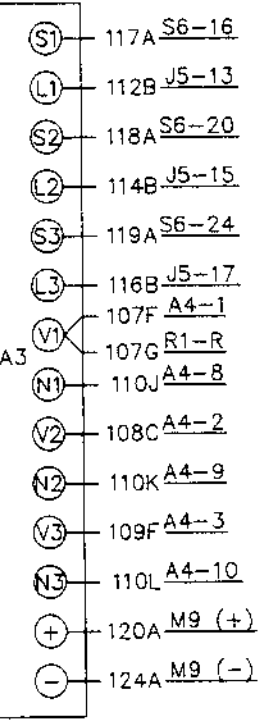
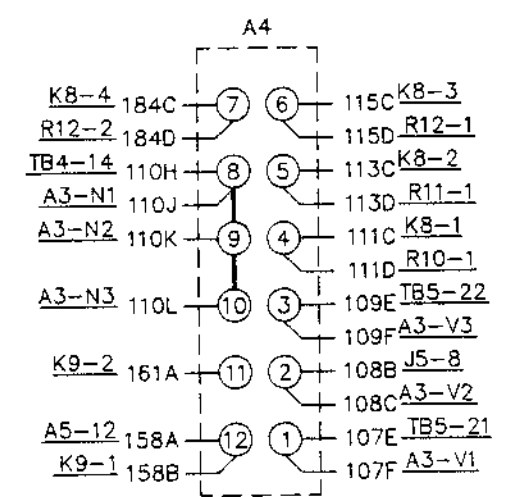
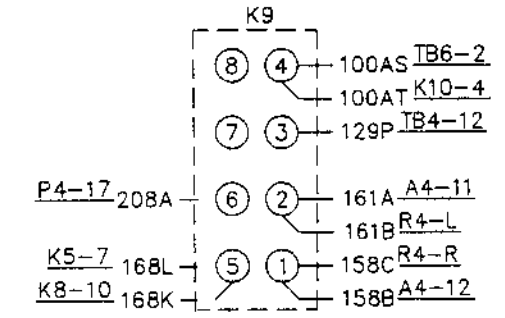
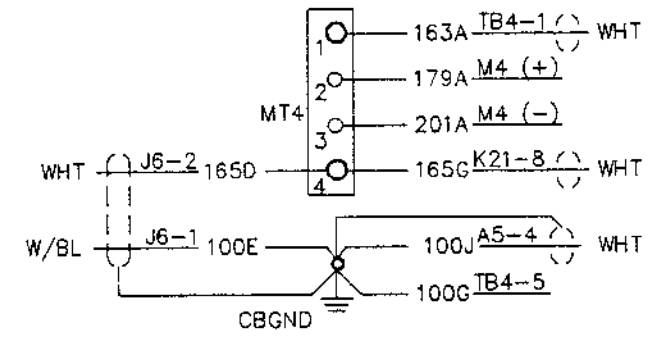
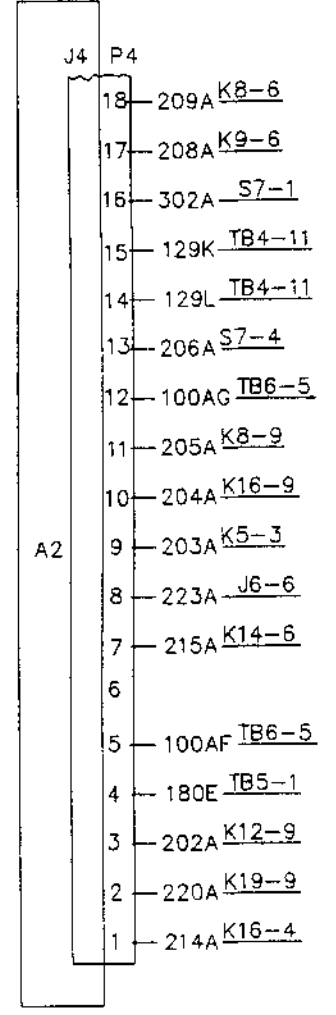
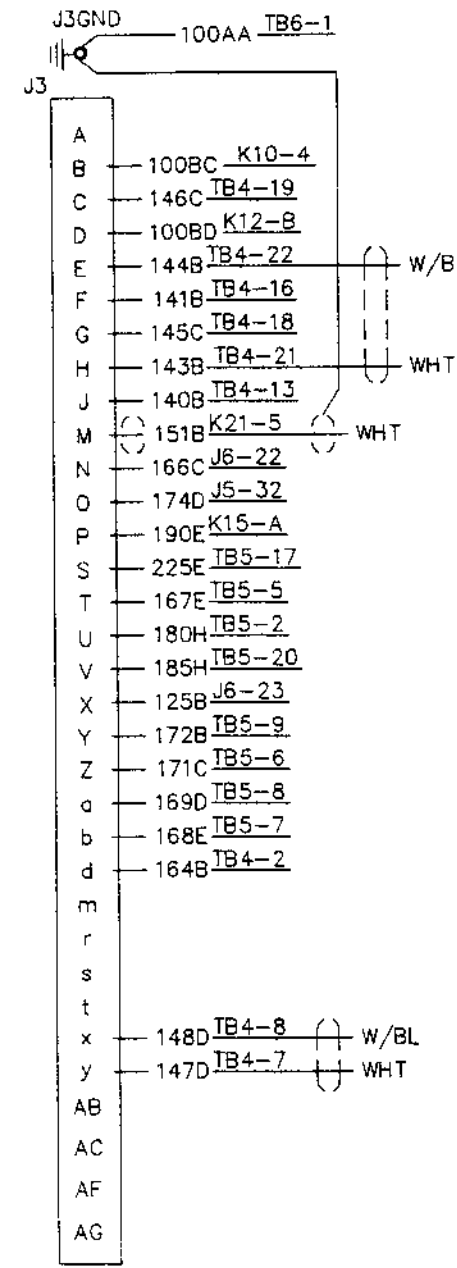
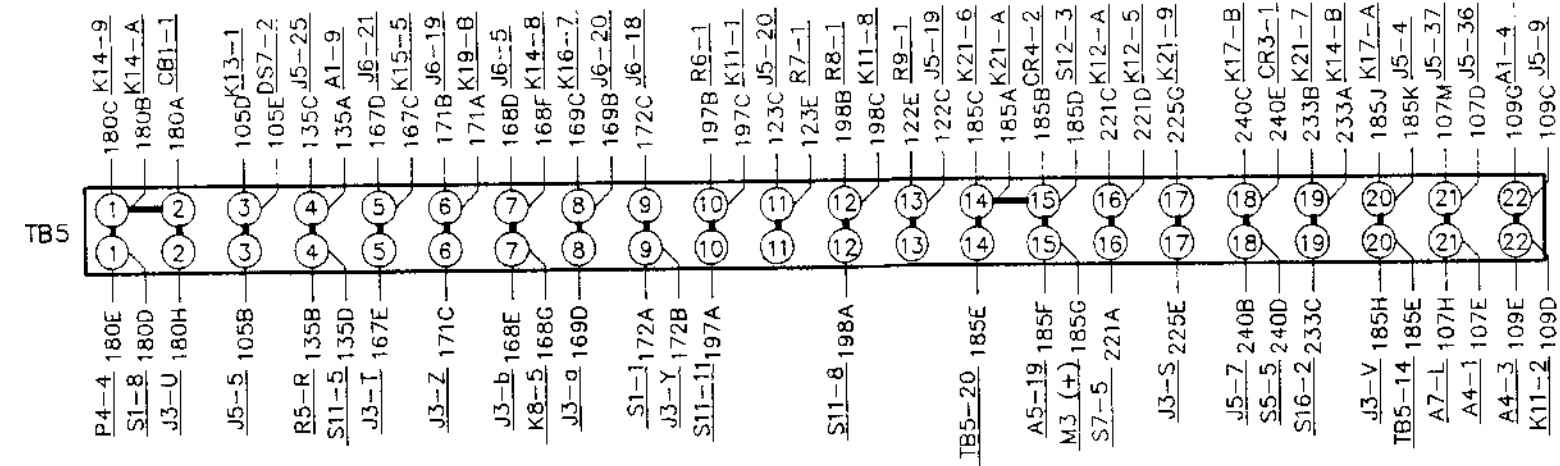

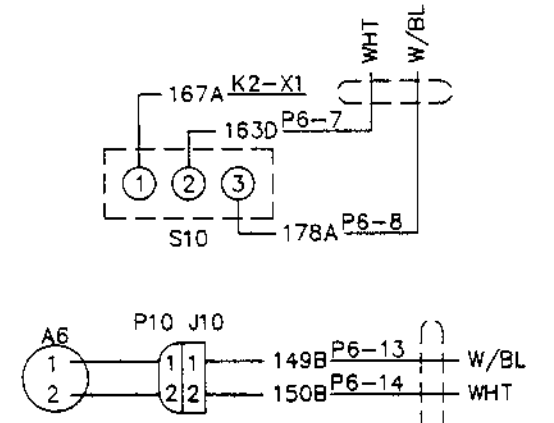
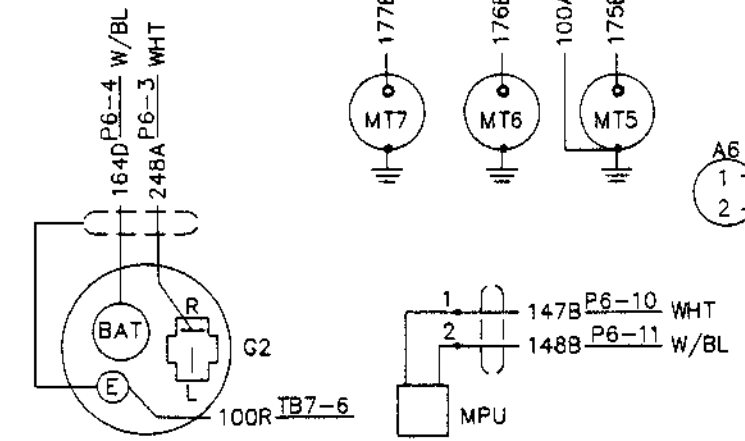
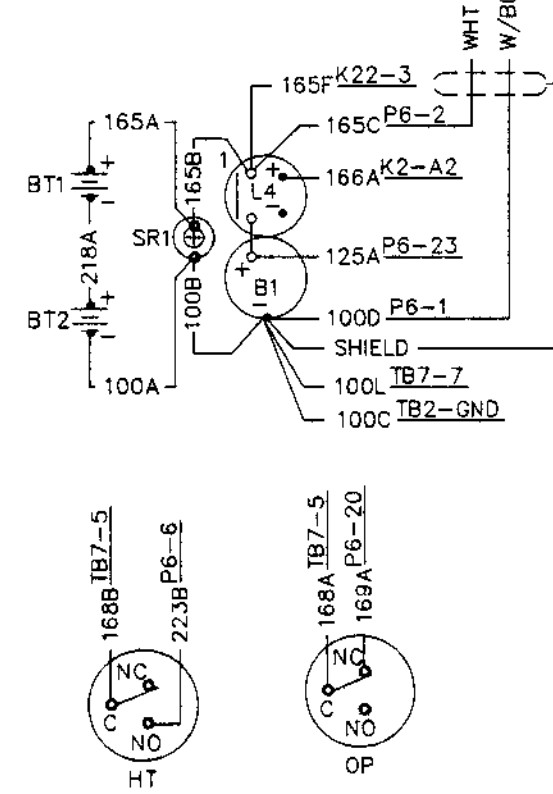
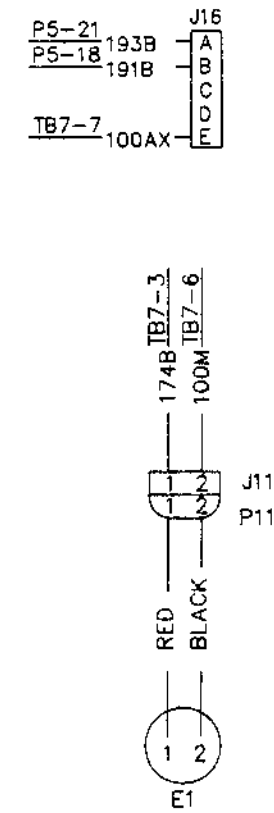
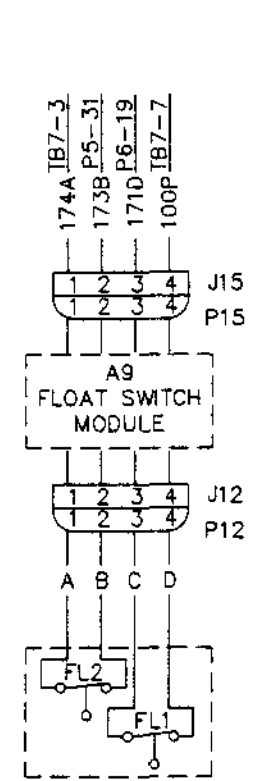
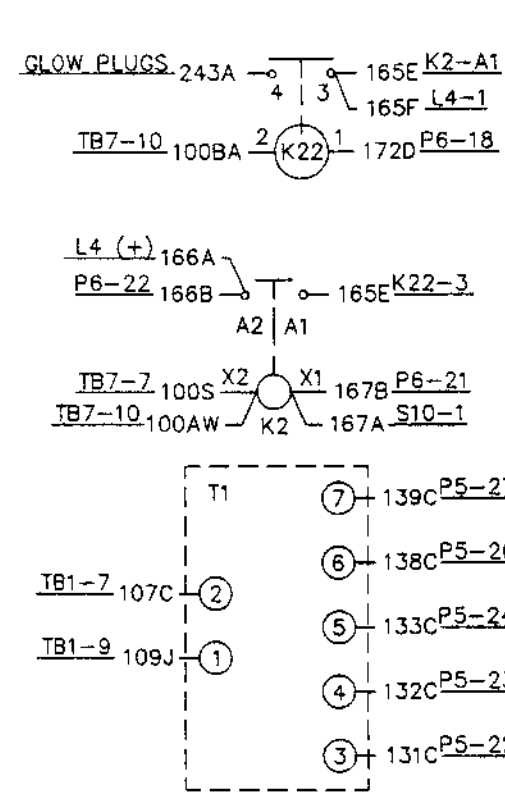
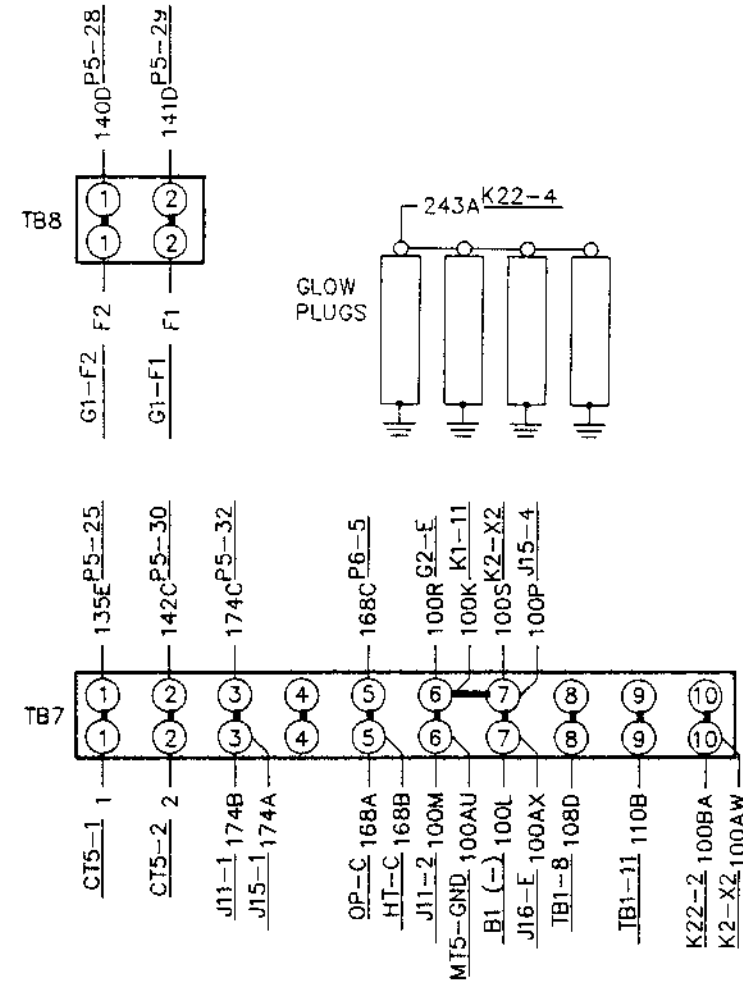
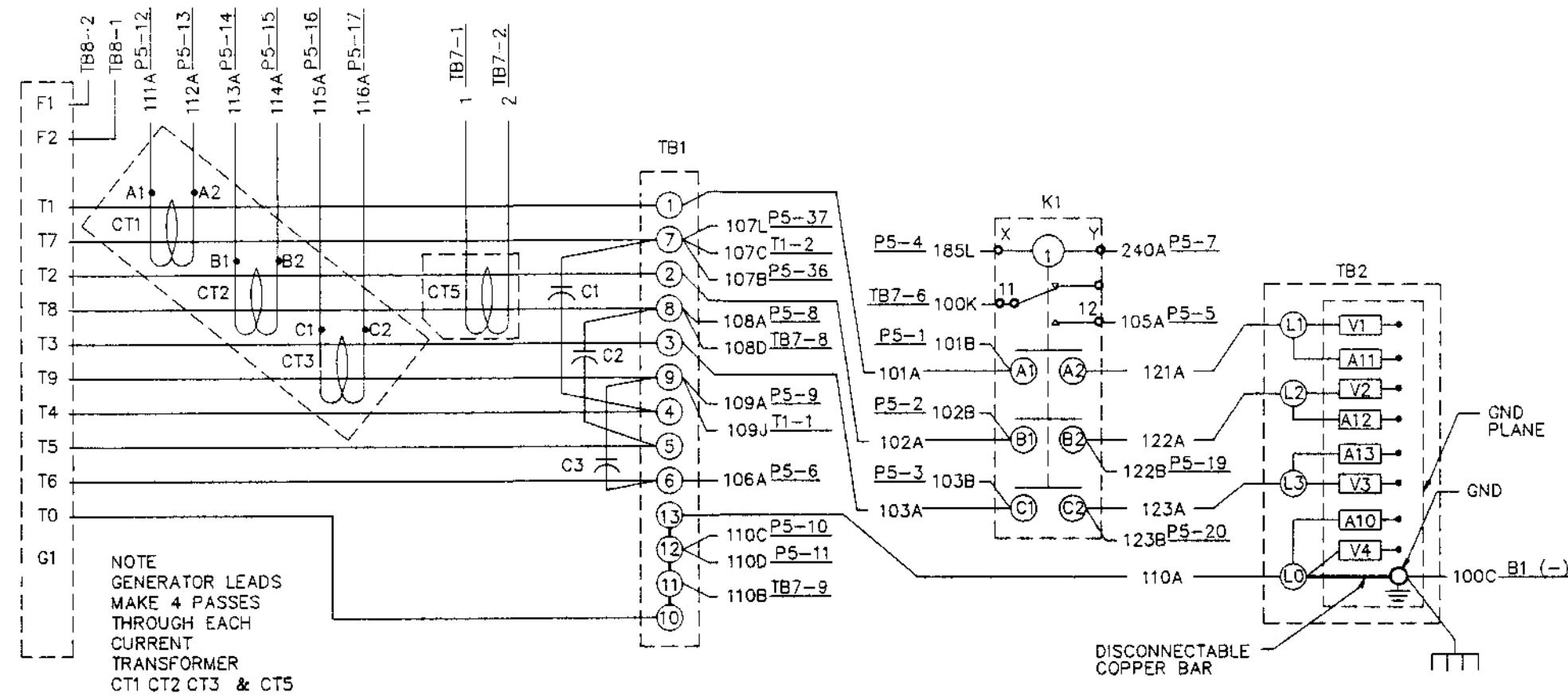

INDEX

A

	Paragraph Figure, Table Number
AC Circuit Interrupter Relay	
Inspection,	2.99.1
Installation,	2.99.4
Removal,	2.99.3
Testing,	2.99.2
AC Circuit Interrupter Switch	
Inspection,	2.36.1
Installation,	2.36.4
Removal,	2.36.2
Testing,	2.36.3
AC Generator	
Description,	4.15
Installation,	4.16.2
Location,	1.13.14
Removal,	4.16.1
AC Voltage Regulator	
Inspection,	2.50
Installation,	4.1.5
Removal,	4.1.4
Testing (400 HZ),	4.1.3
Testing (50/60HZ) (P/N 122-3054),	4.1.1
Testing (50/60HZ) (P/N 19870) ,	4.1.2
AC Voltmeter (VOLTS AC)	
Inspection,	2.31.1
Installation,	2.31.4
Removal,	2.31.3
Testing,	2.31.2
Access Doors	
Inspection,	2.14.2
Installation,	2.14.4
Removal,	2.14.1
Repair,	2.14.3
Air Cleaner Assembly	
Inspection,	2.72.1
Installation,	2.72.4
Location,	1.13.13
Removal,	2.72.3
Service,	2.72.2
Air Cleaner Tubing	
Inspection,	2.74.1
Installation,	2.74.3
Removal,	2.74.2

INDEX - Continued

A - Continued

	Paragraph Figure, Table Number
Air Filter Element	
Inspection,	2.73.2
Installation,	2.73.3
Removal,	2.73.1
Air Restriction Indicator	
Inspection,	2.71.1
Installation,	2.71.3
Removal,	2.71.2
AM-VM Transfer Switch	
Inspection,	2.38.1
Installation,	2.38.4
Removal,	2.38.2
Testing,	2.38.3
Ammeter (PERCENT RATED CURRENT)	
Inspection,	2.29.1
Installation,	2.29.4
Removal,	2.29.3
Testing,	2.29.2
Auxiliary Fuel Pump	
Inspection,	2.86.1
Installation,	2.86.4
Removal,	2.86.3
Testing,	2.86.2

B

Batteries	
Description,	1.13.24
Inspection,	2.12.3
Installation,	2.12.5
Location,	1.13.24
Removal,	2.12.2
Service,	2.12.4
Testing,	2.12.1
BATTERY CHARGE Ammeter	
Inspection,	2.27.1
Installation,	2.27.4
Removal,	2.27.3
Testing,	2.27.2

INDEX - Continued

B - Continued

	Paragraph Figure, Table Number
BATTERY CHARGER FUSE	
Inspection,	2.48.1
Installation,	2.48.3
Removal,	2.48.2
Battery Charging Alternator	
Description,	1.13.19
Location,	1.13.19
BATTLE SHORT Switch	
Inspection,	2.35.1
Installation,	2.35.4
Removal,	2.35.2
Testing,	2.35.3

C

Control Box Assembly	
Inspection,	2.19.1
Installation,	2.19.4
Removal,	2.19.2
Repair,	2.19.3
Control Box Harness	
Inspection, Direct Support,	4.3.2
Inspection, Unit,	2.61.1
Installation,	4.3.5
Removal,	4.3.1
Repair, Direct Support,	4.3.4
Repair, Unit,	2.61.3
Testing, Direct Support,	4.3.3
Testing, Unit,	2.61.2
Control Box Side Panels	
Inspection,	2.68.1
Installation,	2.68.4
Removal,	2.68.2
Repair,	2.68.3
Control Box Top Panel	
Inspection,	2.15.2
Installation,	2.15.4
Removal,	2.15.1
Repair,	2.15.3

INDEX - Continued

C - Continued

	Paragraph Figure, Table Number
Control Box Tray (Bottom)	
Inspection,	2.69.1
Installation,	2.69.4
Removal,	2.69.2
Repair,	2.69.3
Control Panel Assembly	
Inspection,	2.66.1
Installation,	2.66.4
Location,	1.13.2
Removal,	2.66.2
Repair,	2.66.3
Control Panel Frame	
Inspection,	2.67.1
Installation,	2.67.4
Removal,	2.67.2
Repair,	2.67.3
Control Panel Lights	
Assembly,	2.20.4
Disassembly,	2.20.3
Inspection,	2.20.1
Installation,	2.20.5
Removal,	2.20.2
Convenience Receptacle	
Description,	1.13.10
Inspection,	2.45.1
Installation,	2.45.4
Location,	1.13.10
Removal,	2.45.3
Testing,	2.45.2
Coolant High Temperature Switch	
Cleaning,	2.107.3
Inspection,	2.107.3
Installation,	2.107.4
Removal,	2.107.2
Testing,	2.107.1
Coolant Overflow and Drain Hoses	
Inspection,	2.80.1
Installation,	2.80.3
Removal,	2.80.2
Coolant Recovery System	
Inspection,	2.84.1
Installation,	2.84.3
Removal,	2.84.2

INDEX - Continued

C - Continued

	Paragraph Figure, Table Number
Coolant System	
Description,	1.12.3
Service,	2.75.1
Testing,	2.75.1
COOLANT TEMP. Indicator	
Inspection,	2.24.1
Installation,	2.24.4
Removal,	2.24.3
Testing,	2.24.2
Coolant Temperature Sender	
Cleaning,	2.106.3
Inspection,	2.106.3
Installation,	2.106.4
Removal,	2.106.2
Testing,	2.106.1
Cooling Fan	
Inspection,	2.82.2
Installation,	2.82.3
Removal,	2.82.1
Cranking Relay	
Inspection,	2.100.1
Installation,	2.100.4
Removal,	2.100.3
Testing,	2.100.2
Current Transformer	
Inspection,	2.96.1
Installation,	4.10.3
Removal,	4.10.1
Testing,	2.96.2
Testing, Direct Support,	4.10.2

D

DC Control Power Circuit Breaker	
Inspection,	2.49.1
Installation,	2.49.4
Removal,	2.49.3
Testing,	2.49.2

INDEX - Continued

D - Continued

	Paragraph Figure, Table Number
DEAD CRANK Switch	
Description,	1.13.6
Installation,	2.109.3
Location,	1.13.6
Removal,	2.109.2
Testing,	2.109.1
Destruction of Material to Prevent Enemy Use,	1.7
Diagnostic Connector	
Description,	1.13.12
Inspection,	2.62.1
Installation,	2.62.3
Location,	1.13.12
Removal,	2.62.2
Differences Between Models,	1.10
Diodes, Rotating Rectifier	
Installation,	4.17.3
Removal,	4.17.2
Testing,	4.17.1
Dipstick	
Description,	1.13.16
Location,	1.13.16
Droop Current Transformer	
Inspection,	2.97
Installation,	4.11.3
Removal,	4.11.1
Testing,	4.11.2

E

EMERGENCY STOP Switch	
Inspection,	2.40.1
Installation,	2.40.4
Removal,	2.40.3
Testing,	2.40.2
End Bell and Main Bearing (400 Hz)	
Installation,	4.26.2
Removal,	4.26.1
End Bell and Main Bearing (50/60 Hz)	
Installation,	4.18.2
Removal,	4.18.1

INDEX - Continued

E - Continued

	Paragraph Figure, Table Number
Engine and Generator Assembly	
Description,	3.5
Installation,	3.6.2
Removal,	3.6.1
Engine Assembly	
Description,	1.13.17
Installation,	3.7.2
Location,	1.13.17
Removal,	3.7.1
Replacement,	3.7.3
Engine Oil Drain Line	
Inspection,	2.111.1
Installation,	2.111.3
Location,	F 1-12
Removal,	2.111.2
Equipment Characteristics, Capability and Features,	1.1
Equipment Data,	T1-1
Exciter Rotor (400 Hz)	
Description,	4.15.3
Installation,	4.29.3
Removal,	4.29.1
Testing,	4.29.2
Exciter Rotor (50/60 Hz)	
Description,	4.15.3
Installation,	4.21.3
Removal,	4.21.2
Testing,	4.21.1
Exciter Stator (400 Hz)	
Installation,	4.28.3
Removal,	4.28.1
Testing,	4.28.2
Exciter Stator (50/60 Hz)	
Installation,	4.20.3
Removal,	4.20.2
Testing,	4.20.1

INDEX - Continued

F

	Paragraph Figure, Table Number
Fabrication/Assembly of Parts	
Direct and General Support,	3.3
Unit,	2.3
Fan Belt	
Adjustment,	2.83.2
Description,	1.13.20
Inspection,	2.83.1
Installation,	2.83.4
Location,	1.13.20
Removal,	2.83.3
Test,	2.83.2
Fan Guards	
Inspection,	2.77.1
Installation,	2.77.3
Removal,	2.77.2
FREQUENCY Adjust Potentiometer	
Inspection,	2.34.1
Installation,	2.34.4
Removal,	2.84.2
Testing,	2.34.3
Frequency Meter (HERTZ)	
Inspection,	2.28.1
Installation,	2.28.5
Removal,	2.28.4
Testing (400 Hz),	2.28.2
Testing (50/60 Hz),	2.28.3
FREQUENCY SELECT Switch	
Inspection,	2.44.1
Installation,	2.44.4
Removal,	2.44.3
Testing,	2.44.2
Frequency Transducer	
Inspection,	2.51.1
Installation,	2.51.5
Removal,	2.51.4
Testing (400 Hz),	2.51.3
Testing (50/60 Hz),	2.51.2
Front Housing Section	
Inspection,	2.17.2
Installation,	2.17.4
Removal,	2.17.1
Repair,	2.17.3

INDEX - Continued

F - Continued

	Paragraph Figure, Table Number
Fuel Drain Valve	
Installation,	2.88.2
Location,	F 1-12
Removal,	2.88.1
Fuel Filter/Water Separator	
Description,	1.13.5
Inspection,	2.93.1
Installation,	2.93.5
Location,	1.13.5
Removal,	2.93.3
Repair,	2.93.4
Service,	2.93.2
Fuel Float Module	
Inspection,	2.92.1
Installation,	2.92.4
Removal,	2.92.3
Testing,	2.92.2
Fuel Level Indicator	
Inspection,	2.23.1
Installation,	2.23.4
Removal,	2.23.3
Testing,	2.23.2
Fuel Level Sender	
Inspection,	2.89.1
Installation,	2.89.4
Removal,	2.89.2
Testing,	2.89.3
Fuel Pickup	
Inspection,	2.91.2
Installation,	2.91.3
Removal,	2.91.1
Fuel Tank	
Description,	1.13.18
Inspection,	4.6.1
Installation,	4.6.3
Location,	1.13.18
Removal,	4.6.2
Service,	2.1.2.3
Fuel Tank Filler Neck	
Inspection,	2.87.2
Installation,	2.87.3
Removal,	2.87.1

INDEX - Continued

G

	Paragraph Figure, Table Number
Generator Assembly, AC	
Description,	4.15
Installation,	4.16.2
Location,	1.13.14
Removal,	4.16.1
Generator Housing (400 Hz)	
Installation,	4.32.2
Removal,	4.32.1
Generator Housing (50/60 Hz)	
Installation,	4.24.2
Removal,	4.24.1
Generaor Set	
Description,	1.8
Installation,	2.2
Glow Plugs DC Contactor	
Installation,	2.110.3
Removal,	2.110.1
Testing,	2.110.2
Governor Actuator	
Adjustment,	4.14.3
Description,	1.12.9
Installation,	4.14.3
Removal,	4.14.2
Testing,	4.14.1
Governor Control Unit	
Adjustment,	4.2.3
Description,	1.12.9
Inspection,	2.60.1
Installation,	2.60.3
Removal,	2.60.2
Replacement,	4.2.4
Testing,	4.2.1
Ground Fault Circuit Interrupter	
Inspection,	2.46.1
Installation,	2.46.4
Removal,	2.46.3
Testing,	2.46.2

INDEX - Continued

I

	Paragraph Figure, Table Number
Inspecting and Servicing the Equipment,	2.1
Interference Suppression Components	
Primary,	2.8.1
Secondary,	2.8.2

K

Kilowatt Transducer	
Inspection,	2.52.1
Installation,	2.52.4
Removal,	2.52.3
Testing,	2.52.2
Kilowatt Meter (PERCENT POWER)	
Inspection,	2.30.1
Installation,	2.30.4
Removal,	2.30.3
Testing,	2.30.2

L

Levels of Maintenance,	1.6
Load Measuring Unit	
Description,	1.12.9
Inspection,	2.64.1
Installation,	2.64.3
Removal,	2.64.2
Replacement,	4.4.2
Testing,	4.4.1
Load Output Terminal Board Assembly	
Description,	1.13.9
Inspection,	2.101.2
Installation,	2.101.4
Location,	1.13.9
Removal,	2.101.1
Repair,	2.101.3
Load Output Terminals	
Description,	1.13.9
Inspection,	2.102.2
Installation,	2.102.3
Location,	1.13.9
Removal,	2.102.1

INDEX - Continued

L - Continued

	Paragraph Figure, Table Number
LOAD SHARING ADJUST Rheostat	
Inspection,	2.42.1
Installation,	2.42.4
Removal,	2.42.3
Testing,	2.42.2
Location and Description of Major Components,	1.13
Low Fuel Level/Auxiliary Fuel Pump Float Switch	
Inspection,	2.90.1
Installation,	2.90.4
Removal,	2.90.2
Testing,	2.90.3
Low Oil Pressure Switch	
Cleaning,	2.104.3
Inspection,	2.104.3
Installation,	2.104.4
Removal,	2.104.2
Testing,	2.104.1
Low Pressure Fuel Lines and Fittings	
Installation,	2.85.2
Removal,	2.85.1
Lower Coolant Hose	
Cleaning,	2.79.2
Inspection,	2.79.2
Installation,	2.79.3
Removal,	2.79.1
Lubricating Oil, Servicing of,	2.1.2.4

M

Magnetic Pickup	
Adjustment,	2.108.4
Cleaning,	2.108.2
Inspection,	2.108.2
Installation,	2.108.3
Removal,	2.108.1
Main Rotor Assembly (400 Hz)	
Installation,	4.30.3
Removal,	4.30.1
Testing,	4.30.2

INDEX - Continued

M - Continued

	Paragraph Figure, Table Number
Main Rotor Assembly (50/60 Hz)	
Installation,	4.22.3
Removal,	4.22.2
Testing,	4.22.1
Main Stator Assembly (400 Hz)	
Installation,	4.31.3
Removal,	4.31.1
Testing,	4.31.2
Main Stator Assembly (50/60 Hz)	
Installation,	4.23.3
Removal,	4.23.2
Testing,	4.23.1
Maintenance Forms and Records,	1.3
Major Components, Location and Major Description,	1.13
Malfunction Indicator Panel	
Description,	1.13.1
Inspection,	2.47.1
Installation,	2.47.4
Location,	1.13.1
Removal,	2.47.3
Testing,	2.47.2
Marking, for Shipment and Storage,	2.114
MASTER SWITCH	
Inspection,	2.32.1
Installation,	2.32.4
Removal,	2.32.2
Testing,	2.32.3
Model Numbers and Equipment Names,	1.1
Muffler	
Description,	1.13.3
Inspection,	2.70.1
Installation,	2.70.3
Location,	1.13.3
Removal,	2.70.2

INDEX - Continued

N

	Paragraph Figure, Table Number
NATO Slave Receptacle	
Description,	1.13.22
Inspection,	2.13.1
Installation,	2.13.2
Location,	1.13.22
Removal,	2.13.2
Nuclear, Biological, Chemical Contamination,	2.9

O

Oil Filter	
Description,	1.13.7
Location,	1.13.7
OIL PRESSURE Indicator	
Inspection,	2.25.1
Installation,	2.25.4
Removal,	2.25.3
Testing,	2.25.2
Oil Pressure Sender	
Cleaning,	2.105.3
inspection,	2.105.3
Installation,	2.105.4
Removal,	2.105.2
Testing,	2.105.1
Output Box Assembly	
Installation,	4.7.2
Removal,	4.7.1
Output Box Harness	
Inspection,	2.95.1
Inspection, Direct Support,	4.9.1
Installation,	4.9.5
Removal,	4.9.2
Repair, Direct,	4.9.4
Repair, Unit	2.95.3
Testing, Direct Support,	4.9.3
Testing, Unit	2.95.2
Output Box Panels	
Inspection,	4.13.1
Installation,	4.13.4
Removal,	4.13.2
Repair,	4.13.3

INDEX - Continued

O - Continued

	Paragraph Figure, Table Number
Over/Undervoltage Relay	
Inspection,	2.54.1
Installation,	2.54.4
Removal,	2.54.3
Testing,	2.54.2
Overspend Reset Switch	
Inspection,	2.43.1
Installation,	2.43.4
Removal,	2.43.3
Testing,	2.43.2
 P 	
Packing, for Shipment and Storage,	2.113
Panel Lights	
Assembly,	2.20.4
Disassembly,	2.20.3
Inspection,	2.20.1
Installation,	2.20.5
Removal,	2.20.2
PANEL LIGHTS Switch	
Inspection,	2.39.1
Installation,	2.39.4
Removal,	2.39.2
Testing,	2.39.3
Parallel Connector	
Description,	1.13.15
Inspection,	2.63.1
Installation,	2.63.3
Location,	1.13.15
Removal,	2.63.2
PARALLEL UNIT Switch	
Inspection,	2.37.1
Installation,	2.37.4
Removal,	2.37.2
Testing,	2.37.3
Performance Characteristics,	1.2
Permissive Paralleling Relay	
Inspection,	2.56.1
Installation,	2.56.4
Removal,	2.56.3
Testing,	2.56.2

INDEX - Continued

P - Continued

	Paragraph Figure, Table Number
PMCS Procedures,	2.5
Power Potential Transformer	
Inspection,	2.98
Installation,	4.12.4
Removal,	4.12.1
Testing (P/N 171910),	4.12.2
Testing (P/N A1497B),	4.12.3
Preservation, for Shipment and Storage,	2.112
Press to Test Lights	
Inspection,	2.21.1
Installation,	2.21.4
Removal,	2.21.3
Testing,	2.21.2
Principles of Operation	
Applying the Load,	1.12.8.4
Engine Air Intake and Exhaust System,	1.12.6
Engine Cooling System,	1.12.4
Engine Lubrication System,	1.12.5
Engine Starting System,	1.12.8.1
Fault System,	1.12.1
Field Flash,	1.12,8.2
Fuel System,	1.12.2
Generator Set Cooling System,	1.12.3
Governor Control System,	1.12.9
Operation,	1.12.8.3
Output Supply System,	1.12.7
Paralleling,	1.12.8.6
Shutdown,	1.12.8.5
Voltage Regulation System,	1.12.10
Purpose of Equipment,	1.1

R

Radiator	
Cleaning,	2.81.2
Description,	1.13.23
Inspection,	2.81.2
Installation,	2.81.4
Location,	1.13.23
Removal,	2.81.1
Repair,	4.5
Service,	2.1.2.2
Radiator Drain Valve, Location of,	F 1-12

INDEX - Continued

R - Continued

	Paragraph Figure, Table Number
Radiator Filler Hose and Panel	
Cleaning,	2.76.2
Inspection,	2.76.2
Installation,	2.76.3
Removal,	2.76.1
REACTIVE CURRENT ADJUST Rheostat	
Inspection,	2.41.1
Installation,	2.41.4
Removal,	2.41.3
Testing,	2.41.2
Rear Housing Section	
Inspection,	2.18.2
Installation,	2.18.4
Removal,	2.18.1
Repair,	2.18.3
Relays	
Inspection,	2.59.1
Installation,	2.59.4
Removal,	2.59.3
Testing,	2.59.2
Reporting Equipment improvement Recommendations (EIRs),	1.5
Reporting of Errors,	1.4
Resistor-Diode Assembly	
Inspection,	2.65.1
Installation,	2.65.5
Removal,	2.65.3
Repair,	2.65.4
Testing,	2.65.2
Reverse Power Relay	
Inspection,	2.57.1
Installation,	2.57.4
Removal,	2.57.3
Testing,	2.57.2
Rotating Rectifier (400 Hz)	
Description,	4.15.4
Installation,	4.27.2
Removal,	4.27.1
Rotating Ractifier (50/60 Hz)	
Description,	4.15.4
Installation,	4.19.2
Removal,	4.19.1

INDEX - Continued

R - Continued

	Paragraph Figure, Table Number
Rotating Rectifier Diodes (400 Hz)	
Installation,	4.25.3
Removal,	4.25.1
Testing,	4.25.2
Rotating Rectifier Diodes (50/60 Hz)	
Installation,	4.17.3
Removal,	4.17.2
Testing,	4.17.1

S

Short Circuit/Overload Relay	
Inspection,	2.55.1
Installation,	2.55.4
Removal,	2.55.3
Testing,	2.55.2
Shunt	
Inspection,	2.53.1
Installation,	2.53.4
Removal,	2.53.3
Testing,	2.53.2
Skid Base	
Description,	1.13.4
Installation,	4.33.3
Location,	1.13.4
Removal,	4.33.1
Repair,	4.33.2
Starter	
Description,	1.13.15
Location,	1.13.15
Storage,	2.116
SYNCHRONIZING LIGHTS	
Inspection,	2.22.1
Installation,	2.22.3
Removal,	2.22.2

INDEX - Continued

T

	Paragraph Figure, Table Number
Tabulated Data,	T 1-1
Time Meter (TOTAL HOURS)	
Inspection,	2.26.1
Installation,	2.26.4
Removal,	2.26.3
Testing,	2.26.2
Tools and Equipment	
Direct and General Support,	3.2
Unit,	2.4.1
Top Housing Section	
Inspection,	2.16.2
Installation,	2.16.4
Removal,	2.16.1
Repair,	2.16.3
Troubleshooting	
Direct Support,	3.4
Unit,	2.6
Type of Manual,	1.1

U

Upper Coolant Hose	
Cleaning,	2.78.2
Inspection,	2.78.2
Installation,	2.78.3
Removal,	2.78.1

V

Varisors	
Inspection,	2.103.2
Installation,	2.103.3
Removal,	2.103.1
Testing,	2.103.2
VOLTAGE Adjust Potentiometer	
Inspection,	2.33.1
Installation,	2.33.4
Removal,	2.33.2
Testing,	2.33.3

INDEX - Continued

V - Continued

	Paragraph Figure, Table Number
Voltage Reconnection Terminal Board	
Inspection,	2.94.1
Installation, Direct Support,	4.8.2
Installation,	2.94.2
Removal,	2.94.2
Removal, Direct Support,	4.8.1
Voltage Sensing Relay	
Inspection,	2.58.1
Installation,	2.58.4
Removal,	2.58.3
Testing,	2.58.2

W

Water Pump	
Description,	1.13.21
Location,	1.13.21

By Order of the Secretary of the Army:

Official:

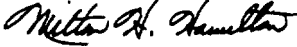
MILTON H. HAMILTON
*Administrative Assistant to the
Secretary of the Army*
05284

GORDON R. SULLIVAN
*General, United States Army
Chief of Staff*

By Order of the Secretary of the Air Force:

Official:

RONALD W. YATES
*General, United States Air Force
Commander, Air Force Materiel Command*

MERRILL A. McPEAK
*General, United States Air Force
Chief of Staff*

DISTRIBUTION:

To be distributed in accordance with DA Form 12-25-E, block no. 5266, requirements for TM 9-6115-643-24.

RECOMMENDED CHANGES TO EQUIPMENT TECHNICAL PUBLICATIONS



THEN... JOT DOWN THE DOPE ABOUT IT ON THIS FORM. CAREFULLY TEAR IT OUT. FOLD IT AND DROP IT IN THE MAIL!

SOMETHING WRONG WITH THIS PUBLICATION?

FROM (PRINT YOUR UNIT'S COMPLETE ADDRESS)

CDR, 1st Br, 65th ADA
ATTN: SP4 J. Brown
Key West, FL 33040

DATE SENT

10 Jun 79

PUBLICATION NUMBER

TM 9-1430-550-34-1

PUBLICATION DATE

7 Sep 72 .

PUBLICATION TITLE

Unit of Radar Set
AN/MPQ-50 Tested at the HFC

BE EXACT PIN-POINT WHERE IT IS

PAGE NO	PARA-GRAPH	FIGURE NO	TABLE NO
---------	------------	-----------	----------

9-19

9-5

21-2

step
1C

21-2

IN THIS SPACE TELL WHAT IS WRONG AND WHAT SHOULD BE DONE ABOUT IT:

"B" Ready Relay K11 is shown with two #9 contacts. That contact which is wired to pin 8 of relay K16 should be changed to contact #10.

Reads: Multimeter B indicates 600 K ohms to 9000 K ohms.

Change to read: Multimeter B indicates 600 K ohms minimum.

Reason: Circuit being checked could measure infinity. Multimeter can read above 9000 K ohms and still be correct.

SAMPLE

PRINTED NAME GRADE OR TITLE AND TELEPHONE NUMBER

SP4 J.T. Brown, Jr.

SIGN HERE

SP4 James Brown, Jr.

DA FORM 2028-2
2 JUL 79

REPLACES DA FORM 2028-2, 1 APR 78 WHICH WILL BE USED UNTIL EXHAUSTED
AMMAM M Overprint 3, 1 Mar 91

P.S.--IF YOUR OUTFIT WANTS TO KNOW ABOUT YOUR RECOMMENDATION MAKE A CARBON COPY OF THIS AND GIVE IT TO YOUR HEADQUARTERS

TEAR ALONG PRIORITIZED LINE

1 Nov 80

FILL IN YOUR
UNITS ADDRESS



FOLD BACK

DEPARTMENT OF THE ARMY

OFFICIAL BUSINESS

COMMANDER
U.S. ARMY AVIATION AND TROOP COMMAND
ATTN: AMSAT-I-MP
4300 GOODFELLOW BOULEVARD
ST. LOUIS, MO 63120-1798

TEAR ALONG PERFORATED LINE

RECOMMENDED CHANGES TO EQUIPMENT TECHNICAL PUBLICATIONS



SOMETHING WRONG WITH THIS PUBLICATION?

THEN JOT DOWN THE DOPE ABOUT IT ON THIS FORM. CAREFULLY TEAR IT OUT, FOLD IT AND DROP IT IN THE MAIL.

FROM (PRINT YOUR UNIT'S COMPLETE ADDRESS)

DATE SENT

PUBLICATION NUMBER

TM 9-6115-643-24

PUBLICATION DATE

1 SEP 93

PUBLICATION TITLE

GENERATOR SET, SKID MOUNTED, TACTICAL QUIET

BE EXACT PIN-POINT WHERE IT IS

PAGE NO	PARA GRAPH	FIGURE NO	TABLE NO

IN THIS SPACE TELL WHAT IS WRONG AND WHAT SHOULD BE DONE ABOUT IT:

TEAR ALONG PERFORATED LINE

PRINTED NAME GRADE OR TITLE AND TELEPHONE NUMBER

SIGN HERE

DA FORM 2028-2
1 JUL 79

PREVIOUS EDITIONS ARE OBSOLETE

P.S. IF YOUR OUTFIT WANTS TO KNOW ABOUT YOUR RECOMMENDATION MAKE A CARBON COPY OF THIS AND GIVE IT TO YOUR HEADQUARTERS

FILL IN YOUR
UNITS ADDRESS



FOLD BACK

DEPARTMENT OF THE ARMY

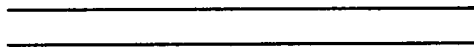

OFFICIAL BUSINESS

COMMANDER
U.S. ARMY AVIATION AND TROOP COMMAND
ATTN: AMSAT-I-MP
4300 GOODFELLOW BOULEVARD
ST. LOUIS, MO 63120-1798

TEAR ALONG PERFORATED LINE

FILL IN YOUR
UNITS ADDRESS



FOLD BACK

DEPARTMENT OF THE ARMY

OFFICIAL BUSINESS

COMMANDER
U.S. ARMY AVIATION AND TROOP COMMAND
ATTN: AMSAT-I-MP
4300 GOODFELLOW BOULEVARD
ST. LOUIS, MO 63120-1798

TEAR ALONG PERFORATED LINE

1 Nov 80

FILL IN YOUR
UNITS ADDRESS



FOLD BACK

DEPARTMENT OF THE ARMY

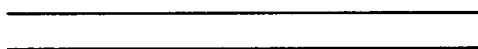

OFFICIAL BUSINESS

COMMANDER
U.S. ARMY AVIATION AND TROOP COMMAND
ATTN: AMSAT-I-MP
4300 GOODFELLOW BOULEVARD
ST. LOUIS, MO 63120-1798

TEAR ALONG PERFORATED LINE

These are the instructions for sending an electronic 2028

The following format must be used if submitting an electronic 2028. The subject line must be exactly the same and all fields must be included; however only the following fields are mandatory: 1, 3, 4, 5, 6, 7, 8, 9, 10, 13, 15, 16, 17, and 27.

From: "Whomever" <whomever@avma27.army.mil>

To: mpmt%avma28@st-louis-emh7.army.mil

Subject: DA Form 2028

1. **From:** Joe Smith
2. **Unit:** home
3. **Address:** 4300 Park
4. **City:** Hometown
5. **St:** MO
6. **Zip:** 77777
7. **Date Sent:** 19-OCT-93
8. **Pub no:** 55-2840-229-23
9. **Pub Title:** TM
10. **Publication Date:** 04-JUL-85
11. **Change Number:** 7
12. **Submitter Rank:** MSG
13. **Submitter FName:** Joe
14. **Submitter MName:** T
15. **Submitter LName:** Smith
16. **Submitter Phone:** 123-123-1234
17. **Problem:** 1
18. **Page:** 2
19. **Paragraph:** 3
20. **Line:** 4
21. **NSN:** 5
22. **Reference:** 6
23. **Figure:** 7
24. **Table:** 8
25. **Item:** 9
26. **Total:** 123
27. **Text:**
This is the text for the problem below line 27.

The Metric System and Equivalents

Linear Measure

1 centimeter = 10 millimeters = .39 inch
 1 decimeter = 10 centimeters = 3.94 inches
 1 meter = 10 decimeters = 39.37 inches
 1 dekameter = 10 meters = 32.8 feet
 1 hectometer = 10 dekameters = 328.08 feet
 1 kilometer = 10 hectometers = 3,280.8 feet

Weights

1 centigram = 10 milligrams = .15 grain
 1 decigram = 10 centigrams = 1.54 grains
 1 gram = 10 decigrams = .035 ounce
 1 dekagram = 10 grams = .35 ounce
 1 hectogram = 10 dekagrams = 3.52 ounces
 1 kilogram = 10 hectograms = 2.2 pounds
 1 quintal = 100 kilograms = 220.46 pounds
 1 metric ton = 10 quintals = 1.1 short tons

Liquid Measure

1 centiliter = 10 milliliters = .34 fl. ounce
 1 deciliter = 10 centiliters = 3.38 fl. ounces
 1 liter = 10 deciliters = 33.81 fl. ounces
 1 dekaliter = 10 liters = 2.64 gallons
 1 hectoliter = 10 dekaliters = 26.42 gallons
 1 kiloliter = 10 hectoliters = 264.18 gallons

Square Measure

1 sq. centimeter = 100 sq. millimeters = .155 sq. inch
 1 sq. decimeter = 100 sq. centimeters = 15.5 sq. inches
 1 sq. meter (centare) = 100 sq. decimeters = 10.76 sq. feet
 1 sq. dekameter (are) = 100 sq. meters = 1,076.4 sq. feet
 1 sq. hectometer (hectare) = 100 sq. dekameters = 2.47 acres
 1 sq. kilometer = 100 sq. hectometers = .386 sq. mile -

Cubic Measure

1 cu. centimeter = 1000 cu. millimeters = .06 cu. inch
 1 cu. decimeter = 1000 cu. centimeters = 61.02 cu. inches
 1 cu. meter = 1000 cu. decimeters = 35.31 cu. feet

Approximate Conversion Factors

To change	To	Multiply by	To change	To	Multiply by
inches	centimeters	2.540	ounce-inches	newton-meters	.007062
feet	meters	.305	centimeters	inches	.394
yards	meters	.914	meters	feet	3.280
miles	kilometers	1.609	meters	yards	1.094
square inches	square centimeters	6.451	kilometers	miles	.621
square feet	square meters	.093	square centimeters	square inches	.155
square yards	square meters	.836	square meters	square feet	10.764
square miles	square kilometers	2.590	square meters	square yards	1.196
acres	square hectometers	.405	square kilometers	square miles	.386
cubic feet	cubic meters	.028	square hectometers	acres	2.471
cubic yards	cubic meters	.765	cubic meters	cubic feet	35.315
fluid ounces	milliliters	29.573	cubic meters	cubic yards	1.308
pints	liters	.473	milliliters	fluid ounces	.034
quarts	liters	.946	liters	pints	2.113
gallons	liters	3.785	liters	quarts	1.057
ounces	grams	28.349	liters	gallons	.264
pounds	kilograms	.454	grams	ounces	.035
short tons	metric tons	.907	kilograms	pounds	2.205
pound-feet	newton-meters	1.356	metric tons	short tons	1.102
pound-inches	newton-meters	.11296			

Temperature (Exact)

°F	Fahrenheit temperature	5/9 (after subtracting 32)	Celsius temperature	°C
----	------------------------	----------------------------	---------------------	----

