

# TM 11-5820-453-20

DEPARTMENT OF THE ARMY TECHNICAL MANUAL

## ORGANIZATIONAL MAINTENANCE MANUAL

### RADIO SETS AN/GRC-87 AND AN/VRC-34

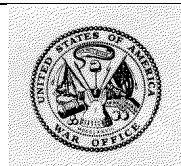

*HEADQUARTERS, DEPARTMENT OF THE ARMY  
10 APRIL 1963*

## **WARNING**

Be careful when working on the high-voltage circuits. Serious injury or death may result if safety precautions are not observed.

**DON'T TAKE CHANCES!**

**EXTREMELY DANGEROUS VOLTAGES EXIST IN  
THE FOLLOWING UNITS:**

RECEIVER-TRANSMITTER RT-77(*)/GRC-9 .....	425 to 580 volts
DYNAMOTOR-POWER SUPPLY DY-88/GRC-9 .....	580 volts
DYNAMOTOR-POWER SUPPLY DY-105(*)/GRC-9X.....	580 volts
GENERATOR, DIRECT CURRENT G-43/G .....	425 volts

CHANGE }  
NO. 1 }

HEADQUARTERS  
DEPARTMENT OF THE ARMY  
WASHINGTON, D.C., 22 September 1976

### Organizational Maintenance Manual Radio Sets AN/GRC- 87 AND AN/VRC-34

TM 11-5820-4 53-20, 10 April 1963 is changed as follows:

Page 2, paragraph 1a, line 3. Delete "The manual includes disassembly and repackaging instructions for shipment and limited storage of the equipment."

Subparagraph b. Delete subparagraph b and substitute:

b. The reporting of errors, omissions, and recommendations for improving this publication by the individual user is encouraged. Reports should be submitted on DA Form 2028 (Recommended Changed to Publications and Blank Forms) and forwarded direct to Commander, US Army Electronics Command, ATTN: DRSEL-MA-Q, Fort Monmouth, NJ 07703.

#### NOTE

For applicable forms and records, refer to TM 11-5820-453-10.

c. The Equipment Serviceability Criteria for

Radio Sets AN/GRC-87 and AN/VRC-34 is contained in TM 11-5820-453-ESC.

d. For procedures, forms and records, and inspections required during administrative storage of this equipment refer to TM 740-90-1.

e. For instructions on the destruction of equipment, refer to TM 750-244-2.

Paragraph 2. Delete paragraph 2 and substitute:

#### 2. Indexes of Publications

a. DA Pam 310-4. Refer to the latest issue of DA Pam 310-4 to determine whether there are new editions, changes, or additional publications pertaining to the equipment.

b. DA Pam 310-7. Refer to DA Pam 310-7 K1 determine whether there are modification work orders (MWOs) pertaining to the equipment.

Page 36, appendix I. Delete appendix I and substitute:

## APPENDIX I REFERENCES

---

DA Pam 310-4	Index of Technical Manuals, Technical Bulletins, Supply Manuals, Supply Bulletins, and Lubrication Orders.
DA Pam 310-7	U.S. Army Equipment Index of Modification Work Orders.
SB 11-131	Vehicular Radio Sets and Authorized Installations.
SB 38-100	Preservation, Packaging, Packing and Marking Materials, Supplies, and Equipment Used By the Army.
TM 11-5122	Direct Current Generator G-43/G.
TM 11-5820-453-10	Operators Manual, Radio Set AN/GRC-87, and AN/VRC-34.
TM 11-5820-453-20P	Organizational Maintenance Repair Parts and Special Tool Lists. Radio Sets AN/GRC-87 and AN/VRC-34
TM 11-5820-479-12P	Operator and Organizational Maintenance Repair Parts and special Tools List and Maintenance Allocation Chart: Mast Base MP-65. MP-65A, and MP-65B.
TM 11-5965-213-14P	Maintenance Repair Parts and special Tools List and Maintenance Allocation Chart for Permanent Magnet Loudspeaker LS-203/U (including LS-7 and LS-7A).
TM 11-5965-267-15P	Operator, Organizational, Field and Depot Maintenance Repair Parts and Special Tools List and Maintenance Allocation Chart: Headset. Electrical I H-16/U.
TM 11-6625-203-12	Operation and Organizational Maintenance Multimeter AN/URM-105, including Multimeter ME-77/U.

TM 11-6625-274-12	Operators and Organizational Maintenance Manual. Test Sets, Electron Tube TV-7/U, TV-7A/U, TV-7B/U, and TV-7D/U.
TM 38-750	The Army Maintenance Management System (TAMMS).
TM 740-90-1	Administrative Storage of Equipment.
TM 750-244-2	Procedures for Destruction of Electronic Material to Prevent Enemy Use (Electronics Command).

Page 37, appendix II. Delete appendix II and substitute:

## APPENDIX II MAINTENANCE ALLOCATION

### Section 1. INTRODUCTION

#### 1. General

This appendix provides a summary of the maintenance operations for the AN/GRC-87 and AN/VRC-34. It authorizes categories of maintenance for specific maintenance functions on repairable items and components and the tools and equipment required to perform each function. This appendix may be used as an aid in planning maintenance operations.

#### 2. Maintenance Function

Maintenance functions will be limited to and defined as follows:

*a. Inspect.* To determine the serviceability of an item by comparing its physical, mechanical, and/or electrical characteristics with established standards through examination.

*b. Test.* To verify serviceability and to detect incipient failure by measuring the mechanical or electrical characteristics of an item and comparing those characteristics with prescribed standards.

*c. Service.* Operations required periodically to keep an item in proper operating condition, i.e., to clean, preserve, drain, paint, or to replenish fuel / lubricants / hydraulic fluids or compressed air supplies.

*d. Adjust.* Maintain within prescribed limits by bringing into proper or exact position, or by setting the operating characteristics to the specified parameters.

*e. Align.* To adjust specified variable elements of an item to about optimum or desired performance.

*f. Calibrate.* To determine and cause corrections to be made or to be adjusted on instruments or test measuring and diagnostic equipment used in precision measurement. Consists of the comparison of two instruments, one of which is a certified standard of known accuracy, to detect and adjust any discrepancy in the accuracy of the instrument being compared.

*g. Install.* The act of emplacing, seating, or fixing into position an item, part, module (component or assembly) in a manner to allow the proper functioning of the equipment/system.

*h. Replace.* The act of substituting a serviceable like-type part, subassembly, model (component or assembly) for an unserviceable counterpart.

*i. Repair.* The application of maintenance services (inspect, test, service, adjust, align, calibrate, replace) or other maintenance actions (welding, grinding, riveting, straightening, facing, remachining, or resurfacing) to restore serviceability to an item by correcting specific damage, fault, malfunction, or failure in a part, subassembly, module / component / assembly, end item or system.

*j. Overhaul.* That periodic maintenance effort (service /action) necessary to restore an item to a completely serviceable/operational condition as prescribed by maintenance standards (e.g., (DMWR) in appropriate technical publications. Overhaul is normally the highest degree of maintenance performed by the Army. Overhaul does not normally return an item to like-new condition.

*k. Rebuild.* Consists of those services/actions necessary for the restoration of unserviceable equipment to a like-new condition in accordance with original manufacturing standards. Rebuild is the highest degree of materiel maintenance applied to Army equipment. The rebuild operation includes the act of returning to zero those age measurements (hours, miles, etc.) considered in classifying Army equipment / components

#### 3. Column Entries

*a. Column 1, Group Number.* Column 1 lists group numbers, the purpose of which is to identify

equipment required to perform the maintenance functions

*d. National/NATO Stock Number.* This column lists the National/NATO stock number of the specific tool or test equipment.

*e. Tool Number:* This column lists the manufacturer's part number of the tool followed by the Federal Supply Code for manufacturers (5-digit) in parentheses.

**A2-5. Remarks (Sec IV).**

*a. Reference Code.* This code refers to the appropriate item in section II, column 6.

*b. Remarks.* This column provides the required explanatory information necessary to clarify items appearing in section II.

SECTION II MAINTENANCE ALLOCATION CHART  
FOR  
RADIO SETS AN/GRC-87 AND AN/VRC-34

(1) GROUP NUMBER	(2) COMPONENT ASSEMBLY	(3) MAINTENANCE FUNCTION	(4) MAINTENANCE CATEGORY					(5) TOOLS AND EQT.	(6) REMARKS
			C	O	F	H	D		
00	RADIO SETS AN/GRC-87 AND AN/VRC-34	Inspect Service Install Test Test  Test   Replace Repair Align  Overhaul Repair	0.1	0.1 0.2 0.2	0.5	0.8	3.0	15 5,12,13 3,7,9,10, 12,13 1,2,4,6, 7,8,10, 12,13,16, 17 1,2,4,6, 7,8,10,11 13,14,16, 17 15 13 3,7,9,10, 12,13 13,14	A B  A  D  P
0.1	ANTENNA ASSEMBLIES AT-101/GRC-9 AND AT-102/GRC-9 (AN/GRC-87 ONLY)	Inspect Service Install Replace Repair	01	02 1.0 1.0	0.5			15 15 13	E E F
02	DYNAMOTOR-POWER SUPPLIES DY-88/GRC-9, DY-105/GRC-9K, DY-105A/GRC-9X, AND DY-105B/GRC-9X	Inspect Service Install Test Test Test Replace Repair Align Align Repair Repair	0.1	0.1 0.2 0.1 0.2 0.2 0.8 0.5	0.5	1.0	1.0 1.0	15 5 7,13 6,7,17 15 13 13 6,13,17 13,14	A G D  G P
03	DIRECT CURRENT GENERATOR G-43/G (AN/GRC-87 ONLY)								H
04	RECEIVER-TRANSMITTER RT-77/GRC-9 AND RT-77A/GRC-9	Inspect Service Install Test Test  Repair Test   Replace Repair Repair Align  Overhaul	0.1	0.2 0.1 0.2	0.5	0.5	3.0	5,12,15 3,7,9,10 12,13 1,2,4,6, 8,10,12 13,16,17 1,2,4,6, 7,8,10,11 13,14,16 17 15 10,13 13,14 2,10,13 17 13,14	A B  C P D  I J K
05	HEADSET H-16/U						15.0	13,14	L
06	LOUDSPEAKER LS-203/U AND LS-7A								M
07	MICROPHONE M-52/U								

SECTION II MAINTENANCE ALLOCATION CHART  
FOR  
RADIO SETS AN/GRC-87 AND AN/ VRC-34

(1) GROUP NUMBER	(2) COMPONENT ASSEMBLY	(3) MAINTENANCE FUNCTION	(4) MAINTENANCE CATEGORY					(5) TOOLS AND EQUIPMENT
			C	O	F	H	D	
00	RADIO SETS AN/GRC-87 AND AN/VRC-34	Inspect	0.1					
		Service		0.1				
		Install		0.2				15
		Test <sup>1</sup>		0.2				5,12,15
		Test <sup>2</sup>				0.8		3,7,9,10,12,13
		Test <sup>3</sup>						2,4,6,7,8,10, 12,13,16
		Test <sup>4</sup>					3.0	2,4,6,7,8,10, 12,13,16
		Replace		0.2				15
		Repair			0.5			13
		Align			1.0		1.0	3,7,9,10,12,13
01	Antenna Assemblies AT-101/GRC-9, AT-102/GRC-9 (AN/GRC-87 only)	Inspect	0.1					
		Service		0.2				
		Install <sup>5</sup>		1.0				15
		Replace <sup>5</sup>		1.0				15
		Repair			0.5			13
		Inspect	0.1					
		Service		0.1				
		Install		0.2				15
		Test <sup>1</sup>		0.1				5
		Test			0.5			7
02	Dynamotor -Power Supplies DY-88/GRC-9, DY-105/GRC-9X, DY-105A/GRC-9X, DY-105B/GRC-9X	Test			0.5			6,7,16
		Replace		0.2		1.0		15
		Repair		0.8				13
		Align			0.5			13
		Align				1.0		6,13,16
		Inspect	0.1					
		Service		0.1				15
		Install		0.2				5
		Test <sup>1</sup>		0.1				7
		Test			0.5			6,7,16
0201	Dynamotors D201 and DY-134/GRC-9X	Replace <sup>7</sup>		0.5				7,13
		Repair <sup>8</sup>			0.5			15
		Align				1.0		13,14
		Inspect	0.1					
		Service		0.1				15
		Install		0.2				5
		Test <sup>1</sup>		0.1				7
		Test			0.5			6,7,16
		Replace		0.2		1.0		15
		Repair		0.8				13
03	Direct Current Generator G-43/G (AN/GRC-87 only) (Refer to TM 11-5122 for maintenance functions)	Align			0.5			13
		Align				1.0		6,13,16
		Inspect	0.1					
		Service		0.1				15
		Install		0.2				5
		Test <sup>1</sup>		0.1				7
		Test			0.5			6,7,16
		Replace		0.2		1.0		15
		Repair		0.8				13
		Align			0.5			13
04	Receiver-Transmitter RT-77/GRC-9, RT-77A/GRC-9	Align			0.5			13
		Align				1.0		6,13,16
		Inspect	0.1					
		Service		0.2				15
		Install		0.1				5
		Test <sup>1</sup>		0.2				7
		Test <sup>2</sup>			0.5			6,7,16
		Test <sup>3</sup>				0.5		15
		Test <sup>4</sup>					3.0	13,14
		Replace		0.2				13,16
05	Accessories <sup>9</sup>	Replace <sup>6</sup>		0.2				15
		Repair <sup>6</sup>			0.5			13
		Repair <sup>8</sup>				1.0		13,14
		Align <sup>6</sup>			0.5			10,13
		Align					1.0	2,10,13,16
		Inspect	0.1					
		Service		0.1				13
		Install	0.1					5
		Repair			0.5			13
		Replace	0.1					1
06	Cable Assembly	Test				0.2		1
		Replace	0.1					5
		Repair		0.1		1.0		13

- (1) Operational Check
- (2) Frequency, tube checks, continuity
- (3) Frequency, tube checks, continuity plus voltages, output waveforms and audio frequency
- (4) All tests
- (5) Includes Mast Base MP-65-B, cord assemblies and bags

- (6) Plus minor repair/alignment
- (7) Result of operation checks
- (8) All repairs
- (9) Includes Headset H-16/U, Key J-45, Loudspeaker LS-203/U, LS-7A, Microphone M-52/U, and Mount MT-350/GRC-9

By Order of the Secretary of the Army:

FRED C. WEYAND  
*General, United States Army*  
*Chief of Staff*

Official:

PAUL T. SMITH  
*Major General, United States Army*  
*The Adjutant General*

Distribution:

To be distributed in accordance with DA Form 12-51 organizational TM literature requirements for AN/GRC-87 and AN/VRC-34 Radio Sets.

\* U.S. GOVERNMENT PRINTING OFFICE: 1976-665668-848



## SECTION IV REMARKS

REFERENCE CODE	REMARKS
A	OPERATIONAL CHECKS AND TUBE CHECKS.
B	FREQUENCY, TUBE CHECKS, CONTINUITY.
C	(2) PLUS VOLTAGES, OUTPUT WAVEFORMS AND AUDIO FREQUENCY.
D	ALL TESTING.
E	INCLUDES MAST BASE, MP-65B, CORD ASSEMBLIES AND BAGS.
F	MP-65B REPAIRED IAW TM 11-5020-479-12P.
G	D201 AND DY-134/GRC-9X.
H	SEE TM 11-5122.
I	MINOR REPAIR AND ALIGNMENT.
J	ALL REPAIRS.
K	COMPLETE ALIGNMENT.
L	SEE TM 11-5965-267-15P
M	SEE TM 11-5965-213-14P
N	LIMITED TO MECHANICAL REPAIRS.
O	SEE TM 11-6625-682-15
P	BY REPLACEMENT FUSES, LAMPS, KNOBS, LENS CAPS AND CABLE ASSEMBLY.

By Order of the Secretary of the Army:

Official:

BERNARD W. ROGERS  
*General, United States Army*  
*Chief of Staff*

J. C. PENNINGTON  
*Brigadier General, United States Army*  
*The Adjutant General*

Distribution:

To be distributed in accordance with DA Form 12-51, Organizational TM literature requirements for AN/GRC-87 and AN/VRC-34 radio sets.

\* U.S. GOVERNMENT PRINTING OFFICE: 1978-765-096/653

CHANGE }  
NO. 2 }

HEADQUARTERS,  
DEPARTMENT OF THE ARMY  
WASHINGTON, D C., 31 March 1978

## ORGANIZATIONAL MAINTENANCE MANUAL

# RADIO SET AN/GRC-87 (NSN 5820-00-889-4277) 12 VOLT (NSN 5820-00-223-7547) 24 VOLT; AND RADIO SET AN/VRC-34 (NSN 5820-00-889-4276) 12 VOLT (NSN 5820-00-223-7414) 24 VOLT

This change is current as of September 1977

TM 11-5820-453-20, 10 April 1963, is changed as follows:  
The title of the manual is changed as shown above.  
Page 37. Appendix II is superseded as follows:

## APPENDIX II MAINTENANCE ALLOCATION

### Section 1. INTRODUCTION

#### A2-1. General

This appendix provides a summary of the maintenance operations for Radio Set AN/ GRC-87 and Radio Set AN/VRC-34. It authorizes categories of maintenance for specific maintenance functions on repairable items and components and the tools and equipment required to perform each function. This appendix may be used as an aid in planning maintenance operations.

#### A2-2. Maintenance Function

Maintenance functions will be limited to and defined as follows:

*a. Inspect.* To determine the serviceability of an item by comparing its physical, mechanical, and/or electrical characteristics with established standards through examination.

*b. Test.* To verify serviceability and to detect incipient failure by measuring the mechanical or electrical characteristics of an item and comparing those characteristics with prescribed standards.

*c. Service.* Operations required periodically to keep an item in proper operating condition, i.e., to clean (decontaminate), to preserve, to drain, to paint, or to replenish fuel, lubricants, hydraulic fluids, or compressed air supplies.

*d. Adjust.* To maintain, within prescribed limits, by bringing into proper or exact position, or by setting the operating characteristics to the specified parameters.

*e. Align.* To adjust specified variable elements of an item to bring about optimum or desired performance.

*f. Calibrate.* To determine and cause corrections to be made or to be adjusted on instruments or test measuring and diagnostic equipments used in precision measurement. Consists of comparisons of two instruments, one of which is a certified standard of known accuracy, to detect and adjust any discrepancy in the accuracy of the instrument being compared.

*g. Install.* The act of emplacing, seating, or fixing into position an item, part module

(component or assembly) in a manner to allow the proper functioning of the equipment or system.

*h. Replace.* The act of substituting a serviceable like type part, subassembly, or module (component or assembly) for an unserviceable counterpart.

*i. Repair.* The application of maintenance services (inspect, test, service, adjust, align, calibrate, replace) or other maintenance actions (welding, grinding, riveting, straightening, facing, remachining, or resurfacing) to restore serviceability to an item by correcting specific damage, fault, malfunction, or failure in a part, subassembly, module (component or assembly), end item, or system.

*j. Overhaul.* That maintenance effort (service/action) necessary to restore an item to a completely serviceable / operational condition as prescribed by maintenance standards (i.e., DMWR) in appropriate technical publications. Overhaul is normally the highest degree of maintenance performed by the Army. Overhaul does not normally return an item to like new condition.

*k. Rebuild.* Consists of those services/actions necessary for the restoration of unserviceable equipment to a like new condition in accordance with original manufacturing standards. Rebuild is the highest degree of materiel maintenance applied to Army equipment. The rebuild operation includes the act of returning to zero those age measurements (hours, miles, etc.) considered in classifying Army equipments/ components.

### **A2-3. Column Entries**

*a. Column 1, Group Number.* Column 1 lists group numbers, the purpose of which is to identify components, assemblies, subassemblies, and modules with the next higher assembly.

*b. Column 2, Component / Assembly.* Column 2 contains the noun names of components, assemblies, subassemblies, and modules for which maintenance is authorized.

*c. Column 3, Maintenance Functions.* Column 3 lists the functions to be performed on the item listed in column 2. When items are listed without maintenance functions, it is solely for purpose of having the group numbers in the MAC and RPSTL coincide.

*d. Column 4, Maintenance Category.* Column 4 specifies, by the listing of a "work time" figure in the appropriate subcolumn(s), the lowest level of maintenance authorized to perform the function listed in column 3. This figure represents the active time required to perform that maintenance function at the indicated category of maintenance. If the number or complexity of the tasks within the listed maintenance function vary at different maintenance categories, appropriate "work time" figures will be shown for each category. The number of task-hours specified by the "work time" figure represents the average time required to restore an item (assembly, subassembly, component, module, end item or system) to a serviceable condition under typical field operating conditions. This time includes preparation time, troubleshooting time, and quality assurance/quality control time in addition to the time required to perform the specific tasks identified for the maintenance functions authorized in the maintenance allocation chart. Subcolumns of column 4 are as follows:

- C-Operator/Crew
- O-Organizational
- F-Direct Support
- H-General Support
- D-Depot

*e. Column 5, Tools and Equipment.* Column 5 specifies by code, those common tool sets (not individual tools) and special tools, test, and support equipment required to perform the designated function.

*f. Column 6, Remarks.* Column 6 contains an alphabetic code which leads to the remark in section IV, Remarks, which is pertinent to the item opposite the particular code.

### **A2-4. Tool and Test Equipment Requirements (Sec III).**

*a. Tool or Test Equipment Reference Code.* The numbers in this column coincide with the numbers used in the tools and equipment column of the MAC. The numbers indicate the applicable tool or test equipment for the maintenance functions.

*b. Maintenance Category.* The codes in this column indicate the maintenance category allocated the tool or test equipment.

*c. Nomenclature.* This column lists the noun name and nomenclature of the tools and test

components, assemblies, subassemblies and modules with the next higher assembly.

*b. Column 2, Component/Assembly.* Column 2 contains the noun names of components, assemblies, subassemblies, and modules for which maintenance is authorized.

*c. Column 3, Maintenance Functions.* Column 3 lists the functions to be performed on the item listed in column 2. When items are listed without maintenance functions, it is solely for the purpose of having the group numbers in the MAC and RPSTL coincide.

*d. Column 4, Maintenance Category.* Column 4 specifies, by the listing of a "worktime" figure in the appropriate subcolumn(s), the lowest level of maintenance authorized to perform the function listed in column 3. This figure represents the active time required to perform maintenance function at the indicated category of maintenance. If the number or complexity of the tasks within the listed maintenance function vary at different maintenance categories, appropriate "worktime" figures will be shown for each category. The number of man-hours specified by the "worktime" figure represents the average time required to restore an item (assembly, subassembly, component, module, end item or system) to a serviceable condition under typical field operating conditions. This time includes preparation time, troubleshooting time and quality assurance/quality control time, in addition to the time required to perform the specific tasks identified for the maintenance functions authorized in the maintenance allocation chart. Subcolumns of column 4 are as follows:

- C - Operator/Crew
- O - Organizational
- F - Direct Support
- H - General Support
- D - Depot

*e. Column 5, Tools and Equipment.* Column 5 specifies by code, those common tool sets (not individual tools) and special tools, test, and support equipment required to perform the designated function.

#### **4. Tool and Test Equipment Requirements (Table 1)**

*a. Tool or Test Equipment Reference Code.* The numbers in this column coincide with the numbers used in the tools and equipment column of the MAC. The numbers indicate the applicable tool or test equipment for the maintenance functions.

*b. Maintenance Category.* The codes in this column indicate the maintenance category allocated the tool or test equipment.

*c. Nomenclature.* This column lists the noun name and nomenclature of the tools and test equipment required to perform the maintenance functions.

*d. National/NATO Stock Number.* This column lists the National/NATO stock number of the specific tool or test equipment.

*e. Tool Number.* This column lists the manufacturer's part number of the tool followed by the Federal Supply Code for manufacturers (5-digit) in parentheses.

**TABLE 1. TOOL AND TEST EQUIPMENT REQUIREMENTS  
FOR  
RADIO SETS AN/GRC-87 AND AN/VRC-34**

TOOL OR TEST EQUIPMENT REF CODE	MAINTENANCE CATEGORY	NOMENCLATURE	NATIONAL/NATO STOCK NUMBER	TOOL NUMBER
1	H,D	SIGNAL GENERATOR SG-71(*)/FCC	6625-00-669-0255	
2	H,D	SIGNAL GENERATOR AN/URM-127	6625-00-783-5965	
3	F	FREQUENCY METER AN/USM-159	6625-00-892-5360	
4	H,D	FREQUENCY METER AN/URM-79		
5	O	MULTIMETR AN/URM-105C	6625-00-999-6282	
6	H	MULTIMETER ME-26D/U	6625-00-913-9781	
7	F,H,D	MULTIMETR TS-352B/U (OR AN/USM-223)	6625-00-553-0142	
8	H,D	OSCILLOSCOPE AN/USM-281A	6625-00-228-2201	
9	H,D F,H,D	POWER SUPPLY PP-1104C/G		
10		SIGNAL GENERATOR AN/URM-25J	6625-00-775-1874	
11	D	TEST SET, ELECTRON TUBE TV-2/U	6625-00-669-0263	
12	O,F,H	TEST SET, ELECTRON TUBE TV-7D/U	6625-00-820-0064	
13	F,H,D	TOOL KIT, ELECTRONIC EQUIPMENT TK-105/G	5180-00-610-8177	
14	H,D	TOOL KIT, ELECTRONIC EQUIPMENT TK-100/G	5180-00-605-0079	
15	O	TOOL KIT, ELECTRONIC EQUIPMENT TK-101/G	5180-00-064-5178	
16	H,D	VOLTMETER ME-30A/U	6625-00-643-1670	

**SECTION II MAINTENANCE ALLOCATION CHART  
FOR  
RADIO SETS AN/GRC-87 AND AN/VRC-34-- CONTINUED**

(1) GROUP NUMBER	(2) COMPONENT ASSEMBLY	(3) MAINTENANCE FUNCTION	(4) MAINTENANCE CATEGORY					(5) TOOLS AND EQPT.	(6) REMARKS
			C	O	F	H	D		
08	MOUNT MT-350-GRC-9	Inspect Service Install Repair Replace	0.1 0.1 0.1	0.1	-5			13	N
09	CABLE ASSEMBLY CX-2031/U	Replace Test Repair	0.1	0.1	1.0			5 13	
10	METER, FIELD STRENGTH ME-61/GRC								0

**SECTION III TOOL AND TEST EQUIPMENT REQUIREMENTS  
FOR  
RADIO SETS AN/GRC-87 AND AN/VRC-34**

TOOL OR TEST EQUIPMENT REF CODE	MAINTENANCE CATEGORY	NOMENCLATURE	NATIONAL/NATO STOCK NUMBER	TOOL NUMBER
1	H,D	SPECTRUM ANALYZER TS-723/U	6625-00-668-9418	
2	H,D	SIGNAL GENERATOR AN/URM-127	6625-00-783-5965	
3	F	FREQUENCY METER AN/USM-159	6625-00-892-5360	
4	H,D	FREQUENCY METER AN/URM-79	6625-00-999-6282	
5	O	MULTIMETER AN/URM-105C	6625-00-999-6282	
6	H,D	MULTIMETER ME-26D/U	6625-00-913-9781	
7	F,H,D	MULTIMETR TS-352B/U ( OR AN/USM-223)	6625-00-553-0142	
8	H,D	OSCILLOSCOPE AN/USM-281A	6625-00-228-2201	
9	F	POWER SUPPLY PP-1243/U	6625-00-542-6217	
10	F,H,D	SIGNAL GENERATOR AN/URM-25J	6625-00-775-1874	
11	D	TEST SET, ELECTRON TUBE TV-2/U	6625-00-669-0263	
12	O,F,H	TEST SET, ELECTRON TUBE TV-7D/U	6625-00-820-0064	
13	F,H,D	TOOL KIT ELECTRONIC EQUIPMENT TK-100/G	5180-00-605-0079	
14	H,D	TOOL KIT, RADAR-RADIO TK-88/U	5120-00-893-1389	
15	O	TOOL KIT, ELECTRONIC EQUIPMENT TK-101/G	5180-00-064-5178	
16	H,D	WATTMETER AN/URM-120	6625-00-813-8430	
17	H,D	MULTIMETER ME-30A/U	6625-00-643-1670	



## RADIO SETS AN/GRC-87 AND AN/VRC-34

			Paragraph	Page
CHAPTER	1.	INSTALLATION		
Section	I.	Service upon receipt of equipment		
		Scope.....	1	2
		Index of publications .....	3	2
		Unpacking .....	4	4
		Component dimensions .....	5	5
		Checking unpacked equipment .....	5	5
	II.	Antenna installation		
		Siting .....	6	5
		Antenna installation instructions .....	7	5
	III.	Ground (man-transportable) and vehicular installation		
		Ground installation of radio and power components .....	8	11
		Vehicular installation of radio and power components .....	9	12
		Connections .....	10	15
CHAPTER	2.	MAINTENANCE INSTRUCTIONS		
Section	I.	General		
		Scope of maintenance instructions .....	11	20
		Internal differences in models .....	12	20
		Tools, materials, and test equipment required .....	13	20
		Preventive maintenance .....	14	20
		Monthly maintenance .....	15	21
		Monthly maintenance service and inspection chart .....	16	21
		Quarterly maintenance .....	17	21
		Quarterly maintenance service and inspection chart .....	18	21
		Lubrication .....	19	26
	II.	Troubleshooting		
		General .....	20	27
		Troubleshooting chart .....	21	27
		Tube testing techniques .....	22	28
		Replacement procedures .....	23	29
CHAPTER	3.	SHIPMENT AND LIMITED STORAGE		
		Disassembly.....	24	34
		Repackaging .....	25	34
APPENDIX	I.	REFERENCES .....		36
	II.	MAINTENANCE ALLOCATION.....		37

---

\*This manual supersedes so much of TM 11-263, 20 June 1956; C1, 15 October 1957; C2, 29 April 1960; C3, 15 November 1960; C4, 21 December 1961; C5, 23 November 1962; and C6, 8 April 1963 as pertains to organizational maintenance and maintenance allocation chart.

# CHAPTER 1 INSTALLATION

## Section I. SERVICE UPON RECEIPT OF EQUIPMENT

### 1. Scope

a. This manual covers installation and second echelon maintenance of Radio Sets AN/GRC-87 and AN/VRC-34. The manual includes disassembly and repackaging instructions for shipment and limited storage of the equipment. The operating instructions are contained in TM11-5820-453-10. The maintenance allocation chart is contained in appendix II.

b. Forward all comments on this publication direct to: Commanding Officer, U. S. Army Electronics Materiel Support Agency, ATTN: SELMS-MP, Fort Monmouth, New Jersey. (DA Form 1598 (Record of Comments on Publications), DA Form 2496 (Disposition Form), or letter may be used.)

*Note:* For applicable forms and records, refer to paragraph 2, TM 11-5820-453-10.

### 2. Index of Publications

Refer to the latest issue of DA PAM 310-4 to determine whether there are new editions, changes or additional publications pertaining to your

equipment. Department of the Army Pamphlet No. 310-4 is a current index of Technical Manuals, Technical Bulletins, Supply Bulletins, Lubrication Orders, and Modification Work Orders that are available through publications supply channels. The index lists the individual parts (-10, -20, -35P, etc.) and the latest changes and revisions of each equipment publication.

### 3. Unpacking

a. *Packaging Data.* For overseas or domestic shipment, the components of the AN/GRC-87 are placed in eight water resistant fiberboard cartons and packed in one wooden box. The components of the AN/VRC-34 are placed in six water resistant fiberboard cartons and packed in one wooden box. Typical packaging for overseas and domestic shipment is shown in figure 1. The dimensions, volume, and contents of each carton and the dimensions volume, and weight of each wooden box are listed in the following charts:

(1) *Cartons.*

Carton No.		Dimensions (in.)			Volume (cu ft)	Contents
AN/GRC-87	AN/VRC-34	Length	Width	Depth		
1 of 8	1 of 6	10-1/8	13-3/4	8	1.3	Receiver-Transmitter RT-77(*)/ GRC-9
2 of 8	2 of 6	16	13-1/2	10-1/8	1.2	Dynamotor-Power Supply DY-105(*)/ GRC-9X or DY-88/GRC-9
3 of 8	3 of 6	43	7-5/8	5-1/2	1.2	Spars and accessories
4 of 8	4 of 6	13-1/4	2-1/2	16-3/4	0.3	Mounting MT-350/GRC-9
5 of 8	5 of 6	6-3/4	3-5/8	10	0.1	Bag CW-420/GRC-9
	6 of 6	8-1/4	7-5/8	43	1.6	Bag CW-419/GRC-9 and accessories
6 of 8	-----	9-3/4	7-5/8	43	1.8	Bag CW-419/GRC-9 and accessories
7 of 8	-----	19-3/4	13-1/2	2	0.4	Bag CW-140/GRC-9
8 of 8	-----	9-3/4	6-1/2	9-3/4	0.3	Generator, Direct Current G-43/G

(2) *Wooden boxes.*

Wooden box No.	Radio Set	Dimensions (in.)			Volume (cu ft)	Weight (lb)
		Length	Width	Depth		
1 of 1	AN/GRC-87	49-1/3	20-3/4	17-1/2	10.2	244
1 of 1	AN/VRC-34	49-3/4	19-7/8	15-3/8	8.7	202

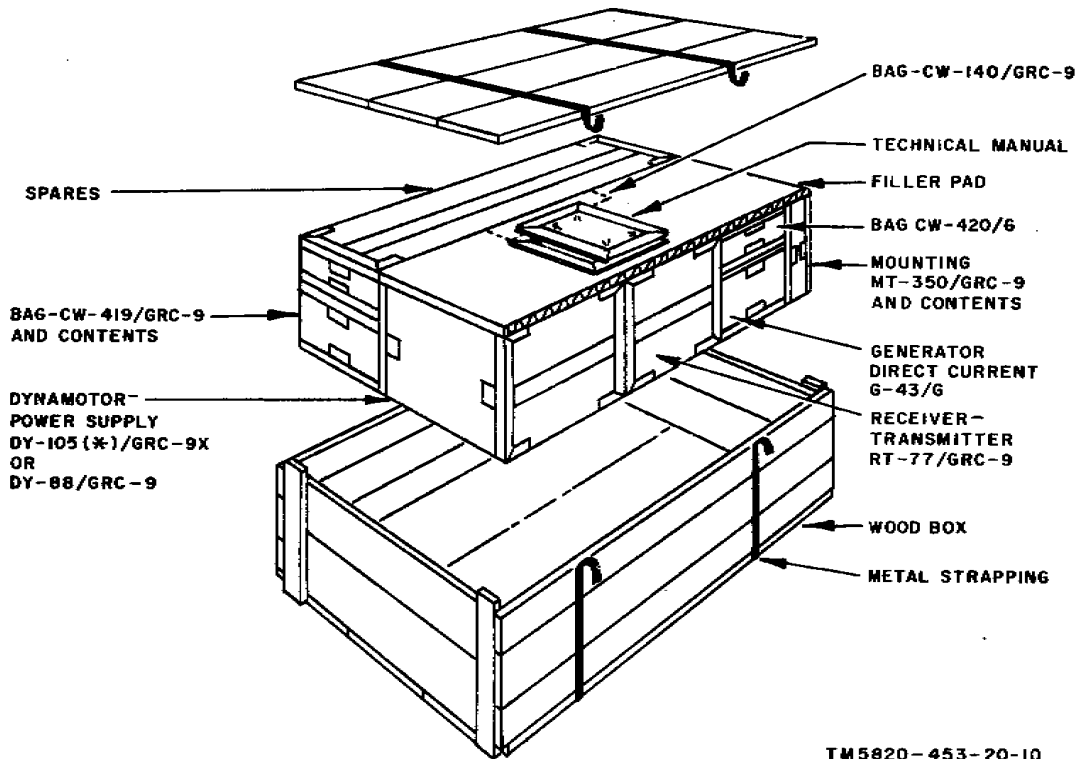

TM5820-453-20-10

Figure 1. Radio Set AN/GRC-87 or AN/VRC-34, typical packaging and packing diagram.

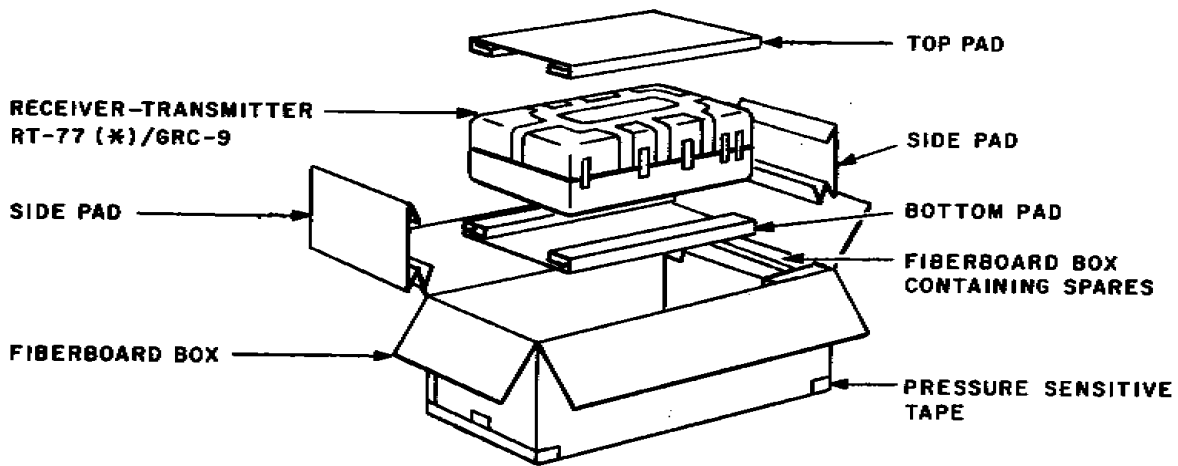

TM5820-453-20-11

Figure 2. RT-77(\*)/GRC-9, typical packaging and packing diagram.

*b. Removing Contents.* Unpack equipment from the wooden box and fiberboard cartons (fig. 1 through 4) as follows:

- (1) Cut and fold back the steel straps.
- (2) Remove the nails from the wooden cover and remove the wooden cover. Do not attempt to pry off the cover because this may damage the equipment.
- (3) Remove the technical manuals and filler pad.
- (4) Remove the fiberboard cartons (eight for the AN/GRC-87, six for the AN/VRC-34).
- (5) Open each fiberboard carton and remove its contents (fig. 2 through 4). Refer to *a* above for contents of fiberboard cartons.

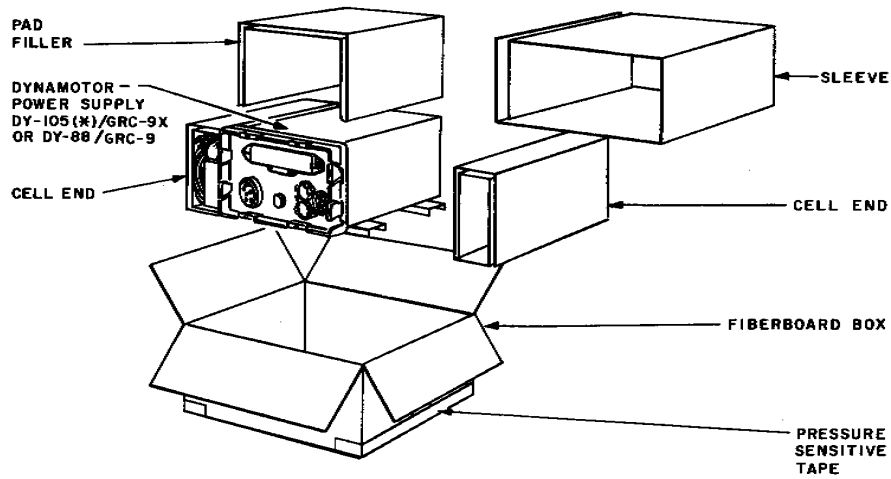

TM5820-453-20-13

Figure 3. Dynamotor-Power Supply DY-105(\*)/GRC-9X, typical packing and packaging diagram

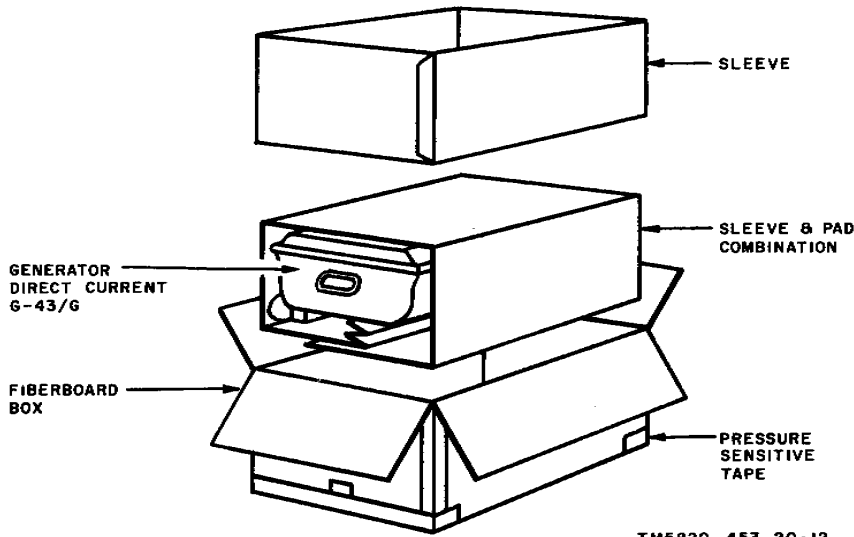

TM5820-453-20-12

Figure 4. Generator, Direct Current G-43/G, typical packing and packaging diagram.

#### 4. Component Dimensions

Component	Overall dimensions (in.)			Volume (cu ft)	Weight (lb)
	Length	Width	Depth		
Receiver-Transmitter RT-77(*)/GRC-9 ----	16	13	8	1.09	32
Dynamotor-Power Supply DY-105(*)//GRC-9X	13-1/8	14-1/2	10	1.6	38
Dynamotor-Power Supply DY-88/GRC-9-----	13	11-1/4	9-1/2	0.8	35
Generator, Direct Current G-43/G-----	9-1/4	5-7/8	9-5/16	0.28	16

Component	Overall dimensions (in.)			Volume (cu ft)	Weight (lb)
	Length	Width	Depth		
Meter, Field Strength ME-61/GRC -----	5-1/4	5-3/4	4-1/4	0.066	3
Mounting MT-350/gRC-9-----	16-5/8	13-9/16	1-5/8	0.5	4
Mast Base MP-65-B -----	17-1/2	3-1/4	3-1/4	0.25	3
Mast Section MS-116-A (0.393 in. Dia)-----	39-1/2				
Mast Section MS-117-A (0.373 in. Dia)-----	39-1/2				
Mast Section MS-118-A (0.246 in. Dia)-----	39-1/2				
Cord CD-307-B -----	65				
Cord CD-1086 -----	84				
Cord CD-1119 -----	36				
Insulator IN-127 -----	12-21/32				

## 5. Checking Unpacked Equipment;

*Cautions:* Because of defects (listed below) in some Cords CD-1086, procured on Order No. 3143-Phila-51, all Cords CD-1086 should be checked to prevent equipment damage. No markings identifying the manufacturer or the order number are on the cords. If any of the defects listed below are found, replace the cord.

1. Cable shield connected to pin 57 of Plug PL-279 (female) instead of to pin 53. Use Multimeter AN/URM-105, arranged as an ohmmeter, and perform a continuity check between the pins and the cable shield.

2. Cable shield not properly dressed; the sharp edges of the cable shield cut into the cable conductors. Use visual inspection to check for defect.

3. Cable connector inserts cracked or

split. Use visual inspection to check for defect.

a. Inspect the equipment for possible damage incurred during shipment. If the equipment has been damaged, refer to paragraph 2, TM 11-5820-453-10, for applicable forms and records.

b. See that the equipment is complete as listed on the packing slip. If a packing slip is not available, check the equipment against the basic issue items list in appendix II, TM 11-5820-453-10.

c. If the equipment has been used or reconditioned, check to see if it has been changed by a modification work order (MWO). If modified, the MWO number will appear on the front panel near the nomenclature plate.

*Note:* Current MWO's applicable to the equipment are listed in DA PAM 310-4.

## Section II. ANTENNA INSTALLATION

### 6. Siting

An equipment site should be an open, level area (preferably an elevated area) away from obstructions such as trees, buildings, or cliffs. Figure 5 illustrates good and bad locations for transmission and reception. Observe the following considerations when selecting an equipment site:

a. Select flat cleared terrain.

b. Be sure that conditions are suitable for anchoring the antenna.

c. Select a site as far as possible from buildings, roads, and powerlines.

d. Be sure that the site is accessible for transporting equipment and supplies.

e. Be sure that sufficient area is available for antenna installation (pare 7).

### 7. Antenna Installation Instructions

a. *Long-Wire Antenna.*

(1) Connect Antenna AT-101/GRC-9 and AT-102/GRC-9 to each other. Attach Halyard M-379 to the loose end of AT-101/GRC-9 and Halyard M378 to the loose end of AT-102/GRC-9.

(2) Open or close the antenna jumpers on the AT-101/GRC-9 and AT102/CTRC-9 as determined by the

# Siting

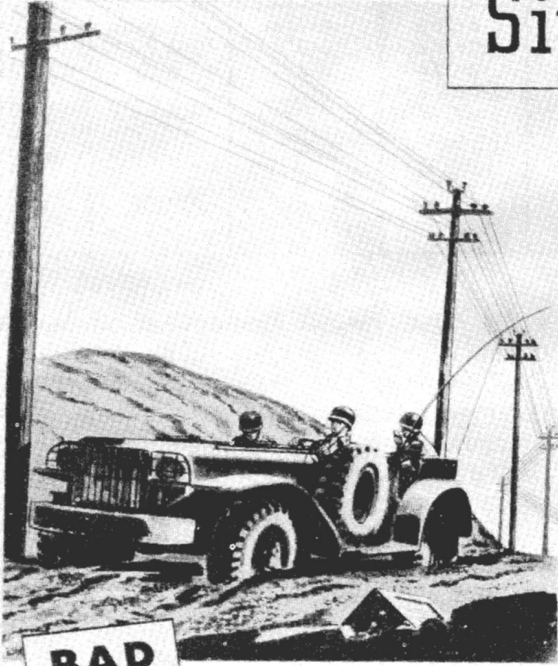

**BAD**

HIGH-TENSION LINES



**BAD**

STEEL BRIDGES



**BAD**

VALLEYS OR DEPRESSIONS



**GOOD**

HILLTOP OR FLAT TERRAIN

TM5820-453-20-158

Figure 5. Operational considerations

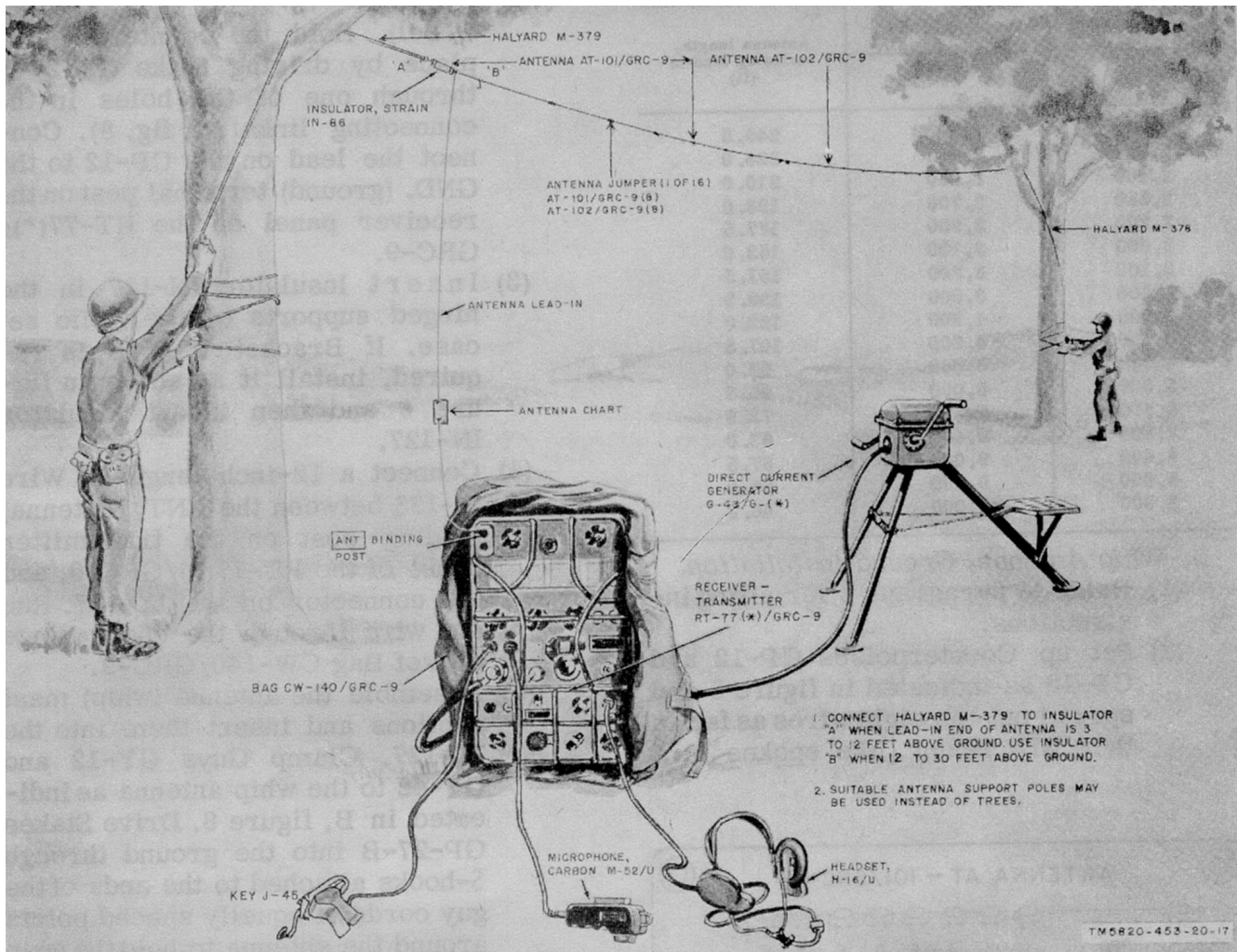

Figure 6. Typical antenna installation, long-wire.

- assigned operating frequency from the antenna chart on the at-101/GRC-9 (fig. 6 and 7).
- (3) Select for antenna supports any suitable tall objects such as posts, trees, or buildings. Allow a distance of approximately 250 feet between antenna supports to accommodate the full lengths of AT-101/ GRC-9 and AT-102/GRC-9.
  - (4) Erect the long-wire antenna as high as possible (not lower than 6 feet) by attaching Halyards M-378 and M-379 to the antenna supports as shown in figure 6 (typical example).
  - (5) Connect the antenna lead-in from the antenna chart on the at-101/GRC-9 to the ANT. binding post of the RT-77(\*)/GRC-9 as shown in figure 6. Do not allow the antenna lead -in to touch the ground or any objects such as trees, buildings, or fences.
  - (6) If Antenna AT-101/GRC-9 or AT102/GRC-9 are lost or destroyed, a replacement antenna can be made from material such as field Wire WD-1/TT. The chart below gives the correct antenna lengths (including lead-in) for the following transmitting frequencies:

Transmitting frequency (kc)		Antenna length, including lead-in (ft)
From	To	
2,000	2,200	245.5
2,200	2,400	228.0
2,400	2,550	210.0
2,550	2,700	193.0
2,700	2,900	177.5
2,900	3,100	163.0
3,100	3,200	151.5
3,200	3,900	139.9
3,900	4,300	122.0
4,300	4,900	107.5
4,900	5,300	93.0
5,300	6,000	85.5
6,000	7,500	73.5
7,500	8,400	63.0
8,400	9,000	57.5
9,000	9,900	53.0
9,900	12,000	46.0

*b. Whip Antenna, Ground Installation.*

- (1) Refer to paragraph 6 for siting instructions.
- (2) Set up Counterpoises CP-12 and CP-13 as indicated in figure 8 and spread out the eight wires as far as they will reach (like spokes in a

**ANTENNA AT - 101/GRC - 9**

FREQ.	1	2	3	4	5	6	7	8
12000-9900	0	0	0	0	0	0	0	0
9900-9000	X	0	0	0	0	0	0	0
9000-8400	X	X	0	0	0	0	0	0
8400-7500	X	X	X	0	0	0	0	0
7500-6000	X	X	X	X	0	0	0	0
6000-5300	X	X	X	X	X	0	0	0
5300-4900	X	X	X	X	X	X	0	0
4900-4300	X	X	X	X	X	X	X	0

X = CLOSED JUMPER  
O = OPEN JUMPER

**ANTENNA AT - 102/GRC - 9**

FREQ.	8	9	10	11	12	13	14	15	16
4300-3900	X	0	0	0	0	0	0	0	0
3900-3200	X	X	0	0	0	0	0	0	0
3200-3100	X	X	X	0	0	0	0	0	0
3100-2900	X	X	X	X	0	0	0	0	0
2900-2700	X	X	X	X	X	0	0	0	0
2700-2550	X	X	X	X	X	X	0	0	0
2550-2400	X	X	X	X	X	X	X	0	0
2400-2200	X	X	X	X	X	X	X	X	0
2200-2000	X	X	X	X	X	X	X	X	X

X = CLOSED JUMPER  
O = OPEN JUMPER

TM5820-453-20-41

Figure 7. Long-wire antenna chart.

wheel). Hold the counterpoise in place by driving Stake GP-27-B through one of the holes in the connecting links (C, fig. 8). Connect the lead on the CP-12 to the GND. (ground) terminal post on the receiver panel of the RT-77(\*)/GRC-9.

- (3) Insert insulator IN-127 in the hinged supports on the radio set case. If Bracket FT-515 is required, install it as shown in figure 9 and then insert Insulator IN-127.
- (4) Connect a 12-inch length of Wire W-128 between the ANT. (antenna) binding post on the transmitter panel of the RT-77(\*)/GRC-9, and the connector on the IX-127. Run the wire through the upper hinge slot of Bag CW-140/GRC-9.
- (5) Assemble the antenna (whip) mast sections and insert them into the IN-127. Clamp Guys GY-12 and GY-42 to the whip antenna as indicated in B. figure 8. Drive Stakes GP-27-B into the ground through S-hooks attached to the ends of the guy cords at equally spaced points around the antenna to hold the whip antenna mast sections erect (A, fig. 8.)

*c. Whip Antenna, Vehicular Installation.* The vehicle antenna consists of five mast sections (three MS-116-A's, one MS117-A, and one MS-118-A) and Mast Base MP-65-B.

- (1) Install the MP-65-B on the bracket mounted on vehicle, such as Mast Bracket MP-50 (fig. 10).

*Note:* Place the rubber washer between the upper insulator bowl and the bracket.

- (2) Assemble the mast sections and insert them into the MP-65-B.

*Note:* If the lead-in wire (W-128) is 19 inches to 6 feet in length and the operating frequency is above 11 megacycles, use one less mast section.

- (3) Connect the antenna lead-in wire (W-128) between the binding post on the MP-65-B and the ANT. binding post on the RT-77 (\*)/GRC-9 (fig. 10).



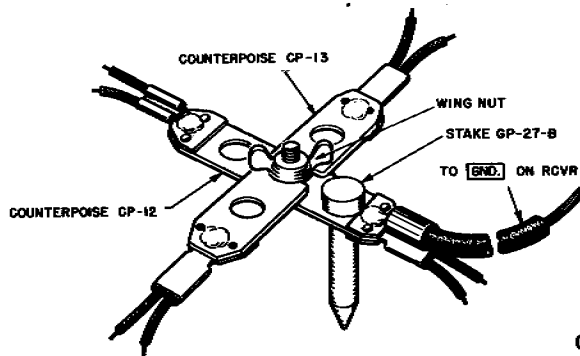
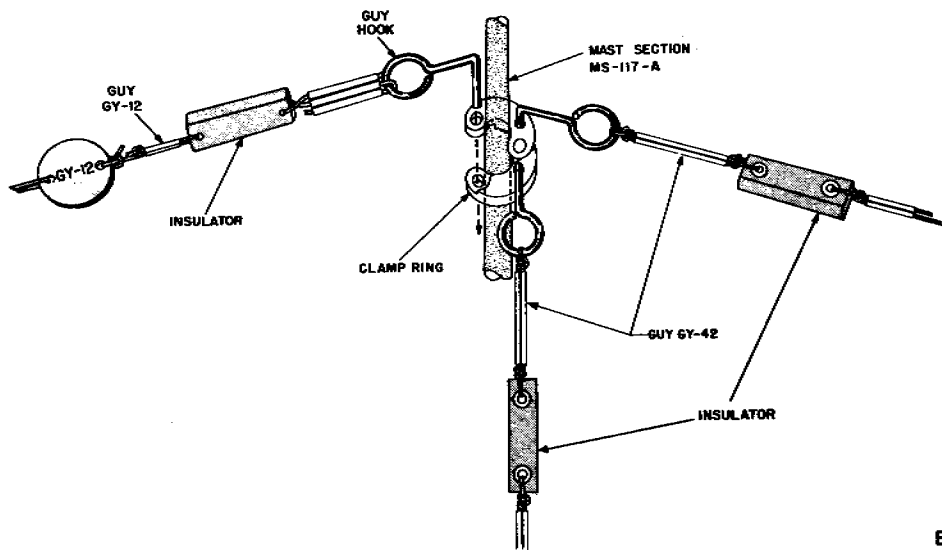
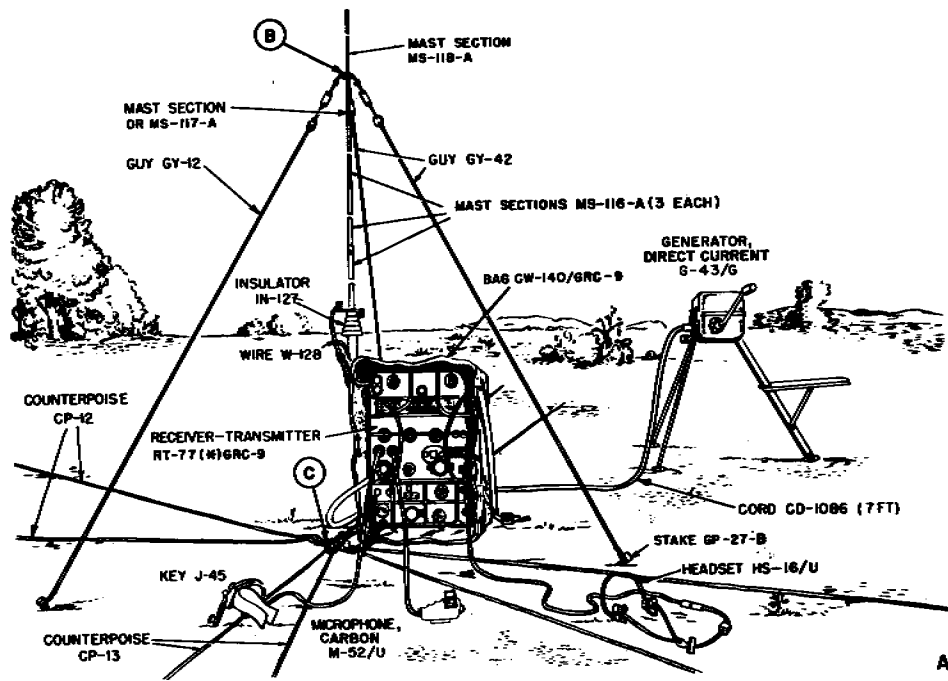

TM5820-453-20-K06

Figure 8. Typical ground installation, whip antenna

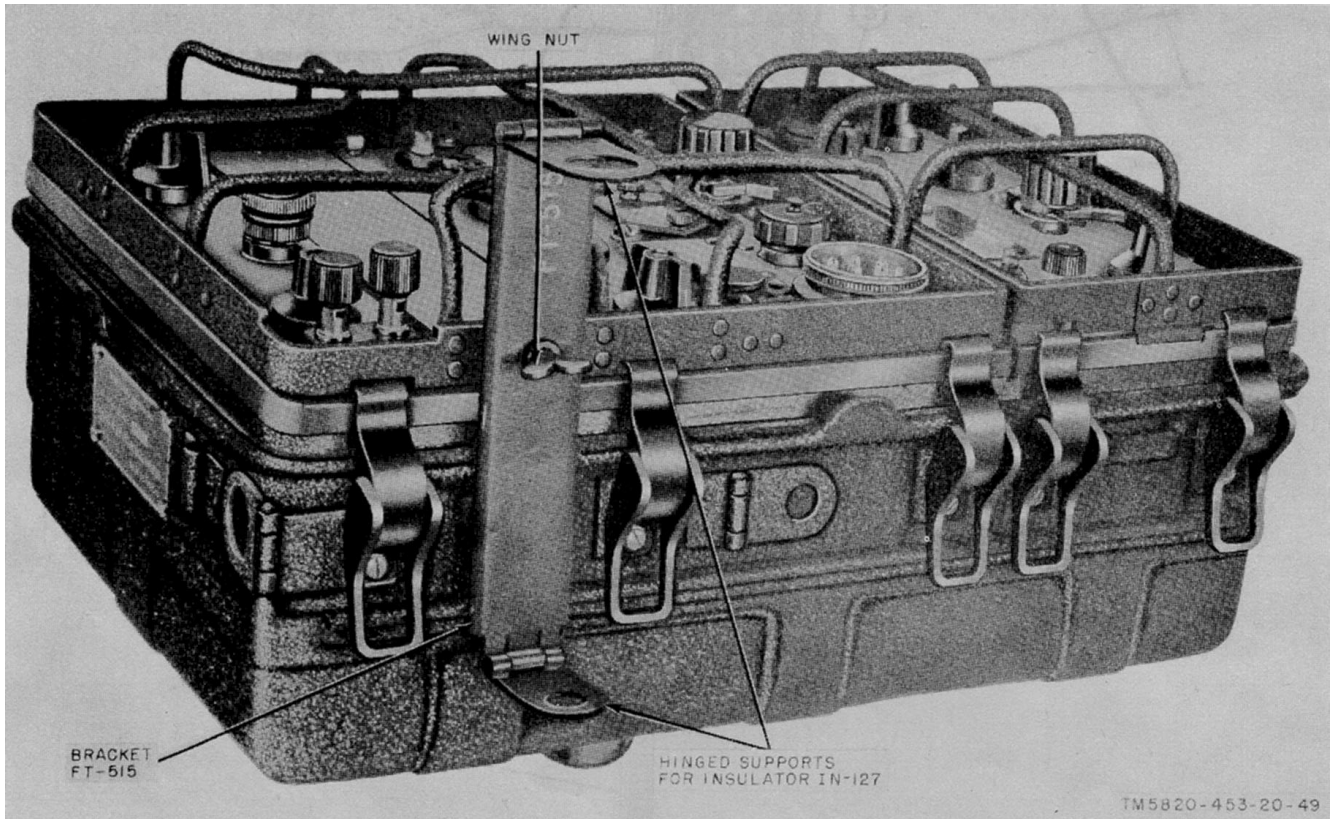

Figure 9. Bracket FT-515, installed

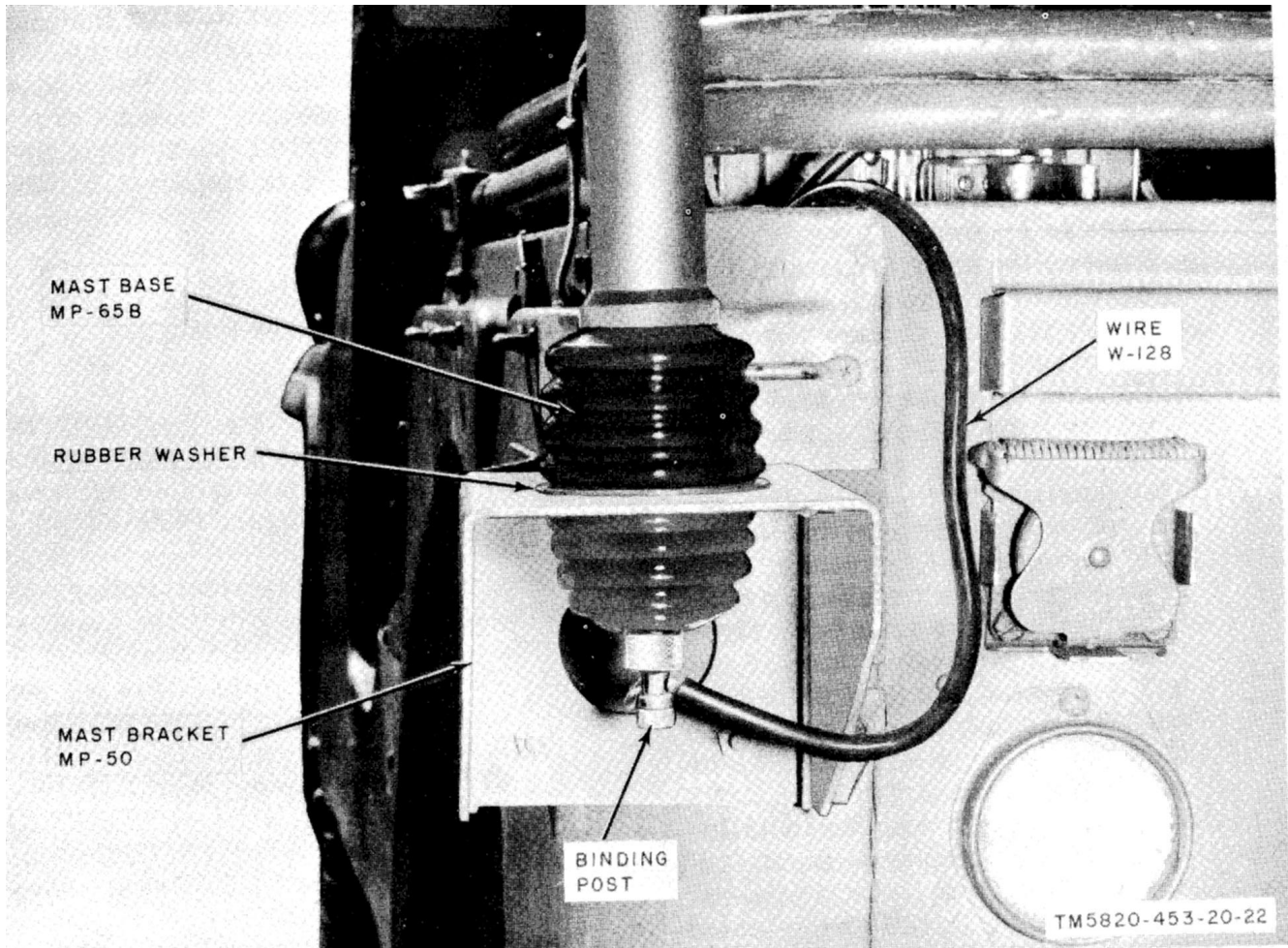

Figure 10. Mast Base MP-65-B typical installation.

### Section III. GROUND (MAN-TRANSPORTABLE) AND VEHICULAR INSTALLATION

#### 8. Ground Installation of Radio and Power Components

a. *Radio Components.* A typical ground (man-transportable) installation is shown in figure 8. Install Receiver-Transmitter RT-77(\*)/GRC-9 as follows:

- (1) Place the receiver-transmitter in a horizontal position and then release the latches that hold Panel Cover CW-109/GRC-9 to the RT77(\*)/GRC-9. Remove the cover.

**Warning:** Do not hold the thumb too close to the latch being released; painful hand injuries may result.

- (2) Partially lift and remove the receiver subassembly out of the case.

- (3) Remove the rear connector plug and completely remove the subassembly.
- (4) Check the installed tubes and receiver calibrating crystal (fig. 11).
- (5) Install Battery, Dry BA-1293/U (Federal stock No. 6135-271-0407) (receiver bias cell). If the receiver bias cell is the wired-in type, the MWO 11-5820-291-35/1 has not been performed; refer to a higher echelon of maintenance.
- (6) Partially lift and remove the transmitter subassembly from the case. Remove the rear connector plug and completely remove the subassembly.

- (7) Remove the transmitter tube shield cover and check the installed tubes (fig. 11).
- (8) Install transmitter tube V103, a type 2E22 (if not installed), in its socket as follows:
  - (a) Line up the tube prongs with their corresponding socket holes.
  - (b) Press the tube straight down into the socket.
  - (c) Connect the plate cap lead on the transmitter to the plate cap on the tube.
- (9) If transmitter crystals are required, select a crystal that is one half the operating (transmitting) frequency. The crystal units (CR8/U) will cover a frequency range from 1,000 kilocycles (kc) to 6,000 kc. A crystal unit is provided for each 5-kc separation from 1,000 kc to 1,800 kc and for each 10-kc separation from 1,810 kc to 6,000 kc. Six crystals may be installed (two for each frequency band), but only one can be selected for use at a given time. Install the selected crystal as follows:
 

*Note: The crystal units are listed by frequency and Federal stock numbers in SB 11-474.*

  - (a) Plug the proper crystal into its corresponding holder on the transmitter chassis; two for each of the three frequency bands.
  - (b) Record the required crystal frequency and dial setting on the CRYSTALS chart on the transmitter panel.
- (10) Replace the transmitter and receiver tube shield covers.
- (11) Replace the transmitter and receiver subassemblies in the case (fig. 12). Replace the connector plugs and dress the cable on the bracket.
- (12) If operation is desired, place the RT-77(\*)/GRC-9 in Bag CW-140/ GRC-9 (fig. 6).
- (13) For temporary storage, replace Panel Cover CW-109/GRC-9 on the RT-77(\*)/GRC-9

- (14) Refer to paragraph 7 for installation of the applicable antenna.

*b. Power Components.* For installation instructions of Generator, Direct Current G-43/G, refer to TM 11-5122. When Battery, Dry BA-317/U is required, connect Cord CD-1119 to the RT-77(\*)/GRC-9 and BA-317/U as shown in figure 16.

### **9. Vehicular Installation of Radio and Power Components**

The applicable vehicular installation kit (SB 11-131 and SB 11-253) must be installed before performing the following instructions. Refer to figure 13 for a typical vehicular installation.

*a. Radio Components.* Installation directions are identical with those in paragraph 8, except for the following:

- (1) Battery, Dry BA-317/U is not required for vehicular installations.
- (2) It is not required to place the RT77(\*)/GRC-9 into Bag CW-140/ GRC-9.
- (3) Place the RT-77(\*)/GRC-9 on Mounting MT-350/GRC-9 as shown in figures 13 and 14.
- (4) Connect the ground lead (as short as possible) from the GND. binding post of the RT-77(\*)/GRC-9 to a nearby grounded portion of the vehicle as shown in figure 14.

*b. Power Components, DY-88/GRC-9.*

- (1) Set the input voltage selector switch to indicate the vehicular battery voltage (6-, 12-, or 24-volt) as follows:
  - (a) Release the eight clamps on the front panel of the DY-88/GRC-
  - (b) Slide the DY-88/GRC-9 chassis out of the shock mounted cover.
  - (c) Set the input voltage selector switch (located at the bottom of the chassis, facing the panel) so that the switch voltage marking observed through the panel window corresponds to the vehicular battery voltage.
  - (d) Slide the DY-88/GRC-9 chassis into the shock-mounted cover and lock the eight clamps on the front panel.

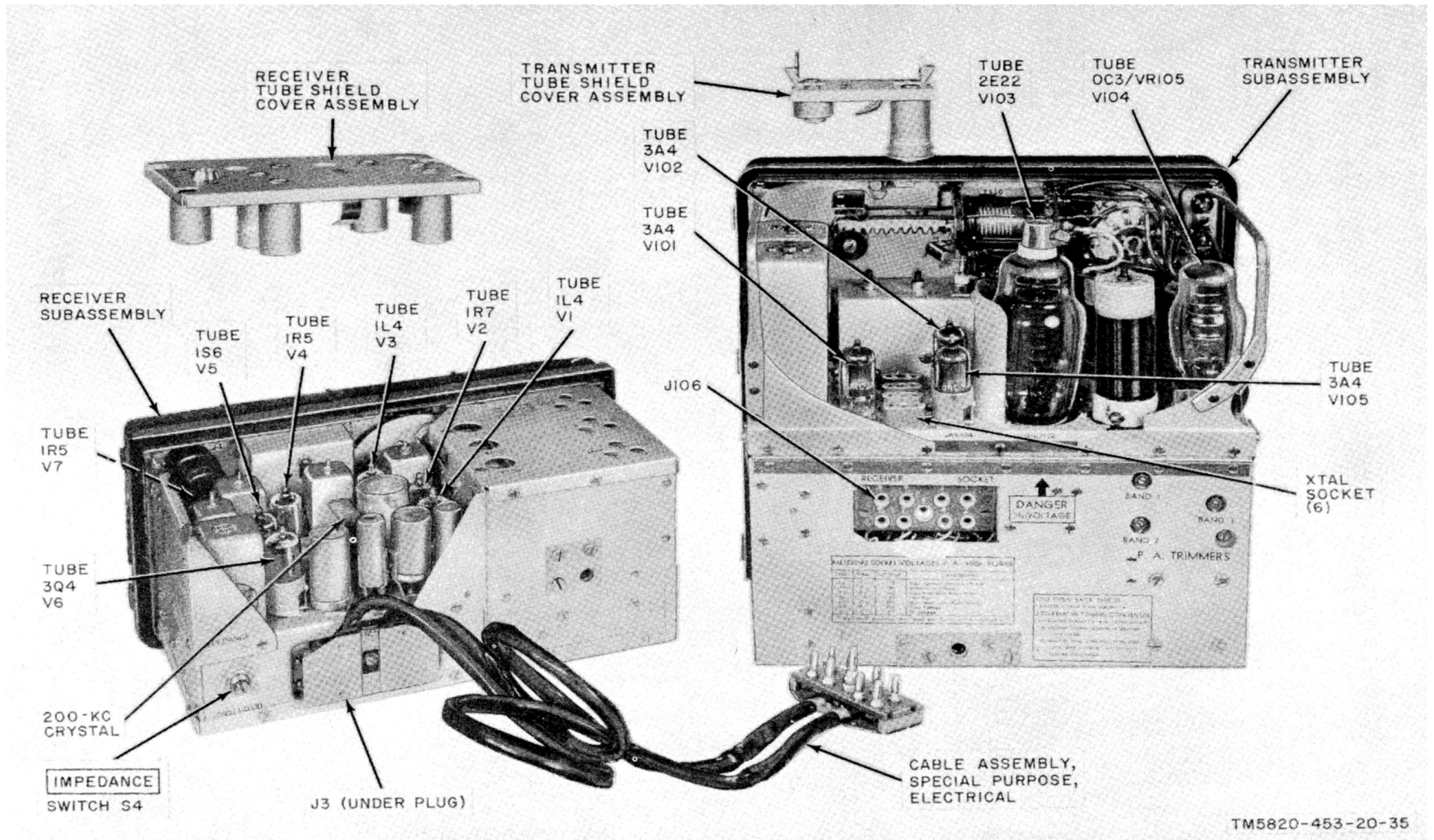

Figure 11. RT-77(\*)/GRC-9, tube location.

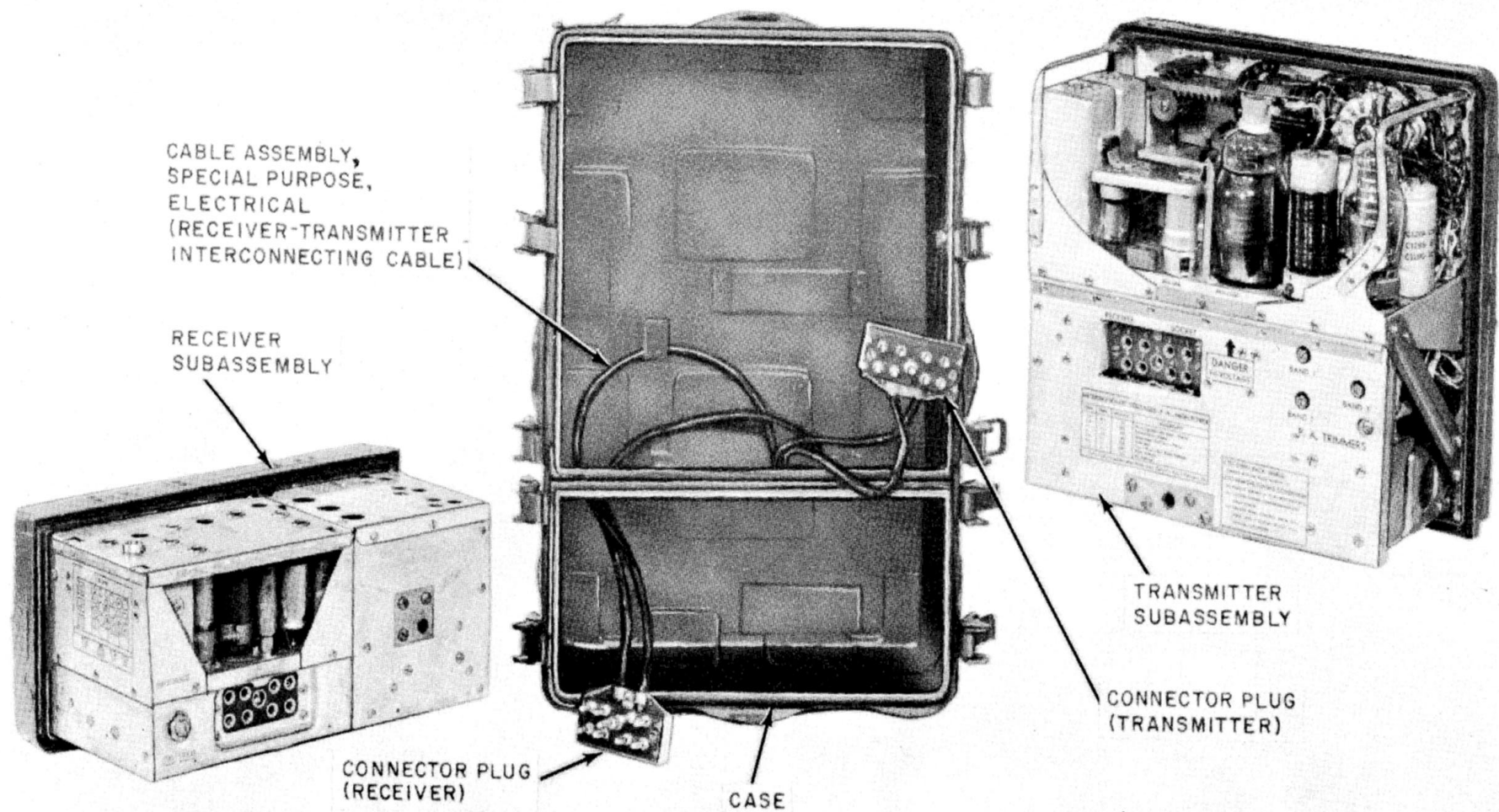

Figure 12. RT-77(\*)/GRC-9, subassemblies removed.

- (2) Place the correct fuses into the DYN. FUSE and VIB. FUSE holders. Refer to the chart below.

Vehicular battery voltage	DYN. FUSE (amperes)	VIB. FUSE (amperes)
6	30	5
12	20	2 (slo-blo type)
24	10	2 (slo-blo type)

c. *Power Component, DY-105(\*)/GRC9X.* The installation of the DY-105(\*)/ GRC-9X (fig. 15) is identical with that of the DY-88/GRC-9 (b above), except for the following:

- (1) Input voltage selector setting is not necessary, because DY-105(\*)/GRC-9X operates only from a 24volt dc source.

- (2) The fuse ratings are as follows:  
 (a) The DYN. FUSE is 10 amperes.  
 (b) The VIB. FUSE is 3 amperes,

## 10. Connections

**Caution:** To avoid equipment damage, make sure that all power switches are set to OFF before making cable connections for ground and vehicular installation of Radio Set AN/GRC-87 and for vehicular installation of the AN/VRC-34.

Connect the equipment as shown in figure 16 for ground operation or in figure 17 for vehicular operation.

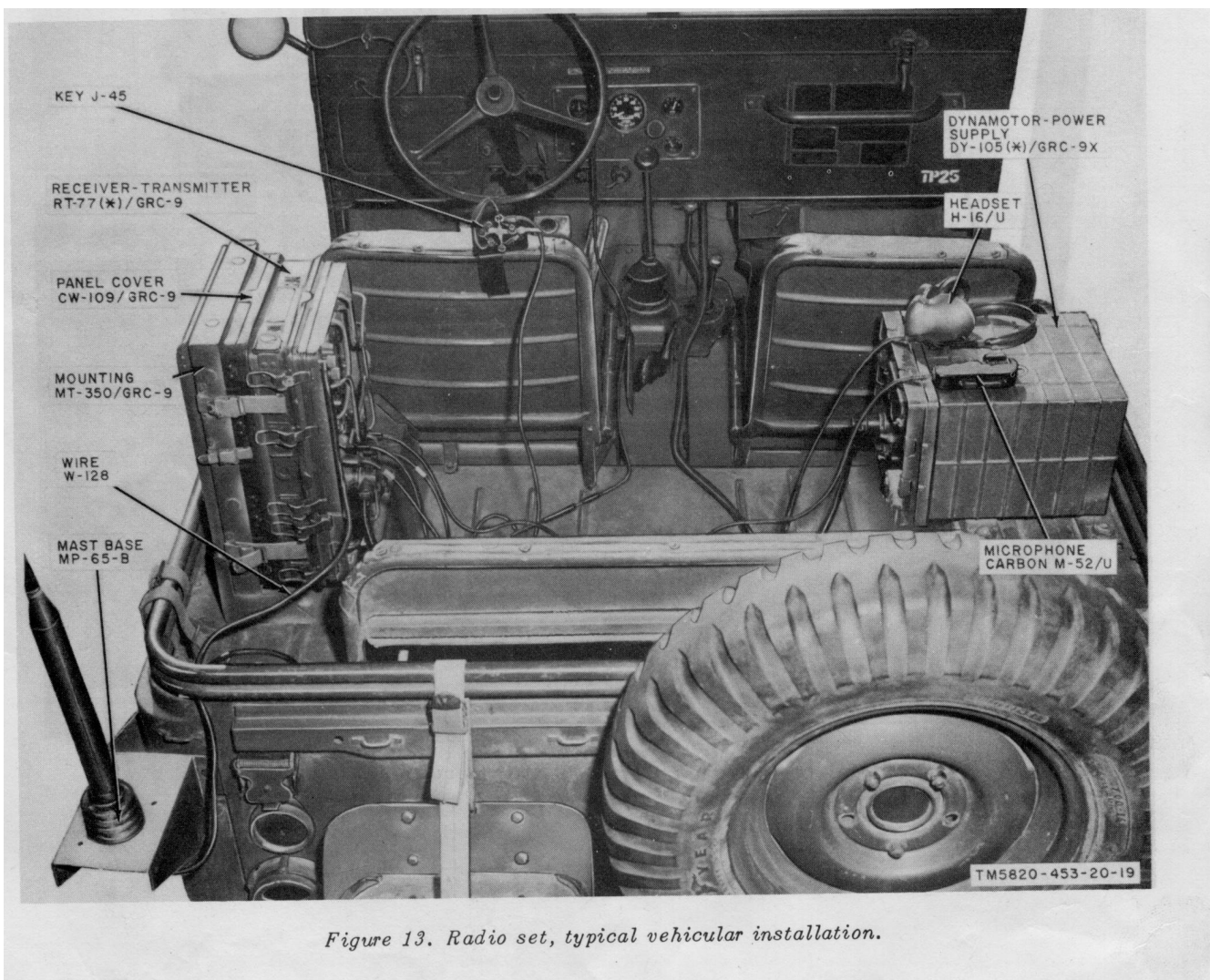
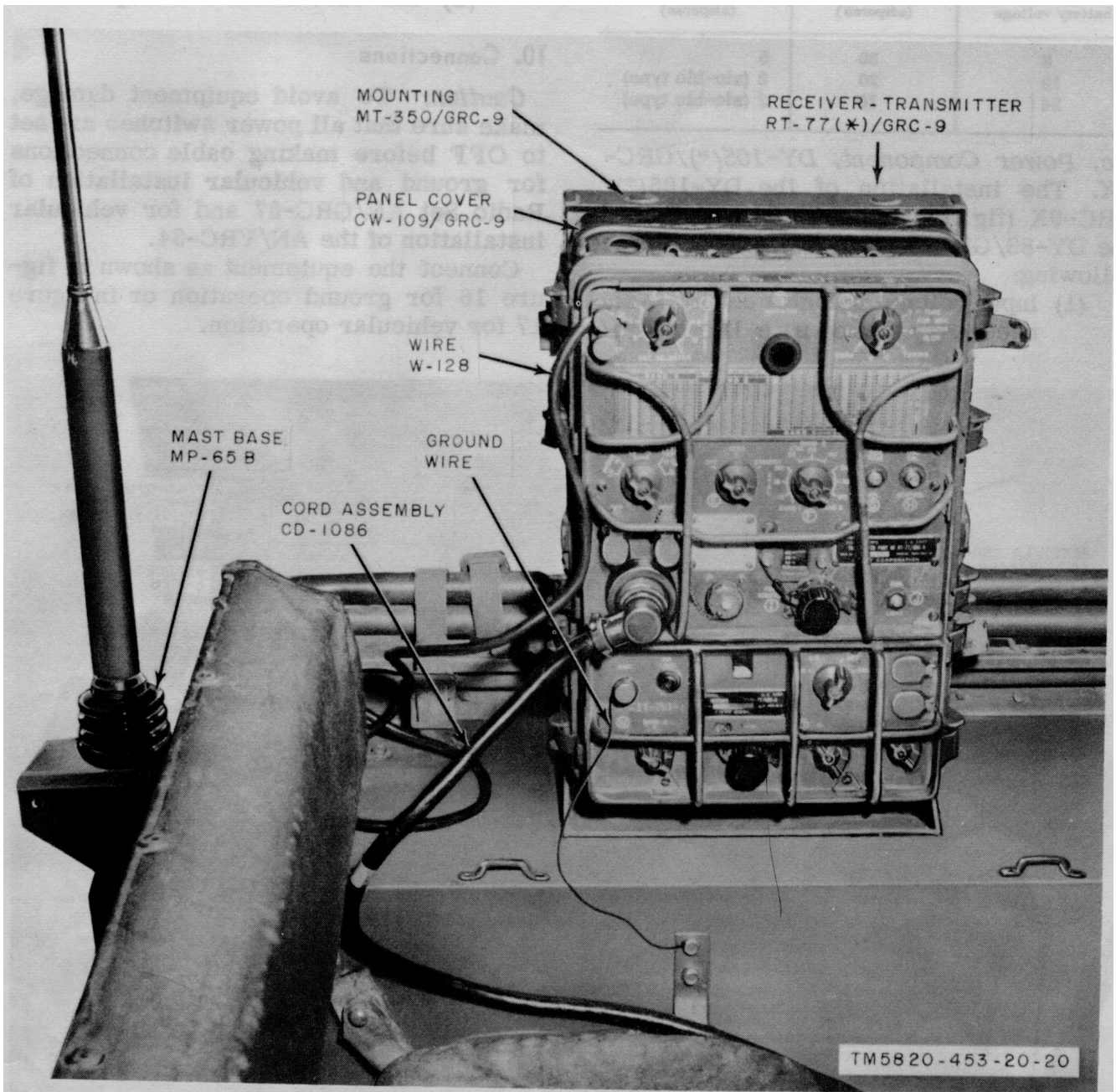

Figure 13. Radio set, typical vehicular installation.

Figure 13. Radio set, typical vehicular installation.



*Figure 14. RT-77(\*)/GRC-9, typical vehicular installation.*

*Figure 14. RT-77(\*)/GRC-9, typical vehicular installation.*



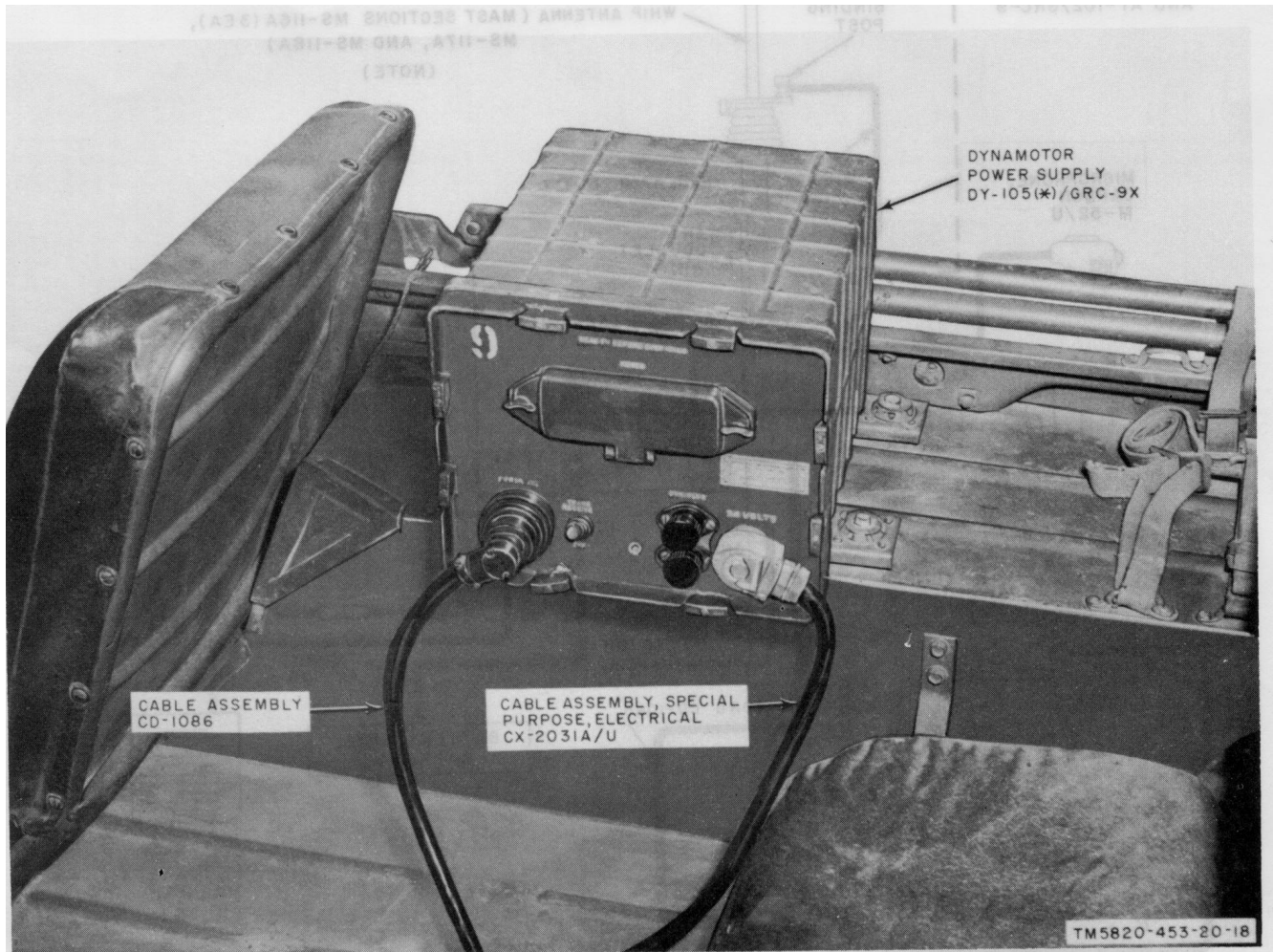
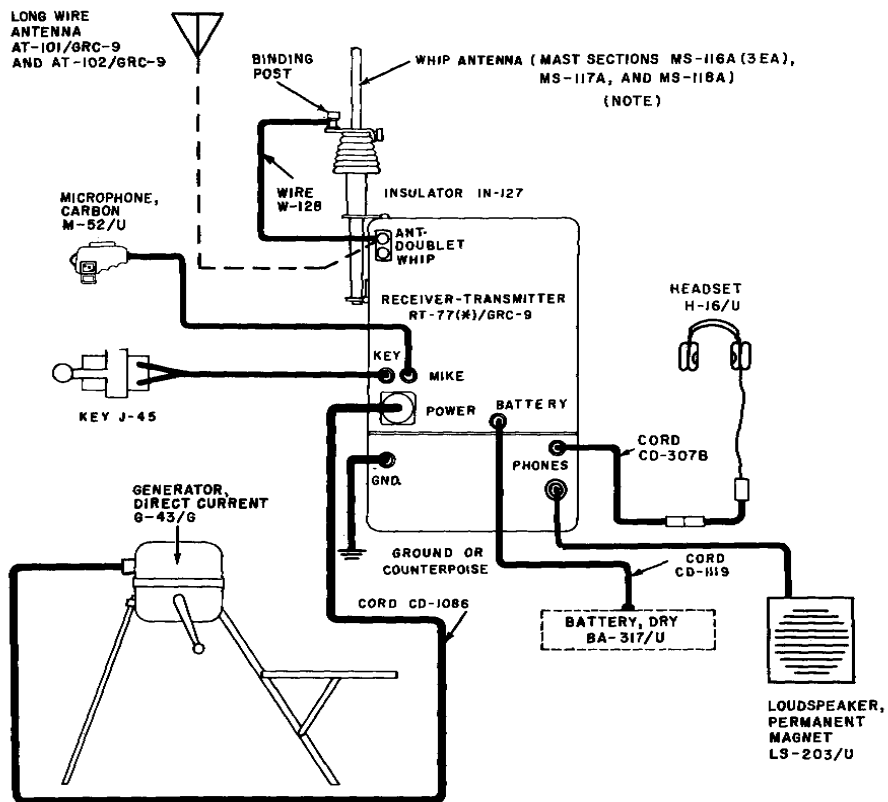

Figure 15. DY-105(\*)/GRC-9X, typical vehicular installation.

Figure 15. DY-105(\*)/GRC-9X, typical vehicular installation.



**NOTE:**  
 USE ONE LESS MAST SECTION IF TRANSMITTING ABOVE 11 MC AND WIRE W-128 IS BETWEEN 19 INCHES AND 6 FEET IN LENGTH.

TM5820-453-20-45

Figure 16. Connection diagram for ground operation.

Figure 16. Connection diagram for ground operation.

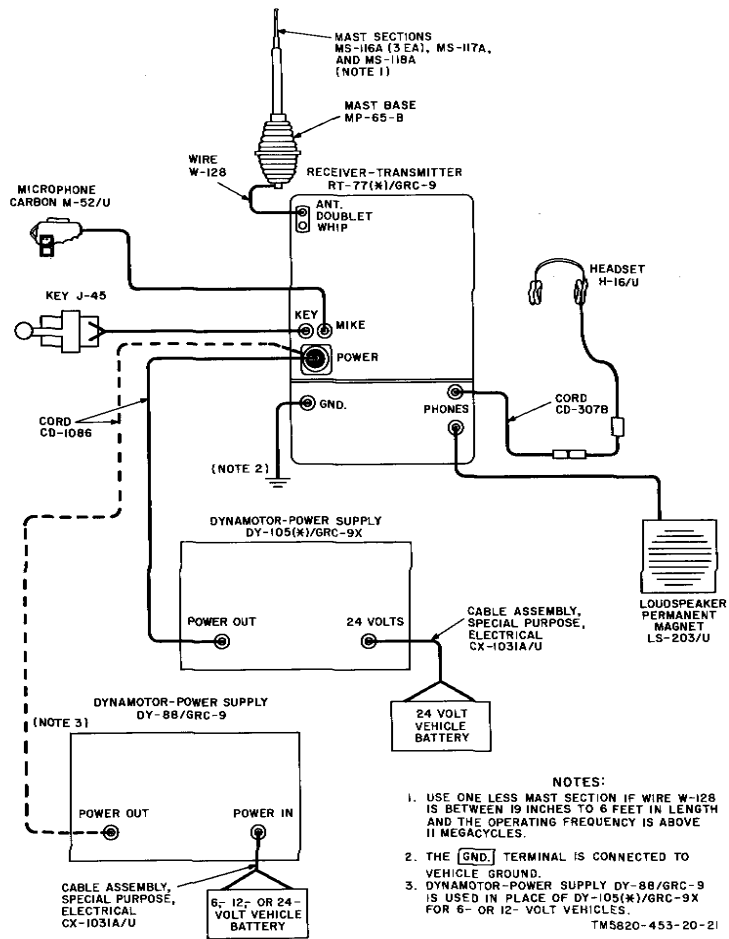

Figure 17. Connection diagram for vehicular operation.

Figure 17. Connection diagram for vehicular operation.

## CHAPTER 2 MAINTENANCE INSTRUCTIONS

---

### Section I. GENERAL

#### 11. Scope of Maintenance Instructions

*a.* The maintenance duties normally performed at second echelon (organizational maintenance) are listed in *b* below. These duties are limited by the available spare parts, tools, materials, and test equipment.

*b.* Second echelon maintenance consists of the following:

- (1) Preventive maintenance (para 14).
- (2) Lubrication (para 19).
- (3) Troubleshooting (para 21).
- (4) Repairs (para 23).

#### 12. Internal Differences in Models

Paragraph 8, TM 11-5820-453-10, lists the internal differences in models applicable to operation and operator's maintenance of Radio Sets AN/GRC-87 and AN/VRC-34. At second echelon maintenance, if MWO 11-5820-291-35/1 has not been performed, bias cell BT1 in the receiver subassembly of the RT-77(\*)/GRC-9 is wired into the circuit. In the receiver subassembly of the RT-77A/GRC-9, the bias cell is a plug-in type Battery, Dry BA1293/U.

#### 13. Tools, Materials, and Test Equipment Required

The parts authorized for second echelon maintenance are listed in TM 11-5820-453-20P. The tools, materials, and test equipment required for organizational maintenance are listed below.

*a. Tools and Materials.*

- (1) Tool Equipment TE-33 ( for Microphone, Carbon M-52/U).
- (2) Tool Kit, Radio Repair TK-115/G.
- (3) Tool Equipment TE-41 (for LS-203/U).
- (4) Cleaning Compound ( Federal stock No. 7930-395-9542).
- (5) Lubricating Oil, General Purpose,

Preservative, MIL-L-644, Federal stock No. 9150-185-0629 (PL-SPECIAL).

- (6) Grease, Aircraft and Instruments, MIL-G-3278, Federal stock No. 9150-261-8297 (GL).
- (7) Sandpaper #000.

*b. Test Equipment.*

- (1) Multimeter AN/URM-105 (TM 11-6625-203-12)
- (2) Test Set, Electron Tube TV-7(\*)/U (TM 11-6625-274-12).
- (3) Meter, Field Strength ME-61/GRC (part of AN/GRC-87 and AN/VRC-34).

#### 14. Preventive Maintenance

*a.* Preventive maintenance is the systematic care, inspection, and servicing of equipment to maintain it in serviceable condition, prevent breakdowns, and assure maximum operational capability. Preventive maintenance is the responsibility of all echelons concerned with the equipment and includes the inspection, testing, and repair or replacement of parts, subassemblies, or units that inspection and tests indicate would probably fail before the next scheduled periodic service. Preventive maintenance service and inspections of the AN/GRC-87 and AN/VRC-34 at second echelon level are made at monthly and quarterly intervals unless otherwise directed by the commanding officer. The maintenance services should be scheduled concurrently with the periodic service schedule of the carrying vehicle for all vehicular installations.

*b.* Maintenance forms and records to be used and maintained on the radio sets (AN/GRC-87 and AN/VRC-34) are specified in TM 38-750. Paragraph 2, TM 11-5820-453-10, contains additional information concerning submission of specific forms.

### 15. Monthly Maintenance

Perform the maintenance functions indicated in the monthly maintenance and inspection chart (pare 16) once each month. A month is defined as approximately 30 calendar days of 8-hour-per-day operation. If the equipment is operated 16 hours a day, monthly maintenance should be performed at 15-day intervals. Adjustment of the maintenance interval must be made to

compensate for any unusual operating conditions. Equipment maintained in a standby (ready for immediate operation) condition must have monthly maintenance performed. Equipment in limited storage (requires service before operation) does not require monthly maintenance.

### 16. Monthly Maintenance Service and Inspection Chart

Item No.	Item	Procedure		Reference
			Normal condition or result	
4	LUBRICATION: Perform the necessary lubrication of the equipment		Mechanisms should not show signs of overlubrication or underlubrication.	Para. 19.
7	PLUCK-OUT ITEMS:			
	a. Inspect clamps and seating of pluck-out items.	a.	All items are properly seated and clamps are correctly positioned and tightened	a. Para 21.
	b. Inspect batteries below for physical and electrical conditions: (1) BA-1293/U (receiver bias cell). (2) BA-317/U (AN/GRC-87 only).	b.	Batteries are in good physical condition.  (1) BA-1293/U minimum voltage is 3 volts. (2) BA-317/U minimum voltage for A section is 1.35 volts and 82.8 volts for B section.	b. Para 21.

### 17. Quarterly Maintenance

Quarterly maintenance on Radio Sets AN/GRC-87 and AN/VRC-34 will be scheduled in accordance with the requirements of TM 38-750. If the equipment is part of a vehicular installation, the quarterly maintenance should be scheduled concurrently with the periodic service schedule of the carrying vehicle to reduce out-of-service time to a minimum. All deficiencies or shortcomings will be recorded, and those not corrected during the inspection and service will be immediately reported to higher echelon by using forms and procedures specified in TM 38-750. Equipment that has a deficiency that cannot be

corrected by second echelon should be deadlined in accordance with TM 38-750. Perform all services listed in the quarterly maintenance and inspection chart (pare 18) in the sequence listed. Whenever a Normal *condition* or *result* is not observed, take corrective action in accordance with the paragraph listed under References.

### 18. Quarterly Maintenance Service and Inspection Chart

Item No.	Item	Procedure		References
			Normal indication or result	
1	SET: Inspect the equipment for: a. Completeness ----- b. Proper installation ----- c. Cleanliness (service)-----	a.	Equipment must be complete	a. Appx II. TM 11-5820-453-10.
		b.	Installation is in accordance with applicable technical manual instructions.	b. Para 6 through 10.
		c.	Units must be clean and dry inside and out; free of grease, dirt, rust, corrosion, and fungus.	c. Para 32, TM 11-5820-453-10.

Item No	Procedure		References				
	Item	Normal indication or result					
	<p><i>d.</i> Preservation -----</p> <p><i>e.</i> Waterproofing -----</p>	<p><i>d.</i> Remove rust and corrosion from metal surfaces by lightly sanding them with fine sandpaper. Brush two thin coats of paint on the bare metal to protect it from further corrosion. Refer to applicable cleaning and re-finishing practices specified in TM 9-2851.</p> <p><i>e.</i> Inspect waterproofing gaskets for leaks and worn or loose edges.</p>	<p><i>d.</i> TM 9-2851.</p> <p><i>e.</i> Para 17.</p>				
2	PUBLICATIONS: Check to see that pertinent publications are available.	<p><i>a.</i> Operator's manual is complete and in usable condition.</p> <p><i>b.</i> All Changes pertinent to the equipment are on hand.</p> <p><i>c.</i> Organizational maintenance manual is complete and in usable condition.</p>	<p><i>a.</i> DA PAM 310-4.</p> <p><i>b.</i> DA PAM 310-4</p> <p><i>c.</i> DA PAM 310-4</p>				
3	MODIFICATION WORK ORDERS: Check to determine if new applicable MWO's have been published.	ALL URGENT MWO's have been applied to the equipment. All ROUTINE MWO's have been schedules.	DA PAM 310-4.				
4	LUBRICATION: Perform the necessary lubrication of the equipment.	Mechanisms should not show signs of overlubrication or underlubrication.	Para 19				
5	CONNECTIONS: Inspect the following: <p><i>a.</i> Cords, cables, and wire connectors.</p> <p><i>b.</i> Telegraph key, headset, loudspeaker, and microphone connections.</p>	<p><i>a.</i> Cords, cables and wires are free from cuts, breaks fraying, deterioration, kinks, and strain.</p> <p><i>b.</i> Plugs and sockets are clean and intact and not loose fitting. Telegraph key is connected to the proper jack on the transmitter. Headset and cords are connected to the proper jack on the receiver. Loudspeaker is connected to the proper jack on the receiver. Microphone is connected to the proper jack on the transmitter.</p>	<p><i>a.</i> Para 17.</p> <p><i>b.</i> Para 10.</p>				
6	MOUNTING: Inspect seating and stability of mountings. Check for loose or missing hardware.	All bolts, nuts and washers are present and properly tightened. Mounting shows no evidence of weakness or deformity.	Para 17.				
7	PLUCK-OUT ITEMS: Inspect clamps and seating of pluck-out items (tubes, crystals, lamps relays, bias cell, and vibrators).	All items are properly seated and clamps are correctly positioned and tightened.	Para 17.				
	FUSES: Check for proper fuses--	<p>The fuses in use and the spares are of the indicated values and are located as follows:</p> <p><i>a.</i> DY-88/GRC -9 front panel: 1 ea spare is located in the SPARE FUSE compartment.</p> <table border="1"> <thead> <tr> <th>DYN. FUSE (amperes)</th> <th>VIB. FUSE (amperes)</th> </tr> </thead> <tbody> <tr> <td>30 (6-volt vehicle battery)</td> <td>5</td> </tr> </tbody> </table>	DYN. FUSE (amperes)	VIB. FUSE (amperes)	30 (6-volt vehicle battery)	5	None
DYN. FUSE (amperes)	VIB. FUSE (amperes)						
30 (6-volt vehicle battery)	5						

Item No.	Procedure			
	Item	Normal condition or result		References
		20 (12-volt vehicle battery). 10 (24-volt vehicle battery).	2 (slo-blo type). 2 (slo-blo type).	
		<i>b.</i> DY-105(*)/GRC-9X front panel: 1 ea 10 amp (DYN.FUSE) and 1ea 3 amp. fuse (VIB, FUSE) in use, 1 ea 10 amp and 1 ea 3 amp fuses in SPARE FUSE compartment.		
9	BRUSHES: Inspect dynamotor (generator) brush assembly for: <i>a.</i> Weak brush spring tension -- <i>b.</i> Chipped or worn condition of brush. (Brush should not be worn less than one-quarter inch from pigtail or below wear-line marking on brush). <i>c.</i> Broken or damaged brush cap	<i>a.</i> Proper spring tension----- <i>b.</i> Brush is not chipped or worn (below minimum standard).  <i>c.</i> Brush cap is not damaged or broken.		<i>a.</i> Para 23 <i>b.</i> Para 23.  <i>c.</i> Para 23
10	KNOBS, DIALS, AND SWITCHES: Check for proper mechanical action by setting each control to each of its settings	Action is positive without backlash, binding, or scraping <i>Note:</i> Knobs that require frequent tightening should have setscrews replaced.		None.
11	ANTENNA: Inspect the installed antenna (whip or long-wire).	Antenna is complete, guy wires (ground installation) are correctly installed and insulators are free of cracks, dirt, and fungus.		None.
12	OPERATIONAL PRESET; POWER SUPPLY: Set the controls of the applicable power supply: <i>a.</i> DY-88/GRC-9 power switch OFF. <i>b.</i> DY-105(*)/GRC-9X power switch: OFF. <i>c.</i> G-43/G handcranks: Do not turn..	<i>a.</i> All controls must be set properly. <i>b.</i> All controls must be set properly. <i>c.</i> All controls must be set properly.		<i>a.</i> None. <i>b.</i> None. <i>c.</i> None.
13	OPERATIONAL PRESET; RECEIVER-TRANSMITTER: Set the controls on the receiver-transmitter: Ⓔ OFF Ⓐ WHIP, REEL, or DOUBLET Ⓞ Midposition Ⓟ Maximum clockwise	All controls must be properly set.		None.
14	START; POWER SUPPLY: Set the controls of the applicable power supply: <i>a.</i> DY-88/GRC-9 power switch: TRANS & RECEIVE <i>b.</i> DY-105(*)/GRC-9X power switch: TRANS RECEIVE. <i>c.</i> G-43/G handcrank: Do not turn.	<i>a.</i> All controls must be properly set. <i>b.</i> All controls must be properly set. <i>c.</i> No output-----		<i>a.</i> None <i>b.</i> None <i>c.</i> None
15	START; RECEIVER-TRANSMITTER: Set the controls of the receiver-transmitter: Ⓔ STANDBY Ⓓ PHONE-HI-hi Ⓕ BAND 1, 2, or 3 and XTAL or MO	If DY-88/GRC-9 or DY-105(*)/GRC-9X is used, then vibrations are felt on the case of the applicable power component. Signal or noise output will be heard from the headset or loudspeaker. Dial lamp will		Para 20.

Item No	Procedure		
	Item	Normal condition or result	References
	(F): Set to required frequency (M): Band 1, 2, or 3	light when control (K) is pressed.	
16	<b>CALIBRATE THE RECEIVER:</b> Note: If Generator, Direct Current G-43/G is used, turn handcranks. If Battery Dry BA-317/U is used with the G-43/G, turning handcranks is not necessary. a. Set control (L) to CAL b. Adjust control (N) to the nearest 200-kc checkpoint of the required operating frequency. c. Adjust control (N) to zero beat.	a. Control (L) is set properly b. A tone is heard in the headset or loudspeaker. c. Zero beat is heard in the headset or loudspeaker.	a. None. b. Para 20 c. Para 20
17	<b>CALIBRATE THE TRANSMITTER:</b> The receiver must be calibrated before performing the procedures below. a. Set control (F) required to MO for the required band of operation. b. Determine the dial setting from the dial calibration chart by using the receiver calibration frequency and set control (I) to indicate that setting. c. When Generator, Direct Current G-43/G is in use (ground installation), set control (E) to SEND and turn handcranks. <i>Note:</i> If BA-317/U is used with the G-43/G, then turning the handcranks is necessary only when transmitting; set control E to STANDBY. d. Set control (U) to NET----- e. Set control (D) to CW or MCW. <i>Note:</i> Calibration is not possible when control (D) is set to PHONE. f. When a dynamotor-power supply (DY-88/GRC-9 or DY-105(*)/GRC-9) is in use (vehicular installation), set control E to SEND. g. Adjust control (H) to obtain zero beat.	a. Control (F) is set properly ----- b. Control (I) is set properly ----- c. Control (E) is set properly and handcranks turn at proper speed (approximately one revolution per second). d. Sidetone is silenced ----- e. Control (D) is set properly ----- f. Control (E) is set properly and hum is heard from dynamotor-power supply. g. Zero beat is heard from headset or loudspeaker.	a. None. b. None. c. None. d. None. e. None. f. Para 20. g. Para 20
18	<b>VOICE OPERATION:</b> a. Set control (D) to PHONE-HI and control (L) to PHONE.	a. Noise or signals are heard in headset or loudspeaker.	a. Para 20

**WARNING: THE FOLLOWING PROCEDURES REQUIRE THE BREAKING OF RADIO SILENCE. THIS MANUAL DOES NOT AUTHORIZE THE BREAKING OF RADIO SILENCE IMPOSED BY ANY COMMAND. UNAUTHORIZED VIOLATION OF RADIO SILENCE COULD RESULT IN COURT MARTIAL OR POSSIBLY DEATH FROM A HOSTILE FORCE.**

b. Set control (U) to the proper dial setting (determined from the transmitter calibration chart) and control (N) to indicate required frequency.	b. Dials are set properly -----	b. None
c. Set control (F) to MO (in required band)	c. None -----	c. None
d. Adjust control (A) to the highest numbered position for the type of antenna in use.	d. None -----	d. None



Item No	Procedure		
	Item	Normal condition or result	References
	<p>e. Adjust INDICATOR (B) Lens until the two red dots on the side of the barrel are in line.</p> <p>f. Press microphone switch, rotate control (C), and observe INDICATOR (B) or ME-61/GRC</p> <p>g. Establish communication</p> <p>h. Depress control (J) and the microphone switch. Release control (J) and the microphone switch.</p> <p>i. During reception, vary control (O) through its entire range.</p> <p>j. During reception, vary control (P) through its entire range.</p>	<p>e. Permits maximum visibility when INDICATOR (B) lamp glows.</p> <p>f. Control (C) is adjusted to the maximum glow of INDICATOR (B) or indication on ME-61/GRC</p> <p><i>Note: If INDICATOR (B) or ME-61/GRC does not indicate, then set control (A) to the next lower number position until it does.</i></p> <p>g. Communication is established.</p> <p>h. The dial light on the transmitter will light and extinguish.</p> <p>i. Audio level varies from zero to maximum as control (O) is rotated clockwise.</p> <p>j. Signal level changes from zero to maximum as control (P) is rotated clockwise.</p>	<p>e. None.</p> <p>f. Para 20</p> <p>g. Para 20</p> <p>h. None</p> <p>i. Para 20</p> <p>j. Para 20.</p>
19	<p>CW OPERATION:</p> <p>a. Set control (D) to CW-HI and control (L) to C.W.</p> <p>b. Set control (I) to the proper dial setting (determined from transmitter calibration chart) and control (N) to indicate the required frequency.</p> <p>c. Set control (F) to MO (on required band).</p> <p>d. Adjust control (A) to the highest numbered position for the type of antenna in use.</p> <p>e. Adjust INDICATOR (B) lens until the two red dots on the side of the barrel are in line.</p> <p>f. Depress telegraph key, rotate control (C) and observe INDICATOR (B) or ME-61/GRC.</p> <p>g. Establish communication</p> <p>h. Depress control (J) and (K)</p> <p>i. During reception, vary controls (O) and (P) through their entire range.</p>	<p>a. Noise or signals heard in headset or loudspeaker.</p> <p>b. Dials are set properly</p> <p>c. None</p> <p>d. None.</p> <p>e. Permits maximum visibility when INDICATOR (B) lamp glows.</p> <p>f. Control (C) is adjusted to the maximum glow of INDICATOR (B) or indication on ME-61/GRC.</p> <p><i>Note: IF INDICATOR (B) or ME-61/GRC does not indicate, then set control (A) to the next lower numbered position until it does.</i></p> <p>g. Communication is established</p> <p>h. The dial lamp on the transmitter and receiver will light and will extinguish</p> <p>i. Audio level will vary from zero the maximum as control (O) is rotated clockwise and signal level will vary from zero to maximum as control (P) is rotated clockwise..</p>	<p>a. Para 20</p> <p>b. None.</p> <p>c. None.</p> <p>d. None.</p> <p>e. None.</p> <p>f. Para20.</p> <p>g. Para 20.</p> <p>h. None.</p> <p>i. Para 20.</p>
20	<p>MCW OPERATION:</p> <p>a. Set control (D) to MCW HI</p> <p>b. Set control (L) to PHONE..</p>	<p>a. Control (D) is set properly</p> <p>b. Control (L) is set properly and noise or MCW signals are heard in headset.</p>	<p>a. None</p> <p>b. Para 20.</p>

Item No.	Procedures		
	Item	Normal condition or result	Reference
	c. Set control (I) to indicate dial setting for the authorized testing or operating frequency.	c. Control (I) is set properly	c. None.
	d. Set control (N) to indicate authorized testing or operating frequency.	d. Control (N) is set properly	d. None.
	e. Set control (E) as follows: (1) Set to send for operation with DY-88/GRC-9, DY-105(*)/GRC-9X or G-43/G (turn handcranks). (2) Set to STANDBY for operation with G-43/G and BA-317/U. Turn handcranks only when transmitting.	e. Control (E) is set properly	e. Para 20
	f. Close key (J-45) and adjust control (C) for maximum indication on INDICATOR (B) or the ME-61/GRC; release key.	f. INDICATOR (B) or ME-61/GRC indicates at a maximum (when key is closed)	f. Para 20
	g. Key transmitter and establish communication with distant authorized station.	g. Communication is established.	g. Para 20.
	h. During signal transmission, vary control (G) through its entire range.	h. Sidetone level varies from zero to maximum.	h. Para 20
	i. During reception, vary control (O) through its entire range.	i. Audio level varies from zero to maximum.	i. Para 20.
	j. During reception, vary control (P) through its entire range.	j. Signal level varies from zero to maximum	j. Para 20
	k. Depress and release controls (J) and (K).	k. Dial lamps light and extinguish.	k. Para 20..

## 19. Lubrication

**Caution:** When lubricating, make sure no oil or grease is applied to the external surfaces of switch contacts or dynamotor and generator commutators.

**Warning:** Cleaning compound is flammable and its fumes are toxic. Do not use near a flame; provide adequate ventilation.

a. *RT-77(\*)/GRC-9.* Clean the exposed bearing surfaces of switch detents, hinges, and fasteners with a lint-free cloth dampened with cleaning compound. Apply oil (PL-SPECIAL) sparingly to the cleaned surfaces. Clean the exposed surfaces of the antenna tuning slug drive gears and apply grease (GL) sparingly to the cleaned surfaces.

b. *DY- 88/GRC-9 and DY-105(\*)/GRC- 9X.* Refer

to paragraph 23 for disassembly of the brush covers.

- (1) Remove the bearing plates and remove old grease from the bearings with a lint-free cloth dampened with cleaning compound. Do not let cleaning compound contact the commutators or armature windings.
  - (2) Relubricate the bearings by spreading grease (GL) evenly and sparingly; avoid letting the grease (GL) contact the brushes, commutators, or brush holders.
  - (3) Replace the bearing plates and brush covers (pare 23).
- c. *G-43/G.* Refer to TM 11-5122 for lubrication instruction for the G-43/G.

## Section II. TROUBLESHOOTING

### 20. General

Troubleshooting at the organizational repair mans level is based upon the operational check in the quarterly maintenance service and inspection chart. To troubleshoot the equipment, perform all functions starting with item number 12 in the quarterly maintenance service and inspection chart (pare 18) and proceed through all items until an abnormal condition or result is observed. When an abnormal

condition or result is observed, note the item number and turn to the corresponding item number in the troubleshooting chart (para 21). Perform the checks and corrective actions indicated in the troubleshooting chart. If the corrective measures indicated do not result in correction of the trouble, higher echelon maintenance is required.

### 21. Troubleshooting Chart

Item No.	Trouble Symptom	Probable trouble	Checks and corrective measures
15	<p><i>a.</i> No vibrations from the dynamotor-power supply in use (vehicular installation, DY-88/GRC-9 or DY-105(*)/GRC-9X)</p> <p><i>b.</i> No output from headset or loudspeaker.</p>	<p><i>a.</i> Defective vibrator or improper seating of input and output cables.</p> <p><i>b.</i> Improper seating of defective headset or loudspeaker, defective tube V5 or V6.</p>	<p><i>a.</i> Check vibrator; replace if necessary. Check seating of input and output cables.</p> <p><i>b.</i> Check headset or loudspeaker; replace if necessary. Test tube with the TV-7(*)/U or by substitution (para 22); replace if necessary.</p>
16	<p><i>a.</i> No output from Generator, Direct Current G-43/G (ground installation if used). No output from Battery, Dry BA-319/U, (if used with G-43/G).</p> <p><i>b.</i> No output from headset or loudspeaker.</p> <p><i>c.</i> Calibration zero beat cannot be obtained</p>	<p><i>a.</i> Improper seating of power cable, defective generator brushes. Improper seating of battery cable or defective battery.</p> <p><i>b.</i> Improper seating of headset or loudspeaker. Defective head-set or loudspeaker</p> <p><i>c.</i> Improper seating of calibrating crystal or defective calibrating crystal. Defective tubes V1 through V7</p>	<p><i>a.</i> Check seating of power cable; replace if necessary. Check brushes; replace if necessary. (TM 11-5122). Check seating of battery cable and the battery; replace if necessary.</p> <p><i>b.</i> Check seating of headset or loudspeaker. Check headset or loudspeaker; replace if necessary.</p> <p><i>c.</i> Check seating of calibration crystal; replace if necessary. Test tubes with TV-7(*)/U or by substitution (para 22); replace if necessary.</p>
17	<p><i>a.</i> No output from G-43/G (ground installation). No output from BA-317/U, when used with the G-43/G.</p> <p><i>b.</i> Hum is not heard from the dynamotor-power supply (vehicular installation, DY-88/GRC-9 or DY-105(*)/GRC-9X).</p> <p><i>c.</i> Zero beat is not heard from the headset or loudspeaker.</p>	<p><i>a.</i> Improper seating of power cable, and defective brushes on G-43/G. Improper seating of battery cable, defective battery.</p> <p><i>b.</i> Improper seating of input and output cables. Defective dynamotor-power s upply vibrator.</p> <p><i>c.</i> Defective headset or loudspeaker, defective transmitter tubes V101 through V103 and receiver tubes V1 through V7.</p>	<p><i>a.</i> Check seating of cable; replace if necessary. Check brushes; replace if necessary (TM 11-5122). Check battery cable; replace if necessary. Check battery; replace if necessary.</p> <p><i>b.</i> Check seating of cables; replace if necessary. Replace the vibrator in the DY-88/GRC-9 or DY-105(*)/GRC-9X if necessary (para 23c and e).</p> <p><i>c.</i> Check headset; replace if necessary. Check tubes with TV-7(*)/U (para 22).</p>
18	<p><i>a.</i> No output from the dynamotor-power supply (DY-88/GRC-9 or DY-105(*)/GRC-9X) for vehicular installations.</p>	<p><i>a.</i> Improper seating of input or output cables, defective cables, defective brushes.</p>	<p><i>a.</i> Check seating of input and output cables; check cables; replace if necessary. Replace defective dynamotor, brushes if necessary (para 23d and f).</p>

Item No.	Trouble symptom	Probable trouble	Checks and corrective measures
19	<p>b. No output from the G-43/G for ground (man-transportable) installations.</p> <p>c. Indicator (B) does not glow.</p> <p>d. No output from headset or loudspeaker.</p> <p>e. Voice signal not transmitted.</p> <p>f. Transmitter dial lamp will not light when control (J) is depressed (microphone switch is depressed).</p> <p>a. No output from headset or loudspeaker. Receiver dial lamp will not light when control (K) is depressed.</p> <p>b. Cw signal is not transmitted.</p> <p>a. No output from headset or loudspeaker.</p>	<p>b. Improper seating of cable, defective cable, defective generator brushes.</p> <p>c. Indicator (B) lamp is loose in socket or is defective, Control (C) is not adjusted properly.</p> <p>d. Improper seating of headset or loudspeaker, defective headset or loudspeaker. Defective tubes V1 through V6.</p> <p>e. Improper seating of all cable connections, defective cables, defective microphone, defective transmitter tubes V101 through V105.</p> <p>f. Transmitter dial lamp is loose in socket or is defective.</p> <p>a. Improper seating of headset or loudspeaker; defective headset or loudspeaker, or defective tube V7. Defective dial lamp.</p> <p>b. Improper seating of all cables defective cables, or defective key. Defective tubes V101 through V105.</p> <p>a. Improper seating of headset or loudspeaker, defective headset or loudspeaker, or defective tubes V1 through V7. Defective controls (O) and (P).</p> <p>b. Improper seating of all cables, defective cables or defective key.</p>	<p>b. Check seating of cable; check cable; replace if necessary. Replace generator brushes if necessary (para 23g).</p> <p>c. Check seating of lamp; replace if necessary (para 33, TM 11-5820-453-10). Adjust control (C) properly.</p> <p>d. Check seating of headset or loudspeaker; check headset or loudspeaker; replace if necessary. Check tubes with TV-7(*)/U or by substitution (para 22); replace if necessary.</p> <p>e. Check seating of all cables; replace if necessary. Check microphone; replace if necessary. Check transmission of signals with ME-61/GRC, Check tubes with TV-7(*)/U or by substitution (para 22); replace if necessary.</p> <p>f. Check dial lamp for proper seating and replace if necessary (para 33, TM 11-5820-453-10).</p> <p>a. Check seating of headset or loudspeaker; check headset or loudspeaker for defects replace as necessary. Check tube with TV-7(*)/U or by substitution (para 23). Replace dial lamp as necessary.</p> <p>b. Check seating of all cables, check cables for defects; replace if necessary. Check key; replace as necessary. Check tubes with TV-7(*)/U or by substitution para 22); replace as necessary (para 23).</p> <p>a. Check seating or headset or loudspeaker; check headset or loudspeaker for defects; replace as necessary. Check tube with TV-7(*)/U or by substitution (para 22); replace as necessary (para 23).</p> <p>b. Check seating of all cables, check cables for defects; replace as necessary. Check tubes with TV-7(*)/U or by substitution (para 22); replace as necessary (para 23).</p>
20	<p>b. Mew signal is not transmitted</p>		<p>a. Check seating or headset or loudspeaker; check headset or loudspeaker for defects; replace as necessary. Check tube with TV-7(*)/U or by substitution (para 22); replace as necessary (para 23).</p> <p>b. Check seating of all cables, check cables for defects; replace as necessary. Check tubes with TV-7(*)/U or by substitution (para 22); replace as necessary (para 23).</p>

## 22. Tube Testing Techniques

When trouble occurs, check all cabling, connections, and batteries before removing any tubes. Try to isolate the trouble to a component or stage. If tube failure is suspected, use the applicable procedure in *a* or *b* below to check the tubes.

*Caution:* Do not rock or rotate a tube when removing it from a socket; pull it straight out with a tube puller.

*a. Use of Tube Tester.* Remove and test one tube at a time. Discard a tube only if its defect is obvious or if the tube tester shows it to be defective. Do not

discard a tube that tests at or near its minimum test limit in the tube tester. Put back the original tube, or insert a new one if required, before testing the next one.

*b. Tube Substitution Method.* Replace a suspected tube with a new one. If the equipment remains inoperative, remove the new tube and put back the original. Repeat this procedure with each suspected tube until the defective tube is located.

### 23. Part-Replacement Procedures

*a. RT-77(\*)/GRC-9 Pluck-Out Items.*

**Warning:** Remove all power cables (dangerous voltages exist in this equipment). The plate cap of transmitter tube V103 (2E22) has 500 volts direct current (dc) regardless of the closed or open position of the key or the microphone switch.

- (1) Remove the RT-77(\*)/GRC-9 subassemblies as directed in paragraph 8 (fig. 11).
- (2) Remove and replace miniature tubes as follows:

- (a) Wait until the tubes are cool (if recently operated).
- (b) Slide the tube puller over the tube envelope (fig. 18) and pull directly upward out of the socket.
- (c) Push the tube towards the handle of the tube puller to remove the tube.
- (d) Replace a miniature tube by rotating it until the tube prongs are lined up with their corresponding socket holes; then press the tube straight down into its socket.

**Caution:** Do not mistake miniature transmitter tubes V101, V102, and V104 (3A4) with the receiver miniature tubes. If a miniature receiver tube is placed into a transmitter miniature tube socket, the tube filament will burn out when the radio set is operated.

- (3) Remove and replace regulator tube V104 (OC3) as follows:

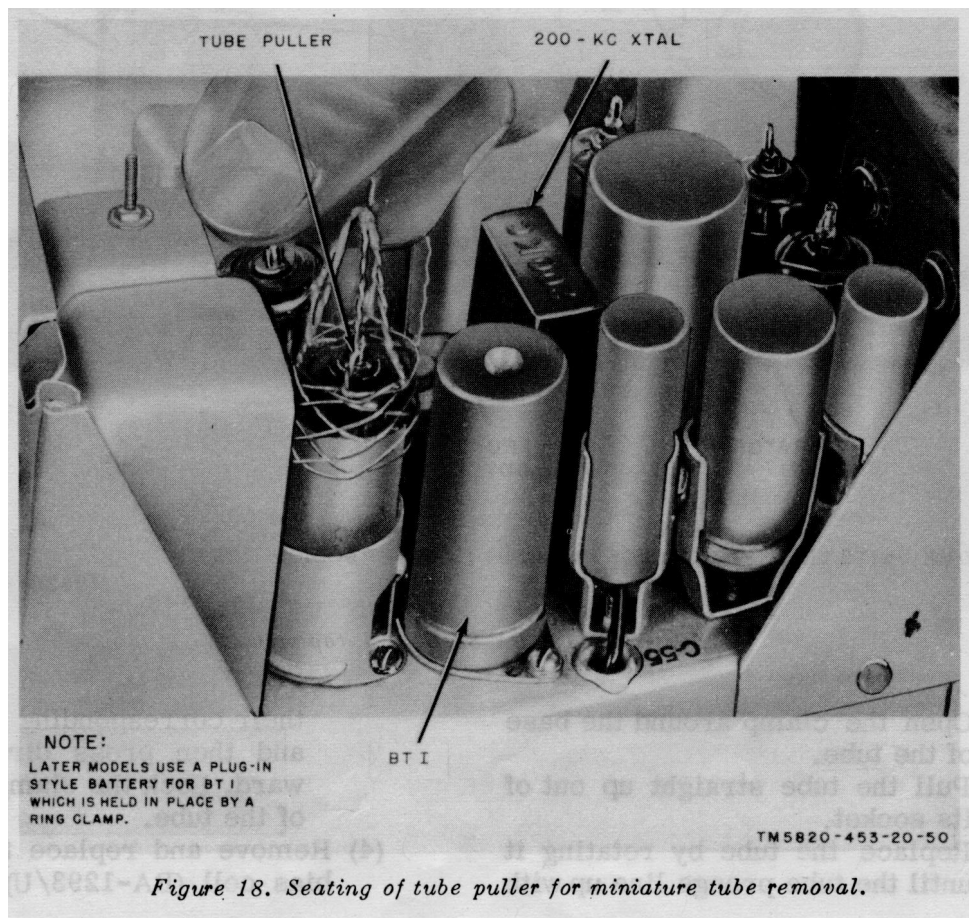

Figure 18. Seating of tube puller for miniature tube removal.

Figure 18. Seating of tube puller for miniature tube removal.

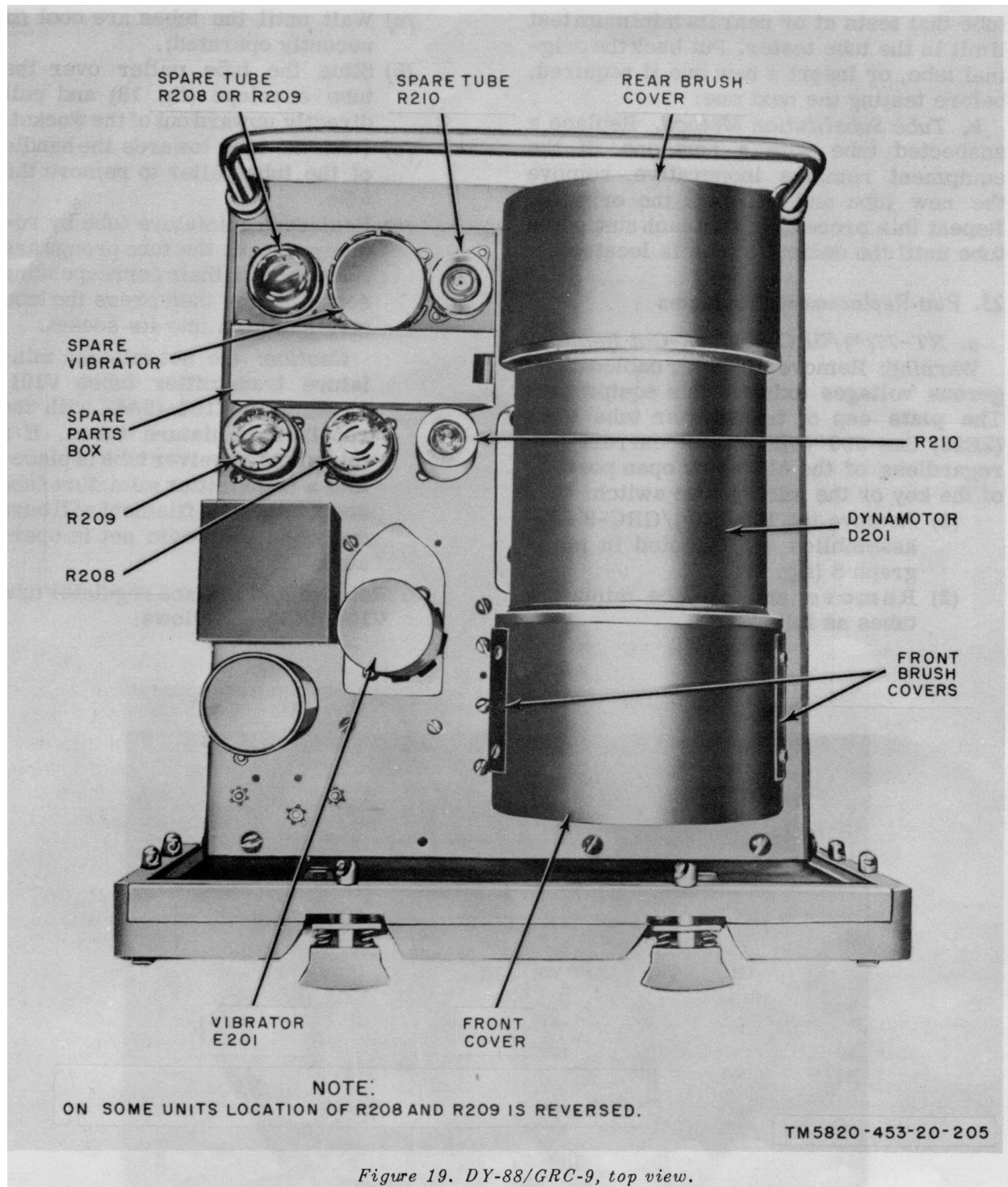



Figure 19. DY-88/GRC-9, top view.

- (a) Open the clamp around the base of the tube.
- (b) Pull the tube straight up out of its socket.
- (c) Replace the tube by rotating it until the tube prongs line up with their corresponding socket holes and then press directly downward. Lock the clamp on the base of the tube.
- (4) Remove and replace the receiver bias cell (BA-1293/U) as follows:

- (a) Loosen the ring clamp (with a screwdriver) at the base of the bias cell.
  - (b) Pull the bias cell straight up out of its socket.
  - (c) Replace the bias cell by lining up its prongs with their corresponding socket holes and pressing it straight downward into the socket.
- (5) No special instructions are required for the removal and replacement of the receiver calibrating crystal.
- (6) No special instructions are required for the removal and replacement of the transmitting crystals, if used.
- (7) Replace the RT-77(\*)/GRC-9 subassemblies as described in paragraph 8 (fig. 12).
- b. *RT-77(\*J)/GRC-9 Control Knob* .
- (1) Remove the screws that hold that dial lock in place.
  - (2) Loosen the setscrew on control knob  and remove the knob.
  - (3) Place the dial lock on the new control knob and seat the knob with the setscrew facing the flat side of the shaft. Tighten the setscrew; allow a slight space between the panel surface and the knob.
- Note:* If the setscrew is tightened on the round portion of the shaft, the dial settings (and the transmitted frequency) will be inaccurate.
- (4) Place the dial lock in approximately the normal position, close the lock, and replace the screws.
- c. *DY-88/GRC-9 Pluck-Out Items.*
- (1) Remove all power cables .
  - (2) Slide the DY-88/GRC-9 chassis out of its cover by loosening the eight clamps attached to the front panel.
  - (3) Remove vibrator E201 and thermal resistors (ballast tubes) R208 and R209 (fig. 19). No special instructions are needed.
  - (4) Remove thermal resistor R210 (fig. 19) from its socket as follows:
    - (a) Remove the metal cylindrical shield that covers R210 by twisting it counterclockwise to unlock it.
    - (b) Pull the shield straight up off the envelope of R210.
    - (c) Remove R210. No special instructions are needed to replace R210.
    - (d) Replace the metal cylindrical shield by seating it over R210 and twisting it clockwise until it locks.
- (5) Remove and replace capacitors C214, C215, and C229 and relays K202, K203, and K204 (fig. 20) as follows:
- (a) Remove the two screws that hold bracket 0214 to the chassis and remove the bracket (fig. 20).
  - (b) Remove and replace the capacitors and relays. No special instructions are needed.
  - (c) Replace bracket 0214 and secure it in the chassis with the two screws.
- (6) Seat the DY-88/GRC-9 chassis into its cover and then tighten the eight clamps attached to the front panel.
- d. *DY-88/GRC-9 Brushes.* When removing and replacing the dynamotor generator brushes, observe the markings and relative position of each brush with respect to its holder. Each brush is marked with a polarity on one side and may be marked with a wear line on the other. Replace each brush into the proper holder; keep the polarity mark facing upwards.
- (1) Loosen the eight clamps attached to the front panel, and slide the DY-88/GRC-9 chassis out of the cover.
  - (2) Remove the screws that hold each of the two front brush covers (fig. 19) to the dynamotor. Remove the front brush covers to expose the 12- and 24-volt brush holders.
  - (3) Remove the screws (fig. 20) that hold the rear brush cover to the dynamotor. Remove the brush cover to expose the 6- and 580-volt brush holders.
  - (4) Remove the applicable brush cap and brush.
  - (5) Replace the brush (polarity mark face up), the brush cap, and front and rear brush covers and secure with their respective screws.

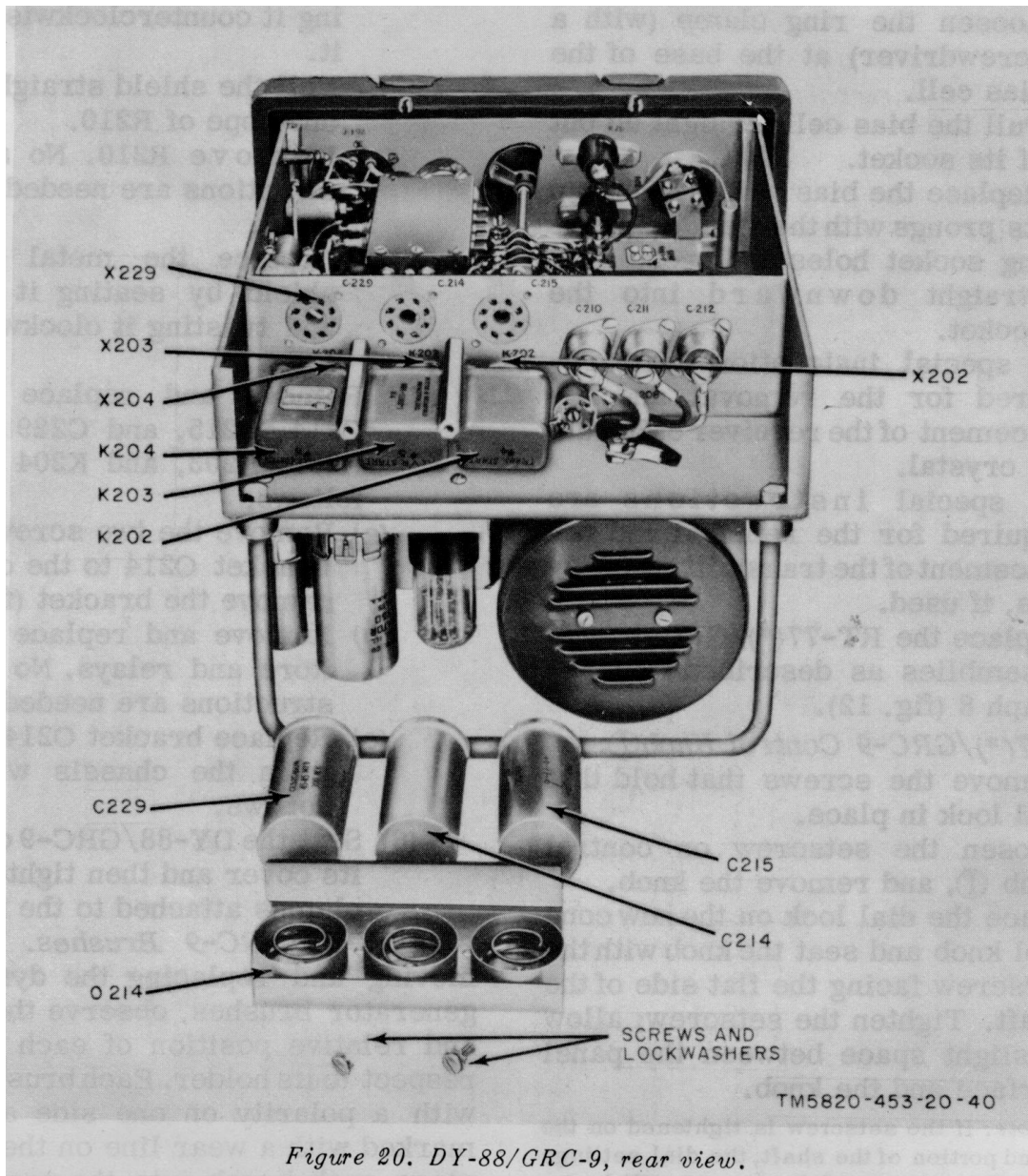

Figure 20. DY-88/GRC-9, rear view.

Figure 20. DY-88/GRC-9, rear view

- (6) Slide the DY-88/GRC-9 chassis into the cover and tighten the eight clamps attached to the front panel.

e. DY-105(\*)/GRC-9X, Pluck-Out Items.

- (1) Remove all power cables.
- (2) Loosen the eight clamps attached to the front panel, and slide the chassis of the DY-105(\*)/GRC-9X out of its cover.
- (3) Remove vibrator G1 and thermal resistors (ballast tubes) RT1 and RT2 (fig. 21). No special instructions are needed.
- (4) Remove and replace thermal resistor RT3 (fig. 21) as follows:

- (a) Remove the metal cylindrical shield that covers RT3 by twisting it counter clockwise until it unlocks; pull straight up off the RT3 envelope.
- (b) Remove RT3 from its socket. No special instructions are needed.
- (c) Replace the metal cylindrical shield by seating it over the envelope of RT3 and twisting it clockwise until it locks,
- (5) Seat DY-105(\*)/GRC-9X into its cover and tighten the eight clamps attached to the front panel.

f. Replacement of DY-105(\*)/GRC-9X Brushes.

- (1) Loosen the eight clamps attached to the front panel and remove the



chassis of the dynamotor-power supply from the cover.

- (2) Remove the screws that fasten each end cover. Remove the end covers to expose the 24-volt brush holder on one end and the 580-volt brush holder on the other (fig. 21).
- (3) Remove the applicable brush cap and brush.
- (4) Replace the new brush (polarity side facing up) and brush caps; replace the end brush

covers and secure with their respective screws.

- (5) Slide the DY-105(\*)/GRC-9X chassis into the cover and tighten the eight clamps attached to the front panel.

*g. Replacement of G-43/G Brushes.* Replacement instructions are found in TM 11-5122.

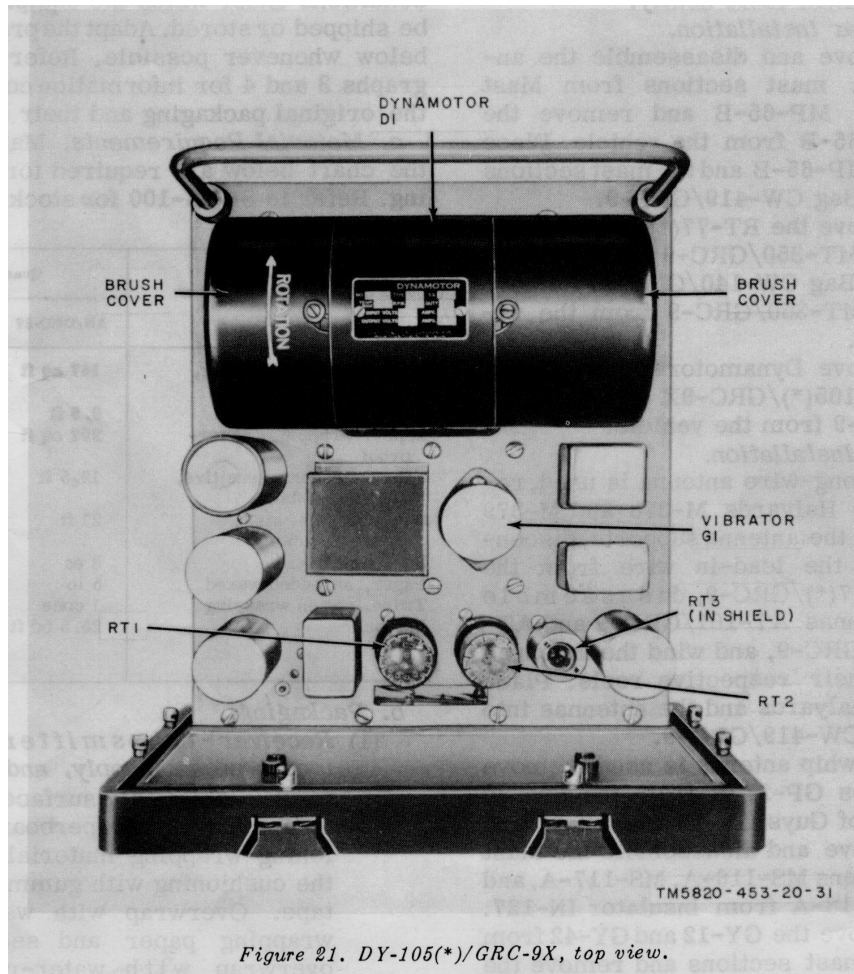

*Figure 21. DY-105(\*)/GRC-9X, top view.*

*Figure 21. DY-105(\*)/GRC-9X, top view*

## CHAPTER 3 SHIPMENT AND LIMITED STORAGE

### 24. Disassembly

The following instructions are used as a guide for preparing each radio set for shipment and storage.

#### a. Cables.

- (1) Disconnect all cables.
- (2) Coil each cable neatly.

#### b. Vehicular Installation.

- (1) Remove and disassemble the antenna mast sections from Mast Base MP-65-B and remove the MP-65-B from the vehicle. Place the MP-65-B end the mast sections into Bag CW-419/GRC-9.
- (2) Remove the RT-77(\*)/GRC-9 from the MT-350/GRC-9 and place it into Bag CW-140/GRC-9. Remove the MT-350/GRC-9 from the vehicle.
- (3) Remove Dynamotor-Power Supply DY - 105(\*)/GRC-9X Or DY-88/GRC-9 from the vehicle.

#### c. Ground Installation.

- (1) If a long-wire antenna is used, remove Halyards M-378 and M-379 from the antenna supports, disconnect the lead-in wire from the RT-77(\*)/GRC-9, disassemble Antennas AT-101/GRC-9 and AT102/GRC-9, and wind the antennas on their respective reels. Place the halyards and the antennas into Bag CW-419/GRC-9.
- (2) If a whip antenna is used, remove Stakes GP-27-B from the ground end of Guys GY-12 and GY-42 and remove and disassemble the Mast Sections MS-116-A, MS-117-A, and MS-118-A from Insulator IN-127. Remove the GY-12 and GY-42 from the mast sections and remove the IN-127 from the RT-77(\*)/GRC-9. Place the mast sections, the guys, the stakes and the insulator into Bag CW-419.
- (3) Disassemble Generator, Direct Current G-43/G as instructed in TM 11-5122 and place into Bag CW-420/GRC-9.

### 25. Repackaging

The exact procedures for repackaging depends on the material available and the conditions under which the equipment is to be shipped or stored. Adapt the

procedures below whenever possible. Refer to paragraphs 3 and 4 for information concerning the original packaging and their contents.

a. *Material Requirements.* Materials in the chart below are required for packaging. Refer to SB 38-100 for stock numbers of materials

Materials (estimated)	Quantity	
	AN/GRC-87	AN/VRC-34
Paperboard, cushioning, wrapping	147 sq ft	146 sq ft
Tape, paper, gummed	9.5 ft	9 ft
Paper, wrapping, water-proof	202 sq ft	200 sq ft
Tape, pressure-sensitive, water-resistant	12.5 ft	12 ft
Strapping, flat steel (5/8 x 0.020)	21 ft	20 ft
Box, fiberboard	8 ea	6 ea
Paper, shredded waxed	5 lb	5 lb
Twine ,cotton wrapping	1 cone	1 cone
Lumber	26.5 bd ft	24.3 bd ft.

#### b. Packaging.

- (1) *Receiver-t r a n s m i t t e r , d y n a - m o t o r - p o w e r s u p p l y , a n d g e n e r a t o r .* Cushion all surfaces of the equipment with paperboard cushioning wrapping material. Secure the cushioning with gummed paper tape. Overwrap with waterproof wrapping paper and secure the overwrap with water-resistant, pressure-sensitive tape.
- (2) *Miscellaneous components.* Wind each cable into a coil of convenient dimensions and tie each coil in three places with cotton wrapping twine; secure the connectors to the coils with the ties. Cushion the accessory bag with paper board cushioning wrapping material and secure it with gummed paper tape. Overwrap with waterproof wrapping paper and secure with water resistant pressure-sensitive tape. Consolidate the miscellaneous components with a cushion of paperboard cushioning material and secure it with gummed paper tape. Overwrap with waterproof wrapping paper and secure with water-resistant pressure-sensitive tape.

(3) *Technical manuals.* Wrap the technical manuals with waterproof wrapping paper and secure with water-resistant pressure-sensitive tape.

c. *Packing.* Place each cushioned item into a fiberboard box and pack each fiberboard box in a nailed wooden box. Fill all voids with shredded waxed paper. Nail down the box lid and strap the nailed wooden box.

# APPENDIX I

## REFERENCES

---

DA PAM 310-4	Index of Technical Manuals, Technical Bulletins, Supply Bulletins, Lubrication Orders, and Modification Work Orders.
MWO SIG 11-263-5	Modification of Dynamotor-Power Supply DY-88/GRC-9 to provide increased cooling capacity for Dynamotor.
MWO 11-5820-291-35/1	Modification of Receiver-Transmitter RT-77/GRC-9 to provide an improved mercury bias cell.
SB 11-131	Distribution of Vehicular Radio Sets.
SB 11-182	Dynamotor power supply DY-105 ( )/GRC-9X.
SB 11-253	Signal Corps Adopted Items of Materiel.
SB 11-265	Replacement of Battery BA-48 by Battery BA-317/U.
SB 11-474	Cross-Reference, Type Number to Federal Stock Number.
SB 11-501	Conversion of Radio Set AN/GRC-9(*) to Radio Set AN/ GRC-87(ground version) and AN/VRC-34 (vehicular version).
SB 38-100	Preservation, Packing, and Packing Materials, Supplies, and Equipment Used by the Army.
TB SIG 109	Headset H-16.
TB SIG 330	Microphone M-52/U and M-52A/U.
TM 10-500-10-2-3	Air Delivery of Supplies and Equipment: Rigging AN/GRC-87 and AN/VRC-18 Radio Set Mounted in M38A1 1/4-Ton Utility Truck on Combat-Expensible Platform.
TM 10-500-10A-3	Air Delivery of Supplies and Equipment: Rigging AN/GRC-87 and AN/VRC-18 Radio Set Mounted in M38A1 1/4-Ton Utility Truck.
TM 11-5122	Direct Current Generator G-43/G.
TM 11-5820-453-10	Operator's Manual, Radio Sets AN/GRC-87 and AN/VRC-34.
TM 11-5820-453-20P	Organizational Maintenance Repair Parts and Special Tool Lists, Radio Sets AN/GRC-87 and AN/VRC-34.
TM 11-5820-479-12P	Operator and Organizational Maintenance Repair Parts and Special Tools List and Maintenance Allocation Chart: Mast Base MP-65, MP-65A, and MP-65B.
TM 11-5965-212-15P	Operator, Organizational, Field and Depot Maintenance Repair Parts and Special Tools List and Maintenance Allocation Chart: Microphone M-52/U and M-52A/U.
TM 11-5965-213-15P	Maintenance Repair Parts and Special Tools List and Maintenance Allocation Chart for Permanent Magnet Loudspeaker LS-203/U (including LS-7 and LS-7A).
TM 11-5965-267-15P	Operator, Organizational, Field and Depot Maintenance Repair Parts and Special Tools List and Maintenance Allocation Chart: Headset, Electrical H-16/U.
TM 11-6625-203-12	Operation and Organizational Maintenance, Multimeter AN/ URM-105, including Multimeter ME-77/U.
TM 11-6625-274-12	Operator's and Organizational Maintenance Manual, Test Sets, Electron Tube TV-7/U, TV-7A/U, TV-7B/U, and TV-7D/U.
TM 38-750	The Army Equipment Record System and Procedure.

# APPENDIX II

## MAINTENANCE ALLOCATION

---

### Section I. INTRODUCTION

#### 1. General

a. This appendix assigns maintenance functions to be performed on components, assemblies, and subassemblies by the lowest appropriate maintenance echelon.

b. Columns in the maintenance allocation chart are as follows:

- (1) *Part or component.* This column shows only the nomenclature or standard item name. Additional descriptive data are included only where clarification is necessary to identify the component. Components, assemblies, and subassemblies are listed in top-down order. That is, the assemblies which are part of a component are listed immediately below that component, and the subassemblies which are part of an assembly are listed immediately below that assembly. Each generation breakdown (components, assemblies, or subassemblies) is listed in disassembly order or alphabetical order.
- (2) *Maintenance function.* This column indicates the various maintenance functions allocated to the echelons.
  - (a) *Service.* To clean, to preserve, and to replenish lubricants.
  - (b) *Adjust.* To regulate periodically to prevent malfunction.
  - (c) *Inspect.* To verify serviceability and to detect incipient electrical or mechanical failure by scrutiny.
  - (d) *Test.* To verify serviceability and to detect incipient electrical or mechanical failure by use of special equipment such as gages, meters, etc.
  - (e) *Replace.* To substitute serviceable components, assemblies, or subassemblies, for unserviceable components, assemblies, or subassemblies.
  - (f) *Repair.* To restore an item to serviceable condition through correction of a specific failure or unserviceable condition. This function includes but is not limited to welding, grinding, riveting, straightening, and replacement of parts other than the trial and error replacement of running spare type items such as fuses, lamps, or electron tubes.
  - (g) *Align.* To adjust two or more components of an electrical system so that their functions are properly synchronized.
  - (h) *Calibrate.* To determine, check, or rectify the graduation of an instrument, weapon, or weapons system, or components of a weapons system.
  - (i) *Overhaul.* To restore an item to *completely serviceable* condition as prescribed by serviceability standards developed and published by heads of technical services. This is accomplished through employment of the technique of "Inspect and Repair Only as Necessary" (IROAN). Maximum utilization of diagnostic and test equipment is combined with minimum disassembly of the item during the overhaul process.
  - (j) *Rebuild.* To restore an item to a standard as near as possible to original or new condition in appearance, performance, and life expectancy. This is accomplished through the maintenance technique of complete disassembly of the item, inspection of all parts or components, repair or replacement of worn or unserviceable elements using original manufacturing tolerances and/or specifications and subsequent reassembly of the item.

- (3) *1st, 2nd, 3d, 4th, 5th echelons.* The symbol X indicates the echelon responsible for performing that particular maintenance operation, but does not necessarily indicate that repair parts will be stocked at that level. Echelons higher than the echelon marked by X are authorized to perform the indicated operation.
- (4) *Tools required.* This column indicates codes assigned to each individual tool equipment, test equipment, and maintenance equipment referenced. The grouping of codes in this column of the maintenance allocation chart indicates the tool, test, and maintenance equipment required to perform the maintenance function.
- (5) *Remarks.* Entries in this column will be utilized when necessary to clarify any of the data cited in the preceding column.

c. Columns in the allocation of tools for maintenance functions are as follows:

- (1) *Tools required for maintenance functions.* This column lists tools, test, and maintenance equipment required to perform the maintenance functions.
- (2) *1st, 2nd, 3rd, 4th, 5th echelon.* The dagger (†) indicates the echelons normally allocated the facility.
- (3) *Tool code.* This column lists the tool code assigned.

## **2. Maintenance by Using Organizations**

When this equipment is used by signal services organizations organic to theater headquarters or communication zones to provide theater communications, those maintenance functions allocated up to and including fourth echelon are authorized to the organization operating this equipment.

## Section II. MAINTENANCE ALLOCATION CHART

PART OR COMPONENT	MAINTENANCE FUNCTION	ECHELON					TOOLS REQUIRED	REMARKS
		1	2	3	4	5		
RADIO SETS AN/GRC-87; AN/VRC-34	service		X					
	adust		X					
	inspect		X				15	Front panel controls
	test						5, 12, 15	For removal of covers
				X			3, 7, 9, 10, 12, 13,	Operational checks
	replace					X	1, 2, 4, 6, 7, 8, 10, 12, 13,	Frequency, tubechecks, continuity
						X	16, 17	Voltages, output waveforms audio,
	repair					X	1, 2, 4, 6, 7, 8, 10, 11, 13,	frequency, continuity, tubechecks
						X	16,17	All tests
	align		X					
overhaul			X				Minor repairs	
			X					
ANTENNA, AT-101/GRC-9, AT-102/GRC-9(AN/GRC-87 ONLY)	service		X				15	
	repair		X				15	Minor repairs
				X			13	
overhaul					X	13, 14	Plus shop facilities	
BAGS	replace	X						
CORD ASSEMBLIES	replace	X						
	repair			X			13	
DYNAMOTOR POWER SUPPLY, DY-88/GRC-9	service		X				15	
	test		X				5	To determine if unit is defective
				X			7	Troubleshooting
	replace		X			X	6, 7, 17	Pluck out parts and running spares
				X			15	
	repair			X			13	
align			X		X	13		
overhaul					X	6, 13, 17	Plus shop facilities	
					X	13, 14		
DYNAMOTOR	service		X				15	
	inspect		X				5	
	test		X				7	Operational checks
				X			15	Output voltages
	replace		X				15	
	repair			X			13	Minor repairs
	align					X	13, 14	
					X	17		
overhaul				X		13		
					X	13, 14	Plus shop facilities	
FASTENER, DZUS	replace	X						
	repair			X			14	
FILTER ASSEMBLY, ELECTRICAL	replace		X				13	Special dzus tool with equipment
	repair			X			13	

AN/GRC-87; AN/VRC-34 3

PART OR COMPONENT	MAINTENANCE FUNCTION	ECHELON					TOOLS REQUIRED	REMARKS
		1	2	3	4	5		
RADIO SETS AN/GRC-87; AN/VRC-34 (continued)								
DYNAMOTOR POWER SUPPLY, DY-105/GRC-9X, DY-105A/GRC-9X, DY-105B/GRC-9X	service test		X X	X			15 5	To determine if unit is defective
	replace		X		X		7	Troubleshooting
	repair			X			6, 7, 17, 15	Pluck out parts and running spares
	align		X				13	
	overhaul				X		13	Plus shop facilities
DYNAMOTOR DY-134/GRC-9X	service		X				6, 13, 17	
	inspect		X X				13, 14	
	replace		X	X			15	Operational checks
	repair			X			5 7	Output voltages
	overhaul				X		15 13	Minor repairs
FASTENER, DZUS	replace	X					13, 14	Plus shop facilities
	repair			X			13, 14	
	service	X	X		X		14	Special deus tool with equipment
GENERATOR, DIRECT CURRENT G-43/G (AN/GRC-87 ONLY)	replace		X				13	Refer to TM 11-5122 for maintenance allocation
HEADSET, ELECTRICAL H-16/U	service	X	X					
	replace		X	X				Minor repairs
KEY, J-45	service	X	X				13	Refer to TM 11-5965-213-15P for maintenance allocation
	replace	X						
	repair	X						
LOUDSPEAKER, PERMANENT MAGNET LS-203/U, LS-7A	service							Refer to TM 11-5820-479-12P for maintenance allocation
MAST BASE MP-65-B	replace							
	replace							



PART OR COMPONENT	MAINTENANCE FUNCTION	ECHELON					TOOLS REQUIRED	REMARKS
		1	2	3	4	5		
RADIO SETS AN/GRC-87; AN/VRC-34 (continued) METER, FIELD STRENGTH, ME-61/GRC	service	X						
	adjust		X				15 13	
	inspect		X	X			15 13	
	test		X		X		5, 12, 15, 7, 10	Operational checks
	replace	X			X		4, 6, 10, 14, 17	Replacement of knobs and screws
	repair				X			
	align				X	X	15 13	
	overhaul						10, 13 13, 14	Plus shop facilities
	service		X					Refer to TM 11-5965-212-15P for maintenance allocation
	replace	X						
MICROPHONE M-52/U	replace	X						
MOUNTING MT-350/GRC-9	replace	X						
	repair			X			13	
RECEIVER-TRANSMITTER, RT- 77/GRC-9, RT-77A/GRC-9	service		X					
	adjust		X					
	inspect		X					
	test		X	X			15	Front panel controls For removal of covers Operational checks
	replace		X		X		5, 12, 15, 3, 7, 9, 10, 12, 13	Frequency, tube checks and continuity
	repair			X		X	1, 2, 4, 6, 7, 8, 10, 12, 13 16, 17	Voltages, output waveforms audio, frequency, continuity, tube checks
	align				X		1, 2, 4, 6, 7, 8, 10, 11, 13 16, 17	All tests
	overhaul					X	15 13,14	Running spares Minor repairs
CABLE ASSEMBLY, SPECIAL PURPOSE, ELECTRICAL	replace	X					10, 13	
	repair			X			2, 10, 13, 17 13, 14	Plus shop facilities
							13	

**Section III. ALLOCATION OF TOOLS FOR MAINTENANCE FUNCTIONS**

TOOLS REQUIRED FOR MAINTENANCE FUNCTIONS	ECHELON					TOOL CODE	REMARKS
	1	2	3	4	5		
RADIO SETS AN/GRC-87; AN/VRC-34 (continued)						1	
ANALYZER, SPECTRUM, TS-723/U				†	†	2	
AUDIO OSCILLATOR, TS-382/U				†	†	3	
FREQUENCY METER, AN/URM-32				†		4	
FREQUENCY METER, AN/URM-79				†	†	5	
MULTIMETER, AN/URM-105		†				6	
MULTIMETER, ME-26/U				†	†	7	
OSCILLOSCOPE, AN/USM-50				†	†	8	
POWER SUPPLY, PP-1243/U				†	†	9	
SIGNAL GENERATOR, AN/URM-25				†		10	
TEST SET, ELECTRON TUBE, TV-2/U				†	†	11	
TEST SET, ELECTRON TUBE, TV-7/U					†	12	
TOOL KIT, TK-87/U		†	†	†		13	
TOOL KIT, TK-88/U			†	†	†	14	
TOOL KIT, TK-115/G				†	†	15	
WATTMETER, AN/URM-120		†				16	
VOLTMETER, METER ME-30/U				†	†	17	

AN/GRC-87; AN/VRC-34

By Order of Secretary of the Army:

EARLE G. WHEELER,  
*General, United States*

*Army,*

*Chief of Staff.*

Official:

J. C. LAMBERT,  
*Major General, United States Army,*  
*The Adjutant General.*

Distribution

*Active Army:*

DASA (6)	USAOSA (1)
USASA (2)	AFIP (1)
CNGB (1)	AMS (1)
CofEngrs (1)	USA Elect Mat Agcy (25)
TSG (1)	Chicago Proc Dist (1)
CSigO (7)	USASSC (4)
CofT (1)	USARCARIB Sig Agcy (1)
USA CD Agcy (1)	Sig Fld Maint Shops (3)
USCONARC (5)	JBUSMC (2)
USAMC (5)	Units org under fol TOE
USAECOM (5)	(2 copies each UNOINDC)
USAMICOM (4)	1-7
ARADCOM (2)	1-17
ARADCOM Rgn (2)	1-37
OS Maj Comd (3)	1-67
OS Base Comd (2)	1-127
LOGCOMD (2)	1-137
MDW (1)	5-5
Armies (2)	5-6
Corps (2)	5-15
USA Corps (3)	5-16
Instl (2) except	5-17
Ft Monmouth (63)	5-25
USATC AD (2)	5-26
USATC Armor (2)	5-27
USATC Engr (2)	5-35
USATC Inf (2)	5-36
USASTC (2)	5-37
Svc Colleges (2)	5-38
Br Svc Sch (2)	5-45
GENDEP (OS) (2)	5-46
Sig Dep (OS) (12)	5-47
Army Dep (2) except	5-49
Ft Worth (8)	5-52
Lexington (12)	5-54
Sacramento (17)	5-97
Tobyhanna (12)	5-112
Sig Sec, GENDEP (OS) (5)	5-114
USA Elct RD Actv (Ft Huachuca) (2)	5-115
USA Elct RD Actv (White Sands) (13)	5-116
WRAMC (1)	5-117
Army Pic Cen (2)	5-118
USA Mbl Spt Cen (1)	5-124
USA Trans Tml Comd (1)	5-145
Army Tml (1)	5-146
<u>POE (1)</u>	5-155

5-156	10-22	19-500 (AA-AE)
5-237	10-202	29-1
5-278	10-206	29-7
5-327	10-445	29-21
5-348	10-446	29-56
5-500 (AA-AD)	10-449	33-105
5-600	10-536	33-106
5-605	11-5	33-107
5-627	11-7	37
6-401	11-16	39-51
6-501	11-55	44-2
6-535	11-57	44-12
6-536	11-96	44-57
6-537	11-97	44-235
7	11-98	44-236
7-31	11-117	44-237
7-32	11-155	44-435
8-15	11-157	44-436
8-16	11-165	44-437
8-17	11-166	44-445
8-18	11-167	44-446
8-35	11-500 (AA-AC) (RM-RU) (4)	44-447
8-36	11-557	44-448
8-137	11-587	44-535
9-9	11-592	44-536
9-12	11-597	44-537
9-47	17	44-544
9-65	17-35	44-545
9-67	17-36	44-546
9-86	17-51	44-547
9-87	17-100	44-548
9-117	17-105	52-2
9-197	17-106	55-56
9-227	19-35	55-500 (AD, AE)
9-377	19-36	57
9-500 (AA-AC)	19-37	

*NG:* State AG (3); Units-Same as Active Army except allowance is one copy for each unit.

*USAR:* None.

For explanation of abbreviations used, see AR 320-50.

RECOMMENDED CHANGES TO EQUIPMENT TECHNICAL PUBLICATIONS

SOMETHING WRONG WITH PUBLICATION



THEN...JOT DOWN THE DOPE ABOUT IT ON THIS FORM. CAREFULLY TEAR IT OUT, FOLD IT AND DROP IT IN THE MAIL.

FROM: (PRINT YOUR UNIT'S COMPLETE ADDRESS)

DATE SENT

PUBLICATION NUMBER

PUBLICATION DATE

PUBLICATION TITLE

BE EXACT PIN-POINT WHERE IT IS

PAGE NO.

PARA-GRAPH

FIGURE NO.

TABLE NO.

IN THIS SPACE, TELL WHAT IS WRONG AND WHAT SHOULD BE DONE ABOUT IT.

TEAR ALONG PERFORATED LINE

PRINTED NAME, GRADE OR TITLE AND TELEPHONE NUMBER

SIGN HERE