

18 OCTOBER 1979 (SUPERSEDES LO5-6115-434-12, 30 December 1968)

**POWER UNIT UTILITY PACK: GAS TURBINE ENGINE  
DRIVEN (AIRESEARCH MODEL PPU85-5 TYPE A)**

Reference: TM5-6115-434-12, C9100-1L

Intervals and related task-hour times are based on normal hours of operation. The task-hour time specified is the time you need to do all the services prescribed for a particular interval. Change the interval if your lubricants are contaminated or if you are operating the equipment under adverse operating conditions, including longer-than-usual operating hours. You may extend the interval during periods of low activity, but you must take adequate preservation precautions.

Clean fittings before lubricating. Clean parts with SOLVENT dry cleaning SD-2. Dry before lubricating. Drain crankcase when HOT. Fill and check level. The lowest level of maintenance authorized to lubricate a point is indicated by one of the following: (C) Operator] crew; or (O) Organizational Maintenance.

.You can Improve this publication by calling attention to errors and by recommending improvements and by stating your reasons for the recommendations. Your letter or DA Form 2028 (Recommended Changes to Publications and Forms) should be mailed direct to Commander, U.S. Army Troop Support and Aviation Material Readiness Command, ATTN: DRSTS-MTPS, 4300 Goodfellow Blvd., St. Louis MO 63120. A reply will be furnished direct to you.

\*The time specified is the time required to perform all services at the particular interval.

LUBRICANT • INTERVAL

LUBRICANT • INTERVAL

Oil Fill Cap and Dipstick  
(Check oil level and replenish as required.)  
(See Note 2.) (O)

Oil Drain Cap  
(Drain and refill.) (O)

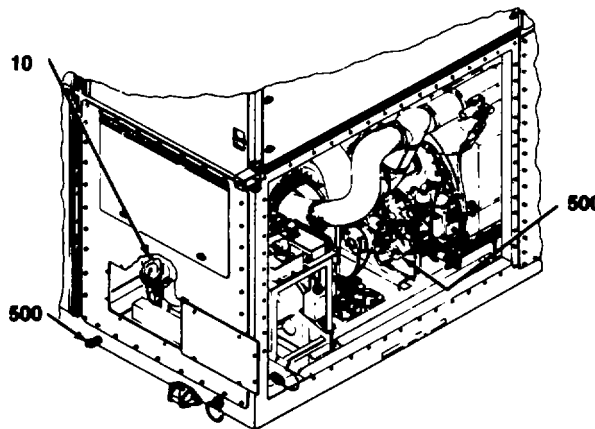

Oil Filter  
(Disassemble, clean housing, renew element, and reassemble.)(See note 1.) (O)

*TOTAL TASK HR.		*TOTAL TASK-HR.	
INTERVAL	TASK-HR	INTERVAL	MAN-HR
10	0.1	500	0.6

-- KEY --

LUBRICANTS	REFILL CAPACITY	ALL TEMPERATURES	INTERVALS
OIL, Turbine Engine	10 qt	MIL-L-7808 or MIL-L-23699 (See note 2)	Intervals given are in hours of normal operation.

**NOTES:**

1. OIL FILTER. After Installing new filter element, fill oil tank, operate engine 5 minutes, check level, check filter housing and lines for leaks.

2. CHANGING OIL BRANDS OR SPECIFICATIONS. Do not mix different brands or specifications of oil. The lubricant system must be flushed and the filter element replaced when changing from one brand or specification of oil to another.

3. LUBRICATION. The following is a list of lubricants with the Military Symbols and applicable specification numbers.  
MIL-L-7808  
MIL-L-23699

Copy of this Lubrication Order will remain with the equipment at all times; instructions contained herein are mandatory.

**By Order of the Secretary of the Army:**

**E. C. MEYER**  
*General United States Army*  
*Chief of Staff*

**Official:**

**J. C. PENNINGTON**  
*Major General, United States Army*  
*The Adjutant General*

**DISTRIBUTION:**

To be distributed in accordance with DA Form 12-25A, Operator Maintenance Requirements for MUST System Equipment.

**STS Form 2273**  
**1 Dec 76**

**CARD 2 of 2**  
**\* U.S.GOVERNMENT PRINTING OFFICE: 1992 - 311-831 (60067)**

RECOMMENDED CHANGES TO EQUIPMENT TECHNICAL PUBLICATIONS

 <p style="font-size: small; margin: 0;"><i>THEN...JOT DOWN THE DOPE ABOUT IT ON THIS FORM. CAREFULLY TEAR IT OUT, FOLD IT AND DROP IT IN THE MAIL.</i></p>		SOMETHING WRONG WITH PUBLICATION	
		FROM: (PRINT YOUR UNIT'S COMPLETE ADDRESS)	
		DATE SENT	
PUBLICATION NUMBER		PUBLICATION DATE	PUBLICATION TITLE
BE EXACT PIN-POINT WHERE IT IS			
PAGE NO.	PARA-GRAPH	FIGURE NO.	TABLE NO.
IN THIS SPACE, TELL WHAT IS WRONG AND WHAT SHOULD BE DONE ABOUT IT.			
PRINTED NAME, GRADE OR TITLE AND TELEPHONE NUMBER			SIGN HERE

# THE METRIC SYSTEM AND EQUIVALENTS

## WEIGHT MEASURE

1 Centimeter = 10 Millimeters = 0.01 Meters = 0.3937 Inches  
 1 Meter = 100 Centimeters = 1000 Millimeters = 39.37 Inches  
 1 Kilometer = 1000 Meters = 0.621 Miles

## WEIGHTS

1 Gram = 0.001 Kilograms = 1000 Milligrams = 0.035 Ounces  
 1 Kilogram = 1000 Grams = 2.2 lb.  
 1 Metric Ton = 1000 Kilograms = 1 Megagram = 1.1 Short Tons

## LIQUID MEASURE

1 Milliliter = 0.001 Liters = 0.0338 Fluid Ounces  
 1 Liter = 1000 Milliliters = 33.82 Fluid Ounces

## SQUARE MEASURE

1 Sq. Centimeter = 100 Sq. Millimeters = 0.155 Sq. Inches  
 1 Sq. Meter = 10,000 Sq. Centimeters = 10.76 Sq. Feet  
 1 Sq. Kilometer = 1,000,000 Sq. Meters = 0.386 Sq. Miles

## CUBIC MEASURE

1 Cu. Centimeter = 1000 Cu. Millimeters = 0.06 Cu. Inches  
 1 Cu. Meter = 1,000,000 Cu. Centimeters = 35.31 Cu. Feet

## TEMPERATURE

$5/9(^{\circ}\text{F} - 32) = ^{\circ}\text{C}$   
 212° Fahrenheit is equivalent to 100° Celsius  
 90° Fahrenheit is equivalent to 32.2° Celsius  
 32° Fahrenheit is equivalent to 0° Celsius  
 $9/5^{\circ}\text{C} + 32 = ^{\circ}\text{F}$

## APPROXIMATE CONVERSION FACTORS

TO CHANGE	TO	MULTIPLY BY
Inches	Centimeters	2.540
Feet	Meters	0.305
Yards	Meters	0.914
Miles	Kilometers	1.609
Square Inches	Square Centimeters	6.451
Square Feet	Square Meters	0.093
Square Yards	Square Meters	0.836
Square Miles	Square Kilometers	2.590
Acres	Square Hectometers	0.405
Cubic Feet	Cubic Meters	0.028
Cubic Yards	Cubic Meters	0.765
Fluid Ounces	Milliliters	29.573
its	Liters	0.473
arts	Liters	0.946
allons	Liters	3.785
Ounces	Grams	28.349
Pounds	Kilograms	0.454
Short Tons	Metric Tons	0.907
Pound-Feet	Newton-Meters	1.356
Pounds per Square Inch	Kilopascals	6.895
Miles per Gallon	Kilometers per Liter	0.425
Miles per Hour	Kilometers per Hour	1.609

TO CHANGE	TO	MULTIPLY BY
Centimeters	Inches	0.394
Meters	Feet	3.280
Meters	Yards	1.094
Kilometers	Miles	0.621
Square Centimeters	Square Inches	0.155
Square Meters	Square Feet	10.764
Square Meters	Square Yards	1.196
Square Kilometers	Square Miles	0.386
Square Hectometers	Acres	2.471
Cubic Meters	Cubic Feet	35.315
Cubic Meters	Cubic Yards	1.308
Milliliters	Fluid Ounces	0.034
Liters	Pints	2.113
Liters	Quarts	1.057
ers	Gallons	0.264
ms	Ounces	0.035
ograms	Pounds	2.205
Metric Tons	Short Tons	1.102
Newton-Meters	Pounds-Feet	0.738
Kilopascals	Pounds per Square Inch	0.145
ometers per Liter	Miles per Gallon	2.354
ometers per Hour	Miles per Hour	0.621

