

✓ 1/4 pd 413
12
TM
1944

TM 9-811

WAR DEPARTMENT TECHNICAL MANUAL

U.S. Dept. of Army

4-TON, 6x6 TRUCKS

(DIAMOND T MODELS

968A CARGO,

969A WRECKER,

970A PONTON,

AND 972 DUMP)

UNIVERSITY of CALIFORNIA
LIBRARY
MAY 27 1947
SERIALS DIVISION

WAR DEPARTMENT

25 JANUARY 1944

WAR DEPARTMENT TECHNICAL MANUAL

*TM 9-811

4-TON, 6x6 TRUCKS
(DIAMOND T MODELS
968A CARGO,
969A WRECKER,
970A PONTON,
AND 972 DUMP)



WAR DEPARTMENT

25 January 1944

***This manual supersedes TB 811-1 dated 22 October 1943. This manual also contains pertinent information from TM 10-1297, TM 10-1335, TM 10-1517, TM 10-1533, TM 10-1605, and TM 10-1607, and, together with TM 9-1811 and TM 9-1832A, supersedes these manuals.**

WAR DEPARTMENT
Washington 25, D. C., 25 January 1944

TM 9-811, 4-ton, 6 x 6 Trucks (Diamond T Models 968A Cargo, 969A Wrecker, 970A Ponton, and 972 Dump) is published for the information and guidance of all concerned.

[A. G. 300.7 (3 June 43)]

BY ORDER OF THE SECRETARY OF WAR:

G. C. MARSHALL,
Chief of Staff.

OFFICIAL:

J. A. ULIO,
Major General,
The Adjutant General.

DISTRIBUTION: X

(For explanation of symbols, see FM 21-6)

U113

2
TM 9-811

TM 9-811

CONTENTS

1944

PART ONE—VEHICLE OPERATING INSTRUCTIONS

SECTION		Paragraphs	Pages
I	Introduction	1	5- 6
II	Description and tabulated data	2-4	7-23
III	Driving controls and operation	5-8	24-37
IV	Operation of auxiliary equipment	9-13	38-53
V	Operation under unusual conditions	14-19	54-66
VI	Inspection and preventive maintenance service.....	20-24	67-76
VII	Lubrication	25-26	77-84
VIII	Tools and equipment stowage on vehicles.....	27-31	85-96

PART TWO—VEHICLE MAINTENANCE INSTRUCTIONS

SECTION IX	FSMWO and major unit as- sembly replacement record.	32	97
X	Organizational tools and equip- ment	33	98
XI	New vehicle run-in test.....	34-36	99-103
XII	Organization preventive main- tenance services.....	37	104-118
XIII	Trouble shooting.....	38-56	119-133
XIV	Engine maintenance and ad- justment in vehicle.....	57-68	134-148
XV	Engine removal and installation	69-70	149-154
XVI	Clutch	71-74	155-160
XVII	Fuel system.....	75-79	161-169
XVIII	Intake and exhaust systems..	80-82	170-173
XIX	Cooling system.....	83-88	174-186
XX	Ignition system.....	89-92	187-192
XXI	Generating system.....	93-95	193-198
XXII	Starting system.....	96-99	199-202

FB74657

TM 9-811

**4-TON, 6 x 6 TRUCKS (DIAMOND T MODELS 968A CARGO,
969A WRECKER, 970A PONTON, AND 972 DUMP)**

	Paragraphs	Pages
SECTION XXIII Batteries and lighting system .	100-102	203-218
XXIV Transmission	103-105	219-225
XXV Transfer	106-109	226-232
XXVI Propeller shafts and universal joints	110-112	233-239
XXVII Front axle	113-117	240-245
XXVIII Rear axles	118-121	246-249
XXIX Brakes	122-136	250-279
XXX Wheels	137-139	280-291
XXXI Suspension	140-144	292-307
XXXII Steering	145-149	308-311
XXXIII Frame and bodies	150-154	312-320
XXXIV Power take-off	155-157	321-323
XXXV Front-mounted winch	158-163	324-330
XXXVI Wrecker	164-171	331-343
XXXVII Wrecker air compressor	172-176	344-348
XXXVIII Dump pump and hoist	177-179	349-354
XXXIX Cab	180-184	355-361
XL Sheet metal	185-190	362-368
XLI Instruments	191-198	369-372
XLII Radio interference suppression	199-203	373-378
XLIII Shipment and temporary storage	204-206	379-383
REFERENCES		384-385
INDEX		386

PART ONE—VEHICLE OPERATING INSTRUCTIONS

Section I

INTRODUCTION

	Paragraph
Scope	1

1. SCOPE.

a. *This technical manual is published for the information and guidance of the using arm personnel charged with the operation and maintenance of this materiel.

b. In addition to a description of the 4-ton, 6 x 6 truck (Diamond T, Models 968A Cargo, 969A Wrecker, 970A Ponton, and 972 Dump), this manual contains technical information required for the identification, use, and care of the materiel. The manual is divided into two parts. Part One, section I through section VIII, contains vehicle operating instructions. Part Two, section IX through section XLIII, contains vehicle maintenance instructions for the using arm personnel charged with the responsibility of doing maintenance work within their jurisdiction.

c. In all cases where the nature of the repair, modifications, or adjustment is beyond the scope or facilities of the unit, the responsible ordnance service should be informed, so that trained personnel with suitable tools and equipment may be provided, or proper instructions issued.

*To provide operating instructions with the materiel, this technical manual has been published in advance of complete technical review. Any errors or omissions will be corrected by changes, or, if extensive, by an early revision.

TM 9-811

2

4-TON, 6 x 6 TRUCKS (DIAMOND T MODELS 968A CARGO,
969A WRECKER, 970A PONTON, AND 972 DUMP)

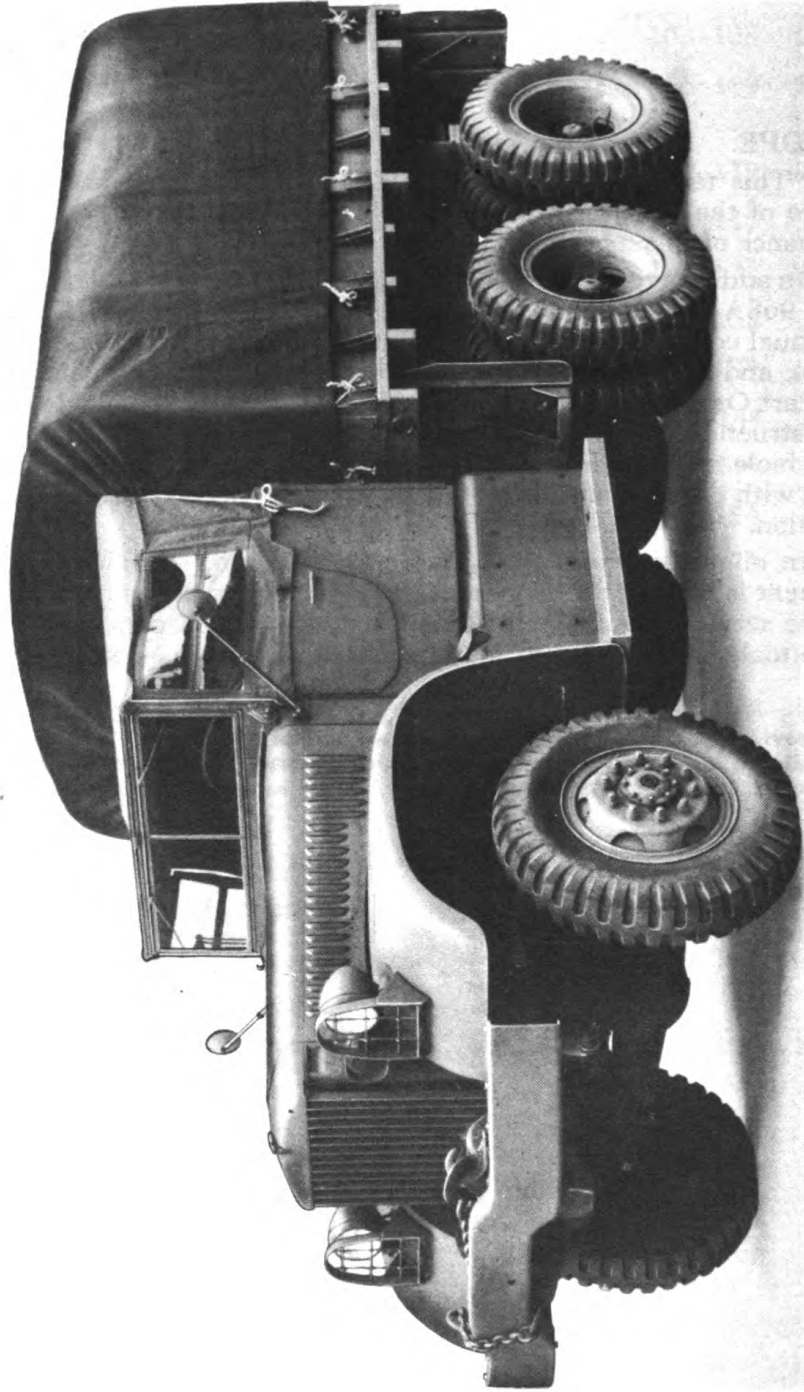

PD 303923

Figure 1—Model 968A Cargo Truck with Open Cab—3/4 Front

Section II

DESCRIPTION AND TABULATED DATA

	Paragraph
Description	2
Designations	3
Data	4

2. DESCRIPTION.

a. General. The various models covered by this publication are all built on the same basic chassis, which is a 4-ton, 6 x 6 job, powered with a conventional six-cylinder gasoline engine. A five-speed overdrive transmission and a direct and underdrive transfer are used on all models. All three axles are driving axles of conventional double-reduction design. Rear axles are dual-wheeled.

b. Identification. The four chassis are similar in appearance, and are built with open-type and closed-type cabs. These vehicles may be recognized by the design of the cabs, the contour of the fenders, and the appearance of the hood and radiator. The axle housings are clearly visible under the vehicle, and may be recognized as the banjo type. The vehicles may be positively identified by the nomenclature plate mounted on the left cowl side under the hood.

c. Differences among Models (figs. 1, 2, 3, and 4).

(1) **CARGO TRUCK (MODEL 968A).** The cargo truck is built on the standard 4-ton, 6 x 6 chassis. Special equipment consists of a standard-type wooden cargo body with a tarpaulin top and troop seats, a power-driven, front-mounted winch, and two spare tires. The power take-off is mounted on the transmission.

(2) **WRECKER TRUCK (MODEL 969A)** (figs. 5, 6, 7, and 8). The wrecker truck is built on the standard 4-ton, 6 x 6 chassis. Special equipment consists of a steel wrecker body, twin boom power-driven wrecker equipment, welding tanks and equipment, a gasoline-driven air compressor unit, a power-driven front-mounted winch, and two spare tires. The power take-off which drives the wrecker equipment is mounted on the transfer, and the power take-off which drives the winch is on the transmission.

(3) **PONTON TRUCK (MODEL 970A)** (figs. 9 and 10). The ponton truck is built on a chassis which is the same as the standard 4-ton, 6 x 6 chassis, except that it has a longer wheelbase (par. 5). Special equipment consists of a standard-type wooden ponton body, with a tarpaulin top and a power-driven front-mounted winch. The power take-off is mounted on the left side of the transmission.

(4) **DUMP TRUCK (MODEL 972)** (figs. 11 and 12). The dump truck is built on the standard 4-ton, 6 x 6 chassis. Special equipment consists of a steel dump body, with power-driven hoist equipment. The power take-off for the hoist is mounted on the transfer case. There is no winch on this model.

TM 9-811

2

4-TON, 6 x 6 TRUCKS (DIAMOND T MODELS 968A CARGO,
969A WRECKER, 970A PONTON, AND 972 DUMP)

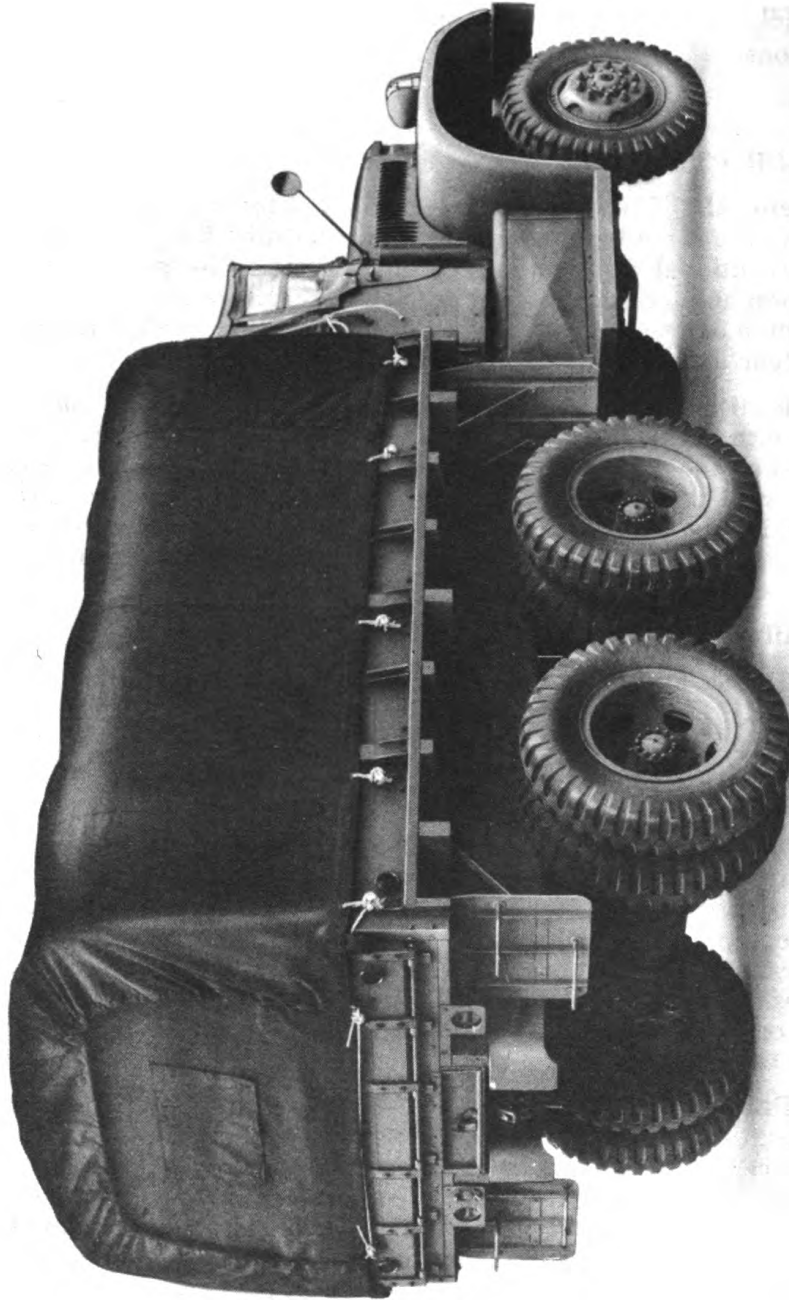

RA PD 303924

Figure 2—Model 968A Cargo Truck with Open Cab—2/3 Rear

DESCRIPTION AND TABULATED DATA

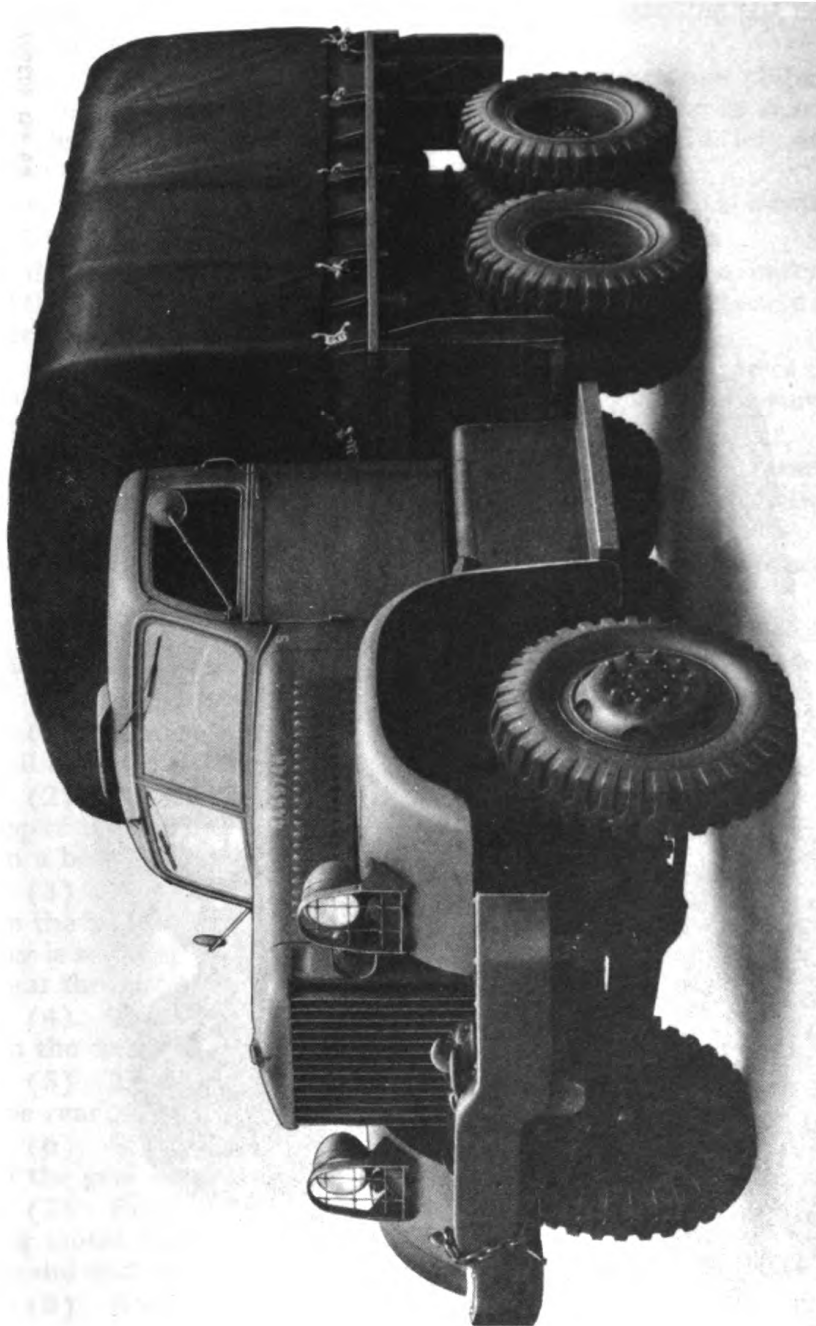

RA PD 303925

Figure 3—Model 968A Cargo Truck with Closed Cab—3/4 Front

TM 9-811
2

4-TON, 6 x 6 TRUCKS (DIAMOND T MODELS 968A CARGO,
969A WRECKER, 970A PONTON, AND 972 DUMP)

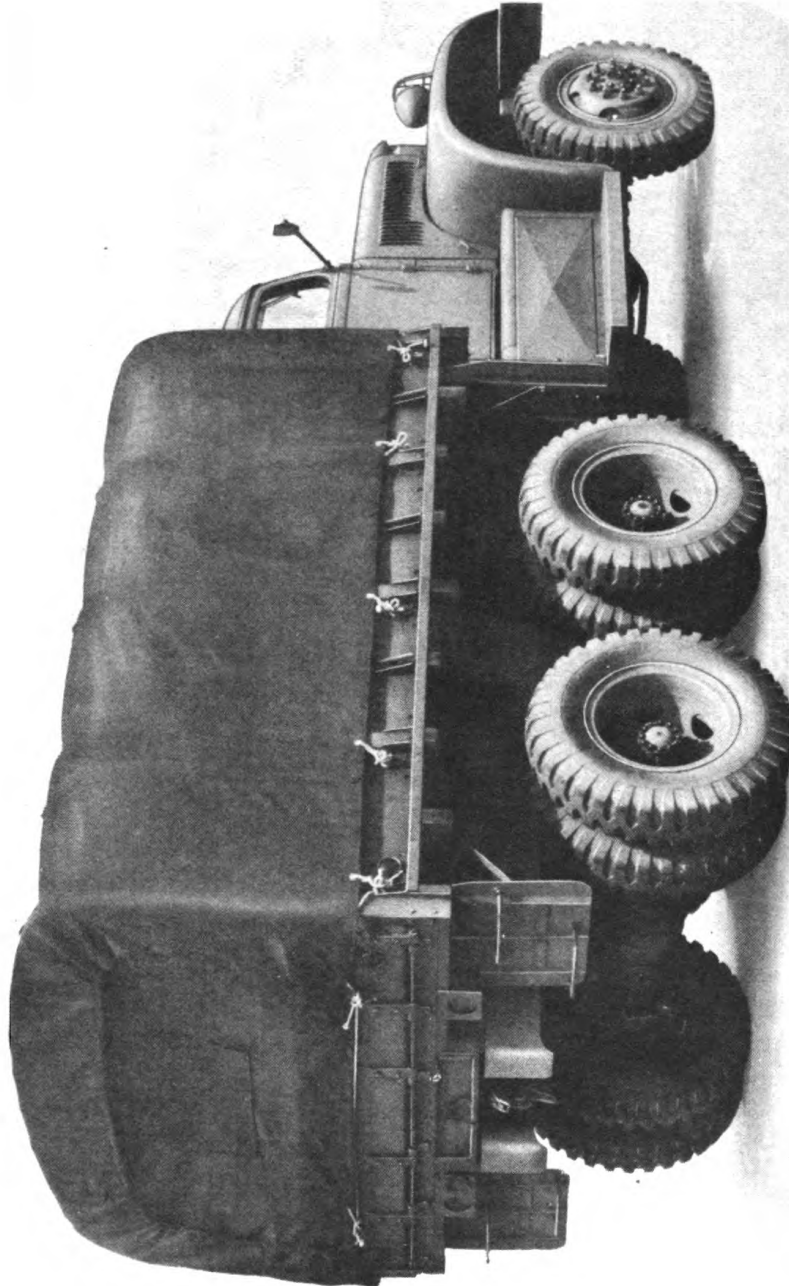

RA PD 303926

Figure 4—Model 968A Cargo Truck with Closed Cab—3/4 Rear

DESCRIPTION AND TABULATED DATA

3. DESIGNATIONS.

a. **General.** Serial numbers and type designations sometimes appear on plates attached to the various units, and sometimes are stamped on the units. Detailed information regarding the location of these follows:

b. **Chassis Plate** (fig. 13). A chassis nomenclature plate, showing the vehicle nomenclature, make, model, weights, serial number, and gasoline and oil recommendations, is attached to the left side of the cowl under the hood.

c. **Engine Plate.** An engine serial number plate is located on the left side of the cylinder block.

d. **Publication Plate** (fig. 14). A plate is mounted on the left side of the cowl under the hood, which lists the Ordnance Department numbers of publications applying to these vehicles.

e. **Winch Plate** (fig. 14). A plate is mounted on top of the winch gear box which gives the model and serial number of the winch assembly. This plate is not found on dump trucks.

f. **Winch Power Take-off Plate** (fig. 14). A serial number plate is mounted on the transmission power take-off shifting cover. This plate is not found on dump trucks.

g. **Wrecker Plate** (fig. 14). A serial number plate is attached to the right side of the wrecker frame.

h. **Wrecker Air Compressor Plates** (fig. 14). A serial number plate is attached to the air compressor units used on wrecker models.

i. **Miscellaneous Designations.**

(1) **FRAME.** Vehicle serial number is stamped on the right side-rail over the front spring rear hanger.

(2) **FRONT AXLE.** The front axle serial number is stamped on the top of the housing banjo, and that of the differential carrier is stamped on a boss at the filler plug.

(3) **REAR AXLES.** The forward rear axle serial number is stamped on the housing just above the level plug. The rear rear axle serial number is stamped on the housing banjo on the side opposite the filler plug near the carrier deck.

(4) **TRANSFER.** The transfer serial number is stamped on a boss on the case next to the filler plug.

(5) **TRANSMISSION.** The transmission serial number is located on the rear face of the case.

(6) **STEERING GEAR.** An identification number is stamped on top of the gear housing.

(7) **ELECTRICAL ACCESSORIES.** The generator, distributor, starting motor, starter switch and solenoid switch have plates designating model and manufacturing data. Generators also carry serial numbers.

(8) **AIR COMPRESSOR.** A plate showing model and manufacturing data is attached to the air compressor.

(9) **GOVERNOR.** A plate showing the serial number is attached to the governor flyball housing.

(10) **BATTERY.** The type designation is stamped on one of the cell connecting bars.

TM 9-811

3

4-TON, 6 x 6 TRUCKS (DIAMOND T MODELS 968A CARGO,
969A WRECKER, 970A PONTON, AND 972 DUMP)

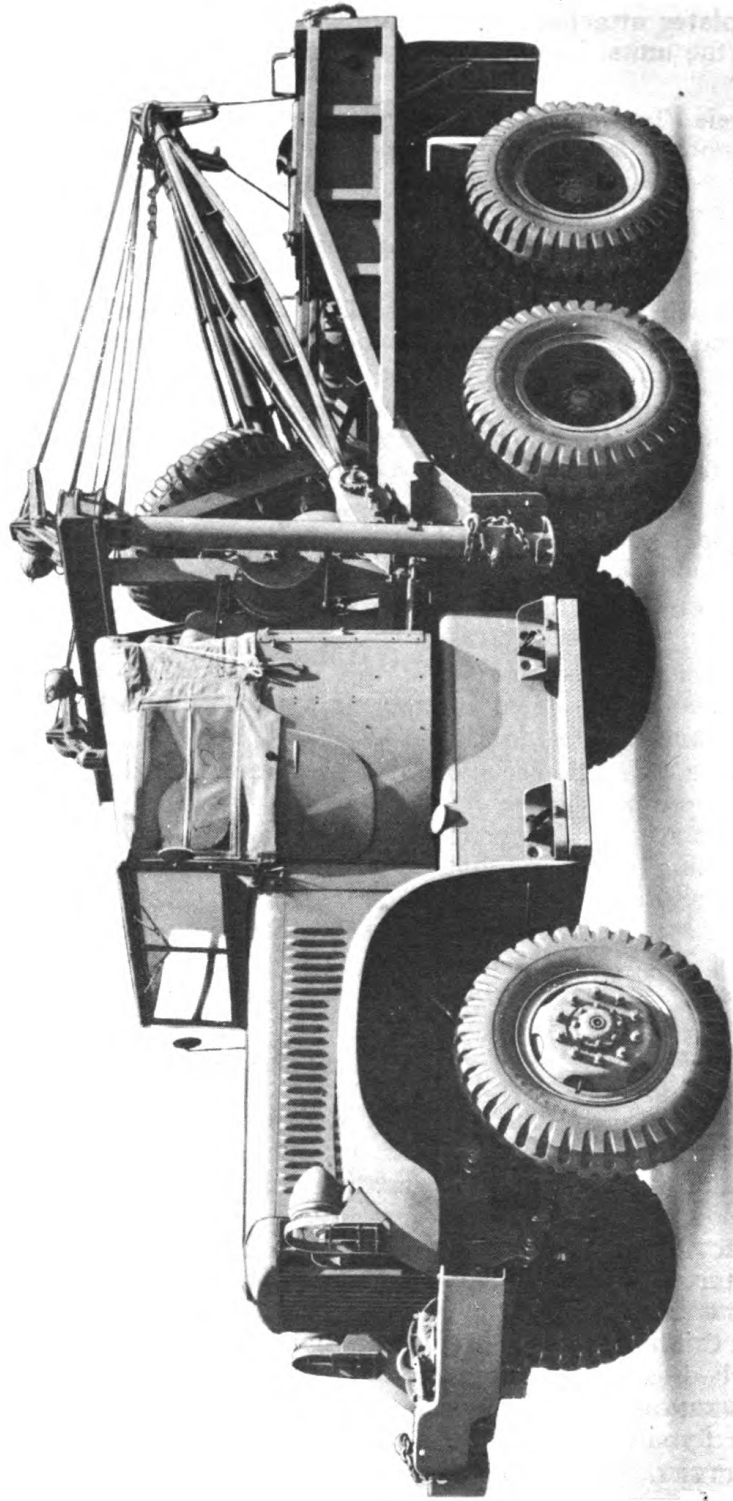

RA PD 303927

Figure 5—Model 969A Wrecker Truck with Open Cab—3/4 Front

DESCRIPTION AND TABULATED DATA

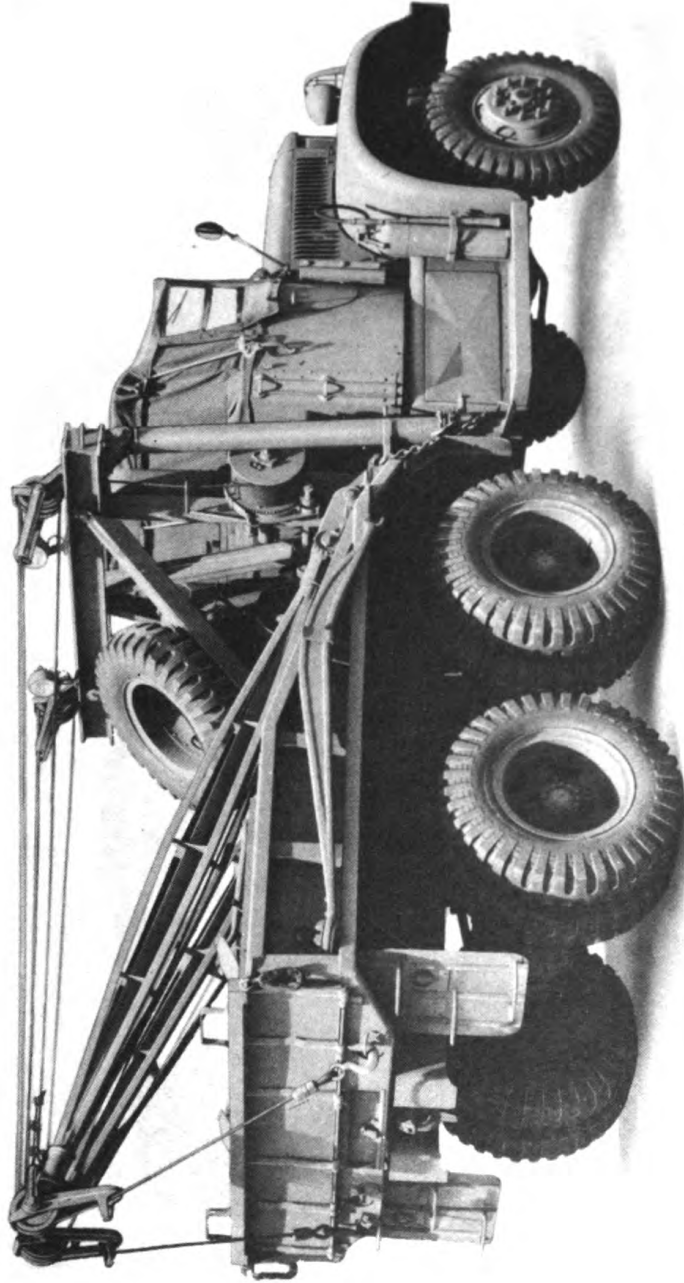

RA PD 303928

Figure 6—Model 969A Wrecker Truck with Open Cab—3/4 Rear

TM 9-811

3

4-TON, 6 x 6 TRUCKS (DIAMOND T MODELS 968A CARGO,
969A WRECKER, 970A PONTON, AND 972 DUMP)

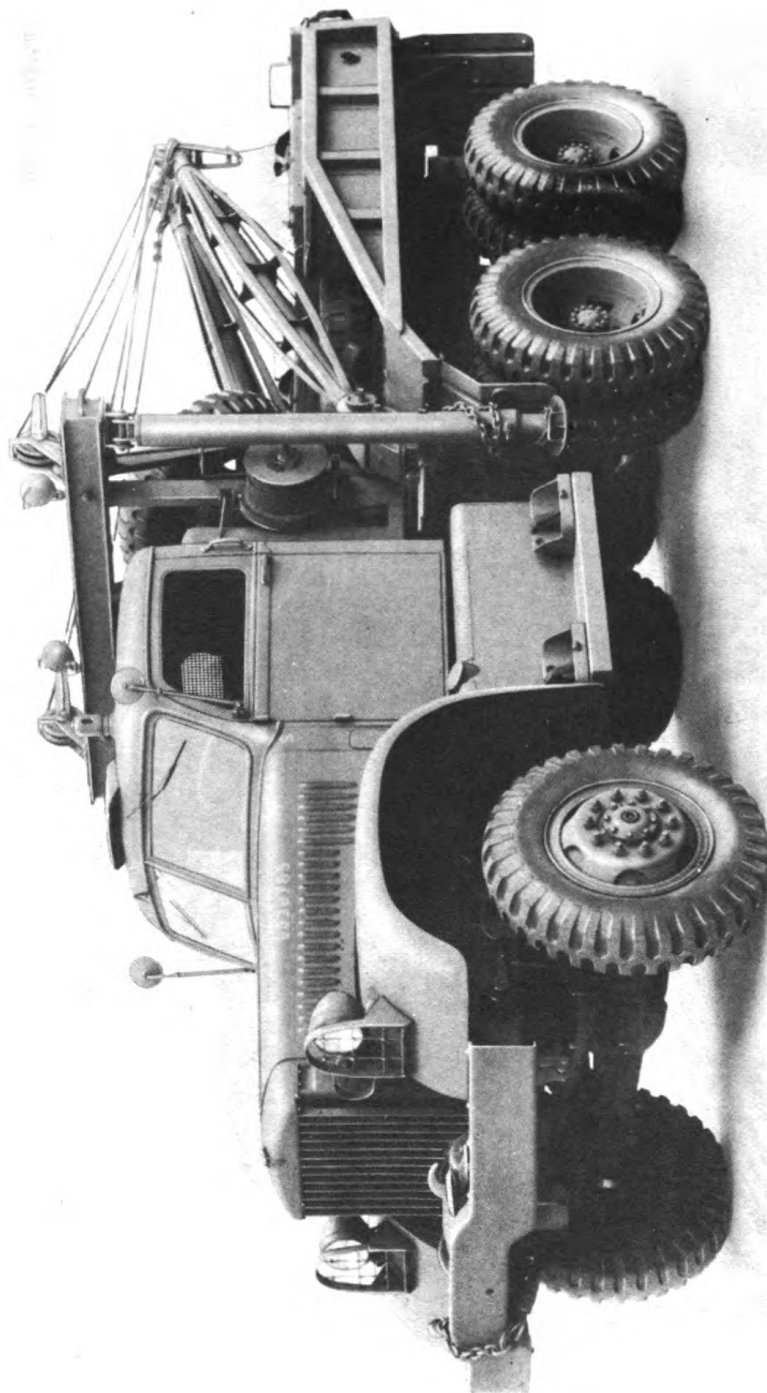

RA PD 303929

Figure 7—Model 969A Wrecker Truck with Closed Cab—3/4 Front

DESCRIPTION AND TABULATED DATA

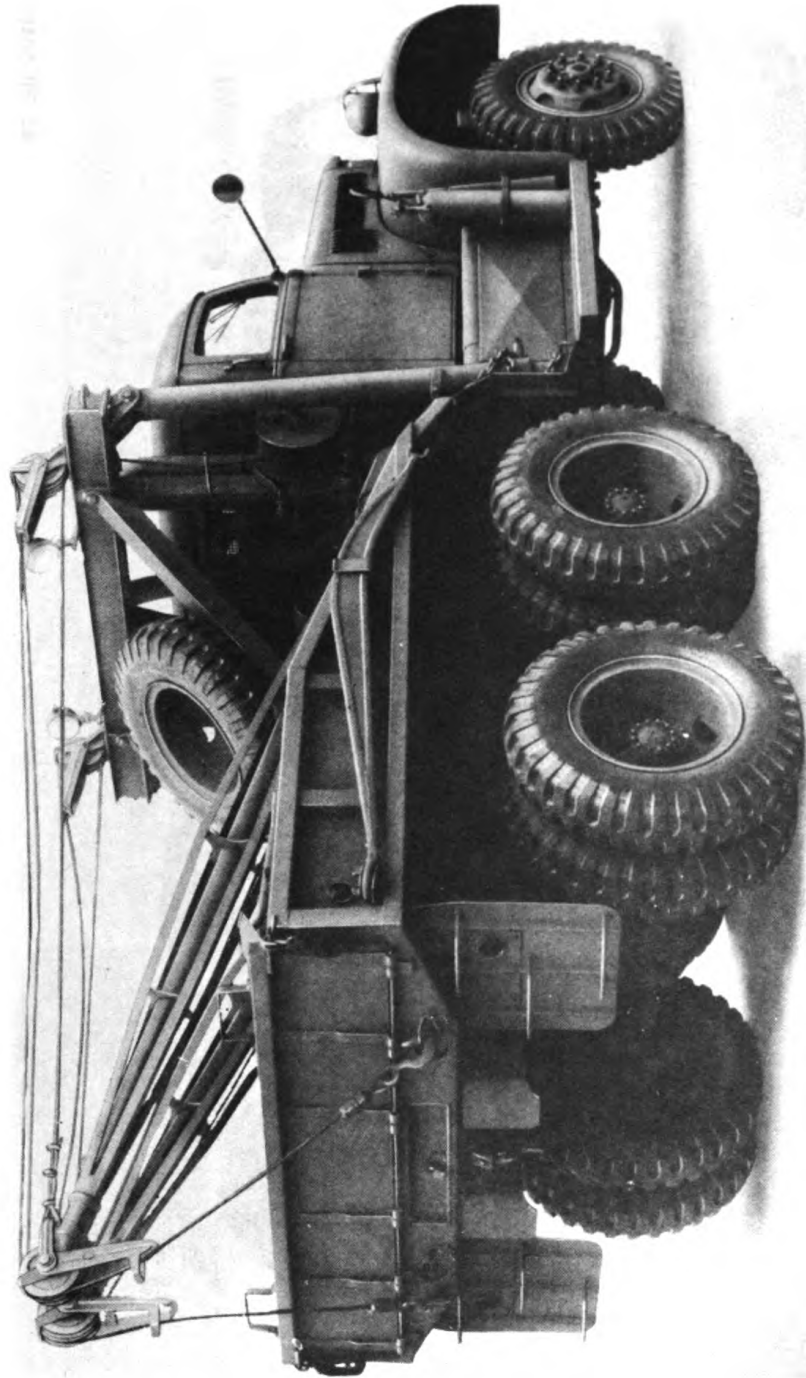

RA PD 303930

Figure 8—Model 969A Wrecker Truck with Closed Cab—3/4 Rear

TM 9-811
3

4-TON, 6 x 6 TRUCKS (DIAMOND T MODELS 968A CARGO,
969A WRECKER, 970A PONTON, AND 972 DUMP)

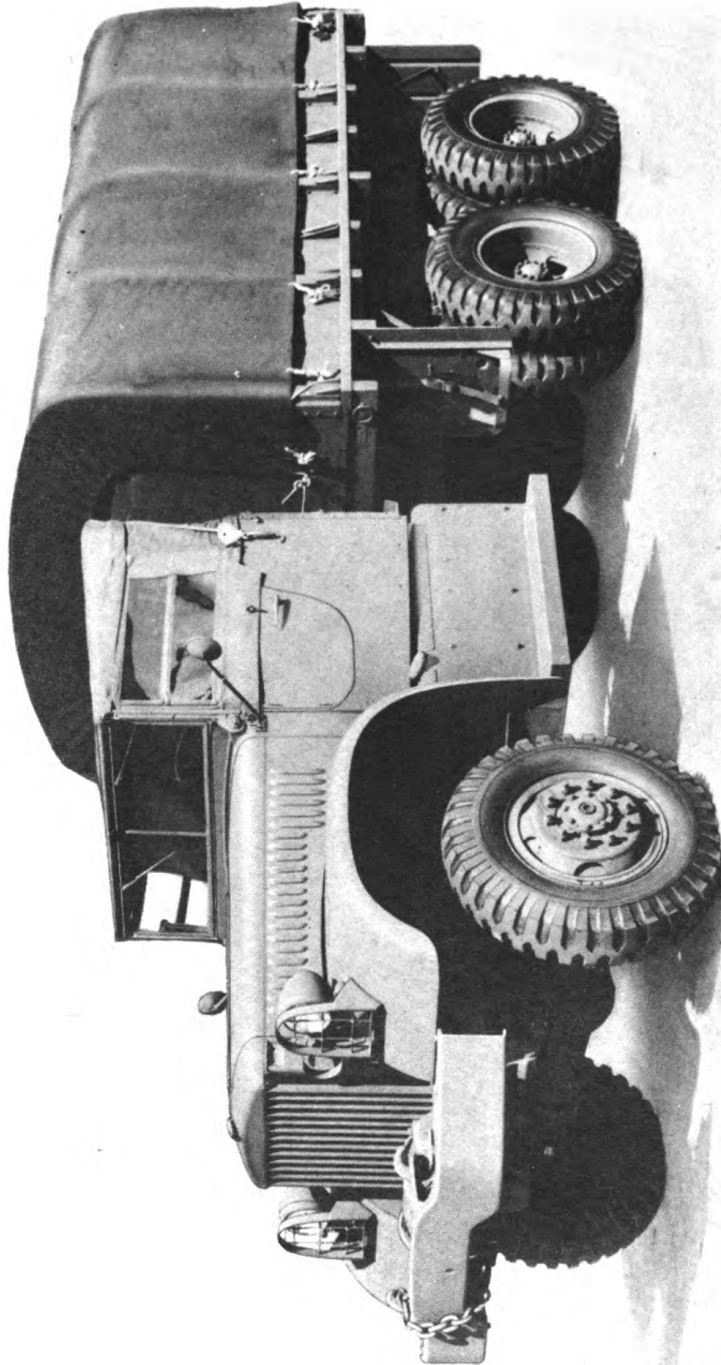

RA PD 303931

Figure 9—Model 970A Ponton Truck with Open Cab—3/4 Front

DESCRIPTION AND TABULATED DATA

RA PD 303932

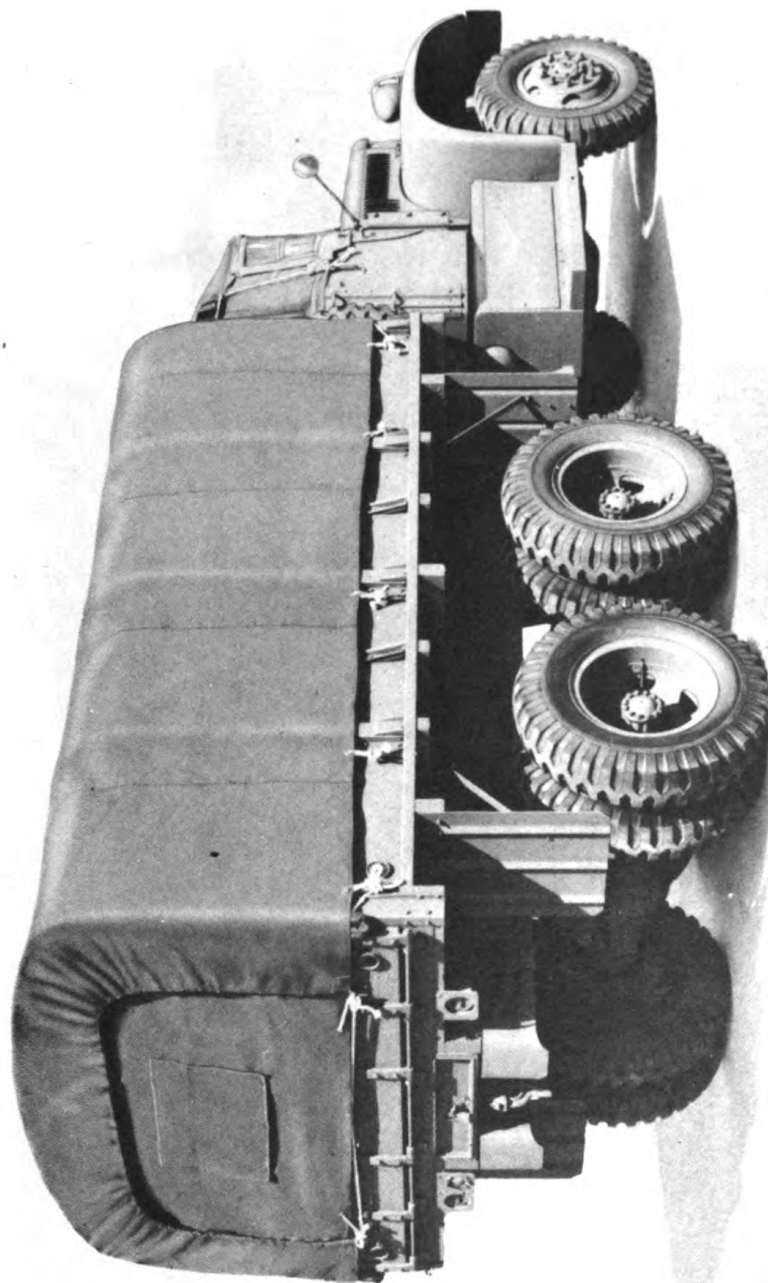
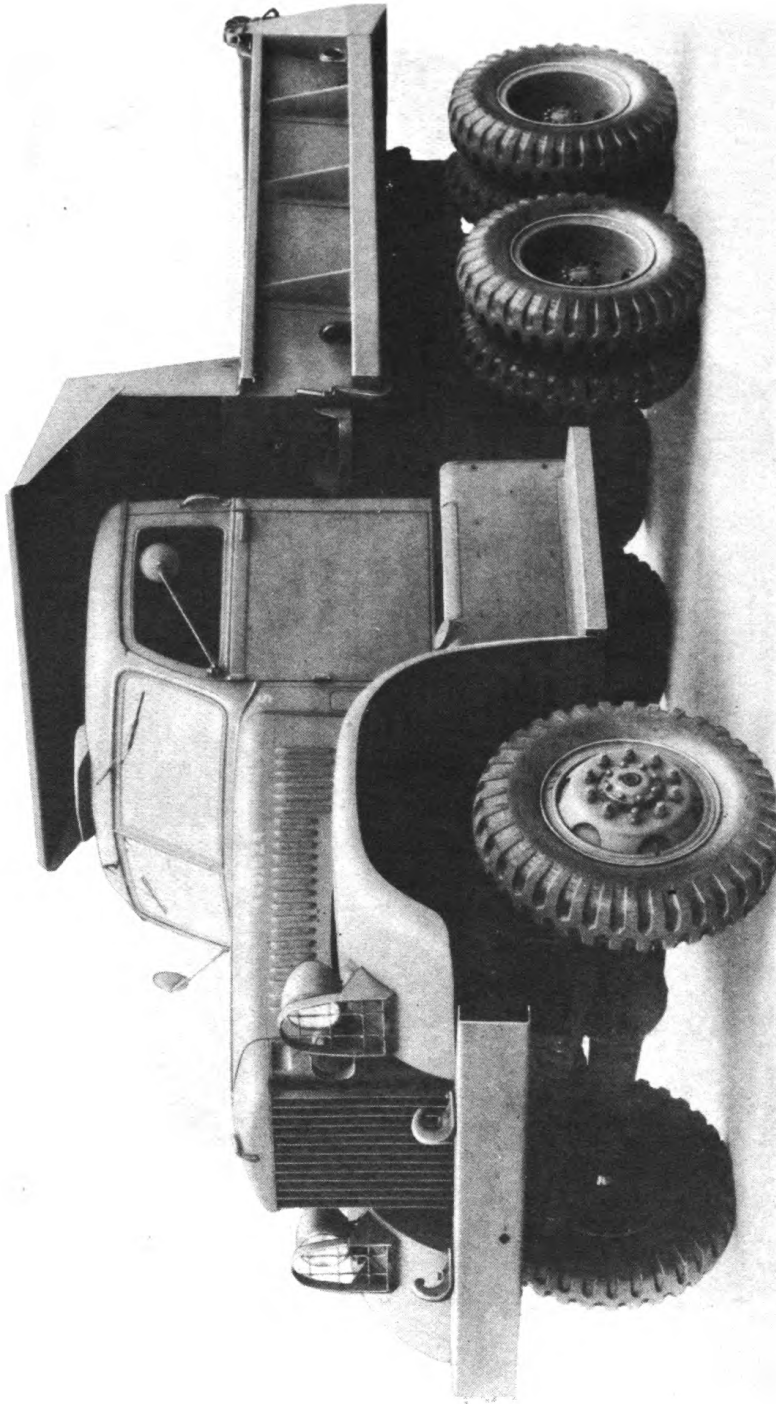

Figure 10—Model 970A Ponton Truck with Open Cab—3/4 Rear

TM 9-811

3

4-TON, 6 x 6 TRUCKS (DIAMOND T MODELS 968A CARGO,
969A WRECKER, 970A PONTON, AND 972 DUMP)



RA PD 303933

Figure 11—Model 972 Dump Truck with Closed Cab—3/4 Front

DESCRIPTION AND TABULATED DATA

RA PD 303934

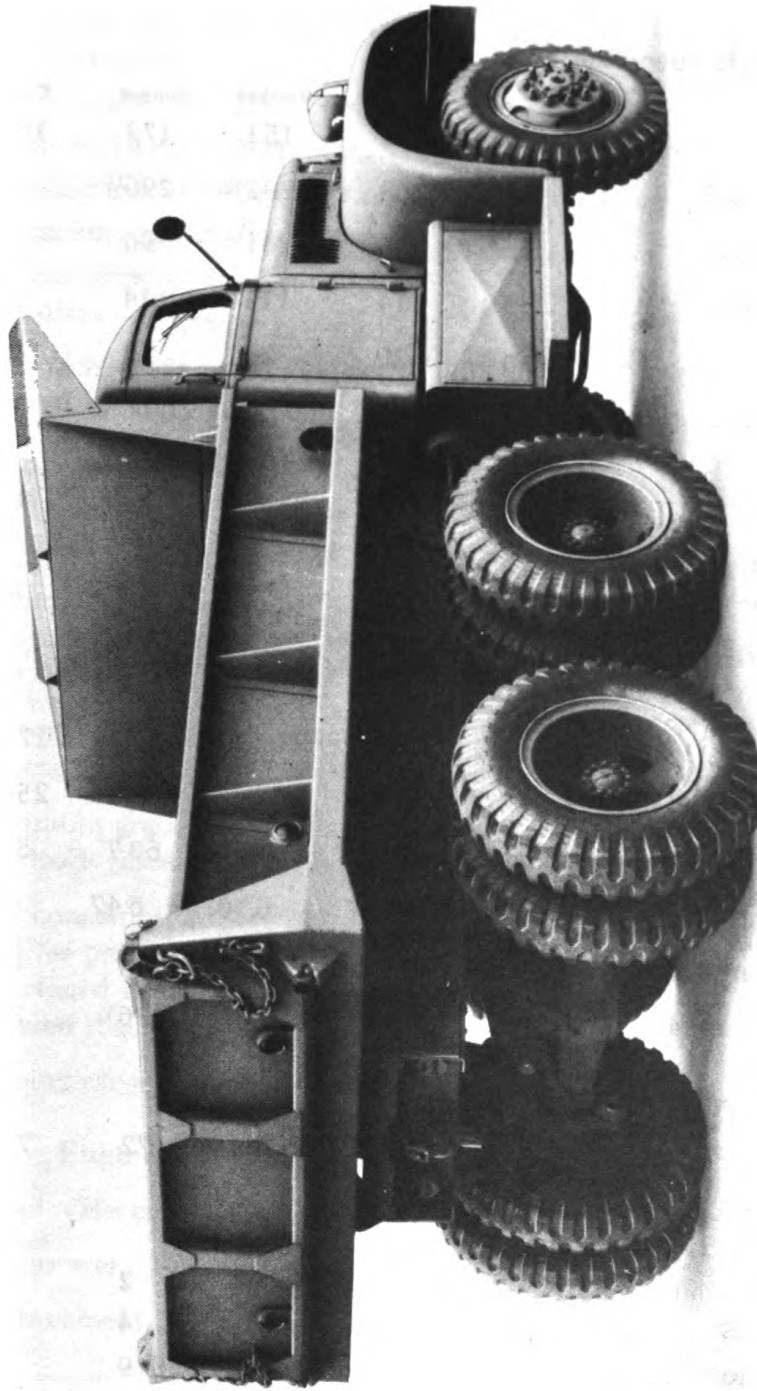

Figure 12—Model 972 Dump Truck with Closed Cab—3/4 Rear

TM 9-811

4

4-TON, 6 x 6 TRUCKS (DIAMOND T MODELS 968A CARGO, 969A WRECKER, 970A PONTON, AND 972 DUMP)

4. DATA.

a. Vehicle Specifications.

	Cargo	Wrecker	Ponton	Dump
Wheelbase (in.)	151	151	172	151
Length, over-all (in.)	268	291 ⁵ / ₈	296 ¹ / ₈	
Width, over-all (in.)	96	101	96	
Height, over-all (in.)	114	111	114	
Wheel size (in.)	20	20	20	20
Tire size (in.)	9.00x20	9.00x20	9.00x20	9.00x20
	Rib	Rib	Rib	Rib
Tire type	Tread	Tread	Tread	Tread
Tread (center to center)				
(front) (in.)	73 ³ / ₄	73 ³ / ₄	73 ³ / ₄	73 ³ / ₄
Tread (center to center)				
(rear) (in.)	72 ³ / ₄	72 ³ / ₄	72 ³ / ₄	72 ³ / ₄
Weight (empty) (lb)	18,400	21,700	18,800	17,725
Weight (loaded) (lb)	26,400	26,800	25,725
Ground pressure (psi max)	60.7	61.6	60.7	53.6
Ground contact (sq in. min)	6.47	6.50	6.47	6.22
Ground clearance (in.)	11	11	11	11
Pintle height (loaded) (in.)	36 ³ / ₄	36 ³ / ₄	36 ³ / ₄	36 ³ / ₄

b. Performance.

Fuel (octane)	72	72	72	72
Maximum speeds in low range in the transfer:				
Transmission in 1st . . . (mph)	2	2	2	2
Transmission in 2nd . . (mph)	4	4	4	4
Transmission in 3rd . . (mph)	9	9	9	9
Transmission in direct (mph)	17	17	17	17
Transmission in over-drive (mph)	22	22	22	22

DESCRIPTION AND TABULATED DATA

	Cargo	Wrecker	Ponton	Dump
Maximum speeds in high range in transfer:				
Transmission in 1st. . . (mph)	4	4	4	4
Transmission in 2nd. . (mph)	8	8	8	8
Transmission in 3rd. . (mph)	16	16	16	16
Transmission in direct (mph)	30	30	30	30
Transmission in over-drive (mph)	40	40	40	40
Approach angle (deg)	37	37	37	37
Departure angle (deg)	46	46	46	46
Minimum turning radius,				
Right (ft in.)	36-5	36-5	38-5	36-5
Left (ft in.)	35-0	35-0	37-0	35-0
Fording depth (height of tail pipe (in.)				
	24	24	24	24
Towing facilities:				
Front (tow hooks)	2	2	2	2
Rear	Pintle	Pintle	Pintle	Pintle
Maximum grade without load (ascending)				
	65%	65%	65%	65%
Fuel consumption:				
Miles per gallon (hard-surfaced roads without towed load)	3	3	3	3
Cruising range (miles)	150-175	150-175	150-175	150-175
c. Engine.				
Model (Hercules)	RXC	RXC	RXC	RXC
Horsepower (SAE)	51.34	51.34	51.34	51.34
Displacement (cu in.)	529	529	529	529
Bore (in.)	4 $\frac{5}{8}$	4 $\frac{5}{8}$	4 $\frac{5}{8}$	4 $\frac{5}{8}$
Stroke (in.)	5 $\frac{1}{4}$	5 $\frac{1}{4}$	5 $\frac{1}{4}$	5 $\frac{1}{4}$
Number of cylinders	6	6	6	6
Governed speed (rpm)	2300	2300	2300	2300

TM 9-811

4

4-TON, 6 x 6 TRUCKS (DIAMOND T MODELS 968A CARGO, 969A WRECKER, 970A PONTON, AND 972 DUMP)

d. Capacities.

Fuel tanks	60 gal
Engine crankcase—refill.....	16 qt
Cooling system	48 qt
Transmission with P.T.O.....	24 pt
Transmission without P.T.O.....	21 pt
Transfer	3 pt
Front axle differential.....	15 pt
Rear axle differential (2 differentials) each.....	7½ pt
Winch	3½ pt
Carburetor air cleaner.....	4½ pt
Engine crankcase breather.....	¼ pt
Briggs and Stratton engine.....	1 pt
Kellogg compressor.....	½ pt
DeVilbiss compressor.....	1 pt
Wrecker transmission	8 pt

NOMENCLATURE TRUCK, 4-TON (HC) 6X6	
SUPPLY ARM OR SERVICE	
MAINTAINING VEHICLE	ORDNANCE DEPT.
MAKE AND MODEL	DIAMOND-T MODEL 968-A
SERIAL NUMBER	
GROSS WEIGHT	LBS
MAXIMUM PAYLOAD	8,000 LBS
MAXIMUM TRAILED LOAD	11,000 LBS
DATE OF DELIVERY	
RECOMMENDED BY MANUFACTURER	
OCTANE RATING OF GASOLINE	72
S. A. E. GRADE OF OIL BELOW 32° F.	10
S. A. E. GRADE OF OIL ABOVE 32° F.	30

NOMENCLATURE TRUCK WRECKER, 4 TON, 6X6	
SUPPLY ARM OR SERVICE	
MAINTAINING VEHICLE	ORDNANCE DEPT.
MAKE AND MODEL	DIAMOND-T MODEL 969-A
SERIAL NUMBER	
GROSS WEIGHT	LBS.
MAXIMUM BOOM LOAD	6,000 LBS.
DATE OF DELIVERY	
RECOMMENDED BY MANUFACTURER	
OCTANE RATING OF GASOLINE	72
S. A. E. GRADE OF OIL BELOW 32° F.	10
S. A. E. GRADE OF OIL ABOVE 32° F.	30

NOMENCLATURE TRUCK, PONTON, 4 TON (HC) 6X6	
SUPPLY ARM OR SERVICE	
MAINTAINING VEHICLE	ORDNANCE DEPT.
MAKE AND MODEL	DIAMOND-T MODEL 970-A
SERIAL NUMBER	
GROSS WEIGHT	LBS.
MAXIMUM PAYLOAD	8,000 LBS.
MAXIMUM TRAILED LOAD	11,000 LBS.
DATE OF DELIVERY	
RECOMMENDED BY MANUFACTURER	
OCTANE RATING OF GASOLINE	72
S. A. E. GRADE OF OIL BELOW 32° F.	10
S. A. E. GRADE OF OIL ABOVE 32° F.	30

NOMENCLATURE TRUCK, DUMP, 4 TON (HC) 6X6	
SUPPLY ARM OR SERVICE	
MAINTAINING VEHICLE	ORDNANCE DEPT.
MAKE AND MODEL	DIAMOND-T MODEL 972
SERIAL NUMBER	
GROSS WEIGHT	26,400 LBS.
MAXIMUM PAYLOAD	LBS.
DATE OF DELIVERY	
RECOMMENDED BY MANUFACTURER	
OCTANE RATING OF GASOLINE	72
S. A. E. GRADE OF OIL BELOW 32° F.	10
S. A. E. GRADE OF OIL ABOVE 32° F.	30

RA PD 303935

Figure 13—Chassis Plates

DESCRIPTION AND TABULATED DATA



WINCH P.T.O. PLATE



AIR COMPRESSOR PLATES

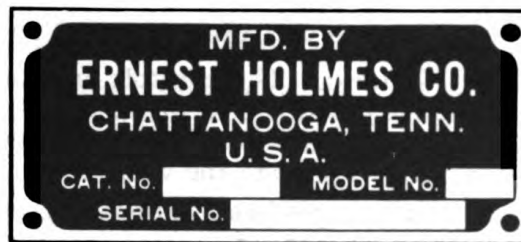

WRECKER PLATE



ENGINE PLATE

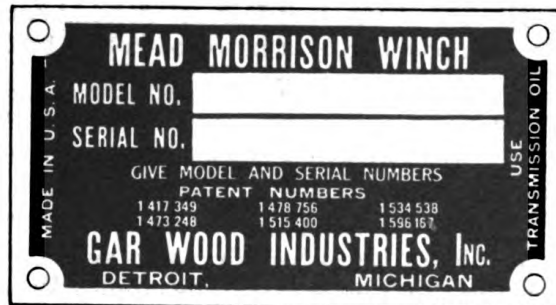

WINCH PLATE



PUBLICATION PLATE

RA PD 313907

Figure 14—Serial Plates

**4-TON, 6 x 6 TRUCKS (DIAMOND T MODELS 968A CARGO,
969A WRECKER, 970A PONTON, AND 972 DUMP)**

Section III

DRIVING CONTROLS AND OPERATION

	Paragraph
Controls and cab equipment	5
Starting and warming up the engine	6
Operating the vehicle	7
Towing the vehicle	8

5. CONTROLS AND CAB EQUIPMENT (figs. 15 and 16).

a. General. The controls are employed according to the usual automotive practice. The driver must become thoroughly familiar with the location and use of all control devices and instruments before attempting to operate the vehicle.

b. Steering Wheel. The vehicle is steered by a conventional type of steering mechanism.

c. Horn Button. A conventional push-button type of horn control switch is located at the center of the steering wheel.

d. Warning Plate (fig. 17). Several plates which contain special information and cautions to be observed in vehicle operation are mounted on the dash inside the cab. The operator should read these plates and become familiar with their content before operating the vehicle.

e. Windshield Wiper. Conventional-type windshield wipers are mounted at the top of each windshield glass. They are controlled by valves at each end of the instrument panel.

f. Hand Control Valve. A hand control valve is mounted on the steering post and is used to control air brakes on a trailed unit.

g. Windshield Wiper Control. Air control valves are mounted at each end of the dash to control the windshield wipers.

h. Instrument Lights. Three instrument lights are arranged at the top of the dash to illuminate the instruments for night driving. These are controlled by a plunger-type switch mounted on the dash.

i. Main Light Switch. This switch, located at the top of the dash, controls the complete lighting circuit. When the button is flush with the dash, all of the lights are out. When pulled out against the latch stop, the blackout lights come into service. With the latch depressed and the button pulled to the second out position, all the service lights come into operation. For day driving the stop lights only are in circuit with the button pulled to the full-out position.

j. Tachometer. A tachometer, or engine revolution counter, is provided to aid the driver in maintaining definite engine speeds, and in intelligently changing gear ratios in the transmission and transfer case. The tachometer has a set hand with a lock, which records the maximum engine speed reached.

DRIVING CONTROLS AND OPERATION

k. Ammeter. A conventional-type ammeter is located near the center of the dash. It is useful in checking operation of generator and regulator.

l. Panel Light Switch. A plunger-type switch is mounted near the center of the dash to control the instrument lights. It will not turn the dash lights on unless the main light switch is in the second out position.

m. Front Battery Ammeter. An indicating ammeter (without graduations) is mounted on the left side of the dash. It indicates when the front battery (which does not register on the ammeter in the charging circuit) is not being charged.

n. Viscometer. A viscometer gage is mounted on the dash on the right side of the instrument group. It indicates the condition of the crankcase lubricant. If the viscosity is not normal on the gage after the engine is thoroughly warmed up, it is an indication of an improper grade of oil, a sludge condition, or dangerous crankcase dilution. **NOTE:** *Run engine at a speed slightly in excess of idling speed.*

o. Speedometer. A conventional mileage recording speedometer with a speed range of 60 miles per hour is used. It is located near the center of the dash.

p. Temperature Gage. This gage is located above and to the right of the ignition switch. It registers the operating temperature of the engine, which should be 160°F to 180°F for good performance.

q. Hand Throttle Button. The throttle button, mounted at the right of the choke, is used when starting or making adjustments on an engine. It should be kept in idling position (flush with dash) during all ordinary driving.

r. Oil Pressure Gage. An oil pressure gage is located at the center of the dash and is an indicator of the efficiency of engine lubrication. Oil pressure should not be less than 5 to 10 pounds at idling speeds and not less than 25 pounds at running speeds.

s. Choke Button. A choke control button is mounted on the dash, to the right of the ignition switch. The choke is used to assist in starting the engine, especially when cold. Choking the engine results in an over-rich mixture which washes lubricant from the cylinder walls and dilutes the crankcase oil. For this reason the choke should be used only when necessary.

t. Ignition Switch. A lever-operated ignition switch is located at the center of the dash. It functions the same as the conventional key-type ignition lock, except that a permanently mounted lever tumbler is used, and no key is required.

u. Fuel Gage. An electric-type fuel gage is mounted on the dash above and to the left of the ignition switch.

v. Spark Control. A manual control, mounted on the dash to the left of the ignition switch, is provided to advance and retard the spark as driving conditions warrant. The spark should be retarded with the engine lugging, to eliminate spark knock.

w. Air Pressure Gage. This gage registers the air pressure (in pounds per square inch) available for brake application. It provides a convenient method of checking the operation of the compressor, and is

4-TON, 6 x 6 TRUCKS (DIAMOND T MODELS 968A CARGO, 969A WRECKER, 970A PONTON, AND 972 DUMP)

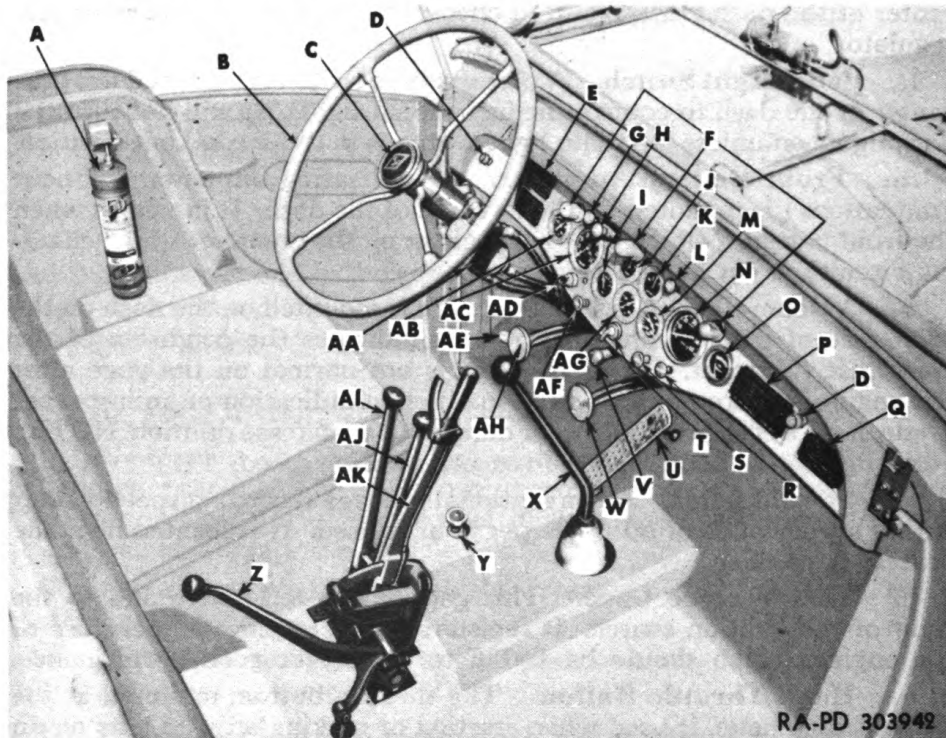

- | | | | |
|----------|---|-----------|-----------------------------------|
| A | FIRE EXTINGUISHER | S | CHOKE CONTROL |
| B | STEERING WHEEL | T | IGNITION SWITCH |
| C | HORN BUTTON | U | ACCELERATION PEDAL |
| D | WINDSHIELD WIPER CONTROL | V | COWL VENTILATOR HANDLE |
| E | WARNING PLATES | W | BRAKE PEDAL |
| F | DASH LAMP | X | TRANSMISSION LEVER |
| G | BLACKOUT DRIVING LAMP SWITCH | Y | STARTER BUTTON |
| H | MAIN LIGHT SWITCH | Z | POWER TAKE-OFF SHIFT LEVER |
| I | FUEL GAGE | AA | HAND BRAKE VALVE |
| J | AMMETER | AB | AIR PRESSURE GAGE |
| K | FRONT BATTERY AMMETER | AC | TACHOMETER |
| L | PANEL LIGHTS | AD | TACHOMETER LOCK |
| M | TEMPERATURE GAGE | AE | DIMMER SWITCH |
| N | SPEEDOMETER | AF | SPARK CONTROL |
| O | VISCOSITY GAGE | AG | OIL PRESSURE GAGE |
| P | WINCH CAUTION PLATE
(Hoist Caution Plate on Dump Truck) | AH | CLUTCH PEDAL |
| Q | COOLING SYSTEM PLATE | AI | TRANSFER SHIFT LEVER |
| R | THROTTLE CONTROL | AJ | TRANSFER DECLUTCH LEVER |
| | | AK | PARKING BRAKE LEVER |

Figure 15—Instruments and Controls—Open Cab

DRIVING CONTROLS AND OPERATION

as much a warning signal as the buzzer. **IMPORTANT:** *Do not drive the vehicle with less than 70 pounds air pressure. If the gage should read below 50 pounds pressure with the vehicle in motion, stop at once and ascertain cause of low air pressure.*

x. Accelerator Pedal. The accelerator pedal is of the conventional type, and is located on the toeboard. It is operated with the right foot, and controls the speed of the engine by regulating the amount of gasoline fed to it.

y. Brake Pedal. The brake pedal is located on the toeboard, and controls the air valve in the air braking system. The pedal should be depressed gradually to avoid slamming on the brakes.

z. Dimmer Switch. The dimmer switch, located on the toeboard to the left of the clutch, is operated with the left foot, and controls the selection of the upper or lower headlamp beam. Pushing down on the switch changes from one selection to the other.

aa. Clutch Pedal. A conventional clutch pedal is located on the toeboard. When it is depressed the engine is disengaged from the transmission, making it possible to shift gears. Do not ride with foot on the clutch pedal as it will cause excessive wear on the clutch facings.

ab. Transmission Lever. The transmission lever is located in the middle of the cab floor, and is used to select the various gear ratios provided in the transmission according to the shifting diagram above the dash. The lever controls this selection (5 speeds forward and 1 reverse) through a set of shifting forks and rails.

ac. Transmission Power Take-off Shift Lever. The power take-off lever is located in back of the transmission lever, and is used to engage the take-off gears with the transmission for winch operation. As illustrated on the shifting plate, the power take-off has a high and a low range, a reverse and two neutral positions.

ad. Hand Brake Lever. The hand brake lever is mounted inside the cab and controls the disk brake in the drive line. It should be used as a parking brake or in emergencies.

ae. Declutching Lever. The declutching lever is located behind the transmission lever, and is used to engage or disengage the declutching unit to the front axle drive.

af. Transfer Case Shift Lever. The transfer case shift lever is located behind the transmission lever, and is used to change the gear ratio in the transfer case according to the positions shown on the shifting plate.

ag. Cranking Motor Switch. A cranking motor switch is located on the floorboard in such a position as to be conveniently reached with the right heel.

ah. Blackout Driving Lamp Switch. A plunger-type switch is mounted on the dash next to the main light switch, and is used to control the blackout driving lamp.

6. STARTING AND WARMING UP THE ENGINE.

a. General. Good driving is perhaps the most important requisite for long and satisfactory service of any automotive vehicle. A real driver is more than a machine with one hand on the transmission lever

4-TON, 6 x 6 TRUCKS (DIAMOND T MODELS 968A CARGO, 969A WRECKER, 970A PONTON, AND 972 DUMP)

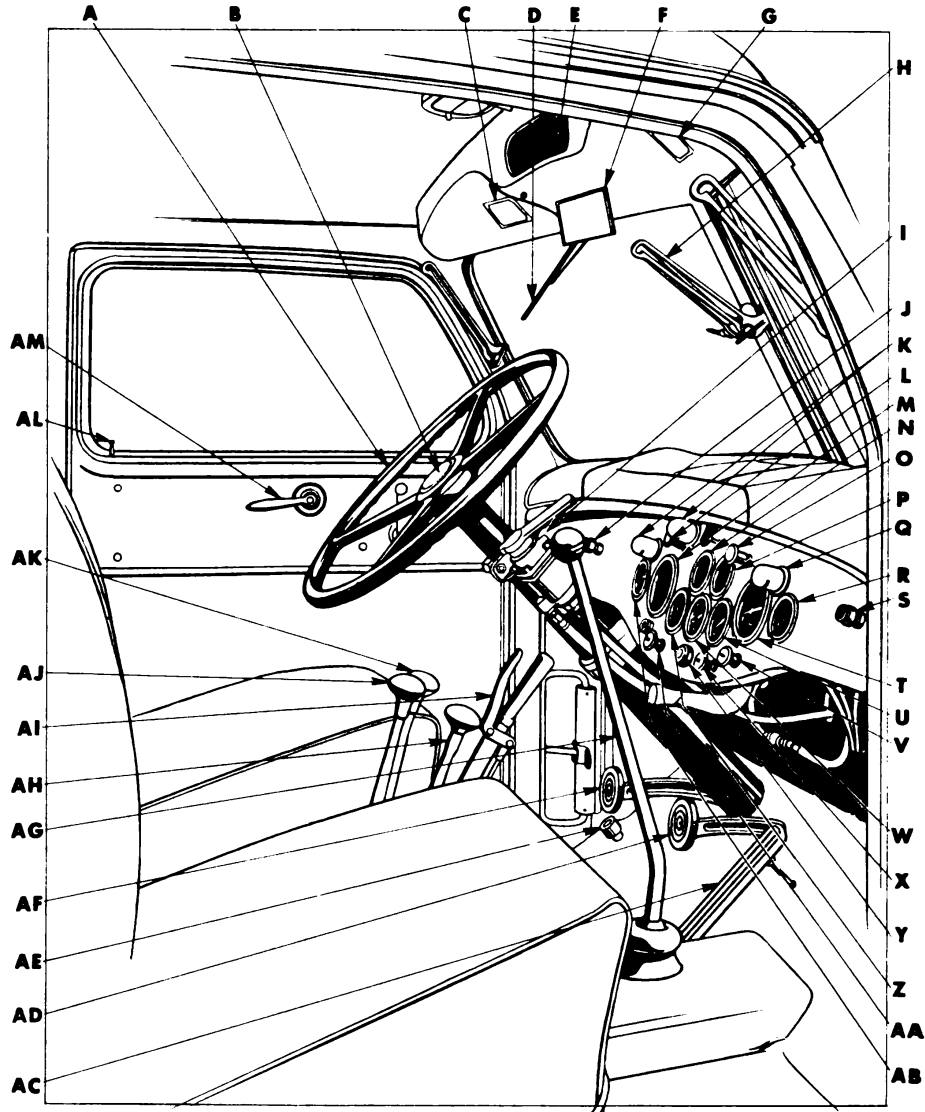

- | | | |
|----------------------------|----------------------------|-------------------------------|
| A STEERING WHEEL | N AMMETER | AA SPARK CONTROL BUTTON |
| B HORN BUTTON | O PANEL LIGHT SWITCH | AB AIR PRESSURE GAGE |
| C WARNING PLATE | P FRONT BATTERY AMMETER | AC ACCELERATOR PEDAL |
| D WINDSHIELD WIPER | Q INSTRUMENT LIGHT | AD BRAKE PEDAL |
| E GLOVE COMPARTMENT | R VISCOMETER | AE DIMMER SWITCH |
| F REAR VIEW MIRROR | S WINDSHIELD WIPER CONTROL | AF CLUTCH PEDAL |
| G CAUTION PLATE | T SPEEDOMETER | AG TRANSMISSION LEVER |
| H WINDSHIELD SECTOR ARM | U TEMPERATURE GAGE | AH POWER TAKE-OFF SHIFT LEVER |
| I HAND AIR VALVE | V HAND THROTTLE BUTTON | AI HAND BRAKE LEVER |
| J WINDSHIELD WIPER CONTROL | W OIL PRESSURE GAGE | AJ DECLUTCHING LEVER |
| K INSTRUMENT LIGHTS | X CHOKE BUTTON | AK TRANSFER CASE SHIFT LEVER |
| L MAIN LIGHT SWITCH | Y IGNITION SWITCH | AL NIGHT LATCH BUTTON |
| M TACHOMETER | Z FUEL GAGE | AM REMOTE CONTROL HANDLE |

RA PD 303943

Figure 16—Instruments and Controls—Closed Cab

DRIVING CONTROLS AND OPERATION

and the other on the steering wheel. He must be able to think and feel his truck. He must recognize any unnatural condition such as vibrations, scrapings, knocks, clicks, sluggishness, etc.

b. Preliminary Instructions. Before the engine is started, make the prestarting inspection outlined in paragraph 21. To start the engine, proceed as follows:

- (1) Place transmission lever in neutral position.
- (2) Set hand brake lever.
- (3) If the engine is cold, crack hand throttle about $\frac{1}{2}$ open, and pull choke button until it is half open. These steps may not be necessary when the engine is warm. If it is very cold, it may be necessary to choke the engine more.
- (4) Turn on ignition.
- (5) Push clutch pedal to floor and hold there until after engine is started.
- (6) Press starter button.
- (7) Release the starter button the moment the engine begins to run. Never press the starter button for more than 10 to 15 seconds at a time. If the engine has not started after two such trials, allow the starter to cool for one minute. If the engine fails to start, or makes a false start, do not press the starter button again until the engine has come to a complete stop. Failure to observe this precaution, especially after a false start, may result in a broken starter motor drive housing.
- (8) After the engine has started, slowly release the clutch. Adjust the hand throttle to prevent the engine from racing. As soon as the engine runs smoothly, push the choke control. Excessive use of the choke will cause dilution of the engine oil and probable engine failure. During the engine warm-up period, operate the engine at 800 to 900 revolutions per minute as indicated by the tachometer. Idling is permissible for only very short periods of time, not to exceed five minutes.

7. OPERATING THE VEHICLE.

a. Starting under Normal Conditions. After the engine has been thoroughly warmed up and checked for satisfactory operation, the vehicle may be started by following the steps listed below. **NOTE:** *Be sure that sufficient air pressure (70 pounds per square inch as shown on dash gage) has been built up to provide adequate braking power (figs. 15 and 16).*

- (1) Push clutch pedal to the toeboard to completely disengage the clutch.
- (2) Disengage the front axle drive by shifting the declutch lever as shown in the shifting diagram. (When extra traction is needed, engage front axle.)
- (3) Shift transfer case lever into proper position. (Transfer case should be in low when heavily loaded, or when starting on a grade, and in high when unloaded or when starting on level ground.)
- (4) Shift the transmission lever into first speed.

TM 9-811

7

**4-TON, 6 x 6 TRUCKS (DIAMOND T MODELS 968A CARGO,
969A WRECKER, 970A PONTON, AND 972 DUMP)**

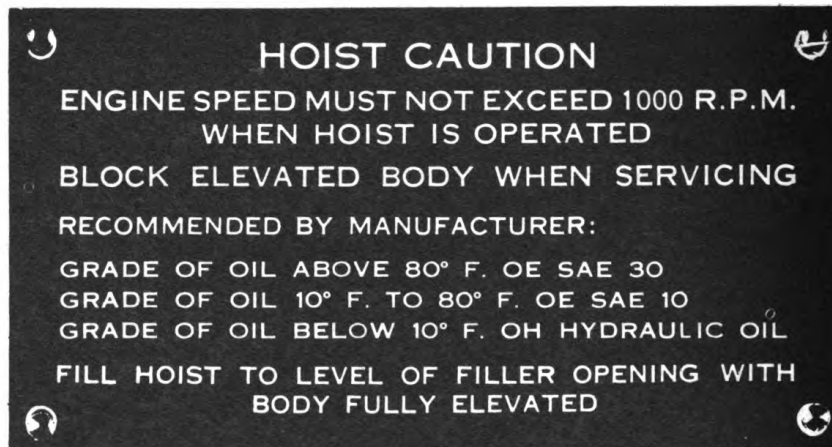
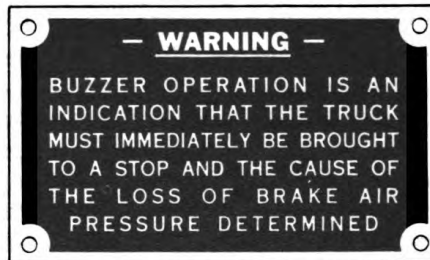
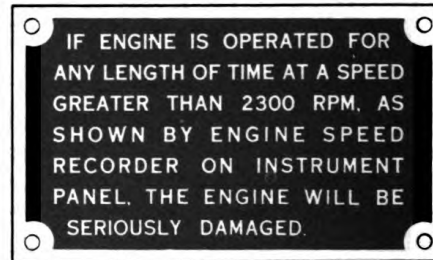
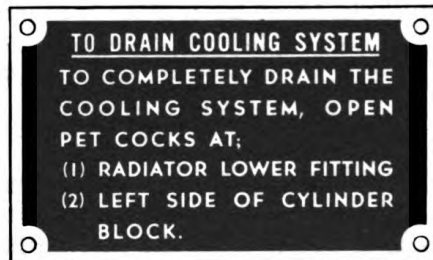
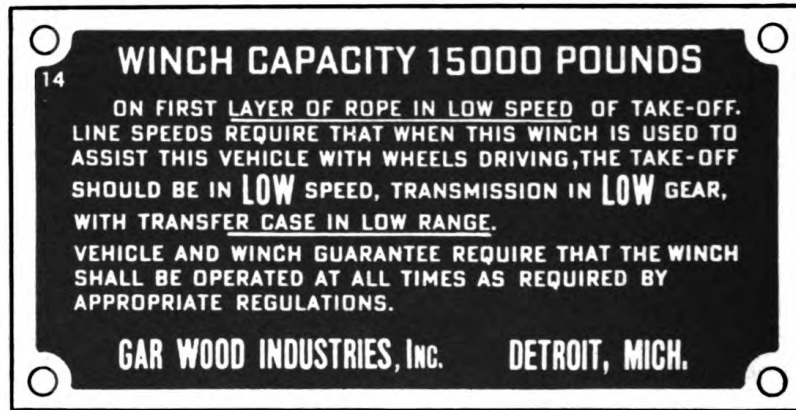
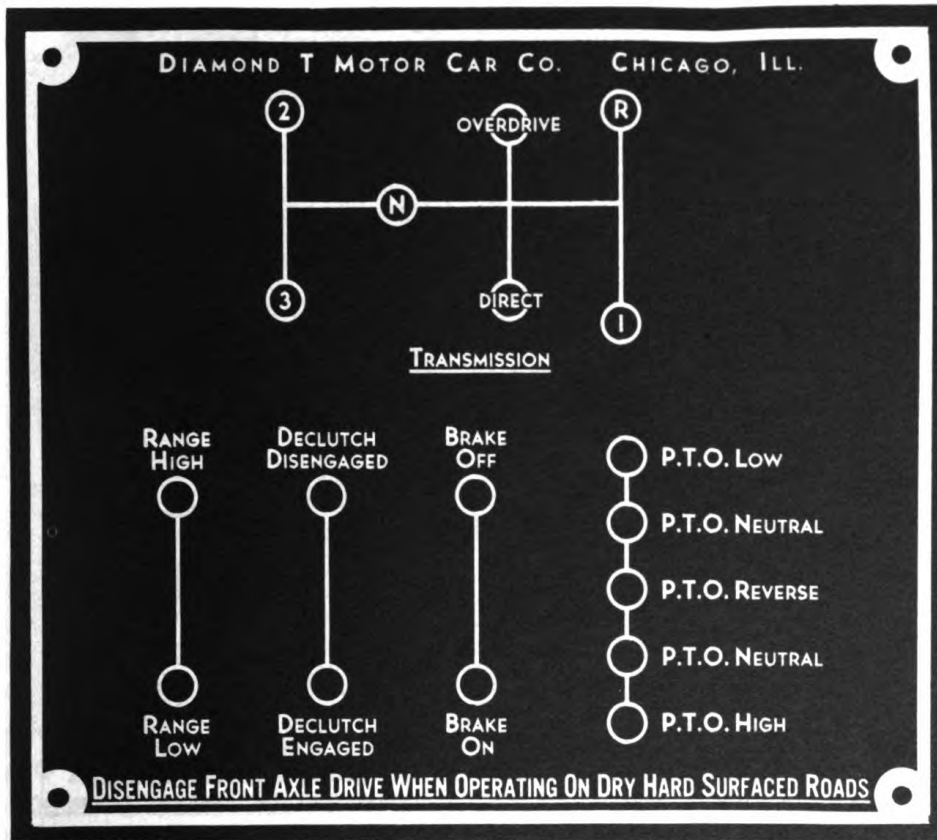

Figure 17—Instruction Plates

RA PD 313908

DRIVING CONTROLS AND OPERATION

- (5) Release the hand brake.
- (6) Push down on the accelerator pedal to speed up the engine and at the same time release the clutch gradually. Feed sufficient gasoline to the engine to insure a smooth even start. Do not race the engine.
- b. **Gearshift (Transmission) (figs. 18, 19 and 20).**
 - (1) After the vehicle is started, to increase speed it is necessary to shift through the transmission to the high position.
 - (2) As the truck increases speed, release the accelerator pedal, disengage the clutch and move the transmission lever into neutral, and



RA PD 303949

Figure 18—Shifting Plate—Cargo and Ponton Vehicles

then into the second speed position. Then release the clutch pedal smoothly, and at the same time accelerate the engine.

(3) Repeat this for each step in the transmission until it is in driving gear. Shifting should be accomplished with a smooth, positive, yet unhurried movement of the transmission lever.

(4) When it is necessary to reverse the truck, stop truck and shift into reverse position in the transmission.

(5) It is very important that every shift made be complete, with the gears fully in mesh. Incomplete shifting leads to uneven gear tooth wear

4-TON, 6 x 6 TRUCKS (DIAMOND T MODELS 968A CARGO, 969A WRECKER, 970A PONTON, AND 972 DUMP)

and expensive repair. With a little experience the driver will feel the poppets engage when gears are completely in mesh.

(6) It is good driving practice to drop a step in the transmission before the vehicle loses too much speed and the engine starts to labor. It is easiest to double-clutch when shifting into a lower gear as follows.

- (a) Disengage clutch and release accelerator pedal.
- (b) Move transmission lever into neutral position.

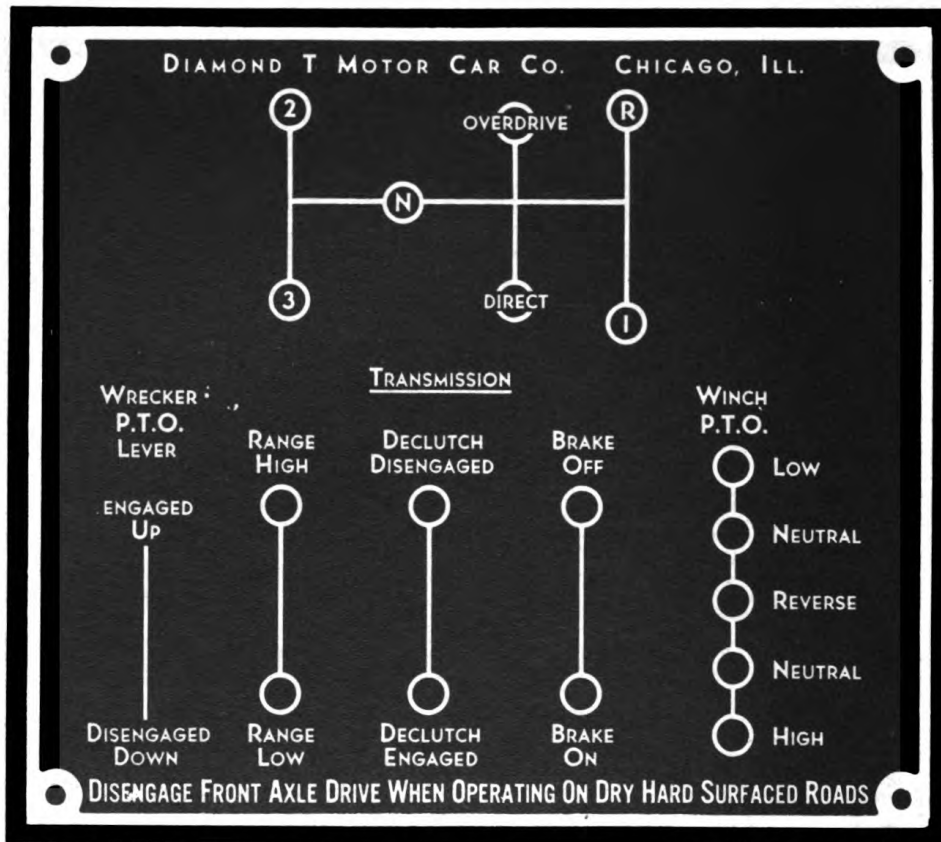

RA PD 303950

Figure 19—Shifting Plate—Wrecker Vehicles

(c) Release clutch pedal and accelerate engine to synchronize it with vehicle speed.

(d) Disengage the clutch once again and shift into lower gear.

(e) Engage clutch smoothly while accelerating the engine. **IMPORTANT:** Never force transmission lever into position or shift into lower gears at high engine speeds.

c. Gearshift (Transfer Case). It is good practice to operate the vehicle in high range over hard-surfaced terrain when there is easy rolling. When there are extreme grades, or when the conditions are so difficult as to require high traction, the low range should be utilized,

DRIVING CONTROLS AND OPERATION

especially when heavily loaded, to help the engine to "hold on" in the main transmission. **NOTE:** *The shift from high to low speed should never be attempted unless the vehicle is standing still, or being operated at low speeds.*

(1) Disengage the clutch and move the shifting lever to a neutral position.

(2) Release clutch and accelerate engine.

(3) Disengage the clutch again, and move the shift lever into the low position.

(4) Release clutch and accelerate engine to synchronize with vehicle speed.

(5) **IMPORTANT:** *Shift smoothly, never forcing the shifting lever, as a sudden shock of gear engagement is likely to damage the transmitting parts.* The shift from low to high may be accomplished at any speed, whether the vehicle is in motion or standing still. Follow the same procedure outlined above except shift into high in the third step.

d. Use of the Tachometer in Gear Ratio Selection.

(1) The tachometer is a valuable aid to intelligent gear ratio selections in the transmission. Best performance will be obtained with the engine operating between 1800 and 2300 revolutions per minute. If conditions are such that the vehicle cannot maintain its speed in the gear ratio being used, shift down in the transmission to keep the engine operating between the recommended limits. When shifting up in the transmission, do not select a higher ratio until after the engine speed reaches 1800 revolutions per minute.

(2) The figures in the table (fig. 21) are based on a maximum engine speed of 2300 revolutions per minute and hence indicate the difference in the readings obtained on the tachometer and speedometer. The tachometer indicates at any time the speed at which the engine is turning over, and might be considered as a measure of the amount of work the engine is doing. Note that the engine can develop its maximum torque and peak horsepower for any gear selection in the transmission or transfer case. The speedometer on the other hand indicates only the linear speed, or distance the vehicle moves per unit of time.

(3) Experienced drivers use the tachometer rather than the speedometer in vehicle operation, especially in the low gears. In that way they can get the most out of their power plant by selecting the proper gear ratios to permit the engine to operate in its most effective range, between 1800 and 2300 revolutions per minute.

e. Cautions.

(1) In shifting from one speed ratio to another, do not skip positions.

(2) Do not ride the clutch. The driver's foot should rest on the clutch only when he is operating it.

(3) Do not engage the clutch suddenly. A sudden engagement is injurious to the mechanism and may stall the engine.

(4) Disengage the clutch fully, to avoid gear damage and shifting difficulties.

4-TON, 6 x 6 TRUCKS (DIAMOND T MODELS 968A CARGO, 969A WRECKER, 970A PONTON, AND 972 DUMP)

f. **Front Axle Drive.** The front axle drive should be engaged before the vehicle leaves hard-surfaced roads to negotiate hazardous conditions. Driven by all wheels, a vehicle can traverse mud, snow, ice or sand which it might not negotiate with the rear drive only. The front axle engagement is controlled by the declutch lever in the cab as indicated on the shifting diagrams (figs. 18, 19 and 20).

(1) **ENGAGING.** If the engagement cannot be made readily, try shifting while turning the vehicle to right or left. The gears involved

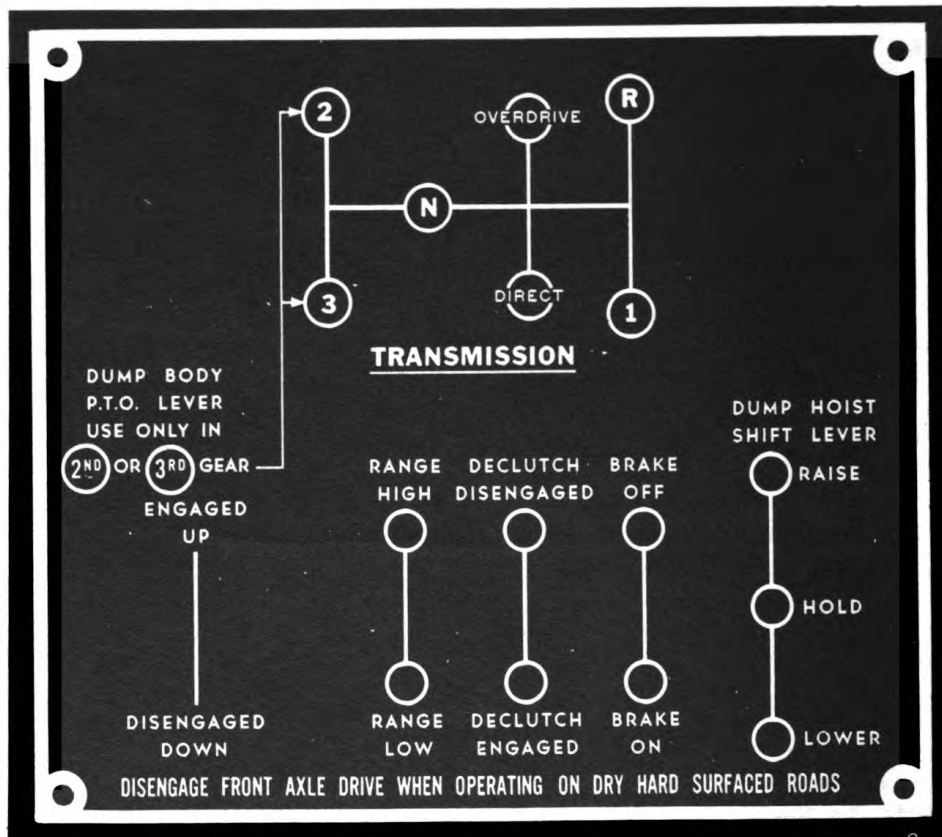

RA PD 303951

Figure 20—Shifting Plate—Dump Vehicles

turn at slightly different speeds while the vehicle negotiates the turn, the difference in their speeds permitting them to engage. *Do not force the shifting lever.*

(2) **DISENGAGING.** It is generally more difficult to disengage the front axle drive than to engage it. Action is aided by exerting moderate pressure on the shift lever while the vehicle is rolling slowly in first or reverse gear. Avoid sudden shock to the driving parts when in low gear. Guard carefully against engaging the clutch suddenly at any time, and especially if the vehicle rolls backward, no matter how slowly.

DRIVING CONTROLS AND OPERATION

(3) **CAUTIONS.** If there is any tendency for the vehicle to roll backwards, block the wheels before attempting to start, and then engage the clutch and accelerator carefully. If it is not convenient to block the wheels, and should conditions permit, by all means allow the vehicle to coast back, under control of the brakes, to a standstill before attempting to start forward. Failure to observe these simple precautions will result in snapping of drive shaft gears and shafts.

(4) It is not possible to drive in the low range with the front axle declutched because of stops on the transfer case and declutch control levers. When in the high range, it is possible to engage or disengage the front axle at will. This is advantageous under easy rolling conditions where the front drive is not required.

g. Stopping. This vehicle is equipped with air brakes providing exceptionally great braking capacity. A person inexperienced with this type of brakes must exercise caution until quite familiar with them, for his own as well as his passengers' comfort and safety.

(1) Release accelerator pedal and depress the brake pedal gradually to apply the brakes smoothly.

(2) When the truck's speed is down to from ten to fifteen miles per hour, disengage the clutch and shift the transmission into neutral.

(3) When the vehicle is completely stopped, release clutch pedal, set hand brake and release brake pedal.

(4) When another unit is trailed behind this vehicle, the air lines are arranged so that when the foot pedal is depressed the brakes are applied on both the truck and the trailed unit. However, the hand brake valve will operate only the trailer brakes.

(5) Hard application of the brakes should cause all wheels to lock; however, note that the maximum retarding effect occurs just before they lock. Intermittent application will reduce wear of brake linings and drums. Application should be gradual with just enough force to accomplish the desired result.

(6) In anticipating a stop, make full use of the engine braking effect, disengaging the clutch in time to avoid stalling the engine. When descending hills, let the engine brake by using the proper gear ratio and applying the brakes from time to time to prevent over-speeding the engine. Do not turn off the ignition. The engine speed when descending a hill should be no greater than the speed necessary for ascending the hill at the same transmission gear ratio. On steep hills, engage the proper gear before the vehicle is started down the hill. Attempting to shift gears after the vehicle has started down a steep slope may result in a runaway vehicle.

(7) After passing through water, set the brakes slightly and operate the vehicle for a short distance until the brakes are dry.

h. Stopping Engine. The engine may be stopped by turning the ignition switch to the left or into the "OFF" position. In the event that

TM 9-811

7-8

4-TON, 6 x 6 TRUCKS (DIAMOND T MODELS 968A CARGO, 969A WRECKER, 970A PONTON, AND 972 DUMP)

the engine is excessively overheated, allow it to idle until a normal temperature (160°F–180°F) is reached before shutting it off.

i. **Traction Aids.** Chains should always be carried with the vehicle. Keep them in serviceable condition to permit installation with a minimum of delay. Remove them promptly when they are no longer necessary in order to prevent unnecessary damage to tires and roads. Apply the chains before the vehicle becomes mired. Install them properly with the fastenings in correct relation to the direction of rotation so that the chains will not be lost. Fairly loose adjustment gives better traction and less tire wear than tight adjustment. Install chains on all wheels.

8. TOWING THE VEHICLE.

a. **Towing to Start Vehicle.** If mechanical difficulties make it impossible to start the vehicle with the starting motor, this can generally

Transmission Selection	MAXIMUM PERMISSIBLE ROAD SPEEDS	
	Transfer Case in Low	Transfer Case in High
1st or Reverse	2 M.P.H.	4 M.P.H.
2nd	4 M.P.H.	8 M.P.H.
3rd	9 M.P.H.	16 M.P.H.
Direct	17 M.P.H.	30 M.P.H.
Overdrive	22 M.P.H.	40 M.P.H.

RA PD 303952

Figure 21—Table of Road Speeds

be accomplished by towing the vehicle. Run a chain or cable over the tow hooks on the front bumper, and attach it securely to the towing vehicle. Shift the transfer into low range and the transmission into direct in the stalled vehicle. When the towing truck starts, the driver of the towed vehicle should disengage the clutch until starting speed is reached. When the vehicles are moving from 10 to 15 miles per hour, the clutch should be released slowly to engage the engine. When the engine starts the clutch should be released, and the hand throttle pulled out far enough to idle the engine at 800 to 900 revolutions per minute as shown on the tachometer. The driver of the towed vehicle should then shift the transmission to neutral, and signal the driver ahead to stop. After the vehicles are stopped, the tow chain may be disconnected. When a vehicle is started in this manner, always report it to the proper authority.

DRIVING CONTROLS AND OPERATION

b. Caution. The driver should always note the reading of the air pressure gage before his vehicle is towed. If less than 70-pounds pressure is indicated, the air brakes are not to be depended upon to stop the vehicle. Check the condition of the hand brake, and if it is satisfactory the vehicle may be stopped with this device. If air pressure is below 70 pounds per square inch and the hand brake is in poor adjustment, no attempt should be made to start the vehicle by towing it.

c. Towing Disabled Vehicle. If a vehicle is disabled with no damage to the running gear or the steering apparatus, it may be towed in the same manner as prescribed for towing to start a vehicle. (See subparagraph a above). Be sure that the vehicle to be towed has brakes. If the brakes are inoperative or the running gear is damaged it will be necessary to use a wrecker to tow the vehicle, making use of a V-type tow bar (par. 9 h).

4-TON, 6 x 6 TRUCKS (DIAMOND T MODELS 968A CARGO, 969A WRECKER, 970A PONTON, AND 972 DUMP)

Section IV

OPERATION OF AUXILIARY EQUIPMENT

	Paragraph
Winch.....	9
Wrecker.....	10
Air compressor.....	11
Dump truck.....	12
Fire extinguisher.....	13

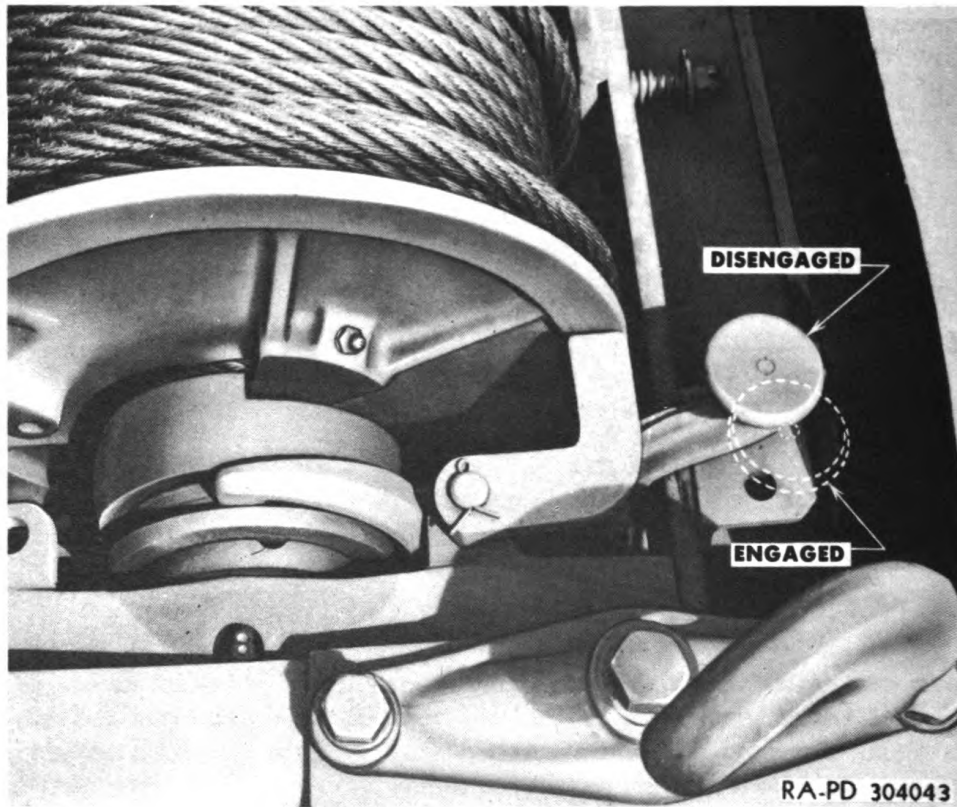

Figure 22—Winch Clutch Poppet Handle

9. WINCH.

a. **General.** A front-mounted winch is used on all cargo, wrecker and ponton vehicles. The winch is power-driven and may be used for pulling, hoisting or lowering. The winch is power-driven through a three-speed power take-off mounted on the side of the vehicle transmission. The driving torque is transferred from the power take-off through a propeller shaft with universal and slip joints to the winch

OPERATION OF AUXILIARY EQUIPMENT

drive shaft. The winch cable is 300 feet long, and has a safe pull capacity of 15,000 pounds on the first layer of cable.

b. Operation. The winch is operated from inside the cab. It has an automatic safety brake which will sustain the load while the power take-off is being shifted. Winch pulling speeds are based on a maximum engine speed of 1000 revolutions per minute, which should not be exceeded in winch operation, as excessive speed will result in strains and failures of parts. Note the instructions on the winch caution plate in the cab (fig. 18).

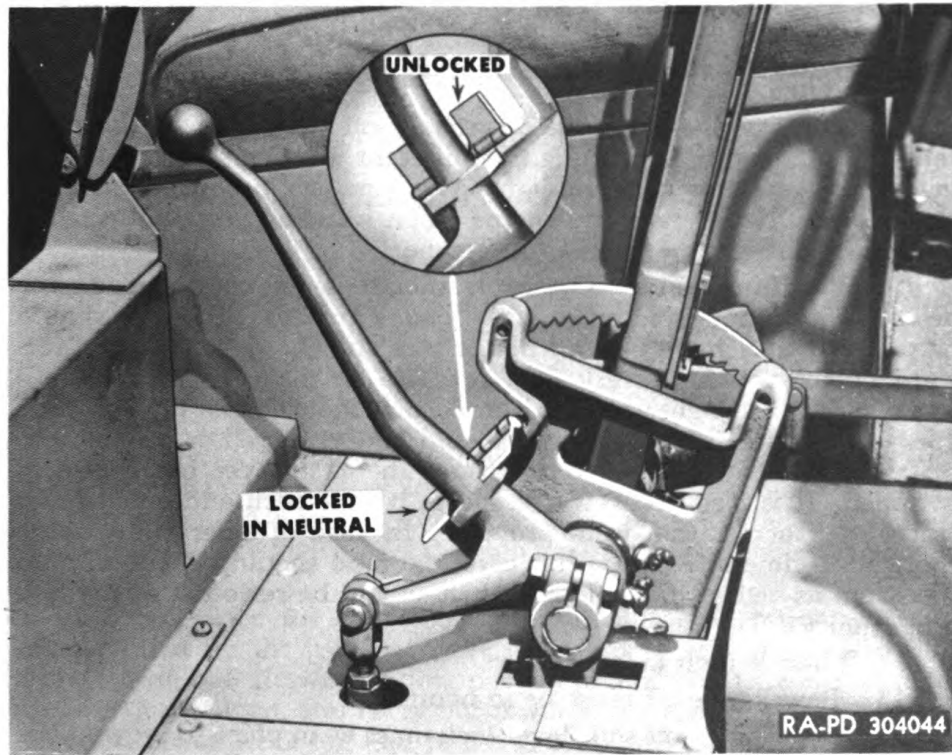

Figure 23—Winch Power Take-off Shift Lever

(1) HOOKING ON.

(a) Disengage the sliding jaw clutch by shifting the poppet handle mounted on the winch (fig. 22).

(b) Pull the cable off the drum by hand. The drag brake will keep the drum from spinning. Care should be exercised to avoid kinking the cable.

(c) Run the cable out to the load and hook on. Take care not to damage cable when hooking on. It is best to wrap a chain or cable around the load and to attach the winch cable to it.

(2) PULLING.

(a) Engage the sliding clutch, making sure that the poppets are locked.

4-TON, 6 x 6 TRUCKS (DIAMOND T MODELS 968A CARGO, 969A WRECKER, 970A PONTON, AND 972 DUMP)

(b) Start the engine, depress the clutch, shift the transmission into neutral, and shift the power take-off into high or low speed. See vehicle shifting plate for power take-off lever positions (figs. 18, 19, 20 and 23).

(c) Release the clutch gradually and accelerate engine to pick up the load. Do not jerk load or exceed 1000 engine revolutions per minute.

(3) **STOPPING.** To stop pulling it is necessary to release the clutch and to shift the power take-off into neutral.

(4) **LOWERING OR REVERSING.** To reverse the winch, it is necessary to disengage the clutch, slip the take-off lever into reverse and to release the clutch pedal. When reversing it is not necessary to accelerate the engine.

c. **Winding Speeds.** The power take-off has a high and low gear ratio for winding in, permitting two different winding speeds. Use the high-speed gears for handling light loads, and the low-speed gears for heavy loads. Never race the engine when winching, especially when pulling a light load or winding in a rope.

d. **Winding Cable.** The cable should never be wound on the drum without some load on it. If no load is available, the rope should be properly attached to an anchor or tree and the vehicle pulled forward by the winch. A very light pressure on the vehicle brake will insure a neat and tight wind. It is important that the first layer of rope goes on in order. If necessary, it should be hammered or pushed into place with a block of wood to insure the first layer being closely wrapped. It is also necessary to see to it that each additional layer starts back across the drum properly. In case of emergency where there is no time to exercise this care, the rope should be wound onto the drum as well as possible and then should be rewound at the first opportunity.

e. **When Winch Is Not in Use.**

(1) Power take-off must be in neutral.

(2) Power take-off shift lever lock must be in place to prevent the power take-off from being thrown into gear accidentally (fig. 23).

(3) Winch sliding clutch must be in mesh with drum clutch so that drum will not turn due to vibration or weight of chains.

(4) End of cable must be securely wrapped around bumper hooks so that it will not come loose and drag.

f. **Shear Pins.** The front universal joint of the winch propeller shaft is connected to the winch drive shaft by means of a shear pin. It is made of a special material so that it will shear before parts fail when the winch is overloaded. *NOTE: Never substitute other rivets, bolts or pins for the standard shear pin, as to do so may result in damage to equipment or personnel.* When a shear pin fails, remove the broken parts and install a new one. (Extra shear pins will be found in vehicle tool kit.) Attempt to correct overload before again operating winch.

g. **Snatch Block.** A snatch block is provided for use in winch operations where the load is very heavy, or where low pulling speeds are desirable with a high engine torque. When using the snatch block,

OPERATION OF AUXILIARY EQUIPMENT

the cable should be run through the block sheave free of twists or kinks, and the free end of the cable brought back to the vehicle bumper hook. The snatch block hook is then attached to the load, and winching is accomplished as already described.

10. WRECKER.

a. General. Twin boom wrecker equipment of 5-ton capacity (10-ton capacity when snatch block is used) is installed on all 4-ton, 6 x 6 wrecker vehicles. The equipment is made up of a wrecker frame mounted on the chassis which supports the wrecker transmission, the winches and the booms. The transmission has a forward and a reverse speed, and is so arranged that it can drive the winches separately or simultaneously. The winches are each provided with 200 feet of cable. The booms are on pivots so that they may be swung out to a position at right angles to the vehicle and may be raised or lowered as desired. A telescoping outboard brace leg is mounted on each side so that these may be swung out to give the vehicle greater stability in wrecking operations. The necessary anchors, blocks, tow bars, clamps, etc., are furnished with the vehicle (fig. 24).

b. Brace Legs.

(1) The two brace legs are tubular steel telescoping in design, the upper and outer portion being pinned to a swivel mounted on the end of the wrecker frame. The lower or sliding member is equipped with a steel foot, to which a chain is attached. The chain, with a grab hook at the free end, serves to limit movement of the brace leg when in use, and to prevent kicking out under load. In traveling position the brace leg is secured in a bracket welded to base of wrecker frame. The sliding portion is secured in its nested position by a spring pin near the bottom of the outer tube which passes through a corresponding hole in the inner or sliding tube.

(2) To place the brace leg in position for operation, operator should lift it by the handle on the foot clear of carrying bracket and draw spring pin, allowing sliding portion to move out. Swing brace leg in direction of load, and carry out towards the load as far as is necessary, dropping brace leg foot to the ground and locking pin in upper-half so that the inner portion cannot slide and the two sections become a single stiff-leg. Tie the chain to loop in the base of the wrecker frame.

(3) The brace leg on the load side only of the wrecker should be used, as if the one on the far side from the load is also lowered, the strain of the pull on the vehicle will tip it towards the load, and the brace leg on far side will tend to slip in towards the wrecker, so that when strain of pull is slacked, the wrecker would not return to its normal position, but would be cocked up by the brace legs.

(4) After operation is complete, raise brace leg and replace in holding bracket before moving vehicle.

c. Operation (fig. 25).

(1) To release cable, winch drum is thrown out of gear by means of a handle controlling a sliding pinion which meshes with the bull gear. A backlash brake prevents cable unwinding when there is no pull on

TM 9-811

10

4-TON, 6 x 6 TRUCKS (DIAMOND T MODELS 968A CARGO,
969A WRECKER, 970A PONTON, AND 972 DUMP)

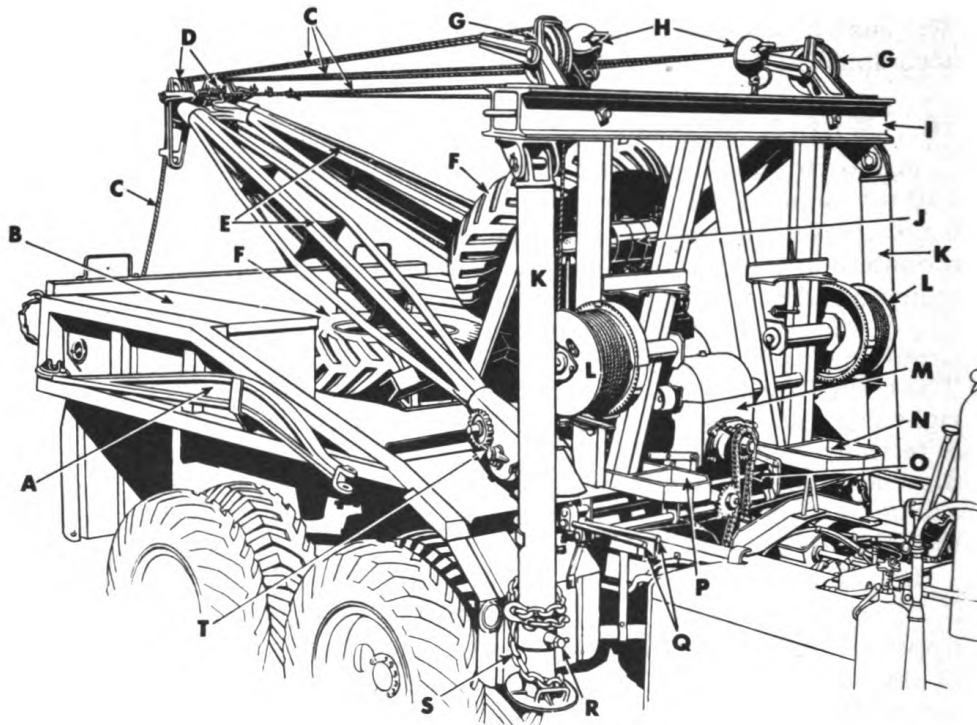

- | | | | |
|---|----------------|---|----------------------------|
| A | TOW BAR | K | BRACE LEGS |
| B | STOWAGE BOX | L | WINCHES |
| C | CABLES | M | WRECKER TRANSMISSION |
| D | BOOM SHEAVES | N | ACETYLENE TANK SUPPORT |
| E | BOOMS | O | TRANSMISSION DRIVE CHAIN |
| F | SPARE TIRES | P | OXYGEN TANK SUPPORT |
| G | MAST SHEAVES | Q | CONTROL HANDLES |
| H | SPOT LIGHTS | R | BRACE LEG LOCK PIN |
| I | CRANE | S | BRACE LEG CHAIN |
| J | AIR COMPRESSOR | T | BOOM DRUM RATCHET AND PAWL |

RA PD 304045

Figure 24—Wrecker Equipment

42

OPERATION OF AUXILIARY EQUIPMENT

the line. When cable is released it may be slacked sufficiently to unhook from loops in back of wrecker body so that it will be free for work at back of truck, or to swing with the boom when the latter is unlocked for rigging in position for work at an alongside position.

(2) Figure 25 identifies operating mechanism. The cable backlash brake loop is shown in brake applied position. Tension on the cable straightens it and, by pulling the loop into a vertical position, releases the brake through an eccentric.

(3) To free cable drum when running out the cable, the pinion shift lever is pushed in, and pulled out when it is desired to again engage the drum with the power mechanism.

(4) The booms are raised or lowered manually by the hand operating crank on the end of the ratchet wheel shaft. The same crank may be used on the cable drum when tightening cable for traveling.

(5) The power operation of the winding (cable) drums can be controlled from either side, there being two handles on each side. The outer handles control the near drums, while the inner handles control the drums on the far side of the wrecker. The inner handles are also equipped with a sleeve which can be twisted to accelerate or decelerate the engine, similar to the throttle control on a motorcycle.

(6) **APPLYING POWER** (fig. 26).

(a) Shift transfer case lever into neutral.

(b) Shift transmission into direct speed, as normal operations can be carried out in this gear. All the speeds in the transmission may be used in wrecker operation except overdrive and reverse.

(c) Engage transfer case power take-off by pulling up the lever at the lower left of the control levers in cab, to engaged position as shown in figure 26.

(d) The chain drive connecting the power take-off with the wrecker transmission main shaft is now in operation. To apply power to the cable drums for pulling or lowering, the load operator should stand on side nearest load. The control handles are held in neutral by a heavy spring so that as soon as pressure is released they return to neutral, stopping movement of drum and cable, the load being held by self-locking brake on worm shaft. To raise load, bear down on handle (fig. 25). To lower load, raise up on handle. Be sure that these shifts are made complete to prevent faulty engagement of the transmission. Speed of haul can be controlled by sleeve throttle control as previously described.

d. Cautions.

(1) Never run engine over 1800 revolutions per minute when operating wrecker. Never race the engine, especially when wrecker is operating without a load or with a very light load.

(2) Always use moderate speeds when pulling heavy loads until the load starts to move.

(3) When pulling over rough ground where possible use crowbars to ease load over rocks or other obstructions.

4-TON, 6 x 6 TRUCKS (DIAMOND T MODELS 968A CARGO,
969A WRECKER, 970A PONTON, AND 972 DUMP)

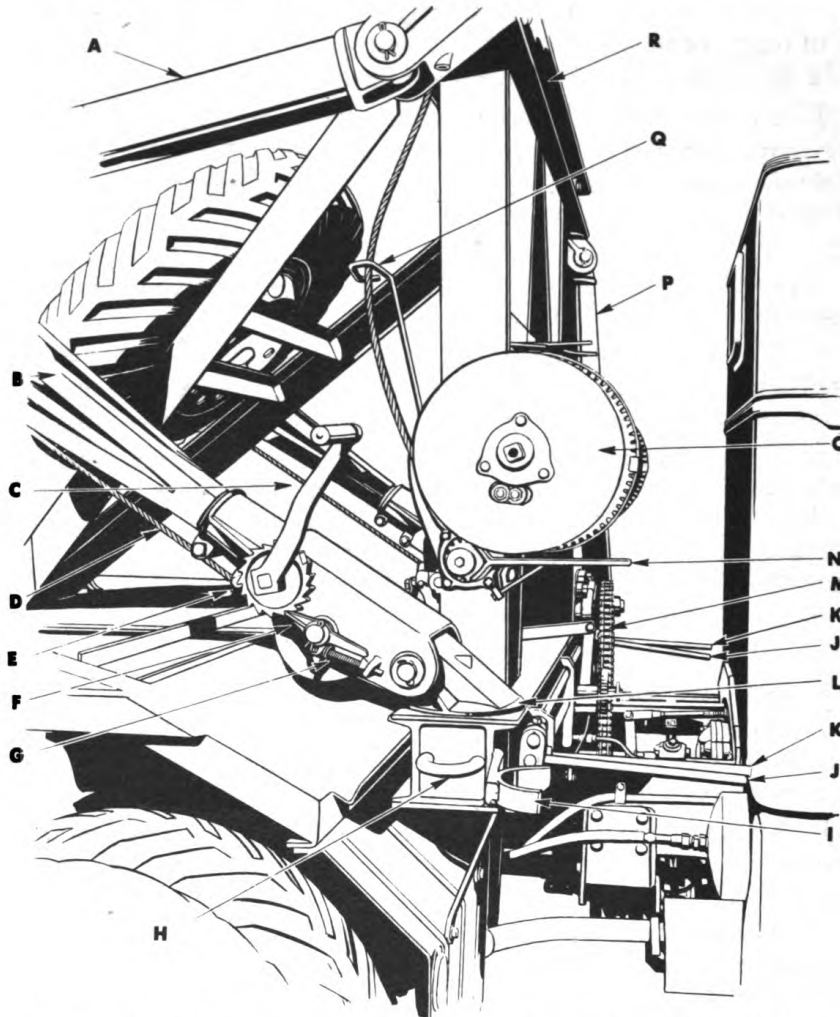

- | | | | |
|----------|-----------------------------|----------|----------------------------|
| A | BRACE LEG | J | R.H. WINCH CONTROLS |
| B | BOOM | K | L.H. WINCH CONTROLS |
| C | HAND OPERATING CRANK | L | BOOM HEEL SWIVEL |
| D | BOOM DRUM CABLE | M | ROLLER CHAIN |
| E | BOOM DRUM RATCHET | N | PINION SHIFT HANDLE |
| F | BOOM DRUM PAWL | O | SERVICE DRUM |
| G | PAWL SPRING | P | BRACE LEG |
| H | BRACE LEG CHAIN LOOP | Q | BACKLASH BRAKE LOOP |
| I | BRACE LEG REST | R | WRECKER FRAME |

RA PD 304051

Figure 25—Wrecker Operating Mechanism

OPERATION OF AUXILIARY EQUIPMENT

- (4) Whenever possible to turn a wreck on its wheels this should be done as early in the operation as possible.
- (5) Watch the cables to see they do not chafe on sharp edges.
- (6) Keep cables free of kinks.
- (7) Anchor lines must always be at least as strong as a service or hauling line.
- (8) Cables should always be wound tight on drums. Wherever possible wind them up under load.

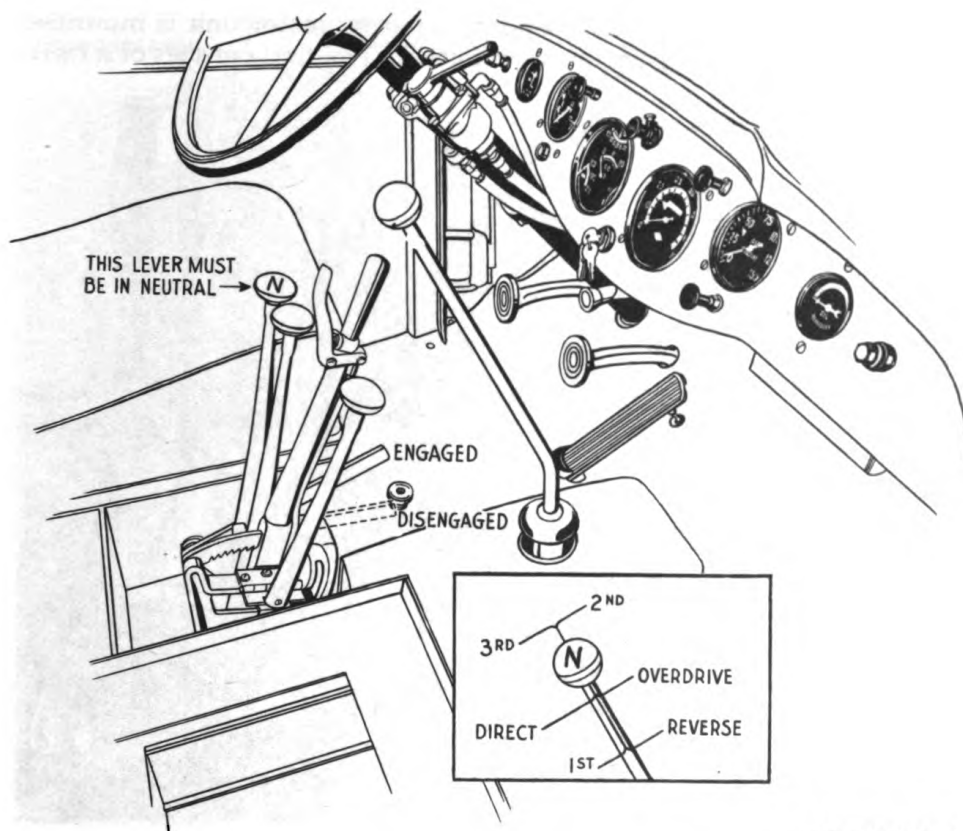

RA PD 304052

Figure 26—Wrecker Cab Controls

e. Safety Rings on Body Bolster (fig. 27).

(1) When the wrecker equipment is not in use, the ends of the cables should be hooked to the safety rings on the rear bolster of the body. These rings are designed so that if an excess tension is placed on the cables, the safety ring strap will open up and release the ring before damaging the body bolster.

f. Stowing Cable.

(1) In order to secure the proper tension on the cables when not in use, the truck transmission should be placed in one of the lower gears to slow down the cable speed and then by means of the winch-operating

TM 9-811
10-11

**4-TON, 6 x 6 TRUCKS (DIAMOND T MODELS 968A CARGO,
969A WRECKER, 970A PONTON, AND 972 DUMP)**

levers, the cable should be wound up until the backlash brake loop is moved forward until there is only $\frac{1}{2}$ -inch to $\frac{3}{4}$ -inch bend in the cable from top sheave to drum. This backlash brake loop serves as an excellent gage for the cable tension, and is in clear view of the operator.

(2) It is necessary that these cables be kept under a slight tension to prevent up-and-down movement of the booms on rough roads.

11. AIR COMPRESSOR (figs. 28 and 29).

a. Description. An independent air compressor unit is mounted on the wrecker body for use in tire inflation. The unit consists of a belt-

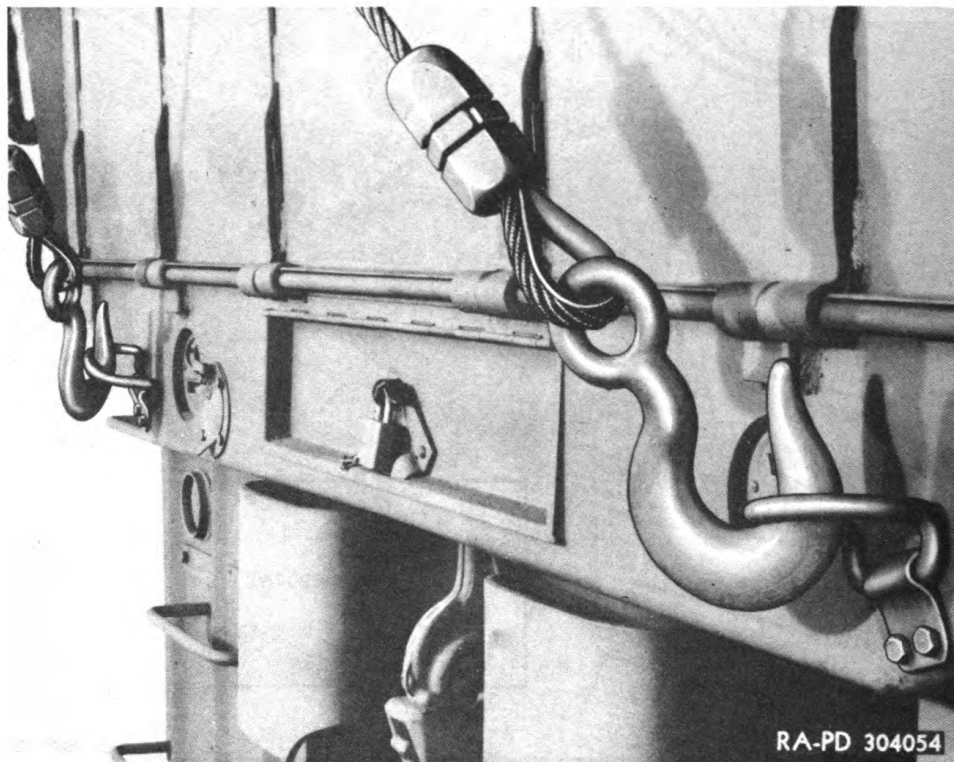

Figure 27—Rings on Body Bolster

driven compressor, a gasoline engine, an air reservoir, an automatic cut-off switch, a check valve, a safety valve and a pressure gage. The cut-off switch automatically shuts off the engine when the reservoir pressure reaches 150 pounds per square inch. The check valve prevents air in the reservoir from flowing back when the compressor stops.

b. Operating Suggestions.

(1) **BELT TENSION.** The belt should be kept in proper adjustment at all times. When adjusting belts be sure pulleys are properly lined up. Belts should be just tight enough to prevent slippage. Heating of motor pulley indicates slipping.

OPERATION OF AUXILIARY EQUIPMENT

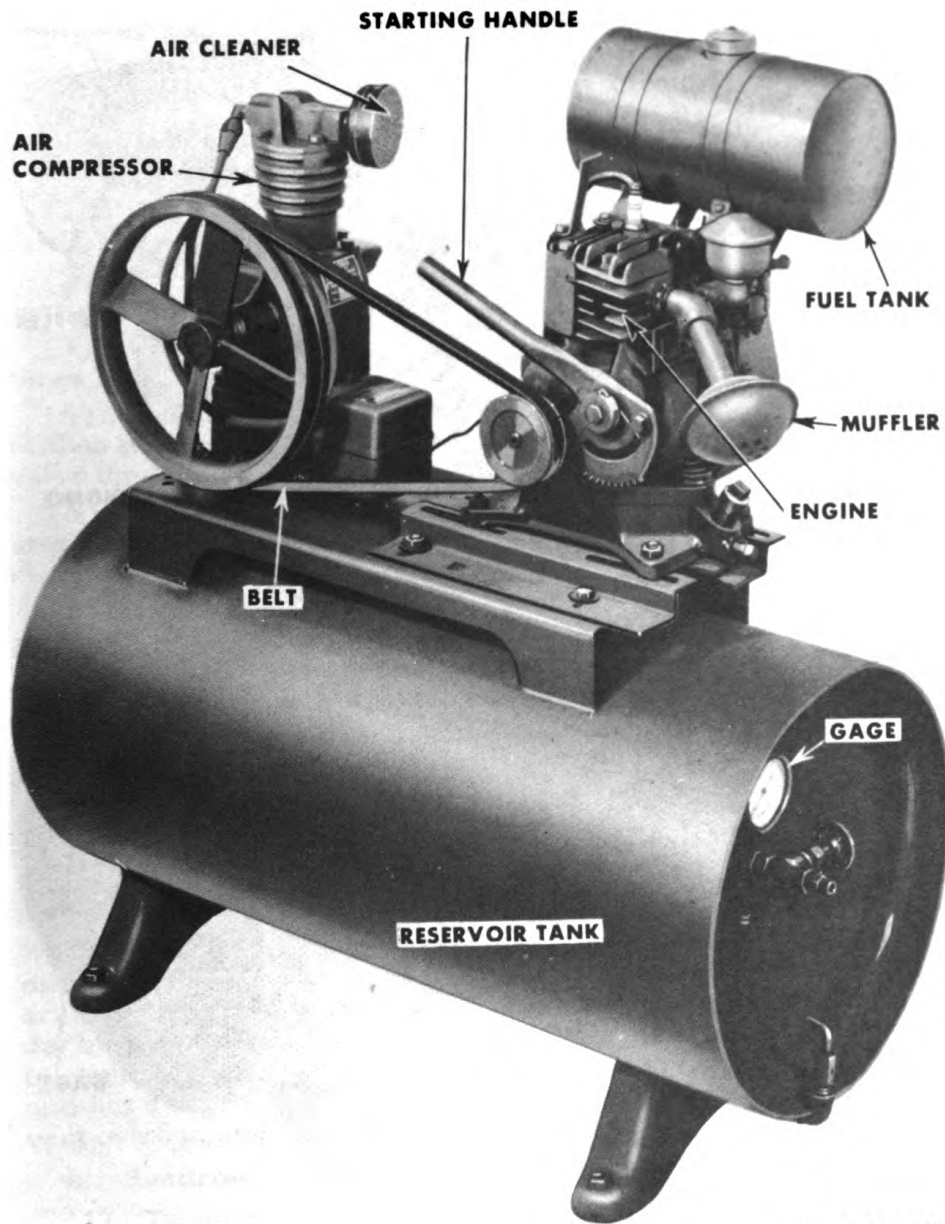

RA PD 304056

Figure 28—Air Compressor Unit—Kellogg

TM 9-811
11

4-TON, 6 x 6 TRUCKS (DIAMOND T MODELS 968A CARGO,
969A WRECKER, 970A PONTON, AND 972 DUMP)

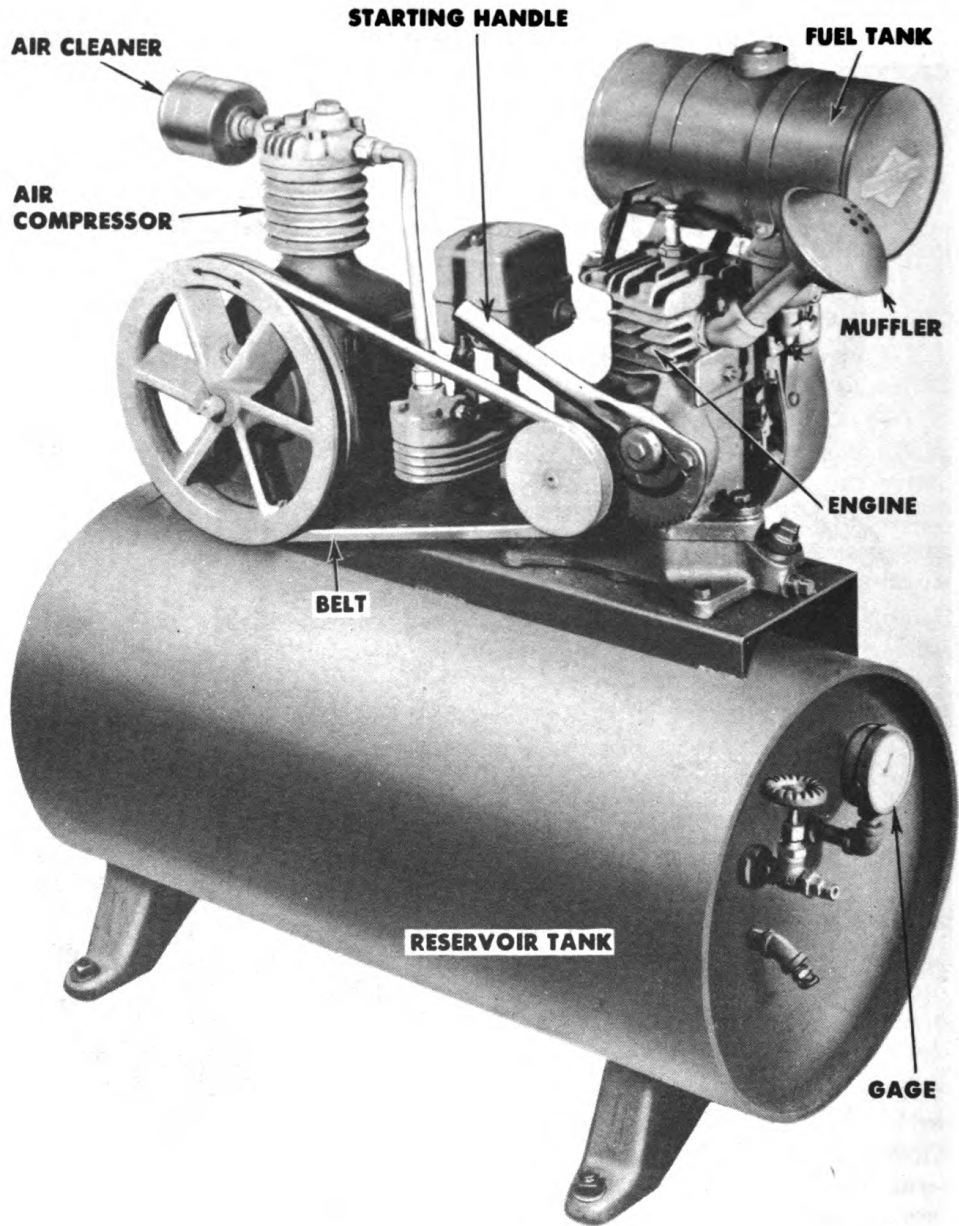

RA PD 304057

Figure 29—Air Compressor Unit—De Vilbiss

OPERATION OF AUXILIARY EQUIPMENT

(2) **DRAINING CONDENSATION.** Open the screen chamber drain and check valve drain every day while the compressor is running to blow out moisture which has condensed in the pipe and tubing.

(3) **KEEP THE MOTOR AND COMPRESSOR CLEAN.** See that no dirt or water enter when adding oil or gasoline. Always wipe off the gasoline cap and oil filler plugs, as well as around them, before refilling.

(4) **EXHAUST TUBING.** Water is condensed in the exhaust after it cools off. For this reason, after stopping motor, place exhaust tube so that water cannot drain into exhaust port of motor to corrode the mechanical parts.

c. Starting Air Compressor Unit.

(1) See that both the compressor and the engine are properly lubricated, and that there is gasoline in the fuel tank.

(2) Open check valve drain to relieve the back pressure on the compressor to assist in starting.

(3) Choke engine and pull quickly on starter lever three or four times to prime the engine.

(4) After motor is primed, open choke about halfway and again pull on starter lever to start motor. After motor is started, close check valve drain to pump air into reservoir tank.

(5) As the motor warms up, adjust the choke until the motor operates smoothly. Use the choke in the same way that the choke on an automobile is used.

(6) To start the motor shortly after having stopped it by choking, and while it is still warm, pull the starter lever three or four times without choking. If it does not start, prime as explained above. A warm motor does not require as much priming as a cold one.

(7) If the motor fails to start after a reasonable number of trials, report to the proper authority.

(8) To stop unit, press the spring clip against the spark plug to short the ignition circuit.

12. DUMP TRUCK (fig. 30).

a. **General.** The dump body is attached to a hoist subframe by means of hinges at the rear and is elevated by a power-driven hydraulic arm type hoist located under it. Pressure is delivered to the hoist cylinder by a hydraulic pump driven from a drive shaft connected to a power take-off on the top of the transfer. The body is of all-steel construction and has a capacity of 4 cubic yards. A stop chain is provided to prevent overdumping and damage to equipment.

b. Controls.

(1) Power hoist controls are installed in the cab as shown in figure 31. Instructions for operating these controls are shown in figure 20.

(2) **POWER TAKE-OFF LEVER.** The dump body power take-off lever has two positions, namely, "engaged" and "disengaged." When it is pulled up to the engaged position, power from the engine is transmitted through drive line from the transfer power take-off to the hoist

TM 9-811
12

**4-TON, 6 x 6 TRUCKS (DIAMOND T MODELS 968A CARGO,
969A WRECKER, 970A PONTON, AND 972 DUMP)**

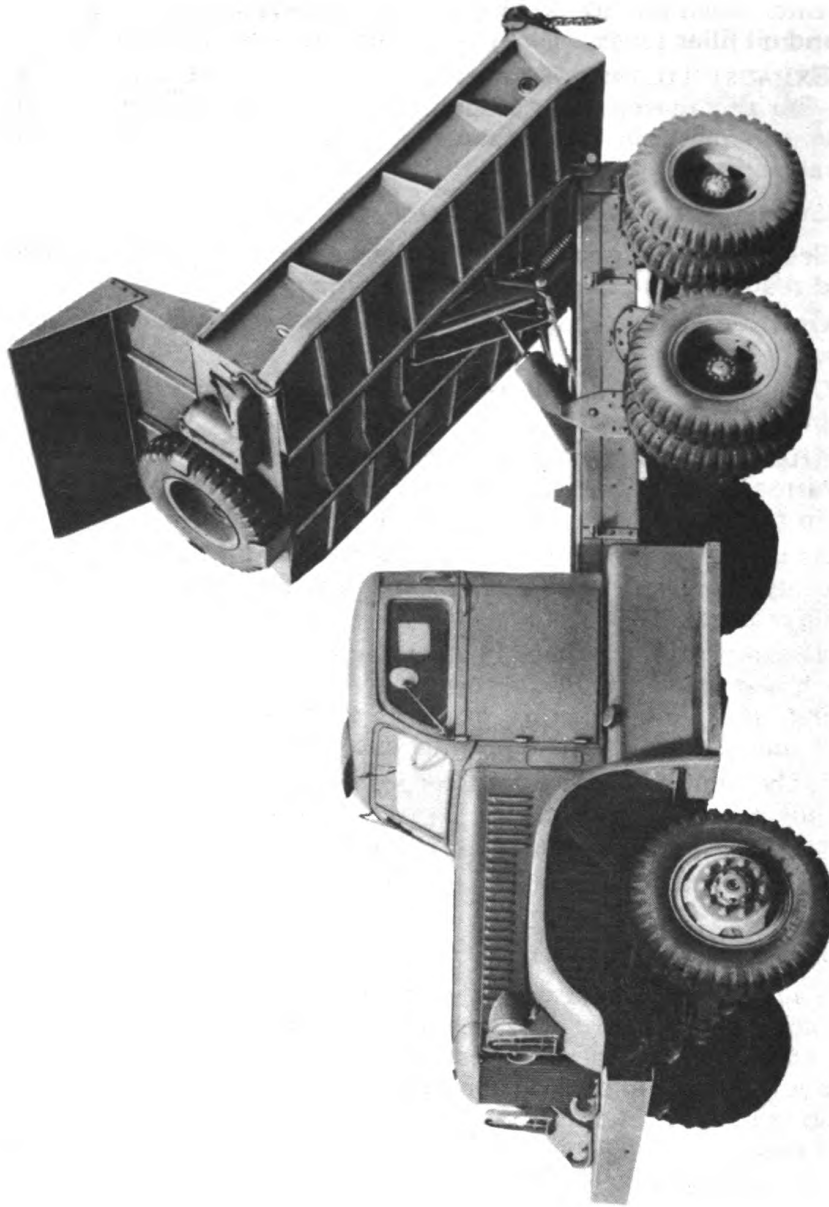

RA PD 304059

Figure 30—Dump Body Raised

OPERATION OF AUXILIARY EQUIPMENT

pump. **NOTE:** *It is important that the operator keep the power take-off disengaged when the hoist is not being operated to prevent damage to the pump.* Dump trucks are being equipped with a warning device which emits a loud rattling noise when the truck is in motion with the power take-off lever engaged. When this noise is heard the operator should stop the truck and disengage the power take-off before proceeding. Vehicles in early production were not equipped with this device and so special care must be exercised to be sure the lever is always in the disengaged position when the vehicle is in motion.

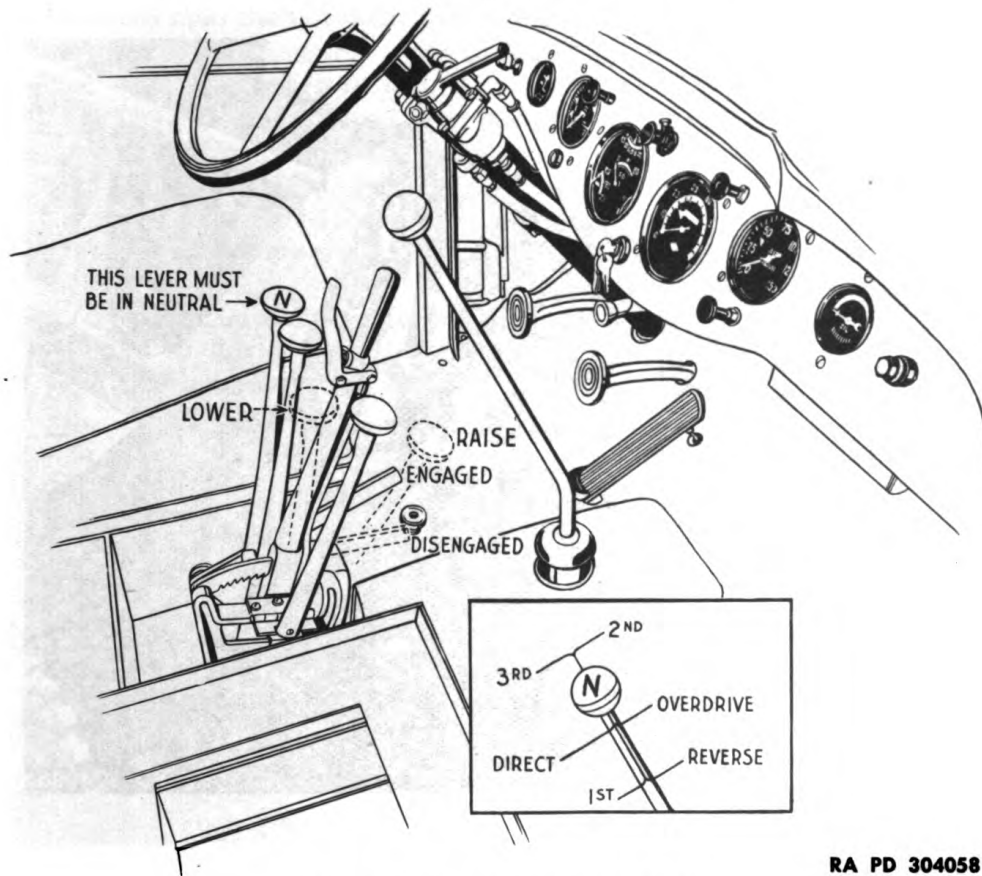

RA PD 304058

Figure 31—Hoist Controls

(3) **PUMP HOIST LEVER.** This lever may be shifted to any one of three different positions, namely, “raise,” “hold” or “lower.” With the lever in the “raise” position, the pump valves are so arranged that fluid is pumped into the cylinder and the body is raised. (When the body reaches the limit of its travel it automatically stops.) When the lever is in the “hold” position, the body remains suspended in whatever position it was in when the lever was shifted. With the lever in the “lower” position, the fluid is forced out of the cylinder by the weight of the body, and the body comes down.

4-TON, 6 x 6 TRUCKS (DIAMOND T MODELS 968A CARGO, 969A WRECKER, 970A PONTON, AND 972 DUMP)

(4) **TAIL GATE CONTROL.** The tail gate is controlled by a lever located at the left front corner of the body. When the lever is against the body, the tail gate hooks are locked, but when it is away from the body, the tail gate hooks are open and the lower end of the tail gate is free to swing out (fig. 40).

c. Operation.

(1) **Release tail gate locking lever.** Start engine if it is not running. Depress clutch pedal. Shift transfer to neutral. Shift transmission to second or third speed.



Figure 32—Tailgate Arranged for Spreading

(2) **Engage the dump power take-off.** Release the clutch pedal. Move the dump hoist lever forward and accelerate the engine to raise the body. Do not exceed an engine speed of 1000 revolutions per minute during this operation. The body will automatically stop when it has reached the limit of its travel.

(3) **To stop the body in any intermediate position,** shift the dump hoist lever to the "hold" position. It is not necessary to use the clutch to accomplish this.

(4) **When the hoist has reached its full stroke,** depress the clutch pedal and disengage the power take-off to prevent wear and tear on the pump.

OPERATION OF AUXILIARY EQUIPMENT

(5) To lower the body, shift the dump hoist lever to the "lower" position, and the body will return to a horizontal position. It is not necessary to run the engine during this operation. Lock tail gate lever.

13. FIRE EXTINGUISHER.

a. Carbon Dioxide Extinguisher.

(1) The wrecker truck is equipped with a large carbon dioxide extinguisher mounted on the right running board. It is held in place by a snap clamp and is easily removed in emergencies. To use the extinguisher, proceed as follows:

(2) Carry extinguisher to fire and then open valve. Carry it in one hand and hold the nozzle at the hose end of the handle with the other.

(3) Direct discharge close to fire. Do not stand at a distance, as effectiveness will then be lost.

(4) Direct discharge first at the edge nearest the operator, or if on a vertical surface, at bottom of fire.

(5) Slowly and deliberately increase the discharge as flame is extinguished. Do not haphazardly direct discharge over various sections of fire. Put out one portion of fire completely before attacking other parts.

(6) Continue discharge after flames are out to coat hot material with carbon dioxide snow.

(7) Recharge extinguisher as soon as possible after use.

b. Carbon Tetrachloride Extinguisher. All vehicles are equipped with a one-quart carbon tetrachloride extinguisher mounted on brackets inside the cab. The extinguisher is operated by twisting the handle past the locking lugs and then pumping, directing the discharge at the fire. Attack the fire in the same manner as described in subparagraph *a* above. Recharge extinguisher as soon as possible after use.

4-TON, 6 x 6 TRUCKS (DIAMOND T MODELS 968A CARGO, 969A WRECKER, 970A PONTON, AND 972 DUMP)

Section V

OPERATION UNDER UNUSUAL CONDITIONS

	Paragraph
Operation in extreme cold	14
Operation on ice	15
Operation in snow	16
Operation in extreme heat	17
Operation in desert or sandy terrain	18
Operation in mud	19

14. OPERATION IN EXTREME COLD.

a. General.

(1) Operation and maintenance of automotive vehicles at low temperatures involve factors not found at normal operating temperatures, and operators must devote more time to protective maintenance. Failure to provide extra service will result in actual damage, unnecessary and unwarranted expense, and failure to start.

(2) Temperatures have been divided into two ranges: above 0°F, and below 0°F. Metals and lubricants undergo changes in their physical properties below 0°F. In subzero temperatures accessory equipment for supplying heat to engine, fuel, oil, and intake air is required.

b. Gasoline for Low Temperatures.

(1) **SELECTION.** Use the winter grade of gasoline procured under U. S. Army Specification 2-103, grade C, latest revision.

(2) The formation of ice crystals from small quantities of water in the fuel sometimes causes considerable trouble. To keep water out of the fuel tank, observe the following precautions:

(3) Strain the gasoline through a filter paper or any other type of strainer that will prevent the passage of water. **CAUTION: Be sure to provide a positive metallic contact between fuel container and gasoline tank, unless both fuel tank and container are independently grounded.**

(4) Insofar as possible, always keep the fuel tanks full. This will reduce the free air space above the fuel from which moisture can be condensed.

(5) Add one quart of denatured alcohol, grade 3, to fuel tank at start of winter season and one pint per month thereafter. This will reduce the hazard of ice formation in the fuel.

(6) Do not store fuel in old drums unless they are free from rust and have been thoroughly cleaned. If time is not an urgent factor, do not pump fuel from drum to vehicle until it has settled for 24 hours after filling or moving the drum. Keep portable fuel pumps clean and protected from snow and frost.

(7) When a drum has been opened, be sure to cover the opening or replace the bung to keep out snow, frost, or other foreign matter. Store drums in a covered building, or cover them with a tarpaulin.

OPERATION UNDER UNUSUAL CONDITIONS**c. Engine Lubrication.**

(1) Engine lubrication at temperatures above 0°F is covered in section VII, and in the Lubrication Guide. The following instructions supplement this information, and apply only to instances where the temperature falls below 0°F for long periods.

(2) Several methods of keeping engine oil sufficiently fluid for proper lubrication at temperatures below 0°F are listed below. Give preference to these methods in the order listed according to available facilities.

(a) Keep the vehicle in a heated enclosure when not in operation.

(b) When engine is stopped, drain crankcase oil while it is hot, and store in a warm place until vehicle is to be operated again. If warm storage is not available, heat the oil before reinstalling. (Avoid overheating the oil; heat only to the point where the bare hand can be inserted without burning.) Tag the vehicle in a conspicuous place in the drive compartment to warn personnel that crankcase is empty. Close both shut-off valves to prevent flooding of the carburetor, and crankcase dilution because of the accumulation of gasoline vapor pressure in the gasoline tanks.

(c) Dilute the crankcase oil with gasoline or Diesel fuel, with preference given to gasoline. For satisfactory starting in subzero temperatures, use one of the following two procedures to provide the engine with properly diluted engine oil.

(3) GASOLINE AS DILUENT.

(a) Fill engine crankcase to the "FULL" mark with the grade of engine oil prescribed for use at temperatures from +32°F to 0°F. Add 1½ quarts of gasoline for each 5 quarts of crankcase oil capacity. **EXAMPLE:** *Crankcase with capacity of 10 quarts will require 3 quarts of gasoline as an oil diluent.*

(b) Run the engine 5 to 10 minutes to mix the lubricant and diluent thoroughly.

(c) Stop the engine and note that the level of the diluted oil is above the normal "FULL" mark on the oil gage. This level should be marked on the gage for future reference.

(d) The presence of a large percentage of light diluent will increase oil consumption and, for that reason, the oil level should be checked frequently. Use the grade of engine oil prescribed for use between +32°F to 0°F to maintain the oil level to manufacturer's "FULL" mark on the gage during operation.

(e) If the vehicle is operated four hours or more at operating temperature, redilution will be necessary if it is anticipated that the vehicle will be left standing unprotected for five hours or more. This can be accomplished by adding engine oil prescribed for use between +32°F to 0°F to the manufacturer's "FULL" mark; then adding gasoline to the dilution mark on the gage described in subparagraph c (3) (c) above.

(4) **DIESEL FUEL AS DILUENT.** Drain the crankcase while the engine is still warm and refill using engine oil prescribed for temperatures between +32°F to 0°F diluted with grade X Diesel fuel oil in the proportion of 1½ quarts of Diesel fuel to 5 quarts of engine oil.

**4-TON, 6 x 6 TRUCKS (DIAMOND T MODELS 968A CARGO,
969A WRECKER, 970A PONTON, AND 972 DUMP)**

The presence of a large percentage of diluent will increase oil consumption and, therefore, the oil level will be checked frequently during operation and maintained with the diluted oil to manufacturer's "FULL" mark on gage.

d. Transmission, Transfer Case and Differentials.

(1) Where the use of SAE 10 engine oil is prescribed for use at temperatures $+32^{\circ}\text{F}$ to 0°F , it will be used undiluted for operation below 0°F .

(2) SAE 80 universal gear lubricant, where prescribed, is suitable for use at temperatures as low as -20°F . If consistent temperature below 0°F is anticipated, drain the gear cases while warm, and refill with grade 75 universal gear lubricant which is suitable for operation at all temperatures below $+32^{\circ}\text{F}$. If grade 75 universal gear lubricant is not available, SAE 80 universal gear lubricant, diluted with the fuel used in the engine in the proportion of 1 part fuel to 6 parts SAE 80 universal gear lubricant, shall be used. Make-up oil will be diluted in the same proportion before it is added to gear cases.

(3) After engine has been warmed up as provided in subparagraph a (2) above, engage clutch and maintain engine speed at fast idle for 5 minutes until gears can be engaged. Put transmission in low (first) gear, and drive vehicle for 100 yards, being careful not to stall engine. This will heat gear lubricants to the point where normal operation can be expected.

e. Chassis Lubricants.

(1) At temperatures below 0°F lubricate chassis points with No. 0 general purpose grease.

(2) Brake bands, particularly on new vehicles, have a tendency to bind when they are very cold. Always have a blowtorch handy to warm up these parts if they bind when you are attempting to move the vehicle. Parking the vehicle with the brake released will eliminate most of the binding. Precaution must be taken, under these circumstances, to block the wheels or otherwise prevent movement of the vehicle.

(3) Inspect the vehicle frequently. Shock resistance of metals, or resistance against breaking, is greatly reduced at extremely low temperatures. Operation of vehicles on hard, frozen ground causes strain and jolting which will result in screws breaking or nuts jarring loose.

(4) Disconnect oil-lubricated speedometer cables at the drive end when operating vehicles at temperatures of -30°F and below. These cables often fail to work properly at these temperatures, and sometimes break due to the excessive drag caused by the high viscosity of the oil with which they are lubricated. Grease-lubricated cables should operate satisfactorily at all temperatures, provided they are coated with No. 0 general purpose grease and there is no excess grease in the housing.

f. Antifreeze.

(1) Protect the cooling system with antifreeze compound for operation below $+32^{\circ}\text{F}$.

(2) Before adding antifreeze compound, be sure the cooling system is clean and completely free from rust.

OPERATION UNDER UNUSUAL CONDITIONS

(3) Inspect all hose and replace if deteriorated. Inspect hose clamps, plugs, and petcocks, and tighten if necessary. Make sure radiator does not leak before adding antifreeze compound, and that no exhaust gas or air leaks into the cooling system.

(4) After the cooling system is clean and tight, fill with water to about one-third capacity. Then add antifreeze compound, using the proportion of antifreeze compound to the cooling system capacity indicated below.

ANTIFREEZE TABLE

Lowest expected temperature	Pints, compound antifreeze per gallon of cooling system capacity
+10°F	2
0°F	2½
-10°F	3
-20°F	3½
-30°F	4
-40°F	4½
-50°F	5

(5) After adding antifreeze compound, fill with water to slightly below the filler neck; then start and warm the engine to normal operating temperature.

(6) The engine should then be stopped and the solution checked with a hydrometer, adding antifreeze compound if required.

(7) Inspect the coolant weekly for strength and color. Rusty solution must be drained, the cooling system thoroughly cleaned, and new solution of the required strength added. **CAUTION:** Use an accurate hydrometer. To test a hydrometer use 1 part antifreeze compound to 2 parts water. This solution should produce a hydrometer reading of 0°F.

g. Other Lubrication Points.

(1) Drain steering gear housing if possible, or use suction gun to remove as much lubricant as possible. Refill with grade 75 universal gear lubricant, or, if not available, with SAE 80 universal gear lubricant diluted with fuel used in the engine in the proportion of 1 part fuel to 6 parts SAE 80 universal gear lubricant. Make-up oil will be diluted in the same proportion before it is added to the housing.

(2) For oilcan points where engine oil is prescribed for above 0°F, use light preservative lubricating oil.

h. Protection of Electrical System.

(1) **GENERATOR AND STARTER.** Inspect the brushes, commutators and bearings. See that the commutators are clean. The large surges of current which occur when starting a cold motor require good contact between brushes and commutators.

(2) **WIRING.** Inspect and clean all connections, especially the battery terminals. Take care that no short circuits are present, or that there is no ice on the spark plugs, wiring, or other electrical equipment.

(3) **COIL.** Check coil for proper functioning.

**4-TON, 6 x 6 TRUCKS (DIAMOND T MODELS 968A CARGO,
969A WRECKER, 970A PONTON, AND 972 DUMP)**

(4) **DISTRIBUTOR.** Clean thoroughly, and clean or replace points. Check the points frequently. In cold weather the current is heavier, and the points may pit and burn more than usual.

(5) **SPARK PLUGS.** Clean, test and replace if necessary. If it is difficult to make the engine fire, reduce the gap 0.005 inches. This will make sparking easier at the reduced voltages likely to prevail.

(6) **TIMING.** Check carefully. Take care that the spark is not unduly advanced or retarded.

(7) **BATTERIES.**

(a) The efficiency of batteries decreases sharply with decreasing temperatures and becomes practically nil at -40°F . Do not attempt to start the engine with the battery when it has been exposed to temperatures below -30°F , until the battery has been warmed unless a warm slave battery is available.

(b) A fully charged battery will not freeze at temperatures likely to be found even in arctic climates, while a fully discharged battery will freeze and rupture at $+5^{\circ}\text{F}$. See that the battery is always fully charged with a hydrometer reading between 1.275 and 1.300.

(c) Do not add water to a battery when it has been exposed to sub-zero temperatures unless the battery is to be charged immediately. If water is added and the battery not put on charge, the layer of water will stay at the top and freeze before it has a chance to mix with the acid. Keep vent holes in filler plugs open. Keep terminals tight and clean. At regular intervals, apply a coating of general purpose grease, No. 0, or light rust preventive compound.

(8) **LIGHTS.** Inspect lights carefully.

i. **General Conditions.**

(1) Make sure that no heavy grease or dirt has been left on the starter throw-out mechanism. Heavy grease or dirt may keep the gears from being meshed, or cause them to remain in mesh after the engine starts and thus ruin the starter.

(2) Pull the choke control all the way out to secure the air-fuel ratio required for cold weather starting. Make sure the butterfly valve in the carburetor closes all the way and otherwise functions properly.

(3) Carburetors which give no appreciable trouble at normal temperatures may not operate satisfactorily at low temperatures. A fuel pump which will deliver enough gasoline at normal starting speeds of 400 revolutions per minute may have leaky valves, or a diaphragm which will prevent it from delivering a sufficient quantity of fuel at cranking speeds of 30 to 60 revolutions per minute. Another source of trouble is the float needle valve which, although a close fit, must move freely. Different expansions of the metals used in the needle valve parts may cause the needle valve to stick at extremely low temperatures.

(4) Inspect the vehicles frequently. Shock resistance of metals or resistance against breaking is greatly reduced at extremely low temperatures. Operation of vehicles on hard, frozen ground causes strain and jolting which will loosen or break bolts and nuts.

OPERATION UNDER UNUSUAL CONDITIONS

(5) Remove or bypass oil filters at temperatures below -30°F , because the viscous oil will not flow freely through them.

(6) Disconnect speedometer and tachometer cables at the drive end for operating vehicles at temperatures of -30°F and below. These cables often fail to work properly at these temperatures, and they sometimes break, because of excessive drag caused by the high viscosity of the lubricating oil.

(7) Remove and clean sediment bulb, strainer, etc., at frequent intervals.

j. Starting and Operation.

(1) It is possible to start gasoline engines with batteries at temperatures as low as -30°F , if the engines are properly lubricated and in good mechanical condition.

(2) To insure that the engine will start on the first attempt, proper preparation of the engine is very important. Should the engine fire a few times and stop, water vapor, which is a product of combustion, may form frost in the combustion chamber and make it impossible to start without heating the engine to above 32°F . Prolonged starting efforts wear down the battery.

(3) Pull the choke lever all the way out for starting, and keep it partially pulled out until the engine has warmed up. Since only the lightest components of the gasoline vaporize in a cold engine, a very rich mixture is necessary. Depress the clutch pedal to ease the starting load.

(4) When attempting to start, turn the engine over as rapidly as possible. All engines have a critical cranking speed, i. e., the engine must be turned over at a certain rate of speed before any start at all is possible. For engines in good mechanical condition, this critical rate of speed may vary from 40 to 70 revolutions per minute. Below this speed, the fuel pump will not deliver fuel fast enough.

(5) After the engine is started, idle it at 800 to 1,000 revolutions per minute until it has warmed up enough to run smoothly. Do not place the vehicle in operation under its own power until its operating temperature of 160°F has been reached. Maintain this temperature by adjusting the radiator shutters during operation.

(6) Cover engine with tarpaulin, tent, or portable shed. Place oil stoves, fire pots, or four or five ordinary kerosene lanterns under the covering about three hours prior to starting time.

(7) Keep vehicles in sheltered areas shielded from wind. Cold winds increase starting difficulties.

k. Stopping. Increase engine speed before turning off ignition. Then turn off ignition and release throttle at the same time. As the engine coasts to a stop, it will blow out all the residual products of combustion, including water vapor, and leave only air and gasoline vapor in the engine.

l. Cold Weather Accessories.

(1) A number of the most commonly used accessories have been mentioned in the preceding sections. These, together with other acces-

TM 9-811
14-15

**4-TON, 6 x 6 TRUCKS (DIAMOND T MODELS 968A CARGO,
969A WRECKER, 970A PONTON, AND 972 DUMP)**

sories and attachments used successfully in northern climates, are listed below. The use of these accessories is not mandatory. They are given only as suggestions, and are to be used at the discretion of officers in charge of the materiel.

(2) Tarpaulins, tents, or collapsible sheds are useful for covering vehicles, particularly the engines.

(3) Fire pots (Primus type) or Van Prag blowtorches, ordinary blowtorches, oil stoves, or kerosene lanterns can be used for heating vehicles.

(4) Extra batteries and facilities for changing batteries quickly help in starting.

(5) Steel drums and suitable metal stands are useful for heating crankcase oil.

(6) Insulation for the fuel line helps prevent ice formation inside the line.

(7) Radiator covers, improvised locally, help keep the engine running at normal temperatures.

15. OPERATION ON ICE.

a. General. It is essential, when driving on ice or slippery terrain, that the operator exercise special care in order to avoid skidding and possible accident. The hazards of this type of operation are greatly increased when visibility is poor and when equipment is trailed behind the vehicle. It is a test of the driver's ability, his judgment, and his "feel" of the truck. In general, automotive vehicles should be operated on ice at slow speeds with all wheels driving.

b. Starting and Accelerating on Ice.

(1) When starting from a dead stop all available traction is required, so that it is necessary that the front axle drive be engaged. Tire chains will make starting easier, but will not prevent the wheels from spinning.

(2) Shift the transfer case into high range, and select a gear ratio in the transmission one step higher than that required for a normal start on dry pavement. The ratio to be selected will depend on the load that is carried, but in general the start should be made with the transmission in second gear when the vehicle is loaded (and with the transmission in third gear when the vehicle is unloaded).

(3) After shifting into the proper gear in the transmission, accelerate the engine slightly more than would be necessary for a normal start to take care of the extra load on it, and release the clutch very slowly until it is all the way out. If the wheels start to spin, immediately release the clutch and start over again.

(4) Accelerate very slowly to avoid spinning the wheels. Shift up in the transmission to driving gear, and accelerate to driving speed. If at any time the wheels start to spin, immediately release the accelerator pedal and then depress it gradually to pick up the load.

c. Vehicle Speed. It is not possible to drive as fast on slippery roadways as it is on dry pavement. The speed at which the vehicle may

OPERATION UNDER UNUSUAL CONDITIONS

be safely operated depends on the skill of the driver and the condition of the road. Drive the vehicle at such a speed that it is under control at all times. Stay far enough behind the vehicle ahead so that it will be possible to coast to a stop without hitting it. Avoid any tendencies toward sudden changes in direction or speed. Make all sharp turns at a very low speed.

d. Stopping on Ice.

(1) **WARNING.** Do not attempt to apply the brakes and make a quick stop on slippery pavement. *This is not possible.* The wheels will lock and the vehicle will skid and more than likely spin. This situation is especially acute on vehicles equipped with air brakes. The ideal method of stopping on slippery pavement is to stop without any brake application.

(2) The driver must at all times be prepared to start to stop well in advance of the real necessity. He must watch the road ahead and anticipate the necessity of halting the vehicle.

(3) When it is necessary to stop, start well in advance and utilize the engine compression as a brake. Shift progressively down in the transmission as the vehicle slows up. If brake application is necessary it must be very light but do not release the clutch when braking, unless the vehicle speed is very low. If the brakes lock and the wheels skid, release the brakes immediately. If possible avoid stopping where it will be necessary to start uphill.

(4) When the vehicle is stopped, shift to neutral, shut off the engine and apply the hand brake. If the vehicle is in a precarious position, block the wheels to prevent accidents.

e. Recoveries.

(1) It will sometimes happen under extremely bad conditions that the vehicle will start to skid and spin in spite of the care exercised by the driver, and it is important that he understand the proper method to attempt recovery. As soon as the wheels start to spin or skid, the driver should immediately release the accelerator or the brake, whichever he is using. In most instances this will be all that is necessary. In the event that the vehicle is skidding or spinning, the driver must steer in front of the vehicle. That is, he must steer in such a direction that the front of the vehicle will stay forward. If the back end swings to the left, steer to the left; if it swings to the right, steer to the right. Straighten out the wheel as the vehicle corrects itself. *Do not apply the brakes.*

(2) When equipment is trailed behind the vehicle there is always the possibility of "jackknifing." In the event this occurs, *do not apply the brakes*, but accelerate the engine slowly and try to stay ahead of the trailer. It is important that the acceleration be gradual enough so that the wheels will not spin. Apply the trailer brakes lightly. The possibility of recovery from this jeopardy depends on the alertness of the driver, as it is impossible to straighten out once the trailer has swung out too far.

f. Vehicle Stalled. If the vehicle is stopped on an incline, in a rut, in a hole or against the curb so that it is impossible to drive the vehicle, *do not accelerate wildly or spin the wheels.* Extra traction may be obtained by scattering sand, ashes, gravel, etc., under the wheels. In

TM 9-811

15-16

4-TON, 6 x 6 TRUCKS (DIAMOND T MODELS 968A CARGO, 969A WRECKER, 970A PONTON, AND 972 DUMP)

emergencies, it is possible to drive out on blankets or tire chains placed on the ice ahead of each wheel. When the latter expedients are used it is of the utmost importance to avoid spinning the wheels, else the blankets or chains be kicked out from under them.

g. Frozen Terrain. In general, tire chains are of great value when going cross country over frozen ground, and may be indispensable. Start and stop slowly, drive cautiously and avoid holes and deep ruts whenever possible.

h. Steep Inclines. It is almost impossible for automotive vehicles to negotiate steep inclines on ice or slippery pavements. Where distances are not too great and where suitable anchors are available, winching operations may be accomplished to raise or lower the vehicle and load. In operations of this type, care should be exercised to prevent injury and damage in the event of accident.

16. OPERATION IN SNOW.

a. General. The conditions of operation in snow vary with its amount and quality. In general, operations in light snow or slush are similar to ice operations. For heavier snow, the driver should avoid unnecessary perils and heavy drifts whenever possible. When a snow plow is available, it should be used to clear a roadway for other vehicles.

b. Light Snow. When driving on light snow or slush, tire chains are not necessary. Operate the vehicle with caution, stop and start slowly and observe the precautions outlined in paragraph 14.

c. Heavy Snow. With all six wheels driving, and with tire chains installed, these trucks can operate successfully in snow up to 18 inches deep. When trucks are traveling in convoy all vehicles should follow in the tracks of the leader. It is important to keep the truck going; select the proper gear ratio in the transmission to permit the engine to operate with full power (1800 to 2300 revolutions per minute) to avoid stalling. In the event the vehicle is stalled, do not attempt to start again bucking heavy snow. Back up in the vehicle tracks far enough before starting so that the vehicle will have acquired sufficient momentum to avoid stalling when it hits the snow.

d. Drifts. In driving through drifts the vehicle transmission should be put into low gear before entering the drift, and should have sufficient momentum before it hits it. Once in the drift, keep the vehicle moving. Stopping or slowing up to change gears in a drift will often result in stalling.

e. Stalled Vehicles. When the vehicle is so badly stalled that it cannot be freed by rocking the vehicle (alternate shifting from forward to reverse speed), the driver should get out and determine the seriousness of the situation. *NOTE: Do not make more than a few attempts at rocking the vehicle as this will only cause the vehicle to dig in and make the situation worse.* Dig out around the wheels and make a path for the vehicle. If chains are not installed, put them on. Drive out cautiously and then keep the vehicle moving to avoid further stalling.

OPERATION UNDER UNUSUAL CONDITIONS

f. Steep Inclines. When inclines are encountered which are too steep to be negotiated in heavy snow, winching operations may be attempted. Observe the same precautions as are observed for winching in icy conditions.

17. OPERATION IN EXTREME HEAT.

a. General. The engine cooling system will require careful attention in torrid regions. The loss of cooling water will cause severe engine damage and prevent operation of the vehicle. In addition to the most careful attention for the cooling system, the operator must exercise special maintenance precautions to prevent failure of critical parts.

b. Overheating.

(1) In order to prevent overheating it is essential that all units be in proper adjustment to permit a cool-running engine. Cooling system checks must be made at every possible opportunity in order to prevent trouble. It is of the utmost importance that all water leaks be discovered and repaired before they can cause damage to the engine. Check possible causes of overheating as follows:

- (a) Keep radiator full of water. Repair leaks.
 - (b) Keep fan belt in proper adjustment.
 - (c) Flush cooling system if it is clogged up.
 - (d) Be sure water pump is properly functioning.
 - (e) Check thermostat for faulty action.
 - (f) Look for rotted or defective rubber hose.
 - (g) Clean dirt or insects from radiator air passages, and clean dirt or sand from bottom of radiator shroud.
 - (h) Check crankcase oil level.
 - (i) See that choke valve will open all the way to prevent a rich mixture.
 - (j) Clean carburetor and check float level to prevent a lean mixture.
 - (k) Check timing.
 - (l) Do not drive with spark too far retarded.
 - (m) Check exhaust for restrictions.
 - (n) Check brakes for dragging.
 - (o) Do not permit engine to labor. Drive in proper gear.
- (2) In torrid regions it may be necessary to permit free circulation of water to get the maximum cooling effect. This may be accomplished by removing the thermostat and blocking off the thermostat bypass tube. If this is done, it is recommended that the vehicle be tagged conspicuously so that the changeover may be reversed if the vehicle moves into another climate.
- (3) Special surge tanks or condensers are available for vehicles operating in extremely hot regions. These are used in connection with pressure cooling systems and serve as a reservoir for water which would be lost with an ordinary cooling system.

TM 9-811

17-18

4-TON, 6 x 6 TRUCKS (DIAMOND T MODELS 968A CARGO, 969A WRECKER, 970A PONTON, AND 972 DUMP)

(4) Scale and rust formations in the cooling system occur more readily than usual during operations in extreme heat. Rust inhibitors should be added to the cooling liquid. Use only clean water and avoid the use of water containing alkalis or other harmful substances.

c. Special Maintenance.

(1) In extremely hot weather preventive maintenance checks must be made as frequently as possible. Rubber hose and diaphragms deteriorate rapidly when exposed to heat.

(2) Lubricating oils thin out and flow past seals more readily than at normal temperatures.

(3) Brake drums become excessively hot, with the danger of galling and cracking.

(4) Tires wear out rapidly and inflation must be checked more frequently than usual.

(5) Excessive heat may cause vapor lock, and it may be necessary to insulate the fuel lines or to install special pressure caps on the gasoline tanks. If vapor lock occurs, pour water over the lines and affected units, or wait until they cool off.

(6) The level of the water in the battery should be checked daily and replenished, if necessary, with drinking water.

18. OPERATION IN DESERT OR SANDY TERRAIN.

a. General. Desert driving calls for great individual skill on the part of the driver because of the necessity for dispersion and for avoiding the tracks of preceding vehicles. It takes considerable experience to develop the quick eye necessary to pick the best ground and the proper gear.

b. Cooling System. In desert operations, it is important that all preventive maintenance practices outlined in paragraph 17 be followed. Special emphasis should be placed on those aspects of preventive maintenance which are concerned with the cooling system as water is at a premium in the desert.

c. Air Cleaners. There is always sand in the air in the desert and more is stirred up by the wind and by the passage of vehicles. In order to prevent damage to the engine, the air cleaners (engine air cleaner, air compressor, air cleaner and auxiliary unit air cleaners where provided) be given very frequent attention. Under extremely bad conditions it may be necessary to clean the air cleaners every hour or so. When cleaning the air cleaners always check the breathers on the engine, transfer case and axles.

d. Tires.

(1) In desert operations the tires must be suitable for almost every type of terrain. The greatest difficulties will be encountered in sand. The tires should be of plain rib tread and of round cross section, as tires with deeply corrugated or raised flat treads will break through the crust and dig into the soft sand underneath. Air pressure must be varied to suit the type of ground surface.

OPERATION UNDER UNUSUAL CONDITIONS

(2) When going over sand or soft powdered clay, the tires should be deflated as much as is possible. By deflating the tires, the area in contact with the ground is increased and hence the unit ground pressure is decreased. The soft tire fits itself into the irregularities of the sand without breaking through the crust. It has been found that tire life is very little shortened by running soft over sandy ground which does not contain rocks or imbedded boulders.

(3) On rocky ground the tires must be fully inflated. Soft tires would be quickly rendered useless from chafing against the rocks.

(4) Since a normal day's march will take a vehicle over different kinds of ground, strict tire discipline is necessary. These vehicles are equipped with an air hose so that air from the air brake reservoirs can be used to inflate the tires.

e. Special Operating Instructions.

(1) Operations over sand should be made with the front axle engaged with the transfer case in low range.

(2) All starts and stops on sandy ground should be made slowly and gradually without spinning or skidding the wheels. When changing gears, release the clutch gradually to prevent sudden changes in vehicle speed. To neglect these precautions will cause the vehicle to break through the crust and become stuck.

(3) The driver should shift gears at the proper time so as not to lose vehicle speed, or cause the engine to labor. He must learn to make full use of momentum to keep from being stuck any more often than can be helped. If possible, the truck should never be parked facing uphill.

(4) As soon as the vehicle has broken through the sand crust and ceased to move, no attempt should be made to get the vehicle out under power, as to do so will only cause the vehicle to sink deeper into the sand. Dig a path out in front of the wheels which are dug in, making it long and of shallow slope and as deep as the wheels are sunken in. Place mats in front of the front wheels and place a single spar between the duals of the rear wheels (so that it will function as a rail) and drive out slowly and carefully. In extreme cases it may be necessary to attempt winching operations.

19. OPERATION IN MUD.

a. **General.** The operation of an automotive vehicle over mud and soft ground calls for the utmost in skill and judgment on the part of the driver. The driver must avoid bad holes and deep ruts, and should steer for those parts of the ground which afford the easiest going.

b. **Preparation.** Operations in mud require all available flotation and traction. If the mud is not very bad, it may not be necessary to make any special installations, but for deep mud it may be desirable to mount the spare wheels on the front axle to provide duals all the way around for extra flotation, and to install tire chains for extra traction.

c. Hints for Operation.

(1) Engage the front axle drive and shift to low range in the transfer case before starting through the mud.

TM 9-811

19

**4-TON, 6 x 6 TRUCKS (DIAMOND T MODELS 968A CARGO,
969A WRECKER, 970A PONTON, AND 972 DUMP)**

(2) Keep the engine wound up and do not permit it to labor. Select the proper gears and shift up or down in the transmission to keep the engine up to its full power (1800 to 2300 revolutions per minute).

(3) Keep the vehicle moving to make full use of its momentum. Change gears quickly.

(4) If the vehicle becomes bogged down, do not attempt to drive out as it will only cause the wheels to dig in deeper. Dig the wheels clear and spread dry soil, sand, branches, etc., in front of them. It may be necessary to attempt winching operations.

Section VI

INSPECTION AND PREVENTIVE MAINTENANCE SERVICE

	Paragraph
Purpose	20
Before-operation service	21
During-operation service	22
At-halt service	23
After-operation and weekly service	24

20. PURPOSE.

a. To insure mechanical efficiency it is necessary that the vehicle be systematically inspected at intervals each day it is operated and weekly, so defects may be discovered and corrected before they result in serious damage or failure. Certain scheduled maintenance services will be performed at these designated intervals. The services set forth in this section are those performed by driver or crew, before operation, during operation, at halt, and after operation and weekly.

b. Driver Preventive Maintenance Services are listed on the back of "Driver's Trip Ticket and Preventive Maintenance Service Record," W.D. Form No. 48, to cover vehicles of all types and models. Items peculiar to specific vehicles, but not listed on W.D. Form No. 48, are covered in manual procedures under the items with which they are related. Certain items listed on the form that do not pertain to the vehicle involved are eliminated from the procedures as written into the manual. Every organization must thoroughly school each driver in performing the maintenance procedures set forth in manuals, whether they are listed specifically on W.D. Form No. 48 or not.

c. The items listed on W.D. Form No. 48 that apply to this vehicle are expanded in this manual to provide specific procedures for accomplishment of the inspections and services. These services are arranged to facilitate inspection and conserve the time of the driver and are not necessarily in the same numerical order as shown on W.D. Form No. 48. The item numbers, however, are identical to those shown on that form.

d. The general inspection of each item applies also to any supporting member or connection, and generally includes a check to see whether the item is in good condition, correctly assembled, secure, or excessively worn.

e. The inspection for "good condition" is usually an external visual inspection to determine whether the unit is damaged beyond safe or serviceable limits. The term good condition is explained further by the following terms: not bent or twisted, not chafed or burned, not broken or cracked, not bare or frayed, not dented or collapsed, not torn or cut.

f. The inspection of a unit to see that it is "correctly assembled" is usually an external visual inspection to see whether it is in its normal assembled position in the vehicle.

g. The inspection of a unit to determine if it is "secure" is usually an external visual examination, a hand-feel, or a pry-bar check for

**4-TON, 6 x 6 TRUCKS (DIAMOND T MODELS 968A CARGO,
969A WRECKER, 970A PONTON, AND 972 DUMP)**

looseness. Such an inspection should include any brackets, lock washers, lock nuts, locking wires, or cotter pins used in assembly.

h. "Excessively worn" will be understood to mean worn close to, or beyond, serviceable limits, and likely to result in a failure if not replaced before the next scheduled inspection.

i. Any defects or unsatisfactory operating characteristics beyond the scope of first echelon to correct must be reported at the earliest opportunity to the designated individual in authority.

21. BEFORE-OPERATION SERVICE.

a. This inspection schedule is designed primarily as a check to see that the vehicle has not been tampered with, or sabotaged since the After-operation Service was performed. Various combat conditions may have rendered the vehicle unsafe for operation, and it is the duty of the driver to determine whether or not the vehicle is in condition to carry out any mission to which it is assigned. This operation will not be entirely omitted, even in extreme tactical situations.

b. **Procedures.** Before-operation Service consists of inspecting items listed below according to the procedure described, and correcting or reporting any deficiencies. Upon completion of the service, results should be reported promptly to the designated individual in authority.

(1) **ITEM 1, TAMPERING AND DAMAGE.** Look for injury to vehicle in general, accessories or equipment, caused by tampering or sabotage, collision, falling debris or shell fire since parking vehicle. Look under hood for signs of tampering or sabotage, such as loosened or damaged accessories, loose fuel, oil or water lines, disconnected wiring or linkage. Dry electrical wiring or accessories, if necessary, to facilitate starting.

(2) **ITEM 2, FIRE EXTINGUISHERS.** Inspect for corrosion, clogged nozzle, full charge (shake to test), and secure mounting.

(3) **ITEM 3, FUEL, OIL AND WATER.** Observe amount of fuel in tanks, vehicle and wrecker air compressor and spare cans; add fuel if necessary. Read crankcase oil level (also oil level of compressor on wrecker). Add oil if necessary. Inspect water level and condition of coolant. If necessary to add considerable water during period when antifreeze is used, have hydrometer check made of coolant and add antifreeze if required. Investigate and report any appreciable change in levels since performing last After-operation Service.

(4) **ITEM 4, ACCESSORIES AND DRIVES.** Examine all accessories such as carburetor, generator, regulator, starter, fuel pump, fuel strainer, fan, and water pump for loose connections and mountings or leaks. Make sure winches are not engaged and that cable is properly wound and fastened. Examine winch transmission roller chain (wrecker) for good condition, and one-half inch deflection from vertical opposite idler gear. Examine fan belts for good condition and one-inch deflection between fan and crankshaft pulleys.

(5) **ITEM 5, AIR BRAKE TANKS.** Inspect air brake valve assemblies for leaks with brakes applied and released; check connections if hooked up to trailer. See that dummy couplings are installed. Exam-

INSPECTION AND PREVENTIVE MAINTENANCE SERVICE

ine air brake reservoir tanks for damage and security of mounting, also air line connections for tightness. Be sure water (condensation) is drained from air tanks. **CAUTION:** *Close drain valves.*

(6) **ITEM 6, LEAKS, GENERAL.** Look under vehicle and on ground for indications of fuel, oil, water, and gear oil leaks. Examine radiator core and hose, oil filters, crankcase, fuel tank and fuel and oil lines for leaks. Correct leaks or report.

(7) **ITEM 7, ENGINE WARM-UP.** Start engine. Observe any tendency toward slow cranking speed, and improper or noisy engaging or disengaging when starting control is operated. Set throttle to give 800 to 900 revolutions per minute (tachometer reading) and warm-up engine while proceeding with the following Before-operation Service. **NOTE:** *During engine warm-up listen for unusual noises and observe instrument indications and engine performance, such as misfiring and rapid temperature rise. If oil pressure does not read at least 5 to 10 pounds at idle immediately after starting, STOP ENGINE, and report.*

(8) **ITEM 8, CHOKE.** At starting, test operation of choke. As engine warms up, push in choke to prevent overchoking and engine oil dilution.

(9) **ITEM 9, INSTRUMENTS.** Inspect for secure mounting, proper connections, damage, and proper readings.

(a) **Oil Pressure Gage.** Normal gage pressure is 5 to 10 pounds at idle and 25 pounds minimum at running speeds, with warm engine. Pressure will be higher before engine warms up.

(b) **Ammeters.** After engine starts and is running at 800 to 900 revolutions per minute (fast idle), both ammeters should show a high positive (+) charge rate for short period until battery current used in starting is restored, then a zero or slight positive (+) charge, with lights and accessories turned off.

(c) **Fuel Gage.** Must register approximate amount of fuel in tank.

(d) **Temperature Gage.** Reading should increase gradually as engine warms up to 160° to 180° F operating temperature.

(e) **Tachometer.** Observe whether tachometer indicates engine revolutions per minute without undue noise or fluctuation.

(f) **Air Brake Pressure Gage and Warning Buzzer.** Gage should show 70-pounds pressure before starting truck. Warning buzzer should operate up to 50- to 60-pounds pressure. If 70-pounds pressure is not reached within reasonable warm-up time, investigate system for faulty operation or leaks. Maximum governed pressure is 105 pounds.

(g) **Viscosity Gage.** Gage may indicate "heavy" during warm-up period, but must indicate "ideal" after warm-up. "Thin" indication shows need for oil change.

(10) **ITEM 10, HORN AND WINDSHIELD WIPER.** If tactical situation permits, test horn. Operate windshield wipers, and observe for blade contact throughout full arc of operation.

(11) **ITEM 11, GLASS AND REAR VIEW MIRROR.** Inspect for damaged frames, brackets, and discolored glass. Clean windshield and door glass. Clean mirror and aim properly.

(12) **ITEM 12, LAMPS (LIGHTS) AND REFLECTORS.** Tactical situation permitting, turn on switches and see that all lights light. See that

TM 9-811
21-22

**4-TON, 6 x 6 TRUCKS (DIAMOND T MODELS 968A CARGO,
969A WRECKER, 970A PONTON, AND 972 DUMP)**

all lights are secure and lenses of lights and reflectors are clean and not broken.

(13) **ITEM 13, WHEEL AND FLANGE NUTS.** Examine all wheel mountings, rim and flange nuts to see they are secure.

(14) **ITEM 14, TIRES.** Look for damage. See that there are no stones, glass or other foreign objects imbedded in treads or carcass, or between duals. Inspect for presence of valve caps. Air pressure should be 65 pounds.

(15) **ITEM 15, SPRINGS AND SUSPENSIONS.** See that they are secure, not damaged or shifted.

(16) **ITEM 16, STEERING LINKAGE.** Inspect steering gear case and all connecting linkage for good condition and security. Make sure there are no excessive lubricant leaks.

(17) **ITEM 17, FENDERS AND BUMPERS.** Inspect for looseness or damage. Inspect 5-gallon cans and bracket for good condition and security.

(18) **ITEM 18, TOWING CONNECTIONS.** (Pintle and two tow hooks.) See that towing connections are secure and not damaged.

(19) **ITEM 19, BODY, LOAD AND TARPAULINS.** Inspect for good condition, security and even load distribution.

(20) **ITEM 20, DECONTAMINATOR.** Inspect for full charge (shake), closed valve, and secure mounting.

(21) **ITEM 21, TOOLS AND EQUIPMENT.** Inspect for presence, serviceability, and proper stowage.

(22) **ITEM 22, ENGINE OPERATION.** Engine should idle smoothly with choke button fully depressed. Accelerate and decelerate, and listen for unusual noises that may indicate compression or exhaust leaks, worn, damaged, loose, or inadequately lubricated engine parts or accessories. Note any unusual smoke from exhaust.

(23) **ITEM 23, DRIVER PERMIT AND FORM NO. 26.** Driver must have his operator's permit and make sure that Standard Accident Report Form No. 26, and Vehicle Operator's Manual are in the vehicle, legible, and safely stowed.

(24) **ITEM 24, DURING-OPERATION SERVICE.** The During-operation Service must start immediately after vehicle is put in motion.

22. DURING-OPERATION SERVICE.

a. While vehicle is in motion, listen for any sounds such as rattles, knocks, squeals, or hums that may indicate trouble. Look for indications of trouble in cooling system and for smoke from any part of the vehicle. Be on the alert to detect any *odor* of overheated components or units such as generator, brakes, clutch, fuel vapor from a leak in fuel system, exhaust gas or other signs of trouble. Any time the brakes are used, gears shifted, or vehicle turned, consider this a test, and notice any unsatisfactory or unusual performance. Watch the instruments constantly. Notice promptly any unusual instrument indication that may signify possible trouble in the system to which the instrument applies.

b. **Procedures.** During-operation Services consist of observing items listed below according to the procedures following each item,

INSPECTION AND PREVENTIVE MAINTENANCE SERVICE

and investigating any indications of serious trouble. Notice minor deficiencies to be corrected or reported at earliest opportunity, usually next scheduled halt.

(1) **ITEM 27, FOOT AND HAND BRAKES.** Foot brake should operate smoothly and effectively without pulling vehicle to right or left. Free travel before brake operation should be $\frac{1}{2}$ to 1 inch. When vehicle is stopped, hand brake should hold vehicle satisfactorily on a reasonable incline. Reserve of $\frac{1}{4}$ to $\frac{1}{3}$ of lever travel must be available.

(2) **ITEM 28, CLUTCH.** Test clutch pedal for one to one and one-half inches free travel before disengagement. Clutch must not chatter, squeal, or slip.

(3) **ITEM 29, TRANSMISSION, (POWER TAKE-OFF ON CARGO, PONTON AND WRECKER TRUCKS).** Gears must shift smoothly, operate quietly, and not creep out of mesh during operation.

(4) **ITEM 30, TRANSFER, (POWER TAKE-OFF ON DUMP TRUCK).** Gears should shift smoothly, operate quietly, and not creep out of mesh during operation.

(5) **ITEM 31, ENGINE AND CONTROLS.** Be alert for deficiencies in engine performance such as lack of usual power, misfiring, unusual noise, stalling, engine overheating, or unusual exhaust smoke. Note whether engine responds to controls satisfactorily and whether controls seem to be in proper adjustment, and not loose.

(6) **ITEM 32, INSTRUMENTS.** Observe all instruments for indication of normal functioning of systems to which they apply.

(a) *Temperature Gage.* Normal operating temperature is 160°F to 180°F.

(b) *Oil Pressure Gage.* Normal oil pressure is 5 to 10 pounds at idle and 25 pounds minimum at running speeds. Any unusual drop, or no pressure, requires immediate stopping of engine.

(c) *Ammeters.* Both should indicate zero or positive (+) reading during operation. Discharge may indicate faulty generator, regulator or other serious electrical trouble.

(d) *Fuel Gage.* Should indicate approximate amount of fuel in tank.

(e) *Speedometer and Odometer.* The speedometer should indicate vehicle speed (except reverse) without noise or fluctuation. Odometer should record accumulating trip and total mileage.

(f) *Tachometer.* Should register engine revolutions per minute without noise or fluctuation.

(g) *Air Pressure Gage.* Should indicate 85 to 105 pounds during operation. Maximum governed pressure is 105 pounds.

(h) *Air Pressure Warning Buzzer.* Indicates dangerously low pressure (50 to 60 pounds or less).

(i) *Viscosity Gage.* Must show "ideal" after engine is fully warmed up.

(7) **ITEM 33, STEERING GEAR.** Test for looseness, binding, pulling to one side, wheel tramp wander, shimmy, or unusual noises.

TM 9-811
22-23

**4-TON, 6 x 6 TRUCKS (DIAMOND T MODELS 968A CARGO,
969A WRECKER, 970A PONTON, AND 972 DUMP)**

(8) **ITEM 34, RUNNING GEAR.** Listen for any unusual noises from wheels, axles or suspension parts, that may indicate looseness or damage.

(9) **ITEM 35, BODY AND TRAILER.** Be alert for shifting load, abnormal sagging or tilting of vehicle, loose top, presence and condition of tarpaulin or curtains, unusual weaving of towed loads, loose hardware, gun mounts, or equipment.

23. AT-HALT SERVICE.

a. At-halt Services may be regarded as minimum maintenance procedures and should be performed under all tactical conditions, even though more extensive maintenance services must be slighted or omitted altogether.

b. **Procedures.** At-halt Services consist of investigating any deficiencies noted during operation, inspecting items listed below according to the procedures following the items, and correcting any deficiencies found. Deficiencies not corrected should be reported promptly to the designated individual in authority.

(1) **ITEM 38, FUEL, OIL AND WATER.** Replenish as required. Fuel filler cap vents must be free.

(2) **ITEM 39, TEMPERATURES: HUBS, BRAKE DRUMS, TRANSFER, TRANSMISSION, AND AXLES.** Feel for overheating. Transfer temperatures will run higher than other gear units. Lower than average temperature of brake drum may indicate inoperative brake.

(3) **ITEM 40, AXLE AND TRANSFER VENTS.** Wipe vents clean and examine for damaged or clogged condition; remove and clean if necessary.

(4) **ITEM 41, PROPELLER SHAFTS.** Examine for looseness, damage, or oil leaks.

(5) **ITEM 42, SPRINGS AND SUSPENSION.** Inspect for broken or shifted spring leaves, damaged or loose clips, U-bolts, eyebolts, shackles, shock absorbers, torque rods, and torque rod pins.

(6) **ITEM 43, STEERING LINKAGE.** Examine steering control mechanism, arms, and linkage for looseness or damage.

(7) **ITEM 44, WHEEL AND FLANGE NUTS.** All nuts must be present and secure.

(8) **ITEM 45, TIRES.** Tires must have 65 pounds maximum pressure (when cool). Examine for flats or damage. Remove foreign matter from treads and from between duals.

(9) **ITEM 46, LEAKS, GENERAL.** Look under hood and under vehicle for indications of fuel, oil, water, or hoist fluid leaks.

(10) **ITEM 47, ACCESSORIES AND BELTS.** Examine for looseness, damage and incorrect alignment. Fan belt must have tension to give one-inch deflection between fan and crankshaft pulley. Wrecker rear winch drive chain tension must have one-half inch deflection.

(11) **ITEM 48, AIR CLEANERS.** Cleaners must be secure and air passages clean. When operating under extremely dirty or sandy con-

INSPECTION AND PREVENTIVE MAINTENANCE SERVICE

ditions, inspect air cleaners and breather caps frequently. Clean and oil the following as required: carburetor and compressor air cleaners, oil filler breather, and air cleaners on air compressor of wrecker.

(12) **ITEM 49, FENDERS AND BUMPERS.** Examine for looseness or damage.

(13) **ITEM 50, TOWING CONNECTIONS.** Make sure all towing connections are secure and locked.

(14) **ITEM 51, BODY, LOAD AND TARPAULIN.** Inspect vehicle load for shifting and tarpaulins for secure fastening and good condition.

(15) **ITEM 52, APPEARANCE AND GLASS.** Clean windshield, door and window glass, rear-view mirror, and lamp lenses, and inspect for damage.

24. AFTER-OPERATION AND WEEKLY SERVICE.

a. After-operation Servicing is particularly important, because at this time the driver inspects his vehicle to detect any deficiencies that may have developed, and corrects those he is permitted to handle. He should report promptly to the designated individual in authority, the results of his inspection. If this schedule is performed thoroughly, the vehicle should be ready to roll again on a moment's notice. The Before-operation Service, with a few exceptions, is then necessary only to ascertain whether the vehicle is in the same condition in which it was left upon completion of the After-operation Service. The After-operation Service should never be entirely omitted even in extreme tactical situations, but may be reduced to the bare fundamental services outlined for the At-halt Service if necessary.

b. **Procedures.** When performing the After-operation Service the driver must remember and consider any irregularities noticed during the day in the Before-operation, During-operation, and At-halt Services. The After-operation Service consists of inspecting and servicing the following items. Those items of the After-operation that are marked by an asterisk (*) require additional weekly services, the procedures for which are indicated in subparagraph (b) of each applicable item.

(1) **ITEM 55, ENGINE OPERATION.** Test for smooth engine idle without stalling. Accelerate and decelerate engine, noting any tendency to miss or backfire, unusual noises, or vibration. Investigate any unsatisfactory engine operating characteristics noted during operation.

(2) **ITEM 56, INSTRUMENTS.** Before stopping engine inspect instruments for good condition, secure mountings, proper connections, and proper readings.

(a) *Oil Pressure Gage.* Oil pressure should be 5 to 10 pounds at idle and a minimum of 25 pounds at running speeds.

(b) *Temperature Gage.* Temperature should range between 160°F to 180°F.

(c) *Ammeters.* Both should read zero or slight positive charge at idle speed (with lights and accessories turned off).

(d) *Fuel Gage.* Gage should indicate approximate contents of tank.

(e) *Tachometer.* Should register engine revolutions per minute without fluctuation of indicator.

**4-TON, 6 x 6 TRUCKS (DIAMOND T MODELS 968A CARGO,
969A WRECKER, 970A PONTON, AND 972 DUMP)**

(f) *Viscometer.* Should indicate "ideal" (normal).

(g) *Air Pressure Gage.* Gage should indicate in excess of 50 pounds and not over 105 pounds with buzzer NOT operating. (Pressures subject to 5 or 6 pounds plus or minus variation.)

(3) **ITEM 54, FUEL, OIL AND WATER.** Fill vehicle fuel tank (and air compressor tank on wrecker, if required) and spare cans. Read engine oil level (and air compressor oil level on wrecker) and fill to proper level with specified oil. Note level of coolant, observe for contamination, and add water if needed. If necessary to add considerable quantity of water during period when antifreeze is used, have hydrometer test made and add antifreeze if required.

(4) **ITEM 57, HORN AND WINDSHIELD WIPERS.** Inspect horn for secure mounting and proper connections, wipers for good condition, smooth operation, full stroke and contact.

(5) **ITEM 58, GLASS AND REAR-VIEW MIRROR.** Clean and examine for good condition and secure mounting. Cover exposed glass to avoid reflections if situation requires camouflage.

(6) **ITEM 59, LAMPS (LIGHTS) AND REFLECTORS.** Observe whether lights go on and off as operated. Inspect all lenses and reflectors for dirt or damage; clean if necessary.

(7) **ITEM 60, FIRE EXTINGUISHER.** Inspect for good condition, leaks, and tight mountings. If extinguisher has been used report for refill or replacement.

(8) **ITEM 61, DECONTAMINATOR.** Inspect for good condition and security of mounting.

(9) **ITEM 62, *BATTERIES.**

(a) Inspect batteries for good condition, secure mounting and connections, proper electrolyte level, and leaks. Vent caps must be clean and secure.

(b) *Weekly.* Clean dirt from top of batteries and remove caps. Add clean drinking water if necessary. When terminals or posts are corroded, clean and grease lightly. Tighten terminal bolts and mounting bolts carefully. Clean and paint battery carrier if corroded.

(10) **ITEM 63, *ACCESSORIES AND BELTS.**

(a) Inspect carburetor, air cleaner, compressor, generator, regulator, starter, fan, and water pump for loose connections or mountings. Inspect air cleaner, carburetor, and water pump for leaks. Test fan belt for one-inch deflection between fan and crankshaft pulleys.

(b) *Weekly.* Tighten, if necessary, all accessories and inspect for any loose connections or leaks.

(11) **ITEM 64, *ELECTRICAL WIRING.**

(a) Inspect ignition wiring and outside of spark plugs and distributor cap for secure connections, cleanliness, and good condition.

(b) *Weekly.* Inspect all accessible low voltage wiring for good condition and security.

INSPECTION AND PREVENTIVE MAINTENANCE SERVICE**(12) ITEM 65, *AIR CLEANERS AND BREATHER CAPS.**

(a) Inspect carburetor air cleaner, crankcase breather mesh, air compressor cleaners, and clean if necessary, according to paragraph 26 c (3).

(b) *Weekly.* Clean, dry and reoil air compressor air cleaners according to paragraph 26 c (3).

(13) ITEM 66, *FUEL FILTER.

(a) Inspect filter for good condition, security of mounting, and leaks.

(b) *Weekly.* Remove drain plug from fuel strainer under left front fender, bottom side edge (not the center bowl nut), allow water and sediment to drain out of bowl and replace and tighten plug securely.

(14) **ITEM 67, ENGINE CONTROLS.** Examine for wear, damage, disconnected linkage, and proper lubrication.

(15) ITEM 68, *TIRES.

(a) Remove all foreign matter such as nails, glass, or stones from tires or from between duals. Inspect tires for signs of low pressure, abnormal tread wear and cuts. Replace missing valve caps. Inflate to 65 pounds pressure, *when tires are cool.*

(b) *Weekly.* Replace badly worn or unserviceable tires. Inspect valve stems on inside and outside duals; stems should be diametrically opposite (180 degrees). Inside dual and front wheel valves point away from vehicle; outside duals point toward vehicle. Change wheel position at first sign of irregular wear.

(16) ITEM 69, *SPRINGS AND SUSPENSIONS.

(a) Inspect springs for abnormal sag, broken or shifted leaves, loose or missing rebound clips, eyebolts, U-bolts, or shackles. Inspect torque rods, pins, and shock absorbers for looseness or damage.

(b) *Weekly.* Aline and tighten securely as necessary.

(17) **ITEM 70, STEERING LINKAGE.** Inspect steering linkage for good condition, loose, or inadequately lubricated parts. Examine steering gear case for leaks.

(18) **ITEM 71, PROPELLER SHAFTS.** Remove excess dirt and grease from around shafts and universal joints. Remove any foreign material wrapped around shafts. Inspect for loose connections, lubricant leaks, and damage.

(19) ITEM 72, *AXLE AND TRANSFER VENTS.

(a) Examine all axle, housing, and transfer vents for presence, good condition and security.

(b) *Weekly.* Free all breather vents of obstructions.

(20) **ITEM 73, LEAKS, GENERAL.** Look under hood and beneath vehicle for indications of fuel, oil, and water leaks. Inspect around brake drums for lubricant leaks. Examine axles, transmission, transfer, and power take-off for gear oil leaks. Inspect hoist and hoist pump and lines on dump truck for fluid leaks. Trace all leaks to source and correct or report.

(21) **ITEM 74, GEAR OIL LEVELS.** Inspect differentials, transmission, and transfer case units for correct lubricant levels (from $\frac{1}{2}$ inch below, when cool, to filler hole level, when hot).

TM 9-811

24

**4-TON, 6 x 6 TRUCKS (DIAMOND T MODELS 968A CARGO,
969A WRECKER, 970A PONTON, AND 972 DUMP)**

(22) **ITEM 75, *AIR BRAKE TANKS AND CONNECTIONS.**

(a) Listen at several points about truck for indications of air leaks. Drain condensation water from both air brake tanks, and close valves after draining. Inspect air brake chambers and linkage for security of mountings.

(b) Tighten tank mounting and all air-line connections that are loose. Clean air-line hose.

(23) **ITEM 76, FENDERS AND BUMPERS.** Inspect for security and good condition.

(24) **ITEM 77, TOWING CONNECTIONS.** Inspect towing hooks and pintle for looseness or damage. Be sure any towed load is secure and safety catches lock properly.

(25) **ITEM 78, BODY, LOAD AND TARPAULIN.** Inspect bodies for damage and loose or missing parts. See that load is evenly distributed and secure. Tarpaulin must be secure and not damaged.

(26) **ITEM 82, *TIGHTEN.**

(a) Tighten all wheel mounting, axle flange, and spring U-bolt nuts securely.

(b) *Weekly.* Tighten all vehicle assembly mounting nuts or screws that inspection indicates need to be tightened; be sure to tighten body mounting bolt nuts.

(27) **ITEM 83, *LUBRICATE AS NEEDED.**

(a) Lubricate all parts which inspection has revealed need lubrication. Wipe all dirt from fittings before applying lubricant. Report any missing fittings.

(b) *Weekly.* If due, lubricate all points indicated on vehicle Lubrication Guide as requiring attention on weekly or mileage basis.

(28) **ITEM 84, *CLEAN ENGINE AND VEHICLE.**

(a) Clean dirt and trash from inside cab and body. Remove excessive dirt and grease from exterior of vehicle and engine.

(b) *Weekly.* Wash vehicle and remove all dirt and excess grease. If washing is impracticable, wipe as clean as possible using care to avoid creating bright spots which would cause glare. **CAUTION: Do not flush out cab, but sweep when necessary. Clean engine and accessories thoroughly.**

(29) **ITEM 85, TOOLS AND EQUIPMENT.** Check all tools and equipment assigned to vehicle against stowage lists to make certain they are in good condition and properly mounted and stowed. See paragraphs 27 through 31 of this manual.

Section VII

LUBRICATION

	Paragraph
Introduction	25
Lubrication Guide	26

25. INTRODUCTION. Lubrication is an essential part of preventive maintenance, determining to a great extent the serviceability of parts and assemblies.

26. LUBRICATION GUIDE.

a. General. Lubrication instructions for this materiel are consolidated in a Lubrication Guide (figs. 33, 34, 35, and 36). These specify the points to be lubricated, the periods of lubrication, and the lubricant to be used. In addition to the items on the Guide, other small moving parts, such as hinges and latches, must be lubricated at frequent intervals.

b. Supplies. In the field it may not be possible to supply a complete assortment of lubricants called for by the Lubrication Guide to meet the recommendations. It will be necessary to make the best use of those available, subject to inspection by the officer concerned, in consultation with responsible ordnance personnel.

c. Lubrication Notes. The following notes apply to the Lubrication Guide (figs. 33, 34, and 35). All note references in the Guide itself are to the subparagraph below having the corresponding number:

(1) **FITTINGS.** Clean before applying lubricant. Lubricate until new lubricant is forced from the bearing, unless otherwise specified. **CAUTION:** *Lubricate chassis points after washing.*

(2) **INTERVALS INDICATED ARE FOR NORMAL SERVICE.** For extreme conditions of speed, heat, water, sand, mud, snow, rough roads, dust, etc., reduce interval by 1/3 or 1/2, or more if conditions warrant.

(3) **AIR CLEANERS.** Daily, check level and refill engine air cleaner oil reservoir to bead level with used crankcase oil or OIL, engine, crankcase grade. Every 2,000 miles (daily under extreme dust conditions) remove air cleaner and wash all parts. **CAUTION:** *Keep all air pipe connections clean and tight.* Every 1,000 miles (daily under extreme dust conditions) remove crankcase breather sump and mesh and wash in SOLVENT, dry-cleaning, and reoil mesh and fill sump to bead level with used crankcase oil or OIL, engine, crankcase grade. Wash cab ventilator air cleaner filter screen in water every 2,000 miles, and renew filter every 15,000 miles. (Closed-type cab only.) Weekly, wash, dry and reoil curled hair in air compressor air cleaner with used crankcase oil or OIL, engine, crankcase grade. Check daily under extreme conditions. Weekly, wash, dry and reoil curled hair and air strainers in wrecker air compressor air cleaner and air compressor engine air cleaner with used crankcase oil or OIL, engine, crankcase grade. Kellogg-type air

4-TON, 6 x 6 TRUCKS (DIAMOND T MODELS 968A CARGO,
969A WRECKER, 970A PONTON, AND 972 DUMP)

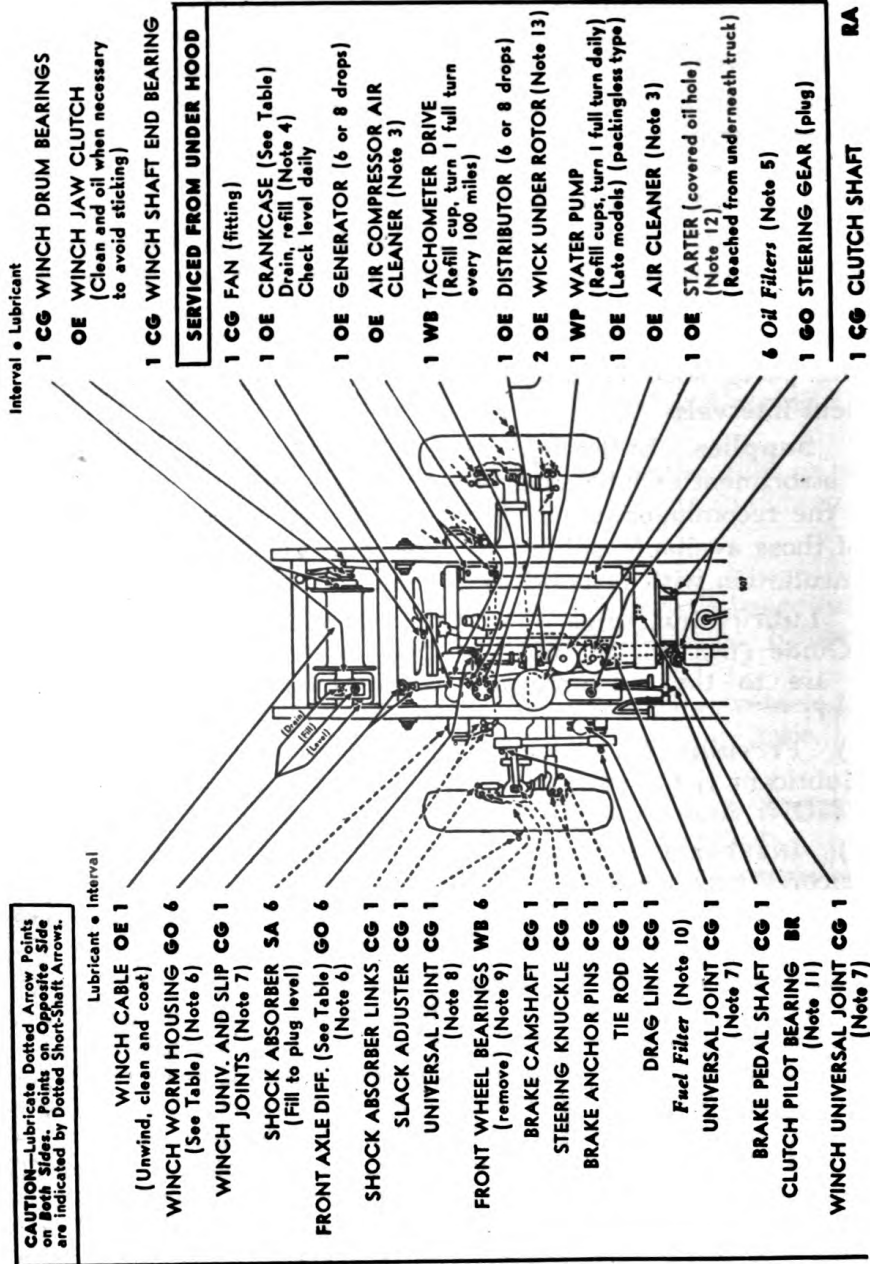

Interval • Lubricant

1 CG WINCH DRUM BEARINGS
OE WINCH JAW CLUTCH
(Clean and oil when necessary to avoid sticking)

1 CG WINCH SHAFT END BEARING

SERVICED FROM UNDER HOOD

1 CG FAN (fitting)
1 OE CRANKCASE (See Table)
Drain, refill (Note 4)
Check level daily
1 OE GENERATOR (6 or 8 drops)
OE AIR COMPRESSOR AIR
CLEANER (Note 3)
1 WB TACHOMETER DRIVE
(Refill cup, turn 1 full turn
every 100 miles)
1 OE DISTRIBUTOR (6 or 8 drops)
2 OE WICK UNDER ROTOR (Note 13)
1 WP WATER PUMP
(Refill cups, turn 1 full turn daily)
1 OE (Late models) (packingless type)
OE AIR CLEANER (Note 3)
1 OE STARTER (covered oil hole)
(Note 12)
(Reached from underneath truck)
6 Oil Filters (Note 5)
1 GO STEERING GEAR (plug)

CAUTION—Lubricate Dotted Arrow Points on Both Sides. Points Opposite Side are Indicated by Dotted Short-Shaft Arrows.

Lubricant • Interval

WINCH CABLE OE 1
(Unwind, clean and coat)
WINCH WORM HOUSING GO 6
(See Table) (Note 6)
WINCH UNIV. AND SLIP CG 1
JOINTS (Note 7)
SHOCK ABSORBER SA 6
(Fill to plug level)
FRONT AXLE DIFF. (See Table) GO 6
(Note 6)
SHOCK ABSORBER LINKS CG 1
SLACK ADJUSTER CG 1
UNIVERSAL JOINT CG 1
(Note 8)
FRONT WHEEL BEARINGS WB 6
(remove) (Note 9)
BRAKE CAMSHAFT CG 1
STEERING KNUCKLE CG 1
BRAKE ANCHOR PINS CG 1
TIE ROD CG 1
DRAG LINK CG 1
Fuel Filter (Note 10)
UNIVERSAL JOINT CG 1
(Note 7)
BRAKE PEDAL SHAFT CG 1
CLUTCH PILOT BEARING BR
(Note 11)
WINCH UNIVERSAL JOINT CG 1
(Note 7)

RA PD 304857

LUBRICATION

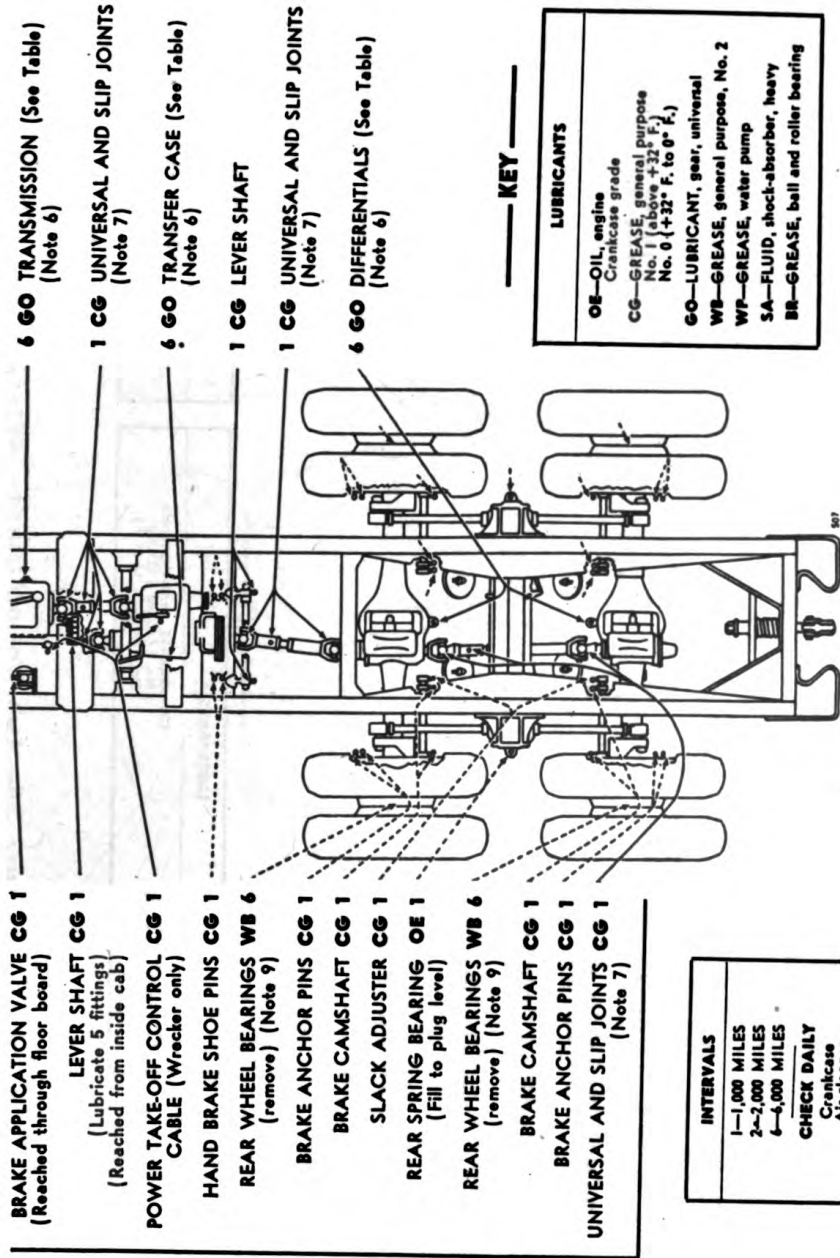

RA PD 304857B

Figure 33—Lubrication Guide

4-TON, 6 x 6 TRUCKS (DIAMOND T MODELS 968A CARGO,
969A WRECKER, 970A PONTON, AND 972 DUMP)

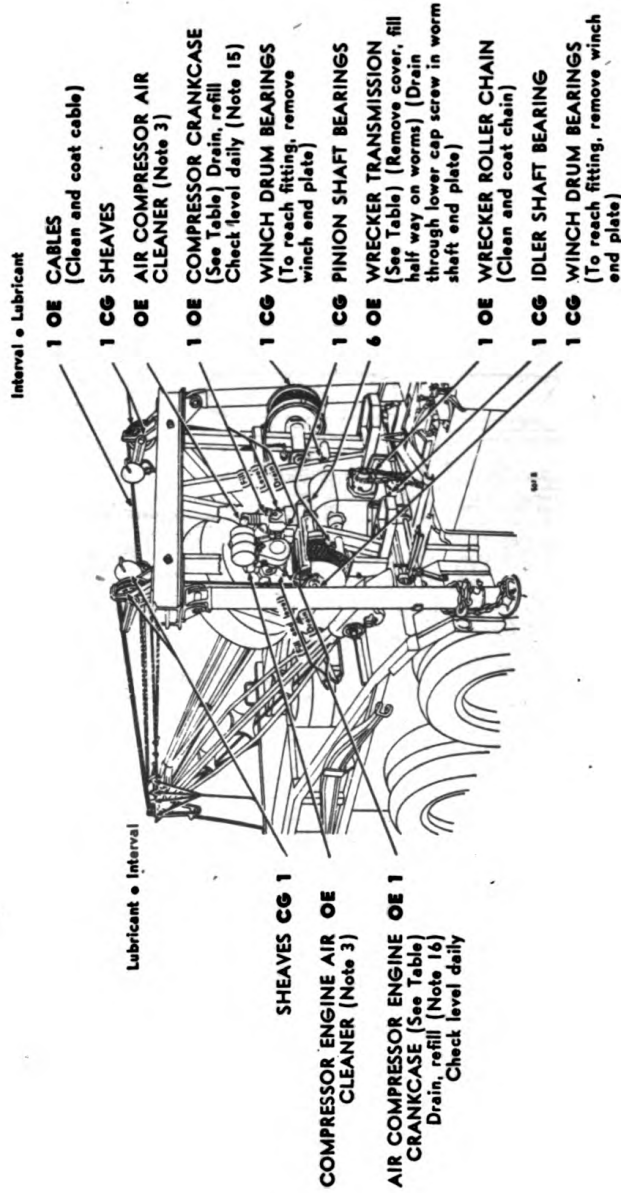

KEY

LUBRICANTS		INTERVALS
OE—OIL, engine Crankcase grade	CG—GREASE, general purpose No. 1 (above +32° F.) No. 0 (+32° F. to 0° F.)	* 1—1,000 MILES 4—4,000 MILES

Figure 34—Lubrication Guide—Wrecker

RA PD 304858

Generated on 2013-06-12 09:27 GMT / http://hdl.handle.net/2027/uc1.b3243767
Public Domain, Google-digitized / http://www.hathitrust.org/access_use#pd-google

LUBRICATION

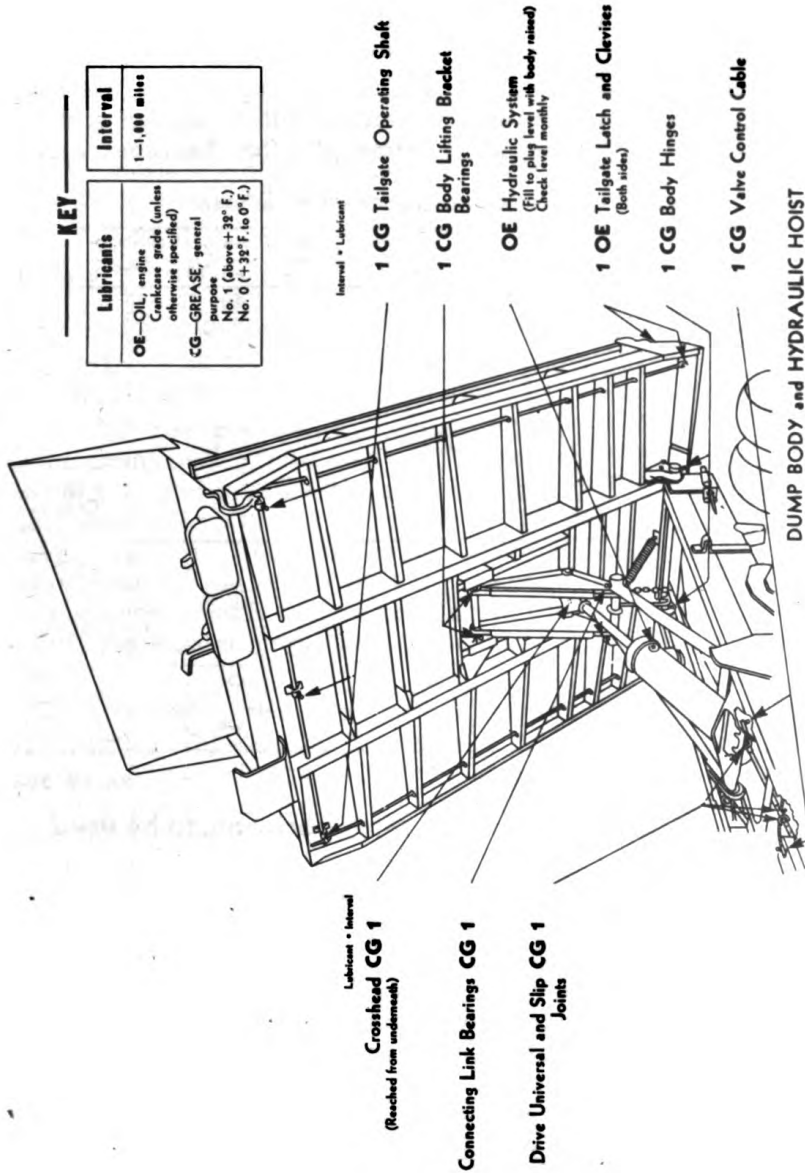

KEY

Lubricants	Interval
OE—Oil, engine Castrol grade (unless otherwise specified)	1—1,000 miles
CG—GREASE, general purpose No. 1 (above +32° F.) No. 0 (+32° F. to 0° F.)	

- Lubricant • Interval
- 1 CG Tailgate Operating Shaft
- 1 CG Body Lifting Bracket Bearings
- OE Hydraulic System
(Fill to plug level with body raised)
Check level monthly
- 1 OE Tailgate Latch and Clevises
(Both sides)
- 1 CG Body Hinges
- 1 CG Valve Control Cable
- DUMP BODY and HYDRAULIC HOIST
- Lubricant • Interval
- Crosshead CG 1
(Reached from underneath)
- Connecting Link Bearings CG 1
- Drive Universal and Slip CG 1
Joints

RA PD 304859

Figure 35—Lubrication Guide—Dump

4-TON, 6 x 6 TRUCKS (DIAMOND T MODELS 968A CARGO, 969A WRECKER, 970A PONTON, AND 972 DUMP)

cleaner has felt disk; remove thin felt layer instead of washing. Proper maintenance of air cleaners is essential to prolonged engine life.

(4) **CRANKCASE.** Drain only when engine is hot. Refill to "FULL" mark on gage. Run engine a few minutes and recheck oil level. **CAUTION:** *Be sure pressure gage indicates oil is circulating.* The viscometer reading should be in normal range with engine completely warm and running at a speed slightly in excess of idling.

(5) **OIL FILTERS.** Every 2,000 miles, or more often if necessary, drain the filters through drain plugs. Remove filter element and clean case. Every 6,000 miles, or more often if filter becomes clogged,

TABLE OF CAPACITIES AND LUBRICANTS TO BE USED

UNIT	CAPACITY (Approx.)	LOWEST EXPECTED AIR TEMPERATURE		
		+32° F. and above	+32° F. to 0° F.	Below 0° F.
Crankcase	16 qt.	OE SAE 30	OE SAE 10	Refer to OFSB 6-11
Transmission with Power Take-off	12 qt.	GO SAE 90	GO SAE 80	
Transmission without Power Take-off	10 1/2 qt.			
Transfer Case	Model 967, 5 qt. others, 1 1/2 qt.			
Front Differential	7 1/2 qt.			
Rear Differentials (Each unit)	3 3/4 qt.			
Winch Worm Housing	1 3/4 qt.			
Wrecker Air Compressor Crankcase	Kellogg	1/4 qt.	OE SAE 30	
	Curtis	3/8 qt.		
	DeVilbiss	1/2 qt.		
Wrecker Air Compressor Engine Crankcase	1/2 qt.		OE SAE 10	
Wrecker Transmission	1/2 qt.	OE SAE 50	OE SAE 30	
Dump Hydraulic System	4 qt.	OE SAE 30	OE SAE 10	

RA PD 304860

Figure 36—Table of Capacities and Lubricants to be used

renew the element. After renewing the element, refill crankcase to "FULL" mark on gage. Run engine a few minutes, recheck level and add oil to "FULL" mark.

(6) **GEAR CASES.** Weekly, check level with truck on level ground and, if necessary, add lubricant to within 1/2 inch of plug level when cold, or to plug level when hot. Drain, flush and refill as indicated at points on Guide. When draining, drain immediately after operation.

(a) *Breathers or vents.* Axle housings, transfer case and steering gear breathers must be cleaned and kept open. Check each time oil is checked and each time truck is operated under extremely dirty or muddy conditions.

(b) *Transfer case declutching unit, power take-off, front axle double reduction gear case.* Upon reassembly of cases, fill through plug opening with LUBRICANT, gear, universal, seasonal grade. To flush, fill cases to about one-half capacity with OIL, engine, SAE 10. Operate mechanism within cases slowly for several minutes and re-

LUBRICATION

drain. Replace drain plugs and refill cases to correct level with lubricant specified on Guide.

(7) **UNIVERSAL JOINTS AND SLIP JOINTS.** Apply **GREASE**, general purpose, seasonal grade, to universal joint until it overflows at relief valve, and to slip joint until lubricant is forced from vent at universal joint end of spline.

(8) **UNIVERSAL JOINTS (FRONT WHEELS).** With truck on level ground, remove inspection plug in rear of joint, and plug in stub shaft. Insert fitting in stub shaft and fill until lubricant comes out inspection plug hole. Replace plugs.

(9) **WHEEL BEARINGS (FRONT AND REAR).** To clean and pack bearings properly, they must be removed from the hub. Follow the procedure below:

(a) Remove bearings from hub (par. 138) and wash in **SOLVENT**, dry-cleaning, until all the old lubricant is removed from both inside and outside of cage.

(b) Lay the bearing cones aside to dry and wash inside of hub and spindle with dry-cleaning solvent.

(c) When bearings are thoroughly dry, coat lightly with **OIL**, engine crankcase grade, and pack races with **GREASE**, general purpose No. 2, and reassemble in hub. To satisfactorily pack a bearing it is necessary to knead lubricant in by hand or to pack into space between the cage and inner race. Coat inside of hub and spindle with a thin coat of grease to prevent rusting. The lubricant packed in bearing races is sufficient to provide lubrication until the next service period. An excess may result in leakage of lubricant into the brake drum.

(d) Replace wheel and adjust bearings according to instructions in paragraph 138.

(10) **FUEL FILTER.** Every 100 to 1,000 miles, depending on operating conditions, remove plug and drain. Every 1,000 miles, remove filter bowl and wash element.

(11) **CLUTCH PILOT BEARING.** At time of disassembly of clutch for inspection, replacement or overhaul, clean and repack bearings with **GREASE**, ball and roller bearing.

(12) **CRANKING MOTOR.** Every 6,000 miles, remove cranking motor, clean and lubricate Bendix drive with 6 or 8 drops of **OIL**, lubricating, preservative, special. When cranking motor is disassembled, wash bushings and soak in **OIL**, engine, crankcase grade.

(13) **DISTRIBUTOR.** Every 2,000 miles, wipe distributor breaker cam lightly with **GREASE**, general purpose, seasonal grade, and lubricate breaker arm pivot with one or two drops of **OIL**, engine, crankcase grade.

(14) **BRAKE GOVERNOR.** Every 20,000 miles, remove cover plate on brake governor, located under hood, and lubricate the valve stem with **OIL**, lubricating, preservative, special.

(15) **WRECKER AIR COMPRESSOR CRANKCASE.** Drain only when compressor is hot. Refill to correct level. The Kellogg model has a dip stick to determine proper oil level. The correct level for the

**4-TON, 6 x 6 TRUCKS (DIAMOND T MODELS 968A CARGO,
969A WRECKER, 970A PONTON, AND 972 DUMP)**

Curtis model is to overflow level at filler plug. The DeVilbiss model has an oil level glass.

(16) **WRECKER AIR COMPRESSOR ENGINE CRANKCASE.** Drain only when engine is hot. Refill to level of filler plug on Johnson and Briggs and Stratton engines.

(17) **WRECKER AND WINCH SNATCH BLOCKS.** Every 1,000 miles, lubricate sheaves through fittings on snatch blocks with **GREASE**, general purpose, seasonal grade.

(18) **OILCAN POINTS.** Every 1,000 miles, lubricate throttle and accelerator linkage, power take-off control linkage, transfer case shift linkage, transfer shaft, winch clutch control handle, ratchet and pawl on winch boom, tow bar, wrecker block and tackle, hinges, latches, air compressor rocker arm, pintle, wrecker controls and linkage with **OIL**, engine, crankcase grade.

(19) **RUBBER BUSHINGS.** Every 1,000 miles, apply **FLUID**, brake, hydraulic, to spring shackles and torque rod bushings. **CAUTION: Do not use oil.**

(20) **POINTS REQUIRING NO LUBRICATION SERVICE.** Springs, brake air compressor, clutch release bearing.

Section VIII

TOOLS AND EQUIPMENT STOWAGE ON VEHICLES

	Paragraph
General	27
Vehicle tools	28
Vehicle equipment	29
Vehicle spare parts	30
Care of tools and equipment	31

27. GENERAL.

a. Each vehicle is equipped with a set of tools, equipment and spare parts, which are adequate for making minor adjustments, changing tires, removing wheels and other maintenance operations which may be performed by the driver in the field.

28. VEHICLE TOOLS.

a. The following tools (one of each) are supplied with all Diamond T 4-ton, 6 x 6 vehicles (fig. 37):

Tool	Where Carried
BAG, tool	Rear tool compartment*
HAMMER, ball peen, 16-oz	Tool bag
PLIERS, 6-in.	Tool bag
SCREWDRIVER, 6-in. blade	Tool bag
WRENCH, spark plug, w/handle, 14mm.	Tool bag
†WRENCH, water pump	Tool bag
WRENCH, crescent, 12-in.	Tool bag
WRENCH, adjustable automotive, 15-in.	Tool bag
WRENCH, open-end, 3/8-in. and 7/16-in. . .	Tool bag
WRENCH, open-end, 1/2-in. and 19/32-in. . .	Tool bag
WRENCH, open-end, 9/16-in. and 11/16-in. . .	Tool bag
WRENCH, open-end, 5/8-in. and 23/32-in. . .	Tool bag
WRENCH, open-end, 3/4-in. and 7/8-in. . . .	Tool bag
WRENCH, wheel bearing, front	Rear tool compartment*
WRENCH, wheel bearing, rear	Rear tool compartment*
WRENCH, wheel nut	Rear tool compartment*
HANDLE, wheel nut wrench	Rear tool compartment*

b. In addition, the following tool is supplied with Diamond T 4-ton, 6 x 6 cargo and ponton trucks only (fig. 38):

Tool	Where Carried
SCREWDRIVER, recessed head, No. 4 . . .	Tool bag

*There is no rear tool compartment on the dump body, and so all items marked with an asterisk are stowed in a carton in the cab.

†Not supplied with packless-type water pump.

4-TON, 6 x 6 TRUCKS (DIAMOND T MODELS 968A CARGO, 969A WRECKER, 970A PONTON, AND 972 DUMP)

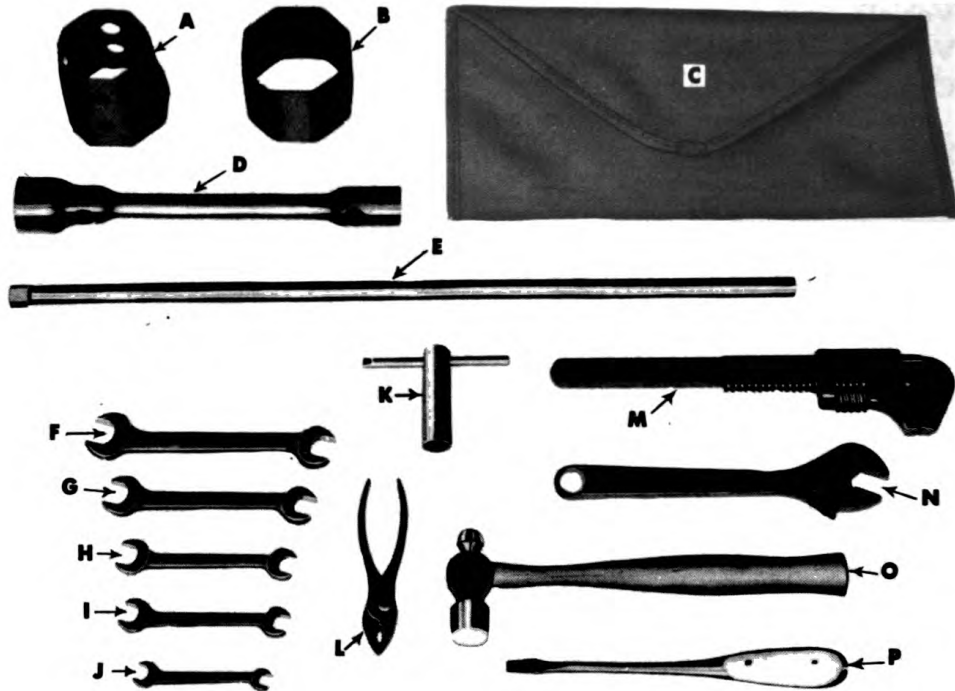

- | | | | |
|----------|---------------------------------|----------|--------------------------------|
| A | REAR WHEEL BEARING NUT WRENCH | I | OPEN END WRENCH, 1/2" x 19/32" |
| B | FRONT WHEEL BEARING NUT WRENCH | J | OPEN END WRENCH, 3/8" x 7/16" |
| C | TOOL BAG | K | SPARK PLUG WRENCH |
| D | WHEEL NUT WRENCH | L | PLIERS |
| E | WHEEL NUT WRENCH HANDLE | M | ADJUSTABLE AUTOMOTIVE WRENCH |
| F | OPEN END WRENCH, 3/4" x 7/8" | N | ADJUSTABLE CRESCENT WRENCH |
| G | OPEN END WRENCH, 5/8" x 25/32" | O | BALL PEEN HAMMER |
| H | OPEN END WRENCH, 9/16" x 11/16" | P | SCREW DRIVER |

RA PD 304879

Figure 37—Tools Supplied with all 4-Ton, 6 x 6 Vehicles

TOOLS AND EQUIPMENT STOWAGE ON VEHICLES

c. In addition, the following tools (one of each) are supplied with Diamond T 4-ton, 6 x 6 vehicles equipped with the open-type cab (fig. 38):

Tool	Where Carried
SCREWDRIVER, recessed head, No. 2 . . .	Tool bag
SCREWDRIVER, recessed head, No. 3 . . .	Tool bag

d. In addition, the following tool is supplied with Diamond T 4-ton, 6 x 6 dump trucks only (fig. 38):

Tool	Where Carried
WRENCH, cylinder plug (1/2-in. square)	Tool bag

e. In addition, the following tools (one of each) are supplied with Diamond T 4-ton, 6 x 6 wrecker trucks only (fig. 38):

Tool	Where Carried
WRENCH, open end, 1 3/16-in. and 9/16-in. opening	On compressor
WRENCH, socket head set screw (1/8-in. hex.)	On compressor

29. VEHICLE EQUIPMENT.

a. All Diamond T 4-ton, 6 x 6 vehicles are equipped with the following materiel (fig. 39):

Item	Number Carried	Where Carried
OILER, (1/2 pt)	1	Rear tool compartment*
EXTINGUISHER, fire (1 qt carbon tetrachloride)	1	In cab
CRANK, starting	1	Rear tool compartment*
GUN, lubrication, Zerk (16 oz.)	1	Rear tool compartment*
JACK, hydraulic (5-ton), w/handle	1	Rear tool compartment*
CHAIN, tire, front (set)	1	Right side compartment
CHAIN, tire, rear (sets)	2	Right side compartment
GAGE, tire-inflation	1	Tool bag
HOSE, tire-inflation (26 1/2 ft) . .	1	Rear tool compartment*
HOSE, coupling	1	Rear tool compartment*
MANUAL, operator's	1	Rear tool compartment*
CATALOG, service parts	1	Rear tool compartment*
KEYS (tool compartment—right side and padlocks)	2	In bag
KEYS, tachometer lock	3	In bag
WHEEL, spare, w/tire and tube . . .	2	Mounted on body†
PADLOCKS (spare tire and rear tool compartment)	‡	Tire carriers and tool compartment

*There is no rear tool compartment on the dump body, and so all items marked with an asterisk are stowed in a carton in the cab.

†Only one spare wheel is supplied with the dump truck.

‡Quantity is 3 for cargo truck, 5 for wrecker truck, 3 for ponton truck and none for dump truck.

TM 9-811
29

4-TON, 6 x 6 TRUCKS (DIAMOND T MODELS 968A CARGO,
969A WRECKER, 970A PONTON, AND 972 DUMP)

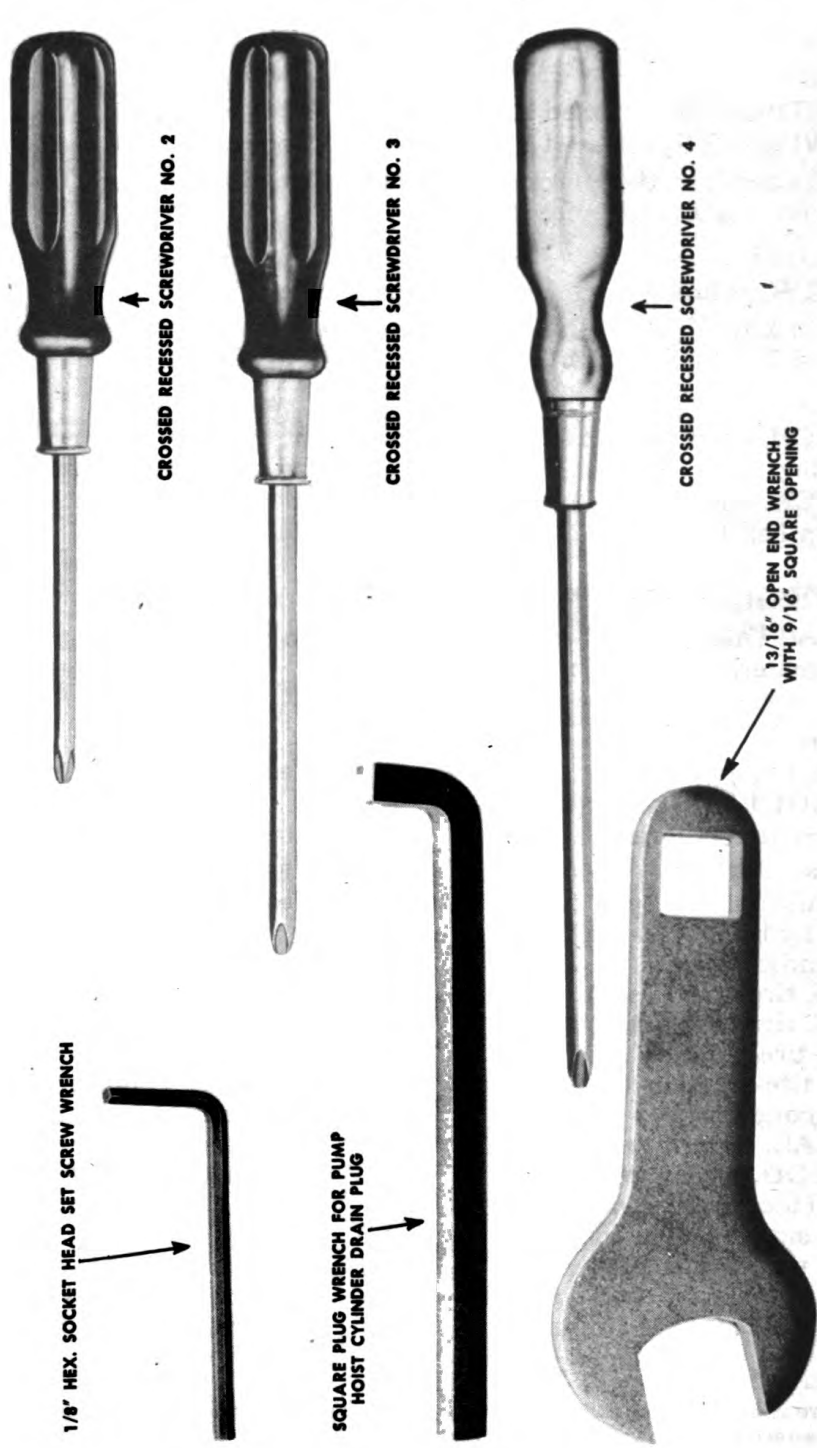

RA PD 313909

Figure 38—Miscellaneous Tools

Generated on 2013-06-12 09:29 GMT / http://hdl.handle.net/2027/uc1.b3243767
Public Domain, Google-digitized / http://www.hathitrust.org/access_use#pd-google

TOOLS AND EQUIPMENT STOWAGE ON VEHICLES

b. In addition, the following materiel is supplied with Diamond T 4-ton, 6 x 6 cargo, wrecker and ponton trucks only (winch-equipped) (fig. 40):

Item	Number Carried	Where Carried
BLOCK, snatch	1	Right side compartment*
CHAIN, tow (20 ft x 5/8-in. dia)	1	Right side compartment*

*Stowed in left body box on wrecker vehicles.

c. In addition, the following materiel is supplied with Diamond T 4-ton, 6 x 6 cargo trucks only (fig. 41):

Item	Number Carried	Where Carried
BOWS, top	5	Stowed in cargo body
CURTAIN, end	2	Stowed in cargo body
SEATS, troop (sets)	2	Stowed in cargo body
STRAP, safety	1	Stowed in cargo body
TARPAULIN, body	1	Stowed in cargo body

d. In addition, the following materiel is supplied with Diamond T 4-ton, 6 x 6 wrecker trucks only (fig. 42):

Item	Number Carried	Where Carried
CHAIN, tow (20 ft x 5/8-in. dia)	1	Left body box
CHAIN, tow, utility (16 ft x 7/16-in. dia)	1	Left body box
CROWBAR (6 ft)	1	On body
SET, block and tackle	1	
Includes:		
Blocks	2	Left body box
Rope (300 ft—1-in. dia)	1	On body
TOOL SETS, pioneer (ax, pick, mattock and shovel)	2	On top body boxes
COMPRESSOR, air (3 cu ft)	1	On body
SET, ground anchor	1	
Includes:		
Stakes	10	Right body box
Anchors	3	Right body box
Sledge hammer	1	Rear tool compartment
BAR, tow	1	Right body box
CLAMP, steering gear	2	Right body box
HEAD, tow bar	1	Right body box
TOOL SET, welder's	1	
Includes:		
Box, tool	1	Left body box
Brush, steel	1	Tool box
Chisel (1/4-in. x 7-in.)	1	Tool box
Chisel (1/2-in. x 6-in.)	1	Tool box

TM 9-811
29

**4-TON, 6 x 6 TRUCKS (DIAMOND T MODELS 968A CARGO,
969A WRECKER, 970A PONTON, AND 972 DUMP)**

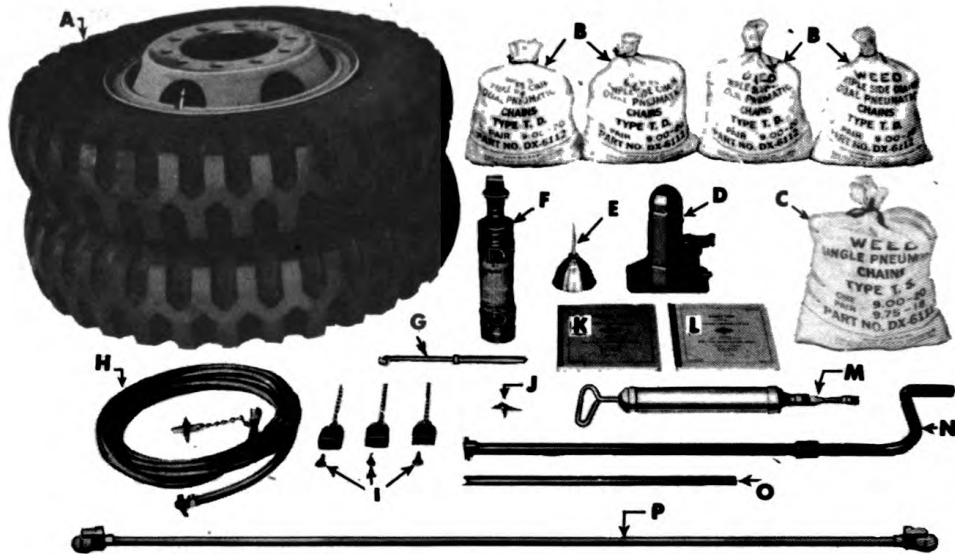

- | | |
|----------------------------|------------------------------------|
| A SPARE TIRES | I SPARE TIRE LOCKS AND KEYS |
| B REAR TIRE CHAINS | J TACHOMETER LOCK KEYS |
| C FRONT TIRE CHAINS | K OPERATOR'S MANUAL |
| D HYDRAULIC JACK | L SERVICE PARTS CATALOGUE |
| E OIL CAN | M GREASE GUN |
| F FIRE EXTINGUISHER | N CRANK |
| G TIRE GAGE | O JACK HANDLE |
| H INFLATION HOSE | P TRAILER COUPLING HOSE |

RA PD 304876

Figure 39—Equipment Supplied with all 4-Ton, 6 x 6 Vehicles

Item	Number Carried	Where Carried
Chisel (3/8-in. x 6-in.).....	1	Tool box
Clamp, C- (1 1/4-in.).....	2	Tool box
Clamp, C- (4-in.).....	2	Tool box
File, flat (10-in.).....	1	Tool box
File, half-round (10-in.)...	1	Tool box
File, mill (12-in.).....	1	Tool box
File, round (12-in.).....	1	Tool box
Gloves, welder's (pr).....	2	Tool box
Goggles (pr).....	1	Tool box
Hammer (32-oz ball peen)	1	Tool box
Handle, tool (1 1/2-in. dia)..	2	Tool box
Handle, tool (1 1/4-in. dia).	2	Tool box
Igniters (with 3 extra tips)	1	Tool box

TOOLS AND EQUIPMENT STORAGE ON VEHICLES

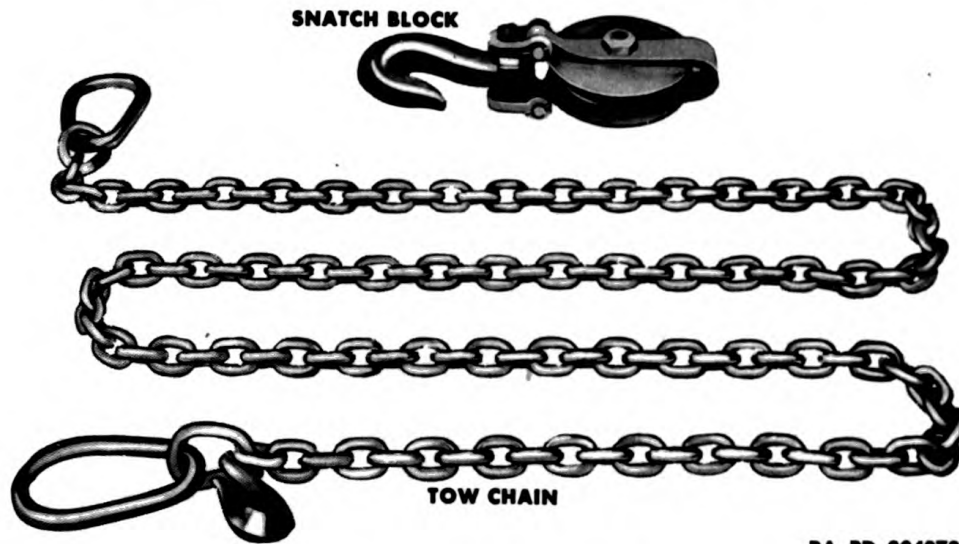

RA PD 304878

Figure 40—Equipment Supplied with Vehicles Equipped with Winch

Item	Number Carried	Where Carried
Pliers (6-in.)	1	Tool box
Rule, folding (36-in.)	1	Tool box
Wrench, crescent (8-in.)	1	Tool box
Wrench, monkey (12-in.)	1	Tool box

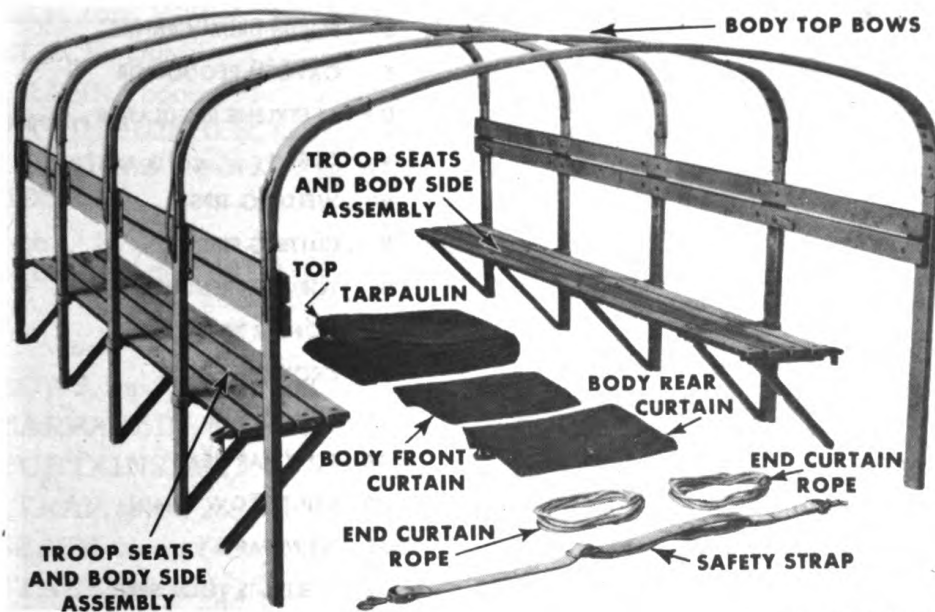

RA PD 313762

Figure 41—Equipment Supplied with Cargo Trucks Only

4-TON, 6 x 6 TRUCKS (DIAMOND T MODELS 968A CARGO,
969A WRECKER, 970A PONTON, AND 972 DUMP)

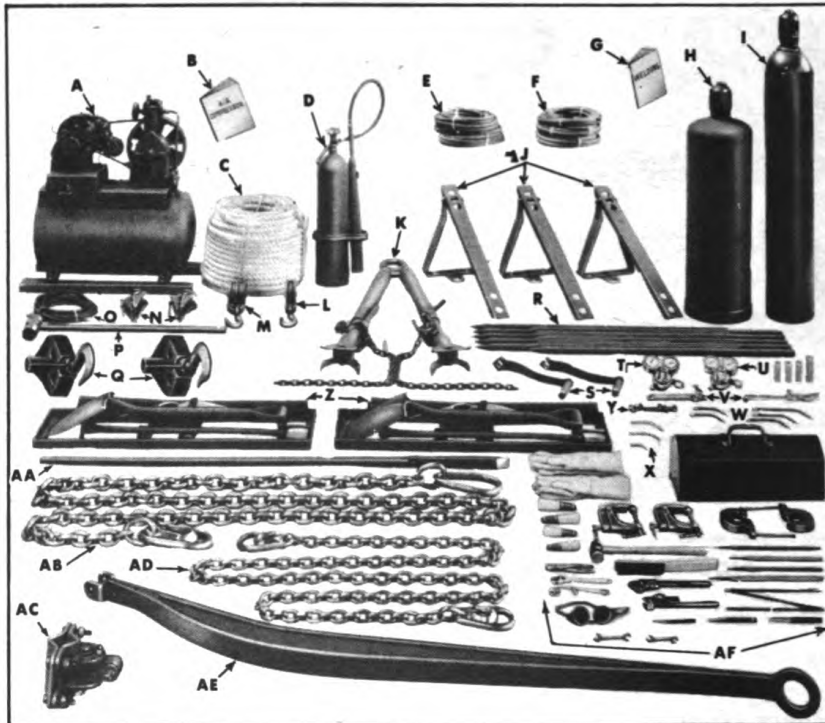

- | | | | |
|----------|--|-----------|-----------------------------|
| A | AIR COMPRESSOR UNIT | P | SLEDGE HAMMER |
| B | AIR COMPRESSOR OPERATION
MANUAL | Q | SNATCH BLOCKS |
| C | ROPE FOR BLOCK AND TACKLE SET | R | GROUND ANCHOR STAKES |
| D | FIRE EXTINGUISHER | S | BOOM DRUM CRANKS |
| E | OXYGEN HOSE | T | OXYGEN REGULATOR |
| F | ACETYLENE HOSE | U | ACETYLENE REGULATOR |
| G | WELDING INSTRUCTION BOOK | V | TORCH |
| H | ACETYLENE TANK | W | WELDING TIPS |
| I | OXYGEN TANK | X | CUTTING TIPS |
| J | GROUND ANCHORS | Y | TORCH WRENCH |
| K | V TOW BAR | Z | PIONEER TOOL SET |
| L | SINGLE BLOCK FOR BLOCK AND
TACKLE SET | AA | CROW BAR |
| M | DOUBLE BLOCK FOR BLOCK AND
TACKLE SET | AB | TOW CHAIN |
| N | STEERING GEAR CLAMPS | AC | TOW BAR HEAD |
| O | AIR COMPRESSOR HOSE | AD | UTILITY TOW CHAIN |
| | | AE | TOW BAR |
| | | AF | WELDER'S TOOL SET |

RA PD 304968

Figure 42—Equipment Supplied with Wrecker Trucks Only

TOOLS AND EQUIPMENT STOWAGE ON VEHICLES

Item	Number Carried	Where Carried
Wrench, pipe (10-in.)	1	Tool box
Wrench, open-end, 1 1/8-in.	1	Tool box
Wrench, open-end, 3/4-in.— 1 1/16-in.	1	Tool box
Wrench, acetylene torch	1	Tool box
WELD SET , unit equipment	1	
Includes:		
Acetylene cylinder (225 cu ft)	1	On body
Oxygen cylinder (200 cu ft)	1	On body
Torch Assembly:	1	Left body box
Acetylene hose (25 ft)	3	Left body box
Oxygen hose (25 ft)	3	Left body box
Acetylene regulator	1	Left body box
Oxygen regulator	1	Left body box
Torch	1	Left body box
Wrench, oxy-acetylene torch	1	Left body box
Welding tips	5	Left body box
Cutting tips	3	Left body box
Welding instruction book	1	Left body box
INSTRUCTIONS , air compressor	1	Tied to air compressor
BAR , tow, V-	1	Right body box
BLOCK , snatch	2	Right body box
CRANK , boom	2	Right body box
EXTINGUISHER , fire (carbon dioxide)	1	Right running board
HOSE , air	1	Tied on air compressor

e. In addition, the following materiel is supplied with Diamond T 4-ton, 6 x 6 ponton trucks only (fig. 43):

Item	Number Carried	Where Carried
BOWS , top	5	Stowed in ponton body
TARPAULIN , body	1	Stowed in ponton body
CURTAINS , end	2	Stowed in ponton body
STRAP , safety	1	Stowed in ponton body
SEATS , troop (sets)	2	Stowed in ponton body
STAKE assembly, front	1	Stowed in ponton body

f. In addition, the following materiel is supplied with Diamond T 4-ton, 6 x 6 vehicles with the open type cab (fig. 44):

4-TON, 6 x 6 TRUCKS (DIAMOND T MODELS 968A CARGO,
969A WRECKER, 970A PONTON, AND 972 DUMP)

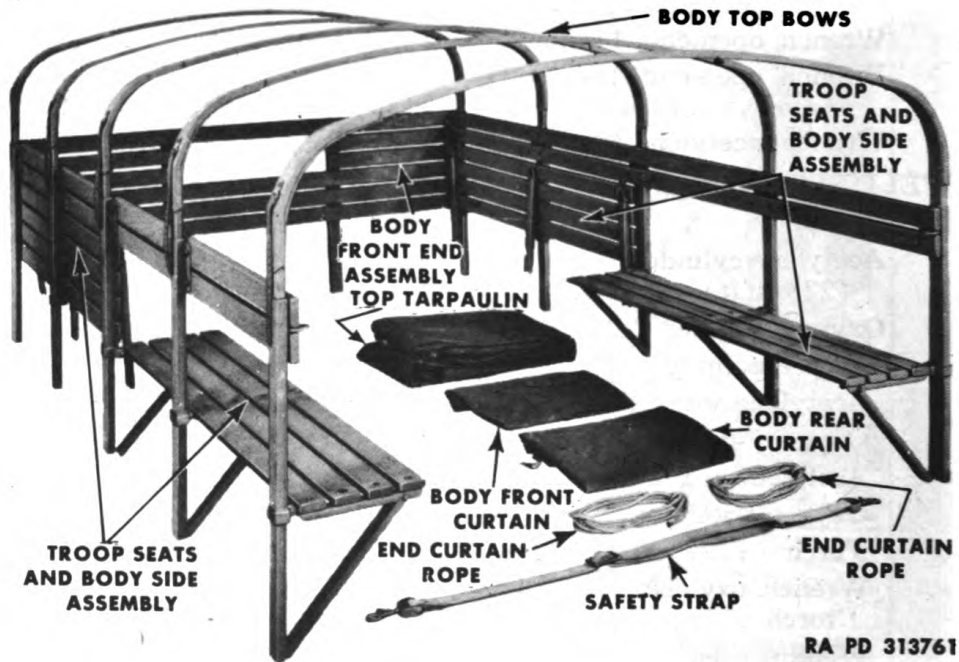

Figure 43—Equipment Supplied with Ponton Trucks Only

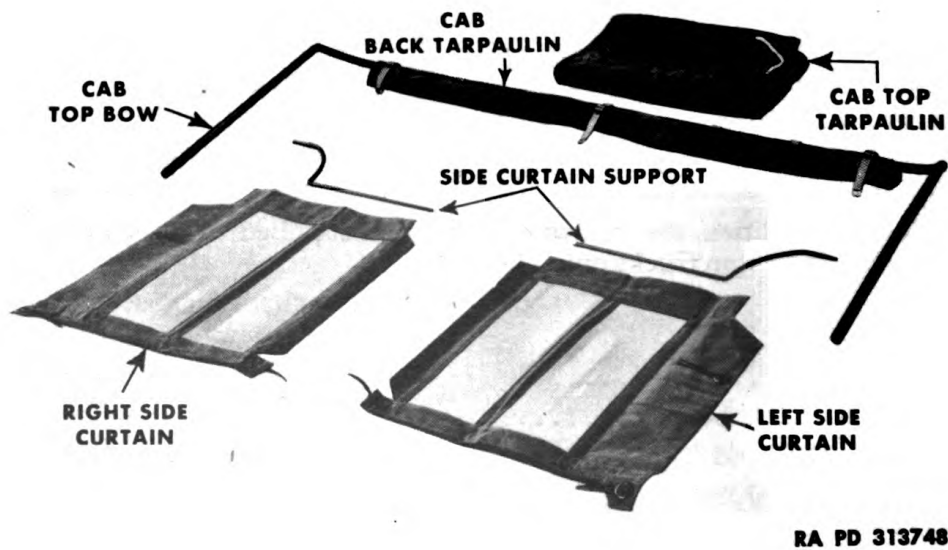
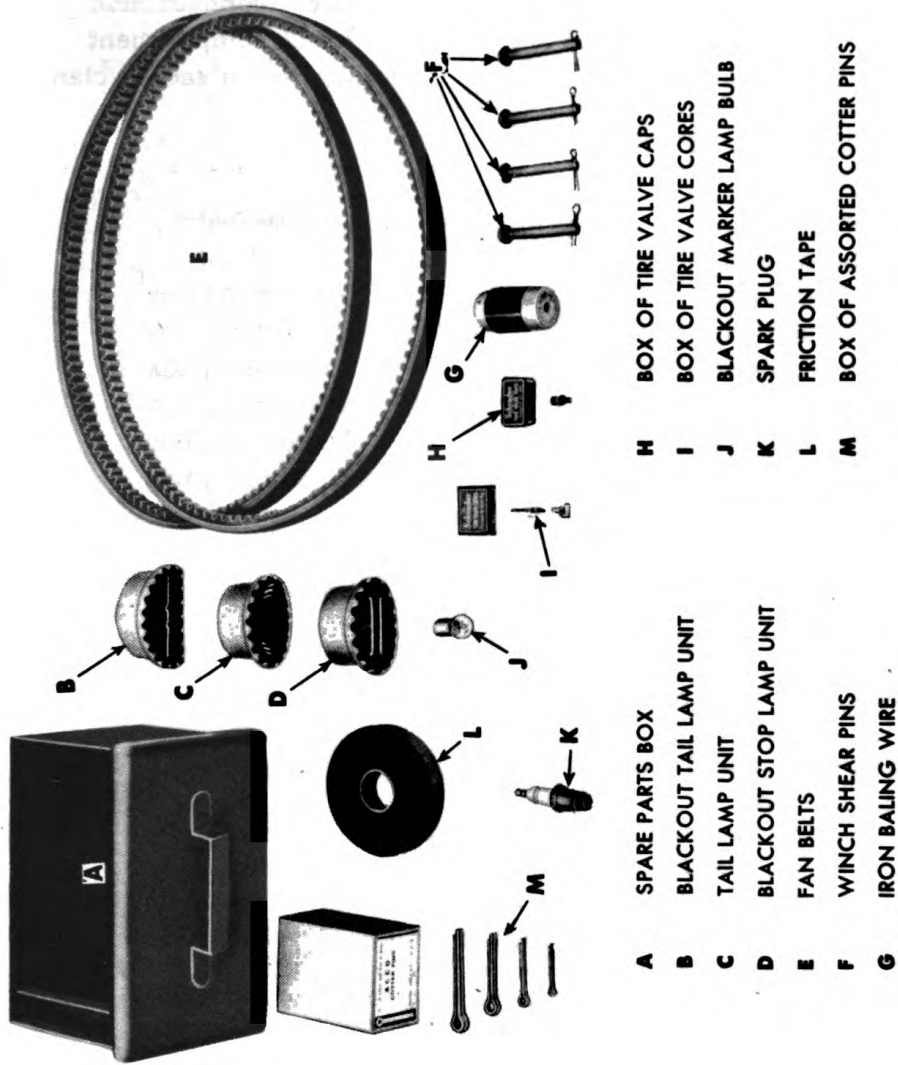

Figure 44—Equipment Supplied with Vehicles with Open Type Cab

TOOLS AND EQUIPMENT STORAGE ON VEHICLES

RA PD 304877



- A SPARE PARTS BOX
- B BLACKOUT TAIL LAMP UNIT
- C TAIL LAMP UNIT
- D BLACKOUT STOP LAMP UNIT
- E FAN BELTS
- F WINCH SHEAR PINS
- G IRON BALING WIRE
- H BOX OF TIRE VALVE CAPS
- I BOX OF TIRE VALVE CORES
- J BLACKOUT MARKER LAMP BULB
- K SPARK PLUG
- L FRICTION TAPE
- M BOX OF ASSORTED COTTER PINS

Figure 45—Vehicle Spare Parts

TM 9-811
29-31

**4-TON, 6 x 6 TRUCKS (DIAMOND T MODELS 968A CARGO,
969A WRECKER, 970A PONTON, AND 972 DUMP)**

Item	Number Carried	Where Carried
TARPAULIN, top.....	1	Roll on top of windshield or stow in cab compartment
TARPAULIN, rear.....	1	Roll on top rear bow
CURTAINS, side.....	2	In cab compartment
RODS, curtain.....	2	In cab compartment
BOW, top.....	1	Lowers in saddle clamps

30. VEHICLE SPARE PARTS (fig. 45).

Item	Number Carried	Where Carried
BOX, spare parts.....	1	*
BELT, fan.....	2	Spare parts box
SET, tire valve cap.....	1	Spare parts box
SET, tire valve core.....	1	Spare parts box
BULB, blackout marker lamp...	1	Spare parts box
PINS, cotter (set).....	1	Spare parts box
PIN, shear (winch vehicles only)	4	Spare parts box
PIN, cotter (for shear pins)....	4	Spare parts box
PLUG, spark, w/gasket.....	1	Spare parts box
TAPE, friction (roll).....	1	Spare parts box
WIRE, iron (roll).....	1	Spare parts box
SEALED UNIT, blackout tail lamp.....	1	Spare parts box
SEALED UNIT, blackout stop and tail lamp...	1	Spare parts box
SEALED UNIT, service stop and tail lamp.....	1	Spare parts box

31. CARE OF TOOLS AND EQUIPMENT.

a. Tools and equipment supplied with these vehicles must be kept clean and in good condition. Keep all of this materiel properly stowed to facilitate its use. Replace all broken or damaged material as soon as possible.

*Carried loose under seat in closed type cab, and is permanently attached in open type cab.

PART TWO—VEHICLE MAINTENANCE INSTRUCTIONS

Section IX

FSMWO AND MAJOR UNIT ASSEMBLY REPLACEMENT RECORD

	Paragraph
FSMWO and major unit assembly replacement record	32

32. FSMWO AND MAJOR UNIT ASSEMBLY REPLACEMENT RECORD.

a. **Description.** Every vehicle is supplied with a copy of A.G.O. Form No. 478, which provides a means of keeping a record of each FSMWO completed or major unit assembly replaced. This form includes spaces for the vehicle name and U. S. A. Registration Number, instructions for use, and information pertinent to the work accomplished. It is very important that the form be used as directed, and that it remain with the vehicle until the vehicle is removed from service.

b. **Instructions for Use.** Personnel performing modifications or major unit assembly replacements must record clearly on the form a description of the work completed, and must initial the form in the columns provided. When each modification is completed, record the date, hours and/or mileage, and FSMWO number. When major unit assemblies, such as engines, transmissions, transfer cases, are replaced, record the date, hours and/or mileage and nomenclature of the unit assembly. Minor repairs and minor parts and accessory replacements need not be recorded.

c. **Early Modifications.** Upon receipt by a third or fourth echelon repair facility of a vehicle for modification or repair, maintenance personnel will record the FSMWO numbers of modifications applied prior to the date of A.G.O. Form No. 478.

TM 9-811

33

**4-TON, 6 x 6 TRUCKS (DIAMOND T MODELS 968A CARGO,
969A WRECKER, 970A PONTON, AND 972 DUMP)**

Section X

ORGANIZATIONAL TOOLS AND EQUIPMENT

Special tools..... **Paragraph 33**

33. SPECIAL TOOLS.

Tools	Federal Stock Number	Mfr's. Number
EYE, engine-lifting, 1/2-in., 13-NC	41E-628	TEC 9-113
PULLER, clutch pilot bearing. . . .	41P-2906-15	J 164
PULLER, torque rod pins.	41P-2956-8	TEC 6-428
WRENCH, engineers' 3/4-in. (opening each end, 15 and 60- degree angle, internal and exter- nal manifold nuts.)	41W-1468-475	TEC 6-117

Section XI

NEW VEHICLE RUN-IN TEST

	Paragraph
Purpose	34
Correction of deficiencies.....	35
Run-in test procedures.....	36

34. PURPOSE.

a. When a new or reconditioned vehicle is first received at the using organization it is necessary for second echelon personnel to determine whether or not the vehicle will operate satisfactorily when placed in service. For this purpose, inspect all accessories, subassemblies, assemblies, tools, and equipment to see that they are in place and correctly adjusted. In addition, they will perform a run-in test of at least 50 miles as directed in AR 850-15, paragraph 25, table III, according to procedures in paragraph 35 below.

35. CORRECTION OF DEFICIENCIES.

a. Deficiencies disclosed during the course of the run-in test will be treated as follows:

- (1) Correct any deficiencies within the scope of the maintenance echelon of the using organization before the vehicle is placed in service.
- (2) Refer deficiencies beyond the scope of the maintenance echelon of the using organization to a higher echelon for correction.
- (3) Bring deficiencies of serious nature to the attention of the supplying organization.

36. RUN-IN TEST PROCEDURES.

a. Preliminary Service.

(1) **FIRE EXTINGUISHER.** See that portable extinguisher is present and in good condition. Test it momentarily for proper operation, and mount it securely. On model 969A Wrecker, also examine CO₂ extinguisher as above, but do not test delivery. If valves appear to have been opened, report to proper authority.

(2) **FUEL, OIL AND WATER.** Fill fuel tank. Check crankcase oil and coolant supply, and add as necessary to bring to correct levels. Allow room for expansion in fuel tank and radiator. During freezing weather, test value of antifreeze and add as necessary to protect cooling system against freezing. **CAUTION:** *If there is a tag attached to filler cap or steering wheel concerning engine oil in crankcase, follow instructions on tag before driving the vehicle.*

(3) **FUEL FILTER.** Inspect fuel filter for leaks, damage and secure mountings and connections. Drain filter sediment bowl. If any appreciable amount of water or dirt is present, remove bowl, and clean bowl and element in dry-cleaning solvent. Also drain accumulated water or dirt from bottom of fuel tank. Drain only until fuel runs clean.

4-TON, 6 x 6 TRUCKS (DIAMOND T MODELS 968A CARGO, 969A WRECKER, 970A PONTON, AND 972 DUMP)

(4) **BATTERIES.** Make hydrometer and voltage test of batteries, and level electrolyte to $\frac{3}{8}$ inch above plates, with distilled or clean water, if necessary.

(5) **AIR CLEANERS AND BREATHER CAP.** Examine carburetor and air compressor air cleaners, and crankcase breather to see if they are in good condition and secure. Remove elements, and wash thoroughly in dry-cleaning solvent. Fill reservoirs to bead level with fresh oil, and reinstall securely. Be sure all gaskets are in good condition, and that ducts and air horn connections are tight.

(6) **ACCESSORIES AND BELTS.** See that all accessories, such as carburetor, generator, regulator, cranking motor, water pump, fan, oil filters, and air compressor, are securely mounted. Make sure fan belts are properly adjusted to have 1-inch finger pressure deflection in center of longest span.

(7) **ELECTRICAL WIRING.** Examine all accessible wiring and conduits to see if they are in good condition, securely connected and properly supported.

(8) **TIRES.** See that all tires, including spare, are properly inflated to 65 pounds cool; that stems are in correct position, all valve caps present and fingertight. Remove objects lodged in treads and carcasses, and between duals, and inspect for damage.

(9) **WHEEL AND FLANGE NUTS.** See that all wheel mounting and axle flange nuts are present and secure.

(10) **FENDERS AND BUMPERS.** Examine fenders, and running boards, splash guards, and bumpers, for looseness or damage.

(11) **TOWING CONNECTIONS.** Examine all towing shackles and pintle hook for looseness and damage, and see that pintle latch operates properly and locks securely.

(12) **BODY AND TARPAULINS.** See that all cab and body mountings are secure. Inspect attachments, hardware, glass, doors, tail gate and release and locking mechanism, to see that they are in good condition, secure, and operate properly. See that cab soft top and cargo body tarpaulins and curtains are properly installed, securely fastened and not damaged. Dump bodies must be in proper alignment with frame, and correctly assembled and mounted. Test hydraulic body hoist for proper oil level, and that there are no oil leaks at pump, cylinder or lines. Test operation of hoist. Test all hinges, locks, windshield and window-lift mechanism, to see that they function satisfactorily.

(13) **WINCH.** Inspect winch for damage, secure mountings and oil leaks. Test winch clutch mechanism for proper operation. Test drag brake to see if it holds drum from spinning, and as cable is unwound; inspect it for wear, damage, and adequate lubrication. Test winch automatic brake by placing vehicle at top of steep incline and attaching cable to another vehicle at bottom. While drawing towed vehicle uphill, release engine clutch; if towed vehicle backs downhill, brakes need adjustment. Start lowering vehicle downhill with winch; throw out engine clutch; if towed vehicle does not stop or drifts more than one or

NEW VEHICLE RUN-IN TEST

two inches, brakes need adjustment. See paragraph 159. After test, rewind cable evenly and tightly on drum, and as winding, clean cable thoroughly and apply a film of engine oil.

(14) **LUBRICATE.** Perform a complete lubrication of the vehicle, covering all intervals, according to the instructions on the Lubrication Guide, paragraph 26, except gear cases, wheel bearings, and other units, lubricated in items 1 to 13. Check all gear case oil levels, and add as necessary to bring to correct level; change only if condition of oil indicates the necessity, or if gear oil is not of proper grade for existing atmospheric temperature. *NOTE: Perform items 15 to 18 during lubrication.*

(15) **SPRINGS AND SUSPENSIONS.** Inspect front shock absorbers, front and rear springs, rear bogie suspension spring seats, and torque rods to see if all are in good condition, correctly assembled and secure, and not leaking lubricant excessively.

(16) **STEERING LINKAGE.** See that all steering arms, rods and connections are in good condition and secure; and that gear case is securely mounted and not leaking excessively.

(17) **PROPELLER SHAFTS.** Inspect all propeller shafts and universal and slip joints to see if they are in good condition, correctly assembled, aligned, and not leaking excessively at seals. Be sure all assembly and mounting nuts or screws are tight.

(18) **AXLE, TRANSFER AND STEERING HOUSING VENTS.** See that all vents are present, in good condition, and not clogged.

(19) **CHOKER.** Examine choke to be sure it opens and closes fully in response to operation of choke button.

(20) **ENGINE WARM-UP.** Start engine, noting if cranking motor action is satisfactory, and any tendency toward hard starting. Set hand throttle to run engine at fast idle during warm-up. During warm-up reset choke button so engine will run smoothly, and to prevent over-choking and oil dilution.

(21) **INSTRUMENTS.**

(a) *Oil Gage.* Immediately after engine starts, observe if oil pressure is satisfactory. Gage must show a minimum of 5 to 10 pounds at idle speed, and 25 pounds at running speeds. Stop engine if pressure is not indicated in 30 seconds.

(b) *Ammeters.* Main ammeter should show slight positive (+) charge. High charge may be indicated until generator restores to batteries current used in starting. Auxiliary ammeter should show positive (+) charge, indicating front battery is receiving charge.

(c) *Temperature Gage.* Engine temperature should rise gradually during warm-up, to normal operating range, 160°F to 180°F.

(d) *Viscometer.* If the viscosity is not normal on gage, after engine is warmed up and running slightly in excess of idle speed, it is an indication of improper grade of oil, a sludge condition, or dangerous crankcase dilution.

(e) *Fuel Gage.* Gage should register "FULL" if tank has been filled.

4-TON, 6 x 6 TRUCKS (DIAMOND T MODELS 968A CARGO, 969A WRECKER, 970A PONTON, AND 972 DUMP)

(f) *Tachometer.* Free pointer should register the engine speed in revolutions per minute. Set hand should register and remain at highest engine speed attained.

(g) *Air Pressure Gage.* During warm-up, air pressure should build up to 105 pounds. Governor should cut off air from compressor at this pressure, and should again cut in if pressure in lines and reservoirs is reduced to 85 pounds. Warning indicator (buzzer) should sound at pressure below 60 pounds.

(22) **ENGINE CONTROLS.** Observe if engine responds properly to controls, and if controls operate without excessive looseness or binding.

(23) **HORN AND WINDSHIELD WIPERS.** See that these items are in good condition and secure. If tactical situation permits, test horn for proper operation and tone. See if wiper arms will operate through their full range, and that blade contacts glass evenly and firmly.

(24) **GLASS AND REAR VIEW MIRRORS.** Clean all body glass and mirrors, and inspect for looseness and damage. Adjust rear view mirrors for correct vision.

(25) **LAMPS (LIGHTS) AND REFLECTORS.** Clean lenses and inspect all units for looseness and damage. If tactical situation permits, open and close all light switches to see if lamps respond properly.

(26) **LEAKS, GENERAL.** Look under vehicle, and within engine compartment, for indications of fuel, oil, or coolant leaks. Trace any found to source, and correct or report them.

(27) **TOOLS AND EQUIPMENT.** Check tools and On Vehicle Stowage Lists, paragraphs 27 through 31, to be sure all items are present, and see that they are serviceable and properly mounted or stowed.

b. Run-in Test. Perform the following procedures (1) to (11) inclusive during the road test of the vehicle. On vehicles which have been driven 50 miles or more in the course of delivery from the supplying to the using organization, reduce the length of the road test to the least mileage necessary to make observations listed below. **CAUTION:** *Continuous operation of the vehicle at speeds approaching the maximums indicated on the caution plate should be avoided during the test.*

(1) **DASH INSTRUMENTS AND GAGES.** Do not move vehicle until engine temperature reaches 135°F. Maximum safe operating temperature is 200°F. Observe readings of oil gage, ammeters, temperature gage, viscometer, fuel gage, tachometer, and air pressure gage, to be sure they are indicating the proper function of the units to which they apply. Also see that speedometer registers the vehicle speed and that odometer records the total accumulating mileage.

(2) **BRAKES: FOOT AND HAND.** Test service air brakes to see if they stop vehicle effectively, without side pull, chatter or squealing. Be sure application valve closes when pedal pressure is released, and that there is not an excessive drop in air pressure when brakes are applied. The parking brake should hold vehicle on a reasonable incline, with $\frac{1}{3}$ ratchet travel in reserve, and should lock securely in applied position. **CAUTION:** *Avoid long application of brakes until*

NEW VEHICLE RUN-IN TEST

shoes have become seated, and do not apply full pedal pressure except for an emergency stop.

(3) **CLUTCH.** Observe if clutch operates smoothly without grab, chatter or squeal on engagement, or slippage when fully engaged, under load. See that pedal has 1 inch free travel before meeting resistance. Do not ride clutch pedal at any time, and do not engage and disengage new clutch severely or unnecessarily until driven and driving disks have become properly worn in. **NOTE:** *Adjust clutch only according to paragraph 72.*

(4) **TRANSMISSION AND TRANSFER.** Gearshift mechanism should operate easily and smoothly, and gears should operate quietly and not slip out of mesh. Test front axle declutching, and power take-off mechanism (on vehicles so equipped) for proper operation.

(5) **STEERING.** Observe steering action for binding or looseness, and note any excessive pull to one side, wander, shimmy or wheel tramp. See that column bracket and wheel are secure.

(6) **ENGINE.** Be on the alert for any abnormal engine operating characteristics or unusual noise, such as lack of pulling power or acceleration; backfiring, misfiring, stalling, overheating, or excessive exhaust smoke. Observe if engine responds properly to all controls.

(7) **UNUSUAL NOISE.** Be on the alert throughout road test for any unusual noise from body and attachments, running gear, suspensions or wheels, that might indicate looseness, damage, wear, inadequate lubrication or underinflated tires.

(8) **HALT VEHICLE AT 10-MILE INTERVALS FOR SERVICES (9) TO (11) BELOW.**

(9) **AIR BRAKE SYSTEM LEAKS.** With air pressure at governed maximum (105 pounds) and brakes applied, stop engine. There should not be an excessive drop in pressure in 1 minute.

(10) **TEMPERATURES.** Cautiously hand-feel each brake drum and wheel hub for abnormal temperatures. Examine transmission, transfer case, and differential housings for indications of overheating and excessive lubricant leaks at seals, gaskets or vents. **NOTE:** *Transfer case temperatures are normally higher than other gear cases.*

(11) **LEAKS.** With engine running, and fuel, engine oil, and cooling systems under pressure, look within engine compartment and under vehicle for indications of leaks.

e. Upon completion of run-in test, correct or report any deficiencies noted. Report general condition of vehicle to designated individual in authority

**4-TON, 6 x 6 TRUCKS (DIAMOND T MODELS 968A CARGO,
969A WRECKER, 970A PONTON, AND 972 DUMP)**

Section XII

ORGANIZATION PREVENTIVE MAINTENANCE SERVICES

Second echelon preventive maintenance services..... **37**

37. SECOND ECHELON PREVENTIVE MAINTENANCE SERVICES.

a. Regular scheduled maintenance inspections and services are a preventive maintenance function of the using arm, and are the responsibility of commanders of operating organization.

(1) **FREQUENCY.** The frequencies of the preventive maintenance services outlined herein are considered a minimum requirement for normal operation of vehicles. Under unusual operating conditions such as extreme temperatures, dusty or sandy terrain, it may be necessary to perform certain maintenance services more frequently.

(2) **FIRST ECHELON PARTICIPATION.** The drivers should accompany their vehicles and assist the mechanics while periodic second echelon preventive maintenance services are performed. Ordinarily the driver should present the vehicle for a scheduled preventive maintenance service in a reasonably clean condition; that is, it should be dry and not caked with mud or grease to such an extent that inspection and servicing will be seriously hampered. However, the vehicle should not be washed or wiped thoroughly clean, since certain types of defects, such as cracks, leaks, and loose or shifted parts or assemblies are more evident if the surfaces are slightly soiled or dusty.

(3) If instructions other than those contained in the general procedures in subparagraph (4) or the specific procedures in subparagraph (5) which follow, are required for the correct performance of a preventive maintenance service or for correction of a deficiency, other sections of the vehicle operator's manual pertaining to the item involved, or a designated individual in authority, should be consulted.

(4) **GENERAL PROCEDURES.** These general procedures are basic instructions which are to be followed when performing the services on items listed in the specific procedures. *NOTE: The second echelon personnel must be thoroughly trained in these procedures so that they will apply them automatically.*

(a) When new or overhauled subassemblies are installed to correct deficiencies, care should be taken to see that they are clean, correctly installed, properly lubricated and adjusted.

(b) When installing new lubricant retainer seals, a coating of the lubricant should be wiped over the sealing surface of the lip of the seal. When the new seal is a leather seal, it should be soaked in SAE No. 10 engine oil (warm if practicable) for at least 30 minutes. Then, the leather lip should be worked carefully by hand before installing the seal. The lip must not be scratched or marred.

ORGANIZATION PREVENTIVE MAINTENANCE SERVICES

(c) The general inspection of each item applies also to any supporting member or connection, and usually includes a check to see whether the item is in good condition, correctly assembled, secure, or excessively worn. The mechanics must be thoroughly trained in the following explanations of these terms.

1. The inspection for "good condition" is usually an external visual inspection to determine whether the unit is damaged beyond safe or serviceable limits. The term good condition is explained further by the following terms: not bent or twisted, not chafed or burned, not broken or cracked, not bare or frayed, not dented or collapsed, not torn or cut.

2. The inspection of a unit to see that it is "correctly assembled" is usually an external visual inspection to see whether it is in its normal assembled position in the vehicle.

3. The inspection of a unit to determine if it is "secure" is usually an external visual examination, a hand-feel, or a pry-bar check for looseness. Such an inspection should include any brackets, lock washers, lock nuts, locking wires, or cotter pins used in assembly.

4. "Excessively worn" will be understood to mean worn, close to or beyond serviceable limits, and likely to result in a failure if not replaced before the next scheduled inspection.

(d) *Special Services.* These are indicated by repeating the item numbers in the columns which show the interval at which the services are to be performed, and show that the parts or assemblies are to receive certain mandatory services. For example, an item number in one or both columns opposite a procedure, means that the actual servicing of the object must be performed. The special services include:

1. *Adjust.* Make all necessary adjustments in accordance with the pertinent section of the vehicle operator's manual, special bulletins, or other current directives.

2. *Clean.* Clean units of the vehicle with dry-cleaning solvent to remove excess lubricant, dirt, and other foreign material. After the parts are cleaned, rinse them in clean fluid and dry them thoroughly. Take care to keep the parts clean until reassembled, and be certain to keep cleaning fluid away from rubber or other material which it will damage. Clean the protective grease coating from new parts, since this material is not a good lubricant.

3. *Special lubrication.* This applies to lubrication operations that do not appear on the vehicle Lubrication Guide and to items that do appear on such charts, but which should be performed in connection with the maintenance operations if parts have to be disassembled for inspection or service.

4. *Serve.* This usually consists of performing special operations, such as replenishing battery water, draining and refilling units with oil, and changing the oil filter cartridge.

5. *Tighten.* All tightening operations should be performed with sufficient wrench torque (force on the wrench handle) to tighten the unit according to good mechanical practice. Use torque-indicating wrench where specified. Do not overtighten, as this may strip threads or cause distortion. Tightening will always be understood to include the

4-TON, 6 x 6 TRUCKS (DIAMOND T MODELS 968A CARGO, 969A WRECKER, 970A PONTON, AND 972 DUMP)

correct installation of lock washers, lock nuts, and cotter pins provided to secure the tightening.

(e) When conditions make it difficult to perform the complete preventive maintenance procedures at one time, they can sometimes be handled in sections, planning to complete all operations within the week if possible. All available time at halts and in bivouac areas must be utilized if necessary to assure that maintenance operations are completed. When limited by the tactical situation, items with special services in the columns should be given first consideration.

(f) The numbers of the preventive maintenance procedures that follow are identical with those outlined on W.D. A.G.O. Form No. 461, which is the Preventive Maintenance Service Work Sheet for Wheeled and Half-track Vehicles. Certain items on the work sheet that do not apply to this vehicle are not included in the procedures in this manual. In general, the numerical sequence of items on the work sheet is followed in the manual procedures, but in some instances there is deviation for conservation of the mechanic's time and effort.

(5) **SPECIFIC PROCEDURES.** The procedures for performing each item in the 1000 miles (monthly) and 6000 miles (six-month) maintenance procedures are described in the following chart. Each page of the chart has two columns at its left edge corresponding to the 6000 mile and the 1000 mile maintenance respectively. Very often it will be found that a particular procedure does not apply to both scheduled maintenances. In order to determine which procedure to follow, look down the column corresponding to the maintenance due, and wherever an item number appears, perform the operations indicated opposite the number.

ROAD TEST

MAINTENANCE	
6000 Mile	1000 Mile
1	1
2	2
3	3

NOTE: When the tactical situation does not permit a full road test, perform those items which require little or no movement of the vehicle. When a road test is possible, it should be for 3 miles, but not over 5 miles.

Before-operation Service. Perform the Before-operation Service outlined in paragraph 23.

Air Pressure. Build up air pressure to 70 pounds. Note action of buzzer (should operate from 0 to 60 pounds, plus or minus 6 pounds). Increase pressure, and observe when governor cuts off pressure (must be at 90 to 105 pounds). Open inflation fitting cut-off cock, and increase pressure to test safety valve (should blow off at 140 to 150 pounds). Exhaust pressure to 100 pounds by brake application, and then close inflation fitting shut-off cock.

Dash Instruments and Gages.

OIL PRESSURE GAGE. Normal readings of gage are 5 to 10 pounds at idle, and 25 pounds minimum at running speeds with engine warm. Reading will be higher before engine warms up.

ORGANIZATION PREVENTIVE MAINTENANCE SERVICES

MAINTENANCE	
6000 Mils	1000 Mils
4	4
5	5
6	6
7	7
8	8
9	9

AMMETERS. After engine starts and is running at 800 to 900 revolutions per minute (fast idle), ammeters may show a high positive (+) charge rate for short period, until battery current used in starting is restored, then a zero or slight positive (+) charge with lights and accessories turned off.

FUEL GAGE. Gage must register approximate amount of fuel in tank.

TEMPERATURE GAGE. Temperature reading should increase gradually as engine warms up to 160°F to 180°F operating temperature.

TACHOMETER. Observe whether tachometer indicates engine revolutions per minute without undue noise or fluctuation.

AIR BRAKE PRESSURE GAGE. Gage should show 70-pounds pressure before starting vehicle.

VISCOSITY GAGE. Gage may indicate **HEAVY** during warm-up period, but must indicate **IDEAL** after warm-up. **THIN** indication shows need for oil change.

Horns, Mirrors and Windshield Wipers. If tactical situation permits, test tone of horns. Examine rear-view mirror for good condition; clean and aim. Test windshield wipers for good condition, good contact, and operation over full arc.

Brakes: Foot, Hand, and Trailer. Test foot brake for quick, smooth stop and emergency stop. There should be no side pull, noise, or chatter. Allowable free pedal travel is 1/2 to 1 inch. Test operation of hand control lever, and observe trailer brake operation (if trailer is attached). Observe pressure gage and listen for open trailer valves or line leaks during road test. Test emergency brake for holding on reasonable grade and for one-third reserve ratchet travel.

Clutch. Test clutch pedal for free travel of 1 to 1 1/2 inches. Clutch must not drag, squeal, chatter, grab, or slip during operation.

Transmission and Transfer. Test both units through entire gear range. Observe units for unusual vibrations (loose mountings). Declutching and lever action must be smooth and easy. Watch for gear clashing, unusual noise, or jumping out of mesh.

Steering. Test free play (1/2 to 1 inch at rim of wheel) allowed at straight ahead position; there must be no binding, wander, shimmy, or abnormal side pull. Observe steering column and wheel for good condition and security of attachment.

Engine. Observe for smooth idle without stalling, satisfactory acceleration, and adequate power in all gear ranges. Listen for unusual noises. Look for excessive

4-TON, 6 x 6 TRUCKS (DIAMOND T MODELS 968A CARGO, 969A WRECKER, 970A PONTON, AND 972 DUMP)

MAINTENANCE	
0000 Mile	1000 Mile
10	10
12	12
14	14
13	13
16	16
17	17
18	18
18	
21	21
19	19
19	

exhaust smoke. Test governor operation with vehicle in second gear; tachometer should read 2300 revolutions per minute and speedometer 9 miles per hour in high transfer range. Reset tachometer set hand to zero after governor test, if key is available.

Unusual Noises (Attachments, Cab, Body, Chassis). Listen for unusual noises which may indicate damaged, defective or loose parts, and inadequate lubrication.

Air Brake System Leaks. (This item, and items 13, 14, and 16 should be performed immediately following road test, with vehicle stationary. Stop engine and test air brake system for leaks (par. 123), with gage at 95 to 105 pounds; brakes off, leakage should not exceed 5 pounds in 10 minutes; brakes on, leakage should not exceed 10 pounds in 10 minutes.

Leaks. Examine beneath hood, under engine, radiator, and tank, and ground under vehicle for evidences of leaks of oil, water, or fuel.

Temperatures. Feel brake drums, hubs, axles, transmission, and transfer for excessive heat. Note any brake drum noticeably cooler than the other drums as an indication of an inoperative brake.

Gear Oil Level and Leaks. Examine gear cases (axle differentials, transmission, and transfer) for correct lubricant level, within 1/2 inch of plug when cold, to filler-plug level when hot. Examine cases for leaks and correct or report.

RAISE VEHICLE—BLOCK SAFELY

Unusual Noises. Investigate and correct or report deficiencies noted during road test in any of the following: engine, fan belt, accessories, transmission, transfer, shafts and joints, axles, and wheel bearings.

Cylinder Head and Gasket. Examine for good condition of head and gasket. Observe for indications of water or compression leaks.

TIGHTEN. Tighten cylinder head nuts with torque indicating wrench to 60 foot-pounds if copper asbestos gaskets are used, 75 foot-pounds if steel asbestos gaskets are used.

Compression Test. Make compression test and record on work sheet. Compression standard is 95 to 110 pounds, with all cylinders measuring within 10 pounds.

Valve Mechanism. Make sure valve gasket covers are tight. Correct valve adjustment if noisy or if engine performance indicates need.

ADJUST. Adjust exhaust valves to 0.010 inch and intake valves to 0.006 inch when hot. Examine valve springs,

ORGANIZATION PREVENTIVE MAINTENANCE SERVICES

MAINTENANCE		
0000 Mile	1000 Mile	
19		tappets, and lock nuts for good condition and security. Observe lubrication and make certain gaskets are tight.
20	20	ADJUST. Adjust cam and idler shaft end play (par. 64). Spark Plugs. Inspect tops of insulators for cracks or breakage, and leakage around insulators or gaskets. Wipe tops of insulators with cloth. Replace unserviceable plugs.
20		REMOVE. Remove, clean, and adjust spark plug gaps to 0.027 inch. CAUTION: <i>Bend grounded electrode only.</i> Do not overtighten on installing.
22	22	Batteries. Examine cases, posts, cell straps, and caps for good condition and security. Observe for leaks. Wash and dry cases, if dirty or corroded. Make hydrometer check and record on work sheets. Reading below 1.225 (corrected for temperature) indicates need for recharge. CAUTION: <i>Report any reddish brown discoloration of electrolyte.</i> Fill cells to 1/2 inch above plates with clean water. Lightly grease terminals and posts, and tighten terminal bolts and mounting bolts, if loose. Clean and paint battery carriers, if corroded. Make high-rate discharge test if hydrometer reading is above 1.225. Report if difference in cells is greater than 30 percent.
23	23	Crankcase Leaks and Oil Level. Examine crankcase for leaks with engine running. Stop engine and test oil level. Drain and refill crankcase.
24	24	Oil Filters and Lines. Inspect these items for good condition, security, and leaks.
24		CLEAN AND SERVE. When due, remove filter cartridges, clean cases, install new cartridges and gaskets, and tighten cover securely.
25	25	Radiator. Examine core for obstructions, and clean, if necessary. Examine for leaks in core, tanks, and hose. Inspect filler cap pressure valve for operation and steam relief tube to determine if clear. Record antifreeze hydrometer reading on work sheet.
25		TIGHTEN. Tighten loose radiator core, shell mountings and hose clamps.
26	26	Water Pump, Fan, and Shroud. Examine these items for good condition, correct assembly, and security. Inspect water pump for leaks. Tighten any loose connections.
26		CLEAN. Clean out bottom of shroud if dirt has accumulated.
27	27	Generator, Generator Ventilating Fan, Starter, and Switch. Examine these units for good condition, secure mounting, and tight wiring connections.
27		CLEAN. Inspect and clean (if required) commutator brushes with 2/0 flint paper, and blow out dirt with

4-TON, 6 x 6 TRUCKS (DIAMOND T MODELS 968A CARGO, 969A WRECKER, 970A PONTON, AND 972 DUMP)

MAINTENANCE		
5000 Mile	1000 Mile	
28	28	compressed air. Examine brushes for freedom of movement in holders. Inspect connections for good condition and security.
		Air Compressor. Inspect compressor and connecting water and air lines to see that they are in good condition and without leaks. Examine compressor mounting gasket for oil leaks. Inspect alinement and secure mounting of compressor; tighten, if necessary.
28		SERVICE. Adjust unloader valve clearance to 0.010 inch to 0.015 inch between top of valves and adjusting screws.
29	29	Drive Belts and Pulleys. Inspect drive belts for good condition. Inspect fan belts for condition and adjustment of one-inch deflection. Inspect pulleys and hubs for good condition and secure mounting.
30	30	Tachometer Drive and Adapter. Inspect unit for security of mounting and good condition of sheath.
31	31	Distributor. Examine distributor cap and rotor for cracks, shorts, or burns. Clean cap and rotor. Inspect points for 0.020-inch gap. Inspect shaft by hand-feel for looseness. Test action of centrifugal advance by turning rotor with fingers and releasing.
31		CLEAN. Remove, clean, dry, relubricate, and reinstall distributor if unserviceably dirty. Dress or replace points if pitted.
31		ADJUST. Adjust breaker points to 0.020-inch gap.
32	32	Coil and Wiring. Examine coil and wires for good condition and secure mounting. Clean high-tension wiring.
33	33	Manifolds. Examine exhaust and intake manifolds for leaks.
33		TIGHTEN. Tighten manifold stud nuts.
34	34	Air Cleaners. Remove, clean, and reoil oil bath cleaner element of engine air cleaner. Clean out reservoir and replenish oil; reassemble cleaner. Remove air cleaners of vehicle air compressor and clean, reoil, and install.
35	35	Breather Cap. Clean and service oil filler and cleaner.
36	36	Carburetor. Inspect carburetor for good condition, correct assembly, and secure mounting. Examine control linkage for wear. See that controls choke is in open fully, that throttle valve opens fully when accelerator is fully depressed and that governor seal is intact. Remove inlet fitting and clean screen.
37	37	Fuel Filters and Lines. Remove element and bowl from fuel filter in line between gas tank and fuel pump.

ORGANIZATION PREVENTIVE MAINTENANCE SERVICES

MAINTENANCE		
0000 Mile	1000 Mile	
38	38	Clean element in dry-cleaning solvent and dry with compressed air. Do not use high pressure as it may damage disks. Inspect gasket and connections for leaks.
38	38	Fuel Pumps. Inspect fuel pump and line for good condition, secure attachment, and leaks. Clean fuel pump filter bowl, and inspect gasket for leaks. SERVICE. Attach fuel pressure test gage to outlet side of pump and test pressure; normal pressure is 3 to 4½ pounds.
39	39	Cranking Motor. Test cranking motor button for operation. Observe cranking motor operation for unusual noise or slow cranking speed.
40	40	Leaks. Examine ground beneath vehicle for evidence of water, oil, or fuel leaks. Examine cooling system, crankcase, oil lines, fuel tank, and fuel lines for leaks. Trace leaks to source and correct.
41	41	Ignition Timing. Check ignition timing, using neon light method. Test operation of spark control.
42	42	Engine Idle and Vacuum Test. Inspect engine for smooth idle at 500 revolutions per minute. Adjust idle speed and mixture with use of vacuum gage. Test for defective valves or gaskets, poor piston ring sealing, or restrictions in carburetor, air cleaner, or exhaust.
43	43	Regulator Unit. Inspect unit for good connections, good condition, and secure mounting. TEST. Test voltage and current regulators and cutout for control of generator output, using low-voltage circuit tester. CAUTION: <i>Test only after regulator has reached normal operating temperature and with battery in fully charged condition.</i>
CHASSIS, BODY, AND ATTACHMENTS		
47	47	Tires and Rims. Inspect valve stems and caps for good condition, 180 degrees opposed, and valve caps for presence and security. Inspect tires for cuts, bruises, breaks, blisters, irregular wear, flat spots, cupping, feather edges, or one-sided wear. Determine and correct mechanical deficiencies causing unusual wear, or report. Wheel positions of tires showing irregular wear should be changed, front to rear, and vice versa. Remove embedded glass, nails, or stones. Directional and nondirectional tires should not be mounted on same vehicle. Directional tires should be mounted so that "V" of chevron points up on front wheels and down on rear wheels. With tires properly inflated, inspect for matching according to over-all circumference (¾-in. variation permissible). Install spare wheel and tire on one of the hubs, and put replaced tire and wheel on spare tire carrier to keep spare in use. Inspect carrier for good condition and security. When tire is mounted

4-TON, 6 x 6 TRUCKS (DIAMOND T MODELS 968A CARGO, 969A WRECKER, 970A PONTON, AND 972 DUMP)

MAINTENANCE	
6000 Mile	1000 Mile
47	47
48	
49	49
49	
50	50
51	51
51	
52	52

on carrier on cargo and ponton trucks, bottom of tire should ride on floor or bracket to take strain off support. Inspect rims and lock rings for good condition and secure mounting of rings.

TIGHTEN. Tighten all wheel nuts securely.

Rear Brakes. Remove rear wheels and drums, clean drums and supports, remove grease, and inspect for good condition, secure mounting, excessive wear, or scoring. Inspect cams and shafts for good condition.

Rear Brake Shoes. Inspect linings through inspection holes for wear and possibility of rivets scoring drums within next 1000 miles of operation. If linings must be replaced, remove all wheels and service all the brakes alike. Clean, lubricate, and adjust all removed bearings, and adjust brakes. Similar inspection of brake linings must be made if vehicle has recently been operated in deep water, mud, loose sand, or dirt which may have entered drum.

INSPECT (drums removed). Inspect brake linings for good condition, security of attachment and good wearing contact with drums. Linings must be free of lubricant and not excessively worn. See that brake shoes are in good condition, properly secured and guided by anchor pins, and properly returned against cams by retracting springs. Clean dust from drums and linings with brush, cloth, or compressed air.

ADJUST. If needed, adjust slack adjusters to give 0.010-0.015-inch clearance at toe end of each shoe (par. 124).

Torque Rods. Examine rods for good condition and secure mounting. Make sure torque rod pins are tight and all bolts and rivets holding torque brackets are tight.

Rear Spring Seats and Bearings. Inspect spring clips for presence, good condition, and tightness. Make sure spring seat is tight against spring by tightening U-bolts and hex clamp studs on spring seats, if necessary.

LUBRICATE. If due, lubricate rear spring seats according to Lubrication Guide. Tighten spring seat bearing side-plate, if road test has indicated necessity.

Rear Wheels. Inspect to see that rear wheels are in good condition. Revolve them and observe if they have excessive run-out. Without removing wheels, revolve and observe for evidence of looseness of adjustment, and damaged or dry wheel bearings. Inspect drive flanges and around brake supports and drums for lubricant leaks. Tighten drive flange nuts. If vehicle has recently been operated in deep water which may have entered wheel bearings, remove one wheel to inspect

ORGANIZATION PREVENTIVE MAINTENANCE SERVICES

MAINTENANCE	
5000 Miles	1000 Miles
52	
53	53
53	
54	54
54	
55	55
55	
56	56
57	57

lubricant for contamination and brake lining for excessive wear. Clean and lubricate bearing of removed wheel before reinstalling. Service other wheels likewise if contamination is found.

SERVICE. Remove wheels and disassemble bearings and oil seals. Clean thoroughly and inspect rollers, cages, and races for good condition. See that cups are secure. Examine machined surfaces, on which bearings are mounted, for good condition. Relubricate wheel bearings, install, and adjust.

53 53 Front Brakes. Clean external dirt and grease from drums and supports. Examine air hose, chambers, and slack adjusters for good condition and secure mounting.

53 INSPECT. Remove wheels and drums. Examine drums for excessive wear or scoring. Tighten brake support and drum mounting bolts securely. Examine backing plate for alinement and distortion. Inspect cams and shafts for good condition.

54 54 Front Brake Shoes. Inspect linings through inspection holes for wear and possibility of rivets scoring drums within next 1000 miles of operation. If linings must be replaced, remove front wheels and service both wheels alike. Clean, lubricate, and adjust all removed bearings, and adjust brakes. Similar inspection must be made if vehicle has recently been operated in deep water, mud, loose sand, or dirt which may have entered drum.

54 SERVICE (Drums removed). Inspect brake linings for good condition, security of attachment, and good wearing contact with drums. Linings must be free of lubricant and not excessively worn. See that brake shoes are in good condition, properly secured and guided by anchor pins, and properly returned against cams by retracting springs. Clean dust from drums and linings with brush, cloth, or compressed air.

54 54 ADJUST. If needed, adjust slack adjusters and anchor pins to give 0.015-inch clearance at heel, and 0.010-0.015-inch clearance at the toe of each shoe (par. 124).

55 55 Steering Knuckles. Examine steering knuckle housing and steering arm for good condition. Observe whether outside seal is in good condition and secure.

55 SERVICE. Remove constant velocity joint, clean, inspect, lubricate and replace.

56 56 Front Springs. Examine for good condition, correct assembly, and secure mounting. Observe for excessive sag. Tighten U-bolts securely.

57 57 Steering (Arms, Tie Rod, Drag Link, Seals, Pitman Arm, Gear Column, and Wheel). Examine for good condition, correct and secure assembly, and mounting. Examine steering gear case for leaks.

4-TON, 6 x 6 TRUCKS (DIAMOND T MODELS 968A CARGO, 969A WRECKER, 970A PONTON, AND 972 DUMP)

MAINTENANCE	
0000 Mile	1000 Mile
57	
58	58
58	
60	60
60	
61	61
62	62
62	
63	63

TIGHTEN. Tighten Pitman arm shaft nut, steering gear case assembly, and mounting nuts or screws securely. **CAUTION:** *Loosen steering column bracket when tightening steering case mounting nuts so as not to distort the column.*

58 58 Front Shock Absorbers and Links. Examine shock absorber bodies and links for good condition, security, and fluid leaks.

58 SERVICE. Fill shock absorber bodies with specified fluid, disconnect link, work arm several times, and add fluid. Repeat operation several times until all air is expelled and reservoir is full. Test to see that action is normal (must offer resistance in both directions).

60 60 Front Wheels. Inspect wheels for good condition. Revolve and observe for excessive run-out, dry, damaged, or loose wheel bearings. Inspect drive flanges, and around brake supports and drums for lubricant leaks. Tighten drive flange nuts. If vehicle has recently been operated in deep water which may have entered wheel bearings, remove one wheel to inspect lubricant for contamination and brake lining for excessive wear. Clean and lubricate bearing of removed wheel before reinstalling.

60 SERVICE. Remove wheels and disassemble bearings and oil seals; clean thoroughly and inspect rollers, cages, and races for good condition. See that cups are secure. Examine machined surfaces, on which bearings are mounted, for good condition. Relubricate wheel bearings, install, and adjust.

61 61 Front Axle. If front axle appears out of line, measure distance from front spring eyebolt to center of axle spring pad on each side. This distance should be about the same on each side. Inspect axle housing for leaks and pinion shaft for excessive end play and leaks. Clean axle housing vent thoroughly.

62 62 Front Propeller Shaft (Joints and Alinement, Seals and Flanges). Inspect shafts for good condition. Make sure assembly and mountings are correct and secure. Inspect U-joints for alinement and excessive wear. Slip joint should be free, not excessively worn, and well lubricated. Seals should not leak excessively.

62 TIGHTEN. Tighten all U-joint assembly and companion flange bolts securely.

63 63 Engine. Inspect mountings of engine for good condition and security. Tighten any loose mounting bolts. Remove oil or grease from rubber mountings. Examine ground straps for firm attachment.

ORGANIZATION PREVENTIVE MAINTENANCE SERVICES

MAINTENANCE		
6000 Mile	1000 Mile	
64	64	Hand brake. Inspect hand brake pawl ratchet for good condition and security. Brake lever should have $\frac{1}{3}$ of travel distance in reserve when applied. Make sure that brake disk is not scored or oily, and that brake lining is not worn thin, or oil-soaked.
64		ADJUST. Clearance between brake disk and lining should be $\frac{1}{32}$ inch. (Par. 136.)
65	65	Clutch Pedal. Test free travel (1 to $1\frac{1}{2}$ inches normal). Inspect pedal for secure mounting and operating linkage for good condition and security. See that return spring is intact and has sufficient tension.
65		ADJUST. Adjust clutch pedal free travel to 1 to $1\frac{1}{2}$ inches.
66	66	Brake Pedal. Allowable free pedal travel is $\frac{1}{2}$ to 1 inch. Inspect brake linkage for good condition and secure attachment. See that return spring is intact and has sufficient tension.
69	69	Air Brake Application Valve. Examine valve for leaks and loose linkage.
70	70	Air Brake Reservoirs. Examine reservoirs for secure mounting and air leaks. Drain both reservoirs.
71	71	Transmission. Inspect transmission case for good condition, seals and gaskets for oil leaks, and control linkage for good condition, proper connection, and security.
71		TIGHTEN. Tighten all transmission and power take-off mounting and external assembly bolts and cap screws securely.
72	72	Transfer. Inspect case for good condition and security of mountings, and seals for leaks. Be sure transfer case breather plate is clean. Tighten mountings and external assembly nuts and screws securely.
73	73	Rear Propeller Shafts. Inspect in same manner as item 62.
73		TIGHTEN. Tighten the U-joint and companion flange bolts securely.
75	75	Rear Axles. Inspect and clean vents in same manner as item 61.
79	79	Cab and Body Mountings. See that all mounting brackets and bolts are present and securely tightened. CAUTION: <i>Do not tighten rear cab spring mounting excessively.</i>
80	80	Frame (Rails and Cross Members). Inspect frame for good condition and correct alinement.
81	81	Wiring, Conduits, and Grommets. Examine those wires running along frame for good condition and secure mounting.

4-TON, 6 x 6 TRUCKS (DIAMOND T MODELS 968A CARGO, 969A WRECKER, 970A PONTON, AND 972 DUMP)

MAINTENANCE	
8000 Mile	1000 Mile
82	82
83	83
84	84
85	85
86	86
87	87
87	
89	89
90	90
91	91

Fuel Tanks, Fittings, and Lines. Examine these items for good condition and secure mounting. Inspect fuel tank cap for defective gasket or plugged vent. See that cap fits securely on filler neck. Look for leaks.

Brake Lines. Examine lines along frame, axles, and leads for damage and secure attachment.

Exhaust Pipes and Muffler. Examine units for good condition and security of attachment. Look for leaks at joints and muffler. Examine tail pipe for obstruction.

Vehicle Lubrication. On any unit where disassembly was necessary for inspection, lubrication must be performed unless vehicle is to be deadlined for repair of that unit. If due, lubricate all points of vehicle and gun mounts in accordance with instructions in this manual, the Lubrication Guide, and current bulletins or directives, and the following instructions: use only clean lubricant and keep all lubricant containers covered. Replace missing or damaged lubrication fittings, flexible lines, vents, and plugs.

Toe-in and Turning Stops. Test toe-in with gage. Specified limits are $\frac{1}{16}$ to $\frac{3}{16}$ inch. Examine wheel stops for presence and for security of weld. Turn front wheels in both directions to see that they engage stops, and that the tires clear all parts of vehicle in this position.

Winch (Clutch, Brake, Drive, Shear Pin for Front Winch, Cable, and Guides). Inspect winch for good condition, correct assembly, and security. See that clutch moves freely and latches securely, and that drag brake linings are in good condition, secure, and correctly adjusted. Inspect automatic brake to see that lining is secure and not excessively worn. Inspect propeller shaft in same manner as in item 62; see that proper shear pin is installed, in good condition, and secure. See that oil level in worm gear case is up to filler plug. Unwind cable and inspect for broken or frayed strands, and for flat or rusty spots.

CLEAN AND SERVE. If due, clean and lubricate cable and drain worm gear case and refill to correct level.

Tractor to Trailer Brake Hose, Wiring, and Connections. Examine these items for good condition and secure fastening.

Hoist. Inspect hoist for security of mounting of drive cylinder and pump. Inspect cylinder for oil leaks and oil level (inspect level when cylinder is in erect position), and refill as required.

Lamps (Lights). Test to see that switches and all lights operate properly. See that foot switch controls

ORGANIZATION PREVENTIVE MAINTENANCE SERVICES

MAINTENANCE		
0000 Mile	1000 Mile	
91		the headlight beams, and that they are properly dimmed. Inspect lights for good condition and security, and check for dirty and broken lenses or discolored reflectors.
92	92	ADJUST. Aim headlight beams.
93	93	Safety Reflectors. Inspect reflectors for presence, security, and good condition.
94	94	Front Bumper, Tow Hooks and Brush Guard. Inspect to see that these units are in good condition and correctly assembled to brackets.
95	95	Hood. See that hood hinges, fasteners, and props are in good condition, secure, and lubricated.
96	96	Front Fenders and Running Boards. Inspect for good condition and security.
98	98	Cab (Doors, Hardware, Glass, Seats, Upholstery and Trim, Floor Boards, Ventilators, and Map Compartment). Inspect these items for good condition. Clean where necessary. CAUTION: <i>Avoid getting water on floorboards of cab where it might get into cranking motor switch. Water can cause switch to become inoperative.</i>
99	99	Circuit Breaker and Fuse Block. Connections must be tight. Replace defective circuit breakers.
100	100	Splash Guards. See that they are in good condition and secure.
101	101	Body (Floor, Bows, Tops, Troop Seats, Tarpaulins, End Curtains, Tail Gate, and Chains). Inspect these items for good condition and security. See that curtain and tarpaulin ropes are properly fastened. Inspect wood body bolts, and tighten if required.
103	103	Rear Bumper and Pintle Hook. Inspect units for good condition and security. Test operation of pintle and latch. Observe whether lock pin is secured with a chain. Lubricate pintle shaft.
104	104	Paint and Markings. Examine for good condition and legibility of markings. Repaint bright spots that might cause reflections.
105	105	Radio Bonding (Suppressors, Filters, Condensers, Shielding, and Bronze Knife-switch Clip Bonds). Examine these items to see if their connections are in good condition, clean and secure, and whether all items are securely mounted. Inspect bronze knife-switch clip bonds on each side of hood for clean contact. NOTE: <i>Any irregularities requiring attention beyond cleaning and tightening should be reported through channels to signal corps personnel.</i>
		Armament (Guns, Mounts, Rails, Spare Parts, and Covers). Examine gun mountings and rails for good condition, clean lines, security, and lubrication.

4-TON, 6 x 6 TRUCKS (DIAMOND T MODELS 968A CARGO, 969A WRECKER, 970A PONTON, AND 972 DUMP)

MAINTENANCE	
6000 Mile	1000 Mile
131	131
132	132
133	133
134	134
135	135
136	136
138	138
139	139
141	141
142	142

TOOLS AND EQUIPMENT

Tools (Vehicle and Pioneer). Check against stowage list, Section VIII in this manual, to see that they are all present, in good condition, clean, and properly stowed or securely mounted. Any tools mounted on outside of vehicle should have bright surfaces painted to eliminate glare or reflection.

Fire Extinguisher. Inspect small fire extinguisher in cab for presence and secure mounting, and check for full charge by shaking. See whether seal is intact on CO₂ fire extinguisher (on wrecker). Full charge of CO₂ extinguisher is determined by weighing; see proper weights marked on extinguisher.

Decontaminator. Inspect unit for good condition, full charge, and secure attachment. Test for charge by shaking. Refer to tag for date of last recharge.

First Aid Kit. Inspect for good condition and presence of all items. See list on box. Report deficiencies immediately.

Publications and Form No. 26. Vehicle and equipment operator's manuals, Lubrication Guide, and Standard Accident Report Form No. 26 should be present, legible, and properly stowed.

Traction Devices (Chains). Inspect chains and connector links for good condition, cleanliness, excessive wear, protection against rust, and proper stowage.

Spare Shear Pins, Bulbs and Parts. See that prescribed number and sizes of items are present, in good condition, and properly stowed.

Fuel and Water Cans and Brackets. See that cans are in good condition and secure and that caps fit tightly and are secured to can with a chain. Examine cans for leaks.

Modification (FSMWO's Completed). Organizational maintenance records must be checked to see that all Field Service Modification Work Orders pertaining to the vehicle have been completed.

Final Road Test. Make final road test, rechecking items 2 to 15 inclusive. Be sure to recheck the transmission, transfer case, and all driving axles to see that lubricant is at the correct level and not leaking. Confine road test to minimum distance necessary to make satisfactory observations. Correct or report all deficiencies found during final road test.

Section XIII

TROUBLE SHOOTING

	Paragraph
Introduction	38
Engine	39
Starting system.....	40
Ignition system.....	41
Fuel system.....	42
Cooling system.....	43
Lubricating system.....	44
Generating system.....	45
Clutch	46
Transmission	47
Transfer case.....	48
Propeller shafts.....	49
Axles	50
Brakes	51
Steering	52
Winch	53
Wrecker equipment.....	54
Air compressor unit.....	55
Dump pump and hoist.....	56

38. INTRODUCTION.

a. Most troubles are noticeable with the vehicle in motion, and it is the mark of an alert driver that he notice anything unusual in the performance of the truck. The instruments on the dash will assist the driver in this diagnosis, and with experience, any change in the rhythm of the vehicle will be noticed. Study the usual symptoms of the more common troubles, and think them over to their root before attempting any adjustments.

b. Trouble shooting procedures for the entire vehicle are given in this section. To trace a trouble to its source go through this section to the observed symptom, and follow the procedure indicated or as outlined in the paragraph reference.

c. Parts of this section are in chart form and parts of it are in narrative form. The chart is a quick reference to isolate a trouble to a system or unit, while the narrative portions give additional information to isolate a fault within a system, or to remedy the trouble.

39. ENGINE.

a. **Instructions.** Step b of this paragraph is the trouble shooting chart for the engine and engine accessory troubles. Step c gives simple tests to determine the mechanical condition of the engine. References in step b refer to step c for engine mechanical troubles or to pertinent paragraphs in this section for system troubles. Lubrication system troubles are discussed in paragraph 44.

4-TON, 6 x 6 TRUCKS (DIAMOND T MODELS 968A CARGO, 969A WRECKER, 970A PONTON, AND 972 DUMP)

b. Trouble Shooting Chart.

(1) **CRANKING MOTOR WILL NOT CRANK ENGINE.**

(a) *Lights of Vehicle Stay Bright When Starting Switch is Closed.* An open circuit may be present in the starting system. Refer to paragraph 40.

(b) *Lights of Vehicle Go Very Dim or Out When Starting Switch is Closed.* If the battery is discharged, replace. Refer to paragraph 101.

(c) *Cranking Motor Hums When Switch is Closed but Engine Does Not Turn Over.* Replace cranking motor. If trouble continues, notify higher authority.

(2) **CRANKING MOTOR CRANKS ENGINE BUT ENGINE WILL NOT START.**

(a) *No Fuel Reaching Carburetor as Evidenced By No Fuel Flowing From Fuel Line When Disconnected From Carburetor and Engine is Cranked With Ignition Switch Off.* Open fuel tank valve, fill tank if necessary.

(b) *Excessive Amount of Fuel Being Drawn Into Engine Cylinders.* The engine may be over-choked. Open choke and throttle. Close cranking motor switch for five or six engine revolutions. Wait 30 seconds and repeat operation if engine does not fire.

(c) *Weak Spark or No Spark Emitted From Spark Plug Wire Connector When Detached From Spark Plug and Held $\frac{1}{16}$ Inch From Engine Block While Engine is Cranked.* Close ignition switch. Refer to paragraph 41, if test is negative.

(d) *Satisfactory Ignition and Fuel Systems But Engine Backfires or Dies.* Refer to paragraph 41, and check ignition timing. If trouble continues, test mechanical condition of engine (subparagraph c below).

(3) **ENGINE IDLES UNEVENLY.**

(a) *Black Smoke Emitted From Exhaust.* Adjust carburetor idle mixture (par. 76 c (3)). Replace carburetor (par. 76 d and e) if idle does not adjust.

(b) *Engine Idles Evenly When Choke is Partially Closed or a Momentary Even Idle is Obtained When Engine is Primed.* Adjust carburetor idle mixture. If mixture does not adjust, check fuel system, paragraph 42, remedy leaky manifold gaskets, then replace defective carburetor (par. 76 d and e).

(c) *Engine Idles Unevenly When Fuel System is Satisfactory and No Leaks Are Present in Inlet Manifold.* Clean, adjust and replace defective spark plugs.

(d) *Engine Idles Unevenly When Fuel and Ignition Systems are Satisfactory.* Test mechanical condition of engine (subpar. c below). Replace cylinder head gasket if defective.

(4) **LACK OF POWER WHEN ENGINE DOES NOT FIRE ON ALL CYLINDERS.** Clean, adjust, and replace defective spark plugs. If trouble continues, test mechanical condition of engine (subpar. c below).

(5) **ENGINE OVERHEATING.** Refer to paragraphs 41 through 44, in the order mentioned, to check the system causing the trouble.

TROUBLE SHOOTING

(6) **ENGINE LACKS POWER WHEN COOLING SYSTEM IS SATISFACTORY.** Clean air cleaner, then check ignition system (par. 41).

(7) **ENGINE LACKS POWER.** Test mechanical condition of engine (subpar. c below).

(8) **ABNORMAL NOISE AT IDLE.**

(a) *Noise Occurs at Half Engine Speed.* Adjust tappets (par. 62). If a broken valve spring or tappet is present, notify higher authority.

(b) *Noise Occurs at Maximum Engine Speed.* Refer to a higher authority.

(9) **DULL THUD NOISE AT OPEN THROTTLE LOW ENGINE SPEED.** Refer to higher authority.

(10) **"PING."** Refer to paragraph 41 and check ignition system. If engine is overheating, refer to step (5) above. Check mechanical condition of engine (subpar. c below).

c. Tests to Determine Mechanical Condition of Engine.

(1) **COMPRESSION TEST.** If possible, make this test with the engine warm. Remove a spark plug from each of the engine cylinders. Install a compression gage in No. 1 cylinder. Open the throttle fully, leave the ignition switch open, and crank the engine. Stop cranking the engine when the maximum reading is obtained on the gage. This will take 8 or 10 revolutions of the engine crankshaft. Repeat this process on the remaining cylinders, recording the compression pressure of each cylinder on a piece of paper. If the compression pressure of one or more cylinders is less than 95 pounds per square inch when the test has been conducted near sea level, the cylinder or cylinders registering this low reading have leaky valves or piston rings. To determine whether the rings or valves leak, repeat the above test on the cylinders having poor compression, adding a half teaspoonful of engine oil through the spark plug hole and onto the valves prior to installing the compression gage. If a low reading is obtained, the valves leak. If a satisfactory reading is obtained, the rings leak. If the readings taken vary more than 10 pounds per square inch, an engine overhaul is indicated.

(2) **VACUUM TEST.** Install vacuum gage connection at the rear of the intake manifold. Remedy all leaks in line to windshield wiper. Warm up engine and idle at 500 revolutions per minute. If manifold connections are tight, carburetor properly adjusted, cylinders all firing evenly, and ignition timing correct, the vacuum gage reading will be between 17 and 21 inches at sea level. If the gage reading is less than 15 inches, investigate the exhaust system for a restriction. When using a vacuum gage to adjust the carburetor idle mixture, the correct idle mixture is indicated when the gage reading is a maximum. Remove vacuum gage.

(3) **ABNORMAL ENGINE NOISE.**

(a) If the noise occurs with each revolution of the engine crankshaft, it is at some point driven by the crankshaft, such as pistons, rings, pins, connecting rod or main bearings, or some member of the engine which is driven at crankshaft speed. A loose main bearing knock is usually a dull thud, more noticeable on a hard pull or quick acceleration. Notify higher authority.

TM 9-811
39-41

**4-TON, 6 x 6 TRUCKS (DIAMOND T MODELS 968A CARGO,
969A WRECKER, 970A PONTON, AND 972 DUMP)**

(b) If the noise occurs once with each two revolutions of the engine crankshaft, the source is at some point driven by the camshaft, such as valves, tappets, etc. Adjust tappets. If noise continues, notify higher authority.

40. STARTING SYSTEM.

a. Solenoid Starting Switch Fails to Click When the Series Parallel Switch is Closed.

(1) Check wiring for loose or corroded connections, and clean and tighten as required.

(2) Test each cell of the batteries with a hydrometer. If any cell is less than 1.220 at 80°F, replace the defective battery (par. 101) with a fully charged one and investigate the generating system (par. 45) for the cause and remedy of the discharged battery. If the switch still fails to click when the series parallel switch is closed, proceed as in the next paragraph.

(3) Using a screwdriver with an insulated handle, short the SW terminal of the solenoid switch (on top of the starter) against the frame. If it fails to click, it is defective and should be replaced (par. 98). If the solenoid does click when the SW terminal is shorted, the switch is all right, and a further check is necessary to locate the trouble. Run a jumper wire from the SW terminal on the series parallel switch to the ammeter terminal on the same switch. If the solenoid clicks, the series parallel switch is defective and should be replaced (par. 99). If the solenoid fails to click, leave this jumper in place and run another wire across the terminals of the circuit breaker in the ammeter line. If the solenoid clicks, the circuit breaker is defective and should be replaced (par. 102). If the solenoid still fails to click, check the battery for sulphated terminals and cover with a clean coat of petrolatum if necessary.

b. Solenoid Starting Switch Clicks When the Series Parallel Switch is Closed.

(1) Test the solenoid starting switch with a jumper. If the cranking motor operates, replace the defective solenoid starting switch (par. 98). If the cranking motor does not operate, proceed with step (2) below.

(2) Remedy all poor connections, short and open circuits in the heavy cable connecting the battery with the cranking motor. Carefully examine and remedy if necessary the ground cable circuit of the battery. If the cranking motor does not rotate the engine crankshaft after performing the preceding steps, replace the defective cranking motor (par. 97). Notify a higher authority if the troubles cannot be corrected.

41. IGNITION SYSTEM.

a. Remedy All Poor Connections in Ignition Wiring System.

b. Ammeter Flicks When Engine is Cranked and Ignition Switch is Closed.

(1) Cease cranking the engine and open the ignition switch.

(2) Remove the distributor cap from the distributor (par. 91). If

TROUBLE SHOOTING

moisture is present inside the cap, wipe it and the rotor dry. Remove all moisture from the exterior of the cap, the high-tension wires, spark plug porcelains and the high-tension terminal of the coil. Install the distributor cap, close the ignition switch, and check the spark as outlined in paragraph 92. If a weak or no spark is obtained, proceed with step (3) below.

(3) Cease cranking the engine and remove the distributor cap from the distributor. Remove the high-tension wire from the center socket of the distributor cap. Rotate the engine crankshaft until the ignition points are closed. Close the ignition switch. Hold the high-tension wire connected to the coil so the free end is about $\frac{5}{16}$ inch from the engine cylinder block, and open and close the ignition points with the fingers. If a good spark is obtained, this spark is lost in the distributor cap, rotor or high-tension wires. Examine the distributor cap and rotor for cracks or a carbon path. If a crack or carbon path is found, replace the defective distributor cap or rotor (par. 91). If the metal spring of the rotor is broken, or the metal segment is badly burned, replace the rotor. Examine the insulation of the high-tension wiring. If the insulation is broken, oil soaked or porous, replace the defective high-tension ignition wiring. If no spark or a poor spark is obtained, proceed with step (4) below.

(4) Remove the distributor cap from the distributor. Remove the high-tension wire from the center socket of the distributor cap. Rotate the engine crankshaft until the points are open. Close the ignition switch. Hold the high-tension wire connected to the coil so the free end is about $\frac{5}{16}$ inch away from the cylinder block. With a screwdriver, make a good ground connection between the movable contact point arm and the ground. If a good spark is obtained from the high-tension wire when the ground connection established by the screwdriver is broken, replace the defective contact points. If no spark or a poor spark is obtained, either the condenser or ignition coil, or both are defective. Replace each of these units in turn, and if only one is defective, install the serviceable unit which was removed (par. 91).

(5) Remove the distributor cap and rotor. If the breaker arm is frozen or the contact points are in poor condition, replace them. Adjust to correct point gap (par. 91).

c. Ammeter Does Not Flick or Show Discharge When Engine is Cranked and Ignition Switch is Closed. Use a test lamp to find the open circuit in the circuit between the battery and the contact points. First check the ignition switch, and make sure current will pass through it when the switch is closed. Then check the coils and make sure the primary circuit through the coil is continuous. If the circuit through the switch is open when the switch is in the closed position, or if the primary circuit of the ignition coil is not continuous, replace the defective unit (pars. 90, 91 and 92). If the circuit is satisfactory to the primary post of the distributor, inspect the grounding cable between the breaker mounting plate and the distributor housing. This cable must be in good order, and tightly connected, to provide a ground for the mounting plate. Assemble and install the distributor cap. Test the spark as outlined in paragraph 92. If no spark or a poor spark is obtained, perform all of step b of this paragraph.

TM 9-811

41-42

4-TON, 6 x 6 TRUCKS (DIAMOND T MODELS 968A CARGO, 969A WRECKER, 970A PONTON, AND 972 DUMP)

d. Ammeter Does Not Flick and Shows a Steady Discharge When Engine is Cranked and Ignition Switch is Closed. Cease cranking the engine, open the ignition switch, and remove the distributor cap. Perform step b (5) of this paragraph. Disconnect the condenser lead from the primary post of the distributor. If, when the ignition switch is closed, the ammeter shows no discharge, replace the defective condenser. If the ammeter shows a steady discharge, connect the condenser lead. The trouble has now been traced down to a short circuit in one or more of three items: the wiring, the ignition switch, or the primary circuit in the ignition coil. Use a test lamp to locate the defective unit or units, and correct the short circuit. After correcting the short circuit, assemble the system, and if a good spark is not obtained (par. 41 b (3)), observe the ammeter to see whether its behavior corresponds to step b or c of this paragraph. Perform the step pertinent to the ammeter's behavior.

e. Satisfactory Spark Delivered to Spark Plug, But Engine Backfires or Does Not Fire.

(1) Check the order of the high-tension wires in the distributor cap, and make sure the firing order of the distributor corresponds to the firing order of the engine (1-5-3-6-2-4).

(2) Check the ignition timing (par. 90).

(3) Test engine compression (par. 39 c (1)).

f. Engine Idles Unevenly. Remove the spark plugs; clean and reset the gaps. Replace defective plugs with serviceable ones. Make certain that the spark plugs used have the correct heat range (par. 92).

g. Lack of Power When Engine Fires On All Cylinders.

(1) Check the ignition timing (par. 90).

(2) As a last resort, replace the distributor, since something might have happened to the automatic spark advance to prevent this device from functioning in its intended manner (par. 91).

42. FUEL SYSTEM.

a. Remove, Disassemble, Clean, and Install Fuel Filter (par. 77).

b. No Fuel Reaching Carburetor, as Evidenced by Disconnecting Fuel Line From Carburetor and Cranking Engine With Ignition Switch Off.

(1) Perform step a of this paragraph.

(2) Inspect the fuel pump for fuel leakage through a drain hole in the lower housing. If fuel has been leaking from this hole, the pump has a ruptured diaphragm. Replace the defective pump (par. 77).

(3) Disconnect both fuel lines from the fuel pump. With the ignition switch open, crank the engine. While the engine is being cranked, close the fitting on the suction line with a finger. If the pump is operating properly, the suction exerted by the pump can be felt by the finger. If the pump does not pass this test, replace it (par. 77).

(4) The cause of lack of fuel to the carburetor has now been

TROUBLE SHOOTING

traced to either a plugged fuel line between the fuel tank and the carburetor or vapor lock. The general procedure for removing an obstruction in a fuel line is to disconnect the line at each end, and blow it out with compressed air. In the case of vapor lock, the vehicle gradually loses power until the carburetor runs out of fuel. When this happens, if water is available, pour it over the fuel pump and the fuel lines subject to engine heat to lower the vapor pressure of the fuel. If no method of cooling these units is available, wait until they cool off.

c. Lack of Power.

(1) INSUFFICIENT PRESSURE IN FUEL LINE TO CARBURETOR.

(a) Clean fuel filter (par. 77).

(b) Connect a liquid pressure gage in the fuel line at the carburetor. Operate the vehicle near its rated engine speed, and with an open throttle, and observe the fuel pressure registered by the gage. If the fuel pressure is less than $2\frac{1}{2}$ pounds per square inch, the fuel pump is defective, or the fuel line between the tank and carburetor has an obstruction in it. Test the fuel pump as outlined in step b (3) of this paragraph. If the pump passes this check, disconnect the fuel lines and blow them out with compressed air. If both these operations fail to attain the required fuel pressure at the carburetor, replace the fuel pump (par. 77).

(2) REQUIRED PRESSURE IN FUEL LINE TO CARBURETOR. Operate the vehicle near its rated speed, and with an open throttle. If partially closing the choke produces more power, replace the defective carburetor (par. 76).

43. COOLING SYSTEM.

a. In the following discussion, it is assumed the operator has not driven the vehicle far enough after the engine temperature gage has reached the danger zone to boil away a sufficient quantity of coolant to interfere with the circulation system.

b. Overheating Not Due to Loss of Coolant.

(1) Remove any foreign obstruction which would tend to retard the passage of air through the core of the radiator. If insects or dirt have plugged a large number of the air passages through the core, remove these obstructions with compressed air or with a stream of water, working from the far side of the radiator core.

(2) Check the condition and adjustment of the fan belt. If necessary, adjust or replace it (par. 86).

(3) Check the ignition timing. If necessary, adjust (par. 90).

(4) Continuous operation at open throttle and low engine speed tends to overheat the engine, particularly on a hot day. Keep the engine near its rated speed in order to take full advantage of the increased flow of air through the radiator core caused by the fan speed.

(5) Check the carburetor for rated fuel delivery at open throttle as outlined in paragraph 68 c.

(6) Replace the engine thermostat (par. 88).

TM 9-811

43-44

4-TON, 6 x 6 TRUCKS (DIAMOND T MODELS 968A CARGO, 969A WRECKER, 970A PONTON, AND 972 DUMP)

(7) In rare cases, the water pump impeller may have become separated from the water pump shaft. Replace pump (par. 87).

(8) If the above steps have not corrected the overheating trouble, the liquid passages in the radiator are probably restricted or plugged. Replace the radiator (par. 85).

c. Overheating Due to Loss of Coolant When Radiator Was Filled Before Starting.

(1) After the engine returns to its normal operating temperature, fill the radiator.

(2) Inspect and remedy all external leaks of the cooling system, such as hose, gaskets, etc. (par. 84). If the radiator leaks, replace it with a serviceable unit (par. 85).

(3) If no external leaks are present, remove the cylinder head (par. 59). A defective cylinder head gasket is probably the cause of a leak between a cylinder combustion chamber and the coolant passage in the head or block of the engine. Install a new gasket and the cylinder head (par. 61).

d. Loss of Coolant When Vehicle Stands. If the cooling system loses coolant when the vehicle is idle, and no external leaks are present, the cylinder head gasket is probably leaking (pars. 59 and 87).

44. LUBRICATING SYSTEM.

a. Detection of Oil Leaks.

(1) **REAR MAIN BEARING.** Spread a large sheet of clean paper directly beneath the oil drain hole in the clutch housing after stopping the vehicle. A few drops of oil appearing upon the paper is a permissible quantity, but two or three teaspoonfuls of engine oil is not. Notify a higher authority if the leak is excessive.

(2) **EXTERNAL LINES AND GASKETS.** Thoroughly clean the line connections and surfaces around the gaskets, and oil drain plugs. After operation of the vehicle, inspect these cleaned areas. Remedy defective connections by installing serviceable ones. Replace defective gaskets, tighten loose oil drain plugs.

b. Excessive Oil Consumption.

(1) Check for oil leaks.

(2) Make sure the oil being used corresponds to the recommendation in the Lubrication Guide (par. 26).

c. Sudden Loss of Oil Pressure.

(1) **LACK OF OIL.** Stop engine immediately and check engine oil level. If the oil level is less than one-third full, fill to full mark and start engine. If oil pressure does not register within 30 seconds after starting, stop engine.

(2) **SUFFICIENT OIL.** If the oil level is up to the half full mark or better, notify a higher authority.

TROUBLE SHOOTING**45. GENERATING SYSTEM.**

a. **General.** When checking the condition of the generating circuit, first depress the starter button for five to ten seconds with the ignition off to run down the batteries enough to show a charging rate on the ammeters. The engine should then be started and the throttle button pulled out far enough to permit the engine to idle at 1000 revolutions per minute.

b. **Ammeter Fails to Register Charge but Front Battery Ammeter Registers Charge.** Replace defective ammeter as flow of current through front battery ammeter indicates that the generating circuit is complete.

c. **Ammeter and Front Battery Ammeter Both Fail to Register Charge.**

(1) Turn on the vehicle lights. If the ammeters do not show discharge, they are defective and should be replaced (par. 192). If the ammeters show discharge, or no improvement is noted after replacing them, proceed as in steps (2) and (3).

(2) Check all wiring for loose or corroded connections, and clean and tighten as required.

(3) Run a jumper wire from the armature terminal on the generator to the armature terminal on the regulator. If the ammeters register the flow of current, the armature lead from the generator to the regulator should be repaired or replaced. If the ammeters still show no deflection, proceed as in step (4).

(4) Run a jumper wire between the armature terminal and the battery terminal on the voltage regulator. If the ammeters show deflection, the voltage regulator is defective and should be replaced (par. 95). If the ammeters still fail to show deflection, proceed as in the next step.

(5) Run a jumper wire between the battery terminal on the regulator and the battery terminal on the dash filterette. If the ammeters show deflection, the wire between the regulator and the filterette should be replaced or repaired. If the ammeters still fail to show deflection, proceed as in the next step.

(6) Short out the dash filterette with the jumper wire connected across the "B" terminal on the engine side of the dash, and the "B" terminal on the cab side of the dash. If the ammeters register deflection, the filterette is defective and should be replaced. If the ammeters still fail to register deflection, proceed as in the next step.

(7) Run a jumper wire between the "B" terminal on the filterette and the ammeter. If the ammeters show deflection, the wire between the filterette and the ammeter should be repaired or replaced. If the ammeters still fail to show deflection, proceed as in the next step.

(8) Run a jumper wire between the ammeter and the "A" minus terminal on the series parallel switch. If the ammeters show deflection, the wire between the series parallel switch and the ammeter should be replaced or repaired. If the ammeters still fail to show deflection, proceed as in the next step.

**4-TON, 6 x 6 TRUCKS (DIAMOND T MODELS 968A CARGO,
969A WRECKER, 970A PONTON, AND 972 DUMP)**

(9) Run a jumper wire between the "A" minus terminal on the series parallel switch and the "A" minus terminal on the rear battery. If the ammeters show deflection, the battery cable between the "A" minus terminal on the series parallel switch and the "A" minus terminal on the rear battery should be replaced. If the ammeters fail to register, proceed as in next step.

(10) Disconnect the voltage regulator field wire and ground it. Then disconnect the regulator armature wire and brush it over a good ground. **CAUTION: Do not hold this wire in contact with ground or it will burn out the generator armature.** If no spark is obtained, the generator is defective and should be replaced (par. 94). If a good spark is obtained, it is an indication that the generator is functioning properly, and the regulator armature and field connections should be replaced before continuing with the next step (11).

(11) Disconnect the regulator battery wire and hold it close to the regulator battery terminal. If a good spark is obtained, the regulator is functioning properly. If no spark is obtained, the regulator is defective and should be replaced (par. 95).

(12) If after making these tests the ammeter registers charge, but the front battery ammeter fails to register, proceed as in paragraph 45 d. If the trouble cannot be located, refer to a higher authority.

d. Ammeter Registers Charge but Front Battery Ammeter Does Not Register Charge.

(1) Repeat items (1) and (2), as outlined in paragraph 45 c.

(2) Run a jumper wire between the "A" minus terminal and the "B" minus terminal on the series parallel switch. If the front battery ammeter shows deflection, the series parallel switch is defective and should be replaced (par. 99). If the front battery ammeter fails to show deflection, proceed as in step (3) (a) (b) (c) following.

(3) Run a jumper wire between the "B" minus terminal on the series parallel switch and the "B" minus terminal on the solenoid switch. If the front battery ammeter shows deflection, there is an open circuit in the wire between the series parallel switch and the solenoid switch. To determine which parts are defective in this circuit proceed as follows:

(a) Run a jumper wire between the "B" minus terminal on the series parallel switch and the circuit breaker in the line. If the ammeter shows deflection, the wire between the series parallel switch and the circuit breaker should be replaced.

(b) Run a jumper wire across the terminals of the circuit breaker. If the ammeter shows deflection the circuit breaker should be replaced (par. 102).

(c) Run a jumper wire between the circuit breaker and the "B" minus terminal of the solenoid switch. If the ammeter shows deflection the wire between the circuit breaker and the solenoid switch should be repaired or replaced.

(4) Run a jumper wire from the battery cable connection on the solenoid switch to the "B" minus terminal of the front battery. If the

TROUBLE SHOOTING

ammeter shows deflection, the battery cable should be replaced. If the ammeter still fails to show deflection, proceed as in steps (5) and (6) following:

(5) Run a jumper wire from the "B" plus terminal of the front battery to the "B" plus terminal of the series parallel switch. If the ammeter shows deflection, the battery cable should be replaced. If the ammeter fails to show deflection, proceed as follows:

(6) Run a jumper wire between the "B" plus terminal and the front battery ammeter terminal on the series parallel switch. If the ammeter shows deflection, the series parallel switch is defective and should be replaced (par. 99). If the ammeter fails to show deflection, proceed as in step (7) (a) (b) (c) and (d) following.

(7) Run a jumper wire from the front battery ammeter terminal on the series parallel switch to the front battery ammeter. If the ammeter shows deflection, there is an open circuit in the wiring between the series parallel switch and the front battery ammeter. To determine which part of the circuit is defective, proceed as follows:

(a) Run a jumper wire between the front battery ammeter terminal on the series parallel switch and the circuit breaker in the line. If the ammeter shows deflection, the wire between the circuit breaker and the series parallel switch should be replaced.

(b) Run a jumper wire across the terminals of the circuit breaker. If the ammeter shows deflection, the circuit breaker is defective and should be replaced (par. 102).

(c) Run a jumper wire between the circuit breaker and the junction block on the cowl. If the ammeter shows deflection, the wire between the circuit breaker and the junction block is defective, and should be replaced or repaired.

(d) Run a jumper wire between the junction block and the ammeter. If the ammeter shows deflection, the wire between the junction block and the ammeter is defective, and should be replaced or repaired.

(8) Run a jumper wire between the front battery ammeter and the ground. If the ammeter shows deflection the ground wire is defective, and should be replaced or repaired.

(9) If the front battery ammeter still fails to show deflection, refer to a higher authority.

46. CLUTCH.

a. **General.** Most clutch troubles will be noticed when the clutch is engaged and the vehicle is started. The driver should note carefully the symptoms of the trouble to facilitate the determination of the cause.

(1) Slipping will be evidenced by the rapid building up of engine speed with little effect on vehicle speed, immediately after the clutch is engaged and the throttle depressed. To remedy slipping, adjust clutch (par. 72). If this fails, replace driven plate. If clutch still slips, notify higher authority.

(2) Grabbing is indicated when the clutch goes into sudden en-

TM 9-811
46-50

**4-TON, 6 x 6 TRUCKS (DIAMOND T MODELS 968A CARGO,
969A WRECKER, 970A PONTON, AND 972 DUMP)**

gement—jerking the vehicle, even though the pedal is released gradually. To remedy a grabby clutch, first make sure the engine mounting bolts are tight. Then, if trouble persists, replace the driven plate. If clutch still grabs, notify higher authority.

(3) A chattering clutch will be noticed by the noise and jerky motion imparted to the vehicle as the clutch disk grabs intermittently during pedal release. To remedy a chattering clutch, replace the clutch driven plate. If this fails, notify higher authority.

(4) Dragging will be evidenced by difficulty in shifting gears quietly with the clutch pedal pushed to the toeboard. To remedy a dragging clutch, adjust clutch. If this fails replace driven plate. If clutch still drags, notify higher authority.

(5) Noise in the clutch will be evident during engagement or after engagement is complete and the vehicle is in motion. Either a defective pilot or release bearing may cause noise. Replace these bearings if defective. If noise continues, notify higher authority.

47. TRANSMISSION.

a. **General.** Transmission troubles may be discovered before operation, while shifting gears and during operation. The symptoms of the usual transmission troubles follow.

(1) Lubricant leaks may be discovered before operation by examining the ground underneath the vehicle for signs of excessive oil loss.

(2) Difficulty in shifting is evidenced by a clashing noise while changing gears.

(3) Slipping out of gear will be noticed after the vehicle is in motion while accelerating or while on a hard pull.

(4) Noise in the transmission will become evident when the vehicle is in motion. Transmission noises are deceptive and may actually originate in other parts of the vehicle. Before any mechanical work is attempted it is suggested that a thorough check be made, giving particular attention to the propeller shafts. If noise persists, after a thorough tightening of loose nuts in propeller shafts, notify higher authority.

48. TRANSFER CASE.

a. Transfer case troubles are very similar to transmission troubles and are evidenced in the same manner. Refer to paragraph 47.

49. PROPELLER SHAFTS.

a. **General.** Propeller shaft noises and vibration generally seem to come from the transmission. These symptoms are generally the first indication of improper conditions in the propeller shaft assemblies. If proper lubrication fails to remedy trouble, replace defective assemblies.

50. AXLES.

a. **General.** The symptoms of axle troubles will be noticed before operation while starting and stopping and during operation. The

TROUBLE SHOOTING

condition of operation of the vehicle (starting, driving, coasting, pulling, etc.) should be noted as the symptom is observed to aid in the diagnosis of the cause.

(1) Lubricant leaks may be discovered before operation by an examination of the ground under the vehicle. Clean the axle breathers and replace all defective gaskets, seals and retainers.

(2) A clicking noise with jerky operation may be noticed when starting or stopping. Tighten axle shaft flange nuts. If trouble persists, notify higher authority.

(3) Humming noises may be noticed while driving at a steady speed, while coasting to a stop or while pulling, as in acceleration or under load. Adjust, or if necessary, replace defective wheel bearings. Notify higher authority if trouble persists.

51. BRAKES.

a. **General.** Brake troubles will be noticed while the vehicle is in motion, during brake application and during brake release. Troubles may be caused by mechanical difficulties as well as by deficiencies in the air equipment.

b. **Brakes Drag.** Adjust brakes and wheel bearings. If air brake valve leaks, replace it. If trouble persists, remove wheels and brake drum, and replace brake shoe retracting spring if defective.

c. **Truck Pulls to One Side When Brakes are Applied.** Tighten loose spring clips and inflate tires to correct pressure. Adjust brake shoes (par. 124). If symptom persists, replace defective brake shoes.

d. **Brakes Lack Power to Stop Vehicle.** Make sure air brake system is operating properly (section XXIX) and the slack adjusters are in proper adjustment. If the air brake system is functioning properly, replace all defective brake drums and shoes.

e. **Brakes Take Hold Slowly.** This symptom indicates trouble in the air brake system. Remedy restrictions in lines and clean if necessary. Adjust slack adjusters. Make sure brake valve and brake chamber are operating properly. Replace defective assemblies.

f. **Brakes Release Slowly.** Lubricate brake camshaft to prevent binding. Adjust slack adjuster, remedy restrictions in lines and clean lines if necessary. Make sure the brake valve lever returns to full release position when pedal is released. Adjust pedal clearance if necessary. If brake valve is defective, replace.

g. **Air Pressure Builds Up Slowly.** This symptom indicates trouble in the air brake system. Remedy all leaks in lines, connections, and the principal assemblies. Clean the air compressor air cleaner and discharge line. Adjust air compressor drive belt if necessary. Replace air compressor if defective.

h. **Quick Loss of Reservoir Pressure When Engine is Stopped.** Remedy all leaks in air brake system. Make sure drain cocks, valves, connections and lines do not leak.

TM 9-811
52-54

**4-TON, 6 x 6 TRUCKS (DIAMOND T MODELS 968A CARGO,
969A WRECKER, 970A PONTON, AND 972 DUMP)**

52. STEERING.

a. **General.** Steering troubles are noticed with the vehicle in operation or while turning. The more common steering troubles are described as follows:

(1) Wheel tramp or shimmy will be noticed with the vehicle in operation at driving speeds. A high-speed wheel tramp which increases in intensity with vehicle speed is most generally caused by faulty wheel balance. A low speed shimmy is usually caused by deficiencies in those items which affect wheel alignment. To remedy either of these symptoms, first inflate tires to correct pressure. Then check and adjust toe-in if necessary. Make sure U-bolts attaching axle to frame are tight. If excessive looseness is evident between the spring shackle pins and rubber bushings, replace worn parts (par. 141). If excessive play is evident in tie rod bushings, install new parts. If the front axle housing assembly is bent, or if symptoms are still present, notify higher authority.

(2) Hard steering or binding in the steering mechanism will be noticed while turning. To remedy this symptom, lubricate all parts of the steering mechanism, make sure the toe-in is correctly adjusted, and that the U-bolts clamping the axle to the springs are tight. If the symptom persists, notify higher authority.

(3) Wandering is the tendency of the vehicle to steer off at angles to the course. It will be noticed at any speed and especially in a high wind or on a highly crowned road. To remedy this symptom, make sure no excessive play exists in the tie rod or drag link connections. If trouble continues notify higher authority.

(4) Road shock transmitted through the steering linkage will be noticed at any speed, and especially while driving over bumpy roads or rough terrain.

53. WINCH.

a. **General.** Winch troubles will be evidenced before operation, while pulling or when holding the load in neutral. The more common troubles are listed in the following paragraph.

b. **Winch Does Not Operate or Suddenly Fails to Operate.** Install a new shear pin (par. 163).

c. **Winch Does Not Hold When Power is Released.** Adjust worn brake. If trouble persists, notify higher authority.

d. **Insufficient Drag on Drum When Clutch is Disengaged.** Adjust drag brake.

54. WRECKER EQUIPMENT.

a. **General.** Troubles with the wrecker equipment are for the most part readily apparent and may be corrected by replacement of defective parts or tightening loose parts. Trouble is usually accompanied by noise from the defective part or assembly. Keep this equipment properly lubricated.

TROUBLE SHOOTING

55. AIR COMPRESSOR UNIT.

- a. **Tank Pressure Fails to Build Up with Engine Operating Satisfactorily.** Adjust belt tension, remedy all leaks, and clean intake filter of air compressor. If this fails to correct trouble, notify higher authority.
- b. **Noisy Compressor.** Lubricate compressor and tighten loose parts. If noise persists, notify higher authority.
- c. **Engine Hard to Crank.** Open unloader valve until engine reaches rated speed. Use correct grade of lubricant in engine.
- d. **Moisture in Air.** Drain air reservoir at prescribed intervals.
- e. **Engine Does Not Start.** Fill fuel tank. Make sure gasoline reaches carburetor by disconnecting fuel line at carburetor. Clean and reconnect fuel line. Remove all moisture from spark plugs and wiring. Replace defective spark plugs and/or wiring. If trouble persists, notify higher authority.
- f. **Engine Misses.** Tighten electrical connections and replace defective spark plug wires or spark plugs.
- g. **Engine Overheats.** Lubricate engine.

56. DUMP PUMP AND HOIST.

- a. **General.** At regular intervals, inspect and tighten, if necessary, all hoist mounting bolts and cap screws, drive shaft companion flange bolts and packing gland nuts. Keep the hoist cylinder filled to the proper level with the correct grade of oil. Lubricate all lubrication fittings, at various points of the power hoist assembly, and drive shaft assembly. Pivot points not equipped with lubrication fittings should be given frequent applications of engine oil.
- b. **Noisy Pump.** Fill hoist cylinder with lubricant to correct level. Do not operate the power take-off after hoist has reached the extreme position or exceed an engine speed of 1000 revolutions per minute during the hoisting operation.
- c. **Power Hoist Fails to Lift.** Fill hoist cylinder with lubricant to correct level. If trouble continues, notify higher authority.
- d. **Pump Body Settles.** Notify higher authority.

4-TON, 6 x 6 TRUCKS (DIAMOND T MODELS 968A CARGO, 969A WRECKER, 970A PONTON, AND 972 DUMP)

Section XIV

ENGINE MAINTENANCE AND ADJUSTMENT IN VEHICLE

	Paragraph
Description and tabulated data	57
Tune-up	58
Cylinder head and gasket removal	59
Cleaning carbon	60
Cylinder head and gasket installation	61
Valve tappet adjustment	62
Intake and exhaust manifolds and gaskets replacement	63
Cam and idler shaft end play adjustment	64
Oil pan	65
Oil filters	66
Crankcase breather	67
Viscometer	68

57. DESCRIPTION AND TABULATED DATA.

a. Description. The engine is a six-cylinder gasoline engine of L-head design. The cylinder block and crankcase are cast in one piece, with the water jackets sloping inward toward the top and outward toward the bottom. The accessory drive for the water pump and distributor is located on the left side of the engine, and is supported in a removable sleeve casting. The generator is driven by the timing gears through a pilot hole on the right side of the engine. The fuel pump is mounted on the left side of the engine, and is driven by a pin working in the engine block between the pump arm and the camshaft eccentric. A flyball governor is piloted in the gear cover, and is driven by a gear bolted on the end of the generator drive gear.

b. Tabulated Data.

Model	Hercules RXC
Brake horsepower	131.5
Number cylinders	6
Bore	4 ⁵ / ₈ in.
Stroke	5 ¹ / ₄ in.
Piston displacement	529 cu in.
Compression ratio	5.41 to 1
Governed speed	2300 rpm
Maximum torque at 1000 rpm	396
Firing order	1-5-3-6-2-4
Crankcase capacity	16 qt
Torque wrench pull on cylinder head bolts	52 ¹ / ₂ ft-lb.
Tappet clearance:	
Intake valves	0.006 in.
Exhaust valves	0.010 in.

ENGINE MAINTENANCE AND ADJUSTMENT IN VEHICLE**58. TUNE-UP.**

a. **General.** The engine tune-up procedure is for the purpose of putting the engine and its accessories in condition to give the best performance possible without any major repairs or adjustments. The operations should be performed in the order indicated. See paragraphs 39 through 45 for methods of locating troubles in the engine or accessories.

b. Tune-Up Procedure.

(1) **CARBURETOR AIR CLEANER.** Clean the carburetor air cleaner (par. 84).

(2) **ENGINE BREATHER.** Clean the engine breather (par. 67).

(3) **FUEL LINES.** Check the fuel lines for leakage. Examine the connections to see that they are tight and free from cracks at the ends. See that there are no kinks or sharp bends. Examine the flexible line between the carburetor and the fuel filter to see that the rubber is in good condition and that it is not kinked or collapsed.

(4) **FUEL PUMP.** Remove the fuel pump bowl and clean the screen. Pour off any foreign material which has accumulated in the bowl (par. 77).

(5) **FUEL FILTER.** Remove the drain plug in the filter bowl and drain off any foreign matter which may have accumulated. If dirt or gum is readily discernible in the drainage, remove the bowl and clean the element (par. 77).

(6) **CARBURETOR.** Remove the inlet plug from the carburetor bowl and clean the screen. Adjust carburetor idling speed (par. 76).

(7) **BATTERIES.** Check the batteries for condition of the electrolyte. If the batteries are discharged they should be replaced or recharged (par. 101).

(8) **BATTERY AND IGNITION CABLES.** Check the battery and ignition cables to see that connections are clean and tight. Wires on which the insulation has been burned or chafed must be replaced or repaired. If battery terminals are corroded they should be cleaned and coated with petrolatum or chassis grease.

(9) **SPARK PLUGS.** Remove spark plugs and examine for burned electrodes or cracked insulators. Replace defective plugs or reset the gaps to 0.027 inch if they are in satisfactory condition (par. 92).

(10) **DISTRIBUTOR.** Remove the distributor cap and clean and inspect for cracks or badly burned contacts. Remove the rotor and clean and examine for cracks or broken spring clip. Inspect, clean and adjust distributor points. Inspect condenser and tighten connections (par. 91).

(11) **COIL.** Clean and inspect coil for tight mounting and good connections. Check coil for good spark (par. 92).

(12) **IGNITION TIMING.** Check ignition timing (par. 90).

(13) **VALVE CLEARANCE.** Remove valve covers and check and adjust valve clearance (par. 62).

(14) **CYLINDER HEAD BOLTS.** Tighten cylinder head bolts with a torque wrench to 52½ foot-pounds (par. 61).

(15) **OIL FILTERS.** Drain and clean elements. Replace if necessary (par. 69).

(16) **VACUUM TEST.** Perform vacuum test (par. 39 c).

4-TON, 6 x 6 TRUCKS (DIAMOND T MODELS 968A CARGO, 969A WRECKER, 970A PONTON, AND 972 DUMP)

59. CYLINDER HEAD AND GASKET REMOVAL.

a. Drain Cooling System. Open the drain cock on the radiator bottom tank outlet fitting and the drain cock on the left side of the cylinder block. If an antifreeze solution is used, arrange to catch it in clean containers so that it may be used again.

b. Remove Water Outlet Manifold. Remove the cap screws, plain washers and lock washers holding the engine water outlet fitting to the thermostat housing. Push the water outlet fitting away from the thermostat housing and remove the gasket. Then remove the cap

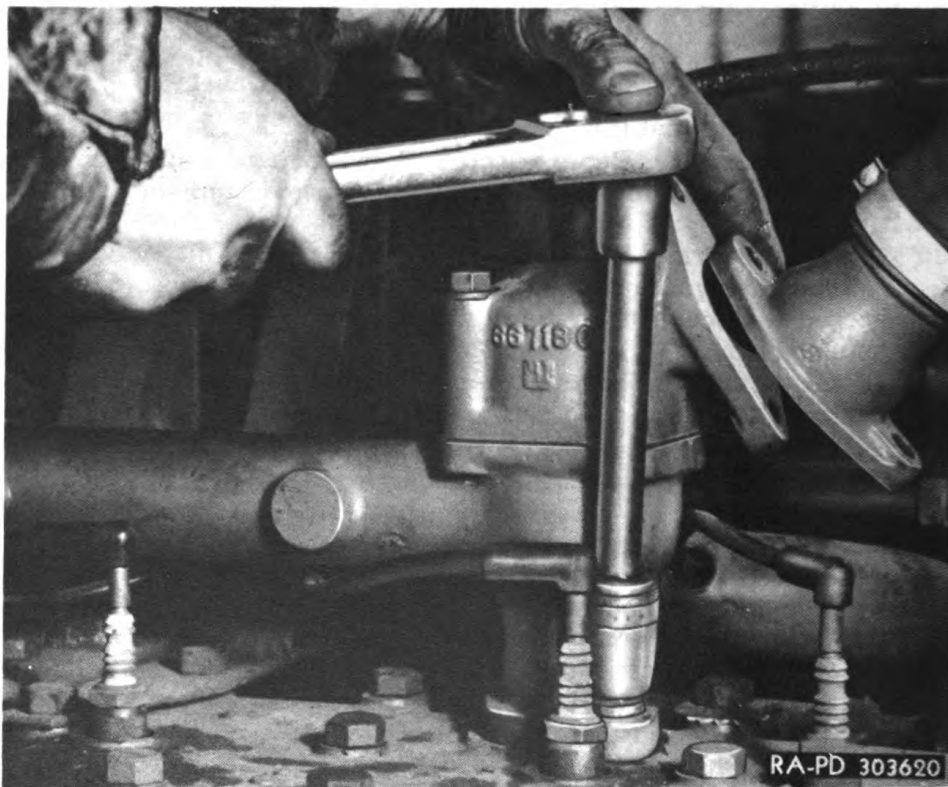

Figure 46—Removing Water Outlet Manifold

screws and lock washers attaching the water outlet manifold to the cylinder heads, and remove the water outlet manifold and gaskets (fig. 46).

c. Disconnect Heat Indicator. Disconnect the heat indicator from the left side of the rear cylinder head by threading out the hexagonal adapter and pulling out the bulb.

d. Remove Spark Plugs. Disconnect spark plug wires and remove the spark plugs and spark plug gaskets using the spark plug wrench.

ENGINE MAINTENANCE AND ADJUSTMENT IN VEHICLE

e. **Disconnect Air Cleaner Tube at Carburetor.** Back off the clamp screw in the clamp at the bottom of the air cleaner tube elbow and lift the tube clear of the neck of the carburetor.

f. **Remove Cylinder Head Cap Screws.** As the cap screws are removed from the heads, the various parts which are fastened to the heads under the cylinder head cap screws may be removed. These parts are the air cleaner and bracket assembly, the ignition coil, the hand throttle cable clip, the ignition cable tube, the plate bond and two toothed lock washers between the heads and the cylinder head to cowl bond strap and toothed lock washers.

g. **Remove cylinder heads and gaskets.**

60. CLEANING CARBON.

a. **Cleaning Carbon from Cylinder Heads.** Place the cylinder heads upside-down on a bench and scrape off the carbon deposits in the combustion space and along the gasket fringe. The carbon may be removed with a hand scraper tool or with a wire brush driven by an electric drill. When the heads are badly carboned the spark plugs will always be in need of attention, and these should be cleaned and the points reset before assembly (par. 92).

b. **Cleaning Carbon from Engine Block.** Using a hand scraper or wire brush, clean carbon from the cylinder block deck, valve heads and piston heads. The engine may be turned over with a hand crank or with the cranking motor to raise the pistons for cleaning. Stuff clean rags into those cylinder barrels with the pistons down so as to avoid getting carbon particles into them which may become trapped around the edges of the pistons and act as an abrasive after the engine is again in service. Blow carbon particles from deck of engine before removing rags and turning over engine to get at the next pair of pistons. Clean out the cap screw holes in the deck.

61. CYLINDER HEAD AND GASKET INSTALLATION.

a. **General.** When replacing the cylinder heads, care should be exercised to avoid injury to the cylinder head gaskets. It is recommended that pilot studs be used as outlined in this procedure. Use new cylinder head gaskets.

b. **Install Pilot Studs in Cylinder Deck.** Procure three studs 4 or 5 inches long with a $\frac{1}{2}$ -13 (std.) thread on one of the ends. Screw these into the cylinder head cap screw holes at the two front corners of the deck, and into one of the holes at the rear of the front cylinder head deck.

c. **Install Front Cylinder Head and Gasket.** Install the front cylinder head gasket over the pilot studs (fig. 47). Lift the front cylinder head and install it over the pilot studs. Drop the cylinder head cap screws into the cap screw holes in the head, and start the threads by screwing in with the fingers. Remove the three pilot studs. **CAUTION:** *If pilot studs are not available, great care must be exercised in this installation.*

TM 9-811

61

4-TON, 6 x 6 TRUCKS (DIAMOND T MODELS 968A CARGO, 969A WRECKER, 970A PONTON, AND 972 DUMP)

d. **Install Rear Cylinder Head and Gasket.** Install the pilot studs in the rear cylinder head deck, and repeat the procedure outlined in step c.

e. **Install Accessories Under Cap Screw Heads.** The parts which are attached to the engine under the cylinder head cap screws must be installed before the screws are tightened down. These parts are the air cleaner and bracket assembly, the ignition coil, the hand throttle cable clip, the ignition cable tube, the plate bond and two toothed lock

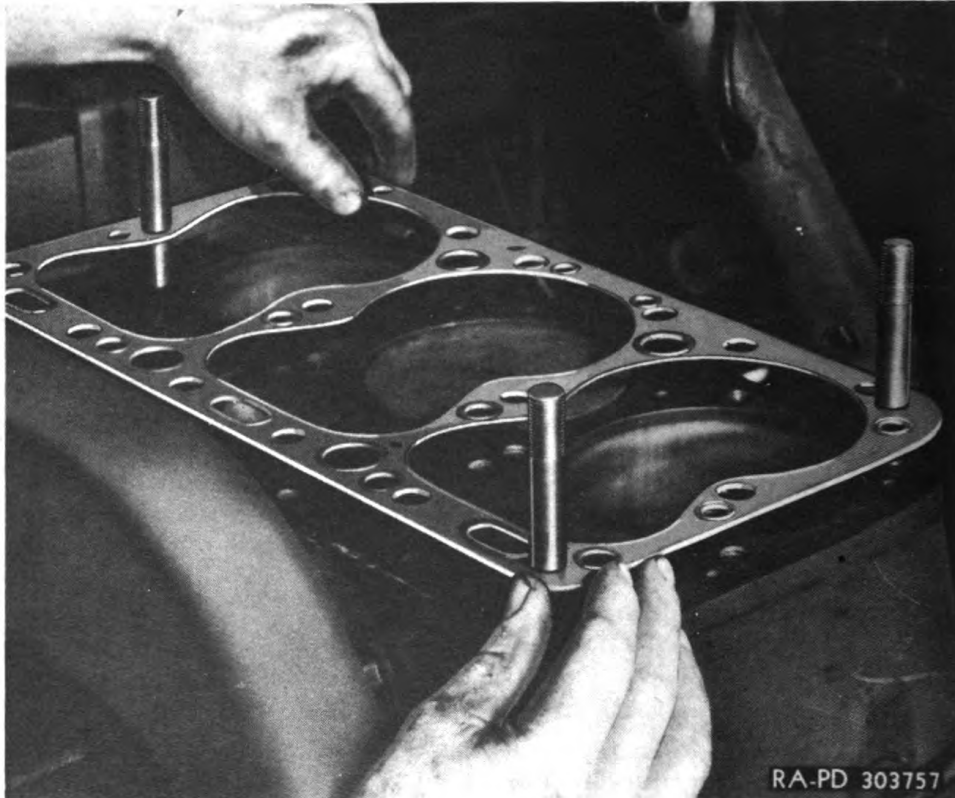

Figure 47—Installing Cylinder Head Gasket

washers between the heads and the cylinder head to cowl bond strap and toothed lock washer.

f. **Tighten Cylinder Head Cap Screws.** Use a speed wrench to run the cap screws down until they start to tighten. Then use a torque wrench to tighten the cap screws uniformly. When the cap screws and cap screw holes are clean, the torque wrench reading should be 60 foot-pounds when copper asbestos gaskets are used, 75 foot-pounds when steel asbestos gaskets are used. Start in the middle and work around each head (fig. 48) drawing the cap screws up gradually until on the last time around the torque wrench reading is 52½ foot-pounds.

ENGINE MAINTENANCE AND ADJUSTMENT IN VEHICLE

g. Connect Air Cleaner Tube. Install the air cleaner elbow over the neck of the carburetor and tighten the clamp screw to hold it securely in position.

h. Install Spark Plugs. Be sure the spark plugs are cleaned and the points set. Install the spark plugs with a gasket under each plug, and tighten with the spark plug wrench. Do not tighten plugs so tightly as to crack the porcelain, but they must be pulled down sufficiently to prevent leakage and assure good heat transfer.

i. Install Spark Plug Wires. Install the spark plug wires with suppressors over the ends of the plugs from which they were removed.

j. Connect Heat Indicator. Insert the bulb into the opening in the rear cylinder head and thread the hexagonal adapter into place and tighten it securely.

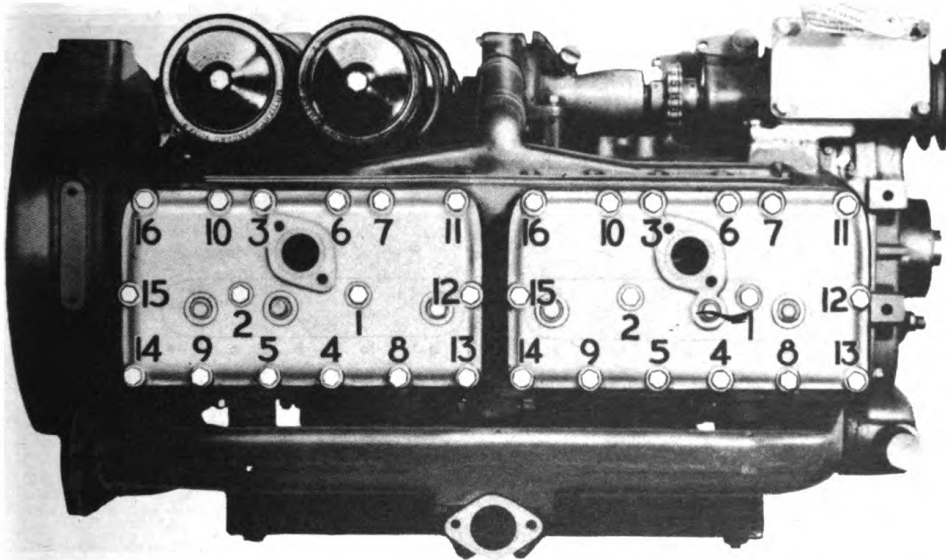

RA PD 304936

Figure 48—Order of Tightening Cylinder Head Cap Screws

k. Install the Water Outlet Manifold. Install new gaskets over the water manifold openings in the cylinder heads and install the manifold with cap screws and lock washers. Using a new gasket install the thermostat housing on the engine water outlet manifold with cap screws and lock washers.

l. Fill Cooling System. Remove the radiator cap and add water until it comes up level with the filler spout. Then start the engine and add water as required.

62. VALVE TAPPET ADJUSTMENT.

a. Remove Right Fender Shield. Remove the screws, cap screws, lock washers, cut washers and the radio suppression toothed lock

TM 9-811
62

**4-TON, 6 x 6 TRUCKS (DIAMOND T MODELS 968A CARGO,
969A WRECKER, 970A PONTON, AND 972 DUMP)**

washer holding the fender shield in place. Disconnect the bond strap under the rear cap screw. Then work it up and out of the engine compartment. It will be necessary to bend the shield slightly to do this.

b. Remove Crankcase Metering Valve. Disconnect the metering valve line from the rear valve cover (fig. 49) and then unscrew the valve from the intake manifold.

c. Remove the Valve Covers. Take out the cap screws and lead washers holding the valve covers in place, and remove the covers and gaskets.



Figure 49—Disconnecting Metering Valve Line

d. Adjust Tappets. Start the engine and let it run at idling speed until it is thoroughly warmed up. Using three wrenches, hold the tappet adjusting screw and loosen the lock nuts on one of the tappets. Hold a feeler gage of the proper thickness between the top of the adjusting nut and the valve stem, and turn the adjusting nut until the proper clearance is obtained. Then hold the adjustment and tighten the lock nuts securely. Check adjustment after tightening lock nut. Repeat this operation for all the tappets. Exhaust valves should have 0.010-inch clearance, and intake valves should have 0.006-inch clearance (fig. 50). When all tappets are adjusted, shut off the engine.

ENGINE MAINTENANCE AND ADJUSTMENT IN VEHICLE

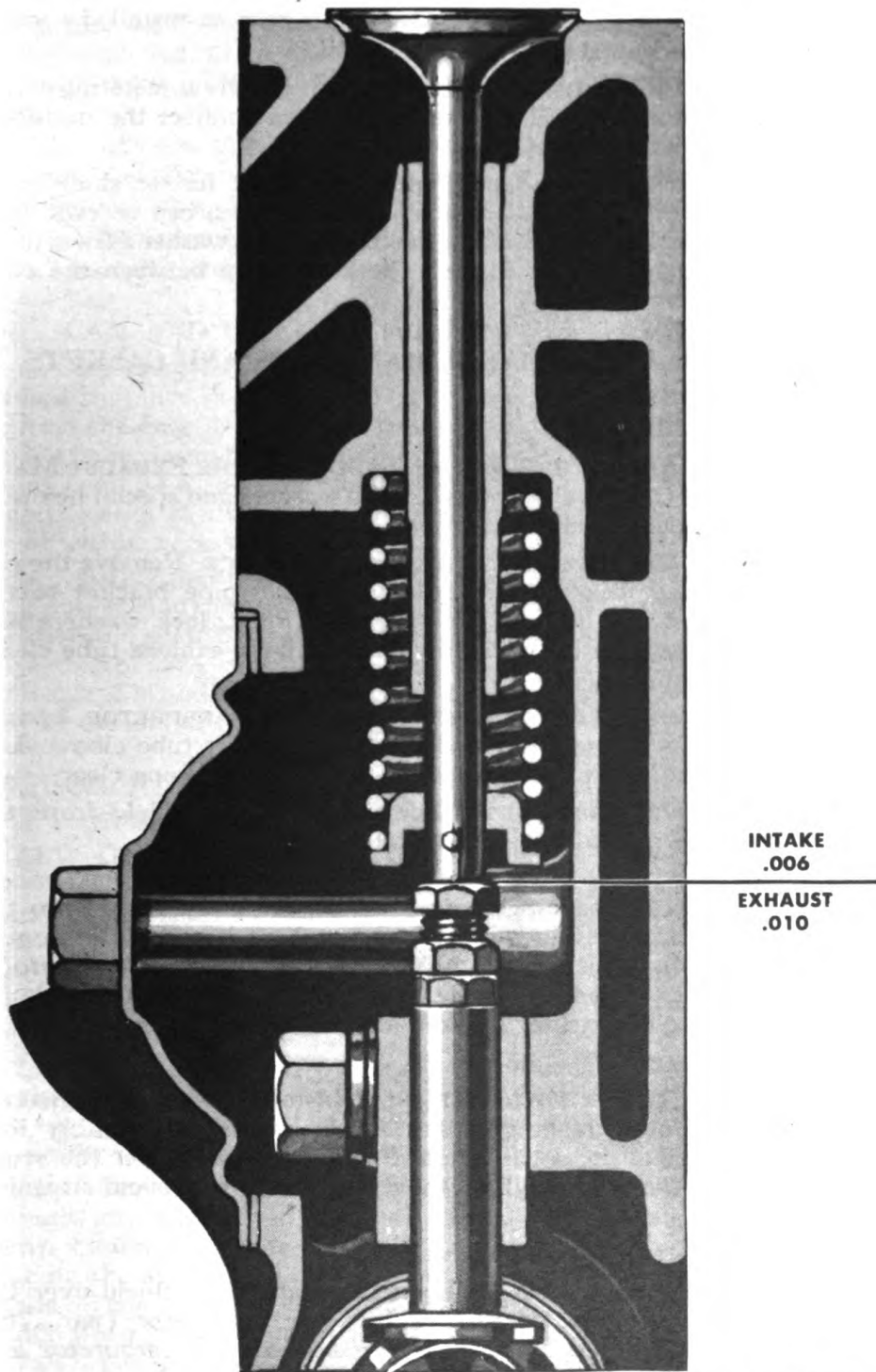

RA PD 313766

Figure 50—Valve Tappet Clearance

TM 9-811

62-63

4-TON, 6 x 6 TRUCKS (DIAMOND T MODELS 968A CARGO, 969A WRECKER, 970A PONTON, AND 972 DUMP)

e. **Install the Valve Covers.** Using new gaskets, install the valve covers with the cap screws and lead washers.

f. **Install the Crankcase Metering Valve.** Screw metering valve into intake manifold until it is tight and then connect the metering valve line to rear valve cover.

g. **Install Right Fender Shield.** Slip right fender shield into place, straighten it up, and attach it with screws, cap screws, lock washers and cut washers. Replace the toothed lock washer between the shield and frame rail, and connect the bond strap between the cowl and rear cap screw.

63. INTAKE AND EXHAUST MANIFOLDS AND GASKETS REPLACEMENT.

a. Removal.

(1) **DISCONNECT THE EXHAUST TUBE FROM THE EXHAUST MANIFOLD.** Remove the three cap screws, plain washers and special hex nuts holding the exhaust flanges together.

(2) **PULL EXHAUST LINE BACK FOR CLEARANCE.** Remove the cap screws, nuts and lock washers holding the tail pipe bracket to the frame. Remove the front muffler support U-bolt, lock washers and nuts. Pull the exhaust line assembly back until the exhaust tube clears the exhaust manifold.

(3) **DISCONNECT AIR CLEANER TUBE FROM CARBURETOR.** Loosen the clamp screw at the lower end of the air cleaner tube elbow. Lift the tube assembly clear of the carburetor neck and swing clear.

(4) **REMOVE CARBURETOR.** Lift the carburetor shield from the studs. Remove carburetor attaching studs.

(5) **REMOVE MANIFOLD ASSEMBLY.** Remove the nuts and spacers from the manifold attaching studs. Pull the assembly away from the engine block until the studs are cleared and lift it out of the engine compartment. Remove gaskets. *NOTE: Do not disassemble manifolds as they must be reassembled on a surface plate. Examine manifolds for signs of warping or cracking and replace the assembly if necessary.*

b. Installation.

(1) **INSTALL MANIFOLD ASSEMBLY.** Install new manifold gaskets over the manifold attaching studs. Lift the manifold assembly into position and install it on the studs. Place the spacers over the studs and thread on the nuts. Tighten the nuts gradually to avoid straining the castings.

(2) Install carburetor attaching studs.

(3) **INSTALL CARBURETOR.** Install the carburetor shield over the carburetor attaching studs and replace the carburetor (par. 76). *NOTE: Be sure to use a slotted gasket between the carburetor and the governor valve box.*

(4) **CONNECT AIR CLEANER TUBE TO CARBURETOR.** Install the air cleaner tube elbow over the carburetor neck and tighten the clamp.

ENGINE MAINTENANCE AND ADJUSTMENT IN VEHICLE

(5) **CONNECT EXHAUST TUBE TO EXHAUST MANIFOLD.** Push exhaust pipe assembly forward until exhaust tube engages exhaust manifold flange. Adjust exhaust tube flange against manifold flange and install three cap screws, washers and special hex nuts. *Do not tighten nuts.*

(6) **ATTACH EXHAUST PIPE MOUNTINGS.** Lift the assembly into position and fasten tail pipe bracket to frame with cap screws, lock washers and nuts. Install front muffler U-bolt, nuts and lock washers.

(7) **TIGHTEN MANIFOLD FLANGE NUTS.** Tighten manifold flange nuts gradually, working around the joint.

64. CAM AND IDLER SHAFT END PLAY ADJUSTMENT.

a. **Description.** The end play in the cam and idler shafts is controlled by plugs in the gear cover. These plugs have fiber tips which contact the ends of the shafts, controlling their end play. These plugs wear out in normal service and must be adjusted at least every 6000 miles (par. 37 a (5)). In the event that end play (as indicated by an engine knock at idling speeds) should develop, more frequent adjustment will be necessary.

b. **Adjustment** (fig. 51). To make the adjustment, loosen the lock nut "B" and then tighten the adjusting plug "A" with a light pressure to force the shaft back to the limit of its end float. Then back off the adjusting plug $\frac{1}{8}$ turn and hold it with a wrench while tightening the lock nut. This adjustment must be made at the end of the cam shaft and at the end of the idler shaft.

65. OIL PAN.

a. Oil Strainer.

(1) **GENERAL.** The oil pan is equipped with a combination strainer and water trap assembly which is attached to the lowest part of the oil pan. The oil strainer is designed with a sump projecting below the bottom of the oil pan trap, and holds any water or heavy abrasive material which may become mixed with the oil. It has a mesh screen which projects around the oil pump to strain sludge or carbon particles from the oil.

(2) **REMOVAL.** Drain the oil from the engine crankcase. The oil strainer assembly may then be removed from the oil pan by taking out the cap screws and lock washers which hold it in place. Then remove the oil strainer assembly and gasket (fig. 52).

(3) **CLEANING.** Immerse the oil strainer assembly in a suitable solvent, and wash off all the sludge and dirty oil. Be sure to clean the sump thoroughly, using a wire brush with a long handle, before replacing the assembly on the oil pan. Scrape sludge from the bottom of the oil pan using a wooden paddle, working through the opening from which the oil strainer was removed.

(4) **INSTALLATION.** Install a new gasket into the attaching flange of the oil strainer assembly, and lift it into place against the oil pan being sure to line up the flat side of the strainer flange with the flat side of the oil pan bolt-on flange. Install cap screws and lock washers and

TM 9-811
65

4-TON, 6 x 6 TRUCKS (DIAMOND T MODELS 968A CARGO,
969A WRECKER, 970A PONTON, AND 972 DUMP)

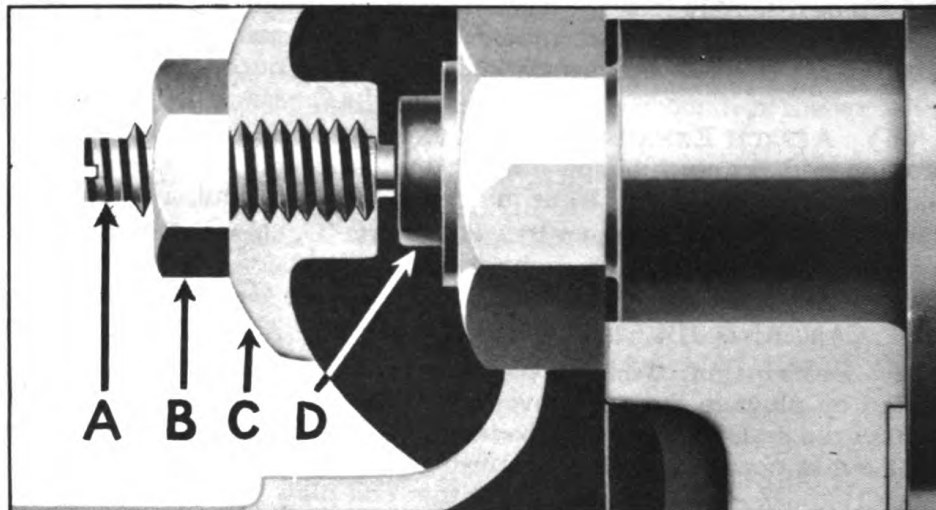

RA PD 313765

Figure 51—Cam and Idler End Play Adjustment.

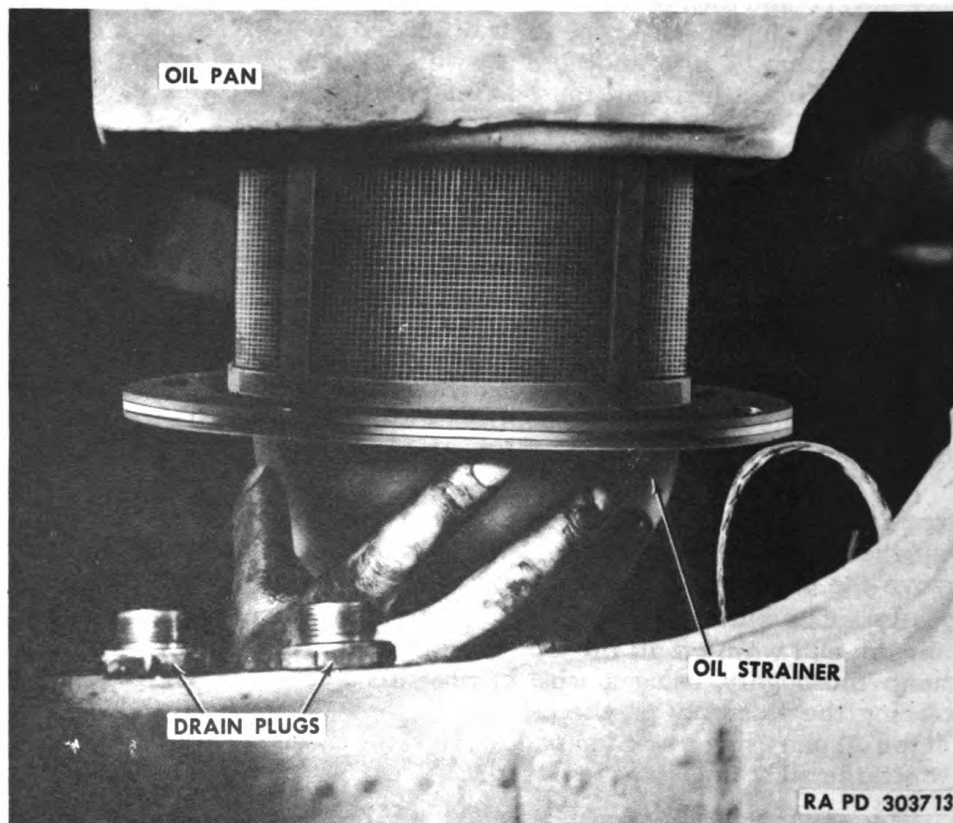

Figure 52—Removing Oil Strainer

ENGINE MAINTENANCE AND ADJUSTMENT IN VEHICLE

tighten them progressively until the assembly is firmly attached. Replace the drain plugs and fill the crankcase with lubricating oil (par. 26).

b. Oil Pan Removal.

(1) **DRAIN OIL FROM ENGINE CRANKCASE.** Remove the drain plug from the oil strainer assembly and from the back of the oil pan, and drain lubricant into suitable receptacle.

(2) **REMOVE OIL STRAINER ASSEMBLY** (par. 65).

(3) **REMOVE CRANKING MOTOR** (par. 97).

(4) **REMOVE OIL PAN.** Remove the cap screws and lock washers holding the pan to the engine bell housing. Remove the cap screws and lock washers holding the oil pan to the engine crankcase. The oil pan may then be slipped out by tilting it to the left and working it back until it is clear of all obstructions.

c. **Oil Pan Cleaning.** Wash the oil pan out with dry-cleaning solvent. Scrape off any hardened sludge or carbon which cannot be removed by scrubbing. Be sure to clean the oil pan chambers behind the baffle plates. Also, clean the oil strainer assembly (par. 65 a).

d. Oil Pan Installation.

(1) **GENERAL.** In installing the oil pan, it is essential that no springing of the bell housing is caused as this would make possible an oil leak due to contact of the oil thrower on the crankshaft, with the opening in the bell housing. Any springing of the oil pan assembly is likely to cause a leak along the joints.

(2) **INSTALL OIL PAN.** Lift the oil pan into place with new gaskets on the horizontal bolt-on flanges of the oil pan, and a new gasket along the bolt-on flange which attaches to the bell housing. This latter gasket may be made up by cutting a bell housing gasket in half and using the lower portion. Install the attaching cap screws and lock washers, and tighten them so they just begin to take hold, then tighten the upper cap screws which attach the pan to the bell housing, and the rear cap screws which attach the pan to the crankcase. Tighten these cap screws in a progressive fashion until all are tight. Then tighten the remaining cap screws between the oil pan and the engine bell housing. After this is done, tighten the remaining cap screws between the oil pan and the engine crankcase. Be sure that all tightening is accomplished gradually, working the wrench around the oil pan.

(3) **INSTALL THE OIL STRAINER ASSEMBLY WITH A NEW GASKET** (par. 65 a).

(4) **INSTALL THE DRAIN PLUGS AND FILL THE CRANKCASE WITH LUBRICANT** (par. 24).

(5) **INSTALL CRANKING MOTOR.** Install the cranking motor as described in paragraph 97.

66. OIL FILTERS.

a. **General.** A double oil filter assembly of the removal cartridge type is mounted on the left side of the engine cylinder block. Oil is delivered directly to the filters from the oil pump where it is cleaned of all dirt and sludge which it may accumulate in passing through the engine.

4-TON, 6 x 6 TRUCKS (DIAMOND T MODELS 968A CARGO, 969A WRECKER, 970A PONTON, AND 972 DUMP)

b. **Service Oil Filters.** Remove the drain plug at the base of each filter assembly and drain out the oil which is held in the filter cases. Remove the nuts from the tops of the filter cases and take off the copper and paper gaskets which are under them. Then lift off the covers. The cartridges can then be lifted out of the cases for cleaning or replacement (fig. 53). If the cartridges are not replaced, the sludge and dirt particles should be scraped from them with a wooden paddle. The oil filter cans should be wiped out to remove all traces of sludge and dirt. **NOTE:** *The rear oil filter is located underneath one of the vehicle horn*

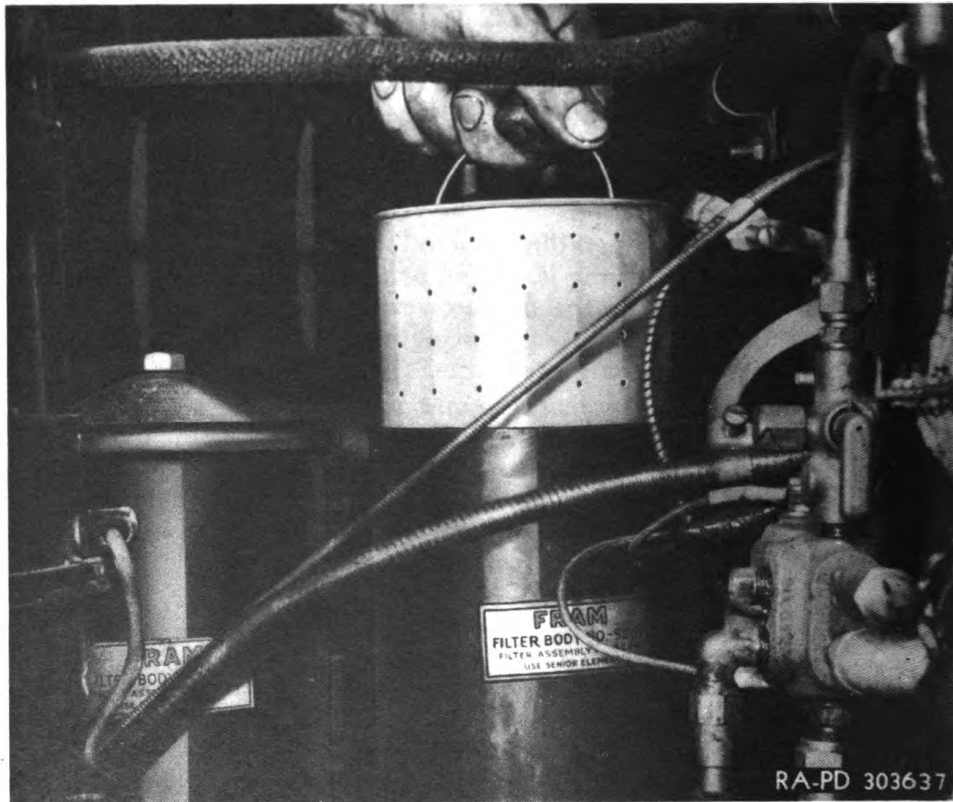

Figure 53—Removing Oil Filter Cartridge

assemblies. Tape the horn relay connection to avoid short-circuiting the hot wire, as the filter cartridge is withdrawn from the case.

c. **Assemble Oil Filters.** Install the drain plugs in each of the filter cases. Insert new cartridges or clean cartridges into the cases from the top, then secure the covers in place with the nuts which were removed, using both paper and copper gaskets under the cover nuts.

d. **Add Lubricant to Engine Crankcase.** Start engine and add lubricant to bring level to full mark on dip stick.

ENGINE MAINTENANCE AND ADJUSTMENT IN VEHICLE

67. CRANKCASE BREATHER.

a. **General.** An oil-bath type breather assembly is installed over the crankcase filler tube.

b. **Servicing Crankcase Breather.**

- (1) Unsnap the clips holding the breather sump to the breather.
- (2) Take out the sump and wire mesh assembly (fig. 54).
- (3) Remove the mesh from the sump and clean these two parts thoroughly in a dry-cleaning solvent.



Figure 54—Removing Breather Sump and Mesh

- (4) Dip the mesh in engine oil and fill the sump to the proper level and install these parts onto the breather assembly, fastening them securely in place with the snap clips.

68. VISCOMETER.

a. **General.** The viscometer consists of a pressure gage which is marked in graduations indicating the viscosity of the engine lubricant. This pressure gage registers the pressure of the oil flowing through a restriction orifice in the oil line, which is an indication of the viscosity of the oil. The oil pan unit is very delicate, and to function properly must be kept clean of sludge and dirt which might clog up the orifice, and thus give a faulty reading on the viscometer gage. There is a wire

TM 9-811

68

**4-TON, 6 x 6 TRUCKS (DIAMOND T MODELS 968A CARGO,
969A WRECKER, 970A PONTON, AND 972 DUMP)**

mesh screen located in the oil pan unit which should be removed periodically for cleaning.

b. Cleaning Viscometer Screen. Remove the hex plug from the oil pan unit and pull out the wire mesh screen. Clean the screen thoroughly in dry-cleaning solvent. Then replace the screen assembly and reinstall the plug (fig. 55).

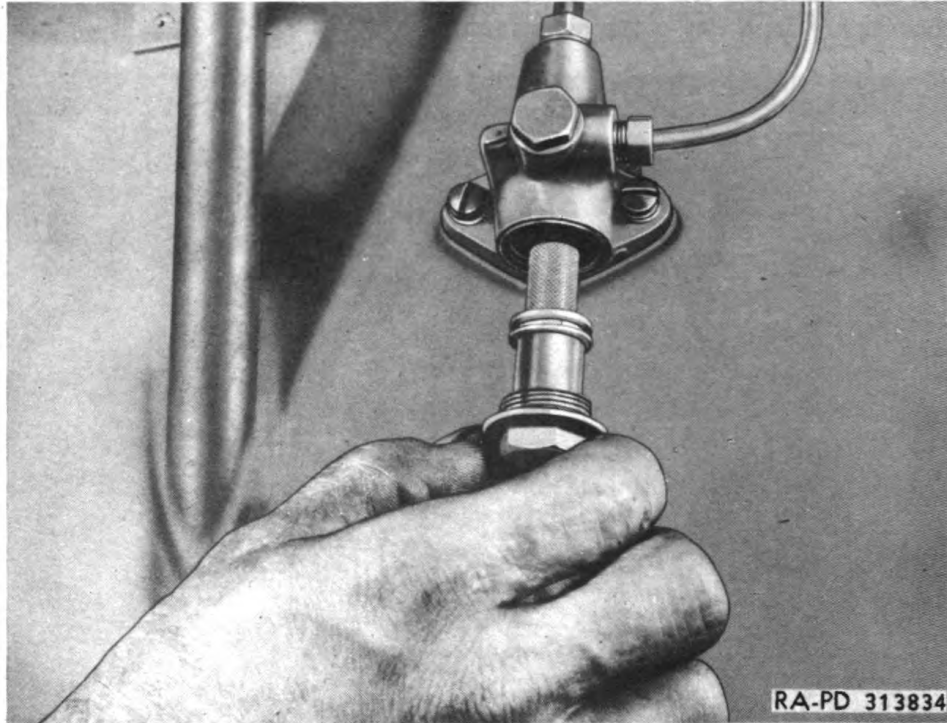
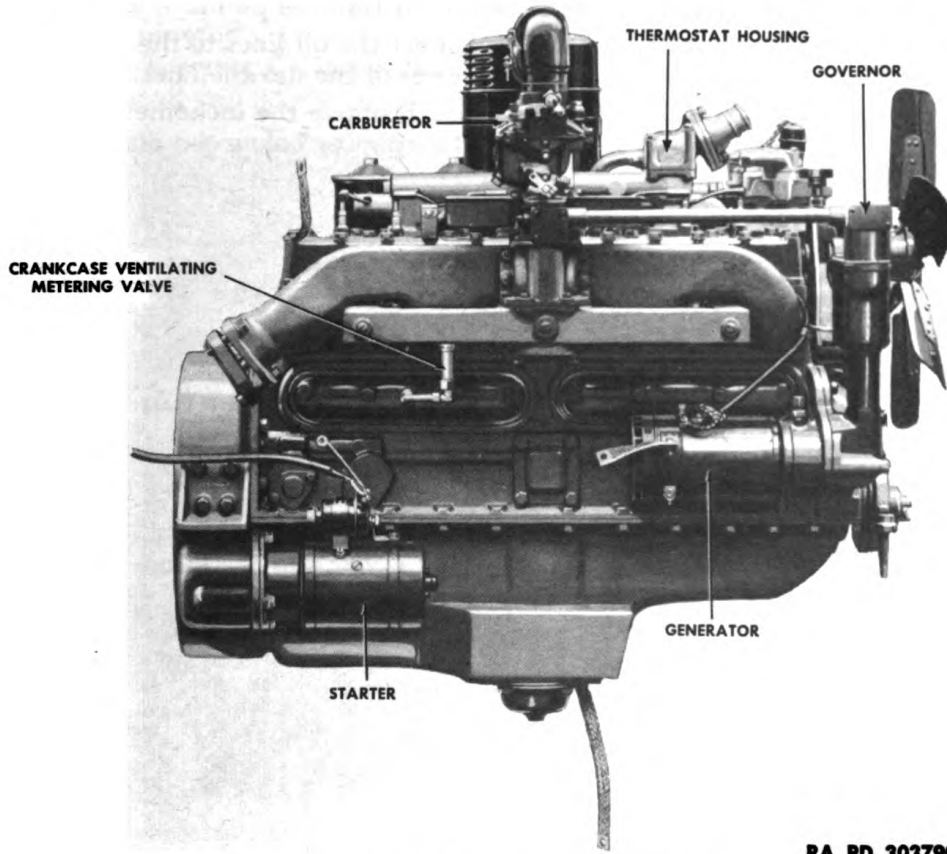

Figure 55—Removing Viscometer Screen

Section XV

ENGINE REMOVAL AND INSTALLATION

	Paragraph
Engine removal.....	69
Engine installation.....	70



RA PD 303790

Figure 56—Engine Assembly, Right Side

69. ENGINE REMOVAL (figs. 56 and 57).

- a. **Drain Cooling System.** Open petcock in radiator inlet fitting, and petcock on left side of cylinder block, and allow water to drain from the radiator and from the block. If an antifreeze solution is used, the water should be drained into a bucket so that it may be used again.
- b. **Drain Oil from Engine.** Remove the two drain plugs in the bottom of the engine oil pan and drain the oil into a clean bucket.
- c. **Remove Engine Hood (par. 185).**
- d. **Remove Radiator (par. 85).**
- e. **Disconnect Bond Strap from Compressor Discharge Line to Left Frame Rail.** Remove the cap screw, lock washer and toothed lock washer holding the bond to the air line and disconnect bond.

4-TON, 6 x 6 TRUCKS (DIAMOND T MODELS 968A CARGO, 969A WRECKER, 970A PONTON, AND 972 DUMP)

- f. **Remove Air Lines to Compressor.** Disconnect the fittings at the end of the air lines between the compressor and the air reservoir and remove this line. Disconnect the fitting at the governor on the end of the line between the governor and the air compressor.
- g. **Disconnect Fuel Line.** Disconnect the flexible fuel line between the fuel filter and the fuel pump at the fuel pump.
- h. **Disconnect Oil Lines.** Disconnect the oil lines to the pressure gage, and to the viscosity gage at the ends of the flexible lines.
- i. **Disconnect Tachometer Cable.** Remove the tachometer cable clamp, and disconnect the cable at the adapter below the distributor.

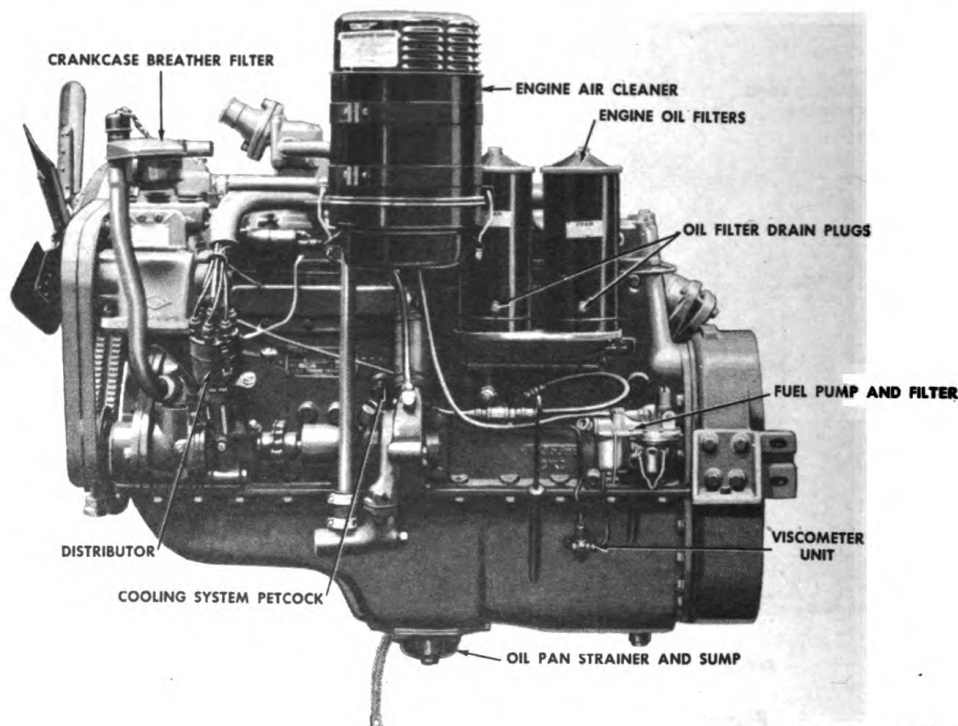

RA PD 303791

Figure 57—Engine Assembly, Left Side

- j. **Disconnect Ignition Wire.** Disconnect the ignition wire at the coil, and remove the two wire clamps.
- k. **Disconnect Distributor Control Cable.** Loosen the distributor control wire screw, and disconnect the control wire at the distributor.
- l. **Disconnect Oil Pan Bond Strap.** Remove the nut and lock washer holding the bond strap to the differential of the front axle, and remove the end of the bond strap and the toothed lock washer from the differential stud.
- m. **Disconnect Generator Wires.** Disconnect the generator ground, armature and field wires at the generator.
- n. **Disconnect Generator Bond Strap.** Remove the screw, lock

ENGINE REMOVAL AND INSTALLATION

washer, toothed lock washer and nut holding the bond strap to the generator.

o. Disconnect Cranking Motor Wires. Disconnect the battery cable and cranking motor switch wires from the solenoid mounted on top of the starter.

p. Disconnect Carburetor Linkage. Disconnect accelerator rod at carburetor, and disconnect the choke and hand throttle control wires at the carburetor.

q. Disconnect Cylinder Head to Cowl Bond. Remove the rear cylinder head cap screw holding the bond between the head and the

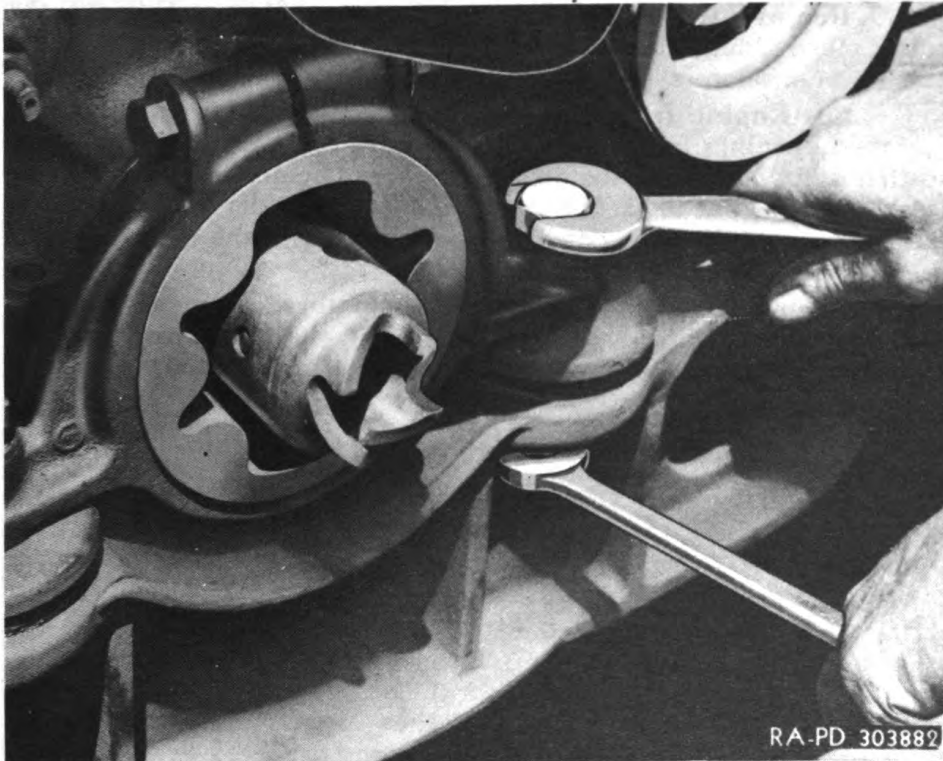

Figure 58—Disconnecting Front Engine Mounting

cowl to the head, disconnect the bond and remove the toothed lock washer.

r. Disconnect Heat Indicator. Remove the hex adapter holding the temperature gage bulb in the rear cylinder head, and disconnect the bulb from the head.

s. Disconnect Air Lines from Top of Flywheel Housing. Remove the cap screws and lock washers holding the air line clamps to the flywheel housing, and pull the lines away from the housing.

t. Disconnect Exhaust Tube. Remove the nuts and bolts attaching the exhaust tube to the exhaust manifold. Loosen up the exhaust line supporting clamps, so that the exhaust line assembly can be shifted back in the chassis (par. 82).

TM 9-811
69-70

**4-TON, 6 x 6 TRUCKS (DIAMOND T MODELS 968A CARGO,
969A WRECKER, 970A PONTON, AND 972 DUMP)**

- u. **Remove Transmission** (par. 104).
- v. **Remove the Top Water Manifold.** Remove the cap screws and lock washers holding the top water manifold to the cylinder head, and remove the manifold and gaskets, as described in par. 59.
- w. **Remove the Rear Engine Mounting Parts—Left Side.** Remove the cotter pin holding the mounting nut, and then remove the bolt, nut and spring.
- x. **Remove the Rear Engine Mounting Parts—Right Side.** Remove the cotter pin holding the nut, and then remove the bolt and nut.
- y. **Remove the Front Engine Mounting Parts.** Remove the cotter pins holding the nuts, and then remove the bolts, nuts, washers and lower insulators (fig. 58).
- z. **Lift Engine from Chassis.** Attach a lifting bar to the water manifold openings in the cylinder head and run a chain over the bar so that a lift hook may be attached. The assembly will have to be worked forward at the same time it is lifted, in order that the rear of the engine will clear the cowl. A wrecker truck crane can be readily used for removing the engine (fig. 59).
- aa. **Remove Engine Mounting Insulators.** Remove the two round insulators from the mounting pads on the front cross member, and remove the two rectangular insulators from the pads on the rear mounting brackets on the frame rails.

70. ENGINE INSTALLATION.

- a. **Install Engine Mounting Insulators.** Install the two large round insulators in place on top of the mounting pads on the front frame cross member, and place the two rectangular insulators on the pads of the rear mounting brackets.
- b. **Install Engine in Chassis.** Attach a lifting bar to the water manifold openings in the cylinder head, and run a chain over the bar so a lift hook may be attached. Lift the engine assembly into position above the engine compartment and then lower it into place, at the same time working it back to get the rear end of the block and the bell housing under the cowl, and to line up the mounting brackets with the mounting insulators. Then lower the assembly into place until mounting brackets on the engine just touch the insulators, and then shift the engine assembly around to line up the holes in the engine mounting brackets, insulators and the frame mounting pads, and install mounting bolts. Then lower the engine and take all the weight off the hoist. Disconnect the hoist from the lifting bar and remove the lifting bar (fig. 59).
- c. **Install the Front Engine Mounting Parts.** Slide a small circular insulator over each of the front trunnion mounting bolts from the bottom and then install the washers and nuts. Tighten the nuts with a torque wrench to a reading of 40 foot-pounds. Then install the cotter pins through the slotted nuts.
- d. **Install Rear Engine Mounting Parts.** Install a spring and nut over the mounting bolt on the left side of the engine and tighten

ENGINE REMOVAL AND INSTALLATION

the nut with a torque wrench to a reading of 20 foot-pounds, and then install a cotter pin through the slotted nut. Install a nut on the mounting bolt on the right side of the engine, and tighten with a torque wrench to a reading of 20 foot-pounds.

e. **Install Transmission** (par. 105).

f. **Install Exhaust Tube.** Slide the exhaust tube assembly forward in the chassis to engage the exhaust flange with the exhaust manifold flange, and bolt the flanges together with the nuts, bolts and washers which were removed. Then tighten the exhaust line U-bolt support and the tail pipe clamp (par. 82).

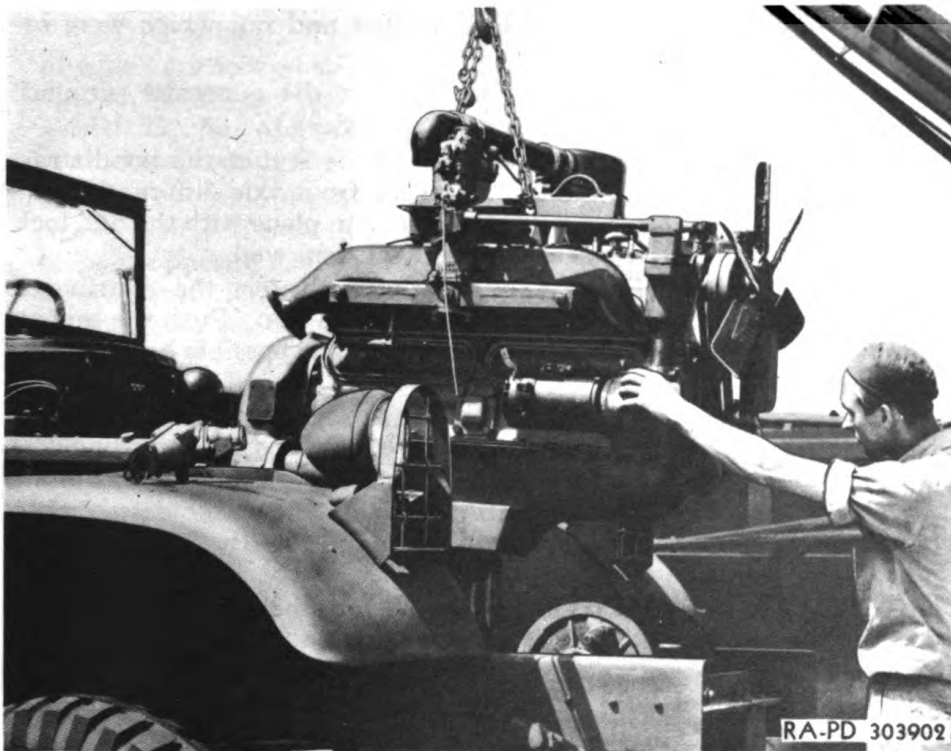

Figure 59—Installing Engine in Chassis

g. **Connect Air Lines to Top of Flywheel Housing.** Lay the air lines into place on top of the flywheel housing, and attach the clamp to the housing with the cap screws and lock washers which were removed.

h. **Install Top Water Manifold.** Install the top water manifold on the engine, as described in paragraph 61.

i. **Install Heat Indicator.** Insert the heat indicator bulb into the hole in the rear cylinder head, and then slide the hexagon adapter into place and screw it up tight. Use white lead on the threads of the adapter to make a good seal.

j. **Install Cylinder Head to Cowl Bond Strap.** Remove the right rear cylinder head cowl bond strap under it, using the toothed lock washer which was removed.

4-TON, 6 x 6 TRUCKS (DIAMOND T MODELS 968A CARGO, 969A WRECKER, 970A PONTON, AND 972 DUMP)

k. Connect Carburetor Linkage. Connect the accelerator rod to the accelerator linkage on the carburetor and fasten in place with a cotter pin. Then connect the choke and hand throttle control wires to the carburetor, adjusting them as described in paragraph 76.

l. Connect Cranking Motor Wires. Connect the battery cable and cranking motor switch wires to the solenoid switch mounted on top of the cranking motor (fig. 82).

m. Connect Generator Bond Strap. Hold the end of the bond strap running between the generator and the frame in place against the mounting clip on the generator head band and attach it in place with the screw, lock washer, toothed lock washer and nut which were removed.

n. Connect Generator Wires. Connect the generator, ground, armature and field wires to the generator (fig. 79).

o. Install Oil Pan Bond Strap. Hold the end of the bond strap running between the engine oil pan and the front axle differential carrier in position against the carrier, and attach in place with the nut, lock washer and toothed lock washer which were removed.

p. Connect Distributor Control Cable. Insert the distributor control wire through the clamp on the advance arm. Push the button flush with the dash, and advance the arm as far as possible before tightening the clamping screw.

q. Connect Ignition Wire. Connect the ignition wire to the coil primary circuit terminal, and attach wire in place by installing the clamps which were disconnected.

r. Connect Tachometer Cable. Install the tachometer cable clamp, install the end of the cable into the adapter under the distributor, and tighten the cable nut.

s. Connect Oil Line. Connect the oil lines between the pressure gage and the engine, and the viscosity gage and the engine at the ends of the flexible lines.

t. Connect Fuel Line. Connect the flexible fuel line running between the fuel filter and the pump to the fuel pump inlet.

u. Install Air Pressure Air Lines. Install the air pressure air line running between the compressor and the air reservoir, using white lead on the connector threads in order to make a tight seal. Then connect the air line running between the air compressor and the governor to the governor, using white lead on the connector threads.

v. Install Bond Strap to Compressor Discharge Line. Attach the bond strap running between the air compressor discharge line and the left frame rail to the line, using the cap screw, lock washer, toothed lock washer and nut which were removed.

w. Install Radiator. Install the radiator, as described in paragraph 85.

x. Install Engine Hood. Install the hood assembly, as described in paragraph 185.

y. Fill Engine Crankcase with Lubricating Oil (par. 26).

z. Fill Cooling System with Water or Antifreeze (par. 84).

Section XVI

CLUTCH

	Paragraph
Description and tabulated data.....	71
Adjustment	72
Removal	73
Installation	74

71. DESCRIPTION AND TABULATED DATA.

a. Description.

(1) **GENERAL.** The clutch is a single-plate, dry-disk type, all parts of which are locked to the flywheel and rotate with it, with the exception of the driven disk which is-disconnected when the clutch is released. Driving pressure is provided by the heavy spiral spring located in the rear face of the clutch cover.

(2) **OPERATION.** When the clutch pedal is depressed the release sleeve is moved toward the flywheel, acting on the hinged levers in a manner opposite to the spring pressure on them. This relieves the pressure against the pressure plate and the retractor springs prevent its contact with the driven plate, thus releasing the clutch. As the pedal is released the spring again transmits pressure through the levers (this pressure is multiplied by the action of 20 ball-mounted levers) to press the driven plate between the pressure plate and the flywheel, thus engaging the clutch. The hinged levers are provided with raised edges which, because of their fan-like action, force cooling air through the clutch spring and into the clutch.

b. Tabulated Data.

Type.....Single-plate, dry-disk
 Make.....W. C. Lipe
 Model..... Z42-S

Facings:

Area.....256 sq in.
 Outside diameter.....15 inches
 Inside diameter..... 8 inches
 Thickness..... $\frac{5}{32}$ in.

Spring:

Type.....Spiral
 Number used..... 1

Clutch throwout bearing:

Type.....Ball with retainer
 Make.....Aetna
 Model.....A-959-1

Clutch pilot bearing:

Type.....Ball
 Make.....New Departure
 Model.....7605

TM 9-811
71

4-TON, 6 x 6 TRUCKS (DIAMOND T MODELS 968A CARGO,
969A WRECKER, 970A PONTON, AND 972 DUMP)

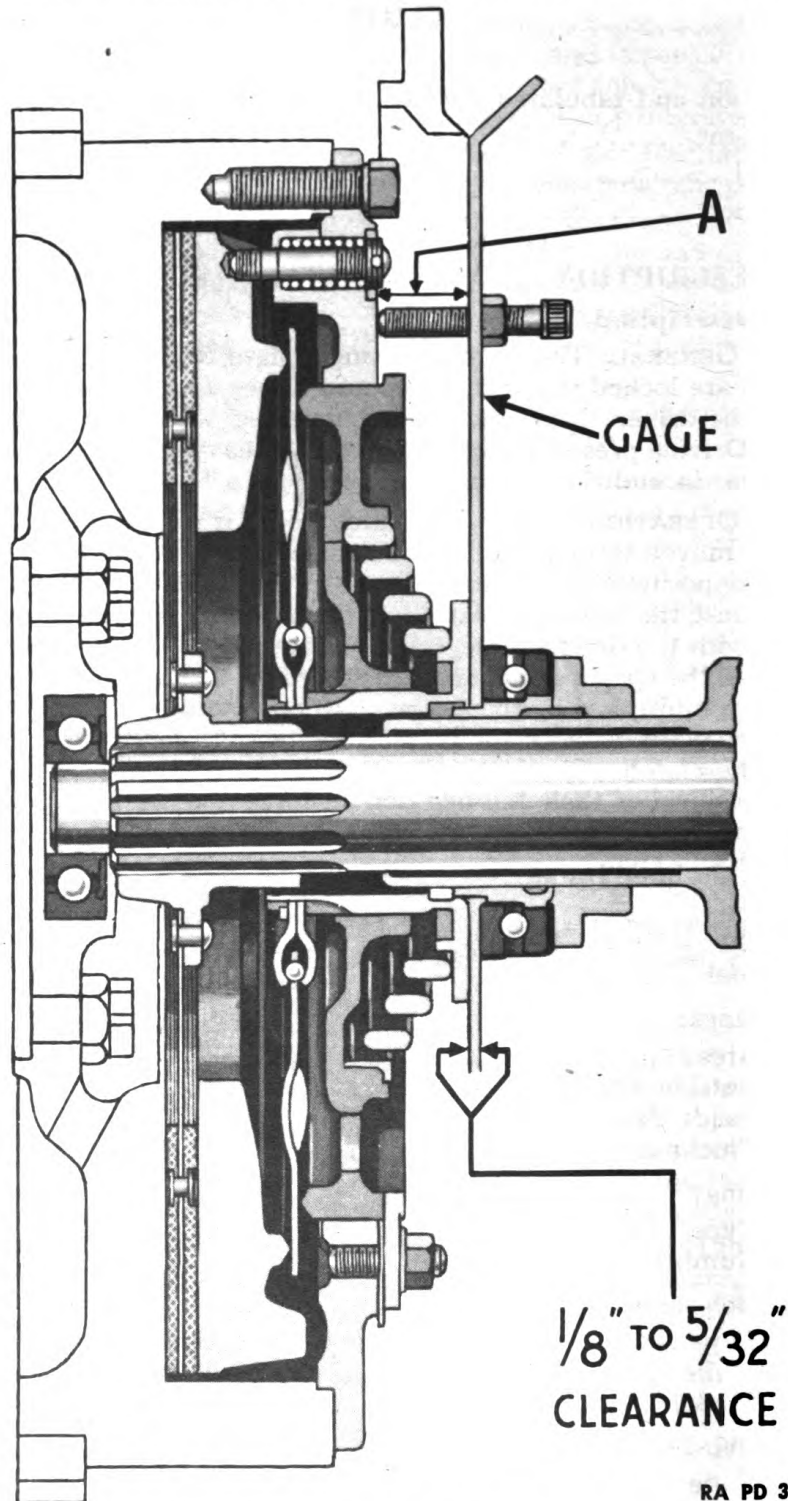

RA PD 304973

Figure 60—Clutch Adjustment

156

CLUTCH

Adjustment:

- Length of sleeve travel $\frac{9}{16}$ in.
- Dimension "A" (fig. 60) from face of flywheel ring to face of release sleeve with clutch engaged $1\frac{1}{8}$ in. + $\frac{1}{16}$ in.—0 in.
- Free pedal travel 1 in.— $1\frac{1}{2}$ in.

72. ADJUSTMENT.

a. **General.** The clutch adjustment is made by means of shims held between the adjusting plate and the flywheel ring. As the facings on the driven disk wear, shims must be removed in order to restore the spring pressure to its normal load and to obtain proper free pedal travel which should be 1 to $1\frac{1}{2}$ inch. As the facings wear, the clutch

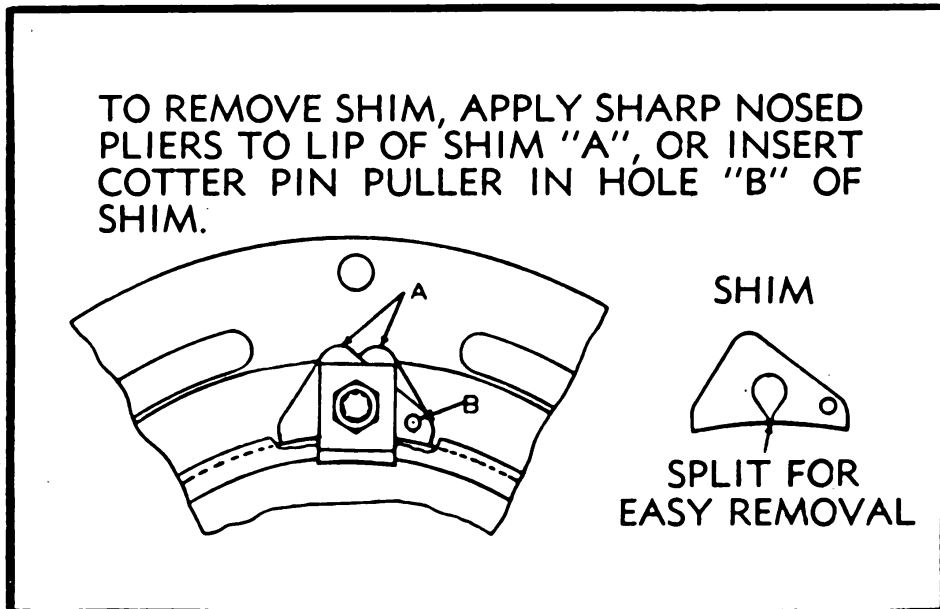

RA PD 313797

Figure 61—Shim Removal

sleeve moves toward the release bearing, reducing the clearance on this sleeve. This reduced clearance will result in a reduction of the free pedal travel. Thus the need for a clutch adjustment is indicated as soon as the free travel becomes less than 1 inch.

(1) **CAUTION.** Never wait for a clutch to slip before adjusting it. It is too late then to make the adjustment, because the facings quickly disintegrate once they become burned through slippage. Never adjust the pedal or pedal linkage to correct the free pedal travel. Always adjust the clutch.

b. Clutch Adjustment.

(1) **REMOVE HANDHOLE COVER FROM BOTTOM OF CLUTCH HOUSING.** Take out the cap screws and lock washers holding the cover

**4-TON, 6 x 6 TRUCKS (DIAMOND T MODELS 968A CARGO,
969A WRECKER, 970A PONTON, AND 972 DUMP)**

to the clutch housing and remove the cover. Block the pedal in the released position.

(2) **BACK OFF ADJUSTING STRAP NUTS.** Back off the six hex nuts holding the adjusting straps and shims to the flywheel ring. It will be necessary to turn the engine over to line up the adjusting strap nuts with the opening in the clutch housing.

(3) **ENGAGE THE CLUTCH.** Remove the block from the clutch pedal to engage the clutch so that the adjusting plate will move out of contact with the adjusting shims.

(4) **REMOVE SHIMS.** Using a long-nose pliers, grip the lip of the top shim under each adjusting strap and pull them from the flywheel ring studs. Be sure that no portion of the shim is left between the adjusting plate and the flywheel ring and also be sure that the same number of shims are removed from under each adjusting strap. A sufficient number of shims should be removed to maintain dimension "A" (fig. 60) at $1\frac{1}{8}$ inch, plus $\frac{1}{16}$ inch. Each shim removed decreases dimension "A" by $\frac{1}{64}$ inch (fig. 61).

(5) **TIGHTEN ADJUSTING STRAP NUTS.** Block the clutch in the released position to allow the adjusting plates to move into contact with the shims, and then tighten each adjusting strap nut while turning the engine over with the hand crank to line up the nuts with the opening in the handhole cover.

(6) **CHECK ADJUSTMENT.** Using the clutch adjusting gage shown in figure 60, check dimension "A" to see that it is $1\frac{1}{8}$ inch + $\frac{1}{16}$ inch—0 inch. If this gage is not available, dimension "A" may be measured using a straightedge and a scale. The straightedge is held in place by pushing the release bearing into contact with it, and then measuring the distance between the flywheel ring and the straightedge. If dimension "A" comes out within the limits indicated, the adjustment is complete. If dimension "A" does not come within these limits, it will be necessary to repeat the operations outlined in (4) above, and to add or remove the necessary number of shims from under each adjusting strap to give the proper adjustment.

(7) **CHECK CLEARANCE BETWEEN THE RELEASE BEARING AND CLUTCH SLEEVE.** Check the clearance between the release bearing and the clutch sleeve to see that it is not less than $\frac{1}{8}$ in. nor more than $\frac{5}{32}$ in. If this clearance is not within the prescribed limits, it will be necessary to adjust the clutch linkage to correct it.

(8) **ADJUST CLUTCH LINKAGE.** Loosen the clamping nut in the clutch pedal adjusting slot and move the pedal into the proper position to give the specified clearance between the release bearing and the clutch sleeve. **CAUTION:** *Never adjust the pedal linkage until after the clutch adjustment has been made.*

(9) **INSTALL HANDHOLE COVER.** After clutch adjustment is complete and all the adjusting strap nuts are tight, install the handhole cover into position, and fasten it with cap screws and lock washers.

CLUTCH

73. REMOVAL.

a. **Remove Transmission.** Disconnect the propeller shaft from the transmission companion flange, remove the cap screws holding the transmission clutch housing to the engine bell housing, and lower the transmission to the ground (par. 104).

b. **Remove the Clutch Assembly.** Remove the cap screws and lock washers holding the clutch flywheel ring to the engine flywheel, and lift the clutch assembly out of the bell housing (see fig. 62).



Figure 62—Removing Clutch and Driven Disk

c. **Remove Driven Disk.** After the clutch assembly is removed, lift the driven disk out of the bell housing.

d. **Remove Clutch Pilot Bearing.** If it is necessary to remove the clutch pilot bearing, it may be pulled, using clutch pilot bearing puller (41-P-2906-15) (fig. 63).

e. **Cleaning.** Clean all parts thoroughly in dry-cleaning solvent.

f. **Inspection.** Examine the clutch assembly for broken or damaged parts which might prevent efficient clutch performance. If defective parts are found, the clutch assembly must be replaced. Examine the driven disk for signs of warpage or defective facings. If the facings are worn thin, or are badly oil-soaked, they must be replaced.

TM 9-811
74

**4-TON, 6 x 6 TRUCKS (DIAMOND T MODELS 968A CARGO,
969A WRECKER, 970A PONTON, AND 972 DUMP)**

74. INSTALLATION.

- a. **Install Pilot Bearing.** Drive the pilot bearing into position in the flywheel, using a drift to pound on the outer race only. Be sure that the shielded side of the bearing is facing out.
- b. **Install Driven Disk.** Place the driven disk into position in the flywheel, with the longer end of the hub facing out.
- c. **Install Clutch Assembly.** Lift the clutch assembly into place against the engine flywheel. Before attaching the clutch assembly in



Figure 63—Pulling Clutch Pilot Bearing with Puller 41-P-2906-15

place, procure a clutch pilot shaft (an extra transmission main drive gear assembly will serve satisfactorily) and install this through the center of the clutch, engaging the splines with those in the driven disk hub and inserting the end of the shaft into the pilot bearing. With the clutch pilot shaft in place, install the cap screws and lock washers which mount the clutch assembly to the flywheel, and tighten these securely. Then remove the clutch pilot shaft.

- d. **Install Transmission.** Install the transmission and connect the propeller shaft (par. 105).

Section XVII

FUEL SYSTEM

	Paragraph
Description and tabulated data	75
Carburetor	76
Fuel pump and filter	77
Governor	78
Fuel tank and lines	79

75. DESCRIPTION AND TABULATED DATA.

a. Description. The fuel system consists of the fuel tank, fuel lines, fuel filter, fuel pump, carburetor and governor. The various units, working together, function to deliver a clean, metered, atomized fuel into the combustion chambers of the engine.

b. Tabulated Data.

(1) FUEL TANK.

Capacity 40 gal
Location Outside L. H. frame rail

(2) FUEL FILTER.

Make Zenith
Type Laminated
Location Outside L. H. frame rail

(3) FUEL PUMP.

Make AC
Type Cam and lever
Model Series "D"
Pressure 2½ lb

(4) CARBURETOR.

Make Zenith
Model IN167SJ
Assembly tag No. DX5787-09840
Fuel valve seat No. 55
Accelerator and power jet No. 20
Idling jet No. 18
Main jet No. 33
Main discharge jet No. 45-1
Well vent No. 26
Venturi No. 34

(5) GOVERNOR.

Make Pierce
Type Mechanical flyball
Model MA-1325A
Setting (max. engine rpm) 2300

76. CARBURETOR.

a. Description. The carburetor is a downdraft type with double venturi. It is a balanced carburetor which maintains the proper depression ratio between the air intake and the fuel bowl. The air cleaner restrictions have a minimum influence on the mixture ratio, because air

FUEL SYSTEM

achieved as indicated by the tachometer on the dash (fig. 64). The idling speed should be between 400 and 500 rpm.

(4) **IDLING ADJUSTMENT.** After the engine is warm, the idling adjusting screw should be turned until the engine runs smoothly (fig. 64). Turn the screw clockwise to richen the mixture, and counterclockwise to lean it. It is best to turn the adjusting screw in until the engine starts to run lumpy, and then back it off and count the number of turns to cause the engine to miss again. Then run the screw in for half that many turns to secure the proper adjustment. Adjusting the idling speed in no way affects carburetor performance at higher engine speed.

c. Carburetor Removal.

(1) **REMOVE AIR CLEANER TUBE.** Back off air cleaner tube clamp screw at the carburetor neck, and lift the tube assembly clear of the carburetor.

(2) **REMOVE CHOKE WIRE.** Loosen the clamping screw holding the choke wire to the carburetor. Loosen the choke cable clamp, and pull the cable and wire assembly clear of the carburetor.

(3) **DISCONNECT ACCELERATOR ROD.** Remove the cotter pin from the accelerator rod at the carburetor, and pull the rod away from the link.

(4) **DISCONNECT THROTTLE WIRE.** Back off the throttle wire clamp screw, and disconnect the wire from the carburetor.

(5) **DISCONNECT FUEL LINE FROM CARBURETOR.** Using two end wrenches, disconnect the fuel inlet line at the carburetor.

(6) **REMOVE THE NUTS FROM THE CARBURETOR BODY FLANGE MOUNTING STUDS.** Turn the nuts from the studs. As the nuts come up from the studs, it will be necessary to lift the carburetor assembly in order to get sufficient clearance to run the nuts off the ends of the studs.

(7) **REMOVE THE CARBURETOR SHIELD AND SLOTTED GASKET.**

d. Carburetor Installation.

(1) **INSTALL NEW GASKET.** Install a new slotted gasket on top of the governor valve box.

(2) **INSTALL CARBURETOR.** Assemble the carburetor shield over the carburetor housing flange, and slide the assembly over the housing studs. Before running the carburetor all the way down on the studs, assemble the stud nuts and tighten these a sufficient amount so that they will clear the carburetor bowl. Then tighten the carburetor housing nuts evenly so as not to distort the housing flange.

(3) **CONNECT FUEL LINE.** Connect the fuel inlet line to the top of the carburetor using two wrenches to insure a tight coupling.

(4) **CONNECT HAND THROTTLE WIRE.** Run the hand throttle wire through the link. Push the throttle button flush with the dash, and then tighten the throttle clamp screw while holding the throttle valve all the way closed.

(5) **CONNECT ACCELERATOR ROD.** Insert the end of the accelerator rod through the accelerator link, and install a cotter pin to hold it in place.

TM 9-811

76-77

4-TON, 6 x 6 TRUCKS (DIAMOND T MODELS 968A CARGO, 969A WRECKER, 970A PONTON, AND 972 DUMP)

(6) **CONNECT CHOKE WIRE.** Insert the choke wire through the hole in the choke valve link arm. Then tighten the choke cable in the cable clamp. With the choke button pressed flush with the dash, tighten the wire clamping screw while holding the choke valve wide open.

(7) **INSTALL AIR CLEANER TUBE.** Assemble the end of the air cleaner tube over the carburetor. Connect and tighten the clamping screw.

77. FUEL PUMP AND FILTER.

a. Fuel Pump.

(1) **DESCRIPTION.** The fuel pump is a diaphragm type, mechanically operated by a pin working in the cylinder block between the camshaft eccentric and fuel pump rocker arm. The pump depends on the vacuum created in the pump chamber by the downward movements of the diaphragm to draw the fuel from the tank to the pumping chamber. Fuel is then forced into the carburetor as the diaphragm is forced upward by the diaphragm spring. A bowl is clamped on the side of the pump which acts as a sediment trap to prevent foreign matter from entering the pump and to collect water from the fuel.

(2) **FUEL BOWL.** To remove the bowl, loosen the thumb screw at the bottom of the bail wire so that the bowl can be slipped out. Clean the bowl, removing any water or dirt which may have accumulated in it. Install the clean bowl on the pump and tighten the bail thumb screw to hold it in place. Start the engine and watch the pump for any signs of leakage around the bowl. If leakage is apparent, replace the bowl gasket.

(3) REMOVAL.

(a) *Disconnect Flexible Fuel Line.* Using two wrenches, disconnect the flexible fuel line from the fuel filter to the fuel pump at the pump.

(b) *Disconnect Copper Fuel Line.* Using two wrenches, disconnect the fuel line between the carburetor and the fuel pump at the pump.

(c) *Remove Fuel Pump.* Remove the cap screws and the lock washers holding the fuel pump to the cylinder block and remove the pump and mounting gaskets.

(4) **TEST OF FUEL PUMP.** Refer to paragraph 42 b.

(5) FUEL PUMP INSTALLATION.

(a) *General.* Care must be exercised when installing the fuel pump to be sure that the rocker arm is against the fuel pump drive pin after the pump assembly is fastened in place. Unless the instructions given below are followed very carefully, a great deal of trouble may be encountered in attempting to make the pump function properly.

(b) *Remove the Slotted Pipe Plug from the Cylinder Block Just Above the Fuel Pump Opening.*

(c) *Insert a 3/8-inch Drift Punch into the Pipe Plug Opening.* Push the drift punch in so that fuel pump drive pin is forced all the way back against the camshaft eccentric (fig. 65). Then turn the engine

FUEL SYSTEM

over until it is in such a position that the punch is all the way back. This position is easy to obtain by exerting pressure against the drift punch and turning the engine over until the punch is as far into the block as it will go. Then remove the drift punch and replace the pipe plug.

(d) *Relieve Diaphragm Spring Pressure from Rocker Arm.* Pull the fuel pump priming handle as far up as it will go and wire the handle in this position to relieve the pressure of the diaphragm spring from the rocker arm.



Figure 65—Locating Drive Pin with Drift

(e) *Install Fuel Pump* (fig. 66). Install the gasket onto the pump, and lift the assembly into place against the engine. Insert the rocker arm through the opening in the cylinder block and then lift the pump up as high as possible. Push it firmly against the mounting bosses and move it down into position to line up the cap screw holes and mounting flange with those in the block. **NOTE:** *This must be done very carefully, holding the pump in a vertical position as it is slid down. The assembly must be held firmly against the block at all times so that the rocker arm will not slip over the drive pin.* Install cap screws and lock washers to attach the assembly to the engine. Remove wire from priming lever.

4-TON, 6 x 6 TRUCKS (DIAMOND T MODELS 968A CARGO, 969A WRECKER, 970A PONTON, AND 972 DUMP)

(f) *Start the Engine to Test the Operation of the Fuel Pump.* If the engine will not run after a reasonable number of tries, remove the fuel pump and repeat the procedure in step (e) above, being careful to see that the push rod is in contact with the drive pin before the pump is attached to the engine.

b. Fuel Filter.

(1) **DESCRIPTION.** The fuel filter is mounted on the outside of the left-hand frame rail between the fuel tank and pump. It consists of a

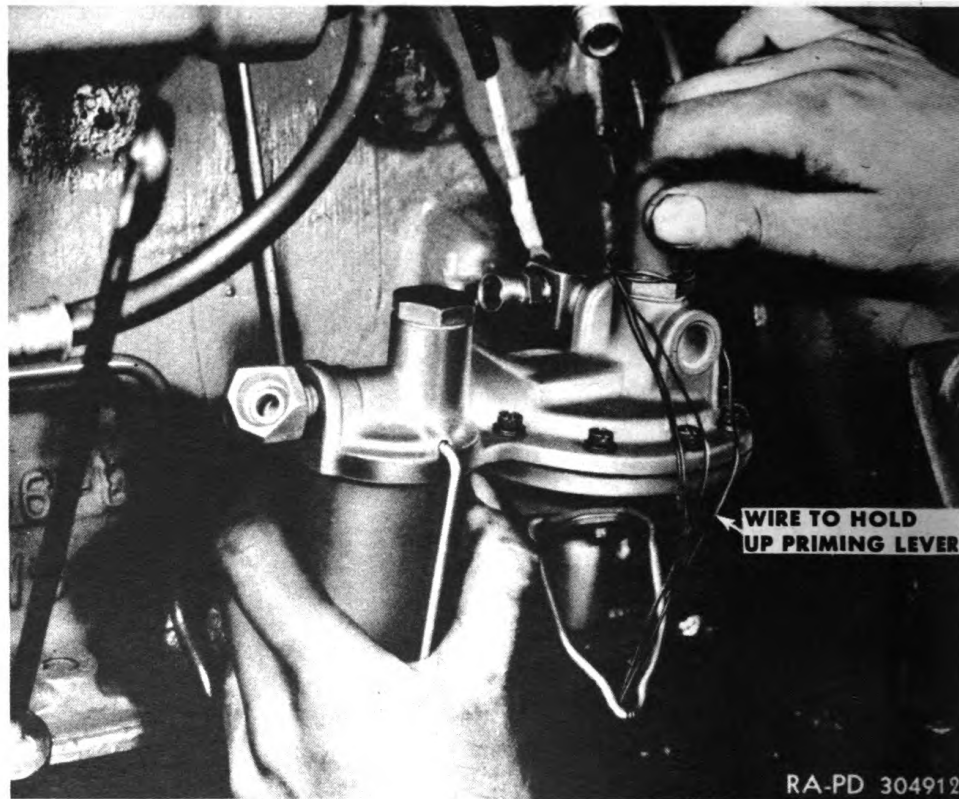

Figure 66—Installing Fuel Pump

filter element encased in a metal bowl. The element is the laminated type made up of a series of thin disks held apart by spacer shims.

(2) **DRAINING FILTER BOWL.** Remove the drain plug from the lower part of the filter bowl and allow its contents to drain. Then replace the drain plug and gasket.

(3) **CLEANING FILTER ELEMENT.**

(a) Remove the bowl nut and bowl nut gasket, and take off the bowl assembly.

(b) Remove the element nut from the assembly stud, and pull the element assembly from the filter body (fig. 67).

FUEL SYSTEM

(c) Wash the element and the bowl in dry-cleaning solvent and blow out with compressed air.

(d) Install the element over the assembly stud, and run the element nut up against it to hold it in place. Fingertightness is sufficient. Do not use any tools on this nut.

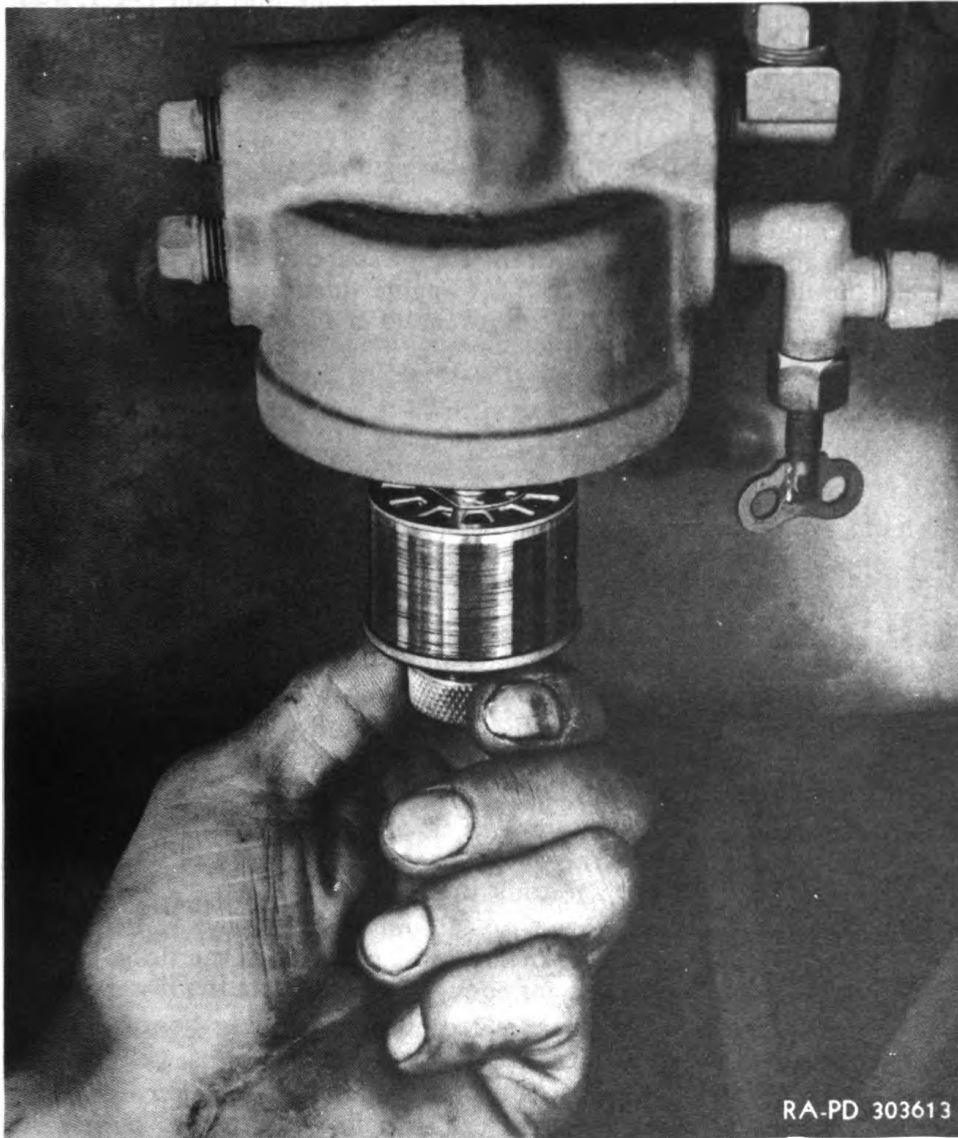

Figure 67—Removing Fuel Filter Element

(e) Replace the filter bowl and gasket over the assembly stud so that it nests with the fuel filter body, and fasten in place with the bowl nut and gasket.

(4) **REMOVAL.** Disconnect the fuel lines running between the fuel pump and the fuel filter and between the fuel tank and the fuel filter

TM 9-811
77-79

**4-TON, 6 x 6 TRUCKS (DIAMOND T MODELS 968A CARGO,
969A WRECKER, 970A PONTON, AND 972 DUMP)**

at the filter. Then remove the cap screws, nuts and lock washers holding the filter assembly to the frame rail, and remove the filter.

(5) **INSTALLATION.** Attach the fuel filter assembly to the frame rail using the cap screws, nuts and lock washers which were removed. Then connect the fuel lines between the fuel tank and fuel filter, and between the fuel pump and fuel filter to the filter.

78. GOVERNOR.

a. The governor is the mechanical-flyball type, actuated by a gear drive through a pilot hole in the camshaft side of the gear cover. The conventional butterfly valve is located in the governor valve box between carburetor and manifold and is controlled by the flyball mechanism. The governor is set to limit the engine speed to 2300 rpm and this setting should not be changed. This engine develops its peak horsepower at this speed and to overrun it results in a loss of power. Do not remove the governor seal.

79. FUEL TANK AND LINES.

a. **Fuel Tank.**

(1) **DESCRIPTION.** A 60-gallon fuel tank is mounted outside the left-hand frame rail under the cab. It is equipped with a large opening filler spout, with the cap chained to the tank. A float-type fuel gage tank unit is mounted in the tank through an opening in the top.

(2) **REMOVAL.**

(a) *Remove Seat Cushions.* Remove the seat cushion on the driver's side of the cab, as described in paragraph 182.

(b) *Disconnect Fuel Line.* Remove the handhole cover in the bottom of the compartment under the driver's seat, and disconnect fuel line from the tank.

(c) *Disconnect Fuel Gage Wires.* Working through the handhole in the compartment under the driver's seat, disconnect the wires from the terminals of the fuel gage tank unit.

(d) *Disconnect Fuel Line Clip.* Remove the screws holding the floor board on the driver's side of the cab, and remove the floor board. Then bend the fuel line clip up far enough to disconnect the line from it.

(e) *Remove Running Board.* Remove the running board on the driver's side of the cab, as described in paragraph 188.

(f) *Remove Fuel Tank and Shield.* Remove the cap screws, nuts and lock washers holding the fuel tank shield and strap to the front running board support. Then remove the cotter pins, nuts, plain washers, springs and cap screws holding the shield and strap to the rear running board support. Slide the fuel tank and shield assembly out from under the cab. The fuel tank may then be slipped out of the shield, and the webbed insulator straps may be removed.

(3) **INSTALLATION.**

(a) *Install Fuel Tank and Shield.* Install the fuel tank into the shield with the webbed strap insulators in place between the tank and

FUEL SYSTEM

shield, and the tank and shield straps. Then place the insulator straps on the running board supports so that they will lie between tank and the supports after the tank is installed. Lift the tank and shield assembly, and support it on the running board supports and slide it into position, being careful to keep the strap insulators in place. Install cap screws, nuts and lock washers holding the shield and strap to the front running board support, and tighten them securely. Install the long cap screws holding the shield and strap to the rear running board support, and then install the spring, plain washer and nut over the end of each of these. Tighten nuts a sufficient amount so that the coils of the springs almost touch each other, and then install cotter pins through the ends of the cap screws and the slotted nuts.

(b) *Replace Running Board.* Replace the running board as described in paragraph 188.

(c) *Connect Fuel Line Clip.* Slide the fuel line into position under the clip on the fuel line tank shield strap, and then bend the clip down to hold the fuel line in place. Install the floorboard on the driver's side of the cab, and fasten it in place with the screws which were removed.

(d) *Connect Fuel Line.* Working through the handhole in the bottom of the compartment under the driver's seat, connect the fuel line to the fuel tank.

(e) *Connect Fuel Gage Wires.* Working through the handhole in the bottom of the compartment under the driver's seat, connect the wires to the terminals of the fuel gage tank unit. Then replace the handhole cover.

(f) *Install Seat Cushion.* Install the driver's seat cushion, as described in paragraph 182.

b. Fuel Lines.

(1) **DESCRIPTION.** All fuel lines running between the fuel tank, fuel filter, fuel pump and carburetor are copper or flexible tubing. Flexible tubing is used between the fuel pump on the engine and the fuel filter on the frame to eliminate fuel line breakage due to vibration. All copper tubing is covered with loom.

(2) **INSTALL FUEL LINES.** Copper tubing is generally stocked in coils of considerable length, so that the first job is cutting it to size. Measure the piece of tubing being replaced, and cut a piece from the coil equal to this length. Then ream out the ends of the tubing with the reamer on the cutting tool to get rid of sharp burs or loose pieces of metal. Install the loom on the tubing and the connector nuts over each end of the tubing with the threaded ends facing out. Then use a flaring tool to form a tight flare on each end of the tubing. If the flare is cracked, it must be cut off and a new one formed. Bend the tubing to shape, being careful to avoid sharp bends and kinks. The fuel lines are held in place with clips, and may be readily replaced.

4-TON, 6 x 6 TRUCKS (DIAMOND T MODELS 968A CARGO,
969A WRECKER, 970A PONTON, AND 972 DUMP)

Section XVIII

INTAKE AND EXHAUST SYSTEMS

	Paragraph
Description	80
Air cleaner	81
Exhaust system	82

80. DESCRIPTION.

a. **Air Cleaner.** The air cleaner is an oil-bath type, mounted on brackets attached to the cylinder head at the left side of the engine (fig. 57). It is intended to keep dust and dirt from entering the engine.

b. **Exhaust System.** The exhaust system comprises an exhaust tube from the engine manifold, a small space tubular baffle manifold, and a tail pipe. The exhaust tube has a flanged coupling which is bolted to the exhaust manifold companion flange. The manifold is supported at the inlet side by a U-bolt, and the tail pipe is hung from the frame side rail.

81. AIR CLEANER.

a. **Servicing Air Cleaner.**

(1) **REMOVE SUMP.** Loosen the wing nuts which hold the sump to the assembly, and lower it out of contact with the cleaner and then lift it from the engine compartment.

(2) **REMOVE FILTER ELEMENT.** Unscrew the long eyebolt which extends through the filter element far enough so that the element assembly may be removed from the cleaner.

(3) **CLEAN AIR CLEANER.** Pour the contaminated oil from the air cleaner sump, and then scrape any hardened mud or dirt which may have accumulated in the bottom of the pan. Wash the sump thoroughly in dry-cleaning solvent. Clean the element mesh by immersion in dry-cleaning solvent. Agitation will speed up the cleaning process. Before the element is reinstalled in the air cleaner it should be dipped in engine oil of the same grade which is used in the crankcase and then allowed to drain a few minutes to permit the excess oil to drain off.

(4) **INSTALL ELEMENT.** Install the element assembly in the air cleaner case with the dished baffle plate facing down. Run the eyebolt through the mesh and screw it into the threaded hole in the top of the cleaner case until it is tight enough to hold the element assembly securely.

(5) **INSTALL SUMP.** Fill sump with engine oil of the same grade as used in the crankcase, to the full mark as indicated by the bead level mark on the pan. Then install the sump into place on the cleaner so that the attaching bolts may be run through the attaching ears on the sump pan. Then install the wing nuts and tighten them securely.

INTAKE AND EXHAUST SYSTEMS

b. Removal.

- (1) **DISCONNECT AIR CLEANER TUBES TO CARBURETOR.** Loosen the clamping screw at the bottom of the air cleaner tube elbow and lift the assembly clear of the carburetor neck.
- (2) **REMOVE AIR CLEANER TUBE.** Loosen the screw in the rubber tubing clamp at the air cleaner outlet, and twist the tube assembly from the carburetor.
- (3) **REMOVE AIR CLEANER.** Remove the two clamp screws and nuts from the air cleaner, bend clamps, and lift the air cleaner assembly out of the engine compartment (fig. 121).

c. Installation.

- (1) **INSTALL THE AIR CLEANER.** Place the air cleaner into position in the mounting clamps with the outlet opening towards the carburetor. Then install the two clamping bolts and nuts, and tighten these securely to hold the carburetor in place.
- (2) **INSTALL AIR CLEANER TUBE.** Work the rubber hose over the end of the air cleaner outlet flange. Then swing the air cleaner tube elbow on the other end into position over the neck of the carburetor, and install it in place. Tighten the clamping screw in the rubber tubing clamp at the air cleaner, and tighten the clamping screw at the bottom of the air cleaner tube elbow at the carburetor.

82. EXHAUST SYSTEM.

a. Exhaust Tube Replacement.

- (1) **DISCONNECT MANIFOLD FLANGE.** Disconnect the manifold flange from the manifold by removing the three bolts, washers and special nuts holding it in place.
- (2) **DISCONNECT U-BOLT AT FRONT OF MUFFLER.** Disconnect the muffler front U-bolt by removing the two nuts and lock washers. Then lift out the U-bolt.
- (3) **DISCONNECT TAIL PIPE CLAMP.** Remove the two cap screws, lock washers and nuts holding the tail pipe clamp to the frame rail.
- (4) **REMOVE EXHAUST TUBE.** Work the exhaust tube back away from the manifold and then twist it out of the front muffler connection.
- (5) **INSTALL NEW EXHAUST TUBE.** Assemble the manifold flange over the new exhaust tube and then work the assembly into position in the chassis. Twist the lower end into the muffler, and then work the whole assembly forward until the tube engages the exhaust manifold opening.
- (6) **TIGHTEN MANIFOLD FLANGE.** Install the three bolts, washers and special nuts which were removed from the manifold flange, and tighten these evenly and securely.
- (7) **INSTALL MUFFLER MOUNTING.** Install the U-bolt over the muffler inlet flange and through the holes in the mounting bracket, and then fasten in place with the nuts and lock washers which were removed.

4-TON, 6 x 6 TRUCKS (DIAMOND T MODELS 968A CARGO, 969A WRECKER, 970A PONTON, AND 972 DUMP)

(8) **FASTEN TAIL PIPE CLAMP.** Bolt the tail pipe clamp to the frame rail with the cap screws, nuts and lock washers which were removed.

b. Muffler Replacement.

(1) **DISCONNECT MUFFLER FRONT U-BOLT.** Remove the nuts and lock washers from the threaded ends of the U-bolt, and then remove it from the muffler (fig. 68).

(2) **DISCONNECT TAIL PIPE BRACKET.** Remove the cap screws, nuts and lock washers holding the tail pipe bracket to the frame rail.

(3) **REMOVE MUFFLER AND TAIL PIPE ASSEMBLY.** Work the muffler and tail pipe assembly clear of the exhaust tube. It may be necessary to twist the assembly, and to tap on the muffler inlet flange with a hammer to help break it loose.

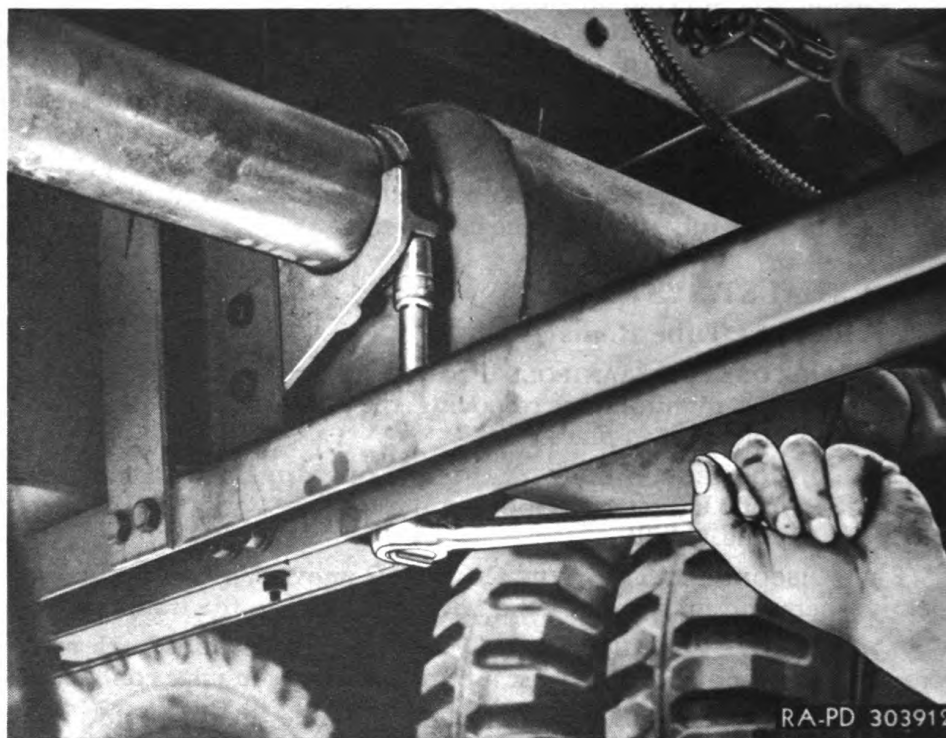

Figure 68—Removing Muffler U-bolt Nuts

(4) **REMOVE TAIL PIPE FROM MUFFLER.** Disconnect the muffler tail pipe U-bolt and clamp by removing the nuts and lock washers, and then pulling off the clamp and U-bolt. Work tail pipe and clamp assembly loose, and remove this part from the muffler.

(5) **INSTALL TAIL PIPE ON NEW MUFFLER.** Work the tail pipe into the outlet opening of the new muffler. Then slip U-bolt and clamp assembly over this flange, and tighten securely with the nuts and lock washers which were removed.

INTAKE AND EXHAUST SYSTEMS

(6) **INSTALL MUFFLER AND TAIL PIPE ASSEMBLY IN VEHICLE.** Lift the assembly into position, and work the lower end of the exhaust tubes into the muffler inlet opening far enough to obtain a secure attachment. Then install the muffler front mounting U-bolt, and fasten in place with the nuts and lock washers which were removed.

(7) **INSTALL TAIL PIPE CLAMP.** Fasten the tail pipe clamp to the frame rail, using the cap screws, nuts and lock washers which were removed.

c. Tail Pipe Replacement.

(1) **DISCONNECT MUFFLER REAR U-BOLT AND CLAMP.** Remove the nuts and lock washers from the U-bolt, and then remove the clamp and bolt.

(2) **DISCONNECT TAIL PIPE CLAMP.** Remove the cap screws, nuts and lock washers holding the tail pipe clamp to the frame rail.

(3) **REMOVE TAIL PIPE.** Twist the tail pipe out of the muffler outlet opening. It may be necessary to tap the muffler outlet flange to help break the tube loose.

(4) **REMOVE CLAMP FROM TAIL PIPE.** Loosen the clamp screw in the tail pipe clamp and remove this part from the pipe.

(5) **INSTALL TAIL PIPE CLAMP OVER NEW TAIL PIPE.** Slide the clamp over the end of the new tail pipe into its approximate position.

(6) **INSTALL TAIL PIPE.** Lift the assembly into position and slide the end of it into the outlet opening of the muffler. Then install the U-bolt and clamps over the outlet opening flange, and tighten it securely with the nuts and lock washers which were removed.

(7) **ATTACH TAIL PIPE CLAMP.** Fasten the tail pipe clamp to the frame rail with the cap screws, nuts and lock washers which were removed.

(8) **TIGHTEN TAIL PIPE CLAMPING SCREW.** Tighten the clamping screw in the lower end of the tail pipe clamp.

4-TON, 6 x 6 TRUCKS (DIAMOND T MODELS 968A CARGO, 969A WRECKER, 970A PONTON, AND 972 DUMP)

Section XIX

COOLING SYSTEM

	Paragraph
Description and tabulated data.....	83
Servicing cooling system.....	84
Radiator	85
Fan	86
Water pump.....	87
Thermostat	88

83. DESCRIPTION AND TABULATED DATA.

a. **General.** The cooling system is made up of the radiator, fan, water pump, thermostat and miscellaneous fittings, tubing and hoses. The temperature may exceed 180°F when the engine is laboring on a hard pull, but if the cooling water reaches the boiling point the vehicle should be stopped, and the cause of overheating determined. This is a pressure cooling system, with a special valve in the radiator cap to maintain the pressure of the system several pounds per square inch above atmospheric pressure. This type of system has the advantage of a great reduction in the loss of cooling water and permits engine operation at higher temperatures, as the liquid has a higher boiling point under the increased pressure in the system.

b. **Radiator.** A conventional-type radiator is installed on the front of the chassis mounted on rubber bushings. The assembly consists of a finned tube-type core, two side members, a top tank and bottom tank, a fan shroud and a brush guard.

c. **Fan.** The fan is a six-bladed, belt-driven type, mounted on a hub and spindle supported on two opposed tapered roller bearings. The fan is driven by two V-type belts which are driven by the engine accessory shaft pulley.

d. **Water Pump.** The water pump assembly is mounted on the left-hand side of the engine block, and is gear driven through a chain coupling. It has the impeller located in the pump body.

e. **Thermostat.** The thermostat is a valve controlling the flow of water to the radiator for the purpose of raising the water temperature quickly after the engine is started, and to maintain the cooling water within the engine at a temperature between 160° and 180°F. The valve is designed to be completely closed at 157°F, is just cracking open at 162°F, and is fully open at 185°F.

f. Tabulated Data.

(1) RADIATOR.

Type.....	Finned tube
Number of fins to inch.....	11
Frontal area.....	636 sq in.
Thickness	3 in.

COOLING SYSTEM

- (2) **FAN.**
 - ModelDT-DX5804
 - DriveDouble belt
 - Blade diameter22 in.
 - Number of blades6
- (3) **FAN BELT.**
 - Part numberDT-N1463E
 - Number used2
- (4) **WATER PUMP.**
 - TypePackless
 - LocationLeft side of engine
 - DriveGear driven coupling
- (5) **THERMOSTAT.**
 - TypeBypass
 - NumberDT-BR7815
 - Thermostat closed at157°F
 - Thermostat fully open at185°F
- (6) **COOLING CAPACITY48 qt**

84. SERVICING COOLING SYSTEM.

a. Adding Water to Cooling System. The radiator cap is the pressure-type which seals the cooling system from the atmosphere until the pressure increases beyond the setting limit, in which event seal is broken and vapor, air or water will escape through the overflow tube until such time as the pressure in the system has returned to its proper level. It is very important that this type of radiator cap be removed slowly when the engine is hot, to prevent scalding the person taking it off. Turn the cap slightly open and allow the pressure to escape so that the cap may be removed safely. After the cap is removed, clean, soft water or antifreeze mixture may be added to the cooling system through the filler neck in the radiator top tank.

b. Draining Cooling System.

- (1) Instructions for draining the cooling system are found on the instruction plate mounted in the cab of the vehicle (fig. 17).
- (2) If the cooling system contains antifreeze compound, it should be saved so that it may be poured into the radiator before the vehicle is again operated.
- (3) Open the petcock located on the bottom of the radiator lower tank outlet fitting.
- (4) Open the petcock on the left side of the cylinder block (fig. 57).

c. Filling Cooling System.

- (1) Close petcock on the radiator lower tank outlet fitting, and on the left side of the cylinder block.
- (2) Remove the radiator cap and pour clean soft water, or the antifreeze mixture which was saved when the cooling system was drained, into the radiator until the level of the liquid is visible through the filler neck.

4-TON, 6 x 6 TRUCKS (DIAMOND T MODELS 968A CARGO, 969A WRECKER, 970A PONTON, AND 972 DUMP)

(3) Start the engine, and add water as required to bring the level up to the top of the overflow.

(4) Replace radiator cap. *NOTE: When replacing the radiator cap, be sure that it is screwed down tightly to prevent the loss of the cooling liquid.*

d. Cleaning Cylinder Block Water Passages.

(1) **DRAIN COOLING SYSTEM** (par. 84 b).

(2) **REMOVE WATER INLET MANIFOLD.** Loosen the clamp screw in the hose clamp at the water inlet manifold inlet and disconnect the hose from the manifold. Then remove the cap screws and lock washers holding the water inlet manifold to the cylinder block, and remove the manifold and gasket.

(3) **REMOVE THERMOSTAT** (par. 88). After the thermostat is removed, reinstall the thermostat housing without the thermostat.

(4) **FLUSH OUT THE BLOCK.** Using a pressure gun, force water into the block through the water outlet manifold. The pressure produces a high velocity and turbulence, carrying off large particles of sediment which will flow out of the water inlet manifold opening. Sludge and sediment in the engine water passages may be loosened by prodding with a short length of welding rod or a wooden stick while the flushing procedure is going on. When the water starts to come out clean, remove the pressure gun from the water outlet manifold.

(5) **INSTALL THERMOSTAT** (par. 88).

(6) **INSTALL WATER INLET MANIFOLD.** Assemble the water inlet manifold to the engine block using a new gasket, and fasten in place with cap screws and lock washers which were removed. Coat the inside of the water inlet manifold hose with white lead, then connect the hose to the water inlet manifold and tighten the clamp screw.

e. Thawing Out Radiator. If the liquid in the cooling system should become frozen, it will be necessary to thaw out the radiator before the vehicle can be operated. The best method of accomplishing this is to tow the vehicle into a warm garage and let it thaw out gradually. If this is not possible, cover the radiator and hood with a blanket and let the engine idle until the blanket steams. Then shut the engine off, let it stand for a few minutes, and repeat the operation as often as it is necessary to get the water circulating. Do not use boiling water to thaw out a frozen radiator.

f. Cooling System Hose. Rubber hose in the cooling system must be kept tight in order to prevent the loss of cooling liquid, and to keep the pump from sucking air into the system which would cause the formation of rust and scale. Check all hose periodically and keep the hose clamps tight. When new pieces of hose are installed, always coat the inner surface of the hose under the clamp with white lead to insure a tight seal. Rubber hose deteriorates in normal service, and must be replaced when it becomes soft and starts to swell.

COOLING SYSTEM

85. RADIATOR.

a. Removal.

- (1) REMOVE THE HOOD ASSEMBLY (par. 185).
- (2) DRAIN WATER FROM THE COOLING SYSTEM (par. 84).
- (3) DISCONNECT INLET FITTING. Remove the cap screws and lock washers holding the radiator inlet fitting to the top tank, and then swing the inlet fitting and hose assembly, which is attached to the radiator stay rod, clear of the radiator, and remove the attaching gasket.

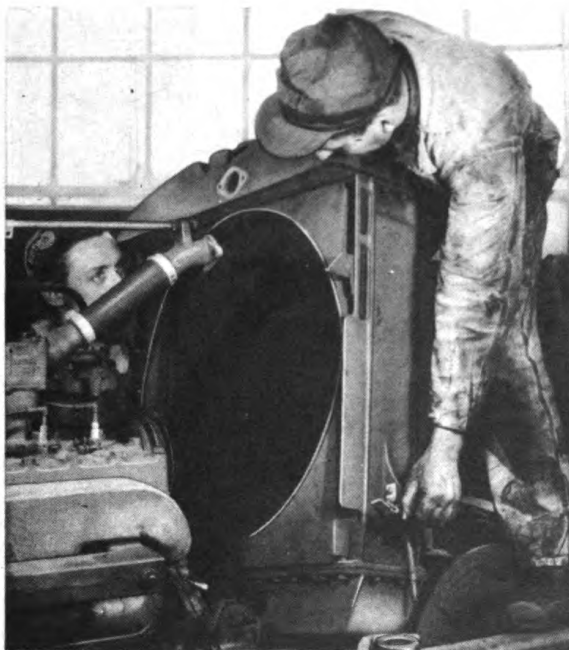

RA PD 303707

Figure 69—Removing Radiator

(4) DISCONNECT RADIATOR OUTLET FITTING. Remove the cap screws and lock washers holding the radiator outlet fitting to the bottom tank, then swing the outlet fitting and hose assembly clear of the radiator and remove the attaching gasket.

(5) REMOVE RADIATOR MOUNTING BOLTS. Remove the cotter pins from the radiator mounting bolt nuts, and remove the bolts, nuts and upper insulators.

(6) REMOVE THE RADIATOR FROM THE CHASSIS. Tip the radiator assembly forward to clear the fan blades, then work it out of the chassis, being careful not to damage the tubes or the blades on the fan (fig. 69). After it is removed, take off the lower radiator mounting insulators.

b. **Cleaning.** Clean the air passages between the tubes to remove dirt or insects which might plug the openings. If the radiator tubes are clogged up with scale or sediment, they may be cleaned by pressure flushing through the filler neck opening.

**4-TON, 6 x 6 TRUCKS (DIAMOND T MODELS 968A CARGO,
969A WRECKER, 970A PONTON, AND 972 DUMP)**

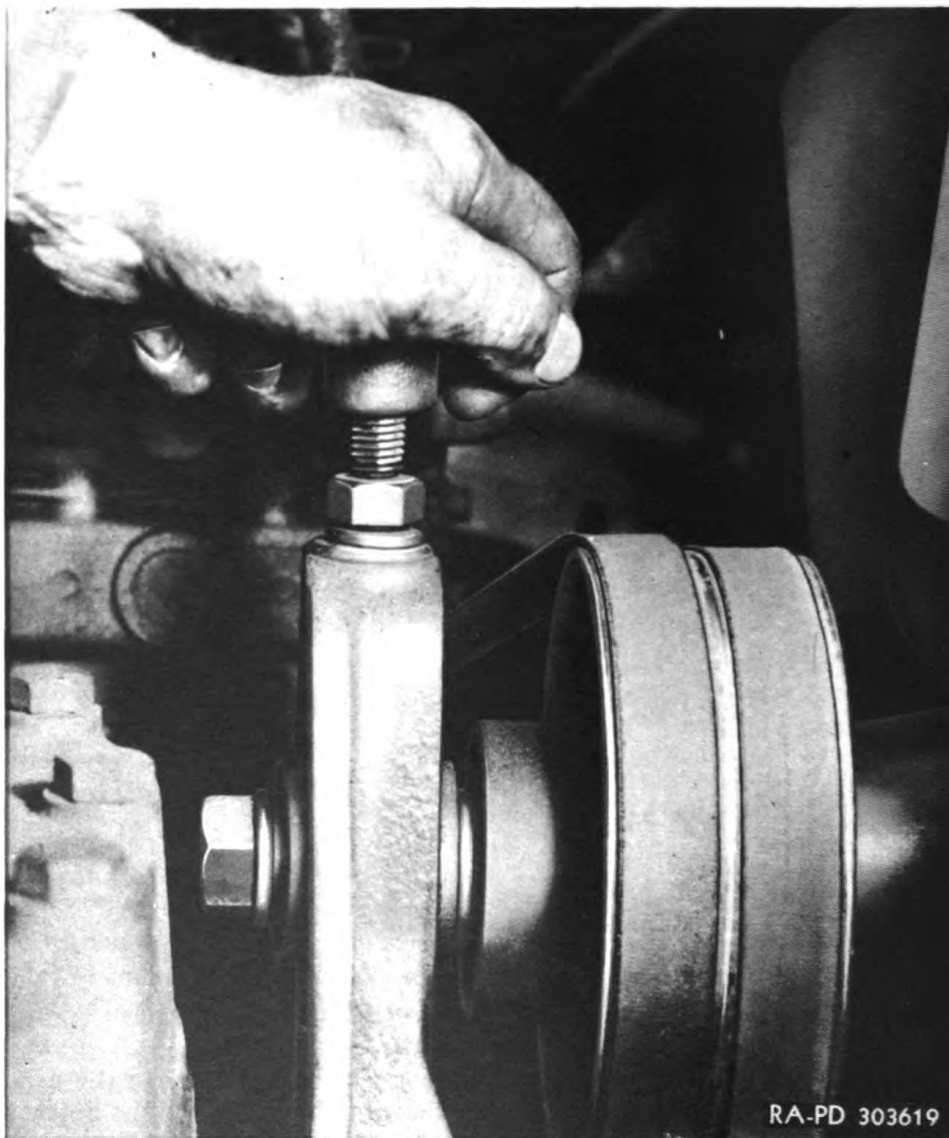

Figure 70—Adjusting Fan Belt Tension

c. Installation.

(1) **REPLACE LOWER INSULATORS.** Install the large radiator mounting insulators over the mounting holes on the frame rails.

(2) **INSTALL RADIATOR.** Lift the radiator assembly into place and work it into position, being careful not to injure the radiator core or the fan blade.

(3) **INSTALL RADIATOR MOUNTING PARTS.** Run the radiator mounting bolts through the frame rails from the under sides, and up through the lower insulators and the holes in the radiator mounting legs.

COOLING SYSTEM

Then replace the upper insulators, the plain washers and the castle nuts on the ends of the bolts. Tighten nuts with torque wrench to 10–12 foot-pounds tension, then install cotter pins through the slots in the nuts.

(4) **CONNECT RADIATOR OUTLET FITTING.** Install a new gasket between the radiator lower tank and the radiator outlet fitting, and

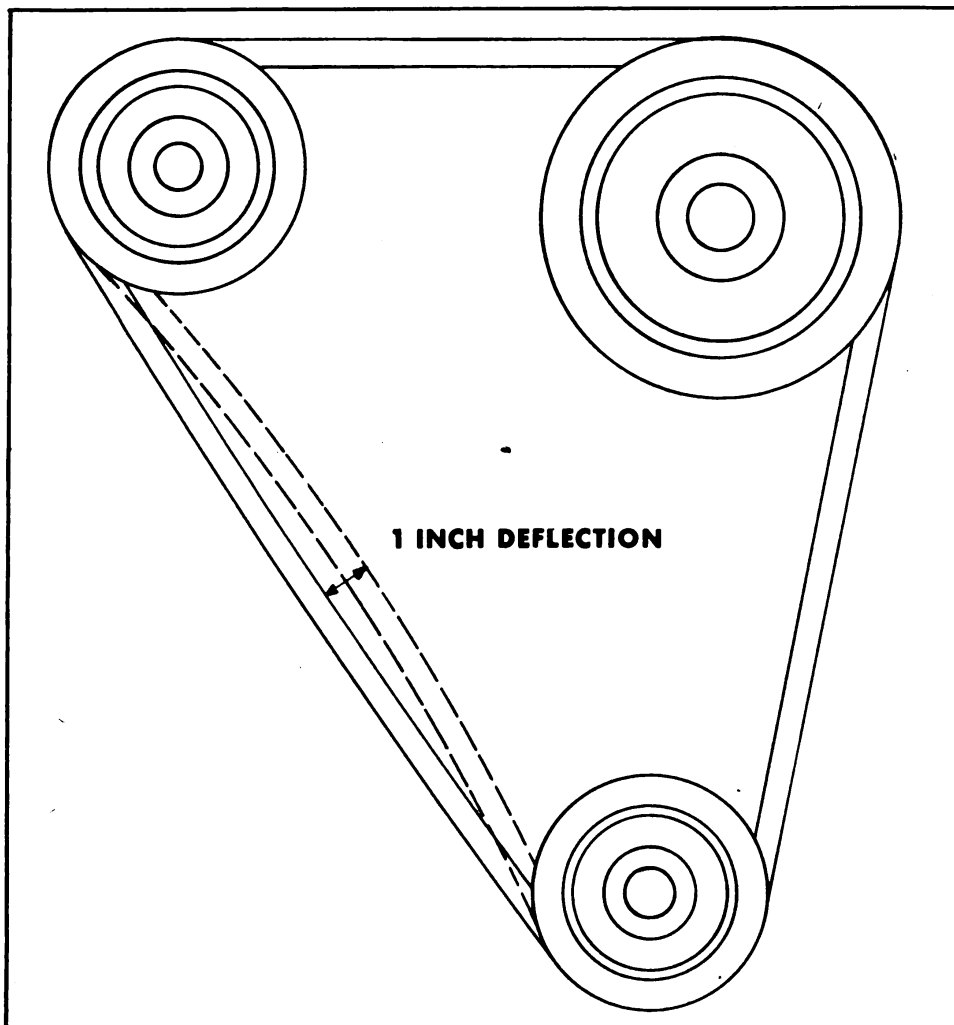

RA PD 304982

Figure 71—Fan Belt Deflection

attach this part to the radiator, using the cap screws and lock washers which were removed.

(5) **CONNECT RADIATOR INLET FITTING.** Install the radiator inlet fitting against the radiator top tank, using a new gasket, and attach in place with cap screws and lock washers which were removed.

(6) **ADD WATER TO COOLING SYSTEM** (par. 84).

(7) **INSTALL HOOD ASSEMBLIES** (par. 185).

TM 9-811

86

4-TON, 6 x 6 TRUCKS (DIAMOND T MODELS 968A CARGO, 969A WRECKER, 970A PONTON, AND 972 DUMP)

86. FAN.

a. Adjustment.

(1) **LOOSEN THE FAN SPINDLE AND CLAMP NUT.** Back off the clamp nut between the front of the engine and the fan mounting bracket (fig. 72). Loosen the spindle in the slot.

(2) **ADJUST FAN.** Back off the fan hub adjusting screw lock nut. Turn the adjusting screw to obtain the proper tension on the fan belt



Figure 72—Tightening Fan Spindle Clamp Nut

(fig. 70). The belts should be tight enough so that they will deflect about one inch (fig. 71).

(3) Hold the adjusting screw and tighten the adjusting screw lock nut.

(4) Tighten the fan spindle clamp nut between the front of the engine and the fan mounting bracket (fig. 72). Check adjustment again.

b. Removal.

(1) **LOOSEN THE FAN SPINDLE CLAMP NUT.** Loosen the clamping nut on the fan spindle between the front of the engine and the fan mounting bracket.

(2) Back off the adjusting screw lock nut.

COOLING SYSTEM

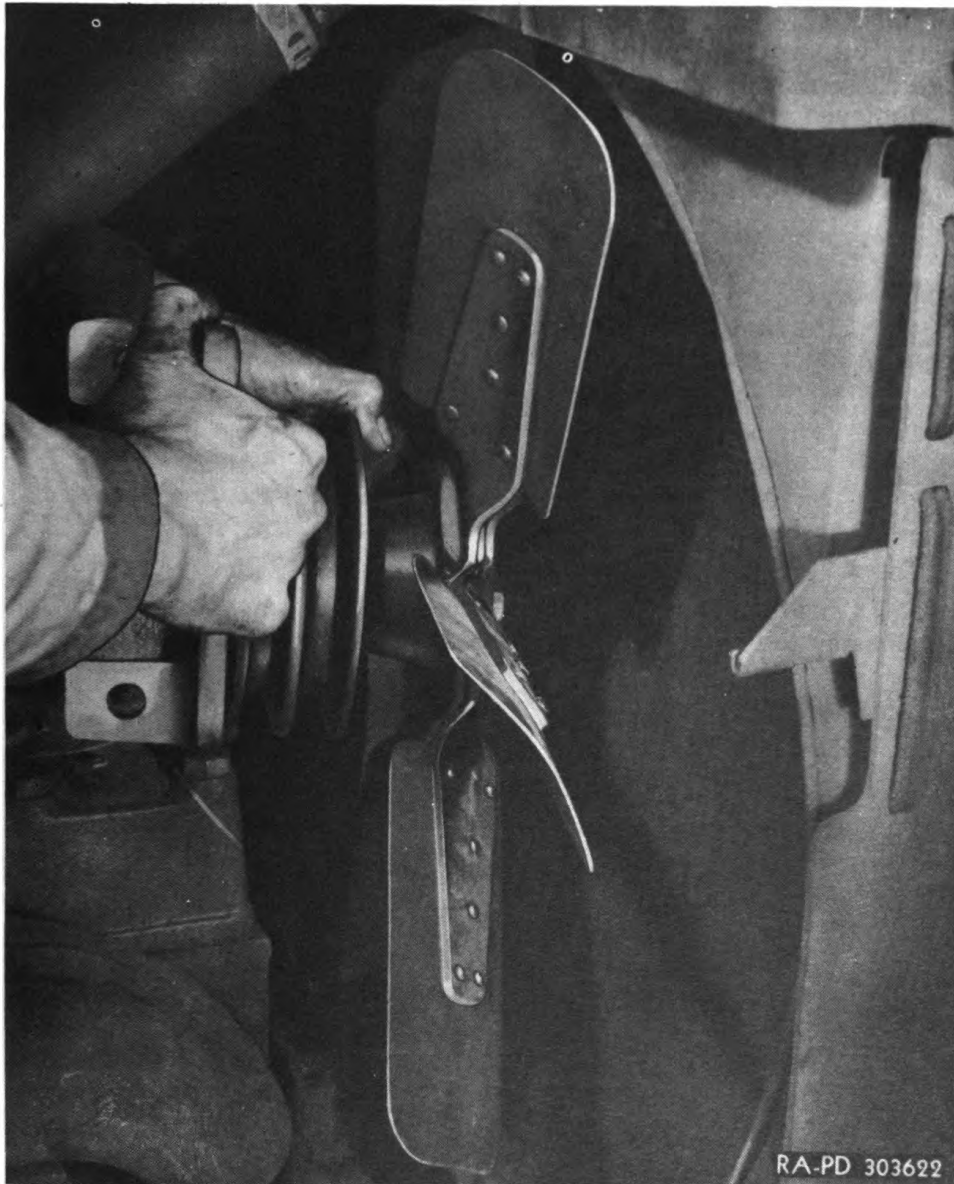

Figure 73—Removing Fan Assembly

- (3) Slacken the fan belt by loosening the adjusting screw.
- (4) **REMOVE THE FAN BELT.** Slip the fan belts off the pulleys, and then work them off around the fan blades.
- (5) **REMOVE THE FAN MOUNTING BRACKET SCREWS.** Remove the fan mounting bracket screws, nuts and lock washers. It will be necessary to use an offset screwdriver to remove the slotted screw.
- (6) **REMOVE FAN ASSEMBLY.** As the fan assembly is removed, it will be necessary to swing the bracket up towards the right side of the

TM 9-811

86-87

4-TON, 6 x 6 TRUCKS (DIAMOND T MODELS 968A CARGO, 969A WRECKER, 970A PONTON, AND 972 DUMP)

engine, and to pull it back so the hub protrudes over the cylinder head with the bottom of the bracket pointing slightly towards the rear of the vehicle so that the fan blades will clear the shrouds (fig. 73). Fan may be removed in this way without forcing, which might injure the radiator core or the fan blades.

c. Installation.

(1) **INSTALL THE FAN ASSEMBLY.** Install the fan assembly into place on the engine, using the same angle by which it was removed to work it past the edges of the shroud (fig. 73).

(2) **INSTALL THE BRACKET SCREWS.** Install the bracket screws, nuts and lock washers. It will be necessary to use an offset screwdriver to tighten the slotted screw.

(3) **INSTALL FAN BELTS.** Install the fan belts over the fan blades and then work them into position in the grooves of the pulleys.

(4) **ADJUST BELTS.** Tighten the fan hub adjusting screw and adjust belt tension as described in paragraph 86.

(5) Tighten the adjusting screw jam nut.

(6) Tighten the fan spindle clamp nut between the front of the engine and the fan mounting bracket.

87. WATER PUMP.

a. Removal.

(1) **DRAIN WATER FROM COOLING SYSTEM.** See paragraph 84.

(2) **DISCONNECT WATER LINE TO AIR COMPRESSOR.** Disconnect the copper tubing running between the water pump and the air compressor at the water pump.

(3) **DISCONNECT INLET FITTING AT THE PUMP.** Remove the cap screws and lock washers attaching the inlet fitting to the water pump, and swing the fitting and hose assembly clear of the pump. Remove the attaching gasket.

(4) **DISCONNECT WATER PUMP OUTLET HOSE.** Loosen the hose clamp at the lower end of the hose between the water pump and the water inlet manifold on the engine.

(5) **DISCONNECT CHAIN.** Remove the lock clip from the coupling pin and connecting link and remove the coupling link from the chain. Then unwrap the chain from the sprocket (fig. 74).

(6) **REMOVE WATER PUMP.** Remove the cap screws and lock washers holding the water pump to the engine, and remove the pump.

b. Installation.

(1) **INSTALL WATER PUMP.** Check it to see that the mounting dowels are in position on the engine block and then install the water pump assembly into position, lining it up on the dowels. Install cap screws and lock washers.

(2) **CONNECT CHAIN.** Wrap the coupling chain around the sprocket, install connecting link into position, and install the connecting link lock.

COOLING SYSTEM

(3) **INSTALL WATER PUMP OUTLET HOSE.** Coat the inside of the water pump outlet hose under the clamp with white lead, then install the hose over the outlet opening on the water pump and tighten the clamps securely.

(4) **CONNECT INLET FITTING.** Install the inlet fitting against the lower side of the pump, using a new gasket, and attach in place with cap screws and lock washers which were removed.

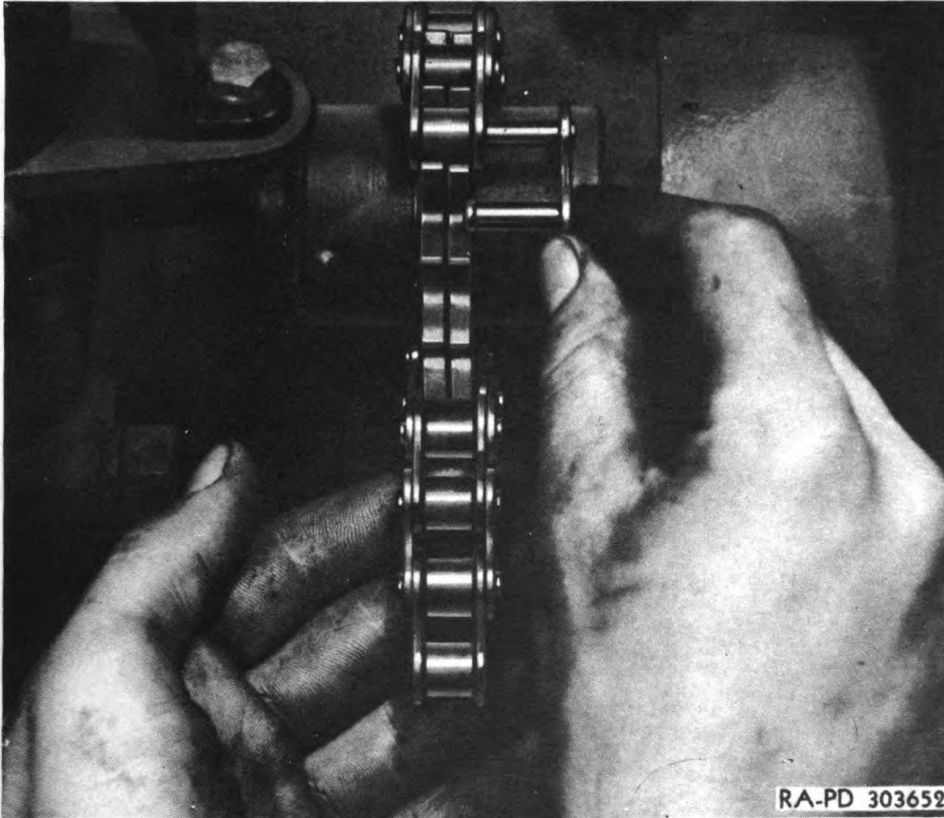

Figure 74—Removing Coupling Chain

(5) **CONNECT AIR COMPRESSOR WATER LINE.** Connect the copper tubing running between the water pump and the air compressor to the tapped hole in the water pump body.

(6) **FILL COOLING SYSTEM WITH WATER** (par. 84).

88. THERMOSTAT.

a. Removal.

(1) **DRAIN WATER FROM COOLING SYSTEM** (par. 84).

(2) **DISCONNECT WATER OUTLET FITTING.** Remove the cap screws and lock washers holding the water outlet fitting to the thermostat housing, and swing the fitting and hose assembly clear of the thermostat housing. Remove gasket.

4-TON, 6 x 6 TRUCKS (DIAMOND T MODELS 968A CARGO, 969A WRECKER, 970A PONTON, AND 972 DUMP)

(3) **DISCONNECT BYPASS HOSE.** Loosen the hose clamp in the bypass line connected to the thermostat housing, and disconnect the hose from the housing outlet.

(4) **REMOVE THERMOSTAT HOUSING.** Remove the cap screws and lock washers holding the thermostat housing to the water outlet manifold and remove the housing and gasket (fig. 75).

(5) **REMOVE THERMOSTAT.** Remove the thermostat from its seat in the water outlet manifold.



Figure 75—Removing Thermostat Housing

b. **Test.** The thermostat may be tested to see that it is functioning properly by immersion in a bucket of hot water. It should be fully open at a temperature of 185°F, and should be closed at 157°F.

c. Installation.

(1) Install the thermostat into its seat in the water outlet manifold with the bellows facing down.

(2) **INSTALL THERMOSTAT HOUSING.** Assemble the thermostat housing over the thermostat using a new gasket. **NOTE: Be sure that the water outlet fitting flange faces towards the front of the engine.** Install the cap screws and lock washers.

COOLING SYSTEM

(3) **CONNECT BYPASS HOSE TO THERMOSTAT HOUSING.** Coat the inside of the bypass hose with white lead, install the hose on the thermostat housing outlet, and tighten the clamps securely.

(4) **CONNECT WATER OUTLET FITTING TO THERMOSTAT HOUSING.** Install a new gasket over the water outlet fitting flange on the thermostat housing, install the water outlet fitting into position, and fasten in place with cap screws and lock washers.

(5) Add water to cooling system (par. 84).

4-TON, 6 x 6 TRUCKS (DIAMOND T MODELS 968A CARGO, 969A WRECKER, 970A PONTON, AND 972 DUMP)

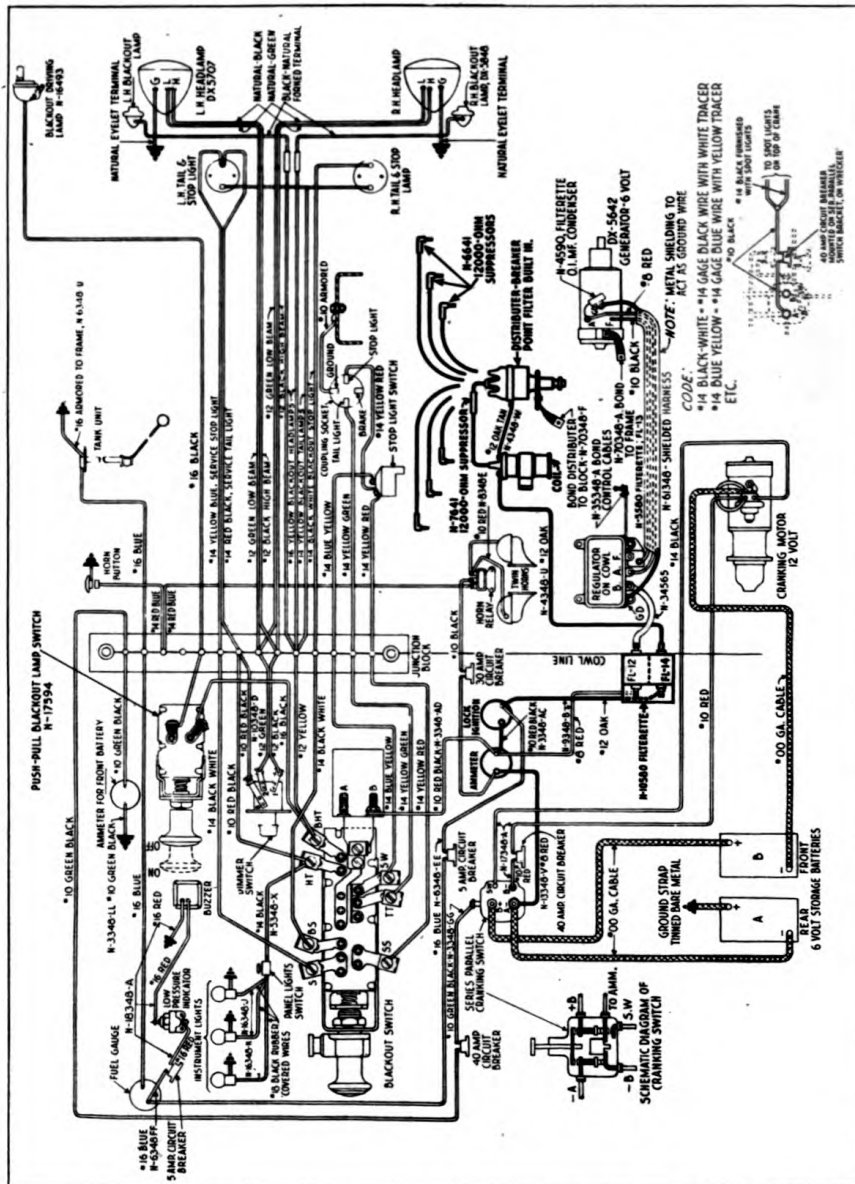

RA PD 313780

Figure 76—Wiring Diagram—Dark Lines Indicate Ignition Circuit

Section XX

IGNITION SYSTEM

	Paragraph
Description and tabulated data.....	89
Ignition timing.....	90
Distributor.....	91
Coil and spark plugs.....	92

89. DESCRIPTION AND TABULATED DATA.

a. **Description** (fig. 76). The ignition system is made up of the ignition switch, distributor, coil, condenser and spark plugs. There are two distinct circuits in the ignition system, namely, the primary and secondary circuits. With the ignition switch turned on and the distributor breaker points closed, the current will flow through the primary winding of the ignition coil, building up a strong magnetic field. Each time the breaker points open, this magnetic field collapses and a high voltage is induced in the secondary winding. This high voltage current is distributed to the spark plugs at the proper firing intervals by the distributor cap and rotor.

b. Tabulated Data.

(1) **DISTRIBUTOR:**

Make Auto-Lite
 Model..... IGC 4701
 Rotation..... Right hand (as viewed from the top)
 Cylinders..... 6
 Control..... Semiautomatic

(2) **CONDENSER.**

Make Auto-Lite
 Capacity..... 0.20-0.25 mfd

(3) **COIL.**

Make Auto-Lite
 Model..... IG 4090

(4) **SPARK PLUGS.**

Make Champion
 Model..... J 10 Com.
 Type..... 14 mm
 Number used..... 6
 Setting..... 0.027

90. IGNITION TIMING.

a. **General.** Before timing the ignition, wipe the distributor cap thoroughly with a clean rag both inside and outside. Clean out the plug wells at the top of the distributor cap and clean the connectors on the ends of the distributor cap wires. Remove the rotor and clean it thoroughly with a clean cloth. Adjust breaker points (par. 91 c). Lubricate the distributor (par. 24).

TM 9-811

90-91

4-TON, 6 x 6 TRUCKS (DIAMOND T MODELS 968A CARGO, 969A WRECKER, 970A PONTON, AND 972 DUMP)

b. Timing.

(1) **LINE UP FLYWHEEL TIMING MARK.** There is a timing hole located on the front face of the bell housing slightly above center and directly behind the fuel pump on the left side of the engine. Crank the engine slowly until the mark on the flywheel is lined up with the center of the timing hole. It will be necessary to use a mirror between the fuel pump and the bell housing in order to see this mark.

(2) Loosen the clamp bolt under the distributor arm and remove the distributor cap.

(3) **CONNECT TIMING LIGHT.** Connect a conventional timing light in series with the primary circuit. This lamp will light when the distributor contacts are closed and will not light when they are open.

(4) **RETARD THE SPARK.** Pull the spark plug button on the dash all the way out.

(5) **TIME DISTRIBUTOR.** Back off the distributor slowly, turning it counterclockwise. Stop the instant the light goes out, and clamp the assembly in position.

(6) **INSTALL THE DISTRIBUTOR CAP.** Install the distributor cap, and remove the test lamp from the primary circuit.

91. DISTRIBUTOR.

a. Description. The distributor is made up of a housing and cap. The governor, breaker points, condenser and rotor are assembled in the housing. The governor provides an automatic advance with increase in distributor speed. The breaker points open and close the primary circuit, inducing the high voltage in the secondary windings. The condenser absorbs the initial surge of current as the primary circuit is broken, and thus prevents excessive arcing across the breaker points. The rotor receives the high-voltage current in the secondary circuit, and delivers it to the proper spark plug wire located in the distributor cap.

b. Installation of Distributor Points.

(1) **REMOVE DISTRIBUTOR CAP.** Loosen distributor cap clips and lift the cap assembly from the housing.

(2) **REMOVE THE SPRING CLIP SCREW.** Remove the screw, nut and lock washer holding the breaker arm spring to the breaker plate.

(3) **REMOVE BREAKER ARM.** Insert the tip of a screwdriver under the breaker arm pivot, and lift it up and off the pivot pin.

(4) **REMOVE BREAKER STATIONARY POINT.** Remove the screw holding the stationary point to the breaker plate, and lift out the stationary contact.

(5) **INSTALL NEW STATIONARY CONTACT.** Install a new stationary contact into position, attaching it to the breaker plate with the screw which was removed. Be sure that the elongated slot in the contact point base is over the eccentric screw in the breaker plate.

(6) **INSTALL BREAKER ARM.** Slide the breaker arm into position over the pivot pin with the spring tensed behind the lip on the breaker plate. Then install screw, nut and lock washer through the lip and

IGNITION SYSTEM

spring. Be sure that the condenser lead is connected under the breaker arm spring screw.

(7) **INSTALL DISTRIBUTOR CAP.** Install the distributor cap and attach in place with the clips. Then adjust distributor points, and check timing.



Figure 77—Adjusting Breaker Point Gap to 0.020 inches

c. Adjust Distributor Points.

(1) **REMOVE DISTRIBUTOR CAP.** Open the clips and remove the distributor cap from the housing.

(2) **REMOVE ROTOR.** Pull the rotor from the end of the distributor shaft.

(3) **POSITION BREAKER ARM ON CAM.** Turn distributor so that the breaker arm leg rests on the high point of the cam. Crank the engine

4-TON, 6 x 6 TRUCKS (DIAMOND T MODELS 968A CARGO, 969A WRECKER, 970A PONTON, AND 972 DUMP)

until it stops with the contact points wide open, as is the case when the breaker arm leg rests on the high point of the cam.

(4) **ADJUST POINT GAP.** Loosen the lock screw holding the stationary point to the breaker plate. Use a 0.020 wire feeler gage between the breaker arm point and the stationary point, and turn the eccentric adjusting screws until the proper gap is obtained (fig. 77). Tighten the lock screw holding the stationary point to the breaker plate. Install rotor and replace distributor cap.

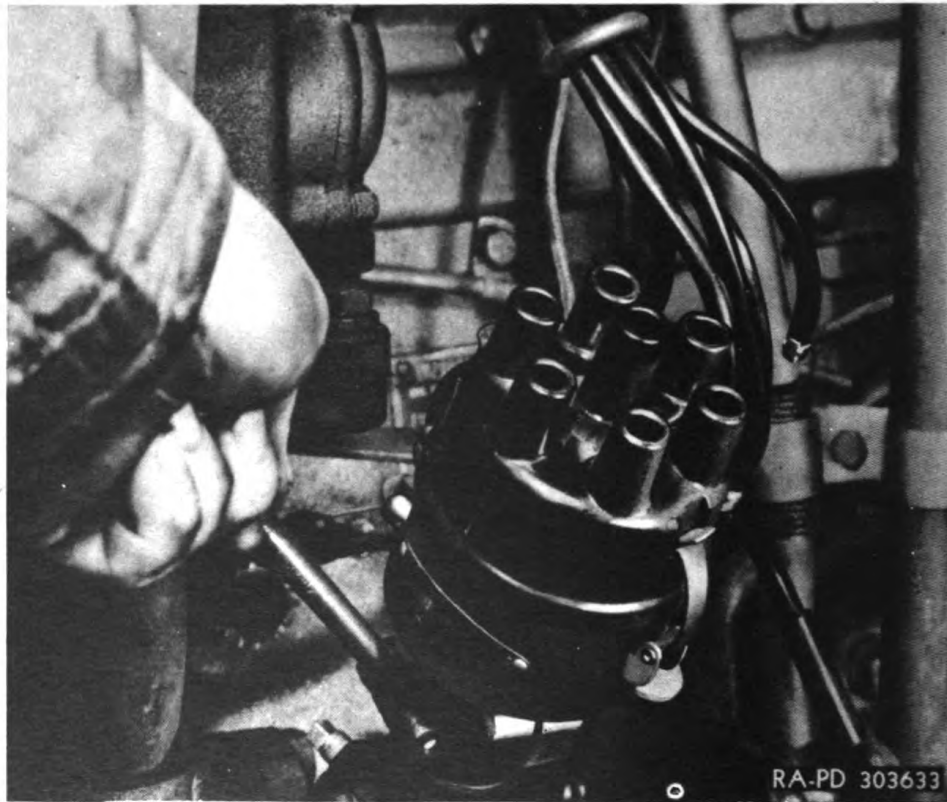

Figure 78—Loosening Distributor Housing Clamp

d. Removal.

(1) **DISCONNECT SPARK CONTROL.** Loosen the set screw in the spark control wire and disconnect the wire.

(2) **DISCONNECT PRIMARY WIRE TO THE DISTRIBUTOR.** Disconnect the wire in the primary circuit between the coil and the distributor at the distributor.

(3) **DISCONNECT SECONDARY WIRE AND SPARK PLUG WIRES FROM DISTRIBUTOR CAP.** Pull the high-tension and spark plug wires out of the distributor cap.

IGNITION SYSTEM

(4) **DISCONNECT DISTRIBUTOR BOND STRAP.** Remove the screw, toothed lock washer, lock washer and nut holding the braided bond strap to the distributor control arm, and swing the bond assembly out of the way.

(5) **REMOVE DISTRIBUTOR.** Back off the distributor housing clamp screw and lift the distributor assembly out of the tachometer adapter (fig. 78).

e. Installation.

(1) **INSTALL DISTRIBUTOR IN TACHOMETER ADAPTER.** Insert the distributor into the tachometer adapter, lining-up the coupling on the end of the distributor shaft with the socket in the adapter. When the assembly is properly seated, tighten the distributor housing clamp screw.

(2) **CONNECT THE BOND STRAP BETWEEN THE ENGINE BLOCK AND THE DISTRIBUTOR CONTROL ARM.** Attach the braided bond strap to the control arm, using the screw, toothed lock washer, lock washer and nut which were removed.

(3) **SET NO. 1 PISTON ON TOP DEAD CENTER ON COMPRESSION.** Piston No. 1 and piston No. 6 will reach top dead center at the same time, so that it will be necessary to determine when No. 1 is on compression. This is done by removing a spark plug and holding the thumb over the spark plug opening while the engine is being cranked. When pressure builds up under the thumb, the No. 1 piston is coming up on compression. Then turn the engine over just far enough to line up the timing mark on the flywheel with the opening on the left side of the bell housing, remove distributor cap and note direction rotor is pointing as this will indicate the position of the No. 1 spark plug wire.

(4) **CONNECT SPARK PLUG WIRE.** Mark the distributor cap opposite the contact point on the rotor arm and connect the No. 1 spark plug wire in the connector well by this mark. Then connect the remaining spark plug wires in the distributor cap, working in a clockwise direction, and following the firing order which is 1-5-3-6-2-4. Replace distributor cap.

(5) **CONNECT SPARK CONTROL WIRE.** Insert the end of the spark control wire into position on the distributor control arm, twist the distributor assembly as far as possible in a counterclockwise direction, and push the spark control button flush with the dash before tightening the spark control wire clamp screw.

92. COIL AND SPARK PLUGS.

a. Coil.

(1) **DESCRIPTION.** The ignition coil has induction windings for the primary and secondary circuits of the ignition system. Its function is to build up the high potential which causes the spark to jump across the points of the spark plug.

(2) **COIL SPARK TEST.** If there is no spark at plugs, disconnect the high-tension wire from the center of the distributor. With the distributor cover removed and the ignition switch turned "ON," crank the engine until the breaker points are closed. Hold the primary circuit

**4-TON, 6 x 6 TRUCKS (DIAMOND T MODELS 968A CARGO,
969A WRECKER, 970A PONTON, AND 972 DUMP)**

wire so that the terminal is about $\frac{1}{4}$ inch from the cylinder head, and with the finger quickly separate the breaker points and allow them to snap back. Repeat this several times. Each time the points open a substantial spark should be produced between the high-tension wire terminal and the cylinder head.

(3) **REMOVAL.**

(a) *Disconnect Wires from Coil.* Disconnect the two primary leads and secondary lead from the coil.

(b) *Remove the Coil.* Remove the cylinder head cap screw which holds the coil attaching bracket to the cylinder head, and remove the coil and bracket assembly. The coil may be removed from the bracket by loosening the bracket clamping screw.

(4) **INSTALLATION.**

(a) *Assemble Coil in Bracket.* Position coil in the bracket clamp and tighten the clamping screw securely.

(b) *Install Coil and Bracket Assembly on the Engine.* Lift the coil and bracket assembly into place, and attach the bracket to the rear cylinder head with the cylinder head cap screw which was removed.

(c) *Connect Coil Wires.* Connect the two primary leads and the secondary lead to the coil.

b. Spark Plugs.

(1) **REMOVAL.** Disconnect suppressor on the end of each spark plug wire from the spark plug terminals. Use the spark plug wrench furnished in the vehicle tool kit, and remove the spark plug and spark plug gasket.

(2) **INSPECTION.** Examine spark plugs for cracked insulators, burned points, blowby, excessive carbon or excessive spacing of gap. Defective spark plugs must be replaced.

(3) **SETTING POINTS.** Use a wire feeler gage to measure the point gap. If it is too large or too small, it must be reset at 0.027 inch. Bend the side electrode (never bend center electrode) to secure the proper gap.

(4) **INSTALLATION.** Thread the plugs into the opening in the cylinder heads, using a new gasket under each plug. Tighten plugs with a spark plug wrench, being careful the wrench does not slip off and crack insulator. Install the suppressor on the end of each spark plug wire over the terminal on each spark plug.

Section XXI

GENERATING SYSTEM

	Paragraph
Description and tabulated data.....	93
Generator	94
Generator regulator.....	95

93. DESCRIPTION AND TABULATED DATA.

a. **Description.** The generating system is made up of the generator, generator regulator, generator filterette, ammeters, batteries and wires as indicated in figure 79. The function of the system is to maintain batteries in a fully charged condition.

b. **Tabulated Data.**

(1) **GENERATOR.**

MakeAuto-Lite
 ModelGEW 4802
 Rotation.....Clockwise at the drive end
 Volts6
 Ground polarity.....Positive
 Poles2
 Brushes2

(2) **GENERATOR REGULATOR.**

MakeAuto-Lite
 TypeVRY 4201A
 Volts6
 Ground polarity.....Positive

94. GENERATOR.

a. **Description.** The generator is a gear-driven, air-cooled unit.

b. **Removal.**

(1) **DISCONNECT BATTERY CABLES.** Loosen the clamp screws in the battery cables on the negative battery terminals, and pull the cables clear of the battery.

(2) **DISCONNECT GENERATOR BOND STRAP.** Remove the cap screw, nut, lock washer, and toothed lock washer holding the generator bond strap to the generator frame, and disconnect the bond strap.

(3) **DISCONNECT GENERATOR WIRES.** Disconnect the wires running between the voltage regulator and the generator at the generator.

(4) **REMOVE GENERATOR PILOT BOLT.** Back off the lock nut from the generator mounting pilot bolt, and then remove the bolt from the generator mounting hole on top of gear cover at drive end of generator.

(5) **REMOVE THE GENERATOR.** Crawl under the vehicle and slide the generator back until it is completely out of the pilot hole and back of the gear cover, and then lower the unit until it is clear of chassis.

c. **Replacement.**

(1) **INSTALL GENERATOR.** Install the generator into position underneath the vehicle and insert the mounting sleeve on the end of the

4-TON, 6 x 6 TRUCKS (DIAMOND T MODELS 968A CARGO,
969A WRECKER, 970A PONTON, AND 972 DUMP)

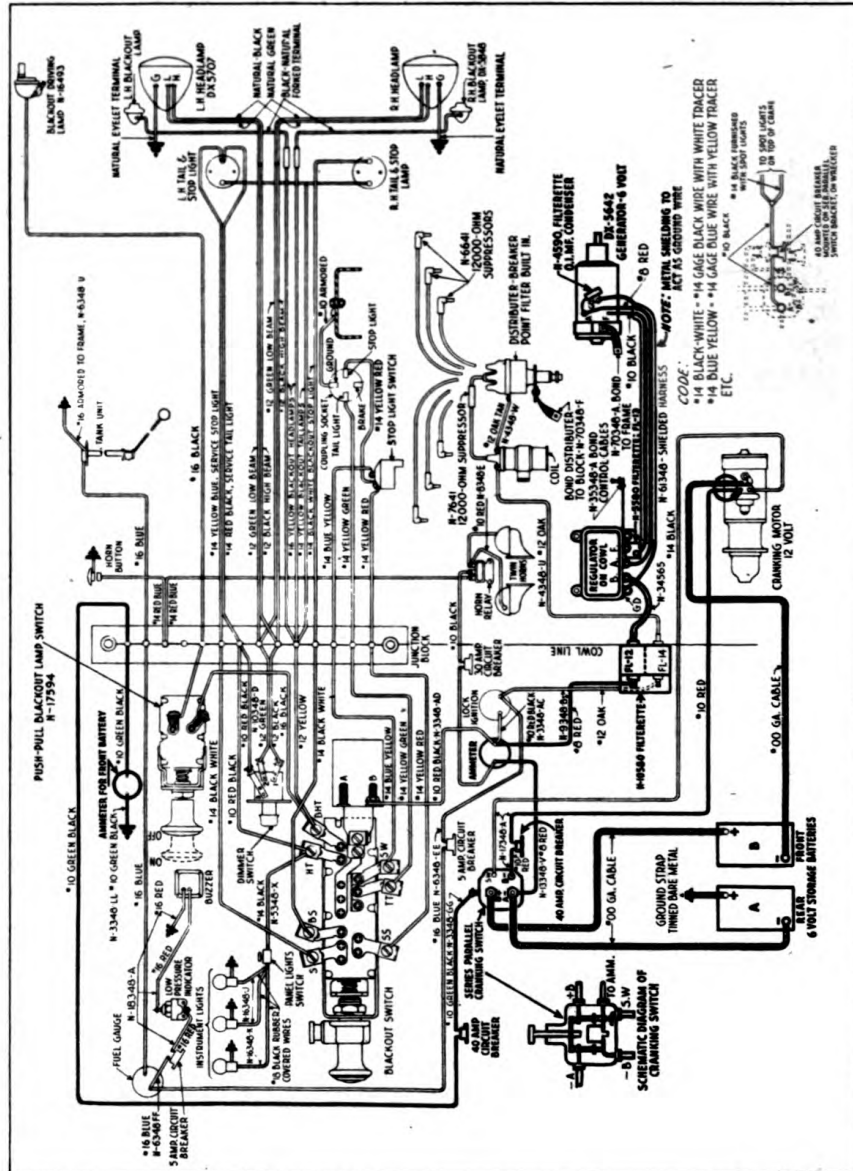

RA PD 313778

Figure 79—Wiring Diagram—Dark Lines Indicate Generating Circuit

GENERATING SYSTEM

generator housing through the pilot hole in back of the gear cover. Slide it forward into position, engaging the generator drive gear with the idler gear, and the governor drive gear with the driven gear (fig. 80).

(2) **INSTALL GENERATOR MOUNTING PILOT BOLT.** Thread the generator mounting bolt into the threaded hole on top of the generator mounting hole and tighten bolt securely, being sure that the tapered portion on the end is properly seated in the hole in the generator mounting sleeve. When this bolt is properly tightened, run lock nut down against the post on top of the casting to keep the mounting secure.



Figure 80—Installing Generator

(3) **CONNECT GENERATOR WIRES.** Connect the wires running between the generator and the regulator to the generator (fig. 79).

(4) **CONNECT GENERATOR BOND STRAP.** Swing the bond strap into position on the chassis frame and fasten it in place with the bolt, nut, lock washer and toothed lock washer which were removed.

(5) **CONNECT BATTERY CABLES.** Connect the battery cables to the negative post of the batteries and tighten cable clamps.

95. GENERATOR REGULATOR.

a. **Description.** The generator regulator is the vibrating type which has three units which perform a distinct and independent function. The circuit breaker operates to open and close the circuit between

4-TON, 6 x 6 TRUCKS (DIAMOND T MODELS 968A CARGO, 969A WRECKER, 970A PONTON, AND 972 DUMP)

the generator and regulator, as the generator voltage rises above or falls below that of the battery. The current limiting regulator controls the maximum output of the generator. The generator regulator is used to hold the system voltage between close limits under the operating conditions of the system's capacity.

b. Removal.

(1) **DISCONNECT BATTERY CABLES.** Loosen the clamp screws and disconnect the cables from the negative terminals of the batteries.



Figure 81—Removing Regulator Mounting Nuts

(2) **DISCONNECT GENERATOR TO REGULATOR WIRING HARNESS.** Disconnect the wiring harness between the generator and regulator at the regulator.

(3) **DISCONNECT THE COPPER STRAP ATTACHED TO THE REGULATOR BATTERY TERMINAL.** Remove the screw and lock washer holding the strap to the regulator terminal and swing the strap out of the way.

(4) **DISCONNECT CONTROL WIRE BOND STRAP FROM THE REGULATOR.** Remove the screw, lock washer, plain washer and toothed lock washer holding the control cable bond strap to the regulator, and swing the strap out of the way.

GENERATING SYSTEM

(5) **REMOVE REGULATOR MOUNTING NUTS.** Remove the nuts, lock washers and toothed lock washers holding the regulator mounting legs to the cowl panel (fig. 81).

(6) **REMOVE THE REGULATOR ASSEMBLY.** Pull the regulator assembly from the mounting bolts, and remove the assembly from the engine compartment.

c. Installation.

(1) **INSTALL REGULATOR.** Install regulator into position over the mounting bolts extending through the cowl panel, and fasten in place with the nuts, lock washers and toothed lock washers which were removed.

(2) **CONNECT THROTTLE AND CHOKE WIRE BOND STRAP.** Swing the throttle and choke wire control bond strap into position against the regulator leg, and attach in place with the screw, lock washer, plain washer and toothed lock washer which were removed.

(3) **CONNECT THE COPPER STRAP TO THE REGULATOR BATTERY TERMINAL.** Install the copper strap into position against the regulator battery terminal and install the screw and lock washer which were removed.

(4) **CONNECT GENERATOR TO REGULATOR WIRING HARNESS.** Connect the wiring harness between the generator and regulator to the regulator terminals. See figure 79.

(5) **CONNECT BATTERY CABLES.** Connect battery cables to the negative terminals of the batteries and tighten cable clamp screw.

4-TON, 6 x 6 TRUCKS (DIAMOND T MODELS 968A CARGO,
969A WRECKER, 970A PONTON, AND 972 DUMP)

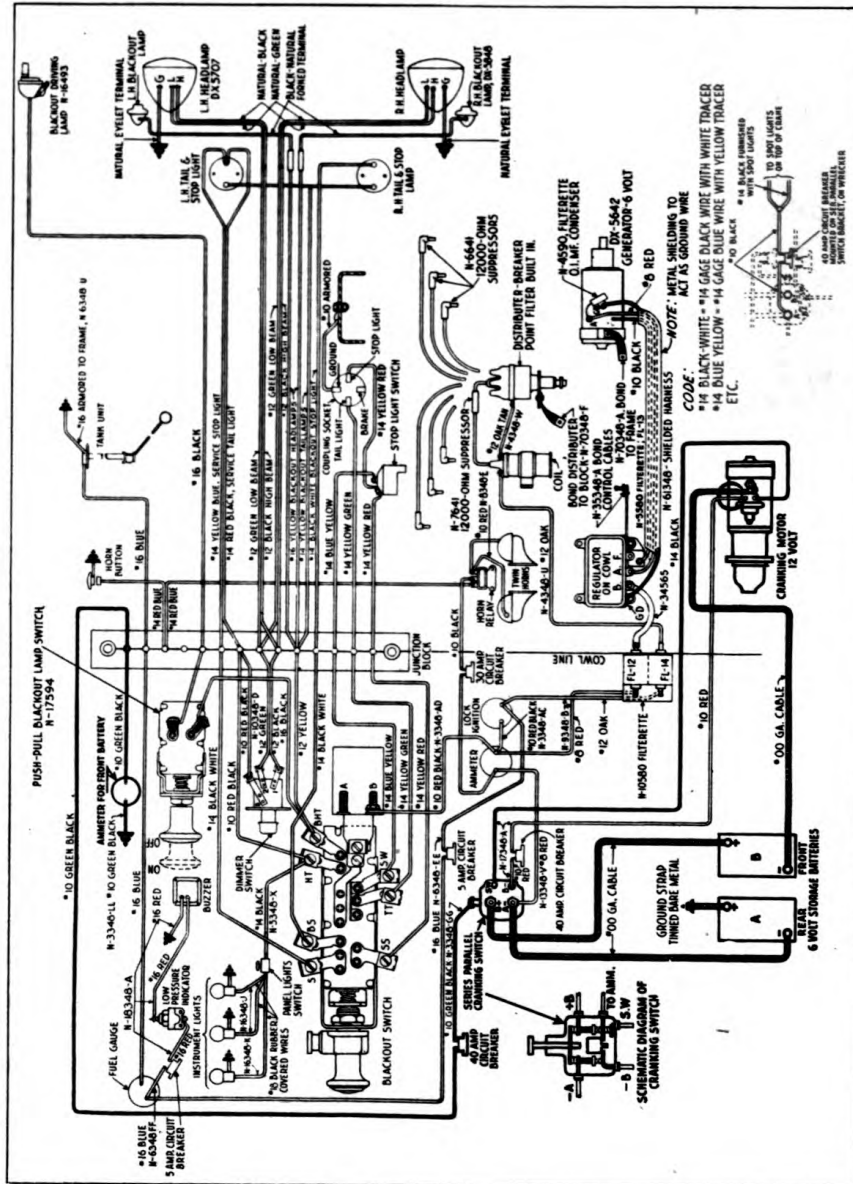

RA PD 313779

Figure 82—Wiring Diagram—Dark Lines Indicate Starting System

Section XXII

STARTING SYSTEM

	Paragraph
Description and tabulated data	96
Cranking motor	97
Solenoid switch	98
Series parallel switch	99

96. DESCRIPTION AND TABULATED DATA.

a. **Description.** The starting system is made up of the cranking motor, solenoid switch, series parallel switch, batteries, and the wiring, as indicated in figure 82. The function of the system is to turn the engine over for starting and it operates only while the starting button is depressed.

b. **Tabulated Data.**

(1) **CRANKING MOTOR.**

Make Auto-Lite
 Model ML 4209
 Rotation Clockwise at drive end
 Volts 12

97. CRANKING MOTOR.

a. **Description.** The cranking motor is a 12-volt unit which is energized by two 6-volt batteries which are connected in series in the starting circuit. The cranking motor is the direct-drive type which engages with the flywheel gear through a conventional Bendix drive.

b. **Removal.**

(1) **DISCONNECT BATTERY CABLES.** Loosen the clamp screws on the ends of the battery cables running to the negative terminals of the batteries and disconnect the cables. Disconnect the wires running to the solenoid switch at the solenoid switch. Remove the nut and lock washer holding the battery cable to the terminal post and disconnect cable from the cranking motor.

(2) **REMOVE CRANKING MOTOR ASSEMBLY.** Remove the cap screws and lock washers holding the cranking motor assembly to the bell housing and then work the assembly forward until the pinion housing clears the bell housing. Then lower the unit until it is clear of chassis obstructions. After the cranking motor is removed, remove the cranking motor adapter from the bell housing attaching studs.

c. **Installation.**

(1) **INSTALL ADAPTER.** Install the cranking motor adapter over the mounting studs on the bell housing.

(2) **INSTALL CRANKING MOTOR.** Lift the cranking motor in position in front of the bell housing and slide it back through the bell housing opening so that the holes in the mounting flange go over the mounting studs in the bell housing (fig. 83). Be sure that the open side of the pinion housing faces toward the flywheel ring gear. Then install the nuts and lock washers which were removed.

TM 9-811
97-98

**4-TON, 6 x 6 TRUCKS (DIAMOND T MODELS 968A CARGO,
969A WRECKER, 970A PONTON, AND 972 DUMP)**

(3) **CONNECT BATTERY CABLES AND WIRES TO CRANKING MOTOR.** Connect all wires running to the cranking motor (fig. 82). Connect the battery cables to the negative terminals of the batteries and tighten the cable clamp screws.

98. SOLENOID SWITCH.

a. **Description.** The solenoid switch is an electromagnetic switch which closes the starting circuit and operates whenever the series parallel switch opens or closes.

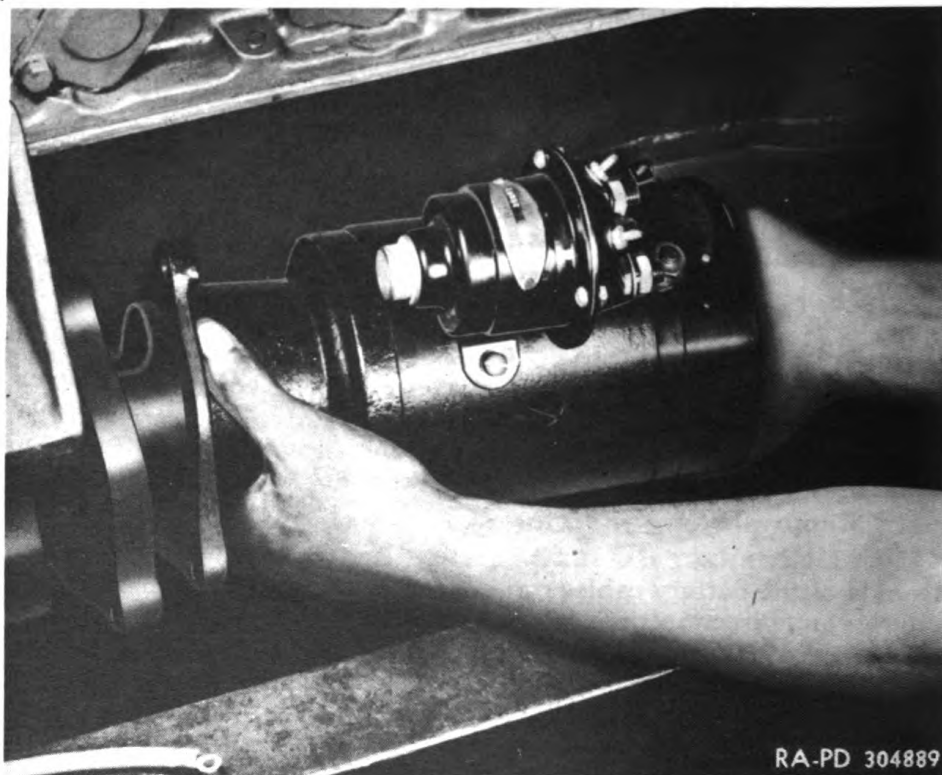

Figure 83—Installing Cranking Motor

b. Removal.

(1) **DISCONNECT WIRES.** Loosen the clamp screw in the battery cables connected to the negative terminals of the battery and disconnect the cables. Disconnect the wires and battery cables running to the solenoid switch.

(2) **DISCONNECT BATTERY TERMINAL CONNECTOR BAR FROM SOLENOID SWITCH.** Remove the nut and lock washer holding the battery cable connector bar running between the solenoid switch and the cranking motor, and disconnect this connector from the solenoid.

(3) **REMOVE SOLENOID SWITCH.** Remove the screws and lock

STARTING SYSTEM

washers holding the solenoid switch to the cranking motor and remove the switch.

c. Installation.

(1) **INSTALL SOLENOID SWITCH ON CRANKING MOTOR.** Place the solenoid switch on top of the cranking motor and fasten it in place with the screws and lock washers which were removed.

(2) **CONNECT BATTERY CABLE CONNECTOR TO THE SOLENOID SWITCH.** Slide the end of the copper bar over the end of the battery

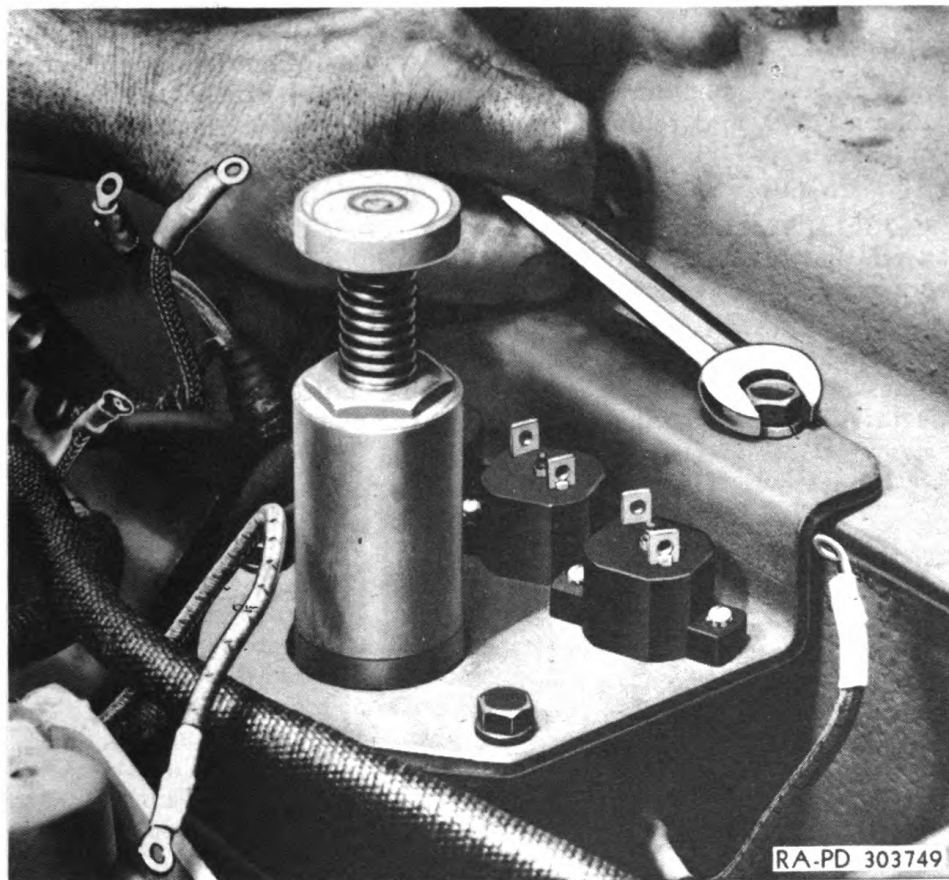

Figure 84—Removing Series Parallel Switch Bracket Cap Screws

cable terminal and the solenoid switch, and fasten in place with the nut and lock washer which were removed.

(3) **CONNECT WIRES.** Connect the battery cables and wires to the solenoid switch (fig. 82). Install the battery cables over the ends of the negative terminals on the battery and tighten the clamping screws.

99. SERIES PARALLEL SWITCH.

a. **Description.** The series parallel switch is a manually operated switch which connects the battery in series, providing a 12-volt starting

**4-TON, 6 x 6 TRUCKS (DIAMOND T MODELS 968A CARGO,
969A WRECKER, 970A PONTON, AND 972 DUMP)**

system whenever the switch is closed. This switch also energizes the solenoid switch, causing the 12-volt current to be delivered to the cranking motor.

b. Removal.

(1) **DISCONNECT WIRES.** Loosen the clamp screws in the battery cables fastened to the negative battery terminals, and disconnect the cables. Disconnect all wires running to the circuit breakers mounted on the series parallel switch bracket. Disconnect series parallel switch wires.

(2) **REMOVE SERIES PARALLEL SWITCH.** Remove the cap screws and lock washers holding the series parallel switch bracket to the transmission cover, and remove the series parallel switch and bracket assembly (fig. 84).

c. Installation.

(1) **INSTALL SERIES PARALLEL SWITCH.** Attach the series parallel switch and bracket assembly to the transmission cover, using the cap screws and lock washers which were removed.

(2) **CONNECT WIRES** (fig. 82). Connect all wires and cables to the series parallel switch. Connect the wires which were disconnected from the circuit breakers. Install battery cables over the ends of the negative battery terminals and tighten the clamp screws.

Section XXIII

BATTERIES AND LIGHTING SYSTEM

	Paragraph
Tabulated data.....	100
Batteries	101
Lighting system and horns	102

100. TABULATED DATA.

a. Battery.

Make	Exide
Model	XH-194
Number of cells.....	3
Volts	6
Capacity	152 amp hours
Full charge specific gravity at 80°F.....	1.280
Number of batteries used.....	2
Over-all dimensions:	
Length	12 ⁵ / ₈ in.
Width	7 ¹ / ₈ in.
Height	9 ¹ / ₁₆ in.

b. Lights.

Headlights:

Type	Sealed beam
Number	DT-DX5707

Lamps:

Headlight (sealed beam unit—925086)	
Upper beam.....	45 watts
Lower beam	35 watts
Service taillights (Mazda No. 63).....	3 cp
Service taillights (Mazda No. 1158).....	21 cp
Instrument lamps (Mazda No. 55).....	3 watts
Beam indicator lamp (Mazda No. 51).....	1 cp
Blackout lamps (Mazda No. 63).....	3 cp
Wrecker spot light (Mazda No. 1183).....	50 cp

101. BATTERIES.

a. Description. These vehicles are equipped with two 6-volt batteries which are connected in a series parallel circuit. They operate in a 6-volt circuit for charging, lights, ignition, etc. They function in series for a 12-volt circuit during cranking motor operation (fig. 85).

b. Adding Water. When adding water, add a sufficient amount to come to about ³/₈ inch above the tops of the separators, that is, to the bottom of the cover well. These batteries have covers and vent plugs which act to limit amount of water added. Excess water added rises in filling tube or well only. Do not remove or injure the lead ring. **CAUTION:** *Take care when adding water with a syringe not to push the lead ring off its seat.* Two batteries of the same serviceable condition should require about the same amount of water when connected

4-TON, 6 x 6 TRUCKS (DIAMOND T MODELS 968A CARGO,
969A WRECKER, 970A PONTON, AND 972 DUMP)

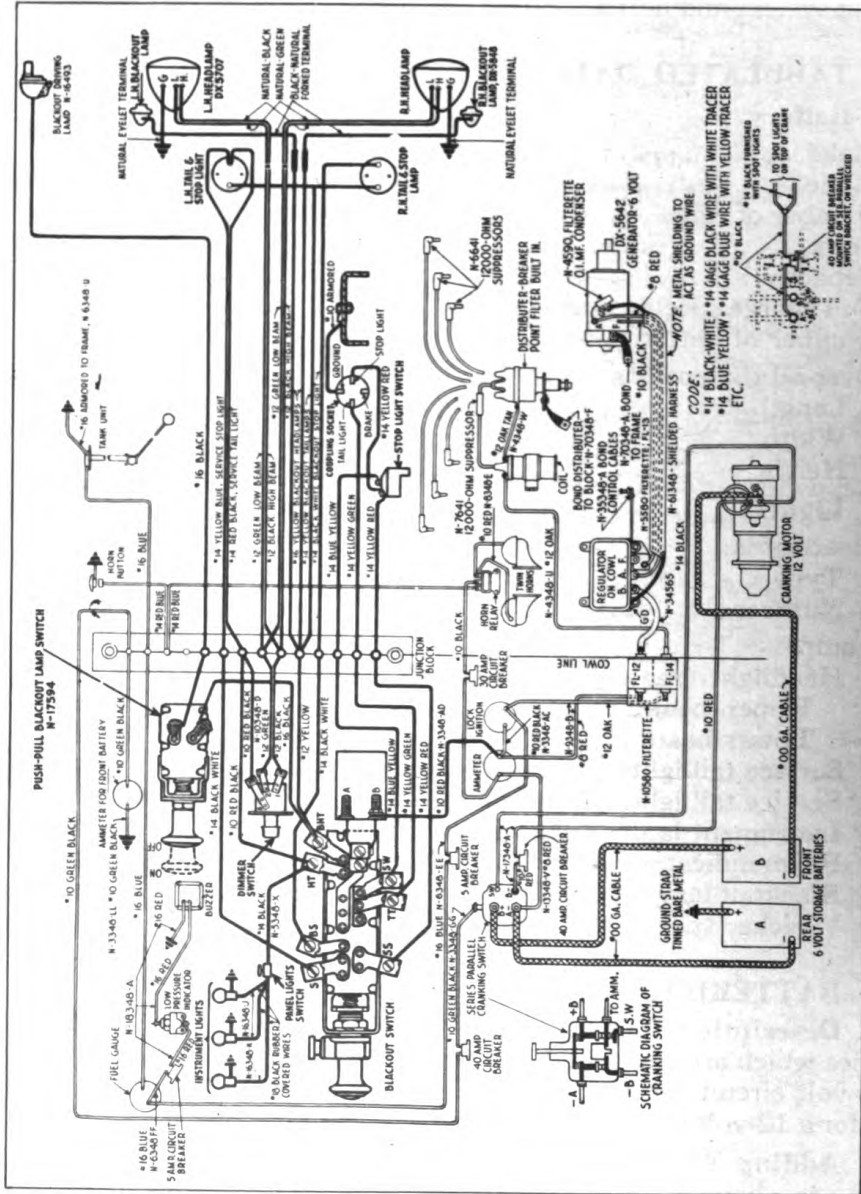

RA PD 313777

Figure 85—Wiring Diagram—Dark Lines Indicate Lighting System

BATTERIES AND LIGHTING SYSTEM

in parallel. If this is not the case, check to see that electrical connections are clean and tight.

c. **Hydrometer Readings** (fig. 86).

(1) To take a hydrometer reading, insert the nozzle of the hydrometer syringe in the electrolyte, squeeze the bulb and slowly release it, drawing up enough electrolyte to float the hydrometer freely. Holding the syringe vertically, the reading on the stem of the hydrometer at the surface of the electrolyte is the specific gravity of the electrolyte. Then return the electrolyte to the same cell (fig. 86).

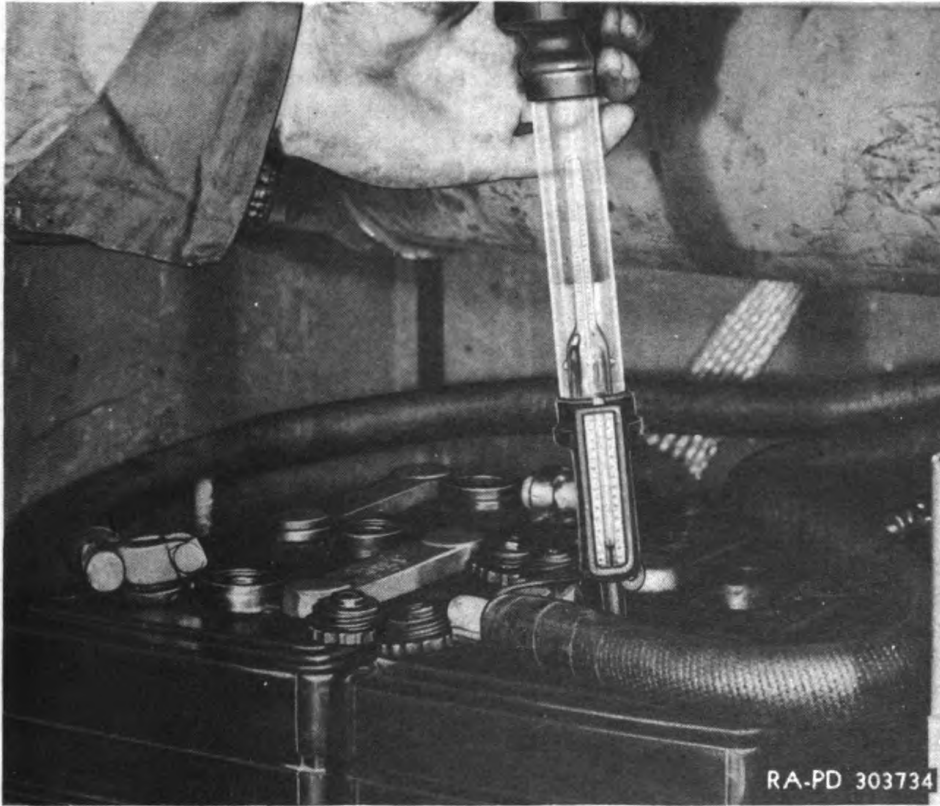

Figure 86—Hydrometer Test

(2) The specific gravity for full charge should be 1.270 to 1.285. Readings above 1.225 are all right but whenever a reading is lower than that, the battery must be removed for a bench charge.

(3) Specific gravity readings must be corrected for the temperature of the electrolyte in the battery at the time of testing. If such correction is not made, the specific gravity reading is misleading as a measure of the condition of charge of the battery. The correction per 10°F of temperature variation is approximately 0.004 in specific gravity. The following table indicates the correction that must be made for various temperatures:

4-TON, 6 x 6 TRUCKS (DIAMOND T MODELS 968A CARGO, 969A WRECKER, 970A PONTON, AND 972 DUMP)

Temperature of Electrolyte	Specific Gravity Correction
+ 110° F.....	Add 12 points to hydrometer reading
+ 100° F.....	Add 8 points to hydrometer reading
+ 90° F.....	Add 4 points to hydrometer reading
+ 80° F.....	No correction required
+ 70° F.....	Subtract 5 points from hydrometer reading
+ 60° F.....	Subtract 8 points from hydrometer reading
+ 50° F.....	Subtract 12 points from hydrometer reading
+ 40° F.....	Subtract 16 points from hydrometer reading
+ 30° F.....	Subtract 20 points from hydrometer reading
+ 20° F.....	Subtract 24 points from hydrometer reading
+ 10° F.....	Subtract 28 points from hydrometer reading
0° F.....	Subtract 32 points from hydrometer reading
- 10° F.....	Subtract 36 points from hydrometer reading
- 20° F.....	Subtract 40 points from hydrometer reading

(4) Do not take hydrometer readings immediately after adding water. Allow a day or so for the water to mix with the electrolyte, otherwise the reading is false. If the battery is on charge and gassing, the water will be mixed within an hour.

(5) Do not use the same cell each time to take the gravity readings. Change around to the various cells. This recommendation is made to avoid lowering the gravity of one cell due to possible loss of a small amount of electrolyte in taking gravity readings. Using all cells spreads the possible loss over all cells, rather than have the loss taken by one cell.

d. **Corrosion.** If any corrosion takes place, it must be scraped or brushed off. The battery should then be washed with, or immersed in, a baking soda solution. (Proportions—one pound of soda to a gallon of water.) Be sure that the vent plugs are tight in place. After the acid has been neutralized, rinse, dry, and cover with a light film of petrolatum.

e. Removal.

(1) **DISCONNECT BATTERY CABLES.** Loosen the clamp screws on the ends of all battery cables, spread the connector clamps and disconnect the cables from the batteries. Swing the cables clear to permit removal of the batteries.

(2) **REMOVE HOLD-DOWN COVER.** Remove the two wing nuts, lock washers and plain washers holding the hold-down cover to the battery container screws, and lift off the cover.

(3) **REMOVE BATTERIES.** Install a battery lifting strap over the terminals of one battery, and lift the battery out of the battery compartment. Then remove the other battery in the same manner (fig. 87).

f. Installation.

(1) **INSTALL BATTERIES.** Lift the batteries with a battery lifting strap and place them in position in the battery compartment.

(2) **INSTALL HOLD-DOWN COVER.** Install the hold-down cover over the battery carrier screws and slide the cover down into position

BATTERIES AND LIGHTING SYSTEM

so that it forms a shoulder around the edges of the batteries. Then fasten the cover in place with the wing nuts, plain washers and lock washers which were removed.

(3) **CONNECT BATTERY CABLES.** Connect the battery cables to the battery terminals and tighten the clamping screws (fig. 85).

102. LIGHTING SYSTEM AND HORNS.

a. Headlights.

(1) **DESCRIPTION.** Two different types of headlights are supplied



Figure 87—Removing Batteries

with the vehicles. The majority of the vehicles (Models 968A, 969A, 970A and 972) are equipped with a conventional sealed-beam type headlight assembly. Some of the vehicles (Model 968B and 969B) are equipped with one hooded-type blackout headlamp. This headlight is not the sealed-beam type.

(2) **REPLACEMENT OF SEALED BEAM UNIT.**

(a) **Remove Headlight Guard.** Remove the nuts and lock washers holding the headlight guard to the fender, and remove the guard.

TM 9-811
102

4-TON, 6 x 6 TRUCKS (DIAMOND T MODELS 968A CARGO,
969A WRECKER, 970A PONTON, AND 972 DUMP)

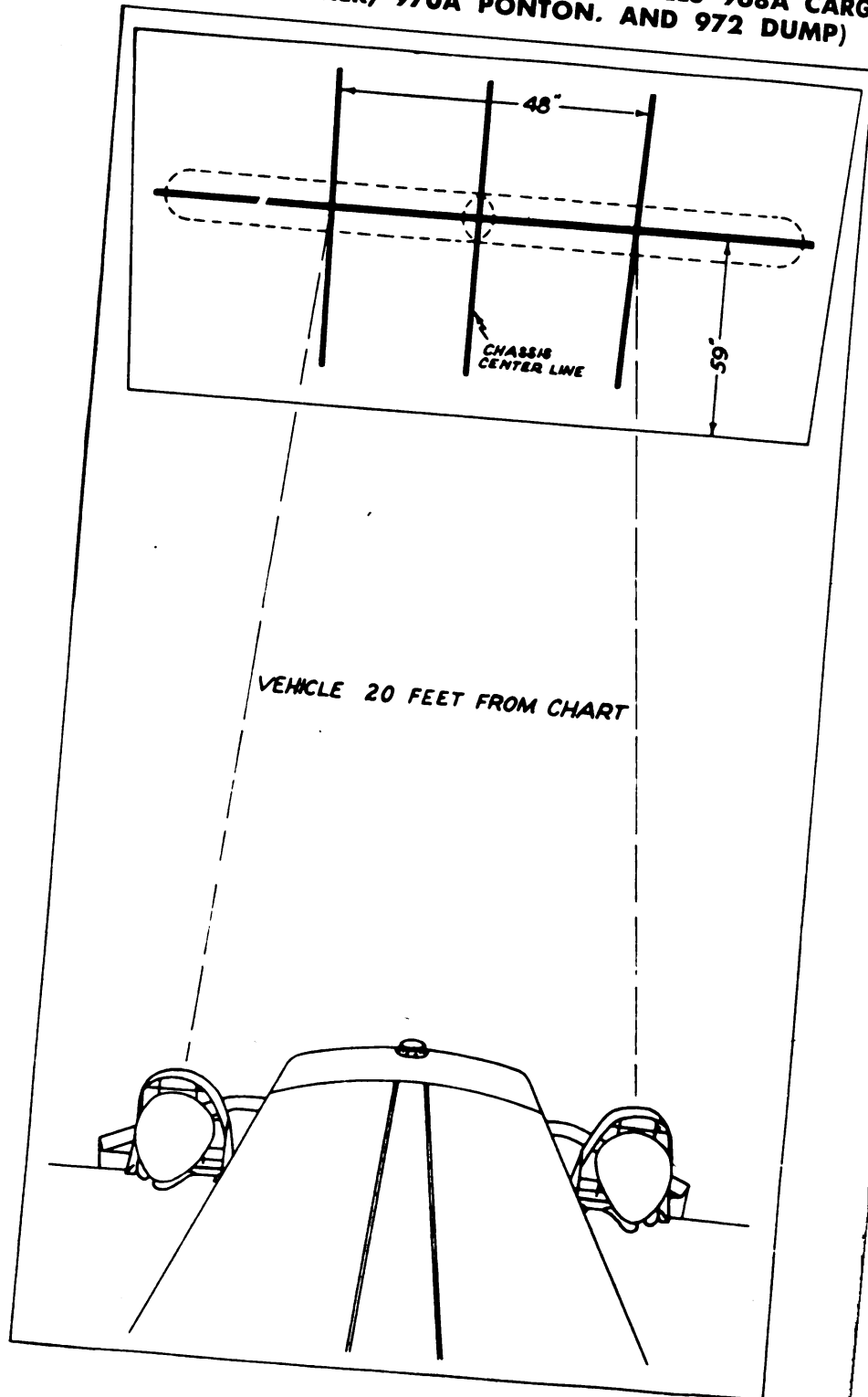

Figure 88—Head Lamp Adjustment

208

RA PD 313799

BATTERIES AND LIGHTING SYSTEM

(b) *Remove Headlight Rim.* Remove the clamp screw at the bottom of the rim assembly, and then spread the rim so that it may be slipped off the headlight body.

(c) *Remove Sealed Beam Unit.* Remove the three screws attaching the sealed beam unit to the headlight body, and pull the unit out far enough so that the wires may be pulled from the connector plug. Then remove the sealed beam unit.

(d) *Install New Sealed Beam Unit.* Lift the new sealed beam unit into place, and plug in the connector. Then push the unit into place in the headlight body and fasten it there with the screws which were removed.

(e) *Install Headlight Rim.* Spread the headlight rim a sufficient amount so that it may be installed over the front of the headlight body.

(f) *Install the Rim Clamp Screw.* Install the rim clamp screw and tighten it securely.

(g) *Install Headlight Guard.* Install the headlight guard, replace on the fender, and attach it there with the bolts, nuts and lock washers which were removed.

(3) LAMP REPLACEMENT FOR BLACKOUT TYPE HEADLIGHT.

(a) *Remove Blackout Mask.* Remove the screw and lock washers holding the blackout mask to the headlight body, and remove the mask, gasket and gasket ring.

(b) *Remove Lamp.* Push the lamp in, and twist to the left and remove it from the socket.

(c) *Install New Lamp.* Push the lamp into the socket, and twist to the right to lock it in place.

(d) *Install Blackout Mask.* Install the blackout mask, gasket and gasket ring into place on the headlight body, and fasten it with the screws and lock washers which were removed.

(4) **HEADLIGHT ADJUSTMENT.** If a headlight tester is available, it will provide a quick and accurate means of obtaining proper headlight adjustment. If this is not available, a chart may be made up as shown in fig. 88. Aim the vehicle at the chart from a distance of about 20 feet, and turn on the headlights. Loosen the support nut under the headlight bracket, and aim the light so that the proper beam travel is obtained on the chart (fig. 88). When the proper adjustment is obtained, tighten the support nut.

(5) HEADLIGHT REMOVAL.

(a) *Remove the Wire Retainer Clips Under Fender.* Remove the nuts and lock washers holding the wire retainer clips to the fender bracket, and pull the headlight wiring assembly down.

(b) *Disconnect Headlight Wires.* Remove the tape from the ends of the loom, and slide the loom down towards the frame rail to uncover the connection. Then break the wires at the connection. Remove the nut and lock washer holding the headlight ground wire to the fender bracket.

4-TON, 6 x 6 TRUCKS (DIAMOND T MODELS 968A CARGO, 969A WRECKER, 970A PONTON, AND 972 DUMP)

(c) *Remove Headlight.* Remove the nut and lock washer holding the headlight pivot ball nut to the headlight bracket, and remove the headlight assembly (fig. 89).

(6) **HEADLIGHT INSTALLATION.**

(a) *Install the Headlight Assembly.* Install the headlight assembly into position on the headlight bracket, with the pivot ball bolt and the headlight wires extending through the hole in the bracket. Then attach the headlight in place with the nut and lock washer which were removed.

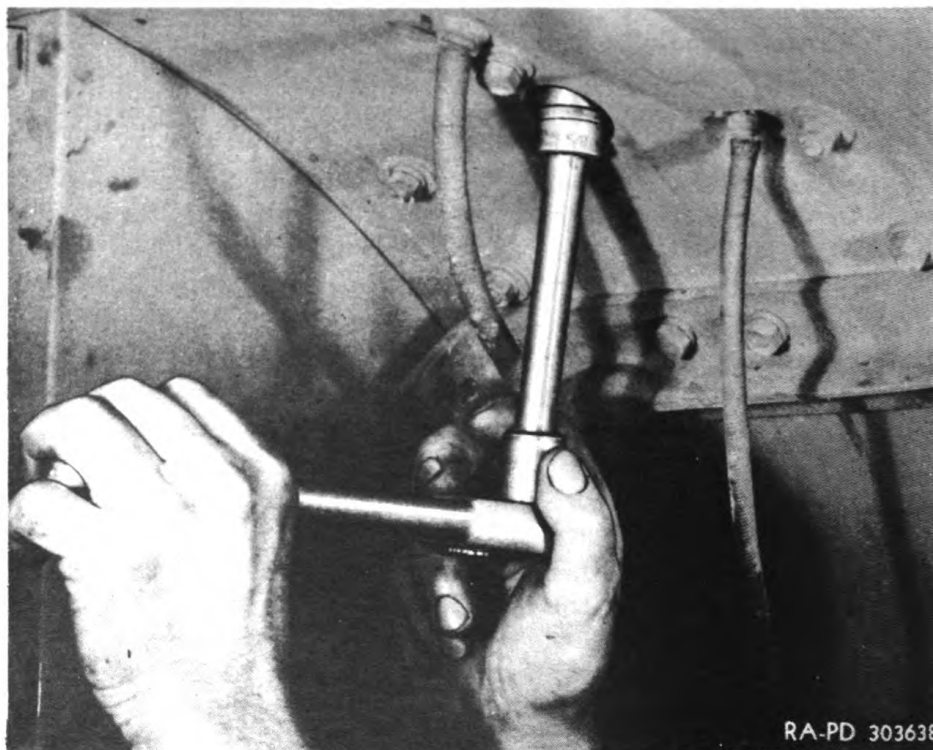

Figure 89—Removing Headlight Mounting Unit

(b) *Connect Headlight Wires.* Attach the headlight ground wire to the fender bracket with the nut and lock washer which were removed. Then connect the front headlight wires according to the color scheme shown in the wiring diagram (fig. 85). Slide the loom up over the connection and tape the loom at each end.

(c) *Install Headlight Wire Clips.* Work the headlight wiring harness into position along the fender bracket, and attach there with the clips, nuts and lock washers which were removed.

(d) *Adjust Headlight.* Adjust the headlight as described in paragraph 100 a (4).

BATTERIES AND LIGHTING SYSTEM

b. Blackout Driving Light.

(1) **DESCRIPTION.** The blackout driving light is a small sealed beam type headlight with a blackout mask over the lens. It is mounted on the left fender beside the regular headlight.

(2) SEALED BEAM UNIT REPLACEMENT.

(a) *Remove Blackout Light Rim.* Remove the retaining screw at the bottom of the blackout mask rim, and then swing the rim and mask assembly out, pushing at the top far enough to disconnect the hooked hinge at the top of the rim.

(b) *Remove Sealed Beam Unit and Blackout Mask Assembly.* Pull the plug from the wire connector in back of the sealed beam unit and remove the sealed beam unit and mask assembly.

(c) *Remove Sealed Beam Unit from Mask.* Using a small screwdriver, release the spring clips holding the sealed beam unit in the blackout mask rim and remove the sealed beam unit.

(d) *Install New Sealed Beam Unit.* Install new sealed beam unit into position on the mask and rim assembly, and fasten in place with the spring clips in the rim.

(e) *Install Sealed Beam Unit and Blackout Mask Assembly.* Lift the assembly into position, and plug in the wire connector at the back of the sealed beam unit. Hook the hinge on the rim into the slot at the top of the lamp body, and swing the assembly into position. Install the rim retaining screw and tighten it securely.

(3) BLACKOUT DRIVING LIGHT REMOVAL.

(a) *Remove Wire Clips.* Remove the nuts and lock washers holding the wire clips to the fender bracket, remove the clips, and pull the wire assembly down.

(b) *Disconnect Wires.* Remove the tape from each end of the harness loom, and then slide the loom back on the wires to expose the connection. Disconnect blackout driving light wire.

(c) *Remove Blackout Driving Light Assembly.* Remove blackout light body mounting bolt, nut and lock washer from the bracket and lift the assembly from the bracket, pulling the wire through the hole in the fender (fig. 90).

(4) BLACKOUT DRIVING LIGHT INSTALLATION.

(a) *Install Blackout Driving Light.* Install the blackout driving light on the blackout driving light bracket with the bolt running through the pivot ball on the bracket and attach in place with the nut and lock washer which were removed. Run the wire through the hole in the fender, using a new fender grommet if the one in place is not in satisfactory condition.

(b) *Connect Wires.* Connect blackout driving light wires and slide the loom up to cover the connection. Tape both ends of the loom (fig. 85).

(c) *Install Headlight Harness.* Push the headlight harness into position along the fender bracket and replace the clips, nuts and lock washers which were removed.

(d) *Adjust Blackout Driving Light.*

TM 9-811

102

4-TON, 6 x 6 TRUCKS (DIAMOND T MODELS 968A CARGO, 969A WRECKER, 970A PONTON, AND 972 DUMP)

c. Blackout Marker Light.

(1) **DESCRIPTION.** A blackout marker light is mounted on each fender beside the headlight. The door shield makes its dim glow visible in only a very limited plane.

(2) **LAMP REPLACEMENT.**

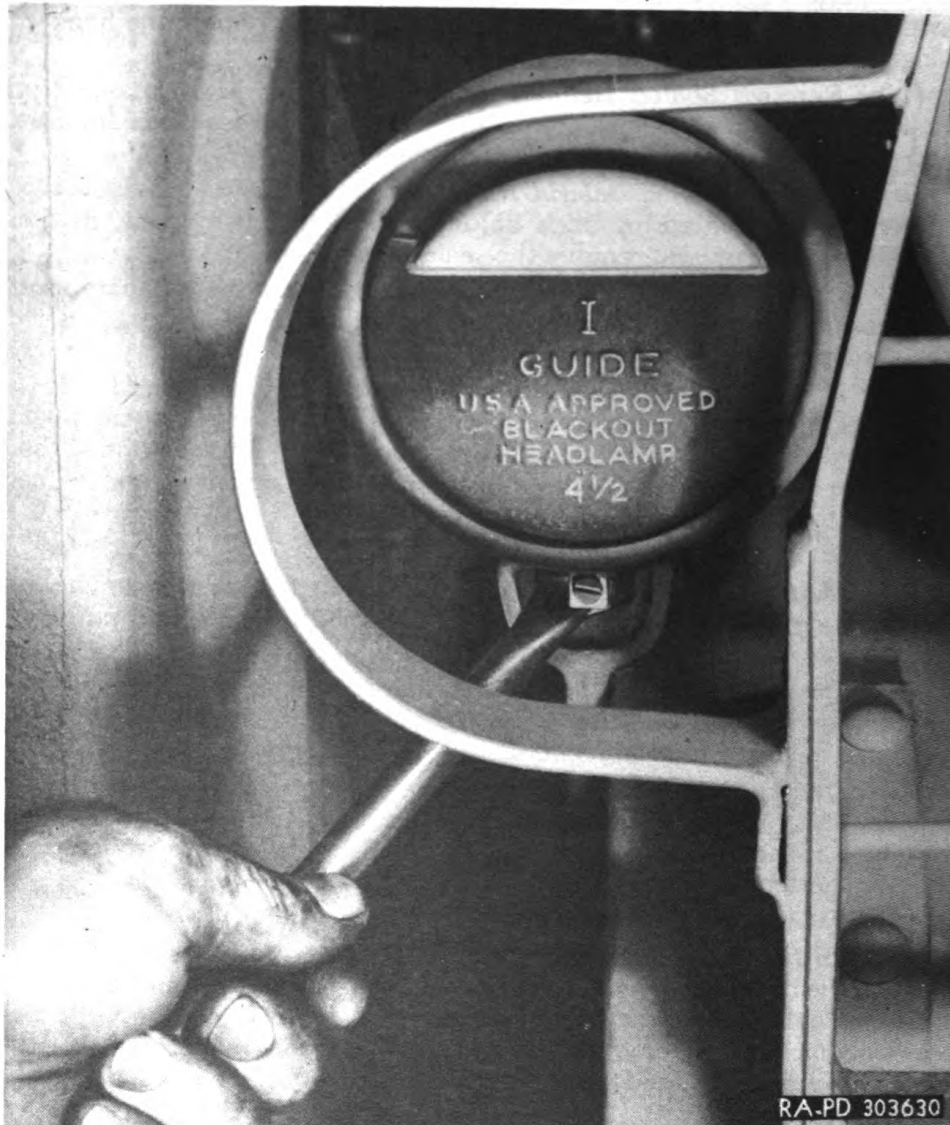

Figure 90—Removing Blackout Driving Light

(a) **Remove Door.** Remove the retainer screw at the bottom of the blackout marker door, and remove the door from the body.

(b) **Remove Lamp.** Push the lamp in, twist to the left and remove it from the socket.

BATTERIES AND LIGHTING SYSTEM

(c) *Install New Lamp.* Push the new lamp into the socket, and twist to the right to lock it in place.

(d) *Install Door.* Insert the door into position over the ends of the body, engaging the hinge pin at the top. Then install the retainer screw at the bottom and tighten it securely.

(3) BLACKOUT MARKER LIGHT REMOVAL.

(a) *Remove Headlight Harness Clips.* Remove the nuts and lock washers holding the headlight harness clips in place, remove the clips, and pull the wires down.



Figure 91—Removing Blackout Marker Light Nut

(b) *Disconnect Blackout Marker Light Wires.* Remove the tape from each end of the loom, and slide the loom down to expose the wire connections. Disconnect blackout marker light wires.

(c) *Remove Blackout Marker Light (fig. 91).* Remove the nut and toothed lock washer holding the blackout marker light to the fender, and remove the light from the fender.

(4) BLACKOUT MARKER LIGHT INSTALLATION.

(a) *Install the Blackout Marker Light.* Install the blackout marker light into place on the fender engaging the bead on the back end of the marker light bracket in the hole in the fender. Then fasten it in place with the nut and toothed lock washer which were removed.

4-TON, 6 x 6 TRUCKS (DIAMOND T MODELS 968A CARGO, 969A WRECKER, 970A PONTON, AND 972 DUMP)

(b) *Connect Blackout Marker Light Wires.* Connect the blackout marker light wires, and slide the loom up to cover the connection (fig. 85). Tape both ends of the loom.

(c) *Install Clips.* Push the headlight wire harness into place along the fender bracket, install the clips, and fasten them in place with the nuts and lock washers which were removed.

d. Stop and Taillights.

(1) **DESCRIPTION.** Most of the vehicles (Models 968A, 969A, 970A and 972) are equipped with two different stop and taillight assemblies. The right-hand stop and taillight contains a blackout taillight unit and blackout stop light unit. The left-hand stop and taillight unit contains a conventional taillight unit and a blackout stop light unit. Some of the vehicles (Model 968B and 969B) are equipped with two stop and taillight assemblies which are identical. Both of these assemblies contain a blackout tail lamp unit and a blackout stop lamp unit.

(2) **TAIL LAMP AND STOP LAMP UNIT REPLACEMENT.**

(a) *Remove Cover.* Remove the screws holding the cover to the stop and tail lamp body and remove the cover.

(b) *Remove Burned-out Unit.* Remove the burned-out unit by pulling it from the socket.

(c) *Install New Stop and Tail Lamp Unit.* Install new stop and tail lamp unit by pushing it into the socket.

(d) *Replace Cover.* Install the cover into place on the stop and taillight body and attach in place with the screws which were removed.

(3) **REMOVAL.**

(a) *Disconnect Stop and Taillight Wires.* Pull the wires from the socket and connectors in back of the stop and taillight assemblies. Remove the nut and lock washer holding the stop and taillight ground wire to the taillight mounting screw, and disconnect the wire.

(b) *Remove Stop and Taillight Assembly.* Remove nuts, screws and lock washers holding the taillight assembly to the taillight bracket and remove the assembly from the chassis.

(4) **INSTALLATION.**

(a) *Install Stop and Taillight Assembly.* Replace the stop and taillight assembly into position on the bracket and attach in place with the nuts and lock washers which were removed.

(b) *Connect Stop and Taillight Wires.* Install the stop and taillight ground wires over the inner attaching screw and fasten it in place with the nut and lock washer which were removed. Then connect the other wires in their respective sockets in back of the stop and taillight assembly.

e. Switches.

(1) **DESCRIPTION.** The main light switch is mounted on the instrument board which controls the headlights and stop lights (fig. 92). There is also a blackout driving light switch on the instrument board which controls the blackout driving light. A switch is mounted on the

BATTERIES AND LIGHTING SYSTEM

instrument board for controlling the instrument panel lights. These switches are all the conventional push-and-pull type, with the exception of the main light switch. This has a special latch plunger which prevents the operator from accidentally turning on the bright lights. There is a dimmer switch on the toeboard to switch the driving lights from high to low beam.

(2) REMOVAL.

(a) *Remove Light Switches.* The light switches may be removed by loosening the set screw in the puller knob, removing the knob, removing the dash nut and then pulling the switch out in back of the dash. (It is also necessary to remove the clamp bolt on the main light switch.) The switch bodies may then be removed after disconnecting the wires.

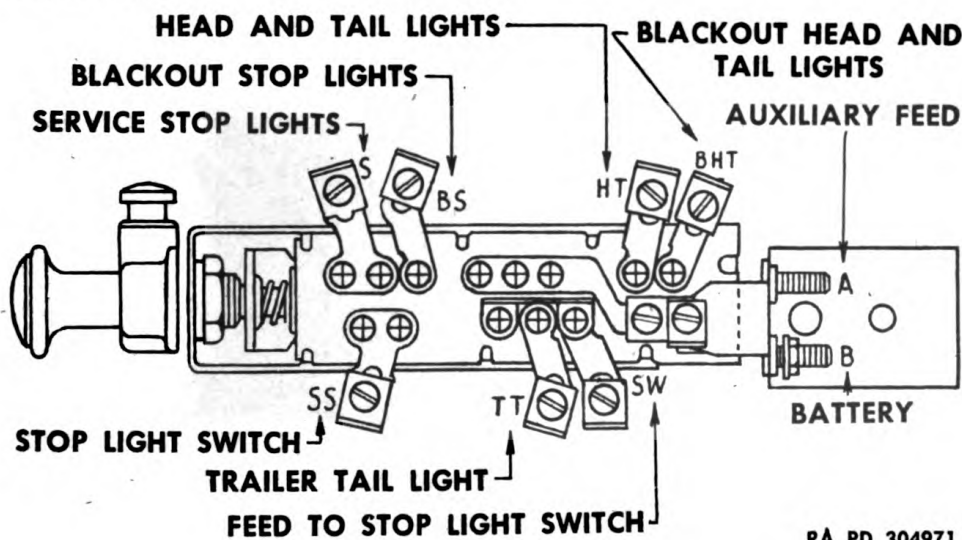

RA PD 304971

Figure 92—Main Light Switch

(b) *Remove Dimmer Switch.* The dimmer switch may be removed by removing the toeboard, disconnecting the wires and removing the screws and lock washers holding it in place (fig. 159) It may then be removed from the under side of the cowl toeboard ledge.

(3) INSTALLATION.

(a) *Installing Light Switches.* When replacing the switches, raise them into position in back of the dash board and connect the wires to the proper terminals, as indicated in the wiring diagram (fig. 85). Then insert the plunger rods through the openings in the dash and install the dash lock nuts. Install the blackout latch and clamp bolt on the main light switch. Then replace the knobs over the plunger rods, and tighten the set screws.

(b) *Installing Dimmer Switch.* Lift the dimmer switch into place through the opening in the bottom of the toeboard ledge on the cowl, and attach in place with the screws and lock washers which were removed. Connect wires as shown in figure 85 and replace the toeboard.

4-TON, 6 x 6 TRUCKS (DIAMOND T MODELS 968A CARGO, 969A WRECKER, 970A PONTON, AND 972 DUMP)

f. Horns.

(1) **DESCRIPTION.** Twin horns are mounted on the cowl panel inside the engine compartment which are controlled by a conventional-type horn button located in the center of the steering wheel.

(2) **HORN BUTTON.**

(a) **Removal.** Twist the horn button far enough to permit the holding ears to clear the clamping legs on the base plates. Then lift the horn button carefully so as not to lose the small parts as the button is removed. The contact cup, contact cup spring and pilot may be removed with the button. Then remove the screws holding the base plate

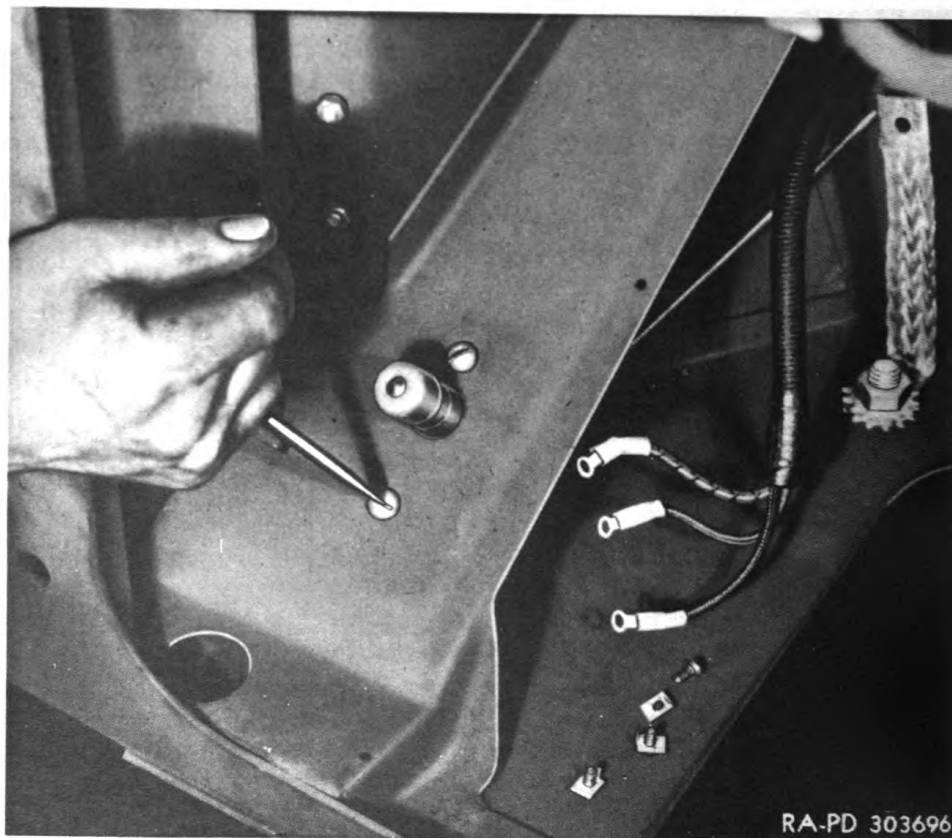

Figure 93—Removing Dimmer Switch

in the steering wheel recess. Lift out the horn wire bushing, horn wire bushing cup and horn wire bushing spring and base plate as an assembly. Untape the horn wire connection at the bottom of the steering column and disconnect the wires, then pull the entire assembly out through the top of the steering wheel.

(b) **Installation.** Assemble the horn wire bushing, horn wire bushing cup, horn wire bushing spring and horn wire through the base plate, and pull the wire through the steering column with a fishing wire. Fasten the base plate to the steering wheel using the screws which were

BATTERIES AND LIGHTING SYSTEM

removed. Install the contact cup, contact cup spring and pilot. Push the horn button over these parts and twist it far enough so that the holding ears are engaged behind the clamping legs of the base plate, then connect the horn wire at the bottom of the steering wheel and tape the connection.

(3) HORN ASSEMBLY.

(a) Removal. Disconnect the wires to the horn, then remove the nuts, screws and lock washers holding the horn assembly to the bracket, and remove the horn.



Figure 94—Removing Circuit Breaker

(b) Installation. Install the horn assembly into position on the bracket and attach in place with the screws, nuts and lock washers which were removed. Connect horn wires to the horn (fig. 85).

(4) HORN RELAY.

(a) Removal. Disconnect the three wires from the relay terminals, then remove the screws, nuts, and lock washers holding the relay to the cowl. Remove the horn relay.

(b) Installation. Install the horn relay into position on the cowl and fasten in place with the screws, nuts, and lock washers which were removed. Connect the wires to the horn relay terminals (fig. 85).

**4-TON, 6 x 6 TRUCKS (DIAMOND T MODELS 968A CARGO,
969A WRECKER, 970A PONTON, AND 972 DUMP)**

g. Circuit Breakers.

(1) **GENERAL.** Circuit breakers are provided in the fuel gage (5 amps), horn relay (30 amps), series parallel switch (40 amps), and cranking motor (40 amps) circuits on all 4-ton 6 x 6 vehicles. In addition a circuit breaker is used in the spotlight (40 amps) circuit on wrecker trucks. These are located on the series parallel switch bracket, and on the steering post bracket under the dash.

(2) **REMOVAL.** Disconnect the wires from the circuit breakers, and remove the screws holding them in place. Then remove the circuit breakers (fig. 94).

(3) **INSTALLATION.** Attach circuit breakers in position using the screws and lock washers which were removed, and connect the wires to the breaker terminals (fig. 85).

Section XXIV

TRANSMISSION

	Paragraph
Description and tabulated data.....	103
Removal	104
Installation	105

103. DESCRIPTION AND TABULATED DATA.

a. Description. The transmission is a five-speed overdrive type with a single reverse speed, and an extra gear in the countershaft for driving and power take-off. It is conventional in design with power transmitted from the main drive gear through the countershaft to the mainshaft. The main drive gear is driven by the engine whenever the clutch is engaged. This gear is in constant mesh with the countershaft drive gear, hence the countershaft rotates when the main drive gear is turning. With the shifting lever in neutral, the main shaft gears will not turn the main shaft, but when the lever is shifted to the various positions, as indicated on the shifting diagram (figs. 18, 19 and 20), the various main shaft gears are engaged with the countershaft gears for power transmission (fig. 95).

b. Tabulated Data.

Model 326-VO-21

Type.....	5-speed overdrive
Weight.....	380 lb
Torque rating.....	375 ft-lb
Gear ratios:	
Reverse	7.08 to 1
First	7.08 to 1
Second	3.82 to 1
Third	1.85 to 1
Direct	1.00 to 1
Overdrive	0.768 to 1
Lubricant capacity.....	12 quarts (With P.T.O.)

104. REMOVAL.

a. Disconnect Batteries. Loosen the cable clamp screw, and disconnect the cables from the negative terminals of the batteries.

b. Drain Air Tanks (par. 123).

c. Drain Oil. Remove the drain plug from the transmission and the lower cap screw from the power take-off rear bearing cap, and let oil drain from transmission and power take-off.

d. Remove Floorboards. Remove the screws and lock washers holding the floorboards in position and remove floorboards from the cab. It will be necessary to disconnect the accelerator rod when removing toeboard.

e. Remove Brake Rod. Remove the cotter pins and clevis pins from the yokes of the brake rod running between the pedal and the brake valve and remove the rod.

TM 9-811
104

**4-TON, 6 x 6 TRUCKS (DIAMOND T MODELS 968A CARGO,
969A WRECKER, 970A PONTON, AND 972 DUMP)**

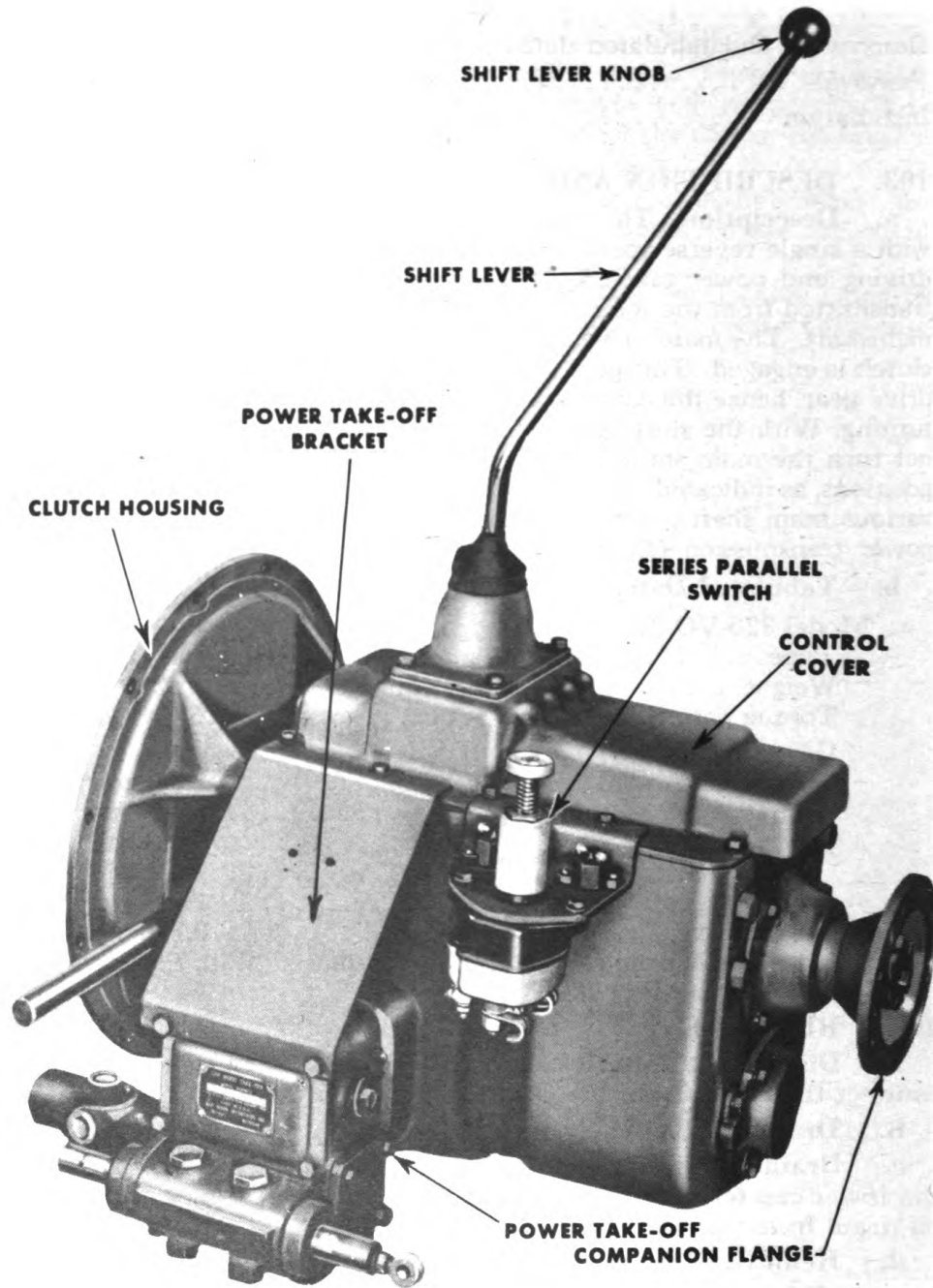

RA PD 304994

Figure 95—Transmission Assembly

220

TRANSMISSION

f. Disconnect Pull-back Spring. Disconnect the brake and clutch pedal pull-back springs from the brake valve.

g. Disconnect Clutch Shaft Support Bracket. Remove the cap screws and lock washers holding the clutch shaft support bracket to the left rear engine mounting.

h. Remove Quick Release Valve Assembly. Disconnect the air lines to the quick release valve, and then remove the cap screws and lock washers holding the quick release valve bracket to the top of the transmission cover and power take-off.

i. Remove Series Parallel Switch. Disconnect all wires from the series parallel switch, and from the circuit breakers mounted on the series parallel switch bracket. Then remove the cap screws and lock washers attaching the series parallel switch bracket to the transmission, and remove the assembly.

j. Remove Front Running Board Cross Member. Remove the bolts, nuts and lock washers attaching the front running board cross members to the support legs, and remove the cross member.

k. Disconnect Front Axle Propeller Shaft. Remove the cap screws, nuts and lock washers from the companion flanges at the transfer case end of the propeller shaft between the front axle and the transfer case. After it is disconnected, the propeller shaft assembly may be lowered to the ground and swung out of the way, so as not to interfere with further operations.

l. Remove Transmission Output Propeller Shaft. Remove the cap screws, nuts and lock washers between the companion flanges of the propeller shaft running between the transmission and the transfer, and remove the shaft assembly from the vehicle.

m. Remove Power Take-off Drive Shaft. Loosen the socket head set screw in the collar in back of the winch drive shaft slip joint, and slip the collar to the rear of the spline. Remove the cotter pin and shear pin from the front universal joint yoke, then slide the slip joint back on the splines to disconnect drive shaft at the front. Then loosen the socket head set screw in the universal yoke at the power take-off, and drive the yoke and shaft assembly forward until it is free of the power take-off output shaft. Remove the power take-off drive shaft from the vehicle.

n. Disconnect Power Take-off Shift Rod. Remove the cotter pin and clevis pin from the power take-off shift rod, and swing the rod and yoke assembly out of the way.

o. Remove Power Take-off Shifting Rod Cross Shaft. Remove the cotter pins, cap screws and nuts holding the cross shaft bracket on the right side of the vehicle, then remove the bracket and slip the cross shaft out of its pivot on the left frame rail.

p. Remove Battery Wire Clamp. Remove the cap screw and lock washer holding the battery wire clamp to the transmission rear bearing cover, and swing the wire and clamp clear of the transmission.

q. Disconnect Brake Rod Air Lines. Disconnect the air lines running between the brake valve and the reservoir tank and between

**4-TON, 6 x 6 TRUCKS (DIAMOND T MODELS 968A CARGO,
969A WRECKER, 970A PONTON, AND 972 DUMP)**

the right front trailer connection and the brake valve at the brake valve.

r. Remove Exhaust Assembly. Remove the bolts, washers and special nuts holding the exhaust tube flange at the exhaust manifold flange. Then remove nuts and lock washers from the front muffler



Figure 96—Removing Transmission

brace U-bolt, and remove the U-bolt. Remove the cap screws, nuts and lock washers holding the tail pipe clamp to the frame rail. Then work the exhaust assembly back and out of the vehicle.

s. Remove Transmission Cover. Remove cap screws and lock

TRANSMISSION

washers holding the transmission cover to the transmission case, and remove the cover assembly.

t. Support Transmission Using a Hoist. Wrap a chain around the transmission assembly, fasten the chain to a hook on the end of a hoist or wrecker boom and lift until the hook just starts to take the weight of the transmission (fig. 96).

u. Remove Transmission. Remove the cap screws and lock washers holding the transmission to the flywheel housing. Remove clutch pedal. Pull the transmission assembly back out of the transmission housing, and tilt the assembly towards the right side of the vehicle far enough to permit removal of the clutch pedal. Work the transmission assembly free from the chassis and lower it to the ground. Cover the opening in the transmission with a clean rag to prevent dirt and dust from getting into the gears and bearings.

105. INSTALLATION.

a. Raise Transmission into Position. With the transmission in place under the vehicle, loop a chain around it and attach to the hook on the end of a hoist or wrecker boom cable, and raise transmission into position. After the transmission is raised high enough, it will be necessary to work it forward so that the main drive gear shaft passes through the center of the clutch assembly to engage the splines in the driven disk. It may be necessary to rock the transmission assembly to engage the shaft splines with the splines on the disk. Before the assembly is completely lined up, it should be twisted to the right to permit the installation of the clutch pedal which was removed when the transmission was taken out.

b. Hold Transmission in Place. When the transmission assembly is properly located on the engine bell housing, it may be fastened in place with the cap screws and lock washers which were removed.

c. Install Transmission Cover. Remove the rags which were inserted into the transmission case to keep dust and dirt from the gears. Shift the gears to neutral, and then assemble the control cover into position with a new gasket between the cover and case. Then install the cap screws and lock washers which were removed.

d. Install the Exhaust Assembly. Work the exhaust assembly into position in the chassis, and tighten the manifold flange bolt, the front muffler nut U-bolt, and the tailpipe clamp in place (par. 82).

e. Connect Air Lines. Connect the air lines between the brake valve and the reservoir tank and between the right front trailer coupling and the brake valve to the brake valve.

f. Install Battery Cable Clamp. Install the battery cable clamp over the cable, and attach the clamp under one of the cap screws on the transmission rear bearing cover.

g. Install Power Take-off Shift Rod Cross Shaft. Working from the right side of the chassis, work the end of the cross shaft into the support bearing under the left frame rail, then hold the shaft in position while installing the bearing cap bracket under the right frame rail and installing bolts, nuts and cotter pins which were removed.

4-TON, 6 x 6 TRUCKS (DIAMOND T MODELS 968A CARGO, 969A WRECKER, 970A PONTON, AND 972 DUMP)

h. Connect Shift Rod to Power Take-off Shift Rail. Lift the power take-off shift rod into position with the yoke over the eye on the end of the power take-off shift rail, and insert the clevis pin through yoke and eye. Then lock the clevis pin in place with the cotter pin.

i. Install Winch Drive Shaft. Install the winch drive shaft into position in the chassis with slip joint towards the front. Then drive the universal joint yoke over the end of the power take-off output shaft, being careful to see that the keyway in the shaft lines up with the keyway in the yoke, then drive the key into position to lock the yoke to the shaft. Tighten the socket head set screw in the yoke at the power take-off shaft. Slide the slip joint as far back as possible on the splines, and install the front universal joint yoke over the winch worm shaft, being careful to line up the hole in the end of the winch drive shaft with the hole in the yoke hub. Insert one of the special winch shear pins through the yoke and the worm shaft and fasten in place with a cotter pin. Slide slip joint collar forward on the splineway to give about $\frac{5}{8}$ -inch clearance between the end of the slip joint sleeve and the forward edge of the collar. Then tighten socket head set screw in the collar.

j. Install Transmission Propeller Shaft. Lift the propeller shaft into position between the transmission and the transfer case, assemble the cap screws, nuts and lock washers through the holes in the edge of the companion flanges and fasten them securely together.

k. Install Front Axle Propeller Shaft. Connect front axle propeller shaft flange and front axle propeller shaft into place, and install cap screws, nuts, and lock washers to hold the flange yoke securely to the companion flange on the transfer case.

l. Install the Front Running Board Cross Member. Raise the front running board cross member into position in the cross member leg, and attach in place with cap screws, nuts and lock washers which were removed.

m. Install the Quick Release Valve and Bracket Assembly on the Transmission. Install the quick release valve and bracket assembly into place on the transmission and attach in place with two cap screws and lock washers holding the transmission cover to the case, and two cap screws and lock washers holding the power take-off cover to the power take-off case. Then connect air lines to the quick release valve.

n. Install the Series Parallel Switch and Bracket Assembly. Attach the series parallel switch and bracket assembly to the transmission cover with the transmission cover cap screws and lock washers. Then connect all wires to the series parallel switch and to the circuit breakers (fig. 82).

o. Install the Clutch Shaft Support Bracket. Install the clutch shaft support bracket into place on the left rear engine mounting bracket, and fasten in place with the bolts which were removed.

TRANSMISSION

p. Connect Pedal Pull-back Spring. Connect the pull-back springs to the brake and clutch pedals, and hook the ends over the ears on the brake valves.

q. Install Brake Rod. Install the brake rod into place with the yoke ends over the pivot holes on the brake pedal and the operating lever on the brake valve, and insert clevis pins into position on each end. Fasten these pins with cotter pins.

r. Install Floorboards. Connect accelerator rod and then place the floorboards into position. Fasten them in place with the screws which were removed.

s. Connect Battery Cable. Reconnect the battery cables which were disconnected before the job was started.

t. Check to See that Reservoir Drain Valves are Closed.

u. Add Lubricant (par. 26).

TM 9-811
106

4-TON, 6 x 6 TRUCKS (DIAMOND T MODELS 968A CARGO,
969A WRECKER, 970A PONTON, AND 972 DUMP)

Section XXV

TRANSFER

	Paragraph
Transfer description.....	106
Transfer breather.....	107
Transfer removal.....	108
Transfer installation.....	109

106. TRANSFER DESCRIPTION.

a. The transfer is a gear box mounted behind the transmission which delivers power to the front and rear axles, and which is offset to permit the forward propeller shaft to clear the engine crankcase. A

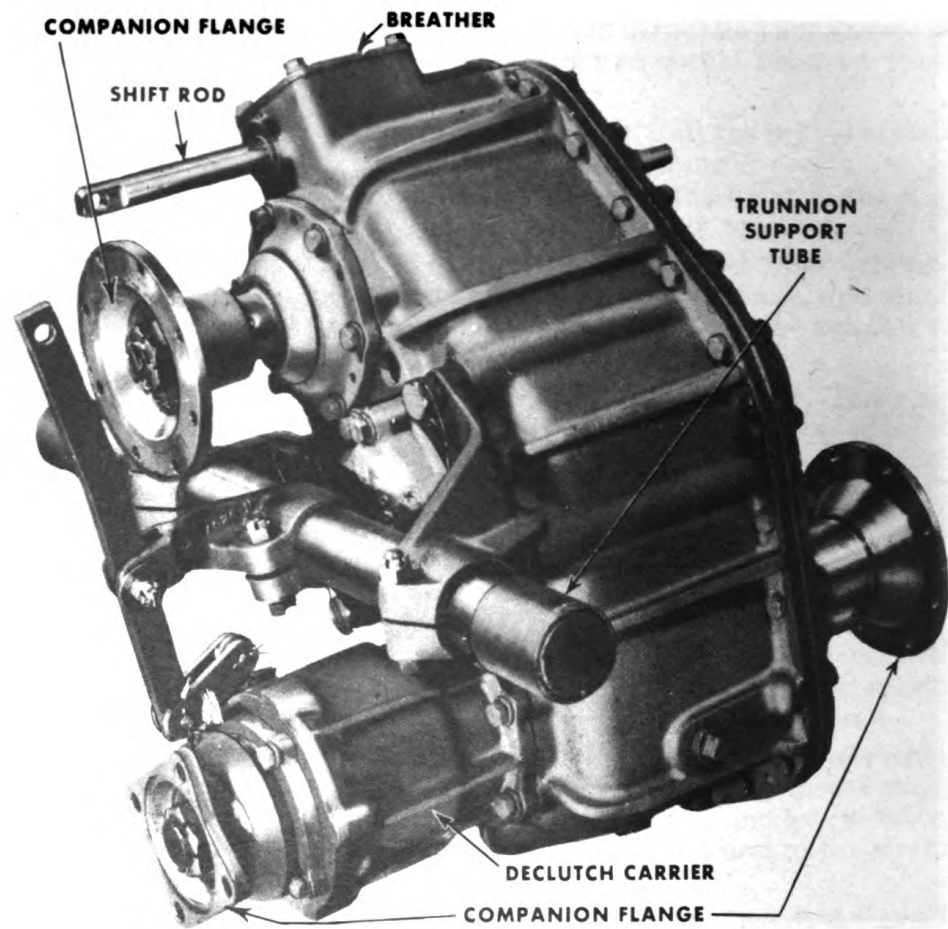

RA PD 304993

Figure 97—Transfer Assembly, without Power Take-off

TRANSFER

speed reduction is provided, the selection of which is controlled by a conventional shift lever in the cab. The unit has two speeds—direct and overdrive. A declutch unit is mounted at the lower end of the case facing towards the front axle which consists of a jaw-type clutch supported in a carrier. The engagement or disengagement of the front axle is accomplished by means of this mechanism which is controlled through linkage by a shift lever in the cab. On wrecker and dump trucks the transfer is equipped with a power take-off mounted at the end of the drive shaft which is used to drive the winches on the wrecker and the pump on the dump truck (fig. 97).

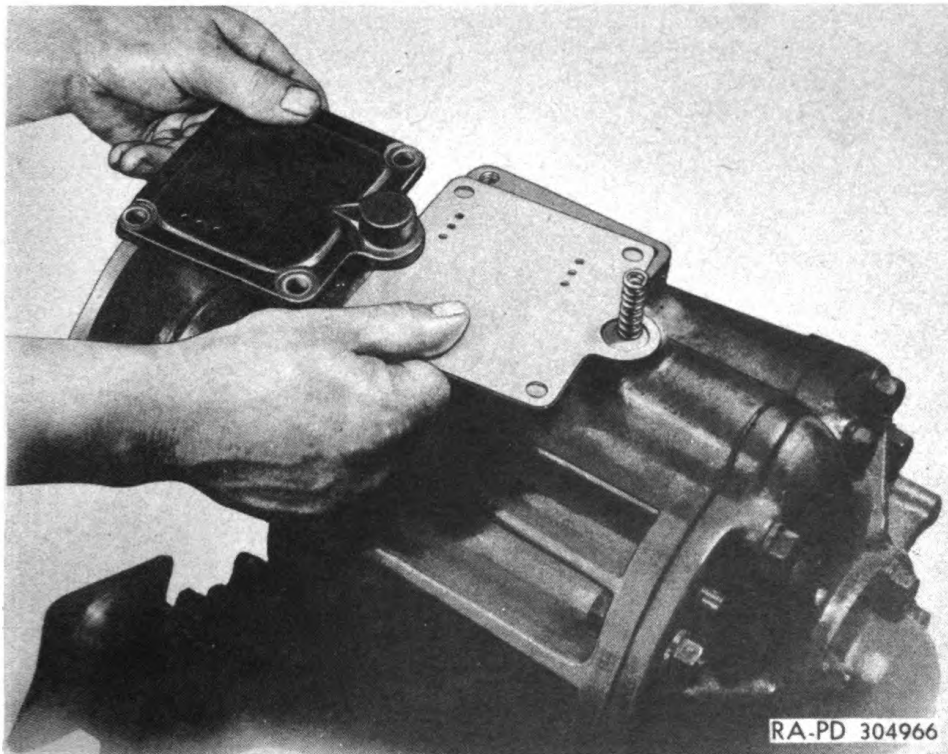

Figure 98—Removing Transfer Breather

107. TRANSFER BREATHER.

a. Description. There is a baffle-type breather mounted on top of the transfer case which permits the unit to breathe, thereby preventing the build-up of pressure from lubricant vapors and heat developed in operation which might cause damage to oil seals. This breather must be kept clean in order to function properly.

b. Cleaning.

(1) Clean the exterior surfaces of the breather cover and the top of the transfer case around the cover with dry-cleaning solvent.

(2) **REMOVE BREATHER PARTS.** Remove the cap screws and lock washers holding the breather cover to the transfer case, then lift the breather cover, breather plate, and gaskets from the transfer case. The

4-TON, 6 x 6 TRUCKS (DIAMOND T MODELS 968A CARGO, 969A WRECKER, 970A PONTON, AND 972 DUMP)

transfer case shift rail poppet ball and spring are held under the cup on the end of the breather cover, and care must be exercised when removing the cover to prevent the loss of the poppet parts (fig. 98).

(3) **CLEANING BREATHER.** Immerse the breather cover and the breather plate in dry-cleaning solvent, and scrub until thoroughly clean. Be sure that all the holes in the cover and the plate are clear. After these parts are clean, dry them thoroughly with compressed air.

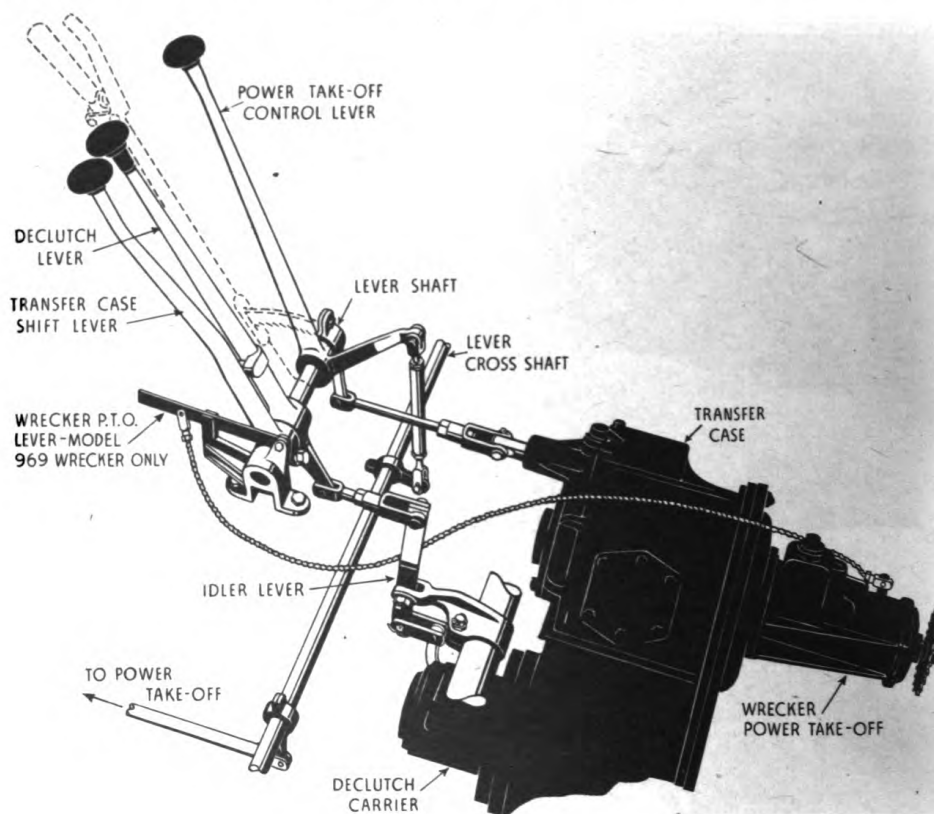

RA PD 313770

Figure 99—Transfer Shift Linkage

(4) **INSTALL BREATHER.** Check to see that the poppet parts are in place before installing the breather. Then install a new gasket over the breather opening at the top of the transfer case. Then place the breather plate over the gasket with the breather holes towards the right side of the case. Place another new gasket over the breather plate, then install the breather plate cover. It will be necessary to force the breather cover down against the compression of the poppet spring while the cap screws and lock washers are installed. Be sure that the breather holes in the breather plate are on the opposite side of the breather holes in the breather cover.

TRANSFER

108. TRANSFER REMOVAL.

a. **Drain Oil.** Remove the drain plug, and drain the oil from the transfer.

b. **Disconnect Front Axle Propeller Shaft.** Remove the cap screws and lock washers holding the front axle propeller shaft universal flange yoke to the transfer drive shaft companion flange, and separate the flange yoke from the companion flange, swinging the propeller shaft assembly clear.

c. **Remove Propeller Shaft Between Transmission and Transfer Case.** Remove the cap screws, nuts and lock washers holding the



Figure 100—Lifting Transfer on Hoist

flange yokes on the propeller shaft between transmission and transfer case to the companion flanges on the transmission main shaft and the transfer case drive shaft. Then remove propeller shaft assembly.

d. **Remove Exhaust Tube, Muffler and Tailpipe.** Disconnect exhaust flange, front muffler U-bolt and tailpipe clamp, and remove exhaust assembly as described in paragraph 82.

e. **Remove the Running Board Rear Cross Member.** Remove the bolts, nuts and lock washers holding the running board rear cross member in place and remove the cotter pins, nuts, washers and springs from the gas tank straps. Remove the cross member.

TM 9-811
108

**4-TON, 6 x 6 TRUCKS (DIAMOND T MODELS 968A CARGO,
969A WRECKER, 970A PONTON, AND 972 DUMP)**

f. Disconnect Speedometer Cable. Thread the speedometer adapter bushing out of the speedometer gear opening in the transfer case idler shaft bearing cap, and swing cable clear.

g. Disconnect Shift Cable to the Transfer Case. Remove the cotter pin and clevis pin from the shift cable yoke at the end of the transfer case shift rail.

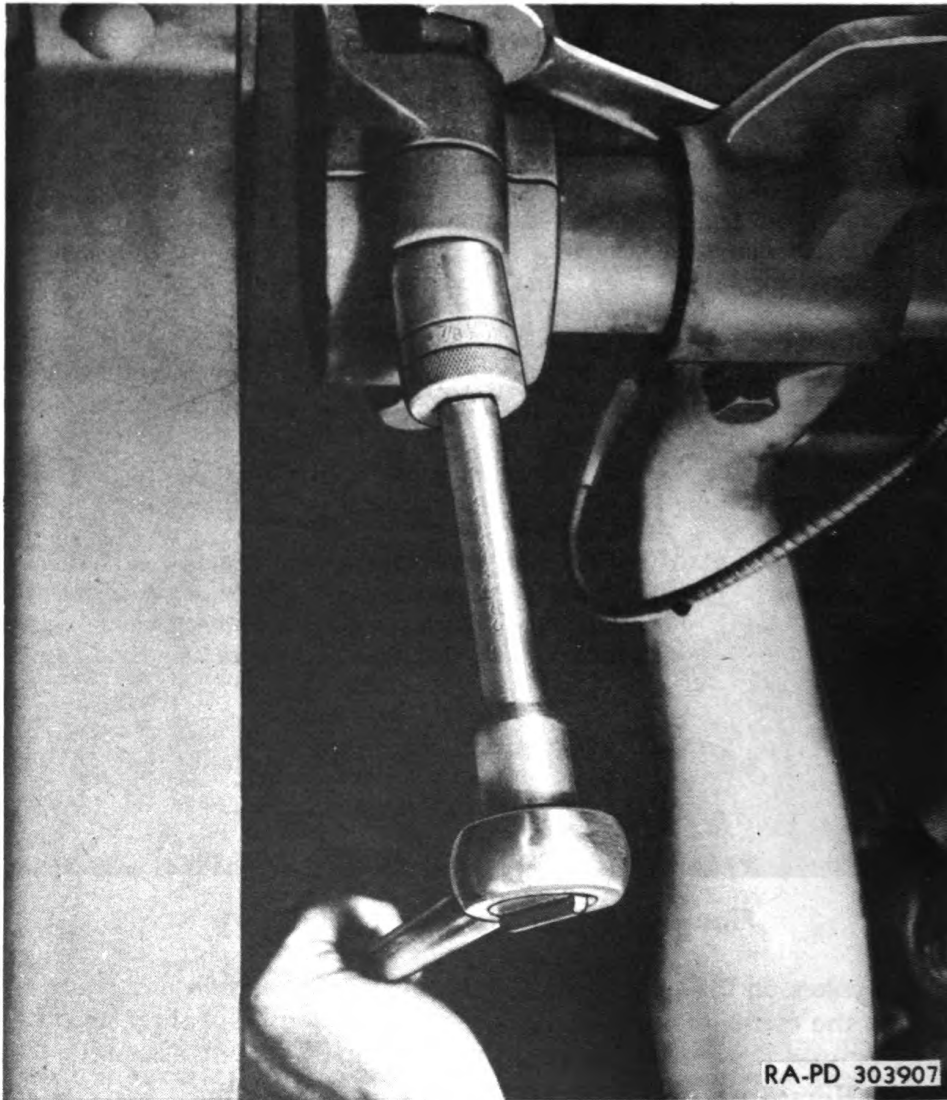

Figure 101—Disconnecting Transfer Front Mounting

h. Disconnect Transfer Case Declutching Linkage. Remove cotter pin and clevis pin from the upper end of the idler lever which is attached to the declutch shift rail, and swing the shift rod out of the way (fig. 99).

TRANSFER

i. Position Hoisting Chain. Remove the cap screw holding the hand brake cable clip to the transfer case, and swing the cable and clip out of the way. Wrap a chain around the idler shaft rear bearing cap and the main shaft front companion flange. Attach this chain to a hook on the hoist, and lift a sufficient amount to cause a slight strain to permit of the removal of the mounting brackets (fig. 100).

j. Remove Front Mounting Bracket Caps. Remove the cotter pins, nuts, and bolts holding the cross shaft caps to the brackets, then remove the caps (fig. 101).

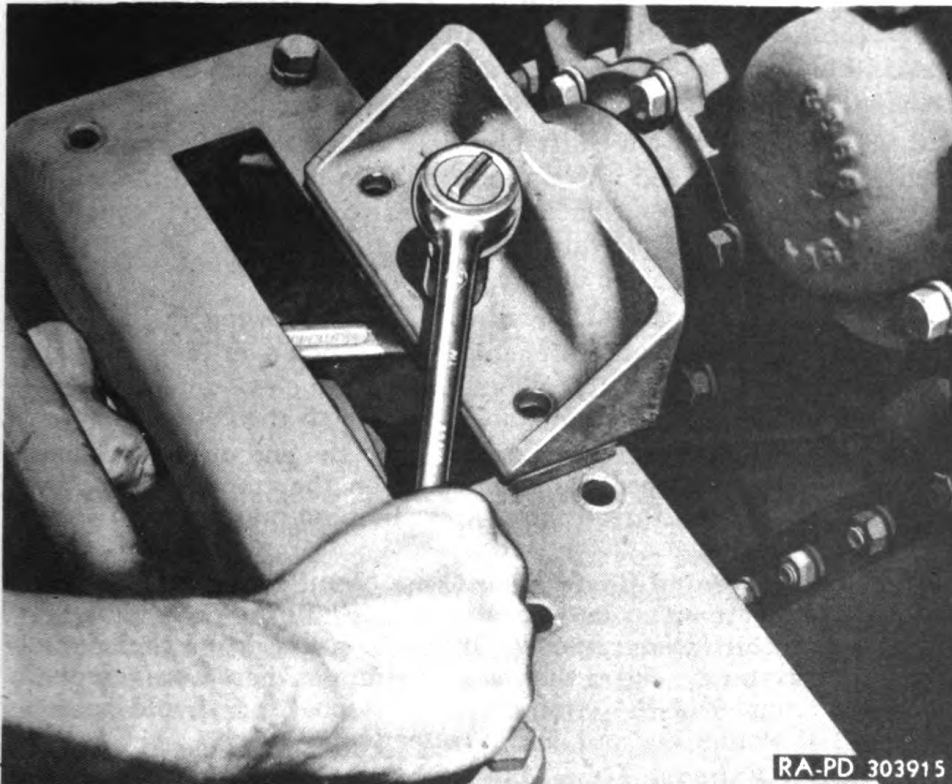

Figure 102—Tightening Rear Mounting Bolts

k. Disconnect Transfer Case Rear Mounting. Remove the cotter pins, nuts and trunnion bolts from the idler shaft rear bearing cap mounting bracket.

l. Lower Transfer to Floor. Lower transfer assembly and work it forward to permit the rear support bracket to clear the frame cross member, then lower it until it rests on the floor.

109. TRANSFER INSTALLATION.

a. Lift Transfer Case into Position on Vehicle. Place transfer into position under chassis, and wrap a chain around it as described for removal. Attach the chain to a hook on the hoist and raise the assembly

**4-TON, 6 x 6 TRUCKS (DIAMOND T MODELS 968A CARGO,
969A WRECKER, 970A PONTON, AND 972 DUMP)**

into position working it back as it comes up to permit the rear trunnion support bracket to slide over the top of the frame cross member.

b. Install Rear Mounting Bolts. Install rear mounting bolts holding the transfer in place and then install the cotter pins and nuts (fig. 102).

c. Install Caps on Front Mounting Brackets. See that the cross tube is socketed in the cross shaft mounting brackets, then install the caps in position and attach with the bolts, nuts and cotter pins.

d. Remove the Chain from the Transfer Assembly.

e. Connect Hand Brake Cable Clip to the Transfer Case. Swing the hand brake cable into position and attach the mounting clip to the transfer case with the cap screw which was removed.

f. Connect Declutch Shift Linkage. Swing the yoke on the end of the declutch shift rod into position through the hole on the end of the declutch idler lever which is attached to the declutch shift rail. Then install the clevis pin through the holes in the yoke and the hole in the idler lever and fasten in place with a cotter pin.

g. Connect Transfer Case Shift Linkage. Swing the yoke on the end of the transfer case shift cable into position over the hole in the end of the transfer case shift rail, and install the clevis pin which was removed. Then lock the clevis pin in place with the cotter pin.

h. Connect Speedometer Cable. Insert the end of the speedometer cable into the speedometer opening on the transfer case idler shaft bearing cap and thread the adapter bushing into the cap to hold it in place.

i. Install Running Board Rear Cross Member. Lift the running board rear cross member into position and install the bolts, nuts and lock washers which were removed. It will be necessary to replace the mounting parts on the end of the gas tank straps as these were removed to permit removal of the cross member. Each strap should have a spring, a flat washer and nut, and a cotter pin.

j. Install Exhaust Tube Manifold and Tail Pipe. Install the exhaust assembly into position on the chassis and then attach the exhaust flange, the front muffler U-bolt and the tail pipe clamp as described in paragraph 82.

k. Install Propeller Shaft between Transmission and Transfer Case. Lift the propeller shaft assembly into position between the transmission and transfer case and attach the universal joint and flange yokes to the companion flanges on the transmission and transfer case, using the cap screws and lock washers which were removed.

l. Connect Front Axle Propeller Shaft. Swing front axle propeller shaft into position so that the universal joint flange yoke is up against the companion flange on the transfer case, and then attach these parts together with the cap screws, nuts and lock washers which were removed.

m. Lubricate Transfer (par. 26).

Section XXVI

PROPELLER SHAFTS AND UNIVERSAL JOINTS

	Paragraph
Description	110
Removal	111
Installation	112

110. DESCRIPTION.

a. Propeller shafts are used between the transmission and transfer, the transfer and the front axle, the transfer and the forward rear axle, the forward rear axle and the rear rear axle, the transmission power take-off and the front mounted winch used on cargo, wrecker and ponton trucks, and the transfer power take-off and the hoist pump used on the dump trucks. These shafts are all of the companion flange type with the exception of (1) the shaft between the rear axles, which is the end-yoke type, and which must be disassembled for removal; and (2) the shaft which drives the hoist pump on the dump truck, and which also drives the front-mounted winch on the cargo, wrecker and ponton trucks, which are special in design. The winch drive propeller shaft is of the end-yoke type, but the joint does not have to be disassembled for removal, as the universal joint yoke hubs may be disconnected from the driving and driven shafts of the units. The hoist pump drive propeller shaft is of the end-yoke type on the rear end, and of the companion flange type on the forward end. The propeller shafts are all tubular in design with the exception of the shaft running between the transmission and the transfer, and between the transmission power take-off and the front-mounted winch. The universal joints are all of the Hooke's coupling type with the trunnion supported on needle roller bearings. A splined slip joint is provided at one end of each propeller shaft to allow for spring action and variations in the distances between the units which they connect (fig. 103).

b. The shafts are rather delicately balanced, and must always be assembled with the parts in exactly the same relation to each other as before disassembly. To make this possible, an arrow is stamped on the spline end of the propeller shaft, and on the spline sleeve of the slip joint, so that these markings may be matched to maintain the original balanced condition of the shaft. It will be noted that when the arrows are lined up, the yokes on each end of the shaft will lie in the same plane, and that the flange yokes on each end of the propeller shaft also lie in the same plane.

111. REMOVAL.

a. Companion Flange Mounted Shafts.

(1) **DISCONNECT SLIP JOINT COMPANION FLANGE.** Remove the cap screws, nuts and lock washers holding the flange yoke at the slip joint end of the propeller shaft to the companion flange on the driving unit. Then lower the end of the shaft until it rests on the ground, or a convenient cross member under the body.

4-TON, 6 x 6 TRUCKS (DIAMOND T MODELS 968A CARGO, 969A WRECKER, 970A PONTON, AND 972 DUMP)

(2) **DISCONNECT REMAINING COMPANION FLANGE.** Remove the cap screws, nuts and lock washers holding the flange yoke at the far end of the shaft to the companion flange of the driven unit. The shaft assembly may then be lowered to the ground or worked clear of cross member to permit its removal.

b. End Yoke Shaft Between Rear Axles.

(1) **REMOVE THE COVER PLATES FROM THE SLIP JOINT YOKE.** Use a small punch to fold the ears of the lock plate away from the cap screw heads to permit removal of the cap screws holding the covers on each end of the slip joint yoke. Then remove the cap screws and take off the lock plates and the covers.

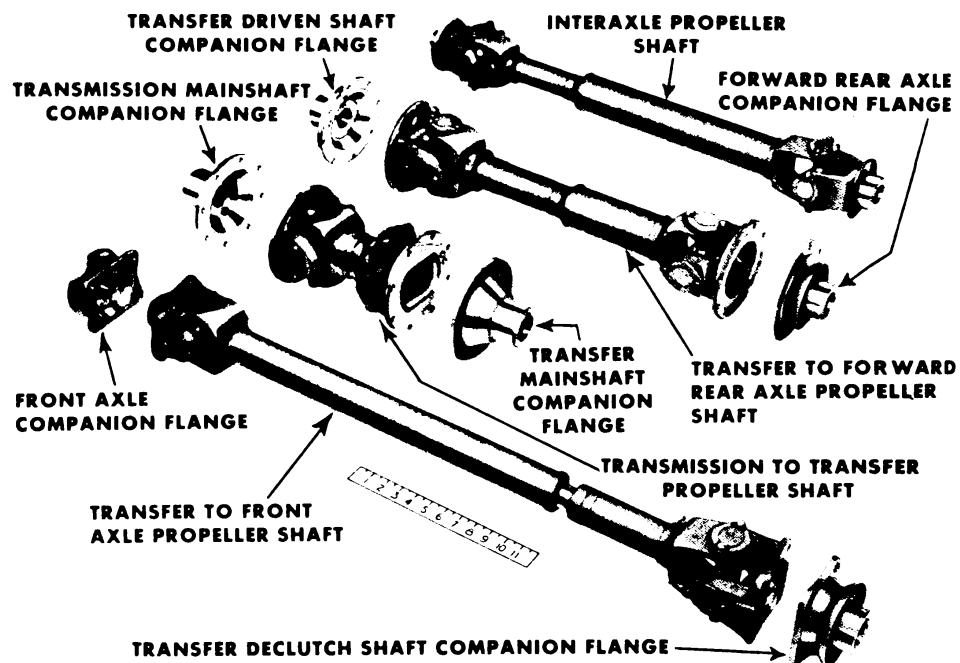

RA PD 304848

Figure 103—Propeller Shaft Assemblies

(2) **DISCONNECT SLIP JOINT END OF SHAFT.** Tap on the exposed face of one of the needle bearing cages until the opposite needle bearing assembly comes out. Remove the needle bearing cage from the end of the trunnion yoke, and then tap the exposed end of the trunnion until the bearing on the opposite end is free, and remove the bearing. With both bearings removed from the yoke, permit the shaft to drop down a sufficient amount so that the lower end of the journal will clear the lower end of the yoke. Then tip the journal assembly so that the lower end moves away from the yoke, then raise the shaft assembly so that the yoke is entirely clear of the journal. The slip joint end of the shaft may then be lowered to the ground.

(3) **REMOVE COVER PLATES FROM END YOKE.** Remove the cover plates from both sides of the end yoke on the other end of the propeller

PROPELLER SHAFTS AND UNIVERSAL JOINTS

shaft in the same manner in which they were removed from the slip joint yoke.

(4) **DISCONNECT END YOKE FROM JOURNAL.** Disconnect the end yoke of the propeller shaft from the universal joint journal in the same manner in which the slip joint yoke was disconnected.

c. Propeller Shaft between Transmission Power Take-off and Front Mounted Winch.

(1) **REMOVE SHEAR PIN.** Remove the cotter pin from the end of the shear pin at the forward end of the winch drive propeller shaft, and then knock out the pin, using a hammer and drift punch.

(2) **LOOSEN STOP COLLAR ON SLIP JOINT SPLINES.** Using a $\frac{1}{8}$ -in. socket head set screw wrench, loosen the set screw in the stop collar on the slip joint splines and then slide the collar back as far as it will go.

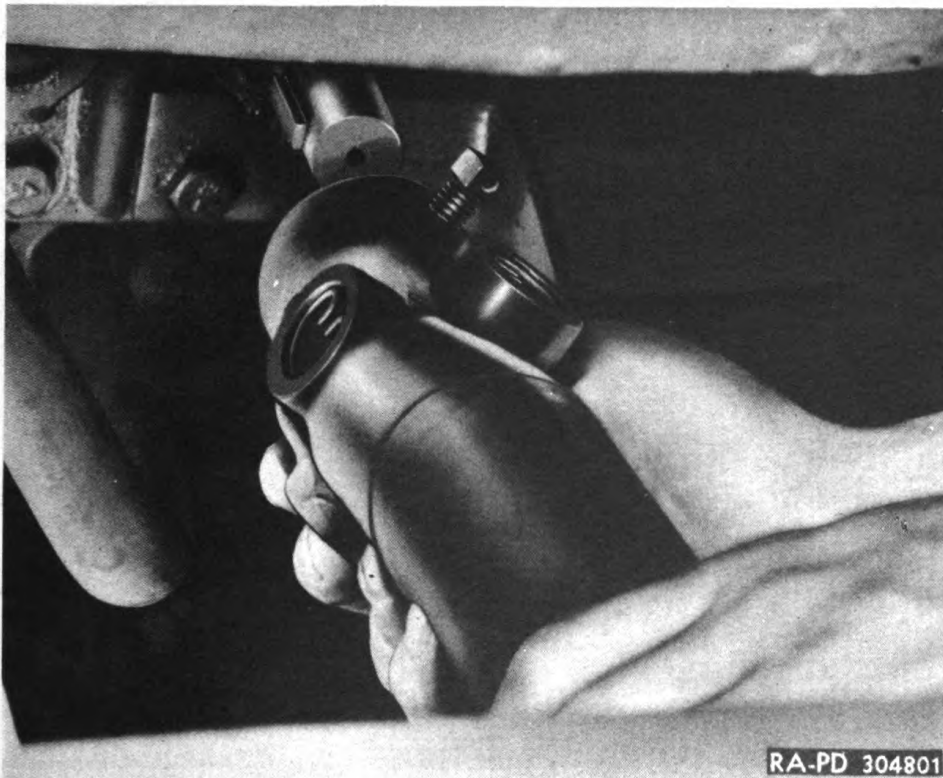

Figure 104—Disconnecting Yoke From Hoist Pump Shaft

(3) **DISCONNECT SLIP JOINT END OF SHAFT.** Slide the slip joint back far enough on the shaft so that the end yoke comes off the winch worm shaft.

(4) **DISCONNECT REAR END OF THE DRIVE SHAFT.** Using a $\frac{1}{8}$ -in. socket head set screw wrench, loosen the set screw holding the end yoke to the power take-off drive shaft. Then drive the end yoke off the power take-off drive shaft and remove the key.

4-TON, 6 x 6 TRUCKS (DIAMOND T MODELS 968A CARGO, 969A WRECKER, 970A PONTON, AND 972 DUMP)

(5) **REMOVE SHAFT ASSEMBLY FROM VEHICLE.** Slide the shaft assembly toward the front, pulling the rear end through the hole in the front motor support cross member, and remove it from the vehicle.

d. Propeller Shaft between Transfer Power Take-off and Hoist Pump.

(1) **DISCONNECT COMPANION FLANGE AT SLIP JOINT END OF SHAFT.** Remove the cap screws, nuts and lock washers holding the flange yoke at the slip joint end of the shaft to the companion flange on the transfer power take-off drive shaft, then separate the flanges. The shaft assembly will be supported in the hole through the frame cross member.

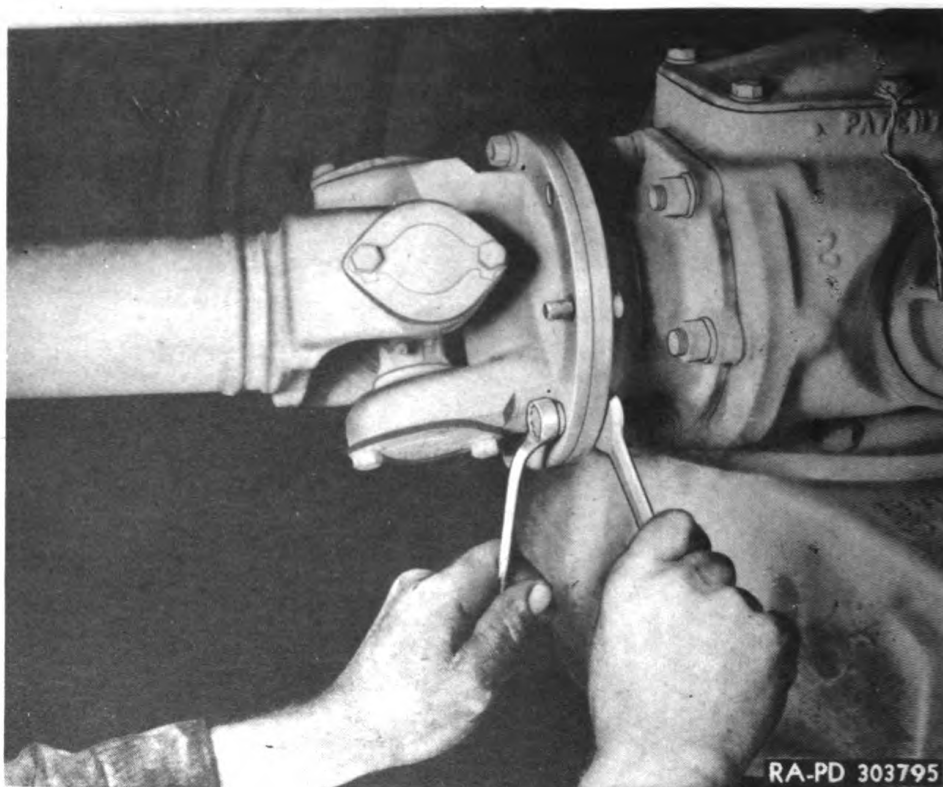

Figure 105—Connecting Companion Flanges

(2) **DISCONNECT END YOKE FROM HOIST PUMP.** Loosen the set screw holding the end yoke to the hoist pump drive shaft. Then drive end yoke off the end of the hoist pump shaft and remove the key (fig. 104).

(3) **REMOVE SHAFT ASSEMBLY FROM VEHICLE.** Work the shaft assembly forward through the hole in the frame cross member and then remove the assembly from the vehicle.

PROPELLER SHAFTS AND UNIVERSAL JOINTS

112. INSTALLATION.

a. Companion Flange Mounted Shafts.

(1) **INSTALL SHAFT ASSEMBLY INTO POSITION.** Raise the shaft assembly into position in the chassis, mating the companion flanges on the driving and driven units with the flange yokes on the end of the propeller shaft assembly, and insert two cap screws through the holes in the flanges to hold the assembly in place. Be sure that the slip joint is facing the source of the power.



Figure 106—Installing Needle Bearing

(2) **CONNECT COMPANION FLANGES.** Install the cap screws, nuts and lock washers which were removed through the holes in the companion flanges and tighten securely (fig. 105).

b. End Yoke Shaft between Rear Axles.

(1) **CONNECT END YOKE OF PROPELLER SHAFT ASSEMBLY TO THE JOURNAL.** Slip the end yoke end of the propeller shaft assembly into position, and tilt the universal joint journal at the front of the through shaft for the rear rear axle in such a way that it may be worked into position in the end yoke of the propeller shaft. Then install one needle bearing cage assembly through the hole on each side of the end yoke and over the trunnion journals (fig. 106). It will be necessary to tap the end of the needle bearing cage lightly in order to drive it into

**4-TON, 6 x 6 TRUCKS (DIAMOND T MODELS 968A CARGO,
969A WRECKER, 970A PONTON, AND 972 DUMP)**

place. When the needle bearing assemblies are in place, line up the slot in the outer face of each with the slot on the bearing cover plate, and install the bearing cover plate, lock plate and cap screws which were removed. (Do not use a lock plate on which both ears have been bent.) Tighten the cap screws securely and fold the unused ear of the locking plate up against the side of the cap screw to hold it in place.

(2) **CONNECT SLIP JOINT YOKE TO THE UNIVERSAL JOINT JOURNAL.** Connect the slip joint yoke to the universal joint journal in the same manner in which the end yoke was installed (fig. 106).



Figure 107—Installing Slip Joint on Winch Propeller Shaft

c. Propeller Shaft between Transmission Power Take-off and Front Mounted Winch.

(1) **INSTALL SHAFT ASSEMBLY INTO PLACE IN VEHICLE.** Working from the front, install the propeller shaft assembly into place in the vehicle, sliding the end yoke end of the shaft through the hole in the front motor support cross member, and back against the power take-off drive shaft. When installing the slip joint on the splined end of the propeller shaft, be sure to line up the shaft yokes as described in paragraph 112 (fig. 107).

(2) **INSTALL UNIVERSAL YOKE TO POWER TAKE-OFF DRIVE SHAFT.** Line up the keyway in the universal joint yoke with the keyway in the power take-off drive shaft, then drive the yoke into place over the shaft and install the key. Tighten the set screw in the hub of the universal joint flange, using a 1/8-inch socket head set screw wrench.

PROPELLER SHAFTS AND UNIVERSAL JOINTS

(3) **CONNECT SLIP JOINT UNIVERSAL TO WINCH WORM SHAFT.** Slide the slip joint and universal joint assembly forward on the splines so that the universal joint yoke hub slides over end of the winch worm shaft, then line up the hole in the yoke end with the hole in the shaft. Install a shear pin through the yoke hub and shaft, and attach in place with a cotter pin through the end of the shear pin.

(4) **SET STOP COLLAR ON SLIP JOINT SPLINES.** Slide the stop collar forward on the slip joint splines until it is $\frac{5}{8}$ inch from the rear end of the slip joint sleeve, then fasten it in place by tightening the set screw, using a $\frac{1}{8}$ -inch socket head set screw wrench.

d. Propeller Shaft between Transfer Power Take-off and Hoist Pump.

(1) **INSTALL SHAFT ASSEMBLY INTO VEHICLE.** Lift the shaft assembly and work it into position in the vehicle, sliding the end yoke end of the shaft through the hole in the frame cross member, and back far enough so that the universal joint yoke is against the hoist pump drive shaft.

(2) **ATTACH UNIVERSAL JOINT YOKE TO HOIST PUMP SHAFT.** Line up the keyway in the hub of the universal joint yoke with the keyway in the shaft, then drive the yoke assembly over the shafts and install the key. Tighten the set screw.

(3) **ATTACH SLIP JOINT FLANGE YOKE TO THE COMPANION FLANGE.** Line up the flange yoke on the end of the forward universal joint with the companion flange on the power take-off drive shaft, and attach it in place with the cap screws, nuts and lock washers which were removed.

TM 9-811
113

**4-TON, 6 x 6 TRUCKS (DIAMOND T MODELS 968A CARGO,
969A WRECKER, 970A PONTON, AND 972 DUMP)**

Section XXVII

FRONT AXLE

	Paragraph
Description and tabulated data.....	113
Tie rod replacement.....	114
Toe-in	115
Axle assembly removal.....	116
Axle assembly installation.....	117

113. DESCRIPTION AND TABULATED DATA.

a. **Description.** The front axle is a driving unit type, with a conventional double-reduction differential bolted to the rear of the banjo axle housing. Power is transmitted from the driven shaft of the transfer through a propeller shaft to a bevel pinion gear mounted at the rear end of the differential carrier assembly. The bevel pinion gear

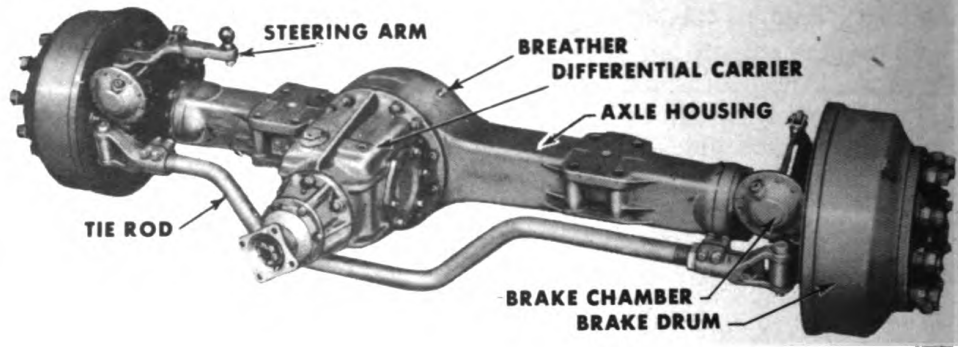

RA PD 304995

Figure 108—Front Axle Assembly

meshes with a conventional ring gear which is mounted on the same shaft with a spur pinion gear. The spur pinion provides a second gear reduction, meshing with a large spur gear to which is bolted the differential assembly. The power is transmitted to the differential gear through the axle shaft, then to constant-velocity type universal joints held in trunnions bolted to the outer ends of the axle housing (fig. 108).

b. **Breather.** A breather is located on top of the axle housing banjo, which permits the unit to breathe as pressure changes occur inside the housing due to heat and lubricant vapors formed in normal operation. The action of the breather prevents damage to the oil seals which might happen due to this pressure, hence it must be kept clean at all times. Check the condition of the breather frequently, and remove it for cleaning as often as may be necessary.

FRONT AXLE

c. Tabulated Data.

Make Timken
Type Double-reduction drive
Model F-2090-W-73
Lubricant capacity 15 pt
Toe-in $\frac{1}{8}$ in. + $\frac{1}{16}$ in. — $\frac{1}{16}$ in.
Steering angle:
 Inside wheel 28° max
 Outside wheel 24° approx



Figure 109—Removing Tie Rod End Pin

114. TIE ROD REPLACEMENT.

a. Remove Clevis Pins from Brake Chamber Push Rods on Both Sides of Vehicle. Remove the cotter pins in the ends of the clevis pins, then the clevis pins may be removed from the push rod yokes.

b. Remove Brake Chambers from Both Sides of Vehicle. Turn the adjusting worms on the slack adjusters until ends of the slack adjusters clear the push rod yokes, and remove the brake chambers as described in paragraph 127.

TM 9-811
114

**4-TON, 6 x 6 TRUCKS (DIAMOND T MODELS 968A CARGO,
969A WRECKER, 970A PONTON, AND 972 DUMP)**

- c. **Remove Tie Rod End Pins.** Remove the nuts and lock washers from the lower ends of each of the tie rod end pins, then drive the pins out of the tie rod end yokes. When the pins are loose, lift them out (fig. 109) and remove tie rod from axle assembly.
- d. **Install Tie Rod.** Lift the rod into position, and install it into place on tie rod bearing bosses extending from the universal flanges.

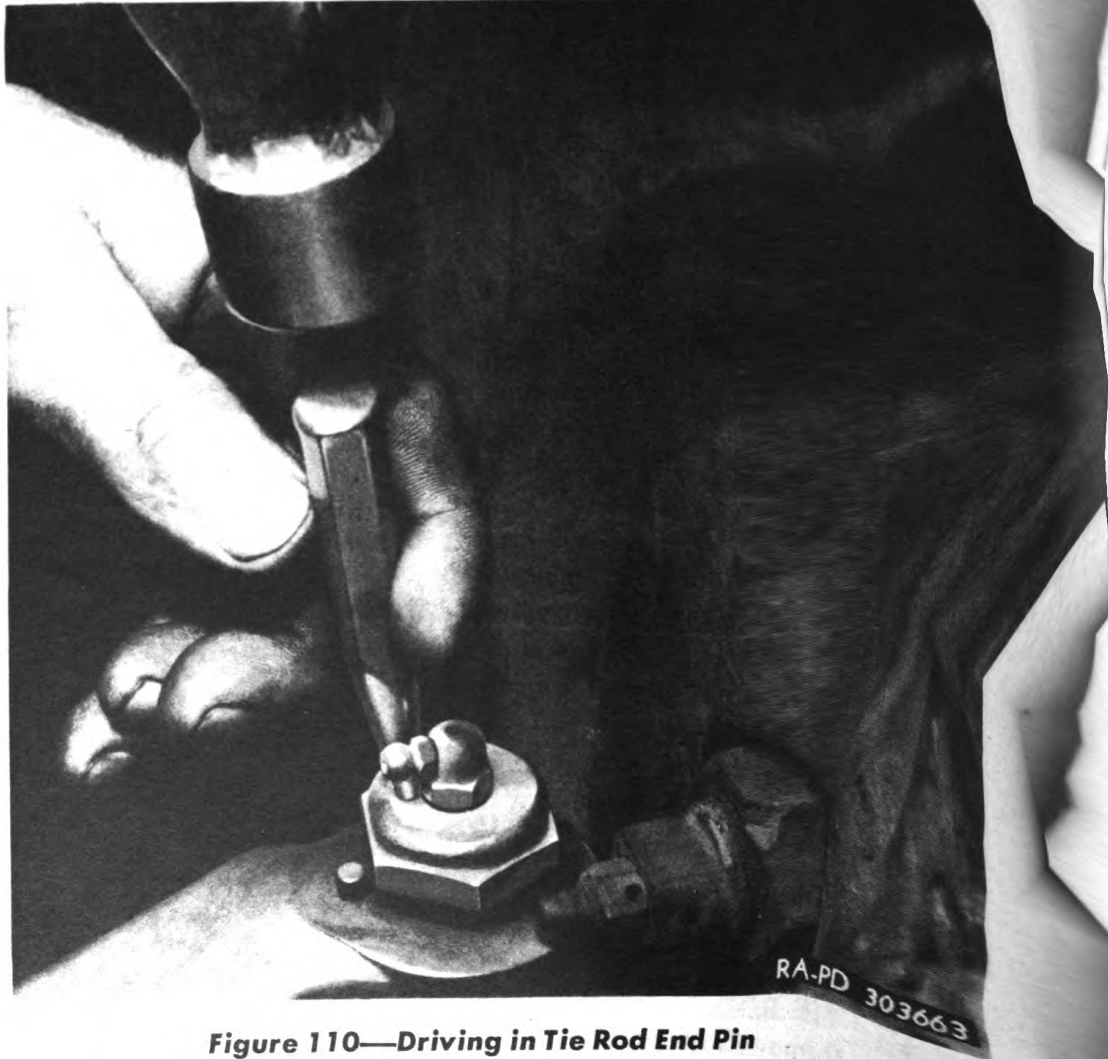

Figure 110—Driving in Tie Rod End Pin

- e. **Install Tie Rod End Pins.** Drive the tie rod end pins into place, using a drift punch, and tapping on the flat surface on top of the pins. Be sure that the flat surfaces on the heads of the pins face the pins in the top of the tie rod yokes to keep the pins from turning. Install the nut and lock washer on the bottom of each end pin (fig. 110).

- f. **Replace Brake Chamber.** Replace brake chamber as described in paragraph 127.

FRONT AXLE

g. Install Slack Adjuster Clevis Pin. Turn the slack adjuster adjusting worms back to their original setting, then install the clevis pin through the slack adjuster arms and the brake chamber push rod yokes, attaching them in place with cotter pins.

h. Adjust Toe-in. Adjust toe-in as described in paragraph 115.

115. TOE-IN.

a. General. Toe-in is measured as the distance that the front wheels are closer together at the front than at the rear, or it is the amount that the wheels are "pigeon-toed" at the front. This is easily seen by reference to figure 111, in which toe-in is dimension "B" minus

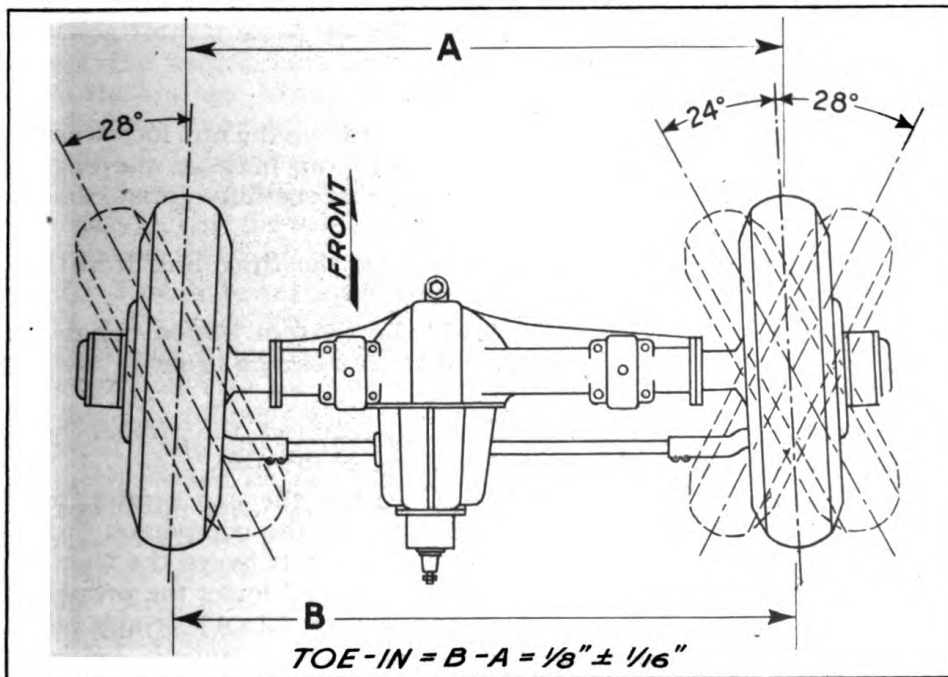

RA PD 313806

Figure 111—Toe-In

"A". Toe-in should be checked at regular intervals and if found incorrect should be adjusted to between $\frac{1}{16}$ in. and $\frac{3}{16}$ in.

b. Adjustment.

(1) **TURN THE WHEELS INTO THE STRAIGHT-AHEAD DRIVING POSITION.**

(2) **MAKE CHALK MARKS ON CENTER OF TIRES.** Jack up the front wheels and start them spinning and then hold a pointed piece of chalk against the center of the tire long enough so that a line will be scribed completely around the circumference of the tire. Lower the jacks so that the front of the vehicle is again supported on the wheels.

(3) **CHECK TOE-IN ADJUSTMENT.** Measure the distance indicated as dimension "A" in figure 111 at a point directly opposite the center of the wheel. Then measure dimension "B" at a point directly opposite

TM 9-811
115-116

**4-TON, 6 x 6 TRUCKS (DIAMOND T MODELS 968A CARGO,
969A WRECKER, 970A PONTON, AND 972 DUMP)**

the center of the wheel. Measurements should be made between the chalk marks on the tires. Then subtract dimension "A" from dimension "B" and the result will be the toe-in of the front wheels. If this is between $\frac{1}{16}$ in. and $\frac{3}{16}$ in. no adjustment is necessary. If toe-in is found to be less than $\frac{1}{16}$ in. or more than $\frac{3}{16}$ in., it will be necessary to adjust the toe-in as described in next step.

(4) **ADJUST TOE-IN.** Disconnect one end of the tie rod as described in paragraph 114. Then loosen the clamping nuts on the tie rod yoke, and turn the yoke end as many turns as are necessary to get the proper toe-in. After the adjustment is made, tighten the clamping nuts and connect the tie rod. Then check toe-in again. Repeat this procedure as often as is necessary to secure proper toe-in.

116. AXLE ASSEMBLY REMOVAL.

a. **Disconnect Oil Pan Bond Strap.** Remove the nut, lock washer and toothed lock washer holding the bond strap between the engine oil pan and the front axle differential carrier to the differential carrier, then disconnect the strap.

b. **Disconnect Drag Link.** Disconnect the drag link from the steering arm as described in paragraph 148.

c. **Release Pressure from Air Brake System.** Open the drain cocks on the air reservoir tanks to permit the escape of air in the air brake system.

d. **Disconnect Air Brake Hose.** Disconnect the rubber hose leading to the brake chambers on each side of the axle.

e. **Disconnect Propeller Shaft.** Remove the cap screws, nuts and lock washers between the flange yoke and the companion flange at the forward end of the propeller shaft running between the transfer and the front axle. Then separate the flanges, and lower the propeller shaft to the ground. Place a 30 in. piece of wood (2 x 4), or any other convenient rod or tube of comparable length and strength, between the axle housing and the tie rod on the right side of the carrier housing. This wooden brace should be installed at an angle pointing down and towards the rear of the vehicle. It is used as a wedge to prevent the axle assembly from tipping when it is removed from the vehicle.

f. **Raise the Vehicle on Jacks.** Place jacks under each end of the axle housing, and raise it so that the front tires clear the ground by about 10 inches.

g. **Remove Front Spring U-bolt.** Remove the nuts and lock washers from each of the front spring U-bolts, and pry the U-bolts off. There is a bracket pad underneath each end of the axle housing which may be removed as the U-bolts are taken out. This bracket is attached to the shock absorber connecting link and need not be disconnected.

h. **Block Vehicle and Lower Axle to Ground.** Place blocks under the front spring rear hanger. Check the position of the 2 x 4 to be sure that it will keep the axle assembly from tipping. Then release the jacks and lower the front axle until the tires touch the ground. Roll the axle assembly forward away from the chassis.

FRONT AXLE**117. AXLE ASSEMBLY INSTALLATION.**

a. Line Up Axle Assembly in Front of Chassis. Roll the axle assembly to a position in front of the vehicle so that the spring pads on the axle housing are approximately in line with the springs, with the carrier facing towards the vehicle.

b. Roll Axle Assembly Under Vehicle. One man, using a piece of 2 x 4 about 4 feet long, can hold the axle assembly to prevent tipping, while the others roll it into position under the vehicle. The 2 x 4 should be inserted between the axle housing and the tie rod on the right side of the axle, so that the free end is pointing up and away from the vehicle. The first man can pull down on the 2 x 4 to keep the axle housing from tipping, while the others roll the assembly into position under the vehicle, and line up the spring pads on the axle housing with the springs. When the axle is in position slide the 30-inch 2 x 4, used when removing the axle, between the tie rod and the axle housing to prop it in place, and remove the 4-foot 2 x 4.

c. Jack Up the Vehicle. Place jacks under each side of the bumper, and lift the vehicle so that the blocks under the spring hangers may be removed.

d. Install Front Spring U-bolt. Lower the vehicle on the jacks until the springs rest on the spring pads of the axle housing. It will be necessary to jockey the axle assembly in order to line up the spring through bolt with the hole in the middle of the spring pad. This can be done by rolling the axle assembly back and forth, and by using a crowbar under the tires to get a sidewise shift. When the springs are properly seated on the spring pads, place the front spring bumpers on top of the upper leaves, and install the four U-bolts. As the U-bolts are installed, swing the lower axle housing pad, which is connected to the shock absorber link, into position and run the U-bolts through them. Then install the nuts and lock washers which were removed from the U-bolts, and tighten these securely.

e. Lower Vehicle to the Ground. Release the jacks and remove them from under the vehicle.

f. Connect Propeller Shaft. Swing propeller shaft into position against the companion flange on the front axle and attach it in place with the cap screws, nuts and lock washers which were removed.

g. Connect Air Lines. Connect the air lines to the brake chambers at each end of the axle assembly.

h. Connect Drag Link to the Steering Arm. Connect the drag link to the axle steering arm as described in paragraph 148.

i. Connect Bond Strap to Differential. Connect the bond strap running between the engine oil pan and the front axle differential carrier to the carrier, using the nut, lock washer and toothed lock washer which were removed.

TM 9-811
118

**4-TON, 6 x 6 TRUCKS (DIAMOND T MODELS 968A CARGO,
969A WRECKER, 970A PONTON, AND 972 DUMP)**

Section XXVIII

REAR AXLES

	Paragraph
Description and tabulated data.....	118
Axle shaft replacement.....	119
Axle assembly removal.....	120
Axle assembly installation.....	121

118. DESCRIPTION AND TABULATED DATA.

a. Description. Tandem rear axles are used on these vehicles, both axles being driving axles. The drive is through a conventional double-reduction differential, which functions in exactly the same manner as that used with the front axle, except that the differential carriers are

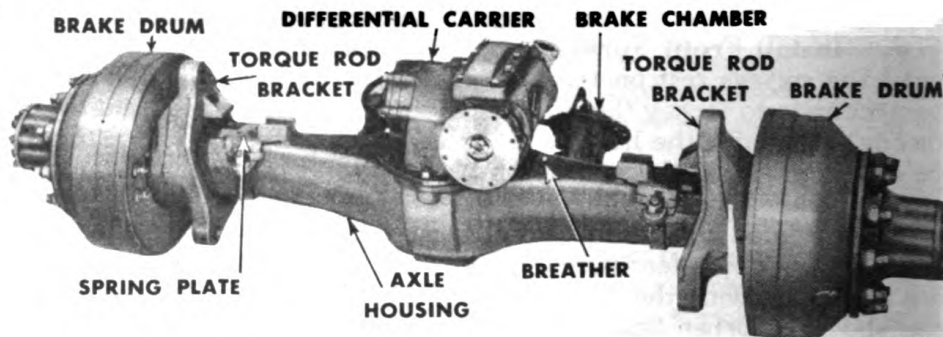

RA PD 304996

Figure 112—Rear Axle Assembly

mounted on top of the axle housings instead of in back of them. Carriers are of the through shaft construction, which means that the pinion shaft passes through the carrier so that power is delivered to the rear rear axle after passing through the through shaft of the forward rear axle. The axles are full-floating, and the axle shaft may be removed without raising the wheels from the ground (fig. 112).

b. Breather. A breather is located on the deck of the axle housing near the differential carrier. It permits the unit to breathe as pressure changes occur inside the housing due to heat and lubricant vapors formed in normal operation. The action of the breather prevents damage to the oil seals which might happen due to this pressure, and hence it must be kept clean at all times. Check the condition of the breather frequently and remove it for cleaning as often as may be necessary.

c. Tabulated Data.

Make	Timken	Model	SFD-154-W
Type.....	Double reduction	Lubricant capacity.....	7 1/2 pt

REAR AXLES

119. AXLE SHAFT REPLACEMENT.

a. **Remove Axle Shaft Studs.** Remove the nuts, lock washers and toothed lock washers from the axle shaft flange studs.

b. **Remove Axle Shaft.** Remove the lock wire from the heads of the puller screws, and then tighten the puller screws alternately to pull the shaft off the studs (fig. 113). When the shaft is free, it may be pulled out of the axle housing. As the drive flange of the axle shaft clears the studs, three tapered dowels may be removed from the stud holes. After shaft is removed, remove the flange gasket.



Figure 113—Tightening Rear Axle Flange Puller Screws

c. **Install New Axle Shaft.** Install new flange gasket over studs on the wheel hub. Slide the new axle shaft through the hub and into the axle housing, meshing the shaft splines with the splines on the differential side gear. Then line up the axle drive flange holes with the studs and tap the shaft into position with a soft hammer.

d. **Install Axle Flange Nuts.** Place the three tapered dowels over the studs which pass through the tapered holes in the axle shaft flange, and push these up snugly as far as they will go. Then install a toothed lock washer over each one of these studs and replace the flange nuts on these studs. Tighten these nuts securely. Then install the remaining nuts and lock washers, and tighten them securely.

**TM 9-811
120-121**

**4-TON, 6 x 6 TRUCKS (DIAMOND T MODELS 968A CARGO,
969A WRECKER, 970A PONTON, AND 972 DUMP)**

120. AXLE ASSEMBLY REMOVAL.

a. Rear Rear Axle.

(1) **DISCONNECT AIR LINES.** Open the drain valves in the reservoir tanks and release the air pressure stored up in the braking system. Then disconnect the flexible air hose at the tee which is mounted on top of the rear rear axle housing.

(2) **DISCONNECT UPPER TORQUE RODS.** Disconnect both upper torque rods on the rear rear axle side of the torque rod bracket at the bracket (par. 144).

(3) **REMOVE LOWER TORQUE RODS.** Remove both lower torque rods on the rear rear axle side of the torque rod bracket (par. 144).

(4) **DISCONNECT PROPELLER SHAFT.** Disconnect the propeller shaft between the rear rear axle and the forward rear axle at the back end (par. 111).

(5) **RAISE REAR OF VEHICLE ON JACKS.** Place a 30-inch 2 x 4 prop between the brake camshaft and axle housing to keep the unit from tipping. Place a jack under each end of the rear axle bogie tube, and raise the vehicle just enough so that the springs clear the pads on top of the rear rear axle housing.

(6) **REMOVE REAR REAR AXLE FROM VEHICLE.** Roll the axle assembly out from under the truck towards the rear.

b. Forward Rear Axle. The forward rear axle can be removed from the vehicle in exactly the same manner as that outlined for the rear rear axle, except that the inter-axle propeller shaft will have to be disconnected at the forward end, the propeller shaft between the transfer and the forward rear axle must be disconnected at the axle, and a special procedure must be followed to get the assembly out from under the vehicle. After the vehicle is raised on jacks placed under the bogie tube, a cradle type jack should be rolled under the axle housing and the axle raised far enough to permit the removal of the wheels. After the wheels are removed, the axle assembly may be lowered and pulled out from under the chassis.

121. AXLE ASSEMBLY INSTALLATION.

a. Rear Rear Axle.

(1) **INSTALL REAR REAR AXLE INTO POSITION UNDER VEHICLE.** Roll the rear rear axle assembly into position under the vehicle and work it forward so that the ends of the springs rest on the axle spring pads and pass under the arms extending from the axle torque rod brackets. While this operation is being performed, the axle assembly must be held in an upright position, that is, with the carrier housing facing up. This can be done using a 2 x 4 between the axle housing and the brake camshaft.

(2) **INSTALL LOWER TORQUE RODS.** Replace the lower torque rods between the axle torque rod brackets and the frame brackets (par. 144).

REAR AXLES

(3) **CONNECT UPPER TORQUE RODS.** Connect the inner ends of the upper torque rods to the torque rod brackets (par. 144).

(4) **LOWER THE JACKS SUPPORTING THE VEHICLE UNDER THE BOGIE TUBE.** Lower the jacks supporting the vehicle under the bogie tube permitting the weight of the vehicle to rest on the springs.

(5) **CONNECT INTER-AXLE PROPELLER SHAFT.** Connect the inter-axle propeller shaft to the yoke on the rear rear axle (par. 112).

(6) **CONNECT AIR LINE.** Connect the air line to the tee which is mounted on top of the rear axle housing.

b. Forward Rear Axle. The forward rear axle may be installed in the vehicle in exactly the same manner as outlined for the rear rear axle, except that the inter-axle propeller shaft will be connected to the forward rear axle at the front end, the propeller shaft between the transfer and the forward rear axle will be connected to the companion flange on the axle, and a special procedure is necessary to work the axle into position. With the axle assembly mounted on a cradle jack, slide it into position under the vehicle and raise the jack high enough to permit installation of the wheels. Then remove the jack and roll the axle assembly into position with the ends of the springs resting on the spring pads of the axle housing.

**4-TON, 6 x 6 TRUCKS (DIAMOND T MODELS 968A CARGO,
969A WRECKER, 970A PONTON, AND 972 DUMP)**

Section XXIX

BRAKES

	Paragraph
Description and tabulated data.....	122
Maintenance	123
Adjustment	124
Brake shoes.....	125
Slack adjusters.....	126
Brake chambers.....	127
Air compressor.....	128
Governor	129
Brake valve.....	130
Hand brake valve.....	131
Quick release valve.....	132
Relay valve.....	133
Stop light switch.....	134
Low-pressure indicator, safety valve and air supply valve....	135
Parking brake.....	136

122. DESCRIPTION AND TABULATED DATA.

a. Description.

(1) **GENERAL.** Two braking systems are provided on these vehicles; the vehicle brakes and the parking brake.

(2) **SERVICE BRAKES.** The service brake system is composed of an air compressor, air compressor governor, air reservoir, safety valve, brake application valve, relay valve, brake chambers, quick relief valve, stop light switch, low pressure indicator and the brake shoes and actuating mechanisms. The brakes are internal-expanding. Cables are provided for air brakes on a trailer (figs. 114 and 115).

(3) **PARKING BRAKE.** The parking brake system is controlled by mechanical linkage and consists of a set of four shoes braking on a soft steel disk mounted in the drive line in back of the transfer.

b. Operation (figs. 114 and 115).

(1) **SERVICE BRAKES.** The air compressor is driven by belts from the engine. The air under governed maximum pressure of 105 pounds is delivered from the air compressor to the reservoirs which are mounted on the vehicle frame. In the event the governor should fail to limit the pressure at 105 pounds per square inch, a safety valve is provided which will blow off when the reservoir pressure exceeds 150 pounds. A low-pressure indicator device is used which will sound a buzzer in the cab whenever the pressure in the reservoirs is too low to satisfactorily operate the brakes. The brake application valve, mounted on the frame and connected by linkage with the brake pedal, delivers air from the reservoirs to the brake chambers whenever the pedal is depressed and releases the pressure in the brake chambers whenever

BRAKES

the brake pedal is released. The relay valve assists the brake valve in more quickly delivering its supply of air to the brake chambers. The quick release valve permits the escape of air under pressure at a point close to the brake chambers, thus speeding up brake release by shortening the distance the air has to travel before it escapes to the atmosphere.

(2) **PARKING BRAKE.** The parking brake is controlled by a brake lever located in the cab. Braking effort is transmitted from the brake lever to the shoe through a cable and brake cross shaft linkage. When the brakes are applied, the brake shoes close against the brake disk to keep it from turning. This brake is a parking brake or emergency brake and should not be used to stop the vehicle unless absolutely necessary.

c. Tabulated Data.

(1) **SERVICE BRAKES SYSTEM.**

Make.....	Bendix Westinghouse
Governed air pressure.....	105 lb per sq in.
Blowout pressure.....	150 lb per sq in.
Compressor capacity.....	7¼ cu ft
Brake size.....	17¼ x 4 in.

Part numbers:

Air compressor.....	BWE-215781
Governor.....	BWE-215639
Safety valve.....	BWE-205105
Brake valve.....	BWE-216231
Hand control valve.....	BWE-215748
Front brake chamber—R.H.....	BWE-220686
Front brake chamber—L.H.....	BWE-220687
Rear brake chamber.....	BWE-220371
Low pressure indicator.....	BWE-215186
Low pressure indicator buzzer.....	BWE-220835
Quick release valve.....	BWE-205000
Relay valve.....	BWE-217383
Stop light switch.....	BWE-215537
Double choke valve.....	BWE-217698
Air supply valve.....	BWE-221192
Slack adjuster front axle.....	BWE-220688
Slack adjuster rear axle—R.H. forward and L.H. rear	BWE-217919
Slack adjuster rear axle—L.H. forward and R.H. rear	BWE-217920

(2) **PARKING BRAKE.**

Make.....	Tru-stop
Type.....	Disk
Mounting.....	Between companion flanges and drive line
Clearance between shoe and disk.....	½ in.

123. MAINTENANCE.

a. Draining Reservoirs. Since the pressure inside the reservoirs is considerably higher than atmospheric pressure, moisture will be condensed and will accumulate in the bottom of the reservoir. This water is

4-TON, 6 x 6 TRUCKS (DIAMOND T MODELS 968A CARGO,
969A WRECKER, 970A PONTON, AND 972 DUMP)

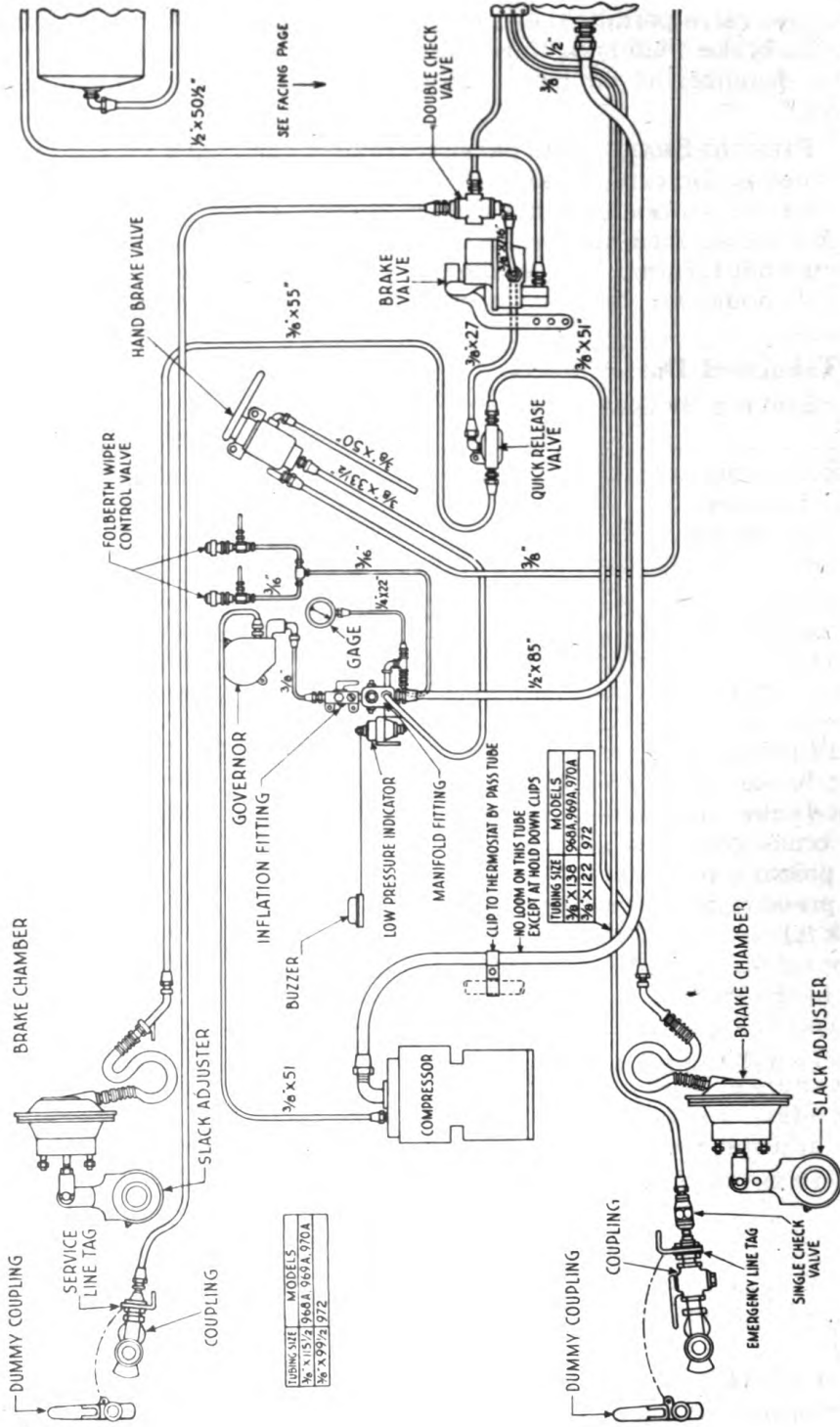

RA PD 313838

Figure 114—Air Piping Diagram, Front

BRAKES

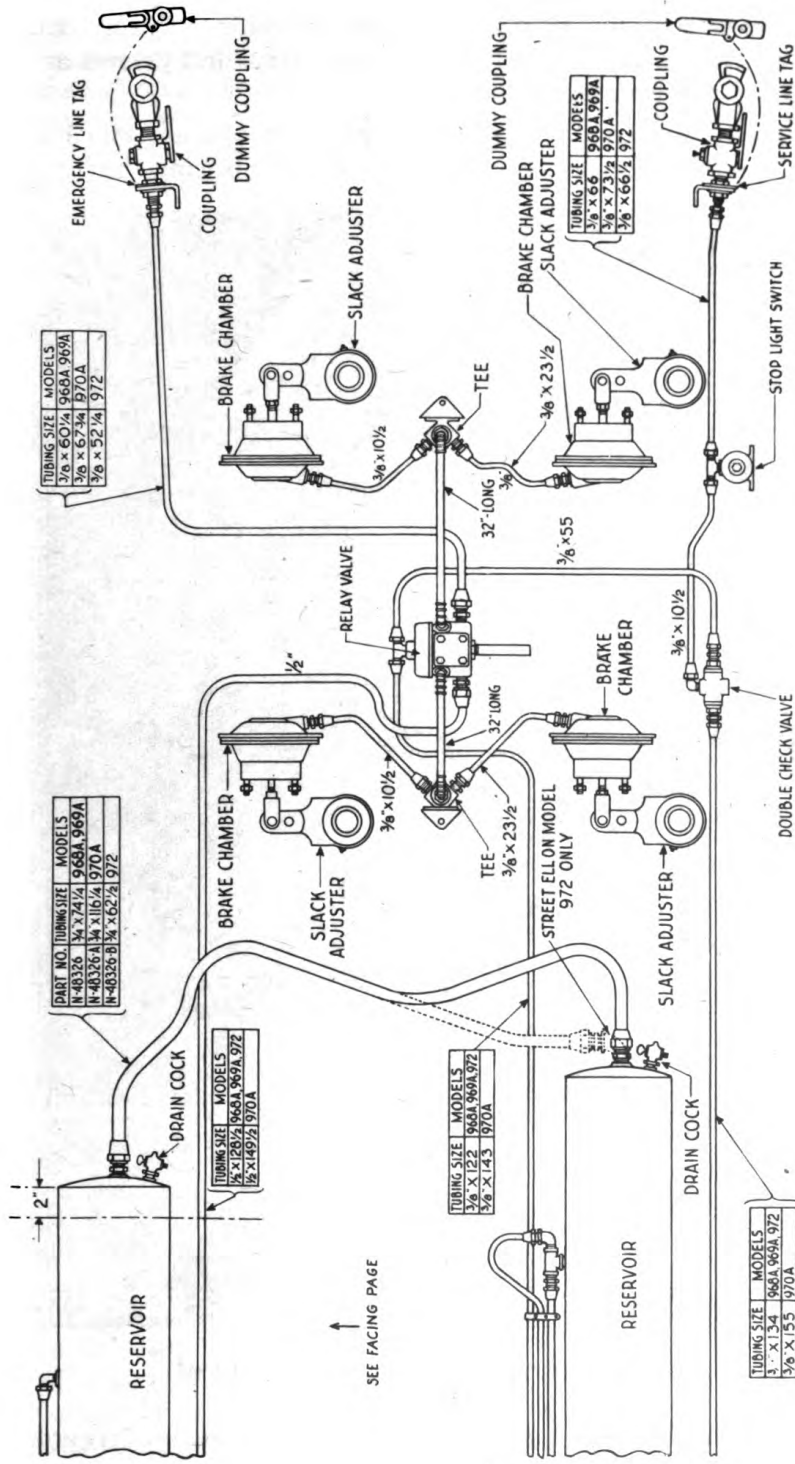

RA PD 313839

Figure 115—Air Piping Diagram, Rear

TM 9-811
123

**4-TON, 6 x 6 TRUCKS (DIAMOND T MODELS 968A CARGO,
969A WRECKER, 970A PONTON, AND 972 DUMP)**

harmful to the units of the air braking system. To remove this moisture, open the drain valve located on each reservoir tank and permit air to escape until all the moisture is blown out.

b. Leakage Test. If the braking system is to operate efficiently, leakage in the air lines and in the various units comprising the system

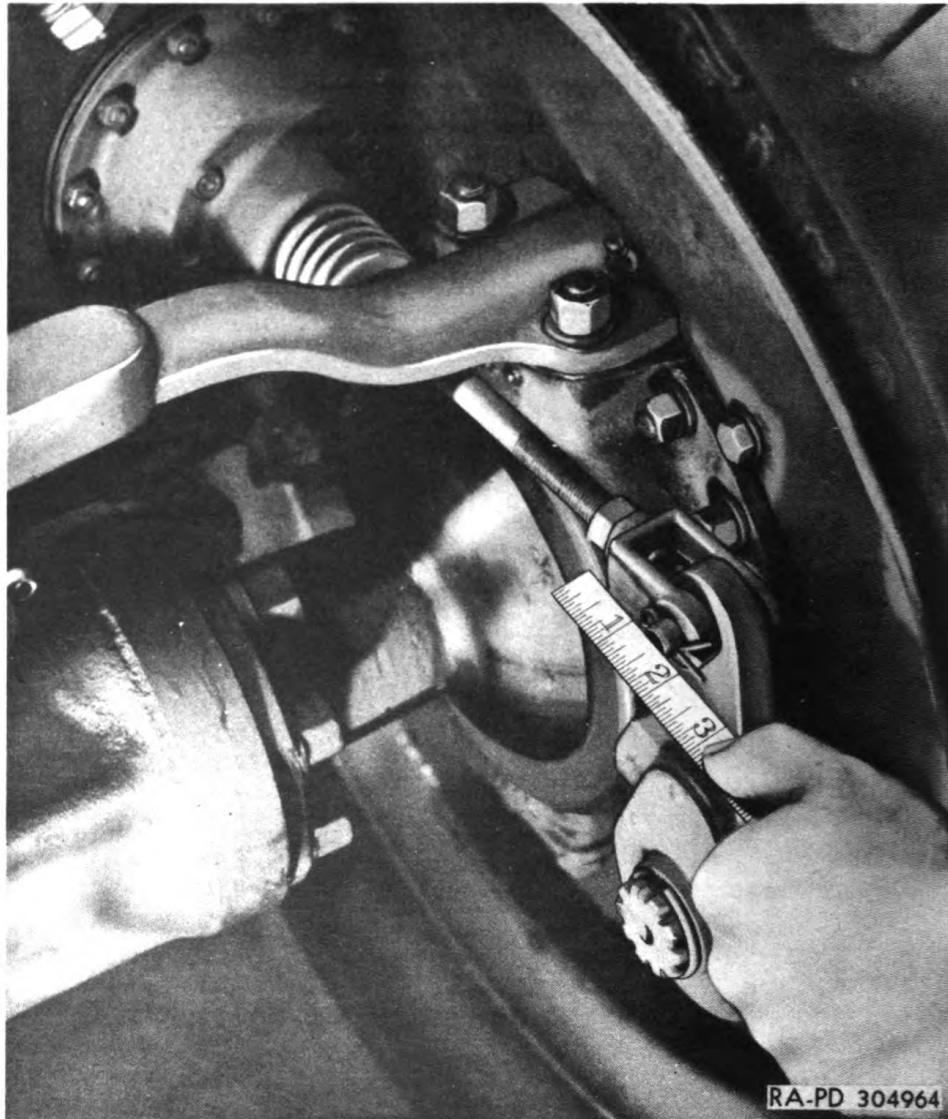

Figure 116—Measuring Push Rod Travel

must be held to a minimum. When checking for leaks, the driver can start the engine and build up air pressure in the reservoirs, then walk around the vehicle listening for leaks with the brakes applied and with the brakes released. If there are leaks in the system which cannot be

BRAKES

discovered by listening, soap bubble tests may be made after the engine has been run sufficiently long to build up a maximum of air pressure in the reservoirs. Tests are made on the various units with the brakes applied and the brakes released. Coat the connections and if necessary, the units, with soap suds, using a clean brush. No leakage is permitted at the brake chambers or the air lines running between the brake application valve and the brake chambers. If leakage is discovered at these units or in the connections on these lines, corrective measures must be taken immediately. On all other units of the braking system, leakage is permissible provided it does not exceed a 3-inch

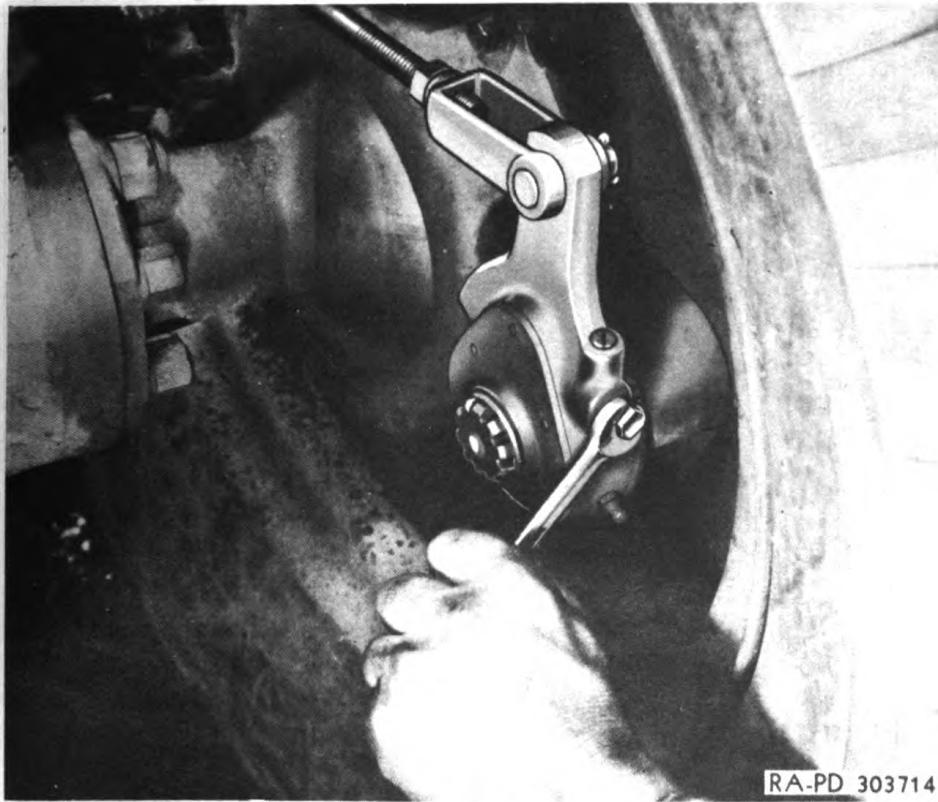

Figure 117—Adjusting Slack Adjuster

bubble in three seconds. If leakage is in excess of this amount, the defective units must be replaced.

c. **Pressure Test.** The pressure delivered from the reservoirs to the brake chambers may be checked, using a test gage on the end of the line running to the brake chambers. Release the air pressure from the reservoirs, then disconnect one of the brake chamber lines. Attach the test gage to the end of the line and start the engine to build up a maximum air pressure in the reservoirs. With the brake pedal fully applied, approximately 105 pounds per square inch of pressure should be delivered to the test gage. If this is not the case, check for leaks (subpar. b above), incorrect adjustment of the governor, or a de-

**TM 9-811
123-124**

**4-TON, 6 x 6 TRUCKS (DIAMOND T MODELS 968A CARGO,
969A WRECKER, 970A PONTON, AND 972 DUMP)**

fective brake valve. The test gage may be used in other parts of the brake system to locate troubles resulting from a loss of air pressure, and may also be used as a test on the gage mounted on the instrument panel.

124. ADJUSTMENT.

a. **General.** The front brakes are different from the rear brakes only in that the brake shoe anchor pins of the front brakes are eccentric, thus providing an adjustment at the heel of the shoe. The rear brake shoes are pivoted on straight anchor pins and hence have no



**Figure 118—Checking Brake Shoe Clearance
(0.010 to 0.015 inch)**

adjustment at the heel. In general, the need of a brake adjustment is indicated when the front brake push rod travel is close to or exceeds $1\frac{3}{8}$ inch, and when the rear brake push rod travel is close to or exceeds $1\frac{3}{4}$ inch (fig. 116).

b. Brake Adjustment.

(1) **BUILD UP AIR PRESSURE.** Start the engine and operate it long enough to build up a pressure of at least 80 pounds per square inch as indicated on the air pressure gage on the dash, and maintain this pressure above 60 pounds per square inch during the adjustment procedure.

(2) **JACK UP WHEELS.** Place a jack under the axle housing on

BRAKES

the side on which the brake is to be adjusted, and raise the axle so that the tires just clear the ground.

(3) **ADJUST SLACK ADJUSTER.** Tighten the slack adjuster adjusting worm until the brake shoes are standing tight against the brake drum. Then back off the worm until the wheel is free to turn (fig. 117). Check the adjustment with the feeler gage inserted through the inspection hole in the brake drum to see that there is 0.010-inch to 0.015-inch clearance at the toe of each brake shoe (fig. 118).

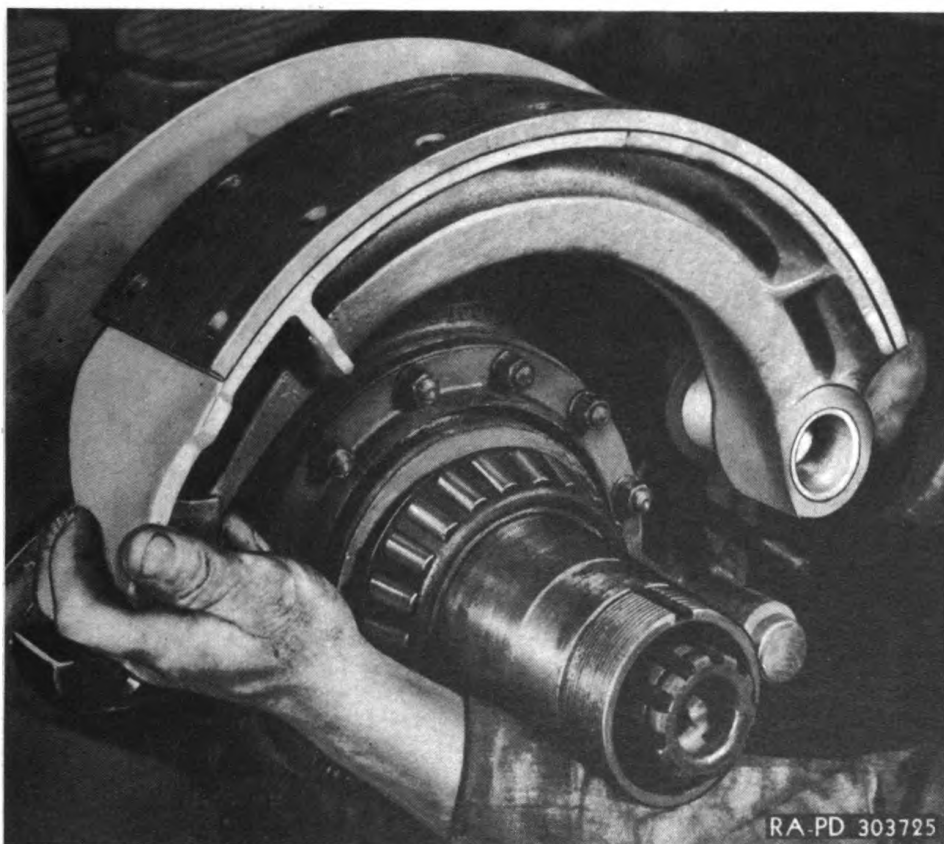

Figure 119—Removing Upper Front Brake Shoe

(4) **CHECK BRAKE CHAMBER PUSH ROD TRAVEL.** When the adjustment is complete, measure the push rod travel, holding a scale alongside of the slack adjuster arm (fig. 116). Then apply the brakes. If adjustment is correct, push rod travel should be around $\frac{5}{8}$ inch for the front brake chamber and around $\frac{3}{4}$ inch for the rear brake chamber.

c. **Front Brake Anchor Pin Adjustment.** Brake lining wear is always greatest at the end of the shoe, and it is seldom necessary to make an adjustment at the heel. However, in the event that it is necessary, the adjustment is made as follows:

(1) Release the jam nuts at the rear of the brake anchor pins.

TM 9-811
124-125

**4-TON, 6 x 6 TRUCKS (DIAMOND T MODELS 968A CARGO,
969A WRECKER, 970A PONTON, AND 972 DUMP)**

(2) Turn the anchor pins until the eccentric provides the proper clearance at the heel of the shoe. This clearance should be 0.015 inch.

(3) When the proper setting is obtained, tighten the jam nuts to hold the adjustment.

125. BRAKE SHOES.

a. **Description.** Internal expanding-type brake shoes are used on each wheel. The front brake shoes are conventional in construction, and utilize a $\frac{3}{8}$ -inch moulded type lining which is riveted to them. The



Figure 120—Driving Out Rear Brake Shoe Anchor Pins

rear brake shoes each have two blocks of $\frac{3}{4}$ -inch moulded lining bolted to them. Both front and rear brake shoes are actuated by a cam control by the brake chambers.

b. Removal.

(1) **FRONT BRAKE SHOE.**

(a) *Remove Front Wheel Assembly.* Jack up the assembly and remove the front wheel assembly as described in paragraph 138.

(b) *Remove Brake Shoe Pull-back Spring.* Using a brake spring pliers, remove the pull-back spring connecting the two brake shoes.

BRAKES

(c) *Remove Brake Shoe Anchor Pin Link.* Remove the cotter pin and nut holding the anchor pin link in place. Then remove the link.

(d) *Remove Brake Shoes.* Slide the brake shoes from the anchor pins (fig. 119).

(2) **REAR BRAKE SHOES.**

(a) *Remove Rear Wheel Assembly.* Jack up the axle and remove the rear wheel assembly as described in paragraph 138.

(b) *Remove Brake Shoe Anchor Pin Link.* Remove the cap screw

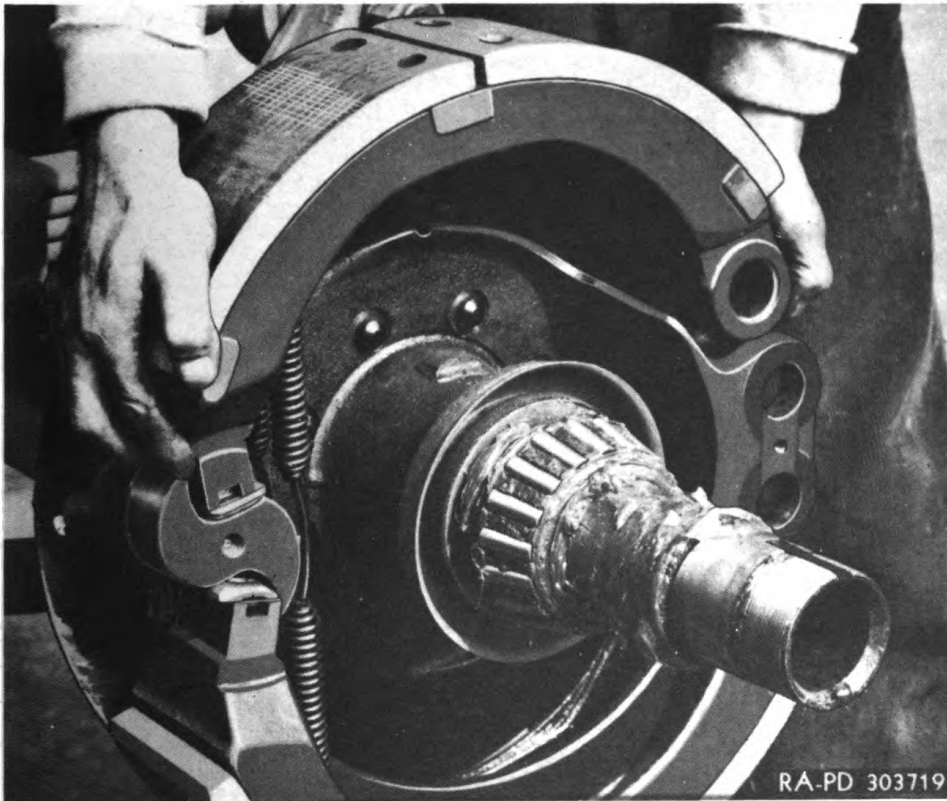

Figure 121—Installing Rear Brake Shoes

and lock washer holding the anchor pin link to the brake support plate. Then drive the link sidewise with a hammer until it falls out.

(c) *Remove Anchor Pins.* Using a hammer and drift punch, drive the two anchor pins out of the brake shoe support plate (fig. 120).

(d) *Remove the Brake Shoes.* Spread the brake shoes apart from the heel end of the shoes, pivoting them on the cam while pulling against the pressure of the retracting springs. Spread them far enough so that the assembly may be removed. Then remove the brake shoe retracting springs.

c. Installation.

(1) **FRONT BRAKE SHOES.**

(a) *Install Brake Shoes on Anchor Pins.* Slide the front brake

4-TON, 6 x 6 TRUCKS (DIAMOND T MODELS 968A CARGO, 969A WRECKER, 970A PONTON, AND 972 DUMP)

shoes over the anchor pins, pushing them all the way back and resting the cam plate on the toe end of the shoes on the cam.

(b) *Install Brake Shoe Retracting Spring.* Using brake spring pliers, install the brake shoe retracting spring between the two shoes.

(c) *Install Brake Shoe Anchor Pin Link.* Lift the anchor pin link into position over the stud. Then install the nut and cotter pin.

(d) *Replace Wheel Assembly.* Install the wheel assembly on the vehicle as described in paragraph 138.

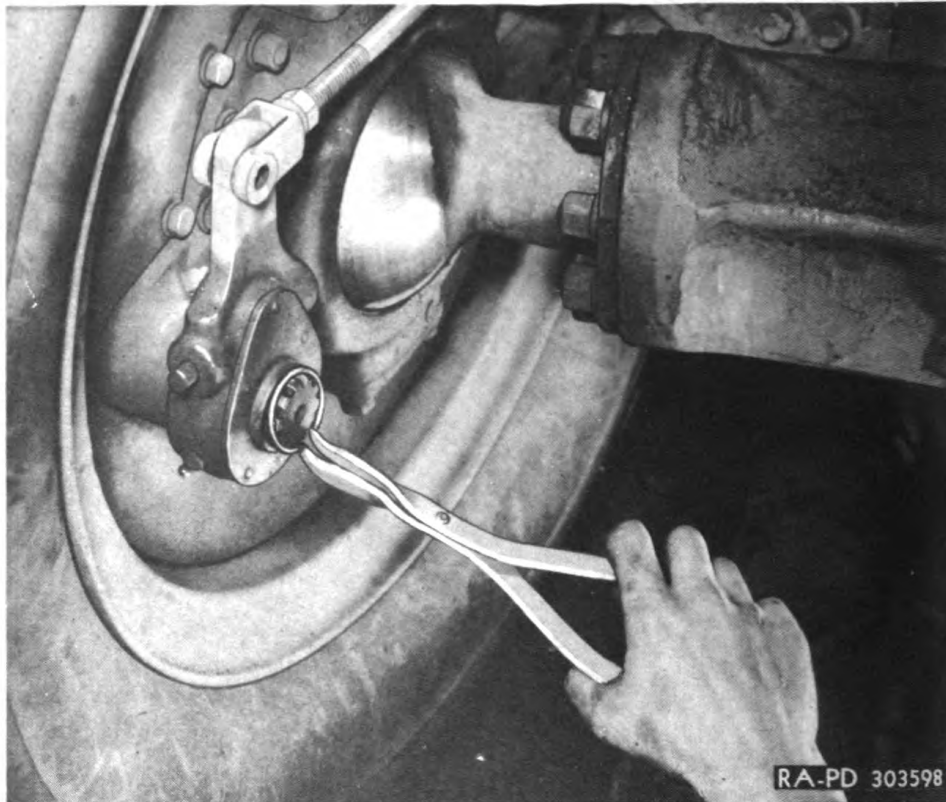

Figure 122—Removing Front Slack Adjuster Retainer Snap Ring

(e) *Adjust Brakes.* Adjust the anchor pins and the slack adjuster as outlined in paragraph 124.

(2) REAR BRAKE SHOES.

(a) *Install Brake Shoes.* Hook the brake shoe retracting springs between the brake shoe assemblies and then slide the cam plates over the cam, at the same time spreading the shoes from the heel end against the tension of the retracting springs, and working them back into position so that when the tension is released, the heels of the shoes will slide into the space between the anchor pin support arms (fig. 121).

(b) *Install Anchor Pins.* Drive the anchor pins through the brake

BRAKES

shoe support plate from the inner side until the anchor pin link slot completely clears the support plate arm.

(c) *Install Brake Shoe Anchor Pin Link.* Line up the slots in the anchor pins to permit installation of the link and then engage the link in the slots and drive it into position lining up the hole with the cap screw hole in the support plate. Lock the link in place with the cap screw and lock washer.

(d) Install the wheel assembly on the axle (par. 138).

(e) Adjust the rear brakes (par. 124).

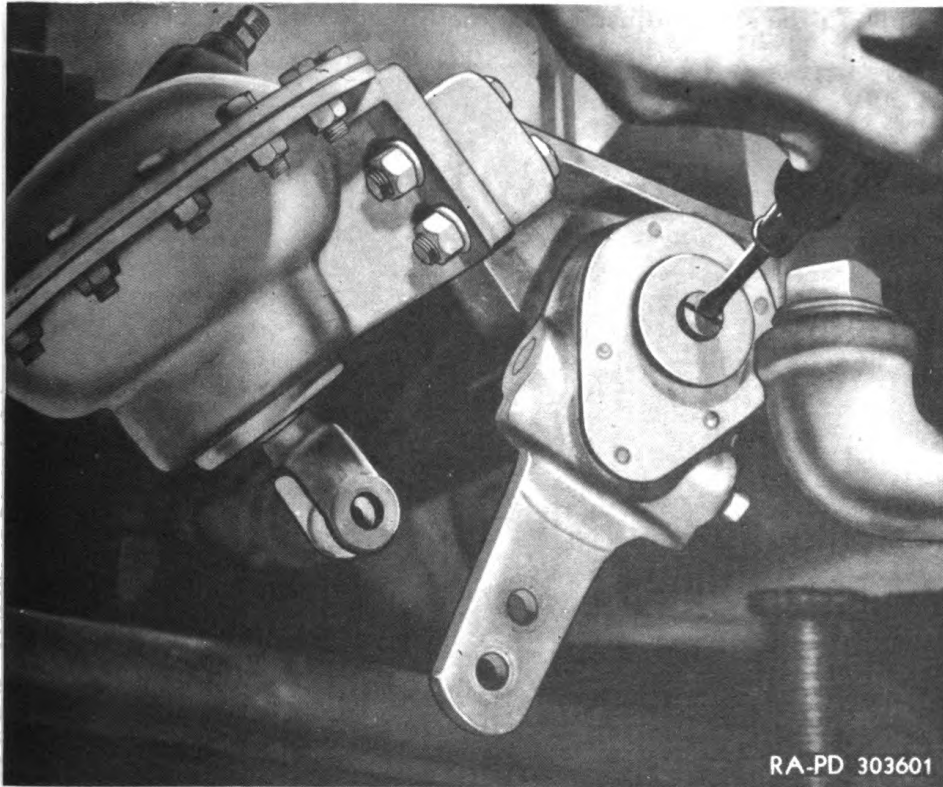

Figure 123—Removing Rear Slack Adjuster Retainer Washer

126. SLACK ADJUSTERS.

a. **Description.** In normal brake operations, the lining wear increases the cam lever travel and the stroke of the push rod. When this travel exceeds maximum limits, brake efficiency is reduced. For this reason slack adjusters are provided which are adjustable to take up the slack caused by normal wear. In normal braking operation, the slack adjuster is held rigid as a unit and rotates bodily with the brake camshaft as the brakes are applied or released. Most efficient brake action is obtained when this arm travel is held to a minimum so that the full length of the lever is used. When adjustment is required, the adjusting worm is turned, rotating a worm gear inside the slack ad-

TM 9-811

126

4-TON, 6 x 6 TRUCKS (DIAMOND T MODELS 968A CARGO, 969A WRECKER, 970A PONTON, AND 972 DUMP)

juster which turns the brake camshaft and cam, expanding the brake shoes out against the drum, so that the slack is taken up and slack adjuster arm travel is returned to its original setting.

b. Adjustment. The procedure for adjusting brakes by means of the slack adjuster is described in paragraph 124.

c. Removal.

(1) FRONT BRAKE SLACK ADJUSTER.

(a) Remove Clevis Pin. Remove the cotter pin holding the clevis pin in the yoke on the end of the brake chamber push rod, and the pivot handle in the slack adjuster arm, then remove the clevis pin.



Figure 124—Removing Brake Chamber Mounting Bolts

(b) Remove Snap Ring. Using snap ring pliers (41-P-1572) remove the snap ring holding the slack adjuster on the brake camshaft (fig. 122).

(c) Back Off Slack Adjuster. Turn the slack adjuster adjusting worm to move the arm away from the yoke. The arm should be moved completely out of contact with the yoke.

(d) Remove Slack Adjuster. Using a prick punch, make a mark on the slack adjuster body, and on one of the splines of the brake cam-

BRAKES

shaft, so that these parts may be reassembled in the same relative positions. Then slide the slack adjuster assembly off the brake camshaft splines.

(2) **REAR BRAKE SLACK ADJUSTER.**

(a) *Remove Clevis Pin.* Remove the cotter pin holding the clevis pin in the yoke on the end of the brake chamber push rod, and the pivot handle in the slack adjuster arm, then remove the clevis pin.

(b) *Back Off Rear Slack Adjuster.* Turn the slack adjuster adjusting worm to move the arm away from the yoke. The arm should be moved completely out of contact with the yoke.

(c) *Remove Slack Adjuster Retainer.* Remove the cap screw holding the slack adjuster retainer washer to the brake camshaft, then remove the retainer (fig. 123).

(d) *Remove Slack Adjuster.* Using a prick punch, make a mark on the slack adjuster body, and on one of the splines of the brake camshaft, so that these parts may be reassembled in the same relative positions. Then slide the slack adjuster assembly off the brake camshaft splines.

d. Installation.

(1) **FRONT BRAKE SLACK ADJUSTER.**

(a) *Install Slack Adjuster.* Line up the punch mark on the slack adjuster body with the mark on the brake camshaft splines, then slide the slack adjuster onto the camshaft.

(b) *Install Snap Ring.* Using snap ring pliers (41-P-1572) install the snap ring in the groove in the splines of the brake camshaft to hold the slack adjuster assembly in place.

(c) *Install Clevis Pin.* Tighten the slack adjuster adjusting worm to move the arm back into the brake chamber push rod yoke, then install the clevis pin through the yoke and the hole in the slack adjuster arm and lock in place with a cotter pin.

(d) Adjust brakes as described in paragraph 124.

(2) **REAR BRAKE SLACK ADJUSTER.**

(a) *Install Slack Adjuster.* Line up the punch mark on the slack adjuster body with the mark on the brake camshaft splines, then slide the slack adjuster onto the camshaft.

(b) *Install Slack Adjuster Retainer.* Install the slack adjuster retainer washer against the end of the brake camshaft and fasten in place with the cap screw which was removed.

(c) *Install Clevis Pin.* Tighten the slack adjuster adjusting worm to move the arm back into the brake chamber push rod yoke, then install the clevis pin through the yoke and the hole in the slack adjuster arm and lock in place with a cotter pin.

(d) Adjust brakes as described in paragraph 124.

127. BRAKE CHAMBERS.

a. Description. The brake chambers consist of two dished metal plates separated by a diaphragm. In front of the diaphragm is the

**4-TON, 6 x 6 TRUCKS (DIAMOND T MODELS 968A CARGO,
969A WRECKER, 970A PONTON, AND 972 DUMP)**

brake chamber push rod, which is held back by a spring when the brakes are released, and which is forced outward by air pressure behind the diaphragm when the brakes are applied. The brake chambers are attached to the axle housing with the push rods hooked onto the slack adjusters.

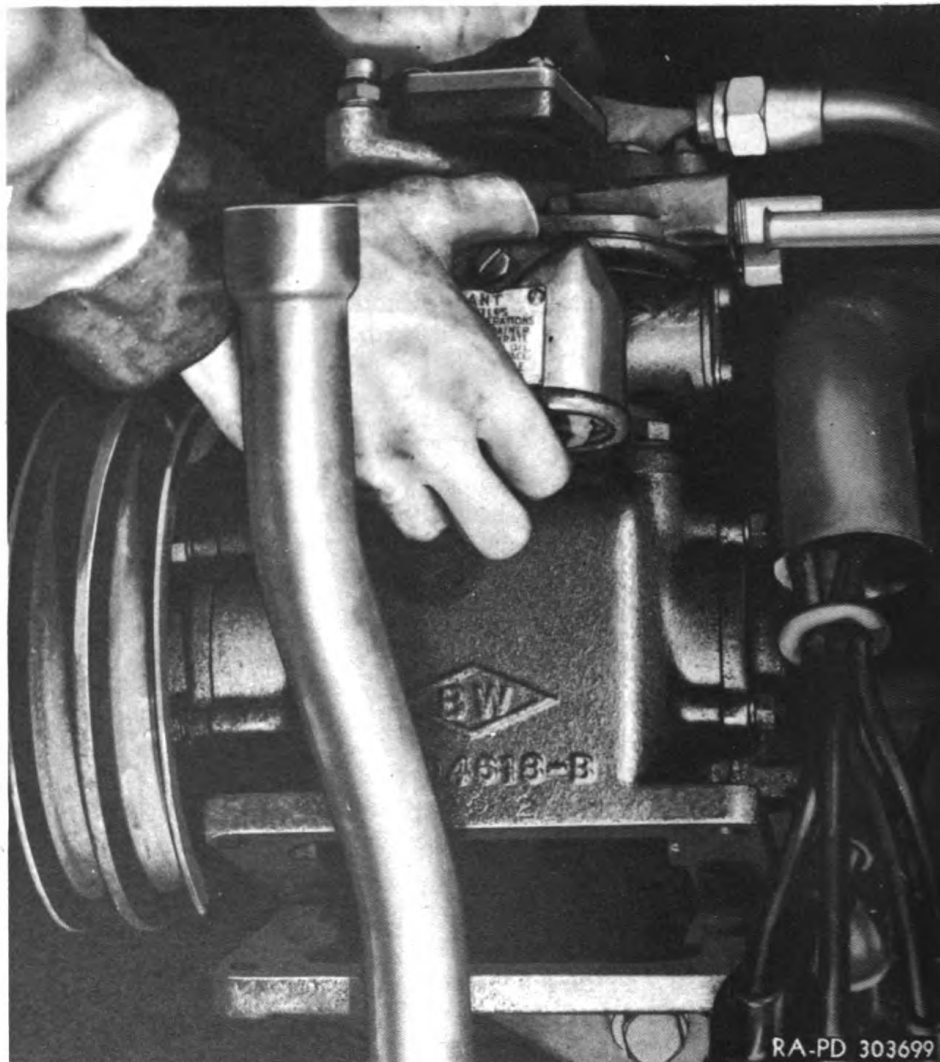

Figure 125—Removing Air Compressor

b. Removal.

(1) FRONT BRAKE CHAMBER.

(a) Release Air Pressure. Open the drain valves in the reservoir tanks and release the air pressure.

(b) Remove Brake Chamber. Remove the cotter pin holding the clevis pin in the brake chamber push rod yoke, and remove the clevis

BRAKES

pin. Disconnect the air line attached to the brake chamber. Remove nut and lock washer from the brake chamber mounting stud, and remove the brake chamber from the axle.

(2) REAR BRAKE CHAMBER.

(a) *Release Air Pressure.* Open the drain valves in the reservoir tanks and release the air pressure.

(b) *Remove Brake Chamber.* Remove the cotter pin holding the clevis pin in the brake chamber push rod yoke, and remove the clevis pin. Disconnect the air line attached to the brake chamber. Remove the bolts, nuts and lock washers attaching the brake chamber to the brake chamber bracket on the axle housing, and remove the brake chamber assembly (fig. 124).

c. Installation.

(1) **INSTALL FRONT BRAKE CHAMBER.** Slide the brake chamber assembly over the mounting stud, at the same time engaging the yoke on the end of the push rod with the slack adjuster arm. Fasten the assembly in place with the nut and lock washer which were removed. Connect the brake chamber air line to the brake chamber. Install the clevis pin through the push rod yoke and the hole in the slack adjuster arm, and lock in place with a cotter pin.

(2) **INSTALL BRAKE CHAMBER.** Install the brake chamber into position on the brake chamber mounting bracket, at the same time engaging the push rod yoke with the slack adjuster arm. Fasten the assembly in place with the bolts, nuts and lock washers which were removed. Connect the brake chamber air line to the brake chamber. Install the clevis pin through the push rod yoke and the hole in the slack adjuster arm and lock in place with a cotter pin.

128. AIR COMPRESSOR.

a. **Description.** The air compressor is a belt-driven, reciprocating, high-speed, single-acting type with two cylinders. At a speed of 1250 revolutions per minute the compressor is capable of compressing $7\frac{1}{4}$ cubic feet of air per minute.

b. **Maintenance.** The air cleaner assembly may be removed from the compressor by removing two attaching screws and lock washers. The curled hair may be removed from the cleaner by removing the retainer clip, baffle plate and strainer plate at the bottom of the assembly. The upper strainer and baffle plates should also be removed from the cleaner housing. All parts should be thoroughly cleaned in dry-cleaning solvent, and then blown dry with compressed air. Do not hold air pressure too close to the hair as it may damage it. After the parts are cleaned, dip the curled hair in engine oil and allow to drain. Then install the parts into the air cleaner body in the following order: upper baffle plate, upper strainer plate, curled hair and spring assembly, lower strainer plate, lower baffle plate and retainer clip. The air cleaner assembly may be installed on the air compressor with the cap screws and lock washers which were removed, using a new gasket between the air cleaner and the air compressor.

4-TON, 6 x 6 TRUCKS (DIAMOND T MODELS 968A CARGO, 969A WRECKER, 970A PONTON, AND 972 DUMP)

c. Removal.

- (1) **DRAIN WATER FROM COOLING SYSTEM.** Drain the water from the cooling system as described in paragraph 84.
- (2) **RELEASE AIR PRESSURE.** Open the drain valve on the reservoirs and release the air pressure from the air brake system.
- (3) **DISCONNECT DISCHARGE LINE.** Disconnect the air compressor discharge air line from the air compressor head.

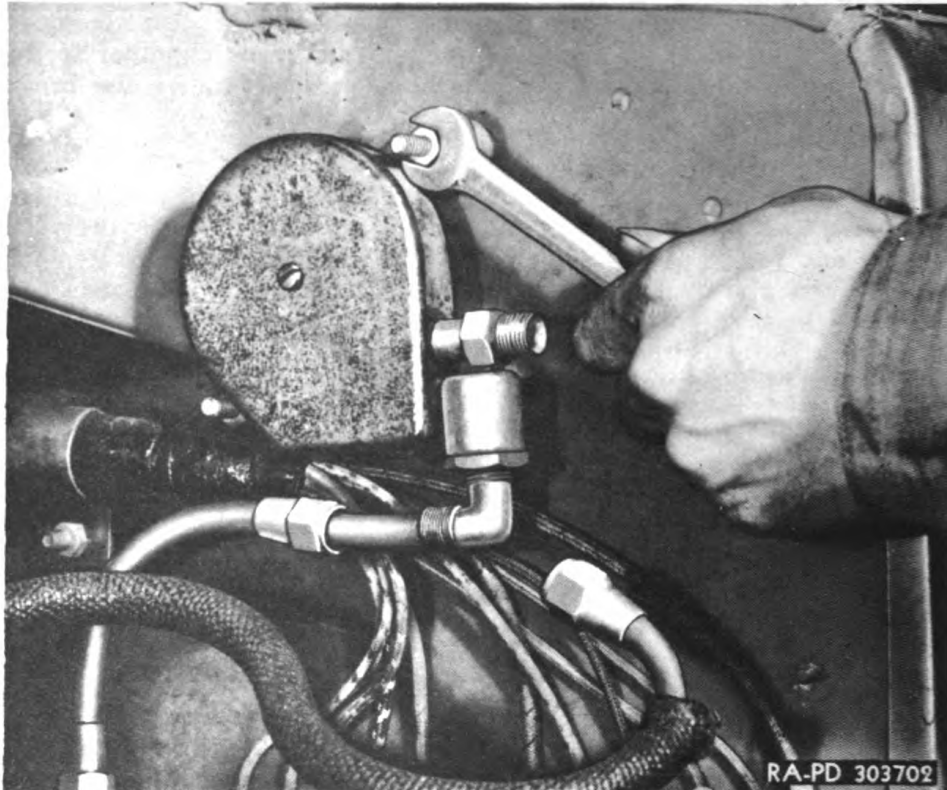

Figure 126—Removing Governor Mounting Nuts

- (4) **DISCONNECT WATER LINES AT COMPRESSOR CYLINDER HEAD.** Disconnect the fitting at the upper end of the air compressor water inlet copper tube. Also loosen the hose clamp on the rubber hose running between the air compressor water outlet and the thermostat bypass line, and disconnect the hose from the air compressor.

- (5) **REMOVE AIR COMPRESSOR.** Remove the cap screws and lock washers attaching the air compressor to the engine mounting bracket, and lift the air compressor assembly out of the engine compartment, working it free of the fan belts. Then remove the air compressor mounting gasket (fig. 125).

d. Installation.

- (1) **INSTALL AIR COMPRESSOR ASSEMBLY.** Place a new gasket on the air compressor mounting bracket, and lift the air compressor

BRAKES

assembly into the engine compartment lowering it into place on the mounting bracket, at the same time working the fan belts over the pulley. Be careful not to damage the gasket while lining the assembly up. Attach the air compressor in place with the cap screws and lock washers which were removed.

(2) **CONNECT AIR COMPRESSOR WATER LINES.** Connect the copper inlet water line to the air compressor inlet fitting on the air compressor head. Install the water pump outlet rubber hose over the end of the outlet tube on the air compressor head and tighten the hose clamp.

(3) **CONNECT COMPRESSOR DISCHARGE LINE.** Connect the air compressor discharge line to the fitting on top of the cylinder head.

(4) **ADD WATER TO COOLING SYSTEM** (par. 84).

129. GOVERNOR.

a. Description. Since the air compressor is running all the time the engine is in operation, a governing device is required to limit the amount of air delivered to the reservoirs. A governor assembly is mounted on the front of the cowl in the engine compartment which limits this pressure to 105 pounds per square inch. The governor consists of a Bourdon tube exerting pressure on a valve. The Bourdon tube is C-shaped and closed at one end with the other end connected with the reservoirs. When the pressure in the reservoir reaches 105 pounds per square inch, the tube is straightened out a sufficient amount by this pressure to operate the valve in the governor which opens an unloader line which discharges all air pumped by the compressor to the atmosphere. When the pressure drops, the tube tends to curl up again, closing the valve which causes air to be delivered to the reservoirs once again.

b. Maintenance. A curled hair air strainer is provided at the base of the governor assembly. Disconnect the air line between the governor and the air supply valve at the governor and then remove the hexagon plug at the bottom of the air strainer elbow and remove the strainer assembly. Wash the strainer assembly in a suitable dry-cleaning solvent, and then dip in engine oil and allow to drain before replacing on the governor. Slide the strainer assembly into the housing at the base of the governor and replace the hexagon plug. Connect the air line between the governor and the air supply valve to the governor.

c. Removal.

(1) **RELEASE AIR PRESSURE.** Open the drain valve on the reservoir, and release the air pressure from the air brake system.

(2) **DISCONNECT AIR LINES.** Disconnect the air lines running between the governor and the air compressor, and between the governor and the air supply valve, at the governor.

(3) **REMOVE GOVERNOR.** Remove the nuts and lock washers holding the governor assembly to the dash, and remove the governor and spacers from the mounting screws (fig. 126).

TM 9-811

129-130

4-TON, 6 x 6 TRUCKS (DIAMOND T MODELS 968A CARGO, 969A WRECKER, 970A PONTON, AND 972 DUMP)

d. Installation.

(1) **INSTALL GOVERNOR.** Install the spacers over the governor mounting screws, install the governor into place, and replace the nuts and lock washers which were removed.

(2) **CONNECT AIR LINES.** Connect the air lines running between the governor and the air compressor, and between the governor and the air supply valve, to the governor.

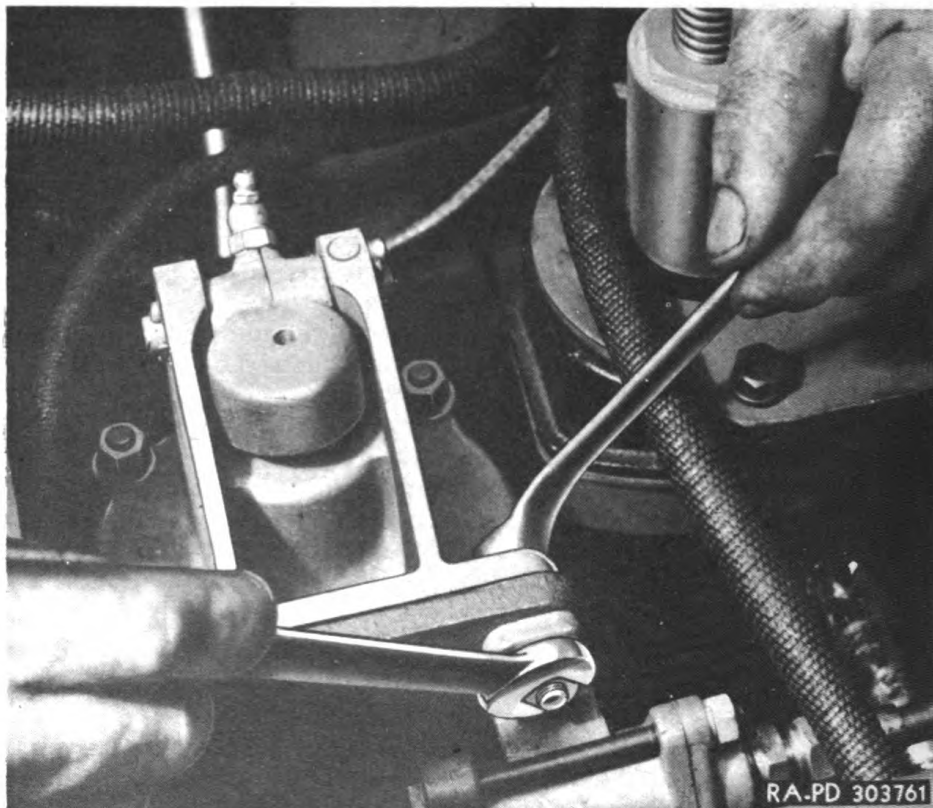

Figure 127—Removing Brake Valve Mounting Screws

130. BRAKE VALVE.

a. **Description.** The brake valve applies and releases the brakes. The amount of air pressure delivered to the brake chambers is in exact proportion to the amount of pedal travel, since the brake valve is designed to balance the pressure controlling the valve in relation to pedal travel and thus controlling the amount of air delivered to the brake chambers. The brake valve is mounted on a bracket attached to the frame rail underneath the floorboards on the driver's side of the cab.

b. Removal.

(1) **REMOVE LEFT FLOORBOARD.** Remove screws holding the floorboard in place, and remove the board from the left side of the cab.

BRAKES

(2) **RELEASE AIR PRESSURE.** Open the drain valves on the drain reservoirs and release the air pressure from the air brake system.

(3) **DISCONNECT AIR LINES.** Disconnect the air lines between the brake valve and the check valve, between the brake valve and the air reservoir, and the brake valve and the quick release valve, at the brake valve.

(4) **DISCONNECT PEDAL PULL-BACK SPRINGS.** Unhook the clutch pedal pull-back springs from the clips on the brake valve body.

(5) **DISCONNECT BRAKE PEDAL LINK.** Remove the cotter pin and clevis pin from the yoke on the end of the brake pedal rod where it attaches to the brake valve arm.

(6) **REMOVE BRAKE VALVE.** Remove the cap screws, nuts and lock washers holding the brake valve assembly to the mounting bracket, and remove the brake valve (fig. 127).

c. Installation.

(1) **INSTALL THE BRAKE VALVE ASSEMBLY.** Install the brake valve assembly into position on the mounting bracket, and fasten in place with cap screws, nuts and lock washers. Note that the upper mounting cap screws must also pass through the mounting flange on the double check valve which is attached to the same bracket.

(2) **CONNECT PEDAL LINK.** Engage the yoke on the end of the brake pedal rod over the end of the brake valve arm so that the holes in the yokes line up with the lowest hole in the brake valve arm and then install the clevis and cotter pins.

(3) **CONNECT PEDAL PULL-BACK SPRINGS.** Connect the brake and clutch pedal pull-back springs to the clips on the brake valve body.

(4) **CONNECT AIR LINES.** Connect the air lines running between the brake valve and the check valve, between the brake valve and the air reservoir, and between the brake valve and the quick release valve, to the brake valve.

(5) **INSTALL FLOORBOARD.** Install the left floorboard and attach it in place with the screws which were removed.

131. HAND BRAKE VALVE.

a. **Description.** The hand brake valve is similar to and performs the same function as the brake valve, the only difference being that the regulating spring is controlled by cam action rather than lever action, and that it has a piston instead of a diaphragm. It is mounted on the steering post and controls the brakes on any unit trailed behind the vehicle.

b. Removal.

(1) **RELEASE AIR PRESSURE.** Open the drain valve on the air reservoirs, and release the pressure from the air brake system.

(2) **DISCONNECT AIR LINES.** Disconnect the air lines running between the hand brake valve and the manifold fitting on the cowl, and between the hand brake valve and the double check valve mounted on the frame, at the hand brake valve. Also disconnect the fitting from the discharge line at the hand brake valve.

TM 9-811
131-132

**4-TON, 6 x 6 TRUCKS (DIAMOND T MODELS 968A CARGO,
969A WRECKER, 970A PONTON, AND 972 DUMP)**

(3) **REMOVE HAND BRAKE VALVE.** Remove the cap screws and nuts clamping the brake valve to the steering post and remove the brake valve mounting cap and brake valve assembly (fig. 128).

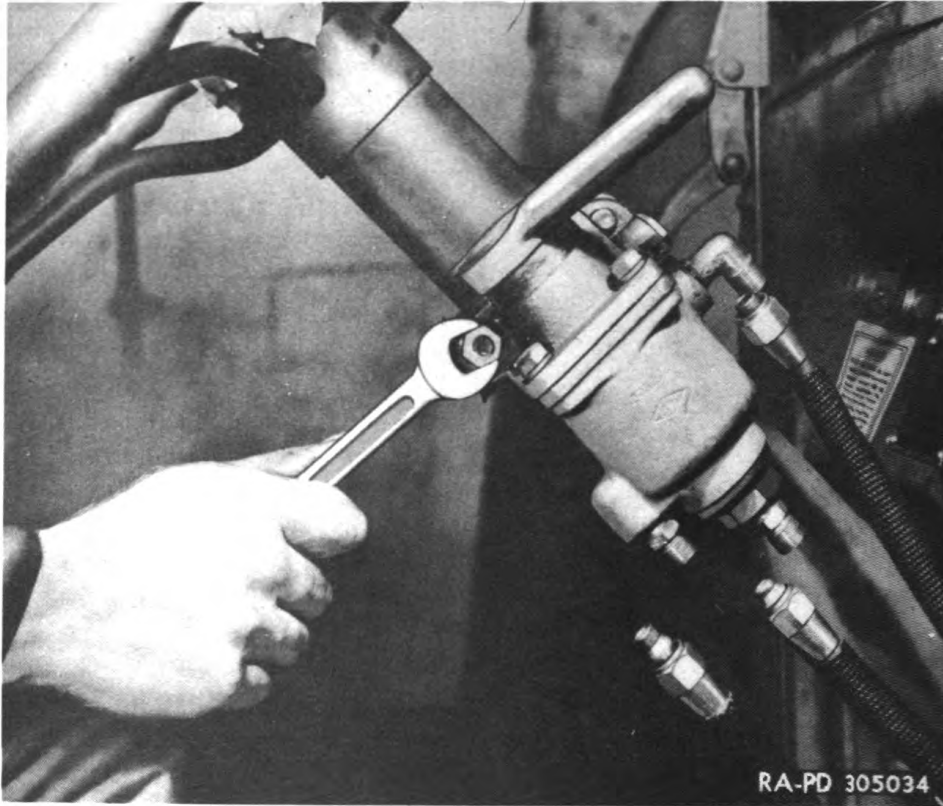

Figure 128—Removing Hand Brake Valve From Steering Post

c. Installation.

(1) **INSTALL HAND BRAKE VALVE.** Place the hand brake valve and mounting cap in position on the steering column, and fasten in place with the cap screws and nuts which were removed.

(2) **CONNECT AIR LINES.** Connect air lines running between the hand brake valve and the manifold fitting on the cowl and between the hand brake valve and the double check valve mounted on the frame, to the hand brake valve. Also connect the fitting on the end of the discharge line to the hand brake valve.

132. QUICK RELEASE VALVE.

a. Description. A quick release valve is provided to speed up the release of air from the brake chambers.

b. Removal.

(1) **RELEASE AIR PRESSURE.** Open the drain valve on the reservoirs and release the air pressure from the air brake system.

BRAKES

(2) **REMOVE LEFT FLOORBOARD.** Remove the screws attaching the floorboard on the left side of the cab and remove the floorboard.

(3) **DISCONNECT AIR LINES.** Disconnect the air lines running between the quick release valve and the brake valve and between the quick release valve and the front brake chambers, at the quick release valve.

(4) **REMOVE QUICK RELEASE VALVE.** Remove the cap screws, nuts and lock washers attaching the quick release valve to the bracket on the transmission, and remove the valve.

c. Installation.

(1) **INSTALL QUICK RELEASE VALVE.** Install a quick release valve into position on the bracket on the transmission and attach it in place with the cap screws, nuts and lock washers which were removed.

(2) **CONNECT AIR LINES.** Connect the two air lines running between the quick release valve and the front brake chambers, and between the quick release valve and the brake valve, to the quick release valve.

(3) **INSTALL FLOORBOARD.** Replace the floorboard in the left side of the cab, and attach it in place with the screws which were removed.

133. RELAY VALVE.

a. **Description.** A relay valve is provided to speed up the application and release of the rear brakes. It functions as a separate brake application valve actuated by pressure from the brake valve. It is mounted on the frame above the rear axles.

b. Removal.

(1) **RELEASE AIR PRESSURE.** Open the drain valves on the reservoirs, and release the pressure from the air brake system.

(2) **DISCONNECT AIR LINES.** Disconnect the air lines running between the relay valve and the tee fittings on the axle housings, between the relay valve and the right rear coupling, between the relay valve and the reservoir, between the relay valve and the double check valve on the frame rail, and between the relay valve and the double check valve on the brake valve bracket, at the relay valve.

(3) **REMOVE RELAY VALVE.** Remove the cap screws and lock washers attaching the relay valve to the frame support bracket, and remove the relay valve (fig. 129).

c. Installation.

(1) **INSTALL RELAY VALVE.** Install the relay valve in position on the frame support bracket, and attach in place with the cap screws and lock washers which were removed.

(2) **CONNECT AIR LINES.** Connect the two air lines running between the relay valve and the tee connections on the axle housings, between the relay valve and the right rear coupling, between the relay valve and the reservoir, between the relay valve and the double check valve on the frame, and between the relay valve and the double check valve on the brake valve bracket, at the relay valve.

TM 9-811

134

4-TON, 6 x 6 TRUCKS (DIAMOND T MODELS 968A CARGO, 969A WRECKER, 970A PONTON, AND 972 DUMP)

134. STOP LIGHT SWITCH.

a. **Description.** The stop light switch is an electro-pneumatic device working in conjunction with the brake valve which operates the stop light on the slightest brake application. The stop light switch is located inside the channel of the left frame rail above the rear axles.

b. Removal.

(1) **RELEASE AIR PRESSURE.** Open the drain valves on the air reservoirs and release the air pressure from the air brake system.

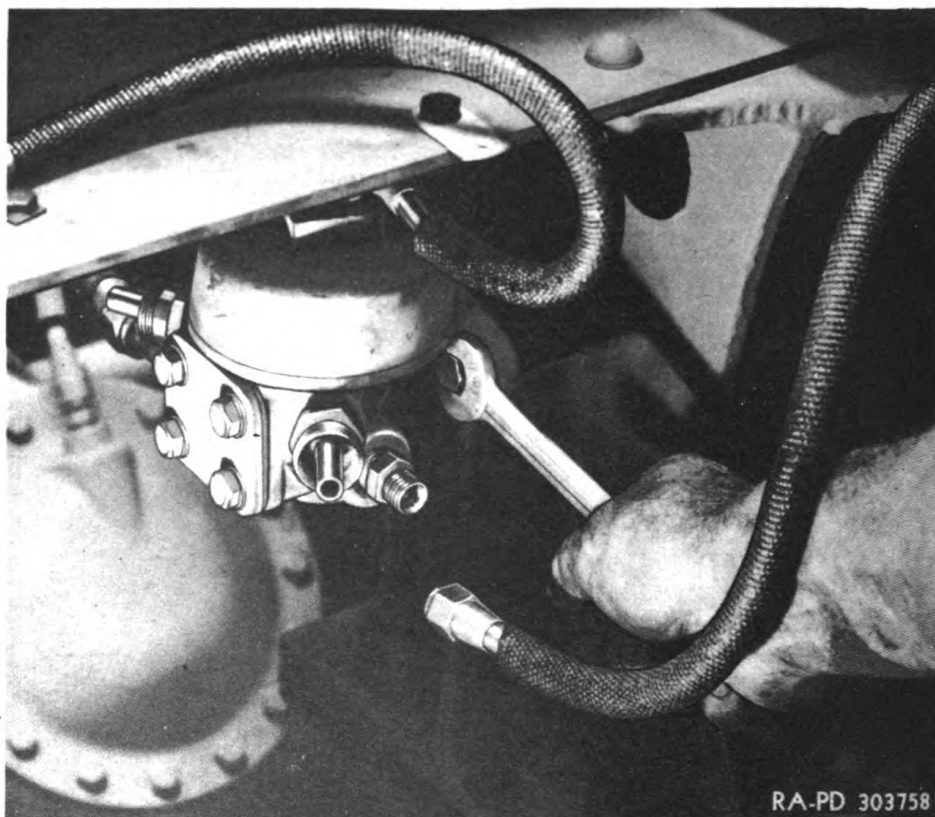

Figure 129—Removing Relay Valve Mounting Cap Screws

(2) **DISCONNECT WIRES.** Remove the terminal nuts and washers and disconnect the wires from the stop light switch.

(3) **DISCONNECT AIR LINES.** Disconnect the air lines running between the stop light switch and the double check valve and between the stop light switch and the left rear coupling, at the stop light switch.

(4) **REMOVE STOP LIGHT SWITCH.** Remove the cap screws, nuts and lock washers holding the stop light switch to the frame rail and remove the switch.

c. Installation.

(1) **INSTALL STOP LIGHT SWITCH.** Install the stop light switch

272

BRAKES

into position on the frame rail and attach in place with the cap screws, nuts and lock washers which were removed.

(2) **CONNECT AIR LINES.** Connect the air lines running between the stop light switch and the double check valve and between the stop light switch and the left rear coupling, at the stop light switch.

(3) **CONNECT WIRES.** Connect the wires to the terminals on top of the stop light switch, and fasten in place with the terminal nuts and washers which were removed (fig. 85).

135. LOW-PRESSURE INDICATOR, SAFETY VALVE AND AIR SUPPLY VALVE.

a. Description (fig. 130).

(1) **LOW-PRESSURE INDICATOR.** The low-pressure indicator is a safety device designed to give automatic warning whenever the reservoir air pressure drops below the minimum amount required for adequate brake application. It is an electro-pneumatic switch mounted on the dash which sounds a buzzer in the cab whenever the air pressure is below 50 pounds per square inch.

(2) **SAFETY VALVE.** The safety valve is a safety device designed to blow off whenever the air pressure in the reservoirs exceed the safety limit of 150 pounds per square inch. It is attached to the manifold fitting on the cowl.

(3) **AIR SUPPLY VALVE.** The air supply valve is mounted above the manifold fitting on the dash and is used as a take-off for a source of air for tire inflation. When used, the inflation hose is screwed into the adapter fitting on the valve and then the valve handle is turned up so that air is delivered under pressure from the reservoirs to the inflation hose. When the inflation hose is removed, the handle should be turned down.

b. Removal.

(1) **GENERAL.** The low-pressure indicator, safety valve and air supply valve may be removed as an assembly with the manifold fitting.

(2) **RELEASE AIR PRESSURE.** Open the drain valves in the reservoirs, and release the air pressure in the air brake system.

(3) **DISCONNECT THE WIRES FROM THE LOW-PRESSURE INDICATOR.** Remove the terminal nuts and washers, and disconnect the wires from the low-pressure indicator.

(4) **DISCONNECT AIR LINES.** Disconnect the air line running between the air supply valve and the governor at the air supply valve. Disconnect the air line running between the hand brake valve and the manifold fitting at the manifold fitting. Disconnect the air line running between the manifold fitting and the reservoir at the manifold fitting. Disconnect the air lines from the windshield wiper tee inside the cowl panel, and remove the tee from the elbow in the line from the manifold fitting.

(5) **REMOVE ASSEMBLY.** Remove the nuts and lock washers attaching the air supply valve and the manifold fitting to the dash and remove the assembly (fig. 131).

TM 9-811
135

4-TON, 6 x 6 TRUCKS (DIAMOND T MODELS 968A CARGO,
969A WRECKER, 970A PONTON, AND 972 DUMP)

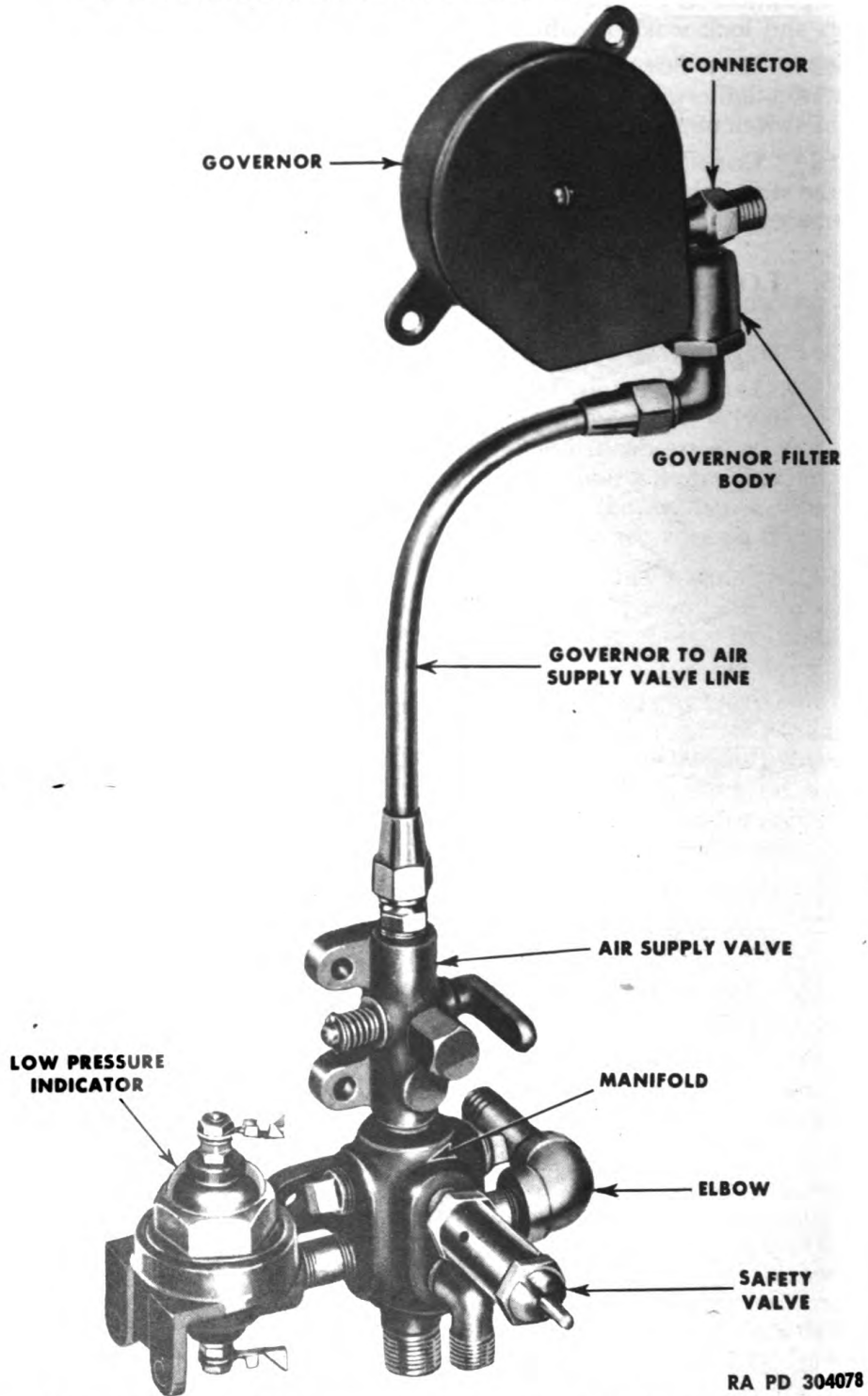

Figure 130—Governor, Air Supply Valve, Safety and Low Pressure Indicator

274

BRAKES

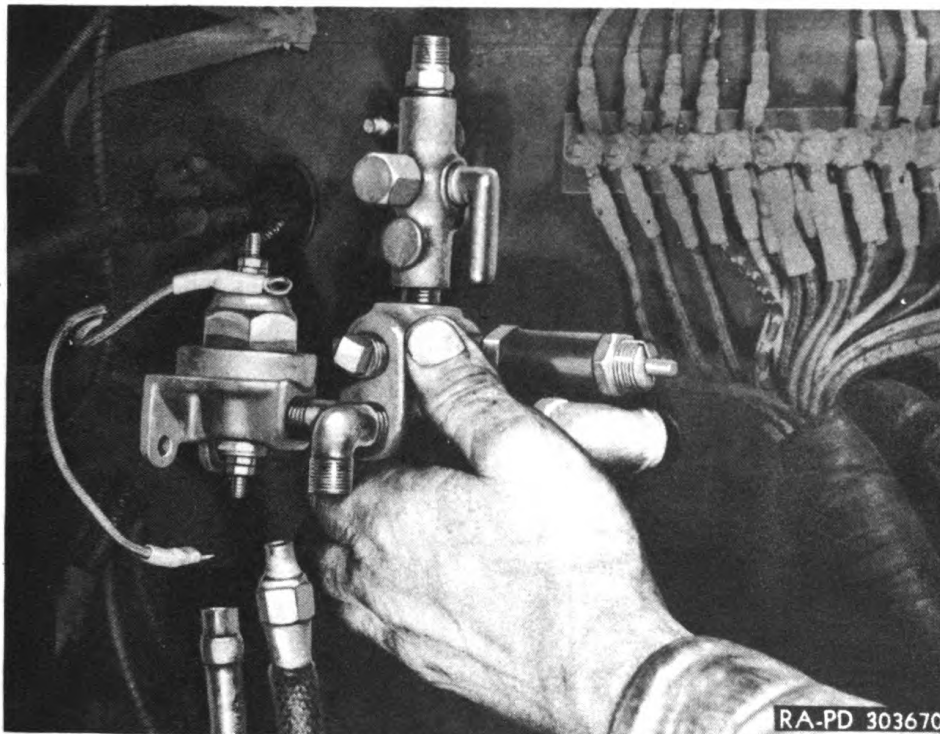

Figure 131—Removing Air Supply Valve, Safety Valve and Low Pressure Indicator Assembly

(6) The low-pressure indicator, safety valve, air supply valve and manifold fitting may then be disassembled from each other (fig. 214).

c. Installation.

(1) Assemble the low-pressure indicator, safety valve, air supply valve and manifold fitting together.

(2) **INSTALL ASSEMBLY.** Place the assembly into position on the cowl and attach in place with the nuts and lock washers which were removed.

(3) **CONNECT AIR LINES.** Connect the air lines between the governor and the air supply valve at the air supply valve. Connect the line between the air supply valve and the hand brake valve at the air supply valve. Connect the line between the air supply valve and the reservoir at the air supply valve. Install the windshield wiper tee into the elbow in the line from the manifold fitting from inside the cab. Then connect the windshield wiper and gage air lines to the tee.

(4) **CONNECT WIRES TO LOW-PRESSURE INDICATOR.** Connect the wires to the terminals on the low-pressure indicator and attach them in place with the terminal nuts and washers which were removed (fig. 85).

BRAKES

First remove the cotter and clevis pins, holding the yoke to the brake cross shaft, then loosen the jam nut and turn the yoke until the proper adjustment is obtained. Connect the yoke to the brake cross shaft with the cotter and clevis pins.

(2) **SHOE ADJUSTMENT.**

(a) Tighten nut A so that spring B exerts enough pressure to bring lever C to stop solidly against lever arm D (fig. 132).

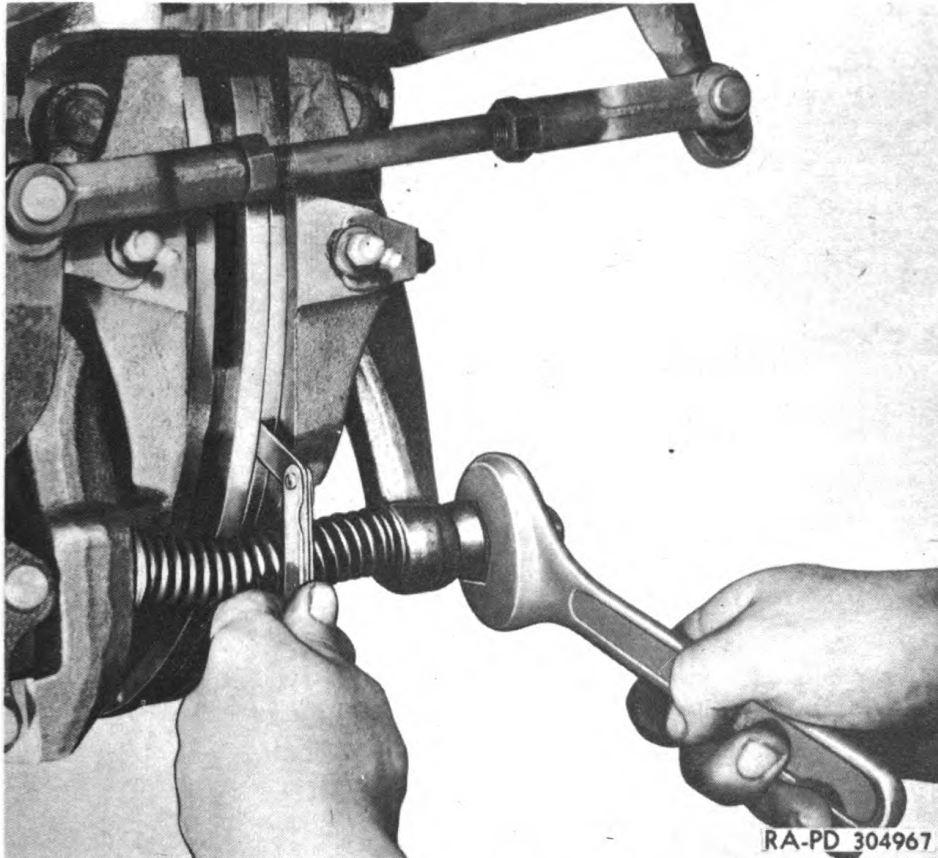

Figure 133—Adjusting Parking Brake

(b) Insert $\frac{1}{32}$ -inch feeler gage between the front shoe lining and disk, and adjust pull rod J to maintain this clearance, first being sure to have hand lever in full release position.

(c) Tighten nut A so that rear lining has $\frac{1}{32}$ -inch clearance with disk (fig. 133).

(d) See that tension spring E is in place, then adjust screws F so that linings are parallel with disk. Remove feeler gage.

c. Removal.

(1) **DISCONNECT PROPELLER SHAFT.** Remove the cap screws, nuts and lock washers holding the flange yoke at the forward end of the

TM 9-811
136

**4-TON, 6 x 6 TRUCKS (DIAMOND T MODELS 968A CARGO,
969A WRECKER, 970A PONTON, AND 972 DUMP)**

propeller shaft between the transfer and the forward rear axle to the companion flange on the transfer, then drop the propeller shaft out of the way.

(2) **DISCONNECT BRAKE CABLE AND CONTROL ARMS.** Remove the three cotter and clevis pins from the brake cable and control arms.

(3) **REMOVE BRAKE SHOE ASSEMBLIES.** Remove the cap screws and lock washers holding the brake shoe assemblies to the frame cross member and remove these (fig. 134).

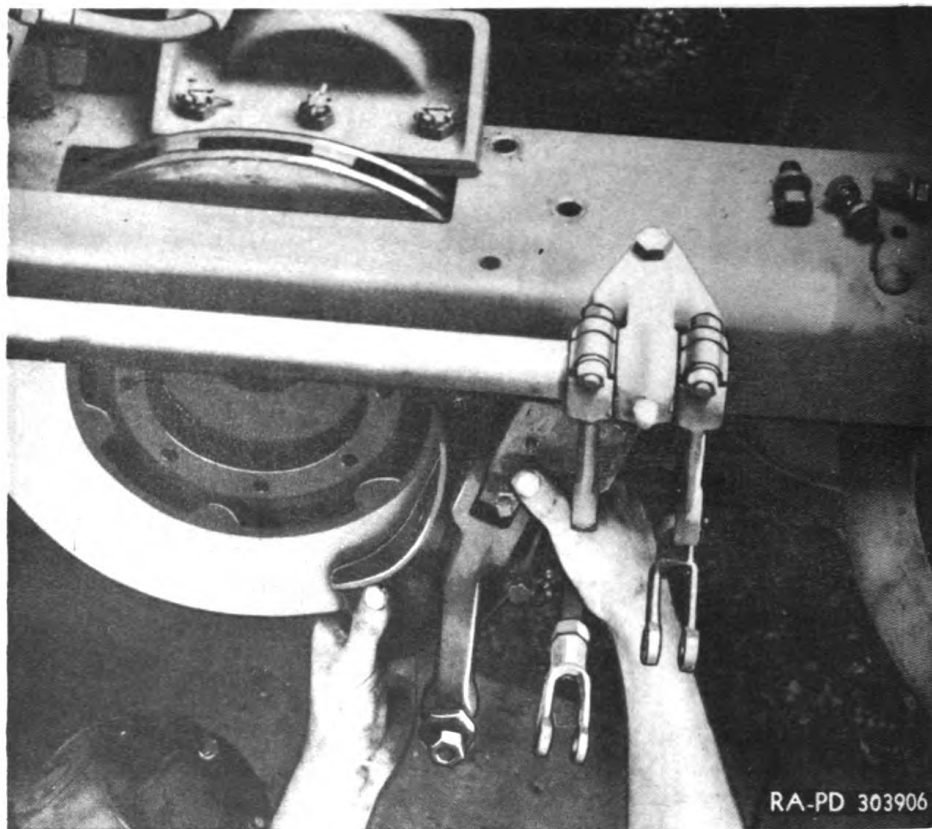

Figure 134—Removing Brake Shoe Assembly

(4) **REMOVE BRAKE DISK.** Remove the brake disk from the transfer companion flange (fig. 135).

d. Installation.

(1) **INSTALL DISK.** Install the disk on the transfer companion flange.

(2) **INSTALL BRAKE SHOE ASSEMBLY.** Install the brake shoe assemblies into position with the shoes over the disk, and attach to the frame cross member with the cap screws and lock washers which were removed.

BRAKES

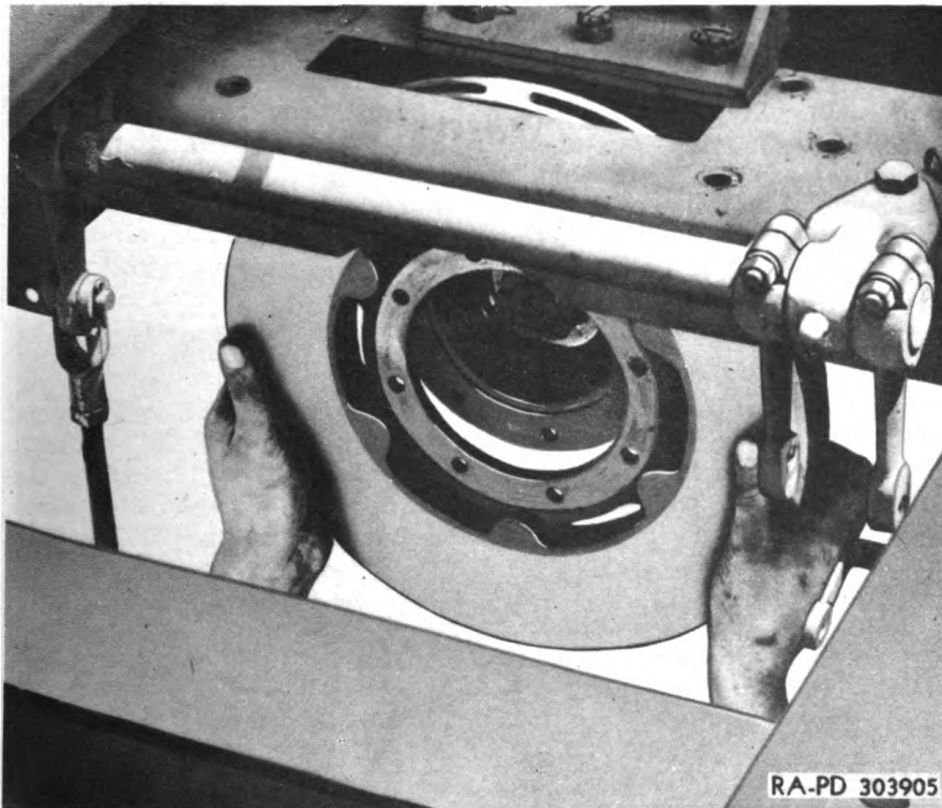

Figure 135—Removing Brake Disk

- (3) **CONNECT BRAKE CABLE AND CONTROL ARMS.** Install the cotter and clevis pins to connect the brake cable and control arms.
- (4) **CONNECT PROPELLER SHAFT.** Swing the propeller shaft into position and bolt the flange yoke to the companion flange on the transfer, using the cap screws, nuts and lock washers which were removed.
- (5) **ADJUST PARKING BRAKE.** Adjust the parking brake as described in paragraph 136 h.

TM 9-811
137-138

**4-TON, 6 x 6 TRUCKS (DIAMOND T MODELS 968A CARGO,
 969A WRECKER, 970A PONTON, AND 972 DUMP)**

Section XXX

WHEELS

	Paragraph
Description and tabulated data	137
Wheels	138
Brake drums	139

137. DESCRIPTION AND TABULATED DATA.

a. Description. The wheels used on all 4-ton, 6 x 6 vehicles are the tapered-disk type. Single wheels are mounted on the front axle with duals mounted on both rear axles. The wheels and the brake drums are bolted to the hubs which turn on a set of opposed tapered roller wheel bearings. The wheels may be removed separately or as assemblies with the hubs and drums.

b. Tabulated Data.

(1) WHEELS.

Make Budd
 Number 44460
 Type Tapered disk
 Size 20 in. x 8
 Offset 6 1/8 in.
 Bolt circle 11 1/4 in. dia
 Number of bolt holes 10

(2) TIRES:

Type Mud and snow
 Number of plies 10
 Size 900 x 20
 Pressure 65 lb psi

(3) WHEEL BEARINGS.

Make Timken
 Type Tapered roller
 Number
 Front
 Inner bearing 592-A cup—594 cone
 Outer bearing 498 cup—493 cone
 Rear 5520 cup—5557 cone

(4) ADJUSTMENT 0.003 in.—0.005 in. loose

138. WHEELS.

a. Wheel Nuts.

(1) All studs and cap nuts are plainly marked "R" and "L" designating right- and left-hand threads which are used to offset any tend-

WHEELS

ency of the cap nuts to work loose. Those marked "R" must be used on the right side of the chassis, while those marked "L" must be used on the left side.

(2) The dual wheels are locked with double cap nuts. The inner dual is individually held by a sleeve-like inner cap nut. The inner dual must be mounted and tightened down before the outer wheel is put on. The other dual slips over the inner cap nuts and is locked in place with the outer nuts. The wheels do not pilot at the hub center; the entire load is distributed over the cap nuts and studs.

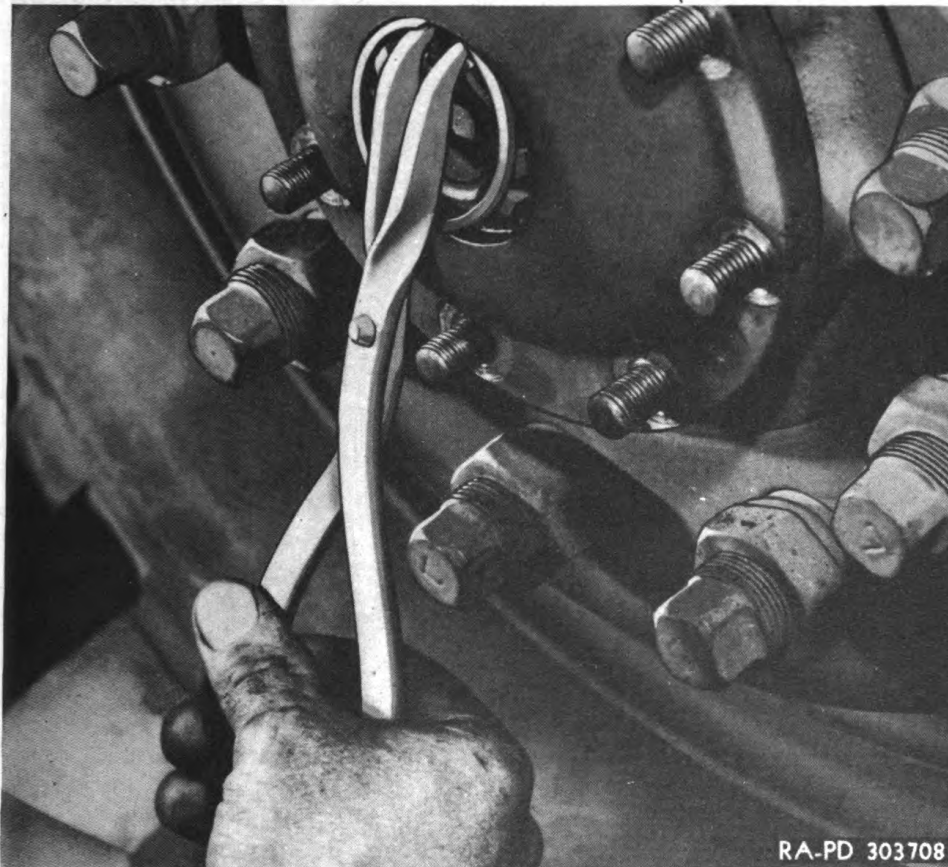

Figure 136—Removing Snap Ring with Pliers (41-P-1572)

(3) It is good practice to make frequent checks for tightness in the studs and cap screws. Always clean the wheels before reassembling, especially at the countersunk holes and bolt on flanges.

b. Wheel Removal.

(1) FRONT WHEELS.

(a) *General.* The wheel nuts provided on the front wheel are exactly the same as those provided for dual mounting of the rear wheel. With a single wheel installation on the front, the outer nut serves no purpose.

TM 9-811

138

4-TON, 6 x 6 TRUCKS (DIAMOND T MODELS 968A CARGO, 969A WRECKER, 970A PONTON, AND 972 DUMP)

(b) *Loosen Wheel Nuts.* Use the wheel nut wrench from the vehicle tool kit, and loosen the inner wheel nuts on the wheel studs.

(c) *Support Vehicle on Jacks.* Install a jack under the front axle housing on the side to be raised, and lift the vehicle so that the tire just clears the ground.

(d) *Remove Wheels.* Remove the wheel nuts from the wheel mounting studs and slide the wheel assembly from the axle. Note that the outer wheel nuts are removed assembled to the inner nuts.



Figure 137—Removing Inner Wheel Bearing Cone

(2) REAR WHEELS.

(a) *Support Vehicle on Jacks.* Place a jack under the rear axle housing on the side of the vehicle of which the wheels are to be removed and raise it so that the tires just clear the ground.

(b) *Remove Outer Wheels.* Using the wheel nut wrench provided with the vehicle tool kit, remove the outer wheel nuts and take off the outer wheel.

(c) *Remove Inner Wheel.* Using the wheel nut wrench provided with the vehicle tool kit, remove the inner wheel nuts and take off the inner wheels.

c. Wheel Installation.

(1) FRONT WHEELS.

(a) *Install Front Wheels.* Lift the front wheel assembly into place and slide it over the wheel mounting studs so that the offset is towards

WHEELS

the vehicle. Then install the wheel nuts on the studs and tighten them securely with the wheel nut wrench. Note that the inner and outer wheel nuts are installed as an assembly.

(b) *Remove Jack.* Lower the vehicle to the ground and remove the jack.

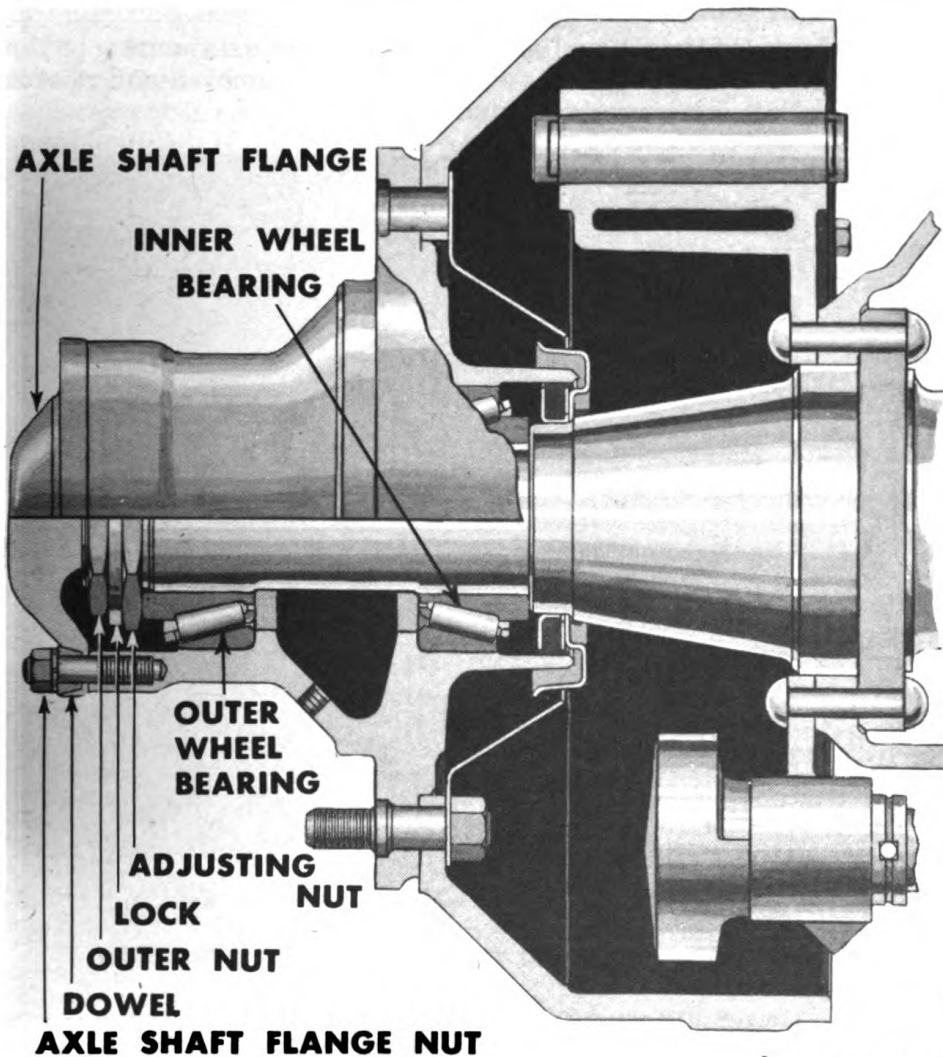

RA PD 304972

Figure 138—Rear Wheel Hub and Bearings

(2) REAR WHEELS.

(a) *Install Inner Wheel.* Lift the inner wheel assembly into position with the offset facing towards the vehicle, and slide the wheel over the wheel mounting studs. Then install the inner wheel nuts and tighten them with the wheel nut wrench.

(b) *Install Outer Wheels.* Lift the outer wheel assembly into position with the offset facing away from the vehicle, and slide it over the

4-TON, 6 x 6 TRUCKS (DIAMOND T MODELS 968A CARGO, 969A WRECKER, 970A PONTON, AND 972 DUMP)

inner wheel nuts. Then install the outer wheel nuts and tighten them securely with the wheel nut wrench.

(c) *Remove Jack.* Lower the vehicle to the ground and remove the jack.

d. Front Wheel Bearing Removal.

(1) **JACK UP VEHICLE.** Place a jack under the axle housing on the side of the vehicle of which the wheels are to be removed and raise it so that the tires just clear the ground.

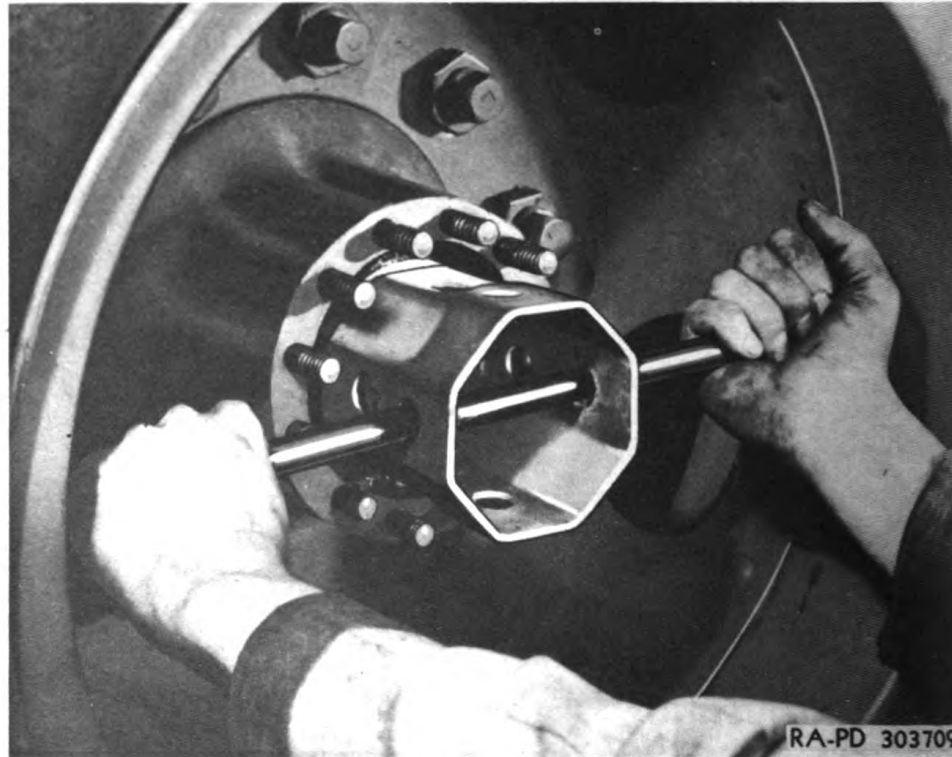

Figure 139—Removing Rear Wheel Bearing Lock Nut

(2) **REMOVE FRONT AXLE DRIVE FLANGE.** Remove the nuts and lock washers holding the drive flange on the hub studs. Using a snap ring spreader, remove the snap ring from the groove in the end of the stub shaft in the center of the drive flange (fig. 136). Then remove the drive flange by tightening two $\frac{3}{8}$ -inch puller screws in the puller screw holes. When the assembly is loose, remove it and take off the gasket.

(3) **REMOVE OUTER WHEEL BEARING CONE.** Straighten out a portion of the wheel bearing nut retainer holding the outer wheel bearing nut, and remove the outer nut with the wrench provided in the vehicle tool kit. Straighten out the portion of the retainer holding the inner wheel nut and remove the retainer and inner wheel nut, using the special wrench provided in the vehicle tool kit. Shake the wheel assembly to jar the bearing cone loose, and remove the cone.

WHEELS

(4) **REMOVE THE WHEEL ASSEMBLY.** Place a greased board under the tire and lower the vehicle on the jack so that the tire rests lightly on the greased board, then pull the wheel assembly from the axle, sliding it along on the greased board.

(5) **REMOVE INNER WHEEL BEARING.** Using an offset screwdriver, pry the cone loose (fig. 137).

(6) **REMOVE THE BEARING CUPS.** Wipe the bearing cups clean and examine them for signs of pitting or wear. If they are damaged so that replacement is necessary, they may be removed from the hub using a suitable puller. If the cups are in satisfactory condition, they should not be removed.

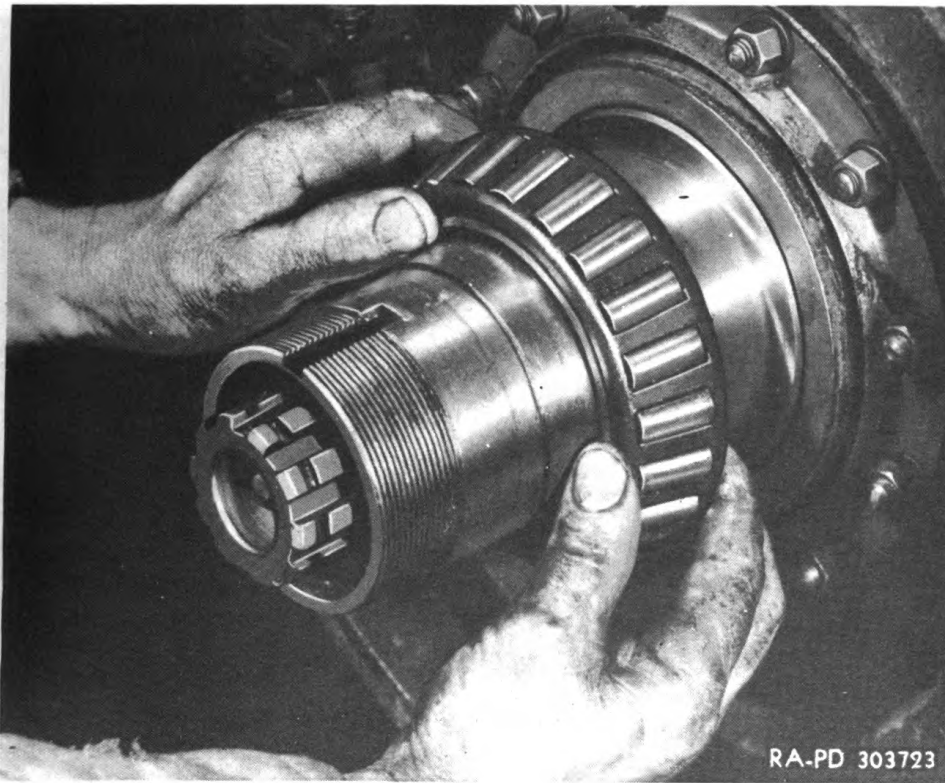

Figure 140—Installing Inner Front Wheel Bearing Cone

e. Rear Wheel Bearing Removal (fig. 138).

(1) **JACK UP VEHICLE.** Place a jack under the axle housing on the side of the vehicle on which wheel bearings are to be removed, and raise the vehicle so that the tires just clear the ground.

(2) **REMOVE AXLE SHAFT.** Remove the axle shaft as described in paragraph 119.

(3) **REMOVE OUTER WHEEL BEARING CONE.** Using the wheel bearing wrench provided with the vehicle tool kit, remove the wheel bearing lock nut (fig. 139). Then remove the wheel bearing lock ring.

4-TON, 6 x 6 TRUCKS (DIAMOND T MODELS 968A CARGO, 969A WRECKER, 970A PONTON, AND 972 DUMP)

Remove the wheel bearing adjusting nut, using the wheel bearing nut wrench. Rock the wheel assembly to jar the outer wheel bearing cone loose, and remove the cone.

(4) **REMOVE WHEEL ASSEMBLY.** Place a greased board under the tires and lower the vehicle so that the tires rest lightly on the board, then slide the wheel assembly from the axle.

(5) **REMOVE INNER WHEEL BEARING CONE.** Using an offset screwdriver, work the inner wheel bearing cone loose and remove it.



Figure 141—Installing Outer Front Wheel Bearing Cone

(6) **REMOVE WHEEL BEARING CUPS.** Wipe the wheel bearing cups clean, and examine them for signs of pitting or wear which might make them unfit for further service. If they are damaged badly enough so that replacement is necessary, they may be removed from the hub, using a suitable puller.

f. Front and Rear Wheel Bearing Installation.

(1) **INSTALL BEARING CUPS.** If the bearing cups were removed from the hub, these will have to be installed. Place the cups into position in the hub with the low side of the taper facing out and drive them into position, using a hammer and drift punch, and working the punch around the cup. One cup is installed from each side of the hub.

(2) **INSTALL INNER WHEEL BEARING.** Pack inner wheel bearing with recommended lubricant, being sure that the grease is thoroughly

WHEELS

worked in on both sides of the rollers. Then slide the inner wheel bearing in place on the axle tube, using a hammer and drift punch to seat it against the shoulder on the tube. Do not pound on the rollers or the cage (fig. 140).

(3) **PACK GREASE INTO THE HUB.** Pack the space in the hub between the two wheel bearing cups with grease until it is $\frac{1}{2}$ to $\frac{3}{8}$ full.

(4) **INSTALL WHEEL ASSEMBLY.** Roll the wheel assembly into position on the greased board and then slide it into position on the axle, pushing it all the way back so that the inner wheel bearing cone seats

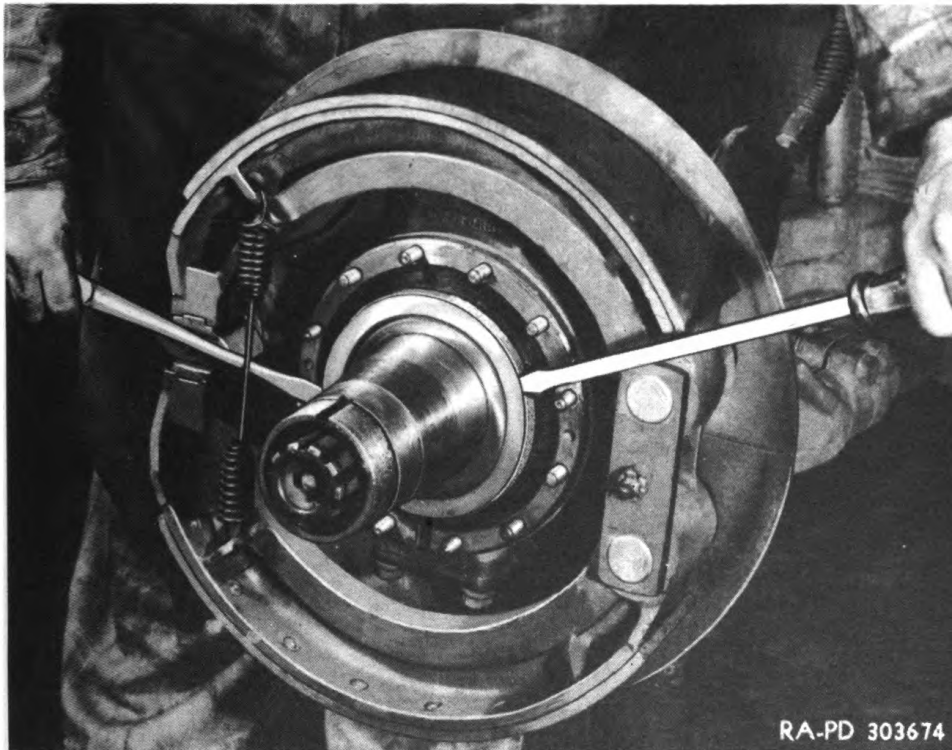

Figure 142—Prying Off Front Wheel Bearing Grease Retainer Outer Ring

in the inner wheel bearing cup. Then hold the wheel in place and press the outer bearing cone firmly into position (fig. 141). Install the inner wheel bearing nut to hold the cone in place.

g. Front and Rear Wheel Bearing Adjustment. Start the wheel assembly rotating and tighten the inner wheel bearing nut until the wheel binds. Then back off the nut just far enough to permit free rotation without end play. When this is done, test the adjustment with a bar used as a lever between the tire and the floor. Hold a finger on the outer bearing cage while working the bar up and down so that it will be possible to detect any excessive play or looseness. If the wheel rotates freely and there is a barely perceptible shake, the adjustment is correct. Proper adjustment is from 0.003 inch to 0.005 inch loose.

**4-TON, 6 x 6 TRUCKS (DIAMOND T MODELS 968A CARGO,
969A WRECKER, 970A PONTON, AND 972 DUMP)**

(1) **INSTALL OUTER WHEEL BEARING NUT.** Replace the locking washer or retainer against the inner nut. Then install the outer wheel bearing nut, and run it up tight against the inner wheel bearing nut. Then test the adjustment again and make any corrections which are necessary. In the case of the front wheel, it will be necessary to bend



Figure 143—Prying Off Rear Wheel Bearing Grease Retainer

the sides of the split retainer against the flat sides of the inner and outer wheel bearing nuts to lock the adjustment.

(2) **INSTALL AXLE SHAFT (REAR AXLE).** Cover the end of the axle tube and the lock nut with grease, and install the axle shaft, using a new gasket as described in paragraph 119.

(3) **INSTALL DRIVE FLANGE (FRONT AXLE).** Pack the end of the axle tube and the wheel bearing nuts with grease, and slide the drive

WHEELS

flange into position over the splines of the stub shaft and over the hub studs, using a new gasket between the flange and the hub. Install the nuts and lock washers which were removed. Install the snap ring in the groove at the outer end of the stub shaft and splines, using snap ring pliers.

(4) **LOWER VEHICLE TO GROUND.** Lower the vehicle to the ground and remove the jack.



Figure 144—Removing Drum Stud Nuts

h. Front Wheel Bearing Grease Retainer Replacement.

(1) **REMOVE WHEELS AND WHEEL BEARINGS.** Remove wheels and wheel bearings as described in paragraph 138 d.

(2) **REMOVE GREASE RETAINER.** Using screwdrivers, pry the outer retainer ring away from the felt and remove this part. Then remove the felt from the inner retainer ring (fig. 142).

(3) **INSTALL NEW GREASE RETAINER.** Install a new felt into position on the inner retainer ring. Slide the outer ring into place and tap it snugly into position.

(4) **INSTALL WHEELS.** Replace wheels and adjust the wheel bearing as described in paragraph 141 d.

TM 9-811
138-139

**4-TON, 6 x 6 TRUCKS (DIAMOND T MODELS 968A CARGO,
969A WRECKER, 970A PONTON, AND 972 DUMP)**

i. Rear Wheel Bearing Grease Retainer Replacement.

(1) **REMOVE WHEELS.** Remove wheel and wheel bearings as described in paragraph 141 d.

(2) **REMOVE GREASE RETAINER SEAL.** Using two screwdrivers, pry the felt retainer ring away from the felt. Then remove two washers and the felt ring (fig. 143).

(3) **INSTALL GREASE SEALS.** Install a new felt ring into position



Figure 145—Locking Drum Stud Nuts with Chisel

on the axle tube with a washer on each side of it. Install the felt retainer ring into place and tap it snugly into position.

(4) **INSTALL WHEELS.** Replace the wheels and adjust the wheel bearings as described in paragraph 138 d.

139. BRAKE DRUMS.

a. Removal.

(1) **REMOVE WHEEL.** Remove wheel, hub and drum assembly as described in paragraph 141 d.

(2) **REMOVE BRAKE DRUM FROM HUB.** Lay the wheel flat on the floor with the brake drum facing up, and remove the brake drum stud nuts, then lift the brake drum from the hub studs (fig. 144).

WHEELS

b. Inspection. Examine the brake drum for signs of cracking, warping or grooving, or any other condition which might affect performance of the vehicle brakes. Drums which are slightly out-of-round and not too badly grooved, can be salvaged by turning them in a lathe to cut a new surface. Drums badly warped or grooved, and drums which are cracked, must be replaced.

c. Installation.

(1) **INSTALL DRUM ASSEMBLY ON HUB.** Install the drum assembly into position over the stud nuts. Tighten these securely after the nuts are tightened. It will be necessary to use a center punch or a chisel to bend the metal in the stud nuts to prevent the nut from shaking loose (fig. 145).

(2) **INSTALL WHEEL.** Replace wheel assembly as described in paragraph 141 d.

TM 9-811
140

**4-TON, 6 x 6 TRUCKS (DIAMOND T MODELS 968A CARGO,
 969A WRECKER, 970A PONTON, AND 972 DUMP)**

Section XXXI

SUSPENSION

	Paragraph
Description and tabulated data	140
Front springs	141
Shock absorbers	142
Rear springs	143
Torque rods	144

140. DESCRIPTION AND TABULATED DATA.

a. Description. The front axle is sprung on a set of heavy-duty rubber-shackled springs. These are semielliptic springs with the shackle at the rear end. Axle drive is transmitted through the spring pins. The rear axles are mounted in tandem suspension with the drive through torque rods. The spring is mounted on a seat which oscillates on a rocker beam attached to the frame with the spring ends resting in clips on top of the axle housings.

b. Tabulated Data.

(1) FRONT SPRINGS.

Length 49 in.
 Material Chrome vanadium steel
 Leaves:
 Number 12
 Width 3 in.
 Total thickness $3\frac{13}{16}$ in.
 Number of rebound clips 4

(2) SHOCK ABSORBERS.

Make Houde
 Type Hydraulic
 Model BBH

(3) REAR SPRINGS.

Length $56\frac{1}{4}$ in.
 Material Chrome vanadium steel
 Leaves (Cargo):
 Number 9
 Width 4 in.
 Total thickness $4\frac{1}{8}$ in.

Leaves (Wrecker):

Number 9
 Width 4 in.
 Total thickness $4\frac{1}{2}$ in.
 Number of rebound clips 4

(4) TORQUE RODS.

Make Timken
 Number of adjustable type 4
 Number of fixed type 4

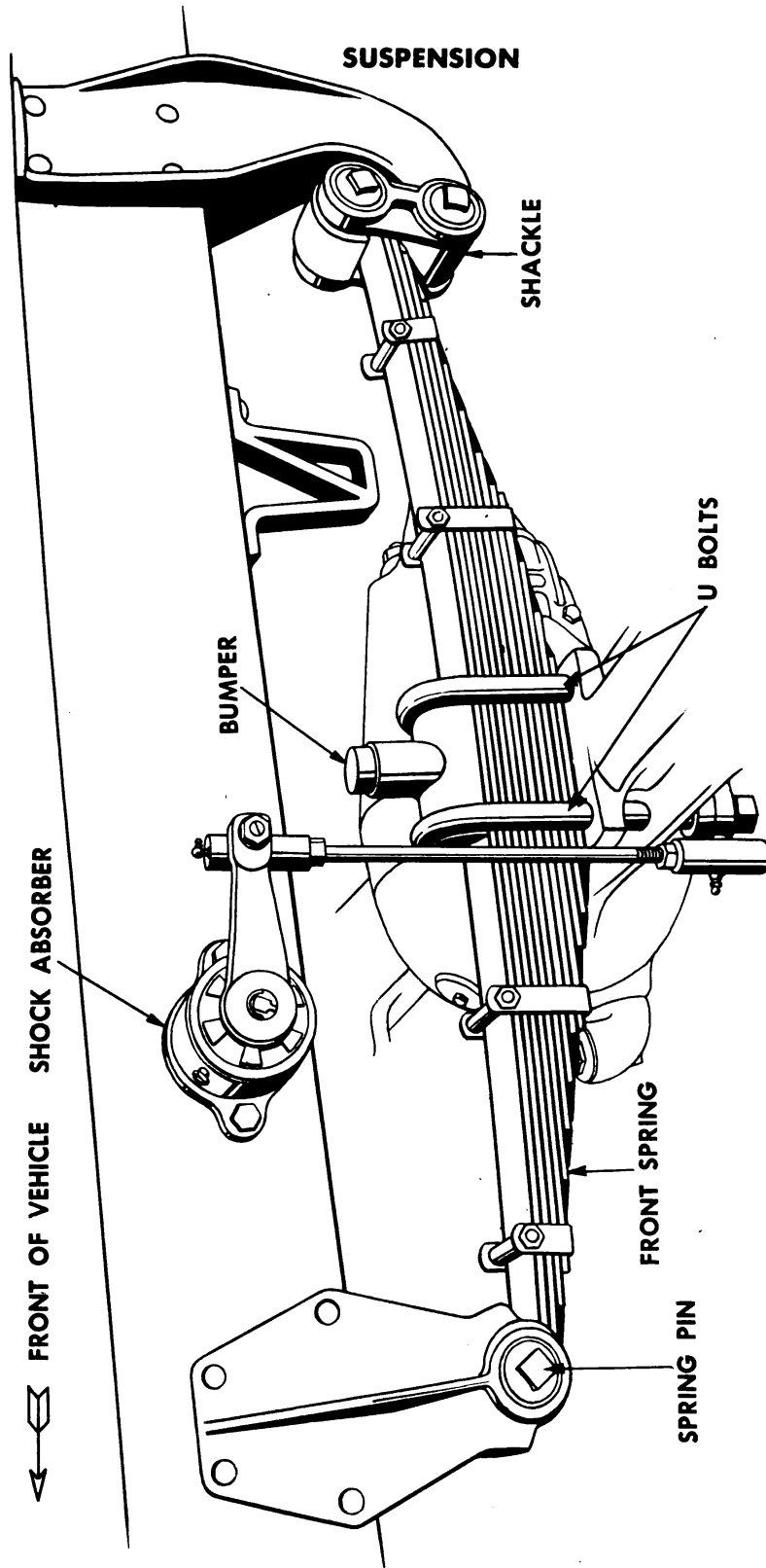

Figure 146—Front Spring Suspension

TM 9-811

141

4-TON, 6 x 6 TRUCKS (DIAMOND T MODELS 968A CARGO, 969A WRECKER, 970A PONTON, AND 972 DUMP)

141. FRONT SPRINGS.

a. **Description.** The front springs are mounted on the axle and attached to the frame as shown in figure 146.

b. **Maintenance.** The spring pins, shackle pins and spring clips must be kept tight. At every vehicle inspection period, the U-bolts attaching the springs to the front axle housing, and the rubber bushed pins through the spring eyes and through the shackles at the rear of the

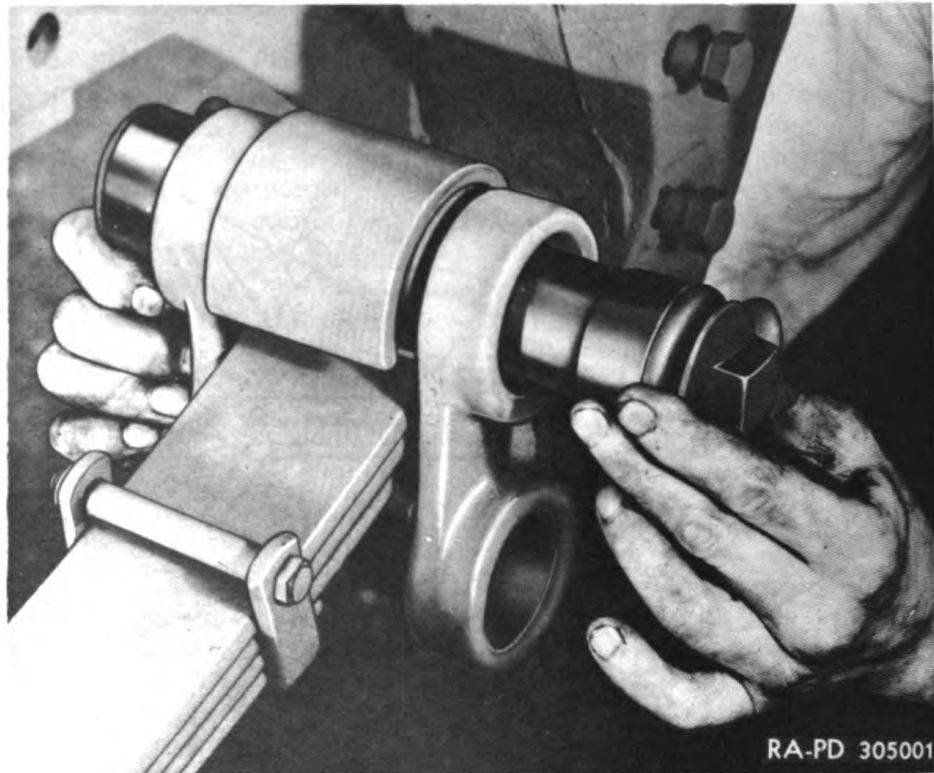

Figure 147—Installing Spring Shackle Rubber Bushings

springs, should be tightened if necessary. The rubber bushings are exposed to the atmosphere around the edges of the spring and shackle pins, and will deteriorate in normal service. This deterioration can be retarded by wiping the edges of the bushings with hydraulic brake fluid at each inspection.

c. **Removal.**

(1) **RAISE VEHICLE ON JACKS.** Raise the vehicle on jacks placed under the front bumper and lift it just high enough to relieve all strain from the front spring eye. If it is too high or too low, there will be sufficient strain on the rubber bushings to make it very difficult to remove the spring pins.

SUSPENSION

(2) **REMOVE SPRING PIN AND BUSHINGS.** Remove the cotter pin from the front spring nut and then remove the nut and washer. The spring pin may then be driven from the bushings in the spring eye. After the pin is removed, the rubber bushings may be pulled out.

(3) **SUPPORT VEHICLES ON BLOCKS.** Raise the vehicle two or three inches more on the jacks and then pile wooden blocks under each corner of the front bumper. Then lower the vehicle onto the blocks and remove the jacks.

(4) **REMOVE U-BOLTS.** Remove the U-bolt nuts and then pry the U-bolts off the springs (fig. 234). Remove the spring bumper from the spring. After the U-bolts are removed, the bracket at the bottom of the axle housing through which the U-bolts pass can be separated from the axle housing but will still be attached to the shock absorber link. It is not necessary to disconnect this part from the shock absorber link.

(5) **REMOVE REAR SHACKLE PIN.** Remove the cotter pin from the upper shackle pin nut and then remove the nut and washer. Drive the shackle pin from the spring eye, and remove the rubber bushings.

(6) **REMOVE FRONT SPRING ASSEMBLY.** The front spring assembly may then be removed from the chassis by pulling it out from the front.

(7) **REMOVE SHACKLE.** Remove the cotter pin from the lower shackle pin nut, and remove the nut and washer. Drive out the shackle pin and remove the rubber bushings. Remove shackle from rear spring hanger.

d. Inspection. Clean the spring assembly in dry-cleaning solvent and examine for signs of broken or cracked leaves. If the spring is broken or improperly arched, it must be replaced. Examine the rubber shackle bushings for signs of wear. If badly worn, they should be replaced; but if they are in good condition, they may be used again. Examine the rubber plug in the spring bumper and replace if necessary.

e. Installation.

(1) **INSTALL SHACKLE.** Wipe the rubber bushings with hydraulic brake fluid to help preserve the rubber and to facilitate installation. Lift the shackle into place on the rear spring hanger with the free end facing up and then insert the rubber bushings, one from each end, through the shackle ends and into the spring hanger eye. Then drive the shackle pin through the bushing. Place a washer over the threaded end of the pin and then replace the nut. Do not tighten the nut.

(2) **INSTALL SPRING ASSEMBLY.** Slide the spring assembly into position engaging the rear spring eye with the upper end of the shackle attached to the rear hanger. Then wipe the rubber bushings with hydraulic brake fluid and push these into place between the shackle, and spring eyes from each side. Then drive the upper shackle pin through the rubber bushings. Install a washer over the threaded end of the shackle pin and then replace the shackle pin nut. Do not tighten the nut (fig. 147).

(3) **INSTALL U-BOLTS.** Position the spring assembly on the axle housing so the spring center bolt engages the hole in the axle housing at the center of the spring seat. Then place the spring bumper in position in the middle of the spring. Install the U-bolts over the springs hooking

**4-TON, 6 x 6 TRUCKS (DIAMOND T. MODELS 968A CARGO,
969A WRECKER, 970A PONTON, AND 972 DUMP)**

them over the grooves in the bumper block and sliding them through the holes drilled in the axle housing. Then grasp the lower U-bolt bracket which is attached to the shock absorber connecting link, and swing this into position seating it tight against the axle housing with the threaded ends of the U-bolt passing through the holes in each corner. Then install the U-bolt nuts and lock washers and tighten them securely.

(4) **LINE UP FRONT SPRING EYE WITH FRONT SPRING HANGER.** Place jacks under the front bumper and raise the vehicle just far

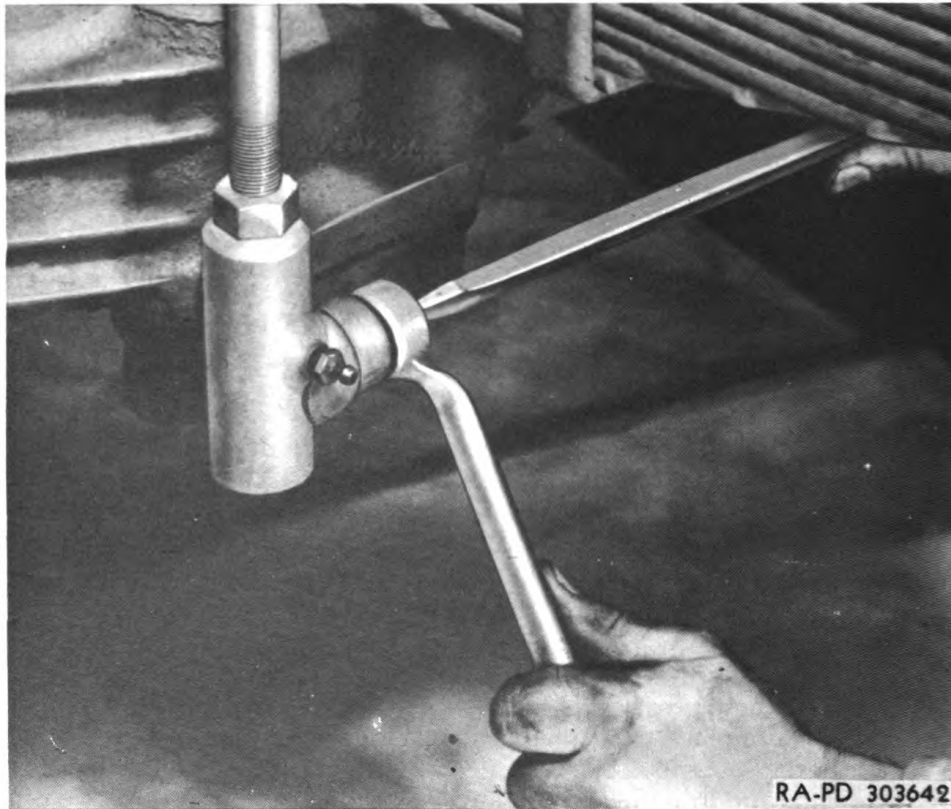

Figure 148—Disconnecting Shock Absorber Link

enough to permit removal of the blocks on which it is supported. Then lower the vehicle slowly until the front spring eye lines up with the front spring hanger eyes.

(5) **INSTALL FRONT SPRING PIN.** Wipe the rubber bushings with hydraulic brake fluid and slide these into the front spring eye from each side of the front hanger. Then drive the spring pin through the rubber bushings. Install a washer on the threaded end of the spring pin and replace the nut.

(6) **TIGHTEN SPRING PIN AND SHACKLE PIN NUTS.** The rubber bushings are made with an excess of rubber which is to be pulled into the spring eyes and hangers causing the rubber to flow tightly against

SUSPENSION

the spring eyes and hangers, forming a flange that insulates the moving parts so that there is no side-slap. Keep the spring eyes centrally located while tightening the nuts so that the space on either side between the spring and the shackle or the hanger will be about $\frac{1}{8}$ inch. Draw the nuts up a sufficient amount so that the rubber begins to flow out around the edges of the pins and washers. The front spring pin and the upper and lower shackle pins are all tightened in the same way. After the nuts are tightened, install cotter pins to lock them in place.

(7) **REMOVE JACKS.** Lower the vehicle to the ground and remove the jacks.

142. SHOCK ABSORBERS.

a. **Description.** Double-acting type hydraulic shock absorbers are used in conjunction with the front springs to control and steady body movement over rough terrain. The shock absorber is the automatic type which adjusts itself to the severity of shock and is also thermostatically controlled so that no adjustment is required for temperature changes.

b. Maintenance.

(1) **FILLING THE SHOCK ABSORBER.** The shock absorber must be kept filled at all times with shock absorber fluid. The level of fluid should be checked with each regular chassis inspection and fluid added as required. To fill the shock absorber, remove the plug in the top of the shock absorber body and add fluid slowly with a lubricating gun filled with shock absorber fluid. When the fluid is up to the level of the plug opening as indicated by fluid oozing out of the opening, install the plug.

(2) **ADJUSTMENT.** The control valves are arranged so that they may be controlled by turning the adjustment located at the center of the shock absorber arm. To increase resistance, turn the valve clockwise, and to decrease resistance, turn it counterclockwise. These adjustments must be made in very gradual steps, not more than $\frac{1}{8}$ inch at a time, as measured in the movement at the end of the pointer on the adjustment. This adjustment should not be made until after fluid has been added to the shock absorber, and then only when it has been definitely established that the resistance offered by shock absorber is not properly adjusted.

c. Removal.

(1) **DISCONNECT CONNECTING LINK.** Disconnect the connecting link at the lower end where it is attached to the U-bolt pad. Use a box wrench on the connecting link ball pin nut, and use a screwdriver in the slotted end of the ball pin to keep it from turning while loosening the nut (fig. 148). Remove the nut and lock washer. Drive the pin from the bracket on the axle.

(2) **REMOVE SHOCK ABSORBER.** Remove the cap screws, nuts and lock washers attaching the shock absorber assembly to the frame rail, then remove the shock absorber and connecting link assembly.

(3) **REMOVE CONNECTING LINK.** Place a box wrench over the nut on the connecting link ball pin, and hold a screwdriver on the slotted end of the pin to keep the pin from turning, then remove the nut and lock washer, and drive the pin from the shock absorber arm.

TM 9-811
142-143

**4-TON, 6 x 6 TRUCKS (DIAMOND T MODELS 968A CARGO,
969A WRECKER, 970A PONTON, AND 972 DUMP)**

d. Installation.

(1) **INSTALL CONNECTING LINK.** Drive connecting link ball pin through the shock absorber arm from the inner side, and install the nut and lock washer. Tighten the nut securely while keeping the connecting link ball pin from turning, by holding the screwdriver in the slot on the end of the pin.

(2) **INSTALL SHOCK ABSORBER ON FRAME RAIL.** Place the shock absorber assembly on the frame rail with the arm pointing toward the rear, and attach it in place with the cap screws, nuts and lock washers which were removed.

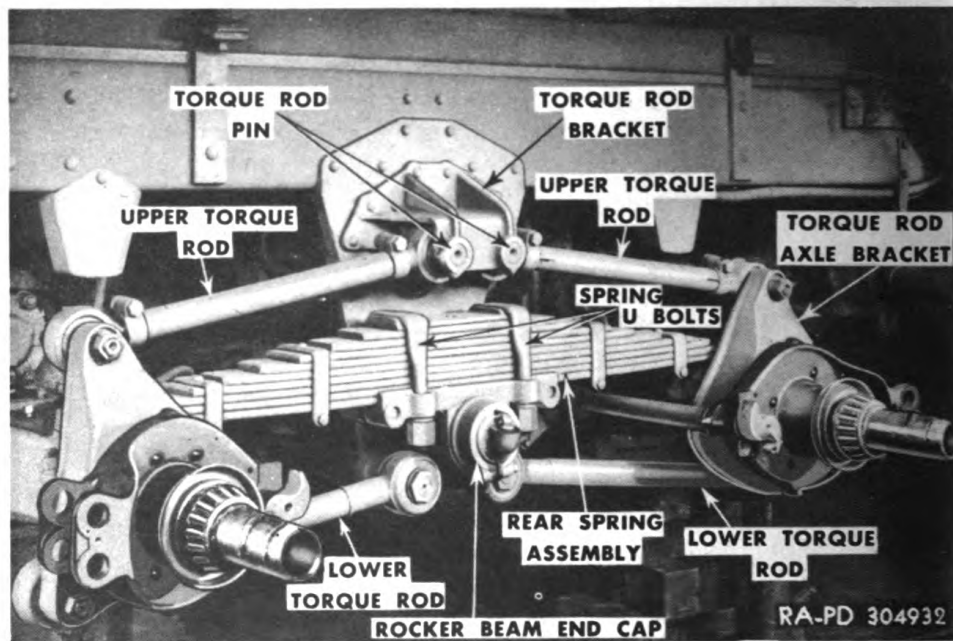

Figure 149—Rear Suspension

(3) **CONNECT CONNECTING LINK.** Drive the ball joint pin in the lower end of the connecting link through the hole in the U-bolt pad under the axle housing, and install the nut and lock washer which were removed. Then tighten the nuts securely while keeping the connecting link ball pin from turning, by holding the screwdriver in the slot on the end of the pin.

143. REAR SPRINGS.

a. Description. The rear springs are mounted on a tandem suspension as shown in figure 149. They act as load-equalizing members, carrying the axle load. They are mounted in an oscillating spring seat which is free to turn on the rocker beam tube with the ends resting on the spring plates on the axle housing so that they are free to move, thus eliminating twisting action. The rear springs used on these vehicles are

SUSPENSION

designed to work under negative arch under rated load. When the vehicle is standing on level ground without load, the springs are approximately level with zero arch, and when the vehicle is fully loaded there will be approximately 2 inches of negative arch.

b. Tightening Spring Seat. Before tightening the U-bolts, tighten the spring seat clamping bolts to line up the spring in the seat (fig. 150). Then tighten the U-bolt nuts to pull the spring down as tightly as possible. This should be done at every regular vehicle inspection.



Figure 150—Tightening Spring Seat Clamping Bolts

c. Removal.

(1) **JACK UP VEHICLE.** Place a jack under the rocker beam tube on the side of the vehicle from which the spring is to be removed, and raise the vehicle just high enough to relieve the spring of all tension.

(2) **REMOVE SPRING.** Remove the nuts and lock washers from each U-bolt and then pry the U-bolts off the springs. After the U-bolts are removed the U-bolt spring plate may be taken out. Back off the spring seat clamp bolts far enough to relieve all tension from the lock washers under the bolt heads. Place a jack under each axle housing on the side of the vehicle from which the spring is being removed and raise the axles high enough to exert pressure on the spring. Using a pry-bar, force the spring out of the spring seat while raising the jacks slowly to increase the load on the spring to assist this operation.

4-TON, 6 x 6 TRUCKS (DIAMOND T MODELS 968A CARGO, 969A WRECKER, 970A PONTON, AND 972 DUMP)

(3) **REMOVE SPRING SEAT.** Remove the clamp bolt, nut and lock washer from the spring seat cap on the end of the rocker beam, and take out the locking plate which is located in the slot cut in the cap. Unscrew the cap from the end of the rocker beam, then remove the outer cork oil seal. Grasp the oscillating spring seat with both hands and pull it off the rocker beam (fig. 151). The inner cork oil seal may then be removed (fig. 152).

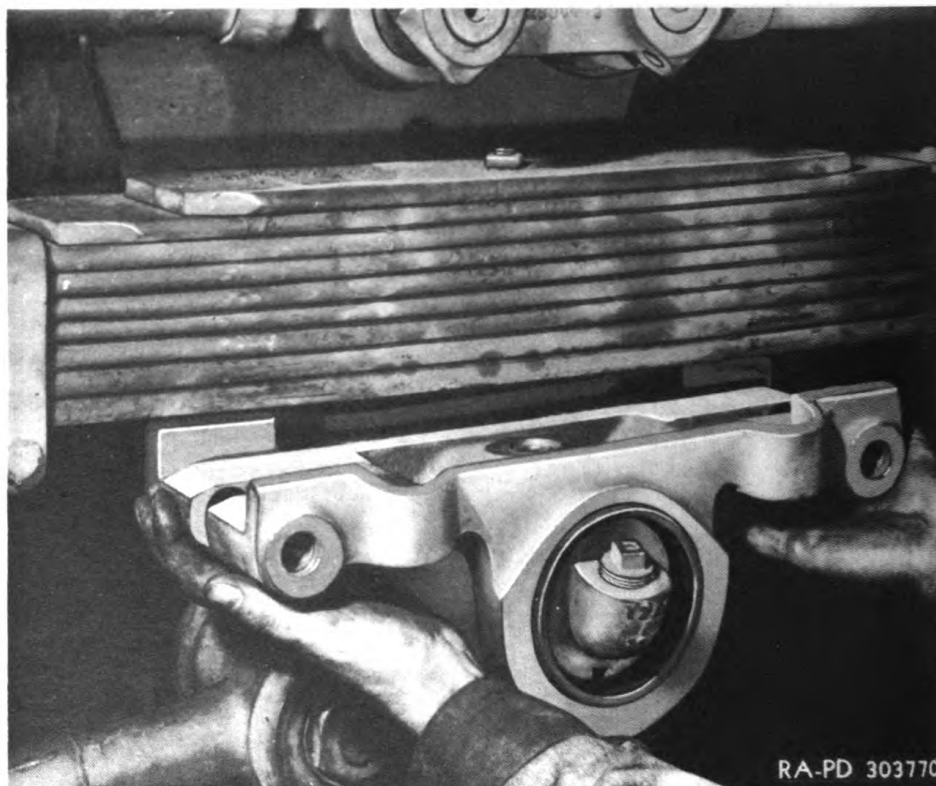

Figure 151—Removing Rear Spring Seat

(4) **LOWER AXLES TO GROUND.** Lower the jacks under the axles so that the axles again rest on the ground.

(5) **REMOVE THE REAR SPRING ASSEMBLY.** Slide the spring assembly forward until the rear end can be worked out of the spring plate on the axle housing and the stop arm on the torque rod bracket. Then pull the spring assembly out from the rear of the vehicle.

d. **Inspection.** Clean the spring assembly, using a dry-cleaning solvent, and examine it carefully for signs of cracks or broken leaves. Defective springs must be replaced. Clean the bushings in the spring seat, and examine them for signs of excessive wear or scoring. If the bushings are found defective, the spring seat assembly must be replaced.

SUSPENSION

e. Installation.

(1) **INSTALL SPRING ASSEMBLY.** Install new cork gasket around spring bolt on the under side of spring, cementing it in place with gasket cement. Slide the spring assembly into position from the rear of the vehicle engaging the flat end under the stop arms on the front spring plate on the axle housing and pushing the axle assembly as far forward as possible. Then line up the rear end of the spring with the rear spring plate on the rear rear axle housing, and move the whole assembly back into position.

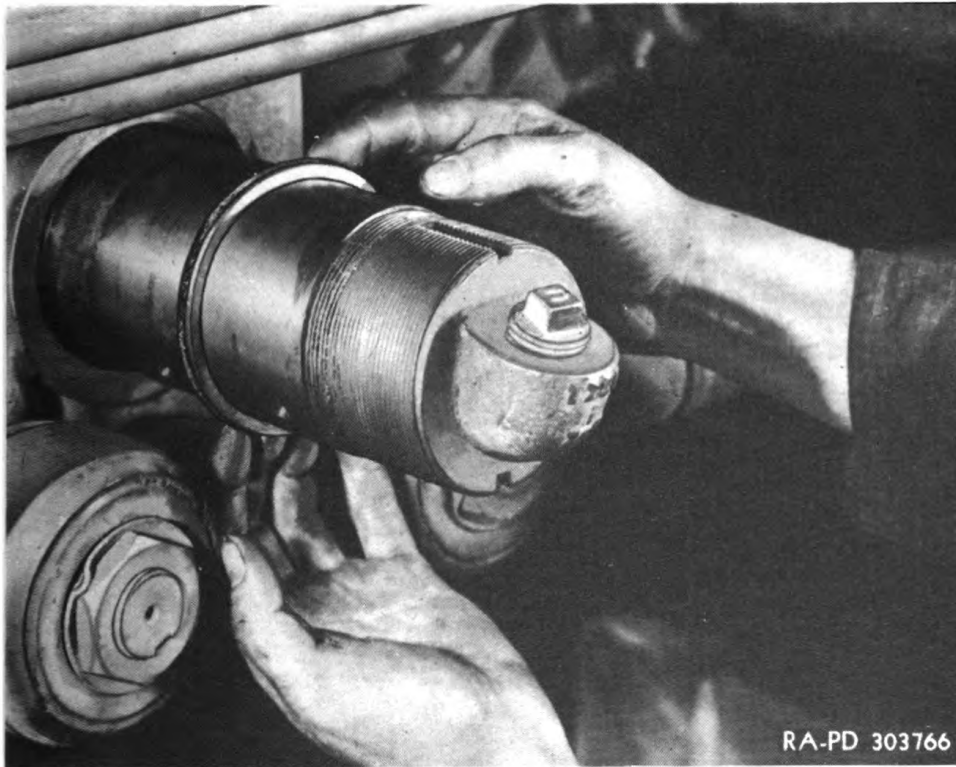

Figure 152—Removing Spring Seat Inner Cork Oil Seal

(2) **RAISE AXLES.** Place jacks under the axle housings on the side of the vehicle on which the spring is being replaced and raise the housing far enough so that there will be clearance to install the spring seat under the spring.

(3) **INSTALL SPRING SEAT.** Note that the spring seat has an inner and outer side and that the outer side can be distinguished by the bushing which extends about $\frac{1}{8}$ inch outside of the outer face. Install a new cork gasket in the recess on the inner side of the spring seat, cementing it in place with gasket cement. Install a spring seat cork in the recess provided for the spring center bolt. This cork will prevent dirt and water from entering the spring seat bearing. Wipe the bushings in the spring seat and the bearing surface on the rocker beam tube with engine

TM 9-811

143

4-TON, 6 x 6 TRUCKS (DIAMOND T MODELS 968A CARGO, 969A WRECKER, 970A PONTON, AND 972 DUMP)

oil and then slide the spring seat into position on the tube with the inner side towards the vehicle (fig. 153).

(4) **WORK SPRING INTO SPRING SEAT.** Lower the jacks under the axle housings so that the axle again rests on the ground and remove the jacks. Then raise the jack under the rocker beam tube, forcing the seat up against the spring. Hammer the spring in place, using a soft hammer. If difficulty is encountered seating the spring, it may be pulled

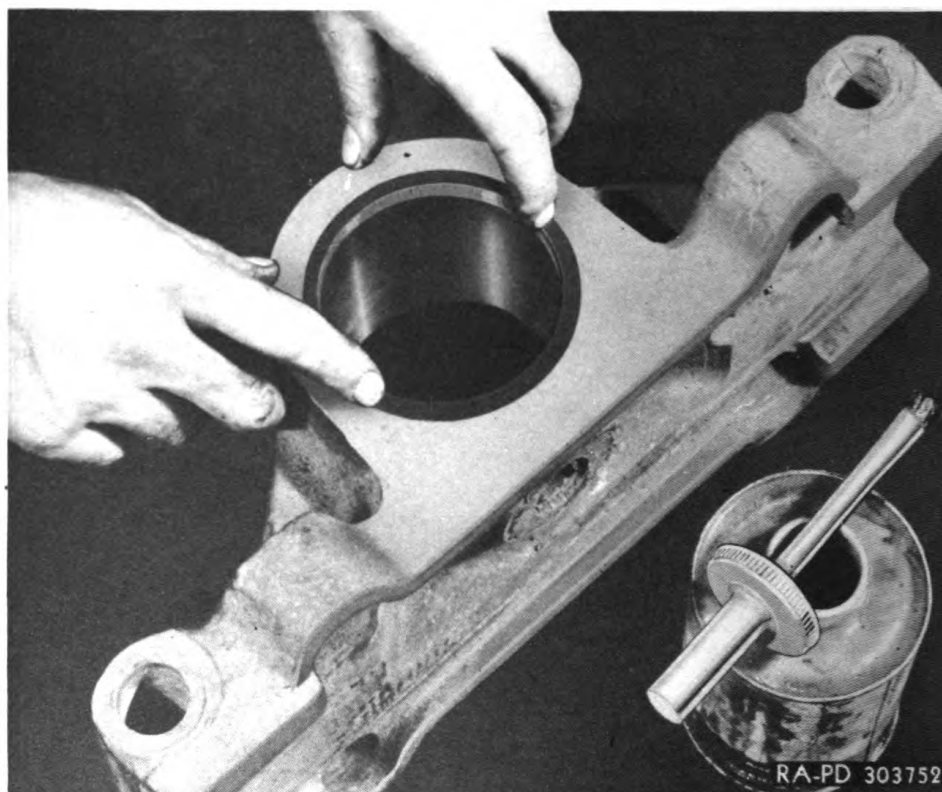
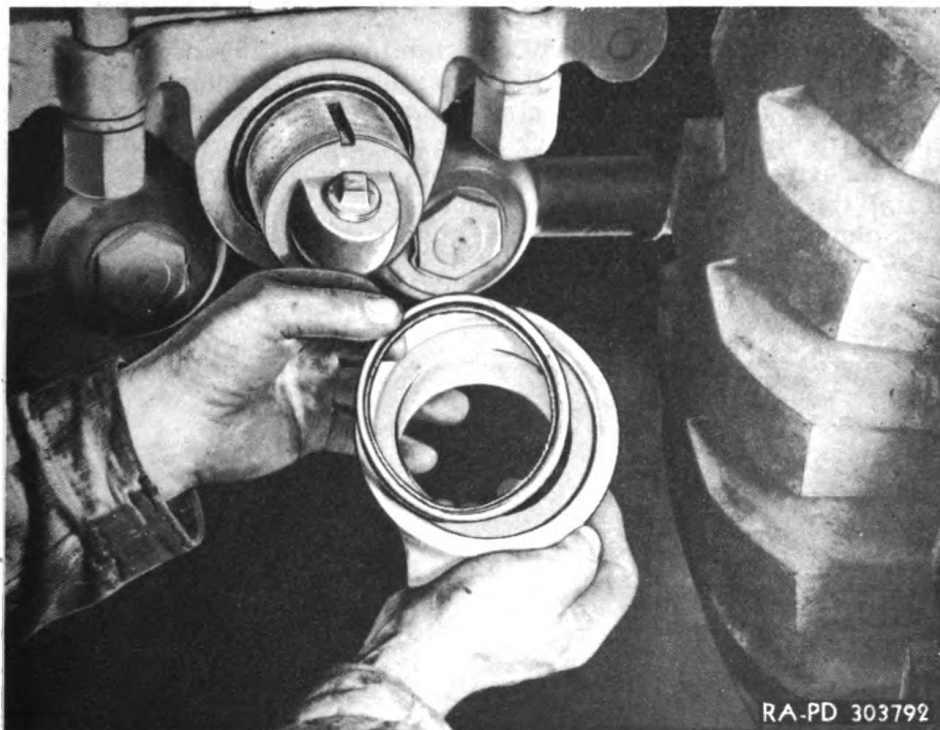

Figure 153—Cementing Cork Oil Seal on Inner Side of Spring Seat

into place with the U-bolts, but care must be exercised to see that the spring bolt engages the hole in the middle of the spring seat.

(5) **INSTALL U-BOLTS.** Place the U-bolt spring plate into position on top of the spring assembly and then install the U-bolts over the plate and through the holes in the axle housing, engaging the U-bolts in the grooves in the U-bolt spring plate. Then install the U-bolts, nuts and lock washers and tighten securely. To pull the spring assembly down square on its seat, loosen the U-bolt nuts and tighten the spring seat clamping nuts to square up the spring assembly in the seat. Then tighten the U-bolt nuts.

SUSPENSION



RA-PD 303792

Figure 154—Installing Spring Seat Cap and Gasket

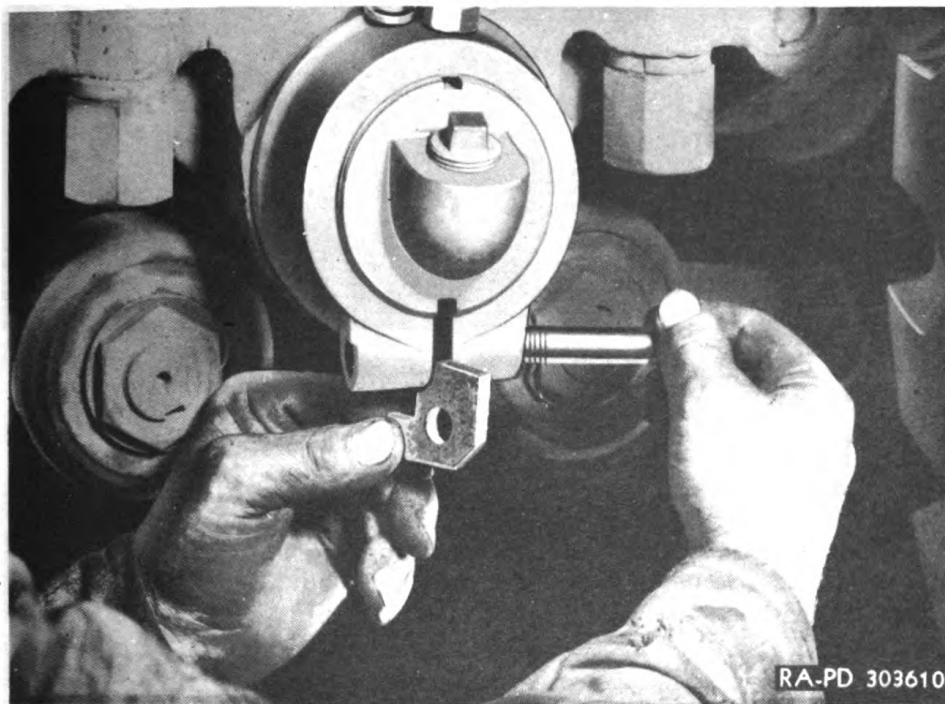

RA-PD 303610

Figure 155—Installing Lock Plate and Clamp Bolt

TM 9-811
143-144

**4-TON, 6 x 6 TRUCKS (DIAMOND T MODELS 968A CARGO,
969A WRECKER, 970A PONTON, AND 972 DUMP)**

(6) **INSTALL SPRING SEAT CAP** (figs. 154 and 155). Cement a new cork oil seal into the recess in the spring seat cap. Then install the cap, tightening it against the spring seat as close as possible but not tight enough to bind. Install the lock plate in the groove in the spring seat cap, engaging it at the same time with a slot in the rocker beam tube. Install the clamp screw through the holes in the spring seat cap and the lock plate. Install the nut and lock washer and tighten securely.

(7) **LOWER VEHICLE TO THE GROUND.** Lower vehicle to the ground and remove the jacks from under the rocker beam tube.



Figure 156—Pulling Upper Torque Rod Center Pin

144. TORQUE RODS.

a. Description. Axle alignment is maintained by means of torque rods which transmit axle torque to the spring seats on these vehicles. Eight torque rods are used, four on each side, two above and two below the axles. The lower torque rods are fixed, but the upper ones are adjustable.

b. Removal.

(1) **SUPPORT VEHICLE ON JACKS.** Place jack under rocker beam tube and raise jack until it just starts to lift on the side from which the torque rods are to be removed. Block axles so they will not tip.

SUSPENSION

(2) **REMOVE UPPER TORQUE RODS.** Drive out the locking pins on the inner ends of the upper torque rods. Using a hammer and drift punch, drive from the underside of the pin as it is tapered and must be removed in this direction. Use the torque rod pin puller (41-P-2956-8) to remove the torque rod pins at the inner ends of the upper rods (fig. 156). Then remove the nuts and lock washers from the torque rod pins on the outer ends of the upper torque rods. Then knock the inner ends of the upper torque rods out of the torque rod bracket and drive the torque rod pin from the torque rod bracket on the axles at the outer ends of the upper torque rods and remove the torque rods (fig. 157).



Figure 157—Removing Upper Torque Rod

(3) **REMOVE LOWER TORQUE RODS.** Remove the nuts and lock washers from the torque rod pins at both ends of the lower torque rods. Then drive the torque rod pins out of the torque rod bracket on the frame and the torque rod brackets on the axles, using a soft hammer. Then remove the lower torque rods.

c. Installation.

(1) **ADJUST TWO OF THE UPPER TORQUE RODS.** Loosen the clamp on the upper torque rod adjustment on two of the rods, and adjust them to the same length as the lower torque rods which are not adjustable. After the rods are adjusted, tighten the clamping nut on the adjustment.

TM 9-811

144

4-TON, 6 x 6 TRUCKS (DIAMOND T MODELS 968A CARGO, 969A WRECKER, 970A PONTON, AND 972 DUMP)

(2) **INSTALL LOWER TORQUE RODS.** Install the lower torque rods into position, driving the tapered pins into their seats in the torque rod frame bracket and the torque rod axle brackets and then install the nuts and lock washers which were removed. Tighten the nuts securely.

(3) **INSTALL TWO UPPER TORQUE RODS.** Install the two upper torque rods which have been previously adjusted to the same length as the lower torque rods, installing one forward on one side of the vehicle, and the other toward the rear on the other side of the vehicle, that is, diagonally across the rocker beam tube. Drive the torque rod pins into the axle brackets for these two rods and install the nuts and lock washers which were removed. Then raise the inner end of the rods to line it up with the holes in the upper frame brackets and drive the torque rod

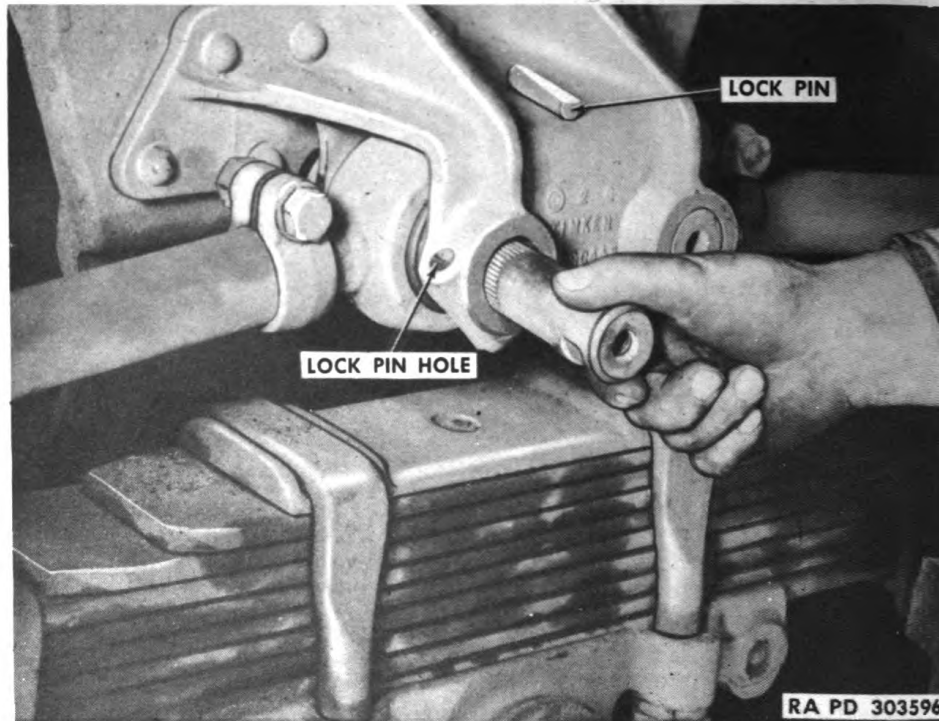

Figure 158—Installing Upper Torque Rod Center Pin

pins through the brackets and through the eyes in the end of the rods, lining up the groove in the pins with the holes in the brackets (fig. 158). Then drive the lock pins into the holes in the brackets with the flat side towards the torque rod pins.

(4) **INSTALL REMAINING TORQUE RODS.** Install the two remaining upper torque rods into position, attaching the outer ends to the axle brackets in the same manner as described in the preceding step. Lower the jacks and remove them from under the rocker beam tube. Slide the

SUSPENSION

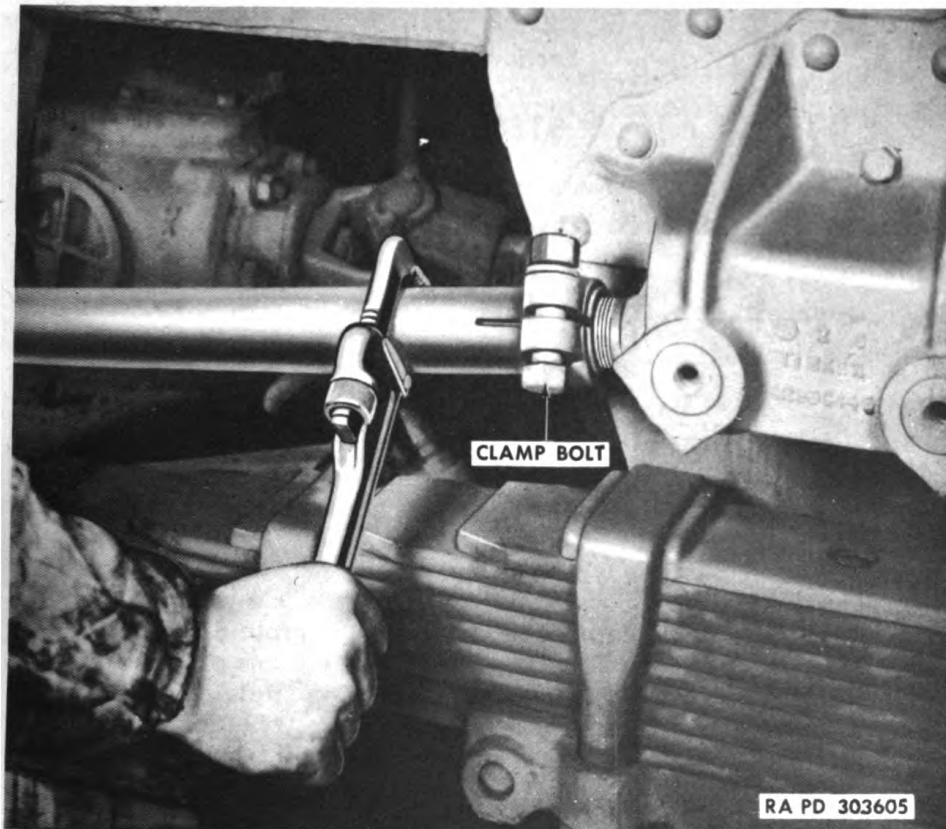

Figure 159—Adjusting Upper Torque Rod

inner ends of the two torque rods into the upper axle rod brackets and check alinement of the holes in the torque rod eyes with the holes in the torque rod brackets. Loosen the clamp screws on each end of these two torque rods and turn the rod with a pipe wrench until the torque rods line up exactly with the holes in the brackets (fig. 159). Then tighten the clamp bolts on each end of each rod. Then install the center torque rod pins and lock pins in the same manner as described in the preceding step.

TM 9-811
145-146

**4-TON, 6 x 6 TRUCKS (DIAMOND T MODELS 968A CARGO,
969A WRECKER, 970A PONTON, AND 972 DUMP)**

Section XXXII

STEERING

	Paragraph
Description and tabulated data	145
Adjustments	146
Steering wheel	147
Drag link	148
Steering Pitman arm	149

145. DESCRIPTION AND TABULATED DATA.

a. Description. The steering gear is a mechanism which controls the direction of the front wheels through a linkage. The gear is of the cam and twin-lever type which automatically provides a variable gear ratio for ease of steering and stability. The cam is a worm of variable ratio (hence the name cam) and the thread is ground slightly higher where the straight-ahead driving action usually takes place to provide closer adjustment of the clearance between the studs and the cam at that point of steering action. The cam is securely held in the steering gear housing and is supported at each end on ball bearings (fig. 160).

b. Operation. The steering gear is actuated by the steering wheel which is under the driver's control. As the steering shaft turns the cam, the follower studs are pulled along the cam groove, which causes the lever arm to turn the lever shaft. The steering arm is securely clamped to the lever shaft and so is moved by it, turning the wheels through a linkage consisting of a drag link and tie rod.

c. Tabulated Data.

Make Ross
Model T-71
Type Roller-mounted cam and twin-lever

146. ADJUSTMENTS.

a. When making steering gear adjustments, free the gear of all loads, preferably by disconnecting the drag link from the steering arm. Free the jacket tube by loosening the instrument board bracket clamp. Tighten the side cover adjusting screw (fig. 160) until a very slight drag is felt at the mid-position when swinging the wheel slowly from one side to the other. The gear must not bind in any position. Only a very slight drag should be felt, and that in the mid-position. A closer adjustment will not correct a steering condition, but will cause damage and wear to the parts and impair operation. After the proper adjustment has been made, tighten the lock nut and give the gear a final test for binding. Make sure that the steering arm is tight on the splined end of the lever shaft and that the lock washer and nut are tight also.

STEERING

147. STEERING WHEEL.

a. Removal.

(1) **REMOVE HORN BUTTON.** Remove the horn button assembly as described in paragraph 102.

(2) **REMOVE STEERING WHEEL.** Remove the nut holding the steering wheel on the end of the cam and wheel tube. Then using a steering wheel puller pull the steering wheel from the end of the cam and wheel tube.

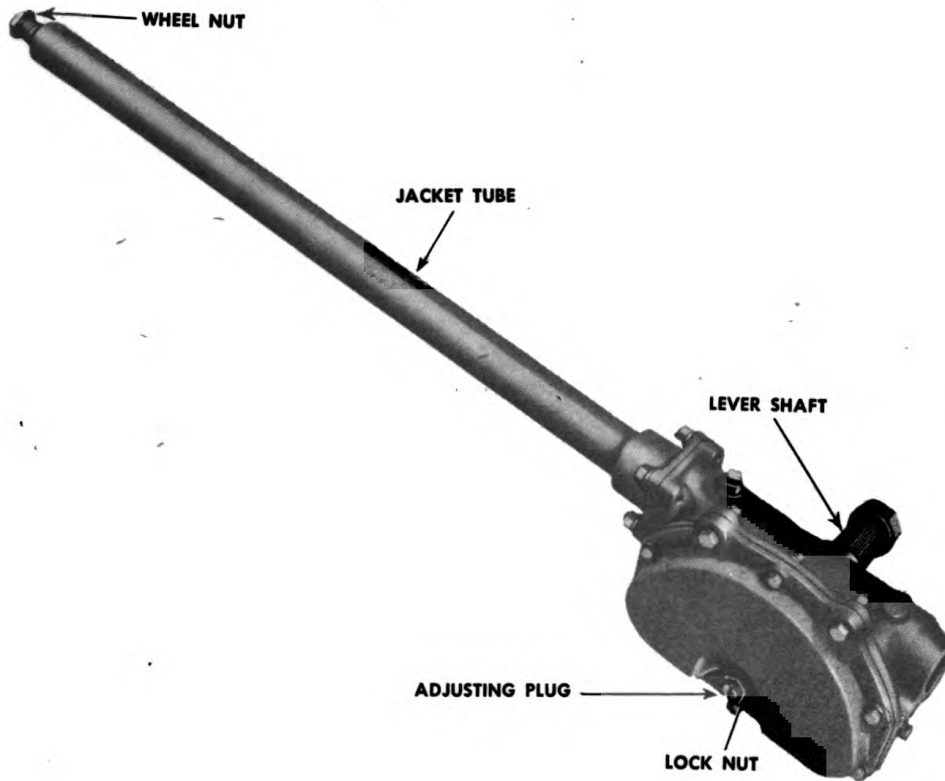

RA PD 313829

Figure 160—Steering Gear Assembly

b. Installation.

(1) **INSTALL STEERING WHEEL.** Install the steering wheel into position on the end of the cam and wheel tube, then place a block of wood over the steering wheel hub and strike the wood three or four sharp blows with a hammer to seat the wheel on the hub. Install the steering wheel nut.

(2) **INSTALL HORN WIRE.** Install the horn wire as described in paragraph 102.

TM 9-811
148

**4-TON, 6 x 6 TRUCKS (DIAMOND T MODELS 968A CARGO,
969A WRECKER, 970A PONTON, AND 972 DUMP)**

148. DRAG LINK.

a. **Removal.** Remove the cotter pins from each end of the drag link tube. Using the offset screwdriver, back off the drag link bearing plugs far enough so that the ball seats can be spread a sufficient amount to permit the drag link to be removed from the balls on the steering and Pitman arms (fig. 161). Remove drag link.

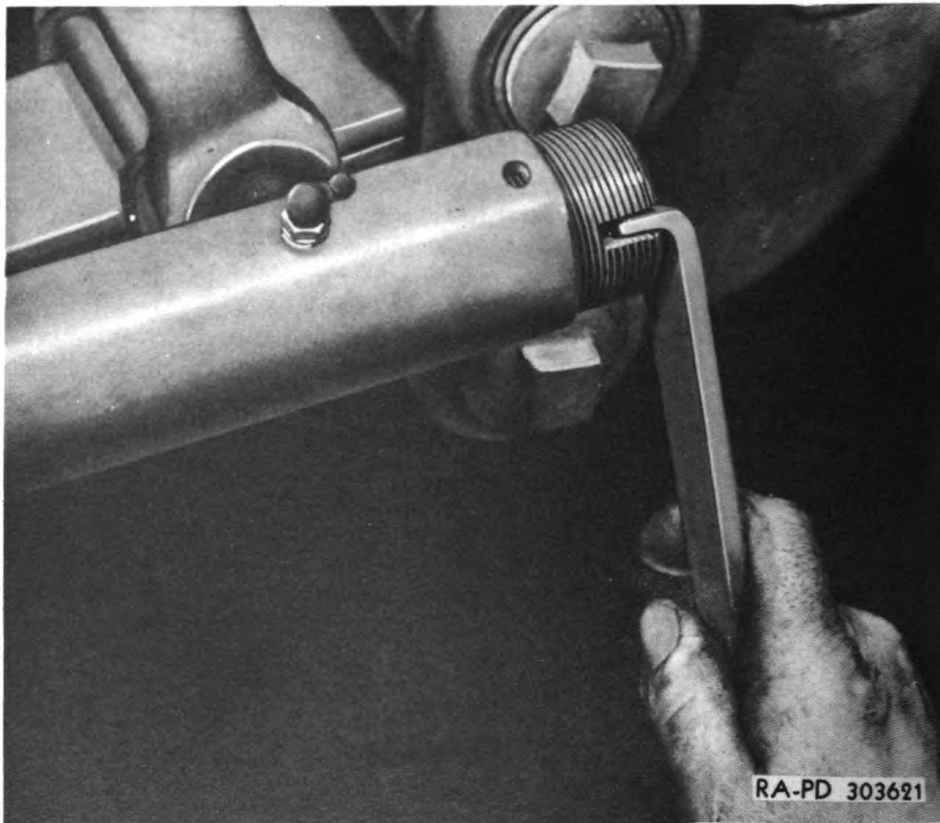

Figure 161—Backing Off Drag Link Bearing Plug

b. **Installation.** Spread the ball seats in the ends of the drag link so that the drag link may be installed over the balls in the steering and Pitman arms. Then using the offset screwdriver, tighten the plugs in each end of the drag link and back the plug off just far enough to permit installation of the cotter pin. This adjustment must be tight enough so that there is no looseness. Install the cotter pins through the holes in the ends of the drag link tube, and through the slots in the adjusting plugs to lock the adjustment.

STEERING

149. STEERING PITMAN ARM.

a. Removal.

(1) **DISCONNECT DRAG LINK AT STEERING PITMAN ARM.** Disconnect the drag link from the steering Pitman arm as described in paragraph 148.

(2) **REMOVE STEERING PITMAN ARM.** Remove the nut and lock washer from the lever shaft. Using a prick punch, mark the lever shaft and the steering Pitman arm to indicate the position of the arm on the serrations of the lever shaft to facilitate replacement. Then remove the steering Pitman arm, using puller (41-P-2952) (fig. 162).

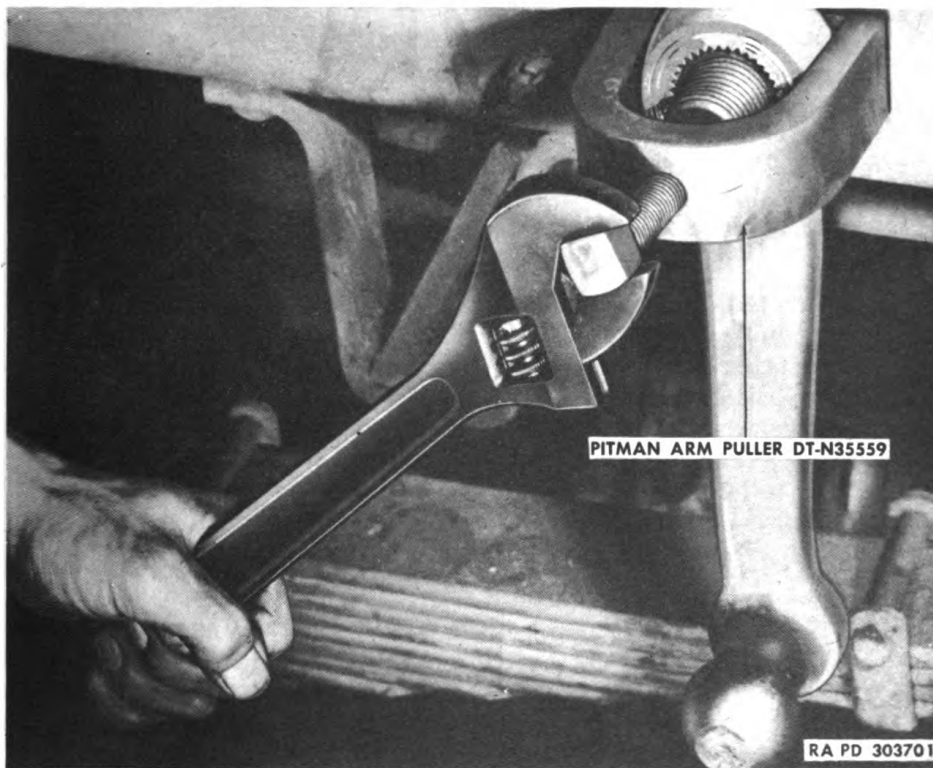

Figure 162—Pulling Steering Pitman Arm with Puller (41-P-2952)

b. Installation.

(1) **INSTALL STEERING PITMAN ARM.** Install the steering Pitman arm over the serrations on the steering gear lever shaft, lining up the punch mark on the Pitman arm with the punch mark on the lever shaft, to be sure that parts are assembled properly. Using a hollow mandrel, drive Pitman arm back until it is solidly seated on the lever shaft. Then install the lever shaft nut and lock washer.

(2) **CONNECT DRAG LINK.** Connect the drag link to the steering Pitman arm, as described in paragraph 148.

4-TON, 6 x 6 TRUCKS (DIAMOND T MODELS 968A CARGO, 969A WRECKER, 970A PONTON, AND 972 DUMP)

Section XXIII

FRAME AND BODIES

	Paragraph
Frame	150
Cargo body.....	151
Wrecker body.....	152
Ponton body.....	153
Dump body.....	154

150. FRAME.

a. **Description.** The frames, as used in these vehicles, are made up of straight steel channels $8\frac{1}{16} \times 3 \times \frac{9}{32}$ inch which are rigidly held together by riveted cross members. The frame used on cargo and wrecker trucks is $256\frac{7}{8}$ inches long, the frame used on the ponton truck is $285\frac{1}{4}$ inches long, and the frame used on the dump truck is 243 inches long. All frames are 34 inches wide and are held together by six cross members.

b. **Maintenance.** The frame is rigidly constructed and is not likely to require any service attention. However, in the event of collision or any other extreme shocks, the frame may take a permanent set, and for this reason should be checked for alinement. When checking alinement, hang a plumb bob from the front spring hanger centers and from the rear axle rocker beam centers, and make chalk marks on a level floor below these points. Then move the vehicle and measure the diagonals. If the frame is twisted or out of line, it must be repaired or replaced. Refer to a higher authority.

c. **Pintle Hook Replacement.**

(1) **REMOVE PINTLE COMPRESSION NUT AND WASHER.** Remove the cotter pin from the slotted compression nut and then remove the nut and washer. It will be necessary to insert a bar through the eye of the hook to prevent it from turning while removing the nut and washer (fig. 163).

(2) **REMOVE PINTLE HOOK FROM FRAME.** Pull the pintle hook assembly out of the rear frame cross member.

(3) **REMOVE PINTLE HOOK COMPRESSION SPRING AND SPRING RETAINER.** Take out cap screws, nuts and lock washers holding pintle brace support to the pintle hook braces, and remove support compression spring and compression spring caps.

(4) **INSTALL PINTLE HOOK COMPRESSION SPRING.** Install compression spring caps into the compression spring with long end of both caps facing towards front, and lift the assembly into position in the frame, inserting short ends of the rear cap through hole in rear cross member. Hold the assembly in this position and install pintle hook brace support into place against the pintle hook braces, sliding long end

FRAME AND BODIES



Figure 163—Removing Pintle Hook

of the forward compression spring cap through hole in support. Attach support to pintle hook braces with cap screws, nuts and lock washers.

(5) **INSTALL PINTLE HOOK.** Slide pintle hook assembly through rear frame cross member and compression spring, and install washer and nut on the threaded end. Insert a bar through the eye of the pintle hook and tighten compression nut a sufficient amount to keep the hook tight, but keep it loose enough so that it may be rotated by hand. Then install cotter pin through the slotted compression nut.

d. Front Bumper Replacement.

(1) **REMOVE FRONT TOW HOOKS.** Remove the bolts, nuts and

TM 9-811
150

4-TON, 6 x 6 TRUCKS (DIAMOND T MODELS 968A CARGO,
969A WRECKER, 970A PONTON, AND 972 DUMP)

RA PD 304990

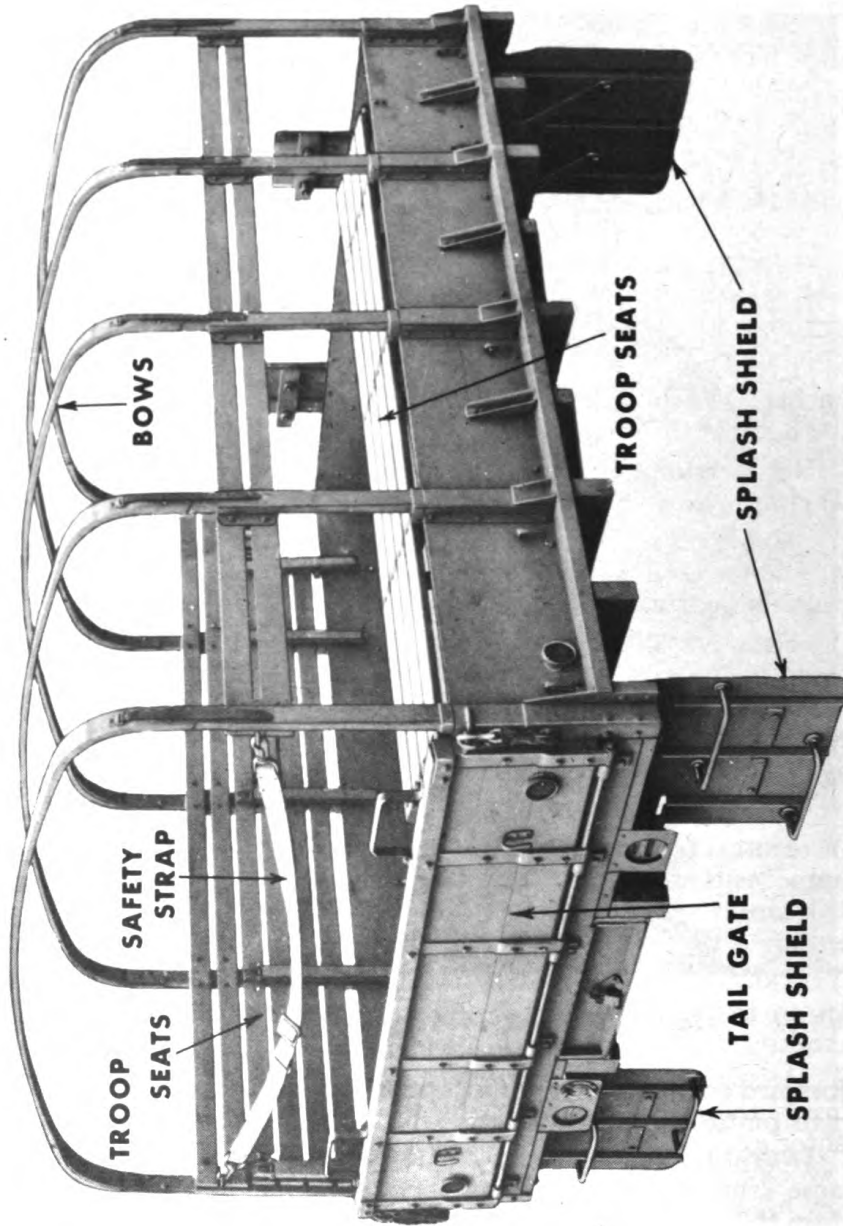

Figure 164—Cargo Body

FRAME AND BODIES

lock washers holding the front tow hooks to the frame rails, and remove the tow hooks.

(2) **REMOVE FRONT BUMPER.** Remove the remaining bolts, nuts and lock washers holding the bumper to the upper and lower channel flanges of the frame rails and pull the bumper off from the front.

(3) **INSTALL FRONT BUMPER.** Lift the front bumper assembly and slide it into position over the end of the frame rails. Install the bolts, nuts and lock washers and tighten them securely. Do not install bolts through tow hook mounting holes (fig. 163).

(4) **INSTALL FRONT TOW HOOKS.** Install the tow hooks in position and attach with the bolts, nuts and lock washers.

151. CARGO BODY.

a. **Description** (fig. 164). The cargo body is made up of wooden sections and timbers bolted together. It is equipped with bows and tarpaulin, troop seats, a conventional type tail gate, and two tire mounting brackets, which make it possible to mount the two spare tires inside the body at the forward end.

b. **Replacement of Body Side Assemblies, Bows, End Curtains and Tarpaulins.**

(1) **REMOVE TARPAULINS AND END CURTAINS.** Untie the ropes holding the tarpaulins and end curtains in place on the body and then remove these parts.

(2) **REMOVE TOP BOWS.** Standing inside the body, lift each top bow assembly out of pockets on each side of the body and remove them from the vehicle.

(3) **REMOVE BODY SIDE ASSEMBLIES.** Lift each body side assembly high enough to clear the stake pockets on the sides of the body, and remove these assemblies from the vehicle.

(4) **INSTALL BODY SIDE ASSEMBLIES.** Lift the body side assemblies into position over the stake pockets on the sides of the body and lower them into position, seating the side assembly legs solidly in the pockets. Be sure that the troop seats are facing in toward the body.

(5) **INSTALL TOP BOWS.** Lift the top bows into position over the pockets in the side assemblies and lower them into position, seating them solidly in the side assembly pockets (fig. 164).

(6) **INSTALL END CURTAINS.** Raise the rear end curtain into position inside the contour of the rear top bow. Then pull the rope from the center eyelet in the top of the end curtain until both ends are even. Then working from the top center eyelet, loop the rope around the top bow again and through the next eyelet, and so on until the end of the rope extends from the last eyelet. Then repeat this operation using the other end of the rope and going in the other direction. Then pull these ropes tight, center the end curtain inside the contour of the rear top bow, and tie the ends of the ropes to the cleats at the rear corner of the body panel. The front end curtain may then be installed in the same manner.

4-TON, 6 x 6 TRUCKS (DIAMOND T MODELS 968A CARGO, 969A WRECKER, 970A PONTON, AND 972 DUMP)

(7) **INSTALL TOP TARPULIN.** Lay the tarpaulin flat on the ground with the inside of the canvas facing down, stretch it out tight and square and pull the ropes which run through the hems in the canvas until the same length of rope extends out of each corner. One man should then grasp one of the hems at the middle, pinching it tightly to hold the rope so that it cannot slip inside the hem; and another man should grasp one end of the rope and pull it taut. The man holding the tarpaulin can then use his free hand to shirr or gather the material at the hem by pulling on it. This operation may then be repeated with the other end of the rope stretched taut. The hem on the other end of the tarpaulin

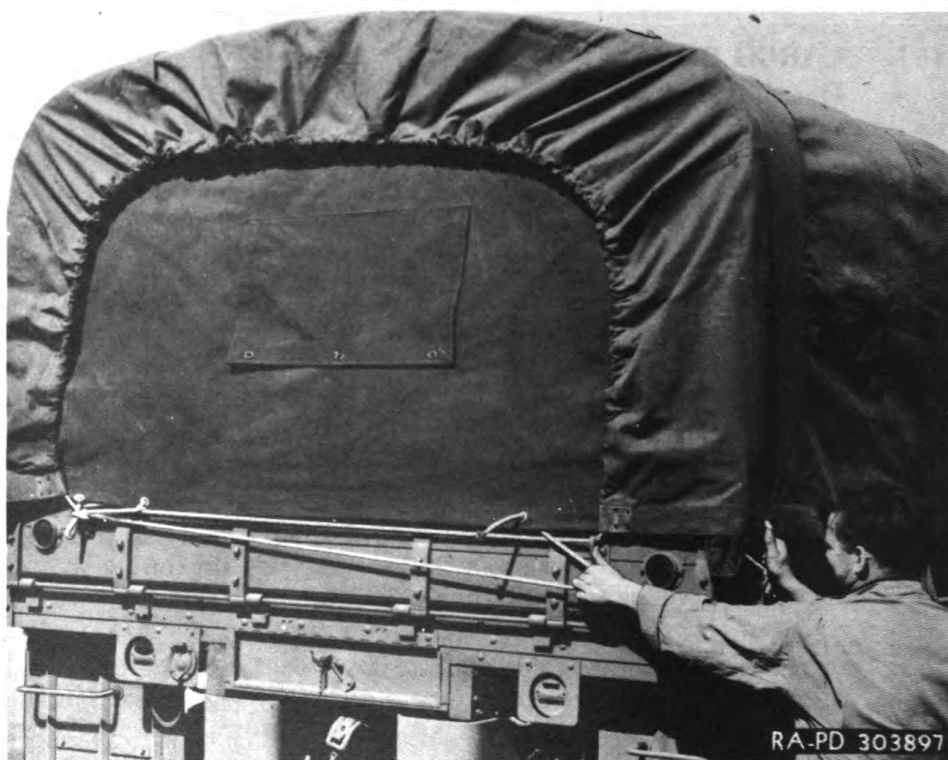

Figure 165—Tying Down Rear Tarpaulin Rope

should be shirred in the same manner. Then fold the canvas to facilitate installation on the vehicle. This may be easily done by folding each side into the middle, then folding each folded edge into the middle, and then folding the whole together. Grasp each end of the roll and fold it to the middle. Lift the folded tarpaulin into the body and raise it high enough so that it may be supported on the top bows and then fold back each end toward the front and rear of the body. The sides may then be unfolded, rolling the canvas down to cover the bows. The shirred ends of the canvas may then be fitted over the edges of the top bows, as shown in figure 165. The ropes extending through the tarpaulin hems should be pulled tight and the tarpaulin squared

FRAME AND BODIES

up on the body. The hem ropes should then be looped under the cleats on the back of the tail gate or on the front body panel, drawn all the way across the tail gate or panel, looped under the cleat on the other side, laced through the eyelet in the lower end of the end curtain and tied securely to the nearest cleat. When the front and rear ends of the tarpaulin are both tight, tie the small ropes along the lower sides of the tarpaulin to the cleats on both side panels (fig. 165).

c. **Rolling up Tarpaulin.** Under ideal weather conditions, it may be desirable to roll the tarpaulin up to permit ventilation inside the body. To do this, untie all the tarpaulin ropes and roll up each side in a flat roll about 8 inches across, fastening the roll in place with the bow straps which may be buckled around the roll and to the top of the tarpaulin. After each side of the tarpaulin has been rolled up, the end curtains may be removed.

d. **Replacement of Tire Carrier.**

(1) **REMOVE TIRE FROM CARRIER.** Remove the tire carrier lock and remove the nuts from the carrier studs and remove the tire.

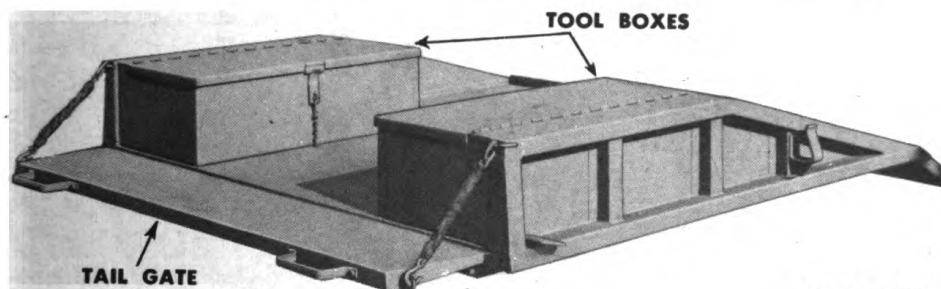

RA PD 313793

Figure 166—Wrecker Body

(2) **REMOVE TIRE CARRIER ATTACHING PARTS.** Remove the bolts, nuts and lock washers attaching the tire carrier assembly to the body. It will be necessary to disconnect the tire carrier from the channel bracket which extends around the top sill on the body front panel.

(3) **REMOVE TIRE CARRIER.** The tire carrier may then be removed by lifting it up into the body, sliding it through the top sill in the front body panel. Then remove channel bracket.

(4) **INSTALL TIRE CARRIER.** Slide the tire carrier assembly through the tire sill on the front body panel with the studs toward the top and facing in toward the body. Then slide the channel bracket into position and fasten the bracket to the tire carrier with the cap screws, nuts and lock washers which were removed. Then install the bolts, nuts and lock washers holding the tire carrier assembly to the front body panel.

(5) **INSTALL TIRE ON CARRIER.** Install the tire into position on the tire carrier so that it rests on the floor with the studs extending through two of the wheel nut holes. Then install the nuts over the studs and tighten these securely. Replace the tire carrier lock.

TM 9-811
151

4-TON, 6 x 6 TRUCKS (DIAMOND T MODELS 968A CARGO,
969A WRECKER, 970A PONTON, AND 972 DUMP)

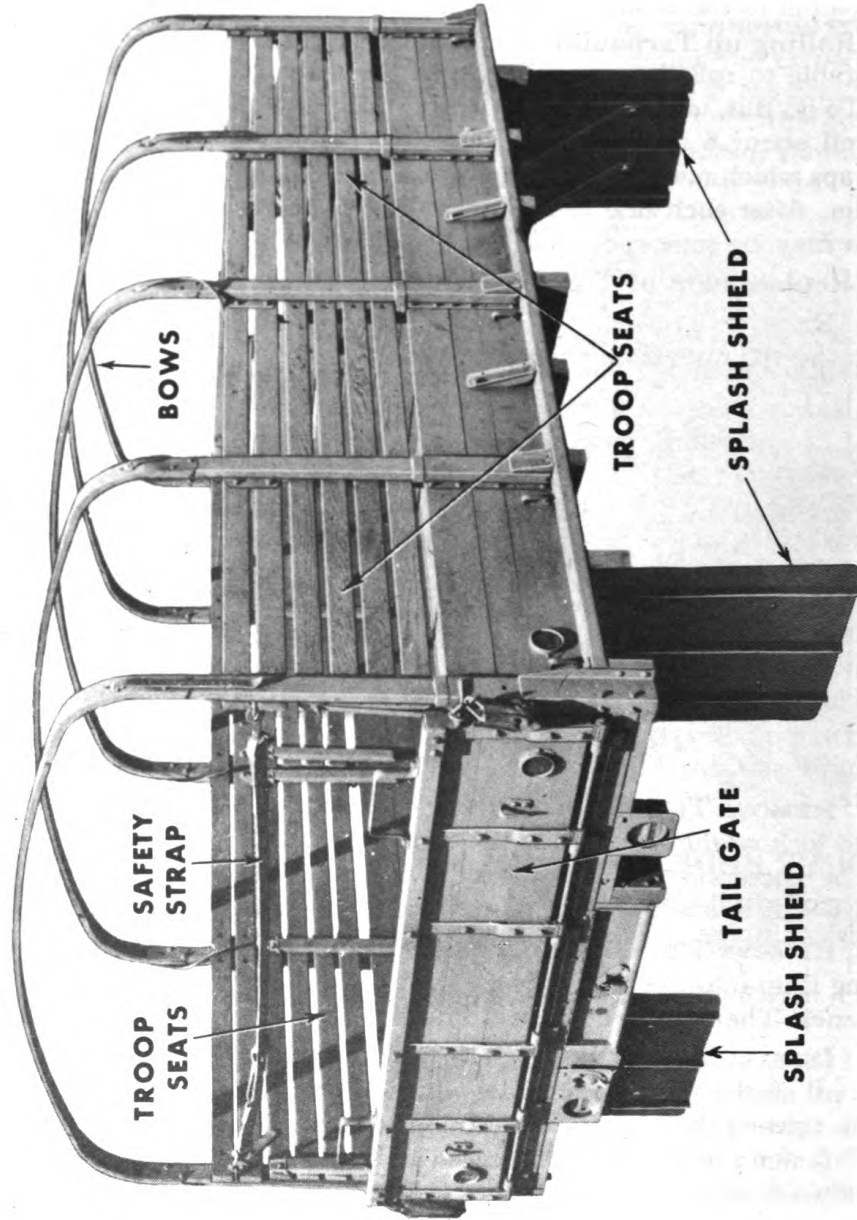

RA PD 304991

Figure 167—Ponton Body

FRAME AND BODIES

152. WRECKER BODY.

a. **Description** (fig. 166). The wrecker truck is equipped with an all-steel wrecker body, two large tool boxes and a conventional-type tail gate.

153. PONTON BODY.

a. **Description** (fig. 167). The ponton body is very similar to the cargo body, except that it is longer, has four sections of troop seats instead of two, has a front stake assembly, and has the spare tires mounted on the outside of the body.

b. **Replacement of Body Side Assemblies, Bows, End Curtains and Tarpaulin.** The side assemblies, top bows, tarpaulin and end curtains may be removed from and installed on the ponton in exactly the same manner as described for the cargo body in paragraph 151, except that there is a front stake assembly on the ponton body which must be removed before the side assemblies are removed, and replaced after the side assemblies are installed.

c. **Replacement of Tire Carrier.**

(1) **REMOVE SPARE TIRES.** Remove the tire locks and then remove the tire attaching nuts and clamps, and remove the spare tires from the carrier.

(2) **REMOVE TIRE CARRIER ASSEMBLY.** Remove the bolts, nuts and lock washers attaching the tire carrier to the tire carrier brackets on each side of the frame. Lift the tire carrier assembly from the vehicle.

(3) **INSTALL TIRE CARRIER ASSEMBLY.** Replace the tire carrier assembly on the brackets on the frame and bolt it into place with bolts, nuts and lock washers.

(4) **INSTALL SPARE TIRES.** Lift the spare tires into position on the carrier and fasten them in place with clamps and nuts. Then replace tire carrier lugs.

154. DUMP BODY.

a. **Description** (fig. 168). The dump trucks are equipped with an all-steel dump body, which is equipped with a cab protector on the front end which extends over the cab roof, and a tail gate at the rear end, which may be opened at the top or bottom.

**TM 9-811
154**

**4-TON, 6 x 6 TRUCKS (DIAMOND T MODELS 968A CARGO,
969A WRECKER, 970A PONTON, AND 972 DUMP)**

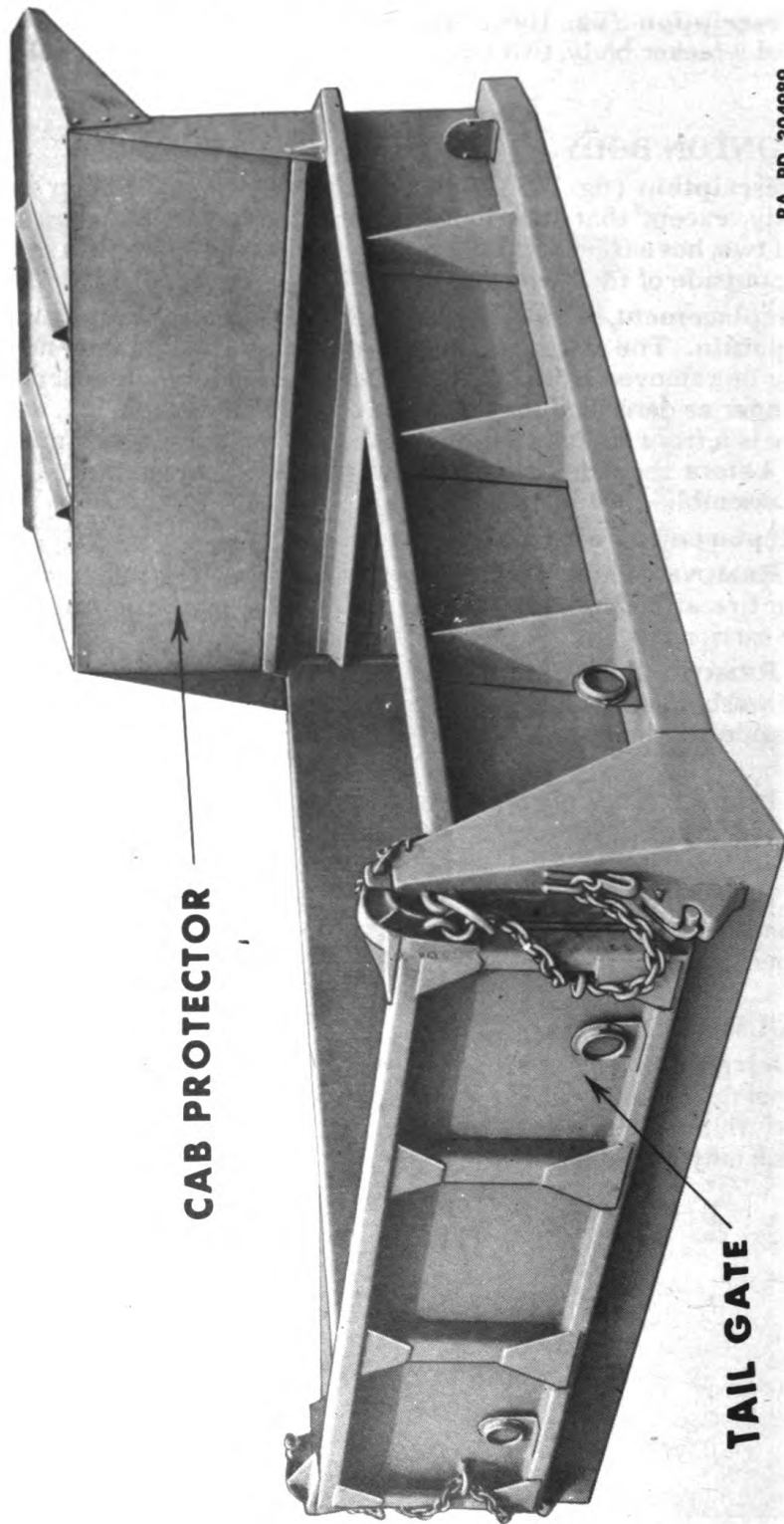

RA PD 304989

CAB PROTECTOR

TAIL GATE

320

Figure 168—Dump Body

Section XXXIV

POWER TAKE-OFF

	Paragraph
Description and tabulated data.....	155
Removal	156
Installation	157

155. DESCRIPTION AND TABULATED DATA.

a. Description. The power take-off is a conventional type take-off mounted on the left side of the vehicle transmission, and is driven by a gear on the transmission countershaft. It has two speeds forward and one reverse. It is used to deliver power to the front-mounted winch on cargo, wrecker and ponton trucks, and is controlled by the shifting lever located inside the cab.

b. Tabulated Data.

Make.....	Gar Wood
Model	74Y6000
Speeds.....	Two forward, one reverse
Drive.....	From transmission

156. REMOVAL.

a. Drain Transmission. Remove the transmission drain plug and the lower cap screw in the power take-off rear bearing cap to drain the oil from these units.

b. Disconnect Power Take-off Shift Rail. Remove the cotter and clevis pins holding the yoke on the end of the shift rod to the eye on the end of the shift rail and separate the rod from the rail.

c. Remove Power Take-off Bracket. Remove the screws holding the floorboard on the left side of the cab and remove the floorboard. Then take out the cap screws and lock washers holding the bracket to the transmission and to the power take-off, and remove the bracket.

d. Disconnect Power Take-off Propeller Shaft. Disconnect the propeller shaft from the winch at the forward end, and disconnect it at the power take-off. Slide it forward out of the way, as described in paragraph 113.

e. Remove Power Take-off Assembly. Remove the stud nuts and lock washers holding the power take-off on the transmission, and remove the power take-off assembly. Use a pry-bar or chisel to pry the unit off the studs (fig. 169).

f. Remove Power Take-off Adapter. The power take-off adapter and the gaskets may be removed by sliding them from the studs.

157. INSTALLATION.

a. Install Power Take-off Adapter. Install a new adapter gasket into position on the studs around the power take-off opening in the transmission case, then slide the adapter assembly into position over the studs, engaging the adapter gear with the power take-off drive gear on the transmission countershaft.

TM 9-811
157

**4-TON, 6 x 6 TRUCKS (DIAMOND T MODELS 968A CARGO,
969A WRECKER, 970A PONTON, AND 972 DUMP)**

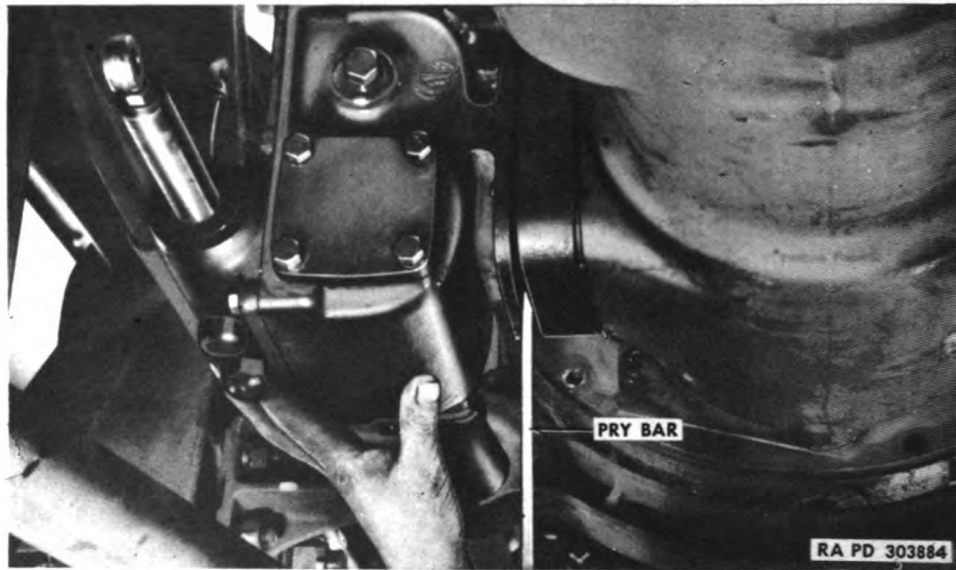

Figure 169—Removing Power Take-off

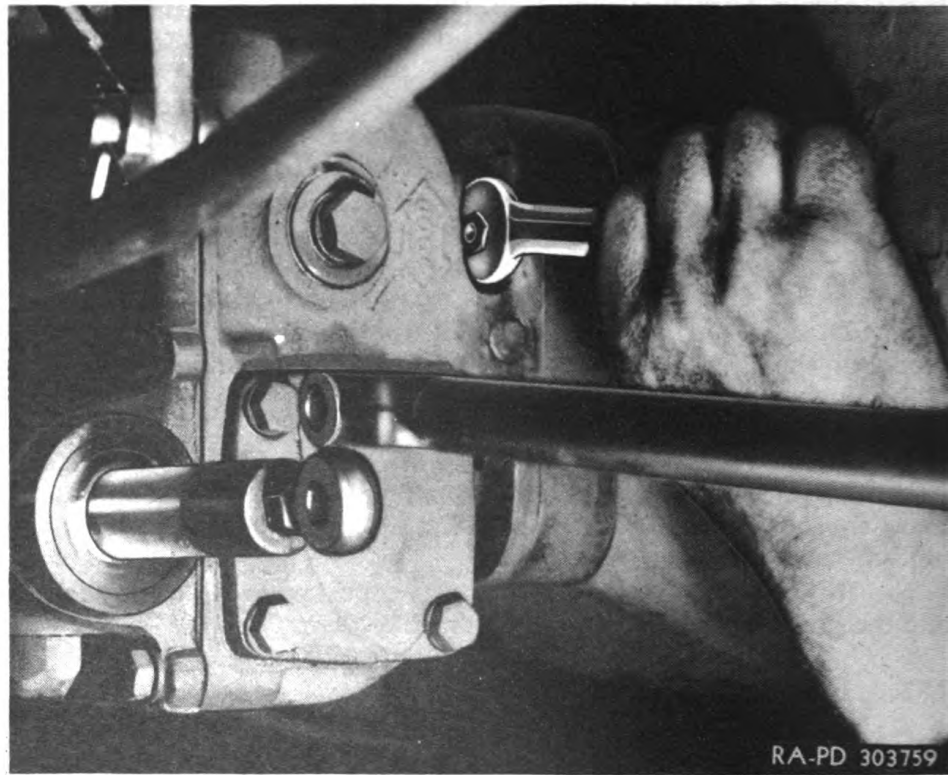

Figure 170—Tightening Power Take-off Mounting Stud Nuts
322

POWER TAKE-OFF

b. Install Power Take-off Assembly. Install a new gasket over the studs and against the adapter, lift the power take-off assembly into position and push it over the studs. Replace the stud nuts and lock washers which were removed, and tighten them gradually to avoid any strain on the power take-off housing (fig. 170).

c. Replace Power Take-off Propeller Shaft. Slide the propeller shaft back into position and connect it to the power take-off driven shaft, then connect the slip joint end to the winch worm shaft, as described in paragraph 114.

d. Install Power Take-off Bracket. Work the power take-off bracket into position, and attach it to the transmission and power take-off with the cap screws and lock washers.

e. Connect Shifting Linkage. Swing the power take-off shift rod into position so that the yoke lines up with the eye on the end of the shift rail, then install cotter and clevis pins.

f. Add Lubricant. Replace the transmission drain plug and the lower cap screw in the power take-off rear bearing cap, and add the required amount of lubricant (par. 26).

**4-TON, 6 x 6 TRUCKS (DIAMOND T MODELS 968A CARGO,
969A WRECKER, 970A PONTON, AND 972 DUMP)**

Section XXXV

FRONT-MOUNTED WINCH

	Paragraph
Description and tabulated data.....	158
Brake adjustments.....	159
Removal	160
Installation	161
Cable replacement.....	162
Shear pin replacement.....	163

158. DESCRIPTION AND TABULATED DATA.

a. **Description (fig. 171).** A winch is mounted between the frame side rails at the front of the cargo, wrecker and ponton trucks. It is driven from the power take-off mounted on the transmission, and is controlled by a shifting lever in the cab.

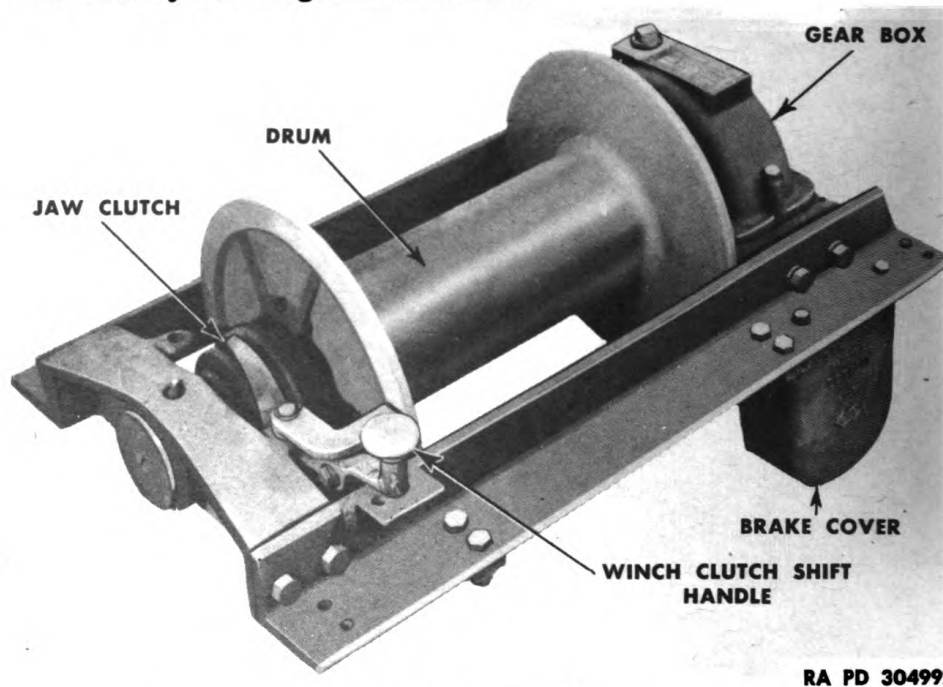

RA PD 304992

Figure 171—Winch Assembly

b. Tabulated Data.

Make.....	Gar Wood
Model	3U-615
Assembly No.....	22Y6337
Drive.....	Power take-off from transmission
Worm reduction.....	29 to 1
Diameter of drum.....	6 in.

FRONT-MOUNTED WINCH

Winding speeds (first layer of rope with engine at 1000 rpm):

High range.....55 ft per min
Low range.....30 ft per min

Cable:

Length.....300 ft
Diameter..... $\frac{5}{8}$ in.
Capacity.....15,000 lb

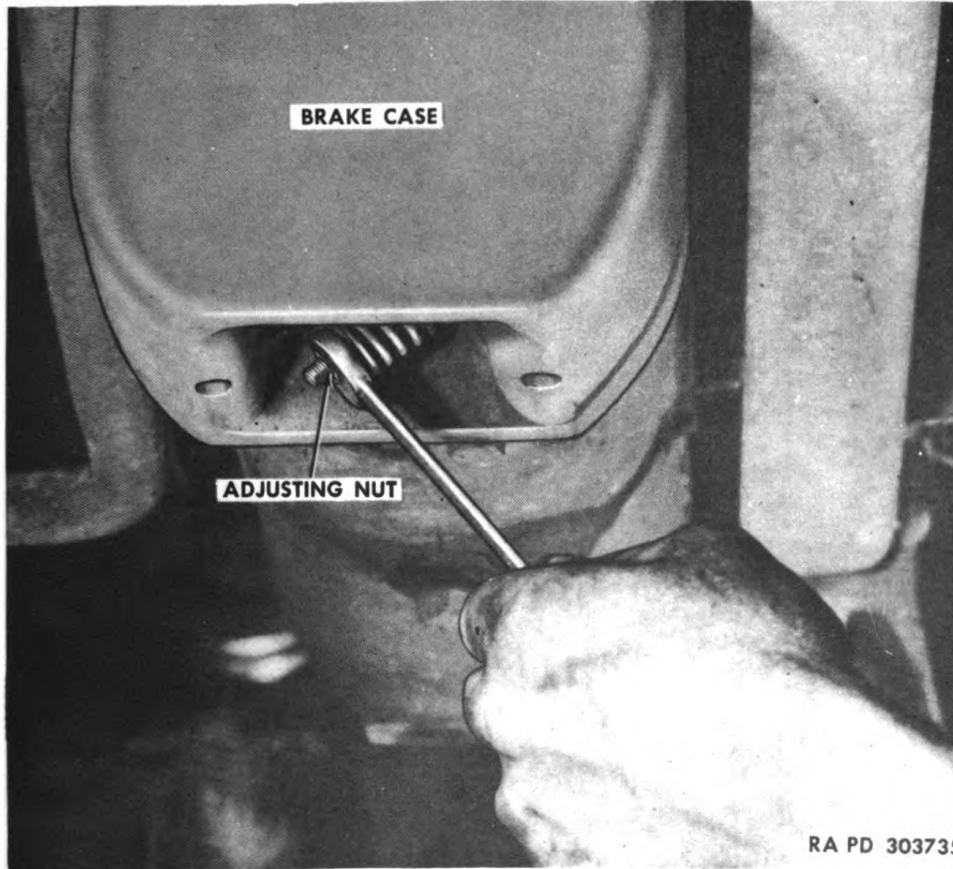

Figure 172—Adjusting Worm Shaft Brake

159. BRAKE ADJUSTMENTS.

a. Worm Shaft Brake Adjustment.

(1) A brake on the worm shaft is used to hold the load while the power take-off is in neutral. If the load slips when the take-off is in neutral, or when the shear pin has failed, the tension of the brake spring can be increased by tightening the adjusting nut on the under side of the case.

(2) Tighten the adjusting nut one-half turn, and then tighten the check nut. Test the brake, and, if it is still too loose, tighten the nut by half turns until the correct adjustment is obtained (fig. 172).

TM 9-811
159-160

**4-TON, 6 x 6 TRUCKS (DIAMOND T MODELS 968A CARGO,
969A WRECKER, 970A PONTON, AND 972 DUMP)**

(3) Even with the brake correctly adjusted the brake case will heat somewhat, and smoke may be noticed due to burning oil on the brake lining. However, if the hand cannot be held on the case, the brake is too tight. It will then be necessary to loosen the adjusting nut and to test again.

b. **Drag Brake Adjustment.** There is a drag brake which is applied whenever the winch clutch is disengaged. Its function is to keep the drum from unreeling unless there is a pull on the cable, and to keep the cable from backlashing. To adjust it, loosen the lock nut and turn the adjusting nut to secure the proper tension on the drum (fig. 173).

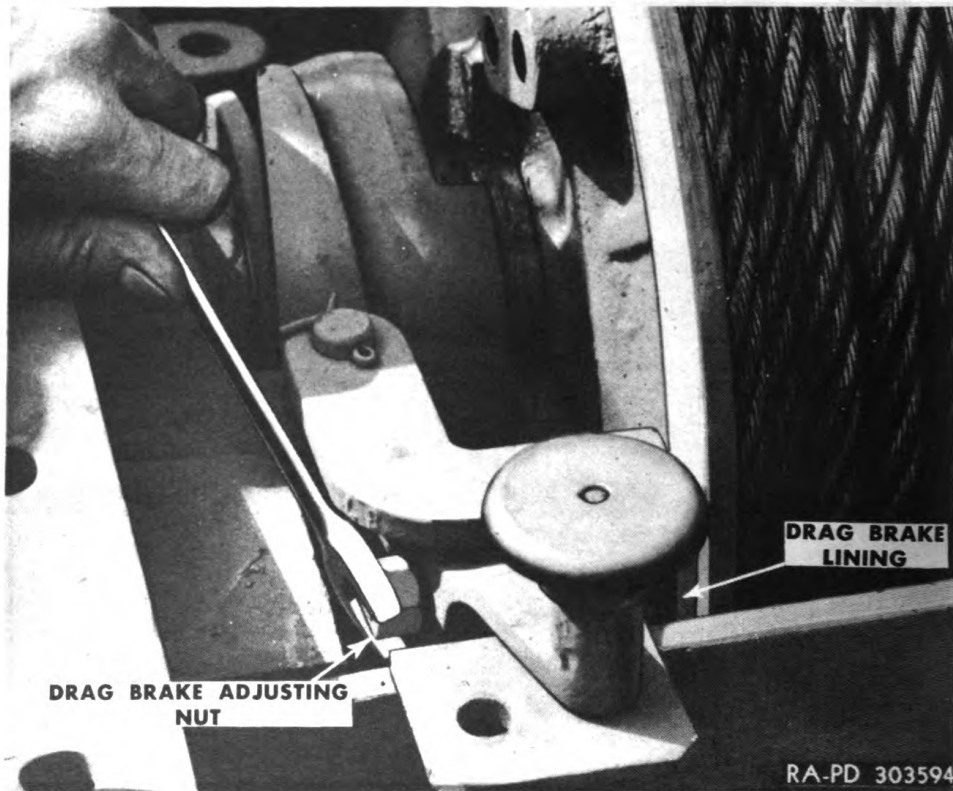

Figure 173—Adjusting Winch Drag Brake

Make this adjustment with winch clutch disengaged. If the brake spring is broken or has taken a set, it must be replaced. When adjustment is complete, tighten the lock nut.

160. REMOVAL.

- a. **Remove Front Bumper.** Remove the front bumper.
- b. **Disconnect Propeller Shaft from Winch.** Disconnect the propeller shaft from the winch, as described in paragraph 111.
- c. **Remove Winch Assembly.** Remove the cap screws, nuts and lock washers holding the winch frame to the frame rail brackets. Then swing a chain around the winch assembly and lift it on a hoist just

FRONT-MOUNTED WINCH

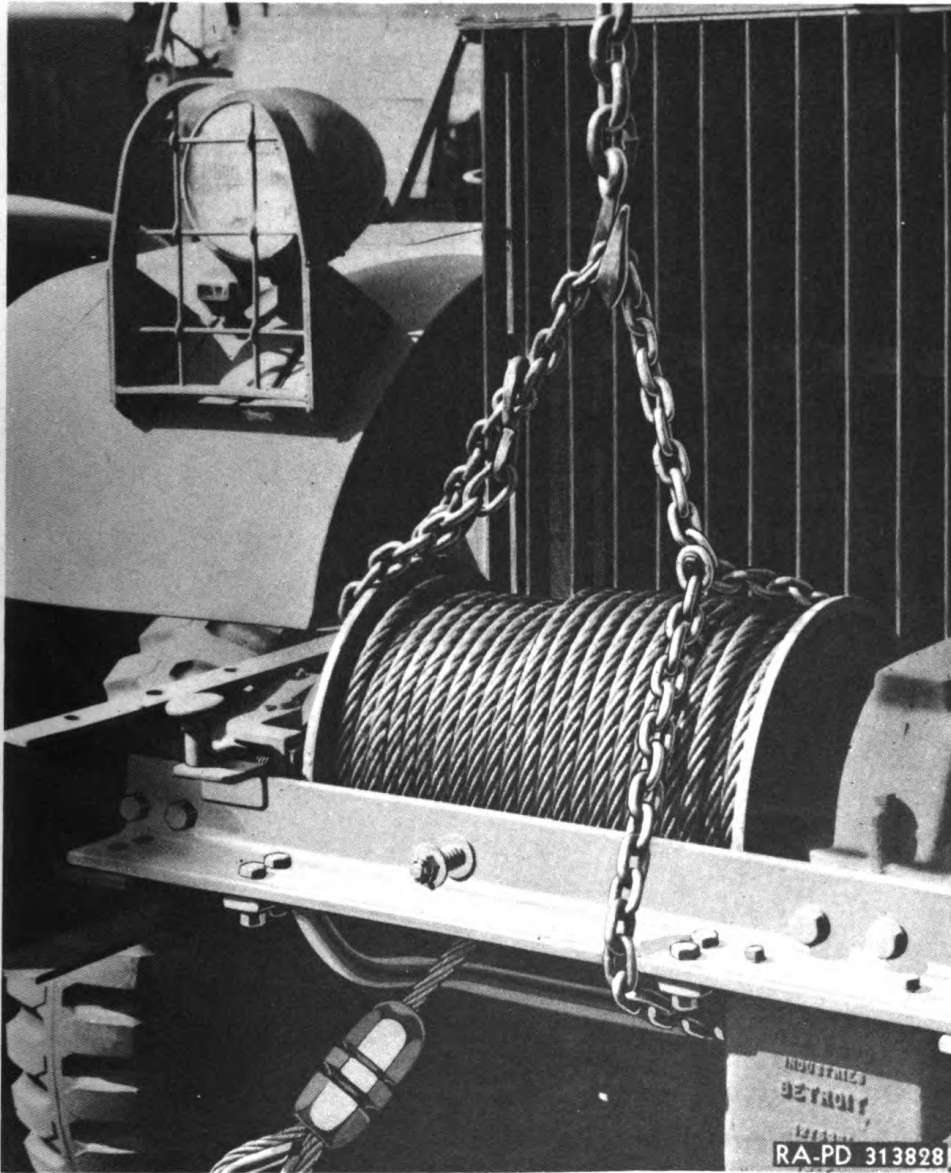

Figure 174—Removing Winch

enough to lift away from the frame brackets (fig. 174). Then slide it out towards the front.

161. INSTALLATION.

a. Install Winch Assembly. Lift the winch assembly on a hoist and line it up in position in front of the truck with the gear box on the left side of the vehicle, then slide it in towards the truck so that the winch frame slides over the supporting brackets. Line up the mounting holes and drop the winch assembly into place. Install the cap screws, nuts and lock washers which were removed to attach the winch assembly to the frame brackets.

**TM 9-811
161-162**

**4-TON, 6 x 6 TRUCKS (DIAMOND T MODELS 968A CARGO,
969A WRECKER, 970A PONTON, AND 972 DUMP)**

b. Connect Winch Propeller Shatt. Connect the winch propeller shaft, as described in paragraph 112.

c. Install Front Bumper. Replace the front bumper on the vehicle, as described in paragraph 150.

162. CABLE REPLACEMENT.

a. Removal. Unhook the end of the winch cable from the tow hooks on the bumper and then release the winch clutch and pull the

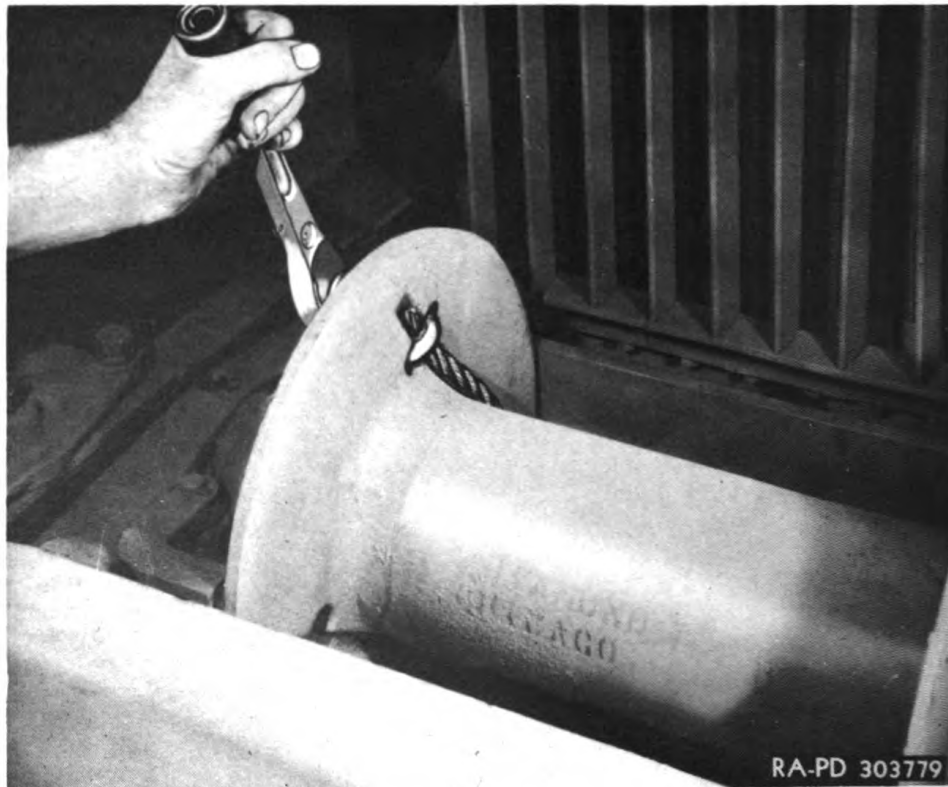

Figure 175—Clamping End of Cable in Drum

cable out from the drum until the end is reached. Then loosen the clamping nuts from the threaded ends of the U-bolts holding the cable in the drum and pull the end of the cable out of the U-bolt eye. After the cable is removed, unscrew the clamp nut at the end of the cable and remove the chain and hook from the cable.

b. Installation. Stretch a new cable out in front of the vehicle to get rid of all twists and kinks. It is best to do this on a clean surface such as would be afforded by a hard-surfaced roadway. Then install the chain and hook on the end of the cable, using a special clamping nut which was removed from the old cable. Take the other end of the cable and run it underneath the bumper, through the brush guard brace under the winch, and around the winch drum and then insert

FRONT-MOUNTED WINCH

it through the U-bolt eye on the side of the drum. Tighten the U-bolt nuts (fig. 175). The end of the cable should extend about an inch through the U-bolt. Then start the engine, engage the power take-off and wind the cable onto the drum. The cable should be under load while it is being wound. This can be done by hooking onto it another vehicle while winding or with a special brake winding fixture. Guide the cable as it is being wound. Be sure that the layers are flat and tight. After the drum is full, loop the end of the chain around the tow hook on one side of the bumper and then run the hook across the bumper and loop it over the other tow hook. Tighten the cable gradually under power, but only take up the slack, and do not continue tightening long enough to damage the winch or the vehicle.

163. SHEAR PIN REPLACEMENT.

a. **Remove Broken Shear Pin.** Loosen the set screw in the propeller shaft slip joint stop collar, and slide it back on the shaft so that

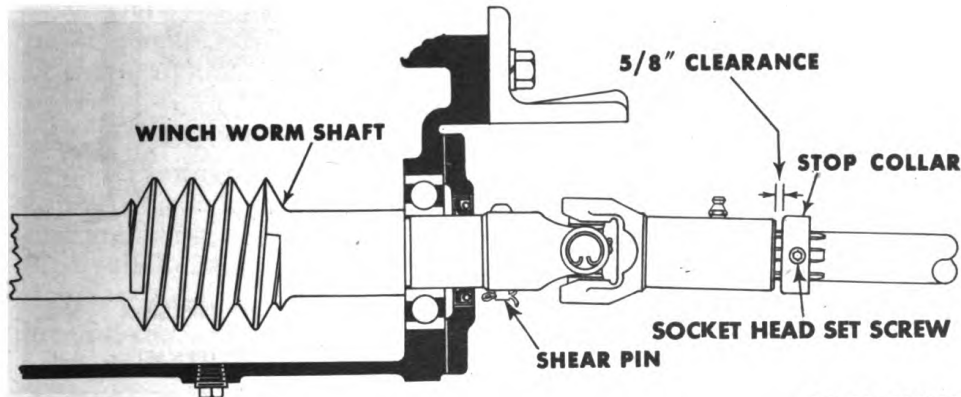

Figure 176—Shear Pin Installation

the slip joint can be moved back far enough to disconnect the universal joint from the winch worm shaft. Then drive the broken piece of the shear pin from the winch worm shaft and from the universal joint yoke, using a hammer and drift punch (fig. 176).

b. **Install New Shear Pin.** Slide the slip joint and universal joint assembly forward, and install it over the end of the winch worm shaft, lining up the holes in the universal joint yoke hub and the worm shaft. Then drive a new shear pin through these holes and install a cotter pin over the other end.

c. **Check Cause of Shear Pin Failure.** If the shear pin fails, it is an indication that the winch has been overloaded and steps must be taken to lighten the load, unless heavier equipment is available which can do the job. Do not use substitute shear pins of unknown strength, as to do so may cause a winch or cable failure which might result in serious damage to equipment or injury to the personnel.

TM 9-811
164

4-TON, 6 x 6 TRUCKS (DIAMOND T MODELS 968A CARGO,
969A WRECKER, 970A PONTON, AND 972 DUMP)

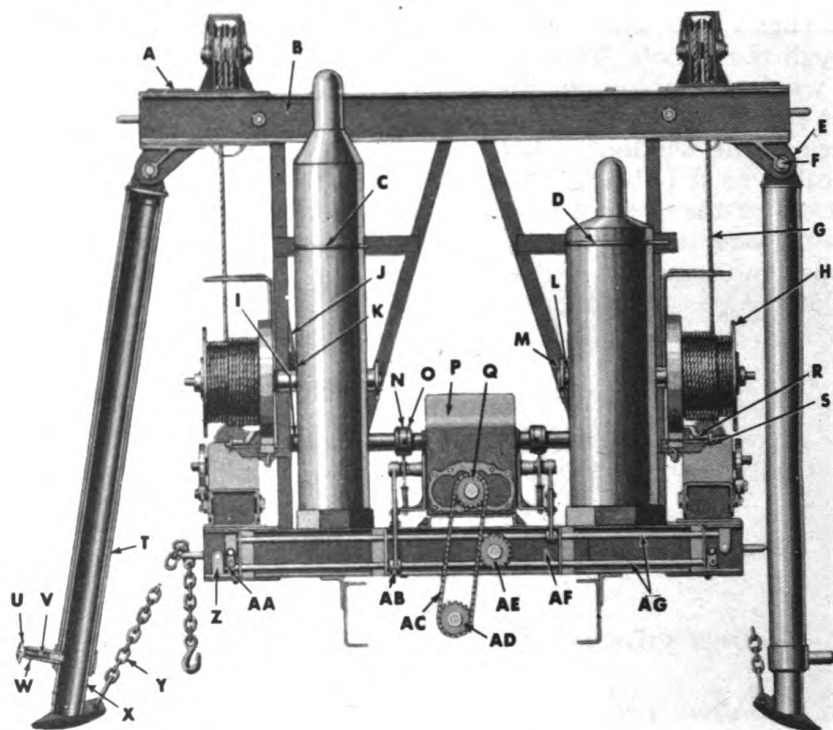

- | | | | |
|----------|-----------------------------|-----------|-------------------------------|
| A | SWIVEL CLAMP WASHER | R | DRUM PINION SHAFT |
| B | WELDED FRAME ASSEMBLY | S | DRUM PINION STOP WASHER |
| C | CLAMP BOLT FOR SMALL TANK | T | OUTBOARD LEG (EXTERNAL) |
| D | CLAMP BOLT FOR LARGE TANK | U | PULL GRIP |
| E | OUTBOARD LEG SWIVEL | V | OUTBOARD LEG LOCK PIN |
| F | MAST SHEAVE SHAFT | W | OUTBOARD LEG LOCK SPRING |
| G | SERVICE CABLE | X | OUTBOARD LEG (INTERNAL) |
| H | SERVICE DRUM | Y | OUTBOARD LEG CHAIN |
| I | PINION SHAFT TUBE (BUSHED) | Z | OPERATING LEVER KNUCKLE |
| J | BRAKE SPRING | AA | SPACER TUBE |
| K | BRAKE SPRING ROD | AB | REMOTE CLUTCH OPERATING LEVER |
| L | SERVICE DRUM SHAFT | AC | ROLLER CHAIN |
| M | DRUM SHAFT ANCHOR WASHER | AD | TAPER SPROCKET |
| N | COUPLING CENTER DISK | AE | IDLER SPROCKET |
| O | FLANGED COUPLING HUB | AF | IDLER BRACKET ASSEMBLY |
| P | TRANSMISSION ASSEMBLY | AG | OPERATING ROD |
| Q | TRANSMISSION SHAFT SPROCKET | | |

RA PD 313776

Figure 177—Wrecker Crane, Front View

Section XXXVI

WRECKER

	Paragraph
Description	164
Transmission roller chain.....	165
Wrecker transmission linkage adjustment.....	166
Wrecker transmission	167
Wrecker boom cable replacement.....	168
Wrecker winch cable replacement.....	169
Outboard brace leg replacement.....	170
Sheave replacement	171

164. DESCRIPTION (figs. 177 and 178).

a. The wrecker assembly consists of the wrecker transmission, two winches, two booms, two winch cables, two boom cables and the necessary sheaves to guide the cables. It is a unit assembly and is mounted on brackets attached to the frame rails. It may be replaced as a unit or the individual parts may be replaced separately.

165. TRANSMISSION ROLLER CHAIN.

a. **Removal.** Remove the two cotter pins from the roller chain connecting link, and remove the connecting link lock plate. The connecting link may then be pulled from the chain, thus breaking the chain. The roller chain may then be pulled from the sprocket wheels.

b. **Installation.** Install the roller chain into position wrapping it around the wrecker transmission sprocket and the transfer case power take-off sprocket with the idler sprocket outside the loop (fig. 179). Then bring the two ends of the chain together and install the connecting link, lock plate and cotter pins.

c. **Roller Chain Adjustment.** The tension on the roller chain is adjusted by means of the sliding idler sprocket. This is done by loosening the four bolts clamping the idler adjusting channel to the base channel and then sliding the idler sprocket forward or backward to obtain the proper chain tension (fig. 179). The idler should be moved up against the chain to give about 1/2-inch deflection on the side opposite the idler. After the adjustment is completed, tighten the clamping bolts and recheck the adjustment. Never attempt to adjust the roller chain while it is running.

166. WRECKER TRANSMISSION LINKAGE ADJUSTMENT.

a. The wrecker transmission linkage has a slot-type adjustment in the arms connecting the control levers to the actuating levers. These arms should be adjusted to a proper length to hold the control handles in horizontal positions. To make this adjustment, loosen the clamping screws, then support the control handle horizontally and tighten the screws. It is seldom necessary to make this adjustment. It will be necessary when replacing an old or installing a new transmission, or if the original adjustment works loose.

TM 9-811
166'

**4-TON, 6 x 6 TRUCKS (DIAMOND T MODELS 968A CARGO,
969A WRECKER, 970A PONTON, AND 972 DUMP)**

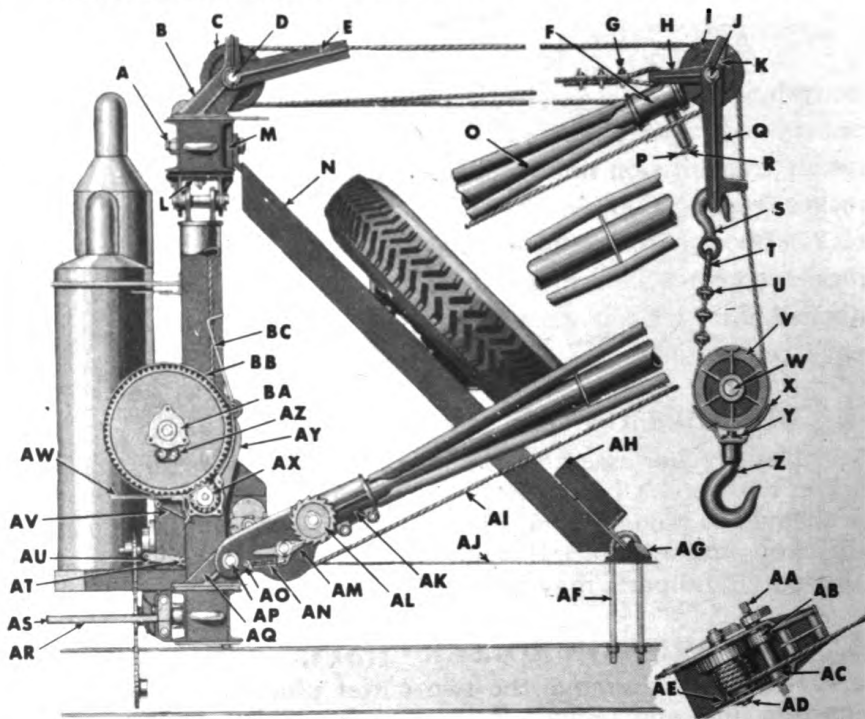

- | | | |
|--|---|--|
| A STIFF LEG ANCHOR BOLT (1" x 9") | V SNATCH BLOCK SHEAVE | AM BOOM DRUM PAWL |
| B MAST SHEAVE YOKE | W SNATCH BLOCK SHEAVE SHAFT | AN BOOM PAWL SPRING |
| C SHEAVE WHEEL (BUSHED) | X SNATCH BLOCK FRAME | AO BOOM DRUM PAWL SPRING ROD |
| D MAST SHEAVE SHAFT | Y SNATCH BLOCK HOOK WASHER | AP BOOM HEEL SWIVEL PIN |
| E MAST CABLE GUIDE | Z SNATCH BLOCK HOOK (NO. 11) | AQ BOOM HEEL SWIVEL |
| F BOOM LOCK ASSEMBLY | AA BOOM DRUM RATCHET WHEEL SHAFT | AR THROTTLE OPERATING HANDLE ASSEMBLY |
| G WIRE ROPE CLAMP | AB BOOM DRUM PINION | AS CLUTCH CONTROL HANDLE |
| H BOOM CABLE ANCHOR YOKE | AC SET COLLAR ON RATCHET WHEEL SHAFT | AT CONNECTING LINK (STRAIGHT) |
| I SHEAVE WHEEL (BUSHED) | AD BOOM DRUM SHAFT | AU CONNECTING LINK (BENT) |
| J BOOM SHEAVE SHAFT | AE BOOM DRUM | AV BRAKE ADJUSTING HOOK |
| K BOOM SHEAVE YOKE | AF STIFF LEG BOLSTER U BOLT | AW PINION SHIFTER LEVER |
| L SWIVEL CLAMP PLATE | AG STIFF LEG BOLSTER SADDLE BLOCK | AX SERVICE DRUM PINION |
| M STIFF LEG CHANNEL BLOCK | AH STIFF LEG BOLSTER ASSEMBLY | AY GEAR GUARD |
| N STIFF LEG | AI BOOM CABLE | AZ WIRE ROPE CLAMP |
| O BOOM ASSEMBLY | AJ BOLSTER TIE PLATE | BA SERVICE DRUM CRANK SQUARE |
| P PULL GRIP | AK BOOM DRUM HOUSING | BB SERVICE DRUM BRAKE BAND |
| Q BOOM END CABLE GUIDE | AL BOOM DRUM RATCHET WHEEL | BC BRAKE ECCENTRIC ASSEMBLY |
| R BOOM LOCK PIN | | |
| S CABLE HOOK (NO. 28) | | |
| T WIRE ROPE THIMBLE | | |
| U WIRE ROPE CLAMP | | |

RA PD 313775

Figure 178—Wrecker Crane, Side View

WRECKER

167. WRECKER TRANSMISSION.

a. **Description.** The wrecker transmission is a double worm wheel type in which each worm is controlled independently of the other. This is accomplished by means of four loose gears riding on the two worm shafts, which are in constant mesh with the main shaft pinions and drive only when the sliding clutch hubs are engaged.

b. **Removal.**

(1) **REMOVE ROLLER CHAIN.** Remove the roller chain as described in paragraph 170.

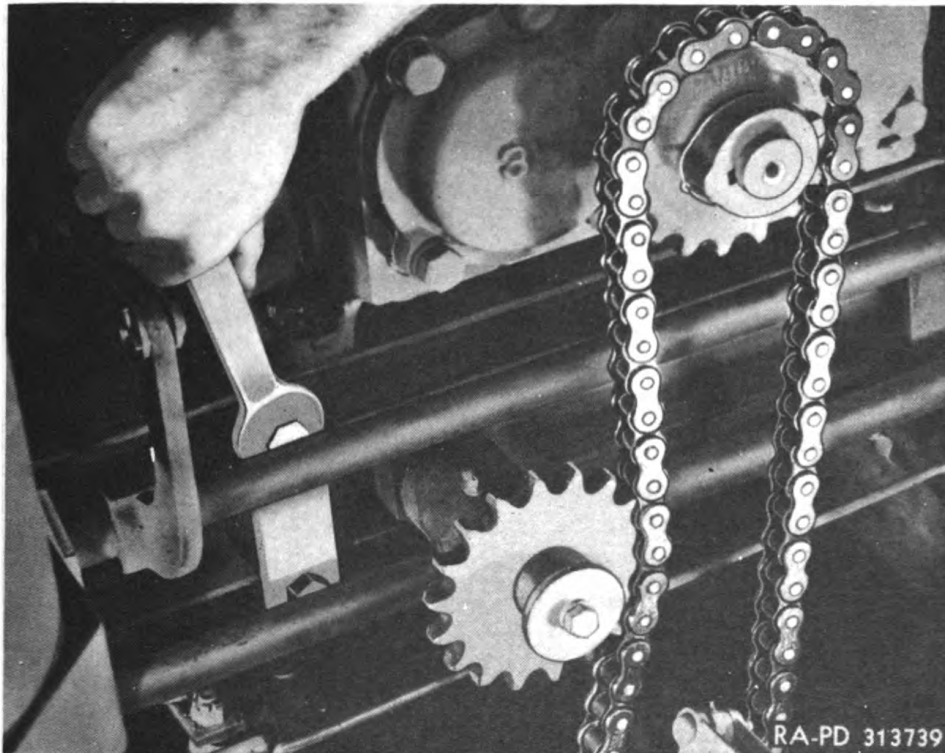

Figure 179—Locking Idler Sprocket Clamp

(2) **REMOVE GEAR CASE COVER.** Remove the single bolt at the top of the gear case cover and then lift the cover from the transmission case.

(3) **REMOVE THE WORM WHEELS.** Remove the cap screws holding the bearing blocks in place and remove the blocks. Then lift the worm wheels out, one at a time, being sure not to lose the coupling center disk at the outer end of each worm wheel shaft (fig. 180).

(4) **DISCONNECT THE FORWARD ENDS OF THE TRANSMISSION OPERATING LINKS.** Remove the cotter and clevis pins from the forward ends of the transmission operating links and disconnect the links from the operating levers.

4-TON, 6 x 6 TRUCKS (DIAMOND T MODELS 968A CARGO, 969A WRECKER, 970A PONTON, AND 972 DUMP)

(5) **REMOVE TRANSMISSION ASSEMBLY.** Remove the cap screws, nuts, lock washers and wedges holding the transmission case to the base assembly and remove the transmission case.

c. Installation.

(1) **INSTALL TRANSMISSION CASE ON BASE FRAME.** Lift the transmission case into place on the base frame with the drive sprocket facing towards the front of the vehicle and then line up the mounting holes

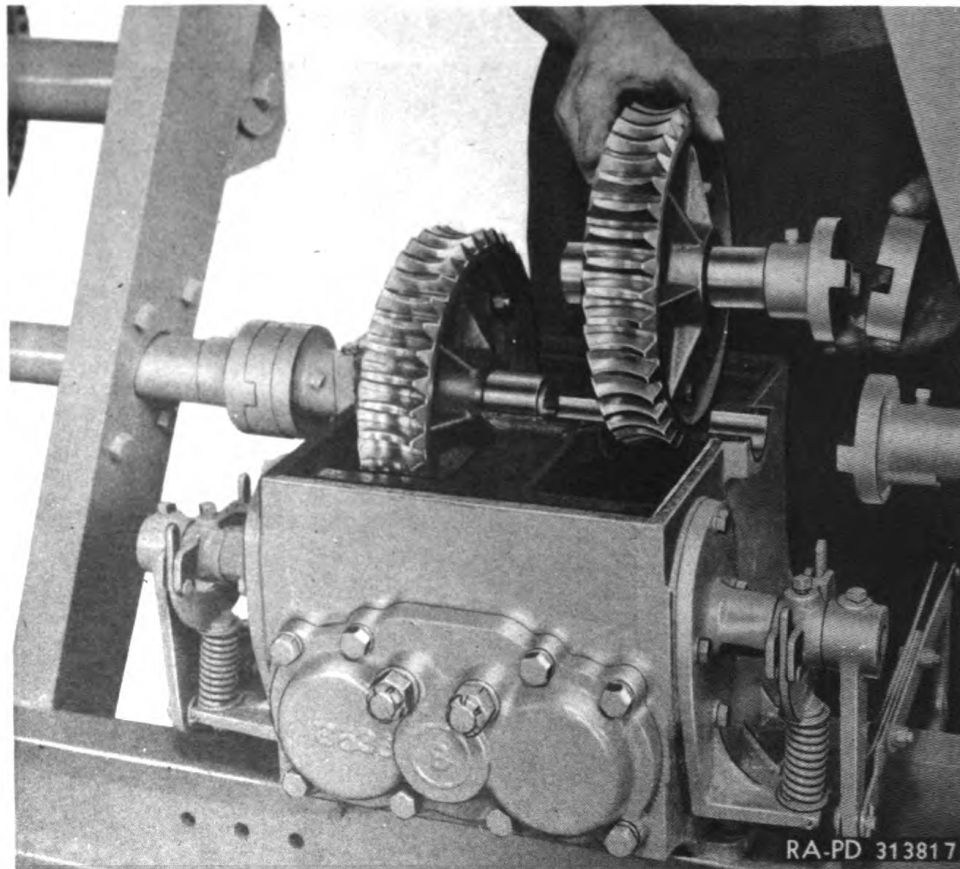

Figure 180—Removing Worm Wheel Assemblies

with the holes in the base frame. Install bolts, nuts, lock washers and wedges.

(2) **CONNECT TRANSMISSION OPERATING LINKS.** Connect the forward ends of the operating links to the operating levers and install cotter and clevis pins.

(3) **INSTALL WORM WHEELS.** Install coupling center disk on one of the transmission worm wheel couplings. Then lower the assembly into place, engaging the slot in the center disk with the tongue on the coupling on the end of the pinion shaft, and seating the worm shaft bushings in place in the transmission case. Repeat this operation with

WRECKER

the other worm wheel. Then install the transmission bearing blocks and attach them in place with cap screws.

(4) **INSTALL GEAR CASE COVER.** Install the gear case cover on top of the transmission, using a new gasket. Then install the single top bolt and tighten it securely.

168. WRECKER BOOM CABLE REPLACEMENT.

a. **Lower the Boom.** Swing the boom out at right angles to the body and then, using the operating crank, lower it until it is supported in a horizontal position on any convenient object.

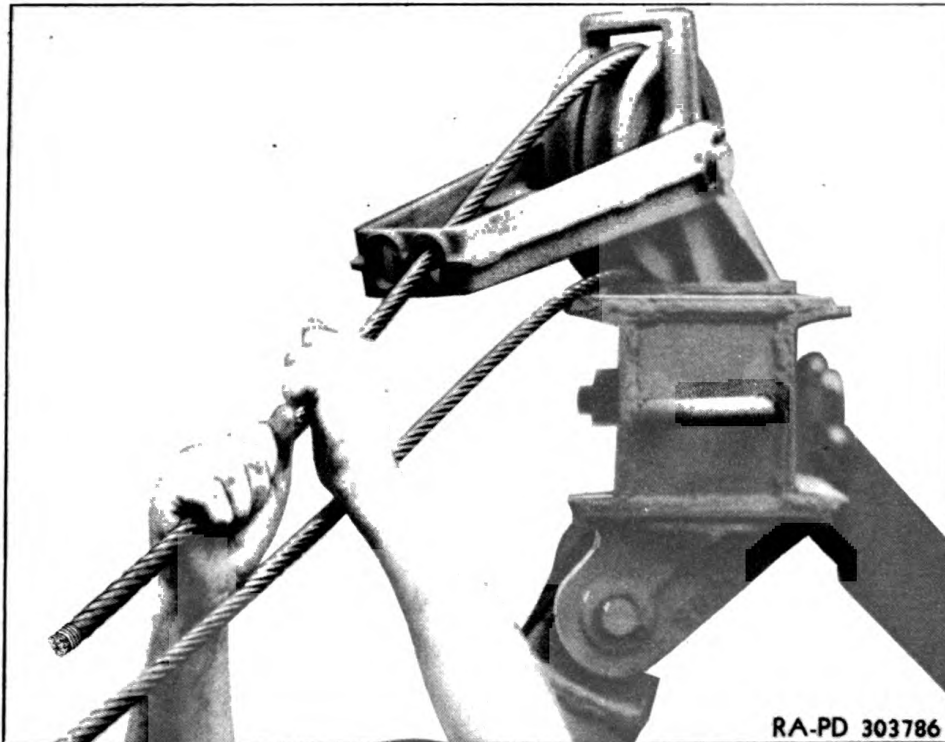

Figure 181—Installing Boom Cable Over Mast Sheave

b. **Disconnect Cable Clamps.** Remove the nuts from the cable clamp U-bolts and then remove the U-bolts and clamps from the end of the boom cable which is hooked to the boom cable anchor yoke. Then spread the ends of the cable and pull it away from the anchor yoke. It is not necessary to remove the thimble from the yoke.

c. **Remove Boom Drum.** Remove the cotter pin from the boom drum shaft and drive the shaft out of the boom pivot housing, using a hammer and punch. After the shaft is knocked out, the punch will support the boom drum. As the punch is withdrawn, the boom drum, ratchet pawl, and spring may be removed.

d. **Remove Cable.** Loosen the U-bolt cable clamp on the side of the boom drum and disconnect the end of the cable from the drum. Then pull the cable from the boom and mast sheaves.

**4-TON, 6 x 6 TRUCKS (DIAMOND T MODELS 968A CARGO,
969A WRECKER, 970A PONTON, AND 972 DUMP)**

e. Install New Cable.

(1) Loop the end of the cable over the thimble on the anchor yoke and double it back about 12 inches and install the three cable clamps which were removed, being sure to tighten the U-bolt nuts securely (fig. 295).

(2) Run the other end of the cable back to the crane and install it over the inside mast sheave from the bottom and run it through the cable guide as it comes over the top of the sheave (fig. 181). Pull the



Figure 182—Installing Boom Cable Over Boom Sheave

cable through the sheave until it is stretched tight between the boom and the crane.

(3) Then run the end of the cable back to the end of the boom and install it over the inside boom sheave from the top, and then double it back along the length of the boom. Do not pass it through the cable guide (fig. 182). Pull the cable over the sheave until it is tight between the crane and the boom.

(4) Attach the end of the cable to the boom drum. Place the boom drum on the ground with the gear end away from the operator and then run the end of the cable under the U-bolt clamp from the right-hand side for the left-hand boom and from the left-hand side for the right-hand boom. The end of the cable should extend two inches through the U-bolt and then the U-bolt nuts should be tightened securely.

WRECKER

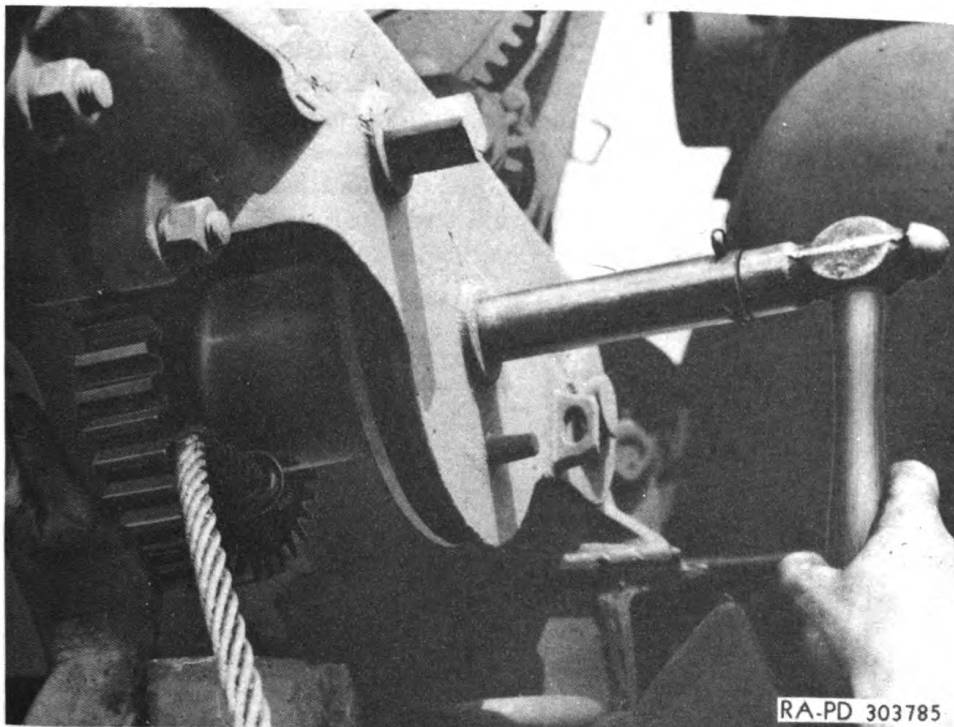

Figure 183—Installing Boom Drum

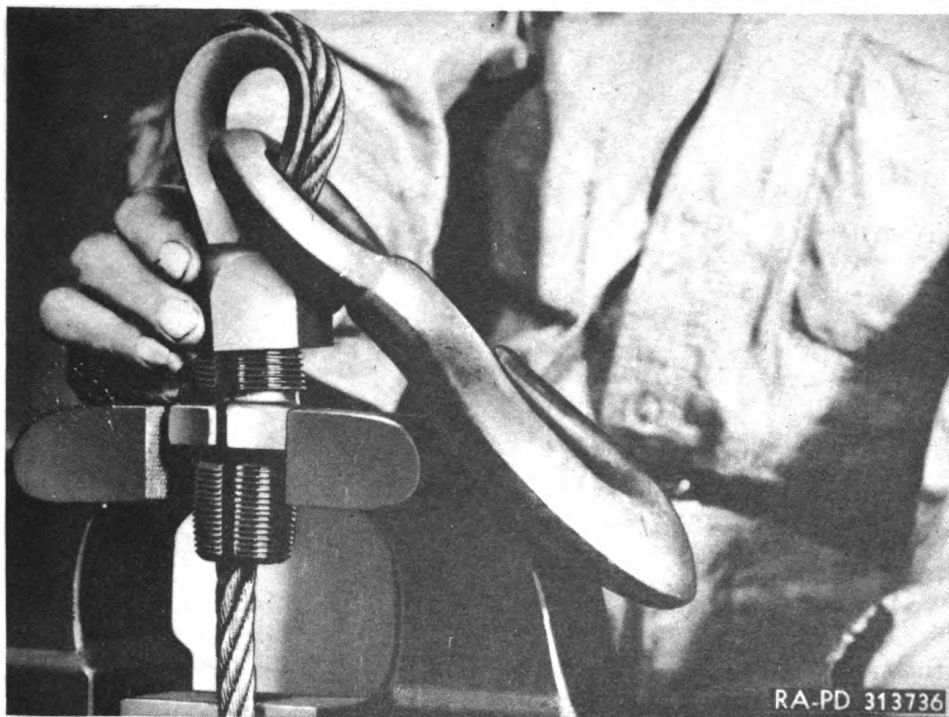

Figure 184—Installing Cable Clamp

734619 O - 47 - 22

337

TM 9-811
168-169

**4-TON, 6 x 6 TRUCKS (DIAMOND T MODELS 968A CARGO,
969A WRECKER, 970A PONTON, AND 972 DUMP)**

(5) Lift the boom drum and install it in position in the boom pivot housing, engaging the drum gear with the pinion gear on the ratchet shaft. Then drive the drum shaft through the boom pivot housing and through the drum until the cotter pin in the head end of the shaft is up against the pivot housing (fig. 183). Then install the ratchet pawl and spring over the end of the drum shaft. After the pawl is in place, install a cotter pin through the hole in the end of the drum shaft.

(6) Using the hand operating crank, wind the boom cable in on the boom drum guiding it by hand to get an even lay to the cable.

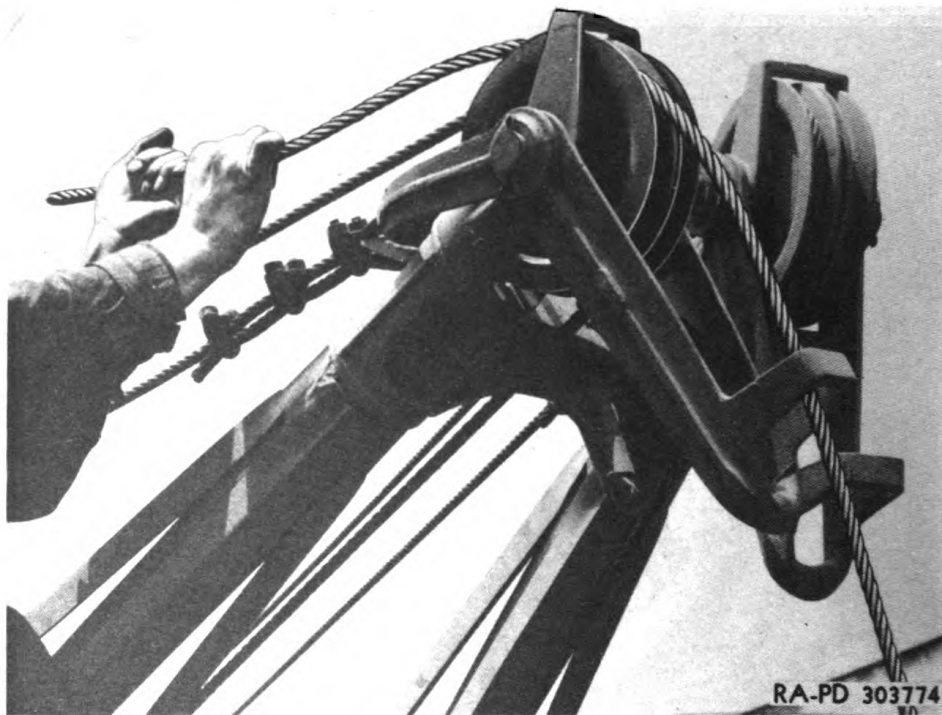

Figure 185—Installing Winch Cable Over Boom Sheave

169. WRECKER WINCH CABLE REPLACEMENT.

a. **Remove Wrecker Winch Cable.** Grasp the end of the wrecker winch cable, completely unwinding it from the drum, then loosen the U-bolt cable clamp on the drum and remove the cable. Pull the cable from the sheaves.

b. **Remove Hook from Cable.** Remove the coupling nuts from the cable clamp and then slide the nuts up along the cable and remove the halves of the clamp. The end of the cable may then be pulled off the thimble and through the eye of the hook. It is not necessary to remove the thimble from the hook. Remove coupling nuts from cable.

WRECKER

c. **Install New Cable on Hook.** Slide the two coupling nuts over the end of the new cable with the flat sides facing each other, then run the end of the cable through the eye of the hook and fold it back over the thimble. Clamp the end of the cable against the cable at the end of the eye, and slide the lower coupling nut down as far as it will go. Install the two halves of the cable clamp and tighten the two coupling nuts over the threads of the clamp (fig. 184).

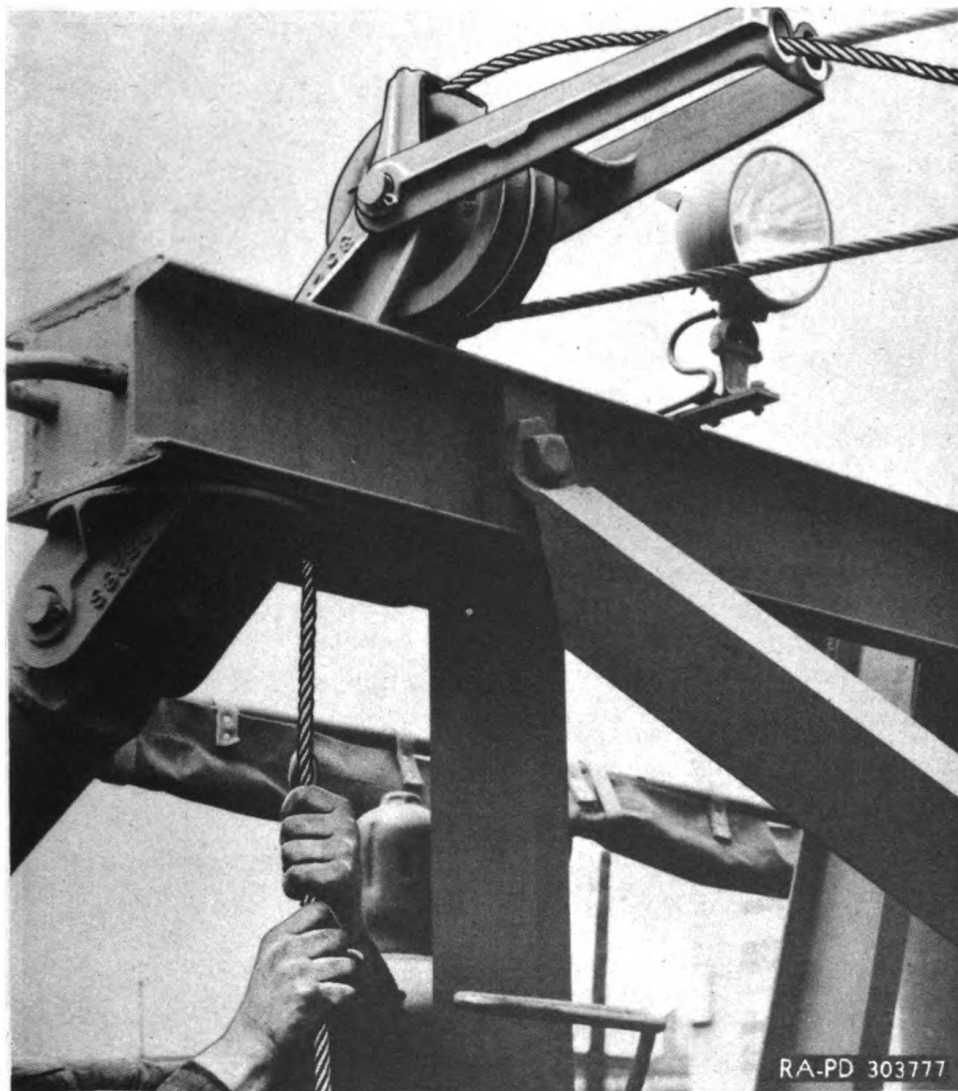

Figure 186—Installing Winch Cable Over Mast Sheave

d. **Install Winch Cable.**

(1) Run the end of the cable through the cable guide on the end of the boom and over the top of the outer boom sheave, then pull it back to the crane (fig. 185). Run it through the outer hole in the mast

TM 9-811
169

**4-TON, 6 x 6 TRUCKS (DIAMOND T MODELS 968A CARGO,
969A WRECKER, 970A PONTON, AND 972 DUMP)**

cable guide, over the outer mast sheave, and then down through the opening in the top of the wrecker frame (fig. 186). Then pull the end of the cable down and engage it in the U-bolt eye of the winch drum

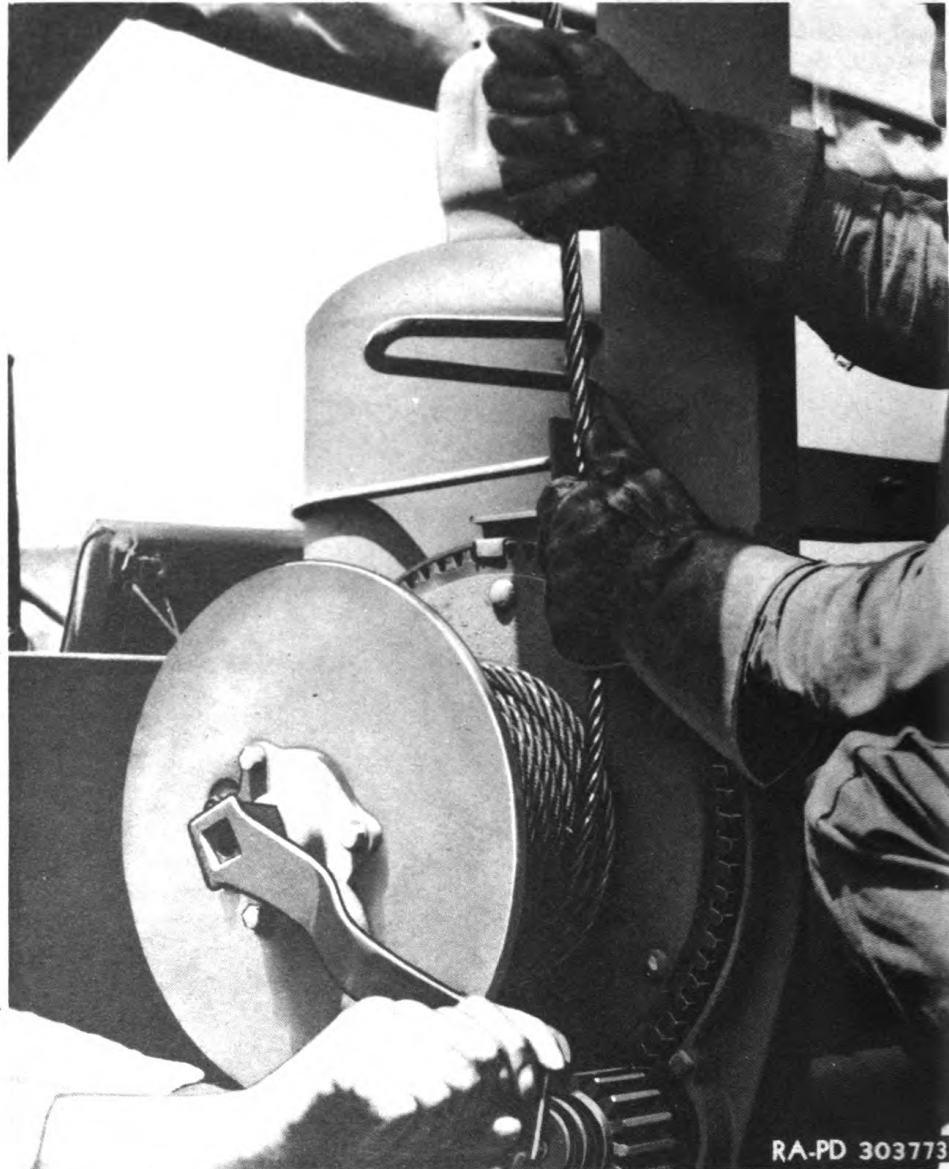

Figure 187—Winding Cable Onto Winch Drum

cable clamp. The winch drum should be turned so that the U-bolt clamp is facing toward the rear of the vehicle, then the cable is pulled straight down and installed through the U-bolt eye. Adjust the cable so that it extends about an inch through the U-bolt, and tighten the U-bolt nuts securely.

WRECKER

(2) **WIND CABLE ONTO DRUM.** Stretch the cable out in back of the truck and hook it on to a light load. Then, using the hand operating crank, wind the cable onto the drum while guiding it with a pair of hands, as shown in figure 187. The man guiding the cable should wear gloves to avoid cutting his hands on sharp strands on the cable. As the layers of the cable approach the edges of the drum, cranking should be done very slowly so that a pry bar may be used to force the layers

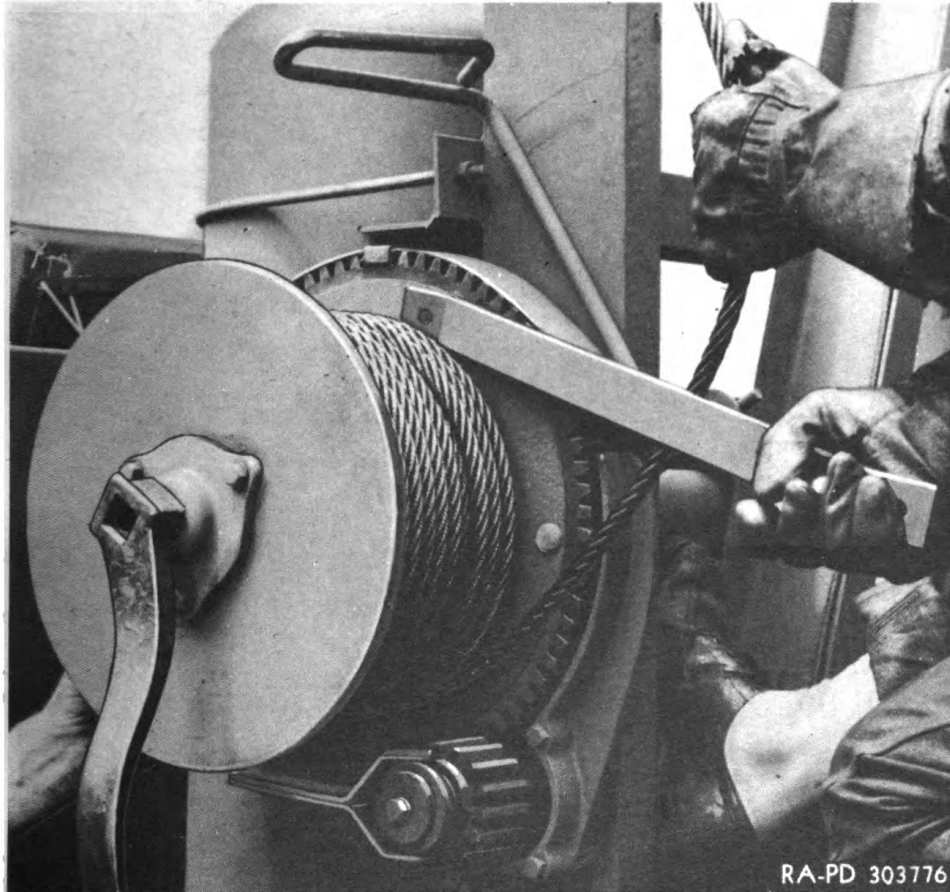

Figure 188—Using Pry Bar to Force Layers of Cable Close Together

of cable close together to get a good tight wind (fig. 188). When the cable has been wound far enough onto the drum, engage the pinion gear with the drum gear to hold it in position.

(3) Grasp the eye of the drag brake arm with one hand and pull it out until the opening at the inner end of the eye is spread far enough so that the cable may be slid through it, then release the arm with the cable running through the brake arm eye. Hook the end of the cable on the body bolster ring and wind the cable tight to secure the boom in a rigid position.

TM 9-811
170-171

**4-TON, 6 x 6 TRUCKS (DIAMOND T MODELS 968A CARGO,
969A WRECKER, 970A PONTON, AND 972 DUMP)**

170. OUTBOARD BRACE LEG REPLACEMENT.

a. **Disconnect Brace Leg Chain.** Unhook the brace leg chain from the brace leg rest on the wrecker crane.

b. **Remove Brace Leg.** Remove one cotter pin from the brace leg pivot pin, and drive the pin out of the pivot bracket, using a hammer and punch (fig. 189). The punch will support the brace leg as the pin is removed. When the punch is taken out, brace leg may be removed.



Figure 189—Driving Out Brace Leg Pivot Pin

c. **Replace Brace Leg.** Lift the brace leg into position in the pivot bracket, and drive the pivot pin through the holes in the bracket and the upper end of the leg. Then install a cotter pin through the hole in the end of the pin to hold it in place.

d. **Install Brace Leg Chain.** Swing the brace leg into position against the brace leg rest on the crane and wrap the chain around it and hook it into position.

171. SHEAVE REPLACEMENT.

a. **General.** The sheave assemblies are supported on the mast and on the end of the booms, loosely mounted in mast or boom tubes. The sheaves are held in place by the load on the cables, therefore no fasteners are required. To replace the sheaves proceed as in the following steps.

WRECKER

b. **Remove Cables from Sheaves.** Using the hand crank, lower the boom so that it rests on the body or any other convenient object. Disconnect the cable clamps at the end of the boom cable which is attached to the anchor yoke on the end of the boom and pull the cable from the sheaves. Remove the hook from the end of the winch cable and pull the winch cable from the sheaves.

c. **Replace Sheave.** The boom or mast sheave assembly may then be lifted from the end of the boom or from the top of the mast, and the new sheave assembly dropped into place. When replacing mast sheave, it will be necessary to turn the assembly so that the shoulder on the sheave lines up with the slot in the crane (fig. 190).

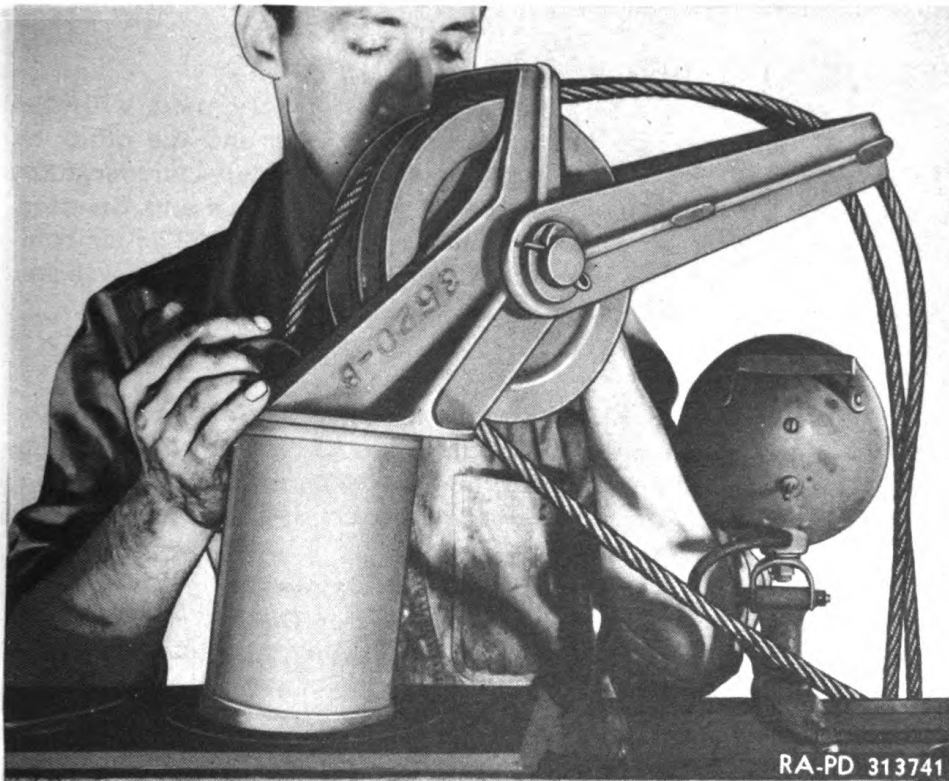

Figure 190—Removing Mast Sheave Assembly

d. **Install Cables.** Run the cables over the sheaves, attach the boom cable to the anchor yoke on the end of the boom, and attach the winch cable to the hook which was removed.

e. **Raise Boom.** Using a hand operating crank, raise the boom to traveling position, hook it on to the other boom, hook the winch cable to the body bolster ring, and tighten the cable.

Section XXXVII

WRECKER AIR COMPRESSOR

	Paragraph
Description	172
Removal	173
Installation	174
Engine replacement.....	175
Air compressor replacement.....	176

172. DESCRIPTION.

a. Two different types of air compressors are used with the wrecker. One being manufactured by De Vilbiss and the other by Kellogg. Each of these compressors is driven by a single-cylinder, four-stroke cycle gasoline engine manufactured by Briggs and Stratton. The engine drives the air compressor through a V-belt. The air compressor is furnished as a unit, and is mounted on top of the wrecker body immediately back of the crane (figs. 28 and 29).

173. REMOVAL.

a. **Remove Spare Tire.** Remove the spare tire mounted on the wrecker crane. Remove the spare tire lock, and take off the mounting nuts. Remove the spare tire from the bracket on the frame, and lay it on top of the other spare tire which is attached to the floor of the wrecker body.

b. **Remove Air Compressor Unit.** Remove the mounting cap screws, nuts and lock washers from the legs on the bottom of the air reservoir (fig. 191). Then slide air compressor unit out from under the crane brace legs far enough to swing a chain around it, then lift it with a hoist and lower it to the ground.

174. INSTALLATION.

a. **Install Air Compressor Unit.** Lift the air compressor unit on a hoist and swing it into position on the body. Slide it under the wrecker crane brace legs and line up the mounting holes in the legs of the reservoir tank with the mounting holes on the body. Install the cap screws, nuts and lock washers.

b. **Replace Spare Tire.** Install the spare tire on the mounting bracket studs on the wrecker crane and replace the stud nuts. Install the spare tire lock.

175. ENGINE REPLACEMENT.

a. **Remove Belt.** Remove the drive belt between the engine pulley and the air compressor flywheel.

WRECKER AIR COMPRESSOR

b. **Remove Engine.** Remove the cap screws, nuts and lock washers holding the engine assembly in place on top of the reservoir tank, and lift the engine assembly from the unit (fig. 192).

c. **Install Engine.** Install the engine into position on top of the reservoir tank and install the cap screws, nuts and lock washers. Do not tighten the cap screws.

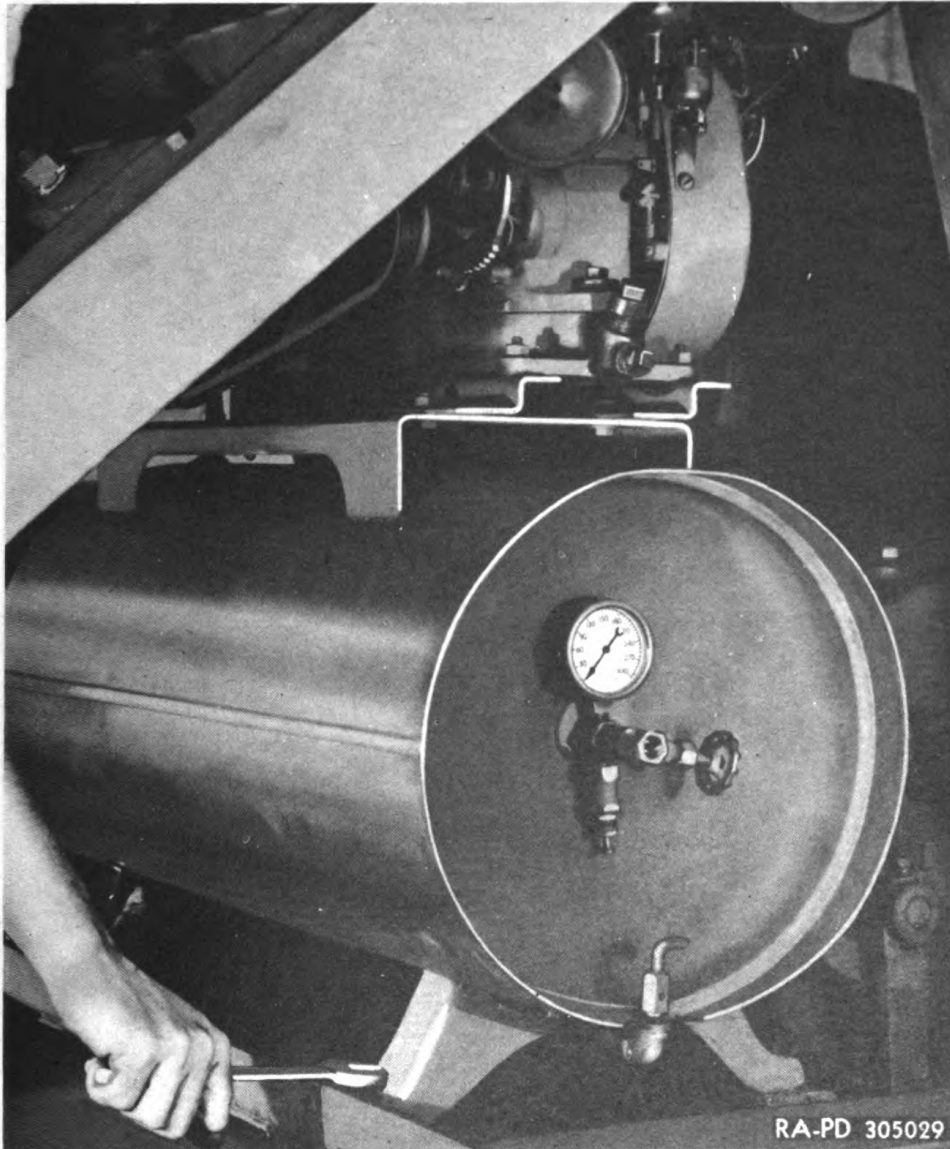

Figure 191—Removing Air Compressor Unit Mounting Bolts

d. **Install Drive Belt.** Install the drive belt over the groove in the air compressor flywheel in the drive pulley on the engine.

e. **Tighten Engine Mountings.** Line up the engine pulley with the air compressor flywheel groove so that the belt is in true alinement,

TM 9-811
175-176

**4-TON, 6 x 6 TRUCKS (DIAMOND T MODELS 968A CARGO,
969A WRECKER, 970A PONTON, AND 972 DUMP)**

then move the engine away from the air compressor the proper distance to get correct belt adjustment. The belt should deflect about 1 inch when the adjustment is correct. Hold the engine in this position and tighten the mounting cap screws. Then check adjustment.

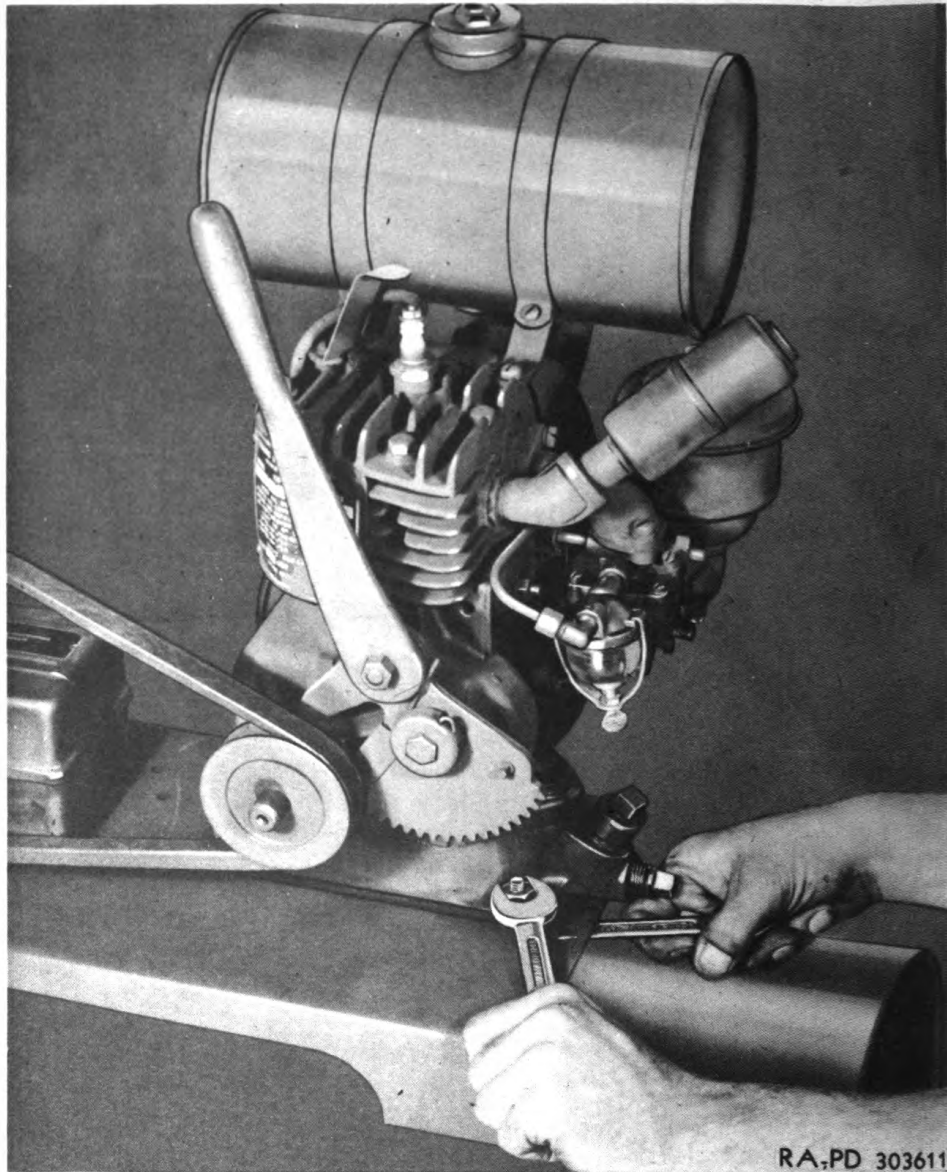

Figure 192—Removing Air Compressor Engine

176. AIR COMPRESSOR REPLACEMENT.

a. Disconnect Air Lines. Disconnect the air lines from the air compressor cylinder head.

WRECKER AIR COMPRESSOR

b. **Remove Drive Belt.** Remove the drive belt between the air compressor flywheel and the engine drive pulley.

c. **Remove Air Compressor.** Remove the air compressor mounting cap screws, nuts and lock washers, and remove the air compressor from the unit (fig. 193).

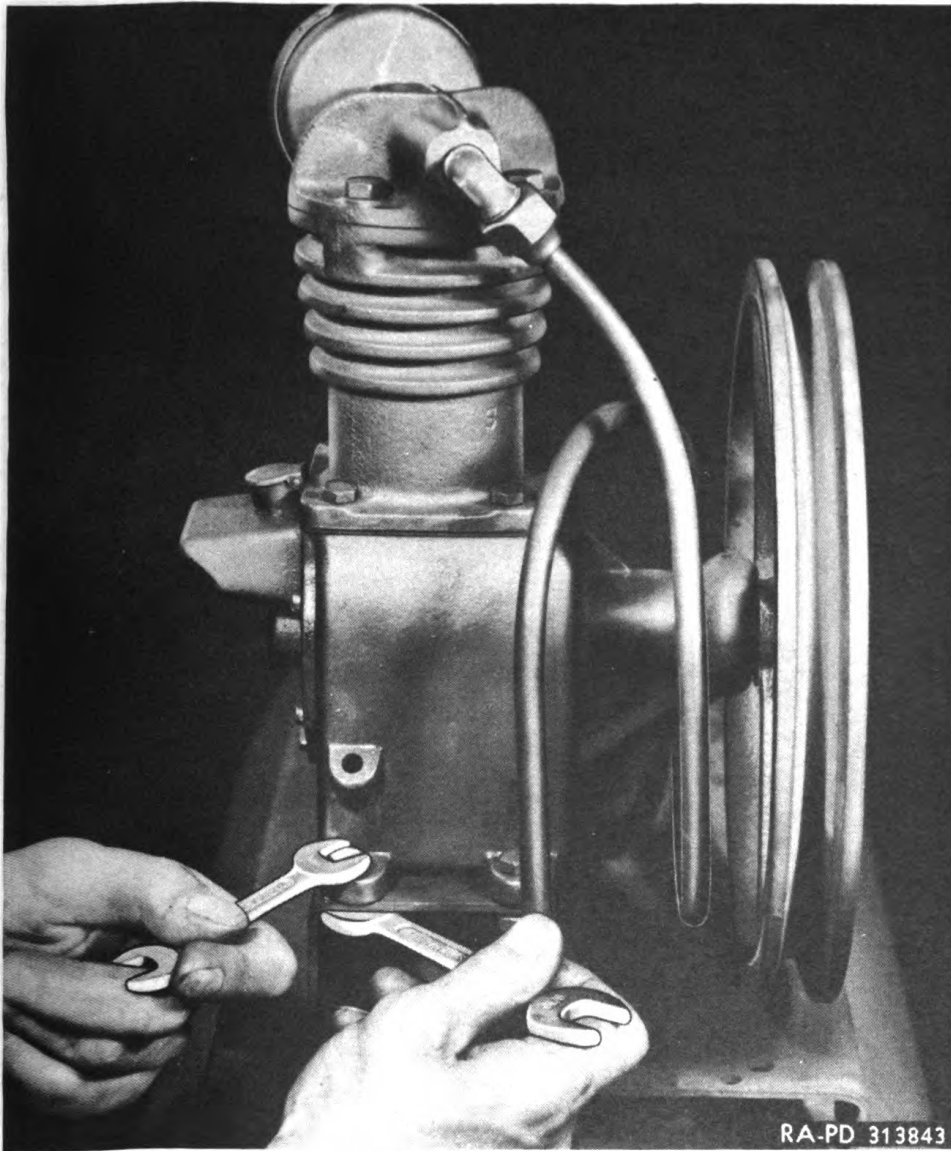

Figure 193—Removing Air Compressor, Kellogg

d. **Install Air Compressor.** Install the air compressor in place on top of the reservoir tank, and replace the cap screws, nuts and lock washers. Do not tighten the cap screws.

e. **Install Drive Belt.** Install the drive belt over the air compressor flywheel and the drive pulley on the engine.

TM 9-811

176

**4-TON, 6 x 6 TRUCKS (DIAMOND T MODELS 968A CARGO,
969A WRECKER, 970A PONTON, AND 972 DUMP)**

f. Tighten Air Compressor Mounting Screws. Shift the air compressor in the mounting slots on top of the reservoir to obtain proper belt alinement and proper belt tension. The belt should deflect about 1 inch for proper adjustment. When the alinement and adjustment are correct, hold air compressor in place, tighten the mounting cap screws, then check adjustment again.

g. Connect Air Lines. Connect the air lines to the air compressor cylinder head.

Section XXXVIII

DUMP PUMP AND HOIST

	Paragraph
Description and tabulated data.....	177
Hoist assembly.....	178
Pump assembly.....	179

177. DESCRIPTION AND TABULATED DATA.

a. **Description** (fig. 194). The pump and hoist assembly is used on the dump trucks and is the conventional hydraulic type. The pump and hoist are bolted together in a unit assembly. The pump is driven through a drive shaft from the power take-off on the end of the transfer main shaft. The pump valve is controlled by a lever inside the cab. In operation, fluid is delivered from the pump to the cylinder forcing the piston rod out to raise the body.

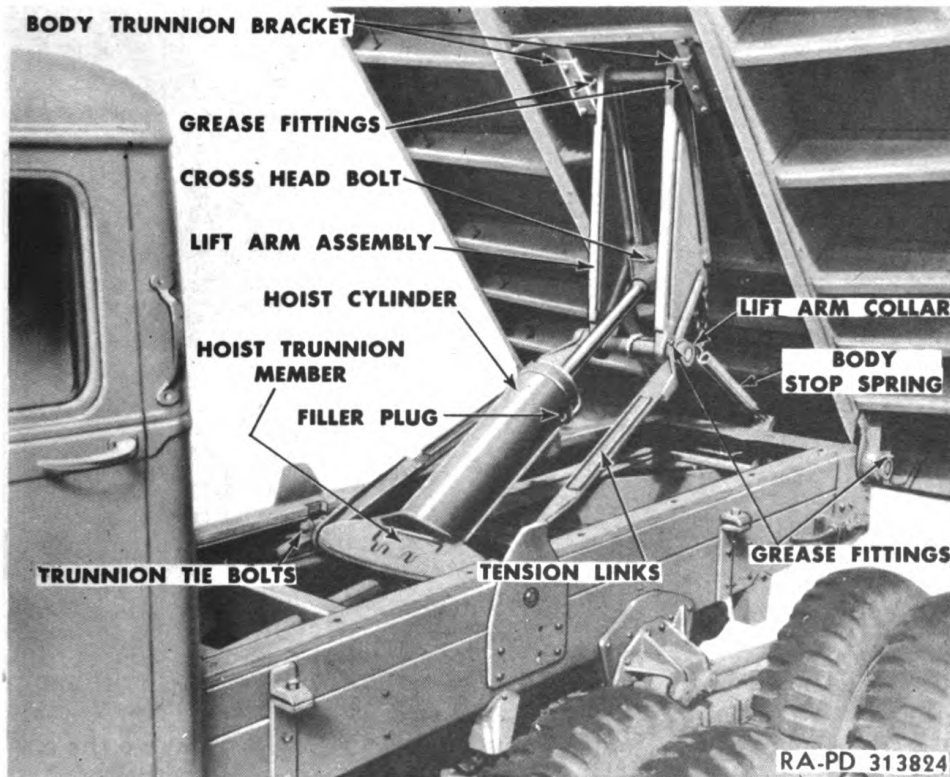

Figure 194—Pump and Hoist Installation

b. Tabulated Data.

Make.....	Gar Wood
Model.....	SA-7
Pump assembly.....	GW-A12-588-A4R
Cylinder assembly.....	GW-A37-862-15

4-TON, 6 x 6 TRUCKS (DIAMOND T MODELS 968A CARGO, 969A WRECKER, 970A PONTON, AND 972 DUMP)

178. HOIST ASSEMBLY.

a. Removal.

(1) **DISCONNECT BODY STOP SPRING.** Cut the wire holding the body stop spring to the rear frame cross member.

(2) **RAISE AND BLOCK BODY.** Raise the body just high enough to permit the installation of two 4 x 4 braces, about 6 feet long, between the torque rod and brackets, and the second cross member under the dump body (fig. 196). Do not raise the body too high, as the automatic stop has been disconnected. Insert the brace in position and then lower the body so that the brace takes the load.



Figure 195—Lifting Hoist Trunnion Out of Frame Sockets

(3) **DISCONNECT PROPELLER SHAFT.** Disconnect the dump pump propeller shaft, as described in paragraph 111.

(4) **DISCONNECT PUMP VALVE CONTROL CABLE.** Remove the cotter pin and clevis pin holding the yoke at the end of the valve control cable to the valve control lever on the pump. Then remove the two nuts and lock washers from the U-bolt holding the control cable assembly to the mounting bracket on the pump, and swing the cable to one side.

(5) **DISCONNECT HOIST CYLINDER PISTON ROD.** Place valve control lever on pump at holding position. Remove the nut and lock washer from the cross head bolt on the end of the cylinder piston rod and then remove the bolt (fig. 194). It will be necessary to hold the

DUMP PUMP AND HOIST

hoist assembly so that it does not fall down. Then shift the valve control lever on the pump to the release position to allow the piston rod to move down into the cylinder. When the piston rod is clear of the body cross head, pull it forward and lower it in a horizontal position so that it rests on 2 x 4 across the frame in front of the hoist trunnion.

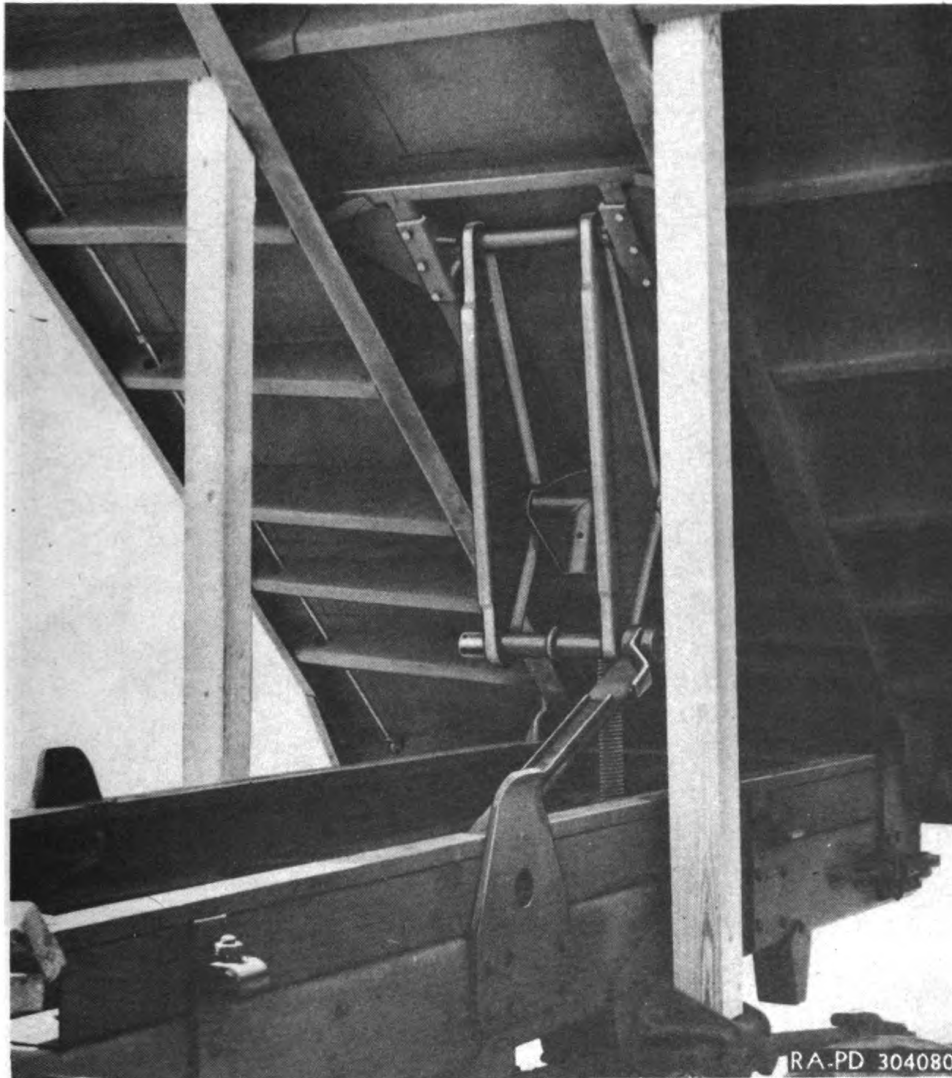

Figure 196—Dump Body Blocked, Hoist Removed

(6) **REMOVE HOIST ASSEMBLY.** Remove cap screws, lock washers and flat washers from the ends of the trunnion journals through the holes in the frame rails and then remove the spacers. Then remove the hoist trunnion tie bolts, nuts and lock washers from the hoist trunnion brackets (fig. 194). Push down on the piston rod to raise the trunnion journals from the sockets in the frame. Support the rear end of the hoist cylinder on another 2 x 4 across the frame (fig. 195). Remove the bolt, nut and lock washer from one of the lift arm collars and then

**4-TON, 6 x 6 TRUCKS (DIAMOND T MODELS 968A CARGO,
969A WRECKER, 970A PONTON, AND 972 DUMP)**

remove collar. Remove tension link which was disconnected when lift arm collar was removed. Then remove hoist assembly from chassis.

b. Installation.

(1) **PLACE HOIST ASSEMBLY IN CHASSIS.** Lift the hoist assembly into position on top of the frame and lay it flat with the trunnion pointing towards the rear of the truck. Install the ends of the connecting links over the trunnion journals and install the lift arm collar (fig. 197). Then work it into position so that the trunnion journals drop into their

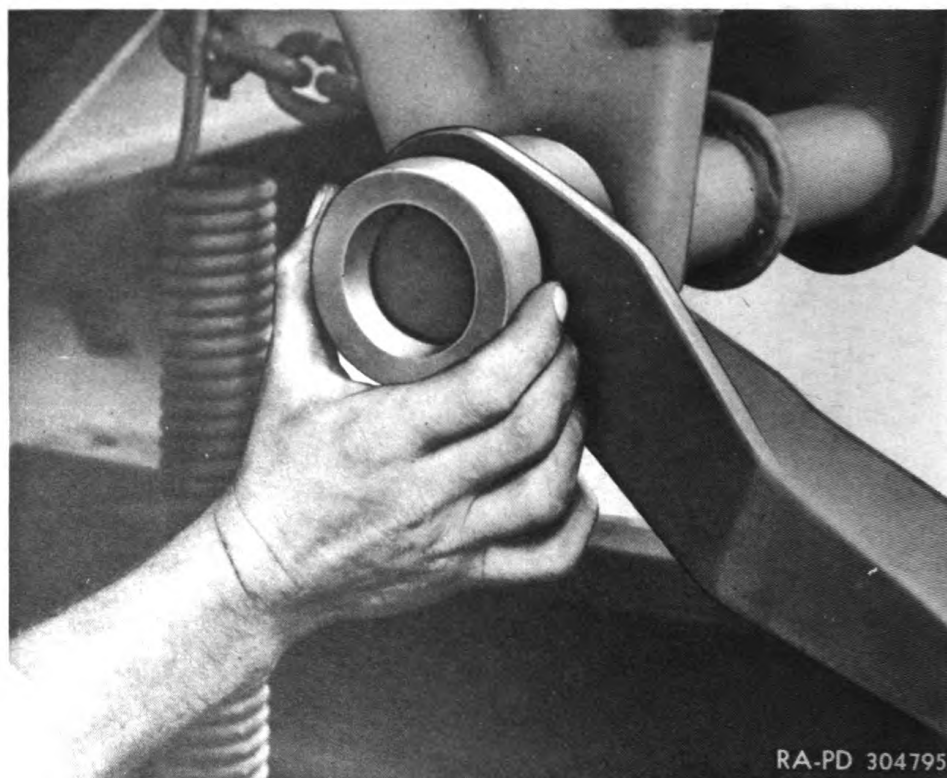

Figure 197—Installing Lift Arm Collar

seats in the sockets in the frame rails and the cylinder is resting on the frame cross member. Install the clamp bolts, nuts and lock washers in the hoist trunnion brackets to hold the journals in place. Install the spacers against the trunnion journals through the openings in the frame rails, and install cap screws, plain washers and lock washers.

(2) **CONNECT PISTON ROD TO CROSS HEAD.** Lift the hoist assembly into a vertical position and release the valve control lever on the pump so that the piston rod may be pulled out (fig. 198). Tip the assembly back and line up the piston rod in the cross head and install the bolt, nut and lock washer, then turn valve control lever on the pump to the hold position.

(3) **CONNECT CONTROL CABLE.** Connect the yoke from the end

DUMP PUMP AND HOIST

of the control cable to the valve lever on the pump, using a cotter and clevis pin, then attach the cable assembly to the bracket on the pump with the U-bolt, nuts and lock washers (fig. 199).

(4) **CONNECT PROPELLER SHAFT.** Connect the propeller shaft between the transfer power take-off and the dump pump, as described in paragraph 112.



Figure 198—Tipping Hoist Cylinder Back

(5) **LOWER BODY.** Raise the body just high enough to permit the removal of the 4 x 4 braces, and lower it until it rests on frame rails.

(6) **CONNECT BODY STOP SPRING.** Wire the body stop spring to the rear frame cross member.

179. PUMP ASSEMBLY.

a. Removal.

(1) Raise the body, and block it in a raised position. Remove the hoist cylinder drain plug and drain the oil.

(2) Disconnect the pump valve control cable, as described in paragraph 178.

**4-TON, 6 x 6 TRUCKS (DIAMOND T MODELS 968A CARGO,
969A WRECKER, 970A PONTON, AND 972 DUMP)**

- (3) Disconnect the propeller shaft between the pump and the transfer power take-off, as described in paragraph 111.
- (4) Disconnect the high-pressure pipe running between the pump and the cylinder at the pump.
- (5) **REMOVE PUMP.** Remove the cap screws and lock washers holding the pump to the cylinder manifold assembly and remove the pump and pump gasket.



Figure 199—Installing Control Cable Clamp U-Bolt

b. Installation.

- (1) Install the pump and gasket in position on the cylinder manifold assembly and replace with cap screws and lock washers which were removed. Use a new gasket.
- (2) Connect the high-pressure pipe running between the pump and the cylinder to the pump.
- (3) Connect the propeller shaft between the power take-off on the transfer and the pump, as described in paragraph 112.
- (4) Connect the pump valve control cable to the valve lever on the pump, as described in paragraph 178.
- (5) Add oil to cylinder (par. 24).
- (6) Remove braces and lower the body.

Section XXXIX

CAB

	Paragraph
Description	180
Cab tarpaulins and side curtains	181
Seat cushions and backrests	182
Windshield	183
Windshield wipers	184

180. DESCRIPTION.

a. **General.** Four ton, 6 x 6 vehicles are supplied with both closed and open type cabs.

b. **Open Type Cab** (fig. 200). The open type cab is equipped with a canvas top and side curtains, and has a seating capacity for three persons. The windshield may be lowered on the side pivots until it rests flat on top of the cowl, and then locked in position with the windshield latch on the hood center panel.

c. **Closed Type Cab.** The closed type cab has a split "V" windshield, each half of which may be opened for ventilation. The

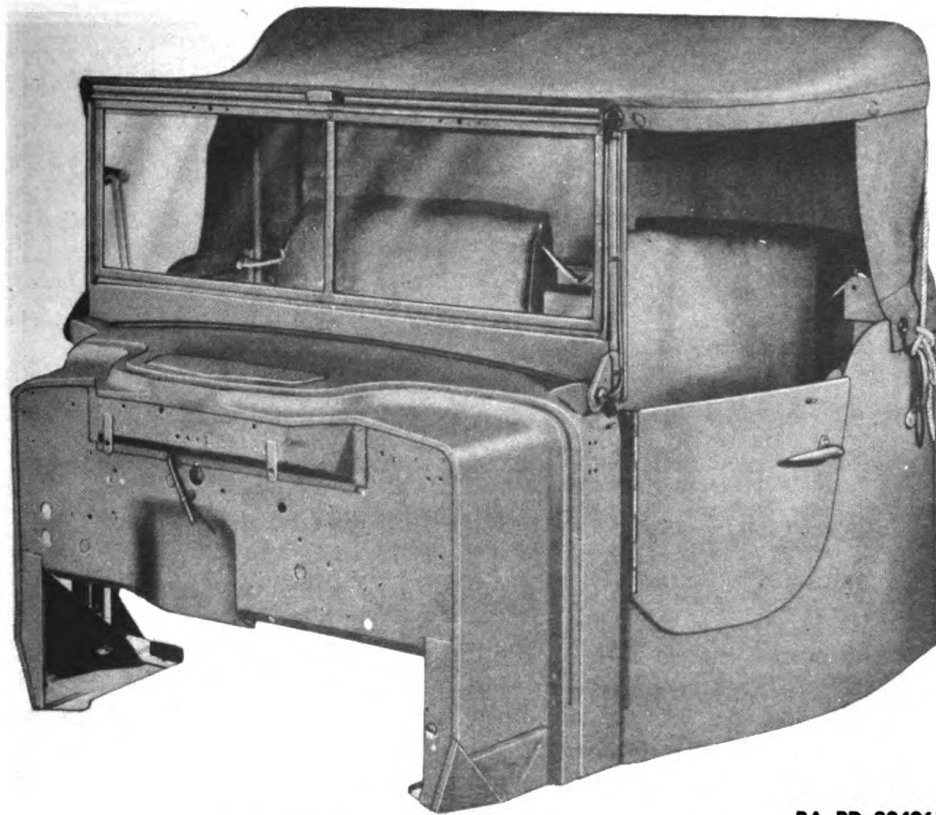

RA PD 304061

Figure 200—Cab Assembly, Open Type

355

**TM 9-811
180-181**

**4-TON, 6 x 6 TRUCKS (DIAMOND T MODELS 968A CARGO,
969A WRECKER, 970A PONTON, AND 972 DUMP)**

windows in each door may also be lowered. There are ventilators on top of the cowl, on the cowl sides, and on the cab top. The ventilator on top of the cab is equipped with a filter to clean the air and is the automatic exhaust and intake type.

181. CAB TARPAULINS AND SIDE CURTAINS.

a. Removal.

(1) **REMOVE SIDE CURTAINS.** Unfasten the three strap and loop fasteners holding the side curtains to the top tarpaulin and to the cowl

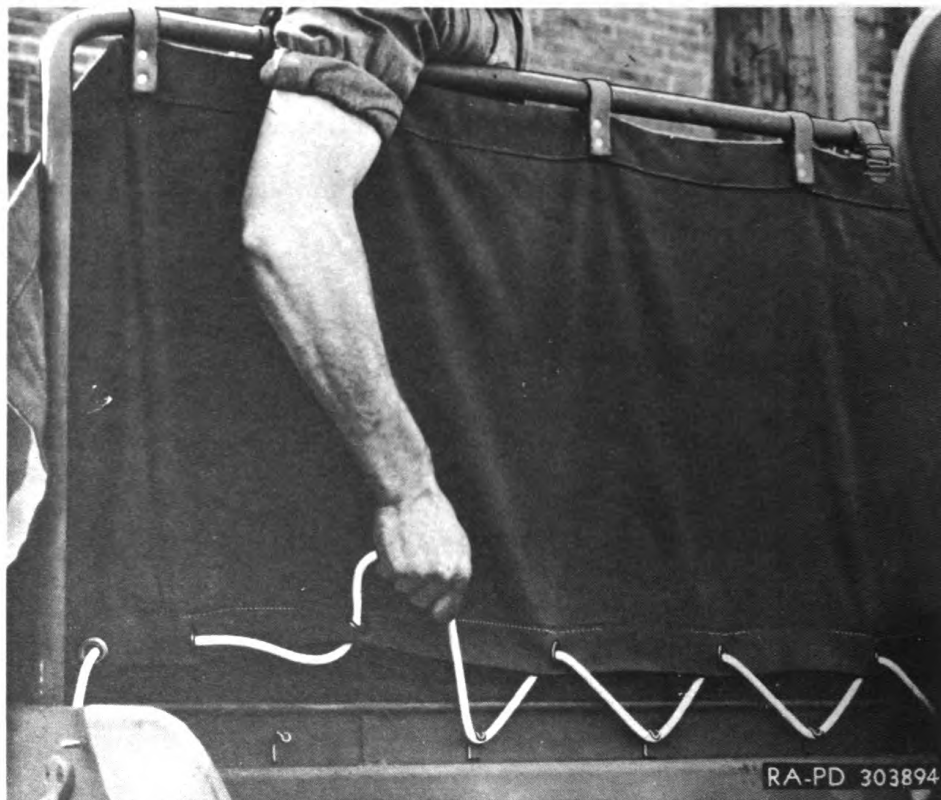

Figure 201—Lacing Rear Tarpaulin to Cab Rear Panel

and door. Then open the cab door and lift the side curtain support rod out of its seat in the top of the door panel, and then remove the support rod from the side curtain (fig. 204). Then grab the side curtain at its forward edge and pull it down to disconnect the side curtain bead from the slotted tube at the edge of the windshield. Repeat this operation for the other side curtain.

(2) **REMOVE TOP TARPAULIN.** Unfasten the two strap and loop fasteners holding the top tarpaulin to the rear tarpaulin. Untie the top tarpaulin holding ropes from the grab handles on the sides of the cab (fig. 203). Unhook the rope from the hook in back of the cab. Then

CAB

move the top tarpaulin forward as far as possible and drape it over the engine hood. Unfasten the two strap and loop fasteners holding the tarpaulin to the top edge of the windshield, then grasp the tarpaulin along one edge and pull it out from the cab to disengage the bead on the front end of the tarpaulin from the slotted tube on top of the windshield (fig. 202).

(3) **ROLL UP REAR TARPAULIN.** Untie each end of the rope, lacing the back tarpaulin to the hooks along the top of the rear cab panel, then slip the rope loose from each hook (fig. 201). Disconnect the strap and loop fasteners holding the bottom corners of the tarpaulin to the

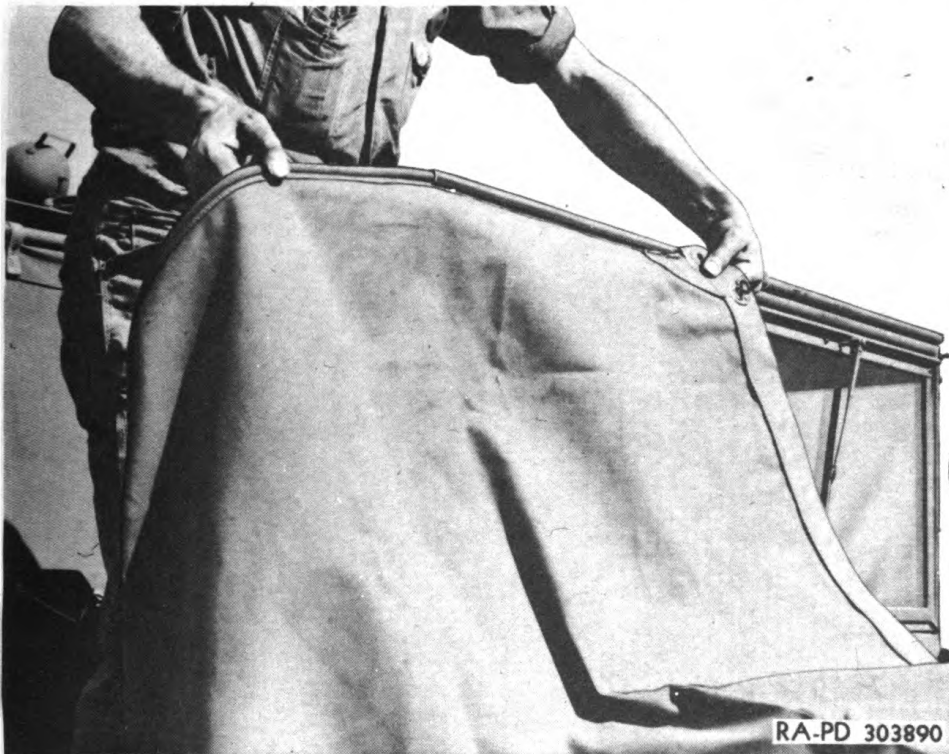

Figure 202—Installing Cab Top Tarpaulin

cab side panels. Fold the outer edges of the tarpaulin against the inner side, and roll the tarpaulin up with the ropes and folded edges inside the roll. Make a tight roll and strap it to the cab tarpaulin support tube with the straps which are attached to the tube.

(4) **LOWER CAB SUPPORT TUBE.** Loosen the wing nuts at each rear corner of the cab side panels, then push the support tube down into the cab as far as it will go, and tighten the wing nuts to keep the assembly from rattling.

b. Installation.

(1) **RAISE TARPAULIN SUPPORT TUBE.** Loosen the wing nuts on the body side panels which clamp the support tube in place and pull

4-TON, 6 x 6 TRUCKS (DIAMOND T MODELS 968A CARGO, 969A WRECKER, 970A PONTON, AND 972 DUMP)

it up as high as it will go, that is, until the cotter pins through the ends of the tube contact the support loop. Tighten the wing nuts again.

(2) **INSTALL CAB REAR TARPAULIN.** Unstrap the roll-up straps holding the rear tarpaulin to the top of the support tube, and unfold the canvas. Straighten the canvas out, and hook the loops in the rope laced through the bottom edge of the tarpaulin over the hooks on the inside of the cab rear panel. Pull the lacing rope tight and stretch the canvas taut (fig. 201). Then tie the ends of the ropes to the tarpaulin support tube. Pull the lower edges of the tarpaulin around the corners



Figure 203—Tying Top Tarpaulin Ropes to Grab Handles

of the cab and fasten the canvas to the cab side panel with the strap and loop fasteners in each corner of the canvas.

(3) **INSTALL TOP TARPAULIN.** Drape the top tarpaulin upside-down on top of the engine hood, with the bead on it facing towards the windshield. Then insert one end of the tarpaulin bead through the slotted tube on top of the windshield and pull the canvas through until it is centered on the windshield (fig. 202). Grasp the rear edge of the tarpaulin and swing it back over the cab, drape it over the cab support tube, and hook the loop in the middle of the tarpaulin rope to the hook on back of the rear cab panel. Connect the two strap and loop fasteners holding the front corners of the tarpaulin to the top of the wind-

CAB

shield frame, and connect the strap and loop fasteners attaching the top tarpaulin to the upper corners of the rear tarpaulin. Pull the top tarpaulin ropes tight, stretch the canvas evenly, and tie the ends of the ropes to the grab handles on the cab side panels (fig. 203).

(4) **INSTALL SIDE CURTAINS.** The side curtains are different for the right and left sides of the cab. To determine which is which, hold curtain up against the side of the cab with the bead edge alongside the windshield, and with the straps for the strap and loop fasteners facing out. If this cannot be done, the side curtain belongs on the other side. Hold the side curtain in position and then lower it alongside the cab



Figure 204—Installing Side Curtain Support Rod

door until the end of the bead can be inserted into the slotted tube at the edge of the windshield frame, then raise it as high as it will go, sliding the bead into the tube. When it is in position, fasten the strap and loop fasteners, attaching the forward edge of the curtain to the top tarpaulin and to the cowl side. Then insert the straight end of the side curtain support rod into the hem at the rear edge of the curtain and swing the lower end of the rod to such a position that it points toward the front of the vehicle (fig. 204). Lift the rear edge of the curtain, and insert the rod into its seat on top of the door panel. Fasten the loop and strap fasteners holding the lower edge of the curtain to the door. Repeat this operation for the other side curtain.

TM 9-811

182-183

4-TON, 6 x 6 TRUCKS (DIAMOND T MODELS 968A CARGO, 969A WRECKER, 970A PONTON, AND 972 DUMP)

182. SEAT CUSHIONS AND BACKRESTS.

a. Removal.

(1) **REMOVE DRIVER'S SEAT CUSHION.** Lift the front edge of the driver's seat cushion and seat cushion adjusting frame and pull them forward to clear the backrest and remove them from the cab.

(2) **REMOVE DRIVER'S SEAT BACKREST.** Remove the cotter pins from the two clevis pins holding the top of the back to the cab panel and then remove the pins. Then lift the backrest assembly, disengaging the screws at the lower end from the slots in the cab panel bracket and remove the backrest.

(3) **REMOVE SEAT AND BACKREST ON RIGHT SIDE OF CAB.** Disengage the seat latch and then pull it up against the backrest. Then remove the cap screws and nuts from the seat and backrest pivot brackets and remove the seat and backrest from the cab.

b. Installation.

(1) **INSTALL SEAT AND BACKREST ON RIGHT SIDE OF CAB.** Lift the seat and backrest into place on the cab with their canvas sides facing each other and the pivot holes lined up with each other, and with the holes in the cab panel pivot brackets. Then install the cap screws and nuts which were removed. Pull the seat down until the seat lock is engaged.

(2) **INSTALL DRIVER'S BACKREST.** Lift the driver's backrest into position with the clevis pin brackets toward the top, then engage the screws at the bottom with the slots in the backrest mounting bracket and push the backrest down to lock the screws in the slots. Install the clevis pins through the holes in the backrest and cab panel brackets and install cotter pins to hold them in place.

(3) **INSTALL DRIVER'S SEAT CUSHION.** Lift the driver's seat cushion adjusting frame into position in the cab with the canvas facing up. Slide the back of the cushion underneath the backrest, and engage the holes in the adjusting frame over the lugs on the seat riser. The position of the seat is controlled by engaging the seat riser lugs in the proper holes in the adjusting frame.

183. WINDSHIELD.

a. Open Cab Windshield.

(1) **REMOVAL.** Loosen thumb screws holding the windshield sector arms lock, and open the windshield three to four inches at the bottom. Remove pivot screw and washer holding each sector arm to the windshield frame. Then swing the glass assembly out to a horizontal position and pull it from the frame, sliding the bead on the top of the glass assembly from the slotted tube in the frame.

(2) **INSTALLATION.** Lift the windshield assembly into position alongside the windshield frame and slide the bead on the top of the glass assembly into the slotted tube on top of the frame. Be sure that the handle on the lower windshield panel faces in towards the cab. Then connect the nuts of the sector arms to the windshield glass frame using the screws and washers which were removed. Loosen the thumb screws, pull the sector arms in to close the windshield, then tighten thumb screws.

CAB

b. Closed Cab Windshields.

(1) **REMOVAL.** Remove the sector arms from the frames. Remove two flathead screws from each hinge, and remove the windshield assembly.

(2) **INSTALLATION.** Position windshield assembly and install two screws in each hinge. Install sector arms on windshield frame.

184. WINDSHIELD WIPERS.

a. Removal. Remove the hex head screw holding the wiper arm and blade assembly to the wiper shaft, and remove the assembly.

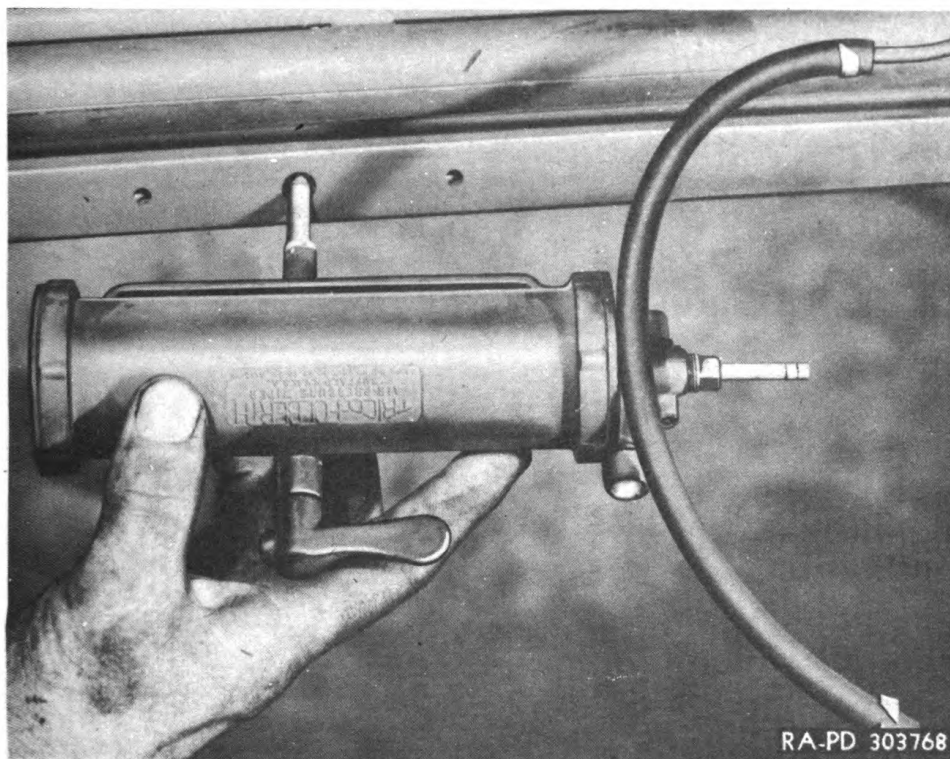

Figure 205—Installing Windshield Wiper

Spread the clamp on the end of the rubber hose leading to the windshield wiper. Disconnect the hose from the wiper. Remove the two screws holding the windshield wiper to the top panel of the windshield frame, and pull the wiper assembly away from the windshield (fig. 205).

b. Installation. Lift the windshield wiper assembly into position with the air inlet fitting facing towards the rubber hose, and slide the wiper shaft through the hole in the top windshield panel (fig. 205). Install screws attaching the wiper assembly to the panel and tighten securely. Slide the end of the rubber hose over the connector tube on the end of the wiper and squeeze the clamp together. Slide the wiper blade and arm assembly over the end of the wiper shaft and replace the hex head screw.

TM 9-811

185

**4-TON, 6 x 6 TRUCKS (DIAMOND T MODELS 968A CARGO,
969A WRECKER, 970A PONTON, AND 972 DUMP)**

Section XL

SHEET METAL

	Paragraph
Hood	185
Fender shields	186
Fenders	187
Running boards	188
Battery box	189
Splash shields	190

185. HOOD.

a. Removal.

(1) **DISCONNECT BOND STRAP.** Open hood and remove the screw, nut, flat washer, and lock washer holding the bond strap to the radiator stay rod (fig. 206).



Figure 206—Disconnecting Hood Bond Strap

362

SHEET METAL

(2) **DISCONNECT HOOD SUPPORT ARMS.** Remove the cotter pins from the clevis pins at the upper ends of the hood support arms, and take out the clevis pins. Pull these support arms from the hood and close the hood sides.

(3) **REMOVE HOOD TO COWL CAP SCREWS.** Using a hammer and punch, flatten out the ears on the lock plate holding the cap screws, and remove the cap screws and lock plate (fig. 207).

(4) **REMOVE HOOD TO RADIATOR CAP SCREWS.** Using a hammer and punch, flatten out the ears on the lock plate, hold it against the



Figure 207—Folding Lock Plate Away From the Hood Center Panel Cap Screws

cap screws, and remove the cap screws, toothed lock washers and lock plate.

(5) **REMOVE HOOD.** Lift the hood from the cowl and radiator, and remove it from the chassis.

b. Installation.

(1) **INSTALL HOOD ASSEMBLY.** Lift the hood assembly and lower it into place over the engine compartment.

(2) **INSTALL HOOD TO RADIATOR CAP SCREWS.** Install the lock plate over the mounting holes in the hood center panel and then install the cap screws and toothed lock washers. After the cap screws are tightened, bend an ear of the lock plate against a flat side on the cap screw.

TM 9-811

185-186

4-TON, 6 x 6 TRUCKS (DIAMOND T MODELS 968A CARGO, 969A WRECKER, 970A PONTON, AND 972 DUMP)

(3) **INSTALL HOOD TO COWL CAP SCREWS.** Install the lock plate over the mounting holes in the hood center panel and then install the cap screws. After the cap screws are tightened, bend an ear of the lock plate against a flat side on the cap screw.

(4) **CONNECT HOOD ARMS.** Lift the hood sides and connect the upper end of the hood support arms to the hood with cotter and clevis pins.

(5) **CONNECT HOOD BOND STRAP.** Connect the hood bond strap to the tinned portion of the radiator stay rod, using the screw, nut, plain washer and lock washer.

186. FENDER SHIELDS.

a. Removal.

(1) **DISCONNECT FENDER SHIELDS FROM FRAME.** Raise hood and remove the cap screws, nuts and lock washers holding the fender shields to the frame rail. As the cap screws are removed, disconnect the bonds and harness clips which are connected under them.

(2) **DISCONNECT FENDER SHIELD FROM FENDER.** Remove the screws, lock washers and plain washers holding the fender shield to the fender. At the same time remove the toothed lock washers which are held between the fender and fender shields under some of the screws.

(3) **DISCONNECT AIR BRAKE CHAMBER HOSE SUPPORT SPRING.** Unhook the air brake chamber support spring from the hole in the bottom of the fender shield.

(4) **DISCONNECT FUEL LINE.** Disconnect the fuel line between the fuel filter and fuel pump. This applies to the left fender shield only.

(5) **REMOVE FENDER SHIELD.** Lift the fender shield out of the engine compartment. It may be necessary to bend the shield on the right side in order to get it out.

b. Installation.

(1) **INSTALL THE FENDER SHIELD.** Install the fender shield into position on top of the frame rail. If the right fender shield was bent during removal, it will be necessary to straighten it after it is installed.

(2) **FASTEN FENDER SHIELD TO FENDER.** Replace the screws, lock washers and plain washers holding the fender shield to the fender. **NOTE:** *Be sure to install toothed lock washers which were removed from between the shield and the fender.*

(3) **FASTEN FENDER SHIELD TO FRAME RAIL.** Install the cap screws, nuts and lock washers which were removed from between fender shield and frame rail. *It will be necessary to install the toothed lock washers, bond straps, and harness clips which were disconnected when the cap screws were removed in exactly the same order in which they were found.*

(4) **HOOK THE AIR BRAKE CHAMBER HOSE SUPPORT SPRING.** Hook the air brake chamber hose support spring through the hole in the fender shield.

SHEET METAL

187. FENDERS.

a. Removal.

(1) **REMOVE CAP SCREW IN FRONT OF FENDER.** Remove the cap screw, plain washer and lock washer holding the front of the fender to the frame rail.

(2) **REMOVE HEAD LAMPS AND MARKER LIGHTS FROM FENDER.** Remove the headlights and marker lights from the fender, as described in paragraph 102. When working on the left hand fender, it will be necessary to remove the blackout driving light also (par. 102).

(3) **REMOVE RADIATOR MOUNTING BOLTS.** Remove the cotter pin, nut and plain washer from the radiator mounting bolt, and remove the bolt.

(4) **DISCONNECT RADIATOR BOND STRAP.** Disconnect the bond strap between the radiator and the frame rail at the frame rail by removing the cap screw, lock washer and toothed lock washer.

(5) **REMOVE FENDER TO FENDER SHIELD SCREWS.** Remove the screws, plain washers and lock washers holding the fender to the fender shield.

(6) **REMOVE FENDER.** Remove the bolts, nuts, and lock washers holding the three fender brackets to the frame rail and to the rear spring hanger and remove the fender and bracket assembly. Then remove the bolts, nuts and lock washers holding the fender brackets to the fender.

b. Installation.

(1) **INSTALL FENDER BRACKETS ON FENDER.** Fasten the fender brackets to the fender with the bolts, nuts and lock washers which were removed.

(2) **INSTALL FENDER ON VEHICLE.** Lift the fender assembly into position on the vehicle and fasten it in place, holding the brackets to the frame rail and rear spring hanger with the bolts, nuts and lock washers.

(3) **FASTEN FENDER TO FENDER SHIELD.** Replace the screws, plain washers and lock washers, fastening the fender to fender shields. **NOTE:** *It will be necessary to install toothed lock washers, between the fender and the shield under the screws with which they were removed.*

(4) **CONNECT RADIATOR BOND STRAP.** Connect the radiator bond strap to the frame rail with the cap screws, lock washers and toothed lock washers which were removed.

(5) **INSTALL RADIATOR MOUNTING BOLT.** Install the radiator mounting bolt through the top insulator and replace the plain washer, nut and cotter pin on the threaded end of the bolt. Tighten the radiator mounting bolt nut with a torque wrench to a reading of 10 to 12 foot-pounds.

(6) **INSTALL CAP SCREW IN FRONT OF FENDER.** Replace the cap screw, plain washer and lock washer holding the front of the fender to the frame rail.

TM 9-811
188-189

**4-TON, 6 x 6 TRUCKS (DIAMOND T MODELS 968A CARGO,
969A WRECKER, 970A PONTON, AND 972 DUMP)**

188. RUNNING BOARDS.

a. Removal.

(1) **REMOVE CARRIAGE BOLTS HOLDING RUNNING BOARD TO THE RUNNING BOARD SUPPORTS.** Remove the carriage bolts, nuts and lock washers holding the running boards to the running board supports hanging under the chassis.

(2) **DISCONNECT RUNNING BOARD FROM BATTERY BOX.** Remove the cap screws, nuts and lock washers holding the running board to the battery box. These cap screws are not used on the left running board.

(3) **REMOVE RUNNING BOARD.** Lift the running board from the running board supports and remove the two wooden spacer blocks from underneath it.

b. Installation.

(1) **INSTALL WOODEN BLOCKS ON RUNNING BOARD SUPPORTS.** Install a wooden block on each running board support arm, lining up the holes in the blocks with the holes in the running board supports.

(2) **INSTALL RUNNING BOARDS.** Place the running boards in position on top of the wooden blocks, lining up the mounting holes with the holes in the blocks and insert the carriage bolts and install the nuts and lock washers which were removed.

(3) **INSTALL CAP SCREWS HOLDING THE RUNNING BOARD TO BATTERY BOX.** Replace the cap screws, nuts and lock washers holding the running board to the battery box. *NOTE: These cap screws are not used on the left side of the vehicle.*

189. BATTERY BOX.

a. Removal.

(1) **REMOVE RUNNING BOARD.** Remove the running board as described in paragraph 188.

(2) **REMOVE BATTERIES.** Open battery box door, disconnect the battery cables, and remove the batteries, as described in paragraph 101.

(3) **REMOVE BATTERY GROUND STRAP.** Remove the cap screw, nut and lock washer attaching the ground strap to the running board support hanger bracket, and remove the ground strap.

(4) **REMOVE COWL MOUNTING PARTS.** Remove the cotter pin, nut and plain washer from the right hand cowl mounting bolt, then remove the bolt, and upper and lower insulators.

(5) **REMOVE BATTERY BOX.** Remove the cap screw, nut and lock washer holding the back of the battery box to the forward running board support hanger bracket, then remove the cap screws, lock washers and nuts through the bottom of the battery box which hold it to the running board supports. Then pull the battery box out and remove it from the chassis.

b. Installation.

(1) **INSTALL BATTERY BOX.** Lift the battery box onto the running board supports, and slide it into position against the frame rail, lining

SHEET METAL

up the mounting holes. Replace the cap screws, nuts and lock washers holding the bottom of the battery box to the running board supports. Replace the cap screw, nut and lock washer holding the back of the battery box to the forward running board support hanger bracket.

(2) **INSTALL BATTERY GROUND STRAP.** Attach the battery ground strap to the back of the battery box, using the cap screw, nut and lock washer which were removed.

(3) **INSTALL COWL MOUNTING PARTS.** Slide the upper cowl mounting insulator into place between the cowl and the battery box. Install the cowl mounting bolt through the cowl, upper insulator, battery box, and cowl mounting bracket. Then install the lower insulator, plain washer, nut and cotter pin.

(4) **INSTALL BATTERIES.** Install the batteries in battery box and connect battery cables as described in paragraph 101.

(5) **INSTALL RUNNING BOARD.** Install the running board, as described in paragraph 188.

190. SPLASH SHIELDS.

a. Removal.

(1) **DISCONNECT BRACES FROM SPLASH SHIELDS.** Remove the cap screws, nuts and lock washers holding the splash shield braces to the shield.

(2) **REMOVE SPLASH SHIELD.** Remove the cap screws, plain washers, nuts and lock washers attaching the splash shield to the body, and remove the splash shield.

b. Installation.

(1) **INSTALL SPLASH SHIELD.** Install the splash shield into position on the body and attach it in place with cap screws, plain washer, nuts and lock washers.

(2) **CONNECT SPLASH SHIELD BRACES.** Fasten the splash shield braces to the splash shield with cap screws, nuts and lock washers.

4-TON, 6 x 6 TRUCKS (DIAMOND T MODELS 968A CARGO,
969A WRECKER, 970A PONTON, AND 972 DUMP)

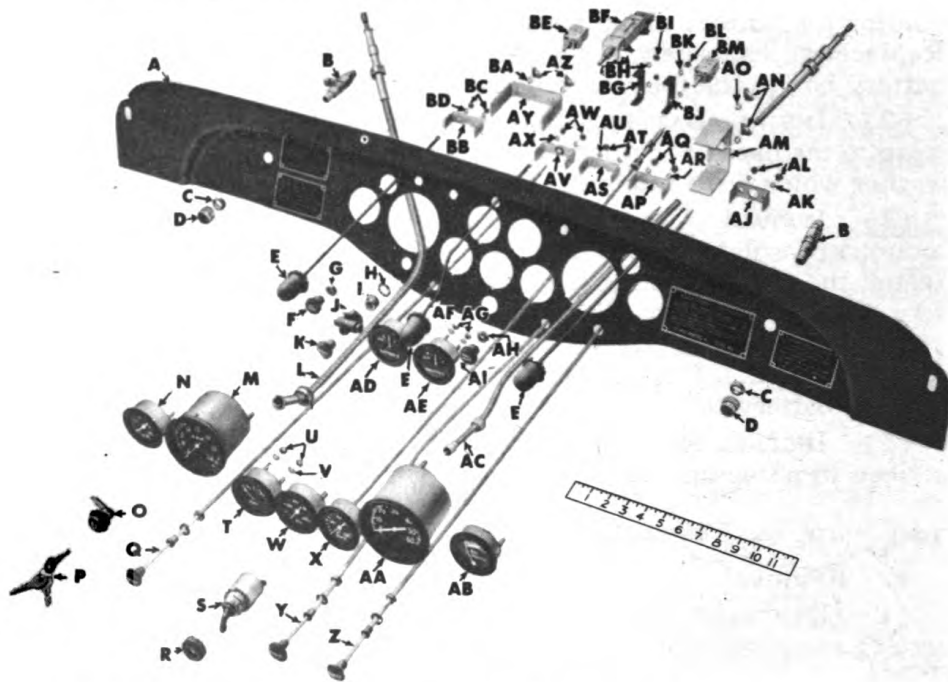

- | | | | |
|----|--|----|---|
| A | DASH PANEL | AI | PANEL LIGHT SWITCH BUTTON |
| B | WINDSHIELD WIPER VALVE | AJ | VISCOMETER BRACKET |
| C | WINDSHIELD WIPER VALVE NUT | AK | VISCOMETER BRACKET LOCK WASHERS |
| D | WINDSHIELD WIPER VALVE KNOB | AL | VISCOMETER BRACKET NUTS |
| E | DASH LIGHT | AM | SPEEDOMETER BRACKET |
| F | BLACKOUT DRIVING LAMP SWITCH
BUTTON | AN | SPEEDOMETER BRACKET WING NUTS |
| G | BLACKOUT DRIVING LAMP SWITCH NUT | AO | SPEEDOMETER BRACKET LOCK WASHERS |
| H | MAIN LIGHT SWITCH LOCK WASHER | AP | TEMPERATURE GAGE BRACKET |
| I | MAIN LIGHT SWITCH NUT | AQ | TEMPERATURE GAGE BRACKET NUTS |
| J | MAIN LIGHT SWITCH LATCH | AR | TEMPERATURE GAGE BRACKET
LOCK WASHERS |
| K | MAIN LIGHT SWITCH BUTTON | AS | OIL PRESSURE GAGE BRACKET |
| L | TACHOMETER CABLE | AT | OIL PRESSURE GAGE BRACKET NUTS |
| M | TACHOMETER | AU | OIL PRESSURE GAGE BRACKET
LOCK WASHERS |
| N | AIR PRESSURE GAGE | AV | FUEL GAGE BRACKET |
| O | TACHOMETER LOCK | AW | FUEL GAGE BRACKET NUTS |
| P | TACHOMETER LOCK KEYS | AX | FUEL GAGE BRACKET LOCK WASHERS |
| Q | SPARK CONTROL WIRE | AY | TACHOMETER BRACKET |
| R | IGNITION SWITCH NUT | AZ | TACHOMETER BRACKET WING NUTS |
| S | IGNITION SWITCH | BA | TACHOMETER BRACKET LOCK WASHERS |
| T | FUEL GAGE | BB | AIR PRESSURE GAGE BRACKET |
| U | FUEL GAGE TERMINAL NUTS | BC | AIR PRESSURE GAGE BRACKET NUTS |
| V | FUEL GAGE TERMINAL LOCK WASHERS | BD | AIR PRESSURE GAGE BRACKET
LOCK WASHERS |
| W | OIL PRESSURE GAGE | BE | BLACKOUT DRIVING LAMP SWITCH |
| X | TEMPERATURE GAGE | BF | MAIN LIGHT SWITCH |
| Y | CHOKE CONTROL WIRE | BG | FRONT BATTERY AMMETER BRACKET |
| Z | THROTTLE CONTROL WIRE | BH | FRONT BATTERY AMMETER BRACKET
LOCK WASHERS |
| AA | SPEEDOMETER | BI | FRONT BATTERY AMMETER BRACKET NUTS |
| AB | VISCOMETER | BJ | AMMETER BRACKET |
| AC | SPEEDOMETER CABLE | BK | AMMETER BRACKET LOCK WASHERS |
| AD | FRONT BATTERY AMMETER | BL | AMMETER BRACKET NUTS |
| AE | AMMETER | BM | PANEL LIGHT SWITCH |
| AF | AMMETER TERMINAL LOCK WASHERS | | |
| AG | AMMETER TERMINAL NUTS | | |
| AH | PANEL LIGHT SWITCH NUT | | |

RA PD 304938

Figure 208—Instruments and Dash

Section XLI

INSTRUMENTS

	Paragraph
Air pressure gage.....	191
Ammeters	192
Fuel gage.....	193
Oil pressure gage.....	194
Speedometer	195
Tachometer	196
Temperature gage.....	197
Viscometer	198

191. AIR PRESSURE GAGE.

a. Removal. Disconnect the air line from the back of the gage. Remove the nuts and lock washers holding the air pressure gage mounting bracket to the instrument, and remove the bracket from in back of the dash. Reach behind the dash panel and push the instrument out far enough to grip it with the other hand and pull it from the hole in the panel.

b. Installation. Slide the air pressure gage into its mounting hole in the dash panel and install the mounting bracket behind the instrument. Fasten the bracket to the instrument with the nuts and lock washers which were removed. Connect the air line to the back of the instrument.

192. AMMETERS.

a. General. Two ammeters are used with all 4-ton, 6 x 6 trucks (fig. 208). The first is a conventional-type which indicates the amount of charge or discharge within the electrical system. The second is an indicating-type ammeter which registers the condition of the front battery only.

b. Removal. Remove the terminal nuts and lock washers, and disconnect the wires from the terminals. Remove the nuts and lock washers holding the mounting bracket to the ammeter and remove the bracket. Reach behind the dash panel and push the instrument out far enough so that it may be gripped with the other hand, and pull it from the dash.

c. Installation. Install the ammeter into position in the proper hole in the dash panel, then install the ammeter mounting bracket into place in back of the panel. Fasten the mounting bracket in place with the nuts and lock washers which were removed. Connect the wires to the ammeter terminals and replace the terminal nuts and washers.

193. FUEL GAGE.

a. Removal. Remove the nuts and lock washers holding the fuel gage mounting bracket in place, and remove the bracket. Disconnect the wire from the fuel gage terminal after removing the terminal nuts and washers. Reach behind the dash panel, and push the gage out far enough to grip it with the other hand, then pull it from the panel.

TM 9-811
193-196

**4-TON, 6 x 6 TRUCKS (DIAMOND T MODELS 968A CARGO,
969A WRECKER, 970A PONTON, AND 972 DUMP)**

b. Installation. Install the fuel gage into place in the hole in the dash panel. Install the fuel gage mounting bracket from behind the dash panel, and fasten it to the instrument with the nuts and lock washers which were removed. Install the fuel gage wire over the terminal stud and replace the terminal nut and washer.

194. OIL PRESSURE GAGE:

a. Removal. Disconnect the oil line in back of the oil pressure gage. Remove the nuts and lock washers holding the oil pressure gage bracket to the instrument and remove the bracket. Reach behind the dash panel and push the oil pressure gage out far enough so that it may be gripped with the other hand, and remove it from the panel.

b. Installation. Install the oil pressure gage into position in the hole in the dash panel and install the mounting bracket against it from in back of the panel. Fasten the mounting bracket to the gage, using the nuts and lock washers which were removed. Connect the oil line to the fitting in back of the gage.

195. SPEEDOMETER.

a. Removal. Back off the thumb screw adapter in back of the speedometer and then disconnect the cable from the instrument. Remove the wing nuts and lock washers holding the speedometer mounting bracket to the speedometer, and remove the bracket. Reach behind the dash panel and push the speedometer out far enough so that it may be gripped with the other hand, and remove it from the panel.

b. Installation. Install the speedometer into place on the dash and replace the mounting bracket behind the dash. Fasten the mounting bracket to the speedometer, using the wing nuts and lock washers which were removed. Slide the end of the speedometer cable into the adapter, then thread the thumb screw over the adapter and tighten it securely. Do not use a wrench on the thumb screw.

196. TACHOMETER.

a. Removal. Back off the thumb screw at the end of the cable and disconnect the cable from the adapter in back of the tachometer. Remove the wing nuts and lock washers holding the tachometer mounting bracket to the tachometer, and remove the bracket. Reach behind the dash and push the tachometer far enough so that it may be gripped with the other hand, then remove it from the dash panel.

b. Installation. Install the tachometer in its mounting hole on the dash panel and install tachometer mounting bracket behind it. Attach the mounting bracket to the tachometer, using wing nuts and lock washers. Engage end of the tachometer cable with the adapter in back of the tachometer, then thread the thumb screw over the head of the adapter and tighten it securely. **NOTE: Do not use a wrench on the thumb screw.**

INSTRUMENTS

197. TEMPERATURE GAGE.

a. **Removal.** Lift the engine hood and unscrew the hexagon adapter holding the bulb in the rear cylinder head, then remove the bulb from the cylinder head. Remove the nuts and lock washers holding the mounting bracket to the temperature gage, and remove the bracket. Pull the temperature gage tube and bulb through the opening in the cowl, then remove the instrument tube and bulb assembly through the hole in the dash panel.

b. **Installation.** Insert the bulb on the end of the temperature gage tube through the opening in the dash panel, then pull the tube through far enough so that the instrument is supported on the dash. Install the temperature gage mounting bracket behind the dash and attach it to the instrument using nuts and lock washers. Push the bulb and tube through the opening in the cowl and into the engine compartment. Then insert the bulb into the opening in the rear cylinder head, and run up the hexagon adapter plug and tighten it securely.

198. VISCOMETER.

a. **Removal.** Disconnect the oil line which is attached to the back of the viscometer. Remove the nuts and lock washers holding the mounting bracket to the viscometer, and remove the bracket. Reach behind the dash panel and push the viscometer out far enough so that it can be gripped with the other hand, then remove it from the dash panel.

b. **Installation.** Install viscometer into the hole in the dash panel and then install the mounting bracket against it from the other side. Fasten the mounting bracket to the viscometer, using nuts and lock washers. Connect the oil line to the back of the viscometer.

4-TON, 6 x 6 TRUCKS (DIAMOND T MODELS 968A CARGO,
969A WRECKER, 970A PONTON, AND 972 DUMP)

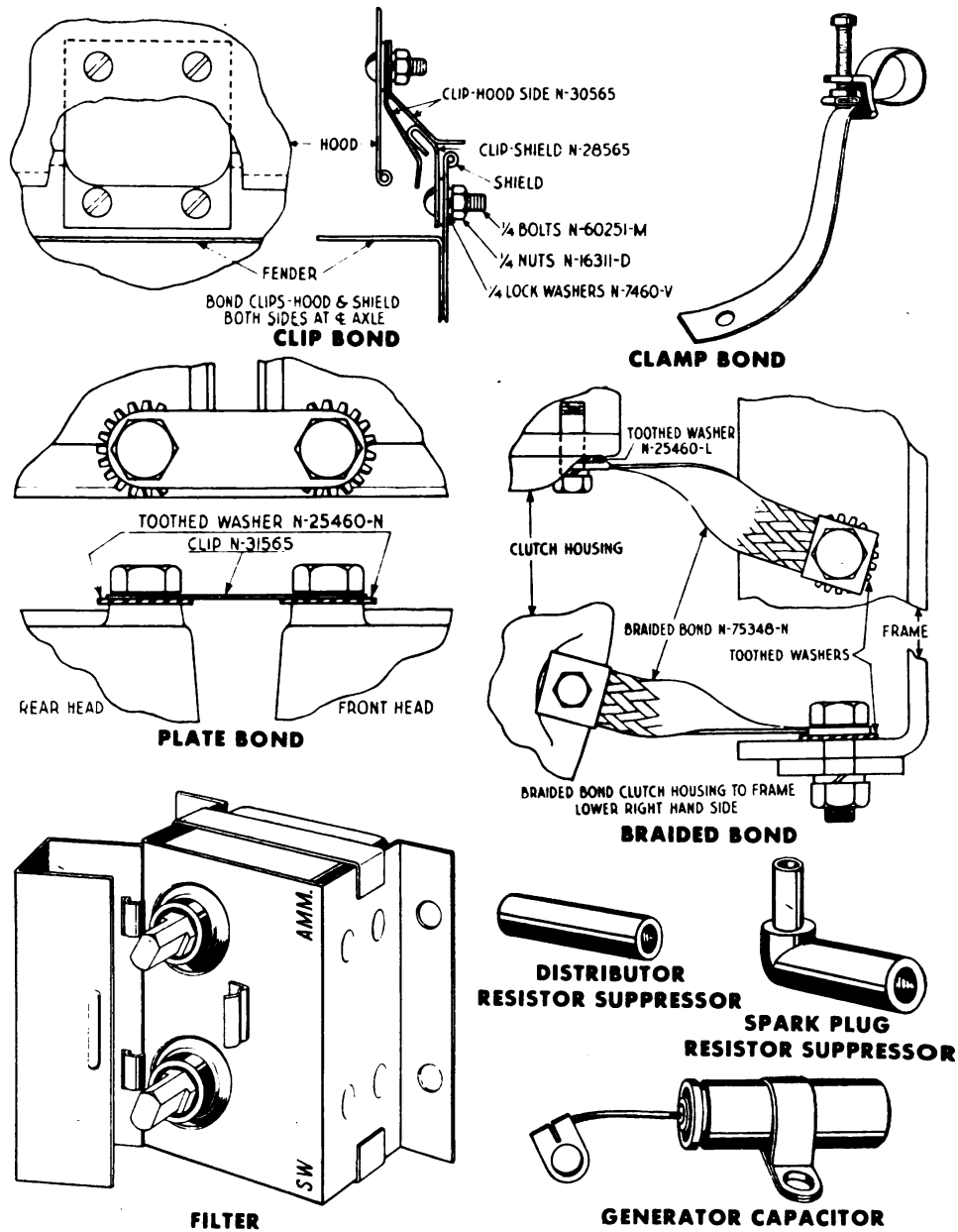

RA PD 313800

Figure 209—Radio Suppression Parts

Section XLII

RADIO INTERFERENCE SUPPRESSION

	Paragraph
Description and tabulated data.....	199
Emergency procedures.....	200
Bonds	201
Location of toothed lock washers.....	202
Radio interference.....	203

199. DESCRIPTION AND TABULATED DATA.

a. **Description.** To prevent interference with radio communication, the electrical systems of all vehicles which have an "S" marked on the cowl shoulder on each side of the vehicle are equipped with filtered power lines, resistance suppressed distributor and spark plugs, bonding and shielding (fig. 209). It is important that the driver and the mechanic understand that the radio interference suppression equipment is necessary and must not be decommissioned except in emergencies where it is important to get the vehicle running again in a hurry.

b. **Tabulated Data.**

Type of Suppression:

Power lines.....	Filtered
Spark and distributor.....	Resistance
Units of vehicle.....	Bonding
Spark plug suppressor resistance.....	15,000 ohms
Distributor suppressor resistance.....	15,000 ohms
Wrecker air compressor spark plug suppressor resistance	15,000 ohms

200. EMERGENCY PROCEDURES.

a. **General.** Filters have been placed in series with the power lines to the regulator field terminal, the regulator battery terminal and the ammeter terminal. The generator armature ("A" terminal) has a capacitor or condenser connected to a ground. The ignition filter and the ammeter regulator "B" and battery filters are in a group on the dash. The terminals are exposed by removing the bracket cover which is held by a friction snap latch in the center of the bracket. The regulator field filter is mounted on the regulator.

b. In the event that failure of the ignition system or charging system appears to be due to open-circuited filters, an emergency repair may be made by running a jumper wire across the terminals of the filter unit in the line. If the ignition or charging circuit functions satisfactorily with the jumper lead, it may be assumed that the trouble was caused by an open-circuited filter. If the jumper wire fails to correct the trouble, disconnect the wires from the filter terminals and connect them together. If this produces satisfactory operation, it may be assumed that the filter was grounded.

TM 9-811
200-201

**4-TON, 6 x 6 TRUCKS (DIAMOND T MODELS 968A CARGO,
969A WRECKER, 970A PONTON, AND 972 DUMP)**

c. The generator capacitor is mounted on the generator and can be checked by removing the bracket of the capacitor from the ground. If shorted, temporary operation of the vehicle can be obtained by leaving the filter ungrounded, or by removing same.

d. Whenever a vehicle has been given an emergency repair for radio suppression equipment as outlined above, this fact must be reported to the proper authorities at the earliest opportunity. Arrangements should be made to turn the vehicle over to the proper maintenance unit for repair or replacement of parts. Remember that these are only emergency repairs and that proper remedial measures must not be neglected.

201. BONDS.

a. **General** (fig. 209). Bonds are used on these vehicles to be sure that all metal parts are positively grounded to prevent any electrical leakage which might cause radio interference. The bond connections must be kept clean and tight in order to provide a low-resistance ground connection.

b. **Types.** The bonding used on these vehicles is of various types as follows:

- (1) Braided bonds.
- (2) Strap clamp bonds.
- (3) Bronze knife switch clip bonds.
- (4) Bronze plate bonds.
- (5) Prepared spots.

c. **Braided Bonds.** The braided bonds consist of a braided strap with a terminal on each end. Thirteen of these are used, connected from a unit to a ground. These are as follows:

- (1) Cowl to frame (2).
- (2) Head to dash (1).
- (3) Distributor to block (1).
- (4) Compressor discharge tube to frame (1).
- (5) Generator to frame (1).
- (6) Bell housing to frame (1).
- (7) Oil pan to front axle (1).
- (8) Radiator to frame (2).
- (9) Hood sides to center panel (2).
- (10) Radiator tie rod to hood center panel (1).

d. **Strap Clamp Bonds.** The strap clamp bonds consist of a soft metal strap which clamps tightly around instrument cables with the free end fastened to a ground. Three of these are used as follows:

- (1) Tachometer cable to cowl (1).
- (2) Spark control and heat indicator cables to cowl (1).
- (3) Throttle and choke cables to cowl (1).

e. **Knife Switch Clip Bonds.** The knife switch clip bonds consist of a pair of bronze clips fastened to the lower edge of the hood

RADIO INTERFERENCE SUPPRESSION

side panel and the top of the fender shield. These come together and make good ground contact when the hood is closed. Two of these are used, one for each hood side.

f. Bronze Plate Bond. The bronze plate bond consists of a plate connecting the two cylinder heads together. It is held under adjacent cylinder head bolts with a toothed lock washer between each head and the plate.

g. Prepared Spots. The prepared spots are a good electrical connection between two metal surfaces accomplished by a toothed lock washer designed to dig into the adjacent metal surfaces. They are used where parts are fastened together. There are twenty-nine of these as follows:

- (1) Filter to cowl mounting (4).
- (2) Regulator to cowl mounting (4).
- (3) Filter to regular mounting (1).
- (4) Fender to shield mounting (4).
- (5) Shield to frame mounting (6).
- (6) Hood top to radiator mounting (2).
- (7) Hood top to cowl mounting (2).
- (8) Coil bracket to head mounting (1).
- (9) Coil bracket to bracket mounting (2).
- (10) Steering column bracket to cowl mounting (2).
- (11) Pinched between steering column bracket and steering column (1).

h. It is important that all bonds be kept tight and clean. Be sure that the toothed lock washers are always in place. When disassembly work on vehicle is necessary, be sure to use these lock washers between parts to be grounded and bond connections, and also between bond connections and grounds when reassembling the vehicle. Do not forget the lock washers to be used at the prepared spots as listed above. It is important that the toothed lock washers used have the proper finish. Use only tin or cadmium plated lock washers with radio suppression devices. Do not use oxide finished lock washers. Bonds should be examined for frayed or broken wires or other damage caused by brush, accident or wear.

202. LOCATION OF TOOTHED LOCK WASHERS.

Description	Toothed Lock Washers	Location of Toothed Lock Washers
Filter—dash (dual) . . .	4	Between filter and dash (one bolt used in common for filter and regulator)
Regulator	4	Between regulator and dash
	1	Between regulator and field filter bracket
Strap clamp bond on tachometer cable . . .	1	Between dash and bond

TM 9-811
202

**4-TON, 6 x 6 TRUCKS (DIAMOND T MODELS 968A CARGO,
 969A WRECKER, 970A PONTON, AND 972 DUMP)**

Description	Toothed Lock Washers	Location of Toothed Lock Washers
Strap clamp bond on heat indicator and spark control cables	2	Bond fastened to dash with same bolt as used for tachometer bond. Bonds are placed adjacent to each other at dash
Bond	2	Between bond and cowl and between bond and nut. Left side
	2	Ditto—right side
	2	Between cowl bond and fender shield and between fender shield and frame. Left side
	2	Ditto—right side
Bond from compressor line to frame	2	Between bond and fender shield and between fender shield and frame
Clip on compressor line end of above bond		One (1) flat washer and one cadmium-plated washer used. Cadmium-plated clip and bond are adjacent
Bond	1	Between distributor and bond
	1	Between block and bond and between bond and bolt head.
Bond	1	Between bond and bell housing
	1	Between bond and frame
	3	Two (2) between steering column bracket and cowl. One (1) placed in a hole cut in steering column bushing to ground column to upper bracket when drawn up tight
Bond	2	Between bond and bolt head and between bond and crankcase sump
	1	Between bond and front axle differential carrier and between bond and bolt head
Bond between front and rear cylinder head . . .	2	One (1) each between bond and each head
Strap clamp bond choke and throttle cables . .	1	Attaching strap clamp to regulator
Bond	1	Between cylinder head and bond
	1	Between engine bond and dash

RADIO INTERFERENCE SUPPRESSION

Description	Toothed Lock Washers	Location of Toothed Lock Washers
Bond	1	Between generator band and bond
	2	Between generator band bond and fender shield. Between fender shield and frame
	2	Between right side fender and fender shield
	2	Ditto—left side
Bond	1	Between right side radiator side frame and bond
	1	Ditto—left side
	2	Between bond and fender and fender and frame right side
	2	Ditto—left side
	2	Between front top hood and radiator top frame
	2	Between back top hood and cowl
Bond	1	Between left side hood cover and bond
	1	Ditto—right side
Clip (cadmium-plated) on radiator tie rod		
Bond	1	Right side hood, left side hood and radiator tie rod to hood center panel
		Washer between hood center panel and bonds
Bond clip	2	Right side—between clip and hood
	2	Ditto—left side
	2	Right side—between clip and fender shield
	2	Ditto—left side
	1	Between coil bracket and head
	2	Between coil and bracket

203. RADIO INTERFERENCE.

a. Due to Ignition.

- (1) Check distributor, spark plugs and suppressors.
- (2) Tighten braided bonding straps.
- (3) Tighten radiator, fender and fender shield bolts.

b. Due to Generator.

- (1) Tighten regulator and generator bonds.
- (2) Check for defective or dirty commutator, brushes, or brush holders.

TM 9-811
203

**4-TON, 6 x 6 TRUCKS (DIAMOND T MODELS 968A CARGO,
969A WRECKER, 970A PONTON, AND 972 DUMP)**

(3) Check for excessively discharged battery causing high charging rate.

c. Due to Erratic Noises.

(1) Check for failure of high-tension insulation.

(2) Check for loose wiring connections or corroded distributor cap towers.

(3) Check for defective switches or gages.

Section XLIII

SHIPMENT AND TEMPORARY STORAGE

	Paragraph
General instructions.....	204
Preparation for temporary storage or domestic shipment...	205
Loading and blocking for rail shipment.....	206

204. GENERAL INSTRUCTIONS.

a. Preparation for domestic shipment of the vehicle is the same as preparation for temporary storage or bivouac. Preparation for shipment by rail includes instructions for loading and unloading the vehicle, blocking necessary to secure the vehicle on freight cars, number of vehicles per freight car, clearance, weight, and other information necessary to properly prepare the vehicle for rail shipment. For more detailed information, and for preparation for indefinite storage, refer to AR 850-18.

205. PREPARATION FOR TEMPORARY STORAGE OR DOMESTIC SHIPMENT.

a. Vehicles to be prepared for temporary storage or domestic shipment are those ready for immediate service, but not used for less than thirty days. If vehicles are to be indefinitely stored after shipment by rail, they will be prepared for such storage at their destination.

b. If the vehicles are to be temporarily stored or bivouacked, take the following precautions:

(1) **LUBRICATION.** Lubricate the vehicle completely (par. 26).

(2) **COOLING SYSTEM.** If freezing temperature may normally be expected during the limited storage or shipment period, test the coolant with a hydrometer and add the proper quantity of antifreeze compound, to afford protection from freezing at the lowest temperature anticipated during the storage or shipping period. Completely inspect the cooling system for leaks.

(3) **BATTERY.** Check battery and terminals for corrosion and, if necessary, clean and thoroughly service battery (par. 101).

(4) **TIRES.** Clean, inspect, and properly inflate all tires. Replace with serviceable tires, all tires requiring retreading or repairing. Do not store vehicles on floors, cinders, or other surfaces which are soaked with oil or grease. Wash off immediately any oil, grease, gasoline, or kerosene which comes in contact with the tires under any circumstances.

(5) **ROAD TEST.** The preparation for limited storage will include a road test of at least five miles, after the battery, cooling system, lubrication, and tire services, to check on general condition of the vehicle. Correct any defects noted in the vehicle operation, before the vehicle is stored, or note on a tag attached to the steering wheel, stating the repairs needed, or describing the condition present. A written report of these items will then be made to the officer in charge.

(6) **FUEL IN TANKS.** It is not necessary to remove the fuel from the tanks for shipment within the United States, nor to label the tanks

**TM 9-811
205-206**

**4-TON, 6 x 6 TRUCKS (DIAMOND T MODELS 968A CARGO,
969A WRECKER, 970A PONTON, AND 972 DUMP)**

under Interstate Commerce Commission Regulations. Leave fuel in the tanks except when storing in locations where fire ordinances or other local regulations require removal of all gasoline before storage.

(7) **EXTERIOR OF VEHICLE.** Remove with sandpaper rust appearing on any part of the vehicle exterior. Repaint surfaces whenever necessary to protect wood or metal from deterioration. Exposed polished metal surfaces which are susceptible to rust, such as winch cables, chains, and, in the case of track-laying vehicles, metal tracks, should be coated with a protective medium grade lubricating oil. Close firmly all cab doors, windows and windshields. Vehicles equipped with open-type cabs with collapsible tops will have the tops raised, all curtains in place, and the windshield closed. Make sure tarpaulins and window curtains are in place and firmly secured. Leave rubber mats, such as floor mats, where provided, in an unrolled position on the floor, and not rolled or curled up. Equipment, such as Pioneer and truck tools, tire chains, and fire extinguishers, will remain in place in the vehicle.

(8) **INSPECTION.** Make a systematic inspection just before shipment or temporary storage, to insure all above steps have been covered, and that the vehicle is ready for operation on call. Make a list of all missing or damaged items and attach it to the steering wheel. Refer to Before-operation Service (par. 21).

(9) **ENGINE.** To prepare the engine for storage, remove the air cleaner from the carburetor. Start the engine and set the throttle to run the engine at a fast idle. Pour one pint of medium grade, preservative lubricating oil, Ordnance Department Specification AXS-674, of the latest issue in effect, into the carburetor throat, being careful not to choke the engine. Turn off the ignition switch as quickly as possible after the oil has been poured into the carburetor. With the engine switch off, open the throttle wide, and turn the engine five complete revolutions by means of the cranking motor. If the engine cannot be turned by the cranking motor with the switch off, turn it by hand, or disconnect the high-tension lead and ground it before turning the engine by means of the cranking motor. Then reinstall the air cleaner.

(10) **BRAKES.** Release brakes and chock the wheels or tracks.

c. Inspection in Limited Storage.

(1) Vehicles in limited storage will be inspected weekly for condition of tires and battery. If water is added when freezing weather is anticipated, recharge the battery with a portable charger, or remove the battery for charging. Do not attempt to charge the battery by running the engine.

206. LOADING AND BLOCKING FOR RAIL SHIPMENT.

a. Preparation. In addition to the preparation described in paragraph 205, when ordnance vehicles are prepared for domestic shipment, the following preparations and precautions will be taken:

(1) **EXTERIOR.** Cover the body of the vehicle with a canvas cover supplied as an accessory.

SHIPMENT AND TEMPORARY STORAGE

(2) **TIRES.** Inflate pneumatic tires from 5 to 10 pounds above normal pressure.

(3) **BATTERY.** Disconnect the battery to prevent its discharge by vandalism or accident. This may be accomplished by disconnecting the positive lead, taping the end of the lead, and tying it back away from the battery.

(4) **BRAKES.** The brakes must be applied and the transmission placed in low gear, after the vehicle has been placed in position with a brake wheel clearance of at least 6 inches (A, fig. 210). The vehicles will be located on the car in such a manner as to prevent the car from carrying an unbalanced load.

(5) All cars containing ordnance vehicles must be placarded "DO NOT HUMP."

(6) Ordnance vehicles may be shipped on flat cars, end-door box cars, side-door box cars, or drop-end gondola cars, whichever type car is the most convenient.

b. Facilities for Loading. Whenever possible, load and unload vehicles from open cars under their own power, using permanent end ramps and spanning platforms. Movement from one flat car to another along the length of the train is made possible by cross-over plates or spanning platforms. If no permanent end ramp is available, an improvised ramp can be made from railroad ties. Vehicles may be loaded in gondola cars without drop ends by using a crane. In case of shipment in side-door box cars, use a dolly-type jack to fit the vehicles into position with the car.

c. Securing Vehicles. In securing or blocking a vehicle, three motions (lengthwise, sidewise, and bouncing), must be prevented. There are two approved methods of blocking the vehicles on freight cars, as described below. When blocking dual wheels, all blocking will be located against the outside wheel of the dual.

(1) **FIRST METHOD** (fig. 210). Locate eight blocks "B", one to the front and one at the rear of each front wheel, one at the front of each forward rear wheel, and one at the back of each rearward wheel. Nail the heel of each block to the car floor with five 40-penny nails, and toenail the portion of each block under the tire to the freight car floor with two 40-penny nails. Locate two cleats "D" against the outside face of each wheel. Nail the lower cleat "D" to the freight car floor with three 40-penny nails and the top cleat to the cleat below with three 40-penny nails. Pass four strands, two wrappings, of No. 8 gage, black annealed wire (C, fig. 210) through the holes in the wheels and pass through the stake pockets. Tighten wires enough to remove slack. **NOTE:** *When a box car is used, this strapping must be applied in similar fashion and attached to the floor by the use of blocking or anchor plates. This strapping is not required when gondolas are used.*

(2) **SECOND METHOD** (fig. 210). Place two blocks "G", one at the front and one at the rear of the front wheels. Place two blocks, "G", one at the front of the forward rear wheels and one at the back of the rearward rear wheels. **NOTE:** *These blocks "G" must be at least eight inches wider than the over-all width of the vehicle at the freight car floor.*

**4-TON, 6 x 6 TRUCKS (DIAMOND T MODELS 968A CARGO,
969A WRECKER, 970A PONTON, AND 972 DUMP)**

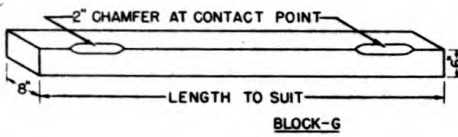
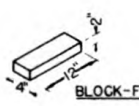
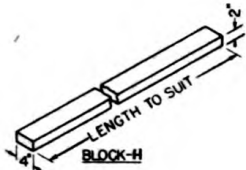
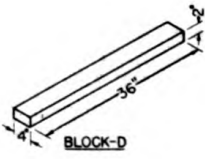
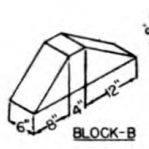
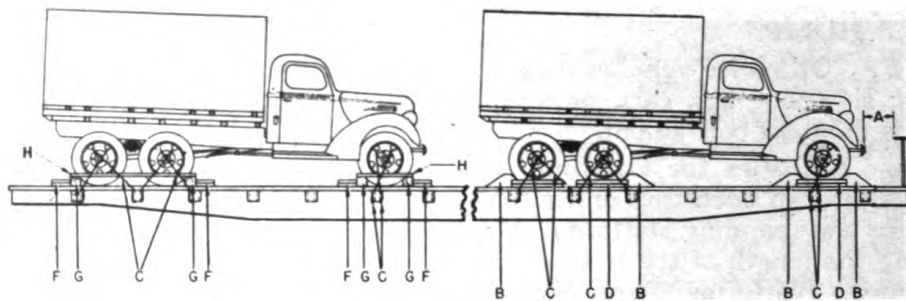

RA PD 318269

RA PD 318269

**Figure 210—Blocking Requirements for Securing Truck
to Railroad Car**

SHIPMENT AND TEMPORARY STORAGE

Locate 16 cleats "F", 2 against blocks "G" at the front and rear of each blocked wheel. Nail lower cleats to freight car floor with the five 40-penny nails, then nail top cleat "F" to lower cleat "F" with five 40-penny nails. Position four cleats "H", one over two cleats "G" and against the outside of each blocked wheel. Nail each end of cleat "H" to cleats "G" with three 40-penny nails. Pass four strands, two wrappings, of No. 8 gage, black annealed wire (C, fig. 210) through the holes in the wheels and pass through the stake pockets. Tighten wires enough to remove slack. *NOTE: When a box car is used, this strapping must be applied in similar fashion and attached to the floor by the use of blocking or anchor plates. This strapping is not required when gondola cars are used.*

d. Shipping Data.

Length over-all, Cargo	268 in.
Wrecker	291 $\frac{5}{8}$ in.
Ponton	296 $\frac{1}{8}$ in.
Width over-all, Cargo	96 in.
Wrecker	101 in.
Ponton	96 in.
Height over-all, Cargo	114 in.
Wrecker	111 in.
Ponton	114 in.
Shipping weight per vehicle:	
Cargo	18,400 lb
Wrecker	21,700 lb
Ponton	18,800 lb
Approximate floor area occupied per vehicle:	
Cargo	178 $\frac{2}{3}$ sq ft
Wrecker	204 sq ft
Ponton	197 sq ft
Approximate volume occupied per vehicle:	
Cargo	1,075 cu ft
Wrecker	1,196 cu ft
Ponton	1,188 cu ft

REFERENCES

STANDARD NOMENCLATURE LISTS.

4-ton, 6 x 6 truck (Diamond T)	SNL G-509
Cleaning, preserving and lubricating materials; re- coil fluids, special oils, and miscellaneous re- lated items	SNL K-1
Soldering, brazing and welding materials, gases, and related items	SNL K-2
Tool sets—motor transport	SNL N-19
Current Standard Nomenclature Lists are listed above. An up-to-date list of SNL's is maintained in the Ordnance Publications for Supply Index	ASF Cat. ORD 2 OPSI

EXPLANATORY PUBLICATIONS.

General.

List of publications for training	FM 21-6
Military motor vehicles	AR 850-15
Driver's manual	TM 10-460
Standard military motor vehicles	TM 9-2800
An up-to-date list of explanatory publications is maintained in index to Ordnance Publications	OFSBI-1

Related Technical Manuals.

Ordnance maintenance: 4-ton, 6 x 6 truck (Diamond T)	TM 9-1811
Ordnance maintenance: Hercules engines	TM 9-1832A

Maintenance and Repair.

Basic Maintenance Manual	TM 38-250
Automotive electricity	TM 10-580
Chassis, body, and trailer units	TM 10-560
Automotive power transmission units	TM 10-585
Automotive brakes	TM 10-565
The internal combustion engine	TM 10-570
Sheet metal work, body, fender and radiator repairs	TM 10-450
Automotive lubrication	TM 10-540
Electrical fundamentals	TM 1-455
Motor vehicle inspections and preventive mainte- nance services	TM 9-2810
Fuels and carburetion	TM 10-550
Maintenance and care of pneumatic tires and rubber treads	TM 31-200
Cleaning, preserving, lubricating and welding materials and similar items issued by the ord- nance department	TM 9-850
Ordnance maintenance: Speedometers and tach- ometers (Stewart-Warner)	TM 9-1829A
Ordnance maintenance: Fuel pumps	TM 9-1828A

TM 9-811

	Ordnance maintenance: Carburetors (Zenith) . . .	TM 9-1826C
	Ordnance maintenance: Electrical equipment (Auto-Lite)	TM 9-1825B
09	Ordnance maintenance: Power brakes systems (Bendix-Westinghouse)	TM 9-1827A
	Cold weather lubrication and service of combat vehicles and automotive materiel	OFSB 6-11
	Detailed lubrication instructions for ordnance materiel	OFSB 6-series
19	Protection of Materiel.	
	Camouflage	FM 5-20
	Explosives and demolitions	FM 5-25
t.	Defense against chemical attack	FM 21-40
OPS:	Decontamination of armored force vehicles	FM 17-59
	Chemical decontamination, materials and equipment	TM 3-220
6	Storage and Shipment.	
1-15	Registration of motor vehicles	AR 850-10
460	Storage of motor vehicle equipment	AR 850-18
1800	Ordnance storage and shipment chart, group G— major items	OSSC-G
1	Rules governing the loading of mechanized and motorized army equipment, also, major caliber guns, for the United States Army and Navy, on open top equipment published by Operations and Maintenance Department of Association of American Railroads.	

1811
1832
-250
-580
-560
-585
-565
-57
45
54
45
280
550
200
350
1825
1825

TM 9-811

**4-TON, 6 x 6 TRUCKS (DIAMOND T MODELS 968A CARGO,
969A WRECKER, 970A PONTON, AND 972 DUMP)**

INDEX

A	Page No.		Page No.
Air compressor (wrecker)	344	horns	216
Air pressure gage	369	stop and taillights	214
Ammeters	369	switches	214
Auxiliary equipment, operation of		Brakes	
air compressor		adjustment	
description	46	brake adjustment	256
operating suggestions	46	front brake anchor pin	
starting air compressor unit	49	adjustment	257
dump truck		air compressor	
controls	49	description	265
operation	52	installation	266
fire extinguisher		maintenance	265
carbon dioxide extinguisher	53	removal	266
carbon tetrachloride		brake chambers	
extinguisher	53	description	263
winch		installation	265
operation	39	removal	264
shear pins	40	brake shoes	
snatch block	40	description	258
winding cable	40	installation	259
winding speeds	40	removal	258
wrecker		brake valve	
brace legs	41	description	268
cautions	43	installation	269
operation	41	removal	268
safety rings on body bolster	45	data, tabulated	251
stowing cable	45	governor	
Axles		description	267
front	240	installation	268
rear	246	maintenance	267
		removal	267
		hand brake valve	
		description	269
		installation	270
		removal	269
		low-pressure indicator, safety valve	
		and air supply valve	
		description	273
		installation	275
		removal	273
		maintenance	
		draining reservoirs	251
		leakage test	254
		pressure test	255
		operation	250

B

Batteries and lighting system

batteries	
adding water	203
corrosion	206
description	203
hydrometer readings	205
installation	206
removal	206
data, tabulated	
battery	203
lights	203
lighting system and horns	
blackout driving light	211
blackout marker light	212
circuit breakers	218
headlights	207

INDEX

B—Cont'd	Page No.	Page No.
Brakes—Cont'd		
parking brake		
adjustment	276	
description	276	
installation	278	
removal	277	
quick release valve		
description	270	
installation	271	
removal	270	
relay valve		
description	271	
installation	271	
removal	271	
slack adjusters		
adjustment	262	
description	261	
installation	263	
removal	262	
stop light switch		
description	272	
installation	272	
removal	272	
C		
Cab		
cab tarpaulins and side curtains		
installation	357	
removal	356	
description	355	
seat cushions and backrests		
installation	360	
removal	360	
windshield		
installation	360	
removal	360	
windshield wipers		
installation	361	
removal	361	
Carburetor	161	
Clutch		
adjustment	157	
data, tabulated	155	
description	155	
installation	160	
removal	159	
Cooling system		
data, tabulated	174	
description		
fan	174	
general	174	
radiator	174	
thermostat	174	
water pump	174	
fan		
adjustment	180	
installation	182	
removal	180	
radiator		
cleaning	177	
installation	178	
removal	177	
servicing		
adding water	175	
cleaning cylinder block water passages	176	
cooling system hose	176	
draining	175	
filling	175	
thawing out radiator	176	
thermostat		
installation	184	
removal	183	
test	184	
water pump		
installation	182	
removal	182	
D		
Data, tabulated		
battery	203	
brakes	251	
clutch	155	
cooling system	174	
dump pump and hoist	349	
front axle	241	
front-mounted winch	324	
fuel system	161	
generating system	193	
ignition system	187	
lights	203	
power take-off	321	
radio interference suppression ..	373	
rear axles	246	
starting system	199	
steering	308	
suspension	202	

TM 9-811

**4-TON, 6 x 6 TRUCKS (DIAMOND T MODELS 968A CARGO,
969A WRECKER, 970A PONTON, AND 972 DUMP)**

D—Cont'd	Page No.	Page No.
Data, tabulated—Cont'd		speedometer 25
transmission	219	starter switch 27
vehicles	20	steering wheel 24
wheels	280	tachometer 24
Description of vehicles		temperature gage 25
data, tabulated		transfer case shift lever 27
capacities	22	transmission lever 27
engine	21	transmission power take-off
performance	20	shift lever 27
vehicle specifications	20	viscometer 25
description		warning plate 24
differences among models	7	windshield wiper 24
general	7	windshield wiper control 24
identification	7	operating the vehicle
designations		cautions 33
chassis plate	11	front axle drive 34
engine plate	11	gearshift (transfer case) 32
general	11	gearshift (transmission) 31
miscellaneous	11	starting under normal
publication plate	11	conditions 29
winch plate	11	stopping 35
winch power take-off plate	11	stopping engine 35
wrecker air compressor plates	11	traction aids 36
wrecker plate	11	use of the tachometer in gear
Driving controls and operation		ratio selection 33
controls and cab equipment		starting and warming up the engine
accelerator pedal	27	general 27
air pressure gage	25	preliminary instructions 29
ammeter	25	towing the vehicle
blackout driving lamp switch	27	caution 37
brake pedal	27	towing disabled vehicle 37
choke button	25	towing to start vehicle 36
clutch pedal	27	Dump pump and hoist
declutching lever	27	data, tabulated 349
dimmer switch	27	description 349
front battery ammeter	25	hoist assembly
fuel gage	25	installation 352
general	24	removal 350
hand brake lever	27	pump assembly
hand control valve	24	installation 354
hand throttle button	25	removal 353
horn button	24	E
ignition switch	25	Engine maintenance and adjustment
instrument lights	24	in vehicle
main light switch	24	cam and idler shaft end play
oil pressure gage	25	adjustment
panel light switch	25	adjustment 143
spark control	25	description 143

INDEX

E—Cont'd	Page No.		Page No.
Engine maintenance and adjustment in vehicle—Cont'd		breather	240
cleaning carbon		data, tabulated	241
cylinder heads, from	137	description	240
engine block, from	137	tie rod replacement	241
crankcase breather	147	toe-in	
cylinder head and gasket installation	137	adjustment	243
cylinder head and gasket removal	137	general	243
data, tabulated	134	Front-mounted winch	
description	134	brake adjustments	
installation	152	drag brake adjustment	326
intake and exhaust manifolds and gaskets replacement		worm shaft brake adjustment	325
installation	142	cable replacement	
removal	142	installation	328
oil filters	145	removal	328
oil pan		data, tabulated	324
installation	143	description	324
oil strainer	143	installation	327
removal	143	removal	326
removal	149	shear pin replacement	329
tune-up		FSMW0 and major unit assembly replacement record	
general	135	description	97
procedure	135	early modifications	97
valve tappet adjustment	139	instructions for use	97
viscometer	147	Fuel system	
		carburetor	
F		adjustments	162
Fan	180	description	161
Fire extinguisher	53	installation	163
Frame and bodies		removal	163
cargo body	315	data, tabulated	161
dump body	319	description	161
frame		fuel pump and filter	
description	312	fuel filter	166
front bumper replacement	313	fuel pump	164
maintenance	312	fuel tank and lines	
pintle hook replacement	312	fuel lines	169
ponton body	319	fuel tank	168
wrecker body	319	gage	369
Front axle		governor	168
axle assembly installation	245	G	
axle assembly removal	244	Generating system	
		data, tabulated	193
		description	193

TM 9-811

4-TON, 6 x 6 TRUCKS (DIAMOND T MODELS 968A CARGO, 969A WRECKER, 970A PONTON, AND 972 DUMP)

G—Cont'd	Page No.	Page No.	
Generating system—Cont'd			
generator		oil pressure gage	
description	193	installation	370
removal	193	removal	370
replacement	193	speedometer	
generator regulator		installation	370
description	195	removal	370
removal	196	tachometer	
installation	197	installation	370
		removal	370
H		temperature gage	
Horns	216	installation	371
		removal	371
I		viscometer	
Ignition system		installation	371
coil and spark plugs		removal	371
coil	191	Intake and exhaust systems	
spark plugs	192	air cleaner	
data, tabulated	187	installation	171
description	187	removal	171
distributor		servicing air cleaner	170
adjusting points	189	description	
description	188	air cleaner	170
installation	191	exhaust system	170
installation of points	188	exhaust system	
removal	190	exhaust tube replacement	171
timing	188	muffler replacement	172
Inspection and preventive maintenance		tail pipe replacement	173
service		Introduction to manual	
after-operation and weekly service		scope	5
procedures	73		
at-halt service		L	
procedures	72	Lighting system	203
before-operation service		Lubrication	
procedures	68	introduction	77
during-operation service		Lubrication Guide	
procedures	70	general	77
purpose	67	lubrication notes	77
Instruments		supplies	77
air pressure gage		N	
installation	369	New vehicle run-in test	
removal	369	correction of deficiencies	99
ammeters		purpose	99
installation	369	run-in procedures	
removal	369	preliminary service	99
fuel gage		run-in test	102
installation	370		
removal	369		

INDEX

O	Page No.	Page No.
Oil pressure gage.....	370	Organization preventive maintenance services
Operation under unusual conditions		road test chart.....
operation in desert or sandy terrain		chassis, body, and attachments
air cleaners	64	tools and equipment.....
cooling system.....	64	second echelon preventive maintenance services.....
general	64	104
special operating instructions	65	Organization tools and equipment
tires	64	special tools.....
operation in extreme cold		98
antifreeze	56	P
chassis lubricants.....	56	Power take-off
cold weather accessories.....	59	data, tabulated.....
engine lubrication.....	55	description
gasoline for low temperatures	54	installation
general	54	removal
general conditions.....	58	Propeller shafts and universal joints
other lubrication points.....	57	description
protection of electrical system	57	installation
starting and operation.....	59	removal
stopping	59	R
transmission, transfer case and differentials	56	Radiator
operation in extreme heat		177
general	63	Radio interference suppression
overheating	63	bonds
special maintenance.....	64	braided bonds.....
operation in mud		bronze plate bond.....
general	65	general
hints for operation.....	65	knife switch clip bonds.....
preparation	65	prepared spots.....
operation in snow		strap clamp bonds.....
drifts	62	types
general	62	data, tabulated.....
heavy snow.....	62	description
light snow.....	62	emergency procedures
stalled vehicles.....	62	general
steep inclines.....	63	location of toothed lock washers.
operation on ice		377
frozen terrain	62	Rear axles
general	60	axle assembly installation
recoveries	61	forward rear axle.....
starting and accelerating on ice	60	rear rear axle.....
steep inclines.....	62	axle assembly removal.....
stopping on ice.....	61	axle shaft replacement.....
vehicle speed.....	60	breather
vehicle stalled.....	61	data, tabulated.....
		description

TM 9-811

**4-TON, 6 x 6 TRUCKS (DIAMOND T MODELS 968A CARGO,
969A WRFCKER, 970A PONTON, AND 972 DUMP)**

R—Cont'd	Page No.	Page No.	
References			
explanatory publications			
general	384		
maintenance and repair	384		
protection of materiel	385		
related technical manuals	384		
storage and shipment	385		
standard nomenclature lists	384		
		series-parallel switch	
		description	201
		installation	202
		removal	202
		solenoid switch	
		description	200
		installation	201
		removal	200
		S	
Seat cushions and backrests	360	Steering	
Sheet metal		adjustments	308
battery box		data, tabulated	308
installation	366	description	308
removal	366	drag link	
fenders		installation	310
installation	365	removal	310
removal	365	operation	308
fender shields		steering Pitman arm	
installation	364	installation	311
removal	364	removal	311
hood		steering wheel	
installation	363	installation	309
removal	362	removal	309
running boards		Suspension	
installation	366	data, tabulated	202
removal	366	description	292
splash shields		front springs	
installation	367	description	294
removal	367	inspection	295
Shipment and temporary storage		installation	295
general instructions	379	maintenance	294
loading and blocking for rail		removal	294
shipment		rear springs	
facilities for loading	381	description	298
preparation	380	inspection	300
securing vehicles	381	installation	301
shipping data	383	removal	299
preparation for temporary stor-		tightening spring seat	299
age or domestic shipment	379	shock absorbers	
Speedometer	370	description	297
Starting system		installation	298
cranking motor		maintenance	297
description	199	removal	297
installation	199	torque rods	
removal	199	description	304
data, tabulated	199	installation	305
description	199	removal	304

INDEX

T	Page No.	W	Page No.
Tachometer	370	Water pump	182
Thermostat	183	Wheels	
Tools and equipment stowage on vehicles		brake drums	
care of tools and equipment....	96	inspection	291
general	85	installation	291
vehicle equipment.....	87	removal	290
vehicle spare parts.....	96	data, tabulated.....	280
vehicle tools.....	85	description	280
Transfer		wheels	
description	226	front and rear wheel bearing	
installation	231	adjustment	287
removal	229	front and rear wheel bearing	
transfer breather		removal	286
cleaning	227	front wheel bearing grease	
description	227	retainer replacement.....	289
Transmission		front wheel bearing removal..	284
data, tabulated.....	219	installation	282
description	219	rear wheel bearing grease	
installation	223	retainer replacement.....	290
removal	219	rear wheel bearing removal..	285
Trouble shooting		removal	281
air compressor unit.....	133	wheel nuts.....	280
axles	130	Winch	38
brakes	131	Windshield wipers	361
clutch	129	Wrecker	
cooling system.....	125	description	331
dump pump and hoist.....	133	outboard brace leg replacement.	342
engine	119	sheave replacement.....	342
fuel system.....	124	transmission roller chain	
generating system.....	127	adjustment	331
ignition system.....	122	installation	331
introduction	119	removal	331
lubricating system.....	126	wrecker boom cable replacement	335
propeller shafts.....	130	wrecker transmission	
starting system.....	122	description	333
steering	132	installation	334
transfer case.....	130	removal	333
transmission	130	wrecker transmission linkage	
winch	132	adjustment	331
wrecker equipment.....	132	wrecker winch cable replacement	338
		Wrecker air compressor	
		air compressor replacement....	346
		description	344
		engine replacement.....	344
		installation	344
		removal	344

RAPDIJUN45-3MR