

67

TM 11-669

DEPARTMENT OF THE ARMY TECHNICAL MANUAL

TRANSIENTS AND WAVEFORMS

DEPARTMENT OF THE ARMY

• NOVEMBER 1951

TRANSIENTS
AND
WAVEFORMS

OFFICIAL:
WM. E. BERGIN
Major General, USA
The Adjutant General

Distribution:

Active Army:

Tech Sec (1); Arm & Svc Bd (1); ATF Bd (as Svc Test Sec) (1); ATF (5); AA Comd (5); OS Maj Comd (25); Base Comd (8); ADW (8); Log Comd (5); A (20); CHG (2); FC (2); Dep (except sec of Gen Dep) (2); Dep II (including Svc Sec of Gen Dep) (20); Jtg Com (2) except II (100); PE OSD (3); Lab II (2); 4th & 5th Bch Main (2); Shop II (2); TO&E II-TN (2); II-TN (2); II-TN (2); II-87N (2); II-87 (2); II-87T (2); II-87 (2); II-87 (2); SPECIAL DISTRIBUTION.

NG—Same as Active Army.

ORC—Same as Active Army.

For explanation of distribution formula, see SR 810-90-1.



DEPARTMENT OF THE ARMY

NOVEMBER 1951

United States Government Printing Office

Washington: 1951

DEPARTMENT OF THE ARMY
WASHINGTON 25, D. C., 12 November 1951

TM 11-669 is published for the information and guidance of all concerned.

[AG 412.42 (19 Oct 51)]

BY ORDER OF THE SECRETARY OF THE ARMY:

OFFICIAL:

WM. E. BERGIN
Major General, USA
The Adjutant General

J. LAWTON COLLINS
Chief of Staff, United States Army

DISTRIBUTION:

Active Army:

Tech Svc (1); Arm & Svc Bd (1); AFF Bd (ea Svc Test Sec) (1); AFF (5); AA Comd (5); OS Maj Comd (25); Base Comd (3); MDW (5); Log Comd (5); A (20); CHQ (2); FC (2); Dep (except Sec of Gen Dep) (2); Dep 11 (including Sig Sec of Gen Dep) (20); Ing Cen (2) except 11 (100); PE, OSD (3); Lab 11 (2); 4th & 5th Ech Maint Shop 11 (2); T/O&E 11-7N (2); 11-15N (2); 11-57N (2); 11-95 (2); 11-537T (2); 11-547 (2); 11-617 (2); SPECIAL DISTRIBUTION.

NG—Same as Active Army.

ORC—Same as Active Army.

For explanation of distribution formula, see SR 310-90-1.



NOVEMBER 1951

DEPARTMENT OF THE ARMY

United States Government Printing Office
Washington 1951

CONTENTS

	Paragraphs
CHAPTER 1. ANALYSIS OF NONSINUSOIDAL WAVEFORMS	1-8
CHAPTER 2. TRANSIENT RESPONSE	9-17
CHAPTER 3. RESPONSE OF R-L CIRCUIT	18-32
CHAPTER 4. RESPONSE OF R-C CIRCUIT	33-43
CHAPTER 5. RESPONSE OF R-L-C CIRCUIT	44-52
CHAPTER 6. APPLICATION OF R-L AND R-C CIRCUITS	
<i>Section I.</i> Effect of time constant on pulse response	53-57
<i>II.</i> Differentiators	58-67
<i>III.</i> Integrating circuits	68-71
<i>IV.</i> D-c restorers	72-74
<i>V.</i> Summary and questions	75-76
CHAPTER 7. FREQUENCY ANALYSIS OF WAVEFORMS	77-85
INDEX	

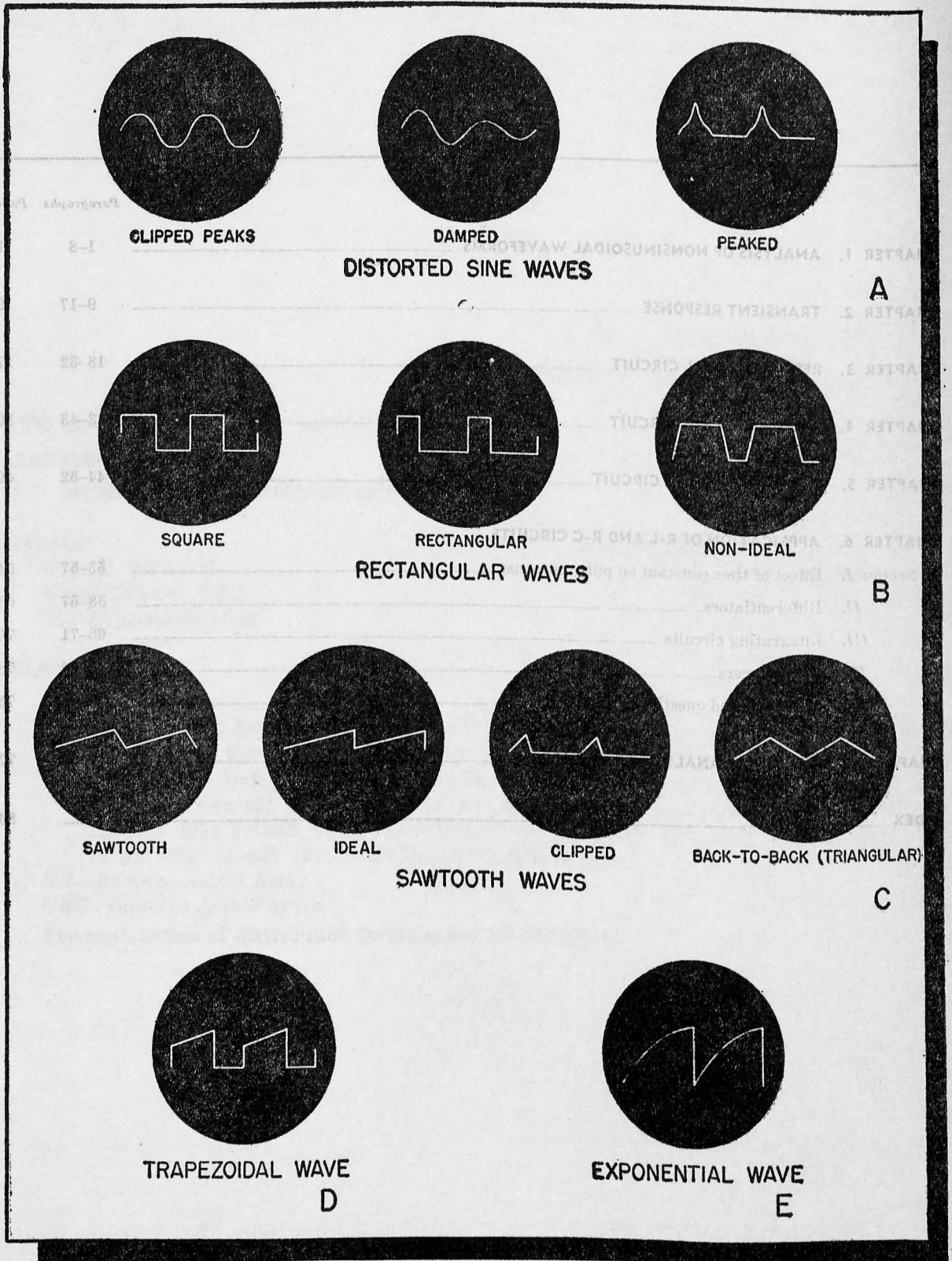

TM 669-1

Figure 1. Periodic nonsinusoidal waveforms.

CHAPTER 1

ANALYSIS OF NONSINUSOIDAL WAVEFORMS

1. Introduction

(fig. 1)

Voltages having complex waveshapes frequently are used in electronic equipment. Since these waveshapes do not follow the conventional sine-wave pattern they are called nonsinusoidal waves. Examples are distorted sine waves, square waves, rectangular waves, trapezoidal waves, and exponential waves. Originally, nonsinusoidal waveforms were regarded as undesirable distortions of sinusoidal waves. Today, however, they are used in many complex circuits, and their study has been extended to determine new ways of producing and utilizing them.

2. Methods of Analyzing Nonsinusoidal Waves

a. Reactance and frequency concepts used for sine waves cannot be applied directly to nonsinusoidal waves. For sine waves, the current flowing through either an inductor or capacitor is equal to the applied voltage divided by the respective reactance. Inductive reactance is equal to $2\pi fL$, and capacitive reactance is equal to $\frac{1}{2}\pi fC$, when f is the frequency of a *pure sine-wave* voltage. If the waveform is not sinusoidal, these formulas do not hold true and current cannot be determined by the relationships used for pure sine waves. Hence, special techniques are required to determine the conditions existing in a circuit when a nonsinusoidal voltage is applied.

b. To study the basic concepts necessary to an understanding of nonsinusoidal waveforms two methods can be used. In one, the wave is expressed in terms of a series of pure sine waves, and the sum of the series is equivalent

to the nonsinusoidal wave. This method permits the direct use of the standard impedance and frequency relationships mentioned above, since the nonsinusoidal wave is reduced to several pure sine waves. The other method, developed in this text (chs. 2 to 6), is known as the *transient-response* method. A transient is a nonsinusoidal wave that appears momentarily when circuit conditions are changed. For example, when a switch is turned on or off in a circuit, the resulting nonsinusoidal waves are known as transients. The transient-response method develops relationships between current and voltage which can be applied direct to nonsinusoidal waves.

3. Harmonic Composition of Nonsinusoidal Waves

a. DEFINITION OF PERIODIC WAVES. There are two types of nonsinusoidal waves—the *aperiodic* wave, which appears at irregular intervals, or only once, and the *periodic* wave (fig. 1) which is repeated at constant intervals. The amplitude of the wave, measured on the vertical or Y-axis, is plotted against time, measured on the horizontal or X-axis. The time axis is calibrated in millionths of a second, or usec (microseconds), rather than seconds. The unit *usec* is used because most transient waveforms occur in very short time periods. The vertical or Y-axis is measured in terms of voltage or current.

b. FUNDAMENTAL AND HARMONIC FREQUENCIES. The rate at which a periodic waveform is repeated is known as the *fundamental* frequency. If a waveform is repeated 1,000 times a second, the fundamental frequency is 1,000 cps (cycles per second). The *second harmonic* of this waveform has a frequency equal to twice the fundamental frequency, or 2,000 cycles.

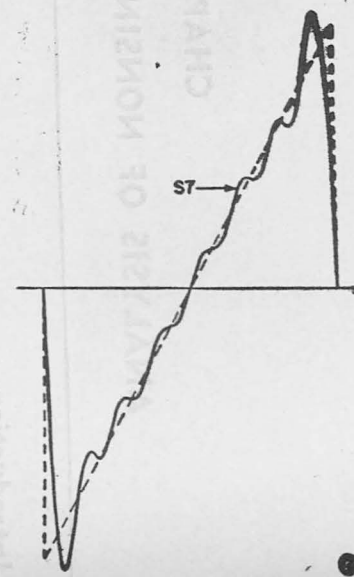
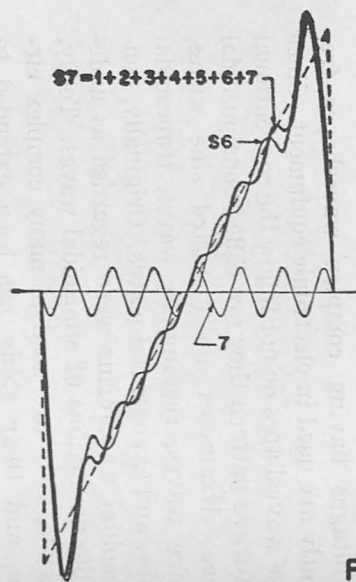
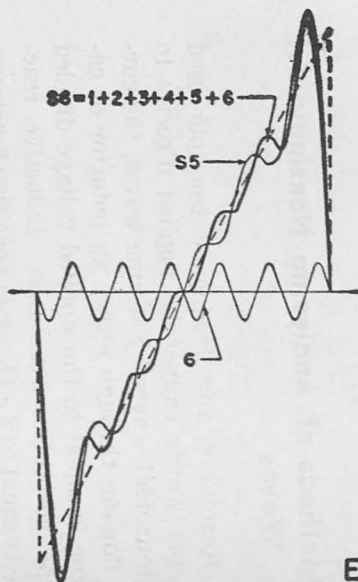
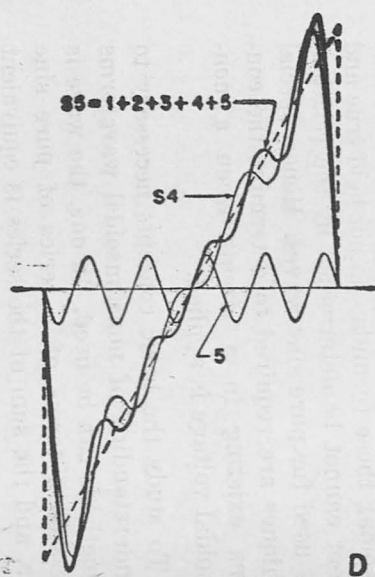
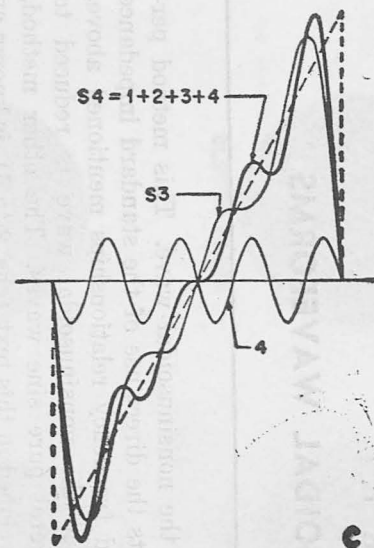
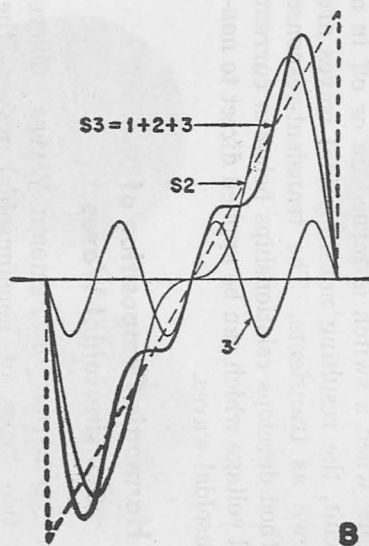
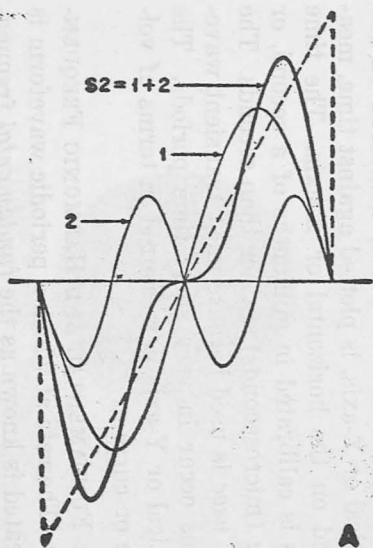

Figure 2. Harmonic composition of a sawtooth.

The *third harmonic* is three times the fundamental frequency, or 3,000 cycles; the *fourth harmonic* is four times the fundamental frequency, or 4,000 cycles, and so on. Generally, the frequency of any harmonic is n times the fundamental frequency, where n is 1, 2, 3, 4, or any other whole number.

c. COMPOSITION OF A SAWTOOTH (fig. 2).

- (1) Any nonsinusoidal waveform that occurs periodically can be constructed by combining a sine wave at the fundamental frequency, sine waves at the harmonic frequencies, and, if necessary, a d-c (direct current) voltage. The sine waves must have the correct amplitude and phase relationships. The sawtooth is obtained by the addition of a fundamental sine wave and its harmonics.
- (2) A of figure 2 shows the addition of the fundamental and its second harmonic. The resultant curve, *S2*, resembles the sawtooth more than the fundamental alone (curve 1). The peaks of curve *S2* are pushed to one side. B shows the resultant curve, *S3*, when the third harmonic is added to the fundamental and the second harmonic. In this curve the peaks are pushed farther to the side and the deviation from the sawtooth is smaller. Each succeeding curve from C to G includes one more harmonic. As each harmonic is added, the resultant curve more nearly resembles the sawtooth voltage. Curve *S7*, in F and G, contains the fundamental plus the second, third, fourth, fifth, sixth, and seventh harmonics. The more harmonics added, the closer the resultant curve approaches the sawtooth. The sawtooth can be reproduced exactly, however, only by the addition of an infinite number of harmonics.

d. COMPOSITION OF SQUARE WAVE.

- (1) Another common waveform used in electronic equipment is the square wave (B of fig. 1). This wave is composed of a fundamental frequency and an infinite number of harmonic fre-

quencies. In this waveform, however, all the *even* harmonic-frequency components—second, fourth, sixth, eighth, and so on—are equal to zero. Only the *odd* harmonics—first, third, fifth, seventh, and so on—are contained in the square wave.

- (2) In A of figure 3 the fundamental and the third harmonics are plotted, and the resultant is curve *S3*. Three cycles occur in curve 3 for each cycle of curve 1. The resultant curve, *S3*, approaches the square wave. In B, the fifth harmonic is added to the third and first, and a fair approximation of the square wave is obtained. The sides of the resultant curve, *S5*, are steeper than before. C shows the waveform when the seventh harmonic is added. Addition of this harmonic increases the steepness of the sides of composite curve *S7*. The more odd harmonics added, the more the resultant curve resembles the square wave. Again, an infinite number of harmonics is necessary to obtain a perfect reproduction of the square wave. A practical square wave or other nonsinusoidal waveform has a finite number of harmonics and the reproduction of these waveforms can be excellent. In practice, 10 harmonics usually are sufficient for good reproduction.

e. OTHER WAVEFORMS. By adding sine waves of the proper frequency, amplitude, and phase it is possible to compose many other waveforms used in electronic equipment (ch. 7). Figures 2 and 3 show that, for all harmonic compositions, the amplitude, and, therefore, the importance, of each succeeding harmonic become less and less. The first, or fundamental, harmonic has the largest amplitude and the following harmonics have progressively smaller amplitudes.

4. Effect of Circuit Bandwidth on Nonsinusoidal Wave

a. When a nonsinusoidal waveform is applied to a circuit, the number of harmonic-frequency components that appear at the output depends

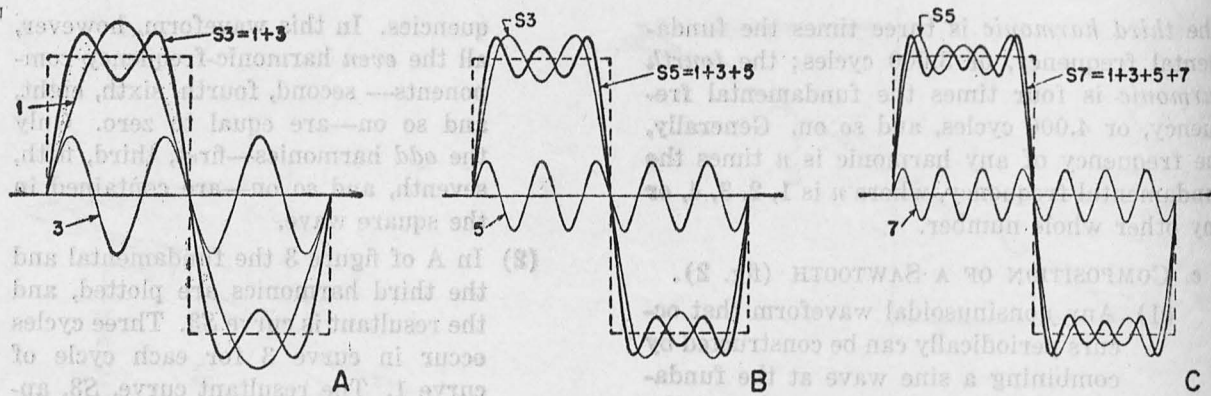

Figure 3. Harmonic composition of a square wave.

TM 669-3

on the circuit bandwidth. The bandwidth represents the range of frequencies that a circuit will pass with a minimum of attenuation. For example, consider the effect of a circuit with a 3,000-cycle bandwidth upon a square wave repeated 1,000 times per second. Since the circuit will pass only frequencies up to 3,000 cps with minimum attenuation, only the fundamental (1,000-cps) and the third harmonic (3,000-cps) appear at the output of this circuit. Although a square wave is applied at the input, the output waveform (A of fig. 4) is distorted badly. If the bandwidth of the circuit is increased to 7,000 cycles, the first, third, fifth, and seventh harmonic frequencies will be passed, and the resultant waveform (B of fig. 4) will show less distortion.

b. When the bandwidth of the circuit is increased, more harmonics are passed, and the output waveform more closely resembles the input waveform. Perfect reproduction of the input waveform at the output requires a circuit with an infinite bandwidth. This circuit cannot be achieved in practice, and actual circuits have bandwidth limitations.

c. The practical bandwidth necessary to pass a nonsinusoidal wave depends on two factors: one, the importance of harmonic relations; two, the function of the waveform in the circuit. The upper frequency limit depends on the fastest change occurring in the waveform. The lower frequency limit depends on the repetition frequency of the waveform. Since the amplitude of each harmonic component usually decreases as the order of harmonics increases, the effect of a higher harmonic is much less than that of a lower harmonic. The tenth harmonic has a much smaller effect on the wave-

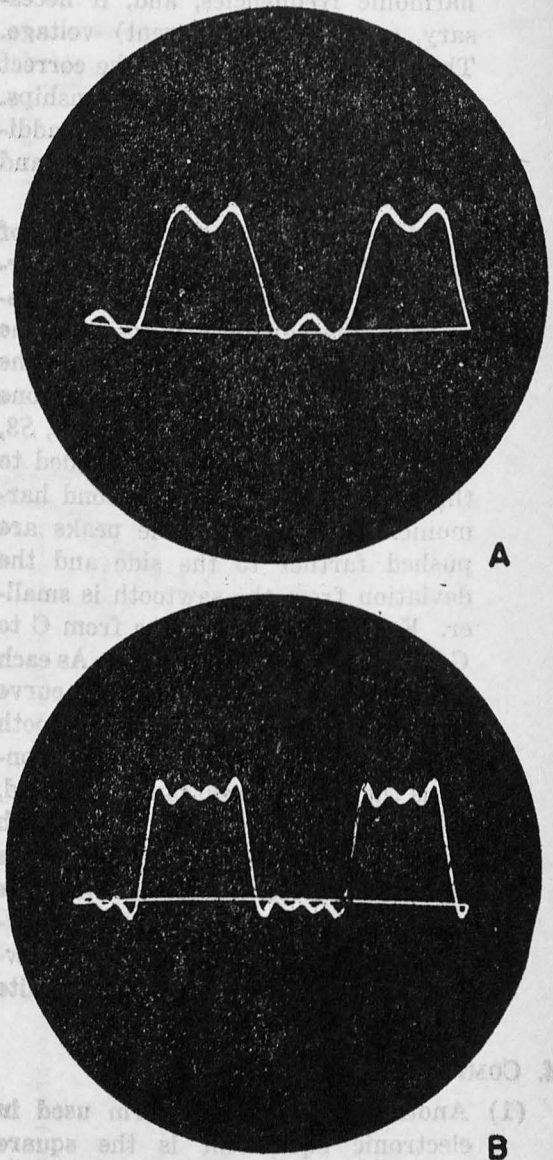

Figure 4. Oscillograms of square wave with low harmonic content.

TM 669-4

form than the second harmonic frequency, the hundredth harmonic has a smaller effect than the tenth harmonic, and so on.

d. A fairly good representation of the waveform can be obtained by using a finite number of harmonics. The effect of the higher-order harmonics depends on the composition of the wave. In some waveshapes, the amplitudes of the higher harmonics decrease rapidly and a narrow bandwidth provides good reproduction of the waveform. In other waveshapes the amplitudes of the higher-order harmonics decrease gradually, and a wider bandwidth is required to obtain good reproduction of the waveform.

e. The minimum bandwidth required also depends on how the waveform is to be used. If the waveform can be modified without seriously affecting the operation of the equipment, a narrower bandwidth can be used. If the waveform must be reproduced with a high degree of fidelity, a wider bandwidth is necessary.

5. Pulse Bandwidth Requirements

a. DEFINITION OF A PULSE. A pulse is defined as a sudden rise and fall of voltage or current. The square wave and the rectangular wave (B of fig. 1) are examples of pulse waveforms that are used in many equipments, such as radar, instrument landing systems, and communication links.

b. PULSE PARAMETERS. The pulse rise time, t_r , is the period required for a pulse to rise from 10 percent to 90 percent of its maximum amplitude (fig. 5). The pulse duration, t_a , is the time the pulse remains at maximum amplitude. The decay time, t_f , is the time required for the pulse to decay (fall) to zero. These times, t_r , t_a , t_f , are the parameters for a pulse. A parameter is a characteristic property which remains constant, or is held constant, during the discussion. The wavefront or rise time of the pulse, t_r , is known as the leading edge of the pulse, and the decay time, t_f , as the trailing edge of the pulse.

c. EFFECT OF HARMONICS ON PULSE RISE AND DECAY TIMES.

- (1) In the composition of the square wave, as higher-order harmonics are added the rise and decay times of the resultant curves become shorter (fig. 3).

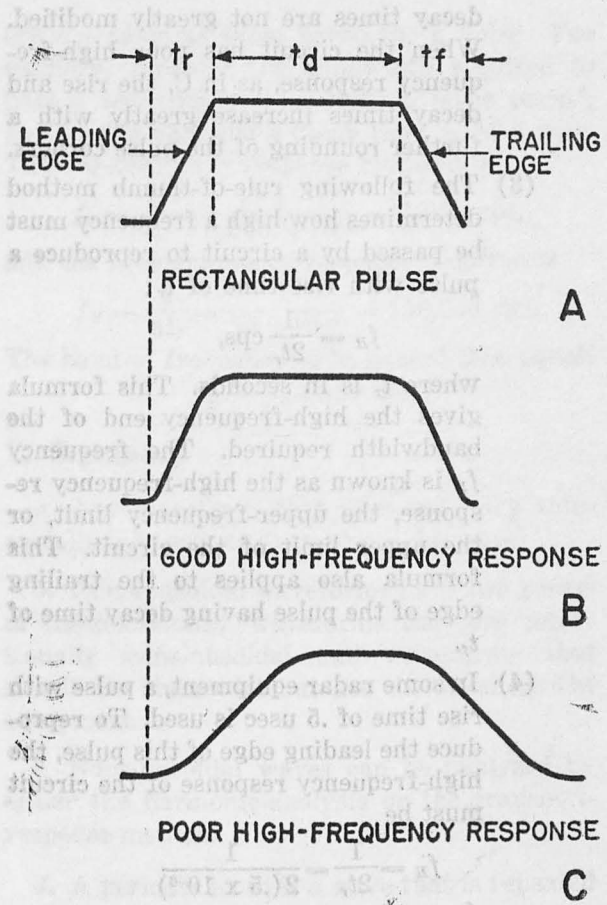

TM 669-5
Figure 5. High-frequency response to rectangular wave.

For example, in C, curve S7 has a shorter rise time than curve S5. In B, curve S5 has a shorter rise time than curve S3. Adding higher-order harmonics to this wave shortens the rise and decay times. For this reason, shape of the pulse during the rise and decay times is determined by the high-frequency response of a circuit. If the circuit has poor high-frequency response, the higher-order harmonics are not reproduced, and the rise and decay times are lengthened (C of fig. 5).

- (2) A rectangular pulse with finite rise and decay times is shown in A of figure 5. Practical circuits modify the shape of this pulse and when a circuit has good high-frequency response, the corners of the pulse are rounded only slightly, as in B; the pulse rise and

decay times are not greatly modified. When the circuit has poor high-frequency response, as in C, the rise and decay times increase greatly with a further rounding of the pulse corners.

- (3) The following rule-of-thumb method determines how high a frequency must be passed by a circuit to reproduce a pulse with rise time of t_r :

$$f_H = \frac{1}{2t_r} \text{ cps,}$$

where t_r is in seconds. This formula gives the high-frequency end of the bandwidth required. The frequency f_H is known as the high-frequency response, the upper-frequency limit, or the upper limit of the circuit. This formula also applies to the trailing edge of the pulse having decay time of t_r .

- (4) In some radar equipment, a pulse with rise time of .5 usec is used. To reproduce the leading edge of this pulse, the high-frequency response of the circuit must be

$$f_H = \frac{1}{2t_r} = \frac{1}{2(.5 \times 10^{-6})}$$

$f_H = 1 \times 10^6 \text{ cps} = 1 \text{ mc (megacycle)}$. The upper-frequency limit of the circuit must be 1 mc to reproduce the leading edge of a pulse having a rise time of .5 usec.

d. EFFECT OF HARMONICS ON PULSE DURATION TIME.

- (1) The duration time t_d of the pulse depends on the low-frequency response of the circuit. Figure 6 shows a square wave passed through a circuit having poor low-frequency response. Note that the curve is not flat over the duration period. To obtain good reproduction of the waveform, the circuit must have good low-frequency, as well as good high-frequency response.
- (2) The lowest frequency f_L that a circuit must pass to reproduce a pulse can be obtained by the formula

$$f_L = \frac{1}{\text{prt}} \text{ cps,}$$

where prt (pulse recurrence time) is

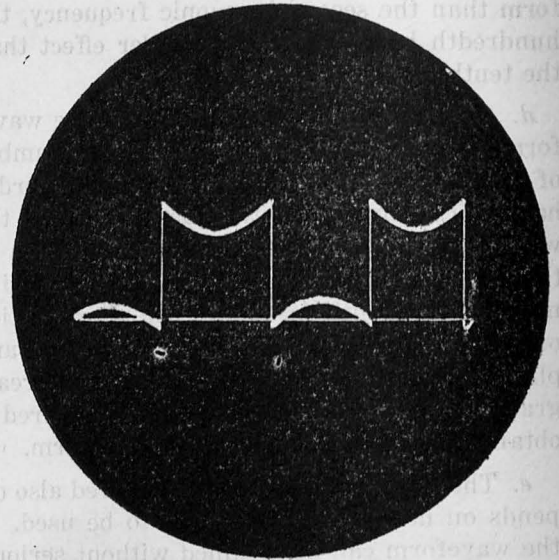

TM 669-6

Figure 6. Effect of poor low-frequency response to square wave.

in seconds. This is the same as saying that

$$f_L = \text{prf,}$$

since the pulse recurrence time is the reciprocal of the prf (pulse recurrence frequency). When the lower-frequency limit of the circuit equals the pulse-recurrence frequency, satisfactory reproduction results. A pulse having a repetition frequency of 1,000 cps requires that the lower limit of the bandwidth be 1,000 cps.

6. Sawtooth Bandwidth Requirements

(fig. 7)

a. The principles discussed in paragraph 5 can be extended to cover other types of non-sinusoidal waveshapes. The high-frequency response affects the pulse during the rise and decay times when the voltage changes most rapidly. The low-frequency response affects the pulse duration when the voltage remains essentially constant. Extending these principles, it can be stated generally that the high-frequency response affects any waveshape when the voltage is changing most rapidly. The low-frequency response affects the waveform when the voltage change is gradual.

b. These principles can be used to determine the effect of the high- and low-frequency response on a sawtooth waveform (fig. 7). The voltage for this waveform increases gradually until the maximum amplitude is reached, and then falls sharply to zero. The low-frequency response affects the rising portion of the sawtooth, and the high-frequency response affects the decay (or flyback) time. B of figure 7 shows the effect of poor low-frequency response on the sawtooth. This waveform is obtained by subtracting the first, second, and third harmonics. In C a poor high-frequency response causes the voltage to decay more gradually and run into the rise time of the next cycle.

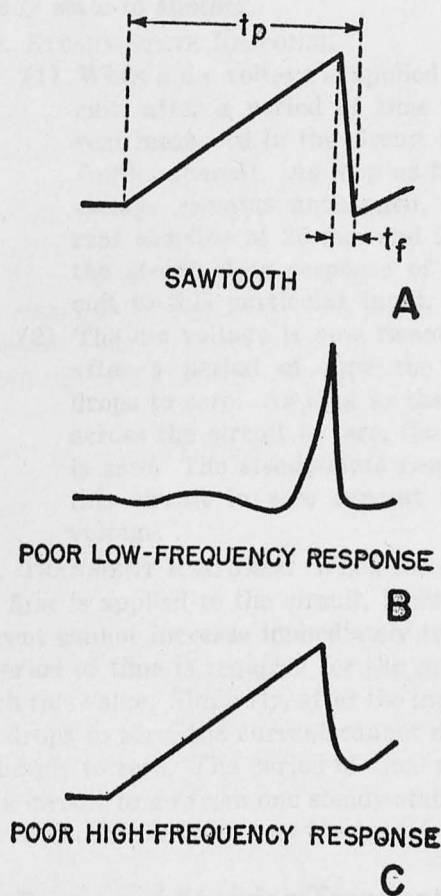

TM 669-7

Figure 7. Effect of bandwidth on sawtooth.

c. The bandwidth of a circuit used to pass a sawtooth voltage should be low enough to pass the fundamental, or $1/t_p$, and sufficiently high to pass a frequency of $1/2t_f$. These equations

are the same as those given for a pulse. For example, consider the bandwidth required to pass a sawtooth voltage with a pulse period, t_p , of 1,000 usec and a decay time, t_f , of 5 usec. The low-frequency response required is

$$f_L = \frac{1}{t_p} = \frac{1}{1,000 \times 10^{-6}} = 1,000 \text{ cps,}$$

and the high frequency response required is

$$f_H = \frac{1}{2t_f} = \frac{1}{10 \times 10^{-6}} = 100,000 \text{ cps.}$$

The band of frequency to be passed then equals

$$f_H - f_L \text{ or } 99 \text{ kc.}$$

7. Summary

a. Any waveform that does not vary sinusoidally is known as a nonsinusoidal wave.

b. Nonsinusoidal waveforms have two general classifications: waveforms that are intentionally nonsinusoidal and waveforms that should be sinusoidal but are distorted by the equipment.

c. Nonsinusoidal waves can be analyzed by either the harmonic-analysis or the transient-response method.

d. A periodic wave is a wave that is repeated at constant intervals.

e. Nonsinusoidal periodic waves can be constructed from a series of harmonically related sine waves.

f. The lowest frequency in this harmonic series is the fundamental, or first harmonic frequency, and it is equal to the waveform repetition frequency.

g. It is possible to obtain good reproduction of a nonsinusoidal waveform by using a finite number of harmonics.

h. The bandwidth of the circuit passing a nonsinusoidal wave should be wide enough to pass the highest and lowest harmonics necessary for good waveform reproduction.

i. Good reproduction of a pulse during rise and decay time depends on the high-frequency response of the circuit.

j. Good reproduction of a pulse over duration time depends on the low-frequency response of the circuit.

8. Review Questions

- What is a nonsinusoidal wave?
- What is a periodic wave?
- Why cannot conventional impedance relationships be used with nonsinusoidal waves?
- A pulse occurs at a rate of 1,000 times per second. What is the frequency of the fifth harmonic?
- What is meant by the bandwidth of a circuit?

f. How does the waveform to be passed determine the necessary upper and lower frequency limits of bandwidths?

g. What is the effect of the amplitudes of the harmonics on bandwidth requirements?

h. Give the bandwidth requirements for passing a pulse repeated 1,000 times a second, having rise and decay times of 2 usec, and duration time of 200 usec. The pulse is flat over the duration time.

Summary

1. Any waveform that does not vary sinusoidally is known as a nonsinusoidal wave.

2. Nonsinusoidal waveforms have two general classifications: waveforms that are intentionally nonsinusoidal and waveforms that should be sinusoidal but are distorted by the equipment.

3. Nonsinusoidal waves can be analyzed by either the harmonic analysis or the transient response method.

4. A periodic wave is a wave that is repeated at constant intervals.

5. Nonsinusoidal periodic waves can be constructed from a series of harmonically related sine waves.

6. The lowest frequency in this harmonic series is the fundamental, or first harmonic frequency, and it is equal to the waveform repetition frequency.

7. It is possible to obtain good reproduction of a nonsinusoidal waveform by using a finite number of harmonics.

8. The bandwidth of the circuit passing a nonsinusoidal wave should be wide enough to pass the highest and lowest harmonics necessary for good waveform reproduction.

9. Good reproduction of a pulse during rise and decay time depends on the high-frequency response of the circuit.

10. Good reproduction of a pulse over duration time depends on the low-frequency response of the circuit.

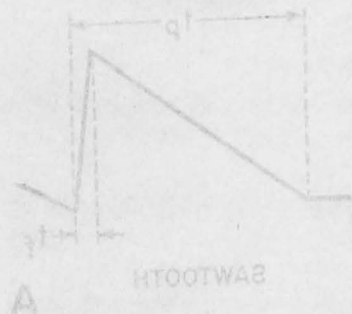

FIGURE 8-1. Effect of bandwidth on sawtooth.



FIGURE 8-2. Effect of bandwidth on sawtooth.

11. The bandwidth of a circuit used to pass a sawtooth voltage should be low enough to pass the fundamental or 1st and sufficiently high to pass a frequency of 1/3rd. These equations

CHAPTER 2

TRANSIENT RESPONSE

9. Steady-State and Transient Response

Electrical circuits have two response characteristics: The *steady-state* response is the long time effect of a voltage, or current, on a circuit; the *transient* response is the effect on a circuit of changing a voltage or current from one steady state to another.

a. STEADY-STATE RESPONSE.

(1) When a d-c voltage is applied to a circuit, after a period of time the current measured in the circuit is 20 ma (milliamperes). As long as the input voltage remains unchanged, the current remains at 20 ma, and 20 ma is the *steady-state* response of the circuit to this particular input.

(2) The d-c voltage is now removed, and after a period of time the current drops to zero. As long as the voltage across the circuit is zero, the current is zero. The *steady-state* response of this circuit in zero current for zero voltage.

b. TRANSIENT RESPONSE. When the d-c voltage first is applied to the circuit, however, the current cannot increase immediately to 20 ma. A period of time is required for the current to reach this value. Similarly, after the input voltage drops to zero, the current cannot drop immediately to zero. The period of time required for a circuit to go from one steady-state condition to another is known as the *transient* time.

10. Purpose of Studying Transient Response

a. To determine the response of a circuit to a nonsinusoidal waveform, it is necessary to describe this waveform in terms of a series of harmonically related sine waves (ch. 1). Since nearly all of the a-c (alternating-current) wave-

forms used in early electrical equipment were sinusoidal, standard impedance relationships were based on the sine wave. All steady-state response characteristics can, therefore, be obtained by using a-c theory.

b. During transient times the voltages are nonsinusoidal, and therefore, the study of transients is the study of the response of networks to nonsinusoidal voltages. Although the harmonic-series method can be used to determine the transient response, this method is cumbersome, and the easier *transient-response* method of analysis is preferable.

11. Types of Transients

a. The original term *transient* was used to describe what occurred during the period of time immediately after a piece of equipment was turned on or off, or after some unusual disturbance occurred in the equipment. Today, the term *transient* has been *expanded* to mean virtually any nonsinusoidal voltage. The reason for this is simple. When nonsinusoidal voltages, such as pulse or sawtooth waveforms, first were used in electronic equipment, it was found that the methods developed to study transients could be applied to all nonsinusoidal waveforms. The meaning of *transient* or *pulse response* was then taken to include the effects of these nonsinusoidal waveforms.

b. When a d-c voltage is applied to or removed from a circuit, a *transient* occurs before the circuit reaches its steady-state condition. Similarly, a transient occurs when a sine-wave generator is turned on. These transients, as well as pulse and sawtooth voltages, are examples of nonsinusoidal waveforms that can be analyzed by *transient-response* methods.

12. Response of Simple R Circuit

a. BASIC PRINCIPLES. The study of transient

response is based on the fundamental, or *natural*, behavior of the three basic elements, *resistance*, *inductance*, and *capacitance* when voltage is applied. The natural behavior of these elements relates the current through the element to the applied voltage, or the voltage across any element to the current flowing through it. It is from these fundamental relations that all impedance equations which assume sinusoidal currents and voltages are derived. This manual will use these fundamental relations to determine the response of circuits to nonsinusoidal waveforms.

b. OHM'S LAW.

- (1) The natural behavior of a resistive circuit is defined by Ohm's law, which in one form states that the voltage across a resistance is equal to the current flowing through it times the resistance. This shows that a simple linear relation exists between current and voltage at any time in a resistive circuit. A resistive circuit therefore *does not* require time to adjust to a change in voltage or current. Consequently, a resistive circuit has no transient response.
- (2) The current and voltage waveforms in a resistive circuit are similar in shape and related in amplitude by the value of resistance R . In figure 8, resistor R

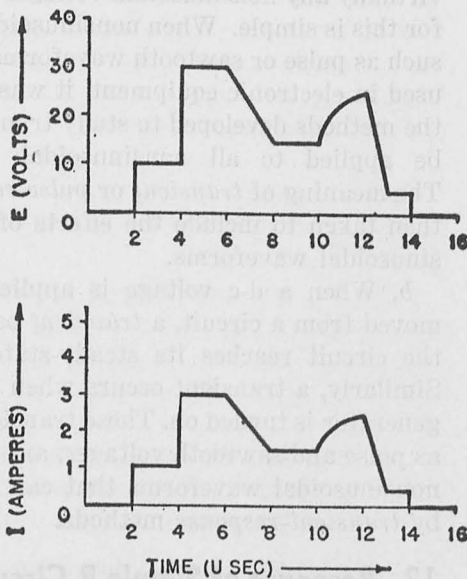

Figure 8. Response of simple R circuit.

is 10 ohms and the numerical value of the current waveform at any time is one-tenth the corresponding value of the voltage waveform. For example, after 8 usec, E is 15 volts and I is 1.5 amperes. Similarly, the voltage after 13 usec is 5 volts and the current is .5 ampere. At any instant of time, the current is equal to the voltage divided by the resistance, *regardless* of whether the waveform is d-c, a-c, or pulsed, and the current waveform is similar to the voltage waveform.

13. Response of Simple L Circuit

a. ANALOGY OF INDUCTANCE AND MASS.

- (1) The relationship between current and voltage in an inductance is shown in the analogy illustrated in figure 9. Inductance L is represented by mass M (a truck), voltage E is represented by force F exerted against the mass, and current I is represented by the velocity, V , at which the mass (truck) moves. The speed, or velocity, of the truck is equal to the distance it travels per unit time. Assume that no resistance, or its equivalent friction, exists in the system.
- (2) A greater force is required to start a

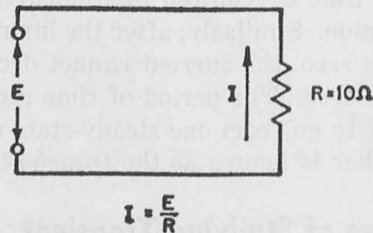

YM 669-B

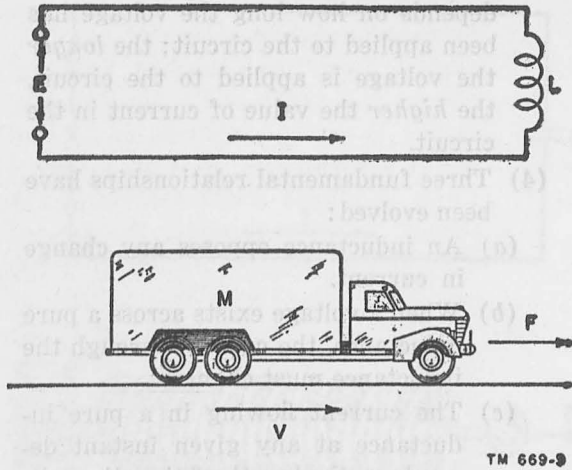

Figure 9. Analogy of inductance and mass.

truck moving than is required to keep it moving. That is why the first gear is used to start the truck and the third gear keeps it moving. The force also varies with the weight of the truck. The heavier the truck, the greater the force required.

(3) For example, once a truck reaches a speed of 40 miles per hour no force is required to maintain this speed if there is no friction between tires and road. When the speed of the truck is increased to 60 miles per hour, a force must be exerted in the forward direction. In other words, it is necessary to step on the gas. In the absence of friction, however, if this force is maintained, the car speed will increase indefinitely. The speed at any time is a function of the force applied to the truck and the time it is maintained. Despite friction, a truck continues to travel after the gas pedal has been released. To stop it, the brakes must be applied to exert a counter force, and the force needed depends on the speed and weight of the truck.

(4) The following, therefore, are fundamental principles: A truck tends to maintain its steady-state conditions. When at rest (zero speed), a force is necessary to build up the speed to 40 miles an hour. If it is traveling at 40 miles an hour, a force is required to

bring it to zero speed. The speed of the truck increases indefinitely when constant force is applied; the speed is proportional to the force applied to the truck.

b. FUNDAMENTAL INDUCTANCE EQUATIONS.

(1) The principles applied to the truck in the preceding discussion are true for a simple inductance circuit. Electrons at rest in an inductance act just as the truck does. They tend to *remain at rest and oppose movement, or flow of current*. Similarly, when electrons are moving, they tend to *maintain their movement and oppose any change in current*. When no current is flowing in the circuit and a voltage (force) is applied, the inductance tends to prevent current from flowing in the circuit. This opposition to the applied voltage is known as *back emf*, or back electromotive force, and is dependent on the size of the inductor. The larger the inductance, the greater the opposition to any change. Similarly, when a current is flowing through an inductance and the applied voltage drops to zero, the back emf tends to maintain the current flow.

(2) When a voltage is applied across a pure inductance, the current through the inductance *increases continuously* (fig. 10). For example, a 5-volt battery with zero internal impedance is connected across a pure inductance, in A. An ammeter is placed in the circuit to measure the current flow, and the reading on the ammeter increases steadily. At the end of 1 second it reads 1 ampere; at the end of 2 seconds, 2 amperes; at the end of 5 seconds, 5 amperes. At the end of every second the current has increased by 1 ampere. This circuit, therefore, has a *rate of current increase* of 1 ampere per second, as in C. Note that the current waveform is different from the waveform of the applied voltage, in B.

(3) The value of inductance, L , can be determined by finding the ratio of the applied voltage (5 volts) to the rate

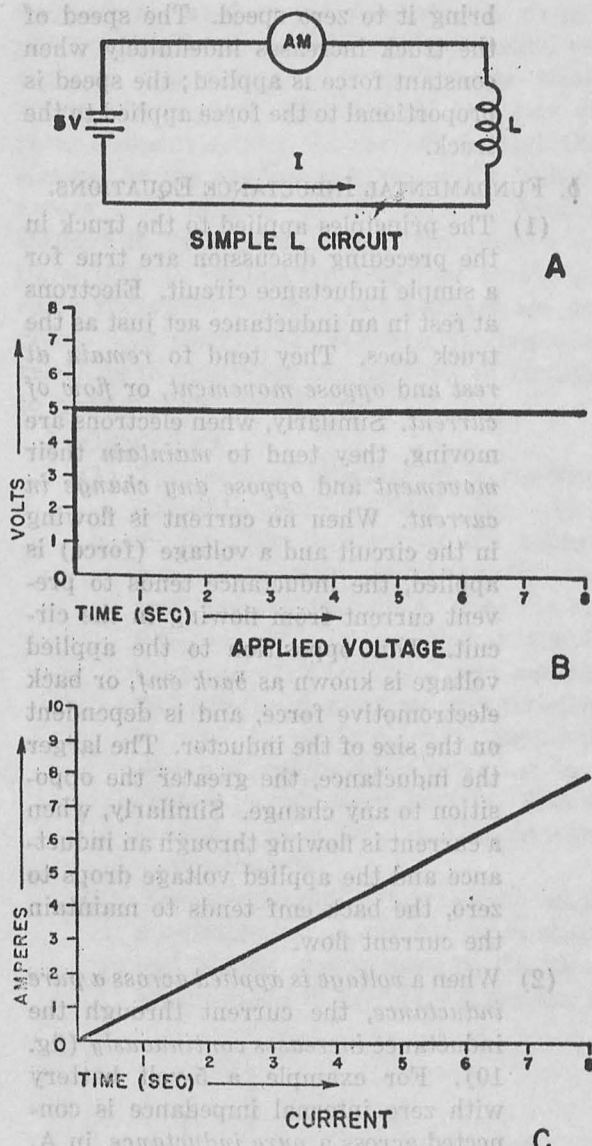

Figure 10. Response of simple L circuit.

of current increase (1 ampere per second), or 5 henrys. When the inductance in this circuit is increased to 10 henrys (with battery voltage constant), the rate of current increase becomes .5 ampere per second. This demonstrates an important fact: the larger the inductance, the greater its opposition to a change in current flow, and the smaller the rate of current increase for a given applied voltage. Since the current increases every second, the value of current at any instant

depends on how long the voltage has been applied to the circuit; the longer the voltage is applied to the circuit, the higher the value of current in the circuit.

- (4) Three fundamental relationships have been evolved:
 - (a) An inductance opposes any change in current.
 - (b) When a voltage exists across a pure inductance, the current through the inductance must change.
 - (c) The current flowing in a pure inductance at any given instant depends on the length of time the voltage has been applied to the circuit.
- (5) From these fundamental relationships it is possible to determine the response of an inductance to any voltage waveform. It is important to note that these relationships assume the existence of a pure inductance. Actual inductors always have series resistance, and the current does not increase indefinitely when a d-c voltage is applied (ch. 3).

14. Response of Simple C Circuit

a. ANALOGY OF CAPACITANCE AND SPRING.

- (1) The relation between charge, current, and voltage in a capacitor is illustrated by analogy in figure 11. The capacitor is represented by a spring; voltage E is represented by a force, F , against the spring. The charge, Q , is represented by distance S to which the spring is stretched. The current in the circuit is equal to the amount of charge flowing into the capacitor per second, and can be represented by the distance per second that the spring is stretched. It is assumed that no resistance, or its equivalent friction, exists in the system.
- (2) When a constant force, F , is applied to a spring, it begins to stretch. It stretches easily at first and the distance it stretches per second is large. The farther the spring is stretched, the smaller the distance covered each

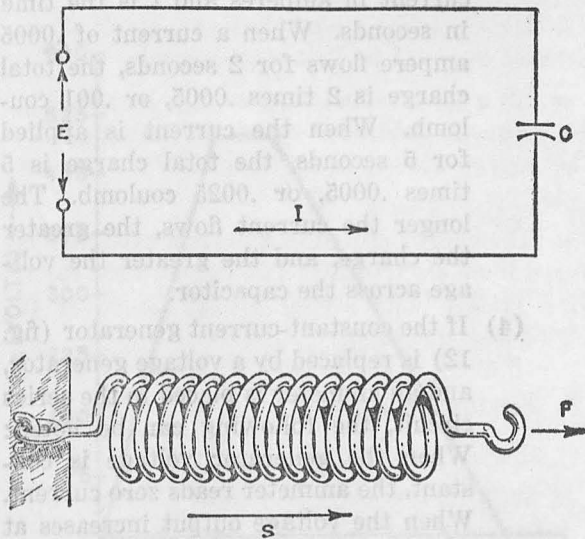

TM 669-11

Figure 11. Analogy of capacitance and spring.

second. Stretching the spring develops a counter force which is opposite to the applied force and tends to return the spring to its original condition. Finally, the spring cannot be stretched any farther, and at this time the counter force is equal to the applied force. (If the applied force is increased, the spring can be stretched farther.)

- (3) When this applied force is released, the spring returns to its original position with a counter force equal to the applied force. The velocity is large at the beginning of the return cycle and, as the spring comes closer to its original state, the counter force decreases and therefore the velocity (distance per second) decreases.
- (4) The total distance, S , that the spring is stretched depends directly on the force, F , and inversely on the stiffness, K , of the spring. Therefore, the velocity of the spring depends directly on the force and inversely on the stiffness.
- (5) The following, therefore, are fundamental principles:
 - (a) When a constant force is applied to a spring it stretches to some distance, S , depending on F and K , and

maintains this position so long as the force is applied.

- (b) The counter force developed by the spring is proportional to the total distance, S , that the spring is stretched and the spring stiffness, K .
- (c) After the spring has been stretched, it can be moved only by *changing* the applied force. When the force is increased, the spring stretches farther; when the force is decreased, the spring contracts. The velocity with which the spring changes its position is proportional to the change in the applied force. If the change in applied force is very large, the spring moves at a high velocity; if the force is small, the spring changes its position slowly.

b. FUNDAMENTAL CAPACITANCE EQUATIONS.

- (1) The fundamental principles cited above for the action of a spring are equally true for the simple capacitance circuit. When a d-c voltage is applied across a capacitor, a current starts to flow. The current flow is large at first, but decreases as the capacitor charges and becomes zero when the voltage charge on the capacitor is equal and opposite to the applied d-c voltage. Thereafter, although the d-c voltage continues to be applied across the capacitor, no further current flows: *A capacitor cannot pass a d-c current.* When the d-c voltage is removed and the capacitor is discharged, the current flow again is large at first and decreases to zero as the capacitor becomes completely discharged.
- (2) When a greater amount of charge is applied to a capacitor, the voltage across it increases. For example, a constant-current generator is connected across an *ideal capacitor* (fig. 12). The generator supplies a current of .0005 ampere, or .0005 coulomb per second. A voltmeter is connected across the capacitor, and the reading on this voltmeter increases steadily.

As the capacitor accumulates more and more charge, the voltage across the capacitor increases. At the end of 1 second, the voltmeter reads 5 volts, at the end of 2 seconds, 10 volts, and at the end of 5 seconds, 25 volts. The voltage across a charged capacitor is proportional to the total amount of charge in the capacitor.

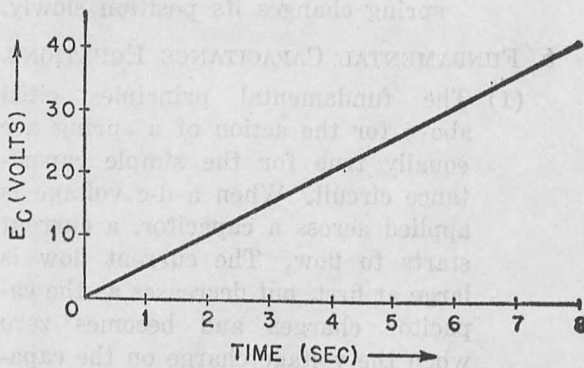
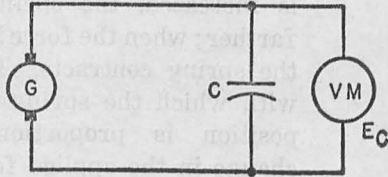

TM 669-12

Figure 12. Voltage response of simple C circuit with current constant.

- (3) The voltage increases 5 volts for every .0005 coulomb of charge added to the capacitor, or 5 volts per second. Capacitance C is equal to the current (charge per second) divided by the voltage rate of change.

$$C = \frac{Q}{E}$$

Therefore, C equals 100 microfarads (.0005 ampere/5 volts). When a smaller capacitance of 10 microfarads is used, the voltage increases at a rate of 50 volts per second. The smaller the capacitor, the greater the voltage across it for a given amount of charge. The total charge in coulombs at any time t is equal to I^t , where I is the

current in amperes and t is the time in seconds. When a current of .0005 ampere flows for 2 seconds, the total charge is 2 times .0005, or .001 coulomb. When the current is applied for 5 seconds, the total charge is 5 times .0005, or .0025 coulomb. The longer the current flows, the greater the charge, and the greater the voltage across the capacitor.

- (4) If the constant-current generator (fig. 12) is replaced by a voltage generator, and an ammeter is placed in the series circuit, the following can be noted: When the generator voltage is constant, the ammeter reads zero current. When the voltage output increases at a rate of 50 volts per second (fig. 13), the ammeter reads 50 ma. As long as the voltage increases at a rate of 50 volts per second, the ammeter reads 50 ma. After 10 seconds, the generator voltage reaches 500 volts and stays at this value for 5 seconds. During this period the voltage is not changing and the ammeter reads zero. After 15 seconds, the voltage begins to decrease at a rate of 25 volts per second. The ammeter now reads 25 ma in the reverse direction, since the applied voltage is decreasing and the capacitor is discharging.

- (5) Capacitance C in the circuit is equal to current I divided by the voltage change. The capacitance is, therefore, 50 times 10^{-3} amperes divided by 50 volts per second, or 10^{-3} farads (1,000 microfarads). If the capacitance in the circuit is 100 microfarads and the voltage rate of the change is 50 volts per second, the ammeter will read 5 ma. Therefore, the smaller the value of capacitance, the smaller the current flow for a given voltage change. The current flow in the circuit is proportional to the magnitude of voltage change.
- (6) Three fundamental relationships have been established:
- A capacitor cannot pass d-c.
 - The voltage across a capacitor is

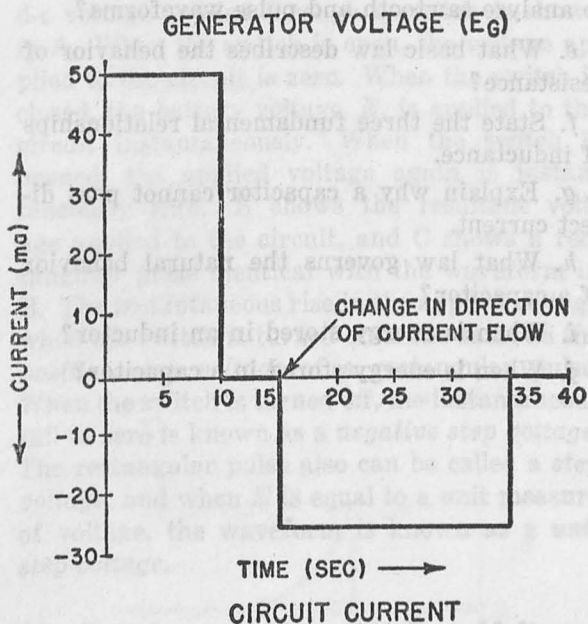
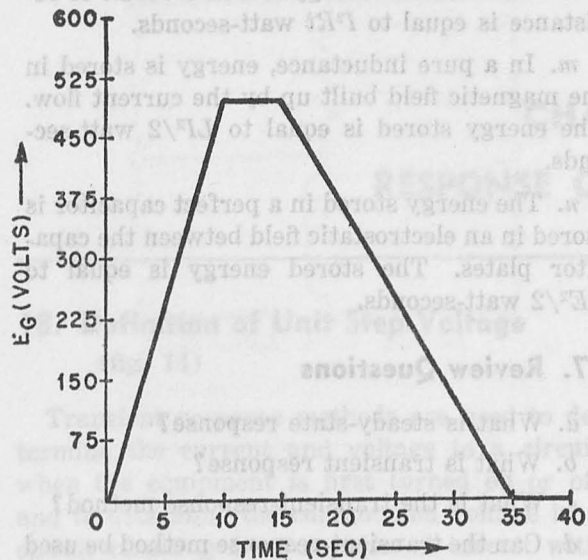

TM 669-13

Figure 13. Current response of simple C circuit with variable voltage.

proportional to the amount of charge in the capacitor.

- (c) The current flowing into a capacitor is proportional to the voltage change across the capacitor.
- (7) From these fundamental relationships it is possible to determine the response of any capacitor to any voltage waveform. It is important to note, how-

ever, that these relationships assume the existence of pure capacitance. Practical capacitances have some series resistance which modifies the current and voltage responses (ch. 4).

15. Energy Considerations

a. IN RESISTANCE. When current flows through a resistance, some of the electrical energy is changed to heat. The amount of power lost as heat when a current, I , flows through a resistance, R , is equal to I^2R watts. The energy in watt-seconds or joules is equal to I^2Rt . Since no practical circuit can be without resistance, a certain amount of electrical energy must be lost as heat.

b. IN INDUCTANCE. When a current starts to flow through an inductance, a magnetic field is created around the inductor that increases as the current increases and collapses as the current decreases. The energy supplied to a pure inductance is stored in this magnetic field, and at any time, with current I flowing through inductance L , is equal to $LI^2/2$ watt-seconds. When the current through the inductance increases, the magnetic field builds up, and energy is stored. When the current in the inductor decreases the magnetic field collapses, and the energy is returned to the line. No power is expended in a pure inductance. It is alternately stored in the magnetic field when the current increases, and returned to the line when the current decreases.

c. IN CAPACITANCE. All of the energy supplied to a capacitor is stored between the capacitor plates in the form of an electrostatic field. The energy in a capacitor increases as the square of the voltage. If the voltage across the capacitor is E and the capacitance is C , the electrostatic energy stored in the capacitor is $CE^2/2$ watt-seconds, or joules. When a capacitor is charging, the electrostatic field becomes stronger, and energy is stored. When a capacitor is discharging, the electrostatic field becomes weaker, and energy is given up. No power is expended in a pure capacitance. When it is charging, the energy is stored between the plates, and on discharge the energy is returned to the line.

16. Summary

a. Electrical circuits have two response characteristics, steady-state and transient.

b. The steady-state response is the long-time effect on voltage and current in a circuit, caused by a change in the input.

c. The transient time is the time required for a circuit to go from one steady-state condition to another.

d. The current or voltage in the circuit during the transient time is known as the transient response.

e. The transient response method can be used for the study of nonsinusoidal waveforms.

f. The study of transient response utilizes the fundamental, or natural, behavior of resistance, inductance, and capacitance when voltage is applied.

g. The natural behavior of a resistance is designated by Ohm's law: $E=IR$. This means that a resistance has no transient response.

h. An inductance opposes any change in current flow.

i. The voltage across an inductance is equal to L times the rate of change in current flow.

j. A capacitance cannot pass direct current.

k. The voltage across a capacitor is equal to the total charge divided by the capacitance.

l. The electrical energy lost as a result of resistance is equal to I^2Rt watt-seconds.

m. In a pure inductance, energy is stored in the magnetic field built up by the current flow. The energy stored is equal to $LI^2/2$ watt-seconds.

n. The energy stored in a perfect capacitor is stored in an electrostatic field between the capacitor plates. The stored energy is equal to $CE^2/2$ watt-seconds.

17. Review Questions

a. What is steady-state response?

b. What is transient response?

c. What is the transient-response method?

d. Can the transient-response method be used to analyze sawtooth and pulse waveforms?

e. What basic law describes the behavior of resistance?

f. State the three fundamental relationships of inductance.

g. Explain why a capacitor cannot pass direct current.

h. What law governs the natural behavior of a capacitor?

i. When is energy stored in an inductor?

j. When is energy stored in a capacitor?

CHAPTER 3

RESPONSE OF R-L CIRCUIT

18. Definition of Unit Step Voltage

(fig. 14)

Transient response methods are used to determine the current and voltage in a circuit when the equipment is first turned on or off and to determine the current and voltage in a circuit resulting from a pulse. A circuit with d-c voltage applied through a switch is shown in A. When the switch is open, the voltage applied to the circuit is zero. When the switch is closed, the battery voltage, E , is applied to the circuit instantaneously. When the switch is opened, the applied voltage again is instantaneously zero. B shows the resultant voltage applied to the circuit, and C shows a rectangular pulse identical with the waveform in B. The instantaneous rise in the applied voltage when the switch is turned on is the same as the *positive step voltage* of a rectangular pulse. When the switch is turned off, the instantaneous fall to zero is known as a *negative step voltage*. The rectangular pulse also can be called a *step voltage*, and when E is equal to a unit measure of voltage, the waveform is known as a *unit step voltage*.

19. Positive and Negative Step Voltages

The response of a circuit is essentially the same for an on-off d-c transient as for a rectangular pulse, and the step voltages can be either positive or negative. A *positive step voltage* occurs when the rectangular pulse first is applied to the circuit (A of fig. 14). Similarly, when the switch is turned off or the rectangular pulse ends, as in B, the instantaneous voltage change from E to zero is called a *negative step voltage*. A rectangular pulse consists of a positive and a negative step voltage, occurring suc-

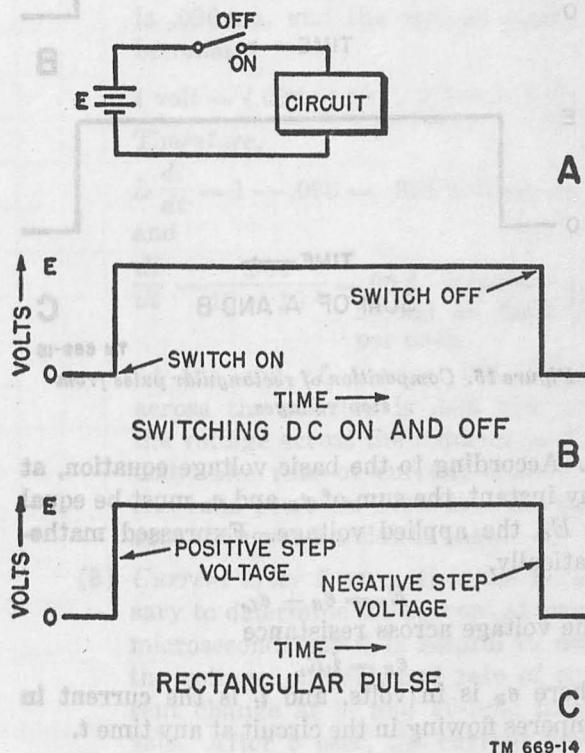

Figure 14. D-c switching and rectangular pulse.

cessively. The addition of these two step voltages is shown in figure 15.

20. Basic Voltage Equation

(fig. 16)

a. To determine the response of any circuit to a step voltage, the basic voltage equation derived from Kirchhoff's law must be used. This equation states that *the sum of the voltage drops in any closed circuit is equal to the applied voltage*. For example, a voltage, E_s , is applied across a series R - L circuit (fig. 16). The voltage drop across R is designated as e_R , and the voltage drop across L is designated as

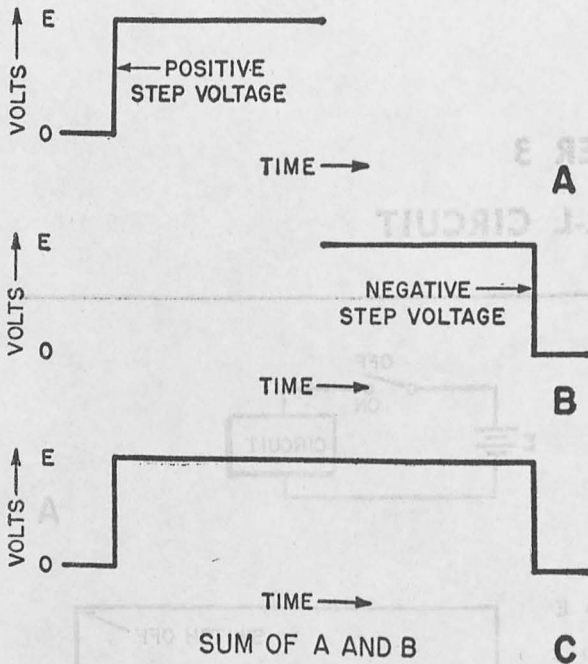

Figure 15. Composition of rectangular pulse from step voltages.

e_L . According to the basic voltage equation, at any instant, the sum of e_R and e_L must be equal to E_b , the applied voltage. Expressed mathematically,

$$E_b = e_R + e_L.$$

The voltage across resistance

$$e_R = i_t R,$$

where e_R is in volts, and i_t is the current in amperes flowing in the circuit at any time t .

b. Voltage e_L across the inductance is expressed by the formula

$$e_L = L \frac{di}{dt},$$

where e_L is in volts, L is in henrys, and di/dt is in amperes per second. The symbol d signifies the rate of change of any quantity. The basic voltage equation for the series R - L circuit then becomes

$$E_b = i_t R + L \frac{di}{dt}$$

at any instant of time t .

21. Response of Series R - L Circuit to Positive Step Voltage

(fig. 16)

a. GENERAL DESCRIPTION.

(1) When the positive step voltage, in B, is

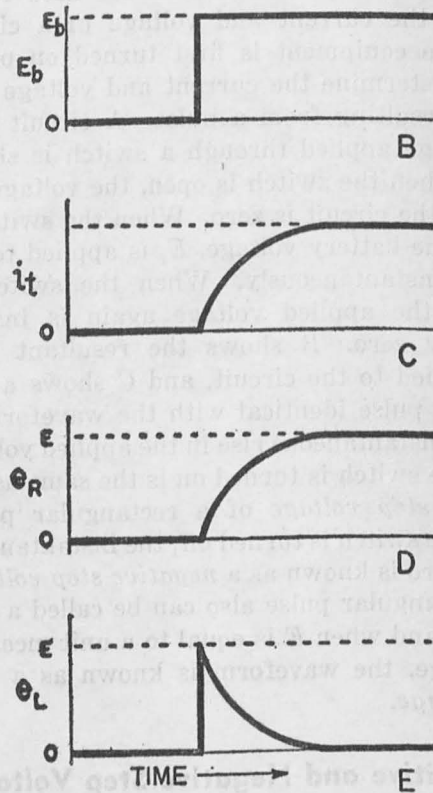
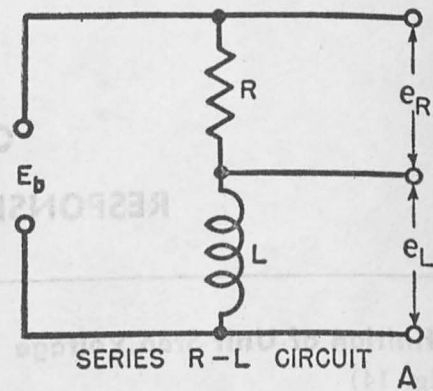

Figure 16. Charge of series R - L circuit.

applied to the series R - L circuit, in A, a voltage, E_b , appears across the circuit. Current attempts to flow, but the inductance opposes this current by building up a back emf that equals E_b , at the instant E_b is applied to the circuit, and

$$E_b - e_L = 0.$$

Consequently, the voltage drop across R is zero, and no current is flowing in

the series circuit. The values of current and voltage at every instant are shown in B, C, D, and E.

- (2) As current starts to flow, a voltage, e_R (equal to $i_t R$), appears across R . This voltage drop represents the difference between E_b and a decreasing e_L . As the voltage drop across R increases, the rate of current change in the circuit decreases; i_t increases at a slower rate; voltage e_R builds up gradually until the entire input voltage is dropped across R , and the steady-state condition is reached. Voltage e_R then is equal to the applied voltage, E_b , voltage e_L is zero, and current i_t is maximum and equal to E_b/R since di/dt now is zero.

b. DETAILED DESCRIPTION.

- (1) *Current during first usec.* The voltage, current, and rate of current change at a number of successive intervals during the transient periods will be discussed in detail to show how these characteristics change with time. The value of current at each instant can be obtained from figure 17, since this is an enlarged version of the curve in C of figure 16. This value of current then is used to find the voltage and current rate of change by means of the equation

$$E = i_t R + L \frac{di}{dt}.$$

Actual values for E , L , and R are given to clarify the discussion. E is 1 volt, L is 10 mh (millihenrys), and R is 1,000 ohms. At the instant that E is applied to the series R - L circuit, t equals zero and the current is zero; therefore, the voltage equation becomes

$$E = 0 \times R + L \frac{di}{dt} = L \frac{di}{dt},$$

and

$$\frac{E}{L} = \frac{di}{dt}.$$

With voltage E across the inductance, the current begins to flow. From the

equation above, the rate at which the current increases is

$$\frac{di}{dt} = \frac{E}{L} = \frac{1}{10 \times 10^{-3}} = 100 \text{ amperes per second} = .1 \text{ ma per usec.}$$

This is the maximum rate of current increase, or, the current has its maximum rate of change when t is zero.

- (2) *Current during second usec.* After 1 usec, figure 17 shows that the current is .096 ma, and the voltage equation becomes

$$1 \text{ volt} = (.096 \times 10^{-3}) \times 10^3 + L \frac{di}{dt}.$$

Therefore,

$$L \frac{di}{dt} = 1 - .096 = .904 \text{ volt across } L, \text{ and}$$

$$\frac{di}{dt} = \frac{.904}{10 \times 10^{-3}} = 90.4 \text{ amperes per second} = .0904 \text{ ma per usec.}$$

At the end of 1 usec, the voltage across the resistor is .096 volt and the voltage across the inductor is .904 volt. The rate of current change is .0904 ma per usec. Note that the current changes at a slower rate.

- (3) *Current after 5 usec.* It is not necessary to determine the current at every microsecond, but it is helpful to note the voltage, current, and rate of current change at 5- and 10-usec intervals. After 5 usec, the current flowing in the circuit is .394 ma and the voltage in the circuit at this time is

$$1 = 10^3 \times .394 \times 10^{-3} + L \frac{di}{dt},$$

or

$$L \frac{di}{dt} = .606 \text{ volt,}$$

and

$$\frac{di}{dt} = \frac{.606}{10 \times 10^{-3}} = .0606 \text{ ma per usec.}$$

At the end of 5 usec, the voltage across the resistor is .394 volt and the voltage across the inductor is .606 volt. The rate of current change is .0606 ma per usec. Note that the rate of current increase is much lower by this time, and the voltage drop across R is greater.

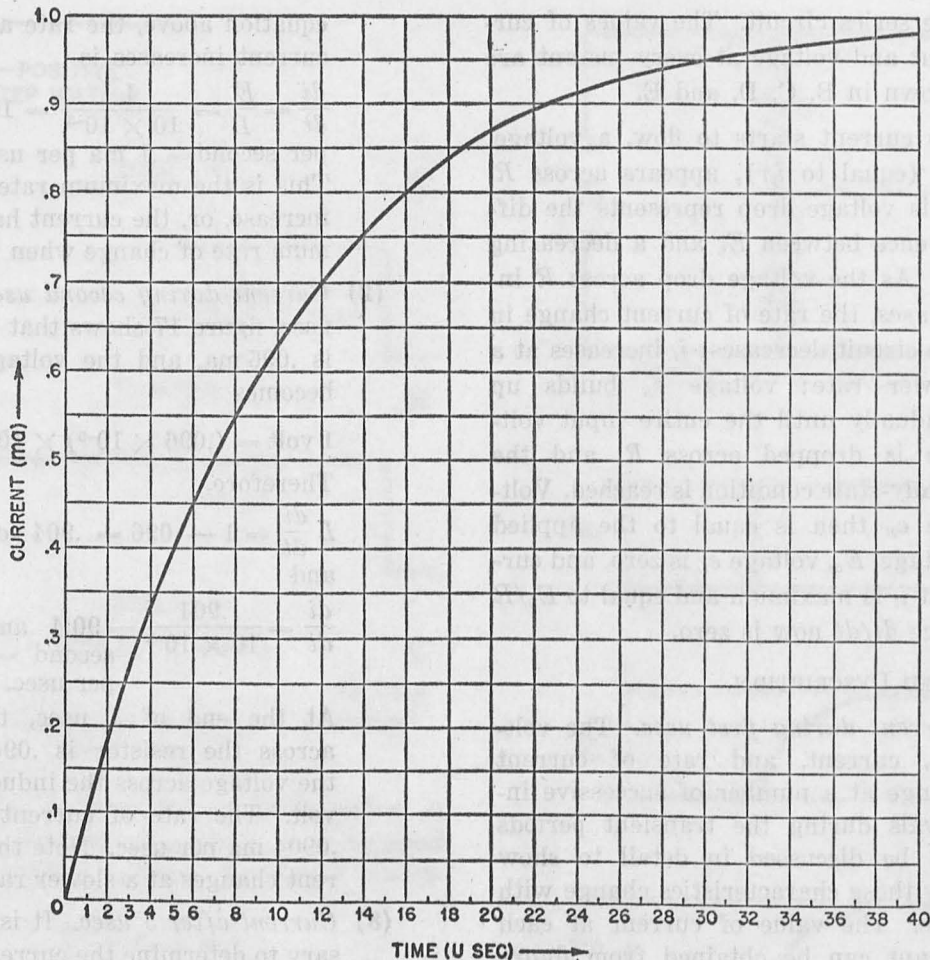

TM 669-17

Figure 17. Current in series R-L circuit.

- (4) *Current rate after 10 usec.* When t equals 10 usec, the current flowing in the circuit is .632 ma. The voltage equation is then

$$1 = 1,000 \times .632 \times 10^{-3} + L \frac{di}{dt}$$

e_R is now equal to .632 and e_L is, therefore, only .368. Most of the applied voltage is now across R , and the rate of current increase is

$$\frac{di}{dt} = \frac{.368}{10 \times 10^{-3}} = .0368 \text{ ma per usec.}$$

- (5) *Current rate after 20 usec.* After 20 usec the current is .871 ma, the voltage across the resistor is .871 volt, and the voltage across the inductor is only .129 volt. The rate of current increase is .0129 ma per usec.

- (6) *Current rate after 40 usec.* After 40

usec the current flow is .982 ma and the rate of current increase is .00182 ma per usec. Theoretically, the current never stops increasing, although it never quite reaches 1 ma. From a practical viewpoint, when the current becomes .999 ma (after 70 usec), it is considered to be equal to 1 ma, and e_L is considered to be zero.

22. Series R-L Circuit Time Constant

a. A period of time is required for the current in a series R-L circuit to reach its steady-state value. A ratio known as the *time constant* has been derived, which allows an immediate prediction whether a long or short period of time is required for the circuit to reach a steady-state. When the time constant is short, the current rises rapidly to its steady-state value.

When the time constant is long, the current rises slowly to its steady-state value.

b. The time constant is defined as being numerically equal to L/R , where the time constant is in seconds, L is in henrys, and R is in ohms. For example, if L is 10 mh and R is 1,000 ohms, the time constant is

$$L/R = \frac{10 \times 10^{-3}}{1,000} = 10 \times 10^{-6} \text{ seconds} = 10 \text{ usec.}$$

23. Time Constant and Response Curve

a. EFFECT OF INDUCTANCE. Inductance in a circuit prevents the current from rising immediately to its steady-state value. The larger the inductance, the greater the opposition to a change in current, and the longer the period of time required for the current to reach its steady-state value. The final, or steady-state value of current for this circuit is equal to E/R . *Increasing the value of L increases the time required to reach the steady-state condition. Decreasing the value of L decreases the time required to reach the steady-state condition.*

b. EFFECT OF RESISTANCE. If the same value of inductance is used and the value of resistance is increased, the rate of current increase remains the same when t is zero. However, the steady-state value of current is reached in a shorter period of time. *Increasing the value of R decreases the time required to reach the steady-state condition. Decreasing the value of R increases the time required to reach the steady-state condition.*

c. EFFECT OF TIME CONSTANT.

(1) The time constant L/R is increased either by increasing L or decreasing R . *Increasing the time constant increases the time required to reach the steady-state condition. Decreasing the time constant decreases the time required to reach the steady-state condition.*

(2) Circuits with the same time constant require the same period of time to reach the steady-state condition. For example, the time constant of a series circuit with L of 10 mh and R of 1,000 ohms is 10 usec. With 1 volt applied to the circuit, 70 usec are required for

the current to reach .999 ma, or 99.9 percent of the steady-state current (E/R equals 1 ma). If the inductance is increased to 20 mh and the resistance is increased to 2,000 ohms, the time constant of the new circuit is also 10 usec. Therefore, 70 usec are required to reach 99.9 percent of the steady-state current. The steady-state current is only .5 ma (E/R equals .5 ma), or one-half of the steady-state value of current for the previous circuit; since L is doubled and the rate of current increase is halved, the same time is required to reach the steady state.

- (3) The period of time required for the current in any $R-L$ circuit to reach 99.9 percent of the steady-state value can be expressed in terms of the time constant. In the example given above, L/R is 10 usec, and the 99.9 percent value is reached in 70 usec. The time 70 usec can be expressed as 7 L/R , or 7 time constants. No matter what the values of L and R , *the time required to reach 99.9 percent of the steady-state value is always 7 L/R .*
- (4) In L/R time, the current always will increase to 63.2 percent of its steady-state value. If L/R is 50 usec, the current reaches 63.2 percent of its steady-state value in 50 usec.

24. Universal Time-constant Chart

a. GENERAL.

(1) When a step voltage is applied to a series $R-L$ circuit, it is possible to determine the values of i , e_R , and e_L through the use of the universal time-constant chart (fig. 18). On this chart, the horizontal axis is plotted in terms of time constants, L/R equals 1. The vertical axis is plotted in terms of relative voltage or current, and 100 percent corresponds to the applied voltage, E , or the current.

(2) The rising curve, A , represents either current i , or voltage e_R across the resistance. Curve B , represents voltage

e_L across the inductor. This graph is valid for only a step voltage input.

b. TIME CONSTANT EQUAL TO 10 USEC.

(1) An illustrative problem follows to show how these curves are used. The current and voltage in a series circuit with L of 10 mh, R of 1,000 ohms, and E of 1 volt will be determined. One time constant equals

$$\frac{L}{R} = \frac{10^{-2}}{10^3} = 10^{-5} \text{ or } 10 \text{ microseconds,}$$

and the current will reach 63.2 percent of its final value at this time.

(2) At the instant E is applied, t equals zero, e_L is 100 percent, or 1 volt, e_R and i_t are zero (fig. 19).

(3) When t is 1 usec, one-tenth of L/R time has elapsed (L/R equals 10 usec). At this time, e_L is 90 percent of maximum or .9 volt, e_R is 10 percent, or .1 volt, and i_t is 10 percent, or .1 ma.

(4) Calculation of these individual points

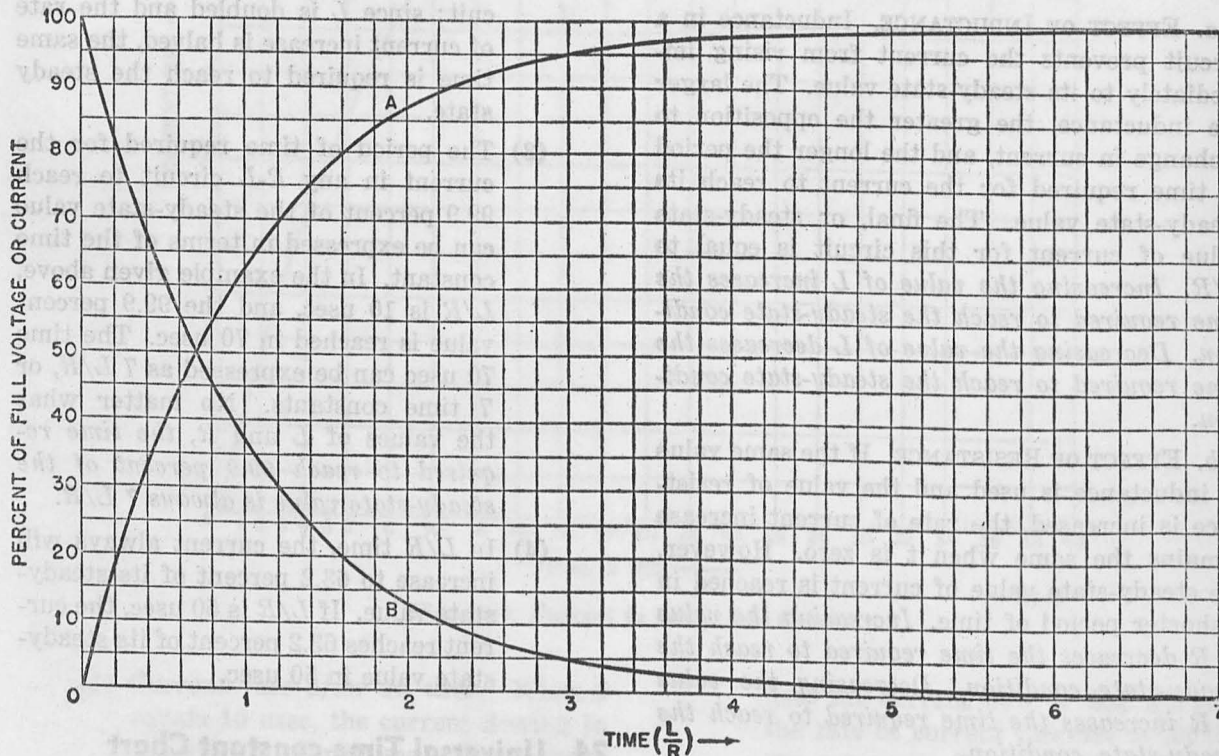

Figure 18. Universal time-constant chart.

TM 669-10

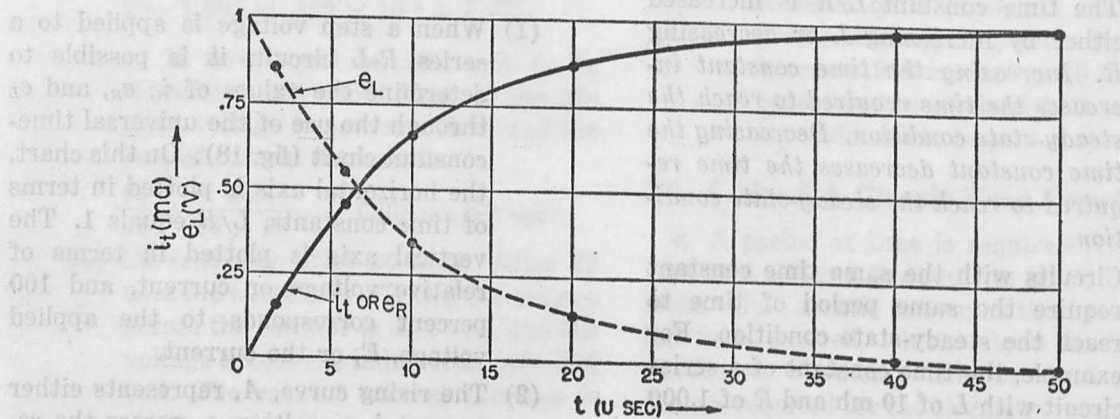

Figure 19. Current and voltages in series R-L circuit with L/R of 10 usec.

TM 669-10

is simplified in table I. The points listed are shown on the universal time-constant chart.

Table I. Calculation of Voltage and Current by Use of Universal Time-constant Chart

t in usec	$\frac{t}{L/R}$	% e_L ∇		% e_R ∇		% i_t ∇	
2	2/10=.2	82	.82	18	.18	18	.18
6	6/10=.6	55	.55	45	.45	45	.45
10	10/10=1	36	.36	64	.64	64	.64
20	20/10=2	14	.14	86	.86	86	.86
40	40/10=4	2	.02	98	.98	98	.98

(5) When 70 usec have passed, 7 time constants have elapsed, e_L reduces to zero, and e_R and i_t become 100 percent, as shown in the chart (fig. 18). Actually e_L is not zero nor is e_R equal to 1 volt at this time. All the points indicated in table I are plotted in figure 19, where they are connected by a smooth exponential curve. Since it is impossible to indicate a very small percentage on the chart, the steady state is almost reached when t is equal to 50 usec. The current and voltages during the transient time of any series R - L circuit can be determined by substituting the appropriate values of E , L , and R .

25. Energy Considerations

a. From figure 18, it is possible to determine the expenditure of power in the series circuit at any given time. Each circuit element receives power at any time equal to the current flowing through it multiplied by the voltage across it. The power expended in the resistance is therefore $i_t e_R$, or $i_t^2 R$, and the power expended in the inductance is equal to $i_t e_L$. The power received by the resistance is dissipated in heat; the power received by the inductance is transformed into a magnetic field around it.

b. When the step voltage first is applied to the R - L circuit, the current is small, and most of the energy supplied to the circuit is stored in the magnetic field around the inductance. However, as the current increases, more power is dissipated in the resistance, and a smaller portion is stored in the inductance. Finally, when the current reaches the steady-state value,

e_L is zero, no more energy is supplied to the magnetic field, and all the energy is dissipated in the resistance. As long as current flows in the circuit, however, a magnetic field exists, and energy remains stored in this field. This energy is equal to $LI^2/2$ watt-seconds, where I is the steady-state current. The energy stored in the magnetic field at any time t is $En = Li_t^2/2$ watt-seconds. The fact that there is no voltage drop across L means that no more energy is being stored, or that the magnetic field is not increasing.

26. Response of Series R-L Circuit to Negative Step Voltage

a. CIRCUIT. B of figure 20 shows a negative step voltage applied to a series R - L circuit. Prior to the application of the negative step voltage, the circuit was operating in its steady-state condition, switch SW , in A, was in position 1, and current I in the circuit was equal to E/R . When SW is placed in position 2 the negative step voltage drops the input voltage from E to zero volts.

b. GENERAL DESCRIPTION.

- (1) When the voltage drops to zero, the current in the circuit also tends to drop to zero because no further energy is being supplied. The inductance resists any change of current flowing through it and attempts to maintain the current flow. The energy for maintaining this current flow is the energy that has been stored in the magnetic field around the inductor. *The inductor, therefore, acts as a source of emf.* To maintain the current flow, a certain amount of power must be expended in the resistance. Since any dissipated energy must come from the energy stored in the magnetic field, the stored energy is gradually dissipated, and the current drops to zero.
- (2) As the emf of the inductance decreases (fig. 20), the current i_t becomes smaller, and the voltage drop across the resistance decreases in direct proportion. Note that the current flow is maintained in the same direction as the current produced by the applied voltage, E . As current continues to

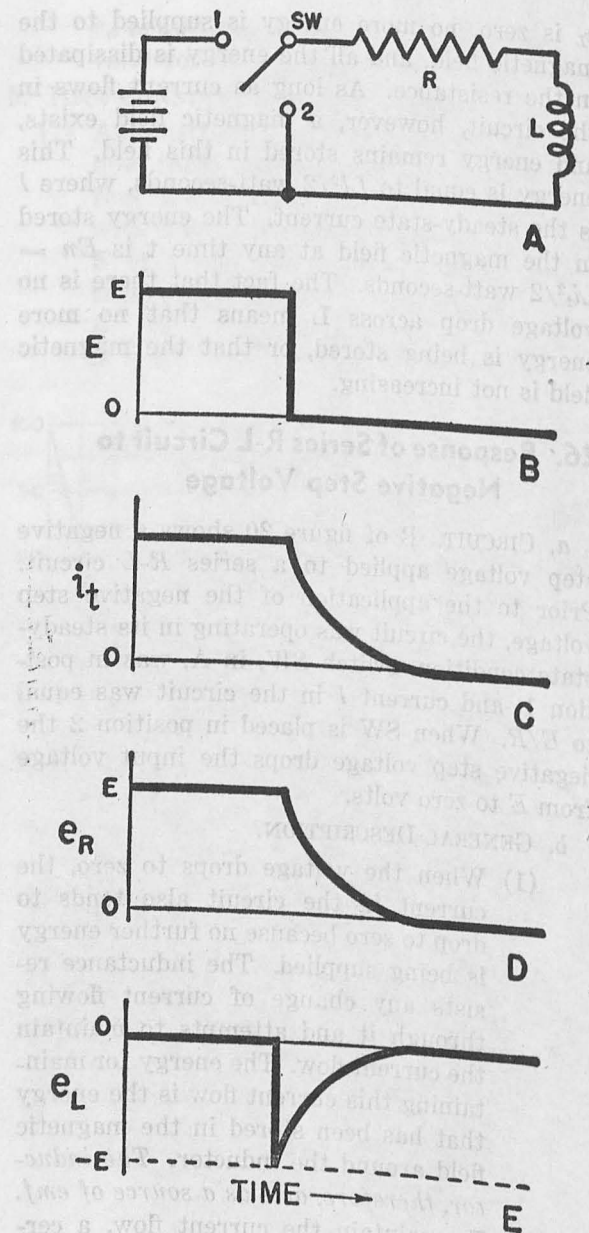

Figure 20. Discharge of series R-L circuit.

flow, the stored energy gradually is dissipated in the resistance until, finally, the stored energy is exhausted, and current flow ceases.

c. DETAILED DESCRIPTION.

(1) *Basic-voltage equation.* Under Kirchhoff's Law, the voltage drops around the circuit must equal the applied voltage. Consequently, e_R is equal to e_L , with e_L being the applied voltage, since

the stored energy in the inductance acts as the source of emf.

Substituting, $iR = L \frac{di}{dt}$.

The detailed response of this circuit can be understood by using actual values for L and R . In the following discussion, therefore, the values L equals 50 mh and R equals 10,000 ohms are used.

(2) *Current after zero time.* At t equals 0, the current flowing through the circuit is equal to E/R . For E equals 1, this is 1/10,000, or .1 ma. Since the input voltage drops instantaneously to zero, this current is maintained only by the emf of the magnetic field around the inductance and must decrease at a rate determined by the following equation:

Since $e_L = L \frac{di}{dt}$,

then

$$\frac{di}{dt} = \frac{e_L}{L} = \frac{1}{50 \times 10^{-3}} = 20 \text{ amperes per second, or } .02 \text{ ma per usec.}$$

(3) *Current after 1 usec.* This means that in 1 usec the current drops from .1 ma to .08 ma. Therefore, the voltage across the resistor drops to .08 times 10^{-3} times 10,000 or .8 ampere. The rate of current decrease after 1 usec, therefore, becomes

$$\frac{di}{dt} = \frac{.8}{50 \times 10^{-3}} = .016 \text{ ma per usec.}$$

Note that the rate of current decrease has become smaller because of the lower emf applied by L .

(4) *Current after 5 usec.* The current at any instant also can be determined by reference to curve B (fig. 18). To use this curve, it is necessary to express the time in terms of the time constant. The time constant L/R is equal to 50 times $10^{-3}/10,000$, or 5 usec. When t is equal to 5 usec, $\frac{t}{L/R}$ is equal to 1 and the current is approximately 36 percent of the initial value, or .036 ma. The voltage across R is .036 times 10^{-3} times 10,000, or .36 volts, and the rate of current change is

$$\frac{di}{dt} = \frac{.36}{50 \times 10^{-3}} \text{ or } .0072 \text{ ma per usec.}$$

(5) *Current after 10 usec.* At t equals 10 usec, $\frac{t}{L/R}$ equals 2 and the current has decreased to 14 percent of its initial value, or .014 ma, as in curve B. The voltage across R is .14 volt. The rate of current change is then .0028 ma per usec and is becoming smaller. Theoretically, the current in the circuit never reaches zero; however, when t equals 35 usec, $\frac{t}{L/R}$ equals 7, and the current has decreased to .1 percent of the initial value. At this time, the current has dropped to a value of .0001 ma, and for all practical purposes has reached its steady-state value, which is considered to be zero.

(6) *Voltage curves.* The voltage curves for e_R and e_L decline along the same curve as current. Therefore, curve B can be used to determine the voltage across either the resistance or the inductance for any time expressed in terms of L/R ; t equals 0, or $\frac{t}{L/R}$ equals 0, corresponds to the time when the negative step voltage is applied to the circuit.

d. SIGNIFICANCE OF TIME CONSTANT. The time constant, L/R , for the negative step voltage response has the same significance that it has for the positive step response. The period of time required for the circuit to reach the steady-state condition depends directly on the magnitude of the time constant. A longer time constant means that a longer period of time is required to reach 99.9 percent of steady-state value; a small time constant means that the steady-state condition is reached in a short time.

27. Precautionary Measures When Switch Is Used

a. When the negative step voltage is obtained by opening a switch (A of fig. 21), precautionary measures must be taken. After the switch is opened, current attempts to continue flowing in the R - L circuit because of the action of the inductance, and no path exists for the current flow. This causes the voltage across the inductance to build up to the point where it breaks

down the air between the switch contact and the blade, and an arc is created across the switch.

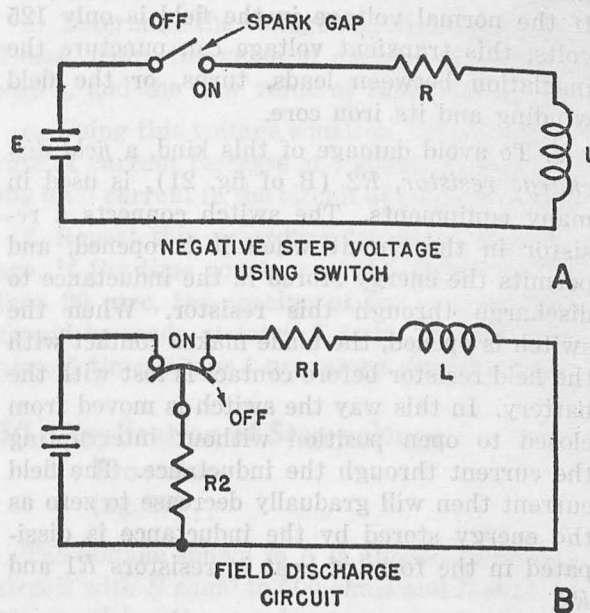

TM 669-21

Figure 21. Field discharge resistor circuit.

b. The magnitude of the inductive voltage which will cause arcing depends on the distance between the switch blade and the contact and the speed with which the switch is opened. When the switch is opened slowly, arcing can occur before the separation is very great, and only a relatively small voltage is required. If the switch is opened rapidly, a much higher voltage is required because a larger air space (greater resistance) is involved.

c. When the switch is opened, the resistance in the circuit is increased, since the open switch acts as a high series resistance. The inductance tends to maintain the same value of current flow in the circuit and, since the series resistance is higher, e_R is larger, and, from the basic voltage equation, e_R equals e_L and the emf developed across inductor L must be greater. The increased R lowers the time constant to such a value that the spark is practically instantaneous. The larger the air gap in the switch, the higher the series resistance, the shorter the time constant, and the larger the emf developed by the inductance.

d. This last consideration emphasizes the practical danger of allowing an inductive circuit to be opened too rapidly. When the direct cur-

rent in the inductive field circuit of a large generator is interrupted, the voltage across the inductor can rise to several thousand volts. If the normal voltage in the field is only 125 volts, this transient voltage can puncture the insulation between leads, turns, or the field winding and its iron core.

e. To avoid damage of this kind, a *field discharge resistor*, R_2 (B of fig. 21), is used in many equipments. The switch connects a resistor in the circuit when it is opened, and permits the energy stored in the inductance to discharge through this resistor. When the switch is opened, the blade makes contact with the field resistor before contact is lost with the battery. In this way the switch is moved from closed to open position without interrupting the current through the inductance. The field current then will gradually decrease to zero as the energy stored by the inductance is dissipated in the form of heat in resistors R_1 and R_2 .

28. Step-by-step Procedure for Determining Transient Response

a. GENERAL.

(1) The value of current in the R - L circuit at any instant of time has been determined directly from an exponential curve. No attempt has been made to derive this curve because higher mathematics are involved. When a universal time-constant chart is not available, an approximation of the response curve may be obtained by use of the basic voltage equation. This method is developed *step-by-step* and can be used for determining transient responses.

(2) The step-by-step method is useful also for obtaining the response of circuits to pulse voltages which do not have the ideal step-voltage form. The curves in figure 18 are valid only for a step voltage in which the voltage is assumed to rise and decay instantaneously. In practical equipment, zero rise and decay times cannot always be assumed, and the step-by-step procedure provides the approximate response of an R - L circuit to any waveform.

(3) In this procedure, it is assumed that the current does not increase continuously, but increases in small steps, and this can be understood by working out a response problem. For example, the current in an R - L circuit for E of 1 volt, L of 10 mh, and R of 1,000 ohms is determined below.

b. CURRENT DURING FIRST USEC. At the instant that the positive step voltage is applied to the circuit, the current is zero and the full voltage appears across L . The initial rate of current increase is E/R , or $1/10$ times 10^{-3} or 100 amperes per second, or .1 ma per usec. It is also assumed that, at the end of 1 usec, the current increases from zero to .1 ma.

c. CURRENT DURING SECOND USEC. With a current of .1 ma flowing in the circuit, there is a voltage drop across R of .1 times 10^{-3} times 1,000, or .1 volt. The voltage drop across L is .9 volt and the rate of current change is reduced to .9/10 times 10^{-3} , or .09 ma per usec. The current still is increasing and at the end of 2 usec it becomes .1 + .09, or .19 ma.

d. TABLE OF CURRENT FROM 2 TO 10 USEC.

(1) The currents and voltages at the end of each microsecond step are shown in table II.

Table II. Step Voltages at End of Each USEC with L/R Equal to 10 USEC

t (usec)	e_R (v)	e_L (v)	$\frac{di}{dt}$ (ma/usec)	i_t (ma)
2-3	.19	.81	.08	.19 + .08 = .27
3-4	.27	.73	.07	.27 + .07 = .34
4-5	.34	.66	.07	.34 + .07 = .41
5-6	.41	.59	.06	.41 + .06 = .47
6-7	.47	.53	.05	.47 + .05 = .52
7-8	.52	.48	.05	.52 + .05 = .57
8-9	.57	.43	.04	.57 + .04 = .61
9-10	.61	.39	.04	.61 + .04 = .65

(2) In a similar manner, it is possible to plot all values of current until the steady-state condition is reached. The currents indicated above are shown in figure 22. Check these values with those given for the same period of time in figure 17. The values obtained by the step-by-step method are slightly higher, but very close to the actual

values. For example, at 10 usec in figure 17 the current is .64 ma; in figure 22, the current is .65.

- (3) The time interval of the step should be one-tenth the time constant of the circuit. In this procedure, 1-usec steps are used because the time constant of the circuit is 10 usec; if the time constant is 100 usec, 10-usec steps should be used.

29. Use of Step-voltage Procedure for Other Waveforms

The procedure outlined above can be applied to any waveform. A good approximation of the series R - L response to the sloping voltage (fig. 23) can be determined by the following procedure.

- Redraw the sloping voltage in terms of a series of small step voltages (B of fig. 23).
- Determine the voltage equation for t equals 1 usec ($E = iR + L \frac{di}{dt}$).
- Using this equation, determine the rate of current increase at t equals 1 usec, and the current in the circuit at t equals 3 usec, assuming

that the rate of current increase is maintained for 2 usec.

- Determine the voltage equation at t equals 3 usec, using the value of current obtained in step c, and the new value of input voltage, E .
- Using this voltage equation, determine the rate of current increase at t equals 3 usec, and the total current in the circuit at t equals 5 usec.
- Repeat this procedure for each step voltage. If the time constant of the circuit is less than 20 usec, the spacing of the step voltages should be made at least $.1 L/R$. If L/R is 10 usec, $.1$ times 10, or 1-usec steps should be used.

30. Application of Step-voltage Procedure (fig. 23)

The voltage shown in A is applied to an R - L circuit with R equal to 500 ohms and L equal to 10 mh. Using the step-by-step method, the following response is obtained.

- CURRENT RATE AT 1 USEC.** From the step representation, in B, the voltage at 1 usec is 1 volt and the current during the first usec is zero. Since there is no voltage drop across R ,

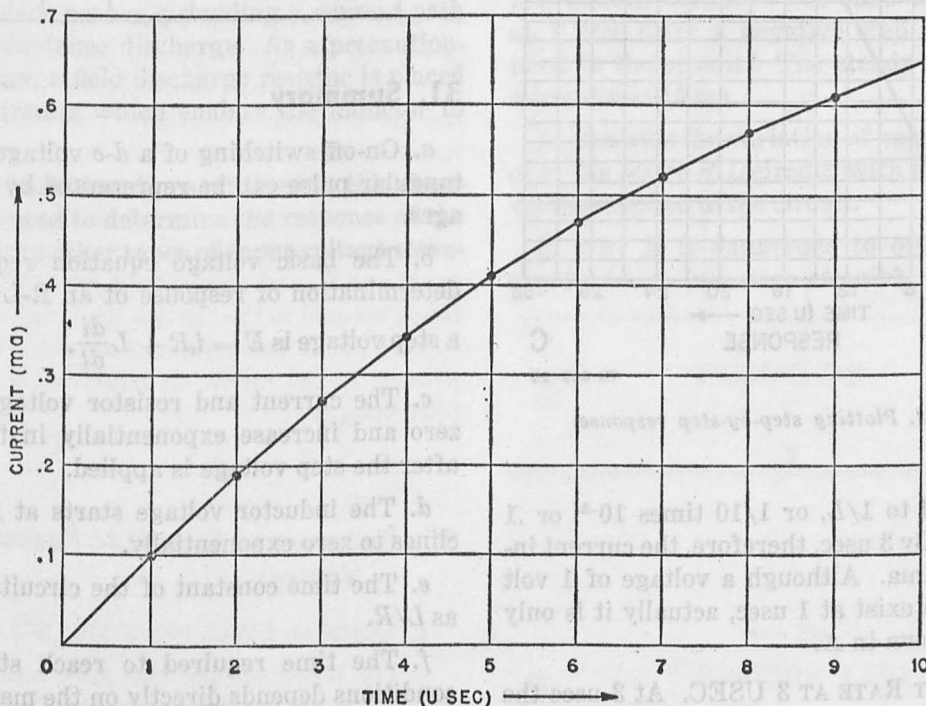
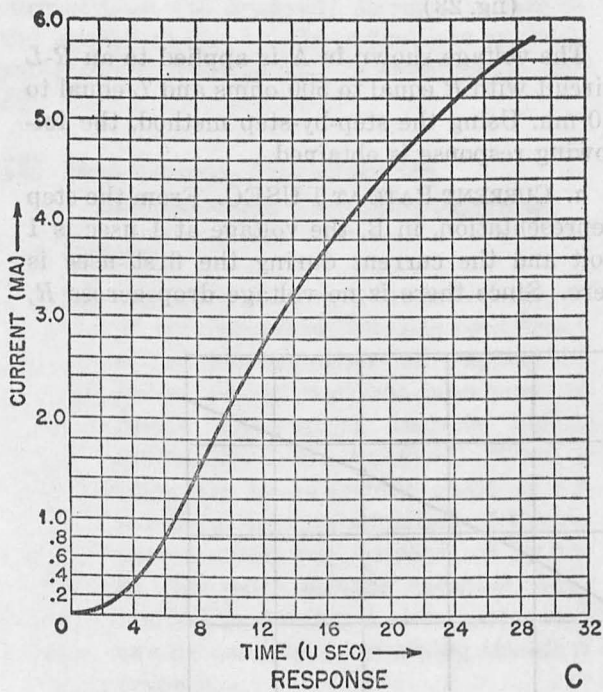
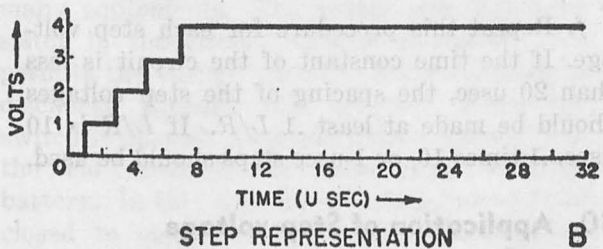
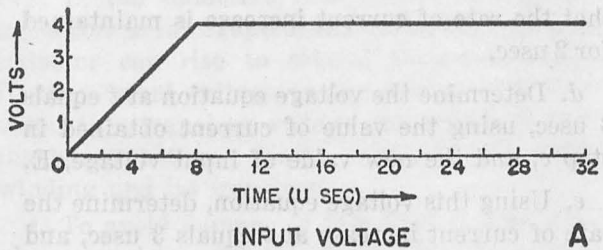

Figure 22. Step-by-step response of series R - L circuit.



TM 669-23

Figure 23. Plotting step-by-step response.

di/dt is equal to $1/L$, or $1/10$ times 10^{-3} , or .1 ma per usec. By 3 usec, therefore, the current increases to .2 ma. Although a voltage of 1 volt is assumed to exist at 1 usec, actually it is only .5 volt, as shown in A.

b. CURRENT RATE AT 3 USEC. At 3 usec the current is .2 ma, and the voltage drop across the resistor is .1 volt. At this time, however, the

applied voltage has increased to 2 volts. Therefore, the voltage across L is 2 minus .1 volt, or 1.9 volts. The current rate of increase then is $1.9/10$ times 10^{-3} , or .19 ma per usec.

c. TABLE OF VALUES FROM 5 TO 29 USEC. Table III indicates the values of current, voltage, and current rate from t equals 5 to t equals 29 usec. These values are plotted in C. Similarly, any L - R transient response can be approximated.

Table III. Step Voltages of R-L Circuit at 2-USEC Intervals

t (usec)	i_t (ma)	iR drop (v)	E (v)	e_L (v)	$\frac{di}{dt}$ (ma/usec)
5	.2 + .19 × 2 = .58	.29	3	2.7	.27
7	.58 + .27 × 2 = 1.12	.56	4	3.4	.34
9	1.12 + .34 × 2 = 1.8	.9	4	3.1	.31
11	1.8 + .31 × 2 = 2.42	1.23	4	2.77	.277
13	2.42 + .277 × 2 = 2.97	1.49	4	2.49	.25
15	2.97 + .25 × 2 = 3.47	1.73	4	2.27	.23
17	3.47 + .23 × 2 = 3.93	1.97	4	2.03	.20
19	3.93 + .20 × 2 = 4.33	2.165	4	1.83	.183
21	4.33 + .183 × 2 = 4.7	2.35	4	1.65	.165
23	4.7 + .165 × 2 = 5.03	2.5	4	1.5	.15
25	5.03 + .15 × 2 = 5.33	2.67	4	1.27	.13
27	5.33 + .13 × 2 = 5.59	2.8	4	1.2	.12
29	5.59 + .12 × 2 = 5.83	2.9	4	1.1	.11

31. Summary

a. On-off switching of a d - c voltage or a rectangular pulse can be represented by step voltages.

b. The basic voltage equation required for determination of response of an R-L circuit to a step voltage is $E = i_t R + L \frac{di}{dt}$.

c. The current and resistor voltage start at zero and increase exponentially in the circuit after the step voltage is applied.

d. The inductor voltage starts at E and declines to zero exponentially.

e. The time constant of the circuit is defined as L/R .

f. The time required to reach steady-state conditions depends directly on the magnitude of L/R . A large time constant means that long periods are required to reach steady-state con-

ditions; a small time constant means that short periods are required to reach steady-state conditions.

g. When time is expressed in terms of L/R , it is possible to determine the relative current and voltages in the circuit from the universal time-constant chart.

h. The energy received by the circuit at any time is equal to $i_i e_r + i_i e_L$.

i. Energy received by resistance is dissipated into heat; energy received by the inductance is stored in the magnetic field around it.

j. When a negative step voltage is applied to the series $R-L$ circuit, reducing input voltage from E to 0, the current in the circuit is maintained by the back emf developed across the inductance.

k. As the energy stored in the inductance is fed back to the line, I , e_R , and e_L decline in accordance with an exponential curve.

l. When the negative step voltage is obtained by opening a switch, a very large voltage can be developed across the inductance since no path exists for the current flow. The voltage increases until the air gap across the switch is broken down and an arcing between switch contact and blade occurs, providing a current path for the inductance discharge. As a precautionary measure, a field discharge resistor is placed in some circuits which enables the inductor to discharge.

m. The basic equations outlined in this chapter can be used to determine the response of the $R-L$ circuit to other types of input voltage waveforms.

32. Review Questions

a. What is a positive step voltage?

b. Describe the current flowing in a series $R-L$ circuit with $L = 50$ mh and $R = 7,500$ ohms at 1 usec after a step voltage of +5 volts is applied to the circuit.

c. What is the steady-state condition of this circuit and how long does it take to reach 99.9 percent of the steady-state condition?

d. How does the value of L determine the time required to reach the steady-state condition?

e. Using the universal time-constant chart, plot i_i , e_R , and e_L for a positive step voltage, $E = 8$ volts, $R = 10,000$ ohms, and $L = 25$ mh.

f. How much energy is dissipated in the resistor at $t = 10$ usec in the example given in question e?

g. How much energy is stored in the inductance when the steady-state condition is reached in the example given in question e?

h. Why does current continue to flow in the $R-L$ circuit after the applied voltage has dropped to zero?

i. What is the rate of current decrease in the $R-L$ circuit, with $R = 500$ ohms and $L = 1$ mh, at 1 usec after a negative step voltage is applied to the circuit? The steady-state value of current was 10 ma.

j. Describe the variation of current, I , e_R , and e_L in the series $R-L$ circuit, with a negative step voltage applied to the circuit.

k. Why is it dangerous to open the switch rapidly in an inductive circuit?

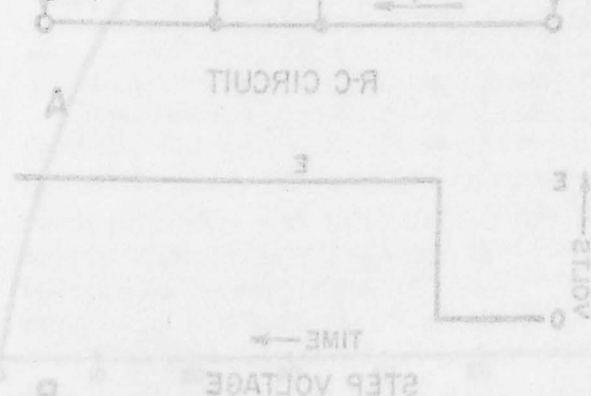

CHAPTER 4

RESPONSE OF R-C CIRCUIT

33. Introduction

(fig. 24)

a. **POSITIVE STEP VOLTAGE.** When a d-c voltage is applied to an *R-C* circuit, as in A, for a period of time, the steady-state current in the circuit is zero because the capacitor cannot pass a d-c current. In this steady-state condition, the emf resulting from the charge on the capacitor is equal and opposite to the applied voltage and no current flows. When the d-c voltage first is applied, however, the capacitor has no charge, and current flows in the circuit until the capacitor charges to the applied voltage. The current and voltage change in the circuit during this transient period is covered in the first part of this chapter.

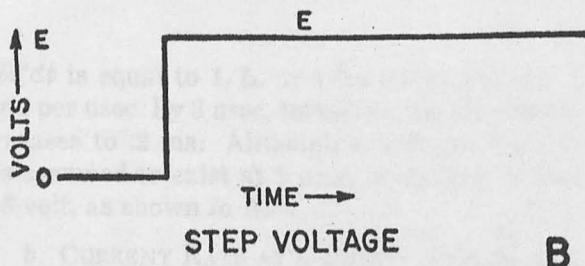
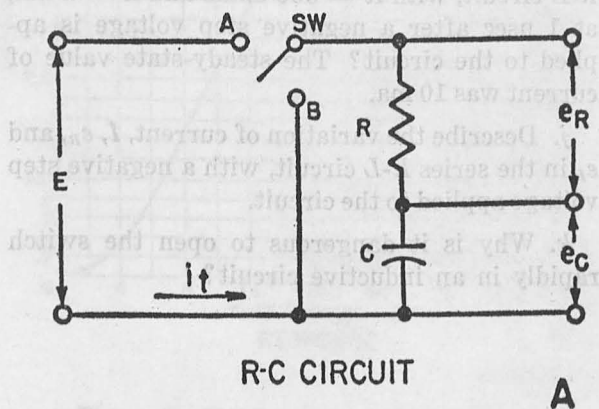

TM 669-24

Figure 24. *R-C* circuit with positive step input.

b. **NEGATIVE STEP VOLTAGE** (fig. 28). When the d-c voltage is removed and the capacitor is discharged, after a period of time the steady-state current is zero. No voltage is applied to the circuit, no charge is left on the capacitor, and there is no current flow in the circuit. When the d-c voltage first is removed, the capacitor has a charge on it equal to the applied voltage, and this emf is applied to the circuit. Current flows, discharging the capacitor, and when there is no charge on the capacitor, current stops flowing and the steady-state current is zero. Current and voltage change during this discharge period is the subject of the second half of this chapter.

c. **BASIC VOLTAGE EQUATION.** The voltage and current in the circuit at any given instant of time between the instant the step voltage is applied to the circuit and the time the steady state is reached can be determined by means of the basic voltage equation. The voltage across the resistance at any time is e_R , the voltage across the capacitance is e_C , and the sum of these voltages is equal to the applied voltage. The voltage across the resistance at any instant is equal to $i_t R$, and the voltage across the capacitance is equal to the charge, designated Q , divided by C . The basic voltage equation can be expressed in the following manner (E is the applied voltage) :

$$E = e_R + e_C = i_t R + \frac{Q}{C}.$$

34. Response of Circuit to Positive Step Voltage

a. **GENERAL DESCRIPTION** (fig. 24).

- (1) When the positive step voltage shown in B is applied to the *R-C* circuit, a voltage, E , appears across the circuit. At the instant the voltage is applied

there is no charge on the capacitor, e_c is equal to zero, the applied voltage appears across R , and the initial current is equal to E/R (A, B, C of fig. 25).

(2) The current flowing in the circuit starts to charge the capacitor (C of fig. 25). Since the emf of the capacitor is proportional to the charge, a small voltage, e_c , appears across it. This emf is opposite in polarity to the applied voltage and subtracts from it. As a result, the voltage across the resistance is E minus e_c and is equal to $i_t R$. Since R is fixed, i_t must decrease and the capacitor charges more slowly. The greater the emf of the capacitor, the smaller the voltage across the resistor, the smaller the current in the circuit, and the lower the rate of charge of the capacitor.

(3) The charging process continues until the capacitor is fully charged to the applied voltage, E . B and C show the relation of e_r to e_c at all times during the charging process. The emf of the capacitor increases rapidly at first and then gradually until it is equal to the applied voltage, following an exponential curve. The voltage across the

resistance declines along a similar exponential curve.

b. DETAILED DESCRIPTION.

(1) Current during first usec.

(a) A tabulation of voltage, current, and rate of charge at a number of successive intervals during the transient period will show how these characteristics change with time. The value of e_c at each of these intervals is obtained from the exponential curve in C.

(b) To aid in the understanding of the material, the following values for R , C , and E are used: E is 1 volt, R is 10,000 ohms, and C is 1,000 μmf (micromicrofarads). At the instant that E is applied to the circuit, t equals 0, the emf of C is zero, and the initial current in the circuit is E/R , or $1/10,000$, or .1 ma.

(c) A current of .1 ma means that .0001 coulomb flows into the capacitor in 1 second, or .0001 times 10^{-6} coulomb in 1 usec. Therefore, at the end of 1 usec, .0001 times 10^{-6} coulomb of charge Q have gone into the capacitor. The emf of the capacitor is equal to Q/C , or $10^{-10}/10^{-9}$, or .1 volt,

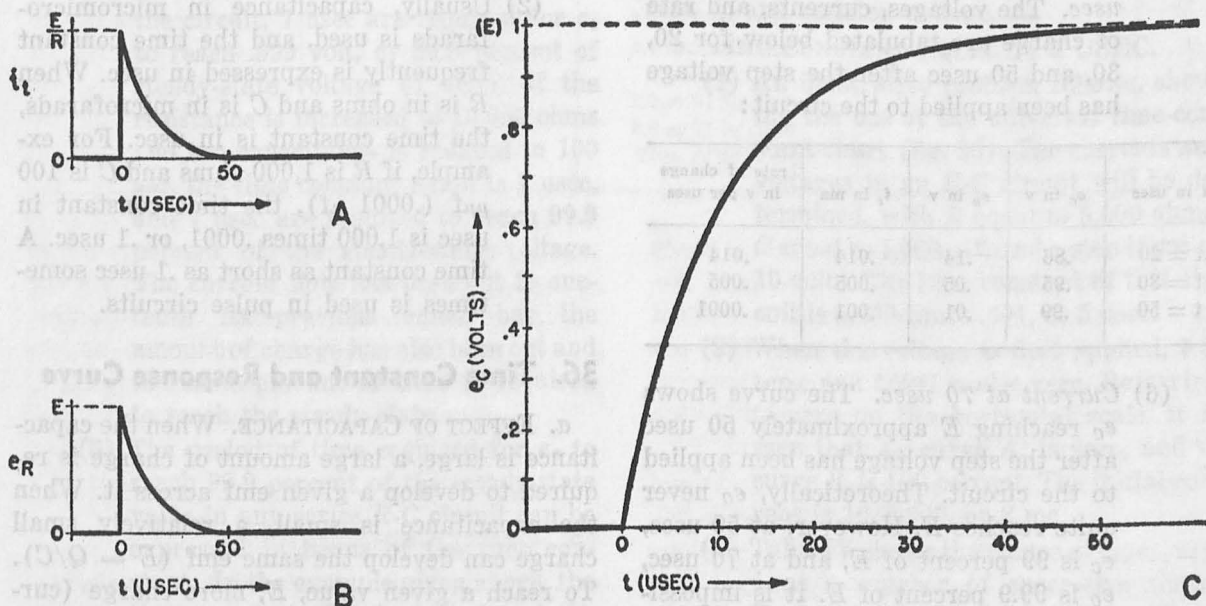

Figure 25. Charge of R-C circuit.

TM 669-25

and the initial rate of voltage charge of the capacitor is .1 volt per usec.

(2) *Current during second usec.* At the end of the first usec, the emf of the capacitor is .1 volt and the voltage across the resistor is 1 minus .1, or .9 volt. The current in the circuit is equal to .9/10,000, or .09 ma. A smaller current flow means that less charge is flowing into the capacitor, and the rate of charge decreases. The rate of voltage charge at this time is .09 times $10^{-9}/1,000$ times 10^{-12} , or .09 volt per usec.

(3) *Current during fifth usec.* At the end of the fifth usec, the emf of the capacitor is approximately .33 volt, e_r then is .67 volt, and the current flow is .67/10,000, or .067 ma; the rate of voltage charge is .067 volt per usec.

(4) *Current during tenth usec.* At the end of the tenth usec the emf of the capacitor is approximately .64 volt. At this time, e_c is over half the applied voltage, and the current flow is less than one-half its initial value. The current is .036 ma and the resultant rate of voltage charge is approximately .036 volt per usec.

(5) *Tabulation of current from 20 to 50 usec.* The voltages, currents, and rate of charge are tabulated below for 20, 30, and 50 usec after the step voltage has been applied to the circuit:

t in usec	e_c in v	e_r in v	i_t in ma	rate of change in v per usec
t = 20	.86	.14	.014	.014
t = 30	.95	.05	.005	.005
t = 50	.99	.01	.001	.0001

(6) *Current at 70 usec.* The curve shows e_c reaching E approximately 50 usec after the step voltage has been applied to the circuit. Theoretically, e_c never quite reaches E . However, at 50 usec, e_c is 99 percent of E , and at 70 usec, e_c is 99.9 percent of E . It is impossible to show such small percentage differences on a graph, and therefore, the

curve reaches E at about 50 usec. For practical purposes, it is safe to assume that the steady state is reached at 70 usec. At this time the current is assumed to be zero, and the emf of the capacitor is equal and opposite to the applied voltage.

35. R-C Circuit Time Constant

a. GENERAL. A period of time is required for the emf of the capacitor and the current in the circuit to reach their steady-state values. A product known as the *time constant* has been evolved which allows immediate prediction whether a long or short period is required for the circuit to reach a steady state. When the time constant is short, the voltage rise and the current decline to steady-state values are rapid. When the time constant is long, the voltage rise and the current decline are gradual.

b. DEFINITION.

(1) The time constant is equal numerically to RC when R is in ohms, if C is in farads, and the time constant is in seconds. For example, if R is 100,000 ohms and C is .00001 farad (10 μf), the time constant in seconds is 100,000 times .00001, or 1 second. This is a long time constant, since R and C are large in value.

(2) Usually, capacitance in micromicrofarads is used, and the time constant frequently is expressed in usec. When R is in ohms and C is in microfarads, the time constant is in usec. For example, if R is 1,000 ohms and C is 100 $\mu\mu\text{f}$ (.0001 μf), the time constant in usec is 1,000 times .0001, or .1 usec. A time constant as short as .1 usec sometimes is used in pulse circuits.

36. Time Constant and Response Curve

a. EFFECT OF CAPACITANCE. When the capacitance is large, a large amount of charge is required to develop a given emf across it. When the capacitance is small, a relatively small charge can develop the same emf ($E = Q/C$). To reach a given value, E , more charge (current flow for a longer period of time) is required for a large than for a small capacitance.

Increasing C increases the time required to reach the steady-state condition. Decreasing C decreases the time required to reach the steady-state condition.

b. EFFECT OF RESISTANCE. The amount of current, or charge per second, that can flow into a given capacitor is controlled by the series resistance. When the resistance is large, a small current flows and a longer period of time is required to charge the capacitor. When the resistance is small, the capacitor charges rapidly, and a large amount of charge flows into it per second. Increasing R decreases the rate of charge of the capacitor, and increases the time required to reach the steady-state. Decreasing R increases the rate of charge, and decreases the time required to reach the steady-state.

c. EFFECT OF TIME CONSTANT.

(1) The time constant RC is increased by increasing either R or C , or both. Increasing the time constant increases the time required to reach the steady-state. Decreasing the time constant decreases the time required to reach the steady-state.

(2) Circuits with the same time constant require the same period of time to reach the steady-state condition. For example, the time constant of a circuit with C of 1,000 μf and R of 1,000 ohms is 1 usec. With 1 volt applied to the circuit, 7 usec are required for e_C to reach .999 volt, or 99.9 percent of steady-state voltage (1 volt). If the resistance is increased to 10,000 ohms and the capacitance is reduced to 100 μf , the time constant again is 1 usec, and 7 usec are required to reach 99.9 percent of the steady-state voltage. The current flow has been cut to one-tenth its previous value, but the amount of charge has also been cut and the same amount of time is required to reach the steady-state.

(3) The period of time required for e_C to reach 99.9 percent of the steady-state value in any series R - C circuit can be expressed in terms of the time constant. In the example given above, the time constant, RC , is 1 usec and the 99.9 percent value is reached in 7 usec.

The time 7 usec can be expressed as 7 time constants, or $7RC$. No matter what the values of R and C , the time required to reach 99.9 percent of the steady-state is always $7RC$.

(4) The emf of the capacitor always reaches 63.2 percent of the applied voltage after a period of time equal to the time constant has elapsed ($t = RC$). For example, if the applied voltage is 10 volts and RC is 3 usec, the emf of the capacitor will rise to 6.32 volt in 3 usec. If E is .1 volt, and RC is 10 usec, e_C is .0632 volt 10 usec after the step voltage has been applied.

Note. The voltages given above for 1 time constant and 7 time constants are true only if a step voltage is applied to the circuit.

37. Universal Time-constant Chart

a. GENERAL. It is possible to determine the value of e_C , e_R , and i_t in an R - C circuit through the use of the universal time-constant chart (fig. 26). This chart can be used only for step-voltage inputs. The horizontal axis is plotted in terms of time constants. The vertical axis is plotted in terms of relative voltage or current, with 100 percent corresponding to E (applied voltage) and E/R (initial current), respectively. Curve A shows the increase of emf across the capacitor, e_C . Curve B shows the decline of current, i_t , and resistor voltage, e_R .

b. TIME CONSTANT EQUAL TO 5 USEC.

(1) An illustrative problem follows, showing the use of the universal time-constant chart (fig. 26). The currents and voltages in an R - C circuit will be determined, with R equal to 5,000 ohms, C equal to 1,000 μf , and a step input of 10 volts. The time constant of this circuit is 5,000 times .001, or 5 usec.

(2) When the voltage is first applied, t is zero, and t/RC is also zero. Referring to zero on the horizontal scale, it is seen that e_C , curve A, is zero, and i_t , curve B, is 100 percent. The initial current is $10/5,000$, or 2 ma.

(3) Table IV shows the values of e_C , e_R , and i_t at a number of successive times. Each point in this table is taken from figure 26.

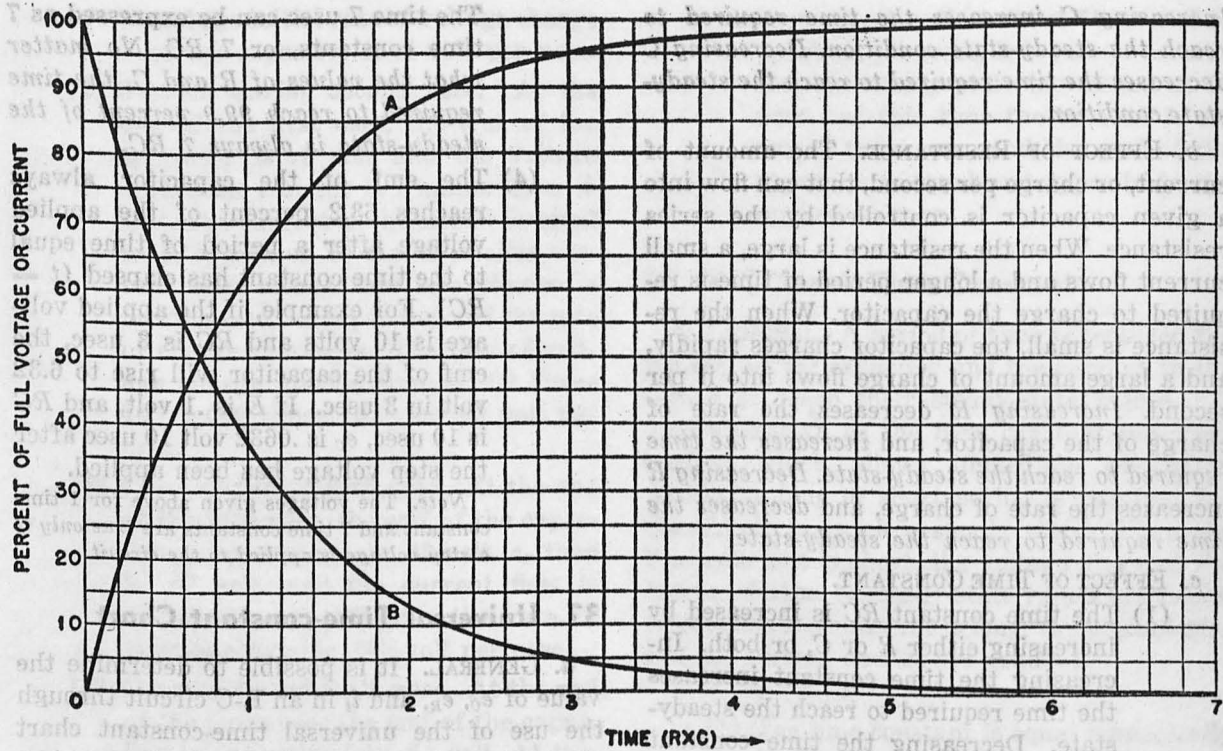

TM 669-26

Figure 26. Universal time-constant chart for R-C circuit.

Table IV. Voltage and Current in R-C Circuit, with RC Equal to 5 Usecs.

t in usec	$\frac{t}{RC}$	e_c in v	e_r in v	i_r in ma
.5	.5/5 = .1	10% of 10 = 1	90% of 10 = 9	90% of 2 = 1.8
1	1/5 = .2	18% of 10 = 1.8	82% of 10 = 8.2	82% of 2 = 1.64
2	2/5 = .4	33% of 10 = 3.3	67% of 10 = 6.7	67% of 2 = 1.34
4	4/5 = .8	55% of 10 = 5.5	45% of 10 = 4.5	45% of 2 = .9
8	8/5 = 1.6	80% of 10 = 8	20% of 10 = 2	20% of 2 = .4
16	16.5 = 3.2	96% of 10 = 9.6	4% of 10 = .4	4% of 2 = .08
20	20/5 = 4	98% of 10 = 9.8	2% of 10 = .2	2% of 2 = .04
25	25/5 = 5	100% of 10 = 10	0 of 10 = 0	0 of 2 = 0

(4) When t/RC is equal to 5, curve A reads 100 percent and curve B is zero. Actually, e_c does not reach 100 percent and i_r is not zero at this time. They are so close to these values, however, (within 1 percent), that the difference cannot be indicated on the graph.

(5) All of the points determined in (2) and (3) above are plotted in figure 27. Time in microseconds is plotted along the horizontal axis; voltage and current are plotted along the vertical axis. The points obtained are connected by

smooth exponential curves, one curve for current, or e_r , and the other for the emf developed across the capacitor, e_c . These curves are known as the transient-response curves for this R-C circuit. Response curves for any R-C circuit can be developed in a similar manner.

38. Energy Considerations

a. During the transient period, energy is supplied to the R-C circuit. Part of the energy is dissipated in the form of heat in the resistor.

The other portion is stored in the capacitor in the form of an electrostatic field. At the instant step voltage is applied, there is no charge in the capacitor and all of the energy supplied to the circuit is dissipated in the form of heat in the resistor. Then, the flow of energy into the capacitor increases, the capacitor accumulates charge, and the emf rises. The current, however, is diminishing, since the rate at which energy is stored in the capacitor has passed a maximum and is decreasing. Finally, when the current is zero, no further energy is supplied to the circuit, and no additional energy is stored.

b. The energy dissipated as heat in the resistor at any instant is equal to i_t times e_R . The energy stored in the electrostatic field at any instant is equal to i_t times e_C . Referring to the universal time-constant chart (fig. 26), note that at first i_t and e_R , curve B, are maximum and maximum heat dissipation occurs. As time passes, both i_t and e_R decline simultaneously, and heat dissipation diminishes rapidly.

c. The rate at which energy is stored is a product of curve A, e_C , and curve B, i_t . One curve rises as the other declines and during the first instant i_t is maximum, but e_C is zero, and no energy is being stored. As e_C rises, the product of e_C times i_t , which is the rate of energy being stored, increases until the capacitor is charged to 50 percent of the applied voltage. This occurs when t is about $.7 RC$. After this time, the decrease in i_t more than offsets the increase in e_C , and the rate at which energy is stored decreases. Finally, when i_t is zero, the rate of energy storage becomes zero, although e_C is maximum.

d. The energy stored in the capacitor after it is fully charged is equal to $CE^2/2$, and the final value of e_C is equal to the applied voltage, E . This energy remains in the capacitor as long as the applied voltage remains across the input, and, since the emf of the capacitor is equal and of opposite polarity, no current can flow in the circuit.

39. Response of R-C Circuit to Negative Step Voltage

a. **CIRCUIT.** Prior to the application of the negative step voltage (fig. 28) to the R-C circuit, the circuit was at steady-state, and the

capacitor was charged to a voltage, E . The step voltage drops the applied voltage from E to zero volts.

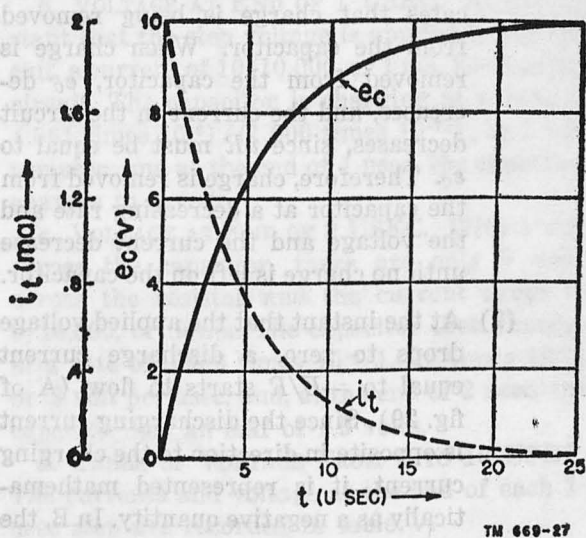

Figure 27. Plot of response curve.

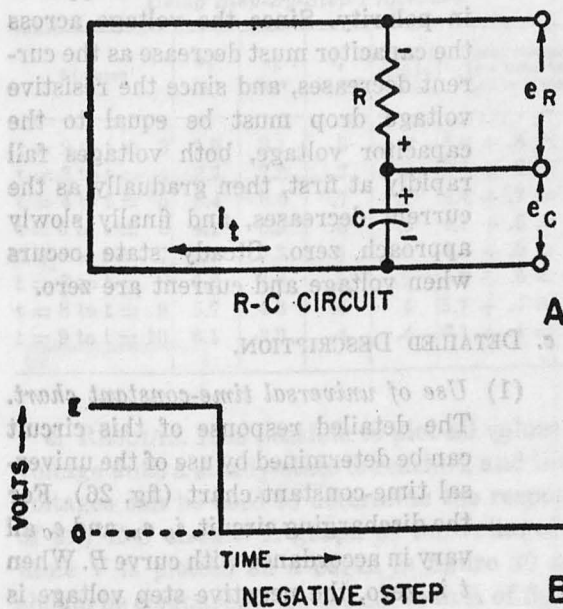

Figure 28. R-C circuit with negative step voltage.

b. GENERAL DESCRIPTION.

- (1) When the applied voltage drops to zero (B of fig. 28) and the circuit is completed as shown in A, the emf of the charged capacitor is unopposed, and

current begins to flow. This current is opposite in direction to the charging current and equal to e_c/R . The current flowing in the opposite direction indicates that charge is being removed from the capacitor. When charge is removed from the capacitor, e_c decreases, and the current in the circuit decreases, since $i_t R$ must be equal to e_c . Therefore, charge is removed from the capacitor at a decreasing rate and the voltage and the current decrease until no charge is left on the capacitor.

- (2) At the instant that the applied voltage drops to zero, a discharge current equal to $-E/R$ starts to flow (A of fig. 29). Since the discharging current is opposite in direction to the charging current, it is represented mathematically as a negative quantity. In B, the voltage drop across the resistor, resulting from the current, is equal to the capacitor voltage in C but is opposite in polarity. Since the voltage across the capacitor must decrease as the current decreases, and since the resistive voltage drop must be equal to the capacitor voltage, both voltages fall rapidly at first, then gradually as the current decreases, and finally slowly approach zero. Steady state occurs when voltage and current are zero.

c. DETAILED DESCRIPTION.

- (1) *Use of universal time-constant chart.* The detailed response of this circuit can be determined by use of the universal time-constant chart (fig. 26). For the discharging circuit, i_t , e_R , and e_c all vary in accordance with curve B. When t is zero, the negative step voltage is applied to the circuit. To use this chart, actual values for R , C , and E are required, and in the following discussion, R is 2,000 ohms, C is .0075 μf , and E is 6 volts. The time constant is 2,000 times .0075, or 15 usec.
- (2) *Current at 1 usec.* During the initial instant, the voltage drop across the resistor must be equal to e_c and of op-

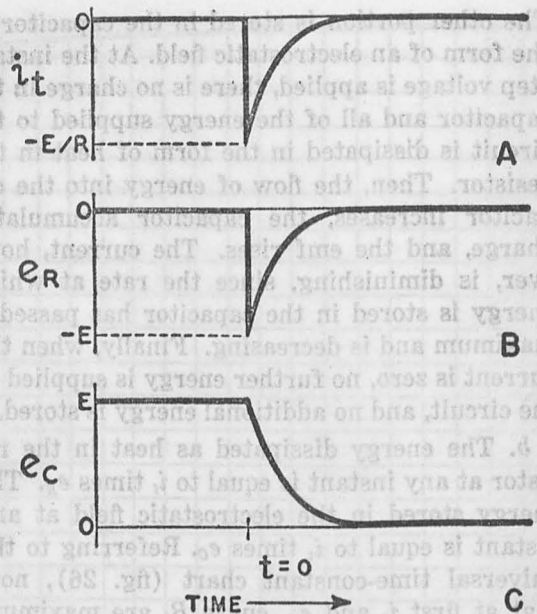

Figure 29. Discharge of R-C circuit.

posite polarity, or -6 volts. The current is $-6/2,000$, or -3 ma, and the minus sign indicates that the capacitor is being discharged. A current of 3 ma means that .003 coulomb of charge is being drawn from the capacitor in 1 second, or .000000003 coulomb, 3 times 10^{-9} per usec. This corresponds to a voltage rate of discharge of (3 times 10^{-9}) / (75 times 10^{-10}), or .4 volt per usec.

- (3) *Current at 5 usec.* The current decreases as the emf of the capacitor decreases. At the end of 5 usec (t/RC equals $1/3$), the current is 2.16 ma, and the rate of voltage decrease in the capacitor is about .29 volt per usec.
- (4) *Current at 1 time constant.* The current decreases to about 37 percent of the initial value, or 1.11 ma, 15 usec (or 1 time constant) after the step voltage is applied. The voltage across the capacitor also has been decreased to 37 percent of its original value, or 2.22 volts, and the rate of voltage decrease is about .15 volt per usec.
- (5) *Current at 2 time constants.* The current and voltage decrease to 13.5 per-

cent of their initial values (fig. 26) 30 usec, or 2 time constants, after the step voltage has been applied. The current is approximately .4 ma, the voltage approximately .8 volt, and the rate of voltage decrease is .05 volt per usec. The voltage is decreasing at a slower rate at this time because of the low value of current in the circuit.

(6) *Current at 7 time constants.* Theoretically, the current and voltage never reach zero value. However, 7 time constants (105 usec) after the transient period has started, the current and voltage reach .1 percent of the initial values, and can be considered zero.

d. *SIGNIFICANCE OF TIME CONSTANT.* The time constant RC for the negative step response has the same significance that it has for the positive step response. The period required to reach the steady-state condition, or the rate at which the voltage declines, depends directly on the magnitude of the time constant. The longer the time constant, the longer the period of time required to discharge the capacitor completely (.1 percent). The shorter the time constant, the faster the capacitor discharges.

40. Step-by-step Procedure for Determining Transient Response

a. GENERAL.

(1) The emf of the capacitor at any instant of time has been determined in this chapter directly from an exponential curve. It is possible to obtain an approximation of this response curve by means of the simple voltage equation, E equals e_R plus e_C . This method is developed step by step, and is useful when a universal time-constant chart is not available. The step-by-step method also is useful in obtaining the approximate response of an $R-C$ circuit to pulse voltages in which rise and decay times are not zero.

(2) In the step-by-step procedure, it is assumed that the current does not decrease continuously, but decreases in small steps, and can be understood by working out a response problem. The

voltage across a 1,000- μf capacitor resulting from a step voltage of 10 volts, with R of 10,000 ohms, will be determined.

b. *VOLTAGE AT END OF 1 USEC.* At the instant that the step voltage is applied to the circuit, a current of 10/10,000, or 1 ma, flows in the circuit. The capacitor is charging at a rate of (.001 times 10^{-6})/(1,000 times 10^{-12}), or 1 volt per usec, and at the end of 1 usec, the capacitor charges to 1 volt.

c. *VOLTAGE AT END OF 2 USEC.* With 1 volt across the capacitor, there are only 9 volts across the resistor and the current drops to 9/10,000, or .9 ma. The capacitor then charges at a rate of .0009 times 10^{-6} /1,000 times 10^{-12} , or .9 volt per usec, and, at the end of 2 usec, the capacitor has an emf of 1.9 volts.

d. *TABLE OF VOLTAGE FROM 3 TO 10 USEC.* The currents and voltage at the end of each 1-usec step are recorded in table V.

Table V. Currents and Voltages in 1-Usec Steps, Using Step-By-Step Procedure

t in usec	e_C in v	e_R in v	i_t in ma	Charge rate in v/usec	total charge in v between each usec step
$t = 2$ to $t = 3$	1.9	8.1	.8	.8	$1.9 + .8 = 2.7$
$t = 3$ to $t = 4$	2.7	7.3	.7	.7	$2.7 + .7 = 3.4$
$t = 4$ to $t = 5$	3.4	6.6	.7	.7	$3.4 + .7 = 4.1$
$t = 5$ to $t = 6$	4.1	5.9	.6	.6	$4.1 + .6 = 4.7$
$t = 6$ to $t = 7$	4.7	5.3	.5	.5	$4.7 + .5 = 5.2$
$t = 7$ to $t = 8$	5.2	4.8	.5	.5	$5.2 + .5 = 5.7$
$t = 8$ to $t = 9$	5.7	4.3	.4	.4	$5.7 + .4 = 6.1$
$t = 9$ to $t = 10$	6.1	3.9	.4	.4	$6.1 + .4 = 6.5$

e. *RESULTS.* It is possible to plot all values of voltage until a steady-state is reached, and these voltages can be used to determine the response of any $R-C$ circuit. A graph of the voltages in table V is plotted on a curve in figure 30 and should be compared with the curve in A of figure 26 where the values obtained by the step-by-step method are slightly lower.

41. Use of Step-by-step Method for Other Waveforms

a. The procedure outlined in paragraph 40 can be applied to any waveform. Practical pulses usually have a finite rise and decay time

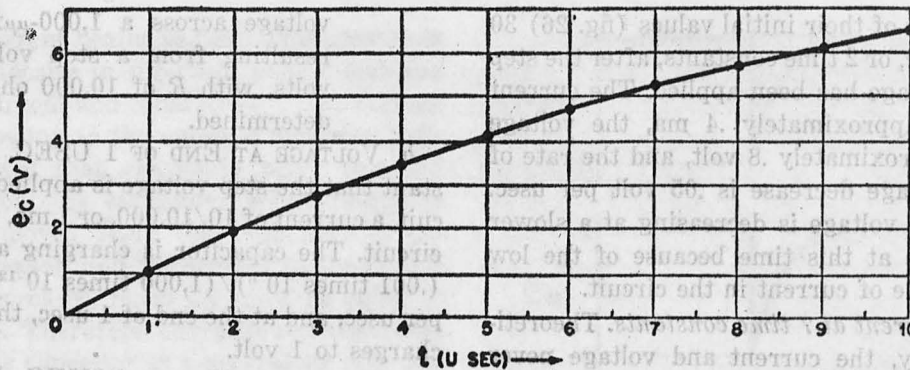

Figure 30. Plot of e_c , step-by-step method.

(A of fig. 31) and an approximation of the response of an R - C circuit having a finite pulse rise time can be obtained by the following procedure.

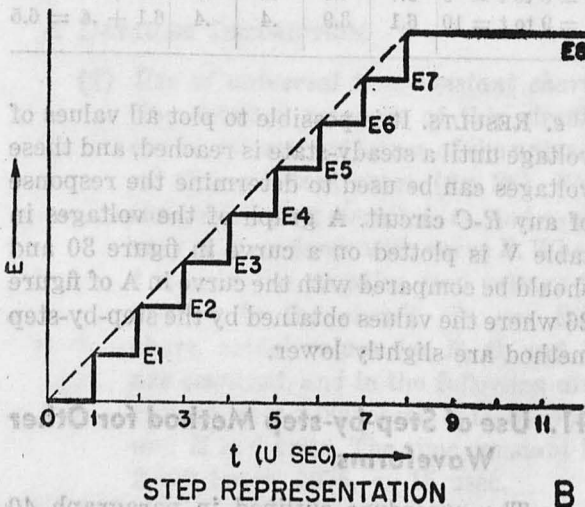
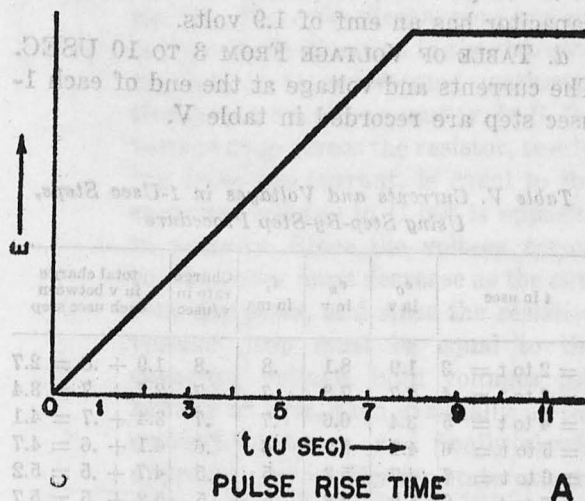

Figure 31. Step representation of pulse rise time.

- (1) Redraw the sloping voltage in terms of a series of small step voltages (B of fig. 31).
- (2) Determine the current flowing through the circuit at the end of 1 usec (E_1/R).
- (3) Using this value of current, obtain the voltage rate of charge during the second usec. This determines e_0 at the end of 2 usec.
- (4) Determine current flowing in circuit at the end of 2 usec. It is equal to E_2 minus e_0/R (B of fig. 31).
- (5) Using this value of current, determine the voltage rate of charge during the third usec, and obtain e_0 at the end of the third usec.
- (6) Repeat this procedure for each step voltage.

b. This procedure is slightly different from paragraph 40 since the voltage increases with each usec and new values of E must be used in each step. The step intervals should be equal to one-tenth the time constant. When the time constant is 10 usec, 1-usec steps should be used; when the time constant is 25 usec, 2.5-usec steps should be used.

42. Summary

a. When a step voltage is applied to an R - C circuit, the emf of the capacitor cannot rise instantaneously, but requires a finite period of time to reach the step-voltage value or steady state.

b. The current in the circuit is, initially, maximum and decreases as the capacitor charges.

c. The capacitor charges to the input voltage, following an exponential curve in which the rate of charge is greatest at the beginning and tapers off as the capacitor accumulates charge.

d. The length of time required to charge the capacitor to the applied voltage depends on RC , the time constant of the circuit.

e. A long time constant means that a long period of time is required for the capacitor to charge.

f. A short time constant means that a short charging period is required.

g. When time is expressed in terms of RC , it is possible to determine the relative current and voltages in the circuit from the universal time-constant chart.

h. The rate at which energy is received by the circuit at any instant is equal to $i_e e_R + i_e e_C$.

i. The rate at which energy is being dissipated in heat is represented by $i_e e_R$; the rate at which energy is being stored in the capacitor is represented by $i_e e_C$.

j. When a negative step voltage is applied to the circuit, the capacitor discharges through the resistor.

k. The time required for the capacitor to discharge depends on the time constant. A long time constant means a long discharge period.

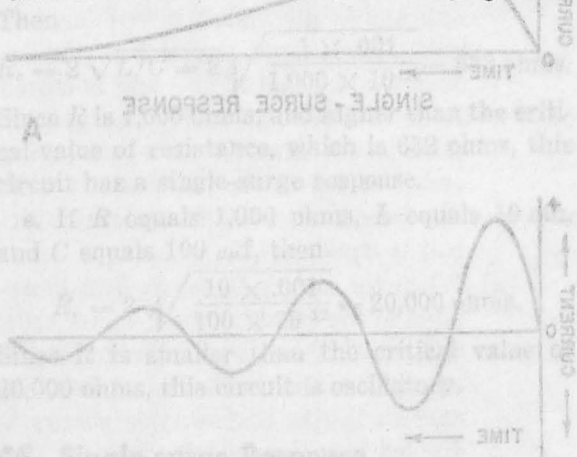

l. The step-by-step method of determining the charge and discharge curves of an $R-C$ circuit can be used for any voltage waveform.

43. Review Questions

a. Describe the current flowing in a series $R-C$ circuit, with R equal to 5,000 ohms and C equal to $.001 \mu f$ with a positive step voltage of 15 volts applied.

b. What is the steady-state condition of this circuit, and how long does it take to reach 99.9 percent of the steady-state values?

c. How does the value of C affect the period of time required to reach the steady state?

d. How much energy has been stored in the capacitor after 10 usec in the circuit described in Review Question a?

e. Using the universal time-constant chart, determine the values for e_C , e_R , and i_e , after .5, 1, 3, and 5 usec resulting from the application of an 18-volt step voltage to a series $R-C$ circuit. R is 100 ohms, and C is $.015 \mu f$.

f. Determine the discharge curve for the circuit in Review Question 5 up to 1.5 usec after the applied voltage is removed. Use .1 $R-C$ steps.

g. Determine the time constants for the following values of R and C : $R = 1$ megohm, $C = .01 \mu f$; $R = 1,000$ ohms, $C = 5 \mu f$; $R = 10,000$ ohms, $C = .001 \mu f$.

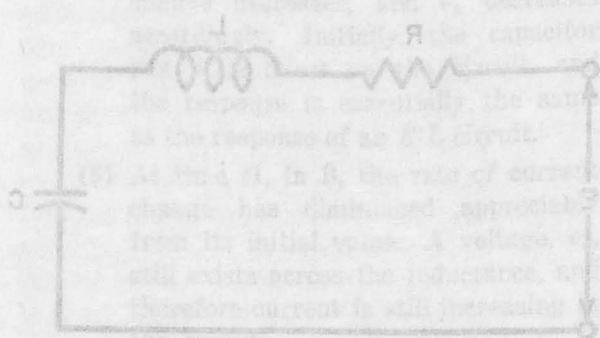

Figure 32. Series $R-L-C$ circuit.

CHAPTER 5

RESPONSE OF R-L-C CIRCUITS

44. Introduction

a. The R - L - C circuit (fig. 32) can be considered a general representation of any network, since a certain amount of resistance, capacitance, and inductance must be present in every practical circuit. In the previous series R - L and R - C circuits the distributed capacitance and inductance were disregarded to avoid complicated calculations, and L and C were considered ideal elements. However, this could not be considered a completely accurate description of a practical circuit. The stray capacitance and inductance that are always present in a circuit affect its operation, and the response characteristics must be modified.

b. Since R , L , and C are present in any circuit, the circuit will be *resonant* to some frequency determined by LC , and oscillations may occur. In pulse circuits the problem of minimizing or avoiding oscillations is sometimes more important than the problem of sustaining them in r - f circuits. The modifications necessary to calculate the response characteristics of these R - L - C circuits as well as the effects of resonance are studied in this chapter.

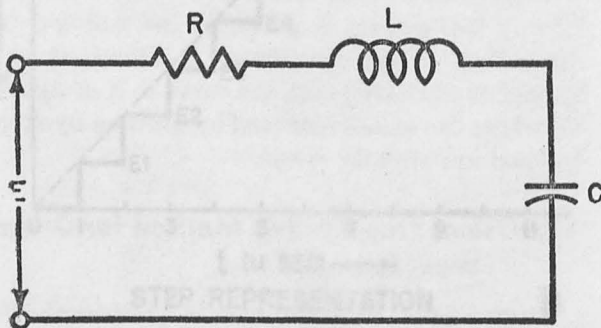

TM 669-32

Figure 32. Series R - L - C circuit.

45. Forms of Solution

a. When a step voltage is applied to a series R - L - C circuit, two response characteristics can result. One is known as a *single surge* or *overdamped* response, in which the current in the circuit rises to some amplitude and then gradually declines to zero (A of fig. 33). The other is known as the *oscillatory* response, in which the current undergoes a series of damped oscillations, as shown in B. The plus and minus signs signify the direction of current flow in these circuits. The steady-state current of both circuits is zero, since a d-c voltage is being applied to a circuit having series capacitance.

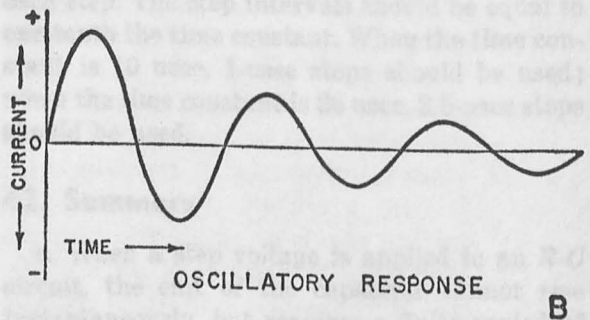
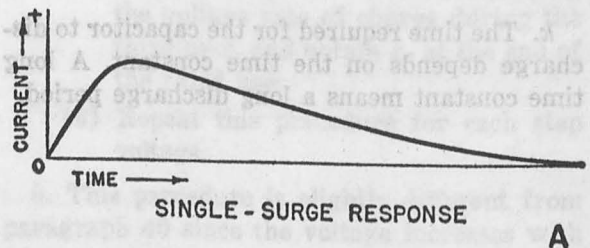

TM 669-33

Figure 33. Forms of R - L - C response.

b. The interchange of energy from the magnetic field of the inductance to the electrostatic field of the capacitance, and then from the elec-

trostatic field to the magnetic field, causes oscillation. The element that limits the extent of this energy transfer is the resistance in the circuit, and the energy dissipated by the resistance is lost to the circuit. When R is increased, the time constant L/R is decreased and if a large circuit resistance is used the field energy is dissipated quickly, and oscillations rapidly die out. As the resistance is increased, a point is reached where the time constant is so short that there can be only one transfer of energy from the magnetic to the electrostatic field. This corresponds to the single-surge response (A of fig. 33).

c. The value of resistance at which the circuit response changes from an oscillatory to a single-surge is known as the critical value of resistance. In the R - L - C circuit, the critical value of resistance is equal to:

$$R_c = 2\sqrt{L/C} \text{ ohms,}$$

where R_c = the critical value of resistance in ohms,

L = the inductance in henrys,

and C = the capacitance in farads.

When the value of resistance in the circuit is lower than R_c , the circuit has an oscillatory response.

d. Consider, for example, a circuit in which R equals 1,000 ohms, L equals .1 mh, and C is equal to 1,000 μ mf.

Then

$$R_c = 2\sqrt{L/C} = 2\sqrt{\frac{.1 \times .001}{1,000 \times 10^{-12}}} = 632 \text{ ohms.}$$

Since R is 1,000 ohms, and higher than the critical value of resistance, which is 632 ohms, this circuit has a single-surge response.

e. If R equals 1,000 ohms, L equals 10 mh, and C equals 100 μ mf, then

$$R_c = 2\sqrt{\frac{10 \times .001}{100 \times 10^{-12}}} = 20,000 \text{ ohms.}$$

Since R is smaller than the critical value of 20,000 ohms, this circuit is oscillatory.

46. Single-surge Response

a. GENERAL DESCRIPTION.

(1) The response of an R - L - C circuit to a positive step voltage is shown in figure 34. This response characteristic is for a value of resistance near the critical value. When the step voltage is first

applied to the circuit, a back emf is developed across the inductance equal to the applied voltage. Therefore, at the first instant no current flows in the circuit, and the full input voltage is across the inductance.

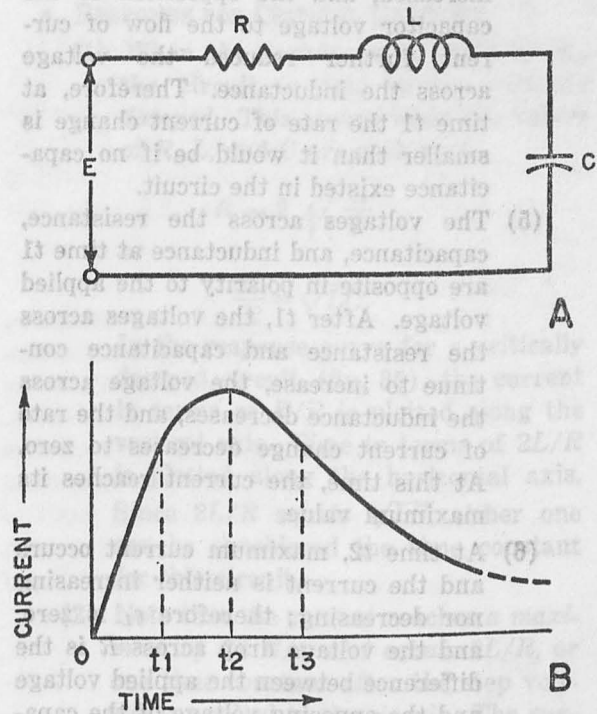

TM 669-34

Figure 34. Single-surge response for resistance near critical value.

(2) This voltage, e_L , across the inductance causes the current in the circuit to increase at a rate proportional to the value of inductance L . As current flows in the circuit, a voltage drop, e_R , appears across R , the rate of current change decreases, and e_L decreases accordingly. Initially, the capacitor has little effect on the circuit, and the response is essentially the same as the response of an R - L circuit.

(3) At time t_1 , in B, the rate of current change has diminished appreciably from its initial value. A voltage, e_L , still exists across the inductance, and therefore current is still increasing in the circuit.

(4) At the same instant that current

started to flow in the circuit above, a charge began to accumulate on the capacitor. The voltage charge on the capacitor built up slowly at first, since the current was small. As the current increased, the charge on the capacitor increased, and the opposition of the capacitor voltage to the flow of current further reduced the voltage across the inductance. Therefore, at time t_1 the rate of current change is smaller than it would be if no capacitance existed in the circuit.

- (5) The voltages across the resistance, capacitance, and inductance at time t_1 are opposite in polarity to the applied voltage. After t_1 , the voltages across the resistance and capacitance continue to increase, the voltage across the inductance decreases, and the rate of current change decreases to zero. At this time, the current reaches its maximum value.
- (6) At time t_2 , maximum current occurs and the current is neither increasing nor decreasing; therefore e_L is zero, and the voltage drop across R is the difference between the applied voltage and the opposing voltage of the capacitance, E minus e_C equals e_R . However, this condition cannot last since the charge on the capacitance accumulates, and the voltage across the capacitor, e_C , increases. As e_C increases, e_R decreases, and the current decreases.
- (7) This decrease in current is opposed by the inductance, and a back emf is developed across L which has the same polarity as the applied voltage. The energy stored in the magnetic field around the inductance tends to keep the current flowing in the circuit and prevents the current from decreasing along the R - C curve (ch. 4). Note that the *inductance* does not prevent the current from decreasing, but stops it from decreasing as fast as it normally would in an R - C circuit (rate of change decreases).
- (8) At time t_3 , the voltage across R is

equal to the applied voltage, E , plus the voltage, e_L , across L , minus the voltage, e_C , across C , which is opposite in polarity to both E and e_L , or

$$E + e_L - e_C = e_R.$$

As time passes beyond t_3 , e_L continues to decrease, reducing the current flow, while e_C increases as charge accumulates on the capacitance. Finally, the steady state is reached when the current is zero, e_L is zero, and the emf of the capacitor is equal and opposite to the applied voltage.

- (9) When the step voltage is applied at time t_1 , the current essentially follows the R - L circuit response curve. After a period of time, the capacitance acts to reduce the rate of current increase so that a lower maximum current is obtained than in an R - L circuit. At time t_2 , the response resembles the R - C current charge curve and the inductor prevents the current from decreasing too rapidly.

b. ENERGY CONSIDERATIONS.

- (1) The energy supplied to a circuit element at any instant is equal to the current at that instant times the voltage across the element. The energy supplied to the resistance is equal to $i_e e_R$, and is dissipated in the form of heat. The energy supplied to the inductance is equal to $i_e e_L$, and is stored in the magnetic field. The energy supplied to the capacitor is equal to $i_e e_C$ and is stored in the electrostatic field. The energy supplied to the entire circuit is equal to $i_e E$.
- (2) When the step voltage, E , first is applied to the circuit, e_R and e_C are zero, and all of the energy supplied to the circuit is stored in the inductance. As current begins to flow, this energy is divided into three parts. Some is dissipated by the resistance, some is stored in the electrostatic field of the capacitor, and the major portion is stored in the magnetic field of the inductance. Until t_2 , in B, the rate of energy stored in the magnetic field is decreasing continuously, since e_L

decreases faster than i_t increases. The rate of energy supplied to the resistor and capacitor is increasing continuously, since i_t , e_R , and e_C are all becoming larger.

(3) At time t_2 the current stops increasing, e_L becomes zero, and no further energy is supplied to the inductance. All of the energy being supplied to the circuit is either dissipated by the resistance or stored in the capacitor. When the current starts decreasing, the energy stored in the magnetic field is returned to the circuit. Part of this energy is dissipated in the resistor, and the rest is stored in the capacitor.

(4) The rate at which energy is dissipated is maximum at time t_2 , since both i_t and e_R are maximum. The rate of energy storage in the capacitor reaches a maximum slightly after t_2 . At this time e_C is increasing faster than i_t is decreasing. As the current decreases, the energy dissipated in the resistor decreases rapidly, and the rate at which energy is stored in the capacitor decreases gradually, since the reduction in current is somewhat offset by a larger e_C . When the steady state is reached, all of the energy stored in the inductor has been re-

turned to the circuit. The capacitor is fully charged, and the total energy stored is $CE^2/2$.

47. Effect of Individual Elements on Single-surge Response

a. RESPONSE FOR CRITICAL DAMPING.

(1) When the resistance is equal to R_C , the circuit is said to be *critically damped*. This occurs when the values of R , L , and C are such that

$$R = 2 \sqrt{\frac{L}{C}}$$

or

$$\frac{2L}{R} = \sqrt{LC}$$

In the response curve for a critically damped circuit (fig. 35), the current in terms of E/R is plotted along the vertical axis. Time in terms of $2L/R$ is plotted along the horizontal axis. Since $2L/R$ equals \sqrt{LC} , either one can be considered the time constant for this circuit.

(2) Note that the current reaches a maximum of $.74 E/R$ at t equals $2L/R$, or one time constant after the step voltage is applied to the circuit. The current reaches zero ($.001 E/R$) 8.5 time constants later.

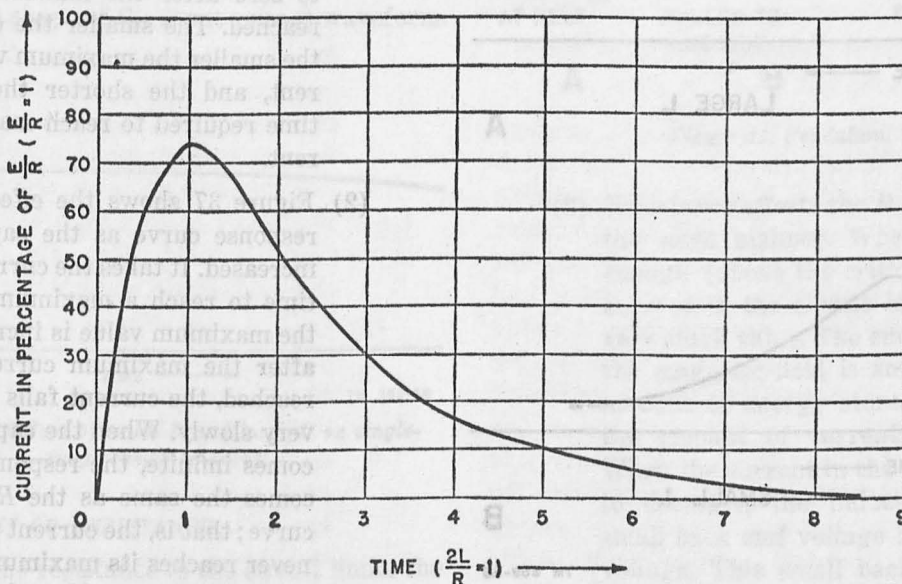

Figure 35. Critically damped circuit response curve.

- (3) For example, a 5-volt step voltage is applied to a circuit in which L equals 1 mh and C equals .001 μ f. The value of resistance required for critical damping is

$$R_c = 2 \sqrt{\frac{1 \times 10^{-3}}{.001 \times 10^{-6}}} = 2,000 \text{ ohms.}$$

The time constant is $2(1 \text{ times } 10^{-3}) / (2,000)$, or $1 \text{ times } 10^{-6}$ second, or 1 usec. The current at this time reaches a maximum value of $.74 E/R$, or 1.85 ma, and then declines, reaching zero about 8.5 usec or 8.5 time constants later.

b. EFFECT OF INDUCTANCE.

- (1) The inductance opposes the change in current. Therefore, it affects the circuit at the very beginning when the current rises to its maximum value. The inductance then acts to maintain the current flow after the maximum value is reached and current tends to decrease. The larger the inductance, the more gradual the rise and decay curves become (A of fig. 36).

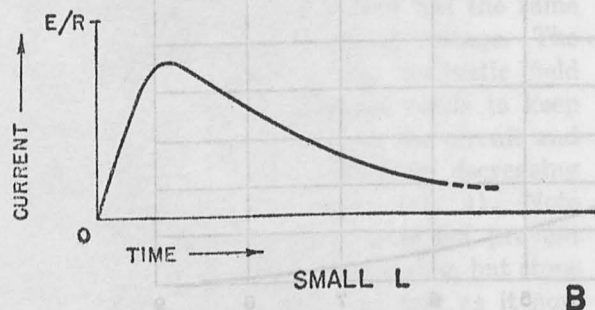
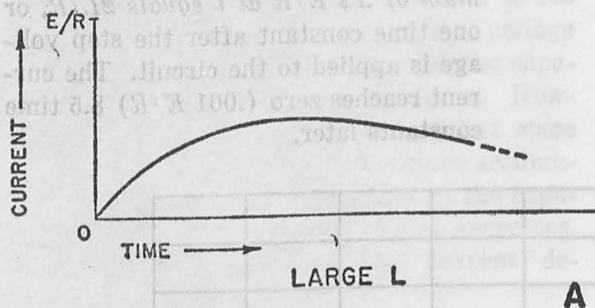

TM 669-36

Figure 36. Effect of inductance on single-surge response curve.

- (2) When the inductance is decreased, the current rises and decays more rapidly. When the inductance is decreased to zero, the response is the same as that for the $R-C$ circuit. The response curve for a smaller L , in B, is similar to the current curve of an $R-C$ circuit. Since it is impossible to have a circuit without a small amount of inductance, it is physically impossible for the current in a circuit to rise instantly from zero to a maximum value as suggested by the $R-C$ curve (fig. 25). The ideal shape of the $R-C$ curve is approached closely when the inductance in the circuit is made very small. Therefore, the solution indicated in chapter 4 can be used for most practical circuits with a negligibly small error. This factor becomes important, however, in circuits using $R-C$ constants lower than .1 usec.

6. EFFECT OF CAPACITANCE.

- (1) In an $R-L$ circuit the current theoretically never reaches its maximum value. The addition of capacitance to the circuit, however, causes the current to reach a definite maximum value. Capacitance also affects the maximum value of current that flows in the circuit and causes the current to decline to zero after the maximum value is reached. The smaller the capacitance, the smaller the maximum value of current, and the shorter the period of time required to reach maximum current.
- (2) Figure 37 shows the effect upon the response curve as the capacitance is increased. It takes the current a longer time to reach a maximum value, and the maximum value is increased. Also, after the maximum current value is reached, the current falls toward zero very slowly. When the capacitance becomes infinite, the response curve becomes the same as the $R-L$ response curve; that is, the current theoretically never reaches its maximum value, and never falls to zero. Note that an infinite capacitance is the equivalent of a short

circuit, since the voltage across such a capacitance is always zero:

$$e_0 = \frac{Q}{C}, \text{ and } Q_\infty = 0.$$

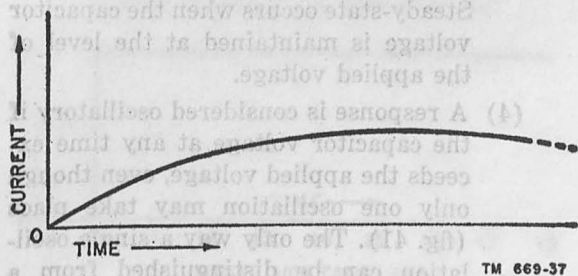

Figure 37. Effect of large capacitance on single-surge response curve.

d. SMALL L AND LARGE C . When L is very small and C is very large (fig. 38), the resistor is the major controlling element in the circuit. The current rises very quickly and then remains constant for a relatively long period of time. The sudden rise in current is possible since the circuit inductance is small. Its decay is slow because a long time is required to charge the large capacitor (large R - C time constant). The response curve closely resembles the input step voltage. In fact, as L approaches zero and C approaches infinity, so that only resistance is left in the circuit, the output waveform approaches the input waveform. This is to be expected since a purely resistive circuit has no transient response, and therefore does not change the shape of the input voltage waveform.

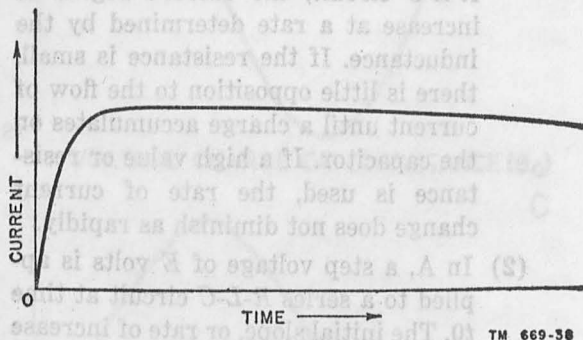

Figure 38. Effect of small L and large C on single-surge response curve.

e. EFFECT OF RESISTANCE.

- (1) The resistance in the circuit limits the flow of current and prevents the voltage from overshooting (exceeding

the applied voltage). Also, it limits the amount of energy that can be stored in the magnetic field around the inductance.

- (2) Compare the R - L - C circuit to a pendulum (fig. 39). The steady-state condition for the pendulum is when it is at rest at the center position, as in A. When it is pulled to one side, in B, and released, C, the force of gravity acts to return it to the center position. When there is little friction, the pendulum picks up speed on its downward swing, and overshoots the center position to swing upward against gravity. If it is immersed in oil so that there is a large frictional force opposing its movement, it cannot pick up a great deal of speed on its way down. If the friction is great enough, the pendulum moves slowly toward the center position and stops there.

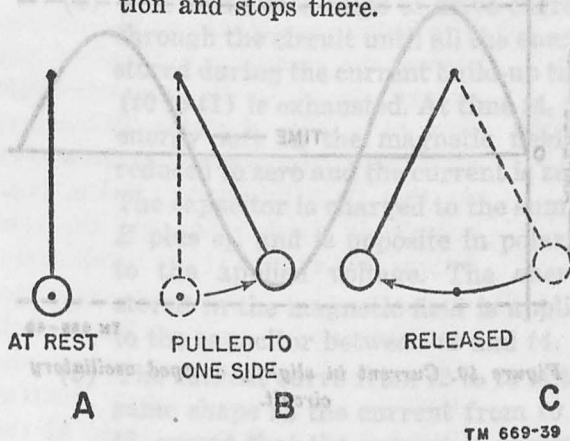

Figure 39. Pendulum.

- (3) Resistance affects the R - L - C circuit in the same manner. When R is large enough (above the critical value) the current in the circuit is limited to a very small value. The energy stored in the magnetic field is small, since the amount of energy stored depends on the amount of current flow, $LI^2/2$. When the current in the circuit begins to decrease, the inductance adds a small back emf voltage to the applied voltage. This small back emf causes the voltage drop across the resistance to increase. Therefore, the stored

energy of the magnetic field cannot cause the capacitor voltage to overshoot or exceed the applied voltage. The resistance acts to slow down the entire cycle and prevent oscillation.

48. Oscillatory Response

a. CHARACTERISTICS.

- (1) When the value of the resistance in the $R-L-C$ circuit is below the critical value, an oscillatory response is obtained (fig. 40). This is a damped sinusoidal current response in which the current alternately swings positive or negative. The amplitude of each successive sine wave of current is smaller than the previous cycle and, eventually, becomes so small that the current is considered to be zero. This is the steady-state condition.

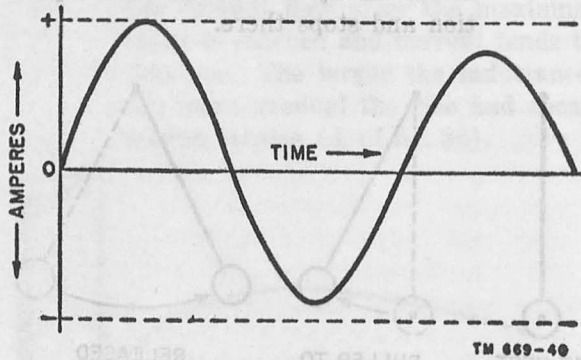

Figure 40. Current in slightly damped oscillatory circuit.

- (2) Referring to the pendulum analogy given in the previous paragraph, a low frictional force permits the pendulum to swing past, or overshoot, the center position. It then comes to rest at some point beyond the center position, and gravity forces the pendulum to swing back and forth several times before coming to rest at the center point. Similarly, when the resistance in the $R-L-C$ circuit is low, more energy is stored in the magnetic field during the current build-up time. This energy then causes the voltage charge on the capacitor to exceed the applied voltage, and oscillations occur.

- (3) The capacitor discharges and again overshoots the applied voltage because of the action of the inductance and must charge up again, and so on. Steady-state occurs when the capacitor voltage is maintained at the level of the applied voltage.

- (4) A response is considered oscillatory if the capacitor voltage at any time exceeds the applied voltage, even though only one oscillation may take place (fig. 41). The only way a single oscillation can be distinguished from a single surge is by the overshoot of capacitor voltage that takes place. This is an important factor in many pulse circuits.

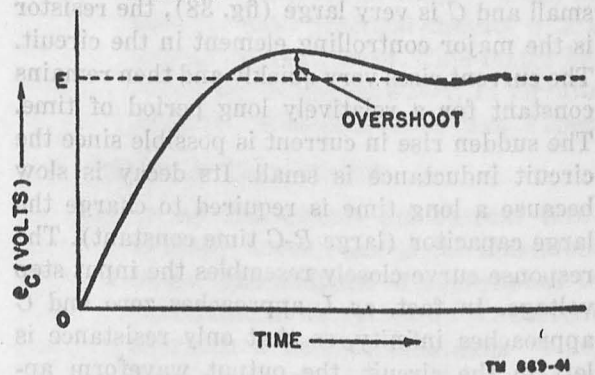

Figure 41. Single oscillation response curve.

b. DETAILED DESCRIPTION (fig. 42).

- (1) When the step voltage is applied to an $R-L-C$ circuit, the current begins to increase at a rate determined by the inductance. If the resistance is small, there is little opposition to the flow of current until a charge accumulates on the capacitor. If a high value of resistance is used, the rate of current change does not diminish as rapidly.
- (2) In A, a step voltage of E volts is applied to a series $R-L-C$ circuit at time t_0 . The initial slope, or rate of increase of the current curve is equal to E/L , as in D. The rate of change decreases as the capacitor charges, decreasing the voltage across the inductance as in B and C. The resistance in this circuit is assumed to be sufficiently low that the voltage drop across it can be

neglected. A little after time t_1 , the applied voltage is divided equally between the inductance and the capacitance, and the current is changing at a rate one-half its initial value.

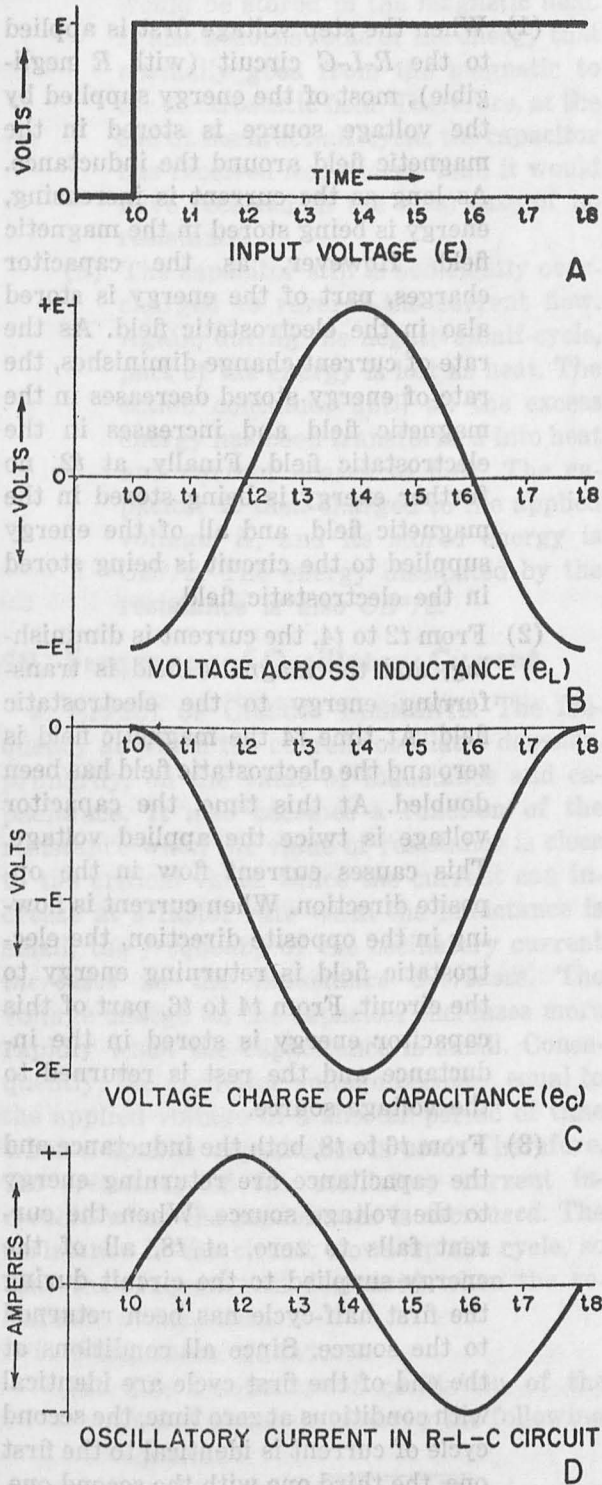

Figure 42. Voltage relations in ideal L-C circuit.

TM 669-42

(3) At time t_2 the current reaches its maximum value and the current stops changing. The rate of change is zero and therefore the voltage e_L across the inductance is zero. The voltage e_C across the capacitance is equal and opposite to E (neglecting any voltage drop across R). Since e_C is equal to E , the current in the circuit attempts to drop to zero. However, a back emf, with the same polarity as the applied voltage, is developed across the inductance. This emf adds to the applied voltage, and current flow continues in the same direction. At first the current decreases slightly, and a small emf exists across L . Later, as the rate of current change becomes larger, e_L increases. At t_4 , the rate of current change is maximum and e_L is equal to E .

(4) The inductance helps to drive current through the circuit until all the energy stored during the current build-up time (t_0 to t_1) is exhausted. At time t_4 , the energy left in the magnetic field is reduced to zero and the current is zero. The capacitor is charged to the sum of E plus e_L , and is opposite in polarity to the applied voltage. The energy stored in the magnetic field is applied to the capacitor between t_2 and t_4 .

(5) The current curve from t_2 to t_4 is the same shape as the current from t_0 to t_2 , except that the current is decreasing instead of increasing. The same average current flows during each of these periods, and therefore the same total charge is driven into the capacitor. If the capacitor voltage is equal to E at t_2 , as in C, it is equal to $2E$ at t_4 .

(6) At time t_4 , the current is equal to zero. The voltage across the inductance is equal to E , since the rate of current change is maximum. The voltage charge on the capacitance is $-2E$, and the applied voltage is E . Therefore, there is a net emf of zero in the circuit:

$$E - 2E + E = 0.$$

(7) Since the capacitor is charged to a voltage of $-2E$, or twice the applied voltage, the capacitor begins to discharge in the opposite direction. The voltage across the inductance is E , and the rate of change of current is $-E/L$. At a time slightly after t_5 , the capacitor has been discharged by a voltage equal to $E/2$. e_L is, therefore, equal to $-E/2$, and the rate of current change is diminished approximately one-half.

(8) The maximum negative current is reached at t_6 , when e_C has decreased to a point equal and opposite to E . The inductor voltage is then zero and the current cannot become more negative. Since e_C is equal to E , there is no net emf in the circuit, and the current tends to drop to zero. This creates a back emf across the inductance, which forces current to continue to flow, and e_C to decrease below E .

(9) The inductance continues to help discharge the capacitor until all of the energy stored in its magnetic field from t_4 to t_6 is exhausted. This occurs at t_8 , when the current becomes zero. At this time the capacitor has been completely discharged, and the conditions that existed at t_0 prevail again.

(10) In the previous discussion, the effect of resistance has been neglected. Actually, resistance acts to reduce the amplitude of the oscillatory current during each successive cycle. At the end of the first quarter-cycle, the voltage charge on the capacitor is not quite equal to E , because there is a voltage drop, E_R , across R . From t_2 to t_4 the capacitor charges to a voltage double that at t_2 , or $2(E \text{ minus } E_R)$, or $2E \text{ minus } 2E_R$. Note that the voltage drop across R has doubled at t_4 . Similarly, at t_6 the voltage charge on the capacitor is $E - 3E_R$. At t_8 the capacitor voltage is not zero, as in the ideal case, but equal to $4E_R$. The voltage across the inductance is $E - 4E_R$, which indicates that the current does not rise as fast during the second cycle. The current has a smaller amp-

litude during this cycle, and the effect of the iR drop is cumulative with each cycle, causing smaller and smaller current amplitudes.

c. ENERGY IN CIRCUIT.

(1) When the step voltage first is applied to the R - L - C circuit (with R negligible), most of the energy supplied by the voltage source is stored in the magnetic field around the inductance. As long as the current is increasing, energy is being stored in the magnetic field. However, as the capacitor charges, part of the energy is stored also in the electrostatic field. As the rate of current change diminishes, the rate of energy stored decreases in the magnetic field and increases in the electrostatic field. Finally, at t_2 , no further energy is being stored in the magnetic field, and all of the energy supplied to the circuit is being stored in the electrostatic field.

(2) From t_2 to t_4 , the current is diminishing, and the magnetic field is transferring energy to the electrostatic field. At time t_4 the magnetic field is zero and the electrostatic field has been doubled. At this time, the capacitor voltage is twice the applied voltage. This causes current flow in the opposite direction. When current is flowing in the opposite direction, the electrostatic field is returning energy to the circuit. From t_4 to t_6 , part of this capacitor energy is stored in the inductance and the rest is returned to the voltage source.

(3) From t_6 to t_8 , both the inductance and the capacitance are returning energy to the voltage source. When the current falls to zero, at t_8 , all of the energy supplied to the circuit during the first half-cycle has been returned to the source. Since all conditions at the end of the first cycle are identical with conditions at zero time, the second cycle of current is identical to the first one, the third one with the second one, and so on.

(4) When the effect of resistance is considered, part of the energy during each cycle is dissipated in the form of heat. During the first cycle, the resistance takes part of the energy that normally would be stored in the magnetic field. It also absorbs some of the energy that normally goes from the magnetic to the electrostatic field. Therefore, at the end of the first half-cycle, the capacitor has received less energy than it would have received in the ideal case of no resistance.

(5) The capacitor still is sufficiently overcharged to reverse the current flow. Again, during the negative half-cycle, part of the energy is lost as heat. The action continues until all the excess energy has been transformed into heat and current ceases to flow. The capacitor is then charged to the applied voltage, E , and its stored energy is $CE^2/2$. The energy dissipated by the resistance is also $CE^2/2$.

49. Frequency of Oscillatory Current

a. EFFECT OF CIRCUIT ELEMENTS. The frequency at which the current oscillates depends, primarily, on the value of inductance and capacitance. It also becomes a function of the resistance when the value of resistance is close to the critical value. Since the current can increase at a faster rate when the inductance is small, the frequency of the oscillatory current increases as the inductance decreases. The voltage charge on the capacitor increases more rapidly when the capacitance is small. Consequently, the capacitor voltage becomes equal to the applied voltage in a shorter period of time when a smaller capacitance is used. Therefore, the frequency of the oscillatory current increases when the capacitance is decreased. The resistance in the circuit slows up the cycle, so that the frequency is decreased when the resistance is increased.

b. FREQUENCY EQUATION.

(1) The frequency of oscillation of the R - L - C circuit is given by the following equation:

$$f_o = \frac{1}{2\pi} \sqrt{\frac{1}{LC} - \frac{R^2}{4L^2}}$$

(2) For example, if $L = 10$ mh, $C = .01$ μ f, and $R = 100$ ohms, the frequency of oscillation is

$$f_o = \frac{1}{2\pi} \sqrt{\frac{1}{10 \times 10^{-3} \times .01 \times 10^{-6}} - \frac{(1 \times 10^2)^2}{4(10 \times 10^{-3})^2}}$$

$$f_o = \frac{1}{2\pi} \sqrt{100 \times 10^8 - 25 \times 10^8} = 15,900 \text{ cps.}$$

(3) The term $R^2/4L^2$ has little effect on the frequency because it is small compared with $1/LC$. When the resistance is small compared with the critical value, the frequency equation can be written as

$$f_o = \frac{1}{2\pi \sqrt{LC}}$$

(4) Although the frequency is affected only slightly by a small amount of resistance, it is reduced considerably when the resistance is anywhere near the critical value (R equal to $2\sqrt{L/C}$). If the value of resistance in the example given above is increased to 1,000 ohms, the frequency of this circuit then becomes

$$f_o = \frac{1}{2\pi} \sqrt{10^{10} - \frac{(10^3)^2}{4 \times 10^{-4}}} = \frac{10^4}{2\pi} \sqrt{75}$$

$$f_o = 13,800 \text{ cps.}$$

When the resistance is increased further to 1,750 ohms, the frequency is reduced to 7,600 cps.

(5) As the resistance is increased further, the frequency is decreased until the resistance is at the critical value, R_c . At this time the frequency is zero. The following chart illustrates the effect of resistance upon the frequency of the circuit:

Resistance (% of R_c)	Reduction in frequency (% of $\frac{1}{2\pi} \sqrt{1/LC}$)
0 (zero resistance)	0 ($f_o = \frac{1}{2\pi} \sqrt{LC}$)
10	.5
30	4.6
50	13.4
70	28.6
90	56.4
100	100 (no oscillation)

The resistance does not have an appreciable effect upon the frequency

10. — until it has a value of about 10 percent of the critical resistance.

50. Damping Factor

a. **AMPLITUDE OF SINE WAVE WITHOUT R.** In an R - L - C circuit, in which the resistance is so small that it can be neglected, the amplitude of the sine wave of current is a function of the circuit inductance and capacitance. The amplitude of the current at the quarter-cycle instant, $t/2$, is

$$I_{\max} = \frac{E}{\sqrt{L/C}} = \frac{E}{L(1/\sqrt{LC})}$$

Since $1/\sqrt{LC} = 2\pi f$, this expression can be written also as

$$I_{\max} = \frac{E}{2\pi fL},$$

which is the familiar expression for the current in a circuit using conventional impedance notation.

b. EFFECT OF RESISTANCE.

(1) The resistance prevents the current from actually reaching the maximum amplitude indicated above. This effect is cumulative, decreasing the amplitude of successive cycles until the amplitude is reduced to the point where it can be considered equal to zero. This effect is known as *damping*, and the resultant sine wave is known as a *damped sine wave*. The degree of damping, or the speed with which the amplitude reduces to zero, is determined by the value of resistance. In figure 43, A illustrates a slightly damped wave caused by a relatively low value of resistance. As the resistance increases, the damping effect increases. B shows a highly damped wave caused by a resistance just below the critical value.

(2) The effect of damping is indicated by a dotted exponential curve which shows how the reduction in current amplitude takes place in the circuit. Figure 44 can be used to determine the response of any oscillatory circuit by expressing time in terms of L/R , the circuit time constant. When this is done, the maximum current in per-

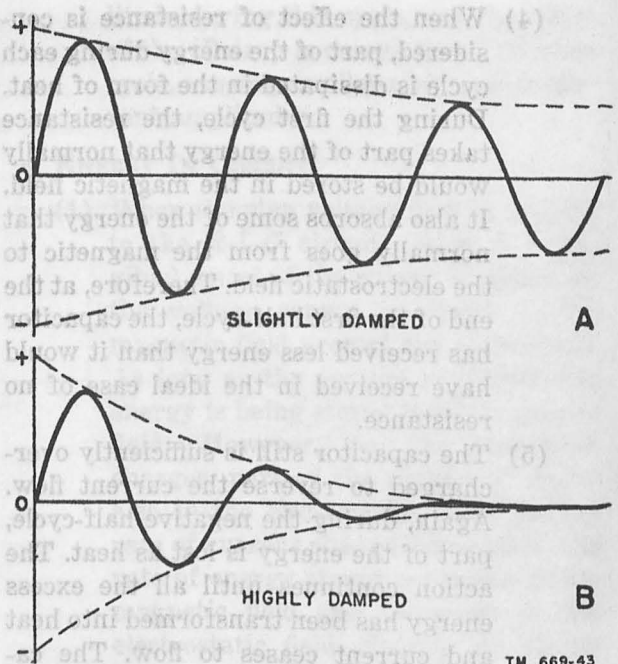
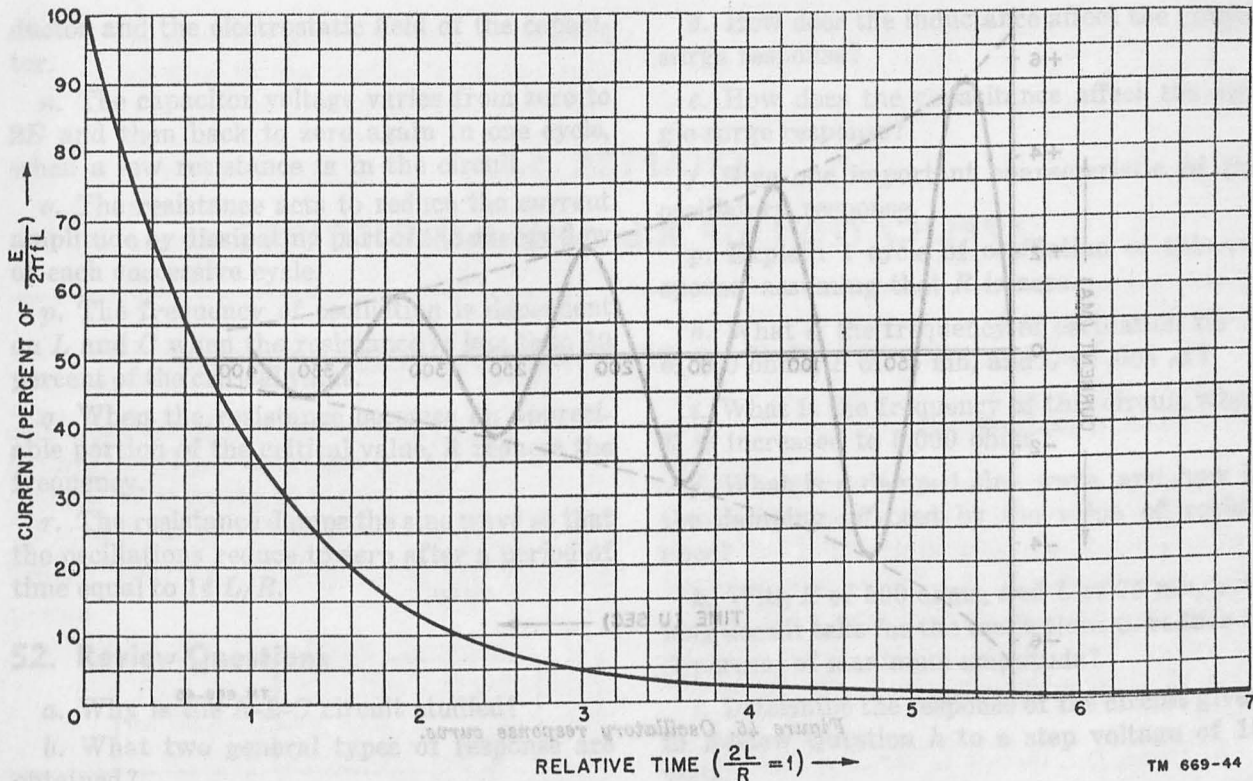

Figure 43. Damped sine wave.

cent can be determined at any time. From this curve, it is noted that the amplitude reduces to zero when t is about 5 time constants, or $10 L/R$. Actually, the amplitude is about 1 percent of maximum at this time, but such a small percentage cannot be shown on the graph. Theoretically, the amplitude never reaches zero, but it can be assumed to be zero when the time elapsed is 7 time constants, or $14 L/R$.

(3) The time required for a series R - L - C circuit to reach a steady-state (zero amplitude) is dependent primarily on the values of R and L . If R is increased, the time constant $2L/R$ is decreased, and the sine wave is damped more strongly. Varying C affects the frequency of the oscillatory current.

(4) To obtain the response of an oscillatory circuit, first determine the frequency, assuming that R is zero for resistance lower than 10 percent of the critical value. Otherwise, use the equation including resistance (par. 49b). Calculate the value of maximum current, using this frequency and as-



TM 669-44

Figure 44. Damping factor curve.

suming that no resistance is in the circuit. Then include the effect of resistance, using the damping factor curve in figure 44.

- (5) The response of an R - L - C circuit with L of 25 mh, C of .01 μ f, and R of 250 ohms, to a step voltage of 10 volts will now be determined.

- (a) The critical value of resistance, $2\sqrt{L/C}$, for this circuit is about 3,160 ohms, so that an R of 250 ohms can be assumed to be zero in determining the frequency.

$$f = \frac{1}{2\pi\sqrt{LC}} = 10,000 \text{ cps.}$$

Maximum current

$$I_t = \frac{E}{2\pi fL} = \frac{10}{2\pi \times 10,000 \times 25 \times 10^{-3}}, \text{ or } .0064 \text{ ampere, or } 6.4 \text{ ma.}$$

- (b) The time constant of this circuit is $2(25 \text{ times } 10^{-3})/250$, .0002 second, or 200 usec. The time required to complete 1 cycle of oscillation is equal to $1/f$, or 100 usec. The sine wave, therefore, reaches its first

maximum amplitude 25 usec, or one-eighth of a time constant, after the step voltage is applied to the circuit. The damping factor after one-eighth of a time constant is 87.5 percent (fig. 44), and the amplitude of the first half-cycle is 87.5 percent of 6.4 ma, or 5.6 ma (fig. 45).

- (c) The first negative peak occurs after three-eighths of a time constant, when the current is only 69 percent of maximum, or about 4.4 ma. Similarly, as in figure 45, each half-cycle reaches a lower amplitude. Fourteen cycles after the step voltage has been applied to the circuit, the current reduces to zero (.0064 ma).

- (6) Increasing the resistance increases the damping factor and decreases the current flow in the circuit, even during the first cycle. A smaller current flow means that the voltage across the capacitor at the end of the first quarter-cycle is lower, or that the over-

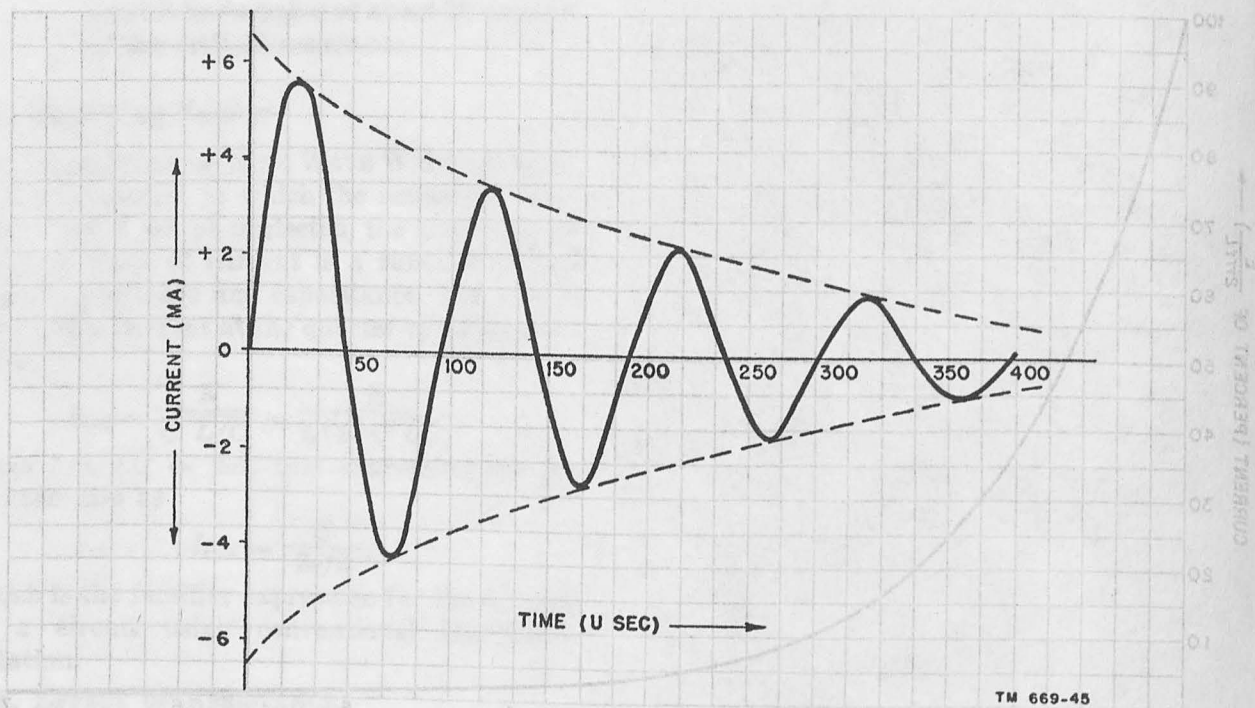

Figure 45. Oscillatory response curve.

shoot is less. Hence, in many circuits where overshoot must be minimized, the value of resistance is increased.

51. Summary

a. The series R - L - C circuit actually is representative of any series network, since all circuits must have some inductance, capacitance, and resistance.

b. An R - L - C circuit may have two forms of response: the single-surge response and the oscillatory response.

c. A single-surge response occurs when the value of resistance in the circuit exceeds the critical resistance.

d. In a single-surge response, the current rises to some maximum value and then decays to zero.

e. The rise time of the current is determined by the resistance and inductance; the capacitance serves to reduce the maximum value of current obtained.

f. The decay period is determined by the resistance and capacitance; the inductance maintains the current flow in the circuit.

g. At the first instant, all of the energy supplied to the circuit is stored in the magnetic field of the inductor.

h. As current flows, energy is dissipated as heat by the resistance and stored in the capacitor in the form of an electrostatic field.

i. When the current reaches its maximum value, no further energy is supplied to the inductance, and all energy supplied to the circuit is either dissipated across the resistance or stored in the capacitor.

j. During the decay period, the inductor returns to the circuit all the energy stored in it during the current build-up period.

k. The resistance acts mainly as a brake in the circuit, preventing current from rising to relatively high values, by controlling the amount of energy stored in the inductor. Consequently, the resistance prevents overshoot of the capacitor voltage.

l. In an oscillatory circuit, the resistance is low, overshoot occurs, and the current undergoes a series of damped oscillations.

m. In the ideal oscillatory circuit (having no resistance), there is a continuous interchange of energy between the magnetic field of the in-

ductor and the electrostatic field of the capacitor.

n. The capacitor voltage varies from zero to $2E$ and then back to zero again in one cycle, when a low resistance is in the circuit.

o. The resistance acts to reduce the current amplitude by dissipating part of the energy flow of each successive cycle.

p. The frequency of oscillation is dependent on L and C when the resistance is less than 10 percent of the critical value.

q. When the resistance becomes an appreciable portion of the critical value, it reduces the frequency.

r. The resistance damps the sine wave so that the oscillations reduce to zero after a period of time equal to $14 L/R$.

52. Review Questions

- Why is the R - L - C circuit studied?
- What two general types of response are obtained?
- What is the critical value of resistance for L of 100 mh and C of 1,000 μf ?

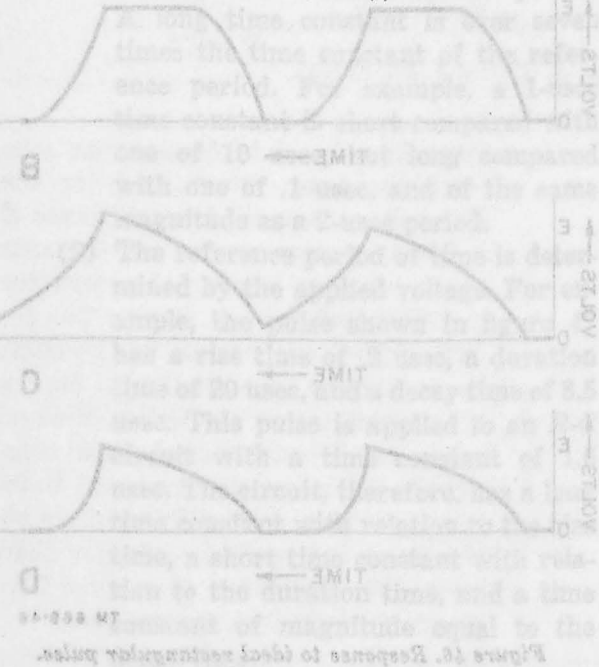

Figure 46. Responses to ideal rectangular pulses. (2) In B, the output voltage reaches E a short time after the pulse is applied and decays to zero when the pulse is removed. The output voltage reaches E more slowly in C, and does not decay

d. How does the inductance affect the single-surge response?

e. How does the capacitance affect the single-surge response?

f. Give one important characteristic of the oscillatory response.

g. Explain 1 cycle of oscillation of this response, assuming that R is zero.

h. What is the frequency of oscillation for R of 500 ohms, L of 75 mh, and C of .001 μf ?

i. What is the frequency of this circuit when R is increased to 5,000 ohms?

j. What is a damped sine wave, and how is the damping affected by the value of resistance?

k. With R of 500 ohms, and L of 75 mh, how long does it take for the oscillations to reduce to .1 percent of maximum amplitude?

l. Determine the response of the circuit given in Review Question h to a step voltage of 15 volts.

m. Determine the response of this circuit when R is increased to 5,000 ohms.

54. Relation of Time Constant to Pulse

Figure A of 46 shows a rectangular pulse; B, C, and D illustrate the response of three different circuits to this pulse.

Until now, discussion has been limited to the circuit response when a positive or a negative step voltage is applied and maintained for a long period of time (long compared to the time constant). However, when a periodic rectangular pulse, shown in A, is applied to the circuit, other factors must be considered. The time constant of the circuit is used to determine the amplitude of the output voltage since this voltage may not reach a value equal to the applied voltage E during

CHAPTER 6

APPLICATION OF R-L AND R-C CIRCUITS

Section I. EFFECT OF TIME CONSTANT ON PULSE RESPONSE

53. Time Constant

a. In the circuits discussed previously ($R-L$, $R-C$, and $R-L-C$), the time required to reach either a maximum or a minimum of current or voltage depended on the circuit time constant. When this time constant is small, the current or voltage can change rapidly, and a short period of time is required to reach the steady-state.

b. In an $R-L$ circuit to which a step voltage has been applied, the time constant is a measure of the time required for the current to *rise* or *fall* to its steady-state value. In the $R-C$ circuit to which a positive step voltage is applied, the time constant is a measure of how fast a capacitor charges or discharges. The time constant may be used to describe either the rise time or the decay time of a current or voltage.

54. Relation of Time Constant to Pulse

Figure A of 46 shows a rectangular pulse; B, C, and D illustrate the response of three different circuits to this pulse.

a. IDEAL RECTANGULAR PULSE.

- (1) Until now, discussion has been limited to the circuit response when a positive or a negative step voltage is applied and maintained for a long period of time (long compared to the time constant). However, when a periodic rectangular pulse, shown in A, is applied to the circuit, other factors must be considered. The time constant of the circuit is used to determine the amplitude of the output voltage since this voltage may not reach a value equal to the applied voltage E during

the rise time. The time constant also is used to determine the time required for the voltage to decay, since the output voltage may not decay to zero before the next pulse is applied to the circuit.

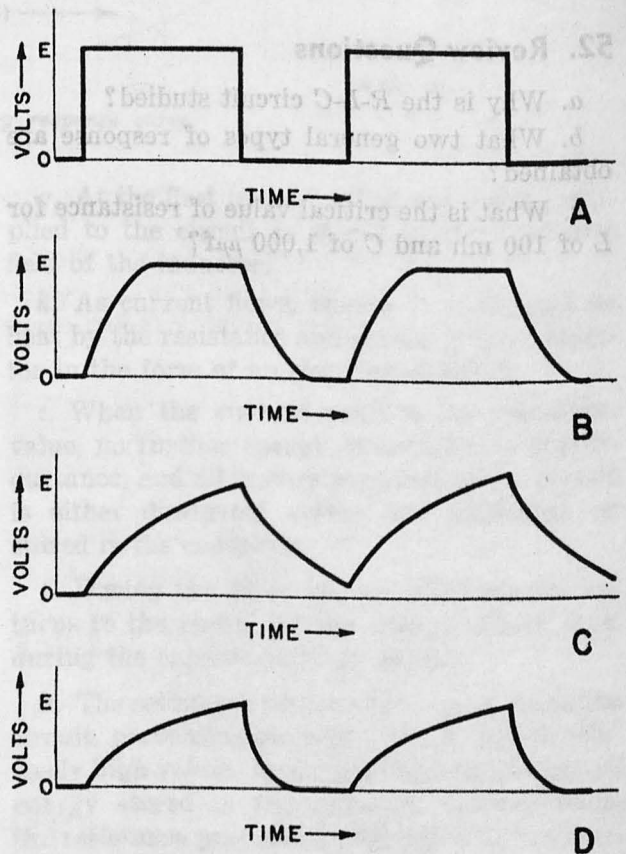

TM 669-46

Figure 46. Response to ideal rectangular pulse.

- (2) In B, the output voltage reaches E a short time after the pulse is applied and decays to zero when the pulse is removed. The output voltage reaches E more slowly in C, and does not decay

to zero by the time the next pulse is applied to the circuit. In D, the voltage does not reach E , but does decay to zero before the next pulse occurs. The output obtained in any circuit depends on the circuit time constant compared with the pulse duration and the time between pulses, or pulse period.

b. **ACTUAL PULSE.** An actual pulse has finite rise and decay times (fig. 47) and the circuit time constant can affect various portions of this pulse differently. The time constant determines whether the circuit voltage can rise as rapidly as the applied voltage. It is used also to determine the decay time and whether the output waveform droops over the duration period.

c. **SHORT AND LONG TIME CONSTANTS.**

(1) Time constants often are referred to as being *short*, *long*, or of the *same* length as some reference period of time. A short time constant is defined in this text as being less than one-seventh that of the reference period. A long time constant is over seven times the time constant of the reference period. For example, a 1-usec time constant is short compared with one of 10 usec, but long compared with one of .1 usec, and of the same magnitude as a 2-usec period.

(2) The reference period of time is determined by the applied voltage. For example, the pulse shown in figure 47 has a rise time of .2 usec, a duration time of 20 usec, and a decay time of 3.5 usec. This pulse is applied to an R - C circuit with a time constant of 1.5 usec. The circuit, therefore, has a long time constant with relation to the rise time, a short time constant with relation to the duration time, and a time constant of magnitude equal to the decay time.

55. Effect of Time Constant on Ideal Rectangular Pulse

The effect of the time constant of an R - C and an R - L circuit upon an ideal rectangular pulse is

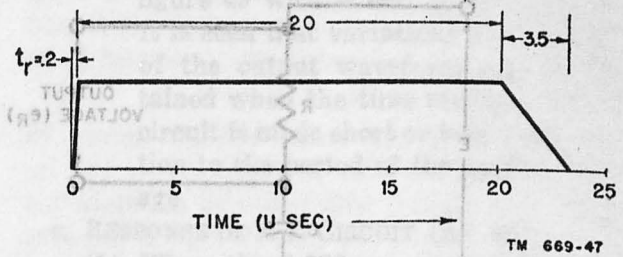

Figure 47. Pulse with rise and decay times.

described to show the variation in output waveform that occurs when the time constant is changed.

a. **TYPES OF R - C AND R - L CIRCUITS.** Two sources of output voltage are available from either the R - C or the R - L circuit (fig. 48). The output can be taken across R , and e_R is proportional to the current flowing in the circuit. The output voltage also can be taken across C or L as in B, and is proportional to the charge in the capacitor for e_C , or the rate of change of current for e_L .

b. **RESPONSE OF R - C CIRCUIT.**

(1) For example, a square wave occurring at a frequency of 1,000 cps and with an amplitude of 10 volts (A of fig. 49) is applied to an R - C circuit with a time constant equal to the pulse period, or 1,000 usec. The output voltage during the first 2 cycles is shown across the resistor in B and across the capacitor in C.

(2) When the pulse is first applied to the circuit, the full input voltage appears across R , since C has no charge. Therefore, e_R is equal to E , and e_C is equal to zero. The capacitor begins to charge to a value determined by the universal time-constant curve (fig. 26, curve A). As the voltage across the capacitor, e_C , increases, the voltage across the resistor, e_R , decreases. At 500 usec, or one-half a time constant, the pulse decays to zero; the capacitor, according to the universal time-constant curve, has charged to 40 percent of E , or 4 volts, and e_R has dropped to 60 percent of E , or 6 volts. If a discharge path is provided during the pulse rest

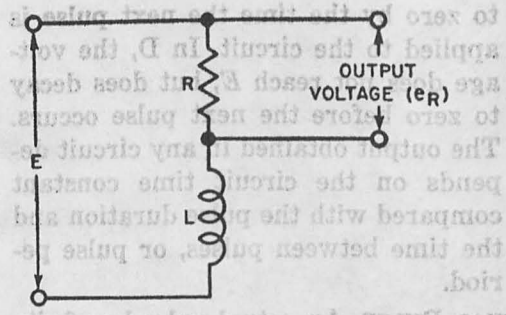
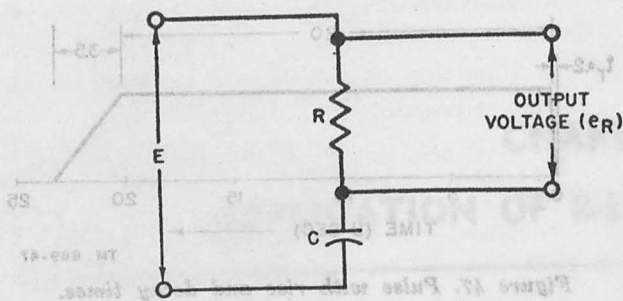

OUTPUT ACROSS R

A

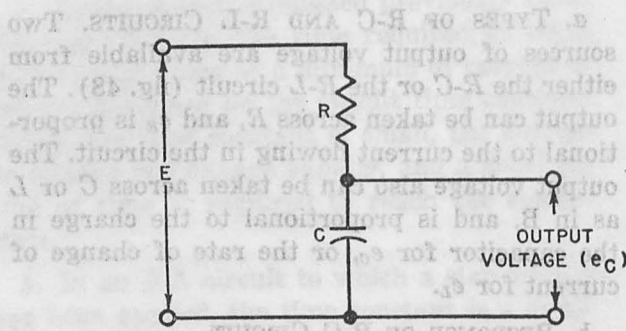

OUTPUT ACROSS C OR L

B

Figure 48. Output voltage sources in R-C and R-L circuits.

period, E equal to 0, the capacitor discharges and causes a negative voltage to appear across R equal to 40 percent of E , or 4 volts. The circuit follows the R - C discharge curve (fig. 26, curve B), and is more gradual than the charge curve for the first pulse. The reason for this is that the capacitor charges from zero toward E during the pulse duration and discharges from 40 percent of E toward zero during the pulse rest time. At 1,000 usec, or one-half a time constant after the pulse decays, the capacitor has discharged to 60 percent of the charge it held at the end of 500 usec. Therefore, it discharges to .4 times .6 E , or 24 percent of E at 1,000 usec.

(3) A of figure 50 shows the effect on the output of varying the time constant with the same applied voltage that was shown in figure 49. The time con-

stant is reduced to 500 usec, or one-tenth the pulse duration. After the step voltage is applied, e_C will reach E in 350 usec, since seven time constants are required to charge the capacitor to the applied voltage. During this period the voltage across the resistor, e_R , declines to zero. Similarly, during the rest period of the pulse, E equal to 0, the capacitor discharges completely, following the universal time-constant decay curve. This is because the pulse rest period is longer than seven time constants, the period necessary for complete discharge.

(4) In B, the output voltage resulting from the square wave is shown when the time constant is increased to 5,000 usec. The capacitor can charge only slightly during the pulse duration, and it discharges slightly during the pulse rest period. Comparing B and C of

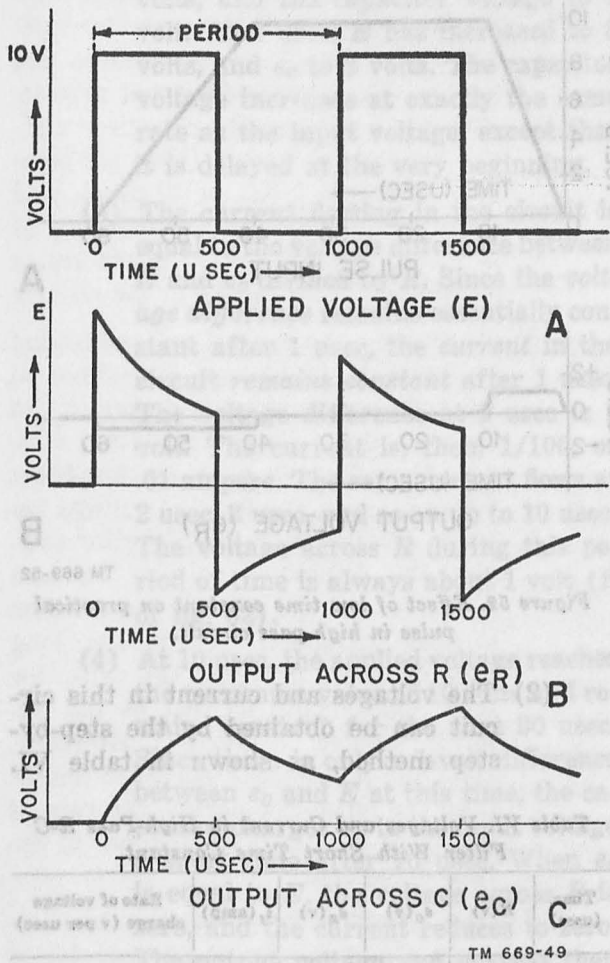

Figure 49. Square-wave response with time constant equal to pulse period.

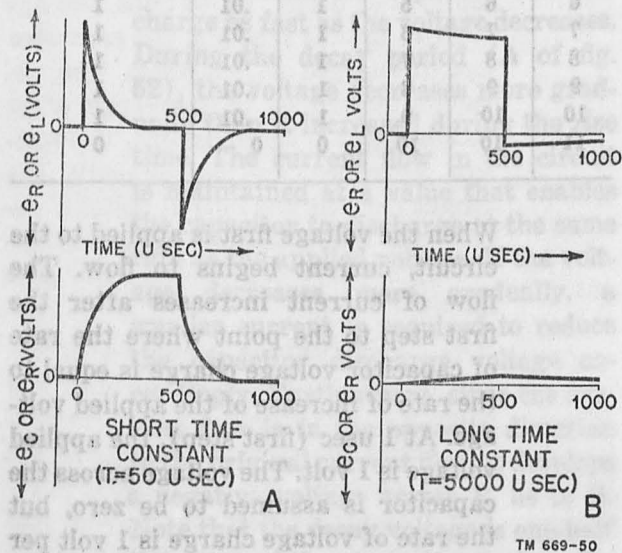

Figure 50. Effect of time constant on square wave.

figure 49 with A and B, of figure 50, it is seen that variations in the shape of the output waveform can be obtained when the time constant of the circuit is made short or long with relation to the period of the applied voltage.

c. RESPONSE OF R-L CIRCUIT (fig. 51).

(1) When the 1,000-cps square-wave input is applied to an R-L circuit with a time constant of 1,000 usec, at the first instant a back emf equal to E is developed across L , and no current flows. Therefore, e_L is equal to E , and e_R is equal to zero. Current begins to flow in the circuit at a rate determined by the universal time-constant chart (fig. 18, curve A). At 500 usec, or one-half a time constant later, the current has increased to 40 percent of its steady-state value, E/R . The volt-

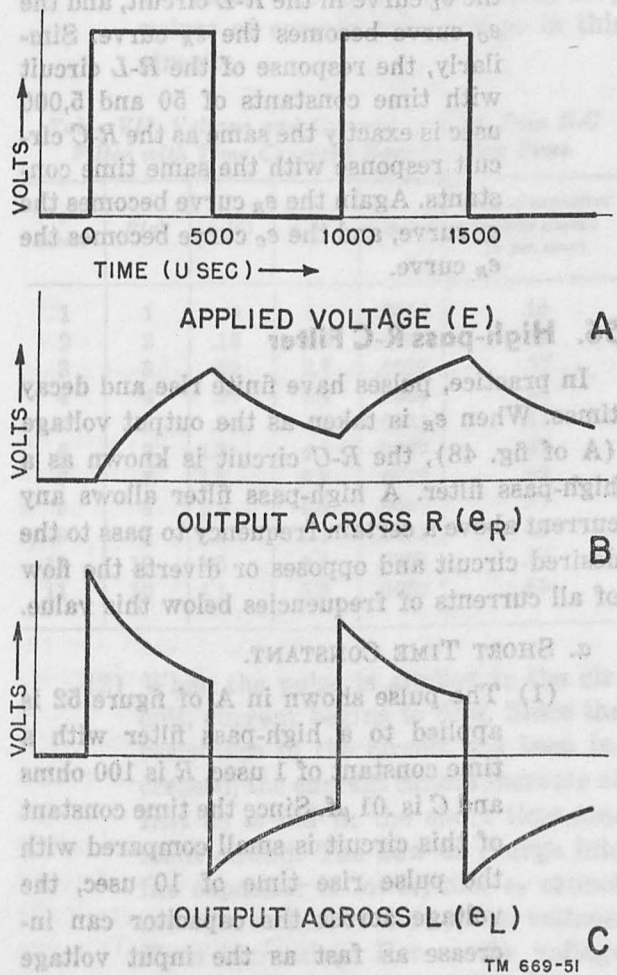

Figure 51. Response of an R-L circuit to a square wave.

age across the resistance, e_R , is equal to 40 percent of E , as shown in B, and e_L has declined to 60 percent of E , as shown in C.

(2) When the pulse voltage decays to zero, an emf develops across the inductance, which acts to maintain the current flow. This voltage is negative with relation to the voltage drop across R , and equal to e_R . Therefore, when the pulse drops to zero, e_L equals $-e_R$, or 40 percent of $-E$. The decrease of voltage across e_L and e_R is determined by the standard current decay curve of the R - L circuit.

(3) Compare figure 49 (response of R - C circuit with 1,000-usec time constant) with figure 51. Note that exactly the same curves are obtained except that the e_R curve in the R - C circuit becomes the e_L curve in the R - L circuit, and the e_O curve becomes the e_R curve. Similarly, the response of the R - L circuit with time constants of 50 and 5,000 usec is exactly the same as the R - C circuit response with the same time constants. Again the e_R curve becomes the e_L curve, and the e_O curve becomes the e_R curve.

56. High-pass R-C Filter

In practice, pulses have finite rise and decay times. When e_R is taken as the output voltage (A of fig. 48), the R - C circuit is known as a high-pass filter. A high-pass filter allows any current above a certain frequency to pass to the desired circuit and opposes or diverts the flow of all currents of frequencies below this value.

a. SHORT TIME CONSTANT.

(1) The pulse shown in A of figure 52 is applied to a high-pass filter with a time constant of 1 usec. R is 100 ohms and C is .01 μ f. Since the time constant of this circuit is small compared with the pulse rise time of 10 usec, the voltage across the capacitor can increase as fast as the input voltage rises.

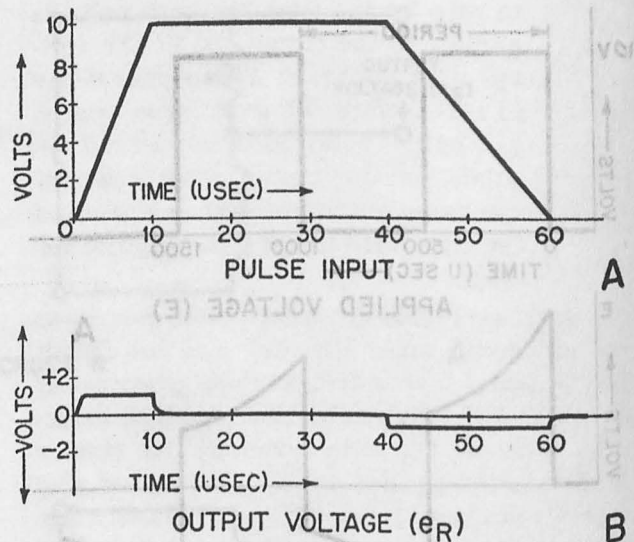

Figure 52. Effect of low time constant on practical pulse in high-pass circuit.

(2) The voltages and current in this circuit can be obtained by the step-by-step method, as shown in table VI.

Table VI. Voltages and Current in High-Pass R-C Filter With Short Time Constant.

Time (usec)	E (v)	e_O (v)	e_R (v)	i_c (amp)	Rate of voltage charge (v per usec)
1	1	0	1	.01	1
2	2	1	1	.01	1
3	3	2	1	.01	1
4	4	3	1	.01	1
5	5	4	1	.01	1
6	6	5	1	.01	1
7	7	6	1	.01	1
8	8	7	1	.01	1
9	9	8	1	.01	1
10	10	9	1	.01	1
11	10	10	0	0	0

When the voltage first is applied to the circuit, current begins to flow. The flow of current increases after the first step to the point where the rate of capacitor voltage charge is equal to the rate of increase of the applied voltage. At 1 usec (first step), the applied voltage is 1 volt. The voltage across the capacitor is assumed to be zero, but the rate of voltage charge is 1 volt per usec. At 2 usec, E has increased to 2

volts, and the capacitor voltage to 1 volt. At 3 usec, E has increased to 3 volts, and e_c to 2 volts. The capacitor voltage increases at exactly the same rate as the input voltage, except that it is delayed at the very beginning.

(3) The current flowing in the circuit is equal to the voltage difference between E and e_c divided by R . Since the voltage difference remains essentially constant after 1 usec, the current in the circuit remains constant after 1 usec. The voltage difference at 1 usec is 1 volt. The current is, then, 1/100, or .01 ampere. The same current flows at 2 usec, 3 usec, and so on up to 10 usec. The voltage across R during this period of time is always about 1 volt (B of fig. 52).

(4) At 10 usec, the applied voltage reaches the maximum value of 10 volts and remains constant for the next 30 usec. Since there is only a 1-volt difference between e_c and E at this time, the capacitor charges up to the input voltage a short time after 10 usec. When e_c is equal to E , the voltage across R is zero, and the current reduces to zero. The output voltage and current then remain zero up to 40 usec.

(5) At 40 usec, the applied voltage begins to decay. Again, because of the low time constant, the capacitor can discharge as fast as the voltage decreases. During the decay period (A of fig. 52), the voltage decreases more gradually than it increased during the rise time. The current flow in the circuit is maintained at a value that enables the capacitor to discharge at the same rate as the applied voltage. If the voltage decreases more gradually, a smaller current is required to reduce the capacitor discharge voltage accordingly. Furthermore, since the current flow is in the opposite direction to the original current flow, it develops a negative voltage across R , as in B. Note that the decay voltage is one-half the value of the rise voltage, since the

decay time is twice as long as the rise time.

(6) At 60 usec, the applied voltage is zero, the capacitor is almost discharged completely, and the current in the circuit reduces rapidly to zero. Compare the input and output pulse waveforms, which are completely different. Similar waveforms are obtained across R whenever the time constant of a high-pass R - C circuit is small compared with the rise and decay times.

b. TIME CONSTANT EQUAL TO RISE TIME.

(1) When the time constant is equal to the rise time, the capacitor cannot charge quite as fast as the applied voltage increases. The pulse shown in A of figure 52 is applied to a high-pass R - C circuit with a time constant of 10 usec. R is now 1,000 ohms, and C is .01 μ f. Table VII shows the step-by-step values of current and voltage in this circuit:

Table VII. Voltage and Current in High-Pass R - C Filter with Time Constant Equal to Rise Time.

t (usec)	E (v)	e_c (v)	e_R (v)	i , (amp)	Rate of capacitor voltage charge (v per usec)
1	1	0	1	.0010	.10
2	2	.10	1.9	.0019	.19
3	3	.29	2.7	.0027	.27
4	4	.56	3.4	.0034	.34
5	5	.90	4.1	.0041	.41
6	6	1.3	4.7	.0047	.47
7	7	1.8	5.2	.0052	.52
8	8	2.3	5.7	.0057	.57
9	9	2.9	6.1	.0061	.61
10	10	3.5	6.5	.0065	.65
11	10	4.1	5.9	.0059	.59

(2) When the pulse is applied to the circuit, current begins to flow. Since the resistance in the circuit has been increased, the current cannot increase as fast as it did in the short time-constant circuit. The flow of charge into the capacitor is lower, and e_c cannot increase as fast as the applied voltage, E , is increasing. Hence, the voltage difference between E and e_c is increas-

ing continuously between zero and 10 usec. Since at 1 usec, the applied voltage is 1 volt (A of fig. 52) and the capacitor voltage is .01 volt, the voltage difference is about 1 volt. At 2 usec, E is 2 volts, e_c is .1 volt, and the difference is 1.9 volts. The voltage difference is the voltage, e_R , across R , or the output voltage. This voltage is shown in A of figure 53.

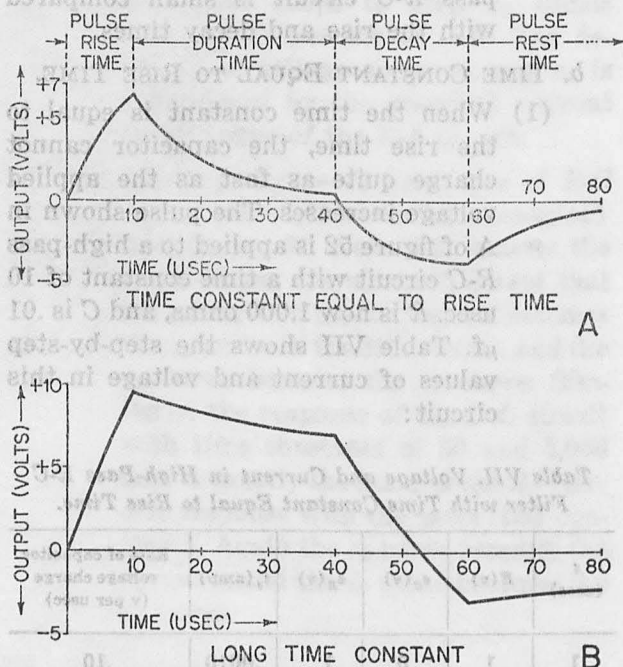

Figure 53. Effect of time constant in high-pass circuit.

(3) Although the voltage difference increases rapidly between zero and 6 usec, it increases slowly between 6 and 10 usec. This reduction in voltage difference is due to the increase of current in the circuit. As current increases, the charging rate of the capacitor approaches the voltage-increase rate. The current in the circuit at any time is equal to the voltage difference, $E - e_c$, divided by the resistance. At 1 usec, it is about .001 ampere, and increases to approximately .005 ampere at 6 usec. From 6 to 10 usec, the current increases gradually from .005 to .0065 ampere. This can be seen in table VII.

(4) From 10 to 40 usec, the applied voltage is constant, and the capacitor voltage charges to E . As e_c increases, the voltage difference and current rate decrease. At 40 usec, the capacitor voltage has not reached E (time for complete charge is $7 RC$, or 70 usec), and there is a small output voltage, e_R , of .4 volt (e_c is 9.6 volts). Therefore, a small current still flows in the circuit.

(5) At 40 usec, the applied voltage begins to decrease. At 41 usec E declines to 9.6 volts and is equal and opposite to the capacitor voltage. The output voltage, therefore, is zero at this time. After 41 usec, the applied voltage becomes smaller than the capacitor voltage, the difference voltage becomes negative, and the current flows in the opposite direction. Again, the long time constant prevents the capacitor from discharging as fast as the applied voltage decreases. However, since the pulse-decay period is longer than the pulse-rise period, the rate of capacitor discharge approaches to the rate of voltage.

(6) The output voltage reaches a maximum of -3.8 volts at 60 usec (A of fig. 53). It is -3.1 volts at 50 usec, and -3.7 volts at 55 usec. This indicates that at approximately 55 usec, the rate of discharge is almost equal to the rate of decay. At 60 usec, the applied voltage is zero and the capacitor has discharged to 3.8 volts. The capacitor continues to discharge after 60 usec until e_c becomes zero. The voltage difference, and consequently the circuit current and output voltage, decrease as the capacitor discharges, following the $R-C$ exponential discharge curve.

(7) The output voltage curve (A of fig. 53) is typical of the waveform of any high-pass $R-C$ circuit whose time constant is of the same magnitude as the pulse rise time. When the pulse duration time is increased, the current and output voltage fall to zero before the

decay time starts. Conversely, if the duration time is decreased, the output voltage during the decay time remains positive for a longer period of time, and negative for a shorter period of time.

c. LONG TIME CONSTANT.

(1) When the time constant is long compared with the rise and duration time, the capacitor charges to a small fraction of the total applied voltage. Most of the voltage exists across R , and the output waveform closely resembles the input pulse voltage.

(2) The pulse shown in A of figure 52 is applied to a high-pass R - C circuit with a time constant of 100 usec. R is now 10,000 ohms, and C is .01 μ f. Because of the high resistance in this circuit, the current flow is small. For example, when E is 1 volt, the current is only 1/10,000 or .0001 ampere. This low value of current results in a low rate of change of the capacitor voltage. During the entire rise time, the capacitor charges up to only .5 volt, and the voltage difference at 10 usec is 9.5 volts. The voltage difference, or output voltage, during this period of time follows the input voltage, as in B.

(3) From 10 to 40 usec, the capacitor charges slowly toward the applied voltage. Because of the long time constant, however, e_c is only 3 volts at the end of 40 usec. This means that the difference voltage, and the output voltage and current, drop about 2.5 volts during this period of time.

(4) After 40 usec, the applied voltage starts to decay and the output voltage follows the same rate of voltage decrease. However, since the voltage across the capacitor was 3 volts at 40 usec, the applied voltage does not equal the capacitor voltage until the pulse has been decaying for 13 usec. At 53 usec, E equals e_c , and the difference voltage, circuit current, and output voltage are, therefore, zero. After 53 usec, the applied voltage becomes less

than the capacitor voltage. Since the capacitor discharges slowly (long time constant), the difference voltage increases to -3 volts at 60 usec. At this time E is equal to 0 and e_c is 3 volts. The capacitor then discharges slowly toward zero.

(5) After 100 usec, or one time constant, the capacitor charge decays to 1.1 volts. After 700 usec, or seven time constants, the output is zero. If this pulse appears periodically, and the pulse rest period is less than 700 usec, the trailing edge (decay time) of the output waveform runs into the leading edge (rise time) of the next pulse. When the time constant of a circuit is increased, the capacitor will charge to a smaller voltage, and therefore, a smaller negative output voltage is obtained. This results in a closer approximation of the input waveform. The longer the time constant, the better a high-pass R - C circuit reproduces the input waveform.

d. PERIODIC PULSES.

(1) When the pulse occurs periodically, the capacitor may not be able to discharge completely by the time the next pulse is applied to the circuit. The response of a high-pass long time-constant R - C circuit to a series of pulses is shown in A of figure 54. The time constant is 100 usec.

(2) The first pulse that is applied to the circuit follows the waveform shown in B of figure 53. Upon application of the second pulse, however, the capacitor still has -2.5 volts of charge obtained during the first pulse (B of fig. 54). When the second pulse is applied, the output voltage rises 9.5 volts (the capacitor charges slightly during rise time) to approximately 7 volts, and there is a net voltage of 3 volts across the capacitor. During the 30-usec duration time, .3 of one time constant, the capacitor charges to 25 percent of

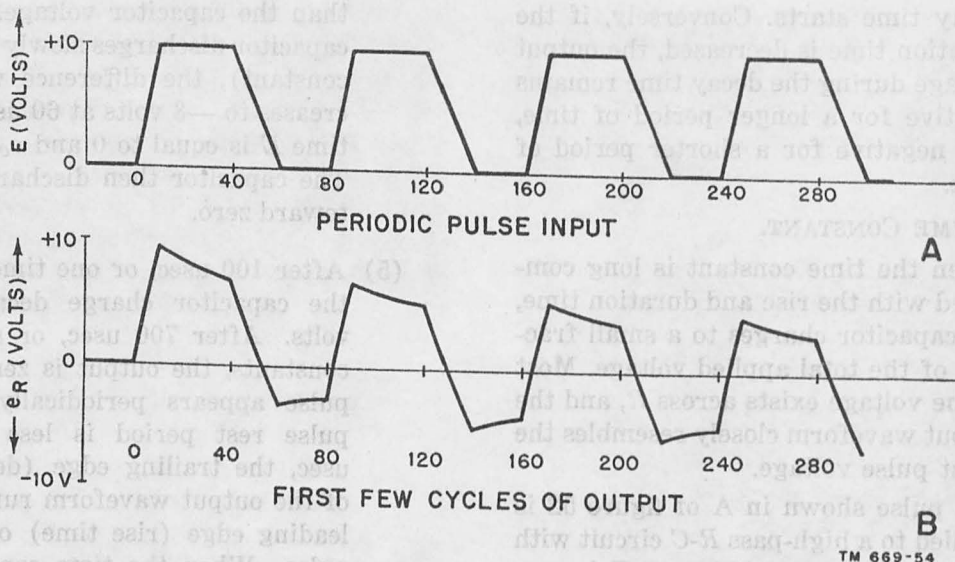

Figure 54. Response of high-pass, large time-constant filter to periodic pulse.

7 volts, or 1.8 volts. The output voltage across R then drops 1.75 volts to 5.2 volts. The output voltage dropped about 2.5 volts during the same period of the first pulse because of the higher net voltage across C .

- (3) The pulse decays 10 volts, from 120 usec to 140 usec, and the output voltage follows a similar curve to -4.8 volts. During the rest time, which is .2 time constant, the capacitor discharges about 18 percent of 4.8, or .9 volts. The output voltage, consequently, goes from -4.8 , to -3.9 volts. The output voltage decreased .6 volt during the first rest period and .9 volt during the second rest period.

- (4) With each succeeding cycle, the charge added to the capacitor over the duration period decreases, and the capacitor discharge voltage during the pulse rest period becomes larger. After a few cycles, a point is reached when the charge added to the capacitor during the duration period is equal to the discharge during the rest period. This condition corresponds to the stable response of the circuit (or its steady-state). A circuit can have a steady-state response to a periodic pulse as well as to a step voltage.

e. SUMMARY OF TIME-CONSTANT EFFECT ON HIGH-PASS FILTER. Compare the output voltages obtained in a high-pass filter for short, equal magnitude, and long time constant relative to rise times (figs. B of 52, and A and B of 53). Increasing the time constant has two effects. First, the output waveform more closely resembles the input waveform; second, the magnitude of the output voltage increases. In the short time-constant circuit, a maximum voltage of 1 volt was obtained, with approximately 6.5 volts for an equal time constant, and 9.5 volts for a large time constant.

57. Low-Pass Filter Response

a. GENERAL. The output in the low-pass filter is taken across the capacitor, and the effect of the time constant on the output voltage is entirely different from that for the high-pass filter. When the time constant of the circuit is short compared with the rise time, the voltage across the capacitor increases at about the same rate as the applied voltage. Therefore, very little change in the leading edge of the waveform results; the output and the input during the rise time are essentially the same. When the time constant is long compared with the rest time, the rate of change of capacitor voltage is decreased and there is considerable change in the leading and trailing edge of the waveform.

b. SHORT TIME CONSTANT.

(1) The pulse voltage in A of figure 52 is applied to an $R-C$ circuit with a time constant of 1 usec. R is 100 ohms and C is $.01 \mu\text{f}$ (the same valuations that were used previously for a short time-constant high-pass filter). When the voltage is first applied to the circuit, the current increases rapidly and the rate of capacitor charge is equal to the rate of applied voltage increases. The output voltage follows the input voltage with the exception of a slight delay at the beginning of the cycle. This delay is equal, approximately, to the time constant, or 1 usec. The top and bottom portions of both the rise and decay times are rounded slightly (A of fig. 55).

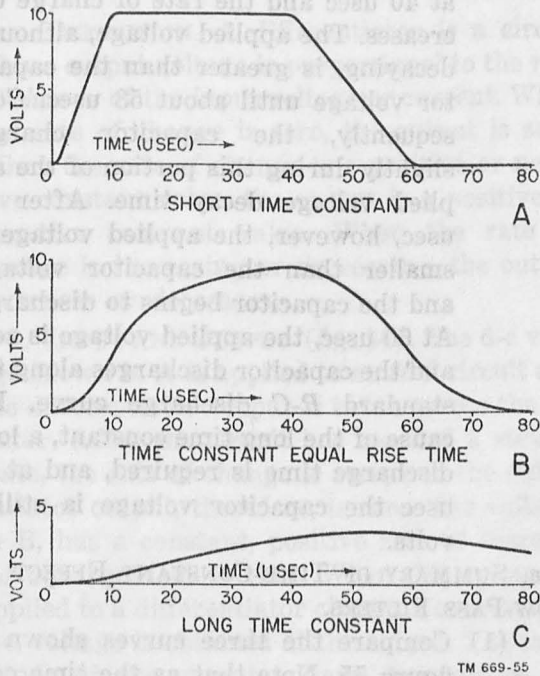

Figure 55. Effect of time constant on low-pass filter.

- (2) At 10 usec, the applied voltage reaches 10 volts and then remains constant for 30 usec. The voltage across the capacitor is nearly equal to the applied voltage at 10 usec, and rises to 10 volts shortly thereafter. The voltage across the capacitor remains at 10 volts as long as the pulse remains at 10 volts.
- (3) At 40 usec, the pulse begins to decay,

and the capacitor starts to discharge. The discharging current increases until the rate of voltage drop across the capacitor is equal to the rate of voltage decay. The output pulse closely follows the input pulse during decay time. There is a slight delay at the beginning of the decay time that is equal, approximately, to the time constant, 1 usec, which causes a rounding of the corners (A of fig. 55).

- (4) The low-pass, short time-constant $R-C$ circuit provides the best reproduction of the pulse waveform. The only circuit with a similar response is the long time-constant, high-pass filter. This circuit, however, requires a long discharge period and can run into succeeding pulses. Varying the time constant of a low-pass $R-C$ circuit up to 25 percent of the rise time (assuming that it is the smallest pulse time period) does not change the circuit response to a great extent except to increase the rise- and decay-time delay periods.

c. TIME CONSTANT EQUAL TO RISE TIME (B of fig. 55).

- (1) When the time constant of the low-pass filter is increased to the same magnitude as the rise time, the capacitor voltage cannot increase as rapidly as the applied voltage. When the applied voltage reaches its maximum amplitude, the capacitor voltage is only a fraction of this voltage, and the capacitor continues to charge, or increase toward E , after the pulse rise time is over. This means that the rise time of the output is increased.

- (2) In A of figure 52 the pulse is applied to a low-pass $R-C$ circuit with a time constant of 10 usec. R is 1,000 ohms and C is $.01 \mu\text{f}$. A lower initial current is obtained because of the greater R , and the voltage across the capacitor does not become appreciable until about 2 usec.
- (3) It then rises slowly until, as in B of figure 55, at 10 usec or one time con-

stant, the capacitor voltage is 3.5 volts. The applied voltage remains constant at 10 volts, and the capacitor follows the standard R - C charging curve. At 40 usec, or 3 time constants later, the capacitor charges to 93 percent of 6.5 volts, or approximately 6.1 volts, and the total voltage across the capacitor is, then, 9.6 volts.

(4) At 40 usec, the applied voltage starts to decay, the rate of capacitor charge decreases almost immediately and, approximately 41 usec later, it stops. At this time, the applied voltage is smaller than the capacitor voltage, and the capacitor starts to discharge. The rate of discharge depends on the difference between E and e_c and the value of resistance. Since R is high, the capacitor cannot discharge as fast as the applied voltage decreases and the voltage difference between them increases. At 55 usec, the voltage difference between E and e_c is large, a relatively large current flows, and the capacitor starts discharging as fast as the applied voltage decreases.

(5) When the applied voltage reaches zero, the capacitor is not discharged completely, and there is still an output voltage. The capacitor now discharges following the R - C discharge curve and becomes, essentially, equal to zero at 80 usec. The output voltage follows the input voltage more closely during the decay time than during the rise time, since the pulse decay time is longer. The circuit time constant of 10 usec is only one-half the decay time of 20 usec, and better decay-time reproduction is obtained.

d. LARGE TIME CONSTANT (C of fig. 55).

(1) When the time constant is large compared with the rise and duration times, the voltage across the capacitor increases slightly during the pulse rise and duration periods. It also discharges slowly during the decay period.

(2) In A of figure 52 the pulse now is ap-

plied to a low-pass R - C circuit with a time constant of 100 usec. R is 10,000 ohms and C is .01 μ f. The capacitor voltage increases slightly during the rise time and does not become appreciable during the first 5 usec. It increases to .5 volt at 10 usec; for the next 30 usec it increases along an essentially straight line, which curves slightly toward the end, and at 40 usec the capacitor voltage is 3 volts. This portion of the curve corresponds to the first .3 of a time constant of the R - C charge curve (fig. 26). Although the over-all R - C charge curve is exponential, it is practically straight for a small part at the beginning of the curve.

(3) The applied voltage starts to decay at 40 usec and the rate of charge decreases. The applied voltage, although decaying, is greater than the capacitor voltage until about 53 usec. Consequently, the capacitor charges slightly during this portion of the applied voltage decay time. After 53 usec, however, the applied voltage is smaller than the capacitor voltage, and the capacitor begins to discharge. At 60 usec, the applied voltage is zero and the capacitor discharges along the standard R - C discharge curve. Because of the long time constant, a long discharge time is required, and at 80 usec the capacitor voltage is still 2 volts.

e. SUMMARY OF TIME-CONSTANT EFFECT ON LOW-PASS FILTERS.

(1) Compare the three curves shown in figure 55. Note that as the time constant increases the rise and decay times of the output voltage increase accordingly. Although good reproduction of the input pulse is obtained with a small time constant, an entirely different waveshape is obtained when a large time constant is used. The time constant of a circuit affects to a great extent, the output voltage of a low-pass filter.

(2) The relative value of time constant,

with relation to the waveform periods, and the element supplying the output voltage determine the output wave-shape. Although an $R-C$ circuit was

used to demonstrate this effect, similar wide variations in response characteristics can be noted in an $R-L$ circuit.

Section II. DIFFERENTIATION

58. Introduction to Shaping Circuits

In practical applications, sometimes it is necessary to change or reshape an input waveform. Reshaping of the waveform can be accomplished through the use of $R-C$ and $R-L$ networks with appropriate time constants. Examples of shaping networks are the *differentiator*, *integrator*, and *d-c restorer* circuits. Each of these shapes the waveform in a different way.

59. Differentiator

a. DEFINITION. A differentiator is a circuit whose output voltage is proportional to the *rate of change* of the input voltage or current. When the rate of change is zero, the output is zero. When the rate of change is a positive or negative constant value, the output is a positive or negative constant value. When the rate of change is increasing or decreasing, the output increases or decreases.

b. INPUT AND OUTPUT (fig. 56). The d-c voltage shown in A is applied to an $R-C$ circuit and the differentiator output is taken across the resistor. After the circuit has reached a steady-state, the rate of change is zero, and the differentiator output, therefore, is zero. The voltage, in B, has a constant, positive rate of increase for equal periods of time. When this voltage is applied to a differentiator circuit, a constant, or d-c, voltage is obtained at the output. The magnitude of the output voltage depends on the speed of the input voltage change. The higher the rate of change, the greater the d-c voltage output.

c. SINE-WAVE INPUT (C of fig. 56). The input to the differentiator circuit varies sinusoidally with time. This voltage is applied to the differentiator circuit, and another sine wave is obtained at the output. When the input voltage is zero, the rate of change is maximum, and the output across the resistor is maximum. When the input voltage is maximum, its rate of change

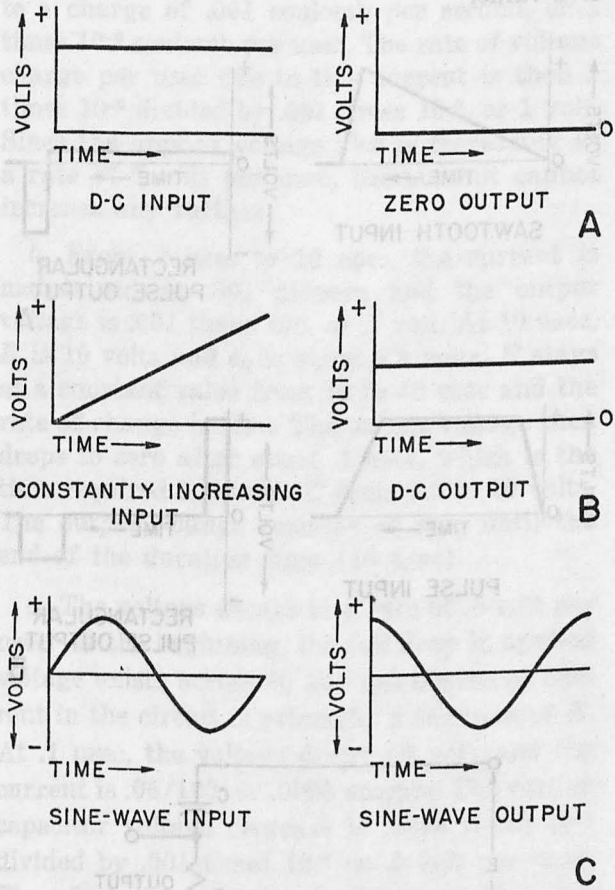

TM 669-56

Figure 56. Differentiator waveforms.

is zero, and the output across the resistor is zero. The sine-wave output is 90° out of phase with the sine-wave input.

60. Differentiator Output for Common Waveshapes

a. SAWTOOTH VOLTAGE. The sawtooth in A of figure 57 is applied to the differentiator circuit C. The waveform rises gradually along a straight line to some maximum amplitude. During this period of time the rate of change remains constant at some small positive value.

The output, therefore, is a small, positive d-c value, whose amplitude is proportional to the rate of change of the input. When the sawtooth decays to zero, the rate of decrease is a constant, negative value of large amplitude. The differentiator output, during this time, is a rectangular pulse and has a high, constant, negative value.

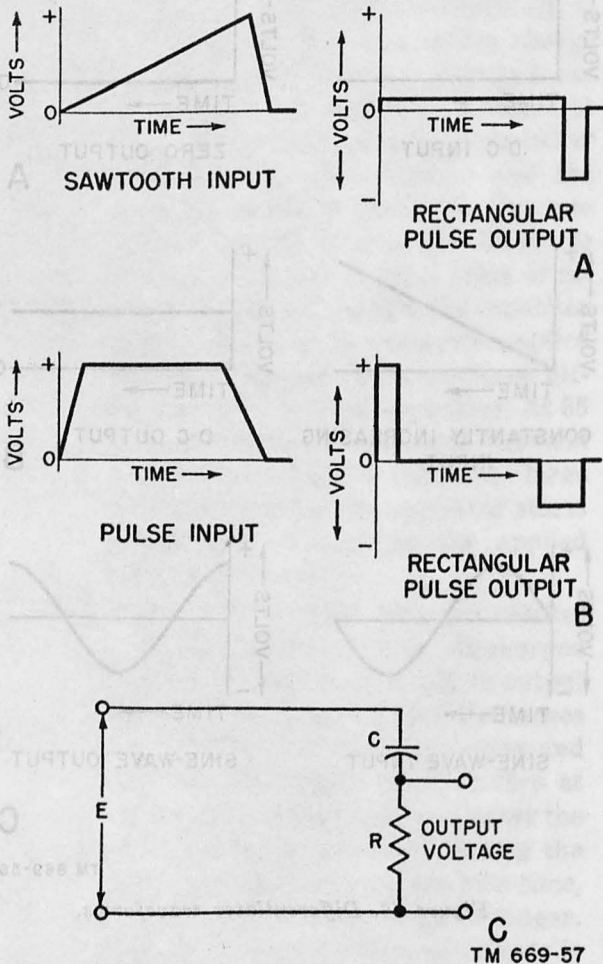

Figure 57. Differentiator output for common waveforms.

b. PULSE VOLTAGE. The pulse voltage in B of figure 57 is applied to an ideal differentiator circuit C. During the rise time, the rate of increase is constant, positive, and relatively large. Consequently, a high value of positive d-c voltage is obtained at the output. The pulse remains at a constant value over the duration period and its rate of change is zero; therefore, zero output is obtained from the differentiator. During the decay period, the rate of decrease is one-half the rate of increase during the rise time.

The differentiator output, then, is negative, and one-half the amplitude of the voltage during the rise time.

61. Basic Types of Differentiators

Three basic circuit components can be used as differentiators. These are the capacitor, the inductor, and the transformer. As shown previously, the current flowing into a capacitor is equal to the capacitance, C , times the rate of change of the applied voltage. The voltage that exists across an inductor is equal to the inductance, L , times the rate of change of current through the inductor. Also, the voltage that exists across the secondary of a transformer is equal to the mutual inductance, M , of the transformer times the rate of change of the current in the primary. The output of each of these elements is proportional to the rate of change of the input.

62. R-C Differentiator

a. BASIC CAPACITANCE EQUATION.

(1) In describing the fundamental capacitor relation in chapter 2, it was noted that when a constant current flowed into a capacitor, the voltage across the capacitor increased at a constant rate. Also, when the voltage applied to a capacitor was increasing at a constant rate, the current flowing into the capacitor was constant. The current is equal to the rate of change of the applied voltage, dE/dt , times capacitance C , or $C dE/dt$. When dE/dt is expressed in volts per second and C in farads, the current is in amperes. The current is also in amperes when dE/dt is expressed in volts per usec and C in μf .

(2) An input voltage which increases at a rate of 10 volts per second is applied to a 10- μf capacitor. The current flowing in this circuit is then 10 times (10 times 10^{-6}), or .0001 ampere, or .1 ma.

(3) As another example, a voltage which increases at a rate of 1 volt per microsecond is applied across a .01- μf capacitor. The current flowing into this

capacitor is 1 times .01, or .01 ampere, or 10 ma.

b. INTRODUCTION OF RESISTANCE. Since a differentiator circuit does not require a large current flow, a small resistor is placed in series with the capacitor. The voltage output is taken across the resistor and is proportional to the current flowing through the circuit. This circuit is the same as the high-pass filter shown in A of figure 48, and is known as an R - C differentiator.

c. EFFECT OF TIME CONSTANT.

(1) Any high-pass R - C circuit which has a short time constant compared with the time periods of the applied waveform acts as a differentiator. In a short time-constant circuit, the capacitor charges as fast as the applied voltage can increase. The basic voltage equation is E equals e_R plus e_C . Since e_C increases as fast as E (except at the beginning), the capacitor voltage becomes much greater than the resistance voltage.

(2) The current flow in the circuit is a function of both the capacitance and the resistance and depends on the relative magnitudes of e_R and e_C . When e_C is much larger than e_R , the current in the circuit follows the basic capacitance equation given in the previous paragraph. When R is increased, e_R becomes larger, and the circuit acts less as a differentiator since R has a greater effect on the current flow. The current flowing through R is proportional to the voltage across it, not to the rate of change of that voltage (i equal to E/R). Therefore, as R and e_R increase and the time constant is longer, the current in the circuit tends to become *directly* proportional to the applied voltage, rather than to the *change* in this voltage. These effects can be understood by considering the waveforms in an R - C differentiator circuit as the time constant is varied.

63. R-C Differentiator with Short Time Constant

a. The pulse in A of figure 52 is applied to an

R - C differentiator circuit (C of fig. 57). R is 100 ohms and C is .001 μ f, and the time constant is .1 usec. At the first instant, there is no charge on the capacitor, and the full applied voltage appears across the resistor. At .1 usec, the applied voltage is equal to .1 volt, and the current is .1/100, or .001 ampere. This corresponds to a charge of .001 coulomb per second, or 1 times 10^{-9} coulomb per usec. The rate of voltage charge per usec due to this current is then 1 times 10^{-9} divided by .001 times 10^{-6} , or 1 volt. Since the applied voltage also is increasing at a rate of 1 volt per usec, the current cannot increase any further.

b. From .1 usec to 10 usec, the current is maintained at .001 ampere and the output voltage is .001 times 100, or .1 volt. At 10 usec, E is 10 volts and e_C is about 9.9 volts. E stays at a constant value from 10 to 40 usec and the rate of change is zero. The output voltage then drops to zero after about .1 usec, which is the time required to charge C from 9.9 to 10 volts. The output voltage remains at zero until the end of the duration time (40 usec).

c. The voltage decays at a rate of .5 volt per usec. At the beginning, the full drop in applied voltage exists across R , and the discharge current in the circuit is primarily a function of R . At .1 usec, the voltage drops .05 volt, and the current is .05/100, or .0005 ampere. The rate of capacitor voltage decrease is .0005 times 10^{-6} divided by .001 times 10^{-6} or .5 volt per usec. Therefore, the capacitor discharges at the same rate that the applied voltage decreases, and the current cannot become larger. The output voltage, therefore, stays at .0005 times 100, or .05 volt for the entire duration period. It rapidly becomes zero at 60 usec, when the applied voltage becomes zero. Hence, with the exception of the beginning and end of the rise and decay times, this circuit acts as an ideal differentiator with output similar to the one shown in B of figure 57.

64. R-C Differentiator with Long Time Constant

(fig. 58)

a. An R - C differentiator is considered to have

a long time constant if it is equal to one-half the smallest waveform time. For example, the pulse shown in A of figure 52 has a rise time of 10 usec, a duration of 30 usec, and a decay time of 20 usec. The rise time is, therefore, the shortest waveform time period. An R - C differentiator time constant of 5 usec is considered long for this pulse.

b. This pulse now is applied to an R - C differentiator with R of 500 ohms, C of .01 μ f, and the time constant is 5 usec. When the pulse first is applied to the circuit, the entire input voltage appears across R . At 1 usec, E is 1 volt, and the current in the circuit increases to $1/500$, or .002 ampere. The rate of capacitor charge is .002 times 10^{-6} divided by .01 times 10^{-6} , or .2 volt per usec. Since the applied voltage is increasing at a rate of 1 volt per usec, the capacitor charge rate is smaller. These values are tabulated below.

Table VIII. Voltage and Current in Long Time-Constant Differentiator Circuit.

Time (usec)	E (v)	e_C (v)	e_R (v)	i , (amp)	Rate of charge (v per usec)
1	1	0	1	.002	.2
2	2	.2	1.8	.0036	.36
3	3	.5	2.5	.0049	.49
4	4	1	3.0	.0059	.59
5	5	1.6	3.4	.0068	.69
6	6	2.3	3.7	.0073	.73
7	7	3.1	3.9	.0079	.79
8	8	3.8	4.2	.0083	.83
9	9	4.7	4.3	.0086	.86
10	10	5.5	4.5	.0089	.89
11	10	6.4	3.6	.0071	.71

c. The current in the circuit increases to .01 ampere before the capacitor charge becomes equal to 1 volt per usec. Because of the large resistor, the current cannot possibly increase to .01 ampere until 5 usec after the pulse is applied to the circuit. During the first 5 usec, however, current has been flowing in the circuit, so that a voltage of 1.6 volts exists across C . Hence the full input voltage, E , does not exist across R . The voltage across R is 3.4 volts, and the current flow is .0068 ampere.

d. At 7 usec, the applied voltage has increased to 7 volts, but the capacitor voltage also has been increased and is 3.1 volts. The voltage

across R has increased to 3.9 volts and the current to .0079 ampere. At 10 usec, the applied voltage is 10 volts and the capacitor voltage is 5.5 volts. The voltage across R is 4.5 volts, and the current is .0089 ampere. With the time constant equal to one-half the rise time, the capacitor never charges as fast as the applied voltage increases and the current never reaches the maximum permitted by the capacitor. The resultant curve (fig. 58) during this period of time is a rising voltage which bears little resemblance to the ideal differentiated curve.

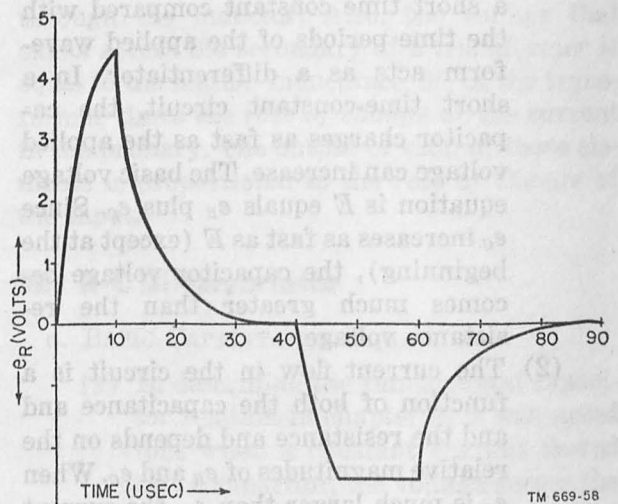

Figure 58. Output of differentiator with large time constant.

e. After 10 usec, the capacitor continues to charge toward the applied voltage (10 volts) following the universal time-constant curve. For practical purposes, it reaches 10 volts, at 35 usec. The voltage across the resistor, from 10 to 30 usec, decreases as the capacitor voltage increases (fig. 58).

f. The time constant of the circuit is one-quarter of the decay period. The circuit acts now more like a differentiator circuit than during the rise time. At 42 usec, the applied voltage has dropped 1 volt, and the voltage across the resistance is about -1 volt (negative because of discharge current). The current is $1/500$, or .002 ampere, resulting in a discharge rate of .2 volt per usec. The rate of applied voltage decrease is .5 volt per usec, so that current can still increase.

g. At 47 usec, the applied voltage is 3.5 volts and the capacitor voltage is about 1 volt. The voltage across R is 2.5 volts, resulting in a current of .005 ampere, and a capacitor discharge rate of .5 volt per usec. This rate is equal to the decay rate and, therefore, the current cannot decrease any further. The output voltage is maintained at 2.5 volts until 60 usec. The input then is zero, and the output decreases to zero in accordance with the universal time-constant discharge curve. The complete output of this differentiator to the pulse input (A of fig. 52) is shown in figure 58.

h. Compare the output voltage obtained in B of figure 57 and figure 58. Increasing the circuit time constant (by increasing the resistance) has two effects. First, the circuit acts less like the ideal differentiator; second, a higher output voltage is obtained. If the time constant is increased further, differentiating action virtually ceases. For example, the output does not reduce to zero over the duration time (A of fig. 53). In most differentiator circuits, it is important that the output does drop to zero shortly after the constant-amplitude duration period starts.

65. Inductive Differentiator

a. BASIC EQUATION.

(1) An inductor can be used as a differentiator because the voltage developed across it is equal to the *rate of change* of current, di/dt , times the inductance, L . This output voltage is negative with relation to the current change; that is, if the current is increasing, the output voltage is negative, or $e_L = -L di/dt$. The output is in volts when di/dt is expressed in amperes per second and L is in henrys. The output is also in volts if di/dt is expressed in amperes per usec and L in μh .

(2) A current pulse increasing at the rate of .1 ampere per sec is driven through an inductor with L of 5 henrys. The voltage across this inductor is then — (.1 times 5), or —.5 volt.

(3) As another example, the current decreases at a rate of .01 ampere per

usec through a 50-mh inductor, which is the same as 50,000 μh (microhenrys), so that the voltage developed across the inductor is

— $[(.01) \times (50 \times 10^3)]$, or 500 volts.

b. NEED FOR RESISTANCE. To obtain a differentiated output from an inductance, the current through the inductance must rise and decay as rapidly as the applied voltage. By placing a large resistor in series with the applied voltage the time constant L/R is made very small. This causes the voltage developed across the inductance to vary almost directly with the applied voltage, since e_L is equal to the rate of change of current times the inductance. The rate of change of current is now fast because the time constant is small, and the current curve is the same as the voltage curve. The resultant circuit acts as a current generator across L , and is called an R - L , or inductive, differentiator.

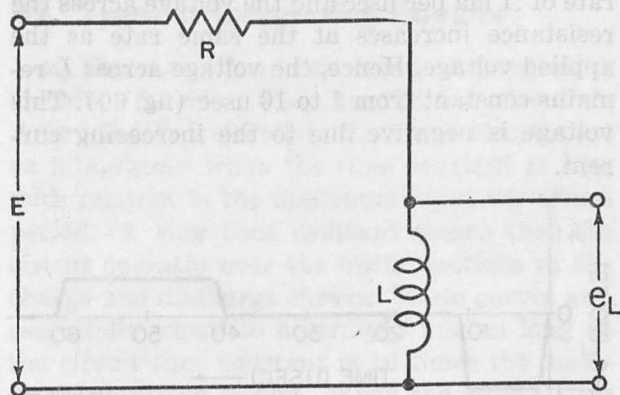

Figure 59. R - L differentiator.

TM 669-59

c. EFFECT OF TIME CONSTANT. When the time constant is small compared with the time periods of the applied voltage, the circuit current can rise or decay as rapidly as the applied voltage. If the time constant is increased sufficiently, the current does not follow the applied voltage curve because it cannot change as fast as this curve. Then the voltage across the inductance is *not* proportional to the rate of voltage change, although it is still proportional to the rate of *current* change. The circuit acts less like a differentiator. These effects are illustrated below by working out two response curves.

66. Time Constant Short Compared to Rise Time

a. The pulse shown in A of figure 52 now is applied to the R - L circuit shown in figure 59. R is 10,000 ohms, L is 10 mh, and the time constant is 1 usec. When the pulse is first applied to this circuit, the full input voltage is developed across L . This generates a back emf and delays the flow of current. At 1 usec, the applied voltage is 1 volt. The voltage across the inductance is about -1 volt. The rate of current increase in the circuit, di/dt , caused by a 1-volt potential across L , is $1/10$ times 10^{-3} , which is $.1$ times 10^3 ampere per second, or $.1$ ma per usec.

b. From 1 to 2 usec, the current increases to about $.1$ ma, and the voltage drop across R is $.1$ times 10,000, or 1 volt. The voltage across the inductance at 2 usec is, then, 2 volts (applied voltage) minus 1 volt (iR drop), or 1 volt. The current, therefore, continues to increase at a rate of $.1$ ma per usec and the voltage across the resistance increases at the same rate as the applied voltage. Hence, the voltage across L remains constant from 1 to 10 usec (fig. 60). This voltage is negative due to the increasing current.

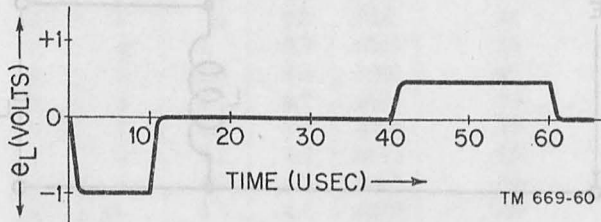

Figure 60. Output of differentiator with low time constant.

c. At 10 usec, the applied voltage remains at 10 volts. The current in the circuit rises from $.9$ ma to about 1 ma at 11 usec and stays at this value. The voltage across the inductance de-

clines to zero during this time, since e_L becomes zero when the current is constant.

d. At 40 usec, the applied voltage decays at a rate of $.5$ volt per usec. At first the entire voltage appears across L . At 41 usec, the voltage across L is $.5$ volt, and the current drops at a rate of $5/10$ times 10^{-3} , or $.05$ ma per usec. The voltage across the resistance, therefore, declines at a rate of $.5$ volt per usec, the same as the decay rate. The inductance voltage is maintained at $.5$ volt from 41 to 60 usec. The current declines to zero from 60 to 61 usec (fig. 60). Note that the output voltage waveform obtained is similar to that of the short time-constant R - C differentiator.

67. Time Constant Equal to One-Half Rise Time

a. When the time constant of the L - R circuit is increased to 5 usec by decreasing R to 2,000 ohms, the voltage across the resistance cannot increase as fast as the applied voltage. At 1 usec, for example, the current increases at a rate of $.1$ ma per usec. A current of $.1$ ma across a 2,000-ohm resistance corresponds to an iR drop of only $.2$ volt. Therefore, at 2 usec the voltage across the inductance decreases to 2 minus $.2$, or 1.8 volt, and the current increases at the higher rate of $.18$ ma. It is possible to obtain the response of the circuit to the entire pulse voltage in this manner. Except for polarity, the R - L differentiator is essentially the same as the R - C differentiator (fig. 58).

b. The effect of the time constant in an R - L differentiator circuit is exactly the same as it is in the R - C differentiator circuit. The major difference between the two circuits is that in the R - L circuit the resistance is increased, while in the R - C it is decreased, to reduce the time constant. Also, the output voltages are opposite in polarity.

Section III. INTEGRATING CIRCUITS

68. Integrating Circuits

a. DEFINITION OF INTEGRATING CIRCUIT. An integrating circuit is a storage circuit in which the output voltage is proportional to the total amount of energy stored. For example, the volt-

age across a capacitor is proportional to the total charge in it. The greater the amount of charge, the higher the amount of energy stored, and the higher the voltage across the capacitor. If a constant amount of current (flow of charge per second) is supplied to a capacitor, the volt-

age across the capacitor increases at a constant rate. The voltage across the capacitor builds up, or is integrated, and the output is taken across the capacitor in an $R-C$ circuit. Similarly, the current in an inductor is proportional to the total voltage across it. Therefore, if a constant voltage is applied across an inductor, the current in the inductor increases at a constant rate. The output of the $R-L$ integrator is taken across the resistor.

b. **OUTPUT FOR COMMON WAVEFORMS.** When a constant, or d-c, voltage is applied to an integrator, the output voltage increases in a straight line (A of fig. 61). The rate of increase of the output voltage is proportional to the magnitude of the d-c voltage. When a constantly increasing voltage is applied to the integrator, as in B, the rate of storage increases continuously and the resultant voltage has a parabolic waveform. The storage voltage due to a sine-wave input varies sinusoidally, but is shifted in phase 90° , as in C.

c. **OUTPUT FOR RECTANGULAR PULSE.** When a rectangular pulse is applied to an integrator,

the output is a triangular pulse (fig. 62). The voltage rises linearly over the duration of the pulse. It then declines along a similar curve when the pulse voltage becomes zero again.

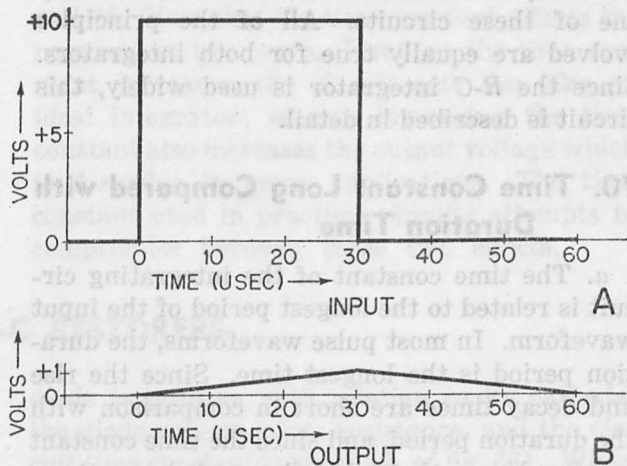

Figure 62. Integrator output-rectangular pulse input (stable condition). TM 669-62

69. Types of Integrating Circuits

a. There are two basic types of integrating circuits (fig. 63). They are the $R-C$ circuit in A and the $R-L$ circuit in B. These circuits act as integrators when the time constant is long with relation to the maximum input waveform period. A long time constant means that the circuit operates over the initial sections of the charge and discharge curves. These curves are, essentially, equal to a straight line as long as the circuit time constant is 10 times the maximum waveform period. When the circuit time constant is reduced, a section of the resultant curve becomes curved. This indicates that the circuit is not an ideal integrating circuit.

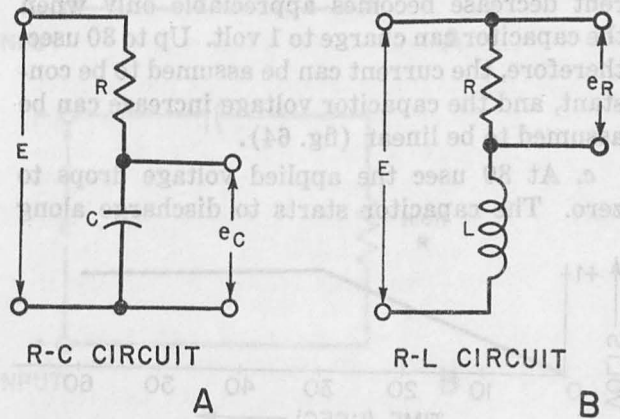

Figure 63. Types of integrators. TM 669-63

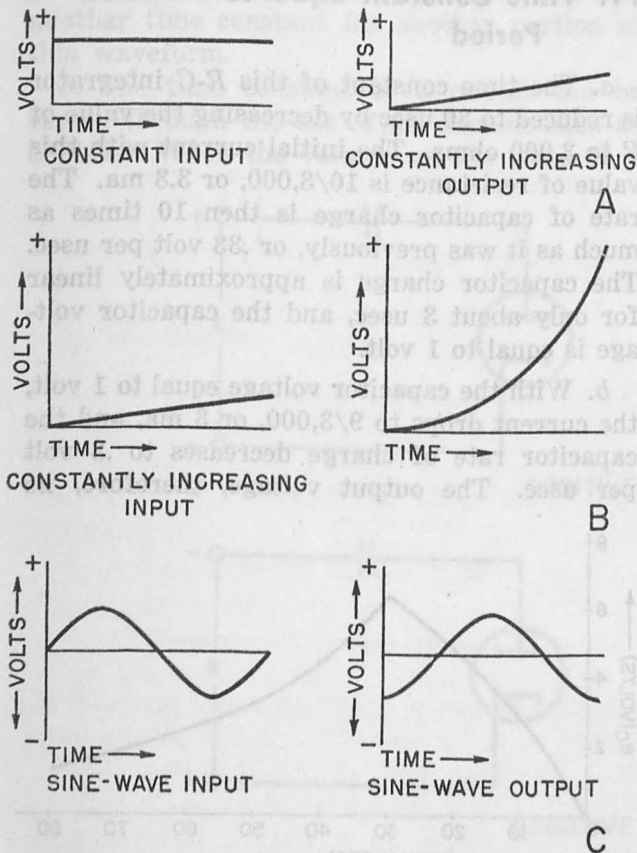

Figure 61. Integrator waveforms. TM 669-61

b. For a given time constant, both the $R-L$ and $R-C$ integrating circuits provide, theoretically, similar output voltages. Therefore, it is necessary to review the characteristics of only one of these circuits. All of the principles evolved are equally true for both integrators. Since the $R-C$ integrator is used widely, this circuit is described in detail.

70. Time Constant Long Compared with Duration Time

a. The time constant of the integrating circuit is related to the longest period of the input waveform. In most pulse waveforms, the duration period is the longest time. Since the rise and decay times are short in comparison with the duration period, and since the time constant is very large, the pulse rise and decay times have little effect upon the output of the integrator circuit.

b. The rectangular pulse in A of figure 62 is applied to an $R-C$ integrator with a time constant of 300 usec. R is 30,000 ohms and C is .01 μf . At the first instant, the capacitor voltage is zero so that the current in the circuit is equal to E/R , which is $10/30,000$, or .33 ma. The voltage across the capacitor resulting from a .33-ma current increases at a rate of Q/C of .33 times $10^{-9}/.01$ times 10^{-6} , or .033 volt per usec. At 10 usec, the voltage across the capacitor is about .33 volt. This voltage is not sufficient to decrease the current in the circuit appreciably. The voltage across the resistor is 10 minus .33, or 9.67 volts, and the current is then .32 ma. This current decrease is negligible and can be neglected for most practical purposes. The current decrease becomes appreciable only when the capacitor can charge to 1 volt. Up to 30 usec, therefore, the current can be assumed to be constant, and the capacitor voltage increase can be assumed to be linear (fig. 64).

c. At 30 usec the applied voltage drops to zero. The capacitor starts to discharge along

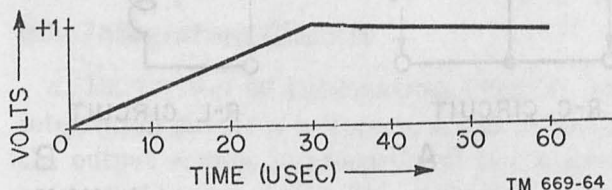

Figure 64. Large time-constant integrator output.

the standard discharge curve. The discharge curve is much more gradual than the charge curve, and the capacitor voltage reaches .9 volt at about 60 usec and .37 volt at 300 usec. In the integrator circuit, an output voltage is obtained for a period of time many times greater than the pulse duration time. Hence, the time between successive pulses must be very large, or the output of one pulse will add to the succeeding pulse.

d. When the time between successive pulses is too short, a charge still exists in the capacitor when the second pulse appears. The charge in the capacitor increases until the amount of charge added during the duration period is equal to the discharge during the pulse rest period (par. 56d). For a 10-volt, 30-usec square wave, the output will have the same shape as in figure 62 when the stable condition is reached, but the triangular wave will vary from +.5 volt to -.5 volt instead of from zero to 1 volt.

71. Time Constant Equal to Duration Period

a. The time constant of this $R-C$ integrator is reduced to 30 usec by decreasing the value of R to 3,000 ohms. The initial current with this value of resistance is $10/3,000$, or 3.3 ma. The rate of capacitor charge is then 10 times as much as it was previously, or .33 volt per usec. The capacitor charge is approximately linear for only about 3 usec, and the capacitor voltage is equal to 1 volt.

b. With the capacitor voltage equal to 1 volt, the current drops to $9/3,000$, or 3 ma, and the capacitor rate of charge decreases to .3 volt per usec. The output voltage, therefore, no

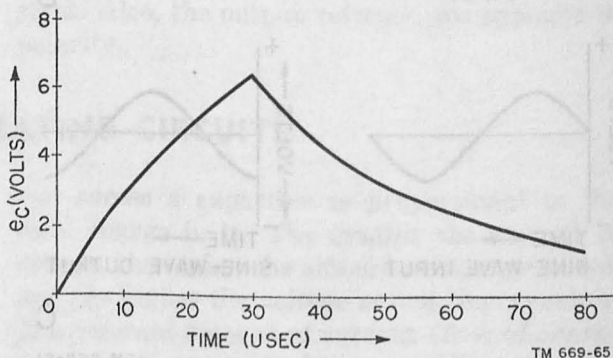

Figure 65. Large time-constant $R-C$ integrator output.

longer increases linearly with relation to time, and becomes more curved as the time increases (fig. 65).

c. At 30 usec, the capacitor voltage is only 6.4 volts, since the capacitor increase is not linear for the entire period of time. The applied voltage drops to zero, and the capacitor discharges in accordance with the standard discharge curve. At 80 usec (fig. 65) there is still charge in the capacitor. At 120 usec, the capacitor voltage reduces to about .3 volt, and it does not drop to .1 volt until about 160 usec.

Note that the output voltage remains appreciable in this circuit for a period of time four times greater than the duration time.

d. Compare the curves given in figures 64 and 65. Note that the time constant affects the response in two ways. First, as the time constant increases, the circuit acts less like an ideal integrator; second, increasing the time constant also increases the output voltage which is desirable in many applications. The time constant used in practical circuits attempts to compromise between these two effects.

Section IV. D-C RESTORERS

72. Introduction

a. In the applications considered thus far, the time constant had one specific value for any given current and affected various portions of the applied voltage differently. To obtain a particular output it is desirable occasionally to have one time constant over one portion of the input voltage waveform, and another time constant for another portion of this waveform.

b. The time constant of a circuit can be varied through the use of an element such as a diode. When the voltage on the plate of a

diode is positive with relation to its cathode, the diode acts as a low resistance, and the circuit time constant is short (A of fig. 66). When the voltage on the plate is negative with relation to its cathode, the diode acts as a high resistance, and the circuit time constant is large, as in B. The d-c restorer, described below, illustrates the use of a varying time constant to obtain a desired output voltage.

73. Definition of D-C Restorer

a. D-C COMPONENT OF WAVEFORM. A non-sinusoidal waveform is composed of a d-c volt-

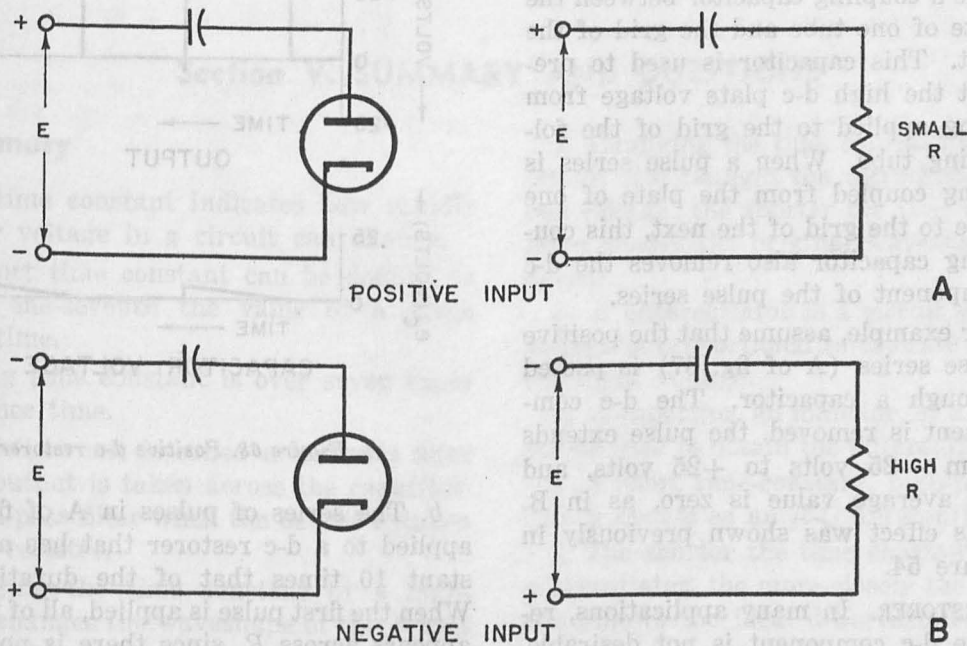
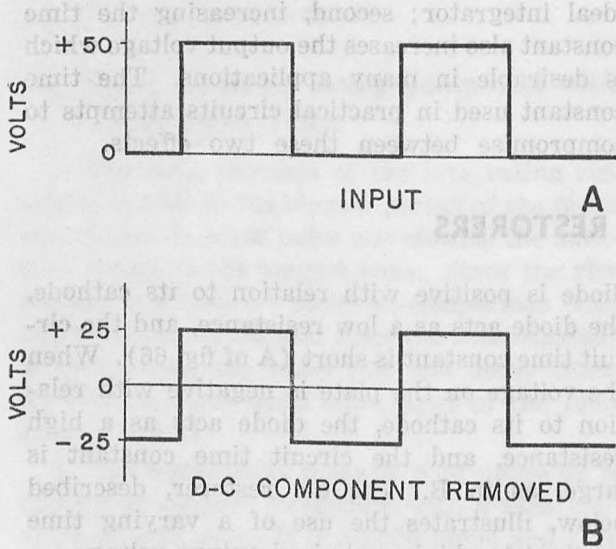

Figure 66. Resistance of diode.

age plus a number of harmonics. The pulse series (A of fig. 67) shows that the d-c component is equal to the average value of the pulses. For example, each pulse is +50 volts for one-half the time and zero for the other half. The average value is, therefore, +25 volts.



TM 669-67

Figure 67. Removal of d-c component.

b. COUPLING CAPACITOR EFFECT.

- (1) Generally, circuits using vacuum tubes have a coupling capacitor between the plate of one tube and the grid of the next. This capacitor is used to prevent the high d-c plate voltage from being applied to the grid of the following tube. When a pulse series is being coupled from the plate of one tube to the grid of the next, this coupling capacitor also removes the d-c component of the pulse series.

- (2) For example, assume that the positive pulse series (A of fig. 67) is passed through a capacitor. The d-c component is removed, the pulse extends from -25 volts to +25 volts, and the average value is zero, as in B. This effect was shown previously in figure 54.

c. D-C RESTORER. In many applications, removal of the d-c component is not desirable. For these applications, a d-c restorer circuit is used which reapplies a d-c voltage to the out-

put of the blocking capacitor in such a manner that the original d-c component of the pulse form is obtained.

74. Positive Diode D-C Restorer

a. D-c restorer circuits can be used to restore either a positive or negative d-c voltage. The circuit shown in A of figure 68 is a positive d-c restorer. The values of R and C provide a long time constant compared with the waveforms applied to the circuit. However, when the voltage across the resistor is positive, the plate is positive with relation to the cathode, the diode acts as a low resistance, and, since it parallels R , the time constant of this circuit is very short.

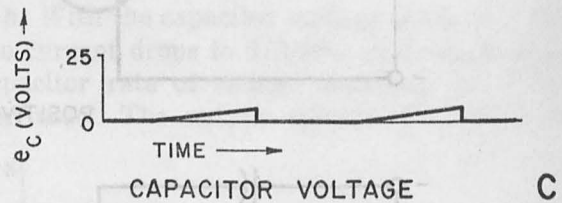
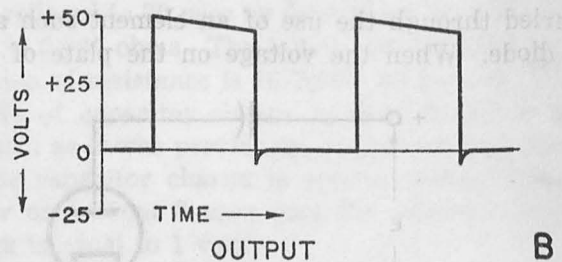
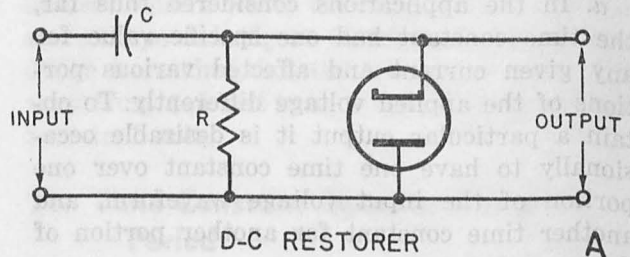

TM 669-68

Figure 68. Positive d-c restorer.

b. The series of pulses in A of figure 67 is applied to a d-c restorer that has a time constant 10 times that of the duration period. When the first pulse is applied, all of the voltage appears across R , since there is no charge in C . The diode acts as a very high resistance during this time, since the cathode is positive

with relation to the plate. Therefore, the circuit has a large time constant and the capacitor charges to only 5 volts over the duration time. The output voltage then drops to 45 volts (B of fig. 68).

c. When the applied voltage drops to zero, the capacitor starts to discharge through R . This develops a -5 volt potential between the cathode and plate of the diode since the discharge current flows in the opposite direction. The diode plate is now positive with relation to the cathode and acts as a low resistance. The capacitor discharges rapidly because of the short time constant and, when the next pulse is applied to the circuit, no charge exists in the capacitor. The same procedure is repeated. Consequently, the capacitor loses all the charge during the pulse rest period that it gained over the duration time. The result is the series of pulses in B of figure 67.

d. In the d-c restorer circuit, the capacitor discharges completely between pulses because of the low time constant provided by the diode when it is conducting. This circuit thereby incorporates all the advantages of good pulse reproduction provided by the large time-constant, high-pass filter, at the same time eliminating its main disadvantage of a long discharge period.

e. If the diode is not placed across the re-

sistance, the circuit remains a large time-constant, high-pass R - C circuit. The capacitor discharges very slowly and there is some charge on it when the succeeding pulse is applied to the circuit. This charge adds to that normally obtained during the duration time (fig. 54). For example, the capacitor voltage is 8 volts instead of 5 volts at the end of the second pulse. The output voltage then becomes 42 volts instead of 45 volts. During each succeeding pulse, the capacitor charges to a higher voltage until the average voltage level is reached.

f. For the pulse series shown in A of figure 67, the average value is 25 volts, and hence the capacitor charge eventually reaches 25 volts. With 25 volts across the capacitor, the charge and discharge curves are exactly alike, since there is a $+25$ -volt potential during pulse duration, and -25 volts during the rest period.

g. This procedure of changing the time constant at the desired time is used in conjunction with other circuits to maintain a desired portion of the output waveform and eliminate an undesirable feature. For example, the long discharge period of the integrator (fig. 65) can be reduced by use of such a circuit. This can be accomplished by taking the output of the d-c restorer (A of fig. 68), across the capacitor. The sawtooth voltage is thereby obtained, as in C.

Section V. SUMMARY AND QUESTIONS

75. Summary

a. The time constant indicates how rapidly current or voltage in a circuit can change.

b. A short time constant can be defined as less than one-seventh the value of a given reference time.

c. A long time constant is over seven times the reference time.

d. An R - C circuit is called a low-pass filter when the output is taken across the capacitor. It is a high-pass filter when the output is taken across the resistor.

e. Changing the time constant of a high-pass filter changes the waveshape of the output voltage; the longer the time constant the more closely the original waveshape is reproduced.

f. Changing the time constant of a low-pass circuit also changes the waveshape of the output voltage; the shorter the time constant, the more closely the original waveshape is reproduced.

g. A differentiator is a circuit whose output voltage is proportional to the rate of change of the input voltage.

h. A capacitor, an inductor, or a transformer can be used to obtain the differentiating action.

i. A short time-constant, high-pass R - C circuit is known as an R - C differentiator.

j. The shorter the time constant of the R - C differentiator, the more closely the output voltage follows the ideal differentiated output.

k. A shorter time constant also means that a lower output voltage is obtained.

l. A short time-constant $R-L$ circuit, with output voltage taken across L , can be used as a differentiator.

m. An $R-L$ differentiator acts like an $R-C$ differentiator when the same time constant is used.

n. An integrating circuit is a storage circuit in which the output voltage is proportional to the total amount of energy stored.

o. A long time-constant, low-pass $R-C$ circuit, with voltage output obtained across R , can be used as an integrator.

p. The longer the time constant of the integrator, the more closely the output approaches ideal integration, and the lower the output voltage.

q. By changing the time constant of a circuit for different portions of a waveshape, it is possible to achieve a desired output voltage. A circuit that does this is the d-c restorer.

r. A d-c restorer circuit is used to restore the d-c component removed by a coupling capacitor.

s. In this circuit a diode is placed across the output. The diode acts as a low resistance when the plate is positive with relation to the cathode, and as a high resistance when the plate is negative with relation to the cathode.

t. In a positive d-c restorer, the circuit has a long time constant when the cathode is positive with relation to the plate, and a short time constant when the cathode is negative with re-

lation to the plate. The converse is true for a negative d-c restorer.

76. Review Questions

a. How does the time constant indicate with reference to a pulse voltage?

b. What is the output waveform of a short time-constant high-pass $R-C$ circuit to a rectangular pulse voltage?

c. How does increasing the time constant of a high-pass filter affect the pulse waveform?

d. What time constant provides the best pulse reproduction in a low-pass $R-C$ filter?

e. Define a differentiating circuit.

f. What is resistance used for in an $R-C$ differentiator?

g. What is the effect of increasing the time constant in an $R-C$ differentiator?

h. Describe the output of an $R-L$ differentiator with a time constant of 2 usec to a pulse with a rise time of 10 usec, a duration time of 50 usec, and a decay time of 4 usec. R is 2,000 ohms and L is 4 mh.

i. What is an integrating circuit?

j. What types of integrating circuits are commonly used?

k. What is the relative time constant of an $R-C$ integrator?

l. What principle does a d-c restorer illustrate?

m. Why is it desirable to have a long time constant while the positive pulse is applied to a positive d-c restorer, and a short time constant after the pulse is removed?

CHAPTER 7

FREQUENCY ANALYSIS OF WAVEFORMS

77. Introduction

Until transient-response methods became widely used, nonsinusoidal waveforms were analyzed by the *frequency-response* method, and this method still is used to analyze nonsinusoidal waveforms. In this chapter, therefore, the output waveforms from *R-C* and *R-L* circuits will be obtained by means of the frequency-response method. These waveforms then will be compared with those obtained using transient-response methods.

78. Fourier Theorem on Waveform Composition

a. FOURIER THEOREM. The theorem that any nonsinusoidal waveform can be represented by a series of harmonically related sine waves plus a d-c voltage first was developed by a French physicist named Joseph Fourier. Consequently, this theorem is called the *Fourier theorem* and the series of sine waves which comprise the nonsinusoidal waveform is called the *Fourier series* of the waveform.

b. AMPLITUDE AND PHASE. The Fourier series indicates not only the frequencies of the harmonic components, but also the amplitude and phase of each component. In the graphical development of a sawtooth from a series of sine waves (fig. 2), the amplitude of each harmonic is selected carefully to obtain the desired result. If different amplitudes are used, a different waveform results. Therefore, it is important to know not only the harmonic content of the waveform, but also the amplitude of each component. Similarly, the phase relations between the various harmonic components must be correct in order to reproduce the waveform.

c. SINE-WAVE SYMBOLS. The meaning of the mathematical term $C \sin (wt + \theta)$ is essential

for the understanding of the Fourier series. In this term, the symbols have the following meaning:

- (1) *sin*: The symbol *sin* means that the waveform varies sinusoidally and is a function of the sine of an angle.
- (2) *w*: The symbol *w* represents the angular velocity of the sine wave, and is equal to $2\pi f$. An angular velocity, *w*, corresponds to the fundamental frequency or *f*, $2w$ corresponds to the second harmonic, or $2f$, and so on.
- (3) *C*: The symbol *C* indicates the maximum amplitude of the sine wave, and is a constant for each harmonic.
- (4) θ : The symbol θ is the phase angle of the sine wave at $t = 0$. In figure 69, for example, one sine wave has zero amplitude at $t = 0$, and θ is zero. The other sine wave starts at its maximum negative value at $t = 0$, and θ is -90° , or $-\pi/2$ radians. Note that the phase angle can be expressed either in degrees or in terms of radians, where $360^\circ = 2\pi$ radians. In the Fourier series, it is often convenient to express θ in terms of π radians. For example, $90^\circ = \pi/2$, $180^\circ = \pi$, and $360^\circ = 2\pi$, etc. The term radian usually is omitted.
- (5) The term $10 \sin (200\pi t + \pi/2)$ represents a waveform which varies sinusoidally at a frequency of $\frac{200\pi}{2\pi}$, or 100 cps. It has a maximum amplitude of 10 volts, and it starts at $t = 0$ with a phase angle of $\pi/2$, or $+90^\circ$.

d. FOURIER SERIES. The Fourier series for nonsinusoidal periodic waveforms states relations between the frequency, amplitude, and

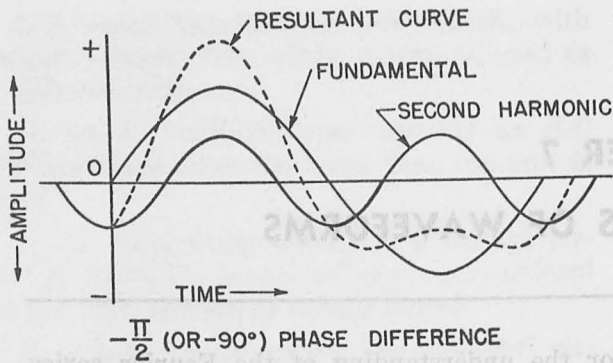

Figure 69. Addition of first and third harmonic.

phase of the harmonic components. Mathematically, the Fourier series is written in the following manner:

$$S_t = C_0 + C_1 \sin (wt + \theta_1) + C_2 \sin (2wt + \theta_2) + C_3 \sin (3wt + \theta_3) + \dots + C_n \sin (nwt + \theta_n).$$

S_t is the amplitude of the nonsinusoidal wave at any time t . C_0 is the d-c component of the wave. C_1 is the maximum amplitude of the fundamental wave, or first harmonic. $\sin wt$ is the fundamental sine wave, and θ_1 is the phase of the fundamental sine wave. C_2 is the maximum amplitude of the second harmonic, $\sin 2wt$ is the second harmonic sine wave, and θ_2 is the phase of the second harmonic. The number in each term (1, 2, 3, . . . n) indicates the frequency of the harmonic compared to the fundamental. For example, $\sin (3wt + \theta_3)$ is the third harmonic, $\sin (nwt + \theta_n)$ is the n th harmonic sine wave.

79. Symmetry of Waves

a. GENERAL. A number of methods are used to determine the maximum amplitudes of the harmonics (C_0, C_1, C_2 , and so on) in the Fourier series of any particular waveform. A large number of these coefficients can be determined by inspection of the graph of the waveform.

b. ZERO-AXIS SYMMETRY. When a periodic waveform has the same shape above and below the zero-amplitude axis, the waveform is said to have *zero-axis symmetry*. The waveform shown in figure 70 is an example of zero-axis symmetry. The amplitude is +2 at $t = 0$, and it declines to zero amplitude at $t = 2$. The wave passes through zero to -2 at $t = 4$. The positive portion of this waveform is the same as

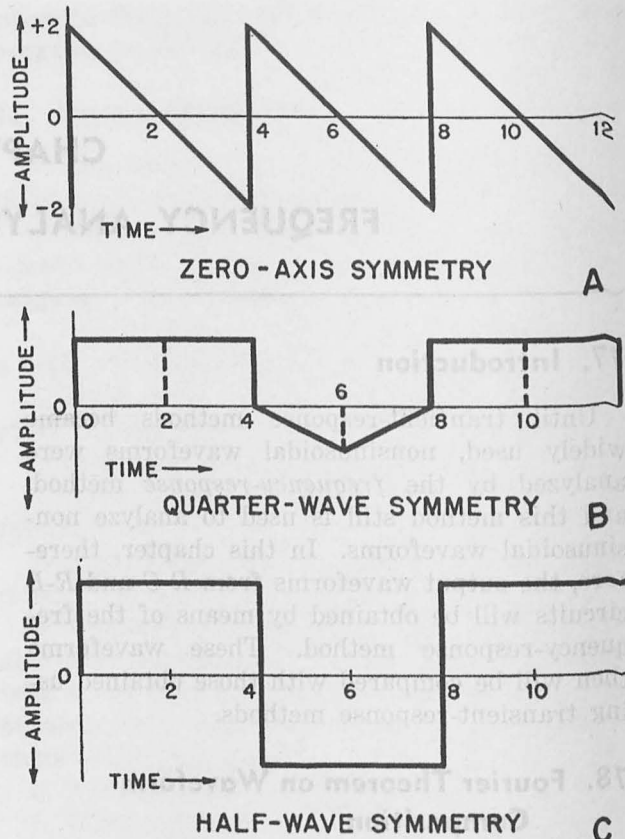

Figure 70. Types of symmetry.

the negative portion. Consequently, it has zero-axis symmetry.

c. QUARTER-WAVE SYMMETRY. A waveform has *quarter-wave symmetry* when the quarter-waves in a half-cycle are symmetrical (B of fig. 70). The half-cycle occurs from zero to $t = 4$. If an axis is drawn down the center of this half-cycle (dotted line in B), the two quarter-waves are exactly alike. Similarly, when a vertical axis is drawn at $t = 6$, the quarter-wave from 4 to 6 is symmetrical to the quarter-wave from 6 to 8. Consequently, this waveform has quarter-wave symmetry.

d. MIRROR SYMMETRY. A waveform has *half-wave, or mirror, symmetry*, as in C, when the positive half-cycle is symmetrical to the negative half-cycle around the zero-amplitude axis. The positive half-cycle from zero to 4 is exactly the same as the negative half-cycle from 4 to 8, except for change in polarity. Note that the waveform in B, which has quarter-wave symmetry, does not have half-wave symmetry because the

positive half-cycle is not the same as the negative half-cycle.

80. Effects of Symmetry on Harmonic Composition

Either the d-c component, or a large number of harmonic-frequency components can be eliminated from the waveform analysis if the waveform has a given symmetry.

a. ZERO-AXIS SYMMETRY EFFECT.

- (1) The effect of zero-axis symmetry is shown in figure 71. In this figure, two sine waves of voltage are plotted. Sine wave 1 is symmetrical about the zero axis. Sine wave 2 has exactly the same shape, but is displaced 10 volts above sine wave 1. Sine wave 2 is not symmetrical around the zero-voltage axis.

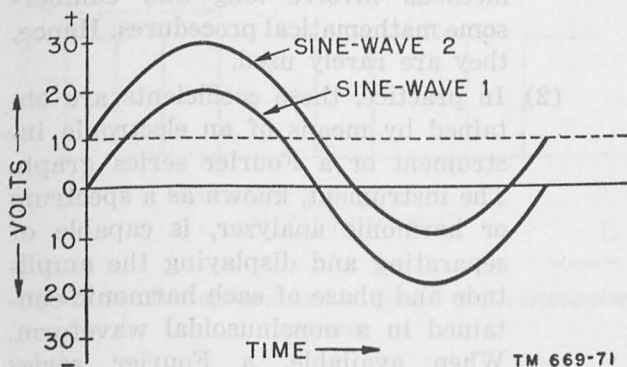

Figure 71. Effect of d-c component.

- (2) If a d-c voltage of 10 volts is added to sine wave 1, the two sine waves coincide. Hence, sine wave 2 equals sine wave 1 plus 10 volts. The addition of a d-c voltage to a sine wave does not distort its waveshape in any way. The d-c voltage can only raise (when positive) or lower (when negative) the position of the curve with relation to the zero-voltage axis.
- (3) When a waveform is symmetrical with relation to the zero-voltage axis, the d-c voltage component is equal to zero. Sine wave 2 is symmetrical about the axis formed by the dotted line at 10 volts. A waveform that is symmetrical about a voltage axis other

than zero has a d-c component equal to the voltage at the axis of symmetry.

b. EFFECT OF EVEN HARMONICS ON WAVEFORM SYMMETRY. A and B of figure 72 shows the resultant curves when a second harmonic is added to the fundamental sine wave in different phase relationships. The resultant waveforms do not have half-wave symmetry. Waveforms lacking half-wave symmetry are also obtained when the fourth, sixth, or any even-order harmonic is added to the fundamental. From this it can be deduced that an even-order harmonic causes the resultant curve to lack half-wave symmetry.

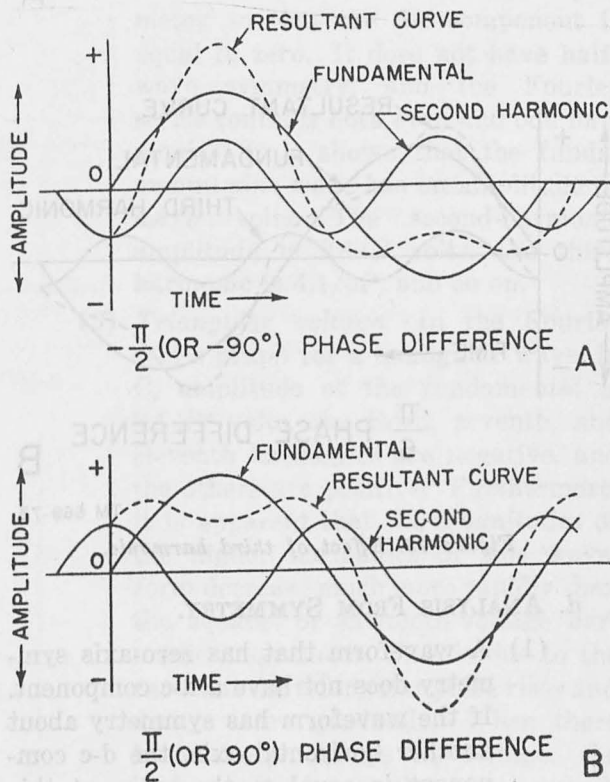
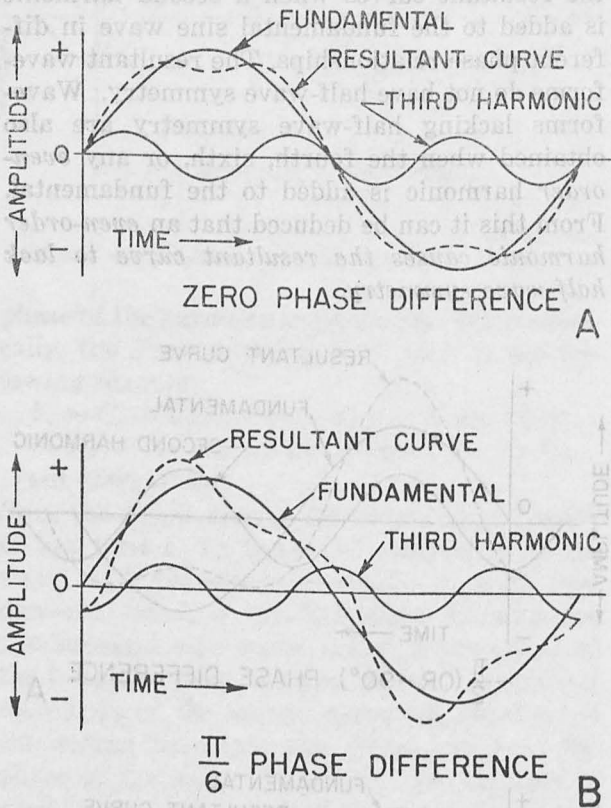

Figure 72. Effect of even harmonics.

c. EFFECT OF ODD HARMONICS ON WAVEFORM SYMMETRY. A and B of figure 73 shows the resultant curves when a third harmonic is added to the fundamental in different phase relationships. Each curve has half-wave symmetry, but only the curve where the phase difference is zero (both waves starting with zero amplitude at $t = 0$) has quarter-wave symmetry. Half-wave symmetry is obtained when

the fifth, seventh, or any odd-order harmonic is added to the fundamental. *An addition of odd harmonics always produces a half-wave symmetrical waveform.*



TM 669-73

Figure 73. Effect of third harmonic.

d. ANALYSIS FROM SYMMETRY.

- (1) A waveform that has zero-axis symmetry does not have a d-c component. If the waveform has symmetry about another horizontal axis, the d-c component is equal to the value at this axis.
- (2) A waveform that has half-wave symmetry has no d-c component and no even-order harmonic component.
- (3) A waveform that has both half- and quarter-wave symmetry has no d-c and no even-order harmonic component, and all its odd-order harmonics are in phase (start with zero amplitude at $t = 0$).
- (4) A waveform displaying half-wave symmetry about a horizontal axis

other than zero has a d-c component equal to the value at the axis of symmetry, but it does not have any even-order harmonics.

81. Determination of Coefficients Not Equal to Zero

a. GENERAL.

- (1) From symmetry, it is possible to note which of the Fourier series coefficients (C_0, C_1, \dots, C_n) are equal to zero. Determination of coefficient values that are not equal to zero is more difficult. The d-c component, C_0 , can be worked out by examination of the waveform. A number of methods, such as the graphical, numerical, and envelope, can be used to evaluate the harmonic coefficients. However, all of these methods involve long and cumbersome mathematical procedures. Hence, they are rarely used.

- (2) In practice, these coefficients are obtained by means of an electronic instrument or a Fourier series graph. The instrument, known as a spectrum or harmonic analyzer, is capable of separating and displaying the amplitude and phase of each harmonic contained in a nonsinusoidal waveform. When available, a Fourier series graph is used which plots amplitude versus number (1, 2, ..n) of harmonic. Several of these graphs are described below.

b. D-C COMPONENT.

- (1) *Definition of average value.* The d-c component of any periodic wave is equal to the average amplitude of the wave during 1 complete cycle. The average amplitude is equal to the sum of all values during 1 cycle divided by the number of values taken. In a wave displaying half-wave and zero-axis symmetry, 1 half-cycle is equal and opposite to the next half-cycle. The sum of 1 cycle is, therefore, zero.
- (2) *Square wave.* In the square wave of voltage (A of fig. 74) the amplitude of the pulse, A, remains constant dur-

ing the pulse width, P , and is zero during the remainder of the cycle. The time in usec, or period for 1 complete cycle is designated as T and, in the square wave, $2P = T$. The average value of a square wave is the amplitude times P/T , or $E_{av} = AP/T$. Since P/T is equal to one-half and the amplitude is A , E_{av} is equal to $A/2$. The d-c component is, therefore, $A/2$.

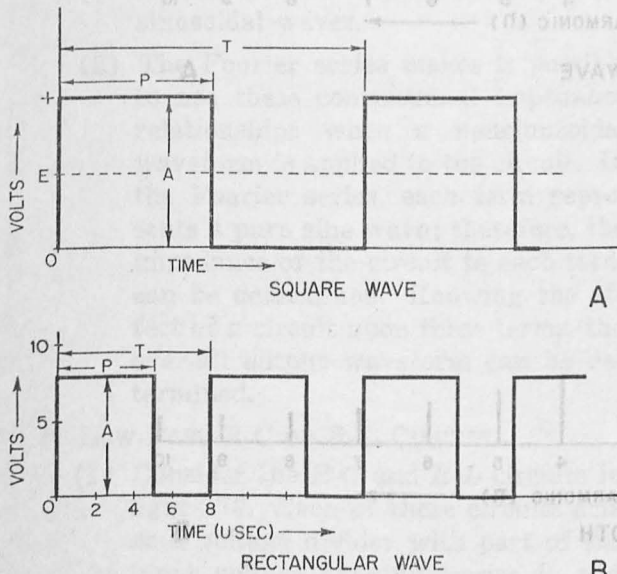

Figure 74. D-c components of square and rectangular waves.

(3) *Rectangular wave.* In a rectangular wave, the average amplitude, E_{av} , is also equal to AP/T . For example, the rectangular wave in B of figure 74 has a pulse width of 5 usec, a period of 8 usec, and a maximum amplitude of 8 volts. E_{av} is, therefore, 8 times $5/8$, or 5 volts.

c. FOURIER SERIES GRAPHS.

(1) Square wave.

(a) In the Fourier series graph for a square wave of voltage (A of fig. 75), the square wave displays zero-axis symmetry, and has no d-c component. Since it has quarter-wave symmetry, all phase angles ($\theta_1, \theta_2 \dots \theta_n$) are zero. It also has half-wave symmetry, and all the even-harmonic components are zero.

(b) The first term in the Fourier series is $C_1 \sin \omega t$. It is shown, in A, that the magnitude of the first harmonic is $4A/P$. If the square wave occurs at a frequency of 1,000 cps, the first harmonic is then a 1,000-cycle sine wave with an amplitude of $4A/P$ volts. The third harmonic, occurring at a frequency of 3,000 cps ($n = 3$), has an amplitude of $4A/3P$ volts. Similarly, the fifth harmonic has an amplitude of $4A/5P$ volts.

(2) *Sawtooth voltage.* In the Fourier series graph for a sawtooth voltage, in B, this wave has zero-axis symmetry so that the d-c component is equal to zero. It does not have half-wave symmetry, and the Fourier series contains both even and odd harmonics. It is shown that the fundamental sine wave has an amplitude of $4A/P$ volts. The second-harmonic amplitude is $2A/P$ volts, the third harmonic is $4A/3P$, and so on.

(3) *Triangular voltage.* In the Fourier series graph for a triangular wave, in C, amplitude of the fundamental is $8A/P^2$ volts, the third, seventh, and eleventh harmonics are negative, and the others are positive. Furthermore, it is apparent that the magnitudes of the higher harmonics of this waveform decrease much more rapidly than the square- or sawtooth-voltage harmonic magnitudes. This is due to the fact that the triangular pulse rises and decays more gradually. When there is a sharp change in voltage, the higher-order harmonics have a much greater effect.

82. Frequency Response of R-C and R-L Circuits

a. GENERAL.

(1) When a nonsinusoidal wave is applied to a circuit containing inductance and/or capacitance, it is necessary to express the nonsinusoidal voltage in terms of a Fourier series in order to use conventional impedance concepts

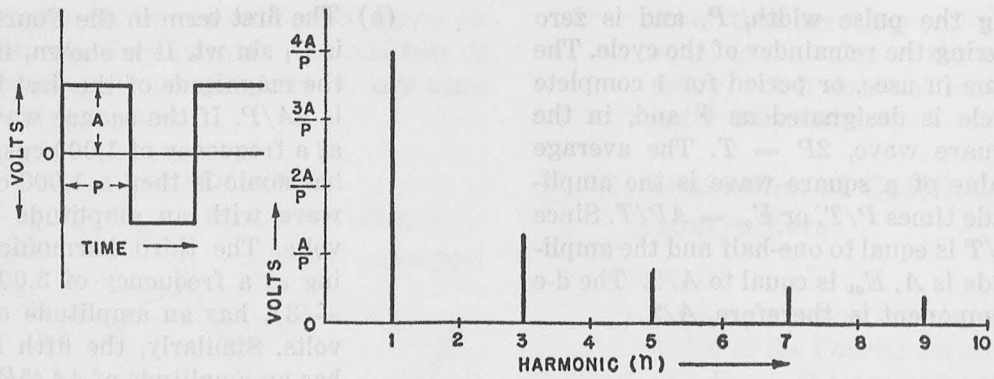

SQUARE WAVE A

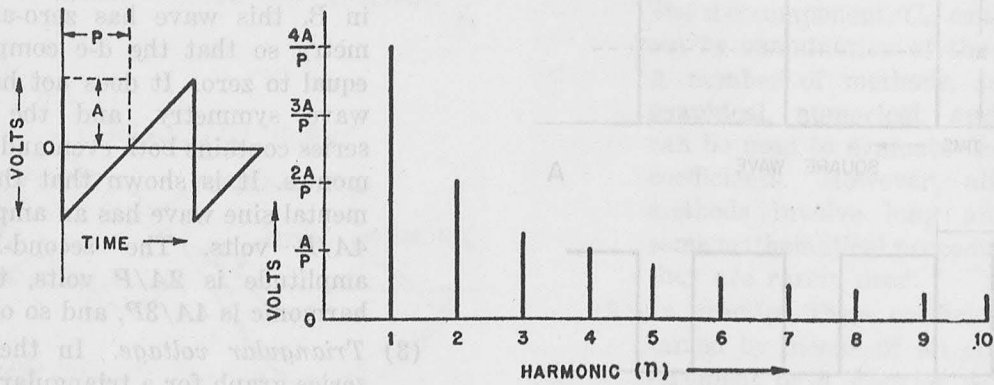

SAWTOOTH B

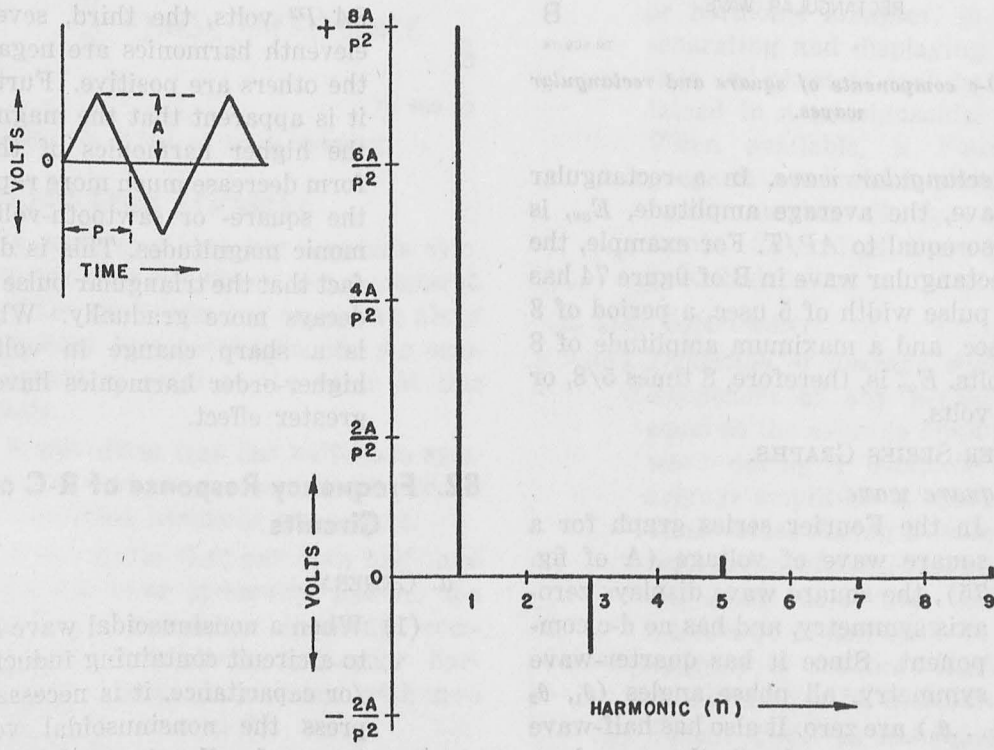

TRIANGULAR C

Figure 75. Fourier series graphs.

TM 669-75

(frequency-response method). It is known that inductive reactance is equal to $2\pi fL$. The factor, f , in this relation is the frequency of the signal in *pure sine waves*. If f represents a waveform that is not purely sinusoidal, the impedance relationship $2\pi fL$ is not true. Similarly, the capacitive reactance is $\frac{1}{2\pi fC}$, and f the frequency, can represent only pure sinusoidal waves.

- (2) The Fourier series makes it possible to use these conventional impedance relationships when a nonsinusoidal waveform is applied to the circuit. In the Fourier series, each term represents a pure sine wave; therefore, the impedance of the circuit to each term can be determined. Knowing the effect of a circuit upon these terms, the over-all output waveform can be determined.

b. LOW-PASS R-C OR R-L CIRCUIT.

- (1) Consider the $R-C$ and $R-L$ circuits in figure 76. Each of these circuits acts as a voltage divider with part of the input voltage existing across R , and the other part across L or C . When R is very much greater than $2\pi fL$, or $\frac{1}{2\pi fC}$, most of the input voltage exists across R .

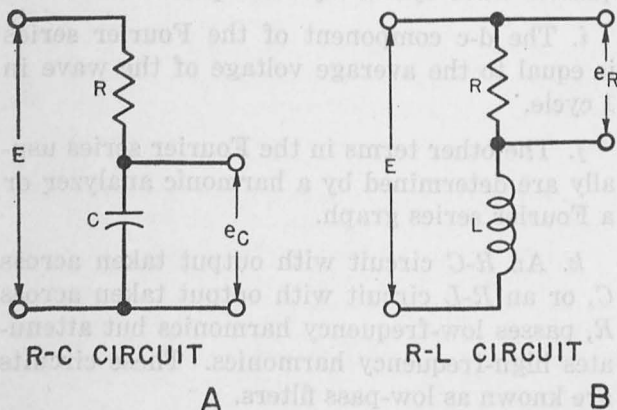

Figure 76. Low-pass filter.

- (2) In the $R-C$ circuit, at low frequencies, e_o (A of fig. 76) is practically equal

to the input voltage when the capacitive impedance is very large. In the $R-L$ circuit, at low frequencies, e_R , in B, is practically equal to the input voltage when the inductive impedance is very low. These circuits do not attenuate the low frequencies appreciably. Hence, they are called low-frequency, or simply low-pass filters.

- (3) As the frequency increases in the $R-C$ circuit, more of the input appears across R and less voltage appears across the output. As the frequency increases in the $R-L$ circuit, more of the input appears across L , and, also, voltage appears across the output R . High frequencies, therefore, are attenuated, or reduced, by the low-pass filter.

- (4) The low-pass filter passes low-frequency harmonics, but greatly attenuates the high-frequency harmonics. Poor high-frequency response affects the waveform when the voltage changes most rapidly. Therefore, the low-pass filter will affect the practical pulse more during the relatively short rise and decay time than during the duration time.

- (5) The bandwidth of this circuit usually is defined as that frequency band for which the attenuation is less than half. However, bandwidth also can be defined as that frequency band for which the attenuation is less than 10 percent, or some other factor. Note that the attenuation is exactly half when the input voltage is divided equally between R and C , or between R and L . This occurs when R is equal to $2\pi fL$, or $\frac{1}{2\pi fC}$. The bandwidth, therefore, is defined sometimes as that frequency at which

$$f_o = \frac{R}{2\pi L} \quad (\text{for } R-L)$$

$$f_o = \frac{1}{2\pi RC} \quad (\text{for } R-C)$$

where f_o is the bandwidth.

- (6) The bandwidth of the $R-C$ circuit increases as the time constant, $R-C$, is

decreased. The greater the circuit bandwidth, the better the high-frequency response, the better the reproduction of pulse rise and decay times. Note that these principles are the same as those developed using the transient-response methods in chapter 6.

c. HIGH-PASS R-C OR R-L CIRCUIT (fig. 77).

- (1) When the output voltage is taken across R in the R - C circuit or L in the R - L circuit, the circuit is known as a high-pass filter. In A, high frequencies are passed with little attenuation since the capacitive impedance is small, and in B the inductive impedance is large and the high frequencies are passed with little attenuation. These circuits highly attenuate low-frequency harmonics when most of the voltage exists across C in an R - C circuit and across R in an R - L circuit.

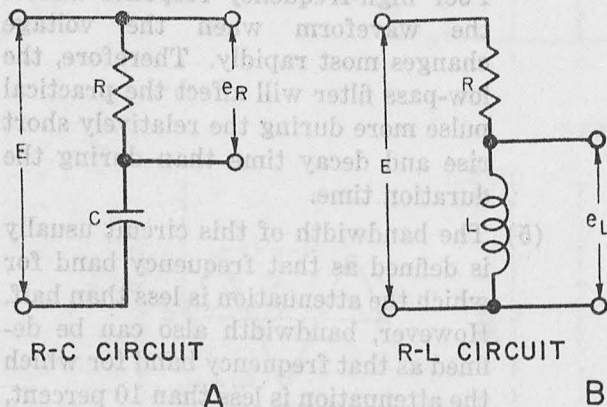

TM 669-77

Figure 77. High-pass filter.

- (2) These circuits have little effect on practical pulse rise and decay times because of good high-frequency response, but may cause a drop over the duration time due to poor low-frequency response. Again, these facts agree with those previously obtained by means of the transient-response method (ch. 6).

83. Conclusion

This text covers two common methods of determining the response of circuits to nonsinusoidal waveforms. The transient-response

method provides this response directly through the use of fundamental relationships and equations. The frequency-response method involves breaking down the nonsinusoidal wave into its Fourier series and determining the effect of each wave upon the circuit using standard impedance relationships.

84. Summary

a. The representation of any nonsinusoidal wave as a series of harmonically related sine waves is known as a Fourier series.

b. A wave with zero-axis symmetry is one which has the same waveform above and below the zero-voltage axis.

c. Quarter-wave symmetry exists if each quarter-wave in a half-cycle is symmetrical.

d. Half-wave symmetry exists when the positive half-cycle is symmetrical to the negative half-cycle.

e. When a waveform has zero-axis symmetry, the d-c component is zero.

f. When a waveform is symmetrical around a voltage axis other than zero, the waveform has a d-c component equal to the voltage at this axis.

g. A waveform that has half-wave symmetry does not have any even-harmonic components.

h. All phase angles in a waveform that has quarter-wave symmetry are equal to zero.

i. The d-c component of the Fourier series is equal to the average voltage of the wave in 1 cycle.

j. The other terms in the Fourier series usually are determined by a harmonic analyzer or a Fourier series graph.

k. An R - C circuit with output taken across C , or an R - L circuit with output taken across R , passes low-frequency harmonics but attenuates high-frequency harmonics. These circuits are known as low-pass filters.

l. An R - C circuit with output taken across R , or an R - L circuit with output taken across L , passes high-frequency harmonics but attenuates low-frequency harmonics. These circuits are known as high-pass filters.

85. Review Questions

- What does the term $15 \sin(100\pi + \frac{\pi}{2})$ mean?
- What is zero-axis symmetry?
- How does half-wave symmetry affect the composition of the wave?
- How is the d-c term in the Fourier series evaluated?

- What two methods are used in practice to determine the coefficients of the harmonic terms of a nonsinusoidal waveform?
- Why is an $R-C$ circuit with output taken across C known as a low-pass filter?
- How does a high-pass filter affect a waveform?
- What is the difference between the transient-response and frequency-response methods of analyzing nonsinusoidal waveforms?

INDEX

	Paragraph	Page
Aperiodic wave.....	3a	1
Back emf:		
Precautionary measure against.....	27	25
Reason for in inductive circuit.....	27a	25
Bandwidth:		
Definition.....	4a	3
Effect on nonsinusoidal wave.....	4	3
Factors determining.....	4d-e	5
For sawtooth wave.....	6	6
Required for highest frequency of pulse.....	5c(3)	6
Required for lowest frequency of pulse.....	5d(2)	6
Basic voltage equation for—		
Capacitance.....	62a	66
Inductance.....	20	17
Capacitance:		
Analogy of, using spring.....	14a	13
Basic equation.....	62a	66
Effect of coupling.....	73b	74
Energy considerations.....	15c	15
Fundamental equations.....	14b	13
Fundamental relationships.....	14b(6)	14
Rate of change.....	14b	13
Response of simple circuit.....	14	12
Critical damping:		
Definition.....	47a	43
Effect of capacitance on.....	47c-d	44-45
Effect of inductance on.....	47b; d	44-45
Effect of resistance on.....	47e	45
Response of R-L-C circuit on.....	47a	43
Critical resistance.....	45c	41
Current in—		
Capacitance circuit.....	14b	13
Inductive circuit.....	13b	11
Resistive circuit.....	12b	10
R-L circuit.....	21b	19
R-L circuit with negative step voltage.....	26c	24
Damping factor.....	50	50
D-c component:		
Definition.....	81b(1)	80
Of square wave.....	81b(2)	80
Of rectangular wave.....	81b(3)	81
D-c restorer:		
Definition.....	73	73
Diode.....	74	74
Effect of coupling capacitor on.....	74	74
Differentiator:		
Components used.....	61	66
Definition.....	59a	65
Effect of resistance on.....	62b	67
Effect of time constant on.....	62c	67
Inductive.....	65	69
Long time constant.....	64	67
Short time constant.....	63	67

	Paragraph	Page
Diode as a d-c restorer	74	74
Energy in—		
Capacitance circuit.....	15c	15
Inductive circuit.....	15b	15
Resistive circuit.....	15a	15
R-L-C circuit.....	46b	42
Field discharge resistor	27e	26
Filter:		
High-pass R-C.....	56	58
Low-pass R-C.....	57	62
Fourier series:		
Amplitude and phase.....	78b	77
Formula used.....	78c	77
For nonsinusoidal periodic wave.....	78d	77
Graphs for sawtooth wave.....	81c(2)	81
Graphs for square wave.....	81c(1)	81
Graphs for triangular wave.....	81c(3)	81
Fourier theorem	78a	77
Frequency of oscillatory circuit:		
Effect of resistance.....	49b	49
Equations governing.....	49b	49
Theory.....	49	49
Frequency response method:		
Definition.....	77	77
Of R-C and R-L circuit.....	82	81
Harmonic:		
Composition, of sawtooth.....	3c(2)	3
Composition, of square wave.....	3d(1)	3
Definition.....	3b	1
Effect of even harmonics on symmetry of waveform.....	80b	79
Effect of odd harmonics on symmetry of waveform.....	80c	79
Effect of zero-axis symmetry on composition of.....	80a	79
Effect on pulse-duration time.....	5d	6
Effect on pulse rise and decay time.....	5c	5
Inductance:		
Analogy of, using truck.....	13a	10
Basic equation.....	65a	69
Energy considerations.....	15b	15
Fundamental equations.....	13b	11
Fundamental relationships.....	13b(4)	12
Response of simple circuit.....	13	10
Inductive differentiator:		
Effect of time constant on.....	65c	69
Need for resistance in.....	65b	69
Short time constant.....	66	70
Time constant equal to one-half of pulse rise time.....	67	70
Input:		
To differentiator.....	59b	65
Sawtooth, to differentiator.....	60a	65
Sine wave, to differentiator.....	59c	65
Integrating circuit:		
Definition.....	68	70
Time constant equal to pulse-duration time in.....	71	72
Time constant long compared to duration time.....	70	72
Types.....	69	71
Kirchhoff's law	20a	17

Low pass filter:		
Current	57	62
Effect of large time constant	57d	64
Effect of short time constant	57b	63
Effect of time constant equal to pulse rise time	57c	63
Nonsinusoidal wave:		
Definition	1	1
Methods of analyzing	2b	1
Oscillatory response:		
Cause	45b	40
Definition	45a	40
Description	48b	46
In R-L-C circuit	48	46
Output:		
Of differentiator	59b	65
Of integrator	68b	71
Sawtooth, of differentiator	60a	65
Sine wave, of differentiator	59c	65
Waveforms of integrator	68b	71
Overshoot	47e	45
Periodic pulses	56d	61
Periodic waves	3a	1
Pulse:		
Definition	5a	5
Effect of harmonics on rise and decay time	5c	5
Effect of harmonics on duration time	5d	6
Rate of current change in—		
Capacitive circuit	14b (2)	13
Inductive circuit	13b	11
Oscillatory circuit	48	46
R-C circuit with negative step voltage	39	35
R-C circuit with positive step voltage	34	30
R-C high-pass filter	56	58
Resistive circuit	12b	10
R-L circuit with negative step voltage	26c	24
R-L circuit with positive step voltage	34	30
When waveshape is other than rectangular	29	27
R-C circuits:		
Basic voltage equation	33c	30
Description of	34b	31
Effect of capacitance on	36a	32
Effect of resistance on	36b	33
Effect of time constant on	36c	33
Negative step voltage applied	39	35
Positive step voltage applied	34	30
Time constant	35	32
Types	55	55
Rectangular pulse:		
Definition	54	54
Effect of time constant	55	55
Resistance:		
Energy considerations	15a	15
Ohm's law	12b	10
Resonance	44	40
Response of simple circuit	12a	9
R-L circuit:		
As an inductive differentiator	65	69
Basic voltage equation	20	17
Description	21b	19
Effect of inductance in	23a	21

	Paragraph	Page
R-L circuit—Continued		
Effect of resistance in.....	23b	21
Effect of time constant in.....	23c	21
Energy considerations.....	25	23
Response to negative step voltage.....	26	23
Response to positive step voltage.....	21	18
Step-by-step procedure.....	28	26
Time constant.....	22a	20
R-L-C circuit:		
Amplitude of sine wave without R.....	50a	50
Analogy of pendulum and resistance.....	47e(2)	45
Critical damping.....	47a	43
Critical resistance.....	45e	41
Effect of damping.....	50b(2)	50
Effect of resistance.....	50b	50
Energy.....	46b	42
Forms of response.....	45	40
Oscillatory response.....	48	46
Single-surge response.....	46	41
Time constant.....	47a	43
Sawtooth:		
Bandwith requirements.....	6	6
Composition.....	3c	3
Single-surge response:		
Definition.....	45b	40
Of R-L-C circuit.....	46	41
Square wave:		
Applied to R-C circuit.....	55b	55
Applied to R-L circuit.....	55c	57
Composition.....	3d	3
D-c component.....	81b(2)	80
Steady-state:		
Definition.....	9a	9
Of periodic pulse.....	56d(4)	62
Step-by-step procedure:		
For determining response of R-C circuit.....	34	30
For determining response of R-L circuit.....	28	26
For pulses other than rectangular.....	41	37
Step voltage:		
Comparison with rectangular pulse.....	19	17
Definition.....	19	17
Step voltage negative:		
Description of R-C circuit with.....	39b-c	35-36
Description of R-L circuit with.....	26c	24
Response of R-C circuit to.....	39	35
Response of R-L circuit to.....	26	23
Step voltage positive:		
Applied to oscillatory circuit.....	48	46
Description of R-C circuit with.....	34b	31
Description of R-L circuit with.....	21	18
Response of R-C circuit to.....	34	30
Response of R-L circuit to.....	21	18
Symmetry:		
Analysis from.....	80d	80
Effect of zero-axis.....	80c-d	79-80
Mirror.....	79d	78
Quarter-wave.....	79c	78
Zero-axis.....	79b	78
Time constant L/R:		
Definition.....	22b	21
Effect of inductance on.....	23a	21

Time constant L/R—Continued

18	Effect of resistance on	23b	21
19	Physical meaning	53	54
20	Significance	26d	25
21	Steady state expressed in	23c(3)	21
Time constant R-C:			
22	Definition	35b	32
23	Effect of capacitance on	36a	32
24	Effect of resistance on	36b	33
25	Effect on high-pass filter	56e	62
26	Physical meaning	53	54
27	Significance	39d	37
Transient:			
28	Definition	11a	9
29	Types	11	9
Transient response:			
30	Basic principles	12a	9
31	Definition	9b	9
32	Purpose of study	10	9
33	Unit step voltage	18	17
Universal time constant chart L/R:			
34	Description	24a	21
35	Energy considerations from	25	23
36	Practical application	24b	22
Universal time constant chart R-C:			
37	Description	37	33
38	Energy considerations from	38	34
39	Practical applications	37b	33
Waveforms:			
40	Amplitude of harmonic	3e	3
41	In capacitive circuit	14b(6)	14
42	In inductive circuit	13b(2)	11
43	In resistive circuit	12b(2)	10