

54 AFDELING VELDARTILLERIE

TECHNICAL MANUAL

T7-391

(FURNISHED IN LIEU OF TM - II - 5038)

CONTROL GROUP AN/GRA-6-FR

GEREGISTREERD
13 OCT. 1958
HKGS-STAF ADJ. GEN.

FRENCH PRODUCTION

Le Matériel Téléphonique

46-47, Quai de Boulogne - BOULOGNE-BILLANCOURT (Seine) FRANCE

JANUARY 1956

TECHNICAL MANUAL

(FURNISHED IN LIEU OF TM - 11 - 5038)

CONTROL GROUP AN/GRA-6-FR

FRENCH PRODUCTION

Le Matériel Téléphonique

46-47, Quai de Boulogne - BOULOGNE-BILLANCOURT (Seine) FRANCE

JANUARY 1956

CONTENTS

CHAPTER 1. INTRODUCTION	Paragraph	Page
Section I. General		
I. Purpose	1	1
II. Scope and limits	2	1
Section II. Description and data		
I. Project and contract	3	1
II. Applications	4	1
III. Technical specifications	5	3
IV. Field of competence	6	4
V. Packaging data	7	3
VI. Additional equipment required	8	3
VII. Description of major components	9	6
VIII. Description of minor components	10	8

The text of this manual has been revised exactly to reflect the production of the control group AN/GRA-6-FR made by the French Company

LE MATERIEL TELEPHONIQUE PARIS - FRANCE

CHAPTER 2. INSTALLATION	Paragraph	Page
Section I. Service upon receipt of equipment		
I. General	11	10
II. Unpacking instructions	12	10
III. Installation of Remote Control C-455/GRC	13	10
IV. Installation of Local Control C-454/GRC	14	11
V. Installation of accessories	15	13
Section II. Presencing and initial adjustments		
I. Preparatory checks and adjustments	17	14
II. Check of telephone circuit	18	14
III. Filling in wire-in breaks on remote control bar	19	15
IV. Checking telephone line connections	20	15
V. Service upon receipt of used or refurbished equipment	21	16

CHAPTER 3. OPERATING INSTRUCTIONS	Paragraph	Page
Section I. Controls and instruments		
I. Hand controls and facilities	22	17
II. Control groups, Local Control C-454/GRC and Remote Control C-455/GRC	23	18

CONTENTS

CHAPTER 1. INTRODUCTION.

Section I. General.

	Paragraph	Page
Scope	1	1
Forms and records	2	1

II. Description and data.

Purpose and use	3	1
Application	4	1
Technical characteristics	5	3
Table of components	6	4
Packaging data	7	5
Additional equipment required	8	5
Description of major components	9	6
Description of minor components	10	9
Running spares	11	9

CHAPTER 2. INSTALLATION INSTRUCTIONS.

Section I. Service upon receipt of materiel.

General	12	10
Unpacking instructions	13	10
Installation of Remote Control C-433/GRC	14	10
Installation of Local Control C-434/GRC	15	11
Installation of accessories	16	13

II. Presetting and initial adjustments.

Preparatory checks and adjustments	17	14
Check of telephone circuit	18	14
Filling in write-in blanks on remote control unit	19	15
Checking telephone line connections	20	15
Service upon receipt of used or reconditioned equipment	21	16

CHAPTER 3. OPERATING INSTRUCTIONS.

Section I. Controls and instruments.

Panel controls and facilities	22	17
Internal controls, Local Control C-434/GRC and Remote Control C-433/GRC	23	18

CONTENTS

	<i>Paragraph</i>	<i>Page</i>
<i>Section II.</i> Operation under usual conditions.		
Preliminary starting procedures	24	19
Modes of operation	25	19
Telephone communication, with ringing, between control units	26	19
Push-to-talk operation from Remote Control C-433/GRC	27	19
Push-to-talk operation from Local Control C-434/GRC	28	20
Monitoring operations at Local Control C-434/GRC	29	21
Monitoring operations at Remote Control C-433/GRC	30	21
Break-in operation	31	21
Stopping procedure	32	22
<i>III.</i> Operation under unusual conditions.		
General	33	22
Operation in arctic climates	34	22
Operation in tropical climates	35	23
Operation in desert climates	36	23
CHAPTER 4. ORGANIZATIONAL MAINTENANCE INSTRUCTIONS.		
<i>Section I.</i> Organizational Tools and Equipment.		
General	37	24
Tools, materials, and equipment for organizational maintenance	38	24
<i>II.</i> Preventive maintenance services.		
Definition of preventive maintenance	39	24
General preventive maintenance techniques	40	24
Performing preventive maintenance	41	24
<i>III.</i> Trouble shooting at organizational maintenance level.		
Scope	42	25
Visual inspection	43	25
Equipment Performance Checklist	44	26
CHAPTER 5. THEORY OF CONTROL GROUP AN/GRA-6.		
General	45	29
Basic circuit elements	46	29
Telephone circuit	47	30

CONTENTS

	<i>Paragraph</i>	<i>Page</i>
Ringling circuits	48	30
Purposes of radio set control	49	31
Relays	50	32
Remote control of Set 1 with control of power from radio set	51	32
Audio signal paths with remote control of Set 1 transmission	52	34
Remote control of Set 2 with control of power at radio set	53	35
Audio signal paths with remote control of Set 2 transmission	54	35
Remote control of either Set 1 or Set 2 with power control at radio set	55	36
Remote control of Set 1 with remote control of radio set power	56	37
Audio signal paths with remote control of radio set power and Set 1 transmission	57	37
Remote control of Set 2 with remote control of radio set power	58	39
Audio signal paths with remote control of radio set power and Set 2 transmission	59	39
Local push-to-talk operation of Set 1 with power control at radio set	60	39
Local push-to-talk operation of Set 2 with control of power at radio set	61	40

CHAPTER 6. FIELD MAINTENANCE INSTRUCTIONS.

Section I. Trouble shooting at field maintenance level.

Trouble-shooting procedures	62	41
Test equipment and tools required for trouble shooting	63	41
Checking key circuits for shorts	64	42
Checking of Handset H-33/PT	65	43
Test set-up for operational checks	66	43
Purpose and use of operational check chart	67	44
Operational check chart	68	45
Localization checks for Remote Control C-433/GRC	69	50
Localization checks for Local Control C-434/GRC	70	51
Check of alternate wiring	71	55
Miscellaneous component data	72	56

II. Repairs.

Repair procedures	73	56
Disassembly of Remote Control C-433/GRC for inspection, cleaning, and repair ..	74	56
Disassembly of Local Control C-434/GRC for inspection, cleaning, and repair	75	57
General inspection of chassis	76	57

CONTENTS

	<i>Paragraph</i>	<i>Page</i>
Cleaning	77	58
Replacement of parts	78	58
Special repair procedures	79	58
Local Control C-434/GRC	80	59
Reassembling the equipment	81	59
Disassembly and replacement of handset parts	82	60
Disassembly procedure for Generator G-25 (*)/PT.....	82.1.	61
<i>Section III.</i> Lubrication and weatherproofing.		
Lubrication	83	64
Weatherproofing and rustproofing	84	64
Refinishing	85	64
<i>IV.</i> Final tests.		
General	86	64
Return of Control Group AN/GRA-6 to service	87	64
CHAPTER 7. SHIPMENT AND LIMITED STORAGE AND DEMOLITION TO PREVENT ENEMY USE.		
Repacking for shipment or limited storage	88	65
Demolition of materiel to prevent enemy use	89	65
APPENDIX I. REFERENCES		66
APPENDIX II. IDENTIFICATION TABLE OF PARTS		72
INDEX		83

ARTIFICIAL RESPIRATION

GENERAL PRINCIPLES

1. Second person should be on the left side of the victim. Don't take time to move the victim unless you are sure that the victim is not breathing. Start respiration as soon as you can. Start with the mouth-to-mouth method.

2. Place the victim's body in a prone position so that any fluids with drainage from the respiratory passages will drain out of the mouth and nostrils. The head should be extended and turned slightly to the right. The chin should be raised to the position of the respiratory passages.

3. Remove any fluid of debris from the mouth with your fingers. Turn the victim's tongue to the left.

4. Begin artificial respiration. Breathe in deeply and without any interruption until the breathing starts of the victim is pronounced. Try to keep the airway unobstructed. If the victim is not breathing, continue.

5. When the victim starts breathing or when artificial help is available, loosen the clothing around the neck. Keep the victim warm. Check around the victim and remove any debris. Don't interrupt the respiration until the victim is pronounced dead.

6. When the victim is breathing, keep your mouth closed. Don't let air escape to breathe. Don't let the victim breathe through your mouth. Keep him lying down with his head on a pillow. Don't let him sit up.

7. Don't let the victim breathe through your mouth. Don't let the victim breathe through your mouth. Don't let the victim breathe through your mouth. Don't let the victim breathe through your mouth.

BACK PRESSURE AND LIFT METHOD

1. Position of victim. Place the victim in the prone (face-down) position. Bend his elbow; place one hand upon the other. Turn his face to one side, placing his cheek upon his hand.

2. Position of operator. Kneel on your left or right knee, at the victim's head, facing him. Your knee

should be at the side of the victim's head close to his forehead. Your knee should be bent at a right angle. Your feet should be on each side of the victim's head. Your feet should be on the feet of the victim. Your feet should be on the feet of the victim. Your feet should be on the feet of the victim.

3. Compression. Rock forward until your arms are approximately vertical and allow the weight of the upper part of your body to exert a slow steady pressure against the victim's chest. Your hands should be on the lower part of the victim's chest, just above the navel.

WARNING

4. Respiration. Push against the pressure, and any fluid that may be in the mouth should be removed. Push against the pressure, and any fluid that may be in the mouth should be removed. Push against the pressure, and any fluid that may be in the mouth should be removed.

HIGH VOLTAGE

is used in the operation of this equipment.

DEATH ON CONTACT

may result if operating personnel fail to observe safety precautions.

Don't bend backward. As you look backward, the victim's arms will be drawn toward you. The arms will expand the chest by pulling on the chest wall, thus acting on the back and reducing the weight on the chest. Turn the arms gently to the ground as you look forward. See C and D.

5. Check the rhythm of the victim. The rhythm of the victim's heart should be checked every 15 to 20 seconds. Use a stethoscope to check the rhythm. The rhythm of the victim's heart should be checked every 15 to 20 seconds. Use a stethoscope to check the rhythm.

6. Check the position of the victim. (a) Respiration. Don't let the victim breathe through your mouth. Don't let the victim breathe through your mouth. Don't let the victim breathe through your mouth.

(b) If you are and another person is available, you can make a trial. Be careful not to break the rhythm in changing. Move to one side and let your replacement come in from the other side. Your replacement should be in the "prone" position after one of the "prone" positions, as you move away.

ARTIFICIAL RESPIRATION

GENERAL PRINCIPLES

1. Seconds count! Begin at once! Don't take time to move the victim unless you must. Don't loosen clothes, apply stimulants or try to warm the victim. Start resuscitation! Get air in the lungs! You may save a life!

2. Place the victim's body in a prone position, so that any fluids will drain from the respiratory passages. The head should be extended and turned sideward *never flexed forward*; the chin shouldn't sag, since obstruction of the respiratory passages may occur.

3. Remove any froth or debris from the mouth with your fingers. Draw the victim's tongue forward.

4. Begin artificial respiration. Continue it rhythmically and without any interruption until natural breathing starts or the victim is pronounced dead. Try to keep the rhythm smooth. Split-second timing is not absolutely essential.

5. When the victim starts breathing, or when additional help is available loosen the clothing; remove it, if it's wet; keep the victim warm. Shock should receive adequate attention. Don't interrupt the rhythmical artificial technique for these measures. Do them only when you have help or when natural breathing has started.

6. When the victim is breathing, adjust your timing to assist him. Don't fight his efforts to breathe. Synchronize your efforts with his. After resuscitation, keep him lying down until seen by a physician or until recovery seems certain.

7. Don't wait for mechanical resuscitation! If an approved model is available, use it, but, since mechanical resuscitators are only slightly more effective than properly performed "push-pull" manual technique, *never* delay manual resuscitation for it.

BACK-PRESSURE ARM LIFT METHOD

1. *Position of Victim.* Place the victim in the prone (face-down) position. Bend his elbows; place one hand upon the other. Turn his face to one side, placing his cheek upon his hands.

2. *Position of Operator.* Kneel on your left or right knee, at the victim's head, facing him. Your knee

should be at the side of the victim's head close to his forearm, your foot should be near his elbow. Kneel on both knees if you find it more comfortable, with one knee on each side of the head. Place your hands on the flat of the victim's back so that their heels are just below the lower tip of his shoulder blades. With the tip of your thumbs touching spread your fingers downward and outward. (See A)

3. *Compression Phase.* Rock forward until your arms are approximately vertical and allow the weight of the upper part of your body to exert a slow, steady, even, downward pressure upon your hands. This forces air out of the lungs. Keep your elbows straight and press almost directly downward on the back. (See B)

4. *Expansion Phase.* Release the pressure, avoid any finish thrust, and commence to rock backward slowly. Place your arms upon the victim's arms just above the elbows, and draw his arms upward and toward you. Apply just enough lift to feel resistance and tension at the victim's shoulders.

Don't bend your elbows. As you rock backward, the victim's arms will be drawn toward you. (The arm lift expands the chest by pulling on the chest muscles, arching the back and relieving the weight on the chest.) Drop the arms gently to the ground or floor. This completes the cycle. (See C and D). Now repeat the cycle.

5. *Cycle Timing and Rhythm.* Repeat the cycle 10 to 12 times per minute. Use a steady uniform rate of Press, Release, Lift, Release. Longer counts of about equal length should be given to the "Press" and "Lift" steps of the compression and expansion phases. Make the "Release" periods of minimum duration.

6. *Changing Position or Operator.*

(a) Remember that you can use either or both knees or can shift knees during the procedure, provided you don't break the rhythm. Observe how you rock forward with the back-pressure and backward with the arm-lift. The rocking motion helps to sustain the rhythm and adds to the ease of operation.

(b) If you tire and another person is available, you can "take turns." Be careful not to break the rhythm in changing. Move to one side and let your replacement come in from the other side. Your replacement begins the "Press-Release" after one of the "Lift-Release" phases, as you move away.

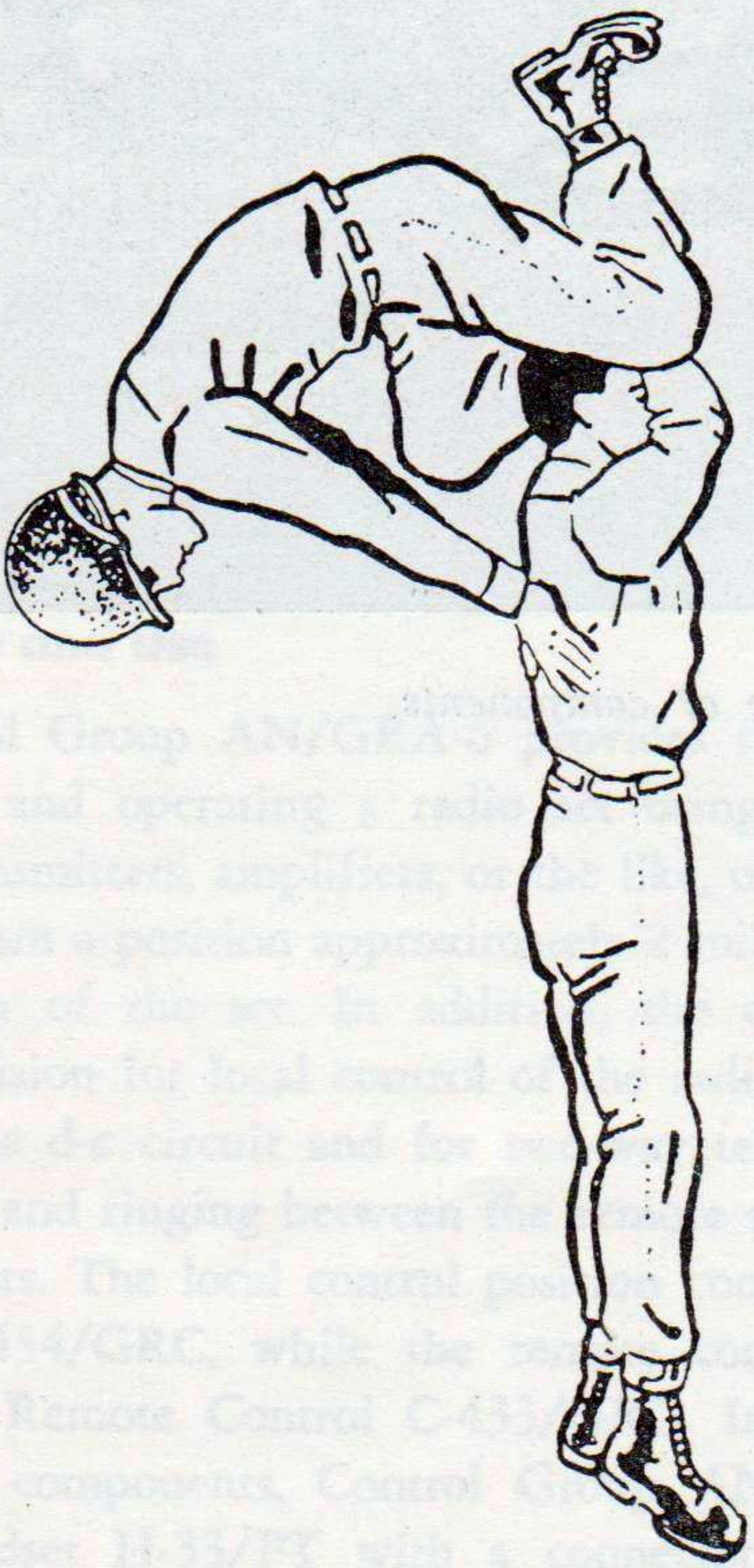

A Position of operator and victim

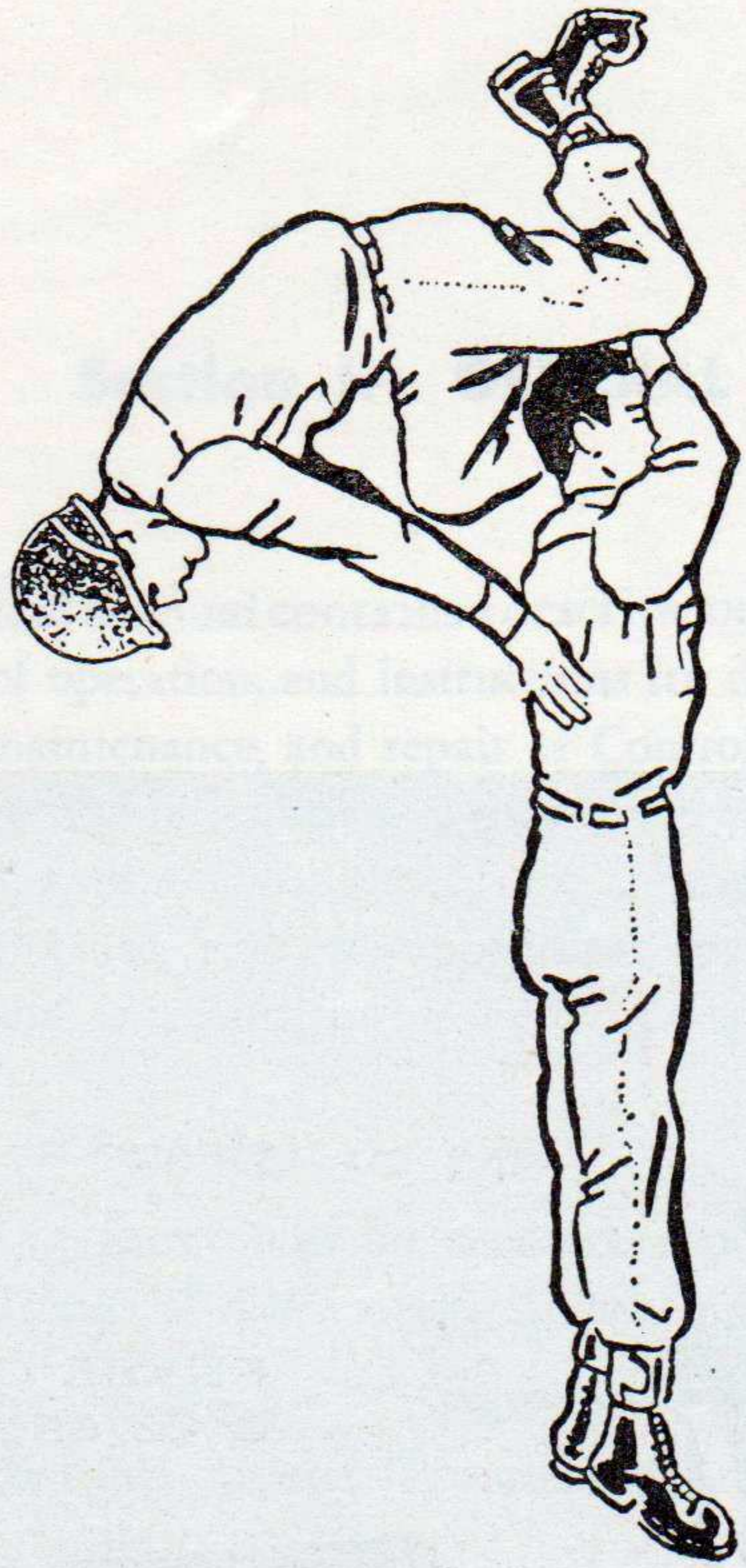

B Compression phase

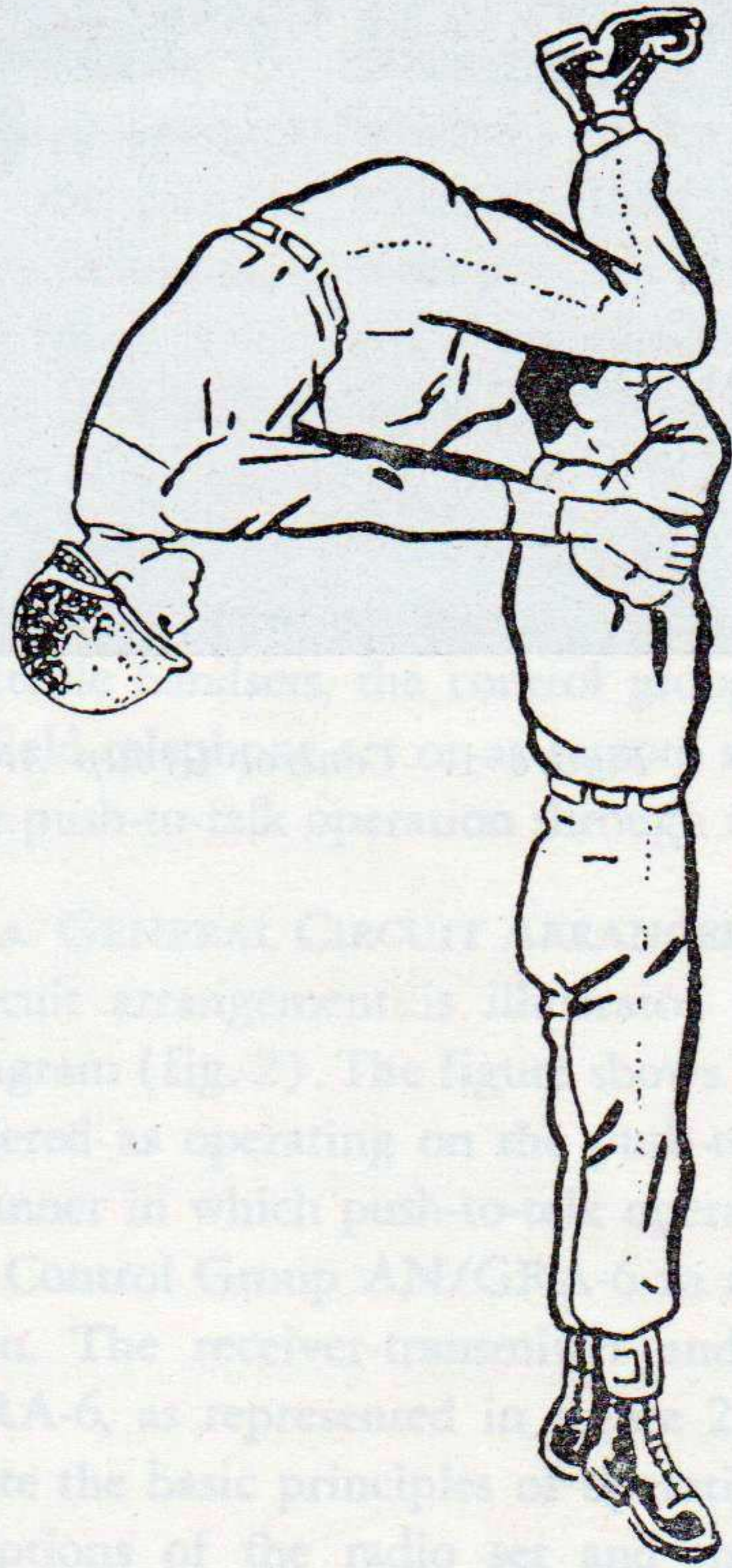

C Expansion phase (arm lift)

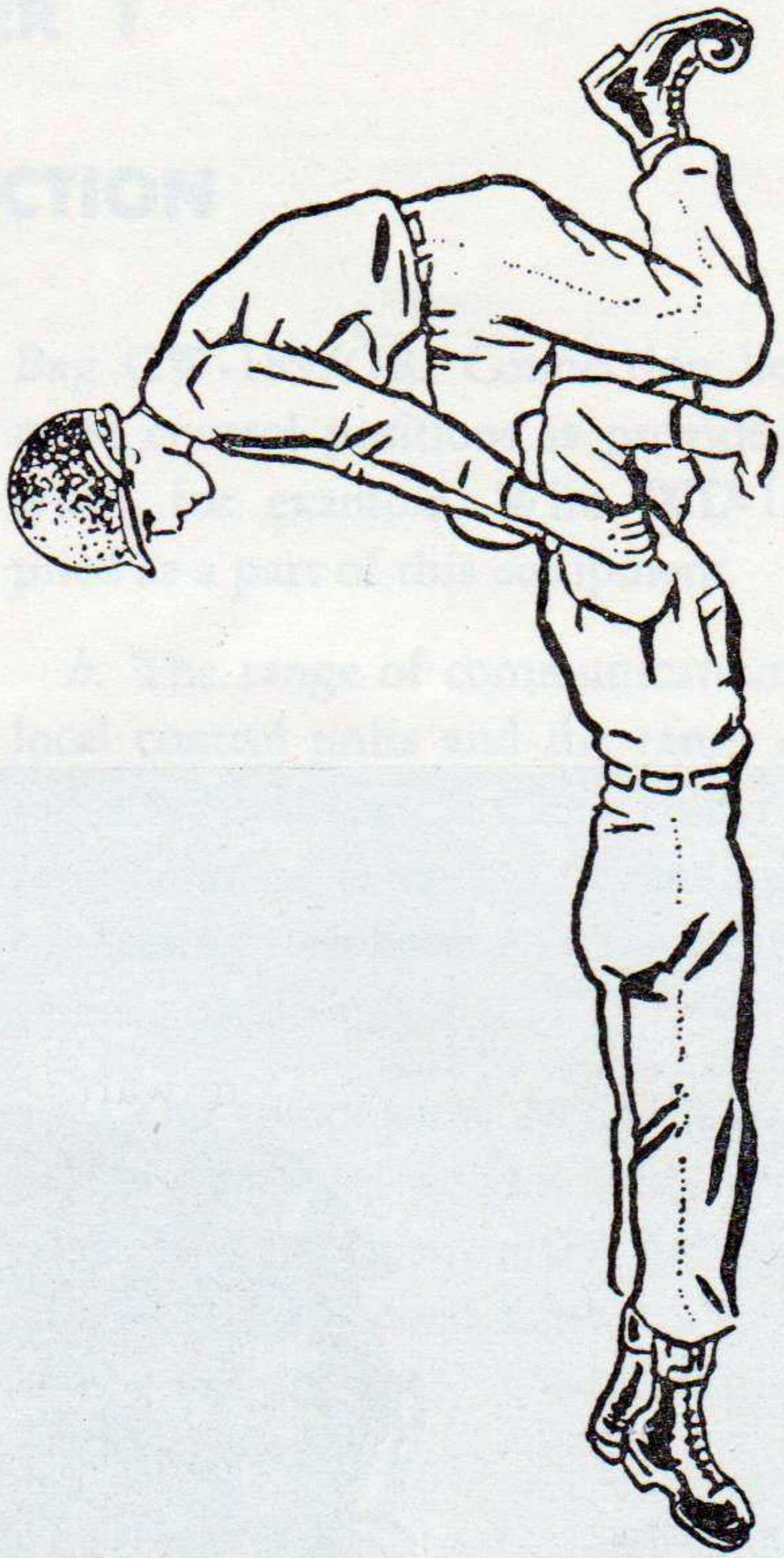

D Expansion phase (arm release)

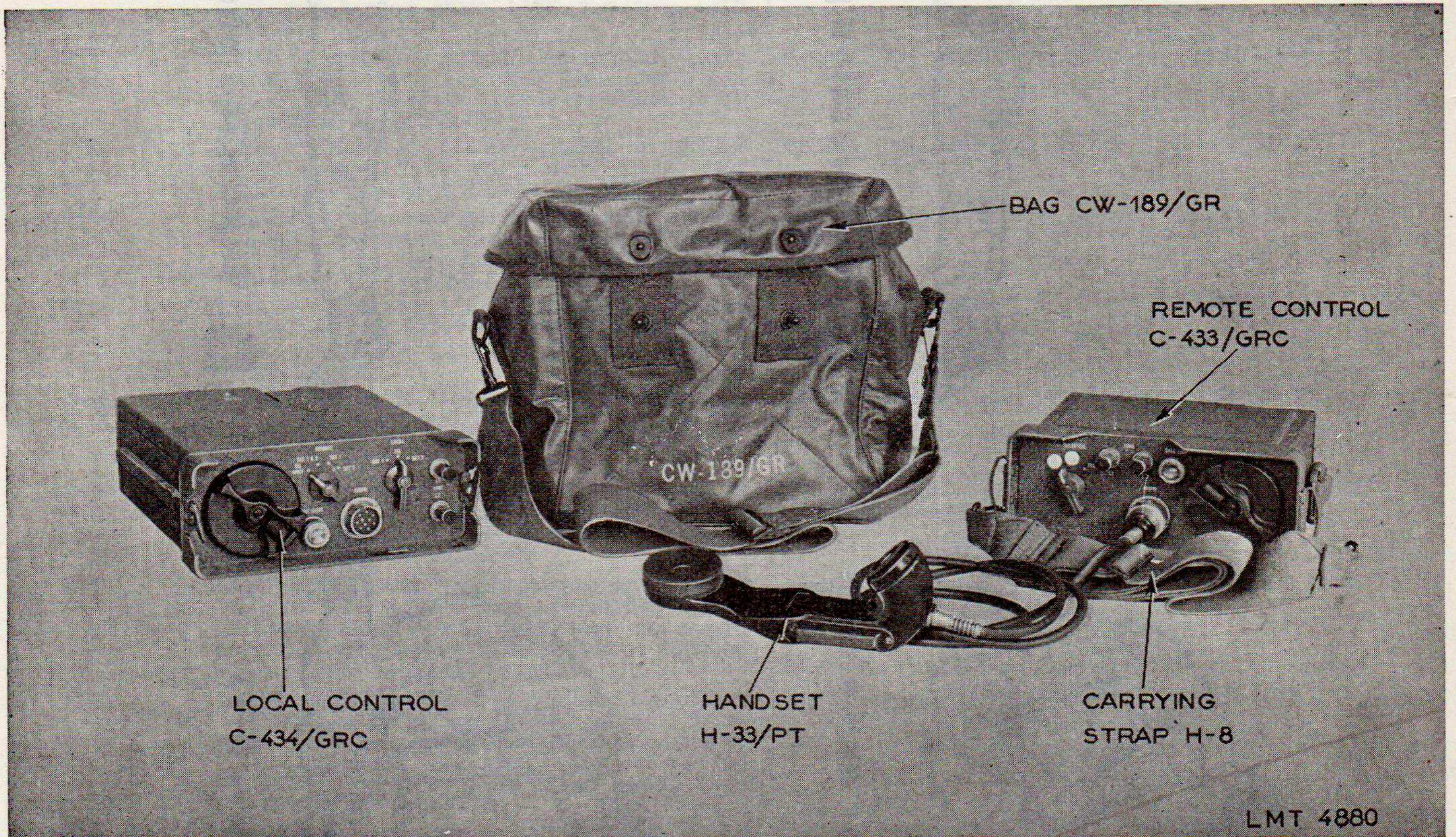

Figure 1. Control Group AN/GR-6, over-all view of components.

CHAPTER 1

INTRODUCTION

Section I. GENERAL

1. Scope

This Technical Manual contains a description, a chapter on the theory of operation, and instructions for the installation, operation, maintenance, and repair of Control Group AN/GRA-6 (fig. 1). In addition, a chapter on the disassembly and repacking of the equipment for shipment or limited storage is included, and two appendixes covering a list of references and an identification table of parts.

2. Forms and Records

The following forms will be used for reporting unsatisfactory conditions of Army materiel and equipment.

a. DD Form 6, Report of Damaged or Improper Shipment, will be filled out and forwarded as prescribed in SR 745-45-5.

b. DA AGO Form 468, Unsatisfactory Equipment Report, will be filled out and forwarded to the Office of the Chief Signal Officer as prescribed in SR 700-45-5.

c. DA AGO Form 419, Preventive Maintenance Checklist for Signal Corps Equipment, will be prepared in accordance with instructions on the back of the form.

d. Use other forms and records as authorized.

Section II. DESCRIPTION AND DATA

3. Purpose and Use

a. Control Group AN/GRA-6 provides the means for controlling and operating a radio set using one or two receiver-transmitters, amplifiers, or the like, of the push-to-talk type from a position approximately 2 miles away from the location of the set. In addition, the control group makes provision for local control of the radio set through a continuous d-c circuit and for two-way telephone communication and ringing between the remote and local control operators. The local control position consists of Local Control C-434/GRC, while the remote control position consists of Remote Control C-433/GRC. In addition to these basic components, Control Group AN/GRA-6 includes Handset H-33/PT with a connector plug and a push-to-talk switch, and a carrying or storing container,

Bag CW-189/GR. Connection between the local and remote control positions is provided by a pair of telephone wires, for example, Wire WD-1/TT which is not supplied as a part of this equipment.

b. The range of communication between the remote and local control units and the range of remote control of the radio set is at least 2 miles. Under favorable conditions, the range may be extended, depending on the condition of the connecting telephone line, the weather, and local noise interference conditions.

c. The components of the control group are small, compact and light in weight. Waterproof construction and fungiproofing treatment make the units suitable for use under adverse climatic conditions.

4. Application

Normally, Control Group AN/GRA-6 is intended for operation with a radio set or sets using one or two receiver-transmitters of the push-to-talk type, for which push-to-talk operation from a remote position is to be provided. In such application, the remote control is carried about by the remote operator by means of the shoulder strap provided for this purpose, while the local control unit is connected directly to the radio set panel by cables, or through a mounting which is designed to accommodate the unit. Interconnection between the remote and local control units is made by a two-wire telephone line. When the two control units are powered with plug-in dry batteries, for which compartments are provided in each unit, and are equipped with suitable handsets, the control group may be used as either a field telephone set or as remote and local control stations for push-to-talk operation through the radio set.

a. GENERAL CIRCUIT ARRANGEMENT (fig 2). A general circuit arrangement is illustrated in the simplified block diagram (fig. 2). The figure shows a radio set, which is considered as operating on the push-to-talk principle, and the manner in which push-to-talk operation is extended by way of Control Group AN/GRA-6 to a remote operating position. The receiver-transmitter and Control Group AN/GRA-6, as represented in figure 2, are simplified to illustrate the basic principles of operation. Detailed circuit descriptions of the radio set and the operation of Control Group AN/GRA-6 with the radio set are given in the instruction book for the particular set.

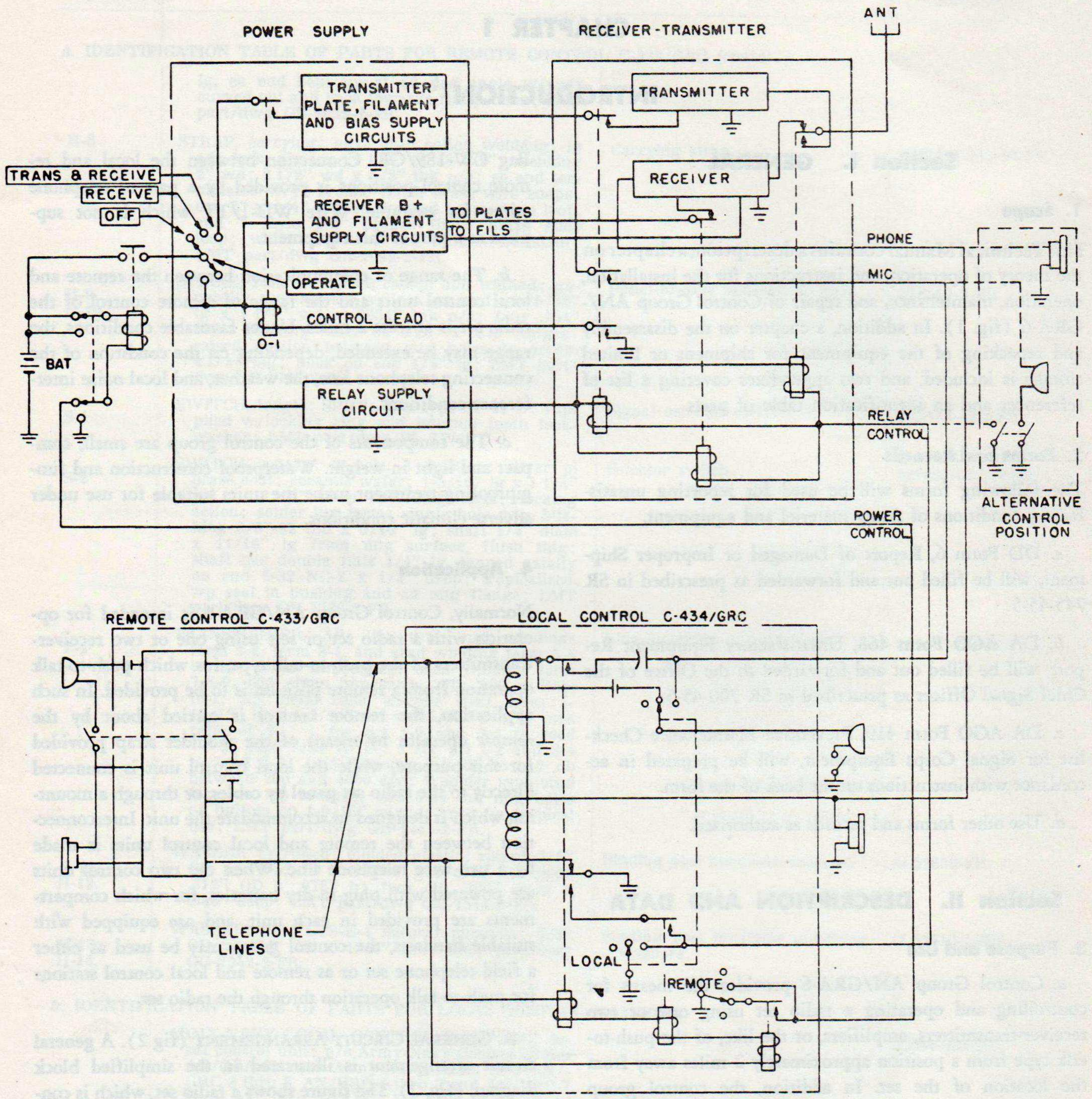

Figure 2. Control Group AN/GRA-6, system application, functional block diagram.

(1) Although Control Group AN/GRA-6 may be operated in conjunction with radio sets using either one or two receiver-transmitters, the basic principles of operation of the control group are shown in figure 2 as applied to a single receiver-transmitter. To provide push-to-talk operation of either one or two receiver-transmitters from the remote position, the control facilities are duplicated for each receiver-transmitter by additional switch positions and relay contacts.

(2) The radio set indicated in figure 2 consists of a receiver, a transmitter, a power supply, and includes a push-to-talk control circuit. Normally, this control circuit of the receiver-transmitter is de-energized since ground return for the relays is open. Under this condition, the receiver is operative and the received signals can be heard by both the local and the remote operators or by neither, depending upon the setting of the control switches of the local operator.

(3) Push-to-talk operation is used when an operator wants to talk over the radio set. By referring to the microphone circuit shown connected directly to the receiver-transmitter (fig. 2), it is seen that closure of the microphone push-to-talk switch completes the ground return connection for the receiver-transmitter relay circuits. These relays become energized, and power is supplied to the transmitter. The transmitter becomes operative and ready to transmit a message, while the receiver becomes inoperative and unable to receive a message.

b. SWITCHING CIRCUIT ARRANGEMENT. Control Group AN/GRA-6 provides the push-to-talk operation from either the local position or the remote position. The local operator sets the REMOTE switch to prepare the connection between the receiver-transmitter and the remote operator. The circuit thus prepared is placed under the control of the push-to-talk and SELECTOR switches of the remote operator. When the remote push-to-talk switch is closed, dc (direct current), which is provided by a battery in the remote unit, flows through the control relays in the local unit, causing these relays to operate. Results which may be accomplished by switching are as follows:

(1) The talking circuit from the remote position may be extended through the local control relay contacts to the transmitter input circuit. The listening circuit to the remote operator is broken.

(2) The ground return connection for the relays in the receiver-transmitter may be completed by pressing the push-to-talk switch, thereby operating the relays. These relays operate and connect the power and the antenna to the transmitter.

(3) By releasing the push-to-talk switch, the remote operator removes the control voltage from the line, de-energizing the control circuits at the local unit and thus returning the receiver-transmitter to the receiving con-

dition. However, the setting of the control switches and the latching arrangement provided on the local control relays insure that the receiver-transmitter will remain connected to the remote operator. Thus, alternate talking and reception without further assistance of the local operator is possible.

(4) Means are provided for releasing the connection between the receiver-transmitter and the remote operator. This is done by reversing the polarity of the control voltage transmitted from the remote control unit to the local control unit by means of the SELECTOR and the push-to-talk switches of the remote operator.

(5) The REMOTE switch on the local control unit permits the operator at that unit to break the connection between the remote operator and the receiver-transmitter at any time. Then, he may take control of either one of the two receiver-transmitters or complete the telephone circuit between himself and the remote operator. This function is referred to as *break-in* operation.

(6) Twenty-cycle ringing from either end of the circuit to the other is possible. For this purpose, a 20-cycle hand-cranked magneto generator is provided as a ringing source and a bell and a lamp are provided as the ringing signal receiving devices. A switch within each unit permits the selection of either one of the two modes of ringing signal reception.

c. LOCAL PUSH-TO-TALK ARRANGEMENT. The facilities provided to the remote operator for push-to-talk operation of either one of the two receiver-transmitters are duplicated at the local control unit. For this purpose, switch contacts duplicating the relay contact connections are provided. Therefore, the local control unit may be used independently of the remote control unit to provide selection of push-to-talk operation over either one of two receiver-transmitters of the installation.

d. OTHER SYSTEM APPLICATIONS. More complex systems than the one illustrated in the block diagram involve the use of two receiver-transmitters with the possible addition of a guard receiver, an interphone amplifier, and a number of control positions in the interphone circuit. For detailed information concerning operation of the various systems with which the Control Group AN/GRA-6 is used, reference should be made to the instruction book for the particular system.

5. Technical Characteristics

a. OVER-ALL EQUIPMENT.

Types of operationDuplex telephone communication with ringing between local and remote control positions. Push-to-talk operation and power con-

Control of radio sets, where applicable, from either the local or remote positions.

Types of signals transmitted ..Voice and 20-cycle ringing and d-c control voltage from remote control unit.

Range of communication2 miles (with Wire WD-1/-TT), approximately.

Terminal impedances:

Line 600 ohms (balanced).

Microphone 150 ohms.

Receiving600 ohms (balanced or unbalanced, depending upon circuit selections).

Remote control line voltage 24 to 45 volts dc.

b. REMOTE CONTROL C-433/GRC.

Microphone supply source ...3 volts dc provided by two Batteries BA-30.

Ringing source20-cycle, hand-cranked, magneto generator.

Ringing signal receiving facilitiesChoice of bell or neon glow lamp (by means of internal switch).

Remote control power source45-volt Battery BA-414/U, plug-in type.

Over-all dimensions3½ inches x 8¼ inches x 7-3/32 inches.

Over-all weight7 pounds, approximately, including batteries.

c. LOCAL CONTROL C-434/GRC.

Microphone supply source ...3 volts dc provided by two plug-in type Batteries BA-30.

Ringing source20-cycle, hand-cranked, magneto generator.

Ringing signal receiving facilitiesChoice of bell or neon glow lamp.

Local control facilitiesSwitching provided to permit local selection of duplex telephone operation or push-to-talk operation over

either one of two receiver-transmitters.

Connecting facilitiesArranged for plug-in connection in radio sets using Mounting MT-297/GR or Mounting MT-298/GR, or for connection to panel receptacles of radio sets not using these mountings, or equivalents.

Over-all dimensions3½ inches x 8-9/16 inches x 10-1/8 inches.

Over-all weight10.5 pounds, approximately, including batteries.

d. HANDSET H-33/PT.

TypeTelephone with push-to-talk switch.

Connecting facilities5-foot interconnection cord terminated in a 10-pin waterproof plug with male terminals.

Microphone elementCarbon type, 40 ohms impedance.

Receiving elementNavy type CW-49505, 300 ohms impedance.

e. RINGING GENERATOR.

Ringing generator output level at line terminals of Remote Control C-433/GRC1.8 watts into 1,500 ohms, 100 volts minimum with open circuit.

20-cycle voltage required at line terminals of Local Control C-434/GRC:

To energize bell45 volts rms, 15 ma (milliamperes) maximum.

To energize CALL LIGHT ...50 volts rms (root mean square).

6. Table of Components (figs. 1 and 4 through 9)

A table of components of Control Group AN/GRA-6 is presented below. All dimensions and weights are approximate. The table includes basic components only. For placing the equipment in operation, the additional equipment listed in paragraph 8 is also required.

Component	Required No.	Height (in.)	Depth (in.)	Length (in.)	Volume (cu ft)	Unit weight (lb)
Local Control C-434/GRC	1	3½	10⅞	8-9/16	.17	10½
Remote Control C-433/GRC	1	3½	7-3/32	8¼	.12	7
Handset H-33/PT	1	2-3/64	3	7⅞	.03	1⅞
Bag CW-189/GR	1	11	7¾	10⅞	.52	2⅞
Running spares	1 set	—	—	—	0.1	0.1
Total					.85	20.85

Note. This list is for general information only. See the appropriate supply publications for information pertaining to the requisitioning of spare parts.

7. Packaging Data

Two sets of the basic components of Control Group AN/GRA-6 (par. 6) are packed for shipment in a single shipping container. The basic components listed in paragraph 6 are individually packed and placed in four moisture-vapor-proof containers. The four containers are then packed in an intermediate carton. Each intermediate carton thus contains a complete set of the basic components of Control Group AN/GRA-6. Each shipping container includes two such intermediate cartons, or two sets of components for Control Group AN/GRA-6. The weights and the volumes of the four individual packages, of each of the intermediate cartons, and of the over-all shipping container, are listed in subparagraph *a* below. The contents of each individual package are listed in subparagraph *b* below. All values are approximate.

a. WEIGHT AND VOLUME OF CONTAINERS.

Box No.	Weight (lb)	Volume (cu ft)
1	8¾	.24
2	12½	.32
3	2¾	.12
4	4½	.38
Intermediate	29½	1.32
Shipping	61	3.32

b. CONTENTS OF EACH BOX.

Box No.	Item	Quantity
1	Remote Control C-433/GRC	1
2	Local Control C-434/GRC	1
3	Handset H-33/PT	1
4	Bag CW-189/GRC	1
	Spare parts (per set) (par. 11)	1
	Technical Manual	2
Intermediate carton	Boxes 1 through 4	1 each
Shipping container	Intermediate cartons	2

8. Additional Equipment Required

To install and operate Control Group AN/GRA-6, the following parts and materials are required in addition to the basic components listed in paragraph 6.

a. Four 1½-volt dry cells, Battery BA-30 (two each for local and remote control units).

b. One 45-volt dry battery, Battery BA-414/U (remote unit only).

c. Telephone line.

d. An additional Handset H-33/PT may be required for field telephone use.

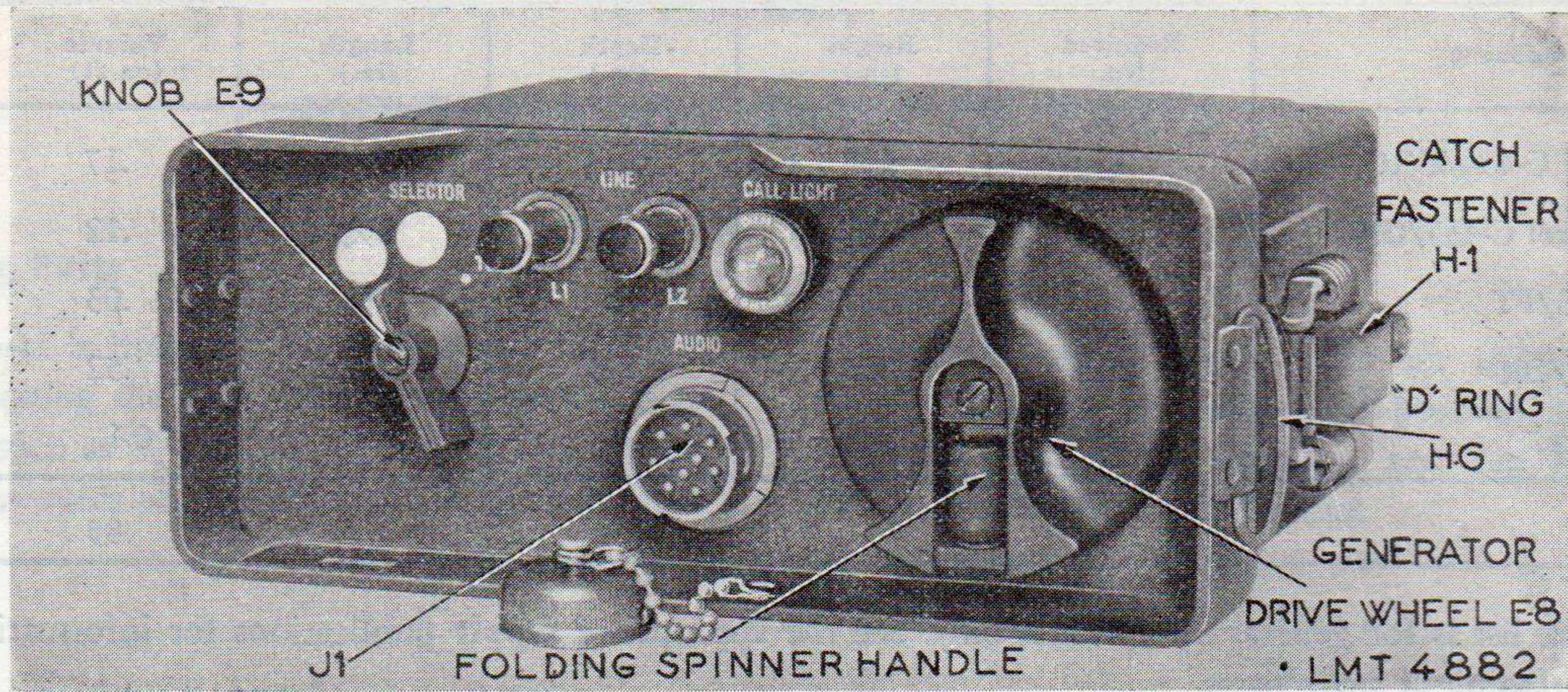

Figure 3. Remote Control C-433/GRC, over-all view

9. Description of Major Components (figs. 3 through 9)

a. GENERAL. The major components of Control Group AN/GRA-6 are shown in figure 1. The control group includes Local Control C-434/GRC, Remote Control C-433/GRC, Handset H-33/PT, and Bag CW-189/GR. The components are compact, lightweight, and suitable for portable use. When not in use, the control units and the handset can be stored in the bag, which is equipped with a carrying

strap (fig. 14). An additional carrying strap is provided for attachment to the remote control unit. The audio device, normally supplied with the radio set with which the control group is to operate, may be used in conjunction with the local control unit. In addition to the components shown in figure 1, a group of additional items is necessary to complete the installation of Control Group AN/GRA-6. These items are listed in paragraph 8 above.

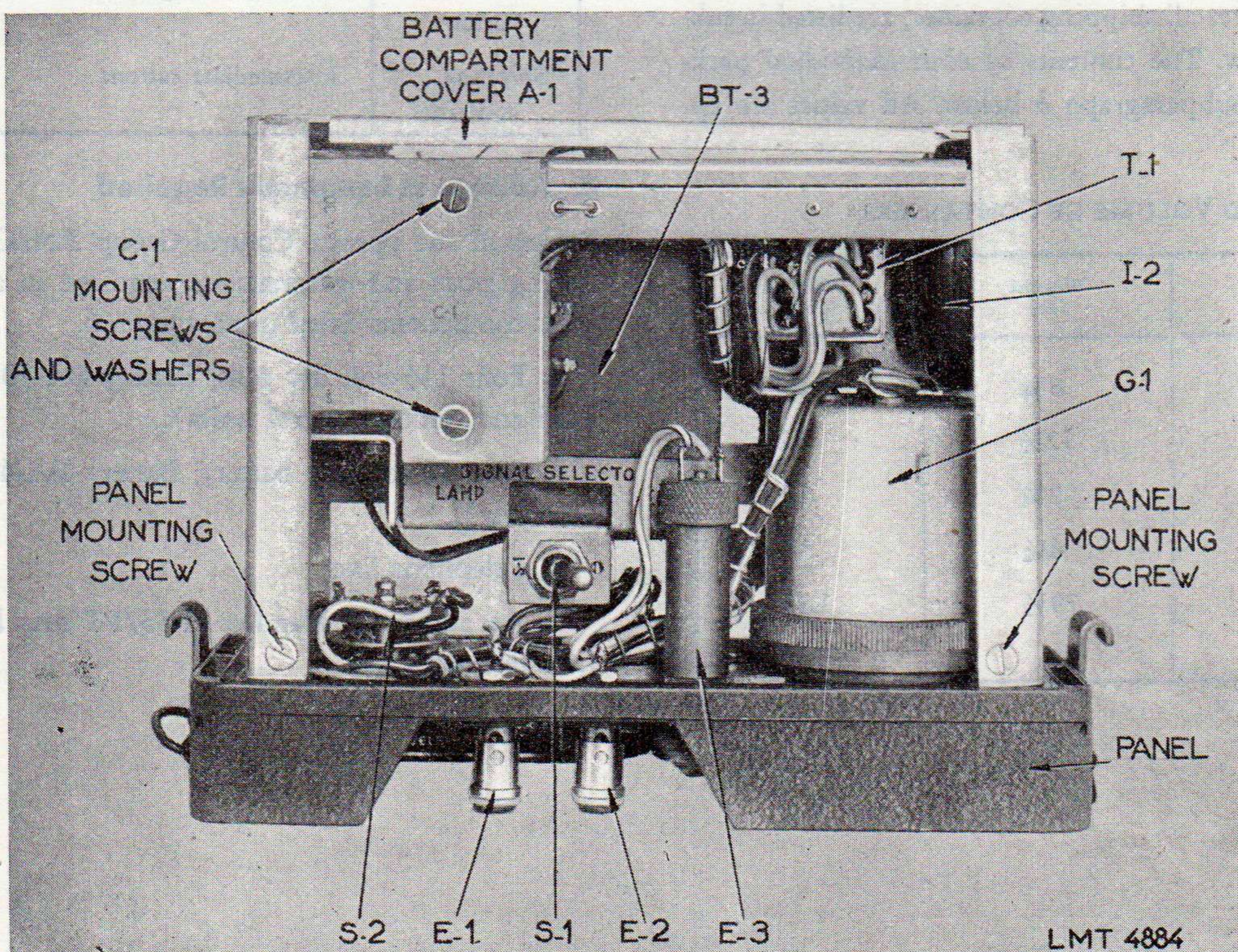

Figure 4. Remote Control C-433/GRC, panel-and-chassis assembly, cover removed, top view of chassis.

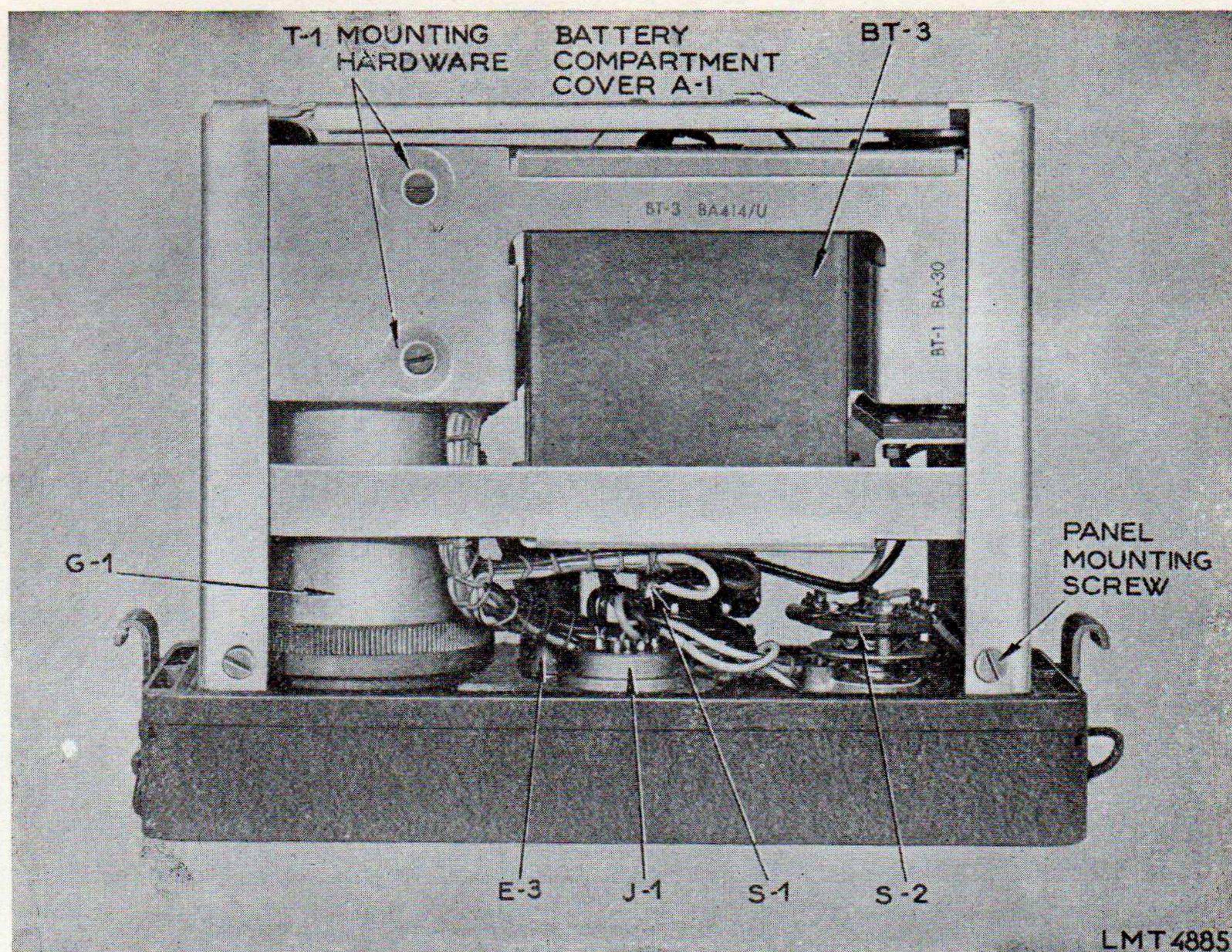

Figure 5. Remote Control C-433/GRC, panel-and-chassis assembly, cover removed, bottom view of chassis.

b. REMOTE CONTROL C-433/GRC (fig. 3). The remote control unit is a compact, lightweight panel-and-chassis assembly with an immersion-proof outer case. The case is held to the panel by means of two snap catches. The unit may be carried by a shoulder strap provided for this purpose. D rings on the sides of the panel are provided for the strap. When the unit is suspended from the strap in its normal carrying position, the panel-mounted operating controls face upward. Panel-mounted components include the crankhandle of the ringing generator, the neon glow CALL LIGHT, two line binding posts (L-1 and L-2), the AUDIO connector for the handset, and the SELECTOR switch. The panel is recessed to prevent damage to the controls due to impact. A cut-out in the flange around the panel is provided to accommodate the line wires. The two white discs associated with the SELECTOR switch are write-in positions, permitting the operator to record the function of the switch position. The panel and the case are finished in olive drab. Interior views of the unit are shown in figures 4, 5, 10, and 22. The bell or *ringer* is mounted in a compartment on the side of the frame. Switch S-1, which selects either the LAMP or the BELL to provide visual or audible indications of an incoming ringing signal, is mounted within the control box.

c. LOCAL CONTROL C-434/GRC (fig. 6). The local control unit is similar to the remote control unit, described in subparagraph *b* above. Bag CW-189/GR provides carry-

ing facilities for this unit. The outer case is held to the panel by means of two wing-type thumbscrews. Channel rails are fitted to the sides of the case to permit inserting the unit into a compartment provided for this purpose on Mountings MT-297/GR and MT-298/GR. A connector at the rear of the control unit plugs into a mating connector on the mounting, establishing a connection between the control unit and the radio sets installed on the mounting. An alternative means for establishing electrical connections between the control unit and radio sets is provided by two cables stored in a compartment at the rear of the control unit. This method of connection is used when the control unit is to be used with radio sets using a mounting in which no provisions are made for accommodating the control unit. A protective cap for the plug is provided; when the plug is used, the cap is mounted on clamps on the storage compartment cover (fig. 13). All operating controls are panel-mounted. These include a crankhandle of the ringing generator, the neon glow call lamp with a dimmer, and REMOTE and LOCAL control switches. The panel is recessed to prevent damage to the controls. The panel and the case are finished in olive drab. Waterproofing is provided by seals and rubber gaskets around bushings and between the outer case and the panel. Interior views of the unit are shown in figures 7, 8, 12, and 23. The lamp or bell selecting switch S-1 is mounted on a bracket on the top of the unit chassis.

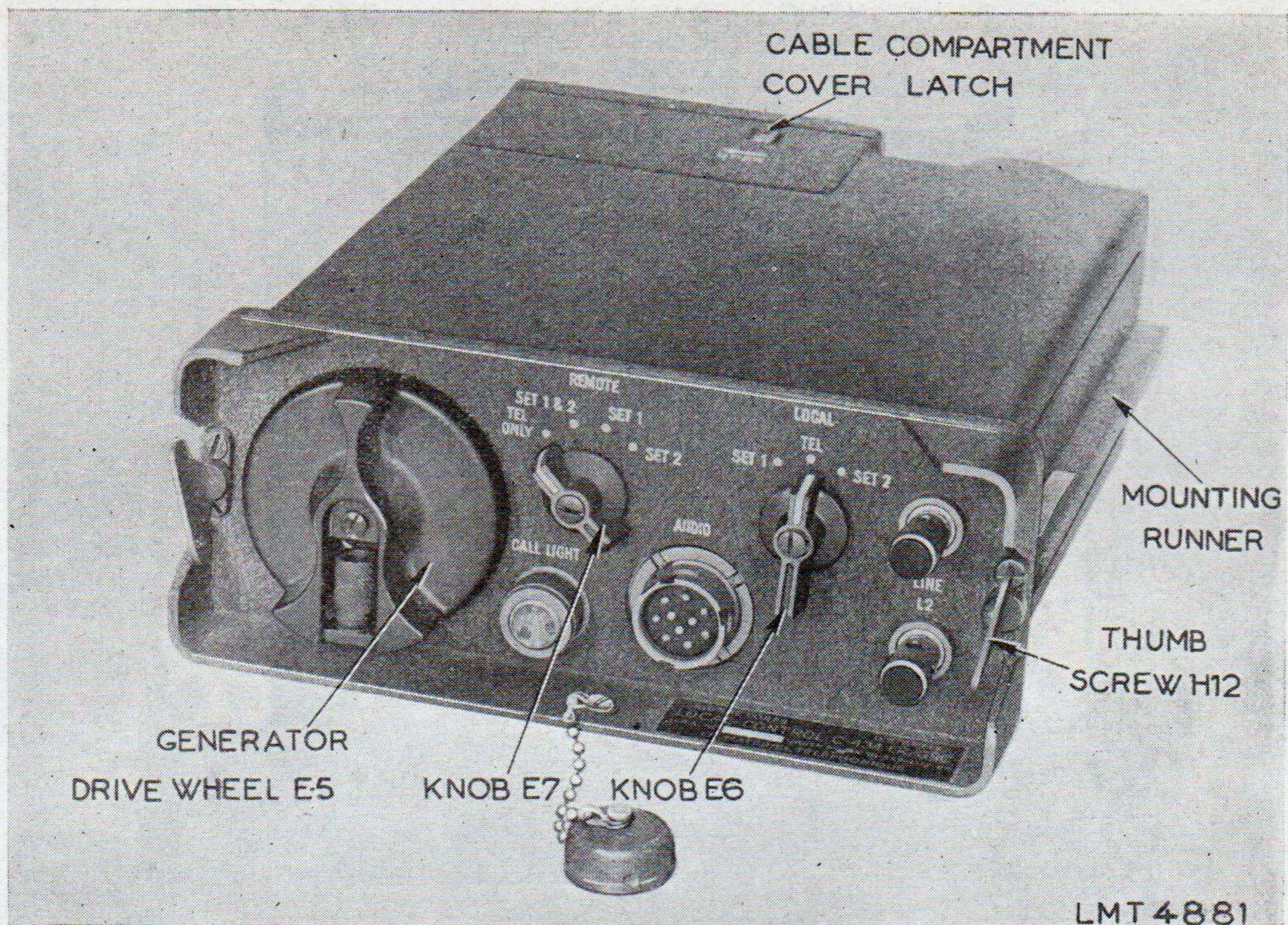

Figure 6. Local Control C-434/GRC, over-all view.

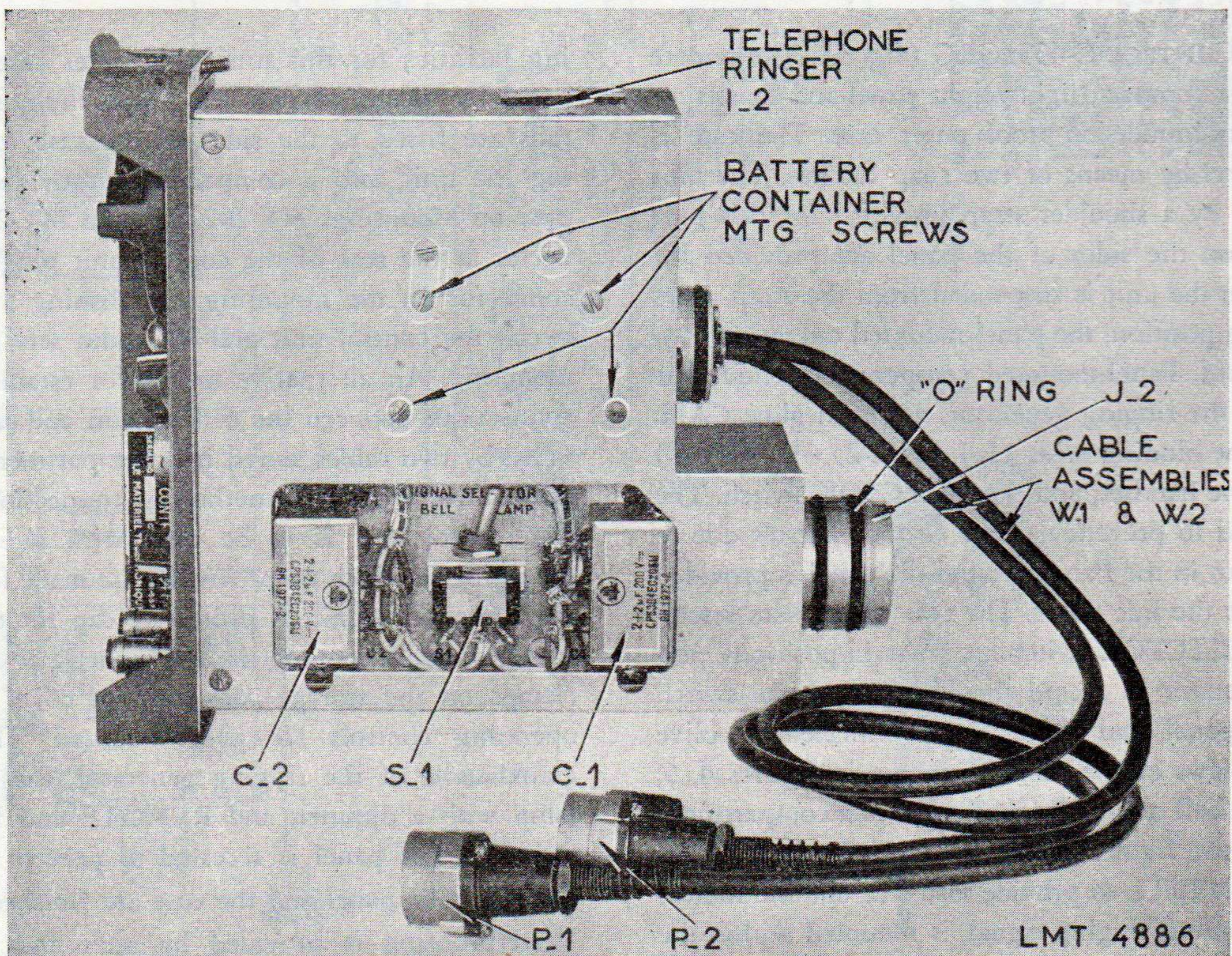

Fig. 7 Local Control C-434/GRC, panel-and-chassis assembly, cover removed, top view of chassis.

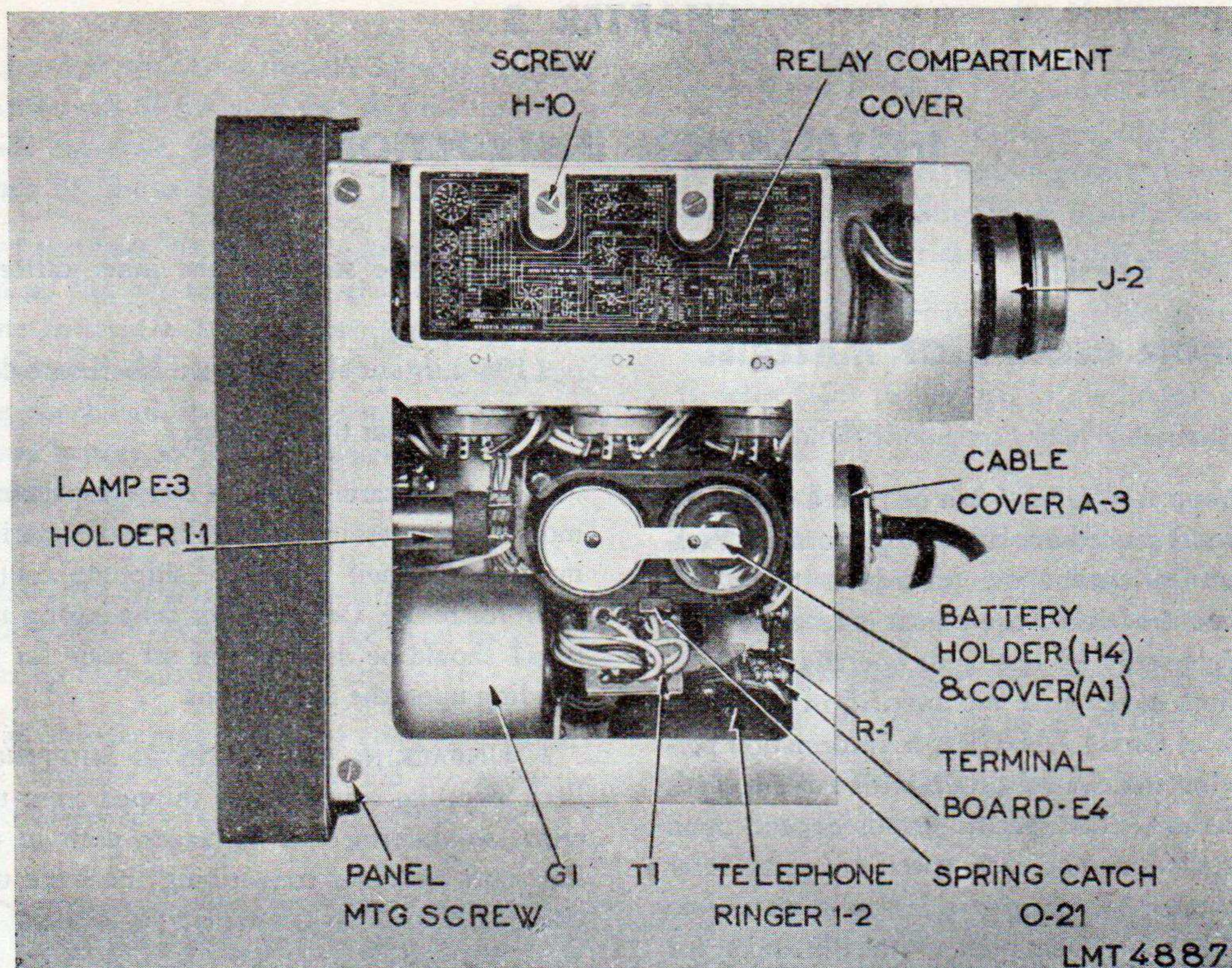

Figure 8. Local Control C-434/GRC, panel-and-chassis assembly, cover removed, bottom view of chassis.

10. Description of Minor Components

a. **HANDSET H-33/PT** (figs. 9 and 29). The handset includes a 40-ohm carbon-type microphone, a 300-ohm ear-piece, a nonlocking push-to-talk switch, and a 5-foot cord which is terminated in a 10-pin connector, which fits into the **AUDIO** connectors of the control units. The push-to-

talk switch receptacle incorporates a DPST (double-pole, single-throw) switch which closes when the bar on the side of the handset grip is depressed.

b. **BAG CW-189/GR** (figs. 1 and 14). This dust- and waterproofed canvas carrying bag is large enough to accommodate the two control units and the handset when not in use. It is equipped with a carrying strap.

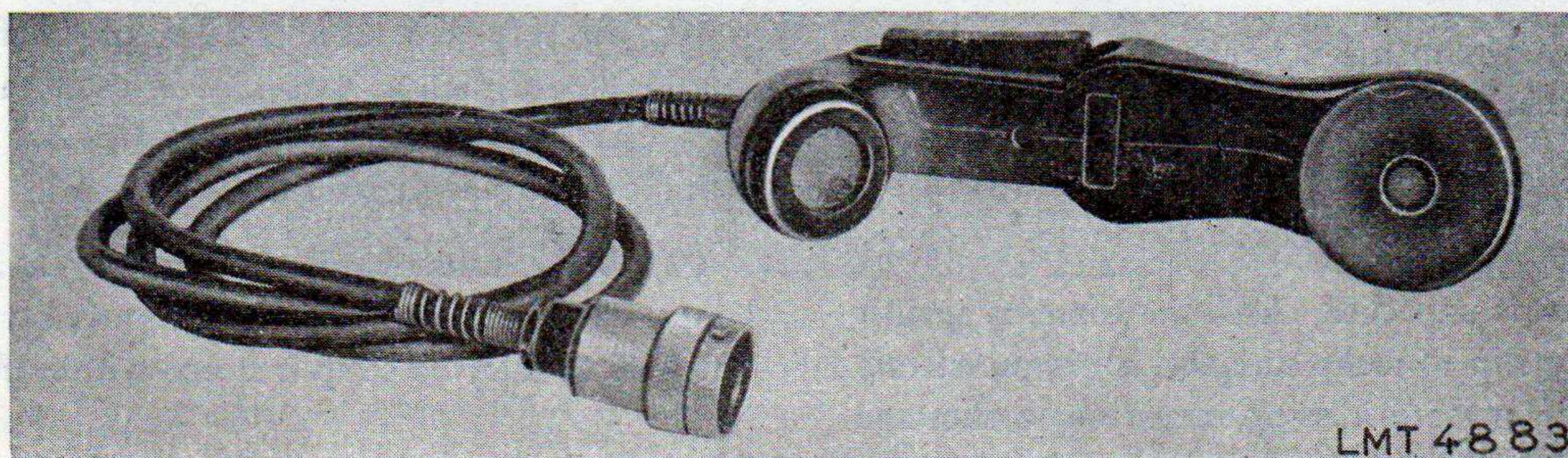

Figure 9. Handset H-33/PT.

11. Running Spares

The running spare parts supplied with each Control

Group AN/GRA-6 are 2 lamps, glow, 125-volt, 1/25-watt. LMT part/dwg PL-776934.

CHAPTER 2

INSTALLATION INSTRUCTIONS

Section I.

SERVICE UPON RECEIPT OF MATERIEL

12. General

Before Control Group AN/GRA-6 can be placed in service, certain preoperational procedures must be performed. Paragraphs 13 through 21 outline the procedures to be followed from the time the packed equipment is received until it is set up and made ready for testing or operation. The installation instructions given here are specific in details as they apply to Control Group AN/GRA-6. Information pertaining to associating the control group with a radio set is more general in nature, since specific details depend upon the particular installation. For such specific details, refer to the technical manual for the particular radio set and to the installation instructions supplied with the units for the particular vehicle.

13. Unpacking Instructions

During unpacking, be careful not to damage the equipment. If the equipment is packed for export shipment, proceed as in subparagraph *a* below. If the equipment is packed for domestic shipment, proceed as in subparagraph *b* below.

a. UNPACKING OF OVERSEAS SHIPPING CONTAINERS. The following points of procedure should be observed whenever possible.

- (1) Pick a location for unpacking that is relatively free from dust, dirt, and moisture.
- (2) Remove and save the packing slip.
- (3) Use cutters to clip metal bands. If cutters are not available, twist the band with pliers until it breaks.
- (4) Use a nail puller to remove the nails and then lift off the sides and/or the tops of boxes.
- (5) As each box is unpacked, check the contents against the master packing slip to make sure that all required materials are there. If any are missing, make out a shortage report as required.
- (6) Lift out unit packages.
- (7) Slit the waterproof barrier at the seams and remove it from the package.
- (8) Slit the seal of the outer carton and remove the package of silica gel.

(9) Slit the seams of the inner carton and open the flaps.

(10) Lift out all corrugated fiberboard cells and pads.

(11) Lift out the contents.

Note. Be careful not to damage packing materials any more than necessary. If possible, store the inside packaging materials in their respective shipping containers and save them for re-use. Desiccants or dehydrating agents (silica gel bags) should be destroyed or set aside for reactivation, depending upon the instructions.

b. UNPACKING OF DOMESTIC SHIPPING CONTAINERS. Each shipping container, as shipped from the factory, contains two intermediate packages, each in turn containing four unit packages constituting the basic units of Control Group AN/GRA-6 (par. 7*b*).

(1) Slit the seams of the shipping container and open the flaps.

(2) Slit the seams of each intermediate carton.

(3) Lift out the four packages within the intermediate carton and the corrugated fiberboard cells.

(4) Slit the seam of each unit package carton, open the carton flaps, and remove the contents.

(5) Slit the waterproof barrier at the seams and open the inner carton.

(6) Remove the silica gel and set it aside for destruction or reactivation.

(7) Remove the kimpack wrapping from each unit.

(8) Be sure to take out the waterproof envelope containing the instruction book. One instruction book is packed with each Local Control C-434/GRC and one with each Remote Control C-433/GRC.

(9) Make sure to take out and store away the spare lamps. These are packed with the carrying bag, Bag CW-189/GR. A carrying strap is stored within the bag.

14. Installation of Remote Control C-433/GRC

The remote control unit is intended for portable use. To prepare the unit, proceed as follows:

a. Set the panel-mounted SELECTOR switch to the TEL position.

b. Release the two snap catches which hold the outer

case to the panel-and-chassis assembly, and remove the unit from the case.

c. Remove the tape which secures the battery compartment cover to the sides of the unit, and remove the cover. To do this, slide the cover back slightly to clear the tab on one side; then lift the cover off (fig. 11).

d. Install two Batteries BA-30 in the compartment provided for them on the left rear of the chassis frame (fig. 10). Install one battery in the compartment so that the bottom of the battery outer case (negative electrode) rests over the spring contact on the battery compartment floor. Install the second battery so that the center post (positive electrode) of the battery rests on the flat contact on the battery compartment floor.

e. Insert Battery BA-414/U into the large battery compartment in the chassis frame, so that the octal socket on the battery faces up (toward the rear of the unit).

f. Insert the octal male plug P-1 at the end of the battery cable (fig 11) into the battery socket. Do not twist the battery cord excessively to accomplish this.

g. To restore the battery compartment cover, insert the two projections at one edge of the cover under the bracket angles on the side of the chassis frame (fig. 11). Press the cover down as shown in figure 11 and slide it forward, until the lip (or tab) at the other edge of the chassis frame slides over the corresponding notch in the cover. Release the pressure, and check to insure that the tab is properly locked, and that the batteries are properly positioned.

h. Set the internal BELL-LAMP switch (fig. 4) in the BELL position if audible indication of the ringing signal is desired. Set this switch in the LAMP position if a visual indication of the ringing signal is desired.

i. Check to see that the pilot lamp is installed in its holder. Access to the pilot light is obtained from the rear of the panel by pulling the lamp socket out of its holder. Pull straight toward the rear of the unit (fig. 22).

j. Restore the panel-and-chassis assembly in the case and fasten it to the panel by means of the snap catches.

k. Attach the carrying strap (stored in Bag CW-189/GR) to the D rings on the outer case of the unit.

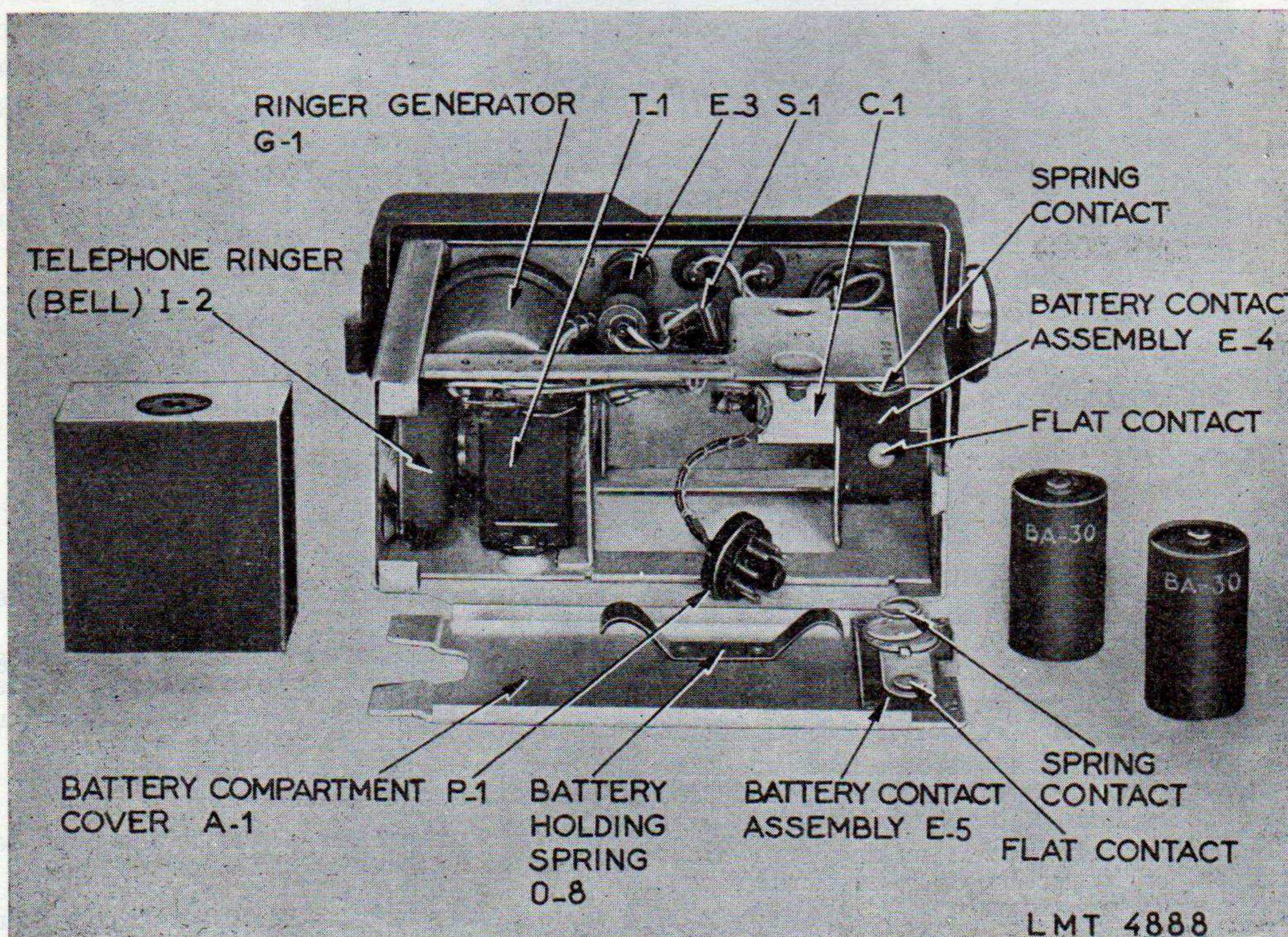

Figure 10. Remote Control C-433/GRC, rear view of panel-and-chassis assembly, battery compartment cover and batteries removed.

15. Installation of Local Control C-434/GRC

The local control unit is intended to be used close to the radio set with which it is to be operated. In some installations it will be inserted in the compartment provided for it in the mounting (Mounting MT-297/GR or Mounting MT-298/GR). In other installations, it must be placed in a

location near the radio set and cabled to the front panel connectors of the set. To prepare the unit for installation, proceed as follows:

a. GENERAL. (1) Loosen the thumbscrew fasteners on the panel of Local Control C-434/GRC and remove the panel-and-chassis assembly from the case.

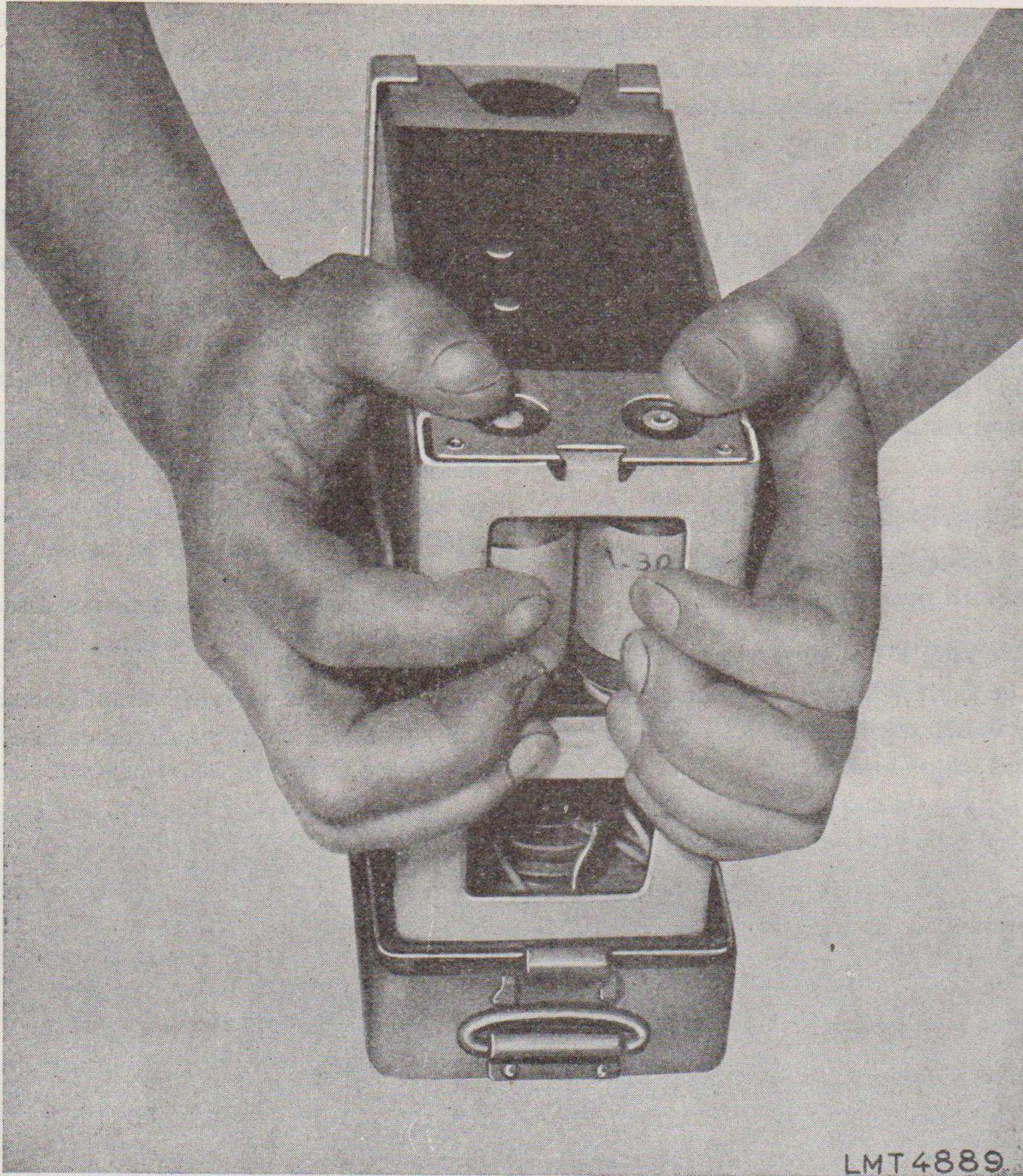

Figure 11. Remote Control C-433/GRC, replacement of battery compartment cover.

(2) To remove the batteries place the panel-and-chassis assembly bottom side up and release the catch holding the battery compartment cover in place. Remove the cover (fig. 12).

(3) Install one battery so that the outer metal base of the battery rests on the spring on the floor of the container.

(4) Install the other battery so that its base faces up, and the center electrode (the positive terminal) rests against the flat battery contact on the floor of the compartment.

(5) Replace the compartment cover, making sure that the batteries make proper connection with the contacts on the cover and within the compartment.

(6) Set the BELL-LAMP switch, mounted on a bracket on the panel-and-chassis assembly (fig. 7), in the BELL position if an audible indication of the ringing signal is desired, or to the LAMP position if a visual ringing signal indication is desired.

(7) Replace the panel-and-chassis assembly in the case, and tighten the screw fasteners.

b. LOCAL CONTROL C-434/GRC INSTALLATION IN MOUNTINGS MT-297/GR AND MT-298/GR. If the unit is to be installed in the mounting of the radio set, proceed as follows:

(1) Remove the protective cover plate from the large plug at the rear of the unit (fig. 13).

(2) To open the storage compartment, press the snap catch at the rear top of the unit. Snap the cover plate onto

the cap retaining brackets on the inside of the storage compartment cover.

(3) Insert the control unit in the mounting frame. Runners are provided for this purpose on the sides of the case.

(4) Use the locking lever on the mounting to lock the unit in place within the mounting frame. This establishes all the necessary electrical connections between Local Control C-434/GRC and the radio set.

Note. Turn off the power to the radio set before connecting the local control unit.

b. 1. DIFFICULTY IN INSTALLATION AND REMOVAL OF CONTROL UNITS. Where difficulty due to incorrect wall taper interferes with easy mating of the connector on Local Control C-434/GRC with Mountings MT-297/GR and MT-298/GR, use the following procedure:

(1) Scrape the paint off the runners of Local Control C-434/GRC.

(2) Test the controls for ease of installation and removal. If difficulty still exists, remove the spring clips from the runners of the controls.

(3) When inserting Local Control C-434/GRC in the mountings, firmly apply pressure to the upper left corner of the control unit, and simultaneously operate the locking lever to the locked position.

(4) Check the overall performance of the equipment.

c. LOCAL CONTROL CONNECTION TO RADIO SET FRONT PANEL CONNECTORS. If the unit is to be installed alongside or near the radio set, proceed as follows:

(1) Press the snap catch (fig. 13) to open the hinged door at the right of the plug at the rear of the unit, and extend the two cables with terminating connector plugs stored within the compartment.

(2) Attach the cable, associated with the identification SET 1 inside the cable compartment, to the AUDIO connector on the unit identified as Set 1 of the radio set. See the instruction book for the particular radio set.

(3) Attach the other cable with the identification SET 2, to the unit identified as Set 2 of the radio set.

(4) If only one cable is used (the radio set has either Set 1 or Set 2, but not both), restore the other cable to the compartment.

(5) Fit the protective cover over the connector. Lock the cover in place by rotating it.

Note. If the radio set involved in the installation has two receiver-transmitters, one will be referred to as Set 1 and the other as Set 2. Refer to the instruction book for the particular radio set to determine which unit of the radio set is Set 1 and which is Set 2. Note also that Set 1 and/or Set 2 may be a receiver-transmitter, a radio receiver, a radio transmitter, an interphone amplifier, or some other push-to-talk (or push-to-transmit) type unit.

16. Installation of Accessories

a. AUDIO ACCESSORIES. To install the handset on either unit, attach the connector plug at the end of the handset cord to the AUDIO connector on the control unit. To do this, line up the flats on the cable-and-panel-mounted connectors, and rotate the cable connector clockwise to lock it in place. A clip, provided on the handset permits attaching it when it is not in use to the pocket or belt of the operator, the rim of the front panel of a control unit, or to the carrying strap of the remote unit. Another Handset H-33/PT may be used at the other control unit in which case it is attached to the AUDIO connector of that unit. Chest Set Group AN/GSA-6 with Headset-Microphone H-63/U may be used at the local control unit as an alternate. If the chest set is used, lock the RADIO switch in the RADIO position by means of the internal lock. Connect the cable from the chest set to the AUDIO connector on the control unit and the cables from Headset-Microphone H-63/U to the corresponding connectors on the chest set. Only one audio accessory is provided for each set of the local and remote units.

b. TELEPHONE LINE. Two line binding posts (LINE L-1, L-2) are provided on each of the two control units for connection of the telephone line wires. To make the connection, strip the insulation off the two wires approximately $\frac{3}{4}$ inch from each end, and, if possible, tin the bared wires before clamping them in the binding posts on each of the two control units.

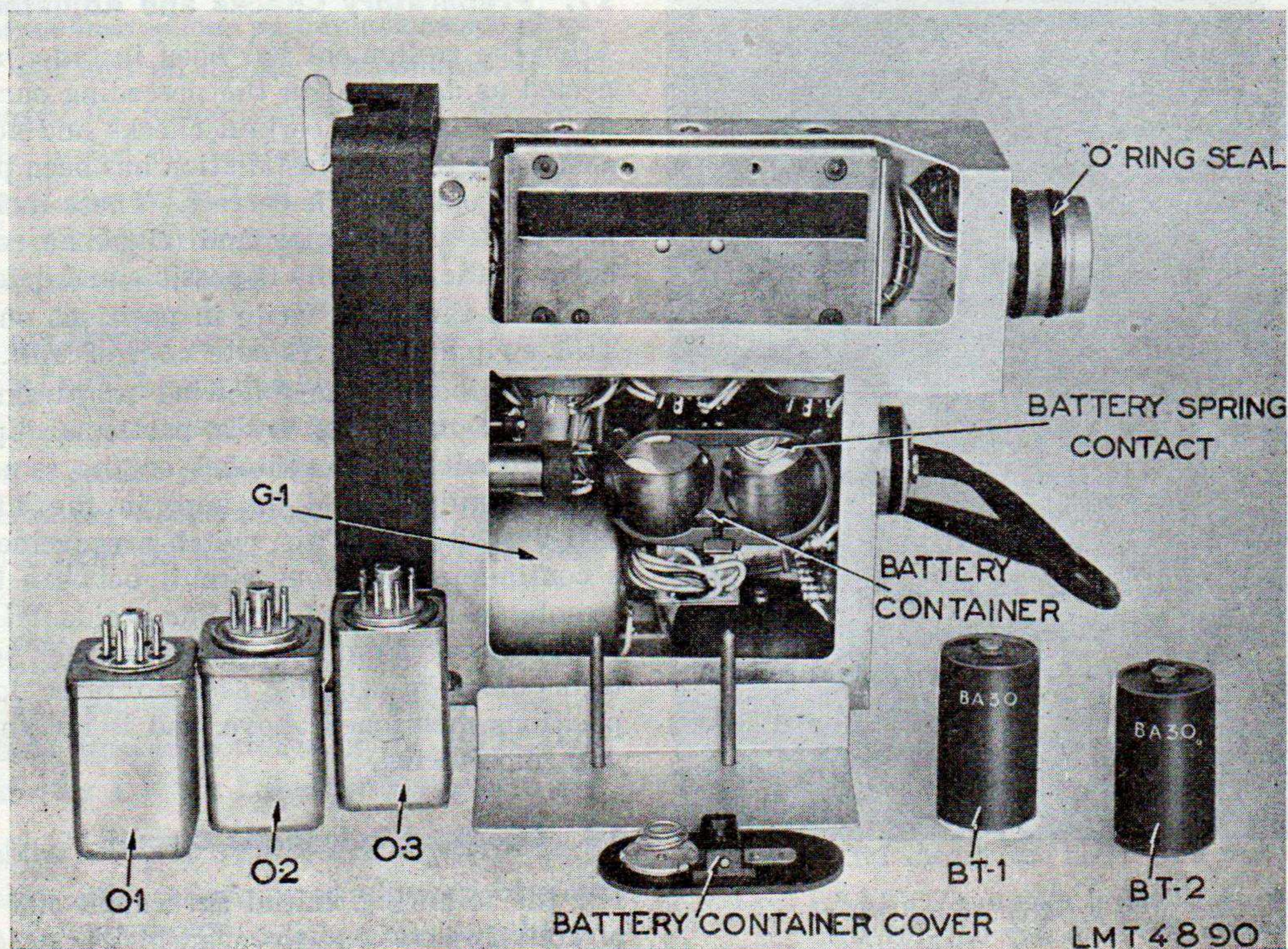

Figure 12. Local Control C-434/GRC, bottom view of panel-and-chassis assembly, battery container cover, batteries, relay cover, and relays removed.

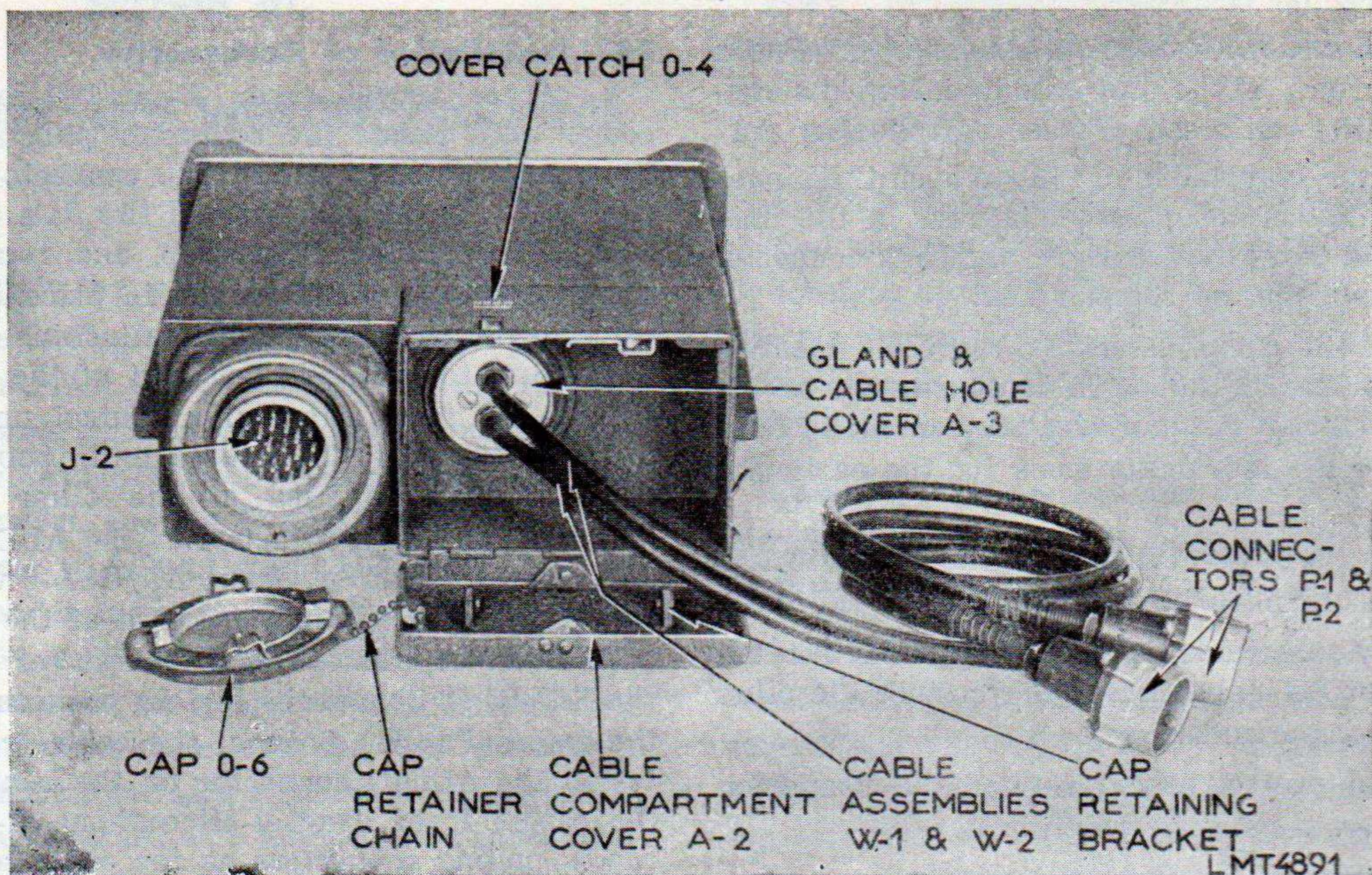

Figure 13. Local Control C-434/GRC, rear view of unit, cable storage compartment open and cables and connector cap removed.

Section II.

PRESETTING AND INITIAL ADJUSTMENTS

17. Preparatory Checks and Adjustments

After the equipment has been installed and interconnected as described in the preceding paragraphs, it is necessary to make certain checks and adjustments to make sure that the installation has been properly made and that operation is correct. These include checking to see whether ringing and telephone communication between the two units is possible and determining how to fill in the blank write in positions on the SELECTOR switch of the remote control unit. These steps are described in the following subparagraphs. Unless otherwise called for by a particular operational or test procedure, the switches on the remote and local control units should be kept in the TEL and TEL ONLY positions. This switch arrangement maintains a continuous telephone circuit between the local and remote operators and prevents accidental operation of the radio set from the remote control position. The term *stand-by* will be used to refer to the switch positions mentioned above, and is not to be confused with monitoring.

18. Check of Telephone Circuit

For the following, initial agreement and coordination of activity between two operators is necessary.

- a. To check whether the ringing circuit is operative and whether the line circuit is unbroken, crank the ringing gen-



Figure 14. Control Group AN/GRA-6, components stored in Bag CW-189/GR.

erator handle mounted on the panel of the control unit. Depending on the setting of the BELL-LAMP switch at the other control unit, the bell should ring or the CALL LIGHT should light. Note that a dimmer control is provided on the face of the lamp to shade the glow to any desired degree. Turn the rim of the panel lamp housing to adjust the dimmer control. This check should be made at each of the two control units.

Caution: The generated voltage at L-1 and L-2 may be as high as 60 volts.

b. With the control switches set as in paragraph 17 above, the circuit is ready for two-way telephone communication. To talk, operate the push-to-talk switch on the handset, and talk into the microphone. Talk directly into the mouthpiece. Duplex operation, both operators talking, is possible. Operate the push-to-talk switch only when talking, to conserve the life of the dry cells.

19. Filling in Write-in Blanks on Remote Control Unit

The control circuits are so arranged that, with the telephone line properly connected, the coordination of the write-in positions of the remote control unit SELECTOR switch with the local control unit REMOTE switch positions is as follows:

a. When the SELECTOR switch is in the left-hand write-in position and the REMOTE switch is in the SET 1 position, operation of the microphone push-to-talk switch of the remote operator will turn on the Set 1 transmitter. If the radio set is arranged for remote power control, the radio set power will be turned on. In this case, the right-hand write-in position of the SELECTOR switch will turn the radio set power off when the microphone push-to-talk switch is operated and then released.

b. When the SELECTOR switch is in the left write-in position and the REMOTE switch is in the SET 2 position, the remote operator's push-to-talk switch will turn on the Set 2 transmitter. If remote power control is provided for, then the radio set power will be turned on. The right-hand write-in position is again the power off and Set 2 off position.

c. When the REMOTE switch is in the SET 1&2 position, power to the radio set is controlled locally, and the left- and right-hand write-in positions of the SELECTOR switch turn on the Set 1 or Set 2 transmitters respectively.

Note. The above set-up is the intended arrangement. If the line connections are reversed, the coordination between the SELECTOR and REMOTE switches also will be reversed. To obtain the desired arrangement outlined above, either one of the criteria included in subparagraphs 20*a*, *b*, or *c* below must be met.

20. Checking Telephone Line Connections

a. CONTINUITY MEASUREMENT. The LINE L-1 binding posts of the remote and local control units must be connected by one wire of the pair and the LINE L-2 binding posts by the other wire of the pair. If both ends of the pair are accessible when the initial installation is being made, this continuity may be established by using an ohmmeter across the ends of the telephone line, and thus identifying the wire ends. The line connections then may be made.

b. CONTROL VOLTAGE POLARITY MEASUREMENT. Another way of checking the same thing without actually turning on the radio set transmitters is outlined below. This check may be made regardless of whether the units are close together or not during initial installation. The telephone circuit is used to coordinate efforts between the two control operators making the check.

(1) Connect the line wires between the control units.

(2) At the remote control unit, turn the SELECTOR switch to the left-hand write-in position and operate the microphone push-to-talk switch.

(3) At the local control unit use a voltmeter, Electronic Multimeter TS-505/U, or equal (with scale selected to read up to 45 volts dc), to check the polarity of the d-c voltage at the telephone line ends.

Requirement: To insure enough line current for infallible operation of the local control relays, the voltage between the two binding posts should be between 24 and 45 volts.

(4) At the remote control unit release the microphone push-to-talk switch and return the SELECTOR switch to the TEL position (stand-by).

(5) At the local control unit connect the positive wire of the telephone line to the LINE L-1 binding post, and the negative wire to the LINE L-2 binding post.

c. PUSH-TO-TALK OPERATION OF THE RADIO SET. If no ohmmeter or voltmeter is available or as a further check upon the installation made in accordance with subparagraph *a* or *b* above, the line wire connections and the write-in positions may be established experimentally as follows:

(1) At the remote unit turn the SELECTOR switch to the left-hand write-in position.

(2) At the local unit turn the REMOTE switch to the SET 1 position.

(3) Turn the main power switch of the radio set for remote control of power if it is so equipped. If the radio set is not equipped for remote power control, turn on power locally. See the instruction book for a particular radio set.

(4) At the remote control unit, operate the microphone push-to-talk switch.

(5) At the radio set location, determine whether the unit of the radio set designated as Set 1 is being controlled

(that is, whether Set 1 transmitter is turned on) and (if it is equipped for remote power control) that power has been turned on.

(6) At the remote control unit, turn the SELECTOR switch to the middle write-in position and momentarily operate the microphone push-to-talk switch.

(7) At the location of the radio set, determine whether the Set 1 transmitter and power (if remotely controlled) has been turned off.

(8) If the requirements of subparagraphs (5) and (7) above have been met, the line connections are correct. If these requirements have not been met, reverse the line wire connections at *one* of the two units, and recheck as in the preceding steps. Release the push-to-talk switch at the remote unit when the connections are being made.

Caution: When the microphone push-to-talk switch is operated at the remote control unit, a potential as high as 45 volts exists at the line binding posts of both units.

Note. Subparagraphs (9) through (15) below do not apply if the radio set does not use a Set 2.

(9) Leave the remote control SELECTOR switch in the left write-in position.

(10) At the local unit turn the REMOTE switch to the SET 2 position.

(11) Repeat subparagraphs (3) and (4) above.

(12) Determine whether the component of the radio set designated as Set 2 has been controlled and (if equipped for remote power control) whether power to the radio has been turned on.

(13) Repeat operations described in subparagraph (6) above.

(14) Determine whether Set 2 and (if remotely controlled) radio set power has been turned off.

(15) If the requirements of subparagraphs (3), (7), (12), and (14) above have all been met, the installation is satisfactory. The blank write-in spaces of the SELECTOR switch of the remote control unit may now be filled in with the pertinent information in accordance with organizational requirements. Use the following table as a guide.

Local unit REMOTE switch position	Desired point of power control *	SELECTOR switch position (remote unit)	
		Left-hand write-in position	Right-hand write-in position
SET 1	remote	Control Set 1; turn on radio set power.	Decontrol Set 1; turn off radio set power.
SET 1	local	Control Set 1.	Decontrol Set 1.
SET 2	remote	Control Set 2; turn on power.	Decontrol Set 2; turn off power.
SET 2	local	Control Set 2.	Decontrol Set 2.
SET 1 & 2	local only	Control Set 1; decontrol Set 2.	Control Set 2; decontrol Set 1.

* Power control of a radio set is only possible when specific provision is made for such control at the radio set. This provision is independent of the control group. Monitoring may be accomplished if the radio set is on, but no transmission is being made.

21. Service upon Receipt of Used or Reconditioned Equipment

The procedures outlined in paragraphs 12 through 17 apply in their entirety to equipments returned to service from the repair depots as well as new equipment. Check for any written notices of changes that may have been made in the wiring or in components. Record such changes on the sche-

matic diagram and in this instruction book. If the units have been returned with batteries installed, check the battery voltages with a voltmeter to make sure that they have the proper operating voltage. If the write-in blanks on the remote control unit SELECTOR switch have been previously filled in and the markings not erased, check the accuracy of the information entered by the procedure of paragraphs 19 and 20 and make changes as necessary.

CHAPTER 3

OPERATING INSTRUCTIONS

Section I.

CONTROLS AND INSTRUMENTS

22. Panel Controls and Facilities

a. LOCAL CONTROL C-434/GRC. Figure 15 illustrates the layout of controls and components on Local Control C-434/GRC. The following chart lists the functions of controls and instruments.

Control or component	Function	
	Position	Function
LOCAL switch (S-3)	SET 1	Allows push-to-talk operation of Set 1.
	TEL	Allows telephone operation with Remote Control C-433/GRC.
	SET 2	Allows push-to-talk operation of Set 2.
REMOTE switch (S-2)	TEL ONLY	Allows for telephone communication between the local and remote control units. May be used to turn off power.
	SET 1 & 2	Places selection of push-to-talk operation over either Set 1 or Set 2 under control of remote operator's SELECTOR switch and turns on radio set power locally (if provided for).
	SET 1	In conjunction with remote control unit SELECTOR switch pro-

Control or component	Function
	Position
	vides for remote control of power (if provided for) for a radio set and push-to-talk operation of Set 1. Monitors Sets 1 and 2.
	SET 2 In conjunction with remote control unit SELECTOR switch provides for remote control of power (if provided for) for a radio set and push-to-talk operation of Set 2. Monitors Sets 1 and 2.
LINE L-1 and L-2	Binding posts; provide telephone line connection facility to remote control.
Ringing generator	Provides means of sending a 20-cycle ringing signal to the remote control position (Remote Control C-433/GRC).
CALL LIGHT (E-3)	Indicates (when lit) that a ringing signal is being received from the remote control unit. (CALL LIGHT indication can be replaced by a bell, by means of an internal switch.) Dimmer control provided for the lamp.
AUDIO connector (J-1)	Provides means for connecting a handset or similar accessory for telephone communication and push-to-talk operation of a radio set.
Dimmer	Dims CALL LIGHT to desired intensity.

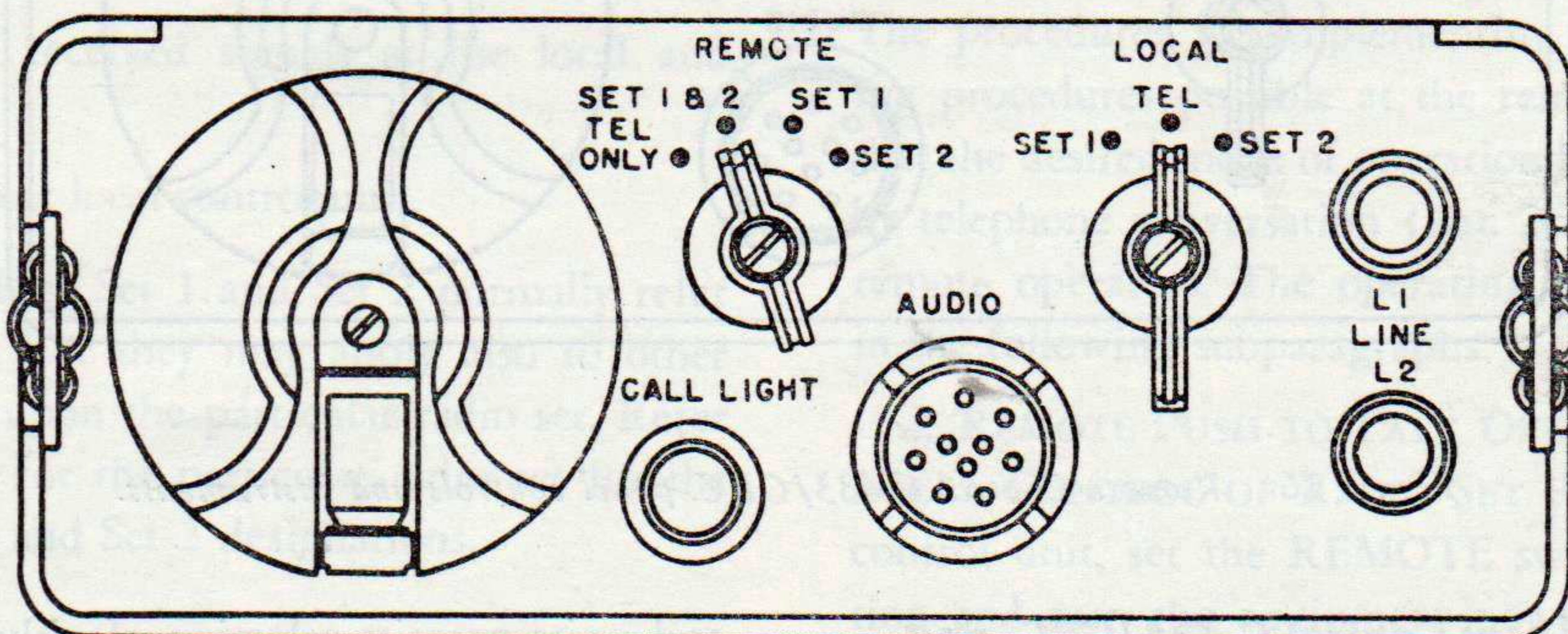

Figure 15. Local Control C-434/GRC, panel controls and instruments.

b. REMOTE CONTROL C-433/GRC. Figure 16 illustrates the controls and components on the front panel of Remote

Control C-433/GRC. The following chart lists the functions of these controls and instruments.

Control or component	Function	Control or component	Function
SELECTOR switch (S-2)	In conjunction with controls at the local unit, provides for any two of the following: (1) remote control of power for the radio set; (2) push-to-talk operation of Set 1; or (3) push-to-talk operation of Set 2; also provides means for limiting operation from remote position to telephone communication.	LINE L-1 and L-2	<i>Position</i>
	<i>Position</i>		<i>Function</i>
	write-in (left)		Power-on position (if provided for) for a radio set and/or Set 1 or Set 2 remote control position, depending on setting of REMOTE switch in local control unit. See note below.
write-in (middle)	Power-off position for the radio set or a remote control position for Set 2, depending on setting of REMOTE switch in local control unit (see note below).	Ringing generator	Provides means for sending a 20-cycle ringing signal to the local control unit.
TEL	Limits operation to telephone communication	CALL LIGHT (E-3)	When lit, it indicates that a ringing signal is being received from the local control unit. (CALL LIGHT indication can be replaced by a bell by means of an internal switch.) Dimmer control provided for the lamp.
		AUDIO connector (J-1)	Provides means for connecting a handset or similar accessory for telephone communication and for push-to-talk operation of the radio set.
		Dimmer	<i>Note.</i> The functions of the write-in positions will be reversed by the reversal of the telephone line connections at either the local or remote control unit.
			Dims CALL LIGHT to desired intensity.

Caution: The REMOTE switch of Local Control C-434/GRC must be in TEL ONLY position; when

ringing generator is operated to prevent accidental operation of the radio set transmitters.

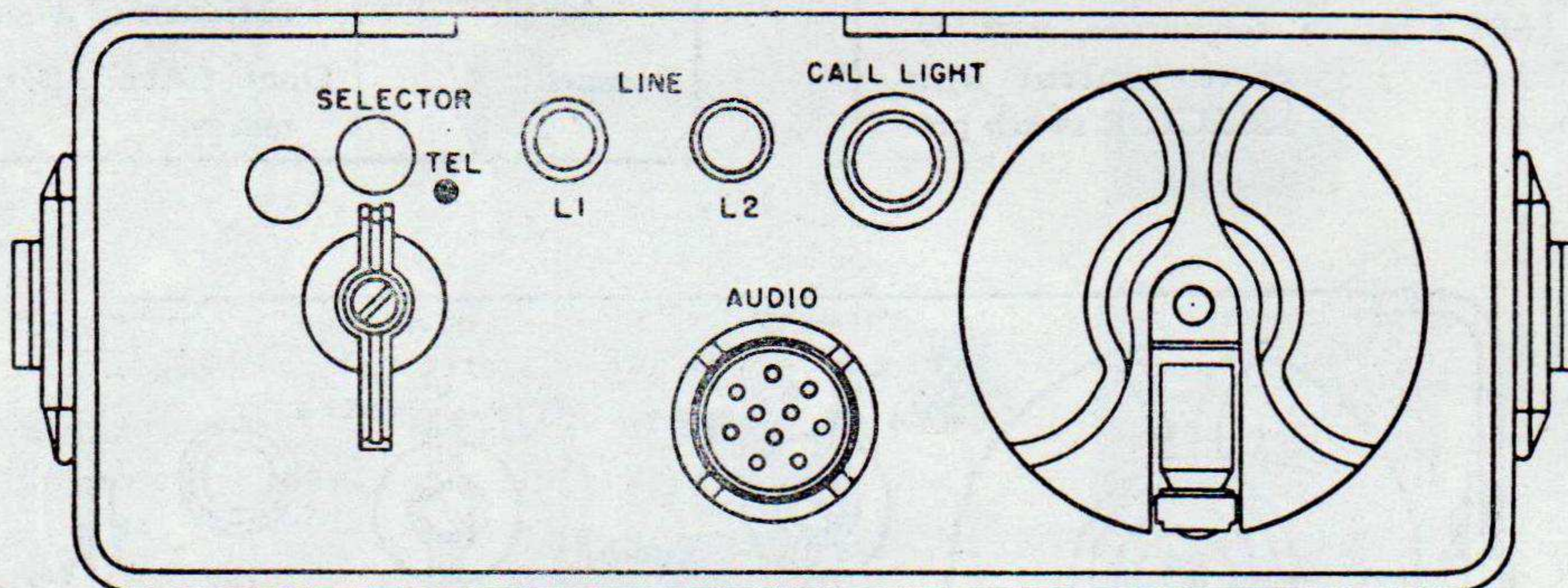

Figure 16. Remote Control C-433/GRC. panel controls and instruments.

23. Internal Controls, Local Control C-434/GRC, and Remote Control C-433/GRC

The SIGNAL SELECTOR switch within each of the con-

trol units permits selection of either the bell or the panel-mounted CALL LIGHT as the receiving device for audible and visual ringing signal indications, respectively.

Section II.

OPERATION UNDER USUAL CONDITIONS

24. Preliminary Starting Procedures

a. If the control group is to be operated as a telephone set only, without association with the radio set, turn the panel-mounted controls to the positions described in paragraph 17. These switch settings must be kept as the normal stand-by condition of the equipment.

b. If Control Group AN/GRA-6 is to be operated in conjunction with a radio set, set the switches as indicated in subparagraph *a* above. These stand-by settings insure immediate telephone communication between the two control units and, in addition, prevent accidental operation of the radio set transmitters. Connect Local Control C-434/GRC as described in the preceding paragraphs and in the instruction book for the particular radio set. Switch settings for the several modes of operation possible are described in the following paragraphs.

25. Modes of Operation

The operational facilities provided by Control Group AN/GRA-6 are summarized below. The operating procedures are described in paragraphs 24 through 32.

a. Telephone communication, with ringing, between the two control units.

b. Remote push-to-talk operation of Set 1 or Set 2 with local control of radio set power. (Selection made by local operator.)

c. Remote push-to-talk operation of Set 1 or Set 2 with local control of radio set power. (Selection made by remote operator.)

d. Remote push-to-talk operation of Set 1 or Set 2 with remote control of radio set power, if provisions are made in the radio set.

e. Local push-to-talk operation of Set 1 or Set 2 with local control of radio set power.

f. Monitoring of all received signals at the local and remote control units.

g. Break-in operation at local control unit.

Note. The designations Set 1 and Set 2 normally refer to receiver-transmitters, but they may apply also to other equipments, depending upon the particular radio set. Refer to the instruction book for the particular radio set for the assignment of the Set 1 and Set 2 designations.

26. Telephone Communication, with Ringing, Between Control Units

Either the local or the remote operator may initiate tele-

phone communication with the distant operator. The procedure for establishing telephone communication between the local and the remote operators is as follows:

a. RINGING SIGNAL TRANSMISSION. The calling operator (local or remote) initiates a telephone conversation with the other operator by transmitting a ringing signal from his unit. To do this, crank the ringing generator handle mounted on the control unit panel. The outgoing ringing signal can be heard in the headphone of the transmitting operator.

Note. To prevent accidental operation of the radio set by a ringing signal, always keep the REMOTE switch of the local control unit in the TEL ONLY position during stand-by and ringing periods.

b. RINGING SIGNAL RECEPTION. A ringing signal may be received at either control unit at any time. There are three ways of receiving a ringing signal.

(1) To prepare the unit for reception of an audible ringing signal, set the internal switch to the BELL position. The incoming ringing signal then will energize the bell.

(2) To prepare the unit for the reception of a visual ringing signal indication, set the internal switch to the LAMP position. The incoming ringing signal will then light the panel-mounted CALL LIGHT. Turn the dimmer control on the face of the lamp on the panel to reduce or eliminate the glow of the lamp.

(3) The incoming ringing signal can also be heard in the earpiece of the handset.

c. TALKING AND LISTENING. With the control switches of the two control units set as indicated in paragraph 17, close the microphone push-to-talk switch in order to talk. Release push-to-talk switch when listening.

d. END OF CONVERSATION. To return the circuit to stand-by condition, release the microphone push-to-talk switches.

27. Push-to-talk Operation from Remote Control C-433/GRC

The procedures for implementing the push-to-talk operating procedures possible at the remote control unit require that the desired mode of operation be established in advance by telephone conversation (par. 26) between the local and remote operators. The operating procedures are described in the following subparagraphs.

a. REMOTE PUSH-TO-TALK OPERATION OF SET 1 WITH LOCAL CONTROL OF RADIO SET POWER. (1) At the local control unit, set the REMOTE switch to the SET 1 position and turn the equipment power on.

(2) At the remote control unit, set the SELECTOR switch to the left-hand write-in position, and momentarily operate the microphone push-to-talk switch.

(3) Operate the microphone push-to-talk switch in order to talk.

(4) Release the microphone push-to-talk switch in order to listen.

(5) At the end of the conversation, release the microphone push-to-talk switch.

(6) Set the SELECTOR switch in the TEL position. At the local control, set the REMOTE switch to the TEL ONLY position; this returns the equipment to the stand-by condition.

b. REMOTE PUSH-TO-TALK OPERATION OF SET 2 WITH LOCAL CONTROL OF RADIO SET POWER. (1) At the local control unit, set the REMOTE switch to the SET 2 position and turn the equipment power on.

(2) At the remote control unit, set the SELECTOR switch in the left-hand write-in position, and momentarily operate the microphone push-to-talk switch.

(3) Operate the microphone push-to-talk switch in order to talk:

(4) Release the microphone push-to-talk switch to listen.

(5) At the end of the conversation, release the microphone push-to-talk switch.

(6) Set the SELECTOR switch to the TEL position. At the local control, set the REMOTE switch to the TEL ONLY position.

c. REMOTE PUSH-TO-TALK OPERATION OF EITHER SET 1 OR SET 2 WITH LOCAL CONTROL OF RADIO SET POWER. (1) At the local control unit, set the REMOTE switch to the SET 1 & 2 position and turn the equipment power on.

(2) At the remote position, turn the SELECTOR switch to the left-hand write-in position for Set 1 operation. Operate the microphone push-to-talk switch in order to transmit over Set 1; release it to listen to either or both Set 1 and Set 2.

(3) Turn the SELECTOR switch to the right-hand write-in position for Set 2 operation. Operate the push-to-talk switch in order to transmit over Set 2; release it to listen to either or both Set 1 and Set 2.

d. REMOTE PUSH-TO-TALK OPERATION OF SET 1 OR SET 2 WITH REMOTE CONTROL OF RADIO SET POWER. This mode of operation is possible only if provisions are made for it in the radio set whose power is to be controlled. The local control unit may be left unattended after the switches have been set as described below.

(1) At the local control unit, place the REMOTE switch in the SET 1 or the SET 2 position, depending on which set is to be used.

(2) Turn the equipment power switch to the remote position.

(3) At the remote control unit, turn the SELECTOR switch to the left-hand write-in position.

(4) Momentarily press the push-to-talk switch on the handset at the remote control unit. The circuit is now ready for operation over the set selected by the REMOTE switch of the local operator.

(5) To talk, operate the push-to-talk switch.

(6) To listen, release the push-to-talk switch.

(7) To turn off the power at the end of an operation, release the push-to-talk switch and turn the SELECTOR switch to the right-hand write-in position. Momentarily operate the push-to-talk switch.

Note. The procedure of step (7) above turns off the power for the radio set, but leaves the control of turning the power on or off at the remote control. The use of the left-hand write-in position as an *on* position and the right-hand write-in position as an *off* position is based on the assumption that the line wires have been connected in the manner described in paragraphs 19 and 20. If the lines are reversed, the functions of the two write-in positions will be reversed.

(8) To restore the telephone circuit to stand-by, set the REMOTE switch in the TEL ONLY position and set the SELECTOR switch in the TEL position.

Note. *Power control of radio set.* Control Group AN/GRA-6 may be made to operate with either one of two types of radio sets.

(1) In one type, power is turned on exclusively by means of switches on the radio set itself.

(2) In another type, switching is provided to give power control to either Control Group AN/GRA-6 (remote) or to the power on-off switch of the radio set. In this latter case, if power is to be controlled by Control Group AN/GRA-6, be sure that the radio set switches are set properly, according to the instructions contained in the radio set manual.

28. Push-to-talk Operation from Local Control **C-434/GRC**

The procedures described here do not include telephone conversation with the remote control unit described in paragraph 26. Monitoring, break-in operation, and other miscellaneous operational possibilities existing at the local control unit are described in paragraphs 29 and 31. The procedures for push-to-talk operation from the local unit are described in the following subparagraphs.

a. LOCAL PUSH-TO-TALK OPERATION OF SET 1. The LOCAL switch of the local control unit is used as the push-

to-talk switch for all push-to-talk operations from the local control unit. Proceed as follows:

- (1) Turn on power for the radio set with the radio set power switch.
- (2) Turn the REMOTE switch to the SET 1 & 2 position.
- (3) Hold the LOCAL switch in the SET 1 (spring return) position.
- (4) Operate the microphone push-to-talk switch to talk over Set 1.
- (5) Release the LOCAL switch to listen.
- (6) At the end of the conversation restore the circuit to stand-by by turning the LOCAL switch to TEL and the REMOTE switch to TEL ONLY.

b. LOCAL PUSH-TO-TALK OPERATION OF SET 2. (1) Repeat steps (1) and (2) of subparagraph *a* above.

- (2) Hold the LOCAL switch in the SET 2 position.
- (3) Repeat the operations of steps (4) through (6) of subparagraph *a* above.

29. Monitoring Operations at Local Control C-434/GRC

The monitoring facilities which are available to the local operator are outlined in the following subparagraphs.

a. AUDIO OUTPUT SIGNALS OF RADIO SET. With the REMOTE switch in any position except the TEL ONLY position, the local operator can hear the audio output of all receivers or receiving circuits of the radio set.

b. MONITORING REMOTE TRANSMISSION OVER RADIO SET. The local operator *cannot* monitor *directly* the transmission of the remote operator over the radio set. However, if the receiver-transmitter of the radio set is equipped with a sidetone circuit, the sidetone speech signals will be heard in the headset of the local operator.

Note. The term *sidetone* refers to that portion of the speech input signal which is routed within the particular receiver-transmitter back into the receiving circuits associated with that set.

c. TELEPHONE AND RADIO RECEPTION. The local operator can monitor simultaneously the output of all receivers of the radio set and speech from the remote operator, provided that the remote SELECTOR switch is in the TEL position and the LOCAL switch is in the TEL position. This is true for any position of the REMOTE switch except the TEL ONLY position.

30. Monitoring Operations at Remote Control C-433/GRC

For any position of the REMOTE switch except the TEL ONLY position, the remote operator can hear the output of all receivers of the radio set and also speech transmission from the local operator. For all modes of reception at the remote control unit, however, the LOCAL switch must be in the TEL position.

31. Break-in Operation

As used here, the term *break-in operation* means the ability of an operator to enter into or interrupt a conversation between any two talking positions. Break-in possibilities exist at both control units. These are discussed below for each of the modes of operation described in the preceding paragraphs. (Note that, since the circuits between each of the two control group operators and the radio set are of the push-to-talk type, timing of the entry of the break-in operator into the conversation may be important.)

a. BREAK-IN ON DUPLEX TELEPHONE CONVERSATION. While the circuit is being operated as a duplex telephone circuit, as described in paragraph 26, neither the local nor the remote operator can hear any of the receiver output signals of the radio set. Thus the distant radio set operator cannot enter upon a duplex telephone conversation between the local and remote control group operators. The local operator can break the duplex telephone circuit at his end of the line and perform any of the available local operations, as described in paragraphs 28 and 29. To do that, turn the LOCAL switch to either the SET 1 or the SET 2 position, as desired, and perform the operational procedures described in paragraphs 28 and 29 for the particular mode of local operation desired.

b. BREAK-IN BY LOCAL OPERATOR ON REMOTE CONTROL OPERATIONS. The operational possibilities available to the local operator while the remote control operator has control of the radio set and carries on a push-to-talk conversation with the distant radio operator are enumerated below.

- (1) The local operator can talk to the remote operator simply by operating the microphone push-to-talk switch (LOCAL switch in TEL position). However, the local operator's message will be transmitted if the push-to-talk switch is operated while the remote operator is talking over the radio set.

- (2) The local operator can take control of the radio set from the remote operator by the following method:

- (a)* If the particular installation provides for power control from the remote unit, turn the radio set power switch from remote control of power to the local power on position.

(b) Turn the REMOTE switch on the local control unit to the SET 1 & 2 position.

(c) Turn the LOCAL switch to the SET 1 or the SET 2 position, depending on the desired talking channel.

(d) Operate the push-to-talk switch on the microphone and talk. Release both switches to listen.

c. BREAK-IN BY REMOTE OPERATOR ON LOCAL CONTROL OPERATIONS. The following break-in operational possibilities are available to the remote operator while the local operator carries on a push-to-talk conversation with the distant radio operator.

(1) The remote operator can send a 20-cycle ringing signal to indicate to the local operator that break-in operation is desired. This is the only available means if the REMOTE switch is in the TEL ONLY position. If the REMOTE switch is in other than TEL ONLY, call by ringing for emergency only.

(2) If the local operator's REMOTE switch is in the SET 1 & 2 position, the remote operator can interrupt the listening circuit of the local operator by turning the SELECTOR switch to either of the write-in positions and by intermittently operating the microphone push-to-talk switch. By previous arrangement, such an interruption may be made to signify the remote operator's desire to break in.

d. BUSY CIRCUIT INDICATION. To determine whether or not the circuit is in use by the local operator, the remote operator turns his SELECTOR switch to either write-in position and operates his microphone push-to-talk switch. He will then hear the local operator's conversation.

32. Stopping Procedure

Power may be removed from the radio set from the control group positions as follows:

a. To shut off power at the local position turn the power on-off switch of the radio set to the off position.

b. To shut off power at the remote position at any time during or after a conversation over the radio set when remote power and push-to-talk control is involved, proceed as follows:

(1) Turn the SELECTOR switch to the right-hand write-in position and operate the microphone push-to-talk switch momentarily. This procedure will turn off power at the radio set.

(2) Restore the control group to the stand-by condition by turning the SELECTOR switch at the remote unit and the REMOTE switch at the local unit to the TEL and TEL ONLY positions, respectively.

c. To disconnect the control group from the radio set, shut off power as in subparagraph (1) above, disconnect

the line and audio accessories, and disengage the local control unit from the radio set or remove the cables, as the case may be.

d. When temporarily not in use, store the components of the control group in Bag CW-189/GR. Figure 14 shows the local and remote control units and Handset H-33/PT stored within the bag.

Caution: If the control group is to remain idle for a long period of time, remove the batteries before storing the units.

SECTION III. OPERATION

UNDER UNUSUAL CONDITIONS

33. General

Control Group AN/GRA-6 is designed to permit operation under adverse conditions of temperature, humidity, and weather. However, special precautions may have to be taken when the equipment is operated in regions where extreme cold, heat, humidity and moisture, sand conditions, etc., prevail. In the following paragraphs, instructions are given on procedures for minimizing the effect of these unusual operating conditions.

34. Operation in Arctic Climates

Subzero temperatures and climatic conditions associated with cold weather affect efficient operation of the equipment. Instructions and precautions for operation under such adverse conditions follow:

a. Handle the equipment carefully.

b. Try to keep the equipment warm and dry. If possible, construct an insulated box for the units. If the units are stored in the bag, line the bag with kimpack, spun glass fiber material, animal skins, or woolen clothing.

c. Heavy coatings of frost will gather on the mouthpiece of the handset in extreme cold weather when the microphone is used in the open air or in a cold room. Frost will form from the breath and will affect speech transmission. A rubber or plastic diaphragm has been provided to protect the microphone. Make sure the diaphragm is in place. If possible, have a spare microphone ready.

d. Handset H-33/PT is of waterproof construction. Make sure that all external parts fit tightly. If water gets into the receivers or if moisture condenses within them, it may freeze and impede the actuation of the diaphragm. When this happens, take off the cap and remove the ice and moisture from the receiver.

e. When equipment which has been exposed to cold is brought into a warm room, it will sweat until it reaches

room temperature. When the equipment has reached room temperature, dry it thoroughly. This condition also arises when equipment warms up during the day after exposure during a cold night.

f. Use any improvised means to protect the dry batteries, since they will fail if not protected against the cold. Refer to TB SIG 66 for further information.

35. Operation in Tropical Climates

When operated in tropical climates, the equipment is subject to extreme conditions of moisture and fungus growth. Ventilation is usually very poor, and the high relative humidity causes condensation of moisture on the equipment. To minimize this condition, take steps to improvise means for prevention of moisture condensation. Place lighted electric bulbs under or near the equipment, when feasible under the circumstances, to minimize this condition. Refer to TB SIG 72 for further information.

36. Operation in Desert Climates

a. Conditions similar to those encountered in tropical

climates often prevail in desert areas. Use the same measures to insure proper operation of the equipment.

b. The main problem which arises with equipment operation in desert areas is the large amount of sand or dust and dirt which enters the moving parts of the equipment, such as the generator and the switches. Try to keep the units as much as possible within dustproof containers. Place wet sacking over the unit and cover the inside walls of the container with heavy paper.

c. Never tie the telephone line, signal cords, or other wiring connections to the inside or the outside of tents. Desert areas are subject to sudden wind squalls which may jerk loose the connections or break the lines.

d. Be careful to keep the equipments as free from dust as possible. Make frequent preventive maintenance checks. Pay particular attention to keep grease or oil out of the units. Excessive amounts of dust, sand or dirt that come in contact with oil and grease result in grit, which will damage the switches and the ringing generator. Refer to TB SIG 75 for further information.

CHAPTER 4

ORGANIZATIONAL MAINTENANCE INSTRUCTIONS

Section 1. ORGANIZATIONAL TOOLS AND EQUIPMENT

37. General

The tools, materials, and test equipments needed to perform the organizational maintenance described in this chapter are listed below. The tools and materials contained in Tool Equipment TE-41 are listed in the Department of the Army Supply Catalog SIG 6-TE-41.

38. Tools, Materials, and Equipments for Organizational Maintenance

a. TOOLS.

1 — Tool Equipment TE-41

b. MATERIALS.

Cleaning fluid: Solvent, dry-cleaning (SD) (Fed spec No. P-S-661a)

Paper, sand, flint #000

Cheesecloth, bleached, lint-free

c. ELECTRICAL PARTS (SPARES).

Battery BA-30, 1½-volt dry cells, two required for each control unit

Battery BA-414/U, 45-volt dry battery, one required for each remote control unit

d. TEST EQUIPMENT.

Electronic Multimeter TS-505/U: d-c voltohmmeter

Microphone and headphones, each equipped with test clips; suitable for connection to points other than the AUDIO connectors

Section II.

PREVENTIVE MAINTENANCE SERVICES

39. Definition of Preventive Maintenance

Preventive maintenance is work performed on equipment (usually when the equipment is not in use) to keep it in good working order so that break-downs and needless interruptions in service will be kept to a minimum. Preventive maintenance differs from trouble shooting and repair since its object is to prevent certain troubles from occurring. See TM 38-650.

40. General Preventive Maintenance Techniques

a. Use #000 sandpaper to remove corrosion.

b. Use a clean, dry, lint-free cloth or a dry brush for cleaning.

(1) If necessary, except for switch and battery contacts, moisten the cloth or brush with solvent, dry-cleaning (SD); then wipe the parts dry with a cloth.

(2) Clean switch and battery contacts with cloth moistened with carbon tetrachloride; then wipe them dry with a cloth.

c. If available, dry compressed air may be used at a line pressure not exceeding 60 P.S.I. to remove dust from inaccessible places; be careful, however, or mechanical damage from the air blast may result.

d. For further information on preventive maintenance techniques, refer to TB SIG 178.

41. Performing Preventive Maintenance

The following preventive maintenance operations should be performed by organizational personnel at the intervals indicated, unless these intervals are changed by the local commander.

Caution: Screws, bolts, and nuts should not be tightened carelessly. Fittings tightened beyond the pressure for which they are designed will be damaged or broken.

a. DAILY. (1) Clean the exterior of local and remote control units and handsets.

(2) Check operation of the ringing generator, bell, and call light by transmitting a ringing signal from one end and receiving it at the other end, with the internal switch set first in the BELL position and then in the LAMP position.

(3) Check operation of the telephone circuit by operating the control group as a field telephone set (par. 26).

b. WEEKLY. (1) Check the dry cells and the 45-volt battery to see that they are in satisfactory operating condition. Discard the 45-volt battery (Battery BA-414/U) if the terminal voltage is 30 volts or less. Replace with a good one. Replace the microphone supply dry cells, Batteries BA-30 (BT-1 and BT-2), if the terminal voltage is less than 1 volt. Do not use a vacuum-tube voltmeter for these checks.

Caution: Remove the batteries before performing the following operations. Upon completion, restore the batteries and check for satisfactory operation.

(2) Clean the panels of the control units and the ear-piece and microphone portions of the handset. Be certain to clean areas surrounding the line binding posts. Remove all dirt and moisture accumulated around them.

(3) Inspect handset cords and plugs for evidences of damage. Check to make certain that proper connection is made.

(4) Check the spring-return action of the spring-loaded switches.

(5) Check the control action of switches and relays by performing each of the operational procedures pertinent to the particular installation (pars. 24 through 32).

c. MONTHLY. Make visual inspection of the following; tighten and/or clean if necessary:

(1) Relay and call light sockets for loose contacts, dirt, and corrosion.

(2) Transformer T-1, switches S-1, S-2, and S-3 (local unit only) terminals for corrosion.

(3) Switches for dirt, corrosion, loose contacts, and improper action.

(4) Multiconnectors for dirt, corrosion, and improper contacts.

(5) Wires, cords, cables, and terminal boards for cracks or cut or frayed insulation.

(6) Mounting hardware for looseness.

d. QUARTERLY. Make visual inspection of the following; clean, refinish, or repair as necessary:

(1) Moisture fungiproof coatings for breaks.

(2) Finish on outer case and panel for scratches.

(3) Capacitors for leakage of dielectric, bulging, or other evidences of damage.

(4) Gaskets on case, "O" rings on connectors and control shafts for evidences of cracking or damage.

Section III. TROUBLE SHOOTING AT ORGANIZATIONAL MAINTENANCE LEVEL

42. Scope

The trouble shooting and repair work that can be performed at the organizational maintenance level (operators and repairmen) is necessarily limited in scope by the tools, test equipment, replaceable parts issued, and by the existing tactical situation. Accordingly, trouble shooting is based on the performance of the equipment and the use of the senses in determining such troubles as burned-out call light, obviously broken or damaged parts, and the like. The para-

graphs which follow in this section will help to determine which of the components of the control group, such as Local Control C-434/GRC, Remote Control C-433/GRC, Handset H-33/PT, or the telephone line, or the associated radio set, are at fault and help to localize the fault in a control group component to the defective circuit section or item.

43. Visual Inspection (figs. 22, 23, and 24)

Visual inspection is the first step in trouble shooting on an organizational level. Many troubles with the equipment can be discovered merely by looking over the equipment and noting an obviously damaged, dirty, or corroded part.

a. LOCAL CONTROL C-434/GRC. Failure of the local control unit to operate properly usually will be caused by one or more of the following faults:

(1) Broken or defective line binding posts.

(2) Loose or corroded line wire connections to the binding posts.

(3) Dirt, corrosion, or moisture accumulated between binding posts may cause partial short-circuit between them, and greatly reduce the efficiency of the line in transferring signal and control voltages between the control units.

(4) Broken, dirty, corroded, or loose panel AUDIO connector or individual contacts of that connector.

(5) Damaged connector cables and/or damaged or dirty connector (J-2) at the rear of the unit.

(6) Broken call light jewel or damaged dimmer control.

(7) Improperly seated or burned-out call light.

(8) Defective, weak, or improperly seated batteries BT-1 and BT-2. Examine batteries for damaged outer cases or leaking electrolyte. Examine battery contacts within the battery container and on the container cover for excessive corrosion. Note whether batteries are installed properly and the electrodes make proper contact with the spring and flat type contacts.

(9) Defective or improperly installed control relays O-1, O-2, and O-3. Remove relays and examine pins to make sure that they are not broken, corroded, or otherwise damaged. Check whether they are all seated in their proper sockets. The correct order of placement from left to right is: relay O-1, relay O-2, and relay O-3.

(10) Pinched wires due to improper reassembly of panel and chassis.

b. REMOTE CONTROL C-433/GRC. The possible causes of failure of the remote control unit to operate properly are similar to those outlined in subparagraph *a* above.

(1) Items (1) through (3) in subparagraph *a* above.

(2) Items (4), (6), and (7) in subparagraph *a* above.

(3) Defective, weak, or improperly seated batteries BT-1 through BT-3. Examine batteries for evidences of damage, such as damaged or corroded outer containers, leaking electrolyte, and defective center electrode. Note whether batteries are installed properly and that the spring and flat type contacts establish proper connection with the BT-1 and BT-2 electrodes.

(4) Item (10) in subparagraph *a* above.

c. HANDSET H-33/PT. Failure of the equipment to operate properly may be caused by a defective handset. The handset may have one or more of the following faults:

(1) The handset cable may not be connected properly within the handset proper, or the cable may be damaged, or wires within the cable broken. The connector at the end of the cable may be damaged. Its contacts may be corroded or broken. The cable connector may not be making proper contact with the panel AUDIO connector. Dirt between or on the connector contacts generally will cause that trouble.

(2) The microphone push-to-talk switch may not be operating properly. Operate the switch and note whether it returns to the unoperated position. Figure 24 shows how to get access to the push-to-talk switch for visual observation of whether or not the switch makes proper contacts when operated, or whether the contacts are separated from each other when the switch is released.

(3) The diaphragm on the microphone or the grille on the earpiece may be damaged. The diaphragm should be glued on the inner rim of the microphone cap. With the diaphragm damaged, moisture and dirt may have accumulated within the capsule holder and thus may have caused improper contact between the capsule and the contacts.

(4) The earpiece or microphone capsules may be damaged or defective.

d. TELEPHONE LINE. If the telephone line is broken, all operation between the local and remote control units will be interrupted. Without meters, the best that can be done is to examine the wire for obvious evidences of a break. If an ohmmeter is available, check for continuity. This may

be done without bringing the two ends of the wire together by placing a temporary short between the two leads at one end of the wire, and measuring for continuity between the two leads at the other end. An infinite or high resistance reading shows that one of the two leads of the wire is broken.

44. Equipment Performance Checklist

a. GENERAL. The equipment performance checklist given in subparagraph *e* below will help the operator to locate trouble in the equipment. This list gives the item number, the item to be checked, the action to be taken, the normal indication, and the possible source of trouble.

b. ACTION OR CONDITION. For some items, the information given in the action or condition column consists of various switch settings under which the item is to be checked. For other items, it represents an action to be taken to check the normal indication given in the normal indications column.

c. NORMAL INDICATIONS. The normal indications listed include the visible and audible signs that the operator should perceive when he checks the items. If the indications are not normal, the operator should apply the recommended corrective measures.

d. CORRECTIVE MEASURES. The corrective measures listed are those that the operator can make without turning in the equipment for repairs. A reference in the table to paragraphs in chapter 6 indicates that the trouble cannot be corrected during operation and that trouble shooting by an experienced repairman is necessary. If the equipment is completely inoperative or if the recommended corrective measures do not yield results, trouble shooting is necessary. However, if the tactical situation requires that communication be maintained, and if the equipment is not completely operative, the operator must maintain the equipment as long as is possible to do so.

Note: Before performing the actions called for in the checklist, check to see that the installation of the equipment has been made properly. Refer to paragraphs 14 through 16 for detailed installation instructions.

e. CHECKLIST.

Item No.	Unit	Item	Action or condition	Normal Indications	Possible defective unit
1	Local control unit.	Generator.	Crank generator and listen in earpiece of handset.	Ringling signal is heard in ear-piece.	Local control unit (par. 70) or handset (par. 65).
2	Local control unit.	Generator (and BELL-LAMP switch in remote unit).	At remote control unit, operate internal BELL-LAMP switch to BELL. At local control unit, crank generator.	Ringling signal is heard at remote control unit.	Remote control unit (par. 69) or telephone line (par. 43d).
3	Local control unit.	Generator (and BELL-LAMP switch in remote unit).	At remote control unit, operate internal BELL-LAMP switch to LAMP. Open dimmer control. At local control unit, crank generator.	CALL LIGHT glows at remote control unit.	Remote control unit call light circuit (par. 69). Replace E-3 and repeat this check.
4	Remote control unit.	SELECTOR switch and push-to-talk switch on handset.	Turn to TEL. Press push-to-talk switch on handset. Talk into mouthpiece and acknowledge call (item 3). Listen in headphones.	Local operator hears remote operator. Remote operator hears sidetone in own ear-piece.	Remote control unit (par. 69) (BT-1 or BT-2). Local control unit (par. 70).
5	Remote control unit.	Generator.	Crank generator and listen in headphone.	Ringling signal is heard in headphone.	Remote control unit (par. 70) or handset (par. 65).
6	Remote control unit.	Ringling signal circuits.	At local control unit operate BELL-LAMP switch to BELL. At remote control unit crank generator.	Ringling signal is heard at local control unit.	Local control unit bell (par. 72d).
7	Remote control unit.	Ringling signal circuits.	At local control unit operate BELL-LAMP switch to LAMP. Open dimmer control. At remote control unit crank generator.	CALL LIGHT glows at local control unit.	Local control unit call light circuit. Replace lamp E-3 and repeat (par. 70).
8	Local control unit.	REMOTE switch.	Turn to TEL ONLY position. Press push-to-talk switch on microphone. Talk into microphone and acknowledge call (item 7). Listen in headphones.	Remote operator hears local operator's speech.	Local control unit (par. 70). Check battery voltage and/or replace with good batteries. Check whether batteries are installed properly.
9	Local control unit.	LOCAL switch.	Turn on power at radio set. Hold LOCAL switch in SET 1 or SET 2 position. ^a Operate microphone push-to-talk switch. Talk into microphone. Release both switches when finished.	Set 1 (or Set 2) transmitter is turned on. Sidetone is heard in operator's own headphones.	Local control unit (par. 70) or radio set.

^a Whichever is used in the particular radio set. If both Set 1 and Set 2 are used, turn switch first to one position and then to the other position. Corresponding indications should be obtained.

Item No.	Unit	Item	Action or condition	Normal Indications	Possible defective unit
10	Remote control unit.	SELECTOR switch and handset.	Turn to left write-in position. Press push-to-talk switch and talk into mouthpiece.		
11	Local control unit.	REMOTE switch.	Turn to SET 1 and 2 position.	Set 1 transmitter is turned on (if used).	Remote control unit (par. 69) or local control unit (par. 70).
12	Remote control unit.	SELECTOR switch and handset.	Turn to right-hand write-in position. Press push-to-talk switch and talk into microphone.	Set 2 transmitter is turned on (if used).	Remote control unit (par. 69). Local control unit (par. 70) or radio set.
13	Local control unit.	REMOTE switch.	Arrange radio set for remote power control. Turn to SET 1 position. (Remote control unit SELECTOR switch in left-hand write-in position, push-to-talk switch unoperated.)	Power for radio set is off. ^b	Handset at remote unit (par. 65).
14	Remote control unit.	Handset.	Operate push-to-talk switch.	At local position radio set power is turned on. ^b Set 1 transmitter (if used) is turned on.	Local control unit (par. 70) or radio set.
15	Remote control unit.	SELECTOR switch and handset.	Turn to right-hand write-in position; operate push-to-talk switch and release.	Radio set power is turned off. ^b Set 1 transmitter (if used) is turned off.	Local control unit (par. 70) or radio set.
16	Local control unit.	REMOTE switch.	Turn to SET 2 position.	Power for radio set stays off.	Local control unit (par. 70) or radio set.
17	Remote control unit.	SELECTOR switch and handset.	Turn to left write-in position and operate push-to-talk switch.	Power for radio set is turned on. ^b Set 2 transmitter (if used) goes on.	Remote control unit (par. 69), handset (par. 66), local control unit (par. 70), or radio set.
18	Remote control unit.	SELECTOR switch and handset.	Turn to middle write-in position and operate; then release push-to-talk switch.	Power for radio set is turned off. ^b Set 2 (if used) is turned off.	Local control unit (par. 70).
19	Remote and local control units.	Control switches.	Turn SELECTOR switch to TEL. Turn REMOTE switch to TEL ONLY.		

^b Provided radio set is arranged for remote power control by Control Group AN/GRA-6.

CHAPTER 5

THEORY OF CONTROL GROUP AN/GRA-6

45. General

Theory of Control Group AN/GRA-6 is presented to provide an understanding of how the units comprising the control group are interrelated with each other and with the operations of the radio sets with which this group is associated. Such an understanding will be an effective aid in trouble shooting the equipment.

a. Control Group AN/GRA-6 provides talking and listening facilities for either one of two receiver-transmitters to a remote point by means of a telephone line. It also provides telephone communication and ringing between the local and remote control positions. The extension of power control of the radio set to the remote position is another function of the control group.

b. The theory discussion given in the following paragraphs is based on the overall schematic diagrams for Remote Control C-433/GRC, Local Control C-434/GRC, and Handset H-33/PT (figs. 27, 28, and 29, respectively) and the block diagram and functional schematics (figs. 17 through 21).

46. Basic Circuit Elements

Figure 17 is a block diagram of Control Group AN/GRA-6, showing the basic elements provided.

a. TELEPHONE CIRCUIT. Each of the two control units provides a line transformer (T-1) with microphone input, receiver output, and balanced 600-ohm line windings. These transformers joined by the telephone line constitute the basic telephone circuit. The term *balanced* means that the impedance to ground of each wire of the two-wire line is approximately the same. With microphones and headsets connected to the microphone and audio output windings of the two transformers, and with the microphone energizing dry cells installed in each of the two units, two-way telephone communication between the local and remote control operators is made possible. Microphone energizing potential is provided in each unit by two flashlight-type dry cells, which are connected in series with the microphone winding of the line transformer.

b. RINGING CIRCUIT. A ringing circuit, consisting of a hand-cranked 20-cycle ringing generator (G-1) as the ringing signal transmitting device, a bell and a lamp (E-3) as the alternate ringing signal receiving devices, and a signal switch (S-1) for selecting audible or visual ringing signal reception constitute the ringing circuit at each unit. These ringing, sending, and receiving devices are effectively con-

nected across the telephone line and are available to the operator at any time. Thus, the operator at either end of the circuit can send out a ringing or *call* signal to the distant operator. Depending on the setting of the internal signal switch S-1, the reception of a call signal is indicated either by the bell or the lamp. The ringing facilities are connected on the line side of the line transformer, T-1, and they have no connection with the radio set which may be associated with the local control unit. They serve merely as a means of alerting the operator of an incoming telephone message from the distant operator.

c. CONTROL CIRCUITS. In addition to the ringing and telephone circuits, the units provide control facilities necessary to turn on power for the radio set and/or to operate on a push-to-talk basis either one of two units of the radio set designated as Set 1 and Set 2. The control facilities at the two units complement each other. The nature of control and the mode of operation provided in a particular instance depend on the combined efforts of both the local and the remote operators, since the settings of control switches at the two units are interrelated with each other.

(1) *Remote Control C-433/GRC.* The control facilities of the remote control unit consist of a three-position SELECTOR switch (S-2) and a control voltage in the form of a 45-volt plug-in type dry battery (BT-3). By means of the SELECTOR switch, the remote operator either can disconnect the battery from the line entirely (TEL position), or connect the battery across the line so that line binding post L-1 is positive and L-2 is negative (left-hand write-in position), or connect the battery across the line so that L-1 is negative and L-2 is positive (right-hand write-in position). Connection of the battery across the line is completed by means of a set of contacts of the microphone push-to-talk switch. Thus, the control functions come into play only when the remote operator desires to talk or transmit over the radio set.

(2) *Local Control C-434/GRC.* The control facilities of the local control unit consist of a set of three relays (O-1, O-2, and O-3), a four-position REMOTE switch, and a three-position LOCAL switch. Briefly, the REMOTE switch (SET 1, SET 2, or SET 1 & 2 position) is effective in connecting the three relays across the line in order to respond to the particular control voltage polarity determined by the setting of the remote operator's SELECTOR switch (subpar. (1) above) to turn on radio set power and/or push-to-talk control of either Set 1 or Set 2. In the TEL ONLY position, the switch removes control of the radio set from the

remote operator, and by means of the LOCAL switch, the local operator can take push-to-talk control of either Set 1

or Set 2. Circuit details are discussed in paragraphs 47 through 59.

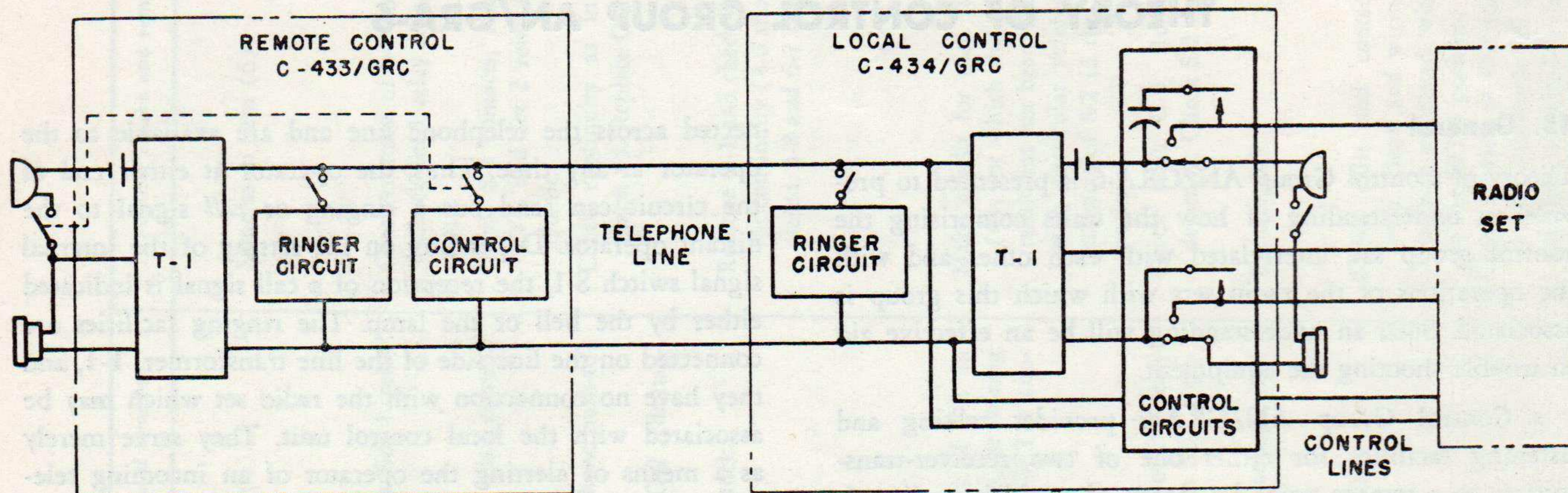

Figure 17. Control Group AN/GRA-6, over-all simplified block diagram.

47. Telephone Circuit (figs. 19, 27, 28, and 29)

The telephone circuit includes, at each end, talking and listening paths, microphone energizing voltages (BT-1 and BT-2), and the ringing facilities, as outlined in paragraph 46. When the SELECTOR switch at the remote control unit and the LOCAL switch at the local control unit are both set in the TEL positions and the REMOTE switch of the local unit is in the TEL ONLY position, the basic duplex telephone circuit is set up as described below. The control voltage (BT-3) at the remote unit and the control relays (O-1 through O-3) of the local unit are disconnected from the line. The resultant circuit arrangement is shown in figure 19 and is described below.

a. At each of the two control units, the carbon element of the microphone of the handset, in series with one set of contacts of the push-to-talk switch, is connected between terminals E and C of AUDIO connector J-1. At the local control unit the microphone circuit is completed through the TEL contacts, Section C of LOCAL switch S-3, to winding 5-6 of T-1. At the remote control unit the microphone circuit is completed directly to winding 5-6 of T-1. In each case, the microphone circuit is completed by closure of the microphone push-to-talk switch.

b. At each control unit the earpiece of the handset is connected between terminals A and B of J-1. At the local control unit the headphone circuit is completed to winding 7-9 of T-1. This winding is returned to ground through the TEL contacts of Section A of switch S-3 and the normally closed contacts 4 and 6 of control relay O-1. At the remote control unit the headphones are connected directly across winding 7-9 of T-1.

c. Speech signals developed across winding 5-6 of T-1, are induced in the line winding circuit consisting of line

windings 1-2 and 3-4 of T-1, joined by a large d-c blocking and audio bypass capacitor C-1B, and are applied to the line binding posts L-1 and L-2. The capacitor is located in the electrical center of the line winding of the transformer. It provides an effective short circuit for speech signals and a relatively high impedance to 20-cycle ringing currents. A portion of the speech signals is developed across winding 7-9 of T-1 and is returned to the sender's headpiece as sidetone. The speech signals developed across L-1 and L-2 are routed over the telephone line to the line binding posts of the distant control unit and are developed across the line circuit of the remote unit which is identical to the one described above. Speech signals induced in winding 7-9 of T-1 are applied to the operator's headphone. It should be noted in the case of the local control unit that, if by turning the local switch away from the TEL position or if by application of a control voltage from the remote end, contacts 4 and 6 of O-1 are opened, the listening circuit of the local operator is broken and the distant operator's message cannot reach him.

48. Ringing Circuits

When the operator cranks the panel-mounted ringer generator crankshaft, a 20-cycle ringing signal is generated by magneto-type generator G-1 and is applied to the telephone line. When not operating, the generator is disconnected from the line by a set of contacts actuated by the crankshaft. When the crankshaft is turned, the contacts close to connect the generator output between terminals 2 and 3 of the line transformer (fig. 19). The ringing signals pass through each half of the line transformer (windings 1-2 and 3-4) and are transmitted over the line to the distant control unit. The ringing signals enter the distant control unit in the same way as audio signals (par. 47), pass

through the line coils, and are applied either across a bell or across neon glow lamp E-3, depending on the position of internal switch S-1. With the switch in the BELL position, the bell in series with a large d-c blocking capacitor, C-1A is connected across d-c blocking capacitor C-1B and between terminals 2 and 3 of the line transformer. With switch S-1 in the LAMP position, the neon glow lamp, in series with voltage-dropping resistor R-1, is connected across the same points in the line circuit. The circuit arrangement described above applies to both the local and remote units, and is completely symmetrical. It should be noted that a pair of contacts of the microphone switch, which is connected between terminals F and H of J-1 of the remote unit, serves to connect the control voltage to the line circuit. The contacts are in series with the normally closed contacts of the ringing generator. During the ringing interval, therefore, when the ringing generator is being cranked and is connected across the line, the microphone push-to-talk switch and the control voltage circuit are disconnected from the line, and remote control operation is not feasible. Similarly, during ringing intervals, contacts of the generator switch effectively disconnect the bell and lamp from the circuit, thus preventing an outgoing ringing signal from actuating these signal receiving devices of the sending unit. Another point to be noted is that the ringing signals developed across the line circuit of the signal sending and receiving units are induced in windings 7-8-9 of T-1 at each unit, and, therefore, can be heard in the headphones of both operators.

49. Purposes of Radio Set Control

a. GENERAL. The control functions provided by Control Group AN/GRA-6 are closely related to the nature and type of radio set of the installation in which the control group is used. Since, without association with the radio set, the control functions of the control group have no meaning, it is necessary to have a clear understanding of the radio set which is to be controlled, and also, what the control functions are attempting to accomplish with respect to the radio set. This is discussed in the following subparagraphs.

b. RECEIVER-TRANSMITTER CONTROL. The receiver-transmitters to be controlled by Control Group AN/GRA-6 must be of the push-to-talk type. This means that they consist of separate receiver and transmitter circuits, but are arranged so that either the receiver or the transmitter is on one at a time.

(1) The function of turning on either one of the two circuits is placed under control of a relay control circuit within the receiver-transmitter unit. Normally, contacts of the relay circuits keep the receiver operative, while the transmitter is in an unoperative condition. Only when the relays within the receiver-transmitter are energized is the

receiver disabled and the transmitter turned on. To permit control of this function from an external control position, the ground return lead for the relay circuits is brought out to mountings and panel connectors, and then to the control unit.

(2) In radio installations where sufficient flexibility exists to allow more than one receiver-transmitter to be used or where more than one control position may exist, it is necessary to select the particular talking circuit. The operator at the control position (local or remote), therefore, must be able to select the audio circuits of the particular receiver-transmitter over which he wishes to communicate. Alternatively, if an interphone system is associated with the radio set, the operator may wish to select the interphone channel as his talking circuit. Furthermore, he may wish to monitor the reception and transmission by an operator at another control position over any one of the talking circuits.

(3) While the talking circuit of the push-to-talk unit is in a stand-by condition, power for the talking circuit normally is off. Also, for the purpose of conserving battery, it is frequently desirable to have power on only when the radio set is in actual use, and to turn off the radio set power when the set is not in actual use. This control group may be associated with two types of radio sets; those which make no provision for remote control of radio set power, and those which do make provision for alternate turning on of power at the radio set or from a control position (remote). The function of turning on radio set power from Control Group AN/GRA-6 is effective in the latter type of set only.

(4) Summarizing the above, the basic control functions of Control Group AN/GRA-6 involve:

(a) Switching of relay control ground return from either the local or remote position.

(b) Switching of the audio circuits (receiving and sending) from either the local or remote position.

(c) In the case of radio sets provided with means for allowing remote power control, switching of power from the remote position, or, only if necessary, from the local position.

c. RADIO SET ARRANGEMENTS. Control Group AN/GRA-6 is equipped to provide push-to-talk control of a radio set which includes either one or two push-to-talk units. These units may be a receiver-transmitter alone, or a receiver-transmitter and an interphone amplifier arranged for push-to-talk operation, or any other unit requiring one or more of the control functions outlined above. The terms Set 1 and Set 2 will be used in the following discussions to designate any unit answering the general descriptions above. In some installations there will be only a Set 1, in others only a Set 2, and still in others both a Set 1 and a Set 2.

50. Relays

a. Of the three relays, relay O-1 is a nonpolarized, nonlocking type. This relay is energized whenever a current of at least .9 ma flows through its coil, regardless of the voltage polarity applied across the coil. When this relay is energized, contact pairs 5-8 and 6-7 are closed and contact pair 4-6 is open. The contacts of the relay return to the normal, unoperated position whenever the energizing voltage is removed.

b. Relays O-2 and O-3 are identical. Each is a polarized relay equipped with a magnetic latch. When a voltage of proper polarity and magnitude is applied across the coil of either relay so that terminal 2 is positive with respect to terminal 3, contacts 4 and 6 of the relay close and contacts 6 and 7 open. A magnetic latch holds contacts 4-6 closed even after the voltage is removed. If the voltage is applied across the relay coil so that terminal 2 is negative with respect to terminal 3, contacts 6 and 7 close (regardless of previous condition) and remain closed even after the voltage has been removed. In either case, a reversal of the applied voltage polarity is necessary to transfer the armature (contact 6) to the open contact. The coils of the three relays

are connected in series with each other between terminals 2 and 3 of T-1 when the REMOTE switch is in either one of the three remote control positions (SET 1, SET 2 or SET 1 & 2). One side of the coil of O-1 is connected permanently to terminal 2 of T-1, and thus, through winding 1-2 of T-1 to L-1. Terminal 3 of O-3 is connected permanently to terminal 3 of T-1, and thus, through winding 3-4 of T-1 to L-2. The other side of the coil of O-1, terminal 2 of O-3, and both terminals of O-2 are associated with each other through contacts of the REMOTE switch S-2 (in the SET 1, SET 2, and SET 1 & 2 positions).

c. The contacts of relay O-1 are associated with the function of switching the microphone lead (contacts 5-8) and of the headphone lead (contacts 4-6-7). Relay O-2 contacts are associated with the function of switching the ground return connection to the receiver-transmitter control relays (contacts 4-6 for Set 1 and contacts 6-7 for Set 2). Relay O-3 contacts function to switch the power supply energizing lead for the radio set (contacts 4-6 closed for power on and contacts 4-6 open for power off). The following chart indicates the positions of the relay contacts for various line polarities and switch positions. This is pictorially represented in figure 18.

Polarity of control voltage		Remote SELECTOR switch	Relay contacts closed for REMOTE switch setting								
			SET 1 and 2			SET 1			SET 2		
L-1	L-2		O-1	O-2	O-3	O-1	O-2	O-3	O-1	O-2	O-3
+	-	Left-hand write-in	5-8 6-7	4-6	4-6	5-8 6-7	4-6	4-6	5-8 6-7	7-6	4-6
-	+	Right-hand write-in	5-8 6-7	7-6	7-6	5-8 6-7	7-6	7-6	5-8 6-7	4-6	7-6

51. Remote Control of Set 1 with Control of Power at Radio Set

a. SWITCH SETTINGS. For this mode of operation the control switches at the local and remote control units are arranged as follows:

LOCAL switch in TEL position.

REMOTE switch in SET 1 position.

SELECTOR switch in left-hand write-in position.

Power turned on at radio set.

b. CIRCUIT ARRANGEMENT FOR TRANSMISSION. The circuit arrangement resulting for the above switch settings is shown in figure 21.

(1) *Control voltage application.* When the remote operator closes his microphone push-to-talk switch, the circuit arranges itself as follows:

(a) The control voltage provided by BT-3 at the remote unit is applied to the telephone line through T-1 so that binding post L-1 is positive and L-2 is negative.

(b) At the local control unit, relays O-1, O-2, and O-3 are connected across the line circuit in series with each other (through T-1, the generator, and S-1). Relays O-2 and O-3 are in a series-aiding connection with respect to each other, that is, terminals 2 of both relay coils are associated with L-1 and terminals 3 of both relays are associated with L-2.

(c) Application of the control voltage so that L-1 is positive and L-2 is negative causes all three relays to operate and arrange their contacts as tabulated below. The results of the relay contact arrangement are given in the subsequent subparagraphs.

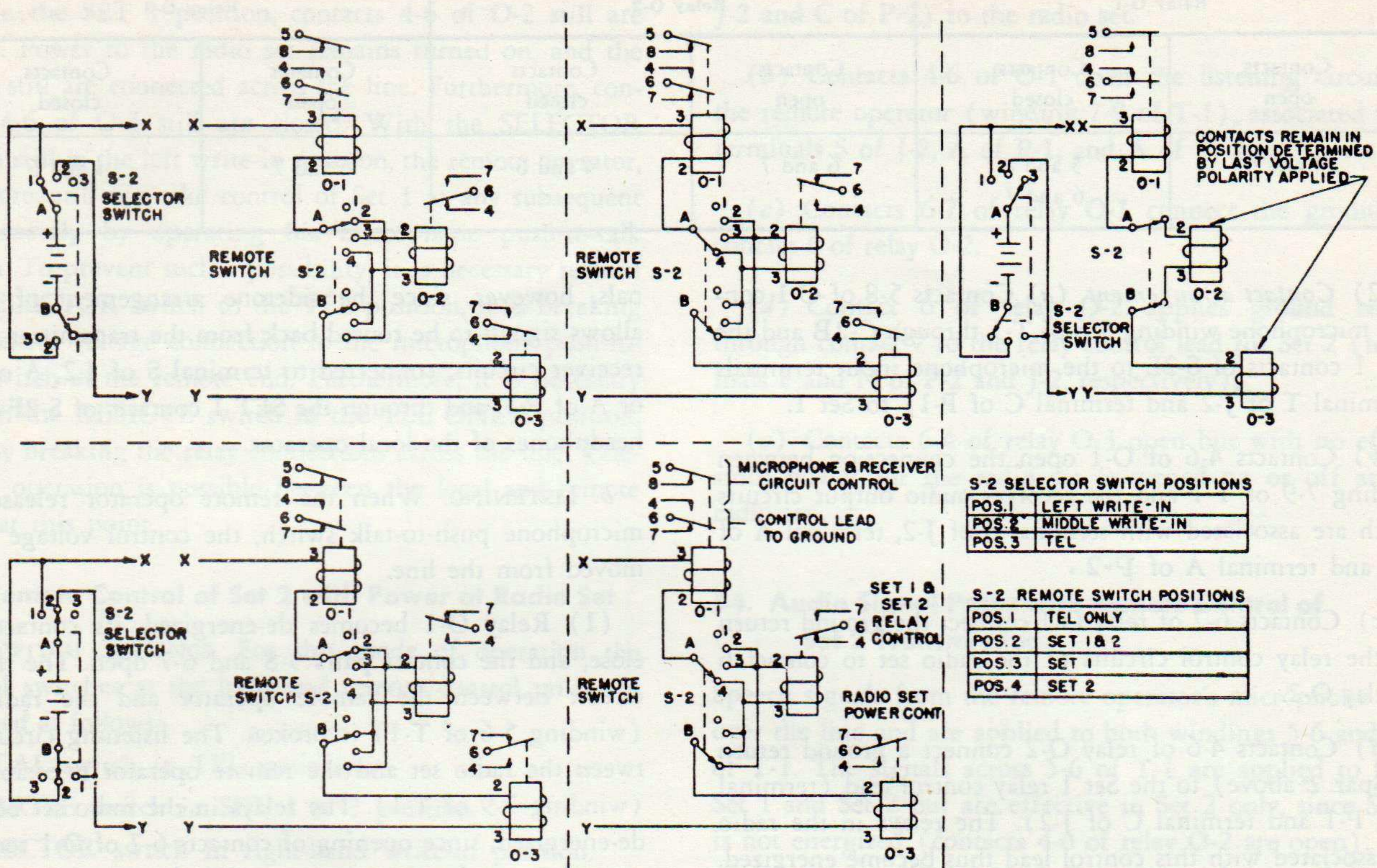

Figure 18. Control voltage polarities and relay contact arrangements.

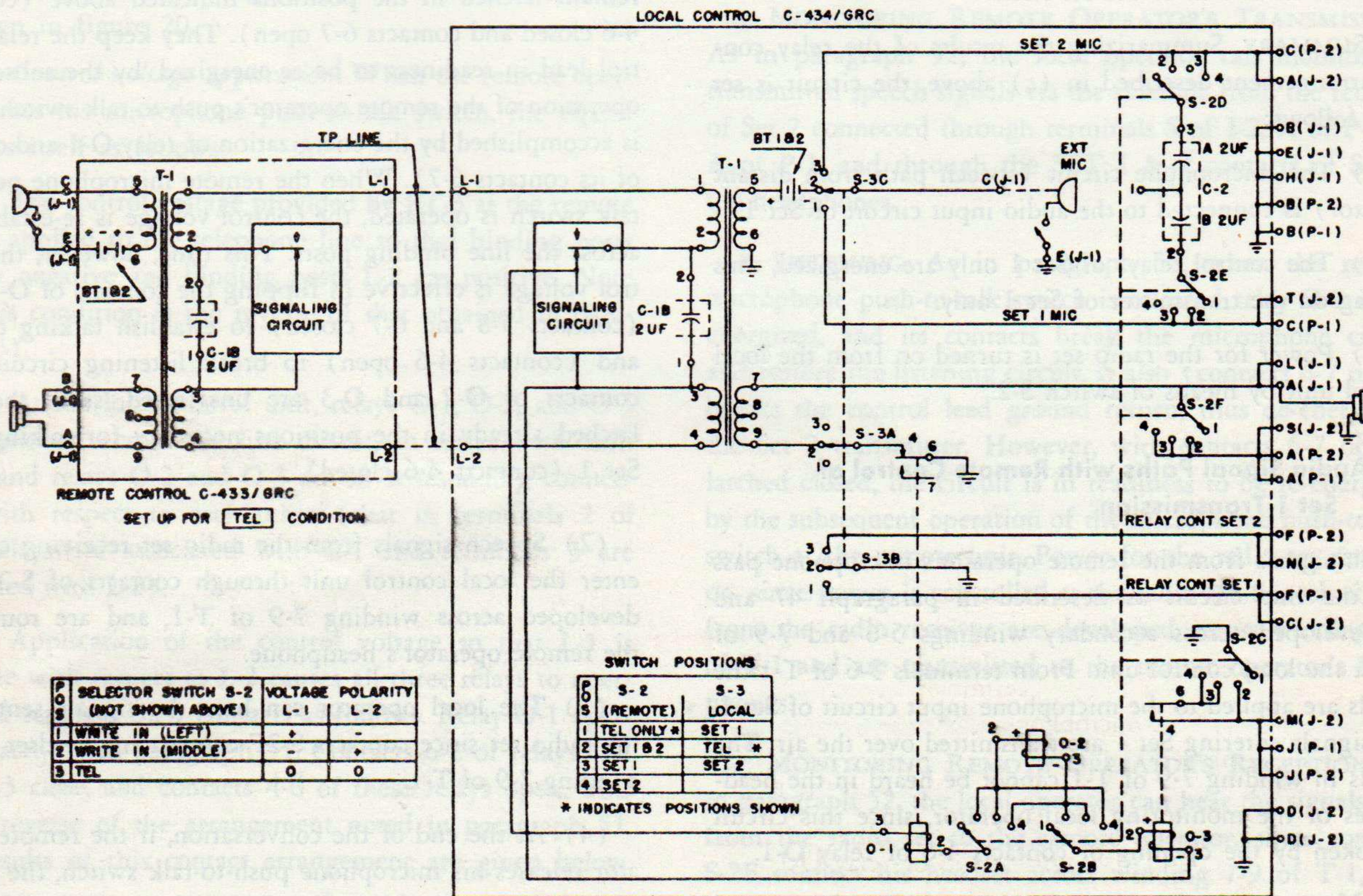

Figure 19. Control Group AN/GRA-6, operation as field telephone set, functional diagram.

Relay O-1		Relay O-2		Relay O-3	
Contacts open	Contacts closed	Contacts open	Contacts closed	Contacts open	Contacts closed
4 and 6	5 and 8 6 and 7	6 and 7	4 and 6	6 and 7	4 and 6

(2) *Contact arrangement.* (a) Contacts 5-8 of O-1 connect microphone winding 5-6 of T-1 through C-2B and the SET 1 contacts of S-2E to the microphone input terminals (terminal T of J-2 and terminal C of P-1) to Set 1.

(b) Contacts 4-6 of O-1 open the connection between winding 7-9 of T-1 and the receiver audio output circuits which are associated with terminal S of J-2, terminal A of P-1, and terminal A of P-2.

(c) Contacts 6-7 of relay O-1 connect the ground return for the relay control circuits of the radio set to contact 6 of relay O-2.

(d) Contacts 4-6 of relay O-2 connect a ground return (subpar. c above) to the Set 1 relay control lead (terminal F of P-1 and terminal C of J-2). The relays in the radio set associated with this control lead thus become energized.

(e) Closure of contacts 4-6 of relay O-3 has no effect since the radio set power is turned on by means of the power on-off switch of the set itself.

c. **SUMMARY.** Summarizing the results of the relay contact arrangement described in (c) above, the circuit is set up as follows:

(1) The microphone circuit (speech path from distant operator) is connected to the audio input circuit of Set 1.

(2) The control relays of Set 1 only are energized, thus turning on the transmitter of Set 1 only.

(3) Power for the radio set is turned on from the local control unit by means of switch S-2.

52. Audio Signal Paths with Remote Control of Set 1 Transmission

Speech signals from the remote operator's microphone pass over the line circuit as described in paragraph 47 and are developed across secondary windings 5-6 and 7-9 of T-1 at the local control unit. From terminals 5-6 of T-1 the signals are applied to the microphone input circuit of Set 1. The signals entering Set 1 are transmitted over the air. The signals in winding 7-9 of T-1 cannot be heard in the headphones of the monitoring local operator, since this circuit is broken by the opening of contacts 4-6 of relay O-1.

a. **MONITORING REMOTE OPERATOR'S TRANSMISSION.** The local operator can monitor the transmitted speech sig-

nals, however, since the sidetone arrangement of Set 1 allows signals to be routed back from the transmitter to the receiver circuits, connected to terminal S of J-2, A of P-2, or A of P-1, and through the SET 1 contacts of S-2F to the headphones of the local operator.

b. **LISTENING.** When the remote operator releases his microphone push-to-talk switch, the control voltage is removed from the line.

(1) Relay O-1 becomes de-energized, its contacts 4-6 close, and the contact pairs 5-8 and 6-7 open. The talking circuit between the remote operator and the radio set (winding 5-6 of T-1) is broken. The listening circuit between the radio set and the remote operator is established (winding 7-9 of T-1). The relays in the radio set become de-energized, since opening of contacts 6-7 of O-1 removes ground return for the relay control lead.

Note. The contacts of relays O-2 and O-3, however, remain latched in the positions indicated above (contacts 4-6 closed and contacts 6-7 open). They keep the relay control lead in readiness to be re-energized, by the subsequent operation of the remote operator's push-to-talk switch. (This is accomplished by the energization of relay O-1 and closure of its contacts 6-7). When the remote microphone push-to-talk switch is operated, the control voltage is re-established across the line binding posts. This time, however, the control voltage is effective in flipping the contacts of O-1 only (contacts 5-8 and 6-7 closed) to establish talking circuit, and (contacts 4-6 open) to break listening circuit. The contacts of O-2 and O-3 are unaffected, since they are latched already in the positions necessary for talking over Set 1 (contacts 4-6 closed).

(2) Speech signals from the radio set receiving circuits enter the local control unit through contacts of S-2F, are developed across winding 7-9 of T-1, and are routed to the remote operator's headphone.

(3) The local operator can hear the signals sent from the radio set since contacts S-2F connect his headset across winding 7-9 of T-1.

(4) At the end of the conversation, if the remote operator releases his microphone push-to-talk switch, the listening circuit is re-established, and the talking circuit is broken by the return of relay O-1 to the unenergized condition.

However, with the REMOTE switch at the local control unit in the SET 1 position, contacts 4-6 of O-2 still are closed. Power to the radio set remains turned on, and the relays still are connected across the line. Furthermore, contacts 4-6 of O-3 still are closed. With the SELECTOR switch still in the left write-in position, the remote operator, therefore, still can take control of Set 1 at any subsequent time merely by operating his microphone push-to-talk switch. To prevent such a possibility, it is necessary to turn the SELECTOR switch to the TEL position, thus breaking the control voltage connection to the microphone push-to-talk switch at the remote end. Furthermore, it is necessary to turn the REMOTE switch to the TEL ONLY position, thereby breaking the relay connections across the line. Telephone operation is possible between the local and remote units at this point.

53. Remote Control of Set 2 with Power at Radio Set

a. SWITCH SETTINGS. For this mode of operation the control switches at the local and remote control units are arranged as follows:

LOCAL switch in TEL position.

REMOTE switch in SET 1 & 2 position.

SELECTOR switch in right-hand write-in position.

Power turned on at radio set.

b. CIRCUIT ARRANGEMENT FOR TRANSMISSION. The circuit arrangement resulting from the above switch settings is shown in figure 20.

(1) *Control voltage application.* When the remote operator closes his microphone push-to-talk switch, the circuit arranges itself as follows:

(*a*) The control voltage provided by BT-3 at the remote unit is applied to the telephone line so that binding posts L-1 are negative and binding posts L-2 are positive. Note that this condition is the reverse of that obtained in paragraph 51.

(*b*) At the local control unit, relays O-1, O-2, and O-3 are connected across the line circuit, in series with each other, and relays O-2 and O-3 are in series-aiding connection with respect to each other (that is, terminals 2 of both relays are associated with L-1 and terminals 3 are associated with L-2).

(*c*) Application of the control voltage so that L-1 is negative with respect to L-2 causes all three relays to operate, and arranges their contacts as follows. Relay O-1 operates exactly as in paragraph 51. Contacts 6-7 of relays O-2 and O-3 close, and contacts 4-6 of these relays open. This is the reverse of the arrangement noted in paragraph 51. The results of this contact arrangement are given below.

(2) *Contact arrangement.* (*a*) Contacts 5-8 of O-1 connect the microphone winding 5-6 of T-1 through C-2A,

S-2D, and the microphone input terminals (terminals A of J-2 and C of P-2) to the radio set.

(*b*) Contacts 4-6 of O-1 open the listening circuit to the remote operator (winding 7-9 of T-1), associated with terminals S of J-2, A of P-1, and A of P-2.

(*c*) Contacts 6-7 of relay O-1 connect the ground to contact 6 of relay O-2.

(*d*) Contact 6 of relay O-2 applies ground return through contact 7 to the relay control lead for Set 2 (terminals F and N of P-2 and J-2, respectively).

(*e*) Contacts 6-4 of relay O-3 open but with no effect, since power for the radio set is turned on or off at the radio set.

54. Audio Signal Paths with Remote Control of Set 2 Transmission

Speech signals from the remote operator's microphone pass over the line and are applied to both windings 5-6 and 7-9 of T-1. The signals across 5-6 of T-1 are applied to both Set 1 and Set 2 but are effective in Set 2 only, since Set 1 is not energized (contacts 4-6 of relay O-2 are open). The signals in winding 7-9 of T-1 cannot be heard in the monitoring local operator's headphone, since this circuit is broken by the opening of contacts 4-6 of relay O-1.

a. MONITORING REMOTE OPERATOR'S TRANSMISSION. As in paragraph 52, the local operator can monitor the transmitted speech signals via the sidetone from the receiver of Set 2 connected through terminals S of J-2, A of P-2, or A of P-1, and through the SET 1 & 2 contacts of S-2 to the headphones.

b. LISTENING. As in paragraph 52, when the remote microphone push-to-talk switch is released relay O-1 is de-energized, and its contacts break the microphone circuit and restore the listening circuit. It also (contacts 6-7 open) breaks the control lead ground return, thus de-energizing the Set 2 transmitter. However, with contacts 6-7 of O-2 latched closed, the circuit is in readiness to be re-energized by the subsequent operation of the microphone push-to-talk switch at the remote unit. Power for the radio set remains on, since power is controlled at the radio set. Speech signals from the radio receiver are developed across winding 7-9 of T-1 and are transmitted to the remote operator's headphones.

c. MONITORING REMOTE OPERATOR'S RECEPTION. As in paragraph 52, the local operator can hear the signals sent from the radio set to the remote operator, since contacts S-2F connect his headset across winding 7-9 of T-1, and that winding now is continuous by the closure of contacts 4-6 of O-1.

d. **REMOTE OPERATOR'S REPLY.** When the remote microphone push-to-talk switch is closed to reply, the control voltage is re-established on the line. It is effective, however, only in flipping the contacts of O-1 to the talking position, as described in paragraph 51. It has no effect in changing the arrangement of the contacts of O-2 and O-3, since contacts 6-7 already are latched.

e. **END OF CONVERSATION.** As in paragraph 51, turning the SELECTOR and REMOTE switches to the TEL and TEL ONLY positions, respectively, breaks the control voltage connection to the remote operator's push-to-talk switch, and disconnects the local control relays from the line, making it impossible to resume operation from the remote unit.

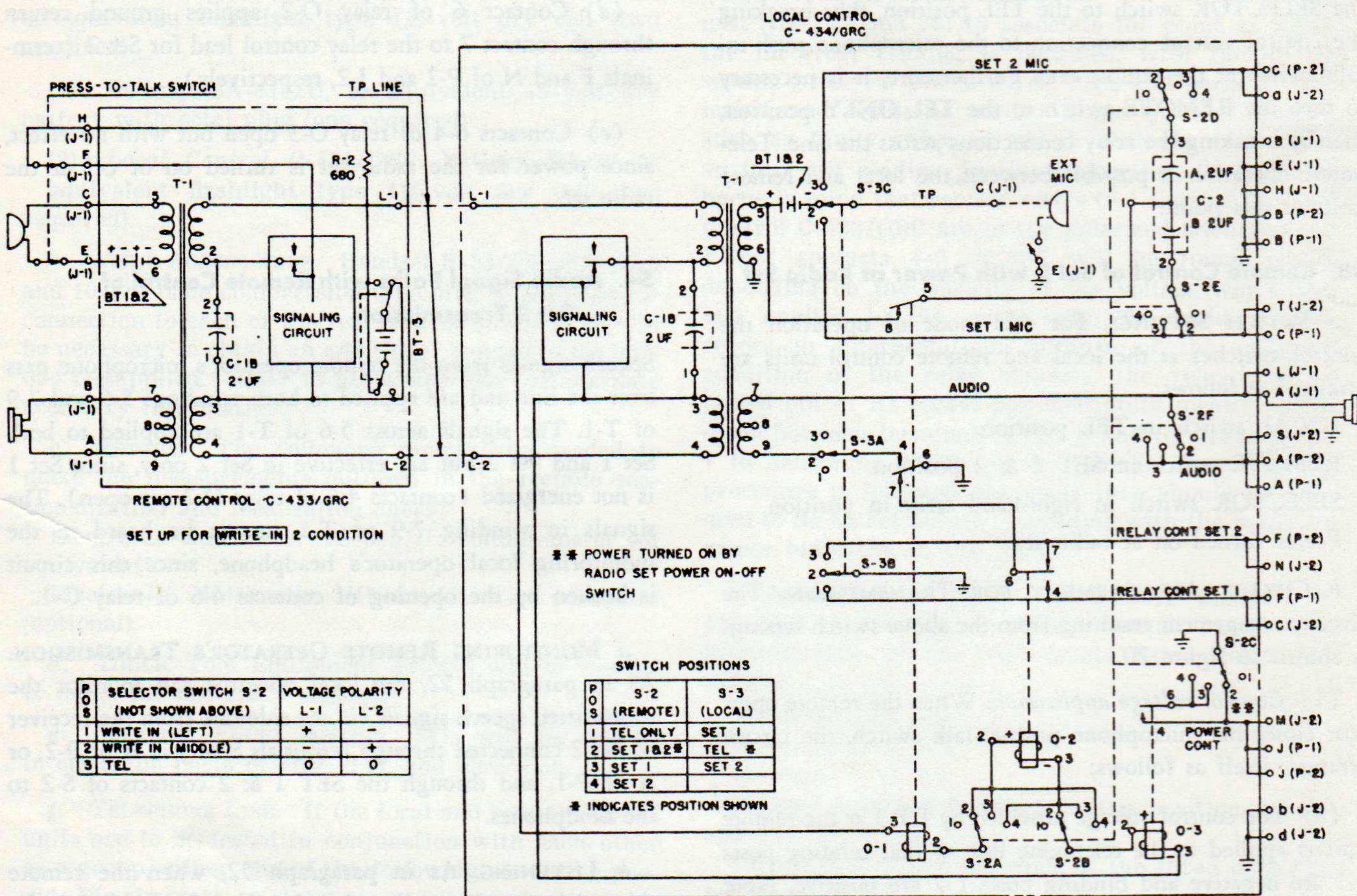

Figure 20. Control Group AN/GRA-6, remote control of Set 2 with local control of power, functional diagram.

55. Remote Control of Either Set 1 or Set 2, with Power Control at Radio Set

A review of the circuit arrangements described in paragraphs 51 through 54 will show that when the REMOTE switch is in the SET 1 & 2 position, the remote operator can operate at will either Set 1 or Set 2.

a. To operate Set 1, the SELECTOR switch is turned to the left-hand write-in position. This applies the control voltage to the line so that when the push-to-talk switch is operated, L-1 is positive with respect to L-2. At the local control unit contacts 4-6 of relay O-2 close, energizing Set 1. Contacts 6-7 of relay O-2 are open, thereby keeping Set 2 inoperative. Relay O-3 is ineffective since power is applied

manually at the radio set. Relay O-1 is independent of control voltage polarity and is energized when the control voltage is applied (microphone push-to-talk switch closed) and de-energized when the control voltage is removed (microphone push-to-talk switch open).

b. Turning the SELECTOR switch to the right-hand write-in position and operating the microphone push-to-talk switch applies the control voltage to the line so that L-1 is negative with respect to L-2. The effect of this polarity (the reverse of that stated in subparagraph a above) at the local control unit is as follows: Relay O-1 operates as before. Relays O-2 and O-3 contacts 6-7 close, grounding the relay control lead for Set 2. Relay O-3 is ineffective,

since power is applied manually at the radio set. Opening of contacts 4-6 of O-2 breaks ground return for Set 1 which disables the transmitter of Set 1.

c. From subparagraphs 55 *a* and *b* above, it follows that when the circuit is set up with the REMOTE switch in SET 1 & 2 position, the remote operator can select operation over either Set 1 or Set 2. The left-hand write-in position of the SELECTOR switch becomes a Set 1 on—Set 2 off position, while the right-hand write-in position becomes a Set 2 on—Set 1 off position. Monitoring, listening, and reply functions remain as described in paragraphs 52 and 54.

56. Remote Control of Set 1 with Remote Control of Radio Set Power

This mode of operation may be made only if provisions have been made on the radio set for remote control of power. The switches on the local and remote units are arranged as follows:

LOCAL switch in TEL position

REMOTE switch in SET 1 position

SELECTOR switch in left-hand write-in position for

power and Set 1 on, and in the right-hand write-in position for radio set power off.

a. **CIRCUIT ARRANGEMENT.** The circuit arrangement resulting from the above switch settings is shown in figure 21. When the remote operator closes his microphone push-to-talk switch while the SELECTOR switch is in the left-hand write-in position, the circuit arranges itself as follows:

(1) The control voltage provided by BT-3 at the remote unit is applied to the telephone line and the local control unit binding posts, so that L-1 is positive and L-2 is negative.

(2) At the local control unit, relays O-1, O-2, and O-3 are in series connected across the line. Relays O-2 and O-3 are arranged in series-aiding polarity as in paragraph 51, with terminals 2 associated with L-1 and terminals 3 associated with L-2. The REMOTE switch connects ground to contact 6 of relay O-3.

(3) With L-1 positive and L-2 negative, the three relays operate to arrange their contacts as tabulated below. The results of the relay contact arrangement are given in the following subparagraphs.

Relay O-1		Relay O-2		Relay O-3	
Contacts open	Contacts closed	Contacts open	Contacts closed	Contacts open	Contacts closed
4 and 6	5 and 8 6 and 7	6 and 7	4 and 6	6 and 7	4 and 6

b. CIRCUIT CONNECTIONS MADE BY RELAY CONTACTS.

(1) Contacts 5-8 of relay O-1 associate the microphone winding (5-6) of T-1 with the microphone input connections to both Sets 1 and 2.

(2) Contacts 4-6 of relay O-1 break the connection between the receiver output connection and winding 7-9 of T-1 and thus to the remote unit.

(3) Contacts 6-7 of relay O-1 connect ground to contact 6 of relay O-2.

(4) With contacts 4-6 of O-2 closed, the ground return connection provided by contacts 6-7 of O-1 is connected to the control lead for Set 1.

(5) With contacts 4-6 of relay O-3 closed, ground return connection provided by the contacts of the REMOTE switch in the SET 1 position is made to the radio set power control lead, and the radio set power is turned on. (This, as was said before, assumes that the radio set is equipped and arranged to permit power control from Control Group AN/GRA-6.)

57. Audio Signal Path with Remote Control of Radio Set Power and Set 1 Transmission

Speech signals from the remote operator enter Set 1 and can be transmitted through that set. As mentioned above (par. 52), with winding 7-9 of T-1 open, the local operator cannot monitor the remote operator's speech transmission directly.

a. **MONITORING REMOTE OPERATOR'S TRANSMISSION.** As in paragraph 52, the local operator can monitor the remote operator's transmission via the sidetone circuit of Set 1 and of the radio set, that is, at the receiver output connections to the local control unit (terminals S of J-2, A of P-2, or A of P-1).

b. **LISTENING.** When the remote operator releases his microphone push-to-talk switch to receive a signal from the radio set, the control voltage is removed from the line (par. 52), relay O-1 of the local control unit transfers its contacts to re-establish the remote operator's listening circuit and to break his radio set transmission circuit. Contacts 4-6 of relays O-2 and O-3 remain latched. The ground re-

turn for the Set 1 control lead is opened by the opening of contacts 6-7 of relay O-1. However, with contacts 4-6 of O-2 latched, the circuit is ready to be completed by subsequent closure of the push-to-talk switch at the remote unit. In this case, the fact that contacts 4-6 of O-3 remain latched is important, since ground return for the radio set power control lead remains connected, and the radio set power remains on. This keeps the receiver energized and capable of providing the distant radio operator's reply to the remote operator, via winding 7-9 of T-1, and the now closed contacts 4-6 of relay O-1.

c. MONITORING REMOTE OPERATOR'S RECEPTION. The local operator can hear the signals from the radio set receiver to the remote operator (par. 52), since contacts of S-2F connect his headset across the now completed winding 7-9 circuit of T-1.

d. REMOTE OPERATOR'S REPLY. When the remote position push-to-talk switch is pressed, the control voltage re-applied to the line binding posts is of the same polarity as before. Therefore, the only effect is to transfer the contacts of O-1 from the listening to the talking positions. The microphone circuit is reconnected to the radio set, the listening circuit is broken, and the relay control lead ground return is re-established through closure of contacts 6-7 of O-1 and through the latched contacts 4-6 of O-2.

e. END OF CONVERSATION. From the above, it will be

noted that opening and closing of the microphone push-to-talk switch at the remote unit, after the first closure of that switch, has no effect on relays O-2 and O-3 at the local control unit. Therefore, with contacts 4-6 of O-3 closed, power remains applied to the radio set. To shut off power from the radio set for this type of operation, it is necessary to reverse the control voltage polarity across the line. This is done by turning the SELECTOR switch to the middle write-in position, and momentarily operating the microphone push-to-talk switch. This procedure results in the reversal of the battery BT-3 connection. The battery is connected across the line momentarily with the pressing of the push-to-talk switch. The control voltage is applied to the line so that L-1 is negative and L-2 is positive. At the local control unit, reversal of the control voltage polarity operates relay O-3, opening contacts 4-6. The ground connection to the power supply control lead is broken, and the radio set power supply becomes de-energized. When the microphone push-to-talk switch is released, the control voltage is removed from the line, and relay O-1 is allowed to return to its stand-by condition (that is, contacts 4-6 closed to re-establish the listening circuit, contacts 5-8 and 6-7 open to break the microphone and relay control circuits, respectively). This last step illustrates the reason for momentarily operating the push-to-talk switch at the remote position to turn off radio set power and to return the circuit to stand-by conditions.

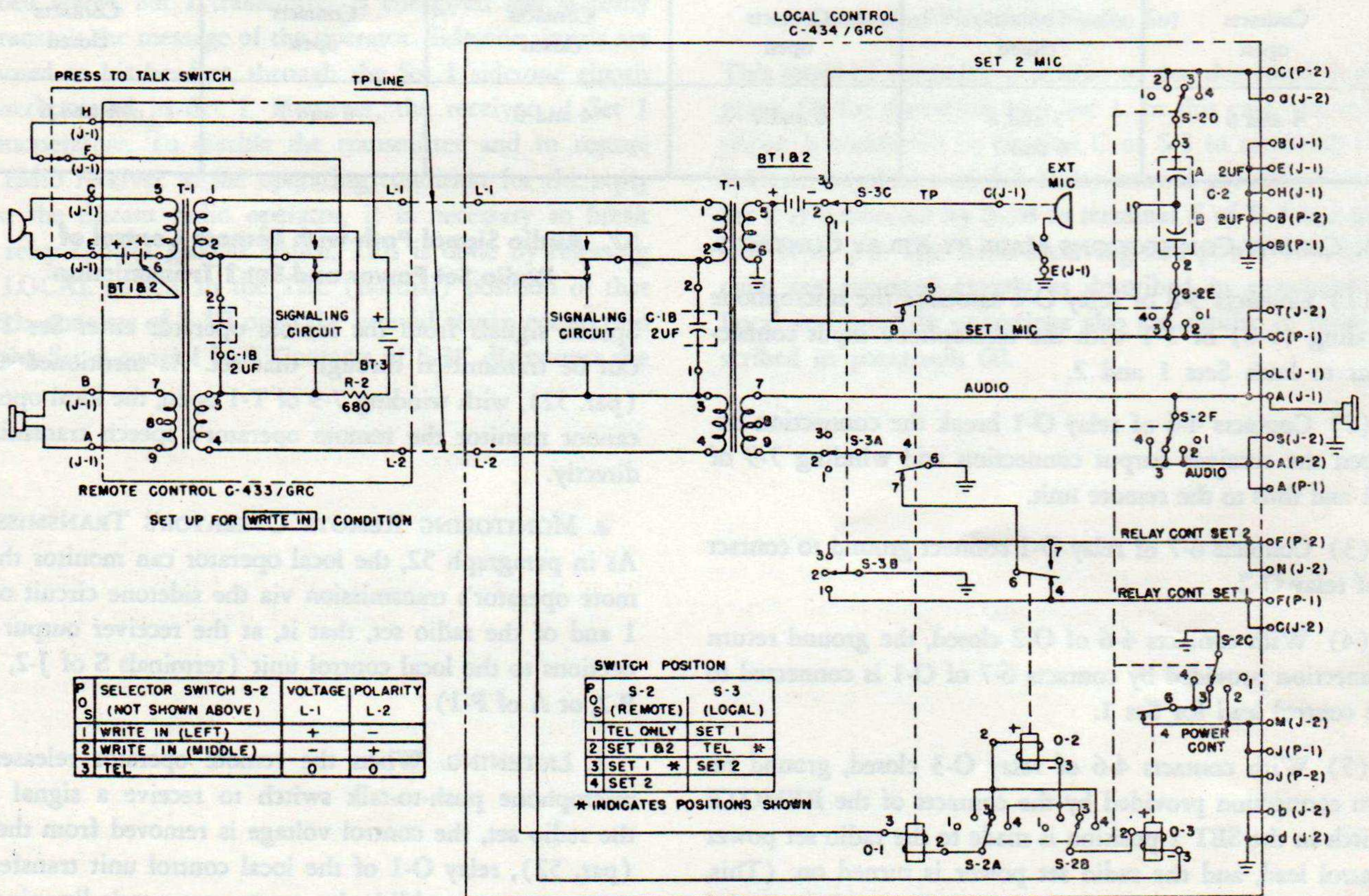

Figure 21. Control Group AN/GRA-6, remote control of Set 1 with remote control of power, functional diagram.

58. Remote Control of Set 2 with Remote Control of Radio Set Power

This mode of operation may be made only if provisions have been made on the radio set for remote control of power. The switches on the local and the remote control units are arranged in the following manner:

LOCAL switch in the TEL position.

REMOTE switch in the SET 2 position.

SELECTOR switch in the left-hand write-in position for Set 2 control and power on, or in the right-hand write-in position for Set 2 transmitter and power off.

a. CIRCUIT ARRANGEMENT. The circuit arrangement resulting from the above switch settings is as follows: When the remote operator closes his microphone push-to-talk switch, the circuit arranges as follows when the SELECTOR switch is in the left-hand write-in position.

(1) The control voltage provided by BT-3 at the remote unit is applied to the line and binding posts so that L-1 is positive and L-2 is negative.

(2) At the local control unit, relays O-1, O-2, and O-3 are connected across the line circuit, and relays O-2 and O-3 are connected in a series-opposing polarity with respect to each other. That is, terminal 3 of relay O-2 and 2 of relay O-3 are associated with L-1, while terminal 2 of O-2 and terminal 3 of O-3 are associated with L-2.

(3) With L-1 positive and L-2 negative, the relays arrange their contacts as indicated in subparagraph *b* below.

b. CIRCUIT CONNECTIONS MADE BY RELAY CONTACTS.

(1) Relay O-1 operates as before; to close the microphone circuit connection to the radio set, to break the listening circuit from the radio set through winding 7-9 of T-1, and to apply ground connection to contact 6 of relay O-2.

(2) Contacts 6-7 of relay O-2 close, connecting the ground return connection to the control lead for Set 2 through contacts 6-7 of relay O-1. Contacts 4-6 of relay O-2 are open, breaking ground return for Set 1.

(3) As in paragraph 56, contacts 4-6 of O-3 close, connecting ground return through the contacts of S-2 in the SET 2 position to the radio set power control lead. Power to the radio set is thus turned on.

(4) Speech signals from the remote operator thus enter Set 2 and are transmitted over the air.

59. Audio Signal Paths with Remote Control of Radio Set Power and Set 2 Transmission

a. MONITORING REMOTE OPERATOR'S TRANSMISSION. As before, with contacts 4-6 of O-1 open, the local operator cannot hear the remote operator's transmission directly.

b. LISTENING. When the remote operator releases his microphone push-to-talk switch to receive the reply, relays O-2 and O-3 remain latched in the positions indicated above. The radio set power remains on, and the relay control lead remains connected to contact 6 of relay O-2. However, the contacts of relay O-1 return to the unoperated positions to break the microphone circuit to the radio set (contacts 5-8 open). The listening circuit from the radio set to the remote operator is established and the ground connection from contact 6 of relay O-2 is removed, de-energizing the control circuits of Set 2.

c. REMOTE OPERATOR'S REPLY. As mentioned before, re-operation of the microphone push-to-talk switch by the remote operator has only the effect of returning the contacts of relay O-1 to the talking condition. Relays O-2 and O-3 remain unaffected.

d. END OF CONVERSATION. If power to the radio set is to be turned off from the remote position after the conversation is finished, the remote operator turns the SELECTOR switch to the right-hand write-in position and momentarily operates the microphone push-to-talk switch. The effect of this procedure is similar to that described in paragraph 57. Application of the control voltage across the line so that L-1 is negative and L-2 is positive causes contacts 4-6 of O-2 to close and 6-7 to open. Connection is made to the control lead of Set 1 and is broken from the control lead of Set 2. Contacts 4-6 of relay O-3 open to disconnect power to the radio set. Release of the microphone push-to-talk switch returns the contacts of relay O-1 to the stand-by condition restoring the listening circuit, breaking the talking circuit, and opening the ground return connection to the control lead.

60. Local push-to-talk Operation of Set 1 with Power Control at Radio Set

For this mode of operation, power to the radio set is applied by means of the radio set power switch. Push-to-talk control is obtained from the unit when the switches are set up as indicated in subparagraph *a* below.

a. SWITCH SETTINGS. Regardless of the settings of the switch at the remote control unit, the LOCAL switch is set in the SET 1 position, and the REMOTE switch is set in the SET 1 & 2 position. If transmission only, but no reply from the radio set is desired, the REMOTE switch may be set in the TEL ONLY position. In the former case, interference or *break-in* from the remote operator is possible. In the latter case, the remote operator cannot enter the circuit, since with the REMOTE switch in the TEL ONLY position, the control relays are disconnected from the line.

b. CIRCUIT ARRANGEMENT (fig. 20). (1) The microphone of the local operator's handset, in series with the

push-to-talk switch, is connected by Section C of S-3 to the Set 1 microphone lead and to terminal T of J-2 and C of P-1, the transmitter input connections of Set 1.

Note. At the local position, the microphone push-to-talk switch is not used in energizing the radio set relays. It completes the microphone circuit. Operation of the Set 1 relays is controlled by the LOCAL switch. In the Set 1 position of the switch, the Set 1 radio transmitter is turned on. When the switch is released from this spring-return position, the transmitter is disabled and the receiver is made operative.

(2) Section B of S-3 connects ground return to the control lead for Set 1 to terminals C of J-2 and F of P-1, and the transmitting circuits of Set 1 become energized, while receiving circuits become de-energized.

(3) Section A of S-3 opens the listening circuit between the radio receiver and the remote operator by opening the ground return connection for winding 7-9 of T-1.

(4) The local operator's headphone is connected through terminal L or A of J-1, and the contacts of S-2F are connected to the receiver output connections at terminal A of P-2 and P-1 and terminal S of J-2.

c. OPERATION. When the circuit is arranged as described above, Set 1 transmitter is energized and is ready to transmit the message of the operator. Sidetone signals are returned to his headset, through the Set 1 sidetone circuit if incorporated in Set 1. However, the receiver of Set 1 is unoperative. To disable the transmitter and to restore the radio receiver to the operating condition for the reply from the distant radio operator, it is necessary to break the relay control ground return. This is done by releasing the LOCAL switch. In the TEL (normal) position of that switch, contacts of S-3B open the ground return connection for the Set 1 control lead. Contacts of S-3C disconnect the

microphone. Contacts of S-3A restore the ground return connection for winding 7-9 of T-1. The incoming reply from the radio receiver thus can be heard not only by the local operator, but is transmitted over the telephone line to the remote operator for monitoring purposes.

d. BREAK-IN OPERATION. Since the relays are connected across the telephone line, and radio set power is turned on at the radio set, the remote operator can enter the conversation and talk over Set 1 simply by operating the SELECTOR switch to the left-hand write-in position and operating the microphone push-to-talk switch. The only effective relay contacts in this case are contacts 5-8 of relay O-1 which close to apply speech from the remote position developed across winding 5-6 of T-1 to the Set 1 microphone input circuits. By turning the switch to the right-hand write-in position, the remote operator can talk similarly over Set 2, while the local operator is talking over Set 1. In this case, contacts 6-7 of relay O-1 and contacts 6-7 of relay O-2 close to energize the Set 2 relay control circuits. Speech signals from the remote operator are applied through winding 5-6 of T-1, over contacts 5-8 of relay O-1 closed to the microphone input connection of both Sets 1 and 2. Since both transmitters now are energized, the signals will be transmitted over both radio sets.

61. Local Push-to-talk Operation of Set 2 with Control of Power at Radio Set

This mode of operation is similar to that described in paragraph 60 for operation over Set 1. In this case, the microphone is connected by Section C of S-3 to terminals C of P-2 and terminal a of J-2. Relay control ground return for Set 2 is connected by S-3B to terminal F of P-2 and terminal N of J-2. The radio receiving and power control circuits are arranged exactly as described in paragraph 60. Local and break-in operations also are similar to those described in paragraph 60.

CHAPTER 6

FIELD MAINTENANCE INSTRUCTIONS

Note. This chapter contains information for field maintenance. The amount of repair that can be performed by units having field maintenance responsibility is limited only by the tools and test equipment available and by the skill of the repairmen.

Section I. TROUBLE SHOOTING AT FIELD MAINTENANCE LEVEL

62. Trouble-shooting Procedures

The test procedures for locating trouble in the components of Control Group AN/GRA-6, described in this section, supplement the organizational maintenance instructions given in chapter 4. Organizational trouble-shooting data assumes that the units are installed under actual conditions and provide the operator with means for determining, on the basis of operational failure, which component of the control group may be defective. The checks outlined in this section assume that the organizational trouble-shooting procedure has been performed and that trouble has been traced to one of the components of Control Group AN/GRA-6. It is further assumed that at least a minimum of test and repair equipment is available. The trouble-shooting procedures described in this section are outlined briefly in the following steps.

a. SHORT-CIRCUIT CHECKS. Resistance measurements are made to locate short circuits which might damage the batteries or the equipment when power is applied (par. 64).

b. OPERATIONAL CHECKS. The operational checks outlined in paragraphs 68, 69, and/or 70 are made to determine at which point the units of Control Group AN/GRA-6 fail to perform their functions properly. These checks follow the pattern used in paragraphs 42 through 44 and include the use of test instruments to permit detailed sectionalization of trouble.

(1) If a component of the control group is being checked apart from the other components, special procedures must be adopted. Paragraphs 69 and 70 give trouble sectionalization procedures for the local and remote control units respectively. Use the procedures in these paragraphs to supplement the information gained from paragraphs 42 through 44 and the checklist in paragraph 68 when the control group is being checked as a whole. In this case, facilities available from the front of the unit panel are utilized in conjunction with a handset, a meter, and other test equipment.

(2) The trouble symptoms obtained will indicate a fault within a unit, and in some cases may sectionalize the trouble to smaller circuit sections. The operational checks must be made in the order given and all troubles must be cleared as they are found. Accordingly, every time a faulty condition is encountered, the additional checks recommended in the chart should be made. Detailed instructions for using the operational check charts (par. 68) are given in paragraph 67.

c. ADDITIONAL TROUBLE SECTIONALIZATION CHECKS. Because of the simplicity of the circuits involved in the components of the control group, and because of the fact that most of the circuitry is simply wiring, most troubles within the units of the control group can be found by simple signal transmission and voltage and resistance measurements. Accordingly, information for checks supplementing (and frequently replacing) the operational checks is given as follows:

(1) *Signal transmission checks.* Speech and ringing signals are transmitted from the particular unit being tested. If a complementary unit known to be in good operating condition is available, signal reception may be checked by means of that unit. Otherwise, the handset and an audio output meter may be used to make these checks (pars. 69a and 70).

(2) *Resistance measurements.* These measurements are made to determine the continuity of circuit sections, that is, transformer and coil windings, proper switch contacts, and the like. In addition, certain control functions are checked by means of resistance and continuity measurements, since without the radio set there is no other way of determining whether or not the control operations are being performed properly by the control circuits (pars. 69c and 70).

(3) *Voltage measurements.* Voltage measurements are made to determine the condition of the batteries used in the units, the transmission of the control voltage from the remote control unit, or its reception and utilization at the local control unit. These measurements also are made to determine defects in components which cannot be located by the preceding methods (pars. 69b and 70).

63. Test Equipment and Tools Required for Trouble Shooting

In general, two audio accessories are sufficient to make signal transmission checks, since the qualitative checks of the circuits for signal continuity is sufficient in most cases.

If an audio output meter is available, it is possible to make these checks on a quantitative basis and thereby gain information as to the condition of audio transformers in a more precise manner. For the resistance and voltage measurements, use Electronic Multimeter TS-505/U. The required and optional test equipments are listed below.

a. BATTERY. The following batteries are required to supply power to the control units:

(1) *Remote Control C-433/GRC.* (a) Battery BA-30, or equivalent flashlight type 1½-volt dry cell (two required).

(b) Battery BA-414/U, or equivalent 45-volt dry battery with octal plug (one required).

(2) *Local Control C-434/GRC.* Battery BA-30 or equivalent flashlight type 1½-volt dry cell (two required).

b. AUDIO ACCESSORIES. Handset H-33/PT with cord and 10-pin male compression type plug is required for connection to each of the two control circuits. It will be necessary to obtain an additional handset since only one is supplied. Refer to paragraph 16*a* for alternate accessory information.

c. METERS. The following meters are needed to make the measurements outlined in the trouble sectionalization and localization checks:

Electronic Multimeter TS-505/U: voltohmmeter (or equivalent).

Electronic Multimeter ME-6A/U: a-c voltmeter (optional).

d. TOOLS. Tool Equipment TE-113 will be needed to make the necessary repairs.

e. CLEANING FLUID. Solvent (SD) will be needed to clean the parts of rust, dirt, and corrosion.

f. TELEPHONE LINE. If the local and remote control units are to be tested in conjunction with each other as a group, either one of the following should be provided to simulate, as closely as possible, actual operating conditions. If none of these items are available, the line binding posts of the units may be interconnected with any pieces of wire.

(1) A coil of field wire (Wire WD-1/TT or equivalent), or

(2) Two 250-ohm, ½-watt resistors, for interconnection between the corresponding binding posts on the local and remote units to simulate the field wire.

(3) A line-simulating network, such as a balanced, H-type attenuator, equivalent to approximately 2 miles of field wire. If possible, the attenuator should be adjustable to represent ½, 1, 1½, and 2 miles of the actual wire.

64. Checking Key Circuits for Shorts

a. GENERAL. For these checks, remove the dry batteries from the units, and disconnect audio accessories. Use Electronic Multimeter TS-505/U, or an equivalent meter, and make the measurements between each of the test points and chassis, indicated in subparagraphs *b* and *c* below. An incorrect reading may be indicative of a defective component or a grounded wire or lug in the particular circuit section. Refer to the schematic diagram for the particular unit (figs. 27 and 28) to associate the point at which the incorrect reading is obtained, with the circuit section involved. Check wires, lugs, and parts as indicated, and repair as needed. Some types of trouble, such as faulty relay or switch contacts, may cause an incorrect reading. In this connection, it should be borne in mind that control relays O-2 and O-3 in Local Control C-433/GRC are of the polarized latching type. Either contacts 4-6 or 6-7 will be found closed, depending on the polarity of the voltage which was last applied to the relay coils. To avoid possible errors in interpretations because of the unknown condition of the relay contacts, the relay may be pulled out of its socket and continuity measurements made between terminals 4 and 6 and terminals 6 and 7 to determine which of the pair is closed. If this procedure is followed, the relay then should be restored to its socket before proceeding with the measurements indicated in the tables.

b. SHORT-CIRCUIT DATA FOR REMOTE CONTROL C-433/GRC. A reading of infinity should be obtained between each of the test points listed below and chassis.

Terminal C of J-1.

Terminal E of J-1.

Terminal F of J-1.

Binding post E-1 for each of the positions of S-1 and S-2.

Terminal H of J-1 for each of the three operating positions of S-2.

Binding post E-2 for each of the operating positions of switches S-2 and S-1.

c. SHORT-CIRCUIT CHECK DATA FOR LOCAL CONTROL C-434/GRC. The readings indicated in the following chart should be obtained at the test points listed for each of the switch settings. If the required readings are not obtained at any of the test points, refer to figures 27 and 28, the schematic diagrams for the remote and local units respectively, to determine the part, or parts, which may be responsible for the trouble. Check each part of the affected circuit and repair as necessary. Do not install the batteries until the trouble has been cleared and all the readings indicated in the table are obtained.

Short-circuit check data for Local Control C-434/GRC

Test point	Test conditions	Required reading
Binding post E-1.	Switch S-2 set in each one of its four operating positions.	Infinity
Binding post E-2.	Switch S-2 set in each one of its four operating positions.	Infinity
Term. C of P-2 or term. A of J-2.	For all positions of S-2 and S-3.	Infinity
Term. T of J-2 or term. C of P-1.	For all positions of S-2 and S-3.	Infinity
Term. F of P-2 or term. N of J-2.	S-3 in TEL or SET 1 position. S-3 in SET 2 position.	Infinity 0
Term. F of P-1 or term. C of J-2.	S-3 in TEL or SET 2 position. S-3 in SET 1 position.	Infinity 0
Term. M of J-2, or term. J of P-1, or term. J of P-2.	S-2 in TEL ONLY position. S-2 in SET 1 and SET 2 position. S-2 in SET 1 or SET 2 positions.	Infinity 0 Infinity or 0, depending on polarity of voltage applied to line terminals prior to this check (see par. a, above).
Term. C of J-1.	For all positions of S-3.	Infinity

65. Checking Handset H-33/PT

Before proceeding with the checks of the following paragraphs, it is desirable to eliminate the handset as a possible cause of the trouble, found by the organizational maintenance procedure. If a handset known to be in good condition is not available, or if the one returned with the

equipment in trouble is to be checked, make the following continuity measurements. These checks determine whether the push-to-talk switch is in proper working order and whether the handset cable wiring is good. Using Electronic Multimeter TS-505/U as an ohmmeter, make the following measurements at the indicated terminals of the cable connector.

Points of measurement	Required reading (ohms)	Test condition
Between terminals A and B.	30 ohms, approximately; click heard when making or breaking connection.	None
Between terminals F and H.	0	Push-to-talk switch operated.
Between terminals F and H.	Infinity	Push-to-talk switch unoperated.
Between terminals E and D.	0	Push-to-talk switch unoperated.
Between terminals E and D.	Infinity	Push-to-talk switch operated.
Between terminals D and C.	150 ohms, approximately; click heard when making or breaking connection.	None
Between terminals F and D.	Infinity	Push-to-talk switch operated or unoperated.

66. Test Set-up for Operational Checks

a. LOCAL CONTROL C-434/GRC. Install the two dry cells (BT-1 and BT-2). Check that the three relays (O-1, O-2, and O-3) are seated firmly in their correct sockets. Make sure that the pilot lamp (E-3) is installed in its socket on the CALL LIGHT holder. Attach the handset cord to the AUDIO connector on the front panel. Be certain to set the REMOTE switch in the TEL ONLY position.

b. REMOTE CONTROL C-433/GRC. Install the two flashlight cells (BT-1 and BT-2), and the 45-volt control voltage battery (BT-3). Check that they are properly posi-

tioned to make firm contact with the battery contacts on the battery compartment and on the battery compartment cover. Check that the battery cable is properly plugged into BT-3. Be certain that the pilot lamp (E-3) is installed in its socket in the CALL LIGHT holder. Attach the handset cord to the AUDIO connector on the front panel. Be certain to set SELECTOR switch in the TEL position.

c. INTERCONNECTIONS. Connect L-1 on the local control to L-1 on the remote control; connect L-2 on the local control to L-2 on the remote control. Refer to paragraph 63f for additional information.

67. Purpose and Use of Operational Check Chart

The operational check chart serves as a sectional step in sectionalizing trouble in Control Group AN/GRA-6 units. The panel-mounted controls and facilities are used to operate the equipment under as close to normal conditions as possible at the test bench. Observation of the test result is made either by listening checks or by actual measurements. The operational check chart supplements the operational checklist (par. 44) and provides a further step in limiting trouble to a particular unit or particular circuits. The trouble symptoms yielded by these checks, when properly interpreted on the basis of the repairman's knowledge of the circuit arrangement of the control units, will point to specific circuit sections as being defective and to additional localization checks necessary to further limit the trouble to a particular part. The tests given in the operational check chart follow a certain specific sequence. In each check, it is assumed that the preceding checks have been made and the troubles discovered have been eliminated. Accordingly, start with item 1 and proceed in the indicated order. The chart includes the following columns:

- a. **ITEM OF CHECK.** This column assigns a numerical sequence to the particular test, and describes briefly the purpose of each test.
- b. **TEST CONDITION AND OPERATION.** This column lists

the switches and controls to be operated and the conditions to be met.

- c. **NORMAL INDICATION.** Both aural and visual indications are outlined to show what to expect after the test conditions have been met. If these indications are not met as specified, a trouble exists. For best results, the repairman should be sufficiently well acquainted with the circuit theory and the actual operation of the units to be able to get correct interpretation of the normal indications.

- d. **POSSIBLE CAUSES OF TROUBLE.** This column indicates the circuit section which may be defective if the normal indication is not obtained. In cases where several types of trouble symptoms are possible, the circuit checks involved in each type of trouble symptom are listed.

- e. **FURTHER CHECKS AND REMARKS.** This column indicates further checks to be made if the normal indication is not obtained. Where further operational checks in the check chart are called for, perform that check, note the resultant indication and if abnormal, follow through as indicated in the further checks column for that operational check. Where reference is made to a trouble localization paragraph, the checks of that paragraph should be made.

Note. The chart which follows assumes that the installation procedures called for in chapter 2 have been performed correctly. It is advisable to check the set-up before proceeding beyond this point.

68. Operational Check Chan

Item of check	Test condition and operation	Normal indication	Possible causes of trouble	Further checks and remarks
<p>Preliminary</p> <p>(1) Ringing signal transmission from remote unit.</p> <p>(2) Ringing signal transmission from local unit.</p> <p>(3) Speech transmission.</p>	<p>Set SELECTOR switch on remote unit to TEL.</p> <p>Set REMOTE switch on local unit to TEL ONLY.</p> <p>Set LOCAL switch on local unit to TEL.</p> <p>Set internal switch on each unit to BELL.</p> <p>Crank ringing generator on the remote unit panel.</p> <p>(a) Listen in headphones of remote unit.</p> <p>(b) Listen for ringing signal of local unit.</p> <p>(c) Listen in headphones of local unit.</p> <p>(d) Turn internal switch of local unit to LAMP.</p> <p>Crank ringing generator on local unit panel.</p> <p>(a) Listen in headphone of local unit.</p> <p>(b) Listen for ringing signal at remote unit.</p> <p>(c) Listen in headphone of remote unit.</p> <p>(d) Turn internal switch of remote unit to LAMP.</p> <p>At local unit, operate handset push-to-talk switch, and talk into microphone.</p>	<p>(a) Ringing signal is heard.</p> <p>(b) Bell rings.</p> <p>(c) Ringing signal heard in headphone.</p> <p>(d) LAMP should light.</p> <p>(a) Ringing signal is heard.</p> <p>(b) Bell rings.</p> <p>(c) Ringing signal is heard.</p> <p>(d) Lamp lights.</p> <p>Speech signals heard in headphones at remote unit.</p>	<p>Defective generator, or T-1, in remote unit.</p> <p>Defective bell C-1 or S-1 in local unit.</p> <p>Defective T-1 in local unit.</p> <p>Defective E-3 or S-1 or R-1 in local unit.</p> <p>(a) Defective generator or T-1 in local unit.</p> <p>(b) Defective C-1, S-1, or bell in remote unit.</p> <p>(c) Defective T-1 in remote unit.</p> <p>(d) Defective E-3, S-1, or R-1 in remote unit.</p> <p>Defective T-1 at local or remote unit or open C-1.</p> <p>Defective or improperly installed Battery BA-30 at local unit.</p>	<p><i>Caution:</i> In making continuity measurements, make sure to remove voltages from points being measured.</p> <p>Check continuity of T-1 windings (par. 70). Check generator as described in paragraph 72.</p> <p>Check capacitor C-1 for an open connection or a short-circuit. Check bell (par. 73).</p> <p>Check T-1 continuity (par. 70).</p> <p>Substitute spare lamp.</p> <p>Check S-1 and R-1 for continuity (par. 70).</p> <p>Check continuity (par. 70).</p> <p>Check generator (par. 72).</p> <p>Check C-1 for short and S-1 for defective contact. Check bell (par. 73).</p> <p>Check continuity (par. 70).</p> <p>Substitute spare lamp.</p> <p>Check S-1 contacts (par. 70).</p> <p>Connect headphones to line binding posts of local control unit. If speech is heard, remote control unit is defective. Otherwise, local control unit is defective.</p>

68. Operational Check Chart (contd)

Item of check	Test condition and operation	Normal indication	Possible causes of trouble	Further checks and remarks
<p>(4) Local control of Set 1 and local control of power at radio set.</p>	<p>At remote unit, operate hand-set push-to-talk switch, and talk into microphone.</p> <p>Remote control SELECTOR switch to TEL.</p> <p>Turn local control REMOTE switch to SET 1 and hold LOCAL switch in SET 1.</p> <p>Make the resistance measurements indicated below:</p> <p>(a) Between M of J-2 and chassis.</p> <p>(b) Between C of J-2 and chassis.</p> <p>(c) Between T of J-2 and C of J-1.</p> <p>(d) Between 8 of J-2 and A or L of J-1.</p>	<p>Speech should be heard in headphone of local unit.</p> <p>(a) Reading should be infinity.</p> <p>(b) Reading should be zero ohm.</p> <p>(c) Reading should be zero ohm.</p> <p>(d) Reading should be zero ohm.</p>	<p>Defective T-1 or open C-1 at remote or local units.</p> <p>Defective or improperly installed Battery BA-30 at local unit.</p> <p>(a) Defective S-2 contacts or power control wiring.</p> <p>(b) Defective S-3 contacts or relay control circuit wiring for Set 1.</p> <p>(c) Defective S-2 or S-3 contacts or Set 1 local microphone circuit.</p> <p>(d) Defective local phone circuit to Set 1.</p>	<p>Make voltage check (par. 71). Check continuity (par. 70) for local or remote unit, as indicated.</p> <p>(a) Check S-2 and power control circuit wiring for continuity.</p> <p>(b) Check S-3 and Set 1 relay control circuit for continuity.</p> <p>(c) Refer to functional diagrams (figs. 19 to 21) and check local microphone circuit to Set 1 for continuity.</p> <p>(d) Check S-2 and local phone circuit for continuity (figs. 19 through 21).</p>
<p>(5) Local control of Set 2 and control of power at radio set.</p>	<p>Set switches as in (4) except set LOCAL switch to SET 2 position.</p> <p>Make continuity measurements as follows:</p> <p>(a) Between N of J-2 and chassis.</p> <p>(b) Between a of J-2 and C of J-1.</p>	<p>(a) Reading should be zero ohm.</p> <p>(b) Reading should be zero ohm.</p>	<p>(a) Defective S-3 or relay control circuit wiring for Set 2.</p> <p>(b) Defective S-2, S-3, or wiring.</p>	<p>(a) Refer to figure 28 and check Set 2 relay control circuit for continuity.</p> <p>(b) Check local microphone circuit to Set 2 for continuity (figs. 19 and 20).</p>

(6)

Remote control of Set 1 with power control at radio set.

At remote control unit, operate S-2 to left write-in position, and push-to-talk switch. Talk into microphone. At local control unit, operate S-2 to SET 1 and leave S-3 in TEL.

(a) The following results should be obtained at the remote control unit: The voltage measured between L-1 and L-2 should be at least 24 volts,

(b) The following results should be obtained at the local control unit:

1. The voltage between L-1 and L-2 should be at least 24 volts. L-1 should be positive and L-2 negative.

2. Speech signals should be heard between T of J-2 and chassis.

3. No speech signals should be heard between a of J-2 and chassis.

4. No speech signals should be heard between A of J-1 and chassis.

5. The resistance measured between C of J-2 and chassis should be zero ohm.

6. The resistance between N of J-2 and chassis should be infinite.

At remote control unit: measure line voltage, and polarity of line voltage.

L-1 should be negative and L-2 positive. Voltage should be at least 24 volts.

Defective BT-3, S-2, contacts, or control voltage circuit at remote unit.

Line wires too long or reversed.

Microphone circuit to Set 1 defective.

Defective relay circuit.

Microphone circuit for Set 2 defective.

Defective contacts of O-1 relay. Broken relay circuit.

Defective O-2 or Set 1 relay control circuit.

Defective Set 2 relay control circuit (O-2 or wiring).

Defective S-2.

Replace BT-3.

Check control voltage circuit for continuity (fig. 27).

Reverse line wire connections.

Check microphone circuit to Set 1 for continuity (contacts 5-8 of O-1 should close when control voltage is applied). Check voltage across coil of O-2. If a no-voltage indication is obtained, relay circuit is defective. Check relay circuit for continuity (S-2 contacts and relay coils).

Check C-2 and associated wiring.

Check continuity between A of J-1 and chassis.

Reading should be infinity, while control voltage is applied. If not, O-1 contacts 4-6 are stuck. Replace relay.

Check relay coil and contacts. Check Set 1 relay control circuit.

Check relay O-2 and Set 2 relay control circuit.

Check control voltage circuit for continuity.

(7)

Remote control of Set 2 with power control at radio set.

At remote control unit, operate S-2 to right-hand write-in position, and handset push-to-talk switch. Talk. At local control unit, leave switches as in (4).

68. Operational Check Chart (contd)

Item of check	Test condition and operation	Normal indication	Possible causes of trouble	Further checks and remarks
<p>(8) Remote control of radio set power and Set 1.</p>	<p>At remote control unit release microphone switch.</p> <p>At remote control unit, turn SELECTOR switch to left-hand write-in position, operate microphone switch and talk.</p> <p>At local control unit, turn REMOTE switch to SET 1 and leave LOCAL switch in TEL position.</p> <p>At remote unit, release microphone push-to-talk switch.</p> <p>At remote control unit, turn SELECTOR switch to right-hand write-in position. Operate and then release handset push-to-talk switch.</p>	<p>At local control unit:</p> <p>(a) Results of (6)</p> <p>(b) 1 through 4 should be obtained (except for voltage polarity).</p> <p>(b) The resistance between C of J-2 and chassis should be infinite.</p> <p>(c) The resistance between N of J-2 and chassis should be zero.</p> <p>(d) Results of (b) should remain as above. Result should be infinity.</p> <p>(e) A resistance reading of 61 ohms should be obtained between A of J-1 and chassis.</p> <p>At remote control unit, results should be as in (6).</p> <p>At local control unit:</p> <p>(a) Results of item (6) should be obtained.</p> <p>(b) The reading between M of J-2 and chassis should be zero ohm.</p> <p>(c) The reading between M of J-2 and chassis should remain zero ohm.</p> <p>(d) Results of (b), (c), and (e) of item (7) should be obtained.</p> <p>(e) The resistance between M of J-2 and chassis should be infinite.</p>	<p>Same as in item (6).</p> <p>Defective O-2 or Set 1 relay control circuit.</p> <p>Defective Set 2 relay control circuit.</p> <p>Defective microphone push-to-talk switch.</p> <p>Defective relay O-2 (demagnetized).</p> <p>Contacts of O-1 stuck.</p> <p>Defective contacts of S-2 in SET 1 position, or wiring associated with SET 1 contacts of S-2.</p> <p>Defective contacts of O-3 relay or S-2 switch in SET 1 position.</p> <p>Defective O-3 (demagnetized latch).</p> <p>Defective O-1 or O-2.</p> <p>Defective O-3.</p>	<p>Same as in item (6).</p> <p>Check contacts of S-2 and O-2. Check Set 1 relay control circuit.</p> <p>Check S-2 contacts, relay coil O-2, and Set 2 relay control circuit.</p> <p>Check continuity as in paragraph 65. Replace O-2.</p> <p>Remove O-1 and check contacts for continuity (4-6 should be closed, 5-8 and 6-7 open).</p> <p>Make checks for each item of (6), for which the required result has not been obtained, with particular reference to contacts of S-2 in the SET 1 position.</p> <p>Check relay O-3. Replace if defective. Check S-2 contacts.</p> <p>Replace O-3.</p> <p>Check coils and contacts of these relays, and wiring and contacts associated with S-2 in the SET 1 position.</p> <p>Check contacts of O-3 for continuity. (Contacts 4-6 should be open, contacts 6-7 closed.) Replace O-3 if defective.</p>

(9)

Remote control of radio set power and of Set 2.

At remote control unit, turn SELECTOR switch to left-hand write-in position, operate microphone push-to-talk switch and talk.

At local control unit, turn REMOTE switch to SET 2 position.

At remote control unit, release handset push-to-talk switch.

At remote control unit, turn SELECTOR switch to right write-in position, operate and release microphone switch.

At the remote control unit, the results should be the same as in (6).

At the local control unit, the results should be as follows:

- (a) Same as in (6)
- (b) 1 through 4.
- (c) The resistance between C of J-2 and chassis should be infinite.
- (d) The resistance between N of J-2 and chassis should be zero ohm.
- (e) The resistance between M of J-2 and chassis should be zero ohm.
- (f) The reading between M of J-2 and chassis should remain zero ohm.
- (g) The resistance between M of J-2 and chassis should become infinite.

Same as in item (6).

Defective O-2 or Set 1 remote relay control circuit.

Defective Set 2 relay control circuit.

Defective O-3 or SET 2 contacts of S-2.

Defective O-3.

Contacts of O-3 stuck.

Same as in item (6).

Check contacts of S-2 in the SET 2 position. Check Set 1 relay control circuits.

Check Set 2 remote relay control circuit, particularly contacts of S-2 in the SET 2 position.

Check power control circuit with reference to the SET 2 contacts of S-2.

Replace O-3.

Check for continuity, and replace O-3 if defective.

**69. Localization Checks for Remote Control
C-433/GRC**

The checks in this paragraph are to localize trouble within Remote Control C-433/GRC, when it is not associated with other components of Control Group AN/GRA-6. These checks may be used to supplement the findings of the equipment performance checklist (par. 44) and of the operational check chart (par. 68). Alternatively, enough data is presented here to locate trouble within the unit without reference to these two paragraphs. Three types of checks are given. Subparagraph *a* describes operational checks within the unit which can be made to limit the trouble to a particular circuit section or to a part. Subparagraphs *b* and *c* give voltage and resistance measurements which can be made to supplement the operational checks.

a. OPERATIONAL CHECKS. For these checks, install the batteries within the unit (par. 14). Connect a handset, known to be good, to the AUDIO connector.

(1) *Ringling checks.* (*a*) Turn the internal BELL-LAMP switch to the BELL position. Make sure that the SELECTOR switch is in the TEL position. Crank generator handle vigorously. The bell should not ring. If it rings, the switch within the generator is defective.

(*b*) Run a temporary wire between that terminal on the holder for E-3 which connects to S-1 and line binding post L-1 (fig. 22). Crank the generator handle. The lamp should glow. If it fails to glow, either the generator, the lamp, capacitor C-1B, or the line windings of T-1 are defective. The lamp may be checked by replacing it with a spare lamp. The dimmer control should be set to show the indication. The transformer and the capacitor may be checked by continuity measurements (subpar. *c* below). Remove the temporary connection after this check is completed.

(*c*) Run the temporary wire from the terminal of the bell which connects to switch S-1 to L-1, and again crank the generator. The bell should ring; if it does not, the bell is defective. Check for continuity of the bell coil (subpar. *c* below). Examine the bell parts for broken leads or defective mechanical parts. Disconnect the temporary wire.

(2) *Talking and listening checks.* Connect a pair of headphones equipped with wire terminals at the end of the cord between L-1 and L-2. Operate the handset push-to-talk switch and talk into the microphone. Speech should be heard in the headphones. If not, the windings of T-1 are open or batteries BT-1 and BT-2 do not make proper contacts, or are defective. Check T-1 continuity by the checks of subparagraph *c* below.

(3) *Control voltage application checks.* (*a*) Turn the SELECTOR switch to the left-hand write-in position. Operate the handset push-to-talk switch. Using Electronic Multimeter TS-505/U, measure the voltage between L-1 and L-2. The voltage should not be less than 24 volts. If less than 24 volts, the battery BT-3 is too weak or defective. If no voltage reading is obtained, check the contacts of S-2 for continuity, check the plug contacts and the wires leading to the battery, and continuity of the transformer windings (fig. 27). If the generator switch is defective (normally closed contacts are open) a no-voltage indication also will be obtained. A defective switch or reversed wiring also will be indicated if L-1 is negative and L-2 is positive.

(*b*) Turn the SELECTOR switch to the TEL position. The voltage between L-1 and L-2 should be zero. If it is not, there is a short between contacts of S-2. Releasing the microphone push-to-talk switch should remove the voltage from the line binding posts while S-2 is still in the left-hand write-in position.

(*c*) Turn S-2 to the right-hand write-in position. The voltage between L-1 and L-2 should be zero. When the handset push-to-talk switch is operated, a voltage of the same magnitude as in subparagraph (*a*) above should be evidenced between L-1 and L-2, but of reverse polarity; L-1 should be negative and L-2 positive. If these conditions are not met, the contacts of S-2 or the wiring associated with it is defective. Make point-to-point voltage and resistance measurements in accordance with subparagraphs *b* and *c* below.

b. VOLTAGE MEASUREMENTS. For the following checks, the batteries should remain in the unit. Disconnect the handset; remove the unit cover.

Point of measurement	Required reading	Probable trouble
Between terminals C and E of J-1.	Between 2 and 3 volts.	Defective winding 5-6 of T-1. Batteries BT-1 or BT-2 weak or dead. Battery compartment cover open or improperly installed. Defective wiring.
Between terminal H of J-1 and binding post E-2 (S-2 in left-hand write-in position).	Between 30 and 45 volts (H is positive, E-2 negative).	Weak or dead Battery BT-3. Open contacts of S-2. Broken winding 3-4 of T-1. Defective R-2.

Point of measurement	Required reading	Probable trouble
Between terminal H of J-1 and E-2 (S-2 in middle write-in position).	Between 30 and 45 volts (H negative, E-2 positive).	Defective contacts of S-2.
Between E-2 and terminal 2 of generator. Place a <i>temporary</i> strap connection between H and F of J-1.	Same as above. (Remove strap after measurement is made.)	Shorted capacitor C-1B.
Between E-2 and E-1. (Place a strap connection between H and F of J-1.)	Same as above.	Defective generator switch (internal) or open winding 1-2 of T-1.

c. RESISTANCE MEASUREMENTS. For the following measurement, remove the dry batteries from the unit. Disconnect handset, and leave the unit cover off. The measure-

ments given below are suggestive only. Others may be made as experience dictates.

Point of measurement	Required reading (ohms)	Probable trouble
From terminal C of J-1 to spring contact within battery (BT-1 and BT-2) compartment.	10	Defective winding 5-6 of T-1 or battery contact, or wiring.
From terminal E of J-1 to flat contact within battery compartment.	0	Defective wire or contact.
Between A and B of J-1.	61	Defective winding 7-9 of T-1 or wiring.
Between E-1 and terminal 2 of T-1.	25	Defective winding 1-2 of T-1.
Between 2 of T-1 and F of J-1.	0	Defective generator switch or wiring.
Between H of J-1 and pin 1 of battery connector plug (S-2 in left-hand write-in position).	680	Defective S-2 contacts, R-2 or wiring.
From pin 3 of battery plug (P-1) to terminal 3 of T-1 (S-2 in left-hand write-in position).	0	Defective S-2 contacts or wiring.
From pin H of J-1 to pin 3 of P-1 (S-2 in left-hand write-in position).	0	Defective S-2 contacts.
From pin 1 of P-1 to terminal H of J-1 (S-2 in right-hand write-in position).	680	Defective S-2 contacts.
From pin 3 of T-1 to E-2.	27	Defective winding 3-4 of T-1.
From cathode terminal of E-3 to pin 1 of generator.	680	Defective R-1.
From pin 2 of generator to pin 1 of C-1 (S-1 in BELL position).	2,550	Defective bell, S-1, contacts, or C-1.
From pin 2 of generator to anode terminal of E-3 (S-1 in LAMP position).	0	Defective S-1 or wiring.
From pin 3 of generator to pin 2 of C-1.	0	Defective wiring.

70. Localization Checks for Local Control C-434/GRC

The checks described in this paragraph follow the same general pattern for the local control unit as those described in paragraph 69 for the remote control unit. For the operational checks, some means of connecting a control voltage across the line binding posts (about 69 volts) must be provided. For these checks, install the batteries

within the unit. Connect the handset to the AUDIO connector on the front panel. Initially, place the REMOTE switch in the TEL ONLY position.

a. RINGING CHECKS. The ringing checks are identical with those described in paragraph 69a. Component reference numbers, conclusions, and probable defects are also the same.

b. TALKING AND LISTENING CHECKS. (1) Operate the

microphone push-to-talk switch and talk into the microphone. Connect a pair of headphones between L-1 and L-2. Speech should be heard in the headphones. If not, either windings of T-1 are open or batteries BT-1 and BT-2 are run down or do not make proper contact with the contacts on the battery compartment cover. Check this by examining the battery compartment cover. To do this, remove the case. The trouble may also be checked by the voltage measurements of subparagraph *d* below. Another trouble possibility is an open contact of S-3 (LOCAL) in the TEL position. This also may be checked by the voltage or resistance measurements of subparagraph *c* below.

(2) Operate S-3 to either the SET 1 or the SET 2 position, and continue talking into the microphone. Speech should not be heard between L-1 and L-2. Otherwise, there is a short between the contacts of S-3. Release the switch. Speech should be heard again. If not, the spring-return mechanism on the switch is defective.

(3) Connect the headphones between terminals S and d of J-2 (the large connector at the rear of the unit). Set the REMOTE switch to the SET 1&2 or the SET 1 or the

SET 2 position, and talk into the microphone as before. Speech should be heard in the headphones connected to J-2. Otherwise, there is a defect in the circuit associated with winding 7-9 of T-1 (contacts 4-6 of O-1, contacts of S-3, or S-2 or the wiring). A continuity check of this circuit then is indicated.

c. CONTROL CIRCUIT CHECKS. For these checks, it is necessary to connect a 45-volt battery in series with a 680-ohm, 1/2-watt resistor between L-1 and L-2. If such parts are not available, this check may be omitted. Simply make the continuity checks indicated below for the controlled circuits and the relays.

(1) First connect the battery through the resistor to L-1 and L-2 so that L-1 is + and L-2 is -. Make the continuity checks given below for each position of switch S-2 as indicated.

(a) Turn switch S-2 to the SET 1 and then to the SET 1&2 position. Leave S-3 in the TEL position, unless otherwise indicated. The following readings should be obtained at each of the indicated test points.

Circuit section	Point of measurement	Reading (ohms)	Probable trouble
Microphone circuit.	From terminal 1 of C-2 to chassis.	10	Open winding of relays O-1, O-2, or O-3; defective contacts of O-1 or S-2.
Receiving circuit.	From A of J-1 to chassis.	Infinity	Defective contacts of O-1.
Set 1 relay control circuit.	From C of J-2 to chassis.	0	Defective O-1 or O-2.
Set 2 relay control circuit.	From N of J-2 to chassis.	Infinity	Defective O-2 or shorted S-3.
Power control circuit.	From M of J-2 to chassis.	0	Defective S-2 or O-3.

(b) Turn switch S-2 to the SET 2 position and repeat the above measurements. The readings for the microphone and the receiving and power control circuits should remain as above. The reading for the Set 1 relay control circuit should become infinity. The reading for Set 2 relay control circuit should become zero. If these two conditions are not met, relay O-2 is defective. If readings for the microphone and receiving circuits are incorrect, relay O-1 is defective. If the power control circuit reading is incorrect, switch S-2 is defective in the SET 2 position.

(c) Turn switch S-2 to the TEL ONLY position and repeat the above measurements. All readings, except the receiving circuit reading, should be infinity. The reading between A of J-1 and chassis should be 61 ohms, representing the resistance of winding 7-9 of T-1.

(d) Return S-2 to the SET 1 position. The readings indicated in subparagraph (a) above should be obtained.

(2) Next, disconnect the battery from the line binding posts, and repeat the measurements for the points listed in subparagraph (a) above for the SET 1 position of S-2. The readings at the microphone and Set 1 and Set 2 relay control terminals of J-2 (see chart in subpar. (a) above) should be infinite. The reading of M of J-2 should be zero ohm. The reading at the receiving circuit, terminal A of J-2 should be 61 ohms, representing the resistance of winding 7-9 of T-1.

(3) Next, reconnect the battery so that L-1 is - and L-2 is +. Repeat the measurements of continuity for each position of S-2. Leave S-3 in the TEL position.

(a) Turn switch S-2 to the SET 1 position. The readings obtained at each of the controlled circuits should be as listed below.

Circuit section	Point of measurement	Reading (ohms)
Microphone circuit.	From term. 1 of C-2 to chassis.	10
Receiving circuit.	From A of J-1 to chassis.	Infinity
Set 1 relay control circuit.	From C of J-2 to chassis.	0
Set 2 relay control circuit.	From N of J-2 to chassis.	Infinity
Power control circuit.	From M of J-2 to chassis.	Infinity

(b) Turn switch S-2 to the SET 1&2 positions. The readings should now be as follows:

Circuit section	Point of measurement	Reading (ohms)
Microphone circuit.	From term. 1 of C-2 to chassis.	10
Receiving circuit.	From A of J-1 to chassis.	Infinity
Set 1 relay control circuit.	From C of J-2 to chassis.	Infinity
Set 2 relay control circuit.	From N of J-2 to chassis.	0
Power control circuit.	From M of J-2 to chassis.	Infinity

(c) Turn switch S-2 to the TEL ONLY position. All readings should become infinity, except that for the receiving circuit, which should show the resistance of winding 7-9 of T-1, namely 61 ohms.

(d) Disconnect the battery.

d. VOLTAGE MEASUREMENT. With the LOCAL switch in the TEL position, measure the voltage between terminals C and E of J-1. A reading of approximately 2 to 3 volts should be obtained. A no-voltage indication shows that the microphone supply circuit is broken. Look for an open or improperly closed cover on the battery container, corroded battery contacts, a defective dry cell, a defective contact on switch S-3C, or an open winding 5-6 of T-1.

e. RESISTANCE MEASUREMENTS. For the resistance measurements listed below, remove the batteries, disconnect all items from the front panel connectors, and remove the unit from the radio set. Pull relays O-2 and O-3 from their sockets and determine the continuity arrangement between terminals 4-6 and 6-7 of each relay. Either terminals 4-6 or 6-7 should show continuity. The other terminal pair should show an infinity or open reading. Remember or record which pair of the two is open and which is closed and replace them in their correct sockets. Use these facts in interpreting the resistance measurement results for relay control and power control measurements.

e. RESISTANCE MEASUREMENTS (contd).

Circuit section	Point of measurement	Nominal reading (ohms)	Probable trouble
Relay coil circuit.	Between L-1 and L-2 (S-2 in either SET 1 or SET 2 or SET 1 & 2 position).	26,000	Open relay coil (O-1, O-2, or O-3). Defective S-2 contact. Shorted C-1B. Open generator switch.
	Between L-1 and L-2 (S-2 in TEL ONLY position).	Infinity	Defective C-1, shorted E-3 or open generator switch.
Line circuit.	Between L-1 and terminal 2 of generator (S-2 in TEL ONLY position).	25	Defective T-1 or generator switch.
Line circuit.	Between L-1 and terminals 1 of C-1 or generator.	27	Defective T-1
Ringing circuit.	Between terminal 2 of generator and terminal 3 of C-1 (S-1 in BELL position).	2,550	Defective bell or S-1.
	Between terminal 2 of generator and anode terminal of E-3 (S-1 in LAMP position).	0	Defective S-1.
	Between cathode terminal of E-3 and terminal 1 of C-1.	680	Defective R-1.
	Between terminals 2 and 3 of O-1.	16,000	Defective relay O-1 coil.
	Between terminals 2 and 3 of O-2.	5,000	Defective relay O-2 coil.
	Between terminals 2 and 3 of O-3.	5,000	Defective O-3 relay coil.
	Power control circuit.	From terminal M of J-2 to chassis: S-2 in TEL ONLY.	Infinity
S-2 in SET 1 & 2.		0	
S-2 in SET 1.		0	
(If contacts 4-6 are closed or infinity if contacts 6-7 are closed).			
Audio receiving circuit.	From terminal A of J-1 to terminal S of J-2: S-2 in TEL ONLY, S-2 in SET 1, SET 2 or SET 1 & 2.	Infinity 0	Defective S-2.
	From terminal A of J-1 to chassis: S-3 in TEL.	61	
	S-3 in SET 1 or SET 2.	Infinity	Defective T-1 or S-3, or O-1 contacts. Shorted S-3 contacts.
	Set 2 relay control circuit.	From terminal N of J-2 to chassis: S-3 in TEL.	Infinity
S-3 in SET 2.		0	
S-3 in SET 1.		Infinity	
From pin 7 of O-2 to N of J-2.		0	
From pin 6 of O-2 to pin 7 of O-1.		0	
Set 1 relay control circuit.	From C of J-2 to chassis: S-3 in TEL.	Infinity	Defective S-3 or O-1. Defective lead or S-3. Defective lead or S-3. Defective wiring.
	S-3 in SET 1.	0	
	S-3 in SET 2.	Infinity	
	From C of J-2 to pin 4 of O-2.	0	
Microphone circuit.	From a of J-2 to 3 of C-2: S-2 in SET 2 or SET 1 & 2.	0	Defective S-2. Shorted S-2 contacts.
	S-2 in SET 1 or TEL ONLY.	Infinity	

e. RESISTANCE MEASUREMENTS (contd).

Circuit section	Point of measurement	Nominal reading (ohms)	Probable trouble
	From a of J-2 to C of J-1: S-3 in SET 2.	0	Defective S-3.
	S-3 in TEL or SET 1.	Infinity	Defective S-3.
	From C of J-1 to spring contact in battery compartment.	0	Defective wiring or battery contact.
	From spring contact to flat contact in battery compartment.	Infinity	Shorted wire or terminal.
	From flat contact in battery compartment to chassis.	10	Defective T-1.
	From E of J-1 to chassis.	0	Broken ground connection.
	From terminal 5 of T-1 to terminal 1 on C-2.	Infinity	Defective relay O-1 contacts.
	From terminal 5 of T-1 to terminal 8 of O-1.	0	Defective wiring.
	From terminal 5 of O-1 to terminal 1 of C-2.	0	Defective wiring.
	From terminal T of J-2 to terminal C of J-1: S-3 in SET 1.	0	Defective S-3 or wiring.
	S-3 in SET 2 or TEL.	Infinity	Defective S-3 or short in wiring.
	From terminal T of J-2 to terminal 2 of C-2: S-2 in SET 1 or SET 1 & 2.	0	Defective S-2.
	S-2 in SET 2 or TEL ONLY.	Infinity	Shorted wiring or S-2.
	From a of J-2 to 1 of C-2 (S-2 in SET 1 & 2).	*Infinity	Shorted or leaky capacitor C-2D.
	From T of J-2 to 1 of C-2 (S-2 in SET 1 & 2).	*Infinity	Shorted or leaky capacitor C-2E.

* May indicate capacitor charge.

71. Check of Alternate Wiring

In some cases the local control unit will fail to function properly with relation to the radio set when it is installed in a mounting, but will function properly when plugged into the set by means of the cables. In other cases, the reverse condition may exist. In either case this may be due to the fact that the parallel connections existing between the large connector and the terminals on the cable connectors are broken. Some troubles may be caused by a broken ground connection intended to complete an external circuit (that is, of the handset or the radio set). The following checks are aimed to eliminate trouble due to breaks in parallel and ground connections. Using Electronic Multimeter TS-505/U as an ohmmeter, make the continuity measurements listed below.

Note. In each case a reading of zero ohms should be obtained.

An infinite or finite resistance reading other than zero indicates a total or partial break in the connection. Refer to the schematic diagram for Local Control C-434/GRC.

- From term. A to term. L of J-1
- From term. B of J-1 to chassis
- From term. E of J-1 and chassis
- From term. H of J-1 and chassis
- From term. C of P-2 to term. a of J-2
- From term. A of P-2 to term. A of P-1
- From term. J of P-2 to term. J of P-1
- From term. F of P-2 to term. N of J-2
- From term B of P-2 and chassis
- From term. A of P-1 to term. S of J-2
- From term. J of P-1 to term. M of J-2
- From term. C of P-1 to term. T of J-2
- From term. F of P-1 to term. C of J-2
- From term. B of P-1 to chassis
- From term. d of J-2 to chassis
- From term. b of J-2 to chassis

The connector reference symbols listed above apply to the connectors which are identified as follows:

J-1 is the front panel AUDIO connector.

J-2 is the large plug-in connector at the rear of the unit.

P-1 is the cable connector identified within the storage compartment as SET 1.

P-2 is the cable connector identified within the storage compartment as SET 2.

72. Miscellaneous Component Data

a. RINGING GENERATOR. The ringing generator may be checked for proper operation as follows:

(1) Measure continuity between terminals 2 and 3 of the generator. A reading of zero ohms should be obtained. An infinite reading shows that the normally closed contacts of the switch within the generator case are open and defective.

(2) Crank the ringing generator handle and again measure continuity between terminals 2 and 3. The reading should be infinite, otherwise the generator switch is stuck.

(3) To check the ringing generator output, connect a 1,500-ohm 2-watt resistor across terminals 1 and 3 of the

generator. Connect an a-c wattmeter capable of reading about 2 watts or about 125 volts in the circuit. Crank the ringing generator handle. The meter should read at least 1.8 watts or about 50 volts. If a much lower reading is obtained, either the generator switch fails to make proper operating contact or the generator is defective. A generator with a lower output can be tolerated in service. Therefore, if a low reading is obtained, it is a matter of judgment whether the generator is to be discarded or retained in use.

b. TRANSFORMER T-1 RESISTANCE DATA. Use Electronic Multimeter TS-505/U to measure the resistances of the windings of the transformer. The transformers in the local and remote control units are identical.

Winding terminals	Nominal resistance reading
1-2	25
3-4	27
5-6	10
7-9	61

c. RELAY COIL RESISTANCE DATA. The resistances of the coils of relays O-1, O-2, and O-3 may be measured across terminals 2 and 3 of each relay. The resistance measurements made on the relay coils and contacts should show the values listed below.

Relay	Point of measurement	Required readings	Remarks
O-1	Between terminals 2 and 3	16,000	
	Between terminals 4 and 6	0	
	Between terminals 6 and 7	Infinity	
	Between terminals 5 and 8	Infinity	
O-2 or O-3	Between terminals 2 and 3	5,000	One pair of contacts should show zero ohm, the other infinity.
	Between terminals 4 and 6	See remarks	
	Between terminals 6 and 7	See remarks	

d. BELL. The resistance measured between the coil terminals of the bell should be approximately 2,550 ohms.

Section II. REPAIRS

73. Repair Procedures

This section describes the procedure for disassembling, cleaning, repair, and replacement of parts and subassemblies of Control Group AN/GRA-6 found to be defective by the trouble-shooting procedures of the preceding section and by the inspection procedure described below.

74. Disassembly of Remote Control C-433/GRC for Inspection, Cleaning, and Repair (figs. 4, 5, 10, 11, and 22)

a. OUTER CASE. To remove the outer case, loosen the two snap catches on the side of the case, and slide the panel-and-chassis assembly out of the case. To gain access to panel-mounted components, it may be necessary to remove the panel.

Caution: Be careful during disassembly procedure. Careless handling may cause damage to parts. Save screws,

nuts, and washers taken out during disassembly procedure. They will be needed for reassembling the unit.

b. BATTERIES. The procedure for removing the battery compartment cover while the batteries are installed is illustrated in figure 11. Place the unit, panel down, on a firm support, so that the left side of the unit is away from the repairman. Grasp the unit with both hands so that the thumbs rest in the two holes at the left edge of the cover. Place the fingers against Batteries BA-30 to prevent them from slipping. Press down on the cover and slide it back. Turn the cover slightly upward and slide it forward to disengage the projections at the rear of the cover from the bracket angles on the left side of the chassis frame. The small dry-cell batteries can be removed directly. To remove Battery BA-414/U, disconnect the octal connector and remove the battery. A view of the unit with the battery compartment cover and battery removed is shown in figure 10.

c. CALL LIGHT. The call light holder and jewel are mounted on the panel. The bayonet type base call light is mounted in a socket which in turn is mounted on the holder from the rear of the panel. To gain access to the call light, pull at the socket toward the rear of the unit in a direction perpendicular to the panel. Be careful not to break wires or damage parts. A view of the unit with the call light and socket removed from the holder is shown in figure 22.

d. PANEL. Only when it is necessary to repair a part on the panel (except the pilot light) will removal of the panel from the chassis frame be necessary. The panel is held in place by means of four machine screws, one at each corner of the chassis frame. Remove the four screws and pull the panel gently away from the frame.

Caution: Be careful not to break or damage the cable which joins the electrical components on the panel to the components within the chassis frame.

e. FURTHER DISASSEMBLY. The procedure for disassembling individual components and parts of the unit are described in paragraph 65.

75. Disassembly of Local Control C-434/GRC for Inspection, Cleaning, and Repair (figs. 7, 8, 12, 13, and 23)

In general the procedure for disassembling the local control unit is similar to that described in paragraph 70. The differences are outlined in the following subparagraphs.

a. OUTER CASE. To remove the outer case proceed as follows:

(1) Rotate the cap which covers the large connector (J-2) at the rear of the unit, and disengage it from the connector.

(2) Press the snap latch at the top rear of the unit thereby releasing the cable compartment cover, and mount the cap on the brackets provided inside the cover for this purpose.

(3) Release the two wing screws on the front panel to disengage the panel from the outer case.

(4) Place the unit on a table, panel down, and lift off the cover. Some difficulty may be encountered in pulling the large connector through the hole in the case. This may be due to the fact that the two "O" rings on the connector may be swollen. Apply a small amount of vaseline or DC-4 grease to the "O" rings. The connector will then slide through the hole easily.

(5) Pass the cables and the cable connectors through the hole in the cable compartment.

b. BATTERIES. The battery compartment is a plastic container. Press the snap catch which holds the cover of the container in place. The cover is located on the bottom of the panel-and-chassis assembly. Lift the two dry cells out of the compartment.

c. CALL LIGHT AND PANEL. These items may be removed exactly as described in paragraph 70 for the remote control unit.

d. FURTHER DISASSEMBLY. The procedures for removing other parts of the local control unit are described in paragraphs 73 et seq.

76. General Inspection of Chassis

After the unit has been disassembled as described in the preceding paragraph, it is possible to inspect all parts and wiring. Inspect the unit thoroughly for any abnormal conditions. If any are found, the causes of such conditions should be determined and the defects remedied. Repair instructions for defective components are given in paragraphs 73 and 74.

a. Inspect all parts for rust, corrosion, breakage, or other damage.

b. Inspect wiring for loose connections, frayed or burnt insulation, and mounting hardware for mechanical defects.

c. Examine the chassis for dirt and corrosion.

d. Examine transformer T-1, ringing generator, switches S-1 and S-2, and the connectors for loose or broken lugs. Examine mounting hardware to make sure that all parts are mounted securely. Loose mounting hardware may cause intermittent noises and eventual break-down of parts.

e. Examine the battery contacts within the battery compartment and on the battery compartment cover to make sure that they are not corroded and that the springs are not broken, loose, or damaged. Check whether proper con-

fact exists between the battery electrodes and the contacts within the compartment and on the cover when the batteries are installed and the cover is in place.

f. Examine the socket on the large battery (BT-3). Examine the battery plug to make sure that all connections to it are made properly, that insulation on wires is not burned, frayed, or torn, and that the pins are not damaged.

77. Cleaning

a. Dirt and corrosion will interfere with electrical continuity and mechanical efficiency of the parts and of the unit by causing circuits to be shorted or insulated, or by causing switches to be jammed. For these reasons, it is important to clean all parts of the chassis and panel carefully and thoroughly.

b. No set method can be given for removal of dirt because of the many ways and places it collects. Cleaning should be done with a lintless cloth, fine sandpaper (#000), crocus cloth, or a soft brush. Dust and grease usually can be removed with a cloth or brush moistened with solvent (SD). *Never use gasoline for cleaning.* Extra care must be exercised in cleaning delicate parts or parts which are difficult to reach, in order to avoid damage to wiring or parts. Where it is necessary to remove portions of moisture-fungiproofing in order to clean a part properly, refinishing is essential. Refinishing information is given in paragraph 85.

c. If available, use an air hose to blow out dust and lint from the chassis. Make sure, however, that no oil or water is carried along with the air stream, and that the stream is controlled so that damage to parts and wiring does not result. To determine whether or not the air stream carries oil or water, place a clean sheet of white paper in its path and observe any evidences of streaking or moisture.

d. When handling the chassis during cleaning, or at any other time, be careful not to break wiring or parts with the fingers.

78. Replacement of Parts

When replacing parts in the components of Control Group AN/GRA-6 observe the precautions given below.

a. TAGGING LEADS. Tagging leads is essential to assure that correct rewiring will be made when a part is replaced. Before unsoldering leads from transformers, tube sockets, panel connectors, or other parts, tie together the leads that are attached to each point. With a small tag or short pieces of adhesive tape, identify all wires in accordance with their numbered conditions. Identify every lead that is to be removed. Refer to the schematic diagram (figs. 27 through 29).

b. PARTS AND SUBSTITUTION. When damaged parts must be replaced, identical parts should be used. If identical

parts are not available and the damaged component is beyond repair, a substitution must be made. The part substituted must have identical electrical properties and must be of equal or higher voltage and current rating.

c. LOCATION. Relocation of substituted parts may develop certain difficulties such as regeneration, hum, noise, or crosstalk and is not recommended.

d. MOUNTING. Mount the new or replaced parts in the same mounting position as that formerly occupied by the damaged part. Fasten all mountings securely.

e. RETROPICALIZATION. If the parts being replaced require a special treatment, such as retropicalization, follow the instructions given in TB SIG 13 and TB SIG 72.

79. Special Repair Procedures

In replacing parts within the control units, care must be exercised not to damage adjacent parts. Special procedures for repairing the generator, bell, springs, switches, and connectors, applicable to either the local or the remote control units, are described in the following subparagraphs. In many cases disassembly of the unit, as described in paragraph 74 or 75 is necessary in order to prevent damage to other parts. The procedures outlined below are applicable to both control units.

a. PANEL CONNECTORS. A spanner wrench or long-nosed pliers is necessary. The procedure is as follows:

(1) Disengage the panel from the rest of the assembly to gain access to the rear of the panel (fig. 22 or 23).

(2) Insert the teeth of the spanner wrench into the notches in the nut of the connector on the front panel. Turn the spanner wrench in a counterclockwise direction until the nut is removed. Remove the lockwasher.

(3) Unsolder and tag all wires.

(4) Remove the connector from the rear of the panel.

(5) In selecting a new connector, make sure that the new part has a rubber gasket.

(6) Resolder all wires to the new connector.

(7) Clean thoroughly to remove solder drops.

(8) Recheck the new connections with those shown on the schematic diagram (fig. 27 or 28).

(9) Reinsert the connector from the rear of the panel.

(10) Reinsert the lockwasher and the nut by the use of the spanner wrench.

(11) Attach the nut to the connector and check the assembly for fitness.

(12) Reassemble the panel to the rest of the unit.

b. SWITCHES. The panel-mounted switch may be removed as follows:

- (1) Disconnect the panel from the rest of the assembly.
- (2) Unsolder and tag all wires from the switch.
- (3) Remove the switch knob by removing the knob retaining screw.

(4) Remove the castellated nut, by means of a spanner wrench or long-nosed pliers.

(5) The switch can now be removed from the rear of the panel. In working the switch away from the panel, make sure not to damage it.

(6) When replacing the switch, make sure that the key on the switch fits into the keyhole on the panel. Be careful in handling the switch since the wafer may break. Examine contacts to make sure that they are made properly and that the switches turn freely to each of their operating positions. Note that in the case of the LOCAL switch, S-2, of the local control unit, the two end positions are spring return. Check whether the switch is returned from each of its end positions to the adjacent near position.

(7) Restore the mounting nut and the knob.

(8) Resolder all connections and check against the schematic diagram (fig. 27 or 28). Clean away all solder drops.

c. REPLACEMENT OF RINGING GENERATOR. The generator is supplied as a unit assembly. No details are given for disassembling the generator. To replace the generator proceed as follows:

(1) Remove the screw on the front panel which holds the generator crank.

(2) Remove the screw and the lockwasher which hold the generator crank to the front panel.

(3) Slide the crank off the shaft.

(4) By means of a wrench remove the nut holding the generator shaft to the panel. Disconnect the leads attached to the rear of the generator case. Lift the generator off the panel.

(5) To replace, reverse the above procedure.

d. BELL. The bell is mounted to the left side of the chassis frame by means of two machine screws.

(1) Remove the three machine screws.

(2) Lift the bell out of the compartment, being careful not to strain or break the wires connected to it.

(3) Unsolder the wire from the terminal board in the space under the bell.

(4) To replace, reverse the above procedure.

e. BATTERY CONTACTS. If either contact of the battery connector strip is damaged, the entire strip must be replaced. The battery contact strip within the chassis assembly

is mounted by means of four rivets. Drill out the rivets and lift the strip out of its compartment, and unsolder the leads connected to it. To replace, follow the reverse of the above procedure.

f. BINDING POSTS. To replace a binding post, disconnect the wire from the stud at the rear of the panel. Remove the nut which holds the binding post in place and lift the post away from the front of the panel.

80. Local Control C-434/GRC

In general, the procedure for replacement and repair of components within Local Control C-434/GRC is similar to that described above for the remote control unit. This applies to the removal and replacement of connectors, switches, transformer, bell, generator, and lamp. The following additional items are involved in this unit.

a. BATTERY COMPARTMENT. The battery compartment is a plastic container, mounted to the chassis frame by means of four machine screws, which are accessible from the top of the unit (fig. 23). Proceed as follows:

(1) Press the snap catch which holds the battery compartment cover in place. The cover is located on the bottom of the panel-and-chassis assembly.

(2) Place the unit in its proper operating position and remove the four machine screws which hold the battery compartment in place. Lift the battery compartment out of the unit. The battery contact strip will remain mounted within the chassis. This strip is riveted to the chassis. To remove the battery strip proceed as follows:

(a) Drill out the four rivets, fastening the contact strip to the chassis.

(b) Clean the chassis thoroughly to remove solder drops and metal chips.

(c) Unsolder the wires connected to the contact strips.

(d) Check that the spring is seated properly and clamped to the large contacts.

b. RELAYS. The plug-in type relays (O-1, O-2, and O-3) are mounted on a shelf, which is protected by a bracket. Remove the two screws which hold the bracket in place and remove the bracket. The relays are now exposed to view. Relay O-1 is nearest to the panel and relay O-3 is farthest away from the panel. Pull the relays out of their sockets. Do not rock or jiggle the relay if difficulty is encountered. This might damage the relay pins on the relay socket. Pry up gently with a screw driver, if necessary. Note whether the shock-absorbing rubber strip is glued on to the side of the chassis section adjacent to the relay shelf.

81. Reassembling the Equipment

The procedure for reassembling the equipment follows the

reverse of the procedure outlined in the preceding paragraph.

a. Attach the panel to the chassis frame and replace the four machine screws.

b. Replace the batteries, as described in paragraphs 14 and 15, and the battery compartment cover, making sure that the Battery BA-30 electrode makes proper contact with the contacts on the battery terminal strip both within the compartment and on the compartment cover. Replace the case.

Note. Unless it is known that the unit will be put into operation within a very short period of time, the batteries should be kept out of the compartment and stored away. All precautions must be taken to save battery drain.

82. Disassembly and Replacement of Handset Parts (fig. 24)

a. RECEIVER ELEMENT. To replace the receiver element, proceed as follows:

(1) Remove the screw and the two washers at the back of the receiver portion of the handset. Save the screw and the metal (H-105) and rubber (H-104) washers for reassembly.

(2) Lift off the receiver cap (O-103), being careful not to lose the water- and frost-shedding diaphragm (Q-101).

(3) Lift out the receiver element (E-101).

b. TRANSMITTER ELEMENT. To remove the transmitter element, unscrew the cap (O-101) on the curved portion of the handset assembly (H-102). Lift out the transmitter element (E-104).

c. HANDSET SWITCH. To gain access to the handset switch proceed as follows:

(1) Remove the two screws and washers (H-108 and H-109) and lift off the switch assembly. Be careful in doing this. The switch assembly is delicate and the ends of the cord assembly are soldered to the switch sections.

(2) Pull off the waterproof switch cover (A-101). This gives access to the switch mounting plate.

d. SWITCH CAVITY COVER. To gain access to the wiring side of the switch for connection or disconnection of the cord and plug assembly, remove the two screws and washers (H-106 and H-107), pull off the waterproof switch cavity cover (A-102), and lift off the switch cavity cover plate.

e. CORD AND PLUG ASSEMBLY. To disconnect or reconnect the cord and plug assembly, remove the switch cavity cover as in subparagraph d. Unsolder the leads and pull the cable through, being careful not to lose the cord and plug assembly packing gland.

f. REASSEMBLY. To reassemble the handset, follow the reverse of the procedure outlined above.

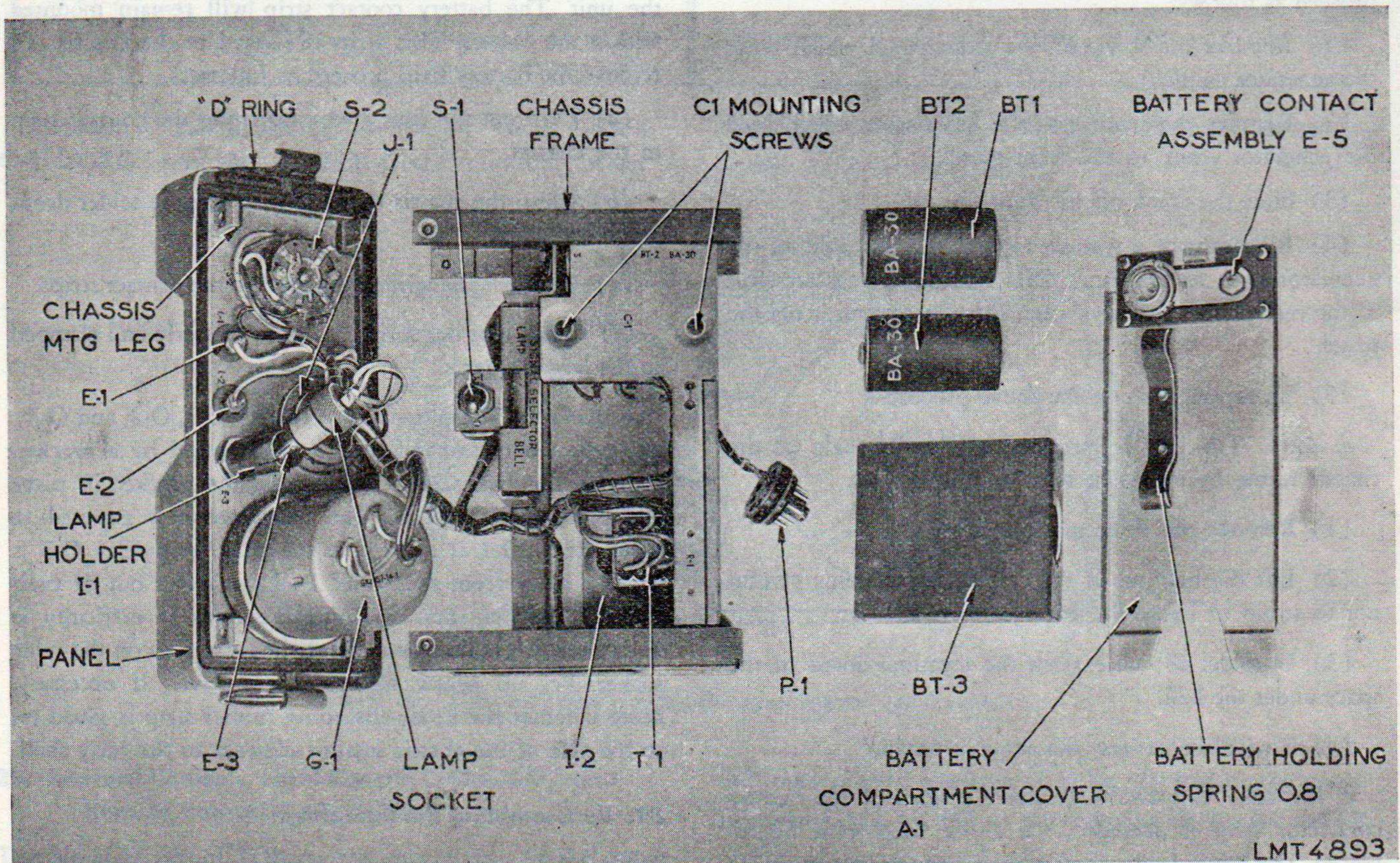

Figure 22. Remote Control C-433/GRC, disassembled view.

82.1. Disassembly Procedure for Generator G—25 (*)/PT

Note: Official nomenclature followed by (*) is used to indicate all models of the item of equipment included in this technical manual.

- a. Remove the screw and lockwasher from the handwheel and take off handwheel.
- b. Remove the hexagonal nut and the lockwasher.
- c. Remove the generator from the panel.
- d. Remove the seal from the front of the generator.
- e. Unscrew the retainer ring from the gear cap.
- f. Separate the generator from the cover and remove the seal.
- g. Remove the two screws securing the rear contact springs; be careful not to lose washers and bushings which are associated with the mounting of the springs.
- h. Repeat operation g for the middle and the front contact springs.
- i. Remove the ball which separates the governor.

j. Remove the governor by placing the screw-driver under the governor at various points and gently rocking the governor off the splined shaft.

k. Remove the four or six screws which secure the stator generator to the base casting. Separate the stator generator from the base casting.

l. Shake the generator stator hard, hitting the edge against the palm of the hand to force the magnetized rotor partly out of the stator generator. Pull out the rotor from the stator.

m. Separate the base and the gear cap by pulling the two pieces apart.

n. Remove the retainer ring and separate the gear cap from shaft assembly.

o. Remove the retainer ring and separate the gear assembly from base.

p. Inspect the parts for signs of wear or damage.

Note: Generators G-25 PT and G-25 A/PT are interchangeable as complete units only. Individual maintenance items vary slightly between the two generators.

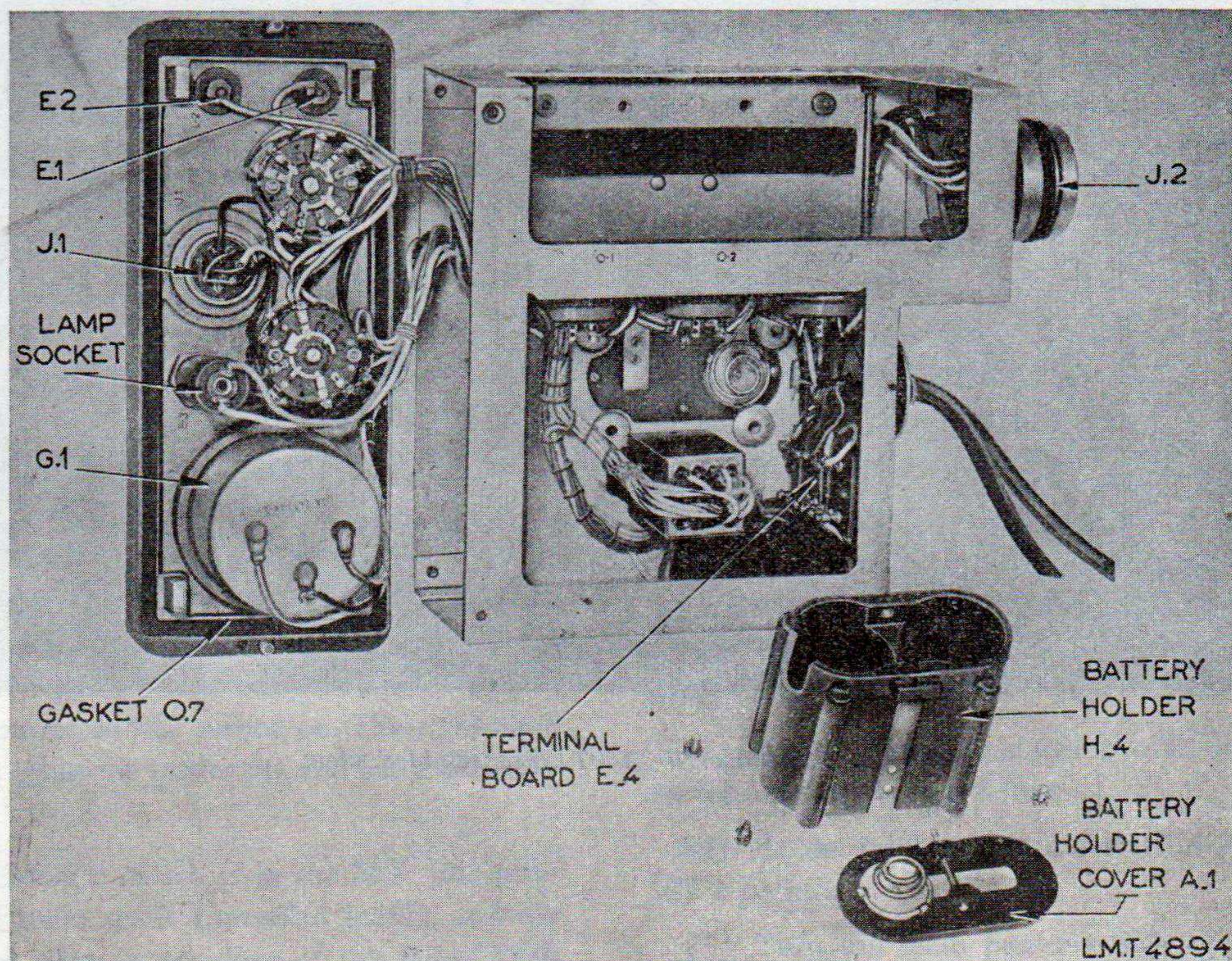

Figure 23. Local Control C-434/GRC, disassembled view

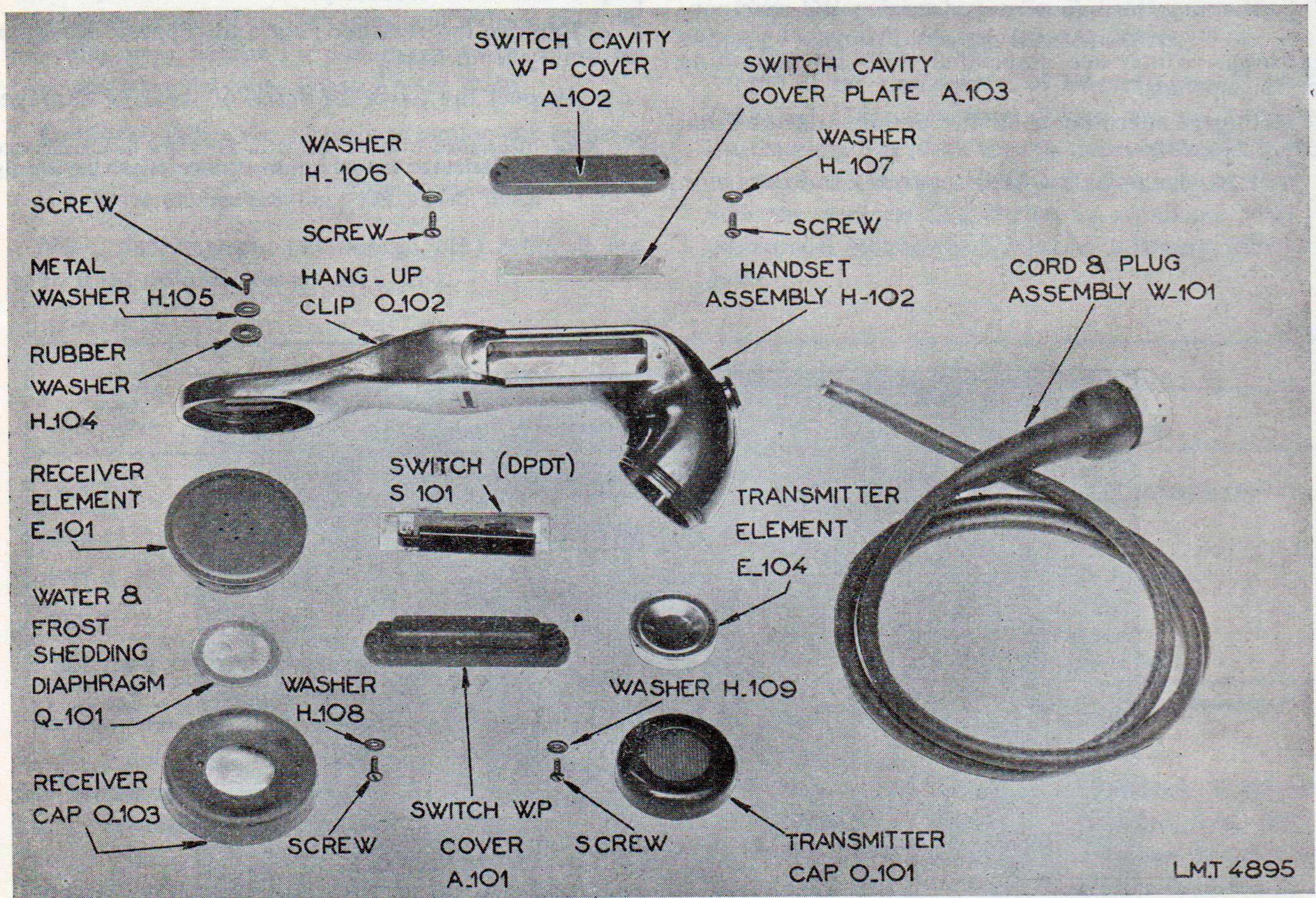

Figure 24. Handset H-33/PT, disassembled view.

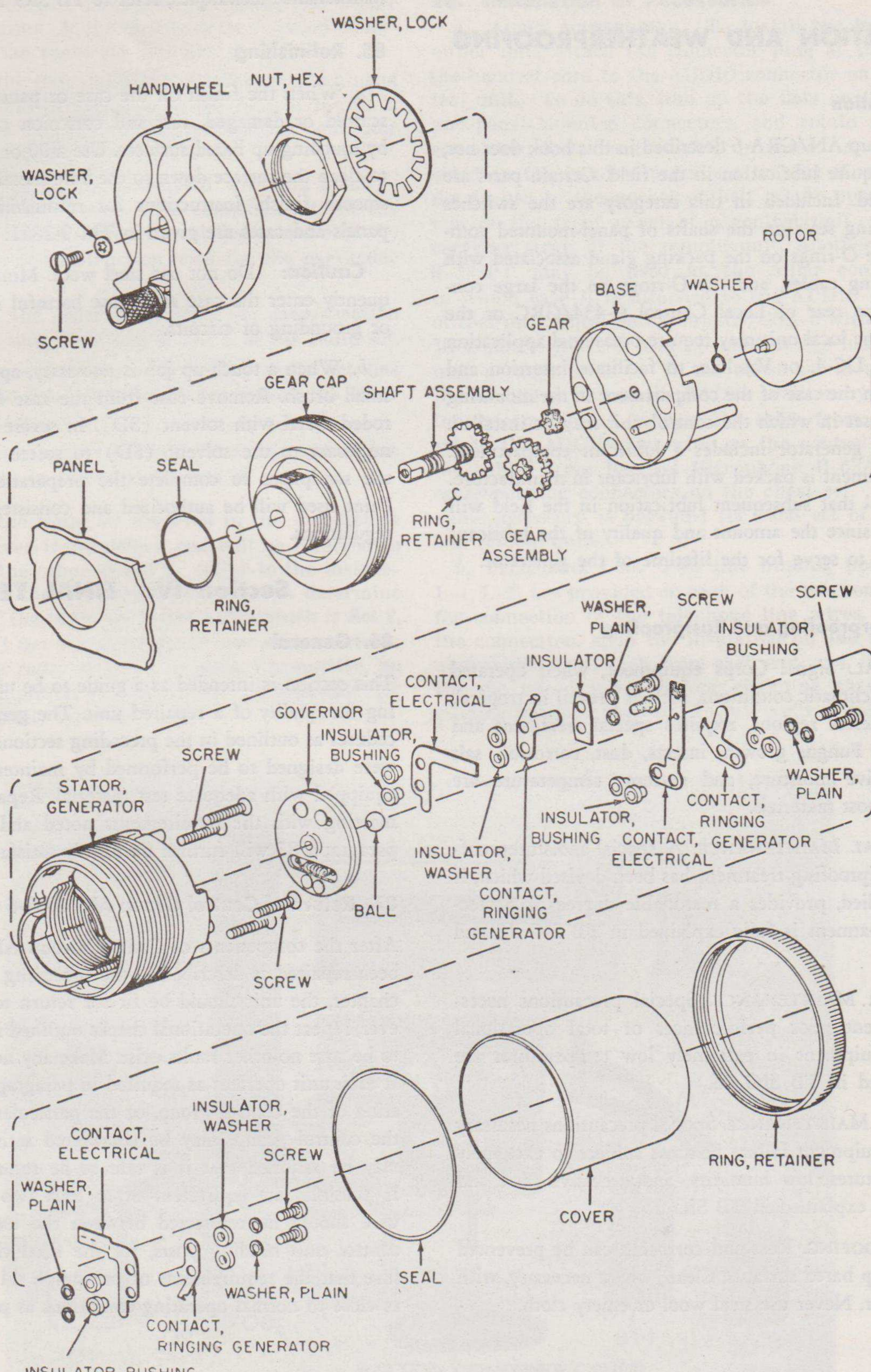

Figure 24.1. Generator G-25(*)/PT, exploded view.

Section III.

LUBRICATION AND WEATHERPROOFING

83. Lubrication

Control Group AN/GRA-6 described in this book does not, as a rule, require lubrication in the field. Certain parts are self-lubricated. Included in this category are the switches and the O-ring seals on the shafts of panel-mounted components. The O-rings on the packing gland associated with the connecting cables, and the O-rings on the large connector on the rear of Local Control C-434/GRC or the runners on the local unit may require occasional application of lubricant DC-4, or Vaseline, to facilitate insertion and removal from the case of the compartment in the mounting of the radio set in which the control unit may be installed. The ringing generator includes a lubricant compartment. This compartment is packed with lubricant in manufacture. It is doubtful that subsequent lubrication in the field will be required, since the amount and quality of the lubricant are designed to serve for the lifetime of the generator.

84. Weatherproofing and Rustproofing

a. GENERAL. Signal Corps equipment, when operated under severe climatic conditions, such as prevail in tropical, arctic, and desert regions, requires special treatment and maintenance. Fungus growth, insects, dust, corrosion, salt spray, excessive moisture, and extreme temperature are harmful to most materials.

b. TROPICAL MAINTENANCE. A special moistureproofing and fungiproofing treatment has been devised which, if properly applied, provides a reasonable degree of protection. This treatment is fully explained in TB SIG 13 and TB SIG 72.

c. WINTER MAINTENANCE. Special precautions necessary to prevent poor performances or total operational failure of equipment in extremely low temperatures are fully explained in TB SIG 66.

d. DESERT MAINTENANCE. Special precautions necessary to prevent equipment failure in areas subject to extremely high temperatures, low humidity, and excessive sand and dust are fully explained in TB SIG 75.

e. RUSTPROOFING. Rust and corrosion can be prevented by touching up bared surfaces. Clean, where necessary, with fine sandpaper. Never use steel wool or emery cloth.

Note. For further information on general preventive maintenance techniques, refer to TB SIG 178.

85. Refinishing

a. When the finish on the case or panel has been badly scarred or damaged, rust and corrosion can be prevented by touching up bared surfaces. Use #00 or #000 sandpaper to clean the surface down to the bare metal; obtain a bright smooth finish. Instructions for refinishing badly marred panels and cases are given in TM 9-2851.

Caution: Do not use steel wool. Minute particles frequently enter the case and cause harmful internal shorting or grounding of circuits.

b. When a touch-up job is necessary, apply paint with a small brush. Remove rust from the case by cleaning corroded metal with solvent (SD). In severe cases, it may be necessary to use solvent (SD) to soften the rust and to use sandpaper to complete the preparation for painting. Paint used will be authorized and consistent with existing regulations.

Section IV. FINAL TESTS

86. General

This section is intended as a guide to be used in determining the quality of a repaired unit. The general repair procedures as outlined in the preceding sections of this chapter were designed to be performed by maintenance personnel equipped with adequate test material. Repaired equipment meeting with the requirements noted and referred to in paragraph 87 will furnish uniformly satisfactory operation.

87. Return of Control Group AN/GRA-6 to Service

After the components of Control Group AN/GRA-6 have been repaired as described in the preceding sections of this chapter, the unit should be fit for return to service. However, repeat the operational checks outlined in paragraph 44 to be sure no other faults exist. Make any necessary repairs. If each unit operates as required in paragraph 44, the operation of the control group, or the particular component of the control group, may be considered satisfactory, and it may be assumed that it is safe to be returned to service. If possible, the equivalent of at least two miles of field wire should be connected between the local and remote control unit binding posts, for the final checks, to make sure that the requirements of paragraph 44 are met under as close to normal operating conditions as possible.

CHAPTER 7

SHIPMENT AND LIMITED STORAGE AND DEMOLITION TO PREVENT ENEMY USE

88. Repacking for Shipment or Limited Storage

Wrap and pack securely according to directions given in packaging specifications or Signal Corps Instructions No. 712-478, revised 15 October 1948, or as directed by the officer-in-charge.

89. Demolition of Materiel to Prevent Enemy Use

The demolition procedures outlined below will be used to prevent the enemy from using or salvaging this equipment. Demolition of the equipment will be accomplished only upon order of the commander. DESTROY EVERYTHING.

a. SMASH. Smash capacitors, transformers, resistors, sock-

ets, plugs, and other components, using sledges, axes, hand-axes, pickaxes, hammers, crowbars, or heavy tools.

b. CUT. Cut wiring, using axes, handaxes, or machetes.

c. BURN. Burn technical manuals, instruction books, records and forms, resistors, capacitors, and transformers, using gasoline, kerosene, oil, flame throwers, or incendiary grenades.

d. BEND. Bend chassis, panels, and covers.

e. EXPLOSIVES. If explosives are necessary, use firearms, grenades, or TNT.

f. DISPOSAL. Bury or scatter the destroyed parts in slit trenches, fox holes, or other holes, or throw them into streams.

APPENDIX I

REFERENCES

Note. For availability of items listed, Check SR-310-20-3 and SR 310-20-4. Check Department of the Army Supply Catalog SIG 1 for Signal Corps supply catalog pamphlets.

1. Army Regulations

AR 380-5 Safeguarding Military Information.

2. Supply Publications

SIG 1 Introduction and Index.

SB 11-76 Signal Corps Kit and Materials for Moisture- and Fungi-Resistant Treatment.

3. Publications on Auxiliary Equipment and Test Equipment

TM 11-2626 Test Unit I-176.

4. Painting, Preserving, and Lubrication

TB SIG 13 Moistureproofing and Fungiproofing Signal Corps Equipment.

TM 9-2851 Painting Instructions for Field use.

5. Demolition

FM 5-25 Explosives and Demolitions.

6. Other Publications

FM 24-18 Field Radio Techniques.

SR 310-20-3 Index of Training Publications (Field Manuals, Training Circulars, Firing Tables and Charts, Army Training Programs, Mobilization Training Programs, Graphic Training Aids, Joint Army-Navy-Air Force Publications, and Combined Communications Board Publications).

SR 310-20-4 Index of Technical Manuals, Technical Regulations, Technical Bulletins, Supply Bulletins, Lubrication Orders, Modification Work Orders, Tables of Organization and Equipment, Reduction Tables, Tables of Allowances, Tables of Organization, Tables of Equipment.

SR 700-45-5 Unsatisfactory Equipment Report (Reports Control Symbol CSGLD-247).

SR 745-45-5 Report of Damaged or Improper Shipment (Reports Control Symbols CSGLD-66 (Army), SandA-70-6 (Navy), and AF-MC-U2 (Air Force)).

TB SIG 66 Winter Maintenance of Signal Equipment.

TB SIG 72 Tropical Maintenance of Ground Signal Equipment.

TB SIG 75 Desert Maintenance of Ground Signal Equipment.

TB SIG 123 Preventive Maintenance Practices for Ground Signal Equipment.

TB SIG 178 Preventive Maintenance Guide for Radio Communication Equipment.

TM 11-430 Batteries for Signal Communication, Except Those Pertaining to Aircraft.

TM 11-453 Shop Work.

TM 11-455 Radio Fundamentals.

TM 11-486 Electrical Communication Systems Engineering.

TM 11-660 Introduction to Electronics.

TM 11-4000 Trouble Shooting and Repair of Radio Equipment.

TM 38-650 Basic Maintenance Manual.

7. Abbreviations

af.....audio frequency
C.....centigrade
db.....decibel (s)
dc.....direct current
F.....Fahrenheit
hf.....high frequency
ma.....milliampere
rf.....radio frequency
rms.....root mean square
uf, uuf.....microfarad, micromicrofarad

8. Glossary

For explanation of terms used in this manual, refer to TM 11-455, Radio Fundamentals.

RESISTOR COLOR CODES

RMA COLOR CODE FOR FIXED COMPOSITION RESISTORS*

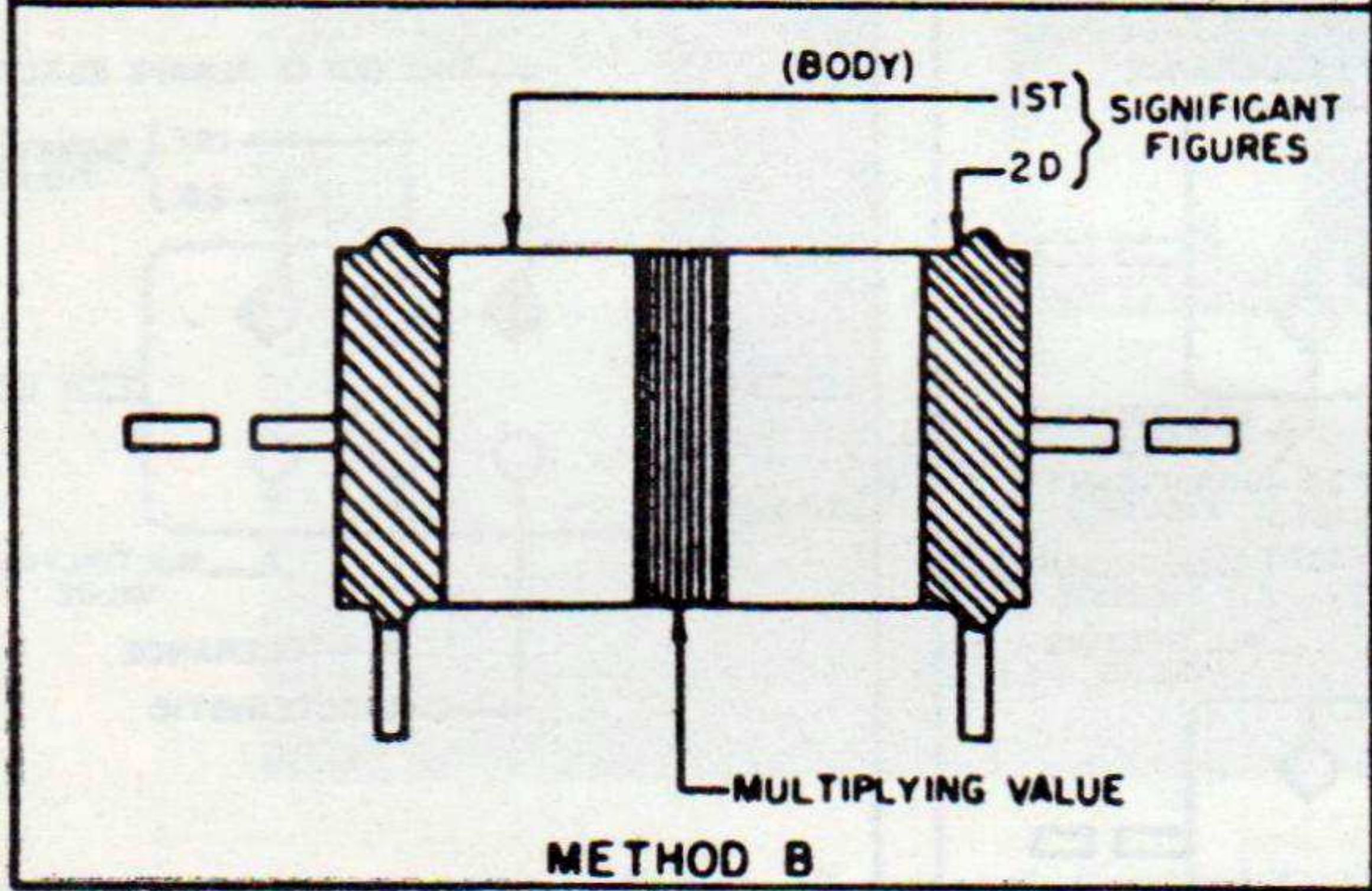
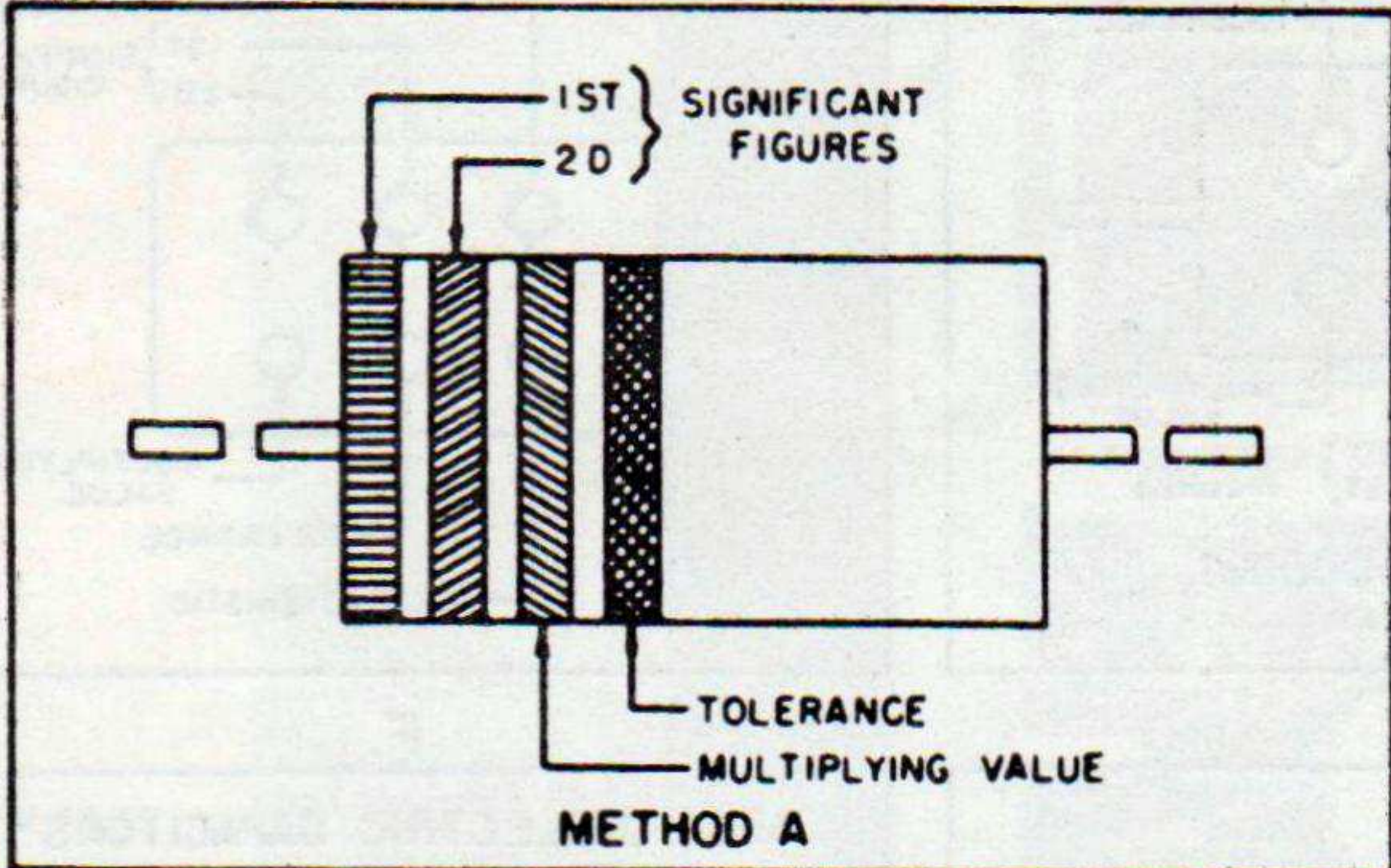

A

JAN COLOR CODE FOR FIXED COMPOSITION RESISTORS†

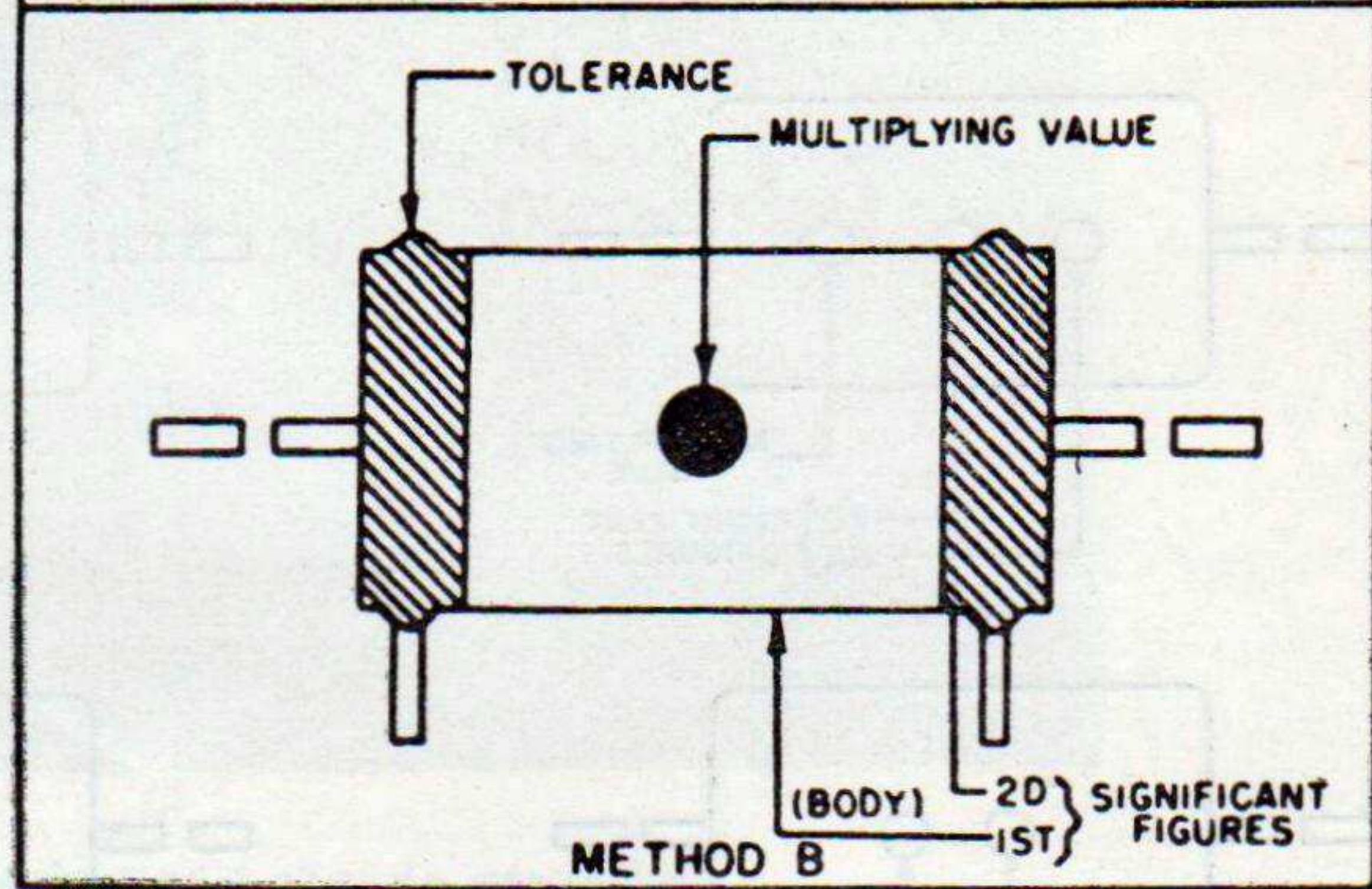
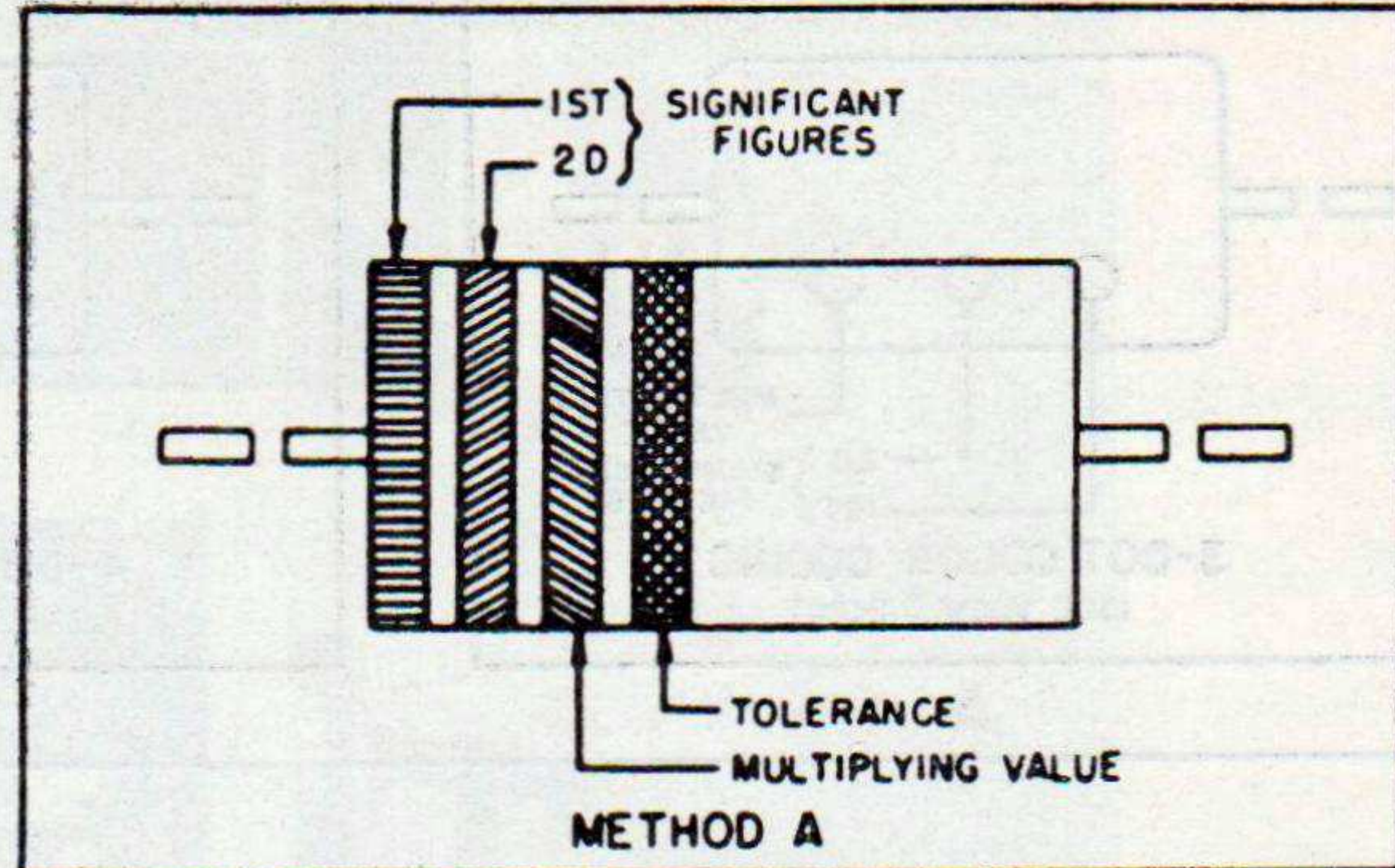

B

COLOR	SIGNIFICANT FIGURE	MULTIPLYING VALUE	TOLERANCE (%)
BLACK	0	1	± -
BROWN	1	10	± 1
RED	2	100	± 2
ORANGE	3	1,000	± 3
YELLOW	4	10,000	± 4
GREEN	5	100,000	± 5
BLUE	6	1,000,000	± 6
VIOLET	7	10,000,000	± 7
GRAY	8	100,000,000	± 8
WHITE	9	1,000,000,000	± 9
GOLD	-	0.1	± 5
SILVER	-	0.01	± 10
NO COLOR	-	-	± 20

NOTES
* INSULATED FIXED COMPOSITION RESISTORS WITH AXIAL LEADS ARE DESIGNATED BY A NATURAL TAN BACKGROUND COLOR. NON-INSULATED FIXED COMPOSITION RESISTORS WITH AXIAL LEADS ARE DESIGNATED BY A BLACK BACKGROUND.
† RESISTORS WITH AXIAL LEADS ARE INSULATED. RESISTORS WITH RADIAL LEADS ARE NON-INSULATED.
RMA RADIO MANUFACTURERS ASSOCIATION
JAN JOINT ARMY-NAVY
THESE COLOR CODES GIVE ALL RESISTANCE VALUES IN OHMS

Figure 25. Resistor color codes.

CAPACITOR COLOR CODES

RMA 3-4-5-&6-DOT COLOR CODES FOR MICA-DIELECTRIC CAPACITORS

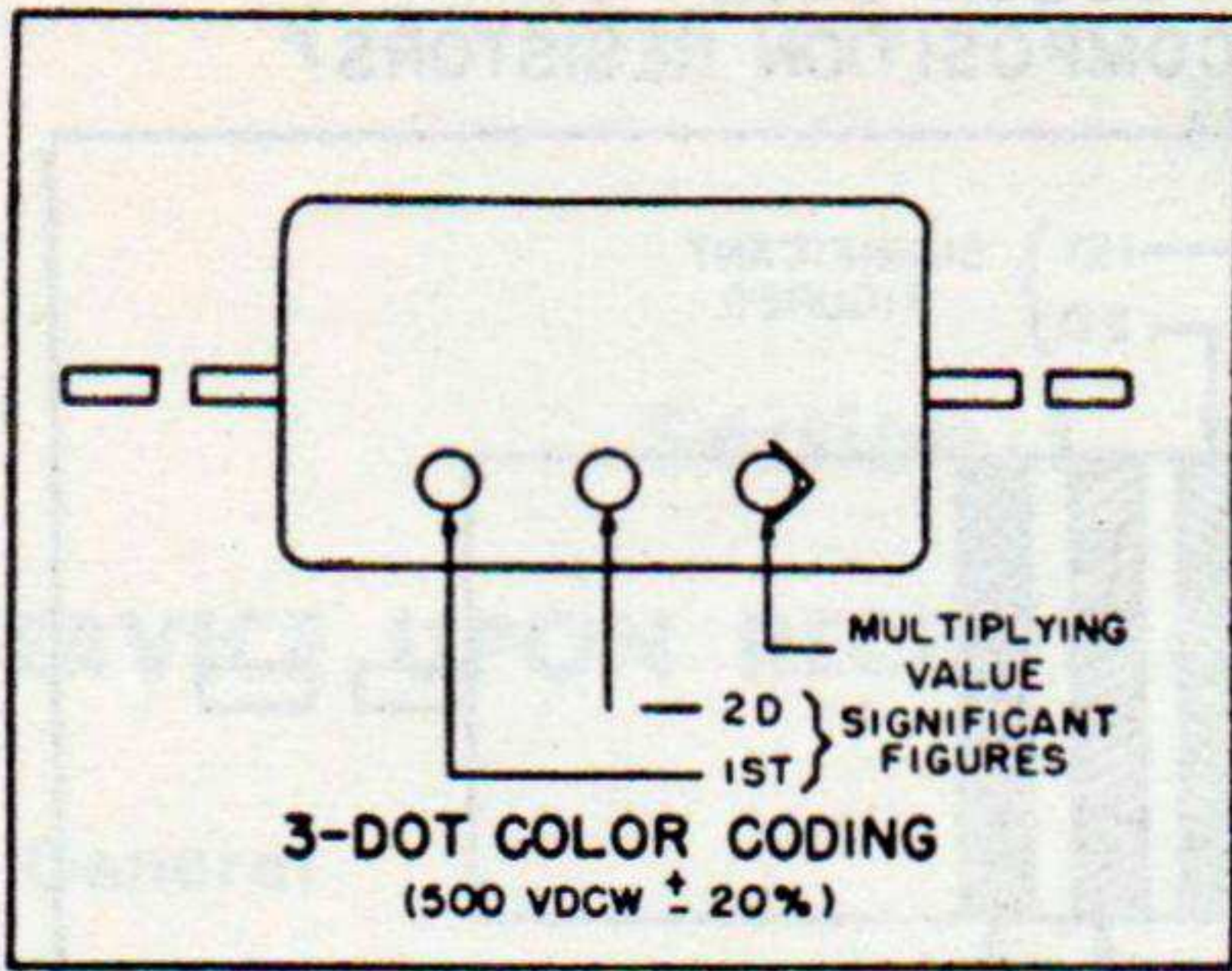

A

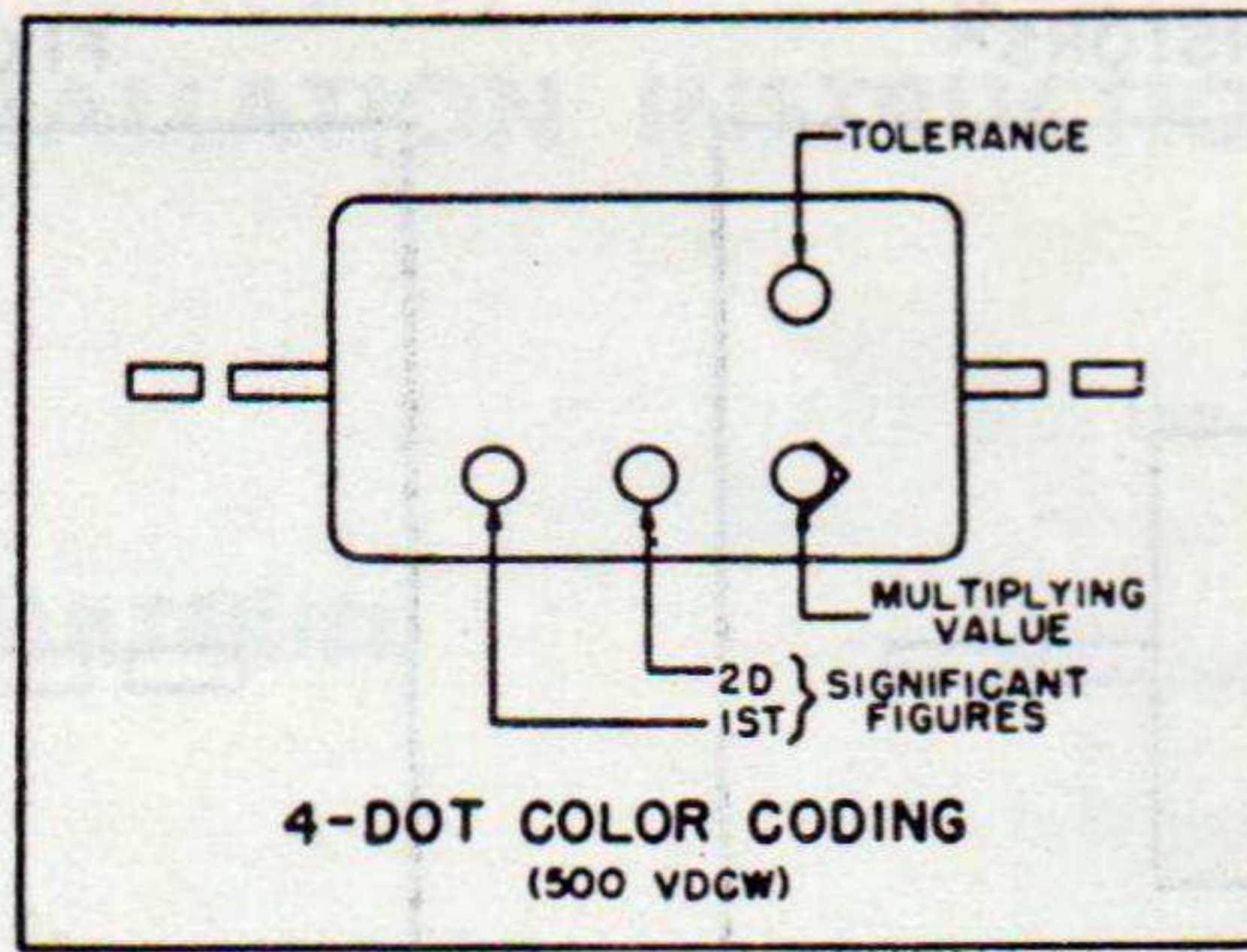

B

JAN 6-DOT COLOR CODES FOR:

PAPER-DIELECTRIC CAPACITORS *

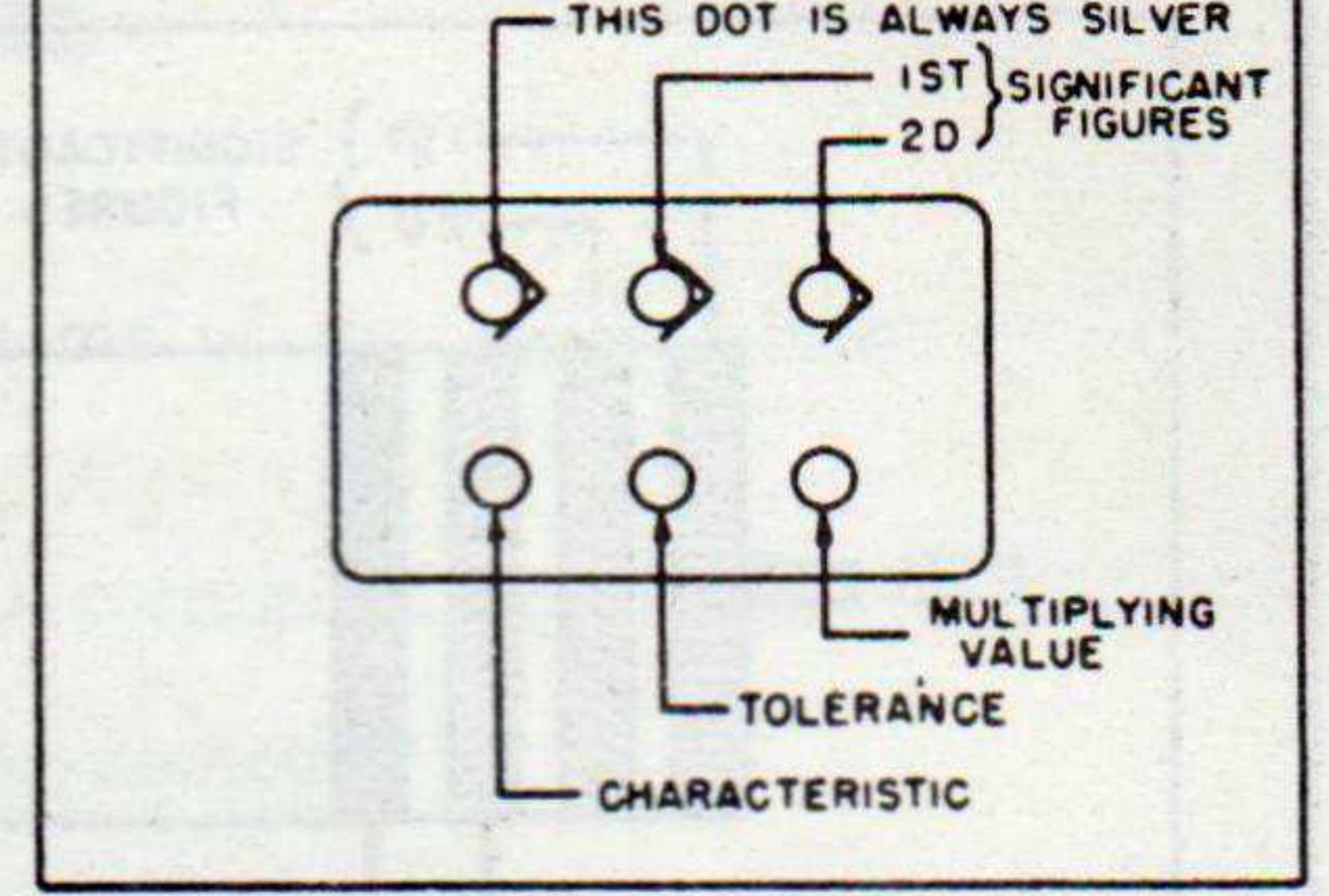

F

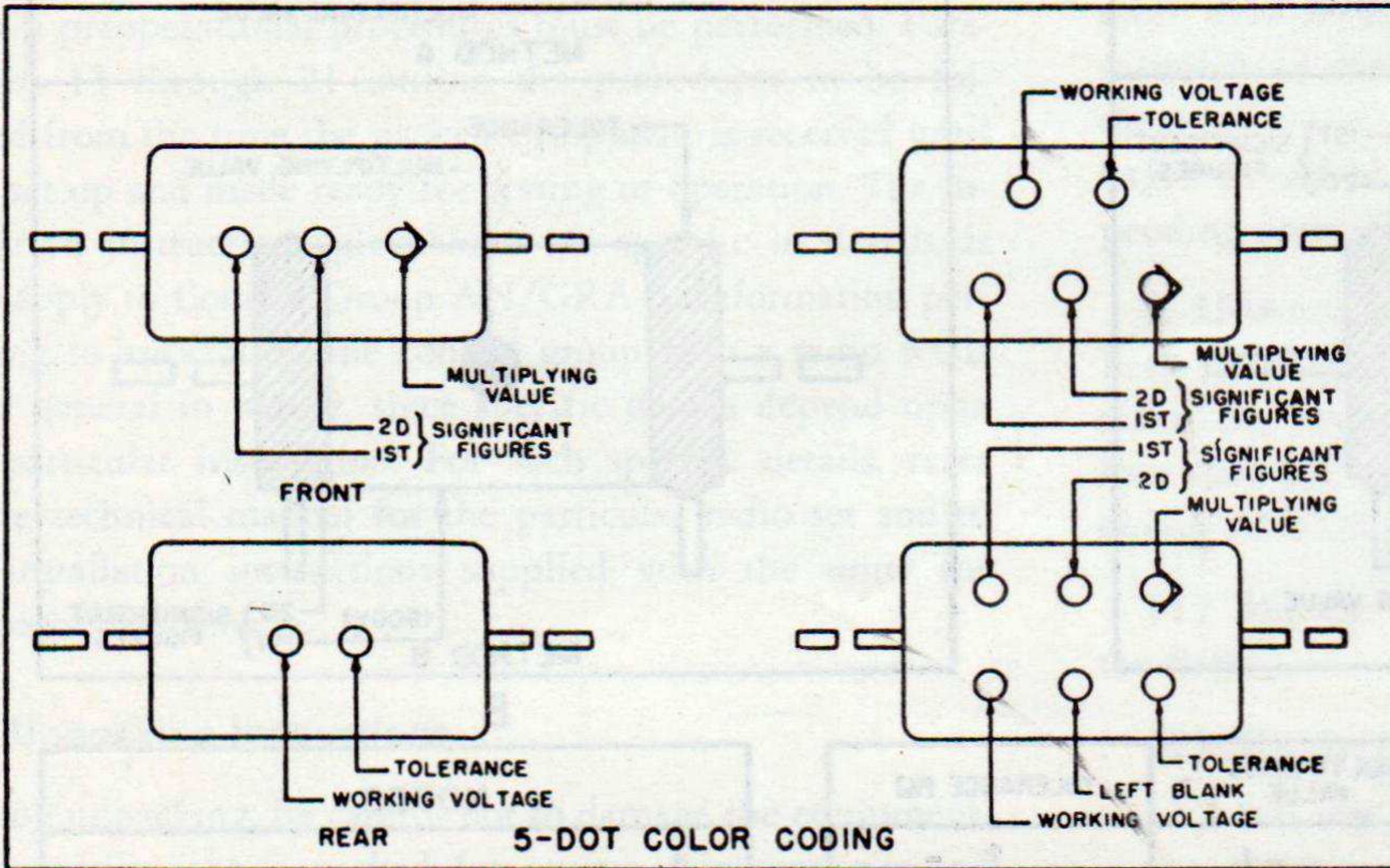

C

MICA-DIELECTRIC CAPACITORS †

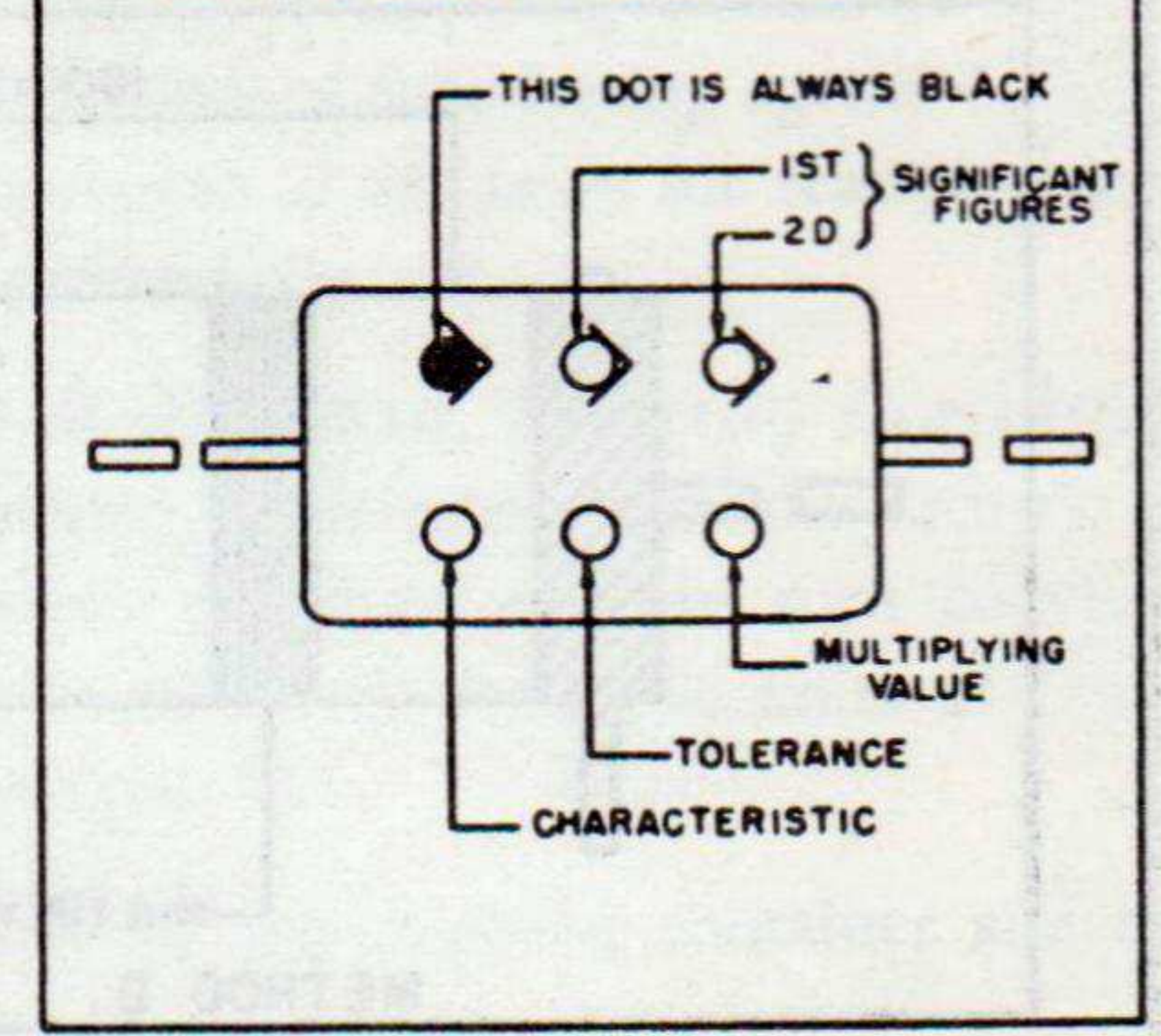

G

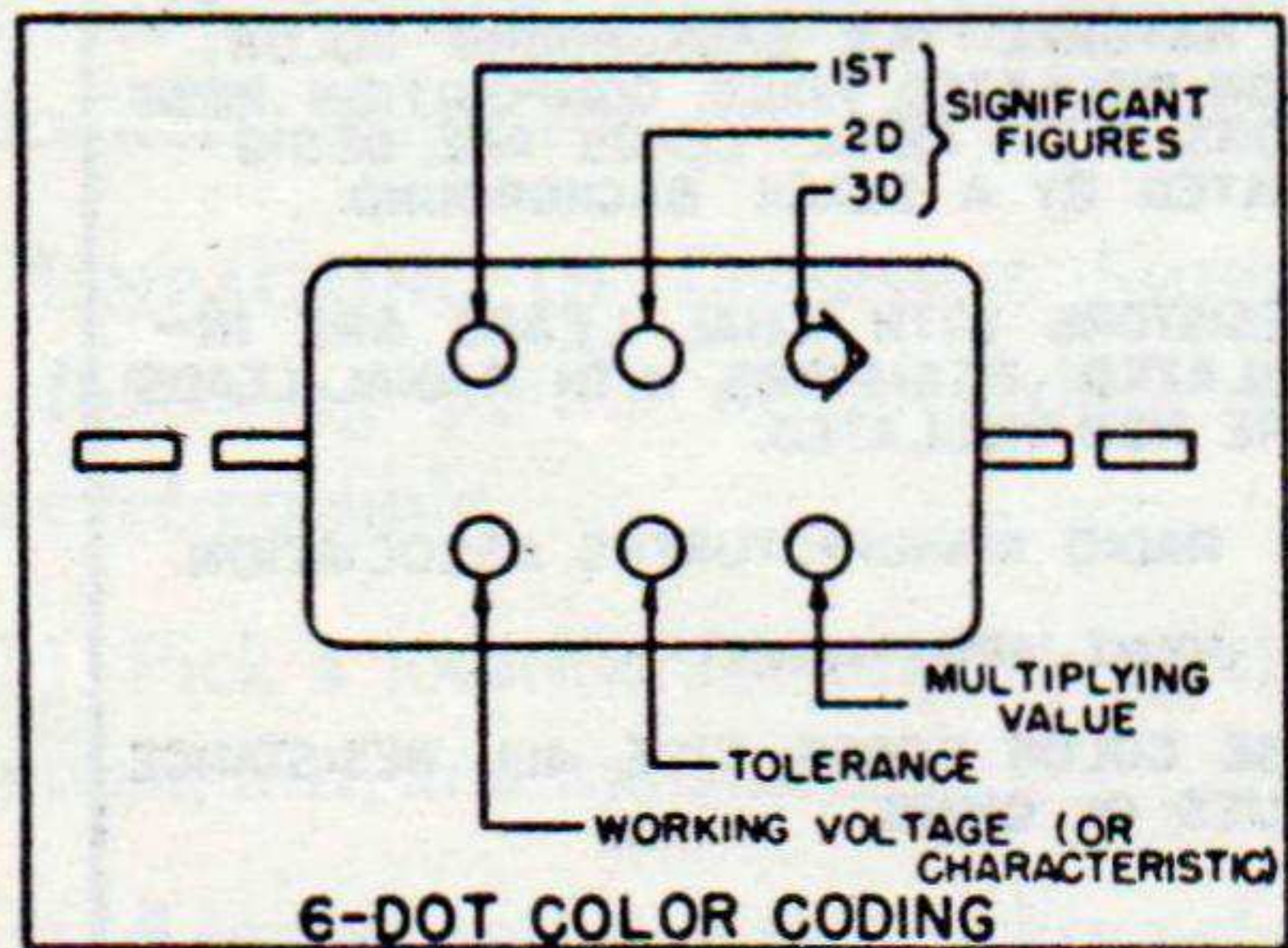

D

RMA COLOR CODE FOR TUBULAR CERAMIC-DIELECTRIC CAPACITORS

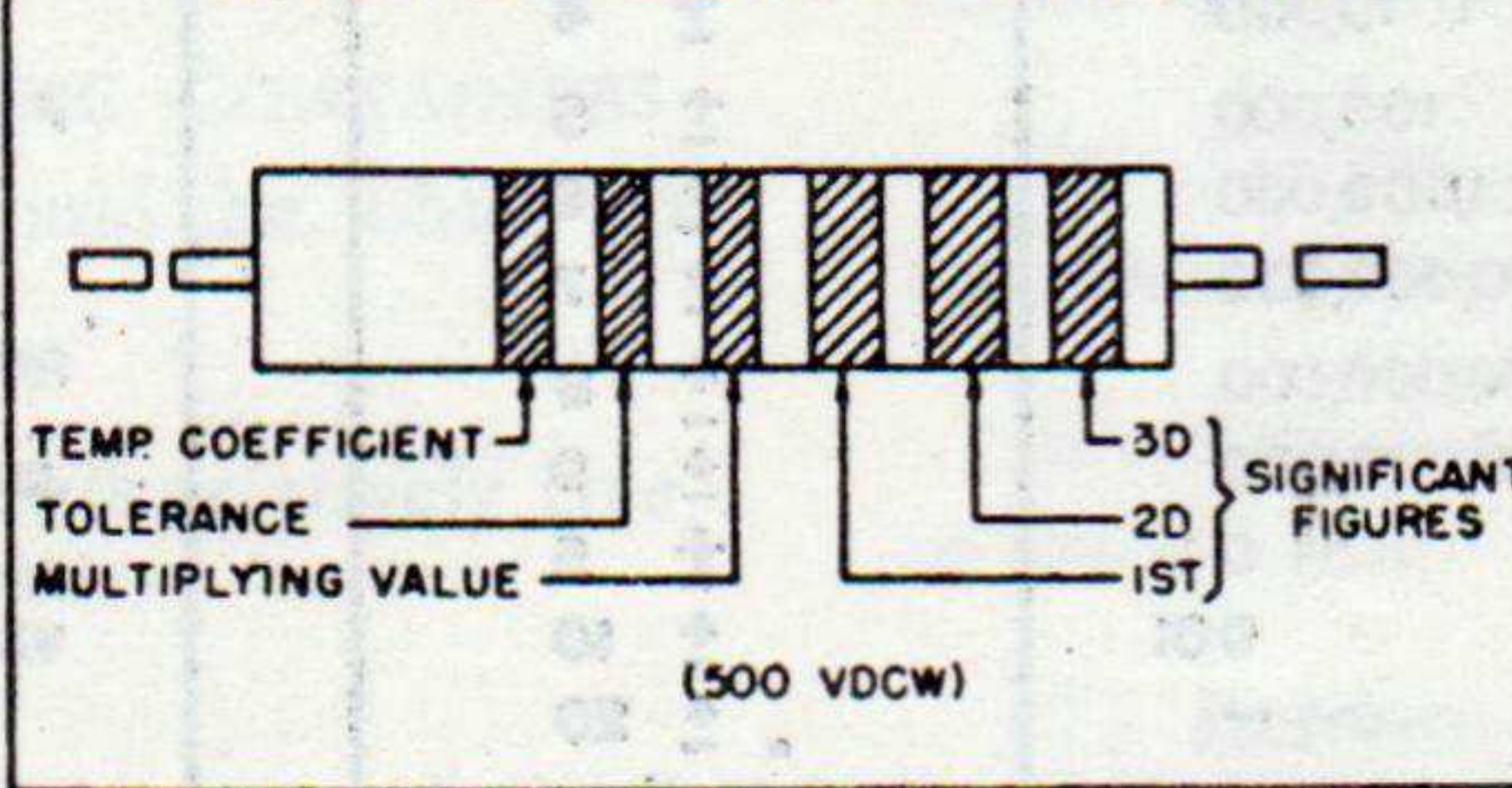

E

CERAMIC-DIELECTRIC CAPACITORS **

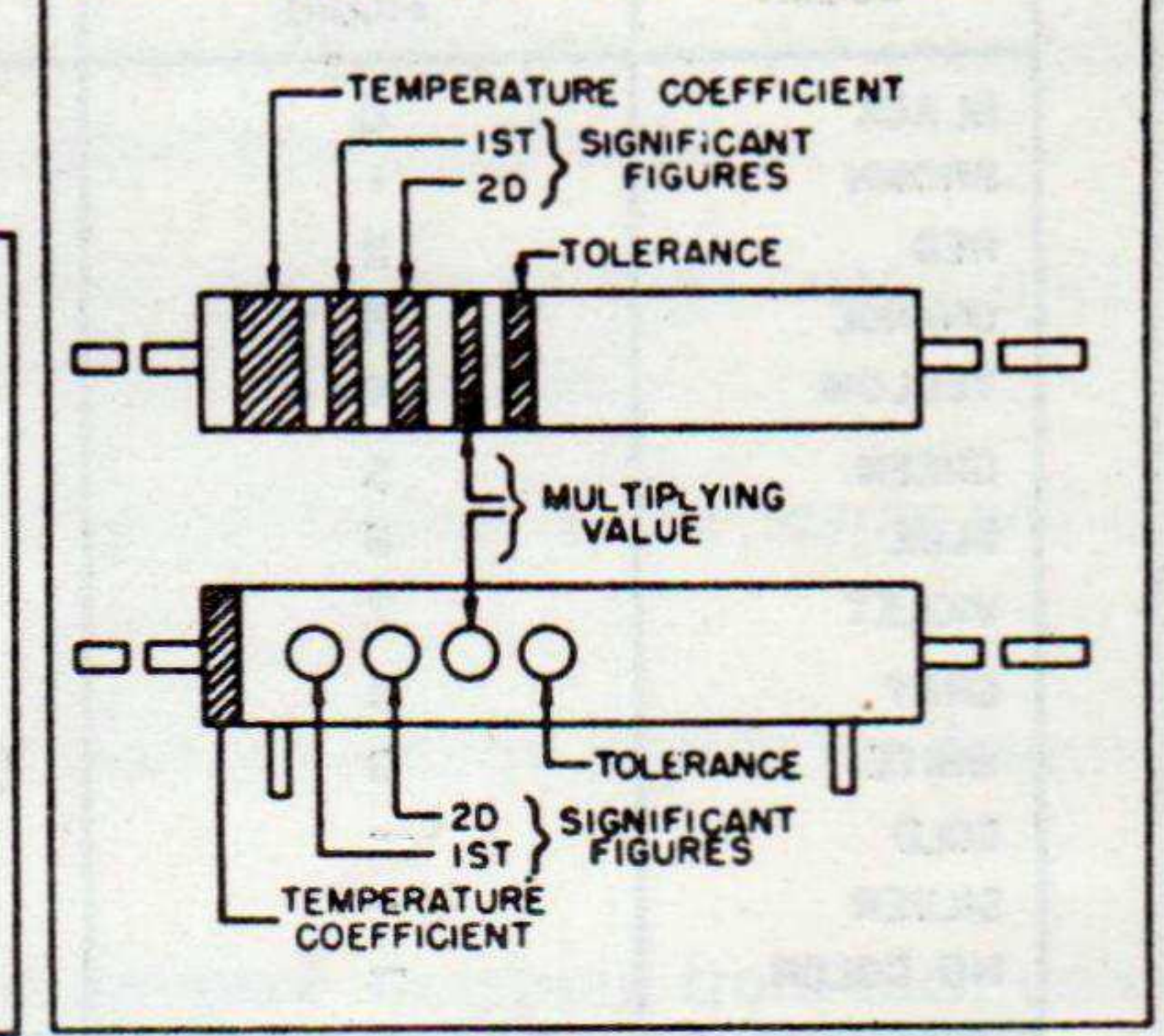

H

COLOR	SIGNIFICANT FIGURE	MULTIPLYING VALUE			RMA VOLTAGE RATING
		RMA MICA-AND CERAMIC-DIELECTRIC	JAN MICA-AND PAPER-DIELECTRIC	JAN CERAMIC-DIELECTRIC	
BLACK	0	1	1	1	-
BROWN	1	10	10	10	100
RED	2	100	100	100	200
ORANGE	3	1,000	1,000	1,000	300
YELLOW	4	10,000	10,000		400
GREEN	5	100,000			500
BLUE	6	1,000,000			600
VIOLET	7	10,000,000			700
GRAY	8	100,000,000		0.01	800
WHITE	9	1,000,000,000		0.1	900
GOLD	-	0.1	0.1		1,000
SILVER	-	0.01	0.01		2,000
NO COLOR	-				500

NOTES

* THE SILVER DOT IDENTIFIES THIS MARKING FOR WORKING VOLTAGES SEE JAN TYPE DESIGNATION CODE.

† THE BLACK DOT IDENTIFIES THIS MARKING FOR WORKING VOLTAGES SEE JAN TYPE DESIGNATION CODE.

** CAPACITORS MARKED WITH THIS CODE HAVE A VOLTAGE RATING OF 500 VDCW. EITHER THE BAND OR DOT CODE MAY BE USED FOR BOTH INSULATED (AXIAL-LEAD) OR UNINSULATED (RADIAL-LEAD) CAPACITORS.

RMA RADIO MANUFACTURERS ASSOCIATION
JAN JOINT ARMY-NAVY
THESE COLOR CODES GIVE CAPACITANCES IN MICROMICROFARADS.

Figure 26. Capacitor color codes.

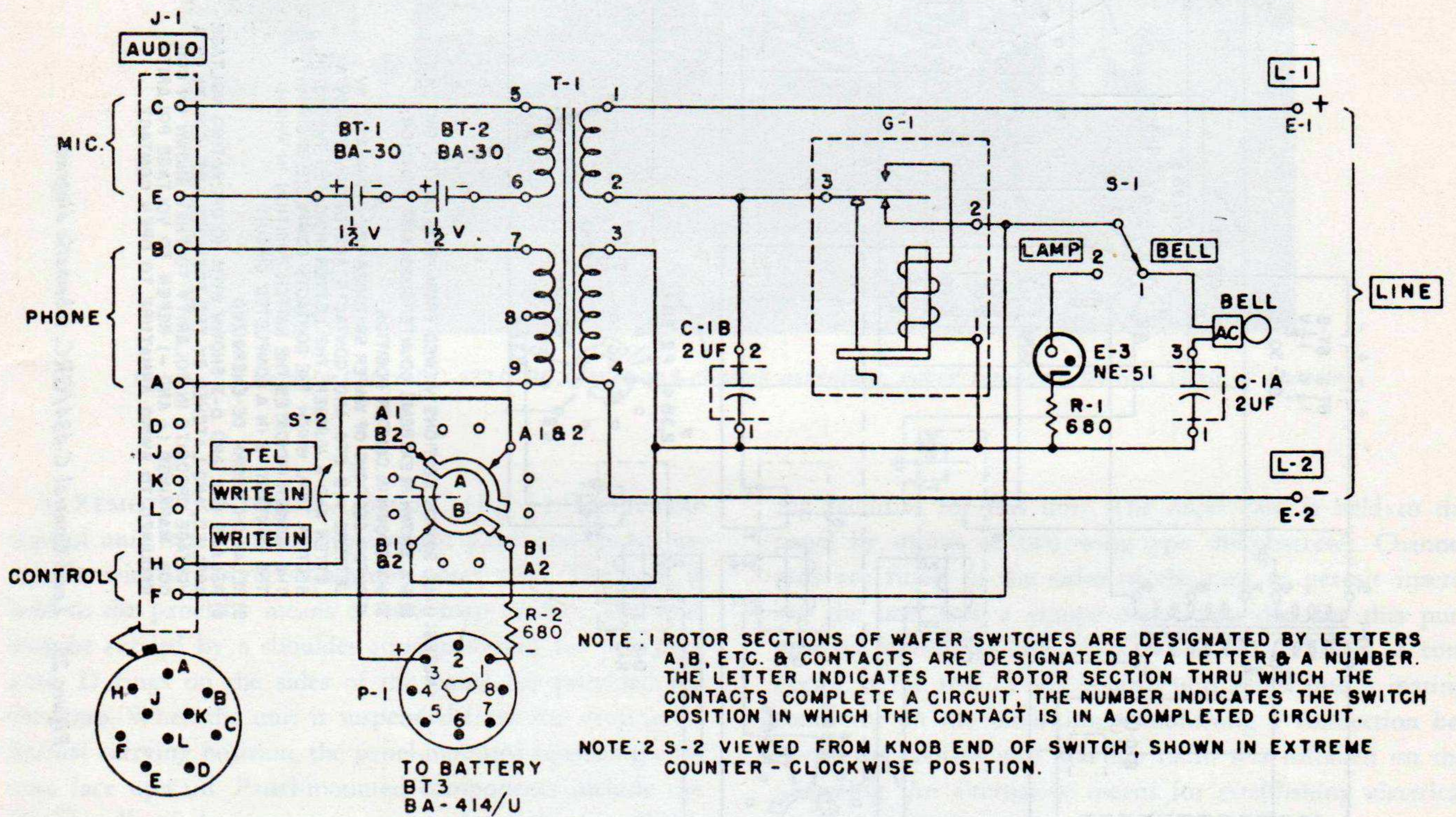
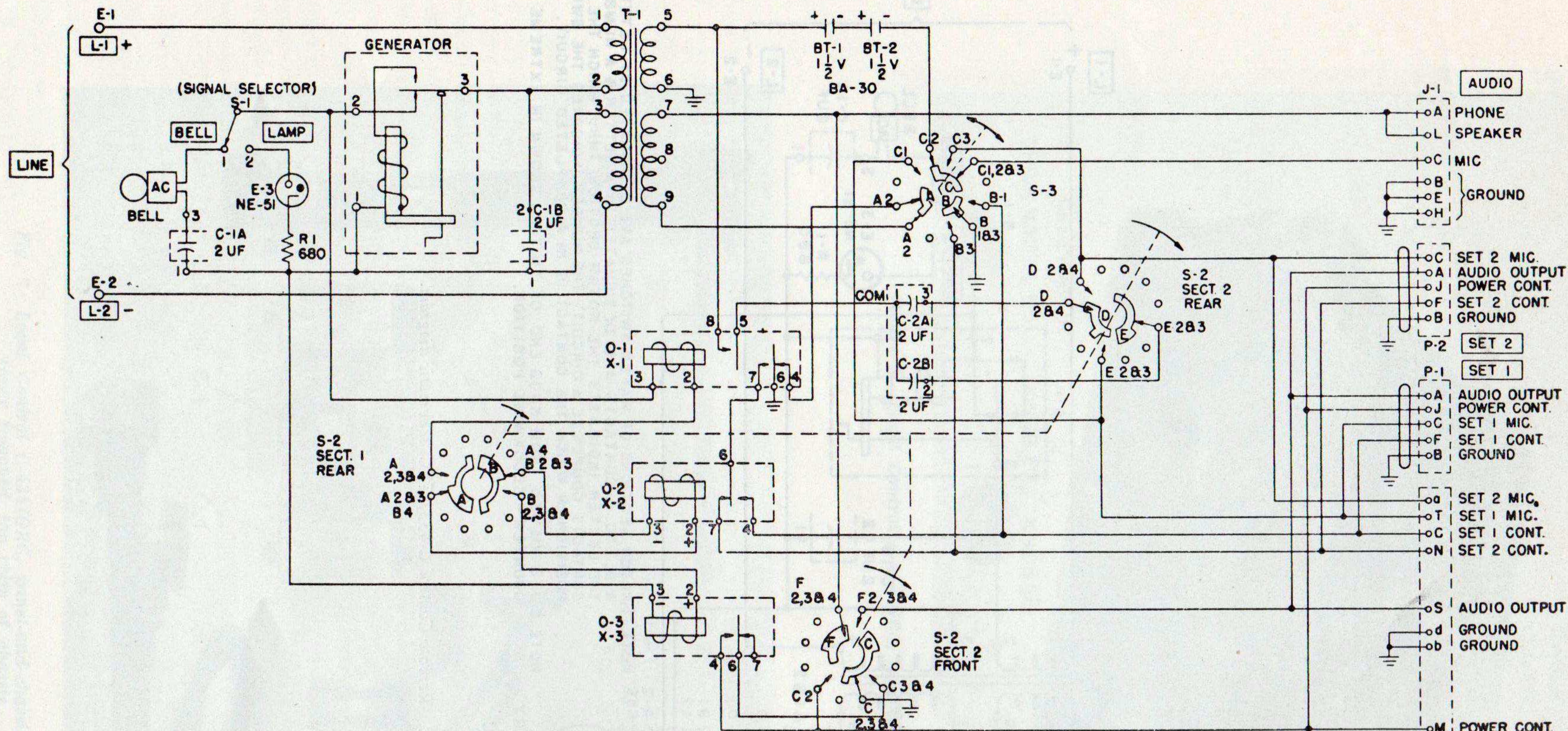

Figure 27. Remote Control C-433/GRC, schematic diagram.



SWITCH:	S-2 (REMOTE)	S-3 (LOCAL)
POS. 1	TEL ONLY	SET 1
POS. 2	SET 1 & 2	TEL
POS. 3	SET 1	SET 2
POS. 4	SET 2	

- NOTES: 1) ALL SWITCH SECTIONS VIEWED FROM KNOB END OF SWITCH.
 2) S-2 SHOWN IN EXTREME COUNTERCLOCKWISE POSITION.
 3) S-3 SHOWN IN CENTER POSITION.
 4) ROTOR SECTIONS OF WAFER SWITCHES ARE DESIGNATED BY LETTERS A, B ETC. AND, CONTACTS ARE DESIGNATED BY A LETTER AND A NUMBER. THE LETTER INDICATES THE ROTOR SECTION THRU WHICH THE CONTACTS COMPLETE A CIRCUIT; THE NUMBER INDICATES THE SWITCH POSITION IN WHICH THE CONTACT IS IN A COMPLETED CIRCUIT.
 5) RELAY O-1 SHOWN DE-ENERGIZED
 6) RELAYS O-2 AND O-3 SHOWN WITH NO OPERATING VOLTAGE APPLIED, AND LATCHED BY THE PREVIOUS APPLICATION OF A VOLTAGE OPPOSITE IN POLARITY TO THAT SHOWN ON COIL. COIL MARKINGS (+ AND -) REFER TO VOLTAGE POLARITY REQUIRED TO SWING ARMATURE TO OPEN CONTACT.

J-1, P-1 OR P-2

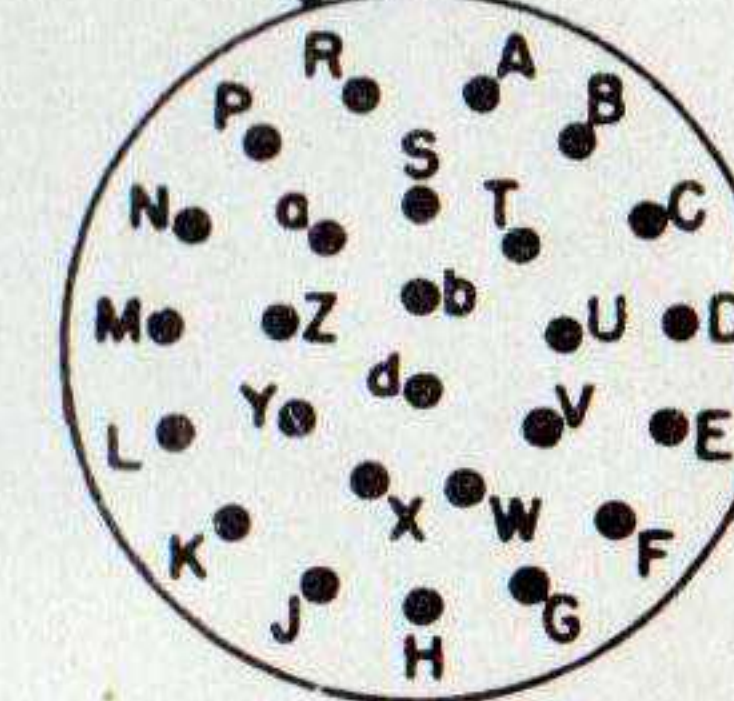
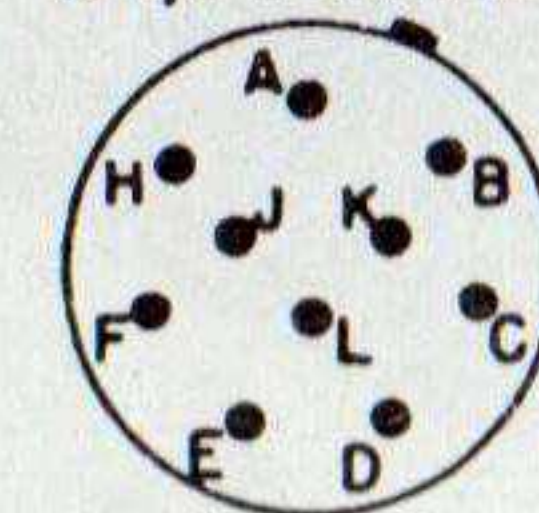

Figure 28. Local Control C-434/GRC, schematic diagram.

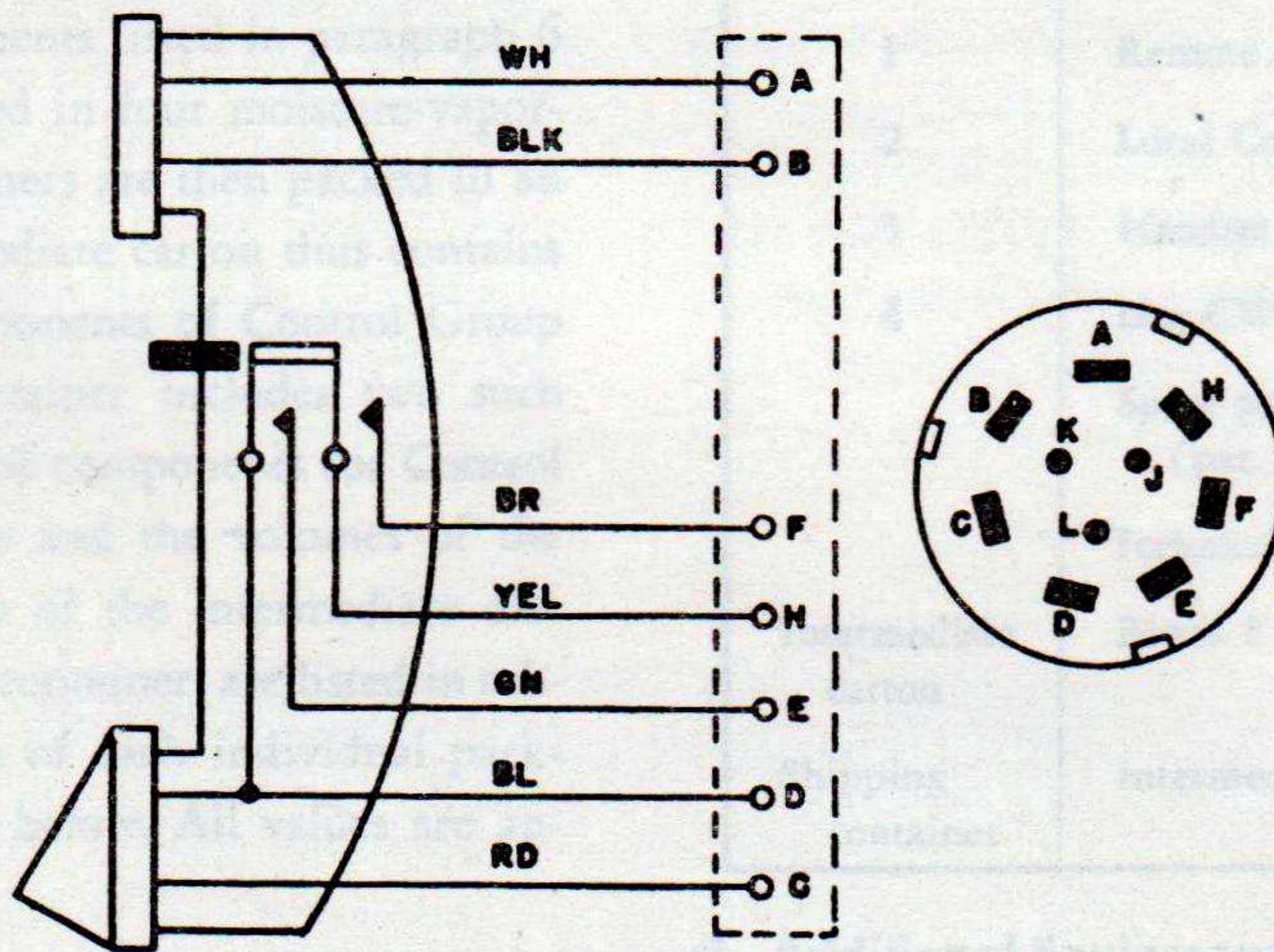

Figure 29. Handset H-33/PT, schematic diagram.

APPENDIX II

IDENTIFICATION TABLE OF PARTS

1. Requisitioning Parts

The fact that a part is listed in this table is not sufficient basis for requisitioning the item. Requisitions must cite an authorized basis, such as T/O&E, T/A, T/BA, SIG 7-8-10, SIG 10, list of allowances of expendable material, or another

authorized supply basis. For an index of available supply catalogs in the Signal portion of the Department of the Army Catalog, see the latest issue of SIG 1, Introduction and index

2. Description of Major Components (figs. 3 through 9)

2. GENERAL. The major components of Control Group AN/GRA-6 are shown in figure 1. The control group includes Local Control C-474/GRC, Remote Control B-474/GRC, Handset H-31/PT, and Bag CW-159/CR. The components are compact, lightweight, and rugged for portable use. When not in use, the control group can be stored in the bag, which is designed for carrying

strap (fig. 10). The carrying strap is provided for attachment to a shoulder strap. The radio design is rugged and reliable, and is suitable for use in the field.

The control group is designed for use in the field. The components are compact, lightweight, and rugged for portable use. When not in use, the control group can be stored in the bag, which is designed for carrying

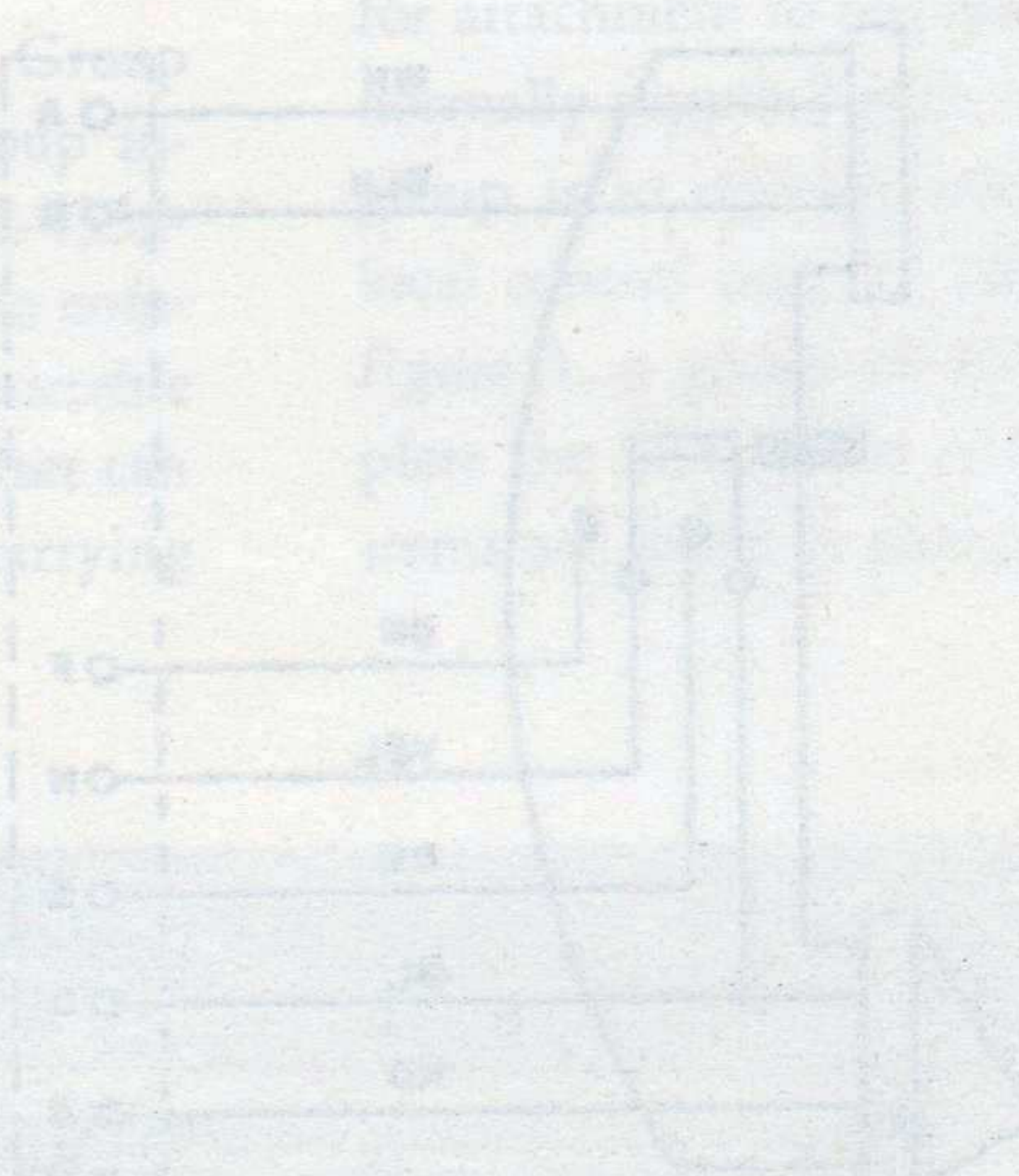

2. Identification Table of Parts for Control Group AN/GRA-6

Ref symbol	Name of part and description	Function of part	Signal Corps stock No.
	ARMY-NAVY CONTROL GROUP AN/GRA-6: control group to provide local and remote control standardized series radio sets; c/o 1 Army-Navy Remote Control C-433/GRC, LMT part/dwg GA-2322-12-FR, 1 Army-Navy local Control C-434/GRC, LMT part/dwg. GA-2264-14-FR, 1 Army-Navy Handset H-33 E/PT. Roanwell Corp. part/dwg 10882, and 1 Army-Navy Bag CW-189/GR, LMT part/dwg GA-1098-14-FR, ea unit has nomenclature marking; p/o Army-Navy Radio Sets AN/GRC-3 thru 8, AN/VRQ-1 thru 3, and AN/VRC-7 thru 10; LMT part/dwg GL-3171-12-FR.; U.S. Army spec 71-3329.		2C684A-6
MS-1	ARMY-NAVY BAG CW-189/GR; wp cotton duck, olive drab color; approx 10 5/8" wd x 11" h x 7 3/4" deep o/a; snap fastener closing; canvas bag w/no supporting frame work, reinforced on bottom by 2 webbing panels, reinforced on top edge and edge of cover by webbing binding, webbing strap around bottom extending up ea side 7" w/metal « D » ring ea end, cloth protective flap at upper rear inside edge under hinged cover, 2 snap fastener buttons on front edge of cover 4 5/8" c to c, 4 snap fastener studs on front side of bag on 2 1/2" x 4 5/8" ctr; water and fungus resistant; supplied w/1 LMT GA-1099-2-FR carrying strap; CW-189/GR; LMT part/dwg GA-1098-14-FR.	Control and handset carrying bag.	2Z553-189-FR
HS-101	ARMY-NAVY HANDSET H-33E/PT rec impedance 300 ohms, xmtr impedance 40 ohms; black phenolic handle; approx 7 7/8" lg x 2-3/64" wd x 3" deep o/a; wp handle, blast proof xmtr unit, submersion proof rec, press-to-talk detented momentary cont sw, frost and water shedding type xmtr and rec cap, clip attached for hanging handle to belt, etc.; Roanwell Corp part/dwg 10882; SIG C spec. MIL-H-11134 LMT dwg PL. 785510.	Handset.	2B620-33-FR
a. IDENTIFICATION TABLE OF PARTS FOR REMOTE CONTROL C-433/GRC.			
	ARMY-NAVY REMOTE CONTROL C-433/GRC: remote control unit; p/o Army-Navy Control Group AN/GRA-6; u/w Army-Navy Radio Sets AN/GRC-3 thru 8, AN/VRQ-1 thru 3, and AN/VRC 7 thru 10; c/o LMT GA-2142-12-FR case assem, 1 GA-2185-12-FR front panel assem, 1 GA-2323-12-FR chassis assem, 1 GA-1099-2-FR carrying strap, and 1 GA-2141-2-FR cover assem; rectangular box shape; approx 9 3/8" wd x 3 1/2" h x 7" deep o/a; control and term designations on panel; metal case fastens to front panel by means of hand operated spring catches; has « D » ring for attaching carrying strap; immersion and fungus resistant; has aural signalling unit; LMT part/dwg GA-2322-12-FR; U.S. Army spec 71-3329.		2C684-433-FR
C-1	CAPACITOR, fixed: metallized paper; 2 sect; ea sect 2 uf $\pm 20\%$; 200 vdcw; HS metal can; case 1-13/16" lg x 1" wd x 7/8" h; mineral oil impr; 3 solder lug term on side of case; no internal ground connections; 2 mtg feet w/ 13/16" diam hole in ea on 2 1/8" ctr; term 1 marked w/C; LMT part/dwg GH-1977-2-FR. FR.	D-c blocking capacitor	3DB2-249-FR
H-1, H-2	CATCH, fastener: c/o 1 lever, 1 back plate, 2 outside links, 2 inside links, 2 springs, and 2 pins; generally rectangular shape; approx 2-55/64" lg x 1-27/32" wd x 9/16" thk o/a; three 7/32" diam mtg holes, .562" c to c; LMT part/dwg GH-4052-FR.	Panel-to-case fastener catches.	6Z3810-49-FR
P-1	CONNECTOR, plug: 8 round male cont; straight: 55/64" lg x 1-5/32" diam o/a; round, black	Battery BA-414/U connector.	2Z3028-56-FR

2. Identification Table of Parts for Control Group AN/GRA-6 (contd)

Ref symbol	Name of part and description	Function of part	Signal Corps stock No.
a. IDENTIFICATION TABLE OF PARTS FOR REMOTE CONTROL C-433/GRC (contd).			
J-1	phenolic body; mts by means of keyed ctr locating pin and cont; 2 square keys on ctr locating pin, 135 deg apart; LMT part/dwg PL-775.737. CONNECTOR, receptable : U-79/U 10 round button cont: straight; 1.286" max OD x 1.197" max lg; cylindrical SS body, sand blast finish, locking, molded phenolic insert; single hole mtg, 1" -32 NS-2 x 5/16" lg mtg bushing; O ring seal on mtg flange; supplied w/spanner type nut; immersion and salt spray resistant; index flat on mtg bushing; LMT part/dwg GH-2079-12-FR.	Handset connector.	2Z7250-79-FR
E-4	CONTACT ASSEMBLY, battery; c/o 1 LMT GP-2042-2-FR board, 1 GA-1381-2-FR spring assem, 1 GB-1377-2-FR cont; phenolic board, metal cont; rectangular; 2-11/16" lg x 1 1/4" wd x 7/8" thk o/a; four .136" diam mtg holes on 1" x 2.375" mtg/c; 1 flat and 1 spring type cont ea/w solder- lug term; LMT part/dwg GA-2040-2-FR.	Battery contact.	2Z3197A-38-FR
E-5	CONTACT ASSEMBLY, battery; c/o 1 LMT GP-2042-2-FR board, 1 GB-1384-2-FR strap, 1 GA-1381-2-FR spring assem, 1 GB-1377-2-FR cont; phenolic board, metal cont; rectangular; 2-11/16" lg x 1 1/4" wd x 5/8" thk o/a; four .136" diam mtg holes on 1" x 2.375" mtg/c; 1 flat and 1 spring type cont connected together by metal strap; LMT part/dwg GA-2041-2-FR.	Battery contact.	2Z3197A-39-FR
A-1	COVER : c/o 1 LMT GB-2062-12-FR cover, 1 GA-2041-2-FR battery connector, 1 GB-2059-2-FR spring, and 1 GD-1054-2-FR circuit label; rectangular; approx 7 1/4" lg x 3" wd x 7/8" thk o/a; mts in slots in chassis by means of 2 mtg tabs on 1 end, has turned over edges which friction-grip sides of compartment on which mtd; battery cont assem on 1 end and battery holding spring in approx ctr; LMT part/dwg GA-2141-2-FR.	Battery compartment cover.	2Z3351-211-FR
O-1, O-2.	DISK, marker: solid white lamicoïd; circular plate shape; .437" diam x 3/64" thk; chamfered around upper edge; LMT part/dwg GG-1080-2-FR.	Marking disk inserts.	2Z3807-27-FR
	DUST CAP for connector U-79/U w/rubber gasket and beaded chain LMT part/dwg LMT 405265.	Connector protector.	2Z3351-723-FR
O-3	GASKET: neoprene; 1 hole; rectangular; 7.937" lg x 3 3/12" wd x .187" thk; hole 7.563" lg x 2.938" wd; 50-60 durometer hardness; LMT part/dwg GR-1378-2-FR.	Panel-to-case waterproof gasket.	6Z4051-22-FR
O-4, O-5.	GASKET: Buna N; 1 hole; circular w/circular cross section; 7/16" OD x 5/16" ID x 1/16" thk; LMT part/dwg GS-1948-1-5-FR.	Binding post mounting gaskets.	2Z4868.768-FR
O-6, O-7.	GASKET: Buna N; 1 hole; circular w/circular cross section; 9/32" OD x 5/32" ID x 1/16" thk; LMT part/dwg GS-1948-1-15-FR.	Binding post gaskets.	2Z4868.877-FR
G-1	GENERATOR, hand ringing: telephone; 1 magnet; 2-9/16" diam x 3 7/8" max lg o/a; double flatted drive shaft w/axial mtd knob mtg screw, panel mtg by means of thd bushing; enclosed case; LMT dwg LMT 405254.	Ringer generator.	4B910-2-FR
H-3, H-4.	INSERT, threaded: steel, cad pl and olive drab iridited; rectangular; 1-11/16" lg x 5/8" wd x .1196" thk o/a; three 10-32 NC-2 mtg holes .562" c to c; LMT part/dwg GB-2068-2-FR.	Catch mounting screws holding inserts.	2Z5400-55-FR
E-6, E-7.	INSULATOR, standoff: round post shape; white unglazed silicone treated ceramic w/metal end caps; .6" lg x .209" diam; rivet type mtg stud	Wiring terminal posts.	3G350-110-FR

2. Identification Table of Parts for Control Group AN/GRA-6 (contd)

Ref symbol	Name of part and description	Function of part	Signal Corps stock No.
a. IDENTIFICATION TABLE OF PARTS FOR REMOTE CONTROL C-433/GRC (contd).			
E-8	on 1 end .094 " diam x .1" lg, solder type stud term other cap; LMT part/dwg GG-1743-2-2-FR. KNOB: round w/finger grip and self-retracting folding spinner handle; olive drab enamel aluminum casting; for 1/4" diam double flatted shaft; fastens to shaft by single 6-32 screw thru face of knob into axial hole in end of shaft; 2.812" diam x 53/64" h o/a; shaft hole extends thru knob; LMT part/dwg GA-2906-14-FR.	Generator drive wheel.	2Z5822-474-FR
E-9	KNOB: round w/bar; olive drab zinc alloy; for 1/4" diam double flatted shaft; single 6-32 screw thru hole in face of knob screws into axially tapped hole in end of shaft; 1 white luminous line on bar portion; 1-7/16" lg x 7/8" wd x 15/32" h o/a; shaft hole .359" deep from bottom surface; luminous marking; LMT part/dwg GC-1690-2-FR.	Switch knob, C-433.	2Z5822-401-FR
N-1	LABEL: decalcomania; 4 1/2" lg x 2 3/4" wd x .007" thk; white print on black background; individually packed; LMT part/dwg GD-1054-2-FR.	Circuit label, C-433.	6D16777-12-FR
E-3	LAMP, glow: 1/25 w; striking v 65 v AC, 90 v DC; bulb T-3-1/4 clear; 1-3/16" lg o/a; single cont miniature bayonet base; W-11 electrode; burn any position; neon gas atmosphere. LMT part/dwg PL-776934.	Signal lamp.	2Z5888-5-FR
I-1	LIGHT, indicator: w/lens; 9/16" diam clear lens, for miniature bayonet base, T-3-1/4 bulb; 110 v, 1/4 amp; enclosed shell; aluminum alloy, olive drab; 2 7/8" lg x 13/16" diam o/a; 9/16" diam mtg hole required; 1/4" max panel thk; vertically mtd socket; lamp replaceable from rear of panel; thd jewel; 2 solder lug term located together on rear end of socket; built in mechanical dimmer; 2 clear wp internal lenses; wp seal between bushing and panel; LMT part/dwg GH-1964-2-FR.	Signal lamp holder.	2Z5991-184-FR
H-5	NUT, castellated: steel, cad pl and olive drab iridited; finished per dwg; 3/8"-32 NS-2 x 1/8" thk; 9/16" OD; 4 slots 3/32" wd x 3/64" deep spaced 90 deg apart; LMT part/dwg GB-1106-2-FR.	Switch mounting nut, C-433.	6L3006-32S-FR
E-1, E-2.	POST, binding: push type; 33/64" diam x 49/64" lg above mtg surface; 3/4" lg x 6-32 NC-2 thd mtg stud; phenolic cap; nickel pl brass body; 1/8" diam wire hole; « D » shaped wire grip hole in cap; LMT part/dwg GM-2253-2-FR.	Line terminals.	3Z737-57-FR
R-1, R-2.	RESISTOR, fixed: comp; JAN type RC20BF681J; 680 ohms $\pm 5\%$; 1/2 w; LMT part/dwg PL-774384.	Current-limiting resistors.	3RC20BF681J-FR
H-6, H-7.	RING, D: steel, cad pl and iridited; 1-13/16" lg x 19/32" wd x .089" thk o/a; LMT part/dwg GB-1735-2-FR.	Carrying strap attaching rings.	6Z7857-8-FR
I-2	RINGER, telephone: 20 cyc harmonic; non adj armature; 2555 ohms $\pm 10\%$; 2 1/2" diam x 1" h max o/a; 2 1/2" diam gong; footed bracket mtg, two 8-32 holes on 2" mtg/c; coil varnish impr and dipped; LMT part/dwg GH-1535-2-FR.	Ringer, telephone bell.	4B3672-FR
O-8	SPRING: flat type; .02" thk spring temper phosphor bronze, unfinished; 2-13/16" lg x 1/2" wd x 11/16" thk o/a; two .136" diam mtg holes on .937" mtg/c; ctr portion flat 1-5/16"	Battery holding spring.	6Z8377-7.1-FR

2. Identification Table of Parts for Control Group AN/GRA-6 (contd)

Ref symbol	Name of part and description	Function of part	Signal Corps stock No.
a. IDENTIFICATION TABLE OF PARTS FOR REMOTE CONTROL C-433/GRC (contd).			
H-8	lg, ea end bent up at 60 deg angle w/ends curved out and back towards flat portion; LMT part/dwg GB-2059-2-FR. STRAP, carrying: olive drab cotton webbing; lg adj from approx 29 1/2" to 48-1/2"; webbing 2" wd; 2 1/2" wd x 5/8" thk o/a; ea end terminated w/1" bronze finish brass wire snaps; one 2" x 1/4" bronze finished brass strap loop, and 1 style 2-2" bronze finish brass slide loop; water repellent and mildew resistant; LMT part/dwg GA-1099-2-FR.	Carrying strap.	QM74-S-333-50-FR
H-9. H-10.	STRIKE, fastener: steel, cad pl and iridited; generally rectangular w/hook on end; 1-25/32" lg x 1 1/4" wd x .3654" thk o/a; four .154" diam esk mtg holes on .593" x .875" mtg/c. raised portion between mtg holes to accom «D» ring; hook on end 1/4" lg; LMT part/dwg GB-1726-2-FR.	Panel-to-case fastener strikes.	6Z8569-5-FR
S-1	SWITCH, toggle: SPDT; JAN type ST-42-D; supplied w/locking ring and internal tooth lock-washer; LMT part/dwg PL-777327.	Signal selector switch.	3Z9863-42D-FR
S-2	SWITCH, rotary: 2 pole, 3 position; silver pl brass cont; ceramic wafer; 1-5/16" lg x 1 1/4" wd x 11/16" deep excluding term; locking action; solder lug term; single hole mtg, bushing 3/8"-32 thd x 5/16" lg; shaft 1/4" diam x 11/16" lg from mtg surface, flush mtg; shaft has double flats 1/4" lg, tapped axially on end 6-32 NC-2 x 1/4" deep; tropicalized, wp seal in bushing and on mtg flange; LMT part/dwg GH-1536-2-FR.	Selector switch.	3Z9825-62.528-FR
T-1	TRANSFORMER, AF: line type; pri windings term 1-2, term 3-4, and secd winding term 5-6 ea 150 ohms impedance; secd winding term 7-8-9, 600 ohms impedance CT; 500 v RMS test; HS metal case, silicone steel core; 1-13/16" lg x 1-3/16" wd x 2-5/32" h o/a; turn ratio of 2 : 1 for pri 1-2 and 3-4 to secd 7-8-9; turn ratio of 1 : 1 for pri 1-2 and 3-4 to secd 5-6; freq response +2 db to -2 db between 200 and 4000 cyc; 9 solder type stud term on top of case; two 6-32 thd mtg holes on bottom on 1-9/16" mtg/c; impr for tropical use; LMT part/dwg GH-1441-2-FR.	Line-matching transformer.	2Z9637.118-FR
H-11, H-12.	WASHER, extruded: molded plastic; round, 5/8" OD x .1405" ID x 13/64" thk o/a; extrusion .312" OD x .072" h; face etb .300" diam x .046" deep; LMT part/dwg GG-1514-2-FR.	Binding post insulator washers.	6L52630-FR
H-13, H-14.	WASHER, flat: LTS-E-4 natural phenolic; 5/8" OD x .154" ID x 1/16" thk; LMT part/dwg GG-2542-2-FR.	Binding post insulator mounting washers.	6L52010-1-FR
b. IDENTIFICATION TABLE OF PARTS FOR LOCAL CONTROL C-434/GRC			
	ARMY-NAVY LOCAL CONTROL C-434/GRC: local control unit; p/o Army-Navy Control Group AN/GRA-6; u/w Army-Navy Radio Sets AN/-GRC-3 thru 8, AN/VRQ-1 thru 3 and AN/VRC-7 thru 10; c/o 1 LMT GA-2128-12-FR front panel assem, 1 GA-2263-14-FR chassis assem, 1 GA-2103-14-FR case assem, and 2 GB-2796-2-FR springs; rectangular box shape; approx 8-9/16" wd x 3-7/16" h x 10 1/4" deep o/a; control and term designations on panel; metal case fastens to panel by means of thumb screw fasteners; has aural signalling unit; moisture and fungus resistant; LMT part/dwg GA-2264-14-FR; U.S. Army spec 71-3329.		2C684-434-FR

2. Identification Table of Parts for Control Group AN/GRA-6 (contd)

Ref symbol	Name of part and description	Function of part	Signal Corps stock No.
b. IDENTIFICATION TABLE OF PARTS FOR LOCAL CONTROL C-434/GRC (contd).			
O-4	BAR, locking: passivated SS; 2-5/16" lg x 3/4" wd x 1/2" thk o/a; LMT part/dwg GB-2997-2-FR.	Cover catch latch bar.	2Z558-48-FR
E-4	BOARD, terminal: 12 solder type turret term; term 3/4" between ctr, spaced 5/16" apart lengthwise on board; 1 1/8" wd x 2 1/2" lg x 15/32" thk o/a; two .166" diam mtg holes on 2 1/8" mtg/c; LMT part/dwg GA-2015-2-FR.	Resistor mounting and wiring terminal board.	3Z770-12.79-FR
O-5	BLOCK, guide: c/o 1 LMT GC-1574-14-FR guide bloc and 4 GB-2048-2-FR pins, aluminum, olive drab enamel finish; square base w/round collar flange; approx 3" sq x 1 1/8" thk o/a; LMT part/dw GA-2592-2-FR.	Connector locking guide block.	2Z700-24-FR
W-1. W-2.	CABLE ASSEMBLY, special purpose: four 24 AWG stranded cond, 41 40 AWG strands, two 18 AWG stranded cond, 165 40 AWG strands; Buna S insulation; color-coded; 300 v working; cellulose acetate yarn separator, Buna S jacket .262" OD; 33 3/8" ±5/8" lg excluding terminating plug; terminated on 1 end w/LMT PL-775675 plug, other end terminated in 5 leads, one 3 1/2" lg, one 3" lg, one 2 1/2" lg, one 2" lg, and one 1 1/2" lg; all leads bared and tinned 1/2" lg; blue cond cut off and not used; LMT part/dwg GA-1917-2-FR.	W-1: Output to set 1. W-2: Output to set 2.	3E7350-1.33-FR
O-6	CAP, c/o - LMT GB-2702-2-FR cap, 4 GB-2750 12-FR springs, 1 GA-2539-2-FR chain assem and 5 rivets; aluminum cap, olive drab finish; round; 2 3/4" diam x 3/4" thk o/a; 4 spring clips on underside of cap for mtg, clips 90 deg apart; bead retaining chain for attaching to case; straight knurl on outside edge; LMT part/dwg GA-2756-2-2-FR.	Waterproof cap for connector aperture.	
C-1, C-2.	CAPACITOR, fixed: metallized paper; 2 sect; ea sect 2 uf ±20%; 20 vdcw; case 1-13/16" lg x 1" wd x 7/8" h; mineral oil impr; 3 solder lug term on side of case; no internal ground connections; 2 mtg feet w/3/16" diam hole in ea on 2 1/8" ctr; term 1 marked w/C; LMT part/dwg GH-1977-2-FR.	D-c blocking capacitors.	3DB2-249-FR
J-1	CONNECTOR, receptacle: U-79/U 10 round button cont; straight; 1.286" max OD x 1.197" max lg; cylindrical SS body, sand blast finish, locking; molded phenolic insert; single hole mtg, 1"-32 NS-2 x 5/16" lg mtg bushing; «O» ring on seal on mtg flange; supplied w/spanner type nut; immersion and salt spray resistant; index flat on mtg bushing; LMT part/dwg GH-2079-12-FR.	Handset connector.	2Z7250-79-FR
J-2	CONNECTOR, receptacle: 26 round male cont; straight; 1.852" diam x 1.312" lg excluding term; cylindrical aluminum body; molded phenolic insert; mts in single hole when used w/retainer plate not supplied as part of connector; 2 grooves in outer circumference for «O» ring seals which are supplied w/connector; flange on rear end 1.852" diam x .093" thk; LMT part/dwg GH-2387-12-FR.	Chassis connector.	2Z3045-57-FR
A-1	COVER: c/o 1 LMT GP-3039-12-FR cover, 1 GA-2738-2-FR cont strip assem, and 2 rivets; molded MTS-EM-1 plastic; oval shape; approx 3-3/32" lg x 1-19/32" wd x 9/16" thk o/a; mts on top of battery holder by means of retaining pin; has battery cont strip and spring on underside; LMT part/dwg GA-3049-12-FR.	Battery holder cover.	2Z3351-212-FR
A-2	COVER: c/o 1 LMT GB-1390-12-FR cover, 1 GA-2781-2-FR cap holder assem, 1 GB-2996-	Cable and cap storage compartment cover.	2Z3351-213-FR

2. Identification Table of Parts for Control Group AN/GRA-6 (contd)

Ref symbol	Name of part and description	Function of part	Signal Corps stock No.
b. IDENTIFICATION TABLE OF PARTS FOR LOCAL CONTROL C-434/GRC (contd).			
A-3	2-FR catch plate and 1 GB-3038-2-FR spring; hollow rectangular box shape; approx 4 1/2" lg x 3-9/16" wd x 5/8" thk o/a; three .099" diam mtg holes, 1.562" c to c; LMT part/dwg GA-2991-12-FR. COVER: aluminum, caustic etch and water dip lacquer finish; round; 2 1/4" diam x 19/32" thk o/a; two 1/4" x .312" oval mtg holes on 1 7/8" mtg/c; groove around outside for « O » ring seal; two 7/16"-32 thd mtg holes for gland packing nut; LMT part/dwg GC-2014-2-FR. DUST CAP for connector U-79/U w/rubber gasket and beaded chain LMT part/dwg LMT 405265.	Cable removal hole cover and gland seat. Connector protector.	2Z3351-214-FR 2Z3351-723-FR
O-7	GASKET: neoprene; 1 hole; rectangular, 7.937" lg x 3.312" wd x .187" thk; hole 7.563" lg x 2.938" wd; 50-60 durometer hardness; LMT part/dwg GR-1378-2-FR.	Panel-to-case waterproof gasket.	6Z4051-22-FR
O-8, O-9.	GASKET: Buna N; 1 hole; circular w/circular cross section; 7/16" OD x 5/16" ID x 1/16" thk; LMT part/dwg GS-1948-1-5-FR.	Binding post mounting gaskets.	2Z4868.768-FR
O-10	GASKET: JW60 crude rubber compound; 1 hole; circular w/circular cross section; 3 1/4" OD x 3" ID x 1/8" thk; Linear Inc 1866-12; LMT part/dwg GS-1946-1-7-FR.	Connector guide block mounting gasket.	6Z4049-6-FR
O-11	GASKET: Buna N; 1 hole; circular w/circular cross section; 1 1/2" OD x 1 1/4" ID x 1/8" thk; Linear Inc 1820-23; LMT part/dwg GS-1948-1-14-FR.	Gland seat gasket.	6Z7465-40-FR
O-12, O-13.	GASKET: Buna N; 1 hole; circular w/circular cross section; 9/32" OD x 5/32" ID x 1/16" thk; Linear Inc 1820-2; LMT part/dwg GS-1948-1-15-FR.	Binding post gaskets.	2Z4868.877-FR
H-1, H-2.	GASKET: neoprene; circular; 25/64" OD x 17/64" ID x 1/8" thk o/a; mts on cable and in hole in gland seat; 50-60 durometer hardness; LMT part/dwg GR-2020-2-FR.	Cable entrance hole waterproof packing glands.	6Z4554-FR
G-1	GENERATOR, hand ringing: telephone; 1 magnet, 2-9/16" diam x 3 7/8" max lg o/a; double flatted drive shaft w/axial mtd knob mtg screw, panel mtg by means of thd bushing; enclosed case; LMT dwg LMT 405254.	Ringer generator.	4B910-2-FR
H-3	HINGE: equal wing continuous hinge; aluminum; 3-23/32" lg x 3/4" wd x 3/16" thk o/a; material .036" thk; non removable aluminum pin; six .099" diam mtg holes, three in ea leaf 1.562" c to c, 1/2" apart across leaves; LMT part/dwg GB-1379-2-FR.	Storage compartment cover hinge.	6Z5081-3-FR
H-4	HOLDER, battery; c/o 1 LMT GP-3027-14-FR battery holder, 1 GB-2594-2-FR spring, and 2 rivets; molded MTS-EM-1 plastic; rectangular box shape; approx 3-1/32" lg x 1-25/32" wd x 2-43/64" h o/a; four 6-32 tapped mtg holes on bottom on 2.718" x 2.125" x .1406" mtg/c; accom 2 Batteries BA-30; spring catch and retaining hole for cover; LMT part/dwg GA-3026-2-FR.	Battery holder.	3B2190-4-FR
E-5	KNOB: round w/finger grip and self-retracting folding spinner handle; olive drab enamel aluminum casting; for 1/4" diam double flatted shaft; fastens to shaft by single 6-32 screw thru face of knob into axial hole in end of shaft; 2.812" diam x 53/64" h o/a; shaft hole extends thru knob; LMT part/dwg GA-2906-14-FR.	Generator drive wheel.	2Z5822-474-FR
E-6	KNOB: round w/bar; olive drab zinc alloy; for 1/4" diam double flatted shaft; single 6-32 screw thru hole in face of knob screws into axially tapped hole in end of shaft; 1 white	Switch knob, C-434.	2Z5822-401-FR

2. Identification Table of Parts for Control Group AN/GRA-6 (contd)

Ref symbol	Name of part and description	Function of part	Signal Corps stock No.
b. IDENTIFICATION TABLE OF PARTS FOR LOCAL CONTROL C-434/GRC (contd).			
	luminous line on bar portion; 1-7/16" lg x 7/8" wd x 15/32" h o/a; shaft hole .359" deep from bottom surface; luminous marking; LMT part/dwg GC-1690-2-FR.		
E-7	KNOB: round w/bar; olive drab zinc alloy; for 1/4" diam double flatted shaft; single 6-32 screw thru hole in face of knob screws into axially tapped hole in end of shaft; 1 white luminous line on bar portion; 1-3/16" lg x 7/8" wd x 15/32" h o/a; shaft hole .359" deep from bottom surface; LMT part/dwg GC-1246-2-FR.	Switch knob, C-434.	2Z5822-402-FR
N-1	LABEL: decalcomania; 4 3/4" lg x 2" wd x .007" thk; white print on black background; individually packed; LMT part/dwg GD-1053-14-FR:	Circuit label, C-434.	6D16777-13-FR
E-3	LAMP, glow; 1/25 w, striking v, 65 v AC, 90 v DC; bulb T-3-1/4 clear; 1-3/16" lg o/a; single cont miniature bayonet base; W-11 electrode; burn any position; neon gas atmosphere; LMT part/dwg PL-776934.	Signal lamp.	2Z5888-5-FR
I-1	LIGHT, indicator: w/lens; 9/16" diam clear lens; for miniature bayonet base, T-3 1/4 bulb; 110 v, 1/4 amp; enclosed shell; aluminum alloy, olive drab; 2 7/8" lg x 13/16" diam o/a; 9/16" diam mtg hole required; 1/4" max panel thk; vertically mtd socket; lamp replaceable from rear of panel; thd jewel; 2 solder lug term located together on rear end of socket; built in mechanical dimmer; 2 clear wp internal lenses; wp seal between bushing and panel; LMT part/dwg GH-1964-2-FR.	Signal lamp holder.	2Z5991-184-FR
H-5. H-6.	NUT, castellated: steel, cad pl and olive drab iridited; finished per dwg; 3/8"-32 NS-2; 1/8" thk; 9/16" OD; 4 slots 3/32" wd x 3/64" deep spaced 90 deg apart; LMT part/dwg GB-1106-2-FR.	Switch mounting nuts, C-434.	6L3006-32S-FR
H-7. H-8.	NUT, packing: aluminum, supersat and water dip lacquer finish; polished bearing surface; 7/16"-32 NS-2 external thd; 15/32" thk; 7/16" across flats; hex drive head, .268" diam axial hole thru ctr; LMT part/dwg GB-2021-2-FR.	Cable gland nuts.	6L3800-1AL-FR
A-4	PLATE, base: c/o 1 LMT GP-2595-12-FR base plate, 1 GA-2739-2-FR cont strip assem, and 1 GB-2492-2-FR cont; throughly rectangular shape; approx 2-27/32" lg x 1-11/32" wd x 9/16" h o/a; four .0635" diam mtg holes on 1" x 2.687" mtg/c; 1 flat and 1 spring type cont on upper surface of plate; LMT part/dwg GA-2740-12-FR.	Battery holder base assembly.	2Z7091-346-FR
H-9	PLATE, catch: passivated SS; 1/2" lg x 15/32" wd x .050" thk o/a; two .099" diam mtg holes on 1/4" mtg/c; LMT part/dwg GB-2996-2-FR.	Cover latch catch plate.	6Z7552-1-FR
O-14. O-15.	PLATE, retainer: steel, zinc pl and bonderized; oval shape; 15/16" lg x 5/16" wd x .1196" thk o/a; two .154" diam csk mtg holes on .625" mtg/c; 10-32 NF-2 tapped hole located midway between mtg holes; LMT part/dwg GB-1376-2-2-FR.	Panel mounting screw retaining plates.	2Z7091-343-FR
O-16	PLATE, retainer: aluminum, caustic etch and water dip lacquer finish; circular, 2 1/2" diam x 3/16" thk; mts on connector flange by means of shouldered hole in ctr 1-9/16" diam; mts on chassis by means of four .159" diam holes on 1-1/16" rad, 45 deg apart; marked	Connector retaining plate.	2Z7091-344-FR

2. Identification Table of Parts for Control Group AN/GRA-6 (contd)

Ref symbol	Name of part and description	Function of part	Signal Corps stock No.
b. IDENTIFICATION TABLE OF PARTS FOR LOCAL CONTROL C-434/GRC (contd).			
	J-1 in black ink; LMT part/dwg GA-2763-2-2-FR.		
O-17	PLATE, retainer: aluminum, dull black primer finish; square plate w/round hole in ctr; 2 3/4" sq x 1/8" thk o/a w/2.062" diam hole in ctr; four .281" csk mtg holes on 2" x 2" mtg/c; LMT part/dwg GB-2568-2-FR.	Guide block retaining plate.	2Z7091-345-FR
E-1, E-2.	POST, binding: push type; 33/64" diam x 49/64" lg above mtg surface; 3/4" lg, 6-32 NC-2 thd mtg stud; phenolic cap, nickel pl brass body; 1/8" diam wire hole; « D » shaped wire grip hole in cap; LMT part/dwg GM-2253-2-FR.	Line terminals.	3Z737-57-FR
O-2, O-3.	RELAY, armature: SPDT; cont rating 2 amp, 28 v DC noninductive load; silver cont; single winding, operates at .9 ma either polarity; DC resistance 5000 ohms $\pm 10\%$; polarized, insulated coil and cont leads terminate in standard octal base pins; 1-19/32" lg x 1-19/32" wd x 2-9/16" h excluding term and locating pin; mts in standard octal socket; fast acting; mtd in HS metal can; LMT part/dwg GH-1972-2-FR.	O-2: Control relay. O-3: Power relay.	2Z7586-192-FR
O-1	RELAY, armature: 1A1C; cont rating 1 amp, 28 v DC noninductive load; silver cont; single winding, max pick up current .9 ma, min drop out current .1 ma; 16,000 ohms $\pm 10\%$ DC resistance; insulated coil; coil and cont leads terminate in standard octal base; 1-19/32" lg x 1-19/32" wd x 2-9/16" h excluding term and locating pin; mts in standard octal socket; fast acting; mtd in HS metal can moisture and fungus treated; LMT part/dwg GH-2925-2-FR.	Line relay.	2Z7599A-246-FR
R 1	RESISTOR, fixed: comp; 680 ohms $\pm 5\%$; 1/2 w; JAN type RC20BF681J; LMT part/dwg PL-774384.	Current-limiting resistor.	3RC20BF681J-FR
I 2	RINGER, telephone: 20 cyc harmonic; non adj armature; 2555 ohms $\pm 10\%$; 2 1/2" diam x 1" h max o/a; 2 1/2" diam gong; footed bracket mtg. two 8-32 holes on 2" mtg/c; coil varnish impr and dipped; LMT part/dwg GH-1535-2-FR.	Ringer, telephone bell.	4B3672-FR
H-10, H-11.	SCREW, captive: slot drive; finished fil Bind II per dwg; cold finished steel, cad pl and olive drab iridited; 10-32 NF-2; 2" lg; thd portion 3/4" lg; head .313" diam x .136" thk max; cone pointed end; LMT part/dwg GB-2022-2-1-FR.	Relay clamp holding screws.	6L4770-32-21S-FR
H-12, H-13.	SCREW, thumb: wing head; steel, cad pl and olive drab iridited; 10-32 NF-2; 7/8" lg; thd portion 5/16" lg; flat point; head 1-5/16" lg x 1/2" wd x 7/8" h, shoulder 3/8" diam x 1/16" thk; LMT part/dwg GA-2701-2-FR.	Panel-to-case fasteners.	6L17110-14S-FR
O-18, O-19.	SLEEVE, spacer: passivated SS; tubular shape; .218" OD x .154" ID x .109" lg o/a; mts in hole in gland seat; LMT part/dwg GB-2013-2-FR.	Gland seat mounting screw spacers.	2Z8552-74-FR
X-1, X-2, X-3.	SOCKET, tube: octal; 1 piece molded in mtg plate; two .156" diam mtg holes on 1 1/2" mtg/c; round molded plastic body; 1.14" diam x .49" h excluding term; beryllium copper silver pl cont; LMT part/dwg GH-2039-2-FR.	Relay sockets.	2Z8678.338-FR
O-20	SPRING: flat type; cover latch actuating spring: .01" thk beryllium copper, heat treated, electro	Cover latch actuating springs.	6Z8377-7.2-FR

2. Identification Table of Parts for Control Group AN/GRA-6 (contd)

Ref symbol	Name of part and description	Function of part	Signal Corps stock No.
b. IDENTIFICATION TABLE OF PARTS FOR LOCAL CONTROL C-434/GRC (contd).			
	lin pl finish; 7/16" lg x 3/8" wd x 1/8" thk o/a; V shaped w/1 end cupped, other end flat 3/32" lg x 3/64" wd; mts by means of cupped and flatted ends; LMT part/dwg GB-2994-2-FR.		
O-21	SPRING: flat type; .025" thk beryllium copper, heat treated and cad pl; 2-15/32" lg x 3/8" wd x 3/16" thk o/a; 1 end flat, other end bent up at 45 deg angle for 3/16" of lg; two .106" diam mtg holes on 3/8" mtg/c; hole .136" diam at bend end; p/o LMT GA-3026-2-FR battery holder; LMT part/dwg GB-2594-2-FR.	Battery holder cover spring catch.	6Z8377-7.3-FR
O-22, O-23.	SPRING: flat type: 22 ga beryllium copper, electro tin pl; 3-29/32" lg x 7/32" wd x 11/16" h o/a; end formed into tabs 5/32" wd x 5/8" lg on 1 3/4" ctr; mts on case rail by inserting tab ends into holes in rail; LMT part/dwg GB-2796-2-FR.	Anti-rattle springs.	2Z8877.646-FR
O-24	SPRING: flat type; .02" thk spring temper phosphor bronze, electro tin pl; 1 1/4" lg x 1/4" wd x 1/4" h o/a; two .099" diam mtg holes on 1/4" mtg/c; LMT part/dwg GB-3038-2-FR.	Cover spring.	6Z8377-7.5-FR
S-3	SWITCH, rotary: 3 pole, 3 position; silver pl brass cont; ceramic wafer; 1-5/16" lg x 1 1/4" wd x 5/8" deep excluding term; locking action; solder lug term; single hole mtg, bushing 3/8"-32 thd x 5/16" lg; shaft 1/4" diam x 11/16" lg from mtg surface, flush mtg; shaft has double flats 1/4" lg, tapped axially on end 6-32 NC-2 x 1/4" deep, tropicalized, wp seal in bushing and on mtg flange; LMT part/dwg GH-1537-2-FR.	Local switch.	3Z9825-62.529-FR
S-2	SWITCH, rotary: 6 pole, 4 position; 2 sect; silver pl brass cont; ceramic wafer; 1-5/16" lg x 1 1/4" wd x 1 1/4" deep excluding term; locking action; solder lug term; single hole mtg, bushing 3/8"-32 thd x 5/16" lg; shaft 1/4" diam x 11/16" lg from mtg surface, flush mtg; shaft has double flats 1/4" lg, tapped axially 6-32 NC-2 x 1/4" deep on end; tropicalized, wp seal in bushing and on mtg flange; LMT part/dwg GH-1538-2-FR.	Remote switch.	3Z9825-62.530-FR
S-1	SWITCH, toggle: SPDT; JAN type ST-42-D; supplied w/locking ring and internal tooth lock-washer; LMT part/dwg PL-777327.	Signal selector switch.	3Z9863-42D-FR
T-1	TRANSFORMER, AF: line type; pri windings term 1-2 and term 3-4, and sec'd winding term 5-6 ea 150 ohms impedance; sec'd winding term 7-8-9 600 ohms impedance CT; 500 v RMS test; HS metal case, silicone steel core: 1-13/16" lg x 1-3/16" wd x 2-5/32" h o/a; turn ratio of 2 : 1 for pri 1-2 and 3-4 to sec'd 7-8-9, turn ratio of 1 : 1 for pri 1-2 and 3-4 to sec'd 5-6; freq response +2 db to -2 db between 200 and 4000 cyc; 9 solder type stud term on top of case; two 6-32 thd mtg holes on bottom on 1-9/16" mtg/c; impr for tropical use; LMT part/dwg GH-1441-2-FR.	Line matching transformer.	2Z9637.118-FR
H-14, H-15.	WASHER, extruded: molded plastic: round, 5/8" OD x .1405 ID x 13/64" thk o/a; extrusion .312" OD x .072" h : face ctb .300" diam x .046 deep; LMT part/dwg GG-1514-2-FR.	Binding post insulated washers.	6L52630-FR
H-16, H-17.	WASHER, flat: LTS-E-4 natural phenolic; 5/8" OD x .154" ID x 1/16" thk; LMT part/dwg GG-2542-2-FR.	Binding post insulated mounting washers.	6L52010-1-FR

2 • Identification Table of Parts for Control Group AN/GRA-6 (contd)

Ref symbol	Model		Name of part and description	Function of part	Signal Corps stock No.
	Unlettered	A			
c. IDENTIFICATION TABLE OF PARTS FOR GENERATOR G-25 (*)/PT.					
			<ul style="list-style-type: none"> GENERATOR: RINGING, HAND G-41/PT: 1 magnet; bridging, normally open; aluminum case; 4" lg x 2-1/2" dia. TECHNICAL MANUAL TM 11-2202. 	Supplies 20-cycle ringing signal.	4B910-1-FRB.
			<ul style="list-style-type: none"> BALL, positioning: .250" dia; LMT part/dwg GP-4107-2-FRB. 		order thru AGC 4Z223-FRB
			<ul style="list-style-type: none"> COLLAR, locking: aluminum, « Alcote » finish: cyl shape; approx 2.535" OD x 2.265" ID x 15/32" lg o/a; int mtg thd, 2.437" dia 28 NS-2 thd; med straight knurl around outside, 1/4" lg from top edge; LMT part/dwg GB-2875-12-FRB. 	Locks cover to gear cap.	3H987-4-FRB
			<ul style="list-style-type: none"> CONTACT, electrical: 1.250" lg x .937" wd x .032 thk; LMT part/dwg GA-4120-2-FRB. 	For opening and closing generator circuit.	2Z3193-148-FRB
			<ul style="list-style-type: none"> CONTACT, electrical: 1.493" lg x .613" wd x .116" thk; LMT part/dwg GA-4118-2-FRB. 	For opening and closing of generator circuit.	2Z3193-150-FRB
			<ul style="list-style-type: none"> CONTACT, electrical: 1-3/16" lg x .937" wd x .156" thk; LMT part/dwg GA-4119-2-FRB. 	For opening and closing of generator circuit.	2Z3194-71-FRB
			<ul style="list-style-type: none"> CONTACT, electrical: LMT part/dwg GB-2871-2-FRB. 	Ringing generator contact.	3H5255-45-FRB
			<ul style="list-style-type: none"> COVER: 2.391" OD x 2.198" lg; LMT part/dwg GA-2874-12-2-FRB. 	Generator cover.	4Z3504-6-FRB
			<ul style="list-style-type: none"> COVER, electrical generator: aluminum alloy: « Alcote » finish; 2.198" lg x 2.319" dia o/a: flange on front edge to accom collar, not furnished as part of cover; term. on rear end stamped 1, 2, 3 for identification; 3 cont stud and term. assemblies on rear end and dimple on side; LMT part/dwg No. GA-2874-12-FRB 	Protective cover case for hand ringing generator.	3H1380-50-FRB
			<ul style="list-style-type: none"> GEAR: spur type; 10 teeth; .375" OD x .1250" dia bore, flatted on two diametrically opposite sides to a wd of .0940", .125" thk; LMT part/dwg GB-4056-2-FRB. 	Rotor pinion in ringing generator.	2Z4878-1490-FRB
			<ul style="list-style-type: none"> GEAR ASSEMBLY: c/o LMT part/dwg GB-2895-2-FRB gear and GB-2878-2-FRB pinion; aluminum gear, steel pinion, pinion and gear pressed together; pinion has 10 involute form teeth, 32 pitch, 20 deg pressure angle and .32" pitch dia, gear 39 involute form teeth, 48 pitch, 20 deg pressure angle and .8125" pitch dia: round; approx 7/8" dia x .265" lg o/a; axial hole .125" dia w/oil groove for mtg on shaft: pinion is case hardened; LMT part/dwg GA-2864-2-FRB. 	Generator rotor drive gear assembly.	3H2231-9-FRB
			<ul style="list-style-type: none"> GEAR ASSEMBLY: gear .750" PD, 24 teeth, pinion 5/16" PD, 10 teeth bore 1/8"; LMT part/dwg GA-2864-2-FRB. 	Stator gear and pinion.	4B821-1-FRB
			<ul style="list-style-type: none"> PIN DOWEL: .115" OD x .492" lg o/a; LMT part/dwg GB-4108-2-FRB. 	Provides guide for movement of positioning ball.	4Z6448-4-FRB
			<ul style="list-style-type: none"> RING, retainer: .114" ID x .154" OD x .020" thk o/a; LMT part/dwg GB-2861-2-FRB. 	Retains gear.	2Z7858-278-FRB
			<ul style="list-style-type: none"> RING, retainer: split ring type; .294" OD x .232" ID x .031" thk; LMT part/dwg GB-2898-2-FRB. 		3H5041.2-5-FRB
			<ul style="list-style-type: none"> SCREW, machine: slot drive; Fil H; 3-48 NC-2 3/8" lg. 		6L6348-6.3S-FRB
			<ul style="list-style-type: none"> SHAFT: shaft 1-1/4" lg x 1/4" OD, gear 3/4" PD 24 teeth; LMT part/dwg GA-2901-12-FRB. 	Rotor shaft and gear.	4Z6878-FRB
			<ul style="list-style-type: none"> SPRING: flat type; nickel silver, .016" thk; approx 15/16" lg x 17/32" wd x .140" thk o/a; two .159" dia mtg hole on .312" mtg/c: has turned up tinned lip to provide soldering term., irregular shape; LMT part/dwg GB-2871-2-FRB. 	Electrical contact spring connector.	3H5255-45-FRB
			<ul style="list-style-type: none"> SPRING, helical extension: .695" lg x .148 OD x .018" dia matl; 20 turns; LMT part/dwg GB-4227-2-FRB. 	Regulates tension on governor.	
			<ul style="list-style-type: none"> WASHER, flat: rd. .156" ID x .312" OD x .004" thk; LMT part/dwg 4105-2-1-FRB. 		6L50102-19-FRB
			<ul style="list-style-type: none"> WASHER, flat: rd. .156" ID x .312" OD x .006" thk; LMT part/dwg GB-4105-2-2-FRB. 		6L50102-20-FRB

INDEX

	<i>Paragraph</i>	<i>Page</i>
A		
Additional equipment required	8	5
Adjustments	17	14
Alternate wiring	71	55
Application	4	1
B		
Basic circuit elements	46	29
Break-in operation	31	21
C		
Checks:		
Alternate wiring	71	55
Equipment performance	44	26
Handset H-33/PT	65	43
Localization in Local Control C-434/GRC	70	51
Localization in Remote Control C-433/GRC	69	50
Operational	67	44
Preparatory	17	14
Short-circuit	64	42
Cleaning	77	58
Components:		
Major description	9	6
Minor description	10	9
Miscellaneous data	72	56
Table	6	4
Containers:		
Disassembly of battery container in Local Control C-434/GRC	80	59
Unpacking oversea shipping containers	13	10
Controls:		
Internal controls	23	18
Panel controls and facilities, Local Control C-434/GRC	22	17
Panel controls and facilities, Remote Control C-433/GRC	22	17
D		
Data:		
Miscellaneous component data	12	56
Packaging	7	5
Technical characteristics	5	3
Demolition of materiel to prevent enemy use	89	65

INDEX

	<i>Paragraph</i>	<i>Page</i>
Description:		
Bag CW-189/GR	10	9
Handset H-33/PT	10	9
Local Control C-434/GRC	9	7
Remote Control C-433/GRC	9	7
Disassembly for inspection, cleaning, and repair:		
Handset H-33/PT	82	60
Local Control C-434/GRC	75	57
Remote Control C-433/GRC	74	56
E		
Equipment performance checklist	44	26
F		
Field maintenance:		
Final tests	87	64
Lubrication and weatherproofing	83-85	64
Repairs	73-82	56-60
Trouble shooting	62-72	41-56
Final tests	87	64
Forms and records	2	1
H		
Handset H-33/PT:		
Application	4	1
Check, trouble-shooting	65	43
Description, general	10	9
Disassembly for repair	82	60
Installation	14-16	10-13
Packaging data	7	5
Technical characteristics	5	3
I		
Identification table of parts	App. II	72
Inspection:		
General, for field maintenance	76	57
Visual, for organizational maintenance	43	25
Installation	12-16	10-13
Internal controls	23	18

INDEX

	<i>Paragraph</i>	<i>Page</i>
L		
Local control:		
Circuits	60-61	39-40
Power	51-54	32-35
Push-to-talk operation of radio set	28	20
Local Control C-434/GRC:		
Application	4	1
Characteristics, technical	5	3
Description	9	6
Disassembly	75	57
Installation	15	11
Internal controls	23	18
Localization checks	70	51
Packaging data	7	5
Panel controls and facilities	22	17
Purpose and use	3	1
Push-to-talk operation	60-61	39-40
Repair procedures	80	59
Running spares	11	9
Local operation:		
Break-in	31	21
Circuit theory	60-61	39-40
Monitoring	29	21
Push-to-talk operation from Local Control C-434/GRC	28	20
Telephone communication	26	19
Localization checks:		
Handset H-33/PT	65	43
Local Control C-434/GRC	70	51
Remote Control C-433/GRC	69	50
M		
Maintenance:		
Field	62-82	41-60
Lubrication	83	64
Materials	38	24
Organizational	42-44	25-26
Preventive	39-41	24
Refinishing	85	64
Weatherproofing	84	64
Major components:		
Description	9	6
Packaging data	7	5
Table	6	4
Technical characteristics	5	3
Minor components, description of	10	9

INDEX

	<i>Paragraph</i>	<i>Page</i>
Miscellaneous component data	72	56
Modes of operation	25	19
Monitoring:		
Circuits	51,61	32,40
Operation	29	21
P		
Packaging data	7	5
Panel:		
Controls and facilities	22	17
Disassembly	74,75	56,57
Performance:		
Checklist Equipment	44	26
Data	5	3
Power control:		
Local	28,50	20,32
	51-55	32-36
	60-61	39-40
Remote	27,49	19,31
	50,56-59	32,37-39
Preventive maintenance:		
Checks	41	24
Definition	39	24
Techniques	40	24
Tools, materials, and equipments	38	24
Push-to-talk:		
Circuit arrangements	51-61	32-40
Local operation	28	
Remote operation	27	19
R		
Refinishing	85	64
Remote Control C-433/GRC:		
Circuit arrangements	51-59	32-39
Description	9	6
Disassembly for inspection, cleaning, and repair	75	57
Localization checks	70	51
Operation	27	19
Packaging data	7	5
Panel controls and facilities	22	17
Purpose and use	3	1
Replacement of batteries	79	58
Repairs:		
Disassembly	74-75,82	56,57-60
Procedures	73	56
Reassembly	81	59
Replacement of parts	78,82	58,60
Special repair procedures	79,80	58,59

INDEX

	Paragraph	Page
Resistance measurements:		
Handset H-33/PT	65	43
Key circuits	64	42
Local Control C-434/GRC	70	51
Remote Control C-433/GRC	70	51
Ringing:		
Circuits	48	30
Operation	26	19
Rustproofing	84	64

T

Tables:		
Components of Control Group AN/GRA-6	6	4
Operational check chart	68	45
Packaging data	7	5
Performance checklist	44	26
Resistance measurements, Handset H-33/PT	65	43
Resistance measurements, Local Control C-434/GRC	70	51
Resistance measurements, Remote Control C-433/GRC	69	50
Technical characteristics	5	3
Telephone:		
Circuits	47	30
Communication	26	19
Test equipment and tools for trouble shooting	63	41
Test set-up for operational checks	66	43
Tools, materials, and equipments for organizational maintenance	38	24
Trouble shooting:		
Alternate wiring	71	55
Data, miscellaneous	72	56
D-c voltage measurements	70	51
Local Control C-434/GRC	70	51
Operational check chart	68	45
Performance checklist	44	26
Procedure	62	41
Remote Control C-433/GRC	69	50
Resistance measurement	64-65	42,43
	69-70	50,51
Test equipment	63	41

V

Voltage measurements:		
Local Control C-434/CRC	70	51
Remote Control C-433/GRC	69	50
Ringing generator	72	56

W

Weatherproofing	84	64
-----------------------	----	----

