

MA(P) 2124.09514.00

CHANGE 1

**ILLUSTRATED PARTS
BREAKDOWN**

**HF -SS r. RADIO SET
RT 936/PRC ^{as} 174**

**THIS MANUAL SUPERSEDES MAINTENANCE MANUAL
MA(P)-2124-09514-00 DATED DECEMBER 1982.**

JANUARY 1987

SECTION II
 MAINTENANCE PARTS LIST

MA(P)-2124-09514-00

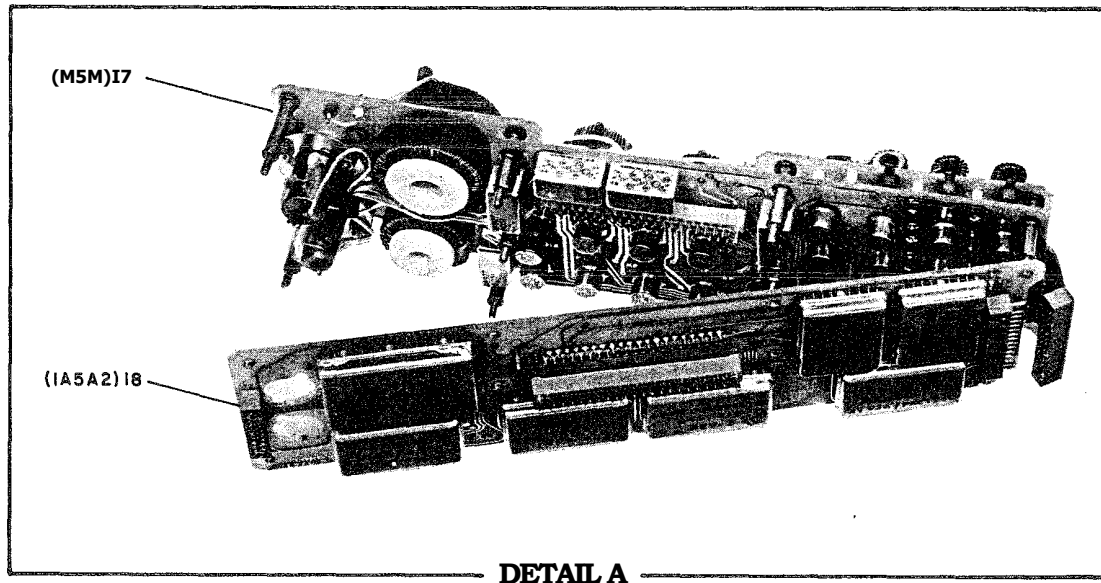
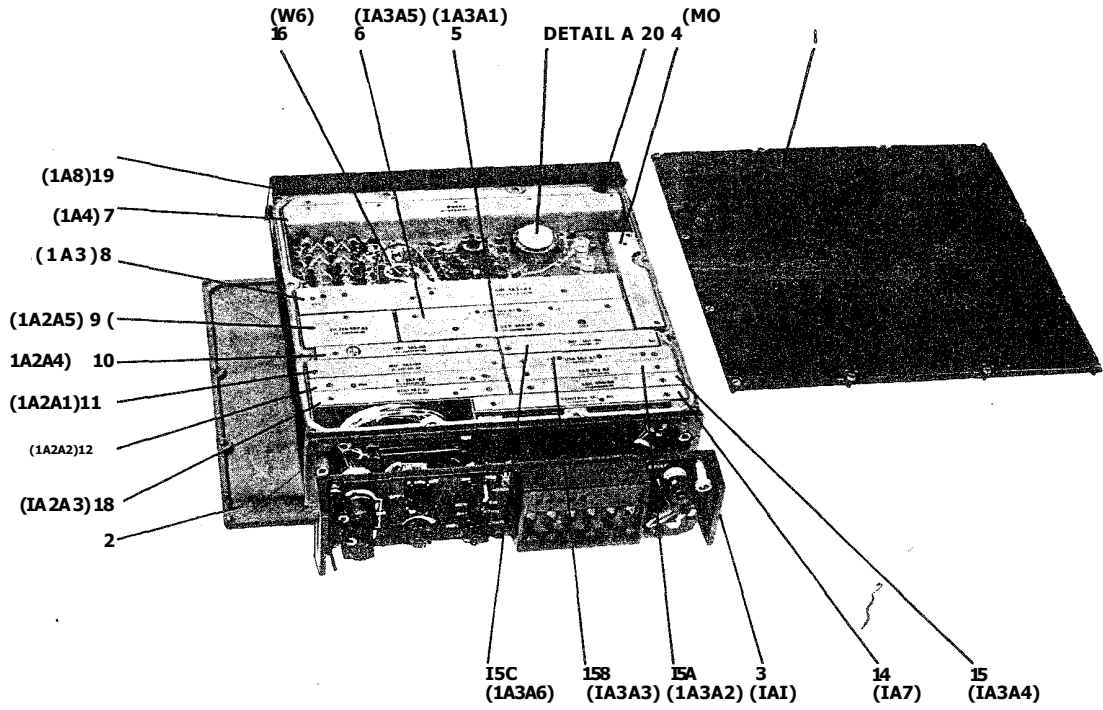
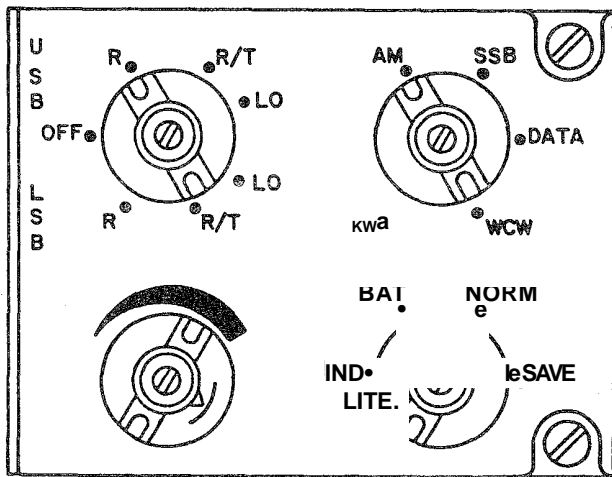
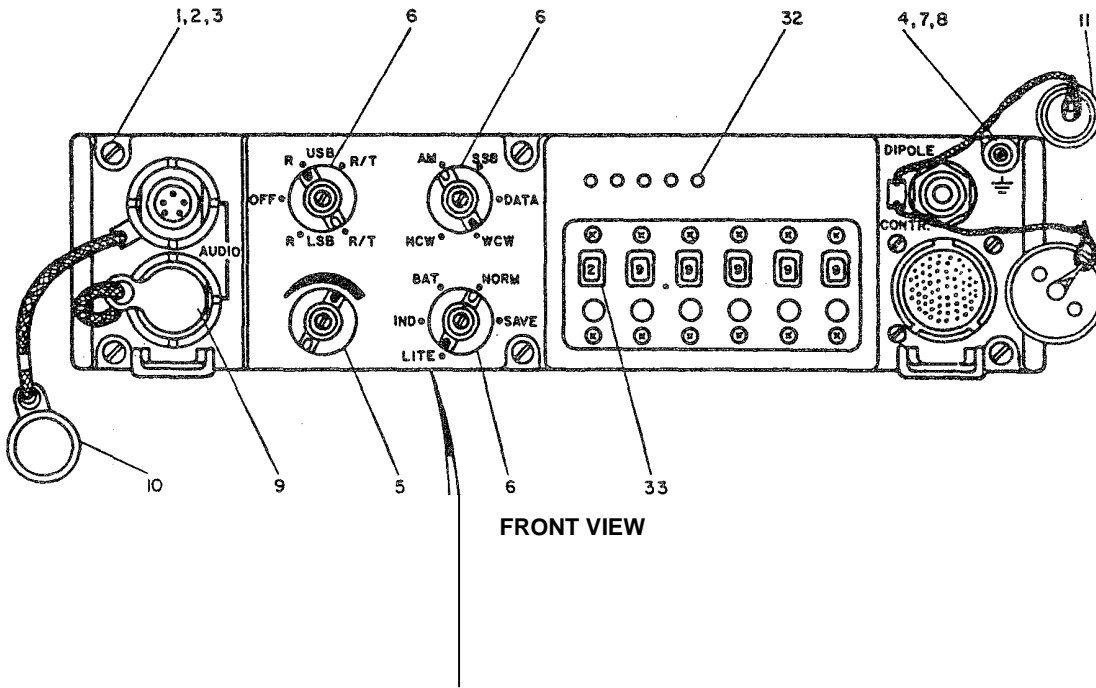

Figure 1. Receiver Transmitter RT-936/PRC

FIGURE & INDEX	PART NUMBER	D E S C R I P T I O N 1234567	UNITS PER ASSY	MFR CODE
1	2124-09040-00	REC. TRANS. RT-936/PRC (REV.H)	REF	
	2124-09044-00	REC. TRANS. RT-936/PRC (MODEL-S)....	1	
-1	2124-43410-00	UPPER COVER.....	1	
-2	2124-43420-00	LOWER COVER..... (ATTACHING PARTS)	1	
	2124-44470-00	SCREW--	24	
	2124-39132-00	WASHER..	24	
	2124-39133-00	WASHER, FLAT.....	24	
-3	2124-96370-00	FRONT PANEL, 1A1(See Figure 2)	1	
-3A	2124-96375-00	FRONT PANEL 1A1 (MODEL-S)(See Figure 2)...	1	
-4	2124-91600-00	PA ASSEMBLY, 1A6(See Figure 28)..... (ATTACHING PARTS)	1	
	2124-37790-00	SCREW, SEAL.....	4	
-5	2124-91720-00	VCP ASSEMBLY, 1A3A1(See Figure 23).....	1	
-6	2124-91350-00	SUM ASSEMBLY, 1A3A5(See Figure 22).....	1	
-7	2124-91750-00	POWER SUPPLY ASSEMBLY, 1A4(See Figure 38). (ATTACHING PARTS)	1	
	2124-37790-00	SCREW, SEAL.....	2	
-8	2124-91530-00	SNF ASSEMBLY, 1A5A3(See Figure 30).....	1	
-8A	2124-91935-00	SNF ASSEMBLY, 1A5A3 (MODEL-S)(See Fig. 30)	1	
-9	2124-91253-00	FILTER ASSEMBLY, 1A2A5(See Figure 21).....	1	
-10	2124-91240-00	PRE ASSEMBLY, 1A2A4(See Figure 20).....	1	
-11	2124-91210-00	MIXER ASSEMBLY, 1A2A1(See Figure 19)	1	
-12	2124-91220-00	IF P.C. BOARD ASSEMBLY 1A2A2(See Fig.18)..	1	
-13	2124-91230-00	AUDIO ASSEMBLY, 1A2A3(See Figure 17).....	1	
-14	2124-91700-00	CONTROL ASSEMBLY, 1A7(See Figure 12).....	1	
-15	2124-91340-00	LOL ASSEMBLY, 1A3A4(See Figure 13)... ..	1	
-15A	2124-91320-00	VAD ASSEMBLY, 1A3A2(See Figure 14).....	1	
-15B	2124-91330-00	USB ASSEMBLY, 1A3A3(See Figure 15)..	1	
-15C	2124-91360-00	REF ASSEMBLY, 1A3A6(See Figure 16).....	1	
-16	2124-93080-00	CABLE ASSEMBLY (W6)..	1	
-17	2124-91510-00	MN ASSEMBLY, 1A5A1(See Figure 26).....	1	
-18	2124-95920-00	LORD PC BOARD ASSEMBLY, 1A5A2 (See Fig.27) (ATTACHING PARTS)	1	
	2124-42160-00			
	2124-42190-00	PIN GUIDE (FOR CONN J3 OF LORD		
	MS15795-803	WASHER FLAT(2124-53030-00)....	10	
-19	2124-91805-00	CHASSIS ASSEMBLY, 1A8(See Figure 10).....	1	
-20	2124-93370-00	COVER, WHIP ASSEMBLY..... (ATTACHING PARTS)	1	
	MS51959-14B	SCREW(2124-52086-00).....	1	
	2124-49490-00			

SECTION II
 MAINTENANCE PARTS LIST

MA(P)-2124-09514-00



MODEL ° S

Figure 2. Front Panel, 1A1 (Sheet 1 of 2)

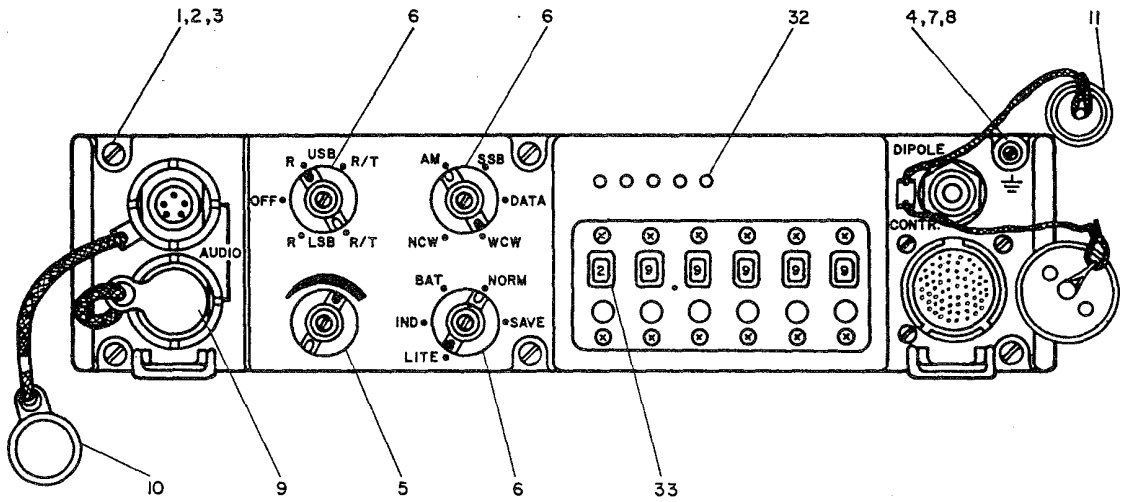

FRONT VIEW

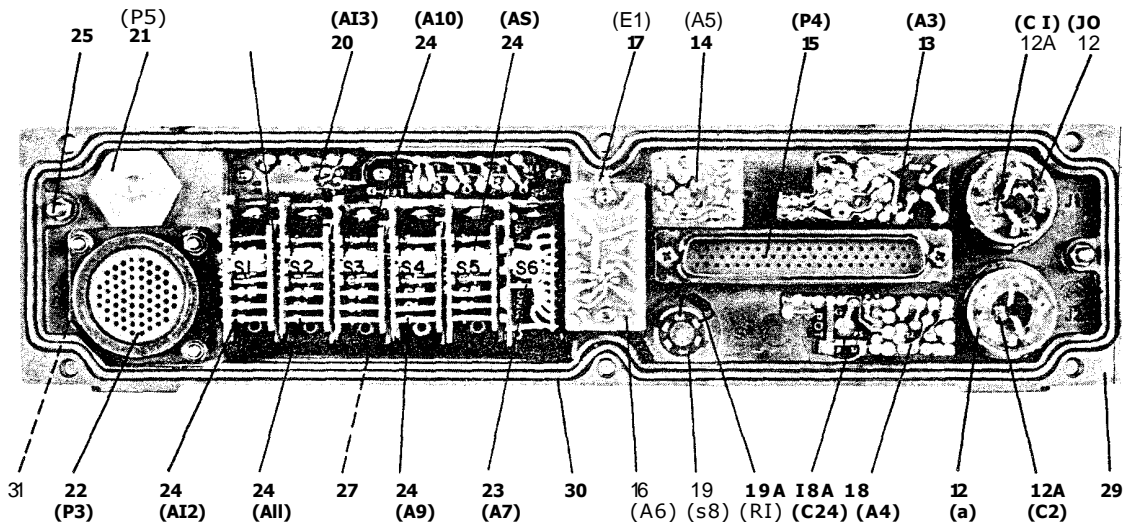

REAR VIEW

Figure 2. Front Panel. 1A1 (Sheet 2 of 2)

SECTION II
 MAINTENANCE PARTS LIST

MA(P)-2124-09514-00

FIGURE INDEX	PART NUMBER	DESCRIPTION 1234567	UNITS PER ASSY	MFR CODE
2	2124-96370-00	FRONT PANEL (1A1)(REV.A)(See NHA Figure 1)	REF	
	2124-96373-00	FRONT PANEL (1A1)	REF	
-1	2124-44230-00	-SCREW, CAPTIVE	5	
-2	2124-39200-00	..WASHER..049000wo66e.....000.....66000•00	5	
-3	2124-39190-00	**WASHER, FLAT	1	
-4	2124-90280-00	..GROUND SCREW..000000000•••00006000000•0•00	1	
-5	2124-92210-00	-KNOB ASSEMBLY66•6•00006000000••60606000•00 60	1	
-6	2124-41320-00	•0KNOB606000000•0•6•0•00•00000••00•000000•000006	3	
		(ATTACHING PARTS)		
	2124-39020-00	0•SCREW00•••••000000•0000000•••••0000	4	
	MS35338-136	..WASHER SPR114G(2124-53080-00).....00000•6	4	
	2124-41820-00	6•NUT060 600000000•0000e6•••00•00•V a 0000•0000•00	1	
		----*----		
-7	2124-42070-00	..WASHER, FLAT•00006•0000000•006•000000 000000••	6	
-8	2124-39200-00	..WASHER SPRING 000•0•0000000•000•00000000000•00	6	
-9	2124-92700-00	*COVER, AUDIO ASSEMBLY•••••	1	
-10	2124-92950-00	•.00VER, AUDIO ASSEMBLY.....	1	
-11	2124-92960-00	0•OLCNER ASSEMBLY.....	1	
-12	2124-95100-00	..AUDIO FILTER ASSEMBLY 0000450.....	2	
-12A	2124-12093-00	-CAPACITOR, 10NF000000000000••00000001300000•00	1	
-13	2124-95160-00	..MAT ASSEMBLY 1A1A3 (See Figure 7).....	1	
		(ATTACHING PARTS)		
	2124-41820-00	•.NUT.....	1	
		----*----		
-13A	2124-95185-00	..MTS PC BOARD ASSEMBLY 1A1A4 (MODEL-S).....	1	
		(See Fig. 6A)		
-14	2124-95460-00	..MOD ASSEMBLY 1A1A5 (See Figure 4).....	1	
		(ATTACHING PARTS)		
	2124-41820-00	•.NUT.....	1	
		----*----		
-15	M24308/4-14	•.CONNECTOR.....	1	
		(ATTACHING PARTS) ..SCREW(2124-52604-00).....	2	
		NAS1635-04LL4		
		----*----		
-16	2124-95140-00	..DOD ASSEMBLY 1A1A6 (See Figure 5)..	2	
		(ATTACHING PARTS)		
	MS51957-3	..SCREW(2124 -52106 -00).....	2	
	MS35338-134	..WASHER SPRING(2124 -53060 -00).....	2	
		----*----		
-17	2124-47050-00	•.LUG.... ooe. es ea a o oemo apes am e oes oawecaps	1	
-18	2124-95150-00	..POT ASSEMBLY 1A1A4 (See Figure 6).....	1	
		(ATTACHING PARTS)		
	2124-41830-00	•.NUT.....	1	
		----*----		
-18A	2124-12163-00	..CAPACITOR, CHIP, 100NF.....	1	
-19	2124-92250-00	SWITCH	1	
		(ATTACHIN3 PARTS)		
	2124-41820-00	a•NUTE•600•0000000•00•6000060600000•0e•Da000	1	
		----*----		

FIGURE & INDEX	PART NUMBER	D E S C R I P T I O N	UNITS PER ASSY	MFR CODE
		1234567		
2 -19A	RWR81S24R9FM	..RESISTOR FXD, 24.9 OHM(2124-11466-00)		
-20	2124-95170-00	LED ASSEMBLY 1A1A13 (See Figure 3) (ATTACHING PARTS)		
	MS51957-4	..SCREW(2124-52534-00)	3	
	MS35338-134	..WASHER SPRING(2124-53060-00).....	3	
	NAS620C2	..WASHER FLAT(2124-53240-00)...	3	
	2124-44150-00	-WASHER, FLAT.....	3	
-21	2124-33066-00	..BULKHEAD ADAPTER	1	98291
-22	2124-93140-00	..CONNECTOR	1	
		(ATTACHING PARTS)		
	2124-39180-00	-SCREW	3	
	NAS620C4L	-WASHER FLAT(2124-53320-00)	3	
	2124-51190-00	..NUT	3	
-23	2124-95120-00	-SWITCH FQC-10M ASSY (S6)(See Figure 8) .	1	
724	2124-95130-00	-SWITCH FQC-LP ASSY (S1-S5)(See Figure 9). (ATTACHING PARTS)	5	
	2124-39080-00	..SCREW.....	12	
-25	2124-43950-00	..PIN GUIDE.--	2	
-26	2124-37050-00	-INSULATOR	5	
-27	2124-44020-00	-GASKET	1	
-28	2124-92940-00	..PANEL ASSEMBLY.	1	
-29	2124-49075-00	..PANEL	1	
-30	2124-49250-00	..RUBBER SEAL.	1	
-31	2124-49015-00	..GASKET (FOR P3).....	1	
-32	2124-43930-00	..PLATE (FOR LED ASSY).....	1	
-33	2124-37830-00	-WINDOW (FOR S1-S6)	6	

SECTION II
 MAINTENANCE PARTS LIST

MA(P)-2124-09514-00

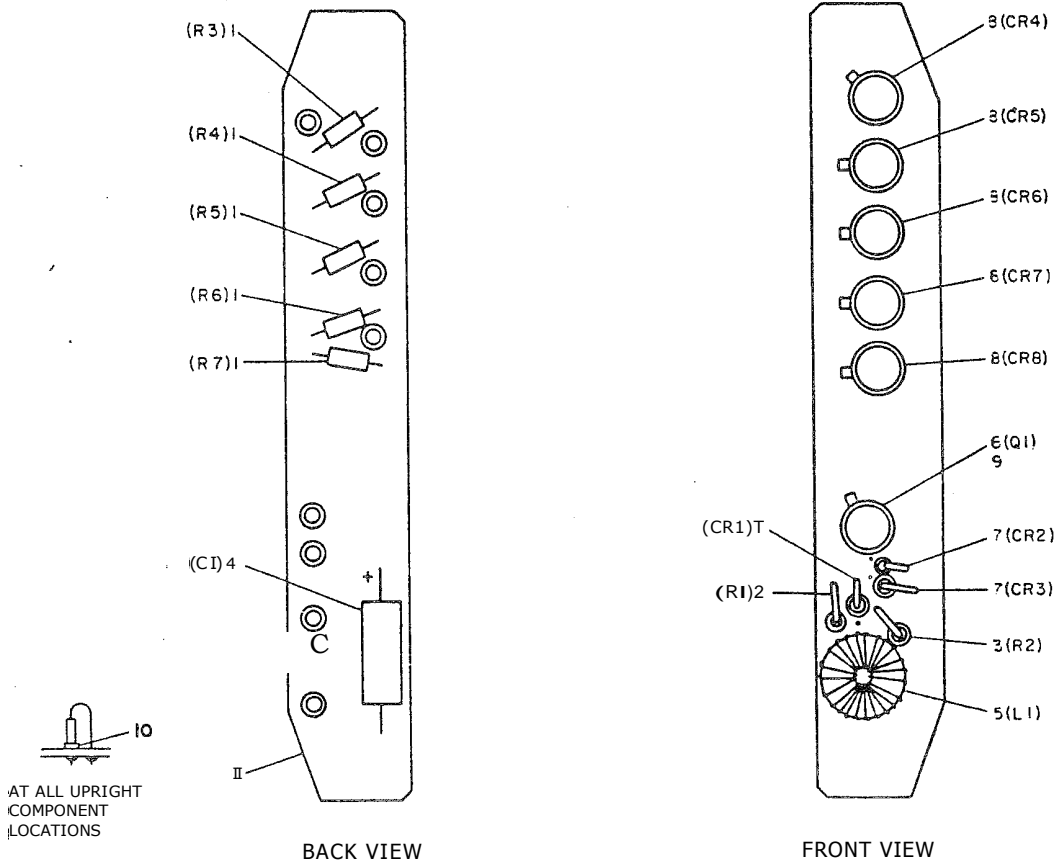

Figure 3. LIED Assembly, 1A1A13

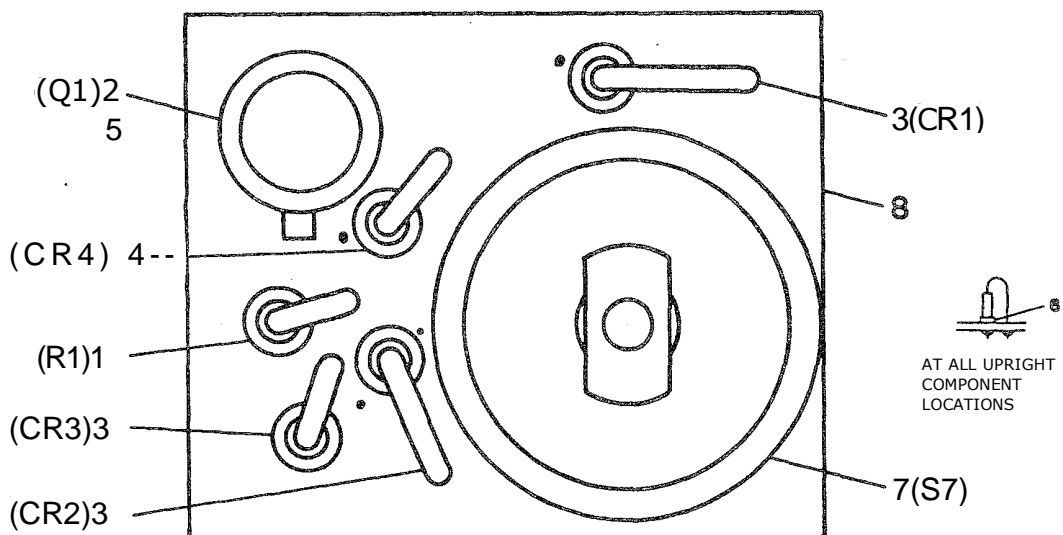
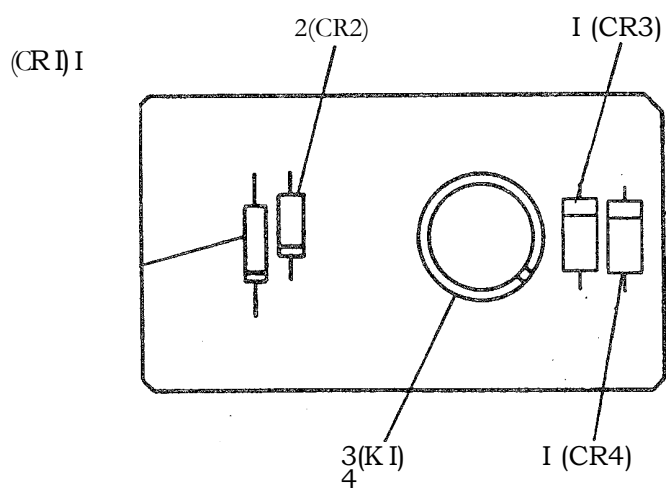

Figure 4. MX Assembly, 1A1A5

SECTION II
MAINTENANCE PARTS LIST

MA(P) 2124 0951440



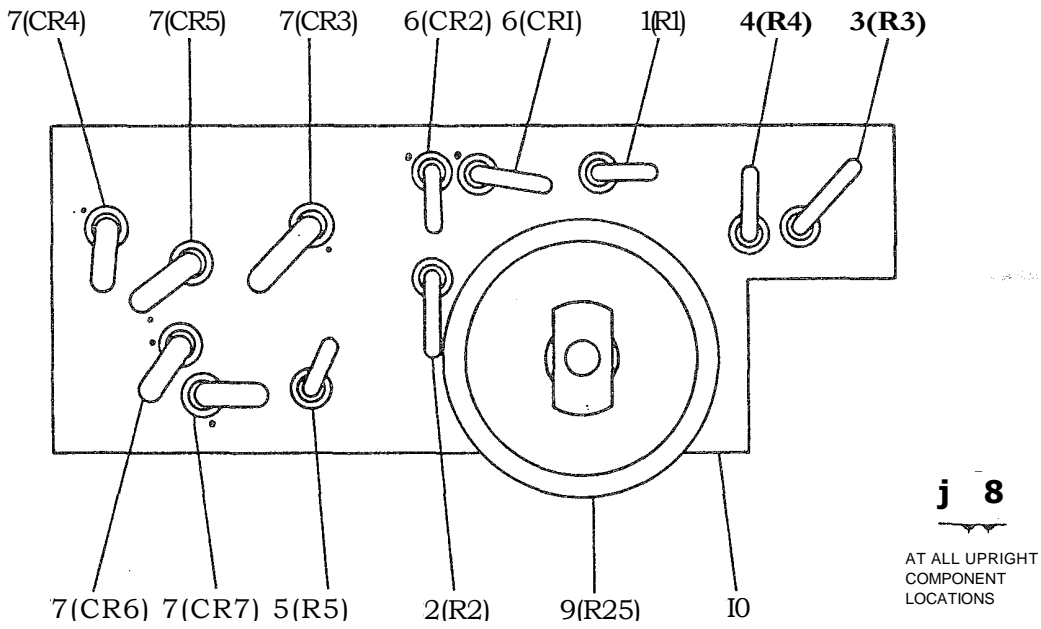

Figure 60 Potentiometer Assembly, 1A1A4

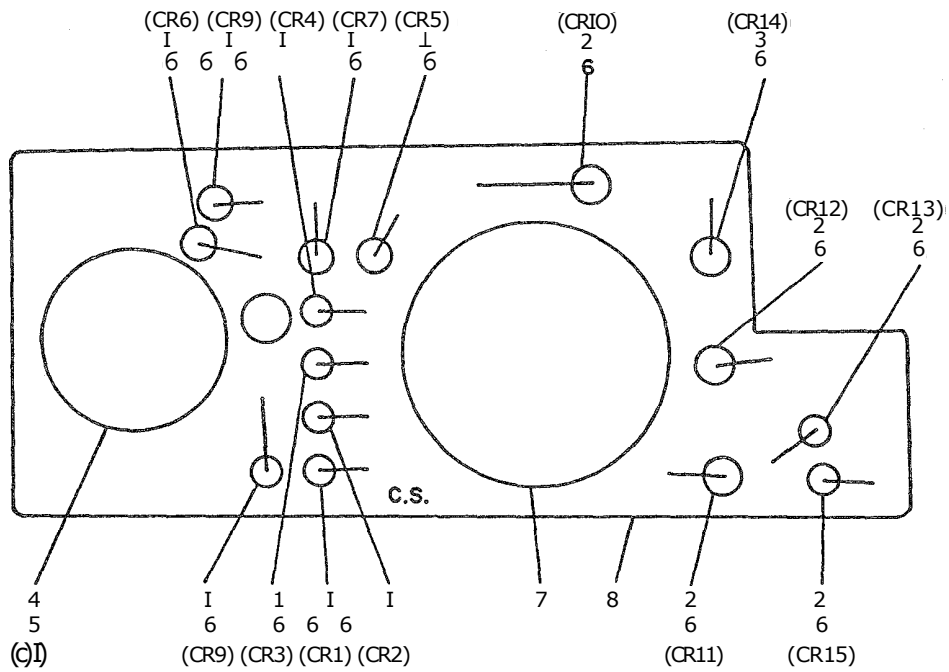

Figure 6A. MTS PC Board Assembly, 1A1A4

SECTION II
MAINTENANCE PARTS LIST

m(P)-2124-09514-00

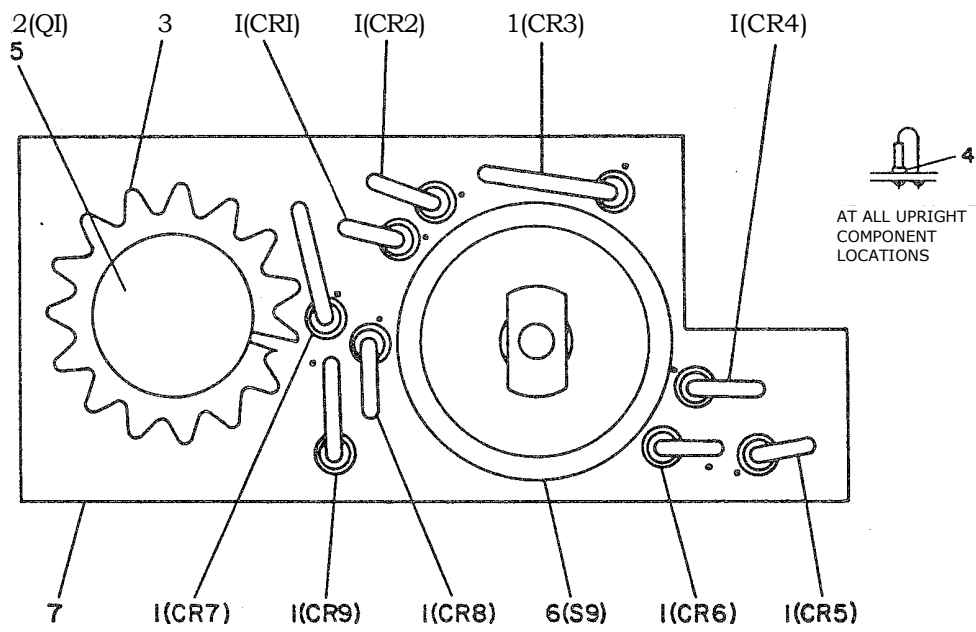

Figure 7. MAT Assembly, 1A1A3

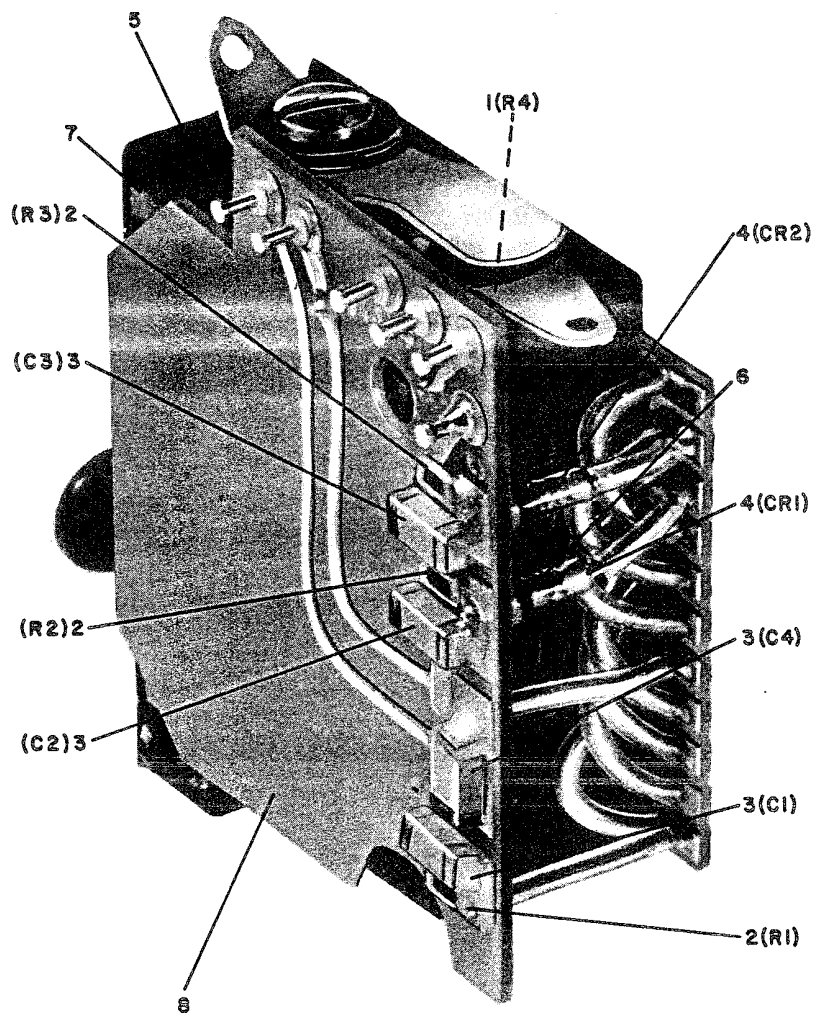

Figure 8. Switch FQC-10M Assembly

SECTION II
MAINTENANCE PARTS LIST

MA(P)-2124-09514-00

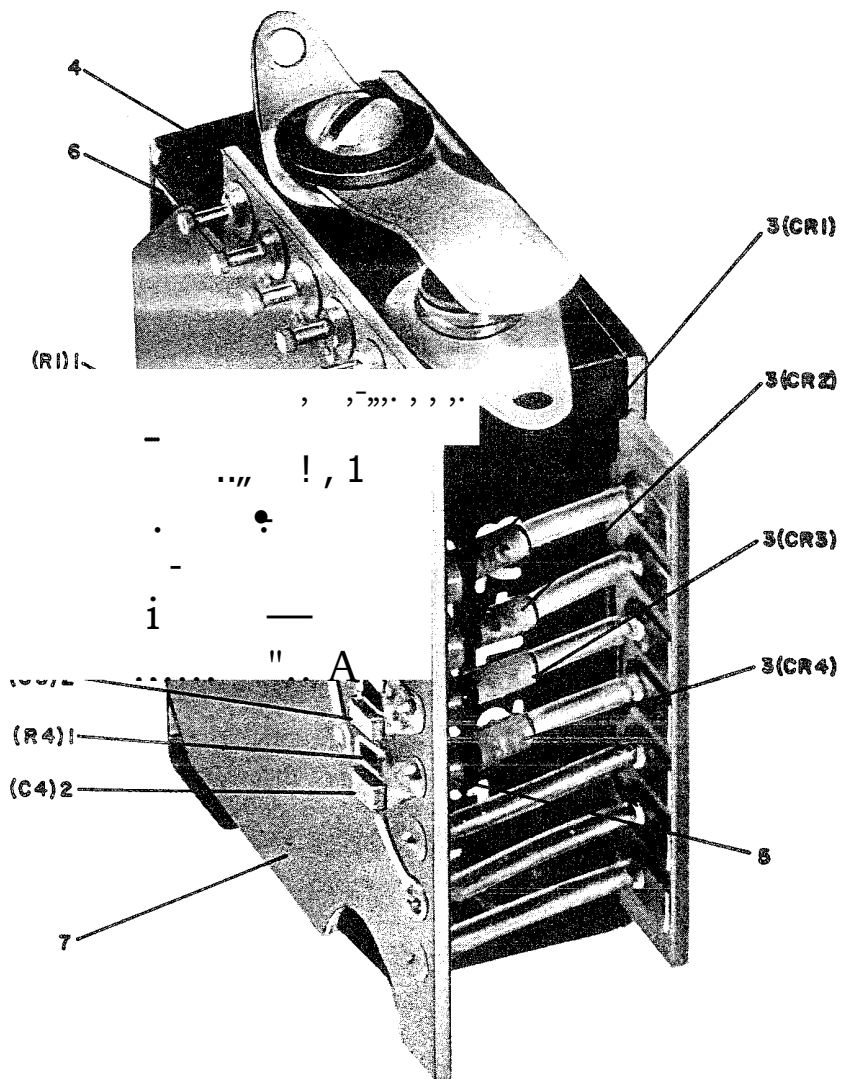

Figure 9. Switch FQC-LP Assembly, 1A1A8

IviA(P)-2124-09514-00

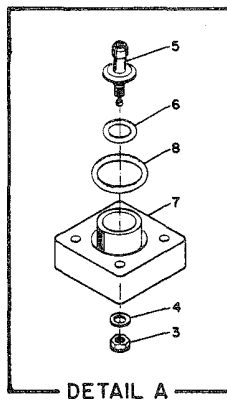
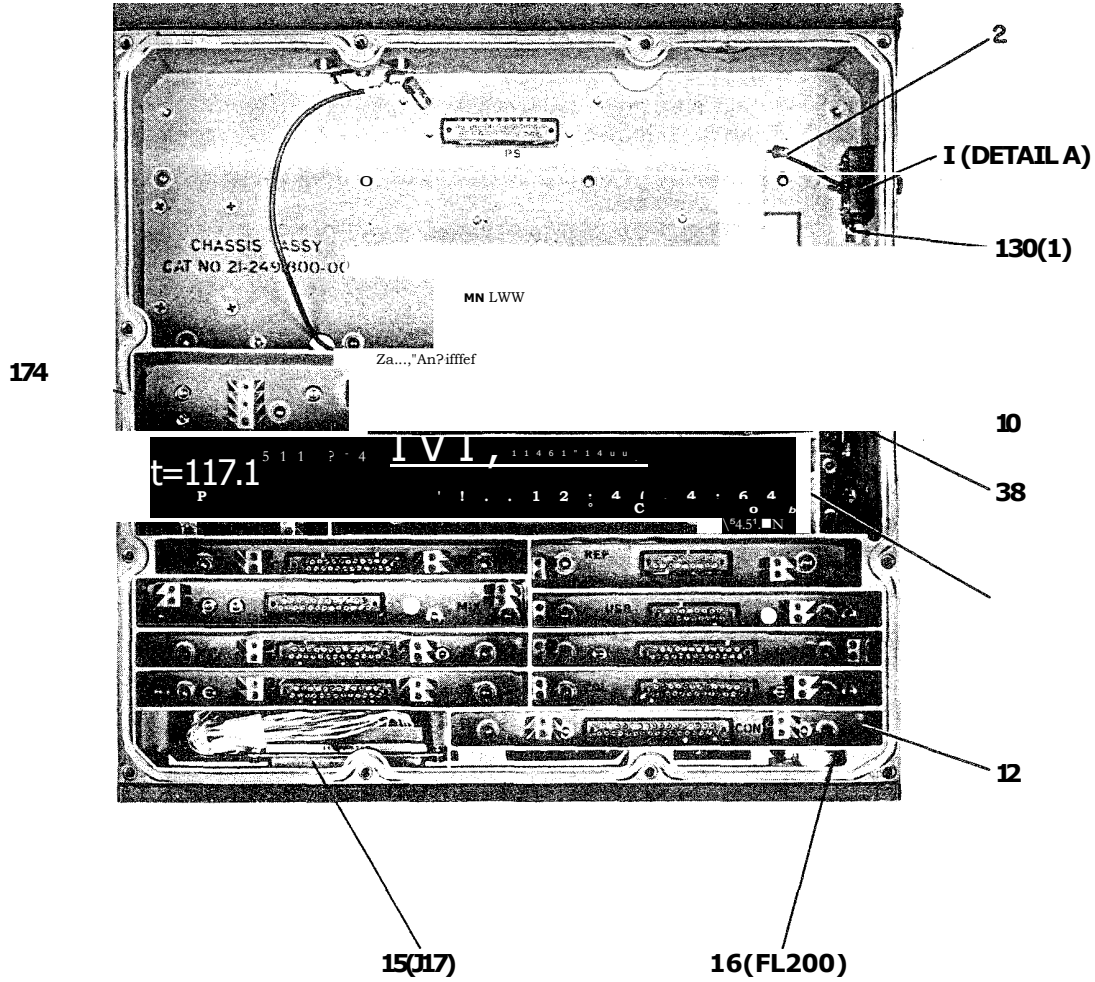

Figure 10. Chassis Assembly, 1A8 (Sheet 1 of 2)

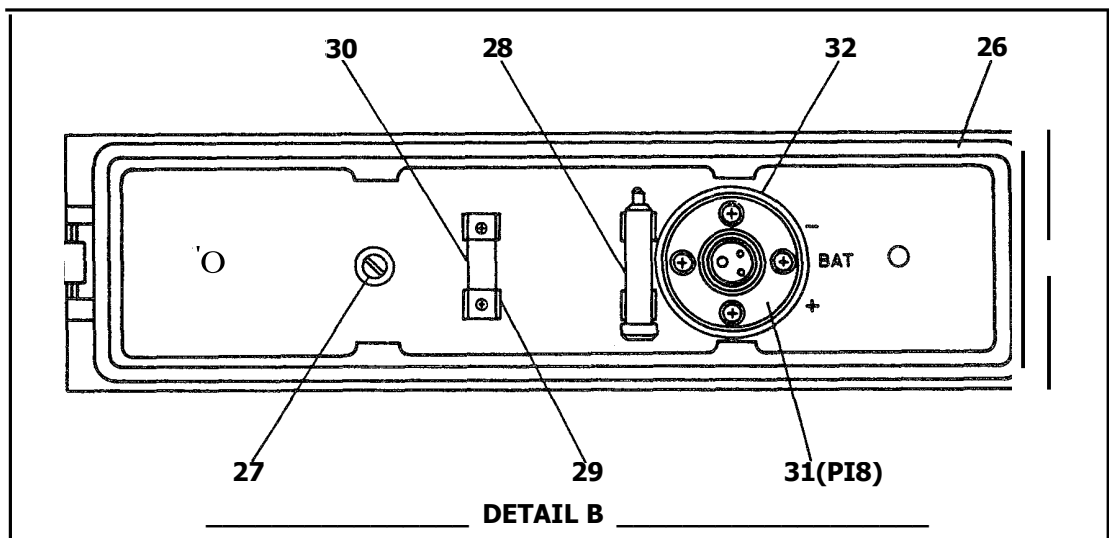
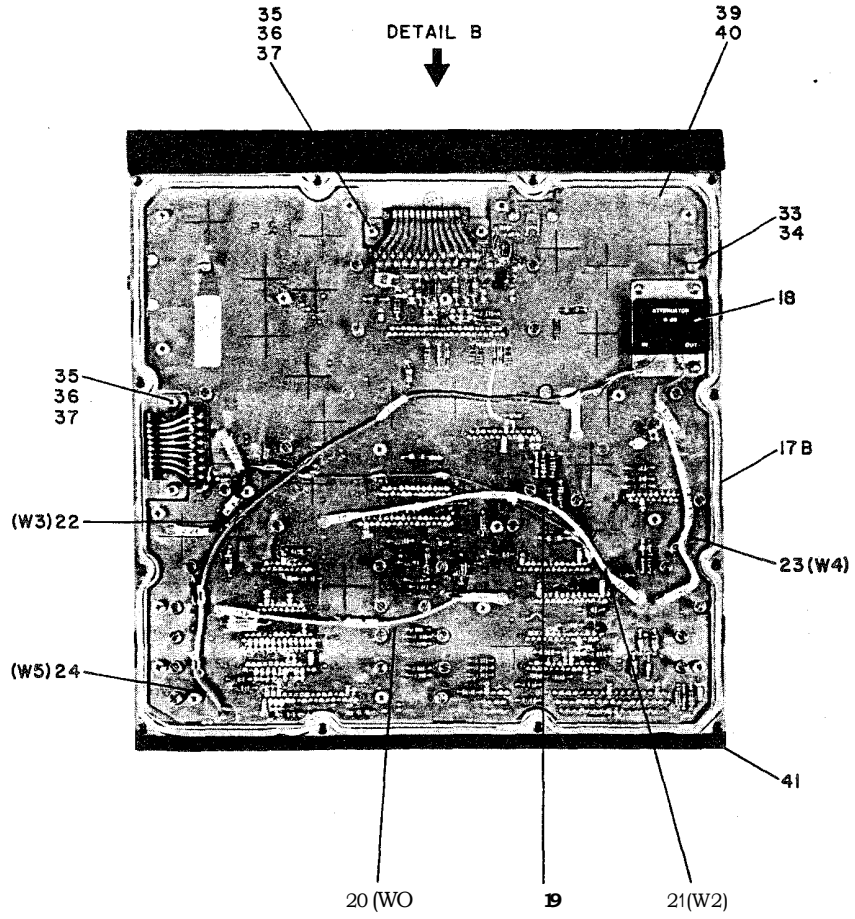

Figure 10, Chassis Assembly, 1A8 (Sheet 2 of 2)

SECTION II
 MAINTENANCE PARTS LIST

MA(P)-2124-09514-00

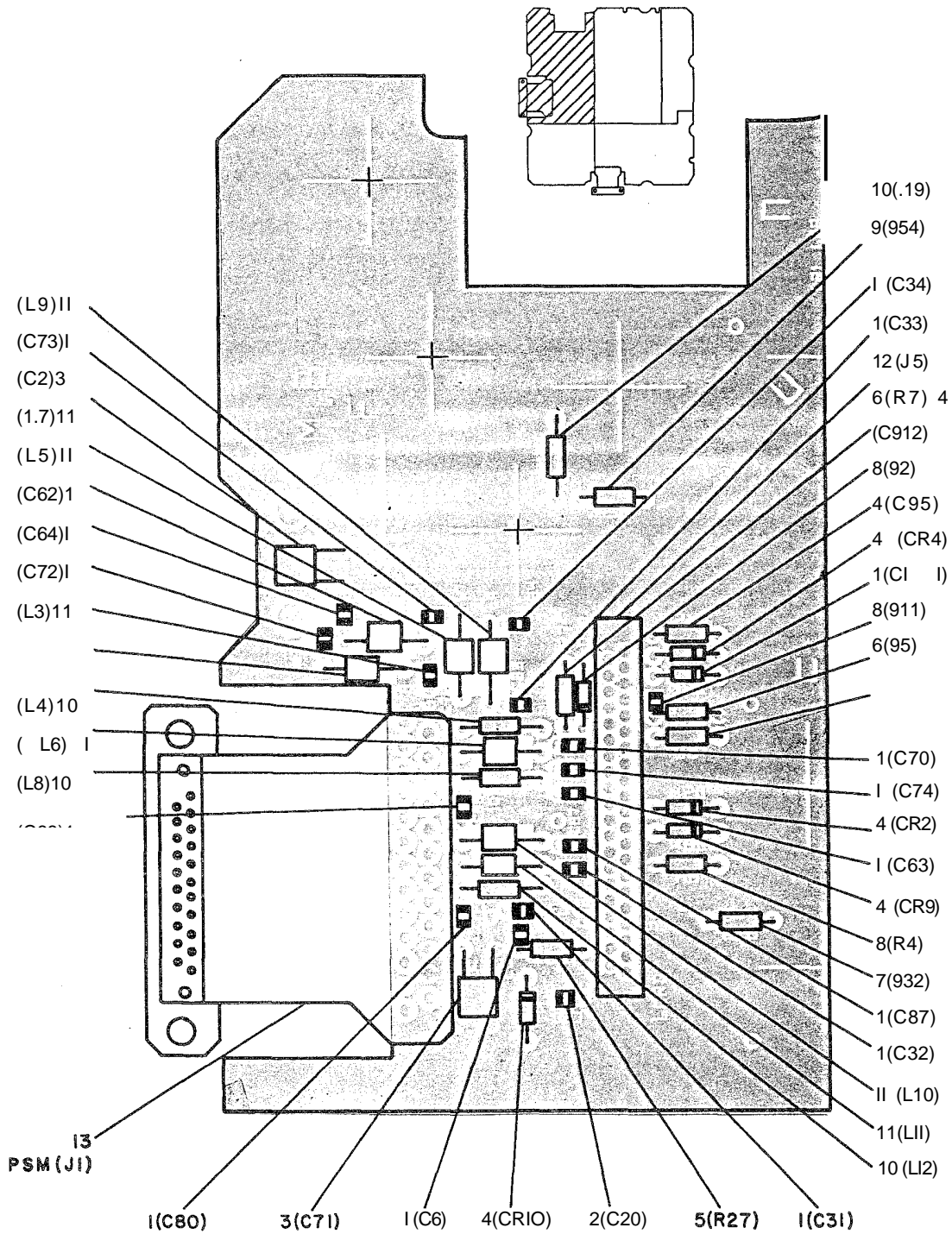

Figure 11. Motherboard Assembly, 1A8A1 (Sheet 1 of 4)

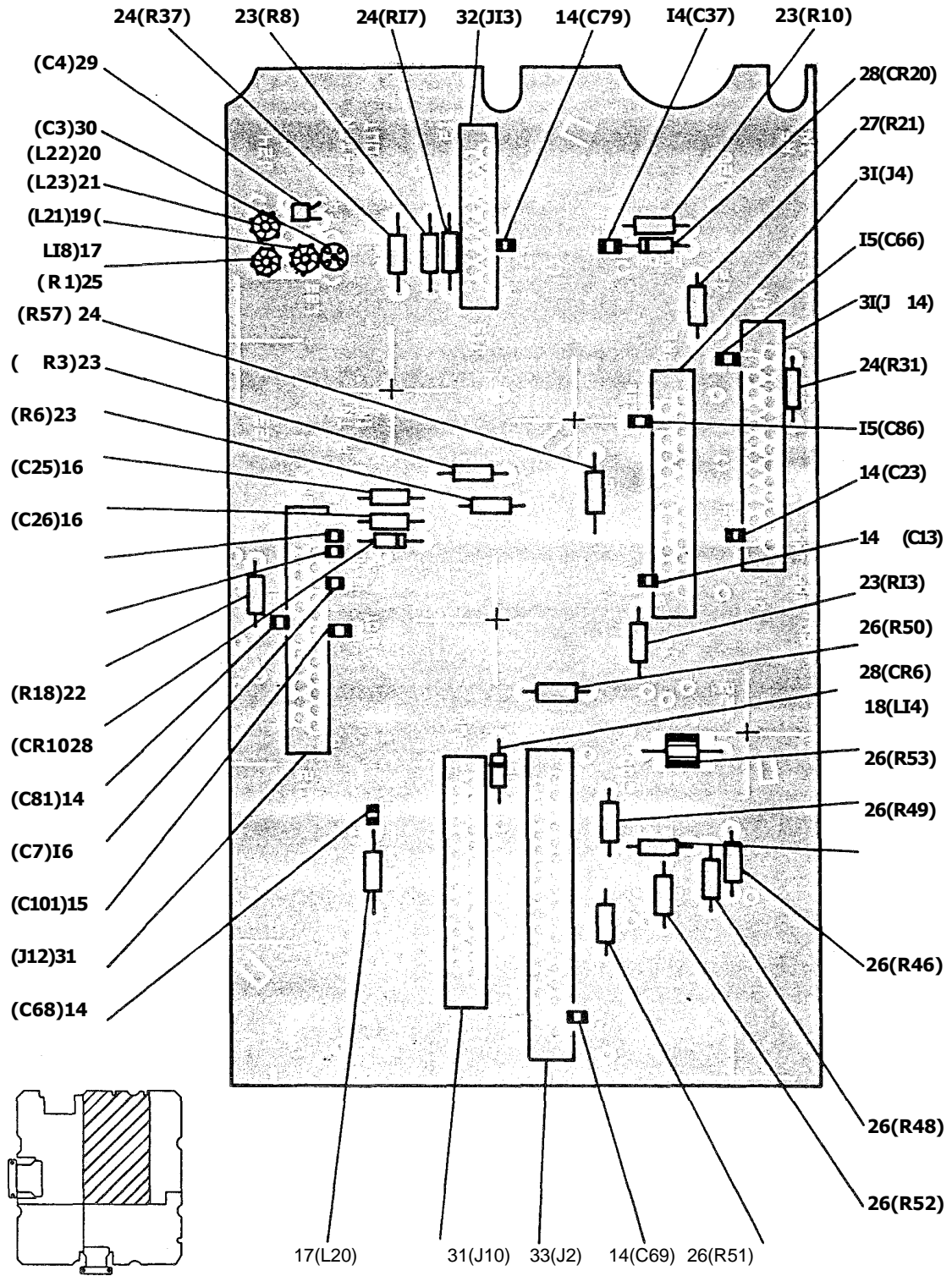

Figure 11, Motherboard Assembly, 1A8A1 (Sheet 2 of 4)

SECTION II
 MAINTENANCE PARTS LIST

MA(P)-2124-09514-00

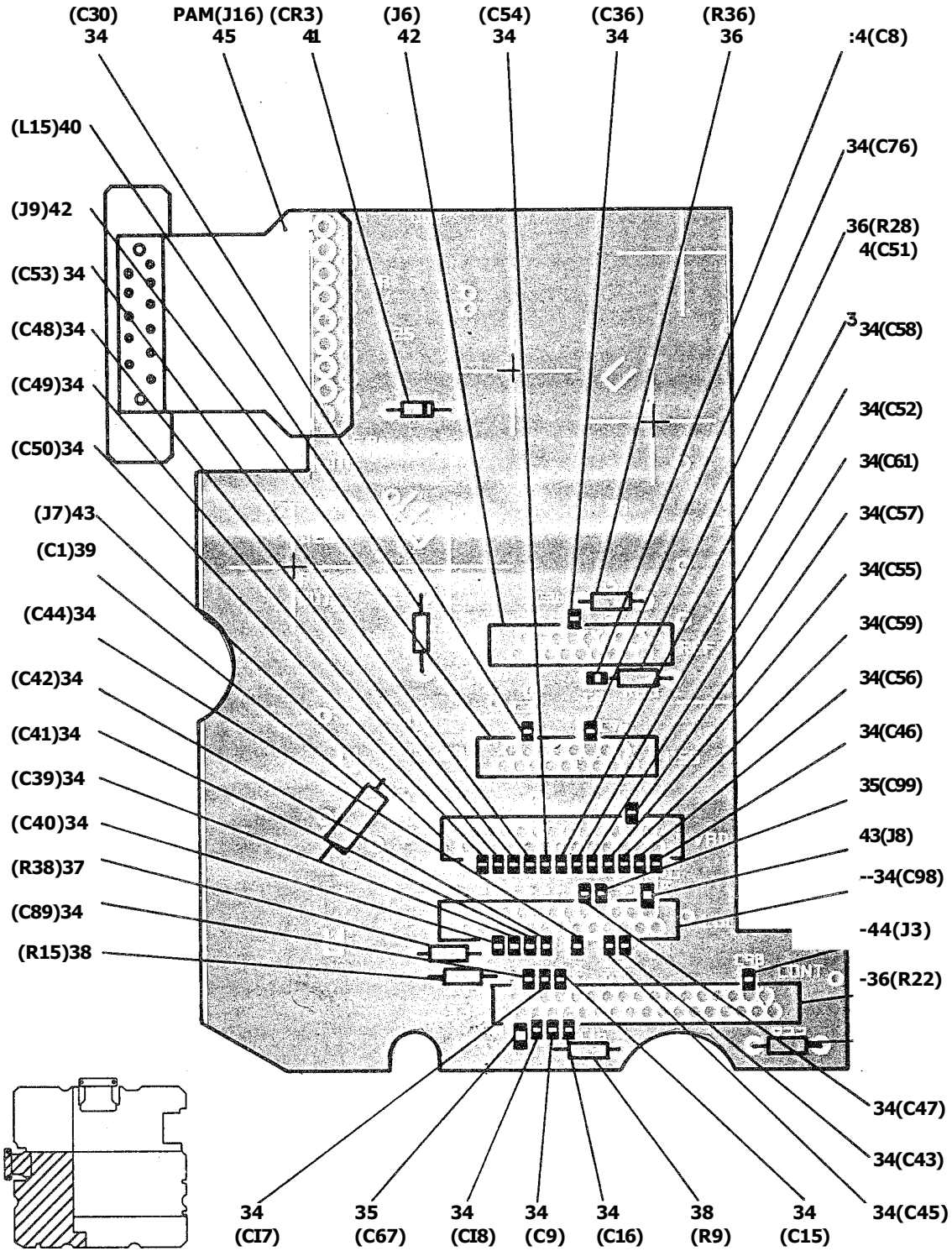

Figure 11. Motherboard Assembly, 1A8A1 (Sheet 3 of 4)

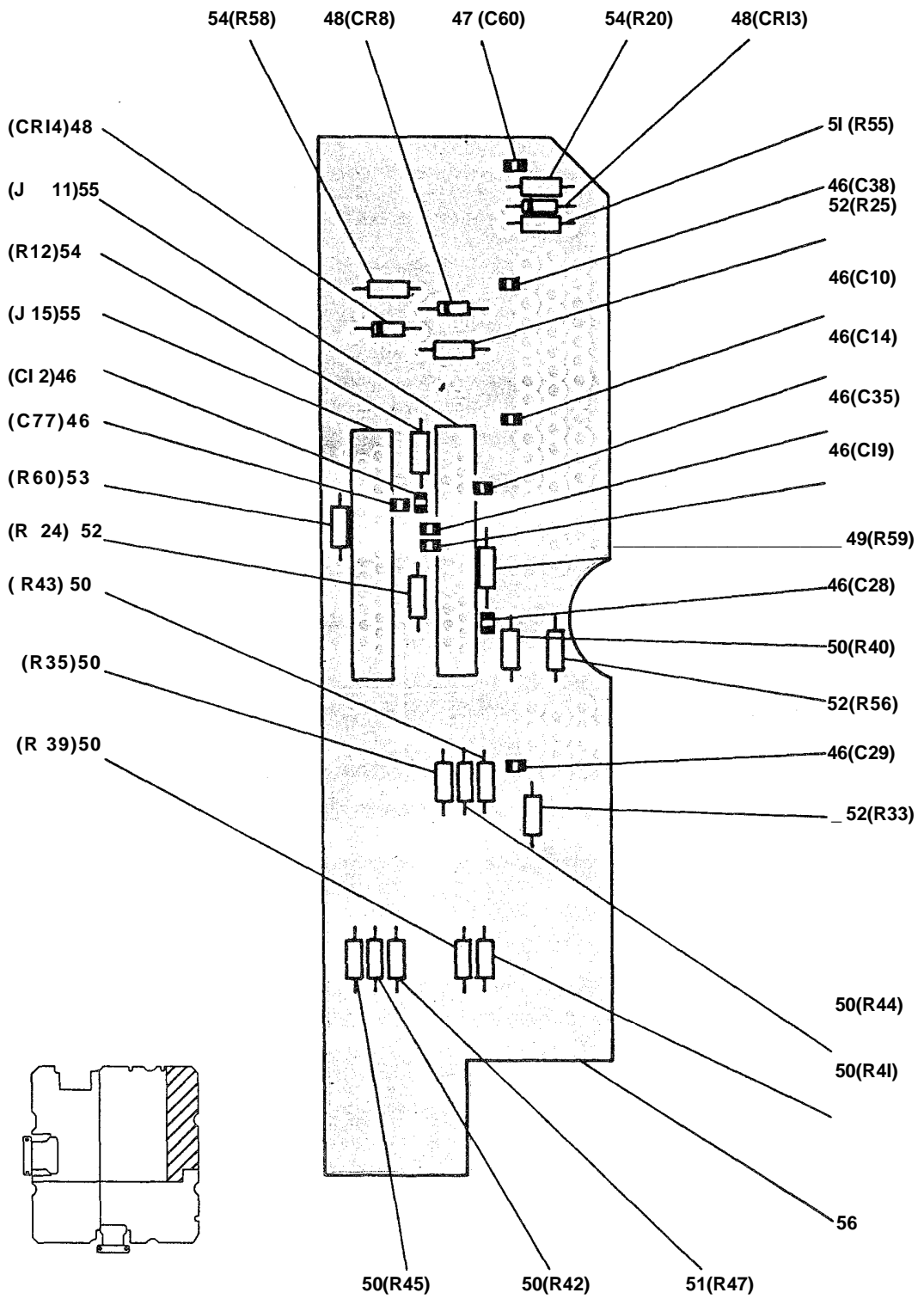

Figure 11. Motherboard Assembly, 1A8A1 (Sheet 4 of 4)

SECTION II
 MAINTENANCE PARTS LIST

MA(P)-2124-09514-00

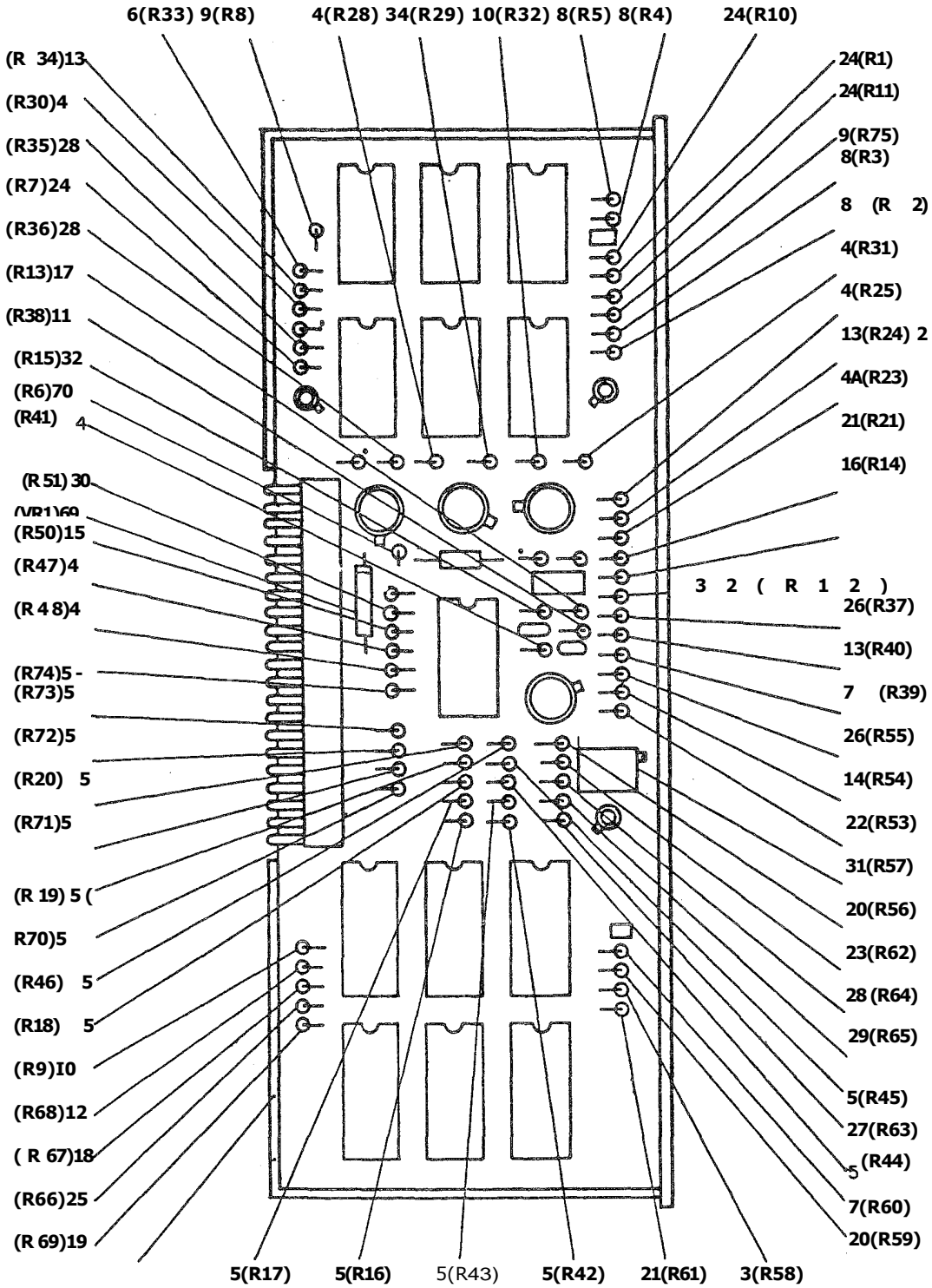
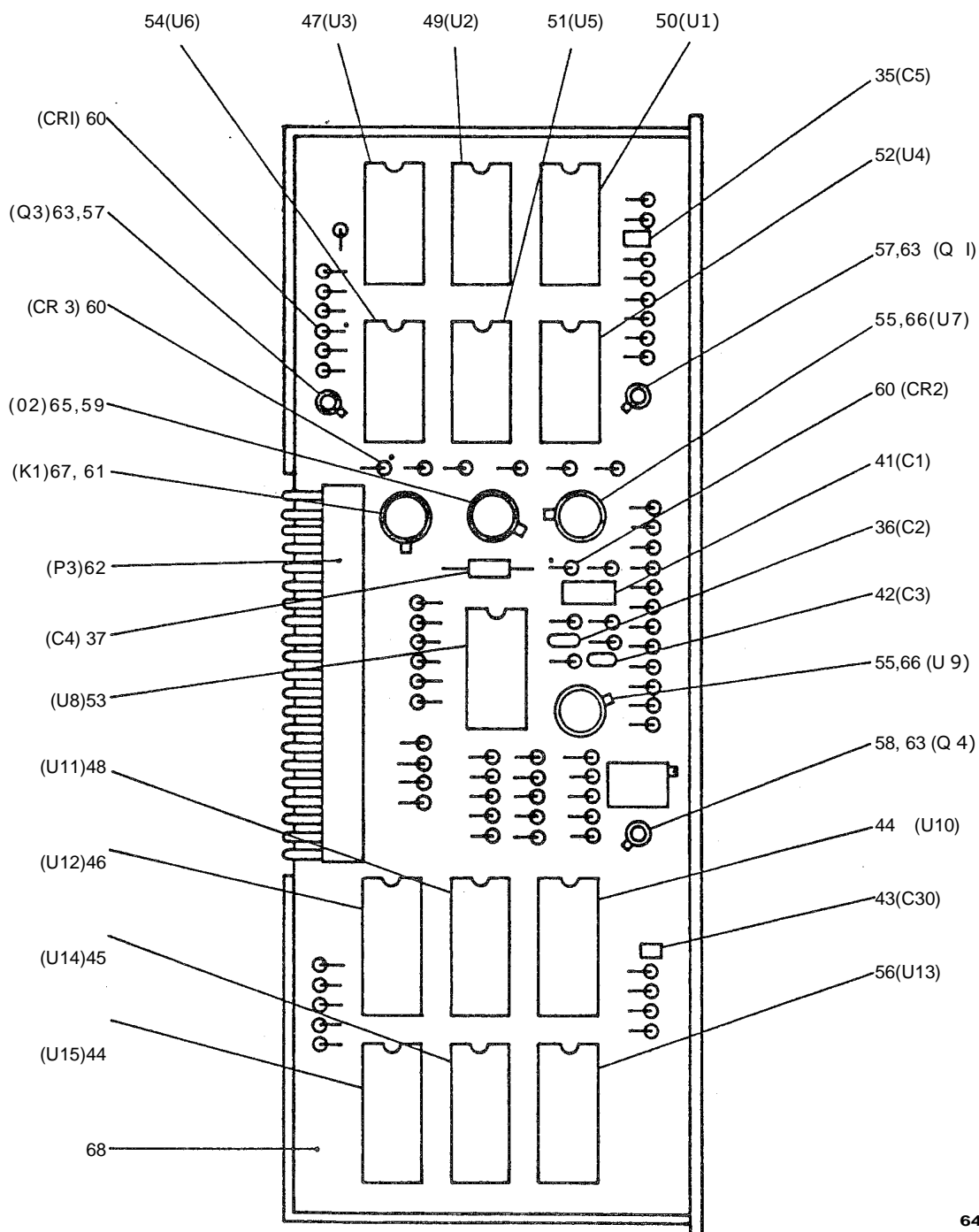

Figure 12. Control Assembly, 1A7 (Sheet 1 of 3)



64

AT ALL UPRIGHT
COMPONENT
LOCATIONS

Figure 12. Control Assembly, 1A7 (Sheet 2 of 3)

SECTION II
 MAINTENANCE PARTS LIST

MA(P) 2124 09514 00

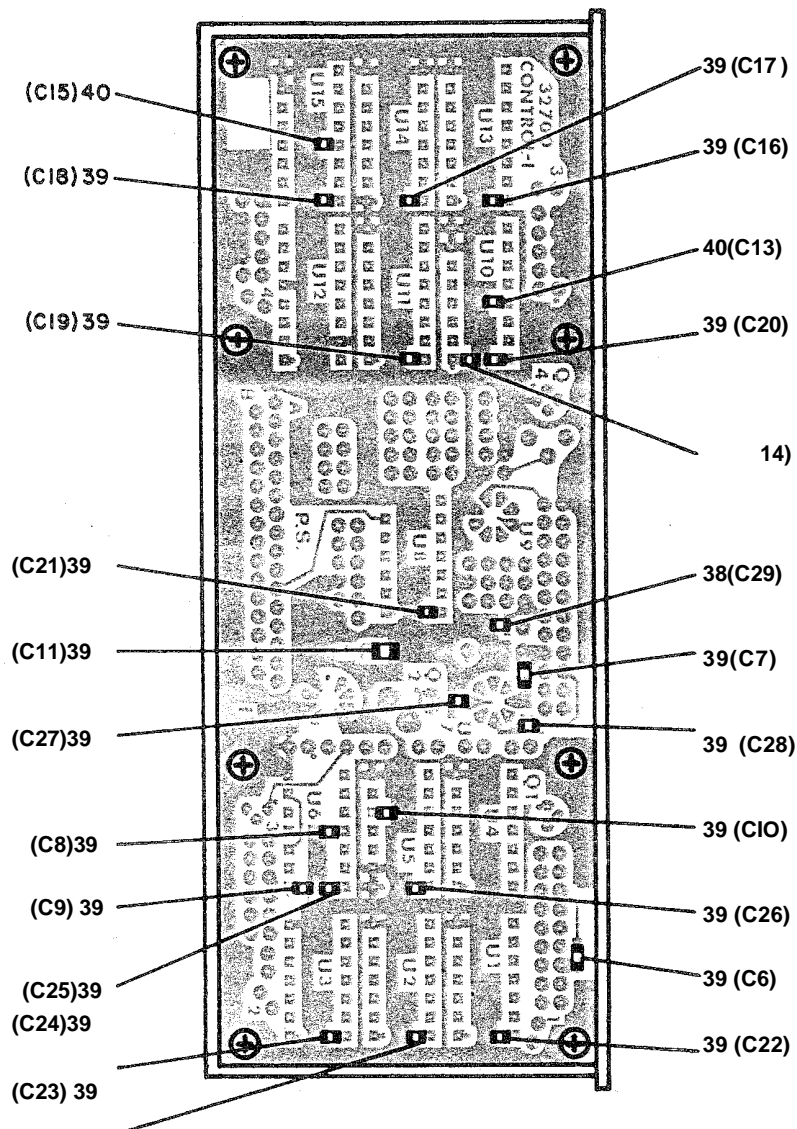

Figure 12, Control Assembly, 1A7 (Sheet 3 of 3)

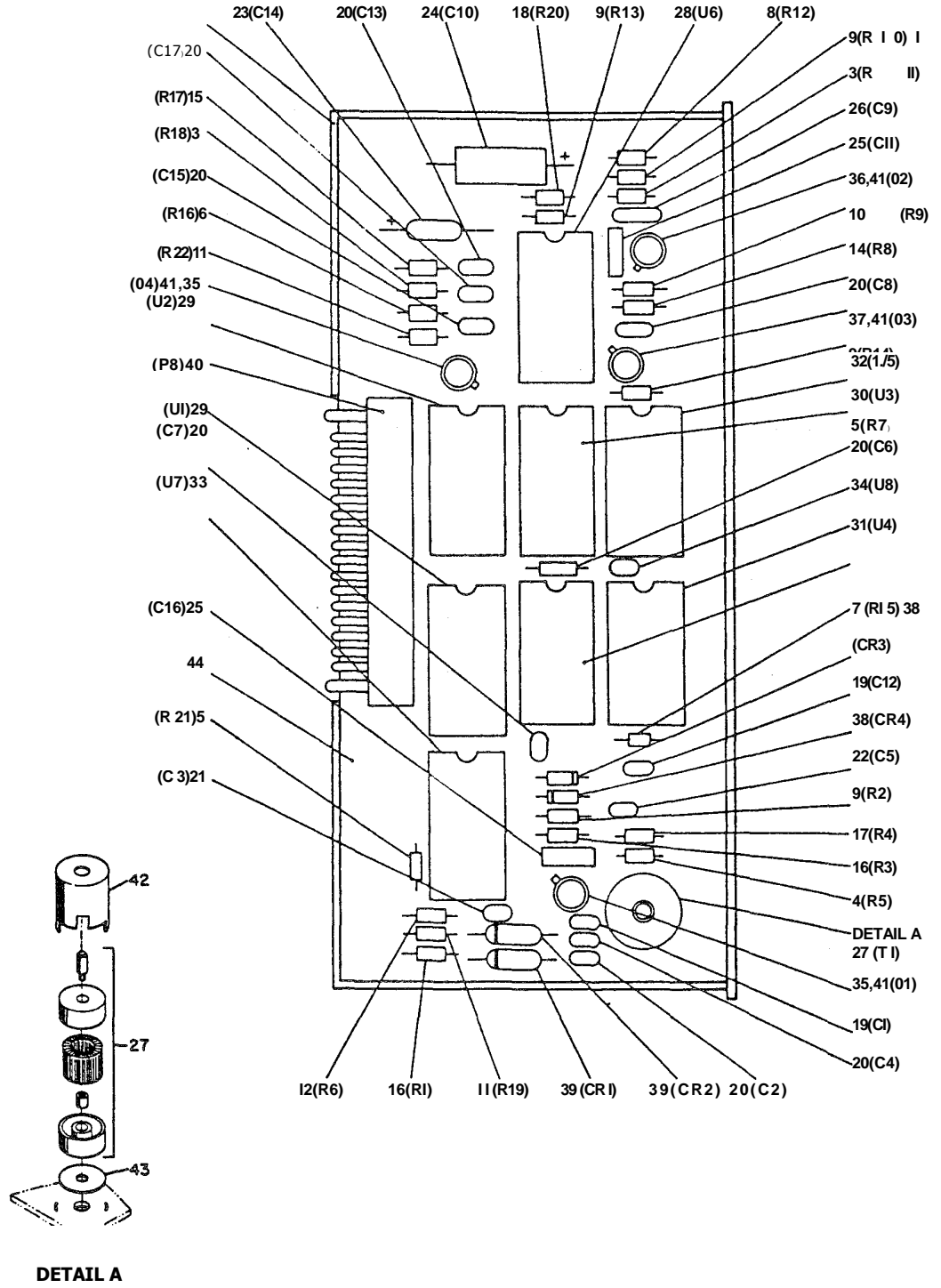

Figure 13 . LOL Assenby, 1A3A4

SECTION II
 MAINTENANCE PARTS LIST

MA(P)-2124-09514-00

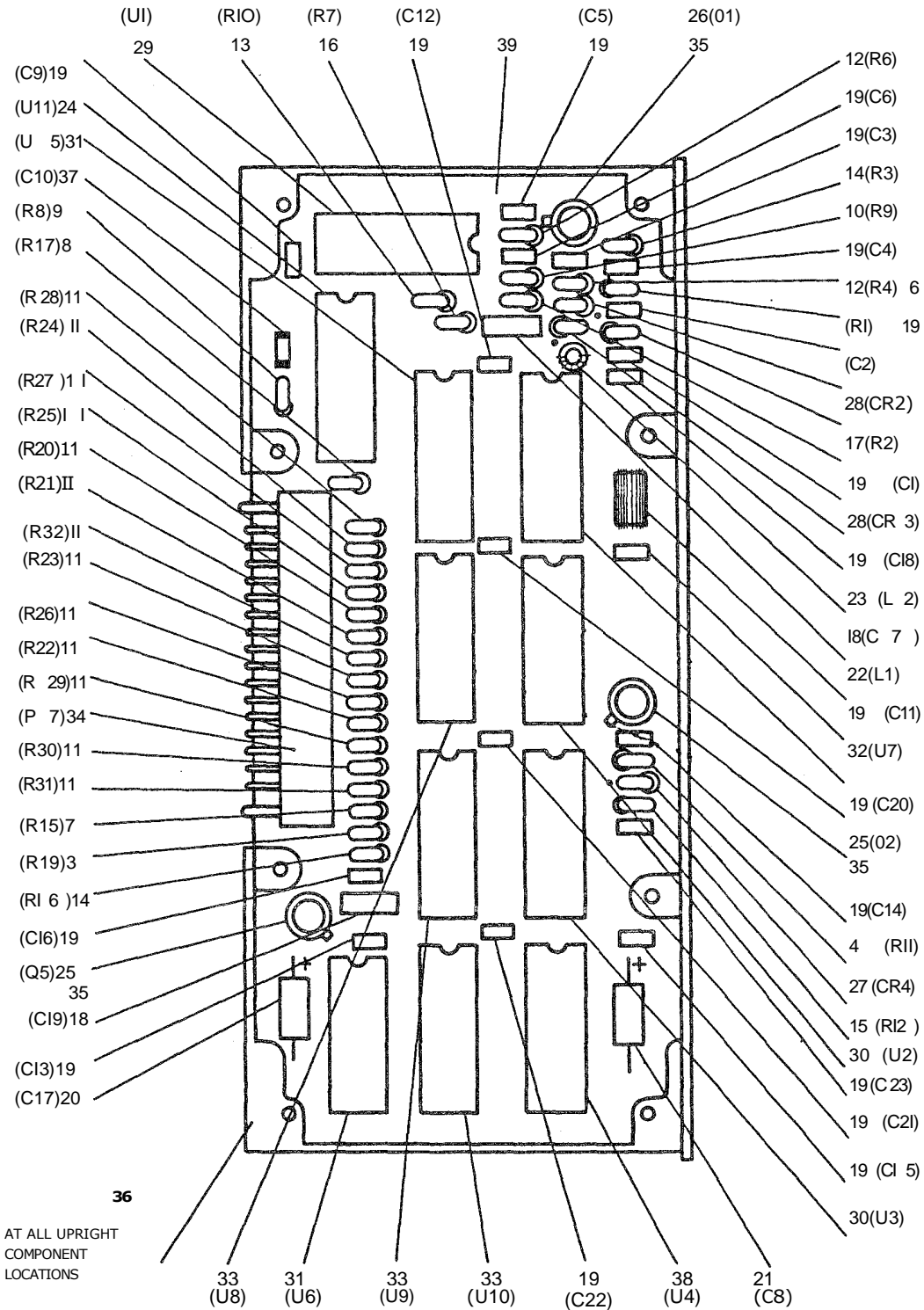

Figure 14. VAD Assembly, 1A3A2

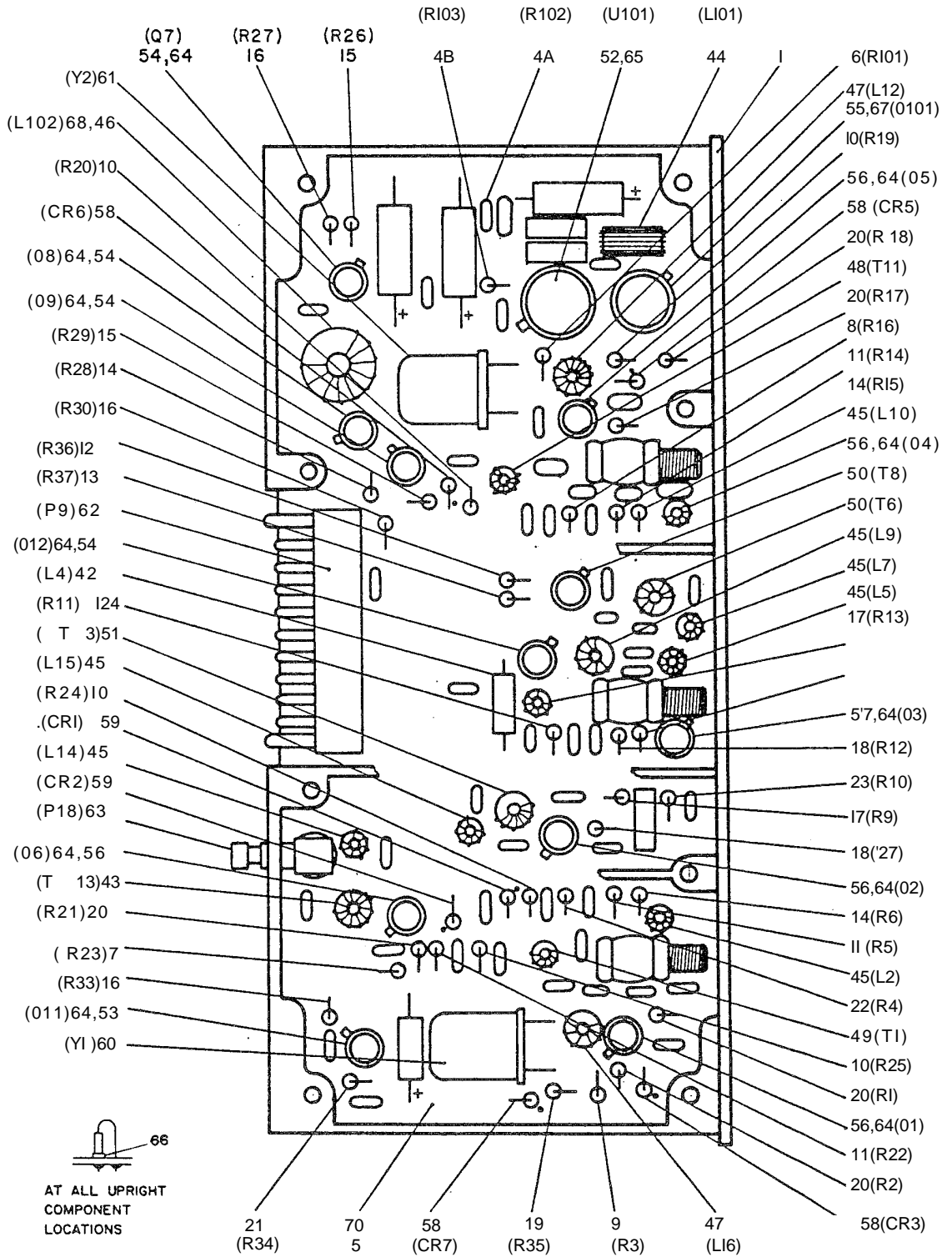

Figure 15. USB Assembly, 1A3A3 (Sheet 1 of 3)

SECTION II
 MAINTENANCE PARTS LIST

MA(P)-2124-09514 -00

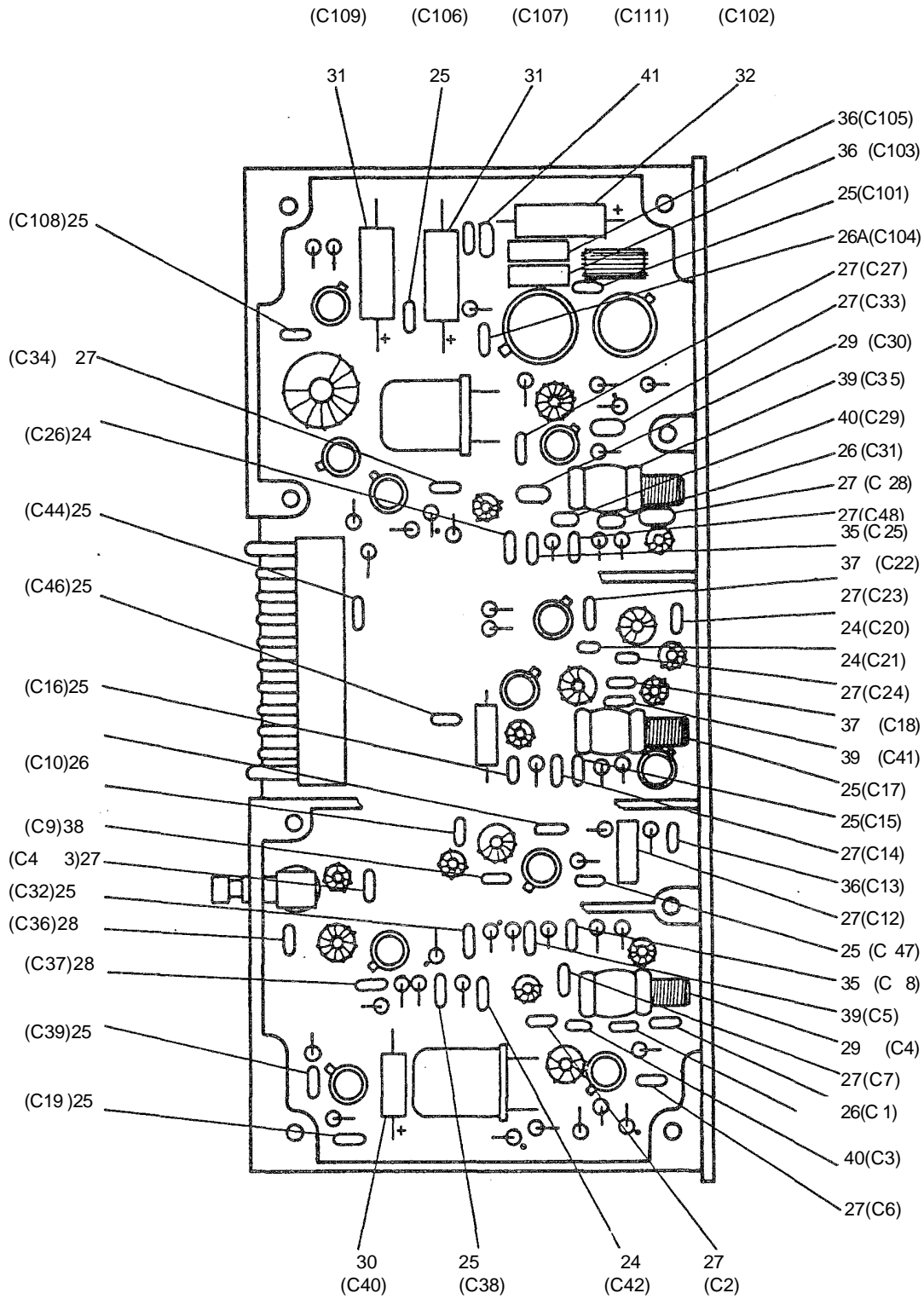

Figure 150 USB Assembly, 1A3A3 (Sheet 2 of 3)

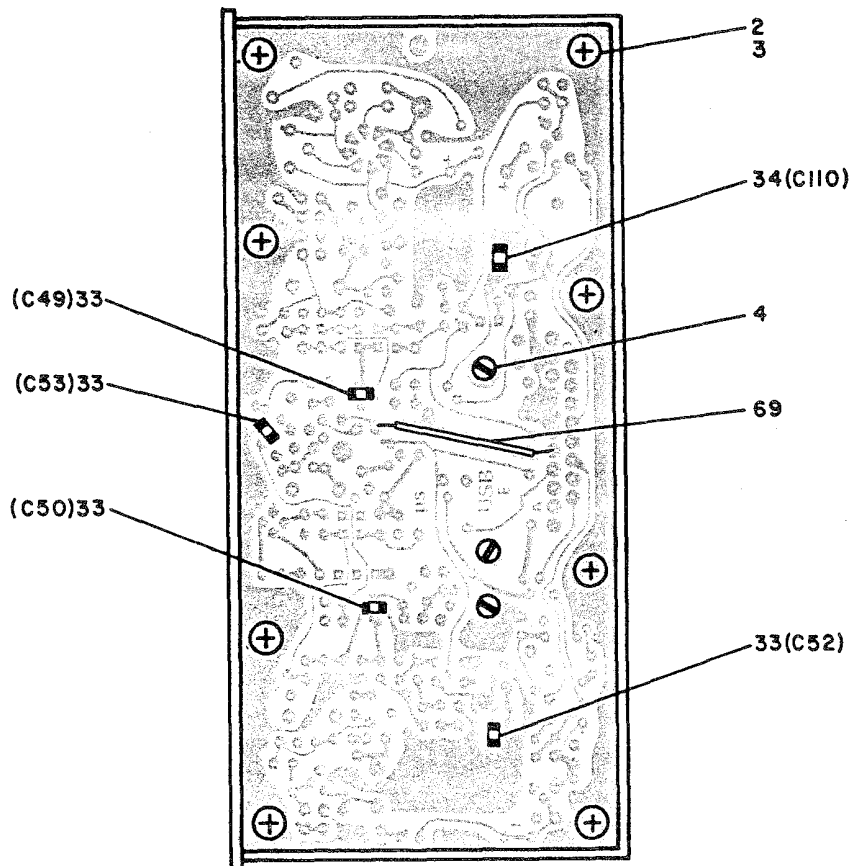

Figure 15. USB Assembly, 1A3A3 (Sheet 3 of 3)

SECTION II
 MAINTENANCE PARTS LIST

MA(P)-2124-09514-00

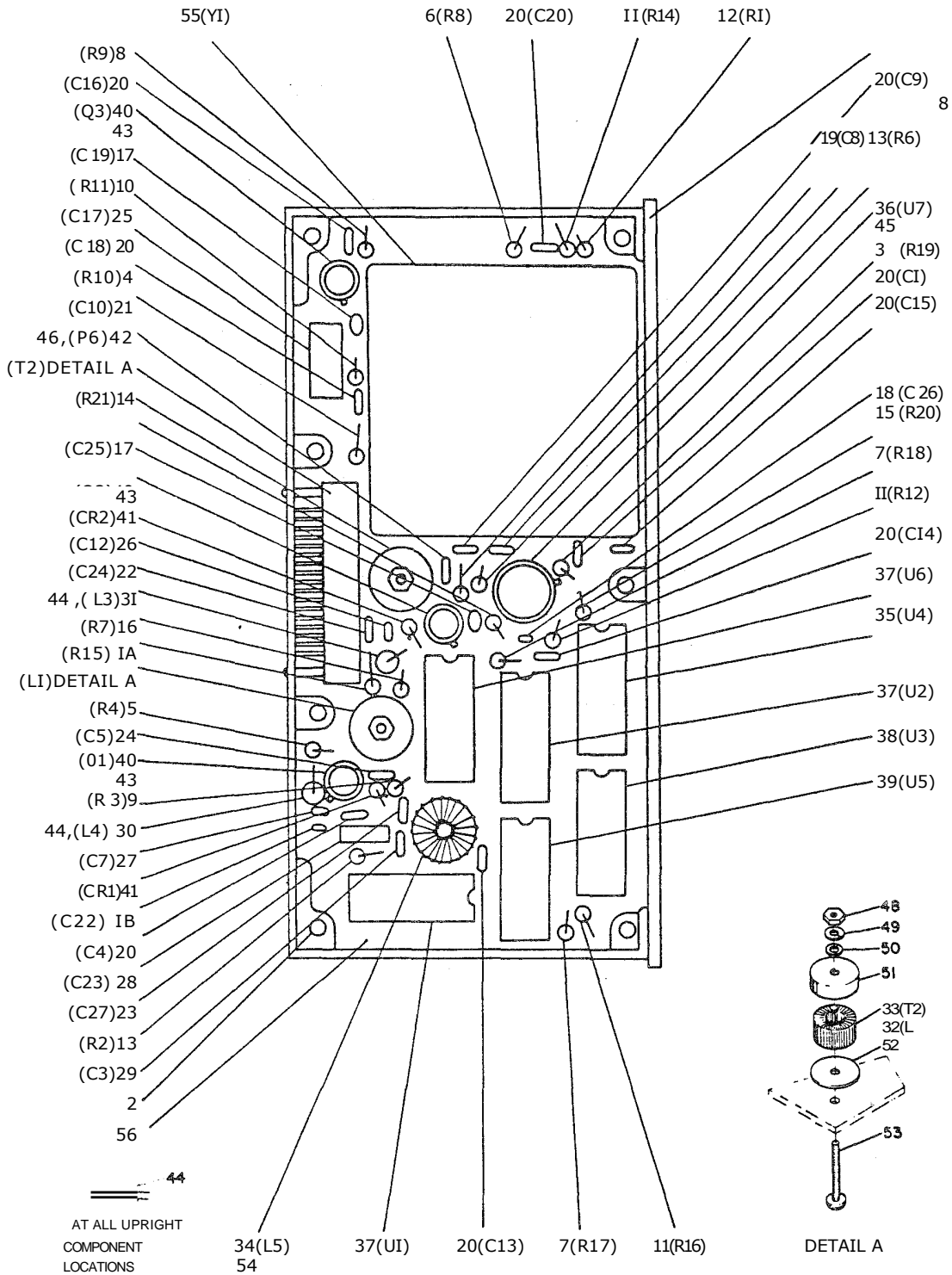

Figure 16. REF Assembly, 1A3A6

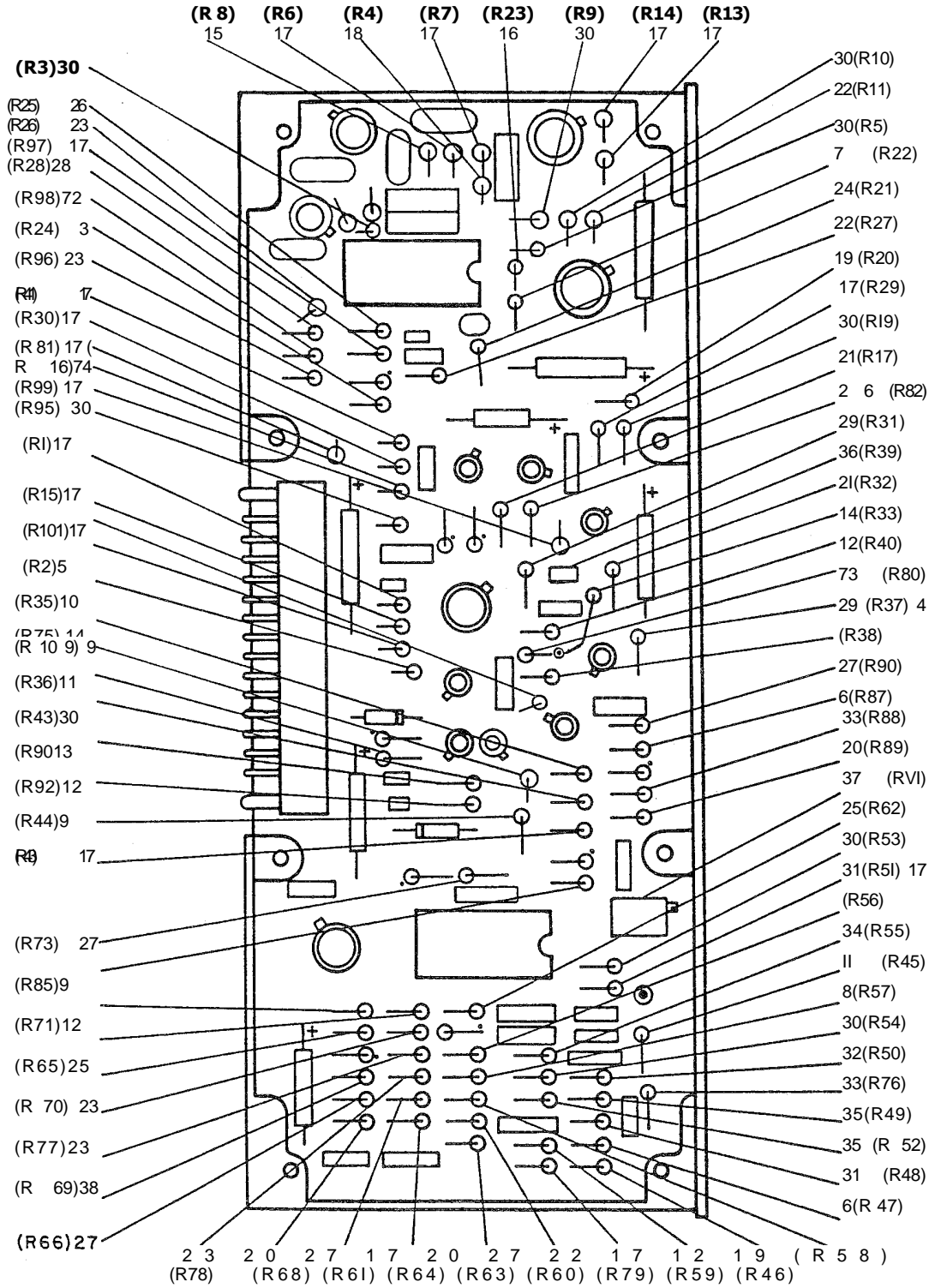

Figure 17. Audio Assembly, 1A2A3 (Sheet 1 of 2)

SECTION II
 MAINTENANCE PARTS LIST

MA(P)-2124-09514-00

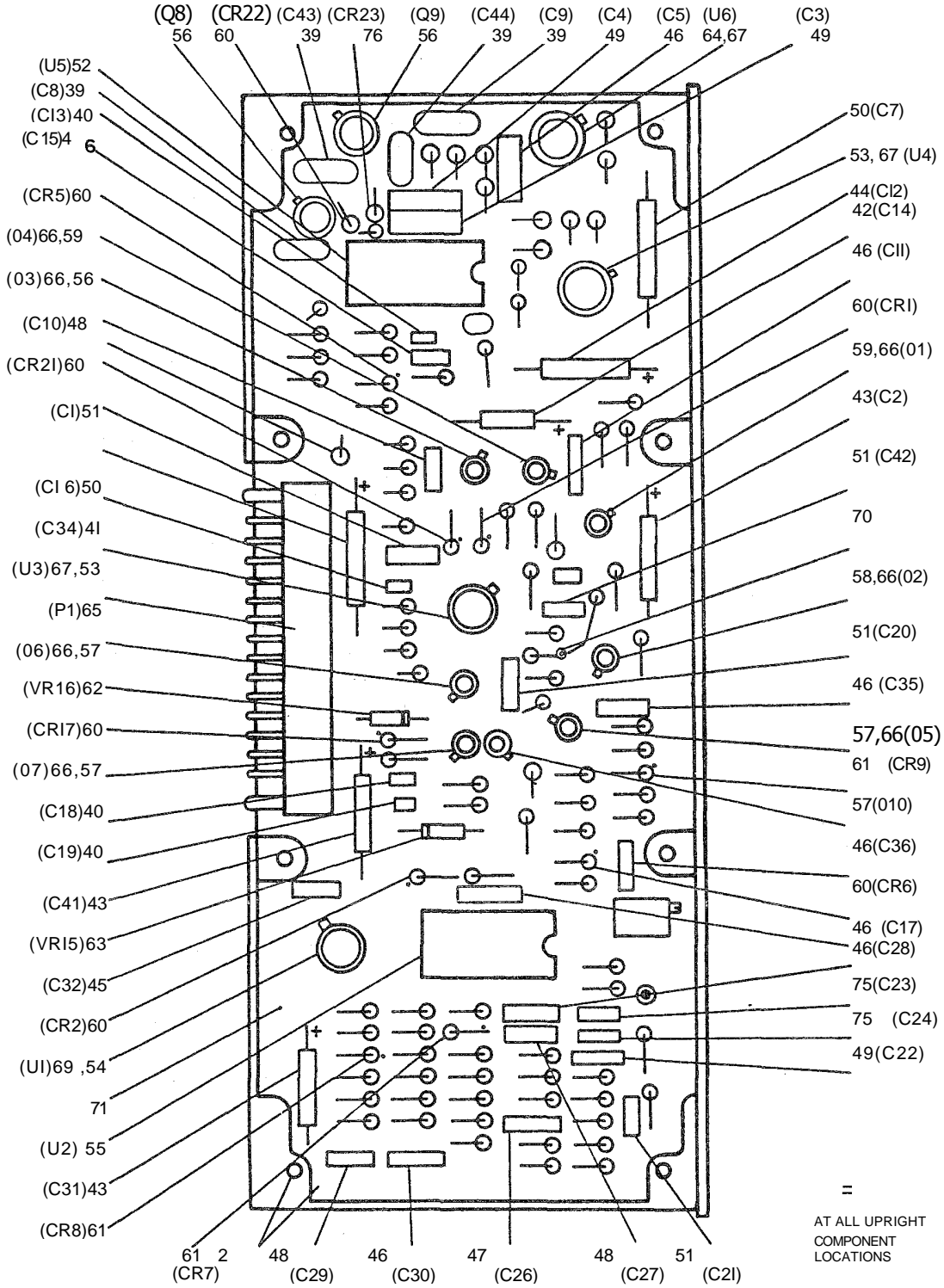

Figure 17. Audio Assembly, 1A2A3 (Sheet 2 of 2)

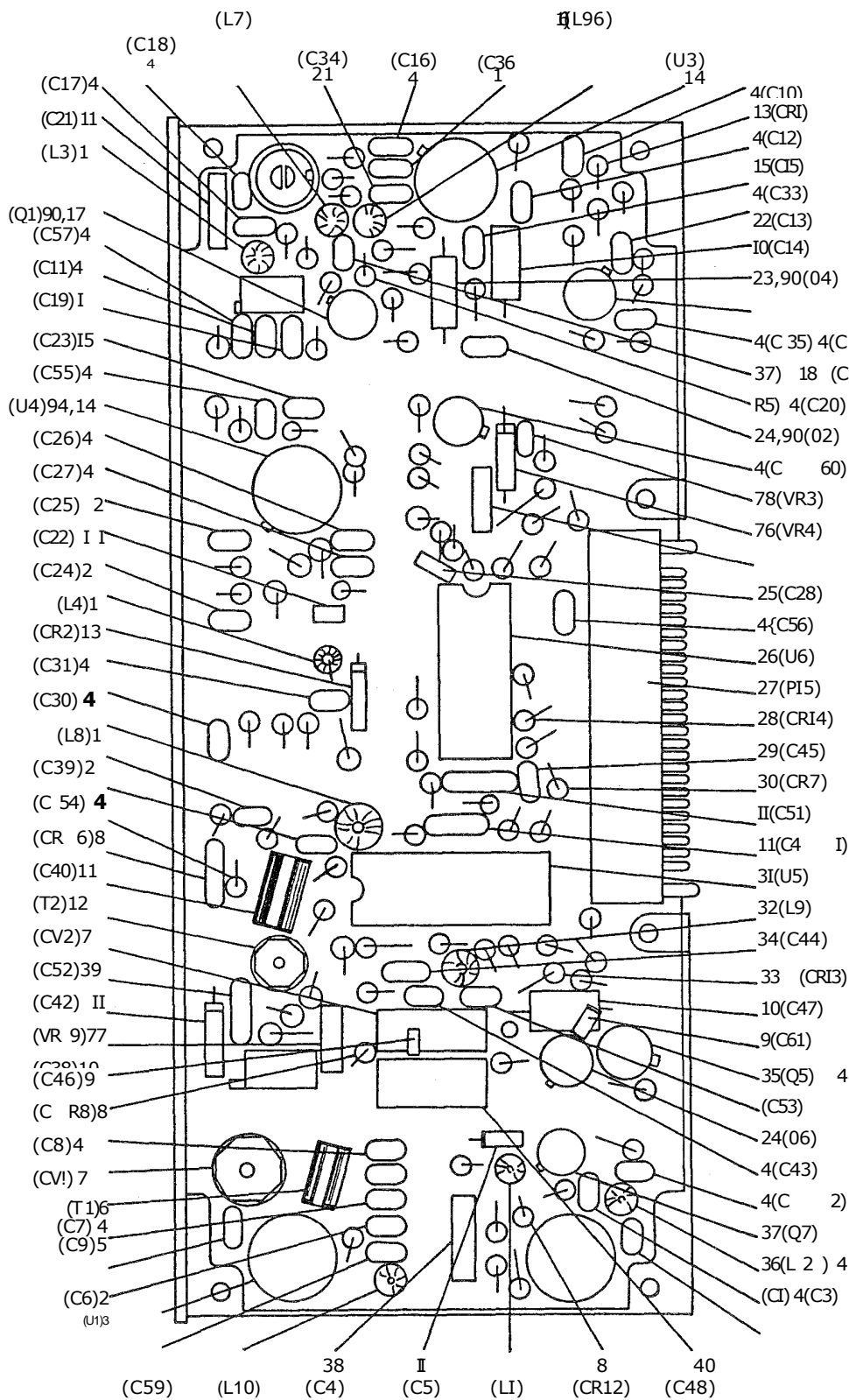

Figure 18. IF PC Board Assembly, 1A2A2 (Sheet 1 of 2)

SECTION II
 MAINTENANCE PARTS LIST

MA(P)-2124-09514-00

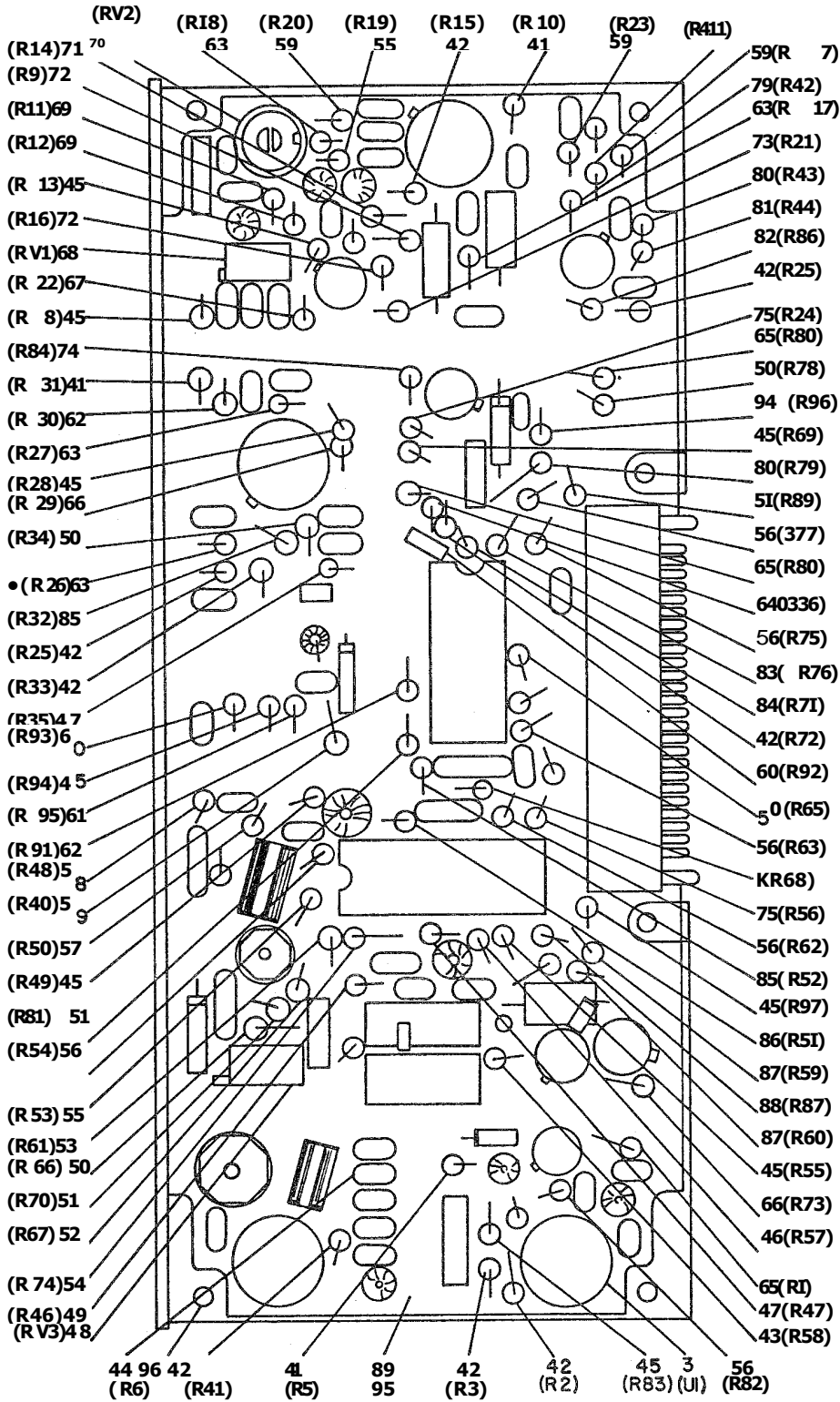

Figure 18, IF PC Board Assembly, 1A2A2 (Sheet 2 of 2)

SECTION II
 MAINTENANCE PARTS LIST

MA(P)-2124-09514-00

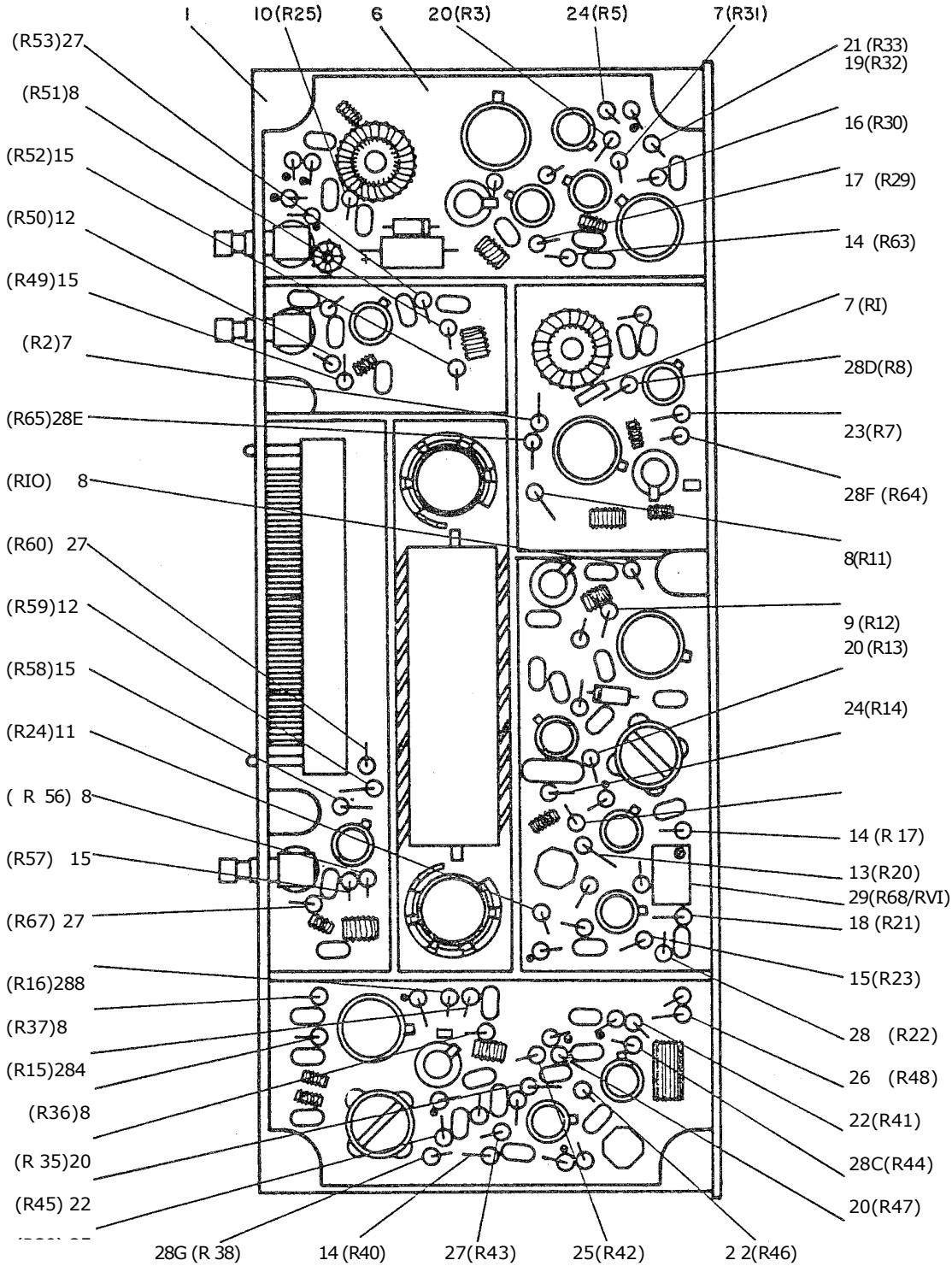

Figure 19. Mixer Assembly, 1A2A1 (Sheet 1 of 4)

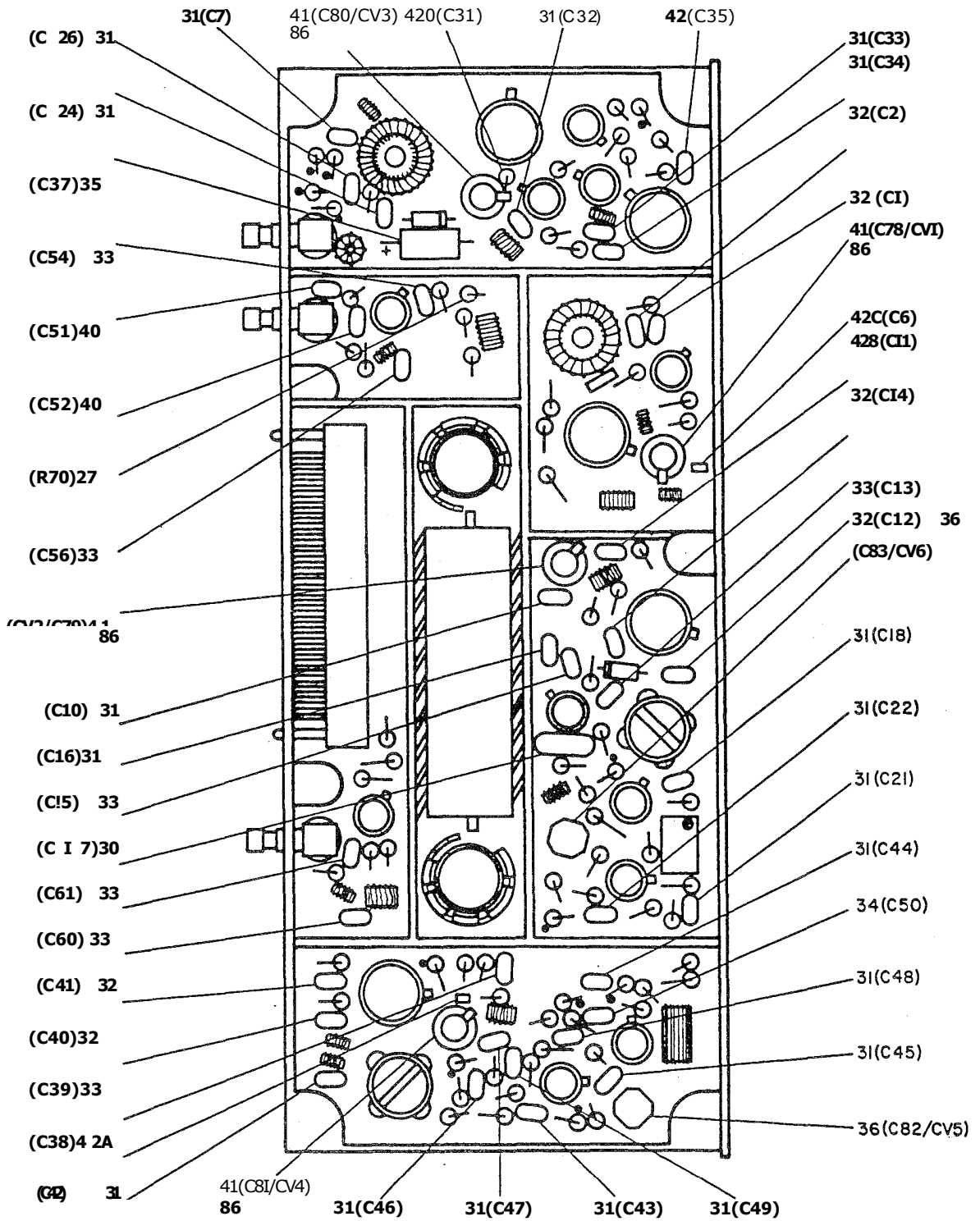

Figure 19. Mixer Assembly, 1A2A1 (Sheet 2 of 4)

SECTION II
 MAINTENANCE PARTS LIST

MA(P)-2124-09514-00

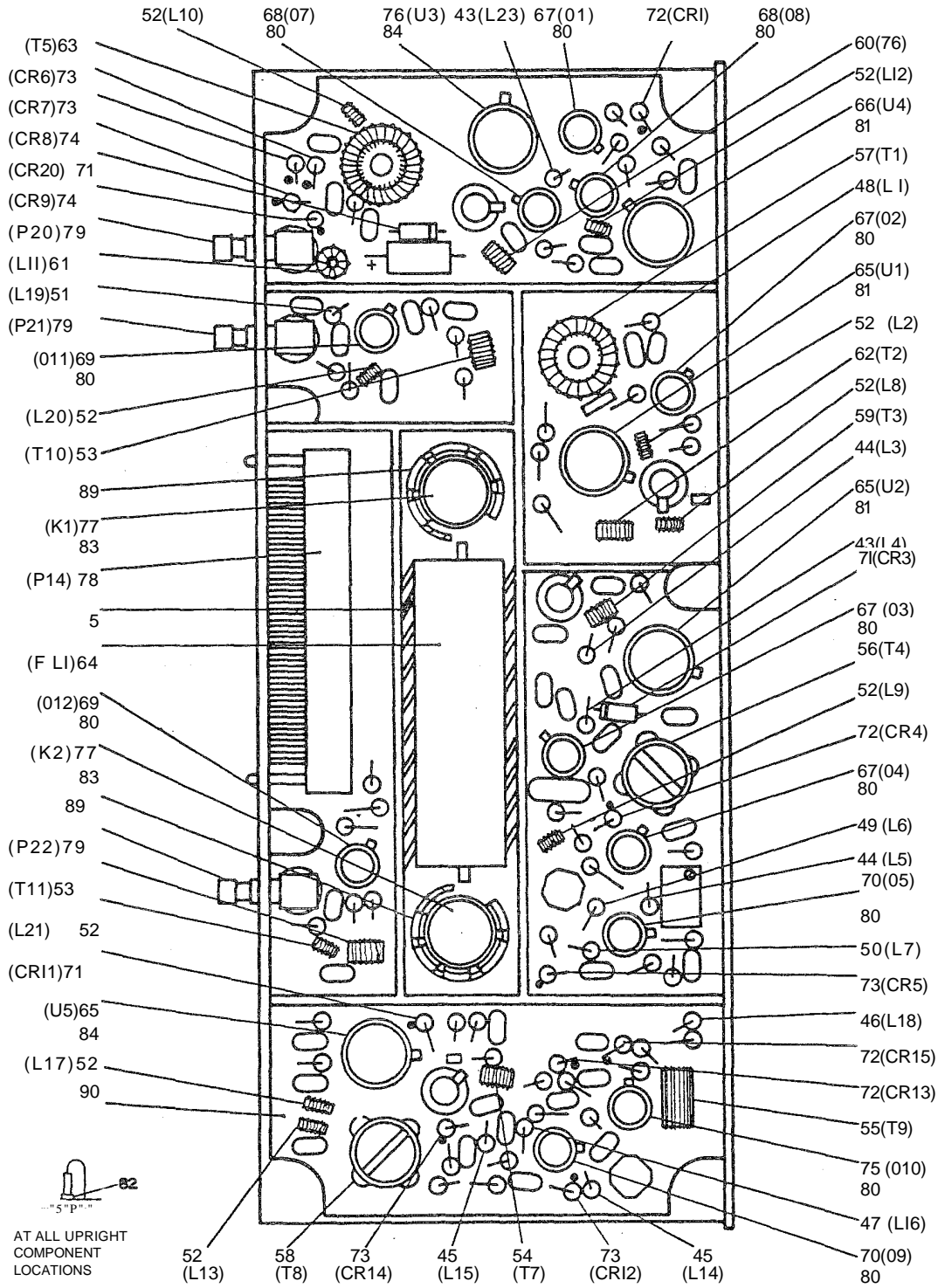

Figure 19. Mixer Assembly, 1A2A1 (Sheet 3 of 4)

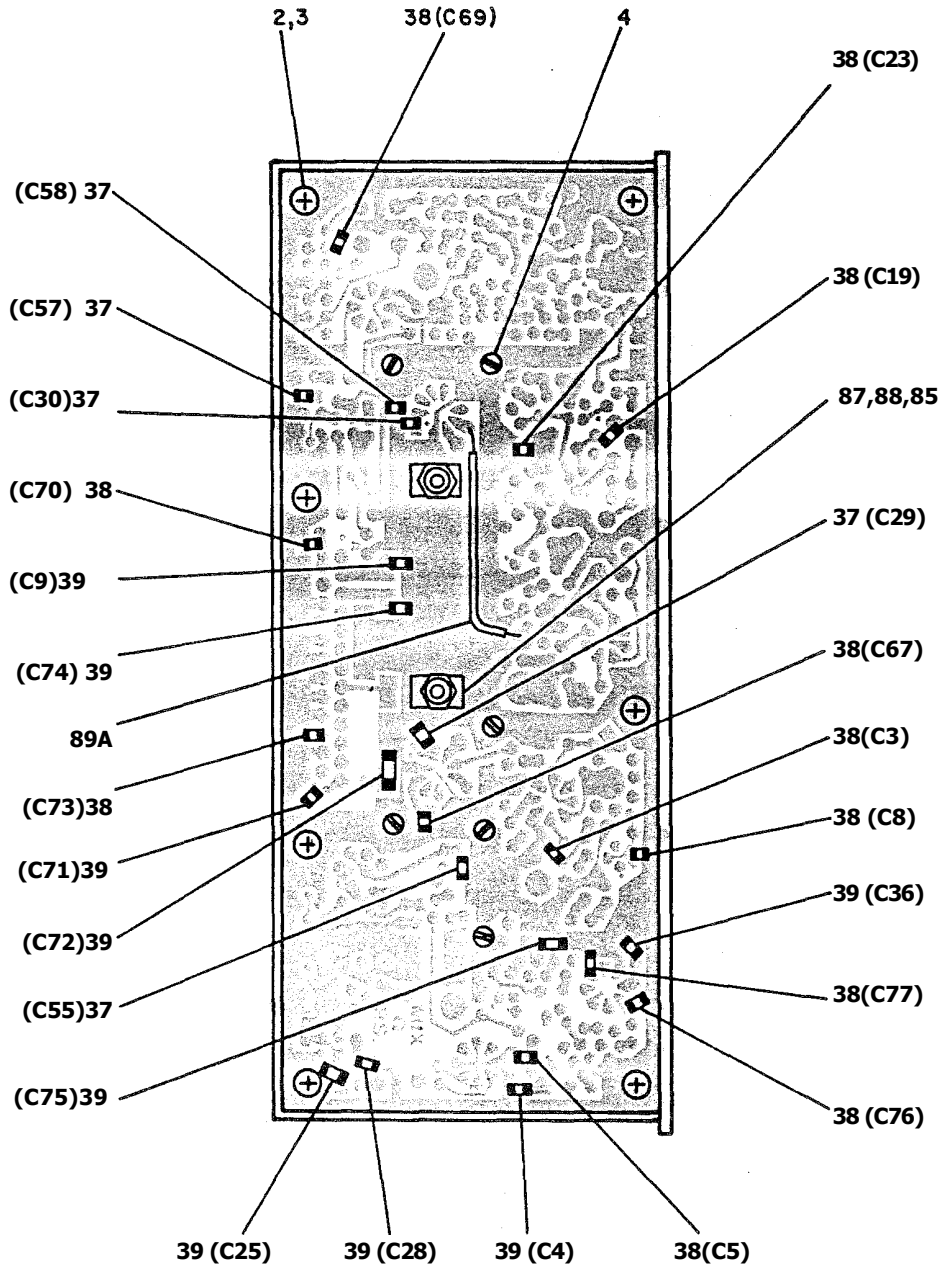

Figure 19, Mixer Assembly, 1A2A1 (Sheet 4 of 4)

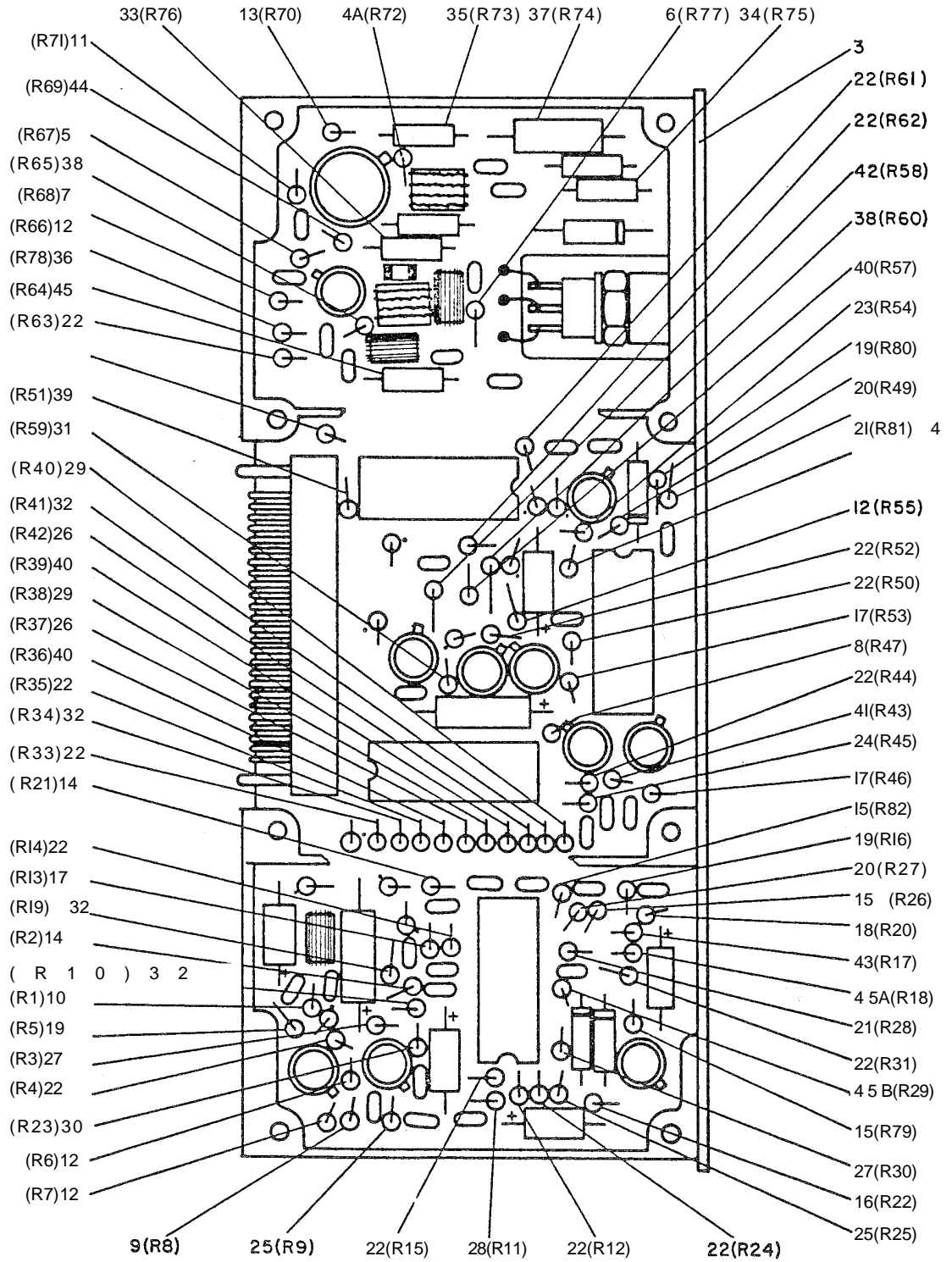

Figure 20, PRE Assembly, 1A2A4 (Sheet 1 of 4)

SECTION II
 MAINTENANCE PARTS LIST

MA(P)-21244)9514-00

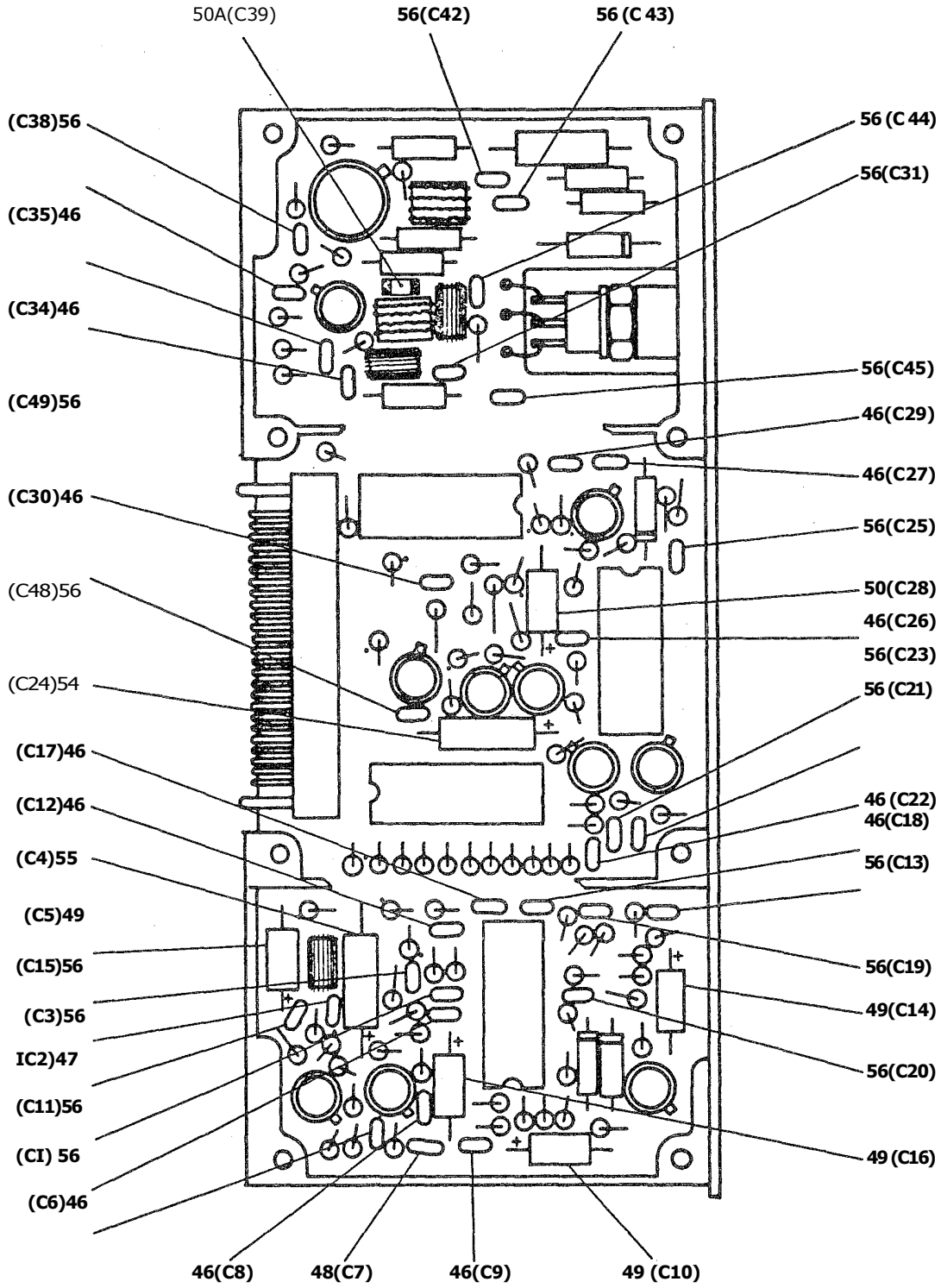

Figure 20. PRE Assembly, 1A2A4 (Sheet 2 of 4)

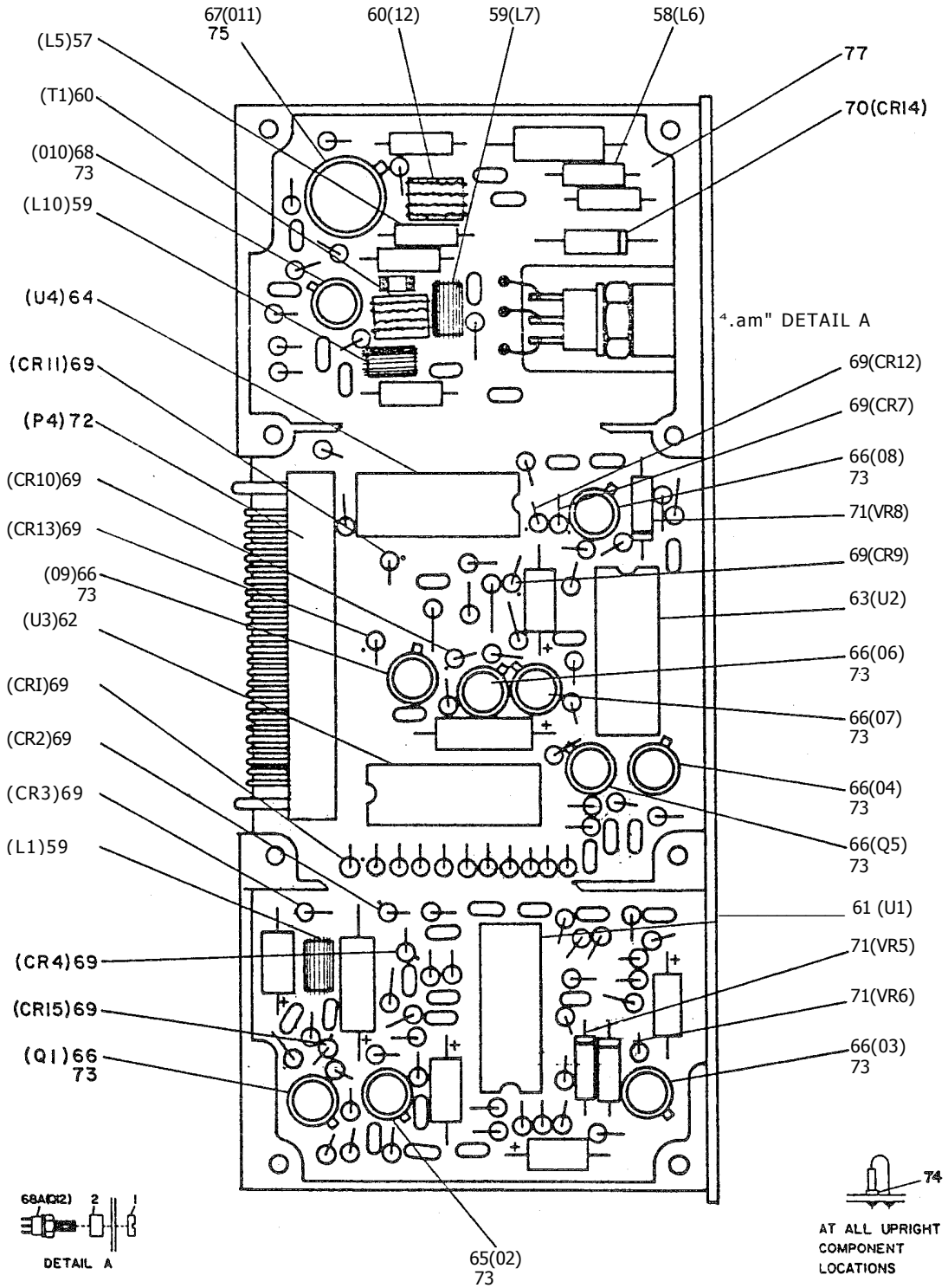

Figure 20, PRE Assembly, 1A2A4 (Sheet 3 of 4)

SECTION II
MAINTENANCE PARTS LIST

MA(P)-2124-09514-00

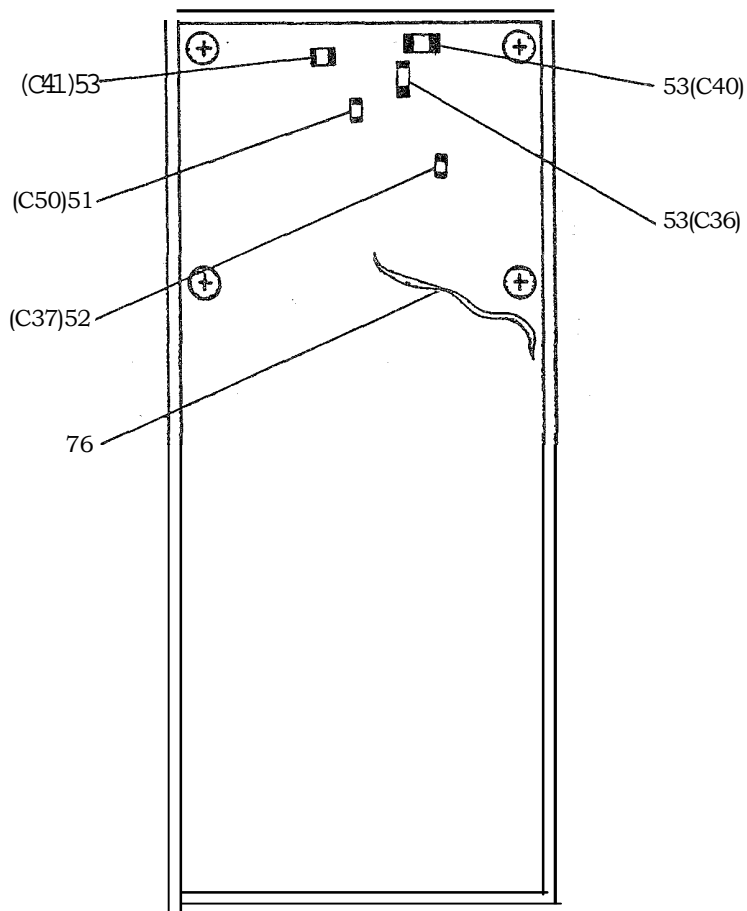

Figure 20. PRE Assembly, 1A2A4 (Sheet 4 of 4)

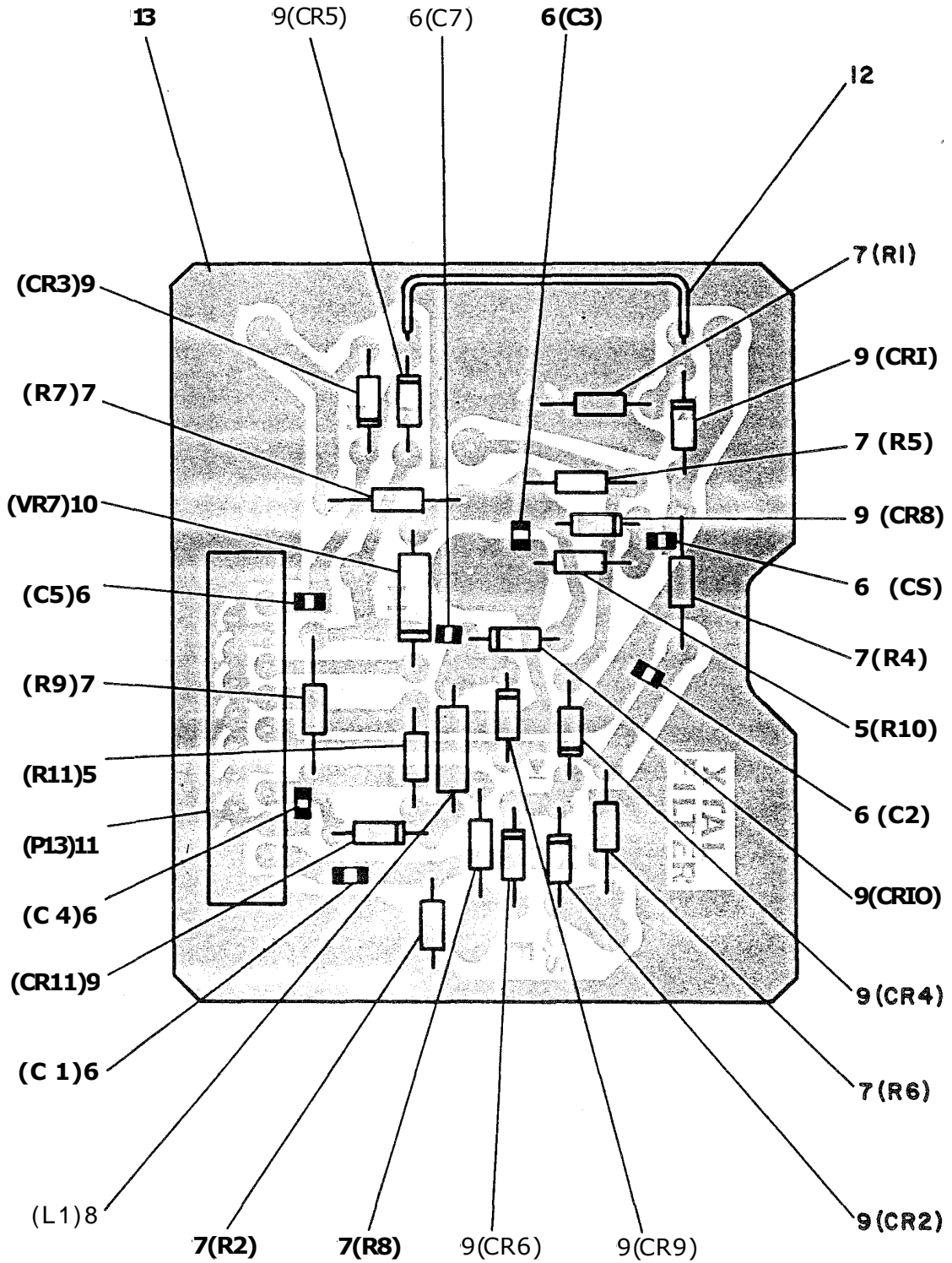

Figure 21. Filter Assembly, 1A2A5 (Sheet 1 of 2)

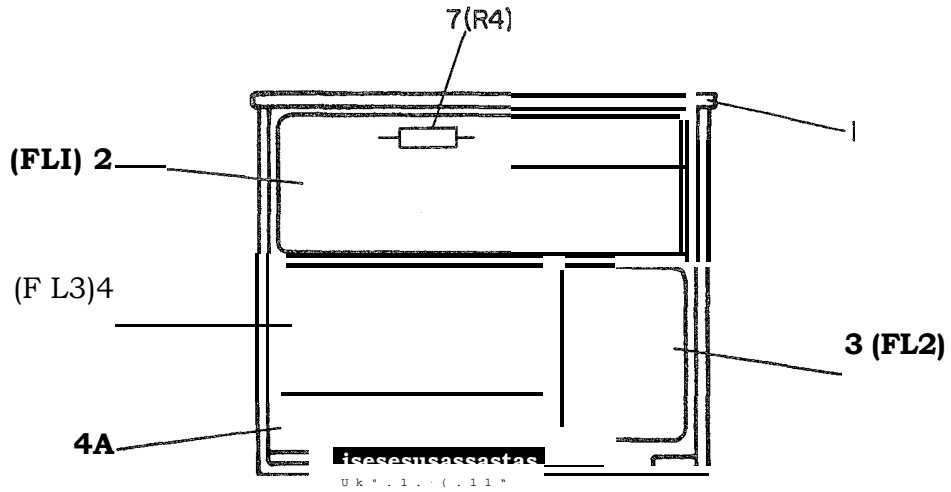

Figure 21. Filter Assembly, 1A2A5 (Sheet 2 of 2)

SECTION II
 MAINTENANCE PARTS LIST

MA (P) -2124-09514-00

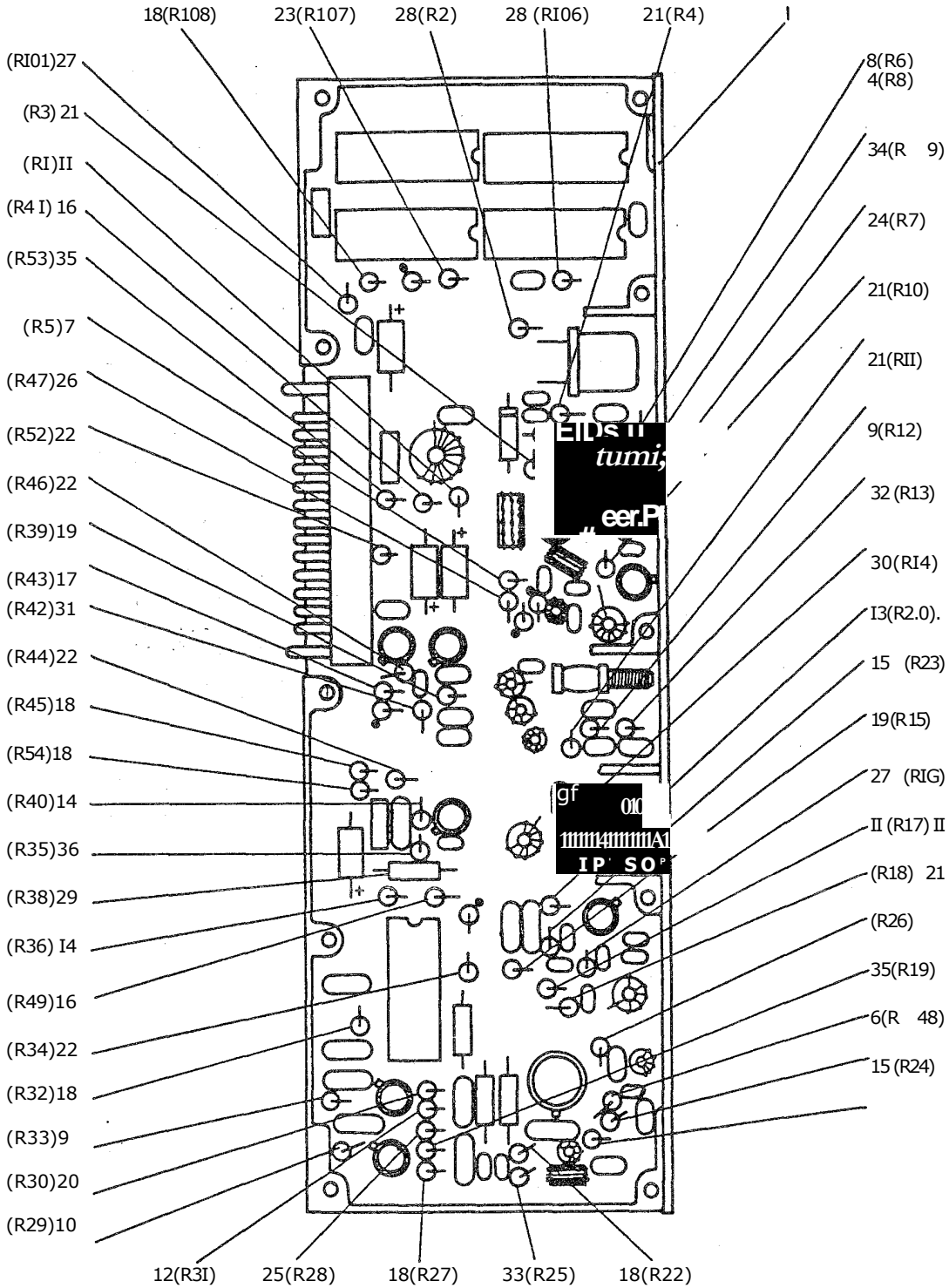

Figure 22. SUM Assembly, 1A3A5 (Sheet 1 of 4)

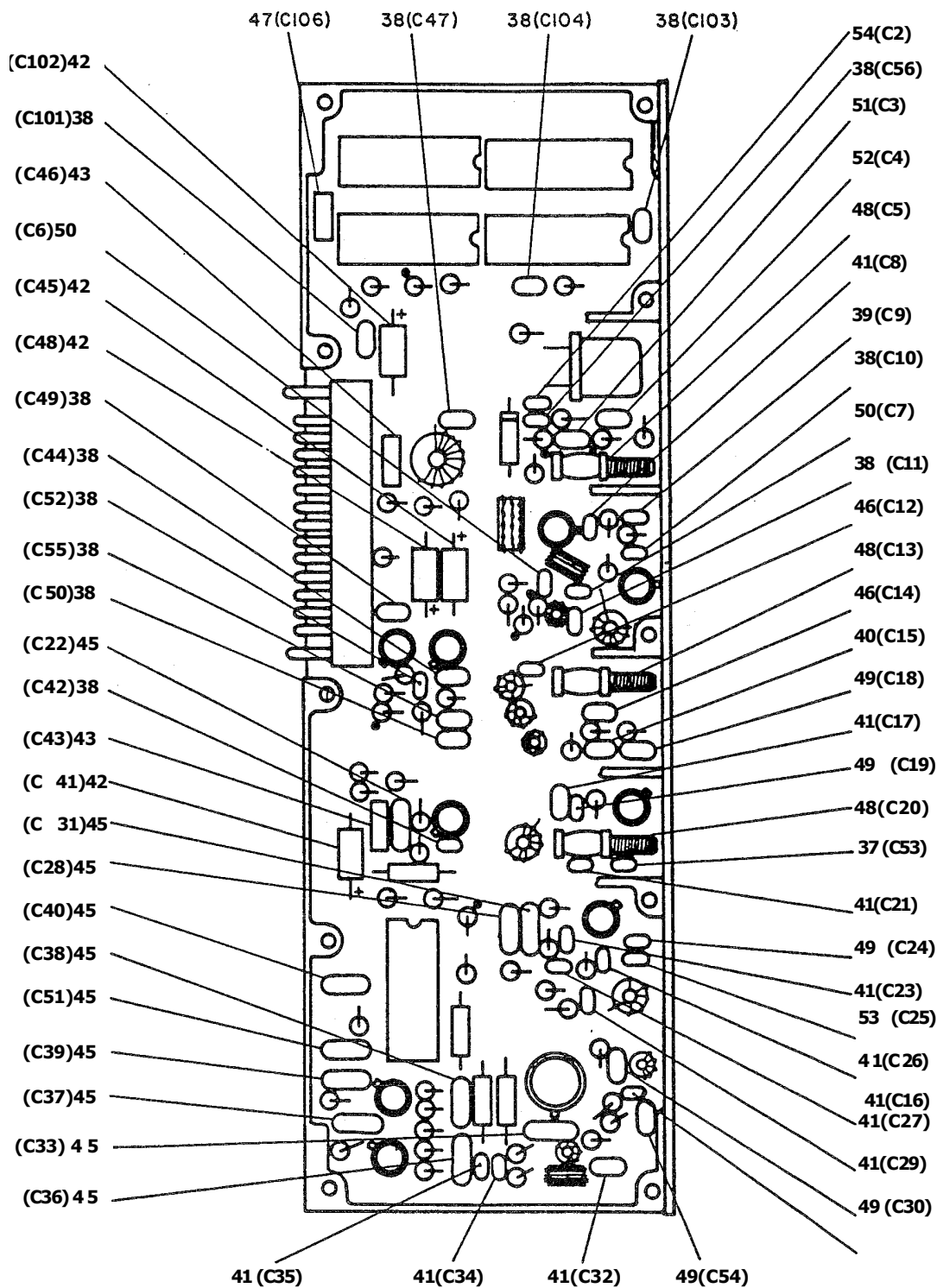

Figure 22. SUM Assembly, 1A3A5 (Sheet 2 of 4)

SECTION II
 MAINTENANCE PARTS LIST

OMA(P)-2124-09514-00

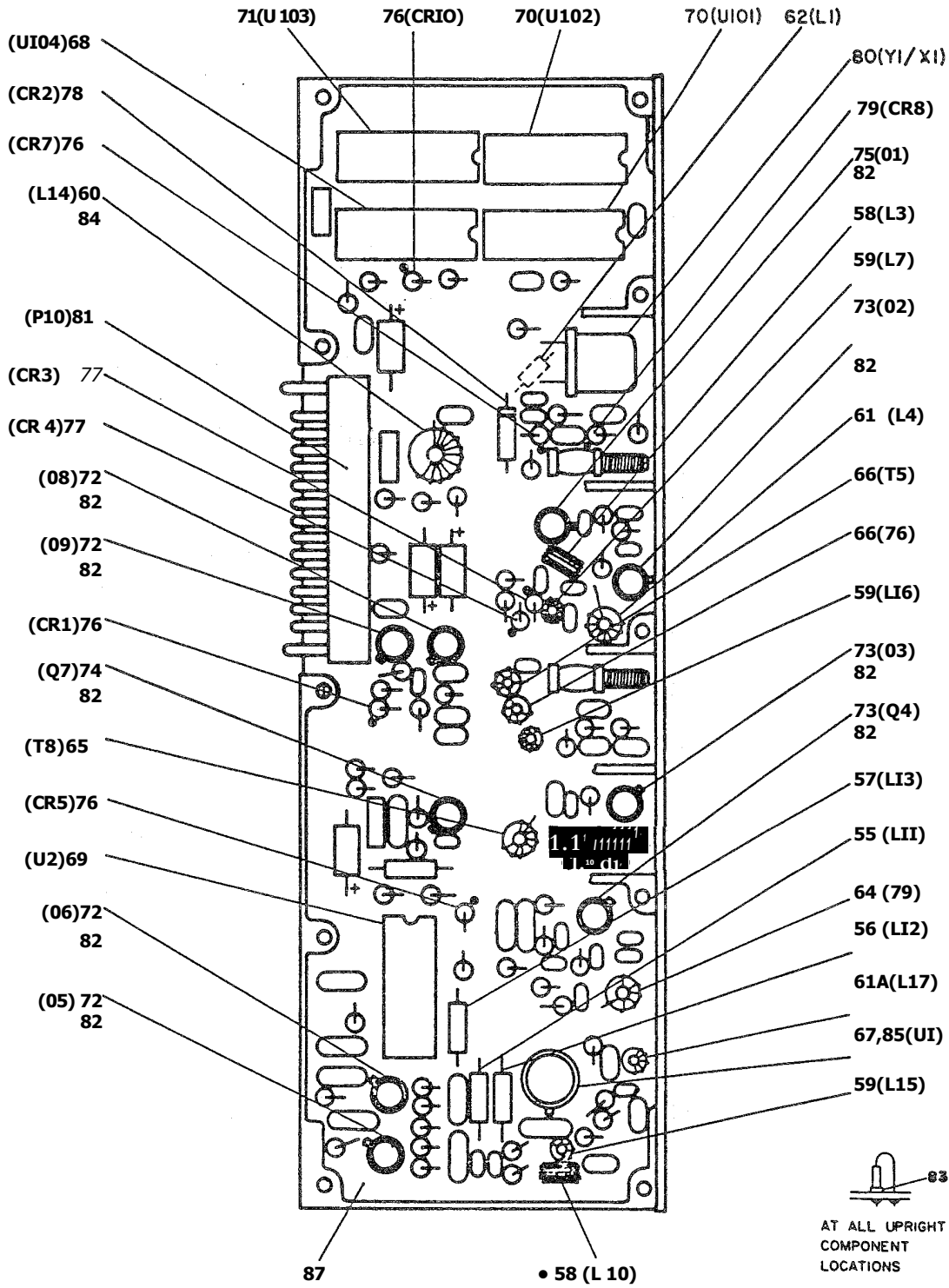

Figure 22. SUM Assembly, 1A3A5 (Sheet 3 of 4)

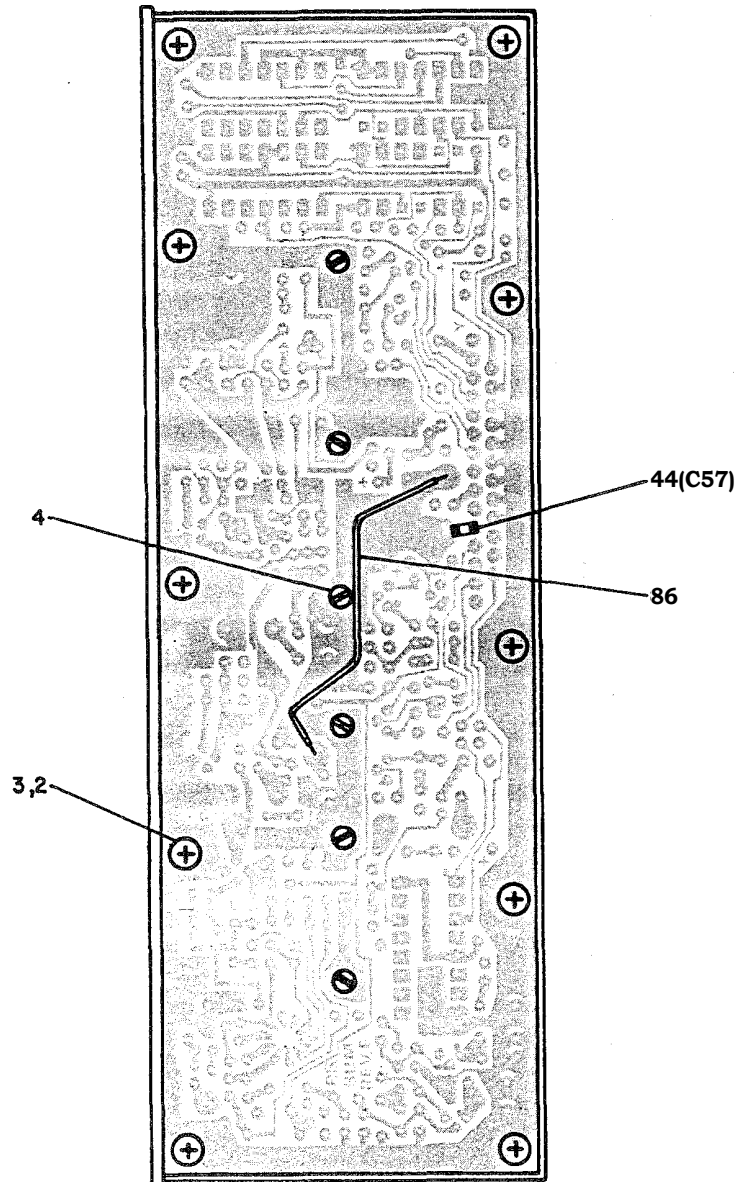

Figure 22. SUM Assembly, 1A3A5 (Sheet 4 of 4)

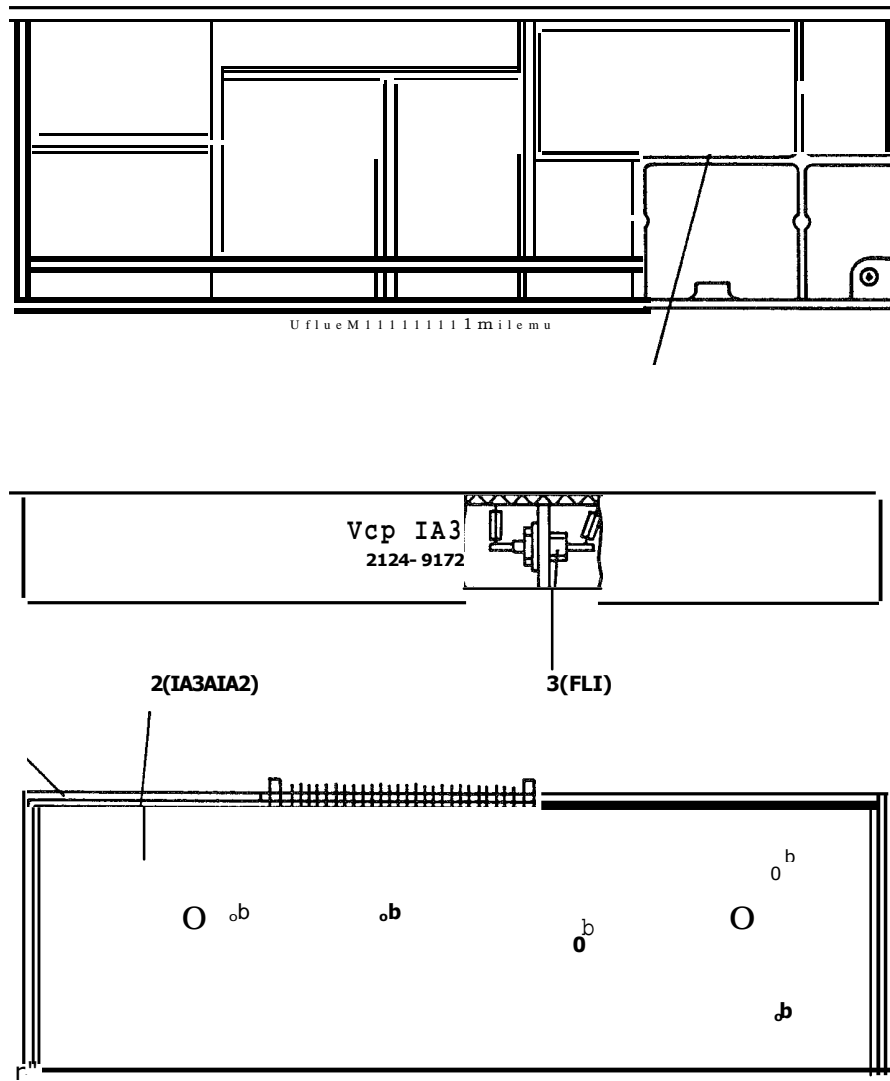

Figure 231 VCS' Assembly, 1A3A1

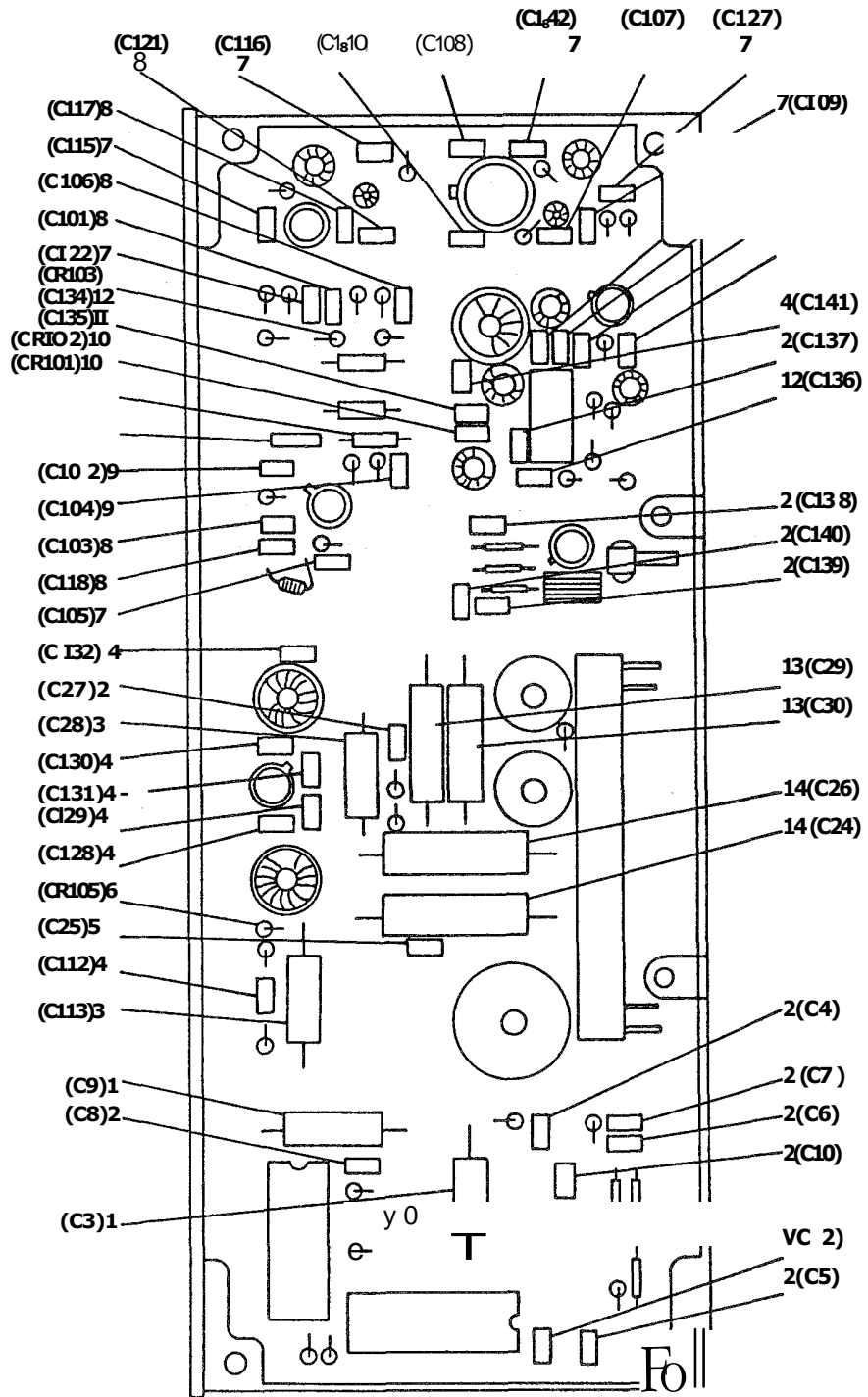

Figure 24, VCP PC Board Assembly, 1A3A1A2 (Sheet 1 of 3)

SECTION II
 MAINTENANCE PARTS LIST

MA(P) -2124-09514-00

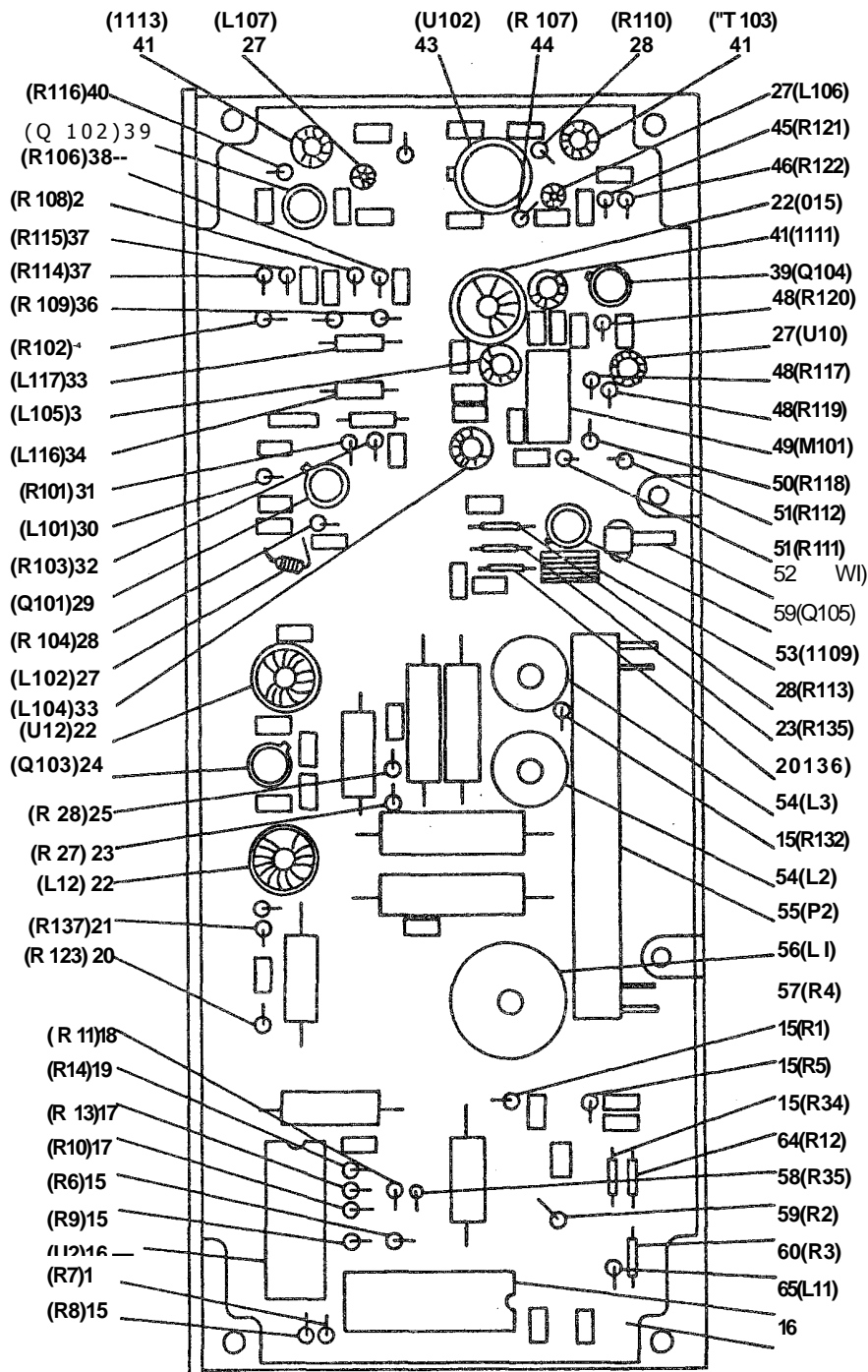

Figure 24, VCP PC Board Assembly, 1A3A1A2 (Sheet 2 of 3)

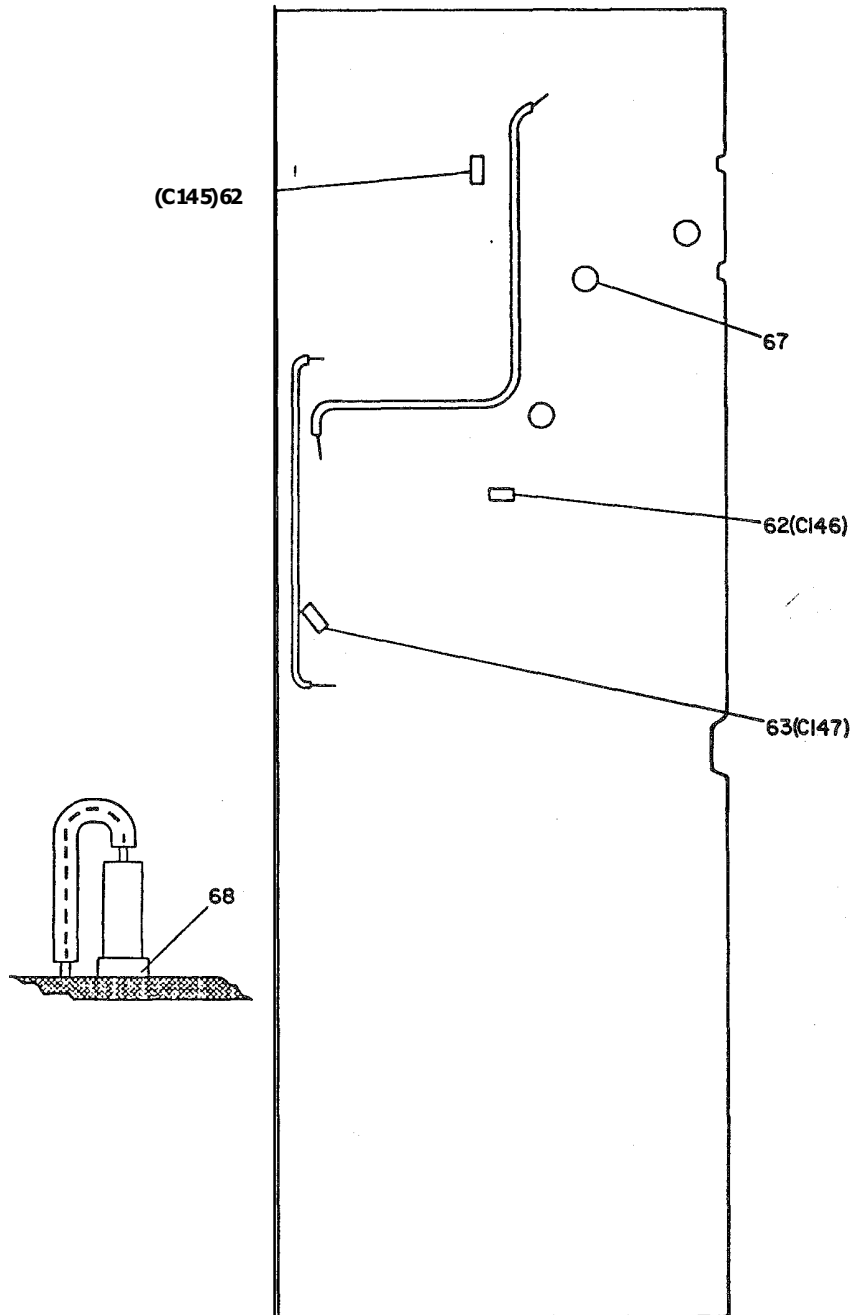

Figure 24. VCP PC Board Assembly, 1A3A1A2 (Sheet 3 of 3)

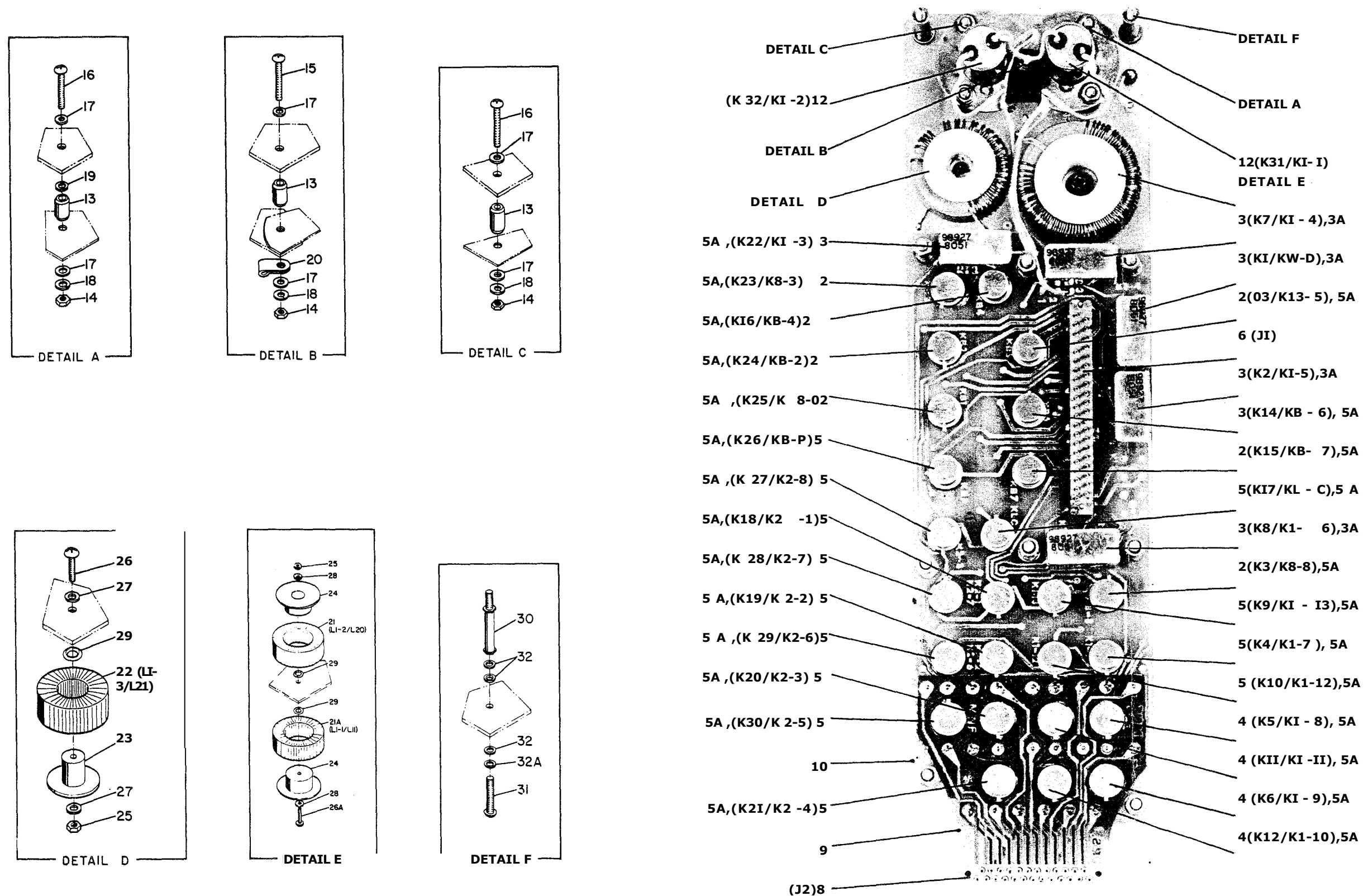

Figure 26. MN Assembly, 1A5A1 (Sheet 1 of 2)

SECTION II
 MAINTENANCE PARTS LIST

MA(P)-2124-09514-00

66(L 4/L1-10)

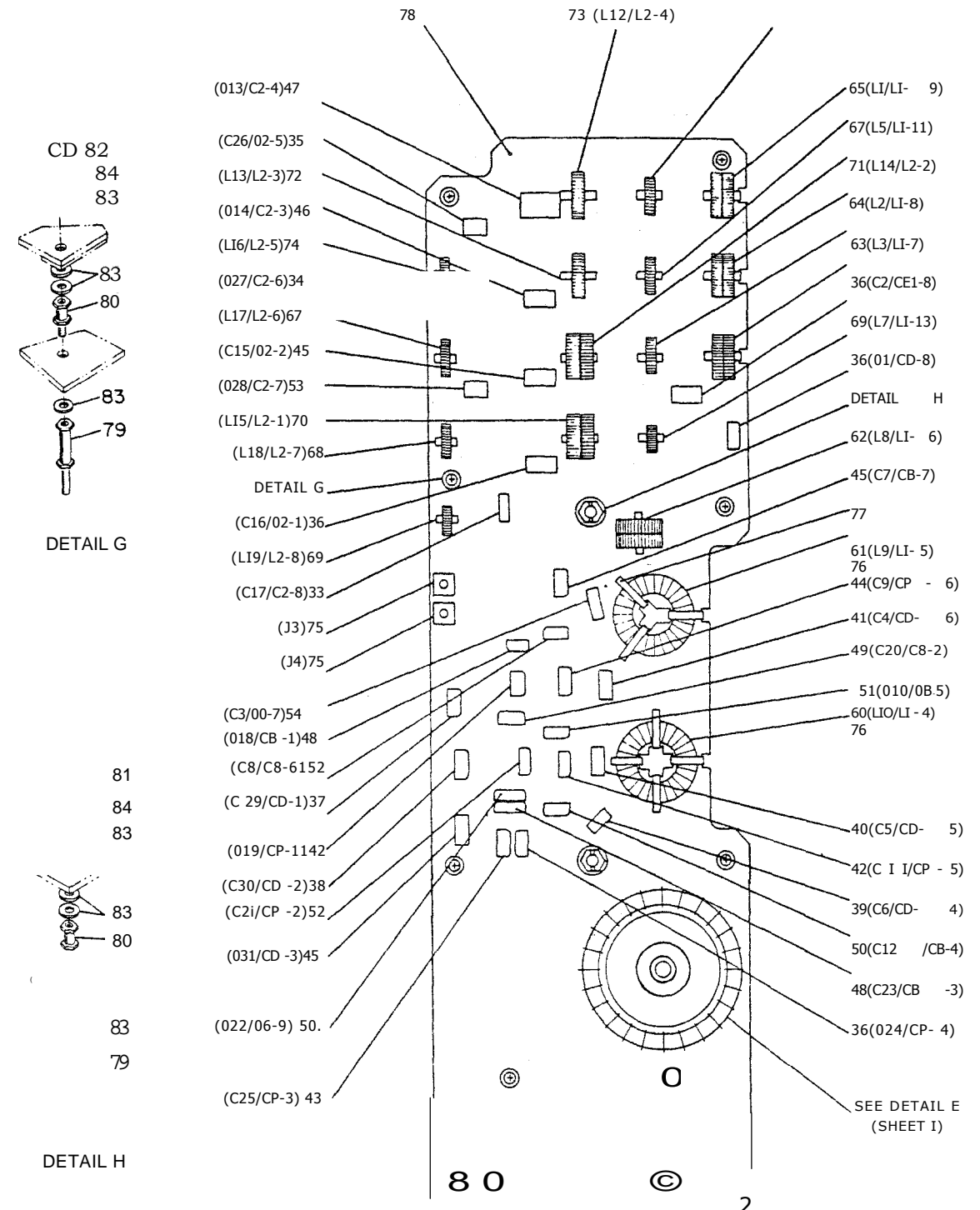

Figure 26. DIN Assembly, 1A5A1 (Sheet 2 of 2)

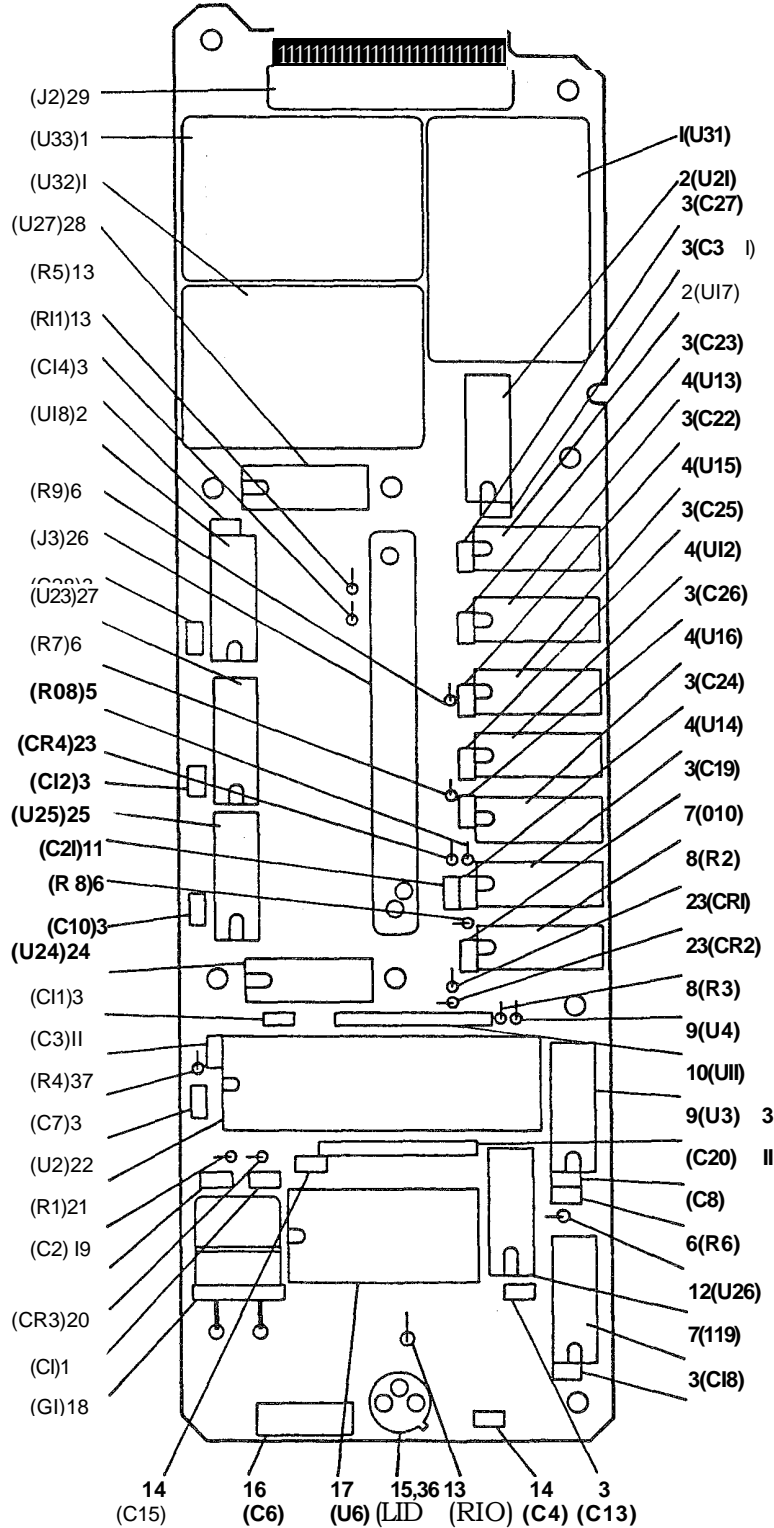

Figure 27, Lord PC Board Assembly, 1A5A2 (Sheet 1 of 2)

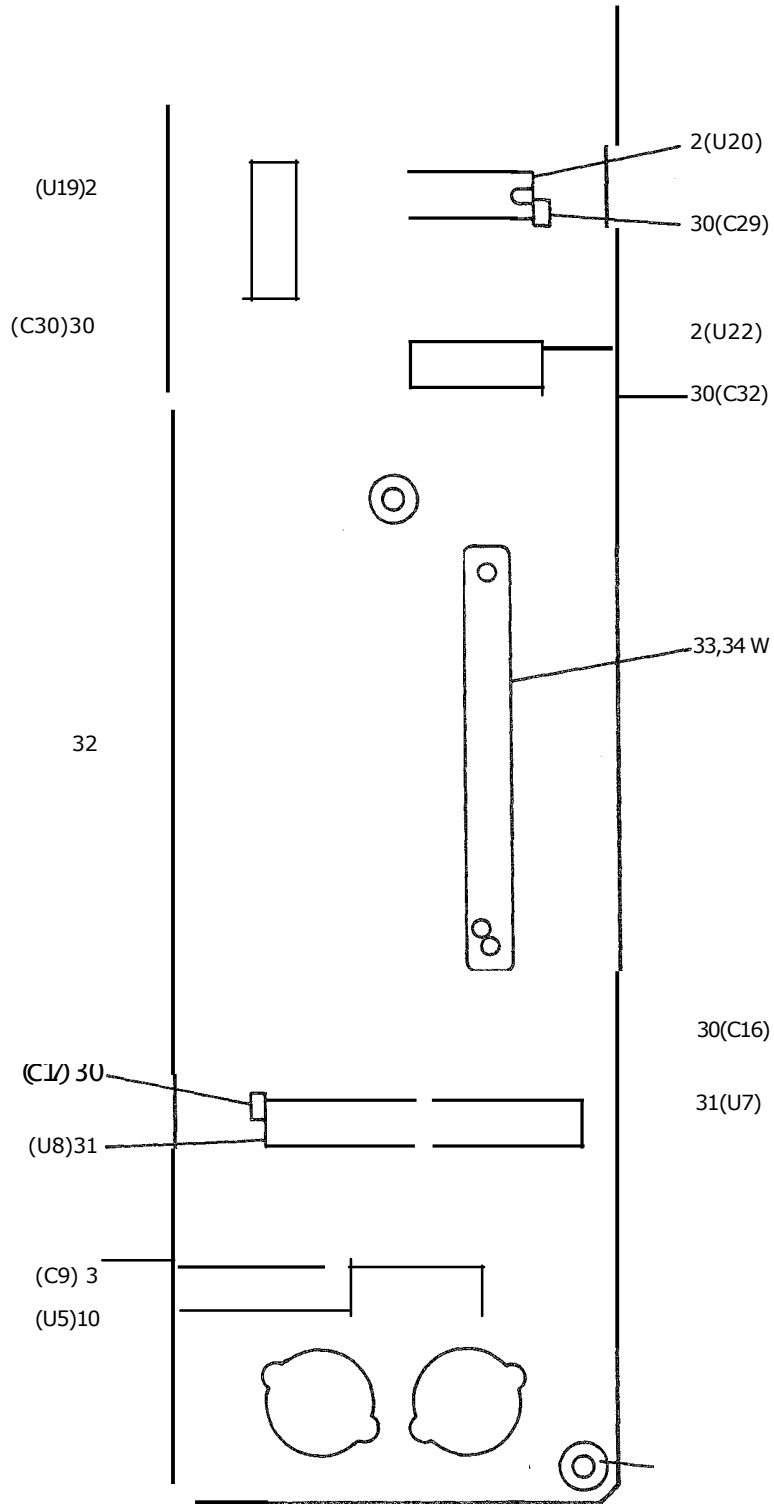

Figure 27. Lord PC Board Assembly, 1A5A2 (Sheet 2 of 2)

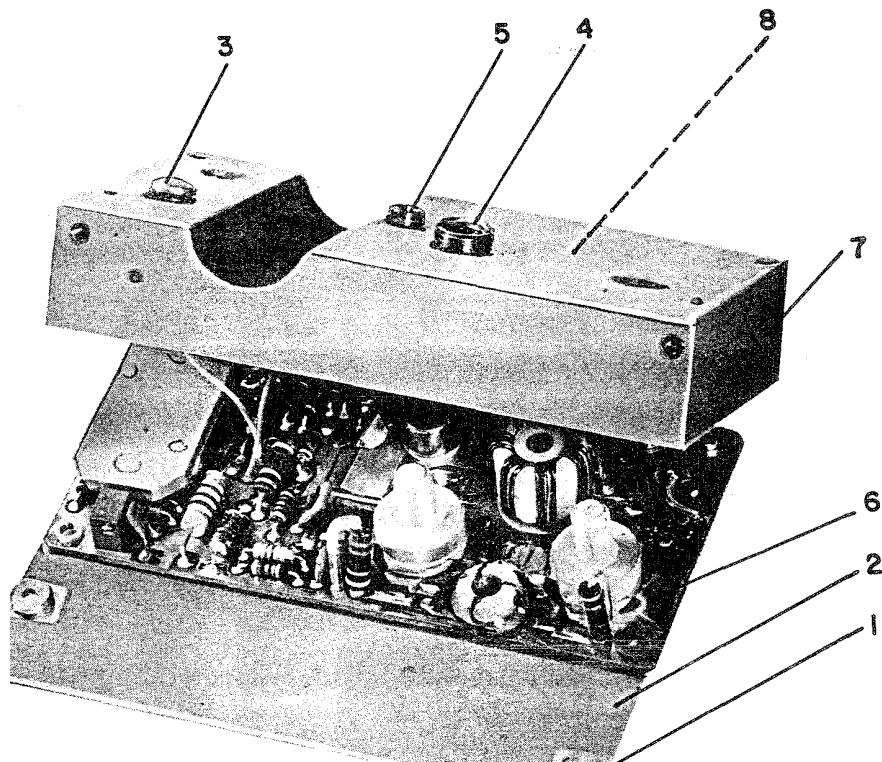
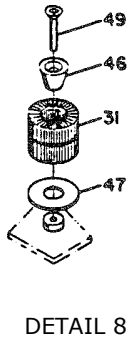
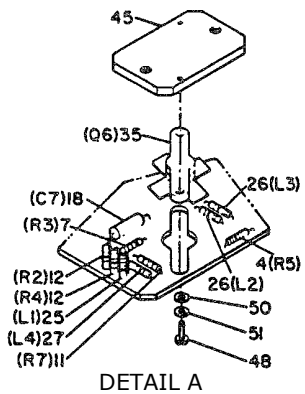
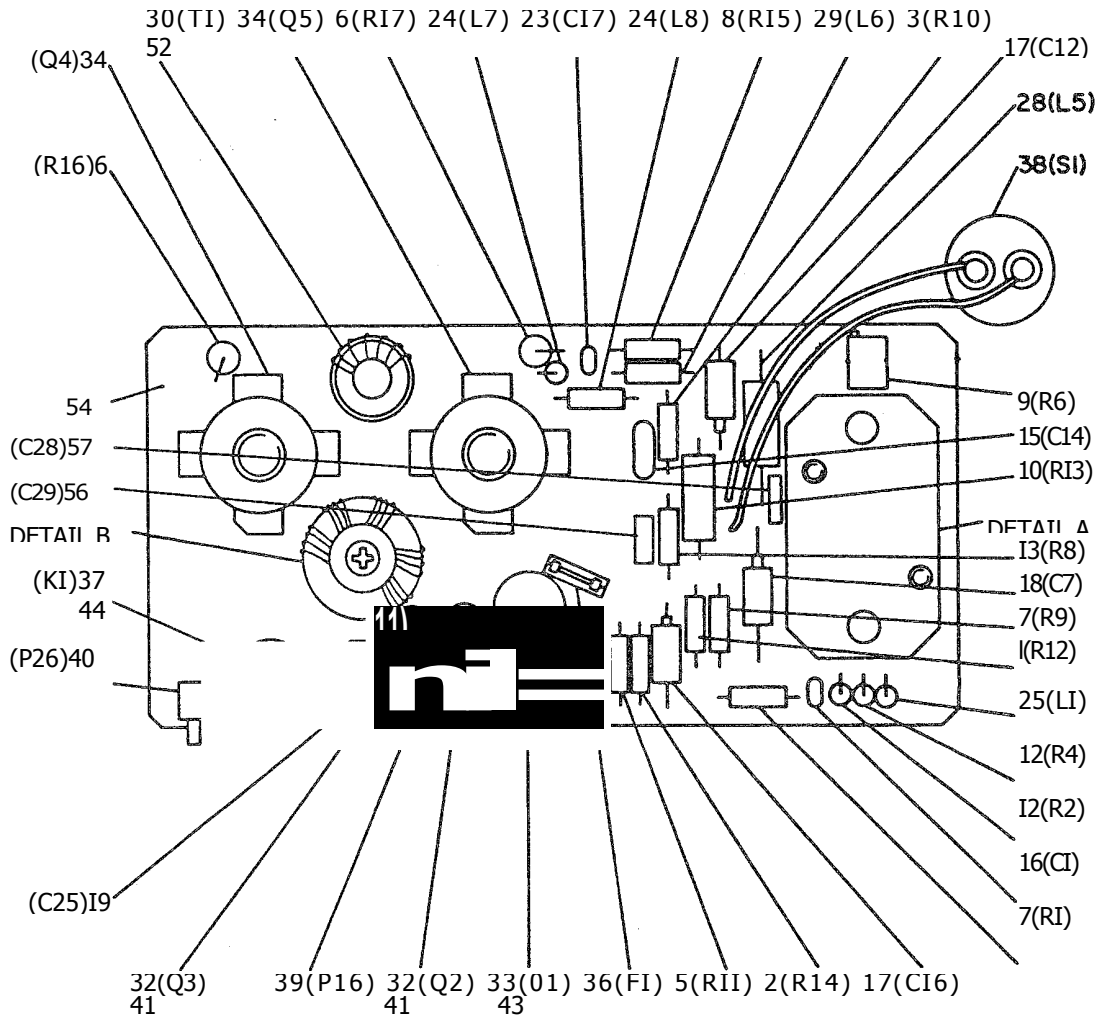

Figure 28, PA Assembly, 1A6

SECTION II
 MAINTENANCE PARTS LIST

MA(P)-2124-09514-00



11- 42

AT ALL UPRIGHT
 COMPONENT
 LOCATIONS

Figure 29. PA PC Board Assembly, (Sheet 1 of 2)

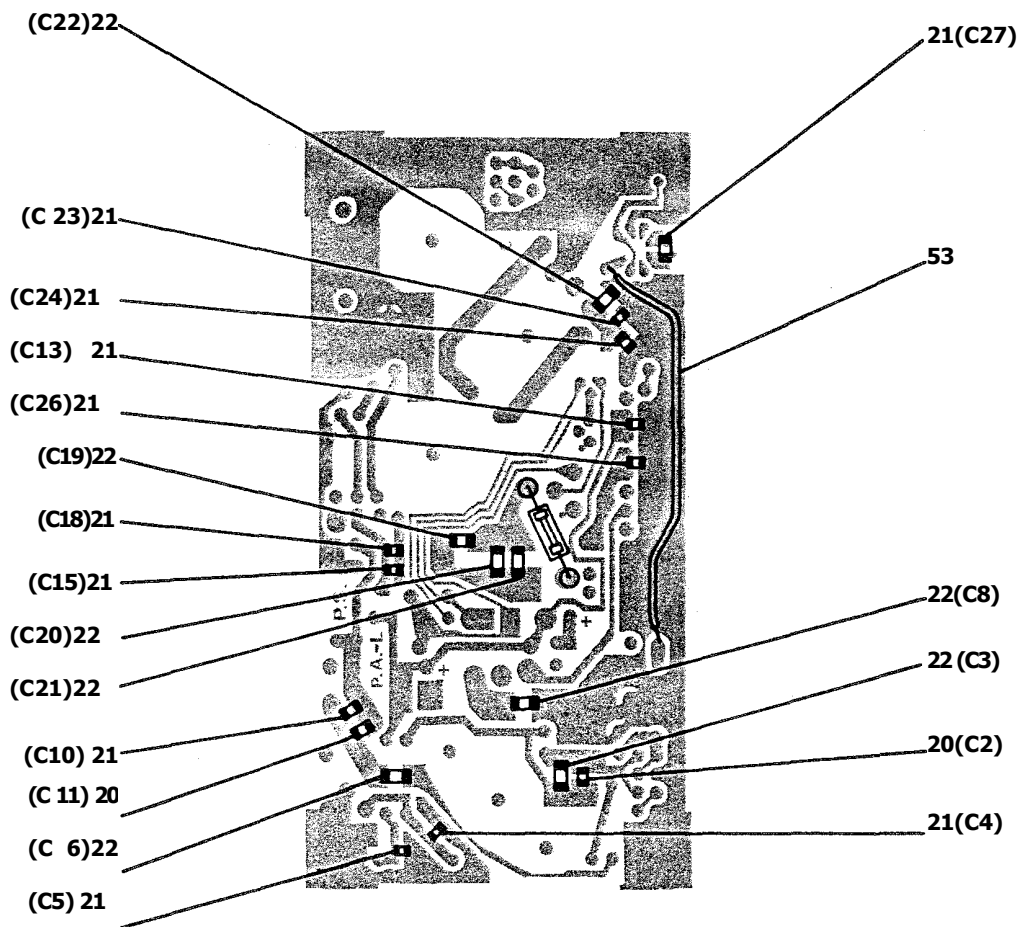

Figure 29. PA PC Board Assembly, (Sheet 2 of 2)

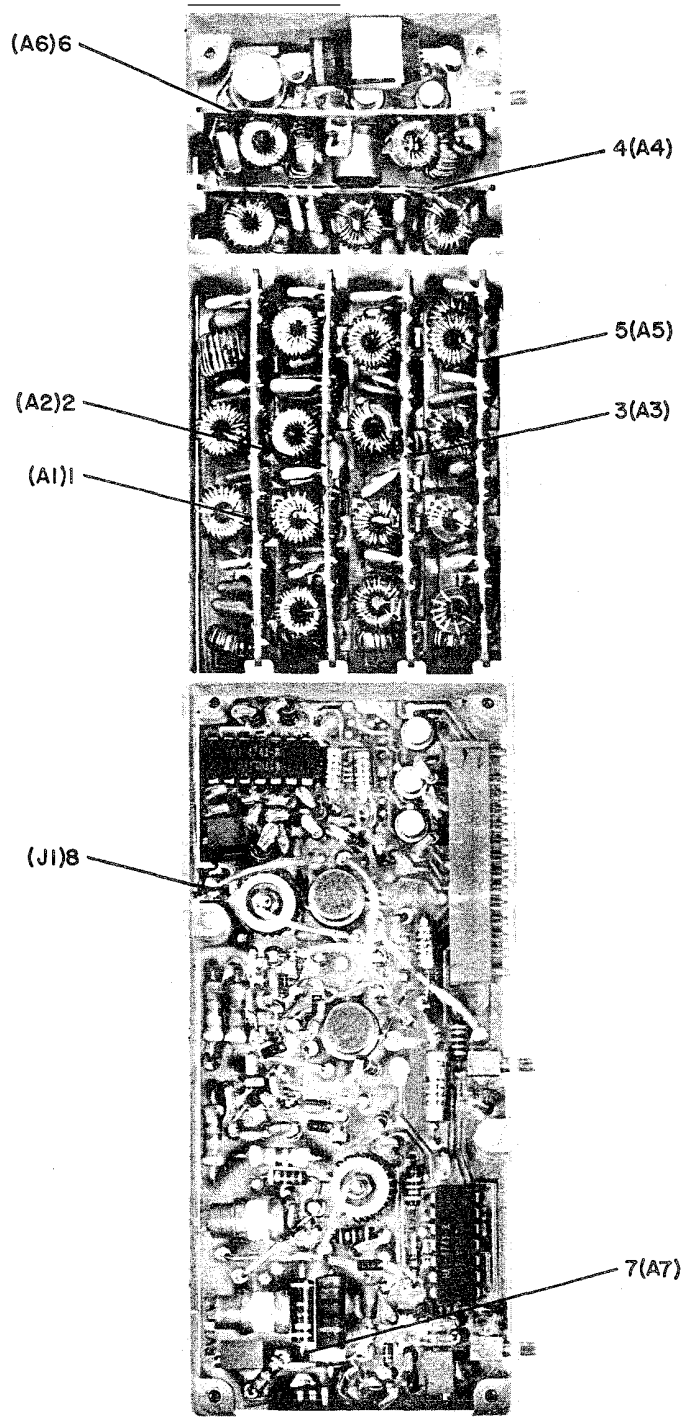

Figure 30. SNF Assembly, 1A5A3

SECTION II
 MAINTENANCE PARTS LIST

MA(P) -2124-09514 -00

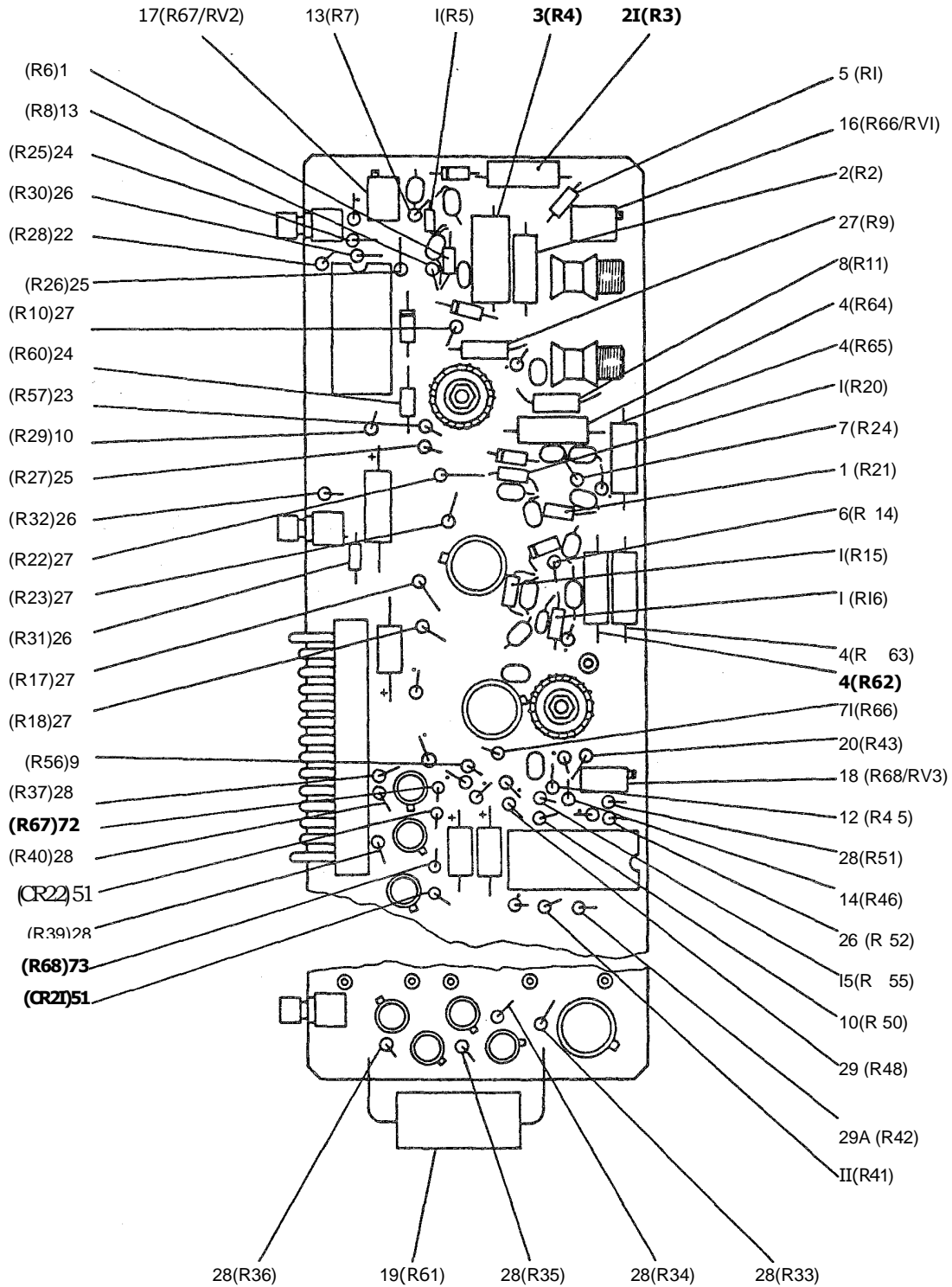

Figure 31. PC Board Assembly, 1A5A3A7 (Sheet 1 of 3)

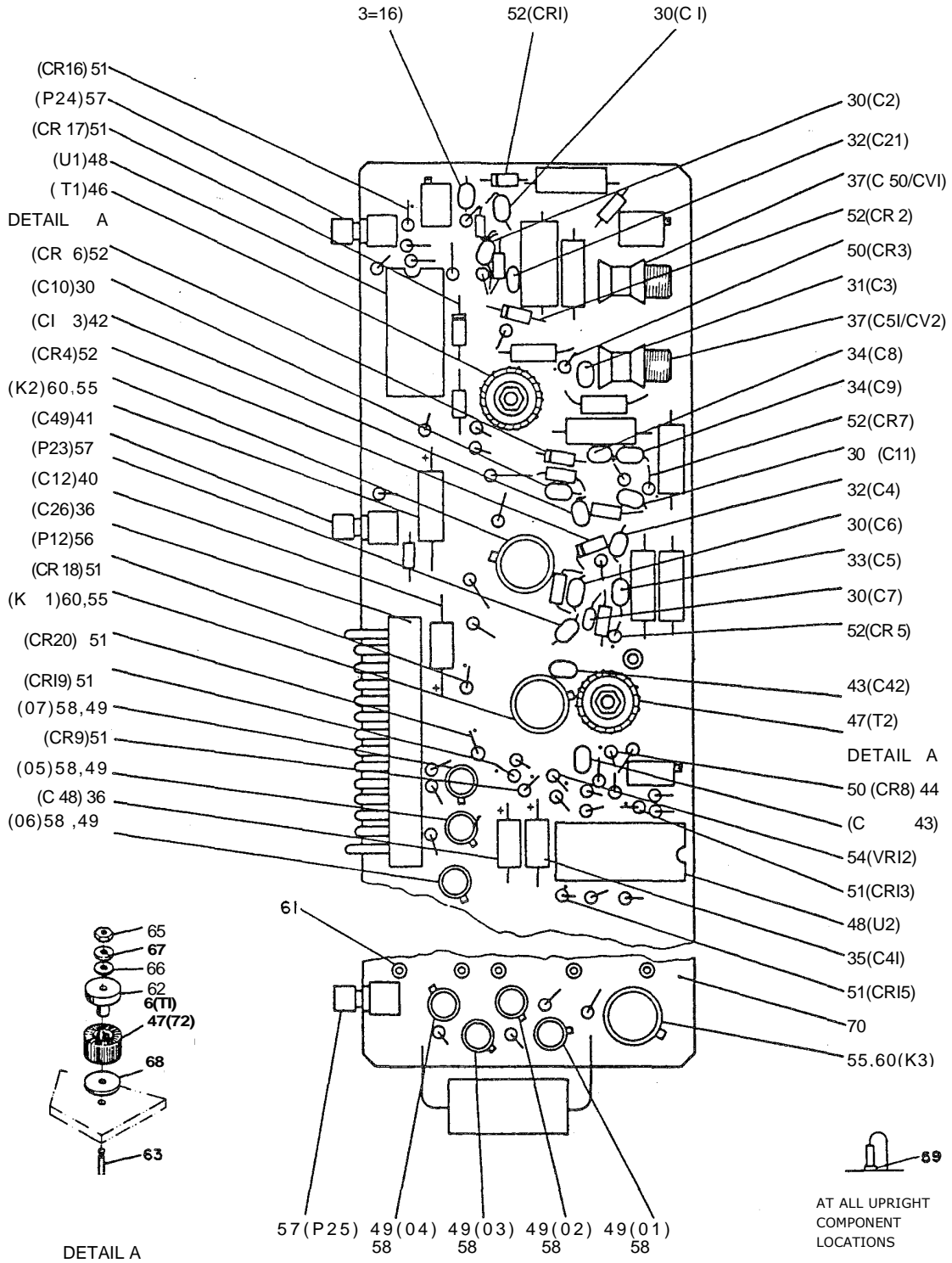

Figure 31. PC Board Assembly, 1A5A3A7 (Sheet 2 of 3)

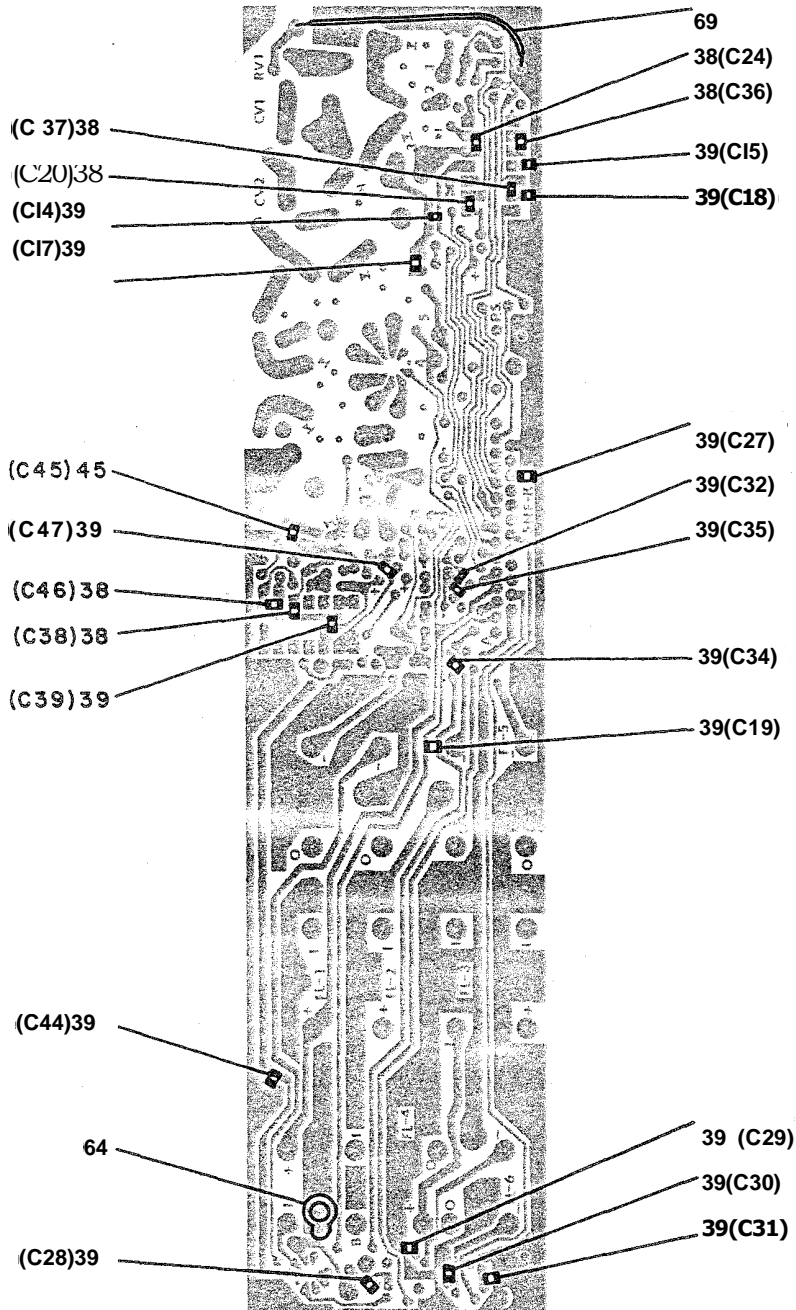

Figure 31, PC Board Assembly, 1A5A3A7 (Sheet 3 of 3)

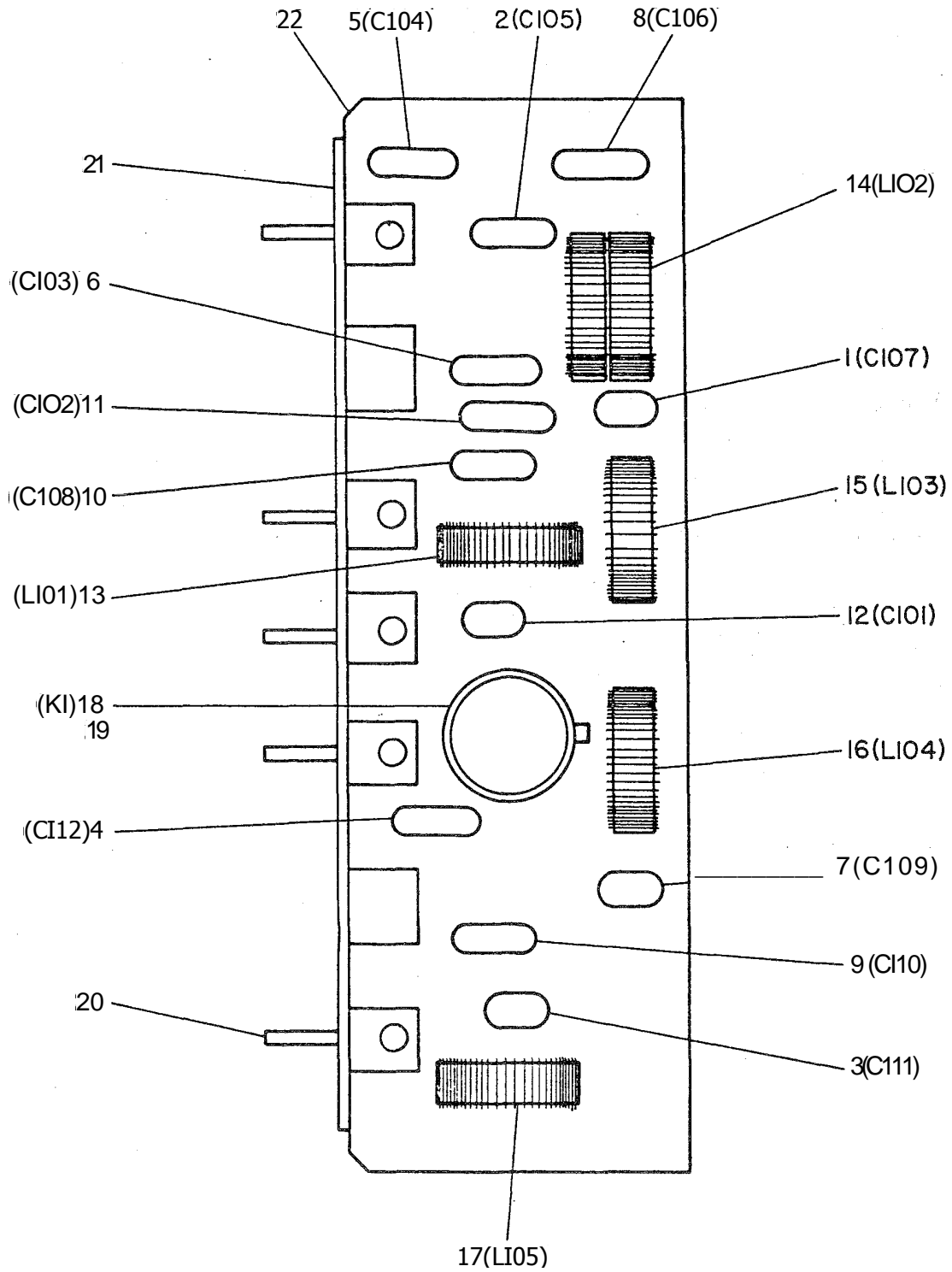

Figure 32. PC Board Assembly, 1A5A3A1 (FLU)

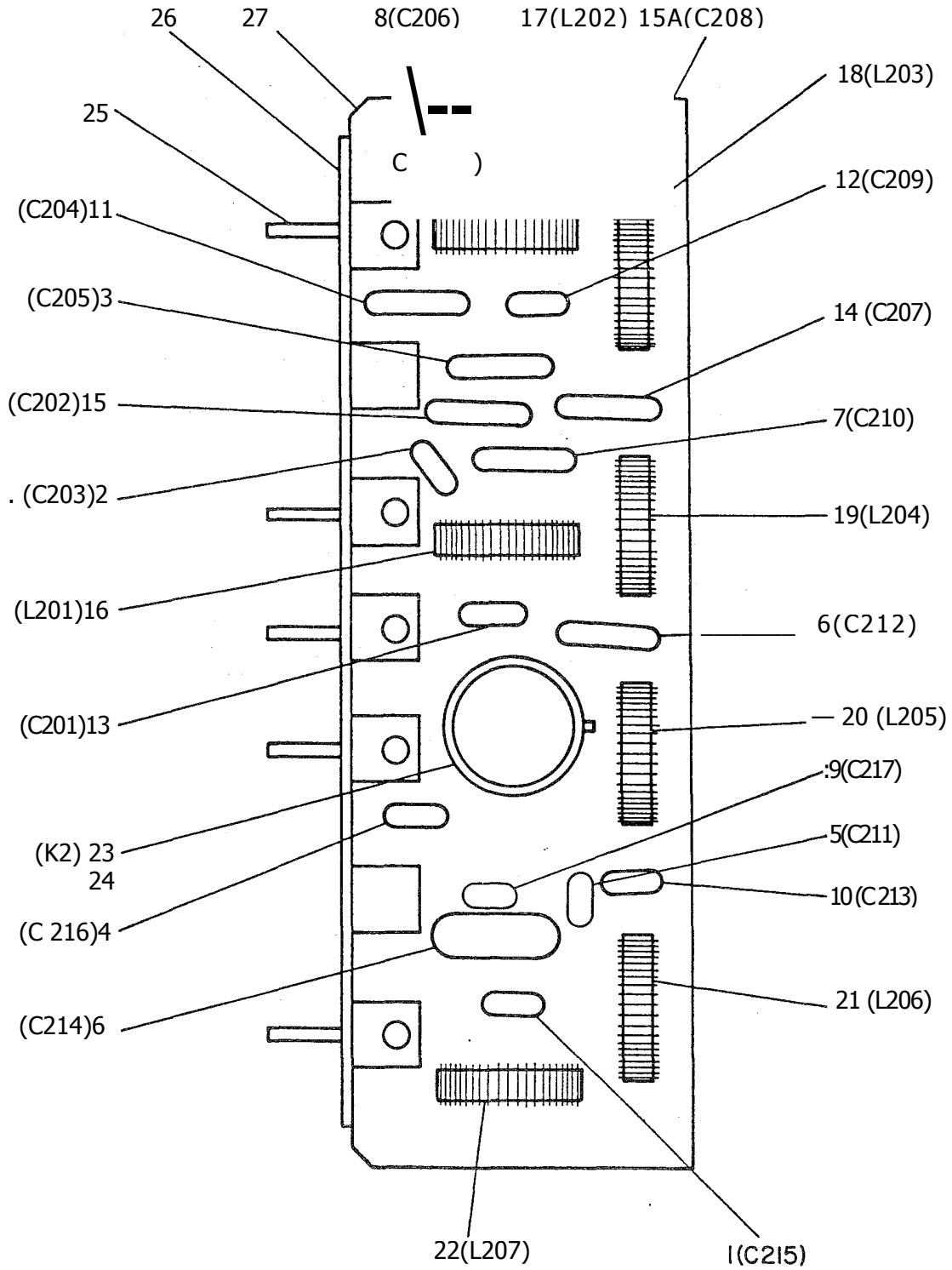

Figure 33. PC Board Assembly, 1A5A3A2 (FL2)

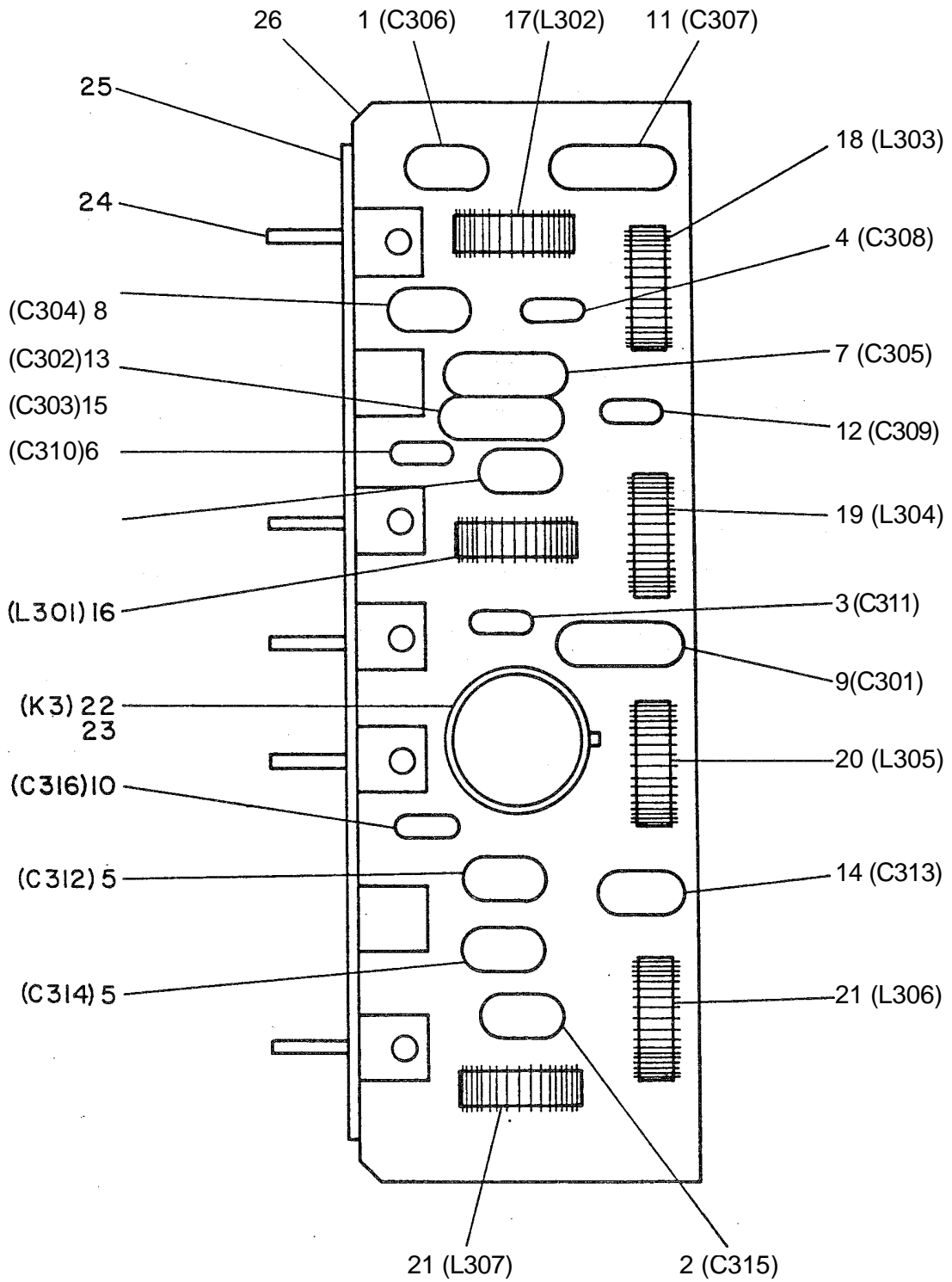

Figure 34, PC Board Assembly, 1A5A3A3 (FL3)

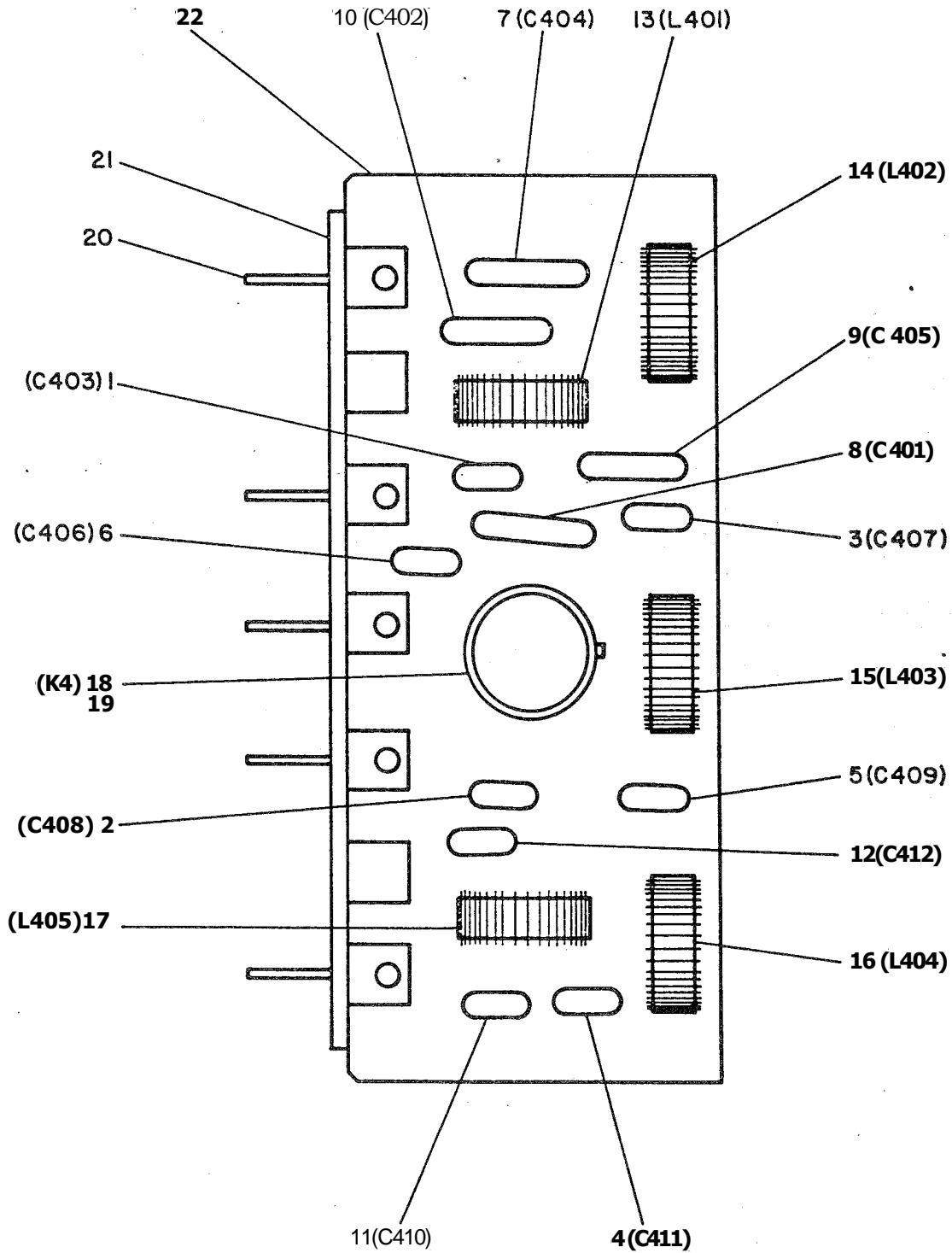

Figure 35. PC Board Assembly, 1A5A3A4 (FL4)

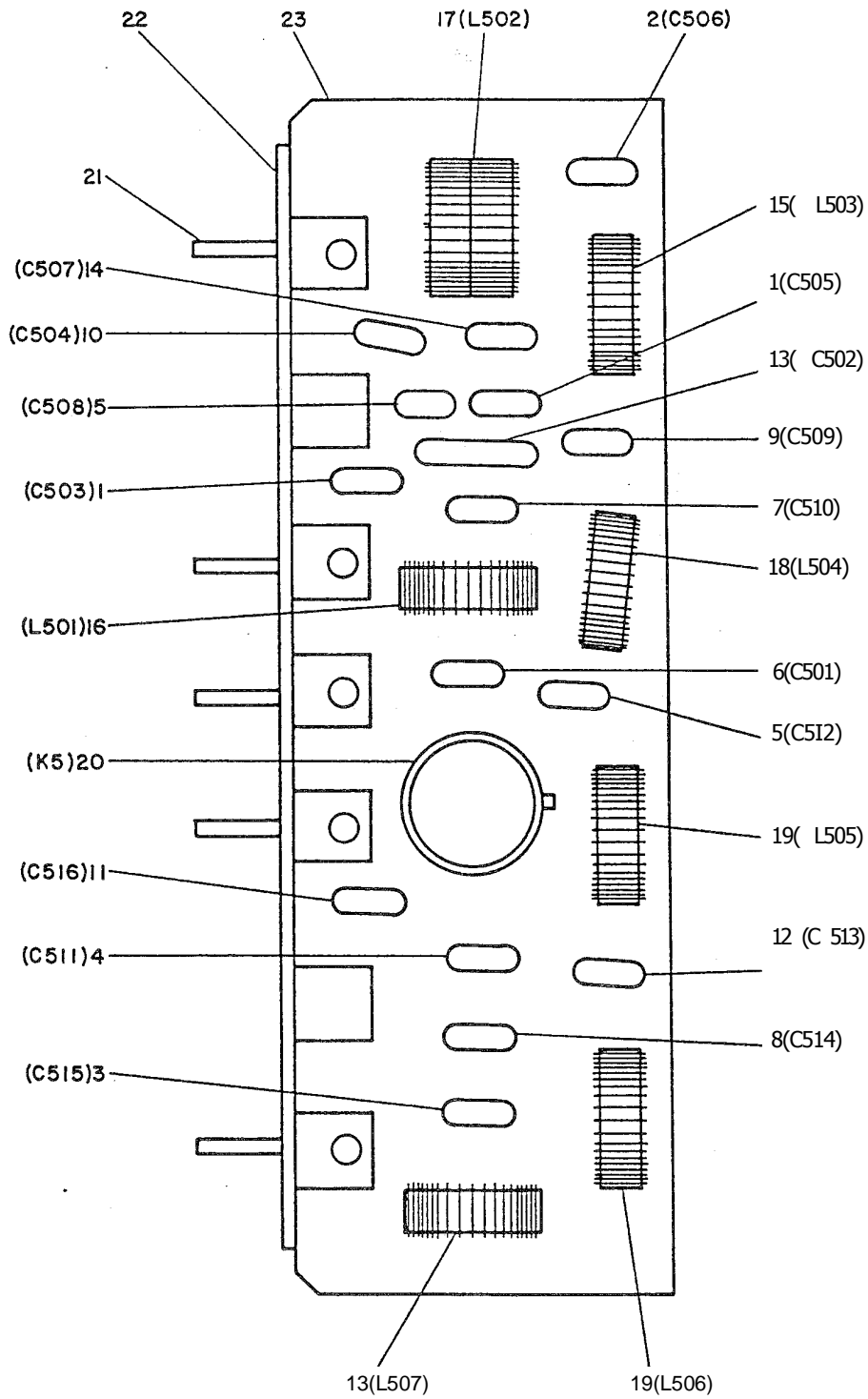

Figure 36. PC Board Assembly, 1A5A3A5 (FL-5)

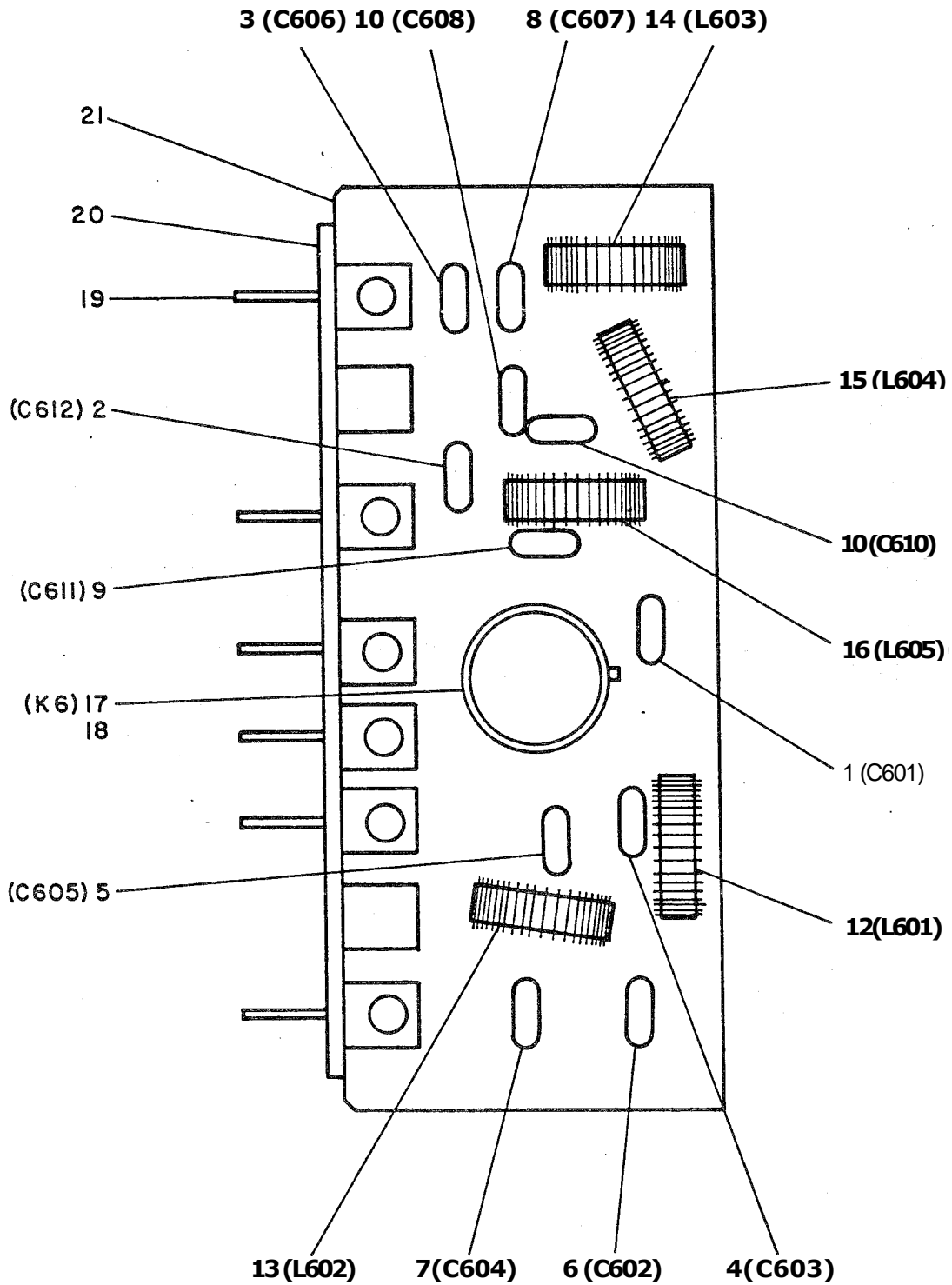
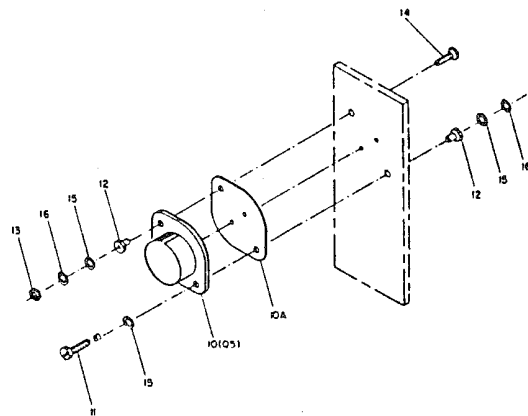
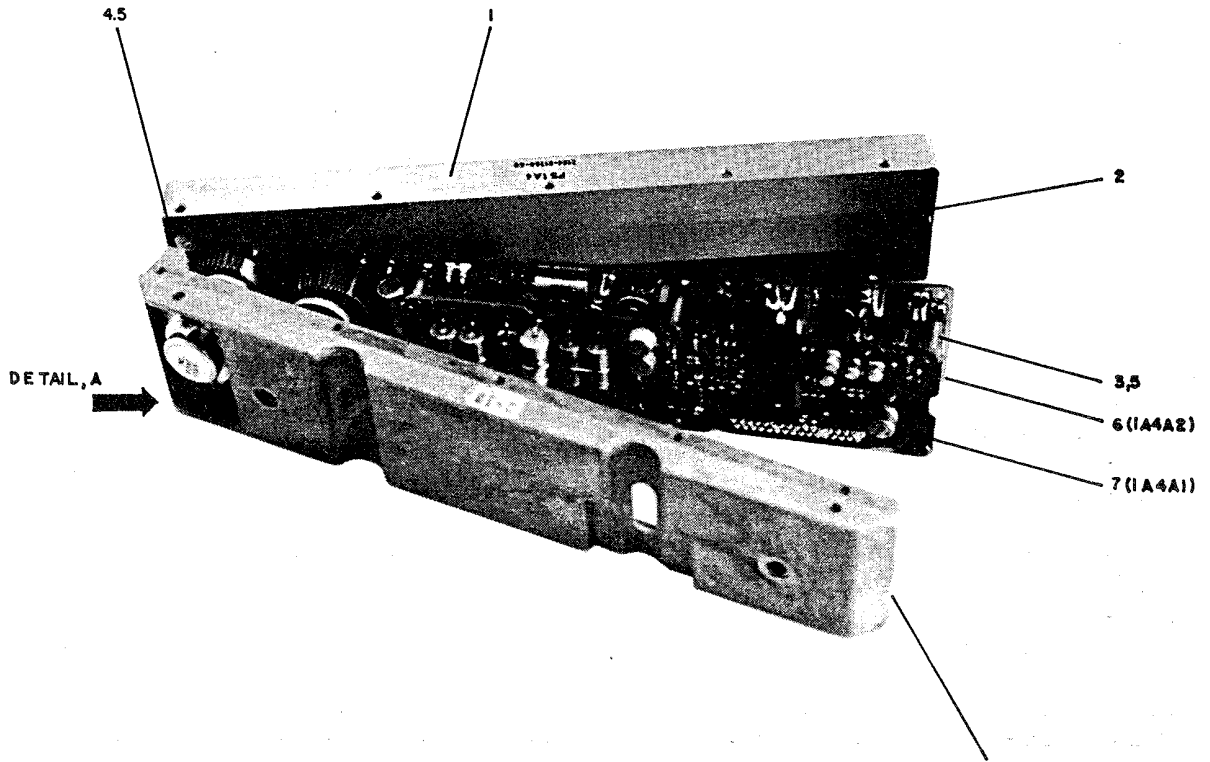

Figure 37. PC Board Assembly, 1A5A3A6 (FL6)



DETAIL A

Figure 38, Power Supply Assembly (1A4)

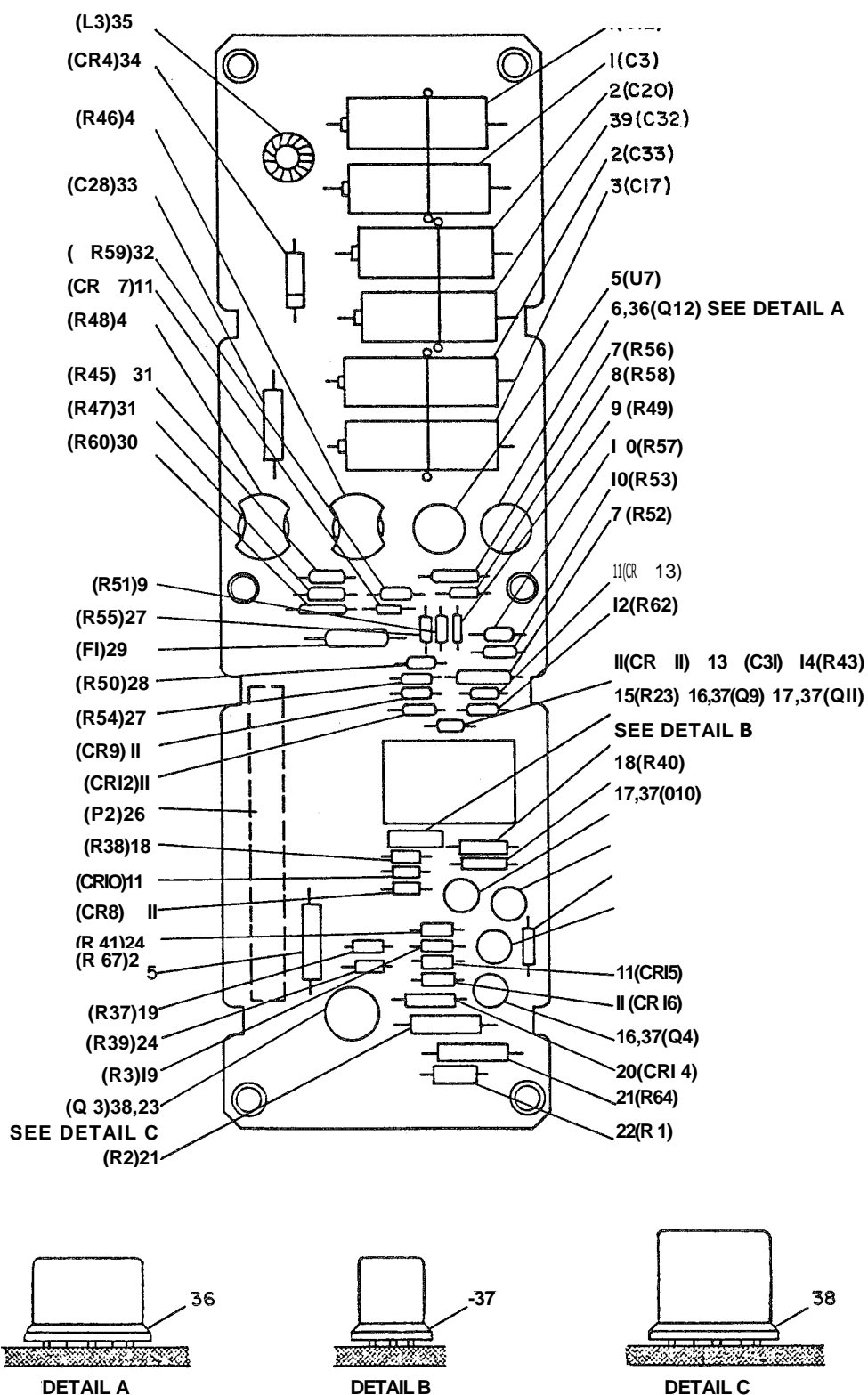

Figure 39. PC Board PS Assembly, PCB2, 1A4A2

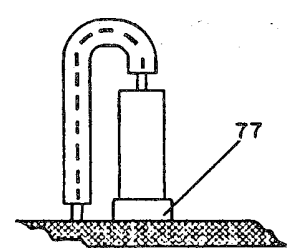
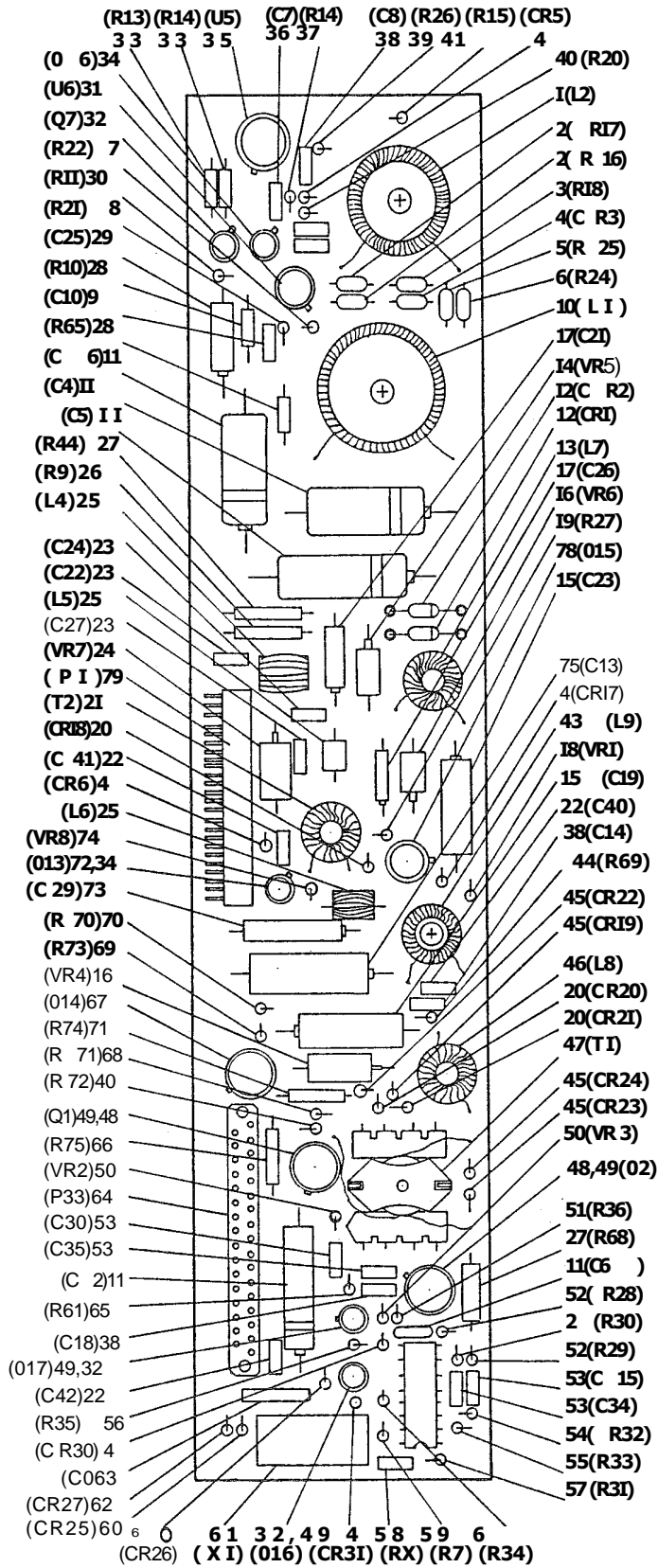

Figure 40. PC Board PS Assembly, PCB1, 1A4A1