

D 101.11:
1-2050

TM 11-2050

DEPARTMENT OF THE ARMY TECHNICAL MANUAL

UNIVERSITY OF VIRGINIA
ALDERMAN LIBRARY

JAN 9 1991

GOVERNMENT DOCUMENTS

TEST SET I-48-B AND OHMMETER ZM-21A/U

UNIVERSITY OF VIRGINIA LIBRARY



X004831768

This copy is a reprint which includes current pages from Change 1.

DEPARTMENT OF THE ARMY • NOVEMBER 1954



WARNING

HIGH VOLTAGE

is used in the operation of
this equipment.

Do not contact
the terminals or test leads
when operating the ohmmeter.

TECHNICAL MANUAL

TEST SET I-48-B AND OHMMETER ZM-21A/U

TM 11-2050

CHANGES No. 1

HEADQUARTERS,
DEPARTMENT OF THE ARMY
WASHINGTON 25, D.C., 4 May 1959

TM 11-2050, 1 November 1954, is changed as indicated so that the manual also applies to the following equipment:

<i>Nomenclature</i>	<i>Order No.</i>	<i>Serial No.</i>
Ohmmeter ZM-21A/U-----	39162-PP-58	1 through 144

Page 2, chapter 1. Add the following note below the title of chapter 1:

Note. Ohmmeter ZM-21A/U, procured on Order No. 39162-PP-58, is similar to Ohmmeter ZM-21A/U covered in the manual. Information in this manual applies to both sets unless otherwise specified.

Page 2, paragraph 2*b*. Delete subparagraph *b* and substitute:
b. Fill out and forward DA Form 468, Unsatisfactory Equipment Report, to the Commanding Officer, U.S. Army Signal Equipment Support Agency, Fort Monmouth, N.J., as prescribed in AR 700-38.

Page 4, paragraph 6*b*, chart. Make the following changes:

"Length" column. After the last item, add: (120 on Order No. 39162-PP-58).

"Weight" column. After the last item, add: (.8 on Order No. 39162-PP-58).

Page 6, paragraph 7*a*(7). Add subparagraphs (8), (9), and (10):

(8) The test leads supplied with Ohmmeter ZM-21A/U procured on Order No. 39162-PP-58 are the same as those supplied with Test Set I-48-B (fig. 3).

(9) Ohmmeter ZM-21A/U, procured on Order No. 39162-PP-58, has antifriction bearings (not shown) on the ends of the generator shaft (fig. 17).

(10) The clutch driven hub on Ohmmeter ZM-21A/U, procured on Order No. 39162-PP-58, is held to the generator shaft with two socket-head set screws (not shown).

Page 46, paragraph 63. Make the following changes:

Add the following after subparagraph *e*:

e.1. On Ohmmeter ZM-21A/U, procured on Order No. 39162-PP-58, loosen the set screws that retain the clutch driven hub (fig. 17) and remove the hub.

Add the following after subparagraph *f*:

f.1. On Ohmmeter ZM-21A, procured on Order No. 39162-PP-58, install the clutch driven hub on the generator shaft by pushing the hub onto the shaft and tightening the set screws.

[AG 413.44 (28 Apr 59)]

By Order of *Wilber M. Brucker*, Secretary of the Army:

MAXWELL D. TAYLOR,
General, United States Army,
Chief of Staff.

Official:

R. V. LEE,
Major General, United States Army,
The Adjutant General.

Distribution:

Active Army:

ASA (2)
CNGB (1)
Tech Stf, DA (1) except
 CSigO (30)
Tech Stf Bd (1)
USA Arty Bd (1)
USA Armor Bd (1)
USA Inf B1 (1)
USA AD Bd (1)
USA Abn & Elct Bd (1)
USA Avn Btl (1)
USA Armor Hd Test Sec (1)
USA AD Bd Test Sec (1)
USA Arctic Test Bd (1)
USCONARC (5)
US ARADCOM (2)
US ARADCOM Rgn (2)
OS Maj Comd (5)
OS Base Comd (5)
Log Comd (5)
MDW (1)
Armies (5) except
 First US Army (7)
Corps (2)
Div (2)
USATC (2)
USMA (5)
Svc Colleges (5)
B Svc Sch (5) except
 USASCS (25)
Gen Dep (2) except
 Atlanta Gen Dep (None)
Sig Sec, Gen Dep (10)
Sig Dep (17)
Army Pictorial Cen (2)
Engr Maint Cen (1)
USA Ord Msl Comd (3)
Fld Comd, AFSWP (5)
TASSA (15)
Mid-Western Rgn Ofc (TASSA)
 (1)

NG: State AG (3).

USAR: None.

For explanation of abbreviations used, see AR 320-50.

White House Army Sig Agcy (2)
USA Sig Pub Agcy (8)
USA Sig Engr Agcy (1)
USA Comm Agcy (2)
USA Sig Egn Spt Agcy (2)
USA Sig Msl Spt Agcy (13)
WitAMC (1)
AFIP (1)
AMS (1)
Yuma Test Sta (2)
Ports of Emb (OS) (2)
Trans Terminal Comd (1)
Army Terminals (1)
OS Sup Agcy (2)
Pine Bluff Arsenal (5)
Frankford Arsenal (5)
Redstone Arsenal (5)
USA Elct PG (1)
Dugway PG (5)
Sig Lab (5)
Sig Fld Maint Shops (3)
Mil Dist (1)
USA Corps (Res) (1)
Sector Comd, USA Corps (Res)
 (1)
JFUSMC (2)
Units organized under following
 TOE's:
 7-52 (2) 11-597 (2)
 11-5 (2) 39-61 (2)
 11-6 (2) 44-145 (2)
 11-7 (2) 44-147 (2)
 11-16 (2) 44-445 (2)
 11-18 (2) 44-447 (2)
 11-55 (2) 44-448 (2)
 11-56 (2) 44-535 (2)
 11-57 (2) 44-537 (2)
 11-500 (AA- 44-545 (2)
 AE) (2) 44-547 (2)
 11-587 (2) 44-549 (2)
 11-592 (2) 55-217 (2)

TEST SET I-48-B AND OHMMETER ZM-21A/U

	<i>Paragraph</i>	<i>Page</i>
CHAPTER 1. INTRODUCTION		
Section I. General.....	1, 2	2
II. Description and data.....	3-8	2
CHAPTER 2. OPERATION		
Section I. Service upon receipt of materiel.....	9-11	12
II. Operation under usual conditions.....	12-29	13
III. Operation under unusual conditions.....	30-33	27
CHAPTER 3. ORGANIZATIONAL MAINTENANCE		
Section I. Organizational equipment.....	34, 35	29
II. Preventive maintenance.....	36-38	30
III. Weatherproofing.....	39-42	33
IV. Troubleshooting at organizational maintenance level.....	43-45	33
CHAPTER 4. THEORY	46-51	35
5. FIELD MAINTENANCE		
Section I. Prerepair procedures.....	52-55	41
II. Troubleshooting at field maintenance level.....	56-59	43
III. Repairs.....	60-70	45
IV. Calibration and adjustment.....	71-73	48
CHAPTER 6. SHIPMENT, LIMITED STORAGE, AND DEMOLITION TO PREVENT ENEMY USE		
Section I. Shipment and limited storage.....	74, 75	53
II. Demolition of materiel to prevent enemy use.....	76, 77	54
INDEX		55

*This manual supersedes TM 11-2050, 14 October 1944.

CHAPTER 1

INTRODUCTION

Section I. GENERAL

1. Scope

This technical manual contains a physical description of Test Set I-48-B and Ohmmeter ZM-21A/U, operating instructions, organizational maintenance information, the theory of operation, repair of the equipment, instructions for removing the equipment from service and repacking for shipment or limited storage, and instructions for demolishing the equipment to prevent enemy use. These instructions apply only to Test Set I-48-B and Ohmmeter ZM-21A/U.

2. Forms and Records

The following forms will be used for reporting unsatisfactory conditions of Army equipment:

a. DD Form 6 (Report of Damaged or Improper Shipment) will be filled out and forwarded as prescribed in SR 745-45-5 (Army), Navy Shipping Guide, Article 1850-4, and AFR 71-4 (Air Force).

b. DA Form 468 (Unsatisfactory Equipment Report) will be filled out and forwarded to the Office of the Chief Signal Officer as prescribed in SR 700-45-5.

c. DD Form 535 (Unsatisfactory Report) will be filled out and forwarded as prescribed in SR 700-45-5 and TO 00-35D-54.

d. Use other forms and records as authorized.

Section II. DESCRIPTION AND DATA

3. Description

Test Set I-48-B and Ohmmeter ZM-21A/U (fig. 1) are self-contained, portable, constant-voltage insulation resistance measuring sets. Each instrument consists of a high-range ohmmeter of special design, mounted in a molded plastic case with a hand-operated direct-current (dc) generator. By removing the end shield, located at one end of the case (fig. 1), the ohmmeter chassis can be removed for inspection and replacement of generator and meter parts. Three binding posts for external connections are located on the end of the case opposite the end shield. The meter scale, located at the top of the case, is protected by a cover hinged to pillow blocks. A condensed summary of operating instructions is mounted on the back of the meter window cover.

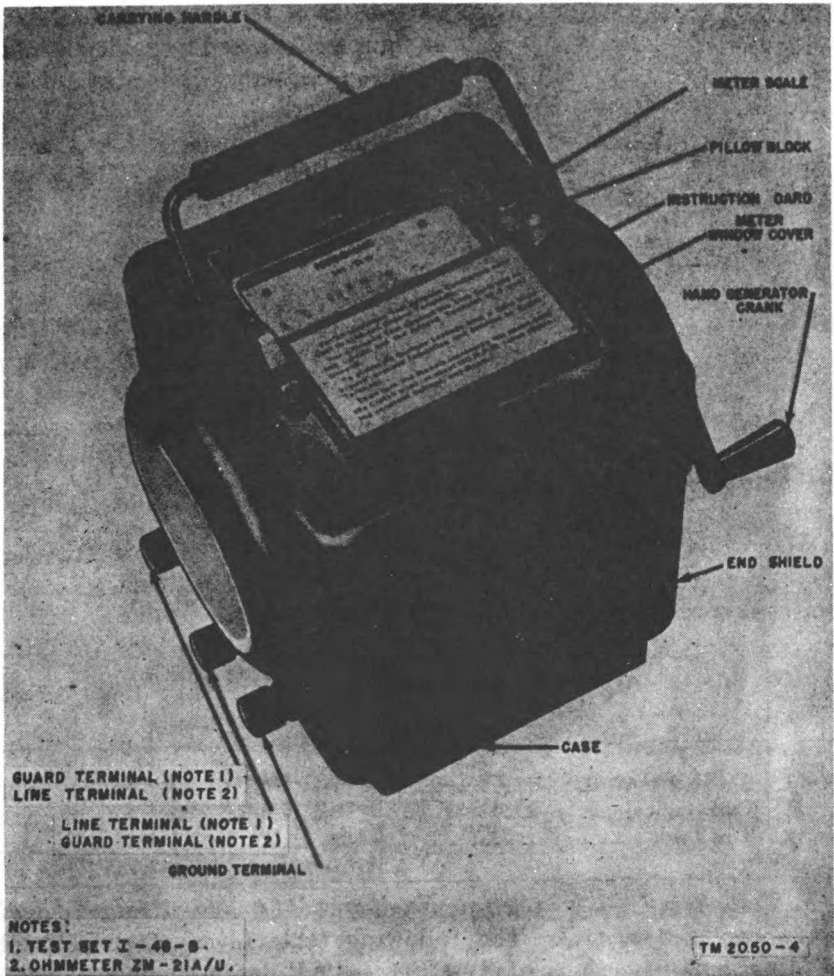

Figure 1. Test set I-48-B or ohmmeter ZM-21A/U.

4. Application

a. Test Set I-48-B or Ohmmeter ZM-21A/U is used to determine the condition of the insulation of the following: telephone cables and wire lines; between conductors of cables; between windings and windings to ground of transformers; between windings and windings to frame of rotating equipment (e. g. motors); all other types of electrical equipment of which insulation resistance is an important factor. In addition, the ohmmeter may be used to locate low insulation resistance in cable.

b. The ohmmeter, which applies a high potential to equipment under test, often will show up low insulation resistance which might read satisfactorily when tested with a conventional ohmmeter which applies a 3- to 6-volt potential.

c. The regular use of Test Set I-48-B or Ohmmeter ZM-21A/U can minimize failure in circuits or equipment caused by faulty insulation. A sudden lowering of insulation resistance indicates a fault that should be investigated immediately.

Caution: Do not use Test Set I-48-B or Ohmmeter ZM-21A/U on equipment having a voltage rating lower than 500 volts. The potential supplied may be destructive to the equipment under test.

5. Technical Characteristics

Resistance range_ 0 through 1,000 megohms.*

Test potential_ 500 volts dc ± 5 percent. (When measuring values below 2 megohms, the voltage drops materially (fig. 22).)

Accuracy _ ± 1 percent of any cardinal calibration point.

6. Table of Equipment

a. *Test Set I-48-B (Serial Numbers Lower than 5527).* The following table gives the unpacked weights and dimensions of Test Set I-48-B (serial numbers lower than 5527) (fig. 2) and of the accessories furnished with this equipment:

Quantity	Item	Dimensions (in.)			Weight (lb)	Volume (cu ft)
		Length	Width	Height		
1	Test Set I-48-B.....	7½	6	7¼	10.7	.2
1	Carrying case.....	9¾	6½	8½	4	.3
2	Test leads.....	120			.6	

b. *Test Set I-48-B (Serial Numbers 5527 and Higher) and Ohmmeter ZM-21A/U.* The following table gives the unpacked weights and dimensions of Test Set I-48-B (serial numbers 5527 and higher) (fig. 3) and Ohmmeter ZM-21A/U and of the accessories furnished with this equipment:

Quantity	Item	Dimensions (in.)			Weight (lb)	Volume (cu ft)
		Length	Width	Height		
1	Test Set I-48-B or Ohmmeter ZM-21A/U.	7½	6	7¼	10.7	.2
1	Carrying case.....	10¾	7¼	8¾	5.3	.42
3	Test leads (I-48-B).....	120			.8	
3	Test leads (ZM-21A/U).....	72			.3	

* Insulation resistance above 1,000 megohms is indicated by a point on the meter scale marked INFINITY.



Figure 2. Test set I-48-B (serial numbers lower than 5527), carrying case, and test leads.

7. Differences in Equipment

a. Ohmmeter ZM-21A/U differs from Test Set I-48-B in the following respects:

- (1) The positions of the GUARD and LINE binding posts have been reversed on Ohmmeter ZM-21A/U. The location of these binding posts on Test Set I-48-B is shown in figure 1.
- (2) On Ohmmeter ZM-21A/U, spring-type connectors (fig. 6) are used, instead of wires, to make internal connection to the binding posts.
- (3) The drive spring and ratchet in the generator drive assembly of Test Set I-48-B (fig. 16) have been replaced in Ohmmeter ZM-21A/U by a solid shaft with a loose pin (fig. 17). This shaft wedges between the shaft and the sleeve when the generator crank is turned in a clockwise direction.
- (4) In Ohmmeter ZM-21A/U, the wire gage used in the potential coil of the meter has been changed, and the number of turns has been decreased from 1,000 to 250. Also, the combined

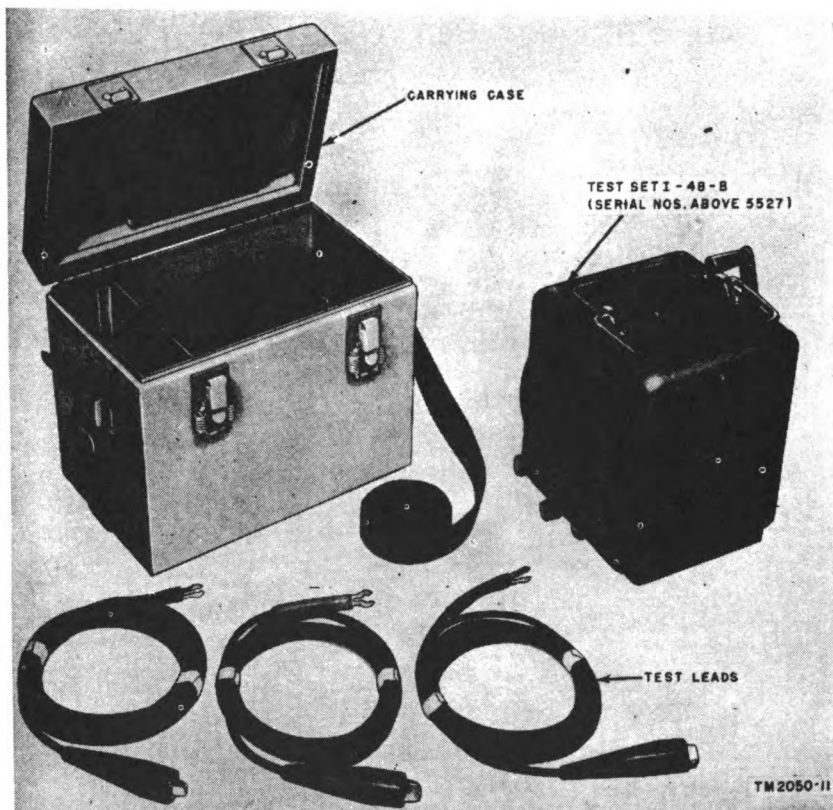

Figure 3. Test set I-48-B (serial numbers 5527 and higher), carrying case, and test leads.

value of resistors R2 in the resistance network has been changed from 2 megohms in Test Set I-48-B to 500,000 ohms in Ohmmeter ZM-21A/U.

- (5) The shield in Ohmmeter ZM-21A/U consists of a plate and a brass tube instead of the open shielded wire use in Test Set I-48-B.
 - (6) The construction of the resistor mounting bracket has been changed (figs. 4 and 6).
 - (7) The test leads supplied with Ohmmeter ZM-21A/U are Cords CD-478, each 6 feet long, instead of the 10-foot long rubber-covered test leads supplied with Test Set I-48-B.
- b. Earlier models of Test Set I-48-B differ from later models bearing the same nomenclature in the following respects:
- (1) In Test Set I-48-B with serial numbers 5527 and higher, the opening in the end shield, through which the generator crank is attached to the generator drive assembly, is equipped with

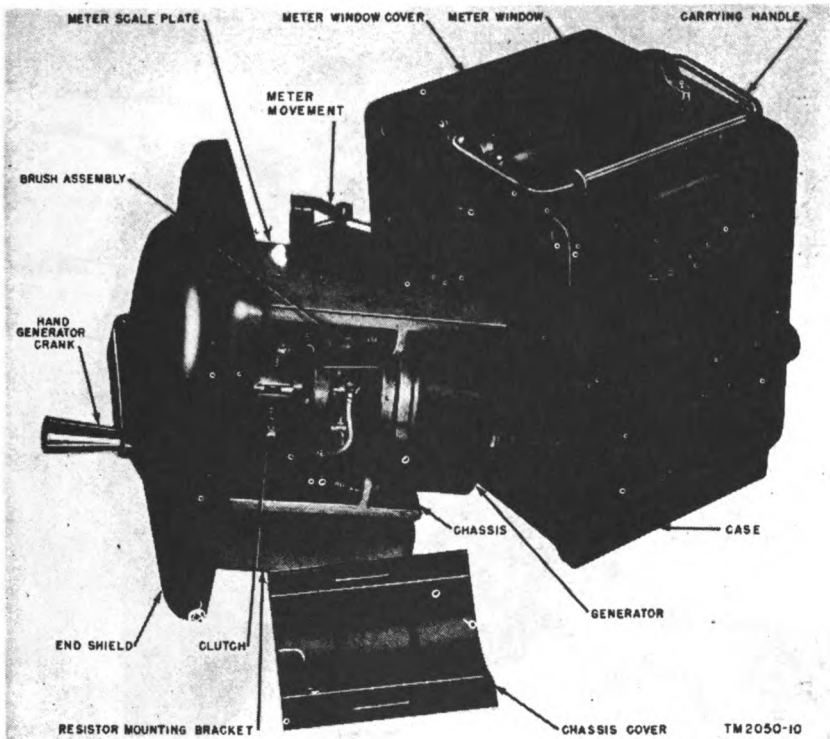

Figure 4. Test set I-48-B with end shield and chassis removed from case.

a pair of seals to prevent moisture from entering the instrument case.

- (2) Test Sets I-48-B with serial numbers lower than 5527 (and approximately 340 units with serial numbers between 5527 and 6996) are supplied with plywood carrying cases in an olive-drab finish (fig. 2). Later models of Test Set I-48-B are supplied with waterproof aluminum carrying cases in a smooth gray enamel finish (fig. 3). Each case has a separate compartment for storing the test leads. The main compartment is lined with sponge rubber.
- (3) The Test Sets I-48-B in the plywood carrying cases ((2) above) are provided with two flexible, insulated test leads. One test lead is equipped with a red battery clip cover on one end and red insulating sleeving above the spade-type terminal on the other end; the other test lead is equipped with a black battery clip cover and black insulating sleeving. Later models of Test Set I-48-B are supplied with three test leads one with a red battery clip cover and red insulating sleeving, and two with black battery clip covers and black insulating sleeving.

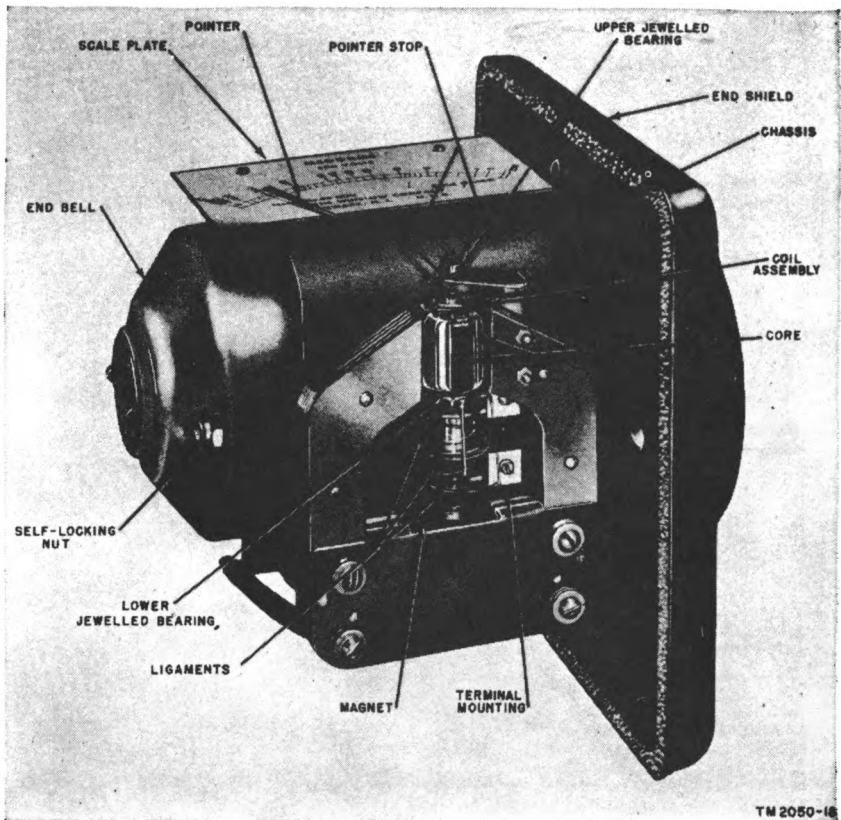

Figure 5. Ohmmeter side of chassis of tests set I-48-B.

8. Packaging Data

Test Set I-48-B and Ohmmeter ZM-21A/U may be packaged for either domestic or oversea shipment, as described in *a* and *b* below. Packaging details are shown in figure 7.

a. Domestic Shipment. Test Set I-48-B (serial numbers 5527 and higher) and Ohmmeter ZM-21A/U are placed in their carrying cases with the test leads provided with each unit packed in their own compartment. The webbed carrying strap is removed from the carrying case and placed in the compartment holding the test leads. Test Set I-48-B (serial numbers lower than 5527) and its accessories are cushioned and secured in the carrying case. For all units, the cover of the carrying case is latched, and the unit is cushioned with fiberboard pads and cells and placed in a close-fitting corrugated fiberboard box. The technical manuals are placed under the lid of the box, and the box is sealed with gummed tape. The dimensions, weight,

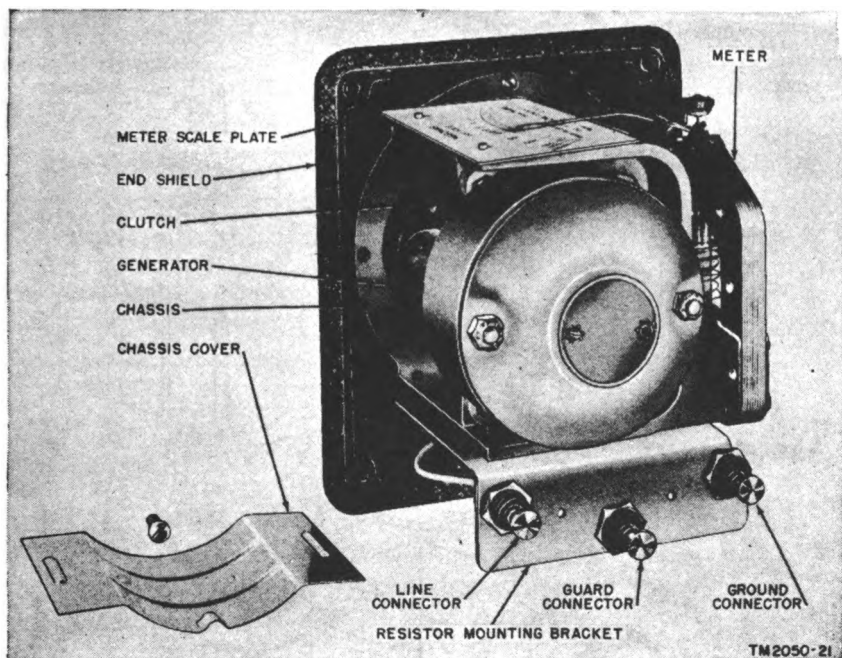

Figure 6. End shield and chassis assembly of ohmmeter ZM-21A/U.

and volume in cubic feet of the equipment packaged for domestic shipment are as follows:

Name of equipment	Dimensions (in.)			Weight (lb)	Volume (cu ft)
	Length	Width	Height		
Test Set I-48-B (serial numbers lower than 5527)-----	12 $\frac{1}{2}$	9	11	16	.7
Test Set I-48-B (serial numbers 5527 and higher) and Ohmmeter ZM-21A/U-----	13 $\frac{1}{2}$	11 $\frac{1}{2}$	13	21	1.2

b. Oversea Shipment. For oversea shipment, the test sets are prepared for packaging in the same manner as for domestic shipment. Each unit is cushioned with fiberboard pads and cells and placed in a corrugated fiberboard box. Desiccant is placed in the cushioning cells, and the box is sealed. The boxed unit then is placed in a waterproof bag that is heat-sealed, and this package is fitted into a waterproof carton. The technical manuals are placed under the lid, and the carton is sealed with waterproof tape. One or several packaged test sets may be placed in a wooden shipping container for oversea shipment. The wooden container is reinforced with flat metal straps. The following table gives the dimensions, weight, and vol-

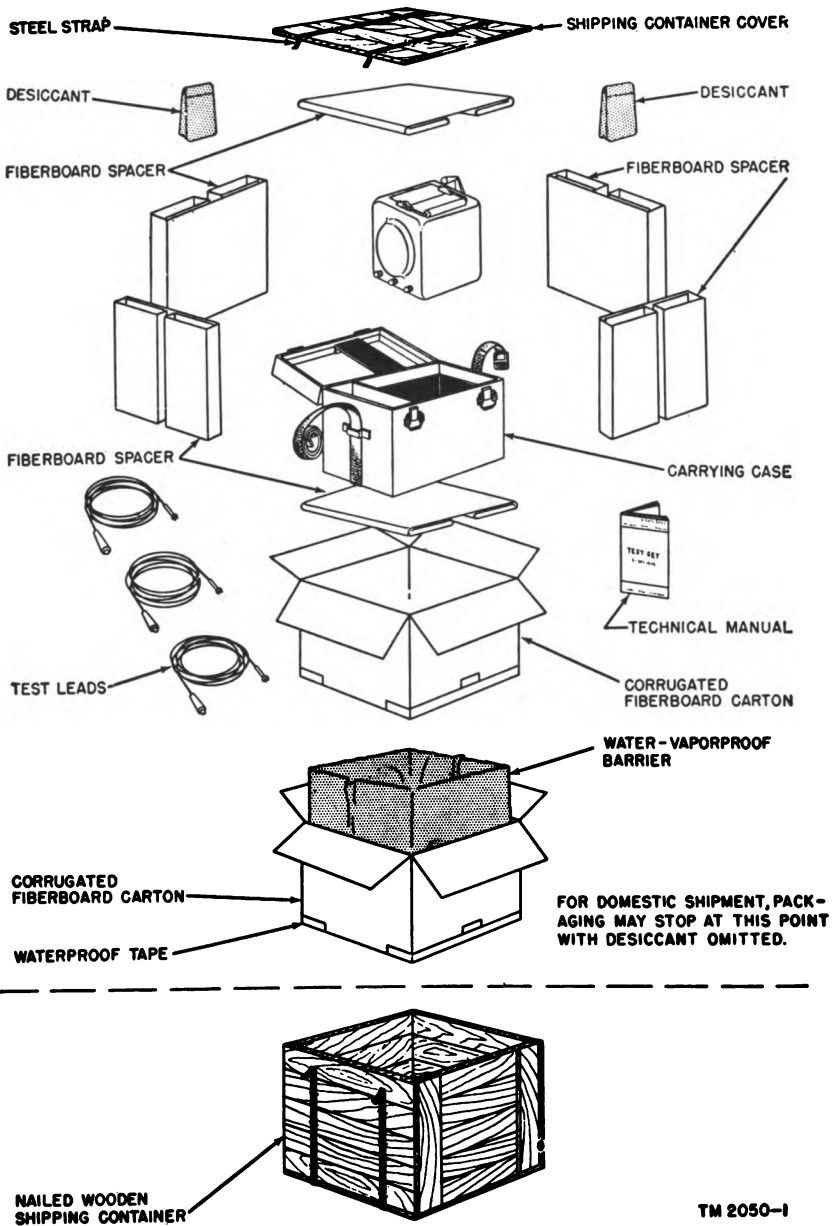

Figure 7. Packaging details for test set I-48-B or ohmmeter ZM-21A/U.

ume in cubic feet of a single item of test equipment packaged for
oversea shipment :

Name of equipment	Dimensions (in.)			Weight (lb)	Volume (cu ft)
	Length	Width	Height		
Test Set I-48-B (serial numbers lower than 5527)-----	14½	10¾	12¾	23	1. 13
Test Set I-48-B (serial numbers 5527 and higher) and Ohmmeter ZM-21A/U-----	17	12	13½	32	1. 6

CHAPTER 2

OPERATION

Section I. SERVICE UPON RECEIPT OF MATERIEL

9. Uncrating, Unpacking, and Checking New Equipment

a. General. Test Set I-48-B and Ohmmeter ZM-21A/U may be packaged for either oversea or domestic shipment (par. 8). When new equipment is received, unpack it in a location where it will not be exposed to dust, dirt, or excessive moisture. Be careful when uncrating and unpacking the equipment. Avoid thrusting tools into the wooden box or fiberboard cartons. When unpacking, do not damage packaging materials any more than necessary. These materials may be used when repacking the equipment for storage or for shipment to base maintenance repair shops. If the equipment is packed for oversea shipment, store the packaging materials carefully in the wooden shipping container. Be careful when handling the equipment as it may be damaged easily when it is not protected by the shipping container.

b. Step-by-Step Instructions for Unpacking Equipment Packed for Domestic Shipment.

- (1) Cut the seals of the corrugated fiberboard box.
- (2) Remove the equipment from the box.
- (3) Check the equipment against the shipping documents.
- (4) Inspect the equipment thoroughly for possible damage.
- (5) Place the cushioning material in the shipping container for use in repacking the equipment.

c. Step-by-Step Instructions for Uncrating and Unpacking Equipment Packed for Oversea Shipment.

- (1) Cut the metal straps with a suitable cutting tool, or twist them with pliers until the straps break. Remove the straps.
- (2) Remove the nails from the top of the wooden box with a nail puller. Remove the top. Do not attempt to pry off the sides and top. The equipment might be damaged.
- (3) Remove the packaged equipment from the shipping container, and carefully cut the adhesive tape sealing the waterproof carton. Be careful not to damage the carton.
- (4) Cut the barrier material along the top as close to the heat-sealed seam as possible so that the barrier may be resealed when required. Carefully remove the packaged equipment and the barrier from the carton.

- (5) Cut the seals of the inner corrugated fiberboard box. Remove the paperboard cells that cushion the test set, and lift the test set in its carrying case from the box.
- (6) Loosen the fastenings of the carrying case cover, and open the cover. Remove the desiccant, and lift the test set from the carrying case.
- (7) Place all the packaging material in the original shipping container for use in repacking the test set.
- (8) Check the equipment against the shipping documents.
- (9) Inspect the equipment thoroughly for possible damage.

10. Installation of Equipment

Test Set I-48-B and Ohmmeter ZM-21A/U are portable, self-contained instruments designed to be used near the equipment, the wire, or the cable line to be tested. Place the equipment on a firm, level surface with the indicator scale plate in a horizontal plane. Do not place it in a strong, external magnetic field similar to that produced by some types of electrical equipment. Before operating the ohmmeter, ground it through the equipment under test by connecting the GROUND terminal on the side of the case to the equipment in accordance with instructions for the type of equipment under test. When the ohmmeter is removed from the carrying case, the hand generator crank is folded against the side of the case with the handle extending over the top of the case (fig. 3): Unfold the crank to bring it into its operating position.

11. Service Upon Receipt of Used or Reconditioned Equipment

- a. Follow the instructions given in paragraph 9 for uncrating, unpacking, and checking the equipment.
- b. Check the used or reconditioned ohmmeter against a new equipment, if available. Make sure the wiring has not been changed and that no parts have been damaged. Operate the ohmmeter according to the procedures given in the equipment performance test (par. 45) to make sure that it is operating properly.

Section II. OPERATION UNDER USUAL CONDITIONS

12. General

Make all measurements with the hand generator crank rotated clockwise fast enough (at apr 160 revolutions per minute (rpm)) to cause the centrifugal clutch to slip. When the clutch slips, maximum steady voltage is being delivered. The position of the pointer on the scale indicates insulation resistance values in megohms. Be careful to read the scale directly above the pointer and the scale; otherwise, readings may be in error because of parallax. The tests described in

paragraphs 16 through 26 are general and cover equipment of all types and designs. Before testing the insulation of any equipment, refer to the technical manual covering the specific equipment under test for definite insulation resistance values and voltage ratings.

13. Preoperational Check

Before connecting Test Set I-48-B or Ohmmeter ZM-21A/U to the equipment to be tested, make the following checks to determine whether the ohmmeter is operating properly:

a. Full Scale Check. With no connection to the ohmmeter terminals, crank the hand generator at operating speed. The pointer will indicate INFINITY if the test set is in good operating condition.

b. Zero Check. Short the LINE and GROUND terminals by connecting them and turn the hand generator crank at operating speed. The pointer will indicate ZERO if the ohmmeter is in good operating condition.

14. Guard Connection

a. To obtain a true resistance value of the insulation under test, both the insulation and the measuring instrument must be protected against surface leakage to eliminate possible errors. Both Test Set I-48-B and Ohmmeter ZM-21A/U have an internal protective or guard system for this purpose. The guard system is connected to the GUARD terminal so that protection against surface leakage can be extended to the insulation under test. For example, figure 11 shows a porcelain insulator bushing under test with the guard connection of the ohmmeter in use. Any leakage current between the base of the insulator and its terminal will be carried back to the test set through the GUARD terminal, and the internal guard circuit of the test set will prevent this leakage from entering the measuring circuit.

b. When using guarded connections, readings are of the insulation resistance only and do not take into account the parallel shunting resistance of surface conditions. A measurement taken with a GUARD connection and compared to a measurement of the same equipment taken without a GUARD connection will establish whether low insulation resistance readings are caused by poor insulation or bad surface conditions. If readings taken with guarded connections are higher than those without guarded connections, the surface of the equipment has a low resistance.

15. Insulation Resistance

a. Unit of Measurement. Insulation resistance is that property of an insulating material which opposes the passage of electrical current. It is expressed in ohms or megohms. Insulation resistance increases

as the thickness of the insulating material increases but decreases as the area of material under test increases. For example, if an insulating material covering a given surface and having a resistance of 100 megohms is extended to 10 times its area, the insulation resistance will drop to 10 megohms. Thus, one mile of spiral-four cable may measure 1,000 megohms but 10 miles will measure 100 megohms. If the insulating material is doubled in thickness, however, the area having an insulation resistance of 100 megohms now will have a resistance of 200 megohms, and the area having an insulation resistance of 10 megohms will have a resistance of 20 megohms.

b. Conditions Affecting Insulation Resistance.

- (1) *Temperature.* The temperature coefficient of the resistance of an insulating material is negative and numerically large. Therefore, even a small increase in temperature will cause a relatively large decrease in insulation resistance. Always make measurements at the same temperature, if possible, because insulation resistance drops at high temperatures. For example, the insulation resistance between the stator winding of a slow-speed generator and the frame is 100 megohms at 80° F., but falls to 10 megohms at 140° F.
- (2) *Moisture and humidity.* Chemically pure water is a nonconductor. However, the impurities that water absorbs from the atmosphere and the surfaces of equipment with which it comes in contact cause it to be partially conductive. Therefore, moisture will become a conductor in parallel with the insulation and cause a decided drop in insulation resistance. In general, an insulation resistance drop caused by moisture is a temporary condition and can be remedied by drying out the equipment.
- (3) *Chemical fumes.* Strong acid or alkali fumes, unlike water vapor, attack insulation and permanently lower its insulation resistance.
- (4) *Surface conditions.* Dirt, especially when mixed with oil or with copper or carbon dust, forms a low-resistance path across the insulation, thus lowering its insulation resistance.

c. Expected Values of Insulation Resistance. As discussed in *b* above, insulation resistance is affected by varying conditions. Therefore, no hard and fast rules can be set up to govern its value. Certain minimum values have been established for different types of equipment (par. 27). Actual values of insulation resistance, however, are not as important as *changes* in insulation resistance since an insulation resistance test is merely an indication of the condition of the insulation. For example, when insulation resistance readings on a cable have been 100 megohms for some time and then start to drop, the insulation of the cable is breaking down at some point. One bad section in a long

spiral-four cable line will lower the reading to that of the bad section for the entire line; replacing the damaged section will raise the insulation resistance for the entire line.

16. Insulation Test of A. C. and D. C. Rotating Machines Rated at 600 Volts or Less

a. Connect a test lead from the LINE terminal of the ohmmeter to a lead, an exposed conductor, or the commutator of the machine (fig. 8).

b. Connect another test lead from the GROUND terminal to the shaft or frame of the equipment under test. Be sure that the surface to which the connection is made is free of paint or any other substance that is a nonconductor.

c. Turn the hand generator crank at operating speed. If the machine is cold, the readings should be between 1 and 10 megohms. If the machine is warm, the reading will be lower. Also, a large machine will have a lower insulation resistance reading than a small machine.

d. If all circuits in the machine are not interconnected, as in separately excited generators, measure each circuit or group of circuits individually.

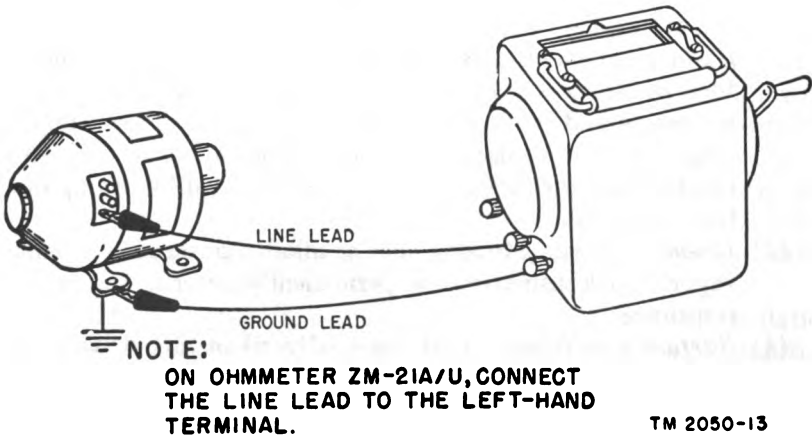

Figure 8. Connections for testing a. c. or d. c. rotating machines.

17. Insulation Test of A. C. and D. C. Rotating Machines Rated over 600 Volts

a. Connect the equipment and test as directed for machines rated at 600 volts or less (par. 16a and b).

b. Turn the hand generator crank at operating speed. If the machine is cold, readings should range between 10 and 100 megohms. Readings will be lower if the equipment is warm.

c. D. c. fields on alternating-current (a. c.) machines should read between 1 and 10 megohms.

18. Insulation Test of Transformers

a. Connect a test lead from the GROUND terminal of the ohmmeter to the core or case of the transformer (fig. 9).

b. Measure the high- and low-voltage windings separately. Connect a test lead from the LINE terminal of the ohmmeter, first to the low-voltage winding and then to the high-voltage winding.

c. Measure between windings by connecting one test lead between the GROUND terminal of the ohmmeter and one winding of the transformer, and connect another test lead between the LINE terminal of the ohmmeter and the other winding.

d. Turn the hand generator crank at operating speed. Readings for all measurements should be 100 megohms or more on air transformers. Readings on oil-filled transformers will be considerably lower. Extremely low readings on oil-filled transformers indicate the presence of moisture in the oil and indicate that the oil should be changed.

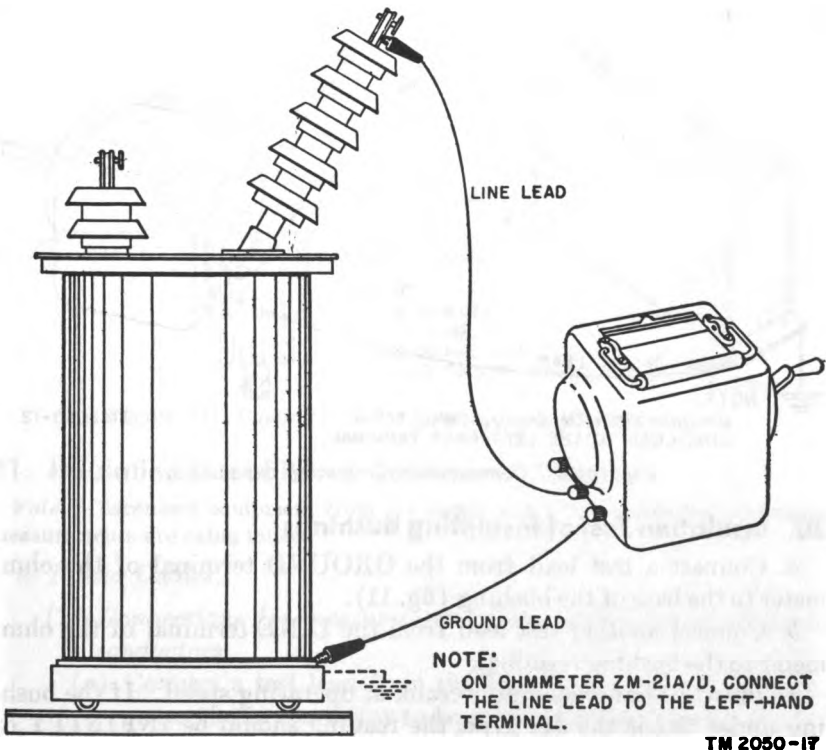

Figure 9. Connections for testing transformers.

19. Insulation Test of Capacitors

a. Connect a test lead from the GROUND terminal of the ohmmeter to the case of the capacitor (fig. 10).

b. Connect another test lead from the LINE terminal of the ohmmeter to one terminal of the capacitor.

c. Turn the hand generator crank at operating speed. The reading obtained is the resistance between the capacitor and its case and should be 500 megohms or more.

d. Remove the GROUND test lead from the case of the capacitor, and connect it to the other terminal of the capacitor.

e. Turn the hand generator crank at operating speed. The meter pointer will dip toward ZERO when the generator crank first is turned, but will move up the scale as the capacitor becomes charged with the test potential. The capacitor must be fully charged at the test potential before its insulation resistance will be indicated. Turn the generator crank for 1 minute or more before taking readings. The insulation resistance should be 500 megohms or more.

Caution: Disconnect the test leads one at a time after an insulation resistance measurement has been made, and short the capacitor terminals. Contact with a fully charged capacitor can cause a dangerous shock.

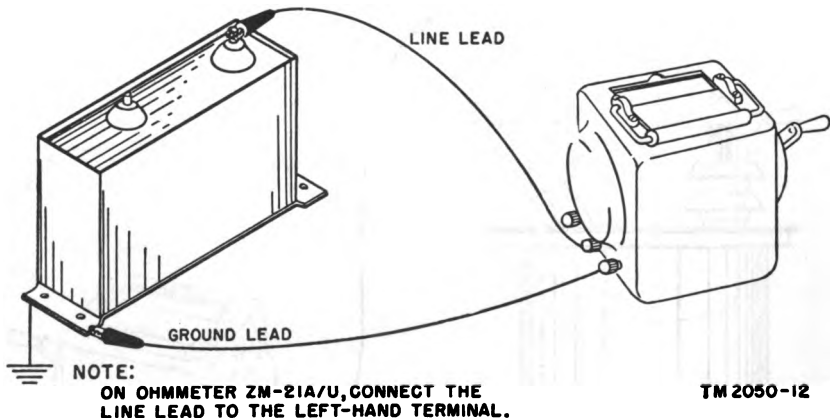

Figure 10. Connections for testing capacitors.

20. Insulation Test of Insulating Bushings

a. Connect a test lead from the GROUND terminal of the ohmmeter to the base of the bushing (fig. 11).

b. Connect another test lead from the LINE terminal of the ohmmeter to the bushing terminal.

c. Turn the hand generator crank at operating speed. If the bushing under test is the dry type, the reading should be INFINITY or near INFINITY. If the bushing under test is the filled type, the reading should be near 1,000 megohms.

d. If the reading is lower than near INFINITY for a dry-type bushing or 1,000 megohms for a filled-type bushing, connect the third test lead to the GUARD terminal of the ohmmeter and to a point approximately at the center of the bushing. Make this connection by wrapping the bushing with tinfoil or with a cloth saturated with salt water and connecting the test clip to the tinfoil or cloth.

e. Operate the hand generator crank. If the reading taken with the GUARD terminal connected is approximately the same as the first reading, the low resistance is caused by a fault in the bushing. If the reading is considerably higher, the low resistance formerly observed is caused by surface leakage. When low resistance is caused by surface leakage, the bushing is serviceable but should be cleaned.

Caution: Use the GUARD connection if insulation tests are made on a damp or humid day. Surface leakage always will be high under such conditions.

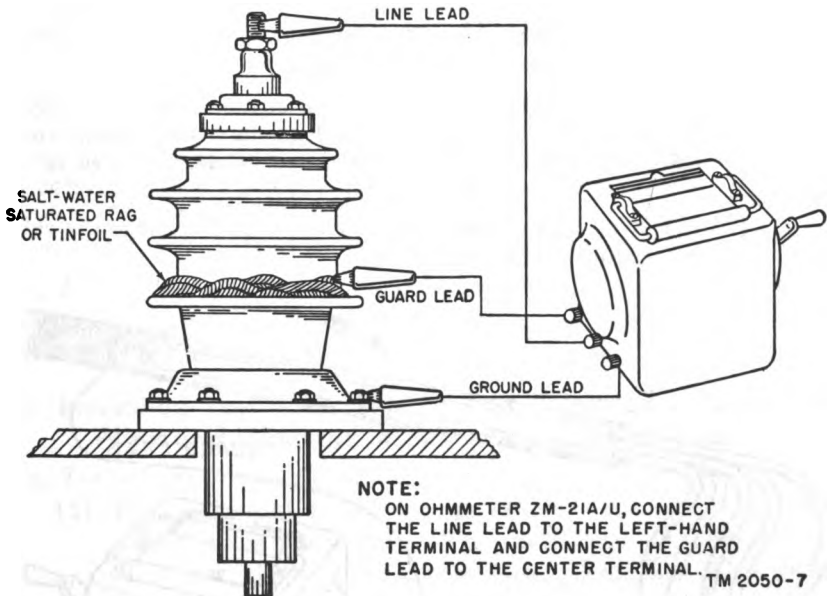

Figure 11. Connections for testing insulating bushings.

21. Insulation Test of Power Cables and Wires

Note. Disconnect equipment from the power line while insulation resistance measurements are being made.

a. Power Cables.

(1) *Connections for measurement of one conductor to all other conductors.*

(a) Connect a test lead from the LINE terminal of the ohmmeter to the conductor to be measured (fig. 12).

(b) Tie all other conductors together, and connect them to the GROUND terminal of the ohmmeter.

- (c) Connect a test lead from the **GUARD** terminal to the cable sheath. Use of the **GUARD** terminal prevents error caused by parallel ground leakage.
- (2) *Connections for measurement of one conductor to ground.*
 - (a) Connect a test lead from the **LINE** terminal of the ohmmeter to the conductor to be measured (fig. 13).
 - (b) Connect a test lead from the **GROUND** terminal to the shield of the cable.
 - (c) Tie all other conductors together and connect them to the **GUARD** terminal. Use of the **GUARD** terminal prevents error caused by leakage in the parallel circuits.
- (3) *Operation.*
 - (a) Turn the hand generator crank at operating speed. A short length of cable usually will have an insulation resistance value of 1,000 megohms or more. The insulation resistance value of a long cable usually will be considerably lower than that of a short cable.

Note. When testing the insulation of a long cable, operate the hand generator for approximately 1 minute before taking a reading. This will eliminate any error that might be caused by the electrostatic capacity of the cable.
 - (b) After all measurements are completed, discharge the cable by grounding all conductors.

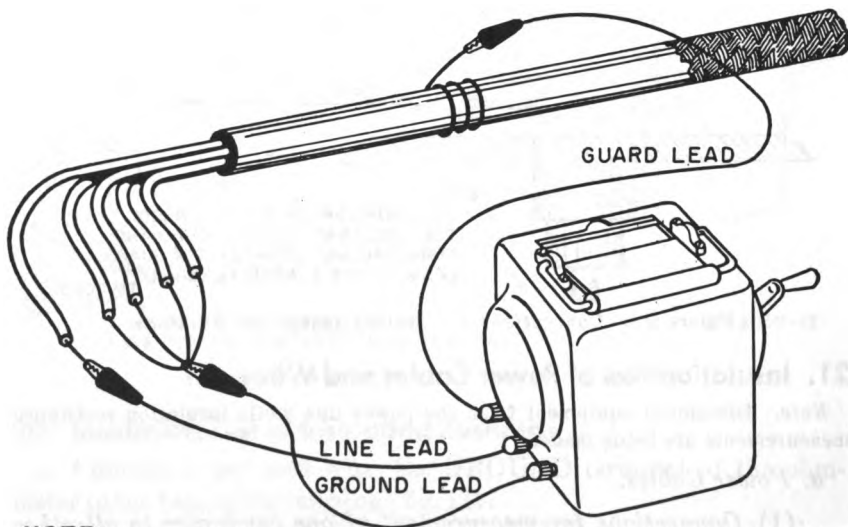

NOTE:

ON OHMMETER ZM-21A/U, CONNECT THE LINE LEAD TO THE LEFT-HAND TERMINAL AND CONNECT THE GUARD LEAD TO THE CENTER TERMINAL.

TM 2050-24

Figure 12. Connections for measuring one cable conductor to all other conductors.

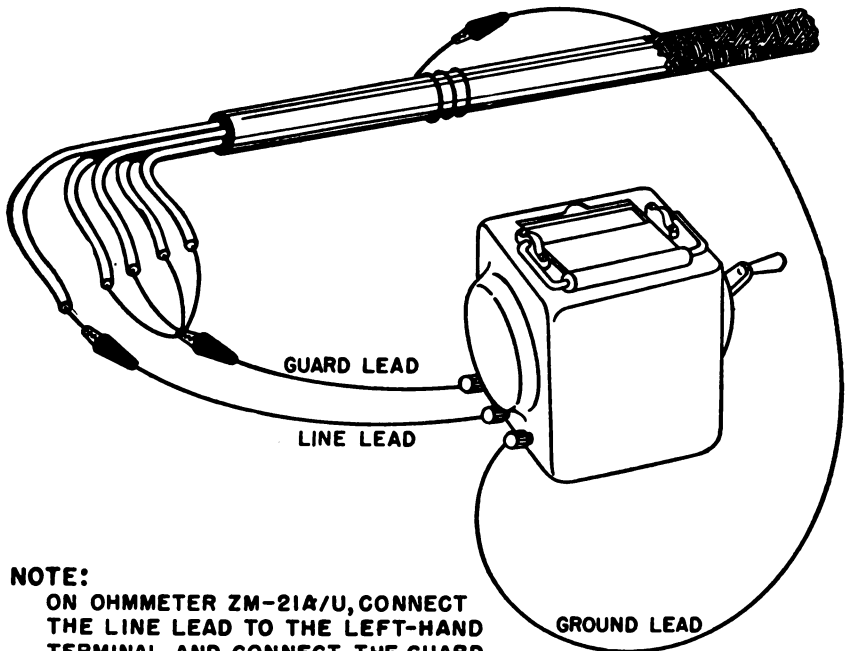

NOTE:

ON OHMMETER ZM-21A/U, CONNECT THE LINE LEAD TO THE LEFT-HAND TERMINAL AND CONNECT THE GUARD LEAD TO THE CENTER TERMINAL.

TM 2050-8

Figure 13. Connections for measuring one cable conductor to ground.

b. Power Wires. Test the insulation of individual power wires in the same manner as cable conductors (*a* above). Make the GROUND connection to the outer sheath, or jacket, of the wire.

22. Insulation Test of Telephone and Telegraph Cables and Wires and Minimum Insulation Resistance Values

a. Testing Insulation Resistance.

- (1) Test the insulation of exchange cables in the same manner as power cables (par. 21a). The conductors of these cables, when new, should have an insulation resistance value of at least 500 megohm-miles.

Note. A conductor is said to have an insulation resistance value of 500 megohm-miles when the insulation resistance of a 1-mile length is 500 megohms. Since short cables usually have a higher insulation resistance value, a 2-mile length will have an insulation resistance of 250 megohms, a 10-mile length will have an insulation resistance of 50 megohms, etc.

- (2) When testing the insulation of large exchange cables, divide the pairs into bunches of 25 to 100 pairs per bunch. Test each bunch in the same manner as a single conductor of a power cable.
- (3) If the insulation resistance of a bunch is a high or higher than the insulation resistance of a single pair, assume that

the insulation resistance of all pairs in the bunch is satisfactory.

- (4) Test each bunch in a cable separately. If the insulation resistance of a bunch is less than that given in the table, in δ below, separate the wires in the bunch, and measure each wire separately against all other wires grounded to the sheath. Each wire should give a reading as high as that given in the table.
- (5) If the insulation resistance of any individual wire is less than that given in the table, disconnect all other bunches from the sheath and measure the wire against these bunches and against the sheath. This will determine whether the trouble is between the wires, between the wire and the sheath, or both.
- (6) After testing all the bunches, measure a few wires of each bunch against the remaining wires in the same bunch to determine whether any conductors with low insulation resistance are in the bunch.

b. Insulation Resistance Requirements for Telephone Cable. The table below gives the insulation resistance requirements for telephone cable of various lengths. These figures are based on the requirement of an insulation resistance of 500 megohms for 1 mile of cable and are the minimum insulation resistance between one wire and the sheath with all other wires of the cable grounded to the sheath at a temperature of 60° F.

Note. Operate the test set for 1 minute before taking a reading.

Length of cable (ft)	Required insulation resistance (megohms)	Length of cable (mi)	Required insulation resistance (megohms)
500.....	5, 280	1	500
1,000.....	2, 640	2	250
1,500.....	1, 760	3	167
2,000.....	1, 230	4	125
3,000.....	880	5	100
4,000.....	660	6	88. 3
5,000.....	528	7	71. 3
6,000.....	440	8	62. 5
7,000.....	377	9	55. 5
8,000.....	330	10	50
9,000.....	293	11	45. 4
10,000.....	264	12	41. 7
		15	33
		20	25
		25	20
		50	10

c. Insulation Resistance Requirements for Spiral-Four Cable.

(1) *General.* Spiral-four cable consists of four individually insulated conductors in a braided metal sheath. Cable WC-548 has a heavy rubber jacket; Cable WF-8/G has a polyethylene plastic covering. For a complete test of the insulation resistance of spiral-four cable, measure each conductor in turn with the other three conductors connected to the braid. Thus a complete test can be made in four measurements.

(2) *Cable WC-548.*

(a) Insulation resistance requirements for various lengths of new Cable WC-548 are as follows:

Cable-length (mi)	Insulation resistance (megohms)
¼ (1 CC-358)	750
1	200
25	10

(b) In the case of working cable, the insulation resistance of one ¼-mile Cable Assembly CC-358 should not drop below 10 megohms, and the insulation resistance of a 25- to 30-mile repeater section should not drop below 1 megohm.

(3) *Cable WF-8/G.*

(a) New Cable WF-8/G, either in ¼-mile lengths of Cable Assembly CX-1065/G or four cable assemblies coupled together during initial installation, should show an insulation resistance above 1,000 megohms. For lengths greater than 1 mile, the minimum insulation resistance can be found by dividing 1,000 by the number of miles in the cable. For example, if a 10-mile length of Cable WF-8/G is to be tested— $1,000 \div 10 = 100$ megohms, the minimum insulation resistance for 10 miles.

Note. Manufacturing specifications require a minimum insulation resistance of 5,000 megohms per 1,000 feet. Insulation resistance above 1,000 megohms is indicated by INFINITY on the meter scales of Test Set I-48-B and Ohmmeter ZM-21A/U.

(b) A cable line may develop low insulation resistance and deteriorate to the point where it will no longer be useful. No matter what length of line is involved, either loaded or nonloaded, locate and remove the cause when the insulation resistance drops below 1 megohm.

d. Computing Minimum Insulation Resistance of Cable. The minimum insulation resistance for any length or size of cable may be found as follows:

- (1) The required minimum insulation resistance between one wire 1 foot long and the cable sheath is 2,640,000 megohms. To find the required minimum insulation resistance for one insulated conductor of any length, divide 2,640,000 by the length of the conductor expressed in feet. For example, to find the required insulation resistance between one conductor and the cable sheath of a cable 672 feet long—

$$2,640,000 \div 672 = 3,928.57 \text{ megohms.}$$

- (2) If the cable is a multiple-pair cable and it is necessary to find the minimum insulation resistance of the entire cable to the cable sheath, divide the requirement for one conductor by the total number of conductors in the cable. In the case of a 51-pair cable, this would be 51×2 or 102 conductors. Thus, to find the minimum insulation resistance requirement for a 51-pair cable 672 feet long—

$$3,928.57 \div 102 = 38.51 \text{ megohms.}$$

23. Insulation Test of Wiring Installations

Wiring systems are tested to see whether they are free from short circuits and grounds. Remove fuses and open switches before making tests.

a. Testing for Grounds.

- (1) Connect the GROUND terminal of the ohmmeter to a good ground.
- (2) Connect the LINE terminal to a wire of the wiring system that is being checked for grounds. Measure one wire at a time. A low reading indicates that the wire is grounded. A high reading indicates that there is no ground and that the insulation is good.

b. Testing for Short Circuits.

- (1) Connect the LINE terminal of the ohmmeter to one wire of the wiring system.
- (2) Connect the GROUND terminal to the other wire.
- (3) Wire circuits of No. 12 or No. 14 AWG wire should have a resistance of approximately 1 megohm. The insulation resistance of wires of larger gage is based on current capacity and should read approximately as follows:

Current capacity (amperes)	Insulation resistance (ohms)
25 through 50.....	250,000
51 through 100.....	100,000

Note. Circuits with a current capacity above 100 amperes cannot be measured on Test Set I-48-B or Ohmmeter ZM-21A/U. The lowest calibration point of the ohmmeter is 100,000 ohms (0.1 megohm).

24. Insulation Test of Electrical Instruments

The insulation resistance between all connected electrical circuits of an electrical instrument and the case should be no lower than 20 megohms. If the instrument has both a current and a voltage circuit, the insulation resistance between the current circuit and the voltage circuit should be no lower than 5 megohms.

25. Insulation Test of Tools and Appliances

The insulation resistance values of tools and appliances should be approximately the same as the insulation resistance value of the wiring system to which they are attached. Tests for short circuits and grounds are made in the same manner as tests of wiring installations (par 23).

26. Measurement of Resistors

Use Test Set I-48-B or Ohmmeter ZM-21A/U to measure the values of resistors in the high megohm range. Resistors of this type are used in telephone and radio equipment. Disconnect resistors before measuring.

27. Insulation Resistance Values of Equipment Under Test

Whenever possible, take minimum insulation resistance values of equipment being tested, using the specifications given in the manual covering the equipment. If specifications are not available, however, use the following table as a guide. The insulation resistance values given below represent minimum requirements for the type of equipment involved.

Type of equipment	Type of test	Insulation resistance (megerohms)
<p>Multiple conductor cables, such as those used to interconnect various parts of radio equipment. (Test with plugs, jacks, and other connecting facilities attached.)</p> <p>Complete power circuit with a current capacity of 5 to 50 amperes.</p> <p>Complete power circuit with a current capacity of 100 amperes or over.</p> <p>Rotating equipment.....</p>	<p>Between single conductor and shield.....</p> <p>Conductor to all other conductors.....</p> <p>Conductor to conductor or conductor to ground.</p> <p>Conductor to conductor or conductor to ground.</p> <p>Between ground and all circuits of equal potential above ground connected together.</p>	<p>100 through 1,000.</p> <p>100 through 500.</p> <p>0.2 through 2.</p> <p>0.1 through 1.</p> <p>Minimum Rated insulation voltage of resistance = equipment. $\frac{Kva \text{ (or kw)}}{\text{rating} + 1,000}$</p> <p>Minimum Rated insulation voltage of resistance = equipment. $\frac{Kva \text{ (or kw)}}{\text{rating} + 1,000}$</p>
Transformers, chokes, and similar apparatus.....	Winding to winding or winding to frame.....	
Ammeters, voltmeters, wattmeters, etc.....	Between all circuits in case to ground..... Between different circuits.....	<p>20 minimum.</p> <p>5 minimum.</p>

28. Locating Low Insulation

a. General. Test Set I-48-B and Ohmmeter ZM-21A/U may be used in locating low insulation of cable caused by moisture. Often in a fault of this type the moisture will dry out, thus restoring the insulation to full effectiveness and clearing the trouble before the trouble can be located. Such a trouble can be made apparent by applying high voltage directly across the fault. This burns in the trouble by breaking down the insulation at the fault and causing the bare wires to make metallic contact. When a solid ground or short circuit has been developed, the fault can be located by a Wheatstone bridge test set or by using tone and an exploring coil.

b. Procedure. To burn in trouble using Test Set I-48-B or Ohmmeter ZM-21A/U, proceed as follows:

- (1) Connect the wire under test to the GUARD terminal of the ohmmeter.
- (2) Connect the cable sheath to the GROUND terminal.
- (3) Turn the hand generator crank at operating speed. Full generator voltage (500 volts) is applied directly across the fault. The current ballast resistors are not in the circuit and there will be no reading on the ohmmeter scale.

29. Stopping Procedure

When insulation resistance tests have been completed, disconnect all test leads from Test Set I-48-B or Ohmmeter ZM-21A/U and from the apparatus being tested. Close the hinged cover on top of the instrument case to protect the meter glass.

Section III. OPERATION UNDER UNUSUAL CONDITIONS

30. General

When operating Test Set I-48-B and Ohmmeter ZM-21A/U in regions where extreme cold, heat, humidity, moisture, or sand conditions prevail, special precautions must be taken to keep the equipment in operating condition at all times. Paragraphs 31 through 33 contain instructions for minimizing the effect of these unusual operating conditions.

31. Operation in Arctic Climates

Since Test Set I-48-B and Ohmmeter ZM-21A/U are intended for both indoor and outdoor use, the equipment may be exposed to extreme cold in actual operation as well as in storage and in transport. When operated at extremely low temperature, the hand generator crank will not operate as easily as at normal room temperatures. Be careful not to force the crank of Test Set I-48-B. The generator drive assem-

bly parts may break. If the ohmmeter is operated in a warm place after exposure to the cold, moisture will condense on the equipment until the equipment reaches room temperature. This condition also arises when the equipment warms up during the day after a cold night. When the ohmmeter has reached room temperature, dry it thoroughly. Perform preventive maintenance operations (par. 38) frequently to keep the unit as moisture-free as possible.

32. Operation in Desert Climates

The main problem when operating the ohmmeter in desert climates is to prevent dirt, dust, and sand from filtering into the equipment. Keep the equipment in the carrying case with the lid closed and latched at all times when not in use, and cover with canvas or other material.

33. Operation in Tropical Climates

When operated in tropical climates, the main difficulty encountered in the operation of the ohmmeter is high relative humidity. Although it is sealed against humidity, moisture still will condense on the outside of the instrument case whenever its temperature becomes lower than the temperature of the air. Moisture collecting between the binding posts lowers the resistance between them and will cause faulty readings. Dry the case with a dry cloth before attempting to make tests with the equipment. Inspect the equipment frequently to keep it free from rust, corrosion, and fungus growth. Perform preventive maintenance operations (par. 38) frequently to keep the unit as moisture-free as possible.

CHAPTER 3

ORGANIZATIONAL MAINTENANCE

Section I. ORGANIZATIONAL EQUIPMENT

34. General

Before starting preventive maintenance procedures, have available all materials needed to perform the operations in the preventive maintenance checklist (par. 38). These materials may be obtained through regular supply channels.

35. Materials

Materials for organizational maintenance operations are listed below:

Signal Corps stock No.	Name of item and description	Used to—
6Z7500-000.....	ABRASIVE, sheet: sandpaper; #000; 9' x 12' sheets.	Remove rust and corrosion from metal parts.
CE supply No. 38-3706.400-130.*	BRUSH, paint: soft hair; flat; 1" wide.	Remove dust, dirt, and lint from scale aperture, from between binding posts, and from interior of carrying case.
CC supply No. 122585.**	CARBON TETRACHLORIDE.	Remove gummy deposits from test lead clips, terminals, and binding post contact surfaces.
6G236.2.....	CLEANING COMPOUND	Remove grease, oil, and corrosion from equipment.
6Z1989.....	CLOTH, textile: cheesecloth; lint-free; 36" wide.	Clean various parts of equipment.
6Z7360.....	STICK: orange.....	Remove fungus growth from equipment.
6N8583.....	TAPE TL-83: friction; 3/4" wide.	Repair test lead insulation.
6G202.11.....	RUBBER CEMENT.....	Cement loose rubber cushions in carrying case.

*Corps of Engineers stock number.

**Chemical Corps stock number.

Caution: Repeated contact of carbon tetrachloride with the skin or prolonged breathing of the fumes is dangerous. Make sure adequate ventilation is provided.

Section II. PREVENTIVE MAINTENANCE

36. Meaning of Preventive Maintenance

Preventive maintenance is a series of systematic operations performed on equipment at regular intervals. It consists of inspections and services designed to keep the equipment in good operating condition. The primary purpose of preventive maintenance is to prevent failures or breakdowns and thus to prevent the necessity of major repairs.

37. General Preventive Maintenance Techniques

- a. Use No. 000 sandpaper to remove corrosion.
- b. Use a clean, dry, lint-free cloth or a dry brush for cleaning.
 - (1) If necessary, except for electrical contacts, moisten or brush with cleaning compound and then wipe the parts with a cloth.
 - (2) Clean electrical contacts with a cloth moistened with carbon tetrachloride and then wipe them dry with a dry cloth.
- c. If available, dry compressed air may be used at a line pressure of not more than 60 pounds per square inch to remove dust from hard-to-reach places. Be careful, however, or mechanical damage from the air blast may result.

Caution: Be careful not to direct the air blast toward the meter movement.

38. Preventive Maintenance

The following check list shows the operator how to maintain the equipment so that trouble shooting and repair can be reduced to a minimum. The list shows what, when, and how to check and precautions to be taken before, during, and after checking the equipment. The operations are self-explanatory.

Item No.	What to Check	When to check*	How to Check	Precautions
1	Exterior of unit-----	W	Inspect for damaged places, dirt, dust, grease, rust, corrosion, fungus, and loose or missing screws. Tighten all loose screws and replace any that are missing. Wipe off dirt and grease with a clean, dry cloth. Use a cloth slightly moistened with cleaning compound to remove dirt, oil, or corrosion. Remove corrosion which cannot be removed with cleaning compound with No. 000 sandpaper and wipe with a dry cloth. If fungus growth is present, be sure the equipment is thoroughly dry before brushing it off. Remove heavy fungus growth with an orange stick and wipe the unit with a clean cloth moistened with cleaning compound.	Do not tighten screws carelessly. Screws tightened beyond the pressure for which they are designed will be damaged or broken.
2	Test leads-----	W	Inspect for loose test clips and terminals, dust, dirt, grease and corrosion on the insulation and the terminations. Use a cloth slightly moistened with cleaning compound to clean leads and terminals. Check leads for breaks in the rubber jacket. If breaks are found, repair by covering with friction tape.	When it is necessary to tape leads, use enough tape to insure good insulation.

Item No.	What to Check	When to check*	How to Check	Precautions
3	Interior of unit-----	M	Carefully remove the mechanism from the bakelite case by removing the four screws that hold the end shield and withdraw the end shield and attached chassis from the case. Inspect for loose or missing mounting screws, dirt, corrosion, loose connections at apparatus terminals, broken wiring, and defective insulation. Tighten loose mounting screws and nuts. Tape leads having defective insulation. Remove dirt and dust from the apparatus and wiring with a soft bristle brush. Wipe accessible parts with a clean, dry cloth. Remove corrosion with a clean cloth moistened with cleaning compound, and use No. 000 sandpaper to loosen corrosion that cannot be removed with solvent. Inspect resistors for blistering, discoloration, and other evidence of overheating.	Tighten screws and nuts securely but do not over-tighten. Be careful not to break connections to terminals of Test Set I-48-B, or to damage wiring. Do not get cleaning compound on insulators. Never use a damp or wet cloth to clean wiring.
4	Carrying case-----	M	Inspect for chipped paint, dirt, dust, grease, corrosion, fungus, and loose or missing screws. Tighten all loose screws and replace any that are missing. Wipe out the interior of the case with a dry cloth and remove dirt adhering to the case with a cloth dampened with cleaning compound. Loosen corrosion that cannot be removed with cleaning compound with No. 000 sandpaper. Examine the sponge rubber case lining. If the lining is loose in any place, fasten it with rubber cement. Check the carrying strap for worn or frayed places, broken or defective buckle parts, and broken or rotted threads in the buckle stitching.	Do not overtighten screws.

*W—Weekly. M—Monthly.

Section III. WEATHERPROOFING

39. Weatherproofing

Signal Corps equipment, when operated under severe climatic conditions such as those prevailing in tropical, arctic, and desert regions, requires special treatment and maintenance. Fungus growth, insects, dust, corrosion, salt spray, excessive moisture, and extreme temperatures are harmful to most materials.

40. Tropical Maintenance

A special moistureproofing and fungiproofing treatment has been devised, which, if properly applied, provides a reasonable degree of protection. This treatment is fully explained in TB SIG 13, Moistureproofing and Fungiproofing Signal Corps Equipment, and TB SIG 72, Tropical Maintenance of Ground Signal Equipment.

41. Winter Maintenance

Special precautions are necessary to prevent poor performance or total operational failure of equipment in extremely low temperatures. These precautions are fully explained in TB SIG 66, Winter Maintenance of Signal Equipment, and TB SIG 219, Operation of Signal Equipment at Low Temperatures.

42. Desert Maintenance

Special precautions are necessary to prevent equipment failure in areas subject to extremely high temperature, low humidity, and excessive sand and dust. These precautions are fully explained in TB SIG 75, Desert Maintenance of Ground Signal Equipment.

Section IV. TROUBLESHOOTING AT ORGANIZATIONAL MAINTENANCE LEVEL

43. Scope

The troubleshooting and repair work that can be performed at the organizational maintenance level (operators and repairmen) is limited in scope by the tools, test equipment, and replaceable parts available and by the existing tactical situation. With the exception of replacing or repairing defective test leads, troubleshooting by the operator consists of the reporting of symptoms to a qualified repairman.

44. Visual Inspection

If the ohmmeter fails to operate properly, inspect the equipment for the following faults before beginning a detailed examination:

- a. Test leads for improper connections.
- b. Test leads for wear, breaks, and disconnections.

45. Equipment Performance Test

a. If visual inspection fails to show any apparent defect in the test leads, test the ohmmeter for full-scale and zero deflection of the pointer on the meter scale. Follow the procedures in paragraph 13.

b. Test the equipment with the **LINE** and **GROUND** terminals connected to resistors of known values.

c. If the pointer fails to move to **INFINITY** or to **ZERO** or to indicate the proper resistance value on the meter scale, turn the equipment in to depot maintenance personnel for complete troubleshooting and repair (pars. 56 through 70).

CHAPTER 4

THEORY

46. General

a. Test Set I-48-B and Ohmmeter ZM-21A/U are designed to measure high values of insulation resistance in megohms of all types of electrical equipment and wiring. The equipment operates from a self-contained power supply which consists of a dc hand generator. The mechanism that drives the hand generator is provided with a centrifugal clutch that disengages when the hand generator crank is turned at a speed of 160 rpm. A constant voltage of 500 volts dc is delivered by the generator. The resistance range of the ohmmeter extends from 0 through 1,000 megohms. The resistance is indicated by a meter mechanism of special design, and the indication shown on the meter scale is as near as possible to a true representation of the insulation resistance of the equipment, the wire, or the cable line under test.

b. The general functioning of the ohmmeter is shown in the block diagram (fig. 14). With the resistor to be measured connected to input terminals E1 and E2, generator G1 applies a potential of 500 volts dc across the insulation being tested. At the same time, the generator supplies the current to operate the moving coil assembly of the meter. The meter measures the test potential applied to the insulation resistance connected across input terminals E1 and E2, and at the same time measures the current through the insulation resistance of the equipment under test.

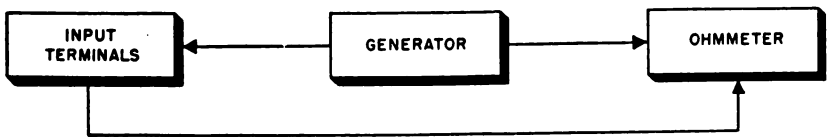

TM 2050-16

Figure 14. Block diagram for test set I-48-B and ohmmeter ZM-21A/U.

47. Meter Movement

a. The meter used in Test Set I-48-B and Ohmmeter ZM-21A/U is shown in figure 15. The indicating instrument consists of two coils, potential coil L2, and current coil L1. These coils, mounted on a common axis and connected so that they oppose each other in a definite ratio, rotate between two pole pieces in a magnetic field. One force tends to move the indicating pointer toward ZERO on the ohmmeter scale; the other force tends to move the pointer toward INFINITY.

b. Current flows to the indicator through flexible ligaments of practically zero torque which connect the ohmmeter terminals to the moving coil assembly. The position at which the pointer finally comes to rest on the scale is determined by the resultant of the two opposing forces that move the coil assembly.

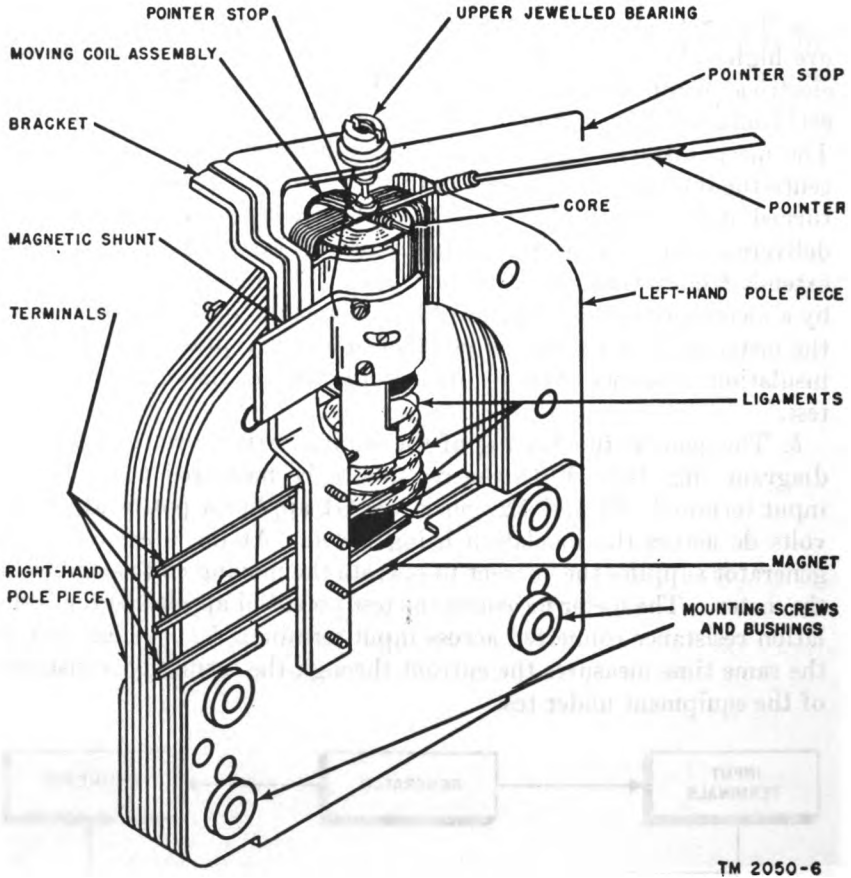

Figure 15. Meter for test set I-48-B and ohmmeter ZM-21A/U.

48. Hand Generator

a. The dc hand generator consists essentially of a rotating armature in a fixed magnetic field. The armature has a 39-bar commutator running between two carbon brushes. When the armature is rotated in the magnetic field, an armature voltage is generated that is led out to the ohmmeter terminals through the carbon brushes. With the generator rotating at the proper speed, the predominant ripple frequency is approximately 1,200 cycles per second (cps) with a peak-to-peak ripple voltage of approximately 6 volts. Because of the low

ac component, no capacitor is required across the output of the generator.

b. The generator drive assemblies of Test Set I-48-B and Ohmmeter ZM-21A/U are shown in figures 16 and 17. The generator is driven by a hand-operated crank through a gear train and clutch assembly. When the crank reaches an operating speed of approximately 160 rpm, centrifugal force disengages the clutch shoes from the hub. Even though the crank may be rotated at a speed greater than 160 rpm, normal voltage will be delivered from the generator.

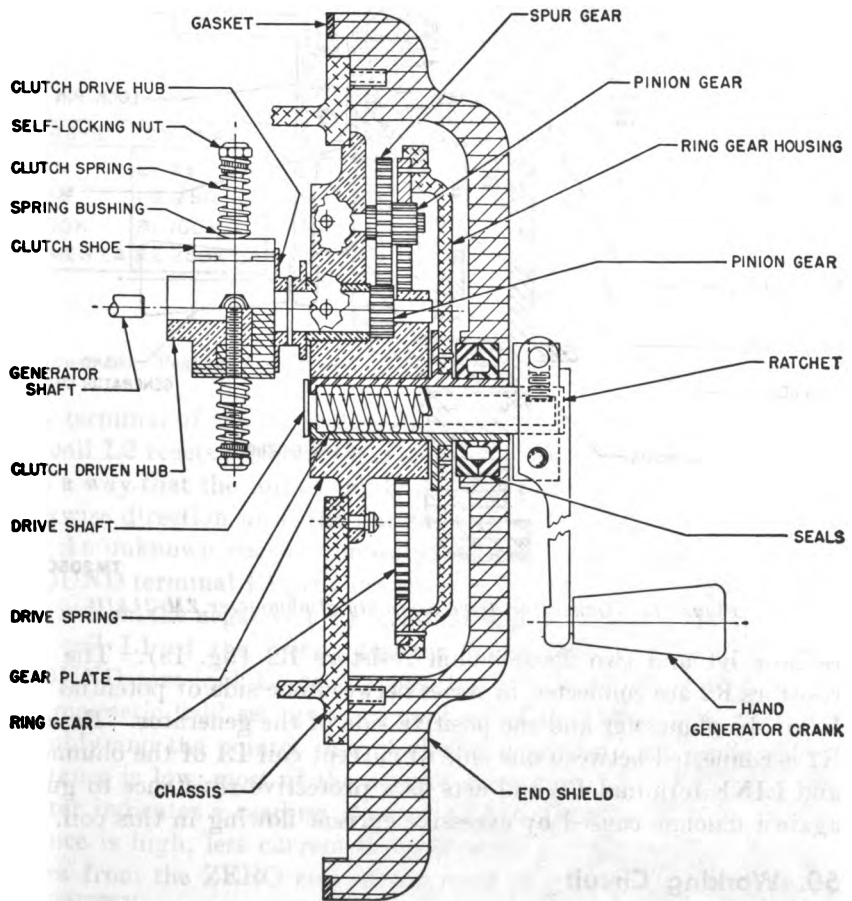

TM 2050-14

Figure 16. Generator drive assembly of test set I-48-B.

49. Resistance Network

The resistance network of Test Set I-48-B consists of one 100,000-ohm resistor R1 and two 1-megohm resistors R2 (fig. 18). The resistance network of Ohmmeter ZM-21A/U consists of one 100,000-ohm

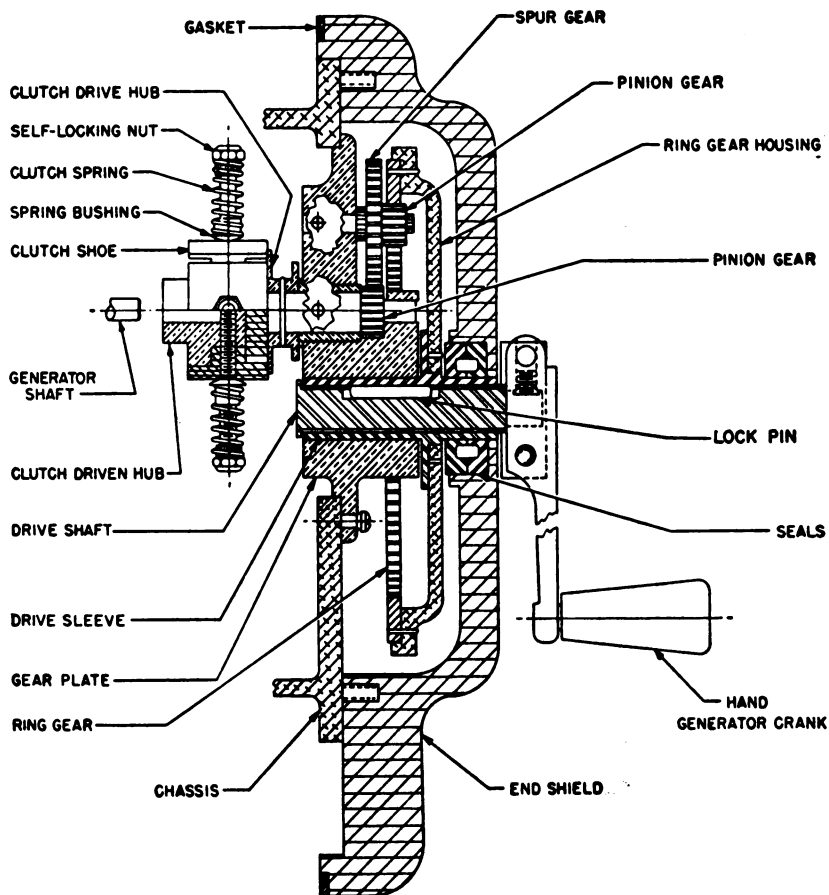

TM2050-20

Figure 17. Generator drive assembly of ohmmeter ZM-21A/U.

resistor **R1** and two 250,000-ohm resistors **R2** (fig. 18). The two resistors **R2** are connected in series between one side of potential coil **L2** of the ohmmeter and the positive side of the generator. Resistor **R1** is connected between one side of current coil **L1** of the ohmmeter and **LINE** terminal **E2** and acts as a protective resistance to guard against damage caused by excessive current flowing in this coil.

50. Working Circuit

a. The working circuit of the insulation resistance measuring set is designated in heavy lines in figure 19. The crank of the hand generator operated at a speed of 160 rpm rotates generator **G1** at approximately 6,000 rpm. The generator delivers a potential of 500 volts dc. With no connections made to the ohmmeter terminals, current flows from the negative (-) terminal of generator **G1**, through potential coil **L2** of the meter, and through the two resistors **R2** to the positive

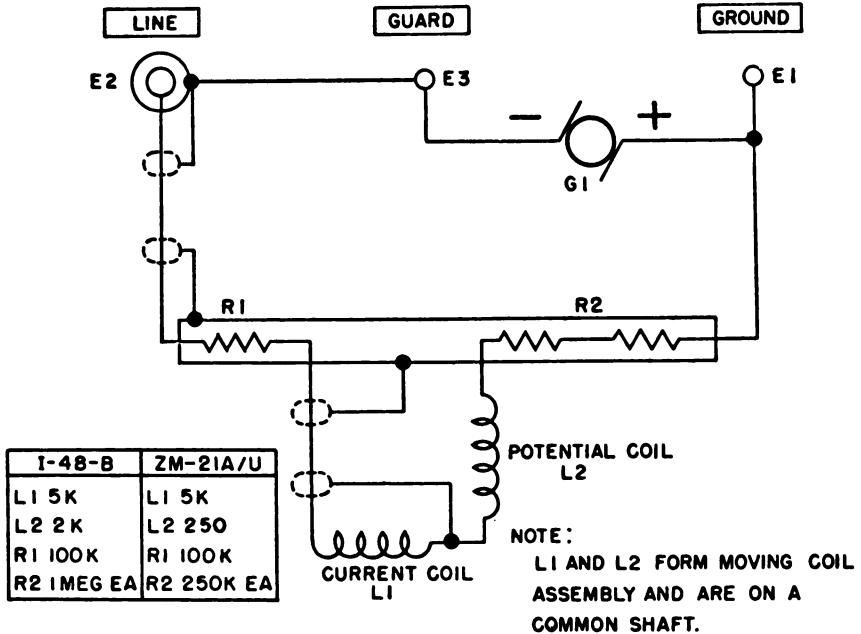

TM 2050-2

Figure 18. Test set I-48-B and ohmmeter ZM-21A/U, schematic diagram.

(+) terminal of the generator. The magnetic field set up by potential coil L2 reacts with the field set up by the permanent magnet in such a way that the coil assembly and the pointer move in a counter-clockwise direction until the pointer indicates INFINITY.

b. An unknown resistor connected between LINE terminal E2 and GROUND terminal E1 provides another path for current flow. This path is from the negative (-) terminal of generator G1, through current coil L1 of the meter, resistor R1, LINE terminal E2, and GROUND terminal E1 to the positive (+) side of generator G1. The magnetic field set up by current coil L1 tends to move the coil assembly and the pointer in a clockwise direction. If the unknown resistance is low, most of the current flows through coil L1 and the pointer indicates a reading close to ZERO. If the value of the resistance is high, less current flows through coil L1 and the pointer moves from the ZERO end of the scale to indicate a point nearer INFINITY.

51. Guard Circuit

The guard circuit is shown in figure 19 in light lines. This circuit is used for measurements over 100 megohms. The guard circuit consists of a metal ring around LINE terminal L2, metal plates on which resistors R1 and R2 are mounted, and, in Test Set I-48-B, a shielded cable that connects the ring and the plates to GUARD terminal E3.

In Ohmmeter ZM-21A/U, a brass tube is used instead of shielded cable. The guard circuit prevents leakage current along the surface of the instrument case between GROUND terminal E1 and LINE terminal E2 from affecting the meter readings. Leakage current to LINE terminal E2 is picked up by the guard ring and led directly to the generator without going through resistor R1 and the meter coils.

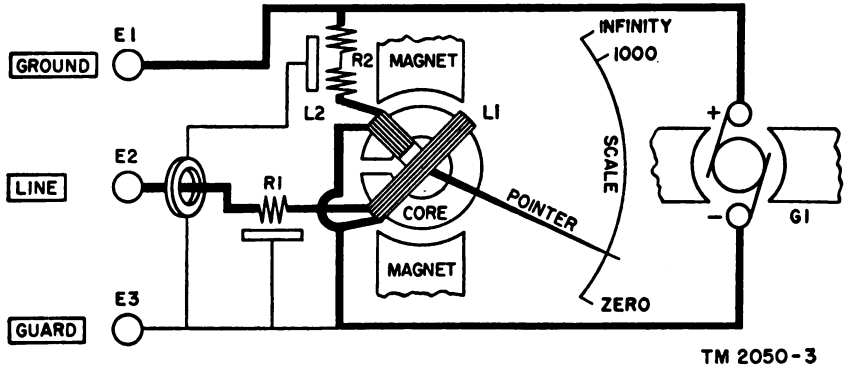

TM 2050-3

Figure 19. Test set I-48-B and Ohmmeter ZM-21A/U, functional diagram.

CHAPTER 5

FIELD MAINTENANCE

Note. This chapter contains information for field maintenance. The amount of repair that can be performed by units having field maintenance responsibility is limited only by the tools and test equipment available and by the skill of the repairman.

Section I. PREREPAIR PROCEDURES

52. Tools, Materials, and Test Equipment

In addition to the materials listed in paragraph 35, the tools, materials, and test equipment required for reconditioning, adjusting, and repairing Test Set I-48-B and Ohmmeter ZM-21A/U are listed in *a* and *b* below.

a. Tools and Materials.

Signal Corps stock No.	Name of item and description	Used to—
6Z2000.....	CLOTH, crocus: 9" x 11".....	Clean commutator.*
6M228-3.....	COMPASS, drafting.....	Mark blank meter scale.
6M614.....	INK: India; black.....	Letter blank meter scale.
6G242.....	INSULATING COMPOUND.....	Caulk meter scale cover.
6Z7515.....	PEGWOOD.....	Clean jewels in meter bearing.
6M1101.....	PEN, ruling.....	Letter blank meter scale.
6Z7517.....	PITHWOOD.....	Clean meter pivots.
6RK19040.1...	SCREWDRIVER: jeweler's; set...	Adjust meter jewels.
6N7531.....	SOLDER 'M-31.....	Resolder equipment wiring.
6R24617.....	SOLDERING IRON TL-117.....	Resolder equipment wiring.

*After using crocus cloth, clean the commutator thoroughly with carbon tetrachloride.

b. Test Equipment.

Signal Corps stock No.	Name of item and description	Used to—
3F4325-505....	ELECTRONIC MULTIMETER TS-505/U: general purpose ac and dc vacuum-tube voltmeter; ranges .05 to 1,000 volts dc, .05 to 200 volts ac, and 1 ohm to 1,000 megohms. (Refer to TM 11-5511.)	Make voltage output and resistance tests.

53. Removal of Chassis and Chassis Cover to Permit Inspection

a. Chassis.

- (1) Break the wax seal covering the screw in the lower right-hand cover of the end shield. Remove this screw and the other three screws that hold the end shield and the attached chassis to the equipment case.
- (2) Extend the hand generator crank until it is at right angles to the end shield. Grasp the crank and withdraw the end shield and the chassis from the case. Be careful not to damage the meter pointer or, in Test Set I-48-B, the wiring to the equipment terminals.

b. Chassis Cover. Remove the screw in the chassis directly in front of the small recessed portion of the chassis cover (fig. 6), and gently pry up the cover on one side. The cover will snap out of the chassis.

54. Inspecting and Cleaning Chassis Assembly

a. Inspecting. When the ohmmeter is turned in for repair and the cause of the trouble is not immediately apparent, make a preliminary inspection of the equipment to determine the extent of repair necessary. Refer to figures 1, 3 through 6, and 15 through 17 for location of parts:

- (1) Inspect the wiring for broken leads and cracked and brittle insulation. Inspect for broken connections to terminals and other parts and for defective soldered connections. Examine for bare wires touching other wires or the chassis.
- (2) Test the operation of the hand generator by turning the crank a number of times. The shaft should move freely and smoothly without binding.
- (3) Inspect for loose or missing screws.
- (4) If there is no indication of damage or fault, operate the unit according to the procedures given in paragraph 45 to see if the test set is operating properly.

b. Cleaning.

- (1) Clean the outside of the equipment with a clean, lint-free cloth.
- (2) Remove dirt and salt spray from the exterior of the equipment with a cloth moistened with clear water. Allow the equipment to dry thoroughly before attempting any further cleaning.
- (3) Brush accumulated carbon dust from the interior of the equipment with a soft bristle brush. Be careful not to damage equipment wiring.
- (4) Remove oil and grease with a cloth moistened with cleaning compound. Wipe dry with a clean, dry cloth.

55. Reassembling Equipment

a. Replace the chassis cover by pushing it into place. It will snap into position when forced gently. Replace the screw on the chassis in front of the chassis cover.

b. Seat the gasket on the ridge on the inside face of the end shield. If the gasket is damaged, replace it with a new one.

c. Grasp the hand generator crank and carefully insert the chassis assembly into the case.

d. Replace the four screws on the end shield and tighten them securely. Reseal the lower right-hand screw by placing sealing wax in the cup provided on the screw.

Section II. TROUBLESHOOTING AT FIELD MAINTENANCE LEVEL

56. Troubleshooting

The purpose of troubleshooting is to locate and remove quickly the cause of faulty operation or the failure of equipment. Operational difficulties have definite symptoms that serve as clues to the cause of the trouble. The chart in paragraph 58 indicates the various troubles that may be experienced, the possible causes, and the suggested remedies. The tests in paragraph 59 give the repairman the procedures to follow to isolate the possible cause of trouble.

57. Troubleshooting Data

Before proceeding with the actual location of trouble, a knowledge of the functioning of the ohmmeter and the theory of operation is necessary. The detailed functioning of Test Set I-48-B and Ohmmeter ZM-21A/U is covered in paragraphs 46 through 51. The troubleshooting chart (par. 58) can be used as a reference when attempting to locate trouble in the equipment. To supplement the theory of operation and to locate parts, refer to the following illustrations:

- a.* Complete schematic diagram (fig. 18).
- b.* Functional diagram (fig. 19).
- c.* Block diagram (fig. 14).
- d.* Illustrations showing locations of parts (fig. 1, 3 through 6, and 15 through 17).

58. Troubleshooting Chart

Symptom	Probable cause	Correction
Meter will not indicate ZERO with GROUND terminal E1 and LINE terminal E2 connected together.	Defective resistor R1-----	Replace resistor R1.
	Loose connection to LINE or GROUND terminal (in I-48-B).	Resolder connection.
	Loose connection to meter terminal.	Resolder connection.
Meter will not indicate INFINITY with no connections to terminals.	Loose connection or broken wire to generator commutator.	Repair connection or replace wire.
	Defective meter armature.	Replace armature (par. 62).
	Defective resistor R2-----	Replace resistor R2.
Meter indication incorrect when testing known resistance.	Loose connection to meter terminal.	Resolder connection.
	Loose connection or broken wire to generator commutator	Repair connection or replace wire.
	Defective meter armature.	Replace armature (par. 62).
Generator does not operate when crank is turned.	Defective resistor R1 or R2.	Replace resistor R1 or R2.
	Defective meter armature.	Replace armature (par. 62).
Generator voltage low-----	Broken drive shaft ratchet (in I-48-B).	Replace ratchet (par. 65).
	Loose clutch shoe adjustment.	Tighten clutch shoes (par 73).
Generator voltage high-----	Defective or worn generator brushes.	Replace brushes (par. 64a and b).
	Defective generator armature.	Replace generator armature (par. 64).
	Tight clutch shoe adjustment.	Loosen clutch shoes (par. 73).

59. Troubleshooting Procedures

a. Indicator Scale Test. The indicator scale test may localize a faulty meter reading to the indicating instrument. Proceed as follows:

- (1) Connect the LINE and GROUND terminals to known resistances.
- (2) Operate the hand generator crank. Note any deviation between the known resistance values and the values shown on the indicator scale of the test set.
- (3) The deviation from any marked point on the scale should not exceed one thirty-second of an inch.

b. Output Voltage Test. The output voltage test may show that the generator is defective or that the clutch needs adjustment. Proceed as follows:

- (1) Connect Electronic Multimeter TS-505/U to the GROUND and GUARD terminals.
- (2) Turn the hand generator crank until the clutch slips. Note the output voltage.
- (3) The output voltage of the generator should be between 500 and 525 volts dc. If the multimeter reading is below 500 volts, adjust the clutch according to directions in paragraph 73e. If the reading is above 525 volts, adjust the clutch according to directions in paragraph 73d.

Note. Low output voltage that cannot be adjusted may be caused by an open current coil in the indicating instrument.

c. Resistance Network Test. Disconnect the three resistors and check each separately with Electronic Multimeter TS-505/U. The resistors should check within 1 percent of their marked values. Normal resistance values are given in figure 18.

d. Continuity Test. Check the continuity of the circuit, point-to-point, with Electronic Multimeter TS-505/U. Check for possible short circuits in the same manner.

e. Intermittent Trouble. Do not overlook the possibility of an intermittent trouble. If an intermittent trouble is suspected, try to make it appear by jarring or tapping the equipment.

Section III. REPAIRS

60. Replacement of Parts

Only competent personnel with adequate tools and equipment are authorized to repair Test Set I-48-B and Ohmmeter ZM-21A/U. All parts can be reached easily for replacement by removing the chassis assembly from the case. When removing wiring from terminals, either by unsoldering or by loosening screw-type terminals, tag each wire to facilitate correct wiring when a new part is installed. Be careful not to damage adjacent parts when removing, installing, and connecting new parts. Any replacement part should be identical with the original and installed in the same physical position as the part that it replaces. When replacing wiring, be sure that each new piece of wire is the same length as the wire being replaced.

61. Replacement of Meter

a. Remove the chassis from the case according to directions in paragraph 53.

b. Unsolder the connections to the meter terminals (fig. 15). Tag the wires so that they may be replaced properly.

c. Remove the mounting screws and bushings from the meter magnet and remove the meter (fig. 15).

d. Install a new meter; use the same screws and bushings that were used to mount the old instrument. Resolder the equipment wiring to the meter terminals.

e. Replace the meter scale plate (figs. 4 and 6) with a blank scale plate. Calibrate and mark the new scale plate as shown in figure 20, according to directions in paragraph 72.

62. Replacement of Meter Armature

a. Remove the meter as directed in paragraph 61*a* through *c*.

b. Disconnect the ligaments and terminals from the moving coil assembly (fig. 15).

c. Back off the upper jewelled bearing, and carefully withdraw the armature from the magnet.

d. Install a new armature, and replace the upper jewelled bearing. Reconnect the ligaments and terminals to the moving coil assembly.

Caution: Be extremely careful not to damage the coil pivots or the pointer.

e. Replace the meter and meter scale plate as instructed in paragraph 61*d* and *e*. Calibrate and mark the new meter scale according to directions in paragraph 72.

63. Replacement of Hand Generator

a. Remove the chassis and chassis cover as directed in paragraph 53.

b. Remove the two snap buttons on the under side of the chassis.

c. Disconnect the leads from the generator brush-holder terminals.

d. Remove the self-locking nuts, two of which can be reached from the top of the chassis and the other two through the holes on the under side of the chassis from which the snap buttons were removed. Withdraw the generator from the chassis.

e. Knock out the taper pin that retains the clutch driven hub (figs. 16 and 17), and remove the hub.

f. Install the clutch hub and the new generator by drilling the generator shaft and pinning the hub to the shaft.

g. Place the new generator on the chassis, and replace the self-locking nuts. On the underside of the chassis, return the snap buttons to the holes from which they were removed.

h. Reconnect the leads to the generator brush-holder terminals.

64. Replacement of Hand Generator Armature

a. Remove the generator in accordance with directions in paragraph 63*a* through *d*.

b. Remove the generator brush caps (fig. 4), and remove the brushes.

- c.* Remove the two self-locking nuts at the front end of the generator (fig. 5).
- d.* Withdraw the armature, and replace it with a new one.
- e.* Place the end bell in position, and replace the self-locking nuts.
- f.* Replace the generator brushes and brush caps.
- g.* Reinstall the generator as instructed in paragraph 63*g* and *h*.

65. Replacement of Drive Shaft Ratchet in Test Set I-48-B

a. Remove the chassis assembly and chassis cover as instructed in paragraph 53.

b. Remove the setscrew from the hand generator crank, and remove the crank and ratchet from the drive shaft.

c. Remove broken pieces of the damaged ratchet by holding the end shield face down and gently shaking the equipment. All broken pieces must be removed.

Caution: Be careful not to disconnect the wiring to the equipment terminals.

d. Press the new ratchet into the crank. Aline the hole in the side of the ratchet with the setscrew hole in the crank.

e. Replace the setscrew, and tighten it until it passes into the ratchet hole. At this point, do not allow the setscrew to pass through the ratchet.

f. Hold the end of the drive shaft against the gear plate with one hand, rotating it if necessary until the flat on the shaft faces upward. With the other hand, slide the ratchet and hand generator crank over the drive shaft. Be sure that the setscrew is positioned over the flat on the shaft. Tighten the setscrew.

g. Reassemble the equipment as directed in paragraph 55.

66. Replacement of Terminals

When replacing terminals, be very careful to install all washer and insulator bushings in the same order in which they were originally installed. Observe this precaution especially in the case of the LINE terminal. This is the terminal on which the guard ring is mounted.

67. Replacement of Meter Window Glass

a. Remove the rectangular nickel-plated bezel from the top surface of the meter window (fig. 1).

b. Lift out the old meter window glass and clean away old insulating compound from around the meter scale aperture.

c. Place insulating compound around the scale aperture, and press the new meter window glass in place.

d. Press the bezel down firmly over the glass.

68. Replacement of Meter Window Cover

- a. Remove the four screws that hold the pillow blocks in place (fig. 1).
- b. Lift off the pillow blocks. Lift the old cover out of the recess above the meter window into which it fits.
- c. Install a new cover and replace the pillow blocks.

69. Lubrication of Ohmmeter at Field Maintenance Level

a. *General.* The generator ball bearings and the drive assembly gear train are lubricated by the manufacturer and ordinarily will require no further lubrication. When the generator is disassembled for repair, however, lubricate these parts in accordance with instructions in *c* below.

b. *Disassembly.*

- (1) Remove the chassis and chassis cover (par. 53) and inspect and clean the chassis assembly as instructed in paragraph 54.
- (2) Clean all parts to be lubricated with a clean, soft brush or a clean, lint-free cloth dampened with cleaning compound.

c. *Lubrication.* Apply a small amount of Grease, Aircraft and Instruments (GL) (QMC supply No. 14-G-160-900) to the generator ball bearings and the entire drive assembly gear train with the tip of a finger. Wipe off excess lubricant with a clean, lint-free cloth. Grease (GL) is an all-weather grease. No special precautions are necessary when this lubricant is used in arctic climates. The grease also is satisfactory for use in high desert and tropical temperatures.

70. Refinishing

a. Refinishing procedures apply only to the carrying cases of Test Set I-48-B and Ohmmeter ZM-21A/U. The molded plastic instrument case cannot be refinished. When painted finishes have been badly marred, retouch the surfaces if the bare parts are restricted to small areas, but refinish the entire case if the damaged areas are large.

b. Use No. 000 sandpaper to clean the surface down to the bare metal or wood. Refinish affected surfaces to match the original finish; applying one coat of enamel or paint. Use authorized paint, consistent with existing regulations.

Section IV. CALIBRATION AND ADJUSTMENT

71. Equipment Required for Calibration of Meter Scale

In addition to Electronic Multimeter TS-505/U (par. 52b), the following equipment is required for calibrating the meter scale:

- a. 10 resistors, .1 megohm ± 1 percent (Sig C stock No. 3Z6700-31).
- b. 10 resistors, 1 megohm ± 1 percent (Sig C stock No. 3Z67801-95).
- c. 10 resistors, 10 megohms ± 1 percent (Sig C stock No. 3Z6810-31).
- d. 10 resistors, 100 megohms ± 1 percent (Sig C stock No. 3Z6901).

72. Calibrating and Marking of Meter Scale

Note. Before calibrating a new meter scale, check the output voltage of the ohmmeter (par. 59b). If the output voltage is above 525 volts or below 500 volts, adjust the clutch as instructed in paragraph 73.

a. Calibrating. To calibrate a blank meter scale, proceed as follows:

- (1) Connect the LINE and GROUND terminals together, and turn the hand generator crank at operating speed. The meter pointer should deflect to the right-hand end of the blank scale plate. This point is the ZERO calibration on the scale. Mark this point in pencil.
- (2) Remove the connector between the LINE and GROUND terminals of the ohmmeter, and again turn the hand generator crank at operating speed. The pointer should deflect to the opposite end of the blank scale plate. This is the INFINITY point on the scale. Mark this point in pencil.
- (3) Connect resistors (par. 71), singly or in series, to obtain the various values of resistance similar to those indicated on the original scale (fig. 20). Connect the resistors between the LINE and GROUND terminals of the ohmmeter. Each time turn the hand generator crank at operating speed. Mark each value of resistance on the blank scale plate in pencil.

b. Marking. Remove the meter scale plate from its bracket and draw in the new points of calibration with India ink. Use a straight-edge and a draftsman's ruling pen. Letter the resistance values on the scale with a LeRoy lettering pen.

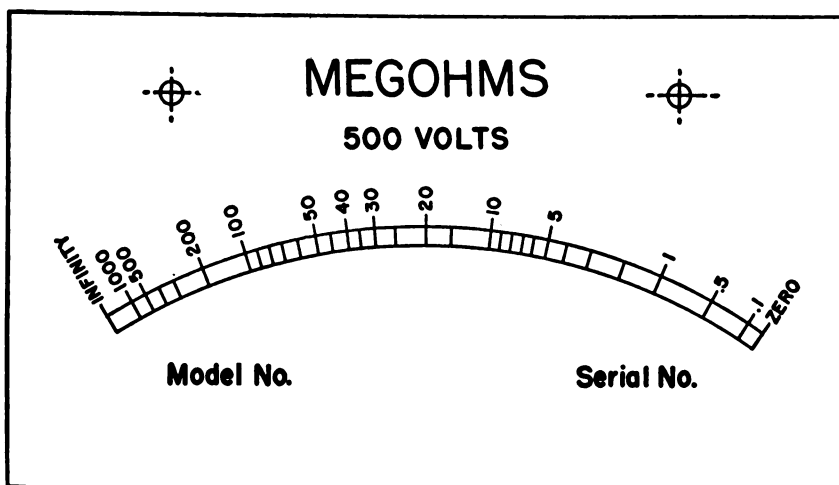

Figure 20. Meter scale.

TM 2050-15

73. Adjustment of Clutch

The clutch adjustment controls the slip-speed of the hand generator which, in turn, controls the output voltage of the generator. The clutch in a properly adjusted instrument slips when the generator is rotating fast enough to develop between 500 and 525 volts. To adjust the clutch slip, vary the pressure exerted upon the clutch drive hub and the clutch driven hub (figs. 16, 17, and 21) as follows:

a. Remove the chassis and chassis cover (par. 53).

b. Connect Electronic Multimeter TS-505/U between the GROUND and GUARD terminals.

c. Turn the hand generator crank, and when the clutch slips, note the output voltage.

d. If the voltage reading is above 525 volts, the slip-speed of the clutch must be lowered. Loosen the self-locking nuts that bear on the clutch springs (fig. 21). Loosen each nut about one-fourth of a turn. Operate the hand generator crank again until the clutch slips. If the voltage still is above 525 volts, repeat the adjustment until the reading on the multimeter is within the 500- to 525-volt range.

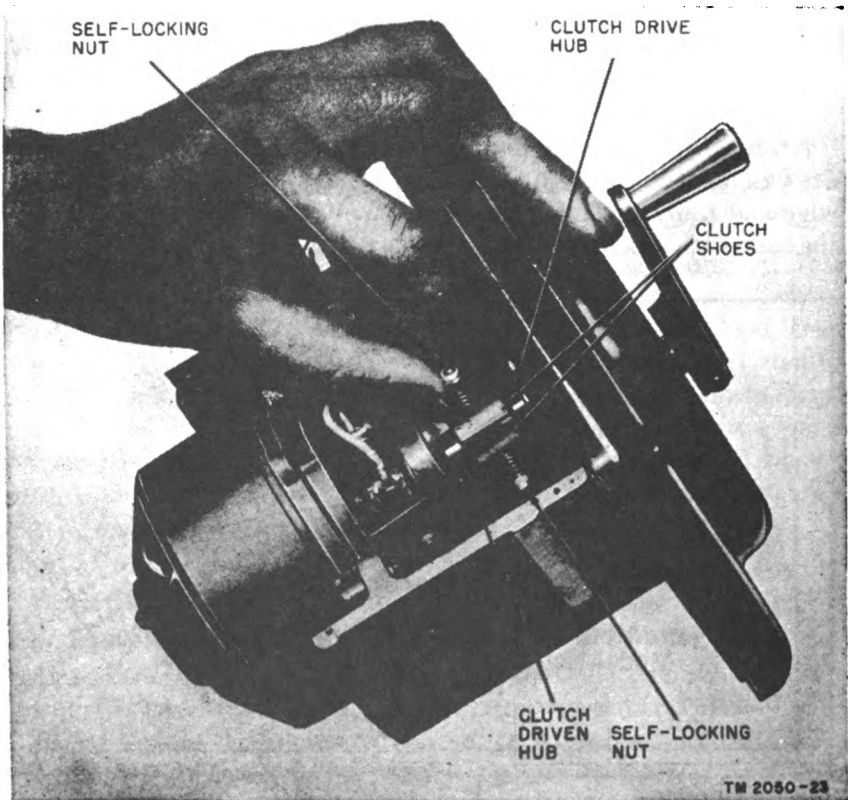

Figure 21. Adjusting output voltage.

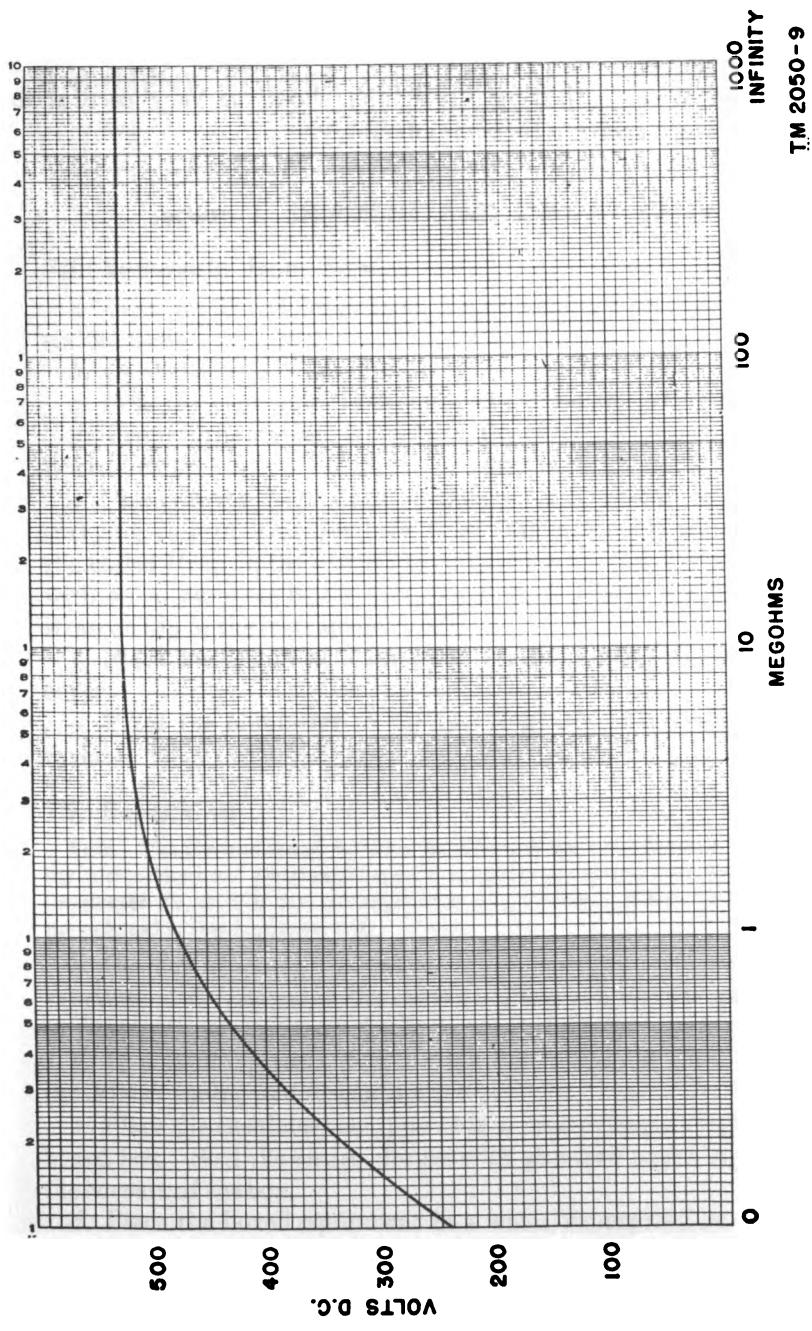

Figure 22. Terminal voltages for various resistances under test.

T.M. 2050-9

e. If the voltage reading is below 500 volts, the slip-speed of the clutch must be raised. Tighten each self-locking nut about one-fourth of a turn, operate the hand generator crank until the clutch slips, and check the voltage. Repeat this adjustment until an output of 500 volts has been obtained.

Caution: When adjusting the clutch shoes, be very careful to tighten or loosen each nut the same amount.

CHAPTER 6

SHIPMENT, LIMITED STORAGE, AND DEMOLITION TO PREVENT ENEMY USE

Section I. SHIPMENT AND LIMITED STORAGE

74. Removing from Service

a. Remove all test leads from the ohmmeter terminals. Coil and tie the leads.

b. Close the meter scale cover.

c. Fold the generator crank handle to its nonoperating position.

d. Remove the webbed strap from the carrying case, coil it, and tie it with cotton tape.

e. Place the test leads in the compartment provided for them in the carrying case of Test Set I-48-B or Ohmmeter ZM-21A/U. Place the coiled strap in the test lead compartment. (In Test Sets I-48-B with serial numbers below 5527, place the test leads and the carrying strap on top of the instrument case.)

f. Place the technical manuals in the holder in the carrying case cover.

g. Place the ohmmeter in the carrying case. Close and latch the cover.

75. Repacking

Note. The circumstances involved in shipment and storage vary. The following instructions are recommended as a guide for preparing Test Set I-48-B and Ohmmeter ZM-21A/U for transportation and storage. Whenever possible, use the original packaging materials.

a. Cushion the cased ohmmeter on all surfaces with cells or pads fabricated of corrugated fiberboard. This will absorb the shock of impact normally encountered in handling and during transit.

b. If possible, place a dehydrating agent, such as silica gel, inside the cells of corrugated fiberboard.

c. Place the cushioned equipment in a close-fitting corrugated fiberboard box. Seal the entire closure with gummed paper tape. Blunt the corners of the box.

d. Place the boxed equipment in a water-vaporproof barrier. Extract the air and heat-seal the barrier.

e. Place the barrier-wrapped box in a second close-fitting corrugated fiberboard box. Seal the box with water-resistant tape or adhesive.

Section II. DEMOLITION OF MATERIEL TO PREVENT ENEMY USE

76. General

The demolition procedures in paragraph 77 will be used to prevent the enemy from using or salvaging this equipment. Demolition of the equipment will be accomplished only upon order of the commander.

77. Methods of Destruction

a. Smash. Smash the meter window glass and break off the indicating needle. Smash the instrument case, chassis, meter, generator, binding posts, and carrying case. Use sledges, axes, handaxes, pickaxes, hammers, crowbars, or heavy tools.

b. Cut. Cut test leads, wiring, and carrying strap. Use axes, handaxes, or machetes.

c. Burn. Burn the carrying strap, Signal Corps forms, office records, technical manuals, and the carrying case of early models of Test Set I-48-B.

d. Disposal. Bury or scatter the destroyed parts in slit trenches, fox holes, or other holes, or throw into streams.

e. Destroy. Destroy everything.

INDEX

	<i>Paragraph</i>	<i>Page</i>
A. c. and d. c. rotating machines, insulation resistance test:		
Rated at 600 volts or less.....	16	16
Rated over 600 volts.....	17	16
Adjustment:		
Clutch.....	73	50
Output voltage:		
High.....	73b	50
Low.....	73c	50
Appliances and tools, insulation resistance test.....	25	25
Application, equipment.....	4	3
Arctic operation.....	31	27
Armature, replacement:		
Hand generator.....	64	46
Meter.....	62	46
Binding posts, location.....	7a	5
Bushings, insulating, insulation resistance test.....	20	18
Cables and wires, insulation resistance test:		
Power.....	21	19
Telephone and telegraph.....	22	21
Calibration of meter scale.....	72	49
Capacitors, insulation resistance test.....	19	18
Characteristics, technical.....	5	4
Check, preoperational.....	13	14
Checking equipment:		
New.....	9	12
Operation.....	13, 45	14, 34
Reconditioned.....	11	13
Used.....	11	13
Checklist, preventive maintenance.....	38	30
Cleaning:		
Chassis assembly.....	54b	42
Techniques, general.....	37	30
Clutch, adjustment.....	73	50
Computing insulation resistance requirements for cable.....	22b	22
Connections:		
Equipment test.....	13, 45	14, 34
Guard circuit.....	14	14
Insulation resistance test:		
A. c. and d. c. rotating machines:		
Rated at 600 volts or less.....	16	16
Rated over 600 volts.....	17	16
Cables and wires:		
Power.....	21	19
Telephone and telegraph.....	22	21
Capacitors.....	19	18

	<i>Paragraph</i>	<i>Page</i>
Connections—Continued		
Insulation resistance test—Continued		
Electrical instruments.....	24	25
Insulating bushings.....	20	18
Radio equipment.....	26	25
Tools and appliances.....	25	25
Transformers.....	18	17
Continuity test, field maintenance.....	59 <i>d</i>	45
Cover, meter window, replacement.....	68	48
Demolition, methods.....	76	54
Description.....	3	2
Desert:		
Maintenance.....	42	33
Operation.....	32	28
Destruction of equipment.....	76	54
Differences in equipment.....	7	5
Dimensions, equipment:		
Packed:		
Domestic shipment.....	8 <i>a</i>	8
Oversea shipment.....	8 <i>b</i>	9
Unpacked.....	6	4
Disassembly, field maintenance.....	53	42
Drive shaft ratchet, I-48-B, replacement.....	65	47
Electrical instruments, insulation resistance test.....	24	25
Equipment:		
Application.....	4	3
Description.....	3	2
Destruction.....	76	54
Performance test.....	45	34
Table.....	6	4
Test:		
Continuity.....	59 <i>d</i>	45
Indicator scale.....	59 <i>a</i>	44
Operational.....	45	34
Output voltage.....	59 <i>b</i>	45
Performance.....	45	34
Preoperational.....	13	14
Resistance network.....	59 <i>c</i>	45
Field maintenance:		
Test equipment.....	52 <i>b</i>	41
Tools and materials.....	52 <i>a</i>	41
Troubleshooting:		
Chart.....	58	44
Procedures.....	59	44
Forms and records.....	2	2
Functioning of equipment.....	46-51	35
Glass, meter window, replacement.....	67	47
Guard circuit, theory.....	51	39
Hand generator:		
Armature, replacement.....	64	46
Replacement.....	63	46
Theory.....	48	36

	<i>Paragraph</i>	<i>Page</i>
Indicator scale test, field maintenance.....	59a	44
Inspecting:		
Chassis assembly, field maintenance.....	54a	42
Visual, troubleshooting, field maintenance.....	54a	42
Insulating bushings, insulation resistance test.....	20	18
Insulation resistance:		
Requirements, cable:		
Computing.....	22b	22
Spiral-four.....	22d	23
Telephone.....	22c	23
Tests.....	16-26	16
Intermittent trouble, checking.....	59e	45
List of equipment.....	6	4
Locating low insulation resistance.....	28	27
Maintenance:		
Arctic.....	41	33
Desert.....	42	33
Field:		
Test equipment.....	52b	41
Tools and materials.....	52a	41
Troubleshooting procedures.....	59	44
Lubrication.....	69	48
Materials:		
Field.....	52a	41
Organizational.....	35	29
Preventive.....	35	29
Organizational:		
Equipment performance test.....	45	34
Materials.....	35	29
Meaning.....	36	30
Preservative application.....	42	33
Preventive:		
Checklist.....	38	30
Materials.....	35	29
Meaning.....	36	30
Refinishing.....	70	48
Test equipment, field.....	52b	41
Tools, field.....	52a	41
Tropical.....	40	33
Winter.....	41	33
Marking meter scale.....	72b	49
Measurements, insulation resistance.....	16-26	16
Meter:		
Scale:		
Calibration.....	72a	49
Marking.....	72b	49
Replacement.....	61	45
Armature.....	62	46
Scale plate.....	61e, 62e	46
Theory.....	47	35
Window, replacement:		
Cover.....	68	48
Glass.....	67	47
Moistureproofing and fungiproofing.....	42	33

	<i>Paragraph</i>	<i>Page</i>
New equipment, checking.....	9	12
Operating procedures.....	16-26	16
Operation:		
Insulation resistance test:		
A. c. and d. c. rotating machines:		
Rated at 600 volts or less.....	16	16
Rated over 600 volts.....	17	16
Cables and wires:		
Power.....	21	19
Telephone and telegraph.....	22	21
Capacitors.....	19	18
Electrical instruments.....	24	25
Insulating bushings.....	20	18
Radio equipment.....	26	25
Tools and appliances.....	25	25
Transformers.....	18	17
Theory.....	51-56	39
Under usual conditions:		
Arctic.....	31	27
Desert.....	32	28
General.....	30	27
Tropical.....	33	28
Under usual conditions.....	16-26	16
Use of ohmmeter in locating low insulation resistance.....	28	27
Operational test.....	45	34
Organizational maintenance:		
Inspection, visual.....	49	37
Materials.....	35	29
Techniques, general.....	37	30
Test.....	45	34
Output voltage test, field maintenance.....	59b	45
Meaning.....	36	30
Packaging data:		
Domestic shipment.....	8a	8
Oversea shipment.....	8b	9
Performing preventive maintenance.....	38	30
Preoperational test.....	13	14
Preventive maintenance:		
Checklist.....	38	30
Materials.....	35	29
Meaning.....	36	30
Performing.....	38	30
Techniques, general.....	37	30
Ratchet, drive shaft replacement, I-48-B.....	65	47
Reassembling equipment, field maintenance.....	55	43
Reconditioned equipment, checking.....	11	13
Refinishing.....	70	48
Repacking for shipment or storage.....	75	53
Repainting.....	70	48
Repair equipment, general.....	60	45
Replacement of parts:		
Drive shaft ratchet, I-48-B.....	65	47
General.....	60	45

Replacement of parts—Continued		<i>Paragraph</i>	<i>Page</i>
Hand generator		63	46
Hand generator, armature		64	46
Meter		61	45
Armature.....		62	46
Scale plate.....	61e, 62e		46
Meter window:			
Cover.....		68	48
Glass.....		67	47
Terminals		66	47
Requirements, insulation resistance, cable:			
Computing.....	22b		22
Spiral-four.....	22d		23
Telephone.....	22c		23
Resistance:			
Network:			
Test, troubleshooting.....	59c		45
Theory.....	49		37
Range, equipment.....	5		4
Resistors, measurement.....	26		25
Scale, meter:			
Calibrating.....	72a		49
Marking.....	72b		49
Scope:			
Maintenance, organizational.....	43		33
Manual.....	1		2
Technical characteristics	5		4
Techniques of preventive maintenance, general	37		30
Terminals, replacement	66		47
Test:			
Connections, equipment.....	13, 45		14, 34
Equipment:			
Calibration and adjustment procedures.....	72, 73		49, 50
Field maintenance.....	52b		41
Theory:			
Equipment, general.....	46		35
Guard circuit.....	51		39
Hand generator.....	48		36
Meter.....	47		35
Resistance network.....	49		37
Working circuit.....	50		38
Tools, field maintenance	52a		41
Tools and appliances, insulation resistance test	25		25
Transformers, insulation resistance test	18		17
Tropical:			
Maintenance.....	40		33
Operation.....	33		28
Troubleshooting:			
Chart, field maintenance.....	58		44
Data.....	57		43
Field maintenance.....	56-59		43
Organizational maintenance.....	44, 45		33, 34
Procedures:			
Field maintenance.....	59		44
Organizational maintenance.....	37		30

	<i>Paragraph</i>	<i>Page</i>
Troubleshooting—Continued		
Test equipment, field maintenance.....	52b	41
Using equipment performance test.....	45	34
Uncrating, unpacking, and checking:		
General instructions.....	9a	12
Packed for domestic shipment.....	9b	12
Packed for oversea shipment.....	9c	12
Unusual conditions, operation.....	31-33	27
Use, equipment.....	4	3
Used equipment, checking.....	11	13
Visual inspection, organizational maintenance.....	44	33
Voltage output.....	5	4
Adjusting.....	73	50
Test, field maintenance.....	59b	45
Weatherproofing.....	39-42	33
Winter maintenance.....	41	33
Working circuit, theory.....	50	38

[AG 413.6 (11 Aug 54)]

BY ORDER OF THE SECRETARY OF THE ARMY:

M. B. RIDGWAY,
General, United States Army,
Chief of Staff.

OFFICIAL:

JOHN A. KLEIN,
Major General, United States Army,
The Adjutant General.

DISTRIBUTION:

Active Army:

Tec Svc, DA (1)
 Tec Svc Bd (1)
 AFF (5)
 AFF Bd (incl ea Test Sec) (1)
 Army AA Comd (2)
 OS Maj Comd (5)
 OS Base Comd (5)
 Log Comd (5)
 MDW (1)
 Armies (5)
 Corps (2)
 Tng Div (2)
 Ft & Cp (2)
 USMA (5)
 Gen & Br Svc Sch (5)
 SigC Sch (25)
 Gen Depots (2)
 SigC Sec, Gen Depots (10)
 SigC Depots (20)
 POE (2)

OS Sup Agencies (2)
 SigC Fld Maint Shops (3)
 SigC Lab (5)
 Mil Dist (1)
 Units organized under following
 T/O & E's:
 5-500A (AA-AC), Engr
 Admin Teams (2)
 11-65, Sig Hv Cons Bn (2)
 11-127, Sig Rep Co (2)
 11-128A, Sig Depot Co (2)
 11-500A (AA-AE), Sig
 Admin Teams (2)
 11-587A, Sig Base Maint Co
 (2)
 11-592A, Hq & Hq Co, Sig
 Base Depot (2)
 11-597A, Sig Base Depot Co
 (2)

NG: Same as Active Army except allowance is one copy for each unit.

USAR: None.

Unless otherwise noted, distribution applies to ConUS and overseas.

For explanation of abbreviations used, see SR 320-50-1.

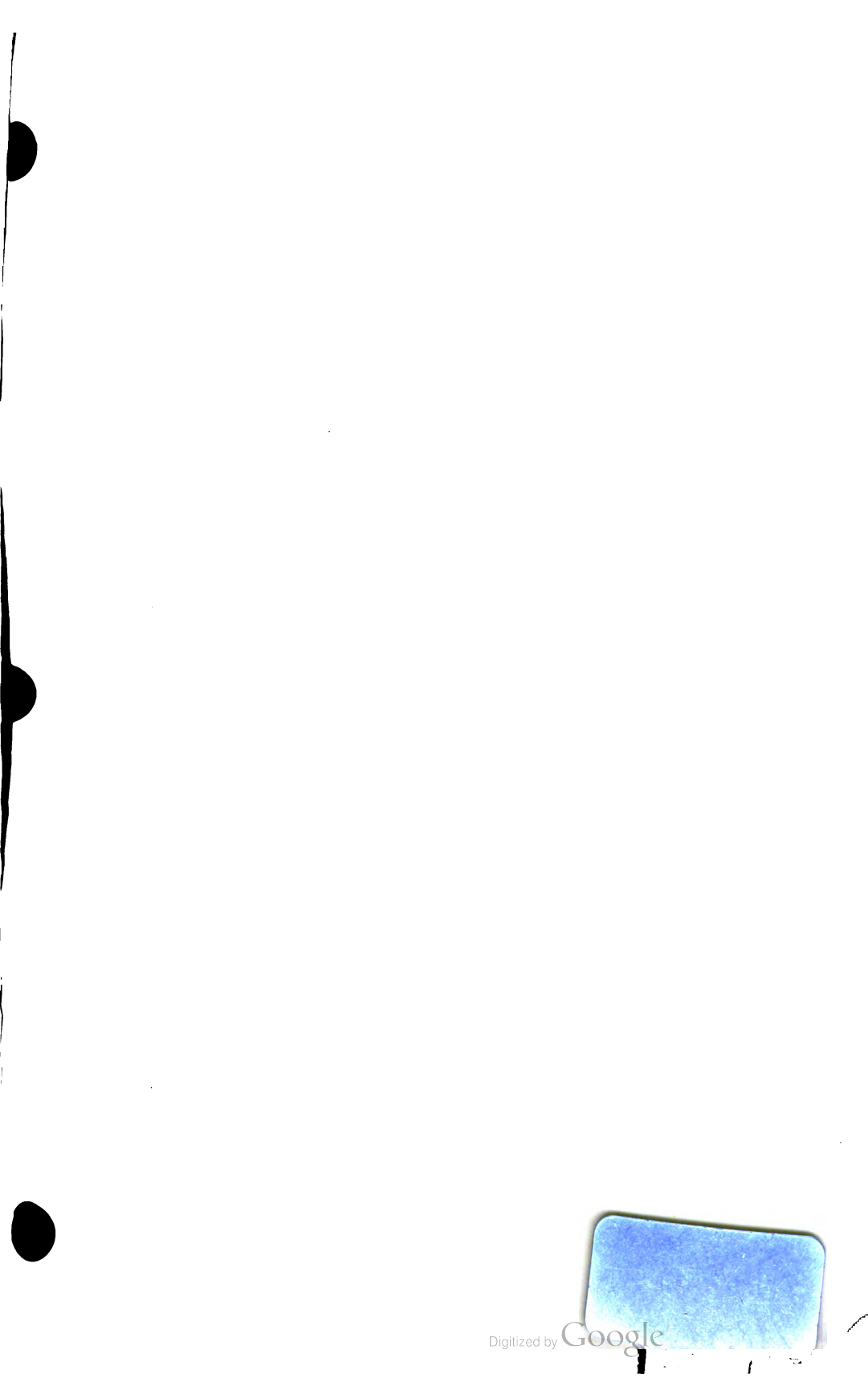

TM 11-2050 TEST SET I-48-B AND OHMMETER ZM-21A/U--1954