

**TECHNICAL MANUAL  
OPERATOR, UNIT, AND DIRECT SUPPORT  
MAINTENANCE MANUAL  
FOR  
TENT, EXTENDABLE, MODULAR, PERSONNEL  
(TEMPER)**

TYPE I, 64 x 20 SURGICAL WORK, GREEN, NSN: 8340-01-185-2616  
 TYPE II, 64 x 20 MEDICAL. GREEN, NSN: 8340-01-185-2617  
 TYPE III, 48 x 20 UTILITY, GREEN, NSN: 8340-01-185-2615  
 TYPE IV, 32 x 20 PERSONNEL, GREEN, NSN: 8340-01-196-6272  
 TYPE V, 16 x 20 MEDICAL. GREEN, NSN: 8340-01-185-2614  
 TYPE VI, 16 x 20 CENTRAL MED SUPPLY, GREEN, NSN: 8340-01-185-2618  
 TYPE VII, 16 x 20 UTILITY. GREEN, NSN: 8340-01-185-2613  
 TYPE VIII, 96 x 20 MEDICAL WARD, GREEN, NSN: 8340-01-257-8468  
 TYPE IX, 80 x 20 MEDICAL SURGICAL. GREEN, NSN: 8340-01-257-8469  
 TYPE X, 64 x 20 MEDICALSUPPORT, GREEN, NSN: 8340-01-257-8470  
 TYPE XI, 32 x 20 MEDICAL SUPPORT, GREEN, NSN: 8340-01-257-8471  
 TYPE XII, 16 x 20 CS SUPPORT, GREEN, NSN: 8340-01-257-8472  
 TYPE XIII, 96 x 20 MEDICAL WARD TROP., GREEN, NSN: 8340-01-257-8473  
 TYPE XIV, 32 x 20 MEDICAL SUPPORT TROP., GREEN, NSN: 8340-01-257-8474  
 TYPE XV, 48 x 20 KITCHEN, GREEN, NSN: 8340-01-325-0131  
 TYPE XVI, 32 x 20 SANITATION CENTER, GREEN, NSN: 8340-01-324-7971

TYPE I, 64 x 20 SURGICAL WORK, TAN, NSN: 8340-01-212-9468  
 TYPE II, 64 x 20 MEDICAL, TAN, NSN: 8340-01-212-9469  
 TYPE III, 48 x 20 UTILITY, TAN, NSN: 8340-01-212-9470  
 TYPE IV, 32 x 20 PERSONNEL, TAN, NSN: 8340-01-185-2628  
 TYPE V, 16 x 20 MEDICAL, TAN, NSN: 8340-01-212-9471  
 TYPE VI, 16 x 20 CENTRAL MED SUPPLY, TAN, NSN: 8340-01-212-9472  
 TYPE VII, 16 x 20 UTILITY, TAN, NSN: 8340-01-212-9473  
 TYPE VIII, 96 x 20 MEDICAL WARD, TAN, NSN: 8340-01-257-8475  
 TYPE IX, 80 x 20 MEDICAL SURGICAL. TAN, NSN: 8340-01-257-8476  
 TYPE X, 64 x 20 MEDICAL SUPPORT, TAN, NSN: 8340-01-257-8477  
 TYPE XI, 32 x 20 MEDICAL SUPPORT, TAN, NSN: 8340-01-257-8478  
 TYPE XII, 16 x 20 CS SUPPORT, TAN, NSN: 8340-01-257-8479  
 TYPE XIII, 96 x 20 MEDICAL WARD TROP., TAN, NSN: 8340-01-258-6482  
 TYPE XIV, 32 x 20 MEDICAL SUPPORT TROP., TAN, NSN: 8340-01-257-8480  
 TYPE XV, 48 x 20 KITCHEN. TAN, NSN: (UNASSIGNED)  
 TYPE XVI, 32 x 20 SANITATION CENTER, TAN, NSN: (UNASSIGNED)

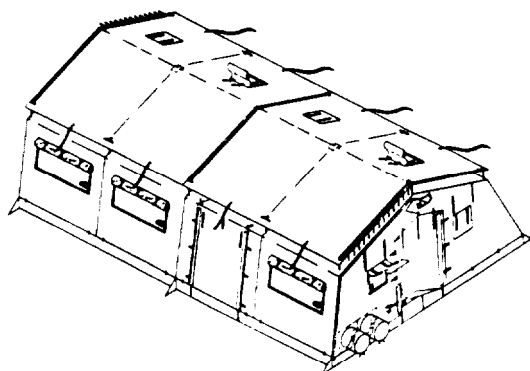

DISTRIBUTION STATEMENT A: Approved for public release;  
distribution is unlimited.

\* This manual together with TM 10-8340-224-23P, dated 31 October 1994,  
supersede TM 10-8340-224-13&P, dated 28 February 1986.

INTRODUCTION	1-1
OPERATOR INSTRUCTIONS	2-1
OPERATOR MAINTENANCE INSTRUCTIONS	3-1
UNIT MAINTENANCE INSTRUCTIONS	4-1
DIRECT SUPPORT MAINTENANCE INSTRUCTIONS	5-1
REFERENCES	A-1
MAINTENANCE ALLOCATION CHART	B-1
COMPONENTS OF END ITEM LIST AND BASIC ISSUE ITEM LIST	C-1
ADDITIONAL AUTHORIZATION LIST	D-1
EXPENDABLE/DURABLE SUPPLIES & MATERIALS LIST	E-1
ILLUSTRATED LIST OF MANUFACTURED ITEMS	F-1
GLOSSARY	GLOSSARY-1
ALPHABETICAL INDEX	INDEX-1

**HEADQUARTERS, DEPARTMENT OF THE ARMY, AIR FORCE AND NAVY**

**1 MARCH 1993**

CHANGE

NO. 2

HEADQUARTERS  
DEPARTMENTS OF THE ARMY  
AIR FORCE AND NAVY  
WASHINGTON, D.C., 13 JANUARY 1995

OPERATOR, UNIT AND DIRECT SUPPORT  
MAINTENANCE MANUAL  
FOR

**TENT, EXTENDABLE, MODULAR, PERSONNEL  
(TEMPER)**

DISTRIBUTION STATEMENT A: Approved for public release; distribution is unlimited

TM 10-8340-224-13/T.O. 35E5-6-1/NAVFAC-P-337.A, 1 March 1993, is changed as follows:

1. Remove and insert pages as indicated below. New or changed text material is indicated by a vertical bar in the margin. An illustration change is indicated by a miniature pointing hand.

Remove pages

Insert pages

i and ii

i and ii

Cover

Cover

2. Retain this sheet in front of manual for reference purposes.

**By Order of the Secretaries of the Army, Air Force and Navy:**

Official:

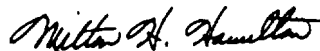
  
MILTON H. HAMILTON

Administrative Assistant to the  
Secretary of the Army

07858

GORDON R. SULLIVAN  
General, United States Army  
Chief of Staff

**TM 10-8340-224-13**  
**NAVFAC-P-337.A**  
**T.O. 35E5-6-1**

**C 2**

**MERRILL A. McPEAK**

General, USAF  
Chief of Staff

**RONALD W. YATES**

General, USAF  
Commander, Air Force Materiel Command

**DAVID E. BOTTORFF**

Rear Admiral, CEC, US Navy  
Commander  
Navy Facilities Engineering  
Command

**DISTRIBUTION:**

To be distributed in accordance with DA Form 12-25-E, block no. 2545, requirements for  
TM 10-8340-224-13.

CHANGE

NO. 1

HEADQUARTERS  
DEPARTMENTS OF THE ARMY, AIR FORCE, AND NAVY  
WASHINGTON, D.C., 28 FEBRUARY 1994

OPERATOR, UNIT, AND DIRECT SUPPORT  
MAINTENANCE MANUAL  
FOR  
TENT, EXTENDABLE, MODULAR, PERSONNEL  
(TEMPER)

DISTRIBUTION STATEMENT A: Approved for public release; distribution is unlimited.

TM 10-8340-224-13/T0 35E5-6-1/NAVFAC-P-337.A, 1 March 1993, is changed as follows:

1. Remove and insert pages as indicated below. New or changed text material is indicated by a vertical bar in the margin. An illustration change is indicated by a miniature pointing hand.

Remove pages

i and ii  
1-3 and 1-4  
5-9 and 5-10

Insert pages

i and ii  
1-3 and 1-4  
5-9 and 5-10

2. Retain this sheet in front of manual for reference purposes.

ARMY TM 10-8340-224-13  
AIR FORCE TO 35 E5-6-1  
NAVY NAVEAC-P-337.A  
C1

By Order of the Secretaries of the Army, Air Force, and Navy:

Official:

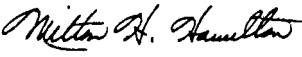
  
MILTON H. HAMILTON  
*Administrative Assistant to the  
Secretary of the Army*  
06138

GORDON R. SULLIVAN  
*General, United States Army  
Chief of Staff*

**MERRILL A. McPEAK**  
*General, USAF  
Chief of Staff*

Official:

**RONALD W. YATES**  
*General, USAF  
Commander, Air Force Materiel Command*

**DAVID E. BOTTORFF**  
*Rear Admiral, CEC, US Navy  
Commander  
Navy Facilities Engineering  
Command*

DISTRIBUTION:

To be distributed in accordance with DA Form 12-25-E, block no. 2545, requirements for  
TM 10-8340-224-13.

#### WARNINGS

- Lethal voltage is present when light set is connected to power source. Disconnect from power source before inspecting or repairing any electrical component. Electrical shock or death may result from failure to heed this warning.
- Lethal voltage is present when the power control system is connected to power source. Disconnect from power source before inspecting or repairing any electrical component. Electrical shock or death may result from failure to heed this warning.
- Lethal voltage is present when cables are connected to power control system. Ensure cables are disconnected from power source when working with cables or fixtures. Electrical shock or death may result from failure to heed this warning.
- Seam sealer and solvent are extremely flammable and the fumes toxic. Do not smoke or use seam sealer or solvent near open flame. Use seam sealer and solvent with goggles and gloves, and indoors with respirator or in an open, well ventilated area, away from sources of combustion. Death or severe injury may result from explosion or fire. Inhalation of fumes may cause toxic sickness.
- Frame assembly hinges can pinch or crush hands and fingers. Keep hands and fingers away from frame assembly ridges and eaves.
- Assembled tent assembly is extremely heavy. Two soldiers should be placed at each arch leg to raise frame. Lift tent from correct squatting position, using legs. Back injury could result if lifted improperly.
- Do not lock handle toward diagonal brace. Arch may collapse causing injury to personnel or damage to equipment if improperly locked.
- Two men are required to lift light set case to avoid injury to personnel.

- Stakes, guy lines and frame feet must be used to prevent excessive movement of the extendable modular tents in high winds. Failure to stake and tie down tent may result in personal injury or damage to equipment.
- All tent lines and frame feet must be staked down. Failure to stake and tie down tent may result in injury to personnel and damage to equipment.
- Eliminate the possibility of tripping. Clear fabric and guy lines. Injury to personnel may result from falls.

#### CAUTIONS

- Do not twist or turn frame components when handling. Damage to equipment may result.
- Do not step on tent components. Material may be torn and dirt ground into material.
- Avoid folding wall fabric into joints. Material may rip or tear if caught in joint.
- Insert quick release pins towards inside of tent on end assemblies. Tent fabric may tear if inserted towards outside.
- Orient hitch clip pins towards inside of vestibule at vestibule door frame. Vestibule door fabric may tear if oriented towards outside.
- Tent frame must be raised uniformly to avoid twisting or turning. Damage to frame may result.
- Lift door ramps prior to placing weight on door frame. Damage to piano hinge may result.
- Clear and level ground before installing floor. Sharp objects or depressions can damage tent floor.
- Allow slack in electrical cables. Strain on cable can damage equipment.

- Avoid damage to fabric and guy lines. Clear all fabric and guy lines from hinge joints. Do not stand on fabric or guy lines. Material may rip or lacerate.
- Unpack components carefully. Improper or hasty handling may result in damage to the TEMPER components and accessories.



TECHNICAL MANUAL

HEADQUARTERS  
DEPARTMENTS OF THE ARMY,  
AIR FORCE AND NAVY  
WASHINGTON D.C., 1 MARCH 1993

NO. 10-8340-224-13

**TECHNICAL MANUAL**  
**Operator, Unit, Direct Support**  
**Maintenance Manual**  
**For**  
**TENT, EXTENDABLE, MODULAR, PERSONNEL (TEMPER)**

**REPORTING ERRORS AND RECOMMENDING IMPROVEMENTS**

You can help improve this manual. If you find any mistakes or if you know of a way to improve these procedures, please let us know. Mail your letter or DA Form 2028 (Recommended Changes to Publications and Blank Forms), or DA Form 2028-2 located in the back of this manual directly to: Commander, US Army Aviation and Troop Command, ATTN: AMSAT-I-MP, 4300 Goodfellow Blvd, St. Louis, MO 63120-1798. A reply will be furnished directly to you.

**DISTRIBUTION STATEMENT A: Approved for public release; distribution is unlimited.**

**TABLE OF CONTENTS**

<b>Chapter/Section</b>	<b>PAGE</b>
CHAPTER 1	<b>INTRODUCTION ..... 1-1</b>
Section I	General Information ..... 1-1
Section II	Equipment Description ..... 1-3
Section III	Technical Principles of Operation . . . . . 1-18
CHAPTER 2	<b>OPERATING INSTRUCTIONS ..... 2-1</b>
Section I	Description and Use of Operator's Controls and Indicator ..... 2-2
Section II	Operator Preventive Maintenance Checks and Services (PMCS) ..... 2-4
Section III	Operations Under Usual Conditions . . . . . 2-17
Section IV	Operations Under Unusual conditions . . . . . 2-76
CHAPTER 3	<b>OPERATOR MAINTENANCE INSTRUCTIONS ..... 3-1</b>
Section I	Lubricating Instructions ..... 3-1
Section II	Operator Troubleshooting Procedures . . . . . 3-1
Section III	Operator Maintenance Procedures ..... 3-5

\* This manual together with TM 10-8340-224-23P, dated 31 October 1994, supersede TM 10-8340-224-13&P, dated 28 February 1986.

TABLE OF CONTENTS CONT'D.

Chapter/Section	Page
CHAPTER 4	UNIT MAINTENANCE INSTRUCTIONS . . . . . 4-1
Section I	Repair Parts, Special Tools, TMDE and Support Equipment . . . . . 4-2
Section II	Service Upon Receipt . . . . . 4-2
Section III	Unit Troubleshooting . . . . . 4-3
Section IV	Unit Maintenance Procedures . . . . . 4-4
Section V	Preparation for Storage or Shipment . . 4-11
CHAPTER 5	DIRECT SUPPORT MAINTENANCE INSTRUCTIONS . . . . . 5-1
Section I	Repair Parts, Special Tools; Test Measurement Diagnostic Equipment (TMDE) and Support Equipment . . . . . 5-1
Section II	Troubleshooting . . . . . 5-1
Section III	Maintenance Procedures . . . . . 5-2
APPENDIX A	REFERENCES . . . . . A-1
APPENDIX B	MAINTENANCE ALLOCATION CHART . . . . . B-1
APPENDIX C	COMPONENTS OF END ITEM AND BASIC ISSUE ITEMS LIST . . . . . C-1
APPENDIX D	ADDITIONAL AUTHORIZATION LIST . . . . . D-1
APPENDIX E	EXPENDABLE/DURABLE SUPPLIES AND MATERIALS LIST . . . . . E-1
APPENDIX F	ILLUSTRATED LIST OF MANUFACTURED ITEMS . . . . . F-1

TABLE OF CONTENTS CONT'D.

Chapter/Section

Page

GLOSSARY . . . . .	GLOSSARY-1
--------------------	------------

ALPHABETICAL INDEX . . . . .	INDEX-1
------------------------------	---------

HOW TO USE THIS MANUAL

This manual, (TM 10-8340-224-13), contains general information, operating instructions, PMCS instructions, troubleshooting steps, and maintenance instructions for the Tent, Extendable, Modular, Personnel (TEMPER). Use the front cover index and thumb bleeds at the edge of the pages to quickly find the sections of the manual shown on the cover.

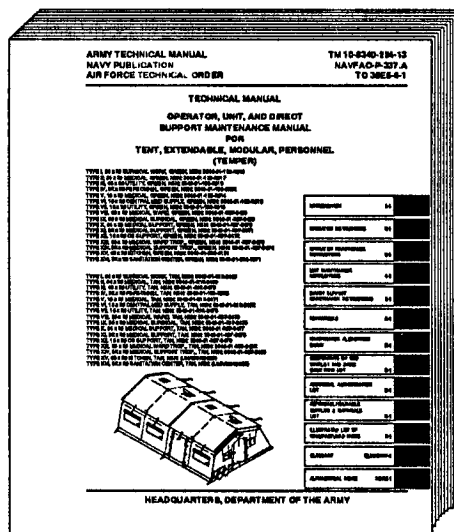

The manual has been divided into chapters, sections and paragraphs that are numbered in sequence. Pages, paragraphs, and illustrations are numbered by chapter. For example, chapter 2, page 3 is marked 2-3; chapter 3, paragraph 5 is marked 3-5; figure 2-3 is the third illustration in chapter 2. To quickly find specific information, use the table of contents. For example, the front cover index states that chapter 1 begins on page 1-1. The table of contents on page i tells you the exact page where the paragraph you want is located.

ARMY TM 10-8340-224-13  
AIR FORCE TO 35E5-6-1  
NAVY NAVFAC-P-337.A

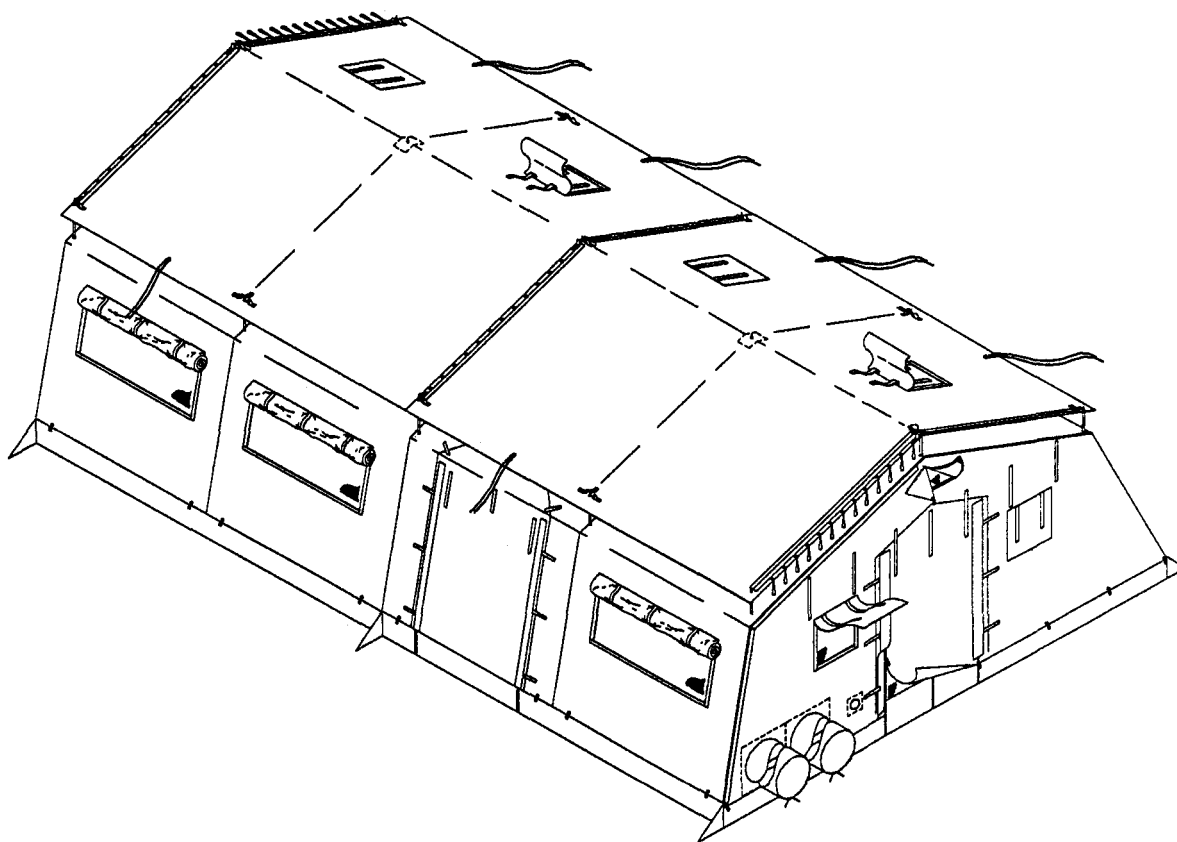

TENT, EXTENDABLE, MODULAR, PERSONNEL (TEMPER)

CHAPTER 1

INTRODUCTION

Subject	Section/Paragraph
General Information . . . . .	I
Scope . . . . .	1-1
Maintenance Forms and Records . . . . .	1-2
Corrosion Prevention and Control (CPC) . . . . .	1-3
Destruction of Material to Prevent Enemy Use . . . . .	1-4
Preparation for Storage or Shipment . . . . .	1-5
Quality Assurance (QA) . . . . .	1-6
Reporting Equipment Improvement Recommendations (EIR) . . . . .	1-7
Warranty Information . . . . .	1-8
Nomenclature Cross-Reference . . . . .	1-9
List of Abbreviations and Terms . . . . .	1-10
Equipment Description . . . . .	II
Equipment Characteristics, Capabilities and Features . . . . .	1-11
Location and Description of Major Parts . . . . .	1-12
Differences Between Models . . . . .	1-13
Equipment Data . . . . .	1-14
Technical Principles of Operation . . . . .	III
Operation of the TEMPER. . . . .	1-15

Section I. GENERAL INFORMATION

1-1. SCOPE.

a. Type of Manual. Operator, Unit, and Direct Support Maintenance Manual that provides instructions for the set-up, operation, take down, maintenance, and repair procedures for all components of the Tent, Extendable Modular (TEMPER).

b. Purpose of Equipment. Provide environmental protection to support command and control, medical, supply and personnel housing operations.

c. Special Feature. Tent sections allow the tent layout to be configured as necessary to suit tactical considerations.

d. Model Number and Equipment Name. Figure 1-6 shows the various tent configurations and nomenclature.

1-2. MAINTENANCE FORMS AND RECORDS. Department of the Army forms and procedures used for equipment maintenance will be those prescribed by DA PAM 738-750, The Army Maintenance Management System (TAMMS).

- 1-3. CORROSION PREVENTION AND CONTROL (CPC). Corrosion Prevention and Control (CPC) of Army material is a continuing concern. It is important that any corrosion problems with this item be reported so that the problem can be corrected and improvements made to prevent the problem in future items. While corrosion is typically associated with rusting of metals, it can also include deterioration of other materials, such as rubber and plastic. Unusual cracking, softening, swelling, or breaking of the materials may be corrosion problems. If a corrosion problem is identified, it can be reported using Standard Form 368, Product Quality Deficiency Report. Use key words such as "rust", "deterioration", "corrosion", or "cracking" to ensure that the information is identified as a CPC problem. The form should be submitted to the address specified in DA Pam 738-750.
- 1-4. DESTRUCTION OF MATERIAL TO PREVENT ENEMY USE. Destruction procedures for TEMPER components covered in this manual are described in TM 750-244-3.
- 1-5. PREPARATION FOR STORAGE OR SHIPMENT. Refer to paragraphs 4-13 and 4-15 to prepare the TEMPER for storage or shipment.
- 1-6. QUALITY ASSURANCE (QA). All maintenance actions will be inspected to assure that applicable Quality Assurance standards are met. Refer to FM 10-16, TM 9-450 and TM 9-237 for fabric repair, metal repair and welding standards respectively.
- 1-7. REPORTING EQUIPMENT IMPROVEMENT RECOMMENDATIONS (EIR). If your TEMPER components need improvement, let us know. Send us an EIR. You, the user, are the only one who can tell us what you don't like about your equipment. Let us know why you don't like the design or performance. Put it on an SF 368 (Product Quality Deficiency Report). Mail it to us at: Commander, U.S. Army Aviation and Troop Command, ATTN: AMSAT-I-MDO 4300 Goodfellow BLVD., St. Louis, MO 63120-1798.
- 1-8. WARRANTY INFORMATION. The TEMPER is warranted by the manufacturer. The warranty starts on the date found on DA Form 2410 or DA Form 2408-16 in the Logbook. Report all defects in material or workmanship to your supervisor who will take appropriate action.

1-9. NOMENCLATURE CROSS-REFERENCE.

COMMON NAME	OFFICIAL NAME
TEMPER	Tent, Extendable, Modular, Personnel
Light Set	Light Set, Portable, Fluorescent, Type I

1-10. LIST OF ABBREVIATIONS AND TERMS.

CPC	Corrosion Prevention and Control
Cu Ft	Cubic Foot/Feet
DS2	Decontamination Solution (ready-to-use)
EIR	Equipment Improvement Report
ESC	Equipment Serviceability Criteria
HZ	Hertz - Unit of frequency equal to one cycle per second
MWO	Modification Work Order
NBC	Nuclear, Biological, Chemical
Pkg Cu	Package Cubic Foot/Feet
Sq Ft	Square Foot/Feet
U/M	Unit of Measure
UOC	Usable On Code
VAC	Volts Alternating Current - Measure of electrical potential
STB	Supertropical Bleach - Decontamination Agent
V-agent	Vector agent

Section II. EQUIPMENT DESCRIPTION

1-11. EQUIPMENT CHARACTERISTICS, CAPABILITIES AND FEATURES. The TEMPER is available in green or tan color for use in different types of climate. Except for color, the characteristics, capabilities and features of both versions are identical.

a. Characteristics.

- .Usable in a variety of climates.
- .Constructed of lightweight materials.
- .Deployed in forward battle areas.
- .Provides blackout protection.
- .Modular configuration permits layout flexibility.



1-11. EQUIPMENT CHARACTERISTICS, CAPABILITIES AND FEATURES CONT

b. Capabilities and Features.

- Can be set up quickly under normal operating conditions.
- TEMPER sections are interchangeable to form different configurations.
- Frame assembly consists of collapsible sections made of aluminum tube that unfold and connect to form a single frame.
- TEMPER is made of water resistant, flame resistant, mildew resistant, polyester duck fabric.
- Can be equipped with single phase or 3-phase electrical power.
- Can be heated or cooled through external sources.
- Designed for steady wind of 50 mph and gusts of 65 mph.

1-12. LOCATION AND DESCRIPTION OF MAJOR PARTS.

a. Tent Sections. The major components of the tent sections are identified in Figure 1-1, and described in paragraphs (1) through (17) below.

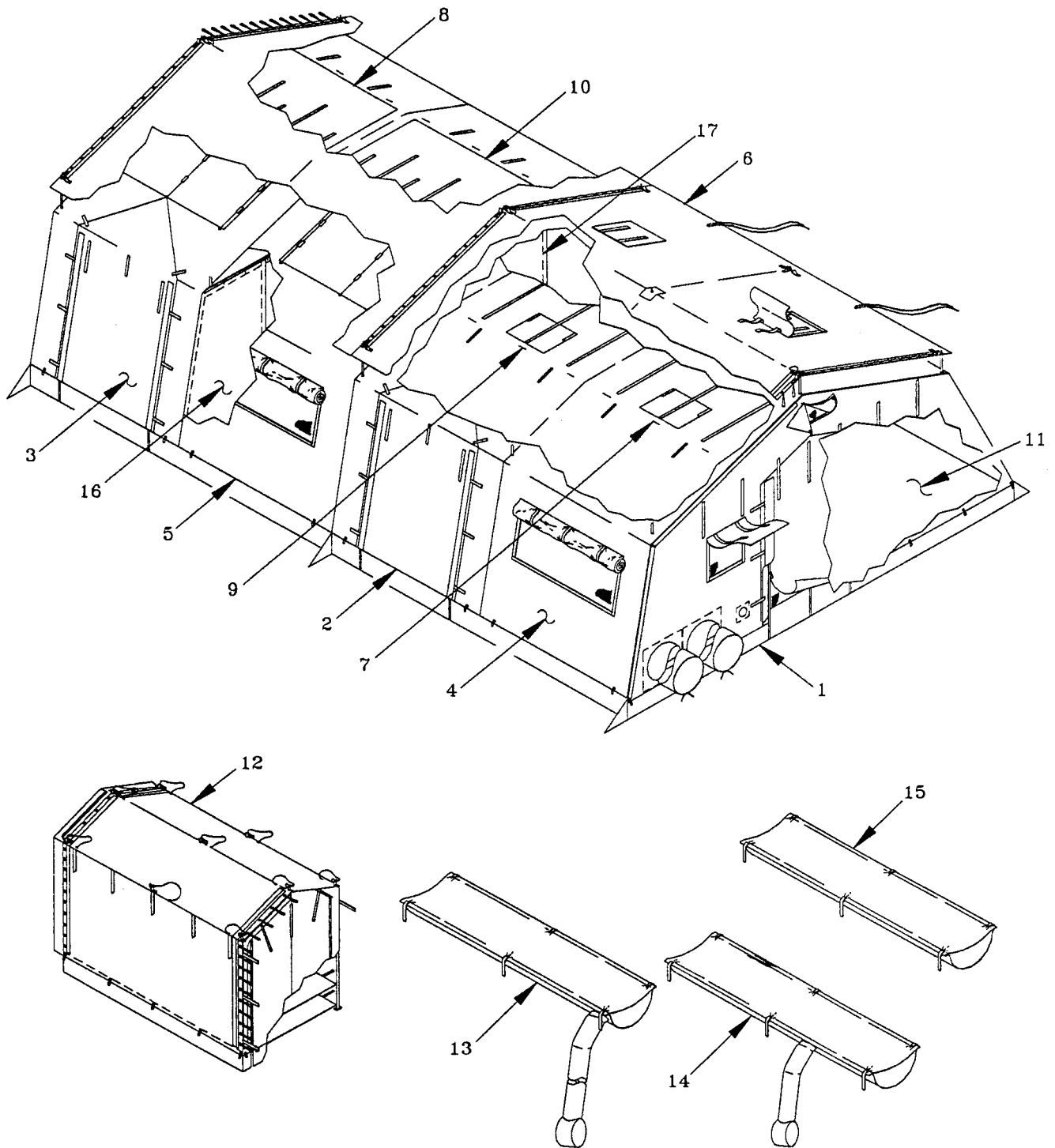

Figure 1-1.  
TENT SECTIONS

1-12. LOCATION AND DESCRIPTION OF MAJOR PARTS (CONT)

(1) End Section. The end section is "A" shaped and constructed of 13.5 oz. mildew and flame resistant, coated, polyester duck. Two screened windows are sewn into the end section. Each window consists of a clear plastic window and blackout flap. Both the window and blackout flap may be rolled up and tied above the window opening. A zipper operated door with inner screen door is located in the center of the end section. Two large air ducts and electrical cable sleeve are located at the bottom left of the door. A ventilator with weather flaps is located in the roof portion of the end section.

(2) Door Section (Temperate). The door section (temperate) is rectangular shaped and constructed of 13.5 oz. mildew and flame resistant, coated, polyester duck. A door, similar in design to that in the end section, is located in each side portion of the door section. An adapter to connect a vestibule or double bump through door to the door section is sewn along the perimeter of both door openings.

(3) Door Section (Desert/Tropical). The door section (desert/tropical) is rectangular shaped and constructed of 13.5 oz. mildew and flame resistant, coated, polyester duck. A door, similar in design to that in the end section, is located in each side portion of the door section. An adapter to connect a vestibule or double bump through door to the door section is sewn along the perimeter of both door openings. Two large screened openings with weather flaps are located in the center roof portions.

(4) Window Section (Temperate). The window section (temperate) is rectangular shaped and constructed of 13.5 oz. mildew and flame resistant, coated, polyester duck. A large window similar in design to those in the end section, is located in each side of the window section. A large air duct sleeve is located under one window and a stovepipe opening with weather flap is located in one of the center roof portions.

(5) Window Section (Desert/Tropical). The window section (desert/tropical) is rectangular shaped and constructed of 13.5 oz. mildew and flame resistant, coated, polyester duck. A large window similar in design to those in the end section, is located in each side of the window section. Two large screened openings with weather flaps are located in the center roof portions.

(6) Fly (8 & 16 foot). The tent flies are constructed of 13.5 oz. mildew and flame resistant, coated, polyester duck. One stovepipe opening with weather flap is located in the 8 foot fly and two stovepipe openings are located in the 16 foot fly.

(7) End Section Liner (Temperate). The end section liner (Temperate) is constructed of 6.8 oz. flame and mildew resistant, natural color, cotton, oxford cloth. It consists of an "A" shaped end liner and an intermediate liner (Temperate) sewn together to form an end section liner. Two clear plastic windows, a door opening with flap and an air duct opening with flap are located in the end liner. An additional opening with flap is provided next to the door opening for easy access to the electrical distribution box.

(8) End Section Liner (Desert/Tropical). The end section liner (Desert/Tropical) is constructed of 6.8 oz. flame and mildew resistant, natural color, cotton, oxford cloth. It consists of an "A" shaped end liner and an intermediate liner (Desert/Tropical) sewn together to form an end section liner. Two clear plastic windows, a door opening with flap and an air duct opening with flap are located in the end liner. An additional opening with flap is provided next to the door opening for easy access to the electrical distribution box.

(9) Intermediate Liner (Temperate). The intermediate liner (temperate) is constructed of 6.8 oz. flame and mildew resistant, natural color, cotton, oxford cloth and is rectangular in shape. Two combination door/window openings are provided at opposite ends of the liner. Two stovepipe openings with weather flaps are located in the center roof portions. An air duct opening with weather flaps is located in one of the door/window flaps.

(10) Intermediate Liner (Desert/Tropical). The intermediate liner (desert/tropical) is constructed of 6.8 oz. flame and mildew resistant, natural color, cotton, oxford cloth and is rectangular in shape. Two combination door/window openings are provided at opposite ends of the liner. Two large openings with weather flaps are located in the center roof portions.

(11) Floor. Floors may be either single ply or insulated. Single-ply floors are 21 feet long and come in widths of 8, 24, and 40 feet. The 24 and 40 foot widths are used when a non-sectionalized floor is desired. Single-ply floors are black on one side and either pale green or gray on the other, depending on the intended application. Hook and pile tape is used to attach the floor sections together, while tie tapes are used to secure the floor to the tent frame. The insulated tent floor is 20 feet long and 8 feet wide, and is made from 1/2 inch thick foam sandwiched between two plies of coated cloth. Hook and pile tape is used to connect floor sections. Tie tapes are not used, since the insulated floor sections are simply laid on top of the single-ply floor.

1-12. LOCATION AND DESCRIPTION OF MAJOR PARTS (CONT)

(12) Vestibule. The vestibule is made from 13.5 oz mildew and flame resistant, coated, polyester duck. It is supported by three aluminum vestibule frame assemblies. Becket loops and grommets are used to attach a removable door to the vestibule, and for attaching the other side of the vestibule to either a tent end section or door section adapter. The vestibule without a door can be used as a passageway when connecting one tent to another.

(13) Plenum, Endwall 16 Foot. The Endwall Plenum is constructed of coated, lightweight, nylon material. The endwall plenum consists of a horizontal body and an extension located at one end. The horizontal body is 16 feet long with a semi-cylindrical shape approximately 3 feet wide. One body section end is capped with a removable plenum cover that is attached with hook and pile fastener tape, the other body end is sealed. The 16 foot body portion of all plenums contains openings with fastener tape flaps that can be opened or closed to adjust the amount of conditioned air entering the tent. Extendable plenum sections can be connected to the capped end, after removal of the cap, with hook and pile fastener tape. A tubular extension approximately 12 inches in diameter is sewn into the plenum near the closed end. The opposite end of the extension is open. Tie lines are provided at the open end of the tubular extension to secure the plenum to the endwall air duct. Tie tapes are provided at the plenum top to secure it to the tent frame.

(14) Plenum, Side Entrance, 16 Foot. The side entrance plenum is constructed of the same material as the endwall plenum. The design, consisting of a horizontal body and an extension, is similar to the endwall plenum however, it is configured to be used where air ducts enter the sidewall of the tent.

(15) Plenum, Extendable, 16 Foot. The extendable plenum is constructed of the same material as the endwall and side entrance plenums. It is a semi-cylindrical tube 3 feet wide and 16 feet long. Both ends are provided with hook and pile fastener tape and a cover to connect either endwall, sidewall, or additional extendable plenums.

(16) Modesty Curtain. The modesty curtain is constructed of 6.8 oz. flame and mildew resistant, natural color, cotton, oxford cloth. The curtain consists of two identical halves and a cable assembly. The curtain halves attach to the cable assembly by snaphooks. The cable assembly attaches to the tent frame at the eaves.

(17) Partition. The partition is constructed of 6.8 oz. flame and mildew resistant, natural color, cotton, oxford cloth. It has a door opening in the center and a "U" shaped opening at the top center which allows the air plenum to pass through.

b. Frame Sections. Three unique frame sections in various quantities compose the TEMPER Tent: End Section, Type I; Extendable Section, Type II; Extendable Door Section, Type III. Each section is composed of interchangeable major components: Arch Assembly; Header Assembly; Purlin Assembly; Eave Extender Assembly; Ridge Extender Assembly; Frame Sections Cover Assembly. Additionally, the Extendable Door Section incorporates two additional components, the Door Sill Assembly and Vestibule Frame Assembly. These major components are illustrated in Figure 1-2 and described in paragraphs (1) through (8).

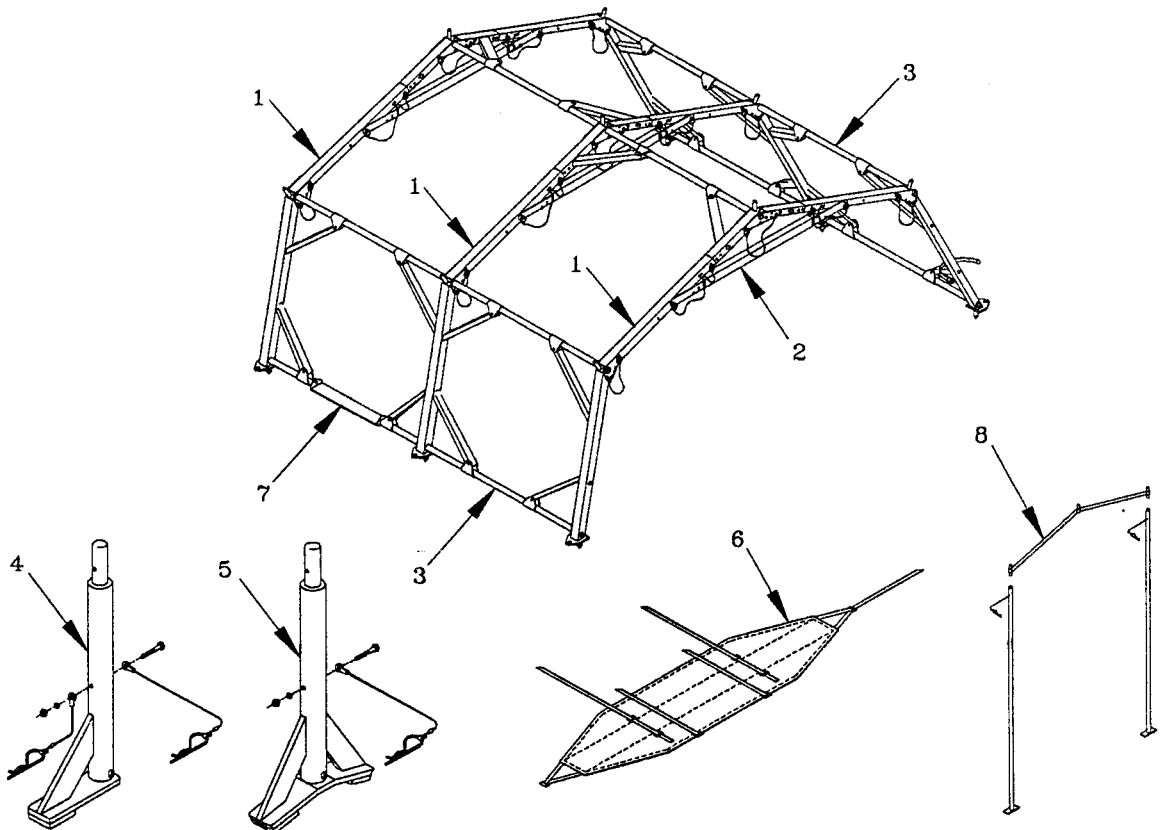

Figure 1-2.  
FRAME SECTION COMPONENTS

1-12. LOCATION AND DESCRIPTION OF MAJOR PARTS (CONT)

(1) Arch Assembly. The arch assembly consists of two aluminum side arch assemblies and an aluminum roof arch assembly. The arch assembly can easily be folded into a closed "W" configuration for easy handling and transport. A non-sectionalized arch assembly and a sectionalized arch assembly are currently fielded. The difference between both types is that the sectionalized arch assembly consists of two interlocking pieces that are joined and held together by a quick release pin. The non-sectionalized arch assembly overall length is 113 inches and the sectionalized arch assembly overall length is 98 inches allowing easy transport by USAF aircraft.

(2) Header Assembly. The header assembly is made from aluminum rectangular tubing with a cross section of 1 1/4 x 2 1/2 inches and has an overall length of 98 inches. Steel plates are riveted to the ends to allow attachment to the arch assembly.

(3) Purlin Assembly. The purlin assembly is made from tubular aluminum approximately 96 inches long x 1 1/2 inches in diameter. Folding diagonal braces which have "U" shaped cross sections are riveted to each end of the purlin. At the end of each brace is a rotating brace stud and brace shackle. The brace stud and the purlin end fitting lock into slots in the arch assembly. Five purlins, one at the ridge, one at both eaves and one at each base are required to join two arch assemblies.

(4) Eave Extender Assembly. The eave extender assembly is made from tubular aluminum with a single foot, web-reinforced base welded to the bottom of the center length of tubing. Two hitch clip pins are fastened to the extender.

(5) Ridge Extender Assembly. The ridge extender assembly is made from tubular aluminum with a two-footed, web-reinforced base welded to the bottom of the center length of tubing. A hitch clip pin is fastened to the extender.

(6) Frame Sections Cover Assembly. The frame sections cover assembly is diaper shaped, made of heavyweight, coated cloth with interior straps to secure frame components and exterior straps which bind the assembly together.

(7) Door Sill Assembly. The door sill assembly is made from tubular aluminum with a four foot long rotating door sill bolted to the center of the tubular section. Folding diagonal braces which have a "U" shaped cross section are riveted to each end of the door sill assembly. At the end of each brace is a rotating brace stud and brace shackle. The brace stud and the door sill end fitting lock into slots at the base of the arch assembly.

(8) Vestibule Frame Assembly. The vestibule assembly is composed of three components made of aluminum tubing: two upright poles with attached baseplate, and a header. Holes in the baseplate permit the assembly to be staked to the ground. Three vestibule frame assemblies are required to support a vestibule with door.

c. Double Bump-Through Door Assembly. The double bump-through doors consist of two spring-loaded swinging doors (1) mounted in an outer frame. The doors are constructed of a honeycombed core sandwiched between aluminum skins. A window (2) and blackout flap (3) are located on each door. Hinged ramps (4) at the bottom of the frame permit easy access by wheeled items. The double bump-through doors are designed for use with tent end section adapters, tent door section adapters, and vestibules. A vestibule door cap must be used to provide complete weather resistance. The doors can also be used at end sections with the adapter rolled back and tied in place. Extenders (5) are supplied with the door and are only used in the end section application. The double bump-through door is illustrated in Figure 1-3.

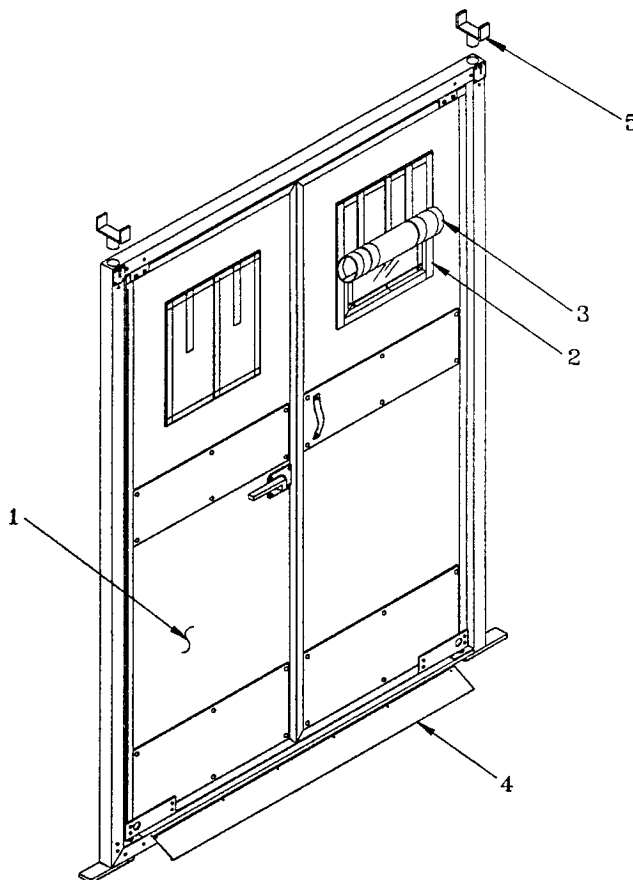

Figure 1-3.  
DOUBLE BUMP-THROUGH DOOR ASSEMBLY



1-12. LOCATION AND DESCRIPTION OF MAJOR PARTS (CONT)

d. Power Control. Either a 120V or a 208V power control system is provided with the TEMPER. The power control system consists of a power distribution box (1), convenience outlets (2), extension cables in 103, 156, 173, 254, and 408-inch lengths (3), and power panel stands (4). External power is provided to the power distribution box which distributes and controls power to the lights and convenience outlets. The power control components are illustrated in Figure 1-4.

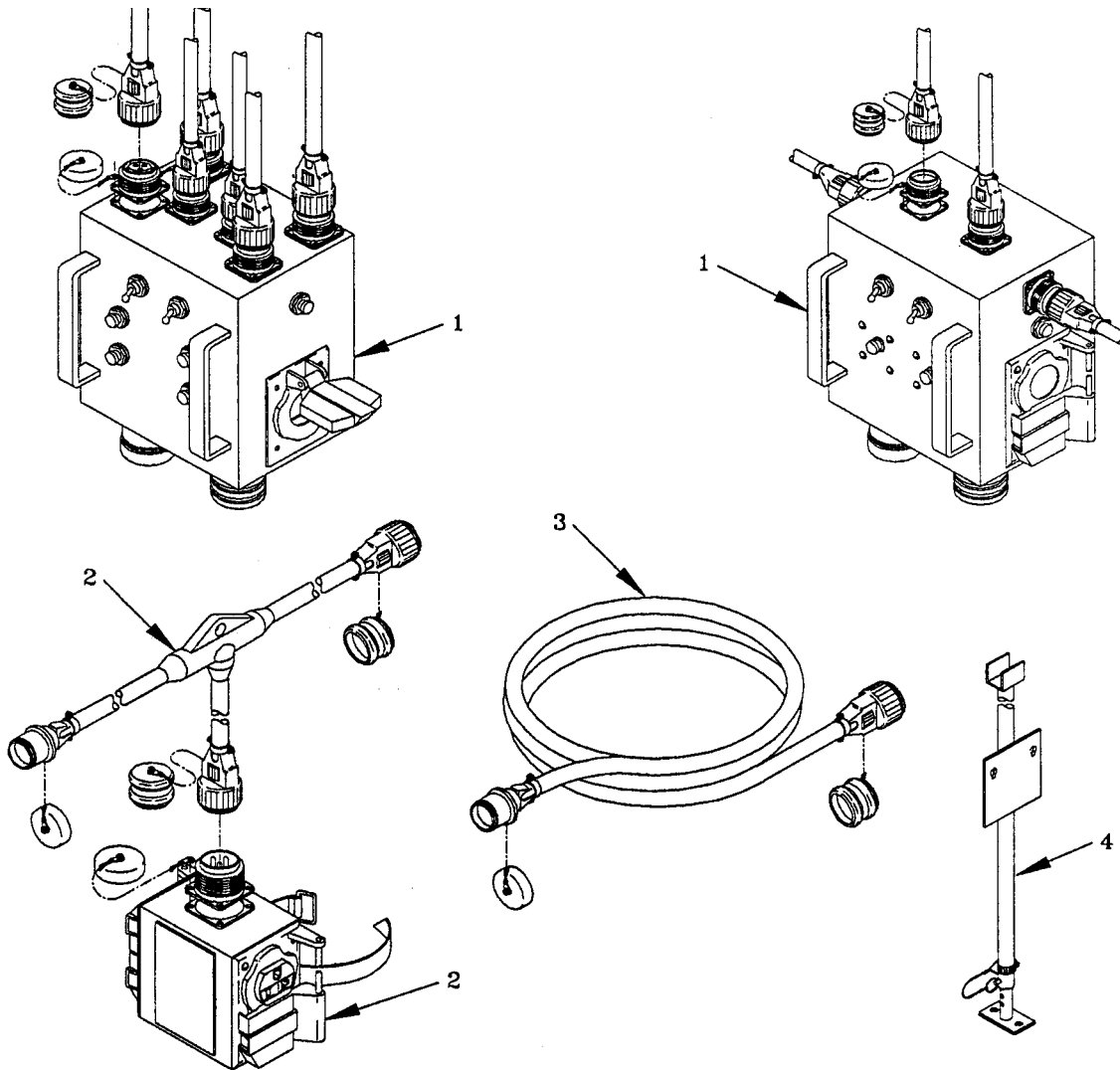

Figure 1-4.  
POWER CONTROL SYSTEM

e. Light Set, Type I. The light set consists of a storage container (1) and four luminaires (2). The storage container is lined with protective foam and holds a spare lamp, spare fuse and fuseholder, and support straps in addition to the luminaires. The storage container is secured with two latches and has a rubber coated, spring-actuated carrying handle at each end and in the center. Each luminaire consists of a fluorescent lamp mounted in a reinforced plastic tube with a molded cap and cable assembly at each end. The cap with the male power cable contains an On/Off switch and fuseholder. The cap with the female cable assembly contains a spare fuse. The light set is illustrated in Figure 1-5.

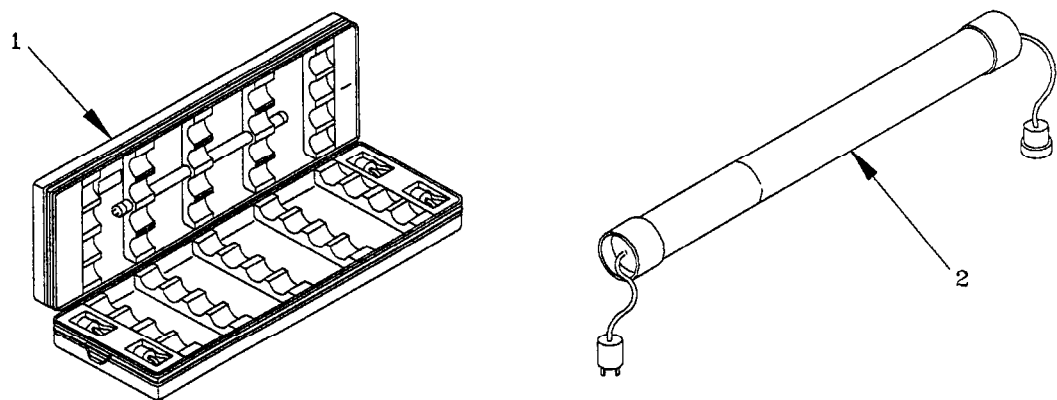

Figure 1-5.  
LIGHT SET, TYPE I

f. Light Cables, Type I & II. The Type I & II Light Cable is a set of two incandescent lights with individual streamers molded to an electrical cable. The cable is fitted with a male and female plug. The light cable may be substituted for the Type I Light Set and is currently in use by the U.S. Air Force only. The light cable is illustrated in Figure 1-6.

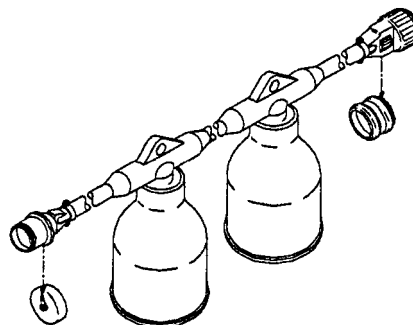

Figure 1-6.  
LIGHT CABLES, TYPE I & II

1-13. DIFFERENCES BETWEEN MODELS.

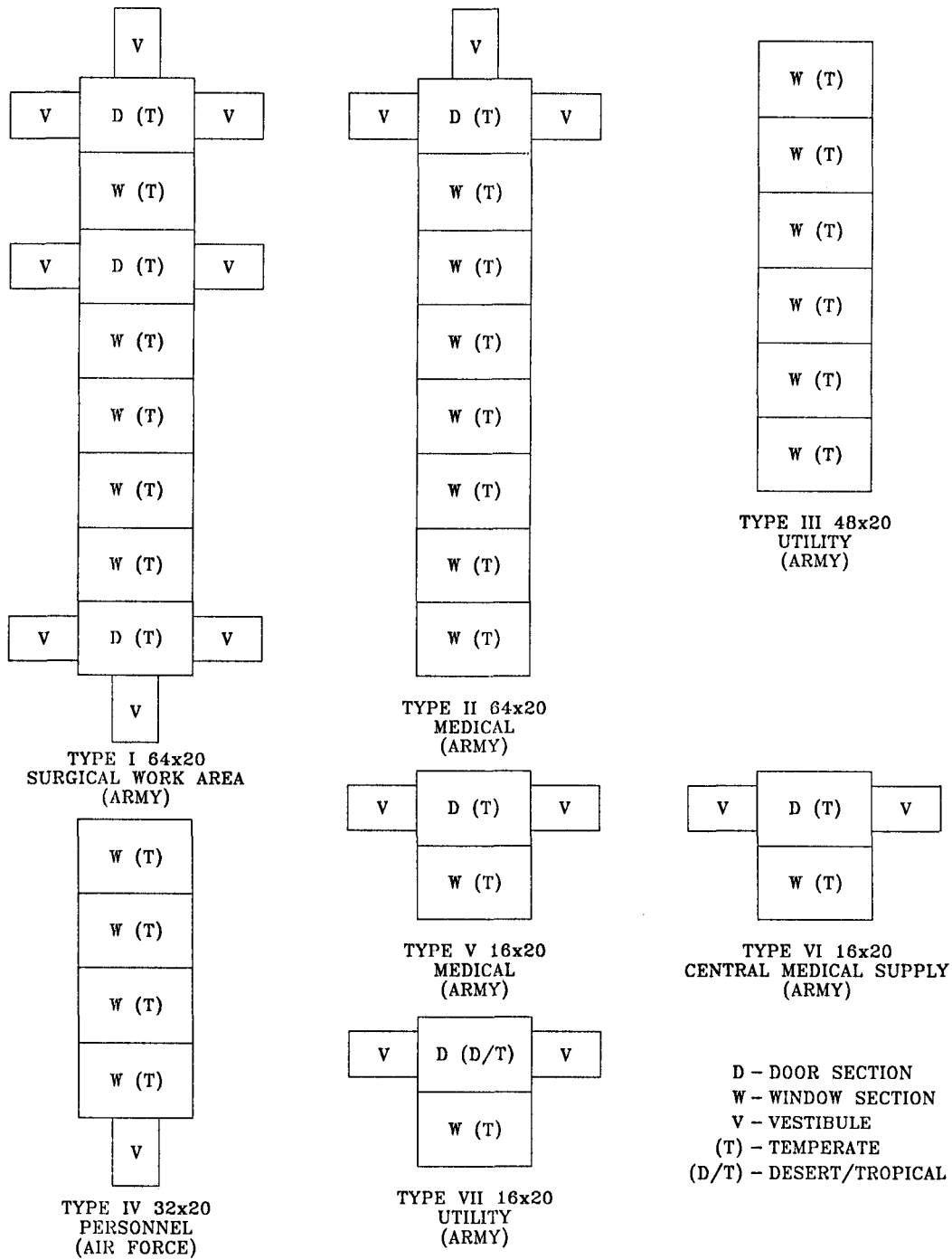
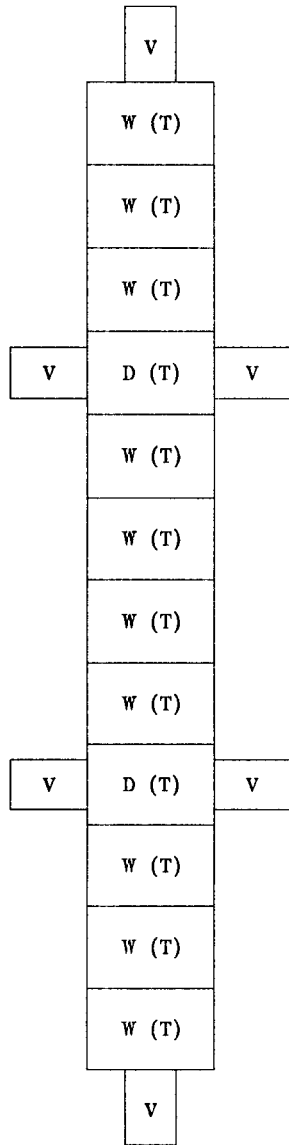
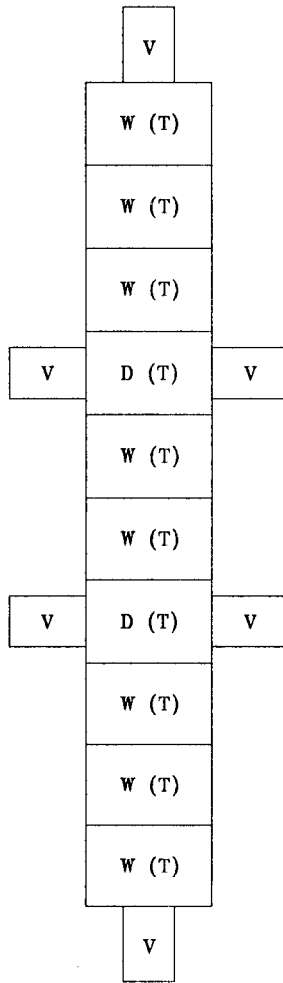

Figure 1-7  
 MODEL DIFFERENCES



TYPE VIII 96x20  
 MEDICAL WARD  
 (AIR FORCE)



TYPE IX 80x20  
 MEDICAL SURGICAL  
 (AIR FORCE)

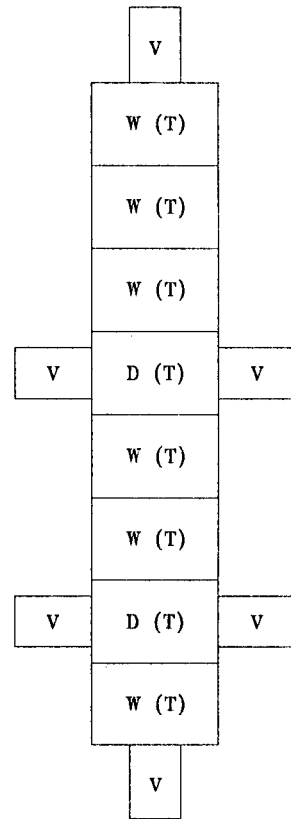

TYPE X 64x20  
 MEDICAL SUPPORT  
 (AIR FORCE)

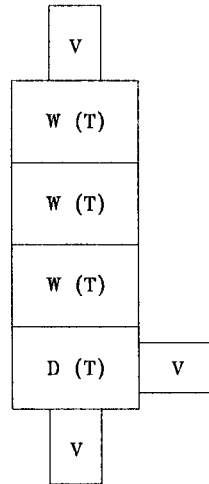

TYPE XI 32x20  
 MEDICAL SUPPORT  
 (AIR FORCE)

Figure 1-7 (CONT)  
 MODEL DIFFERENCES

1-13. DIFFERENCES BETWEEN MODELS (CONT)

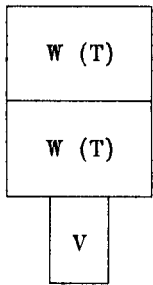

TYPE XII 16x20  
 CS SUPPORT  
 (AIR FORCE)

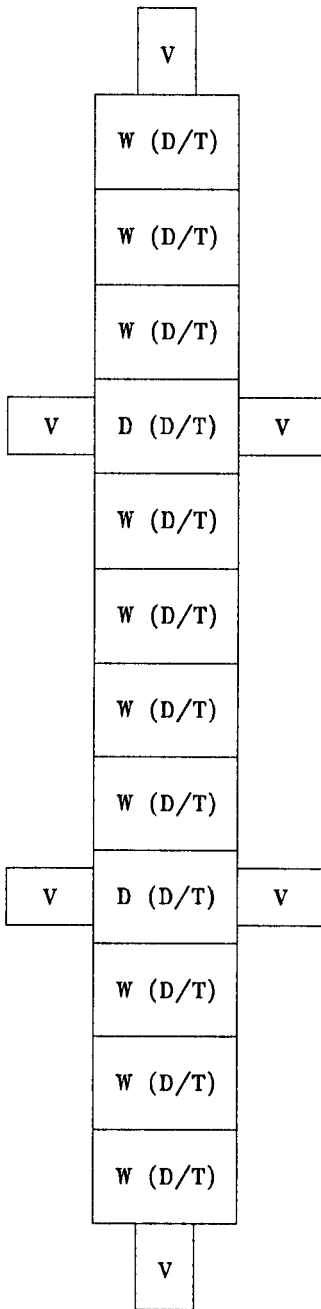

TYPE XIII 96x20  
 MEDICAL WARD  
 (AIR FORCE)

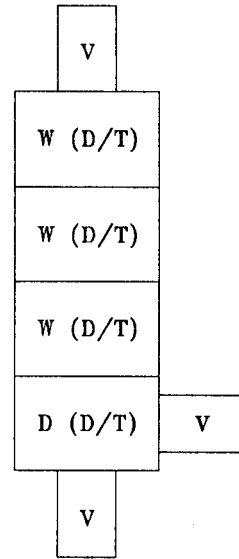

TYPE XIV 32x20  
 MEDICAL SUPPORT  
 (AIR FORCE)

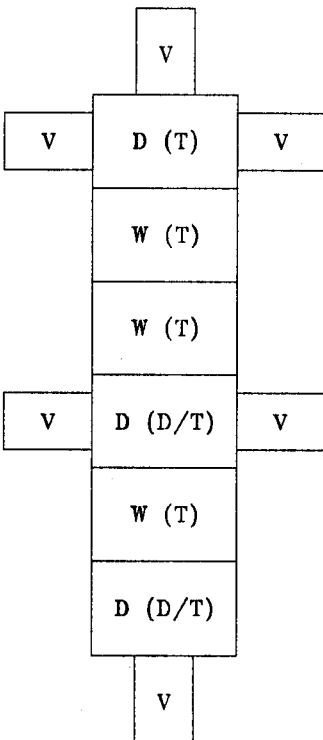

TYPE XV 48x20  
 KITCHEN  
 (ARMY)

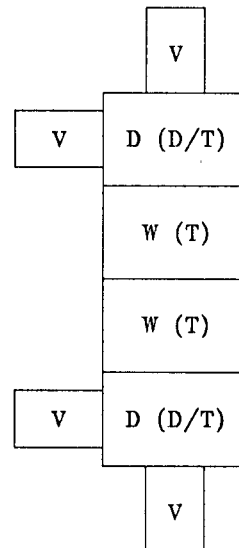

TYPE XVI 32x20  
 SANITATION CENTER  
 (ARMY)

Figure 1-7 (CONT)  
 MODEL DIFFERENCES

1-14. EQUIPMENT DATA. Table 1-1. lists the dimensions, weights, quantity required, as well as packaged dimensions for the separate TEMPER components. Class I denotes green and Class II denotes tan tents.

Table 1-1. Equipment Data

Tent Type	Length	Weight	Pkg cu.
Type I, Class I	64'	4086	320
Type II, Class I	64'	3977	287
Type III, Class I	48'	1532	104
Type IV, Class I	32'	1328	173
Type V, Class I	16'	1196	86
Type VI, Class I	16'	1176	90
Type VII, Class I	16'	876	54
Type VIII, Class I	96'	5822	464
Type IX, Class I	80'	5159	397
Type X, Class I	64'	4391	332
Type XI, Class I	32'	2329	181
Type XII, Class I	16'	1249	94
Type XIII, Class I	96'	5826	466
Type XIV, Class I	32'	2329	183
Type XV, Class I	48'	2553	158
Type XVI, Class I	32'	1751	107
Type I, Class II	64'	4086	320
Type II, Class II	64'	3977	287
Type III, Class II	48'	1532	104
Type IV, Class II	32'	1328	173
Type V, Class II	16'	1196	86
Type VI, Class II	16'	1176	90
Type VII, Class II	16'	876	54
Type VIII, Class II	96'	5822	464
Type IX, Class II	80'	5159	397
Type X, Class II	64'	4391	332
Type XI, Class II	32'	2329	181
Type XII, Class II	16'	1249	94
Type XIII, Class II	96'	5826	466
Type XIV, Class II	32'	2329	183
Type XV, Class II	48'	2553	158
Type XVI, Class II	32'	1751	107

Height at Eaves      6 feet 9 inches

Height at Ridge      10 feet 1/2 inches

Width at Base        20 feet 6 inches

Power Requirements: 120/208 V

### SECTION III. TECHNICAL PRINCIPLES OF OPERATION

#### 1-15. OPERATION OF THE TEMPER.

The Tent, Extendable, Modular, Personnel (TEMPER) is an extendable, modular, frame-supported shelter consisting of a collapsible aluminum frame covered with a coated polyester fabric. Modules are 20 feet, 6 inches wide, and can be extended in 8-foot increments.

The modules can be configured by using becket loops and grommets to attach any combination of window and/or door sections, along with vestibules for module connections. A tent fly is used to reduce solar loading and provide increased environmental protection.

Single-ply and insulated floor sections and liners, modesty curtains, partitions, electrical distribution systems, fluorescent and incandescent lights, air distribution plenums, and double bump-through doors are available to allow configurations that satisfy user requirements.

CHAPTER 2

OPERATING INSTRUCTIONS

Subject	Section/Paragraph
Description and Use of Operator's Controls and Indicators. . . . .	.I
General . . . . .	2-1
Operator's Controls and Indicators . . . . .	2-2
Operator Preventive Maintenance Checks and Services (PMCS) . . . . .	.II
Introduction . . . . .	2-3
Operation Under Usual Conditions . . . . .	.III
Assembly and Preparation for Use . . . . .	2-4
Frame Assembly . . . . .	2-5
Initial Placement of Window and Door Sections . . . . .	2-6
Placement of End Section . . . . .	2-7
Placement of Tent Flys . . . . .	2-8
Becket Lacing Window and Door Sections, End Sections, and Tent Flys . . . . .	2-9
Install Guy Lines . . . . .	2-10
Raising the Frame to Partially-Erect Position. . . . .	2-11
Components . . . . .	2-12
Install Luminaires. . . . .	2-13
Fully Erecting the Frame . . . . .	2-14
Final Installation of Floor and Liner. . . . .	2-15
Electrical Components . . . . .	2-16
Complete Becket Lacing . . . . .	2-17
Stakes and Guy Lines . . . . .	2-18
Vestibule Assembly . . . . .	2-19
Install Double Bump-Through Doors in Vestibule or Vestibule Adapter . . . . .	2-20
Install Double Bump-Through Doors in End Section . . . . .	2-21
Modesty Curtain . . . . .	2-22
Partition . . . . .	2-23
Operation of Doors, Windows and Vents . . . . .	2-24
Decals and Instruction Plates . . . . .	2-25
Preparation for Movement . . . . .	2-26
Operation Under Unusual Condition . . . . .	.IV
General . . . . .	2-27



SECTION I DESCRIPTION AND USE OF OPERATOR'S CONTROLS AND INDICATORS

2-1. GENERAL. The TEMPER has been designed for use in forward combat areas and has relatively few moving parts. Electrical controls are found on the electrical distribution boxes for the power control system and on the light set as described in paragraph 2-2 below.

2-2. OPERATOR'S CONTROLS AND INDICATORS. Refer to table 2-1.

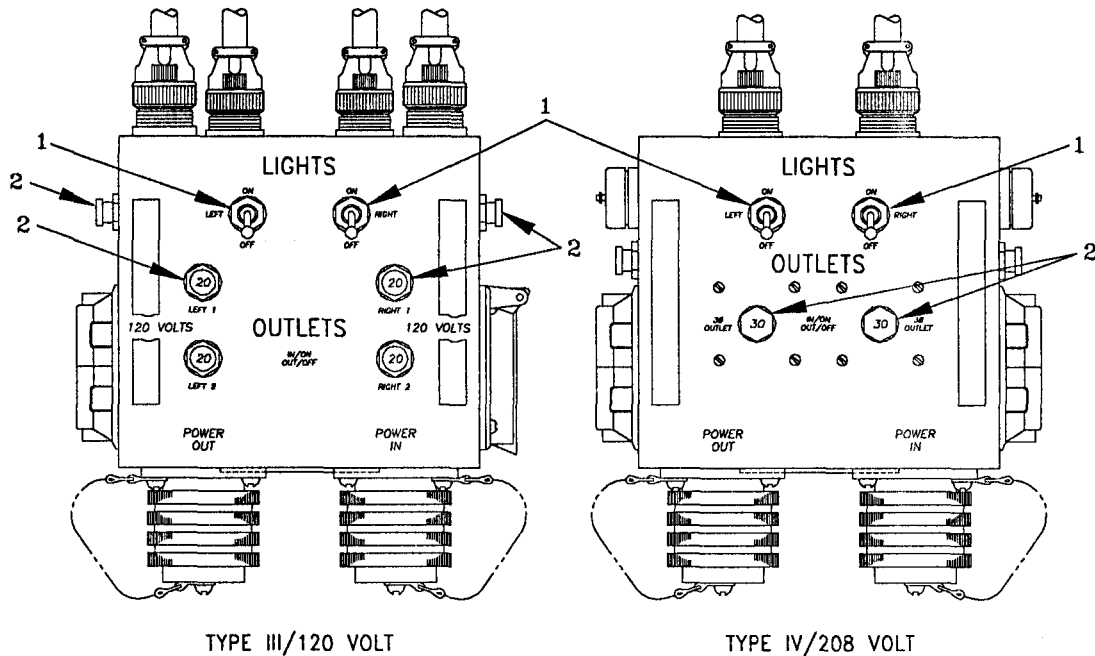

Figure 2-1.  
 ELECTRICAL DISTRIBUTION BOX CONTROLS

Table 2-1 Electrical Distribution Box Controls

Control or Indicator	Function
On/Off Switch (1)	Turns left or right bank electrical circuits on or off.
Circuit Breakers (2)	Provides overload or short-circuit protection. Circuit is interrupted when breaker is out. Push to reset.

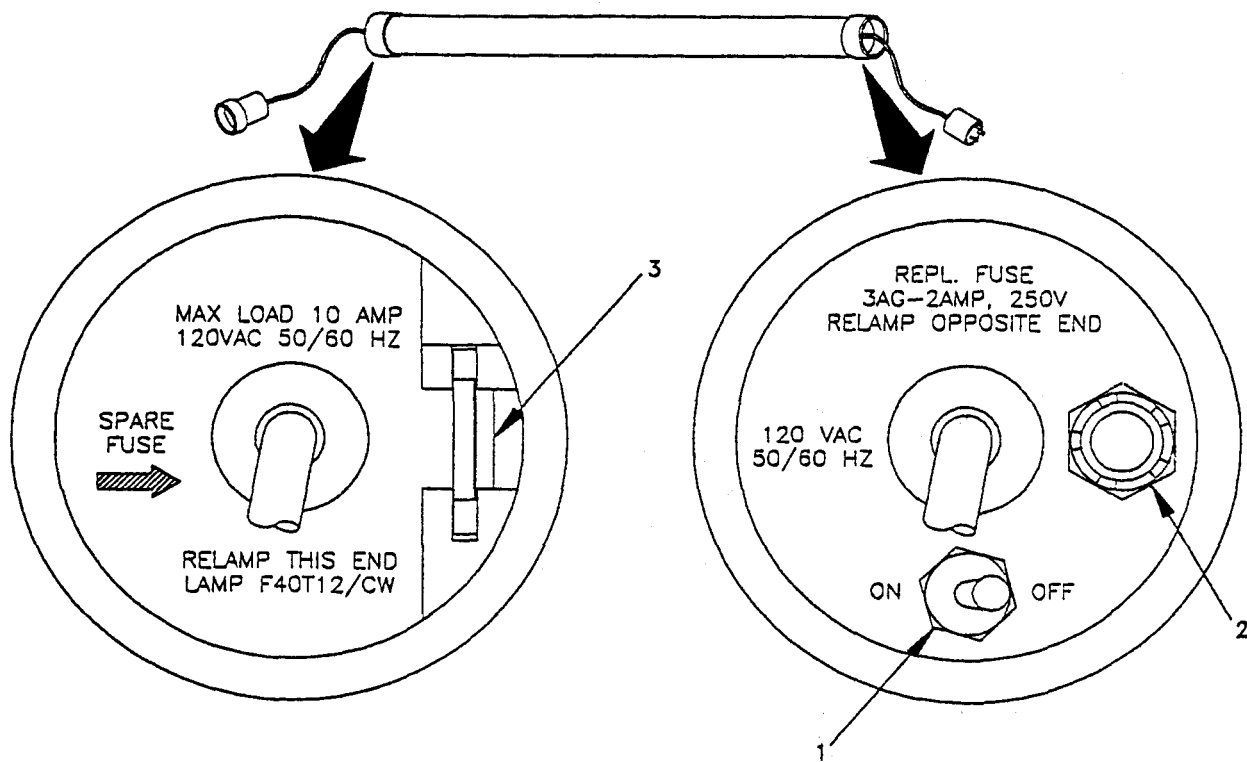

Figure 2-2.  
 LUMINAIRE CONTROLS

Table 2-2 Luminaire Controls

Control or Indicator	Function
On/Off Switch (1)	Turns lamp in luminaire on or off.
Fuse (2)	Protects light set from overload and shorting.
Spare Fuse (3)	Provides for back-up fuse in case of failure.

SECTION II. OPERATOR PREVENTIVE MAINTENANCE CHECKS AND SERVICES  
(PMCS)

2-3. INTRODUCTION. The TEMPER components must be inspected regularly to find and correct defects. Record all defects found during the performance of PMCS and the steps taken to correct them on a DA Form 2404, Equipment Inspection and Maintenance Worksheet. Instructions for reporting /correcting noted deficiencies are contained in DA Pam 738-750

a. General. Table 2-3 (PMCS Table) has been provided so you can keep your equipment in good operating condition and ready for its primary mission.

b. Warnings and Cautions. Always observe the WARNINGS and CAUTIONS appearing in your PMCS table. Warnings and cautions appear before applicable procedures. You must observe these WARNINGS and CAUTIONS to prevent serious injury to yourself and others or to prevent your equipment from being damaged.

c. Explanation of table entries.

(1) Item number column. Numbers in this column are for reference. When completing DA Form 2404 (Equipment Inspection and Maintenance Worksheet), include the item number for the check/service indicating a fault. Item numbers also appear in the order that you must do checks and services for the intervals listed.

(2) Interval column. This column tells you when you must do the procedure in the procedure column. BEFORE procedures must be done before you operate or use the equipment for its intended mission. DURING procedures must be done during the time you are operating or using the equipment for its intended mission. AFTER procedures must be done immediately after you have operated or used the equipment.

(3) Location, check/service column. This column provides the location and the item to be checked or serviced. The item location is underlined.

(4) Procedure column. This column gives the procedure you must do to check or service the item listed in the Check/Service column to know if the equipment is ready or available for its intended mission or for operation. You must do the procedure at the time stated in the interval column.

(5) Not fully mission capable if:column. Information in this column tells You what faults will keep your equipment from being capable of performing its primary mission. If you perform check and service procedures that show faults listed in this column, do not operate the equipment. Follow standard operating procedures for maintaining the equipment or reporting equipment failure.

d. Other table entries. Be sure to observe all special information and notes that appear in your table.

Table 2-3. Preventive Maintenance Checks and Services for Tent, Extendable Modular, Personnel (TEMPER).

Item No	Interval	Location Item to Check/Service	Procedure	Not Fully Mission Capable If:
				
1	Before During After	Fabric Assys	Check for tears, punctures, rips, seams that may have separated in walls (1), liners (2), tent fly (3), and floor (4).	Fabric ripped or torn. Separated seams or fabric punctures.
2	Before During After	Grommets	Check for grommets that are torn away from or out of material.	Grommets are missing or torn away from material causing fabric to tear.

Table 2-3. Preventive Maintenance Checks and Services for Tent, Extendable, Modular, Personnel (TEMPER) (CONT)

Item No	Interval	Location Item to Check/Service	Procedure	Not Fully Mission Capable If:
3	Before During After	Slide Fasteners	Check for smooth operation, missing teeth and separated seams.	Slide Fastener binds, does not open or close, or is torn away from fabric.
4	Before During After	Hook and Pile Fastener	Inspect hook and pile fasteners for proper alignment and cleanliness. Remove dirt by brushing fastener strips.	Fasteners do not hold when pressed together. Strips loose.

Table 2-3. Preventive Maintenance Checks and Services for Tent, Extendable, Modular, Personnel (TEMPER) (CONT).

Item No	Interval	Location Item to Check/Service	Procedure	Not Fully Mission Capable If:
5	Before During After	Tent Lines	Inspect tent lines (1) for cuts or fraying.	Tent lines are cut, frayed, or excessively worn.
6	During		Check for and tighten loose tent lines (1).	
7	Before	Tent Line Slips	Inspect for broken tent line slips (2).	Tent line slips broken or missing.
8	Before After	Straps	Check interior and exterior straps (3,4) for fraying or tears.	Straps loose or missing.

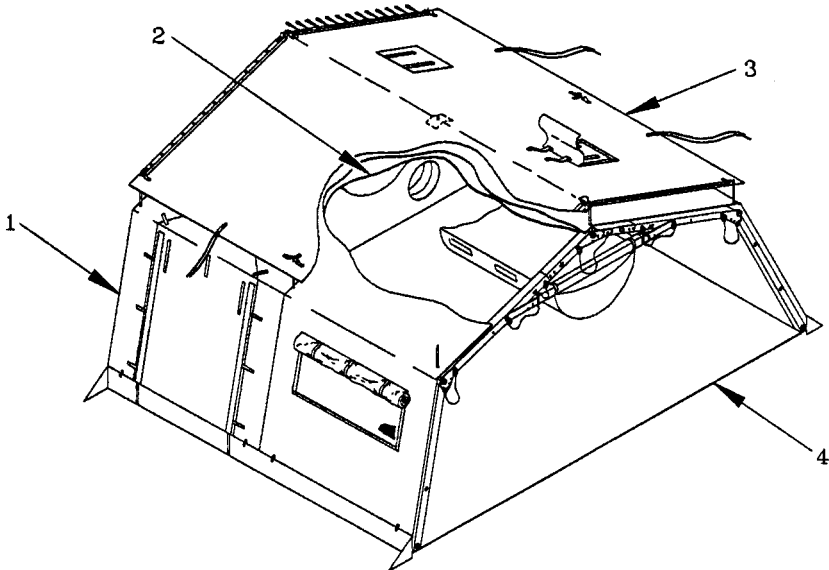
Table 2-3. Preventive Maintenance Checks and Services for Tent, Extendable, Modular, Personnel (TEMPER) (CONT).

Item No	Interval	Location Item to Check/Service	Procedure	Not Fully Mission Capable If:



Table 2-3. Preventive Maintenance Checks and Services for Tent, Extendable, Modular, Personnel (TEMPER) (CONT).

Item No	Interval	Location Item to Check/Service	Procedure	Not Fully Mission Capable If:
9	Before After	Frame Components	Check condition of arch (1), header (2), purlin (3), cave (4) and ridge (5) extenders, door sill assy (6), vestibule frame assy (7), and frame sections cover assy (8). Look for bends or other damage. Check for free movement. Ensure quick release pins (9) and hitch clip pins (10) are present and in proper working order. Inspect binding strap assembly (11) for fraying and presence of buckles.	Sectional arch does not fold, locking tabs on purlin and door sill do not rotate and lock, quick release pins and hitch clip pins are missing or broken.

Table 2-3. Preventive Maintenance Checks and Services for Tent, Extendable, Modular, Personnel (TEMPER) (CONT).

Item No	Interval	Location Item to Check/Service	Procedure	Not Fully Mission Capable If:
				
<p><b>NOTE</b></p> <p>If extenders are lost or broken, doors cannot be used at endwall location.</p>				
10	Before During After	Bump Through Doors	Check for smooth operation and proper closing of doors (1) and hinges (2). Check condition of window (3) and blackout flap (4). Check for presence and condition of extenders (5).	Doors do not close properly. Window broken or blackout flap torn or missing. Extenders are missing or damaged.

Table 2-3. Preventive Maintenance Checks and Services for Tent, Extendable, Modular, Personnel (TEMPER) (CONT)

Item No	Interval	Location Item to Check/Service	Procedure	Not Fully Mission Capable If:
				

Table 2-3. Preventive Maintenance Checks and Services for Tent, Extendable, Modular, Personnel (TEMPER) (CONT).

Item No	Interval	Location Item to Check/ Service	Procedure	Not Fully Mission Capable If:
11	Before During After	Power Control	<p>Check power control assemblies for damage to circuit breakers (1) and toggle switches (2). Push to reset circuit breakers. Check for missing covers (3) and dirt in electrical receptacles (4) or plugs (5). Check cables (6) for fraying and all assemblies for signs of shorts. Check distribution box stand for security of base plate (7) and foot (8). Ensure quick release pin (9) is present and in proper condition. Ensure outer and inner tubes (10,11) move freely.</p>	<p>Circuit breakers and toggle switches do not operate. Covers missing. Cable frayed. Burn marks indicating shorts. Missing or damaged light streamer. Stand has damaged base plate or foot. Quick release pin is missing or not working. Tubes do not slide freely.</p>

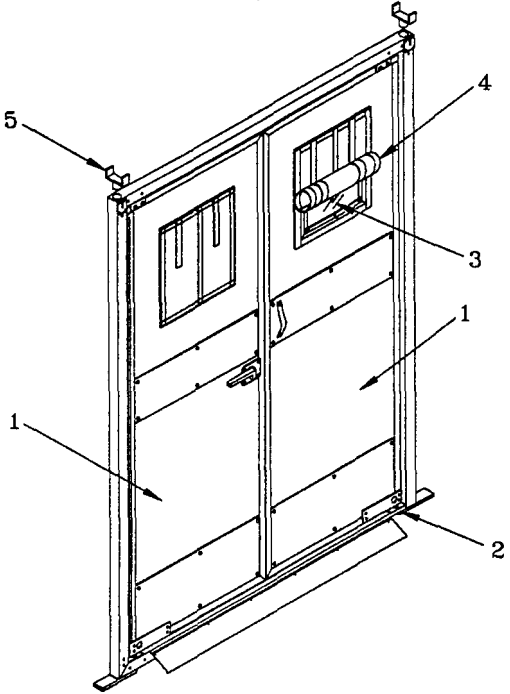
Table 2-3. Preventive Maintenance Checks and Services for Tent, Extendable, Modular, Personnel (TEMPER) (CONT)

Item No	Interval	Location Item to Check/Service	Procedure	Not Fully Mission Capable If:
12	Before After	Light Set, Type I; Light Cables (USAF only)	 <p>Ensure that spare lamp (1), fuseholder (2), straps (3), luminaires (4), and fuses (5) are in the container. Check for damage to light streamers (6). Check for damage such as cracked or broken parts.</p>	Parts of light set missing or damaged.

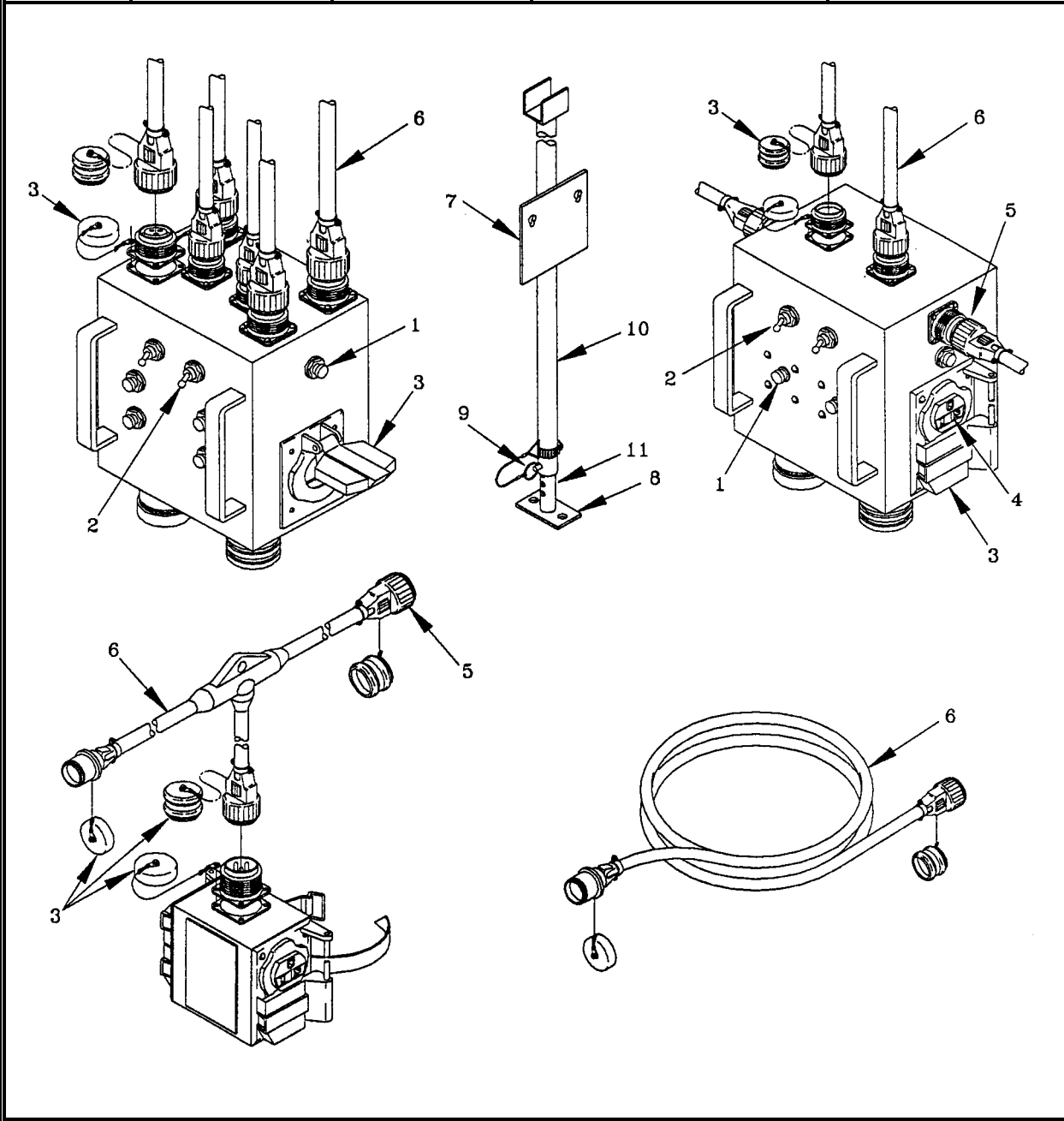
Table 2-3. Preventive Maintenance Checks and Services for Tent, Extendable, Modular, Personnel (TEMPER) (CONT).

Item No	Interval	Location Item to Check/Service	Procedure	Not Fully Mission Capable If:
				
<p><b><u>WARNING</u></b></p> <p>Lethal voltage is present when light set is connected to power source. Disconnect from power source before inspecting or repairing any electrical component. Be careful not to contact electrical connections. Electrical shock or death may result from failure to heed this warning.</p>				
13	Before	Luminaire	Check cable assemblies (1) for cracks, breaks, fraying insulation.	Frayed insulation or broken plugs.
14	Before	Straps	Check four straps (2) for tears or fraying.	Broken, frayed, or missing straps.
15	During	Luminaire	Ensure luminaires (3) operate properly and spare lamp (4) is present and serviceable.	Lamps burned out or flickering.

Table 2-2. Preventive Maintenance Checks and Services for Tent, Extendable, Modular, Personnel (TEMPER) (CONT).

Item No	Interval	Location Item to Check/Service	Procedure	Not Fully Mission Capable If:
16	After	Luminaire	Clean luminaires (3) by wiping with dry cloth.	
17	Before After	Storage Container	Check container (1) for damaged, missing hardware (2) or torn padding (3) .	Case broken, hardware missing.

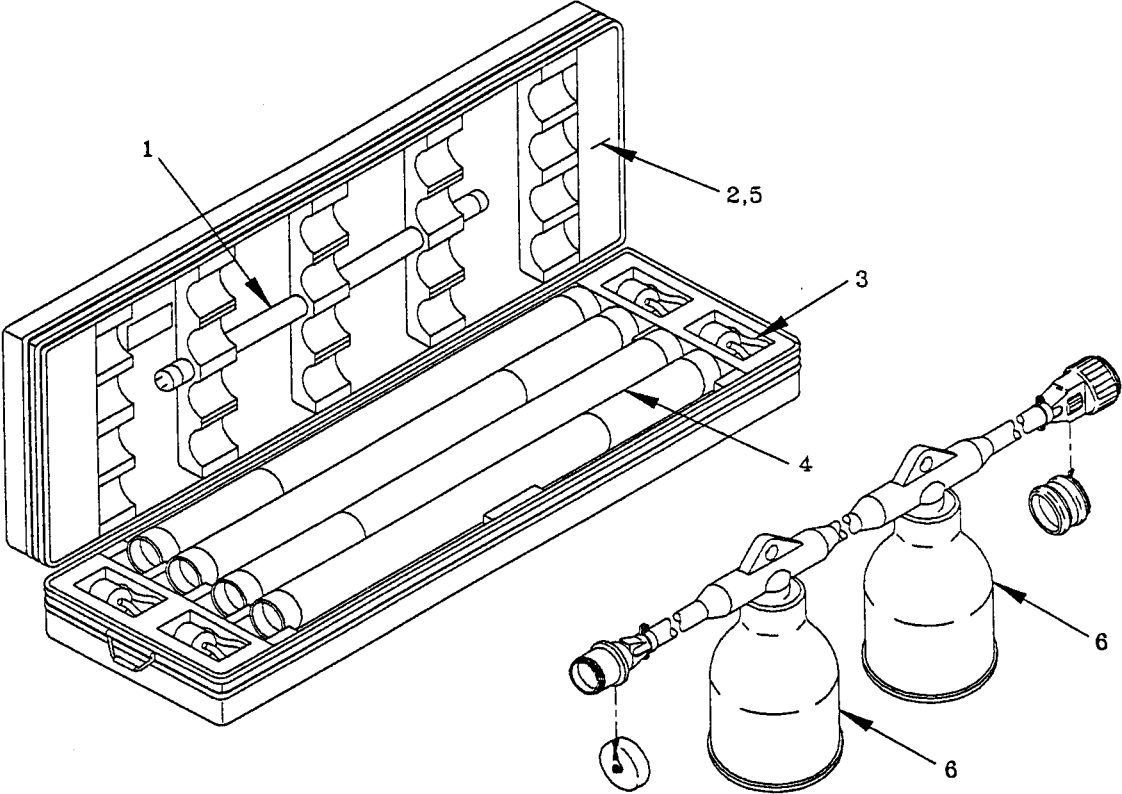
SECTION III. OPERATION UNDER USUAL CONDITIONS

2-4. ASSEMBLY AND PREPARATION FOR USE. This section provides detailed instructions for the erection and disassembly of the TEMPER Tent.

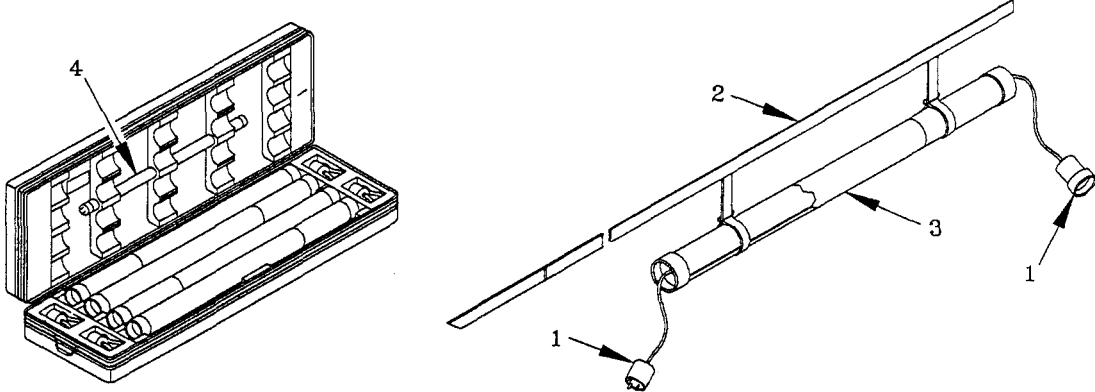
2-5. FRAME ASSEMBLY. The frame assemblies are erected in three stages: kneeling, partially-erect; erect. These stages permit the attachment of components without the aid of ladders. Both rigid and sectionalized arch assemblies are in use in the field. After initial assembly, the sectionalized arch assembly does not vary in function from the rigid arch assembly.

**WARNING**

Frame assembly hinges can pinch or crush hands and fingers. Keep hands and fingers away from frame assembly ridges and eaves.

**CAUTION**

- Do not twist or turn frame components when handling. Damage to equipment may result.
- Clear and level ground before installing floor. Sharp objects or depressions can damage tent floor.

**NOTE**

Erect tent from top to bottom, end section towards opposite end section.



2-5. FRAME ASSEMBLY.

a. Arch Assembly.

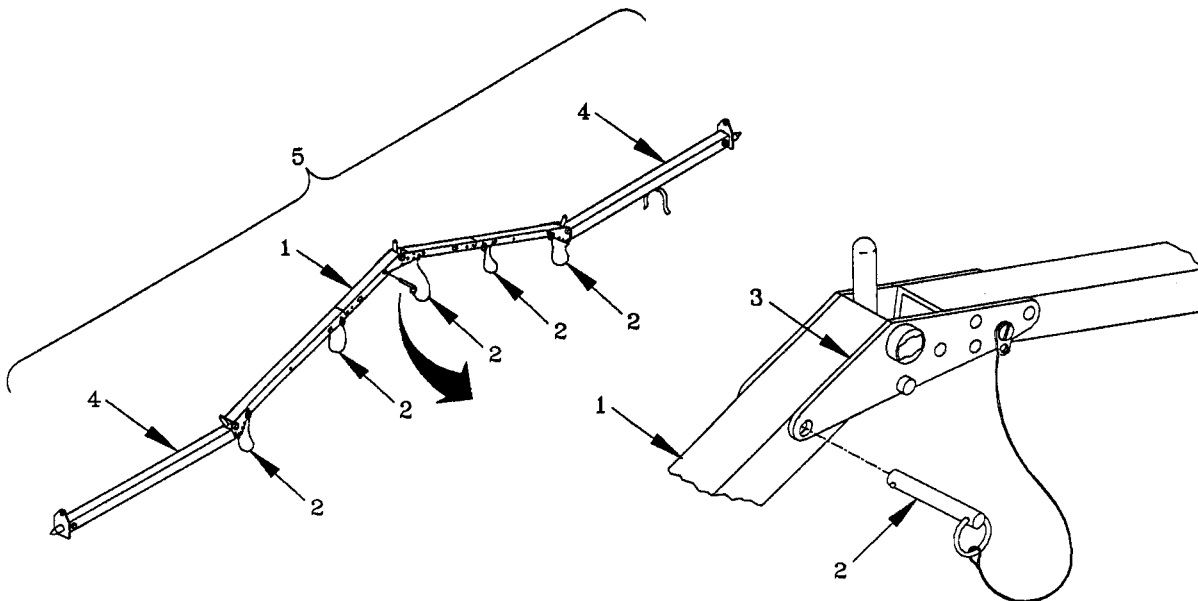

- (1) Remove roof arch assembly (1) and side arch assemblies (4) from frame sections cover assembly bundle.
- (2) Ensure all quick release pins (2) are disengaged.

**CAUTION**

Insert quick release pins towards inside of tent on end assemblies. Tent fabric may tear if inserted towards outside.

- (3) Align holes in roof arch assembly (1) with holes in ridge gusset plate (3). Insert quick release pin (2).
- (4) Move side arch assembly (4) away from roof arch assembly (1) .
- (5) Connect roof arch assembly (1) and side arch assemblies (4) to form arch assembly (5).
- (6) Lay arch assembly (5) flat on the ground.

b. Header Assembly.

**NOTE**

The header assembly will be pinned to the arch assembly between the ridge and eave.

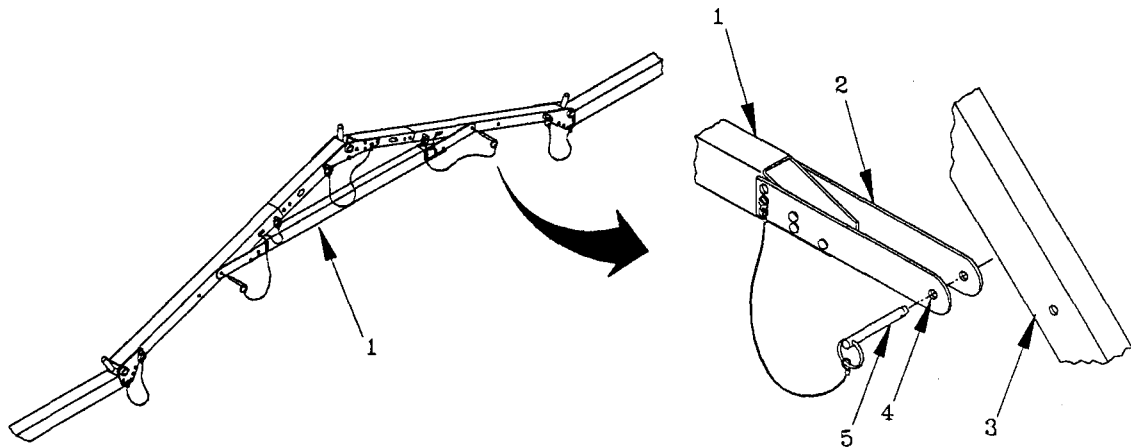

- (1) Identify header assembly (1).
- (2) Slide header assembly end plates (2) over arch assembly (3).
- (3) Align arch assembly (3) and header assembly end plate holes (4).
- (4) Insert quick release pin (5).
- (5) Lay assembly on ground.
- (6) Repeat procedures a and b for each arch assembly.

2-5. FRAME ASSEMBLY (CONT).

c. Purlin Assembly.

**NOTE**

- Ridge, eave and base purlins are identical. Door sill purlin differs only in design and is found only with Extendable Door Section, Type III. Installation procedure is identical.
- Ensure that door sill purlin is used with door section.
- An 8-foot section of the frame will be completed with five purlins. To add sections, continue procedures until the required number of frame sections have been connected.
- Alternate direction of ridge purlin diagonal braces for added support.

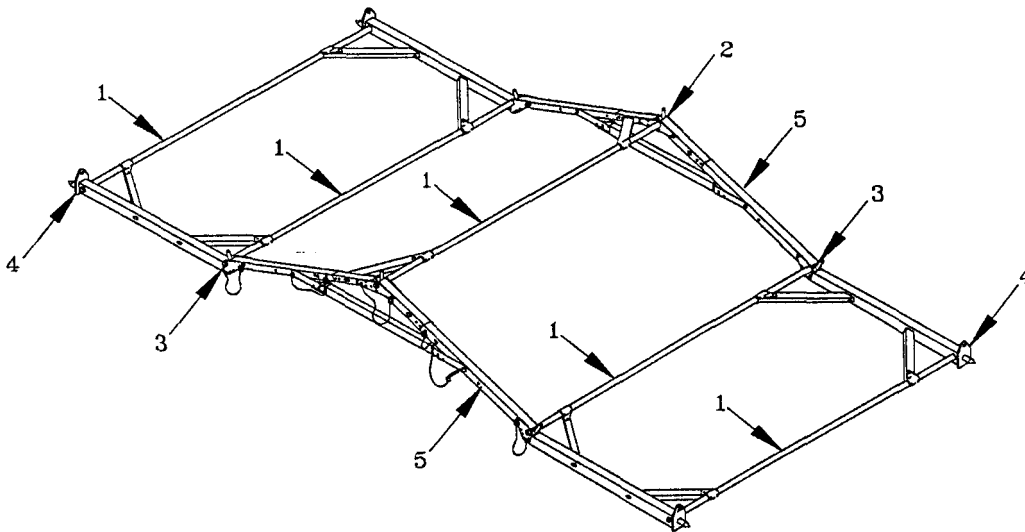

- (1) Identify five purlins (1) for installation at ridge (2), eaves (3) and bases (4).
- (2) Starting at the end arch, hold two arch assemblies (5) upright 8 feet apart in kneeling position.

**NOTE**

Ensure arches are parallel.

- (3) Install purlin (1) at ridge.

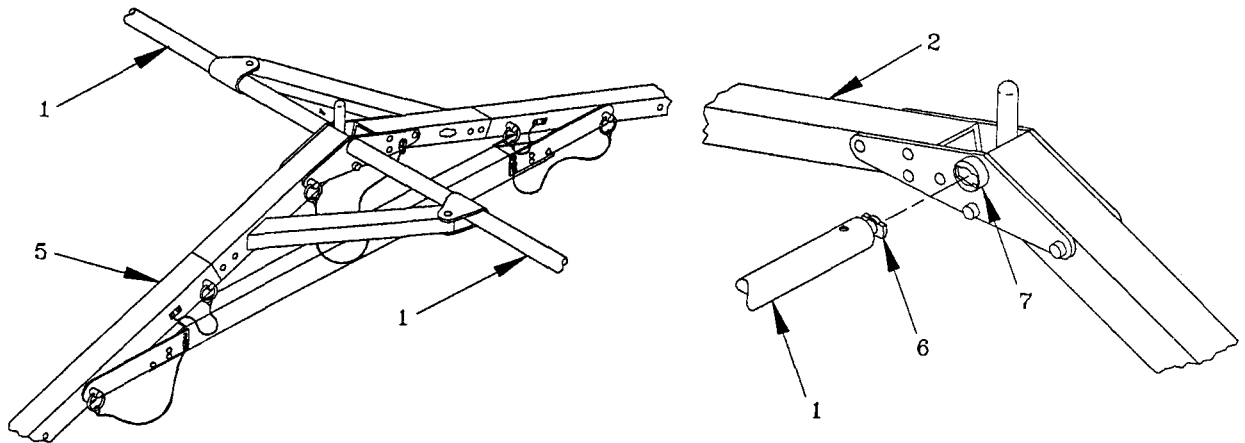

- (4) Identify end fitting (6) on each end of purlin (1).
- (5) Fit end fitting (6) in each arch assembly boss (7) simultaneously.
- (6) Rotate purlin (1) 90° so that end fittings (6) lock into boss (7) at each arch assembly (5).

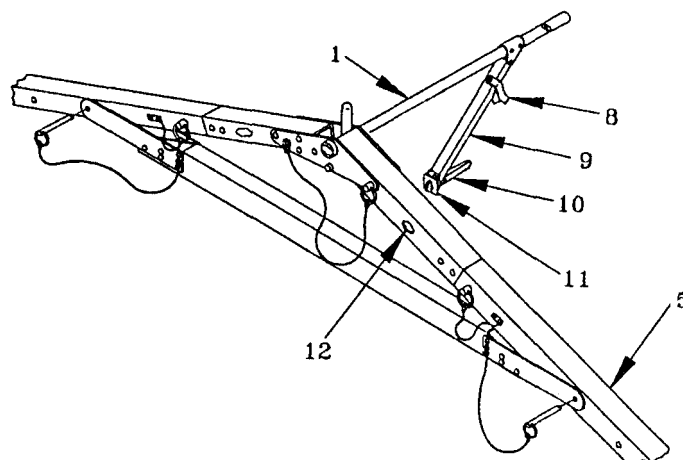

- (7) Unfasten retaining strap (8) and rotate a purlin diagonal brace (9) toward arch assembly (5).

2-5. FRAME ASSEMBLY (CONT).

**NOTE**

The brace stud and brace shackle are located at the end of the purlin diagonal brace. The slot on the arch assembly is approximately two feet from the ridge.

- (8) Holding brace shackle (10), align and place brace stud (11) in arch assembly slot (12) located two feet from ridge.
- (9) Rotate brace shackle (10) 90° to lock brace stud (11) in place.

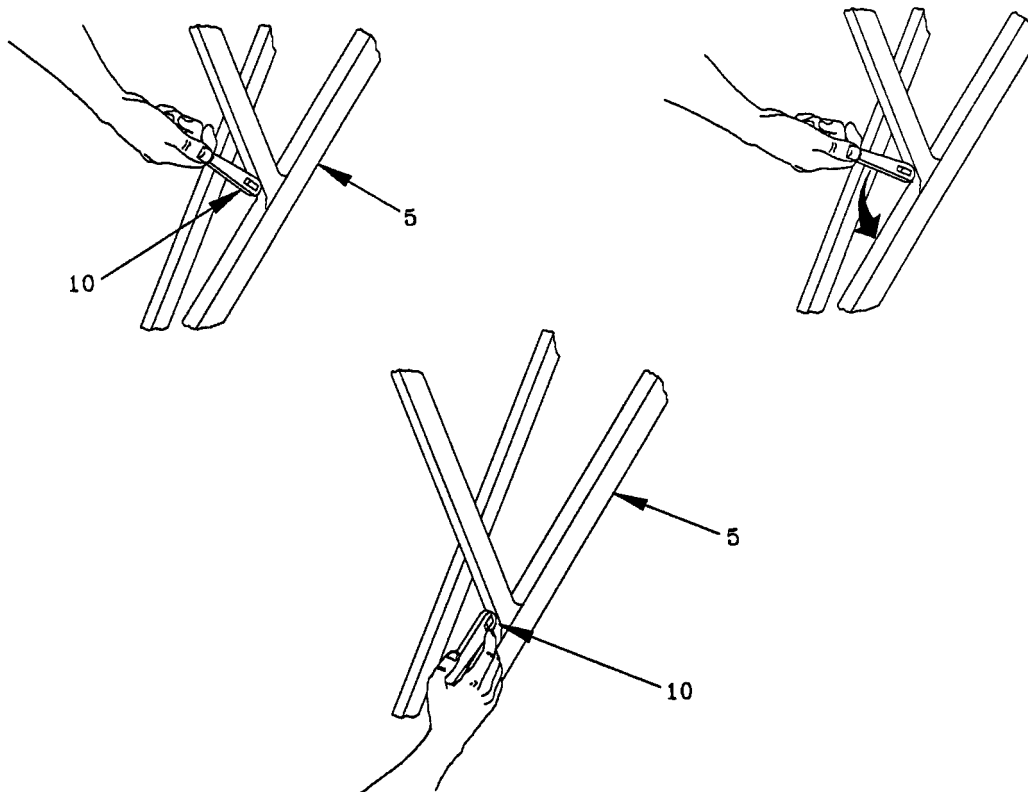

**WARNING**

Do not lock brace shackle toward purlin diagonal brace. Arch assembly may collapse causing injury to personnel or damage to equipment if improperly locked.

- (10) Lock purlin diagonal brace (9) by pressing brace shackle (10) down towards arch assembly (5) until it is secure.
- (11) Install remaining purlin diagonal brace (9) repeating steps 7-10.

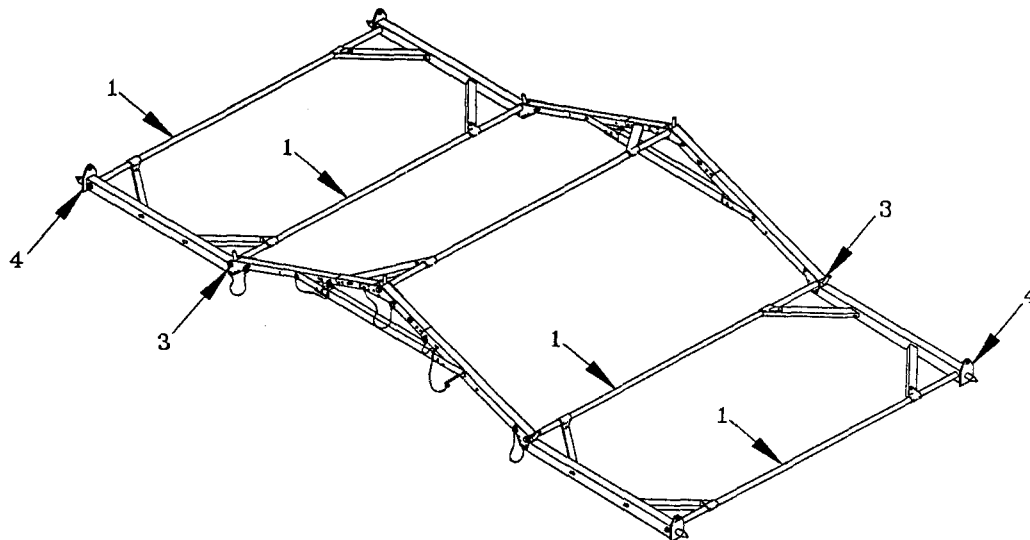

- (12) Install purlin (1) at each eave (3) repeating steps 4-11.

**NOTE**

Ensure that door sill purlin is used with door section.

- (13) Install purlin (1) at each base (4) repeating steps 4-11.
- (14) The frame section is now in a kneeling position.
- (15) Install purlins (1) in remaining arch sections repeating steps 1-13.

2-6. INITIAL PLACEMENT OF WINDOW AND DOOR SECTIONS. Install window and door sections over the frame, as follows:

Window and Door Sections.

- (1) Identify window (1) and door sections (2).
- (2) Place window sections (1) next to end and extendable frame sections.
- (3) Place door sections (2) next to extendable door section frame.

**NOTE**

The stove pipe openings should all be placed on one side. Openings of the window/door section, the liner, and the fly should be aligned.

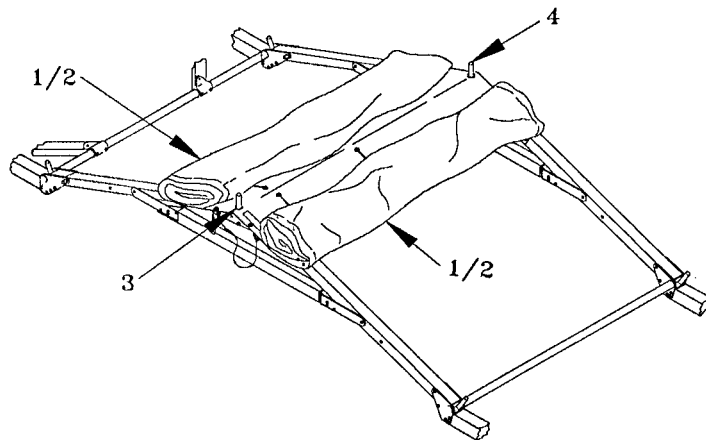

- (4) Identify large, spindle grommets (3) at the center of each side of window/door sections (1,2).

**NOTE**

Four soldiers are required to carry each window/door section to the frame section ridge.

- (5) Place the large spindle grommets (3) over ridge spindles (4).
- (6) Repeat steps 1-5 for each window/door section (1,2).

2-7. PLACEMENT OF END SECTION.

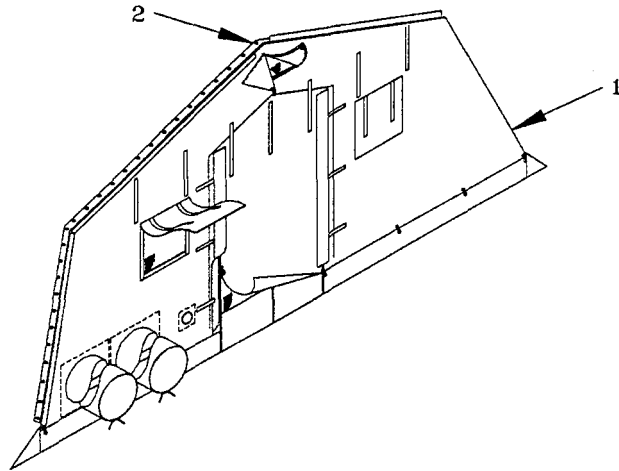

- a. Identify the endwall section (1).

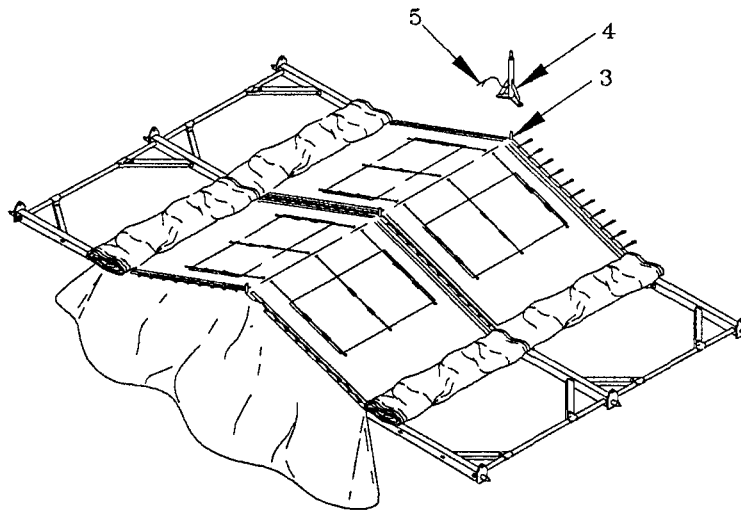

- b. Place large, spindle grommet (2) located at peak of endwall section (1) over ridge spindle (3).



2-7. PLACEMENT OF END SECTION (CONT).

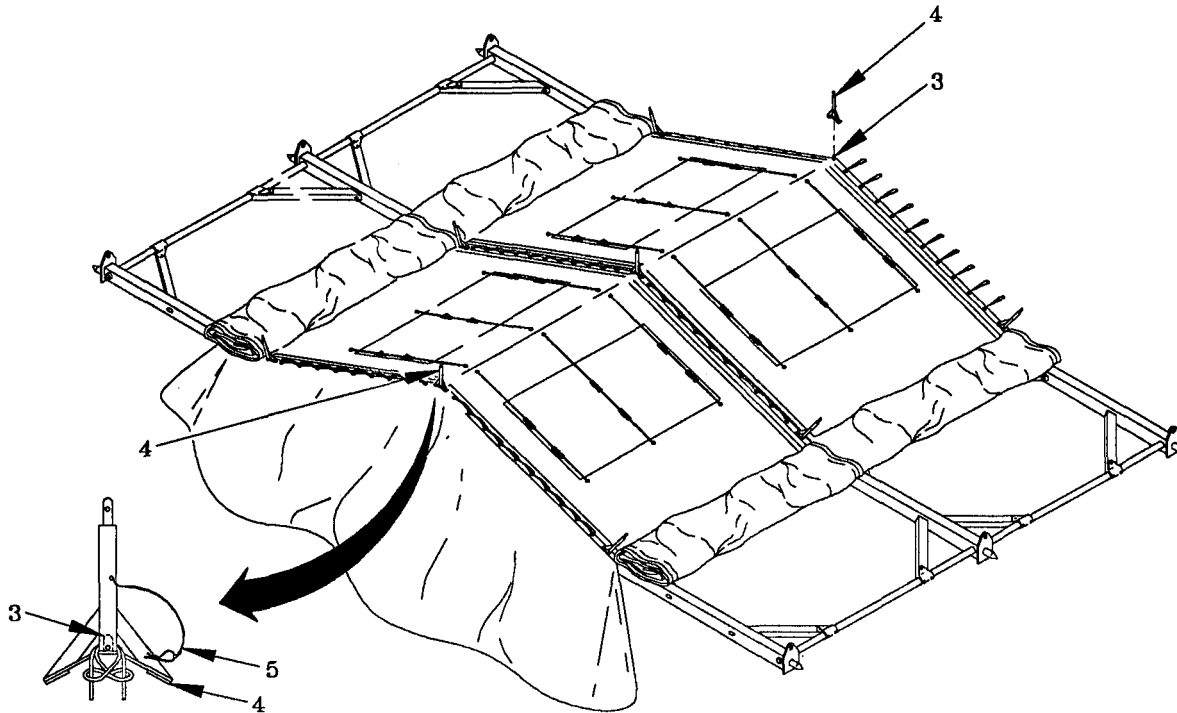

- c. Identify the ridge extenders (4).
- d. Place the ridge extenders (4) over the ridge spindles (3) and align holes in ridge spindles (3) and ridge extenders (4).
- e. Install the attached hitch clip pin (5) through holes in ridge extender (4) and spindle (3), ensuring it secures ridge extender (4) to spindle (3).

2-8. PLACEMENT OF TENT FLYS.

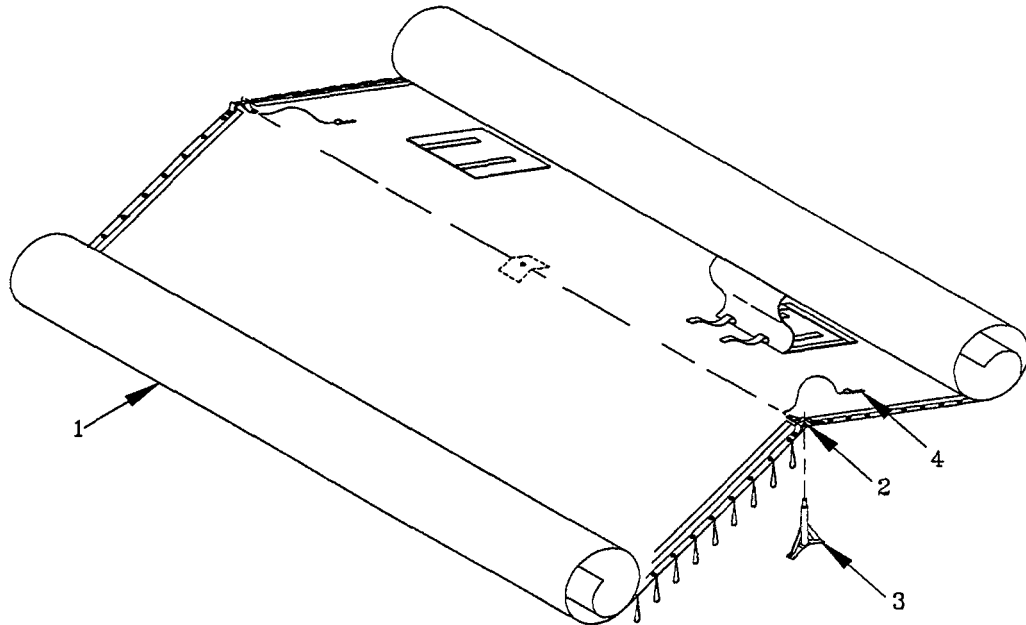

- a. Identify tent fly (1) and lay out beside window/door section.

**NOTE**

- When M-1941 stove is to be used, install two stove pipe sections with diverter. Ensure that diverter guy lines are installed.
- Be sure that the bucket laces on one tent fly line up with the bucket grommets of the adjoining tent fly.

- b. Identify the large, ridge extender spindle grommet (2).
- c. Roll up both sides of fly (1) to large, ridge extender spindle grommet (2).
- d. With a minimum of one individual placed at each large, ridge extender spindle grommet (2), lift and move fly (1) to frame section ridge purlin.

2-8. PLACEMENT OF TENT FLYS (CONT).

- e. Place the large, ridge extender spindle grommets (2) on the ridge extender spindles (3).
- f. Place the fly hitch clip pins (4) through the holes in the ridge extender spindles (3) which protrude through the large, ridge extender spindle grommets (2).

2-9. BECKET LACING WINDOW AND DOOR SECTIONS, END SECTIONS, AND TENT FLYS. At this point, lacing together of window and door sections, window/door and end sections, and tent flys may be accomplished simultaneously. Begin all lacing from the ridge line and work to the eave. Start lacing the window and door section together first, working slightly ahead of the tent fly, rolling material towards the eave as you progress. Lacing of the end section and window/door section can proceed independently of the window/door sections and tent fly. Becket lacing procedure is the same throughout the erection process and is accomplished as follows:

**CAUTION**

Do not step on tent components.  
Material may be torn and dirt  
ground into material.

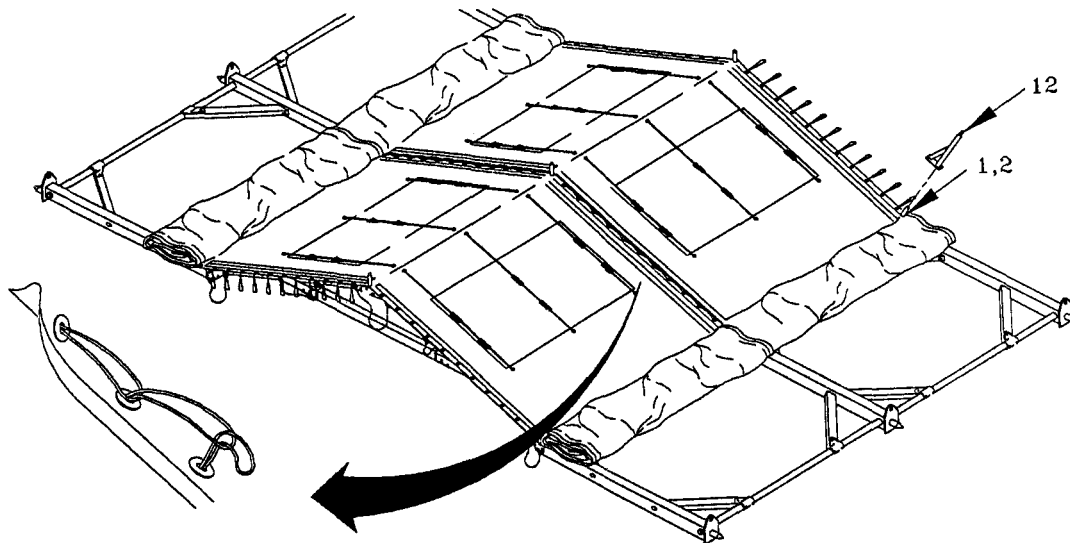

**NOTE**

For easier lacing, place eave grommets with becket laces over eave spindles first, to provide fabric tension, then overlap adjoining window/door section and end section eave grommet without laces.

- a. Place becket side eave grommet (1) over eave spindles (2).

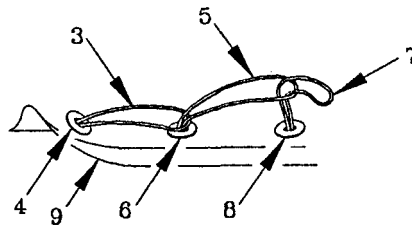

- b. Identify first becket lace (3) and becket grommet (4) near the ridge.
- c. Insert first becket lace (3) through first becket grommet (4) and second becket lace (5) through second becket grommet (6).
- d. Insert second becket lace (5) through loop of first becket lace (3).
- e. Pull second becket lace (5) tight away from ridge.
- f. Insert third becket lace (7) through grommet (8) and through loop of second becket lace (5).
- g. Pull third becket lace (7) tight away from ridge.

**NOTE**

Ensure weather flap fabric is slid under the ridge extender brace.

- h. Continue lacing and close hook and pile weather flap (9) until reaching last becket lace (10).
- i. Place remaining window/door and end section eave grommets over eave spindles.

2-9. BECKET LACING WINDOW AND DOOR SECTIONS, END SECTIONS, AND TENT FLYS (CONT).

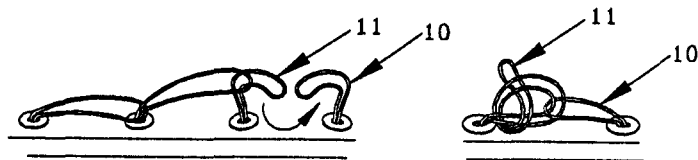

- j. Upon reaching last becket lace (10) at eave, insert next-to-last becket lace (11) through loop of last becket lace (10).
- k. Pull the next-to-last becket lace (11) back towards the ridge and tie off with half-hitch knot.
- l. Complete lacing all window/door sections and end sections up to eave.
- m. Identify the eave extenders (12).

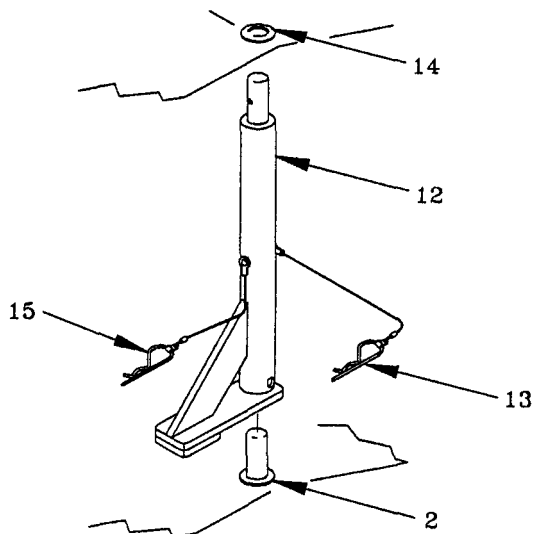

- n. Place eave extenders (12) on eave spindle (2) with brace towards ridge.
- o. Align spindle (2) and eave extender (12) holes and insert the hitch clip pin (13) ensuring it secures eave extender (12) to eave spindle (2).

- p. Place the large, fly grommet (14) on the eave extender (12) spindle and insert hitch clip pin (15) to lock.

**NOTE**

Do not lace any beackets below the eave at this time.

2-10. INSTALL GUY LINES.

- a. Identify one 19-foot guy line (1) and one tent slip (2) for placement at each eave extender (3) base. Identify two 19-foot guy lines (1) and tent slips (2) for placement at the two end ridge extender (4) bases.

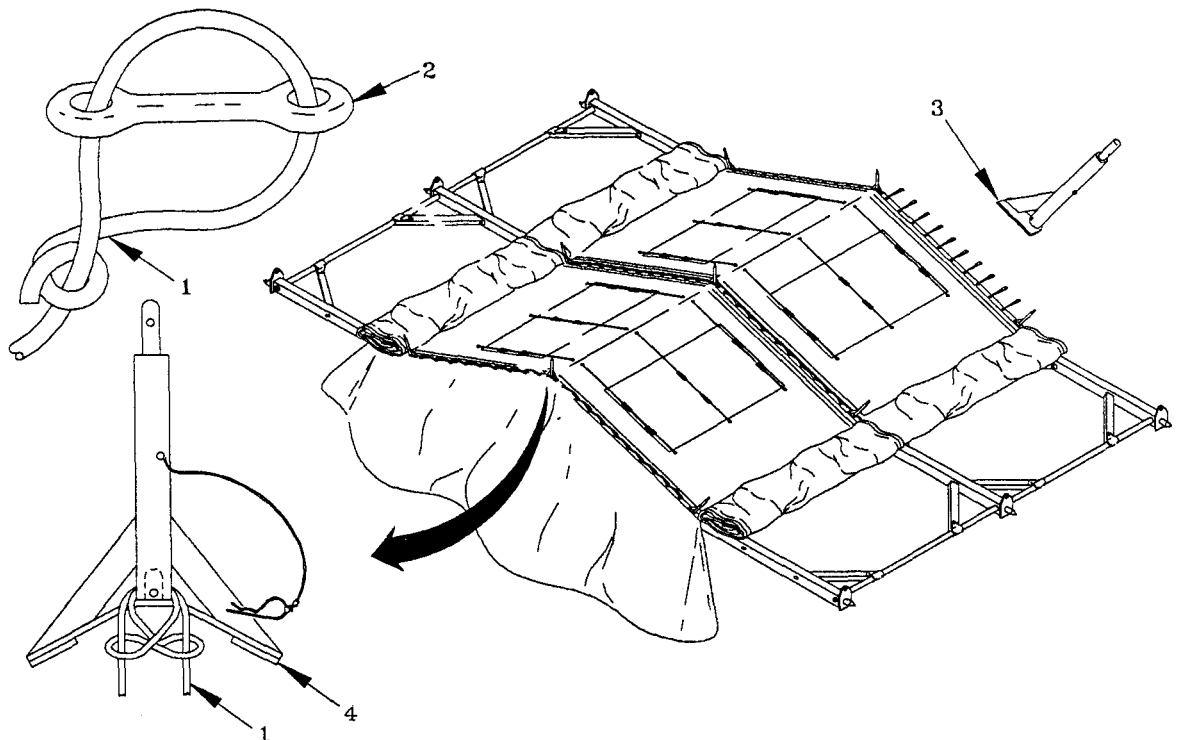

- b. Thread the guy line (1) through one side of the tent slip (2) and then through the brace and around the pole of the eave (3) or ridge extender (4).
- c. Bring guy line (1) through other side of tent slip (2) and tie an overhand knot at end of guy line (1). Repeat steps a-c for all extenders.
- d. Identify one 19-foot guy line (1) and one tent slip (2) for each eave extender (3) spindle. Identify two 19-foot guy lines (1) and tent slips (2) for the two end ridge extender (4) spindles.

2-10. INSTALL GUY LINES (CONT).

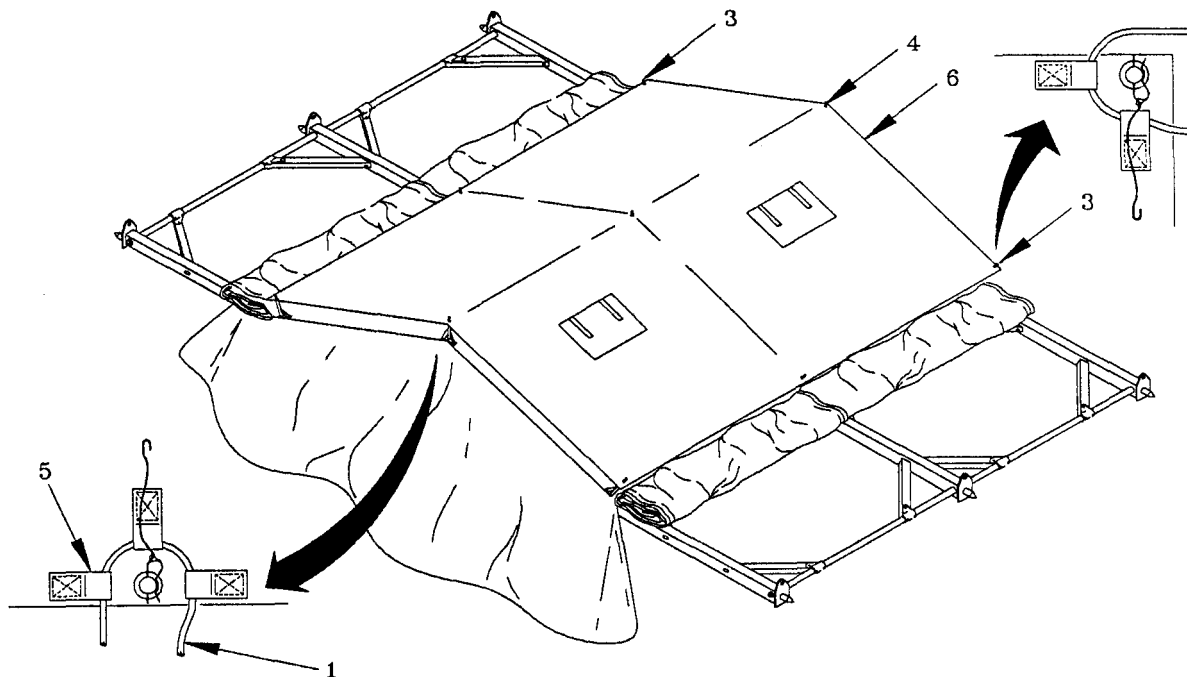

- e. Thread 19-foot guy lines (1) through one side of tent slips (2) and then through webbing loops (5) of tent fly (6) at eave and ridge extender (3,4) spindles.
- f. Thread guy line (1) back through the other side of the tent slip (2) and tie an overhand knot.

**WARNING**

Eliminate the possibility of tripping. Clear fabric and guy lines. Injury to personnel may result from falls.

- g. Place the guy lines (1) on the tent fly (6).

2-11. RAISING THE FRAME TO PARTIALLY-ERECT POSITION. Raise one side of frame as follows:

**CAUTION**

Avoid folding wall fabric into joints. Material may rip or tear if caught in joint.

- a. Fold wall fabric (1) between tent fly (2) and roof (3) to expose eave gussets (4).
- b. Identify quick release pin (5) and ensure it is hanging free.
- c. Identify the locking hole in the side arch assembly (6) and ensure it is free of debris.

**WARNING**

Two soldiers should be placed at each arch leg to raise frame. Lift tent from correct squatting position, using your legs to avoid back injury.

**CAUTION**

Tent frame must be raised uniformly to avoid twisting or turning. Damage to frame can result.

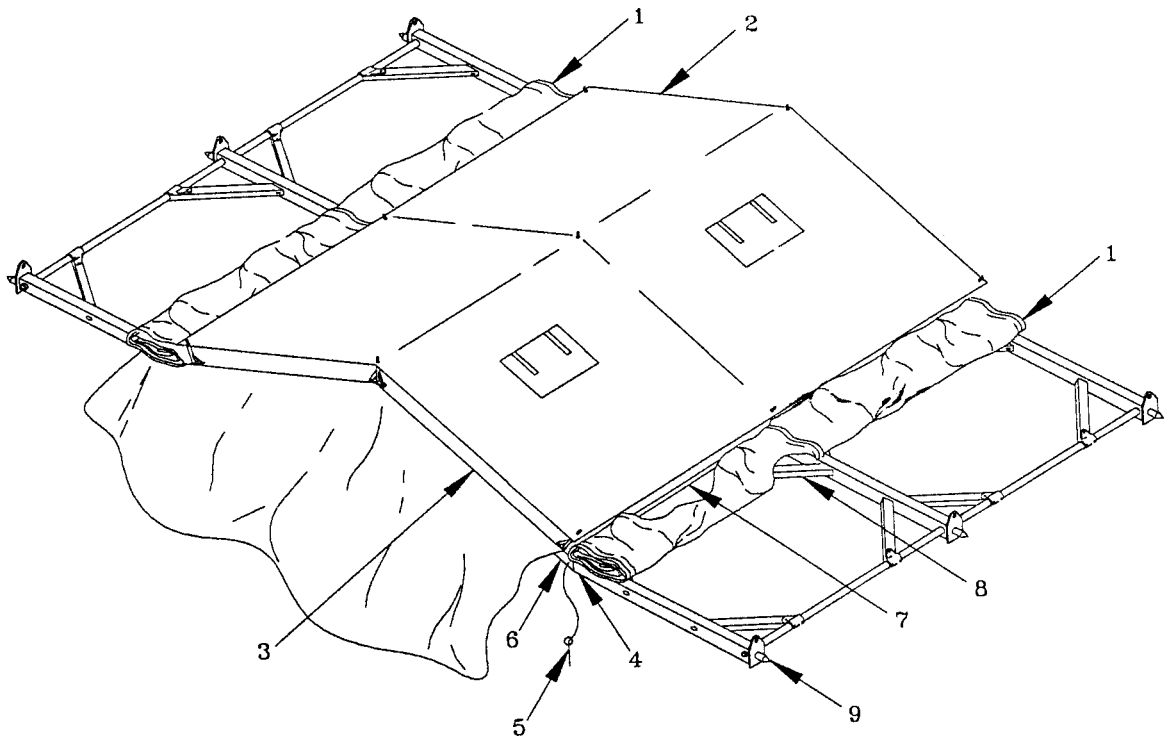



2-11. RAISING THE FRAME TO PARTIALLY-ERECT POSITION (CONT).

- d. Step in next to the eave gusset (4).

**WARNING**

Frame assembly hinges can pinch or crush hands and fingers. Keep hands and fingers away from frame assembly ridges and eaves.

- e. Place one hand on the side arch assembly (6) and one hand on the eave purlin (7) outside the diagonal brace (8).
- f. Get in a stable squatting position.

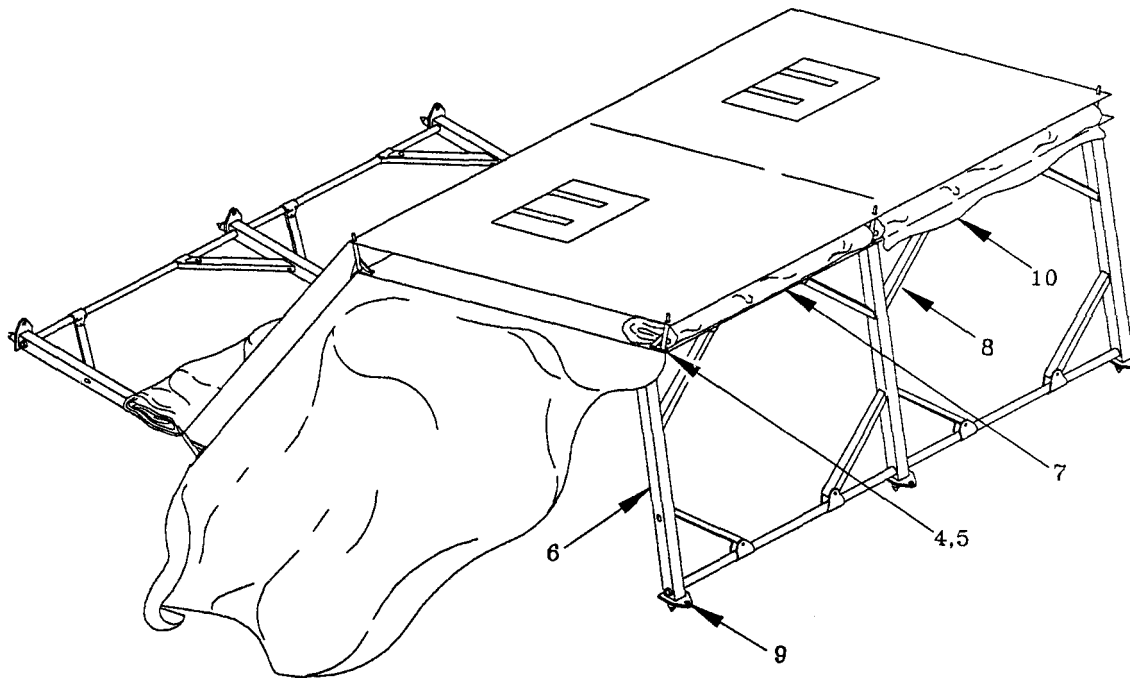

- g. Lift frame straight up to shoulder height, dragging side arch assembly (6) inward.
- h. Place weight of the frame on side arch assembly foot (9).

**CAUTION**

Insert quick release pins towards inside of tent on end assemblies. Tent fabric may tear if inserted towards outside.

- i. Align holes of eave gusset (4) and side arch assembly (6) and install quick release pin (5).
- j. Identify purlin flap (10) on interior of window/roof section.
- k. Secure purlin flap (10) to frame at eave purlin (7) using hook and pile fasteners.
- l. Tent is now in a partially-erect stage.

**NOTE**

The other side of the tent will be raised after installation of interior components.

2-12. COMPONENTS. While the frame is partially-erect install components as follows:

**NOTE**

Use bow knots when tying all tie tapes to prevent tie tapes from becoming knotted and difficult to untie.

- a. Single Ply Floor.

**CAUTION**

Clear and level ground before installing floor. Sharp objects or depressions can damage tent floor.

**NOTE**

Partially install the single ply floor to keep the liner clean while it is being put up. Installation will be completed when tent is fully erected.

2-12. COMPONENTS (CONT).

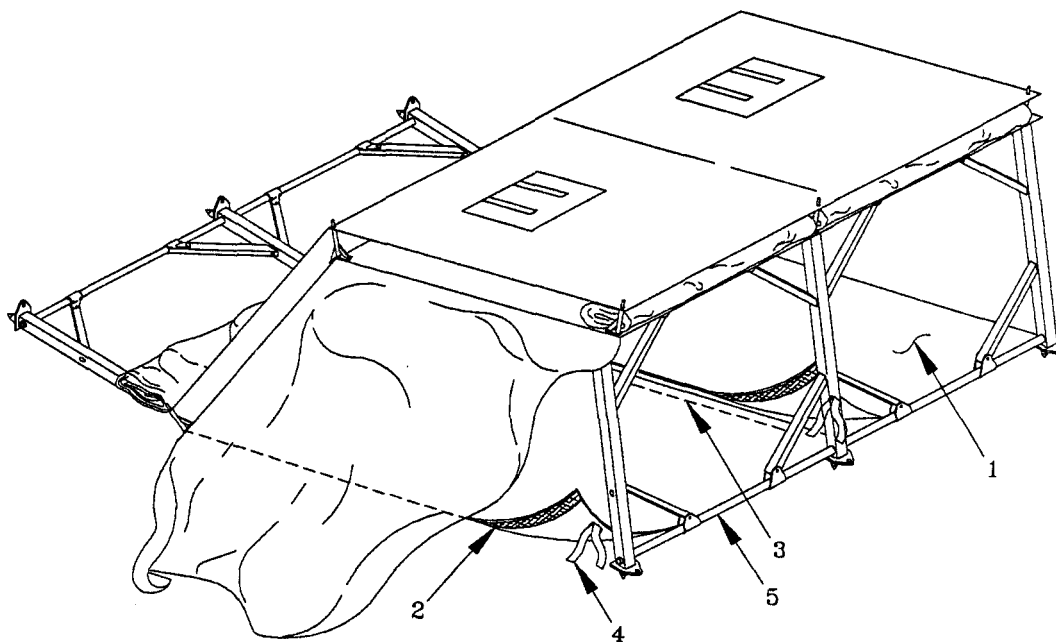

- (1) Identify single ply floor sections (1).
- (2) Unroll floor sections and install black side down.
- (3) Place all floor sections alternating hook and pile fasteners (2,3).
- (4) Secure tie tapes (4) on narrow edge of floor to base purlins (5) on raised side of tent.

b. Electrical cables.

**WARNING**

Lethal voltage is present when cables are connected to power control system. Ensure cables are disconnected from power source when working with cables or fixtures. Electrical shock or death may result from failure to heed this warning.

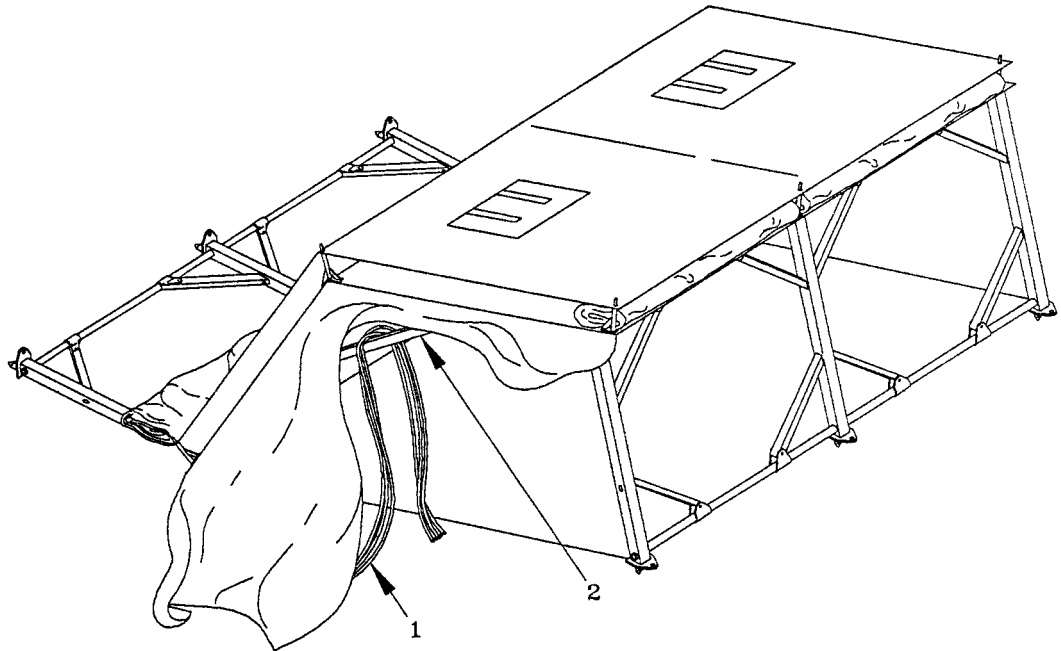

**CAUTION**

Allow slack in electrical cables.  
Strain on cable can damage  
equipment.

- (1) Wrap light and extension (103, 156, 173 254 inch) cables (1) once around the header (2) to relieve strain.

2-12. COMPONENTS (CONT).

c. Light Support Strap Assembly.

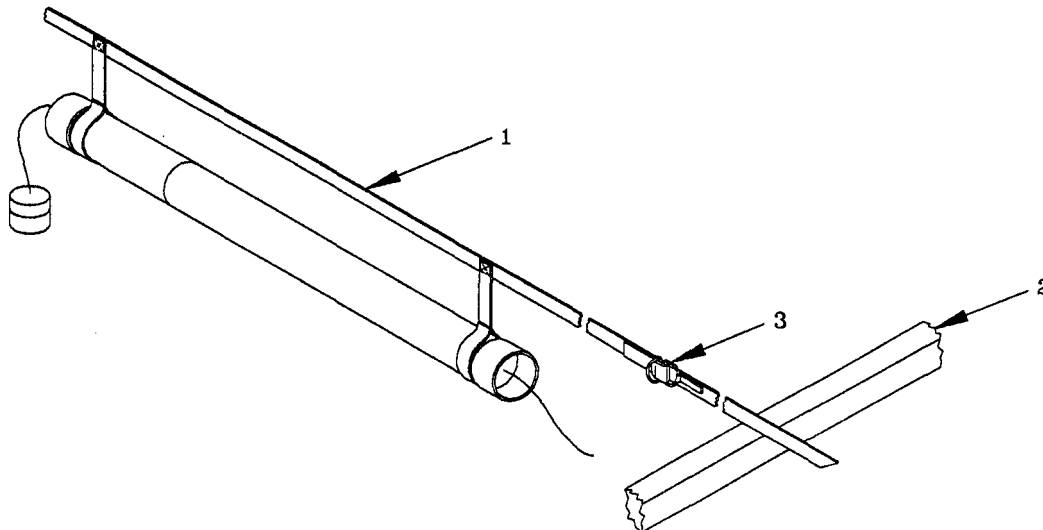

- (1) Identify light support strap assembly (1) in light set case.
- (2) Wrap each running end of light support strap assembly (1) once around header (2) at header/arch joint so the double D-ring (3) faces the tent roof.
- (3) Secure end of light support strap assembly (1) through double D-ring (3) assembly on standing end of strap. Tighten webbing until taut.

d. Liner.

- (1) Identify liner sections (1).
- (2) Unwrap tent liner (1) and unfold it inside tent.
- (3) Identify three liner, nylon support straps (2) and snap hooks (3) at center of liner (1).

**NOTE**

Position outside support straps on ridge purlin, inside the diagonal brace.

- (4) Wrap D-ring (4) portion of outside support straps (2) around ridge purlin (5). Attach to snap hook (3).

- (5) Clip remaining strap around ridge purlin (5) in similar manner.

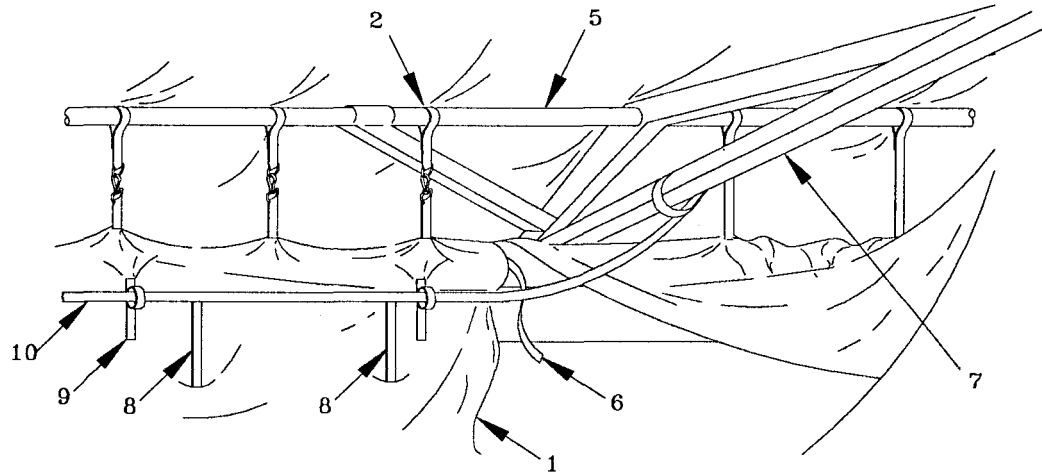
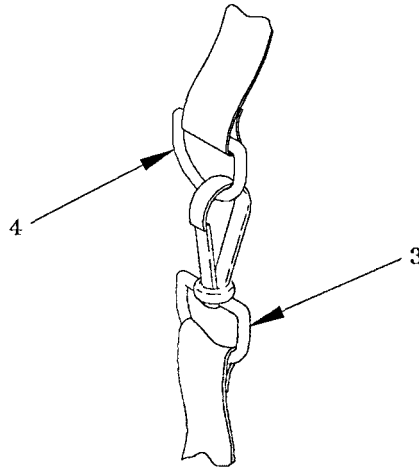

- (6) Identify the tie tape (6) at center edge of liner (1).
- (7) Secure the tie tape (6) to the header (7) using a bow knot.
- (8) Secure the opposite tie tape on the opposite header using a bow knot.
- (9) Secure liner (1) to frame members with tie tapes (6).

2-12. COMPONENTS (CONT).

- (10) Place the light support strap assy hangers (8) through slits in the liner (1).
- (11) Secure liner tie tapes (9) to light support strap assembly (10).
- (12) Press hook and pile fastener together between each liner section.

e. Plenums.

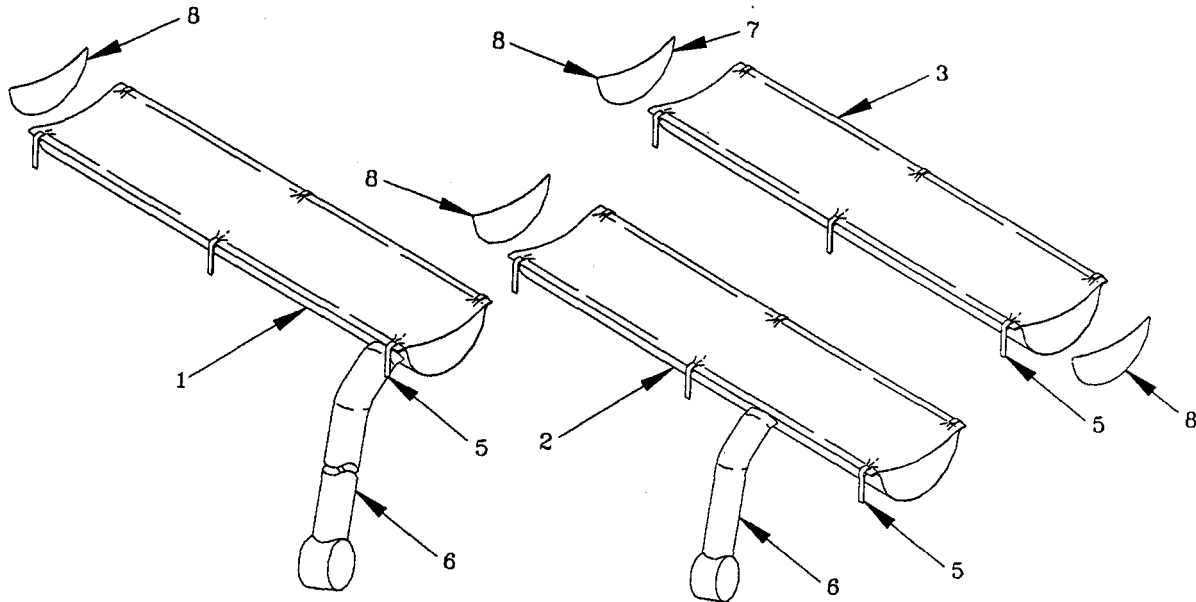

- (1) Identify the endwall, sidewall and extendable plenums (1,2,3).
- (2) Tie end of endwall plenum (1) or sidewall plenum (2) through three slots in liner to frame header (4) with tie tape (5).
- (3) Connect ventilation sleeve (6) to arch assembly at eave with tie tapes (5).
- (4) Connect ventilation sleeve (6) opening to air duct (7) with drawstring.
- (5) To add extendable plenums (3), remove plenum cover (8) and attach additional extendable plenums (3) using hook and pile fasteners in similar manner.

- (6) Continue tying tie tapes (5) to headers (4) identified every eight feet.

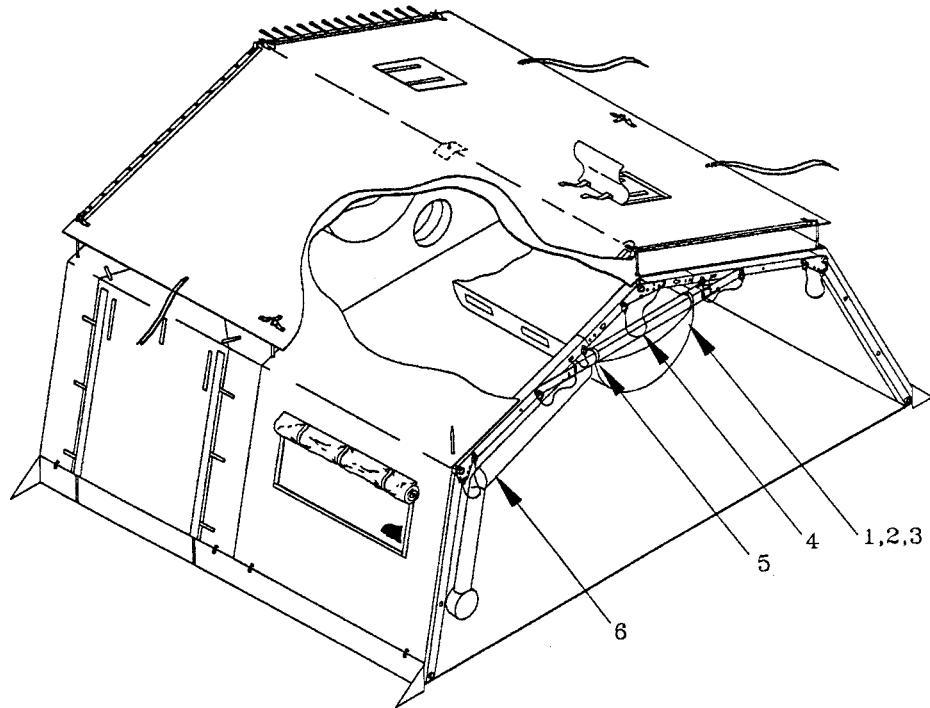

- (7) Install plenum cover (8) on final plenum using hook and pile fasteners.

**NOTE**

If a plenum is needed for an 8-foot section, use a 16-foot plenum, tie it off, and tuck excess in above itself.



2-13. INSTALL LUMINAIRES.

**WARNING**

Two men are required to lift light set case to avoid injury to personnel.

NOTE

- To prevent damage leave luminaires in case until ready to install.
- Be sure male plug end is toward distribution box.

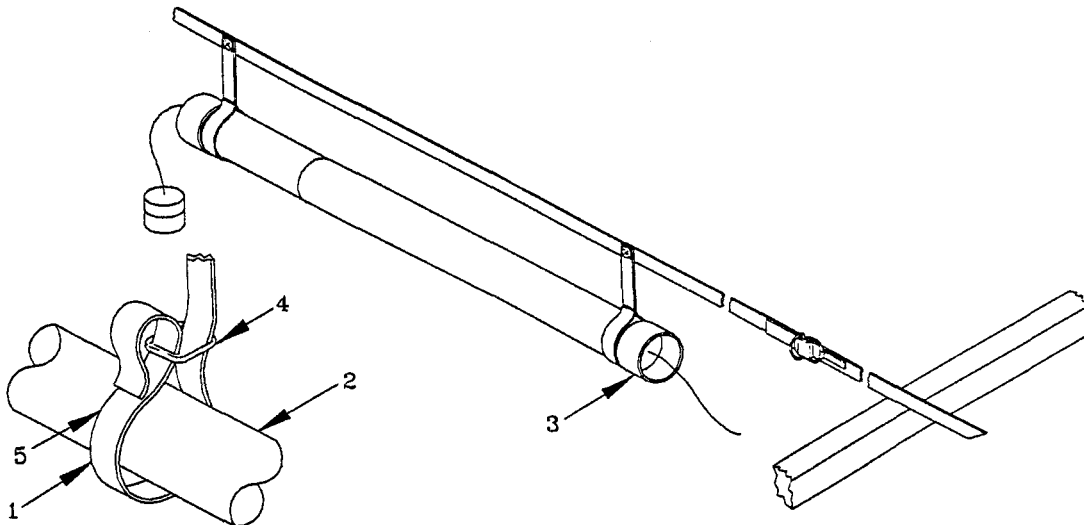

- a. Wrap light hanger strap (1) around each end of luminaire (2) on inside of rubber end caps (3).
- b. Pull strap (1) up through the "D" ring (4) and press down to engage hook and pile fastener (5).
- c. Mate plug properly to next luminaire (2), ensuring reflecting surface faces up and lamp faces down.
- d. Repeat steps a-c for additional luminaires.

**CAUTION**

Do not connect more than 12 luminaires.  
Damage to electrical circuit may result.

- e. Connect luminaires (2).

2-14. FULLY ERECTING THE FRAME. Raise the remaining side of the frame as follows:

**CAUTION**

Avoid folding wall fabric into joints. Material may rip or tear if caught in joint.

- a. Fold wall fabric (1) between tent fly (2) and roof (3) to expose eave gussets (4).
- b. Identify quick release pin (5) and ensure it is hanging free.
- c. Identify the locking hole in the side arch assembly (6) and ensure it is free of debris.

**WARNING**

Two soldiers should be placed at each arch leg to raise frame. Lift tent from correct squatting position, using your legs to avoid back injury.

**CAUTION**

Tent frame must be raised uniformly to avoid twisting or turning. Damage to frame can result.

2-14. FULLY ERECTING THE FRAME (CONT).

- d. Step in next to the eave gusset (4).

**WARNING**

Frame assembly hinges can pinch or crush hands and fingers. Keep hands and fingers away from frame assembly ridges and eaves.

- e. Place one hand on the side arch assembly (6) and one hand on the eave purlin (7) outside the diagonal brace (8).
- f. Get in a stable squatting position.

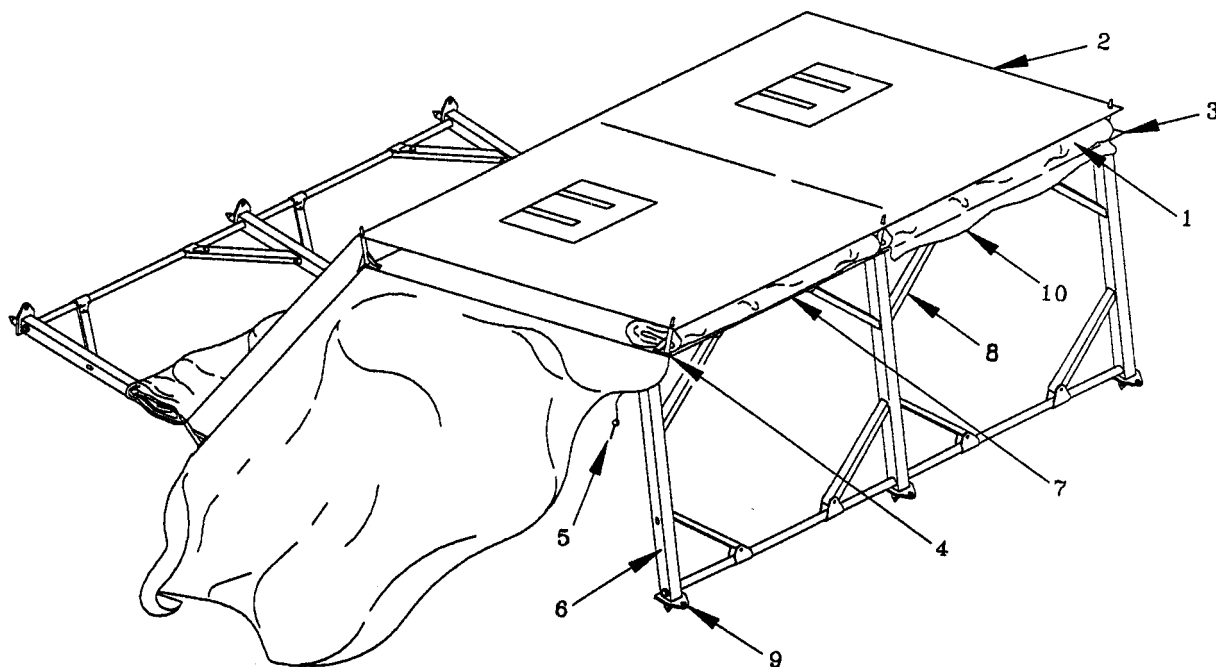

- g. Lift frame straight up to shoulder height, dragging side arch assembly (6) inward.
- h. Place weight of the frame on side arch assembly foot (9).

**CAUTION**

Insert quick release pins towards inside of tent on end assemblies. Tent fabric may tear if inserted towards outside.

- i. Align holes of eave gusset (4) and side arch assembly (6) and install quick release pin (5).
- j. Identify purlin flap (10) on interior of window/roof section.
- k. Secure purlin flap (10) to frame at eave purlin (7) using hook and pile fasteners.

**CAUTION**

Frame bases set more than 20 feet 4 inches apart may cause end section fasteners to tear apart.

- l. Set frame bases 20 feet 4 inches apart.

2-15. FINAL INSTALLATION OF FLOOR AND LINER.

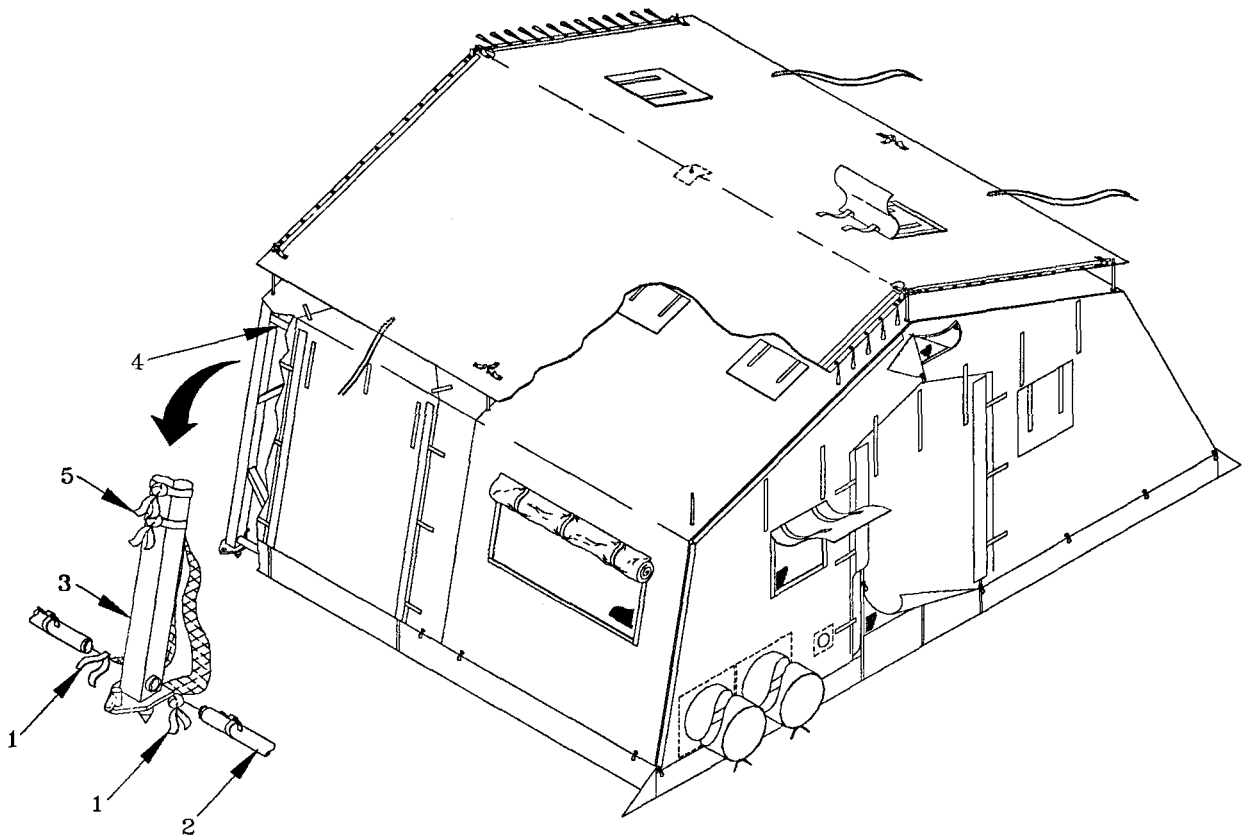

- a. Complete securing floor tie tapes (1) to base purlin (2).
- b. Complete securing liner tie tapes (3) to eave purlin (4) and side arch assembly (5).

2-15. FINAL INSTALLATION OF FLOOR AND LINER (CONT).

- c. Install insulated floors, if authorized as follows:
- (1) Unwrap and spread out floor (1) inside tent so it is flat and smooth.
  - (2) Place one 8-foot section at end of tent.

**NOTE**

After installing first section of insulated floor, be sure to install additional sections so that hook and pile fasteners mate properly.

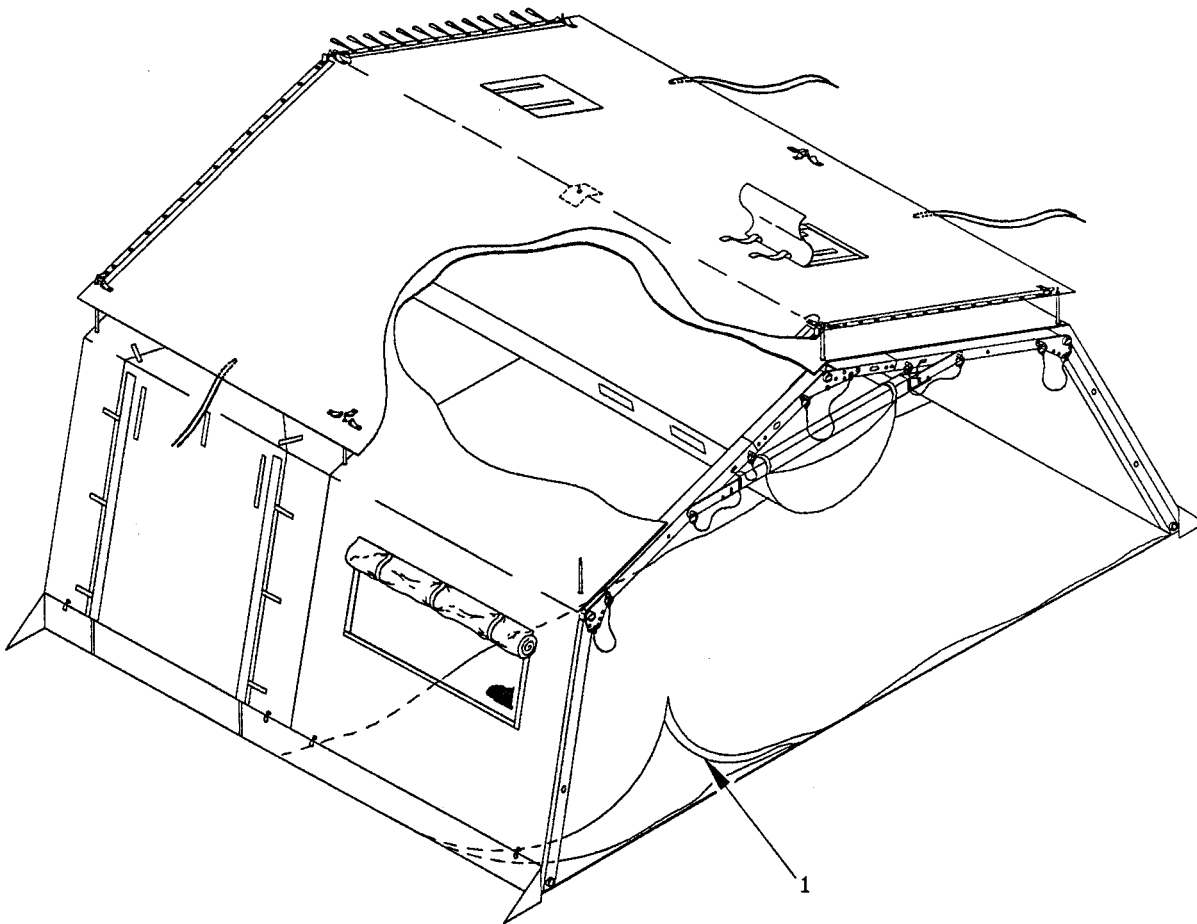

- (3) Install remaining floors until all single ply floors are covered.

2-16. ELECTRICAL COMPONENTS. Install the electrical system as follows:

WARNING

Lethal voltage is present when the power control system is connected to power source. Disconnect from power source before inspecting or repairing any electrical component. Electrical shock or death may result from failure to heed this warning.

- a. Electrical cables and Convenience Outlets.

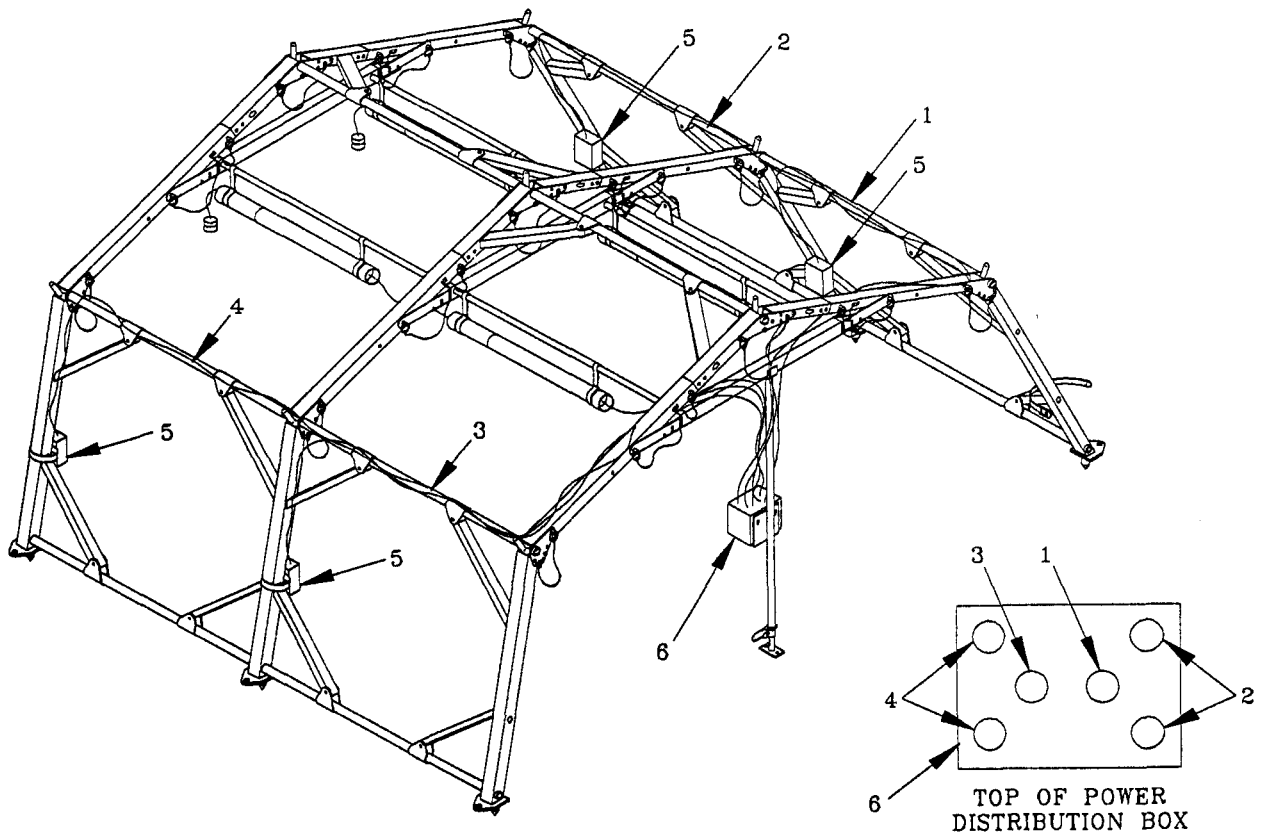

- (1) Place the 103, 156, 173 and 254 inch cables (1,2,3,4) and convenience outlet (5) in tent and connect cables to distribution box (6) as shown.

2-16. ELECTRICAL COMPONENTS (CONT).

b. Power Panel Stand.

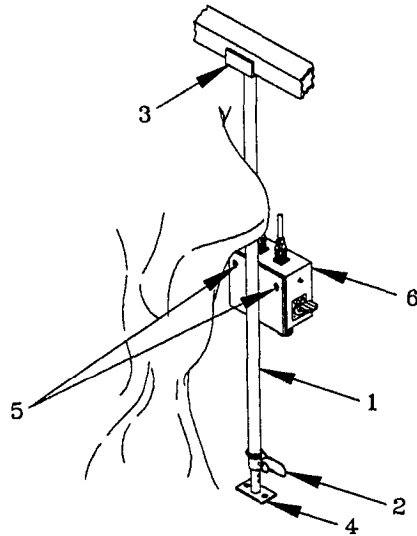

- (1) Place power panel stand (1) between liner and tent fabric at left entrance side of tent.
- (2) Disconnect quick release pin (2) at the bottom of stand.
- (3) Extend outer column of stand to engage frame header in U-clamp (3).
- (4) Step on base plate (4) to provide tension on stand.
- (5) Insert quick release pin (2) to lock stand in place and stake to ground.

**NOTE**

Stand should not move. If necessary readjust hitch pin for sufficient tension on stand.

- (6) Insert mounting bolts (5) in rear of distribution box (6) through keyhole slots in power panel stand (1).

**CAUTION**

Connect all cables and dust caps together. Dirt and dampness may damage electrical connections.

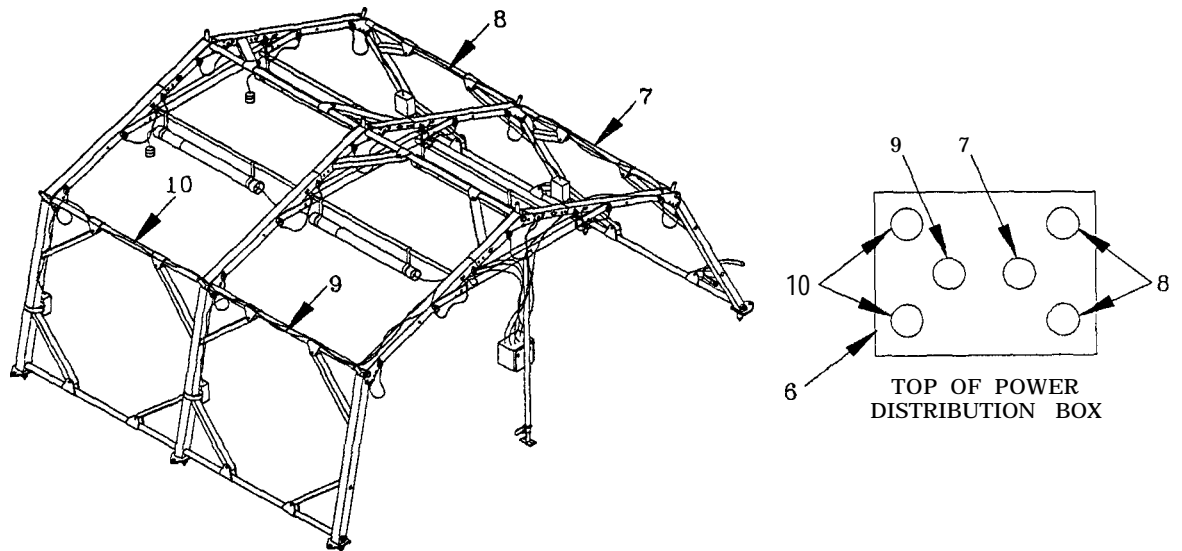

(7) Connect 103,156,173 and 256 inch cables (7,8,9,10) as indicated.

2-17. COMPLETE BECKET LACING.

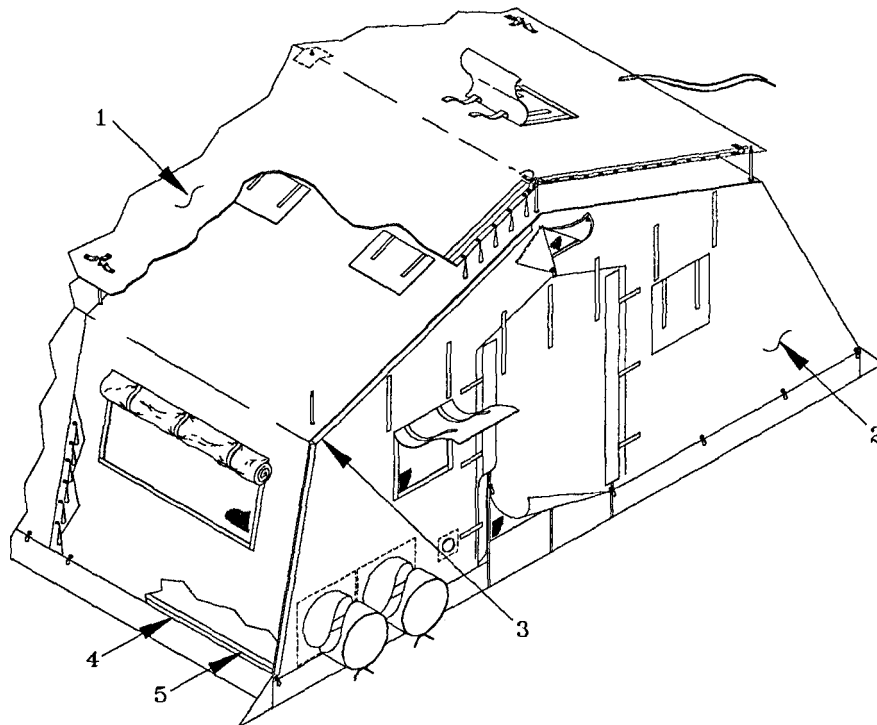

- a. Complete lacing all roof sections (1) and end sections (2) together. Secure weather seal flap (3) .
- b. Pull sod cloth (4) under base purlins (5) and end wall sections (2) .



2-18. STAKES AND GUY LINES. Secure tent to ground as follows.

**WARNING**

Stakes and guy lines must be used to prevent excessive movement of the extendable modular tents in high winds. Failure to stake and tie down tent may result in personal injury or damage to equipment.

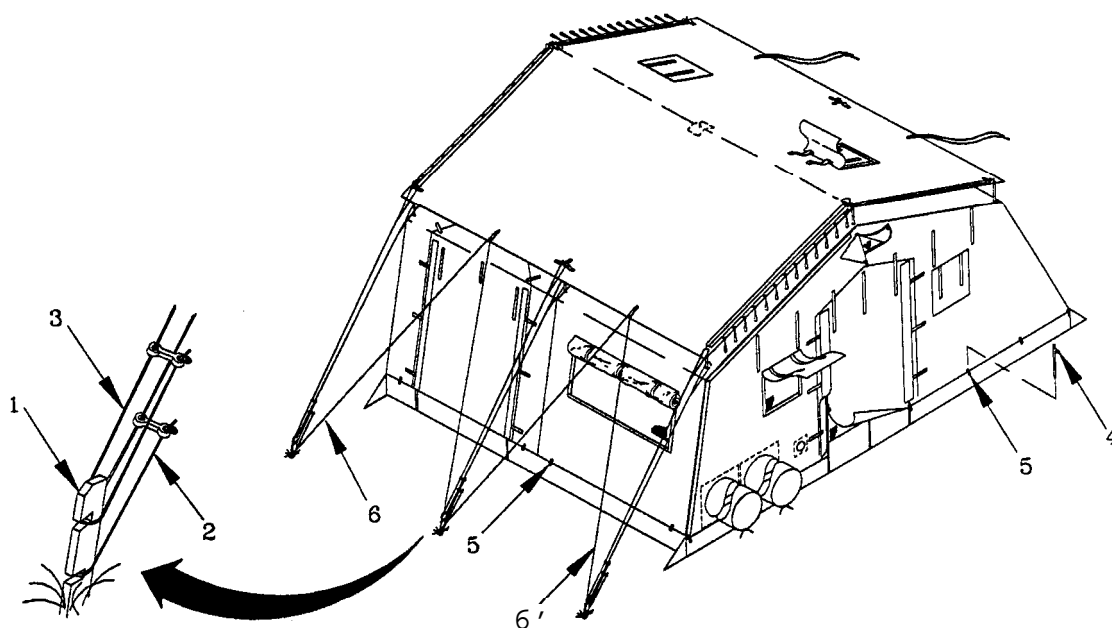

- a. Place a 24-inch wooden stake (1) approximately 10 feet from the side and ends of tent at each cave extender and slant stake(s) towards tent.
- b. Connect loop of cave extender guy line (2) to bottom notch of wooden stake (1) .
- c. Place loop of fly guy line (3) over top notch of stake (1) .
- d. Stake tent frame foot to ground using 12-inch steel pins (4) .

- e. Stake foot loops (5) to ground.
- f. Tighten guy lines (2,3) .
- g. High wind lines (6) are secured to stake (1) at the top notch.

2-19. VESTIBULE ASSEMBLY. When authorized, the vestibule may be used as a passageway or as an entryway. It may be connected to an endwall or a roof section doorway. Erect the vestibule as follows for all configurations.

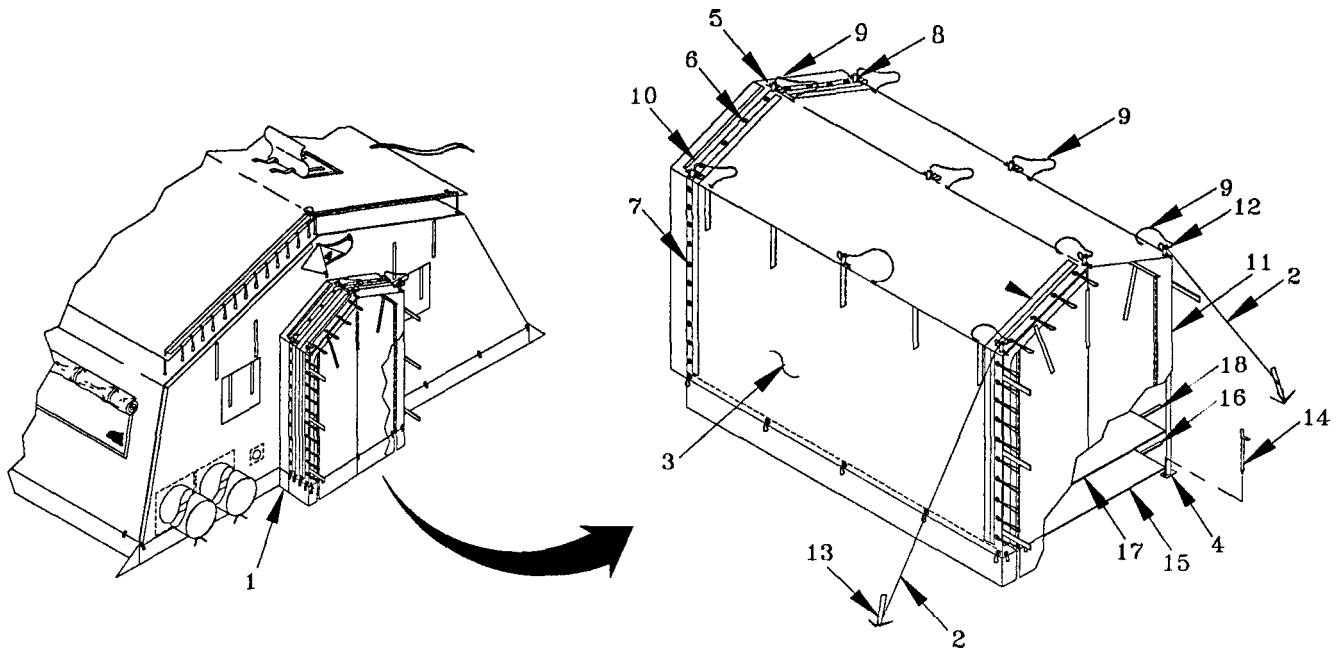

- a. Unroll vestibule adapter (1) tent door.
- b. Identify and lay out guy lines (2) .
- c. Identify and lay out vestibule fabric (3) .
- d. Identify, lay out and assemble vestibule frame sections (4) .
- e. Open tent door and place all assembled frames inside.
- f. Identify ridge spindle grommets (5) at one end of vestibule (3) and vestibule adapter (1) .
- g. Align vestibule spindle grommets (6) with vestibule adapter spindle grommet (7) .

2-19. VESTIBULE ASSEMBLY (CONT) .

- h. Insert vestibule frame spindles (8) in vestibule adapter and vestibule spindle grommets (6,7) . Secure ridge grommets (5) with hitch clip pins (9) .
- i. Becket lace the vestibule fabric (3) to the adapter (1) starting at the ridge and working towards each cave. Tie off at cave with half hitch knot. Cover with weather seal flaps (10). Install remaining hitch clip pins (9) . Complete becket lacing.
- j. Carefully bring one completed vestibule frame (4) underneath vestibule (1) .
- k. Place completed vestibule frame spindles (8) through three grommets (6) at center of vestibule.
- l. Place hitch clip pins (9) through spindles (8) .

**CAUTION**

Orient hitch clip pins towards inside of vestibule at vestibule door frame. Vestibule door fabric may tear if oriented towards outside.

- m. Carefully bring one completed vestibule frame (4) underneath vestibule (1) .
- n. Place completed vestibule frame spindles (8) through three grommets (6) at end of vestibule.
- o. Install vestibule door (11) and secure ridge hitch clip pins (9).
- p. Becket lace from ridge to cave, seal weather flap (10) , install remaining hitch clips pins (9) and complete becket lacing.
- q. Extend frames (4) and fabric (3) .
- r. Install two guy lines (2) under hitch clip pins (9) on cave spindles (12) of last vestibule frame.
- s. Place 24-inch wooden stakes (13) about 6 feet out, facing towards vestibule door.
- t. Tie guy lines (2) to stakes (13) and tighten.

- u. Secure vestibule fabric (3) to vestibule frame (4) with tie tapes.
- v. Install a 12-inch steel pin (14) in base plates of end vestibule frame (4) .
- w. Identify and install single ply floor (15) and secure with tie tapes (16) to vestibule frame (3) .
- x. Install insulated floor (17) on top of single ply floor (15) . Secure with tie tapes (18) .

2-20. INSTALL DOUBLE BUMP-THROUGH DOORS IN VESTIBULE OR VESTIBULE ADAPTER. If authorized, the bump-through doors may be installed in the vestibule doorway or vestibule adapter. Proceed as follows to erect doors:

- a. Stand the double bump-through door (1) up and lock the door in the closed position.
- b. Loosen the set screws (2) on top of doors.

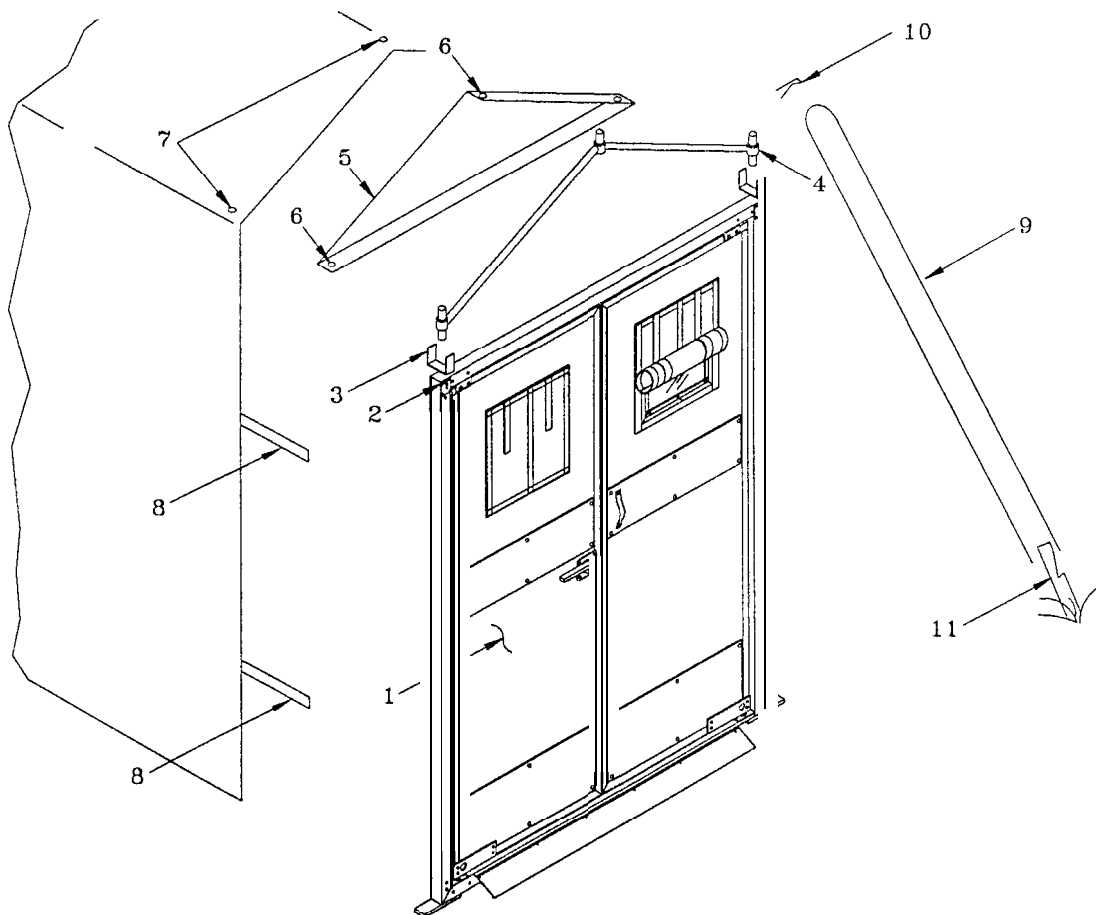

2-20. INSTALL DOUBLE BUMP-THROUGH DOORS IN VESTIBULE OR VESTIBULE ADAPTER (CONT) .

- c. Remove the door extenders (3) .

**NOTE**

To store the door extenders, place them in either side of the doorway between the liner and the endwall or in a foot locker.

- d. Remove the arch (4) from the vestibule frame.
- e. Insert the post of the arch (4) in holes on each side of the top of the double bump-through doors.
- f. Tighten the set screws (2).
- g. Identify the triangular vestibule arch cap (5) .
- h. Place the cap grommets (6) over the arch (4) spindles.
- i. Press the hook fastener of the arch cap to the pile fastener of the door frame.

**CAUTION**

Lift door ramps prior to placing weight on door frame. Damage to piano hinge may result.

- j. Place the double bump-through door into position.
- k. Place the vestibule adapter and vestibule grommets (7) over the arch (4) spindles.

**NOTE**

Place the knot on one side or the other side of the frame so it does not interfere with the movement of the doors.

- l. Move the door (1) to a vertical position.
- m. Tie the tie tapes (8) to the frame of the door.
- n. Install two guy lines (9) under hitch clip pins (10) on arch spindles, if placed at end of vestibule.

- o. Close the weather flaps by sealing them around the double access door frame, if placed at end of vestibule.

p. Tie guy lines (9) to stakes (11) and tighten.

2-21. INSTALL DOUBLE BUMP-THROUGH DOORS IN END SECTION. Proceed with the following to install doors in end section doorway.

- a. Unzip, roll up, and tie the end section fabric door (1) .
- b. Disconnect the hook and pile fastener holding the screening (2) and liner door (3) in place.
- c. Roll up and tie the screen (2) .
- d. Roll up and tie the liner door (3) .
- e. Stand the double bump-through door (1) up and lock the doors in the closed position.
- f. Loosen the set screw (5) on top of the doors.

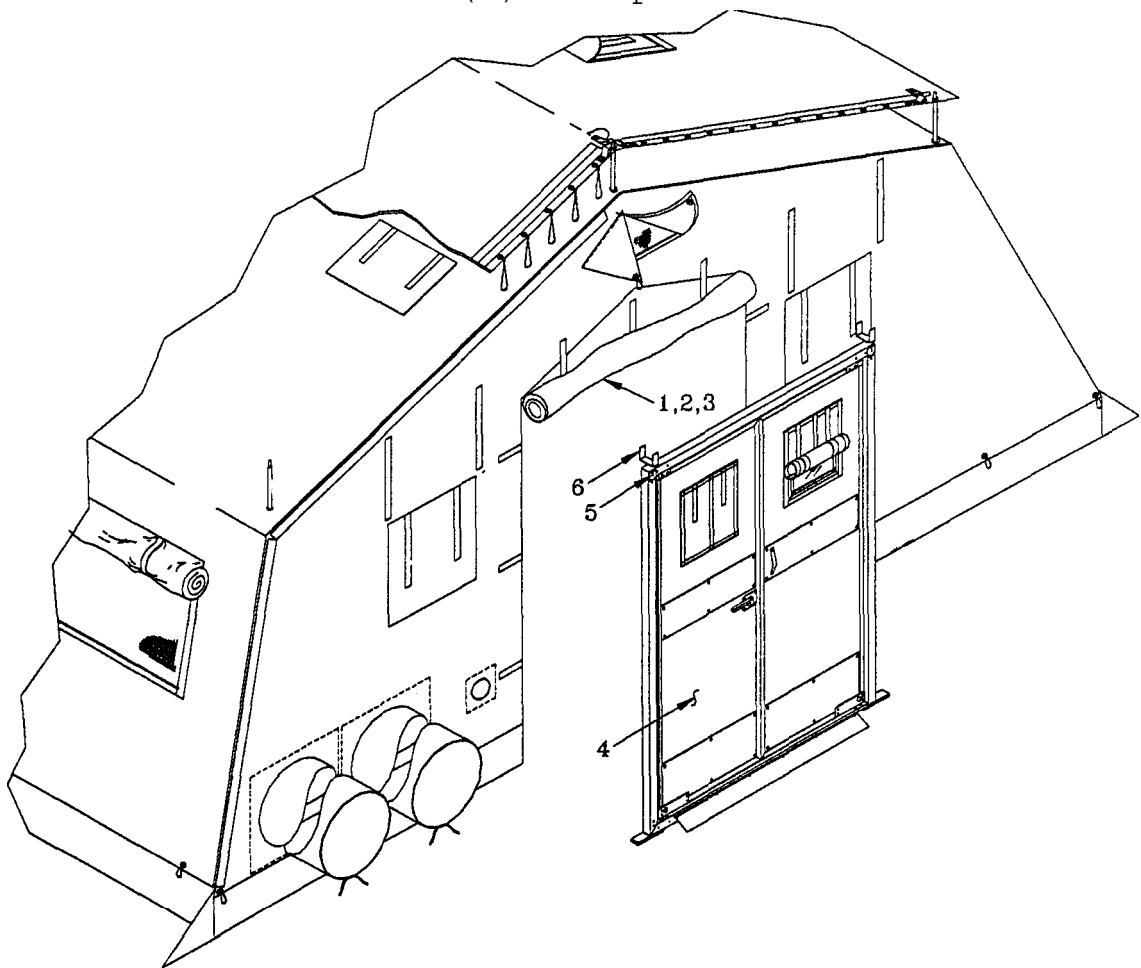

2-21. INSTALL DOUBLE BUMP-THROUGH DOORS IN END SECTION (CONT) .

- g. Place the door extender (6) in its lowest position.

CAUTION

Lift door ramps prior to placing weight on door frame. Damage to piano hinge may result.

- h. Place the door frame between the endwall and liner with one soldier on each side.
- i. Place the door frame in a vertical position and in line with the door opening. Ensure the olive drab/dark brown colored side faces out and the light green/light tan colored side faces in.
- j. Raise the extender (6) to support the header.
- k. Lock the extender (6) in place with the set screw (5) .
- l. Fasten the liner hook and pile fastener at the door base.
- 2-22. MODESTY CURTAIN. When authorized, proceed as follows to install a modesty curtain:

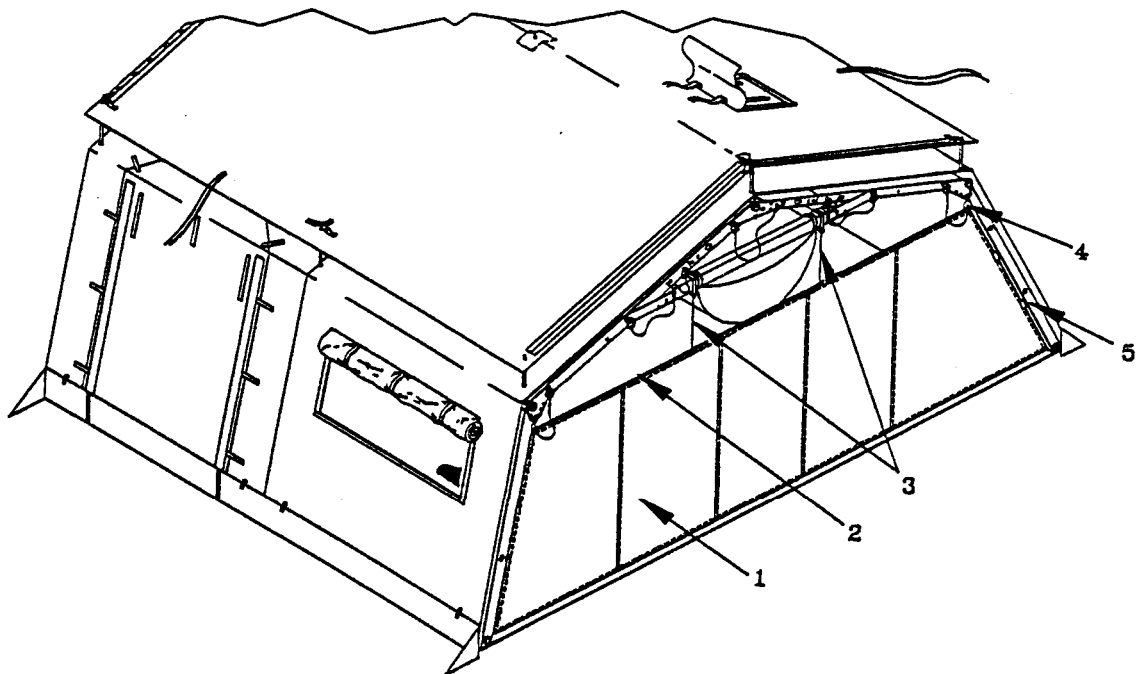

- a. Lay the modesty curtain (1) out flat inside the tent.
- b. Straighten out all the cables (2,3) used for the modesty curtain.
- c. Separate the hook and pile fastener of the liner at the cave purlin height on both sides.
- d. Place the horizontal cable's (2) curved hook (4) through the liner and around the cave purlin next to the frame on both sides.
- e. Suspend curtain by locating each of the short cables (3) with squared off hooks near the center of the cable.
- f. Separate the hook and pile fastener above the cable (3) .
- g. Insert the cable (3) through the liner and hang it on the header.
- h. Close the liner around the modesty curtain cables (3) .
- i. Locate the tie tapes (5) on each side of the modesty curtain.
- j. Separate the liner next to the tie tapes (5) .
- k. Tie the tie tapes (5) and secure hook and pile fasteners to the frame and close the liner around the tabs.

2-23. PARTITION. When authorized, install partition as follows:

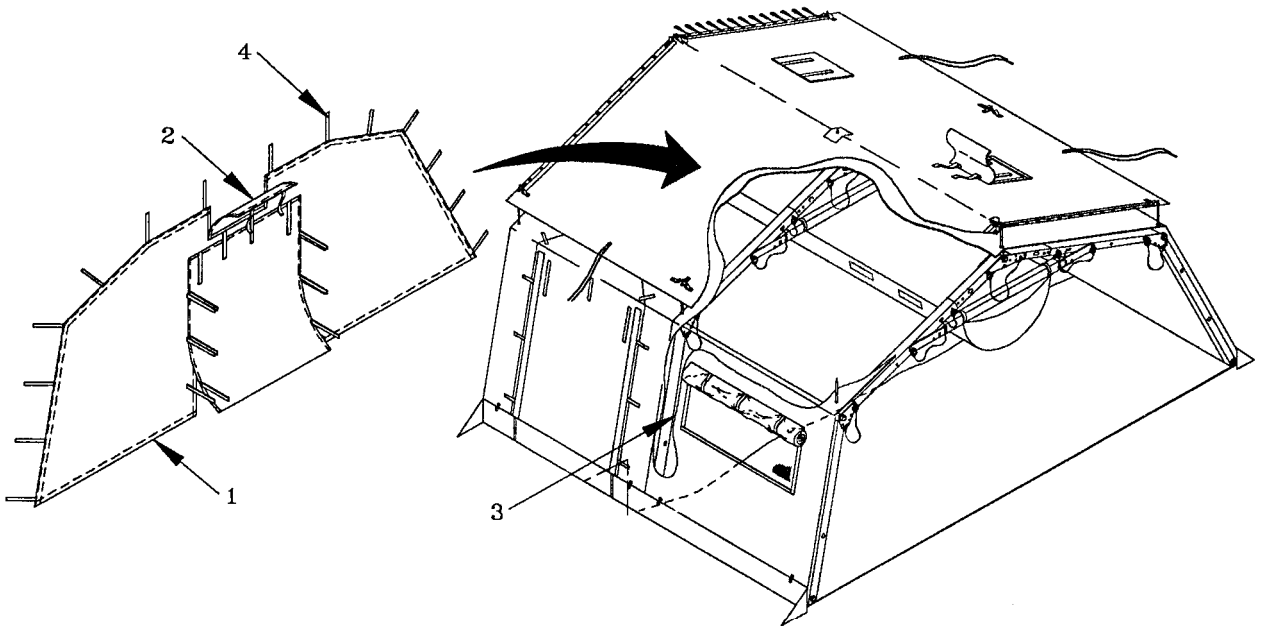



2-23. PARTITION (CONT).

- a. Identify and lay out partition (1) .
- b. Unfasten plenum flap (2) if plenum is installed.
- c. Separate liner (3) at attachment points.
- d. Tie the tie tapes (4) to arch assembly.
- e. Seal liner (3) .

2-24. OPERATION OF DOORS, WINDOWS AND VENTS.

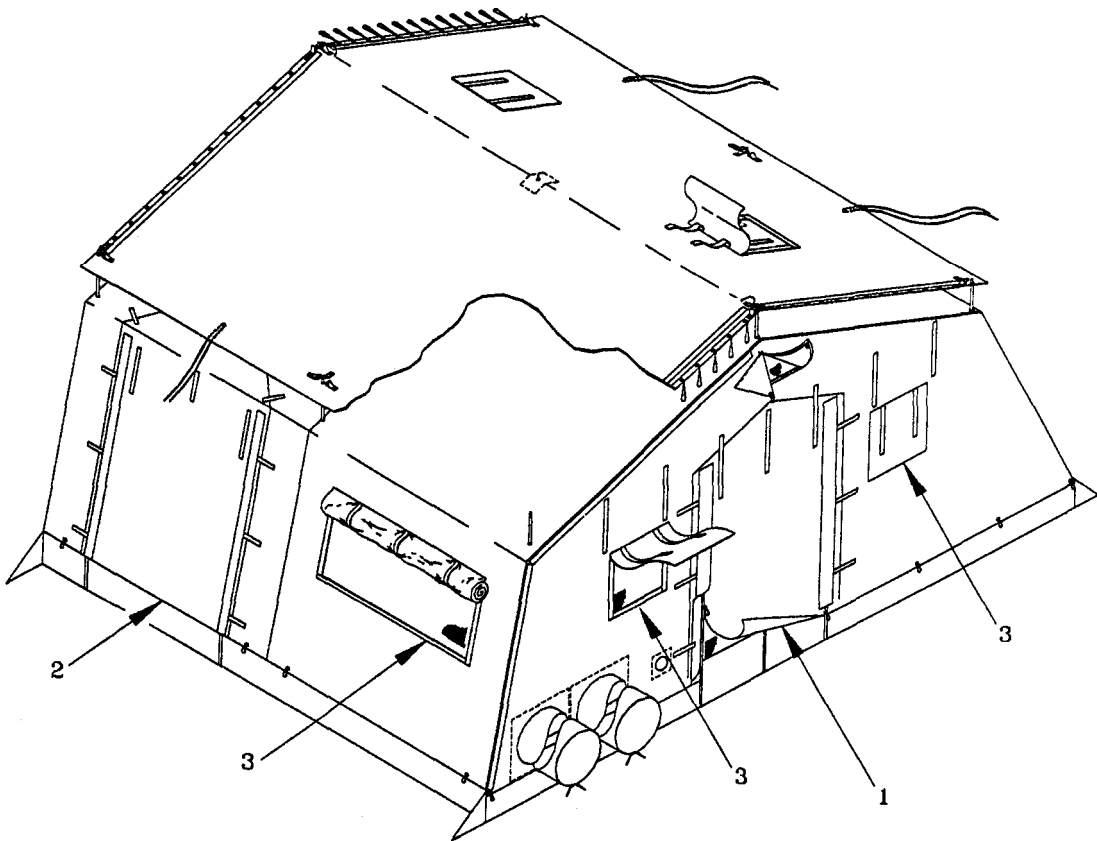

- a. Doors. Tent doors (1,2) are located in the center of the endwalls and on either side of a door section. A door may also be laced to the end of a vestibule. A door is opened by unzipping either side, rolling up, and tying with tie tapes. Inside the fabric outer door a screened door is fastened with hook and pile fastener on either side. It also may be rolled up and tied out of the way.

- b. Windows. Windows (3) are made in three layers: a rain flap on the outside, a clear plastic window in the middle, and a screen on the inside. The rain flaps and plastic windows are closed by hook and pile fasteners. The rain flap and the plastic window can each be held open with tie tapes. Each layer must be rolled up towards the inside to prevent rain from being trapped within the folds. To fully close the rain flap the clear window must first be unrolled and secured.

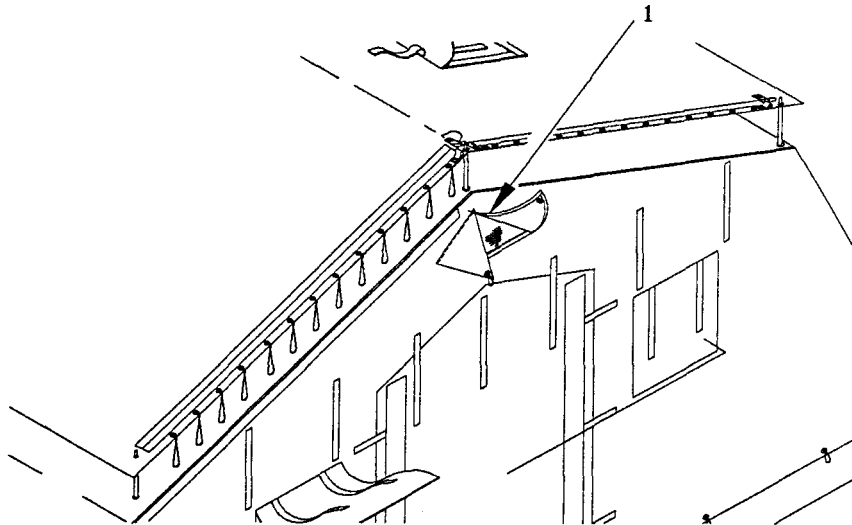

- c. Peak Vent. The tent has a triangular vent (1.) at the peak which may be tied open or closed by the lines being tied to the cave extenders on either side.

2-24. OPERATION OF DOORS, WINDOWS AND VENTS (CONT) .

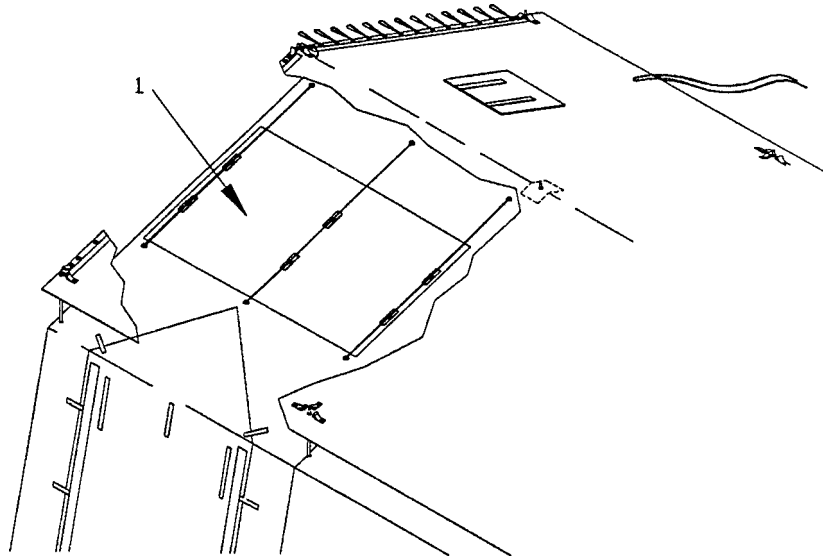

- d. Roof Vent. The desert/tropical TEMPER version has vents (1) on the roof section controlled with lines from the inside of the tent. Three lines control each vent: one in the middle and one at each end. When operating the vents, control them evenly. When the vents are operated from within a lined tent, disconnect the hook and pile tape fastener holding the liner door closed, reach up and pull the adjustment line from the top or bottom to adjust the vents up or down.

2-25. DECALS AND INSTRUCTION PLATES. A CAUTION decal is found inside the cover of the light set storage container (Fig. 2-3) . A label containing abbreviated TEMPER setup instructions is sewn to the inside of the tent cover, end section, and frame sections cover assembly (Fig. 2-4) . Abbreviated set up instructions are provided in Fig. 2-5. Identification labels are found on the inside of each tent fabric assembly, tent cover, frame section cover assembly, vestibule container and pin container (Fig. 2-6) .

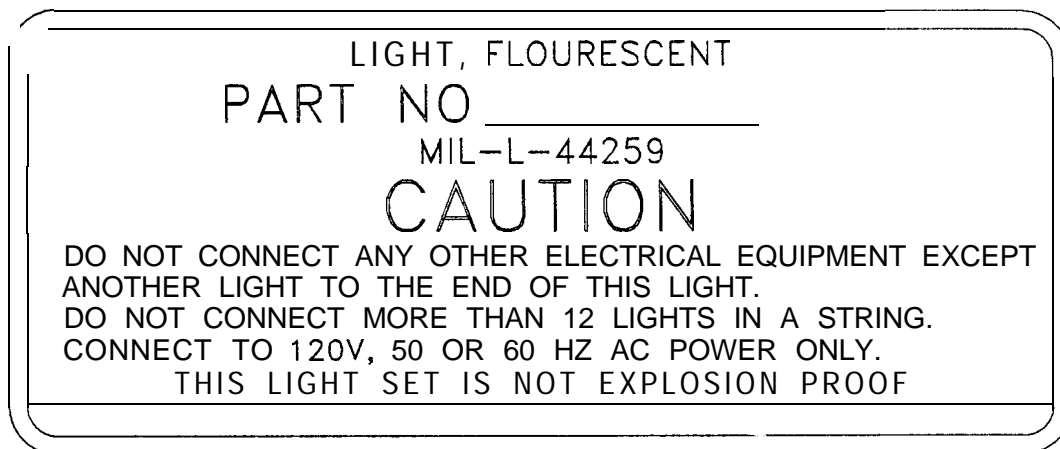

Figure 2-3.  
LIGHT SET, TYPE I, IDENTIFICATION AND CAUTION DECAL

ARMY TM 10-8340-224-13  
AIR FORCE TO 35E5-6-1  
NAVY NAVFAC-P-337.A

2-25. DECALS AND INSTRUCTION PLATES (CONT) .

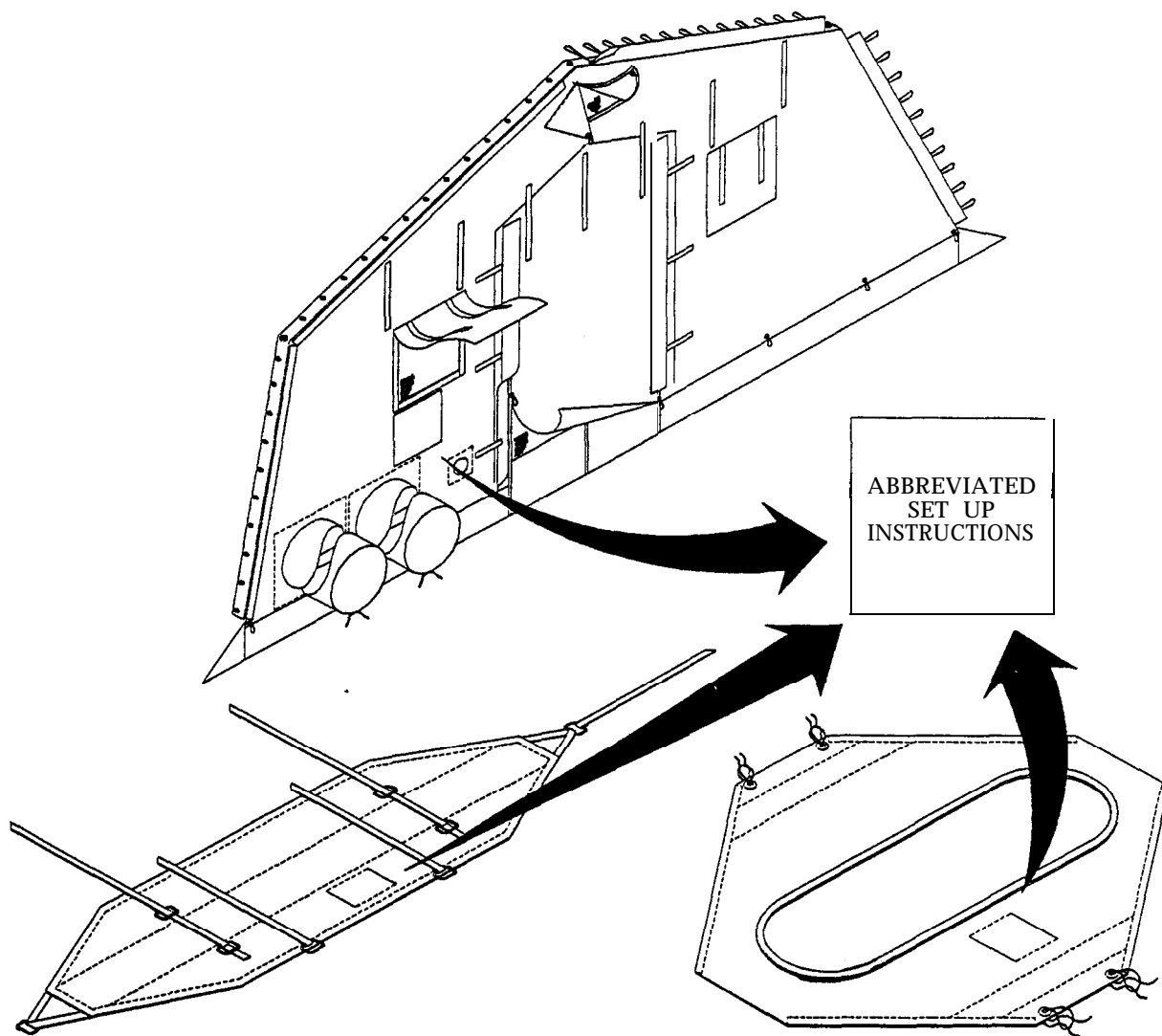

Figure 2-4.  
ABBREVIATED SET UP INSTRUCTIONS LOCATIONS

STEP-1

OPEN UP FRAME AND ALIGN THE HOLE AT THE RIDGE AND LOCK IN PLACE BY INSERTING PIN.

STEP-2

ALIGN HOLES ON HEADER WITH HOLES IN ROOF PORTION OF ARCH AND SECURE IN PLACE WITH PIN. DO SAME TO OTHER SIDE OF HEADER.

STEP-3

START CONSTRUCTING THE FRAME BY JOINING TWO (2) ASSEMBLED ARCHES WITH PURLINS AS FOLLOWS. STARTING AT THE RIDGE, TWO (2) MEN WORKING TOGETHER, ONE ON EACH END OF PURLIN, ALIGN AND INSERT PURLIN STUD IN HOLE IN FRAME AND ROTATE 90° TO LOCK PURLIN TO FRAME. AFTER ROTATING THE PURLIN 90°, ALIGN STUD IN PURLIN DIAGONAL BRACE WITH HOLE IN THE ARCH, INSERT STUD IN HOLE AND LOCK IN PLACE BY ROTATING THE HANDLE RIGHT OR LEFT 90°, THEN PUSH HANDLE DOWN UNTIL IT IS PARALLEL WITH FRAME. NOTE:DO NOT LAY HANDLE IN THE BRACE CHANNEL.

STEP-4

PLACE ROOF SECTION OVER FRAME STARTING AT ONE END, FIND RIDGE GROMMET AND INSERT IT OVER PIN PROTRUDING UP FROM FRAME, THEN DO THE SAME AT THE EAVES.

STEP-5

AFTER THE FIRST ROOF SECTION IS ON THEN JOIN END WALL STARTING AT THE RIDGE. INSERT GROMMET OVER PIN AND THEN JOIN THE ROOF SECTION AND END WALL BY ENGAGING THE LOOPS. PLACE REMAINING ROOF SECTIONS ON FRAME AND JOIN TOGETHER BY ENGAGING THE LOOPS. THEN PUT ON THE OTHER END WALL AND JOIN IT TO THE ROOF SECTIONS.

Figure 2-5.  
ABBREVIATED SET UP INSTRUCTIONS

2-25. DECALS AND INSTRUCTION PLATES (CONT) .

STEP-6

AFTER THE END WALLS AND ROOF SECTIONS ARE IN PLACE AND SECURED WE WILL PLACE AND SECURE THE EXTENDER IN THEIR RESPECTIVE PLACES. PLACE EXTENDERS OVER PIN PROTRUDING FROM FRAME. ALIGN HOLE IN EXTENDER WITH HOLE IN PIN AND LOCK IN PLACE WITH SECURING CLIP. USE ONE 19' GUY LINE ON EAVE EXTENDERS AND TWO 19' GUY LINES ON RIDGE EXTENDERS. PASS SEWN END OF GUY LINE AROUND RIDGE OR EAVE EXTENDERS AND THRU EYE SPLICE AS SHOWN ABOVE. AFTER GUY LINES ARE IN PLACE, PASS SEWN END OF GUY LINES THRU BOTH HOLES IN TENT SLIPS AND PLACE KNOT IN SEWN ENDS.

STEP-7

PLACE FLY ON EXTENDERS STARTING AT THE RIDGE. PLACE GROMMET OVER PIN AND LOCK IN PLACE (SECURING CLIP ATTACHED TO FLY) WITH CLIP THRU HOLE IN PIN. REPEAT THIS SEQUENCE TO SECURE FLY TO EAVE EXTENDERS. (ALL EAVE EXTENDERS HAVE TWO (2) SECURING CLIPS ATTACHED) . ALL EAVE EXTENDERS SHOULD HAVE GUYLINES.

STEP-8

WHEN THE ROOF SECTIONS, ENDWALLS, FLY, AND GUYLINES ARE SECURED IN PLACE WE CAN NOW RAISE THE TENT. PLACE TWO PEOPLE AT EACH ARCH SECTION AT THE EAVE LOCATION. THE NCO IN CHARGE SHOULD MAKE CERTAIN THAT THE FRAME IS RAISED EVENLY AND SIMULTANEOUSLY AT EACH ARCH. ON HIS COMMAND RAISE THE SHELTER (AT EAVE LINE) AND SWING THE LOWER LEG OF THE FRAME INTO PLACE, THEN SECURE IN PLACE WITH PIN. NOTE: THE PERSONNEL AT EACH END OF THE SHELTER SHOULD MAKE CERTAIN THAT THE FABRIC DOES NOT GET CAUGHT IN THE FRAME HINGE .

STEP-9

WE CAN NOW FINISH CLOSING THE TENT BY ENGAGING THE LOOPS AND SECURING THEM. WHEN TENT IS IN THIS POSITION - CHECK SCREEN FLAP LINES AND GUYLINES TO MAKE CERTAIN THEY ARE FREE TO OPERATE.

STEP-10

WE NOW RAISE THE OPPOSITE SIDE IN THE SAME MANNER. FINISH CLOSING THE TENT.

Figure 2-5.  
ABBREVIATED SET UP INSTRUCTIONS (CONT)

STEP-11

NOW GO INSIDE OF TENT TO SECURE THE ROOF SECTIONS TO THE FRAME AT THE EAVE AND LOWER PURLIN BY ENGAGING THE NYLON HOOK AND LOOP FASTENER AROUND THE PURLIN.

STEP-12

AFTER DRESSING THE TENT WE CAN NOW SECURE THE GUYLINES TO THE GROUND STAKES, TWO (2) GUYLINES TO ONE GROUND STAKE. ONE FROM THE FLY AND ONE FROM THE BASE OF THE EXTENDER. BEFORE CLOSING TENT, DRIVE STEEL GROUND PINS IN HOLE IN FOOTPLATE, DOOR PURLINS AND LOOPS ON BOTTOM OF TENT SECTIONS.

STEP-13

INSTALL END SECTION LINER BY SECURING THE TIE TAPES TO THE ARCH AND PURLINS. INTERMEDIATE LINER SHALL BE INSTALLED IN A SIMILAR WAY AND SHALL BE FASTENED TO THE END LINER BY SECURING THE FASTENER TAPE.

STEP-14

ASSEMBLE THREE VESTIBULE FRAMES AND PLACE IN FRONT OF DOORWAY. ATTACH ADAPTER TO ONE FRAME AND PREPARE FOR ASSEMBLY OF VESTIBULE.

STEP-15

PLACE VESTIBULE OVER ADAPTER FRAME AND THE OTHER TWO FRAMES. PLACE GUY LINES OVER FRAME SPINDLES AND SECURE WITH HITCH PINS. SECURE TIE TAPES ON INNER WALLS TO ALL THREE FRAMES. PULL VESTIBULE OUTWARD AWAY FROM TENT AND STAKE GUY LINES TO GROUND WITH WOOD STAKES. INSTALL SINGLE PLY VESTIBULE FLOOR BY SECURING TIE TAPES TO VESTIBULE FRAMES AND FASTENING THE HOOK AND PILE FASTENERS ON THE FLOOR TO THOSE ON THE VESTIBULE WALLS. PLACE VESTIBULE INSULATED FLOOR ON TOP OF SINGLE PLY FLOOR. ATTACH VESTIBULE DOOR TO ADAPTER BY PLACING GROMMETS OVER FRAME SPINDLES THEN LACING LOOPS TOGETHER AS DESCRIBED IN STEP 5. SECURE WEATHER FLAPS OVER LACES BY MEANS OF THE HOOK AND PILE FASTENERS. DRIVE STEEL GROUND PIN THROUGH LOOPS ON BOTTOM OF VESTIBULE.

Figure 2-5.  
ABBREVIATED SET UP INSTRUCTIONS (CONT)



ARMY TM 10-8340-224-13  
AIR FORCE TO 35E5-6-1  
NAVY NAVFAC-P-337.A

2-25. DECALS AND INSTRUCTION PLATES (CONT) .

#### STEP-16

INSTALL ONE OF THE SINGLE PLY TENT FLOOR SECTIONS BY ALIGNING NOTCHES WITH FRAME MEMBERS THEN SECURING TIE TAPES TO FRAME. ADDITIONAL FLOOR SECTIONS ARE INSTALLED BY MATING THE HOOK AND PILE FASTENERS ALONG EDGE OF FLOOR THEN SECURING TIE TAPES TO FRAME .

#### STEP-17

INSULATED FLOOR PANELS ARE INSTALLED BY PLACING THEM OVER THE SINGLE PLY FLOOR SECTIONS AND LOCKING TOGETHER BY MATING HOOK AND PILE FASTENERS ALONG EDGE OF FLOOR SECTIONS.

#### ELECTRICAL DISTRIBUTION SYSTEM

NOTE: AN ELECTRICAL DISTRIBUTION SYSTEM IS AVAILABLE FOR USE WITH THIS TENT. THE ABOVE ILLUSTRATION DEPICTS LOCATION OF THE DISTRIBUTION BOX, LAMPS AND CONVENIENCE OUTLETS.

#### INCANDESCENT LAMPS

A LAMP CABLE ASSEMBLY IS AVAILABLE WHICH CONTAINS MOLDED SOCKETS FOR TWO INCANDESCENT LIGHT BULBS. THESE ASSEMBLIES CAN BE SUBSTITUTED FOR THE FLUORESCENT LIGHTS WHEN LOW LEVEL LIGHTING IS ADEQUATE.

#### FLUORESCENT LAMPS

FOUR LUMINAIRES COME PACKED IN A FIBERGLASS CARRYING CONTAINER. EACH LUMINAIRE IS FURNISHED WITH A LIGHT SUPPORT STRAP WITH FOUR ATTACHED SUPPORT STRAPS. THE LIGHT SUPPORT STRAPS FASTEN OVER THE FRAME HEADER ASSEMBLY. THE LUMINAIRES ARE SUSPENDED FROM THE LIGHT SUPPORT STRAP BY MEANS OF THE 2 SUPPORT STRAPS. WHEN THE LINER IS INSTALLED, THE 2 STRAPS ARE PASSED THRU THE SLITS IN THE LINER AND THEN ATTACHED TO THE LUMINAIRES.

Figure 2-5.  
ABBREVIATED SET UP INSTRUCTIONS (CONT)

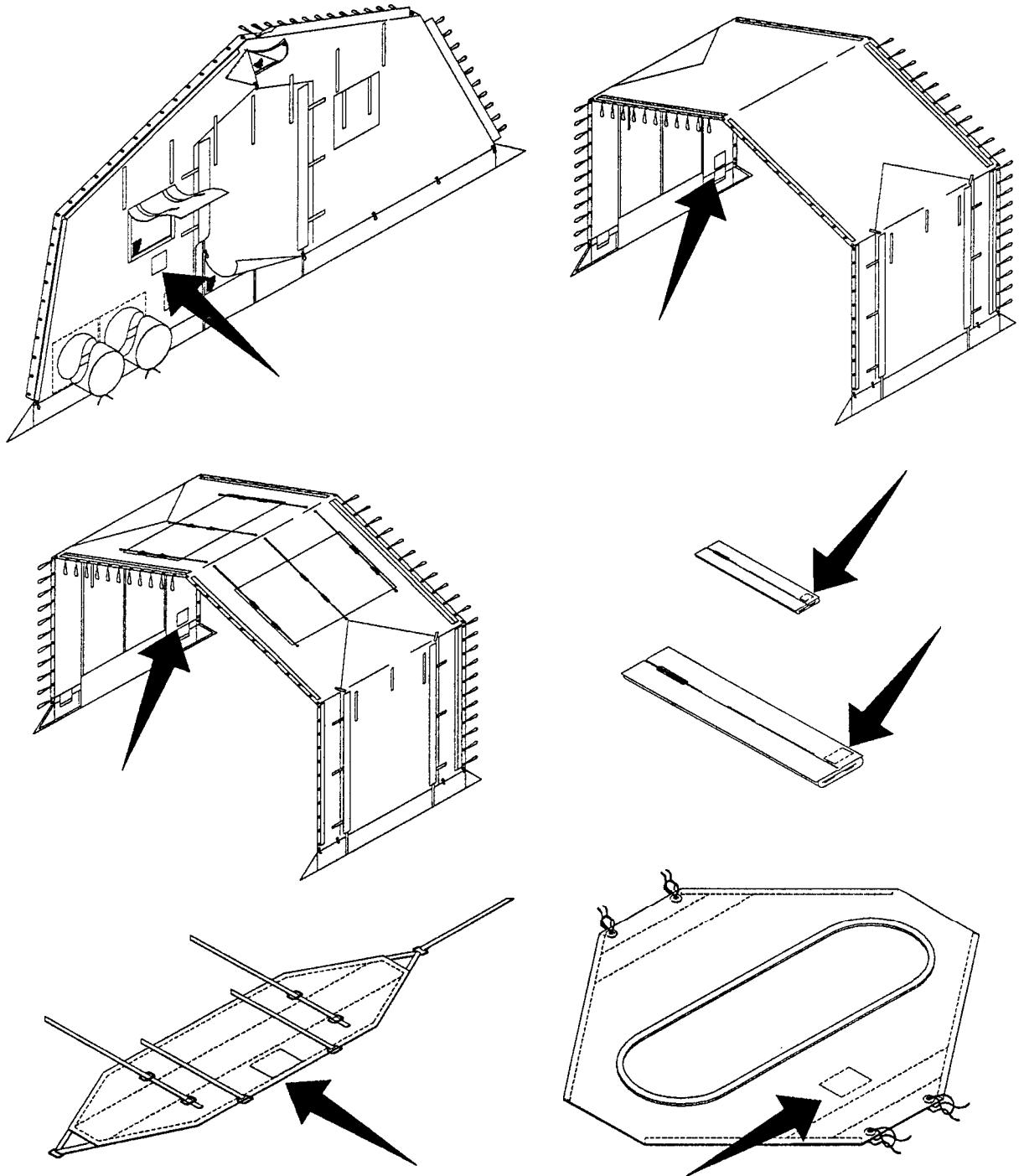

Figure 2-6.  
IDENTIFICATION LABEL LOCATIONS

2-26. PREPARATION FOR MOVEMENT. To prepare the TEMPER for movement, follow the procedures outlined in paragraphs a and b below. Clean and dry tent fabric sections and equipment as described in paragraph 3-6. Package the tent into the transport bags as described in paragraph b below.

a. Take down procedures. First, locate the transport bags and the light set storage container, then proceed as follows:

NOTE

Fold fabric, label side out.

- (1) Insulated Floors.
  - (a) Remove debris and clean insulated floor.
  - (b) Disconnect hook and pile tape fasteners at insulated floor section joints.
  - (c) Fold and remove individual insulated floor sections
- (2) Vestibules.
  - (a) Remove single ply floors (1) .
  - (b) Release tension on all guy lines (2) and remove stakes (3) .
  - (c) Unlace vestibule door (4) sides from vestibule (5) .

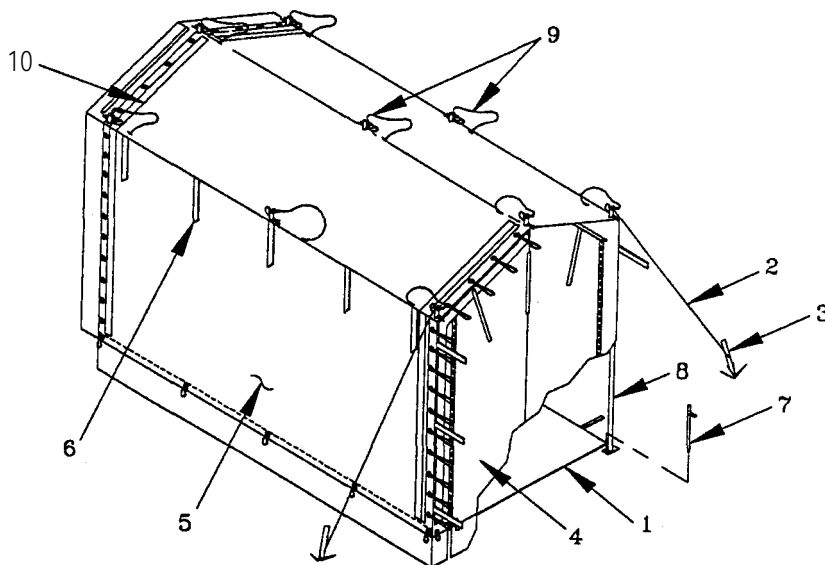

- (d) Untie vestibule tie tapes (6).
  - (e) Remove steel pins (7) in vestibule footstops and frame base plates.
  - (f) Collapse vestibule and position frames (8) against endwall.
  - (g) Remove hitch pins (9) and complete door removal.
  - (h) Remove frames (8) and disassemble.
  - (i) Open weather seal flap (10), unlace vestibule (5), remove and fold.
- (3) Tent Disassembly.

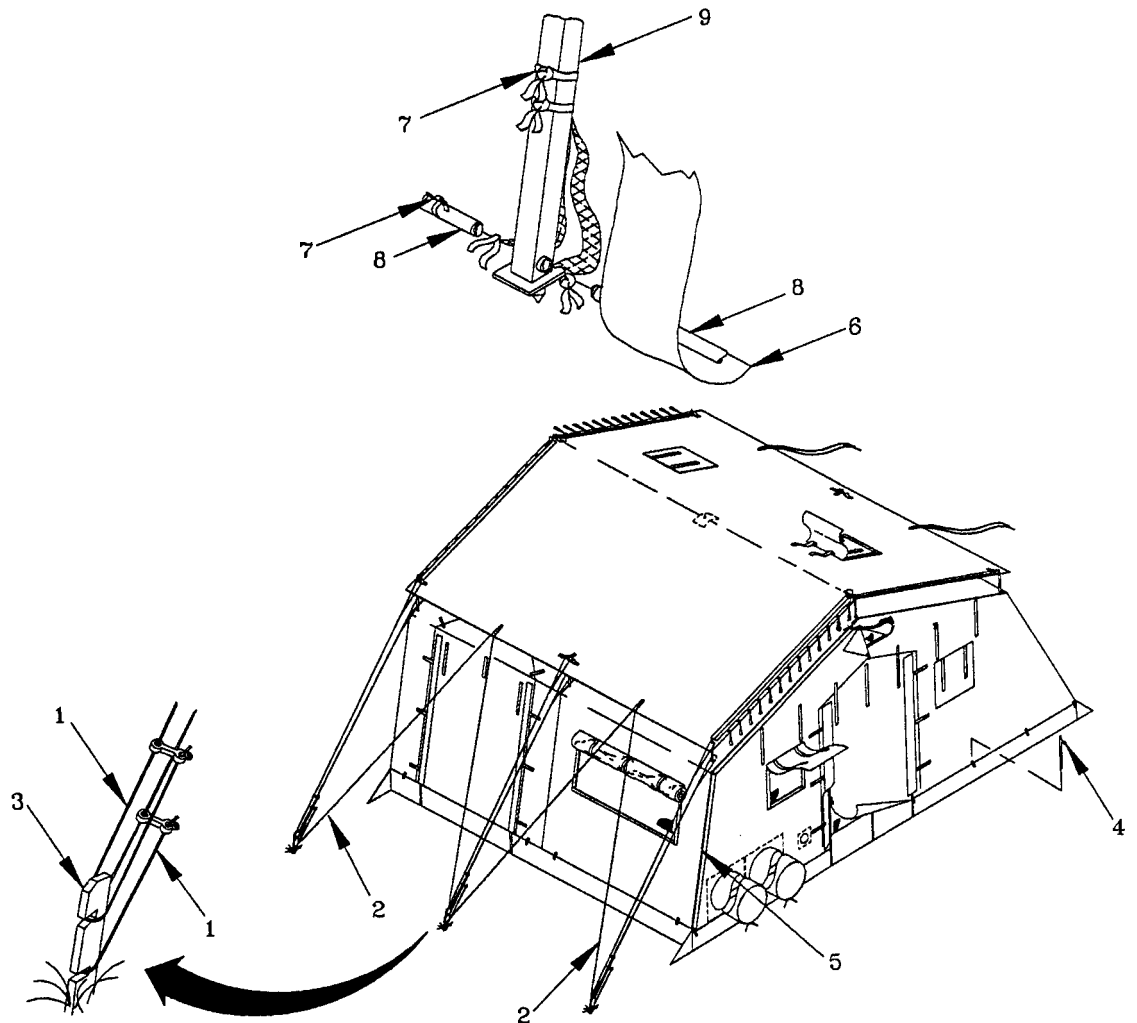

2-26. PREPARATION FOR MOVEMENT (CONT) .

- (a) Release guy line (1) tension except at each tent corner. Release tension on high wind lines (2) and disconnect from wooden stakes (3) .
- (b) Remove the stakes (3) and footstop tent pins (4) .
- (c) Remove partitions and modesty curtains, if installed.
- (d) Disconnect all becket laces (5) up to cave.
- (e) Disconnect all the base purlin flaps (6) .
- (f) Untie liner and floor tie tapes (7) from base purlin (8) and side arch assembly (9) .

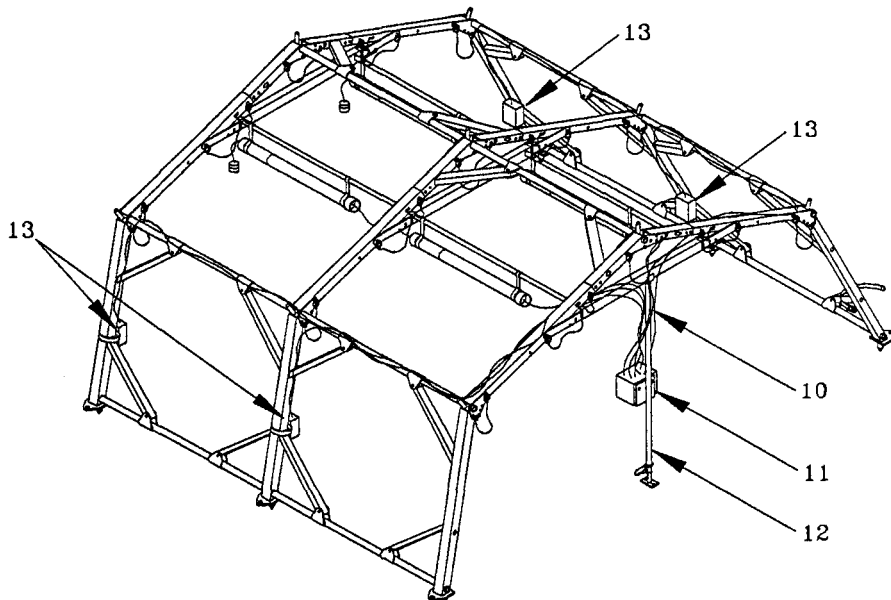

- (g) Disconnect electric cables (10) from distribution box (11) . Remove distribution box (1) from power control stand (12). Remove power control stand (12) .

**CAUTION**

Connect all dust caps together.  
Dirt and dampness may damage  
electrical connections.

- (h) Disconnect and remove electrical cables (10) and outlets (13) .
- (4) Lowering The Frame.
  - (a) Close all windows and doors on all fabric sections.
  - (b) Lift fabric (1) from side of the tent and place underneath fly (2) .
  - (c) Untie and pull. single ply floor (3) back approximately 4 feet from side of tent being lowered.
  - (d) Remove frame foot tent pins (4) .

**WARNING**

Frame assembly hinges can pinch or crush hands and fingers. Keep hands and fingers away from frame assembly ridges and eaves.

**CAUTION**

Avoid folding wall fabric into joints . Material may rip or tear if caught in joint.

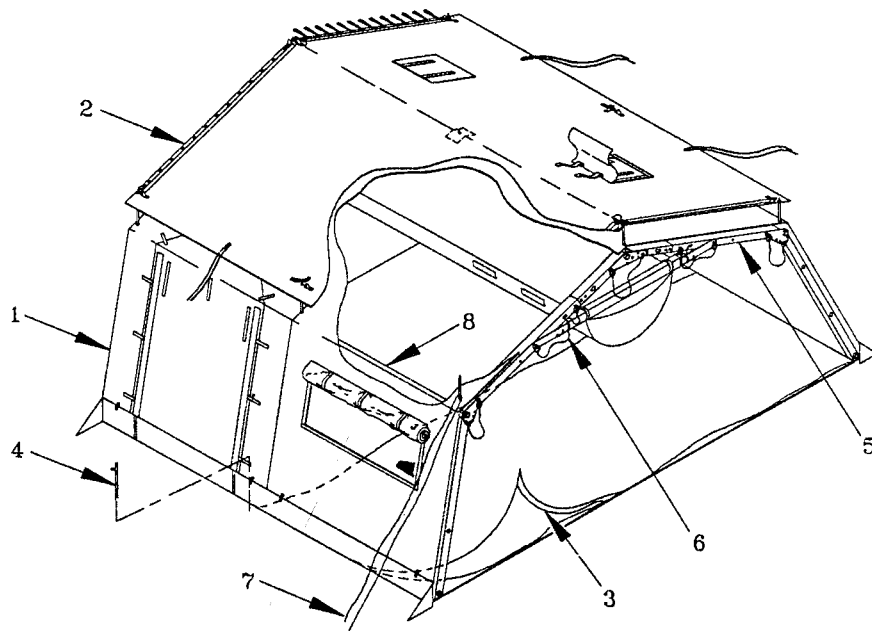

2-26. PREPARATION FOR MOVEMENT (CONT).

- (e) Place two soldiers at each arch (5) on side of the tent being lowered.
- (f) On command, remove quick release pins (6) holding arches erect.

**CAUTION**

Do not twist or turn frame components when handling. Damage to equipment may result.

**NOTE**

If pin cannot be removed easily, loosen corner guy lines and adjust the frame, then remove.

- (g) Relieve tension from four corner ropes.
  - (h) Standing clear of tent place one hand below cave joint of arch (5) and one on the cave purlin (8). Swing out side frame. Extra soldiers may assist in lowering frame.
  - (i) Remove luminaires.
  - (j) Remove plenums.
  - (k) Remove liners.
  - (l) Remove light support strap assemblies.
  - (m) Untie and remove single ply floor.
  - (n) Disconnect cave purlin flaps.
  - (o) Repeat steps a through h to lower other side of the tent.
- (5) Removing The Fabric.
- (a) Disconnect hitch clip pins (1), remove fly (2) from cave extenders (3) and remove cave extenders (3).
  - (b) Untie tie off point and disconnect becket lacing

of all roof sections.

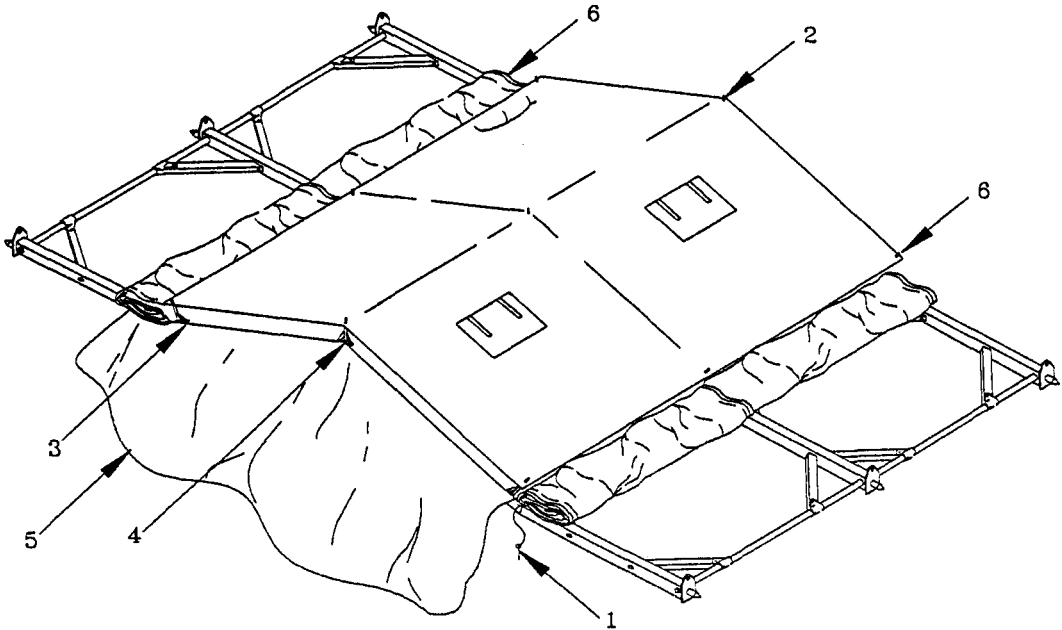

(c) Remove hitch clip pin (1) from ridge extender (4).  
Remove fly (2) and remove ridge extender (4) .

(d) Remove endwalls (5).

NOTE

Fold fabric, label side out.

(e) Remove window/door section (6).



2-26. PREPARATION FOR MOVEMENT (CONT) .

(6) Frame Disassembly.

NOTE

Disassembly sequence is from base to ridge.

- (a) Disconnect each purlin diagonal brace (1), fold and secure.

**WARNING**

Position one soldier at each ridge arch to hold arch upright during frame disassembly. Failure to hold frame upright may allow frame to fall and cause injury to personnel.

- (b) Rotate purlins (2) and remove.
- (c) Remove headers (3).

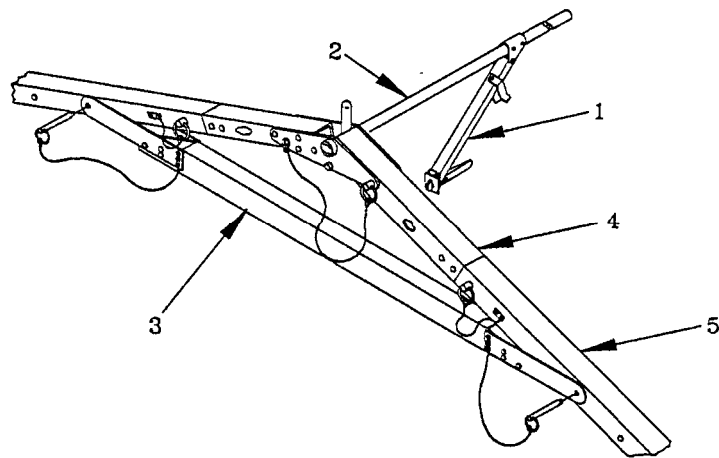

- (d) Disassemble roof arch (4) and side arch assembly (5) and fold.
- (e) Pack in appropriate transport bag.

- b. Packing Instructions. Pack the disassembled TEMPER components into the transport bags as indicated below.

Tent cover

End Section  
Window Section  
Door Section  
Tent Fly  
End Section Liner  
Intermediate Liner  
Tent Floor  
Partition  
Modesty Curtain  
Endwall Plenum  
Extendable Plenum  
Side Entrance Plenum

Vestibule Container

Vestibule  
Vestibule Door  
Vestibule Floor  
Vestibule Door Cap  
Vestibule Door Sliding  
Blackout Curtain

Frame Sections cover Assembly  
(End Section components)

Arch Assembly 2  
Header Assembly 2  
Purlin Assembly 5  
Eave Extender Assembly 4  
Ridge Extender Assembly 2

Frame Sections Cover Assembly  
(Extendable Section Components)

Arch Assembly 1  
Header Assembly 1  
Purlin Assembly 5  
Eave Extender Assembly 2  
Ridge Extender Assembly 1

Frame Sections cover Assembly  
(Extendable Door Section components)

Arch Assembly 1  
Header Assembly 1  
Purlin Assembly 3  
Eave Extender Assembly 2  
Ridge Extender Assembly 1  
Door Sill Assembly 2  
Vestibule Frame Assembly 2

Tent Pin Container

Tent Pin, Steel, 12 inch  
Tent Pin, Wood, 24 inch

SECTION IV. OPERATION UNDER UNUSUAL CONDITIONS

2-27. GENERAL. While it is not possible to prepare for all unusual conditions the TEMPER will be exposed to, the following information should be helpful during unusual climatic conditions.

a. Operation in High Wind.

**WARNING**

All tent lines and frame feet must be staked down. Failure to stake and tie down tent may result in injury to personnel and damage to equipment.

- (1) Replace wooden stakes with ground anchor kit.
- (2) Close and fasten all windows and doors.
- (3) Frequently check all tent pins and lines.
- (4) Secure by placing sandbags around base of tent.

b. Wet Climate.

- (1) If heavy rain is expected or the TEMPER is going to be set up for a long period of time, dig a trench around the outside.
- (2) Tent lines may shrink from dampness, so keep tent lines loose enough to prevent tent pins from being pulled out of the ground.
- (3) Dry all TEMPER components before repacking.
- (4) Make sure no leaks occur near the electrical distribution set or the light set. Disconnect power if leaks occur.

c. Operation in Snow/Extreme cold.

- (1) Sweep snow from fly using snow rake (Appendix E, item 10).
- (2) Gently push up on the roof from inside the TEMPER to remove snow that may have piled up.

- (3) When erecting the TEMPER in snow conditions, gently tamp the snow down to provide a firm surface on which to set up.

**WARNING**

- All tent lines and frame feet must be staked down. Failure to stake and tie down tent may result in injury to personnel and damage to equipment.
  - Stay alert to moisture conditions and adjust all guy lines at tent slips as required before weight or shrinkage damages tent or injures personnel.
- (4) If ground is frozen too hard to drive steel tent pins, chop small holes to set them in. Fill holes with slush or water and allow to freeze and anchor pins .

d. Extreme Heat. Roll up the endwalls and window/roof section fabric to provide maximum ventilation.

- (1) Open weather flaps on both sides of the section to be opened.
- (2) Untie and disconnect becket lacing as high as cave purlin. Tie off becket lacing at cave.
- (3) Disconnect base purlin flaps from inside tent.
- (4) Open the entrance way door and tie back.
- (5) Fold and roll fabric underneath itself and towards top. Tie with tie tape.

e. Nuclear, Biological, and Chemical (NBC) Decontamination.

- (1) If chemical or biological contamination is expected, close all TEMPER openings, such as windows, doors, and stove pipe openings.

2-27. GENERAL (CONT).

NOTE

Perform unit level decontamination of the TEMPER only under supervision of unit NBC personnel.

- (2) If TEMPER is set up, decontaminate the fabric around the entrance way area of nuclear, chemical or biological contamination by applying STB slurry or brushing with hot, soapy water.
- (3) Prepare slurry by mixing approximately equal parts of water with STB. Scrub slurry into fabric.
- (4) Remove slurry promptly with brush (Appendix E Section II, Item 1) and liberal quantities of hot water and soap (Appendix E, Section II, Item 10) then rinse with clear water.

NOTE

STB slurry may leave a harmless, white chalky residue. This is not a cause for concern.

- (5) Decontaminate the remaining sections of the TEMPER by natural methods. Expose the erected tent to the effects of weather and aeration for approximately 2-3 days.

**CAUTION**

Heavy concentrations of DS2 are harmful to the TEMPER fabric. A fine spray mist is recommended. Do not scrub with mop or broom.

NOTE

DS2 will cause some change in fabric color.

- (6) Aeration is not effective against V-agents. If contaminated by V-agent entire TEMPER must be decontaminated with DS2 slurry.

CHAPTER 3

OPERATOR MAINTENANCE INSTRUCTIONS

Subject	Section/Paragraph
Lubricating Instructions . . . . .	1
General . . . . .	3-1
Lubrication Instructions . . . . .	3-2
Troubleshooting Procedures . . . . .	11
General Instructions . . . . .	3-3
Use of Table . . . . .	3-4
Operators Maintenance Procedures . . . . .	111
Inspection . . . . .	3-5
Cleaning . . . . .	3-6
Repair of Light Set, Type I . . . . .	3-7

Section I. LUBRICATING INSTRUCTIONS

3-1. GENERAL. The TEMPER Tent is designed to be used in forward areas and requires little lubrication. The slide fasteners are the only components of the tent which require lubrication. There is no separate Lubrication Order for the TEMPER, therefore all lubrication instructions contained herein are mandatory and to be adhered to as specified. Lubrication materials are listed in Appendix E.

3-2. LUBRICATION PROCEDURES. Ensure slide fasteners are free from dirt and debris. Lubricate the slide fasteners by applying stick lubricant to metal or plastic slide fasteners when they become difficult to operate. Operate slide fastener to ensure overall lubrication.

SECTION II. OPERATOR TROUBLESHOOTING PROCEDURES

3-3. GENERAL INSTRUCTIONS. Table 3-1 contains troubleshooting instructions designed to aid in diagnosing unsatisfactory operation or failure of TEMPER components. The table lists common malfunctions that you may find during normal use or maintenance of the equipment. This manual cannot list all malfunctions that may occur, nor all tests and inspections and corrective actions. If a malfunction is not listed or is not corrected by the prescribed action, notify unit maintenance.

MALFUNCTION INDEX

TEMPER	Troubleshooting Procedures Paragraph
No power to electrical system . . . . .	1
Luminaires do not light . . . . .	2
Temper will not stay taut . . . . .	3

3-4. USE OF TABLE. You should perform the tests/inspections and corrective actions in the order listed.

- a. Malfunction. Check for where or what the malfunction is.
- b. Test or Inspection. Test or inspect the cause of the malfunction.
- c. Corrective Action. Once the malfunction is determined, correct the situation.

TABLE 3-1. OPERATOR TROUBLESHOOTING

---

MALFUNCTION	TEST OR INSPECTION	CORRECTIVE ACTION
-------------	--------------------	-------------------

---

1. NO POWER TO ELECTRICAL SYSTEM.

Step 1. Check security of connectors.

Tighten loose connections.

Step 2. Check for overloaded sockets.

Reset circuit breakers and unplug unnecessary equipment.

Step 3. Check electrical distribution box for popped circuit breakers.

Reset circuit breakers.

If breakers continue to pop, turn power off and refer to direct support maintenance.

TABLE 3-1. OPERATOR TROUBLESHOOTING (CONT)

---

MALFUNCTION	TEST OR INSPECTION	CORRECTIVE ACTION
-------------	--------------------	-------------------

---

2. LUMINAIRES DO NOT LIGHT.

Step 1. Check power source.

Ensure proper power source (110V AC 50/60 HZ) is selected.

Step 2. Check to make sure all electrical connectors are properly connected.

Connect electrical connectors.

Step 3. Check for bad fuse.

Replace fuse if necessary as described in paragraph 3-7.

Step 4. Check for burnt-out fluorescent lamp.

Replace lamp as described in paragraph 3-7.

Refer to Direct Support Maintenance if still unable to illuminate lamp.

Step 5. Check for proper operation of On/Off switch.

Refer to Direct Support Maintenance if switch does not operate.



TABLE 3-1. OPERATOR TROUBLESHOOTING (CONT)

---

MALFUNCTION	TEST OR INSPECTION	CORRECTIVE ACTION
-------------	--------------------	-------------------

---

3. TEMPER WILL NOT STAY TAUT.

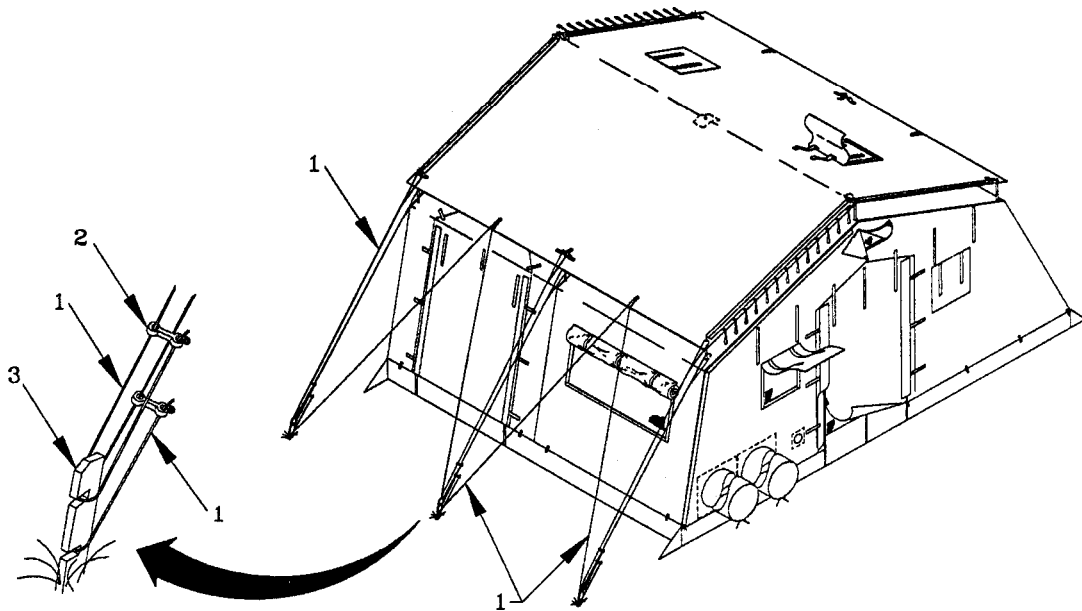

Check tent lines (1), slips (2) and stakes (3) .

Anchor tent lines (1) securely to stakes (3) .  
Replace stakes (3) or lines (1) if necessary.  
Tighten slips (2) .

Section III. OPERATOR MAINTENANCE PROCEDURES

3-5. INSPECTION. Perform inspection as described in Chapter 2, Section II, PMCS. Report defects on DA Form 2404.

3-6. CLEANING. Clean all TEMPER fabric components with a brush (Appendix E, Item 1) and mild soapy water (Appendix E, Item 12). Let fabric components air dry.

3-7. REPAIR LIGHT SET, TYPE I.

This task covers: a. Remove and Install Fuse  
b. Remove and Install Lamp

INITIAL SETUP

Tools :

None

Materials/Parts :

Fuse (TM 8340-224-23P, Figure 27, items 11,34)

Lamp (TM 8340-224-23P, Figure 27, items 33,37)

Equipment Condition:

Luminaire turned off and disconnected

a. Remove and Install Fuse.

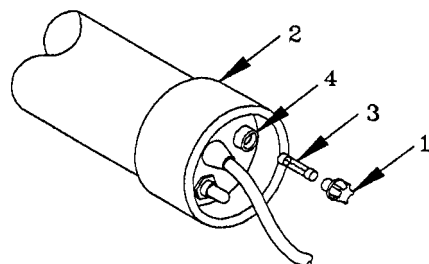
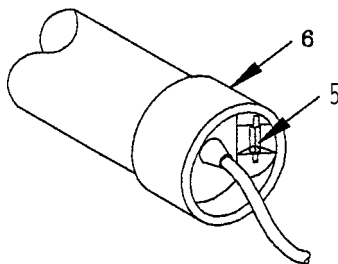

3-7. REPAIR LIGHT SET, TYPE I (CONT)

**WARNING**

Lethal voltage is present when light set is connected to power source. Disconnect from power source before inspecting or repairing any electrical component. Electrical shock or death may result from failure to heed this warning.

- (1) Remove Fuse.



- (a) Push in and turn fuseholder cap (1) on male end cap (2) counterclockwise and remove fuseholder cap (1) and fuse (3) from fuseholder (4)
- (b) Remove spare fuse (5) located in female end cap (6) .
- (2) Install Fuse.
- (a) Install spare fuse (5) into fuseholder (4) on male end cap (2) and turn fuseholder cap (1) counterclockwise.
- (b) Check for proper operation.

b. Remove and Install Lamp.

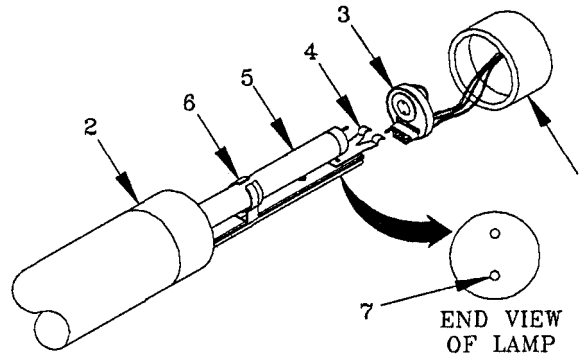

(1) Remove Lamp.

- (a) Pull female end cap (1) off the luminaire (2) .
- (b) Disconnect lampholder (3) by depressing retainer connector (4) .
- (c) Pull lamp (5) out of luminaire (2) .

(2) Install Lamp.

- (a) Push new lamp (5) through retainer clips (6) into luminaire (2), keeping the connector pins (7) in a vertical position.
- (b) Install lampholder (3)
- (c) Install female end cap (1) on luminaire (2) .
- (d) Check for proper operation,

Chapter 4

UNIT MAINTENANCE INSTRUCTIONS

Subject	Section/Paragraph
Repair Parts, Special Tools, TMDE, and Support Equipment . . . .I	
Common Tools and Equipment . . . . .	4-1
Special Tools . . . . .	4-2
Repair Parts . . . . .	4-3
Service Upon Receipt. . . . .	11
Site and Shelter Requirements . . . . .	4-4
Service Upon Receipt of Materiel . . . . .	4-5
Unit Troubleshooting. . . . .	111
General . . . . .	4-6
Unit Maintenance Procedures . . . . .	IV
General . . . . .	4-7
Repair Fabric Assemblies . . . . .	4-8
Repair Frame Sections . . . . .	4-9
Repair Double Bump Through Door Assembly . . . . .	4-10
Repair Power Distribution Components . . . . .	4-11
Preparation for Storage or Shipment . . . . .	V
preparation for Storage . . . . .	4-12
Preservation . . . . .	4-13
Preparation for Shipment . . . . .	4-14

Section I. REPAIR PARTS, SPECIAL TOOLS, TMDE, AND SUPPORT EQUIPMENT.

4-1. COMMON TOOLS AND EQUIPMENT. For authorized common tools and equipment, refer to the Modified Table of Organization and Equipment (MTOE) applicable to your unit.

4-2. SPECIAL TOOLS. Refer to Appendix B, Section II, Tool and Test Equipment Requirements, Maintenance Allocation Chart, for additional tool and equipment requirements.

4-3. REPAIR PARTS. The repair parts required for unit level maintenance are listed and illustrated in TM 10-8340-224-23P, Unit and Direct Support Maintenance Repair Parts and Special Tools List.

Section II. SERVICE UPON RECEIPT.

4-4. SITE AND SHELTER REQUIREMENTS. When selecting a site on which to set up the TEMPER:

- a. Select a level area.
- b. Ensure there is sufficient space to complex the needed number of TEMPER sections.
- c. The area should be accessible to tactical vehicles.
- d. If possible, the area should be sheltered from high winds.
- e. Clear area of rocks and underbrush.
- f. If necessary, dig a drainage ditch around the area to provide adequate drainage.

4-5. SERVICE UPON RECEIPT OF MATERIEL.

a. Unpacking. The TEMPER components, will be packaged in a cleated plywood reusable shipping crate as per FED-SPEC-PPP-B-601 that is 99 inches long, 20 inches wide, and 7 1/2 inches deep. The crate is strapped to a wooden pallet. Upon receipt, check for damage. Report any damage to the carrier and your supervisor.

CAUTION

Unpack components carefully.  
Improper or hasty handling may result in damage to the TEMPER components and accessories.

- (1) Cut and remove retaining straps holding crate to pallet. Remove crate from wooden pallet.
- (2) Position crate to be unpacked with the top facing up.
- (3) Open the crate, remove padding material, and set it aside. Do not cut, rip, or otherwise damage the packing material.
- (4) Lift the components from the crate.

b. Shipping Material. Save the shipping crate and any padding material for reuse.

c. Checking Unpacked Equipment. Inspect the unpacked components for damage, completeness, and application of applicable Modification Work Orders (MWOs) as follows:

(1) Damage. Check the equipment for damage incurred during shipment. Report any damage on DD Form 6, Packaging Improvement Report. Also note damage on DA Form 2404, Equipment Inspection and Maintenance Worksheet, and initiate corrective maintenance procedures in accordance with Section III of this chapter.

(2) Completeness. Inspect the contents of the shipment against the packing slip to see if any items are missing (See Appendix C, Components of End Item). Report any discrepancies noted in accordance with instructions in DA Pam 738-750. The equipment can be placed in service even if accessory or other parts/assemblies that are not affecting proper functioning, are missing.

(3) Modifications. Check DA Pam 25-30 to see if there is any MWO applicable to the TEMPER components you are unpacking. If an MWO is listed, check to see if it has been applied to the equipment. The MWO number will be shown on the case/bag near the equipment nomenclature. If a current MWO is listed in DA Pam 25-30 but there is no evidence that it has been applied to the equipment you are unpacking, note discrepancy on DA Form 2404, Equipment Inspection and Maintenance Worksheet.

### Section III. UNIT TROUBLESHOOTING

4-6. GENERAL. Table 4-1 lists common malfunctions of the equipment and contains instructions for unit personnel diagnosing and correcting each malfunction. Perform the indicated steps in the order listed.

4-6. GENERAL (CONT)

**NOTE**

This manual cannot list all malfunctions that may occur. If a malfunction is either not listed or cannot be corrected by the prescribed procedure, notify your supervisor.

Table 4-1. Unit Troubleshooting

---

Malfunction	Test or Inspection	Corrective Action
<hr/>		
1. FRAME ASSEMBLIES WILL NOT FIT TOGETHER.		
	Check for missing or bent frame components. Inspect for damaged fittings.	Replace any bent or missing frame components.
2. TENT LEAKING		
Step 1.	Check to make sure that windows are sealed, the stove pipe opening is closed, all weather flaps are sealed, and all hook and pile fasteners are secured.	Close stove pipe opening, seal weather flaps and secure all hook and pile fasteners.
Step 2.	Check for rips, tears, holes or separating seams in the roof cap or wall fabric assemblies.	Repair any rips, tears, or holes not exceeding 6 inches in length as described in paragraph 4-8. Refer more extensive damage to direct support maintenance for repair.

Section IV. UNIT MAINTENANCE PROCEDURES

4-7. GENERAL. This section contains unit maintenance procedures applicable to the TEMPER components as authorized by the Maintenance Allocation Chart (MAC), Appendix B, of this manual. The following topics are included as applicable: inspect, adjust, remove, service, repair, and install. Repairs to the tent fabric assemblies will be limited to rips and tears or holes not exceeding 6 inches. Use the tentage repair kit (NSN 8340-00-262-5767) to accomplish the repair. Consult FM 10-16 for specific guidelines of tentage repair. All maintenance procedures in this section can be performed by one person unless otherwise indicated



at the initial setup. Read all warnings, cautions, notes and instructions carefully before performing the procedures. Read and understand all warnings at the front of this manual.

PROCEDURE	PARAGRAPH
Repair Fabric Assemblies . . . . .	4-8
Repair Frame Sections . . . . .	4-9
Repair Double Bump Through Door Assembly . . . . .	4-10
Repair Power Distribution Components . . . . .	4-11

4-8 REPAIR FABRIC ASSEMBLIES.

This task covers: Repair of Fabric Assemblies.

INITIAL SETUP

Tools:

- Brush (Appendix B, Section III, Item 2)
- Tentage Repair Kit (Appendix B, Section III, Item 1)

Materials/Parts:

- Denatured Alcohol (Appendix E, Section II, Item 3)
- Gloves, Latex-Nitrile (Appendix E, Section II, Item 5)
- K-Kote Seam Sealer (Appendix E, Section II, Item 8)
- Respirator, Air Filtering (Appendix E, Section II, Item 11)
- Wiping Rags (Appendix E, Section II, Item 17)

Equipment Conditions:

Although the fabric assemblies can be repaired while the tent is in use, it is recommended that the fabric be repaired when the tent is not in use, since repairs are easier when the fabric assemblies are separated. The fabric assemblies should be clean and dry.

ARMY TM 10-8340-224-13  
AIR FORCE TO 35E5-6-1  
NAVY NAVFAC-P-337.A

#### 4-8 REPAIR FABRIC ASSEMBLIES (CONT)

##### Repair Fabric Assemblies

Repair the following fabric assemblies, as required:

End Section  
Door Section  
Window Section  
Tent Fly  
End Section Liner  
Intermediate Section Liner  
Tent Floors  
Vestibule Container  
Pin Container  
Plenum  
Modesty Curtain  
Frame Sections Cover Assembly

Repair all rips, tears, or holes up to 6 inches in length by sewing or patching using the tools and materials in the tentage repair kit. Replace missing or deformed grommets. Replace tie tape, tent lines, and slips as necessary. Follow the procedures in FM 10-16 to make these repairs. Turn in fabric assemblies to direct support maintenance to repair/replace buckle assemblies, straps, chape and tears, holes 6 inches or larger, and ripped seams.

Apply seam sealer to repaired areas as follows:

#### **WARNING**

Seam sealer and solvent are extremely flammable and the fumes toxic. Do not smoke or use seam sealer or solvent near open flame. Use seam sealer and solvent with goggles and gloves, and indoors with respirator or in an open, well ventilated area away from sources of combustion. Death or severe injury may result from explosion or fire. Inhalation of fumes may cause toxic sickness.

#### **NOTE**

- Tent may be erected or fabric assemblies may be removed and laid flat.
- Do not use a foam brush. Use a bristle brush only.

- Sealer may be applied to outside or inside of fabric assemblies.
  - Sealer should only be applied to new stitches, patches, etc., or those areas that have shown water leakage.
  - Two light coats of sealant are more effective than one thick coat. Do not use excessive amounts of sealer, as this does not increase effectiveness and will give the tent a poor appearance.
  - Do not leave original sealer container open, as sealer will thicken and become unusable. Limit the amount of time container is open.
- (1) Surface to be sealed should be cleaned as thoroughly as practical and completely dry before applying sealer.
  - (2) Pour small amount of sealer into a clean container and immediately reseal the gallon container.
  - (3) Apply sealer to stitching or repair to be sealed, overlapping seam stitching or edges of repair by 1/2".
  - (4) Allow first coat to dry to the touch.
  - (5) Apply second coat as described in step (3).

#### 4-9. REPAIR FRAME SECTIONS.

This task covers: Remove and Install Quick Release Pin with Lanyard Assembly

##### INITIAL SETUP

##### Tools:

Tool Kit, General Mechanics (Appendix B, Section III, Item 3)

##### Materials/Parts:

Quick Release Pin with Lanyard Assembly (TM 10-8340-224-23P, Figure 13, Item 5; Figure 14, Item 2)  
Screw, Tapping-Thread (TM 10-8340-224-23P, Figure 13, Item 7; Figure 14, Item 3; Figure 19, Item 5)

ARMY TM 10-8340-224-13  
AIR FORCE TO 35E5-6-1  
NAVY NAVFAC-P-337.A

#### 4-9. REPAIR FRAME SECTIONS (CONT)

##### REPAIR

Remove and Install Quick Release Pins with Lanyard Assembly.

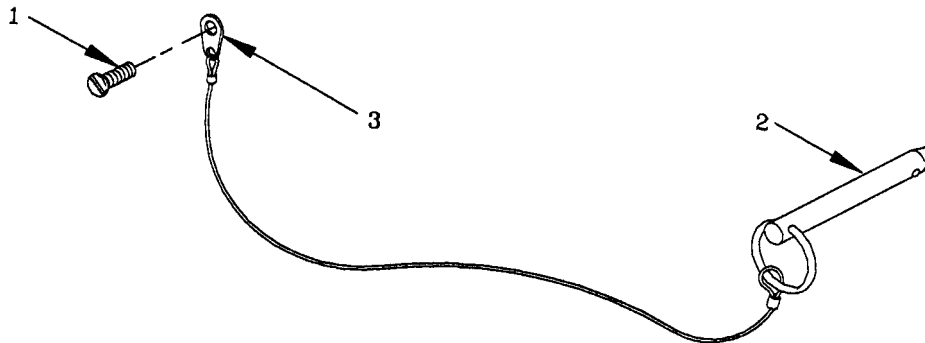

- (1) Remove Quick Release Pins with Lanyard Assembly. Remove screw (1) holding Quick Release Pin (2) to frame section.
- (2) Install Quick Release Pins with Lanyard Assembly. Install screw (1) through eye (3) of Quick Release Pin Lanyard Assembly.

#### 4-10. REPAIR DOUBLE BUMP THROUGH DOOR ASSEMBLY.

This task covers: Remove and install window.

##### INITIAL SETUP

##### Tools:

Tool Kit, General Mechanics (Appendix B, Section III, Item 3)

##### Materials/Parts:

Window (TM 10-8340-224-23P, Figure 21, Item 7,18)  
Gasket (TM 10-8340-224-23P, Figure 21, Item 6,17)  
Screw, Tapping-Thread (TM 10-8340-224-23P, Figure 21, Item 6, 24)

REPAIR

Remove and Install Window.

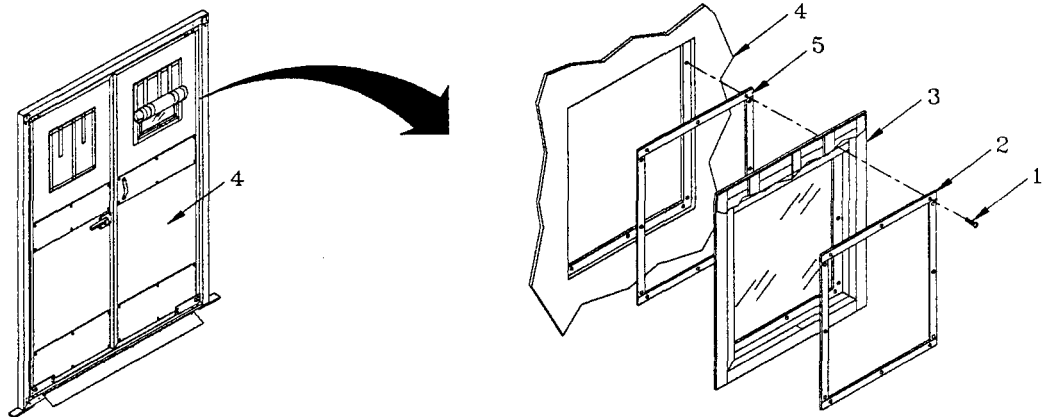

(1) Remove Window.

- (a) Remove screws (1) holding window strips (2) and window (3) to door (4).
- (b) Remove window (3).
- (c) Remove gasket (5).

(2) Install Window.

- (a) Install new gasket (5).
- (b) Install window (3).
- (c) Install window strips (2) and screws (1).

4-11. REPAIR POWER DISTRIBUTION COMPONENTS.

This task covers: Remove and Install Electrical Receptacle Covers.

INITIAL SETUP

Tools:

Tool Kit, General Mechanics (Appendix B, Section III, Item 3)

ARMY TM 10-8340-224-13  
AIR FORCE TO 35E5-6-1  
NAVY NAVFAC-P-337.A

#### 4-11. REPAIR POWER DISTRIBUTION COMPONENTS (CONT)

##### Materials/Parts:

Cover (TM 10-8340-224-23P, Figure 22, Item 5,6; Figure 23, Item 5,6; Figure 24, Item 4,12,14; Figure 26, Item 3,5)  
Screw (TM 10-8340-224-23P, Figure 22, Item 17,33; Figure 23, Item 15,33)

##### Equipment Condition:

Electrical Power must be turned off.

Remove Receptacle Covers.

##### WARNING

Lethal voltage is present when the power control system is connected to power source. Disconnect from power source before inspecting or repairing any electrical component. Electrical shock or death may result from failure to heed this warning.

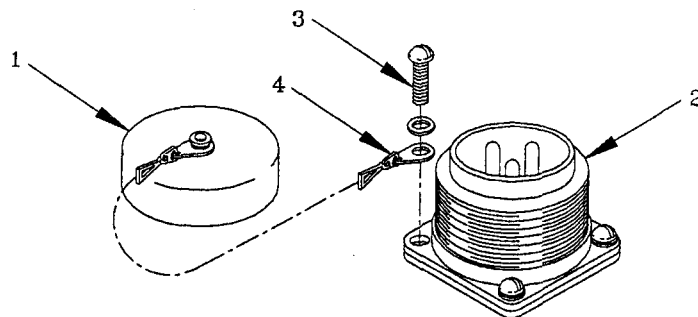

- (1) Remove and Install Receptacle Cover.
  - (a) Remove cover (1) from receptacle (2).
  - (b) Remove screw (3) and cover chain (4) from receptacle (2).
- (2) Install Receptacle Cover.
  - (a) Install screw (3) and cover chain (4) on receptacle (2).
  - (b) Install cover (1) on receptacle (2).

## Section V. Preparation for Storage or Shipment

4-12. PREPARATION FOR STORAGE. To prepare the TEMPER equipment for storage, clean and dry the fabric sections and other components as described in paragraph 3-6. Perform operator PMCS as specified in Table 2-3.

Pack the fabric and frame assemblies into the tent cover and frame sections cover assembly. Place bags onto a wooden pallet and store in a building, shed, or other dry place. Store the light set in its storage container.

### Special Instructions for Administrative Storage.

Placement of equipment in administrative storage should be for short periods of time when a shortage of maintenance resources exist. Items should be in mission readiness within 24 hours or within the time factors as determined by the directing authority. Appropriate maintenance records will be kept during storage.

Before placing equipment in administrative storage, current maintenance services and Equipment Serviceability Criteria (ESC) evaluations should be completed, shortcomings and deficiencies should be corrected, and all Modification Work Orders (MWOs) should be applied.

Storage site selection. Inside storage is preferred for items selected for administrative storage. If inside storage is not available trucks, vans, conex or other containers may be used.

4-13. PRESERVATION. If the TEMPER components are to be stored without regular PMCS being performed, consult TM 38-230-2 for preservation requirements.

4-14. PREPARATION FOR SHIPMENT. Prepare the TEMPER for shipment by packing components into the wooden crate, using the original packing material, in which they were received. Strap crates onto wooden pallet.

CHAPTER 5

DIRECT SUPPORT MAINTENANCE INSTRUCTIONS

Subject	Section/Paragraph
Repair Parts, Special Tools; Test Measurement Diagnostic Equipment (TMDE) and Support Equipment . . . . .	I
Common Tools and Equipment . . . . .	5-1
Special Tools, TMDE, and Support Equipment. . . . .	5-2
Repair Parts . . . . .	5-3
Troubleshooting . . . . .	II
Troubleshooting Procedures . . . . .	5-4
Maintenance Procedures . . . . .	III
General . . . . .	5-5
Machine Stitching. . . . .	5-6
Automatic Stitching. . . . .	5-7
Welding . . . . .	5-8
Repair Fabric Assemblies . . . . .	5-9
Repair Frame Assemblies . . . . .	5-10
Repair Frame Section Components . . . . .	5-11
Repair Frame and Power Control Assemblies . . . . .	5-12
Repair Double Bump-Through Door Assembly. . . . .	5-13
Repair Power Control, Type III/IV . . . . .	5-14
Test and Repair Light Set, Type I . . . . .	5-15

Section I. REPAIR PARTS, SPECIAL TOOLS; TEST MEASUREMENT  
 DIAGNOSTIC EQUIPMENT (TMDE) AND SUPPORT EQUIPMENT

- 5-1. COMMON TOOLS AND EQUIPMENT. For authorized common tools and equipment refer to the Modified Table of Organization and Equipment (MTOE) applicable to your unit.
- 5-2. SPECIAL TOOLS, TMDE, AND SUPPORT EQUIPMENT. No special tools or equipment are required to perform direct support maintenance on the TEMPER.
- 5-3. REPAIR PARTS. Repair Parts are listed and illustrated in TM 10-8340-224-23P.

Section II. TROUBLESHOOTING

- 5-4. TROUBLESHOOTING PROCEDURES. See Tables 3-1 and 4-1 for operator and unit troubleshooting procedures.



### Section III. MAINTENANCE PROCEDURES

5-5. GENERAL. Direct Support maintenance functions identified in Section II, Appendix B, consist of repairing or replacing components that are riveted or sewn, welding new and broken parts, and replacement of electrical components in the power control and light set. Procedures for machine stitching are provided in paragraph 5-6. Specific tentage repair procedures are provided in FM 10-16. Procedures for removal and replacement of rivets are discussed in paragraph TC 9-510. Refer to TC 9-510 for information on metal repairs. Procedures for electrical component repair are provided in paragraphs 5-14 and 5-15.

5-6. MACHINE STITCHING. All stitch types, except bartacking, shall conform to FED-STD 751. Type 301 and 401 stitching requires 5-7 stitches per inch. Bartacking shall be 1/8 inch in width and free of thread breaks and loose stitching.

a. Thread Breaks. Thread breaks in stitching shall be overstitched not less than 1 inch at each break on stitch type 301, and not less than 1 1/2" at each break on stitch type 401. Thread breaks in type 401 may be overstitched with stitch type 301. Thread breaks noted during inspection must be repaired by overstitching the existing stitching starting from a distance of 1 inch beyond the break. The ends of repair stitching are not required to be backstitched.

b. Stitching Ends. The ends of type 301 stitching shall be overstitched not less than 1 inch except where ends are turned under in a hem or held down by other stitching. Where 301 stitchings performed automatically on stitch patterns such as box, box with cross-stitch, "W" stitching or straight line tacking, at least three tying, overlapping, or back stitches shall be used to secure the ends of stitching.

c. Skipped Stitches. Two or more consecutively skipped stitches occurring in type 301 stitching shall be overstitched not less than 1 inch. Any skipped stitches in type 401 stitching shall be overstitched not less than 1 1/2 inches. Skipped stitches in 401 stitching may be overstitched with type 301 stitching. Skipped stitches noted during inspection shall be repaired as specified for thread breaks in a., above.

5-7. AUTOMATIC STITCHING. Automatic stitching machines may be used to perform any of the required stitch patterns provided the requirements of the stitch pattern, stitches per inch, size and type of thread are met, and at least three or more overlapping, tying or backstitches secure the ends of the stitching.

5-8. WELDING. Major components of the TEMPER such as the frame sections, power distribution stand may require welding to repair deformations or broken welds. Refer to TM 9-237 for information on welding theory, application, and procedures.

5-9. REPAIR FABRIC ASSEMBLIES.

This task covers: a. Repair Fabric Assemblies

INITIAL SETUP

Tools:

Sewing Machine (Appendix B, Section III, Item 5)

Materials/Parts:

Refer to TM 10-8340-224-23P, Figures 1 through 12

GENERAL

Repair the following tent fabric sections:

End Section  
Door Section  
Window Section  
Fly  
End Section Liner  
Intermediate Liner  
Floor  
Vestibule  
Plenum  
Blackout Curtain  
Modesty Curtain  
Partition

Repair rips, tears, holes or separated seams, and replace, as necessary, quick disconnect fasteners, hook and pile fasteners, buckles, labels, grommets, windows, straps, tie tapes, chapes, and reinforcements. Follow the procedures outlined in paragraph 5-6 through 5-7, and FM 10-16 to perform the repairs and/or make the items specified in TM 10-8340-224-23P, Repair Parts and Special Tools List, (RPSTL) from bulk material. Use the materials specified in TM 10-8340-224-23P, under the group corresponding to the fabric section being repaired. Cut bulk material to sizes indicated.

ARMY TM 10-8340-224-13  
AIR FORCE TO 35E5-6-1  
NAVY NAVFAC-P-337.A

#### 5-10. REPAIR FRAME SECTIONS.

This task covers: Replace Rivets

INITIAL SETUP

##### Tools:

Tool Kit, Common No 1 (Appendix B, Section III, Item 7)  
Riveting Tool (Appendix B, Section III, Item 6)

##### Materials/Parts:

Refer to TM 10-8340-224-23P, Figures 13 through 20

GENERAL

Repair the following tent frame sections:

Arch Assembly Sectionalized  
Header Assembly  
Purlin Assembly  
Eave Extender Assembly  
Ridge Extender Assembly  
Door Sill Assembly  
Vestibule Frame Assembly

Replace rivets in all frame components IAW general procedures in TC 9-510.

5-11. REPAIR FRAME SECTION COMPONENTS.

This task covers: Remove and Install Purlin Assembly and Door Sill Assembly, End Fittings

INITIAL SETUP

Tools:

Tool Kit, Common No 1 (Appendix B, Section III, Item 3)

Materials/Parts:

End Fitting (TM 10-8340-224-23P, Figure 15, Item 2; Figure 19, Item 3)

Screw, Drive, Round Head (TM 10-8340-224-23P, Figure 15, Item 5; Figure 19, Item 6)

Rivet,

REPAIR

Remove and Install Purlin Assembly and Door Sill Assembly End Fitting.

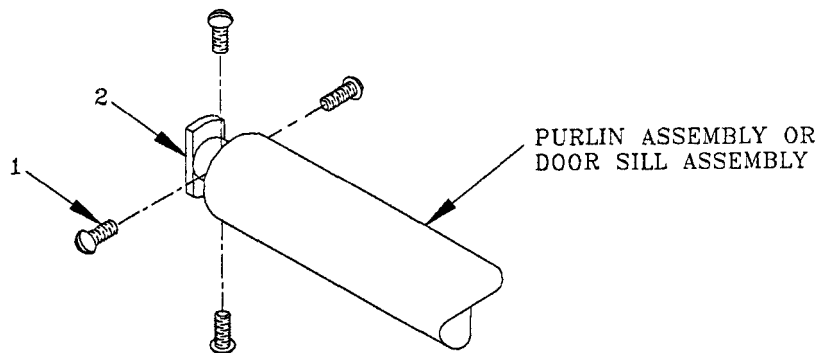

(1) Remove End Fitting

(a) Remove rivets/screws (1) holding end fitting to purlin assembly or door sill assembly

(b) Remove end fitting (2)

(2) Install End Fitting

(a) Insert end fitting (2) into purlin assembly or door sill assembly.

(b) Install rivets/screws (1).

ARMY TM 10-8340-224-13  
AIR FORCE TO 35E5-6-1  
NAVY NAVFAC-P-337.A

## 5-12. REPAIR FRAME AND POWER CONTROL ASSEMBLIES.

This task covers: Repair Frame and Power Control Assemblies

### INITIAL SETUP

#### Tools:

Tool Kit, Common No 1 (Appendix B, Section III, Item 7)

#### Materials/Parts:

Refer to TM 10-8340-224-23P, Figures 13 through 20 and 25

### GENERAL

Repair the following tent frame sections and power control components:

Arch Assembly, Sectionalized and Rigid  
Eave Extender Assembly  
Ridge Extender Assembly  
Power Panel Stand Assembly  
Vestibule Frame Assembly

Repair welds IAW the procedures outlined in TM 9-237 to perform the repairs and/or make the items specified in TM 10-8340-224-23P, Repair Parts and Special Tools List.

5-13. REPAIR DOUBLE BUMP THROUGH DOOR ASSEMBLY.

- This task covers:
- a. Remove and Install Door Assembly (left or right).
  - b. Remove and Install Hinge

INITIAL SETUP

Tools:

Riveting Tool (Appendix B, Section III, Item 6)  
Tool Kit, Common No 1 (Appendix B, Section III, Item 7)

Materials/Parts:

Left Door Assembly (TM 10-8340-224-23P, Figure 21, Item 3)  
Right Door Assembly (TM 10-8340-224-23P, Figure 21, Item 13)  
Hex Head Screw Cap (TM 10-8340-224-23P, Figure 21, Item 34)  
Lock-Spring Washer (TM 10-8340-224-23P, Figure 21, Item 35)

Equipment Condition:

Double Bump Through Door Assembly may or may not be installed.

REPAIR

- a. Remove and Install Door Assembly (left or right).

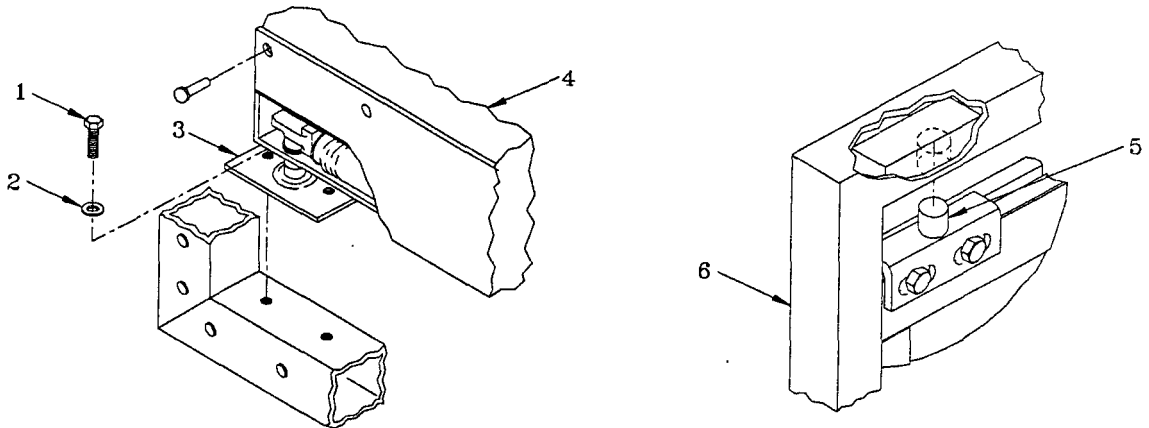

- (1) Remove Door Assembly.

- (a) Remove hex head screw caps (1) and lock-spring washer (2) from hinge base (3)
- (b) Pull door (4) out from bottom allowing pivot (5) to pull free from frame (6).

5-13. REPAIR DOUBLE BUMP THROUGH DOOR ASSEMBLY (CONT).

(2) Replace Door Assembly.

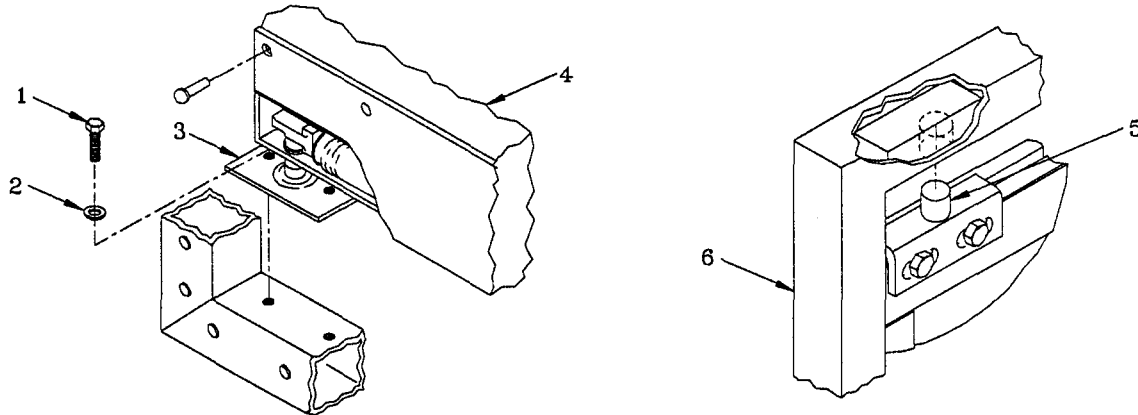

- (a) Insert pivot (5) into door frame (6).
- (b) Slide door (4) into position at bottom of frame (6).
- (c) Install lock spring washers (2) and hex head screw caps (1) into hinge base (3).

b. Remove and Install Hinge Assembly

(1) Remove Hinge Assembly.

- (a) Remove door (1) as described in paragraph 5-13a.
- (b) Remove rivets/screws (2) holding hinge cover plate (3) to door (1) IAW TC 9-510.
- (c) Remove screws and nuts (4) holding hinge assembly (5) to door (1).
- (d) Remove hinge assembly (5).

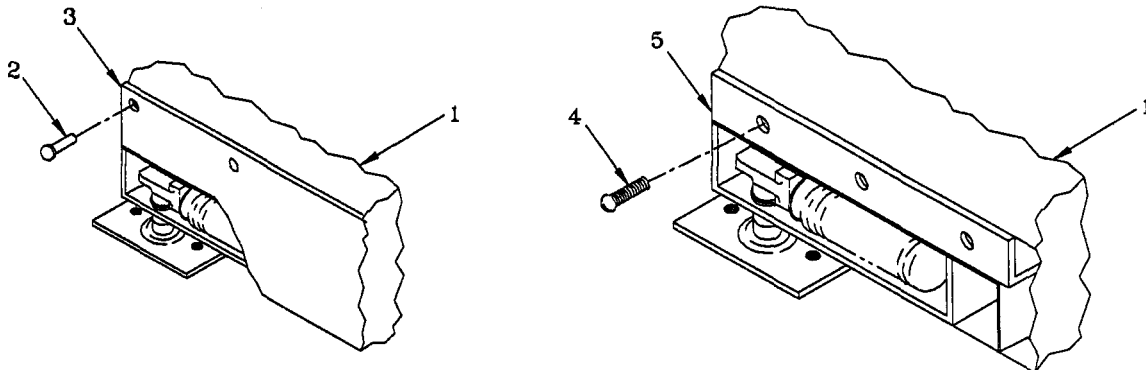

(2) Install Hinge Assembly.

- (a) Install screws and nuts (4) to mount hinge assembly (5) to door (1).
- (b) Install rivets/screws (2) and hinge cover plate (3) on door (1) IAW TC 9-510 as applicable.
- (c) Install door (1) as described in paragraph 5-13a.

5-14. REPAIR POWER CONTROL, TYPE III/IV AND CONVENIENCE OUTLET.

- This task covers:
- a. Remove and install circuit breaker, toggle and push-pull.
  - b. Remove and install receptacle connector with gasket from Power Control/Convenience Outlet.
  - c. Remove and install mounting box receptacle from Power Control/Convenience Outlet.

INITIAL SETUP

Tools:

Tool Kit, Common No 1 (Appendix B, Section III, Item 7)

Materials/Parts:

Circuit breaker, toggle (TM 10-8340-224-23P, Figure 22, Item 14; Figure 23, Item 11)

Circuit breaker, push-pull (TM 10-8340-224-23P, Figure 22, Item 15; Figure 23, Item 12)

Connector, receptacle with gasket (TM 10-8340-224-23P, Figure 22, Item 7,8; Figure 23, Item 7,8; Figure 24, Item 3)

Receptacle, Mounting Box (TM 10-8340-224-23P, Figure 22, Item 10,11; Figure 23, Item 10; Figure 24, Item 5)

Equipment Condition:

External Electrical power disconnected; Power control disconnected.



5-14. REPAIR POWER CONTROL, TYPE III/IV AND CONVENIENCE OUTLET  
(CONT).

REPAIR

a. Remove and Install Circuit Breaker, Toggle or Push-Pull

- (1) Remove Circuit Breaker.

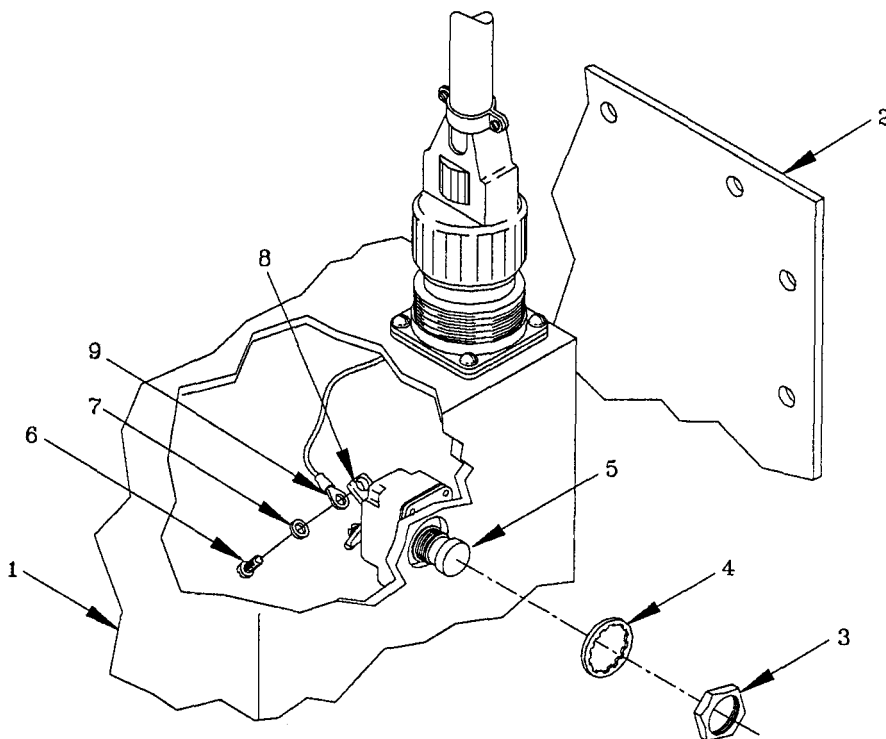

**WARNING**

Lethal voltage is present when the power control system is connected to power source. Disconnect from power source before inspecting or repairing any electrical component. Electrical shock and death may result from failure to heed this warning.

- (a) Disconnect electrical power from distribution box (1).
- (b) Remove back plate (2) from distribution box (1).

- (d) Remove screws (6) and washers (7) from circuit breaker posts (8) and remove terminal lugs (9).
- (2) Install Circuit Breaker.
  - (a) Install screws (6), washers (7) and terminal lugs (9) on circuit breaker posts (8).
  - (b) Place circuit breaker (5) in proper position.
  - (c) Install circuit breaker retaining nut (3) and washer (4).
  - (d) Install back plate (2).
- b. Remove and Install Receptacle Connector with Gasket from Power Control/Convenience Outlet
  - (1) Remove Receptacle Connector with Gasket.

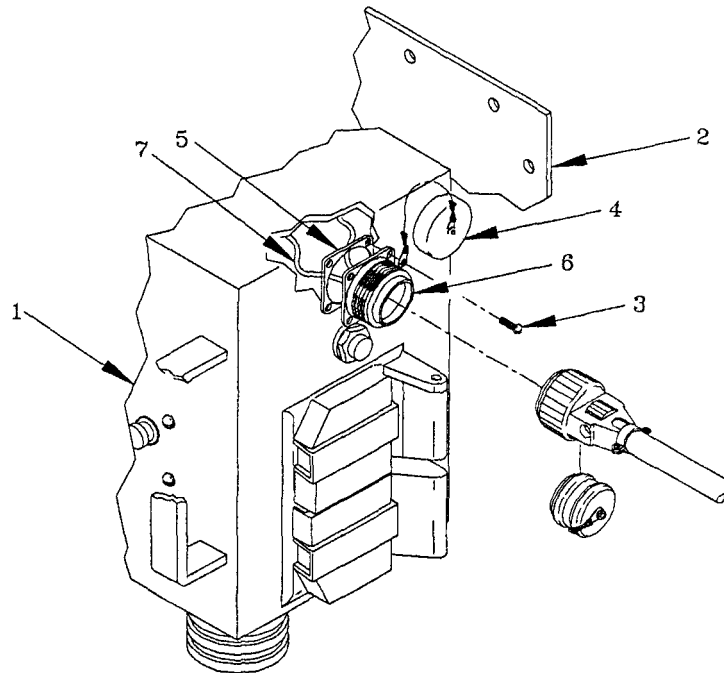

5-14. REPAIR POWER CONTROL, TYPE III/IV AND CONVENIENCE OUTLET  
(Cont).

**WARNING**

Lethal voltage is present when the power control system is connected to power source. Disconnect from power source before inspecting or repairing any electrical component. Electrical shock and death may result from failure to heed this warning.

- (a) Disconnect electrical power from distribution box (1).
  - (b) Remove back plate (2) from distribution box (1) (Distribution box only).
  - (c) Remove screws (3), receptacle cover (4), gasket (5) and receptacle connector (6).
  - (d) Remove wires (7).
- (2) Install Receptacle Connector with Gasket.
- (a) Insert wires (7) into rear of receptacle connector (6).
  - (b) Install receptacle connector (6), gasket (5), receptacle cover (4) and screws (2).
  - (c) Install back plate (2) (Distribution box only).
  - (d) Connect electrical power.
- c. Remove and Install Mounting Box Receptacle from Power Control/Convenience Outlet.

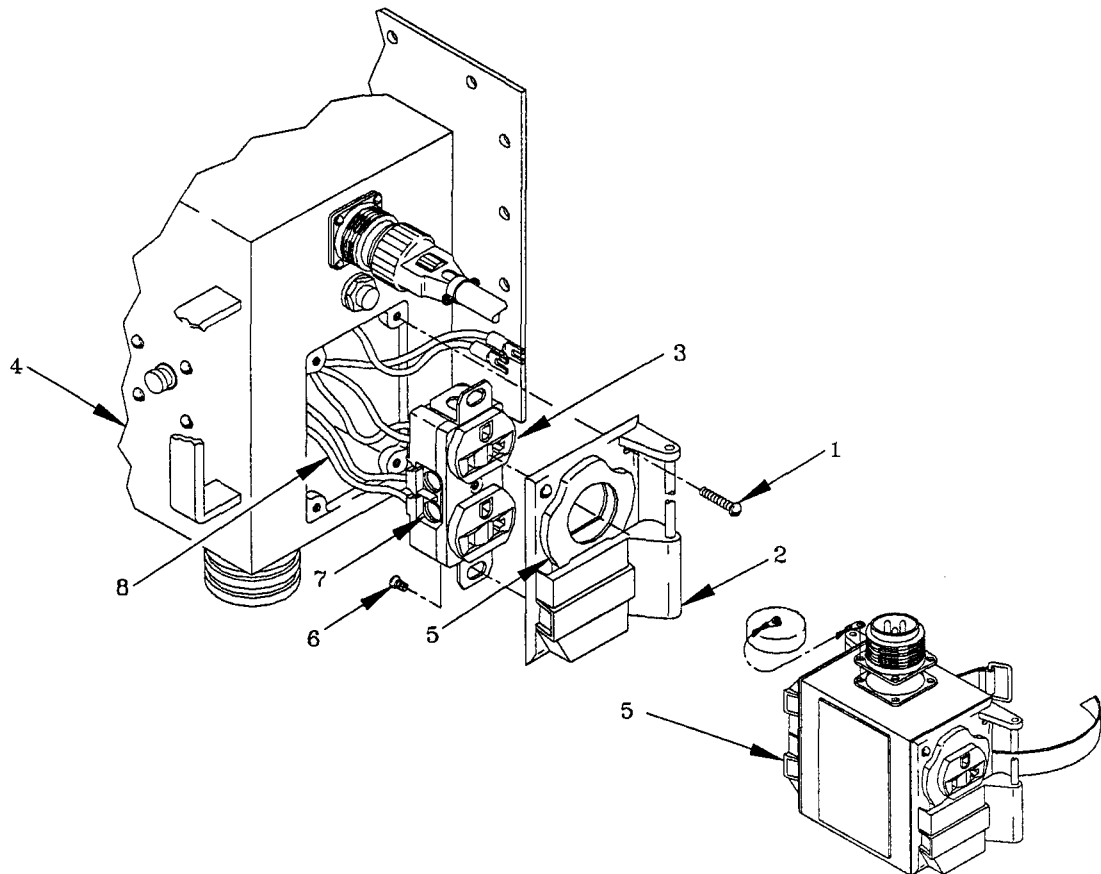

- (1) Remove Mounting Box Receptacle.
  - (a) Remove screws (1), cover (2) and mounting box receptacle (3) from distribution box (4) or convenience outlet (5).
  - (b) Remove screws (6) separating cover (2) and mounting box receptacle (3).
  - (c) Loosen set screws (7) and remove wires (8).
- (2) Install Mounting Box Receptacle.
  - (a) Install wires (8) and tighten set screws (7).
  - (b) Assemble mounting box receptacle (3) and cover (2) with screws (6).
  - (c) Install screws (1) in cover (2).
  - (d) Install mounting box receptacle (3), cover (2) and screws (1) in distribution box (4) or convenience outlet (5).

ARMY TM 10-8340-224-13  
AIR FORCE TO 35E5-6-1  
NAVY NAVFAC-P-337.A

5-15. TEST AND REPAIR LIGHT SET, TYPE I.

- This task covers:
- a. Test Ballast Assembly
  - b. Test Switch
  - c. Test Fuseholder
  - d. Remove and Install Ballast Assembly
  - e. Remove and Install Female Cable Assembly
  - f. Remove and Install Male Cable Assembly
  - g. Remove and Install Switch
  - h. Remove and Install Fuseholder
  - i. Remove and Install Handles, Hinges, and Latches

INITIAL SETUP

Tools:

Tool Kit, Common No 1 (Appendix B, Section III, Item 7)  
Multimeter (Appendix B, Section III, Item 4)  
Electric Soldering Iron (Appendix B, Section III, Item 8)

Materials/Parts:

Ballast Assembly (TM 10-8340-224-23P, Figure 27, Item 7)  
Cable Assembly, Female (TM 10-8340-224-23P, Figure 27, Item 27)  
Cable Assembly, Male (TM 10-8340-224-23P, Figure 27, Item 24)  
Fuseholder (TM 10-8340-224-23P, Figure 27, Item 10,36)  
Switch (TM 10-8340-224-23P, Figure 27, Item 9)  
Insulation Sleeving (Appendix E, Item 7)  
Tape, Electrical Insulation (Appendix E, Item 15)  
Handle (TM 10-8340-224-23P, Figure 27, Item 4)  
Hinge (TM 10-8340-224-23P, Figure 27, Item 5)  
Latch (TM 10-8340-224-23P, Figure 27, Item 3)

a. Test Ballast Assembly.

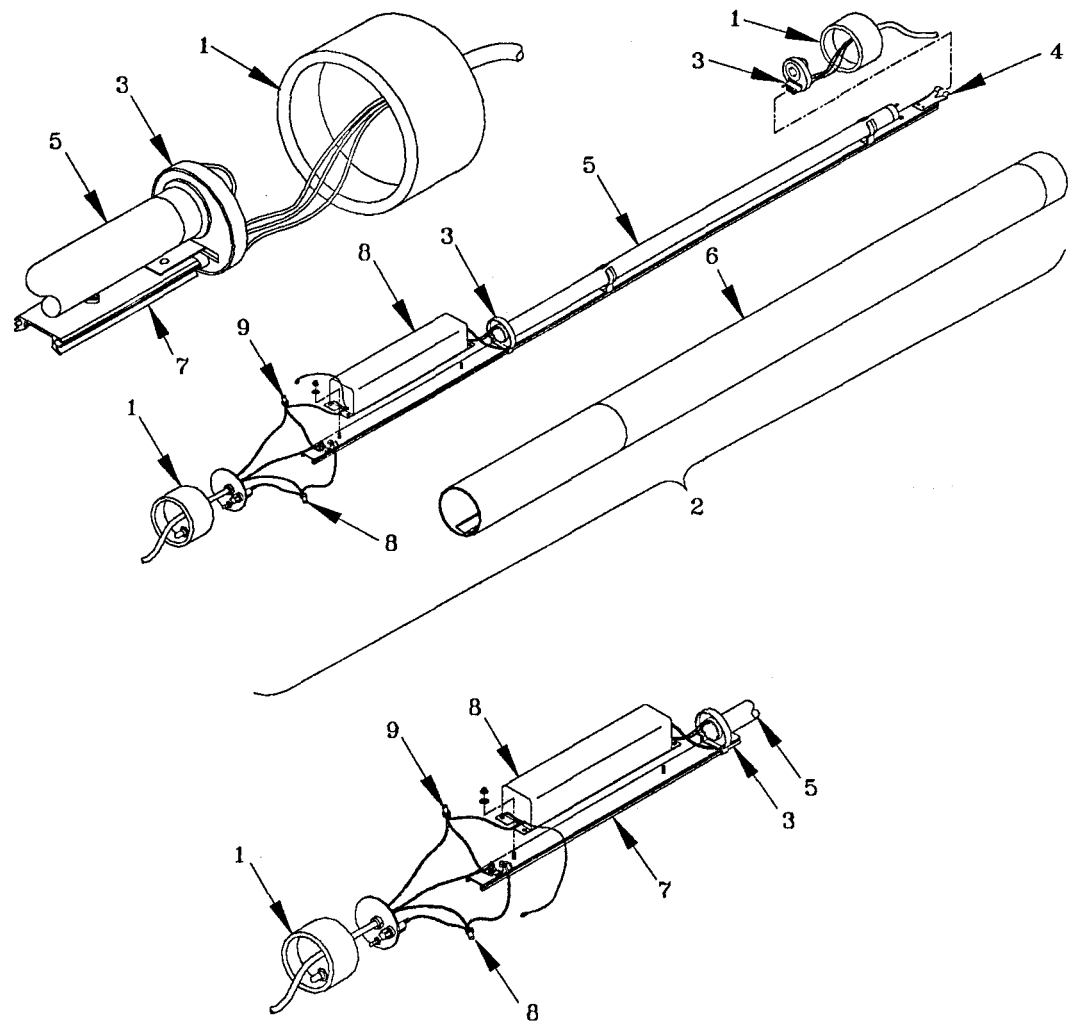

**WARNING**

Lethal voltage is present when the light set is connected to power source. Disconnect from power source before inspecting or repairing any electrical component. Electrical shock and death may result from failure to heed this warning.

- (1) Remove both end caps (1) from luminaire (2).
- (2) Disconnect lampholder (3) by depressing retainer connector (4). Pull lamp (5) out of lens/screen assembly (6).

5-15. TEST AND REPAIR LIGHT SET, Type I (CONT).

- (3) Slide the extrusion assembly (7) out of the lens/screen assembly (6).
- (4) Check condition of wires leading from ballast (8) to lampholders (3) along extrusion assembly (7) for cut, loose, or exposed wires.
- (5) Test for continuity at the power input connection (9) (black and white wire splices).
- (6) Connect lampholder (3) to extrusion assembly (7).
- (7) If continuity exists at the power input connection, test at lampholders (3), (with switch in ON position).

**NOTE**

No continuity at the lampholders indicates a faulty ballast, or wiring.

- (8) Remove and install ballast assembly in accordance with paragraph 5-15d.

b. Test Switch

**WARNING**

Lethal voltage is present when the light set is connected to power source. Disconnect from power source before inspecting or repairing any electrical component. Electrical shock and death may result from failure to heed this warning.

- (1) Complete steps a. (1), through a. (3), to partially disassemble luminaire.
  - (2) Test for continuity at the switch connector posts (with switch in ON position).
  - (3) If continuity does not exist, replace switch IAW para 5-15.g.
- c. Test Fuseholder



5-15. TEST AND REPAIR LIGHT SET, Type I (CONT).

**WARNING**

Lethal voltage is present when the light set is connected to power source. Disconnect from power source before inspecting or repairing any electrical component. Electrical shock and death may result from failure to heed this warning.

- (1) Complete steps a. (1), through a. (3), to partially disassemble luminaire.
- (2) Test for continuity at the fuseholder connection wires (with fuse in place).
- (3) If continuity does not exist, replace fuseholder IAW para 5-15.h.

d. Remove and Install Ballast Assembly.

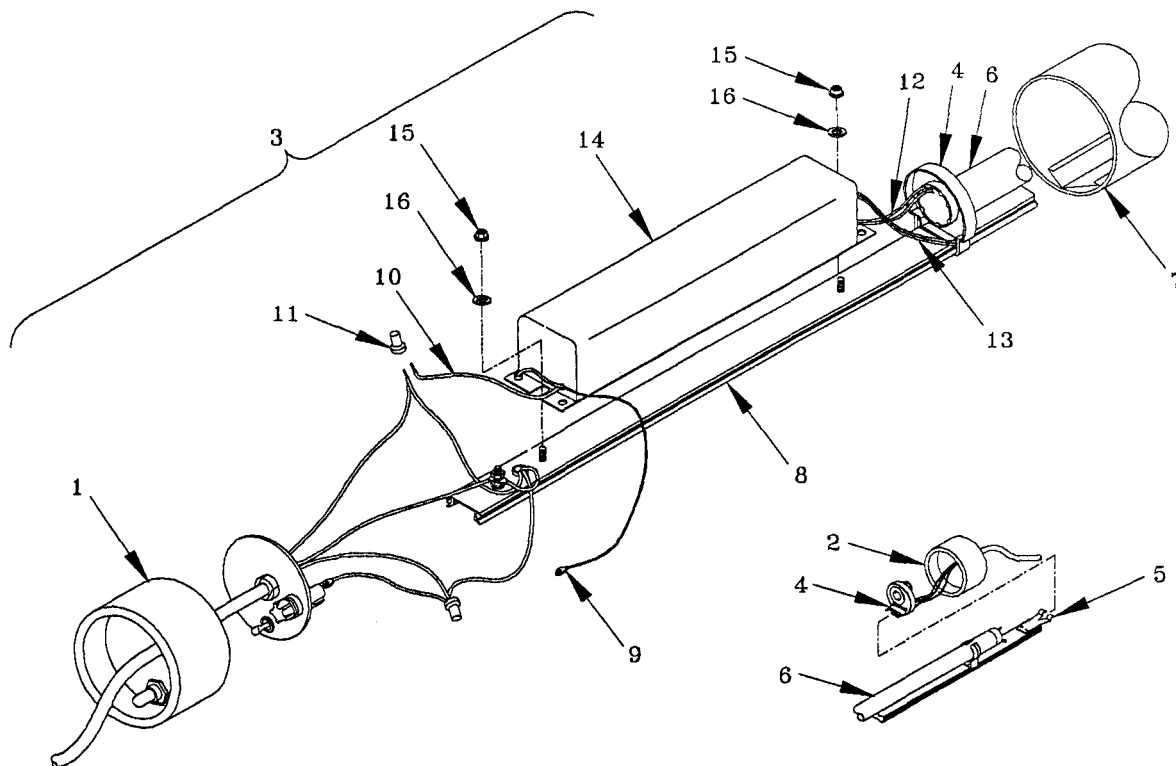

- (1) Remove Ballast Assembly.

**WARNING**

Lethal voltage is present when the light set is connected to power source. Disconnect from power source before inspecting or repairing any electrical component. Electrical shock and death may result from failure to heed this warning.

- (a) Remove male (1) and female (2) end caps from luminaire (3).
  - (b) Disconnect lampholder (4) by depressing retainer connector (5). Pull lamp (6) out of lens/screen assembly (7).
  - (c) Slide the extrusion assembly (8) out of the lens/screen assembly (7) from male side only.
  - (d) Disconnect ring terminal (9) of black wire from switch with flat tip screwdriver.
  - (e) Disconnect white AC wire (10) by removing splice (11) and separating wires.
  - (f) If leads (12,13) from ballast assembly (14) wires are serviceable, cut the wires at point of exit from the ballast assembly (14). If the wires are damaged, remove from lampholders (4) and extrusion assembly (8).
  - (g) Remove two 1/8" hex nuts (15) and washer (16) securing ballast assembly (14) to extrusion assembly (8).
  - (h) Lift ballast assembly (14) off extrusion assembly (8).
- (2) Install Ballast Assembly.
- (a) place ballast assembly (14) onto extrusion assembly (8), and secure with two 1/8" hex nuts (15) and washers (16).

5-15. TEST AND REPAIR LIGHT SET, Type I (CONT).

**NOTE**

Ensure that one set of wires of same color from ballast assembly goes to closest lampholder and one set goes to far lampholder.

- (b) If wire leads (12,13) from ballast assembly (14) were found serviceable, remove 1/4" of insulation from the ends of the wires. Solder the wires on the ballast assembly (14) to wires (12,13) on the extrusion assembly (8). Apply insulation tape after the solder point cools.
- (c) If wire leads (12,13) from ballast assembly (14) were removed from the extrusion assembly (8) entirely, install wires supplied with ballast assembly (14) onto extrusion assembly (8) and lampholders (4).
- (d) Connect AC (white) wire (10) to AC input connection and install splice (10).
- (e) Connect black wire ring terminal (9) to switch.
- (f) Ensure that extrusion assembly (8) aligns with track in lens/screen assembly (7) and ballast assembly (14) is covered by solid portion. Slide extrusion assembly (8) into lens/screen assembly (7).
- (g) Install male end cap assembly (1) on luminaire (3). Install lamp (6).
- (h) Install lampholder (4) and female end cap (2) onto luminaire (3).

e. Remove and Install Female Cable Assembly.

1. Remove Female Cable Assembly.

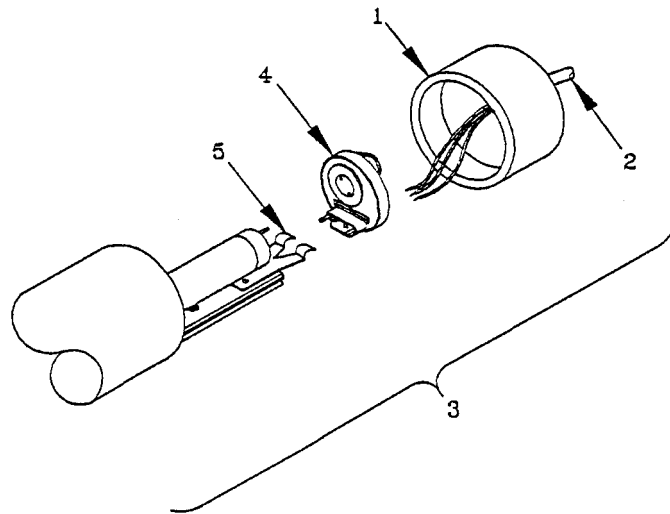

- (a) Remove end cap (1) on female power cord (2) from luminaire (3).
  - (b) Remove lampholder (4) by depressing retainer connector (5).
  - (c) Cut female power cord (2) wires from lampholder (4) and pull power cord (2) out of end cap (1).
- (2) Install Female Cable Assembly.
- (a) Insert loose wire end of new female power cord (2) through end cap (1) so that approximately three inches of the cord are inside the end cap (1).
  - (b) Remove outer insulation from power cord (2) on inside of end cap (1), and approximately 1/2" from individual wires.
  - (c) Solder power cord (2) wires to lampholder (4) wires.
  - (d) Install lampholder (4).
  - (e) Install end cap (1) onto luminaire (3).

5-15. TEST AND REPAIR LIGHT SET, Type I (CONT).

f. Remove and Install Male Cable Assembly.

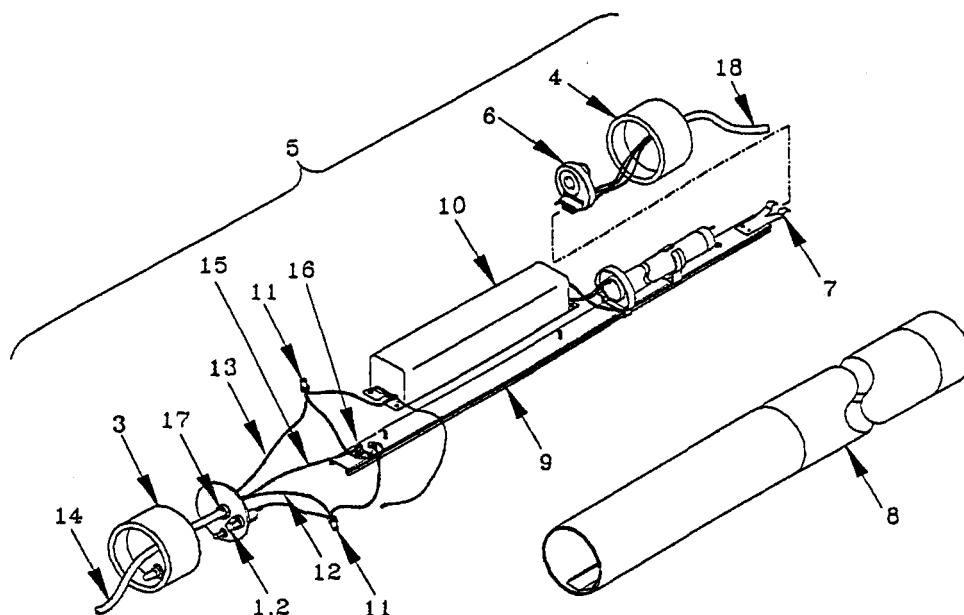

- (1) Remove Male Cable Assembly.
  - (a) Remove fuse cap (1) and fuse (2).
  - (b) Remove molded male and female end caps (3,4) from luminaire (5).
  - (c) Disconnect lampholder (6) by depressing retainer connector (7).
  - (d) Pull the lens/screen (8) off the extrusion assembly (9) to expose the ballast (10).
  - (e) Remove splices (11) and disconnect black (12) and white (13) wires of the male power cord (14).
  - (f) Disconnect the male power cord ground wire (15) from the ground post (16).
  - (g) Pull male power cord (14) out of the molded end cap (3) and bushing (17).

(2) Install Male Cable Assembly.

- (a) Push male power cord (14) through the male molded end cap (3) and bushing (17).
- (b) Connect black (12) and white (13) wires of the male power cord (14) and re-install splices (11).
- (c) Connect the male power cord ground wire (15) to the ground post (16).
- (d) Install molded end cap (3) of male power cord (14) over luminaire (5).
- (e) Install fuse cap (1) and fuse (2).
- (f) Install lampholder (6), and end cap (4) of female power cord (18) over luminaire (5).

g. Remove and Install Switch.

- (1) Remove Switch.

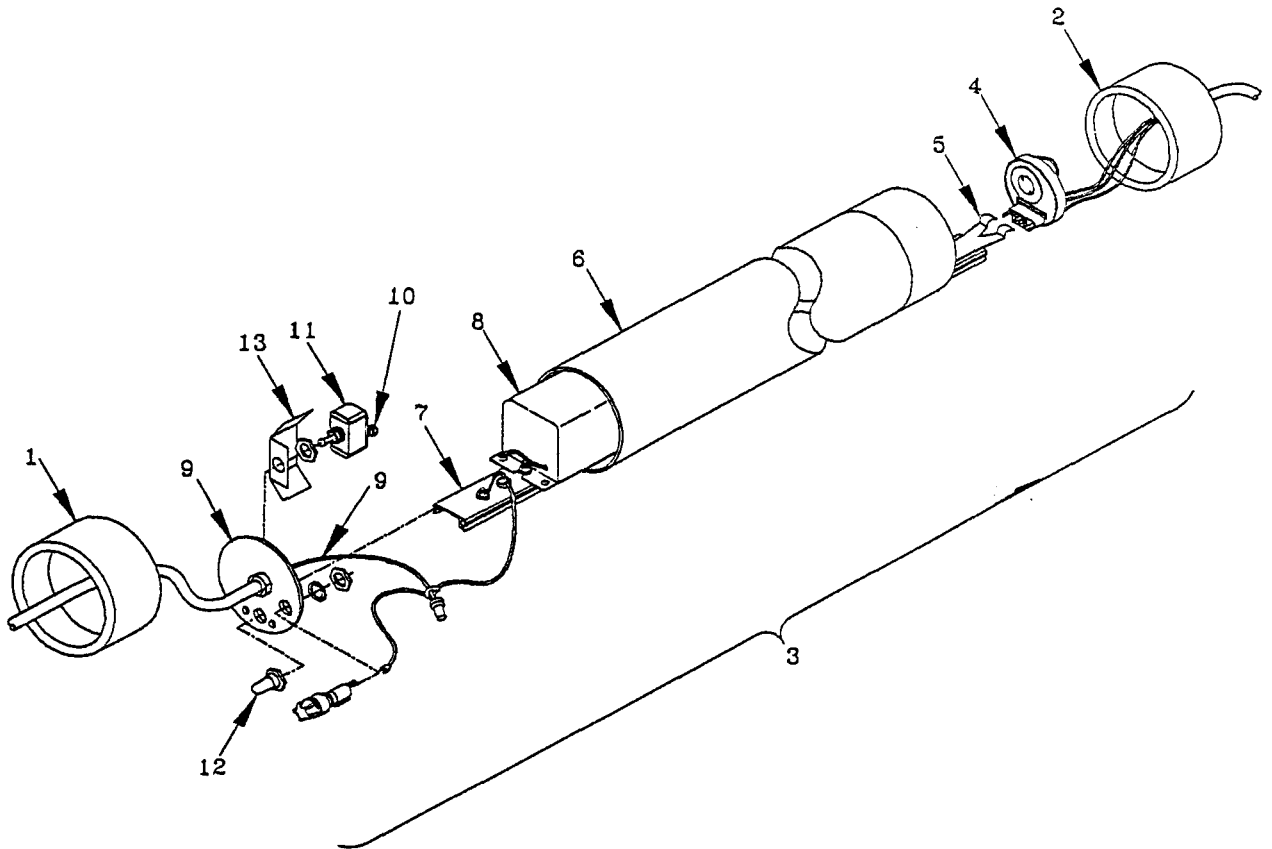

5-15. TEST AND REPAIR LIGHT SET, Type I (CONT).

- (a) Remove fuse cap and fuse.
  - (b) Remove molded male (1) and female (2) end caps from luminaire (3).
  - (c) Disconnect lampholder (4) by pressing retainer (5).
  - (d) Pull lens/screen assembly (6) off the extrusion assembly (7) to expose the ballast (8).
  - (e) Separate bracket (9) from male end cap (1).
  - (f) Remove ring terminals (10) from rear of switch (11).
  - (g) Unscrew switch seal (12) and remove switch (11) and paper insulation (13) from the rear of the bracket (9).
- (2) Install Switch.
- (a) Insert new switch (11) through paper insulator (13) into cutout in bracket (9).
  - (b) Screw switch seal (12) onto threaded toggle sleeve.
  - (c) Connect ring terminals (10) to switch (11).
  - (d) Install bracket (9) into male end cap (1).
  - (e) Slide extrusion assembly (7) into lens/screen assembly (6).
  - (f) Install lampholders (4).
  - (g) Install male (1) and female (2) end caps over luminaire (3).
- h. Remove and Install Fuse Cap and Fuseholder.
- (1) Remove Fuseholder.
- (a) Remove molded male (1) and female (2) end caps from luminaire (3).
  - (b) Disconnect lampholder (4) by pressing retainer (5).
  - (c) Pull lens/screen assembly (6) off the extrusion assembly (7) to expose the ballast (8).

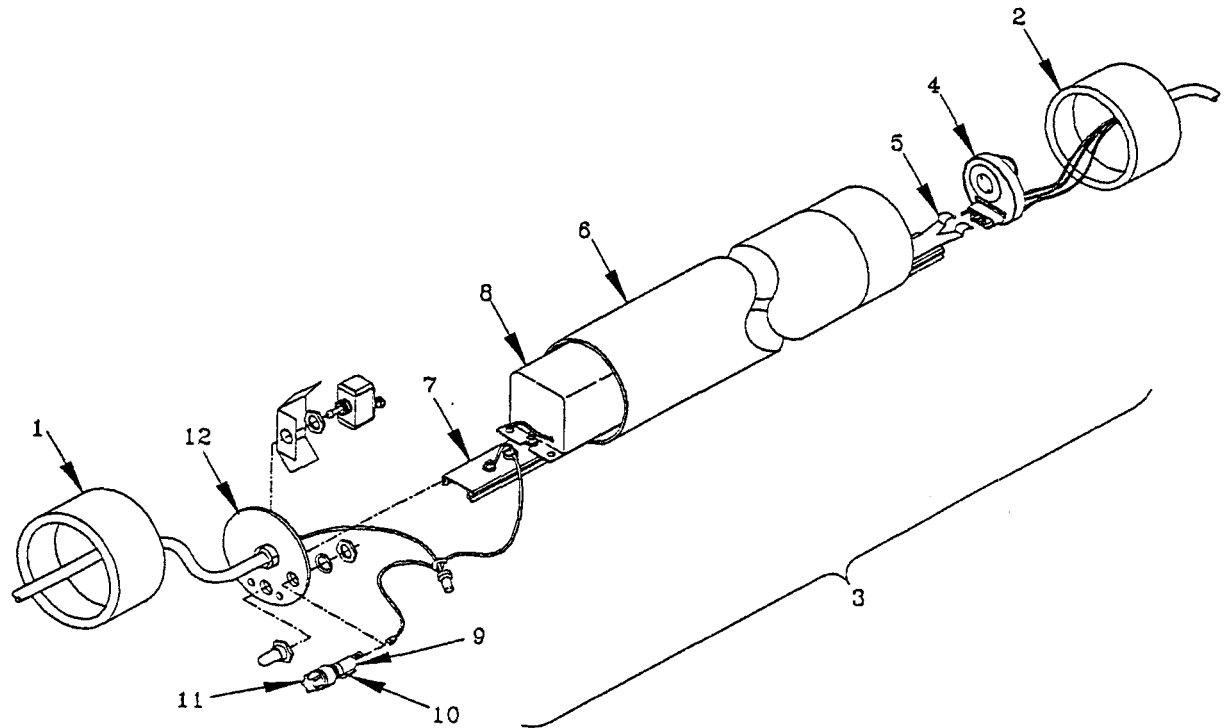

- (d) Remove (cut) insulation tubing (9) from rear of fuseholder (10) and remove wires from fuseholder terminals.
- (e) Unscrew fuseholder cap (11) and remove fuseholder (10) from switch bracket (12).
- (2) Install Fuseholder.
  - (a) Place new fuseholder (10) into position through switch bracket (12).
  - (b) Connect wires to fuseholder (10) terminals and install insulation tubing (9) around terminals.
  - (c) Install cap (11) over fuseholder (10). (Install new fuse if necessary.)
  - (d) Slide extrusion assembly (7) into lens/screen assembly (6).
  - (e) Install lampholder (4).
  - (f) Install male (1) and female (2) molded end caps on luminaire (3).



5-15. TEST AND REPAIR LIGHT SET, Type I (CONT).

- i. Remove and Install Handles, Hinges and Latches.

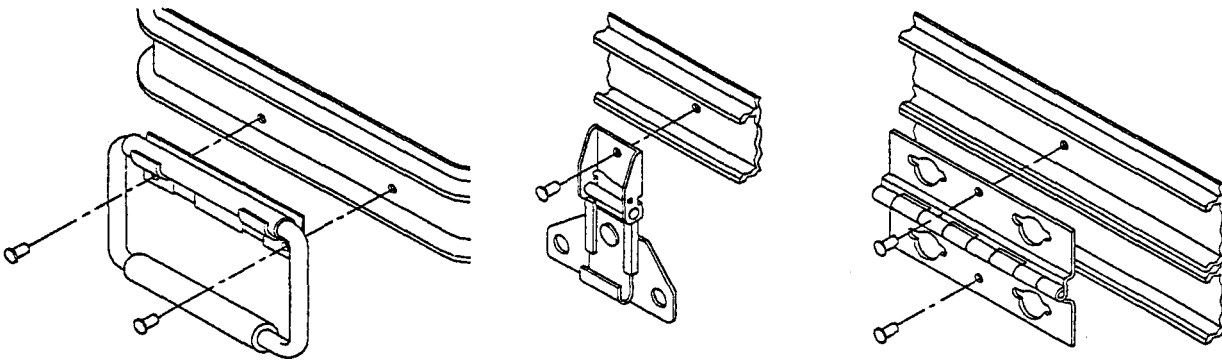

- (1) Remove Handles, Hinges, and Latches.

Remove a handle, hinge or latch from the storage container by removing the rivets as described in TC 9-510.

- (2) Install Handles, Hinges, and Latches.

Align new handle, hinge or latch with holes in case and install rivets as described in TC 9-510.

APPENDIX A

REFERENCES

---

Appendix A contains references to all publications, manuals, directives and forms that are used in the text of the manual and as directed by the contracting agency. Any additional reference to government reference material is also included. Reference information is included in the following paragraphs: Technical Manuals; Field Manuals; DA Pamphlets; Federal Standards; Military Standards; Forms.

A-1. TECHNICAL MANUALS

TC 9-510	Metal Body Repair and Related Operations
TM 5-1080-200-13&P	Camouflage Screen and Screen Support Systems
TM 9-237	Operator's Manual for Welding Theory and Application
TM 38-230-2	Preservation, Packaging and Packing of Military Supplies and Equipment
TM 740-90-1	Administrative Storage of Equipment
TM 750-244-3	Destruction of Army Material to Prevent Enemy Use
TM 10-8340-224-23P	Operator, Unit, and Direct Support Maintenance Repair Parts and Special Tools List for Tent, Extendable, Modular, Personnel (TEMPER)

A-2 . FIELD MANUALS

FM 3-3	NBC Contamination Avoidance
FM 3-4	NBC Protection
FM 3-5	NBC Decontamination
FM 10-16	General Fabric Repair
FM 21-11	First Aid for Soldiers

A-3. DA PAMPHLETS

DA PAM 738-750	The Army Maintenance Management System (TAMMS)
DA PAM 25-30	Modification Work Orders

A-4. FEDERAL STANDARDS

595	Colors
751	Stitches, Seams and Stitchings
PPP-B-601	Boxes, Wood, Cleated-Plywood

ARMY TM 10-8340-224-13  
AIR FORCE TO 35E5-6-1  
NAVY NAVFAC-P-337.A

A-5 MILITARY STANDARDS

147	Palletizing Unit Loads
704	Treatment and Painting of Material
731	Quality of Wood Members for Containers and Pallets

A-6. FORMS

DD Form 6	Packaging Improvement Report
DA Form 2028-2	Recommended Changes to Equipment
	Technical Publications
DA Form 2404	Equipment Inspection and Maintenance Worksheet
DA Form 2408-16	Aircraft Component Historical Record
DA Form 2410	Component Removal and Repair/Overhaul Record
SF 361	Discrepancy in Shipment Report
SF 362	Report of Packaging and Handling Deficiencies
SF 368	Quality Deficiency Report

APPENDIX B  
MAINTENANCE ALLOCATION CHART

---

Section I. Introduction

B-1. GENERAL.

a. This section provides a general explanation of all maintenance and repair functions authorized at various maintenance categories.

b. The Maintenance Allocation Chart (MAC) in section II designates overall authority and responsibility for the performance of maintenance functions on the identified end item or component. The application of the maintenance functions to the end item or component will be consistent with the capacities and capabilities of the designated maintenance categories.

c. Section III lists the tools and test equipment (both special tools and common tool sets) required for each maintenance function as referenced from section II.

d. Section IV contains supplemental instructions and explanatory notes for a particular maintenance function.

B-2. MAINTENANCE FUNCTIONS. Maintenance functions will be limited to and defined as follows:

a. Inspect. To determine the serviceability of an item by comparing its physical, mechanical and/or electrical characteristics with established standards through examination.

b. Test. To verify serviceability and to detect incipient failure by measuring the mechanical or electrical characteristics of an item and comparing those characteristics with prescribed standards.

c. Service. Operations required periodically to keep an item in proper operational condition, i.e., to clean (decontaminate), to preserve, to drain, to paint, or to replenish fuel, lubricants, hydraulic fluids, or compressed air supplies.

d. Adjust. To maintain, within prescribed limits, by bringing into proper or exact position, or by setting the operating characteristics to the specified parameters.

e. Align. To adjust specified variable elements of an item to bring about optimum or desired performance.

B-2 MAINTENANCE FUNCTIONS (CONT)

f. Calibrate. To determine and cause corrections to be made or to be adjusted on instruments or test measuring and diagnostic equipments used in precision measurement. Consists of comparisons of two instruments, one of which is a certified standard of known accuracy, to detect and adjust any discrepancy in the accuracy of the instrument being compared.

g. Remove/Install. The act of emplacing, seating, or fixing into position an item, part, module (component or assembly) in a manner to allow the proper functioning of the equipment or system.

h. Replace. The act of substituting a serviceable like type part, subassembly, or module (component or assembly) for an unserviceable counterpart.

i. Repair. The application of maintenance services (inspect, test, service, adjust, align, calibrate, replace) or other maintenance actions (welding, grinding, riveting, straightening, facing, remachining, or resurfacing) to restore serviceability to an item by correcting specific damage, fault, malfunction, or failure in a part, subassembly, module (component or assembly), end item, or system.

j. Overhaul. The maintenance effort (service/action) necessary to restore an item to a completely serviceable/operational condition as prescribed by maintenance standards (i.e., DMWR) in appropriate technical publications. Overhaul is normally the highest degree of maintenance performed by the Army. Overhaul does not normally return an item to like new condition.

k. Rebuild. Consists of those services/actions necessary for the restoration of unserviceable equipment to a like new condition in accordance with original manufacturing standards. Rebuild is the highest degree of material maintenance applied to Army equipment. The rebuild operation includes the act of returning to zero those age measurements (hours, miles, etc.) considered in classifying Army equipment/components.

B-3. COLUMN ENTRIES

a. Column 1 - Group Number. Column 1 lists group numbers, the purpose of which is to identify components, assemblies, subassemblies, and modules with the next higher assembly.

b. Column 2 - Component/Assembly. Column 2 contains the noun names of components, assemblies, subassemblies, and modules for which maintenance is authorized.

c. Column 3 - Maintenance Functions. Column 3 lists the functions to be performed on the item listed in column 2. When items are listed without maintenance functions, it is solely for the purpose of having the group number in the MAC and RPSTL coincide.

d. Column 4 - Maintenance Category. Column 4 specifies, by the listing of "work time" figures in the appropriate subcolumn(s), the lowest level of maintenance authorized to perform the function listed in column 3. This figure represents the active time required to perform that maintenance function at the indicated category maintenance. If the number or complexity of the tasks within the listed maintenance function vary at different maintenance categories, appropriate "work time" figures will be shown for each category. The number of task-hours specified by the "work time" figure represents the average time required to restore an item (assembly, subassembly, component, module, end item or system) to a serviceable condition under typical field operating conditions. This time includes preparation time, troubleshooting time, and quality assurance/quality control time in addition to the time required to perform the specific tasks identified for the maintenance functions authorized in the maintenance allocation chart. Subcolumns of column 4 are as follows:

- C Operator/Crew
- O Unit
- F Direct Support
- H General Support
- D Depot

e. Column 5 - Tools and Equipment. Column 5 specifies by code, those common tool sets (not individual tools) and special-tools, test, and support equipment required to perform the designated function.

f. Column 6 - Remarks. When applicable, this column contains a letter code, in alphabetical order, which is keyed to the remarks contained in Section IV.

#### B-4 . TOOL AND TEST EQUIPMENT REQUIREMENTS (Sect. III)

a. Tool or Test Equipment Reference Code. The numbers in this column coincide with the numbers used in the tools and equipment column of the MAC. The numbers indicate the applicable tool or test equipment for the maintenance functions.

ARMY TM 10-8340-224-13  
AIR FORCE TO 35E5-6-1  
NAVY NAVFAC-P-337.A

B-4. TOOL AND TEST EQUIPMENT REQUIREMENTS (Sect. III) (CONT)

b. Maintenance Category. The codes in this column indicate the maintenance category allocated the tool or test equipment.

c. Nomenclature. This column lists the noun name and nomenclature of the tools and test equipment required to perform the maintenance functions.

d. National Stock Number. This column lists the National/Nato stock number of the specific tool or test equipment.

e. Tool Number. This column lists the manufacturer's part number of the tool followed by the Federal Supply Code for manufacturers (5-digit) in parentheses.

B-5. REMARKS. (Sect. IV)

a. Reference Code. This code refers to the appropriate item in section II, column 6.

b. Remarks. This column provides the required explanatory information necessary to clarify items appearing in section II.

Section II. MAINTENANCE ALLOCATION CHART									
(1) GROUP NUMBER	(2) COMPONENT/ ASSEMBLY	(3) MAINT FUNCTION	(4) MAINTENANCE CATEGORY					(5) TOOLS & TEST EQUIPT	(6) REMARKS
			C	O	F	H	D		
00	Tent, Extendable, Modular								
01	Tent Sections (Fabric)	Inspect Service Replace Repair	.5 .5					2	
				.5	1.0			1,5	
0101	End Section	Replace Repair		.1 .5		.5		1,5	
0102	Door Section	Replace Repair		.1 .5		.5		1,5	
0103	Window Section	Replace Repair		.1 .5		.5		1,5	
0104	Fly	Replace Repair		.1 .5		.5		1,5	
0105	End Section Liner	Replace Repair		.1 .5		.5		1,5	
0106	Intermediate Section Liner	Replace Repair		.1 .5		.5		1,5	
0107	Floor	Replace Repair		.1 .5		.5		1,5	
0108	Vestibule	Replace Repair		.1 .5		.5		1,5	
0109	Plenum	Replace Repair		.1 .5		.5		1,5	
0110	Modesty Curtain	Replace Repair		.1 .5		.5		1,5	
0111	Partition	Replace Repair		.1 .5		.5		1,5	



ARMY TM 10-8340-224-13  
 AIR FORCE TO 35E5-6-1  
 NAVY NAVFAC-P-337.A

Section II. MAINTENANCE ALLOCATION CHART									
(1) GROUP NUMBER	(2) COMPONENT/ ASSEMBLY	(3) MAINT FUNCTION	(4) MAINTENANCE CATEGORY					(5) TOOLS & TEST EQUIPT	(6) REMARKS
			C	O	F	H	D		
02	Frame Sections	Inspect Service Replace Repair	.5 .5						
				.5 .5	.5			3,6,7	
0201	Arch Assembly	Replace Repair		.1 .2	.5			3,6,7	
0202	Header Assembly	Replace Repair		.1 .2	.5			3,6,7	
0203	Purlin Assembly	Replace Repair		.1 .5	.5			3,6,7	
0204	Eave Extender Assembly	Replace Repair		.1 .2	.5			3,6,7	
0205	Ridge Extender Assembly	Replace Repair		.1 .2	.5			3,6,7	
0206	Door Sill Assembly	Replace Repair		.1 .5	.5			3,6,7	
0207	Vestibule Frame Assembly	Replace Repair		.1 .2	.5			3,6,7	
0208	Frame Sections Cover Assembly	Replace Repair		.1 .2	.5			1,5	A
03	Bump Through Doors	Inspect Service Replace Repair	.2						
				.3 1.0	1.0			3,6,7	
04	Power Control	Inspect Service Replace Repair	.5						
				.2 .3	2.0			3,7	
0401	Power Control Type III/120 V	Replace Repair		.2 .3	2.0			3,7	
0402	Power Control Type IV/208 V	Replace Repair		.2 .3	2.0			3,7	
0403	Convenience Outlet Type III	Replace Repair		.2 .3	1.0			3,7	

Section II. MAINTENANCE ALLOCATION CHART									
(1) GROUP NUMBER	(2) COMPONENT/ ASSEMBLY	(3) MAINT FUNCTION	(4) MAINTENANCE CATEGORY					(5) TOOLS & TEST EQUIPT	(6) REMARKS
			C	O	F	H	D		
0404	Power Panel Stand Assembly	Replace Repair		.1 .5				3,7	
0405	Extension Cable Type III & IV	Replace Repair		.2 .3					
0406	Light Cables	Replace Repair		.2 .3					
05	Light Set Type I	Inspect Service Test Replace Repair	.5 .4  .2 .2		.2 1.0			3,4 6,7,8	
0501	Storage Container	Replace Repair		.1	.2			6,7	
0502	Luminaire	Replace Repair	.1 .1		.5			7,8	

ARMY TM 10-8340-224-13  
 AIR FORCE TO 35E5-6-1  
 NAVY NAVFAC-P-337.A

Section III. TOOL AND TEST EQUIPMENT LIST				
(1) TOOL/ TEST EQUIPT	(2) MAINT CAT	(3) NOMENCLATURE	(4) NSN	(5) TOOL NO
1	O	REPAIR KIT, TENTAGE	8340-00-262-5767 (8340-90-CL-POL)	
2	O	BRUSH	8020-00-597-4761	
3	O	TOOL KIT, GENERAL MECHANIC'S	5180-00-177-7033	
4	F	MULTIMETER, AN/PSM-45	6625-01-139-2512	
5	F	SEWING MACHINE, INDUSTRIAL	3530-00-892-4631	
6	F	RIVETING TOOL	5180-01-201-4978	
7	F	TOOL KIT, COMMON NO.1	4910-00-754-0654	
8	F	ELECTRIC SOLDERING IRON	3439-00-204-3859	

Section IV. REMARKS	
REFERENCE CODE	REMARKS
A	Repair of fabric at unit level is limited to the capability of the tentage repair kit.

## APPENDIX C

### COMPONENTS OF END ITEM AND BASIC ISSUE ITEM LISTS

---

#### SECTION I. INTRODUCTION

C-1. SCOPE. This appendix lists end items and basic issue items for the Tent, Extendable, Modular, Personnel (TEMPER) to help you inventory items required for safe and efficient operation.

C-2. GENERAL. The Components of End Items and Basic Issue Items Lists are divided into the following sections:

a. Section II. Components of End Item List. This listing is for informational purposes only, and does not authorize replacements. The Components of End Item list contains items that must be with the system whenever it is issued or transferred between property accounts. However, these items are removed and separately packaged for transportation or shipment. The end items are illustrated to help identify them.

b. Section III. Basic Issue Item List. This listing is the minimum number of items needed to operate and perform emergency repairs on the TEMPER. Although Basic Issue Items are shipped and packaged separately, they must be with the TEMPER during operation and whenever it is transferred between property accounts. The hard-to identify items are illustrated. This manual is your authority to request/requisition replacement Basic Issue Items, based on TOE/MTOE authorization of the end item.

C-3. EXPLANATION OF COLUMNS. The following provides an explanation of columns found in the Components of End Item and Basic Issue Item Table Listing:

a. Column (1) - Illustration Number (Illus Number) Indicates the number of the illustration in which the item is shown.

b. Column (2) - National Stock Number. Indicates the National stock number assigned to the item. It will be used for requisitioning purposes.

c. Column (3) - Description. Indicates the Federal item name and, if required, a minimum description to identify and locate the item. The last line for each item indicates the Federal Supply Code for Manufacturer (CAGEC) in parentheses followed by the part number. If the item you need is not the same for different models of the equipment, a Usable On Code will appear on the right side of the description column on the same line as the part number. These codes are identified below:

C-3. EXPLANATION OF COLUMNS (CONT)

<u>CODE</u>	<u>USED ON</u>
FDV	Type I, Green
FDW	Type II, Green
FDX	Type III, Green
FDY	Type IV, Green
FDZ	Type V, Green
FEA	Type VI, Green
FEB	Type VII, Green
FEC	Type VIII, Green
FED	Type IX, Green
FEE	Type X, Green
FEF	Type XI, Green
FEG	Type XII, Green
FEH	Type XIII, Green
FEJ	Type XIV, Green
FEK	Type XV, Green
FEL	Type XVI, Green
FEM	Type I, Tan
FEN	Type II, Tan
FEP	Type III, Tan
FEQ	Type IV, Tan
FER	Type V, Tan
FES	Type VI, Tan
FET	Type VII, Tan
FEU	Type VIII, Tan
FEV	Type IX, Tan
FEW	Type X, Tan
FEX	Type XI, Tan
FEY	Type XII, Tan
FEZ	Type XIII, Tan
FFA	Type XIV, Tan
FFB	Type XV, Tan
FFC	Type XVI, Tan

d. Column (4) - Unit of Measure (U/M). Indicates the measure used in performing the actual operational/maintenance function. A two letter abbreviation (e.g., EA, in, PR) is used as the measure.

e. Column (5) - Quantity required (Qty rqr.) Indicates how many of an item are authorized to be used with/on the equipment.

Section II. COMPONENTS OF END ITEM

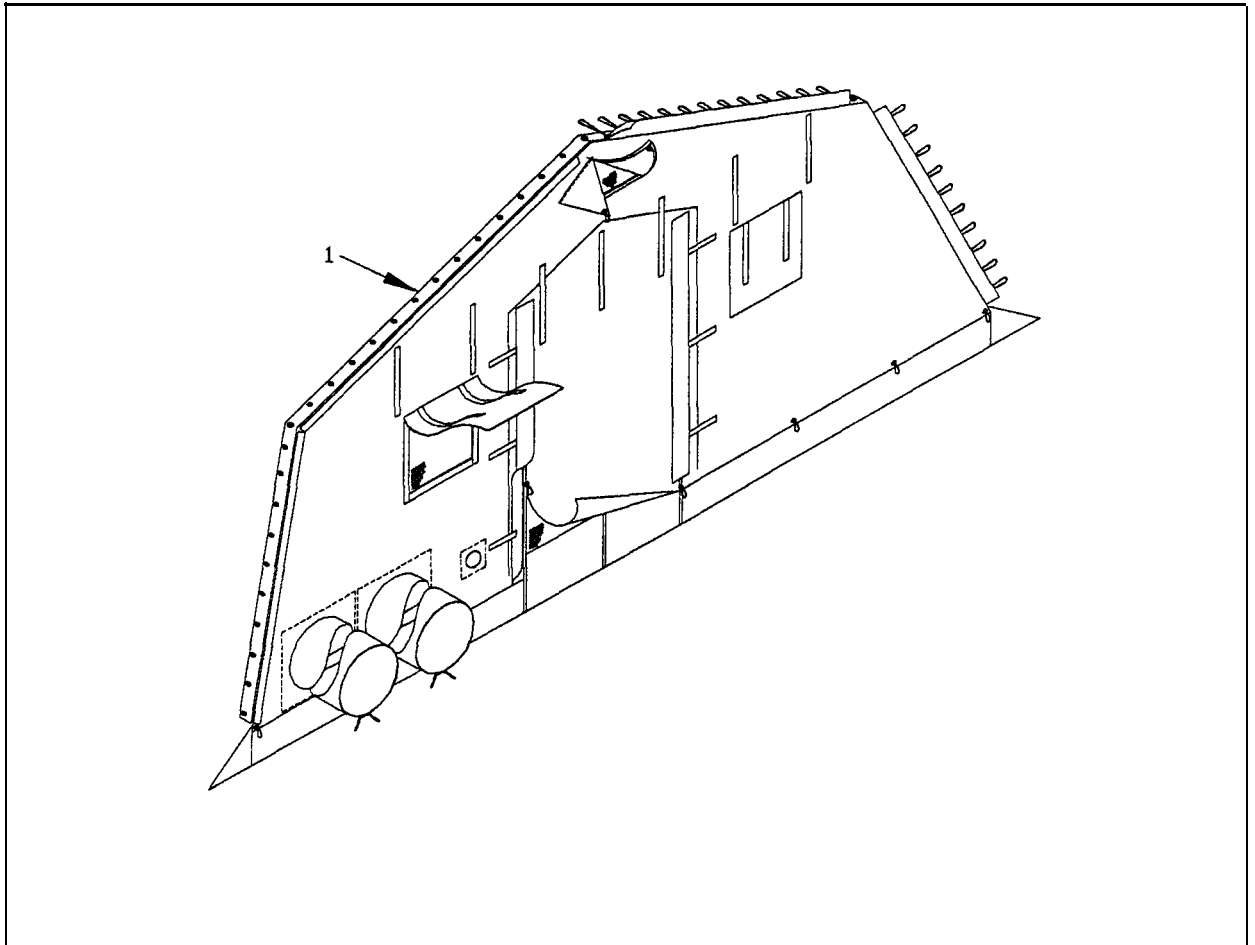

(1) Illus Number	(2) National Stock Number	(3) Description CAGEC & Part No.	Usable On Code	(4) U/M	(5) Qty rqr
1	8340-01-186-3014	End Section Green (81337) 5-4-3350-1	FDV,FDW,FDX, FDY,FDZ,FEA, FEB,FEC,FED, FEE,FEF,FEG, FEH,FEJ,FEK, FEL	EA	2
1	8340-01-198-7618	End Section Tan (81337) 5-4-3350-2	FEM,FEN,FEP, FEQ,FER,FES, FET,FEU,FEV, FEW,FEX,FEY, FEZ,FFA,FFB, FFC	EA	2

Section II. COMPONENTS OF END ITEM (CONT)

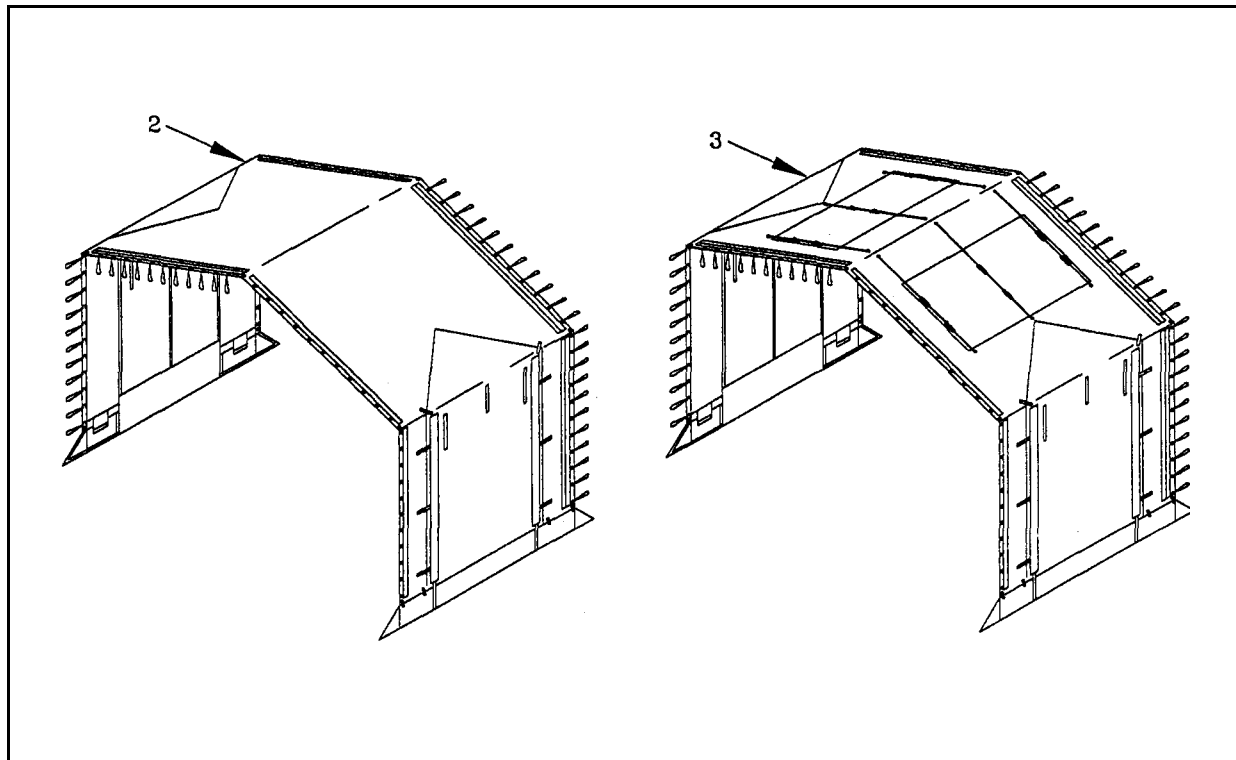

(1) Illus Number	(2) National Stock Number	(3) Description CAGEC & Part No.	Usable On Code	(4) U/M	(5) Qty rqr
2	8340-01-186-3020	Door Section (Temperate) Green (81337) 5-4-3362-1	FDV	EA	3
			FDW, FDZ, FEA, FEF	EA	1
2	8340-01-213-6004	Door Section (Temperate) Tan (81337) 5-4-3362-2	FEP	EA	3
			FEU, FEV, FEW	EA	2
			FEN, FER, FES, FEX	EA	1
3	8340-01-186-3015	Door Section (Desert/Tropical) Green (81337) 5-4-3351-1	FEK	EA	3
			FEH, FEL	EA	2
			FEB, FEJ	EA	1
3	8340-01-213-6003	Door Section (Desert/Tropical) Tan (81337) 5-4-3351-2	FEM	EA	4
			FFB	EA	3
			FEZ, FFC	EA	2
			FET, FEY, FFA	EA	1

Section II. COMPONENTS OF END ITEM (CONT)

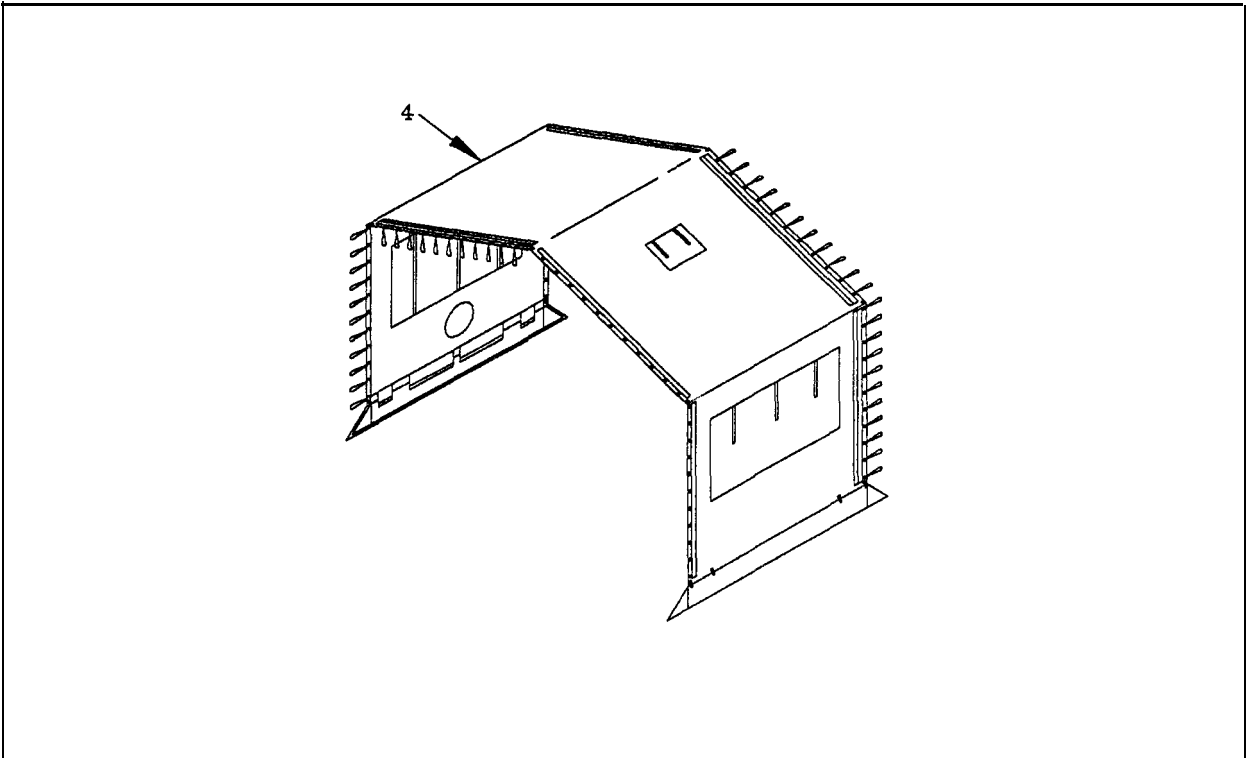

(1) Illus Number	(2) National Stock Number	(3) Description CAGEC & Part No. Usable On Code	(4) U/M	(5) Qty rqr	
4	8340-01-186-3021	Window Section (Temperate) Green (81337) 5-4-3363-1	FEC FED FDW FDX, FEE FDV FDY FEF, FEK FEG, FEL FDZ, FEA, FEB	EA EA EA EA EA EA EA EA EA	10 8 7 6 5 4 3 2 1
4	8340-01-198-7619	Window Section (Temperate) Tan (81337) 5-4-3363-2	FEU FEV FEN FEP, FEW FEM FEQ FEX, FFB FEY, FFC FER, FES, FET	EA EA EA EA EA EA EA EA EA	10 8 7 6 5 4 3 2 1



Section II. COMPONENTS OF END ITEM (CONT)

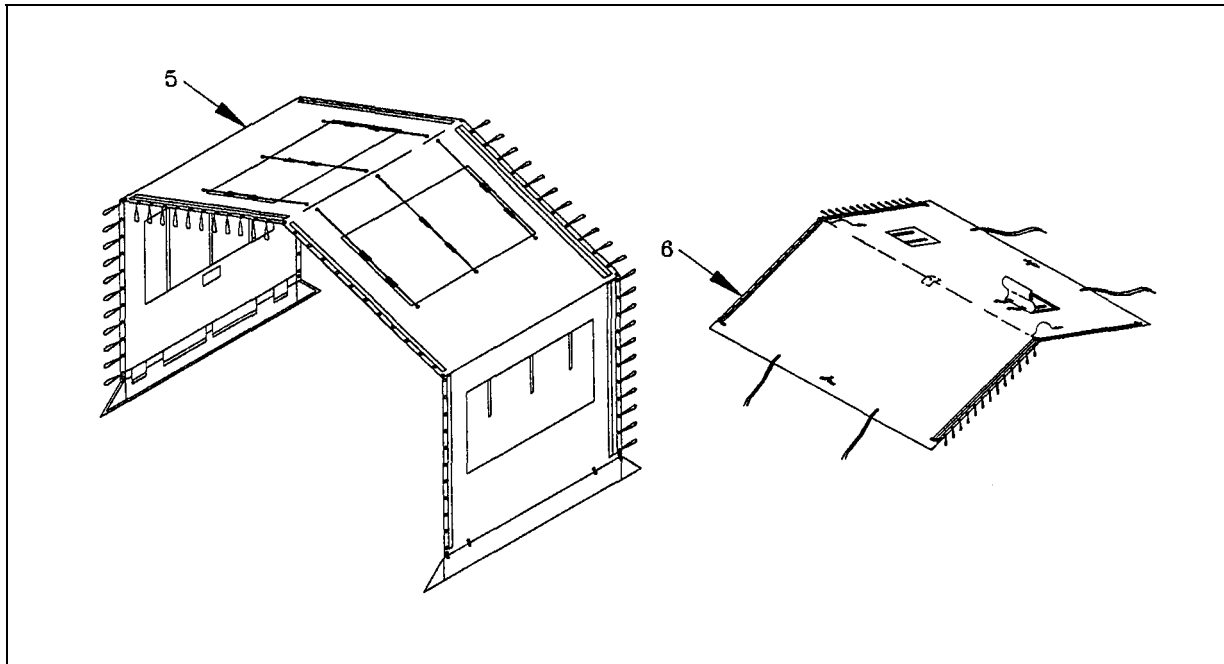

(1) Illus Number	(2) National Stock Number	(3) Description CAGEC & Part No.	Usable On Code	(4) U/M	(5) Qty rqr
5	8340-01-186-3016	Window Section (Desert/Tropical) Green (81337) 5-4-3352-1	FEH	EA	10
			FEJ	EA	3
5	8340-01-213-6006	Window Section (Desert/Tropical) Tan (81337) 5-4-3352-2	FEZ	EA	10
			FFA	EA	3
6	8340-01-186-3018	Tent Fly (16') Green (81337) 5-4-3353-1	FEC, FEH	EA	6
			FED	EA	5
			FDV, FDW, FEE	EA	4
			FDX, FEK	EA	3
			FDY, FEF, FEJ, FEL	EA	2
			FDZ, FEA, FEB, FEG	EA	1
6	8340-01-198-5358	Tent Fly (16') Tan (81337) 5-4-3353-2	FEU, FEZ	EA	6
			FEV	EA	5
			FEN, FEW	EA	4
			FEP, FFB	EA	3
			FEQ, FEX, FFA, FFC	EA	2
			FER, FES, FET	EA	1

Section II. COMPONENTS OF END ITEM (CONT)

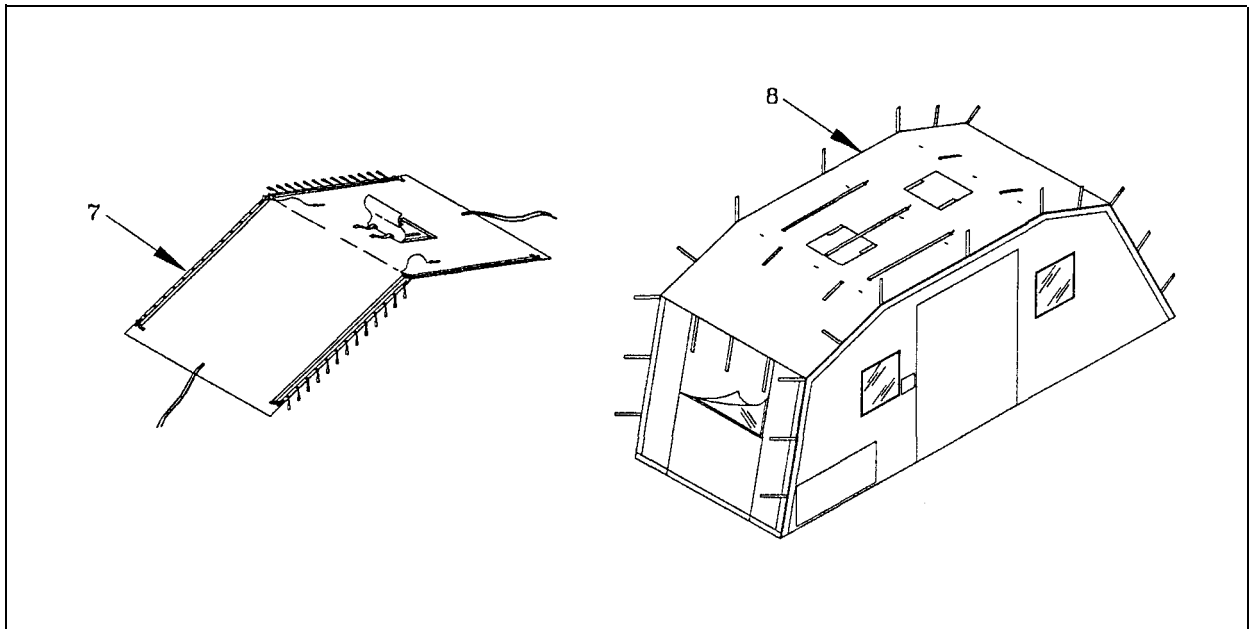

(1) Illus Number	(2) National Stock Number	(3) Description CAGEC & Part No.	Usable On Code	(4) U/M	(5) Qty rqr
7	8340-01-186-3017	Tent Fly (8') Green (81337) 5-4-8486-1 (USAF Only)		EA	V
7	8340-01-213-9565	Tent Fly (8') Tan (81337) 5-4-8486-2 (USAF Only)		EA	V
8	8340-01-186-3022	End Section Liner, Natural (Temperate) (81337) 5-4-3364	FDV,FDW,FDX, FDY,FDZ,FEA, FEC,FED,FEE, FEF,FEG,FEM, FEN,FEP,FEQ, FER,FES,FEU, FEV,FEW,FEX, FEY  FEB,FET	EA           EA	2           1

Section II. COMPONENTS OF END ITEM (CONT)

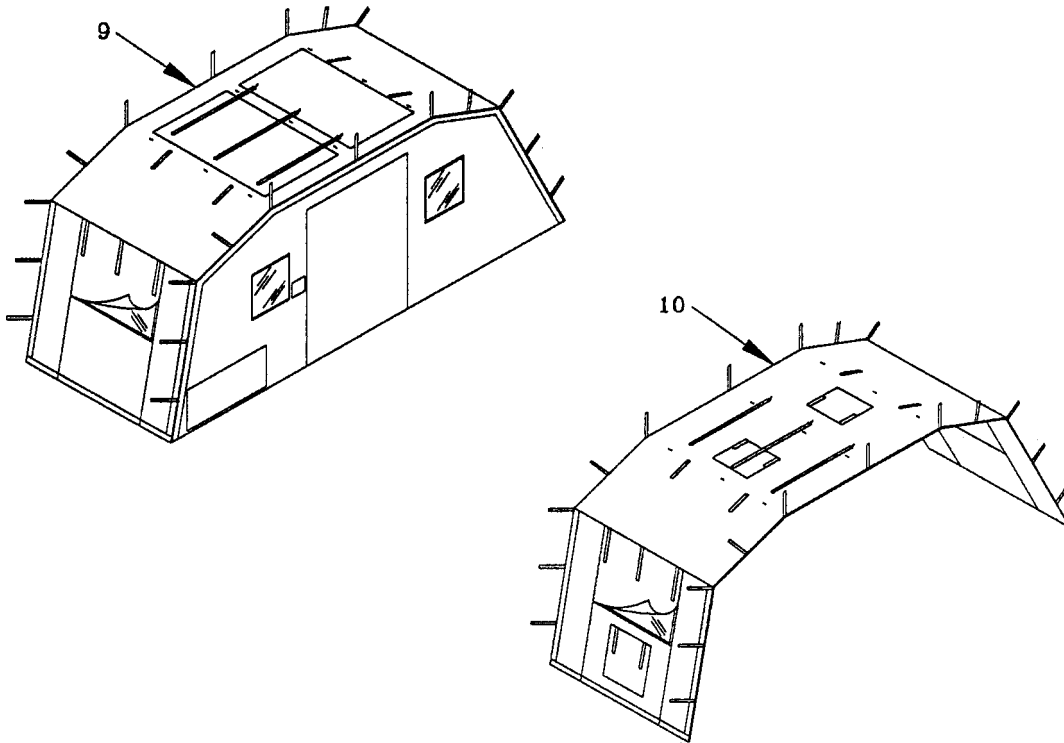

(1) Illus Number	(2) National Stock Number	(3) Description CAGEC & Part No.	Usable On Code	(4) U/M	(5) Qty rqr
9	8340-01-213-9566	End Section Liner, Natural (Desert/Tropical) 5-4-3365	FEH,FEJ, FEK,FEL, FEZ,FFA, FFB,FFC	EA	2
10	8340-01-186-3023	Intermediate Liner, Natural (Temperate) (81337) 5-4-3366	FEC,FEU FED,FEV FDV,FDW,FEE, FEM,FEN,FEW FDX,FEP FEK,FFB FDY,FEF,FEL, FEQ,FEX,FFC	EA EA EA EA EA EA EA	10 8 6 4 3 2

Section II. COMPONENTS OF END ITEM (CONT)

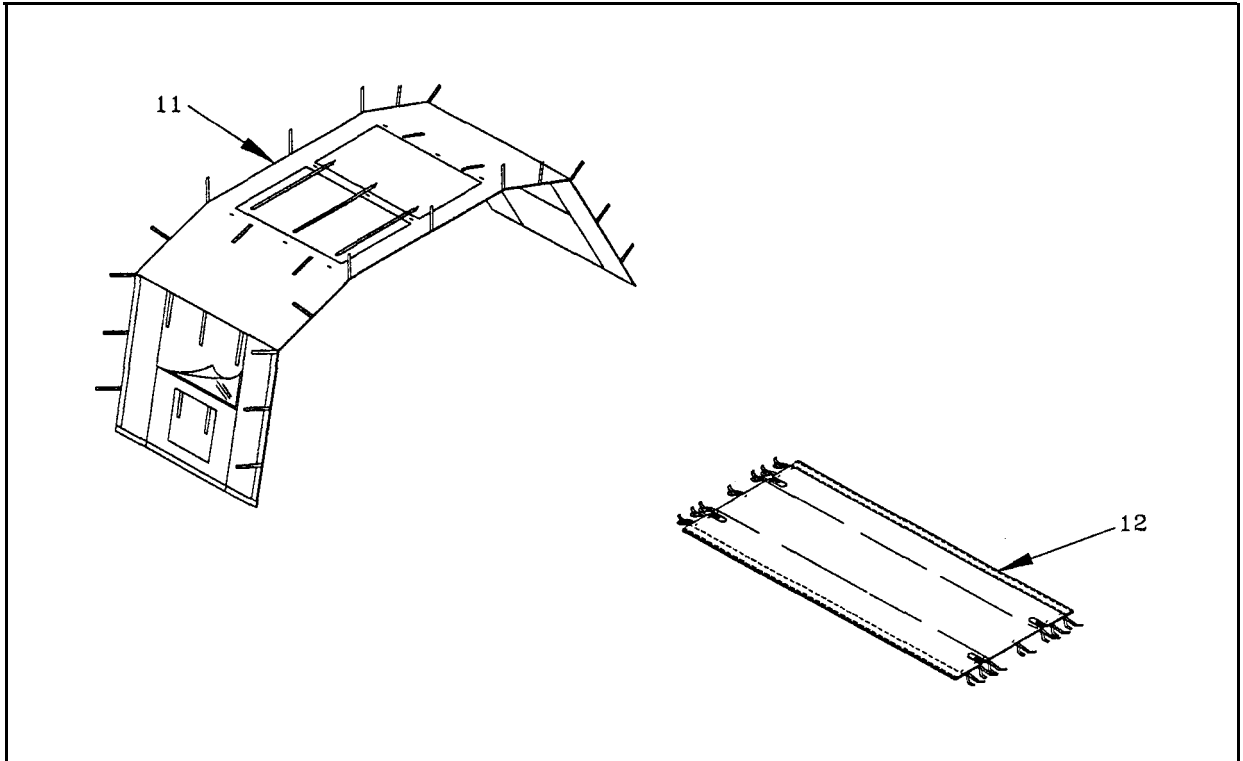

(1) Illus Number	(2) National Stock Number	(3) Description CAGEC & Part No.	Usable On Code	(4) U/M	(5) Qty rqr
11	8340-01-211-9636	Intermediate Liner, Natural (Desert/Tropical) (81337)5-4-3367	FEH,FEZ FEJ,FFA FEK,FFB	EA EA EA	10 2 1
12	8340-01-186-3024	Tent Floor (8') Single Ply, Green (81337) 5-4-3368-1	FEC,FEH,FEU, FEZ FED,FEV FDV,FDW,FEE FEM,FEN,FEW FDY,FEF,FEJ FDZ,FEA,FEG FER,FES,FEY	EA EA EA EA EA EA	12 10 8 6 2
12	8340-01-198-7622	Tent Floor (8') Single Ply, Gray (81337) 5-4-3368-2 (USAF Only)		EA	V

Section II. COMPONENTS OF END ITEM (CONT)

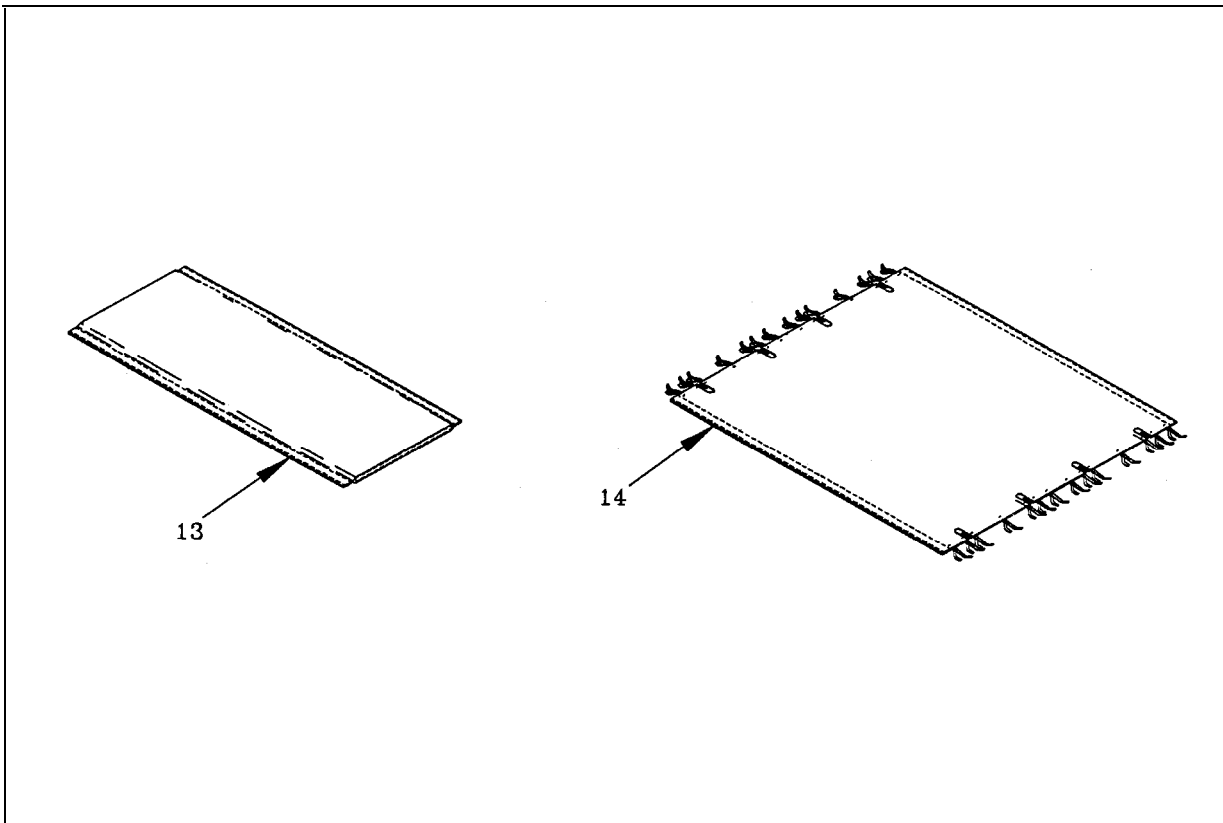

(1) Illus Number	(2) National Stock Number	(3) Description CAGEC & Part No.	(4) Usable On Code U/M	(5) Qty rgr	
13	8340-01-186-3025	Tent Floor (8') (Insulated) Green (81337) 5-4-3369	FED,FEV FDV,FDW,FEE, FEM,FEN,FEW FEF,FEJ,FEX, FFA FDZ,FEA,FEG, FER,FES,FEY	EA EA EA EA EA	10 8 4 2
14		Tent Floor (24') (Single Ply) Green (81337) 5-4-3984-1 (USAF Only)		EA	V
14		Tent Floor (24') (Single Ply) Gray (81337) 5-4-3984-2 (USAF Only)		EA	V

Section II. COMPONENTS OF END ITEM (CONT)

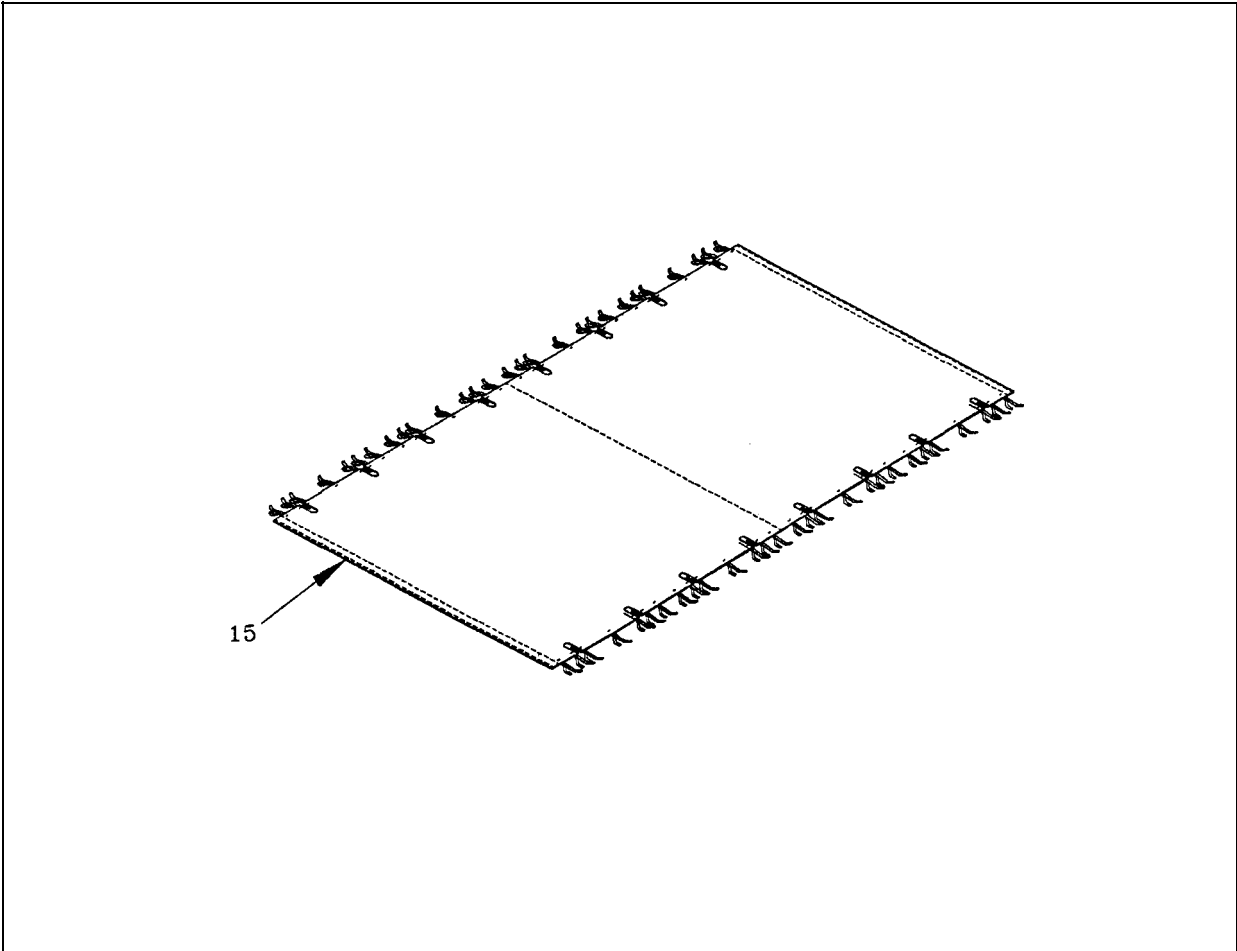

(1) Illus Number	(2) National Stock Number	(3) Description CAGEC & Part No. Usable On Code	(4) U/M	(5) Qty rqr
15	8340-01-254-5758	Tent Floor (40') (Single Ply) Green (81337) 5-4-3985-1 (USAF Only)	EA	V
15		Tent Floor (40') (Single Ply) Gray (81337) 5-4-3985-2 (USAF Only)	EA	V

Section II. COMPONENTS OF END ITEM (CONT)

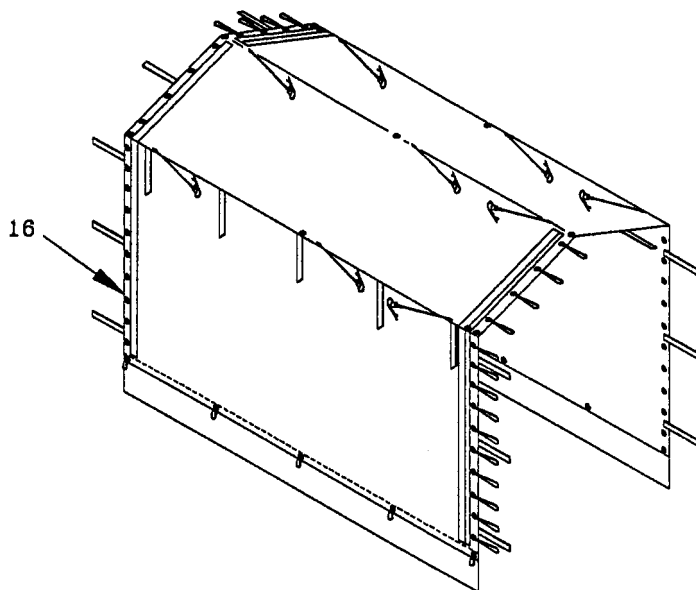

(1) Illus Number	(2) National Stock Number	(3) Description CAGEC & Part No.	(4) Usable On Code	(5) Qty rqr
16	8340-01-186-3026	Vestibule Green (81337) 5-4-3370-1 (Includes door 5-4-3372-1)	FDV FEC, FED, FEE, FEH, FEK FEL FDW, FEF, FEJ FDZ, FEA, FEB FDY, FEG	EA 8 EA 6 EA 4 EA 3 EA 2 EA 1
16	8340-01-198-7621	Vestibule Tan (81337) 5-4-3370-2 (Includes door 5-4-3372-2)	FEM FEU, FEV, FEW, FEZ, FFB FFC FEN, FEX, FFA FER, FES, FET FEQ, FEY	EA 8 EA 6 EA 4 EA 3 EA 2 EA 1

Section II. COMPONENTS OF END ITEM (CONT)

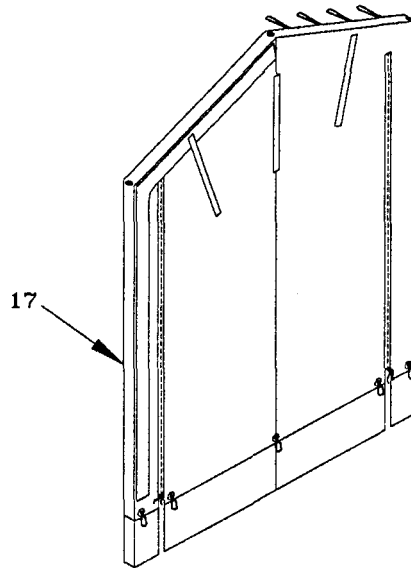

(1) Illus Number	(2) National Stock Number	(3) Description CAGEC & Part No.	Usable On Code	(4) U/M	(5) Qty rqr
17		Vestibule Door Green (81337) 5-4-3371-1	FDV FEC, FED, FEE, FEH, FEK FEL FDW, FEF, FEJ FDZ, FEA, FEB FDY, FEG	EA EA EA EA EA EA	8 6 4 3 2 1
17		Vestibule Door Tan (81337) 5-4-3371-2	FEM FEU, FEV, FEW, FEZ, FFB FFC FEN, FEX, FFA FER, FES, FET FEQ, FEY	EA EA EA EA EA EA	8 6 4 3 2 1



ARMY TM 10-8340-224-13  
 AIR FORCE TO 35E5-6-1  
 NAVY NAVFAC-P-337.A

Section II. COMPONENTS OF END ITEM (CONT)

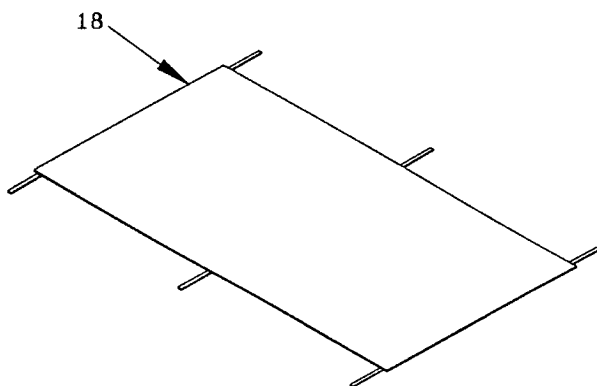

(1) Illus Number	(2) National Stock Number	(3) Description CAGEC & Part No.	(4) Usable On Code U/M	(5) Qty rqr
18	8340-01-186-3027	Vestibule Floor (Single Ply) Green (81337) 5-4-3372-1	FDV, FEM FEC, FED, FEE, FEH, FEK, FEU FEV, FEW, FEZ, FFB FEL, FFC FDW, FEF, FEJ FEN, FEX, FFA FDZ, FEA, FEB FER, FES, FET FDY, FEG, FEQ, FEY	EA 8 EA 6 EA 4 EA 3 EA 2 EA 1
18	1340-01-198-7623	Vestibule Floor (Single Ply) Gray (81337) 5-4-3372-2 (USAF Only)	EA	V

Section II. COMPONENTS OF END ITEM (CONT)

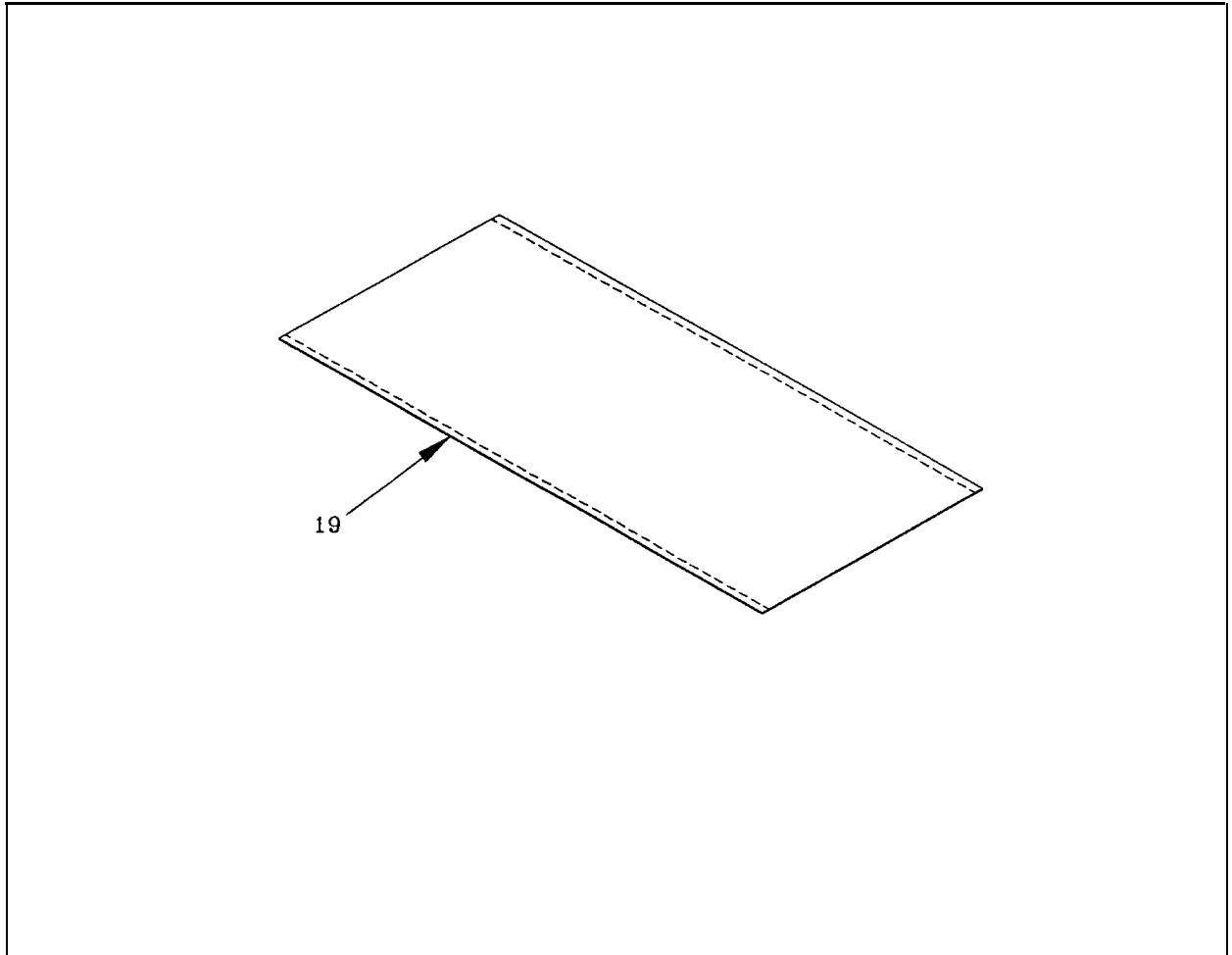

(1) Illus Number	(2) National Stock Number	(3) Description CAGEC & Part No.	(4) Usable On Code	(5) Qty rqr
19	8340-01-186-3028	Vestibule Floor (Insulated) Green (81337) 5-4-3373	FDV, FEM FEC, FED, FEE, FEH, FEU, FEV, FEW, FEZ FDW, FEF, FEJ, FEN, FEX, FFA FDZ, FEA, FEB, FER, FES, FET FEG, FEY	EA 8 EA 6  EA 3 EA 2 EA 1

Section II. COMPONENTS OF END ITEM (CONT)

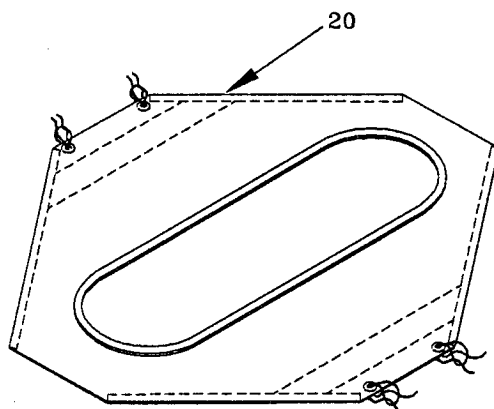

(1) Illus Number	(2) National Stock Number	(3) Description CAGEC & Part No.	Usable On Code	(4) U/M	(5) Qty rqr
20	8340-01-186-3019	Tent Cover Green (81337) 5-4-3359-1	FEC, FEH	EA	12
			FDV, FDW	EA	11
			FED	EA	10
			FEE	EA	8
			FDX, FDZ, FEA, FEK	EA	3
			FDY, FEG, FEL	EA	2
			FEB	EA	1
20	8340-01-198-7620	Tent Cover Tan (81337) 5-4-3359-2	FEU, FEZ	EA	12
			FEM, FEN	EA	11
			FEV	EA	10
			FEW	EA	8
			FEP, FES, FFB	EA	3
			FEQ, FEY, FFC	EA	2
			FET,	EA	1

Section II. COMPONENTS OF END ITEM (CONT)

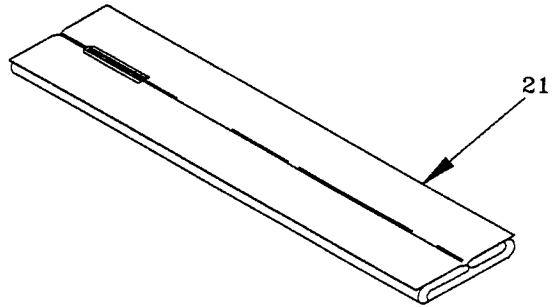

(1) Illus Number	(2) National Stock Number	(3) Description CAGEC & Part No.	Usable On Code	(4) U/M	(5) Qty rqr
21	8340-01-186-3029	Vestibule Container Green (81337) 5-4-3374-1	FDV	EA	8
			FEC, FED, FEE	EA	6
			FEH, FEK		
			FEL	EA	4
			FDW, FEF, FEJ	EA	3
			FDZ, FEA, FEB	EA	2
			FDY, FEG	EA	1
21	5410-01-323-2454	Vestibule Container Tan (81337) 5-4-3374-2	FEM	EA	8
			FEU, FEV, FEW,	EA	6
			FEZ, FFB		
			FFC	EA	4
			FEN, FEX, FFA	EA	3
			FER, FES, FET	EA	2
			FEQ, FEY	EA	1

Section II. COMPONENTS OF END ITEM (CONT)

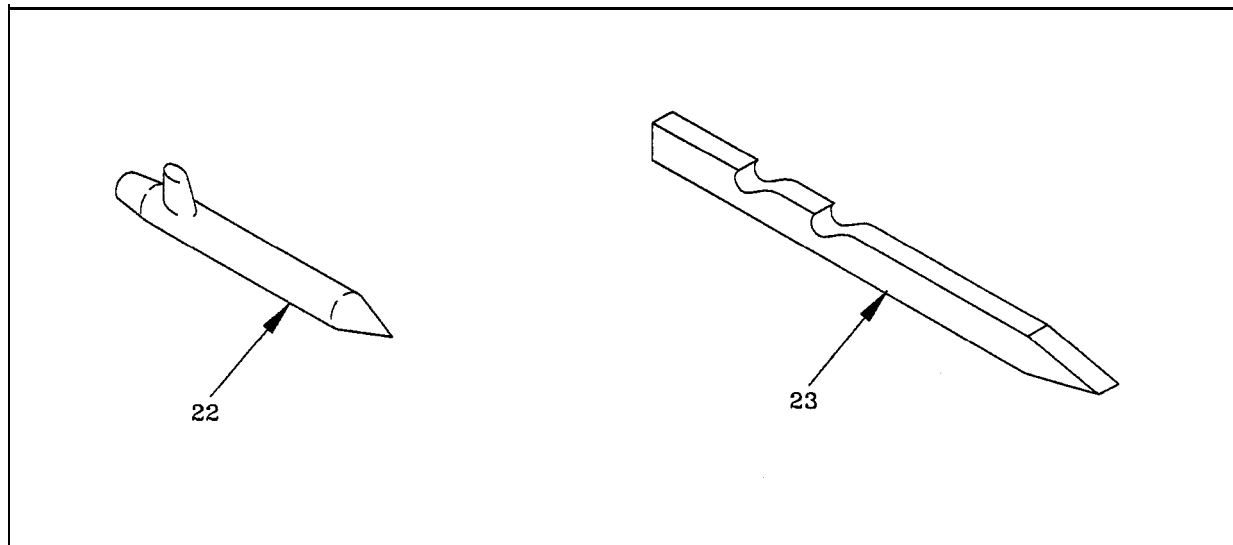

(1) Illus Number	(2) National Stock Number	(3) Description CAGEC & Part No.	Usable On Code	(4) U/M	(5) Qty rqr
22	8340-00-823-7451	Pins, Tent, Metal, Type II (12" L) (81337) 5-4-791	FEC, FED, FEE, FEH, FEU, FEV FEW, FEZ	EA	200
			FDV, FDW, FEM, FEN	EA	106
			FEK, FFB	EA	82
			FEL, FFC	EA	60
			FDX, FEF, FEJ, FEP, FEX, FFA	EA	50
			FEG, FEY	EA	30
			FDZ, FEA, FEB, FER, FES, FET	EA	26
			FEC, FED, FEE, FEH, FEU, FEV, FEW, FEZ	EA	100
			FDV, FDW, FEM, FEN	EA	54
			FEK, FFB	EA	42
23	8340-00-261-9751	Pins, Tent, Wood, Size 2 (24" L) (81337) 5-4-1	FEC, FED, FEE, FEH, FEU, FEV, FEW, FEZ	EA	100
			FDV, FDW, FEM, FEN	EA	54
			FEK, FFB	EA	42
			FEF, FEJ, FEL, FEX, FFA, FFC	EA	30
			FEU, FEQ	EA	25
			FDX, FEP	EA	18
			FEG, FEY	EA	15
			FDZ, FEA, FEB, FER, FES, FET	EA	10

Section II. COMPONENTS OF END ITEM (CONT)

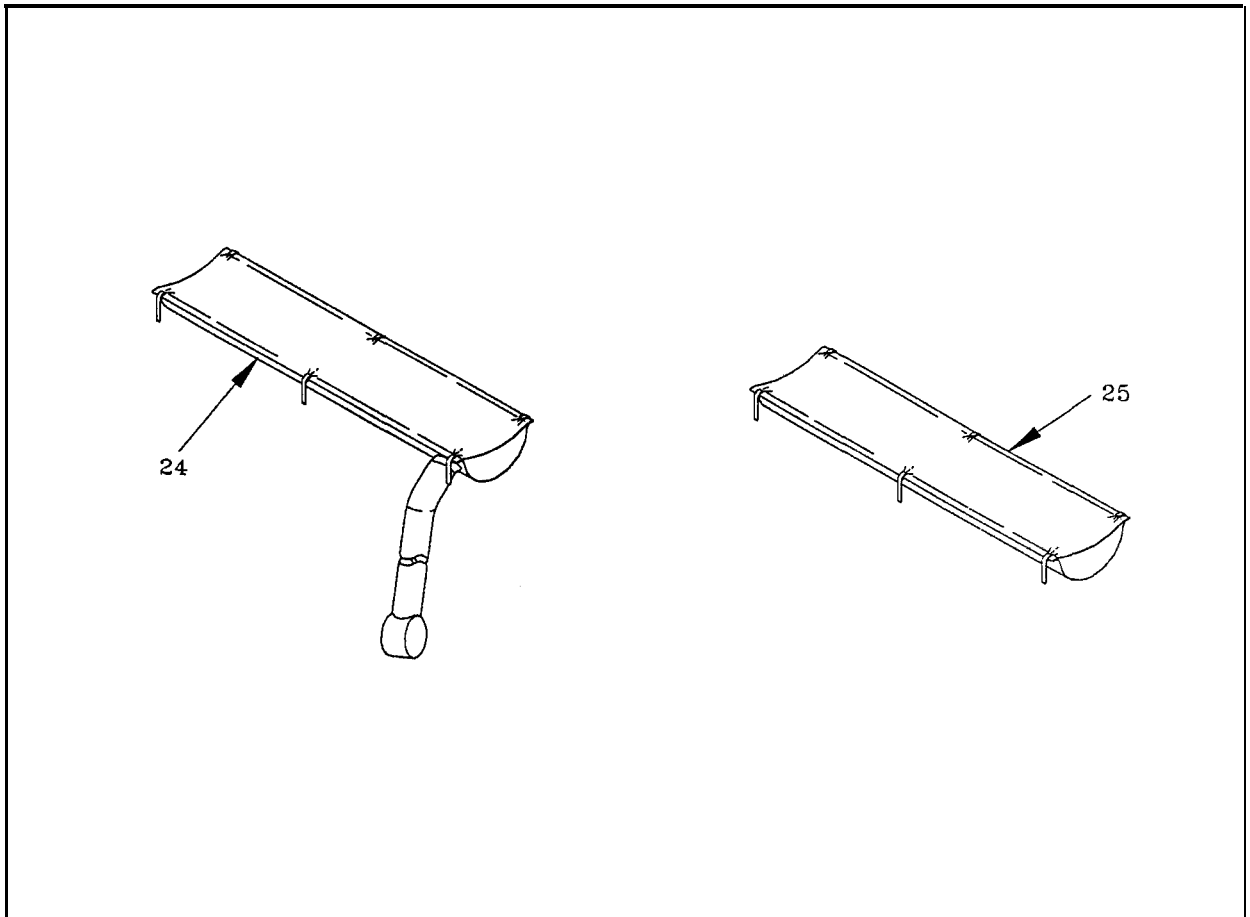

(1) Illus Number	(2) National Stock Number	(3) Description CAGEC & Part No.	Usable On Code	(4) U/M	(5) Qty rqr
24	8340-01-186-3035	Plenum, End Wall (16') Natural (81337) 5-4-3614	FDV,FDW,FEM, FEN	EA	2
			FDZ,FEA,FEH, FEJ,FER,FES, FEZ,FFA	EA	1
25	8340-01-186-3036	Plenum, Ex- tendable (16') Natural (81337) 5-4-3618	FEC,FEH,FEU, FEZ	EA	5
			FED,FEV	EA	4
			FEE,FEW	EA	3
			FDV,FDW,FEM, FEN	EA	2
			FDY,FEF,FEJ, FEQ,FEX,FFA	EA	1

ARMY TM 10-8340-224-13  
 AIR FORCE TO 35E5-6-1  
 NAVY NAVFAC-P-337.A

Section II. COMPONENTS OF END ITEM (CONT)

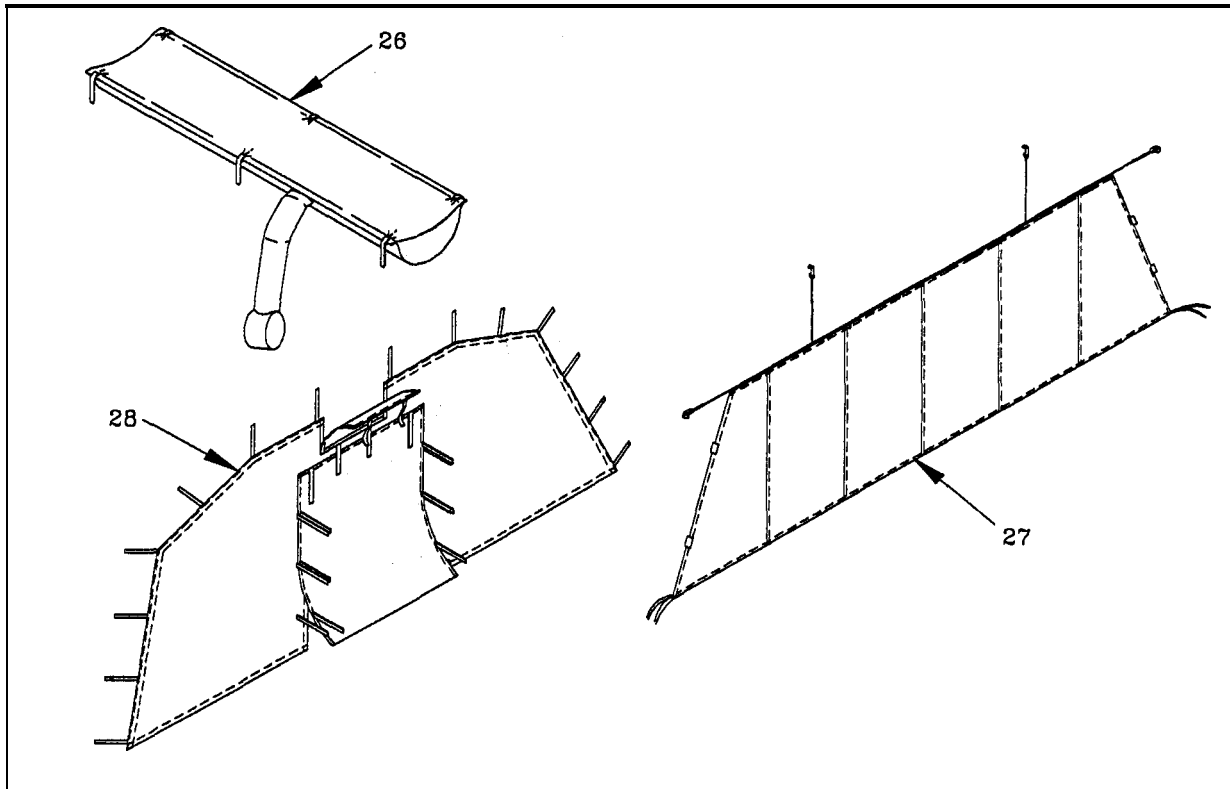

(1) Illus Number	(2) National Stock Number	(3) Description CAGEC & Part No.	Usable On Code	(4) U/M	(5) Qty rqr
26	8340-01-211-6798	Plenum, Side Entrance (16') Natural (81337) 5-4-3620	FDY, FEC, FED, FEE, FEF, FEG, FEQ, FEU, FEV, FEW, FEX, FEY	EA	1
27	8340-01-211-4774	Modesty Curtain Natural (81337) 5-4-3613	FEC, FEH, FEU, FEZ FED, FEV FEE, FEW FEF, FEJ, FEX, FFA	EA EA EA EA	11 9 7 1
28	8340-01-186-3032	Partition Natural (81337) 5-4-3391	FDV, FDW, FEM, FEN FDZ, FEA, FER, FES	EA EA	3 1

Section II. COMPONENTS OF END ITEM (CONT)

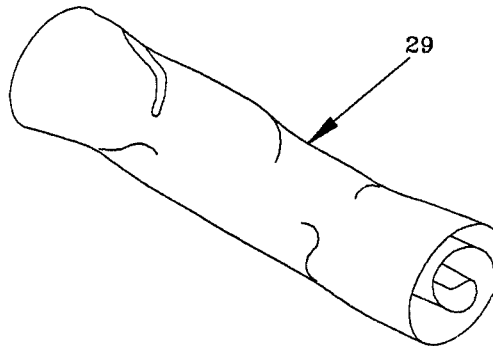

(1) Illus Number	(2) National Stock Number	(3) Description CAGEC & Part No.	Usable On Code	(4) U/M	(5) Qty rqr
29	8340-01-186-3030	Tent Pin Container Green (81337) 5-4-8487-1	FEC, FED, FEH	EA	8
			FDV, FDY, FEE, FEJ, FEK	EA	4
			FDX, FEL	EA	2
			FDZ, FEA, FEB, FEG	EA	1
29		Tent Pin Container Tan (81337) 5-4-8487-2	FEU, FEV, FEZ	EA	8
			FEM, FEN, FEQ, FEP, FFC	EA	4
			FER, FES, FET,	EA	3
			FEY	EA	1



ARMY TM 10-8340-224-13  
 AIR FORCE TO 35E5-6-1  
 NAVY NAVFAC-P-337.A

Section II. COMPONENTS OF END ITEM (CONT)

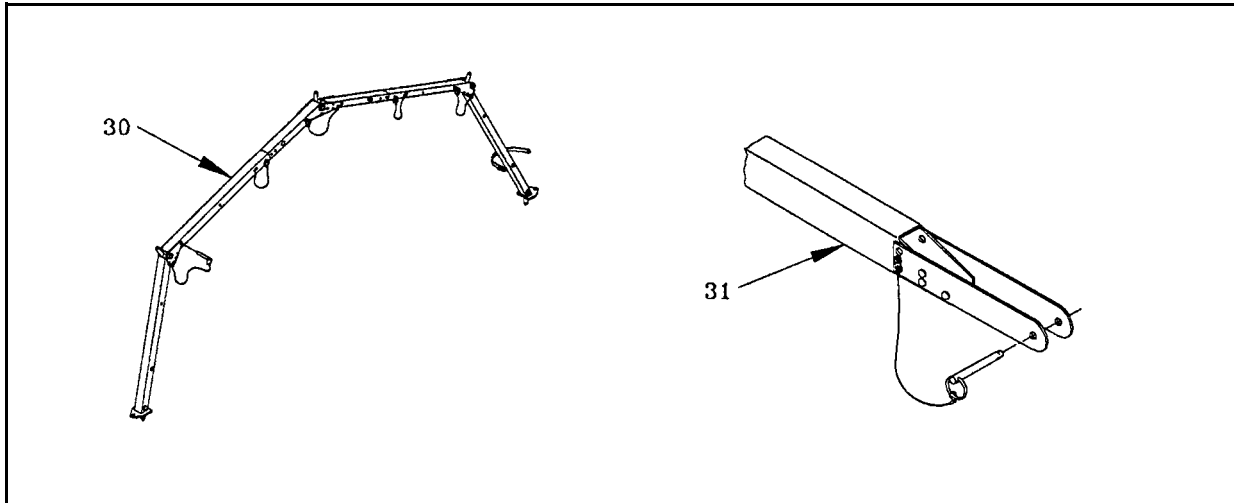

(1) Illus Number	(2) National Stock Number	(3) Description CAGEC & Part No.	Usable On Code	(4) U/M	(5) Qty rqr
30	8340-01-240-5854	Arch Assembly Sectionalized Green (81337) 5-4-4006	FEC, FEH, FEU, FEZ FED, FEV FDV, FDW, FEE, FEM, FEN, FEW FDX, FEK, FEP, FFB FDY, FEF, FEJ, FEL, FEQ, FEX, FFA, FFC FDZ, FEA, FEB, FEG, FER, FES, FET, FEY	EA EA EA EA EA EA EA EA EA EA	13 11 9 7 5 3
31	8340-01-186-3004	Header Assembly Green (81337) 5-4-3325	FEC, FEH, FEU, FEZ FED, FEV FDV, FDW, FEE, FEM, FEN, FEW FDX, FEK, FEP, FFB FDY, FEF, FEJ, FEL, FEQ, FEX, FFA, FFC FDZ, FEA, FEB, FEG, FER, FES, FET, FEY	EA EA EA EA EA EA EA EA EA	13 11 9 7 5 3

Section II. COMPONENTS OF END ITEM (CONT)

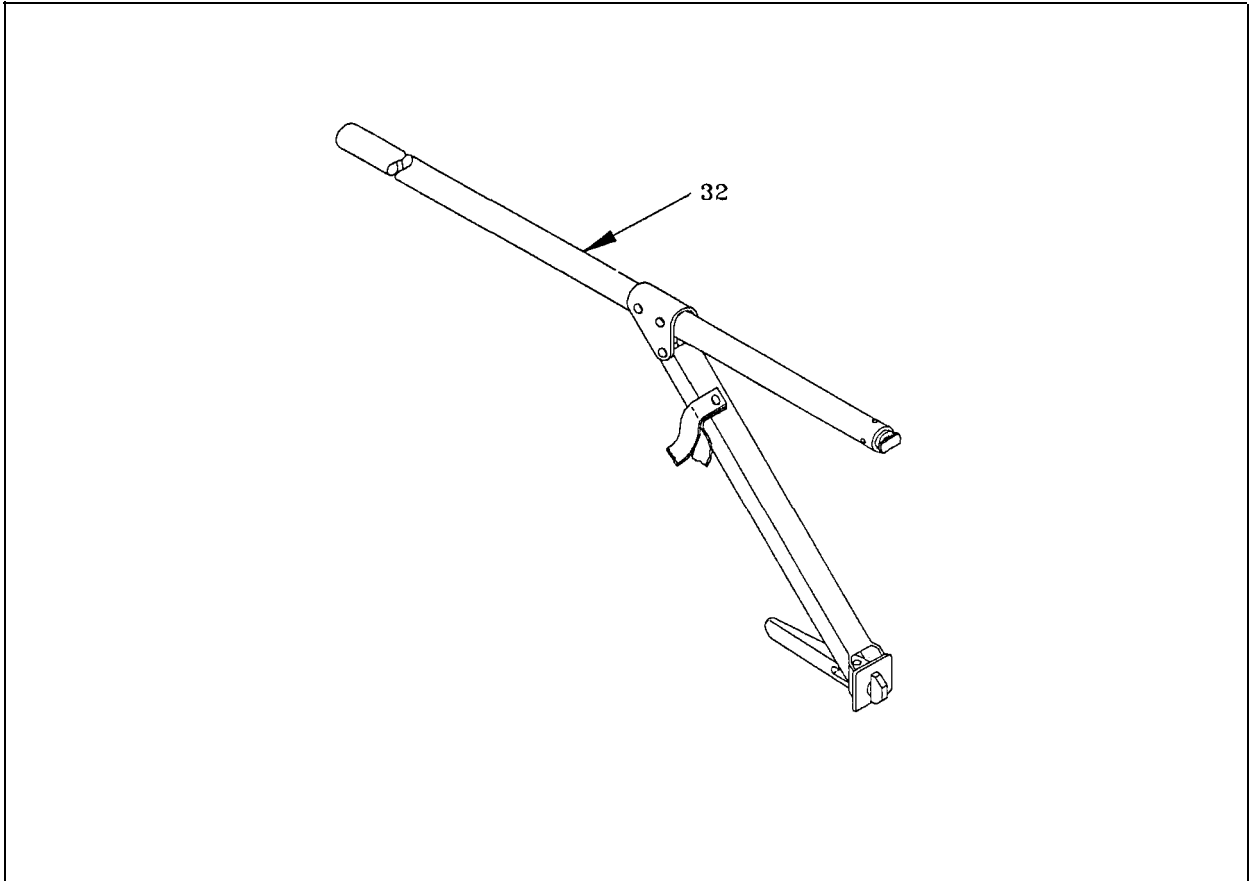

(1) Illus Number	(2) National Stock Number	(3) Description CAGEC & Part No.	(4) Usable On Code	(5) U/M	(6) Qty rqr
32	8340-01-186-3005	Purlin Assembly Green (81337) 5-4-3336	FEC, FEH, FEU, FEZ  FED, FEV FDW, FEN FEE, FEW FDV, FEM FDX, FEP FEK, FFB FDY, FEQ FEF, FEJ, FEX, FFA  FEL, FFCE FEG, FEY FDZ, FEA, FEB, FER, FES, FET	EA  EA EA EA EA EA EA EA EA EA EA EA EA EA EA EA EA EA EA EA	56  46 38 36 34 30 24 20 18  16 10 8

Section II. COMPONENTS OF END ITEM (CONT)

(1) Illus Number	(2) National Stock Number	(3) Description CAGEC & Part No.	(4) Usable On Code	(5) Qty rqr
33	8340-01-186-3009	Eave Extender Assembly Green (81337) 5-4-3341	FEC, FEH, FEU, FEZ FED, FEV FDV, FDW, FEE, FEM, FEN, FEW FDX, FEK, FEP, FFB FDY, FEF, FEJ, FEL, FEQ, FEX, FFA, FFC FDZ, FEA, FEB, FEG, FER, FES, FET, FEY	EA 26 EA 22 EA 18 EA 14 EA 10 EA 6
34	8340-01-186-3008	Ridge Extender Assembly Green (81337) 5-4-3340	FEC, FEH, FEU, FEZ FED, FEV FDV, FDW, FEE, FEM, FEN, FEW FDX, FEK, FEP, FFB FDY, FEF, FEJ, FEL, FEQ, FEX, FFA, FFC FDZ, FEA, FEB, FEG, FER, FES, FET, FEY	EA 13 EA 11 EA 9 EA 7 EA 5 EA 3

Section II. COMPONENTS OF END ITEM (CONT)

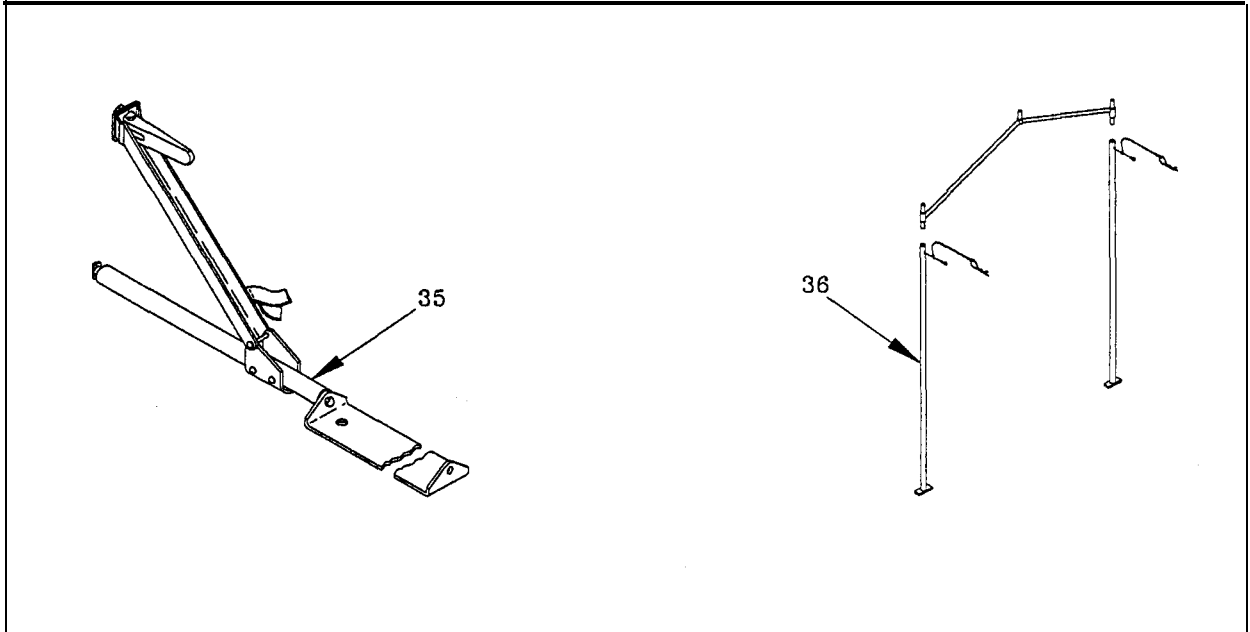

(1) Illus Number	(2) National Stock Number	(3) Description CAGEC & Part No.	Usable On Code	(4) U/M	(5) Qty rqr
35	8340-01-186-3007	Door Sill Assembly Green (81337) 5-4-3337	FDV, FEK, FEM, FFB	EA	6
			FEC, FED, FEE, FEH, FEL, FEU, FEV, FEW, FEZ, FFC	EA	4
			FDW, FDZ, FEA, FEB, FEF, FEJ, FEN, FER, FES, FET, FEX, FFA	EA	2
36	8340-01-186-3010	Vestibule Frame Assembly Green (81337) 5-4-3343	FDV, FEM	EA	30
			FEK, FFB	EA	24
			FEC, FED, FEE, FEH, FEU, FEV, FEW, FEZ	EA	22
			FEL, FFC	EA	16
			FDW, FEF, FEJ, FEN, FEX, FFA	EA	11
			FDZ, FEA, FEB, FER, FES, FET	EA	7
			FDY, FEG, FEQ, FEY	EA	3

ARMY TM 10-8340-224-13  
 AIR FORCE TO 35E5-6-1  
 NAVY NAVFAC-P-337.A

Section II. COMPONENTS OF END ITEM (CONT)

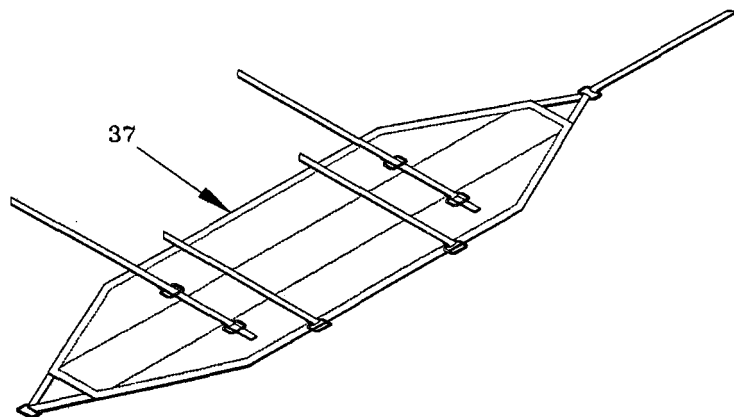

(1) Illus Number	(2) National Stock Number	(3) Description CAGEC & Part No.	Usable On Code	(4) U/M	(5) Qty rqr
37	8340-01-186-3013	Frame Sections	FEC, FEH	EA	12
		Cover Assembly	FED	EA	10
		Green (81337)	FDV, FDW, FEE	EA	8
		5-4-3347-1	FDX, FEK	EA	6
			FDY, FEF, FEJ, FEL	EA	4
			FDZ, FEA, FEB, FEG	EA	2
37	8340-01-213-9557	Frame Sections	FEU, FEZ	EA	12
		Cover Assembly	FEV	EA	10
		Tan (81337)	FEM, FEN, FEW	EA	8
		5-4-3347-2	FEP, FFB	EA	6
			FEQ, FEX, FFA,	EA	4
			FFC		
			FER, FES, FET, FEY	EA	2

Section II. COMPONENTS OF END ITEM (CONT)

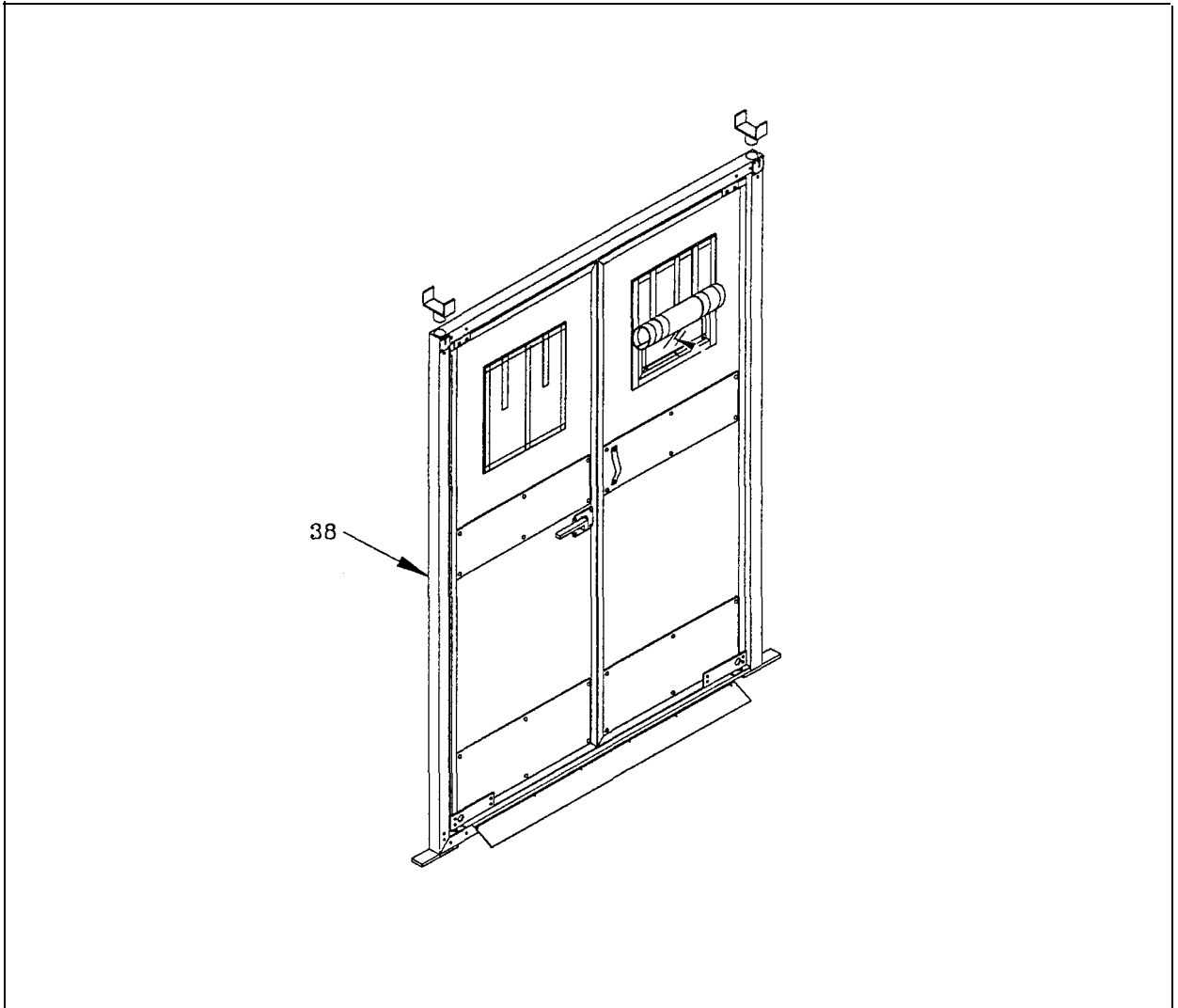

(1) Illus Number	(2) National Stock Number	(3) Description CAGEC & Part No.	Usable On Code	(4) U/M	(5) Qty rqr
38	8340-01-263-2546	Double Bump- Through Doors Green (81337) 5-4-4081-1	FEC, FED, FEE, FEF, FEH, FEJ FEG	EA EA	2 1
38	8340-01-211-6788	Double Bump- Through Doors Tan (81337) 5-4-4081-2	FEU, FEV, FEW, FEX, FEZ, FFA FEY	EA EA	2 1

Section II. COMPONENTS OF END ITEM (CONT)

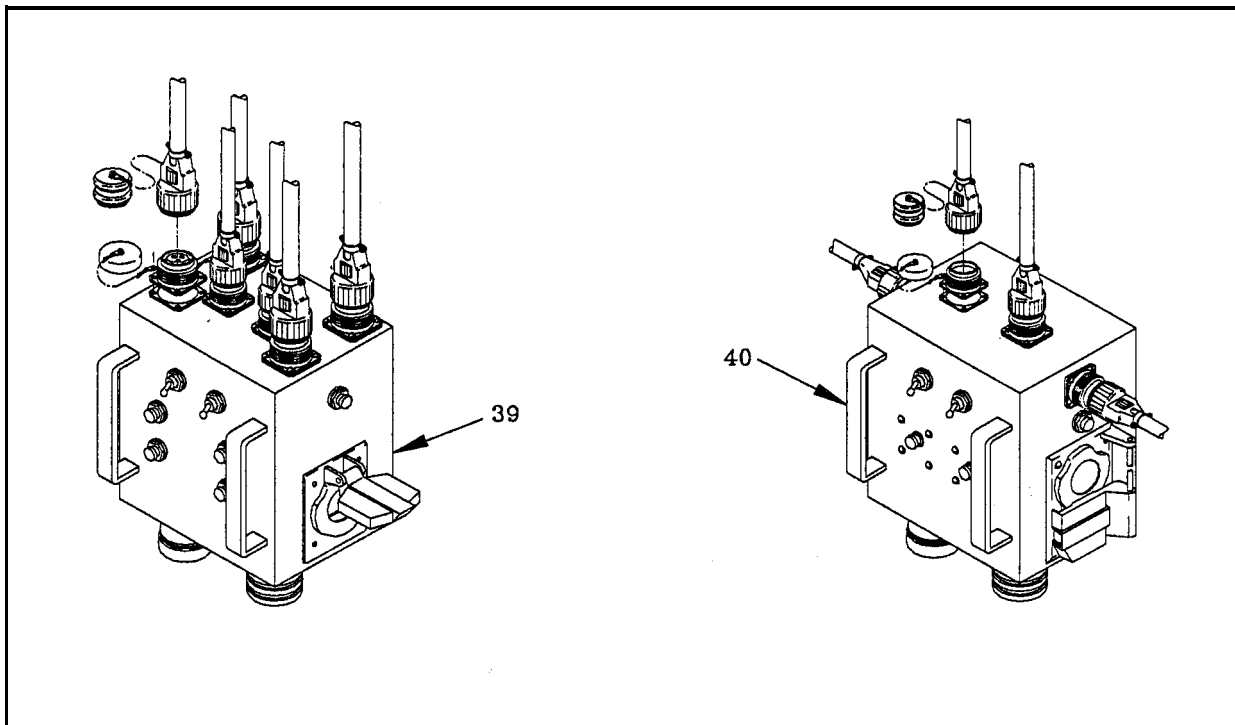

(1) Illus Number	(2) National Stock Number	(3) Description CAGEC & Part No.	Usable On Code	(4) U/M	(5) Qty rqr
39	6110-01-251-0402	Power Control, Type III/120V (81337) 1-6-6041	FDV,FDW,FEC, FED,FEH,FEK, FEM,FEN,FEU, FEV,FEZ,FFB FDZ,FEE,FEF, FEG,FEJ,FEL, FER,FEW,FEX, FEY,FFA,FFC	EA  EA	2  1
40	6110-01-251-0403	Power Control, Type IV/208V (81337) 1-6-6056 (Includes light cables: 1-6-6044-1, 103" L; 1-6-6043-1, 156" L; 1-6-6044-3, 173" L; 1-6-6043-2, 254" L)	FEA,FED,FEE, FEG,FES,FEV, FEW,FEY	EA	1

Section II. COMPONENTS OF END ITEM (CONT)

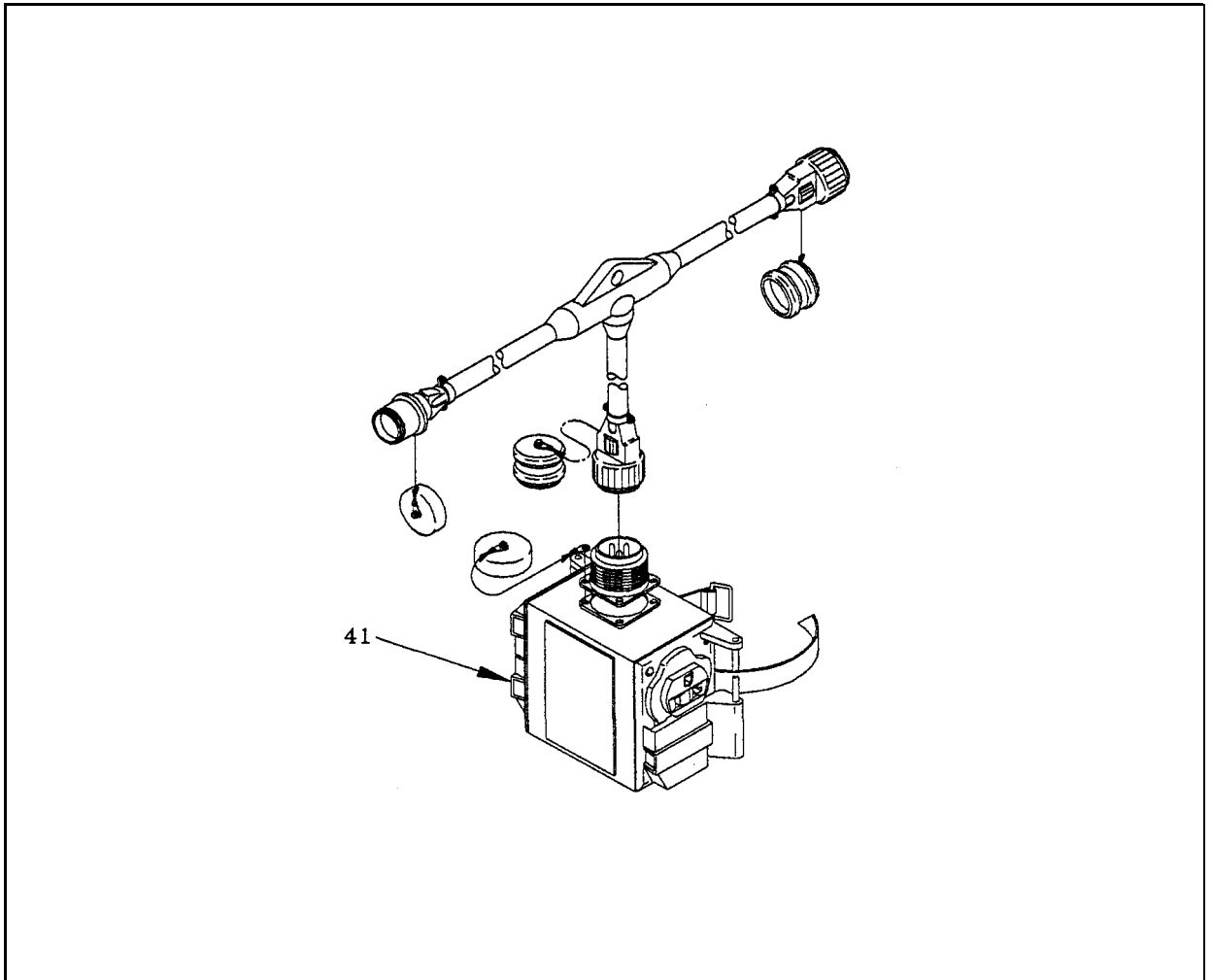

(1) Illus !Jumber	(2) National Stock Number	(3) Description CAGEC & Part No. Usable On Code	(4) U/M	(5) Qty rqr
41	6110-01-251-8157	Convenience Outlet, Type III (81337) 1-6-6046 (Includes Cable Extension, Outlet, Type III NSN 6150-01-355-3238)	FEC, FEH, FEU, FEZ  FED, FEV FDV, FDW, FEE, FEM, FEN, FEW FEK, FFB FEF, FEJ, FEX, FFA FEL, FFC FDZ, FEG, FER, FEY	EA 24  EA 20 EA 16  EA 10 EA 8  EA 6 EA 4



ARMY TM 10-8340-224-13  
 AIR FORCE TO 35E5-6-1  
 NAVY NAVFAC-P-337.A

Section II. COMPONENTS OF END ITEM (CONT)

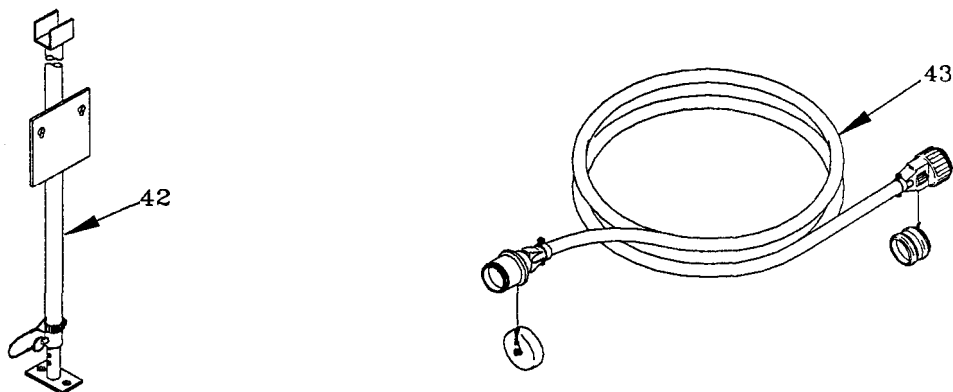

(1) Illus Number	(2) National Stock Number	(3) Description CAGEC & Part No.	Usable On Code	(4) U/M	(5) Qty rqr
42	6110-01-242-6691	Power Panel Stand Assembly (81337) 1-6-6005	FDV,FDW,FEC, FED,FEH,FEK, FEM,FEN,FEU, FEV,FEZ,FFB	EA	2
			FDZ,FEA,FEE, FEF,FEG,FEJ, FEL,FER,FES, FEW,FEX,FEY, FFA,FFC	EA	1
43	6150-01-250-6451	Extension Cable, 34' L Type III & IV, 110V (81337) 1-6-6047	FEC,FEH,FEU, FEZ	EA	4
			FDV,FDW,FED, FEM,FEN,FEV	EA	2
			FEE, FEW	EA	1

Section II. COMPONENTS OF END ITEM (CONT)

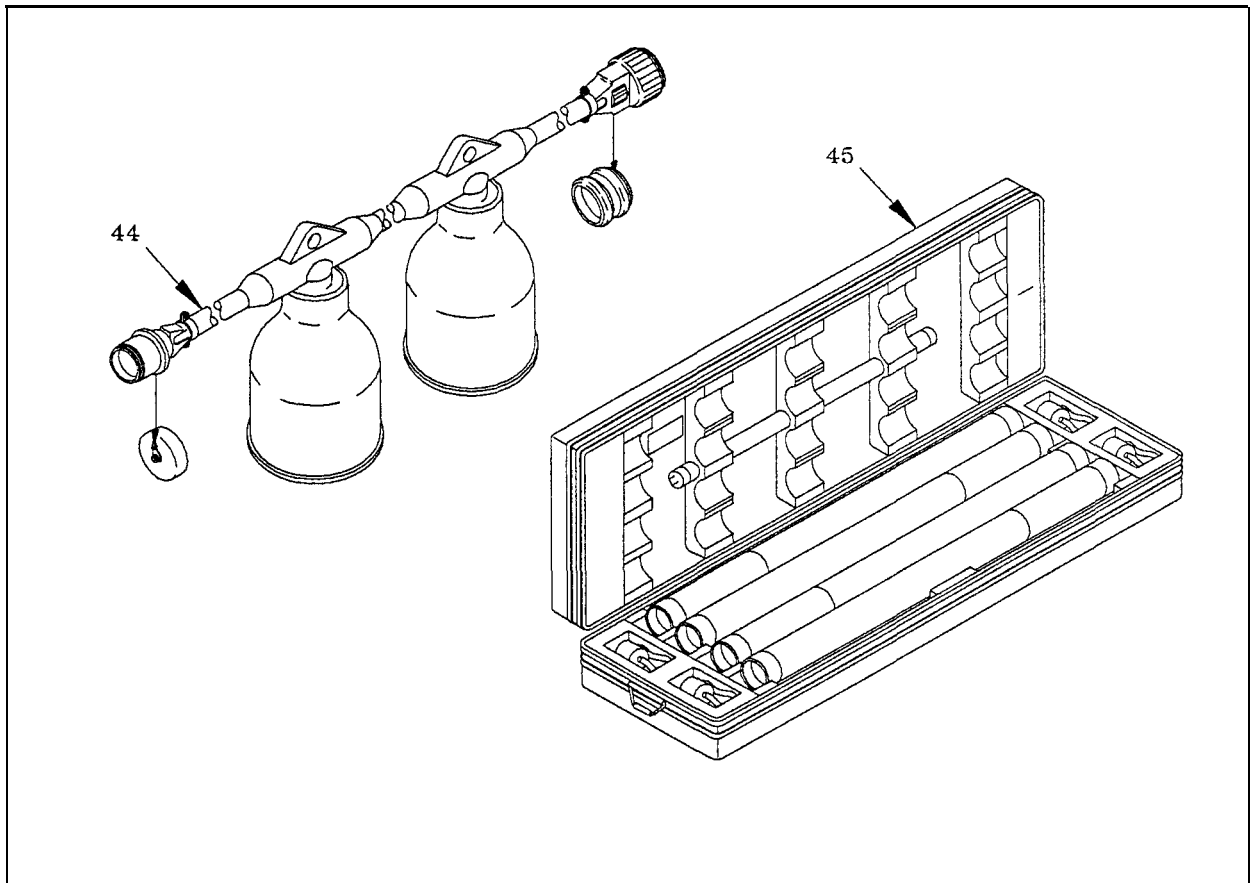

(1) Illus Number	(2) National Stock Number	(3) Description CAGEC & Part No.	Usable On Code	(4) U/M	(5) Qty rqr
44		Light Cables (81337) 1-6-6048 (USAF Only)		EA	V
45	6230-01-242-2016	Light Set, Portable, Flourescent, Type I (81337) 5-4-6824	FEC, FEH, FEU, FEZ  FED, FEV FDV, FDW, FEE, FEM, FEN, FEW FEK, FFB FEF, FEJ, FEL, FEX, FFA, FFC FDZ, FEA, FEG, FER, FES, FEY	EA  EA EA  EA EA  EA	6  5 4  3 2  1

ARMY TM 10-8340-224-13  
 AIR FORCE TO 35E5-6-1  
 NAVY NAVFAC-P-337.A

Section III. BASIC ISSUE ITEMS

(1) Illus Number	(2) National Stock Number	(3) Description CAGEC & Part No. Usable On Code	(4) U/M	(5) Qty rqr
1		Technical Manual Operator, Unit and Direct Support Maintenance Manual TM 10-8340-224-13	EA	1

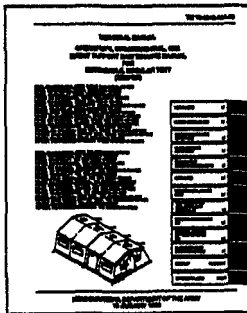

APPENDIX D

ADDITIONAL AUTHORIZATION LIST

Section I. INTRODUCTION

D-1. SCOPE. This appendix lists additional items authorized for use with the Tent, Extendable, Modular, Personnel (TEMPER).

D-2. GENERAL. Section II. identifies items that are not used routinely with, and that do not have to accompany the TEMPER or be turned in with it.

D-3. EXPLANATION OF LISTING. National Stock Number, descriptions, and quantities are provided to help you identify and request the additional items you require to support this equipment. The items are listed in alphabetical sequence by item name under the type document (i.e. CTA, MTOE, TDA or JTA) which authorizes the item(s) to you.

Section II. ADDITIONAL AUTHORIZATION LIST					
(1) ITEM NO	(2) NATIONAL STOCK NUMBER	(3) DESCRIPTION, (CAGEC) & PART NUMBER	USABLE ON CODE	(4) U/M	(5) QTY AUT H
1	8340-00-262-5767	Tentage Repair Kit (81337) 8340-90-CL-POL		EA	1
2	8340-01-211-9637	Liner Intermediate Door Section (insulated) (81337) 5-4-4131		EA	V
3	8340-01-211-9638	Liner, End Section (Insulated) (81337) 5-4-4127-8-9		EA	V
4	8340-01-211-9639	Liner, Door Section (Insulated) (81337) 5-4-4130		EA	V
5	8340-01-211-4775	Vestibule Door Sliding Blackout Curtain (81337) 5-4-3621		EA	V
6	8340-00-951-6423	Ground Anchor Kit (81337)		EA	1

APPENDIX E

EXPENDABLE/DURABLE SUPPLIES AND MATERIALS LIST

---

Section I. INTRODUCTION

E-1. SCOPE. This appendix lists expendable supplies and materials you will need to operate and maintain the Tent, Extendable, Modular, Personnel (TEMPER). The listing is for informational purposes only and is not authority to requisition the listed items. These items are authorized to you by CTA 50-970, Expendable Items (Except Medical, Class V, Repair Parts, and Heraldic Items), or CTA 8-100, Army Medical Department Expendable/Durable Items.

E-2. EXPLANATION OF COLUMNS.

a. Column (1) - Item number. This number is assigned to the entry in the listing and is referenced in the narrative instructions to identify the material (e.g., "Use cleaning compound, item 5, App.D").

b. Column (2) - Level. This column identifies the lowest level of maintenance that requires the listed item.

C Operator/Crew  
O Unit Maintenance  
F Direct Support Maintenance  
H General Support Maintenance  
D Maintenance

c. Column (3) - National Stock Number. This is the National stock number assigned to the item; use it to request or requisition the item.

d. Column (4) - Description. Indicates the Federal item name and, if required, a description to identify the item. The last line for each item indicates the Federal Supply code for manufacturer (FSCM) in parentheses followed by the part number.

e. Column (5) - Unit of Measure (U/M). Indicates the measure used in performing the actual maintenance function. This measure is expressed by a two-character alphabetical abbreviation (e.g., ea, in, pr). If the unit of measure differs from the unit of issue, requisition the lowest unit of issue that will satisfy your requirements.

ARMY TM 10-8340-224-13  
 AIR FORCE TO 35E5-6-1  
 NAVY NAVFAC-P-337.A

Section II.

EXPENDABLE/DURABLE SUPPLIES AND MATERIALS LIST

(1)	(2)	(3)	(4)	(5)
ITEM NUMBER	LEVEL	NATIONAL STOCK NUMBER	DESCRIPTION	U/M
1	c	7920-00-240-7174	Brush, Scrub, w/o Handle	Ea
2	O	8020-00-597-4761	Brush, Varnish	Ea
3	O	6810-00-782-2686	Denatured Alcohol	Gal
4	O	4240-01-204-2827	Filter, Cartridge (55799) 464023	Ea
5	O		Gloves, Latex-Nitrile (55799) 695456 Sz 8-8 1/2 (55799) 695457 Sz 9-9 1/2 (55799) 695458 Sz 10-10 1/2	Pr
6	O		Goggles, Chemical Splash (55799) 695877	Ea
7	F	5970-00-431-8599	Insulation, Sleeving	Ft
8	O	8030-01-350-4984	K-Kote Seam Sealer (OR6N1) 83-234C	Gal
9	C	9150-00-999-7548	Lubricant, Stick Form	Ea
10	O		Rake, Snow (62840) 89-416	Ea
11	O	4240-01-315-1864 4240-01-315-1863 4240-01-311-9013	Respirator, Air Filtering (55799) 479529 Sz Small (55799) 479528 Sz Medium (55799) 479530 Sz Large	Ea
12	C	7930-00-965-4868	Soap, Toilet, Cake, Hand	Box
13	F	3439-00-223-2538	Solder, 50/10/50 Lead	
14	O	5440-00-227-1592	Step Ladder, 4 foot, Wooden, with Bucket Shelf	Ea
15	F	5970-00-644-3167	Tape, Electrical Insula- tion, 3/4 inch width	Ea

EXPENDABLE/DURABLE SUPPLIES AND MATERIALS LIST (CONT)

(1)	(2)	(3)	(4)	(5)
ITEM NUMBER	LEVEL	NATIONAL STOCK NUMBER	DESCRIPTION	U/M
16	0	5210-00-221-1882	Tape, Measure 100 foot	Ea
17	0	7920-00-205-1711	Wiping Rags	Bale

APPENDIX F

ILLUSTRATED LIST OF MANUFACTURED ITEMS

F-1. Scope. This appendix includes simplified line drawings for each item authorized to be manufactured/fabricated, modified or mounted by Direct Support Maintenance Personnel.

F-2. Introduction.

a. This appendix includes complete instructions for making items authorized to be manufactured or fabricated at Direct Support Maintenance.

b. A part number in alphanumeric order is provided for cross-referencing the part number of the item to be manufactured to the figure which covers fabrication criteria.

c. All bulk materials needed for manufacture of an item are listed by part number or specification number in a tabular list on the illustration.

d. All dimensions are given in U.S. Standard measures.

F-3. Manufactured items part number index.

PART NUMBER	NOMENCLATURE	FIG NO
5-4-3357	BECKET, RIDGE TO EAVE	1
5-4-8480	BECKET, EAVE TO GROUND	1
5-4-8481	BECKET, VESTIBULE	1
5-4-3360	WEATHER SEAL, 6' 11-1/4"	2
5-4-8482	WEATHER SEAL, 8' 8"	2
5-4-8483	WEATHER SEAL, 9' 1/2"	2
5-4-8484	WEATHER SEAL, 9' 2"	2
5-4-3356	WINDOW AND FLAP ASSEMBLY	3
5-4-3378	WINDOW AND FLAP ASSEMBLY	4
5-4-3381	STOVEPIPE FLAP	5
5-4-3386	STOVEPIPE SHIELD FLAP	6
5-4-3388	VENT FLAP	7
5-4-3355	VENT FLAP ASSEMBLY	8



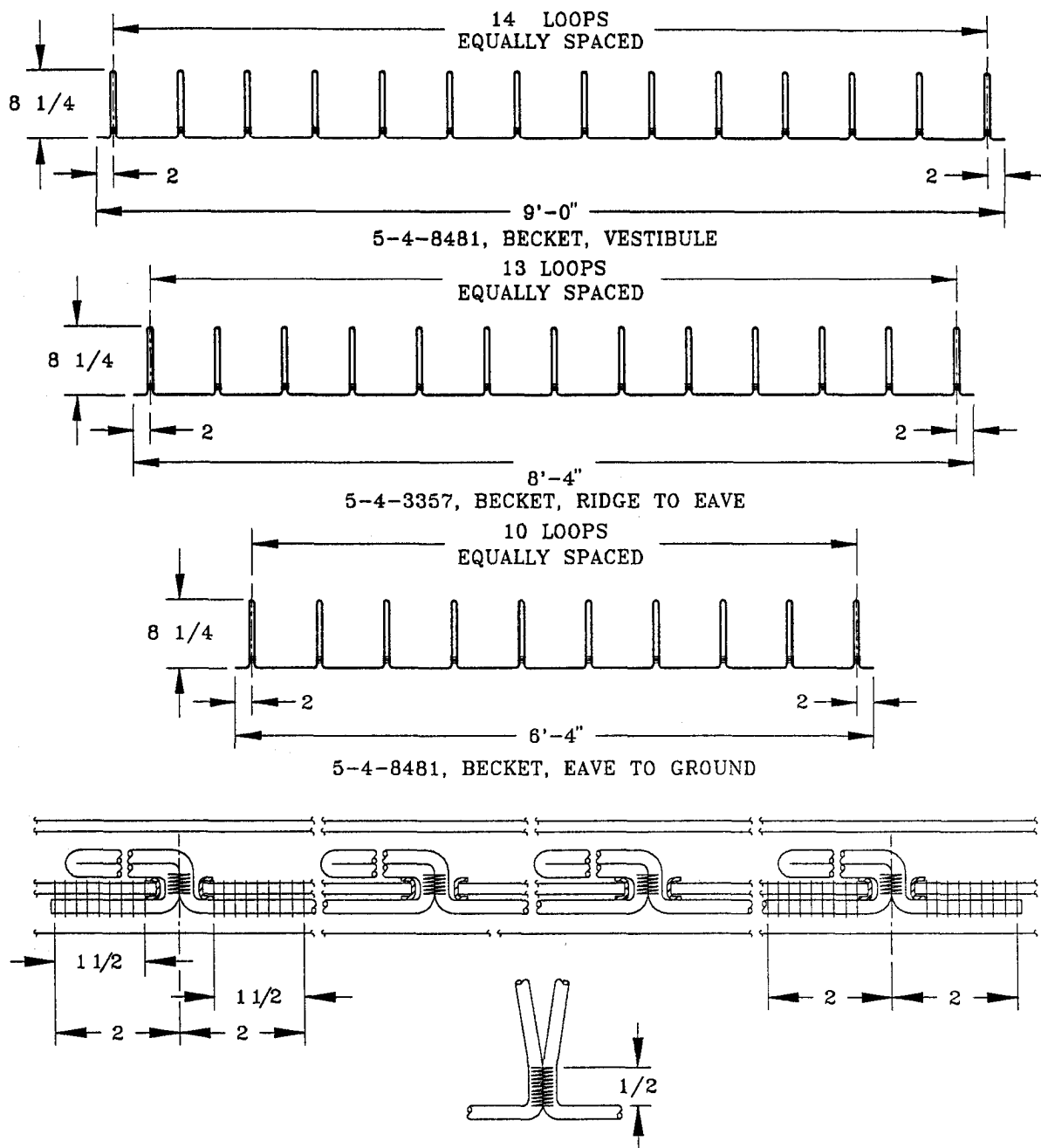

1. MAKE FROM MIL-C-43256  
 CORD, POLYESTER, SOLID  
 BRAID 5/32 DIAMETER.
2. SEW WITH V-T-285, THREAD

Figure F-1. BECKET

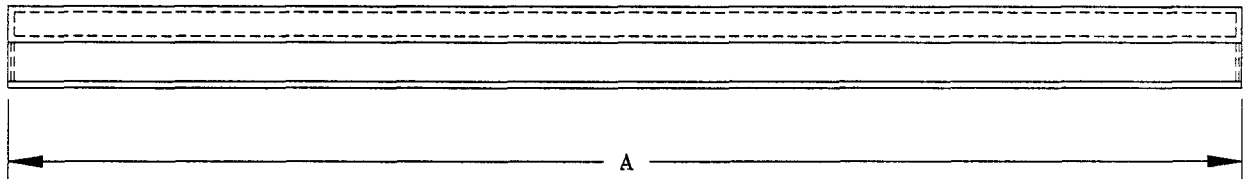

① ② ③

PART NO.	DIM (A)
5-4-3360	6'-11 1/4"
5-4-8482	8'-8"
5-4-8483	9'-1/2"
5-4-8484	9' - 2"

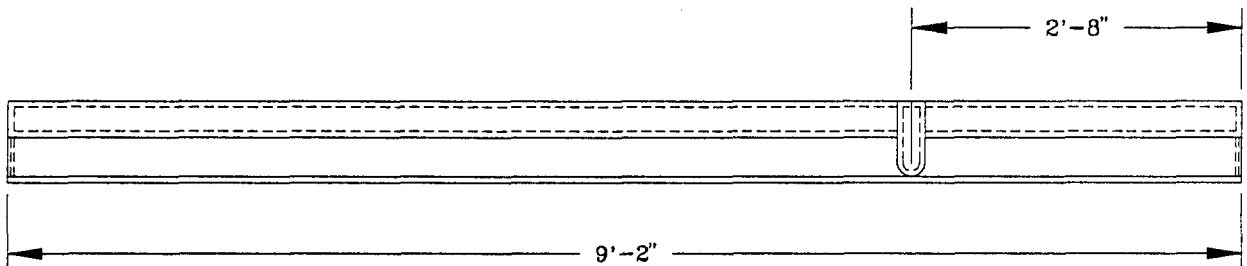

1. MAKE FROM MIL-C-44103,  
 CLOTH, DUCK, POLYESTER,  
 CLASS 1 OR 2.
2. SEW WITH V-T-285, THREAD.

Figure F-2. WEATHER SEAL

ARMY TM 10-8340-224-13  
AIR FORCE TO 35E5-6-1  
NAVY NAVFAC-P-337.A

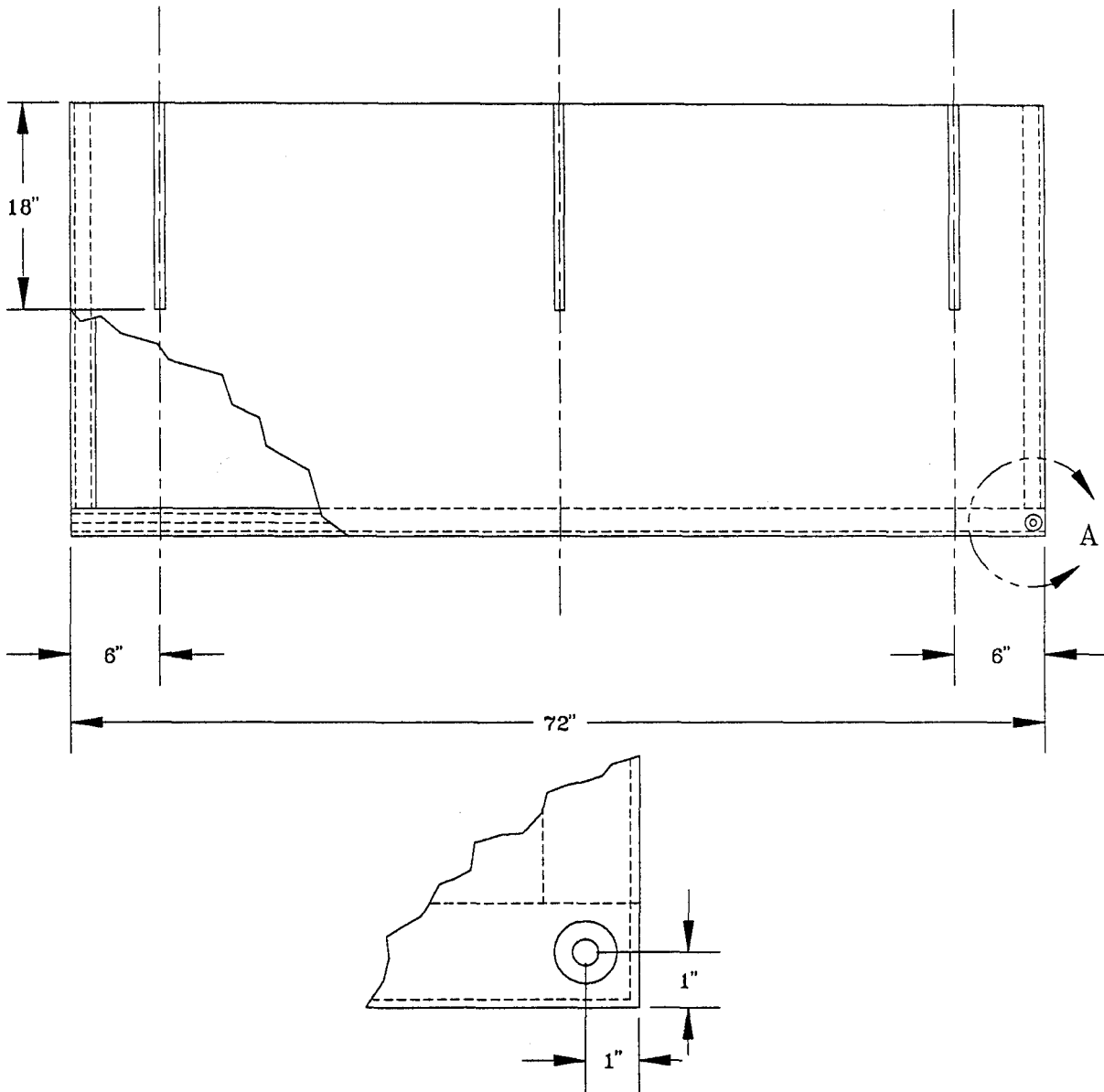

1. MAKE FROM MIL-C-44103, CLOTH, DUCK, POLYESTER, CLASS 1 OR 2, MIL-F-21840, FASTENER, HOOK AND PILE, MIL-T-43566, TAPE, TEXTILE.
2. SEW WITH V-T-285, THREAD.
3. INSTALL MIL-G-16491, GROMMET IAW FM 10-16.

Figure F-3. WINDOW AND FLAP ASSEMBLY

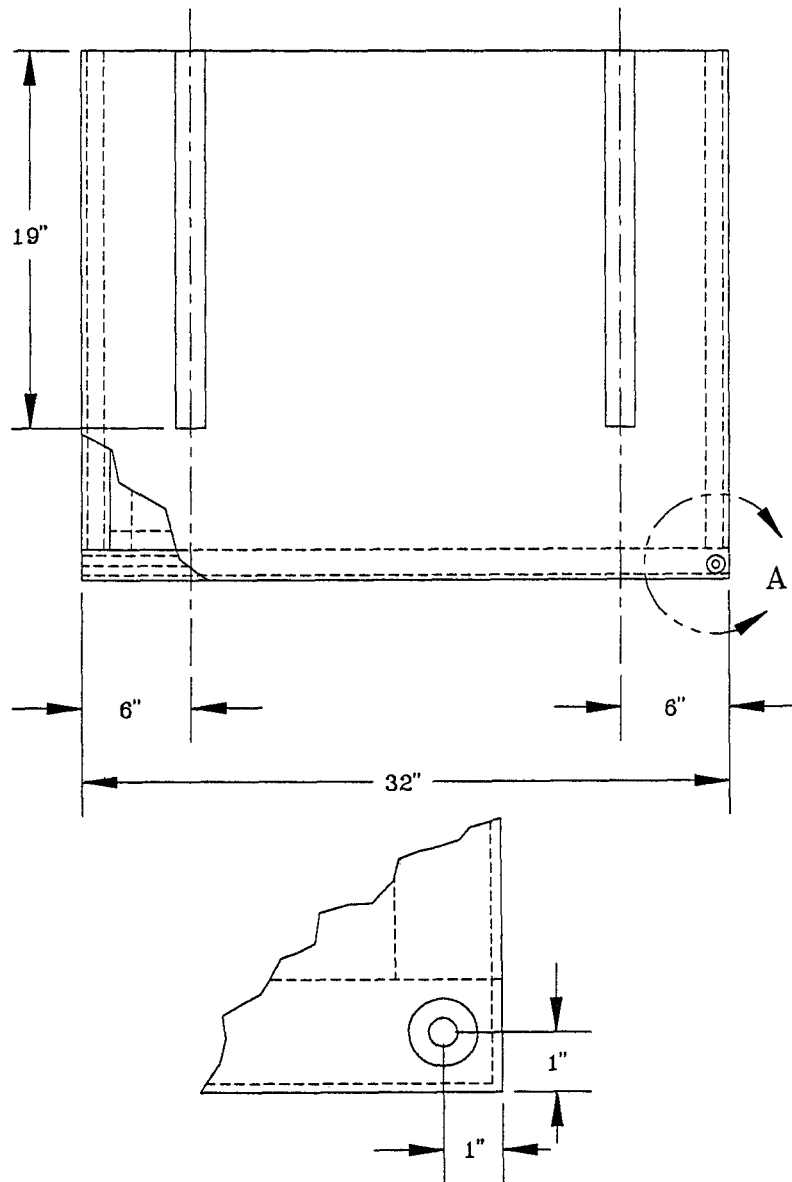

1. MAKE FROM MIL-C-44103, CLOTH, DUCK, POLYESTER, CLASS 1 OR 2. MIL-F-21840, TAPE, FASTENER, HOOK AND PILE, MIL-T-43566, TAPE, TEXTILE.
2. SEW WITH V-T-285, THREAD.
3. INSTALL MIL-G-16491, GROMMET IAW FM 10-16.

Figure F-4. WINDOW AND FLAP ASSEMBLY

ARMY TM 10-8340-224-13  
AIR FORCE TO 35E5-6-1  
NAVY NAVFAC-P-337.A

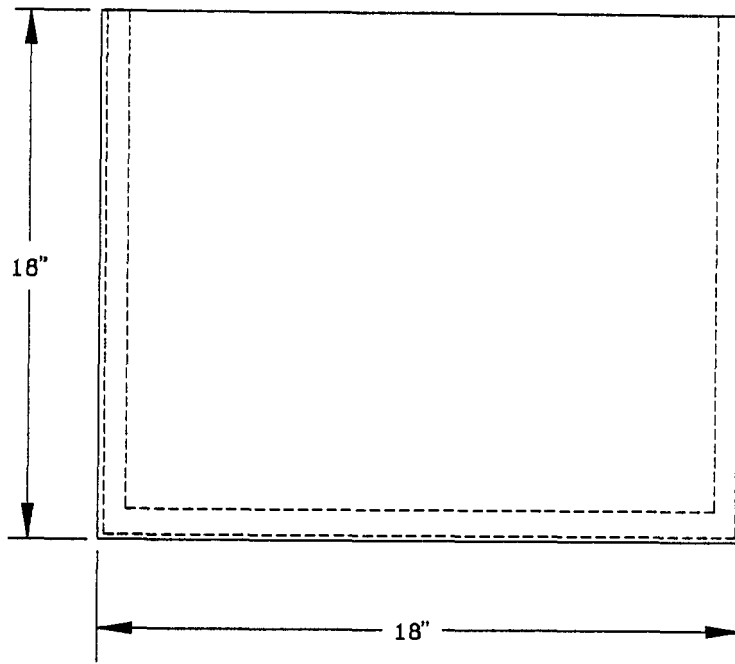

1. MAKE FROM MIL-C-44103,  
CLOTH, DUCK, POLYESTER,  
CLASS 1 OR 2, MIL-F-21840,  
TAPE, FASTENER, HOOK AND PILE,  
MIL-T-43566, TAPE, TEXTILE.
2. SEW WITH V-T-285, THREAD.

Figure F-5. STOVEPIPE FLAP

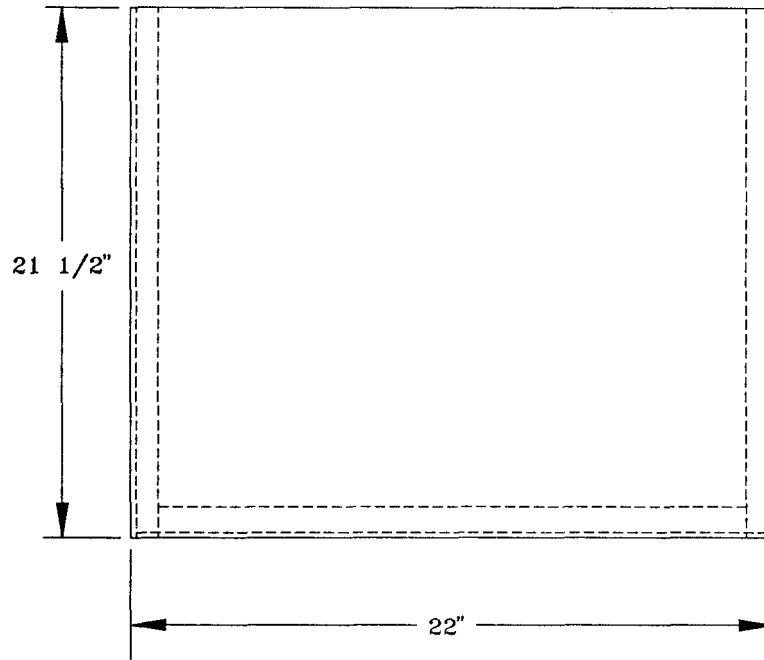

1. MAKE FROM MIL-C-44103,  
CLOTH, DUCK, POLYESTER,  
CLASS 1 OR 2, MIL-F-21840,  
TAPE, FASTENER, HOOK AND PILE,  
MIL-T-43566, TAPE, TEXTILE.
2. SEW WITH V-T-285, THREAD.

Figure F-6. STOVEPIPE SHIELD FLAP

ARMY TM 10-8340-224-13  
AIR FORCE TO 35E5-6-1  
NAVY NAVFAC-P-337.A

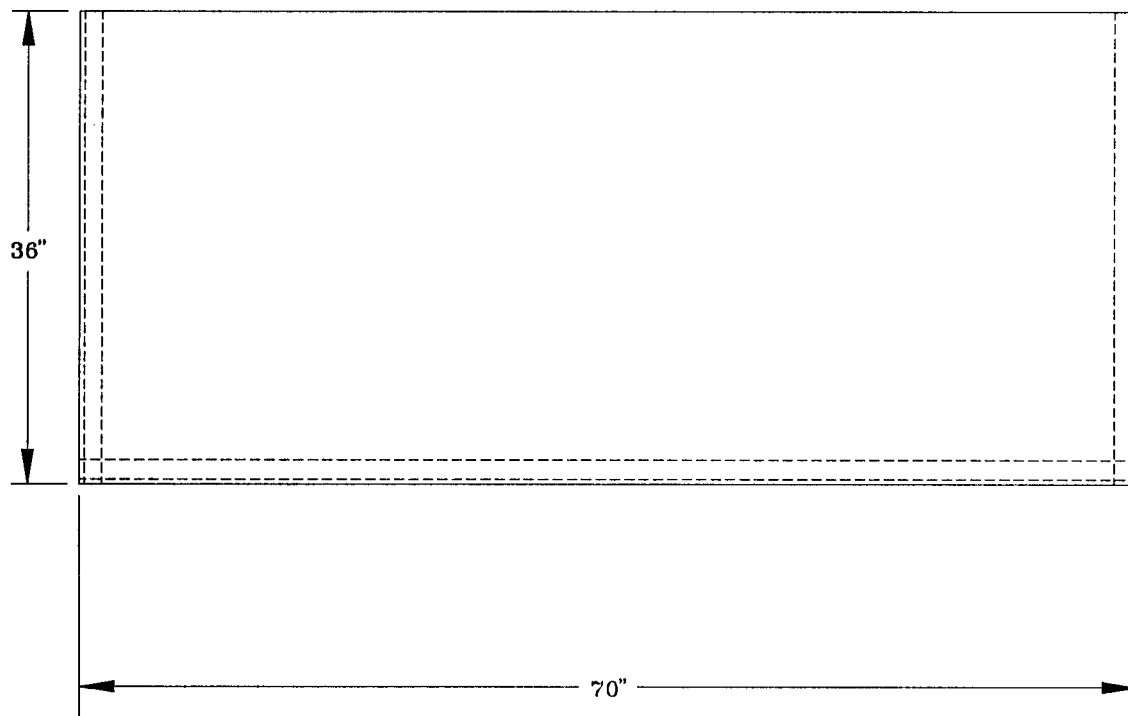

1. MAKE FROM MIL-C-44103,  
CLOTH, DUCK, POLYESTER,  
CLASS 1 OR 2, MIL-F-21840,  
TAPE, FASTENER, HOOK AND PILE,  
MIL-T-43566, TAPE, TEXTILE.
2. SEW WITH V-T-285, THREAD.

Figure F-7. VENT FLAP

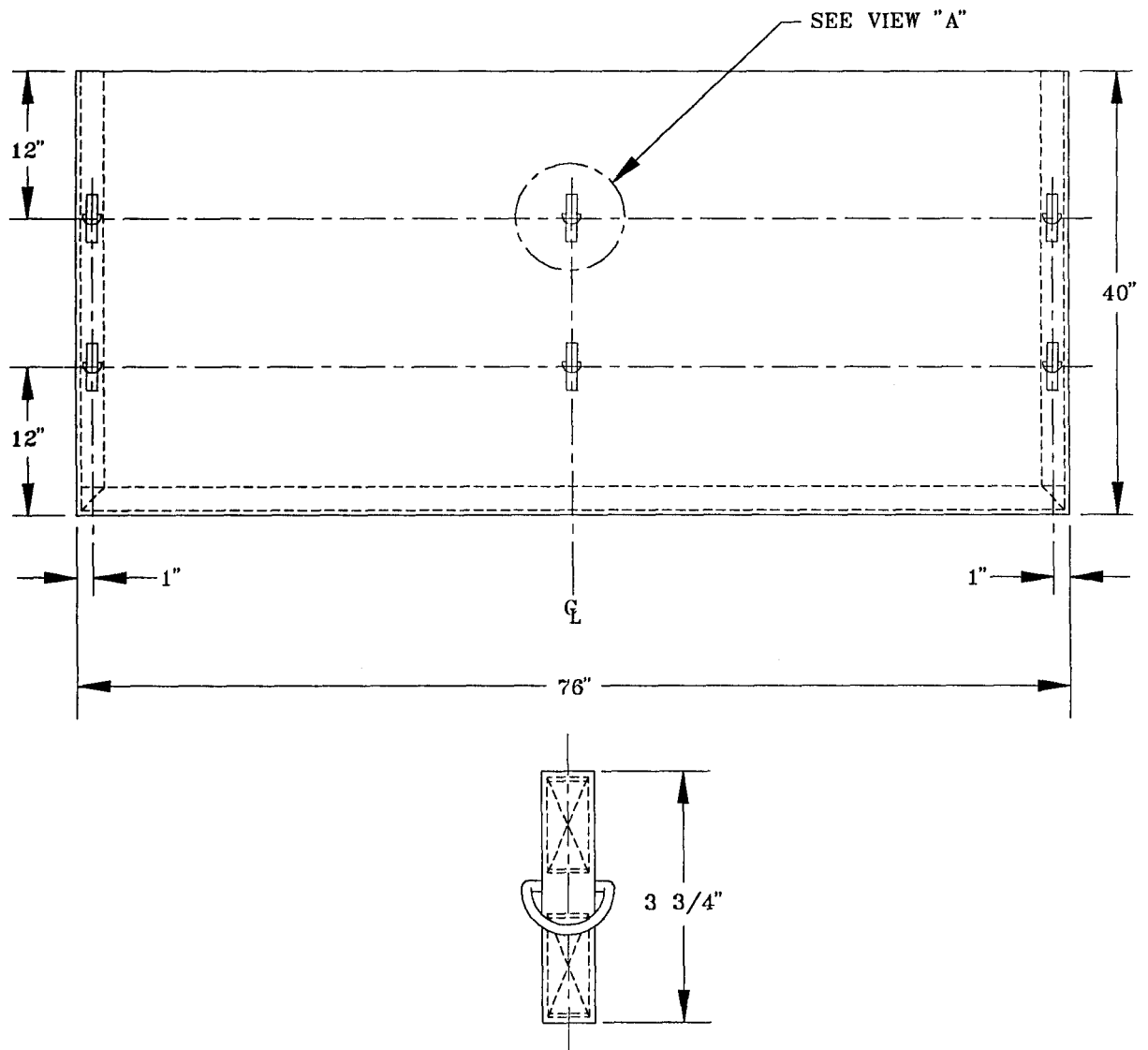

1. MAKE FROM MIL-C-44103, CLOTH, DUCK, POLYESTER, CLASS 1 OR 2, MIL-F-21840, FASTENER, HOOK AND PILE, MIL-T-43566, TAPE, TEXTILE.
2. SEW WITH V-T-285, THREAD.
3. INSTALL MIL-R-3390. RINGS, DEE IAW FM 10-16.

Figure F-8. VENT FLAP ASSEMBLY





## ALPHABETICAL INDEX

### A

Abbreviations and Terms, List of, 1-10  
Additional Authorization List, Appendix D  
Assembly and Preparation for Use, 2-4  
Automatic Stitching, 5-7

### B

Basic Issue Items, Appendix C  
Becket Lacing, Window and Door Sections, End Sections, and Tent Flys, 2-9  
Becket Lacing, Complete, 2-17

### C

Characteristics, Capabilities, and Features, Equipment, 1-11  
Checks and Services, Preventive Maintenance, Operators General, 2-3  
Cleaning, 3-6  
Common Tools and Equipment, 4-1, 5-1  
Components, 2-12  
Components of End Item and Basic Issue Items List, Appendix C  
Controls and Indicators, Operator's, 2-2  
Corrosion Prevention and Control (CPC), 1-3  
Cross-Reference, Nomenclature, 1-9

### D

Data, Equipment, 1-14  
Decals and Instruction Plates, 2-25  
Description of Major Parts, Location and, 1-12  
Destruction of Material to Prevent Enemy Use, 1-4  
Double Bump-Through Door Assy, Repair, 4-10, 5-13

Double Bump-Through Doors, Install, 2-20, 2-21  
Differences Between Models, 1-13  
Direct Support Maintenance, Procedures, 5-5  
Doors, Windows, and Vents, Operation of, 2-24  
Durable Supplies and Materials List, Expendable/, Appendix E

### E

Electrical Components, 2-16  
End Item, Components of, Appendix C  
End Section, Placement of, 2-7  
Equipment Characteristics, Capabilities and Features, 1-11  
Equipment Data, 1-14  
Equipment Improvement Recommendations (EIR), Reporting, 1-7  
Expendable/Durable Supplies and Materials List, Appendix E

### F

Fabric Assemblies, Repair, 4-8, 5-9  
Features, Equipment Characteristics, Capabilities and, 1-11  
Floor and Liner, Final Installation of, 2-15  
Forms and Records, Maintenance, 1-2  
Frame and Power Control Assemblies, Repair, 5-12  
Frame Sections, Repair of, 4-9, 5-10, 5-11  
Frame Assembly, 2-5  
Frame, Fully Erecting, 2-14  
Frame Section Components, Repair, 5-11

**ALPHABETICAL INDEX (CONT)**

**G**

General Instructions for Operator  
Trouble shooting, 3-3  
General, Operator's Controls and  
Indicators, 2-1  
Glossary, Glossary-1  
Guy Lines, Install, 2-10

**I**

Illustrated List of Manufactured  
Items, Appendix F  
Improvement Recommendations  
(EIR), Reporting Equipment,  
1-7  
Indicators, Operator's Controls  
and, 2-2  
Inspection, 3-5  
Instructions, Lubricating,  
General, 3-1  
Introduction to Operator PMCS,  
2-3

**L**

Light Set, Type I, Test and  
Repair, 3-7, 5-15  
List of Abbreviations and Terms,  
1-10  
Location and Description of Major  
Parts, 1-12  
Lubricating Instructions,  
Procedures, 3-2  
Luminaires, Install, 2-13

**M**

Machine, Stitching, 5-6  
Maintenance Allocation Chart  
(MAC), Appendix B  
Maintenance Forms and Records,  
1-2  
Maintenance, General, Direct  
Support, 5-5  
Maintenance Procedures, General,  
Unit, 4-7

Index 2

Major Parts, Location and  
Description of, 1-12  
Materials List, Expendable/  
Durable Supplies and, Appendix  
E  
Models, Differences Between, 1-13  
Modesty Curtain, 2-22

**N**

Nomenclature Cross-Reference, 1-9

**O**

Operation of Doors, Windows and  
Vents, 2-24  
Operation of TEMPER, 1-15  
Operation Under Unusual  
Conditions, General 2-27  
Operation Under Usual Conditions,  
2-4  
Operator PMCS, Introduction, 2-3  
Operator Troubleshooting, Use of  
Table, 3-4  
Operator's Controls and  
Indicators, 2-2

**P**

Partition, 2-23  
Parts, Repair, 4-3, 5-3  
PMCS, Introduction to, 2-3  
Power Control, Type III/IV and  
Convenience Outlet, Repair,  
5-14  
Power Distribution Components,  
Repair, 4-11  
Preparation for Movement, 2-26  
Preparation for Storage or  
Shipment, 1-5, 4-12  
Preparation for Use, Assembly  
and, 2-4  
Preservation, 4-13  
Prevent Enemy Use, Destruction of  
Material to, 1-4

**ALPHABETICAL INDEX (CONT)**

**P**

Procedures, Operator  
  Troubleshooting, General  
  Instructions, 3-3

**Q**

Quality Assurance, 1-6

**R**

Raising the Frame to Partially  
  Erect Position, 2-11  
Records, Maintenance, Forms and,  
  1-2  
References, Appendix A  
Repair Double Bump-Through Door  
  Assembly, 4-10, 5-13  
Repair Fabric Assemblies, 4-8,  
  5-9  
Repair Frame and Power Control  
  Assemblies, 5-12  
Repair Frame Sections, 4-9, 5-10  
Repair Light Set, Type I, 3-7,  
  5-15  
Repair Parts, 4-3, 5-3  
Repair Power Control Type III/IV,  
  5-1 4  
Repair Power Distribution  
  Components, 4-11  
Reporting Equipment Improvement  
  Recommendations (EIR), 1-7

**S**

Scope, 1-1  
Service Upon Receipt, of  
  Material, 4-5  
Shipment, Preparation for, 1-5,  
  4-14  
Site and Shelter Requirements,  
  4-4  
Special Tools, TMDE, and Support  
  Equipment, 4-2, 5-2  
Stakes and Guy Lines, 2-18

Stitching, Automatic, 5-7  
Stitching, Machine, 5-6  
Storage, Preparation for, 1-5,  
  4-12  
Supplies and Materials List,  
  Expendable/Durable, Appendix E

**T**

Tent Flys, Placement of, 2-8  
Terms, List of Abbreviations and,  
  1-10  
Test and Repair Light Set, Type  
  I, 5-15  
Tools and Equipment, Common, 4-1,  
  5-1  
Tool and Test Equipment List,  
  Appendix B  
Troubleshooting Procedures,  
  Operator, General  
  Instructions, 3-3  
Troubleshooting Procedures, Unit,  
  General Instructions, 4-6  
Troubleshooting Procedures,  
  Direct Support, 5-4

**U**

Unit Maintenance Procedures,  
  General, 4-7  
Unit Troubleshooting, General,  
  4-6  
Unusual Conditions, Operation  
  Under, General, 2-27

**V**

Vents, Operation of, 2-24  
Vestibule Assembly, 2-19

**W**

Warranty Information, 1-8  
Welding, 5-8  
Window and Door Sections, Initial  
  Placement of, 2-6  
Windows, Operation of, 2-24

TM 10-8340-224-13  
TO 35E5-6-1  
NAVFAC-P-337.A

By Order of the Secretaries of the Army, Air Force, and Navy:

**GORDON R. SULLIVAN**  
General, United States Army  
Chief of Staff

Official:

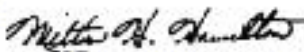
  
**MILTON H. HAMILTON**  
Administrative Assistant to the  
Secretary of the Army  
ns654

**MERRILL A. McPEAK**  
General, USAF  
Chief of Staff

Official:

**RONALD W. YATES**  
General, USAF  
Commander, Air Force Materiel Command

**DAVID E. BOTTORFF**  
Rear Admiral, CEC, US Navy  
Commander  
Navy Facilities Engineering Command

**DISTRIBUTION:**

To be distributed in accordance with DA Form 12-25-E, block no. 2545,  
requirements for TM 10-8340-224-13.

RECOMMENDED CHANGES TO EQUIPMENT TECHNICAL PUBLICATIONS

**SOMETHING WRONG WITH THIS PUBLICATION?**



THEN... JOT DOWN THE DOPE ABOUT IT ON THIS FORM. CAREFULLY TEAR IT OUT. FOLD IT AND DROP IT IN THE MAIL!

FROM (PRINT YOUR UNIT'S COMPLETE ADDRESS)  
 CDR, 1st Br, 65th ADA  
 ATTN: SP4 J. Brown  
 Key West, FL 33040

DATE SENT  
 10 Jun 79

PUBLICATION NUMBER  
 TM 9-1430-550-34-1

PUBLICATION DATE  
 7 Sep 72 .

PUBLICATION TITLE Unit of Radar Set  
 AN/MPQ-50 Tested at the HFC

BE EXACT PIN-POINT WHERE IT IS

PAGE NO	PARA-GRAPH	FIGURE NO	TABLE NO
9-19		9-5	
21-2	step 1C	21-2	

IN THIS SPACE TELL WHAT IS WRONG AND WHAT SHOULD BE DONE ABOUT IT:

"B" Ready Relay K11 is shown with two #9 contacts. That contact which is wired to pin 8 of relay K16 should be changed to contact #10.

Reads: Multimeter B indicates 600 K ohms to 9000 K ohms.

Change to read: Multimeter B indicates 600 K ohms minimum.

Reason: Circuit being checked could measure infinity. Multimeter can read above 9000 K ohms and still be correct.

TEAR ALONG PERFORATED LINE

SAMPLE

PRINTED NAME GRADE OR TITLE AND TELEPHONE NUMBER

SP4 J.T. Brown, Jr.

SIGN HERE

SP4 James Brown, Jr.

DA FORM 2028-2 2 JUL 79

REPLACES DA FORM 2028-2 1 APR 78 WHICH WILL BE USED UNTIL EXHAUSTED  
 AMM/V M Overprint 3, 1 Mar 91

P.S.--IF YOUR OUTFIT WANTS TO KNOW ABOUT YOUR RECOMMENDATION MAKE A CARBON COPY OF THIS AND GIVE IT TO YOUR HEADQUARTERS



1 Nov 80

FILL IN YOUR  
UNITS ADDRESS



FOLD BACK

DEPARTMENT OF THE ARMY

---

---

OFFICIAL BUSINESS

COMMANDER  
U.S. ARMY AVIATION AND TROOP COMMAND  
ATTN: AMSAT-I-MTS  
4300 GOODFELLOW BOULEVARD  
ST. LOUIS, MO 63120-1798

TEAR ALONG PERFORATED LINE



# The Metric System and Equivalents

## Linear Measure

1 centimeter = 10 millimeters = .39 inch  
 1 decimeter = 10 centimeters = 3.94 inches  
 1 meter = 10 decimeters = 39.37 inches  
 1 dekameter = 10 meters = 32.8 feet  
 1 hectometer = 10 dekameters = 328.08 feet  
 1 kilometer = 10 hectometers = 3,280.8 feet

## Weights

1 centigram = 10 milligrams = .15 grain  
 1 decigram = 10 centigrams = 1.54 grains  
 1 gram = 10 decigrams = .035 ounce  
 1 dekagram = 10 grams = .35 ounce  
 1 hectogram = 10 dekagrams = 3.52 ounces  
 1 kilogram = 10 hectograms = 2.2 pounds  
 1 quintal = 100 kilograms = 220.46 pounds  
 1 metric ton = 10 quintals = 1.1 short tons

## Liquid Measure

1 centiliter = 10 milliliters = .34 fl. ounce  
 1 deciliter = 10 centiliters = 3.38 fl. ounces  
 1 liter = 10 deciliters = 33.81 fl. ounces  
 1 dekaliter = 10 liters = 2.64 gallons  
 1 hectoliter = 10 dekaliters = 26.42 gallons  
 1 kiloliter = 10 hectoliters = 264.18 gallons

## Square Measure

1 sq. centimeter = 100 sq. millimeters = .155 sq. inch  
 1 sq. decimeter = 100 sq. centimeters = 15.5 sq. inches  
 1 sq. meter (centare) = 100 sq. decimeters = 10.76 sq. feet  
 1 sq. dekameter (are) = 100 sq. meters = 1,076.4 sq. feet  
 1 sq. hectometer (hectare) = 100 sq. dekameters = 2.47 acres  
 1 sq. kilometer = 100 sq. hectometers = .386 sq. mile

## Cubic Measure

1 cu. centimeter = 1000 cu. millimeters = .06 cu. inch  
 1 cu. decimeter = 1000 cu. centimeters = 61.02 cu. inches  
 1 cu. meter = 1000 cu. decimeters = 35.31 cu. feet

## Approximate Conversion Factors

To change	To	Multiply by	To change	To	Multiply by
inches	centimeters	2.540	ounce-inches	newton-meters	.007062
feet	meters	.305	centimeters	inches	.394
yards	meters	.914	meters	feet	3.280
miles	kilometers	1.609	meters	yards	1.094
square inches	square centimeters	6.451	kilometers	miles	.621
square feet	square meters	.093	square centimeters	square inches	.155
square yards	square meters	.836	square meters	square feet	10.764
square miles	square kilometers	2.590	square meters	square yards	1.196
acres	square hectometers	.405	square kilometers	square miles	.386
cubic feet	cubic meters	.028	square hectometers	acres	2.471
cubic yards	cubic meters	.765	cubic meters	cubic feet	35.315
fluid ounces	milliliters	29.573	cubic meters	cubic yards	1.308
pints	liters	.473	milliliters	fluid ounces	.034
quarts	liters	.946	liters	pints	2.113
gallons	liters	3.785	liters	quarts	1.057
ounces	grams	28.349	liters	gallons	.264
pounds	kilograms	.454	grams	ounces	.035
short tons	metric tons	.907	kilograms	pounds	2.205
pound-feet	newton-meters	1.356	metric tons	short tons	1.102
pound-inches	newton-meters	.11296			

## Temperature (Exact)

°F	Fahrenheit	5/9 (after	Celsius	°C
	temperature	subtracting 32)	temperature	

**PIN: 071122-002**