

EMR
FOR OFFICIAL USE ONLY

LAYING CABLE IN THE FORWARD AREA

(Confidential)

Training Pamphlet
No. 3

*Wire Communication Pamphlet
No. 4*

Signal Corps, U. S. Army
7-27-18

24

Laying Cable in the Forward Area

Table of Contents

	Page
Installing Underground Cable.....	3
Assignment of Pairs.....	4
Two-Man Method.	5
One-Man Method.	6
Splicing Lead-Covered Paper Insulated Cable.....	7
Planning the Splice.....	8
Stripping and Boiling Out.....	8
Wrapping the Splice.....	11
Splicing Ferrin Cable.....	12
Determining the Nature of Cable Trouble.....	12
Short.	13
Ground.	14
Cross.	14
Split Pairs.	15
Open Pair.	15
Locating Cable Troubles.....	16
Varley Loop Test.....	16
Murray Loop Test.....	17
Locating Ground with One Bad Wire of Known Length and Two Good Wires of Unknown Length.	17
Locating Ground with All Wires Bad.....	19
Locating an Open.....	20
Locating a Split Pair.....	21
Locating a Short.....	22
Precautions in Handling Cable.....	22

LAYING CABLE IN THE FORWARD AREA

IN a large part of the wire communication systems from the front positions back over a distance of three to five miles, extensive use is made of underground cable consisting of a number of pairs of wires insulated with paper and covered with a lead sheath, which can be used for telephone, telegraph, buzzerphone, etc., work. The route to be followed for such cable runs, and the size of cable (number of pairs of wire) to be laid is determined by the corps or division signal officer. As a rule, not less than 20 pairs are laid in one trench.

Installing Underground Cable

Trenches for laying the cable are dug to a depth of from 6 ft. to 15 ft., depending on the location and importance of the run, and 24 in. to 36 in. wide. The smaller sizes of cable are received wound on reels in 1000-ft. lengths. When the cable is laid, the reels are jacked up on a shaft to rotate easily and the cable pulled from them. On long runs the cable is usually laid in 1000-ft. lengths between splicing points.

Before the cable is laid a layer of sand or screening at least 3 in. deep should be put in the bottom of the trench to facilitate drainage. The cable should be laid with some slack, so that it will more readily withstand heavy vibration caused by shell fire. In burying the cable, if possible, it is best to cover it with brush and then fill in with soil. This will act as a cushion and give considerable protection against the destructive shells. In laying and covering the cables, utmost care should be exercised to avoid injury to the lead sheath. Particular precaution should be taken to avoid kinking the cable, as this is very likely to make a crack in the lead into which moisture will creep and cause cross talk or short circuits. Care must also be taken to protect the cables from all electrical injury. Where aerial lines join an underground cable a lightning arrester should be installed on the last pole. Telephone stations connected directly to underground cable without any intervening aerial wire or cable do not need to have any lightning protection.

At least every 3000 ft. in a cable run, manholes or testing stations should be installed, the approximate dimensions of the manholes being 6 ft. long x 3½ ft. wide x whatever depth is needed to give the necessary head room and install the roof protection. The long way of the manhole should be parallel to the line of the cable run. The construction of these manholes will of course be governed by the conditions met with, but where possible the ceiling should be 2 ft. below the surface of the surrounding ground and covered with corrugated sheet iron, at least two layers of sand in bags, 6 in. of reinforced concrete blocks, and at least 3 ft. of earth on top, and the fresh soil covered with a brush camouflage. Steps from the surface should be installed to lead into the manhole at one end, the long sides being kept clear for racking the cable in an orderly manner to facilitate splicing, testing, etc. A manhole is used as a test station, as a point from which to take off branch cables to aerial lines, as a place to cross-connect and reroute pairs, to lead off twisted pair lines, etc. In case of injury to the cable, or a breakdown between two manholes, twisted pair sometimes may be temporarily run between the two manholes until repairs can be made. To facilitate repair in this manner it is therefore desirable to have manholes as frequently as practicable with the cost in mind.

Greatest care must be taken when working with paper insulated cable to prevent moisture from getting into it. The presence of the slightest dampness seriously impairs the transmission of communications through the cable, making it necessary to promptly locate the leak, open up the sheath, boil out the cable with paraffin and close up the opening with a standard splice. The longer the delay in removing a bad place in a cable, the farther the moisture creeps in, it sometimes being necessary to cut out several feet and splice in a new section of cable. The method of locating such faults is taken up in a later section.

Assignment of Pairs

In all the lead-covered cables used for Signal Corps purposes the wire conductors are twisted in pairs, so that in a cable having 20 pairs of wires there are 20 separate, direct telephone or telegraph two-wire circuits. In all cases the two wires are wrapped in different colored paper, usually one red,

blue or brown, and one white. The colored wire is usually called the "line," and the white wire of the pair, the "mate."

Whenever two men are available for testing purposes, a cable can be tested out satisfactorily for assignment to proper terminals in a very few minutes. Sometimes only one man is available, however, and a method is necessary whereby he can make the test alone. Each of these methods is described.

Two-Man Method.—One end of the cable is led into a terminal box placed at the proper location. The wires are brought out and each pair is connected to terminals provided for the purpose inside the box. In all cases the line wire (colored) is connected to the upper terminal and the mate (white) to the lower terminal of a pair. The terminals are numbered successively.

The helper remains at the terminal box which has been connected up and numbered as outlined above, and the splicer goes to the other end, at which is located the terminal box to be connected up to the other end of the cable.

The splicer selects a pair of wires and connects to one of them one side of a circuit consisting of a dry battery and an ordinary watch case telephone receiver, Fig. 1. The other side of this circuit is grounded by connecting it to the lead sheath of the cable. The helper has a simple circuit containing nothing but a telephone receiver, one side of which is connected to the lead sheath. With the wire from the other side, he taps the terminals of the first terminal box, in which the pairs are numbered, until he hears a click in the receiver. This tells him that he is on the other end of the wire to which the splicer has connected his circuit. The helper uses his receiver as a transmitter and tells the splicer the number of the pair and whether the wire he is on is line or mate. The splicer then marks the pair and selects another one. The same procedure is gone through with until the entire cable is tested and the wires properly tagged.

After having obtained the click on the first wire, it is best for the splicer to leave this connection secure and use another flexible lead connected to the same circuit to make the further tests. This is advisable, as it maintains connection on one circuit over which splicer and helper can always get into communication in case they are unable to pick each other up at any time.

One-Man Method.—Assume that pairs No. 1, No. 2 and No. 3, Fig. 2, represent three pairs of wires in a cable. One man can test out the cable without assistance by using the following method. All the wires are connected at one end of

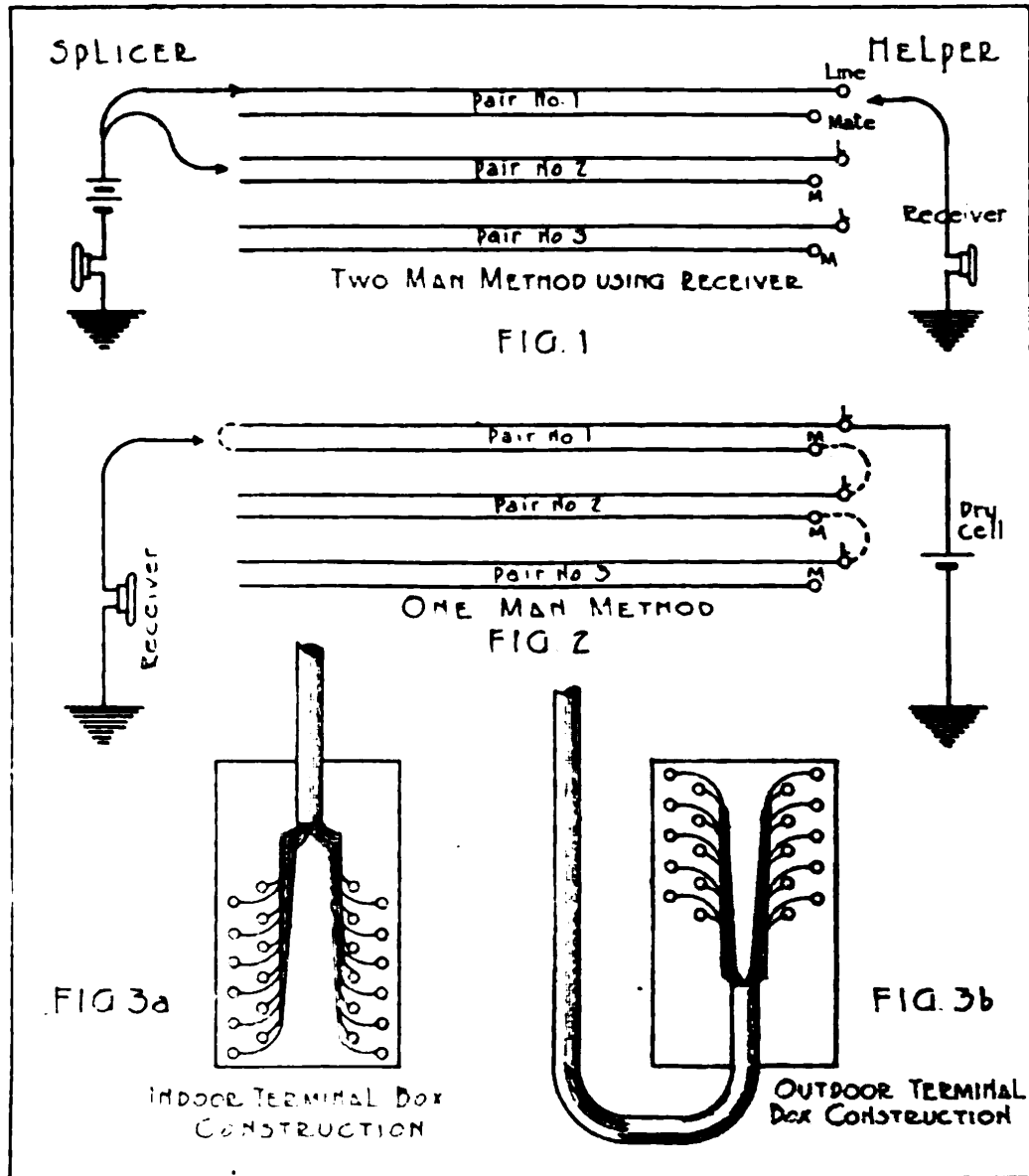

the cable to the terminals in the terminal box. Then the pairs are cross-connected down the panel as indicated by the dotted lines at the right, Fig. 2, connecting the mate of pair No. 1 to the line of pair No. 2, the mate of pair No. 2 to the line of pair No. 3, etc. The line of pair No. 1 is connected to ground (lead sheath) through a dry cell. After all these connections are made firm the tester goes to the other end of the cable section and connects a head set to ground on one side and to a piece of wire on the other. About 2 in. of

the paper insulation is skinned off at the ends of the wires. The ends are then touched with the free receiver connection until a wire is found which causes a click in the receiver. This will identify that wire as the line wire of pair No. 1, since this is the only circuit through the battery at the far end. This wire is twisted lightly with its mate (just enough to make an electrical contact) and is marked "Pair No. 1 with some sort of tag. The two ends of pair No. 1 are thus connected as shown by the dotted line at the left of Fig. 2. Next, the tester begins touching the other wire ends with the receiver contact wire until another click is obtained. This wire must be the line wire of pair No. 2, as will be seen by tracing out the circuit, Fig. 2. This wire is connected to its mate and tagged "No. 2." The test is repeated until all the pairs of the cable are identified. The wires are then permanently connected in the terminal box in their proper order. To clear the lines, the temporary connections between pairs which were made at the beginning of the test are removed from the first terminal box.

From the above it is seen that the main object in testing out cables newly installed is to identify the various pairs so that they may be given the same numbers at all terminals, as this greatly expedites assignment of pairs and location of trouble.

On installations inside of buildings the cable may be brought into a terminal box at the top or bottom, whichever gives the most direct route, Fig. 3-a. At all outside terminal boxes or at boxes installed in dugouts, the cable must be brought into the bottom of the terminal box so that the water running down the cable will drip off below the box and not get into the exposed wiring, Fig. 3-b.

Splicing of Lead Covered Paper Insulated Cable.

Cables and communicating systems installed near the front are constructed with no great aim toward permanency. The life of any cable system in the area subjected to heavy shelling is not long, and the standard construction methods are therefore abandoned in favor of a temporary construction which serves the purpose just as well. The following instructions cover the method of making splices on the small, for-

ward cables and they should not be used to govern work on the more permanent cable systems farther back.

Materials Required.	Tools Required.
Paper sleeves	Pliers
Paraffin	Cable knife
Rolls of muslin strip	Hammer, claw
Rubber tape	Paraffin kettle
Friction tape	Dipper
Insulating compound	Gasoline furnace
Wooden splice box	Compound kettle
Nails (1½ doz. 10-penny)	Blow torch
Gasoline	

Planning the Splice.—The lead sheath should not be opened until ready to work on the wires and all the necessary material is at hand. The longer a cable is open to the atmosphere, the more likely it is to absorb moisture with resulting bad operation. The length of time a cable is open should be made the minimum possible, and it should never be left open over night without being thoroughly wrapped with muslin and rubber tape and boiled out next morning when re-opened. Whenever a piece of cable is cut off a reel, both ends thus exposed must be sealed immediately with solder to keep out the moisture.

Stripping and Boiling Out.—The first step in making a splice is to dismantle the splice box, taking off the top and removable end. Each end of the box has a hole bored in it which will just admit the cable with a fairly snug fit. The splice box is placed on one cable end and the free end of the box on the other, both being slipped back out of the way, Fig. 4. The inside dimensions of the splice box are 3 in. x 3 in. x 13 in., and it should be made out of 1-in. boards, preferably pine.

The two cable ends are brought up together so that they overlap about 4 in., Fig. 8. About 6 in. of sheath is measured off on each cable and a ring made around each at these points by cutting a slight notch around the sheath with a cable knife. The sheath is then cut lengthwise from the ring to the end by driving the corner of the cable knife along the cable with a hammer, while holding the knife as nearly tangent to the cable as possible and still make it cut. This

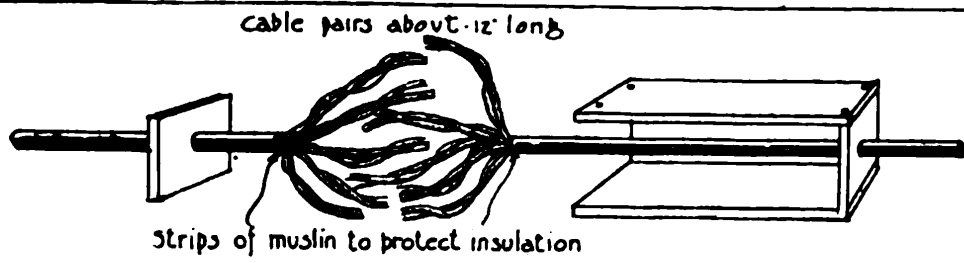

FIG. 4

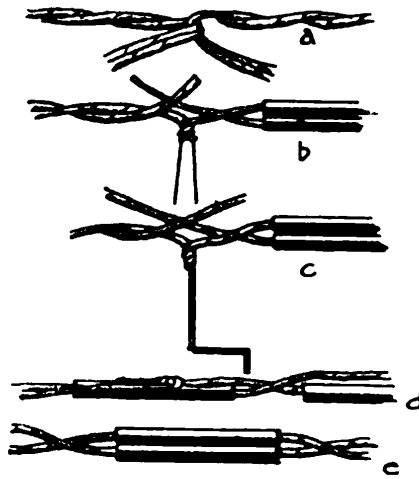

FIG. 5

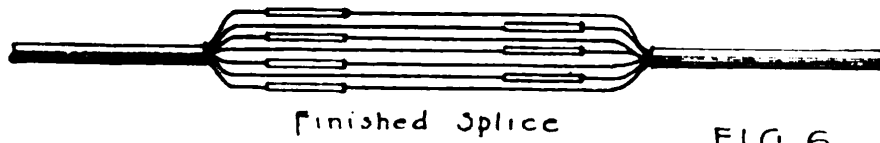

FIG. 6

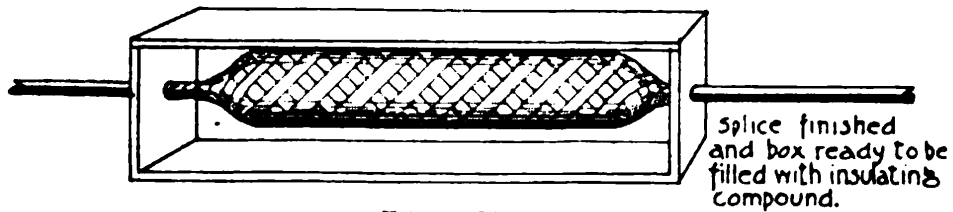

FIG. 7

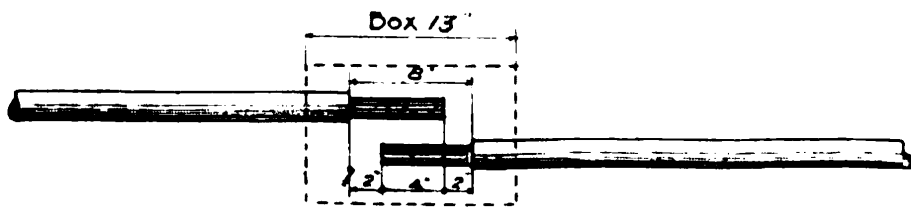

FIG. 8

will avoid cutting the paper insulation. After the sheath is thus cut open it is pulled back each way around the cable with the claws of the hammer and broken off at the ring. When completed the splice should be something less than 13 inches long over-all, so that it will be easily enclosed by the 13-in. splice box.

When the sheath is removed, the cable core should be served at the edges of the sheath with several wrappings of muslin. The paper wrapping is then removed from the core and hot paraffin poured over the muslin and open wire to assist in keeping the moisture out while the joint is open. The muslin will prevent the sheath from injuring the insulation of the wires when they are bent back preparatory to splicing. The paraffin should always be poured from the sheath toward the center of the splice. This tends to drive any moisture toward the center of the opening rather than back into the sheath. The temperature of paraffin should be above that of boiling water (212 deg. F.), but not hot enough to scorch the paper insulation. If the temperature is not higher than that of boiling water, the moisture will not be driven out. A common and effective test is to expectorate in the paraffin. If a considerable sputtering results, the paraffin is hot enough. If the paraffin is allowed to become too hot, it will catch fire on the surface very readily, so that this may be used as an indication of overheating. This "boiling out" of cable is absolutely essential and must be carefully done and never omitted. If not done properly, a faulty splice will develop.

After boiling out, the wires of each pair are twisted together tightly, so that no "split pairs" will result. This is very important. The conductors are now bent back over the sheath out of the way. Starting with the far layer of pairs, a pair of wires from each cable end which have approximately the corresponding positions in the cables are brought together, Fig. 5-a. The ends of the two wires of one pair are untwisted and a paper sleeve slipped over each wire of that pair and pushed back out of the way. The two line wires are brought together, allowing some slack, and given two or three twists, Fig. 5-b. The mates are then brought together in the same manner. The ends of both are cut off about 2 in. from the twist and the insulating paper removed up to the wist. The bare ends of the two line wires are now bent into

a crank handle, Fig. 5-c, and the two ends wound up until there is about 1 in. of tight twist, having at least 10 half-turns. The ends are cut off below the twist and the twisted portion bent over against and parallel to the insulated portion, Fig. 5-d. The operation is repeated with mate ends. The paper sleeves are then slipped up over the bare twists and the two wires of each pair given a few twists about each other to hold them together and keep the paper sleeves in place, Fig. 5-e.

In bringing successive pairs together for splicing, the locations of the twists should be staggered to distribute along the splice the bulkiness of the paper sleeves, Fig. 6. Before using the paper sleeves they must always be thoroughly boiled out in hot paraffin and then allowed to drain and cool.

The above "crank-handle method" of splicing can be used satisfactorily only on the smaller sizes of wire, such as Nos 19 and 22 gauge, which are the sizes most commonly employed. Where larger than No. 16 gauge wire is encountered, it will be necessary to use copper sleeves and solder instead of a twisted connection.

Wrapping the Splice.—After the wires are all spliced, muslin strips are wrapped closely around the splice. The splice is then thoroughly saturated with hot paraffin to remove any possible moisture present before closing up the joint. The paraffin is then carefully cleaned off the lead sheath and two reversed layers of rubber tape tightly wrapped around the muslin and extended onto the sheath for a distance of $1\frac{1}{2}$ in. at each end of the splice. Over the rubber tape two layers of friction tape are wound and extended onto the sheath for a length of $\frac{1}{2}$ in. beyond the rubber tape. The tape must be wrapped particularly tight at both ends to insure a water-tight joint. Care must be taken that the taping is not extended over the sheath for too great a length, as this would cause the splice to buckle in the splice box when this was closed.

The box is now assembled around the splice and the unattached end nailed in place, Fig. 7. The box is then filled with very hot insulating compound and the top nailed on. The box must not be disturbed while the compound is cooling, or the seal which it provides will be broken. The effect of this hot compound is not only to seal the joint when it sets, but also, by virtue of its temperature, to actually vulcanize the rubber tape, friction tape and muslin into a unit water-proof covering.

Splicing Ferrin Cable

Where less than a 10-pair cable is needed, it is now quite general practice with the American Expeditionary Forces to make use of Ferrin cable, commonly called "loom" cable. This consists of a tar, cloth and rubber casing enclosing rubber covered wire twisted in pairs. The manner of splicing is quite different from that employed with lead covered cable. The covering at the two ends of the cable is cut open along the cable as short a distance back from the end as possible and give sufficient length of wire to make the splice (approximately 6 in. on each end). About 2 in. of insulation is scraped off on each wire and the proper wires twisted together, using the Western Union joint and taking special precaution to make the length of each wire between cable sheath ends uniform. This is important in order that any strain on the cable will be borne equally by all wires, as the opened sheath will not take up the strain. If practicable, each joint should be soldered, but if solder is not available, a layer of tinfoil or paper should be placed over the bare joint before it is wrapped with the rubber tape. This will prevent oxidation of the copper due to the action of the rubber, which would take place if there were no protection. The joint is then heated with a candle or other flame and moulded slightly with the fingers to partially vulcanize the rubber and seal the insulation.

After all the wires are treated in this manner, the split ends of the sheath are put back in place, cutting them to fit together as snugly as possible around the core. A double layer of friction tape is wrapped over the sheath, after which two reverse layers of rubber tape are applied. This taping is heated to vulcanize and form it into a unit insulation and then served with two or three layers of friction tape for protection.

Determining the Nature of Cable Trouble

In splicing cable, any one of the following troubles may occur: short, ground, cross, split pairs or open pairs. All these faults except split pairs are sometimes found in the cable upon receipt from the manufacturer, but this is rare as the cable is tested before being shipped. The methods of testing given in the following paragraphs are intended pri-

marily for use at the time the cable is installed before pairs are assigned and in use. Determining the nature of these faults after the cable is in use is simplified, as it is usually known just which pair the trouble is in.

Short.—This trouble in a pair of wires means that, due to faulty insulation, the two wires are short circuited and therefore cannot be used as a pair for communication purposes, Fig. 9. The illustration is of course exaggerated inasmuch as a shorted pair can result from a very small defect in the insulation.

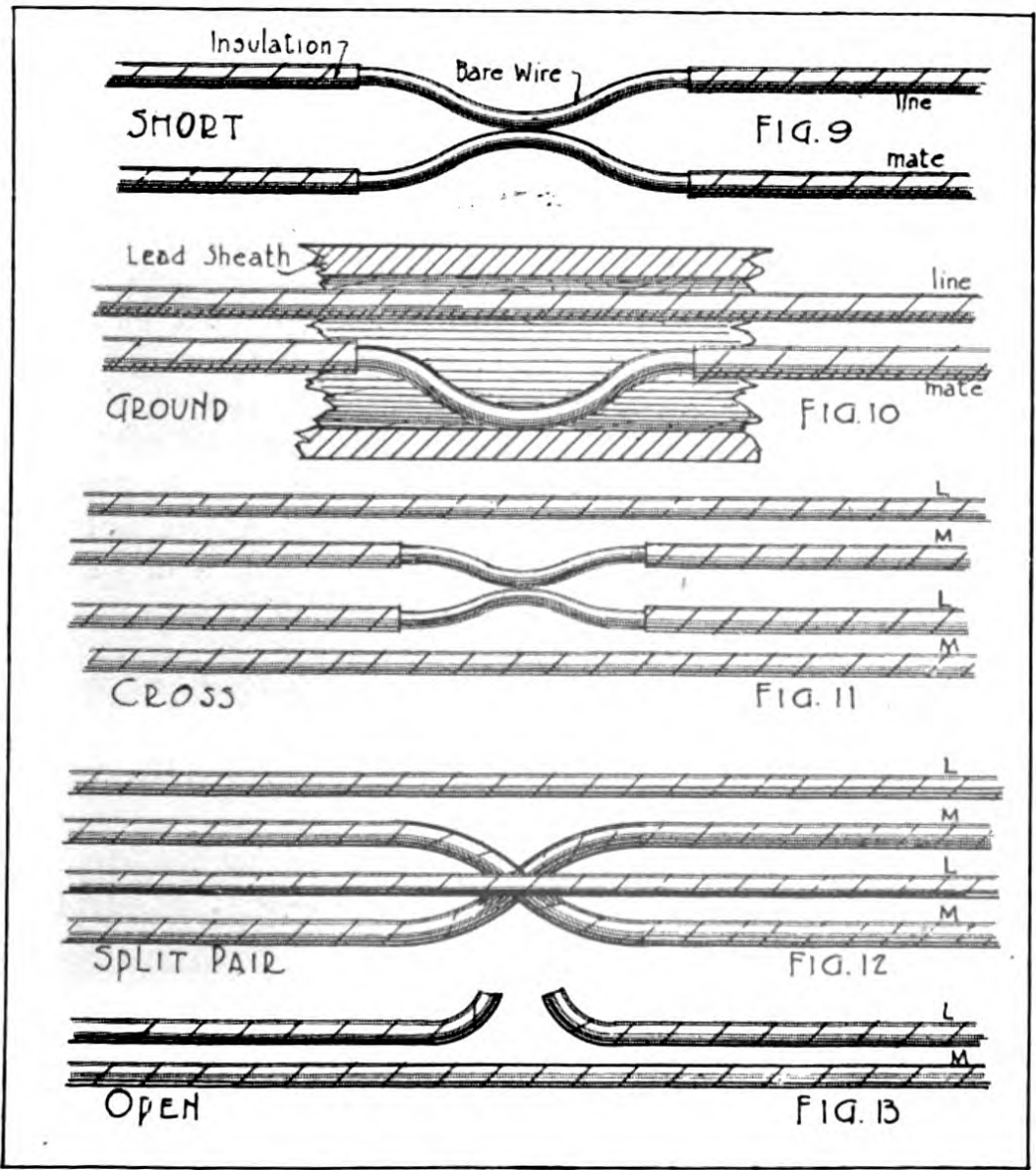

To test out a cable for shorts, a circuit consisting of an ordinary watch case telephone receiver and a dry cell is connected successively across the wires of each pair of the

cable. If a click is heard in the receiver upon touching the two ends of any pair, when it is known that that pair is open at the opposite end of the cable, this signifies that there is a short-circuit between the two wires. In long cable runs it is possible that there will be enough static capacity to cause a click even though the pair is not shorted. It is therefore best to tap the test circuit connection to the wires of the pair several times, and if a click is heard after the first or second tap, it is a certain indication that a short exists. This same precaution against static clicks must be observed in connection with testing out for the troubles described in the following paragraphs.

Ground.—A ground in a pair of wires in such a condition as is shown in an exaggerated way in Fig. 10. In this case one of the wires is grounded on the lead sheath of the cable or on some other grounded object inside the cable, and while the pair can be used for conversation, the transmission usually will be poor and there likely will be a scratching, sizzling noise in the receiver. In case both wires of a pair are grounded, there exists the equivalent of a shorted pair, and this pair cannot be used for communication purposes.

To test out for a ground in any of the pairs of a cable the same circuit referred to above is used, one side being connected to the ground or cable sheath and the other side to all of the wire ends in the cable successively. If a click is heard when connection is made to any wire, it signifies that this wire is grounded, thereby completing the circuit through the test circuit receiver.

Cross.—When pairs are crossed, conversation can be had over either pair, but both cannot be used at the same time, as both conversations will be heard over both pairs. A ring on either pair will probably cause the signals of both at the exchange to drop. Both pairs will be noisy. An illustration of crossed pairs is shown in Fig. 11.

To test a cable for crossed pairs, using the receiver and dry cell circuit, one side of the test circuit is connected successively to each of the wire ends of the entire cable, and for each such connection the other side of the test circuit is touched to all other wire ends. As seen from Fig. 11, if a cross exists in the cable, one combination of interconnection between pairs will form a circuit and a click will be heard in the receiver. This will identify the pairs in trouble, since if

all were perfect such a connection would give no click whatever.

Split Pairs.—This fault is caused by the splicer being careless in splicing the pairs together. A split pair practically never occurs in the cable traceable to any other cause than the work of the splicer. A split pair exists when the two wires of one pair are connected to one wire each of two opposite pairs. This fault defeats the purpose of the transpositions in the cable, which are made about every 3 in., and results in cross talk. Fig. 12 illustrates a split pair in a cable.

To test out for this trouble, two men are necessary. The helper goes to the far end of the cable section and cross-connects the two wires of each pair. At the opposite end of the section the splicer connects one side of a test circuit, consisting of a receiver and a dry cell, to the line wire of each pair successively, and for each such connection, touches the other side of the test circuit to all the other wire ends in the cable. If a split pair exists, one wire other than the mate of the line wire to which the first side of the test circuit is connected will be found which will give a click in the receiver. There will probably be two such combinations of connections, since if one pair is split, it will necessitate the splitting of another pair in order to make the pairs come out even.

Open Pair.—An open pair exists when one wire of a pair is broken, Fig. 13. Such a pair cannot be used for communication purposes. It can be used only as a one-wire grounded line for emergency purposes.

The test for open pair is to use the same receiver and dry cell circuit, and connect all terminals together at one end of the cable section. One receiver lead is then held on any terminal at the opposite end of the section and the other side of the test circuit touched to all other terminals. Any wire which does not give a click indicates an open circuit in that wire.

General.—In making the tests as described above, a tone machine or buzzer, or a magneto may be employed effectively. When using the tone machine, a buzz will be heard by the tester when the trouble is located, except when there is an open. With the magneto, a bell may be used, or a receiver, to designate the circuits in trouble. When a cable section has

been installed and connections made in both terminals, it should be tested out for all the faults indicated above.

Locating Cable Troubles

After having determined the nature of the trouble in a pair of wires by using any one or all of the foregoing methods, it then becomes necessary to locate the exact point of the trouble, so that it can be removed. An accurate method of locating trouble is to use a Wheatstone bridge, which will determine quite closely the distance out on a cable at which the trouble exists, in terms of the resistance of the intervening wire.

Varley Loop Test.—The Varley loop test is a very accurate method of locating a cross or a ground, provided there is a good wire running parallel to the defective one. A Wheatstone bridge and galvanometer are required. Connections are made as shown in Fig. 14. R , R_1 and R_2 are variable known

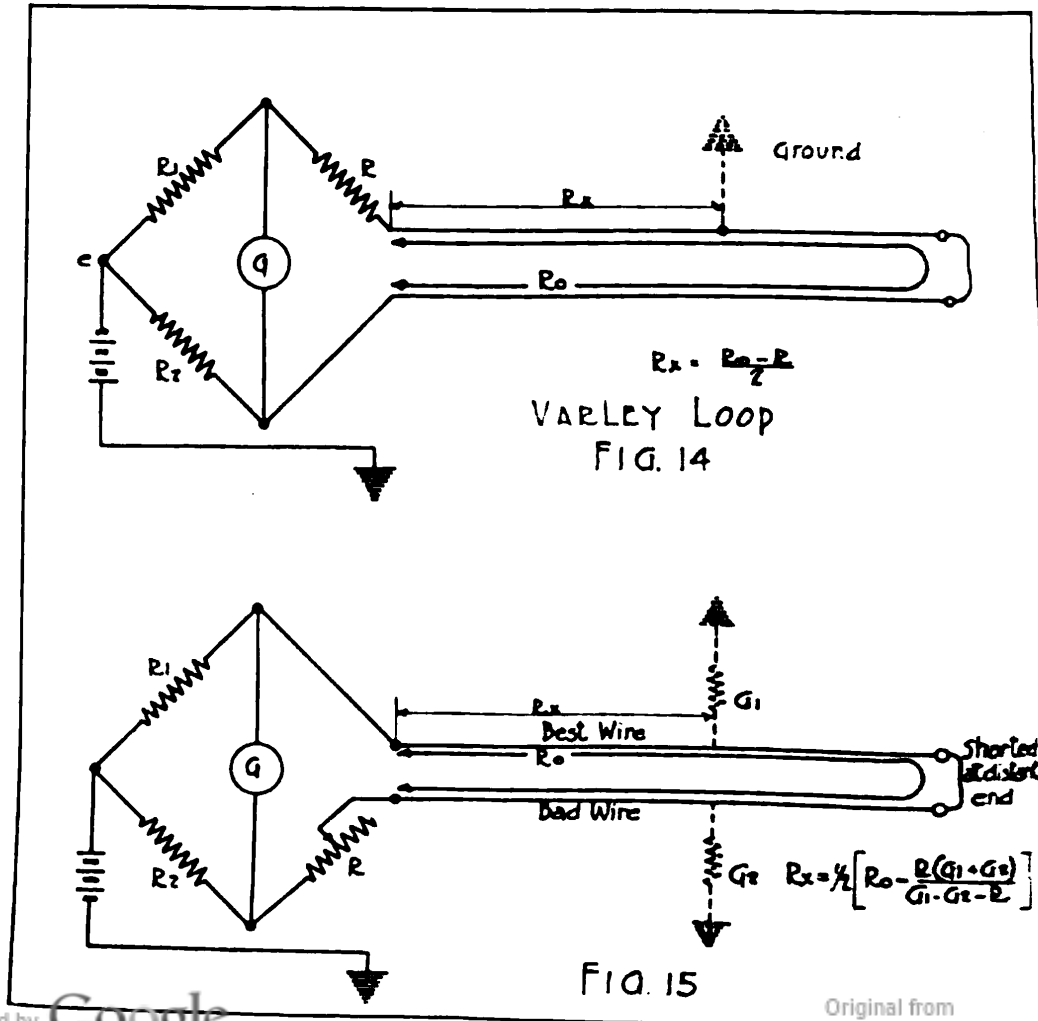

resistances. When R_1 is made equal to R_2 , and R is adjusted until no deflection of the galvanometer takes place, then the following equation is true:

$$R_x = \frac{R_0 - R}{2},$$

where R_x is the resistance out to the ground. R_0 is the resistance of a complete loop consisting of the good wire and the grounded wire, and R is the resistance of the bridge arm. R_0 can be obtained from standard wire tables if the size or resistance of the wire and distance between sections are known. The distance to the ground may then be computed by dividing the resistance R_x by the resistance per foot as obtained from the tables.

Murray Loop Test.—The Murray loop test is used when only two bridge resistance arms and a galvanometer are available. Connections are made as in Fig. 16 and when R_1 and R_2 are so adjusted that no deflection of the galvanometer is noted, the following equation may be solved to determine the resistance of the bad wire out to the fault, from which the distance to the fault can be computed as outlined in the Varley loop test:

$$R_x = \frac{R_1 R_0}{R_1 + R_2}$$

Faulty Wire of Known Length and Two Good Wires of Unknown Length.—The above described loop methods, the **Murray and Varley**, are the ones most frequently used. Some other loop methods and various modifications of these tests have been worked out to meet specific requirements. One of the most important follows. This method has a wide application, because either good aerial cable sheath or any good cable wires, or both, may be used for the good wires, the only requisite being that they terminate at the same point as the faulty wire. The length of the two good wires does not need to be known.

First, connections are made as for the Murray loop test, Fig. 18. The two arms R_1 and R_2 of the bridge are so arranged that they can be varied until a balance is secured. In the types of testing sets having a variable rheostat, the rheostat should be used for one of the arms. Where the resistance of the faulty wire to the grounded point is called

R_x , the total resistance of the faulty wire is called r , and the resistance of one of the other wires joined to it to complete the loop is called n , then

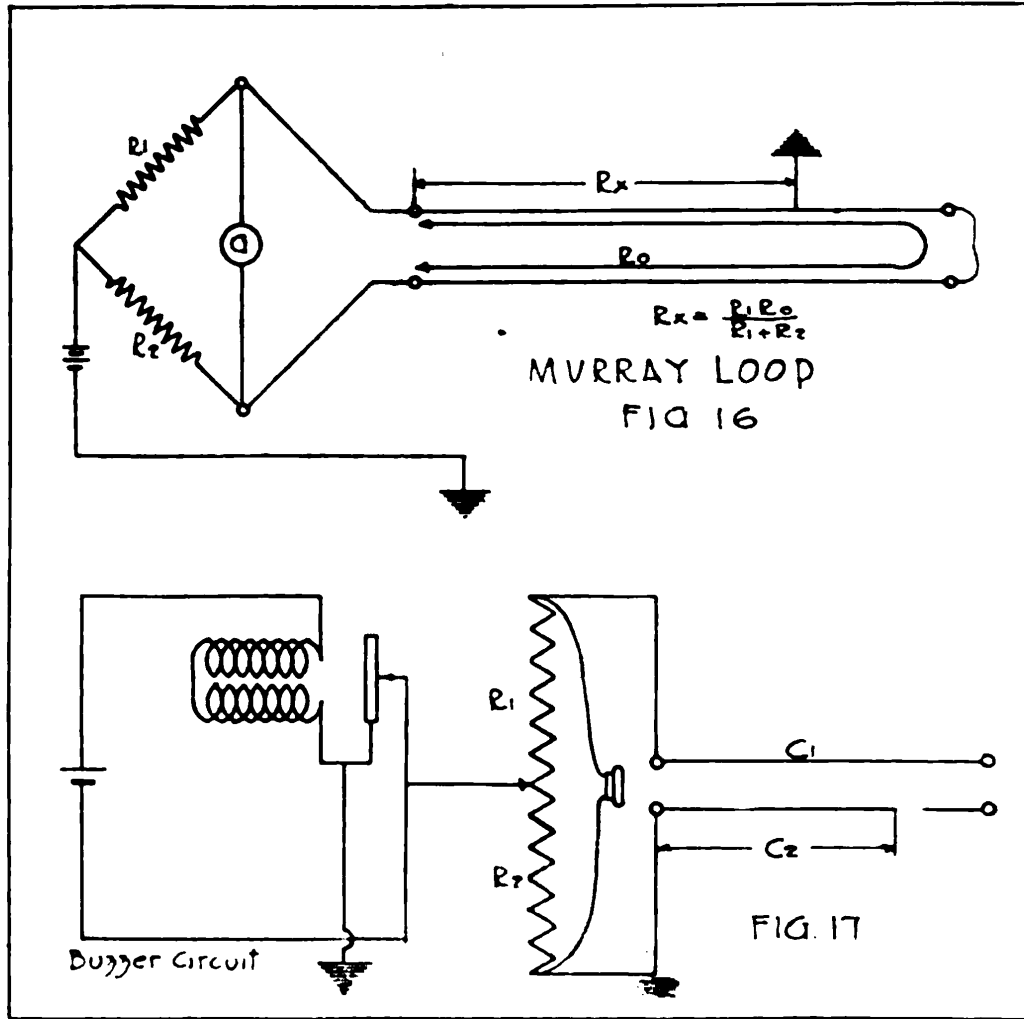

$$\frac{R_1}{R_2} = \frac{r - R_x + n}{R_x} \text{ and } n = \frac{R_1 R_x + R_2 R_x - R_2 r}{R_2}$$

Now, connecting as shown in Fig. 19, and adjusting for a new balance, calling the new readings R'_1 and R'_2

$$\frac{R'_1}{R'_2} = \frac{n}{r} \text{ and } n = \frac{R'_1 r}{R'_2}$$

Equating the two values of n and clearing,

$$R_x = \frac{R_2 (R'_1 + R'_2) r}{R'_2 (R_1 + R_2)}$$

In the types of bridges in which the R_1 to R_2 ratio is made by sliding a contact along a uniform resistance, $R_1 + R_2$ is always equal to $R'_1 + R'_2$, and the above reduces to

$$R_x = \frac{R_2}{R'_2} r$$

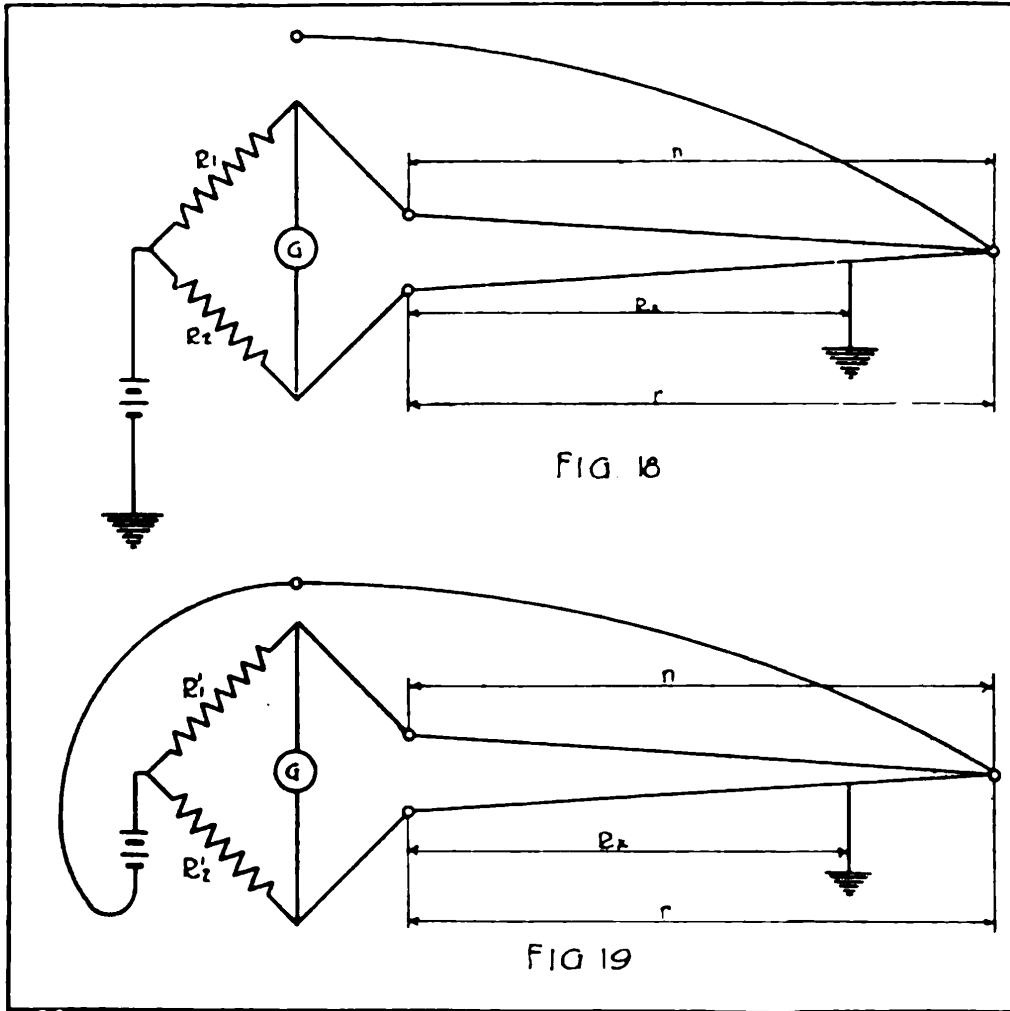

Since the length of L of the faulty wire is known, then the equation may be written

$$d = \frac{R_2}{R'_2} L,$$

where d is the distance to the fault.

Locating Ground with All Wires Bad.—In the Varley loop and most other methods of locating grounds, it is necessary to have one good wire throughout the length of the cable. It may happen that at a certain point every wire of a cable is defective, due usually to moisture. In this case the more

common Wheatstone bridge methods cannot be used. If a megger, galvanometer or voltmeter is available for determining the insulation resistance to ground of two wires, the following method may be employed to locate the trouble, Fig. 15.

R , R_1 and R_2 are the bridge arms, G_1 is the insulation resistance to ground of the best wire, G_2 is the insulation resistance to ground of a bad wire, R_0 is the full loop resistance as estimated from wire tables, and R_x is the resistance of a single conductor out to the fault. The wires for determining the insulation resistances G_1 and G_2 should be selected so that G_2 will always be less than G_1 .

When the two wires are shorted at the far end as shown and a balance secured on the bridge, the following equation is true:

$$R_x = \frac{1}{2} \left[R_0 - \frac{R(G_1 + G_2)}{G_1 - G_2 - R} \right]$$

The distance out to the fault can then be computed by dividing the resistance R_x by the resistance per foot of the wire.

Locating an Open.—To locate an open circuit in a wire, a simple capacitance test can be used effectively. The far terminals of the pair are left open. A buzzer circuit is used and connected between a known variable resistance arm and ground, Fig. 17. A telephone receiver is connected across the total resistance. Calling C_1 the capacitance of the good wire and C_2 the capacitance of the faulty wire out to the break, the resistances R_1 and R_2 are adjusted until the buzz in the receiver is a minimum. Under this condition the following ratio is true:

$$\frac{R_1}{R_2} = \frac{C_1}{C_2}$$

In uniform wires and cables the capacitance is directly proportional to the length, so that in the above equation,

$$\frac{R_1}{R_2} = \frac{C_1}{C_2} = \frac{D_1}{D_2}$$

where D_1 is the length of the good wire and D_2 the length of the bad wire out to the open.

D_1 is known, so

$$D_2 = \frac{D_1 R_2}{R_1}$$

Locating a Split Pair.—When a split pair is found, it is usually corrected by changing the connections of wires at the terminal box. This makeshift defeats the object of the transpositions and the two pairs involved may be noisy and produce cross talk. It is sometimes not worth while to attempt to locate a split, particularly if the cable is a long one with many splices. This serves to emphasize to the splicer

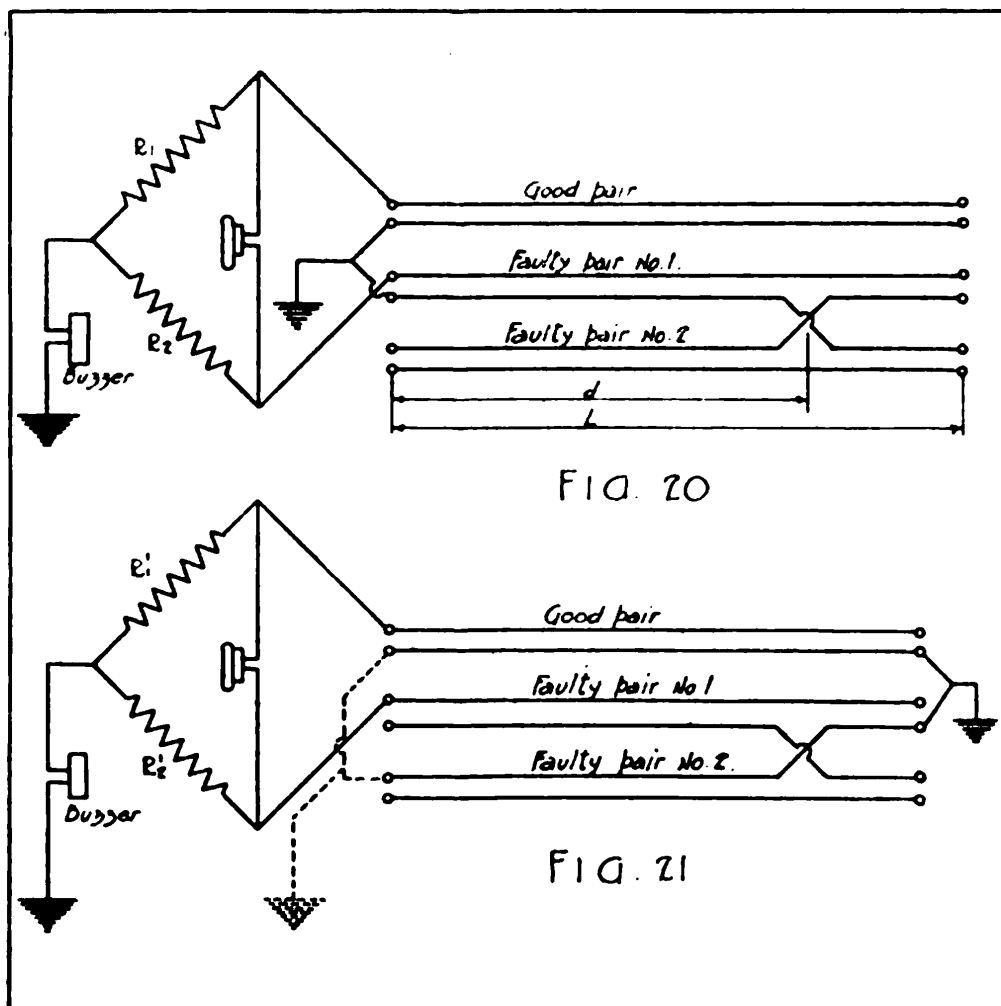

the importance of connecting the pairs properly at every joint he makes, otherwise there will result two practically useless pairs in the cable, which must remain permanently so. If there is a shortage of pairs, it may save considerable time when a long run of cable is involved to test out to locate the split in a pair rather than to open up joints until it is found.

A Wheatstone bridge may be used in this test, provided one good cable pair is available. The connections are first made as shown in Fig. 20, a telephone receiver being used in place of the galvanometer and a buzzer in place of the bat-

tery. The resistance R_2 is adjusted until no sound is heard in the receiver. The ground connections are then changed, as shown in Fig. 21. These ground connections may be made either at the far end of the cable, as shown by the full lines, or at the near end of the cable, as shown by the dotted lines. The value of R'_2 for a balance is found as before.

Now, where d represents the distance to the cross and L the length of a pair of wires,

$$d = \frac{LR_2(R'_2 - R'_1)}{2R_2R'_2 - R_1R'_2 - R'_1R_2}$$

(For the purpose of this pamphlet, it is not considered necessary to enter into the rather lengthy proof of the above formula.)

Locating a Short.—The location of a short circuit is a simple Wheatstone bridge test, whereby the resistance of the wire out to the short and return is measured and divided by two in figuring the equivalent distance.

Precautions in Handling Cable

Circular No. 78, A.E.F., dated July 6, 1918, contains the following instructions relative to handling cable:

Results obtained over the lead cable and Ferrin cable systems in use by the Signal Corps "will depend largely upon the manner in which the cable is handled prior to installation. For this reason the following instructions will be observed:

- "(a) Reels containing cable will be so located in yards or warehouses as to minimize the possibility of damage to the cable.
- "(b) Reels containing cable will be relagged after a section of the cable is removed.
- "(c) Cable on lagged and unlagged reels will be securely lashed and fastened to the reel in such a manner as to prevent movement of the cable on the reel while being transported.
- "(d) All paper cable on reels and sections of reels during installation will be securely sealed by means of a floated solder seal.
- "(e) Paper insulated cable will not be used as jumper cable by forming it in the shape usually prescribed for switchboard cable, thereby exposing the paper insulation."

