

TECHNICAL MANUAL

**OPERATOR'S, ORGANIZATIONAL, DIRECT SUPPORT,
AND GENERAL SUPPORT MAINTENANCE MANUAL**

INCLUDING REPAIR PARTS AND SPECIAL TOOLS LIST

**ANTENNA AS-2259/GR
(NSN 5985-00-106-6130)**

**HEADQUARTERS, DEPARTMENT OF THE ARMY
14 FEBRUARY 1986**



5

SAFETY STEPS TO FOLLOW IF SOMEONE IS THE VICTIM OF ELECTRICAL SHOCK

1

DO NOT TRY TO PULL OR GRAB THE INDIVIDUAL

2

IF POSSIBLE, TURN OFF THE ELECTRICAL POWER

3

IF YOU CANNOT TURN OFF THE ELECTRICAL POWER, PULL, PUSH, OR LIFT THE PERSON TO SAFETY USING A WOODEN POLE OR A ROPE OR SOME OTHER INSULATING MATERIAL

4

SEND FOR HELP AS SOON AS POSSIBLE

5

AFTER THE INJURED PERSON IS FREE OF CONTACT WITH THE SOURCE OF ELECTRICAL SHOCK, MOVE THE PERSON A SHORT DISTANCE AWAY AND IMMEDIATELY START ARTIFICIAL RESUSCITATION

WARNING

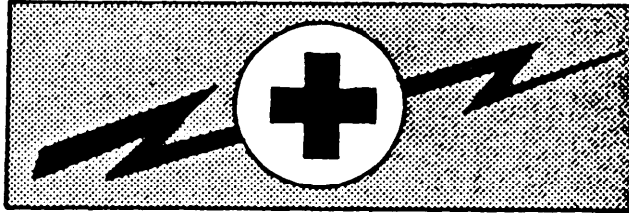

HIGH VOLTAGE

is used in the operation of this equipment

DEATH ON CONTACT

may result if personnel fail to observe safety precautions

Never work on electronic equipment unless there is another person nearby who is familiar with the operation and hazards of the equipment and who is competent in administering first aid. When the technician is aided by operators, he must warn thereabout dangerous areas.

Whenever possible, the power supply to the equipment must be shutoff before beginning work on the equipment. Take particular care to ground every capacitor likely to hold a dangerous potential. When working inside the equipment, after the power has been turned off, always ground every part before touching it.

Be careful not to contact high-voltage connections or 115 volt ac input connections when installing or operating this equipment.

Whenever the nature of the operation permits, keep one hand away from the equipment to reduce the hazard of current flowing through the body.

Warning: Do not be misled by the term "low voltage." Potentials as low as 50 volts may cause death under adverse conditions.

For Artificial Respiration, refer to FM 21-11.

SAFETY SUMMARY

The following are general safety precautions that are not related to any specific procedures and therefore do not appear elsewhere in this publication. These are recommended precautions that personnel must understand and apply during many phases of operation and maintenance.

KEEP AWAY FROM LIVE CIRCUITS

Operating personnel must at all times observe all safety regulations. Unless specifically directed in this manual, do not replace components or make adjustments inside the equipment with any power supply turned on. Under certain conditions, dangerous potentials may exist in the power supplies when the power control is in the off position. To avoid casualties, always remove power and discharge and ground a circuit before touching it.

DO NOT SERVICE OR ADJUST ALONE

Under no circumstances should any person reach into or enter the enclosure for the purpose of servicing or adjusting the equipment except in the presence of someone who is capable of rendering aid.

RESUSCITATION

FIRST AID

Each person engaged in electrical operations will be trained in first aid, particularly in the technique of mouth to mouth resuscitation and closed chest heart massage (FM 21-11).

The following warnings appear in this volume, and are repeated here for emphasis.

WARNING

A 3-wire (line, neutral, and safety ground) AC line power connections is required when operating the equipment. If a 3-wire safety grounded' AC power receptacle is not available, a separate ground wire must be installed from the chassis ground to an earth ground. Without an adequate ground, the equipment chassis and frame will float to a dangerously high potential.

WARNING

Lethal voltage is used in the operational checkout of this unit. Death on contact may result if personnel fail to observe the following safety precautions. Remove watches and rings and exercise extreme caution when working inside the equipment throughout the remainder of this procedure.

WARNING

Antenna must be installed a distance equal to at least twice the height of the antenna from power lines.

WARNING

When antenna is up for an extended period of time insure the mast is directly grounded through ground stake.

WARNING

Lifting heavy equipment incorrectly can cause serious injury. Do not try to lift more than 35 pounds by yourself. Get a helper. Bend legs while lifting. Don't support heavy weight with your back.

WARNING

Adequate ventilation should be provided while using TRICHLOROTRIFLUOROETHANE. Prolonged breathing of vapor should be avoided. The solvent should not be used near heat or open flame, the products of decomposition are toxic and irritating. Since TRICHLOROTRIFLUOROETHANE dissolves natural oils, prolonged contact with skin should be avoided. When necessary use gloves which the solvent cannot penetrate. If the solvent is taken internally, consult a physician.

Compressed air shall not be used for cleaning purposes except where reduced to less than 29 psi and then only with effective chip guarding and personnel protective equipment. Do not use compressed air to dry parts when TRICHLOROTRIFLUOROETHANE has been used. Compressed air is dangerous and can cause serious bodily harm if protective means or methods are not observed to prevent chip or particle (of whatever size) from being blown into the eyes or unbroken skin of the operator or other personnel.

Technical Manual

No. 11-5985-379-14 & P

HEADQUARTERS
DEPARTMENT OF THE ARMY
Washington, DC, 14 February 1986

**OPERATOR'S, ORGANIZATIONAL, DIRECT SUPPORT
AND GENERAL SUPPORT MAINTENANCE MANUAL**

INCLUDING REPAIR PARTS AND SPECIAL TOOLS LIST

**ANTENNA AS-2259/GR
(NSN 5985-00-106-6130)**

REPORTING ERRORS AND RECOMMENDING IMPROVEMENTS

You can help improve this manual. If you find any mistakes or if you know of a way to improve the procedures, please let us know. Mail your letter, DA Form 2028 (Recommended Changes to Publications and Blank Forms), or DA Form 2028-2 located in the back of this manual direct to: Commander, US Army Communications-Electronics Command and Fort Monmouth, ATTN: AMSEL-ME-MP, Fort Monmouth, NJ 07703-5007. A reply will be furnished to you.

TABLE OF CONTENTS

Section		Page
	WARNINGS	A through D
0	GENERAL	0-1
0-1	Scope	0-1
0-2	Consolidated Index of Army Publications and Blank Forms	0-1
0-3	Maintenance Forms, Records and Reports	0-1
0-4	Reporting Equipment Improvement Recommendations	0-1
0-5	Administrative Storage	0-1
0-6	Destruction of Army Electronics Materiel	0-1

TABLE OF CONTENTS

<u>Paragraph</u>		<u>Page</u>
SECTION I GENERAL INFORMATION		
1.0	Introduction	1-1
1.1	Equipment Description	1-1
1.2	Equipment Characteristics	1-3
1.3	Leading Particulars	1-3
SECTION II INSTALLATION		
2.0	General	2-1
2.1	Site Selection	2-1
2.2	Assembly Procedure	2-1
2.2.1	Vehicular Installation	2-2
2.3	Disassembly Procedure	2-2
2.4	Repacking Procedure	2-2
SECTION III THEORY OF OPERATION		
3.1	General	3-1
SECTION IV MAINTENANCE		
4.1	Routine Maintenance	4-1
4.2	Repair	4-1
SECTION V MAINTENANCE PARTS		
5.0	General	5-1
5.1	Item No.	5-1
5.2	Description	5-1
5.3	Entron Part Number	5-1
5.4	Illustrations	5-1
APPENDIX		
A	References	A-1
B	Maintenance Allocation	B-1
C	Components of End Item List	C-1
D	Additional Authorization List (Not applicable)	
E	Part Number-National Stock Number Cross Reference Index	E-1
F	Expendable Supplies and Materials List	F-1

LIST OF ILLUSTRATIONS

<u>Figure Number</u>		<u>Page</u>
1-1	AS-2259/GR Manpack HP Antenna.	1-2
2-1	AS-2259/GR Installation.	2-3
2-2	AS-2259/GR Antenna Stowed for Transporting in the Back-Pack Manner.	2-4
2-3	AS-2259/GR Being Unpacked.	2-5
2-4	AS-2259/GR Being Erected.	2-6
2-5	Vehicular Installation of AS-2259/GR, using Adapter MX-9313/GR.	2-7
3-1	Groundwave and Skywave Propagation from Vertical Antenna.	3-2
3-2	Surface-Wave Field Intensity.	3-3
3-3	Atmospheric Noise for 1-kHz B2 Vietnam July 1967.	3-4
3-4	Horizontal Antenna Mounted for Short-Range Sky-Wave.	3-5
3-5	Sky-Wave Versus Surface-Wave Propagation.	3-6
3-6	Conditions Under Which Antenna Must Operate.	3-7
3-7	Maximum Usable Frequencies in Vietnam.	3-7
3-8	Required Signal Level.	3-8
3-9	Required Antenna Gain.	3-8
3-10	Typical Input Resistance in Ohms Compared to Power Lost in dB Versus Antenna Height.	3-9
3-11	AS-2259/GR Antenna.	3-10
3-12	2.5 MHz Azimuth Plane Pattern, Average Ground.	3-11
3-13	2.5 MHz Elevation Plane Pattern, Average Ground.	3-11
3-14	6.0 MHz Azimuth Plane Pattern, Average Ground.	3-12
3-15	6.0 MHz Elevation Plane Pattern, Average Ground.	3-12
3-16	9.5 MHz Azimuth Plane Pattern, Average Ground.	3-13
3-17	9.5 MHz Elevation Plane Pattern, Average Ground.	3-13
3-18	15.5 MHz Azimuth Plane Pattern, Average Ground.	3-14
3-19	15.5 MHz Elevation Plane Pattern, Average Ground.	3-14
5-1	AS-2259/GR Antenna, Parts Location.	5-2
5-2	Base Assembly, Parts Location	5-4
5-3	Adapter, MX-9313/GR, Parts Location	5-5

LIST OF TABLES

<u>Table</u>		<u>Page</u>
1-1	Summary of Equipment.	1-1
1-2	Leading Particulars.	1-3
1-3	Equipment Supplied.	1-4

SECTION 0

GENERAL

0-1. SCOPE. This manual covers Antenna AS-2259/GR. This manual covers operator's, organizational, direct support and general support maintenance.

0-2. CONSOLIDATED INDEX OF ARMY PUBLICATIONS AND BLANK FORMS. Refer to the latest issue of DA Pam 310-1 to determine whether there are new editions, changes or additional publications pertaining to the equipment.

0-3. MAINTENANCE FORMS, RECORDS, AND REPORTS

a. Reports of Maintenance and Unsatisfactory Equipment. Department of the Army forms and procedures used for equipment maintenance will be those prescribed by DA Pam 738-750 as contained in Maintenance Management Update.

b. Report of Packaging and Handling Deficiencies. Fill out and forward SF 364 (Report of Discrepancy (ROD)) as prescribed in AR 735-11-2/DLAR 4140.55/NAVMATINST 4355.74A/AFR-400-54/MCO 4430.3F.

c. Discrepancy in Shipment Report (DISREP) (SF 361). Fill out and forward Discrepancy in Shipment Report (DISREP) (SF 361) as prescribed in AR 55-38/NAVSUPINST 4610.33C/AFR 75-18/MCO P4610. 19/DLAR 4500.15.

0-4. REPORTING EQUIPMENT IMPROVEMENT RECOMMENDATIONS (EIR). If your Antenna AS-2259/GR needs improvement, let us know. Send us an EIR. You, the user, are the only one who can tell us what you don't like about your equipment. Put it on an SF 368 (Quality Deficiency Report). Mail it to Commander, US Army Communications-Electronics Command and Fort Monmouth, ATTN: AMSEL-ME-MP, Fort Monmouth, New Jersey 07703-5007. We'll send you a reply.

0-5. ADMINISTRATIVE STORAGE. Administrative Storage of equipment issued to and used by Army activities will have preventive maintenance performed in accordance with the PMCS charts before storing. When removing the equipment from administrative storage the PMCS should be performed to assure operational readiness. Disassembly and repacking of equipment for shipment or limited storage are covered in TM 740-90-1.

0-6. DESTRUCTION OF ARMY ELECTRONICS MATERIEL. Destruction of Army electronics materiel to prevent enemy use shall be in accordance with TM 750-244-2.

SECTION I

GENERAL INFORMATION

1.0 INTRODUCTION

This instruction manual contains technical data, installation procedures, theory of operation, maintenance instructions, and an illustrated parts list covering the AS-2259/GR Manpack Antenna and the Adapter, MX-9313/GR.

The antenna was designed to be used with short range tactical hf radio sets that use a 15-foot whip antenna, such as the AN/PRC-47. The Adapter, MX-9313/GR is used to interface the antenna with heavier radio sets such as the AN/TRC-75, AN/MRC-83, AN/MRC-87, and AN/TSC-15.

The instruction manual is divided into five sections. These sections provide general information, installation procedures, theory of operation, maintenance instructions! and maintenance parts lists.

Table 1-1 SUMMARY OF EQUIPMENT	
MILITARY TYPE NO.	DESCRIPTION OF EQUIPMENT
AS-2259/GR	An antenna which may be used directly with hf manpack radios that tune a 15-foot whip antenna, such as the AN/PRC-47. The antenna is rated at 1000 watts pep or average rf power.
MX-9313/GR	An adapter fitting for mounting the antenna on vehicles or shelters equipped with hf radios. Adapts Antenna AS-2259/GR to the AN/TRC-75, AN/MRC-83, AN/MRC-87, AN/TSC-15, and similar radios employing 1-inch 8 threads per inch whip bases and automatic couplers.

1.1 EQUIPMENT DESCRIPTION

The AS-2259/GR Manpack HF Antenna (Figure 1-1) is essentially a dipole antenna fed with a low-loss, foam-dielectric, coaxial mast that also serves as a support structure. The dipole system uses a set of crossed sloping dipoles positioned at right angles to each other. Physically the antenna consists of eight light-weight coaxial mast sections and four radiating elements that also serve as guys. The antenna is transported in a canvas pack similar to a tool roll. The total packed weight of the antenna is 14.7 pounds. Erection is accomplished by two men in 5 minutes without the use of any tools.

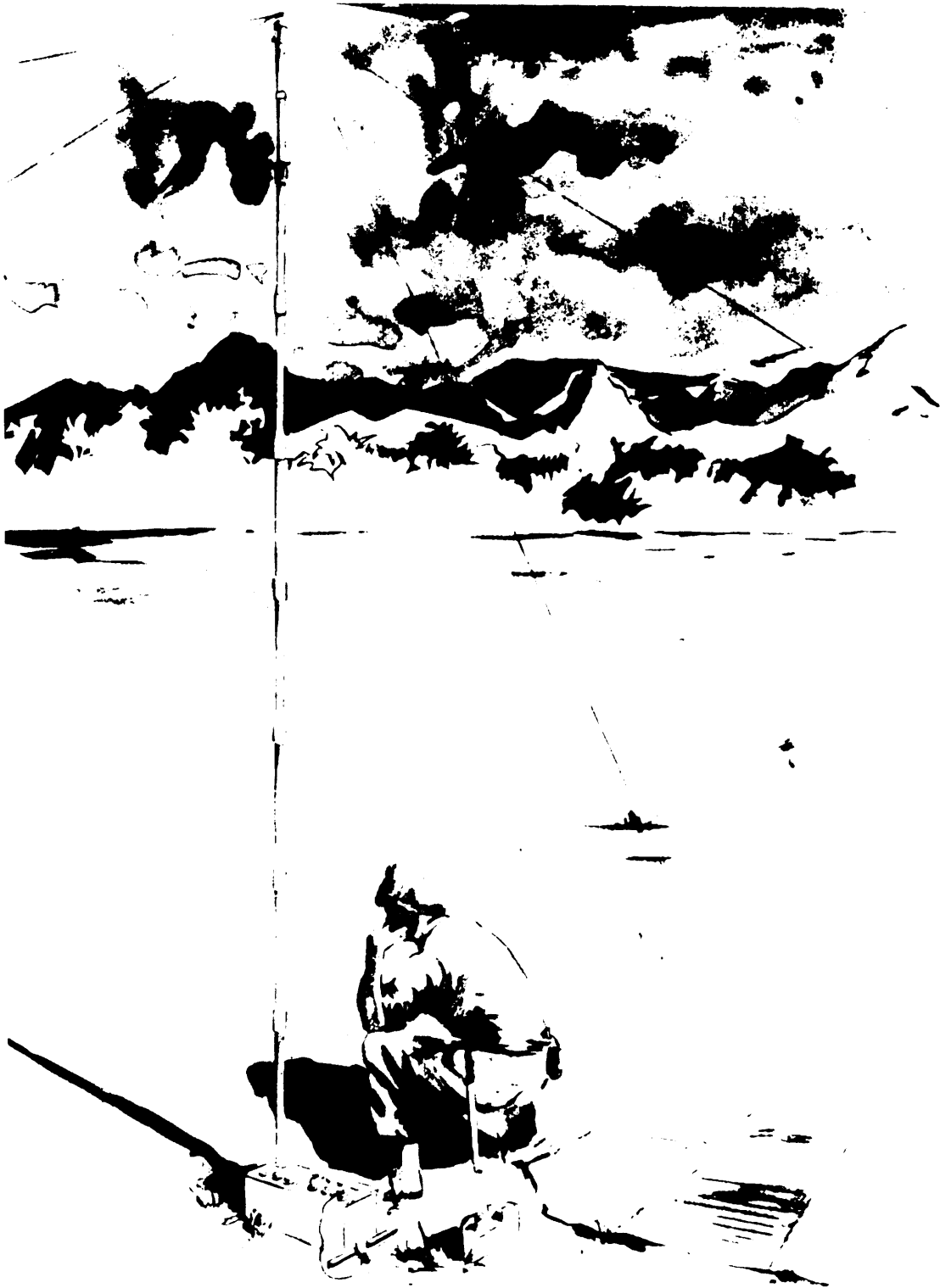

Figure 1-1. AS-2259/GR Manpack HF Antenna.

1.2 EQUIPMENT CHARACTERISTICS

The AS-2259/GR antenna is designed to provide high-angle radiation (near vertical incidence) to permit short-range skywave propagation over communication circuits varying from 0 to 300 miles. The AS-2259/GR may be used with tactical hf radios that tune a 15-foot whip antenna, such as the AN/PRC-47. The frequency range of the antenna is 2.0 to 30.0 MHz and maximum rf power capacity is 1000 watts pep, or average.

1.3 LEADING PARTICULARS

Leading particulars and equipment supplied for the AS-2259/GR are listed in Tables 1-2 and 1-3. Personnel should become thoroughly familiar with data and procedures contained in the entire instruction manual before working on or using the antenna.

Table 1-2 Leading Particulars	
ITEM	LEADING PARTICULARS
Electrical Characteristics:	
Frequency range	2.0 to 30.0 MHz.
Polarization	Horizontal and vertical simultaneously.
RF power capacity	1000 watts pep or average.
Input impedance	Compatible with output of radios using 15-foot whips, such as the AN/PRC-47.
Radiation pattern:	
Azimuth	Omnidirectional.
Elevation	Near vertical incidence.
Gain:	Similar to a dipole mounted horizontally, 10 feet above same type ground.
Physical Characteristics:	
Wind and ice	Survives 60 mph wind with no ice.
Height erected	15 feet.
Land area required	60 by 60 feet.
Erection time	Two men, 5 minutes; one man 15 minutes.
Packed weight	Less than 14.7 pounds.

Table 1-2 Leading Particulars (cont'd)	
ITEM	LEADING PARTICULARS
Packed dimensions:	
Length	27 inches.
Diameter	Less than 7 inches.

Table 1-3 Equipment Supplied.		
ITEM	PART NUMBER	QUANTITY
AS-2259/GR Antenna	7270-5377-001	1
Mast assembly, top	7270-5067-001	1
Section, Mast	7270-5043-001	7
Case, carrying	7270-5065-001	1
Base assembly	7270-5061-001	1

Note: Refer to section V, Parts list, for detailed breakdown of Antenna, base assembly, and Adapter parts.

SECTION II

INSTALLATION

2.0 GENERAL

Erection and disassembly procedures for the AS-2259/GR antenna are given in the following paragraphs. Erection can be accomplished by two men in 5 minutes. See Figures 2-1 through 2-4 for pictorial sequence of transporting, unpacking, and erection. Figure 2-5 illustrates the use of Adapter MX-9313/GR for use with vehicular mounted radios.

2.1 SITE SELECTION

For maximum antenna operating efficiency, the AS-2259/GR should be located in the center of a clear area. Installation of the antenna near any tall metal object or under heavy foliage should be avoided. Under no circumstances should structures come in contact with the antenna.

2.2 ASSEMBLY PROCEDURE

WARNING

Be sure transmitter power is off before proceeding with antenna assembly. Electrical burns will result if contact is made with the antenna when the transmitter is keyed. Electrical burns will result if contact is made with the antenna mast or metal portion of antenna guys.

WARNING

Antenna must be installed a distance equal to at least twice the height of the antenna from power lines.

WARNING

When antenna is up for an extended period of time insure the mast indirectly grounded through ground stake.

- a. Open antenna pack and remove base assembly. Install base on AN/PRC-47 antenna input connector. Connect ground wire from base to ground terminal provided on the radio.
- b. Remove top mast assembly, install in mast base, and uncoil elements (see Figures 2-1A and 2-1D). Note that the antenna elements are stretched along the direction in which they leave the top housing and are not shorted to each other or to the mast.
- c. Measure anchor positions, using the sleeve cable markers as guides, and install anchors as shown in Figure 2-1B.

NOTE

Before connecting mast sections, wipe unpainted surfaces clean of mud or dirt to ensure good electrical contact.

- d. Assemble mast by raising top mast assembly and inserting mast sections as shown in Figure 2-1C.
- e. Adjust tension on all elements until mast is plumb. Elements need not be excessively taut. A tension of approximately 3 to 5 pounds is sufficient.

2.2.1 VEHICULAR INSTALLATION

Installation of the AS-2259/CR antenna on vehicular mounts is the same as that of the antenna as described in 2.2 above, except the vehicular whip mount is used rather than the AN/PRC-47 radio, and the Adapter MX-9313/GR is used instead of the base assembly. Use only as many mast sections as are necessary to raise the top of the antenna to approximately 16 feet 9 inches high. See Figure 2-5.

2.3 DISASSEMBLY PROCEDURE

Disassembly is performed in the reverse order of assembly. Remove stakes, disassemble mast, and coil elements on hooks provided on top mast section. When coiling the radiating elements, first pull all four anchor stakes and leave them on the ground. Return to the mast and coil each element onto the hooks, pulling the element toward the mast as it is coiled. Otherwise kinks in the elements may result and the elements may become entangled. Secure the elements in place on the top mast assembly with the web belt.

2.4 REPACKING PROCEDURE

Insert top mast assembly, with elements coiled on it, in the large pocket in the carrying case. Insert the remaining mast sections in the pockets provided. The antenna packs more compactly if the base assembly is inserted in a mast section which is inserted into the third pocket (one pocket away from the top mast assembly). Be sure the tune-load chart is attached to the base assembly. Fold over the side flaps, roll the pack tightly, and buckle the two small belts.

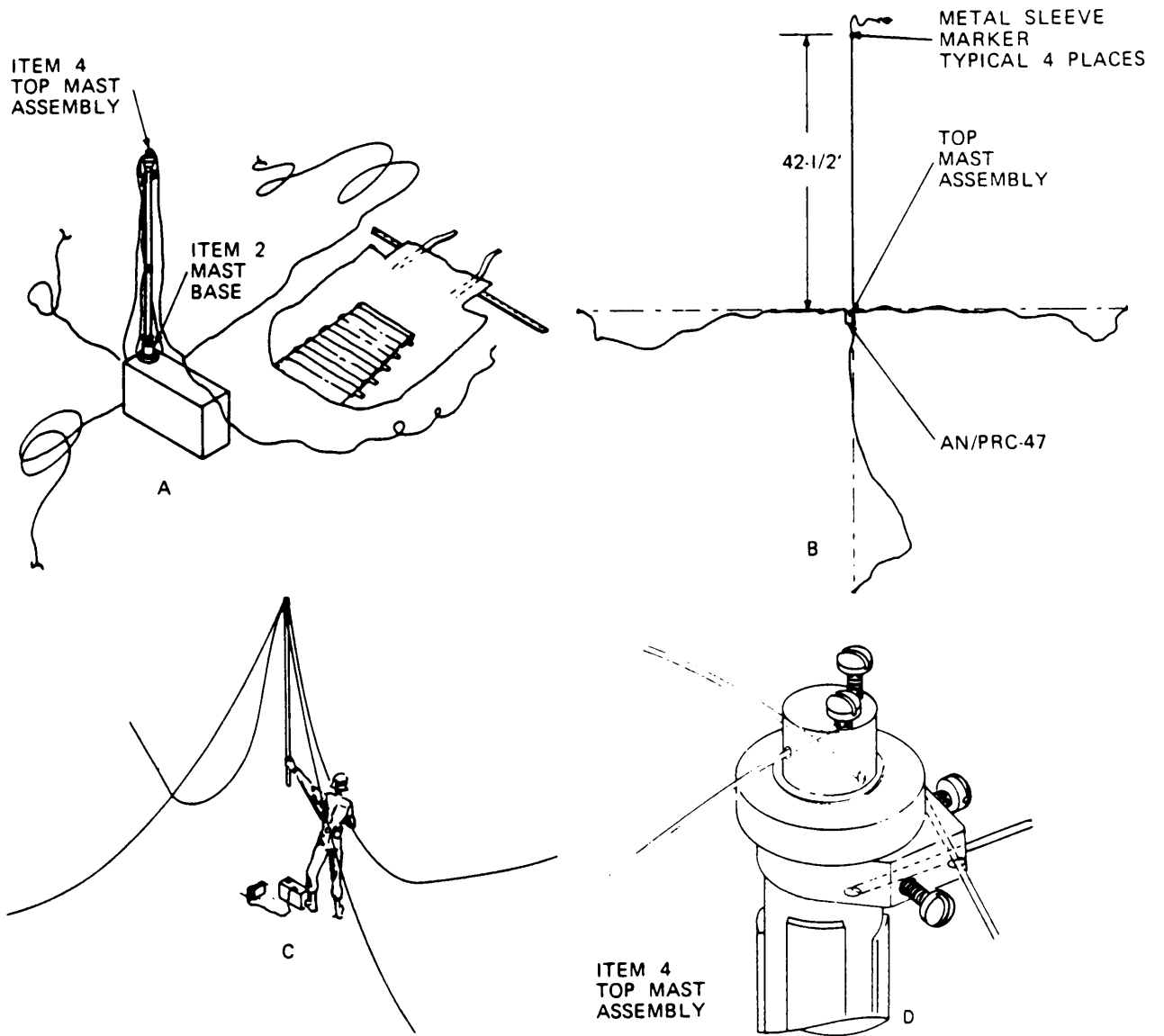

Figure 2-1. AS-2259/GR Installation.



Figure 2-2. AS-2259/GR Antenna Stowed for Transporting in the Back-Pack Manner.



Figure 2-3. AS-2259/GR being Unpacked.

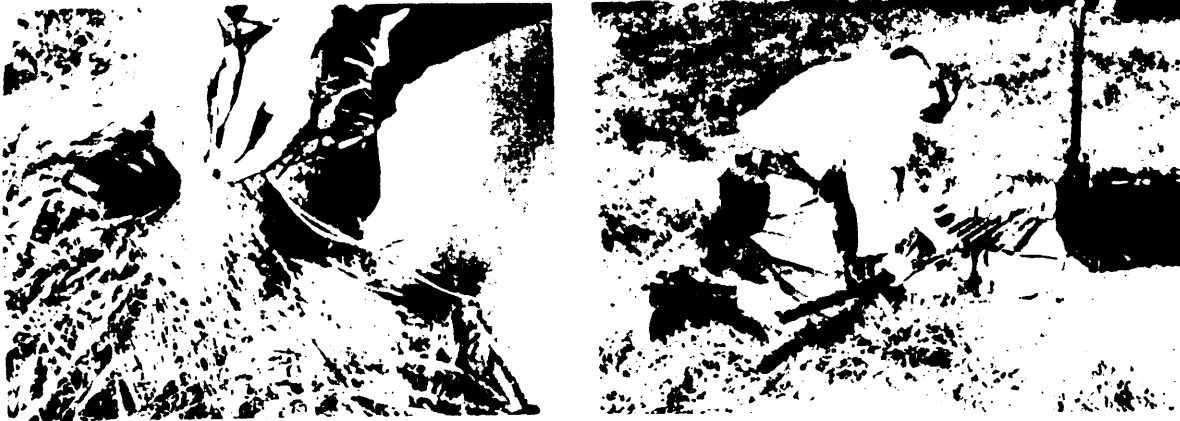

Figure 2-4. AS-2259/GR being Erected.

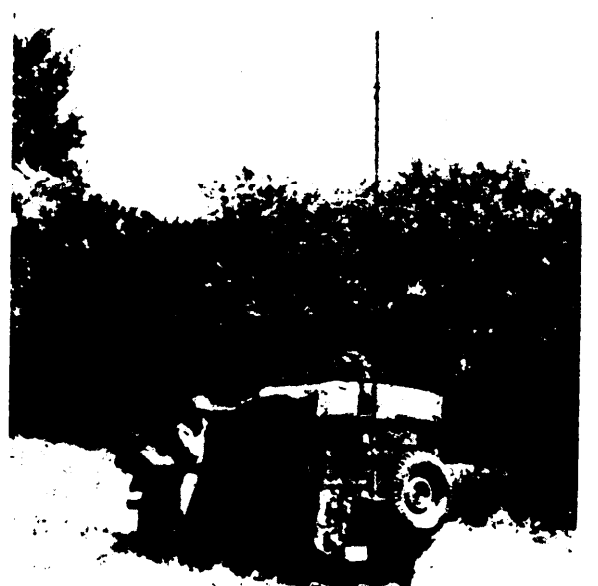

Figure 2-5. Vehicular Installation of AS-2259/GR Antenna using Adapter MX-9313/GR.

section 3

theory of operation

3.1 GENERAL

In the past, most short-range hf communication circuits used vertical whip antennas. With these antennas, communications are achieved on very short ranges by ground-wave (surface-wave propagation), and longer paths are achieved by sky-wave propagation. See figure 3-1. An inherent characteristic of radio-wave propagation, using whip antennas, is the zone of silence (skip zone) between the point where the ground-wave signal becomes unusable and the sky-wave signal starts to become usable. (For example, see Radio Amateur's Handbook, Ionospheric Propagation, most editions). Depending upon terrain, ground conductivity, operating frequency, noise levels, etc., ground-wave signals (1-kW transmitters) are usable up to about 70 miles over average soil. Also, minimum distances for sky-wave paths, using whips, are generally 200 miles (E-layer) during the day and 400 miles (F-layer) at night.

While the skip zone, described above, severely limits the usefulness of whip antennas for short-range communications, conditions become even worse in an adverse environment, such as a hilly or jungle-type terrain. This occurs because of the restricted range of ground-wave signals in these environments.

Figure 3-2 shows the expected signal levels for ground-wave propagation, as a function of distance, for several types of soil conditions and for dense jungle environments. These signals assume 1-kW transmitters, operating frequency of 2 MHz (attenuation is lowest for lower hf frequencies), and a 16-foot whip with a minimum-type ground screen, such as a shelter-mounted whip. Signal levels are plotted in dB above 1 microvolt per meter.

The inverse distance field is the field that would be present if there were no attenuation due to the surface over which the signal is propagated. The strongest practical signals occur over seawater. As the soil conductivity decreases or as the foliage increases, the signal strength at a distance decreases rapidly. The important consideration

for communications is not the value of signal level, but the signal-to-noise ratio,

As an example of typical noise encountered, figure 3-3 shows the upper and lower limits of noise as a function of time of day at the frequency of 2-MHz and 1-kHz bandwidth for Vietnam in July of 1967 (reference CCIR Report 322). Also figure 3-3 depicts (for a 1-kW transmitter and a 16-foot whip) signal levels of 10, 25, and 40 dB above 1 microvolt per meter with corresponding distances taken from figure 3-2 for various types of soil conditions. Good ground-wave communications are expected at 25 miles at any time of the day for good ground conditions, and the range may be as much as 100 miles for a couple of hours at midday. However, if the environment is dense jungle instead of good ground, the maximum ground-wave communication range is 1 mile or less,

From the above discussion, it is clear that a skip zone is present when vertical whip antennas are used. The extent of the skip zone is dependent upon soil conditions. For average environments, the skip zone lies between 70 and 200/300 miles; however, in extreme environments, it may include the range from 1 to 200/300 miles.

The skip zone is of a very critical range for most tactical communication systems including manpack, vehicular, and shelter equipments. Most tactical requirements necessitate good communications in the 0- to 300-mile range. If hf communications are to be effective in this range, different antennas and propagation modes are necessary.

The solution to the short-range communication problem is the use of sky-wave instead of ground-wave propagation on the short paths. This requires radiation from the antenna at very high elevation angles (near vertical incidence) as shown in figure 3-4 and 3-5. Radiation characteristics of this type are achieved through the use of horizontal antennas mounted above ground up to a height of about one-quarter

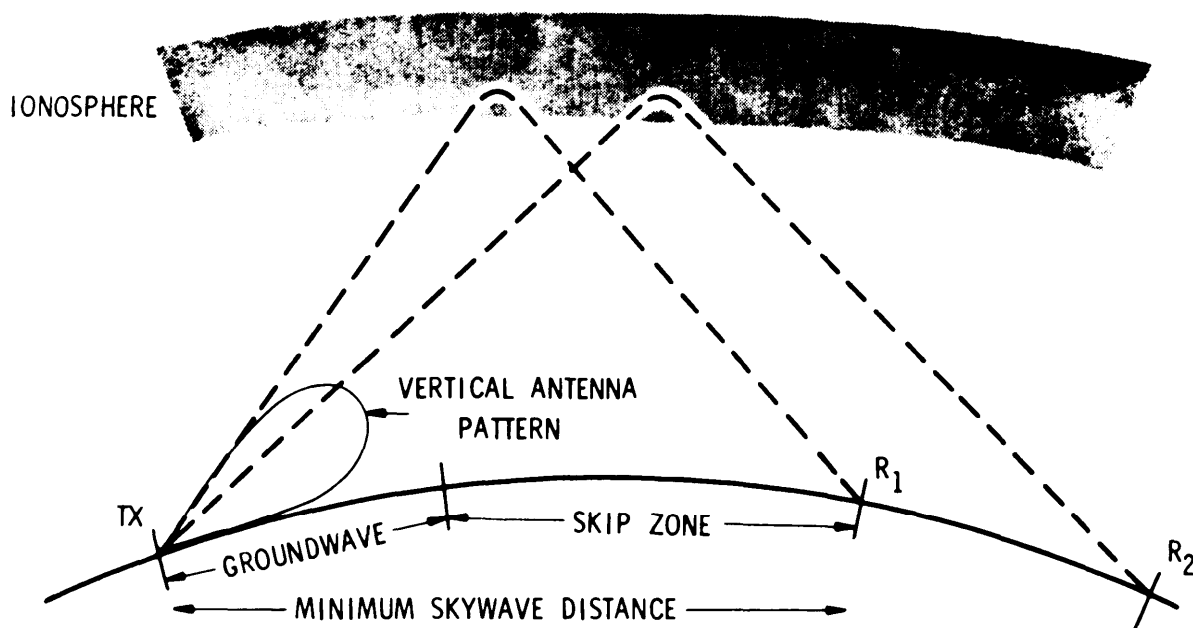

Figure 3-1. Ground-Wave and Sky-Wave Propagation From Vertical Antenna.

wavelength. Such radiation characteristics are omnidirectional in azimuth and provide a 1-hop range of about 300 miles. The antenna gain varies mainly with the height of the antenna above ground. Because it is highly desirable to have minimum height and weight for tactical antennas, the immediate problem becomes one of determining the minimum effective antenna height required.

In order to determine the required antenna height, a minimum acceptable level of performance is established as necessary to permit communications in South Vietnam. Figure 3-6 specifies the conditions for which communications are required. June 1965 was picked because of the low sunspot number and consequently, the requirement for low-operating frequency. An analysis was conducted, using 0500 hours local time because of the difficulty in communicating in the hours just before dawn. The AN/PRC-47 radio was selected because of its extensive use. A service factor of 28-dB signal-to-median noise was selected to provide 90 percent intelligibility, 50 percent of the time. (For example, see Median Signal Power Required for Reception of Radio Transmission in the Presence of Noise, US Army Signal Radio Propaga-

tion Agency Technical Report No. 5, Revised June, 1961, ASTIA AD 262 209.)

The first step of the analysis determined the operating frequency for the conditions cited. Figure 3-7 shows the maximum usable frequencies (MUF). This data is taken from Central Radio Propagation Laboratory, Ionospheric Predictions, National Bureau of Standards (now Environmental Science Service Administration). As shown in figure 3-7, the lowest MUF is 3.5 MHz, which occurred at 0500 local time.

The next step determines the noise levels. These were computed, using CCIR Report 322. Noise levels at 3.5 MHz for the above location and time were found to be: median, 1 dB above 1 microvolt per meter ($\mu\text{v}/\text{m}$); lower decile, -10 dB >1 $\mu\text{v}/\text{m}$; and upper decile +12 dB >1 $\mu\text{v}/\text{m}$. The required signal level (field strength) is then the median noise level plus the service factor, or 29 dB above 1 microvolt/meter. An additional 4 dB is added to this figure to ensure field strength down to 45 degrees above the horizon. Figure 3-8 shows the required field strength to be 33 dB above 1 microvolt/meter.

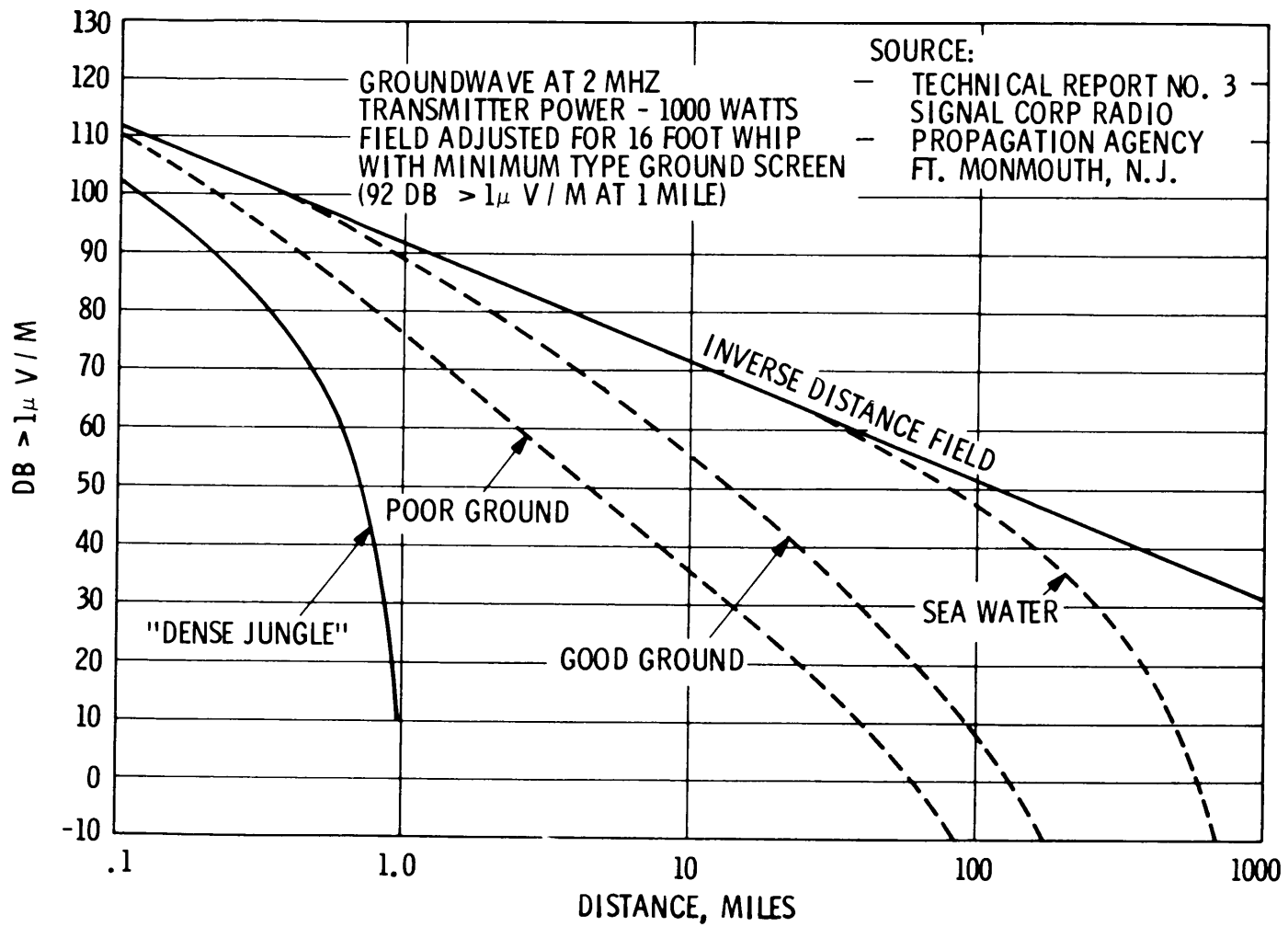

Figure 3-2. Surface-Wave Field Intensity.

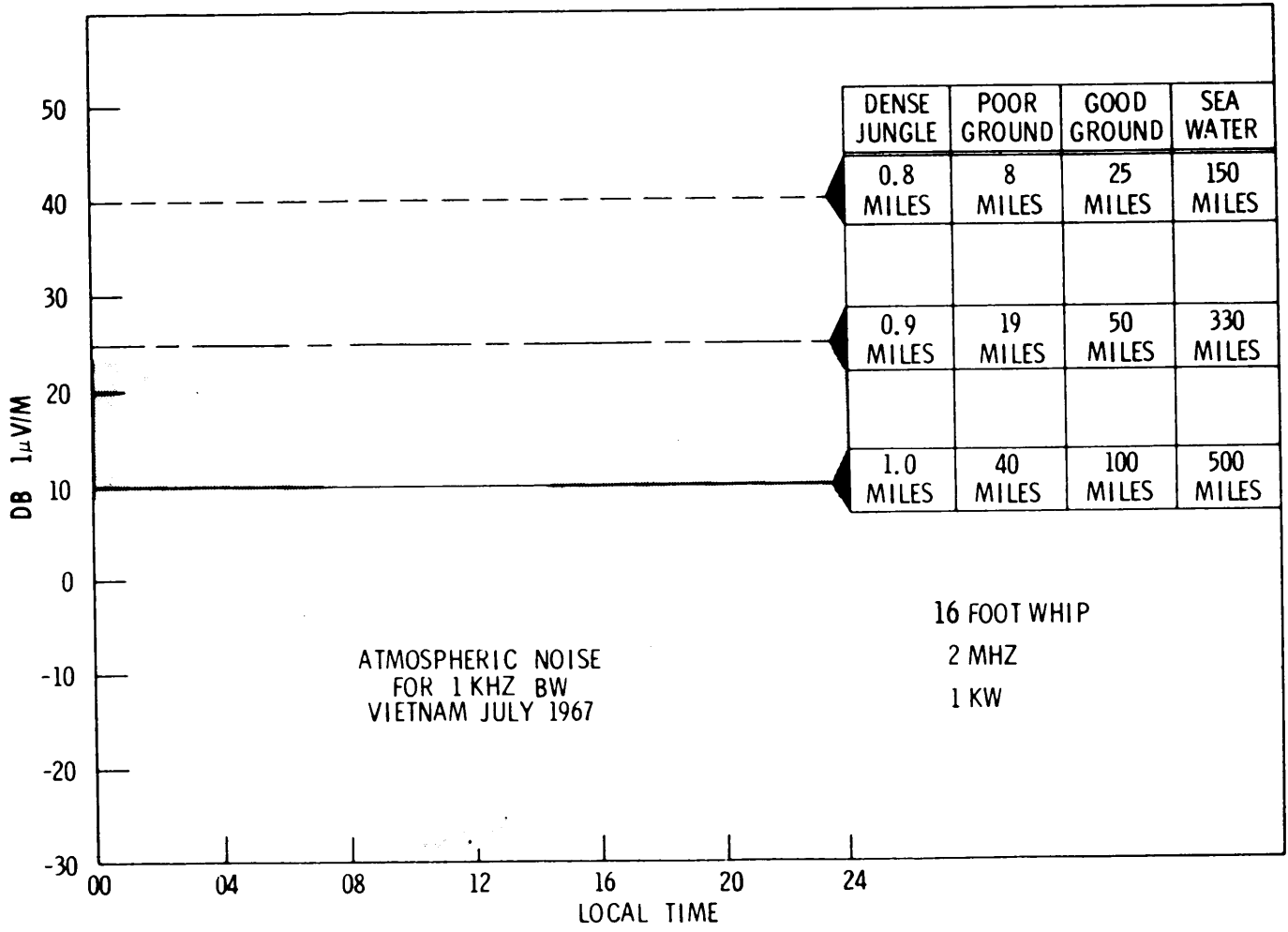

Figure 3-3. Atmospheric Noise for 1-KHz B2, Vietnam July 1967.

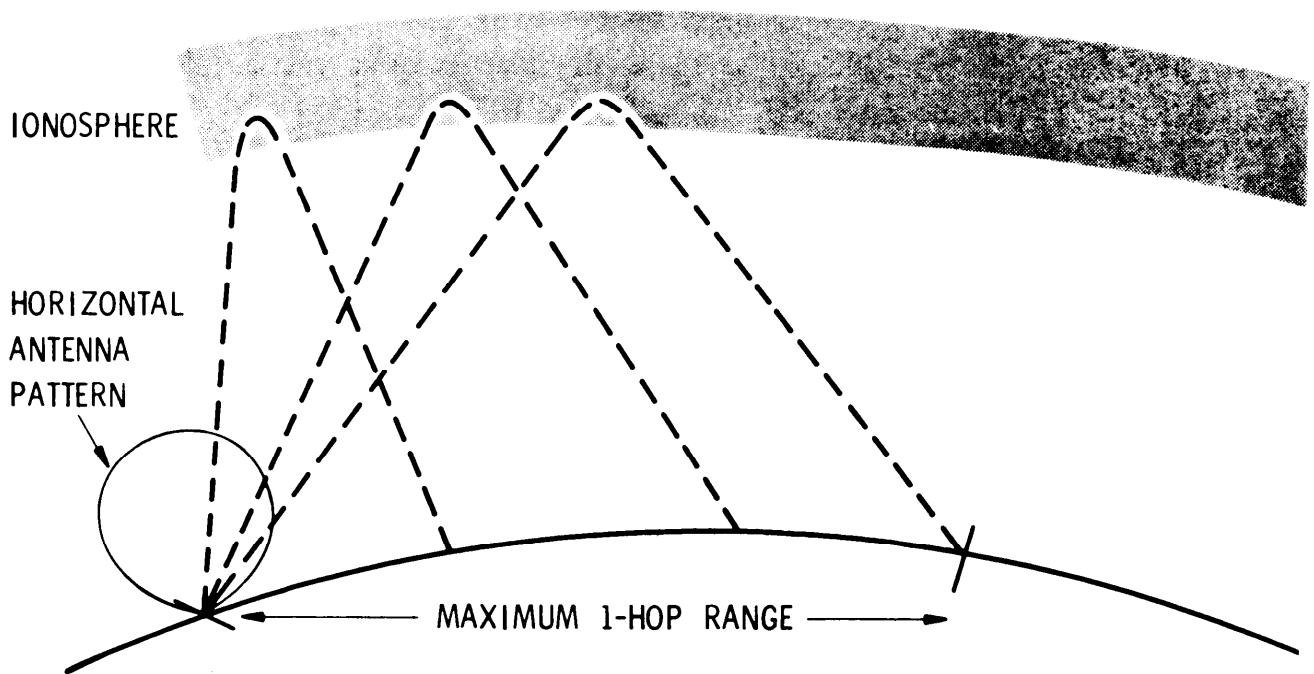

Figure 3-4. Horizontal Antenna Mounted for Short-Range Sky Wave.

The required antenna gain is computed to provide a given field strength at a receiver site from the total propagation path loss, the operating frequency, and the transmitter power. The total path loss is found to be 101 dB (NBS Report 72491). The power delivered to the antenna by the AN/PRC-47 is assumed to be 25 watts, taking into account coupler losses. The equation for computing the required antenna gain is shown in figure 3-9. The gain is 2 dB above an isotropic radiator.

The required effective height of the antenna is found by considering the following.

When a horizontal antenna is close to ground, energy is radiated in two modes. The desired dipole mode produces radiation with a maximum in the vertical direction. The undesirable Beverage mode creates a vertical electric field between the conductor and ground, producing vertically polarized ground-wave signal with a maximum in

the direction off the dipole or wire ends. Due to the proximity of the antenna to ground, this latter mode radiates like a lossy transmission line and its efficiency is generally poorer than a whip.

The shape of the radiation pattern of the horizontal dipole is essentially constant for heights not exceeding one-quarter wavelength. The directive gain of these horizontal antennas is 7 dB above an isotropic. Half-power beamwidths of the vertically radiated lobe are 80 degrees in the plane of the dipole and 100 degrees in the plane normal to the dipole axis.

For a fixed height above ground, the amount of the input power radiated proportionately in each of these modes is a function of the relative percentage of the antenna input resistance characterizing each mode. Each of these, in turn, is a function of the height above ground. Figure 3-10 shows the total input resistance and that portion due to the dipole mode as the dipole height is varied. As the height

¹Haydon, G. W., Lucas, D. L., and Harrison, R. A., "Technical Considerations in the Selection of Optimum Frequencies for High Frequency Skywave Communication Services," p. 45, NBS Report 7249, U. S. Dept. of Commerce, Boulder, Colorado.

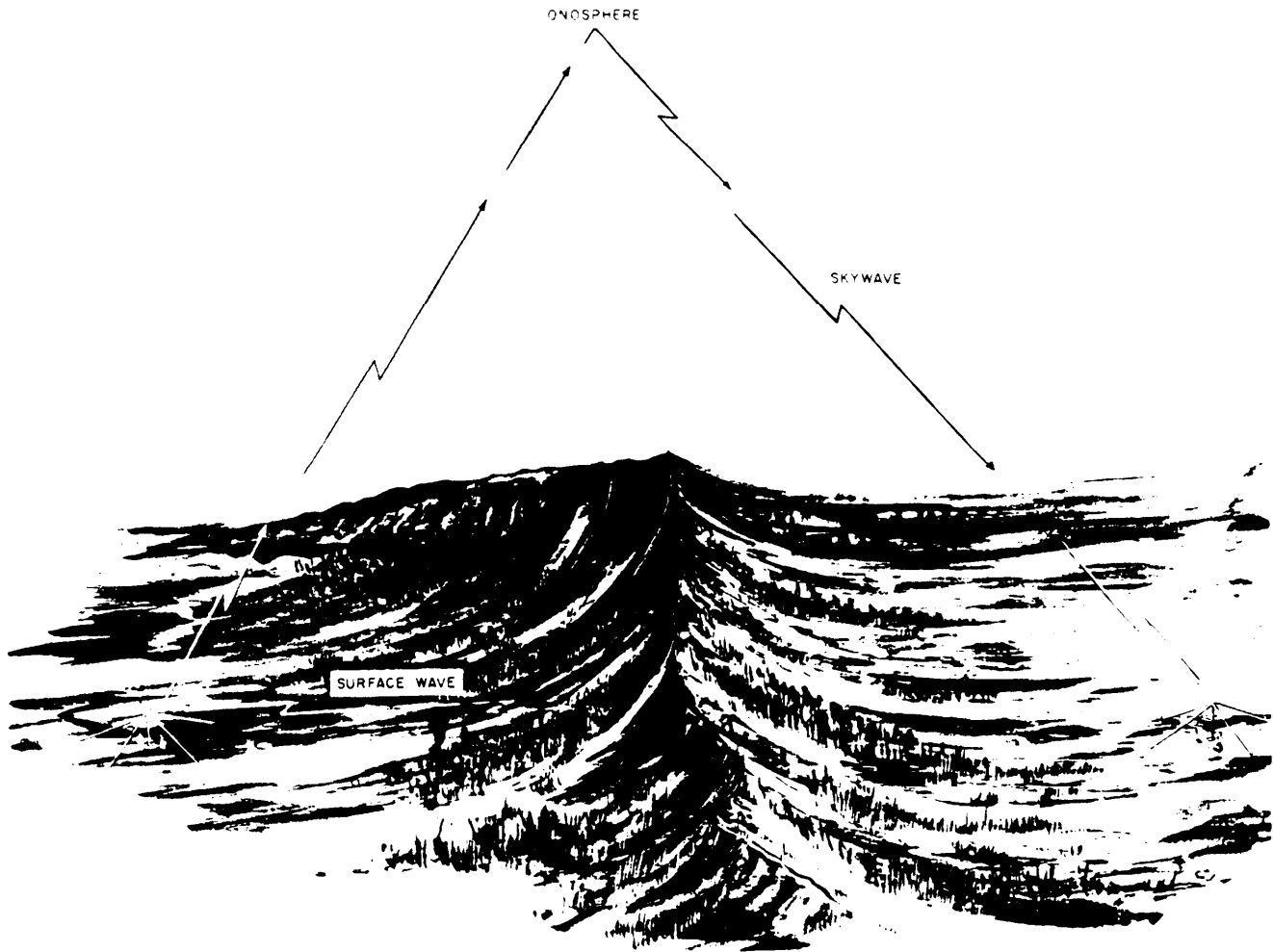

Figure 3-5. Sky-Wave Versus Surface-Wave Propagation.

increases, a larger part of the input signal is radiated in the dipole mode. These resistances are typical of those encountered over average ground.

The efficiency of the dipole mode is then the ratio of the dipole mode resistance to the total input resistance. The gain of the horizontal dipole antenna is then

$$G = 7-10 \log \frac{\text{Total Resistance}}{\text{Dipole Mode Resistance.}}$$

The required antenna gain was previously found to be +2 dBi. Assuming 0.5 dB transmission line losses, 2.5 dBi is allowed for the antenna, leaving

an acceptable loss of 4.5 dB due to ground (Beverage mode). This requires an antenna height of 0.035 wavelength $\left[\text{figure 3-10 } \left(10 \log \frac{39}{14} = 4.5 \text{ dB} \right) \right]$.

An effective height of 0.035 wavelength is about 10 feet at 3.5 MHz.

An effective height of 10 feet can be achieved by a horizontal dipole mounted between two 10-foot towers or by a sloping dipole mounted from a taller single mast at its center. The latter is desirable for tactical requirements because weight, volume, and erection time need be minimized. The single mast may also serve as a very low-loss transmission line feeding the dipole element. An

- HF SKY-WAVE MODE
- LOCATION SOUTH VIETNAM
- MANPACK RADIO - AN/PRC-47
- JUNE 1965
- LOW SUNSPOT NUMBER 16
- TIME OF DAY 0500 HOURS, L. T.
- 28-DB SIGNAL TO NOISE (1-KHZ BANDWIDTH)

Figure 3-6. Conditions Under Which Antenna Must Operate.

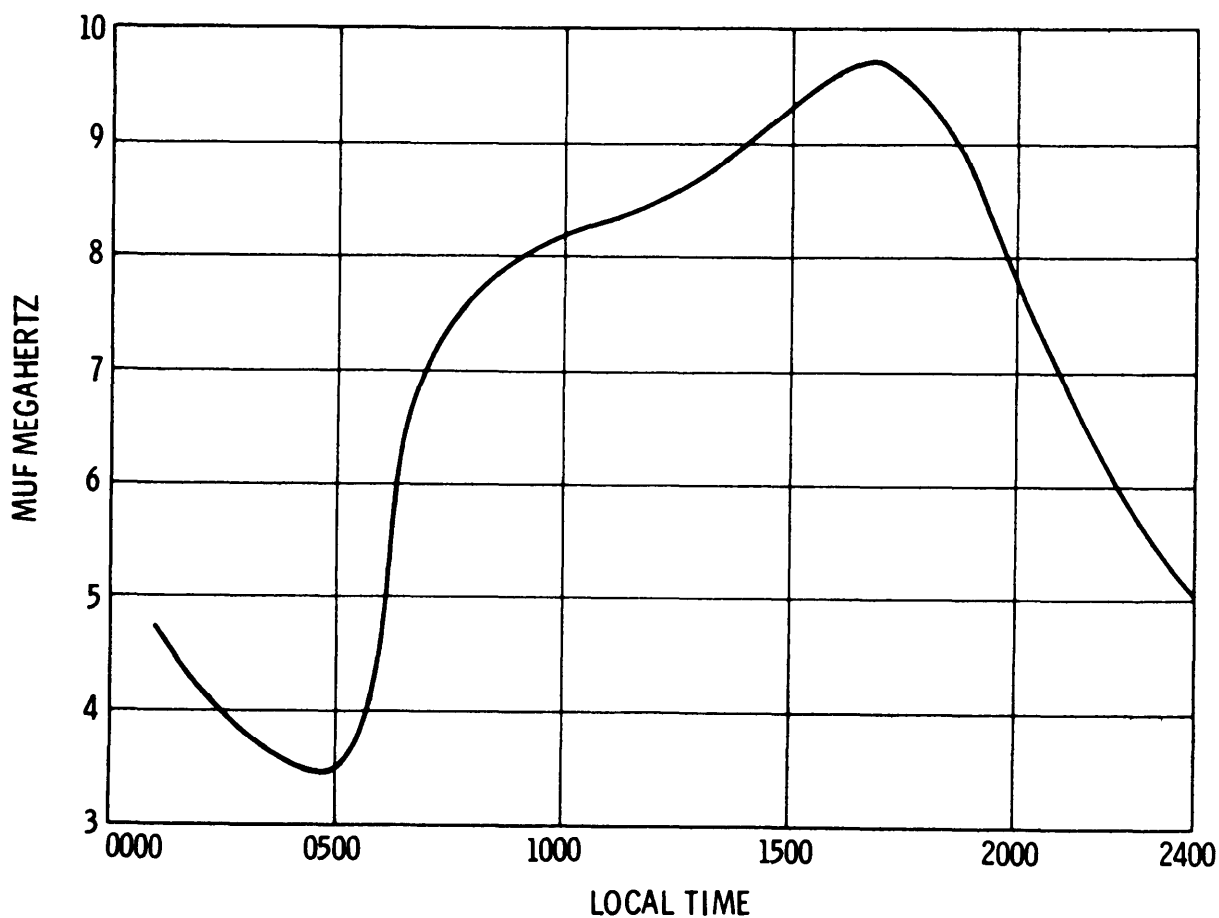

Figure 3-7. Maximum Usable Frequencies in Vietnam.

MEDIAN NOISE (CCIR RPT 322)	1 DB $>1\mu V / M$
SERVICE FACTOR (90% INTELLIGIBILITY)	28 DB
ELEVATION PATTERN COVERAGE TO 45°	4 DB
	<hr/>
REQUIRED SIGNAL LEVEL	33 DB ABOVE $1\mu V / M$

Figure 3-8. Required Signal Level.

$$G - E + L - 107.2 - 20 \text{ LOG } F - 10 \text{ LOG } P$$

G - REQUIRED ANTENNA GAIN, DB ABOVE ISOTROPIC
 E - REQUIRED FIELD STRENGTH AT RECEIVER SITE (33),
 DB $>1\mu V / M$
 L - TOTAL PATH LOSS (101), DB
 P - TRANSMITTER POWER (25), WATTS

$$G - 33 + 101 - 107.2 - 10.8 - 14$$

REQUIRED ANTENNA GAIN - 2 DBI

Figure 3-9. Required Antenna Gain.

additional advantage of the sloping dipole configuration is the vertically polarized component (a figure eight-type radiation pattern) produced at the low frequencies that permits compatibility with whip antennas where propagation conditions permit.

In order to provide an acceptable impedance to the tuner of the AN/PRC-47, it is necessary to make the sloping dipole fat. This is done by using two wires for each half of the dipole. The four wires are equally spaced about the mast and serve as guys as well as radiators.

Figure 3-11 shows the AS-2259 antenna (Collins 637K-1) and depicts the design of the mast, feed, insulators, and ground stakes. The mast also serves as the transmission line, feeding

the dipole elements at a height of 15 feet. The coaxial mast consists of eight identical sections, and is constructed of aluminum. The inner conductor of the coaxial mast is held concentrically within the outer conductor with a polyurethane foam. Bayonet-type joints allow the mast sections to be joined together quickly and positively.

The dipole radiating elements consist of four wires positioned at right angles to one another. They slope down to the earth and are made of flexible phosphor bronze wire with short lengths of nylon rope attached to the ends through insulators. Two of the elements are connected to the inner conductor of the coaxial mast and the other two are connected to the outer conductor.

Typical Input Resistance of Halfwave Dipole Over Ground

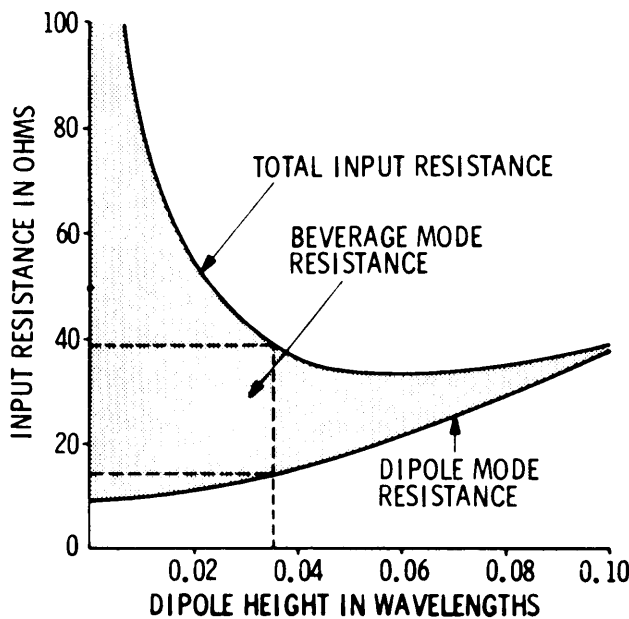

Power Lost to Beverage Mode in Dipole Over Ground

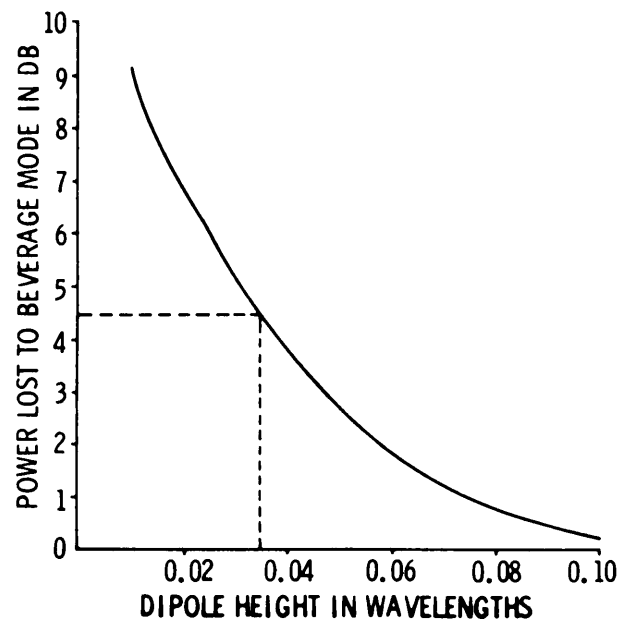

Figure 3-10. Typical Input Resistance in Ohms Compared to Power Lost in dB Versus Antenna Height.

A full-scale antenna was erected and antenna current distributions were measured at a number of frequencies. Radiation patterns and antenna gains are computed from these currents to provide full-scale performance data. Field patterns are provided at a number of frequencies (figures 3-12 through 3-19) followed by gain contours of the antenna plotted on a general propagation chart (figure 3-10). As shown by the general propagation chart, the antenna provides good gain on short paths varying from 0 to about 300 miles.

The performance of the 637K antenna was verified in December 1967. Tests were conducted

by the U. S. Marine Corps and Collins Radio Co. at the Panama Canal Zone in the jungle environment. Five test sites, varying from 10 to 300 miles from the main transmitting site, were selected. Jungle canopy varied from 50 to approximately 200 feet. Comparisons were made, using the 637K Antenna and a 15-foot whip antenna. All the tests confirmed the superior performance of the 637K on short-range circuits.

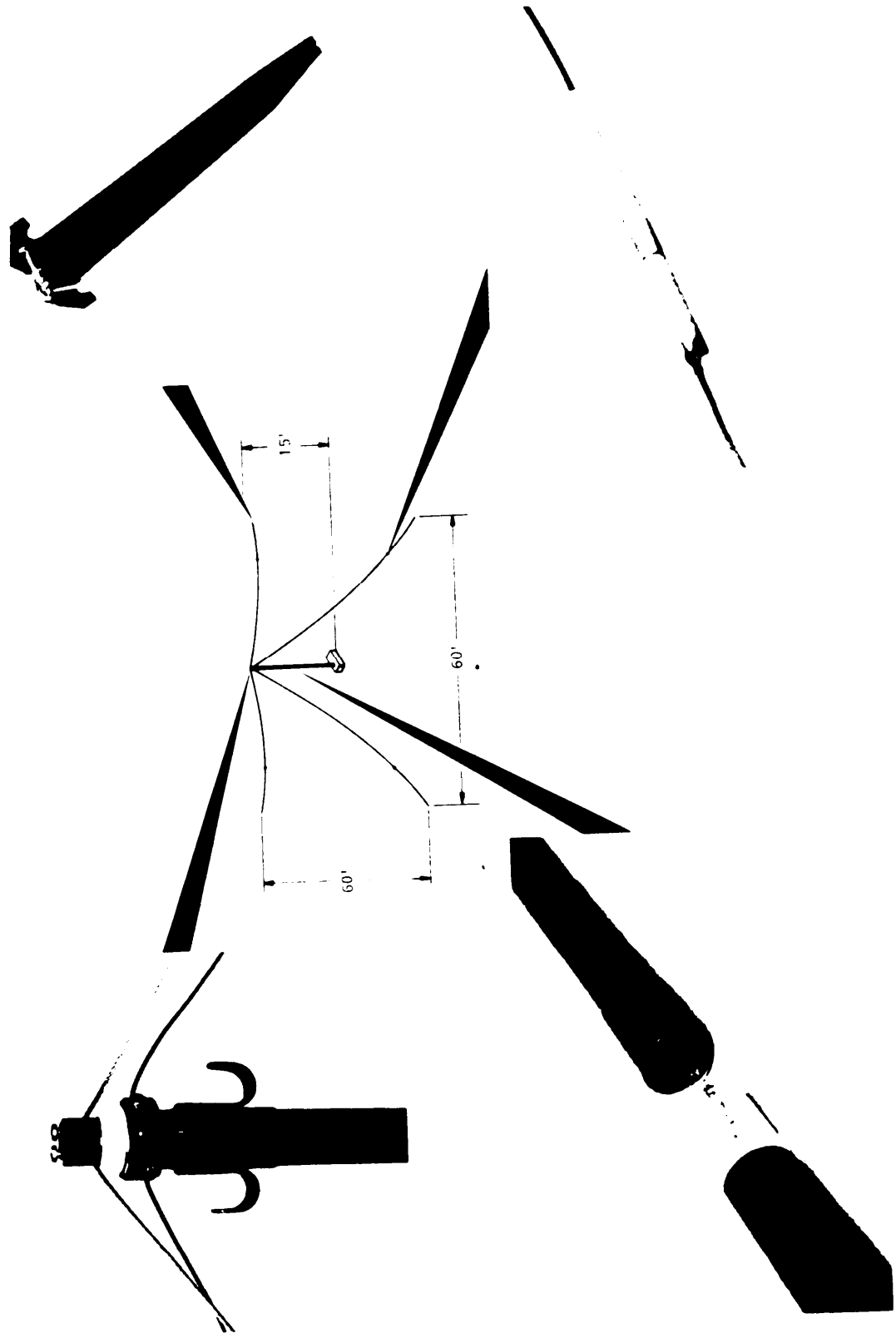

Figure 3-11. AS-2259 Antenna

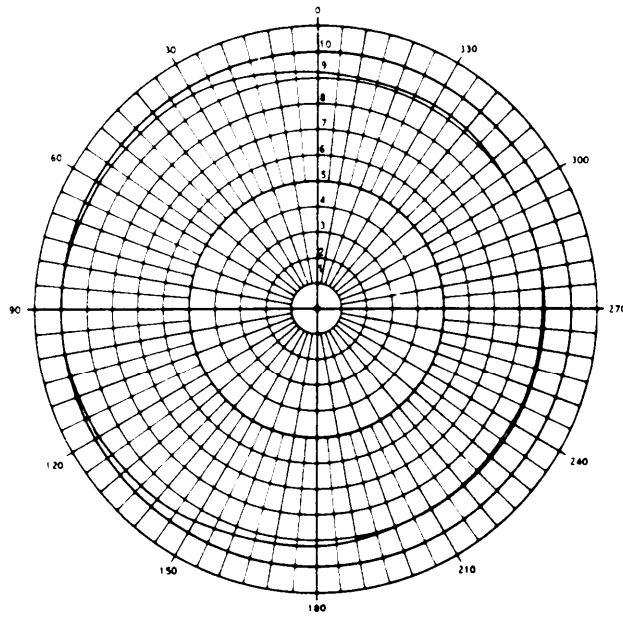

Figure 3-12. 2.5-MHz Azimuth Plane Pattern, Average Ground.

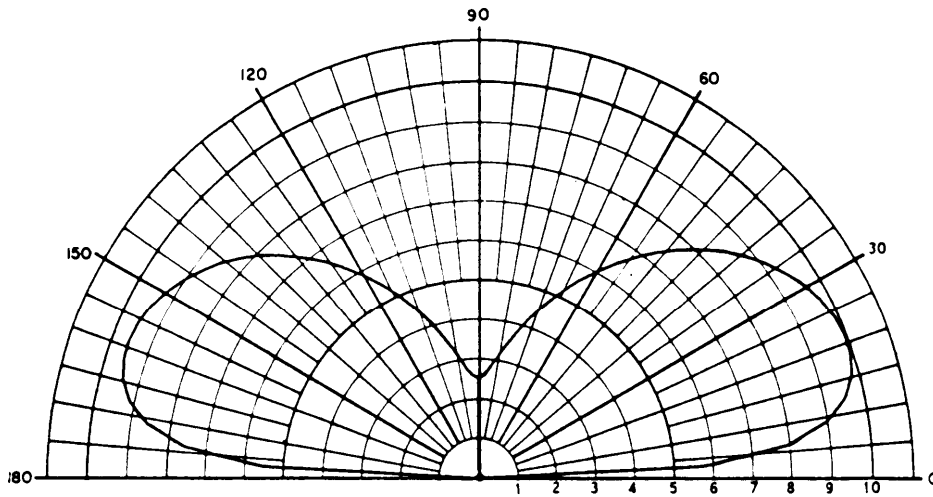

Figure 3-13. 2.5-MHz Elevation Plane Pattern, Average Ground.

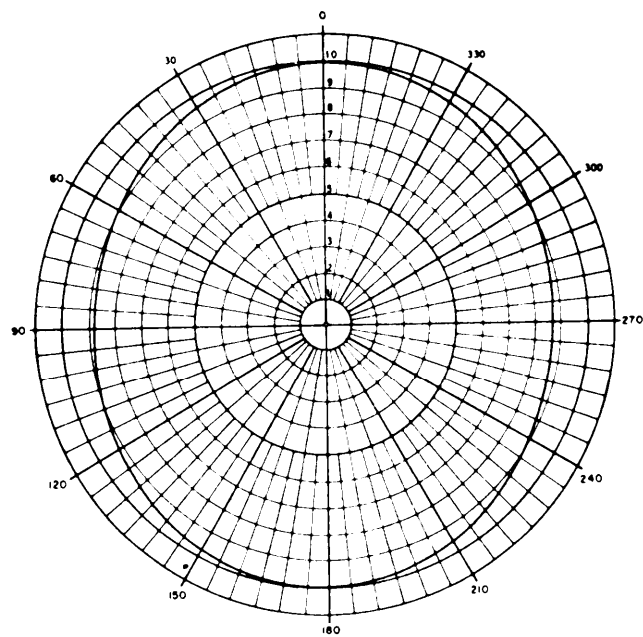

Figure 3-14. 6.0-MHZ Azimuth Plane Pattern, Average Ground.

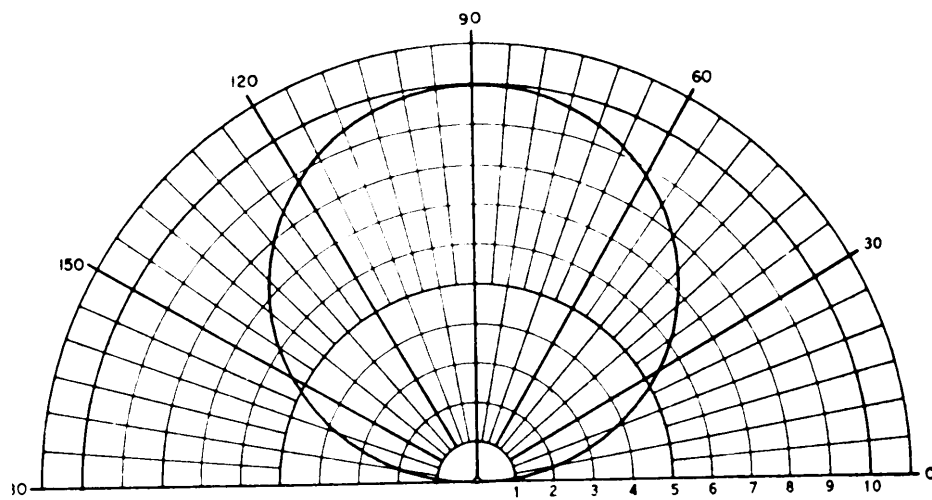

Figure 3-15. 6.0-MHZ Elevation Plane Pattern, Average Ground.

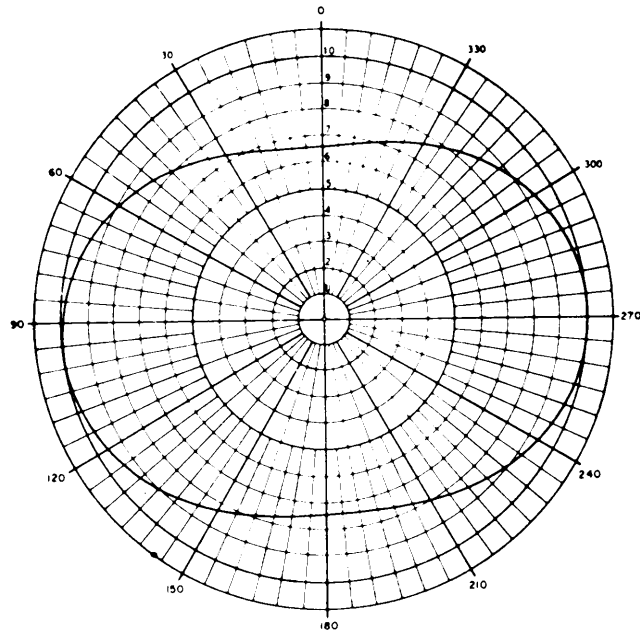

Figure 3-16. 9.5-MHz Azimuth Plane Pattern, Average Ground.

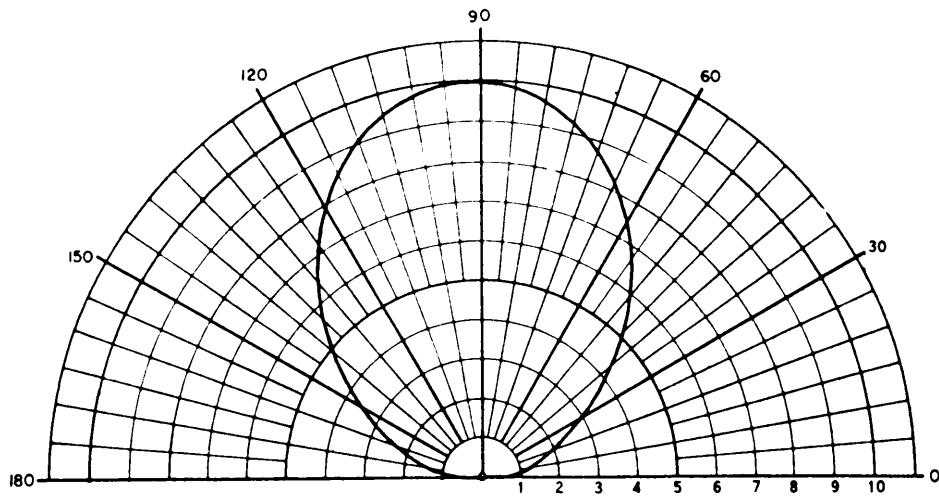

Figure 3-17. 9.5-MHz Elevation Plane Pattern, Average Ground.

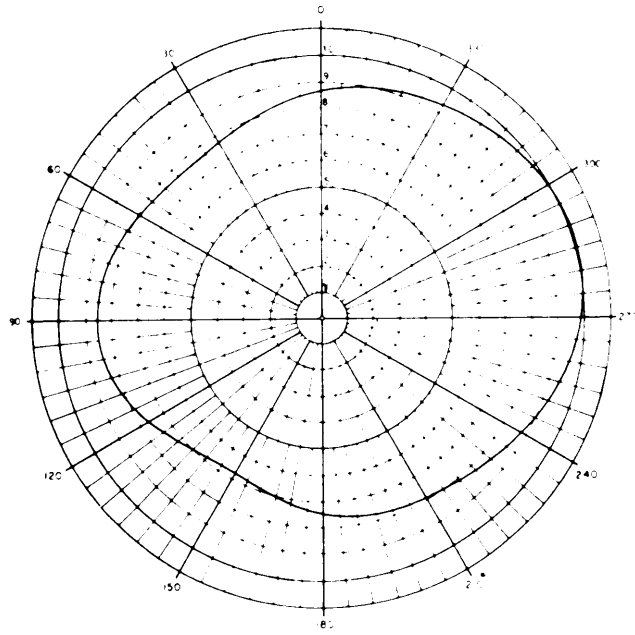

Figure 3-18. 15. 5-MHz Azimuth Plane Pattern, Average Ground.

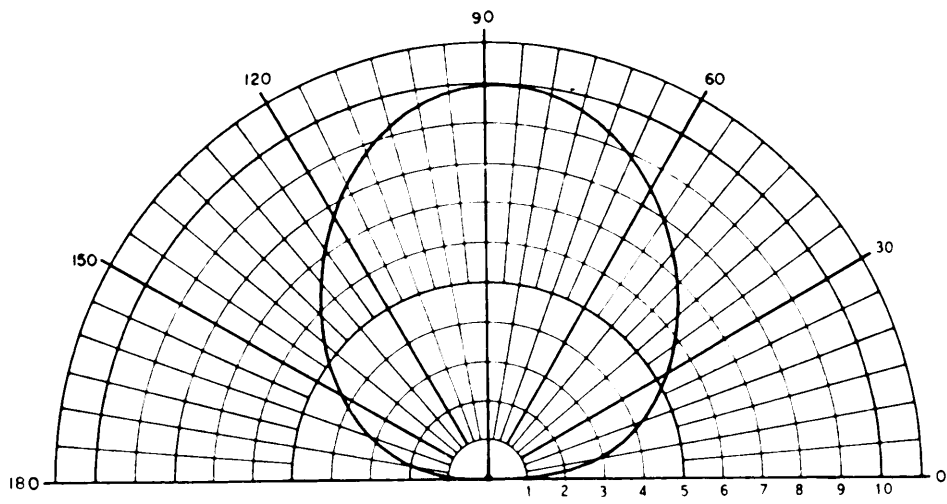

Figure 3-19. 15.5-MHz Elevation Plane Pattern, Average Ground.

SECTION IV

MAINTENANCE

4.1 ROUTINE MAINTENANCE

Perform the following procedure on a routine basis.

- a. Before assembly check all mounting hardware for looseness, corrosion or any physical damage.
- b. Be sure all unpainted surfaces of the mast sections are free of dirt. Heavy mud can be cleaned off with water.
- c. If antenna is up for an extended period of time the following maintenance should be performed on a weekly basis: '

Remove power from the antenna.

Check element tension.

Check tightness of attachment screws (items 28 and 29, Figure 5-1) holding the element wires at the mast top.

Check tightness of ground wire attachment screw (item 7, Figure 5-2) of the base assembly.

Check tightness of ground wire to AN/PRC-47 ground terminal.

If Adapter MX-9313/GR is used, check tightness of ground wire attachment screw (item 2, Figure 5-3) and ground connection to vehicle.

4.2 REPAIR

If top mast sections become damaged, the top assembly and the hook assembly can be removed and installed on any other mast section.

The antenna can be operated with fewer than eight mast sections if sections become lost or damaged.

SECTION V
MAINTENANCE PARTS

5.0 GENERAL

This section contains a list of all repairable/replaceable electrical and critical mechanical parts for the AS-2259/GR Antenna and Adapter MX-9313/GR.

5.1 ITEM NO.

This column contains the item number of parts identified by call-outs on corresponding illustrations.

5.2 DESCRIPTION

This column contains an identifying noun or item name followed by a brief description.

5.3 ENTRON PART NUMBER

This column contains the Entron specification or drawing numbers for each item in the parts lists.

5.4 ILLUSTRATIONS

All parts listed in the ITEM NO column are located on corresponding illustrations.

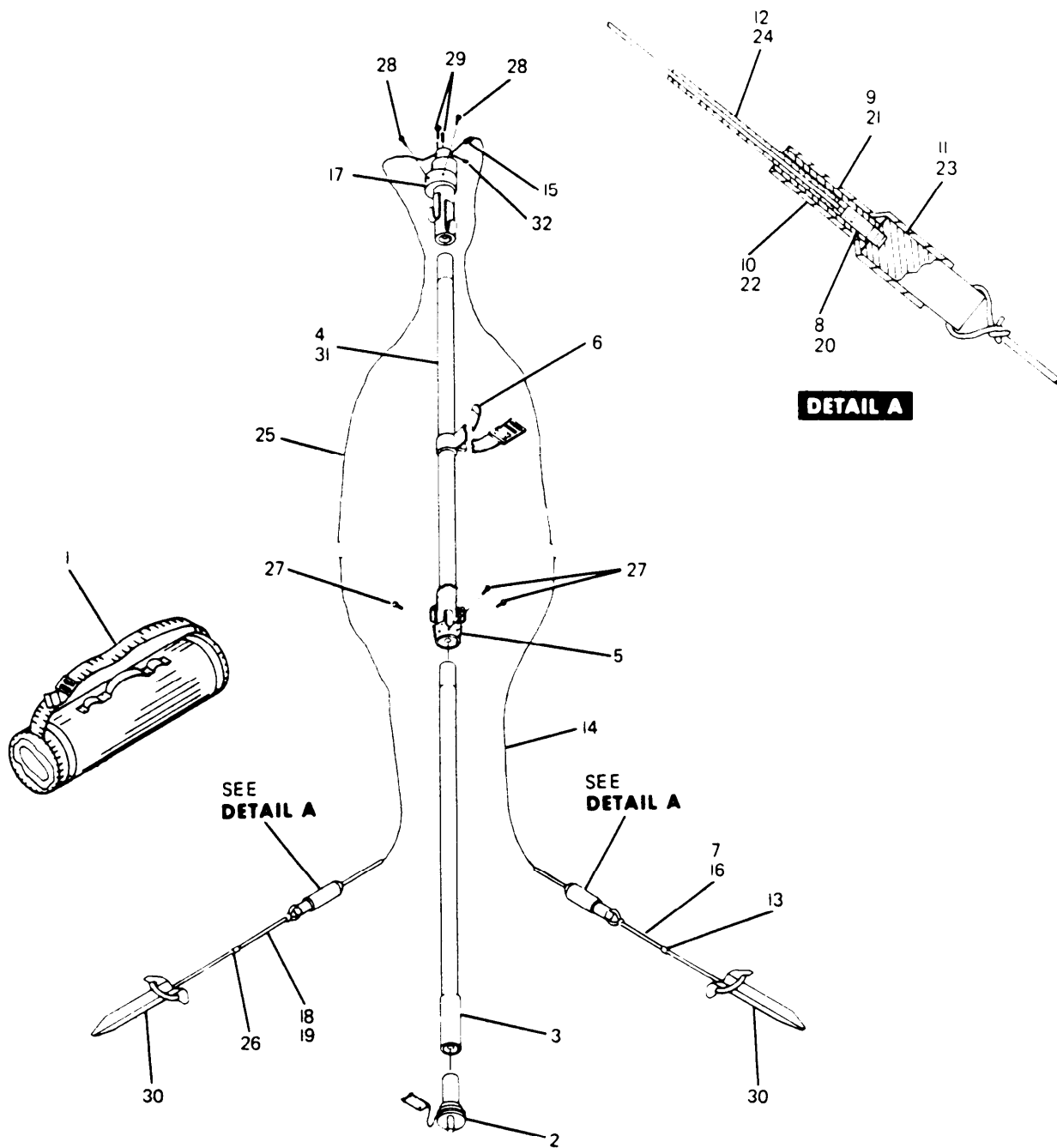

Figure 5-1. AS-2259/GR Antenna, parts location.

ITEM NO.	DESCRIPTION	ENTRON PART NO.
	AS-2259/GR MANPACK HF ANTENNA	7270-5377-001
1	CASE, CARRYING	7270-5065-001
2	BASE ASSEMBLY	7270-5061-001
	SEE BREAKDOWN, FIG. 5-2.	
3	MAST SECTION, QTY 7	7270-4094-001
4	MAST ASSEMBLY, TOP	7270-5067-001
	INCLUDES	
5	RING, ROPE HOOK	7270-4098-001
6	STRAP, BELT	7270-5062-001
7	ELEMENT, LONG, QTY 2	7270-5066-001
	INCLUDES:	
8	SLEEVE, QTY 1	7270-7055-001
9	SLEEVING, INSULATOR, QTY AR	7270-3991-000
10	SLEEVING, INSULATOR, QTY AR	7270-3993-000
11	INSULATOR, QTY AR	7270-7054-001
12	SLEEVE, TEFLON, QTY AR	7270-2603-000
13	SPACER, MARKER	7270-1672-001
14	ROPE, WIRE, 3/32 IN. DIA.	7270-1269-020
	QTY AR	
15	SLEEVING, INSULATOR	7270-3969-000
16	ROPE, NYLON, 3/32 IN. DIA.	7270-0532-010
	QTY AR	
17	MAST, TOP	7270-5083-001
18	ELEMENT, SHORT, QTY 2	7270-5084-001
	INCLUDES:	
19	ROPE, NYLON, 3/32 IN DIA.	7270-0532-010
	QTY AR	
20	SLEEVE, QTY 1	7270-7055-001
21	SLEEVING, INSULATOR, QTY AR	7270-3991-000
22	SLEEVING, INSULATOR, QTY AR	7270-3993-000
23	INSULATOR, QTY AR	7270-7054-001
24	SLEEVE, TEFLON, QTY AR	7270-2603-000
25	ROPE, WIRE, 3/32 IN. DIA.	7270-1269-020
	QTY AR	
26	SPACER, MARKER	7270-1672-001
27	SCREW, MACHINE, 6/32 X 3/8 LG.	7270-1669-140
	QTY 4	
28	SCREW, MACHINE, 10/32 X 3/8 LG.	7270-0891-010
	QTY 2	
29	SCREW, MACHINE, 10/32 X 5/8 LG.	7270-0891-020
	QTY 2	
30	STAKE, TENT, QTY 4	7270-3392-010
31	MAST SECTION	7270-4094-001
32	STOP, SLEEVE, QTY 4	7270-4093-001

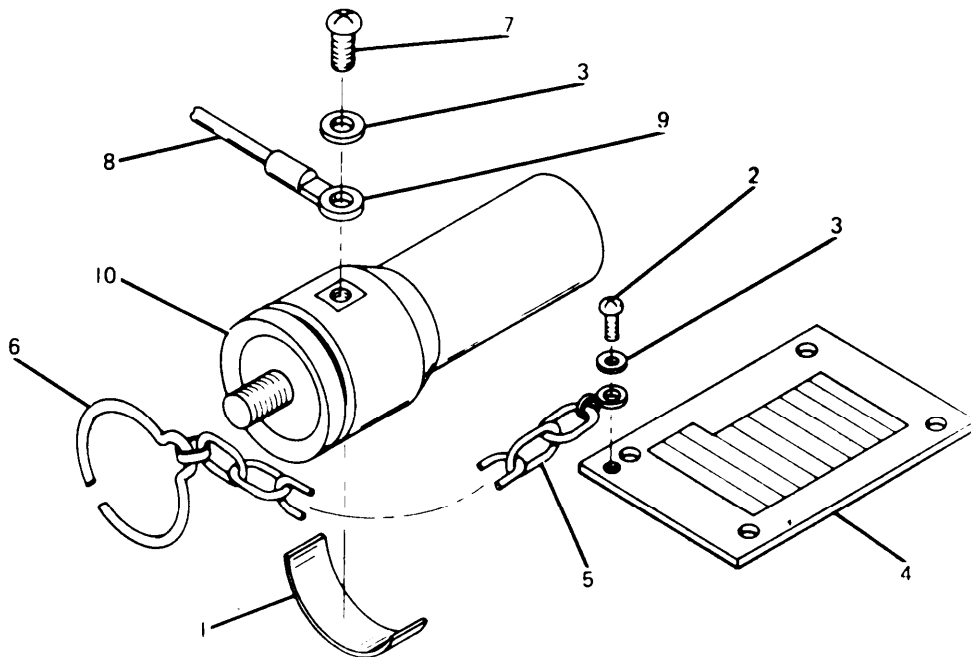

Figure 5-2. Base Assembly, parts location.

ITEM NO.	DESCRIPTION	ENTRON PART NO.
	Base Assembly	7270-5061-001
1	Plate, Identification	7270-CC1
2	Screw, Machine, 6/32 x 5/16 In. Lg.	7270-0302-150
3	Washer, Spring, 0.138 In. ID, Qty 2	7270-0097-000
4	Plate, Tuning Chart	7270-5048-001
5	Chain, Weldless, Qty AR	7270-0260-030
6	Ring, Slip	7270-5051-001
7	Screw, Machine, 6/32 x 1/4 In. Lg	7270-0302-140
8	Rope, Wire, 3/32 In. Dia, Qty AR	7270-1269-020
9	Terminal, Lug	7270-0026-000
10	Base Assembly, Bonded	7270-5057-001

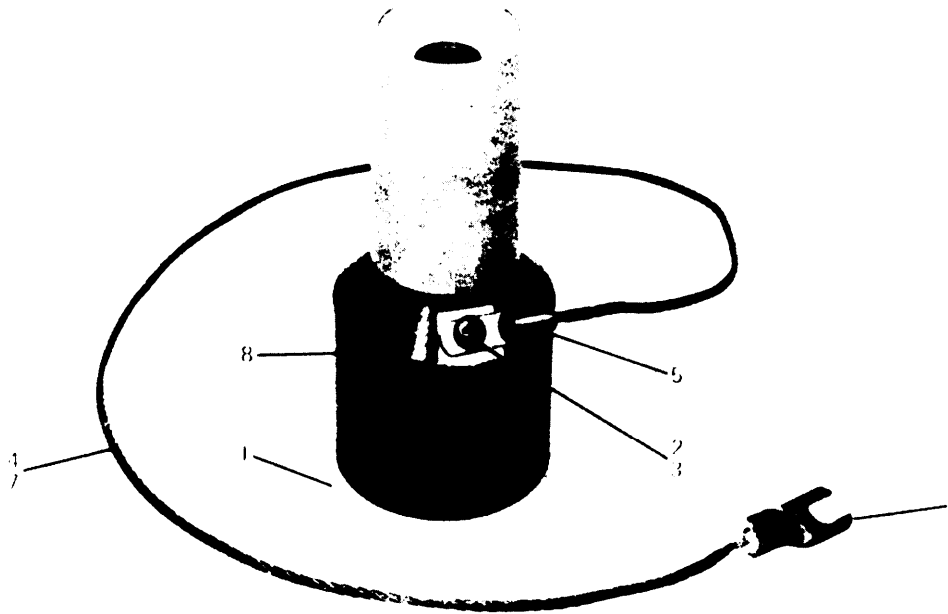

Figure 5-3. Adapter, MX-9313/GR, parts location.

ITEM NO.	DESCRIPTION	ENTRON PART NO.
	Adapter, MX-9313/GR	7270-7760-001
1	Adapters Whip	7270-8078-001
2	Screw, Machine, 6/32 x 1/4 in. lg.	7270-0302-140
3	Washer, Lock, 0.141 in. ID	7270-0097-000
4	Lead, Electrical	7270-8079-001
	Includes:	
5	Terminal, Lug	7270-0026-000
6	Terminal, Lug	7270-0217-000
7	Rope, Wire, 3/32 in. dia, Qty AR	7270-1269-020
8	Plate, Identification	7270-002
(not shown)	Bag, cotton	7270-0664-010

APPENDIX A**REFERENCES**

AR 55-38	Report of Transportation Discrepancies in Shipments
AR 735-11-2	Reporting of Item and Packaging Discrepancies
DA Pam 310-1	Consolidated Index of Army Publications and Blank Forms
DA Pam 738-750	The Army Maintenance Management System (TAMMS)
TM 11-5820-919-12	Operator's and Organizational Maintenance Manual: Radio Set AN/PRC-104A
TM 11-5820-919-24P	Organizational, Direct Support and General Support Maintenance Repair Parts and Special Tools List for Radio Set AN/PRC-104A
TM 11-5820-919-40-1	General Support Maintenance Manual: Radio Set AN/PRC-104A
TM 11-5820-919-40-2	General Support Maintenance Manual: Radio Set AN/PRC-104A
TM 740-90-1	Administrative Storage of Equipment
TM 750-244-2	Procedures for Destruction of Electronic Materiel to Prevent Enemy Use (Electronics Command)

APPENDIX B

MAINTENANCE ALLOCATION

Section I. INTRODUCTION

B-1. General

This appendix provides a summary of the maintenance operations for the AS-2259/GR. It authorizes categories of maintenance for specific maintenance functions on repairable items and components and the tools and equipment required to perform each function. This appendix may be used as an aid in planning maintenance operations.

B-2. Maintenance Function

Maintenance functions will be limited to and defined as follows:

a. Inspect. To determine the serviceability of an item by comparing its physical, mechanical, and/or electrical characteristics with established standards through examination.

b. Test. To verify serviceability and to detect incipient failure by measuring the mechanical or electrical characteristics of an item and comparing those characteristics with prescribed standards.

c. Service. Operations required periodically to keep an item in proper operating condition, i.e., to clean (decontaminate), to preserve, to drain, to paint, or to replenish fuel, lubricants, hydraulic fluids, or compressed air supplies.

d. Adjust. To maintain, within prescribed limits, by bringing into proper or exact position, or by setting the operating characteristics to the specified parameters.

e. Align. To adjust specified variable elements of an item to bring about optimum or desired performance.

f. Calibrate. To determine and cause corrections to be made or to be adjusted on instruments or test measuring and diagnostic equipments used in precision measurement. Consists of comparisons of two instruments, one of which is a certified standard of known accuracy, to detect and adjust any discrepancy in the accuracy of the instrument being compared.

g. Install. The act of emplacing, seating, or fixing into position an item, part, module (component or assembly) in a manner to allow the proper functioning of the equipment or system.

h. Replace. The act of substituting a serviceable like type part, subassembly, or module (component or assembly) for an unserviceable counterpart.

i. Repair. The application of maintenance services (inspect, test, service, adjust, align, calibrate, replace) or other maintenance actions (welding, grinding, riveting, straightening, facing, remachining, or resurfacing) to restore serviceability to an item by correcting specific damage, fault, malfunction, or failure in a part, subassembly, module (component or assembly), end item, or system.

j. Overhaul. That maintenance effort (service/action) necessary to restore an item to a completely serviceable/operational condition as prescribed by maintenance standards (i. e., DMWR) in appropriate technical publications. Overhaul is normally the highest degree of maintenance performed by the Army. Overhaul does not normally return an item to like new condition.

k. Rebuild. Consists of those services/actions necessary for the restoration of unserviceable equipment to a like new condition in accordance with original manufacturing standards. Rebuild is the highest degree of materiel maintenance applied to Army equipment. The rebuild operation includes the act of returning to zero those age measurements (hours, miles, etc.) considered in classifying Army equipments/components.

B-3. Column Entries

a. Column 1, Group Number. Column 1 lists group numbers, the purpose of which is to identify components, assemblies, subassemblies, and modules with the next higher assembly.

b. Column 2, Component/Assembly. Column 2 contains the noun names of components, assemblies, subassemblies, and modules for which maintenance is authorized.

c. Column 3, Maintenance Functions. Column 3 lists the functions to be performed on the item listed in column 2. When items are listed without maintenance functions, it is solely for purpose of having the group numbers in the MAC and RPSTL coincide.

d. Column 4, Maintenance Category. Column 4 specifies, by the listing of a "work time" figure in the appropriate subcolumn(s), the lowest level of maintenance authorized to perform the function listed in column 3. This figure represents the active time required to perform that maintenance function at the indicated category of maintenance. If the number or complexity of the tasks within the listed maintenance function vary at different maintenance categories, appropriate "work time" figures will be shown for each category. The number of task-hours specified by the "work time" figure represents the average time required to restore an item (assembly, subassembly, component, module, end item or system) to a serviceable condition under typical field operating conditions. This time includes preparation time, troubleshooting time, and quality assurance/quality control time in addition to the time required to perform the specific tasks identified for the maintenance functions authorized in the maintenance allocation chart. Subcolumns of column 4 are as follows:

- C - Operator/Crew
- O - Organizational
- F - Direct Support
- H - General Support
- D - Depot

e. Column 5, Tools and Equipment. Column 5 specifies by code, those common tool sets (not individual tools) and special tools, test, and support equipment required to perform the designated function

f. Column 6, Remarks. Column 6 contains an alphabetic code which leads to the remark in section IV, Remarks, which is pertinent to the item opposite the particular code.

B-4. Tool and Test Equipment Requirements (Sect. III)

a. Tool or Test Equipment Reference Code. The numbers in this column coincide with the numbers used in the tools and equipment column of the MAC. The numbers indicate the applicable tool or test equipment for the maintenance functions.

b. Maintenance Category. The codes in this column indicate the maintenance category allocated the tool or test equipment.

c. Nomenclature. This column lists the noun name and nomenclature of the tools and test equipment required to perform the maintenance functions.

d. National/NATO Stock Number. This column lists the National/NATO stock number of the specific tool or test equipment.

e. Tool Number. This column lists the manufacturer's part number of the tool followed by the Federal Supply Code for manufacturers (5-digit) in parentheses.

B-5. Remarks (Sect. IV)

a. Reference Code. This code refers to the appropriate item in section II, column 6.

b. Remarks. This column provides the required explanatory information necessary to clarify items appearing in section II.

SECTION II MAINTENANCE ALLOCATION CHART
FOR

ANTENNA AS-2259/GR

(1) GROUP NUMBER	(2) COMPONENT/ASSEMBLY	(3) MAINTENANCE FUNCTION	(4) MAINTENANCE CATEGORY					(5) TOOLS AND EQPT.	(6) REMARKS	
			C	O	F	H	D			
00	ANTENNA AS-2259/GR	Inspect	0.5						A	
		Service	0.5						B	
		Install	0.2							
01	MAST ASSEMBLY, TOP	Test		0.5				1,2		
		Replace		0.5						
		Repair			0.5				3	C
02	BASE ASSY	Inspect		0.2						
		Replace		0.5					1	D
		Repair			0.5				2,3	E
03	CASE ASSY	Inspect		0.2						
		Test		0.5					2	D
		Replace		0.5						
03	CASE ASSY	Repair			0.5				2,3	F
		Inspect	0.1							D
		Replace	0.1							G

SECTION III TOOL AND TEST EQUIPMENT REQUIREMENTS
 FOR
 ANTENNA AS-2259-GR

TOOL OR TEST EQUIPMENT REF CODE	MAINTENANCE CATEGORY	NOMENCLATURE	NATIONAL/NATO STOCK NUMBER	TOOL NUMBER
1	O	TOOL KIT, ELECTRONIC EQUIPMENT TK-101/G	5180-00-064-5178	
2	O,F	MULTIMETER, DIGITAL AN/PSM-45	6625-01-139-2512	
3	F	TOOL KIT, ELECTRONIC EQUIPMENT TK-105/G	5180-00-610-8177	

SECTION IV. REMARKS

REFERENCE CODE	REMARKS
A	INSPECT FOR TIGHTNESS OF ATTACHING SCREWS, WIRE, STAKES.
B	PERFORM ROUTINE CLEANING OF ACCESSIBLE UNPAINTED SURFACES.
C	REPAIR BY REPLACING MAST ASSEMBLY TOP, MAST SECTIONS, BASE ASSEMBLY, CASE ASSEMBLY.
D	VISUAL INSPECTION.
E	REPAIR BY REPLACING ELEMENTS, MAST TOP, MAST SECTION, STAKES.
F	REPAIR BY REPLACING ATTACHING HARDWARE.
G	REPAIR BY REPLACING SNAPS, SNIPPERS, STRAPS AND MENDING.

B-7/(B-8 blank)

APPENDIX C

COMPONENTS OF END ITEM LIST

Section I. INTRODUCTION

C-1. Scope

This appendix lists integral components of and basic issue items for the AS-2259/GR to help you inventory items required for safe and efficient operation.

C-2. General

This Components of End Item List is divided into the following sections:

a. Section II. Integral Components of the End Item. These items, when assembled, comprise the AS-2259/GR and must accompany it whenever it is transferred or turned in. The illustrations will help you identify these items.

b. Section III. Basic Issue Items. These are the minimum essential items required to place the AS-2259/GR in operation, to operate it, and to perform emergency repairs. Although shipped separately packed they must accompany the AS-2259/GR during operation and whenever it is transferred between accountable officers. The illustrations will assist you with hard-to-identify items. This manual is your authority to requisition replacement BII, based on TOE/MTOE authorization of the end item.

C-3. Explanation of Columns

a. Illustration. This column is divided as follows:

(1) *Figure number.* Indicates the figure number of the illustration on which the item is shown.

(2) *Item number.* The number used to identify item called out in the illustration.

b. National Stock Number. Indicates the National stock number assigned to the item and will be used for requisitioning.

c. Part Number. Indicates the primary number used by the manufacturer, which controls the design and characteristics of the item by means of its engineering drawings, specifications, standards, and inspection requirements to identify an item or range of items. Following the part number, the Federal Supply Code for Manufacturers (FSCM) is shown in parentheses.

d. Description. Indicates the Federal item name and, if required, a minimum description to identify the item.

e. Location. The physical location of each item listed is given in this column. The lists are designed to inventory all items in one area of the major item item before moving on to an adjacent area.

f. Usable on Code. Not applicable.

g. Quantity Required (Qty Reqd). This column lists the quantity of each item required for a complete major item.

h. Quantity. This Column is left blank for use during an inventory. Under the Rcvd column, list the quantity you actually receive on your major item. The Date columns are for your use when you inventory the major item at a later date; such as for shipment to another site.

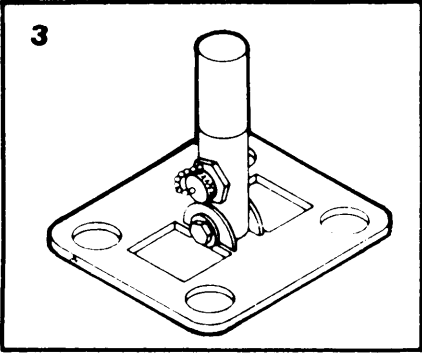
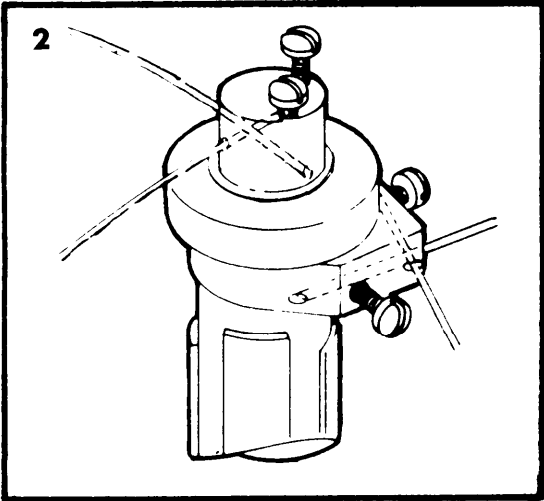
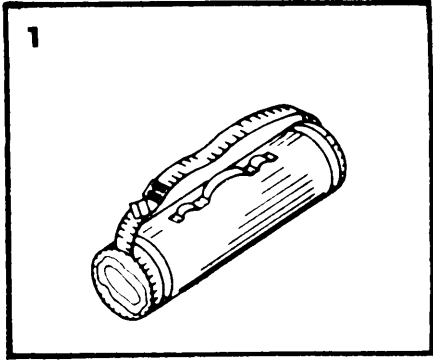

(C-3 blank)/C-4

(1) ILLUSTRATION (A) FIG NO.	(2) NATIONAL STOCK NUMBER	(3) DESCRIPTION PART NUMBER (FSCM)	(4) LOCATION	(5) USABLE ON CODE	(6) QTY REQD	(7) QUANTITY RCVD DATE
1			CASE ASSEMBLY 7270-5065-001			1
2			MAST ASSEMBLY, TOP 7270-5067-001			1
3			BASE ASSEMBLY 7270-5061-001			1

SECTION III BASIC ISSUED ITEMS

(1)	(2)	(3)	(4)	(5)	(6)	(7)
ILLUSTRATION	NATIONAL	DESCRIPTION	LOCATION	USABLE	QTY	QUANTITY
(A)	(B)			ON	REQD	
FIG	ITEM			CODE		RCVD DATE
NO.	NO.	PART NUMBER	(FSCM)			

TECHNICAL MANUAL TM 11-5985-379-14&P

APPENDIX E**PART NUMBER - NATIONAL STOCK NUMBER
CROSS-REFERENCE INDEX**

Section I. INTRODUCTION

CROSS-REFERENCE INDEX. The Cross-Reference Index is a cross-reference listing of part number to National Stock Number.

a. Use of Cross-Reference Index. To order a part listed in the Cross-Reference Index, note part number and then cross-reference that Part number to the National Stock Number in the cross-reference index. Then order through normal ordering channels.

b. Ordering Part Numbers Without National Stock Number. If the part number does not have a National Stock Number, then order the part through normal ordering channels using the part number and the FSCM.

SECTION II

PART NUMBERS - NATIONAL STOCK NUMBER

CROSS REFERENCE INDEX

PART NUMBER	FSCM	NATIONAL STOCK NUMBER	PART NUMBER	FSCM	NATIONAL STOCK NUMBER
AS-2259/GR	80058		604-4094-001	13499	5985-00-141-8300
A3-16	77860		607-4098-001	13499	
MIL-P-501	81349	8340-00-261-9749	781-5048-001	13499	
P323-0302-140	77250		781-5051-001	13499	
P323-0302-150	77250		781-5057-001	13499	
P330-1669-140	77250		781-5061-001	13499	5985-00-001-6768
10643	82423	5310-00-545-8402	781-5062-001	13499	
233-0260-030	72671		781-5065-001	13499	5985-00-001-6769
310-0097-000	79807	5310-00-151-5527	781-5066-001	13499	
343-0891-010	70318		781-5067-001	13499	5985-00-001-6770
343-0891-020	70318		781-5083-001	13499	5985-00-001-6771
432-1269-020	13499		781-5084-001	13499	
607-4093-001	13499		788-7790-002	13499	

APPENDIX F

EXPENDABLE SUPPLIES AND MATERIALS LIST

Section I. INTRODUCTION

F-1. Scope

This appendix lists expendable supplies and materials you will need to operate and maintain the AS-2259/GR. These items are authorized to you by CTA 50-970, Expendable Items (Except Medical, Class V, Repair Parts, and Heraldic Items).

F-2. Explanation of Columns

a. *Column 1 — Item Number.* This number is assigned to the entry in the listing and is referenced in the narrative instructions to identify the material (e. g., "Use cleaning compound, item 5, App. D").

b. *Column 2 — Level.* This column identifies the lowest level of maintenance that requires the listed term.

- C - Operator/Crew
- O - Organizational Maintenance
- F - Direct Support Maintenance
- H - General Support Maintenance

c. *Column 3 — National Stock Number.* This is the National stock number assigned to the item; use it to request or requisition the item.

d. *Column 4 — Description.* Indicates the Federal item name and, if required, a description to identify the item. The last line for each item indicates the part number followed by the Federal Supply Code for Manufacturer (FSCM) in parentheses, if applicable.

e. *Column 5 — Unit of Measure (U/M).* Indicates the measure used in performing the actual maintenance function. This measure is expressed by a two-character alphabetical abbreviation (e.g., ea, in, pr). If the unit of measure differs from the unit of issue, requisition the lowest unit of issue that will satisfy your requirements.

SECTION II EXPENDABLE SUPPLIES AND MATERIALS LIST

(1) ITEM NO.	(2) LEVEL	(3) NATIONAL STOCK NUMBER	(4) DESCRIPTION	(5) UNIT OF MEAS
1	C	8305-00-267-3015	CHEESE CLOTH (81348)	YD
2	C	5340-00-906-3666	BRUSH, SOFT BRISTLED	EA
3	C	7930-01-055-6121	DETERGENT, GP, LIQ	GL

RECOMMENDED CHANGES TO EQUIPMENT TECHNICAL PUBLICATIONS



THEN... JOT DOWN THE DOPE ABOUT IT ON THIS FORM. CAREFULLY TEAR IT OUT. FOLD IT AND DROP IT IN THE MAIL!

SOMETHING WRONG WITH THIS PUBLICATION?

FROM (PRINT YOUR UNIT'S COMPLETE ADDRESS)
 Commander
 Stateside Army Depot
 ATTN: AMSTA-US
 Stateside, N.J. 07703-5007

DATE SENT
 4 April 1978

PUBLICATION NUMBER
 TM 11-5840-340-14&P

PUBLICATION DATE
 23 Jan 74

PUBLICATION TITLE
 Radar Set AN/PRC-76

BE EXACT PIN-POINT WHERE IT IS

PAGE NO	PARA-GRAPH	FIGURE NO	TABLE NO
2-25	2-28		
3-10	3-3		3-1
5-6	5-8		
E-5			
E-8		E-3	
E-9			

IN THIS SPACE TELL WHAT IS WRONG AND WHAT SHOULD BE DONE ABOUT IT:

Recommend that the installation antenna alignment procedure be changed throughout to specify a 2° IFF antenna lag rather than 1°.

REASON: Experience has shown that with only a 1° lag, the antenna servo system is too sensitive to wind gusting in excess of 25 knots, and has a tendency to rapidly accelerate and decelerate as it hunts, causing strain to the drive train. Hunting is minimized by adjusting the lag to 2° without degradation of operation.

Item 5, Function column Change "2 db" to "3db."

REASON: The adjustment procedure for the TRANS POWER FAULT indicator calls for a 3 db (500 watts) adjustment to light the TRANS POWER FAULT indicator.

Add new step f.1 to read, "Replace cover plate removed in step e.1, above."

REASON: To replace the cover plate.

For item 2, change the NSN to read: 5835-00-134-9186.

REASON: Accuracy.

Identify the cover on the junction box (item no. 5).

REASON: It is a separate item and is not called out on figure 19.

Add the cover of the junction box as an item in the listing for figure 19.

REASON: Same as above.

PRINTED NAME, GRADE OR TITLE, AND TELEPHONE NUMBER

SSG I. M. DeSpirito 999-1776

SIGN HERE

TEAR ALONG PERFORATED LINE

FILL IN YOUR
UNIT'S ADDRESS

FOLD BACK

DEPARTMENT OF THE ARMY

POSTAGE AND FEES PAID
DEPARTMENT OF THE ARMY
DOD 314



OFFICIAL BUSINESS
PENALTY FOR PRIVATE USE \$300

SAMPLE

Commander
US Army Communications-Electronics Command
and Fort Monmouth
ATTN: AMSEL-ME-MP
Fort Monmouth, New Jersey 07703-5007

TEAR ALONG PERFORATED LINE

FILL IN YOUR
UNIT'S ADDRESS

FOLD BACK

DEPARTMENT OF THE ARMY

POSTAGE AND FEES PAID
DEPARTMENT OF THE ARMY
DOD 314



OFFICIAL BUSINESS
PENALTY FOR PRIVATE USE \$300

TEAR ALONG PERFORATED LINE

Commander
US Army Communications-Electronics Command
and Fort Monmouth
ATTN: AMSEL-ME-MP
Fort Monmouth, New Jersey 07703-5007

RECOMMENDED CHANGES TO EQUIPMENT TECHNICAL PUBLICATIONS

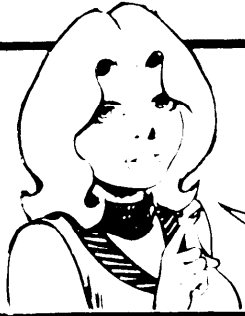

THEN...JOT DOWN THE DOPE ABOUT IT ON THIS FORM. CAREFULLY TEAR IT OUT, FOLD IT AND DROP IT IN THE MAIL.

SOMETHING WRONG WITH THIS PUBLICATION?

FROM: (PRINT YOUR UNIT'S COMPLETE ADDRESS)

DATE SENT

PUBLICATION NUMBER

TM 11-5985-379-14&P

PUBLICATION DATE

14 Feb 1986

PUBLICATION TITLE

Antenna AS-2259/GR

BE EXACT PIN-POINT WHERE IT IS

PAGE NO.	PARA-GRAPH	FIGURE NO.	TABLE NO.

IN THIS SPACE TELL WHAT IS WRONG AND WHAT SHOULD BE DONE ABOUT IT:

TEAR ALONG PERFORATED LINE

PRINTED NAME GRADE OR TITLE AND TELEPHONE NUMBER

SIGN HERE

DA FORM 1 JUL 79 2028-2

PREVIOUS EDITIONS ARE OBSOLETE

P.S...IF YOUR OUTFIT WANTS TO KNOW ABOUT YOUR RECOMMENDATION MAKE A CARBON COPE OF THIS AND GIVE IT TO YOUR HEADQUARTERS.

FILL IN YOUR
UNIT'S ADDRESS

FOLD BACK

DEPARTMENT OF THE ARMY

POSTAGE AND FEES PAID
DEPARTMENT OF THE ARMY
DOD 314



OFFICIAL BUSINESS
PENALTY FOR PRIVATE USE \$300

TEAR ALONG PERFORATED LINE

Commander
US Army Communications-Electronics Command
and Fort Monmouth
ATTN: AMSEL-ME-MP
Fort Monmouth, New Jersey 07703-5007

FILL IN YOUR
UNIT'S ADDRESS

FOLD BACK

DEPARTMENT OF THE ARMY

OFFICIAL BUSINESS
PENALTY FOR PRIVATE USE \$300

POSTAGE AND FEES PAID
DEPARTMENT OF THE ARMY
DOD 314



TEAR ALONG PERFORATED LINE

Commander
US Army Communications-Electronics Command
and Fort Monmouth
ATTN: AMSEL-ME-MP
Fort Monmouth, New Jersey 07703-5007

By Order of the Secretary of the Army:

Official:

JOHN A. WICKHAM JR.
General, United States Army
Chief of Staff

MILDRED E. HEDBERG
Brigadier General, United States Army
The Adjutant General

Distribution:

To be distributed in accordance with special list.

