

1113
12
TM
1945

TM 11-2362

AR DEPARTMENT TECHNICAL MANUAL

U.S. Dept of Army

PRINTER PH-507/PF

RESTRICTED. DISSEMINATION OF RESTRICTED MATTER.
No person is entitled solely by virtue of his grade or position to knowledge or possession of classified matter. Such matter is entrusted only to those individuals whose official duties require such knowledge or possession. (See also paragraph 23b, AR 380-5, 15 March 1944.)

AR DEPARTMENT • 2 JANUARY 1945

WAR DEPARTMENT TECHNICAL MANUAL
TM 11-2362

PRINTER PH-507/PF



WAR DEPARTMENT *2 JANUARY 1945*

RESTRICTED. DISSEMINATION OF RESTRICTED MATTER.

No person is entitled solely by virtue of his grade or position to knowledge or possession of classified matter. Such matter is entrusted only to those individuals whose official duties require such knowledge or possession. (See also paragraph 23*b*, AR 380-5, 15 March 1944.)

WAR DEPARTMENT,
WASHINGTON 25, D. C., 2 January 1945.

TM 11-2362, Printer PH-507/PF, is published for the information and guidance of all concerned.

[A. G. 300.7 (17 Sep 44).]

BY ORDER OF THE SECRETARY OF WAR:

G. C. MARSHALL,
Chief of Staff.

OFFICIAL:

J. A. ULIO,
Major General,
The Adjutant General.

DISTRIBUTION:

AAF (2); AGF (2); ASF (2); T of Opn (2); Dept (2);
Def Comd (2); Arm & Sv Bd (2); S Div ASF (1); Tech
Sv (2); SvC (2); PE (2); Gen Overseas SOS Dep (Sig Sec)
(2); Dep 11 (2); Gen & Sp Sv Sch (2); USMA (2); WDGS
Lib (5); Lab 11 (2); A (2); T/O & E: 11-37 (3); 11-107
(3); 11-127 (3); 11-237 (3); 11-267 (3); 11-587 (3);
11-592 (3); 11-597 (3).

For explanation of symbols see FM 21-6.

46113
 12
 TM 1112362
 1945
 ★ ★

TABLE OF CONTENTS

	<i>Paragraph</i>	<i>Page</i>
PART ONE. Introduction.		
SECTION I. Description.		
General	1	1
Application	2	1
Components	3	1
Carrying case	4	1
Exterior of printer.....	5	2
Interior of printer.....	6	2
II. Installation and assembly.		
Unpacking	7	3
Checking	8	3
Assembly of equipment.....	9	5
Interconnections	10	5
PART TWO. Operating instructions.		
III. Step-by-step operating procedure.		
Mixing chemicals	11	7
Preoperation procedures	12	7
Setting equipment in operation..	13	10
Operation	14	11
Indications of normal operation..	15	12
PART THREE. Preventive maintenance.		
IV. Itemized preventive maintenance.		
Meaning of preventive mainten- ance	16	13
Preventive maintenance procedure.	17	13
Moistureproofing and fungiproof- ing	18	13
V. Lubrication.		
Lubrication	19	13

Generated on 2016-04-16 16:57 GMT / http://hdl.handle.net/2027/uc1.b3245502
 Public Domain, Google-digitized / http://www.hathitrust.org/access_use#pd-google

TABLE OF CONTENTS

	<i>Paragraph</i>	<i>Page</i>
PART FOUR. Auxiliary equipment.		
VI. Non-essential aids.		
Auxiliary equipment	20	14
PART FIVE. Repair instructions.		
VII. Trouble shooting.		
Trouble chart	21	15
VIII. Repair.		
Replacement of parts.....	22	17
Electrical repairs	23	22
Unsatisfactory Equipment Report	24	22
APPENDIX.		
IX. Maintenance parts list.		
Maintenance parts list for Printer PH-507/PF	25	23

LIST OF ILLUSTRATIONS

<i>Fig. No.</i>	<i>Title</i>	<i>Page</i>
1	Printer PH-507/PF with supplementary and auxiliary equipment, assembled for operation.....	VI
2	Removing printer from carrying case.....	4
3	Component parts of Printer PH-507/PF.....	6
4	Printer, showing removable front panel.....	8
5	Printer, showing installation of paper in roll paper compartment	12
6	Printer, with front panel, plate glass, and opal glass removed.	18
7	Wiring diagram	20

DESTRUCTION NOTICE

WHY — To prevent the enemy from using or salvaging this equipment for his benefit.

WHEN— When ordered by your commander.

HOW — 1. Smash—Use sledges, axes, handaxes, pickaxes, hammers, crowbars, heavy tools.
2. Cut—Use axes, handaxes, machetes.
3. Burn—Use gasoline, kerosene, oil, flame throwers, incendiary grenades.
4. Explosives—Use firearms, grenades, TNT.
5. Disposal—Bury in slit trenches, fox holes, other holes. Throw in streams. Scatter.

USE ANYTHING IMMEDIATELY AVAILABLE FOR DESTRUCTION OF THIS EQUIPMENT.

WHAT— 1. Smash—Carrying case, printer case, plate glass, opal glass, all lamps, both time devices, rotary switch.
2. Cut—Both filters, cable assemblies, developer containers.
3. Burn—Carrying case, printer case, developer containers, this manual.
4. Bury or scatter—All that remains.

DESTROY EVERYTHING.

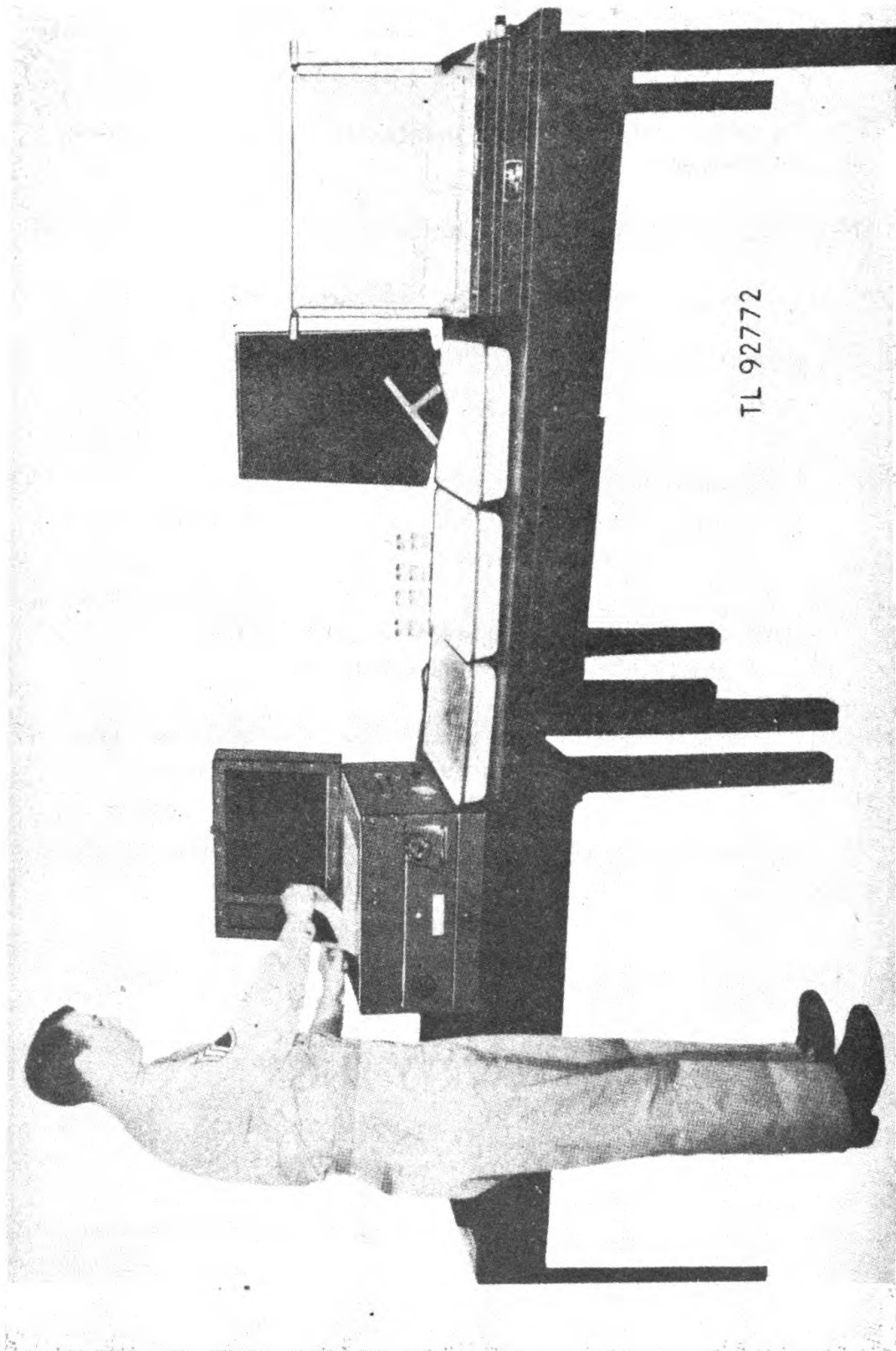

Figure 1. Printer PH-507/PF with supplementary and auxiliary equipment, assembled for operation.

RESTRICTED

PART ONE INTRODUCTION

SECTION I

DESCRIPTION OF PRINTER PH-507/PF

1. GENERAL.

Printer PH-507/PF (fig. 1) is portable equipment which includes a printer, electrical connecting cable assemblies, developer, and certain spare parts.

2. APPLICATION.

Printer PH-507/PF is designed to make both photographic prints and reproductions, and it may also be used as a light box for blocking and retouching. The printer can make prints from negatives and X-ray films, and can reproduce anything written, printed, typed, traced, drawn, sketched, photographed, or blueprinted, up to 11 by 14 inches in size. Images may be reproduced either in white on black (negative), or in black on white (positive). Applicable for either field or office use, the printer operates from a 105- to 125-volt, a-c or d-c power source, or from a 12-volt storage battery.

3. COMPONENTS.

Printer PH-507/PF complete, as packed in the carrying case, weighs 102 pounds, and is made up of the following components: one carrying case, one printer, one 14-foot cable assembly with battery clips, one 14½ foot cable assembly with male and female plug, 24 2-quart containers of developer, and spare parts. The spare parts supplied with the equipment include one time device, one amber lamacoid filter, six 25-watt, 12-volt lamps, and six 60-watt, 115-volt lamps.

4. CARRYING CASE (fig. 2).

Printer PH-507/PF is inclosed in a wooden carrying case which weighs 50 pounds and measures 33 by 16 by 16¾ inches. The case has a hinged cover with a solid brass auto hasp and a snap clasp which is attached to the case by a metal chain. Wooden strips nailed across each end of the

carrying case serve as carrying handles. The interior of the case is divided into two compartments. One compartment contains the printer and the other compartment serves as a storage place for the developer and spare parts.

5. EXTERIOR OF PRINTER (figs. 3 and 4).

The printer weighs 39 pounds and measures 21 inches long, $14\frac{5}{8}$ inches wide, and 14 inches high. The printer case consists of a cover and a lamp housing with removable front panel. The hinged cover has a brass safety latch and two holding clips for the filters when not in use. Two leather handles are attached to the lamp housing by mounting strips and rings. On one side of the housing are two male receptacles, one marked 12 for the 12-volt cable and the other marked 110 for the 110-volt cable. A small jewel for indicating whether the printer is on or off is located on the front center of the lamp housing (fig. 6).

a. **Time Device (fig. 6).** The time device, which assures proper exposure through automatic control of the printer lamps, is set in the retractable time panel on the front of the lamp housing. It has a metallic face calibrated in seconds, a stop post, a time setting knob, and a switch which operates both the time device and the printer lamps.

b. **Rotary Switch (fig. 6).** The rotary switch is located on the front of the lamp housing. It has a metallic face marked 110 VOLTS and 12 VOLTS, and a pointer knob for setting the switch. The switch makes the connection between the power source used and the proper lamps in the lamp housing.

c. **Drawer (fig. 6).** The drawer in the bottom of the lamp housing is used for storing sensitized paper in cut sheets up to 11 by 14 inches.

d. **Switch (fig. 4).** A steel toggle switch marked ON and OFF is located on the side of the lamp housing. This switch is used to operate the lamps for blocking and retouching. It may also be used when the automatic time device is out of order.

6. INTERIOR OF PRINTER (figs. 4 and 6).

A rectangular, felt pressure pad is glued to a piece of plywood on the inside of the cover of the printer. The plywood is held in position on the cover by a series of springs. An $11\frac{3}{4}$ -by- $14\frac{7}{8}$ -inch, amber, lamacoid filter, used in making negatives, fits under the three filter clips which are mounted on the top of the lamp housing side and back. A fabric measuring tape is mounted on the back top of the lamp housing. A sheet of clear plate glass, 12 inches long and $14\frac{7}{8}$ inches wide, rests in grooves near the top of the lamp housing, and is held in position by the three filter clips. Resting in grooves below the plate glass is an $11\frac{3}{4}$ by $14\frac{3}{4}$ sheet

of double-thick, flaked, opal glass. Six 25-watt, 12-volt lamps and six 60-watt, 115-volt lamps are screwed in sockets which are set around the outer edge of a wooden platform underneath the opal glass. The lamps are alternately placed, to assure even distribution of light on either electrical circuit. The wiring for the printer runs underneath the lamp platform. At one side of the lamp housing is a roll paper compartment (fig. 5) with a cover assembly. The cover assembly incorporates a crinkled cover with slide fastener and knob, and a fabric-covered feed plate with cutting edge, for feeding the sensitized roll paper onto the copying surface of the printer.

SECTION II

INSTALLATION AND ASSEMBLY

7. UNPACKING.

Remove the equipment from the carrying case. The printer is easily removed by grasping the handles at each end of the printer case and lifting it straight out (fig. 2).

8. CHECKING.

Check all items of equipment with the check list below. If any parts are damaged or missing, refer to the maintenance parts list (par. 25). If damaged or missing parts are given in the maintenance parts list, they may be replaced. After the equipment has been checked, repack the developer containers and all spare parts which will not be needed for immediate operation.

a. Printer.

- 1 filter, lamacoid, amber.
- 1 glass, plate.
- 1 glass, opal.
- 6 lamps, 25-watt, 12-volt.
- 6 lamps, 60-watt, 115-volt.
- 1 time device.
- 1 cover assembly, roll paper compartment.

b. Additional Equipment.

- 1 case, carrying.
- 1 cable assembly with battery clips.
- 1 cable assembly with male, female plug.
- 1 time device.
- 1 filter lamacoid, amber.
- 6 lamps, 25-watt, 12-volt.

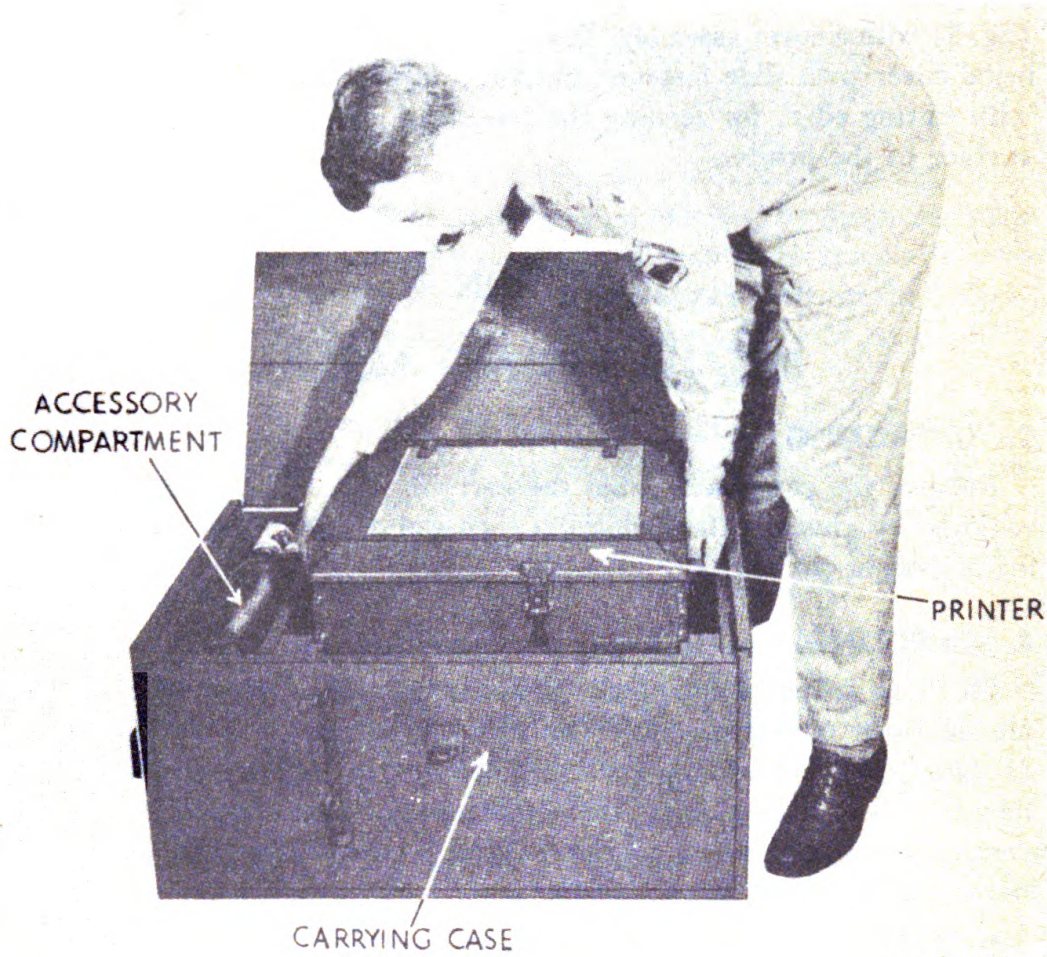

TL 92774

Figure 2. Removing printer from carrying case.

6 lamps, 60-watt, 115-volt.
24 developers, 2-quart containers.

9. ASSEMBLY OF EQUIPMENT.

a. Although a dark room is not required, the use of a spot with as little natural daylight as possible is recommended. Dim artificial lighting does not quickly affect the sensitized paper. Sunlight and daylight, however, rapidly cause fogging. If operating in a jungle or open field, a shelter-half or a piece of canvas, if available, should be stretched between trees or poles directly over the printer and developing tray.

b. In addition to the equipment supplied with Printer PH-507/PF, three enamel, stainless steel, or hard rubber trays, daylight reflex photocopying paper and acid fixer chemicals are necessary for the functioning of the equipment. A fourth tray may be useful for washing purposes. Assemble the trays, fixer chemicals, developer containers, and whatever auxiliary equipment is to be used (par. 20). Arrange the equipment as shown in figure 1, with the printer at the extreme left of the table, desk, or case. Place the developer tray near the printer, the hypo tray in the center, and the water tray on the extreme right.

NOTE: If washing equipment and running water are available the three trays may be used for developer, short stop, and hypo respectively.

10. INTERCONNECTIONS.

a. **Operation on 105- to 125-volt, Alternating or Direct Current.** Use the electric cable assembly with male plug at one end and female plug at the other (fig. 3). Attach the male plug into the outlet in the floor or wall, and place the female plug in the small male receptacle marked 110, on the side of the lamp housing. Turn the pointer knob on the rotary switch (fig. 6) to the position marked 110 VOLTS. Snap the toggle switch (fig. 4) on the side of the lamp housing to ON. When satisfied that the current is reaching the light source, throw the toggle switch to OFF. When operating on 105- to 125-volt a-c or d-c power source, light is furnished by the six 60-watt, 115-volt lamps.

b. **Operation on Storage Batteries.** Use the electric cable assembly with the battery clips at one end and the large female plug at the other (fig. 3). Place the female plug in the large male receptacle marked 12, on the side of the lamp housing. Attach the battery clips to either a 12-volt battery or to two 6-volt batteries, connected in series. Turn the pointer knob on the rotary switch to the position marked 12 VOLTS. Snap the toggle switch on the side of the lamp housing to ON. When satisfied that the current is reaching the light source, throw the toggle switch to OFF. When operating from storage batteries, light is furnished by six 25-watt, 12-volt lamps.

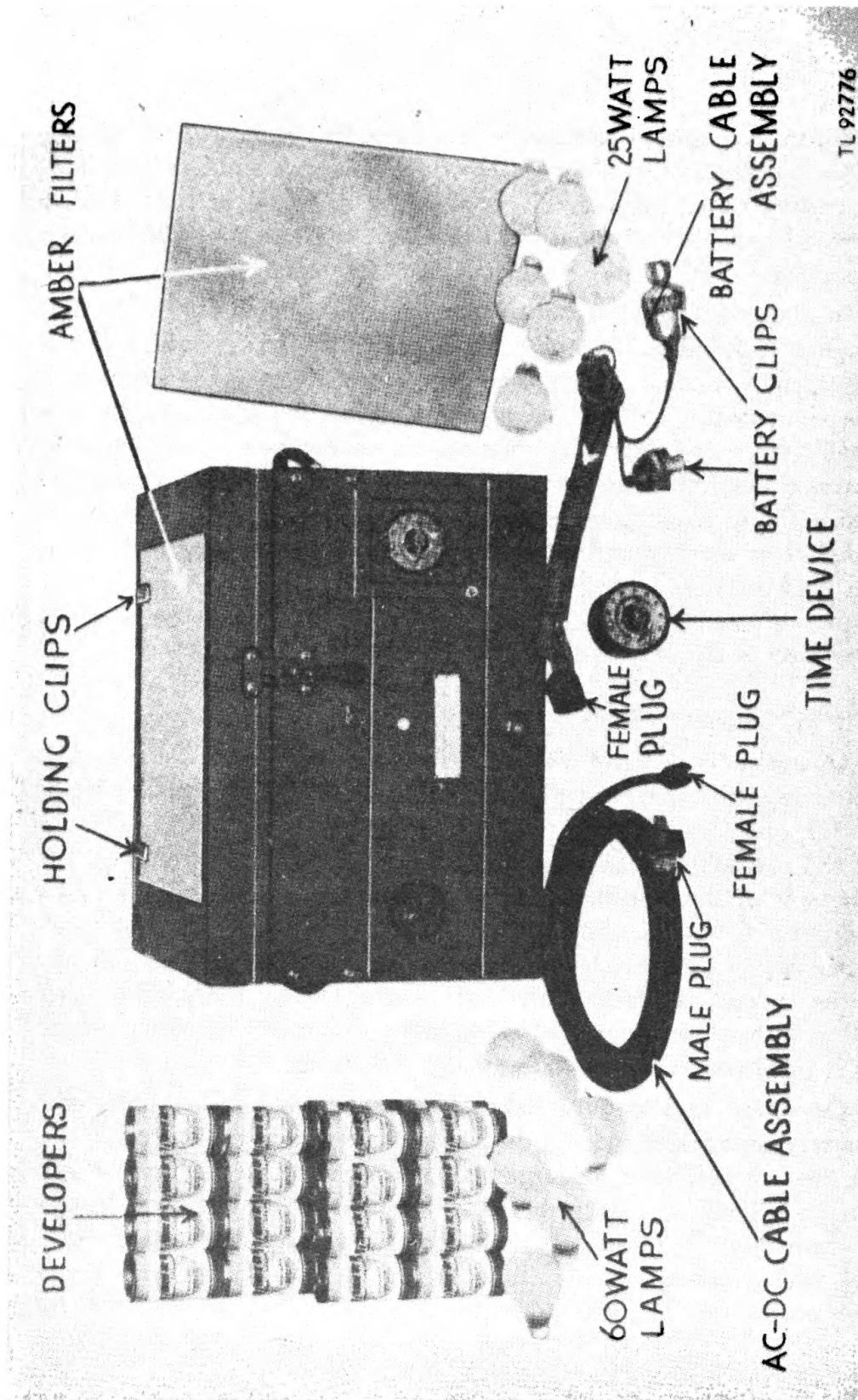

TL 92776

Figure 3. Component parts of Printer PH-507/PF.

PART TWO

OPERATING INSTRUCTIONS

NOTE: For information on destroying this equipment to prevent enemy use, see the destruction notice at the front of this manual.

SECTION III

STEP-BY-STEP OPERATING PROCEDURE

11. MIXING CHEMICALS.

a. Developer. Place 1 quart of water which has been heated to 100 to 120° F, in the tray nearest the printer. Although hot water is preferred, cold water may be used when absolutely necessary. Open a container of developer (fig. 3) by raising the metal lid with a coin, key, or screwdriver. Dissolve the contents of the inner package in the water, stirring until thoroughly dissolved. Add 1 quart of cold water and the contents of the outer package. Stir until all crystals are completely dissolved and the solution becomes red.

b. Fixing Bath. Mix the fixer chemicals in the center tray as directed on the container.

c. Water. Half fill the third tray with plain water.

NOTE: If the three trays are used for developer, short stop, and hypo, the middle tray will contain the stop bath and the end tray the hypo. The stop bath is a mixture of 1½ ounces of 28 percent (commercial) acetic acid per quart of water. Used or partially exhausted hypo solution or plain water can be used as a substitute, however. The short stop arrests the action of the developer and protects the working qualities of the hypo. The normal fixer will process 30 8- by 10-inch prints per quart with the stop bath, 15 with the intermediate water rinse, and less when neither is used.

12. PREOPERATION PROCEDURES.

Open the printer by raising the safety latch attached to the front of the cover. Remove the roll paper compartment cover assembly by pushing the slide fastener toward the center of the compartment (fig. 5). Lift out by the knob and install a roll of photocopying paper in the compart-

e. **Print from Film Negative.** Remove the amber filter from the top of the glass and insert in the filter holding clips on top of the printer cover. Place the film dull side up on the plate glass, and cover with photocopying paper, sensitized side down. Close the printer cover. Set the time device according to the exposure time table in subparagraph *f* below, basing the time on the density of the film.

f. **Exposure Time Table.** Printing times vary according to whether the printer is connected to 105- to 125-volt, a-c or d-c power source, or to a storage battery. The approximate printing time for each type of reproduction is given below. The exposures are gauged for 105- to 125-volt, a-c or d-c power sources or for fully charged 12-volt batteries. If a-c or d-c power is above or below these voltages, or the batteries are run down, exposure times must be altered accordingly.

<i>Type of reproduction</i>	<i>Approximate exposure time (sec)</i>	
	<i>a-c or d-c power source</i>	<i>Storage battery</i>
Direct negative	5-7	25
Readable negative	2-4	18
Reflex negative	6-8	20
Positive from paper negative	3-5	18-20
Print from film negative	1-3	3-9
Positive from a blueprint	8-10	30-35

NOTE: Exposures are all approximate and are based on average weight originals with clearly printed, typed, or written matter. If the original weighs less or more than average, or is lighter or darker than average, exposures should be varied accordingly. It is recommended that the inexperienced operator make test strips to learn the exposures required.

g. **Retouching and Blocking.** To examine paper or film negatives which require retouching or blocking, place the paper or film negative on top of the plate glass, emulsion side down. Throw the toggle switch to ON.

13. SETTING EQUIPMENT IN OPERATION (fig. 6).

For all operations involving printing, make sure that the toggle switch is OFF before starting the time device. Set the time device pointer knob for the desired time and throw on the time device switch. If a series of exposures of identical length is to be made, set the stop post before rotating the pointer knob. To set the stop post, loosen the knurled knob and turn the stop post to the desired calibration on the dial. Tighten the knob to lock the stop post in position.

CAUTION. After the switch on the time device has been thrown, do not move the stop post or time setting knob on the time device, either forward or back.

14. OPERATION.

a. **Printer.** If the time device is being used, the printer will shut itself off automatically at the end of the set exposure time. If the time device is not being used, throw the toggle switch to OFF at the end of the desired exposure time, or when retouching and blocking have been completed. When the jewel in the front of the lamp housing goes off, open the cover of the printer case and remove the exposed paper. Place the paper immediately in the developer tray, face down.

b. **Developer Tray.** After placing the exposed paper quickly in the developer solution face down, it may be turned face up, so that the operator can watch the development. Be sure that the print makes uniform, all-over contact with the solution. Although developing times vary slightly according to the type of paper used, the approximate developing time for a print is from 5 to 15 seconds with the developer at 70° F. Care must be taken not to overdevelop.

NOTE: If the stop bath is used, see note in paragraph 11c.

c. **Hypo Tray.** Quickly place the print in the fixing solution, face down. To assure permanent reproductions, leave the print in fresh fixer for at least 5 minutes or in used fixer for 10 minutes. It is recommended that the prints be allowed to accumulate in the fixer tray until the operator is through exposing and developing, or until the tray is nearly filled. Prints, however, should never be allowed to stand in the fresh fixer for more than 1 hour, as over-long fixing will result in a faded image.

d. **Water Tray.** Remove the prints from the fixer and place them all together in the water tray or washer. If possible, rinse each print separately under running water. If running water is not available, clean water in the tray will serve the purpose. Be sure, however, to rinse each print separately to eliminate the possibility of any chemicals remaining on the prints. For normal processing, a 10-minute running-water wash with occasional muddling, or a 1-minute wash with agitation in each of five changes of water is sufficient. For rush or field processing, a 1-minute wash with agitation in five changes of water is ideal, but a 1-minute wash in fresh water for a dozen or less prints gives satisfactory results. If the 1-minute wash in fresh water is used, however, the prints should be washed again at a later date to insure permanence.

e. **Drying.** After the prints have been washed thoroughly, dry them in a blotter roll, between the pages of a blotter book, or by clipping them on a suspended string. If a dryer is available, follow the instructions issued with the drying equipment.

NOTE: Paper negatives from which positive prints are to be made must be dried with a minimum of wrinkle in order to avoid loss of contact in making positives. A pre-drying bath of 10 percent solution of glycerine in water is helpful.

15. INDICATIONS OF NORMAL OPERATION.

When the printer is operating normally, the small jewel on the front of the lamp housing will light up, indicating that the lamps in the printer are on. The time device makes a steady buzzing sound while in operation and an audible click when switching off.

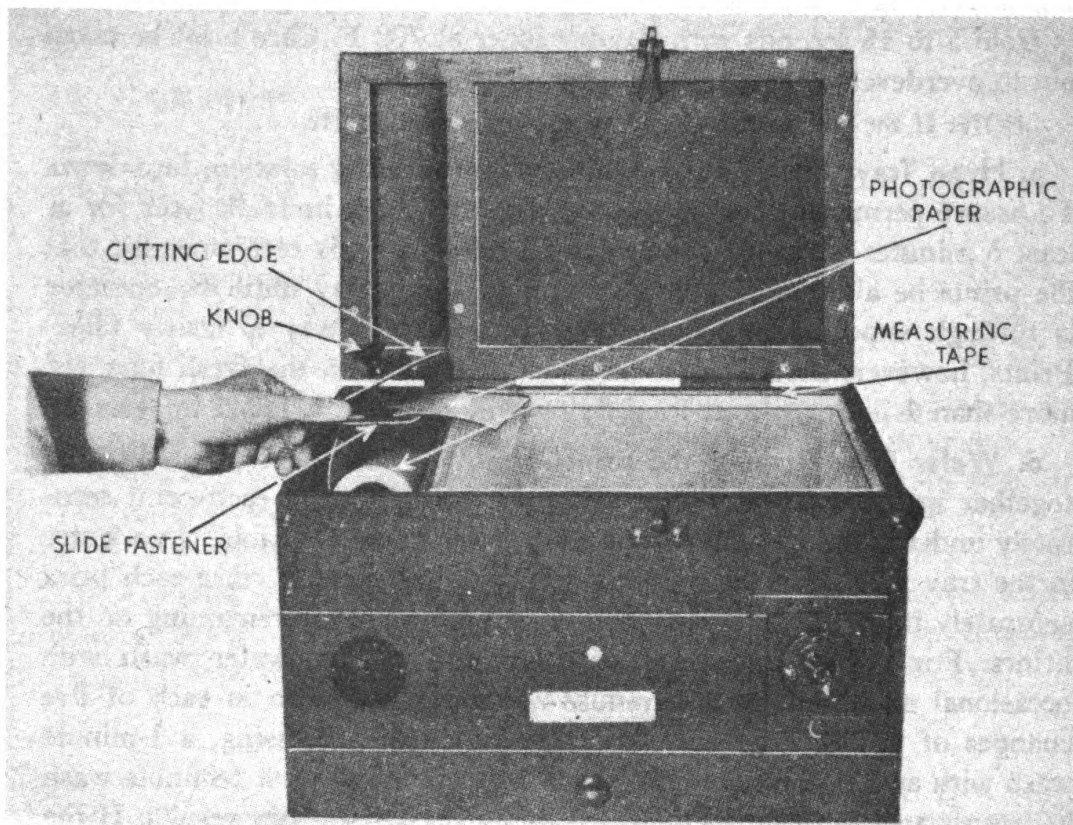

Figure 5. Printer, showing installation of paper in roll paper compartment.

PART THREE

PREVENTIVE MAINTENANCE

SECTION IV

ITEMIZED PREVENTIVE MAINTENANCE

16. MEANING OF PREVENTIVE MAINTENANCE.

Preventive maintenance may be defined as a series of operations performed on equipment to minimize interruptions in service and to eliminate major breakdowns. The function of trouble shooting and repair, on the other hand, is to locate and correct existing defects. This section of the manual contains specific instructions and serves as a guide for personnel assigned to perform the basic maintenance operations.

17. PREVENTIVE MAINTENANCE PROCEDURE.

Little preventive maintenance is necessary for Printer PH-507/PF. If the printer is idle for a period of 24 hours or more, heat it to an operating temperature for a short period each day. This prevents moisture from accumulating on the equipment. Keep the felt pressure pad and the fabric-covered feed plate in the roll paper compartment cover dry and free of lint, dust, and sand particles. Keep the printer cover closed at all times when not in use.

18. MOISTUREPROOFING AND FUNGIPROOFING.

Moistureproofing and fungiproofing are not required for Printer PH-507/PF. Heating the equipment to operating temperature each day, as required in preventive maintenance (par. 17), will check fungus growth or the formation of moisture on the equipment surface.

SECTION V

LUBRICATION

19. LUBRICATION.

No lubrication is required for either the operation or maintenance of this equipment.

PART FOUR

AUXILIARY EQUIPMENT

SECTION VI

NON-ESSENTIAL AIDS

20. AUXILIARY EQUIPMENT fig. (1).

a. **Print Dryer.** This piece of equipment is not supplied with Printer PH-507/PF, but may be used to advantage whenever speedy drying is desired. Instructions for the use of dryers may be found in the following manuals: TM 11-2354, Dryer PH-75; TM 11-2381, Dryer PH-288, and TM 11-2355, Dryer PH-176.

b. **Draining Board.** Uniform drying of prints may be secured by placing wet prints on a draining board, filter, or piece of glass, and removing the excess water with a sponge or squeegee.

c. **Sponge or Squeegee.** See subparagraph *b* above.

d. **Reference.** For information concerning standard darkroom equipment see TM 1-219, Basic Photography.

PART FIVE

REPAIR INSTRUCTIONS

NOTE: Failure or unsatisfactory performance of equipment used by Army Ground Forces and Army Service Forces will be reported on W.D., A.G.O. Form No. 468 (Unsatisfactory Equipment Report). For particulars see paragraph 24. If Form No. 468 is not available, see TM 38-250. Failure or unsatisfactory performance of equipment used by Army Air Forces will be reported on Army Air Forces Form No. 54 (unsatisfactory report).

SECTION VII

TROUBLE SHOOTING

21. TROUBLE CHART.

<i>Trouble</i>	<i>Probable cause</i>	<i>Remedy</i>
Unsteady or flickering light.	Connections to batteries loose.	Check clips. Clean battery terminals.
	Plug not firmly in wall socket.	Check outlet and plug.
	Cable plugs not correctly placed in printer receptacle.	Check plug in receptacle.
	Toggle switch out of order.	Replace toggle switch.
	Time device out of order or not functioning properly.	Replace time device.
	Rotary switch out of order.	Replace rotary switch.
	Loose wires leading to receptacles, toggle switch, time device, or rotary switch socket.	Check loose screws at terminals. Check soldering on rotary switch.
	Broken wires.	Splice and tape.
	Loose lamps.	Tighten lamps in sockets.
	Lack of contact.	Pressure pad support sticking to cover.
Uneven felt pad.		Replace pad. Place cardboard between print and pressure pad.
Heavy creases in document.		Place cardboard between print and pressure pad.
Wrinkled negative.		Wet and re-dry negative or draw it over table edge to remove curl.

<i>Trouble</i>	<i>Probable cause</i>	<i>Remedy</i>
No light.	Broken wires.	Splice and tape.
	No power.	Attach plug to wall socket or clips to batteries. Connect plug to printer receptacle. Check power.
	Faulty rotary switch.	Replace rotary switch.
Dead spots in reproduced image.	Rotary switch not set properly.	Turn pointer knob to power required. Tighten set-screw in pointer knob.
	Broken time device or toggle switch.	Replace either or both.
	One or more lamps not functioning.	Tighten or replace lamps.
Light print.	Insufficient exposure.	Lengthen exposure.
	Insufficient development.	Develop longer.
	Developer exhausted.	Mix fresh developer.
Dark print.	Overexposure.	Shorten exposure.
	Overdevelopment.	Develop less.
No print.	Fixer chemicals mixed with developer, or developer exhausted.	Mix fresh developer.
	No emulsion on paper.	Test strip of fresh sheet.
	Paper placed wrong side up.	Reverse paper.
	No light.	Check cord connections.
Uneven print.	Improper lighting.	Check lamps. Check lamp platform for dust and dirt. Clean thoroughly.
Spotted print.	Uneven contact with developer.	Place print quickly in developer solution and agitate to remove air bubbles.
	Undissolved fixer chemicals.	Thoroughly dissolve fixer chemicals.
Bleached print.	Too long in fixer.	No remedy. Make print over.
	Fixer too warm.	Cool the fixer.
Fogged print.	Unnecessarily exposed to light.	Do not expose paper to too much light.
	Overdevelopment.	Do not prolong development over recommended time.
Stained print.	Exhausted developer.	Mix new developer.

SECTION VIII

REPAIR INSTRUCTIONS

22. REPLACEMENT OF PARTS.

NOTE: Before attempting to replace any of the parts which may appear to be defective, refer to the trouble, cause, and remedy chart (par. 21) to make certain that the defect warrants a new installation.

Printer PH-507/PF is simply constructed and has few parts that may go out of order. Most of these parts, if they do become defective through rough handling or hard usage, can be replaced by following the instructions given below.

a. Installation of New Time Device.

- (1) Disconnect the cable plug at receptacle.
- (2) Remove the paper from roll compartment.
- (3) Remove the four screws and washers from the front panel of the printer and pull the panel out (fig. 4).
- (4) Gently pull the plate glass and opal glass out.
- (5) Place the panel, screws, washers, plate glass, and opal glass in a safe place.
- (6) Remove the lamp from the socket nearest the time device panel.
- (7) Leave the retractable time device panel flush with front of machine.
- (8) Loosen the setscrew in the white ring back of the time device and gently push the time device out of the cabinet.
- (9) Remove the brass screws which hold the two wires to the right side of the time device.
- (10) Attach the wires to the new time device in the way they were originally attached.
- (11) Repeat process for the wires attached to left-hand side of the old time device.
- (12) Place the time device back in the hole flush with the front of the retractable time device panel, being sure that the name DUOPHOTO on the time device dial is parallel to the bottom of the printer.
- (13) Place the ring on the back of the time device and tighten the setscrew.
- (14) Replace the lamp securely in the socket; replace the opal glass in the lower slot, shiny side up; slide the plate glass on the ledge as far back as possible; replace the panel as originally found and place washers and screws in their original holes.

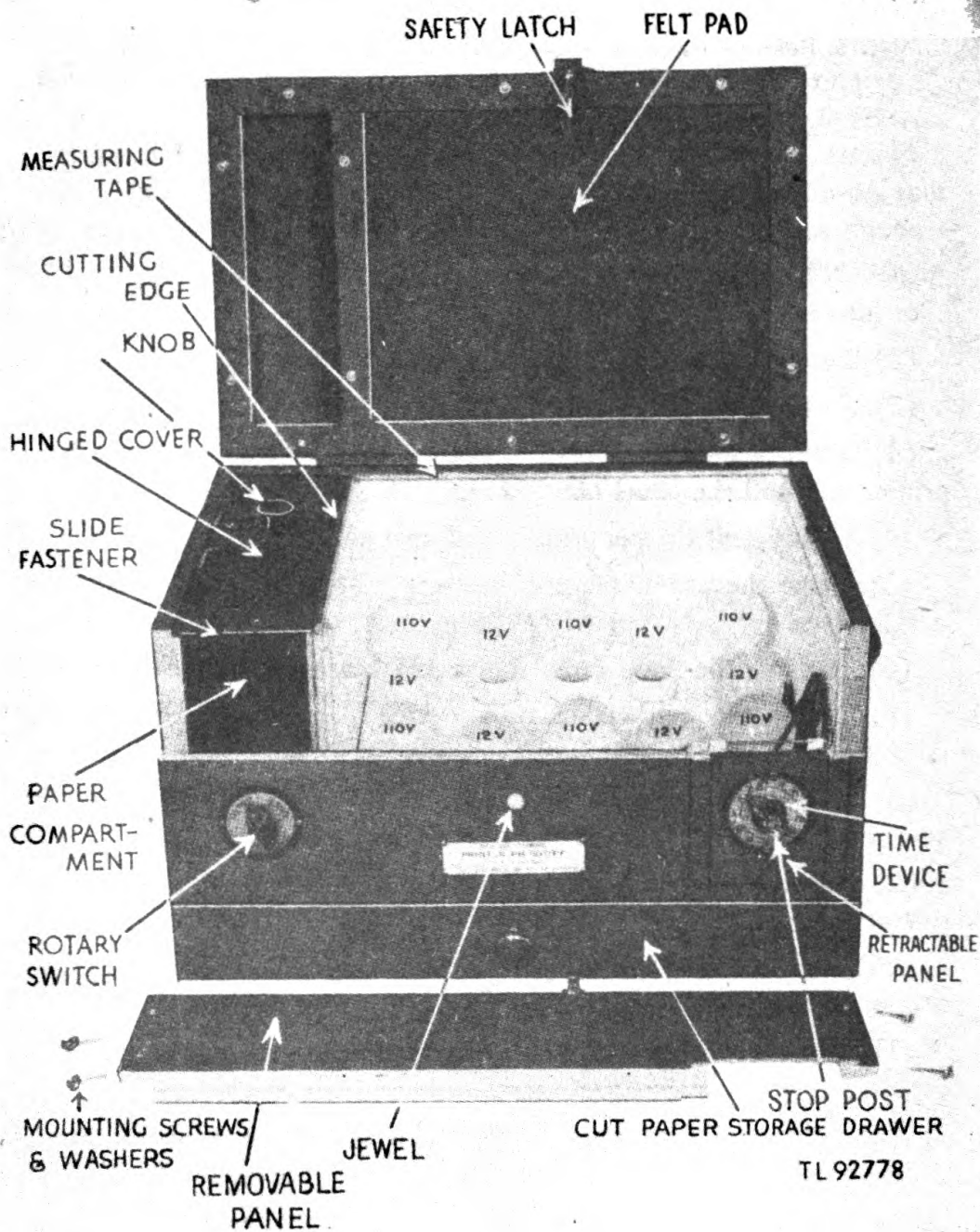

Figure 6. Printer, with front panel, plate glass, and opal glass removed.

b. Installation of Toggle Switch.

- (1) Remove all parts as instructed in subparagraph *a*(1) through (6) above.
- (2) Using pliers, remove the outside nut on the toggle switch.
- (3) Remove the ON and OFF indicator plate.
- (4) Ease the toggle through the hole, twisting slightly to the left until out of cabinet.
- (5) With a hot soldering iron, melt the solder off the toggle switch terminals, loosening the leads from the switch.
- (6) Solder the leads back onto the new toggle switch in exactly the same positions as before.
- (7) Ease the toggle switch back in the cabinet, making sure that the leads are at the bottom of the switch when replaced.
- (8) Replace the ON and OFF indicator plate, being certain that the key in the hole of the plate fits snugly in the groove at the bottom of the switch.
- (9) Replace the nut and tighten with pliers.
- (10) Replace the lamp, opal glass, plate glass, panel, and screws as instructed in subparagraph *a*(14) above.

c. Replacing Lamps.

NOTE: Before attempting to replace the lamps, tighten each lamp in its socket and turn on the power. If lamp or lamps are defective, replace with new ones.

- (1) Remove the front panel of printer as described in subparagraph *a*(3) above.
- (2) Gently pull out plate glass and opal glass.
- (3) Put panel screws, washers, plate glass, and diffusing glass in a safe place.
- (4) Attach the cord to the receptacle for 110 volts and plug in to 110-volt outlet. Throw the toggle switch to ON. Tighten the unlit lamps in their sockets.
- (5) If the lamp or lamps are still unlit or weak, throw the toggle switch to OFF and remove the lamp by grasping firmly and turning to the left until clear of the socket.
- (6) Place the new lamp in the socket and tighten.
- (7) Replace the opal glass, plate glass, panel, washers, and screws as instructed in subparagraph *a*(14) above.

NOTE: Be sure to replace the 115-volt lamps with 115-volt lamps and 12-volt lamps with 12-volt lamps.

d. Replacing Plate and Flaked Glass.

- (1) Remove the four screws and washers from the front panel and pull the panel out.

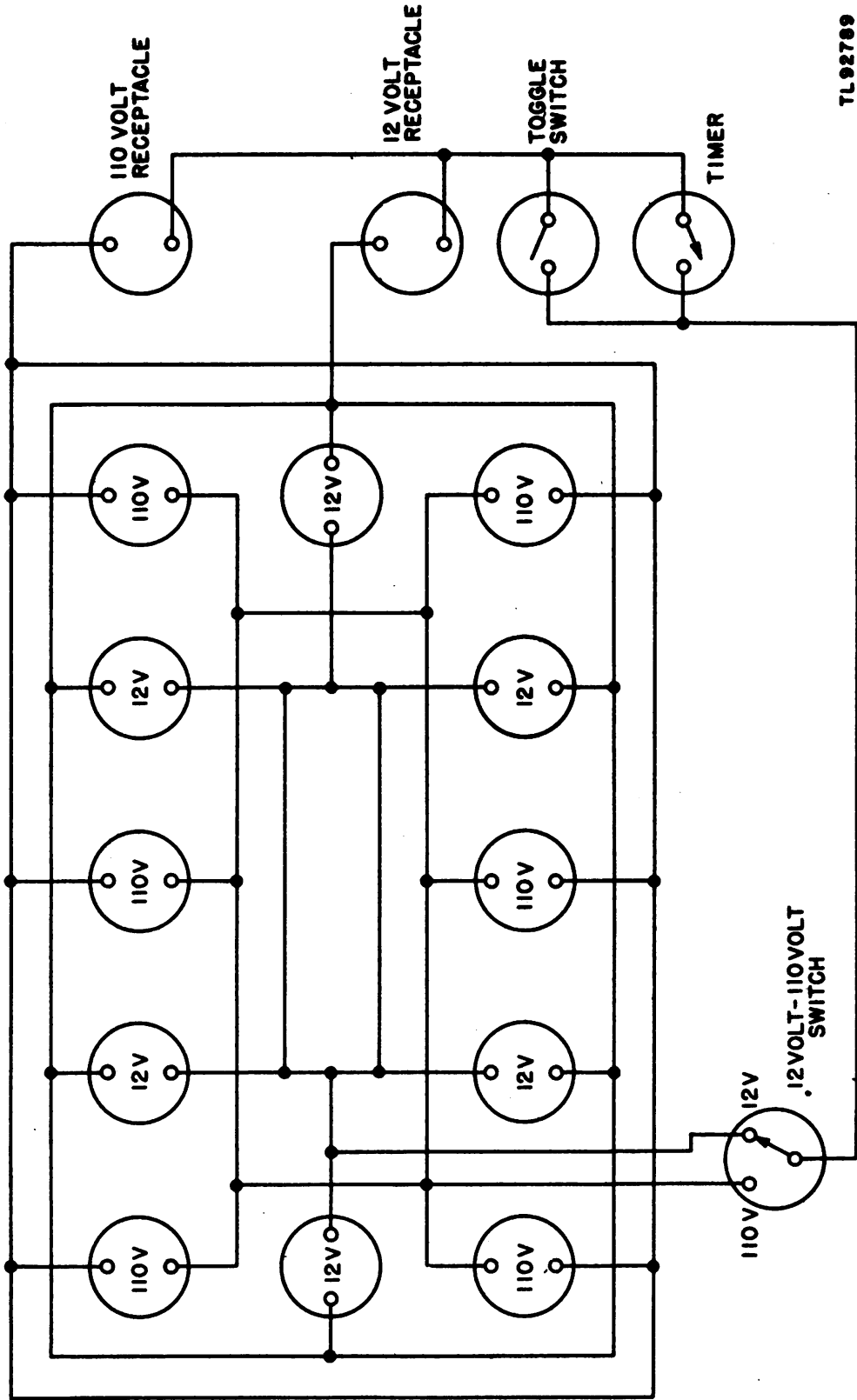

TL 92789

Figure 7. Wiring diagram.

(2) Gently pull out the plate glass and opal glass.

(3) If any particles of broken glass have fallen to the floor in the machine, remove them, after ascertaining that the power is off.

(4) Replace the new opal glass in the lower slot which is located about 1 inch below the printing surface of the unit, being sure that the shiny surface is to the top.

(5) Slide the new plate glass along the ledge above the opal glass slot and push back as far as it will go.

(6) Replace the front panel as originally found, being sure that the screws are replaced in the original holes from which they were taken.

e. Replacing Printer Case Handles.

(1) Unscrew the four screws which hold the handle mounting strips to the side of the case.

(2) Extend the rings and slip the leather handle over the free ends.

(3) Slip the new handle over the rings.

(4) Place the two rings, flat side toward the case, in the grooves of the mounting strips and screw the strips to the case.

(5) Replace the second handle in the same manner.

f. Replacing Pressure Pad.

(1) Carefully tear the felt pressure pad from the board on which it is glued.

(2) Scrape the board free of all felt.

(3) Spread glue on the surface of the board and mount the new pressure pad.

(4) Clean off all excess glue and close the printer until the glue sets.

g. Replacing Rotary Switch Bar Knob.

(1) Remove the setscrew which attaches the knob to the rotary switch bar.

(2) Remove the knob, place the new knob on the rotary switch bar and replace the setscrew.

h. Replacing Rotary Switch.

(1) Remove the front panel of the printer as described in paragraph 22a(3).

(2) Remove the hinged cover and the floor of the paper compartment.

(3) Remove the rotary switch bar knob as described in subparagraph *g* above. Remove the hexagonal nut.

(4) Reach into the paper compartment and pull out the rotary bar.

(5) Two wires are attached to one end of the operating portion of the switch. Mark the wire nearest to the rotary switch bar with some adequate

means of identification such as adhesive tape, and note carefully to which terminal the wire corresponds.

(6) Give a distinguishing mark to the wire which attaches to the one terminal on the other end of the operating portion of the switch.

(7) Unsolder the three wires, and remove the rotary switch.

(8) Insert the bar of the new switch through the hole in the printer case, positioning it so that when the knob is on the bar, the knob will point to 110 VOLTS when the rotary switch bar is turned to the left.

(9) Solder the three wires to their correct terminals, replace the hexagonal nut and mount the rotary switch bar knob as directed in subparagraph *g*(2) above.

(10) Replace the floor and cover of the paper compartment and the front panel of the printer.

23. ELECTRICAL REPAIR.

The wiring of the printer is fully illustrated in the wiring diagram (fig. 7). No additional electrical repair instructions are necessary.

24. UNSATISFACTORY EQUIPMENT REPORT.

a. When trouble in equipment used by Army Ground Forces or Army Service Forces occurs more often than repair personnel feel is normal, War Department Unsatisfactory Equipment Report, W.D., A.G.O. Form No. 468 should be filled out and forwarded through channels to the Office of the Chief Signal Officer, Washington 25, D. C. Refer to TM 38-250 for complete instructions on the handling of this report.

b. When trouble in equipment used by Army Air Forces occurs more often than repair personnel feel is normal, Army Air Forces Form No. 54 should be filled out and forwarded through channels.

APPENDIX SECTION IX

MAINTENANCE PARTS LIST 25. MAINTENANCE PARTS LIST FOR PRINTER PH-507/PF.

Ref symbol	Signal Corps stock No.	Name of part and description	Quan per unit	Run-ning spares	Orgn stock	3d ech	4th ech	5th ech	Depot stock
Fig. 3	3E4515	CABLE ASSEMBLY: power; insulated; copper tinned; stranded; two #14 AWG Cond; 34 #30 AWG strands; $\frac{3}{16}$ " OD; rubber insulation 14 ft lg; DuoPhoto #1002, (one side has female socket Hubbell #15A, 125V; #110A, 250V; 2 battery clips other end, Mueller Elec 50 Amps 1" clips; p/o Army-Navy Printer PH-507/PF).	1				**	**	*
Fig. 3	3EA515-1	CABLE ASSEMBLY: power; photo-printer; rubber covered and jacketed; round, $\frac{3}{8}$ " OD; 14 $\frac{1}{2}$ ft lg; 2 cond #16 AWG; (rubber insulated cond; not color coded male plug Graybar #9973 at 1 end; Midget type female plug AH&H #MB at other end; p/o Army-Navy Printer PH-507/PF).	1				**	**	*
Fig. 2	8A3104/C1	CASE: photographic printer; wood, olive drab; empty; intended for printer, bulbs, films; 33" lg x 16" D x 16 $\frac{3}{4}$ " wd; (has 1 compartment 5" wd x 15" lg, w/hinged cover 31" lg x 16 $\frac{3}{4}$ " wd x $\frac{3}{4}$ " thk; p/o Army-Navy Printer PH-507/PF).	1				**	**	*

* Indicates stock available.

** Indicates parts may be requisitioned as needed from depot stocks.

25. MAINTENANCE PARTS LIST FOR PRINTER PH-507/PF (contd).

Ref symbol	Signal Corps stock No.	Name of part and description	Quan per unit	Run-ning spares	Orgn stock	3d ech	4th ech	5th ech	Depot stock
Fig. 3	8C59	DEVELOPER: photographic; powder; 2 qt. size cardboard container; primarily for duophoto copying development; (technical purity; special; p/o Army-Navy Printer PH-507/PF).	24						
Fig. 3	8A3829-B	DEVICE: time interval spring clock work, electro mechanical; direct reading, manual start, 2 $\frac{3}{4}$ " diam x 1 $\frac{1}{4}$ " thk, Mark timer, circular dial calibrated 0 to 60 sec, manually wound, 2 circuit control 115V 30 amp 25V.	2	1					
Fig. 3	8A1125	FILTER: light amber; lamacoid, (plastic); 14 $\frac{7}{8}$ " lg x 11 $\frac{1}{4}$ " wd x $\frac{1}{32}$ " thk; (unmounted; p/o Army-Navy Printer PH-507/PF).	2				**	**	*
Fig. 4	6Z4996-5	HANDLE: case, leather; 5 $\frac{1}{4}$ " lg x 14" thk x $\frac{3}{4}$ " wd at center tapering at both ends to $\frac{1}{2}$ " wd, w/mtg rings; Louis Lefkowitz & Co; 2 tin mtg strips, 1 $\frac{1}{4}$ " lg x $\frac{3}{4}$ " wd x $\frac{1}{32}$ " thk; 2 #6 mtg holes; p/o Army Navy Printer PH-507/PF.	2				**	**	*
Fig. 6	2Z5840-4	KNOB: bar; black bakelite; $\frac{1}{4}$ " shaft hole; #6-32 set screw; 1 $\frac{1}{16}$ " lg x $\frac{5}{8}$ " h x $\frac{3}{4}$ " w; (shaft hole $\frac{3}{8}$ " d; pointer arrow marking; p/o Army Navy Printer PH-507/PF).	1				**	**	*
Fig. 6	8A3104/P1	PAD: felt; rectangular; glued 1 side; 13 $\frac{1}{4}$ " lg x 11 $\frac{1}{4}$ " wd x $\frac{1}{4}$ " thk; (used as pressure pad; p/o Army-Navy Printer PH-507/PF).	1				**	**	*

Fig. 6	3Z9858-2.109	SWITCH: rotary; SPDT; metal; 1" lg x 3/4" thk; AH&H #1565 U; (1 amp, 250V; 3 amp 125V; normally open; nonshorting type cont; mtg bushing 3/8"-32 x 5/8" lg; hex nut, steel, 1/2" across flats x 7/16" thk; p/o Army-Navy Printer PH-507/PF).	1			**	**	*
Fig. 4	3ZK9848.14	SWITCH: toggle SPST: fibre & steel 2" lg x 7/16" wd x 1 1/2" high; Hand H #20993, NA-250V, 1 amp 125V, nonshorting; single mounting bushing 1/2" 32 x 1" lg. Hex nut and round nut mounting.	1			**	**	*
Fig. 6	6Z6812-6	LAMP: incandescent 25-watt, 12V A19 inside frosted medium screw base, 3 3/4" max overall length, Sylvania or Equal.	6	*		*	**	*
Fig. 6	6Z6815-16	LAMP: incandescent 115 volt, 60 watt, A19 inside frosted, medium screw base, max O/A length 4 1/4", Sylvania or Equal.	6	*		*	**	*
Fig. 6	6L50243N	WASHER: cup; brass, nickel plated; 3/16" ID; 15/32" OD; 1/32" thk; 1/8" h p/o Army-Navy Printer PH-507/PF.	4			**	**	*
Fig. 4	6Z4574	GLASS: plate; clear; 12" wd x 14 7/8" lg x 1/4" thk; N. Teitlebaum and Sons; (p/o Army-Navy Printer PH-507/PF).	1		*	*	**	*
Fig. 4	6Z4575	GLASS: plate; flaked opal; 14 3/4" lg x 11 3/4" wd x 3/16" thk (used in printer to diffuse lighting; p/o Army-Navy Printer PH-507/PF).	1		*	*	**	*

* Indicates stock available.

** Indicates parts may be requisitioned as needed from depot stocks.

12299—Phila—45-54; 2785; 2 Jan. 45.

U. S. GOVERNMENT PRINTING OFFICE: 1945 O - 640492

Original from
UNIVERSITY OF CALIFORNIA

