

DEPARTMENT OF THE ARMY TECHNICAL MANUAL

DEPARTMENT OF THE AIR FORCE TECHNICAL ORDER

TM 11-295

TO 16-30-GRR5-5

**RADIO
RECEIVING
SET
AN/GRR-5**

Scanned from original manual by OldRadio.jp.
Feb 2003 Hideo Inoue

*DEPARTMENTS OF THE ARMY AND THE AIR FORCE
AUGUST 1952*

AGO 313A—July

RADIO
RECEIVING
SET
AN/GRR-5



United States Government Printing Office
Washington: 1952

DEPARTMENTS OF THE ARMY AND
THE AIR FORCE
WASHINGTON 25, D. C., 8 August 1952

TM 11-295/TO 16-30-GRR5-5 is published for the information and guidance of all concerned.

[AG 413.44 (9 Jul 52)]

BY ORDER OF THE SECRETARIES OF THE ARMY AND THE AIR FORCE:

OFFICIAL:

WM. E. BERGIN
Major General, USA
The Adjutant General

J. LAWTON COLLINS
Chief of Staff, United States Army

OFFICIAL:

K. E. THIEBAUD
Colonel, USAF
Air Force General

N. F. TWINING
Acting Chief of Staff, United States Air Force

DISTRIBUTION:

Active Army:

Tech Svc (1); Tech Svc Bd (1); AFF Bd (ea Svc Test Sec) (1); AFF (5); AA Comd (2); OS Maj Comd (5); Base Comd (5); Log Comd (5); A (20); MDW (5); CHQ (2); FT (2); Sch (5) except 11 (25); Gen Dep (2); Dep 11 (20) except Sig Sec, Gen Dep (10); Tng Div (2); POE (10), OSD (2); Lab 11 (5); Mil Dist (3); 4th & 5th Ech Maint Shops 11 (3); Two (2) copies to each of the following T/O&E's: 11-107; 11-127A; 11-128; 11-500, CA, CB, CC, CD; 11-587; 11-592; 11-597.

NG: Same as Active Army except one copy to each unit.

ORC: Same as Active Army except one copy to each unit.

For explanation of distribution formula, see SR 310-90-1.

CONTENTS

		Paragraphs	Page
CHAPTER 1. INTRODUCTION			
<i>Section I.</i>	General.....	1, 2	1
<i>II.</i>	Description and data.....	3-10	1
CHAPTER 2. OPERATING INSTRUCTIONS			
<i>Section I.</i>	Service upon receipt of Radio Receiving Set AN/GRR-5.....	11-17	8
<i>II.</i>	Controls and instruments.....	18, 19	15
<i>III.</i>	Operation under usual conditions.....	20-25	17
<i>IV.</i>	Operation under unusual conditions.....	26-29	18
CHAPTER 3. ORGANIZATIONAL MAINTENANCE INSTRUCTIONS			
<i>Section I.</i>	Organizational tools.....	30, 31	20, 21
<i>II.</i>	Preventive maintenance services.....	32-35	22
<i>III.</i>	Lubrication.....	36, 37	23, 24
<i>IV.</i>	Weatherproofing.....	38, 39	24
<i>V.</i>	Trouble shooting at organizational maintenance level.....	40-43	25
CHAPTER 4. THEORY			
<i>Section I.</i>	Power Supply PP-308/URR.....	44-50	28
<i>II.</i>	Radio Receiver R-174/URR.....	51-68	37
CHAPTER 5. FIELD MAINTENANCE INSTRUCTIONS			
<i>Section I.</i>	Trouble shooting at field maintenance level.....	69-87	55
<i>II.</i>	Repairs.....	88-91	71
<i>III.</i>	Alinement procedures.....	92-97	73
<i>IV.</i>	Final testing.....	98-102	77
CHAPTER 6. SHIPMENT AND LIMITED STORAGE AND DEMOLITION TO PREVENT ENEMY USE			
<i>Section I.</i>	Shipment and limited storage.....	103, 104	80
<i>II.</i>	Demolition of matériel to prevent enemy use.....	105, 106	80
APPENDIX I. REFERENCES			
			81
II. IDENTIFICATION TABLE OF PARTS			
			84
INDEX			
			107

WARNING

HIGH VOLTAGE

is used in the operation
of this equipment.

DEATH ON CONTACT

may result if personnel fail
to observe safety precautions.



RESCUE.

In case of electric shock, shut off the high voltage at once and ground the circuits. If the high voltage cannot be turned off without delay, free the victim from contact with the live conductor as promptly as possible. Avoid direct contact with either the live conductor or the victim's body. Use a dry board, dry clothing, or other nonconductor to free the victim. An ax may be used to cut the high-voltage wire. Use extreme caution to avoid the resulting electric flash.

SYMPTOMS.

a. Breathing stops abruptly in electric shock if the current passes through the breathing center at the base of the brain. If the shock has not been too severe, the breath center recovers after a while and normal breathing is resumed, provided that a sufficient supply of air has been furnished meanwhile by artificial respiration.

b. The victim is usually very white or blue. The pulse is very weak or entirely absent and unconsciousness is complete. Burns are usually present. The victim's body may become rigid or stiff in a very few minutes. This condition is due to the action of electricity and is not to be considered rigor mortis. Artificial respiration must still be given, as several such cases are reported to have recovered. The ordinary and general tests for death should never be accepted.

TREATMENT.

a. Start artificial respiration immediately. At the same time send for a medical officer, if assistance is available. Do not leave the victim unattended. Perform artificial respiration at the scene of the accident, unless the victim's or operator's life is endangered from such action. *In this case only*, remove the victim to another location, but no farther than

is necessary for safety. If the new location is more than a few feet away, artificial respiration should be given while the victim is being moved. If the method of transportation prohibits the use of the Shaeffer prone pressure method, other methods of resuscitation may be used. Pressure may be exerted on the front of the victim's diaphragm, or the direct mouth-to-mouth method may be used. Artificial respiration, once started, must be continued, without loss of rhythm.

b. Lay the victim in a prone position, one arm extended directly overhead, and the other arm bent at the elbow so that the back of the hand supports the head. The face should be turned away from the bent elbow so that the nose and mouth are free for breathing.

c. Open the victim's mouth and remove any foreign bodies, such as false teeth, chewing gum, or tobacco. The mouth should remain open, with the tongue extended. Do not permit the victim to draw his tongue back into his mouth or throat:

d. If an assistant is available during resuscitation, he should loosen any tight clothing to permit free circulation of blood and to prevent restriction of breathing. He should see that the victim is kept warm, by applying blankets or other covering, or by applying hot rocks or bricks wrapped in cloth or paper to prevent injury to the victim. The assistant should also be ever watchful to see that the victim does not swallow his tongue. He should continually wipe from the victim's mouth any frothy mucus or saliva that may collect and interfere with respiration.

e. The resuscitating operator should straddle the victim's thighs, or one leg, in such manner that:

(1) the operator's arms and thighs will be vertical while applying pressure on the small of the victim's back;

(2) the operator's fingers are in a natural position on the victim's back with the little finger lying on the last rib;

(3) the heels of the hands rest on either side of the spine as far apart as convenient without allowing the hands to slip off the victim;

(4) the operator's elbows are straight and locked.

f. The resuscitation procedure is as follows:

(1) Exert downward pressure, not exceeding 60 pounds, for 1 second.

(2) Swing back, suddenly releasing pressure, and sit on the heels.

(3) After 2 seconds rest, swing forward again, positioning the hands exactly as before, and apply pressure for another second.

g. The forward swing, positioning of the hands, and the downward pressure should be accomplished in one continuous motion, which requires 1 second. The release and backward swing require 1 second. The addition of the 2-second rest makes a total of 4

TL15338-D

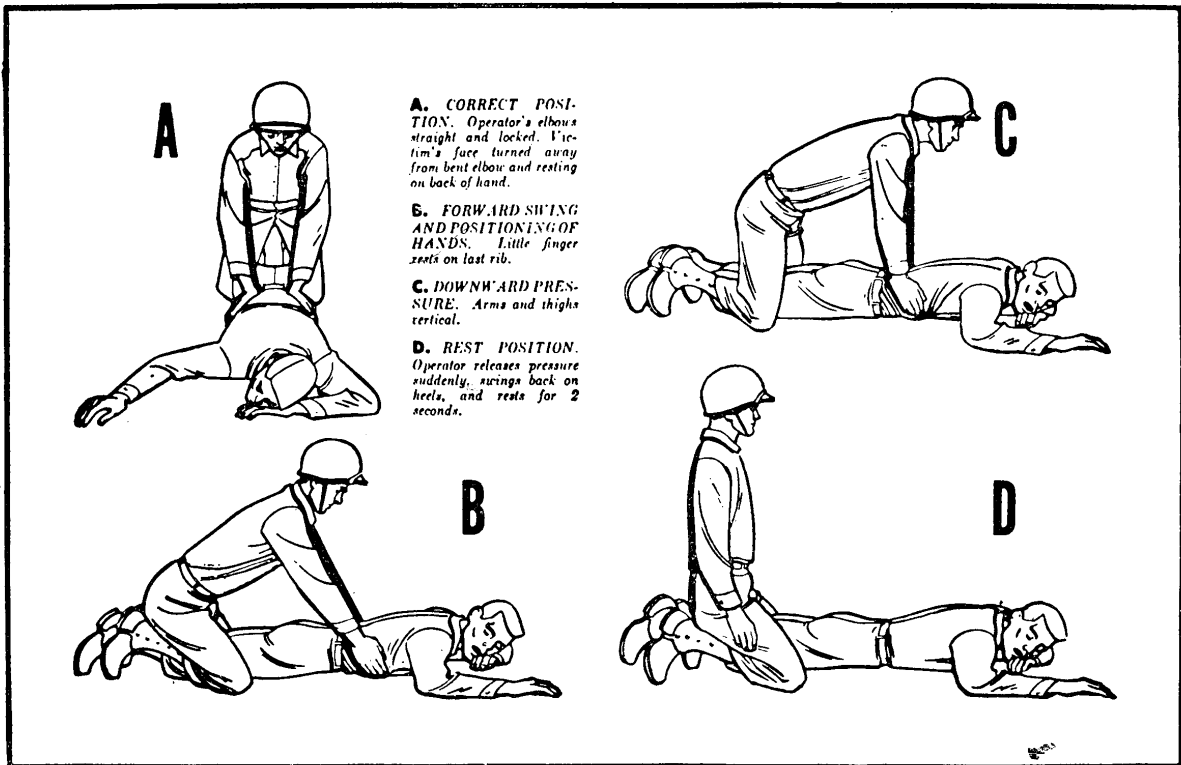

seconds for a complete cycle. Until the operator is thoroughly familiar with the correct cadence of the cycle, he should count the seconds aloud, speaking distinctly and counting evenly in thousands. Example: one thousand and one, one thousand and two, etc.

h. Artificial respiration should be continued until the victim regains normal breathing or is pronounced dead by a medical officer. Since it may be necessary to continue resuscitation for several hours, relief operators should be used if available.

RELIEVING OPERATOR.

The relief operator kneels beside the operator and follows him through several complete cycles. When the relief operator is sure he has the correct rhythm, he places his hands on the operator's hands without applying pressure. This indicates that he is ready to take over. On the backward swing, the operator moves and the relief operator takes his position. The relieved operator follows through several complete cycles to be sure that the new operator has the correct rhythm. He remains alert to take over instantly if the new operator falters or hesitates on the cycle.

STIMULANTS.

a. If an inhalant stimulant is used, such as aromatic

spirits of ammonia, the individual administering the stimulant should first test it himself to see how close he can hold the inhalant to his own nostril for comfortable breathing. Be sure that the inhalant is not held any closer to the victim's nostrils, and then for only 1 or 2 seconds every minute.

b. After the victim has regained consciousness, he may be given hot coffee, hot tea, or a glass of water containing $\frac{1}{2}$ teaspoon of aromatic spirits of ammonia. *Do not give any liquids to an unconscious victim.*

CAUTIONS.

a. After the victim revives, keep him LYING QUIETLY. Any injury a person may have received may cause a condition of shock. Shock is present if the victim is pale and has a cold sweat, his pulse is weak and rapid, and his breathing is short and gasping.

b. Keep the victim lying flat on his back, with his head lower than the rest of his body and his hips elevated. Be sure that there is no tight clothing to restrict the free circulation of blood or hinder natural breathing. Keep him warm and quiet.

c. A resuscitated victim must be watched carefully as he may suddenly stop breathing. *Never leave a resuscitated person alone until it is CERTAIN that he is fully conscious and breathing normally.*

TL15338-E



TM 295-1

Figure 1. Radio Receiving Set AN/GRR-5.

CHAPTER 1

INTRODUCTION

Section I. GENERAL

1. Scope

This manual contains instructions for the installation, operation, maintenance, and repair of Radio Receiving Set AN/GRR-5 (fig. 1). In addition to these instructions, there are two appendixes covering a list of references and an identification table of parts.

2. Forms and Records

The following forms will be used for reporting unsatisfactory conditions of Army equipment.

a. DD Form 6, Report of Damaged or Improper Shipment, will be filled out and forwarded as prescribed in SR 745-45-5 (Army) and AFR 71-4 (Air Force).

b. DA Form 468, Unsatisfactory Equipment Report, will be filled out and forwarded to the

Office of the Chief Signal Officer as prescribed in SR 700-45-5.

c. AF Form 54, Unsatisfactory Report, will be filled out and forwarded to Commanding General, Air Matériel Command, Wright-Patterson Air Force Base, Dayton, Ohio, as prescribed in SR 700-45-5 and AFR 65-26.

d. DA AGO Form 11-238, Operator First Echelon Maintenance Check List for Signal Corps Equipment (Radio Communication, Direction Finding, Carrier, Radar), will be prepared in accordance with instructions on the back of the form.

e. DA AGO Form 11-239, Second and Third Echelon Maintenance Check List for Signal Corps Equipment (Radio Communication, Direction Finding, Carrier, Radar), will be prepared in accordance with instructions on the back of the form.

f. Use other forms and records as authorized.

Section II. DESCRIPTION AND DATA

3. Purpose and Use

a. Radio Receiving Set AN/GRR-5 (fig. 1) is a mobile radio receiver used for tactical purposes. The radio set provides facilities for operation either with a loudspeaker, contained within the unit, or with Headset CW-49507-A (Navy type), connected externally, or with both loudspeaker and headset.

b. Radio Receiving Set AN/GRR-5 is capable of receiving a-m (amplitude-modulated) or c-w (continuous-wave) signals over a frequency range of 1.5 mc (megacycles) to 18 mc. The equipment is intended for use in a fixed-field station and for mobile operation. The operating components required for normal operation are

shown in figure 4. The power requirements are 115 volts ac (alternating current), 6 volts dc (direct current), 12 volts dc, 24 volts dc, or dry batteries (90 volts and 1.5 volts).

4. System Application (fig. 2)

Radio Receiving Set AN/GRR-5 may be used alone as a conventional radio receiving set, or with an appropriate a-m transmitter in a particular communication system. Figure 2 shows its application as an anti-aircraft-warning receiving set in conjunction with Radio Set AN/VRC-8, 9, or 10 and Intercommunication Set AN/UIC-1.

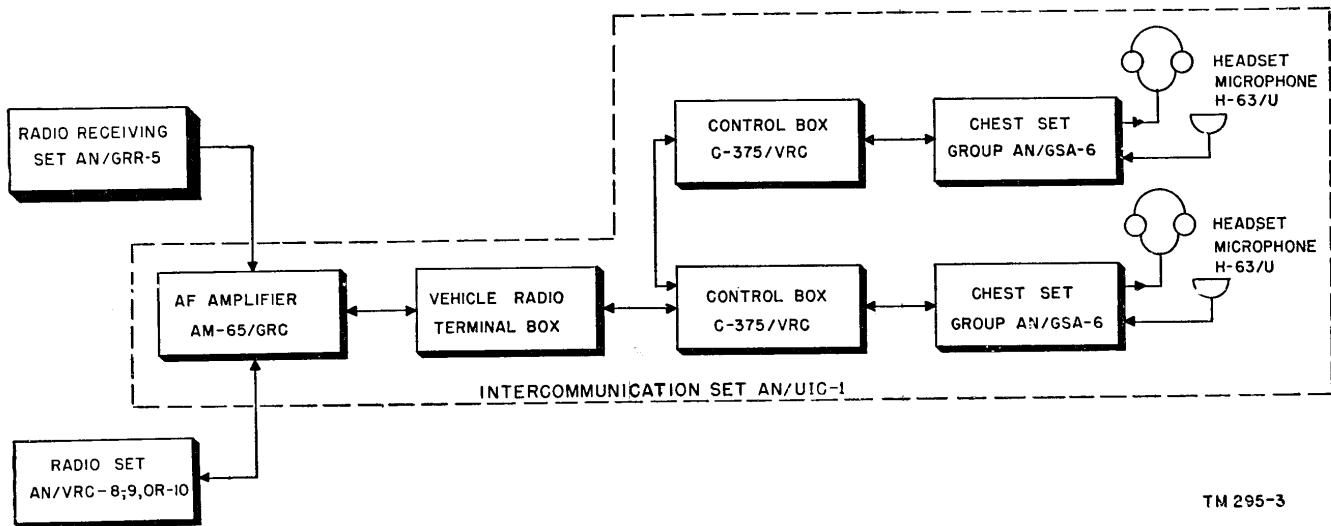

Figure 2. Radio Receiving Set AN/GRR-5, typical system application, simplified block diagram.

5. Technical Characteristics of Radio Receiving Set AN/GRR-5

Receiver type..... Superheterodyne.

Types of signals which can be received..... A-m, c-w, or m-c-w (modulated continuous wave).

Frequency range:

Band 1..... 1.5 mc to 2.7 mc.
 Band 2..... 2.7 mc to 5 mc.
 Band 3..... 5 mc to 9.5 mc.
 Band 4..... 9.5 mc to 18 mc.

Type of tuning..... Continuous, with provision for presetting detents for any 10 channel frequencies.

Number of tubes:

Receiver..... 8.
 Power supply..... 4.

Intermediate

frequency..... 455 kc (kilocycle).

Method of

calibration..... Built-in crystal frequency calibrator.

Calibration

points..... Every 200 kc.

Audio output:

High..... 90 mw (milliwatt).
 Low..... 20 mw.

Distortion..... 10 percent or less for 70 mw output, measured at 5 mc with 400-cycle, 30 percent modulation.

Sensitivity:

a-m..... 5 uv (microvolt) or better for 10 mw output, with a signal-plus-noise to noise ratio of 10 to 1.

c-w..... 2 uv or better for 10 mw output, with a signal-plus-noise to noise ratio of 10 to 1.

I-f selectivity:

6 db (decibel) down..... 6.5 kc.
 20 db down..... 13 kc.
 40 db down..... 20 kc.
 60 db down..... 28 kc.

Power input:

For vehicular operation:

6 volts..... 6.9 amperes, 41.4 watts.
 12 volts..... 3.22 amperes, 38.6 watts.
 24 volts..... 2.55 amperes, 61.2 watts.

For field operation:

90 volts
 (2 Battery
 BA-419/U)..... 27 ma (milliampere).

1.5 volts
 (1 Battery
 BA-405/U)..... 350 ma.

For fixed installation:

115 volts ac,
 50 or 60 cyc..... 455 ma, 52.4 watts.

Antenna..... Mast Sections MS-116-A (2 ea), MS-117-A, and MS-118-A or any suitable reel antenna.

Weight of receiver and power supply in cabinet..... 60.5 lb.

Weight of accessories..... 15.05 lb.

6. Packaging Data

a. When packaged for export shipment, the components of Radio Receiving Set AN/GRR-5 are placed in waterproof containers and are packed in a wooden export crate. Typical packaging is illustrated in figure 3. The size, weight, and volume of the crate are indicated in the following chart:

Note. Items may be packaged in a manner different from that shown, depending on supply channel.

Type of packaging	Number of crates	Height (in.)	Width (in.)	Depth (in.)	Volume (cu ft)	Total weight (lb)
Domestic	1	27 $\frac{1}{4}$	15 $\frac{1}{4}$	46 $\frac{1}{4}$	11.1	110
Export	1	31	19	50	17	162

b. The following list indicates the contents of the cartons within the crate. See the packing list attached to the crate for the exact contents.

Carton dimensions (in.)	Contents	Notes
10 x 6 x 44 $\frac{1}{2}$	Bag CW-206/GR containing: Electron Tube Case CY-1031/URR. Mast Sections 2 MS-116-A 1 MS-117-A 1 MS-118-A Power Cable Assemblies CX-1358/U CX-1359/U CX-1360/U Bag CW-212/U Headset Cord CX-1334/U Headset CW-49507-A (Navy type)	See packing list for items in Electron Tube Case CY-1031/URR.
18 x 14 x 18 $\frac{7}{8}$	Cover CW-211/U containing: Electrical Equipment Cabinet CY-615/URR Radio Receiver R-174/URR Power Supply PP-308/URR Mounting MT-768/URR Receiver-power supply interconnecting cable	Receiver and power supply are secured into the case. Shock mounting is secured to the case. Shipped already connected.

7. Table of Components

Component	Required No.	Height (in.)	Depth (in.)	Length (in.)	Volume (cu ft)	Unit weight (lb)
Electrical Equipment Cabinet CY-615/URR.	1	13 $\frac{7}{8}$	8 $\frac{1}{8}$	12 $\frac{1}{8}$	1.1	8.6
Radio Receiver R-174/URR.	1	5 $\frac{1}{8}$	7 $\frac{7}{8}$	12	.3	18.9
Power Supply PP-308/URR.	1	5 $\frac{1}{2}$	8	12	.3	26.
Mounting MT-768/URR	1	5 $\frac{1}{2}$	9 $\frac{5}{8}$	13 $\frac{1}{8}$.13	7.
Cover CW-211/U	1	15 $\frac{3}{4}$	11	14 $\frac{1}{2}$	2.3	1.75
Bag CW-206/GR	1		27	44		3.5
Electron Tube Case CY-1031/URR.	1	3	9 $\frac{3}{4}$	4 $\frac{3}{4}$.07	2.9
Mast Section MS-116-A	2			39 $\frac{1}{2}$.15
Mast Section MS-117-A	1			39 $\frac{1}{2}$.15

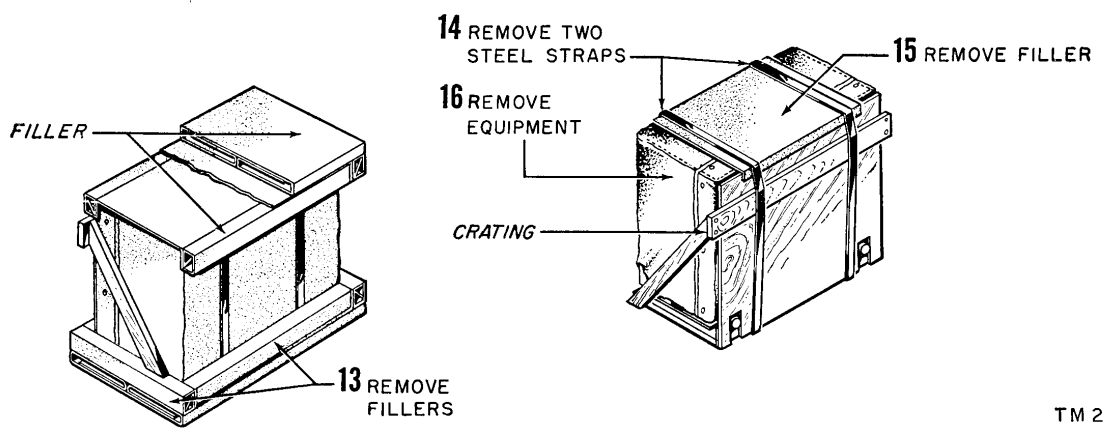
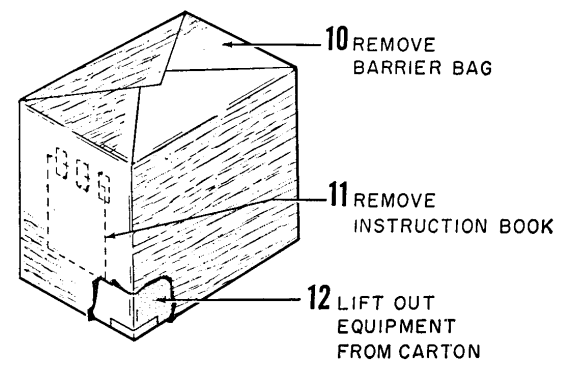
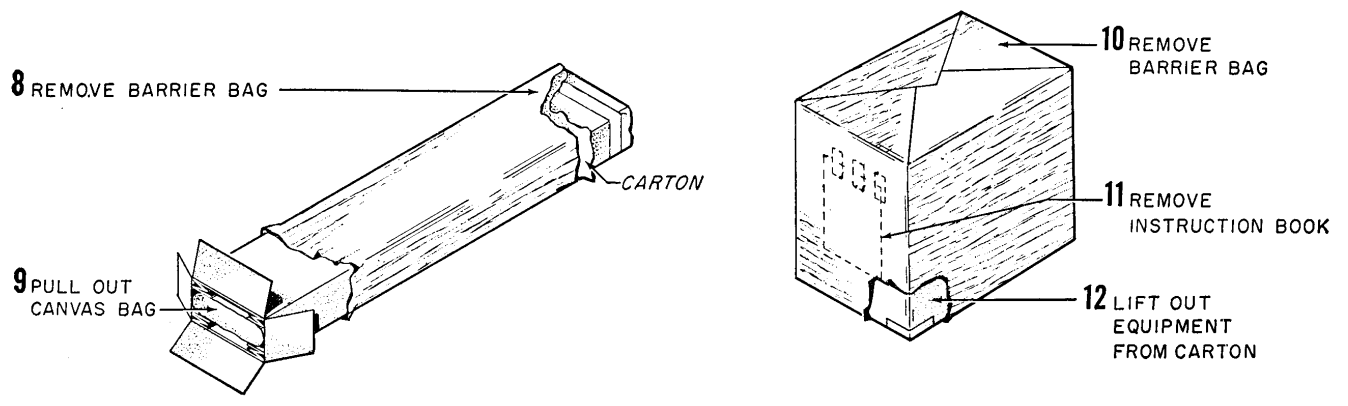
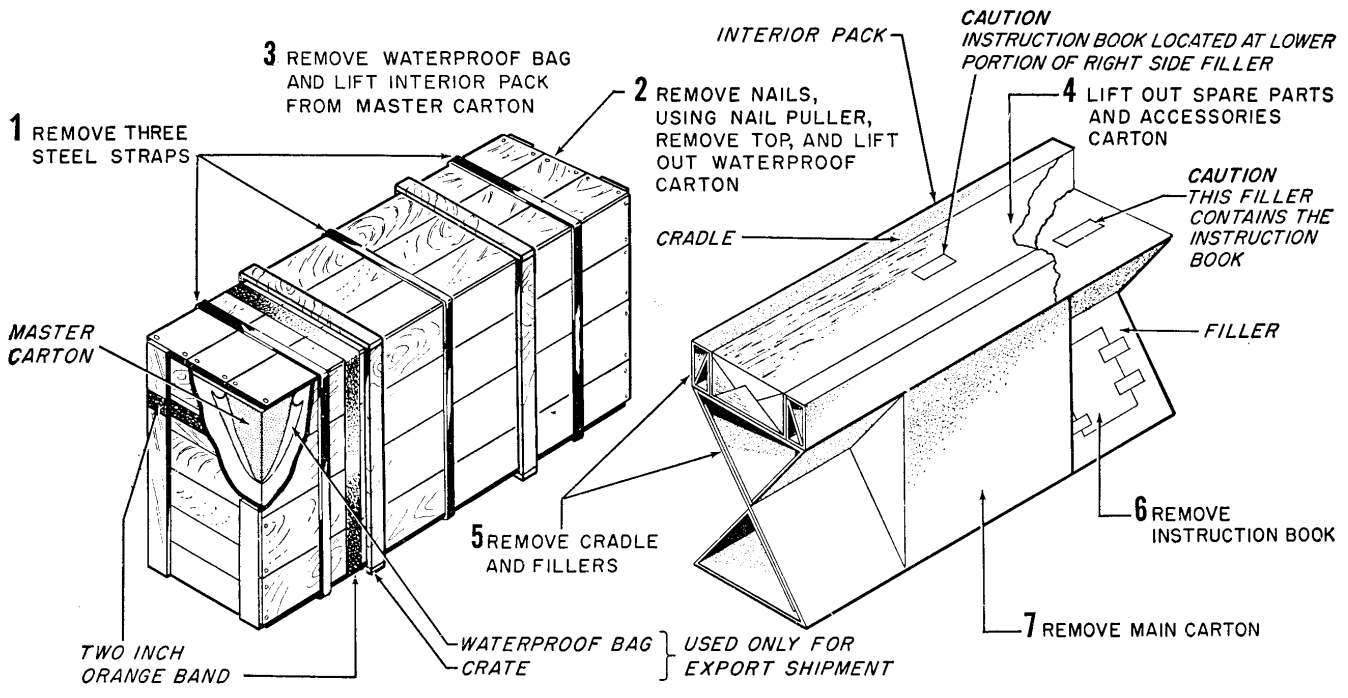

Figure 3. Radio Receiving Set AN/GRR-5, packing and packaging.

TM 295-4

AGO 313A

Component	Required No.	Height (in.)	Depth (in.)	Length (in.)	Volume (cu ft)	Unit weight (lb)
Mast Section MS-118-A	1			39 ½		.20
Bag CW-212/U	1	5 ½	11	13 ¼	.5	1.5
Power Cable Assembly CX-1358/U.	1			96		1
Power Cable Assembly CX-1359/U.	1			114		1.5
Power Cable Assembly CX-1360/U.	1			24		.9
Headset Cord CX-1334/U	1			78		.2
Receiver-Power supply connecting cable.	1			36		.4
Headset CW-49507-A (Navy type).	1					.4
Instruction book for Radio Receiving Set AN/GRR-5.	2	½	8	11	.03	.5
Total						75.55

Note. This list is for general information only. Refer to appropriate supply publications for information pertaining to requisition of spare parts.

8. Description of Radio Receiving Set AN/GRR-5 (fig. 1)

a. Radio Receiving Set AN/GRR-5. This equipment is a superheterodyne radio receiving set designed for reception of a-m or c-w signals within the frequency range of 1.5 mc to 18 mc. The receiver and power supply are secured in Electrical Equipment Cabinet CY-615/URR, and the case is inserted into Cover CW-211/U. Cover CW-211/U is secured to the cabinet with snap fasteners and two straps which join through the holes on the bottom skirt of the power-supply panel. The front-panel control markings have phosphorescent lettering to permit operation in the dark.

Note. The phosphorescent lettering will be activated for approximately 6 hours after it has been exposed to daylight for a short period of time. To activate lettering, a source of light such as a flashlight, may be used.

b. Radio Receiver R-174/URR (figs. 4 and 12). Radio Receiver R-174/URR is an eight-tube superheterodyne receiver designed for reception of a-m or c-w signals within the frequency range of 1.5 mc to 18 mc. The receiver is secured into Electrical Equipment Cabinet CY-615/URR by four latches located on the sides of the case. The four holes located on the sides of the receiver are used as finger grips for removing the receiver from the case, and/or

for the straps of battery Bag CW-212/U which may be mounted on top of the case. On top of the upper left-hand corner of the receiver is the antenna mounting receptacle for the mast sections. The front panel contains all the operating controls required for operating the receiver. These controls include the band switch, antenna trimmer, output switch, a-f (audio-frequency) and r-f (radio-frequency) gain controls, bfo (beat-frequency oscillator) control, function switch, manual-preset-tuning control, dial-light switch, antenna posts, headset connectors, and monitoring input receptacle.

c. Power Supply PP-308/URR (figs. 4 and 13). Power Supply PP-308/URR is designed to supply d-c voltages adequate to operate Radio Receiver R-174/URR. The power supply is secured into Electrical Equipment Cabinet CY-615/URR by four latches located on the sides of the case. The four holes located on the sides of the power supply are used as finger grips for removing the power supply from the case, and the two holes on the bottom skirt are for holding the straps of Cover CW-211/U. The power supply can be operated from a 115-volt a-c source in a fixed installation, or from a 6-, 12-, or 24-volt d-c source in a vehicular operation, or as a connecting point to the receiver from 90- and 1.5-volt batteries. The front panel contains the fuses, spare fuses, the var-

ious controls for correct operation of the power supply, and in addition, the loudspeaker for the receiver. The various controls include the power-selector switch, power on-off switch, and speaker on-off switch.

d. *Minor Components of Radio Receiving Set AN/GRR-5* (fig. 4). Included among the minor components of Radio Receiving Set AN/GRR-5 are the headset, headset cord, mast sections, and cable assemblies. See appendix II for complete descriptions.

- 2 Mast Sections MS-116-A.
- 1 Mast Section MS-117-A.
- 1 Mast Section MS-118-A.
- 3 tubes, type 1L4.
- 3 tubes, type 1R5.
- 2 tubes, type 1U5.
- 2 tubes, type 3V4.
- 2 tubes, type 6AG7.
- 2 tubes, type CK1007.
- 2 tubes, type OB2.

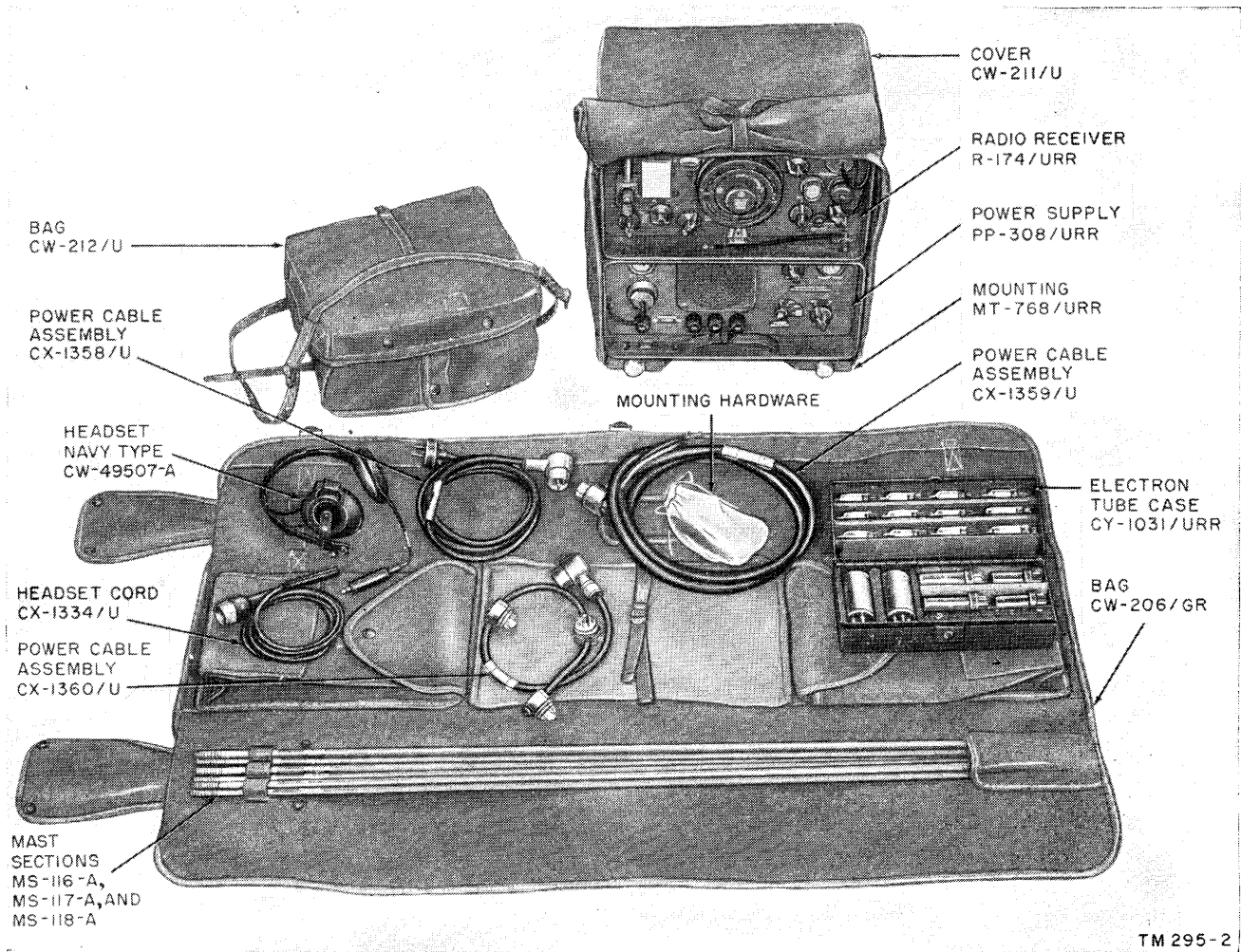

Figure 4. Radio Receiving Set AN/GRR-5, operating components.

9. Running Spares

Running spares are provided for all normally expendable items such as tubes, pilot lamps, and fuses. All running spares except the mast sections are stored in Electron Tube Case CY-1031/URR. The tube case and mast sections are stored in Bag CW-206/GR (fig. 4). Following is a list of running spares:

- 1 lamp, dial, 2-volt, .06-ampere, GE 49, or equal.
- 1 vibrator Oak No. 6556, or equal.
- 1 vibrator Oak No. 6606, or equal.
- 1 fuse, 1-ampere, type 3AG.
- 1 fuse, 3-ampere, type 3AG.
- 1 fuse, 4-ampere, type 3AG.
- 1 fuse, 8-ampere, type 3AG.

10. Additional Equipment Required

a. The following power sources are not supplied as part of Radio Receiving Set AN/GRR-5 but are required for its installation and operation:

- (1) 115 volts ac, 50 or 60 cps (cycles per second) for fixed installation.
- (2) 6-volt, 12-volt, or 24-volt d-c storage battery for vehicular installation.
- (3) Two 90-volt batteries in parallel (B+ and bias supply) and one 1.5-volt battery (filament supply) for field installation.

b. If the radio set is to be installed in a vehicle, a separate installation unit is supplied (or must be requisitioned) for each vehicular installation, since such items as cables, junction boxes, and mounting hardware vary with the type of vehicle. The chart below indicates the installation units which can be used with Radio Receiving Set AN/GRR-5 for several vehicles. The complete equipment consists of a basic unit and an installation unit. The basic unit consists of items common to practically all uses of the radio set. The installation unit consists of all components and accessories which are required to install the radio set in a specific vehicle.

Radio Receiving Set	Type of vehicle	Stock No.		
		Complete equipment	Basic unit	Installation unit
AN/GRR-5	Carriage, motor multiple, gun, M16	2S2505-5-V69	2S2505-5	2S2505-5-V69/50
AN/GRR-5	Carriage, motor, twin, 40-mm gun, M19A1	2S2505-5-V97	2S2505-5	2S2505-5-V97/50
AN/GRR-5	Carrier, personnel, half-track, M3A1	2S2505-5-V68	2S2505-5	2S2505-5-V68/50
AN/GRR-5	Vehicle, armored, infantry, full track, T18E1	2S2505-5-V57	2S2505-5	2S2505-5-V57/50
AN/GRR-5	Vehicle, armored, utility, M39	2S2505-5-V91	2S2505-5	2S2505-5-V91/50

CHAPTER 2

OPERATING INSTRUCTIONS

Section I. SERVICE UPON RECEIPT OF RADIO RECEIVING SET AN/GRR-5

11. Siting

a. External Requirements. The location for radio equipment depends on the tactical situation and local conditions. Depressions, valleys, and other low places generally are poor locations for radio reception because the surrounding terrain absorbs r-f energy. Weak or undesirable signals may be expected if the set is operated under or close to steel bridges, underpasses, power lines, or power units. Choose, if possible, a location on a hilltop or elevation. Flat ground is desirable. Normally, reception over water is better than over land.

b. Interior Requirements. The shelter for the equipment must meet the following requirements:

- (1) Sufficient space must be available for possible repair work.
- (2) The receiver should be located near connections for external power.

12. Uncrating, Unpacking, and Checking New Equipment

(fig. 3)

Note. For used or reconditioned equipment, refer to paragraph 17.

a. General. When new equipment is received, select a location where the equipment may be unpacked without exposure to the elements and which is convenient to the permanent or semi-permanent installation of the equipment. The location should be chosen so that the equipment may be unpacked without damaging other equipments.

Caution: Be careful in uncrating, unpacking, and handling the equipment; it is damaged easily. If it becomes damaged, a complete overhaul might be required or the equipment might be rendered useless.

b. Step-By-Step Instructions for Uncrating and Unpacking.

- (1) Place the packing case as near the operating position as convenient.
- (2) Unpack the equipment as shown in figure 3. (The crate and waterproof bag are used only for export shipments.)
- (3) Place the equipment on a workbench or near its final location.
- (4) Inspect the equipment for possible damage incurred during shipment.
- (5) Check the contents of the packing case against the master packing slip.

Note. Save the original packing cases and containers for both export and domestic shipments. They can be used again when the equipment is repacked for storage or shipment.

13. Installation of Receiver and Power Supply

a. General. The receiver and power supply may be used as a fixed-field installation, as a vehicular installation, or as a portable field installation. The radio set is shipped with tubes, vibrators, fuses, pilot lamp, and crystal already installed. Remove the power supply and receiver from Electrical Equipment Cabinet CY-615/URR by opening the eight latches at the sides of the cabinet, sliding the two units forward, and disconnecting the plug and receptacle at the rear of the receiver and power supply, respectively. Loosen the covers by removing the screws and loosening the captive screws, and check to see that all tubes and vibrators are firmly seated in their proper sockets (figs. 5 and 6). See that the receiver-power supply connecting cable (fig. 9) is connected properly to the cabinet. When the check is complete, reconnect the units and replace them in the cabinet.

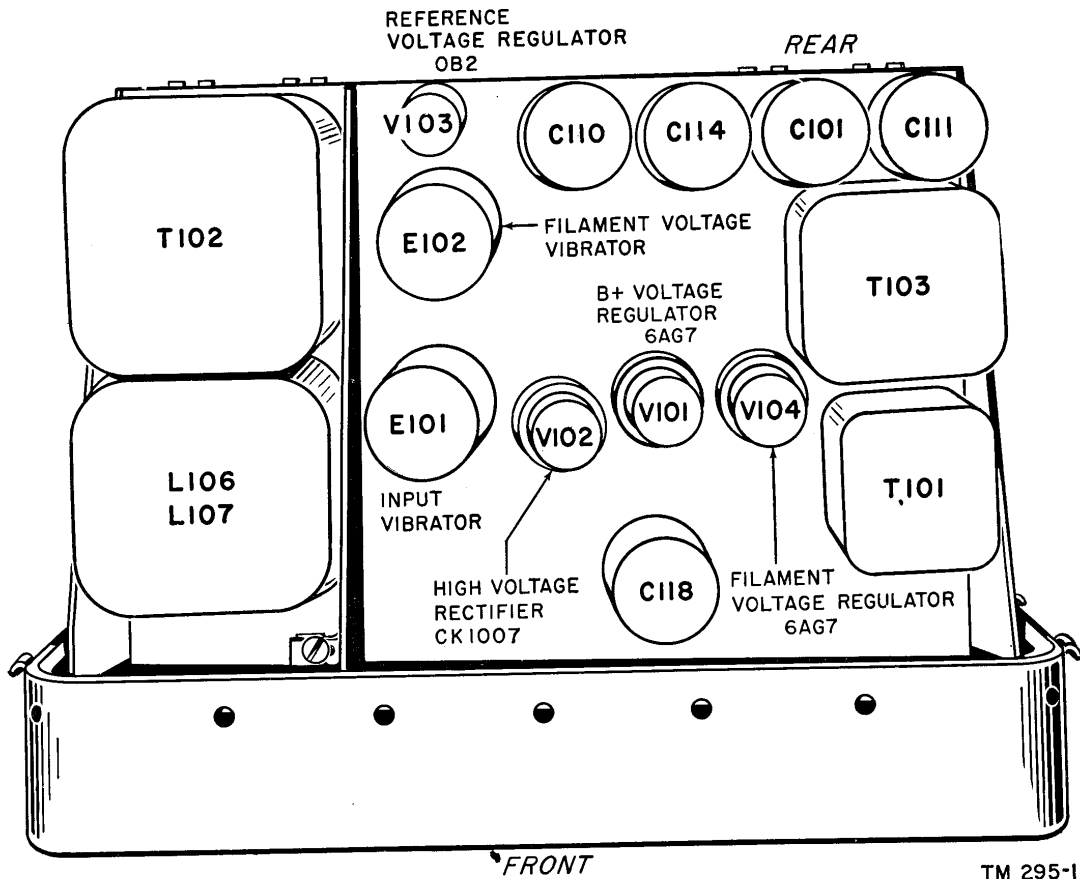

Figure 5. Power Supply PP-308/URR, tube location.

TM 295-11

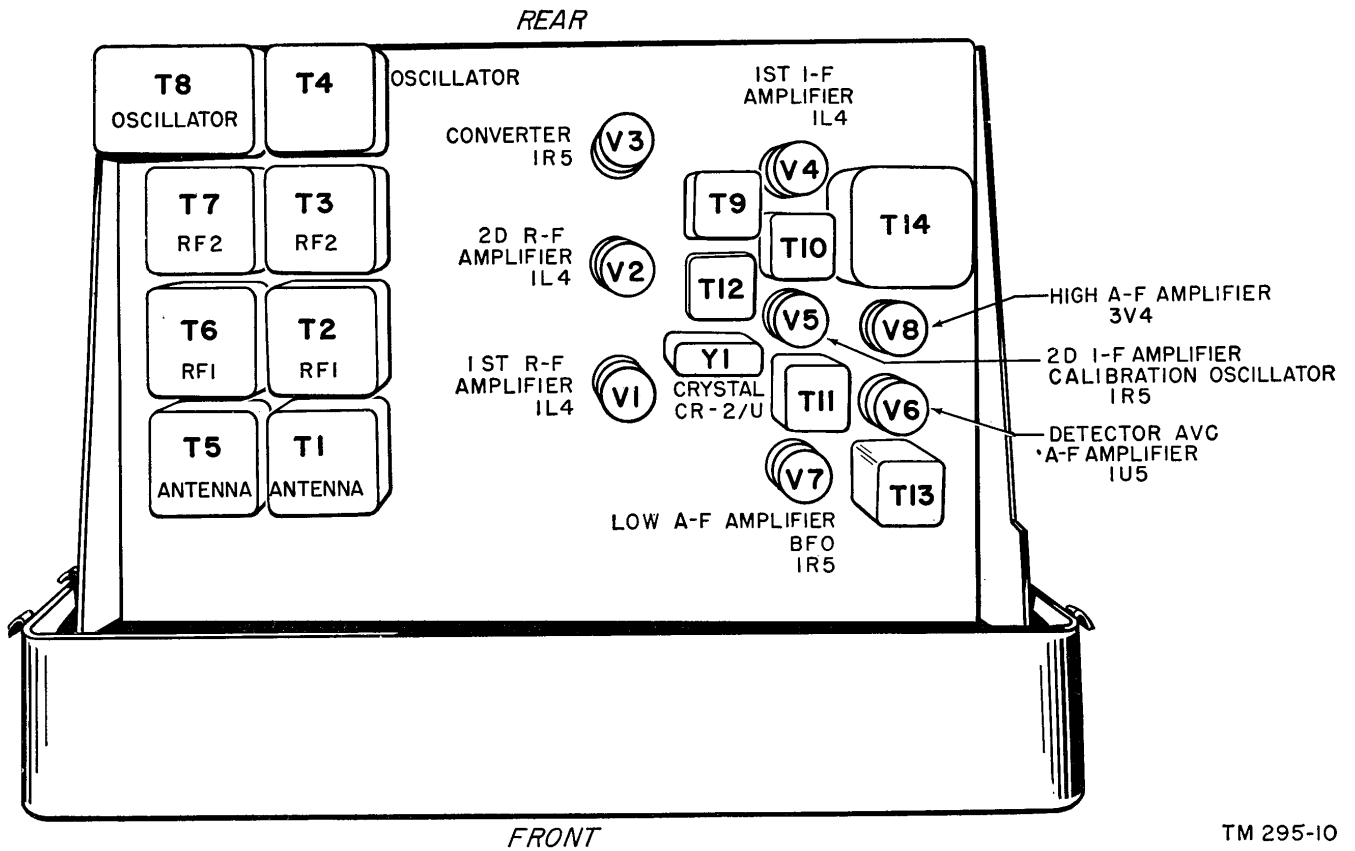

Figure 6. Radio Receiver R-174/URR, tube location.

TM 295-10

b. *Field Installation.* If the equipment is to be exposed to the weather, keep the radio set in Cover CW-211/U. In very hot weather, the cover should be removed to provide proper ventilation.

c. *Fixed-Field Installation.* If the equipment is to be used as a fixed-field installation, remove Cover CW-211/U from the radio set, remove Electrical Equipment Cabinet CY-615/URR from Mounting MT-768/URR, and secure the shock-mount assembly with the six screws, nuts, and lockwashers provided in the spare parts bag. Figure 7 shows the location of the mounting holes. The shock-mount assembly may be used as a template to locate holes for drilling.

Replace Electrical Equipment Cabinet CY-615/URR.

d. *Vehicular Installation.* In general, the procedure outlined in c above will be followed for all vehicular installations. For specific procedures, refer to the instructions supplied with the installation unit for the particular vehicle (par. 10b).

14. Installation of Antenna Equipment

All components necessary to install the antenna for field installations are provided in Bag CW-206/GR. For vehicular installations additional equipment is supplied with the vehicular installation unit.

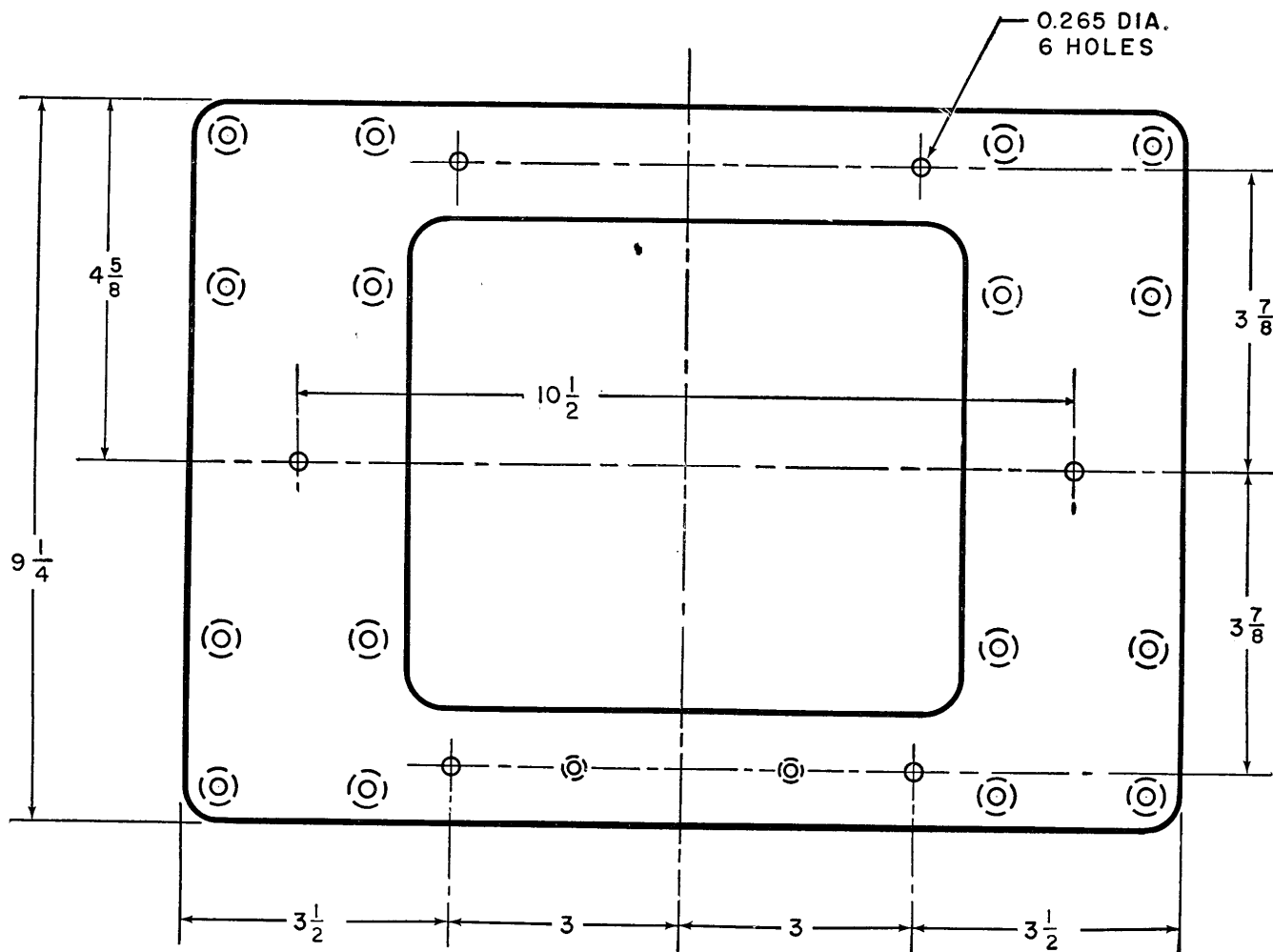

NOTE:

ALL DIMENSIONS ARE IN INCHES.
TOLERANCE $\pm \frac{1}{64}$

TM 295-9

Figure 7. Radio Receiving Set AN/GRR-5, location of mounting holes for shock-mount assembly.

Caution: When unpacking, keep sand and mud from the ends of the mast sections.

a. Field Installations.

(1) Insert Mast Section MS-117-A into internal threaded portion of Mast Section MS-118-A, and tighten. Insert Mast Section MS-116-A into internal threaded portion of Mast Section MS-117-A, and tighten. Insert Mast Section MS-116-A into another Mast Section MS-116-A, and tighten. Insert Mast Section MS-116-A into receiver at the left-hand front portion of the top of the case, and tighten in place (fig. 38).

(2) If tactical operation requires the use of a reel antenna, disregard *a*(1) above, connect the antenna lead-in wire to the post marked A on the receiver panel, and connect post G to a secure ground (fig. 12).

b. Vehicular Installations. Vehicular installations require the use of Mast Base AB-15/GR, supplied with the installation unit. The location of the antenna mast base, in most cases, is determined by the vehicle. In general, the mast base should be placed as high as possible. After the location of the antenna is determined and the mounting hole is drilled, install the mast base (fig. 8) and antenna in accordance with the instructions outlined below.

- (1) Place one large rubber washer and the upper insulator over the mounting hole.
- (2) Place the two small washers on the stem of the mast base body.
- (3) Insert the mast base body into the hole in the upper insulator.
- (4) Place the other large rubber washer on the lower insulator.
- (5) The ground ring strap and hose clamp supplied with the mast base are not required for wire lead-ins. Store these items in Bag CW-206/GR.
- (6) Insert the lower insulator into the mounting hole from underneath.
- (7) Assemble the mast base by holding the lower insulator and turning the mast base body until the mast base is secure.

(8) Screw together Mast Sections MS-116-A (2 each), MS-117-A, and MS-118-A, then turn the assembly into the mast base.

(9) To attach the antenna lead-in to the mast base, tin the end of the wire lead-in and attach it to the binding post on the lower insulator. Attach the other end of the lead-in to the post marked A on the receiver panel. Ground the post marked G.

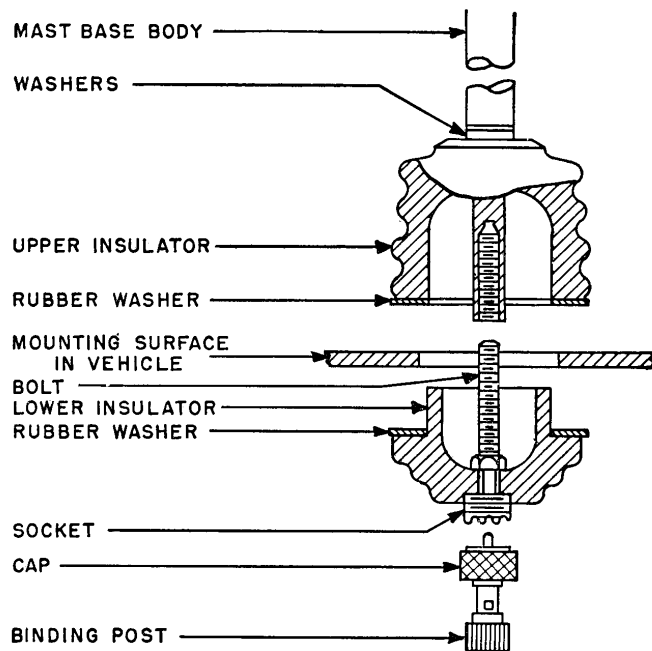

Figure 8. Mast Base AB-15/GR, installation drawing.

15. Connections and Initial Adjustment

Set the POWER SELECTOR switch for the desired mode of operation and make the applicable connections as described below.

a. 115-Volt A-C Operation (figs. 12 and 13). Connect one end of Power Cable Assembly CX-1358/U to POWER INPUT receptacle J105, and secure the connector in place. Connect the male end of the cable to a 115-volt a-c power line.

b. 6-, 12-, or 24-Volt D-C Operation. Connect Power Cable Assembly CX-1359/U to POWER INPUT receptacle J103, and secure the connector in place. Connect the other end to the d-c source. This end contains 2 lugs. Connect the lug on the inner wire to the positive (+) ter-

minal of the source, and connect the lug on the shield to the negative (—) terminal of the source.

c. Dry-Battery Operation. Connect Power Cable Assembly CX-1360/U to DRY BATTERY receptacle J104, and secure the connector in place. Connect Battery BA-405/U to the plug on the cable nearest to the power supply chassis, and then connect two Batteries BA-419/U to the outer sockets on the cable. Secure batteries in Bag CW-212/U.

Note. The initial adjustment below is not to be made when the equipment is connected for dry-battery operation.

d. Initial Adjustment. Turn POWER ON-OFF switch S103 to ON, and allow 5 minutes for warm-up time. Slide the power supply unit partially out of the cabinet (par. 13). Connect a 20,000-ohms-per-volt meter to the *filament voltage test point* (J102) on the right side of the power supply (fig. 11) and adjust the *filament voltage control* (R116) until the meter reads 1.4 volts dc. If the proper voltage cannot be obtained, refer to the equipment performance checklist (par. 43). Replace the power supply.

e. Headset. Connect Headset CW-49507-A (Navy type) to Headset Cord CX-1334/U. Connect cord to either PHONES receptacle on the receiver.

f. Monitoring Input. If the radio set is to be used to monitor the output of another receiver, to monitor the sidetone output of an associated transmitter, or to supply a monitoring signal to associated equipment, the MONITORING INPUT receptacle must be connected to the associated equipment. For this purpose, a nine-conductor cable, terminated in a suitable plug, is required. (Neither cable nor plug is supplied with the radio set.) Circuit details of the connections to be made are included in paragraph 68.

16. Presetting Radio Receiver R-174/URR

(fig. 12)

Presetting the receiver consists of adjusting the MANUAL-PRESET TUNING mechanism to allow instantaneous selection of any 10 detented channels. A signal source (loosely

coupled signal generator or distant transmitter) is required for presetting each channel.

a. Preliminary Adjustments.

- (1) Rotate the MANUAL-PRESET TUNING control to see that all the numbered detents are situated within the tuning azimuth by placing the *arrowed hole* over all the detents.
- (2) If a detent is not in the tuning range, place either hole of the MANUAL-PRESET TUNING control over the detent nut, place the locking key over the nut, and loosen.
- (3) With the key in place on the nut, rotate the control until the detent is within the tuning azimuth. Tighten and remove the locking key.

b. Setting the Preset Channels.

- (1) Set the BAND SW, and MANUAL-PRESET TUNING controls for the desired channel frequency.
- (2) Place the *arrowed hole* over the closest (or desired) numbered detent by rotating the MANUAL-PRESET TUNING control.
- (3) Loosen the numbered nut by using the locking key assembly, and lift the *cam arm*.
- (4) Leave the locking key in place and rotate the MANUAL-PRESET TUNING control back to the channel frequency.
- (5) Push in the fine-tuning knob and make a fine-tuning adjustment.
- (6) Adjust the ANT. TRIMMER control for maximum signal.
- (7) Rock the fine-tuning control to insure maximum signal.
- (8) Tighten the numbered nut securing the detent, push down the cam arm, and remove the locking key.
- (9) Write the band and frequency on the detent-frequency chart located on the front panel.
- (10) Repeat the procedure for as many preset channels as desired.

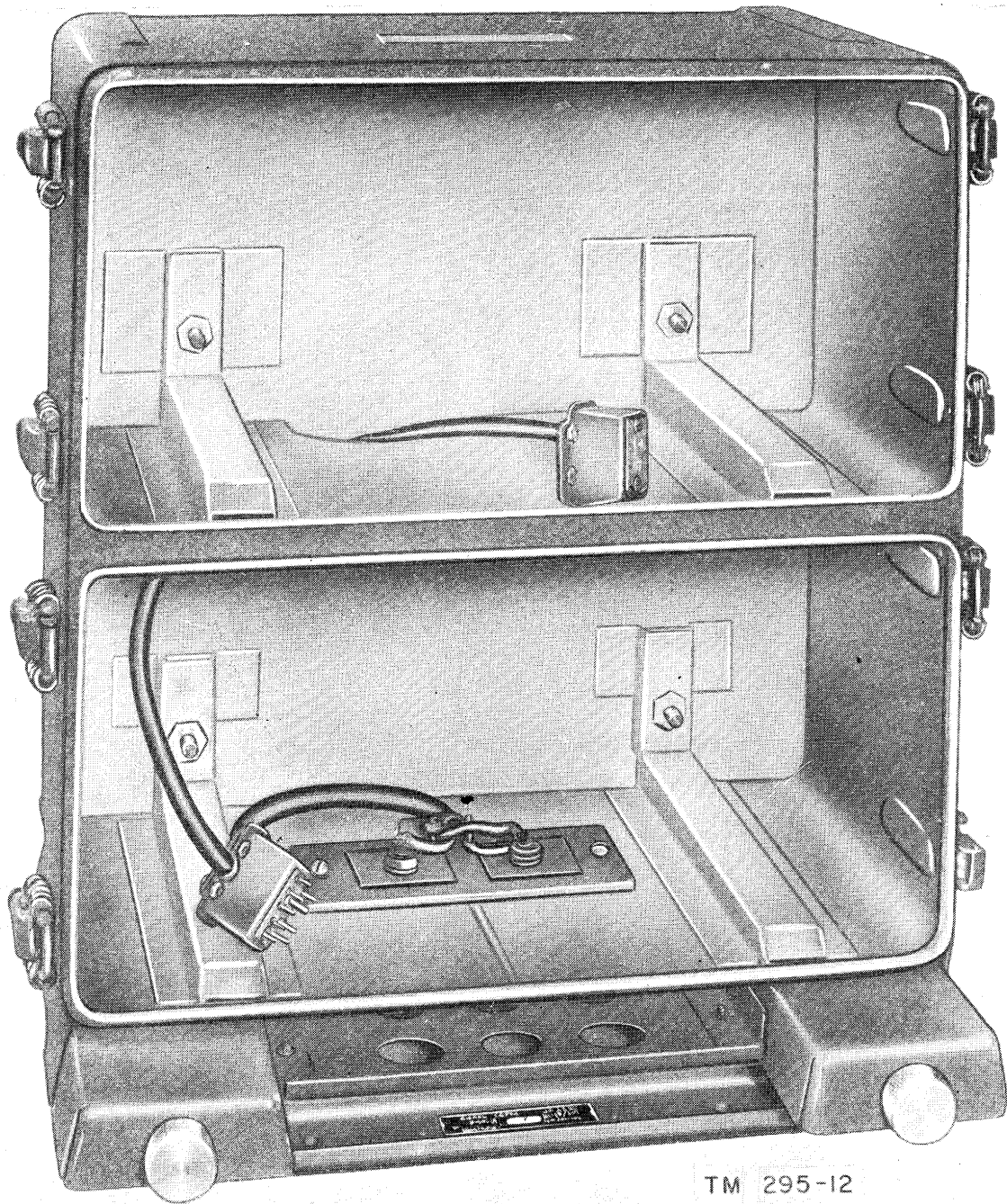

Figure 9. Electronic Equipment Cabinet CY-615/URR, receiver and power supply removed.

17. Service upon Receipt of Used or Reconditioned Equipment

a. Follow the instructions in paragraph 12 for uncrating, unpacking, and checking new equipment.

b. Check the used or reconditioned equipment for tags or other indications pertaining to changes in the wiring of the equipment. If changes in wiring have been made, note the

changes in this manual, preferably on the schematic diagram.

c. Check the operating controls for ease of rotation. If lubrication is required, refer to the lubrication instructions in chapter 3, section III.

d. Perform the installation, connection, and presetting procedures given in paragraphs 13, 14, 15, and 16.

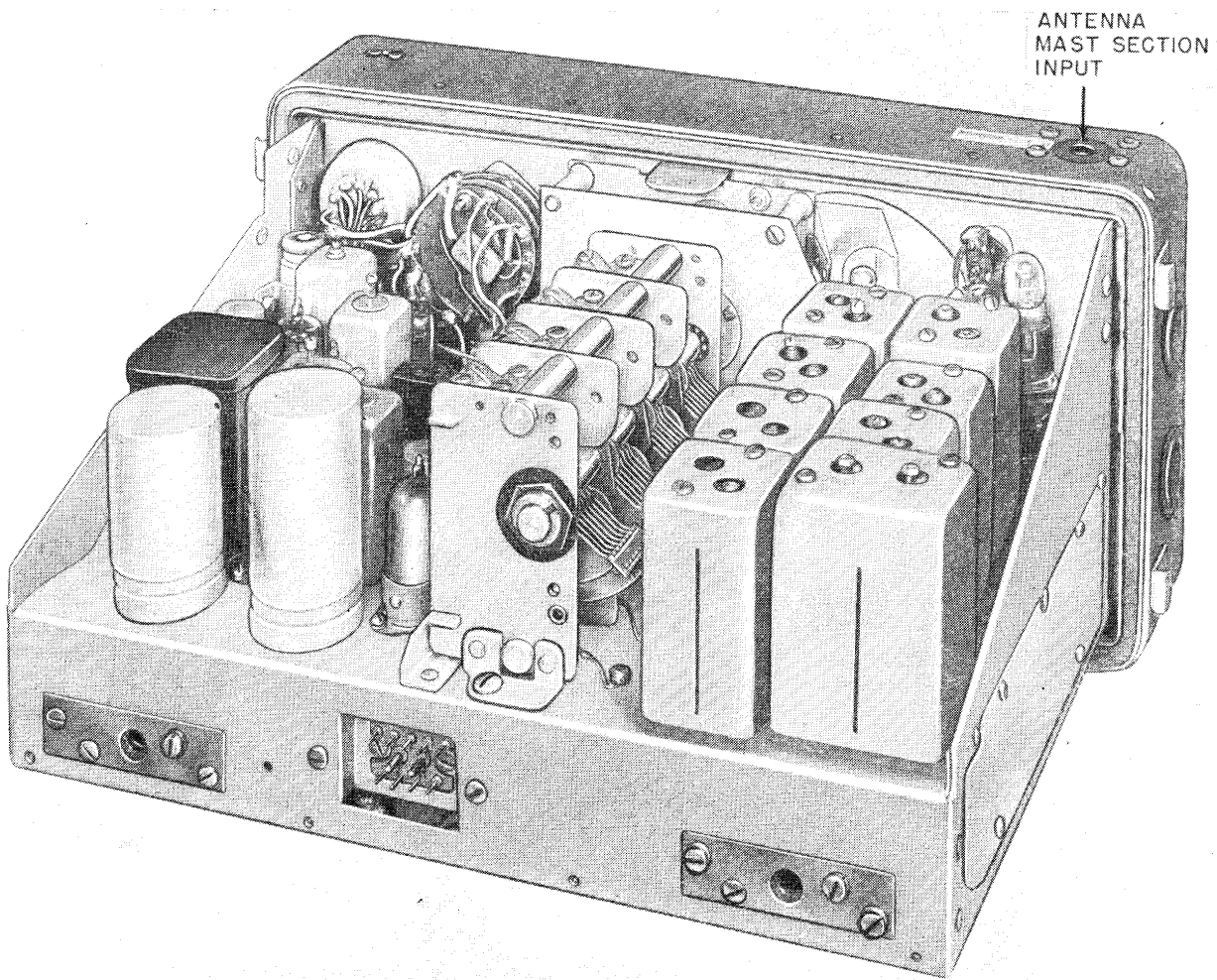

Figure 10. Radio Receiver R-174/URR, rear oblique view.

TM 295-13

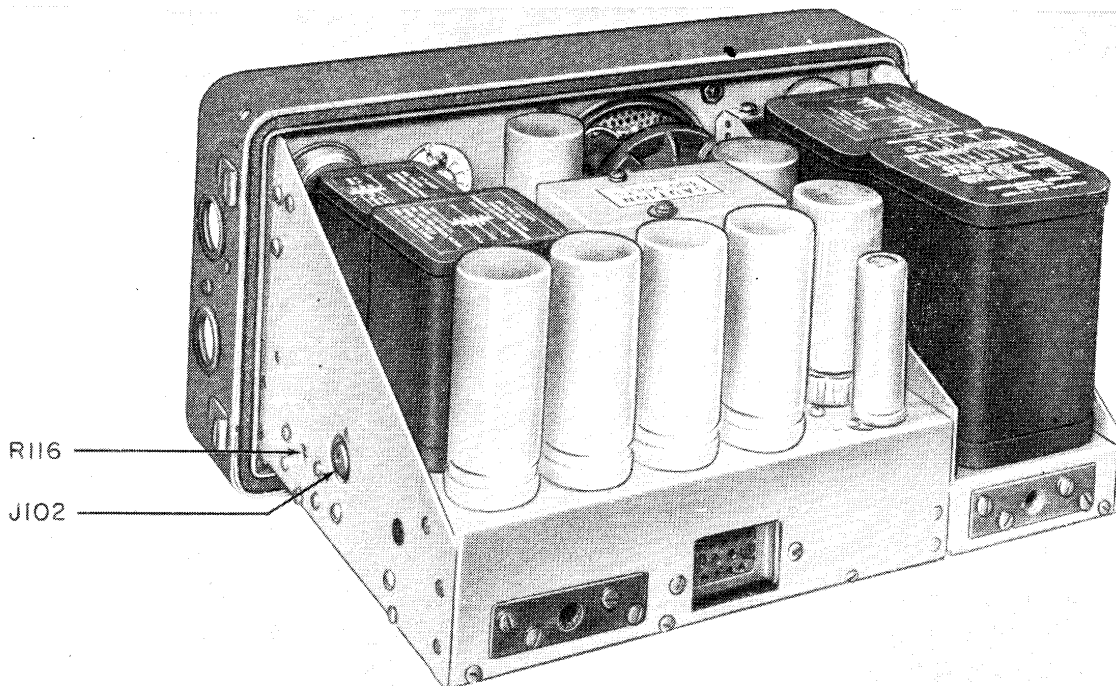

Figure 11. Power Supply PP-308/URR, rear oblique view.

TM 295-14

Section II. CONTROLS AND INSTRUMENTS

18. Radio Receiver R-174/URR

(figs. 10, 12, and 40)

The following table lists the controls of the receiver and indicates their functions:

Control	Function										
Terminals A and G	Provide means of connecting reel antenna.										
Antenna input receptacle (on top left side).	Provides means of connecting antenna mast sections.										
R.F. GAIN control (R32).	Controls the screen voltage of V1 and V4.										
BAND SW. (S1)	Selects band in which the receiver is to be operated: <table style="margin-left: 40px; border: none;"> <tr> <td style="text-align: center;"><i>Position</i></td> <td style="text-align: center;"><i>Band</i></td> </tr> <tr> <td style="text-align: center;">1. 1.5 mc to</td> <td style="text-align: center;">2.7 mc</td> </tr> <tr> <td style="text-align: center;">2. 2.7 mc to</td> <td style="text-align: center;">5 mc</td> </tr> <tr> <td style="text-align: center;">3. 5 mc to</td> <td style="text-align: center;">9.5 mc</td> </tr> <tr> <td style="text-align: center;">4. 9.5 mc to</td> <td style="text-align: center;">18 mc</td> </tr> </table>	<i>Position</i>	<i>Band</i>	1. 1.5 mc to	2.7 mc	2. 2.7 mc to	5 mc	3. 5 mc to	9.5 mc	4. 9.5 mc to	18 mc
<i>Position</i>	<i>Band</i>										
1. 1.5 mc to	2.7 mc										
2. 2.7 mc to	5 mc										
3. 5 mc to	9.5 mc										
4. 9.5 mc to	18 mc										
ANT. TRIMMER (C2).	Peaks signal input reception.										
Number detents (0 to 9).	Provide means for presetting as many as 10 channels.										
Fine-tuning control (marked PULL OUT BEFORE PRESET TUNING).	Fine tunes the receiver to the desired frequency. Pulling out of fine-tuning control, lifting of the cam arm, and rotation of the MANUAL-PRESET TUNING control tunes the receiver to any one of 10 preset channels.										
MANUAL-PRESET TUNING control (C1A, C1B, C1C, and C1D).	Controls operating frequency of receiver. Rotation of dial tunes the receiver to the desired frequency. A dial lock is provided to prevent shifting after the dial has been set.										
B.F.O. control (C44)	Adjusts the bfo for zero-beat and tone signal.										
OUTPUT switch (S4).	Connects the receiver to deliver either a high-level or low-level audio output, on the HIGH or LOW position, respectively.										
A.F. GAIN control (R19A, R19B).	Adjusts the level of audio output.										
PHN.-C.W.-NET-CAL. switch (S2).	Selects the type of operation, PHN., C.W., NET, or CAL.										
DIAL LIGHT switch (S3).	A momentary contact switch to illuminate the dial when tuning. It also reduces the power output of the receiver when operating with OUTPUT switch S4 in the HIGH position.										
Antenna shorting switch.	Provides means of shorting out antenna when checking calibration of the receiver.										

Control	Function
PHONES jacks (J2 and J3).	Provide connections for two pairs of headsets.
MONITORING INPUT receptacle (J1).	Provides for connection of the receiver with associated transmitting or receiving equipment (par. 68).
Receiver power input receptacle (J4) (on back of chassis).	Provides connection for receiver-power supply connecting cable.

19. Power Supply PP-308/URR

(figs. 11 and 13)

The following table lists the controls of the power supply and indicates their functions:

Control	Function
POWER SELECTOR switch (S101).	Selects type of operation for power supply. This switch may be in any position for 115-volt a-c operation except when the receiver is operated with a transmitter. The switch must then be in either the 6V or DRY BAT. position.
POWER switch (S103)	Turns power supply on or off.
SPEAKER switch (S102).	Switches the loudspeaker in or out of receiver output circuit.
Filament voltage test point (J102) (on right side of chassis).	Provides means for measuring filament voltage for receiver.
Filament voltage control (R116) (on right side of chassis).	Controls filament voltage for tubes in receiver.
POWER INPUT receptacle (J103).	Power input connector for 115-volt a-c, 6-, 12-, or 24-volt d-c operation.
DRY BATTERY receptacle (J104).	Power input connector for dry-battery operation.
OPERATING FUSES 110V, 1A.-24V. 3A.-12V. 4A.-6V. 8A.	Fuse power supply for different power input voltages.
SPARE FUSES receptacle.	Retains spare fuses.

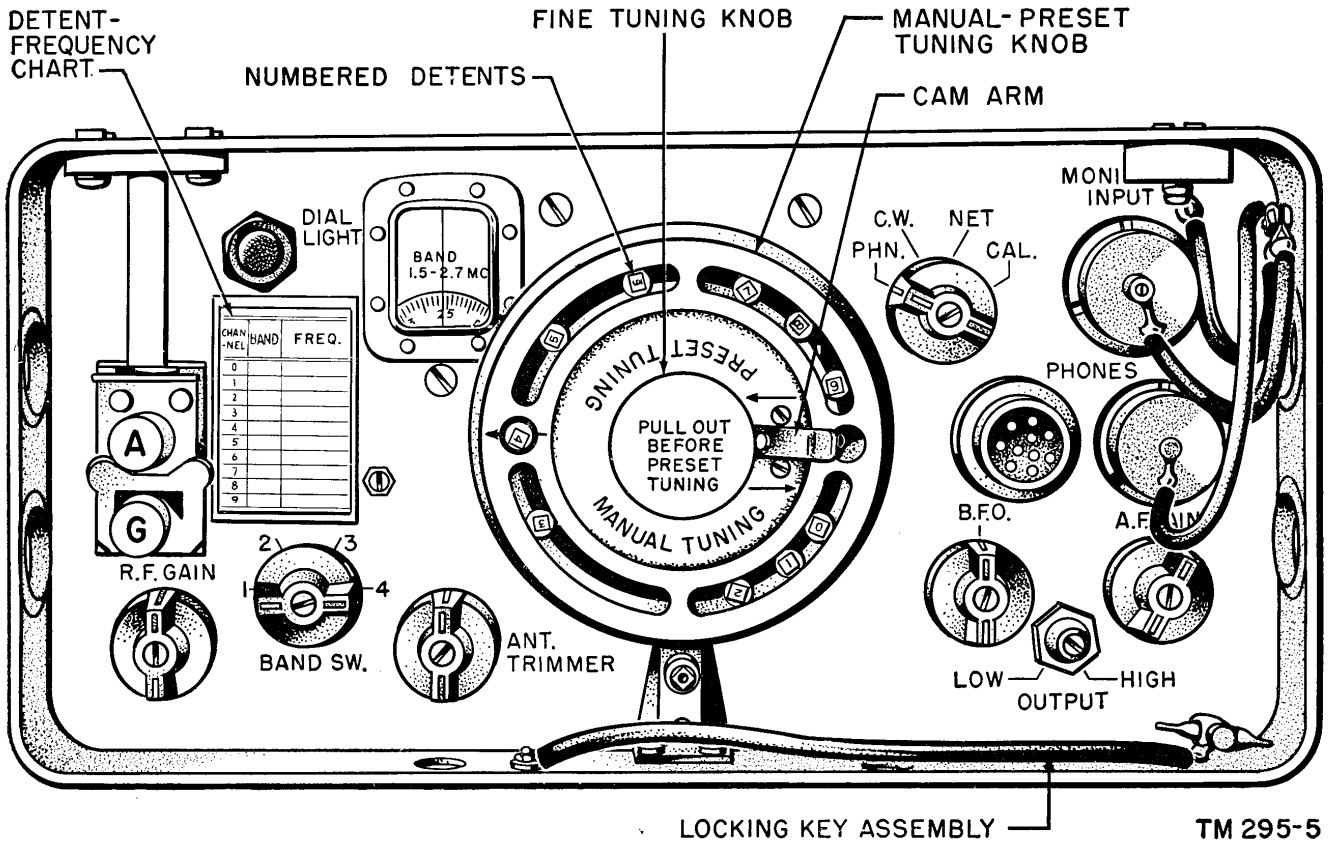

Figure 12. Radio Receiver R-174/URR, front panel.

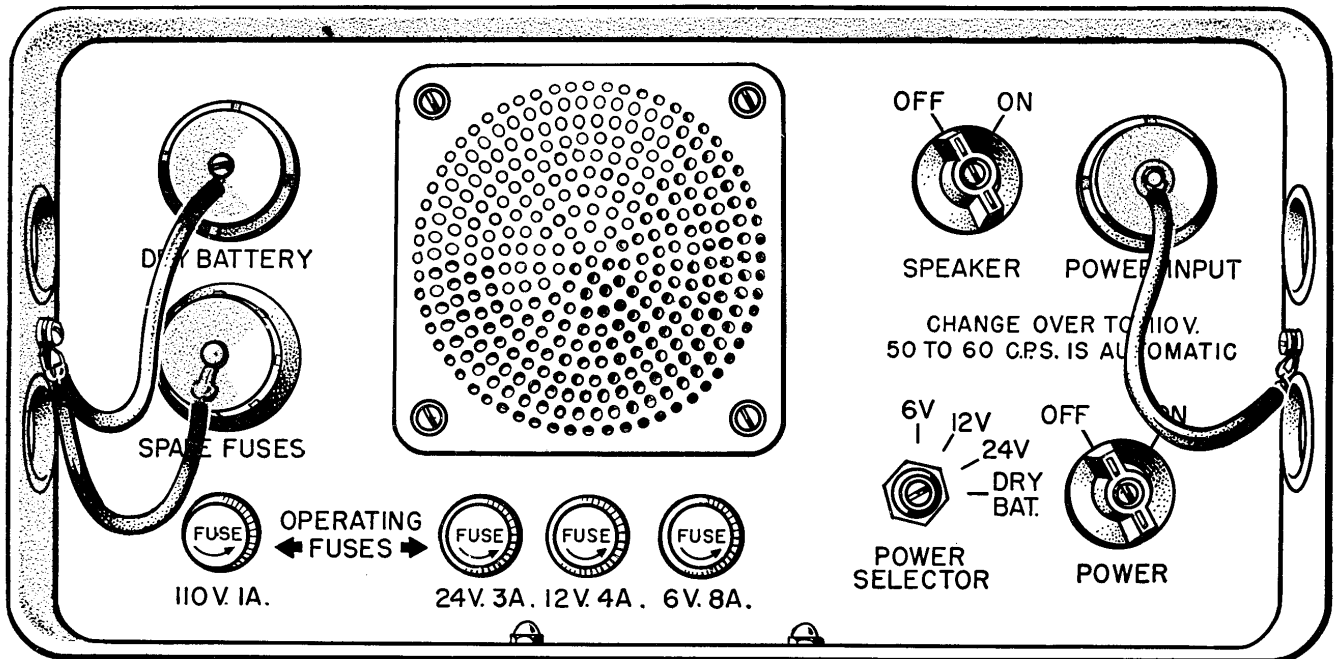

Figure 13. Power Supply PP-308/URR, front panel.

Section III. OPERATION UNDER USUAL CONDITIONS

Caution: Reception on the loudspeaker of early models of the receiving set has a tendency to become distorted after short periods of operation, because of air pressure which builds up within the power supply and has no outlet. To prevent this condition, loosen the cap of the SPARE FUSES compartment before operating the set. A hole has been drilled in the rear of the SPARE FUSES compartment to allow reduction of air pressure. All units which incorporate this expedient have a caution notice affixed to the lower flange of the receiver front panel.

20. Preliminary Control Setting

Before starting the equipment (and during shut-down periods) set the front panel controls as follows:

Control	Position
POWER SELECTOR switch.	6V, 12V, 24V, or DRY.BAT.
POWER switch	OFF.
SPEAKER switch	ON (OFF, if headset is used alone).
OUTPUT switch	HIGH (LOW when dry batteries are used).
A.F. GAIN control	Halfway clockwise.
R.F. GAIN control	Halfway clockwise.

NOTES

1. For 115-volt a-c operation, the POWER SELECTOR switch may be in any position except when the receiver is used with a transmitter. The switch must then be in either the 6V or DRY BAT. position.

2. Although the OUTPUT switch normally is set at LOW, when power source is dry batteries, it may be set at HIGH for emergency. The normal LOW setting conserves the batteries.

21. Reception of Modulated Signals

With the equipment connected properly for the available power source (par. 15), and controls set as directed in paragraph 20, operate the equipment in the following manner.

a. Turn the POWER switch to ON.

b. If the equipment has not been used for one week or longer, connect a 20,000-ohm-per-volt meter to J102 on the power supply (fig. 11),

and adjust R116 for a reading of 1.4 volts (par. 15*d*).

c. Set the BAND SW. switch (S1) to the band which includes the desired frequency.

d. Turn PHN.-C.W.-NET-CAL. switch S2 to PHN.

e. Tune the receiver to the desired frequency. Depress the DIAL LIGHT switch while tuning, only if the receiver is being operated in an area that is poorly lit.

(1) If the desired frequency has not been preset, tune to the signal by rotating the outer ring of the MANUAL-PRESET TUNING control.

(2) If the desired frequency has been preset, pull out the fine-tuning control, lift the cam arm, and rotate the MANUAL-PRESET TUNING CONTROL until the *arrowed hole* is over the desired numbered detent.

f. Adjust the ANT. TRIMMER control for maximum output signal.

g. Adjust the R.F. GAIN and A.F. GAIN controls to the desired level.

22. Code Reception

With the equipment connected properly for the available power source (par. 15), and controls set as directed in paragraph 20, operate the equipment in the following manner.

a. Turn the POWER switch to ON.

b. If the equipment has not been used for a week or longer, connect a 20,000 ohms per-volt meter to J102 on the power supply (fig. 11), and adjust R116 for a reading of 1.4 volts (par. 15*d*).

c. Set PHN.-C.W.-NET-CAL. switch to C.W.

d. Set the BAND SW. switch (S1) to the band that includes the desired frequency.

e. Tune in a coded signal and adjust the B.F.O. control to obtain the desired pitch of the beat note. The desired tone may be obtained by setting the B.F.O. control to either side of zero beat. Depress the DIAL LIGHT switch for illumination, if necessary.

(1) If the desired frequency has not been preset, tune to the signal by rotating

the outer ring of the MANUAL-PRESET TUNING control.

- (2) If the desired frequency has been preset, pull out the fine-tuning control, lift the cam arm, and rotate the MANUAL-PRESET TUNING CONTROL until the *arrowed hole* is over the desired numbered detent.

f. Adjust the ANT. TRIMMER for maximum output signal.

g. Keep the R.F. GAIN control low for strong signals to prevent overloading; the volume can be regulated by the R.F. GAIN control.

23. Net Operation

a. Repeat the procedure outlined in paragraph 21 or 22, using the frequency of the net control station.

b. Set a numbered detent (if available and not already set) to this frequency channel.

c. Set the PHN.-C.W.-NET-CAL. switch to the NET position.

d. Without disturbing the receiver, tune the *exciter* of the local transmitter to the net-control-station frequency by tuning (the exciter) for a zero-beat indication on the receiver.

e. Set the PHN.-C.W.-NET-CAL. switch to the PHN. or C.W. position, as required.

f. Complete the tuning of the transmitter.

24. Calibration

To calibrate the receiver, perform the following steps:

a. Turn the POWER switch to ON.

b. Adjust the filament voltage (par. 15*d*).

c. Turn PHN.-C.W.-NET-CAL. to CAL.

d. Short the antenna with the shorting switch and check the calibration of the MANUAL-PRESET TUNING control over the complete range of tuning for all four bands. A beat note should be heard at every integral multiple of 200 kc. If necessary, tune ANT. TRIMMER control for maximum beat signal. When the beat note does not occur at integral multiples of 200 kc, it is necessary to realine the receiver.

25. Stopping Procedure

a. Turn the POWER switch to OFF.

b. Turn the MANUAL-PRESET TUNING control to the l-f (low-frequency) end of the tuning range of any band. This protects tuning-capacitor plates.

Section IV. OPERATION UNDER UNUSUAL CONDITIONS

Note. Radio Receiving Set AN/GRR-5 is waterproof and should be kept in its cabinet at all times except for maintenance purposes. Tighten cap of SPARE FUSES compartment when set is not in use.

26. General

The operation of Radio Receiving Set AN/GRR-5 may be difficult in regions of extreme cold, heat, humidity, sand, mud, snow, etc. In paragraphs 27, 28, and 29, instructions are given on procedures for minimizing the effect of these unusual operating conditions.

27. Operation in Arctic Climates

Subzero temperatures and climatic conditions associated with cold weather may affect the efficient operation of the equipment. Instructions and precautions for operation under such adverse conditions follow:

a. Handle the equipment carefully.

b. Keep the equipment warm and dry. If the set is not in a heated inclosure, construct an insulated box for the set. Keep the filaments of the vacuum tubes lighted constantly, unless this overtaxes the power supply.

c. Wear a knitted woolen cap over the ear-phones when operating in the open air with headsets that do not have rubber earpieces. Frequently, when headsets without rubber earpieces are worn, the edges of the ears may freeze without the operator being conscious of this condition. Never flex rubber earcaps, since this action may render them useless. If water gets into the receivers, or if moisture condenses within them, it may freeze and impede the actuation of the diaphragm. When this happens, remove the bakelite cap and remove the ice and moisture.

d. When equipment which has been exposed to the cold is brought into a warm room, it will sweat and will continue to do so until it reaches room temperature. When the equipment has reached room temperature, dry it thoroughly. This condition also arises when equipment warms up during the day after exposure during a cold night.

e. Use any improvised means to protect dry batteries, since they will fail if not protected against the cold. Preheat the batteries. To prevent heat loss, place them in bags lined with kapok, spun-glass fiber materials, animal skins, or woolen clothing.

28. Operation in Tropical Climates

When operated in tropical climates, radio equipment may be installed in tents, huts, or, when necessary, in underground dugouts. When equipment is installed below ground and when it is set up in swampy areas, moisture conditions are more acute than normal in the tropics. Ventilation usually is very poor, and the high relative humidity causes condensation of moisture on the equipment whenever the temperature of the equipment becomes lower than the ambient air. To minimize this condition, place lighted electric bulbs under the equipment.

29. Operation in Desert Climates

a. Conditions similar to those encountered in tropical climates often prevail in desert areas. Use the same measures to insure proper operation of the equipment.

b. The main problem which arises with equipment operation in desert areas is the large amount of sand or dirt and dust which enters the moving parts of radio equipment. The ideal preventive is to house the equipment in a dust-proof shelter. Since such a building is seldom available and would require air conditioning, the next best precaution is to make the building in which the equipment is located as dustproof as possible with available materials. Hang wet sacking over the windows and doors, cover the inside walls with heavy paper, and secure the side walls of tents with sand to prevent their flapping in the wind.

c. Never tie power cords, signal cords, or other wire connections to the outside or inside of the tent. Desert areas are subject to sudden wind squalls which may jerk the connections loose or break the lines.

d. Take care to keep the equipment as free from dust as possible. Make frequent preventive maintenance checks (ch. 3). Pay particular attention to the lubricants.

CHAPTER 3

ORGANIZATIONAL MAINTENANCE INSTRUCTIONS

Section I. ORGANIZATIONAL TOOLS

30. Tools and Material Used with Radio Receiving Set AN/GRR-5

Tools and materials used with the radio set are listed in *a* and *b* below.

a. Tools.

- Pliers TL-13, side cutting, 6"
- Pliers TL-103, diagonal cutting, 5"
- Pliers TL-126, long chain nose, 6"

- Screw driver, 2½" blade
- Screw driver, 5" blade
- Wrench set, midget

b. Materials.

- Cheesecloth, bleached, lint-free
- Paper, sand, flint No. 000
- Solvent, dry-cleaning (SD) (Fed. spec. No. P-S-661a)

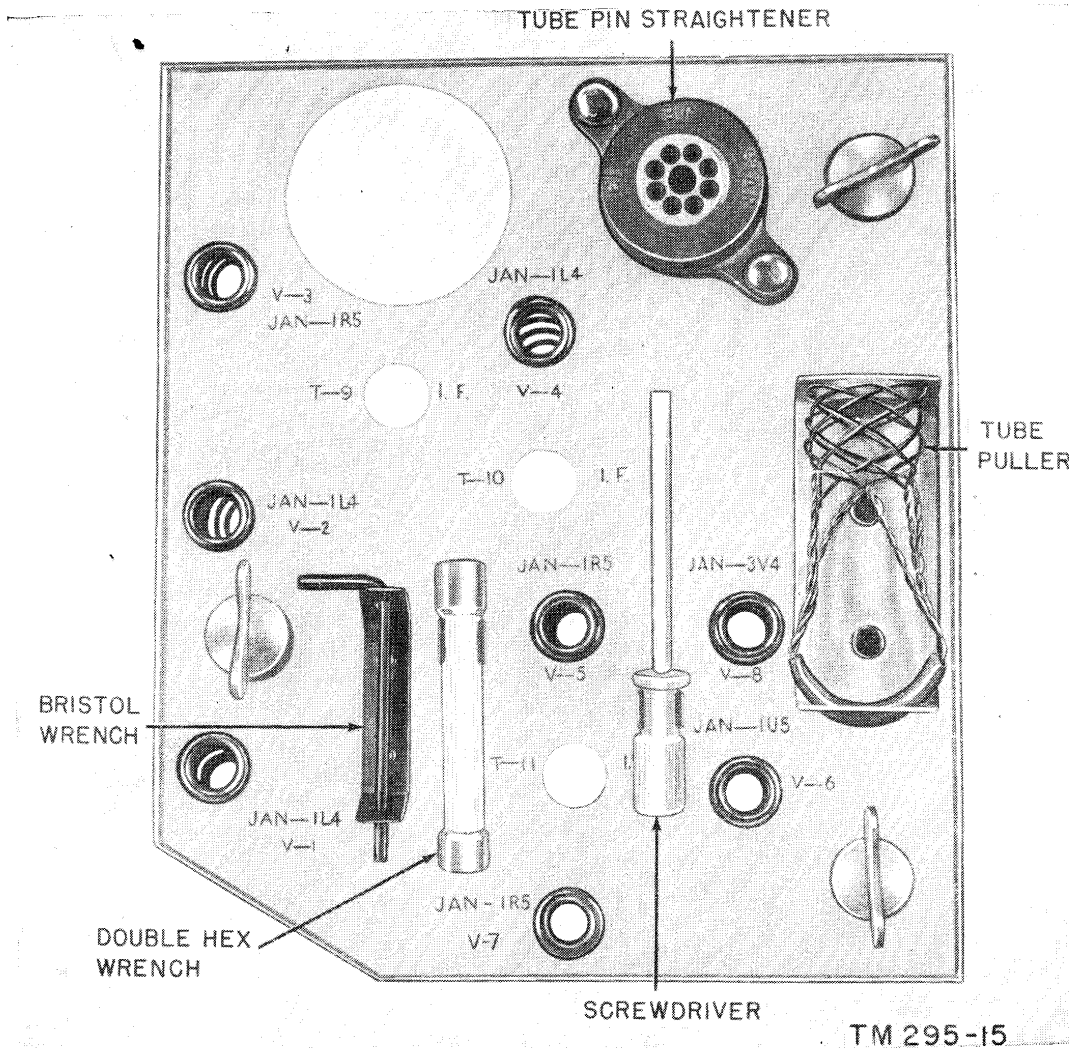

Figure 14. Radio Receiving Set AN/GRR-5, tools supplied.

31. Special Tools Supplied with Radio Receiving Set AN/GRR-5

All the tools supplied with the radio set are located on the top cover of the receiver (fig. 14) except the locking *key assembly* which is secured on the front panel. In order to have access to the tools on the cover of the receiver, remove the receiver chassis (par. 13). The use of the special tools supplied is described below.

a. Tube Puller. When it is necessary to remove a tube, remove the tube puller from the cover. Place the tube puller over the tube to be removed. Press tool down firmly over the tube until the wire mesh locks on the envelope. Pull tube and tool upward while wobbling the tube around in the socket. After the tube has been removed from the chassis, remove the tube from the tool by pushing the tube toward the handle (fig. 15).

b. Bristol Wrench. The Bristol wrench is used to loosen or tighten the setscrews on the fine tuning knob and the gears on the band switch and associated mechanisms. It also may be used for the setscrews on the ANT. TRIMMER OUTPUT, and MANUAL-PRESET TUNING controls.

c. Wrench, Double Hexagonal. The double hexagonal wrench is used for locking the adjustable slugs on the r-f, i-f (intermediate-frequency), bfo, and crystal-calibrator transformers and the r-f and oscillator trimmers.

d. Screw Driver. The screw driver is used in conjunction with the double hexagonal wrench for adjusting the trimmer capacitors and the adjustable transformers. The screw driver may be inserted through the hollow shaft of the double hexagonal wrench.

e. Tube-Pin Straightener. The tube-pin straightener cannot be removed from the cover.

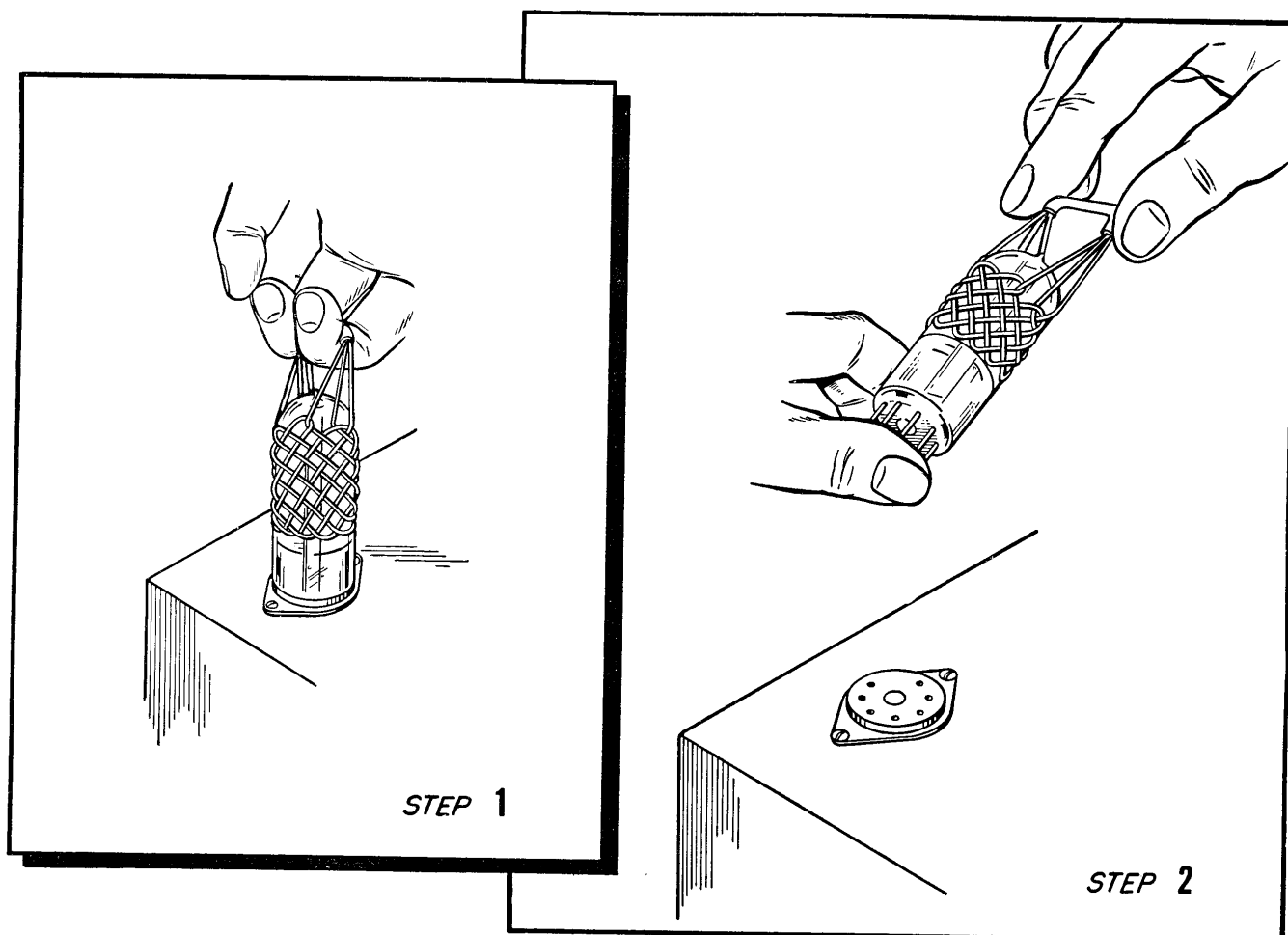

Figure 15. Radio Set AN/GRR-5, method of using tube puller.

TM 295-16

When a tube is to be inserted into the receiver, either after maintenance or for replacement purposes, the tube first should be inserted into the pin straightener to aline the pins properly.

f. *Locking Key Assembly.* The locking key assembly, located on the front panel of the re-

ceiver, is used to lock the preset channel detents. It also may be used to turn the OUTPUT and POWER SELECTOR switches, and to remove the screw which holds the spare fuses in place.

Section II. PREVENTIVE MAINTENANCE SERVICES

32. Definition of Preventive Maintenance

Preventive maintenance is work performed on equipment (usually when the equipment is not in use) to keep it in good working order so that breakdowns and needless interruptions in service will be kept to a minimum. Preventive maintenance differs from trouble shooting and repair, since its object is to prevent certain troubles from occurring. Refer to AR-750-5.

33. General Preventive Maintenance Techniques

a. Use No. 0000 sandpaper to remove corrosion.

b. Use a clean, dry, lint-free cloth or a dry brush for cleaning.

(1) If necessary, except for electrical contacts, moisten the cloth or brush with solvent (SD); then wipe the parts dry with a cloth.

(2) Clean electrical contacts with a cloth moistened with carbon tetrachloride; then wipe them dry with a dry cloth.

Caution: Repeated contact of carbon tetrachloride with the skin or prolonged breathing of fumes is dangerous. Make sure adequate ventilation is provided.

c. If available, dry compressed air may be used at a line pressure not exceeding 60 pounds per square inch to remove dust from inaccessible places; be careful, however, or mechanical damage from the air blast may result.

d. For further information on preventive maintenance techniques, refer to TB SIG 178.

34. Use of Preventive Maintenance Forms

a. The information in paragraph 35 is presented as a guide to the individual making an

inspection of equipment in accordance with instructions on DA AGO Forms 11-238 and 11-239. The decision as to which items on the form are applicable to this equipment is a tactical decision to be made in the case of first echelon maintenance by the communications officer/ chief or his designated representative, and in the case of second and third echelon maintenance, by the individual making this inspection. Instructions for the use of each form appear on the reverse side of the form.

b. The first two columns in the chart in paragraph 35 serve as a cross reference between the item numbers of DA AGO Forms 11-238 and 11-239 and the preventive maintenance information in this manual.

35. Performing Preventive Maintenance

The following preventive maintenance operations should be performed by organizational personnel at the intervals indicated, unless these intervals are reduced by the local commander.

Caution: Do not tighten screws, bolts, and nuts carelessly. Fittings tightened beyond normal pressures for which they are designed will be damaged or broken.

DA AGO Form 11-238 item No.	DA AGO Form 11-239 item No.	Preventive maintenance operations
		DAILY
1	1	Check for completeness and general condition of equipment. The components are listed in paragraph 7 and illustrated in figure 4.
2	2	Check suitability of location and installation for normal operation.
3	3	Clean dirt and moisture from antenna, headsets, connectors, jacks, plugs, carrying bags, and component panels.

DA AGO Form 11-238 item No.	DA AGO Form 11-239 item No.	Preventive maintenance operations
		DAILY—continued.
4	4	Inspect the seating of readily accessible <i>pluck-out</i> items: tubes, crystals, lamps, fuses, and vibrators.
5	5	Inspect controls for binding, scraping, excessive looseness, worn or chipped gears, misalignment, positive action.
6	6	Check for normal operation (par. 43).
		WEEKLY
		Caution: Disconnect all power before performing the following operations. Upon completion, reconnect power and check for satisfactory operation.
7	7	Clean and tighten exterior of components and case, mounting, antenna posts, and connectors.
8	8	Inspect case, front panels, mounting, antenna terminals, and exposed metal surfaces for rust, corrosion, and moisture.
9	9	Inspect cords, cables, wires, and shock mount for cuts, breaks, fraying, deterioration, kinks, and strain.
10	10	Inspect mast sections and antenna for eccentricities, corrosion, loose fit, and damaged insulators and reflectors.
11	11	Inspect all canvas items and technical manuals for tears, mildew, or fraying.
12	12	Inspect for looseness of accessible items; switches, knobs, jacks, connectors, electrical transformers, relay, capacitors, and pilot light assembly.
13	13	Inspect storage batteries for dirt, loose terminals, electrolyte level and specific gravity, and damaged cases.
14	14	Clean dial window.
16	16	Inspect shelters and covers for adequacy of weatherproofing.
		MONTHLY
	19	Inspect electron tubes for loose envelopes, cracked sockets, and insufficient socket spring tension; clean dust and dirt carefully; check emission of tubes.

DA AGO Form 11-238 item No.	DA AGO Form 11-239 item No.	Preventive maintenance operations
		MONTHLY—continued
	21	Insert fixed capacitors for leaks, bulges, and discoloration.
	22	Inspect relay for loose mountings, burned, pitted, or corroded contacts; misalignment of contacts and spring; insufficient spring tension; binding of plungers and hinge parts.
	23	Inspect variable capacitors for dirt, moisture, and loose mountings.
	24	Inspect resistors, bushings, and insulators for cracks, chippings, blistering, discoloration and moisture.
	25	Inspect terminals of large fixed capacitors and resistors for corrosion, dirt, and loose contacts.
	26	Clean and tighten switches, terminal blocks, relay case, and interior of chassis not readily accessible.
	27	Inspect terminal blocks for loose connections, cracks, and breaks.
	29	Lubricate equipment in accordance with applicable Department of the Army lubrication order.
	31	Clean and tighten connections and mountings for transformers, chokes, potentiometers, and rheostats.
	32	Inspect transformers, chokes, and potentiometers for overheating and oil leakage.
	33	Before shipping or storing, remove batteries.
	35	Inspect batteries for shorts and dead cells.
	36	Inspect for leaky waterproof gaskets and worn or loose parts.
	37	Check adequacy of moistureproof and fungiproof treatment.
	38	If deficiencies noted are not corrected during inspection, indicate what action was taken for correction.

Section III. LUBRICATION

36. Lubrication Instructions

Caution: Do not allow lubricating oil to contact material such as rubber, paint, and certain

plastics on which the lubricant may have a solvent effect.

a. Approximately once a month clean exposed

bearing surfaces of switch detents, band-switch mechanisms, and fasteners, and sparingly apply oil, lubricating, preservative, special (PL-Special). Remove excess oil to prevent possible malfunctioning of other parts, especially switch contacts.

b. Approximately once every 6 months, lubricate the tuning drive gears. Expose the gears by removing the receiver from the cabinet and the top cover from the receiver, and where possible, wipe the gears clean with a lint-free cloth moistened with solvent (SD); then wipe with a dry cloth. Lubricate by applying Grease MIL-G-3278 to the gear teeth, and turn the gear assembly to spread a light coating of grease evenly on all gear teeth. Wipe away excess grease from face of gears.

Note. If grease is removed from the two setscrews located on the dial-gear hub of the gear assembly, it should be replaced.

c. Grease MIL-G-3278 contains a rust and corrosion inhibitor. It may be used in regions

which have temperatures ranging from -70° F to $+160^{\circ}$ F.

37. Lubrication Under Unusual Conditions

a. *Arctic Regions.* Lubricants which are satisfactory at moderate temperatures stiffen and solidify at subzero temperatures; as a result, moving parts bind or become inoperative. When preparing the equipment for low-temperature operation, see that lubricants used for moderate temperatures are thoroughly removed. Even small amounts of such lubricants, if allowed to remain, may impair the operation of moving parts. Be sure to use Grease MIL-G-3278 as specified.

b. *Tropical or Desert Regions.* High temperatures and moisture caused by rain, condensation, etc., may cause lubricants which are normally satisfactory to flow from moving parts and other surfaces. Inspect the equipment daily and lubricate it as required; use Grease MIL-G-3278.

Section IV. WEATHERPROOFING

38. Weatherproofing

a. *General.* Signal Corps equipment, when operated under severe climatic conditions such as prevail in tropical, arctic, and desert regions, requires special treatment and maintenance. Fungus growth, insects, dust, corrosion, salt spray, excessive moisture, and extreme temperatures are harmful to most materials.

b. *Tropical Maintenance.* A special moistureproofing and fungiproofing treatment has been devised which, if properly applied, provides a reasonable degree of protection. This treatment is explained in TB SIG 13 and TB SIG 72. The equipment is given the moistureproofing and fungiproofing treatment at the factory and it is only necessary to use this treatment when parts are replaced or repaired.

c. *Desert Maintenance.* Special precautions necessary to prevent equipment failure in areas subject to extremely high temperatures, low humidity, and excessive sand and dust are explained in TB SIG 75.

d. *Winter Maintenance.* Special precautions

necessary to prevent poor performance or total operational failure of equipment in extremely low temperatures are explained in TB SIG 66 and TB SIG 219.

39. Rustproofing and Painting

a. When the finish on the case has been badly scarred or damaged, rust and corrosion can be prevented by touching up bared surfaces. Use No. 00 or No. 000 sandpaper to clean the surface down to the bare metal; obtain a bright smooth finish.

Caution: Do not use steel wool. Minute particles frequently enter the case and cause harmful internal shorting or grounding of circuits.

b. When a touch-up job is necessary, apply paint with a small brush. Remove rust from the case by cleaning corroded metal with solvent (SD). In severe cases it may be necessary to use solvent (SD) to soften the rust and to use sandpaper to complete the preparation for painting. Paint used will be authorized and consistent with existing regulations.

Section V. TROUBLE SHOOTING AT ORGANIZATIONAL MAINTENANCE LEVEL

40. Scope

a. The trouble shooting and repair work that can be performed at the organizational maintenance level is necessarily limited in scope by the tools, test equipment, and replaceable parts issued, and by the existing tactical situation. Accordingly, trouble shooting is based on the performance of the equipment and the use of the senses in determining such troubles as burned-out tubes, damaged insulators, etc.

b. The paragraphs which follow in this section help in determining which of the components is at fault and in localizing the fault in that component to the defective item, such as a tube or fuse.

41. Visual Inspection

a. Failure of this equipment to operate properly will usually be caused by one or more of the following faults:

- (1) Improperly connected or broken power cords or plugs.
- (2) Improperly connected headphones.
- (3) Burned-out fuses.
- (4) Defective tubes.
- (5) Relay contacts burned or pitted because of overloads.
- (6) Inactive (dirty or cracked) crystal.
- (7) Defective switches.
- (8) Defective vibrators.
- (9) Defective gear or tuning mechanism.
- (10) Dirty or bent plates of variable capacitor.

b. When failure is encountered and the cause is not immediately apparent, check as many of the above items as is practicable before starting a detailed examination of the radio set. If possible, obtain information from the operator of the equipment regarding performance at the time trouble occurred.

c. Visually inspect the antenna for obvious abnormalities.

42. Trouble Shooting by Using Equipment Performance Checklist

a. General. The equipment performance checklist (par. 43) will help the operator to locate trouble in the equipment. The list gives the item to be checked, the conditions under which the item is checked, the normal indications and tolerances of correct operation, and the corrective measures the operator can take. *To use this list, follow the items in numerical sequence.*

b. Action or Condition. For some items, the information given in the action or condition column consists of specific control settings with which the item is to be checked. For other items, it represents an action that must be taken to check the normal indication given in the normal indications column.

c. Normal Indications. The normal indications listed include the visible and audible signs that the operator should perceive when he checks the items. If the indications are not normal, the operator should apply the recommended corrective measures.

d. Corrective Measures. The corrective measures listed are those that the operator can make without turning in the equipment for repairs. A reference in the table to chapter 5 indicates that the trouble cannot be corrected during operation and that trouble shooting by an experienced repairman is necessary. If the receiver is completely inoperative or if the recommended corrective measures do not yield results, trouble shooting is necessary. However, if the tactical situation requires that communication be maintained, and if the set is not completely inoperative, the operator must maintain the set in operation as long as it is possible to do so.

43. Equipment Performance Checklist

	Item No.	Item	Action or condition	Normal indications	Corrective measures
P R E P A R A T O R Y	1	Antenna.	Mast Sections MS-116-A (2 ea), MS-117-A, and MS-118-A connected to antenna input, or reel antenna connected to terminal A on front panel. G terminal connected to a secure ground.		
	2	Headset CW-49507-A (Navy type).	Headset plugged into Headset Cord CX-1334/U which is connected to PHONES jack.		
	3	PHN.-C. W.-NET-CAL. function switch.	Set to PHN. position.		
	4	A.F. GAIN control.	Set to maximum clockwise position.		
	5	OUTPUT HIGH-LOW switch.	Set to HIGH position (LOW when dry batteries are used).		
	6	R.F. GAIN control.	Set to maximum clockwise position.		
	7	POWER ON-OFF switch.	Set to OFF position.		
	8	SPEAKER ON-OFF switch.	Set to ON position.		
	9	POWER SELECTOR 6V-12V-24V-DRY BAT. switch.	Set to 6V, 12V, 24V, or DRY BAT. position depending on voltage source. For 115-volt a-c operation, set switch to 6V or DRY BAT. position. (See par. 20).		
	10	Power Cable Assembly CX-1358/U, CX-1359/U, or CX-1360/U.	Connected to POWER INPUT or DRY BATTERY receptacle. Other end connected to power source.		Fasten securely. Connect according to instructions given in paragraph 15.
S T A R T	11	POWER ON-OFF switch.	Set to ON position.	After short warm-up period, rushing noise is heard in speaker and headset.	Check proper fuse and tubes. Refer to chapter 5.
	12	Filament voltage control.	A 20,000-ohm-per-volt meter connected to J102 and chassis.	Voltage should be 1.4 volts dc.	Adjust filament-voltage control. Check vibrator E102 and power-supply tubes. Refer to chapter 5.
	13	DIAL LIGHT switch.	Depress.	Dial light is illuminated.	Check light, and switch S3. Refer to chapter 5.

	Item No.	Item	Action or condition	Normal indications	Corrective measures
E Q U I P M E N T	14	BAND SW., PHN.-C.W.-NET-CAL. switch, and MANUAL PRESET TUNING control.	Set BAND SW to position 1 and PHN.-C.W.-NET-CAL. switch to CAL. Rotate MANUAL-PRESET TUNING control over entire band.	Signal heard every 200 kc on all bands.	If signals are weak or not obtained, check tubes in the receiver and power supply.
		ANT. TRIMMER.	Adjust for maximum signal strength.	Signal strength varies as ANT. TRIMMER is adjusted.	Inspect ANT. TRIMMER for bent plates. Refer to chapter 5.
	15	R.F. GAIN and A.F. GAIN controls.	Turn counterclockwise.	Signal strength decreases.	Check tubes. Refer to chapter 5.
	16	OUTPUT HIGH-LOW switch.	Set to LOW position.	Strength of output signal decreases.	Refer to chapter 5.
	17	MANUAL-PRESET TUNING control.	Tune across the entire band as test signals are applied.	Signals appear at respective test frequencies.	Refer to chapter 5.
	18	BAND SW.	Check each band. Use the procedure in steps 14 and 17.	Same as normal indications in steps 14 and 17.	Refer to chapter 5.
	19	PHN.-C.W.-NET-CAL. switch.	Rotate to C.W. position. Provide a C-W test signal.	Tone signal should be heard.	Rotate B.F.O. control. Check V7. Refer to chapter 5.
	20	B.F.O. control.	Rotate B.F.O. trimmer.	Tone signal varies in pitch.	Refer to chapter 5.
	21	PHN.-C.W.-NET-CAL. switch.	Set to CAL. position. Rotate MANUAL-PRESET TUNING control.	Signals heard every 200 kc on all bands. If necessary tune ANT. TRIMMER control for maximum beat signal.	Check V5. Check crystal. Refer to chapter 5.
S T O P	22	POWER ON-OFF switch.	Turn to OFF position.	No signals are heard.	Check switch S103. Refer to chapter 5.

CHAPTER 4

THEORY

Section I. POWER SUPPLY PP-308/URR

44. Block Diagram

(fig. 16)

a. Operating voltage for the receiver is obtained from Power Supply PP-308/URR. This unit operates from a standard 115-volt 60-cycle line; a 6-, 12-, or 24-volt, d-c vehicular storage battery; or a 90-volt and 1.5-volt dry-battery source. Output voltages are 90 volts dc ± 3 volts, 1.4 volts dc, and -4.2 volts dc.

b. For 115-volt a-c operation, the line voltage is stepped down by a transformer and the lower voltage is supplied to rectifier CR101 (fig. 18). The rectified voltage energizes relay K101. When relay K101 is energized, the 115-volt a-c line is completed to the rectifier circuit associated with V102, and the output of rectifier CR101 is supplied to filament voltage vibrator E102. Bias and hv (high voltage) are developed by the circuit associated with V102. Filament voltage is developed by V104, E102, and CR102. Regulator tubes V101, V103, and V104 maintain substantially constant output voltages.

c. For 6-volt, 12-volt, or 24-volt operation, the input voltage energizes vibrator E101, which develops an alternating voltage to drive the rectifier circuit associated with V102. Rectification, filtering, and regulation are the same as for 115-volt a-c operation. E102 also is energized by the input voltage (K101 is inoperative) and, in conjunction with V104 and CR102, develops filament voltage.

d. For dry-battery operation, the voltages are supplied from the batteries to the receiver through the power supply.

45. H-v Rectifier, Filament Voltage, and Voltage Regulation Circuits

(fig. 17)

a. In all modes of operation, except dry-battery, the h-v rectifier develops the B+, bias, and filament voltages for the receiver. Voltage regulation is used to deliver a constant output despite changes in input voltage. In the following analysis, the circuits connected to the secondary of transformer T102 (common to all modes of operation) are discussed in detail. Primary voltage of T102 is discussed in detail in the analysis of the different modes of operation (pars. 46 through 50).

b. High voltages from the transformer secondary are connected to the plates of rectifier tube V102 (type CK1007) through hash filters L111 and L112. Capacitor C113 is a buffer for the vibrator circuit associated with the primary of T102 during 6-, 12-, and 24-volt operation (pars. 47 through 49). Since each plate is connected to opposite ends of the transformer secondary and the center tap is returned to ground through resistor R109 (or resistors R108 and R109), tube V102 operates as a conventional full-wave rectifier. The pulsating dc is filtered by capacitor C114 and bleeder resistor R110.

c. Resistor R108 in the B— circuit is shorted to ground through section 6, rear, of POWER SELECTOR switch S101 for all modes of operation except DRY BATTERY, and resistor R109 is used to develop bias for tubes V7 and V8 in the receiver. For DRY BATTERY operation, resistor R108 is added in series with R109. The bias voltage is supplied to the receiver through pin 8 of J101.

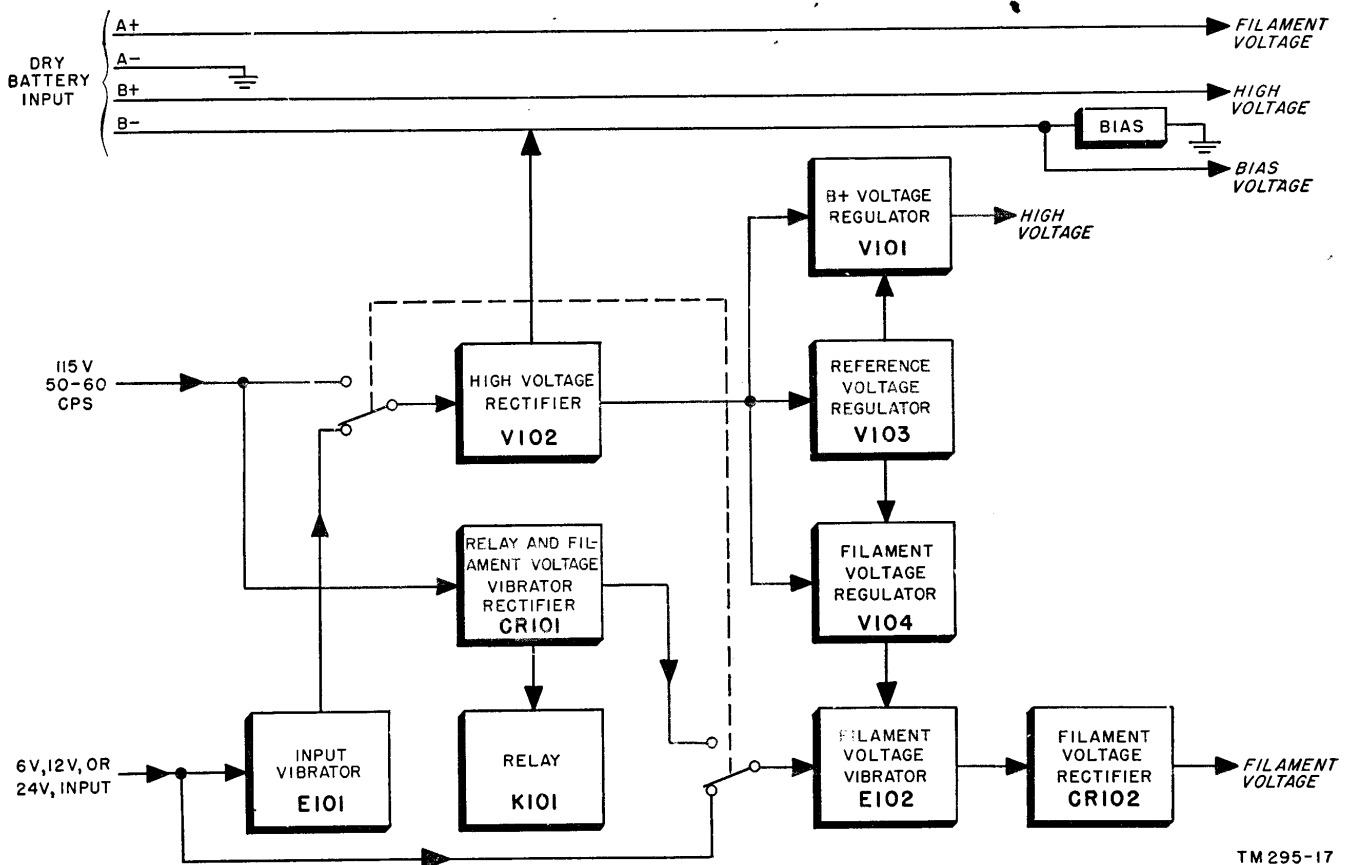

TM 295-17

Figure 16. Power Supply PP-308/URR, block diagram.

d. For 115-volt a-c operation, the positive voltage across capacitor C114 is supplied to the receiver through series regulator V101, resistor R111, contacts 3 and 2 of relay K101, and pin 6 of J101. For d-c operation, contacts of POWER SELECTOR switch S101 and contacts 1 and 2 of K101 are used in place of relay contacts 3 and 2.

e. The positive voltage across C114 also is supplied to contacts of filament voltage vibrator E102 through a series circuit which includes regulator V104, resistors R115 and R116, the primary winding of T103, and chokes L109 and L110. Operation of the vibrator is explained in g below.

f. Series regulators V101 and V104 maintain the receiver B+ and filament voltages constant, despite changes in input voltage. For this purpose, the full positive output across C114 is supplied to the plates and screens of V101 and V104 and the control grids of these tubes are maintained at a constant potential by the action of reference-voltage regulator V103. The reference-voltage regulator is connected in series

with current-limiting resistor R113 between the full B+ output and ground. If the B+ voltage increases or decreases, the resistance of V103 changes so as to maintain a constant voltage across the tube. It is this constant voltage which is supplied to the control grids of V101 and V104. In the case of V104, the voltage is supplied through isolation and grid-current-limiting resistor R114. Although the control grids of the regulators are held at a constant potential, variations in B+ voltage (because of the variations of input voltage) are present at the plates of these tubes. Variation in plate voltage causes a change in plate current and a corresponding change in cathode bias. Although an increased plate potential lowers the resistance of the regulators, the resultant increase in bias raises the resistance. Similarly, decreased plate voltage causes increased resistance and decreased cathode bias, but the decreased bias causes a decrease in resistance. The overall effect is a substantially constant load potential at the cathodes of V101 and V104. The cathode potential of V101 is supplied to the re-

ceiver as B+ voltage (*d* above) and the cathode potential of V104 is supplied to the filament-voltage vibrator, E102. Potentiometer R116 in the cathode circuit of V104 provides a means of adjusting the level of voltage which is supplied to the vibrator.

Note. The metal cases of the 6AG7 regulator tubes are connected to the suppressor grids which are at a high potential above ground. Do not replace the insulated clamps used on the 6AG7 tubes with the metallic clamps used on the CK1007 tube.

g. Filament voltage for the receiver is developed when the coil of vibrator E102 is energized. For 115-volt a-c operation, the coil is energized by the rectified output of T101

through normally open contacts 20 and 21 of relay K101. For 6-, 12-, or 24-volt d-c operation, a d-c voltage is supplied to the coils through normally closed contacts 21 and 22 of relay K101 (pars. 47 through 49). D-c voltage, to be interrupted by the vibrator, is supplied from the cathode circuit of V104 through the primary of transformer T103 and coils L109 and L110. Capacitors C115, C116, and C117, in conjunction with L108, L109, and L110, are hash filters. Changing the setting of R116 regulates the d-c voltage to the vibrator. C119 is the buffer capacitor. The interrupted d-c voltage is stepped down by transformer T103 and

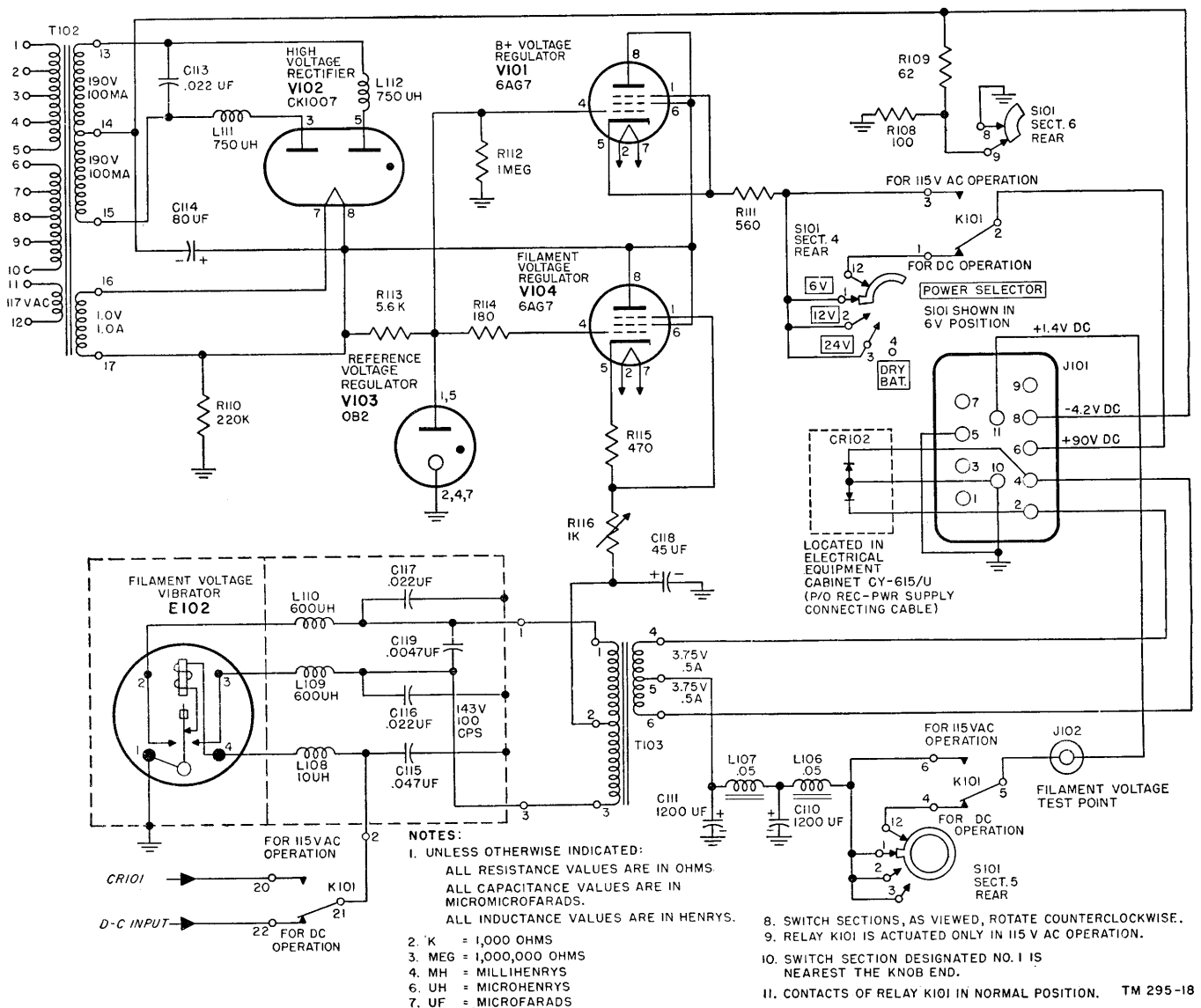

Figure 17. Power Supply PP-308/URR, h-v rectifier, voltage regulator, and filament voltage supply, functional schematic.

fed to selenium rectifier CR102, located on Electrical Equipment Cabinet CY-615/URR, through pins 2 and 4 of J101. The filter circuit, connected to the center tap of the secondary winding of T103, consists of L106, L107, C110, and C111. The filament voltage is fed to jack J102 and to pin 11 on J101 through relay K101 contacts 6 and 5, for 115-volt a-c operation, or through POWER SELECTOR switch S101 and normally closed contacts 4 and 5 of relay K101 for d-c operation.

46. Analysis of 115-volt A-c Operation (fig. 18)

For 115-volt a-c operation, the line voltage is supplied directly to h-v transformer T102 (par. 45b) and a stepped-down a-c voltage is supplied to the driving coil of filament-voltage

vibrator E102 (par. 45g). Operation of power supply on 115 volts ac is independent of the setting of POWER SELECTOR switch S101. Circuit details are as follows:

a. The 115-volt line at contacts A and D of POWER INPUT receptacle J103 is connected to the primary of T101 through fuse F101 (110V. 1A), and section 1 of POWER ON-OFF switch S103. Capacitors C102A and C102B are line filters. The secondary voltage of T101 is rectified by CR101, filtered by C101, and fed to the operating coil of relay K101. When K101 is energized, the 115-volt a-c line is completed to the primary of T102 through relay contacts 14 and 13, and the 6-volt d-c output of the rectifier is supplied to filament-voltage vibrator E102 through relay contacts 20 and 21.

b. In this mode of operation, winding 1-4 of

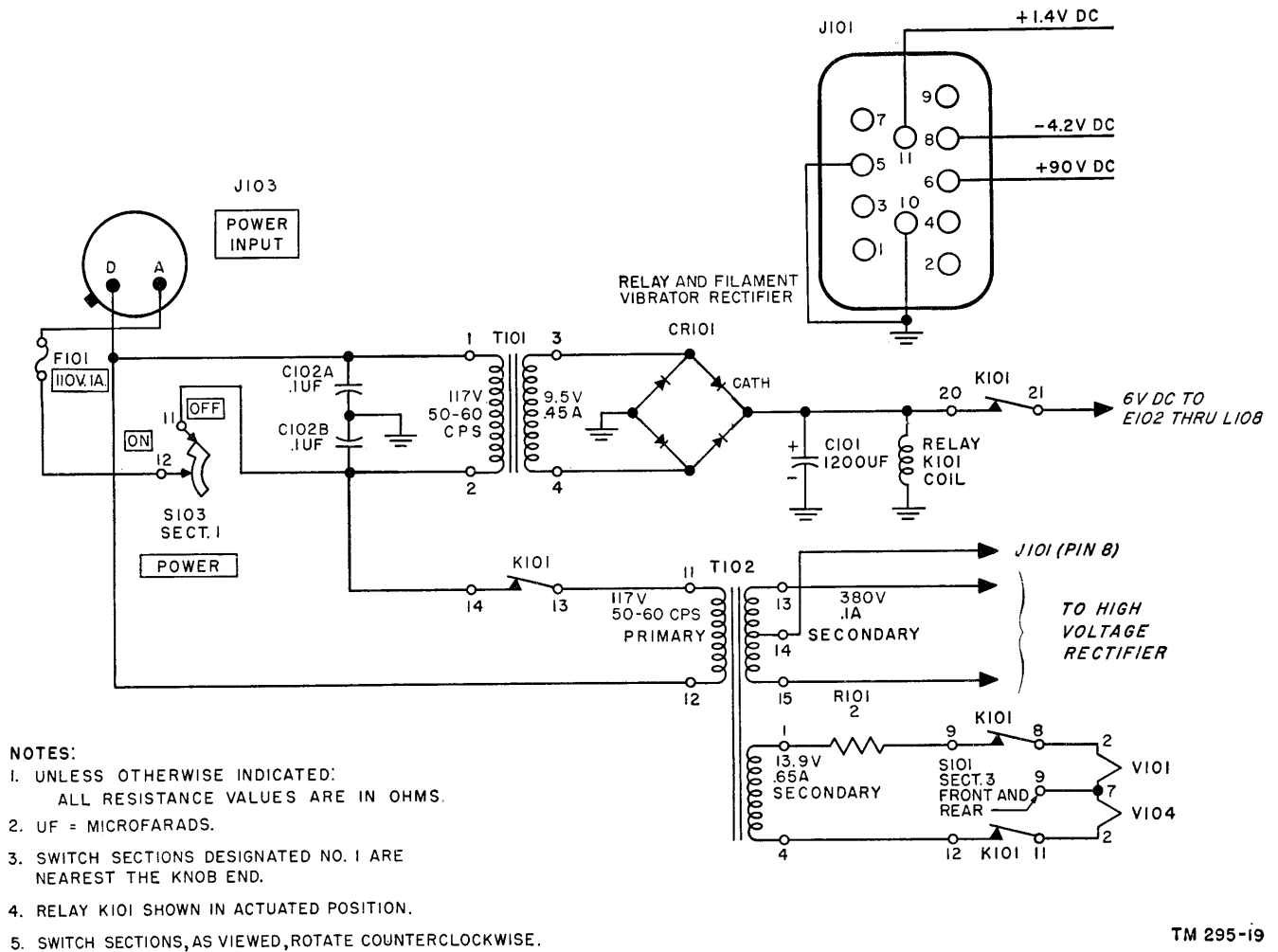

Figure 18. Power Supply PP-308/URR, 115-volt a-c operation, functional schematic.

T102 is connected as a secondary winding, and the voltage developed is used for the filaments of V101 and V104. The filaments are series connected across the winding in series with resistor R101, contacts 9 and 8 of relay K101, and contacts 11 and 12 of relay K101.

c. The voltage across secondary winding 13-14-15 of T102 is supplied to the h-v rectifier where it is utilized as explained in paragraph 45.

47. Analysis of 6-volt D-c Operation

(fig. 19)

For 6-volt d-c operation, the input voltage is supplied directly to the driving coil of filament-voltage vibrator E102 (par. 45g) and to the coil and contacts of input vibrator E101. Vibrator E101 develops an a-c voltage which is supplied to the primary of T102.

a. The 6-volt d-c potential required to energize the vibrator is supplied from contact B of J103 to contact 3 of E101 through section 1 of S101, fuse F104 (6V. 8A.), paralleled contacts 7 and 8 of sections 1 and 2 of S103, normally closed contacts 23 and 24 of relay K101, section 2 of S101, and L101. The combination of capacitor C104 and coil L101 make up a hash filter. Sections 1 and 2 of S103 are connected in parallel to prevent burning of the contacts.

b. The 6-volt d-c potential to be interrupted at contacts 2 and 5 of E101 is fed from contact B of POWER INPUT receptacle J103 to contact 2 of input vibrator E101 through section 1 of POWER SELECTOR switch S101, fuse F104, section 2 of POWER ON-OFF switch S103, contacts 26 and 25 paralleled by contacts 27 and 28 of relay K101, section 3 of S101, winding 7-6 of T102, section 4, front, of S101 and L102. The 6-volt d-c potential at terminal 7 of T102 also is fed to contact 5 of E101 through the primary winding 7-8 of T102, section 1 of S101, and L104. The voltage to be interrupted at contacts 1 and 4 of E101 is taken from the junction of contacts 25 and 28 of K101 and is fed to terminal 4 of T102 through section 3 of S101. From terminal 4 of T102, the voltage

is fed to contact 1 of E101 through winding 4-3 of T102, section 2 of S101, and L105. The voltage at terminal 4 of T102 also is fed to contact 4 of E101 through winding 4-5 of T102, section 6, front, of S101, and L103. L101 through L105 and C104 through C108 are hash filters. Capacitor C109 is a line filter. Capacitor C112 is a buffer capacitor. When the vibrator is energized, pulsating d-c voltage is developed across windings 3-4-5 and 6-7-8 of T102. The secondary circuits of T102 are the same as described in paragraph 45.

c. The 6-volt potential at contact B of POWER INPUT receptacle J103 also is supplied to the operating coil of filament-voltage vibrator E102 through section 1 of S101, fuse F104, paralleled contacts 7 and 8 of sections 1 and 2 on S103, normally closed contacts 23 and 24 of relay K101, section 1 of S101, and contacts 22 and 21 of relay K101. (Refer to paragraph 45g for circuit details of vibrator E102.)

d. For 6-volt operation, the heaters of V101 and V104 are connected in parallel. The 6-volt d-c potential required for the heaters is taken from the junction of contacts 25 and 28 of K101 and is supplied through contacts 7 and 8 of K101 to pin 2 of V101, and through section 5 of S101 and contacts 10 and 11 of K101 to pin 2 of V104. Pins 7 of V101 and V104 are connected together and completed to ground through section 3 of S101 and contacts 18 and 19 of K101.

48. 12-volt D-c Operation

(fig. 20)

The circuit of the power supply for 12-volt operation is similar to that for 6-volt operation, except for the addition of series resistance to limit the current to the vibrator coils, the use of different taps on transformer T102, the series connections of the heaters of V101 and V104, and the fuse used.

a. Voltage for the driving coil of vibrator E101 is supplied from J103, contact B, through section 1 of POWER SELECTOR switch S101, fuse F103 (12V.4A.), parallel contacts 7 and 8 on sections 1 and 2 of POWER ON-OFF

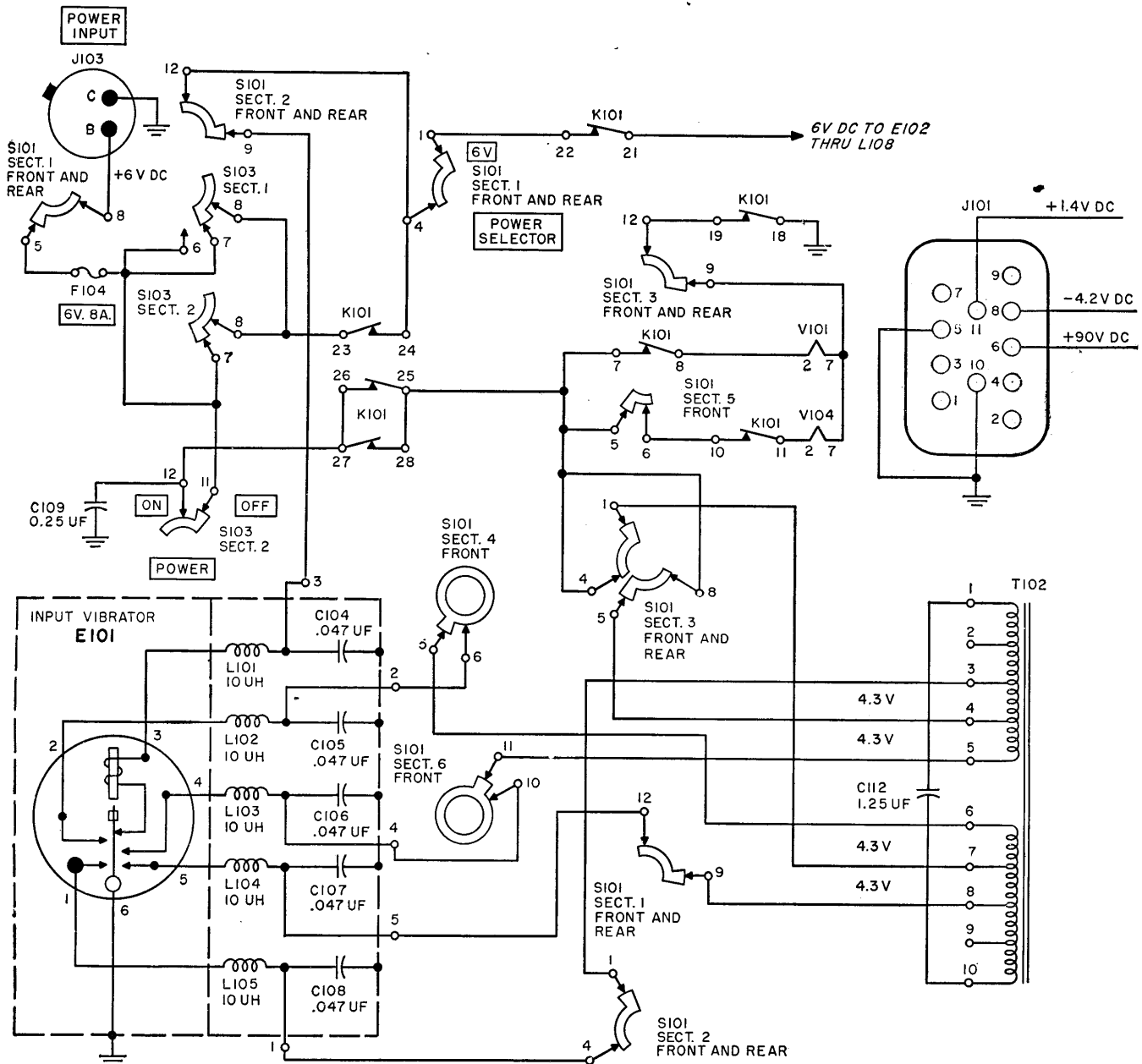

NOTES:

1. UNLESS OTHERWISE INDICATED:
ALL CAPACITANCE VALUES ARE IN MICROMICROFARADS.
ALL INDUCTANCE VALUES ARE IN HENRYS.
2. UH = MICROHENRYS.
3. UF = MICROFARADS.
4. SWITCH SECTIONS DESIGNATED NO.1 ARE NEAREST THE KNOB END.
5. CONTACTS OF K101 NORMALLY CLOSED.
6. SWITCH SECTIONS, AS VIEWED, ROTATE COUNTERCLOCKWISE.

TM 295-20

Figure 19. Power Supply PP-308/URR, 6-volt d-c operation, functional schematic.

E101 VIBRATOR Nonsynchronous:
 INPUT 6VDCW, 150 ma; single reed;
 110 cps; ± 6% cylindrical shape;
 2 7/8" lg x 1 1/2" dia o/a excluding
 prongs; Oak part # 6606.

switch S103, contacts 23 and 24 of relay K101, section 2 of S101, resistor R104, and L101. R104 drops the 12-volt input voltage to the 6 volts required to energize E101. The combination of L101 and C104 makes up a hash filter.

b. The 12-volt d-c potential to be interrupted by the vibrator is fed from POWER INPUT receptacle J103, contact B, to pins 1 and 5 of vibrator E101. The voltage is fed through section 1 of POWER SELECTOR switch S101, fuse F103, section 2 of POWER ON-OFF switch S103, contacts 26 and 25 paralleled by 27 and 28 of relay K101, to section 3 of POWER SELECTOR switch S101. From this point, the voltage is supplied to contact 5 of E101 through winding 6-9 of T102, section 1 of S101, and L104, and to contact 1 of E101 through winding 5-2 of T102, section 2 of S101, and L105. C112 is a buffer capacitor; capacitors C107 and C108, in conjunction with L104 and L105, are hash filters. The interrupted voltage is used as the primary voltage for T102. High voltage is developed in the secondary of T102 in the same manner as described in paragraph 45.

c. Voltage for the driving coil of vibrator E102 is taken from the junction of contact 24 of K101 and contact 12 on section 2 of S101, and supplied through section 1 of S101, resistor R102, contacts 22 and 21 of K101, and L108. Resistor R102 drops the input voltage to 6 volts. Operation of E102 is described in paragraph 45*g*.

d. In the 12-volt operation, the heaters of V101 and V104 are connected in series. The required 12-volt potential is taken from the junction of paralleled contacts 27-28 and 26-25 on K101 (*a* above) and is connected across the heater through contacts 7 and 8 of K101, contacts 11 and 10 of relay K101, section 3 of S101, and contacts 19 and 18 of relay K101.

e. The 12-volt d-c potential available at contact 24 of K101 also is connected through section 4, rear, of S101 to pin 7 of J101. This potential is used for receiver disabling.

49. 24-volt D-c Operation

(fig. 21)

In 24-volt operation, the circuit of the power supply is the same as for 12-volt operation, except for the addition of voltage-dropping resistors, a change in the winding used as primary of T102, and the use of fuse F102 (24V. 3A.).

a. In this mode of operation, resistors R102 and R103 are in series, and R104 and R105 are in series, to limit the current to the driving coils of the vibrators. Operation of the vibrators is the same as for 12-volt operation. Windings 1-5 and 6-10 are used as the primary of transformer T102. Resistor R107 is used to limit the current through the primary windings, thus reducing the primary interrupted voltage to give a secondary voltage of the same magnitude as the other modes of operation.

b. The filaments of V101 and V104 are connected in series, with resistor R106 to limit the current and to reduce the 24 volts input to 12 volts across the heaters.

c. The 24-volt d-c potential is taken from contact 24 of K101 and connected through section 4, rear, of S101 to pin 1 of J101 as a receiver disabling voltage source.

50. Dry-battery Operation

(fig. 22)

In dry-battery operation, the power supply is used merely as a connecting device.

a. B+ voltage (90 volts dc) is fed from DRY BATTERY receptacle J104, contact A, to pin 6 of J101 through section 1 of POWER ON-OFF switch S103, section 4 of POWER SELECTOR switch S101, and contacts 1 and 2 of relay K101.

b. Filament voltage (1.4 volts dc) is fed from J104, contact B, to J102 and pin 11 of J101, through section 2 of S103, section 5 of S101, and contacts 4 and 5 of relay K101.

c. Bias for tubes V7 and V8 in the receiver is supplied from J104, contact D, to pin 8 of J101. Pin 8 of J101 is -4.2 volts dc from ground because of the ground return through resistors R109 and R108.

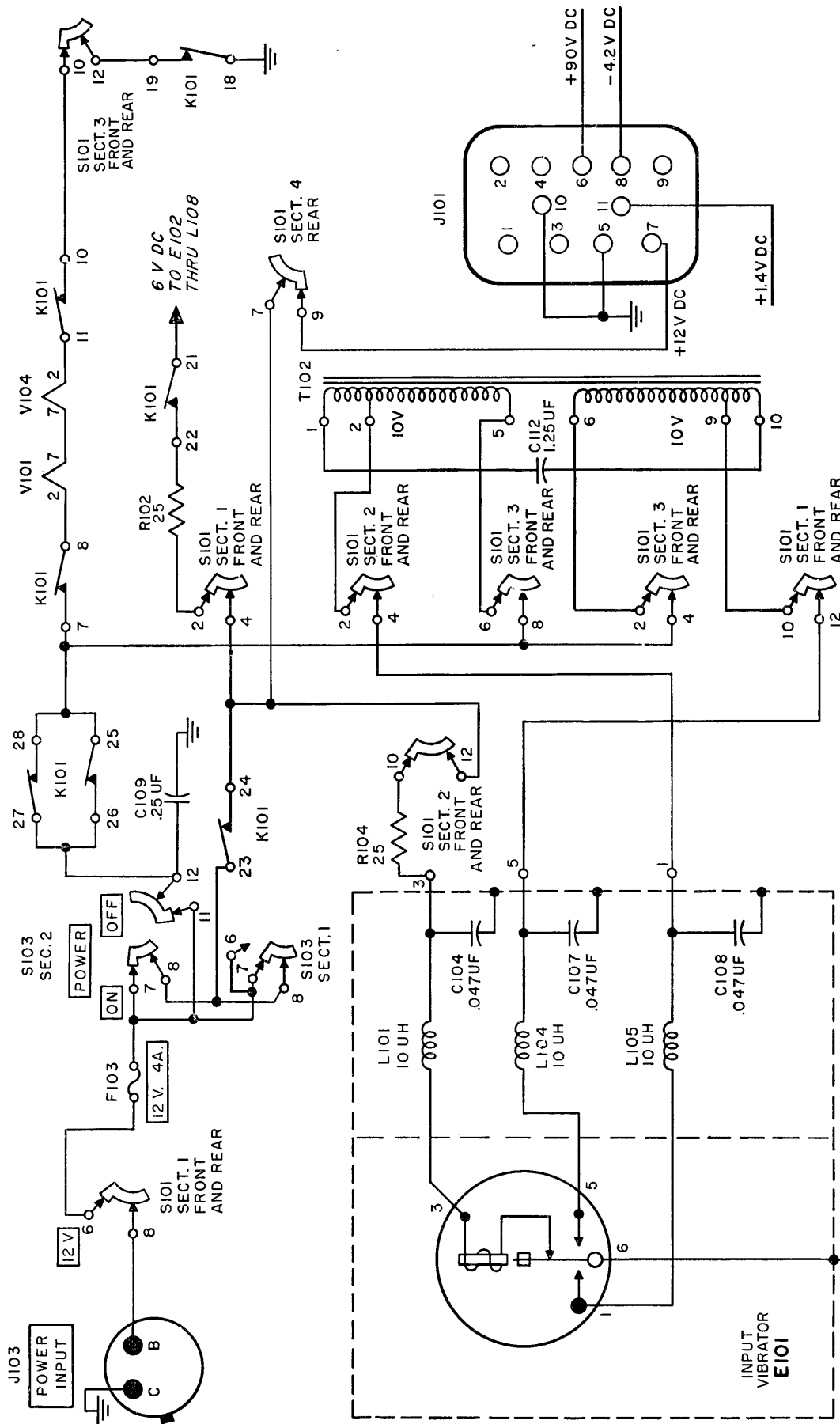

NOTES:

1. UNLESS OTHERWISE INDICATED:
ALL RESISTANCE VALUES ARE IN OHMS.
ALL CAPACITANCE VALUES ARE IN MICROMICROFARADS.
ALL INDUCTANCE VALUES ARE IN HENRYS.
2. UF = MICROFARADS. 3. UH = MICROHENRYS.

4. SWITCH SECTIONS, AS VIEWED, ROTATE COUNTERCLOCKWISE.
5. SWITCH SECTIONS DESIGNATED NO. 1 ARE NEAREST THE KNOB END.
6. CONTACTS OF K101 NORMALLY CLOSED.

Figure 20. Power Supply PP-308/URR, 12-volt d-c operation, functional schematic.

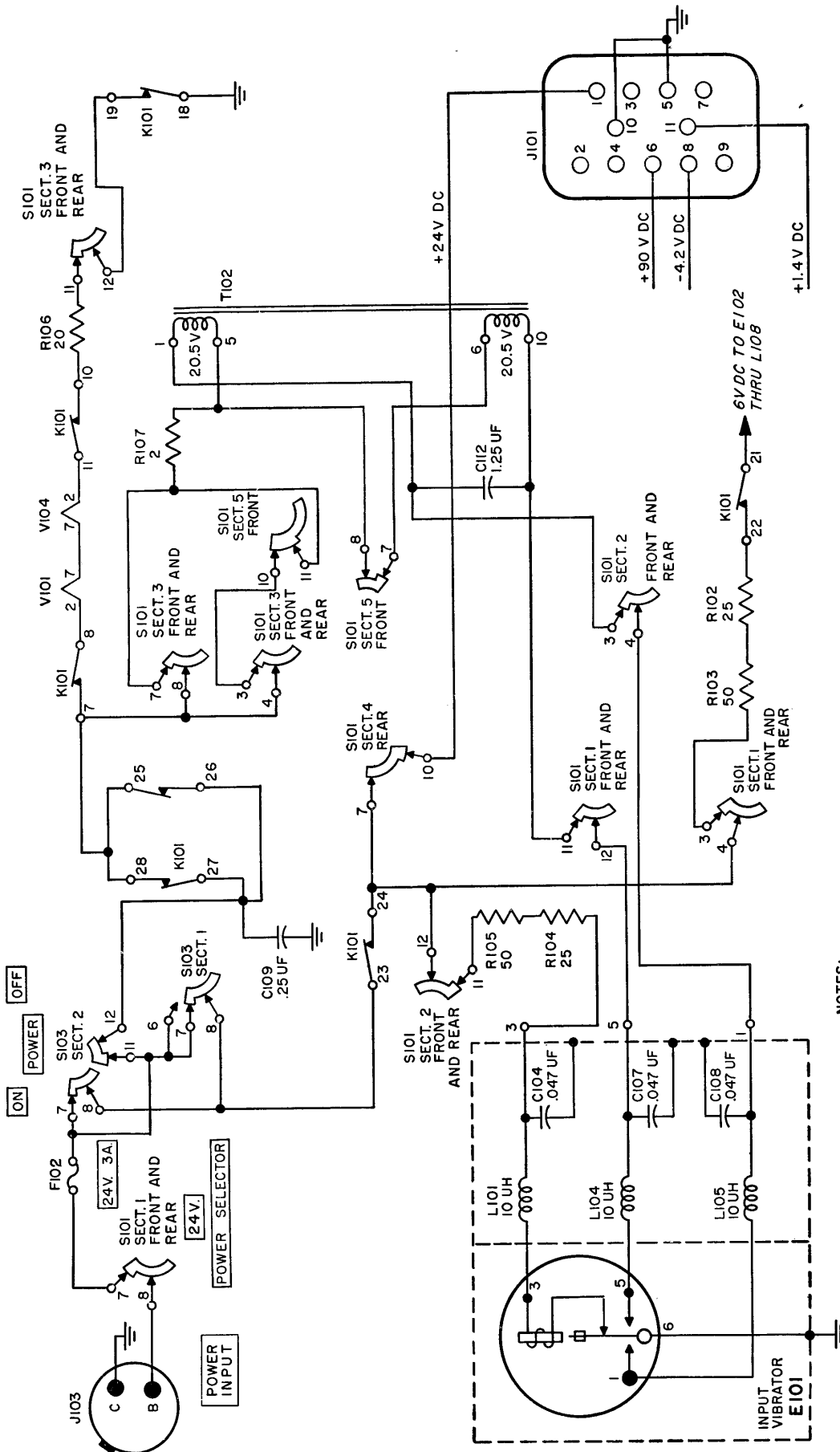

- NOTES:
1. UNLESS OTHERWISE INDICATED ALL RESISTANCE VALUES ARE IN OHMS
 2. UH = MICROHENRYS
 3. UF = MICROFARADS
 4. CONTACTS OF K101 NORMALLY CLOSED
 5. SWITCH SECTIONS DESIGNATED NO. 1 ARE NEAREST THE KNOB END.
 6. SWITCH SECTIONS, AS VIEWED, ROTATE COUNTERCLOCKWISE.

Figure 21. Power Supply PP-308/URR, 24-volt d-c operation, functional schematic.

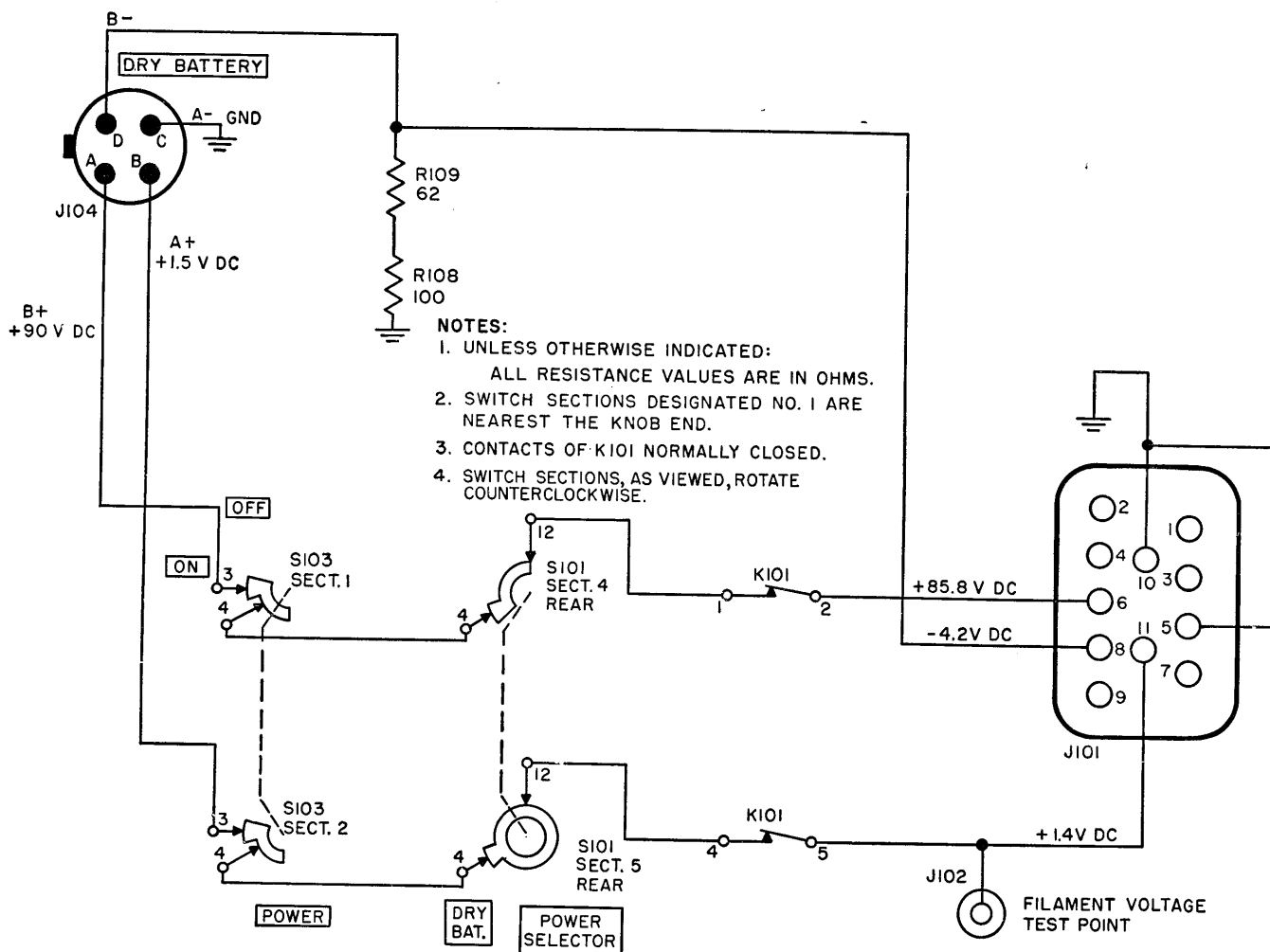

TM 295-23

Figure 22. Power Supply PP-308/URR, dry-battery operation, functional schematic.

Section II. RADIO RECEIVER R-174/URR

51. Block Diagram

(fig. 23)

a. Radio Receiver R-174/URR is a portable receiver operating over a frequency range of 1.5 mc to 18 mc. Either a-m or c-w signals may be received. The signal path is shown in figure 23.

b. The signal voltage induced in the antenna is amplified by r-f amplifier stages V1 and V2 connected in cascade, and the amplified signal is coupled into converter tube V3. The antenna, r-f amplifier, and converter input circuits are tuned manually to the radio-frequency signal. A locally generated signal, which tracks 455 kc above the received signal, is mixed electronically with the incoming signal in the con-

verter stage. The output of converter tube V3 is tuned to the difference frequency (455 kc), and this signal is supplied to the first i-f amplifier tube, V4.

c. The 455-kc i-f signal is amplified successively in the first and second i-f stages, V4 and V5 respectively. The i-f output of V5 is fed to the diode section of tube V6.

d. The diode section of V6 rectifies the i-f signal, and a detected audio signal is coupled to the pentode section of V6. Audio amplification is provided by the pentode section of V6 and by either V7 or V8. The output of either V7 or V8 is supplied through OUTPUT HIGH-LOW switch S4 to the PHONES connectors and the loudspeaker in Power Supply PP-308/URR.

SPEAKER ON-OFF switch S102 can be used to open the speaker circuit and permit operation of the receiver with headsets only.

e. Voltage for AVC is developed across a portion of the diode load in the circuit of V6. This voltage is fed to i-f amplifier tube V4 and r-f amplifier tubes V1 and V2, when PHN.-C.W.-NET-CAL. switch S2 is in the PHN. position. For all other positions of S2, the AVC voltage is grounded.

f. For reception of continuous waves (switch S2 in C.W. position), the triode section of tube V7 functions as a bfo at a frequency of 151.66 kc, ± 1 to 1.167 kc. The third harmonic of the oscillator output (455 kc ± 3.5 kc) is coupled to second i-f amplifier tube V5, where it mixes with the i-f signal to produce an audio tone in the detector portion of V6. The bfo tube is operative also when switch S2 is set at NET or

CAL.; it is inoperative only for the PHN. setting of S2.

g. For checking the calibration of the receiver dial, the triode section of V5 functions as a crystal-controlled oscillator at a fundamental frequency of 200 kc. The output of the oscillator (200 kc and the harmonics) is radiated within the receiver. The signals are picked up by the r-f section of the receiver, amplified, detected, and beat with the bfo to develop a beat note every 200 kc on the dial. The crystal calibration oscillator is disabled when PHN.-C.W.-NET-CAL. switch S2 is in any position other than CAL.

h. For monitoring purposes, a-f amplifier V6 is disabled, the sidetone signal of a transmitter may be connected to the receiver audio section, and the audio output of the receiver may be coupled to the remote location.

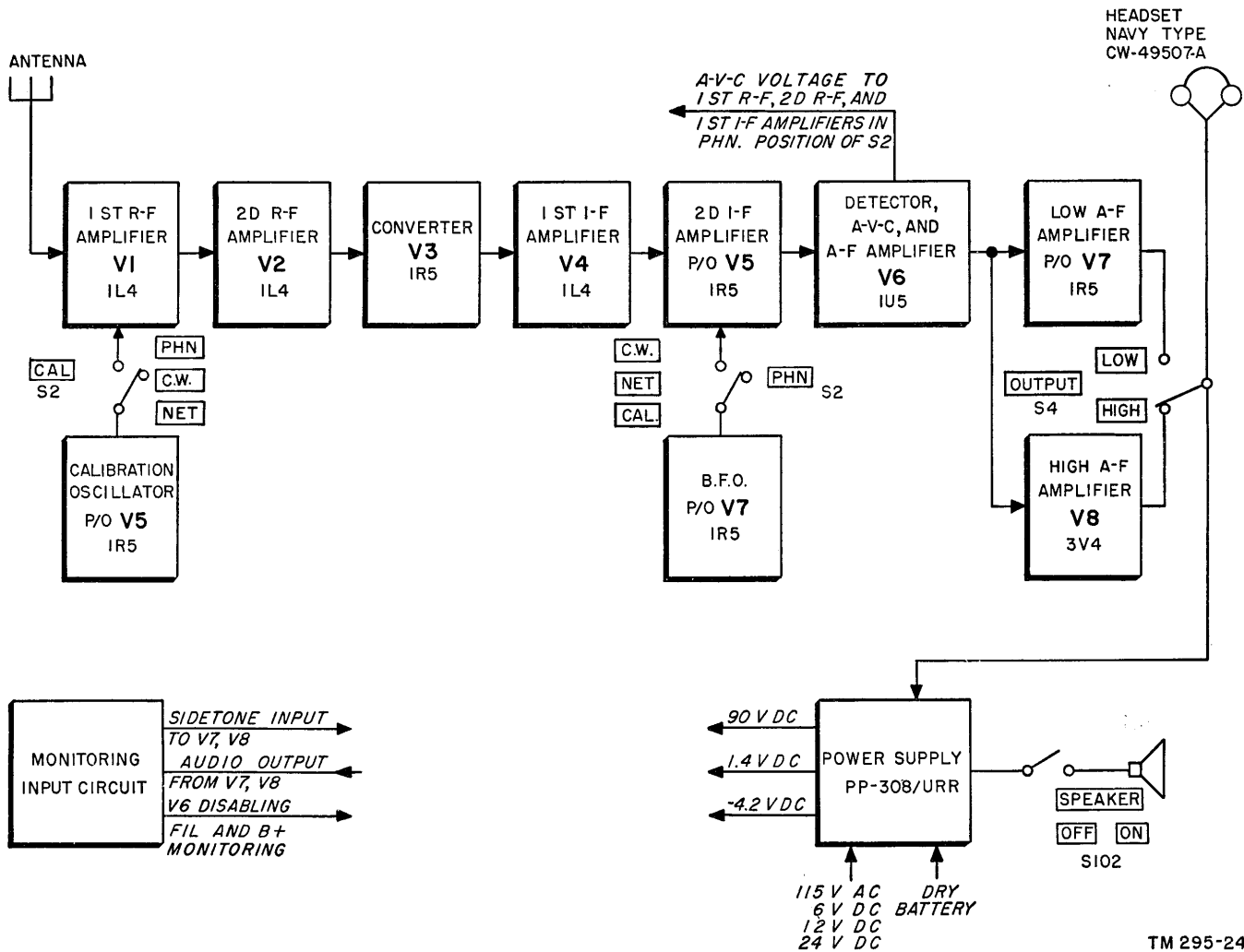

Figure 23. Radio Receiver R-174/URR, block diagram.

52. First R-f Amplifier V1

(figs. 24 and 43)

The first r-f amplifier covers the tuning range of the receiver in four bands. In the following analysis, the band 1 circuits (1.5 to 2.7 mc) are discussed in complete detail. The analyses of bands 2, 3, and 4 are concerned only with the circuit variations that are accomplished by band switching.

a. The signals picked up by the antenna are developed across the primary winding of transformer T1 (fig. 43). Contacts on PHN.-C.W.-NET-CAL. switch S2 (section 2, rear) and BAND SW. switch S1 (section 2, rear) couple the antenna to the transformer winding. Neon tube E2 protects the transformer primary winding from overload. The primary of T1 is shunted by a 75- $\mu\mu\text{f}$ (micromicrofarad) capacitor connected internally within the transformer assembly.

b. The secondary winding of transformer T1 is tuned by one section of the MANUAL-PRE-SET TUNING capacitor, C1A, and ANT. TRIMMER C2 (fig. 43). Section 3, rear, of the BAND SW. switch connects the capacitors across the winding. The tuned circuit is coupled to the grid (pin 6) of V1 through capacitor C3. Resistor R1 and avc circuit provide a d-c return for the grid circuit. Capacitor C11 is a part of the avc filter circuit. While band 1 is in use, another section of the BAND SW. switch (section 3, front) grounds the secondaries of all antenna coils not in use—in this case, winding C of T1 and B and D windings of T5 (fig. 24).

c. The first r-f amplifier utilizes a 1L4 pentode tube (fig. 43). Filament voltage for the tube is obtained from the 1.4-volt d-c potential at pin 11 of J4. Screen voltage is supplied from the arm of R.F. GAIN control R32 through voltage-dropping resistor R2 and section 3, rear, of function switch S2. The gain control is connected across the 90-volt potential present between pin 6 of J4 and ground. Capacitor C49 provides noise filtering, and capacitor C4 places the screen at r-f ground potential. Plate voltage is obtained from the 90-volt supply through resistor R3, the primary of T2 (winding C) and section 4, front, of BAND SW. switch S1. Resistor R3 and capacitor C5 form a plate-circuit decoupling network.

d. Tube V1 amplifies the antenna signals and develops the amplified signal across the untuned primary of T2 (winding C). The signal is coupled inductively to the tuned secondary winding in the grid circuit of second r-f amplifier V2. C10 couples the signal from the secondary winding of T2 to the control grid of V2.

e. When BAND SW. switch S1 is placed in the band 2 position, the following circuit changes are effected to allow coverage of the 2.7- to 5-mc band (fig. 24).

- (1) Section 2, rear, and section 3, rear, select the C windings of T1 in place of the B windings as the antenna coil.
- (2) Section 3, front, removes the ground from the C winding of T1, and places a ground on the B winding.
- (3) Section 4 selects the D section of T2, in place of the C section, as the plate load for V1.

f. When BAND SW. switch is placed in band 3 position (fig. 24), coverage of the 5- to 9.5-mc band is provided through circuit changes similar to those detailed for band 2. When switch S1 is set to band 3, sections 2, rear, and 4, front, select the B windings of T5 and the D windings of T6 as antenna coil and V1 plate load, respectively. Section 3, front, of the switch grounds the unused secondaries of the antenna transformers. A 25- $\mu\mu\text{f}$ capacitor is in shunt with the primary of the antenna coil.

g. When BAND SW. switch is in band 4 position (fig. 24), windings D of T5 and winding E of T6 are selected to provide coverage of the 9.5- to 18-mc band. A 2,400- $\mu\mu\text{f}$ capacitor (in series with the secondary of T5) is used as a padder to provide proper tracking.

h. Function switch S2, section 2, rear (fig. 43), connects the antenna to transformer T1 or T5 in the PHN. C.W., and NET positions. When the switch is turned to CAL., section 2, rear, grounds the antenna coil and opens the antenna circuit. The calibration signal may be supplied to the r-f amplifier in place of the antenna signal (par. 67).

53. Second R-f Amplifier V2

(figs. 24 and 43)

The second r-f amplifier covers the tuning range of the receiver in the same manner as the first r-f amplifier.

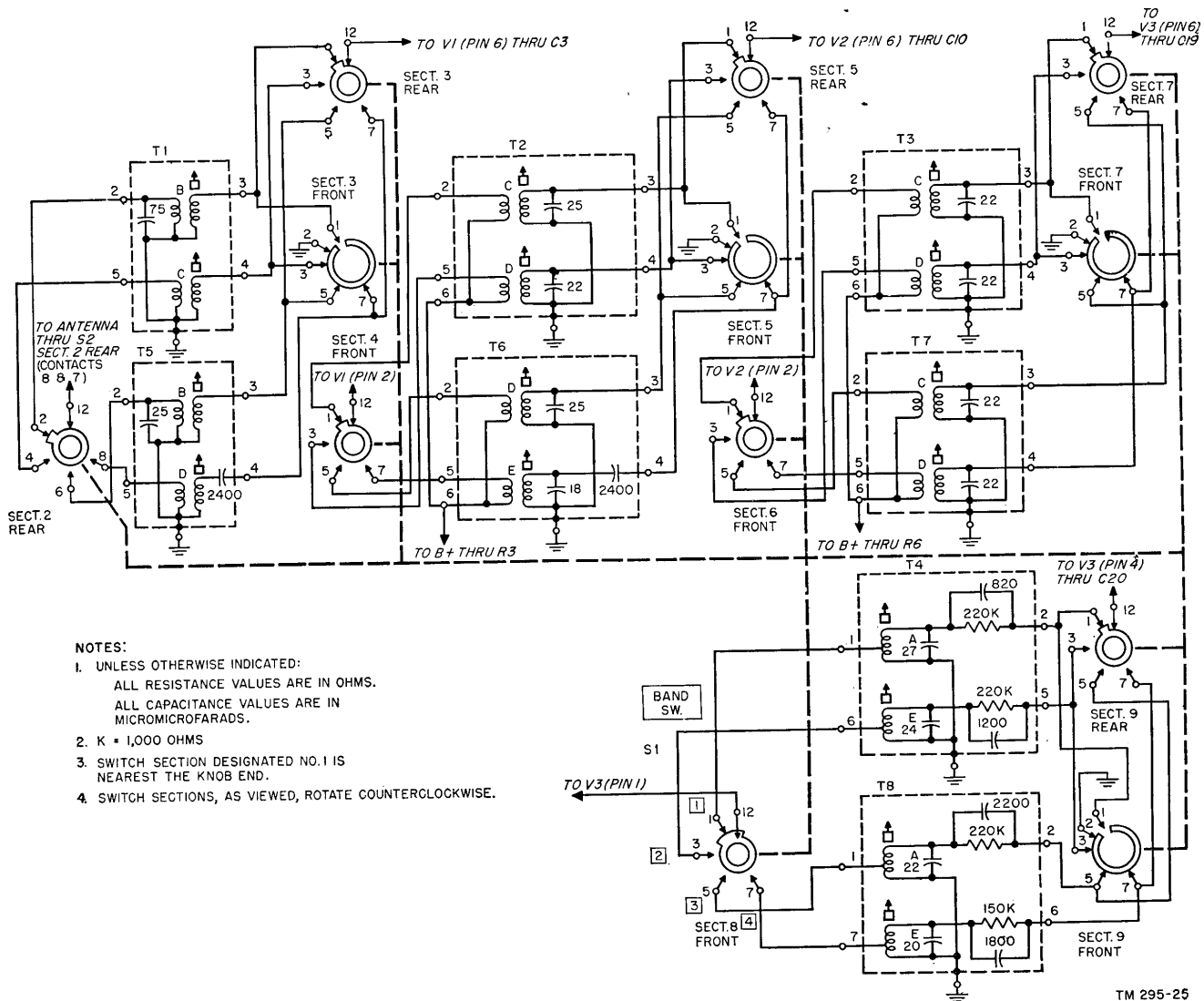

- NOTES:
1. UNLESS OTHERWISE INDICATED:
ALL RESISTANCE VALUES ARE IN OHMS.
ALL CAPACITANCE VALUES ARE IN MICROMICROFARADS.
 2. K = 1,000 OHMS
 3. SWITCH SECTION DESIGNATED NO. 1 IS NEAREST THE KNOB END.
 4. SWITCH SECTIONS, AS VIEWED, ROTATE COUNTERCLOCKWISE.

TM 295-25

Figure 24. Radio Receiver R-174/URR, simplified control circuit of BAND SW. switch.

a. The signals amplified by V1 are coupled inductively to the second r-f amplifier (fig. 43, par. 52d). On band 1, the signals developed across the secondary of winding C of T2 are supplied to the grid (pin 6) of tube V2 through section 5, rear, of S1 and capacitor C10. The switch also shunts tuning capacitor C1B across the transformer. The tuning circuit of this band consists of a 25- μ f fixed capacitor, connected internally in the transformer assembly, MANUAL-PRESET TUNING capacitor C1B, and trimmer C9. Resistor R4 and the avc circuit provide a d-c return for the grid circuit. While band 1 is in use, section 5, front, of the BAND SW. switch (fig. 24) grounds the secondaries of the first r-f plate coils not in use—in this case, winding D of T2 and windings D and E of T6.

b. The second r-f amplifier utilizes a 1L4 pentode tube (fig. 43). Filament voltage for the tube is obtained from the 1.4-volt d-c potential at pin 11 of J4. Capacitor C12 bypasses the filament for rf to ground. Screen voltage is supplied through voltage-dropping resistor R5 from the 90-volt potential present between pin 6 of J4 and ground. Capacitor C13 places the screen at r-f ground potential. Plate voltage is obtained from pin 6 of J4, through voltage-dropping resistor R6, the C winding of T3, and section 6 of BAND SW. switch S1. Resistor R6 and capacitor C14 form a plate-circuit decoupling network.

c. Tube V2 amplifies the r-f signals and develops these signals across the untuned primary of T3 (winding C). The signal is coupled in-

ductively to the tuned secondary winding in the grid circuit of converter tube V3.

d. When BAND SW. switch S1 is placed in the band 2 position (fig. 24), the following circuit changes are effected to allow coverage of the 2.7- to 5-mc band.

- (1) Section 5, rear, selects the D winding of T2 in place of the C winding as the grid r-f coil. In parallel with the D winding is a 22- μmf fixed tuning capacitor.
- (2) Section 5, front, removes the ground from the D winding and trimmer capacitor C8 (fig. 48), and places a ground on the C winding and capacitor C9
- (3) Section 6, front, selects the D winding of T3 in place of the C winding as the plate load for V2.

e. When BAND SW. switch is placed in band 3 position (fig. 24), coverage of the 5- to 9.5-mc band is provided through circuit changes similar to those detailed for band 2. Sections 5, rear, and 6, front, select the D winding of T6 and the C winding of T7 as the V2 grid coil and plate coil, respectively. A 25- μmf capacitor acts as the fixed tuned capacitor in parallel with the D winding of T6. Section 5, front, grounds the unused r-f coils.

f. When BAND SW. switch is set to band 4 position (fig. 24) windings E of T6 (paralleled by an 18- μmf fixed tuned capacitor) and D of T7 are selected to provide coverage of the 9.5- to 18-mc band. Section 5, front, grounds the unused coils. A 2,400- μmf capacitor (connected in series with secondary winding E of T6) is the padder to provide proper tracking.

54. Local Oscillator of V3

(figs. 24 and 25)

The local oscillator covers the range of the receiver tuning at a frequency 455 kc above the incoming signals on all four bands. In the following analysis, the circuit for band 1 is discussed in detail, and the analyses of bands 2, 3, and 4 discuss only the variations which are accomplished by band switching.

a. The local oscillator uses a tapped Hartley circuit with the plate circuit (second grid of

V3) at r-f ground (fig. 25). The grid circuit is tuned by the A winding of T4, a 27- μmf fixed tuning capacitor, trimmer capacitor C50, and MANUAL-PRESET TUNING capacitor C1D.

b. Section 8, front, of BAND SW. switch S1 connects the tap of the A winding to the filament cathode, and section 9, rear, connects the tuned output of the tank across C1D and thence to the grid circuit. The 220K-ohm grid d-c return resistor and the 820- μmf fixed padder capacitor are connected internally in the coil assembly. Resistor R8 and capacitor C20 form the grid-leak bias network for the oscillator. Section 9, front, of BAND SW. switch S1 grounds the unused winding E of T4 and windings A and E of T8 (fig. 24).

c. The local oscillator uses the filament and first two grids of a 1R5 pentagrid converter tube (fig. 25). Filament voltage for the tube is obtained from the 1.4-volt d-c potential at pin 11 of J4, through r-f choke L1. L1 maintains the filament above r-f ground potential. Oscillator plate (pin 3) voltage is supplied through voltage-dropping resistor R9 from the 90-volt d-c potential appearing between pin 6 of J4 and ground. Capacitor C21 places the oscillator plate at r-f ground potential.

d. When BAND SW. switch is placed in band 2, the following circuit changes are effected (fig. 24):

- (1) Section 8, front, removes winding A of T4 from the cathode circuit and connects in winding E of T4.
- (2) Section 9, rear, removes winding A of T4 from the grid circuit and connects in winding E of T4.
- (3) Section 9, front, grounds winding A of T4, and removes the ground from winding E.
- (4) A 1,200- μmf capacitor is the padder, and the 220K-ohm resistor provides the oscillator grid d-c return. This parallel network is connected to the grid-leak bias network, and trimmer capacitor C51 is substituted in the tuning circuit (fig. 48).

e. When BAND SW. switch S1 is placed in band 3 position (fig. 24), circuit changes are provided similar to those detailed for band 2.

Sections 8 and 9, rear, select winding A of T8. Section 9, front, grounds the unused windings. The padder network changes.

f. When BAND SW. switch S1 is placed in band 4 position (fig. 24), winding E of T8 is used, and all other windings are grounded.

g. The capacitors connected across the windings of all the r-f transformers except T1 and T5, and contained within the coil assemblies, are negative-temperature compensating capacitors. These capacitors are used to prevent drift of the oscillator. Thus, on all bands, the oscillator is temperature-stabilized to compensate for the normally expected expansion of other components and thus minimize oscillator frequency drift.

55. Converter V3

(figs. 24 and 25)

The analysis of the converter stage will be discussed in complete detail for band 1. The analyses of bands 2, 3, and 4 will discuss the circuit variations that are accomplished by band switching.

a. The incoming signals are coupled inductively to the secondary of winding C of T3 (fig. 25). This winding is tuned by section C1C of the MANUAL-PRESET TUNING capacitor. Section 7, rear, of BAND SW. switch S1 connects the capacitor across the winding. The tuned circuit is coupled to the grid (pin 6) of V3 through capacitor C19. Resistor R7 provides bias voltage and a d-c return for the grid circuit. When BAND SW. switch S1 is in band 1 position, section 7, front (fig. 24), grounds the secondaries of the r-f transformers not in use—in this case, D winding of T3, C and D windings of T7.

b. The converter utilizes a 1R5 pentagrid converter tube. Filament voltage for the tube is obtained from pin 11 of J4 through r-f choke L1. Screen voltage is supplied through voltage-dropping resistor R9 from the 90-volt d-c potential present between pin 6 of J4 and ground. Capacitor C21 provides an r-f ground for the screen. Plate voltage is obtained from the 90-volt d-c potential through the primary of T9 which is fixed tuned by a 270- $\mu\mu\text{f}$ capacitor.

c. Tube V3 mixes the r-f signal input and the signal of the local oscillator (par. 54), and de-

velops a signal at the difference frequency of 455 kc. The signal is developed in the primary of T9 and coupled inductively to the secondary of T9.

d. When BAND SW. switch S1 is in band 2 position, the following circuit changes are effected (fig. 24):

- (1) Section 7, rear, selects the D winding of T3 in place of the C winding.
- (2) Section 7, front, grounds the C winding of T3 and removes the ground from the D winding.

e. In band 3 position of BAND SW. switch S1 (fig. 24), section 7, rear, selects the C winding of T7, and section 7, front, grounds the D winding of T3.

f. In band 4 position of BAND SW. switch S1 (fig. 24), section 7, rear, selects C winding of T7, and section 7, front, grounds D winding of T7.

56. First I-f Amplifier V4

(fig. 26)

The i-f amplifier stage is tuned to 455 kc and operates at this frequency for all bands of operation of the receiver.

a. The signal developed in the converter stage is coupled inductively to the grid (pin 6) of V4, through the windings of transformer T9. The avc circuit (through R15 and R18) provides a d-c return for the grid, when PHN.-C.W.-NET-CAL. switch S2 is in PHN. position. Capacitor C22 is the avc filter capacitor. When function switch S2 is in any position other than PHN., the grid is returned to ground through section 1, rear, of S2.

b. The first i-f amplifier uses a 1L4 pentode tube. Filament voltage for the tube is obtained from the 1.4-volt d-c potential at pin 11 of J4. Screen voltage is supplied through voltage-dropping resistor R10 and section 3, rear, of function switch S2 from the arm of R.F. GAIN control R32. The gain control is connected across the 90-volt potential present between pin 6 of J4 and ground. Capacitor C49 is a noise filter, and capacitor C23 places the screen at r-f ground potential. Plate voltage is supplied from the 90-volt potential through the primary of T10.

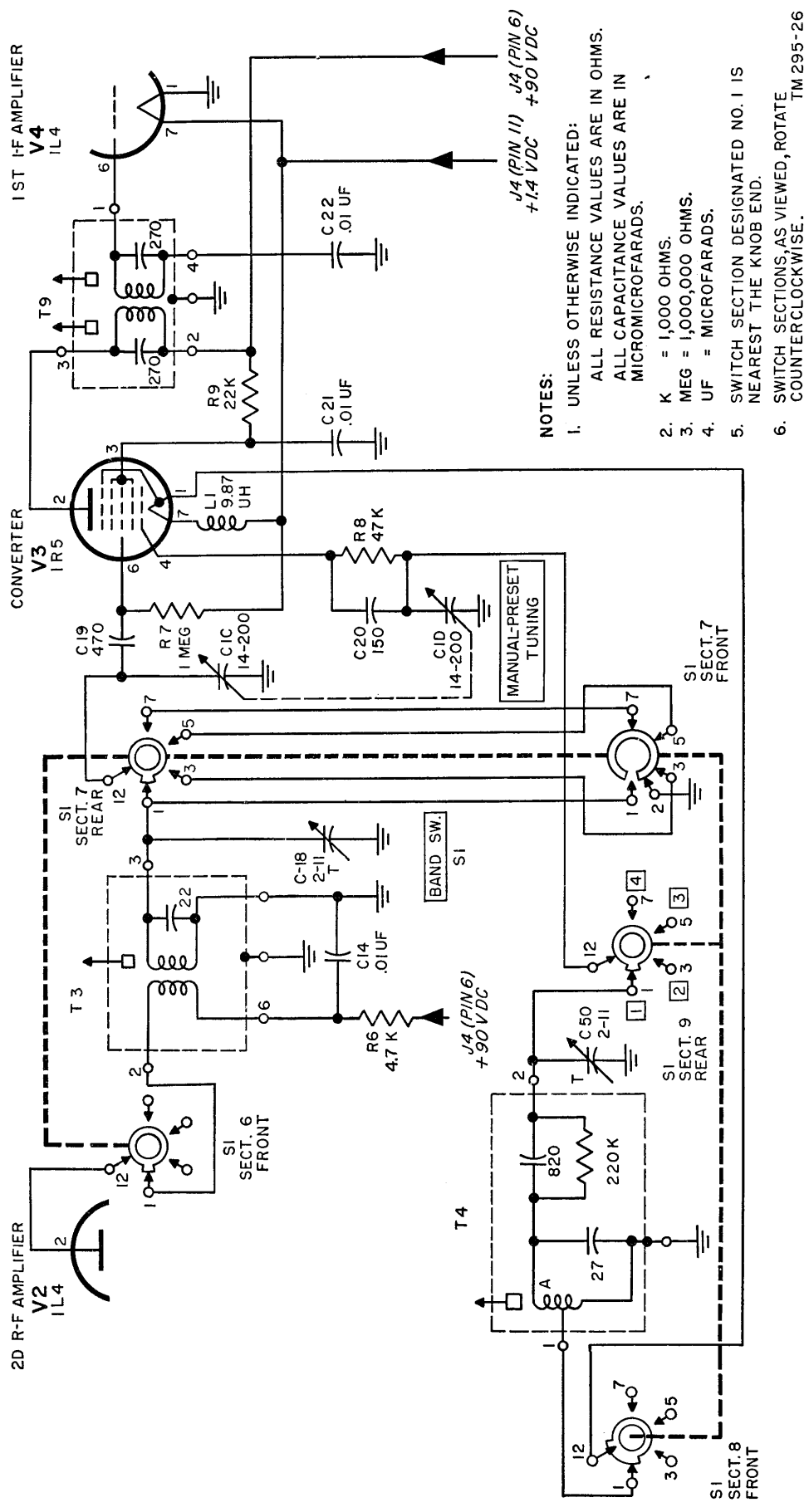

J4 (PIN 11) J4 (PIN 6)
+1.4 VDC +90 VDC

NOTES:

1. UNLESS OTHERWISE INDICATED:
ALL RESISTANCE VALUES ARE IN OHMS.
ALL CAPACITANCE VALUES ARE IN
MICROMICROFARADS.
2. K = 1,000 OHMS.
3. MEG = 1,000,000 OHMS.
4. UF = MICROFARADS.
5. SWITCH SECTION DESIGNATED NO. 1 IS
NEAREST THE KNOB END.
6. SWITCH SECTIONS, AS VIEWED, ROTATE
COUNTERCLOCKWISE. TM 295-26

Figure 25. Radio Receiver R-174/URR, local oscillator and converter for band 1, functional schematic.

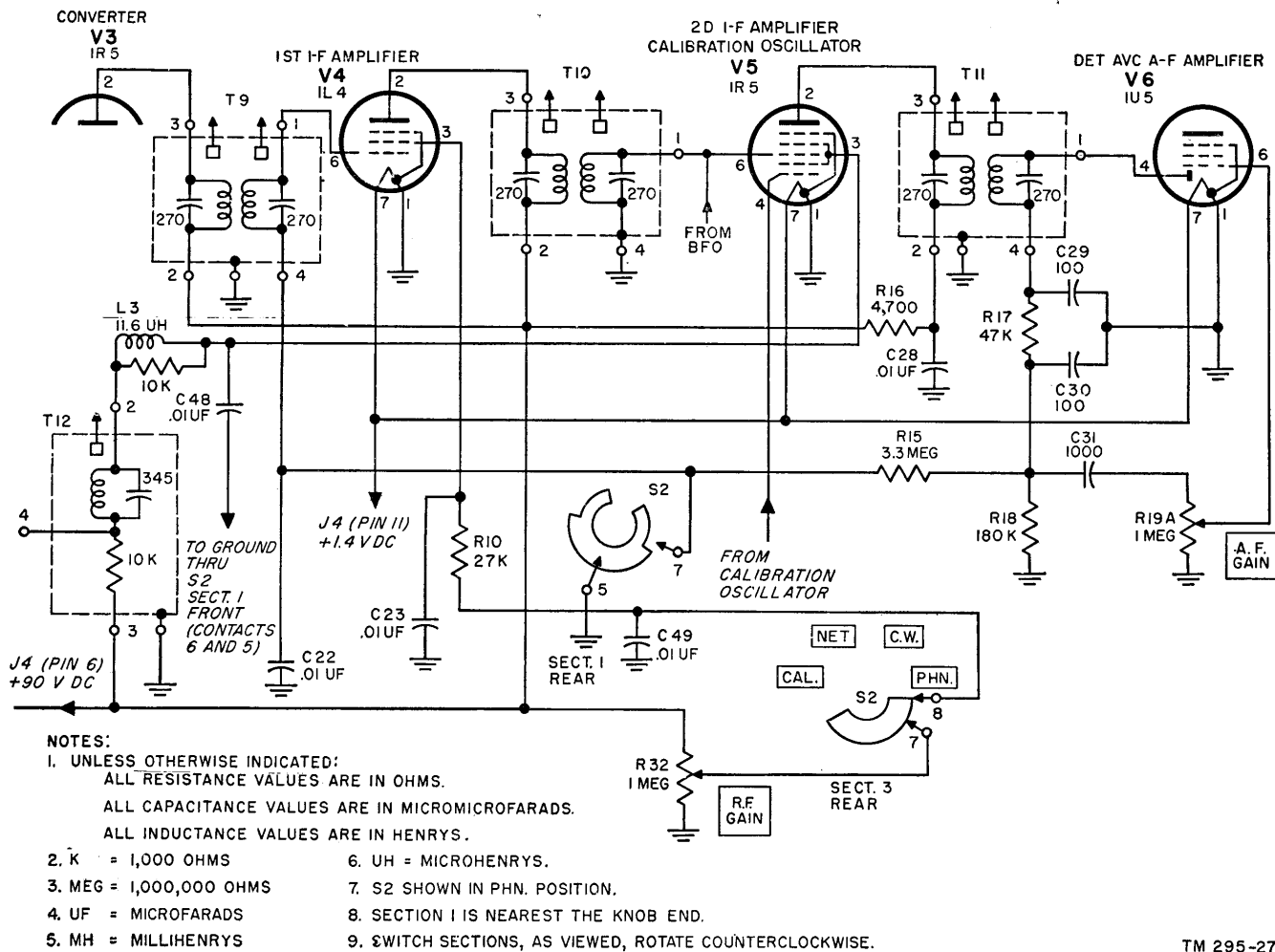

TM 295-27

Figure 26. Radio Receiver R-174/URR, first and second i-f amplifiers, functional schematic.

c. Tube V4 amplifies the i-f signal and develops the signal across the tuned primary of i-f transformer T10. The signal is coupled inductively to the tuned secondary winding in the grid circuit of the second i-f amplifier V5.

57. Second I-f Amplifier V5

(fig. 26)

The operation of the second i-f amplifier is similar to the operation of the first i-f amplifier.

a. The signals amplified by i-f amplifier tube V4 are coupled inductively to the secondary of T10, and fed to the grid (pin 6) of the second i-f amplifier tube V5. The grid circuit is returned directly to ground. During C.W., NET, and CAL. operation, the output of the bfo also is supplied to the grid of V5 (par. 62).

b. The second i-f amplifier tube is a pentagrid converter 1R5 tube. In this circuit, only the filament (cathode), the last three grids, and the plate are used as the i-f amplifier. (The remaining grids are used in the calibration oscillator circuit (par. 63).) Filament voltage for the tube is obtained from the 1.4-volt d-c potential at pin 11 of J4. Screen voltage is supplied through the 10K-ohm voltage-dropping resistor, the coil in T12 assembly, and parasitic suppressor L3. Capacitor C48 places the screen at r-f ground potential. Plate voltage is supplied from the 90-volt d-c potential between pin 6 of J4 and ground, through voltage-dropping resistor R16 and the primary winding of T11. Capacitor C28 and resistor R16 form a plate-circuit decoupling network.

c. The tube amplifies the i-f signals and develops the amplified signal across the primary of T11. The signal is coupled inductively to the secondary of T11 in the detector circuit.

58. Detector and Avc Stage V6 (fig. 27)

The detector circuit converts the i-f signals to intelligence for all modes of operation. The avc circuit develops the avc bias for the first r-f, second r-f, and first i-f tubes in the receiver.

a. The i-f signal is coupled inductively to the secondary winding of T11 and fed to the diode plate (pin 4) of tube V6, a type 1U5 diode-pentode tube. Tube V6 rectifies the i-f signal, and the audio component of the signal is developed across the diode load resistors, R17 and R18. Capacitors C29 and C30, are i-f filters. The audio signal is coupled capacitively to A.F. GAIN control R19A through capacitor C31.

b. At the junction of R17, R18, and C30, avc voltage is picked off by resistor R15. Avc filter

capacitor C22 and resistor R15 determine the time-constant of the avc network. The avc voltage is grounded when section 1, rear, of PHN.-C.W.-NET-CAL. switch S2 is in any position other than PHN. For other settings of the switch, the avc voltage is supplied to the r-f stages and the 1st i-f stage.

59. A-f Amplifier V6 (fig. 27)

The a-f amplifier section of V6 amplifies the audio component of the detector output. The circuit is operative for all modes of operation.

a. The audio signal is coupled to the control grid circuit of V6 from the arm of A.F. GAIN control R19A.

b. Filament voltage is supplied from pin 11 of J4. Screen voltage is supplied from pin 6 of J4 (90 volts) through voltage-dropping resistor R20 and contacts C and D of relay K1. (Relay K1 normally is de-energized, and contacts C and D are closed. In system applica-

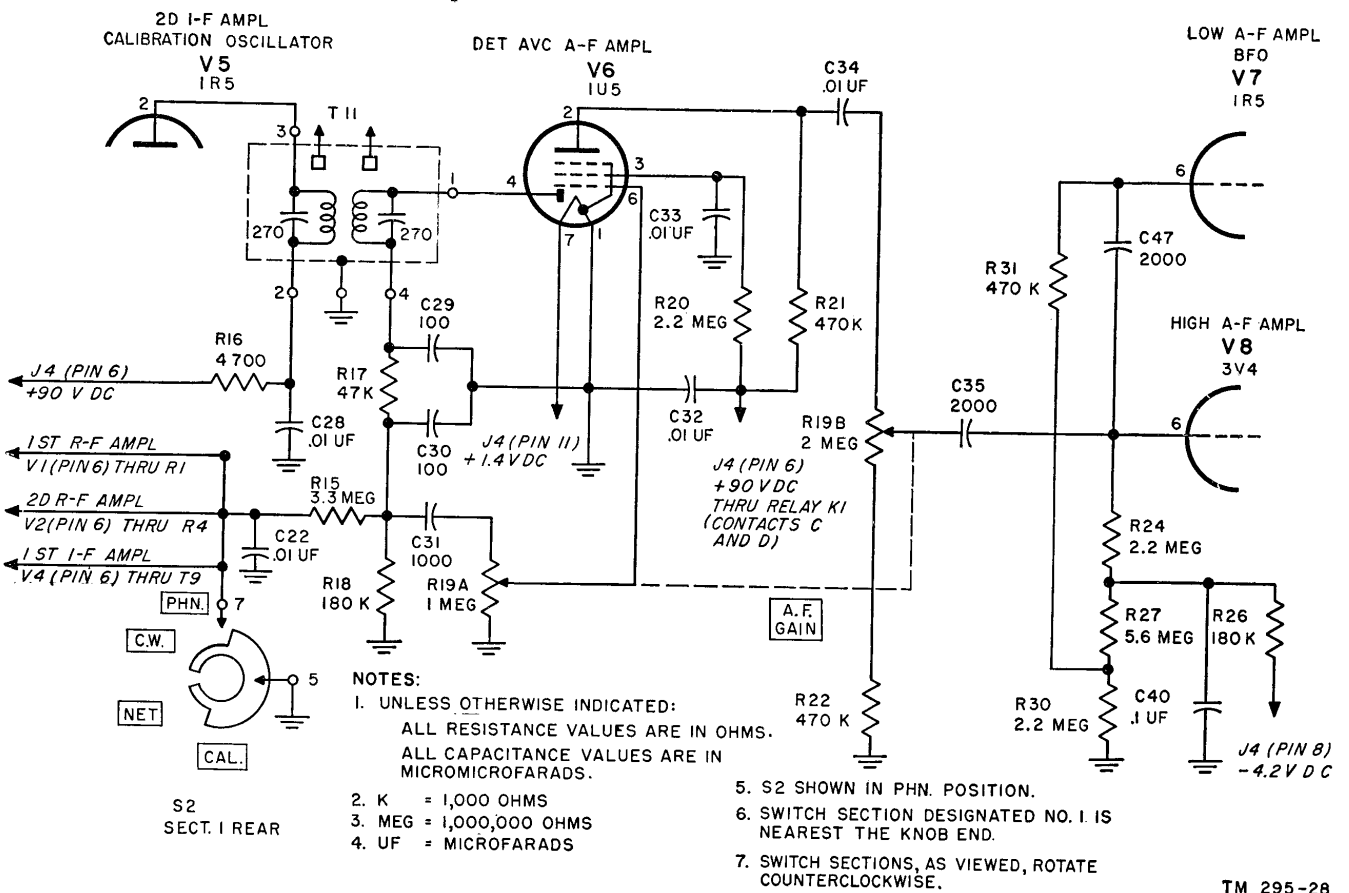

Figure 27. Radio Receiver R-174/URR, detector, avc and a-f amplifier, functional schematic.

tions, relay K1 can be energized through connection to an associated transmitter, to disable the receiver during transmissions.) Capacitor C33 places the screen at a-f ground potential, and C32 decouples the plate and screen circuits from the B+ supply. Plate voltage is supplied from pin 6 of J4 through plate load resistor R21 and the relay circuit.

c. The amplified audio signal is developed across R21 and is coupled capacitively by C34 to A.F. GAIN control R19B and resistor R22. R22 determines the minimum signal voltage fed to the low and high a-f amplifiers. A portion of this signal voltage (depending on A.F. GAIN control setting) is coupled to the high a-f amplifier through C35, and is coupled to the low a-f amplifier through C35 and C47.

60. Low A-f Amplifier V7

(fig. 28)

A-f amplifier V7 is used only when OUTPUT HIGH-LOW switch S4 is in the LOW position. The tube amplifies the audio signal taken from V6 and couples it to the loudspeaker and the headset. The loudspeaker, which is located in the power supply, may be disconnected when SPEAKER ON-OFF switch S102 is in the OFF position.

a. The input signal to tube V7 is coupled from the output of V6 through capacitors C35 and C47. R30 and R31 act as the d-c return resistors for the control grid. R30 also functions as part of a voltage divider (R26, R27, and R30) for the negative voltage present between pin 8 of J4 and ground. The voltage at the junction of resistors R30 and R27 is supplied to the grid of V7 as bias voltage. Section 1, rear, of PHN.-C.W.-NET-CAL. switch S2 short-circuits R30 to ground on all positions of the switch except PHN. This action removes the fixed bias from the stage and improves its stability.

b. The low a-f amplifier stage uses a portion of a 1R5 pentagrid tube, with the filament, last four grids, and the plate as a pentode amplifier. Filament voltage is supplied from the 1.4-volt d-c potential at pin 11 of J4 through r-f choke L2. Capacitor C45 bypasses af to ground at the filament. Screen voltage is supplied from pin 6 of J4 through voltage-dropping resistor R28

and a portion of the winding of bfo tank transformer T13. Capacitor C41 decouples the screen circuit from the power supply. Plate voltage is supplied through the full primary winding of T14 and OUTPUT HIGH-LOW switch S4. Capacitor C42 is an h-f bypass.

c. The signals are amplified by the tube and the output is coupled inductively from the primary of T14 to the secondary of T14. The full secondary winding of T14 is connected to PHONES connectors J2 and J3, and a portion of the secondary is tapped for the loudspeaker. The signal for the speaker is supplied from pin 9 of J4 to pin 9 of J101 in the power supply, thence through SPEAKER ON-OFF switch S102 to the speaker.

d. Section 3, rear, of PHN.-C.W.-NET-CAL. switch S2 connects voltage-dropping resistor R29 in parallel with R28 and increases the screen (bfo plate) voltage of the tube in all positions of function switch S2, except PHN.

61. High A-f Amplifier V8

(fig. 29)

A-f amplifier tube V8 is used only when OUTPUT HIGH-LOW switch S4 is in the HIGH position. The tube amplifies the audio signal taken from V6 and couples it to the loudspeaker and/or phones. The speaker may be disconnected in this mode of operation by turning the SPEAKER ON-OFF switch to OFF.

a. The input signal to tube V8 is coupled from the output of V6 through capacitor C35. Bias voltage is supplied from the voltage divider (R26, R27, and R30) which is connected between pin 8 of J4 and ground. The negative voltage at the junction of R26 and R27 is supplied as bias to the grid (pin 6) of V8 through R24. R24, R27, and R30 form the grid d-c return circuit for the PHN. setting of PHN.-C.W.-NET-CAL. switch S2. For all other settings of the switch, resistor R30 is short-circuited to ground, thus increasing the bias voltage on V8.

b. The high a-f amplifier stage uses a 3V4 pentode tube. The filaments of the tube are connected in parallel through S3 and contacts 4 and 5 of S4 for 1.4-volt operation. Filament voltage is supplied from pin 11 of J4. Capacitor C39 is an a-f filter for the filament circuit.

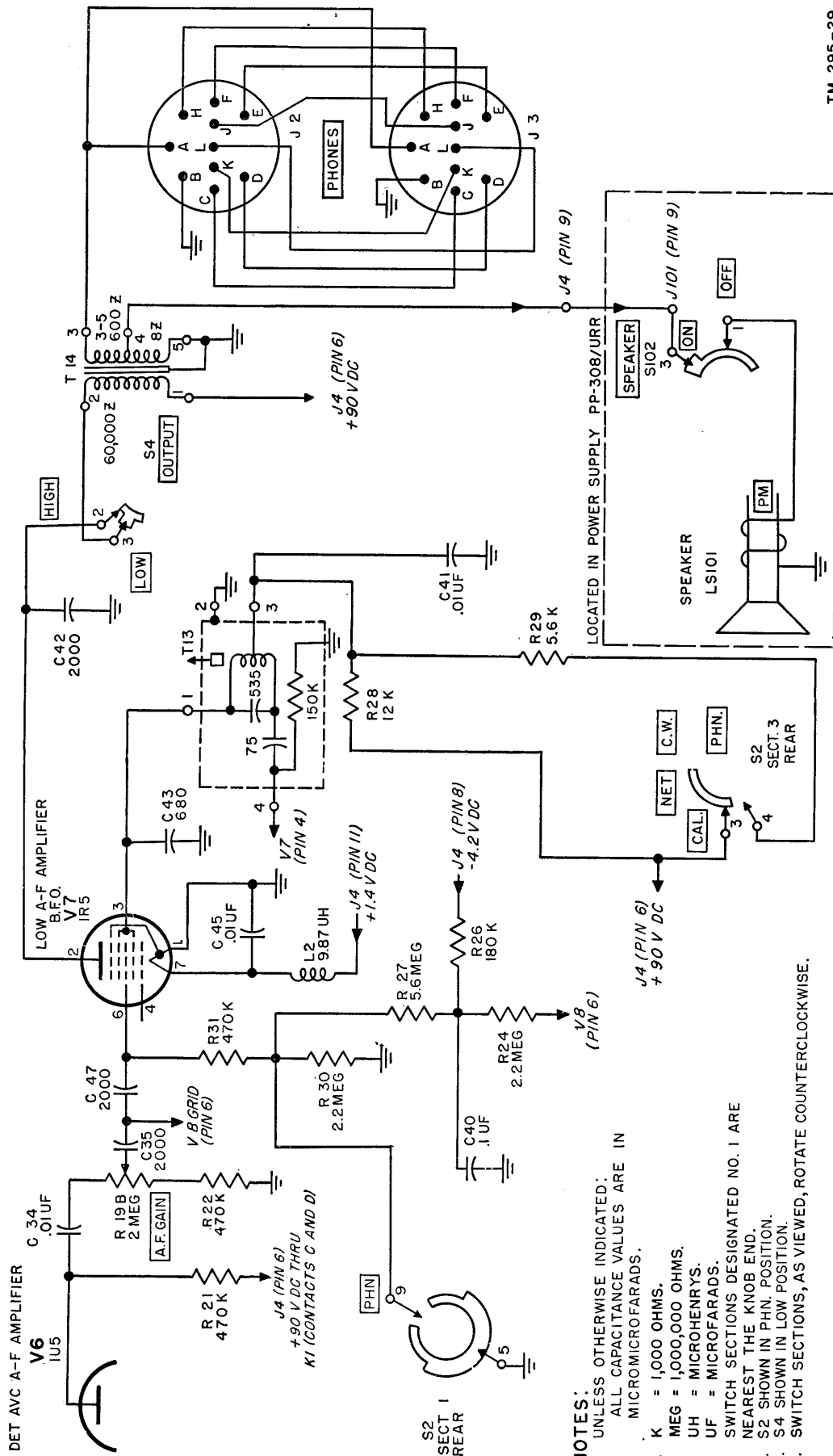

TM 295-29

- NOTES:**
1. UNLESS OTHERWISE INDICATED: ALL CAPACITANCE VALUES ARE IN MICROMICROFARADS.
 2. K = 1,000 OHMS.
 3. MEG = 1,000,000 OHMS.
 4. UH = MICROHENRYS.
 5. UF = MICROFARADS.
 6. SWITCH SECTIONS DESIGNATED NO. 1 ARE NEAREST THE KNOB END.
 7. S2 SHOWN IN PHN. POSITION.
 8. S4 SHOWN IN LOW POSITION.
 9. SWITCH SECTIONS, AS VIEWED, ROTATE COUNTERCLOCKWISE.

Figure 28. Radio Receiver R-174/URR, low a-f amplifier, functional schematic.

Screen voltage is supplied from the 90-volt d-c potential at pin 6 of J4, through voltage-dropping resistor R25 and OUTPUT HIGH-LOW switch S4 (in HIGH position). Capacitor C38 places the screen at a-f ground potential. Plate voltage is supplied from pin 6 of J4 through a portion of the winding of T14 and OUTPUT HIGH-LOW switch S4. Capacitor C36 is an h-f a-f filter.

c. The signals are amplified by the tube, and the output is inductively coupled from a portion of the primary of T14 to the secondary of T14, thence to the PHONES connectors and the loudspeaker.

d. In the HIGH operation of OUTPUT HIGH-LOW switch S4, B+ voltage (90 volts dc) is connected directly to the plate of low a-f amplifier V7, with a-f bypass capacitor C37 connected from plate to ground. This effectively cancels any output signal from V7.

e. DIAL LIGHT switch S3 can be used to illuminate dial light E1 when required, but reduces the output of tube V8 by removing the filament voltage from half of the filament.

62. Beat-frequency Oscillator, Part of V7 (fig. 30)

The bfo is operative in all positions of PHN.-C.W.-NET-CAL. switch S2, except PHN. The filament and first two grids of V7 are used in the bfo circuit.

a. The oscillator is a self-sustaining, series-fed Hartley oscillator operating at a fundamental frequency of $151.66 \text{ kc} \pm 1$ to 1.167 kc . The third harmonic ($455 \text{ kc} \pm 3.5 \text{ kc}$) is coupled to the grid (pin 6) of second i-f amplifier tube V5. The circuit is tuned by T13, the capacitor ($535 \mu\mu\text{f}$) connected in the assembly and capacitor C43. Capacitor C44 (B.F.O. trimmer) is used to vary the frequency of the bfo and produce the beat note for the audio section of the receiver.

b. The $75\text{-}\mu\mu\text{f}$ capacitor and the 150K-ohm resistor in the coil assembly form the grid-leak bias network for the tube.

c. The bfo utilizes the filament and first two grids of a 1R5 pentagrid tube. Filament voltage is obtained from the 1.4-volt d-c potential at pin 11 of J4 through r-f filter choke L2. Capacitor C45 bypasses to ground the audio frequency at the filament. Oscillator plate voltage is supplied from the 90-volt d-c potential

at pin 6 of J4 through a portion of T13 and voltage-dropping resistors R28 and R29 connected in parallel, when switch S2 is in C.W., NET, or CAL. position. Capacitor C41 keeps the center tap of the bfo tank coil at r-f ground potential.

d. The third harmonic of the bfo signal is coupled from the grid (pin 4) of V7 and fed through resistor R11 and capacitor C24 to the grid of second i-f amplifier tube V5. The bfo signal mixes with the i-f signal to produce an audible difference frequency, which is detected and amplified in the usual manner.

e. Section 1, rear, of PHN.-C.W.-NET-CAL. switch S2 disables the bfo when the switch is in PHN. position, by connecting the bfo plate circuit to r-f ground through capacitor C46.

63. Calibration Oscillator, Part of V5 (fig. 31)

a. A portion of V5 is connected as a crystal oscillator when PHN.-C.W.-NET-CAL. switch S2 is in the CAL. position, and the output of the oscillator is used to calibrate the receiver dial. The harmonics of the 200-kc fundamental frequency are converted to the intermediate i-f frequency, which is used to beat against the bfo and provide an audio beat for calibration purposes. The filament and first two grids of V5 (pentagrid 1R5) are used in the oscillator circuit.

b. The oscillator is a self-sustaining modified Pierce oscillator, the fundamental frequency of which is crystal controlled. The output at the calibration oscillator plate (pin 3) of V5 is coupled to section 2, front, of BAND SW. switch S1 by means of a long wire used as a radiating element when the oscillator is functioning, and used as a disabling element, connected to ground, in the PHN., C.W., and NET positions of PHN.-C.W.-NET-CAL. switch S2. The tuned circuit for the oscillator consists of Crystal Unit CR-2/U and the paralleled coil and $345\text{-}\mu\mu\text{f}$ capacitor connected within coil assembly T12.

c. Grid-leak bias is developed when the crystal is excited. Resistor R14 and capacitor C25 form the grid-leak bias network. Filament voltage is obtained from the 1.4-volt d-c potential at pin 11 of J4. Plate voltage is supplied from the 90-volt d-c potential at pin 6 of J4 through the 10K-ohm resistor in T12 coil assembly, the

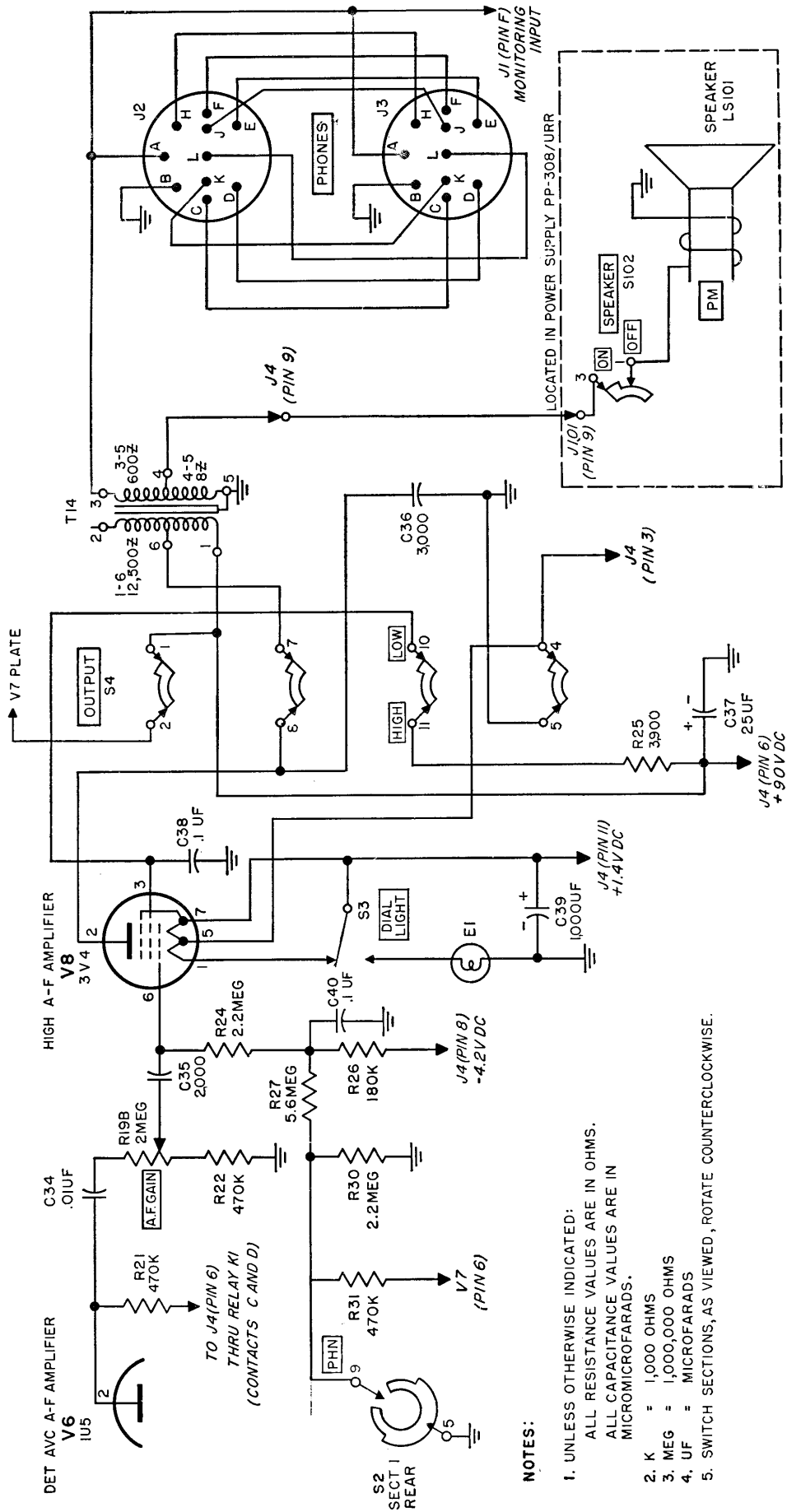

TM 295-30

Figure 29. Radio Receiver R-174/URR, high alpha-f amplifier, functional schematic.

- NOTES:**
1. UNLESS OTHERWISE INDICATED: ALL RESISTANCE VALUES ARE IN OHMS. ALL CAPACITANCE VALUES ARE IN MICROMICROFARADS.
 2. K = 1,000 OHMS
 3. MEG = 1,000,000 OHMS
 4. UF = MICROFARADS
 5. SWITCH SECTIONS, AS VIEWED, ROTATE COUNTERCLOCKWISE.

NOTES:

1. UNLESS OTHERWISE INDICATED:
ALL CAPACITANCE VALUES ARE IN MICROMICROFARADS.
2. K = 1,000 OHMS
3. UH = MICROHENRYS
4. UF = MICROFARADS
5. SWITCH SECTION DESIGNATED NO.1 IS NEAREST THE KNOB END.
6. S2 SHOWN IN C.W. POSITION.
7. SWITCH SECTIONS, AS VIEWED, ROTATE COUNTERCLOCKWISE.

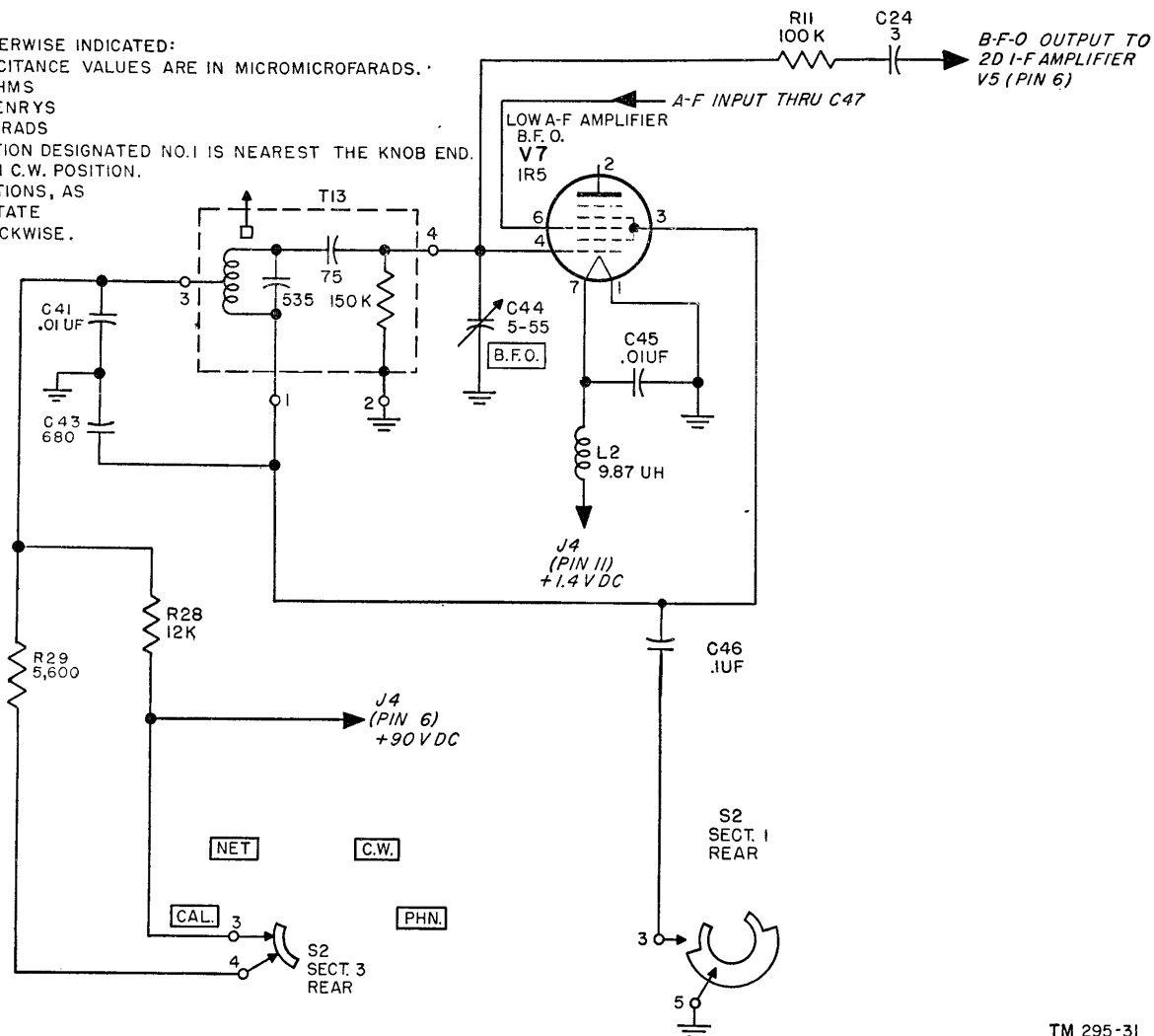

TM 295-31

Figure 30. Radio Receiver R-174/URR, bfo, functional schematic.

coil, and parasitic suppressor L3. The 10K-ohm resistor and R13 form a voltage divider. C26 places the oscillator plate return at r-f ground potential.

d. The harmonic frequencies of the oscillator are radiated and picked up by the first r-f amplifier. The signals are amplified through the receiver and beat with the bfo to produce a difference frequency to be detected. This develops a beat note every 200 kc, for calibration of the receiver on bands 1, 2, and 3. When BAND SW. switch S1 is in the band 4 position, the harmonic frequencies are injected into the grid circuit of r-f amplifier tube V1 through section 2, front, of switch S1, capacitor C54, and section 3, rear, of BAND SW. switch S1. Capacitor C3 couples the signals from the tuned grid circuit to the grid (pin 1) of V1.

e. In all positions of PHN.-C.W.-NET-CAL.

switch S2, except CAL., the oscillator plate and radiating element is grounded for rf through C48 and section 1, front, of S2.

64. PHN. Operation
(fig. 32)

In the PHN. position of PHN.-C.W.-NET-CAL. switch S2, the receiver is operative for voice signals. The bfo and the crystal calibration oscillator circuits are inoperative. Capacitor C46 is a low-impedance path to ground for the bfo signal, and capacitor C48 is a low-impedance path to ground for the crystal calibration oscillator signal. In this mode of operation, C46 places the screen grid (bfo plate) at a-f ground potential, and C48 is used as an r-f bypass for the screen grid (calibration oscillator plate) of V5. The control grid of V5 also is grounded.

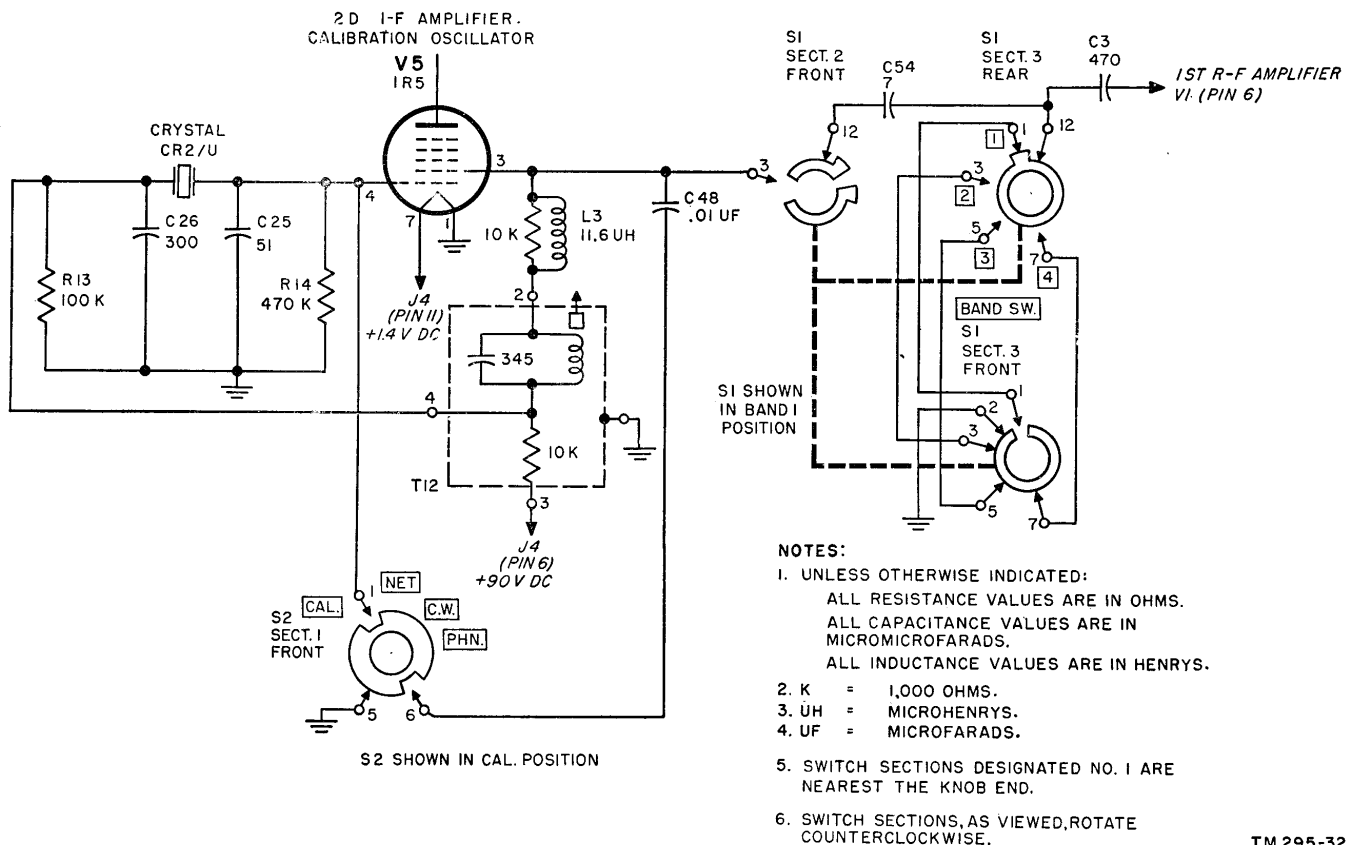

Figure 31. Radio Receiver R-174/URR, calibration oscillator, functional schematic.

65. C.W. Operation

(fig. 32)

When the PHN.-C.W.-NET-CAL. switch is in the C.W. position, the bfo is operative, and the avc voltage is grounded, increasing the gain of the receiver. Section 1, rear, of the switch removes the bfo ground connection and places a ground on the avc bus.

66. NET Operation

(figs. 32 and 34)

In the NET position of the PHN.-C.W.-NET-CAL. switch, the receiver operates in a manner similar to that of C.W., except that the circuit to relay K1 is opened. Section 2, rear, of the switch performs this function. Disabling the relay permits the tuning of the *exciter* of the local transmitter to the Net Control Station frequency. This is accomplished by tuning the receiver to the Net Control Station frequency and tuning the local transmitter *exciter* to the tuned receiver frequency (par. 23). Opening the relay circuit prevents the disabling of the receiver when the local transmitter is turned on

during the exciter tuning. After the *exciter* is tuned, the PHN.-C.W.-NET-CAL. switch should be set to PHN. or C.W., before the tuning of the transmitter is completed.

67. CAL. Operation

(figs. 32 and 33)

a. In the CAL. position of PHN.-C.W.-NET-CAL. switch, the receiver is capable of receiving signals only from the crystal calibration oscillator. The conditions are the same as C.W., except that the crystal calibration oscillator is operative (fig. 32), the antenna circuit is open (fig. 33), and the primary of antenna transformer T1 or T5 is shorted (fig. 33). The R.F. GAIN control is inoperative.

b. In this mode of operation, screen voltage for r-f tube V1 and i-f tube V4 is obtained from the 90-volt d-c potential at pin 6 of J4 through section 3, rear, of PHN.-C.W.-NET-CAL. switch S2 and section 1 of BAND SW. switch S1, and the voltage-dropping resistor network consisting of R35, R34, and R33 (fig. 33). These resistors are eliminated successively from the screen circuits of V1 and V4 as BAND SW.

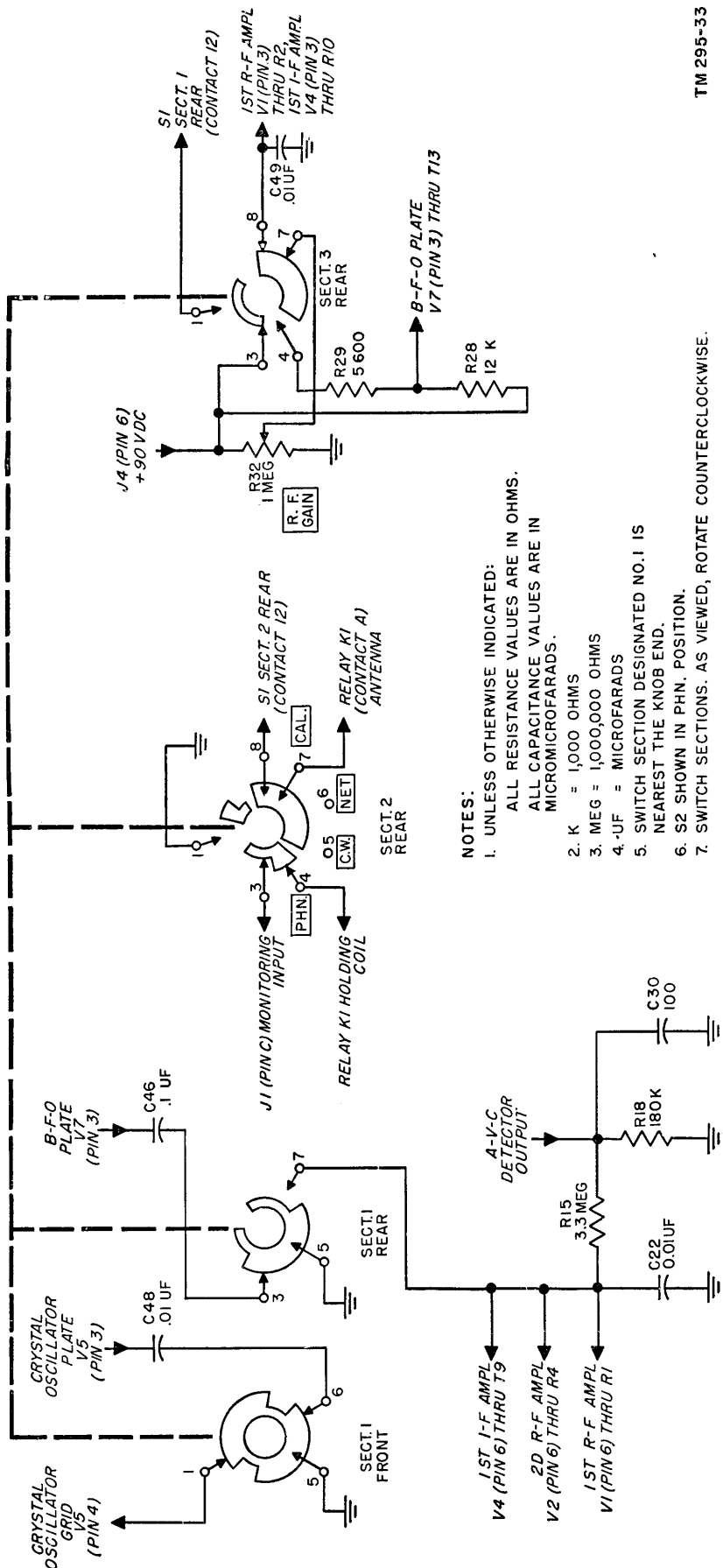

- NOTES:
1. UNLESS OTHERWISE INDICATED: ALL RESISTANCE VALUES ARE IN OHMS. ALL CAPACITANCE VALUES ARE IN MICROMICROFARADS.
 2. K = 1,000 OHMS
 3. MEG = 1,000,000 OHMS
 4. UF = MICROFARADS
 5. SWITCH SECTION DESIGNATED NO. 1 IS NEAREST THE KNOB END.
 6. S2 SHOWN IN PHN. POSITION.
 7. SWITCH SECTIONS. AS VIEWED, ROTATE COUNTERCLOCKWISE.

Figure 32. Radio Receiver R-174/URR, circuit of PHN.-C.W.-NET.-CAL. switch.

switch S1 is turned from position 1 to position 4. This changes the sensitivity of the tubes, increasing it for each higher frequency band.

c. Because of rich harmonic frequencies of the bfo and the calibration oscillator, there is a mixing of the third harmonic of the calibration oscillator and the fourth harmonic of the bfo, causing an audio tone of 6.66 kc in the background which is undesirable but unavoidable.

68. Monitoring Operation

(fig. 34)

a. For purposes of monitoring sidetone in system applications, connection is made from an external transmitter to MONITORING INPUT receptacle J1. In this mode of operation, a 12-volt d-c or a 24-volt d-c input may be used to energize relay K1. This opens the plate and

screen voltage for a-f amplifier tube V6, disabling the tube, and shorts the antenna to ground. The low and high a-f amplifiers are still operative.

- (1) For 12- and 24-volt vehicular operation, the disabling voltage is obtained directly from the power supply. In 24-volt operation, R23 drops the 24-volt supply to 12 volts to activate relay K1. The coil of disabling relay K1 is completed to ground at the transmitter through pin C of J1, and normally will be connected in such a manner as to cause operation of the relay when the push-to-talk circuit of the transmitter is closed.
- (2) For 6-volt vehicular, dry-battery, or 115-volt a-c operation, external dis-

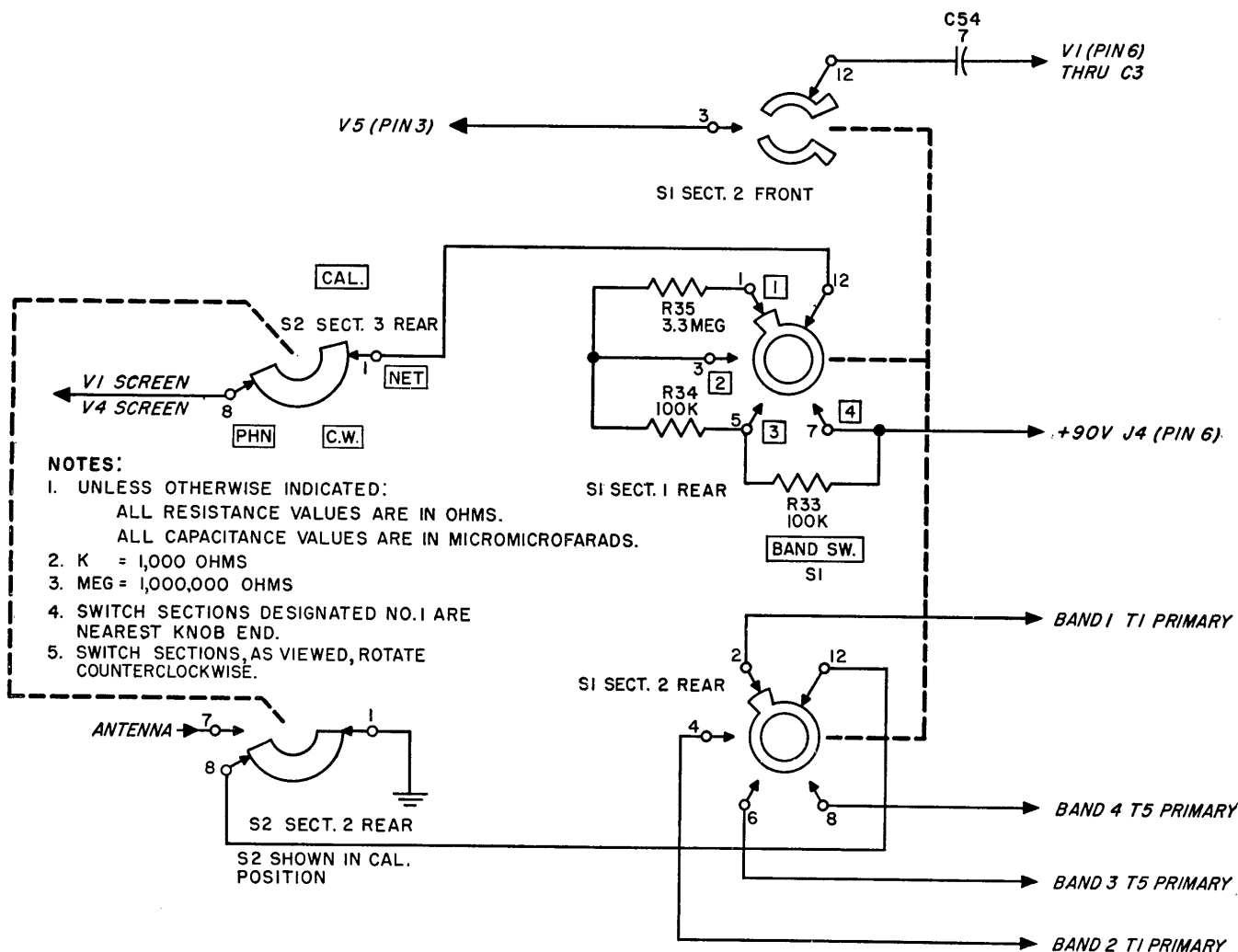

Figure 33. Radio Receiver R-174/URR, calibration, section 1 of BAND SW switch S1, functional schematic.

abling voltage of 12 or 24 volts dc must be supplied by the transmitter. When a 12-volt d-c source for disabling is used, the +12 volts is applied to pin A of J1, and the ground return circuit is connected to pin C of J1. When a 24-volt d-c source is used, the +24 volts is applied to pin B of J1, and the ground return is connected to pin C of J1.

b. The sidetone output of the transmitter should have an impedance of 600 ohms, and one side free to be grounded. Sidetone input is connected to pin D of J1 and pin E of J1 (ground).

(1) Sidetone input voltage is impressed across R36 and is fed into V7 through fixed attenuator R12 and coupling capacitors C27 and C47.

(2) Sidetone input voltage is fed into V8 through R12 and C27.

c. The audio output connections, pin F of J1 and pin E of J1 (ground), are used to supply

the receiver output to the transmitter for local monitoring. The audio output of the receiver is taken from the 600-ohm secondary terminal of T14 (pin A of J2 and J3).

d. It is possible to use Radio Receiver R-174/URR without Power Supply PP-308/URR. For this purpose, A+, B+, B—, and ground connections were brought out to J1.

(1) For such operation, the positive terminal of the 1.5-volt d-c source (A+) should connect to pin H and the negative terminal (A—) to pin E (ground). The positive terminal of the 90-volt d-c source (B+) should connect to pin K and the negative terminal (B—) to pin J. Also, it will be necessary to connect a 160-ohm resistor across pins 8 and 10 of J4.

(2) A suitable cabinet should be used that will fit properly against the waterproof gasket around the rim of the receiver.

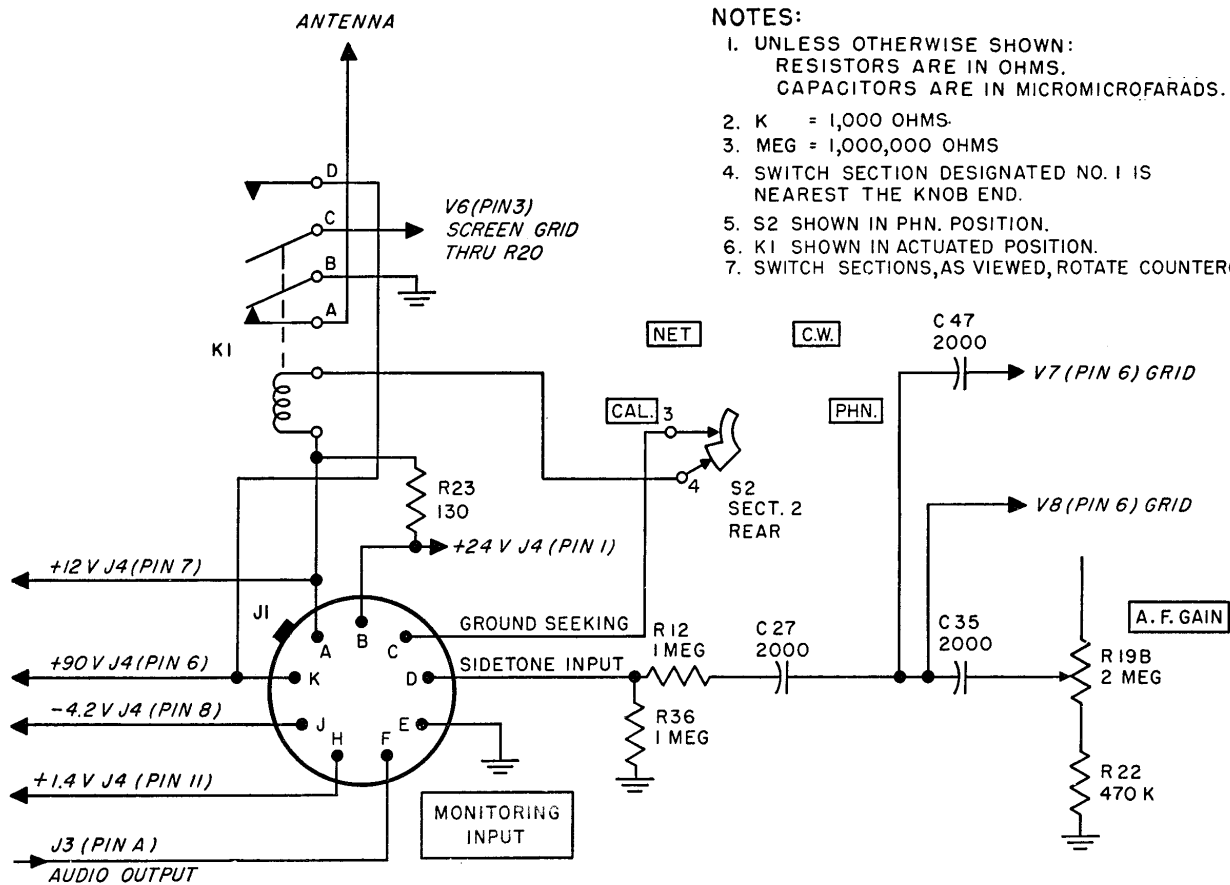

NOTES:

1. UNLESS OTHERWISE SHOWN: RESISTORS ARE IN OHMS. CAPACITORS ARE IN MICROMICROFARADS.
2. K = 1,000 OHMS.
3. MEG = 1,000,000 OHMS
4. SWITCH SECTION DESIGNATED NO. 1 IS NEAREST THE KNOB END.
5. S2 SHOWN IN PHN. POSITION.
6. K1 SHOWN IN ACTUATED POSITION.
7. SWITCH SECTIONS, AS VIEWED, ROTATE COUNTERCLOCKWISE.

Figure 34. Radio Receiver R-174/URR, monitoring input, functional schematic.

TM 295-35

CHAPTER 5

FIELD MAINTENANCE INSTRUCTIONS

Note. This chapter contains information for field maintenance. The amount of repair that can be performed by units having field maintenance responsibility is limited only by the tools and test equipment available and by the skill of the repairman.

Section I. TROUBLE SHOOTING AT FIELD MAINTENANCE LEVEL

69. Trouble-Shooting Procedures

a. General. The first step in servicing a defective radio set is to sectionalize the fault. Sectionalization means tracing the fault to the *major component or circuit* responsible for the abnormal operation of the set. The second step is to localize the fault. Localization means tracing the fault to the defective *part* responsible for the abnormal condition. Some faults such as burned-out resistors, r-f arcing, and shorted transformers often can be located by sight, smell, and hearing. The majority of faults, however, must be localized by *checking voltage and resistance*.

b. Component Sectionalization and Localization. The tests listed below aid in isolating the source of trouble. To be effective, the procedure should be followed in the order given. Remember that servicing procedure should cause no further damage to the receiver or power supply. First, trouble should be localized to a single stage or circuit. Then, the trouble may be isolated within that stage or circuit by appropriate voltage, resistance, and continuity measurements. The service procedure is summarized as follows:

(1) *Visual inspection.* The purpose of visual inspection is to locate any visible trouble. Through this inspection alone, the repairman frequently may discover the trouble or determine the stage in which the trouble exists. This inspection is valuable in avoiding ad-

ditional damage which might occur to the receiver through improper servicing methods, and in forestalling future failures.

- (2) *Input resistance measurements.* These measurements (pars. 73 and 74) prevent further damage to the receiver from possible short circuits. Since this test gives an indication of the condition of the filter circuits, its function is more than preventive.
- (3) *Operational test.* The operational test (pars. 75 and 76) is important because it frequently indicates the general location of trouble. In many instances, the information gained will determine the exact nature of the fault. To utilize this information fully, all symptoms must be interpreted in relation to one another.
- (4) *Trouble-shooting chart.* The trouble symptoms listed in these charts (pars. 77 and 78) will aid greatly in localizing trouble.
- (5) *Signal substitution.* The principal advantage of the signal substitution method (pars. 80 through 84) is that it usually enables the repairman to localize a trouble accurately and quickly to a given stage when the general location of the trouble is not immediately evident from the above tests.

(6) *Stage gain charts.* These charts (par. 87) can be used to localize obscure, hard-to-find troubles.

(7) *Intermittents.* In all these tests, the possibility of intermittents should not be overlooked. If present, this type of trouble may be made to appear by tapping or jarring the set. It is possible that the trouble is not in the radio itself, but in the installation, or the trouble may be caused by external conditions. In this event, test the installation, if possible.

70. Trouble-Shooting Data

Take advantage of the material supplied in this manual. It will help in the rapid location of faults. Consult the following trouble-shooting data:

a. Power Supply PP-308/URR.

Fig. or Par. No.	Description
Fig. 35	Power Supply PP-308/URR, top view of chassis, with cover removed.
Fig. 36	Power Supply PP-308/URR, bottom view of chassis, with cover removed.
Fig. 44	Power Supply PP-308/URR, tube socket voltage and resistance diagram.
Fig. 47	Power Supply PP-308/URR, schematic diagram.
Par. 73	Input resistance measurements for Power Supply PP-308/URR.
Par. 85	D-c resistances of coils and transformers of Power Supply PP-308/URR.

b. Radio Receiver R-174/URR.

Fig. or Par. No.	Description
Fig. 37	Radio Receiver R-174/URR, resistor-capacitor board voltage and resistance diagram.
Fig. 38	Radio Receiver R-174/URR, top view of chassis, with cover removed.
Fig. 39	Radio Receiver R-174/URR, bottom view of chassis, with cover removed.

Fig. or Par. No.	Description
Fig. 45	Radio Receiver R-174/URR, tube socket voltage and resistance diagram.
Fig. 48	Radio Receiver R-174/URR, schematic diagram.
Par. 74	Input resistance measurements for Radio Receiver R-174/URR.
Pars. 80 through 84	Signal substitution.
Par. 86	D-c resistances of coils and transformers of Radio Receiver R-174/URR.
Par. 87	Stage gain charts.

71. Tools and Test Equipment Required for Trouble Shooting

The tools required for trouble shooting Radio Receiving Set AN/GRR-5 are listed in paragraphs 30 and 31. The test equipment required for trouble shooting is listed below. The technical manuals associated with the test equipment also are listed.

Test equipment	Instruction manual
RF Signal Generator Set AN/URM-25 or Signal Generator TS-588/U, or equal.	NAVSHIPS 91283 TM 11-5018
Output Meter TS-585A/U or equal	TM 11-5017
Frequency Meter Set SCR-211	TM 11-300
Electronic Multimeter TS-505/U, or equal.	TM 11-5511
Tube Tester I-177, I-177-A, or equal.	TM 11-2627
Audio Oscillator TS-382A/U	TO 16-35T5382-2
.05- μ f capacitor	
.01- μ f capacitor	
110- μ f capacitor	

72. Visual Inspection

When a radio set is brought in from the field for check or repair, remove the power supply and the receiver from the case, remove the top cover of the receiver and bottom covers of both units, and inspect both as follows:

a. Examine for burned insulation and resistors. Examine for wax leakage and any discoloration of apparatus and wire.

b. Inspect for broken connections to tube sockets, plugs, and other apparatus, as well as for defective soldered connections. Examine

for bare wires touching the chassis or other wires.

c. Be sure that the labels on the tubes in the various sockets correspond to the correct tube numbers for these positions as given in the manual. Replace or interchange any tubes which have the wrong numbers. Replace broken tubes. Inspect for loose tube-socket contacts.

d. Inspect the fuses. Check carefully for short circuits wherever a power supply with a blown fuse is found.

e. Inspect the dial mechanism. Be sure that the dial turns smoothly.

f. Check all switches and controls for ease of operation.

g. Inspect all power plugs and cables. Replace or repair any plugs or cables that are broken.

h. Inspect for loose or missing screws, especially those which fasten tube sockets in place.

73. Input Resistance Measurements for Power Supply PP-308/URR

(fig. 44)

a. Trouble within the power supply often may be detected by checking the resistance of the filament and h-v circuits before applying power to the unit. Make the following checks before attempting to put the power supply into operation. Disconnect the power source and the receiver-power supply interconnecting cable.

b. The resistance between terminals 6 and 10 of J101 should read infinity. If there is a resistance reading, check tube V101, resistor R111, and the wiring to these components.

c. The resistance between terminals 8 and 10 (ground) of J101 should read 62 ohms for all settings of POWER SELECTOR switch, except DRY BAT. In this latter mode of operation, the resistance should read 162 ohms. If the resistance varies appreciably more than 10 percent, check resistors R108, R109, and the wiring to section 6 of S101.

d. The resistance between terminals 2 and 4 of J101 should read 1.1 ohms. If the reading does not correspond to this value, check T103.

e. The resistance between J103A and J103D (POWER INPUT receptacle) should be 12 ohms with POWER ON-OFF switch turned to ON. If the reading is higher, check T101 primary and T102 terminals 11 to 12. If the reading is lower, check T101, T102, C102A, and C102B. Turn POWER ON-OFF switch to OFF; the reading should be infinity.

f. The resistance between J103B and J103C should read infinity. Turn POWER ON-OFF switch to ON; the resistance should read .2 ohm for the 6 V setting, .04 ohm for the 12 V setting, and 2.2 ohms for the 24 V setting of S101.

g. Measurements of resistance from J104D to J104C, (DRY BATTERY receptacle) should be 162 ohms when POWER SELECTOR switch S101 is turned to DRY BAT. and 62 ohms when switched to any other mode of operation. If resistance reading is incorrect, check R108 and R109.

h. Resistance from J104A to J104D should read infinity. Check S101, S103, and the contacts of relay K101.

74. Input Resistance Measurements for Radio Receiver R-174/URR

(fig. 45)

Trouble within the receiver often may be detected by checking the resistance of the filament and h-v circuits before applying power to the equipment. Make the following checks before attempting to put the receiver into operation. Disconnect all cables to the receiver; turn R.F. GAIN and A.F. GAIN controls to maximum clockwise direction; turn OUTPUT HIGH-LOW switch to HIGH; turn BAND SW. switch to band 1; and turn PHN.-C.W.-NET-CAL. function switch to PHN.

a. The resistance between terminal 6 and terminal 10 of J4 should read 110K ohms ± 10 percent. If the resistance is appreciably lower, check capacitor C37, the wiring to pins 2 and 3 of all tubes, and pin K of J1. If the resistance is appreciably higher than 110K ohms, R113 or the 10,000-ohm resistor in T12 is probably open; check the B+ circuit. To prevent possible damage to the power supply, correct all abnormal conditions before connecting the power supply.

b. The resistance between terminal 11 and terminal 10 of J4 should read almost zero with all tubes in place. If the reading is appreciably higher, check for an open filament line from pin 11 or an open ground connection from pin 1.

c. The resistance between terminals 8 and 10 of J4 should read 8 megohms. If the reading is lower than this value, check resistors R26, R27, and R30 and capacitor C40. If capacitor C47 is shorted, the input resistance will be lower; check C47 and resistors R24 and R31, and check the wiring to pin J of J1.

d. The resistance between terminals 9 and 10 of J4 should read .5 ohm. If the reading is higher or lower, check transformer T14.

e. The resistance between 7 and 1 of J4 should read 130 ohms. If the reading is different, check R23. This reading will appear at pins A and B of J1.

f. The resistance between A and C of J1 should read 125 ohms. If the reading is incorrect, check the coil of relay K1.

g. The resistance between D and E of J1 should be 1 megohm. If the reading is incorrect, check R12, R36, and C27.

h. The resistance between E and F of J1 should read 22.6 ohms. If the reading is incorrect, check connections to J2 and J3, pins A, and secondary of T14.

i. To prevent possible damage to the power supply, correct all abnormal conditions before connecting the receiver to the power supply.

a. *Sectionalizing Trouble.*

75. Operational Test of Power Supply PP-308/URR

Operate the equipment as described in the equipment performance checklist (par. 43). This checklist is important because it frequently indicates the general location of trouble. Listen for cracking or buzzing noises which indicate h-v arcing. Check the power supply for smoke and for the odor of burned or overheated parts.

76. Operational Test of Radio Receiver R-174/URR

Operate the equipment as described in the equipment performance checklist (par. 43). This checklist is important because it frequently indicates the general location of trouble. Listen for signal noise in the receiver or for received signals. Depress DIAL LIGHT switch to check filaments. Check for h-v arcing, smoke, and the odor of burned or overheated parts.

77. Trouble-Shooting Charts for Power Supply PP-308/URR (figs. 35, 36, and 44)

The following charts are supplied as an aid in locating trouble in the power supply. These charts list the symptoms which the operator or serviceman may observe while making a few simple tests. *The charts also indicate how to sectionalize trouble quickly to a particular stage or circuit.* A tube check and voltage and resistance measurements in the circuit ordinarily should be sufficient to isolate the defective part.

Symptom	Probable trouble	Correction
POWER ON-OFF switch in ON position; K101 is not actuated for 115-volt a-c operation; set inoperative for any mode of operation.	No voltage at J103 for 6-, 12-, or 24-volt d-c operation, or 115-volt a-c operation. No voltage at J104 for DRY BATTERY operation; wrong polarity of d-c line voltage; or dead batteries. Open fuse F101 (110V.1A.); connecting leads to fuseholder or switch S103 broken; switch S103 defective; defective l-v rectifier circuit.	Check power source. Check Power Cable Assemblies CX-1355/U and CX-1359/U. Check Power Cable Assembly CX-1360/U. Reverse polarity of input. Replace batteries. Replace fuse F101. Repair or replace switch S103. Check relay K101. Localize trouble in the l-v rectifier circuit (<i>b</i> below), and replace defective part.
Vibrator E101 or E102 inoperative for 6-, 12-, or 24-volt d-c input.	Open fuse F104, F103, or F102; defective S101 or S103; defective vibrator E101 or defective circuit component.	Repair or replace defective part. Localize trouble in circuit (<i>b</i> below), and replace defective part.

Symptom	Probable trouble	Correction
B+ voltage not proper value.	Defective h-v circuit; defective filter circuit; or defective voltage control circuit.	Localize trouble (<i>b</i> below), and replace defective part.
No filament voltage at pin 11 of J101.	Defective filament voltage vibrator E102 and associated components.	Localize trouble (<i>b</i> below), and replace defective part.

b. Localizing Trouble.

Symptom	Probable trouble	Correction
Relay K101 does not trip in 115-volt a-c operation.	No input voltage to power supply; open fuse F101 (110V.1A.); open coil of relay or defective transformer T101; capacitor C102 shorted or CR101 defective; capacitor C101 shorted.	Repair or replace defective component.
No interrupted voltage at vibrator E101 for 6-volt d-c operation.	Burned-out fuse F104; defective vibrator. No input voltage to vibrator contacts; open or shorted turns on transformer T102 primary; coil L101, L102, L103, L104, or L105 open; capacitors C104 through C109 or C112 shorted.	Replace defective vibrator or part. Replace defective part.
No interrupted voltage from vibrator E101 for 12-volt operation ^a .	Burned-out fuse F103; Defective vibrator; no input voltage to vibrator E101; shorted or open turns of transformer T102 primary, open resistor R104; L104 or L105 open; shorted capacitor C107 or C108.	Replace defective part.
No interrupted voltage from vibrator E101 for 24-volt operation ^a .	Burned-out fuse F102; defective vibrator; no input voltage to vibrator E101; shorted or open turns of transformer T102 primary; open resistor R104, R105, or R107; L104 or L105 open; capacitor C107 or C108 shorted.	Replace defective part.
No B+ voltage at junction of R110 and C114.	Defective h-v circuit; defective tube or filament circuit; defective transformer; shorted capacitor C113 or C114.	Check and replace V102, R101, R106, C113, or C114. Check secondary of T102.
No B+ output voltage after previous checks have been made.	Defective voltage regulator tubes; resistor R111, R112, or R113 open.	Check tubes. Replace defective part.
No voltage at cathode (pin 5) of V104 for 6-, 12-, or 24-volt operation after previous checks have been made.	Shorted capacitor C118; burned-out resistor R115 or R116; defective V104.	Replace defective part.
No filament voltage at pin 11 of J101 after all previous checks have been made.	Defective wiring; defective rectifier CR102; defective transformer secondary of T103; defective filament filter circuit; L106 or L107 open; C110 or C111 shorted.	Repair or replace defective parts.

^a IN AN EMERGENCY, for 12- or 24-volt d-c operation only, should contact 1 or 5 or both of E101 become defective and if the vibrator will still vibrate and there are no spares on hand, the leads on terminals 1 and 2 and terminals 4 and 5 of E101 filter may be interchanged. A tag should be put on the power supply noting the changes made.

78. Trouble-Shooting Charts for Radio Receiver R-174/URR

(figs. 38, 39, and 45)

The following charts are supplied as an aid in locating trouble in the receiver. These charts list the symptoms which the operator or serv-

iceman may observe, either visually or audibly, while making a few simple tests. *The charts also indicate how to sectionalize trouble quickly to the particular stage or circuit.* The signal substitution tests outlined in paragraphs 80 through 84 then can be used to supplement this

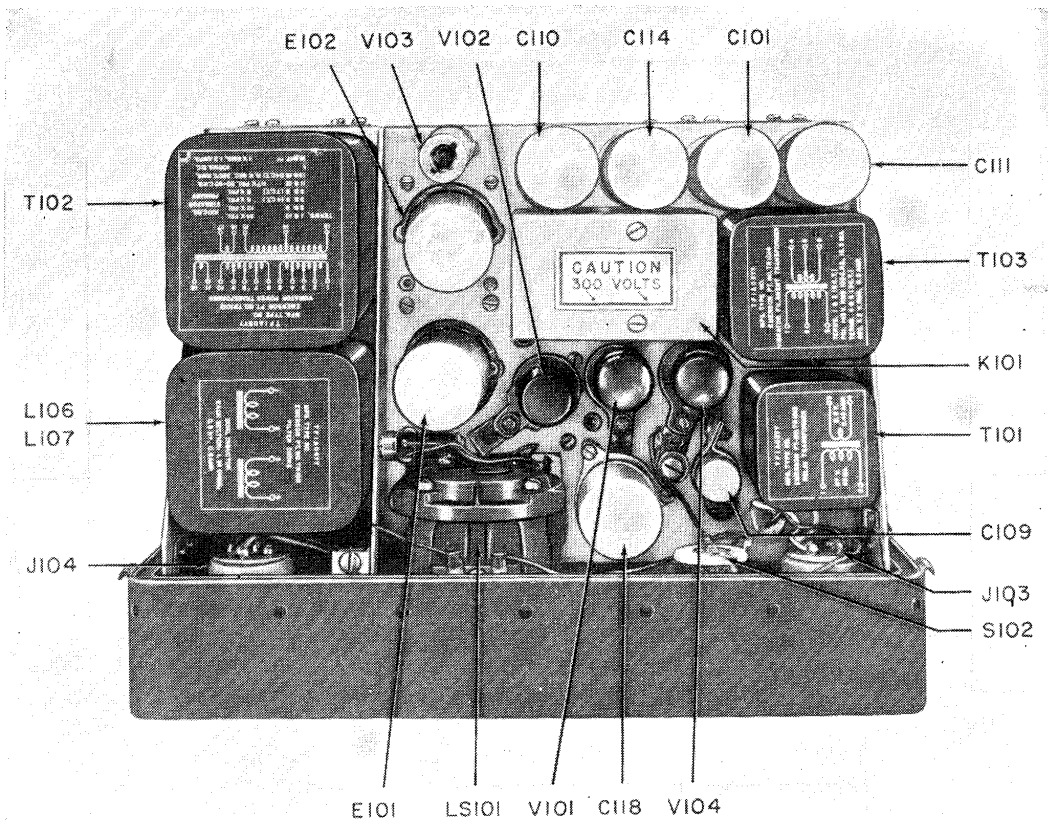

TM 295-36

Figure 35. Power Supply PP-308/URR, top view of chassis, with cover removed.

procedure and to determine the defective circuit. A tube check and voltage and resistance measurements in the circuit ordinarily should be sufficient to isolate the defective part.

Note. In the following tests, the power supply is connected to the receiver, the power is turned on, and the power supply is operative. Set the receiver controls as in the preparatory section of the equipment performance checklist.

a. Sectionalizing Trouble.

Symptom	Probable trouble	Correction
Dial lamp inoperative when DIAL LIGHT switch S3 is depressed.	Defective dial lamp. Defective filament circuit. Defective switch S3.	Repair or replace defective part.
No receiver output, but dial lamp lights when S3 is depressed.	Defective tube. Defective loudspeaker or headset.	Check tubes. Repair or replace defective part.
Receiver operative, but excessive hum in loudspeaker or headphones.	Defective filter capacitor C114, C118 (power supply), or C37 (receiver). Avc circuit open, R15 or R18 open.	Replace defective part.
No signal in loudspeaker and headset, with a signal fed from an audio oscillator through a .05- μ f capacitor to pin 6 of V6.	Faulty a-f stage.	Check tubes. Use signal substitution in the audio stages (par. 80). Repair or replace defective part.
No signal output in loudspeaker and headset, with a modulated 455-kc signal from a signal generator coupled to pin 6 of V3 through a .01- μ f capacitor, PHN.-C.W.-NET-CAL. switch S2 set to PHN. position, and audio stages checked.	Faulty i-f or detector stage.	Check tubes. Use signal substitution in i-f stages (par. 81). Repair and replace defective part.

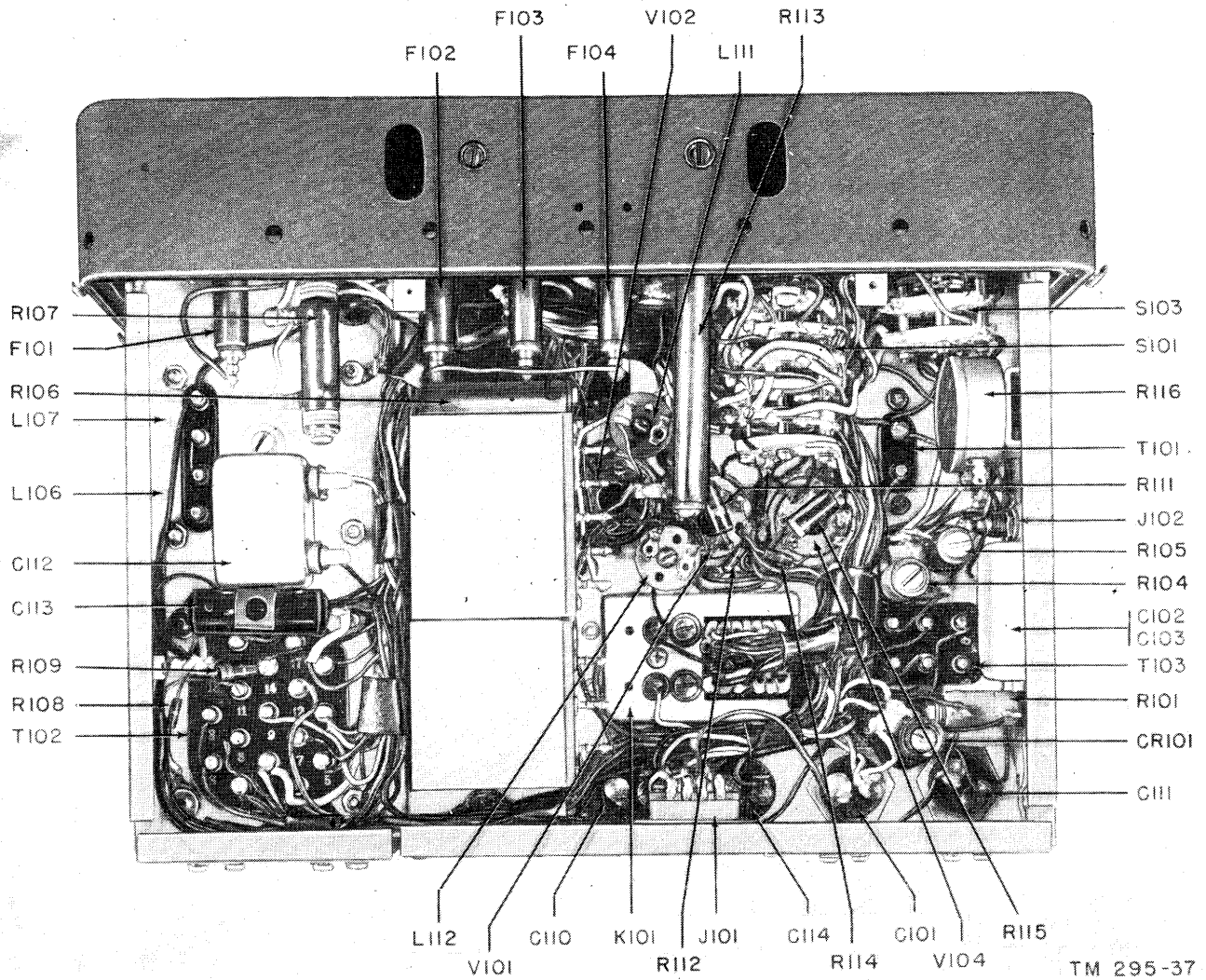

TM 295-37

Figure 36. Power Supply PP-308/URR, bottom view of chassis, with cover removed.

Symptom	Probable trouble	Correction
No signal output in receiver after previous checks have been made.	Defective h-f oscillator stage.	Check tube and replace if defective. Use signal substitution method (par. 82) to locate defective part; replace.
With r-f signal from signal generator connected through a 110- μ f capacitor to terminal A, and the ground of the signal generator connected to terminal G, there is no output in loudspeaker after previous checks have been made.	Defective tube V1, V2, or V3. Defective antenna transformer, r-f amplifiers, or mixer.	Check tubes. Use signal substitution method (par. 82) to localize the defective part.
Receiver output satisfactory with signal generator connector to antenna terminals, but output weak on received signals when using antenna.	Open or loose antenna lead.	Repair antenna lead. Check and repair connections to antenna.

Symptom	Probable trouble	Correction
No output signal heard as B.F.O. trimmer is rotated and a 455-kc, 400-cycle modulated signal is connected through a .05- μ f capacitor to pin 6 of V3, and PHN.-C.W.-NET-CAL. switch S2 turned to C.W. position, after previous checks have been made.	Defective bfo stage. Defective tube V7. Open transformer T13.	Check tube V7 and replace if defective. Replace or repair transformer. Use signal substitution test in paragraph 81 to localize trouble.
No output signal is heard, with PHN.-C.W.-NET-CAL. switch S2 set to CAL. position as tuning capacitor is varied, after previous checks have been made.	Defective crystal calibration tube, crystal, or circuit.	Check tube V5 and crystal; replace if defective. Check resistors R13 and R14, capacitors C25 and C26, and transformer T12; replace. Use signal substitution test (par. 81) to localize trouble.

b. Localizing Trouble.

Symptom	Probable trouble	Correction
Receiver inoperative with OUTPUT HIGH-LOW switch S4 set to HIGH position.	Defective a-f stage V6 or V8. No plate or screen voltage at V6 or V8. Defective speaker.	Check tubes V6 and V8. Use signal substitution (par. 80) to check each stage. Repair or replace defective component.
Receiver inoperative with OUTPUT HIGH-LOW switch S4 set to LOW position after previous checks have been made.	Defective tube V7 or defective a-f stage.	Use signal substitution (par. 80) to check a-f stage. Repair or replace defective component.
Oscillation (indicated by whistle or howl).	Defective tube, poor shielding, or high-resistance solder connection to chassis.	Check tubes. Check wiring to ground solder points. Use signal substitution tests (pars. 80 through 84) to localize trouble. Repair or replace defective part.
Reception distorted; objectionable hum in output.	Open grid resistor or leaky capacitor in audio circuits. Open capacitor in the power supply filter circuit.	To check grid circuits, measure resistances to locate faulty components. Replace faulty components.
Noisy, fading, or weak reception.	Faulty gain control. Defective avc circuit. Faulty antenna.	Check wiping contact on A.F. GAIN and R.F. GAIN controls. Check avc circuit. Check antenna installation for poor connections. Use signal substitution tests (par. 80 through 84) to localize trouble.
Intermittent noise.	Defective tube, resistor, or capacitor.	With an insulated prod, gently tap and slightly move all tubes, resistors, and capacitors to locate loose elements or loose connections. Use signal substitution tests (pars. 80 through 84) to localize trouble. Repair or replace defective part.

79. General Signal Substitution Notes

a. Signal substitution requires a source of audio, i-f, and r-f signals. A headset or the loudspeaker also is required.

b. Note the volume, and listen for serious

distortion from the loudspeaker or headset at the various points in the signal substitution procedure. When possible, compare operation with a receiver known to be in good condition.

c. Check the wiring and soldering in each stage during the procedure.

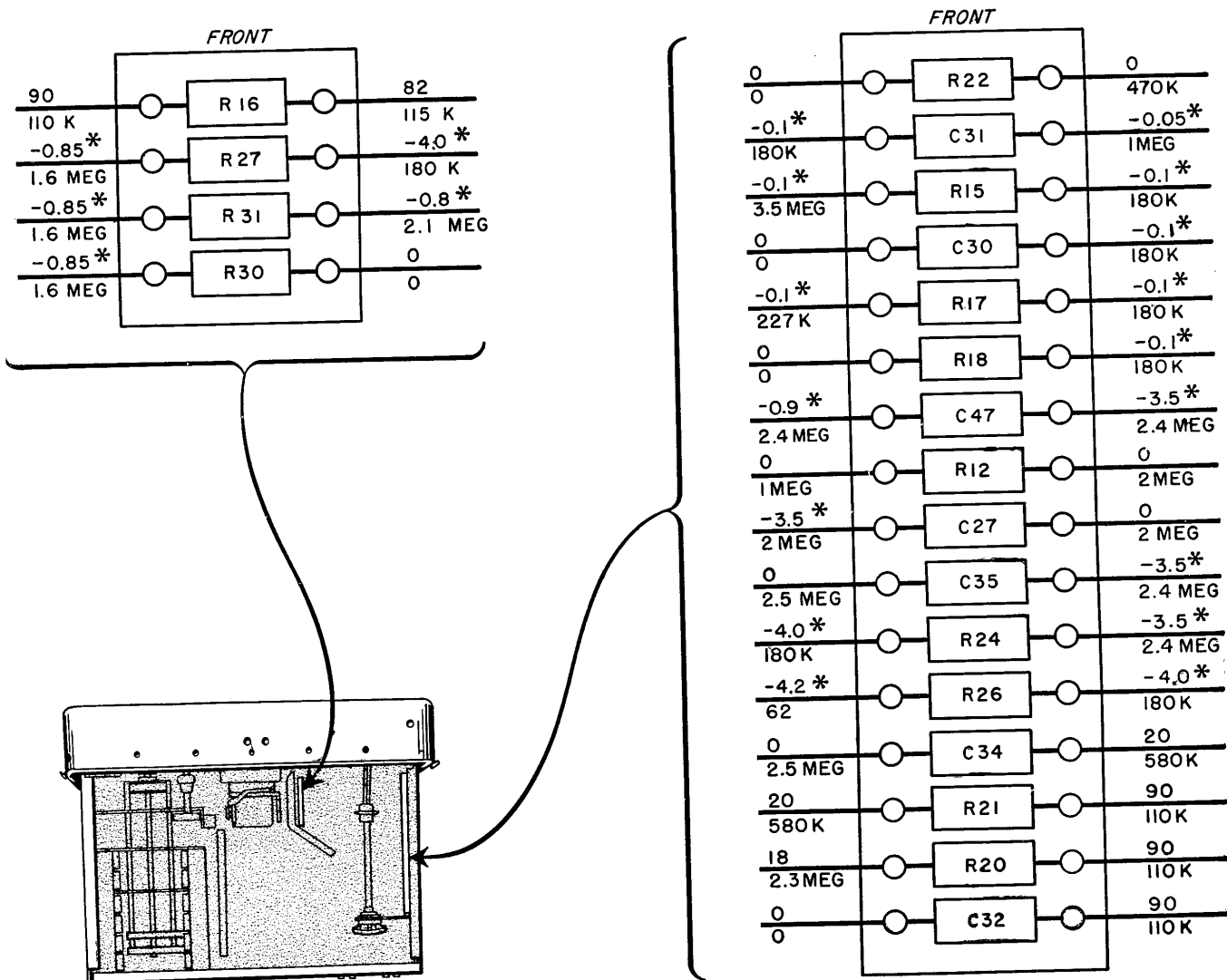

NOTES:

1. ALL VOLTAGES TO GROUND. READINGS TAKEN WITH 20,000 OHM-PER-VOLT METER.
- *2. THESE READINGS TAKEN WITH VACUUM TUBE VOLTMETER.
3. BAND SWITCH SET TO **BAND I**.
4. R.F. GAIN AND A.F. GAIN SET TO **MAXIMUM**.
5. FUNCTION SWITCH SET TO PHN.
6. OUTPUT SWITCH SET TO **HIGH**.
7. MEASUREMENTS TAKEN WITH RECEIVER CONNECTED IN NORMAL INSTALLATION.
8. UNLESS OTHERWISE SHOWN: RESISTORS ARE IN OHMS
9. K=1,000 OHMS.
10. MEG= 1,000,000 OHMS

TM 295-38

Figure 37. Radio Receiver R-174/URR, resistor-capacitor board voltage and resistance diagram.

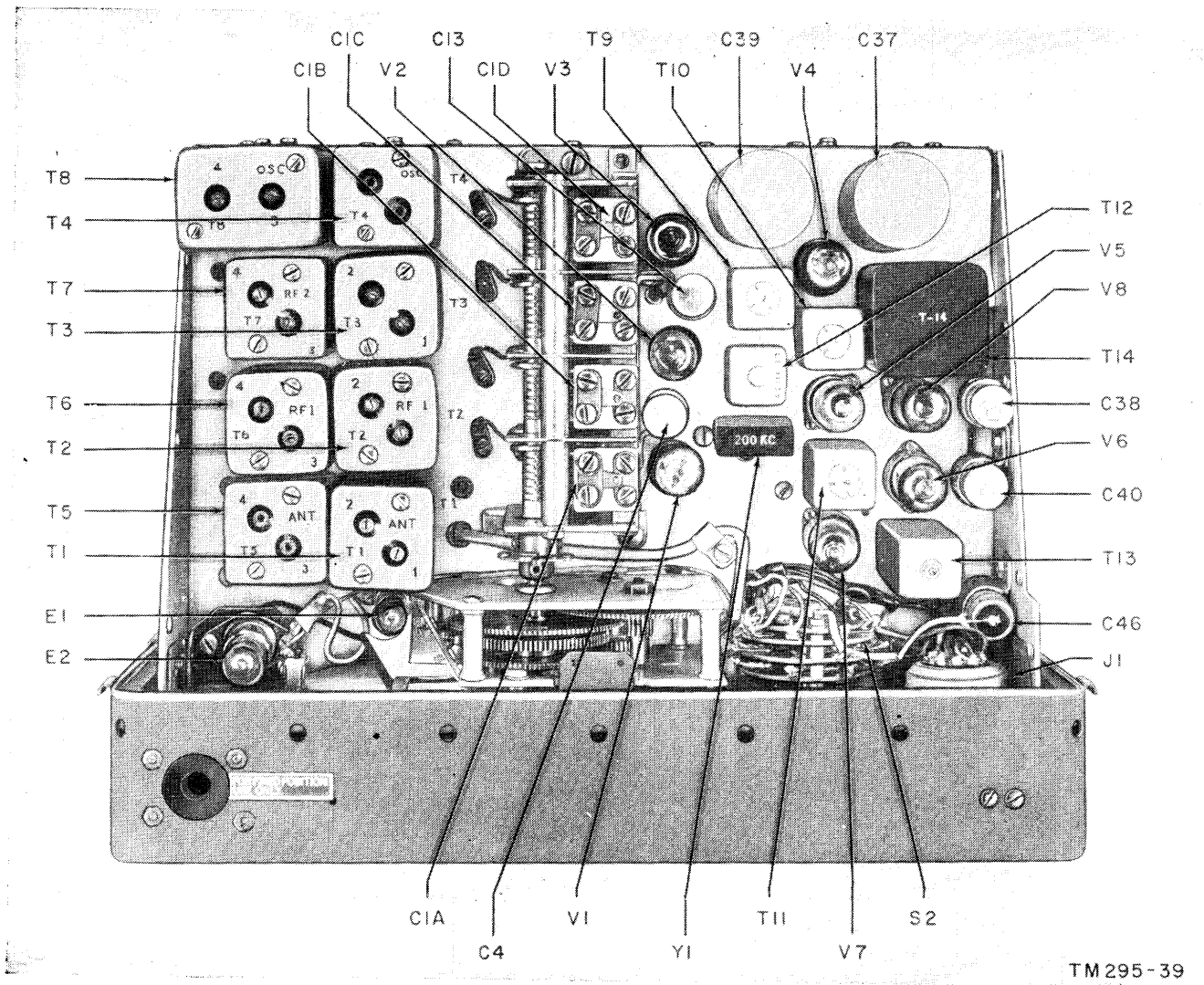

Figure 38. Radio Receiver R-174/URR, top view of chassis with cover removed.

Note. Do not remove r-f and i-f shields from the chassis or shield cans from the tuned units until the trouble has been traced definitely to the particular unit. Do not damage wiring by pushing it back and forth during inspection. Be careful not to damage the receiver in any other way.

d. Misalignment of one or more stages of the receiver will cause reduced output. Misalignment of the h-f (high-frequency) oscillator may prevent any output.

e. When trouble is localized in a given stage, test the tube, measure the voltage, and measure the resistance of the tube socket of that stage.

f. Trouble in a circuit or stage may not cause changes in voltages and resistance measurements at the tube socket. The notes included in this paragraph are merely a guide and should suggest other procedures, such as volt-

age and resistance measurements on individual parts.

g. Remove only one tube at a time when testing. Check the number of the tube and test it; if the tube is not defective, return it to its proper socket before another tube is removed.

h. Each step presupposes the satisfactory completion of all previous steps. Isolate and clear any trouble located before proceeding with any succeeding steps.

80. A-f Signal Substitution Tests

a. *High Output.* In these tests, turn OUTPUT HIGH-LOW switch S4 to HIGH, and apply a 1,000-cycle audio signal from an audio generator through a .05- μ f (microfarad) capacitor.

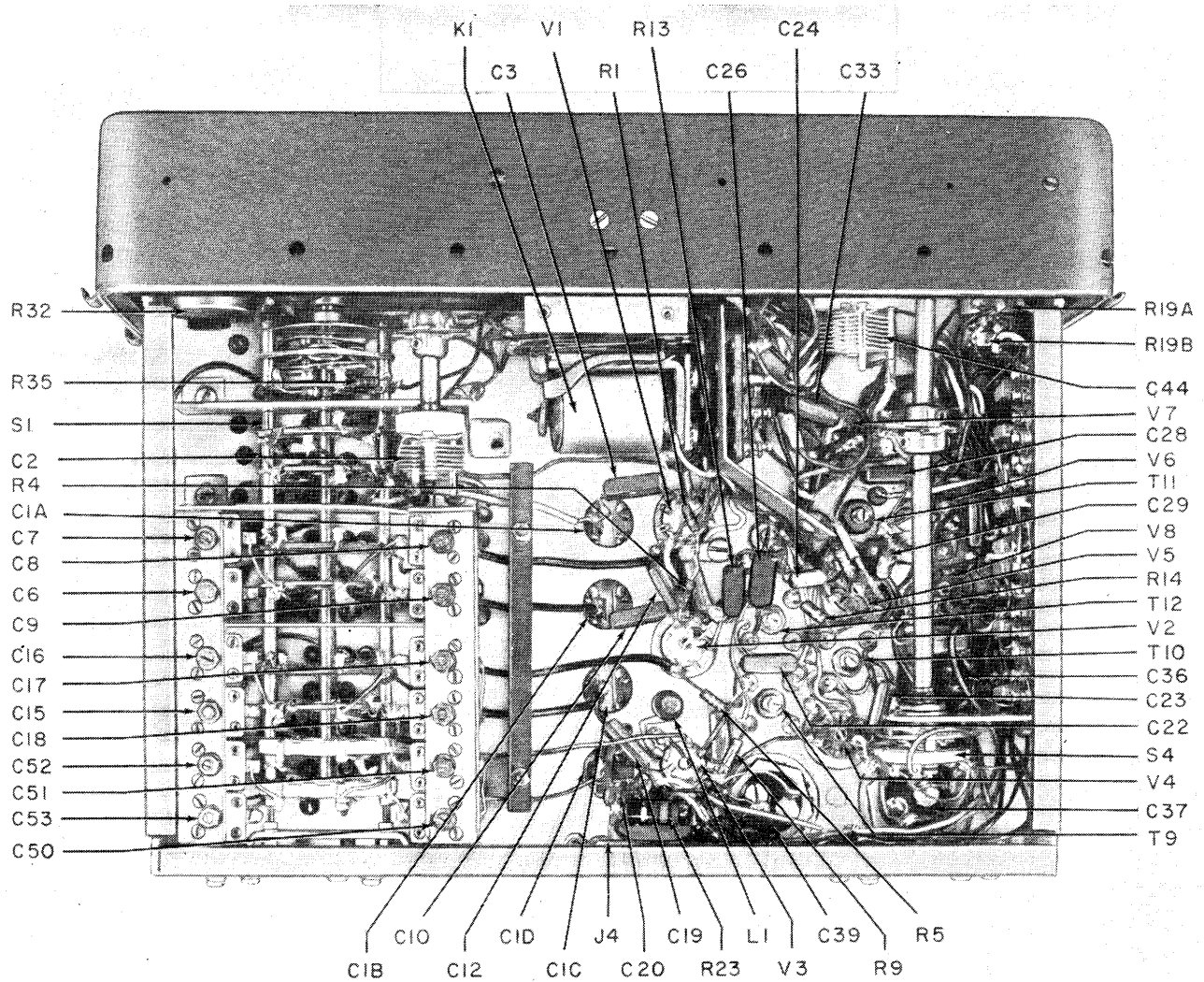

TM 295-40

Figure 39. Radio Receiver R-174/URR, bottom view of chassis, with cover removed.

- (1) Apply a signal to terminal 2 of V8, and listen for a low-volume signal in both the speaker and headset. This will check the speaker, headset, output transformer, headset connectors, and speaker switch. If there is no signal, examine these components and associated wiring.
- (2) Place the audio signal on pin 6 of V8. Listen for an increased output (relative to the test in (1) above) in the headset or speaker. If the output is weak or distorted, check the tube. If no signal is heard, check for -4 volts dc at pin 8 of J4, B+ and screen voltage of V8. Check resistors R24, R25, and R26 and capacitors C37 and C38.
- (3) Apply the audio signal to pin 2 of V6 and listen for the signal in the headset or speaker. If there is no signal, check capacitor C34, resistor R19B (A.F. GAIN control), resistor R22, and capacitor C35.
- (4) Apply the audio signal to pin 6 of V6 and listen for an increased output (relative to (1), (2), and (3) above) in the speaker or headset. If the signal is weak, check the plate and screen voltages of V6. If there is no signal, check the tube and the wiring. If the signal is distorted, check coupling ca-

capacitor C31, resistors R19A (A.F. GAIN control), R18, R20, R21, and capacitors C32 and C33.

b. Low Output. Turn OUTPUT HIGH-LOW switch S4 to LOW and apply signals as in *a* above.

- (1) Apply audio signal to pin 2 of V7. Listen for a weak output signal (relative to signal in *a* above) in the headset or loudspeaker. If no signal is heard, check C42 and T14.
- (2) Apply audio signal to pin 6 of V7. Listen for an increased output signal (relative to signal in (1) above) in the headset or loudspeaker. If the signal is weak, check tube V7, resistors R31 and R27, and capacitor C46.

81. I-f Signal Substitution Tests

Set the R.F. GAIN and the A.F. GAIN controls to the maximum clockwise settings, and set the PHN.-C.W.-NET-CAL. switch to the PHN. setting. Adjust the signal generator to 455 kc with a 400-cycle modulation applied. Feed this signal in series with a .05- μ f capacitor into the set at the points indicated in *a* through *f* below, in turn, and listen for the signal in the speaker or headset. An increase in signal should be noted when a signal is fed at the control grid as compared to the plate of a particular tube.

Note. If it is determined that the receiver is misaligned, refer to paragraphs 94, 95, and 96.

a. Terminal 4 of V6 (Detector Plate). If there is no signal or if the signal is distorted, check resistors R17 and R18 and capacitors C29 and C30. If there is no signal, the secondary winding of T11 may be open, the capacitor in the transformer may be shorted, or the transformer may be misaligned.

b. Terminal 2 of V5 (Plate of Second i-f Amplifier). If there is no signal, the primary of T11 may be open, misaligned, or shorted. Check the winding and internal capacitor.

c. Terminal 6 of V5 (Grid of Second i-f Amplifier). If there is no signal, check the tube, the plate and screen voltages, resistor R16, and capacitor C28. The secondary winding of transformer T10 may be shorted or misaligned; capacitor in transformer may be shorted.

d. Terminal 2 of V4 (Plate of First i-f Amplifier). If there is no signal, check the primary of transformer T10. It may be open, shorted, or misaligned. Check the winding, and check the capacitor in the transformer.

e. Terminal 6 of V4 (Grid of First i-f Amplifier). If there is no signal, check the tube and the plate and screen voltages at the tube. Check resistors R10 and R32 (R.F. GAIN) and capacitors C4 and C23. The secondary of T9 may be open, shorted, or misaligned. Check the winding and check the capacitor in the transformer.

f. Terminal 2 of V3 (Plate of Converter). If there is no signal, check the primary of T9. It may be open, shorted, or misaligned. Check the winding and check the capacitor in the transformer.

82. R-f Signal Substitution Tests

(figs. 24 and 48)

Set the signal generator to 1.5 mc with a 400-cycle modulation applied through a 110- μ f capacitor to the points listed in *a* through *f* below. Set the receiver controls as follows:

Control	Setting
R.F. GAIN control	Maximum clockwise
A.F. GAIN control	Maximum clockwise
PHN.-C.W.-NET-CAL. switch	PHN.
BAND SW. switch	Band 1
MANUAL-PRESET TUNING control	1.5 MC.

a. Terminal 6 of V3 (Grid of Converter).

- (1) Tune the receiver for an output signal in the loudspeaker and headset. If there is no signal, the r-f section of the tube may be inoperative. Check the tube, plate, and screen voltages, resistor R9, and capacitor C21. The grid circuit may be shorted. Check resistor R7, capacitors C18, C19, and C1C, and BAND SW. switch S1. The C winding of transformer T3 may be misaligned, open, or shorted, or the capacitor connected in the transformer may be shorted.
- (2) The h-f oscillator may be inoperative. Check the tube. Use a vacuum-tube voltmeter to measure the grid voltage

at pin 4 of V3. Voltage should be —4 volts dc. Check R8, C20, S1, and C50. A winding of T4 may be open, shorted, or misaligned. Check the winding, the capacitor across the winding, the 220K-ohm resistor, and the 820- $\mu\mu\text{f}$ capacitor in the assembly.

- (3) Repeat (1) above for all bands. The table below indicates the frequencies to be checked and the circuit components for each band. Tune the receiver to the signal generator frequency.

Band	Frequency	Components
2	2.7 mc	C17, D winding of T3, internal capacitor, and band switch.
3	5 mc	C16, C winding of T7, internal capacitor, and band switch.
4	9.5 mc	C15, D winding of T7, internal capacitor, and band switch.

- (4) Repeat (2) above for all bands. The table below indicates the frequencies to be checked and the circuit components for each band. Tune the receiver to the signal generator frequency.

Band	Frequency	Components
2	2.7 mc	C51, B winding of T4, capacitor across winding, 220K-ohm resistor and 1,200- $\mu\mu\text{f}$ capacitor in transformer assembly, and band switch.
3	5 mc	C52, A winding of T8, capacitor across winding, 220K-ohm resistor and 2,200- $\mu\mu\text{f}$ capacitor in transformer assembly, and band switch.
4	9.5 mc	C53, E winding of T8, capacitor across winding, 150K-ohm resistor and 1,800- $\mu\mu\text{f}$ capacitor in transformer, and band switch.

b. Terminal 2 of V2 (Plate of Second r-f Amplifier). Set the receiver controls to the same settings as used for the converter stage. Perform signal substitution in the same manner as for the converter stage. If no signal is heard, check the primary of T3 or T7. To check all bands, use frequencies designated in *a(4)* above.

c. Terminal 6 of V2 (Grid of Second r-f Amplifier). Set up the equipment as described in *a* above.

- (1) If no signal is heard, check tube V2 and screen and plate voltages. Check resistors R5 and R6 and capacitors C13 and C14.
- (2) The grid circuit of V2 may be misaligned, shorted, or open. Check resistor R4 and capacitors C9, C10, C11, and C1B. Check the band switch, the C winding of T2, and the internal capacitor.
- (3) Repeat (2) above for any inoperative band, using frequencies designated in converter stages. This will check the following components:

Band	Components
2	Band switch, D winding of T2, internal capacitor, and C8.
3	Band switch, D winding of T6, internal capacitor, and C7.
4	Band switch, E winding of T6, internal capacitor, and C6.

d. Terminal 2 of V1 (Plate of First r-f Amplifier).

- (1) If no signal is heard, check the secondary winding of transformer T2 for misalignment. Check the primary and secondary windings for opens or shorts.
- (2) Repeat the procedure for any inoperative band using frequencies designated in *a(3)* above. This will check T2 and T6.

e. Terminal 6 of V1 (Grid of First r-f Amplifier).

- (1) If no signal is heard, check tube V1 and screen and plate voltages. Check resistors R2 and R3 and capacitors C4 and C5.
- (2) Grid circuit of V2 may be misaligned, shorted, or open. Check resistor R1, capacitors C3, C1A, and C2 (ANT. TRIMMER), band switch, and secondary of B winding of transformer T1.

- (3) Repeat (2) above for any inoperative band, using frequencies designated in *a* above. This will check the following components:

Band	Components
2	C winding of T1 (secondary).
3	B winding of T5 (secondary).
4	D winding of T5 (secondary) and 2,400- μf capacitor.

f. Antenna Terminal A.

- (1) If no signal is heard, check the contacts of relay K1, PHN.-C.W.-NET-CAL. switch, band switch, primary of T1, and the internal capacitor.
- (2) Repeat the procedure for any inoperative band, using frequencies designated in *a* above. This will check T1 and T5 and the following components:

Band	Components
2	Primary of C winding of T1 and band switch.
3	Primary of B winding of T5, internal capacitor, and band switch.
4	Primary of D winding of T5 and band switch.

83. Bfo Signal Substitution Tests

Turn PHN.-C.W.-NET-CAL. switch to C.W. Feed an unmodulated signal at 455 kc through a .05- μf series capacitor from the signal generator to pin 6 of V3 (signal grid of the converter). A tone signal should be heard in the loudspeaker or headphones. If not, check tube V7; tube voltages; C44 (B.F.O. trimmer); T13 for misalignment, open, or short; internal capacitors, 75 μf and 535 μf ; and the 150K-ohm resistor. Check resistors R28, R29, and R11 and capacitors C41, C43, and C24. The voltage measured at the bfo grid, pin 4 of V7, should be between -15 and -20 volts dc.

84. Crystal Calibration Signal Tests

Turn PHN.-C.W.-NET-CAL. switch to CAL. Tune the receiver through the entire tuning range for each band. A beat note should be heard every 200 kc on the dial. If no signal is

heard, the crystal calibration oscillator may be defective. Check the following points in turn:

- Check the voltage at terminal 3 of V5 (plate of calibration oscillator).
- Check the band switch and resistors R33, R34, and R35.
- Check L3, R13, C26 and the 10K-ohm resistor in the T12 assembly.
- Check for an oscillator grid voltage of -25 volts dc. If there is considerable variance from this value, check R14 and C25, the crystal, and the tuning of T12.
- If the beat signal is present on all bands, but not present on band 4, C54 is open or ANT. TRIMMER control might need retuning.

85. D-c Resistances of Coils and Transformers of Power Supply PP-308/URR

The d-c resistance of the transformers and coils in the power supply are listed below:

Transformer or coil	Terminals	Ohms	Special conditions
T101	1 to 2	80	
	3 to 4	1.2	
T102	1 to 2	.4	
	2 to 3	.1	
	3 to 4	.1	
	4 to 5	.2	
	6 to 7	.2	
	7 to 8	.4	
	8 to 9	.1	
	9 to 10	.4	
	11 to 12	14	
	13 to 14	160	
14 to 15	160		
16 to 17	1.5		
T103	1 to 2	180	
	2 to 3	180	
	4 to 5	.7	
	5 to 6	.7	
L106		1.2	Vibrator E101 removed from socket. Measurements are taken
L107		1.2	
L111		10	
L112		10	
K101		50	
L101	E101-3 to 3	.04	
L102	E101-2 to 2	.04	
L103	E101-4 to 4	.04	

Transformer or coil	Terminals	Ohms	Special conditions
L104 L105	E101—5 to 5 E101—1 to 1	.04 .04	from pin of vibrator socket to pin of terminal board of filter assembly into which the vibrator is connected.
L108 L109 L110	E102—4 to 2 E102—3 to 3 E102—2 to 1	20 .02 .02	Vibrator E102 removed from socket. Measurements are taken from pin of vibrator socket to pin of terminal board of filter assembly into which the vibrator is connected.

86. D-c Resistances of Coils and Transformers of Radio Receiver R-174/URR

Note. When measuring the resistance of the transformers, make sure that BAND SW. switch S1 is set to the indicated band.

Transformer or coil	Terminals	Ohms	Band
T1	2 to ground	1.2	1
	3 to ground	1.2	1
	5 to ground	1.3	2
	4 to ground	.8	2
T2	2 to 6	.8	1
	3 to ground	1.6	1
	5 to 6	.8	2
	4 to ground	1	2
T3	2 to 6	35	1
	3 to ground	1.5	1
	5 to 6	16	2
	4 to ground	.8	2
T4	1 to 2	220K	1
	1 to ground	.1	1
	5 to 6	220K	2
	6 to ground	.1	2
T5	2 to ground	2.5	3
	3 to ground	.4	3
	5 to ground	.6	4
	4 to ground	infinity	4
T6	2 to 6	.8	3
	3 to ground	.4	3
	5 to 6	.3	4
	4 to ground	infinity	4
T7	2 to 6	6	3
	3 to ground	.1	3
	5 to 6	2.2	4
	4 to ground	.1	4

Transformer or coil	Terminals	Ohms	Band
T8	1 to 2	220K	3
	1 to ground	.1	3
	6 to 7	150K	4
	7 to ground	.1	4
T9	2 to 3	10.5	
	1 to 4	10.5	
T10	2 to 3	10.5	
	1 to 4	10.5	
T11	2 to 3	10.5	
	1 to 4	10.5	
T12	2 to 4	23	
	3 to 4	10K	
T13	1 to 3	3.8	
	3 to 4	infinity	
T14	1 to 6	430	
	2 to 6	670	
	3 to 4	22.7	
	4 to 5	.5	
K1	J1A to J1C	125	
L1	J4 pin 11 to V3 pin 7	.1	
L2	J4 pin 11 to V7 pin 7	.1	
L3	T12 pin 2 to V5 pin 3	2	

87. Stage Gain Charts

The stage gain charts in this paragraph list the average input voltage required at each of the r-f and i-f stages of the receiver to produce a signal output of 10 mw (equivalent to 2.5 volts across an output load resistance of 600 ohms). Use these charts as standards when trouble shooting to check the over-all gain of the receiver and the gain of each r-f or i-f stage, or group of stages. When the receiver output is low, localize the defective stage by checking the signal voltage level of each stage against the chart while using either the signal tracing method of trouble shooting or by measuring the individual stage gain.

a. Receiver Controls. Set the receiver controls as follows:

Control	Setting
PHN.-C.W.-NET-CAL. switch	PHN.
R.F. GAIN control	Maximum clockwise
A.F. GAIN control	Maximum clockwise
SPEAKER ON-OFF switch	OFF
OUTPUT HIGH-LOW switch	HIGH

b. Signal Generator. The signal generator should be connected to the receiver through short, heavy, well-shielded leads to minimize

radiation and stray coupling, particularly at the higher frequencies. Ground the signal generator to the receiver chassis, but do not attach an external ground to either one. Feed the r-f and i-f signals, modulated 30 percent at 400 cycles, through a 110- $\mu\mu\text{f}$ capacitor to the points specified in the charts, and use the output meter, set for a 600-ohm load, plugged into one of the PHONES connectors.

c. Signal-Plus-Noise To Noise Ratio. A 10 to 1 signal-plus-noise to noise ratio is specified for some of the r-f gain measurements listed in *d* below. To obtain the required ratio, perform the following steps:

- (1) Set the A.F. GAIN control to maximum clockwise position.
- (2) Connect the signal generator to antenna terminal A through a 110- $\mu\mu\text{f}$ capacitor. Adjust the generator output to produce a reading at the output meter.
- (3) Turn off the signal generator modulation and turn the A.F. GAIN control until the output meter reads 1 mw (approximately .8 volt).
- (4) If the meter reads 1 mw (approximately .8 volt) or less with the A.F. GAIN control at maximum and the signal generator modulation off, leave the control at maximum.
- (5) Turn the generator modulation on and readjust the generator output level to produce an output of 10 mw (approximately 2.5 volts).

d. R-f Stage Gain. The receiver output for all the measurements tabulated below should be constant at 10 mw. The A.F. GAIN control should be set for a 10-to-1 signal-plus-noise to noise ratio with a signal fed into the antenna.

Signal generator output connection	Band	Frequency mc	Signal generator output μV
Antenna terminal A through a 110- $\mu\mu\text{f}$ capacitor.	1	1.5	5 or less
	1	2.7	5 or less
	2	2.7	5 or less
	2	3.85	5 or less
	2	5	5 or less
	3	5	5 or less
	3	7.25	5 or less
	3	9.5	5 or less
	4	9.5	5 or less
	4	13.75	5 or less

Signal generator output connection	Band	Frequency mc	Signal generator output μV	
Control grid, pin 6 of V1, through a .05- μf capacitor.	4	18	5 or less	
	1	1.5	20	
	1	2.7	22	
	2	2.7	12	
	2	5	38	
	3	5	12	
	3	9.5	21	
	4	9.5	18	
	4	18	18.5	
	Control grid, pin 6 of V2, through a .05- μf capacitor.	1	1.5	26
1		2.7	45	
2		2.7	76	
2		5	340	
3		5	39	
3		9.5	118	
4		9.5	30	
4		18	53	
Control grid, pin 6 of V3, through a .05- μf capacitor.		1	1.5	290
		1	2.7	114
	2	2.7	340	
	2	5	720	
	3	5	120	
	3	9.5	160	
	4	9.5	96	
	4	18	130	
	Control grid, pin 6 of V3, through a .05- μf capacitor with signal frequency of 455-kc modulated 30%.	1	1.5	220
		1	2.7	102
2		2.7	260	
2		5	600	
3		5	90	
3		9.5	120	
4		9.5	56	
4		18	103	

e. I-f Stage Gain.

- (1) With receiver controls set as in *a* above, set additional controls as follows:

Control	Setting
BAND SW. switch	Band 2
MANUAL-PRESET TUNING control	5 mc

- (2) The gain of the i-f stage is as follows:

Signal generator frequency	Signal generator output connection	Signal Generator output μV	Output meter reading
455 kc, 400 cycles, 30% modulation.	Converter grid, pin 6 of V3.	38	10 mw
	Control grid, pin 6 of V4.	410	10 mw
	Control grid, pin 6 of V5.	16,000	10 mw

Section II. REPAIRS

88. General Precautions

Whenever the equipment is to be serviced, observe the following precautions:

a. When making measurements with the power on, be careful not to touch the incoming power terminals. Severe shock or burn may be caused by low voltages if conditions are such that current flow is high.

b. Before touching any part in the set after the power has been removed, discharge capacitors C114 and C118 in the power supply and capacitor C37 in the receiver.

c. Careless replacement of parts often makes new faults inevitable. Note the following points:

- (1) Before a part is unsoldered, note the position of the leads. If the part, such as an r-f or power transformer, has a number of connections, tag each of the leads to it.
- (2) Be careful not to damage other leads by pulling or pushing them out of the way.
- (3) Do not allow drops of solder to fall into the set; they may cause short circuits. If solder does drop into the set, remove the solder immediately, because it is very often forgotten.
- (4) Keep the hot soldering iron away from other parts; excessive heat may damage them.
- (5) A carelessly soldered connection may create a new fault. It is very important to make a well-soldered joint; a poorly soldered joint is one of the most difficult faults to find.
- (6) When a part is replaced in r-f or i-f circuits, place it in exactly the same position as the original one. A part which has the same electrical value, but different physical size, may cause trouble in r-f circuits. Give particular attention to grounding when replacing a part. Use the same ground point as in the original wiring. Failure to ob-

serve these precautions may result in decreased gain, oscillation of the circuit, or increase in the radiation of the h-f oscillator.

89. Replacement of Parts

a. Most of the parts in Radio Receiving Set AN/GRR-5 are readily accessible and easily replaceable, if found to be faulty. When the BAND SW. switch (S1) in the receiver requires replacement, mark the wires connected to the switch carefully with tags or other devices to avoid errors in connection when a new switch is installed. Be equally careful when replacing PHN.-C.W.-NET-CAL. switch S2. When POWER SELECTOR switch S101 or POWER ON-OFF switch S103 in the power supply requires replacement, follow the same procedure. Follow this practice when replacing any component which has numerous connections.

b. When replacing one of the transformers T1 to T8 inclusive in the receiver, be extremely careful when inserting tools through the band-switch assembly. An alternate method of gaining access to the transformers is to remove the band switch by removing the front panel (par. 91), and then removing the 6 screws and lock-washers holding the band switch.

90. Refinishing

Instructions for rustproofing and touch-up painting are given in paragraph 39. Instructions for refinishing badly marred panels or exterior cabinets are given in TM 9-2851.

91. Disassembly Procedure

(fig. 46)

a. Gear Assembly. Loosen the coupling at the back of the gear assembly by loosening the two setscrews, using the wrench supplied, and processed as follows:

- (1) Remove the three cap and chain assemblies from the three connectors and remove the three locking rings and the one lockwasher around the connectors.
- (2) Remove the six knobs by removing

the screws and lockwashers in the head of each knob; then remove the seal nuts, lockwashers, and bushings around the shafts.

- (3) Remove the dial lock assembly by removing the two screws, nuts, and lockwashers; remove the key and chain by removing the one screw, nut, and lockwasher.
- (4) Remove the fine-tuning knob by loosening the two setscrews; use the Bristol wrench supplied.
- (5) Remove the MANUAL - PRESET TUNING knob by removing the one nut and lockwasher.
- (6) Remove the preset base and gasket by removing the three seal screws.
- (7) Loosen the gear assembly by removing the two seal screws.
- (8) Remove the microswitch by rotating it 180° clockwise, squeezing the tab, and lifting it off.
- (9) Remove the dial-light switch plunger by removing the one nut and lockwasher.
- (10) Remove the front panel, the four screws, and lockwashers; unsolder the antenna lead at antenna post A and the black lead to the R. F. GAIN control; slide the front panel forward and slide the gear assembly toward the rear.
- (11) Remove the dial scale by removing the four screws.
- (12) Remove the lucite light guide and bracket by removing the two screws holding the bracket to the gear assembly and the two screws holding the light guide to the bracket.
- (13) Remove the dial-light bracket by removing the two screws, nuts, and lockwashers.

Note. To reassemble the gear assembly, follow the procedure in reverse order. Check lubrication instructions in paragraph 36.

b. Preset Base. After removing the preset base (a(6) above) use the dial lock key to remove the numbered cap nuts for replacement purposes. Unscrew the cap nuts over the slot in the preset base so that the screw will fall out and release the nut.

c. Manual-Preset Knob Assembly. After the preset knob assembly has been removed (a(5) above), follow the procedure below for repair or replacement purposes:

- (1) Remove the two screws, the two lockwashers, and the spring retainer.
- (2) Remove the two screws, the two lockwashers, and the detent positioner retainer.
- (3) Remove the detent positioner.
- (4) Remove the spring and cap.
- (5) Remove the two detent guides.
- (6) Remove the spring bracket by removing the two screws and lockwashers.
- (7) Remove the four screws and lockwashers.
- (8) Remove the two cam brackets.
- (9) Remove the cam arm from the cam by removing the two screws and lockwashers.
- (10) Remove the two springs and dial window.

d. Band Switch. To remove the band switch, first remove the front panel and then remove the six screws and lockwashers (a(1), (2), (8), and (10) above). Unsolder and tag all leads to the band switch.

e. Dial Shutter and Gears. Follow the procedure in a above and then perform the functions below.

- (1) Remove the dial shutter by removing the hexagonal nut, lockwasher, axle, spring washer, and seal screw.
- (2) Remove the shoulder screw, O ring, gear (large), spring washer, lockwasher, and cap nut.
- (3) Remove the small gear by loosening the two setscrews; use the Bristol wrench supplied.

Section III. ALINEMENT PROCEDURES

92. Test Instruments Required for Alinement

a. Signal Generator. The signal generator should be an accurately calibrated instrument producing modulated and unmodulated r-f signals, such as Signal Generator TS-588/U or RF Signal Generator AN/URM-25. The frequency range must extend from 400 kc to 25 mc. The alinement frequencies are shown in paragraphs 94 through 96. If necessary, the second harmonic generally can be used when the fundamental is not available. The generator should have an output of at least 5,000 μ V for best results in alining the r-f, h-f oscillator, and i-f circuits. Frequency calibration of the signal generator is extremely important to insure that the receiver dial calibration will be correct.

b. Output Meter. The output meter should respond to audio frequencies and should provide at least half-scale deflection for 2.5 volts (approximately 10 mw). It should have a 600-ohm input impedance. Use Output Meter TS-585/U (or an equivalent meter), set at 600 ohms.

c. Frequency Meter. When a highly accurate signal generator is not available, use a frequency meter to check the accuracy of the generator. Frequency Meter Set SCR-211 is suitable.

d. Headset or Permanent-Magnet Loudspeaker. The integrally mounted loudspeaker or the headset supplied may be used for rough alinement.

e. Alinement Tools. A suitable alinement tool, supplied with the receiver, or an insulated screw driver and insulated nut driver are required.

93. Calibration of Signal Generator

When the signal generator calibration is not acceptable, accurate alinement of the h-f oscillator in the receiver requires the use of a frequency meter to check the signal generator setting, as follows:

a. Place the generator and the frequency meter near each other.

b. Turn on both equipments and allow them to warm up for at least 15 minutes.

c. Calibrate the frequency meter according to the instructions furnished with that unit.

d. Attach a piece of wire to the signal generator output connection and place the wire near the frequency meter antenna.

e. Set the meter to the exact frequency at which the generator is to be used.

f. While listening to the headset connected to the frequency meter, tune the generator to zero beat with the meter. The signal generator is now set for the frequency desired.

g. Turn off the frequency meter and remove the wire attached to the signal generator output connection.

94. I-f Alinement Procedure (figs. 38, 39, and 40)

Note. Keep the output reading at 10 mw during these tests.

a. Set the output meter to 600 ohms and connect it to the receiver PHONES connector. Connect a suitable headset into the other connector for listening purposes.

b. Set the signal generator to 455 kc, modulated 30 percent at 400 cycles, and connect its output through a .05- μ f, or larger, blocking capacitor to the signal grid of the second i-f amplifier tube (pin 6 of V5).

c. Set the receiver and power supply front panel controls as follows:

Control	Setting
OUTPUT HIGH-LOW switch (S4)	HIGH
PHN.-C.W.-NET-CAL. switch (S2)	PHN.
R.F. GAIN control (R32)	Maximum
SPEAKER ON-OFF switch (S102)	OFF
BAND SW. switch (S1)	Band 2
MANUAL-PRESET TUNING control.	5 mc
A.F.-GAIN (R19A and R19B)	Adjusted to read to 10 mw on output meter
POWER SELECTOR switch (S101).	Mode of operation used
POWER ON-OFF switch (S103)	ON

d. Allow the receiver and power supply to warm up for approximately 5 minutes before making any adjustments. Be sure that no outside signal is coming in through the antenna circuit. Adjust filament voltage control R116

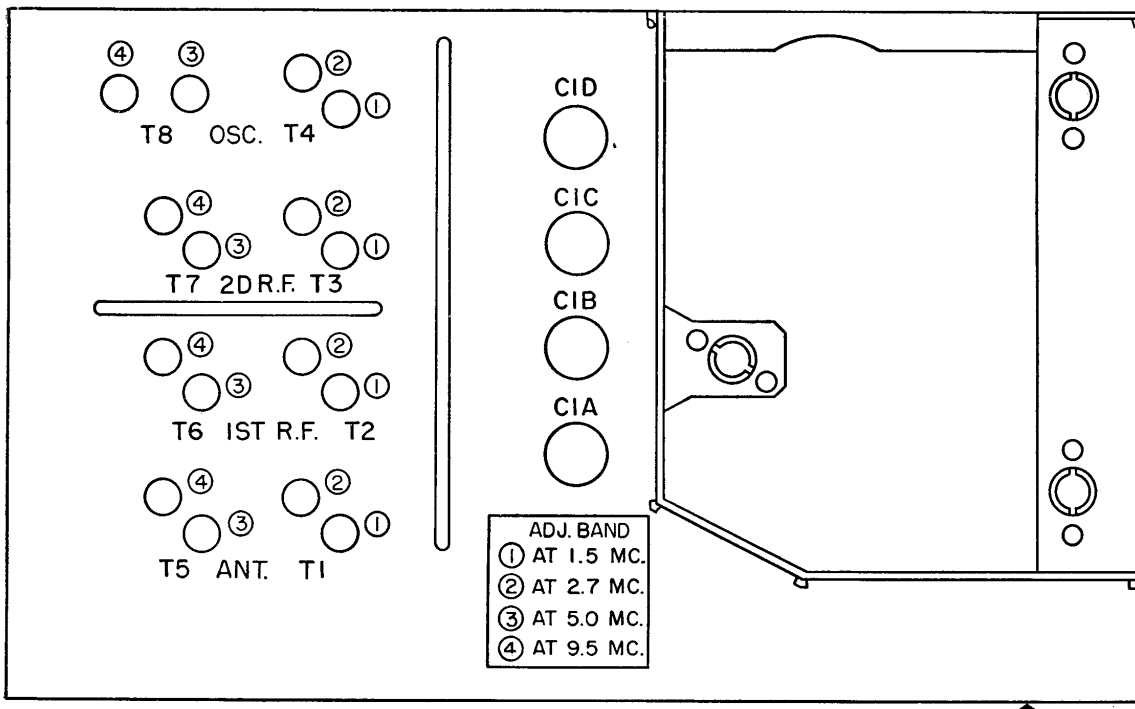

FRONT

TOP COVER

BOTTOM COVER

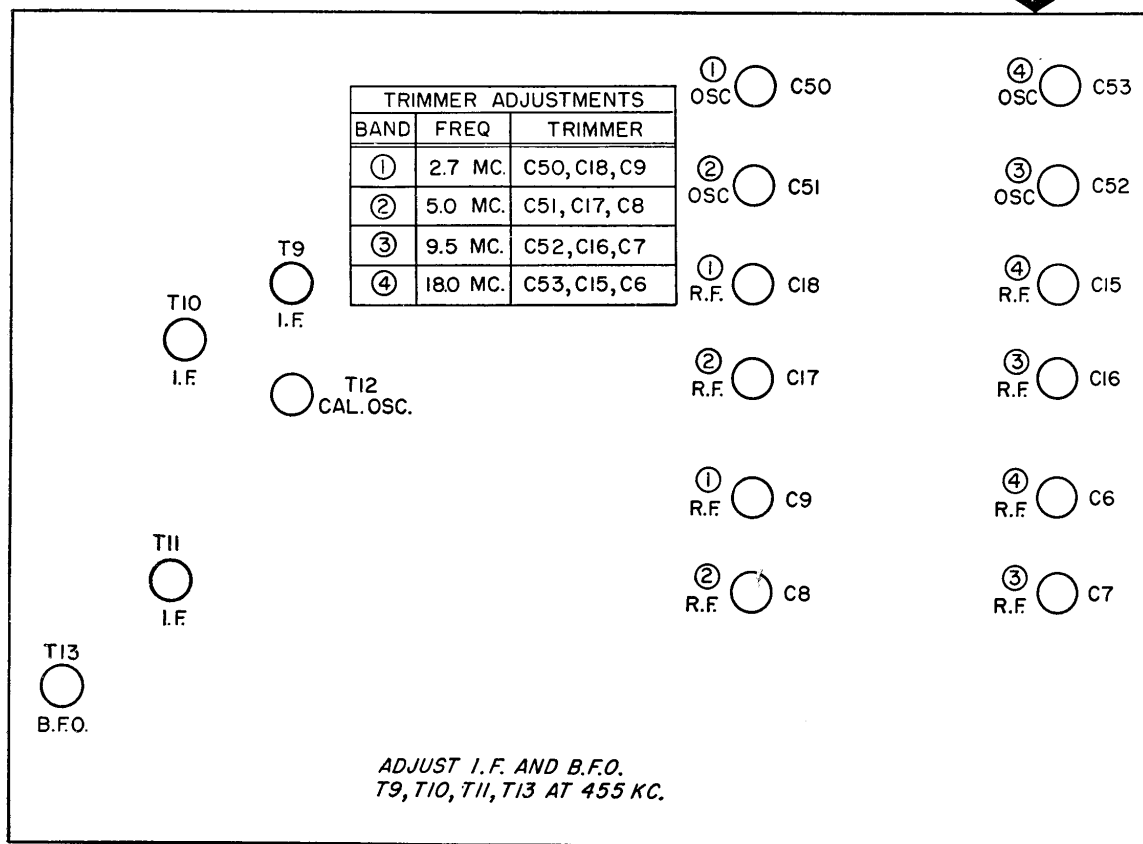

FRONT

TM 295-41

Figure 40. Radio Receiver R-174/URR, alinement charts.

to obtain a reading of 1.4 volts dc at J102 (par. 15).

e. Adjust the top and bottom slugs of transformer T11 for maximum output indication on the output meter.

f. Connect the signal generator lead to the grid of the first i-f stage (pin 6 of V4) and adjust the top and bottom of transformer T10; lower the input signal from the generator as each circuit is tuned.

g. To aline the first i-f transformer, connect the signal generator to the stator terminal of C1C (fig. 38) and adjust the slugs of transformer T9 for maximum output indication. At this point, peaking of all i-f transformers should be rechecked to overcome any slight regeneration that may be present.

95. Bfo Alinement Procedure

(figs. 38, 39, and 40)

a. Set the signal generator to 455 kc unmodulated. Connect the generator output through a .05- μ f capacitor to the grid (pin 6 of V4) of the first i-f amplifier. Set the B.F.O. trimmer to the vertical white line on the panel. Set the PHN.-C.W.-NET-CAL. switch to C.W.

b. Connect an output meter and headset as instructed in paragraph 94a. Adjust coil T13 at the bottom of the receiver chassis until a zero-beat note is heard, or adjust it to minimum output indication on the output meter. Connect a vacuum-tube voltmeter through a 68,000-ohm isolating resistor to pin 4 of V7. The voltage at the grid, pin 4, should read approximately —15 volts dc to —20 volts dc.

96. R-f Alinement Procedure

(figs. 38, 39, and 40)

The step-by-step procedure for r-f alinement is indicated in the chart in *g* below.

a. *Panel Controls.* Set the panel controls as follows:

Control	Setting
OUTPUT HIGH-LOW switch (S4)	HIGH
PHN.-C.W.-NET-CAL. switch (S2)	PHN.
BAND SW. switch (S1)	1
R.F. GAIN control (R32)	Maximum clockwise
SPEAKER ON-OFF switch (S102)	ON

Control	Setting
POWER ON-OFF switch (S103)	ON
A.F. GAIN control (R19A, R19B)	Adjusted to 10 mw on output meter

b. *Dial Pointer Check.* Before proceeding with the alinement, see that the dial pointer coincides with the vertical master line.

c. *Trimmer Locations.* Adjustments are located on the top and bottom of the receiver chassis (figs. 38, 39, and 40). Adjustments are to be made with the special tools provided.

d. *Calibration Accuracy.* The accuracy of the tuning calibration depends largely on the h-f oscillator operating frequency, which is continuously set at 455 kc above the operating frequency. Although the frequency of this oscillator can be measured directly, it is simpler to use the system indicated in the chart, where the tuning dial is adjusted to the operating frequency, and then the trimmers are used to peak the signal.

e. *Image Frequency Check.* To check the receiver for correct alinement, set the signal generator to the image frequency which will appear at a higher frequency on the signal generator dial. This is the radio frequency plus twice the intermediate frequency. As an example, with the receiver dial set at 2.7 mc, the image will appear at 3.6 mc (2.7 mc + .910 mc) on the generator dial. The image must be the weaker signal, and a large input from the generator should be required to obtain the desired output. The procedure should be followed to check the alinement on all bands. If the signal frequency appears at a lower frequency on the generator dial than that indicated on the receiver dial, the receiver is alined incorrectly and must be realined. Note that in the alinement of the oscillator, two signal peaks will appear when the trimmer is varied. The peak with the minimum capacity is the correct peak.

f. *Connections.* Connect the signal generator to terminal post A through a 110- μ f capacitor, and the ground lead of the generator to terminal G. Connect the output meter in parallel with a 600-ohm resistor across one of the PHONES connectors.

g. R-f Alinement, Band 1.

Step	Generator freq (mc)	Receiver tuning dial (mc)	Tuned circuit adjustment for peak output	Circuit	Remarks
1	1.5	1.5	T4(1)	Oscillator tank.	Rock.
2	2.7	2.7	C50	Oscillator tank.	
3	Repeat steps 1 and 2.	Repeat steps 1 and 2.			
4	1.5	1.5	T3(1) T2(1) T1(1)	R-f transformers.	Low end calibration point.
5	2.7	2.7	C18 C9 C2	Second r-f transformer. First r-f transformer. ANT. TRIMMER.	Rock high end calibration point. Rock.
6	Repeat steps 4 and 5.	Repeat steps 4 and 5			
7	3.61	2.7			Image frequency check.

h. R-f Alinement, Band 2.

Step	Generator freq (mc)	Receiver tuning dial (mc)	Tuned circuit adjustment for peak output	Circuit	Remarks
1	2.7	2.7	T4(2)	Oscillator tank.	Rock.
2	5	5	C51	Oscillator tank.	
3	Repeat steps 1 and 2.	Repeat steps 1 and 2.			
4	2.7	2.7	T3(2) T2(2) T1(2)	R-f transformers.	Low end calibration point.
5	5	5	C17 C8 C2	Second r-f transformer. First r-f transformer. ANT. TRIMMER.	Rock. Rock. High end calibration point.
6	Repeat steps 4 and 5.	Repeat steps 4 and 5.			
7	5.91	5			Image frequency check.

i. R-f Alinement, Band 3.

Step	Generator freq (mc)	Receiver tuning dial (mc)	Tuned circuit adjustment for peak output	Circuit	Remarks
1	5	5	T8(3)	Oscillator tank.	Rock.
2	9.5	9.5	C52	Oscillator tank.	
3	Repeat steps 1 and 2.	Repeat steps 1 and 2.			
4	5	5	T7(3) T6(3) T5(3)	R-f transformers.	Low end calibration point.

Step	Generator freq (mc)	Receiver tuning dial (mc)	Tuned circuit adjustment for peak output	Circuit	Remarks
5	9.5	9.5	C16 C7 C2	Second r-f transformer. First r-f transformer. ANT. TRIMMER.	Rock. Rock. High end calibration point.
6	Repeat steps 4 and 5.	Repeat steps 4 and 5.			
7	10.41	9.5			Image frequency check.

j. R-f Alinement, Band 4.

Step	Generator freq (mc)	Receiver tuning dial (mc)	Tuned circuit adjustment for peak output	Circuit	Remarks
1	9.5	9.5	T8(4)	Oscillator low end.	
2	18	18	C53	Oscillator high end.	Rock.
3	Repeat steps 1 and 2.	Repeat steps 1 and 2.			
4	9.5	9.5	T7(4) T6(4) T5(4)	R-f transformers.	Low end calibration point.
5	18	18	C15 C6 C2	Second r-f transformer. First r-f transformer. ANT. TRIMMER	High end calibration point.
6	Repeat steps 4 and 5.	Repeat steps 4 and 5.			
7	18.91	18			Image frequency check.

97. Calibration Oscillator Alinement Procedure
(fig. 40)

Set PHN.-C.W.-NET-CAL. function switch

to CAL. Connect a vacuum-tube voltmeter through a 68K-ohm isolating resistor to pin 4 of V5. Adjust the bottom slug of T12 for maximum deflection of the meter. The reading should be approximately —25 volts dc.

Section IV. FINAL TESTING

98. General

This section is intended as a guide in determining the quality of a repaired Radio Receiving Set AN/GRR-5. The minimum test requirements are outlined in the paragraphs 99 through 102. These may be performed by maintenance personnel with adequate test equipment and the necessary skills. Repaired equipment meeting these requirements will furnish uniformly satisfactory operation. All

of the following tests are to be performed while operating the receiver with a 115-volt a-c input, if available. Allow the receiver to warm up for a few minutes before making any measurements.

99. Test Equipment Required

The instruments needed for testing the repaired equipment are listed in paragraph 71. Use equivalent instruments when the items listed cannot be obtained.

100. Voltage Checks

Before testing the receiver further, make the following voltage checks:

a. Measure the d-c voltage between the positive 90-volt supply (capacitor C37) and the negative lead (chassis). The voltage may vary between 87 and 93 volts dc.

b. Check the h-f oscillator plate voltage. The voltage between pin 3 of tube V3 and the chassis should be approximately 43 volts.

c. Measure the voltage from pin 11 of J4 to ground; adjust R116 to 1.4 volts dc (par. 15).

d. Measure the bias voltage from pin 8 of J4 to ground (—4.2 volts dc).

101. Operation of Controls

A complete check of the operation of the receiver controls should be made in accordance with the equipment performance checklist (par. 43). If there is reason for suspecting improper operation of the circuits, also check as follows:

a. Manual-Preset Tuning. Turn the PHN.-C.W.-NET-CAL. function switch to CAL. Check the calibration of the tuning dial every 200 kc in each frequency band. Note that the receiver tuning dial reads correctly within one-half of a scale division. If not, realine the receiver.

b. BFO Operation. Turn the function switch to C.W. Turn off the modulation. Adjust the bfo to give a beat note in the loudspeaker. If the beat note is not heard, refer to paragraph 83.

102. Receiver Characteristics

Note. The tests outlined in *a* through *e* below normally need not be made unless there is reason to suspect improper operation or unless a new component has been inserted in the circuits involved.

a. Sensitivity, Modulated Signals. The receiver should be set up in accordance with the instructions given in paragraph 87. The overall a-m sensitivity of the receiver should correspond to the antenna input readings given in paragraph 87d.

b. Sensitivity, C-W Signals. Check the c-w sensitivity at the same points as those referred to in *a* above. Turn the signal generator modulation

off and turn the function switch to C.W. Tune the B.F.O. control to a 1,000-cycle beat note. Turn the signal generator off, and adjust the A.F. GAIN control for 1-mw output indication on the output meter. Turn the signal generator on and adjust it to give 10-mw output on the output meter. Switch the signal generator off to check noise reading at 1-mw output and readjust the A.F. GAIN control, if necessary. Recheck the 10-mw output with the signal generator. The value of signal input should be 2 μ v or less.

c. Selectivity. This test should be carried out at 5 mc on band 2. Set the signal generator, modulated 30 percent at 400 cycles, to the above frequency; tune the receiver exactly to it; and adjust the signal input to give a reading of 10 mw on the output meter. Double the signal input; detune the signal generator, first on one side and then on the other side of resonance; and note the frequencies that give 10 mw on the output meter. These are the off resonant frequencies. Repeat observations for ratios of input voltage off resonance to voltage at resonance of 10, 100, and 1,000. Bandwidths should be within the limits in the following table.

Ratio of input voltage off resonance to voltage at resonance	Total maximum bandwidth kc
2 (6-db attenuation)	Less than 6.5
10 (20-db attenuation)	Less than 13
100 (40-db attenuation)	Less than 20
1,000 (60-db attenuation)	Less than 28

d. Image-Rejection Ratio. Perform this test on all bands by measuring the sensitivity of the receiver at a frequency equal to the signal frequency plus twice the intermediate frequency (2 x 455 kc or 910 kc). The following procedure is recommended:

- (1) With the PHN.-C.W.-NET-CAL. switch S2 in the PHN. position, set the A.F. GAIN control to maximum, and adjust the R.F. GAIN control to give a 10-mw output with a 10- μ v input.
- (2) With the signal generator and receiver tuned to the test frequency, rotate the signal generator to the image

frequency and adjust the generator output to give 10-mw output. Note the signal generator output. This figure divided by $10 \mu\text{v}$ is the ratio given in the table below.

Band	Signal frequency (mc)	Image frequency (mc)	Image-rejection ratio	db
1	2.7	3.61	10,000 to 1	80
2	5.0	5.91	3,160 to 1	70
3	9.5	10.41	2,000 to 1	60
4	18	18.91	316 to 1	50

e. Fidelity. This is a test of the over-all a-f response of the receiver. Set the signal generator to 5 mc, modulated 30 percent and with the PHN.-C.W.-NET-CAL. switch in PHN. position; tune the receiver to the signal. Adjust the signal output of the generator to $50 \mu\text{v}$ and maintain this level throughout the tests. Vary the modulating frequency from 250 to 2,500 cps; use the internal variable-frequency audio oscillator or an external calibrated oscillator. Adjust the R.F. GAIN and A.F. GAIN controls to produce a level at which there is no over-

loading as the modulating frequency is varied. Note the change in power output in db as the modulating frequency is varied. The a-f response should be flat within 3 db from 400 to 2,000 cps and within 7 db from 250 to 2,500 cps.

f. AVC Characteristic. Perform this test in conjunction with the sensitivity test given in *a* above. With the PHN.-C.W.-NET-CAL. switch S2 in the PHN. position, proceed as follows:

- (1) Set the R.F. GAIN control at maximum clockwise position.
- (2) Adjust the signal generator to supply a $1.5\text{-}\mu\text{v}$ signal, modulated 30 percent at 400 cycles.
- (3) Adjust the receiver A.F. GAIN control to produce a 10-mw power output.
- (4) An increase of signal input to $10 \mu\text{v}$ should not produce an increase in power output of more than 15 db, and a further increase in signal input to $10,000 \mu\text{v}$ should not produce an additional increase in power output of more than 3 db.

CHAPTER 6

SHIPMENT AND LIMITED STORAGE AND DEMOLITION TO PREVENT ENEMY USE

Section I. SHIPMENT AND LIMITED STORAGE

103. Disassembly

Since the circumstances involved in shipment and storage vary, no definite procedure for repacking can be given. The following instructions are recommended as a guide for preparing the radio receiving set for transportation and storage. To disassemble the equipment, reverse the procedure for setting up the unit (sec. I, ch. 2).

- a. Disconnect all the cables connected to the front panels of the receiver and power supply.
- b. Remove and store the mast sections.
- c. Store the cables and the headset.

104. Repacking for Shipment or Limited Storage

- a. The exact procedure in repacking for ship-

ment or limited storage depends on the material available and the conditions under which the equipment is to be stored or shipped. See paragraphs 6 and 12 and figure 3, and follow in reverse order the instructions given.

- b. Whenever practicable, place a dehydrating agent, such as silica gel, inside the receiver and power supply. Box or package the headset. Wrap each unit in corrugated paper and protect each package with a waterproof barrier. Seal the seams of the paper barrier with a waterproof sealing compound or tape. Pack the protected components in a wooden case; provide at least 3 inches of excelsior padding, or other similar material, between the paper barrier and the packing case.

Section II. DEMOLITION OF MATÉRIEL TO PREVENT ENEMY USE

105. General

The demolition procedures in paragraph 106 will be used to prevent the enemy from using or salvaging this equipment. Demolition of the equipment will be accomplished only upon order of the commander.

106. Methods of Destruction

- a. *Smash.* Smash the controls, tubes, switches, capacitors, and transformers, using sledges, axes, handaxes, pickaxes, hammers, crowbars, or heavy tools.

- b. *Cut.* Cut internal and external wires and cables, using axes, handaxes, or machetes.

- c. *Burn.* Burn cords, resistors, capacitors, wiring, and instruction books, using gasoline, kerosene, oil, flame throwers, or incendiary grenades.

- d. *Bend.* Bend panels and chassis.

- e. *Explosives.* If explosives are necessary use firearms, grenades, or TNT.

- f. *Disposal.* Bury or scatter the destroyed parts in slit trenches, fox holes, or other holes, or throw them into streams.

- g. *Destroy.* Destroy everything.

APPENDIX I

REFERENCES

Note. For availability of items listed, check SR 310-20-3, SR 310-20-4, and SR 310-20-5. Check Department of the Army Supply Catalog SIG 1 for Signal Corps supply catalog pamphlets.

1. Army Regulations

- AR 380-5 Military Security (Safeguarding Military Information).
AR 750-5 Maintenance of Supplies and Equipment (Maintenance Responsibilities and Shop Operation).

2. Supply Publications

- SB 11-6 Dry Battery Supply Data.
SB 11-47 Preparation and Submission of Requisitions for Signal Corps Supplies.
SB 11-76 Signal Corps Kit and Materials for Moisture- and Fungi-Resistant Treatment.

3. Auxiliary Equipment and Test Equipment

- TM 11-300 Frequency Meter Sets SCR-211-A, B, C, D, E, F, J, K, L, M, N, O, P, Q, R, T, AA, AC, AE, AF, AG, AH, AJ, AK, AL and AN.
TM 11-307 Signal Generators I-72-G, H, J, K, and L.
TM 11-472 Repair and Calibration of Electrical Measuring Instruments.
TM 11-2627 Tube Tester I-177 and I-177-A.
TM 11-5017 Output Meter TS-585A/U.
TM 11-5018 Signal Generator TS-588/U.
TM 11-5511 Electronic Multimeter TS-505/U.
TM 11-5527 Multimeter TS-352/U.
NAVSHIPS 91283 RF Signal Generator Set AN/URM-25.
TO 16-35T5382-2 Audio Oscillator TS-382A/U.

4. Painting, Preserving, and Lubrication

- TB SIG 13 Moistureproofing and Fungiproofing Signal Corps Equipment.
TB SIG 69 Lubrication of Ground Signal Equipment.
TM 9-2851 Painting Instructions for Field Use.

5. Camouflage, Decontamination, and Demolition

- FM 5-20 Camouflage, Basic Principles.
FM 5-25 Explosives and Demolitions.
TM 3-220 Decontamination.

6. Other Publications

- FM 24-18 Field Radio Techniques.
FM 72-20 Jungle Warfare.

SR 310-20-3	Index of Training Publications.
SR 310-20-4	Index of Technical Manuals, Technical Regulations, Technical Bulletins, Supply Bulletins, Lubrication Orders, Modification Work Orders, Tables of Organization and Equipment, Reduction Tables, Tables of Allowances, Tables of Organization, and Tables of Equipment.
SR 310-20-5	Index of Administrative Publications.
SR 700-45-5	Unsatisfactory Equipment Report (Reports Control Symbol CSGLD-247).
SR 745-45-5/ AFR 71-4	Report of Damaged or Improper Shipment (Reports Control Symbols CSGLD-66 (Army) and AF-MC-U2 (Air Force)).
TB SIG 4	Methods of Improving the Effectiveness of Jungle Radio Communication.
TB SIG 25	Preventive Maintenance of Power Cords.
TB SIG 66	Winter Maintenance of Signal Equipment.
TB SIG 72	Tropical Maintenance of Ground Signal Equipment.
TB SIG 75	Desert Maintenance of Ground Signal Equipment.
TB SIG 123	Preventive Maintenance Practices for Ground Signal Equipment.
TB SIG 178	Preventive Maintenance Guide for Radio Communication Equipment.
TB SIG 219	Operation of Signal Equipment at Low Temperatures.
TB SIG 223	Field Expedients for Wire and Radio.
TB 11-499-()*	Basic Radio Propagation Predictions.
TM 9-2851	Painting Instructions for Field Use.
TM 9-2857	Storage Batteries Lead-Acid Type.
TM 11-314	Antennas and Antenna Systems.
TM 11-415	Dry Batteries.
TM 11-430	Batteries for Signal Communication. Except those pertaining to Aircraft.
TM 11-453	Shop Work.
TM 11-455	Radio Fundamentals.
TM 11-466	Radar Electronic Fundamentals.
TM 11-476	Radio Direction Finding.
TM 11-483	Suppression of Radio Noises.
TM 11-486	Electrical Communication Systems Engineering.
TM 11-496	Training Text and Applicatory Exercises for Amplitude-Modulated Radio Sets.
TM 11-499	Radio Propagation Handbook.
TM 11-660	Introduction to Electronics.
TM 11-661	Electrical Fundamentals (Direct Current).
TM 11-681	Electrical Fundamentals (Alternating Current).
TM 11-4000	Trouble Shooting and Repair of Radio Equipment.

* A new TB in this series is issued monthly which gives propagation predictions 3 months in advance.

9. Abbreviations

a-c	alternating-current	l-f	low-frequency
a-f	audio-frequency	lg	long
a-m	amplitude-modulated	ma	milliampere
amp	ampere	max	maximum
avc	automatic volume control	mc	megacycle
bfo	beat-frequency oscillator	meg	megohm
CAL.	calibration	mh	millihenry
ch.	chapter	min	minimum
cps	cycles per second	mv	millivolt
cu	cubic	mw	milliwatt
c-w	continuous-wave	ocs	oscillator
db	decibel	par.	paragraph
d-c	direct-current	PHN.	phone
ea	each	r-f	radio-frequency
fig.	figure	Sig C	Signal Corps
ft	feet	μ f	microfarad
h-f	high-frequency	$\mu\mu$ f	micromicrofarad
i-f	intermediate-frequency	μ v	microvolt
in.	inch	v or V	volt
JAN	Joint Army-Navy	VTVM	vacuum-tube voltmeter
kc	kilocycle	w	watt
lb	pound		

APPENDIX II

IDENTIFICATION TABLE OF PARTS

Note. The fact that a part is listed in this table is not sufficient basis for requisitioning the item. Requisitions must cite an authorized basis, such as a specific T/O&E, T/A, SIG 7 & 8, list of allowances of expendable material, or another authorized supply basis. The Department of the Army Supply Catalog applicable to the equipment covered in this manual is SIG 7 & 8 AN/GRR-5. For an index of available supply catalogs in the Signal portion of the Department of the Army Supply Catalog, see the latest issue of SIG 1.

1. Identification Table of Parts for Radio Receiving Set AN/GRR-5

Ref. symbol	Name of part and description	Function of part	Signal Corps stock No.
	RADIO RECEIVING SET AN/GRR-5: A ₁ and A ₂ reception; 1.5 mc to 18 mc, 4 bands, 10 channels; power requirements 115 v, 60 cyc, single phase, 455 ma; or dc, 6 v, 6.9 amp; or dc 12 v, 3.22 amp; or dc 24 v, 2.55 amp; or dc from dry battery, 90 v, 32 ma and 1.5 v, 450 ma; inclosed in 3 portable carrying bags; 72" lg x 52" wd x 14" h; 8 tubes in receiver, 4 tubes in power supply; superheterodyne circuit; built-in crystal calibrating oscillator and BFO; includes 1 Radio Receiver R-174/URR, 1 Power Supply PP-308/URR, Antenna Sections MS-116-A, MS-117-A, and MS-118-A; 1 Electrical Equipment Cabinet CY-615/URR, 1 Mounting MT-768/U, 1 Emerson Rad mounting part/dwg #AS-1227, 1 Headset Cord CX-1334/U, 1 Power Cable Assembly CX-1358/U, 1 Power Cable Assembly CX-1359/U, 1 Power Cable Assembly CX-1360/U, 1 Electron Tube Case CY-1031/URR; 1 Cover CW-211/U; 1 Bag CW-206/GR; 1 Bag CW-212/U; 1 Headset, Navy Type CW-49507-A; 1 Receiver-power supply connecting cable.		2S2505-5
	RADIO RECEIVER R-174/URR: A ₁ and A ₂ reception; frequency data 1.5 mc to 18 mc, 4 bands, 10 channels; power requirements 90 v dc at 32 ma, 1.5 v dc at 450 ma; mounted in aluminum case; 12" lg x 7 $\frac{7}{8}$ " wd x 5 $\frac{5}{16}$ " h; 8 electron tubes; superheterodyne, built-in crystal calibrating and bfo.	Radio receiver for Radio Receiving Set AN/GRR-5.	2C4180-174
	POWER SUPPLY PP-308/URR: full-wave rectification; output data 90 v dc, 35 ma regulated; 1.4 v dc, 450 ma regulated; input data 115 v, 60 cyc, single phase, 455 ma; or 6 v dc, 6.9 amp; or 12 v dc, 3.22 amp; or 24 v dc, 2.55 amp; or dc from dry battery 90 v, 27 ma and 1.5 v, 350 ma; 12" lg x 8" wd x 5 $\frac{1}{2}$ " h.	Power supply for Radio Receiving Set AN/GRR-5.	3H4497-308
	ELECTRICAL EQUIPMENT CABINET CY-615/URR: aluminum; 13 $\frac{5}{8}$ " lg x 12 $\frac{1}{8}$ " wd x 8 $\frac{1}{16}$ " d; 2 compartments; mounts 8 catches; Emerson Rad part/dwg #AS-1046.	Houses receiver and power supply.	6F300-615

1. Identification Table of Parts for Radio Receiving Set AN/GRR-5—Continued

Ref. symbol	Name of part and description	Function of part	Signal Corps stock No.
	MOUNTING MT-768/URR: cadmium plated, lusterless olive drab finish; case rests on mtg channels, case positioned by 2 pins at rear of mtg channels and spot welded to mtg channels, 4 shock mounts located between mtg channels and base; c/o of Emerson Rad base part #MS-1111, channel assy part #AS-1072, shock mount assy part #AS-1227, grounding strap, and hardware; Emerson Rad part/dwg #AS-1073.	Shock mount assembly for mounting radio receiver and power supply.	2Z6763-768
	ELECTRON TUBE CASE CY-1031/URR: aluminum, caustic etch, olive drab wrinkle finish; 9 $\frac{3}{4}$ " lg x 4 $\frac{1}{4}$ " wd x 3" h; 4 aluminum partitions subdividing case into 5 compartments lined with felt; lid hinged to body of case; water and mildew resistant; Emerson Rad part/dwg #MS-1273.	Spare parts box for Radio Receiving Set AN/GRR-5.	6F300-1031
	BAG CW-206/GR: cotton duck, olive drab; 44" lg x 27" wd; strap and snap fastens around parts contained; 1" wd hem reinforcement; one compartment; water repellent; Emerson Rad part/dwg #FC-1005.	Spare parts, mast, and cable container.	2Z553-206
	BAG CW-212/U: cotton duck, olive drab; 13 $\frac{1}{4}$ " lg x 11" wd x 5 $\frac{1}{2}$ " h; strap and snap fastens around battery; 1" hem reinforcement; water repellent; Emerson Rad part/dwg #FC-1006.	Canvas bag for dry batteries.	3B295-212
	CABLE ASSEMBLY, special purpose: electrical; Gavitt Mfg Co part #FC-26A; Hazacord part #65; 2 cond, stranded, #18 AWG; 6 cond, stranded, #26 AWG; 3 cond, stranded #18-41/34; 36" lg; term. fittings on first end 1 female connector American Phenolic Corp part #26-805; term. fittings on second end 1 male connector American Phenolic Corp part #26-804; term. fittings on third end 1 selenium rectifier plate Rad Receptor part #2Q-0897; Emerson Rad part #AW-1010.	Receiver-power supply connecting cable.	3E7350-1.20.26
	CABLE ASSEMBLY, power: electrical; Cable Assembly CX-1358/U; 2 cond, stranded, #18 gage, cotton and rubber compound; 8 ft lg; term fittings on first end 1 connector Hubbell part #7057; term. fittings on second end 1 connector Winchester Electronics Inc part #RA4S-PR-R; Emerson Rad part #AW-1000.	115 v a-c power input cable.	3E5999-6.35
	CABLE ASSEMBLY, power: electrical; Cable Assembly CX-1359/U; CO-129; 1 stranded #14 gage rubber, 9 $\frac{1}{2}$ " lg o/a; term. fittings on first end 2 term. lugs Pat MacGuyer part #2050; term. fittings on second end 1 connector Emerson Rad Winchester Electronics Co part #RA4S-PR-R modified by Emerson Rad #KS-1057.	Power input cable for 6, 12, and 24 volts dc.	3E5999-6.34
	CABLE ASSEMBLY, power: electrical; Cable Assembly CX-1360/U; CO-129; 4 stranded #20 AWG rubber; term. fittings on first end 1 connector Winchester Electronics Co part #RA4S-PR-R; term fittings on second end 1 connector Breeze part #EC-3543; branched; one connector located 6 $\frac{1}{4}$ " from end, second connector located 13 $\frac{1}{2}$ " from same end; each connector Breeze types EC-3543 and EC-3547, respectively; Special Design Prod Co part #CX-1360/U.	Battery input power cable.	3E5999-6.33

1. Identification Table of Parts for Radio Receiving Set AN/GRR-5—Continued

Ref. symbol	Name of part and description	Function of part	Signal Corps stock No.
E15, E18	CABLE ASSEMBLY, special purpose: electrical; Cable Assembly AW-1006; CO-219; 2 stranded #23 AWG rubber jacket; 6 ft 6" lg o/a; term. fittings on first end 1 extension jack Switchcraft Inc JJ-026; term. fittings on second end 1 connector Amphenol part #164-8; Emerson Rad part #AW-1006.	Headset cord-----	3E6000-1334.1
	COVER CW-211/U: cotton duck dyed olive drab; 14½" lg x 15¾" h x 11" wd; bag strapped to case, after insertion, with strap and buckle mounted on bag; Emerson Rad part/dwg #FC-1004.	Canvas cover for receiver and power supply cases.	2Z3351-362
	HEADSET, electrical: Navy type #49507-A; magnetic; 600 ohms impedance; 2 receivers w/cushions; single metal, flat, black plastic cover headband w/22½" cord; two cord tips on one end, two cord tips on other end; WECO part/dwg #D173329.	Headset-----	2B955
E16	MAST SECTION: Mast Section MS-116-A; whip type tapered; bottom section of 3 elements; 39½" lg; wall thickness .026"; cold drawn steel; semigloss olive drab finish; mounts by male threaded termination on one end and female threaded termination 2⅜" from other end; p/o receiving antenna; Croyden Mfg Co type #MS-116A.	Signal pickup-----	2A2416
E17	MAST SECTION: Mast Section MS-117-A; whip type; tapered; middle section of 3 elements; 39½" lg; wall thickness .015"; cold drawn steel; semigloss olive drab finish; mounts by male threaded termination on one end and female threaded termination 2⅜" from other end; p/o receiving antenna; Croyden Mfg Co type #MS-117A.	Signal pickup-----	2A2417
E17	MAST SECTION: Mast Section MS-118-A; whip type; tapered; top section of 3 elements; 39½" lg; wall thickness .012"; one end terminated with a ⅜" steel ball; cold drawn steel; semigloss olive drab finish; mounts by male threaded termination on one end; p/o receiving antenna; Croyden Mfg Co type #MS-118A.	Signal pickup-----	2A2418

2. Identification Table of Parts for Electrical Equipment Cabinet CY-615/URR

Ref. symbol	Name of part and description	Function of part	Signal Corps stock No.
O110, O130, O131, O132, O133, O134, O135, O136	FASTENER, latch: 2¼" lg x 1½" wd x ½" h; Emerson Rad part #AS-1048.	Fastens receiver and power supply to case.	6Z6918-8
H106, H142	FASTENER, screw: brass; flat fillister head; slot drive; #8-32 thread, NC-2, ¼" lg; ¼" threaded; United Carr stud #559.	Fasten case to canvas cover.	6Z3809H
H130, H131, H132, H133	PIN, locating: stainless steel; 1" lg x ⅜" across flats of hex. nut; Emerson Radio and Phono Corp part #SM-1036.	Serve as anchor pins for receiver and power supply.	2Z6978-22

2. Identification Table of Parts for Electrical Equipment Cabinet CY-615/URR— Continued

Ref. symbol	Name of part and description	Function of part	Signal Corps stock No.
A131 thru A134	PLATE, mounting: attached by anchor pin; Emerson Rad part #MS-1074.	Backing plates for cabinet	2Z6820.450
H104, H134 thru H140	PLATE, retainer: steel; .921" lg x $\frac{5}{16}$ " wd, .215" flange; w/two #6-32, NC-2 holes; Emerson Rad part/dwg #MS-1110.	Attach catches to case	2Z7090.117
H109, H145	SPRING, helical, compression: .032" dia stainless steel; $1\frac{1}{2}$ " lg, .250" ID; 17 turns; squared ends; Emerson Rad part #SV-1004.	Lock case to shock mount	2Z8877.706
H107, H143	STUD: stainless steel; 2.046" lg x $\frac{3}{8}$ " dia shoulder; one end threaded $\frac{3}{8}$ " dia x .531" lg, 32 threads per inch; knurled end; Emerson Rad part #SM-1031.	Lock case to shock mount	6L31146-8
H105, H141	STUD: steel; $\frac{3}{16}$ " lg, hex. shoulder $\frac{3}{4}$ " across flats; $\frac{1}{16}$ "-2 NEF thread on outside, $\frac{1}{16}$ " lg thread; Emerson Rad dwg #SM-1035.	Fasten case to shock mount	2Z8634-60

3. Identification Table of Parts for Headset Cord CX-1334/U

Ref. symbol	Name of part and description	Function of part	Signal Corps stock No.
W103	CABLE ASSEMBLY, special purpose: electrical; Sig C Cable CO-219; 2 cond stranded, #23 AWG; rubber insul; rubber jacket; shield around both cond; 6'1" lg o/a; term. fittings on first end 1 female connector Amphenol part #164-8, cond on other end extends $\frac{3}{8}$ " beyond jacket, wires twisted and tinned; Emerson Rad dwg #AW-1012.	Connector and cable for Headset Cord CX-1334/U.	3E2219
P109	CONNECTOR, plug: 10 female flat cont; straight type; $3\frac{1}{8}$ " x $1\frac{1}{2}$ "; truncated cone-shape rubber-molded steel body.	Connector for headset cord assembly.	
J104	JACK, telephone: for 2 cond plug $2\frac{7}{8}$ " lg; Switchcraft Inc part #JJ-026.	Extension jack	2Z5526
O117	INSULATION SLEEVING, electrical: synthetic rubber; $1\frac{1}{4}$ " lg x $\frac{1}{16}$ " OD for $\frac{3}{4}$ " of lg and $\frac{1}{2}$ " OD for $\frac{1}{2}$ " of lg, $\frac{1}{4}$ " ID; force-fits on jack; Band Rubber Co part #CT-3361.	Cord sleeve	2Z8552-111

4. Identification Table of Parts for Mounting MT-768/URR

Ref. symbol	Name of part and description	Function of part	Signal Corps stock No.
A125, A126, A127, A139	BRACKET FT-512: aluminum alloy; mounts to shock absorber by four #10-32 NF-2 internally threaded holes on 1.939" mtg centers; mounts to flat mtg plate of shock absorber by four #10-32 slotted hex. screws; US Rubber part #FT-512.	Bases for shock absorber	2Z1203-512
A135	PLATE, base: steel, cadmium plated; $12\frac{1}{8}$ " lg x $9\frac{1}{16}$ " wd x .9" thk; four mtg holes .265" dia x $3\frac{1}{16}$ " x $\frac{3}{16}$ "; Emerson Rad part #MS-1111.	Base for shock mounting assembly.	2Z7090.123
A123, A136, A137, A138	SHOCK MOUNT M-449: p/o Emerson Rad shock mounting assy part #AS-1227; load rating 17 to 30 lb; $2\frac{3}{8}$ " lg x $2\frac{3}{8}$ " wd x 1.058" h; mounted to base by four .203" dia holes on 1.937" x 1.937" mtg centers; Emerson Rad part #MV-1002.	Shock absorbers	2Z8415-449

5. Identification Table of Parts for Power Supply PP-308/URR

Ref. symbol	Name of part and description	Function of part	Signal Corps stock No.
H103, H129	BOLT, machine: brass; 8-32 thd; ¼" lg; ¼" thd; United Carr stud #559.	Means of retaining canvas cover in place.	6Z3809H
W102	CABLE, power: electrical; 2 cond, #18 AWG; 6 cond, #26 AWG; 21½" lg; Emerson Rad part/dwg #WR-1116.	Interconnecting power cable between receiver and power supply.	1B3026-8
W104	CABLE, special purpose: electrical CO-129; p/o Power Cable Assembly CX-1359/U; 1 #14 AWG, copper, solid cond; rubber insul; .484" dia; Emerson Rad part/dwg #WR-1112.	Power cable for Power Cable Assembly CX-1359/U.	3E2129
W105	CABLE, special purpose: electrical CO-146; p/o Power Cable Assembly CX-1360/U; 4 #20 AWG copper, stranded cond; rubber insul; .340" dia; Sig C Cable CO-146; Emerson Rad part/dwg #WR-1111.	Cable for Power Cable Assembly CX-1360/U.	3E2146
W101	CABLE, special purpose: electrical; 3 cond, #18 AWG, stranded; 14" lg; Emerson Rad part #WR-1115.	Connects power supply to selenium rectifier.	1B3018-3.9
H102	CAP, electrical: aluminum alloy; 1 1/16" dia x 1/16" thk o/a; rubber gasket for sealing; Amphenol part #9760-18.	Captive cover for spare fuse holder.	2Z1619-49
C118	CAPACITOR, fixed: electrolytic; 45 µf; 350 vdcw; JAN CE41C-45OP.	Filter for output of filament voltage regulator.	3DB45-13
C114	CAPACITOR, fixed: electrolytic; 80 µf; 350 vdcw.	B+ input filter	3DB80-19
C101, C110, C111	CAPACITOR, fixed: electrolytic; 1200 µf; 15 vdcw.	C101: CR101 output filter C110 and C111: Filament voltage supply filters.	3DB1200-5
C119	CAPACITOR, fixed: paper dielectric; 4700 µµf, ±10%; 1600 vdcw; Sprague type #84P.	Buffer capacitor for primary of T103.	3DA4.700-22
C113	CAPACITOR, fixed: paper dielectric; 22,000 µµf ±10%; 1600 vdcw; Sprague type #84P.	Buffer capacitor for secondary T102.	3DA22-18
C116, C117	CAPACITOR, fixed: paper dielectric; 22,000 µµf ±20%; 400 vdcw; Sprague part #181P2230451.	E102 hash filter capacitor	3DA22-19
C104 thru C108, C115	CAPACITOR, fixed: paper dielectric; .047 µf ±20%; 200 vdcw; Sprague part #181P4730251.	C104 thru C108: E101 hash filter. C115: E102 hash filter.	3DA47-16
C102A, C102B	CAPACITOR, fixed: paper dielectric; 2 sect.; two .1 µf ±15%; 600 vdcw; JAN-CP53B4EF104L.	Line input filters	3DA100-731
C109	CAPACITOR, fixed: paper dielectric; .25 µf ±10%; 200 vdcw; JAN-CP-29A1EC254K.	Input filter for 6, 12, and 24 volts.	3DA250-610
C112	CAPACITOR, fixed: paper dielectric; 1.25 µf +14 -6%; 100 vdcw; Sprague type #Y21721.	Buffer capacitor for transformer primary of T102.	3DB1E25-2
E103, E105	CLAMP, electrical: spring steel; 1 1/16" dia x 1 1/2" h o/a; mtd by two 3/16" dia holes spaced 1 1/2" c to c; holds material 1 1/2" max dia; Oak part #2025-3.	E103: Secures vibrator and maintains a good electrical contact between vibrator case and chassis. E105: Holds vibrator in place and supplies electrical ground.	2Z2642.581
O104	CLAMP, electrical: steel; screw type; 3/16" lg x 7/8" wd x 3/16" d o/a; holds material with 1/16" radius; Emerson Rad part #MS-1167.	Retains octal tube	2Z2642.582
A198	CLAMP, electrical: beryllium copper; spring action; 1/2" lg x 3/8" d x 1 1/8" h o/a; Emerson Rad part/dwg #MS-1496.	Capacitor clip for C113	2Z2642.580
A199	CLAMP, electrical: beryllium copper; screw type; .58" lg x .203" h x 1/16" wd o/a; Emerson Rad part/dwg #KL-1019.	Holds capacitor C119	2Z2642.583

5. Identification Table of Parts for Power Supply PP-308/URR—Continued

Ref symbol	Name of part and description	Function of part	Signal Corps stock No.
O103, O122	CLAMP, electrical: phenolic; screw type; $\frac{3}{16}$ " lg x $\frac{7}{8}$ " wd x $\frac{3}{16}$ " d o/a; holds material with $\frac{1}{16}$ " radius; Emerson Rad part #PB-1021.	Retains octal tube-----	2Z2642-579
L109, L110	COIL, radio frequency: 600 μ h measured at 60 cyc, 20 ohms dc res, $\frac{1}{2}$ amp; one wnd #34 AWG; copper; universal wnd; $\frac{3}{16}$ " lg x .375" dia o/a; Emerson Rad Part #LT-1021.	E102 hash filters-----	3C1084Z89-1
L111, L112	COIL, radio frequency: 750 μ h $\pm 10\%$; 10 ohms $\pm 10\%$ dc res, pie universal wnd; $\frac{3}{8}$ " dia x $\frac{1}{8}$ " lg o/a; Emerson Rad part/dwg #LT-1020.	V102 hash filters-----	3C1084Z89-2
P104	CONNECTOR, plug: p/o Power Cable Assembly CX-1358/U; 2 male flat prong; straight; $1\frac{1}{2}$ " lg x $1\frac{1}{2}$ " h x $1\frac{1}{2}$ " dia; contacts, electrical rating 10 amp, 250 v; cylindrical shaped steel body; $\frac{3}{16}$ " dia max cable opening; Hubbell part #7057.	A-c power input-----	6Z1727
P105	CONNECTOR, plug: p/o Power Cable Assembly CX-1359/U; 4 female round cont; angle type, 90 deg angle; $2\frac{1}{2}$ " lg x $1\frac{1}{16}$ " wd x $1\frac{1}{2}$ " h; "T" shape aluminum body; .500" max cable opening; Winchester Electronics Inc part #RA4S-PR-R.	Storage battery power input	2Z3065-110
P103	CONNECTOR, plug: p/o Power Cable Assembly CX-1358/U; 4 female round cont; angle type, 90 deg angle; $2\frac{1}{2}$ " lg x $1\frac{1}{16}$ " wd x $1\frac{1}{2}$ " h; "T" shape aluminum body; .310 max cable opening; Winchester Electronics Inc part #RA4S-PR-R.	A-c power input-----	2Z3065-112
P108	CONNECTOR, plug: p/o Power Cable Assembly CX-1360/U; 4 rd female cont; angle type, 90 deg angle; $2\frac{1}{2}$ " lg x $1\frac{1}{16}$ " wd x $1\frac{1}{2}$ " h; "T" shape aluminum body; .355" max cable opening; Winchester Electronics Inc part #RA4S-PR-R.	Battery input-----	2Z3065-111
P106	CONNECTOR, plug: p/o Power Cable Assembly CX-1360/U; 8 male pin type cont; straight type; 1.25" lg including protruding cont and term.; 1.26" dia; rd molded phenolic body; Breeze part #EC-3547.	Filament supply battery-----	2Z3028-73
P107, P110	CONNECTOR, plug: p/o Power Cable Assembly CX-1360/U; 8 male pin type cont; straight type; 1.25" lg including protruding cont and term.; 1.26" dia; rd molded phenolic body; Breeze part #EC-3543.	B+ supply battery-----	2Z3028-67
J102	CONNECTOR, receptacle: round; 1 cont, female; straight type; $1\frac{1}{16}$ " lg less cont and term. $\frac{1}{2}$ " dia; Johnson EF part #105-418-14.	Filament voltage test point	2Z3062-267
J103, J104	CONNECTOR, receptacle: four round male cont; straight type; o/a 1" lg, excl cont, $1\frac{1}{16}$ " dia o/a; 20 amp; 800 v rms; cylindrical shape.	J103: POWER INPUT receptacle. J104: DRY BATTERY receptacle.	2Z3024-109
J101	CONNECTOR, receptacle: phenolic; 11 cont, female round; straight type; $1\frac{1}{4}$ " lg x $\frac{3}{4}$ " h x .415" thk o/a; electrical rating 1 amp per pin, 250 v ac; rectangular shape; Amphenol part #26-805.	Provides means of connecting power supply to receiver.	2Z3072-8
P102	CONNECTOR, plug: 11 rd male cont; straight type; 1.171" lg x .750" wd x .384" h less prongs and terminals; rectangular phenolic body; Amphenol part #26-804.	Connects receiver-power supply cable to power supply.	2Z3031-10

5. Identification Table of Parts for Power Supply PP-308/URR—Continued

Ref symbol	Name of part and description	Function of part	Signal Corps stock No.
P111	CONNECTOR, plug: 11 flat female cont; straight type; 1 $\frac{1}{4}$ " lg x $\frac{3}{4}$ " wd x .415" h; square block body; Amphenol part #26-805.	Connects receiver-power supply cable to receiver.	2Z3072-8
A121	COVER, power supply: rectangular shape; 12.015" lg x 7.781" wd x $\frac{3}{8}$ " h; Emerson Rad part/dwg #AS-1102.	Protects bottom of power supply chassis.	2Z3351-380
A122, A124	COVER, electrical connector: 1 $\frac{1}{2}$ " lg x 1 $\frac{3}{8}$ " wd; four .128" dia mtg holes on .625" x 1.125" mtg/c; Emerson Rad part #MS-1374.	Connector covers	2Z3351-364
H101, H118	COVER, electrical connector: aluminum alloy 1 $\frac{1}{4}$ " dia x $\frac{1}{4}$ " thk o/a; Winchester Electronics part #RA4-CR.	Captive covers for power input and dry battery receptacles.	2Z3351-363
V101, V104	ELECTRON TUBE: pentode; metal envelope; 8 term.; pin type; located on bottom; JAN type 6AG7.	V101: B+ voltage regulator V104: Filament voltage regulator.	2J6AG7
V102	ELECTRON TUBE: JAN type 1007	H-v rectifier	2J1007
V103	ELECTRON TUBE: glass envelope JAN type OB2	Reference voltage regulator	2JOB2
F101	FUSE, cartridge: 1 amp, 250 v; quick acting, 135% for 0 to 1 hr, 200% for 0 to 2 min; ferrule type; glass body; one time; 1 $\frac{1}{4}$ " lg x $\frac{1}{4}$ " dia o/a; Littelfuse cat. #312001.	110 V. 1A. fuse	3Z1926
F102	FUSE, cartridge: 3 amp, 250 v; quick acting, 135% for 0 to 1 hr, 200% for 0 to 2 min; ferrule type; glass body; one time; 1 $\frac{1}{4}$ " lg x $\frac{1}{4}$ " dia o/a; Littelfuse cat. #312003.	24 V. 3A. fuse	3Z1950
F103	FUSE, cartridge: 4 amp, 250 v; quick acting, 135% for 0 to 1 hr, 200% for 0 to 2 min; ferrule type; glass body; one time; 1 $\frac{1}{4}$ " lg x $\frac{1}{4}$ " dia o/a; Littelfuse cat. #312004.	12 V. 4A. fuse	3Z2604.12
F104	FUSE, cartridge: 8 amp, 250 v; quick acting, 135% for 0 to 1 hr, 200% for 0 to 2 min; ferrule type; glass body; one time; 1 $\frac{1}{4}$ " lg x $\frac{1}{4}$ " dia o/a; Littelfuse cat. #312008.	6 V. 8A. fuse	3Z2608.8
E109	FUSEHOLDER: cylindrical type; accom four cartridge type fuses; 1 $\frac{3}{8}$ " lg x 1 $\frac{3}{8}$ " dia o/a; Emerson Rad part #MA-1014.	Container for SPARE FUSES.	3Z3282-13.1
E110, E112, E113, E114	FUSEHOLDER: retainer type; accom one type 3AG fuse; 2 $\frac{1}{2}$ " lg x 1" dia o/a; two solder lug term.; Special Design Products Co. part #SO-497-3.	Containers for OPERATING FUSES.	3Z3282-12.2
A120	GASKET: coprene, ribbon; rectangular shape, 39" lg x $\frac{3}{8}$ " h x .265" thk; Emerson Rad part/dwg #GA-1000.	Watertight assembly of front panel to case.	2Z4868.1174
O199	GASKET: velutex material; University Loudspeakers, Inc. part #60G21.	Loudspeaker diaphragm gasket.	2Z4868.1178
H119	GASKET: rubber; one hole; ring, 1 $\frac{7}{16}$ " OD, 1 $\frac{1}{4}$ " ID, .103" thk; Emerson Rad dwg BR-1037.	Watertight gasket for fuseholder.	2Z4868.1173
O106	GASKET: round, 3 $\frac{3}{4}$ " OD, 3 $\frac{1}{4}$ " ID, $\frac{3}{8}$ " thk; Emerson Rad part/dwg #BR-1022.	Speaker gasket, provides water seal.	2Z4868.1176
O109, O128	KNOB: round; aluminum; accom rd shaft $\frac{3}{16}$ " dia x 4 $\frac{3}{4}$ " d shaft hole; for screw attachment #6-32, NC-2, hole, $\frac{3}{8}$ " d; o/a dim $\frac{7}{8}$ " lg x 1 $\frac{1}{8}$ " dia; Emerson Rad part/dwg #KN-1004.	Means of rotating controls mounted on panel.	2Z5822-660
LS101	LOUDSPEAKER, dynamic: permanent magnetic field; 100 milliwatts—160 milliwatts 4"; dim 2 $\frac{1}{2}$ " lg x 4 $\frac{1}{16}$ " wd x 4 $\frac{1}{16}$ " h o/a; University Loudspeaker Co. model BCM-4.	Speaker	6C35-29
A104	MOUNTING: aluminum alloy; Emerson Rad part/dwg #MS-1161.	Support electrolytic capacitor	2Z6820.451

5. Identification Table of Parts for Power Supply PP-308/URR—Continued

Ref symbol	Name of part and description	Function of part	Signal Corps stock No.
H112 thru H115	NUT, plain cap: brass; 10-24, NC-2 thd; $\frac{1}{16}$ " h, $\frac{3}{8}$ " across flats; Special Design Products Co part #439-17.	Serve as pressure seals-----	6L3770-24-6.7
O108, O126, O127	NUT, plain cap: brass; wrench type; # $\frac{3}{8}$ -32 NEF-2 thd; $\frac{5}{8}$ " wd across flats, .421" h; Emerson Rad part/dwg #AS-1209.	Provide watertight seal-----	6L3677-32.4
A102, A103	PLATE, electrical ground: c/o following Emerson Rad parts: jack plate, part #MS-1159; ground spring, part #SV-1010; rectangular shape; 2 $\frac{3}{8}$ " lg x $\frac{3}{4}$ " wd; four tapped mtg holes #6-32, NC-2; N/A Emerson Rad part/dwg #AS-1095.	Ground power supply chassis to case through anchor pin.	2Z7090.119
O101, O119	PLATE, mounting: rectangular; center hole .375" dia; outside 2 $\frac{1}{2}$ " lg x $\frac{3}{4}$ " wd x .026" thk; Emerson Rad part/dwg #MS-1162.	Applies tension to jack plate assembly A20.	6L58026-91
O102, O120, O121	POST, spacing: aluminum alloy; cylindrical shape; axial tapped mtg hole at ea end, .164" dia, 32 thd per in. $\frac{1}{4}$ " d; Emerson Rad part #SM-1082.	Offset capacitor from chassis	3H4426-1
L101 thru L105	REACTOR: 1 sect.; 10 μ h .04 ohms dc; 2000 v rms test voltage; Emerson Rad part/dwg #LT-1023.	E101 hash filters-----	3C575Z7-4
L106, L107	REACTOR: 2 sect.; .05 hy ea sect., .5 amp dc ea sect.; 1.36 ohms dc ea sect.; insulation test 500 v; hs metal case; 3 $\frac{3}{4}$ " lg x 2 $\frac{5}{16}$ " wd x 3 $\frac{1}{16}$ " h o/a less term.; four solder lug type term.; Emerson Rad part/dwg #TR-1011.	Filament voltage filters-----	3C575Z7-5
L108	REACTOR: 10 μ h .02 ohms dc res; 2000 v rms test voltage; metal case; $\frac{1}{16}$ " lg x 1" dia o/a; Emerson Rad part/dwg #LT-1022.	E102 hash filter-----	3C575Z7-6
CR101	RECTIFIER, metallic: copper sulphide; 10.5 v ac, single ph input; 8.1 vdcw, 1.1 amp output; cylindrical shape; o/a dim 1 $\frac{1}{8}$ " lg x $\frac{5}{8}$ " dia; Mallory part #1B-16R.	Relay and filament voltage vibrator rectifier.	3H4860-188
CR102	RECTIFIER ASSEMBLY, metallic: 2 selenium rectifiers; input 8 v, 100 cycles, single ph; 1.5 vdcw, .5 amp output; 3 solder lug term. 5 $\frac{1}{8}$ " lg x 2 $\frac{1}{4}$ " wd x $\frac{7}{16}$ " h; two .218" dia mtg holes on 4 $\frac{1}{2}$ " centers; Radio Receptor Co. part #2Q-0897.	Rectifies ac for filament voltage and relay operation.	3H4860-45.1
K101	RELAY, armature: normally open con, single break, ac-dc; cont; 1, 2, and 3 = .05 amp at 100 vdcw; 4, 5, and 6 = .5 amp at 1.5 vdcw; 7, 8, and 9 at 1.5 amp at 6 vdcw or .4 amp at 24 vdcw; 10, 11, and 12 = 1.5 amp at 6 vdcw or .4 amp at 24 vdcw; 13 and 14 = 1 amp at 115 v ac; 15 and 16 = .01 amp at 1.5 vdcw; 17, 18, and 19 = 1 amp at 6 vdcw or .25 amp at 24 vdcw; 20, 21, and 22 = .2 amp at 6 vdcw; 23 and 24 = 6 amp at 6 vdcw or 1.5 amp at 24 vdcw; 25 and 26 = 6 amp at 6 vdcw or 2 amp at 24 vdcw; 27 and 28 = 6 amp at 6 vdcw or 2 amp at 24 vdcw. 1 wnd 50 ohms dc res 5.6 vdcw 28 term. on cont, 2 term on coil; o/a dim 3 $\frac{1}{16}$ " lg less term., 2 $\frac{1}{16}$ " wd; Clare CP part #29EC.	Automatic switching relay for 117-volt operation.	2Z7599A-347

5. Identification Table of Parts for Power Supply PP-308/URR—Continued

Ref symbol	Name of part and description	Function of part	Signal Corps stock No.
R107, R101	RESISTOR, fixed: WW; 2 ohms $\pm 5\%$; 8 w; JAN type RW30F2RO.	R107: Current limiting resistor for T102 primary circuit during 24-volt operation. R101: V101 and V104 filament voltage-dropping resistor during 115 v a-c operation.	3RW8102
R106	RESISTOR, fixed: WW; 20 ohms $\pm 5\%$; 12w; JAN type RW32G200.	V101 and V104 filament voltage-dropping resistor during 24 v d-c operation.	3RW14103
R102, R104	RESISTOR, fixed: WW; 25 ohms $\pm 5\%$; 8 w; JAN type RW30G250.	R102: E102 driving coil voltage dropping. R104: E101 driving coil voltage dropping.	3RW14708
R103, R105	RESISTOR, fixed: WW; 50 ohms $\pm 5\%$; 8 w; JAN type RW30G500.	R103: E102 driving coil voltage dropping. R105: E101 driving coil voltage dropping.	3RW-16507
R109	RESISTOR, fixed: comp; 62 ohms $\pm 5\%$; 1 w; JAN type RC30BF620J.	Bias resistor for a-f output tubes.	3RC30BF620J
R108	RESISTOR, fixed: comp; 100 ohms $\pm 5\%$; $\frac{1}{2}$ w; JAN-RC20BF101J.	Bias network resistor in dry battery operation.	3RC20BF101J
R114	RESISTOR, fixed: comp; 180 ohms $\pm 10\%$; $\frac{1}{2}$ w; JAN type RC20BF181K.	V104 control grid isolating	3RC20BF181K
R115	RESISTOR, fixed: comp; 470 ohms $\pm 5\%$; JAN type RC42BE471J.	V104 output voltage dropping	3RC42BE471J
R111	RESISTOR, fixed: comp; 560 ohms $\pm 5\%$; 2 w; JAN type RC42BE561J.	B+ voltage dropping	3RC42BE561J
R113	RESISTOR, fixed: WW; 5600 ohms $\pm 5\%$; 11 w; JAN type RW33J562.	V103 current limiting	3RW28810
R110	RESISTOR, fixed: comp; 220,000 ohms $\pm 5\%$; $\frac{1}{2}$ w; JAN type RC20BE224J.	Unregulated B+ bleeder	3RC20BF224J
R112	RESISTOR, fixed: comp; 1 meg $\pm 10\%$; $\frac{1}{2}$ w; JAN type RC20BF105K.	V101 and V104 control grids d-c return.	3RC20BF105K
R116	RESISTOR, variable: WW; 1000 ohms $\pm 10\%$; 3 w; JAN type RA25A1SA102AK.	Filament voltage control	3RA5717
O112, O115	SHELL, electrical connector: steel; rectangular shape; $1\frac{1}{2}$ " lg x $1\frac{3}{8}$ " wd x $\frac{7}{8}$ " thk; four .128" dia holes in flanges with mtg/c of .625" by 1.125"; Emerson Rad part #MS-1367.	Housings for connector	2Z8276-71
E108	SHIELD, electron tube: brass; cylindrical shape; $2\frac{1}{4}$ " h x .930" dia o/a; JAN type TSFOT103.	Shield for tube	2Z8304.277
X101, X102, X104	SOCKET, electron tube: 8 cont; octal; oval shape; 1.8125" lg x 1.87" wd x .50" h o/a excluding term.; Cinch part #51B-13416.	X101: Mounts V101. X102: Mounts V102. X104: Mounts V104.	2Z8679.21
X103	SOCKET, electron tube: 7 cont; miniature; oval shape; $1\frac{3}{8}$ " lg x .625" wd x .170" h o/a excluding term.; ceramic; JAN type TS102C01.	Mounts V103	2Z8677.99
X105	SOCKET, vibrator: 4 cont; oval shape; $1\frac{3}{8}$ " lg x $1\frac{3}{8}$ " wd x $\frac{1}{8}$ " h o/a, excluding term.; molded plastic body; Cinch part #X-154.	Mounts E102	2Z8674.183
X106	SOCKET, vibrator: 6 cont; oval shape; $1\frac{3}{8}$ " lg x $1\frac{1}{2}$ " wd x $\frac{3}{8}$ " h o/a excluding term.; molded plastic body; Cinch part #Z-154.	Mounts E101	2Z8676.100
O107, O123 thru O125	SPRING, HELICAL COMPRESSION: $\frac{1}{16}$ " lg x $\frac{1}{4}$ " wd x $\frac{3}{16}$ " dia; 8 turns; conical shape; Emerson Rad part/dwg #SV-1024.	Hold spare fuses tightly in place.	2Z8877.705

5. Identification Table of Parts for Power Supply PP-308/URR—Continued

Ref symbol	Name of part and description	Function of part	Signal Corps stock No.
S101	SWITCH, rotary: 2 sect.; 4 positions, 6 poles; $2\frac{1}{8}$ " lg x $1\frac{1}{4}$ " wd x $1\frac{1}{16}$ " h; solder lug term.; Oak type No. FC.	POWER SELECTOR switch	3Z9825-62.692
S102	SWITCH, rotary: 1 sect.; 2 positions, 3 poles, 2 throws; $1\frac{1}{8}$ " lg x $1\frac{1}{16}$ " wd x $1\frac{1}{16}$ " thk; solder lug term.; Oak type H.	SPEAKER ON-OFF switch	3Z9825-62.690
S103	SWITCH, rotary: 2 sect.; 2 positions, 6 poles, 3 stator cont per sect., 2 throws; $1\frac{5}{16}$ " lg x $1\frac{5}{16}$ " wd x $1\frac{1}{4}$ " h; solder lug term.; Oak type FC.	POWER ON-OFF switch	3Z9825-62.693
E198, E199	TERMINAL, lug: anchor ring type; copper; one $\frac{3}{32}$ " dia wire mtg hole and one $\frac{1}{4}$ " dia term. mtg hole; Pat-MacGuyer part #2050.	Terminal lugs for Power Cable Assembly CX-1359/U.	3Z12045
T101	TRANSFORMER, power: step-down; hs metal case; 117 v ac, 50-60 cps, single ph; 1 output wnd, 9.2 v, full load, .60 amp; $2\frac{1}{8}$ " lg x $2\frac{1}{16}$ " wd x $2\frac{1}{16}$ " h; four solder lug type term.; Emerson Rad part/dwg #TR-1012.	Couples 115 v a-c input to CR101.	2Z9629-440
T103	TRANSFORMER, power: step-down; hs metal case; 143 v ac, rms, 100 cps, single ph; 1 output wnd, 7.2 v ac rms, .5 amp, ct; 3" lg x $2\frac{3}{8}$ " wd x $2\frac{3}{4}$ " h; six solder lug type term.; Emerson Rad part/dwg #TR-1014.	Filament voltage vibrator transformer.	2Z9621-407
T102	TRANSFORMER, power: vibrator; sealed metal case; input 6 v ac, 100 cps; or 12 v ac, 100 cps; or 24 v ac, 100 cps; or 117 v ac, 50-60 cps; $\frac{1}{2}$ amp on pri; output 430 v ac rms, 100 ma, 1.0 v ac, 1.2 amp; $4\frac{3}{8}$ " lg x $3\frac{1}{2}$ " wd x $3\frac{1}{16}$ " h; 17 pilar type term.; Emerson Rad part/dwg #TR-1013.	Power transformer	2Z9629-441
E101	VIBRATOR, nonsynchronous: input 6 vdcw, 150 ma; single reed; 110 cps; $\pm 6\%$; cylindrical shape; $2\frac{7}{8}$ " lg x $1\frac{1}{2}$ " dia o/a excluding prongs; Oak part #6606.	Input vibrator	3H6690-23
E102	VIBRATOR, nonsynchronous: input 6 vdcw, 1.5 amp; single reed; 100 cps; $\pm 7\%$; cylindrical shape; $2\frac{7}{8}$ " lg x $1\frac{1}{2}$ " dia o/a excluding prongs; Oak part #V-6556.	Filament voltage vibrator	3H6691-15

6. Identification Table of Parts for Radio Receiver R-174/URR

Ref symbol	Name of part and description	Function of part	Signal Corps stock No.
H99	BOLT, machine: brass; cadmium or zinc plate plus olive drab iridite finish; self-sealing; fillister head; 8-32 thd, $\frac{1}{4}$ in. min lg; Special Design Products Co. #SP-328-5-1/4M.	Seal screw on preset base	6L20808-4.3C
H15, H16, H17	BOLT, machine: brass; cadmium or zinc plate plus olive drab iridite finish; 8-32" thd $\frac{1}{4}$ " min lg; Emerson Rad #SC-9047.	Provide pressure seal and attach components.	6L20808-4-2
H18, H19	BOLT, machine: brass; cadmium or zinc plate plus olive drab iridite finish; 8-32 thd, $\frac{3}{8}$ " min lg; Emerson Rad #SC-9048.	Provide pressure seal and attach components.	6L20808-6
H4	BOLT, machine: steel, cadmium plate; #6-32, $\frac{1}{8}$ " lg; thd portion $\frac{7}{16}$ " lg; head $\frac{5}{16}$ " dia and $\frac{5}{32}$ " thk; Special Design Products Co. #SP-328-3 $\frac{7}{16}$.	Assemble dial shutter D14 to front panel.	6L20806-9.3SC

6. Identification Table of Parts for Radio Receiver R-174/URR—Continued

Ref symbol	Name of part and description	Function of part	Signal Corps stock No.
H5	BOLT, machine: SS; #6-32; .296" lg; thd portion .16" lg; head .109" thk and 1/2" dia o/a; shoulder .281" dia; Emerson Rad #SM-1222.	Bearing shaft for intermediate gear O17.	6L20806-5
O7, O10, O27	BUSHING: brass; female; .406" lg, .343" OD, .251" ID and 1/2" shoulder; Emerson Rad #SM-1220.	O7 and O10: Through panel bushings for antenna trimmer shaft. O27: Bearing for band switch shaft through panel.	2Z1409-285
O99	CAM: SS; mts by two 3-48 NC-2 tap holes 1/8" d; Emerson Rad #MA-1046.	Tuning shaft cam-----	2Z1600-143
C24	CAPACITOR, fixed: ceramic dielectric; 3 μμf ±.5 μμf; 500 vdcw; JAN type CC21CJ030D.	Bfo output coupling capacitor.	3D9003-35
C54	CAPACITOR, fixed: ceramic dielectric; 7 μμf ±.5 μμf; 500 vdcw; JAN type CC21CH070D.	Crystal calibrator output coupling capacitor to V1 grid circuit for band 4.	3D9007-10
C25	CAPACITOR, fixed: ceramic dielectric; 51 μμf ±.5%; 500 vdcw; JAN type CC21SL510J.	Crystal calibrator grid leak--	3D9051-14
C37	CAPACITOR, fixed: electrolytic; 25 μf; 300 vdcw; JAN type CE41C250N.	B+ filter-----	3DB25-131
C39	CAPACITOR, fixed: electrolytic; 1000 μf; 15 vdcw; JAN type CE41C102E.	V8 filament a-f bypass-----	3DB1000-22
C29, C30	CAPACITOR, fixed: mica dielectric; 100 μμf ±10%; 500 vdcw; JAN type CM20C101K.	Detector i-f filters-----	3K2010131
C20	CAPACITOR, fixed: mica dielectric; 150 μμf ±5%; 500 vdcw; JAN type CM20C151J.	V3 oscillator control grid leak	3K2015132
C26	CAPACITOR, fixed: mica dielectric; 300 μμf ±5%; 500 vdcw; JAN type CM20B301J.	Calibration oscillator tank r-f return.	3K2030122
C3, C10, C19	CAPACITOR, fixed: mica dielectric; 470 μμf ±10%; 500 vdcw; JAN type CM20D471K.	C3: V1 grid coupling. C10: V2 grid coupling. C19: Converter r-f grid coupling.	3K2047142
C43	CAPACITOR, fixed: mica dielectric; 680 μμf ±5%; 500 vdcw; JAN type CM30D681J.	Bfo harmonic suppressor----	3K3068142
C31	CAPACITOR, fixed: paper dielectric; 1000 μμf ±20%; 400 vdcw; JAN type CM20A102M Mica-mold #339-110.	Detector to a-f amplifier control grid audio coupling.	3DA1-215
C5, C11, C12, C14, C21, C22, C23, C28, C32, C33, C34, C41, C45, C48, C49	CAPACITOR, fixed: paper dielectric; 10,000 μμf ±20%; 120 vdcw; JAN type CN20E103M.	C5: V1 plate circuit decoupling. C11: V2 avc filter. C12: V2 filament a-f bypass. C14: V2 plate circuit decoupling. C21: Converter screen grid r-f bypass. C22: V4 avc filter. C23: V4 screen grid r-f bypass. C28: V5 plate circuit decoupling. C32: V6 plate circuit decoupling. C33: V6 screen grid a-f bypass. C34: V6 plate a-f coupling. C41: Bfo tank center tap r-f return. C45: V7 filament a-f bypass.	3DA10-380

6. Identification Table of Parts for Radio Receiver R-174/URR—Continued

Ref symbol	Name of part and description	Function of part	Signal Corps stock No.
C27, C35, C42, C47	CAPACITOR, fixed: paper dielectric; 2000 $\mu\mu\text{f}$ $\pm 20\%$; 200 vdcw; JAN type CN20A202M.	C48: V5 screen grid a-f bypass. C49: R-f gain control r-f bypass. C27: Sidetone input coupling. C35: A.F. GAIN control to V8 control grid a-f coupling. C42: V7 plate noise limiting. C47: V7 control grid coupling.	3DA2-192
C36	CAPACITOR, fixed: paper dielectric; 3000 $\mu\mu\text{f}$ $\pm 20\%$; 400 vdcw; JAN type CN22E302M.	V8 plate noise limiting-----	3DA3-125
C4, C13, C38, C40	CAPACITOR, fixed: paper dielectric; 100,000 $\mu\mu\text{f}$ $\pm 10\%$; 200 vdcw; JAN type CP29A2EC104K.	C4: V1 screen grid r-f bypass. C13: V2 screen grid r-f bypass. C38: V8 screen grid a-f bypass. C40: V8 bias filter.	3DA100-1115
C46	CAPACITOR, fixed: paper dielectric; 100,000 $\mu\mu\text{f}$ $\pm 10\%$; 200 vdcw; JAN type CP29A1EC104K.	C46: Places bfo plate at r-f ground potential in PHN. operation.	3DA100-738
C6 thru C9, C15 thru C18, C50 thru C53	CAPACITOR, variable: air dielectric; plate meshing type; 11 $\mu\mu\text{f}$ max, 2 $\mu\mu\text{f}$ min; straight line tuning; extended shaft; 360° rotation; Hammarlund #29751-3.	C6: Band 4 second r-f amplifier grid tank trimmer. C7: Band 3 second r-f amplifier grid tank trimmer. C8: Band 2 second r-f amplifier grid tank trimmer. C9: Band 1 second r-f amplifier grid tank trimmer. C15: Band 4 converter signal grid tank trimmer. C16: Band 3 converter signal grid tank trimmer. C17: Band 2 converter signal grid tank trimmer. C18: Band 1 converter signal grid tank trimmer. C50: Band 1 converter oscillator grid tank trimmer. C51: Band 2 converter oscillator grid tank trimmer. C52: Band 3 converter oscillator grid tank trimmer. C53: Band 4 converter oscillator grid tank trimmer.	3D9011V-7
C2	CAPACITOR, variable: air dielectric; plate meshing type; 42 $\mu\mu\text{f}$ max, 5 $\mu\mu\text{f}$ min; 750 v ac peak; 360° rotation; Sickles FW. #E-102090.	ANT. TRIMMER control----	3D9042V-15
C44	CAPACITOR, variable: air dielectric; plate meshing type; 55 $\mu\mu\text{f}$ max, 5 $\mu\mu\text{f}$ min; JAN type CT1E055.	B.F.O. control-----	3D9055V-19
C1A, B, C, D	CAPACITOR, variable: air dielectric; plate meshing type; 4 sect.; 200 $\mu\mu\text{f}$ max, 14 $\mu\mu\text{f}$ min; 1000 v ac peak; RCC #17.	MANUAL PRESET TUNING control.	3D9200V-19
N1	CHART: 2 $\frac{5}{16}$ " lg x 1 $\frac{13}{16}$ " wd; Emerson Rad #PD-1028.	Means of recording station settings for preset tuner.	6D10105-57

6. Identification Table of Parts for Radio Receiver R-174/URR—Continued

Ref symbol	Name of part and description	Function of part	Signal Corps stock No.
O25	CLIP, electrical: clip type holder; phosphor bronze body; dim $1\frac{1}{2}$ " lg x $\frac{1}{16}$ " wd x $\frac{3}{16}$ " h o/a; Littelfuse #121002.	Holds key for preset tuner	2Z2712-272
L1	COIL, RF: 9.87 μ h measured at 2.5 mc; .18 ohms; 20 turns, #28, copper, single silk covered enamel, 1 wnd, untapped, unshielded; phenolic form; powdered iron core; 1" lg x $\frac{1}{4}$ " dia; mtd by 6-32 threaded brass shoulder stud; Emerson Rad #LT-1041.	V3 filament r-f filter	3C1084Z89-4
L2	COIL, RF: 9.87 μ h measured at 2.5 mc; .18 ohms; 20 turns, #28, copper, single silk covered enamel, 1 wnd, untapped, unshielded; phenolic form; powdered iron core; $1\frac{1}{16}$ " lg x $\frac{1}{4}$ " dia o/a; mtd by 6-32 threaded brass shoulder stud; Emerson Rad #LT-1042.	V7 filament r-f filter	3C1084Z89-3
J4	CONNECTOR, receptacle: 11 male cont, pin type; straight type; .384" lg excl cont and term x .750" wd x 1.171" h o/a excluding cont and term.; rectangular shape, molded phenolic; Amphenol #26-804.	Receives receiver-power supply connecting cable.	2Z3031-10
J1	CONNECTOR, receptacle: 9 male round cont; polarized; straight locking; o/a dim 1" lg x $1\frac{1}{16}$ " dia excluding cont; cylindrical shape; phenolic insert; Winchester Electronics, Inc. #RA9P-PR-R.	MONITORING INPUT receptacle.	2Z3029-36
J2, J3	CONNECTOR, receptacle: 10 round cont; straight type; $1\frac{1}{16}$ " lg x $1\frac{3}{16}$ " dia o/a; cylindrical shape; rubber, bayonet; Amphenol #164-7.	PHONES receptacles	2Z7250-79
S5	CONTACT, electrical: 2 points, silver plate; $\frac{1}{16}$ " dia x $\frac{1}{32}$ " h; phosphor bronze, silver plate finish; $1\frac{1}{16}$ " lg x $\frac{3}{16}$ " wd x $\frac{1}{16}$ " d o/a; Emerson Rad #MS-1269.	Grounds antenna momentarily.	2Z3194-63
O2, O4, O8	COUPLING, flexible: phosphor bronze, nickel plate; 1.094" dia x .650" d; Oak #6403.	O4: Couples antenna trimmer on band switch to dial shutter. O8: Couples output switch to panel.	2Z3295-176
A16	COVER: rectangular shape; $12\frac{1}{8}$ " lg x $7\frac{1}{8}$ " wd; Emerson Rad #AS-1088.	Protective cover for receiver	2Z3351-366
A15	COVER: $6\frac{1}{4}$ " lg x $5\frac{1}{4}$ " wd; Emerson Rad #AS-1406.	Removable access plate for tubes.	2Z3351-361
A11	COVER: rectangular shape; $12\frac{1}{2}$ " lg x $7\frac{5}{8}$ " wd; Emerson Rad #AS-1188.	Protective cover for bottom of chassis.	2Z3351-365
E14, E20	COVER, electrical connector: steel, cadmium plate; o/a .608" lg excluding chain, 1.024" dia o/a; Amphenol #164-377.	Captive covers for audio receptacle.	2Z3351-367
E13	COVER, electrical connector: brass, cadmium plate; $\frac{5}{8}$ " lg excluding chain, 1 $\frac{1}{8}$ " dia o/a; Amphenol #164-496.	Captive cover for MONITORING INPUT receptacle.	2Z3351-368
Y1	CRYSTAL UNIT, quartz: Crystal Holder FT-241-A; 2 pins spaced .486" c to c; solid pin, $\frac{3}{16}$ " dia x $\frac{1}{16}$ " lg; rectangular shape; phenolic; $1\frac{1}{8}$ " lg x $\frac{1}{16}$ " wd x $1\frac{1}{16}$ " h; Emerson Rad dwg No. XT1020.	200-kc crystal for crystal calibration oscillator.	2X105-200
N2	DECAL: decalomania; $6\frac{1}{4}$ " lg x $3\frac{5}{8}$ " wd; Emerson Rad #ST-1036.	Receiver circuit schematic, part of Radio Receiver R-174-URR.	6D16840-6

6. Identification Table of Parts for Radio Receiver R-174/URR—Continued

Ref symbol	Name of part and description	Function of part	Signal Corps stock No.
A10	DIAL, scale: 297° arc; round; 3¼" dia x .050" thk x .50" dia ctr hole; Croname #DA-1005.	Scale for dial-----	2Z3723-340
A13	DRIVE, tuning: circular shape, 3.859" dia; Emerson Rad #AS-1195.	Holds engraved channel markers in any position for presetting stations.	2Z3876.146
V1, V2, V4	ELECTRON TUBE: pentode; JAN type 1L4 ----	V1: First r-f amplifier.	2J1L4
V3, V5, V7	ELECTRON TUBE: pentagrid; JAN type 1R5----	V2: Second r-f amplifier. V4: First i-f amplifier. V3: Converter. V5: Second i-f amplifier and calibration oscillator. V7: Low a-f amplifier and beat-frequency oscillator.	2J1R5
V6	ELECTRON TUBE: diode pentode; JAN type 1U5.	Detector and a-f amplifier--	2J1U5
V8	ELECTRON TUBE: pentode; JAN type 3V4----	High a-f amplifier -----	2J3V4
H6	GASKET: watertight seal; ring, ⅝" OD, ⅜" ID, .070 ±.003 thk; Emerson Rad #BR-1030.	Watertights shoulder screw to front panel assembly.	2Z4868.877
O50, O51	GASKET: watertight seal; ring, 1.073" OD, 1" ID; Emerson Rad #BR-1033.	Watertight gasket for ten contact audio receptacles.	2Z4868.1175
A12	GASKET: rubber; ring, 1.312" OD, 1.250" ID, .062" thk; Emerson Rad #BR-1034.	Seals dial window-----	2Z4868.1180
A14	GASKET: 4 holes incl mtg holes; round shape, 3⅞" dia .031" thk; Emerson Rad #BR-1035.	Provides watertight seal between preset base and panel.	2Z4868.1177
O26	GASKET: rectangular ribbon, ⅜" h x .265" thk x 37" lg; Emerson Rad #GA-1000.	Watertight assembly of front panel to case.	2Z4868.1174
O22	GEAR ASSEMBLY: 4 tapped mtg holes; Croname #AS-1194.	Tuning variable capacitor and rotating calibrated dial scale.	2Z4875-435
O5	GEAR: spur type; brass; straight teeth; 36 teeth, 48 pitch; .750" OD, .251" ID, and ⅜" thk; straight face; hub ⅜" dia extends ¼" from face of gear; Emerson Rad #MA-1030.	Transmits position of band switch to dial shutter.	2Z4878-1438
O17	GEAR: spur type; straight teeth; 96 teeth, 48 pitch, 2" pitch dia; .3755 to .3765 ID; straight face; .3760" hole; Emerson Rad #MA-1033.	Transmits setting of band switch S1 to dial shutter O14.	2Z4878-1437
H1, H13	GROMMET: ⅜" OD, ⅛" ID, ⅜" neck dia, ⅜" thk, ⅛" neck thk; ⅜" dia mtg fl; Canfield Rub #1983.	Insulate leads brought through chassis.	6Z4854-6
E7	INSULATOR, bushing: rectangular shape; black molded phenolic; 1⅝" lg x 1¼" wd x ⅜" thk; four mtg holes .156" dia; Emerson Rad #MP-1031.	Insulated mount for top end of antenna.	3G100-243
E9	INSULATOR, bushing: round; black molded phenolic; .312" h o/a, ⅜" dia, .171" hole; Emerson Rad #MP-1033.	Insulates antenna terminal from panel.	3G100-242
E3, E19	INSULATOR, standoff: white ceramic; 7500 v; cylindrical pillar shape; one #6-32 thd tapped mtg hole at ea end; JAN type NS4W0106; AISI-Mag #1703.	Insulate solder tie points---	3G3501-06.1
E12	KEY, machine: sq type; 1¼" lg x ⅜" wd; Emerson Rad #AS-1198.	Tool for loosening channel marker stops on preset assembly.	6L996-20-7
O18	KNOB: round; aluminum; 4.526" dia x .695" thk o/a; Emerson Rad #AS-1196.	Knob for tuning receiver---	2Z5822-663

6. Identification Table of Parts for Radio Receiver R-174/URR—Continued

Ref symbol	Name of part and description	Function of part	Signal Corps stock No.
O29, O35 thru O39	KNOB: round; aluminum; $1\frac{1}{16}$ " dia x $\frac{7}{8}$ " thk o/a; Emerson Rad #KN-1004.	Rotating controls mounted on panel.	2Z5822-660
O23	KNOB: round; aluminum; $1\frac{1}{2}$ " dia x $\frac{3}{8}$ " thk o/a; luminous markings; Emerson Rad #KN-1005.	Fine tuning knob for tuning receiver marked PULL OUT BEFORE PRESET TUNING.	2Z5822-662
E2	LAMP, glow: 105-125 v, $\frac{1}{4}$ w; 65 v ac striking voltage; 90 v dc striking voltage; double cont bayonet, candelabra base; cylindrical bulb; GE #NE-48.	Protects antenna coils	2Z5889-3
E1	LAMP, incandescent: 2 v, .12 w, .06 amp; miniature bayonet base; $1\frac{1}{16}$ " max o/a h; GE #49.	Illuminates dial scale	2Z5971.1
X99	LAMPHOLDER: accom miniature bayonet base lamp; metal shell; $1\frac{1}{4}$ " lg x $\frac{1}{16}$ " dia o/a; 1 solder lug term. shell is ground term.; Croname #95-P-69810-A.	Dial light socket	2Z5882-81
X9	LAMPHOLDER: double cont bayonet candelabra indexing; $1\frac{3}{8}$ " lg x $\frac{1}{8}$ " dia o/a; Millen #33992.	Socket for E2	2Z5885-31
A98	LENS, light: nonfocusing; clear lucite; $1\frac{1}{4}$ " max thk; mtd by two #4-40 NC-2 holes $\frac{5}{32}$ " d; $1\frac{3}{8}$ " lg x $1\frac{1}{4}$ " wd x $\frac{7}{8}$ " d; Croname #79-P-69848.	Directs light to tuning dial	2Z6125-142
O21, O28, O30 thru O34	NUT, plain cap: brass; wrench type drive, $\frac{5}{8}$ "; # $\frac{3}{8}$ -32 thd; $\frac{5}{8}$ " wd, .421" h; Emerson Rad #AS-1209.	Make watertight shaft and panel seal assembly.	6L3677-32.4
O48, O49	NUT, self-sealing: welding; #8-32 thd; $\frac{3}{32}$ " d x $\frac{1}{16}$ " h o/a x $\frac{3}{8}$ " wd; Emerson Rad #NT-9032.	O48: Seal nut for antenna post. O49: Seal nut for ground post.	6L3658-32-6.6
A3, A9	PLATE, electrical grounding: p/o chassis of Radio Set AN/GRR-5; assem c/o plate w/mtg holes and spring riveted to plate; rectangular shape, flat; 2.062" lg x $\frac{3}{4}$ " wd x .093" thk; Emerson Rad #AS-1095.	Guide, position, and ground chassis within case.	2Z7090.119
O98	PLATE, lock: ss; $2\frac{1}{16}$ " lg x 1.11" wd x .094" thk o/a; Emerson Rad #MA-1048.	Locks tuning mechanism	2Z7090.118
H2, H14	PLATE, mounting: rectangular; Emerson Rad #MS-1162.	Guides and positions chassis within case.	6L58006-6
E10	POST, binding: $\frac{3}{32}$ " above mtg surface, .515" OD; mtg stud 1" lg, .164" dia; 32 thd per in.; Emerson Rad #LU-1019.	Provides means of attaching antenna wire (marked A).	3Z741-43.1
E11	POST, binding: $\frac{3}{32}$ " above mtg surface, .515" OD of post; mtg stud $\frac{5}{8}$ " lg, .164" dia; 32 thd per in.; Emerson Rad #LU-1020.	Provides means of attaching ground wire (marked G).	3Z741-43.2
H8	PULLER, tube: $2\frac{3}{4}$ " lg x 1" wd; Emerson Rad #AC-1002.	Tool for extracting miniature tube from sockets.	6R7443-4
K1	RELAY, solenoid: normally closed, single break, dc voltage, 10 ma dc; 1 winding; 125 ohms, 11 to 15 v dc; $2\frac{1}{2}$ " lg x $1\frac{1}{16}$ " wd x $1\frac{3}{16}$ " h o/a; Clare CP #G.	Receiver disabling relay	2Z7599A-346
R23	RESISTOR, fixed: comp; 130 ohms $\pm 10\%$; 2 w; JAN type RC42BE131K.	K1 operating coil voltage-dropping resistor when 24 v d-c supply is used.	3RC42BE131K
R25	RESISTOR, fixed: comp; 3,900 ohms $\pm 10\%$; $\frac{1}{2}$ w; JAN type RC20BF392K.	V8 screen grid voltage dropping.	3RC20BF392K

6. Identification Table of Parts for Radio Receiver R-174/URR—Continued

Ref symbol	Name of part and description	Function of part	Signal Corps stock No.
R3, R6, R16	RESISTOR, fixed: comp; 4,700 ohms $\pm 10\%$; $\frac{1}{2}$ w; JAN type RC20BF472K.	R3: V1 plate circuit decoupling. R6: V2 plate circuit decoupling. R16: V5 plate circuit decoupling.	3RC20BF472K
R29	RESISTOR, fixed: comp; 5,600 ohms $\pm 10\%$; $\frac{1}{2}$ w; JAN type RC20BF562K.	Increases bfo plate voltage in all positions of S2 but PHN.	3RC20BF562K
R28	RESISTOR, fixed: comp; 12,000 ohms $\pm 10\%$; $\frac{1}{2}$ w; JAN type RC20BF123K.	V7 screen grid voltage dropping.	3RC20BF123K
R9	RESISTOR, fixed: comp; 22,000 ohms $\pm 10\%$; $\frac{1}{2}$ w; JAN type RC20BF223K.	V3 screen grid voltage dropping.	3RC20BF223K
R10	RESISTOR, fixed: comp; 27,000 ohms $\pm 10\%$; $\frac{1}{2}$ w; JAN type RC20BF273K.	V4 screen grid voltage dropping.	3RC20BF273K
R2, R5	RESISTOR, fixed: comp; 33,000 ohms $\pm 10\%$; $\frac{1}{2}$ w; JAN type RC20BF333K.	R2: V1 screen grid voltage dropping. R5: V2 screen grid voltage dropping.	3RC20BF333K
R8, R17	RESISTOR, fixed: comp; 47,000 ohms $\pm 10\%$; $\frac{1}{2}$ w; JAN type RC20BF473K.	R8: Converter oscillator grid leak. R17: Part of detector load.	3RC20BF473K
R11, R13, R33, R34	RESISTOR, fixed: comp; 100,000 ohms $\pm 10\%$; $\frac{1}{2}$ w; JAN type RC20BF104K.	R11: Bfo output limiting. R13: Part of calibration oscillator plate voltage dividing network. R33 and R34: V1 and V4 screen voltage dropping; vary sensitivity of receiver for bands 2 and 3 during calibration.	3RC20BF104K
R18, R26	RESISTOR, fixed: comp; 180,000 ohms $\pm 10\%$; $\frac{1}{2}$ w; JAN type RC20BF184K.	R18: Part of detector load. R26: Part of V7 and V8 grid bias voltage-dividing network.	3RC20BF184K
R14, R21, R22, R31	RESISTOR, fixed: comp; 470,000 ohms $\pm 10\%$; $\frac{1}{2}$ w; JAN type RC20BF474K.	R14: Crystal calibration oscillator grid leak. R21: V6 plate load. R22: Prevents shorting of sidetone signal. R31: V7 signal grid d-c return.	3RC20BF474K
R1, R4, R7, R12, R36	RESISTOR, fixed: comp; 1 meg $\pm 10\%$; $\frac{1}{2}$ w; JAN type RC20BF105K.	R1: V1 control grid d-c return. R4: V2 control grid d-c return. R7: V3 control grid d-c return. R12: Sidetone input limiting. R36: Sidetone input load.	3RC20BF105K
R20, R24, R30	RESISTOR, fixed: comp; 2.2 meg $\pm 10\%$; $\frac{1}{2}$ w; JAN type RC20BF225K.	R20: V6 screen grid voltage dropping. R24: V8 control grid d-c return. R30: V7 signal grid bias.	3RC20BF225K

6. Identification Table of Parts for Radio Receiver R-174/URR—Continued

Ref symbol	Name of part and description	Function of part	Signal Corps stock No.
R15, R35	RESISTOR, fixed: comp; 3.3 meg $\pm 10\%$; $\frac{1}{2}$ w; JAN type RC20BF335K.	R15: Avc filter. R35: V1 and V4 screen voltage dropping; varies sensitivity of receiver for band 1 during calibration.	3RC20BF335K
R27	RESISTOR, fixed: comp; 5.6 meg $\pm 10\%$; $\frac{1}{2}$ w; JAN type RC20BF565K.	V8 control grid bias-----	3RC20BF565K
R32	RESISTOR, variable: 1 meg $\pm 20\%$; $\frac{1}{2}$ w; CTS #35.	R.F. GAIN control-----	3Z7499-1.151
R19A, B	RESISTOR, variable: 2 sect.; 1 meg first sect.; 2 meg, second sect.; $\pm 20\%$; $\frac{1}{4}$ w; CTS #2-45.	A.F. GAIN control-----	3Z7499-2.22
H11, H36, H37	RING, retainer: steel; zinc plate and iridite finish; circular shape; Emerson Rad #WA-9018.	Used with fastener for fastening tube cover to top cover.	2Z7858-256
H12	SCREW DRIVER, common: 2" lg blade; $3\frac{3}{32}$ " lg o/a, $\frac{1}{8}$ " dia round shank; $\frac{1}{8}$ " wd x .125" thk bit; Emerson Rad #AC-1010.	Alinement and general purpose tool.	6R15195-2
O6	SHAFTING, rigid: brass, nickel plate; $1\frac{13}{16}$ " lg, .247" dia; mtd by integrally thd hole; Emerson Rad #SM-1201.	Through panel shaft for antenna trimmer.	2Z8205A-3
O13	SHUTTER, dial: $3\frac{3}{4}$ " dia x .032" thk; Emerson Rad #AS-1191.	Mask all but selected calibration on dial scale.	2Z8278
X10	SOCKET, crystal: $\frac{3}{16}$ " dia pins accom spaced $\frac{3}{16}$ " c to c; rectangular shape; o/a dim, excl term.; $\frac{1}{16}$ " lg x $\frac{1}{16}$ " wd x $\frac{3}{16}$ " h o/a excl term.; Cinch #9816.	Socket for crystal Y1-----	2Z8672.8
X4 thru X8	SOCKET, electron tube: 7 cont; miniature size; JAN type TS102P01.	X4: Socket for tube V4----- X5: Socket for tube V5 X6: Socket for tube V6 X7: Socket for tube V7 X8: Socket for tube V8	2Z8677.171
X1 thru X3	SOCKET, electron tube: 7 cont; miniature size; JAN type TS102C01; o/a dim, excl term.; $1\frac{1}{8}$ " lg x .80" dia x $\frac{3}{16}$ " h; ceramic.	X1: Socket for tube V1----- X2: Socket for tube V2 X3: Socket for tube V3	2Z8677.99
O40 thru O47	SPRING, helical, compression: $\frac{7}{8}$ " lg x $\frac{3}{16}$ " OD max x $\frac{1}{16}$ " ID min; 6 turns; closed ends; cone shaped; Emerson Rad #SV-1011.	Tube shield springs-----	2Z8877.703
O97	SPRING, helical, compression: .034" dia; SS; $1\frac{1}{4}$ " lg x .251" to .257" ID x .285" to .291" OD; 17 turns; sq ends; Emerson Rad #SV1045.	Dial locking spring-----	2Z8877.704
O24	STOP, dial: 1.799" h x 1" wd x $\frac{3}{16}$ " d o/a; Emerson Rad #AS-1197.	Lock for dial-----	2Z8996-30
H10, H34, H35	STUD: steel; $\frac{3}{16}$ " h; wing shaped top for turning Emerson Rad #FA-1005.	Clamp tube cover to top cover riveting assembly.	2Z8634-59
L3	SUPPRESSOR, parasitic: resistor and coil type; 55 turns, #36 AWG on 10,000 ohm, $\frac{1}{2}$ w resistance; $\frac{1}{16}$ " lg; $\frac{1}{16}$ " dia o/a; Emerson Rad #LT-1043.	Parasitic suppressor-----	3Z1891A-19
S1	SWITCH, rotary: 9 sect.; 4 positions; $7\frac{3}{4}$ " lg x $1\frac{1}{16}$ " wd x $1\frac{7}{8}$ " h o/a; round shaft $1\frac{3}{8}$ " lg x $\frac{1}{4}$ " dia; Emerson Rad #SW-1006.	BAND SW. switch-----	3Z9825-128
S4	SWITCH, rotary: 1 sect.; 2 positions; nonadj end stops; $4\frac{1}{2}$ " lg x $1\frac{1}{4}$ " wd x $1\frac{1}{16}$ " h o/a; mtd by $\frac{3}{8}$ "-32, NSF-2 thd sleeve, $\frac{3}{8}$ " lg; round shaft $3\frac{1}{16}$ " lg x $\frac{1}{4}$ " dia; Oak #FC-2.	OUTPUT HIGH-LOW switch	3Z9825-62.691
S2	SWITCH, rotary: 3 sect.; 4 positions; $1\frac{7}{16}$ " lg x $1\frac{3}{16}$ " wd x 1.852" d x 1.852" h o/a; mtd by $\frac{1}{4}$ " lg x $\frac{3}{8}$ "-32 thd bushing; flat shaft $\frac{5}{8}$ " lg x .187" wd; Oak #DH.	PHN.-C.W.-NET-CAL. function switch.	3Z9825-62.694

6. Identification Table of Parts for Radio Receiver R-174/URR—Continued

Ref symbol	Name of part and description	Function of part	Signal Corps stock No.
S3	SWITCH, sensitive: SPST; plunger type; 125/250 v ac, 28 v dc, 5 amp ac, 1.5 amp dc, phenolic; momentary action; Minneapolis Honey #3887.	DIAL LIGHT switch-----	3Z9823-15.29
E6	TERMINAL BOARD: bakelite; 32 term., double turret type; o/a dim 4 $\frac{1}{2}$ " lg x 1 $\frac{3}{8}$ " wd x .078" thk; Precision Metal Products #103.	Mounts resistors and capacitors.	3Z770-32.15
T1	TRANSFORMER ASSEMBLY: 2 transf; 1.44 to 2.78 mc; 2.64 to 5.08 mc; o/a dim 2 $\frac{1}{8}$ " lg x 1 $\frac{1}{16}$ " wd x 1 $\frac{1}{16}$ " d o/a; Emerson Rad #LT-1030.	Couples antenna to first r-f amplifier in bands 1 and 2.	2Z10003-3
T5	TRANSFORMER ASSEMBLY: 2 transf; 4.95 mc to 9.6 mc, 9.4 mc to 18.2 mc; dim 2 $\frac{1}{8}$ " lg x 1 $\frac{1}{16}$ " wd x 1 $\frac{1}{16}$ " d o/a; Emerson Rad #LT-1034.	Couples antenna to first r-f amplifier in bands 3 and 4.	2Z1003-4
T2	TRANSFORMER ASSEMBLY: 2 transf; 1.44 mc to 2.78 mc, 2.64 to 5.08 mc; dim 2 $\frac{1}{8}$ " lg x 1 $\frac{1}{16}$ " wd x 1 $\frac{1}{16}$ " d o/a; Emerson Rad #LT-1031.	Couples first r-f amplifier to second r-f amplifier in bands 1 and 2.	2Z10003-5
T6	TRANSFORMER ASSEMBLY: 2 transf; 4.95 mc to 9.6 mc, 9.4 mc to 18.2 mc; dim 2 $\frac{1}{8}$ " lg x 1 $\frac{1}{16}$ " wd x 1 $\frac{1}{16}$ " d o/a; Emerson Rad #LT-1035.	Couples first r-f amplifier to second r-f amplifier in bands 3 and 4.	2Z10003-6
T3	TRANSFORMER ASSEMBLY: 2 transf; 1.44 mc to 2.78 mc, 2.64 mc to 5.08 mc; dim 2 $\frac{1}{8}$ " lg x 1 $\frac{1}{16}$ " wd x 1 $\frac{1}{16}$ " d o/a; Emerson Rad #LT-1032.	Couples second r-f amplifier to converter in bands 1 and 2.	2Z10003-7
T7	TRANSFORMER ASSEMBLY: 2 transf; 4.95 mc to 9.6 mc, 9.4 mc to 18.2 mc; dim 2 $\frac{1}{8}$ " lg x 1 $\frac{1}{16}$ " wd x 1 $\frac{1}{16}$ " d o/a; Emerson Rad #LT-1036.	Couples second r-f amplifier to converter in bands 3 and 4.	2Z10003-8
T4	TRANSFORMER ASSEMBLY: 2 transf; 1.895 mc to 3.235 mc, 3.095 mc to 5.535 mc; dim 2 $\frac{1}{8}$ " lg x 1 $\frac{1}{16}$ " wd x 1 $\frac{1}{16}$ " d o/a; Emerson Rad #LT-1033.	Converter oscillator tank for bands 1 and 2.	2Z10003-9
T8	TRANSFORMER ASSEMBLY: 2 transf; 5.405 mc to 10.055 mc, 9.855 mc to 18.655 mc; dim 2 $\frac{1}{8}$ " lg x 1 $\frac{1}{16}$ " wd x 1 $\frac{1}{16}$ " d o/a; Emerson Rad #LT-1037.	Converter oscillator tank for bands 3 and 4.	2Z10003-10
T14	TRANSFORMER, AF: plate coupling type; HS; pri, 60,000 ohms, tapped 12,500 ohms; sec, 600 ohms, tapped 8 ohms; pri rated at 7.5 ma dc max, pri tap rated at 3 ma max; 500 v ac test voltage; dim 1 $\frac{5}{8}$ " lg x 1 $\frac{5}{8}$ " wd x 2 $\frac{3}{8}$ " h o/a; 160 mw max audio operating level; \pm 2 db from 200-3000 cys freq response; 6 solder lug term.; New England Transformer Co. #E-1039S.	Audio output transformer---	2Z9632.684
T13	TRANSFORMER, RF: universal wnd; 1.4 mh to 3.1 mh measured at 1 kc; 520 turns #38 AWG; 24 ohms dc resistance; adj iron core, scdr adj; Emerson Rad #LT-1040.	Bfo tank-----	2Z9629-442
T12	TRANSFORMER, RF: universal wnd; 1 mh to 1.85 mh measured at 250 kc; 425 turns #38 AWG; adj iron core, scdr adj; Emerson Rad #LT-1039.	Calibration oscillator tank---	2Z9629-439
T9, T10, T11	TRANSFORMER, RF: 2 wnd, universal wnd, pri 221 mh measured at 790 kc, secd 221 mh measured at 790 kc; ea wnd 225 turns #44; adj iron core, scdr adj; Emerson Rad #LT-1038.	T9: Couples converter to first i-f amplifier. T10: Couples first i-f amplifier to second i-f amplifier grid. T11: Couples V5 to detector plate.	2Z9629-438
O16	WASHER, spring tension: round, 45° bend; recess in ctr; Emerson Rad #MS-1267.	Assembly washer for dial shutter O14.	6L50112-26
O12	WASHER, spring tension: round, U-bend; phosphor bronze; 74,000 lb per sq in. min yield strength.	Eliminates end play on dial shutter assembly O13.	6L73654-6

6. Identification Table of Parts for Radio Receiver R-174/URR—Continued

Ref symbol	Name of part and description	Function of part	Signal Corps stock No.
MS1	WINDOW, dial: glass; rectangular shape; dim 1.375" lg x 1.109" wd x .156" thk o/a; Emerson Rad #MP-1030.	Permits viewing of dial-----	6Z9461-5
H9	WRENCH: .094" across flats; dim 1 $\frac{3}{4}$ " lg x $\frac{3}{16}$ " h o/a; seamless steel tubing; head bent at $\frac{5}{16}$ " rad from shank; round straight handle; Emerson Rad #AC-1000.	Tool for #8 bristol setscrews	6R55231.1
H38	WRENCH, socket: double hex. socket wrench; opening on 1 end .252" to .257" across flats; on other end .189" to .194" across flats; 2 $\frac{1}{4}$ " lg x $\frac{1}{4}$ " dia of body, socket ends 1 end $\frac{3}{16}$ " dia, other end $\frac{5}{16}$ " dia; straight; Emerson Rad #AC-1007.	Locks and unlocks nuts for tuning coils.	6R57408-5

RESISTOR COLOR AND LETTER CODE

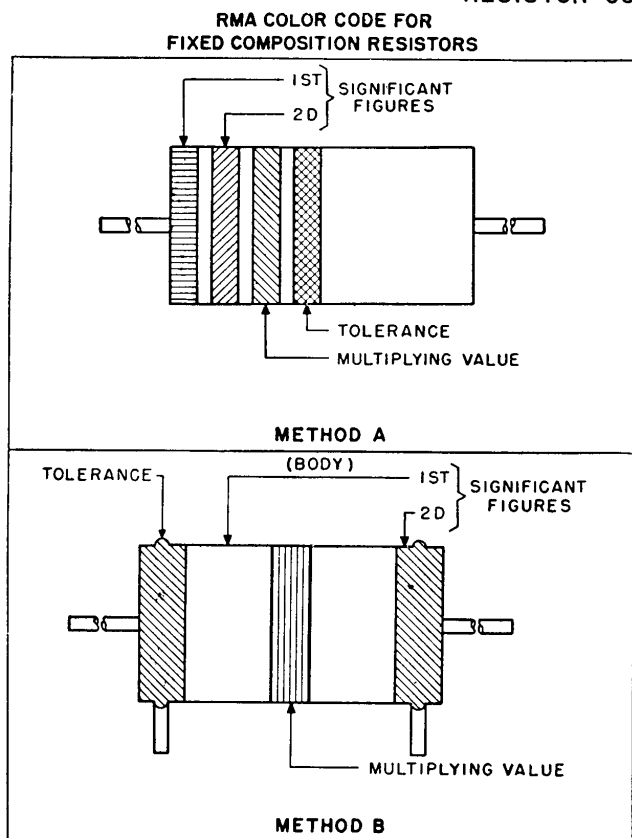

A

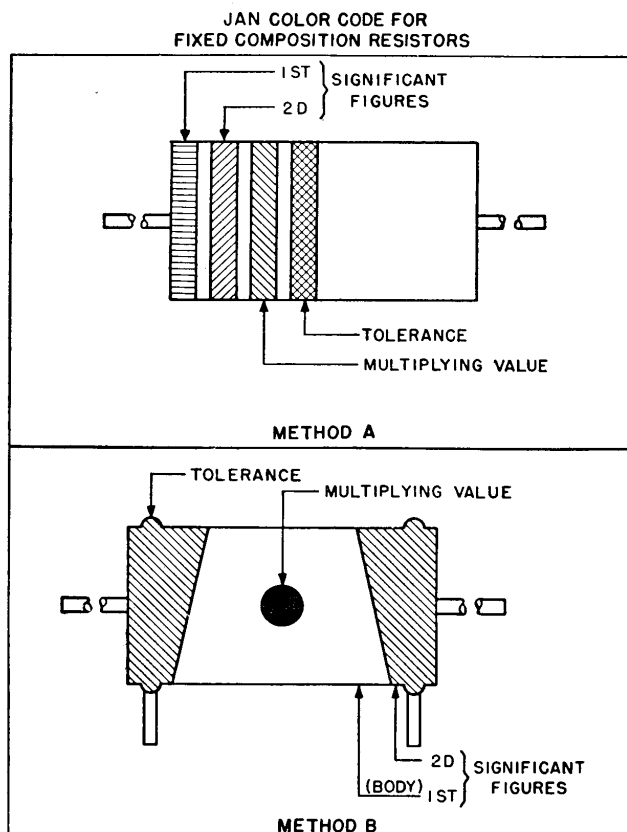

B

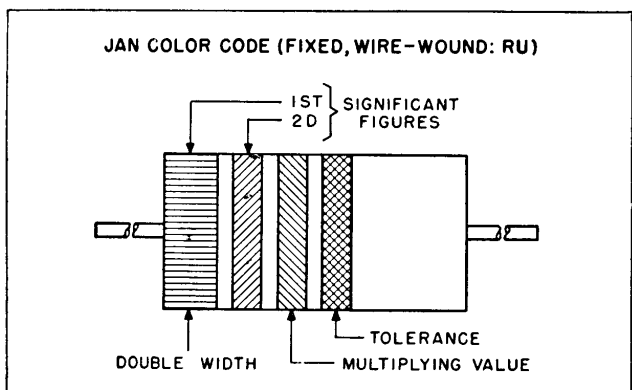

C

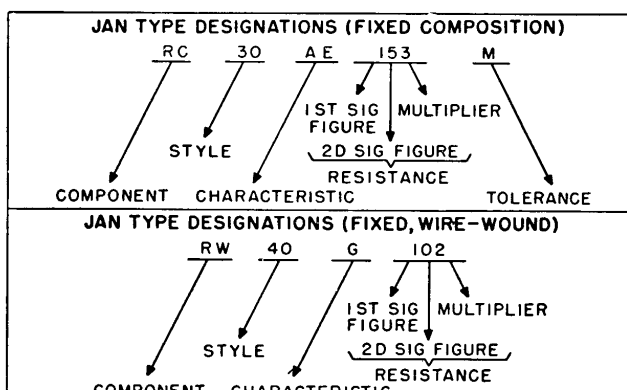

D

STANDARDS				
COLOR	SIGNIFICANT FIGURE	MULTIPLYING VALUE	TOLERANCE (%)	JAN LETTER TOLERANCE
BLACK	0	1	—	—
BROWN	1	10	± 1	F
RED	2	100	± 2	G
ORANGE	3	1,000	± 3	—
YELLOW	4	10,000	± 4	—
GREEN	5	100,000	± 5	—
BLUE	6	1,000,000	± 6	—
VIOLET	7	10,000,000	± 7	—
GRAY	8	100,000,000	± 8	—
WHITE	9	1,000,000,000	± 9	—
GOLD	—	0.1	± 5	J
SILVER	—	0.01	± 10	K
NO COLOR	—	—	± 20	M

- NOTES:**
1. RESISTORS WITH AXIAL LEADS ARE INSULATED. RESISTORS WITH RADIAL LEADS ARE NON-INSULATED.
 2. RMA: RADIO MANUFACTURERS ASSOCIATION.
 3. JAN: JOINT ARMY - NAVY.
 4. THESE COLOR AND NUMBER CODES GIVE ALL RESISTANCE VALUES IN OHMS.
 5. RESISTIVE COMPONENTS USED FOR LETTER TOLERANCES ARE: RC, RN, AND RU.
 6. WATTAGE FOR RW TYPES IS FOUND IN THE JAN SPECIFICATIONS UNDER CHARACTERISTICS.

TMRC

Figure 41. Resistor color and letter code.

CAPACITOR COLOR AND LETTER CODES

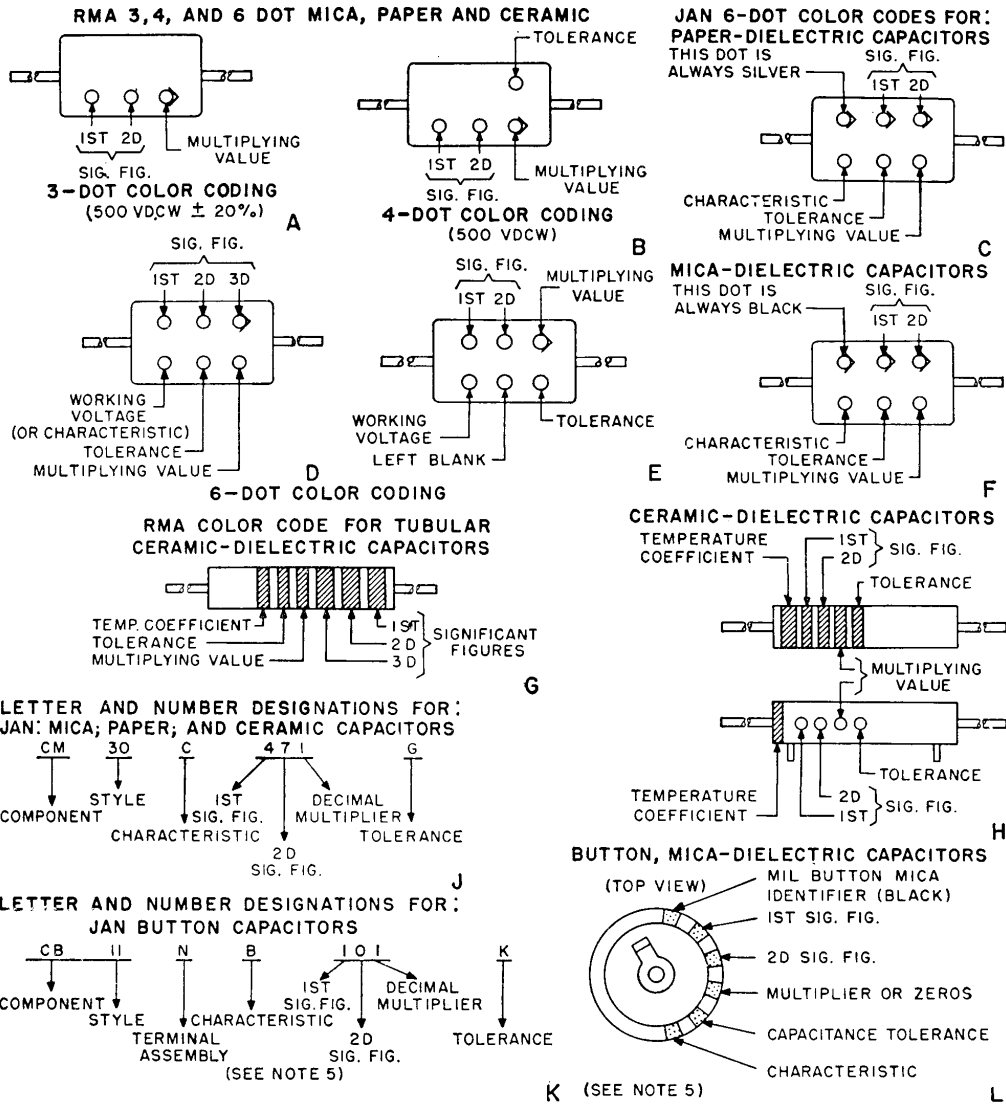

- STANDARDS -					JAN MICA-CN		JAN PAPER-CN		JAN CERAMIC-CC					
COLOR	SIG. FIG.	DECIMAL MULTIPLIER	% TOL.	VDCW	LETTER TOL.	CHARAC-TERISTIC	LETTER TOL.	CHARAC-TERISTIC	DEC. MULT.	%	LETTER DESIGN-NATION	UUF	LETTER DESIGN-NATION	CHARAC-TERISTIC
BLACK	0	1	±20	500	M	A	M	.A	1	±20	M	±2.0	G	C
BROWN	1	10	±1	100	-	B	-	E	10	±1	F	-	-	H
RED	2	100	±2	200	G	C	-	H	100	±2	G	-	-	L
ORANGE	3	1,000	±3	300	-	D	N*	J	1,000	-	-	-	-	P
YELLOW	4	10,000	±4	400	-	E	-	P	-	-	-	-	-	R
GREEN	5	100,000	±5	500	-	F	-	R	-	±5	J	±0.5	D	S
BLUE	6	1,000,000	±6	600	-	G	-	S	-	-	-	-	-	T
VIOLET	7	10,000,000	±7	700	-	-	-	T	-	-	-	-	-	U
GRAY	8	100,000,000	±8	800	-	-	-	-	0.01	-	-	±0.25	C	B
WHITE	9	1,000,000,000	±9	900	-	-	-	-	0.1	±10	K	±1.0	F	SL
GOLD	-	0.1	±5	1,000	J	-	-	-	-	-	-	-	-	A
SILVER	-	0.01	±10	2,000	K	-	-	-	-	-	-	-	-	-
NO COLOR	-	-	±20	500	-	-	-	-	-	-	-	-	-	-

* THE TOLERANCE OF THIS CAPACITOR IS ±30%, NOT ±20%

- NOTES**
- JAN: JOINT ARMY-NAVY
 - RMA: RADIO MANUFACTURERS ASSOCIATION
 - THESE COLOR AND LETTER CODES GIVE CAPACITANCES IN MICROMICROFARADS
 - THIS TABLE IS ADAPTED FOR JAN AND RMA COLOR AND JAN LETTER TYPE DESIGNATIONS
 - CERAMIC AND MICA CAPACITORS, BOTH JAN AND RMA, ARE GENERALLY 500 VDCW
 - BUTTON CAPACITORS ARE GENERALLY 300 VDCW
 - READ BUTTON CAPACITOR TOLERANCE UNDER CERAMICS OF MORE THAN 10 UUF
 - CHARACTERISTICS ARE AVAILABLE IN JAN CAPACITOR SPECIFICATION MANUALS
 - THE COMPONENTS USED ABOVE FOR JAN LETTER TYPE DESIGNATIONS ARE:
 CC MICA BUTTON; CC CERAMIC; CN MICA MOULDED; CN PAPER MOULDED

TM CC

Figure 42. Capacitor color and letter code.

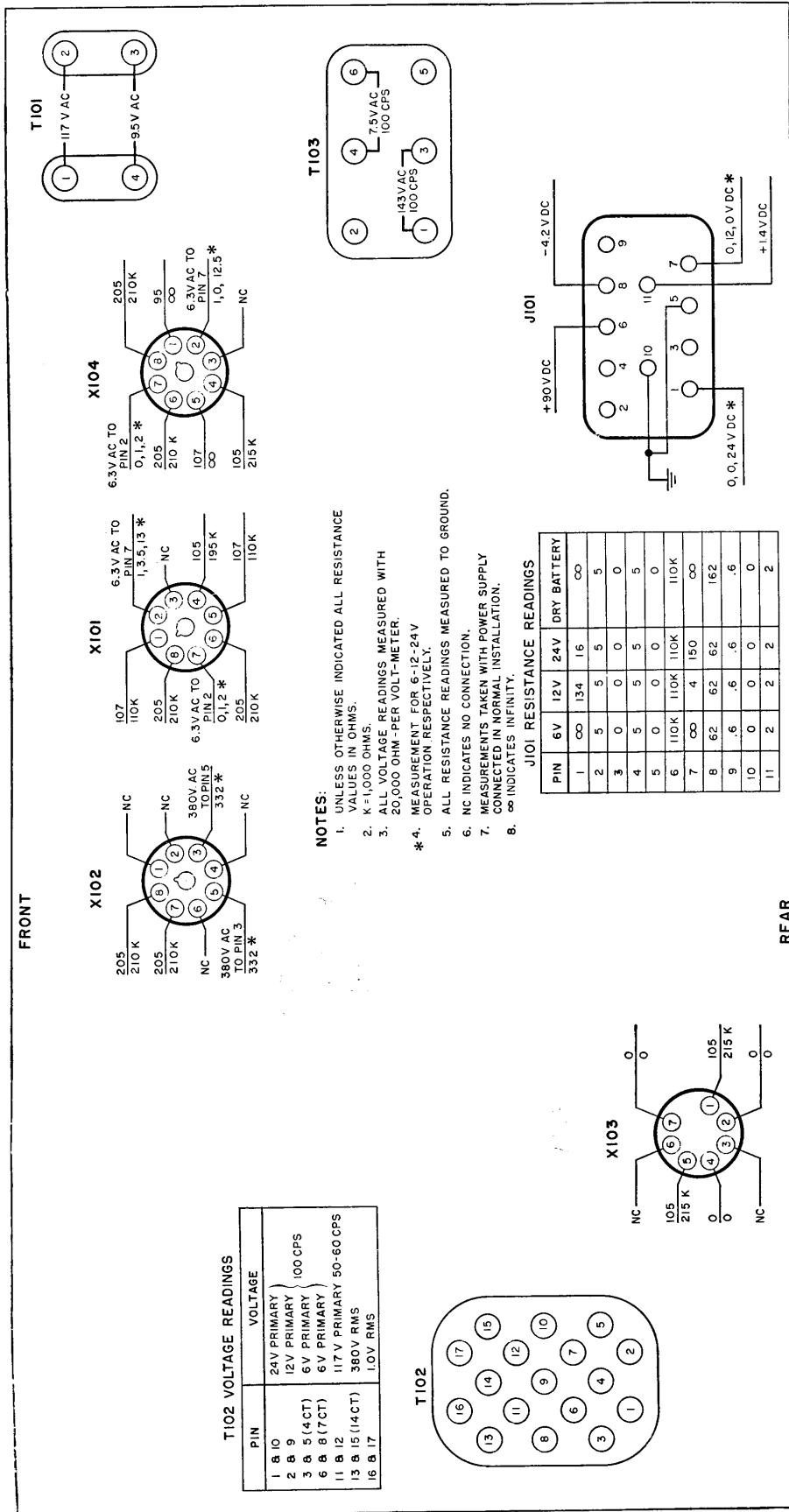

Figure 44. Power Supply PP-308/URR, tube socket voltage and resistance diagram.

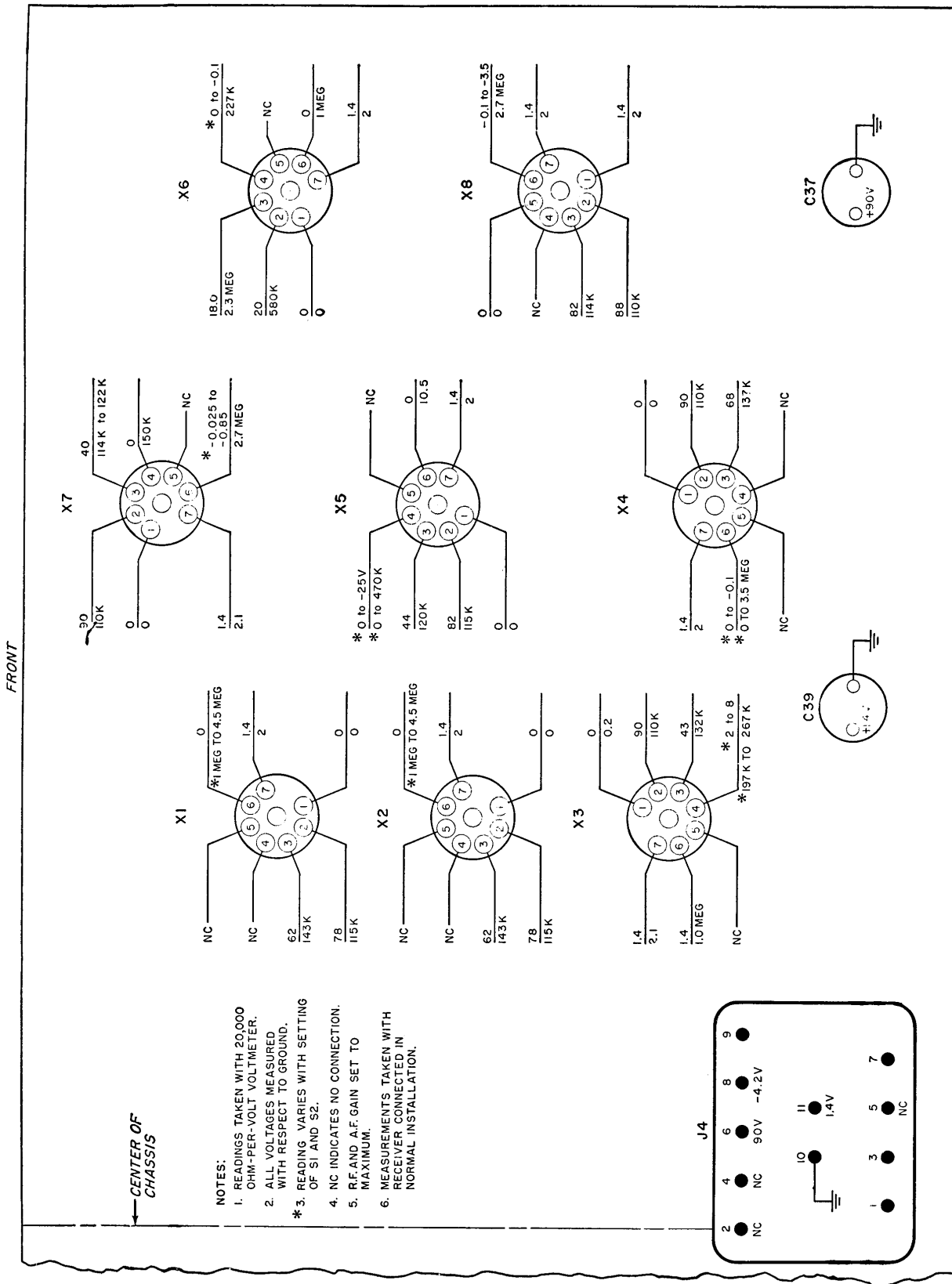
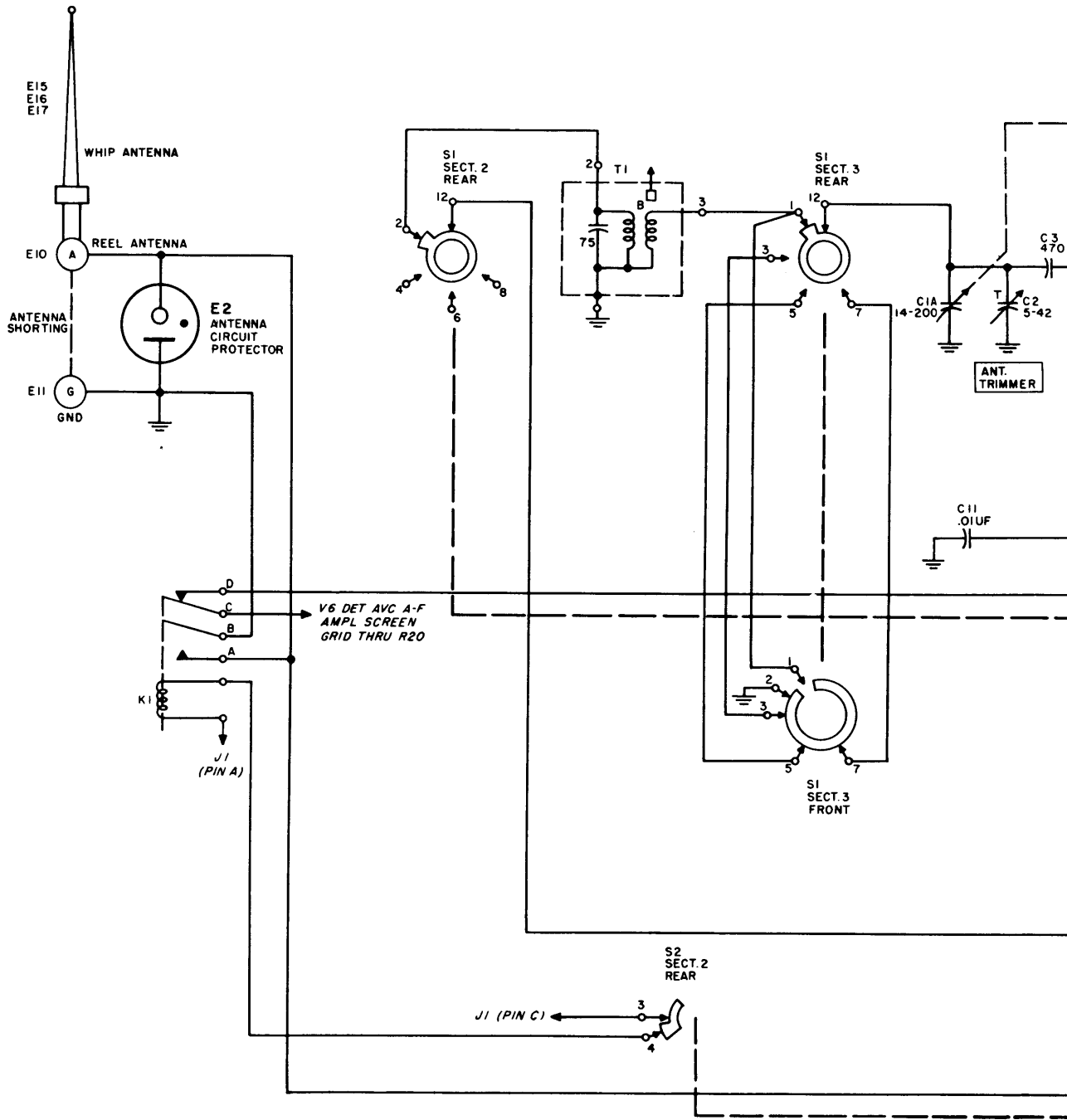

Figure 45. Radio Receiver R-174/URR, tube socket voltage and resistance diagram.

INDEX

	<i>Paragraphs</i>	<i>Page</i>		<i>Paragraphs</i>	<i>Page</i>
Abbreviations.....	App. I	81	Equipment—Continued		
Alinement:			Performance checklist.....	43	26
Beat-frequency oscillator.....	95	75	Test, for alinement.....	92	73
Calibration oscillator.....	97	77	Test, for trouble shooting.....	71	56
I-f amplifier.....	94	73	Used, service upon receipt.....	17	13
Local oscillator.....	96	75	Fidelity.....	102	78
R-f amplifier.....	96	75	Forms.....	2, 34	1, 22
Test instruments.....	92	73	Gain, stage charts.....	87	69
Antenna:			Ground installation.....	13	8
Installation.....	14	10	Headset:		
Type.....	5	2	Description.....	8	5
Assembly of equipment.....	13	8	Operation.....	60	46
Automatic volume control circuit.....	58	45	Performance checklist.....	43	26
Beat-frequency oscillator:			Identification table of parts.....	App. II	84
Alinement.....	95	75	Image rejection:		
Circuit.....	62	48	Check.....	96	75
Operation.....	65	51	Ratio.....	102	78
Test, signal substitution.....	83	68	Inspection, visual.....	41, 72	25, 56
Block diagram:			Installation:		
Power Supply PP-308/URR.....	44	28	Antenna and ground.....	14	10
Radio Receiver R-174/URR.....	51	37	Electrical connection.....	15	11
Calibration oscillator:			Mounting and assembly of equipment.....	11	8
Alinement.....	97	77	Siting.....	11	8
Circuit.....	63	48	Intermediate frequency:		
Operation.....	67	51	Alinement.....	94	73
Test, signal substitution.....	84	68	Amplifier circuit.....	56, 57	42, 44
Calibration, signal generator.....	93	73	Test, signal substitution.....	81	66
Checking:			Localization of trouble:		
New equipment.....	12	8	Power Supply PP-308/URR.....	77	58
Voltage, Power Supply PP-308/URR.....	100	78	Radio Receiver R-174/URR.....	78	59
Voltage, Radio Receiver R-174/URR.....	100	78	Lubrication:		
Checklist:			Detailed instructions.....	36	23
Equipment performance.....	43	26	Unusual conditions.....	37	24
Purpose and use.....	42	25	Maintenance:		
Code reception.....	22	17	Preventive, checklists.....	35	22
Components, table.....	7	3	Preventive, definition.....	32	22
Connections.....	15	11	Monitoring.....	71	56
Continuous-wave reception.....	65	51	Mounting.....	11	8
Controls:			Operation:		
Operation.....	101	78	Of controls, testing.....	101	78
Settings, preliminary.....	19	15	Arctic conditions.....	27	18
Use.....	18	15	Desert conditions.....	29	19
Demolition.....	106	80	Tropical conditions.....	28	19
Description.....	8	5	Oscillator:		
Destruction.....	106	80	Beat-frequency.....	62	48
Detector.....	58	45	Calibration.....	63	48
Disassembly.....	91	71	Local.....	54	41
Equipment:					
Mounting and assembly.....	13	8			

	<i>Paragraphs</i>	<i>Page</i>		<i>Paragraphs</i>	<i>Page</i>
Output circuits:			Relay:		
High	61	46	Monitoring input	71	56
Low	60	46	Rectifier	46	31
Packaging data	6, 7	3	Repacking	104	80
Painting	39	24	Repair, general precautions	88	71
Performance:			Replacement of parts	89	71
Checklist, equipment	43	26	Report, unsatisfactory equipment	2	1
Checklist, purpose and use	42	25	Resistance measurements:		
Power, input	5	2	Coils and transformers, Power Supply	85	68
Power Supply PP-308/URR circuits:			PP-308/URR.		
6 v dc	47	32	Coils and transformers, Radio	86	69
12 v dc	48	32	Receiver R-174/URR.		
24 v dc	49	34	Input of Power Supply PP-308/URR	73	57
115 v ac	46	31	Input of Radio Receiver R-174/URR	74	57
Description	8	5	Rustproofing	39	24
Dry battery	50	34	Scope:		
Input measurements, resistance	73	57	Maintenance	40	25
Operational test	75	58	Radio Receiving Set AN/GRR-5	1	1
Trouble shooting	77	58	Sectionalization of trouble:		
Precautions, repairs	88	71	Power Supply PP-308/URR	77	58
Preventive maintenance:			Radio Receiver R-174/URR	78	59
Definition	32	22	Selectivity	102	78
Forms	34	22	Radio Receiver R-174/URR	51	37
Performing	35	22	System application	4	1
Techniques	33	22	Tools:		
R-f alinement	96	75	Special, supplied with Radio Receiv-	31	21
Radio Receiver R-174/URR:			ing Set AN/GRR-5.		
A-f amplifier	59	45	Trouble shooting	71	56
Beat-frequency oscillator	62	48	Used with Radio Receiving Set	30	20
Block diagram	51	37	AN/GRR-5.		
Calibration oscillator	63	48	Trouble shooting:		
Characteristics	102	78	Charts for Power Supply PP-308/	77	58
Converter	55	42	URR.		
Description	8	5	Charts for Radio Receiver R-174/	78	59
Detector, avc and a-f amplifier	58, 59	45	URR.		
High a-f amplifier	61	46	Data	70	56
I-f amplifier, first	56	42	Localization in Power Supply	77	58
I-f amplifier, second	57	44	PP-308/URR.		
Local oscillator	54	41	Localization in Radio Receiver	78	59
Low a-f amplifier	60	46	R-174/URR.		
R-f amplifier, first	52	39	Procedures	69	55
R-f amplifier, second	53	39	Sectionalization in Power Supply	77	58
Reception:			PP-308/URR.		
Code	20, 65	17, 51	Sectionalization in Radio Receiver	78	59
Net	23, 66	18, 51	R-174/URR.		
Voice	21, 64	17, 50	Unpacking procedure	12	8
Records	2	1	Unsatisfactory equipment report	2	1
Rectifier:			Visual inspection	41, 72	25, 56
Filament voltage	46	31	Voice reception	21	17
High voltage	45	28	Voltage checks:		
References	App. I	81	Power Supply PP-308/URR	100	78
Refinishing	90	71	Radio Receiver R-174/URR	100	78
			Weatherproofing	38	24



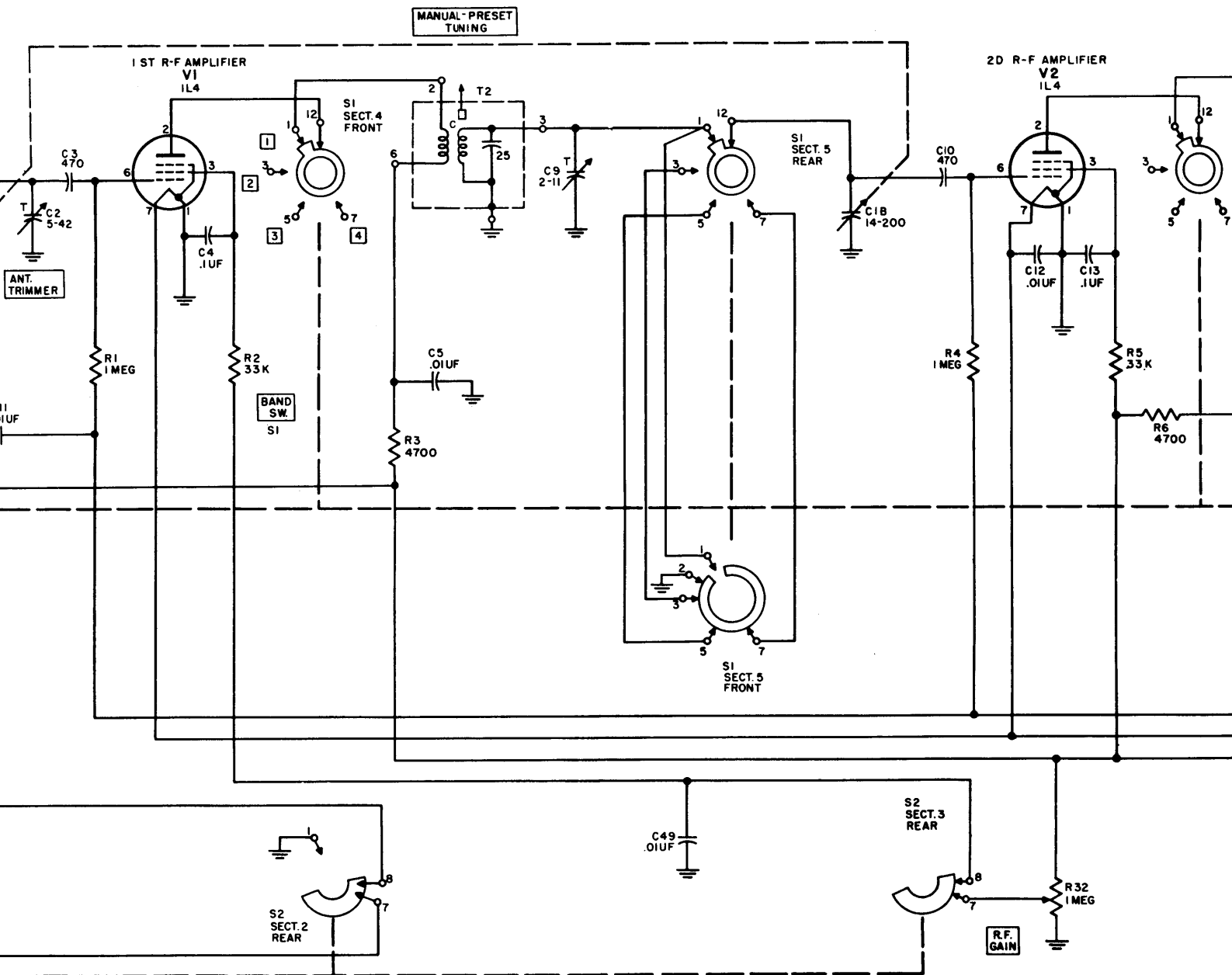
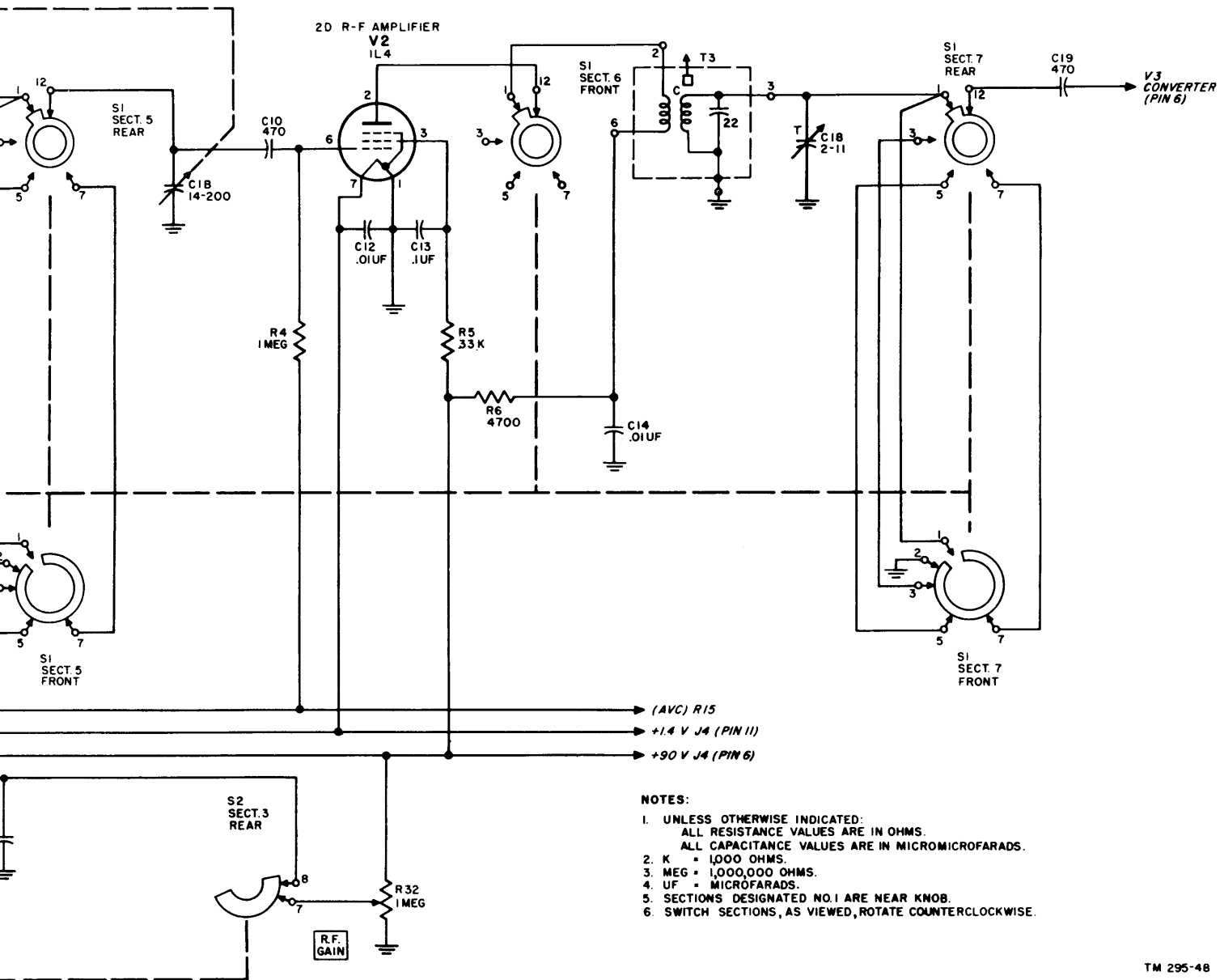

Figure 43. Radio Receiver R-174/URR, r-f amplifiers, for band 1, functional schematic.



functional schematic.

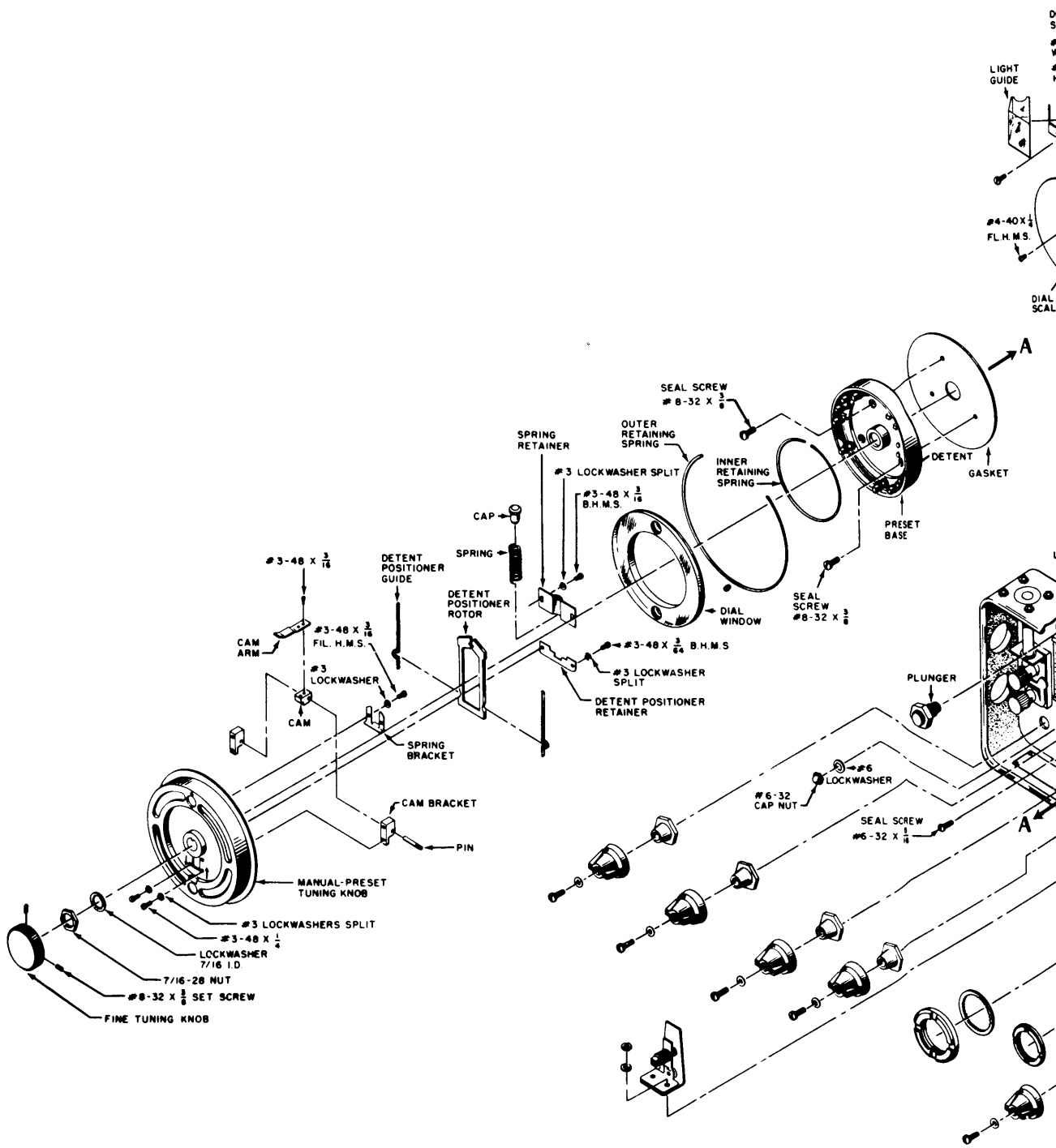

Figure 46. Radio Receiver R-174/URR, f

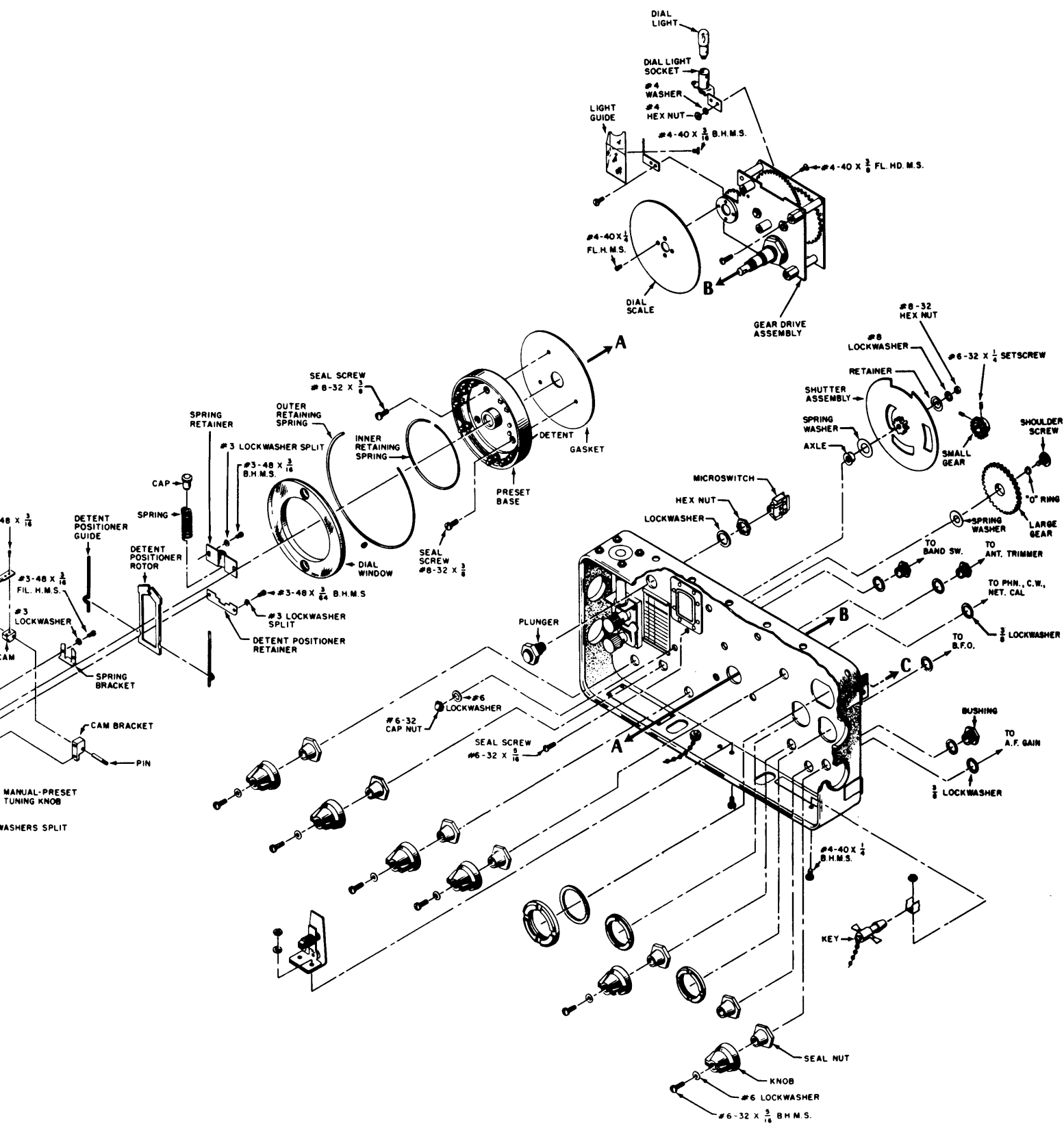
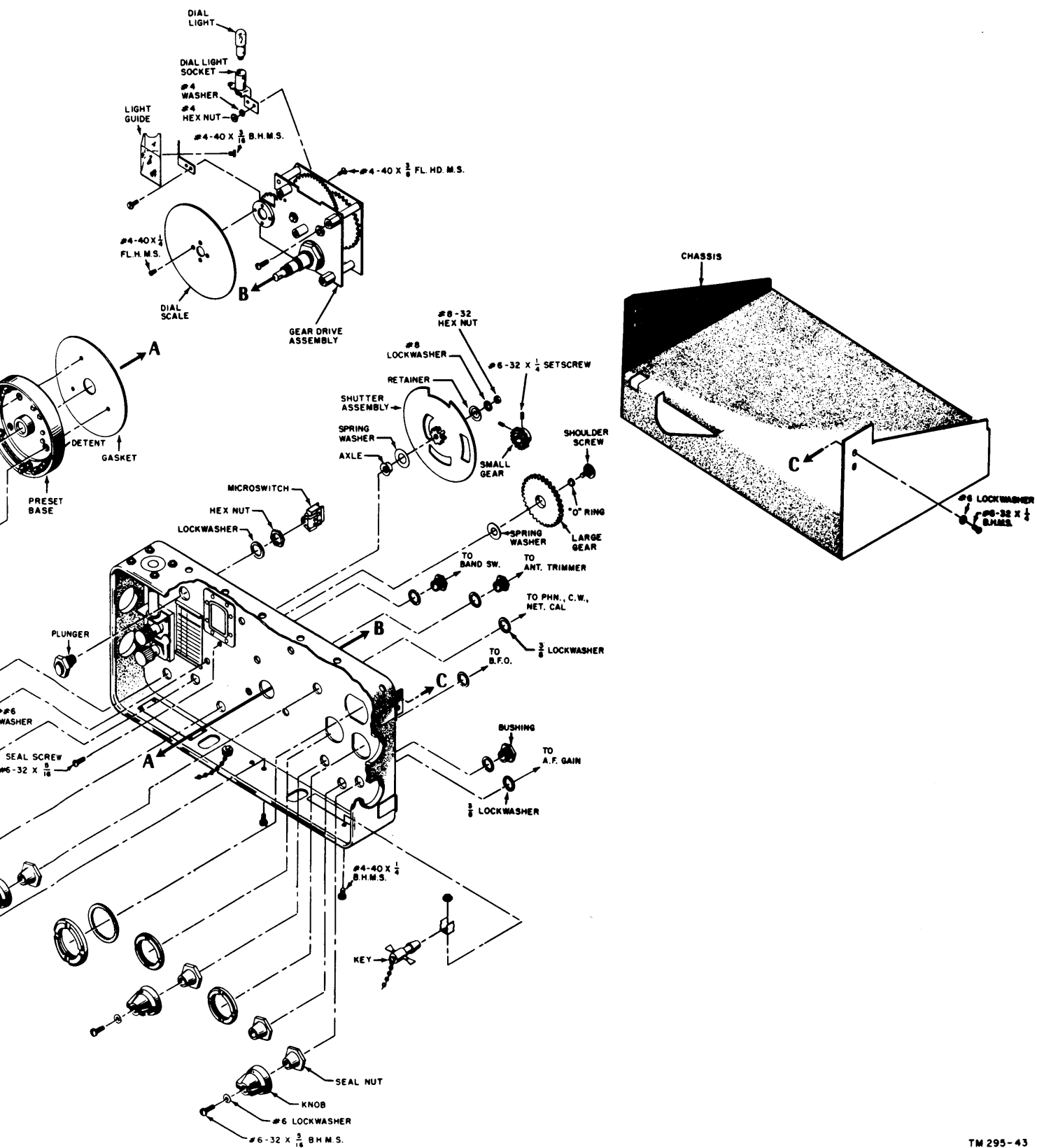

Figure 46. Radio Receiver R-174/URR, front panel assembly, exploded view.



Receiver R-174/URR, front panel assembly, exploded view.

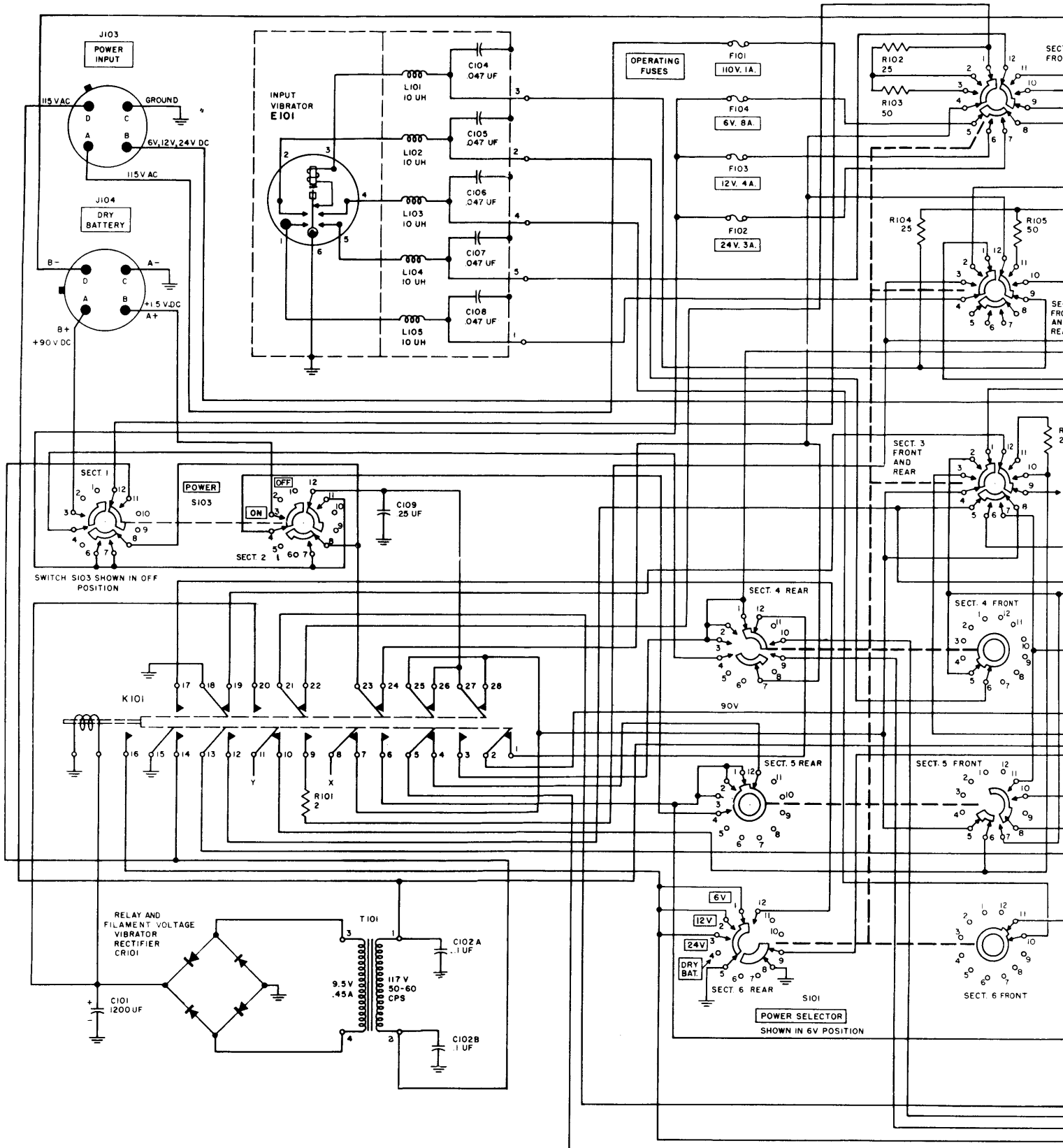
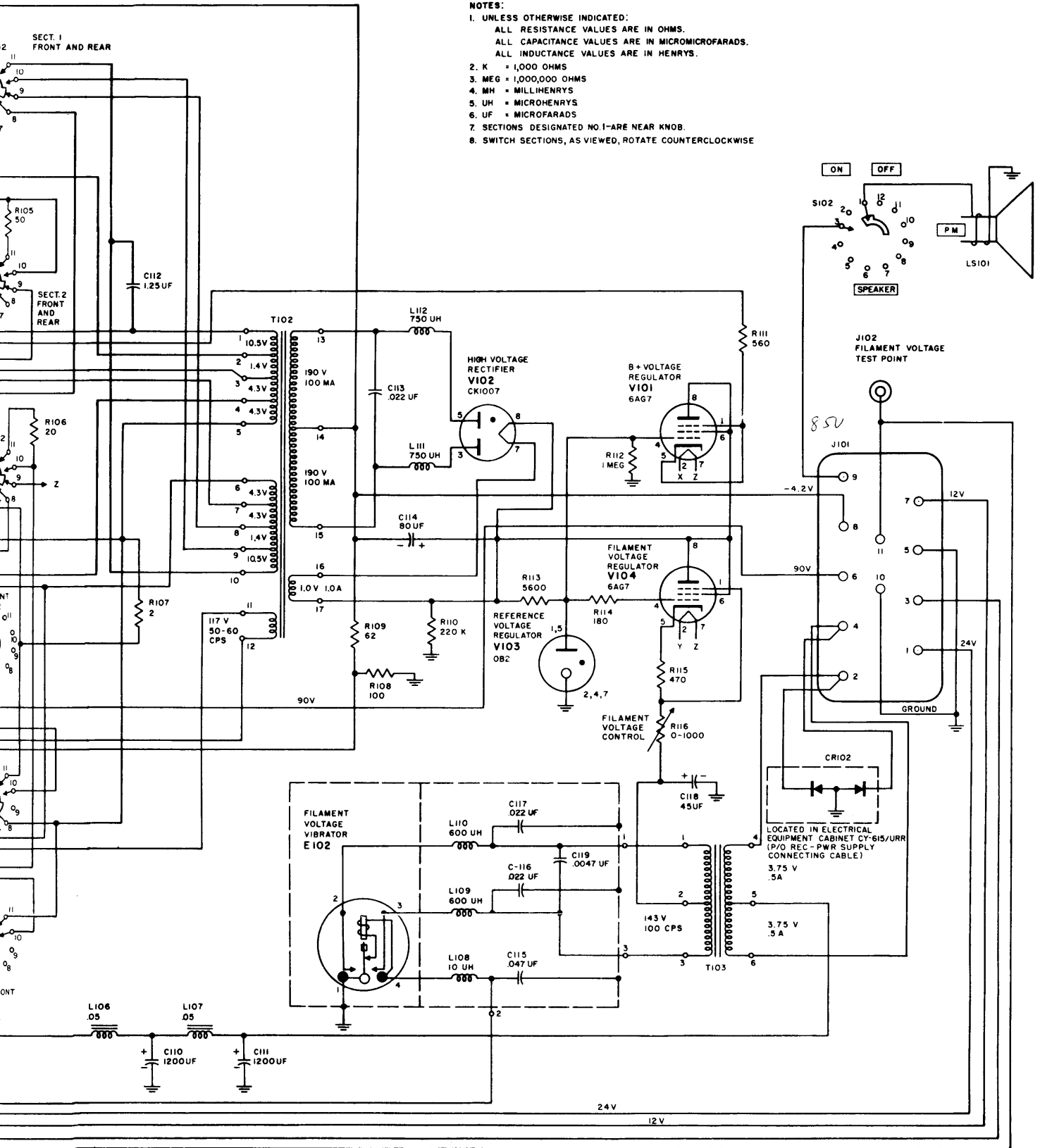
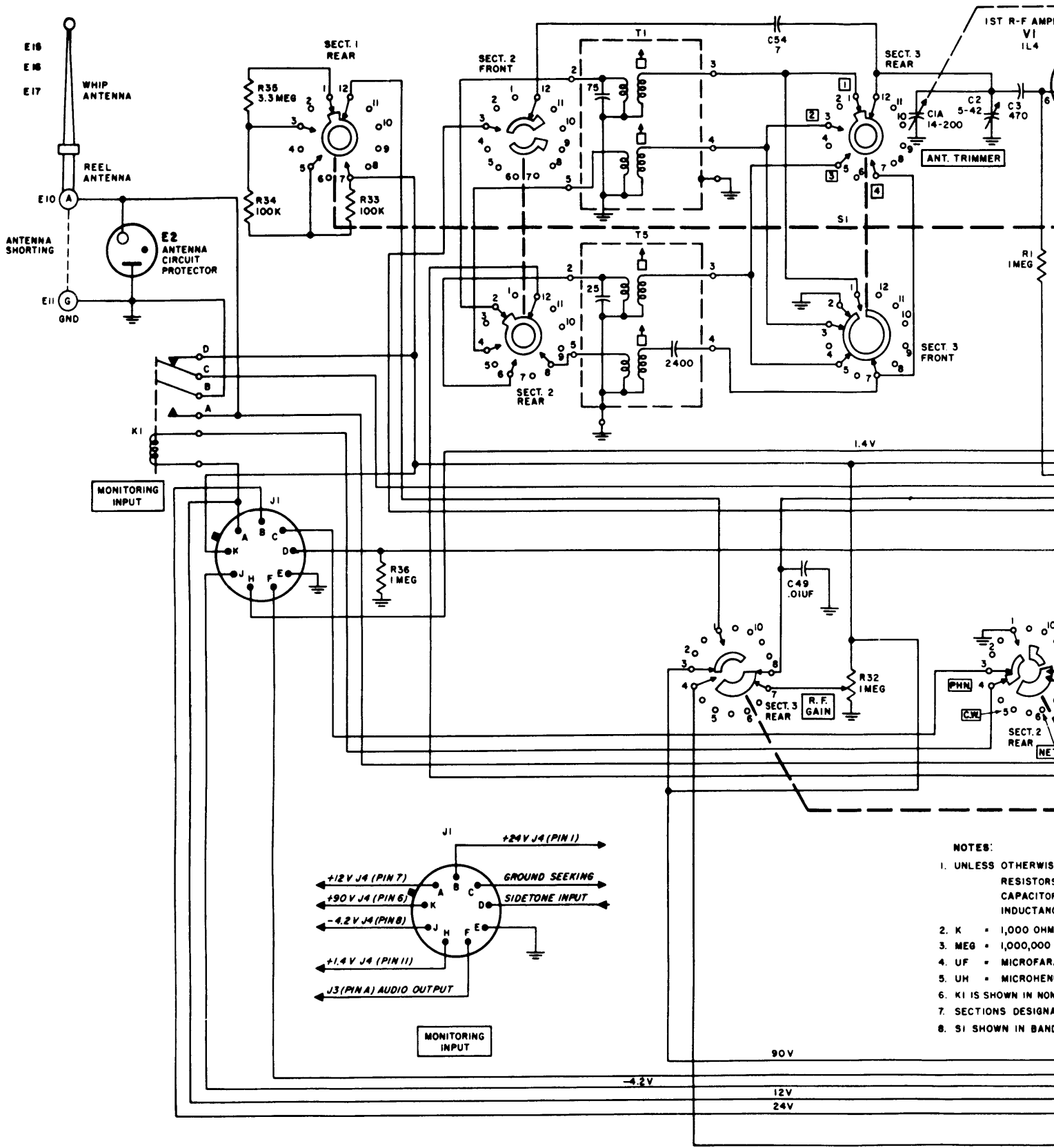

Figure 47. Power Supply PP-308/UK



- NOTES:**
1. UNLESS OTHERWISE INDICATED:
 ALL RESISTANCE VALUES ARE IN OHMS.
 ALL CAPACITANCE VALUES ARE IN MICROMICROFARADS.
 ALL INDUCTANCE VALUES ARE IN HENRYS.
 2. K = 1,000 OHMS
 3. MEG = 1,000,000 OHMS
 4. MH = MILLIHENRYS
 5. UH = MICROHENRYS
 6. UF = MICROFARADS
 7. SECTIONS DESIGNATED NO.1-ARE NEAR KNOB.
 8. SWITCH SECTIONS, AS VIEWED, ROTATE COUNTERCLOCKWISE

808/URR, schematic diagram.



NOTES:

1. UNLESS OTHERWISE SPECIFIED, RESISTORS ARE IN OHMS, CAPACITORS IN MICROFARADS, AND INDUCTANCES IN MICROHENRIES.
2. K = 1,000 OHMS
3. MEG = 1,000,000 OHMS
4. UF = MICROFARAD
5. UH = MICROHENRY
6. K1 IS SHOWN IN NORMAL POSITION
7. SECTIONS DESIGNATED BY LETTERS
8. S1 SHOWN IN BAND POSITION

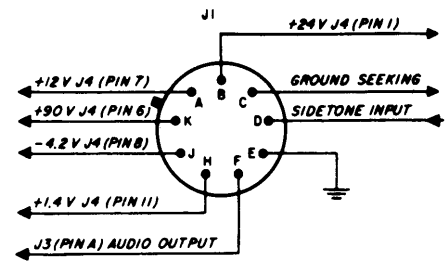

MONITORING INPUT

90V

-4.2V

12V

24V

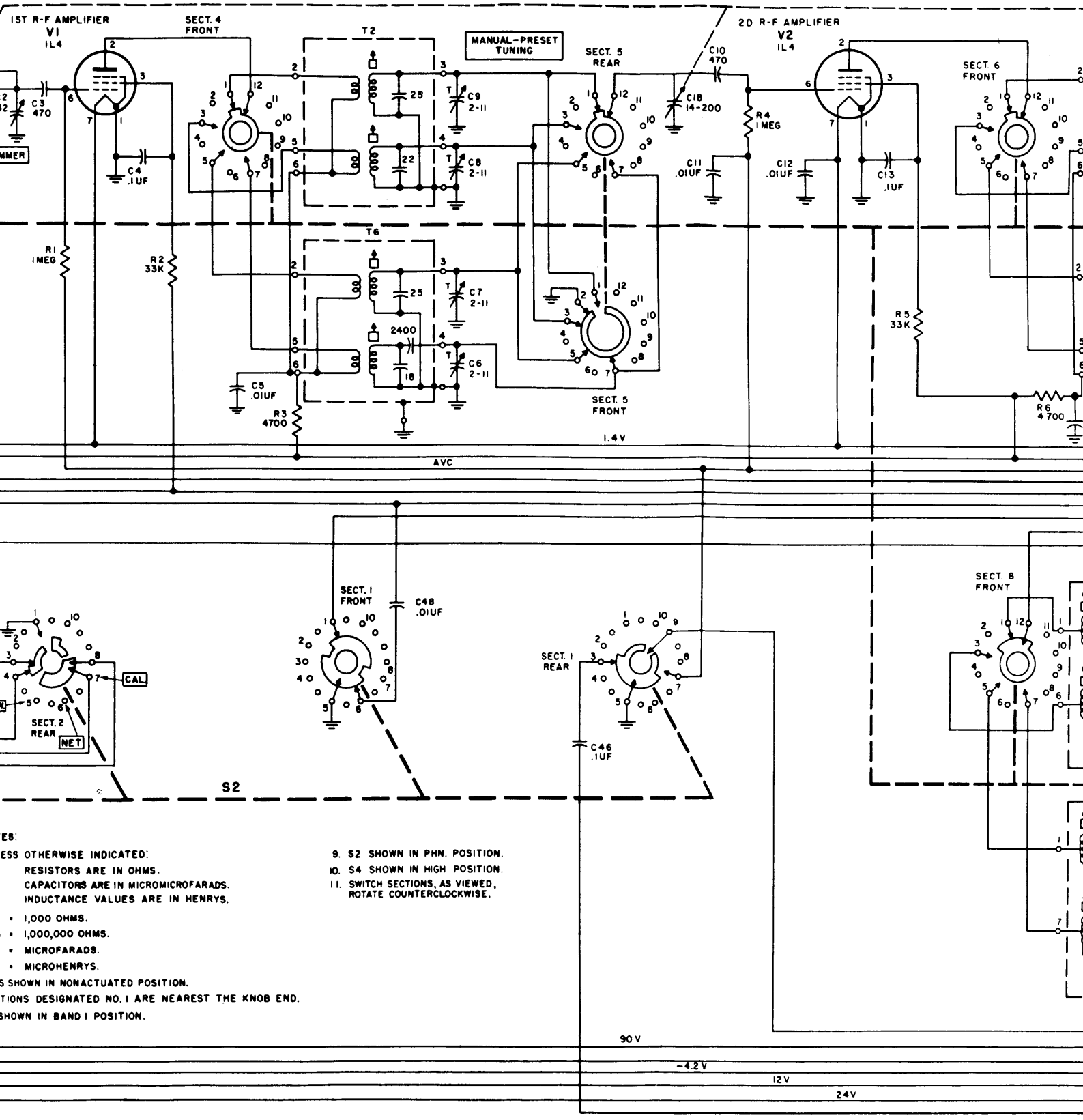

RESISTORS:
 UNLESS OTHERWISE INDICATED:
 RESISTORS ARE IN OHMS.
 CAPACITORS ARE IN MICROMICROFARADS.
 INDUCTANCE VALUES ARE IN HENRYS.

- 1,000 OHMS.
- 1,000,000 OHMS.
- MICROFARADS.
- MICROHENRYS.

SWITCHES SHOWN IN NONACTUATED POSITION.
 POSITIONS DESIGNATED NO. 1 ARE NEAREST THE KNOB END.
 S2 SHOWN IN BAND 1 POSITION.

9. S2 SHOWN IN PHN. POSITION.
 10. S4 SHOWN IN HIGH POSITION.
 11. SWITCH SECTIONS, AS VIEWED,
 ROTATE COUNTERCLOCKWISE.

Figure 4

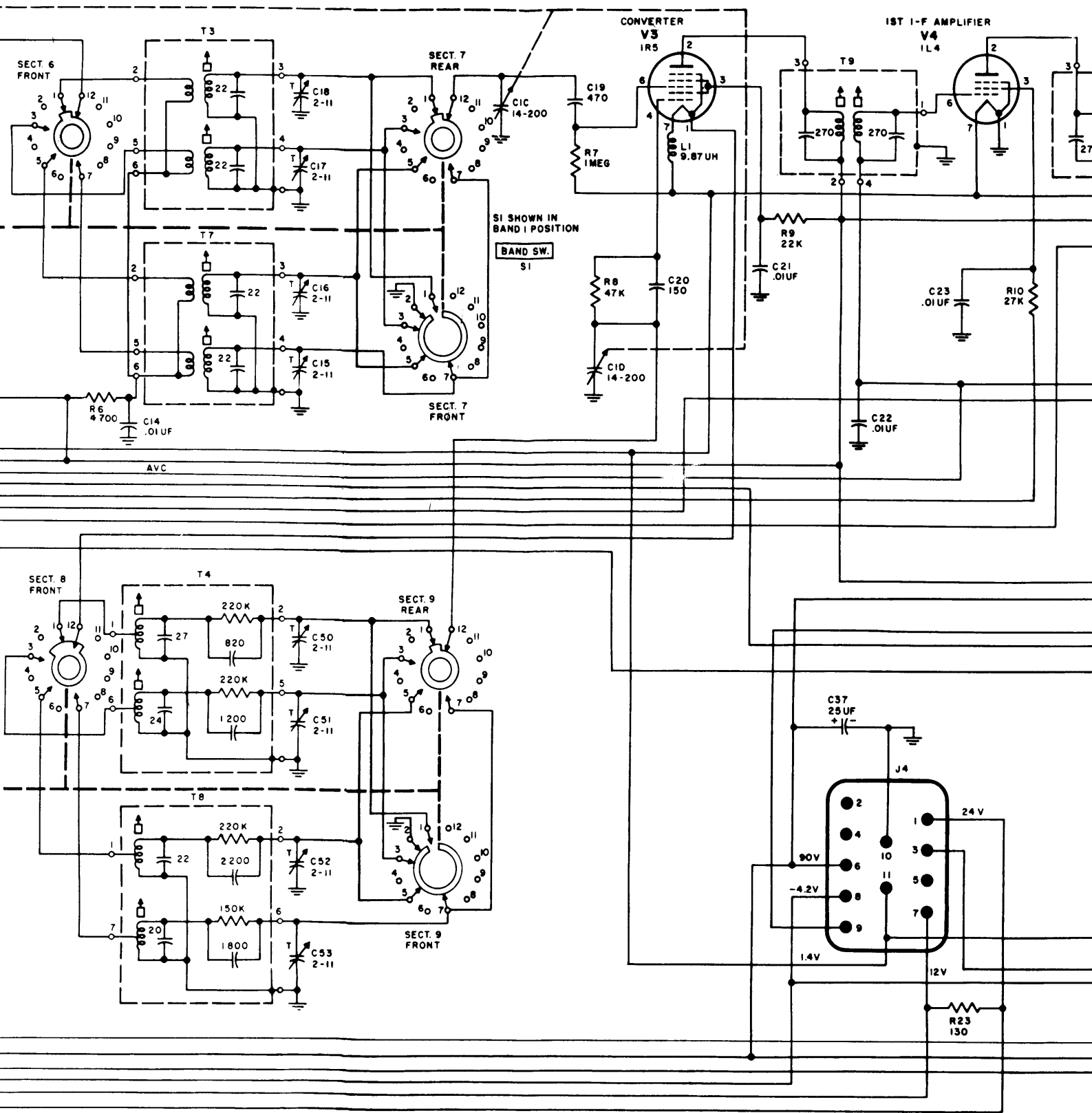

Figure 48. Radio Receiver R-174/URR, schematic diagram.

