

---

TECHNICAL MANUAL

Operator and Organizational  
Maintenance Manual

GENERATOR SET, DIESEL ENGINE DRIVEN, TACTICAL  
SKID MTD., 500 KW, 3 PHASE, 4 WIRE, 120/208 AND 240/416 VOLTS

<u>DOD MODELS</u>	<u>CLASS</u>	<u>HERTZ</u>	<u>NSN</u>
MEP-029A	UTILITY	50/60	6115-01-030-6085
MEP-029B	UTILITY	50/60	6115-01-318-6302

INCLUDING OPTIONAL KITS

<u>DOD MODELS</u>	<u>NOMENCLATURE</u>	<u>NSN</u>
MEP-029AHK	HOUSING KIT	6115-01-070-7550
MEP-029ACM	AUTOMATIC CONTROL MODULE	6115-01-275-7912
MEP-029ARC	REMOTE CONTROL MODULE	6110-01-070-7553
MEP-029ACC	REMOTE CONTROL CABLE	6110-01-087-4127

Approved for public release; distribution is unlimited.

\*This manual supersedes TM 5-6115-593-12/NAVFAC P-8-631-1/2TO-35C2-3-463-1, dated 21 September 1981, including all changes.

---

PUBLISHED UNDER THE AUTHORITY OF THE DEPARTMENTS OF THE ARMY & AIR FORCE

17 JULY 1990

**WARNING**

**HIGH VOLTAGE**

is produced when this generator set is in operation,

**DEATH**

or severe burns may result if personnel fail to observe safety precautions. Do not operate this generator set until the ground terminal stud has been connected to a suitable ground. Disconnect the battery ground cable before removing and installing components on the engine or in the electrical control panel system.

Do not attempt to service or otherwise make any adjustments, connections or reconnections of wires or cables until generator set is shut-down and completely de-energized.

**WARNING**

**DANGEROUS GASES**

Batteries generate explosive gas during charging; therefore, utilize extreme caution, do not smoke, or use open flame in vicinity when servicing batteries.

Exhaust discharge contains noxious and deadly fumes. Do not operate generator sets in enclosed areas unless exhaust discharge is properly vented to the outside.

When filling fuel tank, maintain metal to metal contact between filler nozzle and fuel tank. Do not smoke or use an open flame in the vicinity.

**WARNING**

**LIQUIDS UNDER PRESSURE**

are generated as a result of operation of the generator set. Do not expose any part of the body to a high pressure leak in the fuel or hydraulic system of the generator set.

Relieve pressure from radiator before removing radiator cap.

**WARNING**

Shutters will snap shut rapidly with considerable force when generator set is stopped. Ensure all personnel are clear of shutters before placing MASTER switch to STOP. Serious injury could result.

**WARNING**

**NOISE HAZARD**

Operation of this equipment presents a noise hazard to personnel in the area. The noise level exceeds the allowable limits for unprotected personnel. Wear ear muffs or ear plugs which were fitted by a trained professional.

**WARNING**

All specific cautions and warning contained in this manual shall be strictly adhered to. Otherwise, severe injury, death and/or damage to the equipment may result.

**WARNING**

Disconnect all input bars, bussing, cables and control circuits to breaker before starting test procedure.

**WARNING**

Before performing maintenance and accidental cranking set MAINTENANCE LOCKOUT switch to LOCKOUT. Disconnect negative cable from batteries. Remove external power by opening CB101 and disconnecting load terminals of generator set circuit breaker (CB2) may still be energized with the bus voltage.

**WARNING**

Do not operate the generator set unless the ground terminal stud has been connected to a suitable ground. Electrical faults in the generator set, load lines or load equipment, can cause injury or electrocution with an ungrounded system.

**WARNING**

Make sure that no tools, parts or loose items are on any part of the engine since they might cause bodily harm to personnel when the engine is started.

**WARNING**

Placing AC PWR CKT BKR to CLOSE applies power to output load terminals and load lines. Ensure all personnel are clear of output load terminals. Serious injury or death could result from contact with output voltage.

HEADQUARTERS  
DEPARTMENTS OF THE ARMY, NAVY & AIR FORCE  
WASHINGTON, D.C., 17 July 1990

**Operator and Organizational  
Maintenance Manual**

**GENERATOR SET, DIESEL ENGINE DRIVEN, TACTICAL  
SKID MTD., 500 KW, 3 PHASE, 4 WIRE, 120/208 AND 240/416 VOLTS**

<u>DOD MODELS</u>	<u>CLASS</u>	<u>HERTZ</u>	<u>NSN</u>
MEP-029A	UTILITY	50/60	6115-01-030-6085
MEP-029B	UTILITY	50/60	6115-01-318-6302

**INCLUDING OPTIONAL KITS**

<u>DOD MODELS</u>	<u>NOMENCLATURE</u>	<u>NSN</u>
MEP-029AHK	HOUSING KIT	6115-01-070-7550
MEP-029ACM	AUTOMATIC CONTROL MODULE	6115-01-275-7912
MEP-029ARC	REMOTE CONTROL MODULE	6110-01-070-7553
MEP-029ACC	REMOTE CONTROL CABLE	6110-01-087-4127

**Approved for public release; distribution is unlimited.**

\*This manual supersedes TM 5-6115-593-12/NAVFAC P-8-631-12/TO-35C2-3-463-21, dated 21 September 1981, including all changes.

TABLE OF CONTENTS

			Paragraph	Page
CHAPTER	1.	INTRODUCTION		1-1
Section	I	General	1-1	1-1
	II	Description and Data	1-9	1-2
	III	System operation	1-13	1-23
CHAPTER	2.	OPERATING INSTRUCTIONS		2-1
Section	I	Operating Procedures	2-1	2-1
	II	Operation of auxiliary material used in conjunction with the equipment	2-8	2-20
	III	Operation Under Unusual Conditions	2-11	2-46
CHAPTER	3.	OPERATOR/CREW MAINTENANCE INSTRUCTIONS		3-1
Section	I	Consumable operating and maintenance supplies	3-1	3-1
	II	Lubrication instructions	3-2	3-3
	III	Preventive maintenance checks and services (PMCS)	3-3	3-3
	IV	Troubleshooting	3-5	3-3
	V	Operator/crew maintenance	3-6	3-10
CHAPTER	4.	ORGANIZATIONAL MAINTENANCE		4-1
Section	I	Service upon receipt of equipment	4-1	4-1
	II	Movement to a new worksite	4-5	4-14
	III	Repair parts; special tools; special test measurement and diagnostic equipment (TMDE); and special support equipment	4-6	4-15
	IV	Lubrication instructions	4-8	4-15
	V	Preventive maintenance checks and services (PMCS)	4-9	4-17
	VI	Troubleshooting	4-10	4-17
	VII	Radio interference suppression	4-11	4-17
	VIII	Maintenance of batteries and related items	4-13	4-34
	IX	Maintenance of muffler and exhaust	4-17	4-37
	X	Maintenance of external power box assembly	4-19	4-38
	XI	Maintenance of AC-DC control box assembly	4-28	4-50
	XII	Maintenance of control cubicle	4-40	4-58
	XIII	Maintenance of air cleaner	4-42	4-71
	XIV	Maintenance of tool box assembly	4-45	4-74
	XV	Maintenance of document compartment	4-46	4-76
	XVI	Maintenance of support frame assembly	4-47	4-76
	XVII	Maintenance of radiator assembly	4-49	4-76
	XVIII	Maintenance of fuel lines and fittings	4-50	4-82
	XIX	Maintenance of engine preheat	4-51	4-82
	XX	Maintenance of fuel transfer pump	4-52	4-88
	XXI	Maintenance of fuel tank assembly	4-54	4-90
	XXII	Maintenance of interconnecting electrical wiring harness	4-57	4-95
	XXIII	Maintenance of generator and reconnection assembly	4-59	4-95
	XXIV	Maintenance of electric hydraulic actuator	4-64	4-96

TABLE OF CONTENTS - CONTINUED

			Paragraph	Page
CHAPTER	4.			
Section	XXV	Maintenance of ether kit	4-65	4-98
	XXVI	Maintenance of engine assembly	4-66	4-99
	XXVII	Maintenance of base assembly	4-88	4-127
CHAPTER	5.	AUXILIARY EQUIPMENT USED IN CONJUNCTION WITH THE GENERATOR SET		5-1
Section	I	Introduction	5-1	5-1
	II	Remote control module	5-2	5-1
	III	Remote control cable assembly	5-10	5-13
	IV	Automatic control module	5-12	5-13
	V	Housing kit	5-30	5-20
APPENDIX	A.	REFERENCES		A-1
APPENDIX	B.	BASIC ISSUE ITEM LIST AND ITEMS TROOP INSTALLED OR AUTHORIZED LIST		B-1
Section	I	Introduction		B-1
	II	Integral components of end item		B-2
	III	Basic issue items		B-3
	IV	Troop installed or authorized list		B-4
APPENDIX	C.	MAINTENANCE ALLOCATION CHART (MAC)		C-1
Section	I	Introduction		C-1
	II	Maintenance allocation chart		C-3
	III	Tools, test and support equipment requirements		C-16
	IV	Remarks		C-17
APPENDIX	D.	ADDITIONAL AUTHORIZATION LIST		D-1
Section	I	Introduction		D-1
	II	Additional authorization list		D-2

LIST OF ILLUSTRATIONS

Figure	Title	Page
1-1.	Generator Set, Left Side .....	1-3
1-2.	Generator Set, Right Side .....	1-4
1-3.	Generator Set, Rear .....	1-5
1-4.	Generator Set, Top .....	1-6
1-5.	Remote Control Module .....	1-7
1-6.	Automatic Control Module.....	1-8
1-7.	Housing Kit, Installed on Generator Set .....	1-9
1-8.	Fuel System Diagram.....	1-20
1-9.	Instruction Plate Locations .....	1-21
2-1.	Engine Control Panel (Part of Control Cubicle).....	2-3
2-2.	Generator Control Panel (Part of Control Cubicle).....	2-5
2-3.	AC-DC Control Panel .....	2-9
2-4.	External Power Box Control Panel .....	2-11
2-5.	Preparation for Starting (3 Sheets) .....	2-12
2-6.	Starting Instructions (3 Sheets) .....	2-15
2-7.	Stopping Instructions.....	2-18
2-8.	Single Generator Unit, Operating Instructions.....	2-19
2-9.	Preparation for Starting with Housing Kit Installed (3 Sheets) .....	2-20
2-10.	Starting Instructions when Ambient Temperature is from 40°F to -25° (4.4°C to -32 <sup>0</sup> C) and Housing Kit is installed (3 Sheets).....	2-23
2-11.	Stopping Instructions with Housing Kit Installed.....	2-26
2-12.	Single Generator Unit, Operating Instructions with Housing Kit Installed .....	2-27
2-13.	Remote Control Module Panel .....	2-29
2-14.	Jumper Connections to be Removed when a Remote Control Module is Connected .....	2-32
2-15.	Preparation for Starting Using Remote Control Module .....	2-33
2-16.	Starting Instructions Using Remote Control Module (2 Sheets).....	2-34
2-17.	Stopping Instructions Using Remote Control Module .....	2-36
2-18.	Operating Instructions, Single Generator Unit Using Remote Control Module .....	2-37
2-19.	Automatic Control Module.....	2-40
2-20.	Jumper Connections When Automatic Control Module is Used .....	2-42
2-21.	Operating Instructions, Manually Operated in parallel (2 Sheets).....	2-43
3-1.	Air Cleaner, Exploded View.....	3-11
3-2.	Fuel Transfer Pump Inspection Points.....	3-13
4-1.	Fan Belt Tension Check.....	4-2
4-2.	Cooling System Drain and Shut-off Cock .....	4-3
4-3.	Location of Engine Water Drains.....	4-4
4-4.	Location of Engine Crankcase Drain and Drain Valve .....	4-5
4-5.	Location of Fuel Tank Drain Cock .....	4-6
4-6.	Installation Plan.....	4-8
4-7.	Grounding Procedures (3 Sheets) .....	4-9
4-8.	Output Voltage Conversion Connections.....	4-14
4-8A.	Crankcase Breather .....	4-16
4-9.	Batteries and Related Items, Exploded View .....	4-35
4-10.	Battery Cable Fabrication.....	4-36
4-11.	Muffler and Exhaust, Exploded View.....	4-39
4-12.	External Power Box Assembly, Exploded View .....	4-40
4-13.	External Power Box Assembly, Control Panel, Exploded View .....	4-42
4-14.	Contactors K107, K108, K109 and Main Circuit Breaker CB2 Schematic.....	4-45
4-15.	Main Circuit Breaker, CB2.....	4-46

LIST OF ILLUSTRATIONS-CONTINUED

Figure	Title	Page
4-16.	External Power Box Assembly, Plate and Sleeve Assembly Exploded View .....	4-49
4-17.	AC-DC Control Box Assembly, Exploded View .....	4-51
4-18.	AC-DC Control Box Assembly, Component Panel Assembly, Exploded View .....	4-53
4-19.	AC-DC Control Box Assembly, Component Panel Assembly, Exploded View .....	4-55
4-20.	Control Cubicle, (3 Sheets) .....	4-59
4-21.	Control Cubicle, Engine Panel, Exploded View .....	4-63
4-22.	Control Cubicle, Generator Panel, Exploded View (2 Sheets) .....	4-65
4-23.	Air Cleaner and Related Parts .....	4-72
4-24.	Tool Box Assembly .....	4-75
4-25.	Document Compartment .....	4-77
4-26.	Support Frame Assembly .....	4-78
4-27.	Radiator Assembly, Exploded View .....	4-79
4-28.	Fan Belt Adjustment and Replacement .....	4-80
4-29.	Fuel Lines (2 Sheets) .....	4-84
4-30.	Engine Preheat Installation (2 Sheets) .....	4-86
4-31.	Fuel Transfer Pump Installation, Exploded View .....	4-91
4-32.	Fuel Transfer Pump Contractor K20 .....	4-92
4-33.	Fuel Tank Assembly, Exploded View .....	4-93
4-34.	Fuel Level Switch Test Data .....	4-94
4-35.	Liquid Quantity Transmitter .....	4-94
4-36.	Generator and Reconnection Board .....	4-96
4-37.	Electric Hydraulic Actuator .....	4-97
4-38.	Ether Kit .....	4-98
4-39.	Ether Installation .....	4-100
4-40.	Engine Components (2 Sheets) .....	4-101
4-41.	Water Pump Belt Adjustment .....	4-103
4-42.	Speed Switch .....	4-104
4-43.	Oil Level Sight Gauge and Filler .....	4-105
4-44.	Starter Assembly .....	4-107
4-45.	Oil Pressure Transmitter .....	4-108
4-46.	Pressure Switches .....	4-108
4-47.	Oil Filters .....	4-110
4-48.	Secondary Fuel Filter .....	4-111
4-49.	Lube Oil Cooler .....	4-112
4-50.	Fuel Injector .....	4-114
4-51.	Turbocharger .....	4-115
4-52.	Water Pump and Idler Pulley Assembly .....	4-117
4-53.	Thermostat Removal .....	4-118
4-54.	Coolant Temperature Transmitter .....	4-120
4-55.	Coolant Temperature Switch .....	4-121
4-56.	Intercooler .....	4-123
4-57.	Exhaust Manifold .....	4-124
4-58.	Water Manifold .....	4-125
4-59.	Rocker Arm and Shaft Assembly .....	4-126
4-60.	Base Assembly, Exploded View .....	4-129
4-61.	Breather Lines and Fittings .....	4-132
5-1.	Remote Control Module .....	5-2
5-2.	Remote Control Module, Plate Assembly .....	5-11
5-3.	Remote Control Module, Annunciator Control Assembly .....	5-12
5-4.	Actuator Control Relay Assembly .....	5-23
5-5.	Housing Kit, Installed on Generator Set .....	5-24



LIST OF ILLUSTRATIONS-CONTINUED

Figure	Title	Page
B-1.	Basic Issue Items .....	B-3
FO-1.	DC Schematic .....	FO-1
FO-2.	AC Schematic .....	FO-2
FO-3.	DC Wiring Diagram (Troubleshooting).....	FO-3.1
FO-4.	AC Wiring Diagram (Troubleshooting) .....	FO-4.1
FO-5.	AC/DC Control Box Wiring Diagram (Troubleshooting) .....	FO-5.1
FO-6.	External Power Box Wiring Diagram (Troubleshooting) .....	DO-6.1
FO-7.	Unit Control Box Wiring Diagram (Troubleshooting) .....	FO-7.1
FO-8.	Remote Control Module Schematic .....	FO-8
FO-9.	Remote Control Module Wiring Diagram (Troubleshooting) .....	FO-9.1
FO-10.	Generator Reconnection Box Wiring Diagram (Troubleshooting) .....	FO-10
FO-11.	Engine Accessories Wiring Diagram (Troubleshooting) .....	FO-11
FO-12.	Automatic Control Module Schematic .....	FO-12.1
FO-13.	Automatic Control Module Wiring Diagram (Troubleshooting) .....	FO-13
FO-14.	Remote Control Module Interconnect Wiring Diagram .....	FO-14
FO-15.	Automatic Control Module Wiring Interconnect Diagram .....	FO-15
FO-16.	Louver Control Schematic .....	FO-16
FO-17.	Louver Control Harness .....	FO-17

LIST OF TABLES

Figure	Title	Page
1-1.	Torque Data .....	1-22
2-1.	Engine Control Panel, Controls and Instruments .....	2-2
2-2.	Generator Control Panel, Controls and Instruments .....	2-4
2-3.	AC-DC Control Panel, Controls and Instruments .....	2-8
2-4.	External Power Box Control Panel, Controls and Instruments.....	2-10
2-5.	Remote Control Panel, Controls and Instruments .....	2-28
2-6.	Automatic Control Module, Controls and Instruments .....	2-41
3-1.	Consumable Operating and maintenance Supplies .....	3-1
3-2.	Preventive Maintenance Checks and Services .....	3-4
3-3.	Troubleshooting .....	3-6
4-1.	Freezing Points, Composition, and Specific Gravities of Military Antifreeze.....	4-7
4-2.	Preventive Maintenance Checks and Services .....	4-18
4-3.	Troubleshooting .....	4-20
5-1.	Preventive Maintenance Checks and Services, Remote Control Module .....	5-3
5-2.	Remote Control Module Troubleshooting (Operator/Crew Level) .....	5-4
5-3.	Remote Control Module Troubleshooting (Organizational Level) .....	5-7
5-4.	Preventive Maintenance Checks and Services, Automatic Control Module .....	5-16
5-5.	Automatic Control Module Troubleshooting (Operator/Crew Level) .....	5-16
5-6.	Automatic Control Module Troubleshooting (Organizational Level).....	5-17
5-7.	Preventive Maintenance Checks and Services, Housing Kit .....	5-22
5-8.	Housing Kit Troubleshooting.....	5-22

**CHAPTER 1**  
**INTRODUCTION**  
**Section I. GENERAL**

1-1. SCOPE. This manual is for your use in operating and maintaining the 500 KW Diesel Engine Driven Generator Set. The 50/60 Hertz, (Mode I) Tactical Utility (Type I, Class 2A) Set is used in applications where precise power is not required. This manual also includes a description of accessory modules and their functions in relations to other components.

1-2. LIMITED APPLICABILITY. Some portions of this publication are not applicable to all services. These portions are prefixed to indicate the services to which they pertain: (A) for Army, (F) for Air Force, (N) for Navy, and (MC) for Marine Corps. Portions not prefixed are applicable to all services.

1-3. MAINTENANCE FORMS AND RECORDS. The forms and records used for maintenance purposes by the various services are specified as follows:

- a. (A) Maintenance forms and records used by Army personnel are prescribed by DA PAM 738-750.
- b. (F) Maintenance forms and records used by Air Force personnel are prescribed in AFM-66-1 and the applicable 00-20 Series Technical Orders.
- c. (N) Navy users should refer to their service peculiar directives to determine applicable maintenance forms and records to be used.
- d. (MC) Maintenance forms and records used by Marine Corps personnel are prescribed by TM 4700-15/1

1-4. REPORTING OF ERRORS. Report of errors, omissions, and recommendations for improvement of this publication by the individual user is encouraged. Reports should be submitted as follows:

- a. (A) Army - DA Form 2028 directly to:  
Commander, U.S. Army Troop Support

Command, ATTN: AMSTR-MCTS, 4300  
Goodfellow Boulevard, St. Louis, MO 63120-  
1798

- b. (F) Air Force - AFTO Form 22 directly to:  
Commander, Sacramento Air Logistics Center,  
ATTN: SM-ALC-MMEDTA, McClellan Air Force  
Base, CA 95652-5609 in accordance with TO-00-  
5-1.
- c. (N) Navy - by letter directly to: Commanding  
Officer, Naval Construction Battalion Center,  
ATTN: Code 15741 Bldg. 43, Port Hueneme, CA  
93043-5000.
- d. (MC) Marine Corps - by NAVMC Form 10772  
directly to: Commanding General, Marine Corps  
Logistics Base, (Code 850) Albany, GA 31704-  
5000.

1-5. LEVELS OF MAINTENANCE ACCOMPLISHMENT. The authorized maintenance and repair functions will be accomplished as follows:

- a. (AMC) Army and Marine Corps users shall refer to the Maintenance Allocation Chart (MAC) for tasks and levels of maintenance to be performed.
- b. (F) Air Force users shall accomplish maintenance at the user level consistent with their capability in accordance with policies established in AFM-66-1.
- c. (N) Navy users shall determine their maintenance levels in accordance with their service directives.

1-6. DESTRUCTION OF ARMY MATERIEL. (AMC) Demolition of material to prevent enemy use will be in accordance with the requirements of TM750-244-3. (Procedures For Destruction of Equipment to Prevent Enemy Use).

1-7. ADMINISTRATIVE STORAGE. (A,F,MC) Detailed information pertaining to administrative storage for the various services is contained in the following documents. Processing and Inspection of Aerospace Ground Equipment for Storage and Shipment, T035-1-4 is applicable to Air Force personnel, MCOP4450.7 is applicable to Marine Corps personnel and for Army personnel:

- a. Placement of equipment in administrative storage should be for short periods of time when a storage of maintenance effort exists. Items should be in mission readiness within 24 hours or within the time factors are determined by the directing authority. During the storage period appropriate maintenance records will be kept.
- b. Before placing equipment in administrative storage, current maintenance services and equipment serviceable criteria (ESC) evaluations

should be corrected, and all modification work orders (MWO's) should be applied.

- c. Storage site selection. Inside storage is preferred for items selected for administrative storage. If inside storage is not available, trucks, vans, conex containers and other containers may be used.

1-8. PREPARATION FOR SHIPMENT AND STORAGE. The requirements pertaining to the preparation for shipment and storage for the various services are contained in the following documents.

- a. (A) Army - Refer to TB740-97-2.
- b. (F) Air Force - Refer to T035-1-4 for end item generator sets and T038-1-5 for installed engine.
- c. (N,MC) Navy and Marine Corps refer to individual service directives for requirements.

## Section II. DESCRIPTION AND DATA

1-9. DESCRIPTION.

- a. General. The generator set, military model MEP-029A and MEP-029B (figures 1-1, 1-2, 1-3, and 1-4), is a skid-mounted, self-contained unit. The generator is provided with controls, instruments and accessories necessary for operation as a single unit, or in parallel, with up to three additional units of the same class and mode. Housing kit (military model MEP-029 AHK) is available for field installation. The housing kit encloses the top, sides, and ends of the set and is removable to provide access for overhaul or replacement of the major components. The housing kit is attached to a skid base by bolted construction to provide a rain proof enclosure. When the doors, covers, and louvers are closed, rain, snow, and sand are excluded from the interior of the housing. An automatic control module (ACM), remote control module (RCM),

and remote control cable are also available for use with the generator set. The automatic control module provides for parallel operation of up to four generator sets. The automatic control module senses and initiates the unattended sequence when the normal 120V AC supply voltage varies more than plus or minus 10 percent and/or the frequency varies more than 3.0 percent. The remote control module permits remote start, stop, monitor, and control of the generator set from a location up to 100 feet (30 meters) via the remote control cable.

- b. Generator Set. A brief description of the major components comprising the generator set is provided in the following paragraphs:

- (1) Engine. The engine is a liquid-cooled, 12-cylinder,

1710 cubic inch (28 liter) displacement, four-stroke cycle, turbocharged diesel engine.

60 Hz output can be generated according to engine rpm.

(2) Generator. The 50/60 Hz generator is a 417/500 kw, brushless, permanent magnet, single bearing, air-cooled, open drip-proof unit. It is a reconnectable generator capable of producing different voltages. Either 50 or

(3) Control Cubicle. The control cubicle contains the engine control panel and the generator control panel. The engine control panel has controls, switches, and instruments necessary to start, stop, operate, and monitor the engine. The

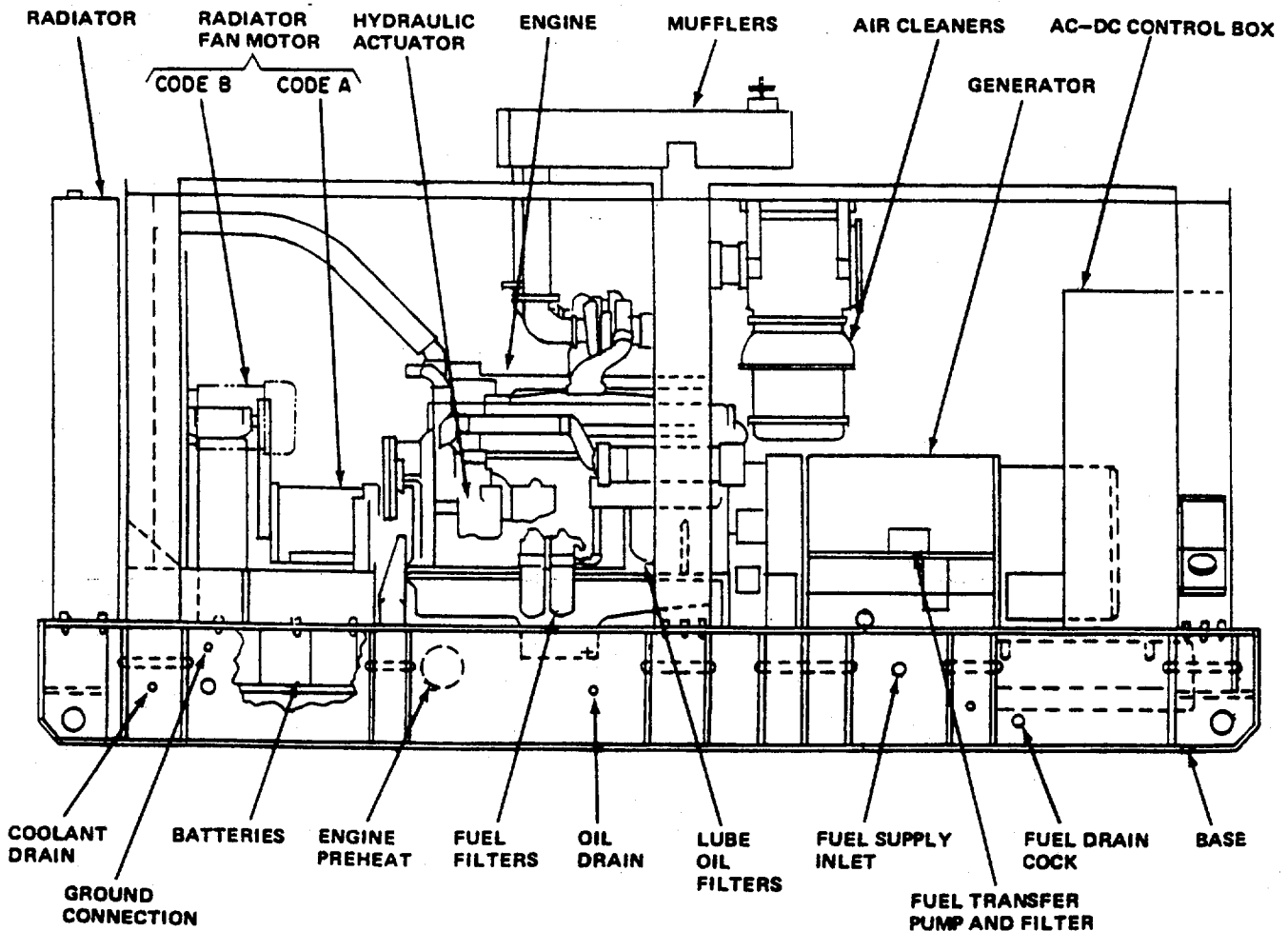

Figure 1-1. Generator Set, Left Side

generator control panel has controls, switches, and instruments necessary to operate and monitor the generator.

- (4) AC-DC Control Box Assembly. The AC-DC control box assembly consists of a control panel, governor controller, voltage regulator, motor-operated potentiometers, and battery

charger. The control panel contains switches, circuit breaker, potentiometers, and receptacles. The governor controller has a load sharing and speed control unit consisting of an electric governing control that provides isochronous control with load sharing for parallel operations. The voltage regulator regulates

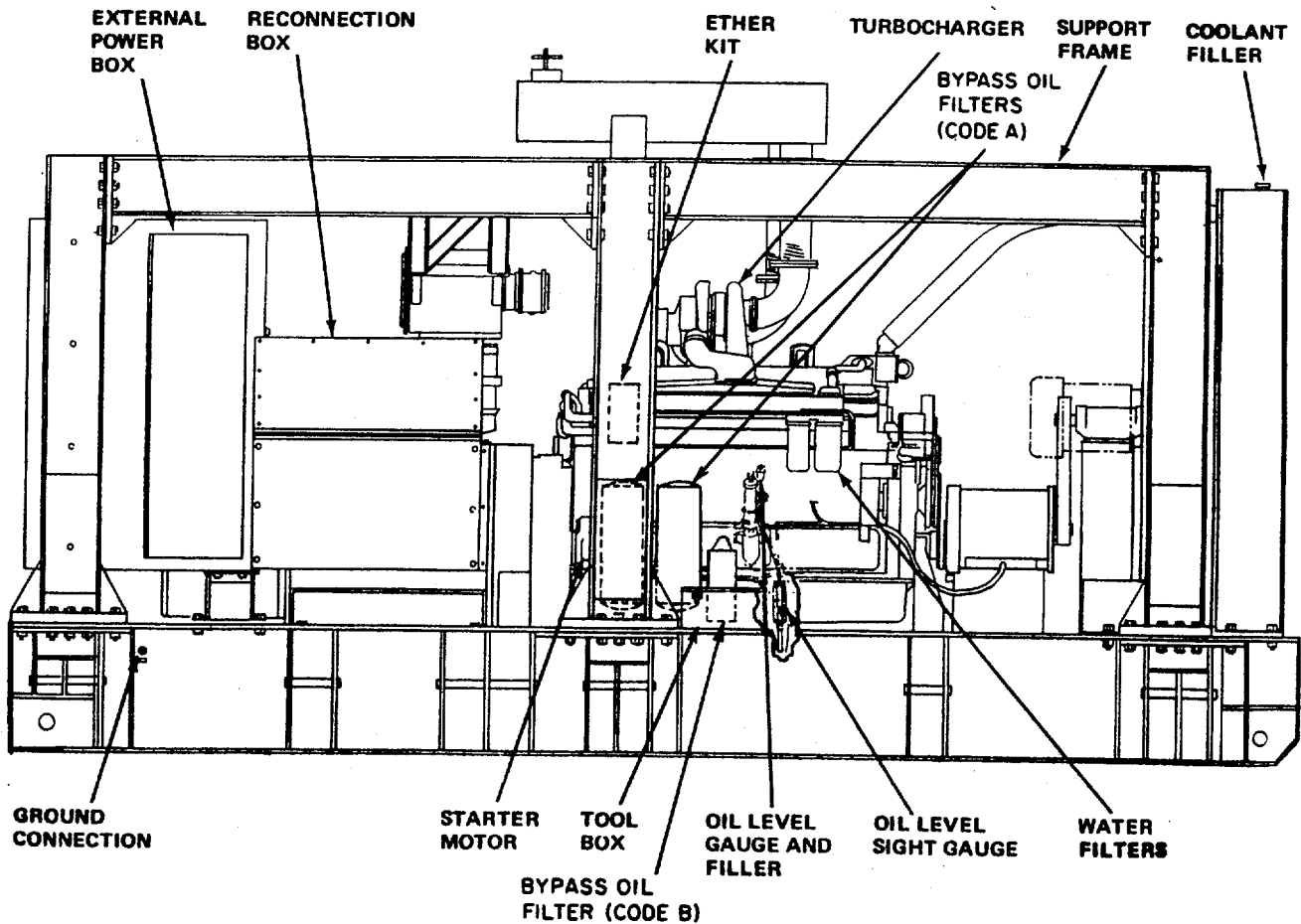

Figure 1-2. Generator Set, Right Side

generator voltage and has controls to adjust stability, voltage, and voltage range. The motor-operated potentiometers are used to adjust voltage and speed settings.

- (5) External Power Box Assembly. The external power box assembly provides a means of accepting a supply of power from a single

phase 120/240V AC, 50/60 Hz external source to energize its circuits when internal power is not available. The battery charger and convenience receptacle circuits automatically transfer from internal power to external power when internal power is not available and the circuit breaker is closed.

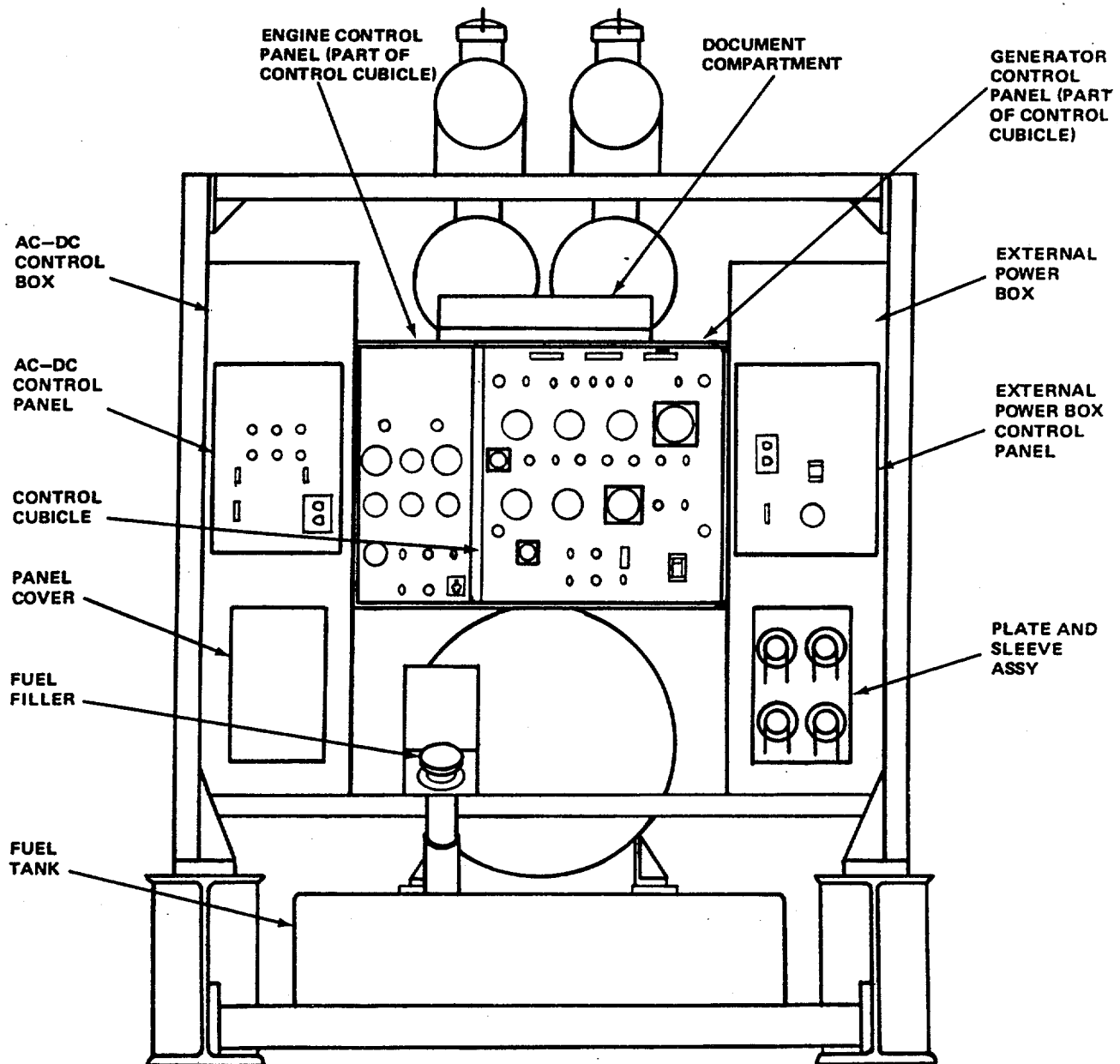

Figure 1-3. Generator Set, Rear

c. **Accessory Items.** Accessory items consist of a remote control module (figure.1-5); remote control cable assembly; a automatic control module (figure 1-6); and, if required, a housing kit (figure 1-7).

Mode .....	50/60 Hertz, 3 phase, 4 wire
Class .....	Utility
Operating temperature range	
Unhoused .....	125 to 32°F (52 to 0° C)
Housed .....	125 to -25°F (52 to 0° C)
Power output .....	417 kw at 50 Hz 500 kw at 60 Hz
Voltage output .....	120/208 volts and 240/416 volts
Power factor .....	0.8 pf lagging
Parallel operation .....	Not more than 2 (zero speed droop) percent voltage droop

1-10. TABULATED DATA

a. **Generator Set**

DOD Drawing Number .....76-029  
 Manufacturer .....Fermont Division Dynamics Corporation of America

Model .....MEP-029A and MEP-029B

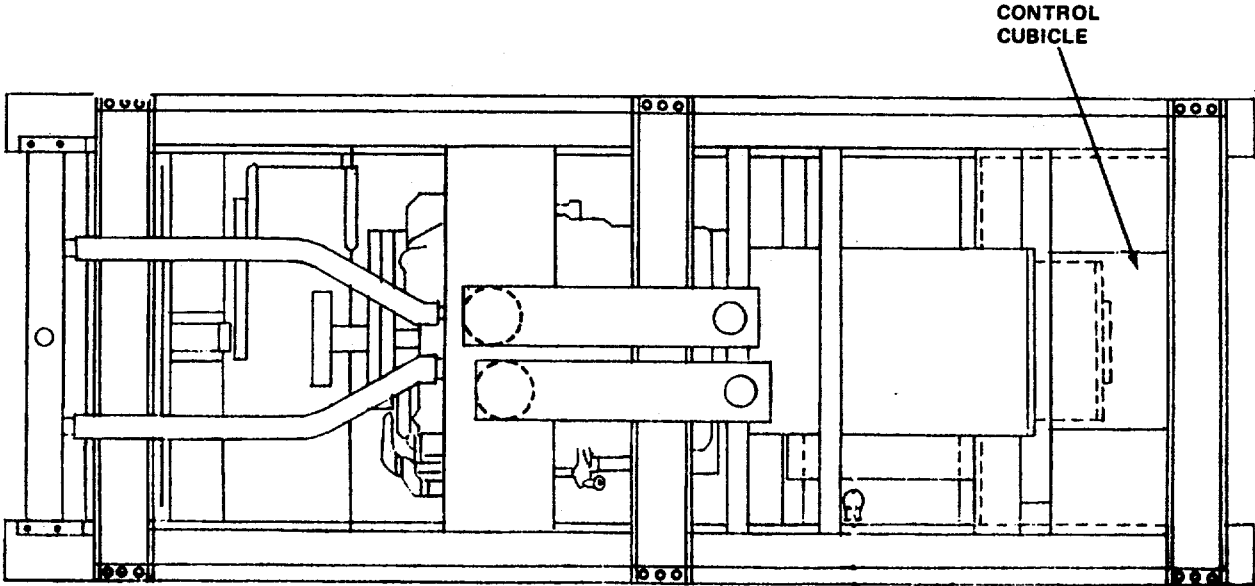

Figure 1-4. Generator Set, Top



Parallel operation ..... Not more than 3 (3 percent speed      percent voltage droop)                      droop	Overall width ..... 88 inches (226 centime- ters)
Capacities	Overall height ..... 120 inches (with muffler)      (304.8 centi- meters)
Fuel system ..... 117 gallons (443 liters)	Dry weight ..... 32,550 pounds (14,764 kilo- grams)
Cooling system ..... 52 gallons (197.6 liters)	Net weight ..... 34,050 pounds (filled)      (15,445 killo- grams)
Lubricating oil ..... 18 gallons (68 liters)	Cubage ..... 1,337 cubic feet (40 cubic meters)
Dimensions and weights	
Overall length ..... 219 inches (556 centime- ters)	

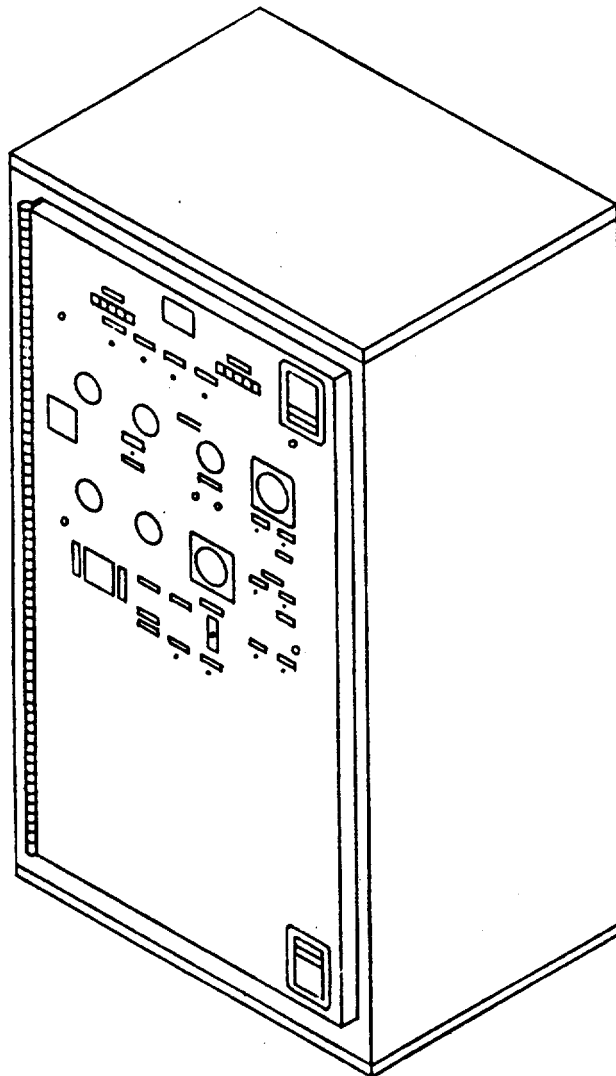

Figure 1-5. Remote Control Module

b. Batteries and Cables.

Cables

76-11424-01.....	Blk .....	81	in .....	206	cm
76-11424-02.....	Blk .....	96	in.. .....	244	cm
76-11422-01.....	Red.....	91	in.. .....	231	cm
76-11422-02.....	Red.....	101	in. ....	256.6	cm
76-11423.....	Red.....	7.5	in .....	19	cm
76-11423.....	Blk .....	7.5	in .....	19	cm

Batteries

DOD Drawing Number..	76-11252
Type .....	Lead acid, 174 plates
Rating .....	12 volt, 200 am-pere-hours, 20 hour rate
Weight (wet) .....	150 pounds (67.5 kilograms)

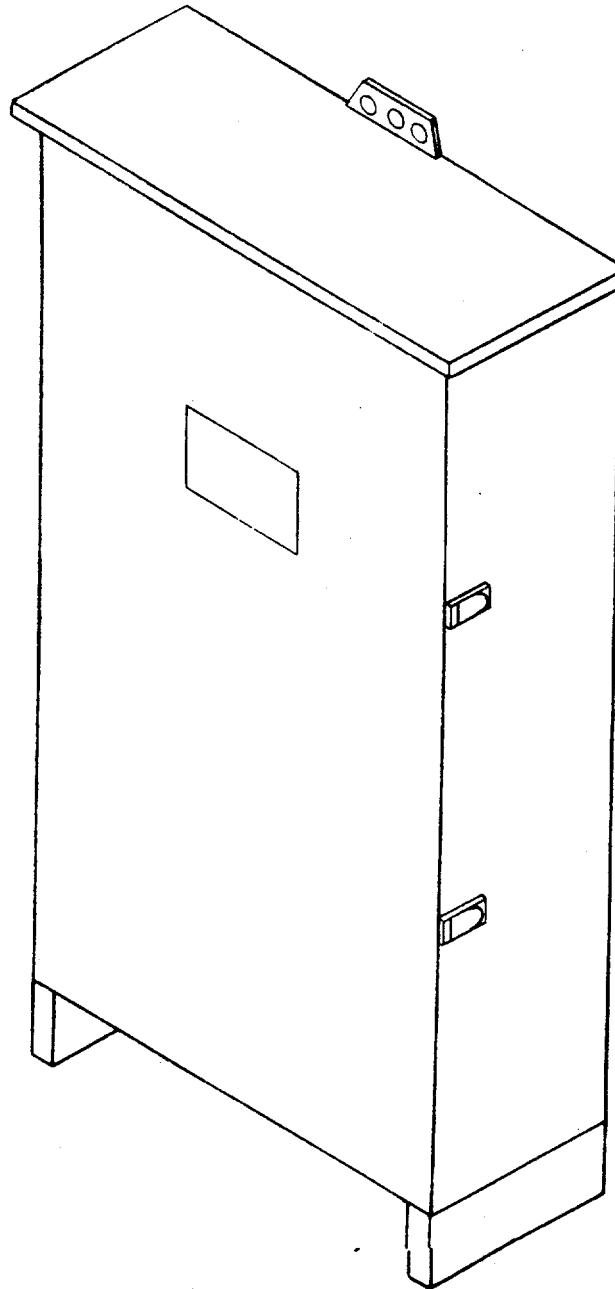

Figure 1-6. Automatic Control Module

Number in gen-.....Four, series-  
erator set parallel, 24V DC

at 208V AC, 868  
amps, continuous at  
416V AC, 60 Hz.

c. External Power Box Assembly

Motor.....Ratings: 114/143V  
AC at 50/60 Hz

Motor-Operator Circuit Breaker  
DOD Drawing Number ..76-11205  
Main contacts .....3 pole breaker  
rated 2000 amps.  
Minimum current  
ratings: 1734  
amps, continuous

Heater System Contactors  
DOD Drawing Number.. 76-11202  
Type .....AC magnetic,  
open, NEMA Size  
1  
Coil voltage ..... 120V AC, 50/60  
..... Hz, 2 pole

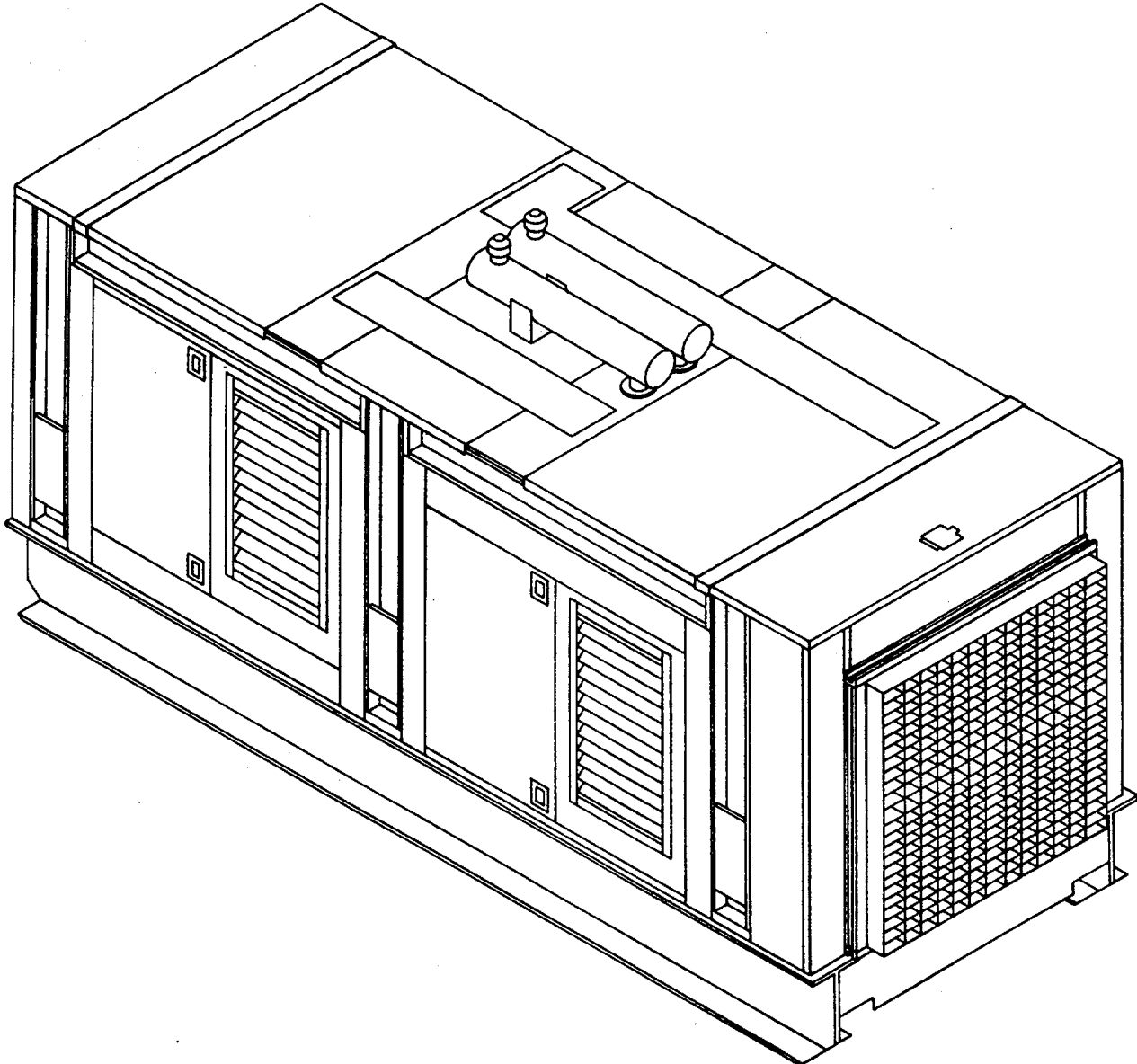

Figure 1-7. Housing Kit, Installed on Generator Set

Transfer Contactor  
DOD Drawing Number ..... 76-11203  
Type ..... AC reversing,  
open, NEMA Size  
2  
Coil voltage ..... 120V AC, 50/60  
Hz, 3 pole,  
electrically and  
mechanically  
interlocked

d. AC-DC Control Box Assembly.

AC-DC Control Relay Assembly  
DOD Drawing Number ..... 76-11300  
Eight relays ..... 10 amp, DPDT  
Type ..... M5757/23-003  
(MIL-R-5757)

Battle Short and Run-Stop Relays  
DOD Drawing Number ..... 76-11302  
Type ..... 24V DC coil, 14  
pin, 6 pole (4  
pole NO, 2 pole  
NC)  
Contacts ..... 10 amp

Fuel Transfer Pump Relay  
DOD Drawing Number ..... 70-1140  
Type ..... 24V DC coil, 50  
to 60 ohms  
Contacts ..... 50 amp, 2 NO  
contacts

Integrated Time Delay Modules  
DOD Drawing Number ..... 76-11304-1 and  
76-11305  
Types ..... 76-11304-1  
24V DC, 30  
second turn on  
delay  
76-11305  
24V DC, times on  
and off periods  
averaging 5  
second delay

Manual Potentiometer  
DOD Drawing Number ..... 76-11210  
Type ..... Wire wound,  
500 ohm  
Power rating ..... 2 watts at  
158°F (70°C)  
0 watts at  
248°F  
(125°C)

Shunt ..... MS91586-1  
Type ..... MSA300  
Current rating ..... 30 amps  
Voltage rating ..... 50 millivolts

Motor Operated Potentiometers  
DOD Drawing Number ..... 76-11213 and

76-11214  
76-11213  
Resistance ..... 500 ohm, 3 watt,  
3 turn  
Motor ..... 24V DC, re-  
versing, 1/20 hp  
Clutch ..... Adjusted for 20  
±5 inch-ounces  
(0.08 joules)  
torque  
76-11214  
Resistance ..... 250 ohm, 3 watt,  
3 turn  
Motor ..... 24V DC, re-  
versing, 1/20 hp  
Clutch ..... Adjusted for 20  
±5 inch-ounces  
(0.08 joules)  
torque

e. Control Cubicle Assembly

Frequency Transducer  
DOD Drawing Number ..... 69-578  
AC input ..... 120V AC, single  
phase, 50/60 Hz

**NOTE**

**Transducer and meter furnished only as a  
matched set which consists of the  
transducer and frequency meter.**

Thermal Watt Converter  
DOD Drawing Number ..69-589  
Volts ..... 100/130V AC  
Current ..... 1 ampere  
Elements ..... 3  
Phase ..... 3  
Number of wires ..... 4  
Output ..... 20MV DC, open  
circuit  
Output circuit ..... 4.97 ohms  
resistance  
Watts per element ..... 96.26  
Accuracy ..... Measure 1 percent  
full scale  
Potential Transformer  
DOD Drawing Number ..... 76-11237, 600V AC  
25VA at 50/60 Hz  
Secondary volts ..... 115V AC  
Voltage Input with Primary Connected:  
Parallel ..... 240 input  
Series ..... 480 input  
Voltage output ..... 120 output  
secondary

24V DC Relay  
 DOD Drawing Number ..... 76-11302  
 Plug-in type ..... 24V DC coil,  
 4P-NO, 2P-NC, 10  
 ampere contacts

Overvoltage Relay  
 DOD Drawing Number ..... 70-1138  
 Nominal voltage ..... 120 volts, 50 to  
 450 Hz. Operates  
 at 153 ±3 volts  
 for frequencies  
 50 to 450 Hz

Time delay ..... Operates when  
 overvoltage  
 condition is  
 sustained for a  
 minimum of 200  
 milliseconds

Trip time ..... Less than 1  
 second after  
 voltage reaches  
 and stays in  
 pull-in value

Contact rating ..... 10 ampere, 28.5  
 volts, resis-  
 tance

Temperature limits ..... -65 to 170°F  
 (-54 to 77°C)

Temperature effect..... 77 to -65°F  
 on pull-in..... (25 to -54°C)  
 voltage..... decreases 1  
 volt,  
 77 to 170°F  
 (25 to 77°C)  
 changes ±1 volt

Phase Sequence Relay  
 DOD Drawing Number ..... 76-11238  
 Input ..... 190 to 520V AC, 3  
 phase, line-to-  
 line, 50/60 Hz  
 Operating temper-..... -67 to 365°F  
 ature range ..... (-40 to 185°C)

Reverse Power Relay  
 DOD Drawing Number ..... 76-11240  
 Input voltage ..... 120V AC ±10V AC,  
 50/60 Hz  
 Input current ..... 0-5 amps from CT  
 secondary  
 Power requirement..... 18VA  
 Trip point ..... 2 to 20 percent  
 adjustment of full load  
 Output ..... SPDT, 10 amps at  
 115V AC  
 Temperature range..... -25 to 125°F  
 (-31 to 52°C)

Short Circuit Relay  
 DOD Drawing Number ..... 70-1137  
 Trip voltage ..... 24 volts ±1V, any  
 phase to neutral

Contact rating ..... 10 amperes, 28V  
 DC  
 Frequency ..... 50/400 Hz  
 Temperature range ..... 65 to 170°F  
 (-54 to 77° C)

Temperature effect. .... -65 to 77°F  
 on trip point ..... (-54 to 25°C) ±2  
 percent max change  
 77 to 170°F  
 ±3 percent max  
 change

Synchronizing Check Relay  
 DOD Drawing Number ..... 76-11239  
 Input ..... 120V AC  
 10 volts  
 50/60 Hz  
 Output ..... Isolated contact,  
 SPDT, NO, 10 amps  
 at 115V AC  
 Temperature range ..... 25 to 125°F  
 (-31 to 52°C)

Undervoltage Relay  
 DOD Drawing Number ..... 70-1120  
 Nominal input ..... 120 volts, 50 to  
 400 Hz, 100  
 milliamperes max  
 Dropout voltage ..... 99 volts 4± volts  
 Frequency range ..... 50 to 400 Hz  
 Temperature limits..... -65 to 170°F  
 (-54 to 77°C)  
 Time delay ..... 6 ±2 seconds  
 above 72 volts,  
 instantaneous  
 below 48 volts  
 Pull-in voltage ..... 110V AC ±3V AC

Integrated Time Delay Module  
 DOD Drawing Number ..... 76-11304-2  
 Type ..... 24V DC, 4 second  
 turn on delay

Coolant Temperature Gauge  
 DOD Drawing Number ..... 76-11229, used  
 with 76-11249  
 sender and  
 76-11230 resistor  
 for 24V DC  
 operation.  
 160° F (71°C) -  
 161 ohms, 280°F  
 (138°C) - 48.8  
 ohms  
 Scale ..... 100 to 280°F  
 50 to 100°C

DC Ammeter  
 DOD Drawing Number ..... 76-11233  
 Range ..... 25-0-50MV  
 Scale ..... 10/0/20 amps,  
 -10 to 0 amps-red  
 0 to 20 amps-green

DC Voltmeter		tor for 24V DC operation.
DOD Drawing Number	..... 76-11234	200°F (93°C)
Scale	..... 0 to 30V DC	- 548 ohms
Accuracy	..... ± 2 percent	300°F
Frequency Meter		(149°C) - 108 ohms
DOD Drawing Number	..... 69-595	
Scale	..... 48 to 53 Hz and	Scale ..... 150 to 350°F
	57 to 62 Hz; 250 degree scale calibrated in Hz from 48 to 62 Hz, scale divisions of 0.1 Hertz	(100 to 150°C)
Input	..... 120 volts, 1 phase 50/60 Hz (matched with frequency transducer 69-578)	Lube Oil Pressure Gauge
		DOD Drawing Number ..... 76-11227, used with 76-11255 sender and 76-11230 resistor for 24V DC operation.
		0 psi - 240 ohms
		80 psi - 60.3 ohms
		Scale ..... 0 to 100 psig
Fuel Level Gauge		Oil Pressure Gauge
DOD Drawing Number	..... 69-575	DOD Drawing Number ..76-11104
Input	..... 24V DC	Pressure range .....10 to 150 psi
		(0.7 Jo 10.5 kg/cm <sup>2</sup> )
Type	..... Fuel, empty to full, calibrated 1/4, 1/2, 3/4	Mechanism ..... C" shape bourbon tube
Sender resistance.	..... Empty - 0 ohms, 1/2 full - 15 ohms, full - 30 ohms	Power Factor Meter
		DOD Drawing Number ..... 76-11216
		Power ..... 120V AC ±10 percent, 50/60 Hz
		Sensing Input ..... 0.25 to 5.0 amps from current transformer
Kilowatt Meter		Accuracy ..... ±1 percent full scale
DOD Drawing Number	..... 70-4012	Scale ..... 7 inch, 250 degree deflection
Scale	..... Percent power, blue mark at 83 percent, red mark at 100 percent; full scale 0 to 133 percent	Time Totalizing Meter
Accuracy	..... 2 percent full scale	DOD Drawing Number ..... 73-0507
		Type ..... Indicates total hours of running time
Kilovar Meter		Scale ..... 0 to 9999
DOD Drawing Number	..... 76-11215	Voltage Meter
Type	..... Percent kilovar	DOD Drawing Number ..... .69-599
Scale	..... Blue mark at 83 percent, red mark at 100 percent, full scale 0 to 133 percent	Type ..... 250 degree, 0 to 500 volt scale, each scale, division: 5 volts
Lube Oil Temperature Gauge		Accuracy ..... 2-1/2 percent of full scale (integral rectifiers)
DOD Drawing Number	..... 76-11228, used with 76-11249 sender and 76-11230 resistor for 24 V DC operation.	

Under/Overvoltage Device  
 Manufacturer ..... Wilmar Electronics  
 Inc. (77-11003)\*  
 Part Number ..... 250-12X  
 Voltage rating..... 120V AC, single  
 phase, 50 to 400  
 Hz  
 Undervoltage trip..... .95 to 120V,  
 adjustable  
 Overvoltage trip ..... 120 to 140V,  
 adjustable  
 Contacts ..... SPDT

Underfrequency Device  
 Manufacturer ..... Wilmar Electronics  
 Inc. (77-11002)\*  
 Part number ..... 20-050-17X  
 Voltage rating ..... 120V AC, 50/60 Hz  
 Trip ..... 50 Hz - adjust-  
 able 45 - 50 Hz  
 60 Hz - adjust-  
 able 54 - 60 Hz  
 Contacts ..... SPDT

Overfrequency Device  
 Manufacturer ..... Wilmar Electronics  
 Inc. (77-11001)\*  
 Part number ..... 20-060-5X  
 Voltage rating ..... 120V AC, 50/60 Hz  
 Trip ..... 50 Hz - adjust-  
 able 50 - 55 Hz  
 60 Hz - adjust-  
 able 60 - 66 Hz  
 Contacts ..... SPDT

Speed/Voltage Matching Synchronizer  
 Manufacturer ..... Konell Enterprise  
 (77-11006)\*  
 Part number ..... SRM-60EV-MSTG  
 DOD Drawing Number ..... 77-11006  
 Voltage rating ..... 120V AC, Single  
 phase, 50/60 Hz  
 Input voltages ..... One from gener-  
 ator. One from  
 buss output  
 Automatic mode ..... Frequency differ-  
 ential  $\pm 0.1$  Hz,  
 phase differen-  
 tial  $\pm 10$  degrees  
 voltage differen-  
 tial  $\pm 10$  percent

Control Relay  
 Manufacturer ..... Westinghouse  
 Electric Corp.  
 Voltage rating ..... 110/120V AC,  
 50/60 Hz  
 Coil Burden ..... 96VA  
 Contact rating ..... 120V AC, 6 amps  
 inductive  
 Type ..... AR412A, three-

\*DOD Drawing Number

pole, 2-NC, 1-NO  
 AR420A, (77-  
 11005)\* two-  
 pole, 2-NO  
 AR401A, (77-  
 11004)\* single  
 pole, 1-NC  
 DOD Drawing Number..... 77-11007  
 (Respectively) ..... 77-11005  
 77-11004

f. Radiator/Fan Motor

DOD Drawing Number ..... 76-11059  
 Type ..... Remote radiator,  
 electric motor  
 driven  
 Heat rejection ..... 500 kw output:  
 at generator 390.0 BTU/sec -  
 set output 23,400 BTU/min  
 550 kw output:  
 429.1 BTU/sec -  
 25 750 BTU/min  
 Top tank ..... 200°F (93°C)  
 temperature at 500 kw output  
 210°F (99°C)  
 at 550 kw output  
 Motor ..... 15 hp

**NOTE**

**Unit to operate at any loads between no  
 load and rated load at the following line-to-  
 line voltages.**

Voltage operating ..... Between 395 and  
 range..... 500 volts for  
 the 240/416 volt  
 connection and  
 between 197 and  
 250 volts for  
 the 120/208 volt  
 connection for  
 60 Hz operation.  
 Between 380 and  
 426 volts for  
 the 240/416 volt  
 connection and  
 between 190 and  
 213 volts for  
 the 120/208 volt  
 connection for  
 50 Hz operation

g. Engine Preheat System

DOD Drawing Number ..... 76-11092  
 Type ..... Electric, thermo-  
 statically  
 controlled  
 Ambient temperature ..... 32 to 125°F (6  
 range, starting to 52°C); -25  
 to 125°F (-32  
 to 52°C) with  
 housing kit)

Lube Oil Heater		range for 60 Hz.....	for 240/416
DOD Drawing Number .....	77-11019-02	operation (line- .....	volts, 197 to
Water Heater		to-line .....	250 volts for
DOD Drawing Number .....	77-11019-01		120/208 volts
h. Fuel Transfer Pump		Flywheel and .....	SAE 0
DOD Drawing Number .....	76-11076	coupling disc	
Delivery .....	Up to 75 gallons	Coupling disc .....	SAE S14 J162
	(284 liters) per	arrangement	
	hour and pres-	Weight	
	sures to 22 psi	Complete gener- .....	4000 lbs (1814
	(1.8 kg/cm <sup>2</sup> )	ator	kg)
Lift capacity .....	12 feet (3.7	Complete rotor .....	1900 lbs (862 kg)
	meters) through	k. <u>Electric Hydraulic Actuator</u>	
	25 feet (7.6	DOD Drawing Number .....	76-11251
	meters) of No. 6	Manufacturer .....	Woodward Governor
	hose	Company	
Temperature .....	-65 to 155°F	Model .....	8240-792-EGB-1P
	(-54 to 68°C)	Operating pressure .....	330 to 375 psi
Motor .....	24V DC, 3.25 amps		(325 psi plus
i. Fuel Tank			inlet pressure)
Fuel Level Switch		Useful work .....	1.5 foot-pounds
DOD Drawing Number .....	76-11247-1, -2	capacity	at 350 psi
Electrical rating .....	0.5 amp resistive		0.85 foot-pounds
	or inductive at		at 200 psi
	6 to 32V DC	Max work .....	25 foot-pounds
Fuel Level Transmitter		capacity .....	at 350 psi
Type .....	MS500040-3	Supply pressure .....	Min 10 in (water)
Resistance			suction
Empty .....	0-00 to 0.50 ohms		max 50 psi
Full .....	29.50 to 31.50	Control characteristics	
ohms		Steady state .....	±0.25 percent of
j. Generator		speed band.....	rated speed
DOD Drawing Number .....	76-11329	Variable speed .....	2400 to 3600 rpm
Manufacturer .....	Kato Engineering	range	
Company		Drop .....	Normally set 3 to
Model .....	4P4-1950		6 percent over
Rating .....	417/500 kw		full output
Power factor .....	0.8 lagging		travel
Voltage .....	120/208 or	Operating temper- .....	to 200°F (-18
	240/416V AC	ature.....	to 93°C)
Current rating .....	1449 amps	Transducer .....	Unidirectional DC
(50 Hz)			control signal
Current rating .....	1736 amps	Transducer coil .....	30 to 35 ohms at
(60 Hz)			68°F (20°C)
Phase .....	3 phase	Max current .....	400 milliamps
Frequency .....	50 or 60 Hz	Nominal input .....	20 to 160 milli-
Poles .....	Four	range	amps
Speed .....	1500 rpm at 50 Hz	1. Engine and Controls	
	1800 rpm at 60 Hz	DOD Drawing Number .....	76-11063
Voltage operating .....	380 to 426 volts	Manufacturer .....	Cummins Engine
range for 50 Hz .....	for 240/416	Company, Inc.	
operation (line- .....	volts, 190 to	Model .....	VTA28-G1
to-line) .....	213 volts for	Type .....	Four-stroke
	120/208 volts		cycle, liquid-
			cooled, turbo-
			charged diesel
Voltage operating .....	395 to 500 volts	Number of cylinders...12	



Displacement ..... 1710 cubic inches  
(28.027 cubic centimeters)  
Horsepower ..... 750 at 1800 rpm  
Rotation ..... Clockwise, viewed  
from radiator  
(front) end

**CAUTION**

Fuel JP5 is considered an emergency fuel only.

Fuel ..... Diesel fuel  
VV-F-800 or JP5

**Overspeed Switch**

DOD Drawing Number ..... 70-1105-5  
Type ..... Centrifugal, 3-  
element; 2 auto  
reset, 1 manual  
reset

Operating temper- ..... -65 to 150°F  
ature range  
(-54 to 66°C)

Element No. 1 ..... Transfer to 290  
to 310 rpm  
rising speed,  
auto reset 100  
rpm max below  
trip speed

Element No. 2 ..... Transfer at 590  
to 610 rpm  
rising speed,  
auto reset 100  
rpm max below  
trip speed

Element No. 3 ..... Transfer at 1100  
to 1150 rpm  
rising speed,  
manual reset

**Starter Motor**

Type ..... Heavy duty  
Operating voltage ..... 24V DC  
Current rating of starter:  
Brushes ..... Eight brushes in  
four brush  
holders

Rotation ..... Clockwise, drive  
end

Actuation ..... Shifting sole-  
noid, mounted on  
motor

**Oil Pressure Sender**

DOD Drawing Number ..... 76-11255  
0 psi ..... 227 to 257 ohms  
25 psi ..... 142 to 162.5 ohms  
75 psi ..... 58.2 to 74.4 ohms

**Oil Pressure Switch**

DOD Drawing Number ..... 76-11385  
Type ..... Single circuit  
open switch

Contact rating ..... 4 amp at 24V DC  
Circuit ..... NO contact to  
close on rising  
pressure at 4  
psi (9.28  
kg/cm<sup>2</sup>)

**Coolant Temperature Sender**

DOD Drawing Number ..... 76-11249-1  
Maximum operating ..... 300°F (149°C)  
temperature  
Nominal value ..... 190°F (88°C)  
0 -143 ±14.5  
ohms

**Coolant Temperature Switch**

DOD Drawing Number ..... 76-11308  
Rating ..... 10 amp, 28V DC  
Connector ..... MS3102E-14S-2P  
Circuit ..... Two independent  
double-break  
circuits, one NO  
and one NC  
Temperature range ..... NC contact opens  
at 222 ±3 F  
(105 ±1°C); NO  
contact closes  
at 212 +3°F  
(100 ±1°C)

m. Remote Control Cable

DOD Drawing Number ..... 76-11025  
Length ..... 1,000 feet (300  
meters)

n. Remote Control Module

DOD Drawing Number ..... 76-11339  
Dimensions and weight:  
Length ..... 33.8 inches  
(86 centimeters)  
Width ..... 23.5 inches  
(60 centimeters)  
Height ..... 58.8 inches  
(149 centi-  
meters)  
Weight ..... 371 pounds  
(168 kilograms)

**Frequency Transducer**

DOD Drawing Number ..... 69-578  
AC input ..... 120V AC, single  
phase, 50/60 Hz

**NOTE**

Transducer and meter furnished only  
as matched set which consists of the transducer  
and frequency meter.

**Thermal Watt Converter**

DOD Drawing Number ..... 69-589  
Volts ..... 100/130V AC

Current .....	1 ampere	Reverse Power Relay	
Elements .....	3	DOD Drawing Number .....	76-11240
Phase .....	3	Input voltage .....	120V AC $\pm$ 10V AC, 50/60 Hz
Number of wires .....	4	Input current .....	0-5 amps from CT secondary
Output .....	20MV DC, open circuit	Power requirement.....	18VA
Output circuit .....	4.97 ohms resistance	Trip point .....	2 to 20 percent adjustment of full load
Watts per element.....	96.26	Output .....	SPDT, 10 amps at 115V AC
Accuracy .....	Measure 1 percent full scale	Temperature range.....	-25 to 125°F (-31 to 52°C)
Potential Transformer		Short Circuit Relay	
DOD Drawing Number .....	76-11237, 600V AC 25VA at 50/60 Hz	DOD Drawing Number .....	70-1137
Voltage input .....	240/480V	Trip voltage .....	24 volts $\pm$ 1, any phase to neutral
Voltage output .....	120V secondary	Contact rating.....	10 amperes, 28V DC
24V DC Relay		Frequency .....	50/400 Hz
DOD Drawing.....	Number..76-11302	Temperature range .....	-65 to 170°F (-54 to 77°C)
Plug-in type .....	24V DC coil, 4P-NO, 2P-NC, 10 ampere contacts	Temperature effect .....	-65 to 77°F on trip point (-54 to 25°C) $\pm$ 2 percent max change 77 to 170°F (25 to 77°C) +3 percent max change
Overvoltage Relay		Synchronizing Check Relay	
DOD Drawing Number .....	70-1138	DOD Drawing Number .....	76-11239
Nominal voltage .....	120 volts, 50 to 450 Hz. Operates at 153 $\pm$ 3 volts for frequencies 50 to 450 Hz	Input .....	120V AC $\pm$ 10 volts, 50/60 Hz
Time delay .....	Operates when overvoltage con- dition is sus- tained for a minimum of 200 milliseconds	Output .....	Isolated contact SPDT, NO, 10 amps at 115V AC
Trip time .....	Less than 1 second after voltage reaches and stays in pull-in value	Temperature range .....	-25 to 125°F (-31 to 52°C)
Contact rating .....	10 ampere, 28.5 volts, resis- tance	Undervoltage Relay	
Temperature limits..	-65 to 170°F (-54 to 77°C)	DOD Drawing Number .....	70-1120
Temperature effect..	77 to -65°F (25 to -54°C) de- creases 1 volt, 77 to 170°F (25 to 77°C) changes $\pm$ 1 volt	Nominal input .....	120 volts, 50 to 400 Hz, 100 milliamperes max
Phase Sequence Relay		Dropout Voltage .....	99 volts $\pm$ 4 volts
DOD Drawing Number .....	-11238	Frequency range .....	50 to 400 Hz
Input .....	190 to 520V AC, 3 phase, line-to- line, 50/60 Hz	Temperature limits.....	-65 to 170°F (-54 to 77°C)
Operating temper- ature range .....	-40 to 185°F (-40 to 82°C)	Time delay .....	6 $\pm$ 2 seconds above 72 volts, instantaneous below 48 volts
		Pull-in voltage .....	110V AC $\pm$ 3V AC
		Integrated Time Delay Module	
		DOD, Drawing Number .....	76-11304-2
		Type .....	24V DC, 4 second turn on delay

Coolant Temperature Gauge  
 DOD Drawing Number .....76-11229, used  
 with 76-11249  
 sender and  
 76-11230  
 resistor for 24V  
 DC operation.  
 160°F (71°C)  
 - 161 ohms,  
 280°F  
 (138°C) - 48,8  
 ohms  
 Scale ..... 100 to 280°F  
 (50 to 100°C)

DC Ammeter  
 DOD Drawing Number ..... 76-11233  
 Range ..... 25-0-50MV  
 Scale ..... 10/0/20 amps, -10  
 to 0 amps - red,  
 0 to 20 amps -  
 green

DC Voltmeter  
 DOD Drawing Number ..... 76-11234  
 Scale ..... 0 to 30V DC  
 Accuracy ..... 2 percent

Frequency Meter  
 DOD Drawing Number .....69-595  
 Scale ..... 48 to 53 Hz and  
 57 to 62 Hz; 250  
 degree scale  
 calibrated in Hz  
 from 48 to 62  
 Hz, scale divi-  
 sions of 0.1  
 Hertz  
 Input ..... 120 volts, 1  
 phase 50/60 Hz  
 (matched with  
 frequency trans-  
 ducer 69-578)

Fuel Level Gauge  
 DOD Drawing Number ..... 69-575  
 Input ..... 24V DC  
 Type ..... Fuel, empty to  
 full, calibrated  
 1/4, 1/2, 3/4  
 Sender resistance ..... Empty - 0 ohms,  
 1/2 full - 15  
 ohms, full - 30  
 ohms

Kilowatt Meter  
 DOD Drawing Number ..... 70-4012  
 Scale ..... Percent power,  
 blue mark at 83  
 percent, red  
 mark at 100  
 percent; full  
 scale 0 to 133  
 percent

Accuracy ..... 2 percent full  
 scale

Kilovar Meter  
 DOD Drawing Number ..... 76-11215  
 Type ..... Percent kilovar  
 Scale ..... Blue mark at 83  
 percent, red  
 mark at 100  
 percent, full  
 scale 0 to 133  
 percent

Lube Oil Temperature Gauge  
 DOD Drawing Number ..... 76-11228, used  
 with 76-11249  
 sender and  
 76-11230  
 resistor for 24V  
 DC operation.  
 200°F (93°C)  
 - 548 ohms  
 300°F  
 (149°C) - 108  
 ohms  
 Scale ..... 150 to 350°F  
 (100 to 150°C)

Lube Oil Pressure Gauge  
 DOD Drawing Number..76-11227, used  
 with 76-11255  
 sender and  
 76-11230 resis-  
 tor for 24V DC  
 operation.  
 0 psi - 240 ohms  
 80 psi - 60.3  
 ohms  
 Scale ..... 0 to 100 psig

Oil Pressure Gauge  
 DOD Drawing Number ..... 76-11104  
 Pressure range ..... 10 to 150 psi  
 (0.7 So 10.5  
 kg/cm<sup>2</sup> )

Mechanism ..... "C" shape bourbon  
 tube

Power Factor Meter  
 DOD Drawing Number ..... ..76-11216  
 Power ..... 120V AC ±10 per-  
 cent, 50/60 Hz

Sensing input ..... 0.25 to 5.0 amps  
 from current  
 transformer

Accuracy ..... ±1 percent full  
 scale

Scale ..... 7 inch, 250  
 degree  
 deflection

Time Totalizing Meter  
 DOD Drawing Number ..... 73-0507

Type ..... Indicates total house of running time  
Scale ..... 0 to 9999  
Voltage Meter  
DOD Drawing Number ..... 69-599  
Type ..... 250 degree, 0 to 500 volt scale, each scale division: 5 volts  
Accuracy ..... 2-1/2 percent of full scale (integral rectifiers)

o. Automatic Control Module

DOD Drawing Number....81-11022

Dimensions and weight:

Length ..... 30.8 inches (78 centimeters)  
Width ..... 13.3 inches (34 centimeters)  
Height ..... 66.4 inches (169 centimeters)  
Weight ..... 267 pounds (121 kilograms)  
Electrical In terface ..... Sensing, 120 volt, single phase

Under/Overvoltage Device

Manufacturer ..... Wilmar Electronics Inc.  
Part Number ..... 250-12X  
Voltage trip ..... 120V AC, single phase, 50 to 400 Hz  
Undervoltage trip ..... 95 to 120V, adjustable  
Overvoltage trip ..... 120 to 140 V, adjustable  
Contacts ..... SPDT

Underfrequency Device

Manufacturer ..... Wilmar Electronics Inc.  
Part Number ..... 20-050-17X  
Voltage ..... 120V AC, 50/60 Hz  
Trip ..... 50 Hz - adjustable  
45 to 50 Hz  
60 Hz - adjustable  
54 to 60 Hz  
Contacts ..... SPDT

Overfrequency Device

Manufacturer ..... Wilmar Electronics Inc.  
Part Number ..... 20-060-5X  
Voltage ..... 120V AC, 50/60 Hz  
Trip ..... 50 Hz - adjustable  
50 to 55 Hz,  
60 Hz - adjustable  
60 to 66 Hz  
Contacts ..... SPDT

Time Delay Relay

Manufacturer ..... Agastat Division of Amerace Corp.  
Part Number ..... 7022-AC  
Voltage ..... 120V AC, 50/60 Hz  
Type ..... Delay on drop out, timed off 604 sec, adjustable 1.5 to 15 sec  
Contacts ..... DPDT

Control Relay

Manufacturer ..... Westinghouse Electric Corp.  
Voltage ..... 110/120V AC, 50/60 Hz  
Coil Burden ..... 96VA  
Contact rating ..... 120V AC inductive at 6 amps  
Type ..... AR420A, one-pole, 1-NO  
AR633A, five-pole, 3 NC, 2-NO  
AR421A, three-pole, 1 NC, 2 NO

Diode Packs

R1-DOD Drawing No. 88-11046  
R2-DOD Drawing No. 88-11045  
R3-DOD Drawing No. 88-11044  
R4-DOD Drawing No. 88-11043

Control Relays

Manufacturer ..... Westinghouse Electric Corp.  
Voltage ..... 110/120V AC, 50/60 Hz  
Coil burden ..... 96VA  
Contact Rating ..... 120V AC, 6 amps inductive  
Type ..... AR422A, 2-NC, 2-NO  
AR422L, (DC coil), 2-NC, 2-NO

NOTE: Contacts to be arranged per wiring diagrams.

Time Delay Relay

Manufacturer .....Agastat Division  
of Amerace  
Corp.  
Part number.....7012AH  
Voltage .....120V AC, 50/60 Hz  
Type .....Time delay on  
energize  
adjustable, 3 to  
30 min.  
Contacts .....DPDT

Time Delay Relay

Manufacturer .....Agastat Division  
of Amerace  
Corp.  
Part number .....70220K  
Voltage .....24V DC  
Type .....Time delay on de-  
energize, adjust-  
able, 5 min.  
Contacts .....DPDT

Time Delay Relay

Manufacturer .....Westinghouse  
Electric Corp.  
Part number.....ARPT-20  
Type .....Mechanical  
Contacts .....1-NO, 1-NC

p. Fuel System Diagram. See figure 1-8 for the generator set fuel system diagram.

q. Instruction Plate Information. The generator set has instruction plates located throughout the set. See Figure 1-9 for the location of the plates. The document compartment contains lamination of all instruction plates. On unhooused sets, several of the plates can be found only in the document compartment.

r. Schematics and Wiring Diagrams. FO-1 through FO-16 are the schematic and wiring diagrams for the generator set major components and auxiliary equipment.

**1-11. TORQUE DATA.** Torque data applicable to operator/crew and organizational maintenance is given in Table 1-1.

**1-12. DIFFERENCE BETWEEN MODELS.** Differences between generator sets are delineated in the Repair Parts and Tools List, TM5-6115-593-24P, Intermediate (Field) (Direct and General Support) and Depot Level Maintenance TM5-6115-593-34, and in this manual.

**NOTE**

Throughout this technical manual MEP-029A is referred to as code A and MEP-029B is referred to as Code B.

NOTES

1. FUEL SOLENOID IS CONTROLLED BY THE FUEL LEVEL SWITCH AND IS USED IN CONJUNCTION WITH FUEL PUMPS TO KEEP FUEL TANK FULL.
2. REPLACEMENT ELEMENTS ARE MIL-F-20627, TYPE 11, CLASS 11, NSN: 2910-287-1912.
3. ELEMENT CAN BE WASHED AND REUSED
4. ENTIRE FUEL SYSTEM IS VENTED THROUGH THE FILLER CAP. THE VENT VALVE ON THE FILLER CAP MUST BE LEFT IN OPEN POSITION WHEN SET IS RUNNING (VALVE IS ON UNDER SIDE OF CAP).

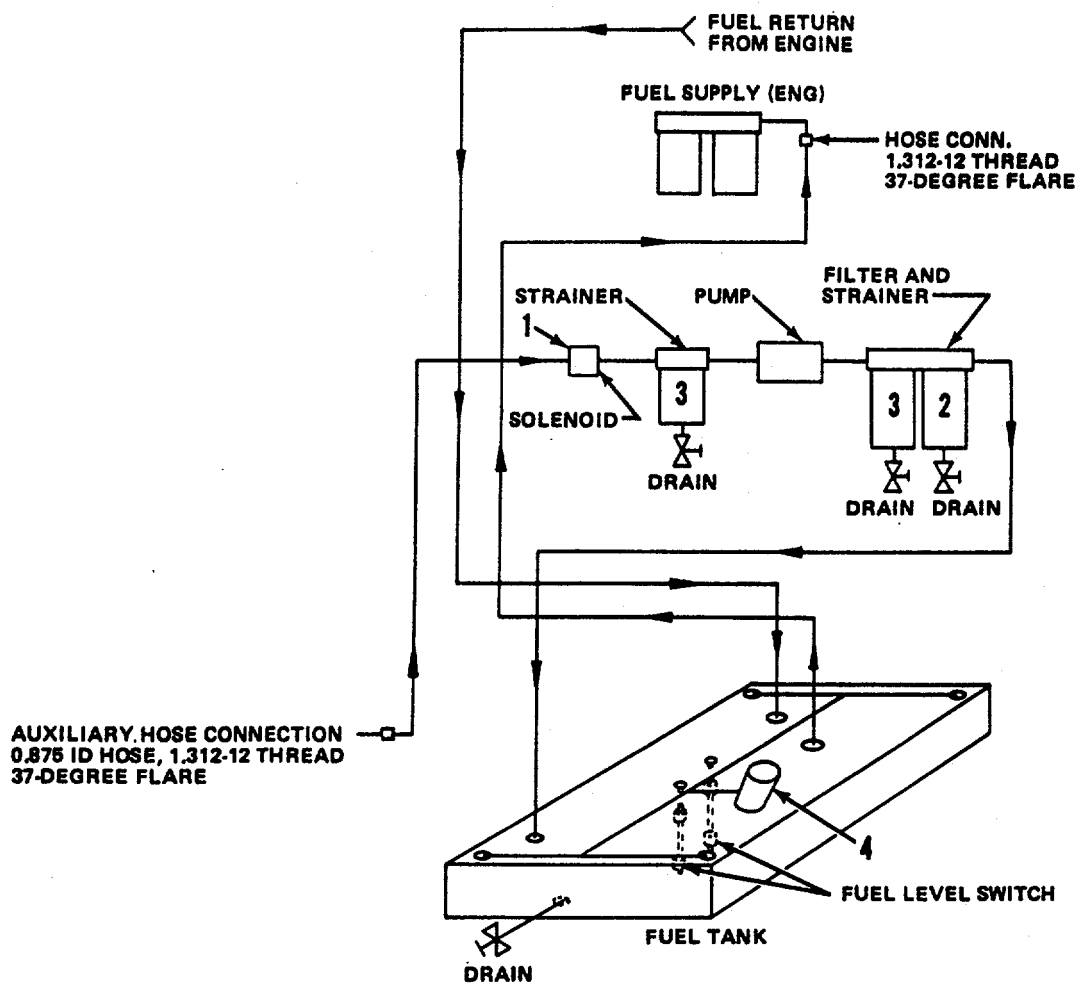
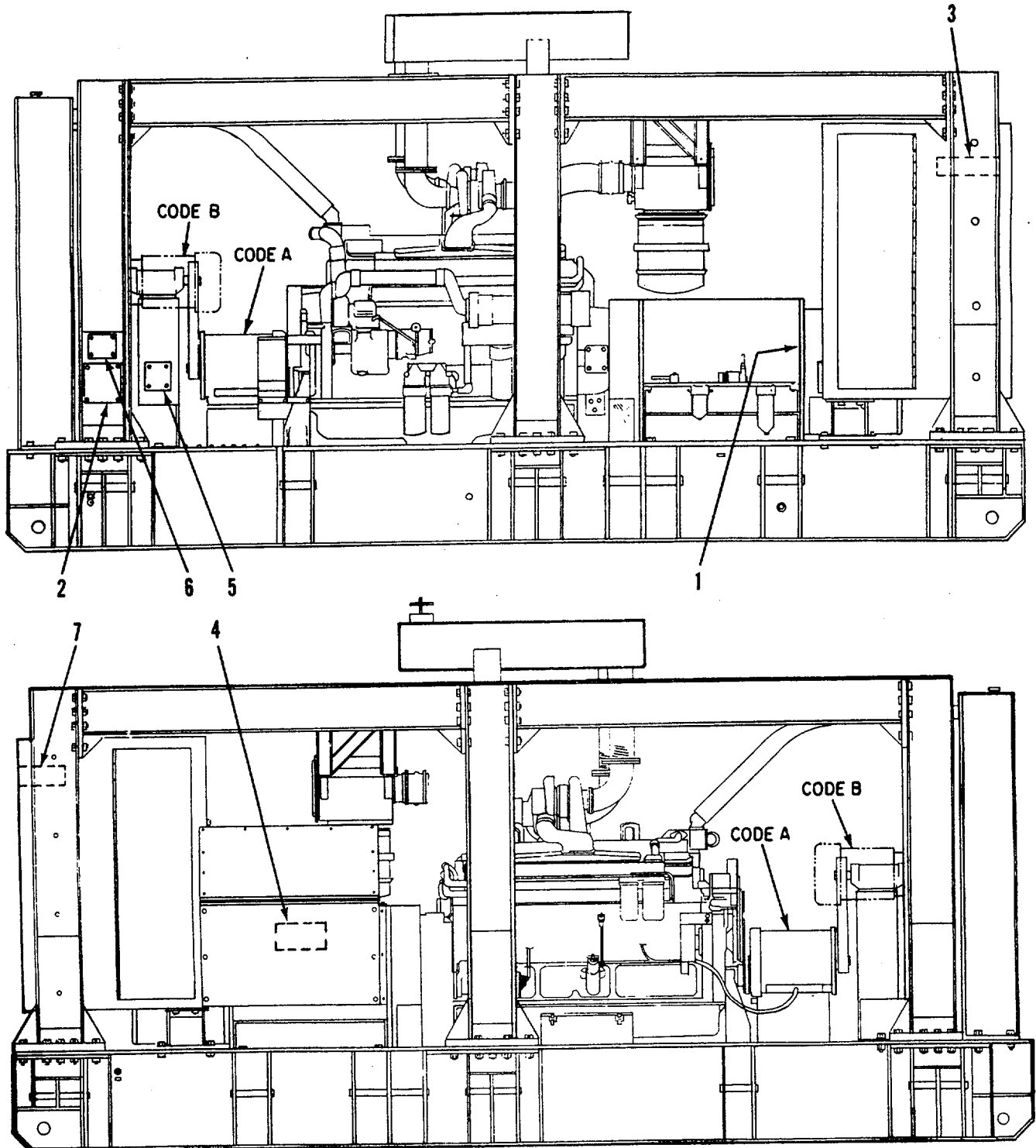

Figure 1-8. Fuel System Diagram



- |                                  |  |
|----------------------------------|--|
| 1. Fuel system instruction plate | 4. Reconnection box instruction plate                  |
| 2. Lifting instruction plate     | 5. Battery instruction plate                           |
| 3. Operating instructions plate  | 6. Information plate                                   |
|                                  | 7. Document compartment containing plastic laminations |

Figure 1-9. Instruction Plate Locations

**Table 1-1. Torque Data**

**NOTE**

Lubricate threads prior to torquing.

COMPONENT	TORQUE VALUE	
	FT/LBS	JOULES
Oil Pressure Switches	20	27
Spin-on filters Mounting capscrew	25 to 35	34 to 47
Fuel filter capscrews	20 to 25	27 to 34
Injector hold-down capscrews in increments of	11 to 12 4	15 to 16 5
Turbocharger V-Band clamp tension	32 to 36*	3.6 to 4.1
Lubricating oil drain fitting	50	68
Diffuser plate capscrew	5 to 7	7 to 10
Intercooler capscrews in increments of	30 to 35 15	41 to 47 20
Exhaust Manifold capscrews in increments of	35 8	47 11

\* In-lbs

**Section III. SYSTEM OPERATION**

**1-13. GENERAL.** This section covers theory of operation for the following \*generator set systems:

- a. DC Electrical and Control System
- b. AC Power Generation and Control System
- c. Fuel System
- d. Cooling System
- e. Lube Oil System

These systems are multipurposed in that there is some overlapping functions from one system to another. Certain operations may be described, to avoid redundancy, under one system where as they actually function within two or more systems.

**1-14. DC ELECTRICAL AND CONTROL SYSTEM.  
(See FO-1.)**

- a. Introduction. The DC electrical and control system's primary function is to enable the starting, stopping and operation of the diesel engine under a variety of operating conditions.



- b. Engine Starting. When the operator toggles spring-loaded MASTER SWITCH S1 to the START position, normal start/stop/run/ relay K5 becomes energized through normally closed contacts 5 and 6, and normally open contacts 3 and 2 of S1. Upon release of S1, relay K5 is held in its energized state by its selflatching contacts 2 and 4. With K5 energized, run pilot relay K54 energizes through the normally open contacts 1 and 5 of K5, and as a result normally open contacts 1 and 2 of K54 close. Starter crank limit relay K3 now energizes through forward-biased CR1 and the following closed contacts: K19, speed switch SS1, K6, K50, and K54. At this time magnetizing current is applied to start solenoid L4 (through K3 contacts 1 and 2), and the heavy duty contactors of L4 close, bringing current to starter motor B2 causing it to crank the engine. Simultaneous with the previously described action, fuel solenoid L1 and engine run relay K1 are both activated (through normally closed contacts K21, K19, K6, K50, diode CR23, and contacts 1 and 2 of K54), allowing the passage of fuel to the engine. Prior to starting, K1 normally closed contacts place a short across terminals 22 and 23 of governor controller A106. This ultimately sets the engine's hydraulic governor for zero fuel output. Energizing K1 at start time negates this function and allows the passage of fuel.
- c. Starter Motor Protection. Depending on which occurs first, cranking power will be applied until the engine reaches a speed in excess of 600 rpm or total cranking time exceeds 30 seconds. When the engine attains a speed over 600 rpm (in less than 30 seconds), speed switch SS1 opens, subsequently deenergizing K3 and, then, L4. With L4 deactivated, cranking action ceases when the contactors of L4 disconnect power from starter motor B2. If the engine does not start, that is, does not reach a speed in excess of 600 rpm, and cranking time exceeds approximately 30 seconds, cranking will automatically cease thereby preventing the possible burnout of starter motor B2. Initially, when cranking begins, time delay relay assembly TD1 is turned on (through closed contacts of SS1, K6, K50, and K54) and the timing process commences. After a period of about 30 seconds, TD1 stops timing and connects overcrank shutdown relay K19 to +24V DC through contacts of SS1, K6, K50, and K54 thereby energizing K19. K19 now energized, opens its normally closed contacts in series with cranking relay K3 causing K3 to deenergize, and subsequently, power is removed from B2. To indicate that this has occurred, OVER CRANK lamp DS51 lights when it is returned to +24V DC through the normally open contacts of K19 (in series with DS51) and the path consisting of SS1, K6, K50, and K54. If, as was previously mentioned, engine speed goes over 600 rpm, SS1 opens and the just described action does not occur.
- d. Ether Starting. As an aid to cold weather starting, provisions are made to inject ether into both of the engine air intake manifolds while the engine is being cranked. The application of this highly volatile fluid is controlled by the ether solenoid, ether aid control relay K24, and START AID switch S2. During crank time, K24 is energized through closed contacts of K6, K50, and K54. At this time the normally open contacts of K24, which are in series with the ether aid control S2, close. Operating S2 to the ON position activates the ether aid control solenoid causing a measured amount of ether to be loaded into the ether aid device. Upon release of S2, this measured amount of ether is forcefully injected into the air intake manifolds. The ether aid device may be used at any engine speed up to 1200 rpm and for approximately 5 seconds afterwards (the 5-second delay is explained in subparagraph 1-14th(2), below).
- e. Louver Operation (Housed Sets). The auxiliary housing kit

contains four motor-operated louvers which open during engine operation and close at engine shutdown. Louver control relays K60 through K63, louver motor pilot travel-limiting switches S60 through S63, and louver motors B10 through B13 (each capable of two-way operation) control the four louver assemblies. When the engine starts, each louver control relay energizes and 24V DC is applied, by way of the louver motor pilot switches, to the louver motors and the louvers open. Upon reaching their full-open position the louvers set the travel-limit switches to their opposite position, deactivating the louver motors. Louver operation at the shut down is exactly the same except that the motors operate in the reverse direction and 24V DC is applied through the normally closed contacts of the deenergized louver control relays.

- f. Engine Stopping. When it is required to stop the engine after a period of normal operation, the operator momentarily sets the spring loaded MASTER SWITCH S1 to the STOP position, thereby deenergizing relay K5. With K5 now deenergized, run pilot relay K54 drops out, its contacts 1 and 2 open and +24V DC magnetizing voltage is removed from fuel solenoid L1. After the small amount of fuel remaining in the lines past the point of fuel cutoff is consumed, the engine comes to a halt.
- g. Emergency Stopping. When an emergency exists, such as might pose a threat to personnel or equipment, as quick a shutdown as possible is required. To ensure this, the air boxes in series with the air intake manifolds are closed and the fuel supply is shut off, thus interrupting the engine's air and fuel supply and quickly bringing the engine to a stop. Operating EMERGENCY SHUTDOWN switch S22 to ON, energizes emergency stop relay K21 and, when solenoids L2 and L22 are actuated (through normally open contacts of K21) the air boxes close interrupting the

stream of air to the engine. When the engine shuts down, oil pressure switch OP3 opens and disconnects 24V DC from L2 and L22. A second set of K21 contacts removes +24V DC from solenoid L1 and cuts off the engine's fuel supply.

- h. Engine Protection. Operation will continue as long as no fault condition occurs which might cause damage to the engine. Once such a condition does occur, engine operation is automatically brought to a halt. The following subparagraphs describe the fault which will stop the engine and by what circuitry this stoppage is implemented.
  - (1) Engine Overspeed. If engine speed increases to a point where damage may occur, overspeed switch SS3 (set to operate at approximately 2250 rpm) closes activating overspeed relay K31. As a result, the normally open contacts of K31 (in parallel with EMERGENCY SHUTDOWN SWITCH S22) close and energize relay K21. The action from this point on is the same as for emergency stopping.
  - (2) Low Oil Pressure. If lubricating oil pressure falls below 21  $\pm$ 2 psi (1.5 kg/cm ) the contacts of oil pressure switch OP1 open and remove power from fuel solenoid L1. Because engine oil does not build to its required pressure immediately, the engine may shut down "thinking" a fault has occurred. To avoid this premature operation, time delay assembly TD3 inhibits the operation of relay K6 for 5 seconds--allowing pressure to build.
  - (3) Oil Temperature. If lubricating oil temperature rises above 255  $\pm$ 3°F (124  $\pm$ 1° C), damage to the engine may occur. To prevent this, oil temperature switch OT1

(when it senses this condition) opens its normally closed contacts, thereby deenergizing fuel solenoid L1.

- (4) Coolant Temperature. If the engine coolant rises above 213 +3°F (100 +0.7°C), engine damage may occur. Water temperature switch WT1 senses coolant temperature and operates to an open position when this temperature becomes too high.
- (5) Low Fuel Level. In addition to the fact that engine damage may occur, if the engine ran completely out of fuel, trying to restart the engine with a new supply of fuel would require an elaborate and time-consuming "bleeding" procedure. To avoid this, fuel level switch FL1 is used to sense when there is only enough fuel for one more hour of engine operation and shuts the engine down by deactivating relay K8 (K8 contacts open the circuit holding fuel solenoid L1 energized).

- i. Engine Fault Indicators. If an engine fault occurs, the engine will shut down and one of several indicator lamps (mounted on the Generator Control Panel) will light. In addition to the indicator lamp an annunciator (horn) will sound to alarm crew members not in the immediate vicinity. To ensure proper operation of these faults indicators, a means whereby the lamps and the annunciator may be tested is provided. Since all of these circuits act in a similar manner only one will be described.

If a high oil temperature condition exists, the normally open contacts of switch OT2 will close, applying +24-volts dc to energize K28. Relay K28 is held energized by self-latching contacts in parallel with OT2. At this time ENG FAULT indicator lamp DS28 lights as 24V DC is applied to closed contacts of S14, thermal fuse FC1, diode CR30 through DS28, CR7, and relay contacts K28 to the 24 volt return. Coincident with this action relay K28 energizes (through normally closed contacts

S13, OT2 and K28) and as a result the horn activates via normally open contacts K26 and normally closed contacts K25B.

When ANNUNCIATOR TEST switch S13 is set to on, the horn is activated to its test position through contacts 8 and 15 of S13. To test indicator lamp DS28, -24V DC is applied through contacts 7 and 4, diode CR6, DS28, and back to +24V DC through contacts 2 and 3 of S13 (the path consisting of CR7 and K28 is disconnected from +24V DC by open contacts 6 and 11 of S13). Occasionally it may be beneficial to silence the annunciator by toggling ALARM SILENCE switch S12 to the on position. With S12 on, relay K25A and K25B energize. The contacts of K25A hold the K25A and K25B coil energized when S12 is released and the contacts K25B disconnect the horn circuit. Operating ANNUNCIATOR RESET switch S14 to on disconnects K25A and K25B from -24V DC and re-enables the horn circuit.

- j. Engine Operation. Once the engine is running it is only necessary to monitor various operating parameters and to vary engine speed as required to set the generator output frequency.

- (1) Engine Speed. Controlling engine speed is achieved by varying engine fuel intake by means of an electro hydraulic governor. The operation of this governor is electrically determined by governor controller A106. Engine speed may be manually adjusted by setting FREQUENCY ADJUST switch S5 to either INCREASE or DECREASE. S5 controls two-way motor B4 which is mechanically coupled to potentiometer R102. R102 is electrically connected to A106 and affects its operation.

- (2) Engine Monitoring. Located on the Engine Control Panel are four gauges M1 through M4 which, respectively, monitor

the following engine operating conditions: oil pressure, oil temperature, water temperature and fuel level. Transmitters MT1 through MT4 which are connected to gauges M1 through M4, are actually variable resistors whose resistance changes as a function of the parameter being monitored. Once the engine starts all of these circuits are activated through normally open contacts 3 and 4 of relay K1. Meter M5 is an elapsed time meter which is energized by K1 contacts only when the engine is running.

- (3) Fuel Transfer. Prolonged operation of the engine generator set is obtained by the use of additional fuel tanks. The transfer of fuel from these tanks to the day tank is controlled automatically by fuel level switches FL1 and FL2. FL2 senses when day tank fuel falls below a certain level and closes to energize relay K20 through FUEL PUMP AUTO-OFF switch S9 and high-level switch FL1. With K20 energized, motor B1 starts pumping fuel to the day tank. When full, FL1 opens, deenergizing K20 which subsequently stops motor B1. FUEL PUMP indicator lamp DS1 connected across B1, lights anytime fuel is being pumped.
- (4) Battle Short. During battle conditions, the requirement of continued engine operation may override the need to protect the engine. BATTLE SHORT switch S7 when set to ON, energizes selfholding relay K50. Closed contacts 3 and 4 of K50 bypass the fault-sensing contacts of low fuel relay K8, water temperature switch WT1, oil temperature switch OT1, oil pressure switch OP1, and overvoltage relay K32.

- k. Miscellaneous. The following subparagraphs briefly describe those DC

circuits not directly related to engine operation:

- (1) BATTERY CHRG AMPS meter M21 monitors battery charging current. It is connected in series with the battery charger.
- (2) BATTERY CHRG VOLTS meters M20 monitors DC electrical system voltage.
- (3) The digital CLOCK M111 indicates daily time. Switch S52 (50 Hz) enables clock operation at either 50 or 60 Hertz.
- (4) The panel lights are controlled by PANEL LT SW S11.
- (5) 24V DC CONTROL CIRCUIT BREAKER CB1 controls the application of 24V DC to the DC Electrical Control System and may be used to shut down the engine during an emergency.
- (6) OPERATION-MAINTENANCE LOCKOUT switch S2 prevents the engine from being started during maintenance. It may also be used for emergency shut down.

#### 1-15. AC POWER GENERATION AND CONTROL SYSTEM. (See FO-2.)

- a. Introduction. The purpose of the engine generator set is to produce an electrical output. To accomplish this end, an AC 3-phase, brushless-type generator is directly coupled to the diesel engine. The AC power generator and control system monitors and controls the generator set to ensure that a constant output in terms of amplitude, phase, and frequency is maintained under all permissible load conditions and modes of operation. The following paragraphs explain and describe the various functions of this control system.

b. Single Unit Operation. Once the engine has stabilized and is running normally, the load may be applied to the main generator G1 output terminals through the heavy duty contacts of motor driven circuit breaker CB2. CB2 closes when relay K22 is energized through a series circuit which consists of various relay contacts of the generator fault protection circuit and AC PWR CKT BKR switch S3. With K22 energized, the motor of CB2 is activated, closing its contacts and applying main power to the load.

(1) Output Frequency Regulation. With the AC output now applied to the load, the generator output frequency must be maintained at either the 50 or 60 Hz required by the load. Generator or output frequency is controlled by adjusting engine speed (frequency is directly proportional to engine speed). A magnet imbedded in the magnetic pickup PU1, which is mounted in close proximity to the flywheel, induces a series of voltage pulses for every revolution of the engine. These voltage pulses, whose number per minute indicates engine rpm, are sent to governor actuator controller A106. A106 processes and amplifies these pulses in conjunction with other generator load sensing inputs (such as a generator current and voltage) and generates a control voltage proportionate to engine speed and generator output requirements. This output is applied to governor actuator solenoid L101. In response, L101 varies the amount of control placed on the fuel injection pump by the electro hydraulic governor actuator. The fuel injection pump regulates engine speed by adjusting the engine's rate of fuel consumption.

(2) Output Voltage Regulation. Generator G1 output voltage is indirectly controlled by the amount of current flowing in the generator's

exciter field. The extent of this control is determined by voltage regulator VR101 which senses generator output voltage. The source of the control current is a permanent magnet generator mounted on the same shaft as the main generator exciter. After being made proportional to the G1 output voltage by VR101, the permanent magnet generator output (in addition to supplying short circuit current) is used to determine exciter field current. A motor-driven potentiometer R101 (controlled by VOLT ADJ switch S6) is used to manually adjust main generator output voltage. This potentiometer which is driven by B5, is connected to VR 101.

c. Parallel Operation. To increase the total available power, the generator set may be operated in parallel with as many as three additional generator sets. During the parallel mode of operation the phase, frequency, and amplitude of the generator sets must be made to coincide. Amplitudes can be made to coincide by manually adjusting and comparing the outputs of the various generator sets.

The phase sequence of one generator set must first be determined and then compared with the phase sequence of the set to be paralleled. This is accomplished by PHASE SEQUENCE switch S103 and relays K103-1 and K103-2. If the phase sequence of the generator windings are 1-2-3, relay K103-1 will energize, closing its 4-5 contacts causing the 1-2-3 indicator lamp DS41 to light. If the phase sequence is 1-3-2, relay K103-2 will energize and the 1-3-2 indicator lamp DS42 will light. Switch S103 determines whether the generator windings or the generator buss is to be monitored.

After phase sequence has been established, the operator must set switch S8 to PARALLEL OPERATION, thereby energizing relay K23 and

lighting PARALLEL indicator lamp DS7 (K23 is held energized by self-latching contacts 5 and 6). With K23 energized, power is applied (through K23 contacts 9, 10, 11, and 12) from power transformers T101 and T102 to the frequency paralleling circuit K106, DS 101, DS102, and K106 is a synchronizing check relay which only allows the AC power CKT BKR (CB2) to close to a dead bus or to a "synchronized" energized bus, SYNCHROSCOPE M109. K106 is a synchronizing check relay which only allows the AC power CKT BKR (CB2) to close to a dead bus or to a "synchronized" energized bus.

Power transformer T102 senses the bus voltage, and power transformer T101 senses the output of the incoming generator. SYNC light DS101 is connected from the output terminal T101 to the output terminal of T102. DS102 is similarly connected across the remaining outputs. The greater the frequency difference of the generator sets, the greater the voltage across the SYNC lights and the greater the rate of which they will blink on and off. As the sets approach a zero frequency difference, the lights dim and finally extinguish. SYNCHROSCOPE M109 performs essentially the same function and also indicates relative frequency between the generators to be paralleled. When SYNCHROSCOPE M109 points to 12 O'clock, the generator is in sync with the energized buss. If the droop (regulation) characteristics of the separate generators involved in parallel operation are different, their ability to equally share the load is diminished. To compensate for these inherent differences in droop, REACTIVE LOAD COMPENSATION CONTROL R104 allows the operator to offset the output voltage of a particular generator. When connected to a load, this generator will droop to a voltage level that will enable equal load sharing. Similar readings of each generator set's AMMETER will reflect this equal load sharing.

- d. Generator Faults. As a means of either protecting the generator set and/or the load,

various fault-sensing devices have been wired into the AC generator and control circuit. All of the generator fault circuit relays K32 through K36 and indicator lamps DS32 through DS36, respectively, are selflatching, that is, they will stay energized even though the fault which caused them to operate will no longer manifest itself when the main contactors open. Therefore, when a fault does occur, the crew should note which fault indicator lamp is lit prior to operating the ANNUNCIATOR RESET switch S14. Also when any fault occurs, alarm horn AI will sound when relay K26 energizes and its normally open contacts complete the 24-volt return of AI. Current transformers are used in many of the generator fault sensing circuits. The faults, how they are monitored, and how damage is prevented are described in the following paragraphs:

- (1) Overvoltage Protection. If engine speed were to become excessive or voltage regulator VR101 malfunction, the generator output voltage might rise to a level harmful to either the load, the generator, or engine controls. To prevent this, overvoltage relay K102 (connected across one of the generator output windings) senses when this occurs, and activates to initiate the following sequence: K32 energizes (OVERVOLTAGE indicator lamp DS32 lights); the engine fault circuit opens; fuel solenoid L1 deactivates (shutting down the engine); and K1 deenergizes opening the AC POWER CKT BKR (CB2) (disconnecting the load).
- (2) Undervoltage Protection. It is possible that voltage regulator VR101 could malfunction in such manner as to create an undervoltage condition capable of damaging the load. Connected across one of the generator output windings, relay Kill senses if the output voltage becomes too

low and deenergizes when it does. Contacts 7 and 8 of K11 open deenergizing the CB2 trip coil which in turn, disconnects the generator from the load. Simultaneous with this action, K11 contacts 3 and 4 close activating relay K33 and UNDERVOLTAGE indicator lamp DS33. A false undervoltage condition will, of course, exist while the engine is shut down or is in the process of picking up speed. To prevent the needless disconnecting of generator G1, relay K11 contacts 3 and 4 have been placed in series with normally open contacts 7 and 9 of K52. Relay K52 will not energize until engine speed is in excess of 1200 rpm and speed switch SS2 closes.

- (3) Reverse Power Protection. While in a parallel mode of operation, an out-of-phase or an undervoltage situation could cause the current of one generator to feed the second generator. Such a condition might either burn out the second generator or cause it to "motor" (the generator functions as motor). Relay K112 activates upon sensing a reverse-power condition and through its normally open contacts 3 and 5, energizes K34 and lights REVERSE POWER indicator lamp DS34. Relay K34 normally closed contacts, in series with the generator circuit breaker control circuit, open and subsequently disconnect the generator from the main buss.
- (4) Overload Protection. If the output current of any phase winding of G1 exceeds an amount that might possibly be harmful to the generator, thermal relay K114, after a short period of time, activates. Consequently, relay K35 and indicator lamp DS35 both energize, and normally closed contacts of K34 open

to interrupt the generator circuit breaker control circuit. As before, when this occurs, the generator output is immediately disconnected from the main buss. Generator G1 is capable of safe operation while overloaded for short periods of time. This accounts for the delayed operation of K114.

- (5) Short Circuit Protection. In the event of a short circuit, the generator must be immediately disconnected from the load. Relay K113, upon sensing excessive current, will energize and close its contacts 7 and 8; then, relay K36 and short circuit indicator lamp DS36 will energize. Normally closed contacts of K36, in series with the generator circuit breaker control circuit, open and consequently CB2 disconnects the generator from the main buss.
- (6) Generator Output Monitoring. The voltage, current, frequency, power, KVAR, and power factor of the output must be continually monitored to ensure proper use of the generator. The voltage and current are measured by voltmeter M101 and ammeter M102 and switched, as required, by S101 and S102 respectively from one generator winding to another. Output frequency is monitored by a circuit consisting of A103 and M103. A103 is a frequency converter which produces a voltage analog of the output frequency. This voltage is applied to and metered by M103 which indicates the output frequency in Hertz. Power (kilowatts) and KVAR (kilovolts-amperes reactive) are measured by KW meter M107 and KVAR meter M108 in conjunction with converters A107 and A108, respectively. A107 and A108 convert current and voltage into an output

proportional to their product. Power factor, the ratio of actual power to apparent power, is measured by POWER FACTOR meter M110.

- e. Preheat System. To facilitate cold weather starting, a means is provided whereby engine temperature may be maintained at a predetermined value. To achieve this, two electrical heating coils are immersed in the engine coolant and one heating element located in the engine oil. Constant coolant temperature is maintained by thermostatic switch S301 in series with relay K109, the contacts of which are in series with H101, H102 and H103. PREHEAT SYSTEM switch S105 controls the application of external AC power to relay K107 (engine run relay K1 contacts 1 and 2 inhibit this function when the engine is running). The contactors of K107, in turn, control the application of external AC power to the preheat system.
- f. Battery Charger. Battery Charger BC1 maintains the generator set starting batteries at full charge. The source of AC power for BC 1 is either external or from the generator. Relays K108A and K108B ensure that BC1 receives power from only one of the sources or that the external source will be used when both options are available.

**1-16. LUBE OIL SYSTEM.** Lubricating oil is used to reduce wear and overheating due to friction and to enable close tolerances and ease of movement between engine parts moving adjacent to each other. The engine is pressure lubricated, pressure being supplied by a gear-type, self-regulating pump mounted inside the oil pan and mechanically coupled to the engine crankshaft. Because overheated oil loses some of its lubricating properties, the oil, prior to being filtered is fed to an oil cooler located on the right-hand side of the engine. The oil is then filtered by three full-flow filters which are mounted just below the oil cooler. The filtered oil is supplied to the engine's main oil header and moving

parts. Oil pressure gauges are connected at the input and output sides of the fuel filter assembly to ensure its proper operation. As insurance against the interruption of this flow by a dirty or clogged line, an automatic bypass valve is mounted in the filter assembly. In addition to the oil level dipstick, an oil level sight gauge provides the operator with a visual readout of the lube oil level while the engine is running. Oil pressure is monitored by a meter located on the Engine Control Panel.

**1-17. COOLING SYSTEM.** The purpose of the engine cooling system is to remove excessive heat created by normal engine operation. To accomplish this, a liquid coolant is circulated through liners located around the engine cylinders, cylinder heads, and fuel injector sleeves. The coolant, driven by an engine-mounted centrifugal pump, removes the heat generated at these points and carries it to the radiator assembly where it is dissipated by air forced into motion by an electric motor B102 (powered by main generator G1) and a fan. Optimum engine operating temperature is obtained by a thermostatic control valve which regulates coolant flow. In order to keep the engine warm in preparation for cold-weather starting, the coolant water is electrically preheated and circulated throughout the engine by the preheat system. A small amount of coolant from the main channel is passed through a combination filtering and treating assembly which acts to inhibit the formation of rust. During severe cold weather conditions (with the housing kit installed), the radiator louvers are indirectly controlled by coolant temperature. As coolant temperature drops, the louver doors are automatically moved toward the closed position by a hydraulically operated actuator.

**1-18. FUEL SYSTEM.** (See figure 1-8.) The prime purpose of the fuel system is to bring the fuel (under pressure) from a point of temporary storage (the day tank) to the point of final use -the engine's combustion chamber. A second and equally important function is to regulate engine speed by controlling the rate of fuel consumption. A fuel injection pump at the side of the engine takes fuel from the day, or



supply tank then runs it through a filter and delivers it, under pressure, to the individual cam-operated injectors of each cylinder. The fuel injectors receive fuel from the pump under pressure, meter a small portion of it, and then inject it into the combustion chambers in the form of fine spray. Engine speed regulation is accomplished by a hydraulic actuator which is mechanically linked to the fuel injection pump. The actuator, in turn, is controlled by governor controller A106 which senses engine speed by means of a magnetic pickup. Any time engine speed varies, A106 outputs a control voltage to the actuator. The actuator, in response, affects the rate of fuel output from the fuel injection pump.

## CHAPTER 2

### OPERATING INSTRUCTIONS

#### Section I. OPERATING PROCEDURES

##### 2-1. GENERAL.

a. Instructions in this section are provided for information and guidance for personnel responsible for operation of the generator set.

b. The operator must know how to perform every operation of which the generator set is capable of performing. This section describes and illustrates the various controls and instruments required to operate the generator set, and step-by-step instructions with supporting illustrations for operating the generator set under normal conditions.

**2-2.** The purpose and location of generator set controls and instruments are described in tables 2-1 through 2-4 and illustrated in figures 2-1 through 2-4.

**2-3. NORMAL OPERATING CONDITIONS WITHOUT HOUSING KIT INSTALLED.** The following paragraphs provide step-by-step procedures with supporting illustrations. Preparation for starting (figure 2-5), starting instructions (figure 2-6), stopping instructions (figure 2-7), and operating instructions for a single generator unit (figure 2-8). See par. 2-9 for operation with housing kit installed.

##### 2-4. STARTING.

a. Preparation for Starting. Instructions to be followed when preparing to start the engine generator set are shown in figure 2-5. Preventive maintenance procedures to be performed before operation are provided in table 3-2.

b. Starting. After performing the preparation for starting procedure, start the engine generator set as shown in figure 2-6. If the engine will not start, or if any

other abnormality is observed, notify higher level maintenance personnel.

##### 2-5. STOPPING.

a. Normal Stopping. (See figure 2-7). Preventive maintenance procedures to be performed after equipment operation are provided in table 3-2.

b. Stopping by Safety Devices. The generator set is equipped with safety device electrical circuits that automatically stop the engine and simultaneously open the main AC circuit breaker in the case of: (1) high coolant temperature, (2) low oil pressure, (3) engine overspeed, (4) overvoltage, (5) no fuel, or (6) high oil temperature. A short circuit, overload, or reverse power protective relay will automatically open the main AC circuit breaker but will not stop the engine. Undervoltage relay protective circuit will similarly open the main AC circuit breaker but will also not stop the engine. A specific fault indicator (five for the engine and five for the generator, figure 2-2) will light when any of these abnormal conditions occur. Once the generator set has been stopped due to the action of one of these safety devices, the problem must be corrected before the generator set is placed back in operation.

c. Emergency Stopping. To stop the generator set in an emergency, open the 24V DC CONTROL CIRCUIT BREAKER (figure 2-7) or EMERGENCY SHUT DOWN switch (figure 2-3).

##### 2-6. OPERATION OF EQUIPMENT.

a. Remote Control Module Operation. See par. 2-10.

b. Automatic Control Module Operation. See par. 2-11.

c. Single Engine Generator Set Operation. See figure 2-8 for single generator set operating instructions.

d. Emergency Operation. If any emergency situation requires continued operation of the generator set after being shut down by one of the safety device electrical circuits, the BATTLE SHORT switch can be used to override all safety devices, except reverse power, overload, overspeed and short circuit, as follows:

- (1) Place BATTLE SHORT switch in OFF position (figure 2-7).
- (2) Hold MASTER SWITCH in START position (figure 2-5) and start engine.
- (3) Place BATTLE SHORT switch to the ON position.
- (4) Release MASTER SWITCH from START position, and place BATTLE SHORT switch in OFF position as soon as possible after emergency has passed.

**NOTE**

The BATTLE SHORT switch may be actuated, in emergency, any time the generator set is operating.

**2-7. EXERCISE OF ENGINE ON STANDBY SERVICE.**

An engine on standby service, customarily operated under optimum conditions, should be exercised at least on a monthly basis. However, under environmental conditions involving extreme temperatures, humidity, dust, sand, etc., it may be necessary to shorten the interval between exercise periods to as often as weekly. Exercise period should be long enough so that the engine attains normal operating temperature (160-200°F, (71 to 93°C) and if possible, with at least 50 percent of its normal load. Exercise engine as follows:

- a. Perform the preparation for starting instructions shown in figure 2-5. Make complete visual inspection of unit to be sure it is in proper operating condition.
- b. Start engine as shown in figure 2-6. After the warmup period, run engine at rated speed with whatever load is available, up to full load, for the period of time required to obtain two consecutive water temperature readings of 160°F (71° C) minimum taken at 15-minute intervals. Continue to operate engine for 30 minutes. Check and correct any coolant or oil leaks.

**Table 2-1. Engine Control Panel, Controls and Instruments**

FIGURE, INDEX NO.	CONTROL AND INSTRUMENT	FUNCTION	NORMAL READING/SETTING
2-1,1	MASTER SWITCH START-STOP	Switch starts and stops the generator set.	Neutral
2-1,2	FUEL gauge	Indicates level of fuel in tank	Midrange
2-1,3	FUEL PUMP AUTO-OFF switch	Activates fuel transfer (as required).	AUTO
2-1,4	ENGINE OIL TEMP gauge	Indicates temperature of oil	200 to 220°F (93 to 104°C)
2-1,5	ENGINE OIL PRESS gauge	Indicates engine oil pressure	60 to 80 psi (42,186 to 56,248 kgs/m <sup>2</sup> )
2-1,6	BATTERY CHRG AMPS meter	Indicates battery charging current.	Positive range
2-1,7	ELAPSED TIME meter	Indicates operating time of generator set.	_____

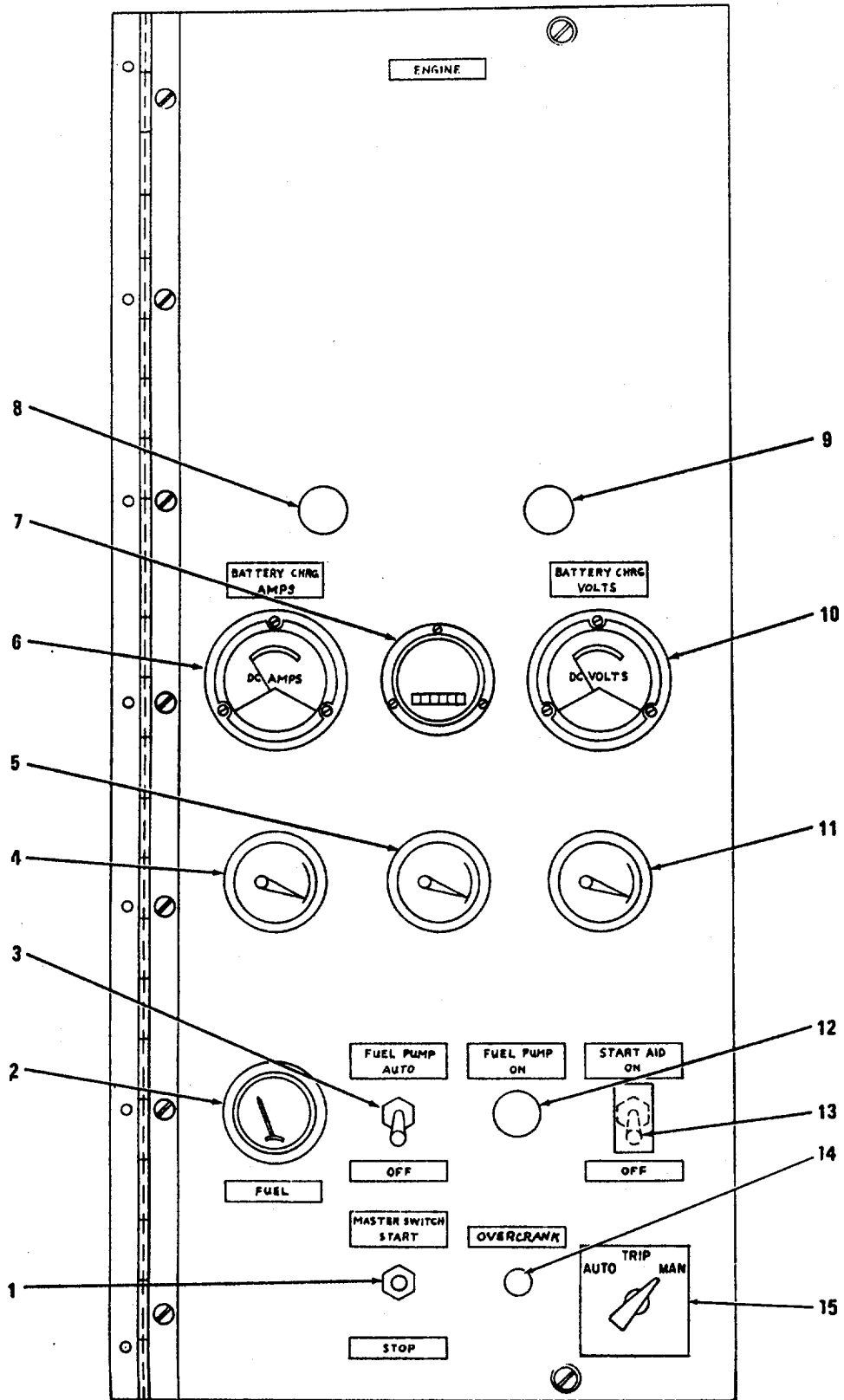

Figure 2-1. Engine Control Panel (Part of Control Cubicle)

**Table 2-1. Engine Control Panel, Controls and Instruments-Continued**

FIGURE, INDEX NO.	CONTROL AND INSTRUMENT	FUNCTION	NORMAL READING/SETTING
2-1,8	Panel lamp	Illuminates engine panel.	_____
2-1,9	Panel lamp	Illuminates engine panel.	_____
2-1,10	BATTERY CHRG VOLTS meter	Indicates dc system voltage	26.8V DC
2-1,11	WATER TEMP gauge	Indicates engine coolant temperature	180 to 200°F (356 to 382°C)
2-1,12	FUEL PUMP ON lamp	Illuminates indicating fuel transfer pump is in operation.	Cycles On and Off
2-1,13	START AID ON-OFF switch	Actuates either starting aid as required while engine is cranking at speeds up to 1200 rpm.-	OFF
2-1,14	OVER CRANK lamp	Indicates cranking time has been exceeded.	OFF
2-1,15	AUTO/MAN OPERATION switch	Select whether operation is to be via control panel or automatic control module	MAN

**Table 2-2. Generator Control Panel, Controls and Instruments**

FIGURE, INDEX NO.	CONTROL AND INSTRUMENT	FUNCTION	NORMAL READING/SETTING
2-2,1	VOLTS AC meter	Indicates AC output voltage.	120/208 or 240/416
2-2,2	Panel lamp	Illuminates panel.	_____
2-2,3	1-2-3 lamp	Lights to indicate phase sequence 1,2,3	On
2-2,4	AMMETER switch	Selects phase 1,2, or 3 voltage.	As desired.
2-2,5	KW meter	Indicates power output of 3 phase, 4 wire generator.	Less than 100 percent nominal.
2-2,6	AMMETER meter	Indicates percent rated current for selected phase.	Less than 100 percent.
2-2,7	Panel lamp	Illuminates panel.	_____
2-2,8	ANNUNCIATOR RESET	Resets annunciating	OFF
2-2,9	ALARM SILENCE switch	Silences alarm.	OFF

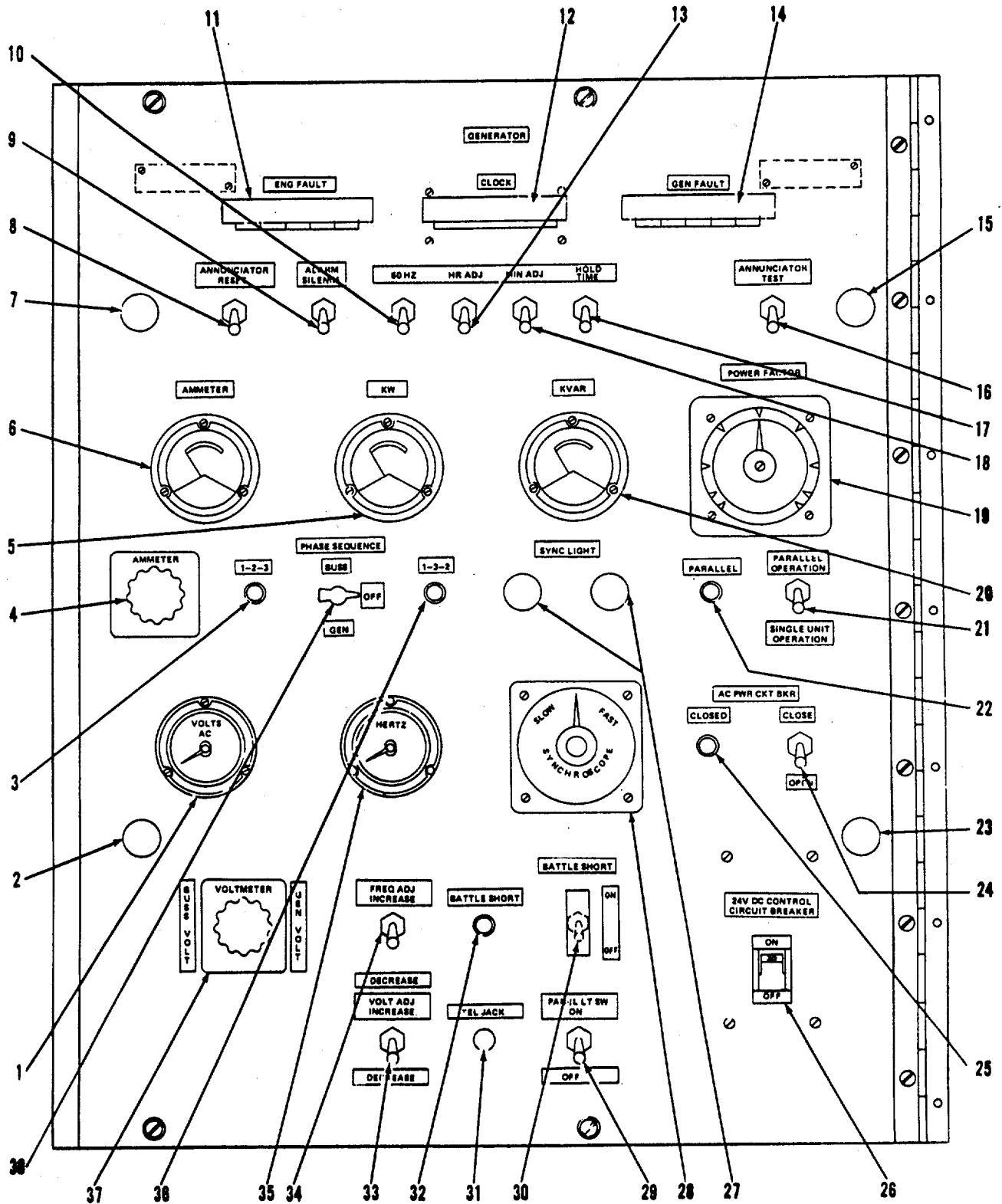

Figure 2-2. Generator Control Panel (Part of Control Cubicle)

Table 2-2. Generator Control Panel, Controls and Instruments-Continued

FIGURE, INDEX NO.	CONTROL AND INSTRUMENT	FUNCTION	NORMAL READING/SETTING
2-2,10	Clock 50 HZ switch	Allows clock operation on 60 HZ	As applicable.
2-2,11	ENG FAULT INDICATORS	Indicates engine fault.	OFF
	HI COOL TEMP	Lights if coolant temperature rises above $-213 \pm 3^{\circ}\text{F}$ ( $100 \pm 0.7^{\circ}\text{C}$ )	OFF
	HI LUBE TEMP	Lights if lube temperature rises above $255 \pm 3^{\circ}\text{F}$ ( $124 \pm 1^{\circ}\text{C}$ ).	OFF
2-2,11	LOW OIL PRESS	Lights if oil pressure drops below $21 \pm 2$ psi ( $1.5$ kg/cm <sup>2</sup> ).	OFF
	LOW FUEL LEVEL	Lights indicating fuel in day tank is at a low level (1-hour operation).	OFF
	OVERSPEED	Lights if engine rpm reaches 2200 to 2300 rpm.	OFF
2-2,12	CLOCK	Digital clock, indicates time in hours, minutes, and seconds.	_____
2-2,13	CLOCK HR ADJ switch	Adjusts clock hour setting. engine is cranking at	OFF
2-2,14	GEN FAULT indicators	Indicates cranking time	OFF
	OVERLOAD	Lights if any phase current exceeds 110 percent rated load.	OFF
	OVERVOLT	Indicates an overvoltage condition	OFF
	UNDERVOLT	Indicates an undervoltage condition.	OFF
	REVERSE POWER	Indicates a reverse power condition.	OFF
	SHORT CIRCUIT	Indicates a short circuit.	OFF
2-2,15	Panel lamp	Illuminates panel.	_____
2-2,16	ANNUNCIATOR TEST switch	Activates audible alarm and checks indicator bulbs.	OFF
2-2,17	HOLD TIME switch	Holds clock time.	OFF

**Table 2-2. Generator Control Panel, Controls and Instruments-Continued**

FIGURE, INDEX NO.	CONTROL AND INSTRUMENT	FUNCTION	NORMAL READING/SETTING
2-2,18	CLOCK MIN ADJ switch	Adjusts clock minute setting.	OFF
2-2,19	POWER FACTOR meter	Indicates power factor of generator set load.	0.8 lagging to 1.0
2-2,20	KVAR meter	Indicates KVAR of 3-phase, 4-wire circuits.	Less than 75 percent
2-2,21	PARALLEL OPERATION- SINGLE UNIT OPERATION switch	In PARALLEL OPERATION position, activates all parallel circuits; in SINGLE UNIT OPERATION position, it deactivates all parallel circuits.	As required
2-2,22	PARALLEL lamp	Lights indicating that PARALLEL switch is in PARALLEL position.	OFF
2-2,23	Panel lamp	Illuminates panel.	OFF
2-2,24	AC PWR CKT BKR-CLOSE- OPEN circuit	Closes/opens AC power circuit breaker	Neutral
2-2,25	AC PWR CKT BRK-CLOSED lamp	Indicates AC power circuit breaker is in closed position.	——
2-2,26	24V DC CONTROL CIRCUIT BREAKER switch	Controls application of 24V DC to control circuits.	ON
2-2,27	SYNC light lamps	Indicates synchronization of frequency for paralleling of generator set.	OFF
2-2,28	SYNCHROSCOPE meter	Indicates synchronization of frequency for paralleling of generator set.	Floats
2-2,29	PANEL LT SW ON-OFF switch	Switches panel lamps on and off.	——
2-2,30	BATTLE SHORT ON-OFF switch	Bypasses generator set protective circuits during an emergency, except overspeed and short circuits.	OFF
2-2,31	TEL JACK	Allows telephone connection to remote control module.	——
2-2,32	BATTLE SHORT lamp	Indicates BATTLE SHORT switch is ON.	OFF



**Table 2-2. Generator Control Panel, Controls and Instruments-Continued**

FIGURE, INDEX NO.	CONTROL AND INSTRUMENT	FUNCTION	NORMAL READING/SETTING
2-2,33	VOLT ADJ INCREASE- DECREASE switch	Switch to adjust generator set voltage.-	Neutral
2-2,34	FREQ ADJ INCREASE- DECREASE switch	Switch to adjust generator set frequency	Neutral
2-2,35	HERTZ frequency meter	Indicates generator set frequency in Hz	50Hz: 48.2-51.8 Hz 60 Hz: 58.2-61.8 Hz
2-2,36	1-3-2 lamp	Lights to indicate phase sequence 1,3,2	OFF
2-2,37	VOLTMETER-BUSS VOLT- GEN VOLT switch	Selects BUSS 1-2, GEN 1-2, GEN 2-3, BUSS 2-3 GEN 3-1, and BUSS 3-1.	_____
2-2,38	PHASE SEQUENCE-BUSS- OFF switch	Selects buss, generator, or off.	_____

**Table 2-3. AC-DC Control Panel, Controls and Instruments**

FIGURE, INDEX NO.	CONTROL AND INSTRUMENT	FUNCTION	NORMAL READING/SETTING
2-3,1	120V RECEPTACLE BREAKER RECEPT.	Controls power to CONV	ON
2-3,2	REACTIVE LOAD COMPENSATION CONTROL -	Adjusts reactive load sharing of generator sets in parallel.	_____
2-3,3	EMERGENCY SHUTDOWN-ON-OFF switch	Shuts down generator set during an emergency and activates air boxes on engine.	OFF
2-3,4	FREQUENCY SELECTOR 50 Hz-60 Hz switch	Selects either 50 Hz or 60 Hz	_____
2-3,5,6	REACTIVE LOAD COMPENSATION receptacles -	Receptacles to interconnect voltage regulators.	_____
2-3,7,8,9	GOVERNOR PARALLELING CIRCUIT receptacles	Receptacles to interconnect governors for paralleling generator sets with paralleling cables.	_____
2-3,10	REACTIVE LOAD COMPENSATION receptacle -	With shorting plug in place allows droop voltages parallel operation.	_____
2-3,11	FREQUENCY DROOP- ISOCHRONOUS switch	Allows selection of either droop or isochronous operation.	_____

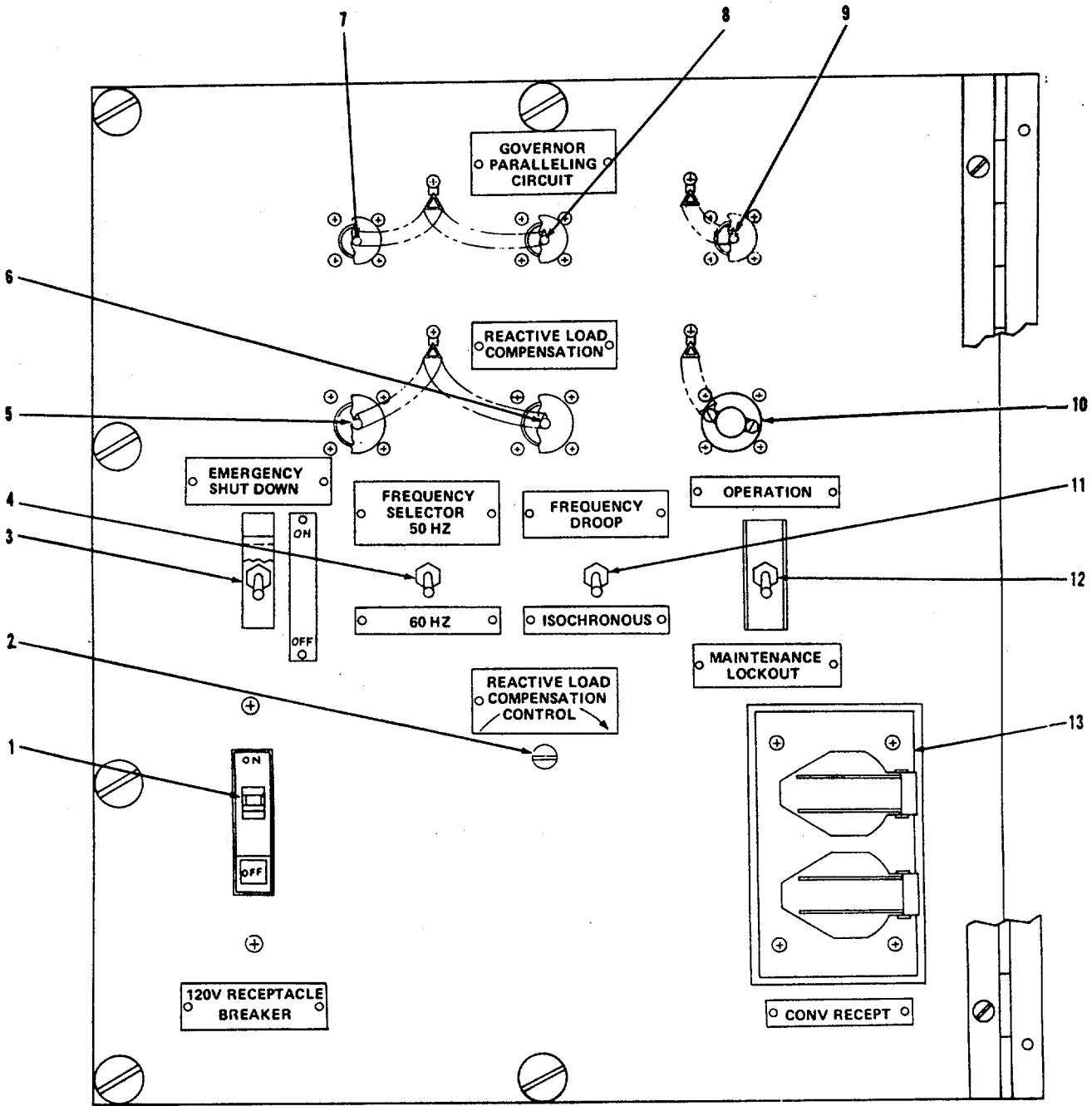

Figure 2-3. AC-DC Control Panel

FIGURE, INDEX NO.	CONTROL AND INSTRUMENT	FUNCTION	NORMAL READING/SETTING
2-3,12	MAINTENANCE LOCKOUT- OPERATION switch	Used during maintenance. When switch is in LOCK-OUT position, prevents energizing of all circuits energized by external power.	OPERATION
2-3,13	CONV RECEPT receptacle	Provides 120V AC at generator set operating frequency.	_____

**Table 2-4. External Power Box Control Panel, Controls and Instruments**

FIGURE, INDEX NO.	CONTROL AND INSTRUMENT	FUNCTION	NORMAL READING/SETTING
2-4,1	120V RECEPTACLE BREAKER	Protects 120V AC to CONV RECEPT.	ON
2-4,2	CONV RECP	120V AC convenience outlet.	
2-4,3	EXTERNAL POWER BREAKER- ON-OFF	Switches external power on and off.	OFF
2-4,4	PREHEAT SYSTEM ON-OFF switch	Switches preheat system on and off.	OFF
2-4,5	EXTERNAL POWER	Receptacle for 120/240V AC external power.	_____

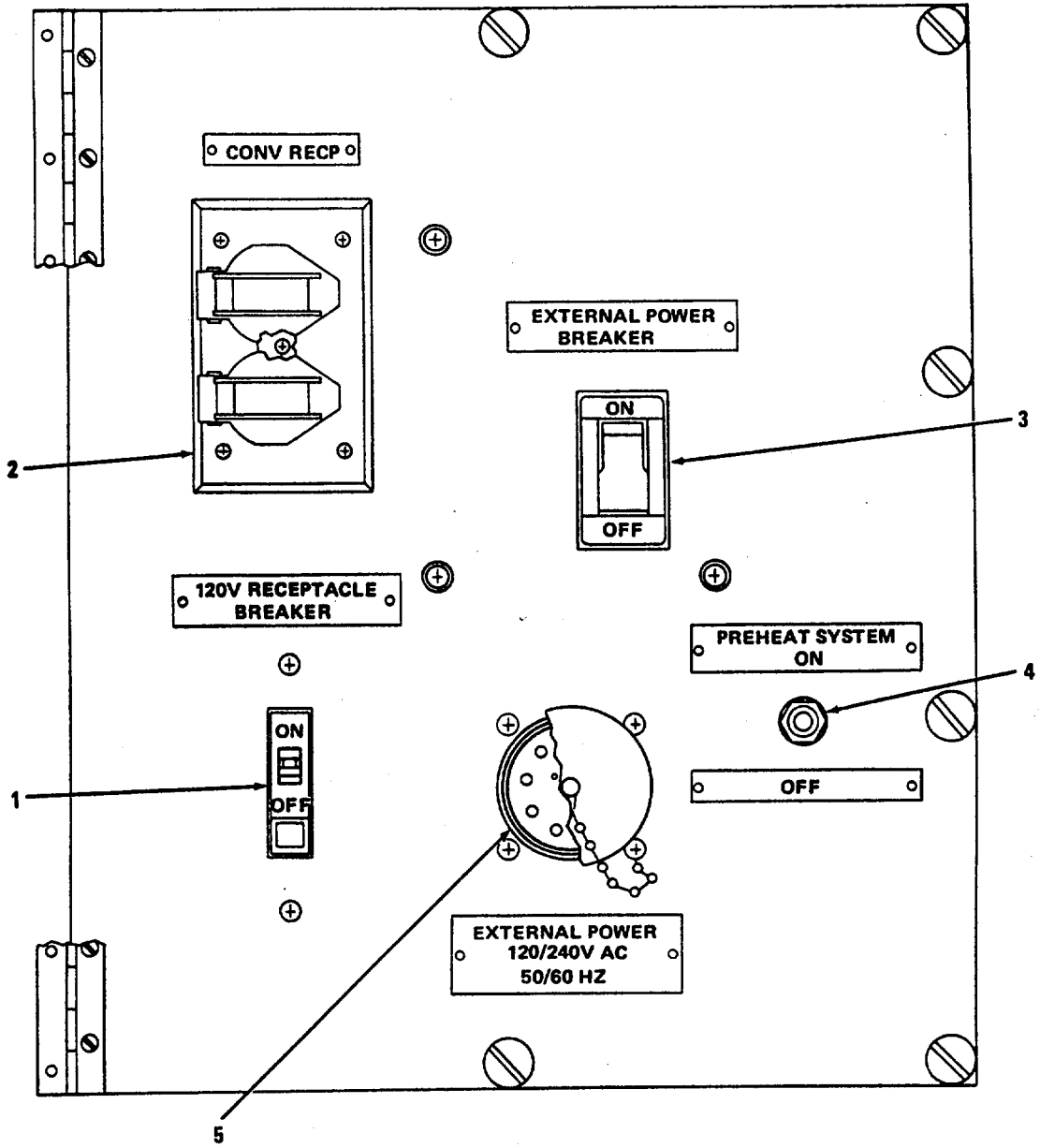
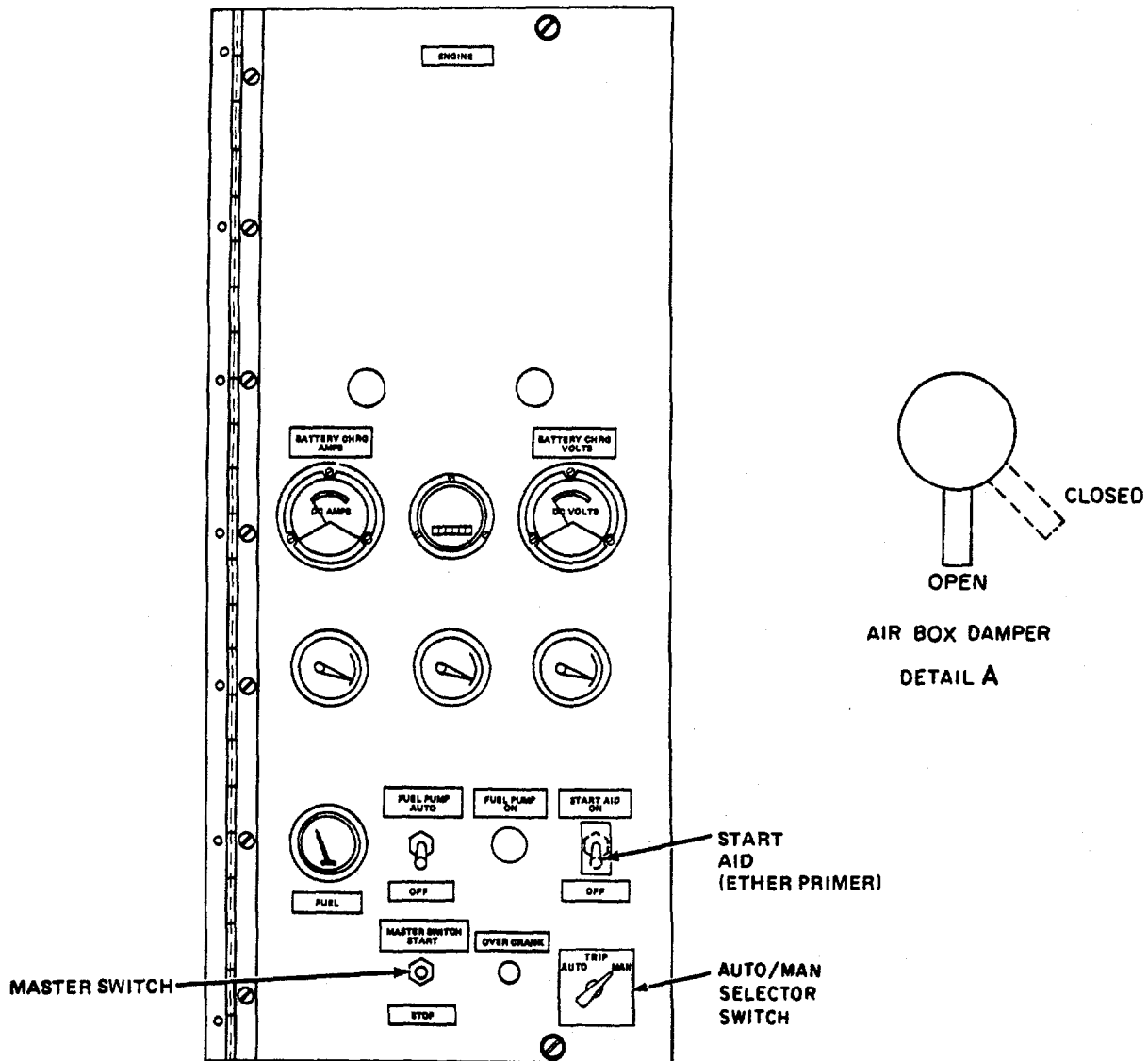

Figure 2-4. External Power Box Control Panel



**A. ENGINE OPERATING CONTROLS AND INSTRUMENTS  
( PART OF CONTROL CUBICLE )**

- STEP 1. CHECK LUBRICATING COOLANT LEVELS.
- STEP 2. CHECK AIR BOX DAMPER POSITION AND RESET MANUALLY TO OPEN (SEE DETAIL A) IF REQUIRED.
- STEP 3. CHECK BATTERY TERMINALS, MINUS (-) TO GROUND.
- STEP 4. PLACE 24V DC CONTROL CIRCUIT BREAKER TO ON POSITION ON GENERATOR PANEL.
- STEP 5. ENSURE MAINTENANCE SWITCH IS IN OPERATION POSITION ON AC-DC CONTROL PANEL.
- STEP 6. CHECK FUEL LEVEL BY PLACING BATTLE SHORT SWITCH IN THE ON POSITION ON GENERATOR PANEL AND THEN THE MASTER SWITCH IN START POSITION ON ENGINE PANEL.
- STEP 7. RETURN MASTER SWITCH TO STOP AND THEN THE BATTLE SHORT SWITCH TO OFF.
- STEP 8. CHECK ENG FAULT INDICATORS AND ANNUNCIATOR BY PLACING ANNUNCIATOR TEST SWITCH IN TEST POSITION ON GENERATOR PANEL. IF NONE OF THE LIGHTS ARE ON AFTER BEING TESTED, PROCEED WITH THE NEXT STEP. IF A LIGHT DOES NOT COME ON, CORRECT THE INDICATED FAULT BEFORE PROCEEDING.
- STEP 9. CHECK VOLTAGE AND FREQUENCY REQUIREMENTS OF THE LOAD AGAINST THE VOLTAGE AND FREQUENCY CONNECTION OF THE SET.
- STEP 10. PLACE AUTO/TRIP/MAN SWITCH IN MAN POSITION.

Figure 2-5. Preparation for Starting (Sheet 1 of 3)

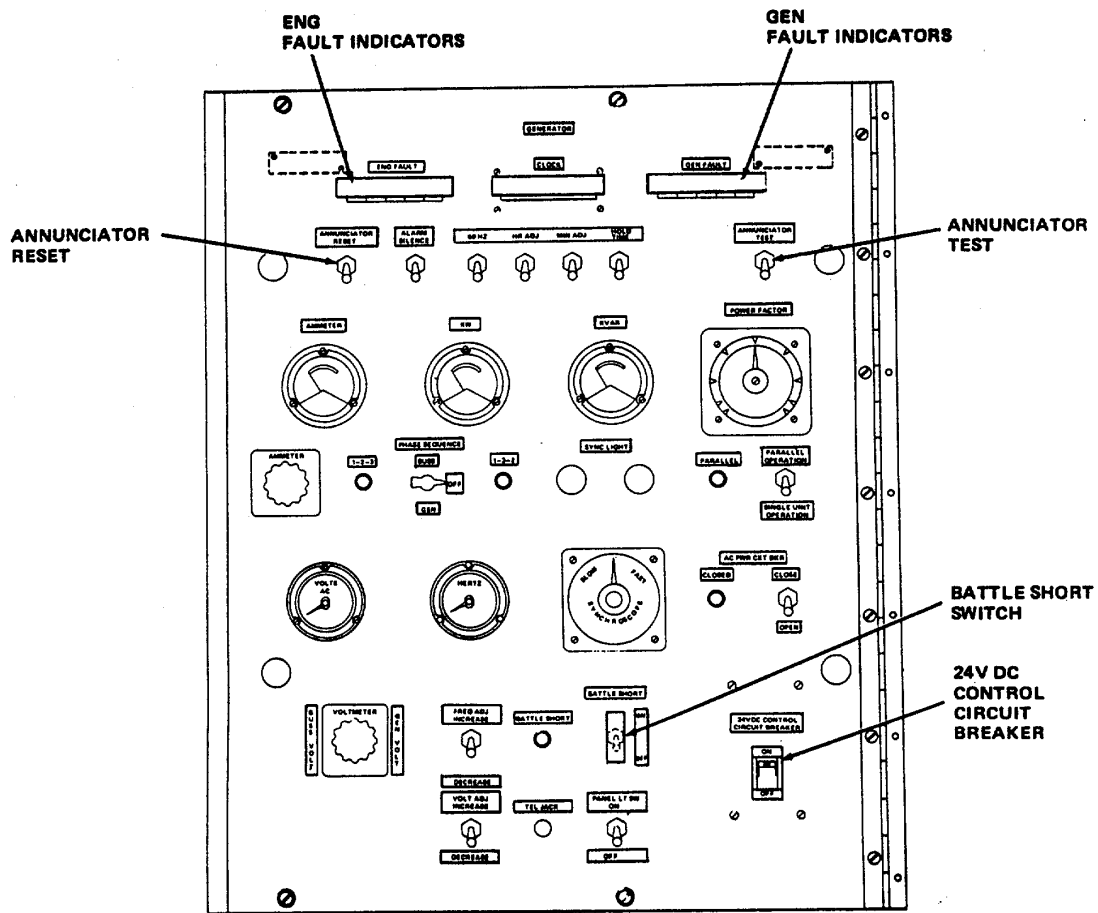

B. GENERATOR CONTROL PANEL (PART OF CONTROL CUBICLE)

Figure 2-5. Preparation for Starting (Sheet 2 of 3)

**WARNING**

DO NOT OPERATE THE GENERATOR SET UNLESS THE GROUND TERMINAL STUD HAS BEEN CONNECTED TO A SUITABLE GROUND. ELECTRICAL FAULTS IN THE GENERATOR SET, LOAD LINES, OR LOAD EQUIPMENT, CAN CAUSE INJURY OR ELECTROCUTION WITH AN UNGROUNDED SYSTEM.

**WARNING**

MAKE SURE THAT NO TOLLS, PARTS, OR LOOSE ITEMS ARE ON ANY PART OF THE ENGINE SINCE THEY MIGHT CAUSE BODILY HARM TO PERSONNEL WHEN THE ENGINE IS STARTED.

**CAUTION**

IF ENGINE DOES NOT START IN 45 SECONDS, OVERCRANK PROTECTION WILL TERMINATE THE CRANKING CYCLE. RESET AND ALLOW 1-MINUTE REST BEFORE STARTING ANOTHER CRANK CYCLE.

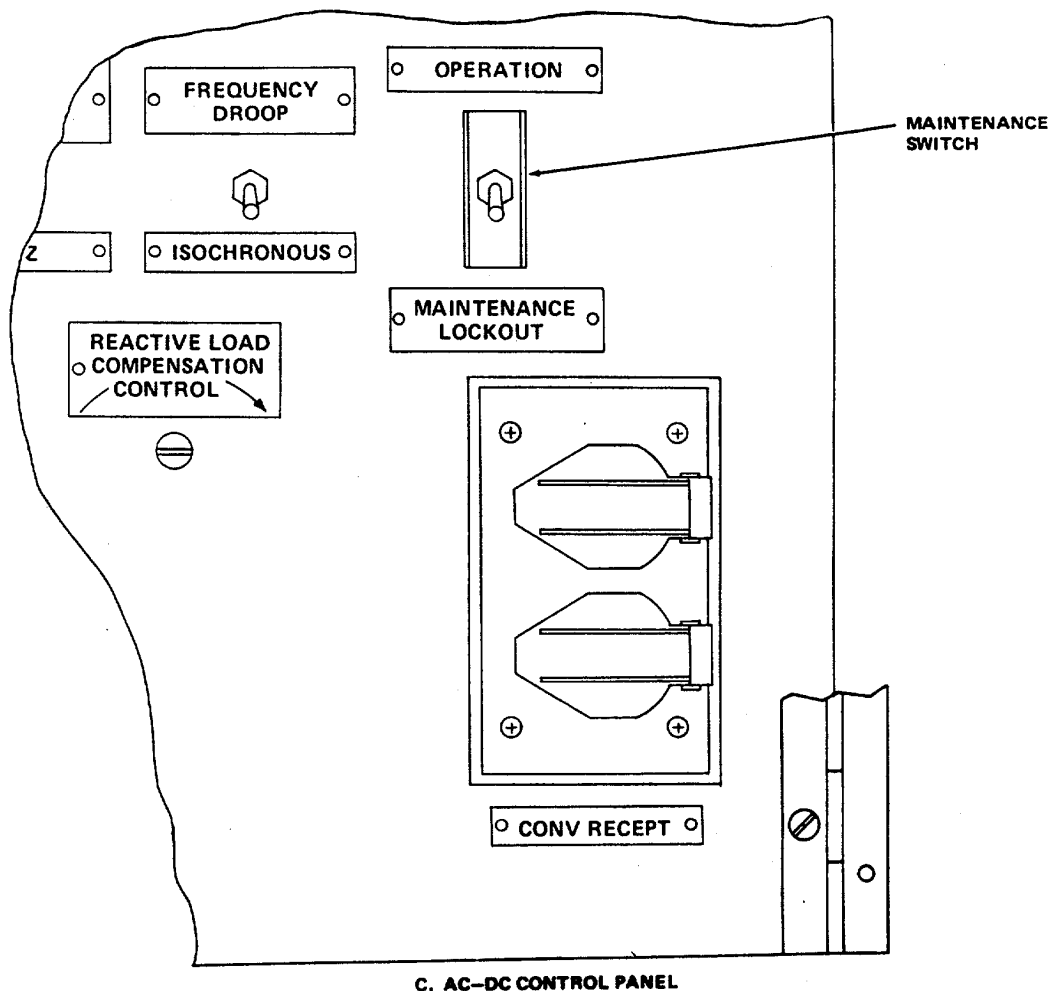
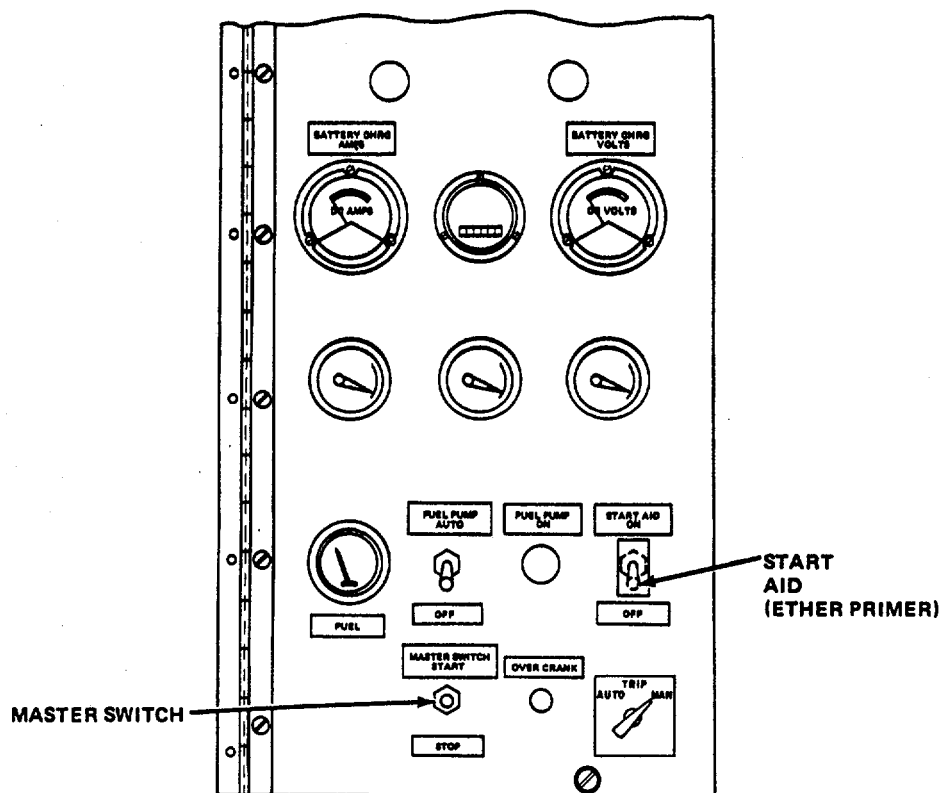

Figure 2-5. Preparation for Starting (Sheet 3 of 3)



A. ENGINE CONTROL PANEL

A. STARTING WHEN AMBIENT TEMPERATURE IS ABOVE 40° F (4° C) AND THE PREHEAT SYSTEM HAS NOT BEEN USED:

- STEP 1. TOGGLE THE MASTER SWITCH TO THE START POSITION ON THE ENGINE PANEL.
- STEP 2. WHEN THE AIR TEMPERATURE IS ABOVE 40° F (4° C), AND THE PREHEATER HAS NOT BEEN USED, ENGINE ETHER PRIMER MAY BE REQUIRED. TO USE ETHER PRIMER, MOMENTARILY PLACE START AID SWITCH IN THE ON POSITION AND RELEASE WHILE CRANKING THE ENGINE. EACH TIME START AID SWITCH IS CYCLED, ETHER IS INJECTED INTO THE ENGINE AIR INTAKE SYSTEM. AFTER START OCCURS, IF ENGINE SPEED OR FREQUENCY BEGIN TO DECREASE, ADDITIONAL ETHER CAN BE INJECTED BY CYCLING START AID SWITCH AS LONG AS THE ENGINE RPM IS BELOW 1200 RPM.
- STEP 3. WARM ENGINE FOR AT LEAST 15 MINUTES AT NO LOAD AFTER IT HAS STARTED.
- STEP 4. WHEN ENGINE HAS BEEN WARMED UP, ADJUST THE FREQUENCY AND THE VOLTAGE TO THE DESIRED VALUES. REF. 33 AND 34, FIG. 2-2.

Figure 2-6. Starting Instructions (Sheet 1 of 3)



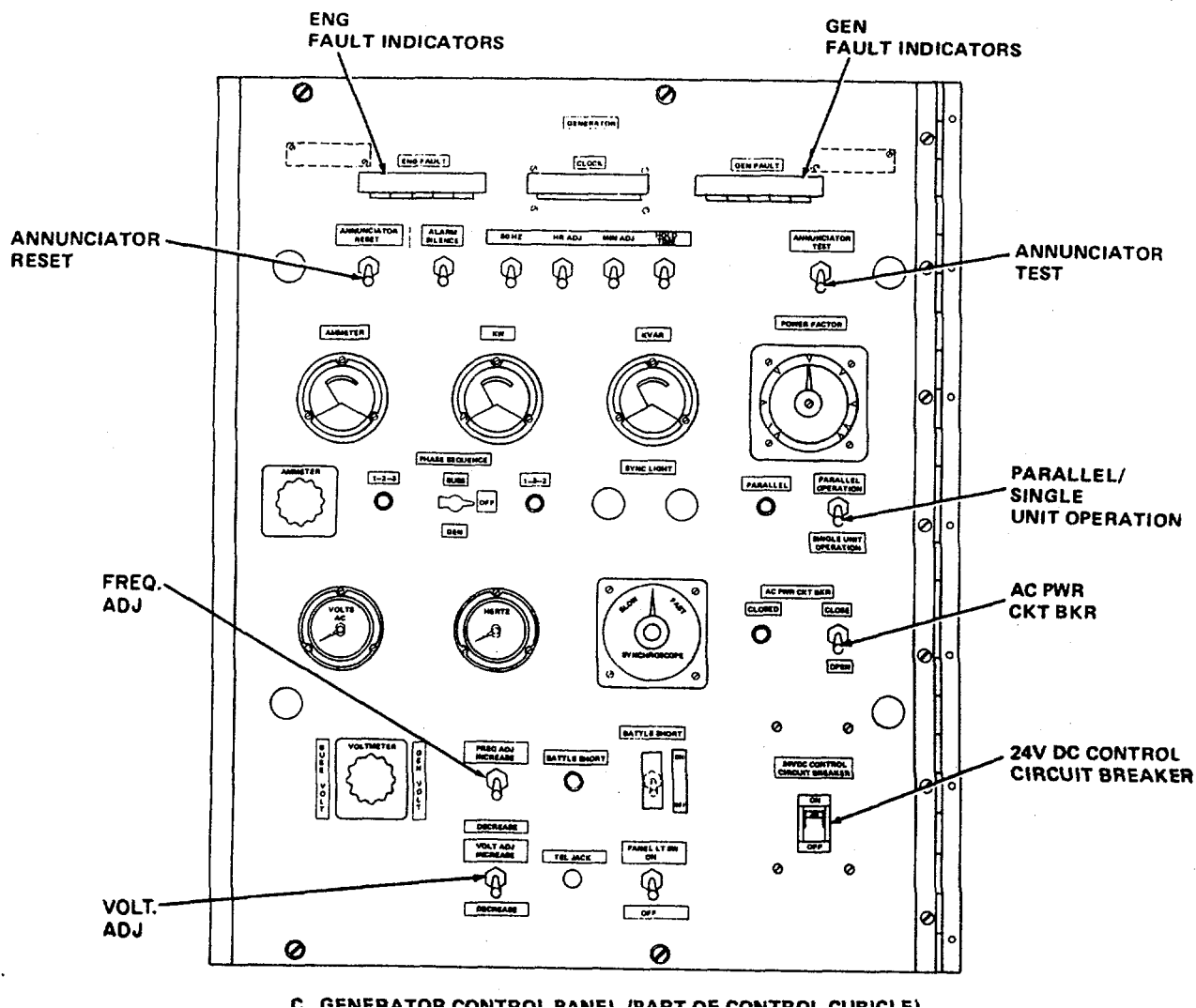

C. GENERATOR CONTROL PANEL (PART OF CONTROL CUBICLE)

- STEP 5. PRIOR TO CLOSING THE MAIN CIRCUIT BREAKER (AS EXPLAINED IN STEP 7, BELOW), CHECK GEN FAULT INDICATORS AND ANNUNCIATOR BY PLACING ANNUNCIATOR TEST SWITCH IN THE TEST POSITION. IF NONE OF THE LIGHTS ARE ON AFTER BEING TESTED PROCEED WITH STEP 6. IF A LIGHT DOES COME ON. CORRECT THE INDICATED FAULT BEFORE PROCEEDING.
- STEP 6. PLACE THE PARALLEL/SINGLE UNIT OPERATION SWITCH IN THE SINGLE UNIT OPERATION POSITION.

**WARNING**

PLACING AC PWR CKT BKR TO CLOSE APPLIES POWER TO OUTPUT LOAD TERMINALS AND LOAD LINES. ENSURE ALL PERSONNEL ARE CLEAR OF OUTPUT LOAD TERMINALS. SERIOUS INJURY OR DEATH COULD RESULT FROM CONTACT WITH THE OUTPUT VOLTAGES.

- STEP 7. PLACE THE AC PWR CKT BKR TO CLOSE POSITION FOR APPROXIMATELY 2 OR 3 SECONDS TO CLOSE THE MAIN CIRCUIT BREAKER. CLOSED INDICATOR SHOULD COME ON.

Figure 2-6. Starting Instructions (Sheet 2 of 3)

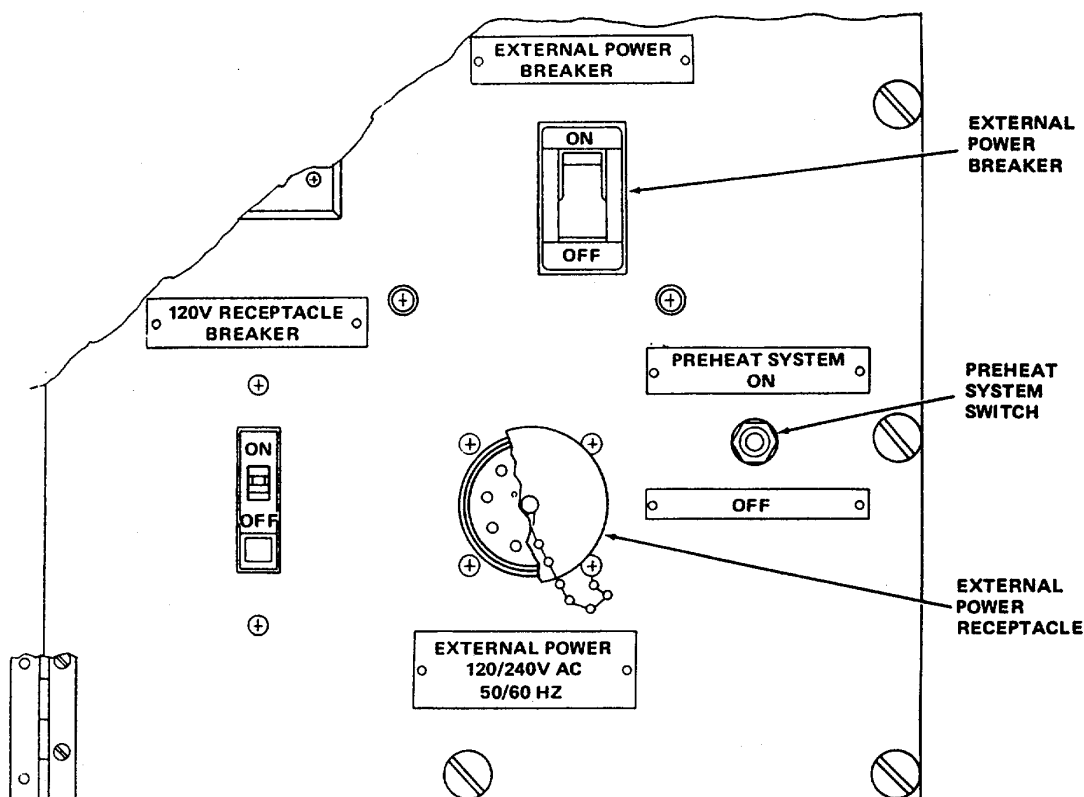

C. EXTERNAL POWER BOX CONTROL PANEL

B. STARTING WHEN AMBIENT TEMPERATURE IS ABOVE 40°F (4°C) AND THE PREHEAT SYSTEM HAS BEEN USED:

STEP 1. ENSURE THAT THE PREHEAT SYSTEM HAS BEEN OPERATED A MINIMUM OF 6 HOURS PRIOR TO STARTING. THE PREHEAT SYSTEM IS ACTIVATED AS FOLLOWS:

- (A) ENSURE THAT JUMPER IS CONNECTED BETWEEN TERMINALS 1 AND 3 ONLY IF THE GENERATOR SET IS PERMANENTLY CONNECTED TO EXTERNAL POWER TO PERMIT BATTERY CHARGE OPERATION, AS SHOWN BELOW ON TERMINAL BOARD TB20 LOCATED IN THE AC-DC CONTROL BOX.

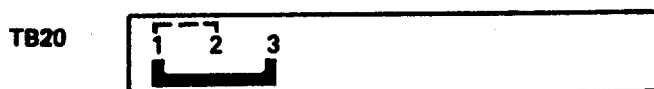

- (B) CONNECT 120/240 VAC EXTERNAL POWER SOURCE TO ETERNAL POWER RECEPTACLE ON EXTERNAL POWER BOX CONTROL PANEL.
- (C) SWITCH EXTERNAL POWER BREAK TO ON.
- (D) SWITCH PREHEAT SYSTEM SWITCH TO ON.

STEP 2. TOGGLE THE MASTER SWITCH TO THE START POSITION ON ENGINE PANEL.

STEP 3. PROCEED AS IN A, ABOVE, STEPS 4 THROUGH 7.

Figure 2-6. Starting Instructions (Sheet 3 of 3)

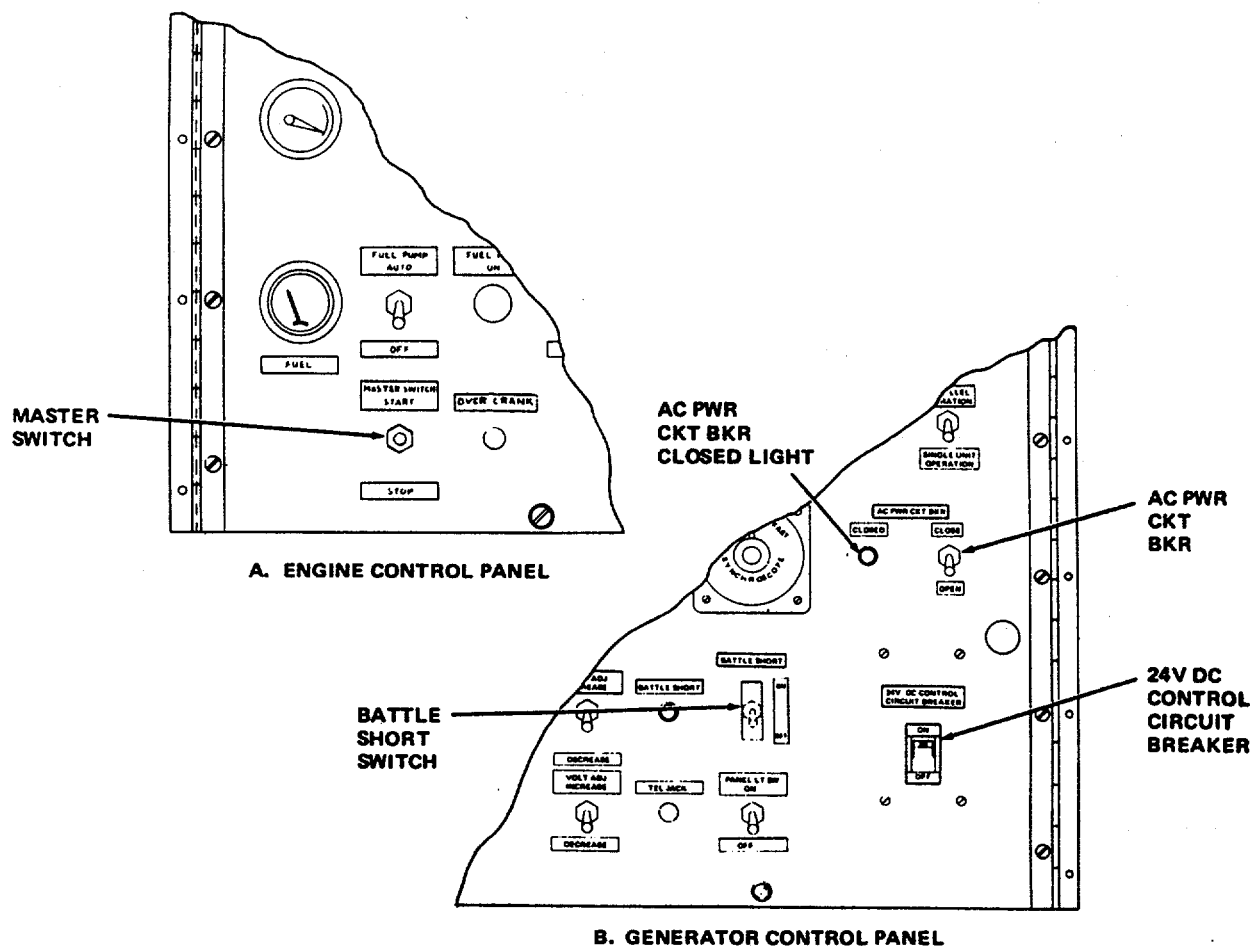

STEP 1. PLACE AC PWR CKT BKR IN OPEN POSITION APPROXIMATELY 2 OR 3 SECONDS; THE AC PER CKT BKR CLOSED LIGHT, SHOULD GO OUT.

**WARNING**

**SHUTTERS WILL SNAP SHUT RAPIDLY WITH CONSIDERABLE FORCE WHEN GENERATOR SET IS STOPPED. ENSURE ALL PERSONNEL ARE CLEAR OF SHUTTERS BEFORE PLACING MASTER SWITCH TO STOP. SERIOUS INJURY COULD RESULT.**

STEP 2. PLACE MASTER SWITCH IN STOP POSITION AFTER ALLOWING TO COOL BY OPERATING AT NO LOAD FOR APPROXIMATELY 5 MINUTES.

STEP 3. AFTER ENGINE STOPS, REMOVE DC CONTROL POWER BY SETTING 24V DC CONTROL CIRCUIT BREAKER TO OFF POSITION.

Figure 2-7. Stopping Instructions

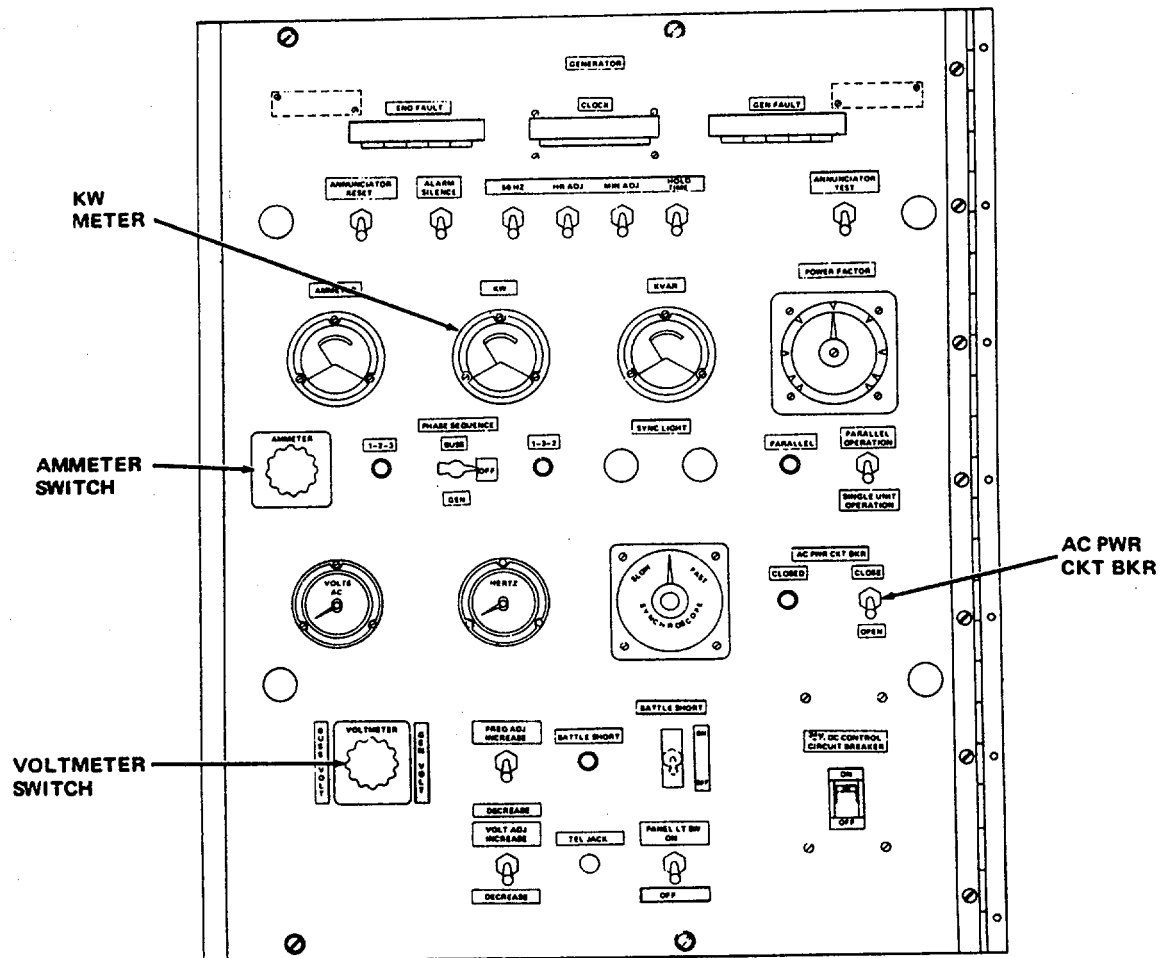

**A. GENERATOR CONTROL PANEL**

- STEP 1. PREPARE GENERATOR SET FOR STARTING (FIGURE 2-5).
- STEP 2. START GENERATOR SET (FIGURE 2-6).
- STEP 3. ROTATE AMMETER SWITCH TO EACH PHASE POSITION, WHILE OBSERVING AMMETER. IF MORE THAN 100 PERCENT RATED CURRENT IS INDICATED IN ANY PHASE POSITION, REDUCE THE LOAD.
- STEP 4. IF MORE THAN 100 PERCENT LOAD IS INDICATED OK THE KW METER, REDUCE THE LOAD.

**Figure 2-8. Single Generator Unit, Operating Instructions**

## Section II. OPERATION OF AUXILIARY MATERIAL USED IN CONJUNCTION WITH THE EQUIPMENT

**2-8. GENERAL.** This section provides step-by-step procedures with supporting illustrations for operating the generator set in conjunction with the auxiliary housing kit, the remote control module and cable, and the automatic control module.

**2-9. OPERATION WITH THE HOUSING KIT.** The auxiliary housing kit encloses the top, sides, and ends of the generator set and is removable to provide access for overhaul or replacement of major components of the generator set. The housing is attached to the base assembly and the support frame assembly to provide a

rain-proof enclosure, and prevent rain, snow, or sand from entering the interior of the housing. The housing doors allow access to the inside of the generator set. The shutter assembly at the radiator end of the generator set is automatically controlled and opens as necessary to facilitate air circulation. Installation of the housing kit extends the operational capability of the generator set down to temperatures from 40°F to -25°F (4.4°C to -32°C). Preparation procedures for starting the generator set with the housing kit installed are given in figure 2-9.

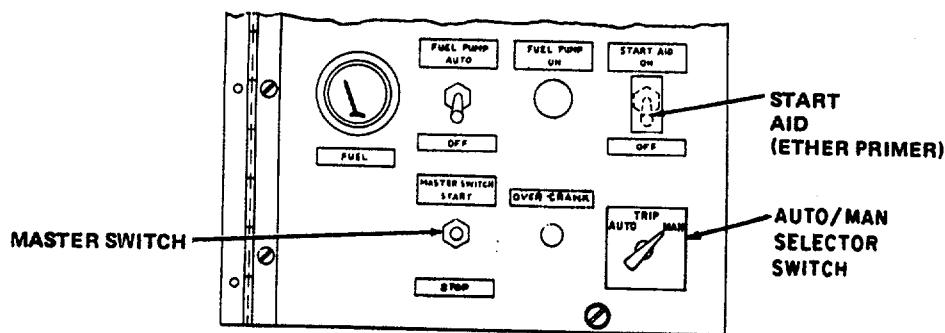

**A. ENGINE OPERATING CONTROLS AND INSTRUMENTS  
( PART OF CONTROL CUBICLE )**

- STEP 1. CHECK LUBRICATING AND COOLANT LEVELS.
- STEP 2. CHECK AIR BOX DAMPER POSITION AND RESET MANUALLY TO OPEN IF P E. S FIG. 2-5 SHEET 1.
- STEP 3. CHECK BATTERY TERMINALS, S (-) TO GROUND.
- STEP 4. PLACE 24V DC CONTROL CIRCUIT BREAKER TO ON POSITION ON GENERATOR PANEL.
- STEP 5. ENSURE MAINTENANCE SWITCH IS IN OPERATION POSITION ON AC-DC CONTROL PANEL.
- STEP 6. CHECK FUEL LEVEL AND SIDE DOOR SHUTTER OPERATION BY PLACING BATTLE SHORT SWITCH IN THE ON POSITION ON GENERATOR PANEL AND THEN THE MASTER SWITCH IN START POSITION ON ENGINE PANEL.
- STEP 7. RETURN MASTER SWITCH TO STOP AND THEN THE BATTLE SHORT SWITCH TO OFF.
- STEP 8. CHECK ENG FAULT INDICATORS BY PLACING ANNUNCIATOR TEST SWITCH IN TEST POSITION ON GENERAL PANEL.. IF NONE OF THE LIGHTS ARE ON AFTER BEING TESTED PROCEED WITH THE NEXT STEP. IF A LIGHT DOES COME ON, CORRECT THE INDICATED FAULT BEFORE PROCEEDING.
- STEP 9. CHECK VOLTAGE AND FREQUENCY OF THE LOAD AGAINST THE VOLTAGE AND FREQUENCY CONNECTION OF THE SET.
- STEP 10. ENSURE THAT THE SHUTTERS ON THE RADIATOR END OF THE SET ARE NOT MANUALLY LOCKED OPEN.
- STEP 11. CLOSE ALL DOORS EXCEPT CONTROL BOX END.
- STEP 12. PLACE AUTO/TRIP/MAN SELECTOR SWITCH IN MAN POSITION.

**Figure 2-9. Preparation for Starting with Housing  
Kit Installed (Sheet 1 of 3)**

**NOTE**

Prior to starting the generator set in temperatures down to -25°F (-32°C), also ensure that the requirements of

paragraph 2-14 have been complied with. Figures 2-10, 2-11, and 2-12 provide starting, stopping, and operating instructions for housed generator sets.

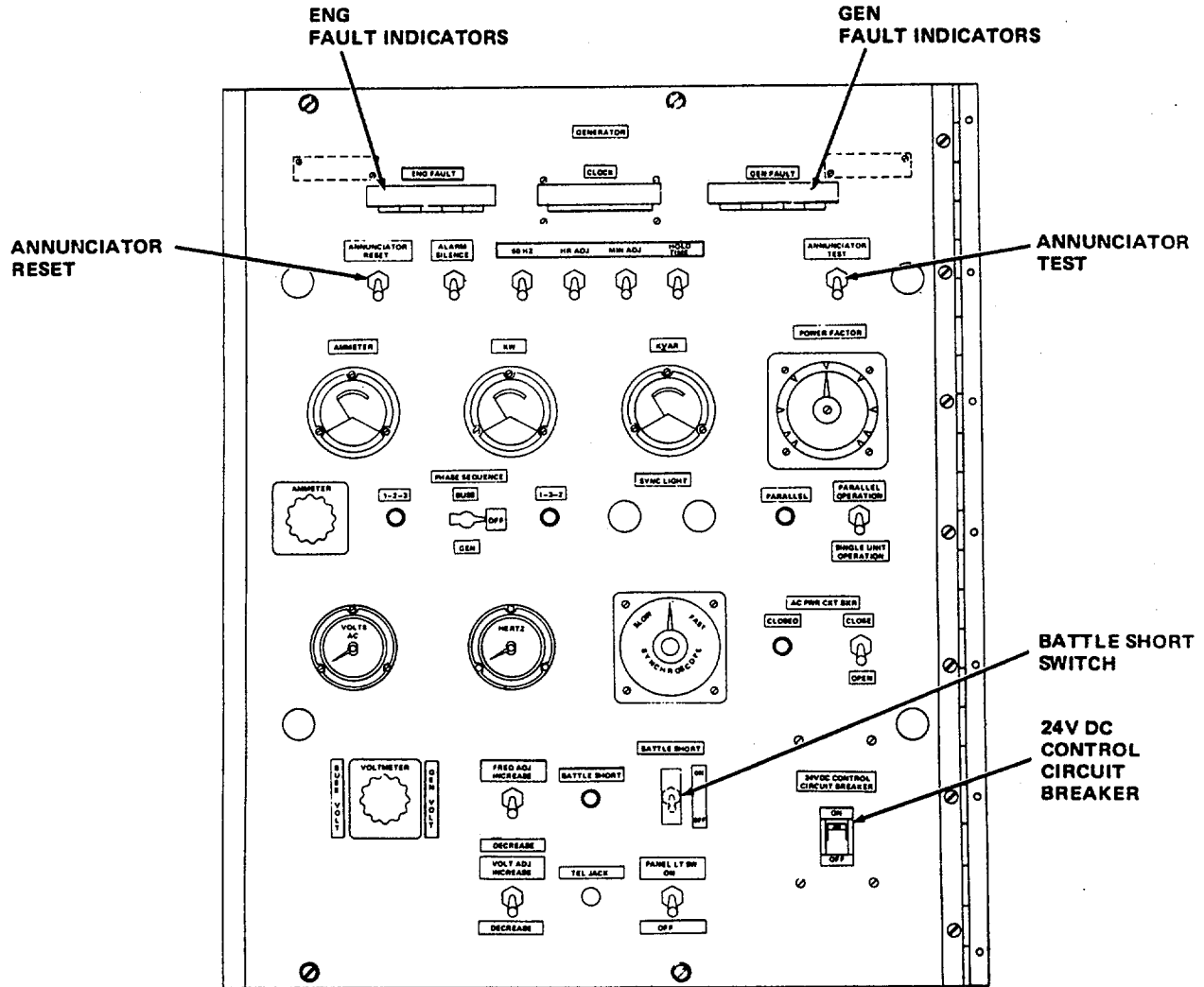

**B. GENERATOR CONTROL PANEL (PART OF CONTROL CUBICLE)**

**Figure 2-9. Preparation for Starting with Housing Kit Installed (Sheet 2 of 3)**

**WARNING**

DO NOT OPERATE THE GENERATOR SET UNLESS THE GROUND TERMINAL STUD HAS BEEN CONNECTED TO A SUITABLE GROUND. ELECTRICAL FAULTS IN THE GENERATOR SET, LOAD LINES OR LOAD EQUIPMENT, CAN CAUSE INJURY OR LOAD LINES OR LOAD EQUIPMENT, CAN CAUSE INJURY OR ELECTROCUTION WITH AN UNGROUNDED SYSTEM.

**WARNING**

MAKE SURE THAT NO TOOLS, PARTS OR LOOSE ITEMS ARE ON ANY PART OF THE ENGINE SINCE THEY MIGHT CAUSE BODILY HARM TO PERSONNEL WHEN THE ENGINE IS STARTED.

**CAUTION**

IF ENGINE DOES NOT START IN 45 SECONDS, OVERCRANK PROTECTION WILL TERMINATE THE CRANKING CYCLE. RESET AND ALLOW 1-MINUTE REST BEFORE STARTING ANOTHER CRANK CYCLE.

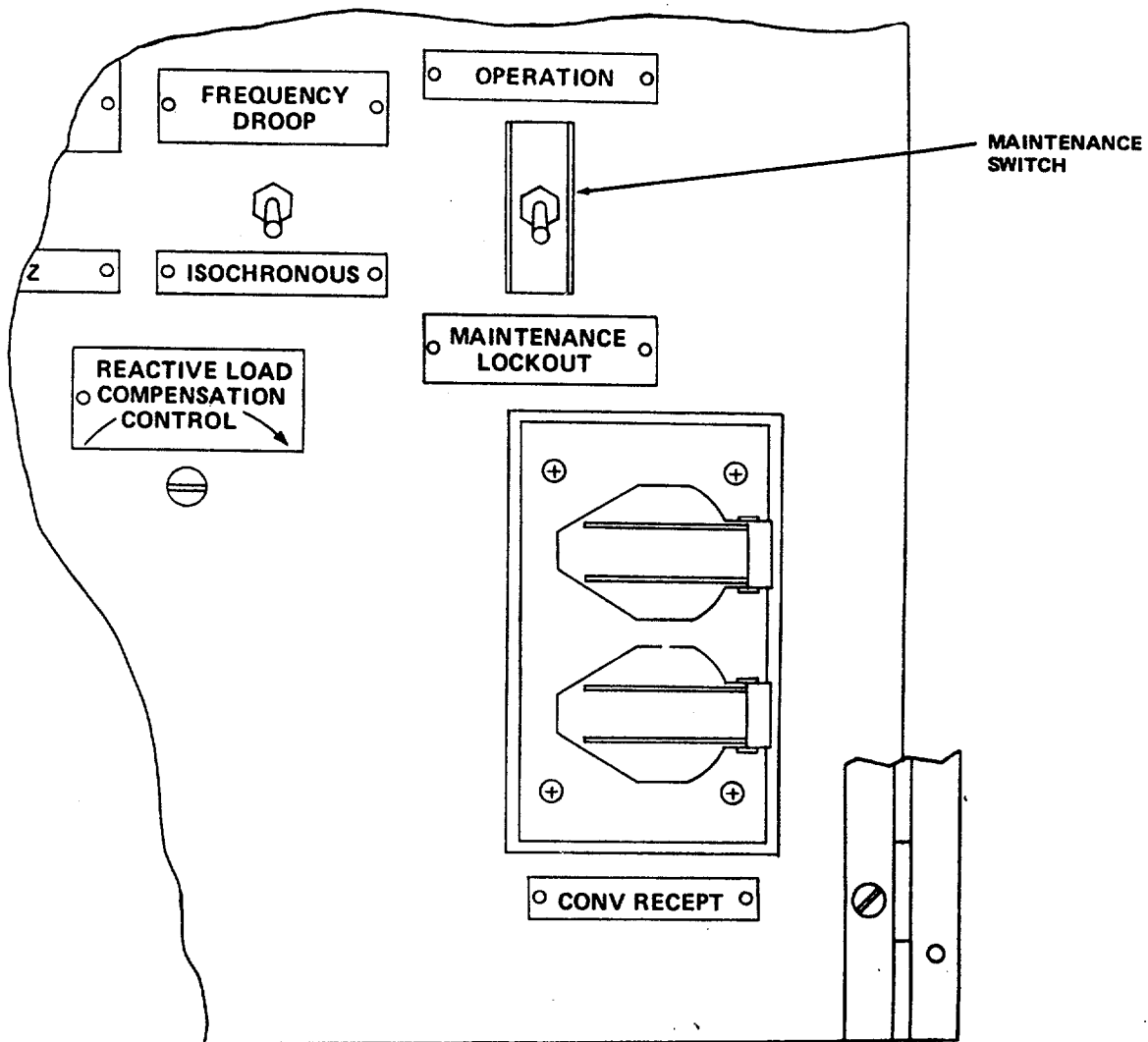
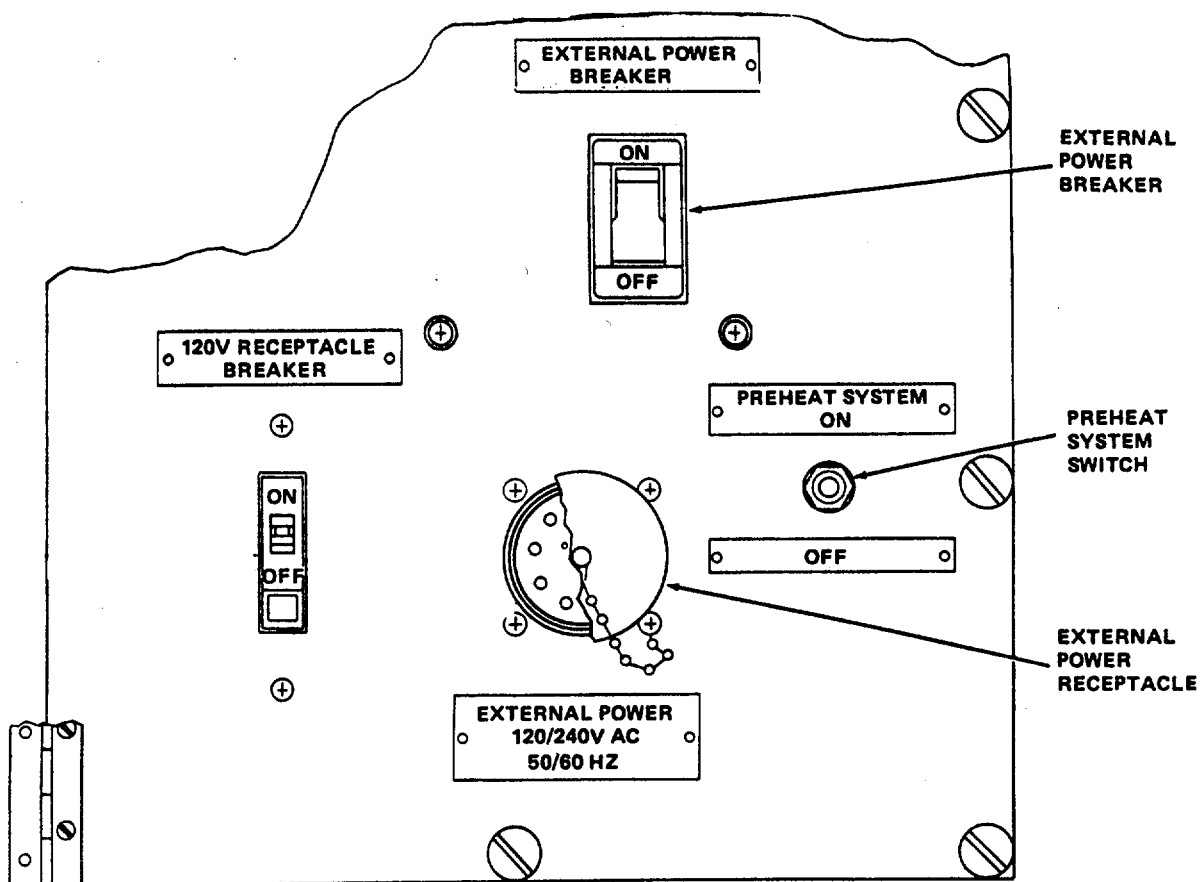

Figure 2-9. Preparation for Starting with Housing Kit Installed (Sheet 3 of 3)



**A. EXTERNAL POWER BOX CONTROL PANEL**

STEP 1. ENSURE THAT THE PREHEAT SYSTEM HAS BEEN OPERATED A MINIMUM OF 6 HOURS PRIOR TO STARTING. THE PREHEAT SYSTEM IS ACTIVATED AS FOLLOWS:

- A. ENSURE THAT JUMPER IS ON BETWEEN TERMINALS 1 AND 3 ON TERMINAL BOARD 20 (LOCATED IN THE AC-DC CONTROL BOX) AS SHOWN BELOW, ONLY IF THE GENERATOR SET IS PERMANENTLY CONNECTED TO EXTERNAL POWER TO PERMIT BATTERY CHARGE OPERATION.

TB20

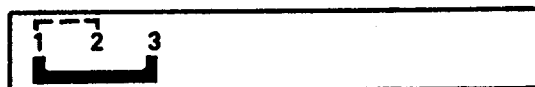

- B. CONNECT 120/240V AC ETERNAL POWER SOURCE TO EXTERNAL POWER RECEPTACLE ON EXTERNAL POWER BOX CONTROL PANEL.
- C. SWITCH EXTERNAL POWER BREAKER TO ON.
- D. SWITCH PREHEAT SYSTEM SWITCH TO ON.

**Figure 2-10. Starting Instructions when Ambient Temperature is from 40°F to -25°F (4.4°C to -32°C) and Housing Kit is Installed (Sheet 1 of 3)**



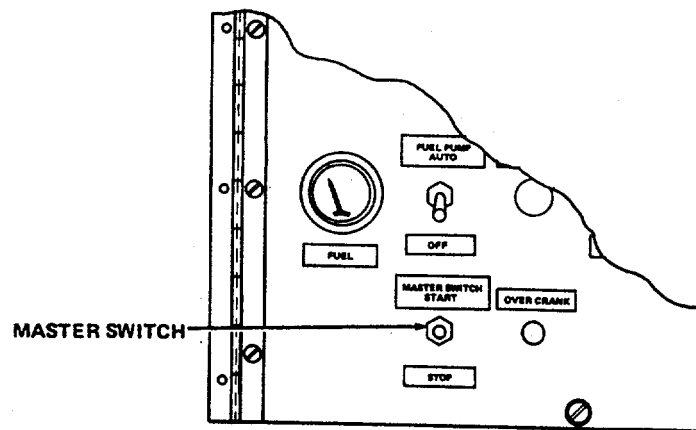

**B. ENGINE CONTROL PANEL**

STEP 2. TOGGLE THE MASTER SWITCH TO THE START POSITION ON ENGINE PANEL.

**Figure 2-10. Starting Instructions when Ambient Temperature is from 40°F to -25°F (4.4°C to -32°C) and Housing Kit is Installed (Sheet 2 of 3)**

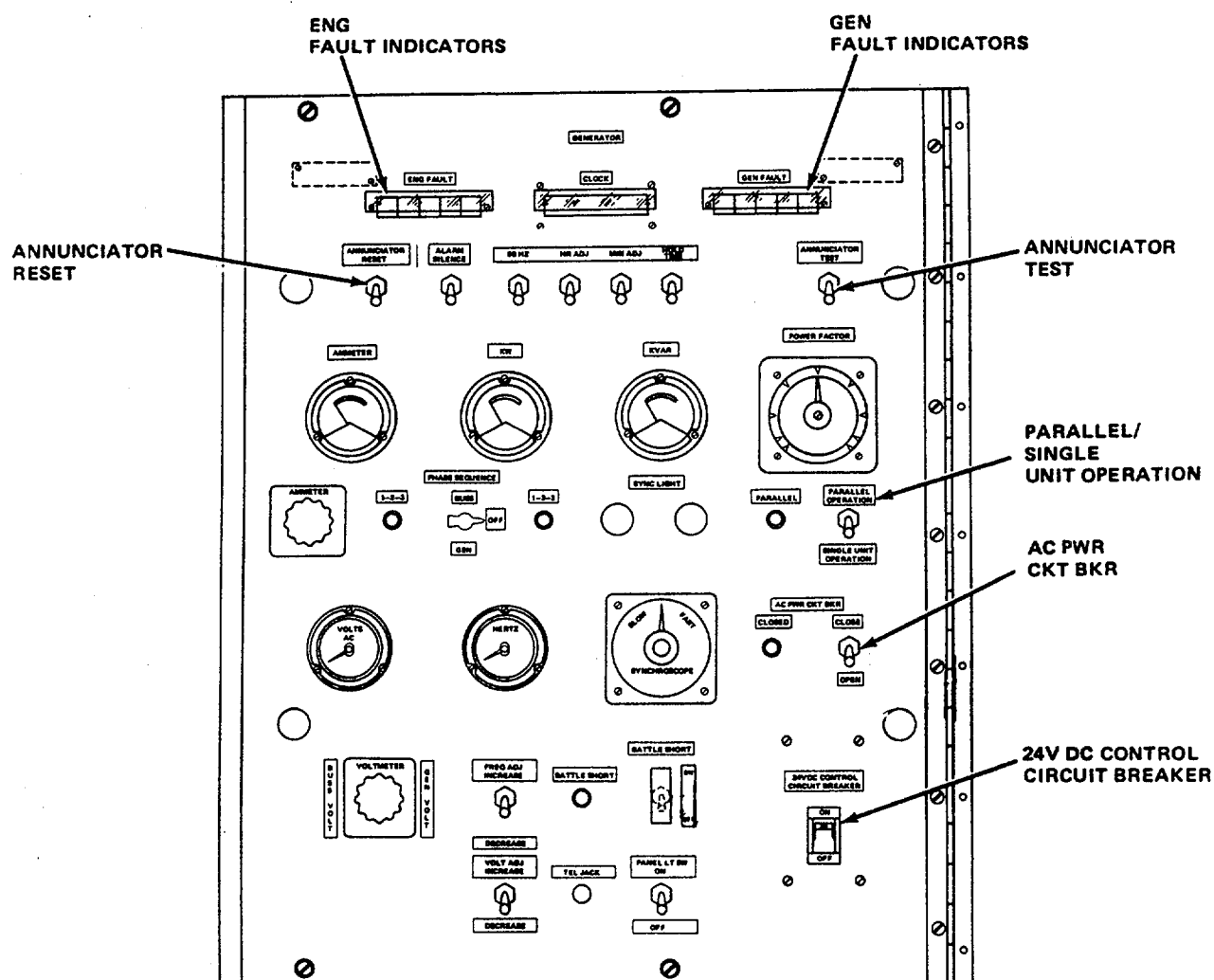

**C. GENERATOR CONTROL PANEL (PART OF CONTROL CUBICLE)**

- STEP 3. WHEN THE ENGINE HAS STARTED, ADJUST THE FREQUENCY AND VOLTAGE TO THE DESIRED VALUES.
- STEP 4. PRIOR TO CLOSING THE MAIN CIRCUIT BREAKER (AS EXPLAINED IN STEP 6, BELOW), CHECK GEN FAULT INDICATORS BY PLACING ANNUNCIATOR TEST SWITCH IN THE TEST POSITION. IF NONE OF THE LIGHTS ARE ON AFTER BEING TESTED, PROCEED WITH STEP 5. IF A LIGHT DOES COME ON, CORRECT THE INDICATED FAULT BEFORE PROCEEDING.
- STEP 5. PLACE THE PARALLEL/SINGLE UNIT OPERATION SWITCH IN THE SINGLE UNIT OPERATION POSITION.
- STEP 6. PLACE THE AC PWR CKT BKR TO CLOSE POSITION FOR APPROXIMATELY 2 OR 3 SECONDS TO CLOSE THE MAIN CIRCUIT BREAKER. CLOSED INDICATOR SHOULD COME ON.

**Figure 2-10. Starting Instructions when Ambient Temperature is from 40°F to -25°F (4.4°C to -32°C) and Housing Kit is Installed (Sheet 3 of 3)**

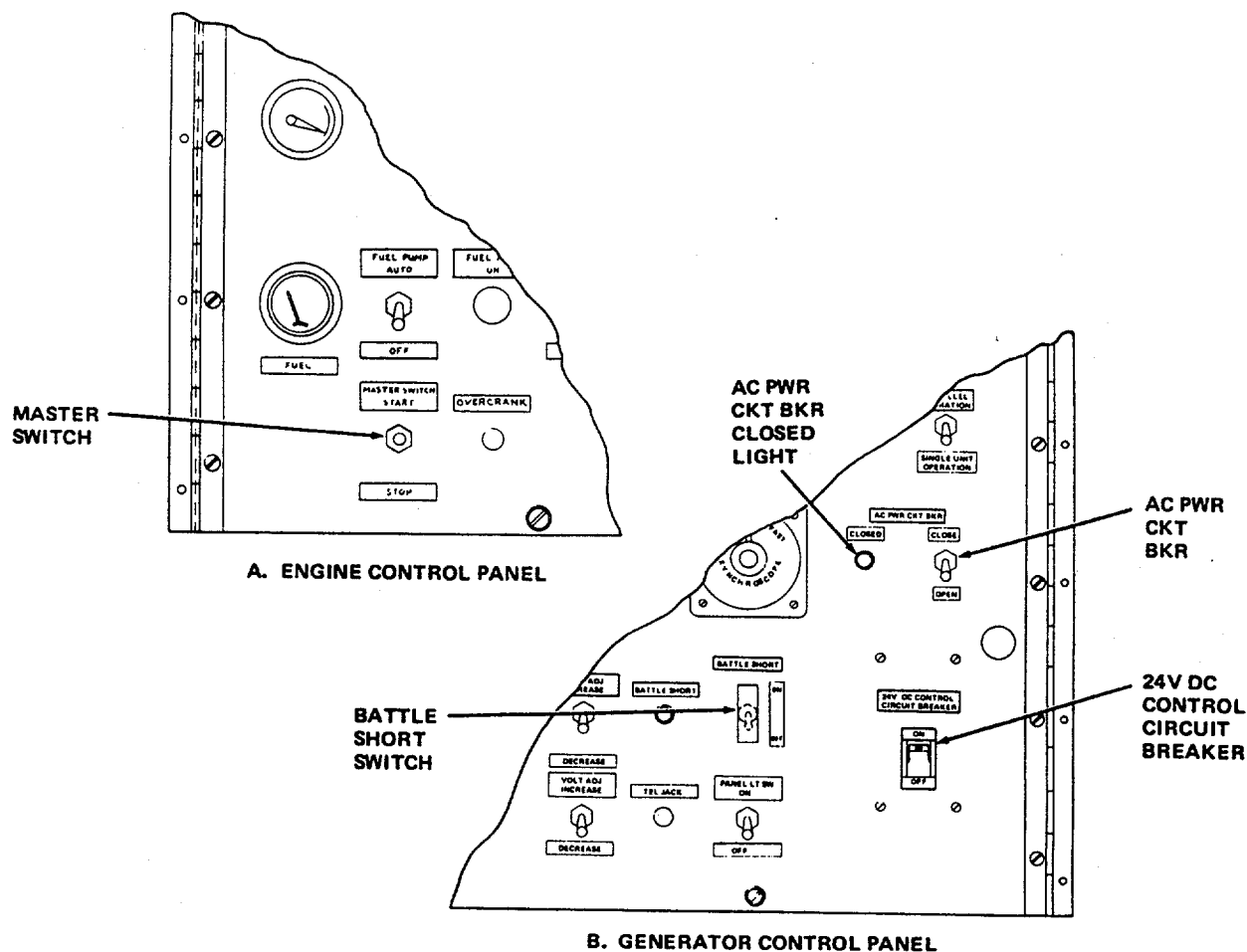

STEP 1. PLACE AC PWR CKT BKR IN OPEN POSITION APPROXIMATELY 2 OR 3 SECONDS; THE AC PWR CKT BKR CLOSED LIGHT SHOULD GO OUT.

**WARNING**

Shutters will snap shut rapidly with considerable force when generator set is stopped. Ensure all personnel are clear of shutters before placing MASTER switch to STOP. Serious injury could result.

STEP 2. PLACE MASTER SWITCH IN STOP POSITION AFTER ALLOWING ENGINE TO COOL BY OPERATING AT NO LOAD FOR APPROXIMATELY 5 MINUTES.

STEP 3. AFTER ENGINE STOPS, REMOVE DC CONTROL POWER BY SETTING 24V DC CONTROL CIRCUIT BREAKER TO OFF POSITION.

Figure 2-11. Stopping Instructions with Housing Kit Installed.

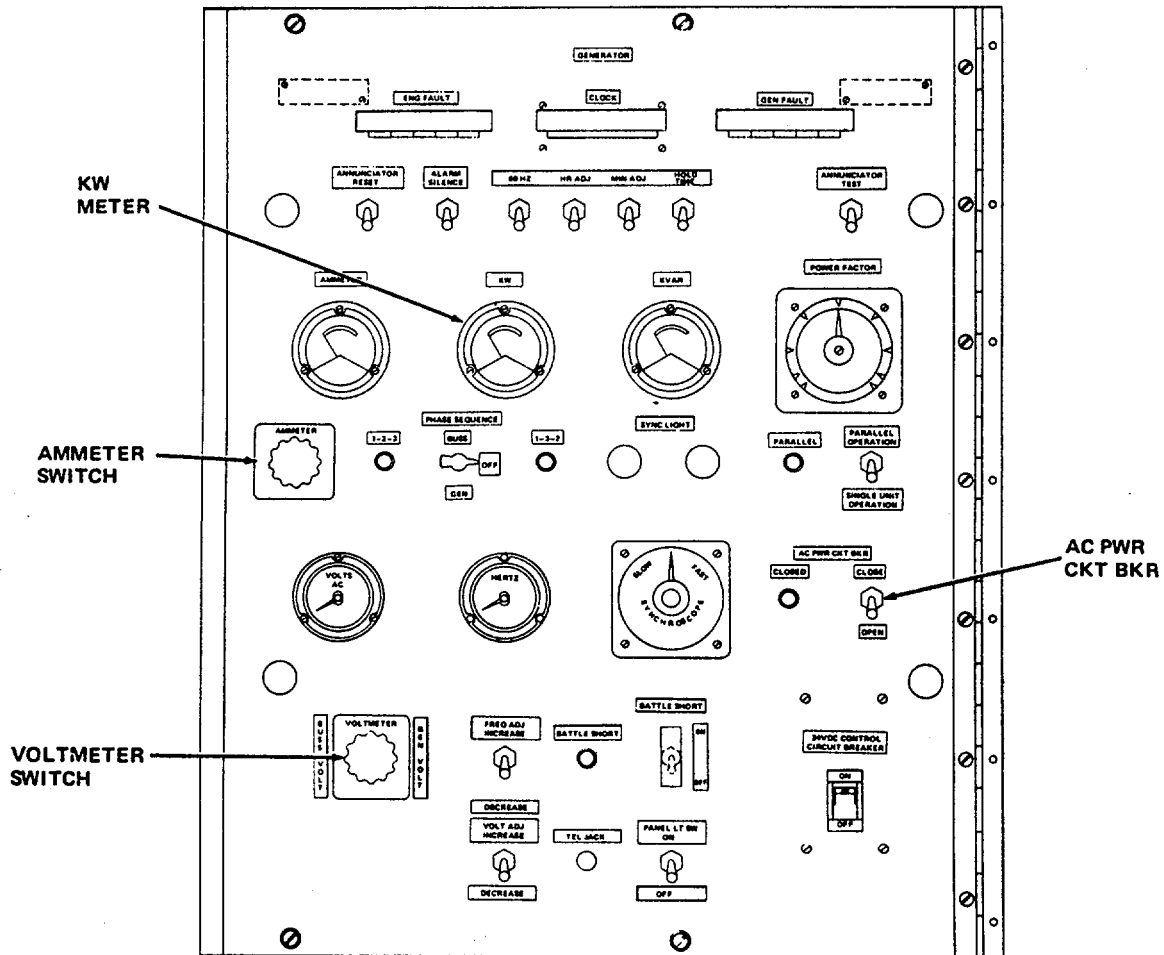

**A. GENERATOR CONTROL PANEL**

- STEP 1. PREPARE GENERATOR SET FOR STARTING (FIGURE 2-9).
- STEP 2. START GENERATOR SET (FIGURE 2-10).
- STEP 3. ROTATE AMMETER TO EACH PHASE POSITION, WHILE OBSERVING AMMETER. IF MORE THAN 100 PERCENT RATED CURRENT IS INDICATED IN ANY PHASE POSITION, REDUCE THE LOAD.
- STEP 4. IF MORE THAN 100 PERCENT LOAD IS INDICATED ON THE KW METER REDUCE THE LOAD.

**Figure 2-12. Single Generator Unit, Operating Instructions with Housing Kit Installed**

2-10. OPERATION WITH THE REMOTE CONTROL MODULE AND CABLE. Addition of the remote control module and cable allows operation of the engine/generator set from distances of up to 100 feet (30 meters). The purpose and location of controls on the remote control module panel are described in table 2-5 and illustrated in figure 2-13. It should be noted that the controls on the remote control module are almost identical to those on the generator control panel.

a. Connection Procedure for Using Remote Control Module and Cable.

**WARNING**

**Do not attempt to make connections to the control cubicle while generator set is in operation.**

- (1) Connect the remote control cable to the remote control module by connecting plug P4 to receptacle J4, plug P1 to receptacle J1, and plug P2 to receptacle J2.
- (2) Connect the other end of the remote control cables to the back side of generator set control cubicle by connecting plug P4 to receptacle J4, plug P1 to receptacle J1, and plug P2 to receptacle J2.
- (3) Remove terminal board jumper connections in control cubicle as shown in figure 2-14.

b. Use of Remote Control Module. Figures 2-15, 2-16, 2-17, and 2-18 provide preparation, starting, stopping and operating instructions for generator set equipped with a remote control module.

c. Emergency Stopping. To stop the generator set from the remote control module in an emergency, place the EMERGENCY SHUT-DOWN switch in the ON position.

**Table 2-5. Remote Control Panel, Controls and Instruments**

FIGURE, INDEX NO.	NORMAL CONTROL AND INSTRUMENT	FUNCTION	READING/SETTING
2-13,1	VOLT ADJ INCREASE-DECREASE	Permits adjustment of generator set voltage output.	Neutral
2-13,2	BATTLE SHORT lamp	Indicates BATTLE SHORT switch is ON.	OFF
2-13,3	VOLTMETER-BUSS VOLT-GEN VOLT switch	Selects BUSS 1-2, GEN 1-2, GEN 2-3, BUSS 2-3, GEN 3-1, and BUSS 3-1.	—
2-13,4	FREQ ADJ INCREASE-DECREASE	Switch to adjust generator at frequency	Neutral
2-13,5	VOLTS AC meter	Indicates AC output voltage.	120/208 or 240/416
2-13,6 48.2-	HERTZ frequency meter	Indicates generator set. frequency in Hz.	50 Hz: 51.8 Hz 58.2 60 Hz: 61.8 Hz
2-13,7	AMMETER switch	Selects phase 1, 2 or 3.	As desired.

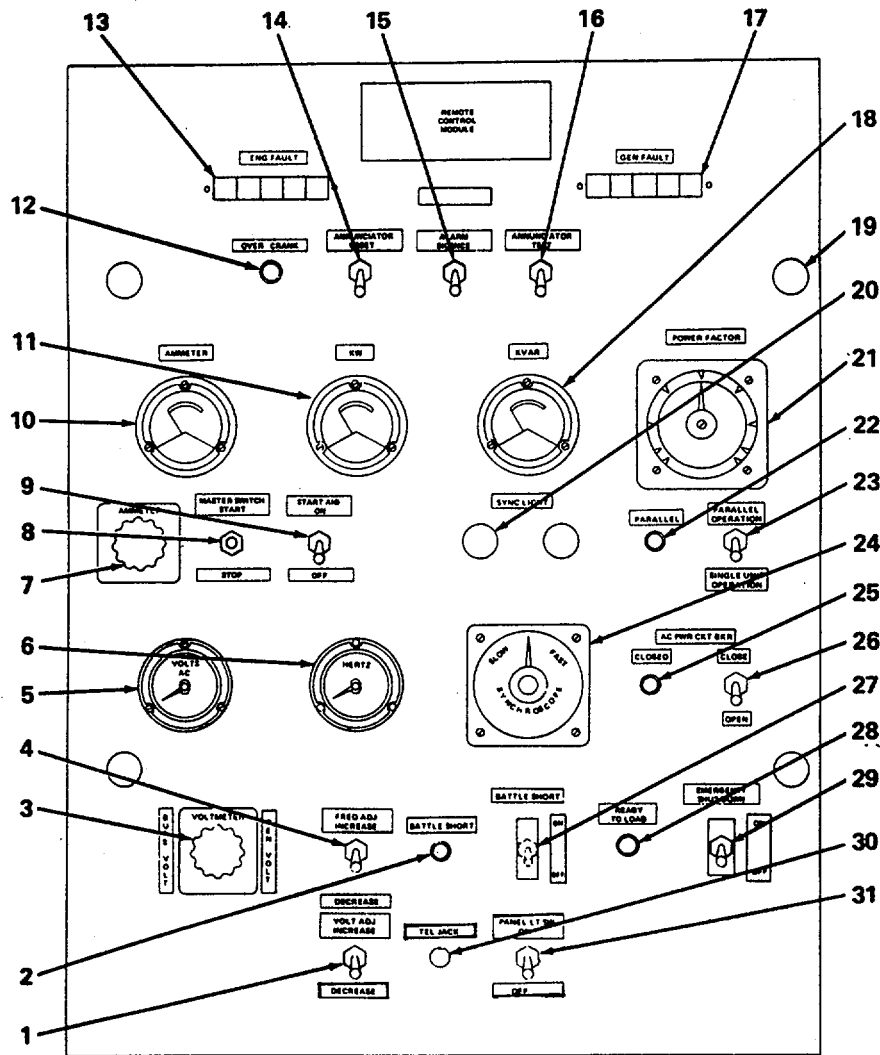

Figure 2-13. Remote Control Module Panel

Table 2-5. Remote Control Panel, Controls and Instruments-Continued

FIGURE, INDEX NO.	CONTROL AND INSTRUMENT	FUNCTION	NORMAL READING/SETTING
2-13,8	MASTER SWITCH START-STOP switch	Switch starts and stops generator operation.	Neutral
2-13,9	START AID ON-OFF switch	Actuates ether starting aid as required while engine is cranking at speeds up to 1200 rpm.	OFF

Table 2-5. Remote Control Panel, Controls and Instruments-Continued

FIGURE, INDEX NO.	CONTROL AND INSTRUMENT	FUNCTION	NORMAL READING/SETTING
2-13,10	AMMETER meter	Indicates percent rated current for selected phase.	Less than 100%
2-13,11	KW meter	Indicates power output of 3-phase, 4-wire generator	Less than 100%
2-13,12	OVER CRANK lamp	Lights if cranking time has been exceeded.	OFF
2-13,13	ENG FAULT indicators	Indicates engine fault.	OFF
	HI COOL TEMP	Lights if coolant temperature rises above $213 \pm 3^{\circ}\text{F}$ ( $100 + 0.7 \times \text{C}$ ).	OFF
	HI LUB TEMP	Lights if lube temperature rises above $255 \pm 3^{\circ}\text{F}$ ( $124 \pm 1^{\circ}\text{C}$ ).	OFF
	LOW OIL PRESS	Lights if oil pressure drops below $21 \pm 2$ psi ( $1.47 \text{ kg/cm}^2$ ).	OFF
	LOW FUEL LEVEL	Lights indicating fuel in day tank at a low level (1-hour operation).	OFF
	OVERSPEED	Lights if engine speed reaches 2200 to 2300 rpm.	OFF
	2-13,14	ANNUNCIATOR RESET switch	Resets annunciating system.
2-13,15	ALARM SILENCE switch	Silences alarm	OFF
2-13,16	ANNUNCIATOR TEST switch	Activates audible alarm and checks indicator bulbs.	OFF
2-13,17	GEN FAULT indicators	Indicates generator fault	OFF
	OVERLOAD	Lights if any phase current exceeds 110 percent rated load.	OFF
	OVERVOLT	Indicates an overvoltage condition.	OFF
	UNDERVOLT	Indicates an undervoltage condition.	OFF
	REVERSE POWER	Indicates a reverse power condition.	OFF

Table 2-5. Remote Control Panel, Controls and Instruments-Continued

FIGURE, INDEX NO.	CONTROL AND INSTRUMENT	FUNCTION	NORMAL READING/SETTING
2-13,17 (cont'd)	SHORT CIRCUIT	Indicates a short circuit.	OFF
2-13,18	KVAR meter	Indicates KVAR of 3-phase, 4-wire circuits.	Less than 100%
2-13,19	Panel lamps	Four lamps to illuminate panel.	—
2-13,20	SYNC lamps	Indicates synchronization of frequency for paralleling of generator set.	OFF
2-13,21	POWER FACTOR meter	Indicates power factor of generator set load.	0.8 lagging to 1.0
2-13,22	PARALLEL lamp	Lights indicating that PARALLEL switch is on parallel position.	OFF
2-13,23	PARALLEL OPERATION-SINGLE UNIT OPERATION	In PARALLEL OPERATION position activates all parallel circuits; in SINGLE UNIT OPERATION position it deactivates all parallel circuits.	As required.
2-13,24'	SYNCHROSCOPE meter	Indicates synchronization of frequency of paralleling of generator set.	Floats
2-13,25	AC PWR CKT BKR-CLOSED lamp	Indicates AC PWR CKT BKR is in CLOSED position.	
2-13,26	AC PWR CKT BKR-CLOSED-OPEN circuit breaker switch	Closes/opens AC power circuit breaker.	Neutral
2-13,27	BATTLE SHORT ON-OFF switch	Bypasses generator set protective circuits during an emergency except over-speed and short circuits.	OFF
2-13,28	READY-TO-LOAD	Indicates unit is ready for loading.	—
2-13,29	EMERGENCY SHUT-DOWN-ON-OFF switch	Controls 24V DC to control circuits to shut down engine.	—
2-13,30	TELJACK	Allows telephone connection from generator set.	—
2-13,31	PANEL LT SW ON-OFF switch	Switches panel lamps on and off.	—



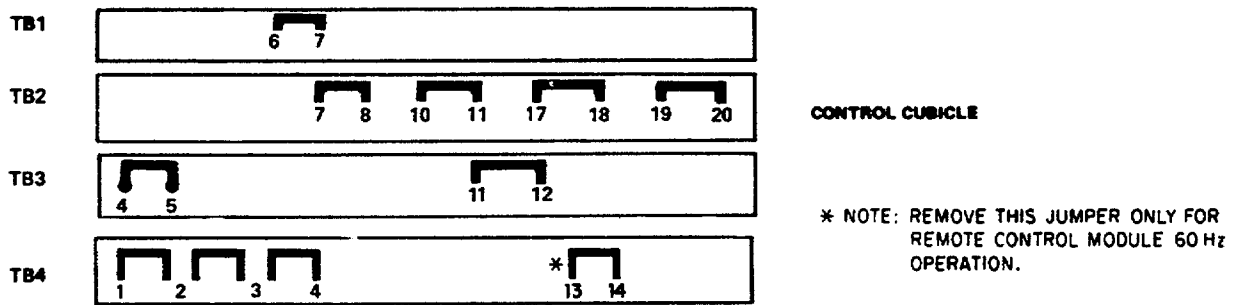
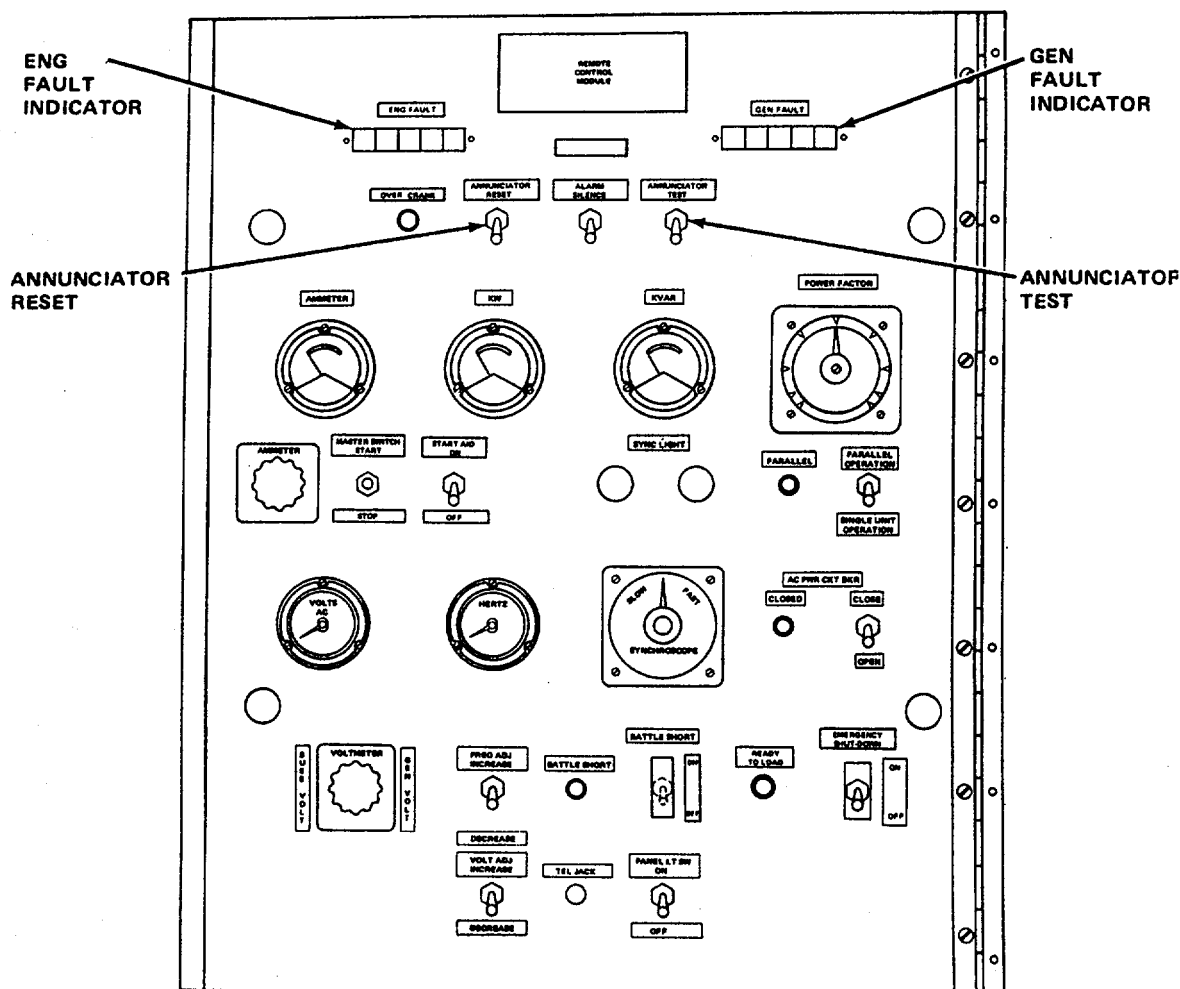

Figure 2-14. Jumper Connections to be Removed when a Remote Control Module is Connected



**A. REMOTE CONTROL MODULE PANEL**

- STEP 1. PERFORM STEPS 1 THROUGH 7 OF FIGURE 2-5.
- STEP 2. ON THE REMOTE CONTROL MODULE PANEL CHECK ENGINE AND GEN FAULT INDICATORS BY PLACING ANNUNCIATOR TEST SWITCH IN TEST POSITION TO VERIFY THAT ALL INDICATORS LIGHT.
- STEP 3. CHECK VOLTAGE AND FREQUENCY REQUIREMENTS OF THE LOAD AGAINST THE VOLTAGE AND FREQUENCY CONNECTIONS ON THE SET.

**WARNING**

**MAKE CERTAIN THAT NO TOOLS, PARTS, OR LOOSE ITEMS ARE ON ANY PART OF THE ENGINE SINCE THEY MIGHT CAUSE BODILY INJURY TO PERSONNEL WHEN THE ENGINE IS STARTED.**

**Figure 2-15. Preparation for Starting Using Remote Control Module**

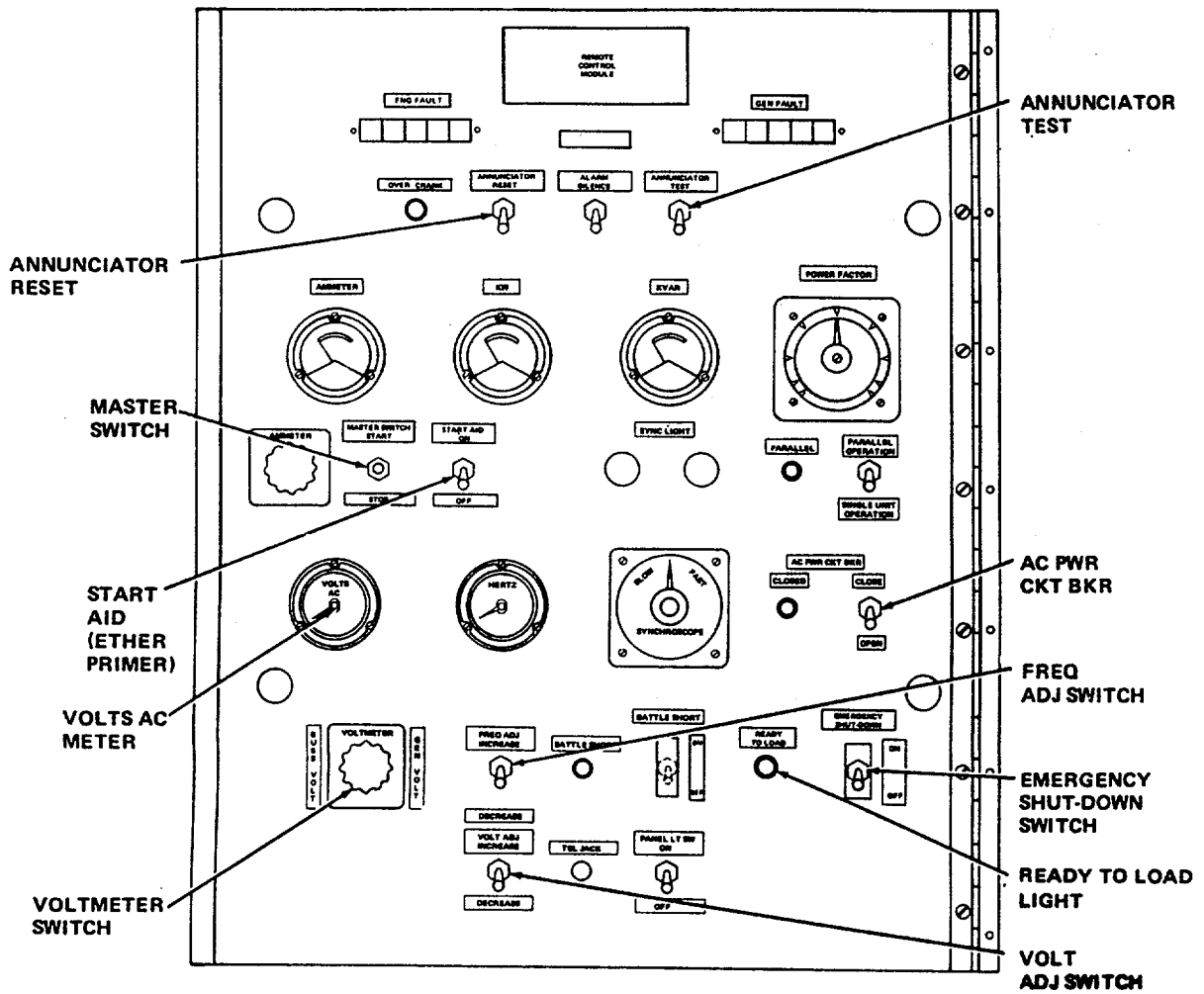

Figure 2-16. Starting Instructions Using Remote Control Module  
(Sheet 1 of 2)

A. STARTING WHEN AMBIENT TEMPERATURE IS ABOVE 40°F (4°C) AND PREHEAT HAS NOT BEEN USED:

- STEP 1. TOGGLE MASTER SWITCH TO THE START POSITION.
- STEP 2. WHEN THE AIR TEMPERATURE IS ABOVE 40°F (4°C) AND THE PREHEAT SYSTEM HAS NOT BEEN USED, ENGINE ETHER PRIMER MAY BE REQUIRED. DO USE ETHER PRIMER, MOMENTARILY PLACE START AID SWITCH IN THE ON POSITION AND RELEASE WHILE CRANKING ENGINE. EACH TIME START AID SWITCH IS CYCLED, ETHER IS INJECTED INTO THE ENGINE AIR INTAKE SYSTEM. AFTER START OCCURS, IF ENGINE SPEED OR FREQUENCY BEGIN TO DECREASE, ADDITIONAL ETHER CAN BE INJECTED BY CYCLING START AID SWITCH AS LONG AS ENGINE RPM IS BELOW 1200 RPM.
- STEP 3. CHECK ERG FAULT INDICATORS AND ANNUNCIATOR BY PLACING ANNUNCIATOR TEST SWITCH IN TEST POSITION. IF NONE OF THE LIGHTS ARE ON AFTER BEING TESTED, PROCEED WITH THE NEXT STEP. IF A LIGHT DOES COME ON, THE INDICATED FAULT BEFORE PROCEEDING.
- STEP 4. VOLTS AC METER SHOULD INDICATE 208 OR 416 VOLTS IF VOLTMETER SWITCH IS SET AT GEN 1-2, GEN 2-3, OR GEN 3-1.
- STEP 5. ALLOW ENGINE TO WARM UP FOR 15 MINUTES AT NO LOAD.
- STEP 6. SET VOLT ADJ SWITCH AS REQUIRED TO OBTAIN PROPER VOLTAGE OUTPUT STATED IN STEP 4, ABOVE.
- STEP 7. OPERATE FREQ ADJ SWITCH TO OBTAIN PROPER FREQUENCY.
- STEP 8. PRIOR TO CLOSING THE MAIN CIRCUIT BREAKER (AS EXPLAINED IN STEP 9, BELOW), CHECK GEN FAULT INDICATOR AND ANNUNCIATOR BY PLACING ANNUNCIATOR TEST SWITCH IN THE TEST POSITION. IF NONE OF THE LIGHTS ARE ON AFTER BEING TESTED PROCEED WITH STEP 9. IF A LIGHT DOES COME ON, CORRECT THE INDICATED FAULT BEFORE PROCEEDING.

**WARNING**

**PLACING AC PWR CKT BKR TO CLOSE APPLIES POWER TO OUTPUT LOAD TERMINALS AND LOAD LINES. ENSURE ALL PERSONNEL ARE CLEAR OF OUTPUT LOAD TERMINALS. SERIOUS INJURY OR DEATH COULD RESULT.**

- STEP 9. TOGGLE THE AC PWR CKT BKR SWITCH TO THE CLOSE POSITION FOR 2 OR 3 SECONDS TO CLOSE MAIN CIRCUIT BREAKER. CLOSED INDICATOR SHOULD COME ON.

B. STARTING WHEN AMBIENT TEMPERATURE IS ABOVE 40°F (4°C) AND PREHEAT IS USED:

**NOTE**

**ENGINE PREHEAT SYSTEM COT BE ACTIVATED FROM THE RBE CONTROL MODULE.**

- STEP 1. ENSURE THAT PREHEAT SYSTEM HAS BEEN OPERATED A MINIMUM OF 6 HOURS PRIOR TO START-UP. (STEP B1(A), (B), (C) AND (D) OF FIGURE 2-6.)
- STEP 2. TOGGLE MASTER SWITCH ON R CONTROL NODULE TO THE START POSITION.
- STEP 3. CONTINUE AS IN STEPS 3 THROUGH 9, ABOVE.

**NOTE**

**WHEN ENGINE PREHEAT AT SYSTEM HAS BEEN USED, NO ADDITIONAL WARN-UP TIME IS NEEDED.**

**Figure 2-16. Starting Instructions Using Remote Control Module  
(Sheet 2 of 2)**

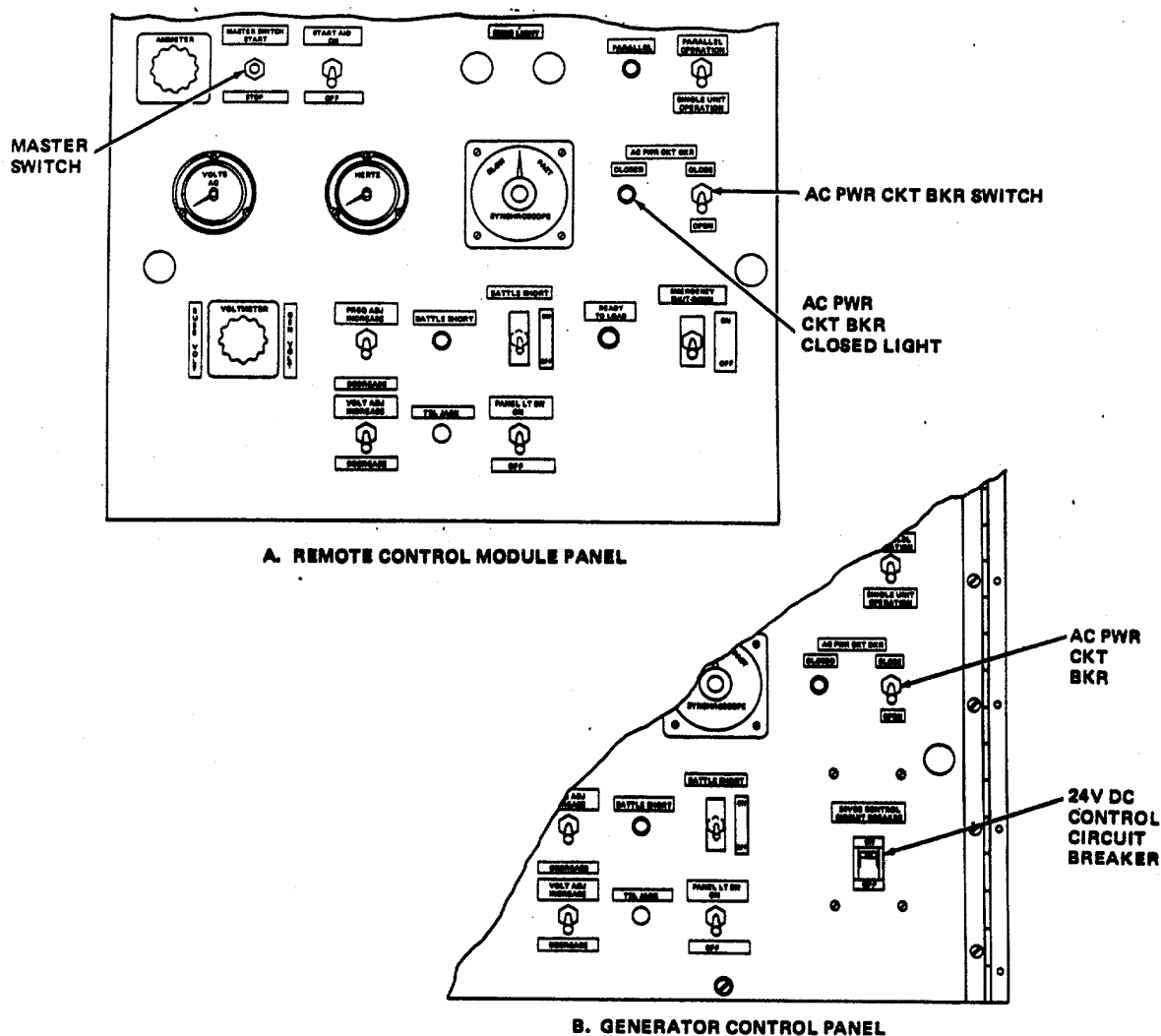

STEP 1. PLACE AC PWR CKT BKR SWITCH IN OPEN POSITION FOR APPROXIMATELY 2 OR 3 SECONDS, THE AC PWR CKT BKR CLOSED LIGHT SHOULD GO OUT.

**WARNING**

**WILL SNAP SHUT RAPIDLY WITH CONSIDERABLE FORCE WHEN GENERATOR SET IS STOPPED. ENSURE ALL PERSONNEL ARE CLEAR OF SHUTTERS BEFORE PLACING MASTER SWITCH TO STOP. SERIOUS INJURY COULD RESULT.**

STEP 2. PLACE MASTER SWITCH IN STOP POSITION AFTER ALLOWING ENGINE TO COOL BY OPERATING AT NO LOAD FOR APPROXIMATELY 5 MINUTES.

STEP 3. AFTER ENGINE HAS STOPPED, REMOVE DC POWER CONTROL BY SETTING 24V DC CONTROL CIRCUIT BREAKER (ON GENERATOR CONTROL PANEL) TO OFF POSITION. (ON GENERATOR CONTROL PANEL) TO OFF POSITION.

Figure 2-17. Stopping Instructions Using Remote Control Module

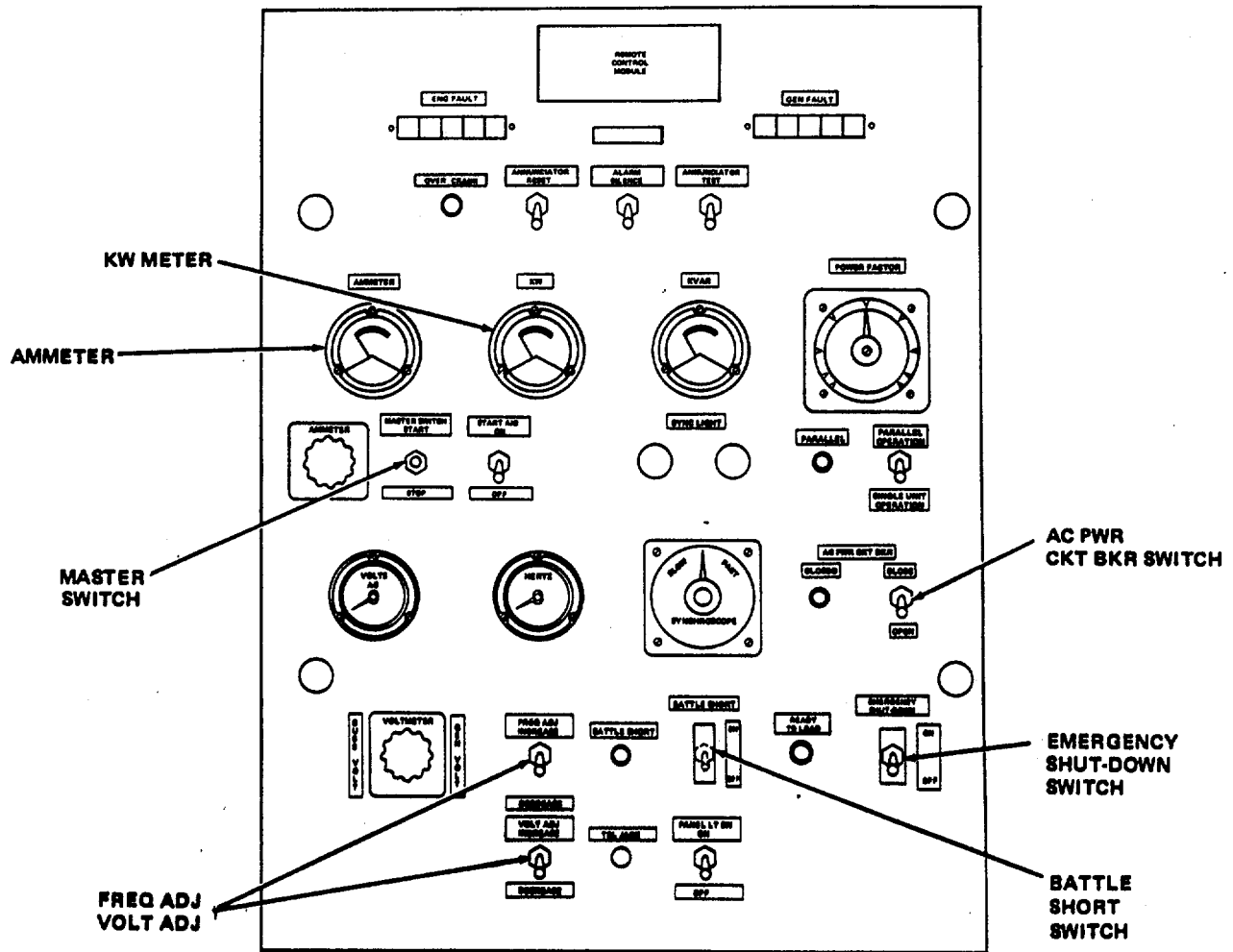

**A. REMOTE CONTROL MODULE PANEL**

- STEP 1. CONNECT REMOVE CONTROL MODULE AND CABLE (PARA. 2-10A).
- STEP 2. PREPARE GENERATOR SET/REMOTE CONTROL MODULE FOR STARTING (FIGURE 2-15).
- STEP 3. START GENERATOR (FIGURE 2-16).
- STEP 4. ROTATE AMMETER SWITCH TO EACH PHASE POSITION WHILE OBSERVING AMMETER. IF MORE THAN 100 PERCENT RATED CURRENT IS INDICATED IN ANY PHASE POSITION, REDUCE THE LOAD.
- STEP 5. IF MORE THAN 100 PERCENT LOAD IS INDICATED ON THE KW METER, REDUCE THE LOAD.

**Figure 2-18. Operating Instructions, Single Generator Unit Using Remote Control Module**

± The addition of a automatic control module allows unattended control of one to four generator sets. The automatic control module monitors the bus (utility) power source, and controls the starting and sequential loading of one to four generator sets whenever the bus voltage or frequency fails or deviates from a pre-set value. Only those generators with the AUTO/MAN selector switch in the AUTO position will be controlled via the automatic control module. The controls are illustrated in figure 2-19 and described in table 2-6. Reference also Chapter 5 Section IV.

a. Connecting the Automatic Control Module

- (1) Change jumper connections as shown in figure 2-20.
- (2) Interconnect generator set and automatic control module by wiring supplied J3 connector plug on back of control cubicle (to be wired by user) on rear of generator control box to TB1 thru TB4 terminal boards in automatic control module in accordance with FO-15. Connect the load feeder breakers (supplied by user) to the appropriate control contacts (via TB4). See FO-15 for all interconnection wiring instructions.

**NOTE**

**LR1, LRTD1 are No. 1 priority feeder controls. They will activate first regardless of which generator first comes on line. LR energizes instantly, LRTD energizes 2-5 seconds after LR. LR2, LRTD2 are No. 2 priority feeder controls and will activate only when a second generator comes on line. Priority No. 3 and No. 4 feeder controls work in a similar manner when generator 3 and 4 come on line. The total load to be supplied to any one load feeder breaker 1 thru 8 shall not exceed 250 KW.**

- (3) Set the NO RETURN/TD RETURN/

INSTANT RETURN mode selector switch S1 and the FREQ. SELECT 50 HZ/60 HZ switch S2 to the appropriate or desired position.

- (4) Connect 120V AC from the line side of the utility breaker to TB1-5 and TB1-6 of the automatic control module. The neutral wire should be connected to TB1-5.

**NOTE**

**The over/under voltage relay is normally set for a ± 10% deviation of a L-N voltage of 120V AC. The over and under frequency relays are normally set for a ± 3% deviation of a bus frequency of either 50 or 60 Hz.**

b. ACM Operating Procedure

- (1) Manual Operation If manual operation and control of the generators is desired, place the AUTO/TRIP/ MAN switch (S53) located on the generator set control panel, to MAN position. Place the NO RETURN/TD RETURN/INSTANT RETURN mode selector switch (S1) located on the ACM, to NO RETURN. The generator set will not be under control of the ACM and the set controls will be strictly manual via generator control panel. No relays will be caused to energize or deenergize in the ACM, thereby precluding any effect to the utility breaker or feeder control relays. If manual paralleling is desired, place the generator set parallel switch to parallel.
- (2) Automatic Operation If automatic operation is desired, first insure that 120 VAC utility power is available to ACM by indication of the UTILITY POWER AVAILABLE lamp. Determine which type of automatic power transfer is desired (instant, time delay or no return) and set

selector switch S1 accordingly. Set FREQ. SELECT 50 Hz/60 Hz switch to applicable position. Place all AUTO-TRIP-MAN switches (S53) on generator set control panels to AUTO, figure 2-6. Place parallel switches on all units to PARALLEL. The 24 V DC control circuit breaker (located on the generator control panel) must be left ON in the automatic mode.

The external power connector (generator set power box control panel) should be connected to station (utility) power and the external power breaker to ON. Place the PRE HEAT SYSTEM switch ON (figure 2-6). Pre heat must be in operation six hours prior to generator set start up. All units are now ready to start in the event of a utility power failure. If the units have been automatically started on line and it's desired to shut one unit down, simply turn that unit's AUTO-TRIP-MAN switch (S53) to the MAN position. As the switch passes through the TRIP position, that unit's circuit breaker and the least priority feeder breakers will open. After five minutes, allowing for engine cool-down, simply place the master START-STOP switch (S1) to the STOP position as you normally would in manual operation.

If any unit, which has been automatically started and paralleled to the bus, develops a fault and trips off the bus, always switch that unit's AUTO-TRIP-MAN switch to MAN first then back to AUTO after resetting the fault indicator. Do not switch NO RETURN/TD RETURN/ INSTANT RETURN mode selector switch S1 to the NO RETURN position while units are running during a cool-down cycle.

When the utility (normal) power becomes available (NORMAL POWER AVAILABLE light ON) and the mode selector switch is at NO RETURN, the generator set(s) will continue supplying power. The TD RETURN position allows a 330 minute (adjustable) delay until the generator set(s) automatically trip off the bus. The INSTANT RETURN position immediately trips the generator set(s) off the bus. After the generator set(s) are automatically disconnected from the bus an automatic five minute (adjustable) engine cool-down cycle occurs before the generator set(s) stop.

### (3) Optional Uses

Terminal board points TB1-7, 8, and 9 are available for customer use as remote indication of utility power.

Additional normally closed contacts of the BR relays are available between TB3-9 thru TB3-16 for remote indication of each units circuit breaker status (in automatic operation only).

Each generator has governor control summing junctions available through J3-H (Shield) J3-G and J3-F whenever a units circuit breaker is closed (in automatic operation only). Future use of these terminals are dependent upon the user.

J3-S, on the generator set, is for remote indication or T-7 winding (120 VAC) available whenever the generator is running, regardless of circuit breaker being closed or open. Functional use is dependent upon user.

Terminal board points TB3-17-18-19 can be wired to control an electrically operated utility breaker and/or transfer switch.



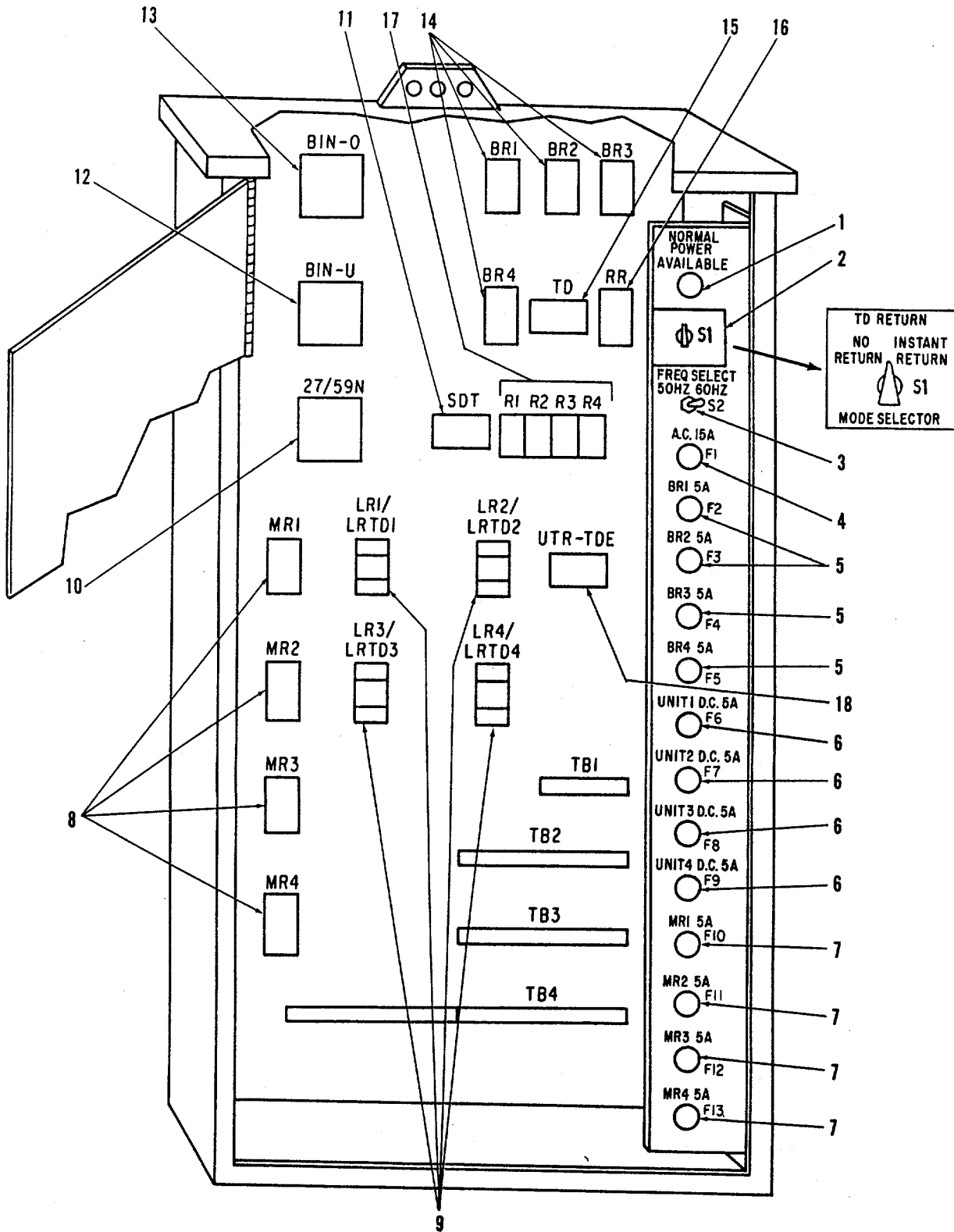

Figure 2-19. Automatic Control Module

Table 2-6. Automatic Control Module, Controls and Instruments

FIGURE, INDEX NO.	NORMAL CONTROL AND INSTRUMENT	FUNCTION	READING/SETTING
2-19,1	UTILITY POWER AVAILABLE LAMP	Indicates availability of utility/bus voltage within proper limits.	ON
2-19,2	MODE SELECTOR switch	Selects whether load will be transferred back to utility after a predetermined time delay, instantly, or will not transfer at all until manually selected.	T.D. Return
2-19,3	FREQUENCY SELECT switch	Selects the proper trip points of the over and under frequency relays.	As required by system running frequency.
2-19,4	A.C. UTILITY POWER FUSE 15A	Protects wiring of utility monitoring circuit.	—
2-19,5	BR1-4 A.C. Fuses 5A	Protects wiring of BR1 thru BR4 circuitry.	—
2-19,6	Unit 1-4 D.C. Fuses 5A	Protects D.C. sensing wires between units 1 thru 4 and automatic control module.	—
2-19,7	MR1-4 A.C. Fuses 5A	Protects wiring of MR1 thru MR4 circuitry.	—
2-19,8	MASTER CONTROL RELAY (MR1-MR4)	Closes the generator circuit breaker only on the first unit to reach acceptable voltage and frequency.	—
2-19,9	LOAD RELAYS LR 1 thru 4 and LRTD 1 thru 4	Relay contacts will control customer load feeder breakers. LRTD time delay relays adjustable from 0.2 to 20 seconds.	—
2-19,10	OVER/UNDER VOLTAGE RELAY (27/59)	Senses utility voltage at $120 \pm 10\%$ . Trips at 108V AC (under) and 132V AC (over) voltage.	—
2-19,11	TIME DELAY RELAY (SDT)	Allows generator(s) to continue to run (cool down) after utility power has returned. (Adjustable 1-300 sec.)	As desired.

Table 2-6. Automatic Control Module, Controls and Instruments - Continued

FIGURE, INDEX NO.	CONTROL AND INSTRUMENT	FUNCTION	NORMAL READING/SETTING
2-19,12	UNDERFREQUENCY RELAY (81U)	Senses utility frequency and trips at 58.2 or 48.5 Hz.	—
2-19,13	OVERFREQUENCY RELAY (810)	Senses utility frequency and trips at 61.8 or 51.5 Hz.	—
2-19,14	BREAKER CONTROL RELAY (BR1-BR4)	Upon generator circuit breaker closure will provide steering logic for load relay circuitry. Auxiliary contacts provided for future customer use of generator circuit breaker closure indication.	—
2-19,15	TIME DELAY RELAY (TD)	Delays start of generator(s) upon loss of utility power. (Adjustable 1.5-15 sec.)	As desired.
2-19,16	RUN RELAY (RR)	When de-energized, contacts initiate start of generator(s).	—
2-19,17	DIODE PACKS (R1-R4)	Diodes act as logic steering or blocking for internal circuitry.	—
2-19,18	TIME DELAY RELAY (UTR)	Disallows load to be transferred back to utility source until timed out, if TD RETURN mode is selected. (Adjustable 3-30 minutes)	As desired

TB20



TERMINAL BOARD 20, AC-DC CONTROL BOX

REMOVE JUMPER BETWEEN TERMINALS 1 AND 2 OF TERMINAL BOARD 20, AND INSTALL JUMPER BETWEEN TERMINALS 1 AND 3.

Figure 2-20. Jumper Connections When Automatic Control Module is Used

2-12. PARALLEL OPERATION OF GENERATOR SETS. Engine/generator sets may be manually operated in parallel in two ways, frequency droop or isochronous, or operated in parallel automatically. The automatic control module provides an unattended automatic control system. When an automatic system of one to four generator sets is necessary only one automatic control module is required.

provided in figure 2-21 for droop paralleling and isochronous paralleling (paralleling cables required).

- a. Manual Operation in Parallel. Instructions for the manual operation of generator sets in parallel are

- b. Automatic Operation in Parallel. Ref. paragraph 2-11b, ACM Operating Instructions. Figure 2-21. Operating Instructions, Manually Operated in Parallel (Sheet 1 of 3)

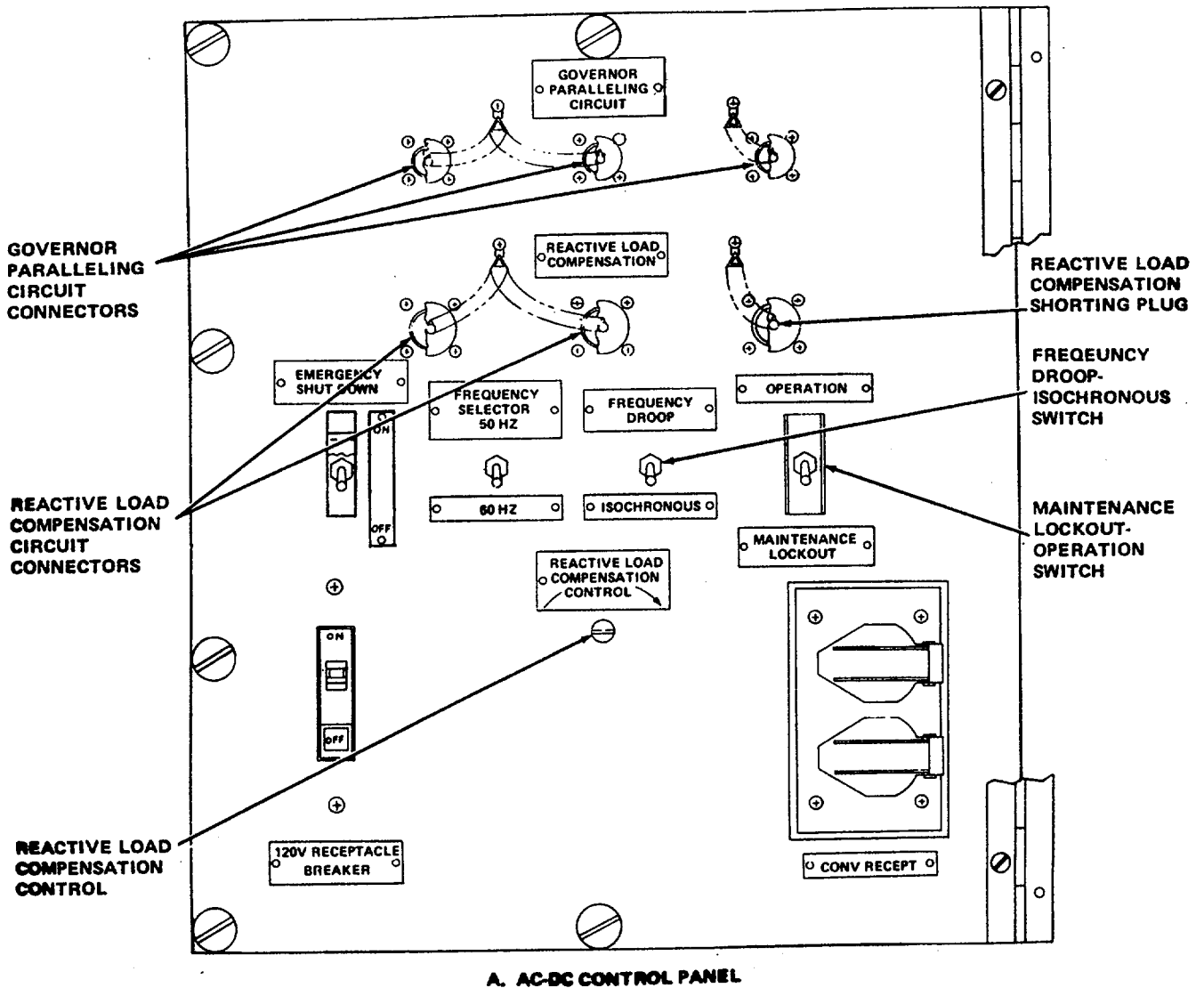

Figure 2-21. Operating Instructions, Manually Operated in Parallel (Sheet 1 of 3)

## A. DROOP PARALLELING

STEP 1. ENSURE THAT A SHORTING PLUG IS INSTALLED IN ONE REACTIVE LOAD COMPENSATION CONNECTOR OR ON EACH SET AND THAT ALL FREQUENCY DROOP-ISOCHRONOUS SWITCHES ARE IN DROOP POSITION. DESIGNATE ONE SET AS MASTER AND SECOND SET AS ONCOMING.

### WARNING

**USE EXTREME CAUTION. LOAD TERMINALS OF GENERATOR SET CIRCUIT BREAKER (CB2) MAY STILL BE ENERGIZED WITH THE BUS VOLTAGE. SERIOUS INJURY OR DEATH COULD RESULT.**

STEP 2. INTERCONNECT POWER OUTPUT TERMINALS (LO-LO, L1-L1, L2-L2, L3-L3) OF THE TWO SETS. [THESE INTERCONNECTS SHOULD BE MADE VIA 3-PHASE DISCONNECT SWITCH (STATION SWITCH GEAR) ON THE LOAD SIDE OF EACH GENERATOR SET CIRCUIT BREAKER (CB2)].

### WARNING

**DEATH OR SERIOUS INJURY MAY RESULT IF PERSONNEL FAIL TO OBSERVE SAFETY PRECAUTIONS. DO NOT ATTEMPT TO MAKE ANY CONNECTIONS UNTIL GENERATOR SET IS COMPLETELY SHOT DOWN AND MAINTENANCE LOCKOUT SWITCH IS IN LOCKOUT POSITION.**

- STEP 3. PREPARE AND START MASTER SET PER INSTRUCTIONS GIVEN IN FIGURES 2-5 AND 2-8.
- STEP 4. ONCE AC PWR CKT BKR IS CLOSED, PLACE THE PARALLEL OPERATION-SINGLE UNIT OPERATION SWITCH IN THE PARALLEL POSITION.
- STEP 5. START ONCOMING SET PER FIGURES 2-5 AND 2-8.
- STEP 6. CHECK PHASE SEQUENCE OF ONCOMING SET USING PHASE SEQUENCE 1-2-3 AND 1-3-2 LAMPS. ENSURE THAT SETS ARE IN SEQUENCE BEFORE PROCEEDING.
- STEP 7. PLACE PARALLEL OPERATION-SINGLE UNIT OPERATION SWITCH ON ONCOMING SET TO PARALLEL OPERATION POSITION.
- STEP 8. SYNC LIGHTS AND SYNCHROSCOPE ON ONCOMING SET SHOULD NOW INDICATE THE DIFFERENCES IN VOLTAGE AND FREQUENCY BETWEEN THE TWO SETS.
- STEP 9. ADJUST THE FREQUENCY OF ONCOMING SET UNTIL THE SYNC LIGHTS ARE BLINKING VERY SLOWLY AND/OR SYNCHROSCOPE INDICATES THAT THE SETS ARE IN PHASE. THE ONCOMING SET FREQUENCY SHOULD BE SLIGHTLY HIGHER AS INDICATED BY THE SYNCHROSCOPE.
- STEP 10. ADJUST THE VOLTAGE OF THE ONCOMING; SET USING VOLTMETER SELECTOR SWITCH AND VOLTMETER UNTIL THE VOLTAGES ARE IDENTICAL.
- STEP 11. CLOSE THE AC PWR CKT BKR ON THE ONCOMING SET THE SYNCH LIGHTS ARE DARK AND THE SYNCHROSCOPE NEEDLE IS IN THE 12 O'CLOCK POSITION.
- STEP 12. TRIM THE VOLTAGE AND FREQUENCY TO BALANCE THE LOAD ON BOTH SETS AS INDICATED BY THE KVAR AND KW METERS. IF LOAD SHIFTS BETWEEN UNITS TRIM REACTIVE LOAD COMPENSATION CONTROL AND LOAD GAIN SETTING ON GOVERNOR CONTROLLER.
- STEP 13. IF INCOMING SET IS ALREADY HOOKED UP, REPEAT STEPS 5 THRU 12.

## B. ISOCHRONOUS PARALLELING.

- STEP 1. REMOVE SHORTING PLUGS FROM ALL SETS AND INTERCONNECT REACTIVE LOAD COMPENSATION AND GOVERNOR PARALLELING CIRCUIT CABLES.
- STEP 2. ENSURE THAT FREQUENCY DROOP-ISOCHRONOUS SWITCH IS IN THE ISOCHRONOUS POSITION.
- STEP 3. PROCEED AS IN A., ABOVE, STEPS 2 THROUGH 12.

Figure 2-21. Operating Instructions, Manually Operated  
in Parallel (Sheet 2 of 3)

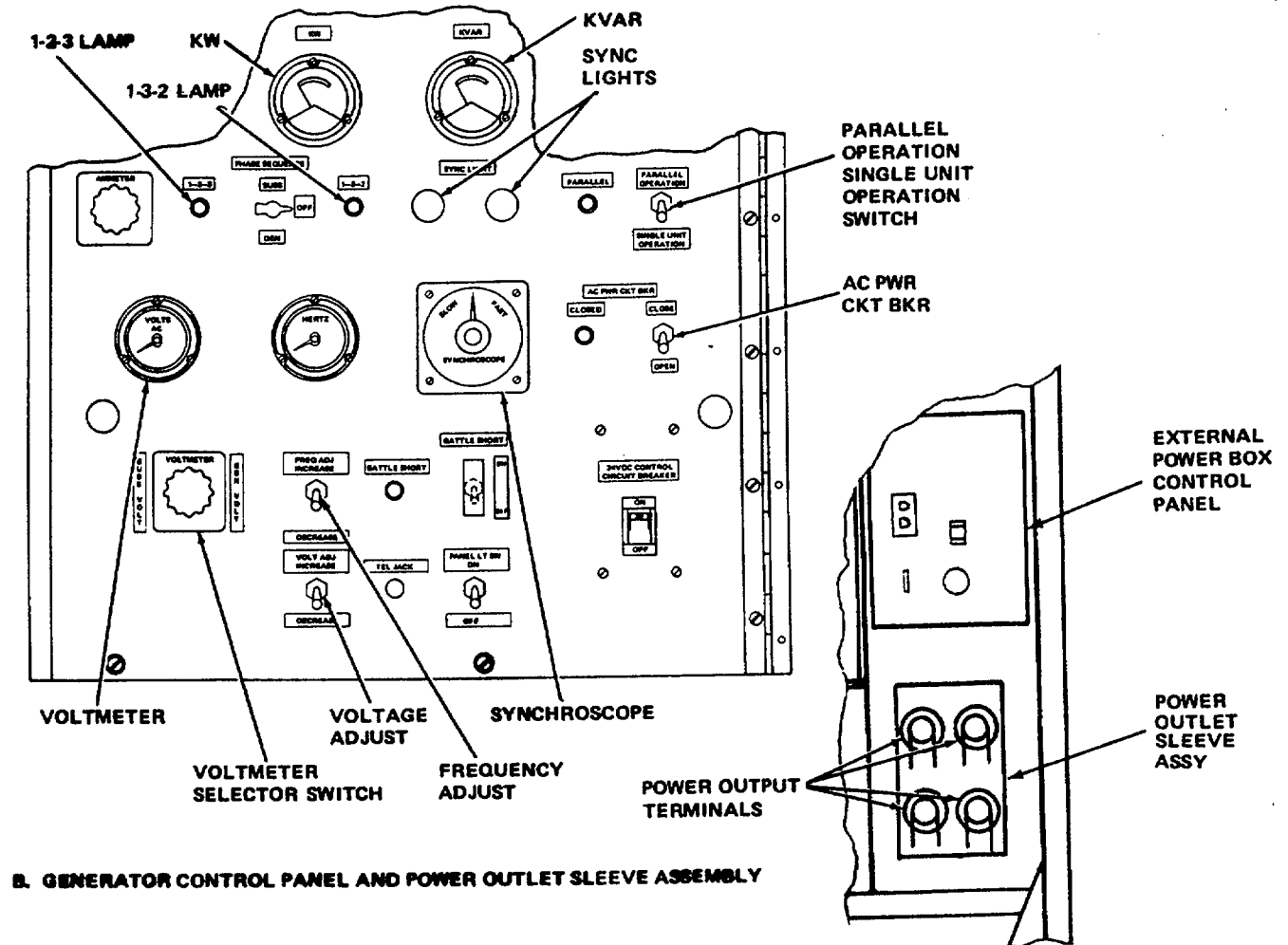

**B. GENERATOR CONTROL PANEL AND POWER OUTLET SLEEVE ASSEMBLY**

Figure 2-21. Operating Instructions, Manually Operated in Parallel (Sheet 3 of 3)

### Section III. OPERATION UNDER UNUSUAL CONDITIONS

#### 2-13. OPERATION IN COLD (40°F to -25°F) (4.4 to -32°C).

- a. General. The generator set operates in temperatures down to -25° (-32°C) with the housing kit installed. To operate successfully down to this temperature, the engine is heated by an integrally mounted preheat system which receives auxiliary power from an external source.
- b. Fuel System. Be sure proper grade of fuel is used for existing temperatures. Service fuel filters and strainers more frequently than normal. Remove ice, snow, and moisture from the filler cap and filler neck. At end of day's operation, drain water from fuel tank and from the fuel filters.
- c. Engine Electrical System. Clean batteries and cables and inspect for cracked or damaged cases. Be sure the battery terminals are tight, clean and lightly greased. See that the battery cap vent holes are open. The electro-lyte level must be 3/8 inch (9.5 mm) above the plates. See that batteries are kept fully charged. Inspect all electrical wiring for cracks, breaks, and fraying. Tighten loose connections.

#### NOTE

**After adding water to the batteries in freezing temperatures, operate the battery charger for at least 1 hour.**

- d. Lubrication. Lubricate in accordance with instructions in Chapter 3, Section II.
- e. Cooling System. Inspect level of coolant in radiator by checking sight glass. Inspect cooling system for leaks, paying particular attention to gaskets and hose connections. Verify that antifreeze mixture is in accordance with table 3-1.

#### 2-14. OPERATION IN EXTREME HEAT (UP TO 125°F) (52°C).

- a. Keep the cooling system free from rust and scale by changing water filters. Keep cooling system filled with clean coolant. Avoid use of alkaline water or salt water, which causes the accumulation of rust and scale. Inspect belts for proper adjustment. Be sure engine generator set is free of dust and dirt. Check for obstructions in radiator cooling fins and make sure shutter controls are operating properly.
- b. Lubricate in accordance with the instructions in Chapter 3, Section II.
- c. Inspect battery electrolyte level daily. The plates should be covered with 3/8 inch (9.5 mm) of water. Add water if necessary.
- d. Be sure generator set is free of airflow restrictions. When operating indoors, make provisions for adequate ventilation and the venting of exhaust fumes to the outside.
- e. Keep external surface of engine clean.
- f. Run generator set at no load, for 5 minutes, to allow the engine to cool prior to shutdown.

#### 2-15. OPERATION IN DUSTY OR SANDY AREAS.

- a. Housing kit must be installed.
- b. Where water is available, keep the immediate area wetted down. Keep the unit as clean as possible, paying special attention to screens and grilles.
- c. Clean filters and strainers more frequently than under normal conditions. Be sure that all lubricant containers are tightly sealed and stored in an area free from dust and sand.
- d. Take all necessary precautions to

**TM 5-6115-593-12**  
**TO 35C2-3-463-1**

keep dirt and grit out of the fuel tank.

2-16. OPERATION UNDER RAINY OR HUMID CONDITIONS. The housing kit must be installed for operation under rainy or humid conditions. During dry periods when the set is not operating, open the doors and allow the set to dry out. Drain water and sediment from fuel tank more frequently.

2-17. OPERATION IN SALT WATER AREAS.

- a. Housing Kit must be installed.
- b. Salt water causes corrosive action on metal. Care must be taken to avoid equipment contact with salt water. If contact is made, or if the unit is exposed to salt spray, wash the generator set frequently with clean, fresh water.
- c. Remove rust or other corrosion and paint all damaged pre-painted surfaces in accordance with service requirements.

2-18. OPERATION AT HIGH ALTITUDES. The generator set will operate at elevations up to 1500 feet (457 meters) above seal level without special

adjustment or reduction in load. A reduction in the load at higher altitudes may be necessary, since engines are more likely to overheat. The following derating factors are applicable.

60 Hz  
500 KW to 1500 ft ( 457 m) at 125°F (52°C)  
400 KW to 5000 ft (1410 m) at 100°F (39°C)  
375 KW to 8000 ft (2435 m) at 90°F (32°C)

50 Hz  
417 KW to 1500 ft ( 457 m) at 125°F (52°C)  
332 KW to 5000 ft (1410 m) at 100°F (39°C)  
312 KW to 8000 ft (2435 m) at 90°F (32°C)

2-19. OPERATION IN SNOW. The housing kit must be installed for operation in snow. Drain water and sediment from fuel tank more frequently. Check coolant anti-freeze protection and check batteries. Ensure that drifting snow does not obstruct normal cooling air flow.

2-20. EMERGENCY OPERATION ON JP5 FUEL. Engine/generator sets require no adjustments to engine timing or fuel injectors for operation on JP5 fuel. When JP5 fuel is used, power output is reduced by a factor of 20 percent.



CHAPTER 3

OPERATOR/CREW MAINTENANCE INSTRUCTIONS

Section I. CONSUMABLE OPERATING AND MAINTENANCE SUPPLIES

3-1. Refer to table 3-1 for a listing of the consumable operating and maintenance supplies.

Table 3-1. Consumable Operating and Maintenance Supplies

COMPONENT APPLICATION	NATIONAL STOCK NUMBER	DESCRIPTION	QTY REQUIRED FOR INITIAL OPERATION	QTY REQUIRED 8 HOURS OPERATION	NOTES
Tank, Fuel	9130-00-273-2379(1)	Fuel JP5 MIL-T-5624	(3)	(4)	(1) See Federal Supply Catalog C9100-1L for additional requisitioning data
	9140-00-286-5294(1)	Regular Grade, DF2	(3)	(4)	(2) See Federal Supply catalog C6800-1L for
	9140-00-286-5283(1)	Artic Grade, DFA	(3)	(4)	additional requisitioning data.
Ether Starting System	2910-00-209-4997	Tank, ether	(5)	(5)	(3) Tank Capacity 117 gal. (442.8)
Crankcase		Oil Lubricating 5 gal. (19 1) pail			(4) Average Fuel Consumption a. 1/4 load 11.4 gal./hr (43.3 1/hr) b. 1/2 load 19.2 gal./hr (73 1/hr) c. 3/4 load 27 gal./hr (103 1/hr) d. Full load 37 gal./hr (141 1/hr)
	9150-00-265-9435(1)	Grade, OE/HDO 30 MIL-L-2140	(6)	(9)	(5) One tank, if required for cold weather starting

Table 3-1. Consumable Operating and Maintenance Supplies - Continued

COMPONENT APPLICATION	NATIONAL STOCK NUMBER	DESCRIPTION	QTY REQUIRED FOR INITIAL OPERATION	QTY REQUIRED 8 HOURS OPERATION	NOTES
Crankcase (Cont'd)	9150-00-265-9435(1)	Grade, OE/HDO 30 MIL-L-2140	(6)	(9)	(5) One tank, if required for cold weather starting
	9150-00-265-9428(1)	Grade, OE/HDO 10 MIL-L-2104	(6)	(9)	
	9150-00-242-7603(1)	55 Gal Drum (209 1)			
	9150-00-265-9436(1)	Grade, OE/HDO 30 MIL-L-2104	(6)	(9)	(6) Crankcase Capacity 19 gal. (68 1)
	9150-00-191-2972(1)	Grade, OE/HDO 10 MIL-L-2104	(6)	(9)	(7) Cooling System Capacity 52 gal. (197 1)
	9150-00-242-7604(1)	Grade OES MIL-L-10295	(5)	(9)	(8) See LO for lube points (9) See LO for grade application and replenishment intervals.
Electric Hydraulic Actuator	9150-00-242-7604(1)	Grade OES MIL-L-10295	(10)	(9)	(10) Electric Hydraulic Actuator Sump Capacity 1 gal. (3.7 1)
Parts, Cleaning	6950-00-281-1985(2)	Solvent (1 gal 3.8 1) Can FED-P-D-680			.
Batteries	6810-00-249-9354	Electrolyte	(10)		(10) Requires 3 1/2 gal. fill batteries
Radiator	6850-00-243-1992(2)	Coolant Anti-Freeze Inhibited Glycol		(7)	(7)
	6850-00-174-1806	Anti-Freeze Compound Artic	(7)	(7)	

## Section II. LUBRICATION INSTRUCTIONS

3-1. This section contains lubrication instructions which are supplement to, and not covered in the lubrication order. Refer to Lubrication Order L05-6115-593-12 for lubrication instructions.

Refer to DA PAM 310-4 (Army) and SL-1-3 (MC) to ensure the latest edition of the LO is used.

### WARNING

**To avoid accidental cranking to startup, set MAINTENANCE LOCKOUT switch (12, figure 2-3) to LOCKOUT position, disconnect negative cable from battery negative terminal, and remove external power, prior to servicing the generator set. Reconnect cable at completion of service procedure.**

## Section III. PREVENTIVE MAINTENANCE CHECKS AND SERVICES (PMCS)

3-3. GENERAL. To ensure that the generator set is ready for operation at all times, it must be inspected systematically so that defects may be discovered and corrected before they result in serious damage or failure. The necessary preventive maintenance services to be performed are listed and described in table 3-2 (A,MC). Item numbers indicate the sequence of minimum inspection requirements. Defects discovered during operation of the unit shall be noted for future correction, to be made as soon as operation has ceased. Stop operation immediately if a deficiency is noticed which would damage the equipment if operation were continued.

Air Force users shall refer to the applicable inspection manuals and work card sets in T.O. 35C2-3-Series for periodic preventive maintenance requirements and table 3-2 for detailed procedures. Marine Corps users should refer to the current issue of TM 11275-15/1.

3-4. PREVENTIVE MAINTENANCE CHECKS AND SERVICES (A,MC). Table 3-2 contains a tabulated listing of PMCS which shall be performed by the operator crew personnel. The item numbers are listed consecutively and indicate the sequence of minimum requirements.

## Section IV. TROUBLESHOOTING

3-5. GENERAL.

- a. Table 3-3 contains troubleshooting information for locating and correcting operating troubles which may develop in the generator set. Each malfunction for an individual component, unit, or system is followed by a list of tests or inspections which will help you to determine probable causes and corrective actions to take. You should perform the tests/inspections and corrective actions in the order listed.

- b. This manual cannot list all malfunctions that may occur, nor all tests or inspections and corrective actions. If a malfunction is not listed or cannot be corrected by listed corrective actions, notify your supervisor.

### NOTE

Before you use table 3-3, be sure you have performed all applicable operating checks.

**TABLE 3-2. OPERATOR/CREW PREVENTIVE MAINTENANCE CHECKS AND SERVICES**

NOTE: Within designated interval, these checks are to be performed in the order listed.

B-BEFORE  
D-DURING      A-AFTER

ITEM NO.	INTERVAL				ITEM TO BE INSPECTED	PROCEDURES CHECK FOR AND HAVE REPAIRED OR ADJUSTED AS NECESSARY	EQUIPMENT IS NOT READY/ AVAILABLE IF:
	B	D	A				
1	o				Batteries and related items	<p>Check batteries for electrolyte level and check for security. Ref par. 2-13C. Inspect exhaust installation for condition, security, and leakage. Check that rain caps move freely. Check for proper ground connection. Inspect for damage and loose mounting. Operate press-to-test indicator. Check the following for proper operation.</p> <p>Battery charging volts. Battery charging ammeter green portion of scale.</p> <p>Fuel level gauge. Coolant temperature gauge 180 to 200 F (81 to 93 C). Oil Pressure Gauge 30 to 255 psi (2.1 to 3.5 kg/cm ). AC Voltmeter 120/208, 240/416 volts* AC Ammeter Not to exceed 100% Kilowatt Meter Not to exceed 100%</p> <p>Frequency Meter 50-60 Hz* Fault Indicators All lamps out during operation. Check lamp operation using press to test switch.</p>	<p>Cables are loose Electrolyte level low</p> <p>Rain caps are stuck closed.</p> <p>Unit is not grounded</p>
2		o		Muffler and exhaust			
3	o			Ground Terminal			
4	o	o		Controls and instruments Engine Panel			
4		o		Generator Panel			

\* These values are nominal, refer to paragraph 1-10 for permissible voltage or frequency operating range for unusual installations.

**TABLE 3-2. OPERATOR/CREW PREVENTIVE MAINTENANCE CHECKS AND SERVICES**

NOTE: Within designated interval, these checks are to be performed in the order listed.

B-BEFORE      A-AFTER  
D-DURING

ITEM NO.	INTERVAL				ITEM TO BE INSPECTED	PROCEDURES CHECK FOR AND HAVE REPAIRED OR ADJUSTED AS NECESSARY	EQUIPMENT IS NOT READY/ AVAILABLE IF:
	B	D	A				
5	o				Air Cleaners	Check service indicator	Indicator in Red
6	o				Radiator Assembly	<p><b>CAUTION</b></p> <p>Relieve pressure in radiator by loosening radiator cap and waiting two minutes before removing cap. Check for leaks</p> <p>Check and service radiator (using sight gauge) for sufficient coolant.</p> <p>Check louvers for freedom of operation</p> <p>Check fan belts for wear and proper tension Check radiator fins for damage or obstruction.</p>	<p>Ref. par. 2-13e</p> <p>No coolant showing in sight gauge</p>
7	o	o	o		Fuel System	<p>Check fuel lines for leaks and security</p> <p><b>WARNING</b></p> <p>When handling diesel fuel, always provide a metal-to-metal contact between the container and fuel tank. This will prevent a spark from being generated as fuel flows over the metal surface.</p> <p>Never service generator set when in operation. After operation, assure that tank is full to prevent moisture condensation.</p> <p>Check position of valve to OPEN on inside of fuel filler neck cap.</p> <p>Add fuel as required Drain water and sediment from filters. Inspect filters.</p>	
	o	o					

**TABLE 3-3. OPERATOR/CREW TROUBLESHOOTING**

MALFUNCTION
TEST OR INSPECTION
CORRECTIVE ACTION

1. ENGINE FAILS TO CRANK OR CRANKS SLOWLY WHEN MASTER SWITCH IS MOVED TO START.

Step 1. Check BATTERY CHRG AMPS and BATTERY CHRG VOLTS meters on Engine Control Panel. Current and voltage reading should be within 0 and 2 and 22 to 26, respectively.

If readings are within limits indicated, refer malfunction to next higher level of maintenance. If not proceed to steps 2, 3, and 4, as required.

Step 2. Check for defective, corroded, or loose battery cables and battery terminals.

If cables or terminals are defective, refer to next higher maintenance for repair. Step 3. Check electrolyte level of batteries. Level should be at bottom of fill hole for each battery cell.

If necessary add distilled or clean water to required level.

Step 4. Check OVER CRANK indicator lamp. If lit, wait until light goes out and try cranking again. If light is lit and will not go out, refer malfunction to next higher level of maintenance.

2. ENGINE CRANKS BUT WILL NOT START.

Step 1. Visually check for closed air boxes.

Manually reset to open position if required.

Step 2. Inspect air cleaner assembly for excessive dirt.

If excessive dirt is present, refer to next higher maintenance replacement.

Step 3. Inspect all fuel lines and fittings for leaks, loose connections, and any signs of obvious damage.

If fuel lines or fittings are loose or damaged, refer to next higher maintenance for replacement.

**TABLE 3-3. OPERATOR/CREW TROUBLESHOOTING**

MALFUNCTION	TEST OR INSPECTION	CORRECTIVE ACTION
-------------	--------------------	-------------------

2. ENGINE CRANKS BUT WILL NOT START - Continued

Step 4. Check LOW FUEL LEVEL indicator lamp on Generator Control Panel.

If lit, temporarily set BATTLE SHORT switch to ON. If engine starts set MASTER SWITCH to STOP and check fuel oil levels in auxiliary tanks. Set FUEL PUMP switch to AUTO if not already in this position. If LOW FUEL LEVEL indicator lamp is not lit refer malfunction to next higher level of maintenance.

3. ENGINE SHUTS DOWN SOON AFTER STARTING.

Check engine fault indicators.  
Check for low fuel oil level in day tank.

Add fuel oil as required.

4. ENGINE SHUTS DOWN AND WILL NOT RESTART.

Step 1. Check ENG FAULT indicator lamps on Generator Control Panel.

If any one of them is lit refer to appropriate subsequent step.

Step 2. If HI COOL TEMP indicator lamp is lit, check coolant level at radiator sight glass.

If low add coolant (as required by weather conditions).

**WARNING**

**Remove radiator cap slowly to permit pressure to escape prior to removal of cap.**

If coolant level normal, refer to next higher level of maintenance.

Step 3. If HI LUB TEMP indicator lamp is lit, check lube oil level using oil level sight gauge.

Add lube oil as required.

Step 4. If LOW OIL PRESS indicator lamp is lit, check lube oil level using oil level sight gauge.

Add lube oil as required.

**TABLE 3-3. OPERATOR/CREW TROUBLESHOOTING**

MALFUNCTION	TEST OR INSPECTION	CORRECTIVE ACTION
-------------	--------------------	-------------------

4. ENGINE SHUTS DOWN AND WILL NOT RESTART-Continued

Step 5. If LOW FUEL LEVEL indicator lamp is lit, check level of fuel in auxiliary tank.

If empty, refill as required.

Step 6. Check OVERSPEED indicator lamp.

If lit, refer to next higher level of maintenance.

5. ENGINE RUNS ERRATICALLY OR MISFIRES.

Step 1. Check engine fuel oil for contamination.

If contaminated, drain fuel system and fill with proper fuel.

Step 2. Inspect air cleaner assembly for excessive dirt.

If excessive dirt is present, refer to next higher maintenance for replacement.

6. ENGINE EXHAUST EXCESSIVELY BLACK.

Step 1. Inspect air cleaner assembly for excessive dirt.

If excessive dirt is present, refer to next higher maintenance for replacement.

Step 2. Check KW meter on Generator Control Panel.

Reduce load to rated level. If KW meter reading is within rated level, refer to next higher level of maintenance.

7. ENGINE EXHAUST WHITE OR BLUE.

Step 1. Check for improper fuel.

Drain fuel system and fill with proper fuel.

Step 2. Check for excessive lube oil using dipstick or sight gauge.

Drain crankcase until proper level is indicated.



**TABLE 3-3. OPERATOR/CREW TROUBLESHOOTING**

MALFUNCTION
TEST OR INSPECTION
CORRECTIVE ACTION

8. GENERATOR OUTPUT FREQUENCY INCORRECT.

Check HERTZ meter on Generator Control Panel.

If incorrect, set FREQ ADJ switch to either INCREASE or DECREASE as required, to return HERTZ meter reading to correct frequency. If adjustment cannot be made refer to next higher level of maintenance.

9. GENERATOR OUTPUT VOLTAGE INCORRECT.

Check VOLTS AC meter on Generator Control Panel.

If incorrect, set VOLT ADJ switch to either INCREASE or DECREASE as required, to return VOLTS AC meter reading to correct voltage. If adjustment cannot be made refer to next higher level of maintenance.

10. GEN or ENG FAULT INDICATOR LAMPS FAIL TO LIGHT.

Check FAULT indicator lamps by using ANNUNCIATOR TEST switch

If any lamps fail to light or light dimly, replace lamp. If replacing lamp fails to correct problem, refer to next higher level of maintenance.

11. HIGH COOLANT TEMPERATURE.

Step 1. Coolant level low.

Add coolant.

Step 2. Low oil level.

Add lube oil.

Step 3. Generator set overloaded.

Reduce load to rated level.

## Section V. OPERATOR/CREW MAINTENANCE

3-6. GENERAL. Instructions in this section are provided to assist the operator/crew in maintaining the generator set. If during inspections defective components are noted, refer to higher level maintenance for replacement or repair.

### 3-7. MAINTENANCE OF BATTERIES AND RELATED ITEMS.

#### a. Inspection

(1) Inspect cables and connectors for corrosion and looseness.

(2) Inspect batteries for damage or cracked cases.

#### b. Service. Service at intervals shown in table 3-2.

(1) Check electrolyte level of batteries. If low, fill with distilled water to 3/8 inch (9.5 mm) above plates. Refer to next higher level of maintenance.

(2) Apply grease to cable connectors to prevent corrosion. If connectors are corroded, clean prior to applying grease. (3) Replace batteries when cracked. Refer to next higher level of maintenance.

(4) Tighten loose cable connectors. Refer to next higher level of maintenance.

### 3-8. MAINTENANCE OF MUFFLER AND EXHAUST.

#### **WARNING**

**Be certain that the exhaust is not fed back into the system, or back into the immediate area of working personnel. Exhaust may be injurious to the health of personnel. Inspect the mufflers and exhaust system as follows (see figure 4-11):**

a. Inspect mufflers for looseness, rust, and damage.

b. Inspect metal hoses for rust and dents.

c. Inspect entire exhaust system for evidence of leaks, particularly around gasket areas.

d. Inspect weather cap for proper operation. Cap must open and close freely.

e. Inspect entire assembly for loose nuts and bolts.

3-9 MAINTENANCE OF EXTERNAL POWER BOX ASSEMBLY. See figure 4-12 and inspect receptacles, circuit breakers, switches, and plate and sleeve assembly for loose mounting and loose electrical connections.

3-10. MAINTENANCE OF AC-DC CONTROL BOX ASSEMBLY. Inspect the AC-DC Control Box Assembly as follows (see figure 4-17):

a. Inspect circuit breaker, switches, potentiometer, and DC amp shunt for cracks, breaks, corroded terminals and loose electrical connections.

b. Inspect receptacles and shorting plug for damaged threads, bent, loose or missing pins.

c. Inspect wiring for defective insulation.

3-11. MAINTENANCE OF CONTROL CUBICLE. See figures 4-20 and 4-22 and proceed as follows:

a. Inspection.

(1) Inspect transformers, switches, and circuit breakers for cracks, breaks, corroded terminals, and loose electrical connections.

(2) Inspect gauges and instruments for damage.

(3) Inspect lamps for loose electrical connections.

(4) Inspect receptacles for damaged threads, bent, loose, or missing pins. Inspect telephone jack for loose mounting.

(5) Inspect wiring for defective insulation.

b. Replacement.

(1) Replace defective bulbs in lamp assemblies. Refer to next higher level of maintenance.

(2) Replace defective telephone jack as follows:  
Refer to next higher level of maintenance.

(a) Tag and remove wires connected to the jack.

(b) Remove the hex nut and flat washer attaching jack to panel and remove jack.

3-12. MAINTENANCE OF AIR CLEANER. (See figure 3-1)

a. Inspect air cleaner service indicator (17, figure 3-1) for a red restriction indication.

b. Inspect service indicator for loose mounting and damage.

c. Inspect air cleaner filter elements (4 and 7, figure 3-1) for signs of blocking and holes.

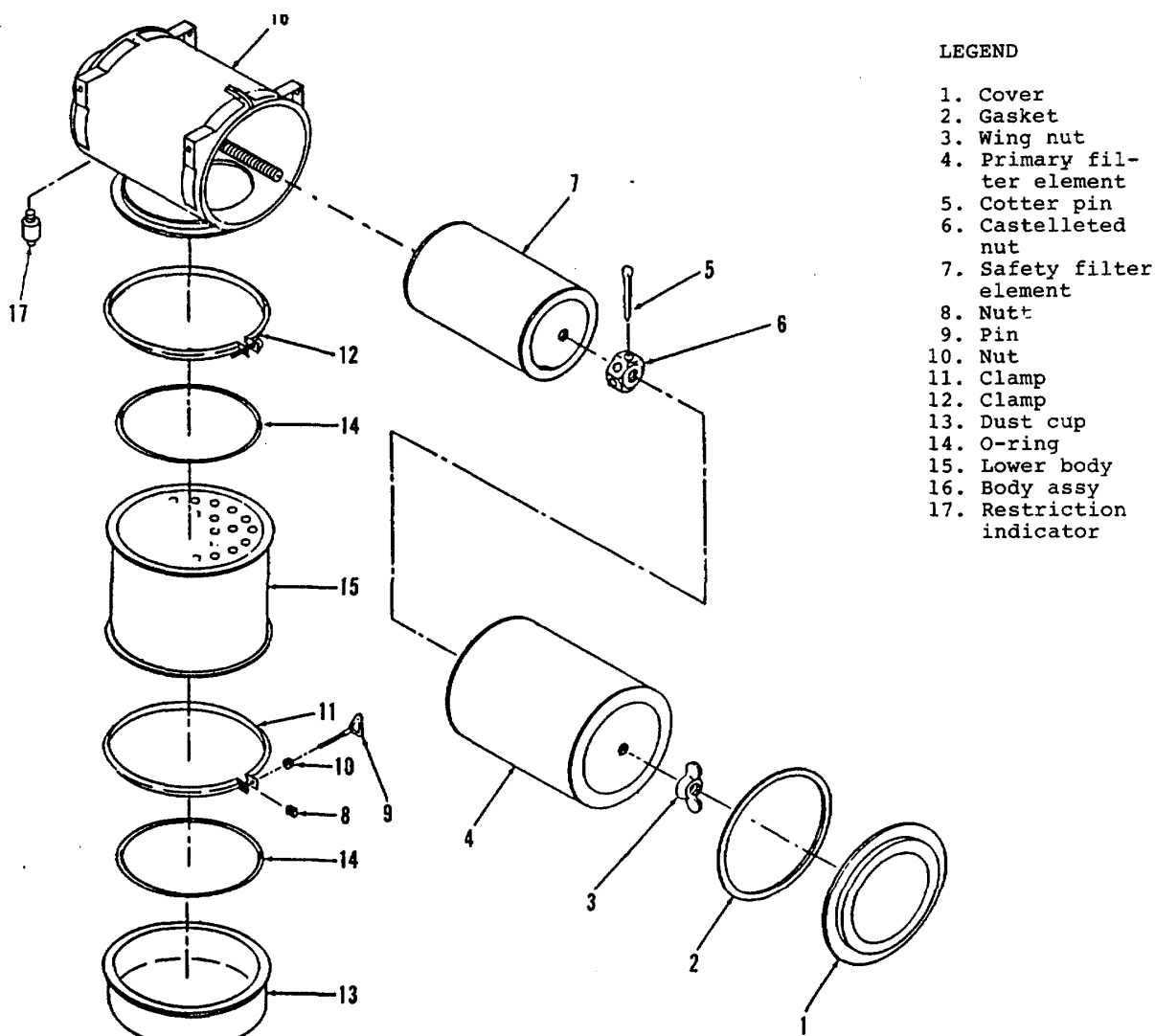

LEGEND

- 1. Cover
- 2. Gasket
- 3. Wing nut
- 4. Primary filter element
- 5. Cotter pin
- 6. Castellated nut
- 7. Safety filter element
- 8. Nut
- 9. Pin
- 10. Nut
- 11. Clamp
- 12. Clamp
- 13. Dust cup
- 14. O-ring
- 15. Lower body
- 16. Body assy
- 17. Restriction indicator

Figure 3-1. Air Cleaner, Exploded view

- d. Inspect gasket (2, figure 3-1), dust cap (13) and O-ring (14) for damage.
- e. Remove and empty dust cap (13).
- f. Inspect air cleaner for loose induction system connections.

### 3-13. MAINTENANCE OF RADIATOR ASSEMBLY.

#### a. Inspection. (See figure 4-27.)

- (1) Inspect radiator core, sight glass, piping, and hose connections for leaks.
- (2) Inspect hoses for leaks.
- (3) Inspect motor for evidence of overheating and loose mounting.
- (4) Inspect fan belt guard and fan guard for loose mounting.
- (5) Remove fan guard mounting nuts and fan guard, figure 4-28. Inspect fan belt for tears, breaks, or frayed edges.
- (6) Check fan belts to see that they do not move more than 1/2 inch (12.7mm) when applying pressure with the thumb against each belt (see figure 4-1).
- (7) Reinstall fan guard and mounting screws and nuts.

- b. Service. Service the radiator as follows:

#### **WARNING**

**Remove radiator cap slowly to permit pressure to escape prior to removal of cap.**

- (1) Check coolant level at sight glass. If low, remove cap and add coolant.
- (2) Check coolant strength with a hydrometer for winterization protection. If weak, add same

type of coolant presently in radiator. Refer to table 3-1 for proper coolant.

- (3) Open radiator cap access door on top of unit and fill radiator until coolant level is 2 inches (51 mm) below filter neck (center of sight glass).
- (4) Fasten tag near radiator cap indicates date, type of coolant, and level of protection. Replace cap and close access door.

### 3-14. MAINTENANCE OF FUEL LINES AND FITTINGS. See figure 4-29 and inspect all fuel lines and fittings for loose connections, leaks, and breaks.

### 3-15. MAINTENANCE OF FUEL TRANSFER PUMP ASSEMBLIES.

- a. Inspection. See figure 3-2 and inspect fuel transfer pump for leaks at elbows, connectors, drain cocks, and filters. Tighten as necessary. Inspect motor for overheating indications.

- b. Service. Service the filter and strainers as follows (see figure 4-31):

- (1) Remove screw (24), washer (25), large can (26), and filter element (27) in can and install with gasket (28), washer (25), and screw (24). Tighten securely. Replace gasket (28) if defective.
- (2) Remove nut (30), washer (31), small can (32), and metal strainer (33). Replace strainer and tighten strainer assembly with nut (30). Removal and replacement of both strainers are the same.

### 3-16. MAINTENANCE OF FUEL TANK ASSEMBLY. (See figures 4-33, 4-34, and 4-35)

- a. Fuel Level Switches.

- (1) Inspect the wires to the switch for secure connection.
- (2) Inspect, for loose terminals or other signs of damage.
- (3) If defective, refer to next higher maintenance.

b. Fuel Level Indicator Transmitter.

- (1) Inspect the wires to the switch for looseness and damage.
- (2) Inspect wires to transmitter.
- (3) If defective, refer to next higher maintenance.

3-17. MAINTENANCE OF INTERCONNECTION ELECTRICAL HARNESS.

**CAUTION**

Disconnect the battery ground cable from the battery before inspecting the wiring. Inspect wiring for defective insulation.

Inspect connectors for damaged threads, bent, loose, or missing pins.

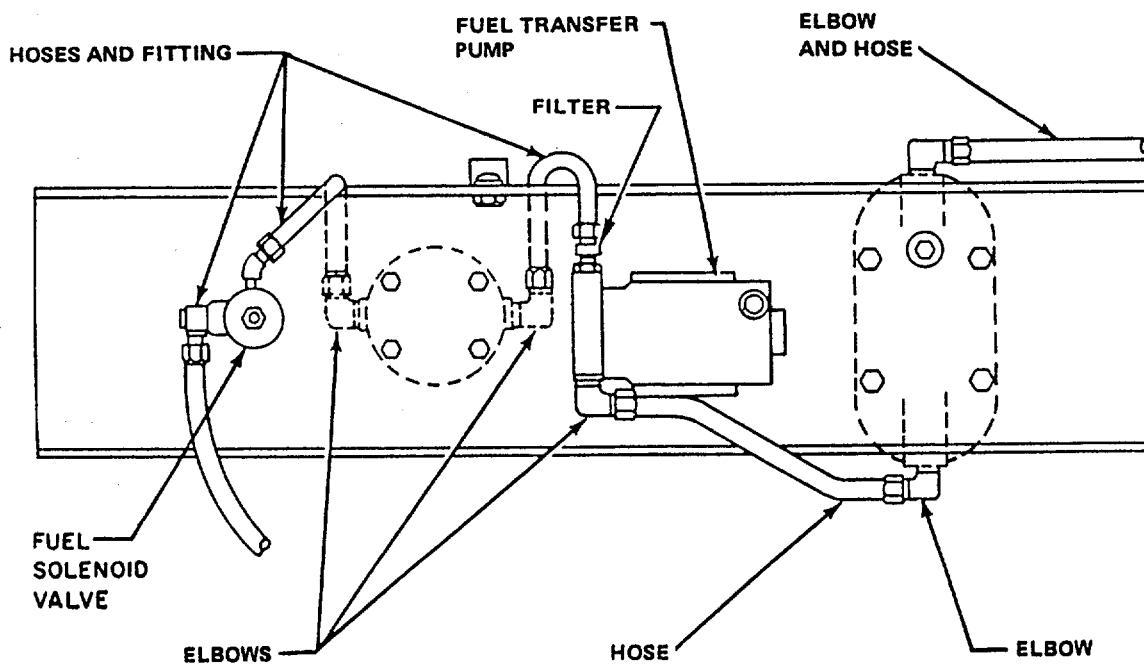

Figure 3-2. Fuel Transfer Pump Inspection Points

3-18. MAINTENANCE OF ELECTRIC HYDRAULIC ACTUATOR. See figure 4-37 and inspect sump tank for leaks, cracks, or distortion. Inspect linkage for binding.

broken glass. Check seal in oil level gauge cap for tears.

3-19. MAINTENANCE OF ETHER KIT. (See figure 4-38.)

a. Inspection.

- (1) Inspect all lines from ether tank to engine for damage.
- (2) Inspect all clamps securing lines for looseness.
- (3) Inspect ether tank and solenoid valve for secure mounting.

d. Inspect the oil filler for dents, damaged threads, damaged oil filler cap, or damaged seal.

e. Inspect the starter assembly for cracks, dents, loose, damaged electrical connections, and loose mounting.

f. Inspect the oil pressure transmitter for leaks, cracks, loose mounting and loose electrical connections.

g. Inspect the oil filter for leaks, cracks, breaks, and dents.

h. Inspect the primary fuel filter for breaks or cracks. Inspect threaded parts for damaged or stripped threads.

i. Inspect the temperature transmitter for leaks, cracks, breaks, and loose connections.

j. Inspect the oil pan assembly drain fittings, valves, and hose connections for leaks, cracks, and loose mounting. Inspect hose for deterioration, and tears. Inspect oil pan for cracks, dents, and leaks.

k. Inspect fuel injection pump for leaks, cracks, loose mounting and loose connections.

l. Inspect the secondary fuel filters.

m. Inspect oil breathers on rocker arm assembly covers. Refer to par. 4-8 a (5).

b. Service.

(1) Remove ether tank. Shake the ether tank to determine existing supply. If empty, replace ether tank.

(2) Replace the tank in support frame.

3-20. MAINTENANCE OF THE ENGINE ASSEMBLY. Refer to figure 4-40 and inspect the engine assembly as follows:

a. Inspect water pump belt for looseness, signs of wear, and oil soaking. Inspect the water pump for leaks, cracks, breaks, and loose mounting.

b. Inspect the speed switch connector by removing the connector and examining for corrosion to pins, connectors, wires, and connections.

c. Inspect oil level gauge for

CHAPTER 4  
ORGANIZATIONAL MAINTENANCE

Section I. SERVICE UPON RECEIPT OF EQUIPMENT

4-1. UNLOADING THE GENERATOR SET.

**WARNING**

Use the slings provided and a lifting device with a capacity of 20 tons (18,000 kg). Do not allow the generator set to swing while it is suspended. Failure to observe this warning may result in serious injury or death to personnel.

4-2. INSPECTION AND SERVICING THE EQUIPMENT.

a. Inspection.

- (1) Inspect radiator for damage.
- (2) Inspect radiator fan drive belt for proper tension (figure 4-1). Code A.
- (3) Check that pulley guard and vibration damper guard are secure.
- (4) Inspect all air cleaner connections for tightness.
- (5) Inspect the fuel, water, and coolant lines for cracks and leaks.
- (6) Inspect that the cooling system shut-off cock (figure 4-2) is closed and the three engine water drain points (figure 4-3) are closed.
- (7) Make certain that the crankcase drain is closed (figure 4-4).
- (8) Inspect that fuel tank drain cock (figure 4-5) is closed.
- (9) Make a thorough visual inspection of the entire generator set and accessories for loose or missing mounting hardware, fuses, bulbs, or damaged or other missing parts. Report all damaged or missing parts.

b. Servicing.

**WARNING**

Do not smoke or use an open flame in the vicinity when filling fuel tank.

- (1) Fill fuel tank with appropriate fuel. (See Appendix B for quantity and type of fuel required.)
- (2) Fill radiator with arctic antifreeze solution in accordance with table 4-1.

**WARNING**

Do not smoke or use an open flame in the vicinity when servicing batteries. Batteries generate a highly explosive hydrogen gas during charging. Electrolyte is sulfuric acid diluted with water and can cause severe acid burns when spilled on skin or clothing. Use extreme care in handling while servicing batteries. When servicing batteries reference TM 9-6140-200-14.

- (3) Batteries are shipped in a dry state. Battery electrolyte must be requisitioned separately. See table 3-1 for quantity and electrolyte stock number. To activate the battery, remove cell caps and fill battery cells 3/8 inch (9.5 mm) above plates with electrolyte. Make sure vent holes in cell caps are open, and replace caps. The electrolyte level must be rechecked approximately 30 minutes after initial filling as the plates and separators will absorb the solution, thus resulting in

a lower level. If the battery is not to be used within 12 hours after initial filling, it should be put on a charger and brought up to the correct specific gravity of 1.250 or higher at 80°F (27°C).

- (4) Check crankcase oil level and add oil as necessary in accordance with the lubrication order.
- (5) Install ether tank.
- (6) Perform the "before operation" preventive maintenance services specified in table 3-2.

#### 4-3. INSTALLATION.

- a. General. The generator set should be installed on a level site, clear of obstacles, and with ample

ventilation. Site must be within 100 feet (30 m) of any generator set to be paralleled with, and 24 feet (7.3 m) of any auxiliary fuel supply, and 1000 feet (300 m) of any remote control area. Refer to intermediate (Field) (Direct and General Support) and Depot Maintenance Manual, Chapter 17, for general installation practices.

- b. Outdoor Installation. When preparing for a permanent installation, be sure that the base is solid enough to support the weight of the unit. See figure 4-6 for dimensions of the generator set. Select a location where there will be sufficient space on all sides for service and operation for the engine generator set. When preparing a temporary installation, move the engine generator set as close to the worksite as practical. Use suitable planks, logs, or other material for a base in an area where the ground is soft.

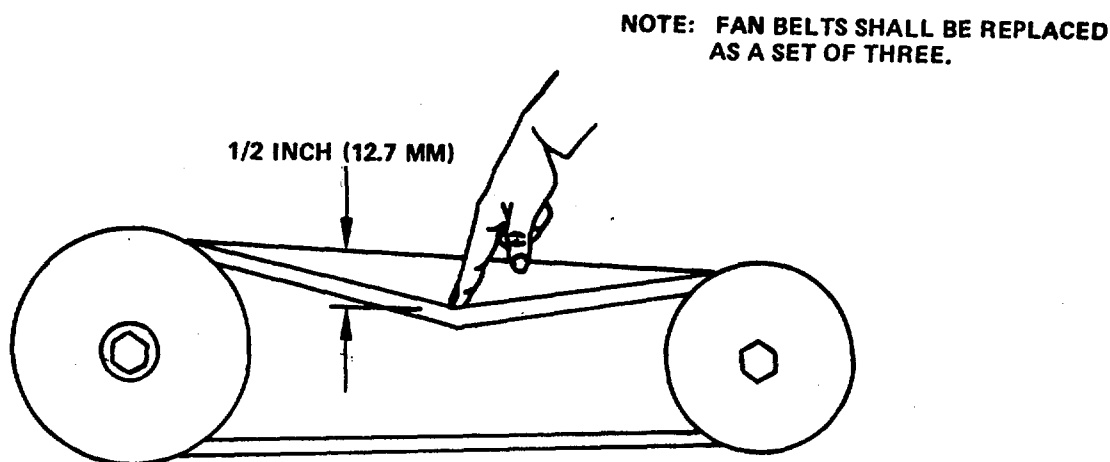

Figure 4-1. Fan Belt tension Check



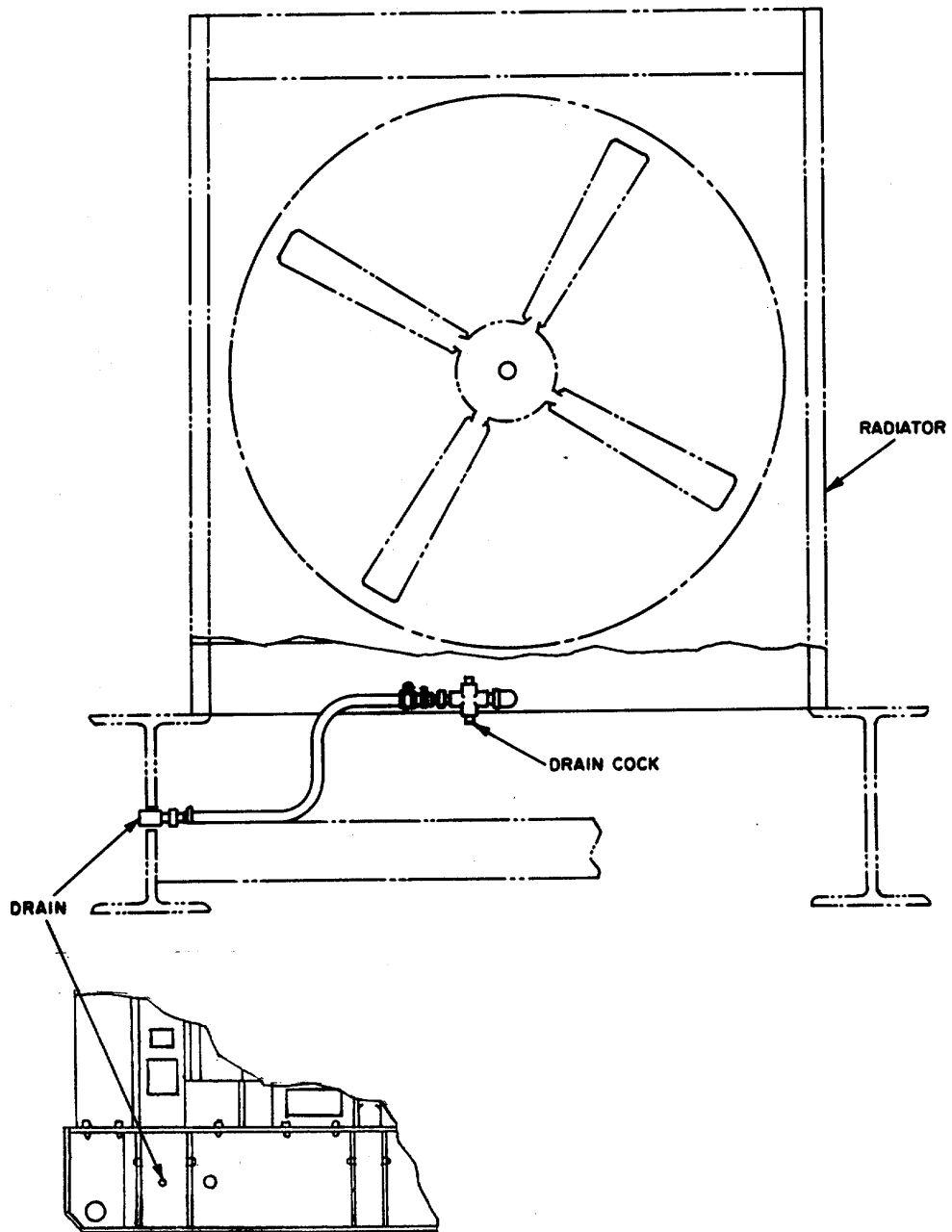

Figure 4-2. Cooling System Drain and Shut -off Cock

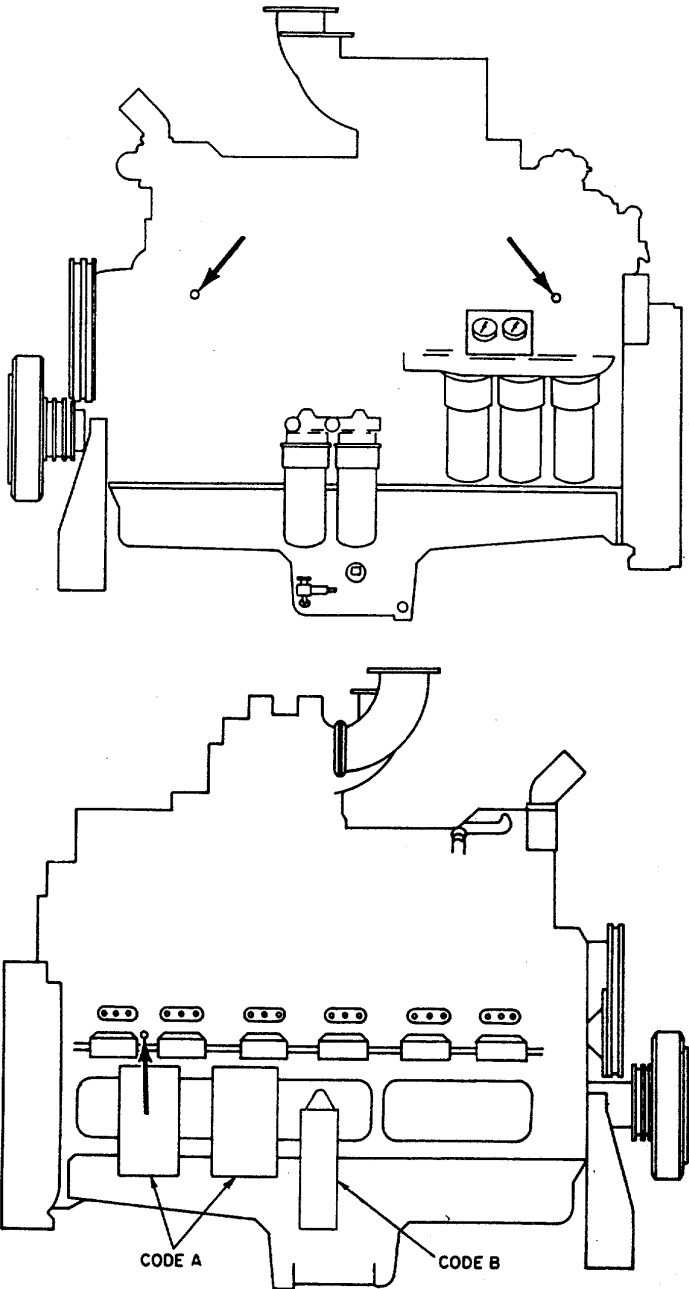

Figure 4-3. Location of Engine Water Drains

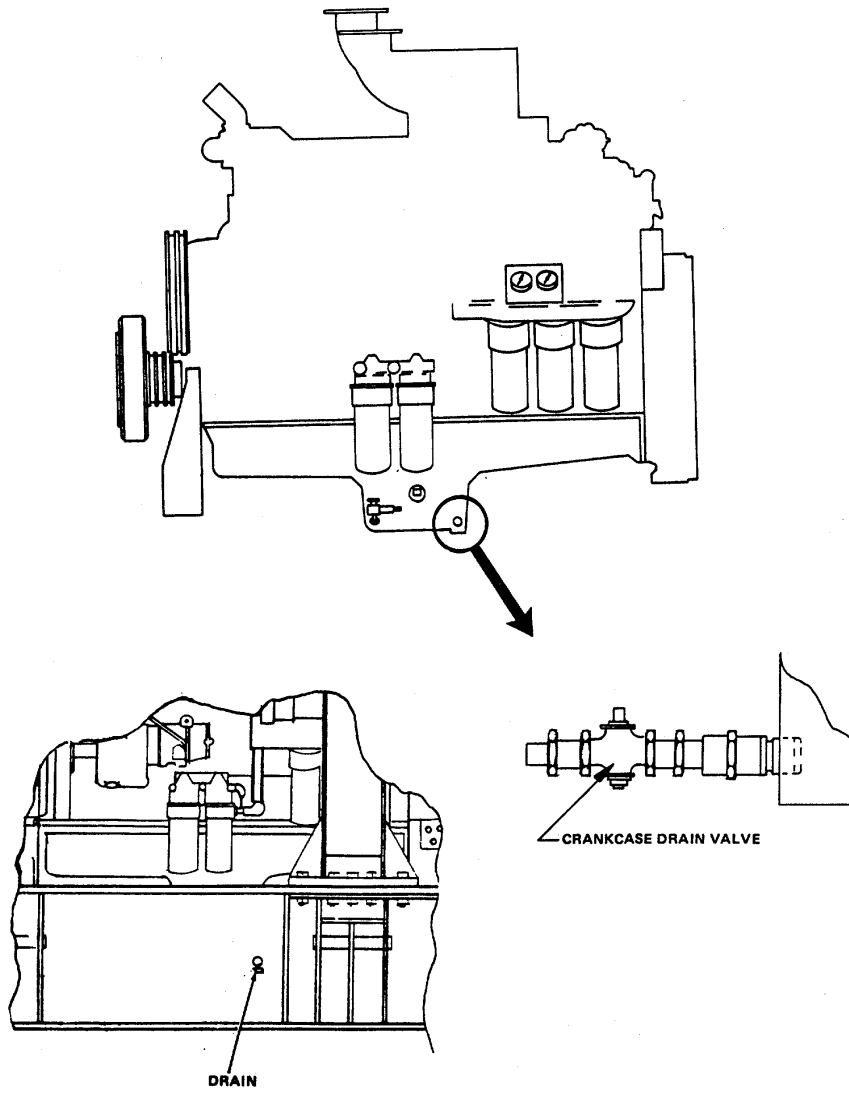

Figure 4-4. Location of Engine Crankcase  
Drain and Drain Valve

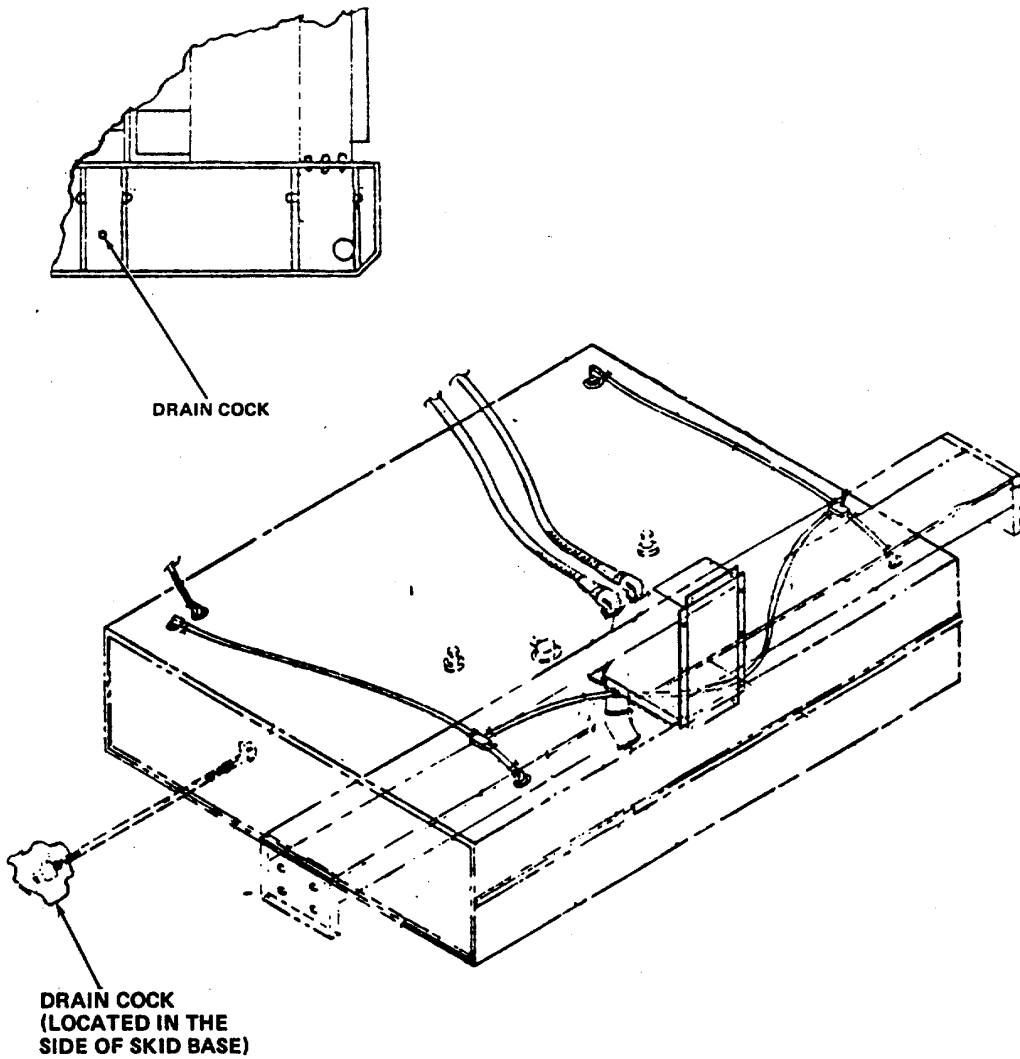
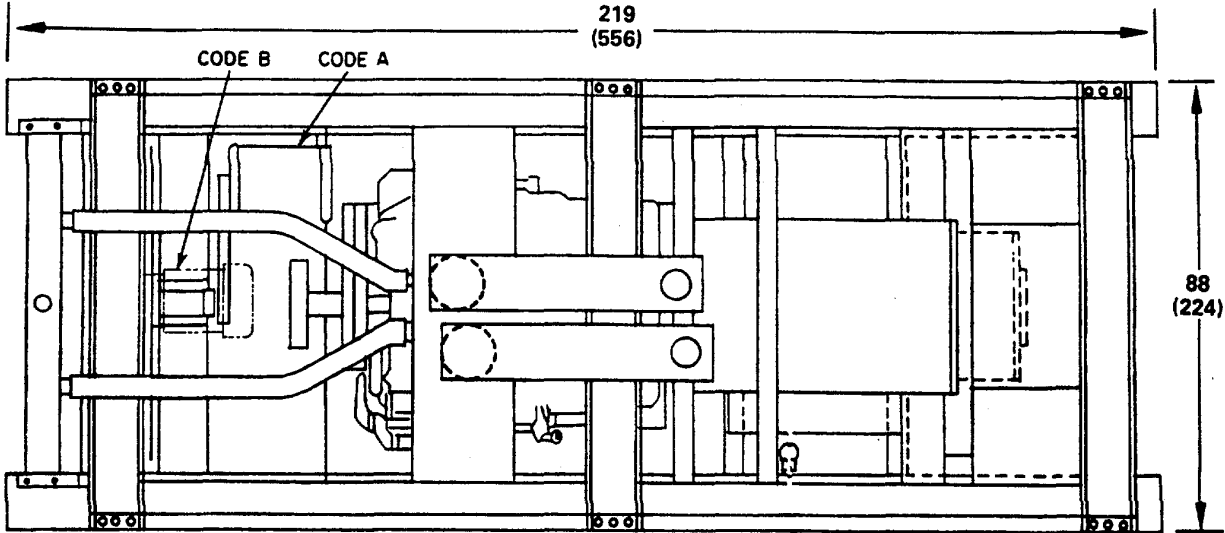

Figure 4-5. Location of Fuel Tank Drain Cock

**Table 4-1. Freezing Points, Composition, and Specific Gravities of Military Antifreeze**

LOWEST EXPECTED AMBIENT TEMPERATURE OF (0C)	PINTS (LITERS OF INHIBITED GLYCOL PER GALLONS (LITERS) OF COOLANT PINTS LITERS)	COMPOUND, ANTIFREEZE ARTIC	ETHYLENE GLYCOL COOLANT SOLUTION SPECIFIC GRAVITY AT 680F (200C)
+20 (-6.7)	1-1/2 (0.7098)	Issued full strength and ready mixed for 0 to-65°F (-17.8 to -54°C) temperatures for both initial installation and replenishment of losses  DO NOT DILUTE WITH WATER OR ANY OTHER SUBSTANCE	1.022
+10 (-12.2)	2 (0.9464)		1.036
0 (-17.8)	2-3/4 (1.3013)		1.047
-10 (-23.3)	3-1/4 (1.5379)		1.055
-20 (-28.9)	3-1/2 (1.6562)		1.062
-30 (-34.4)	4 (1.8927)		1.067
-40 (40.0)	4-1/4 (2.0111)		.1.073
-50 (-45.6)	ARTIC		
-60 (-51.1)	ANTIFREEZE		
-75 (-59.4)	PREFERRED		

1. Maximum protection is obtained at 60 percent volume (4.8 pints (2.27 liters)) of ethylene glycol per gallon (3.785 liters) of solution.
2. Military Specification MIL-A-11755 Arctic type, nonvolatile antifreeze compound is intended for use in the cooling system of liquid-cooled internal combustion engines. It is used for protection against freezing primarily in Arctic regions where ambient temperature remains for extended periods close to -40°F (-40°C) or drops below, to as low as -75°F (-59.4°C).
3. Fasten a tag near the radiator filler cap indicating the type antifreeze.



NOTE: ALL DIMENSIONS ARE IN INCHES (CM)

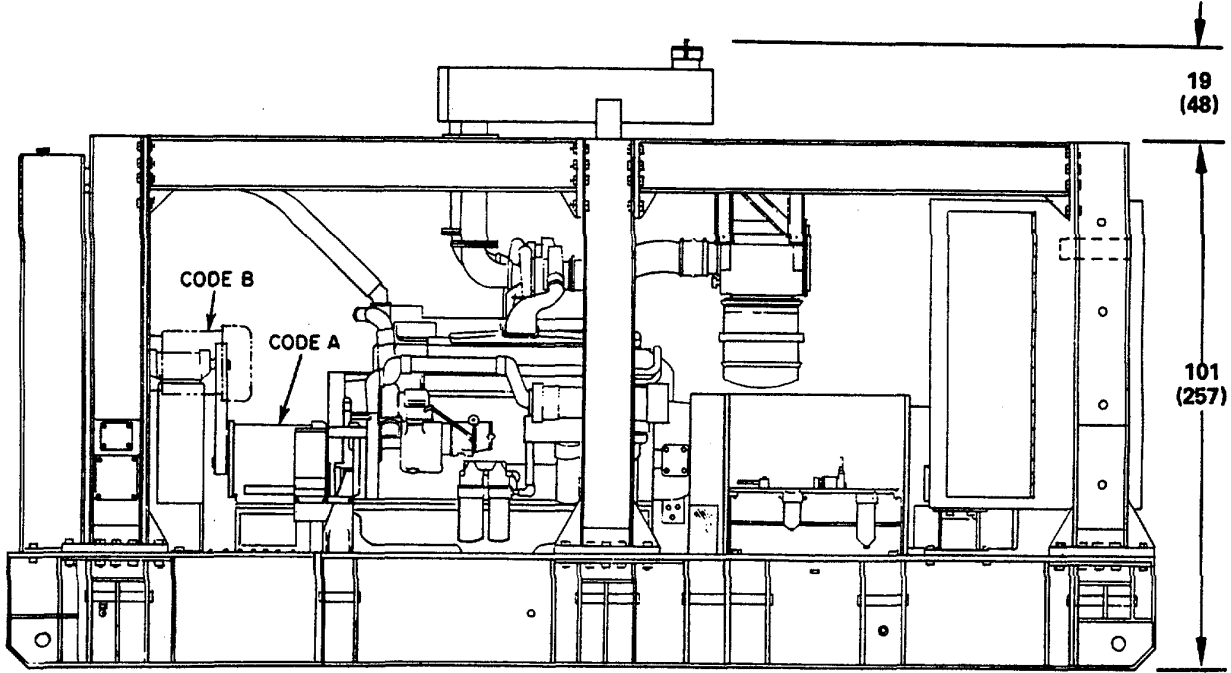

**AIR REQUIREMENTS**

ENGINE RPM	CFM AND CMM		
	COMBUSTION	COOLING	TOTAL
1800	1640 (46.4 cu m)	33,500 (948 cu m)	35,140 (998 cu m)

Figure 4-6. Installation Plan

**WARNING**

**DO NOT OPERATE ENGINE GENERATOR SET UNLESS A GROUND CABLE HAS BEEN CONNECTED TO THE GROUND TERMINAL STUD AND THEN TO A SUITABLE GROUND. ELECTRICAL FAULTS IN THE GENERATOR SET, LOAD LINES, OR LOAD EQUIPMENT, CAN CAUSE INJURY OR ELECTROCUTION FROM CONTACT WITH AN UNGROUNDED SYSTEM.**

- STEP 1. INSERT GROUND CABLE INTO SLOT IN GROUND TERMINAL STUD AND TIGHTEN NUT.
- STEP 2. PERFORM EXCAVATION TO EXPOSE BURIED WATER PIPE FOR AT LEAST 10 FEET AS SHOWN AND CHECK THAT NO INSULATED SECTION APPEARS WITHIN THE 10 FEET. IF INSULATED SECTIONS EXIST, PROCEDURE OF SHEET 2 OR 3 MUST ALSO BE PERFORMED.
- STEP 3. ATTACH GROUND CABLE TO GROUND ROD USING GROUND ROD AND CLAMP AS SHOWN, BY TIGHTENING SCREW ON CLAMP.
- STEP 4. SECURE GROUND ROD TO WATER PIPE AND CHECK THAT A GOOD ELECTRICAL BOND IS ACHIEVED.

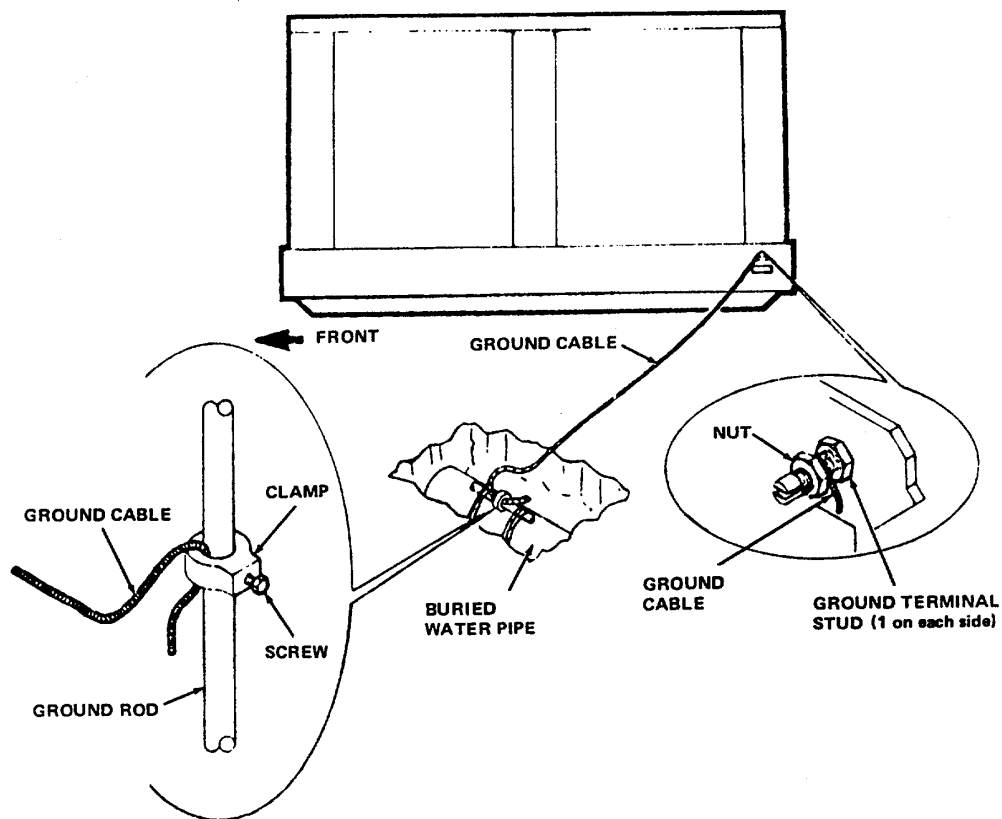

Figure 4-7. Grounding Procedures (Sheet 1 of 3)

**WARNING**

**DO NOT OPERATE ENGINE GENERATOR SET UNLESS A GROUND CABLE HAS BEEN TO THE GROUND TERMINAL STUD AND THEN TO A SUITABLE GROUND. ELECTRICAL FAULTS IN THE GENERATOR SET, LOAD LINES OR LOAD EQUIPMENT, CAN CAUSE INJURY OR ELECTROCUTION FROM CONTACT WITH AN UNGROUNDED SYSTEM.**

NOTE: FOLLOW SLIDE HAMMER PROCEDURE IN PARAGRAPH 4.3 f.

- STEP 1. INSERT GROUND CABLE INTO SLOT IN GROUND TERMINAL STUD AND TIGHTEN NUT.
- STEP 2. CONNECT COUPLING TO GROUND ROD AND INSERT SLIDE HAMMER IN COUPLING.
- STEP 3. DRIVE GROUND ROD INTO GROUND UNTIL COUPLING IS JUST ABOVE THE GROUND LEVEL.
- STEP 4. CONNECT ADDITIONAL GROUND RODS, AS REQUIRED, BY REMOVING SLIDE HAMMER FROM COUPLING AND INSTALLING ANOTHER GROUND ROD IN COUPLING. MAKE SURE EACH NEW GROUND ROD IS BOTTOMED ON ROD PREVIOUSLY INSTALLED. CONNECT ANOTHER COUPLING ON NEW GROUND ROD AND INSERT SLIDE HAMMER.
- STEP 5. AFTER GROUND RODS HAVE BEEN DRIVEN INTO THE GROUND REMOVE SLIDE HAMMER AND TOP COUPLING.
- STEP 6. CONNECT CLAMP AND GROUND CABLE TO TOP OF EXPOSED GROUND ROD AND SECURE BY TIGHTENING SCREW.

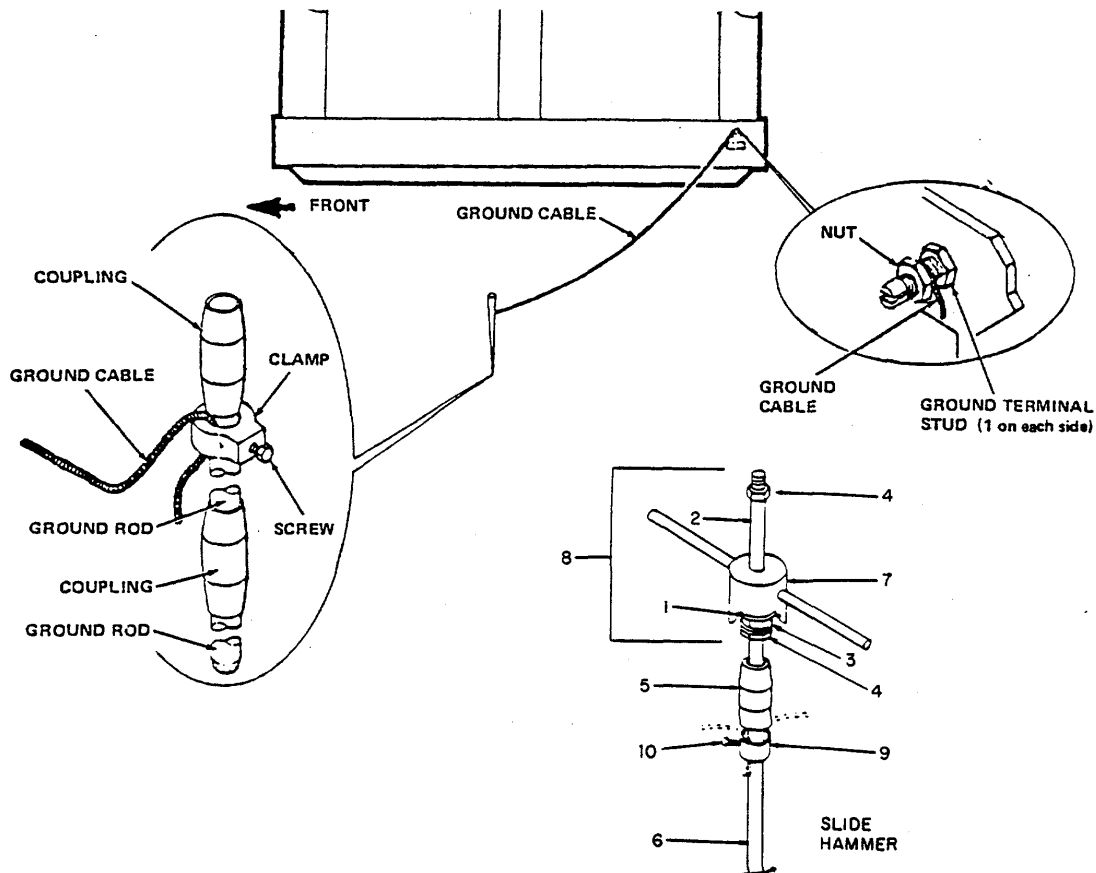
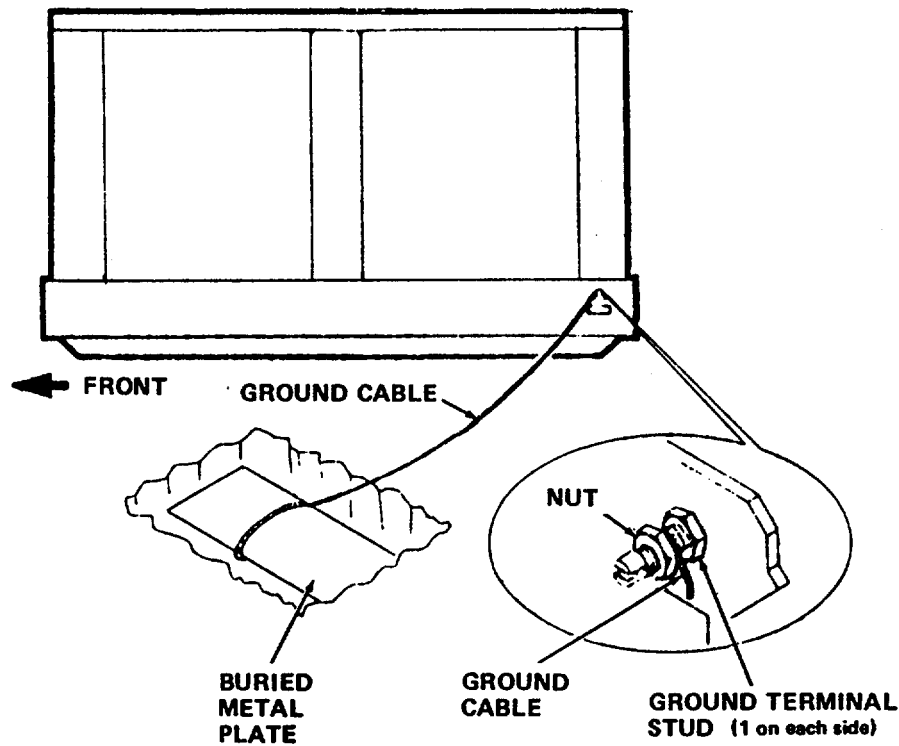

Figure 4-7. Grounding Procedures (Sheet 2 of 3)



**WARNING**

**DO NOT OPERATE ENGINE GENERATOR SET UNLESS A GROUND CABLE HAS BEEN CONNECTED TO THE GROUND TERMINAL STUD AND THEN TO A SUITABLE GROUND. ELECTRICAL FAULTS IN THE GENERATOR SET, LOAD LINES, OR LOAD EQUIPMENT, CAN CAUSE INJURY OR ELECTROCUTION FROM CONTACT WITH AN UNGROUNDED SYSTEM.**



**Figure 4-7. Grounding Procedures (Sheet 3 of 3)**

- STEP 1. INSERT GROUND CABLE INTO SLOT IN GROUND TERMINAL STUD AND TIGHTEN NUT.
- STEP 2. PERFORM EXCAVATION AND BURY A METAL PLATE AS SHOWN.
- STEP 3. ATTACH GROUND CABLE TO METAL PLATE AND CHECK THAT GOOD ELECTRICAL BOND IS ACHIEVED. .

c. **Indoor Installation.** Keep the area well ventilated at all times, so that the engine generator set will receive a maximum supply of air. If a free supply of fresh air is not available, provide duct work, with an opening at least as large as the radiator, to the outside of the installation. If louvers are used at the air entrance, increase the duct work size by 25 to 50 percent. Loosen the screw and nut which secure the weather cap to the exhaust outlet and remove the weather cap. Install a gas-tight metal pipe exhaust outlet to the outside of the installation. The termination of the exhaust pipe shall be such that hot gases or sparks will be discharged harmlessly and will not be directed against combustible material or into an area containing flammable gases or vapors. Use as few bends in the pipe and as short a pipe as possible. The exhaust pipe should include a low point with suitable means for draining of condensate. Provide metal shields, 12 inches (305 mm) larger in diameter than the exhaust pipe where the line passes through flammable walls. Wrap the exhaust pipe with asbestos if there is any danger of anyone touching it. Refer to figure 4-6 for dimensions, air flow requirements.

**WARNING**

**Do not operate the engine generator set in an enclosed area unless the exhaust gases are piped to the outside. Inhalation of exhaust fumes will result in serious illness or death.**

- d. **Leveling.** Set up the unit as level as possible (within 5 degrees), and keep it as level as possible during operation.
- e. **Grounding.** The engine generator set must be grounded prior to operation. The ground can be, in order of preference: (1) an underground metallic water piping system, (2) a driven metal rod, or (3) a buried metal plate (figure 4-7). If the effectively grounded portion of the buried metallic water pipe is less than 10 feet (3 m) due to insulated sections or joints, this preferred grounding method must be supplemented by an additional driven metal

rod ground or a buried metal plate ground. A driven metal ground rod must have a minimum diameter of 5/8 inch (16 mm), if solid, or 3/4 inch (19 mm) if pipe, and driven to a minimum depth of 8 feet (2.4 m). A buried metal ground plate must have a minimum area of 9 square feet (0.8 m<sup>2</sup>), minimum thickness of 1/4 inch (6.4 mm), and be buried at a minimum depth of 4 feet (1.2 m). The ground lead must be at least No. 6 AWG copper wire. The procedures for making a ground connection are shown in figure 4-7.

- f. **Slide Hammer Procedure.**

**WARNING**

**Nuts must be tight on the slide hammer rod. Loose hardware may result in serious injury.**

**CAUTION**

**The slide hammer (figure 4-7, sheet 2) striker plate and top nut must be tightened to the end of the threads on the slide hammer rod. The slide hammer rod and ground rod section must make firm contact inside the ground rod coupler. Damage to rods, plate and couplers could result if left loose.**

**NOTE**

**If the slide hammer is assembled, go to step (b).**

- (a) Connect the slide hammer striker plate (1) to bottom of the slide hammer rod (2). Tighten to the end of threads. Connect lockwasher (3) and nut (4) to bottom of the slide hammer rod (2). Tighten firmly against the striker plate (1). Connect the ground rod coupler (5) to the bottom of the slide hammer rod (2). Connect the ground rod section (6) to the other end of the ground rod coupler (5). Tighten the ground rod section (6) to make firm contact with the slide hammer rod (2).
- (b) Remove nut (4) from the top of

the slide hammer rod (2) if necessary, and place the slide hammer (7) on top of the slide hammer rod. Slide down until it rests on the striker plate (1). Attach nut (4) to the top of the slide hammer rod. Tighten to the end of the threads.

- (c) While holding in a vertical position, lift the slide hammer (7). Slide it downward to drive the ground rod section (6) into the ground. Continue driving the ground rod section (6) until approximately 4 inches (10 centimeters) remains above ground level.
- (d) Disconnect the slide hammer assembly (8) from the ground rod coupler (5).
- (e) Attach the ground rod section (6) to the ground rod coupler (5). Attach another ground rod coupler (5) to the top of a new ground rod section (6). Connect the slide hammer assembly (8) to the new ground rod coupler (5).
- (f) Repeat steps (c), (d) and (e) until at least 8 feet (2.4 meters) of ground rod is buried. Disconnect nut (4), and remove the slide hammer (7) from the slide hammer assembly (8). Disconnect the top ground rod coupler (5).
- (g) Connect a clamp (9) to top of the ground rod and reconnect the ground rod coupler (5). Connect loose end of the ground wire assembly to the clamp. Tighten the clamp screw (10). Ensure that all ground wire connections are tight.
- g. Connecting Remote Control Module. The remote control module can be located up to 1000 feet (300 m) from the generator set.

Refer to FO-14 and FO-9 for interconnecting information. Allow at least 3 feet (91 cm) in front and behind module for access during maintenance. Refer to par. 2-10.

- h. Connecting Automatic Control Module. Refer to FO-15 for interconnecting diagram. Refer to par. 2-11.

#### 4-4. EQUIPMENT CONVERSION.

- a. To convert generator set output voltage from 120/280V AC to 240/416V AC, refer to figure 4-8 and proceed as follows:

#### **WARNING**

**When making any electrical connections, make sure that the MAINTENANCE LOCKOUT switch is in the MAINTENANCE position.**

- (1) Unscrew fasteners on reconnection box cover and lift cover to obtain access to the movable jumpers.
  - (2) Remove attaching hardware and adjust jumper bars for low wye, 120/208V AC (A, figure 4-8) or high wye, 240/416V AC (B, figure 4-8) configuration.
  - (3) Securely reinstall attaching hardware and close reconnection box cover.
- b. To convert generator set from 50 to 60 Hz, move the FREQUENCY SELECTOR switch (4, figure 2-3) to the desired position. Also, if using the automatic control module switch the frequency select switch to the corresponding position.

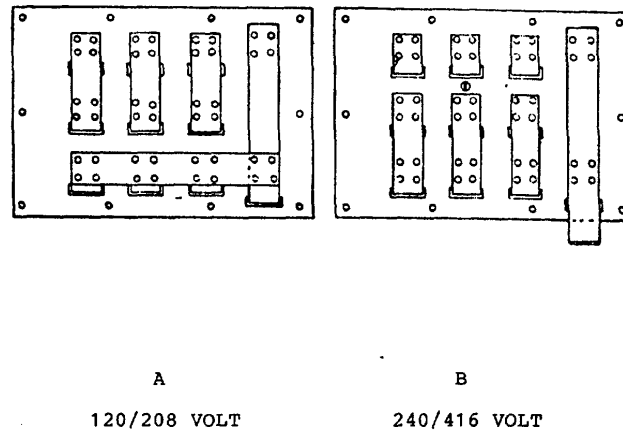

Figure 4-8. Output Voltage Conversion Connections

## Section II. MOVEMENT TO A NEW WORKSITE

### 4-5. DISMANTLING FOR MOVEMENT.

#### **WARNING**

**Make certain that generator set is not operating in a standby mode, or connected to a parallel buss.**

#### a. Preparation for Movement.

- (1) Disconnect, insulate and secure negative battery cable.
- (2) Disconnect the load cables and tag for identification. (3) If applicable, disconnect wiring to automatic control module.
- (4) Drain fuel and coolant if transportation by railroad is

- anticipated or the distance to be traveled is great.
- (5) Disconnect the ground lead.
  - (6) Disconnect any other external hoses, lines, and cables, if used.
  - (7) Close and secure all doors and panels.

#### **WARNING**

**Unit weight is approximately 36,000 pounds (16,329 kg). Use the slings supplied and lifting device with a capacity of 20 tons (18,000 kg).**

- #### b. Movement.
- Refer to installation procedures, par. 4-3.

**Section III. REPAIR PARTS; SPECIAL TOOLS; SPECIAL TEST MEASUREMENT  
AND DIAGNOSTIC EQUIPMENT (TMDE);  
AND SPECIAL SUPPORT EQUIPMENT**

4-6. TOOLS AND EQUIPMENT. No special tools or equipment are required by organizational maintenance personnel for maintenance of the generator set.

parts and equipment are listed and illustrated in the Organization, Intermediate (Field) (Direct and General Support) and Depot Maintenance Repair Parts and Special Tools List, (A) TM5-6115-593-24P.

4-7. MAINTENANCE REPAIR PARTS. Repair

**Section IV. LUBRICATION INSTRUCTIONS**

4-8. GENERAL. This section contains special organizational lubrication instructions not included in the lubrication order. Army personnel should refer to DA PAM 310-4 and Marine Corps personnel to SL-1-3 to ensure the latest edition of the lubrication order L05-6115-593-12 is being used.

**WARNING**

**To avoid accidental engine cracking or startup, place MAINTENANCE LOCKOUT switch in the MAINTENANCE LOCKOUT position prior to servicing the generator set. Return switch to OPERATION position only after completion of service procedures.**

a. Lubrication Information.

- (1) When the engine is not running, the oil level gauge (dip stick) (figure 4-40) allows the operator to check the oil level. The gauge is stamped with an "H" (high, full) and an "L" (low) level mark to indicate lubricating oil supply. The crankcase should be filled to the "H" mark on the dipstick.

**CAUTION**

**Never fill crankcase above "H" mark on dipstick.**

- (2) When the engine is running, check the oil level using the sight gauge. Set sight

gauge high level marker (2, figure 4-43) while engine is not running and dipstick shows oil at "H" (full). Set sight gauge low level marker (4, figure 4-43) to indicate oil level while engine is running. The sight gauge will then show both operating and nonoperating levels. Recheck oil level on dipstick after setting sight gauge markers to ensure that no oil was leaking during the setting of the markers. After setting sight gauge level markers, use the sight gauge rather than the dipstick to monitor oil levels.

- (3) Keep oil free of water and abrasives by proper handling and storage.
  - (4) Inspect engine for evidence of oil leaks.
  - (5) After each operating interval of 300 hours, remove breather and clean with cleaning solvent, blow out with compressed air, and reinstall on engine. See figure 4-8A.
- b. Lubricating Instructions. Oil shall be changed every 300 hours or 3 months, whichever comes first. Oil may require changing more frequently than usual because contamination by dilution and sludge formation will increase under cold weather operation conditions.

- (1) Before draining the oil system, operate the engine

until a minimum coolant temperature of 160°F (71°C) is obtained. Then shut engine off and move MAINTENANCE LOCKOUT switch to MAINTENANCE LOCKOUT position.

- (2) Remove oil drain plug on skid base (figure 1-1), then open engine oil drain valve and allow oil to drain into a container.
- (3) Install drain plug and close oil drain valve. Add oil to full mark.
- (4) Move MAINTENANCE LOCKOUT switch to OPERATION position. Start and operate engine for approximately 5 minutes.
- (5) Stop engine and allow oil to drain back into crankcase before rechecking oil level using dipstick. Check for leaks.

**NOTE**

Do not remove dipstick when engine is operating. Use oil level sight gauge to monitor oil level while engine is running.

c. Oil Filter Service. (See figure 4-47).

- (1) Refer to Chapter 13 of the Intermediate (Field) (Direct and General Support) and Depot Level Maintenance Manual (A) TM5-6115-593-34 for servicing of the bypass oil filters. Note that the service function is the same

as replacing the filters.

- (2) Service spin-on type oil filters (see figure 4-47) as follows:

**NOTE**

Oil pressure drop reading across filters is the best way to determine change periods. If pressure drop from inlet to outlet exceeds pressure logged after latest installation of spin-on oil filters by more than 10 psi (0.7 kg/cm ) with 140°F (60°C) oil temperature, change the filters.

- (a) Drain the oil system, par. 4-8b.
- (b) Unscrew, remove, and discard the filters and gaskets.
- (c) Fill new filters with proper lubricant (see table 3-1), attach new gaskets and screw on new filters. Hand tighten, then turn an additional three-fourths of a turn.
- (d) Fill engine to "H" mark on dipstick.
- (e) Run engine and check for leakage.
- (f) Stop engine and allow several minutes for oil to drain back to oil crankcase, then recheck level.
- (g) Run engine and record oil pressure reading.
- (h) Check/reset sight gauge per par. 4-8 a (2).

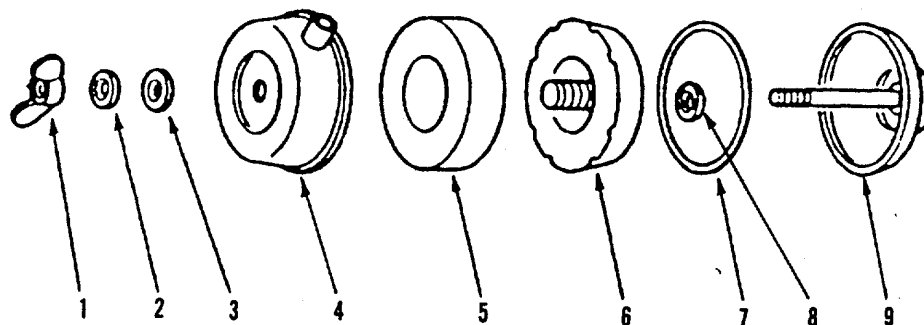

1. Wing nut
2. Washer
3. Gasket
4. Upper body
5. Element
6. Vapor Element
7. Gasket
8. Gasket
9. Lower Body

Figure 4-8A. Crankcase Breather

## Section V. PREVENTIVE MAINTENANCE CHECKS AND SERVICES (PMCS)

4-9. GENERAL. To ensure that the equipment is ready for operation at all times, it must be inspected systematically so that defects may be discovered and corrected before they result in serious damage or failure. This section contains information pertinent to organizational maintenance. Table 4-2 contains a tabulated listing of preventive maintenance checks and services which must be performed by organizational maintenance personnel at weekly, monthly and semiannual intervals.

## Section VI. TROUBLESHOOTING

4-10. GENERAL.

- a. Table 4-3 contains troubleshooting information for locating and correcting operating troubles which may develop in the generator set. Each malfunction for an individual component unit, or system, is followed by a list of tests or inspections which will help you to determine probable causes and corrective actions to take. Perform the tests, inspections, and corrective actions in the order listed.
- b. This manual cannot list all malfunctions that may occur, nor all tests or inspections and corrective actions. If a malfunction cannot be corrected by listed corrective actions, notify your supervisor.

## Section VII. RADIO INTERFERENCE SUPPRESSION

4-11. GENERAL METHODS USED TO ATTAIN PROPER SUPPRESSION. Essentially suppression is attained by providing a low resistance path to ground for stray currents. The methods used include shielding the wires, grounding the frame with bonding straps, and using filtering systems.

4-12. INTERFERENCE SUPPRESSION COMPONENTS.

- a. Primary Suppression Components. The primary suppression components are those whose function is to suppress radio interference. The voltage regulator contains an electromagnetic interference (EMI) suppression assembly to suppress EMI from this assembly
- b. Secondary Suppression Components. These components have radio suppression functions which are incidental or secondary to their primary function. No secondary suppression components are included in this generator set.

**TABLE 4-2. ORGANIZATIONAL PREVENTIVE MAINTENANCE CHECKS AND SERVICES.**

NOTE: Within designated interval, these checks are to be performed in the order listed.

W-WEEKLY (40 HRS)

M-MONTHLY (100 HRS)

S-SEMIANNUALLY (500 HRS)

ITEM NO.	INTERVAL			ITEM TO BE INSPECTED	PROCEDURES CHECK FOR AND HAVE REPAIRED OR ADJUSTED AS NECESSARY	Equipment is Not Ready/Available If:
	W	M	S			
1	o			Controls and instruments Air Cleaner	Inspect for damage and loose mounting Replace or clean the primary element when service indicator indicates a red restriction indication Do not clean safety element. Replace safety element after third primary element change or cleaning.	Restricted
2						
	0	-			Inspect and empty dust cup. When reinstalling, make sure dust cup seals entirely around the air cleaner body. Ref. par. 4-42. -Inspect and clean cyclone tubes with a stiff fiber brush	
			0			
3			o	Support Frame	Inspect for breaks, cracks, loose mounting, loose or missing hardware, corrosion and rust.	
4	o			Radiator Assembly	Inspect radiator fan motor. Check for excessive noise or evidence of overheating. Ref. par. 4-49.	
5	o			Engine Preheat	Inspect thermo switch heaters and pump for poor electrical connections and loose mounting. Ref. par. 4-51.	
6	o			Fuel Transfer Pump wear.	Inspect motor brushes for Replace if less than 1/4 inch (6 mm) long. Ref. par. 4-52.	
			0		Change oil filter and strainers.	
7	o			Generator and Reconnection Assembly	Inspect reconnection board and buss bars for looseness or corrosion. Ref. par. 4-59.	
			0		Inspect generator for noisy or overheated bearings and any other signs of damage	
8	o			Hydraulic Sump Governor	Check fluid level. Add fluid required. Ref. par. 4-64.	No fluid is present



**TABLE 4-2. ORGANIZATIONAL PREVENTIVE MAINTENANCE CHECKS AND SERVICES.**

NOTE: Within designated interval, these checks are to be performed in the order listed.

W-WEEKLY (40 HRS)

M-MONTHLY (100 HRS)

S-SEMIANNUALLY (500 HRS)

ITEM NO.	INTERVAL			ITEM TO BE INSPECTED	PROCEDURES CHECK FOR AND HAVE REPAIRED OR ADJUSTED AS NECESSARY	Equipment is Not Ready/Available If:
	W	M	S			
9		o	o	Drain and refill sump Ether Kit	Check ether tank for fullness Shake to determine contents: if empty then replace tank. Ref. par. 4-65.	
10		o		Engine Assembly	Ref. Section XXVI. Inspect water pump belt for wear and proper adjustment. Ref. par. 4-67. Inspect engine for loose connections, leaks in oil, fuel, and water system. Change fuel filters. Ref. par. 4-53 and 4-75.	
11		o	o		Clean crankcase breather Ref. par. 4-8a (5). Check valve tappet clearance and reset, if necessary. Ref. par. 4-87 b.	
		o		Inspect oil pressure switch, (par. 4-73), lube oil cooler (par. 4-76), injectors (par. 4-78) for signs of damage.		
		o		Inspect temperature switch (par. 4-82), vibration damp- er (par. 4-83), intercooler (par. 4-84), exhaust manifold (par. 4-85), and water mani- fold (par. 4-86) for signs of damage.		
		o		Inspect rocker arm shaft and rocker arm assemblies for evidence of misalignment or damage. Ref. par. 4-87.		
	o			Check oil filter pressure differential. Pressure drop from inlet to outlet should not exceed pressure logged after latest installation of spin-on oil filters by more than 10 psi (0.7 kg/cm <sup>2</sup> ) with 140°F (60°C) oil temperature Service water filter. Ref. par.-4-68.		
		o				

**Table 4-3. Organizational Troubleshooting**

MALFUNCTION
TEST OR INSPECTION
CORRECTIVE ACTION

1. ENGINE FAILS TO CRANK WHEN MASTER SWITCH IS MOVED TO START.

Step 1. Using a hydrometer, measure the specific gravity of the electrolyte in each cell (refer to paragraph 4-16)

If batteries are not charged, ensure that the battery charger is operating and allow sufficient time to charge. If batteries fail to hold charge, refer malfunction to next higher level of maintenance.  
Step 2. Check OVER CRANK indicator lamp.

If OVER CRANK indicator lamp is lit, wait until light goes out. If light fails to go out after 1 minute, disconnect terminal 4 of the time delay relay (15, figure 4-19) from -24V DC.

If OVER CRANK indicator goes out, then TD1 may be defective and must be referred to next higher maintenance.

If the light remains lit, timing overcrank shutdown relay K19 (part of AC-DC control relay assembly, 18, figure 4-19) may be defective and must be referred to next higher maintenance.

Step 3. Using a multimeter, check for 24V DC across coil of start/stop/run relay K5 (located on TB10, 92, figure 4-20, sheet 2).

If 24V DC is absent, then test MASTER SWITCH (38, figure 4-21) and replace if defective (see paragraph 4-40).

If 24V DC is present, proceed to next step.

Step 4. Using a multimeter, check for 24V DC across coil or relay K54 (part of AC-DC control relay assembly, 18, figure 4-19).

If voltage is absent, K5 may be defective and must be referred to next high maintenance.

If 24V DC is present, check for 24V DC across contacts 1 and 2 of K54. If 24V DC is present, K54 may be defective and must be referred to next higher maintenance.

If reading is zero, proceed to next step.

**Table 4-3. Organizational Troubleshooting -Continued**

MALFUNCTION
TEST OR INSPECTION
CORRECTIVE ACTION

1. ENGINE FAILS TO CRANK WHEN MASTER SWITCH IS MOVED TO START-continued

Step 5 Test starter and starter solenoid (L4) using operational test (see paragraph 4-71).

If starter solenoid emits an audible noise each time the MASTER SWITCH is cycled into START position, and engine does not turn over, the starter assembly must be referred to next higher maintenance for repair.

If no noise is heard, cranking relay K3 may be defective, and must be referred to next higher maintenance.

Step 6. Using a multimeter, check for 24V DC across speed switch, SS1 (see figure 4-40 and 4-42).

**NOTE**

To check this component refer to FO-3 to determine where these points are electrically accessible to meter probes.

If 24V DC is present, SS1 may be defective and must be referred to next higher maintenance.

If 24V DC is absent, proceed to next step.

Step 7. Using a multimeter, check for 24V DC across diode CR1 (part of AC-DC control relay assembly, 18, figure 4-19)

If voltage is present, CR1 may be defective, and must be referred to next higher maintenance. If voltage is absent, proceed to next step.

Step 8. Using a multimeter, check for 24V DC across timing relay crank disconnect relay K6 (part of AC-DC control relay assembly, 18, figure 4-19).

If voltage is present, K6 may be defective and must be referred to next higher maintenance.

If voltage is absent, the malfunction is beyond the scope of organizational level maintenance and must be referred to the next higher level of maintenance.

2. ENGINE CRANKS AT NORMAL SPEED BUT WILL NOT START.

Step 1. Check LOW FUEL LEVEL indicator lamp on Generator Control Panel and fuel oil level in auxiliary tank.

**Table 4-3. Organizational Troubleshooting-Continued**

MALFUNCTION
TEST OR INSPECTION
CORRECTIVE ACTION

2. ENGINE CRANKS AT NORMAL SPEED WILL NOT START-continued

If there is fuel in auxiliary tank, test fuel transfer pump (see paragraph 4-52).

If the fuel transfer pump is functioning, check for clogged lines between transfer pump and day tank, and between the day tank and fuel filter assembly.

Step 2. Check that fuel oil is reaching fuel injectors as the engine is being cranked.

Disconnect fuel return line going to fuel tank (see figure 4-29). Use a suitable container to catch fuel oil.

If fuel oil is present at fuel return, refer malfunction to next higher level of maintenance.

If fuel oil is absent, reconnect fuel return. Disconnect fuel line at input of secondary fuel filters (see figures 4-40 and 4-48), and check for the presence of fuel oil.

If fuel oil is present, replace secondary fuel filters (see paragraphs 4-75).

Step 3. Check EMERGENCY SHUT DOWN switch S22 (20, figure 4-18).

Check that switch is in OFF position; if ON, replace switch (see paragraph 4-32).

Step 4. Check ENG FAULT OVERSPEED indicator lamp.

If lamp is lit, operate ANNUNCIATOR RESET switch. If lamp goes out, re crank engine. If lamp remains lit check for 24V DC across coils of speed switch SS3 (see figures 4-40 and 4-42).

**NOTE**

To check this component refer to FO-3 to determine where these points are electrically accessible to meter probes.

If voltage is present, SS3 may be defective and must be referred to next higher maintenance.

Step 5. Using a multimeter, check for 24V DC across fuel solenoid L1 (see figure 4-40).

**Table 4-3. Organizational Troubleshooting-Continued**

MALFUNCTION	TEST OR INSPECTION	CORRECTIVE ACTION
-------------	--------------------	-------------------

2. ENGINE CRANKS AT NORMAL SPEED WILL NOT START-continued

**NOTE**

To check this component, refer to FO-3 to determine where these points are electrically accessible to meter probes.

If present, L1 may be defective and must be referred to next higher maintenance.

If 24V DC is absent, diode CR23 (part of AC-DC control relay assembly, 18, figure 4-19) may be defective and must be referred to higher maintenance.

3. ENGINE SHUTS DOWN SOON AFTER STARTING.

Step 1. Using a multimeter, check 24V DC across the starter solenoid L1 (see figure 4-40) and crank engine until it starts. Note voltage reading across L1 when engine shuts down.

**NOTE**

To check this component refer to FO-3 to determine where these points are electrically accessible to meter probes.

If reading remains at 24V DC after shut down, L1 may be defective and must be referred to next higher maintenance.

If reading drops to zero as engine shuts down, proceed to next step.

Step 2. Place a temporary short across oil pressure switch OP1 (see figures 4-40 and 4-46) and, using a multimeter, check for presence of 24V DC across contacts 3 and 4 or run-stop relay K1 (7, figure 4-19).

**NOTE**

To check this component refer to FO-3 to determine where these points are electrically accessible to jumper.

If present, K1 may be defective and should be referred to next higher level of maintenance. If 24V DC is present, proceed to next step.

**Table 4-3. Organizational Troubleshooting-Continued**

MALFUNCTION	TEST OR INSPECTION	CORRECTIVE ACTION
-------------	--------------------	-------------------

3. ENGINE SHUTS DOWN SOON AFTER STARTING-continued

Step 3. Remove short from OP1, and use multimeter to check for presence of 24V DC across oil pressure switch OP1 while engine is being cranked.

If 24V DC is present, check lube oil level. If level is low, add oil as required, and proceed to next step. If voltage across OP1 reads zero at any time during test, proceed to next step.

Step 4. Place temporary short across oil pressure switch OP1 and use multimeter to check for presence of 24V DC across oil temperature switch OT1 (see figure 4-40)

**NOTE**

To check this component refer to FO-3 to determine where these points are electrically accessible to jumper. If 24V DC is present, switch OT1 may be defective and must be referred to next higher maintenance. If voltage is absent, proceed to next step.

Step 5. Use a multimeter to check for presence of 24V DC across coolant temperature switch WT1 (see figure 4-40).

**NOTE**

To check this component refer to FO-3 to determine where these points are electrically accessible to jumper.

If 24V DC is present, test coolant temperature switch and replace if defective (see paragraph 4-82).

If 24V DC is absent, proceed to next step.

Step 6. Use a multimeter to check for presence of 24V DC across contacts of low fuel shutdown relay K8 (part of AC-DC control relay assembly, 18, figure 4-19).

If 24V DC is present, proceed to next step.

If voltage is absent, remove temporary short from OP1 and refer to paragraph 4-50 on fuel line maintenance and proceed to Malfunction 2, Step 2.

**Table 4-3. Organizational Troubleshooting-Continued**

MALFUNCTION	TEST OR INSPECTION	CORRECTIVE ACTION
-------------	--------------------	-------------------

3. ENGINE SHUTS DOWN SOON AFTER STARTING-continued

Step 7. Remove temporary short from oil pressure switch OP1 and use multimeter to check for presence of 24V DC across fuel level switch FL4 (see figures 4-33 and 4-34).

If 24V DC is present, test the fuel level switch, and replace switch if defective (see paragraph 4-55).

If 24V DC is absent, low fuel shutdown relay K8 may be defective and must be referred to higher maintenance.

Step 8. Check oil pressure gauges (see figure 4-40).

If INPUT gauge reading is normal and OUTPUT gauge reads low, check and service spin-on oil filter (see paragraph 4-8 c (2)).

If INPUT gauge read low and OUTPUT gauge reads normal, check lube oil lines for damage or blockage. Replace defective hoses and fittings.

If both gauges are normal, refer to next higher level of maintenance.

4. ENGINE SHUTS DOWN AND WILL NOT RESTART.

Step 1. If HI COOL TEMP indicator lamp is lit, and coolant level is normal, test thermostats (paragraph 4-80).

Replace thermostats if defective.

If high coolant temperature condition persists, refer to next step.

Step 2. Refer to paragraph 4-49 on radiator assembly maintenance and check fan belt tension, Code A only. No fan belt on Code B.

Adjust or replace belts as necessary, Code A.

If high coolant temperature condition persists, refer to next step.

Step 3. If HI LUBE TEMP indicator lamp is lit, and lube oil level is normal, check INPUT and OUTPUT OIL PRESSURE GAUGES (figure 4-40).

If INPUT GAUGE reading is normal, and OUTPUT GAUGE is low, or if INPUT GAUGE reading is low and OUTPUT GAUGE is normal, refer to Malfunction 3, Step 8.

If both gauges are normal, refer to next higher level of maintenance.

**Table 4-3. Organizational Troubleshooting-Continued**

MALFUNCTION
TEST OR INSPECTION
CORRECTIVE ACTION

4. ENGINE SHUTS DOWN AND WILL NOT RESTART-continued

Step 4. If OVERSPEED indicator lamp is lit, check for 24V DC across emergency stop relay K21 (part of AC-DC control relay assembly, 18, figure 4-19).

If 24V,DC is present, proceed to next step. If voltage is absent, K21 may be defective and must be referred to next higher level of maintenance.

Step 5. Use a multimeter to check for 24V DC across speed switch SS3 (see figures 4-40 and 4-42).

**NOTE**

To check this component refer to FO-3 to determine where these points are electrically accessible to meter probes.

If 24V DC is absent, SS3 or its shutdown relay K31 (part of annunciator control assembly, 76, figure 4-20) may be defective and must be referred to next higher level of maintenance.

5. ENGINE RUNS ERRATICALLY OR MISFIRES.

Step 1. Refer to paragraph 4-50, and check fuel lines into and out of the fuel injection pump for damage or blockage.

If fuel lines are defective, refer to paragraph 4-50 for replacement procedures.

If fuel lines are free of obstruction or defect, refer malfunction to next higher level of maintenance.

Step 2. Check the air intake system (see figure 4-23), especially air valves (27), air cleaners (29), service indicator (28), hoses (25), and adapters (26). Inspect turbochargers (see paragraph 4-78) and intercoolers (see paragraph 4-84).

Clear any blockages, or service air intake system components as necessary (see paragraphs 4-42, 4-43, and 4-44). Clear obstructions in turbochargers or intercoolers, or replace if defective (see paragraphs 4-78 and 4-84).

If air intake system appears to be working properly, refer to next higher level of maintenance.

Step 3. If feasible, temporarily disconnect the generator load by



**Table 4-3. Organizational Troubleshooting-Continued**

MALFUNCTION	TEST OR INSPECTION	CORRECTIVE ACTION
-------------	--------------------	-------------------

5. ENGINE RUNS ERRATICALLY OR MISFIRES-continued

setting AC PWR CKT BKR to OPEN.

If engine now runs smoothly, reconnect load by setting AC PWR CKT BKR to CLOSE, and proceed to next step.

Step 4. Check KW and KVAR readings on Generator Control Panel.

If readings indicate excessive power draw, rearrange load distribution to restore normal power consumption.

If KW and KVAR reading are normal, refer to next higher level of maintenance.

6. ENGINE EXHAUST EXCESSIVELY BLACK

Visually check fuel; if contaminated with water or dirt, drain fuel and fill with clean fuel. If fuel is not contaminated, refer to Malfunction 5, Steps 1 through 4.

7. ENGINE EXHAUST WHITE OR BLUE

Step 1. Check for excessive lube oil using sight gauge, then dipstick.

If lube oil level too high, drain crankcase (see paragraph 4-8) until proper level is indicated.

Step 2. Visually check engine fuel for contamination (see Malfunction 6).

If contaminated, replace fuel.

8. GENERATOR OUTPUT FREQUENCY INCORRECT

Test FREQ ADJ switch S5 (88, figure 4-22) in accordance with paragraph 4-40).

Replace FREQ ADJ switch S5 if defective (see paragraph 4-40).

**NOTE**

If S5 is not defective, inspect motoroperated potentiometer B4 (2, figure 4-19) according to paragraph 4-35 and refer to next higher level of maintenance for testing.

**Table 4-3. Organizational Troubleshooting-Continued**

MALFUNCTION
TEST OR INSPECTION
CORRECTIVE ACTION

9. GENERATOR OUTPUT VOLTAGE INCORRECT.

Test VOLT ADJ switch S6 (88, figure 4-22) in accordance with paragraph 4-40.

Replace VOLT ADJ switch S6 if defective (see paragraph 4-40).

**NOTE**

If S6 is not defective, inspect motoroperated potentiometer B5 (4, figure 4-19) according to paragraph 4-35 and refer to next higher level of maintenance for testing.

10. ENGINE WILL NOT START IN COLD WEATHER

**NOTE**

If following procedures indicate cold weather starting devices are functioning, refer to troubleshooting procedures listed under ENGINE CRANKS AT NORMAL SPEED BUT WILL NOT START.

Step 1. Refer to paragraph 4-65, and disconnect tubing from bottom end of ether kit assembly. Toggle START AID switch to ON position.

**WARNING**

Ether is highly flammable fuel. Do not expose to open flame, lit cigarettes, or hot surfaces.

If ether is ejected out of opened end of ether kit assembly, perform inspection procedures in paragraph 3-19.

If no ether appears, proceed to next step.

Step 2. Test ether tank by shaking tank to determine if empty.

If empty, replace with new ether tank.

If there is still ether in tank, test START AID switch S2 (20, figure 4-21) and replace if defective (see paragraph 4-40).

**Table 4-3. Organizational Troubleshooting-Continued**

MALFUNCTION	TEST OR INSPECTION	CORRECTIVE ACTION
-------------	--------------------	-------------------

10. ENGINE WILL NOT START IN COLD WEATHER-continued

If S2 is not defective, the ether aid control relay K24 (part of AC-DC control relay assembly, 18, figure 4-19) or the ether solenoid (14, figure 4-39) may be defective. The ether solenoid can be replaced as part of the ether kit (see paragraph 4-65). Relay K24 must be referred to next higher level of maintenance for testing or replacement.

Step 3. Check WATER TEMP gauge. Coolant temperature should read between 60 and 110°F (16° and 43°C).

If temperature is below range, proceed to next step.

If temperature is within range, the preheat system is functioning normally and malfunction must be referred to next higher level of maintenance.

Step 4. Use a multimeter to check for 120V AC across the coil of preheat contactor relay K107 (54, figure 4-12).

If 120V AC is present, proceed to next step.

If 120V AC is absent, test PREHEAT SYSTEM switch S105 (27, figure 4-13) and replace if defective (see paragraph 4-22).

If S105 is not defective, check run/stop relay K1 (7, figure 4-19) for 24V DC across contacts 3 and 4.

If 24V DC is present K1 may be defective and should be referred to next higher level of maintenance for testing.

Step 5. Test preheat contactor relay K107 according to paragraph 4-23.

Replace K107 if defective (see paragraph 4-23).

If K107 is not defective, proceed to next step.

Step 6. Test heater contactor K109 (54, figure 4-12) according to paragraph 4-23.

Replace K109 if defective, (see paragraph 4-23).

If K109 is not defective, proceed to next step.

Step 7. Test thermo immersion switch, S30 (13, figure 4-30A) according to paragraph 4-51.

**Table 4-3. Organizational Troubleshooting-Continued**

MALFUNCTION	TEST OR INSPECTION	CORRECTIVE ACTION
-------------	--------------------	-------------------

10. ENGINE WILL NOT START IN COLD WEATHER-continued

Replace switch if defective (see paragraph 4-51). If S30 is not defective proceed to next step.

Step 8. Test heater elements H101 and H102 (6 and 41, figure 4-30A) according to paragraph 4-51.

Replace heaters if defective (see paragraph 4-51). If heaters are not defective, refer malfunction to next higher level of maintenance.

11. GENERATOR AC PWR CKT BKR CLOSED LAMP GOES OUT (LOAD DISCONNECTS).

Step. 1. Check AMMETER and KW meter to see if unit is delivering power.

If generator set is delivering power check and replace AC PWR CKT BKR CLOSED indicator lamp DS6 (16, figure 4-22).

If generator set is not delivering power proceed to next step.

Step 2. Use a multimeter to check for 24V DC across main circuit breaker CB2 (44, figure 4-12) trip coil.

If present, shut down engine and test CB2 according to paragraph 4-24.

Replace main circuit breaker CB2 if defective (see paragraph 4-24).

If CB 2 is not defective, undervoltage relay K111 (78, figure 4-20) or short circuit relay K113 (71, figure 4-20) may be defective and must be referred to next higher level of maintenance for testing.

Step 3. If OVERLOAD indicator lamp is lit, set AC PWR CKT BKR to OPEN. Toggle ANNUNCIATOR RESET switch to up position, and observe OVERLOAD indicator lamp.

If lamp goes out, refer to next higher level of maintenance, as problem exists.

If lamp stays lit, overload relay K114 (62, figure 4-20) or relay K35 (part of annunciator control assembly, 76, figure 4-20) may be defective and must be referred to next higher level of maintenance for testing or replacement.

**Table 4-3. Organizational Troubleshooting-Continued**

MALFUNCTION	TEST OR INSPECTION	CORRECTIVE ACTION
-------------	--------------------	-------------------

11. GENERATOR AC PWR CKT BKR CLOSED LAMP GOES OUT (LOAD DISCONNECTS)-continued

Step 4 If UNDERVOLT indicator lamp is lit, toggle ANNUNCIATOR RESET switch to up position and observe UNDERVOLT indicator lamp.

If lamp goes out, refer to next higher level of maintenance, as problem exists.

If lamp remains lit, check VOLT AC meter for each generator winding.

If normal undervoltage relay K111 (78, figure 4-20) or relay K33 (part of annunciator control assembly, 76, figure 4-20) may be defective and must be referred to next higher level of maintenance for testing.

If VOLTS AC meter reads low, refer voltage regulator VR1 (48, figure 4-17) to next higher level of maintenance for testing.

Step 5 If REVERSE POWER indicator lamp is lit, toggle PARALLEL OPERATION switch to SINGLE UNIT OPERATION; toggle ANNUNCIATOR RESET switch to up position; toggle AC PWR CKT BKR to CLOSE; observe REVERSE POWER indicator lamp.

If lamp goes out, check that controls have been properly set for parallel operation.

If malfunction persists, refer malfunction to next higher level of maintenance.

If lamp remains lit, relay K34 (part of annunciator control relay assembly, 76, figure 4-20) or reverse power sensing relay K112 (67, figure 4-20) may be defective and must be referred to next higher maintenance for testing.

Step 6. If SHORT CIRCUIT indicator lamp is lit, toggle ANNUNCIATOR RESET switch to up position and observe SHORT CIRCUIT indicator lamp.

If lamp goes out, refer external load circuits to the next higher level of maintenance.

If lamp stays lit, relay K36 (annunciator control relay assembly, 76, figure 4-20) or short circuit relay K113 (71, figure 4-20) may be defective and must be referred to next higher level of maintenance for testing.

**Table 4-3. Organizational Troubleshooting-Continued**

MALFUNCTION
TEST OR INSPECTION
CORRECTIVE ACTION

**12. CLOCK FAILS TO OPERATE.**

Step 1. Use multimeter to check for 24V DC across re crank inhibit relay K6 (part of AC-DC control relay assembly, 18, figure 4-19).

If present, refer K6 to next higher level of maintenance for testing.

If 24V DC is absent, proceed to next step.

Step 2. Use a multimeter (set for AC voltage) to check for 120V AC at terminals 1 and 2 of digital clock M111 (78, figure 4-22).

If 120V AC is absent, check wiring connections.

If 120V AC is present, refer digital clock to next higher level of maintenance for testing.

**13. CLOCK CANNOT BE ADJUSTED**

Step 1. Test 50/60 Hz switch S52 (9, figure 4-22) according to paragraph 4-40.

If defective, replace switch (see paragraph 4-40).

Step 2. Test HR ADJ switch S51 (10, figure 4-22) according to paragraph 4-40.

If defective, replace switch (see paragraph 4-40).

Step 3. Test MIN ADJ switch S50 (10, figure 4-22) according to paragraph 4-40.

If defective, replace switch (see paragraph 4-40).

Step 4. Test HOLD TIME switch S49 (10, figure 4-22) according to paragraph 4-40.

If defective, replace switch (see paragraph 4-40).

If malfunction persists, refer digital clock M111 (78, figure 4-22) to next higher level of maintenance for testing.

**14. GENERATORS CANNOT BE SET UP IN PARALLEL (DROOP).**

**NOTE**

This malfunction assumes that each generator functions properly as a single unit.

**Table 4-3. Organizational Troubleshooting-Continued**

MALFUNCTION
TEST OR INSPECTION
CORRECTIVE ACTION

14. GENERATORS CANNOT BE SET UP IN PARALLEL (DROOP)-continued

Visually inspect the parallel and governor control cables.

Repair as required.

---

## Section VIII. MAINTENANCE OF BATTERIES AND RELATED ITEMS

4-13. GENERAL. This section contains information on the batteries, battery tray, and battery cables of the engine generator set. Four 12-volt, 200 ampere hour, 20-hour rate, lead-acid type batteries in series-parallel connection supply 24V DC for starting the engine in the generator set.

### 4-14. CABLES.

#### a. Replacement. (See Figure 4-9)

#### **WARNING**

**Remove negative battery cables first, and insulate and secure.**

- (1) Disconnect all negative cables first then positive, and jumper cables from the batteries. Disconnect the battery leads from the starter motor (see figure 4-44).
- (2) Reconnect positive cables (4 and 3, figure 4-9) numbered P140XX and P140H to the positive post of batteries BR3 and BT2.
- (3) Reconnect two jumpers (1) between the negative and positive post of batteries BT1 and BT2; and BT3 and BT4.
- (4) Reconnect negative cables (5 and 2) numbered P55XX and P55YY to the negative post of batteries BT1 and BT4 and to ground post P2 on engine block.

#### b. Repair.

- (1) If terminals are damaged, remove damaged terminals and insulation sleeving, and clean wire lead.
- (2) Orient new terminal in same position as the one removed, and crimp terminal onto cable.
- (3) Tape connection so that no bare wire is exposed.
- (4) If wire is damaged, replace entire cable assembly.

### 4-15. CABLE FABRICATION.

a. Cable Construction. There are six separate battery cables (five different lengths and terminations) constructed as follows:

#### (1) Materials required:

Wire, electrical, 4/0 (P/N MIL-C-5756)

Terminal lug (P/N MS25036-141)

Battery terminal lug (P/N 76-11294-01 and 76-11294-02).

Insulation, sleeving 1-1/2 in. (38. 1 mm) ID, red and black

#### (2) Cable P/N 76-11424-01, see figure 4-10, detail A.

- a. Cut wire to 81 inches (206 cm) and strip insulation from both ends. Strip 0. 62 inch (15. 7 mm) at terminal lug end, and 0. 75 inch (19 mm) at battery terminal lug end.
- b. Attach battery terminal lugs on ends of wire as shown. Orient the lugs as shown, then crimp the terminals securely.
- c. Push sleeving up to terminals and apply heat of 400°F (204°C) for 3 to 5 seconds to obtain proper shrinkage.

#### **NOTE**

Cables 76-11424-02, 76-11422-01, and 76-11422-02 can be constructed the same way, only length of wire differs.

- (3) Cable P/N 76-11423 is fabricated similar to other cables, except that the wire has battery terminal lugs at both ends, see figure 4-10, detail B.



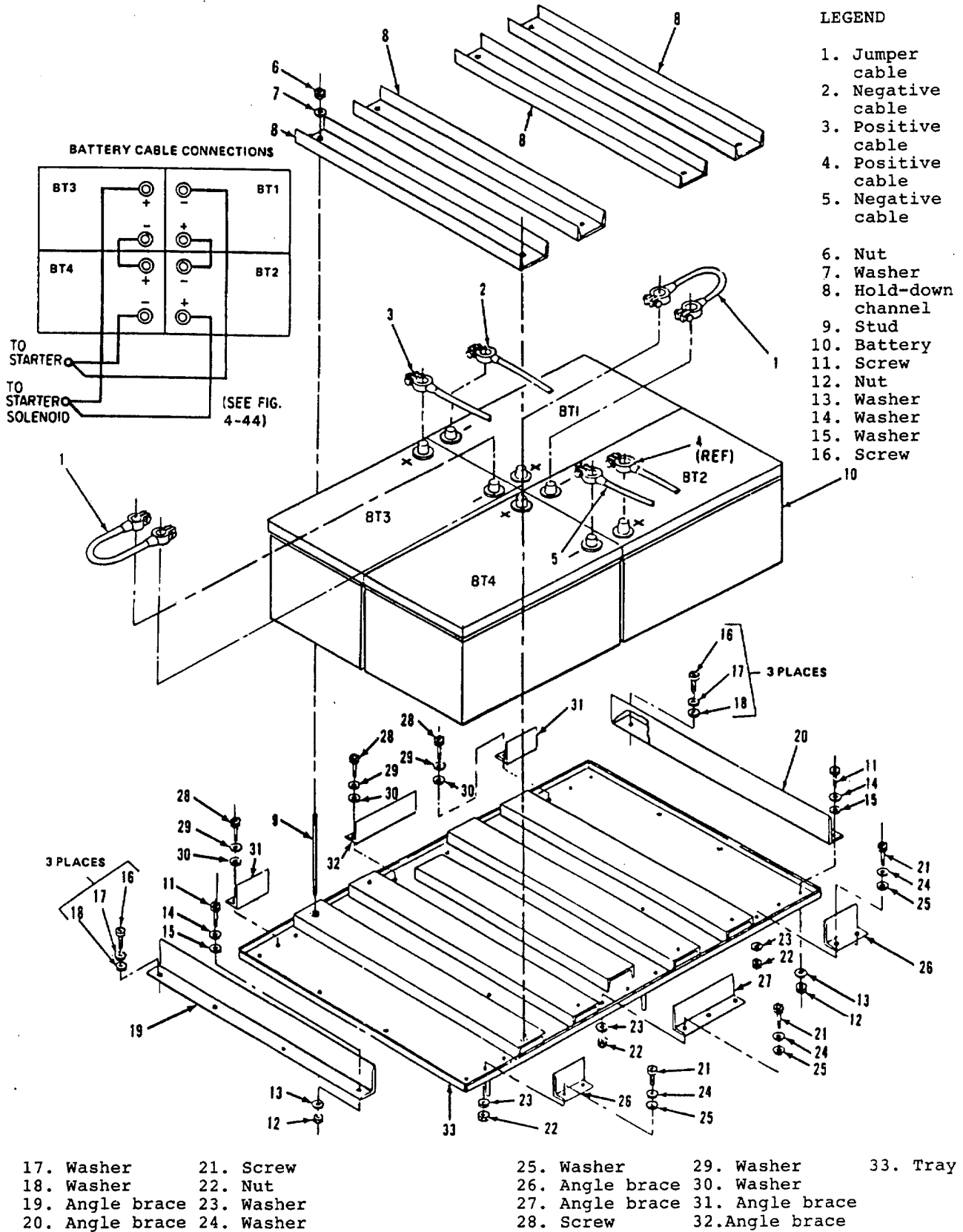

Figure 4-9. Batteries and Related Items, Exploded View

- a. Cut two pieces of sleeving one black and one red 2 inches (5 cm) long, and place them over wire ends.
- b. Attach terminal lug on end of wire that was previously stripped 0.62 inch (15.7 mm). Orient the lug as shown, then crimp the terminal securely.
- c. Attach battery terminal lug on other end of wire. Orient the lug as shown, then crimp the terminal securely.
- d. Push sleeving up to terminals and apply heat of 400°F (204°C) for 3 to 5 seconds to obtain proper shrinkage.

4-16. BATTERIES

**WARNING**

Do not smoke or use an open flame in the vicinity when servicing batteries. Batteries generate a highly explosive hydrogen gas during charging. Electrolyte is sulfuric acid diluted with water and can cause severe acid burns when spilled on skin or clothing. Use extreme care in handling while servicing batteries. When servicing batteries reference TM9-6140-200-14.

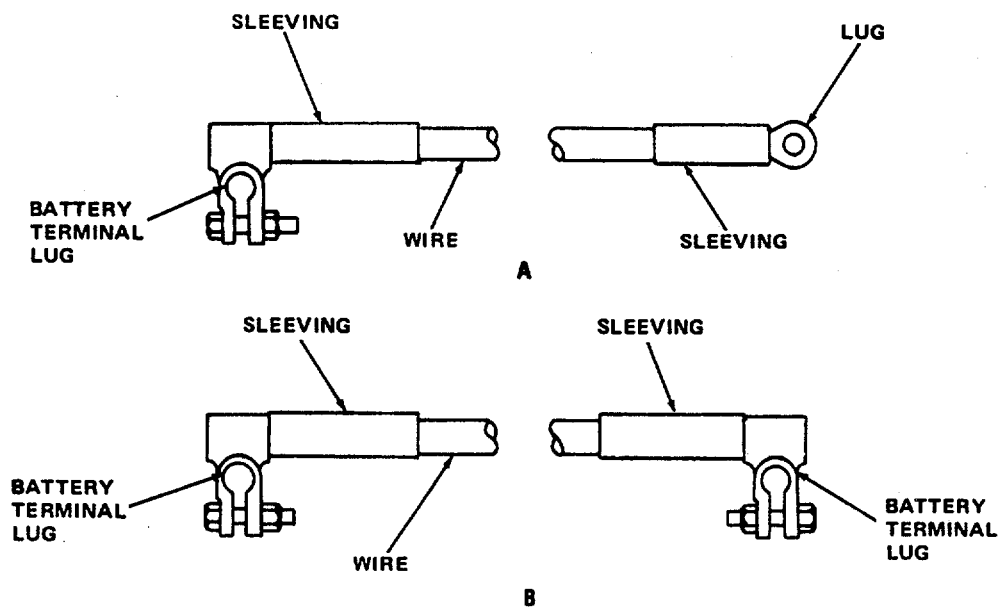

Sleeving Color	Cable P/N	Wire length		Ref. Designator
		Inches	Cm	
BLK	76-11424-01	81	206	P55XX
BLK	76-11424-02	96	244	P55YY
RED	76-11422-01	91	231	PI40XX
RED	76-11422-02	101	256.6	PI40.H
1-RED	76-11423	7.5	19	
1-BLK	76-11423	7.5	19	

Figure 4-10. Battery Cable Fabrication

- a. **Battery Testing.** Test batteries with hydrometer. Always test a battery before adding water. The specific gravity between the cells should be within 0.025. A dangerously low point of charge indicated by a hydrometer reading of 1.150 or less will cause the batteries to freeze at 5°F (-15°C). With specific gravity of 1.280 the battery will withstand temperatures as low as -65°F (-53.88°C) without freezing. An acceptable hydrometer reading of 1.270 to 1.280 at 80°F (26.66°C) will be obtained from a fully charged battery (2.2 to 2.4 volts DC per cell).
- b. **Replacement.** (See figure 4-9). (1) Disconnect both battery negative cables (2 and 5) both positive cable (3 and 4) and both jumper cables (1) from storage batteries (10).
  - (2) Remove the eight nuts (6) and washers (7) and remove the four battery hold-down channels (8). It is necessary to remove studs (9).
  - (3) Lift batteries out.
  - (4) Reinstall batteries in tray (install so that terminals are oriented as shown).
  - (5) Install the battery hold-down channels (8) onto studs (9) with washers (7) and nuts (6).
  - (6) Connect cables as shown in figure 4-9.

## Section IX. MAINTENANCE OF MUFFLER AND EXHAUST

4-17. GENERAL. The muffler and exhaust, figure 4-11, expel engine exhaust gases from the engine manifold through the turbochargers, metal exhaust hoses, mufflers, and out through the muffler rain caps. The rain caps include a balancing device for counterbalancing rain cap opening and closing.

### WARNING

**Be sure that the exhaust is not fed back into the system, or back into the immediate area of working personnel. Exhaust may be injurious to health.**

4-18. MUFFLER AND EXHAUST REPLACEMENT. (See figure 4-11).

### WARNING

**Allow exhaust pipe and muffler to cool if engine has been running.**

- a. Remove the eight screws (1), the eight split lockwashers (2) and the eight hex nuts (3).
- b. Remove the four screws (5) securing the front mounting brackets, the four split lockwashers (6), and muffler (8).
- c. Remove rain cap (7) from the muffler (8).
- d. Separate and remove the upper and lower gaskets (4).
- e. Remove the eight screws (9), lockwashers (10), and nuts (11) which attach metal exhaust hose (12) to exhaust elbow (16) and remove metal exhaust hose (12).
- f. Remove gasket (14).
- g. Repeat steps a. through f. for the other side of the exhaust system.
- h. Reassemble gasket (14) between exhaust elbow (16) and metal exhaust hose (12).
- i. Install eight screws (9), lockwashers (10), and nuts (11).

- j. Install gasket (4) between frame and top of metal exhaust hose (12) and another gasket (4) on top of frame between the muffler (8) and frame.
- k. Install rain cap (7) on muffler (8).

- l. Install eight screws (1), lockwashers (2), and nuts (3) to secure muffler to frame and exhaust hose.
- m. Install four screws (5) and front mounting bracket, and four lockwashers (6).
- n. Repeat steps h. through m. for reassembly of other side of the exhaust system.

## Section X. MAINTENANCE OF EXTERNAL POWER BOX ASSEMBLY

4-19. GENERAL. This section contains inspection, test, and replacement information for the external power box assembly. See figure 4-12 and 4-13 and proceed as follows:

- a. Inspection. Inspect components of the external power assembly for defective, broken, or cracked components. Inspect wiring for loose connections.
- b. Testing. Testing of components of the external power assembly is described under the appropriate heading in paragraph 4-20 through 4-24.
- c. Repair. Repair by replacement of components which do not function properly during testing.

### WARNING

**Set MAINTENANCE LOCKOUT switch to LOCKOUT. Disconnect negative cable from batteries. Remove external power by opening EXTERNAL POWER BREAKER CB101 and disconnecting power cable from EXTERNAL POWER receptacle J101. Load terminals of generator set circuit breaker (CB2) may still be energized with bus voltage.**

- d. Replacement. If a component needs replacement, gain access to the inside of the external power box assembly by loosening the captive screws and permitting the panel (4, figure 4-12) to pivot about its hinges in a forward

direction. Replace in step b (Testing) as indicated in following paragraphs.

4-20. PANEL MOUNTED CIRCUIT BREAKER CB101 and CB102. (See figure 4-13. )

- a. Test.
  - (1) Position CB101 circuit breaker (14, figure 4-13) and CB102 circuit breaker (23) to ensure that they are in the reset position.
  - (2) At the rear of the panel, remove terminal leads from one side of circuit breaker on each circuit breaker.
  - (3) With an ohmmeter (Rxl scale), test circuit breakers for closed contacts. If meter indicates an open circuit in either circuit breaker replace circuit breaker.
  - (4) Position circuit breakers in open position. With ohmmeter on same setting, test breakers for open contacts. If meter indicates closed circuit in either circuit breaker, replace circuit breaker.
- b. Replacement. Replace defective circuit breakers CB101 and CB102 (14 and 23, figure 4-13) as follows:
  - (1) Removal.
    - a. At rear of panel, tag and remove wires to CB101 and CB102.
    - b. Remove CB101 (14) by removing screws (12) and nuts (13).

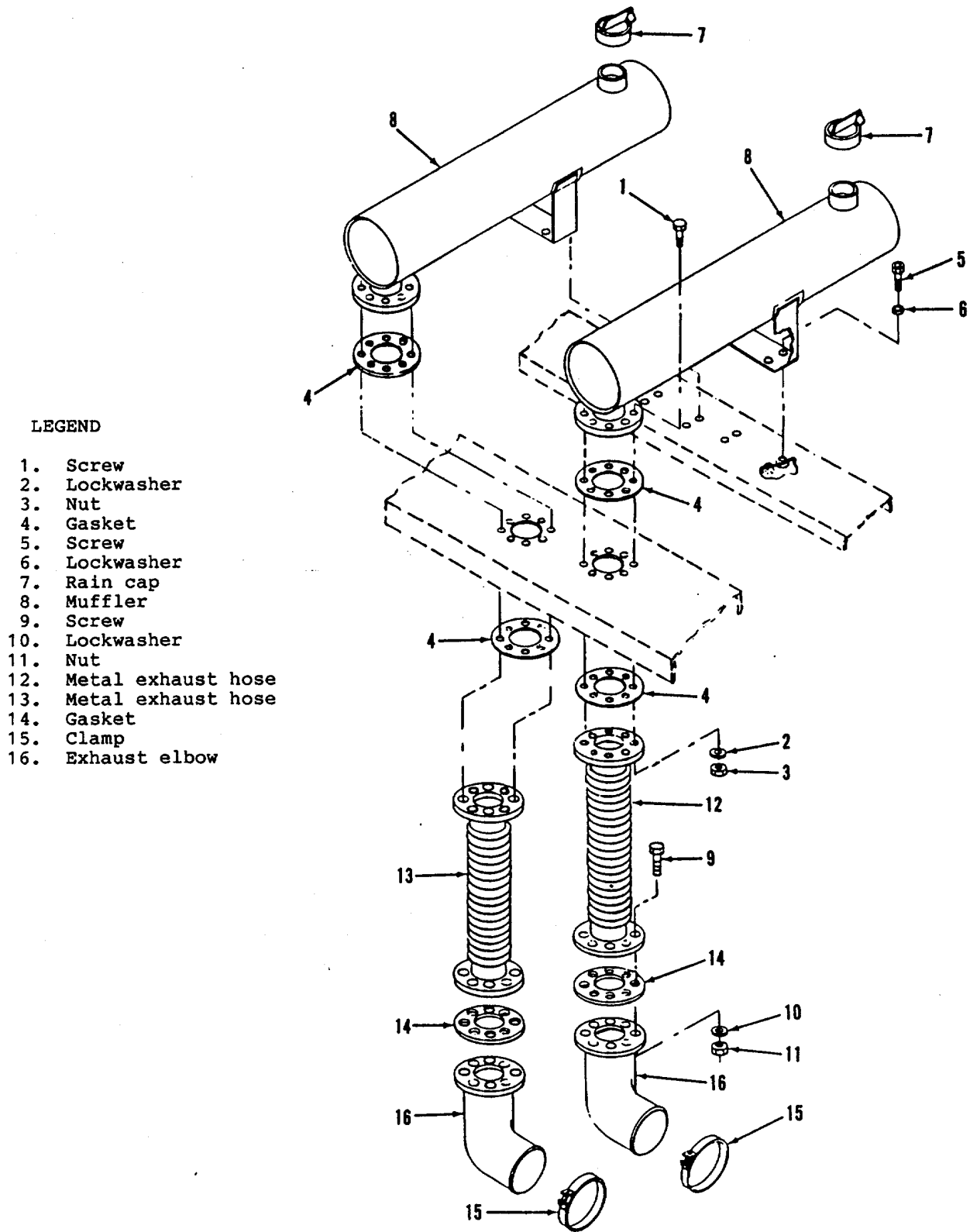

LEGEND

- 1. Screw
- 2. Lockwasher
- 3. Nut
- 4. Gasket
- 5. Screw
- 6. Lockwasher
- 7. Rain cap
- 8. Muffler
- 9. Screw
- 10. Lockwasher
- 11. Nut
- 12. Metal exhaust hose
- 13. Metal exhaust hose
- 14. Gasket
- 15. Clamp
- 16. Exhaust elbow

Figure 4-11. Muffler and Exhaust, Exploded View

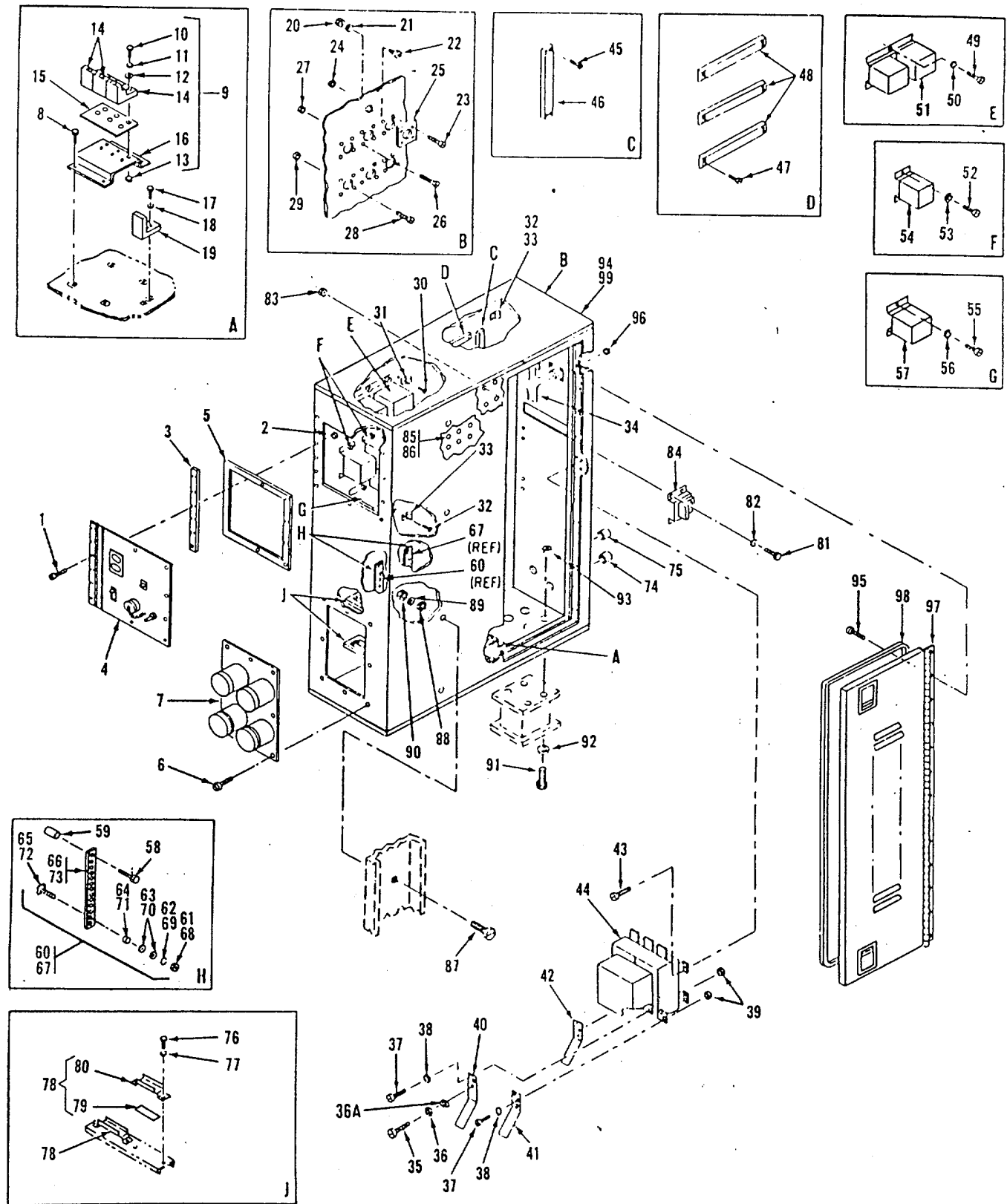
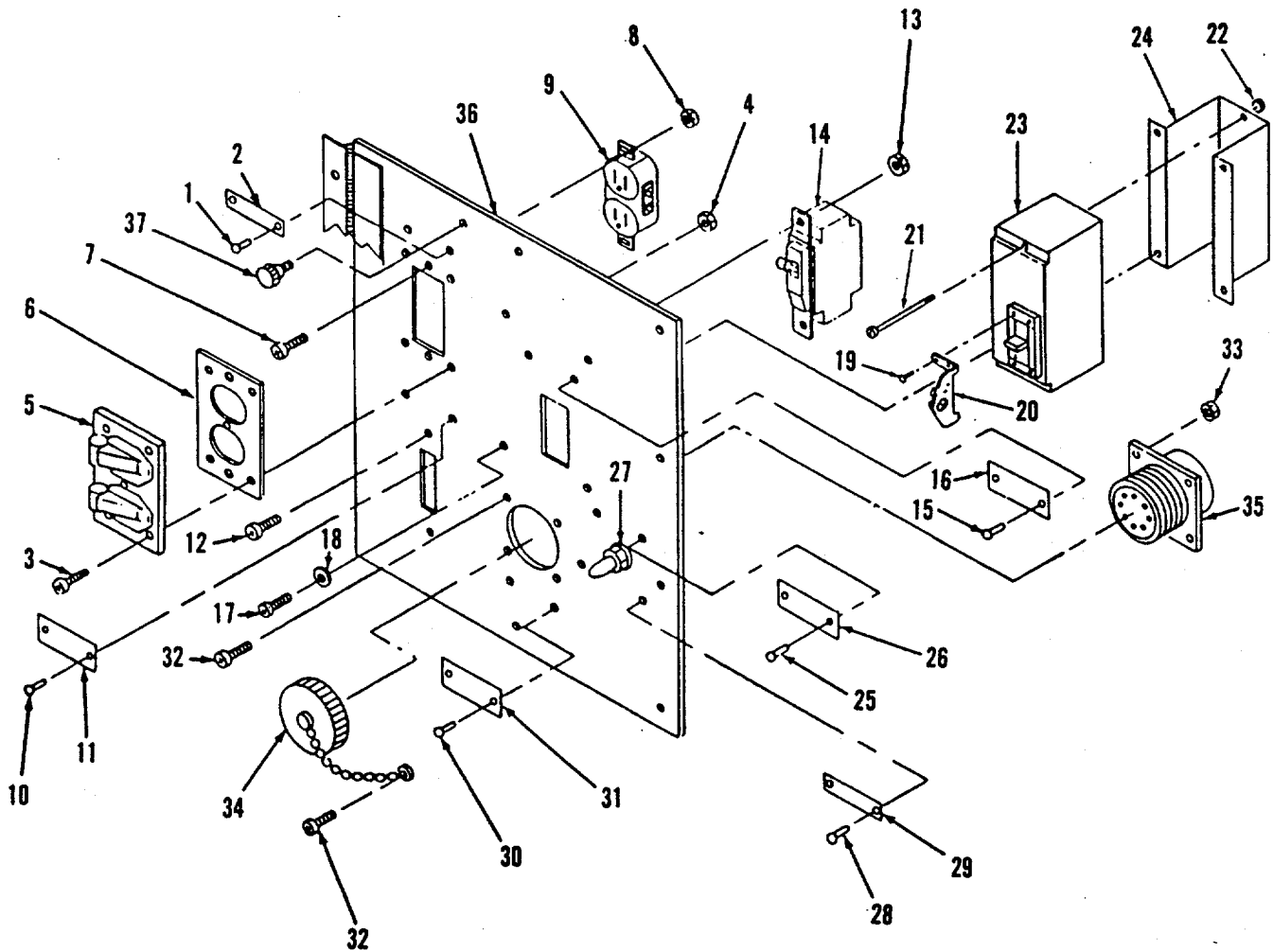

Figure 4-12. External Power Box Assembly, Exploded View

**LEGEND FOR FIGURE 4-12**

- |                          |  |
|--------------------------|--|
| 1. Screw                 | 51. Transfer contactor K108            |
| 2. Nut                   | 52. Screw                              |
| 3. Spacer bar            | 53. Lockwasher                         |
| 4. Panel control assy    | 54. Heater contactor K107 and K109     |
| 5. Weather stripping     | 55. Screw                              |
| 6. Screw                 | 56. Lockwasher                         |
| 7. Plate and sleeve assy | 57. Motor starter relay contactor K120 |
| 8. Screw                 | 58. Screw                              |
| 9. Neutral bar assy      | 59. Spacer                             |
| 10. Screw                | 60. Terminal block assy                |
| 11. Nut                  | 61. Nut                                |
| 12. Lockwasher           | 62. Lockwasher                         |
| 13. Washer               | 63. Washer                             |
| 14. Compression lug      | 64. Nut                                |
| 15. Plate                | 65. Bolt                               |
| 16. Bracket              | 66. Terminal block                     |
| 17. Screw                | 67. Terminal block assy                |
| 18. Lockwasher           | 68. Nut                                |
| 19. Compression lug      | 69. Lockwasher                         |
| 20. Locknut              | 70. Washer                             |
| 21. Washer               | 71. Jam nut                            |
| 22. Connector            | 72. Bolt                               |
| 23. Screw                | 73. Terminal block                     |
| 24. Nut                  | 74. Bushing                            |
| 25. Cover                | 75. Bushing                            |
| 26. Screw                | 76. Screw                              |
| 27. Nut                  | 77. Lockwasher                         |
| 28. Screw                | 78. Clamp assy                         |
| 29. Nut                  | 79. Cushion                            |
| 30. Screw                | 80. Clamp                              |
| 31. Clamp                | 81. Screw                              |
| 32. Screw                | 82. Washer                             |
| 33. Clamp                | 83. Nut                                |
| 34. Harness assy         | 84. Relay board assy                   |
| 35. Screw                | 85. Screw                              |
| 36. Washer               | 86. Lockwasher                         |
| 37. Bolt                 | 87. Screw                              |
| 38. Lockwasher           | 88. Washer                             |
| 39. Nut                  | 89. Lockwasher                         |
| 40. Buss bar             | 90. Nut                                |
| 41. Buss bar             | 91. Screw                              |
| 42. Buss bar             | 92. Lockwasher                         |
| 43. Screw                | 93. Nut                                |
| 44. Circuit breaker      | 94. Box and door assy                  |
| 45. Screw                | 95. Screw                              |
| 46. Terminal board       | 96. Nut                                |
| 47. Screw                | 97. Door assy                          |
| 48. Terminal board       | 98. Seal                               |
| 49. Screw                | 99. Enclosure                          |
| 50. Lockwasher           |  |



**LEGEND**

- |               |                     |                   |
|---------------|---------------------|-------------------|
| 1. Rivet      | 14. Circuit breaker | 26. Nameplate     |
| 2. Nameplate  | 15. Rivet           | 27. Toggle switch |
| 3. Screw      | 16. Nameplate       | 28. Rivet         |
| 4. Nut        | 17. Screw           | 29. Nameplate     |
| 5. Cover      | 18. Washer          | 30. Rivet         |
| 6. Gasket     | 19. Screw           | 31. Nameplate     |
| 7. Screw      | 20. Padlock device  | 32. Screw         |
| 8. Nut        | 21. Screw           | 33. Nut           |
| 9. Receptacle | 22. Nut             | 34. Dust cap      |
| 10. Rivet     | 23. Circuit breaker | 35. Receptacle    |
| 11. Nameplate | 24. Bracket         | 36. Panel         |
| 12. Screw     | 25. Rivet           | 37. Screw         |
| 13. Nut       |                     |                   |

**Figure 4-13. External Power Box Assembly, Control Panel, Exploded View**



- c. Remove CB102 (23) by removing screws (17) and lockwashers (18) to release circuit breaker and bracket (24) from the panel. Remove screw (19) to remove circuit breaker padlock device (20), then remove screw (21) and nut (22) to free CB102 (23) from bracket (24).

(2) Installation.

- a. Install CB101 (14) using screws (12) and nuts (13).
- b. Prepare CB102 (23) for installation by securing padlock device (20) to the face of the circuit breaker with screws (19), and then securing CB102 to its mounting bracket (24) with screws (21) and nuts (22). Mount CB102 (23) by securing bracket (24) to panel (37) with screws (17) and lockwashers (18).
- c. Reconnect wires to circuit breakers, and remove tags.

#### 4-21. PANEL MOUNTED RECEPTACLES.

Replace defective receptacles J101 and J102 (9 and 35, figure 4-13) as follows:

a. Removal

- (1) At rear of panel tag and remove wires from receptacles.
- (2) Remove J101 and J102 receptacle mounting hardware and remove receptacle.

- b. Installation. Install receptacles onto front panel with mounting hardware. Attach wires to J102 with screws and washers. Carefully solder wires to J101. Remove wire tags.

#### 4-22. PREHEAT SWITCH S105.

a. Test

- (1) Wire contactors K107 and K108 into test set-up as shown in figure 4-14.

- (1) Toggle switch (27, figure 4-13) to the ON position.

- (2) At the rear of the panel, remove one lead from the switch.

- (3) With an ohmmeter (Rxl scale), test switch for closed circuit. If meter indicates an open circuit, replace switch.

- (4) Place toggle switch to OFF position. Using ohmmeter on Rxl scale, test switch for open circuit. If meter indicates a closed circuit, replace switch.

- b. Replacement. Replace defective toggle switch S105 (27, figure 4-13) as follows:

(1) Removal.

- (a) At rear of panel, tag leads and remove wires to switch.

- (b) Remove switch mounting hardware and remove switch.

- (2) Installation. Install switch onto panel with mounting hardware. Attach wires to switch and remove tags.

#### 4-23. CONTACTORS K107, K108, K109 AND K120.

- a. Inspect. Inspect contactors K107 and K109 (54, figure 4-12) and K108 (51) for damage to phenolic and metal parts. Inspect K108 for binding or damaged mechanical interlock. Inspect K120 (57) for damage. Refer to TM5-6115-593-34 for maintenance of K120.

**WARNING**

**Use extreme care when connecting power supply to avoid electrical shock.**

- b. Test. Disconnect and tag wires to contactors K107, K108, and K109 and proceed as follows:

- (2) Plug test set-up into 120V AC power supply.
  - (3) Observe that neither of the 120V AC test lamps light.
  - (4) Depress and hold pushbutton A; lamp A should light and lamp B should remain extinguished.
  - (5) Release pushbutton A and depress and hold pushbutton B; lamp A should extinguish and lamp B should light.
  - (6) Depress and hold pushbutton A and then also depress and hold pushbutton B; note that transfer does not take place.
  - (7) Wire contactor K109 into test set-up as shown in figure 4-14.
  - (8) Plug test set-up into 120V AC power supply.
  - (9) Observe that test lamp does not light.
  - (10) Depress and hold pushbutton; test lamp should light.
  - (11) Release pushbutton; test lamp should extinguish.
  - (12) Refer to next higher maintenance for repair of any defective contactors.
- c. Replacement. Replace defective contactors as follows:
- (1) Remove contactors K107 and K109 (54) by disconnecting and tagging lead wires, and removing screws (52) and washers (53).
  - (2) Remove contactor K108 (51) by disconnecting and tagging lead wires, and removing screws (49) and washers (50).
  - (3) Install contactors K107 and K109 (54) using screws (52) and washers (53) to secure contactors side wall of external power enclosure (94). Connect wires and remove tags.
  - (4) Install contactor K108 (51) using screws (49) and washers (50) to mount contactor. Connect wires and remove tags.

#### 4-24. MAIN CIRCUIT BREAKER CB2.

- a. Inspect. Inspect main circuit breaker CB2 (44, figure 4-12) for loose or broken wires and damaged case.
- b. Removal. Remove circuit breaker CB2 (44, figure 4-12) as follows:

#### **WARNING**

**Set MAINTENANCE LOCKOUT switch to MAINTENANCE LOCKOUT. Disconnect negative cable from batteries. Remove external power by opening CB101 and disconnecting. Load terminals of generator set circuit breaker (CB2) may still be energized with the bus voltage. (1) Disconnect input bars from reconnection panel to CB2.**

- (2) Disconnect buss bars (40, 41, and 42) by removing bolts (37) and screws (35), washers (38) and nuts (39).
  - (3) Free upper set of circuit breaker buss bars by removing fastening hardware.
  - (4) Remove circuit breaker CB2 (44) from enclosure (99) by removing eight screws (38).
- c. Test. Refer to figures 4-14 and 4-15 and proceed as follows:

#### **WARNING**

**Disconnect all input bars, bussing, cables and control circuits to breaker before starting test procedure.**

#### **NOTES**

1. Manual operation of circuit breaker disorders the sequence of electrical control, Do not attempt to operate the breaker from OPEN (OFF) to CLOSED (ON) without energizing the undervoltage trip. To restore electrical mode of operation, the breaker must be cycled into CLOSED (ON) or OPEN (OFF) position as indicated on motor cover.

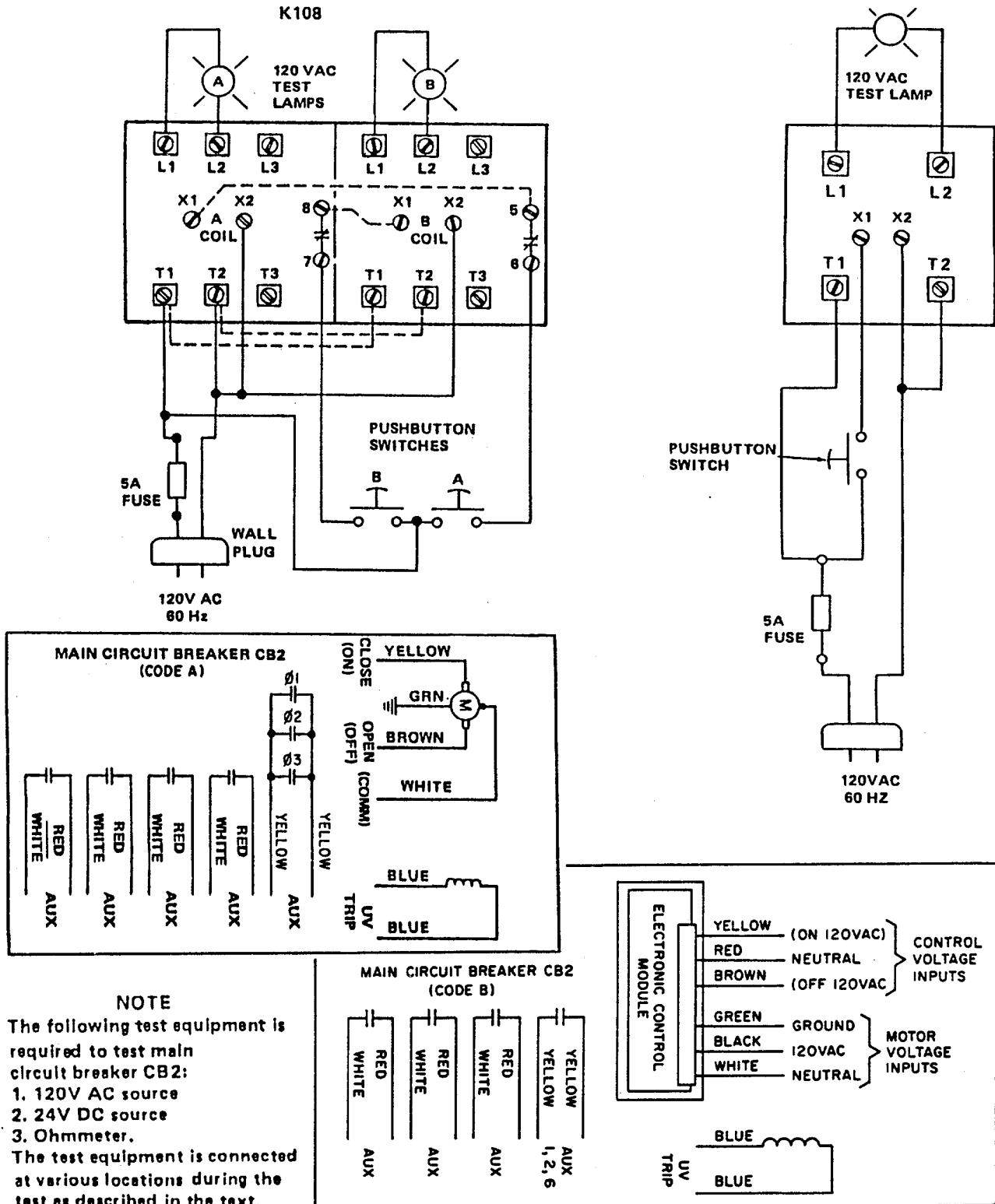

**NOTE**

The following test equipment is required to test main circuit breaker CB2:

1. 120V AC source
2. 24V DC source
3. Ohmmeter.

The test equipment is connected at various locations during the test as described in the text.

Figure 4-14. Contactors K107, K108, K109 and Main Circuit Breaker CB2, Schematic

2. To cycle the breaker to CLOSED, connect a 120V AC (12 amps or greater) power supply between the yellow and white leads.
3. To cycle the breaker to OPEN (ON), connect a 120 V AC (12 amps or greater) power supply between the brown and white leads.

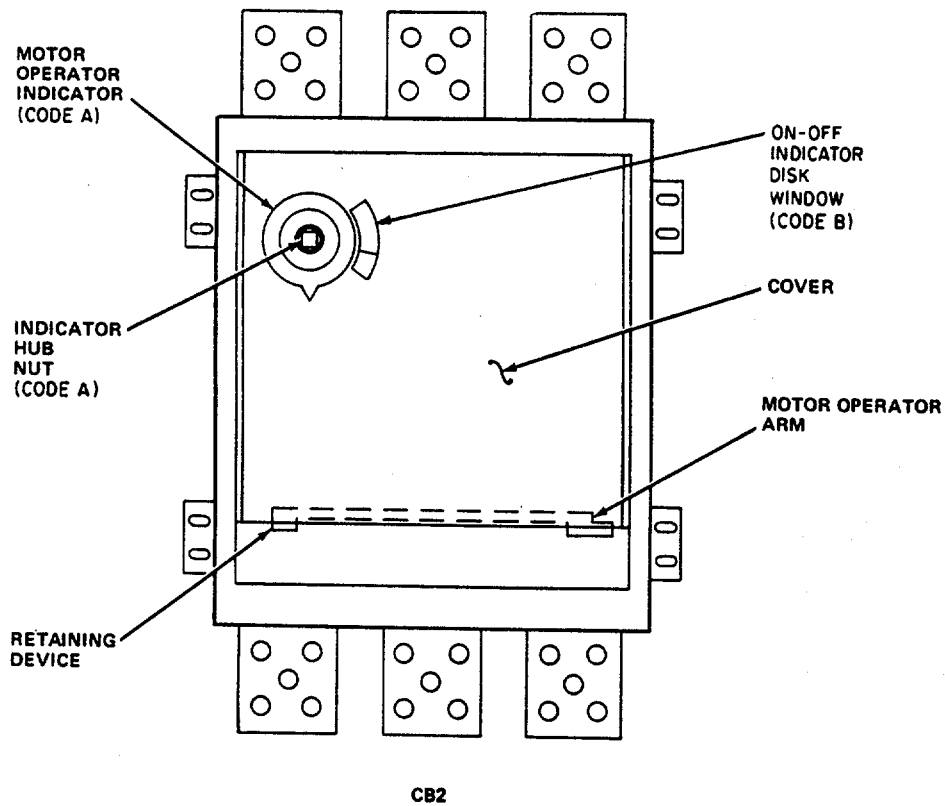

Figure 4-15. Main Circuit Breaker, CB2

### CAUTION

When operating the breaker electrically, do not disconnect the voltage source until the motor operator arm has reached the end of its travel and stopped.

- (1) Disconnect all input bars, bussing, cables and control circuits to breaker CB2. The circuit breaker should be OPEN (OFF) or tripped position. If not, cycle breaker to OPEN (OFF) by connecting 120V AC to brown and white leads.
- (2) Using an ohmmeter, verify that all poles are open by checking for continuity between line and load of each pole.
- (3) Verify that all auxiliary switches are open by checking between each pair (one red and one white wire in tubing) and between both yellow wires.
- (4) Connect 24V DC (0.5 amp or greater) supply to under-voltage trip (blue leads).
- (5) Cycle breaker to CLOSED (ON) by connecting 120V AC supply between yellow and white leads. Wait for motor operator arm to stop moving before disconnecting power source.
- (6) Verify that all poles and auxiliary switches are closed (see steps 2 and 3, above).
- (7) Trip breaker by removing voltage from undervoltage trip.
- (8) Check that all poles and auxiliary switches are open.
- (9) Reconnect 24V DC supply to undervoltage trip (blue leads).
- (10) Reset breaker to OPEN by connection 120V AC to supply between brown and white leads. Indicator should point to OFF (OPEN).
- (11) Turn breaker ON (CLOSED) by connection 120V AC supply between

yellow and white leads. Indicator should point to ON.

- (12) Verify that all poles are closed.
- (13) Turn breaker OFF (OPEN) by connecting 120V AC supply between brown and white leads. Indicator should point to OFF.
- (14) Verify that all poles are open.
- (15) Disconnect all voltage supplies.
- (16) Refer to next higher maintenance for repair if necessary.

#### d. Installation.

- (1) Install circuit breaker CB2 (44, figure 4-12) using eight screws (43). Connect buss bars (40, 41 and 42) using bolts (37) and screws (35), washers (36 and 38) and nuts (39).

### NOTE

Indicator on cover shows position of operator arm and not motor operator drive, except when sequence is proper.

### CAUTION

Manual operation of circuit breaker CB2 can be achieved by removing operator arm retaining device, removing operator arm, and installing arm onto indicator hub nut. If arm is to be manually operated from OFF to ON (OPEN to CLOSED), the undervoltage trip (blue leads) must be energized.

- (2) Refer to figure 4-15 and manually restore electrical sequence by removing operator arm retaining device and removing operator arm, then install arm onto indicator hub nut and connect a 24V DC (0.5 amp or greater) power supply to the undervoltage trip (blue leads). Manually operate the breaker by moving the operator arm.

a. If motor operator indicates ON (CLOSED), supply power to off leads (brown and white) and check for proper sequencing as follows:

1. Motor runs-Breaker cycles OFF (OPEN) as shown by indicator, sequence is proper.
2. Motor runs-Breaker not cycled to OFF (OPEN) per motor indicator. To engage drive, electrically cycle motor operator to ON (CLOSED), and then OFF (OPEN). Drive is engaged and breaker will be turned OFF per motor operator indicator. Sequence is proper.
3. Motor does not run - Sequence is out of order, switch supply power to motor operator ON leads. Motor will run to ON position and stop. Again switch supply power to motor operator OFF leads. Motor operator will run to OFF position and stop. Breaker will be turned OFF per motor operator indicator. Sequence is proper.

b. If motor operator indicates OFF (OPEN), supply power to ON (CLOSED) leads (yellow and white) and check for proper sequencing as follows:

1. Motor runs-Breaker cycles ON as shown by motor operator indicator. Sequence is proper.
2. Motor runs-Breaker not cycled to ON per motor operator indicator. Drive is not engaged. To engage drive electrically, cycle motor operator to OFF and then to ON. Drive is engaged and breaker will be turned ON per motor operator indicator. Sequence is proper.
3. Motor does not run - Sequence is out of order. Switch supply power to motor

operator OFF leads. Motor will run to OFF position and stop. Again switch supply power to motor operator ON leads. Motor runs, breaker cycles ON as shown by motor operator indicator. Sequence is proper.

#### NOTE

Due to the switching arrangement, the motor operator must run to the limit of its travel in one direction before it will run in the opposite direction. However, it will always run in one direction or the other. If motor operator will run in neither direction, problems other than sequence exist.

- (3) Replace operator arm as shown in figure 4-15.

#### 4-25. PLATE AND SLEEVE ASSEMBLY.

Replace the plate and sleeve assembly (7, figure 4-12) as follows:

- a. Removal. Remove plate and sleeve assembly (7) from enclosure (99) by removing eight screws (6). Referring to figure 4-16, sleeves may be removed by removing four screws (1) and four nuts (2) attaching retainer plate (3). Remove bushing (4) and sleeve (5).
- b. Installation. Install plate and sleeve assembly (7, figure 4-12) onto enclosure (99) with eight screws (6). Replace sleeves by installing sleeve (5, figure 4-16) with bushing (4) into plate hole. Fasten with retainer plate (3), four screws (1), and four nuts (2).

#### 4-26. WEATHER STRIPPING AND SEALS.

- a. Inspection. Inspect weather stripping (5, figure 4-12) and door seal (98) for signs of excessive wear, rot, or damage.

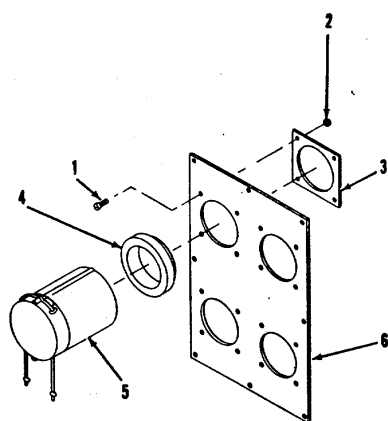

LEGEND

- |             |                |
|-------------|----------------|
| 1. Screw    | 4. Bushing     |
| 2. Nut      | 5. Sleeve      |
| 3. Retainer | 6. Plate cover |

**Figure 4-16. External Power Box Assembly, Plate and Sleeve Assembly, Exploded View**

b. Replacement of Weather Stripping.

- (1) Tag and disconnect wires to circuit breakers (14 and 23, figure 4-13) receptacle (9), and toggle switch (27). Remove receptacle (35) from the panel by unscrewing dust cap (34) and removing screws (32) and nuts (33).
- (2) Remove external power control panel (4, figure 4-12) by removing screws (1, figure 4-12) and nuts (2). Spacer bar (3) and weather stripping (5) are now easily removable.

**NOTE**

Weather stripping (5) consists of four separate pieces.

- (3) Position spacer bar (3) and fresh weather stripping (5) on panel (4) using screws (1). Mount panel (4), with spacer bar and weather stripping, on external power box enclosure and secure with nuts (2).
- (4) Install receptacle (35, figure 4-13) using screws (32) and nuts (33). Screw dust cap (34) into place.

- (5) Connect wires to circuit breakers (14 and 23), receptacle (9), and toggle switch (27). Remove wire tags.

c. Replacement of Door Seals

- (1) Remove door by removing screws (95, figure 4-12) and nuts (96).
- (2) Separate seal (98) from door (97).
- (3) Install fresh seal (98) onto door (97).
- (4) Install door (97) using screws (95) and nuts (96).

**4-27. HARNESS ASSEMBLY.**

a. Inspection.

**WARNING**

Set MAINTENANCE LOCKOUT switch to LOCK- OUT. Disconnect negative cable from batteries, Remove external power by opening CB101 (120V RECEPTACLE BREAK- ER). Load terminals of generator set circuit breaker (CB2) may still be energized with the bus voltage.

- (1) Inspect all connectors for damaged threads and bent, loose, or missing pins.
- (2) Inspect all connections for security and condition.
- (3) Inspect all wiring for defective insulation.

- b. Test. Perform continuity check, using an ohmmeter between connecting points in the wiring harness (see FO-6, External Power Box, Wiring Diagram). Check for short circuits between connector pins of the same receptacle, plug, or terminal board.

c. Repair.

- (1) If a broken wire is accessible, remove sufficient insulation from each side of the break to allow a good connection of the bared ends

by twisting them together. Solder the connection and wrap with electrical tape.

- (2) If a wire is broken from a terminal lug, replace the lug. If a wire is broken from a connector, resolder and reassemble.

### CAUTION

Under no condition leave the bare connection exposed.

- (3) If a break in the wire is inaccessible within the wiring harness, disconnect it at both ends and tape both ends. Lace a new lead of the same gauge and insulation outside the harness and connect it to the proper terminals or pins. Properly tag both ends of all replacement wires.
- (4) If more than 30 percent of the harness wires are defective, refer to next higher level of maintenance for replacement.

## Section XI. MAINTENANCE OF AC-DC CONTROL BOX ASSEMBLY

**4-28. GENERAL.** This section contains inspection, test, and replacement information for the AC-DC Control Box Assembly. See figure 4-17, 4-18 and 4-19 and proceed as follows:

- a. Gain access to the components of the AC-DC Control Box by loosening six captive screws on the AC-DC control panel (3, figure 4-17). Use the top and bottom latches to release and open the side door (73, figure 4-17) to the AC-DC Control Box.
- b. Inspection. Inspection components of the AC-DC Control Box Assembly for defective, broken, or cracked components. Inspect wiring for loose connections.
- c. Testing. Testing of components of the AC-DC Control Box Assembly is described under the appropriate heading in paragraphs 4-29 through 4-35.
- d. Repair. Repair by replacement of components which do not function properly during testing. Small dents in the control panel may be hammered out and refinished.

### WARNING

Set MAINTENANCE LOCKOUT switch to LOCKOUT. Disconnect negative cable from batteries. Remove external power. Load terminals of generator set circuit

breaker (CB2 may still be energized with bus voltage.

- e. Replacement. Replace components which do not function properly in step c (Testing) as indicated in following paragraphs. Replace control panel (3) by first loosening six captive screws, then tag and disconnect leads and remove screws (1). Install new cover panel by installing panel using screws (1), then reconnect leads, remove tags, and tighten captive screws.

### 4-29. CIRCUIT BREAKER CB103 (42, figure 4-18)

- a. Test.
  - (1) Place circuit breaker switch to the ON (closed) position.
  - (2) At the rear of the panel, remove leads from one side of circuit breaker.
  - (3) With an ohmmeter (Rx1 scale), test circuit breaker for closed contacts. If meter indicates an open circuit, replace circuit breaker.
  - (4) Place circuit breaker in OFF position (open). Using ohmmeter on Rx1 scale, test circuit breaker for open contacts. If meter indicates a closed circuit replace circuit breaker.



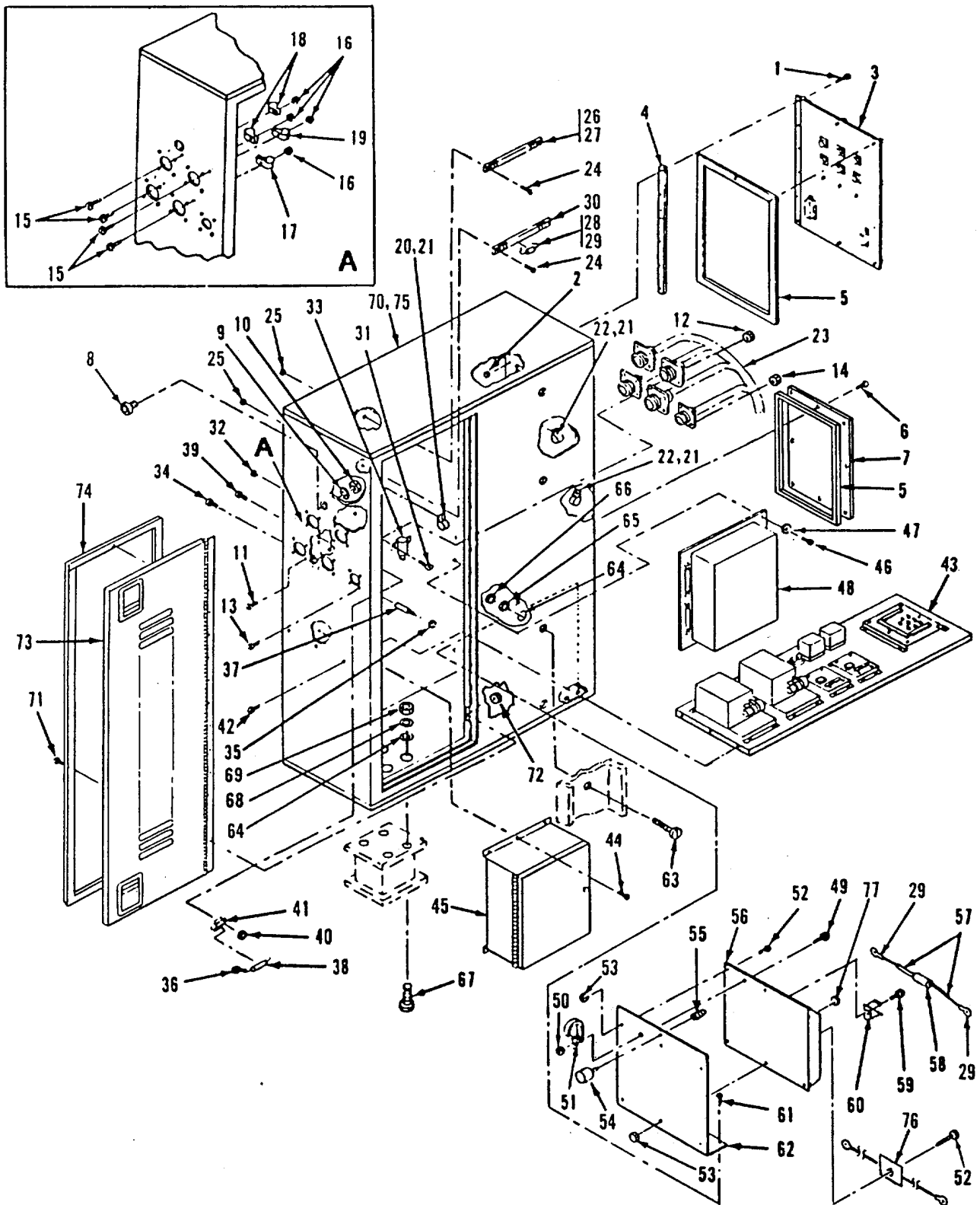

Figure 4-17. AC-DC Control Box Assembly, Exploded View

LEGEND FOR FIGURE 4-17

1.	Screw	40.	Nut
2.	Nut	41.	Clip
3.	AC-DC control panel	42.	Screw
4.	Spacer bar	43.	Compartment panel assy
5.	Weather stripping	44.	Screw
6.	Screw	45.	Battery charger
7.	Cover	46.	Screw
8.	Connector	47.	Washer
9.	Washer	48.	Voltage regulator
10.	Lock nut	49.	Screw
11.	Screw	50.	Nut
12.	Nut	51.	Clamp
13.	Screw	52.	Screw
14.	Nut	53.	Nut
15.	Screw	54.	Potentiometer
16.	Nut	55.	Shaftlock
17.	Clamp	56.	Governor
18.	Clamp	57.	Plastic sleeve
19.	Clamp	58.	Capacitor
20.	Clamp	59.	Screw
21.	Screw	60.	Clip
22.	Clamp	61.	Screw
23.	Harness assy	62.	Bracket
24.	Screw	63.	Screw
25.	Nut	64.	Washer
26.	Terminal board	65.	Nut
27.	Jumper	66.	Nut
28.	Diode	67.	Screw
29.	Terminal lug	68.	Washer
30.	Terminal board	69.	Nut
31.	Screw	70.	AC-DC box assy
32.	Nut	71.	Screw
33.	Relay	72.	Nut
34.	Screw	73.	Door
35.	Nut	74.	Door seal
36.	Lug	75.	Enclosure assy
37.	Standoff	76.	Resistor assy
38.	Resistor	77.	Lockwasher
39.	Screw		

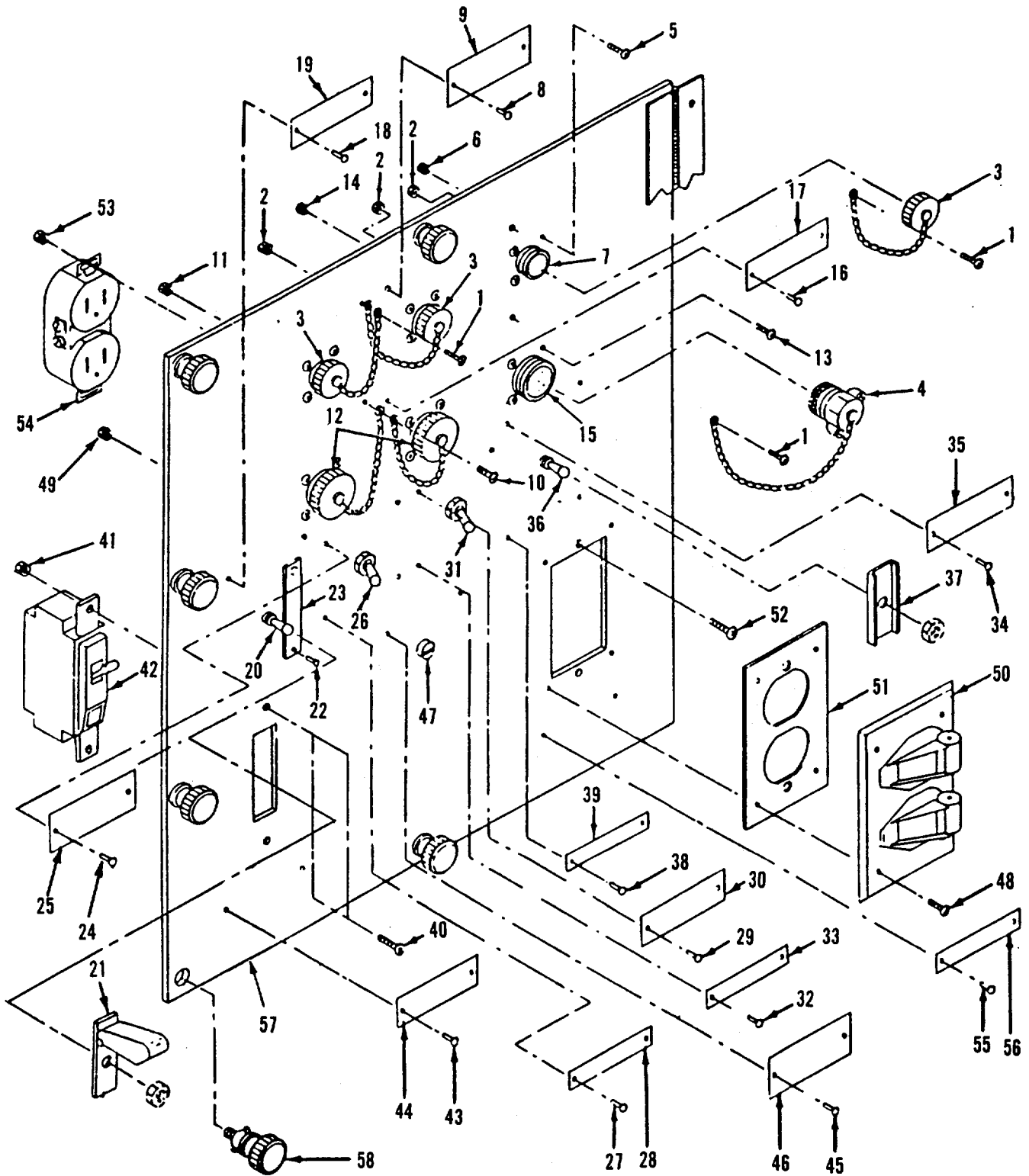
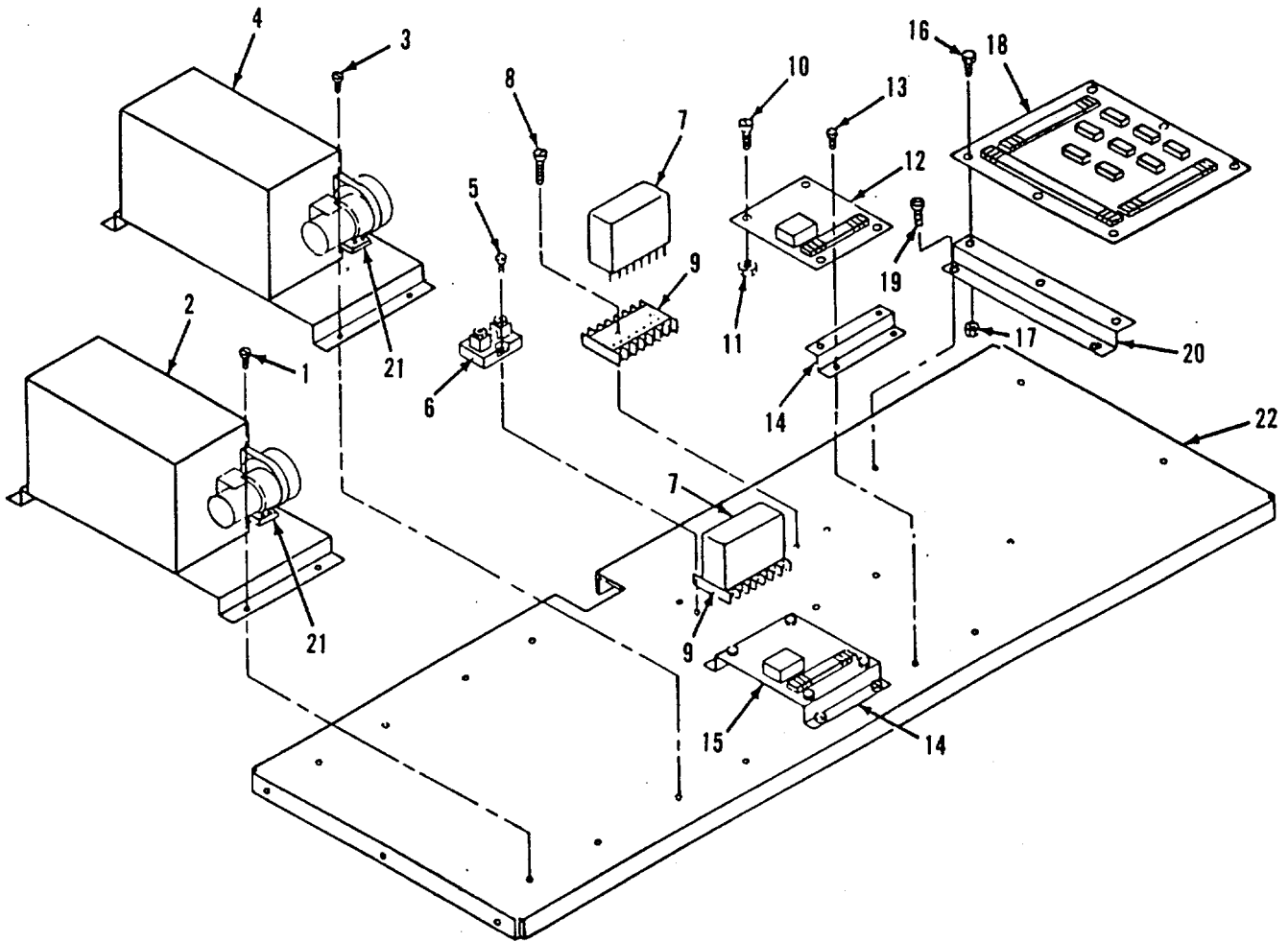

Figure 4-18. AC-DC Control Box Assembly, Component Panel Assembly, Exploded View

**LEGEND FOR FIGURE 4-18**

- |     |               |     |                 |
|-----|---------------|-----|-----------------|
| 1.  | Screw         | 30. | Nameplate       |
| 2.  | Nut           | 31. | Toggle switch   |
| 3.  | Dust cover    | 32. | Rivet           |
| 4.  | Plug          | 33. | Nameplate       |
| 5.  | Screw         | 34. | Rivet           |
| 6.  | Nut           | 35. | Nameplate       |
| 7.  | Receptacle    | 36. | Toggle switch   |
| 8.  | Rivet         | 37. | Guard           |
| 9.  | Nameplate     | 38. | Rivet           |
| 10. | Screw         | 39. | Nameplate       |
| 11. | Nut           | 40. | Screw           |
| 12. | Dust cover    | 41. | Nut             |
| 13. | Screw         | 42. | Circuit breaker |
| 14. | Nut           | 43. | Rivet           |
| 15. | Receptacle    | 44. | Nameplate       |
| 16. | Rivet         | 45. | Rivet           |
| 17. | Nameplate     | 46. | Nameplate       |
| 18. | Rivet         | 47. | Potentiometer   |
| 19. | Nameplate     | 48. | Screw           |
| 20. | Toggle switch | 49. | Nut             |
| 21. | Guard         | 50. | Cover           |
| 22. | Rivet         | 51. | Gasket          |
| 23. | Nameplate     | 52. | Screw           |
| 24. | Rivet         | 53. | Nut             |
| 25. | Nameplate     | 54. | Rceptacle       |
| 26. | Toggle switch | 55. | Rivet           |
| 27. | Rivet         | 56. | Nameplate       |
| 28. | Nameplate     | 57. | Plate           |
| 29. | Rivet         | 58. | Screw           |



LEGEND

- |                  |                           |                              |
|------------------|---------------------------|------------------------------|
| 1. Screw         | 9. Socket                 | 16. Screw                    |
| 2. Potentiometer | 10. Screw                 | 17. Nut                      |
| 3. Screw         | 11. Nut                   | 18. AC-DC control relay assy |
| 4. Potentiometer | 12. Time delay module TD3 | 19. Screw                    |
| 5. Screw         | 13. Screw                 | 20. Bracket                  |
| 6. Shunt         | 14. Bracket               | 21. Jumper                   |
| 7. Relay         | 15. Time delay module TD1 | 22. Panel                    |
| 8. Screw         |                           |                              |

Figure 4-19. AC-DC Control Box Assembly  
Component Panel Assembly, Exploded View

- b. Replacement. Replace defective circuit breaker CB103 (42, figure 4-18) as follows:

- (1) Removal.
  - a. At rear of panel, tag wire leads and remove screws and washers which secure leads to the circuit breaker.
  - b. Remove circuit breaker mounting hardware (40 and 41) and remove circuit breaker.
- (2) Installation. Install circuit breaker onto panel with mounting hardware (40 and 41). Attach wires with screws and washers. Remove tags from wires.

#### 4-30. PANEL MOUNTED RECEPTACLES J103 AND J104 THROUGH J109 (54, 7 and 15, figure 4-18).

##### NOTE

Defective receptacles may be replaced individually, as necessary.

- a. Removal.
  - (1) At rear of panel, tag and remove wires from receptacle J103 (54). Tag and unsolder wires from receptacles J104 through J109 (7 and 15).
  - (2) Remove receptacle J103 (54) by removing screws (48), nuts (49), cover (50), gasket (51), screws (52), and nuts (53).
  - (3) To remove receptacles J104 through J109 (7 and 15), unscrew dust cover (3 or 12) and remove mounting hardware (13 and 14).
- b. Installation. Install receptacle J103 (54) with screws (52), and nuts (53). Then position gasket (51) and cover (50) and secure with screws (48) and nuts (49). Resolder wires and remove wire tags. Install receptacles J104 through J109 (7 and 15) with mounting hardware (13 and 14). Reconnect wires and then remove wire tags.

#### 4-31. SHORTING PLUG (4, figure 4-18)

- a. Test. With an ohmmeter (Rx1 scale) check for continuity between pins A and B. If meter indicates an open circuit, replace short plug.
- b. Replacement. To remove shorting plug (4) remove screw (1) which attaches the chain, then unscrew the shorting plug from the receptacle.

#### 4-32. PANEL MOUNTED SWITCHES S22, S21, S106 and S20 (20, 26, 31, and 36, figure 4-18).

- a. Test.
  - (1) Check switches for continuity in one direction and an open circuit when operated in the other direction.
  - (2) At rear of panel, remove one lead from switch.
  - (3) With an ohmmeter (Rx1 scale), test switch as indicated in step (1). If switch fails to meet this test, replace switch.
- b. Replacement S22, S21, S106 and S20. Replace defective switches (20, 26, 31, and 36, figure 4-18) as follows:
  - (1) Removal.
    - (a) At rear of panel, tag leads and remove wires to switch.
    - (b) Remove switch mounting hardware and guards (21 and 37) and remove switch.
  - (2) Installation.
    - (a) Install switches S21 and S106 (26 and 31) onto front panel with mounting hardware.
    - (b) Attach wires to S21 and S106 switches (26 and 31) and remove tags.
    - (c) Install switches S22 and S20 (20 and 36)

with guards (21 and 37) onto front panel with mounting hardware.

- (d) Attach wires to switches S22 and S20 (20 and 36) and remove tags.

#### 4-33. POTENTIOMETER R104 REACTIVE LOAD COMPENSATION CONTROL (47, figure 4-18).

a. Test

- (1) Tag and unsolder leads from R104 (47, figure 4-18).
- (2) Connect an ohmmeter (Rx1 scale to each of the terminals on the potentiometer.
- (3) Turn potentiometer slowly throughout its range (0 to 1 ohm). As potentiometer is rotated, the ohmmeter reading should move at the same rate as the rotating shaft. If ohmmeter pointer does not move, or moves erratically the potentiometer is defective and should be replaced.

b. Replacement. Replace defective potentiometer (47) as follows:

- (1) Removal. Tag leads and remove mounting hardware.
- (2) Installation. Install potentiometer in panel with mounting hardware. Solder wires and remove tags.

#### 4-34. POTENTIOMETER R103 (54, FIGURE 4-17).

a. Test. This potentiometer is located at the top of the governor controller assembly (56, figure 4-17).

- (1) Tag and unsolder leads from R103 (54).
- (2) Connect an ohmmeter to each of the terminals on the potentiometer.
- (3) Turn potentiometer slowly throughout its range (0 to 500 ohms). As the potentiometer is rotated, the ohmmeter reading should move at the same rate as the rotating shaft. If the ohmmeter pointer does not move, or

moves erratically, the potentiometer is defective and should be replaced.

b. Replacement. Replace defective potentiometer (54) as follows:

- (1) Removal. Tag and remove wires. Remove shaftlock (55) to remove potentiometer.
- (2) Installation. Install potentiometer (54) and secure with shaftlock. Solder wires and remove tags.

#### 4-35. MOTOR-OPERATED POTENTIOMETERS B4 (2, figure 4-19) and B5 (4, figure 4-19).

Inspect motor-operated potentiometers B4 (2, figure 4-19) and B5 (4, figure 4-19) for loose connections, broken leads, cracking, or loose mounting.

#### 4-36. DC AMP SHUNT (6, figure 4-19).

a. Test.

- (1) Connect a 0 to 30 amp DC power supply to the terminals of the DC amp shunt (6, figure 4-19).
- (2) Connect a 0 to 0.10 volt DC meter to the terminals of the DC amp shunt.
- (3) Increase power to 30 amps; the voltmeter should read 0.05 volts +10 percent.
- (4) If correct reading is not obtained, refer to next higher level of maintenance.

#### 4-37. RELAYS.

Inspect K20, K1 and K50 relays (33, figure 4-17 and 7 and 18, figure 4-19) respectively for loose mounting, loose connections, cracking, or damaged castings.

#### 4-38. HARNESS ASSEMBLY.

##### WARNING

Set MAINTENANCE LOCKOUT switch to LOCKOUT. Disconnect negative cable from batteries. Remove external power by opening CB101 (120V RECEPTACLE BREAKER). Load terminals of generator set circuit breaker (CB2) may still be energized with bus voltage.

- a. Inspection.
  - (1) Inspect connectors for damaged threads and bent, loose, or missing pins.
  - (2) Inspect connections for security and condition.
  - (3) Inspect wiring for defective insulation.
- b. Test. Perform continuity check, using ohmmeter between connecting points in the wiring harness. (See FO-5, AC-DC Control Box, Wiring Diagram.) Check for short circuits between connector pins of the same receptacle or terminal board.
- c. Repair.
  - (1) If a broken wire is accessible, remove sufficient insulation from each side of the break to allow a good connection of the bared ends by twisting them together. Solder the connection and wrap with electrical tape.
  - (2) If a wire is broken from a terminal lug, replace the lug. If a wire is broken from a connector, resolder and reassemble.

#### CAUTION

Under no condition leave the bare connection exposed.

- (3) If a break in the wire is inaccessible within the wiring harness, disconnect

it at both ends and tape both ends. Lace a new lead of the same gauge and insulation outside the harness and connect it to the proper terminals or pins. Properly tag both ends of all replacement wires.

- (4) If more than 30 percent of the harness wires are defective, refer to next higher maintenance for replacement.

#### 4-39. WEATHER STRIPPING

- a. Inspection. Inspect weather stripping (5, figure 4-17) around cover (7), AC-DC control panel (3) and seal (74) on door (73) for signs of excessive wear, rot, or damage.
- b. Replacement of Weather Stripping.
  - (1) Remove door (73) by removing screws (71) and nuts (72).
  - (2) Remove seal (74) from door (73).
  - (3) Remove weather stripping (5) from AC-DC box (70) and enclosure (75), AC-DC control panel (3) or cover (7).
  - (4) Install four pieces of fresh weather stripping (5) on AC-DC box (70) and enclosure (75), panel (3) or cover (7).
  - (5) Install new seal (74) on door (73).
  - (6) Reinstall door (73), screws (71) and nuts (72).

#### Section XII. MAINTENANCE OF CONTROL CUBICLE

**4-40.** The control cubicle contains four major assemblies, the engine control panel (see figure 4-21), the generator control panel (figure 4-22), the component shelf (see figure 4-20, sheet 2) and the rear relay panel (see figure 4-20, sheet 3).

- (2) Inspect two lamps on engine panel, and four lamps on generator panel.
- (3) Inspect transducers, relays, and time delay modules for looseness and poor



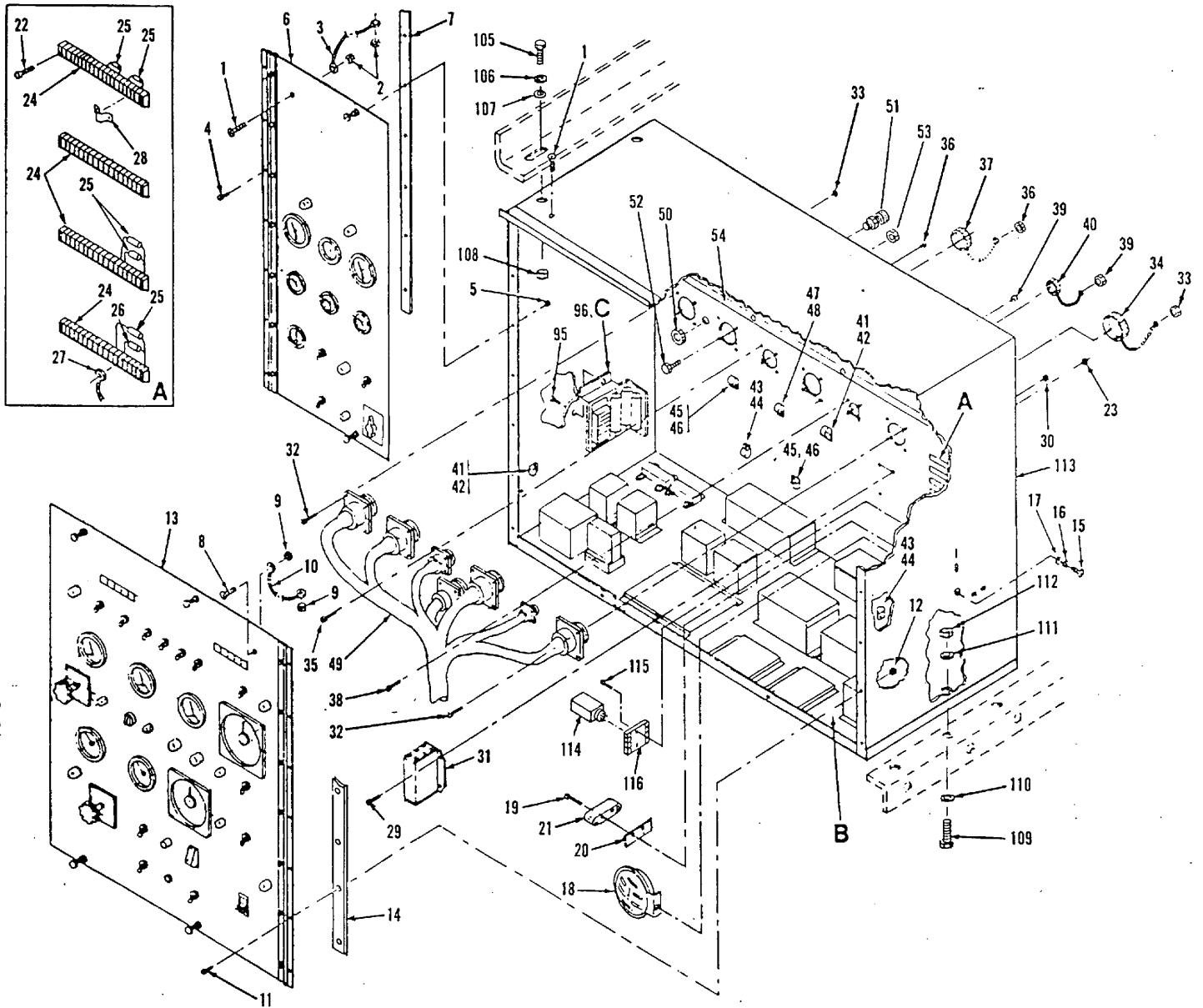

Figure 4-20. Control Cubicle, (Sheet 1 of 3)

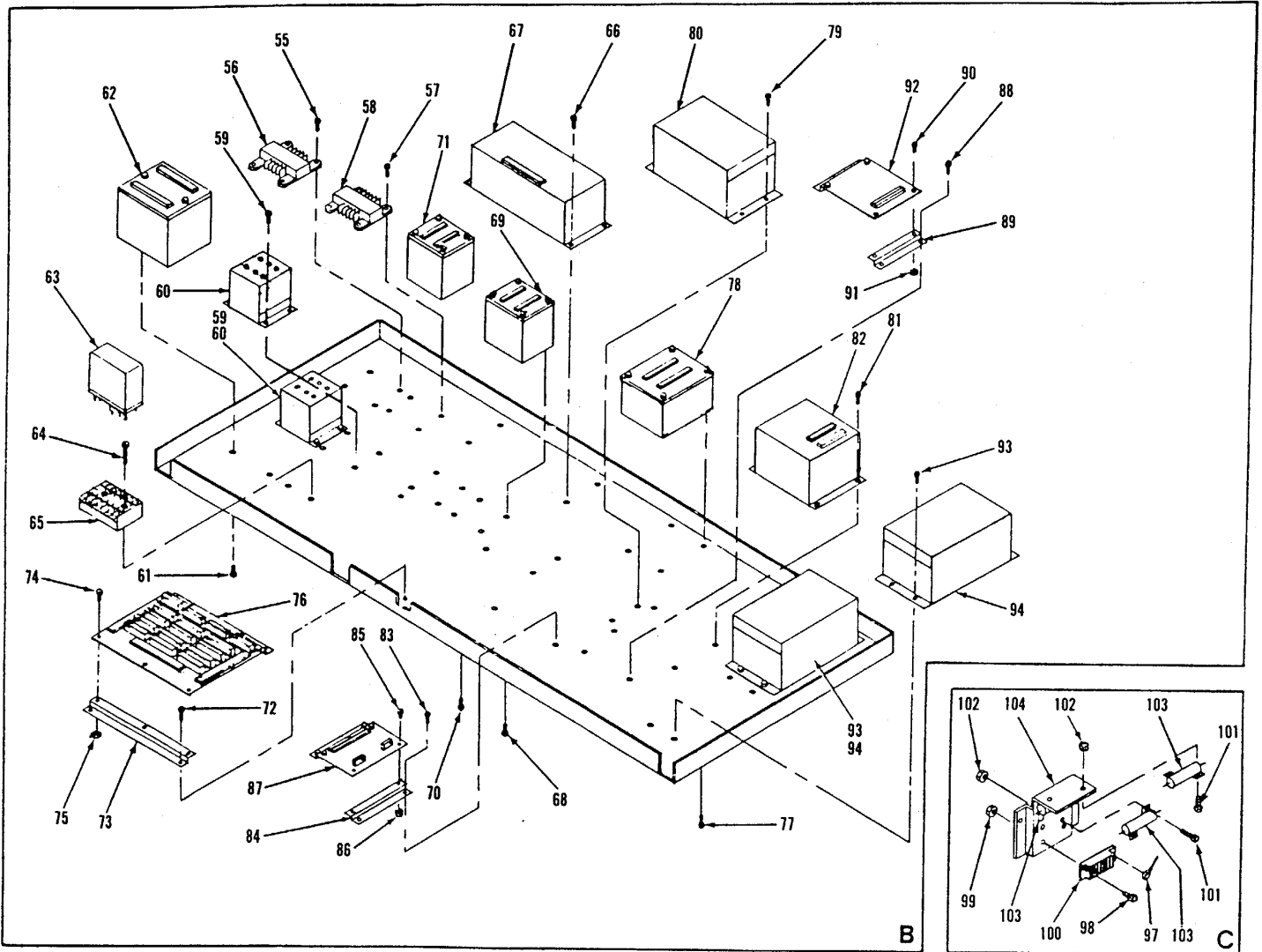
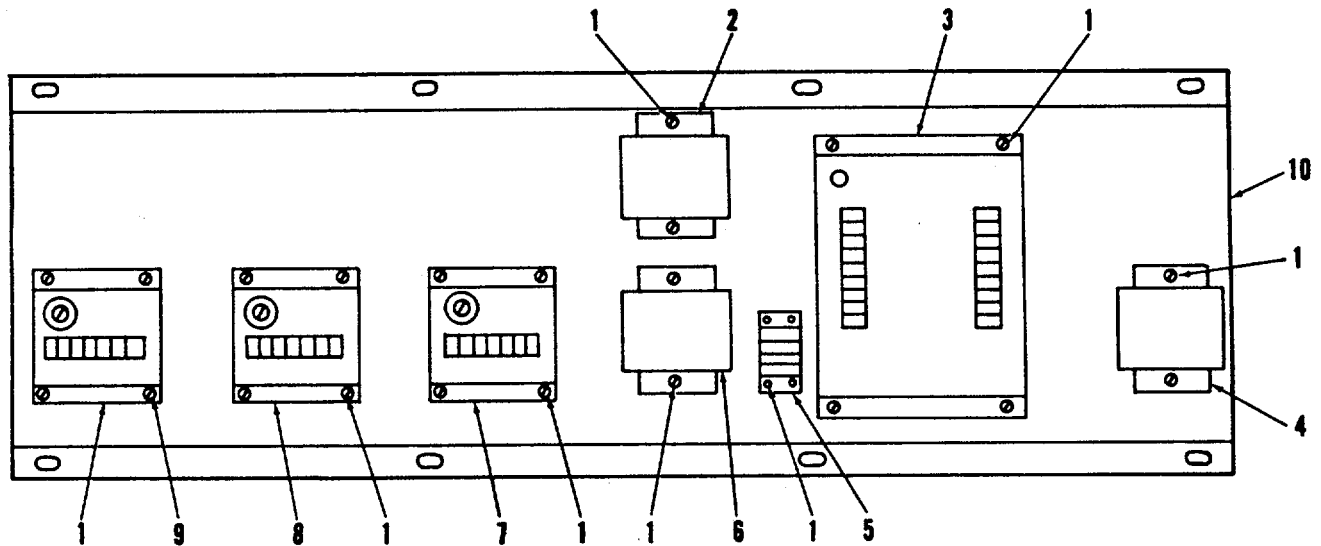

Figure 4-20. Control Cubicle, (Sheet 2 of 3)

mounting, and loose wires.

- (2) Inspect two lamps on engine panel, and four lamps on generator panel.
- (3) Inspect transducers, relays, and time delay modules for looseness and poor connection.
- (4) Inspect flasher for security in terminal box . Inspect terminal box.

b. Test. Test 24V DC control circuit breaker CB1 (87, figure 4-22, sheet 2) as follows:



**LEGEND**

- |                   |                             |
|-------------------|-----------------------------|
| 1. Screw          | 6. CR relay                 |
| 2. BCR relay      | 7. Over/under voltage realy |
| 3. Synch relay    | 8. Overfrequency relay      |
| 4. BTR realy      | 9. Underfrequency relay     |
| 5. Terminal Block | 10. Mounting plate          |

**Figure 4-20. Control Cubicle, (Sheet 3 of 3)**

**LEGEND FOR FIGURE 4-20**

Sheet 1 and Sheet 2

1. Screw	55. Screw	109. Screw
2. Nut	56. Transformer	110. Washer
3. Door holder	57. Screw	111. Lockwasher
4. Screw	58. Transformer	112. Nut
5. Nut	59. Screw	113. Control box
6. Engine Panel	60. Phase sequence relay	114. Flasher
7. Spacer	61. Screw	115. Screw
8. Screw	62. Overload device	116. Socket
9. Nut	63. Relay	
10. Door holder	64. Screw	
11. Screw	65. Relay socket	
12. Nut	66. Screw	
13. Generator panel	67. Reverse power relay	
14. Spacer	68. Screw	
15. Screw	69. Overvoltage relay	
16. Lockwasher	70. Screw	
17. Washer	71. Short circuit relay	
18. Horn	72. Screw	
19. Screw	73. Bracket	
20. Flasher	74. Screw	
21. Terminal block	75. Nut	
22. Screw	76. Annunciator control assy	
23. Nut	77. Screw	
24. Terminal board	78. Undervoltage relay	
25. Diode	79. Screw	
26. Resistor	80. Transformer	
27. Lug	81. Screw	
28. Jumper	82. Sync check relay	
29. Screw	83. Screw	
30. Nut	84. Bracket	
31. Transducer	85. Screw	
32. Screw	86. Nut	
33. Nut	87. Integrated time delay module	
34. Receptacle cover	88. Screw	
35. Screw	89. Bracket	
36. Nut	90. Screw	
37. Receptacle cover	91. Nut	
38. Screw	92. Control relay assy	
39. Nut	93. Screw	
40. Receptacle cover	94. Transducer	
41. Screw	95. Screw	
42. Clamp	96. Resistor assy	
43. Screw	97. Terminal lug	
44. Clamp	98. Screw	
45. Screw	99. Nut	
46. Clamp	100. Terminal board	
47. Screw	101. Screw	
48. Clamp	102. Nut	
49. Harness assy	103. Rectifier	
50. Locknut	104. Bracket	
51. Connector	105. Screw	
52. Screw	106. Lockwasher	
53. Nut	107. Washer	
54. Relay assy	108. Nut	

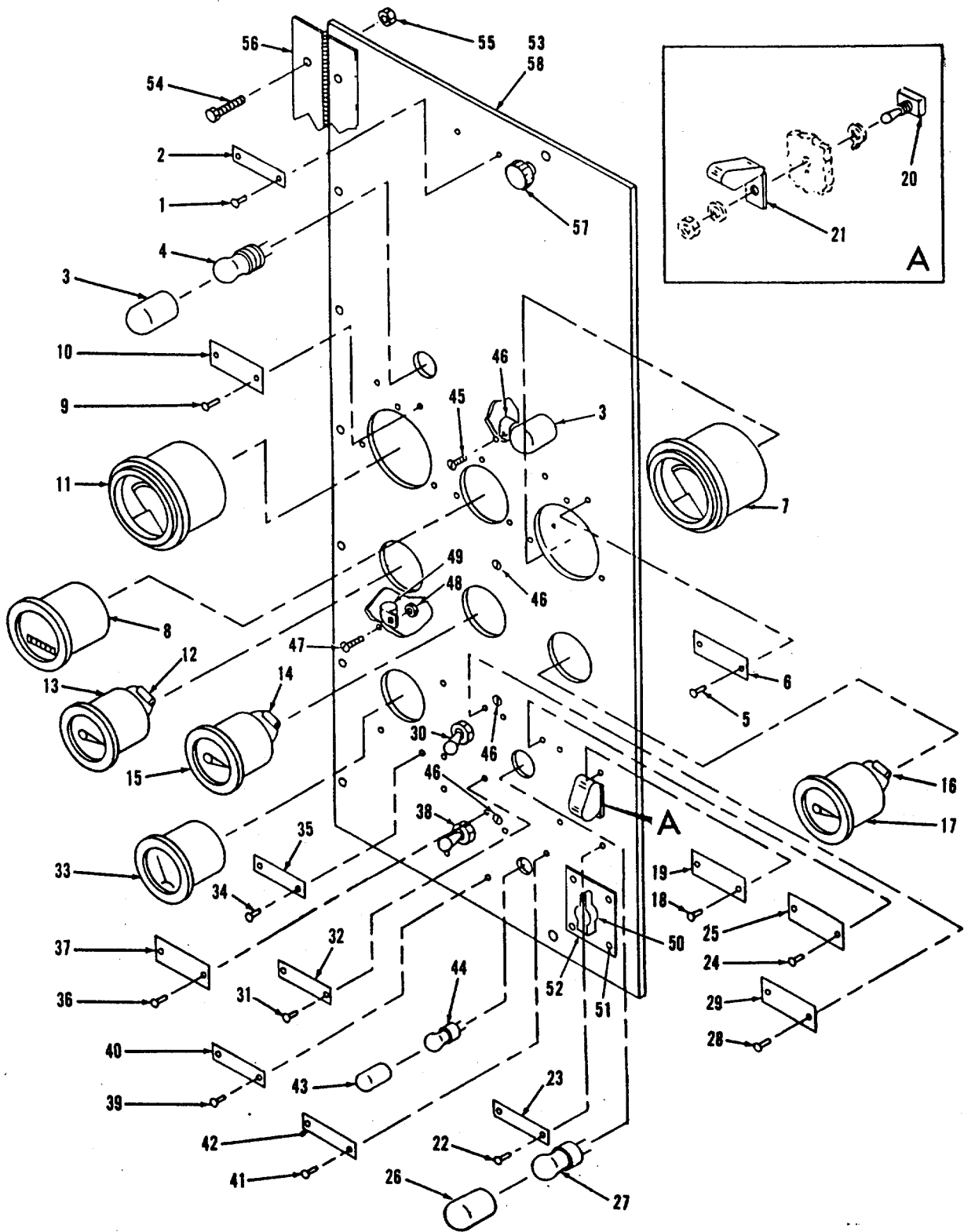

Figure 4-21. Control Cubicle, Engine Panel, Exploded View

LEGEND FOR FIGURE 4-21

1.	Rivet	30.	Toggle switch
2.	Nameplate	31.	Rivet
3.	Light assy	32.	Nameplate
4.	Lamp	33.	Fuel level gauge
5.	Rivet	34.	Rivet
6.	Nameplate	35.	Nameplate
7.	DC voltmeter	36.	Rivet
8.	Running time meter	37.	Nameplate
9.	Rivet	38.	Toggle switch
10.	Nameplate	39.	Rivet
11.	Meter	40.	Nameplate
12.	Resistor	41.	Rivet
13.	Lube oil temperature gauge	42.	Nameplate
14.	Gauge resistor	43.	Lamp assy
15.	Lube oil pressure gauge	44.	Lamp
16.	Resistor	45.	Screw
17.	Coolant temperature gauge	46.	Clamp
18.	Rivet	47.	Screw
19.	Nameplate	48.	Nut
20.	Toggle switch	49.	Clamp
21.	Guard	50.	Switch
22.	Rivet	51.	Rivet
23.	Nameplate	52.	Nameplate
24.	Rivet	53.	Panel
25.	Nameplate	54.	Screw
26.	Lamp assy	55.	Nut
27.	Lamp	56.	Hinge
28.	Rivet	57.	Screw
29.	Nameplate	58.	Sheet

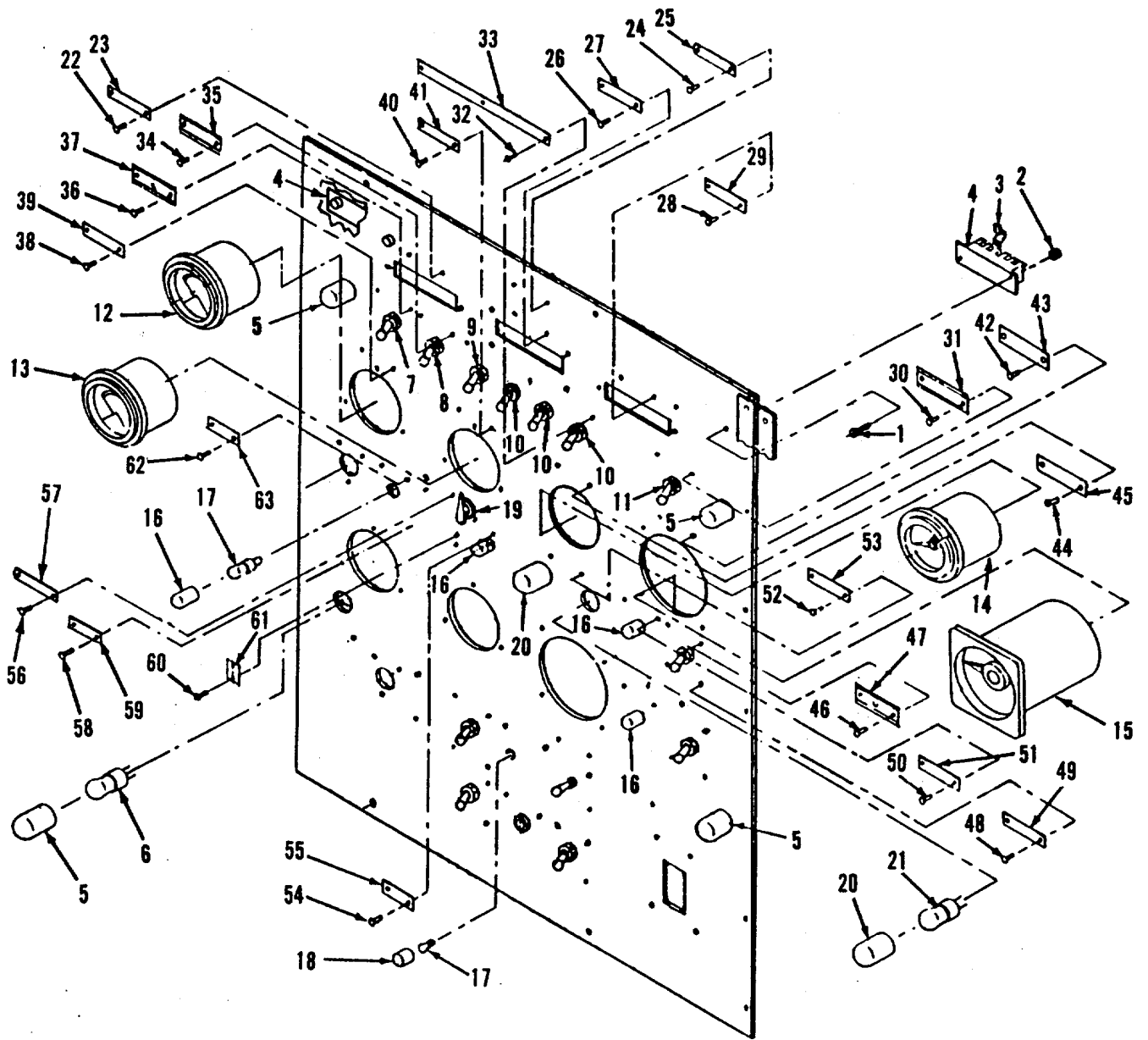

Figure 4-22. Control Cubicle, Generator Panel, Exploded View (Sheet 1 of 2)

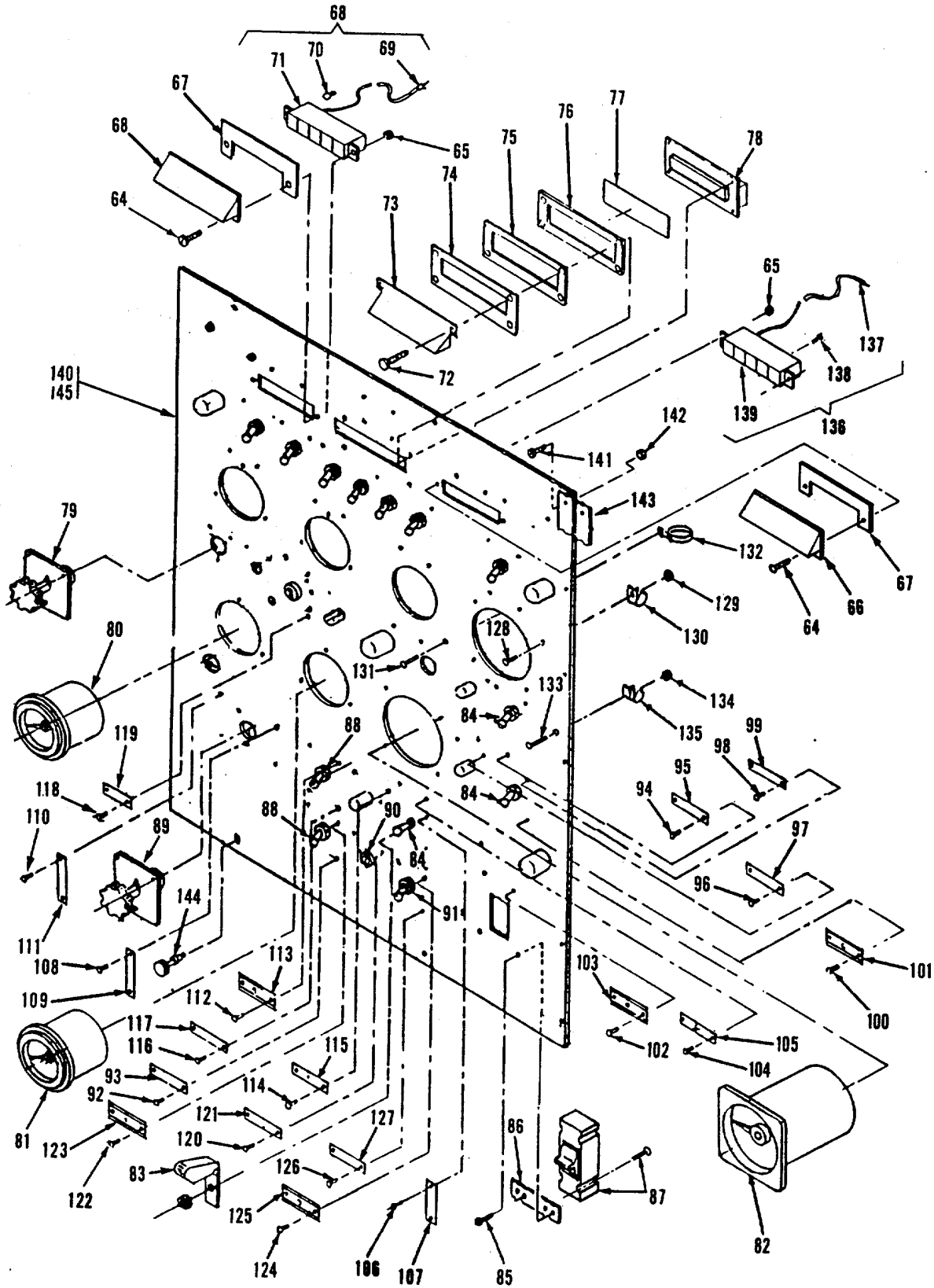

Figure 4-22. Control Cubicle, Generator Panel, Exploded View (Sheet 2 of 2)



LEGEND FOR FIGURE 4-22

Sheet 1

1. Screw
2. Nut
3. Jumper
4. Terminal block
5. Lamp assy
6. Lamp
7. Toggle switch
8. Toggle switch
9. Toggle switch
10. Toggle switch
11. Toggle switch
12. Ammeter
13. Kilowatt meter
14. Kilovar meter
15. Power factor meter
16. Lamp assy
17. Bulb
18. Lamp assy
19. Rotary switch
20. Lamp assy
21. Lamp
22. Rivet
23. Nameplate
24. Rivet
25. Nameplate
26. Rivet
27. Nameplate
28. Rivet
29. Nameplate
30. Rivet
31. Nameplate
32. Rivet
33. Nameplate
34. Rivet
35. Nameplate
36. Rivet
37. Nameplate
38. Rivet
39. Nameplate
40. Rivet
41. Nameplate
42. Rivet
43. Nameplate
44. Rivet
45. Nameplate
46. Rivet
47. Nameplate
48. Rivet
49. Nameplate
50. Rivet
51. Nameplate
52. Rivet
53. Nameplate

54. Rivet
55. Nameplate
56. Rivet
57. Nameplate
58. Rivet
59. Nameplate
60. Rivet
61. Nameplate
62. Rivet
63. Nameplate

Sheet 2

64. Screw
65. Nut
66. Shield
67. Gasket
68. Fault indicator
69. Terminal lug
70. Lamp
71. Lamp assy
72. Screw
73. Shield
74. Plate
75. Plate
76. Gasket
77. Light control film
78. Digital clock
79. Switch
80. Voltmeter
81. Frequency meter
82. Synchroscope
83. Guard
84. Toggle switch
85. Screw
86. Bracket
87. Circuit breaker
88. Toggle Switch
89. Switch
90. Telephone jack
91. Toggle switch
92. Rivet
93. Nameplate
94. Rivet
95. Nameplate
96. Rivet
97. Nameplate
98. Rivet
99. Nameplate
100. Rivet
101. Nameplate
102. Rivet

103. Nameplate
104. Rivet
105. Nameplate
106. Rivet
107. Nameplate
108. Rivet
109. Nameplate
110. Rivet
111. Nameplate
112. Rivet
113. Nameplate
114. Rivet
115. Nameplate
116. Rivet
117. Nameplate
118. Rivet
119. Nameplate
120. Rivet
121. Nameplate
122. Rivet
123. Nameplate
124. Rivet
125. Nameplate
126. Rivet
127. Nameplate
128. Screw
129. Nut
130. Clamp
131. Screw
132. Clamp
133. Screw
134. Nut
135. Clamp
136. Fault indicator
137. Terminal lug
138. Lamp
139. Lamp assy
140. Control box panel
141. Screw
142. Nut
143. Hinge
144. Screw
145. Sheet

**WARNING**

Set MAINTENANCE LOCKOUT switch to LOCKOUT. Disconnect negative cable from batteries. Remove external power by opening CB101 and disconnecting power from receptacle J101. Load terminals of generator set circuit breaker (CB2) may still be energized with bus voltage.

- (1) Position circuit breaker CB1 (87, figure 4-22, sheet 2) in the ON position.
  - (2) At rear of panel, remove and tag leads to circuit breaker.
  - (3) Using an ohmmeter (Rx1 scale), test breaker for closed contacts. If meter indicates an open circuit, replace breaker.
  - (4) Position circuit breaker in open position. With ohmmeter at Rx1 scale, test breaker for open contacts. If meter indicates a closed circuit, replace breaker.
- c. Test for SPST (single-pole, single-throw) toggle switches.
- (1) Toggle switch to the ON position.
  - (2) At the rear of the panel, remove one lead from the switch.
  - (3) Using an ohmmeter (Rx1 scale), test switch for a closed circuit. If meter indicates an open circuit, replace switch.
  - (4) Toggle switch to OFF position. Using ohmmeter on Rx1 scale, test for open circuit. If meter indicates a closed circuit, replace switch.
- d. Test for SPTT (double-pole, triple-throw) toggle switches.
- (1) With switch in center (neutral) position, check that contacts 1-2 and 5-6 have continuity. Ohmmeter should be set to Rx1 scale.
  - (2) With switch in up (ON) position, check that contacts 2-3 and 5-6 have continuity.
  - (3) With switch in down (OFF) position, check that contacts 1-2 and 4-5 have continuity.
- e. Test for BATTERY CHRG AMPS meter (11, figure 4-21).
- (1) Disconnect minus lead from BATTERY CHRG AMPS meter M21.
  - (2) Observing polarity, connect a multimeter (set to measure DC amps) in series with disconnected minus lead and open terminal of meter M21.
  - (3) Meter M21 reading should be within +10 percent of multimeter reading.
  - (4) Disconnect test equipment and reconnect lead to step (1).
- f. Test of ELAPSED TIME meter (8, figure 4-21). To test ELAPSED TIME meter M5, check against any time source standard such as a wristwatch or a wall clock. Meter M5 should be within +5 percent of time source.
- g. Test of BATTERY CHRG VOLTS (7, figure 4-21). To test BATTERY CHRG VOLTS meter M20, connect a multimeter across meter M20 terminals. Meter M20 should be within +5 percent of multimeter reading.
- h. Test of ENGINE OIL TEMP meter (13, figure 4-21).
- (1) Disconnect negative lead from ENGINE OIL TEMP meter M2.
  - (2) Connect one end of a precision (+1 percent) 1,096-ohm resistor to open terminal of meter M2.
  - (3) Connect positive side of 24V DC source to the resistor connected to the positive terminal of meter M2.
  - (4) Connect open end of precision resistor to minus side of 24V DC source.

Meter M2 should read 200°F (93°C)  
±4 percent.

- (5) Disconnect all test equipment and reconnect lead of step (1).

i. Test of ENGINE OIL PRESS meter (15, figure 4-21).

- (1) Disconnect negative lead from ENGINE OIL PRESS meter M1.
- (2) Connect one end of a precision (±1 percent) 120-ohm resistor to open terminal of meter M1.
- (3) Connect positive side of 24V DC source to the resistor connected to the positive terminal of meter M2.
- (4) Connect open end of precision resistor to minus side of 24V DC source. Meter M1 should read 80 psi +4 percent.
- (5) Disconnect all test equipment and reconnect lead to step (1).

j. Test of WATER TEMP meter (17, figure 4-21).

- (1) Disconnect negative lead from WATER TEMP meter M3.
- (2) Connect one end of precision (+1 percent) 97.6-ohm resistor to open terminal of meter M3.
- (3) Connect positive side of 24V DC source to the resistor connected to the positive terminal of meter M3.
- (4) Connect open end of precision resistor to minus side of 24V DC source. Meter M2 should read 280°F (1390C) +4 percent.
- (5) Disconnect all test equipment and reconnect lead to step (1).

k. Test of FUEL LEVEL meter (33, figure 4-21).

- (1) Disconnect negative lead from FUEL LEVEL meter M4.

- (2) Connect one end of precision (+1 percent) 30-ohm resistor to open terminal of meter M4.

- (3) Connect positive side of 24V DC source to positive terminal of meter M4.

- (4) Connect open end of precision resistor to minus side of 24V DC. Meter M4 should read F (full); meter pointer should be over some part of letter F.

- (5) Disconnect all test equipment and reconnect lead to step (1).

l. Test of AMMETER (12, figure 4-22).

- (1) Disconnect either lead from AMMETER M102.

- (2) Connect a test AC ammeter (full-scale reading of 1 ampere) in series with disconnected lead and open terminal of meter M102.

- (3) Meter M102 reading should be within +3 percent of test ammeter reading.

- (4) Disconnect all test equipment and reconnect lead to step (1).

m. Test of KW meter (13, figure 4-22).

- (1) Disconnect minus lead from KW meter M107.

- (2) Observing polarity, connect a multimeter (set to measure 0-1 milliamp DC) in series with disconnected minus lead and open terminal of meter M107.

- (3) Meter reading should be within +3 percent of multimeter reading.

- (4) Disconnect test equipment and reconnect lead to step (1).

n. Test of KVAR meter (14, figure 4-22).

- (1) Disconnect minus lead from KVAR meter M108.
  - (2) Observing polarity, connect a multimeter (set to measure 0-1 miliamp DC) in series with disconnected minus lead and open terminal of meter M108.
  - (3) Meter reading should be within  $\pm 3$  percent of multimeter reading.
  - (4) Disconnect test equipment and reconnect lead to step (1).
- o. Test of POWER FACTOR meter (15, figure 4-22).
- (1) Tag and disconnect all leads connected to meter terminals 1 through 4.
  - (2) Using an ohmmeter set to Rx1 scale, measure resistance across terminals 1 and 2. Reading should be less than 1 ohm.
  - (3) Using an ohmmeter set to Rx100 scale, measure resistance across terminals 3 and 4. Reading should be 950 ohms  $\pm 20$  percent.
  - (4) Remove tags and reconnect leads to meter terminals.
- p. Test of VOLTS AC meter (80, figure 4-22).
- (1) Connect a multimeter (set to measure AC volts) across terminals of VOLTS AC meter M101.
  - (2) Meter reading should be within  $\pm 3$  percent of multimeter reading.
- q. Replacement.
- (1) Replace inoperative or defective gauges and switches on control panels as follows:
    - (a) Tag wires to gauges, switches or circuit breaker.
    - (b) Remove wires.
    - (c) Remove mounting hardware.
- (2) Installation.
    - (a) Mount gauges and switches onto control panel with mounting hardware.
    - (b) Reconnect wires and remove tags.
  - (3) Removal of circuit breaker CB1.
    - (a) Tag and remove wires to CB1 (87, figure 4-22).
    - (b) Remove bracket mounting screws (86) to release circuit breaker (87) from panel.
    - (c) Remove circuit breaker mounting screws (85) to release circuit breaker from mounting bracket (86).
  - (4) Installation of CB1.
    - (a) Install mounting bracket (86) onto circuit breaker (87) with screws (85).
    - (b) Mount circuit breaker (87) by securing mounting bracket (86) to panel with screws.
    - (c) Connect lead wires and remove wire tags.

#### 4-41. HARNESS ASSEMBLY.

##### a. Inspection.

#### **WARNING**

Set MAINTENANCE LOCKOUT switch to LOCKOUT. Disconnect negative cable from batteries. Remove external power by opening CB101 (120V RECEPTACLE BREAKER). Load terminals of generator set circuit breaker (CB2) may still be energized with bus voltage.

- (1) Inspect connectors for damaged threads and bent, loose, or missing pins.

- (2) Inspect connections for security and condition.
- (3) Inspect wiring for defective insulation.
- b. Test. Perform continuity check, using ohmmeter between connecting points in the wiring harness. (See FO-7, Control Cubicle, Wiring Diagram.) Check for short circuits between connector pins of the same receptacle or terminal board.
- c. Repair.
  - (1) If a broken wire is accessible, remove sufficient insulation from each side of the break to allow a good connection of the bared ends by twisting them together. Solder the connection and wrap with electrical tape.
  - (2) If a wire is broken from a terminal lug, replace the lug. If a wire is broken from a connector, resolder and reassemble.

**CAUTION**

Under no condition leave the bare connection exposed.

- (3) If a break in the wire is inaccessible within the wiring harness, disconnect it at both ends and tape both ends. Lace a new lead of the same gauge and insulation outside the harness and connect it to the proper terminals or pins. Properly tag both ends of all replacement wires.
- d. Replacement. If 30 percent of the harness wires are defective, refer to next higher level of maintenance for replacement.

**Section XIII. MAINTENANCE OF AIR CLEANER**

**4-42. AIR CLEANER. (See figure 4-23.)**

- a. Removal. Remove both air cleaners as follows:
  - (1) Loosen eight hose clamps (24).
  - (2) Remove six screws (15), nuts (16), and lockwashers (17) from mounting brackets (18 and 19).
  - (3) Remove air cleaners (29).
- b. Service. Check the air cleaner service indicator. If indicator is in red, proceed as follows (see figure 3-1):
  - (1) Remove and empty dust cup (13) when three-quarters full.
  - (2) Reinstall dust cup (13) and O-ring (14).
  - (3) Clean air cleaner tubes with a stiff brush. If heavy plugging is evident, remove lower body section (15) and clean with compressed air or water not exceeding 1600F (71°C).

**CAUTION**

Never clean air cleaner tubes with compressed air unless both filter elements are installed in the air cleaner. Do not steam clean air cleaner tubes.

- (4) Unfasten cover latches and remove cover (1). Remove wing nut (3) and remove primary filter element (4).
- (5) Remove cotter pin (5), castellated nut (6), and safety filter element (7). Replace with new element at interval indicated in table 4-2 and secure with castellated nut (6) and cotter pin (5). Do not clean safety filter element (7).
- (6) Clean primary filter element (4) by either method (a) or (b), as follows:

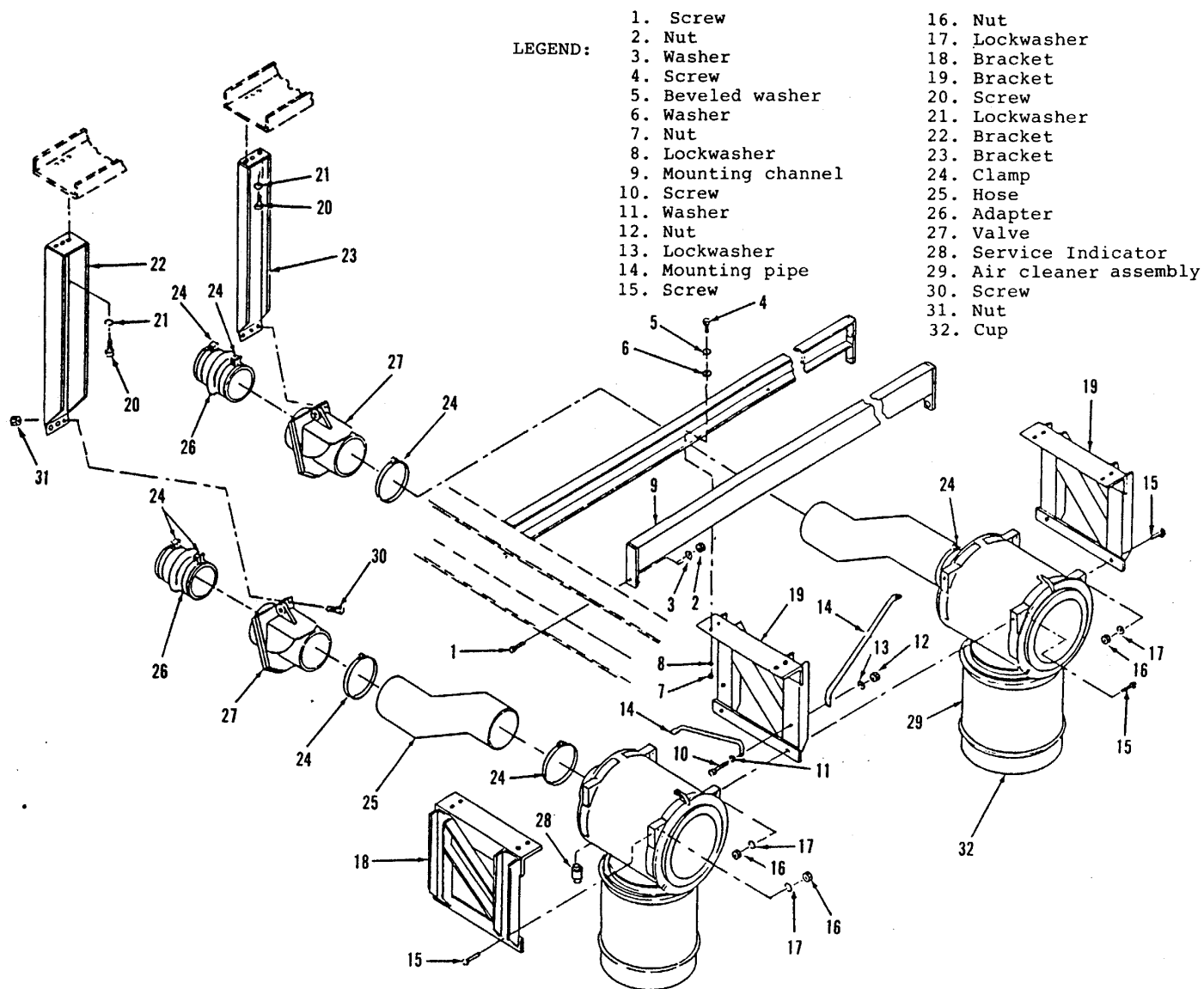

Figure 4-23. Air Cleaner and Related Parts

### CAUTION

Do not clean in gasoline or other petroleum products.

(a) Compressed Air. Direct compressed air (100 psi max) through filter element opposite airflow direction.

(b) Washing with Water. Soak 15 minutes in water with mild detergent. Rinse until clean. Air dry. Do not use compressed air.

(7) Replace defective gaskets or O-rings.

(8) Replace primary filter element (4), gasket (2), secure with wing nut (3), and secure cover (1) with cover latches.

(9) Reset service indicator to green.

c. Replacement of Air Cleaner Element. Refer to paragraph b, above.

d. Replacement of Indicator. Remove the indicator (28, figure 4-23) by unscrewing it from the air cleaner assembly. Screw a new indicator in place.

e. Replacement of Air Cleaner.

(1) Be sure hose clamps (24) are in their proper location as shown in figure 4-23.

(2) Attach air cleaner (29) to mounting brackets (18 and 19) with six screws (15), lockwashers (17) and nuts (16).

(3) Attach hoses to air cleaner and tighten hose clamps (24).

#### 4-43. AIR SHUT-OFF VALVE. (27, figure 4-23.)

a. Inspect

(1) Check all lead wires for secure connection.

(2) Check springs, shafts, and mountings for security, mechanical defects (stretched springs, bent shafts), and freedom from binding.

b. Test

(1) Tag and disconnect lead wires to valve.

(2) Valve is normally open. Trip valve by applying 24V DC across leads: valve should close.

(3) Remove 24V DC; valve should open.

c. Replacement.

(1) Tag and disconnect lead wires.

(2) Loosen clamps (24) at either end of valve (27).

(3) Remove mounting screws (30) and nuts (31) which hold valve to bracket (22 and 23).

(4) Remove valve (27) by sliding adapter hose (26) and then duct hose (25) away from valve.

(5) Install valve (27) by sliding one end into adapter hose (26), other into duct hose (25).

(6) Secure to bracket (22 and 23) using mounting screws (30) and nuts (31).

(7) Tighten clamps (24) at either end of valve.

(8) Connect lead wires and remove wire tags.

#### 4-44. DUCTS AND HOSES.

a. Inspect.

(1) Loosen clamps (24) holding adapter hose (26).

(2) Check inside hose for accumulation of dirt.

- (3) Check hose for cracking or leakage.
  - (4) Loosen clamps (24) holding duct hose (25).
  - (5) Check inside hose for accumulation of dirt.
  - (6) Check hose for cracking or leakage.
  - (7) If hoses are damaged, then replace as follows. If no damage is found tighten all clamps (24) to secure hoses.
- a. Replacement.
- (1) Remove duct hose (25) by sliding it off valve (27) and away from air cleaner (29).
  - (2) Remove adapter hose (26) by sliding it off valve (27) and away from turbocharger.
  - (3) Install adapter hose (26) by sliding it over valve (27) and onto turbocharger. Secure with clamps (24).
  - (4) Install duct hose (25) by sliding it over valve (27) and onto air cleaner (29). Secure with clamps (24).

#### **Section XIV. MAINTENANCE OF TOOL BOX ASSEMBLY**

##### **4-45. TOOL BOX ASSEMBLY. (See figure 4-24)**

- a. Replacement. The tool box assembly is mounted on the right side of the main frame assembly next to the engine.
- (1) Removal. Remove two screws (1), washers (2), lock-washers (3), and nuts (4), at the bottom of the tool box supporting it to the frame.
  - (2) Installation. Install tool box in place on frame, line up two holes at bottom of tool box with holes in frame, and secure with two screws (1), washers (2), lockwashers (3), and nuts (4).
- b. Repair.
- (1) Replace latches (11) by removing screws (9) and nuts (10).
  - (2) If box is dented, straighten box. If any signs of rust or corrosion, sand and clean area and repaint tool box.



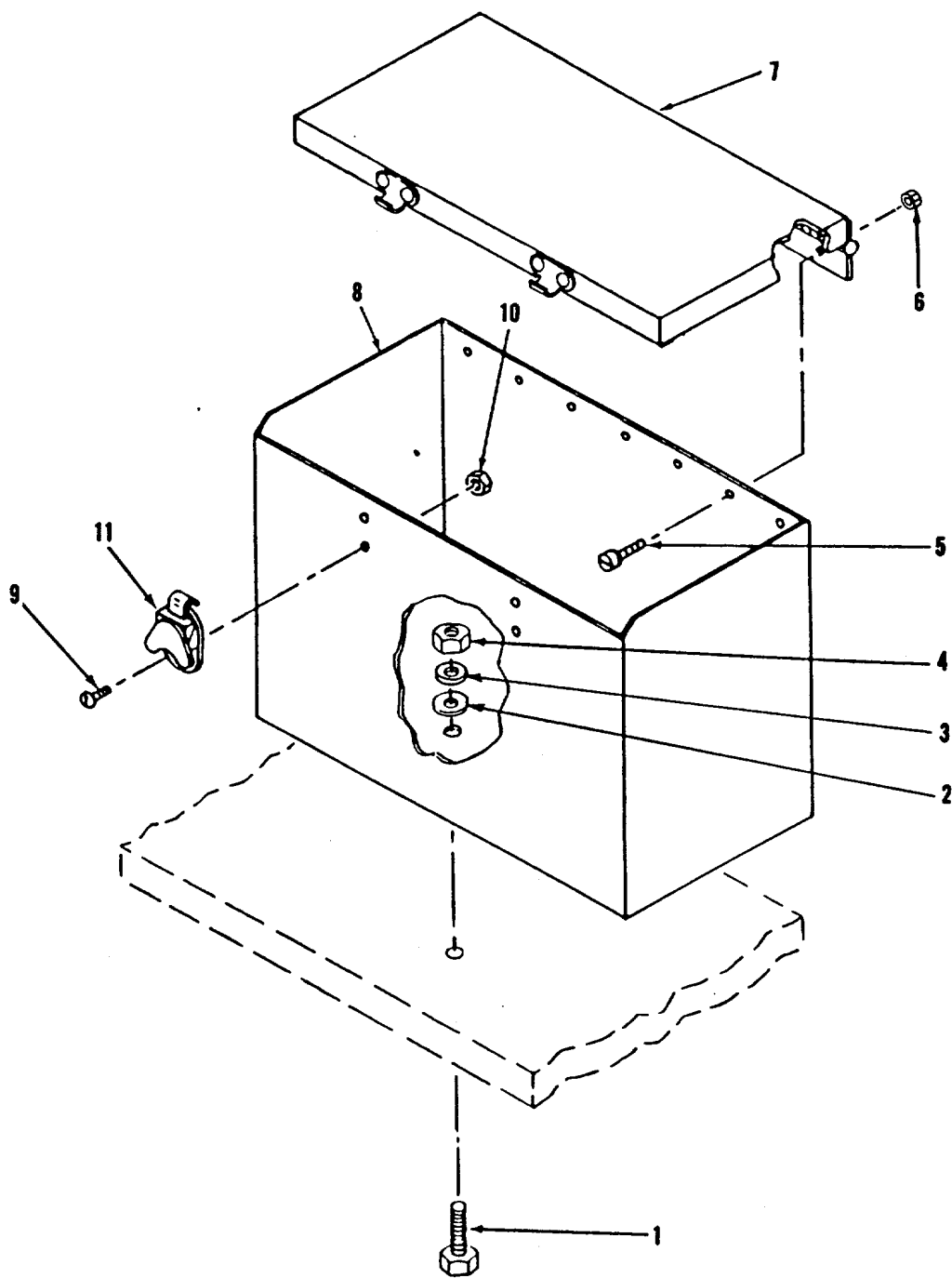

LEGEND

- |               |             |
|---------------|-------------|
| 1. Screw      | 7. Cover    |
| 2. Washer     | 8. Tool box |
| 3. Lockwasher | 9. Screw    |
| 4. Nut        | 10. Nut     |
| 5. Screw      | 11. Latch   |
| 6. Nut        |             |

Figure 4-24. Tool Box Assembly  
4-75

### Section XV. MAINTENANCE OF DOCUMENT COMPARTMENT

4-46. DOCUMENT COMPARTMENT. (See figure 4-25.)

Attach six screws (1), lockwashers (2), and nuts (3).

a. Replacement. The document compartment is mounted above the control cubicle.

b. Repair.

(1) Removal. Remove six screws (1), lockwashers (2), and nuts (3) supporting document compartment of the control cubicle.

(1) Replace gasket (12) if defective.

(2) Replace latches (8) by removing screws (6), nuts (7) and spacer (9).

(2) Installation. Install document compartment on top of the control cubicle. Line up six holes in document compartment with holes on top of control cubicle.

(3) If dented, straighten out. If any signs of rust or corrosion, sand and clean area, and repaint document compartment.

### Section XVI. MAINTENANCE OF SUPPORT FRAME ASSEMBLY

4-47. GENERAL. The support frame assembly (figure 4-26) provides support for major assemblies of the generator set, acts as a spreader bar when lifting the set, and provides a frame for the housing kit (when the kit is used).

4-48. INSPECTION. Inspect the tie bars, front frame, center frame, and rear frame for loose mounting, breaks, cracks, loose or missing hardware, and corrosion. Refer to higher level maintenance for repair of replacement.

### Section XVII. MAINTENANCE OF RADIATOR ASSEMBLY

4-49. RADIATOR ASSEMBLY.

Using a hydrometer, verify that antifreeze is in accordance with table 3-1.

a. Preliminary Inspection. Preliminary inspections consist of checking for leaks (especially at hose connections), and coolant level may be checked at the sight glass. If coolant level is below sight glass, remove radiator cap and check level in upper tank.

b. Fan Belt Adjustment (Code A).

(1) Refer to figure 4-28 and remove two halves of fan belt guard (3) by removing screws (1) and nuts (2).

(2) Check tension of each of the three fan belts (see figures 4-1 and 4-28). Apply thumb pressure at center of belt and check for no more than 1/2 inch (13 mm) movement, as shown in figure 4-28.

(3) If belts require tensioning, tighten motor mount

#### WARNING

**Whenever generator set has just been shut down, remove radiator cap slowly to allow pressure to escape before removing cap.**

**Refill radiator with proper coolant to approximately 2 inches (50 mm) below filler neck level.**

LEGEND

1. Screw
2. Lockwasher
3. Washer
4. Nut
5. Box assy
6. Screw
7. Nut
8. Fastener
9. Spacer
10. Screw
11. Nut
12. Gasket
13. Door

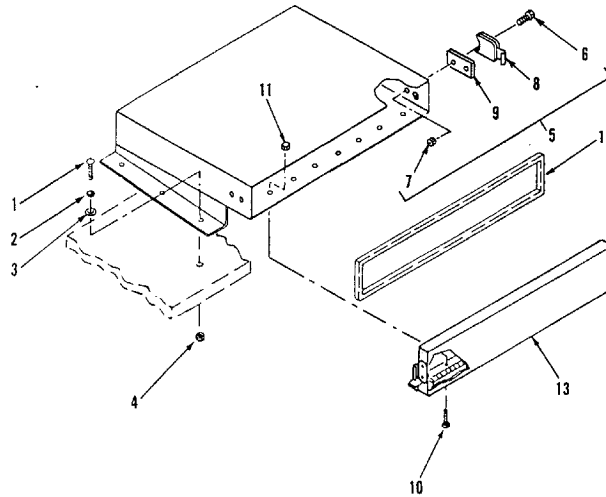
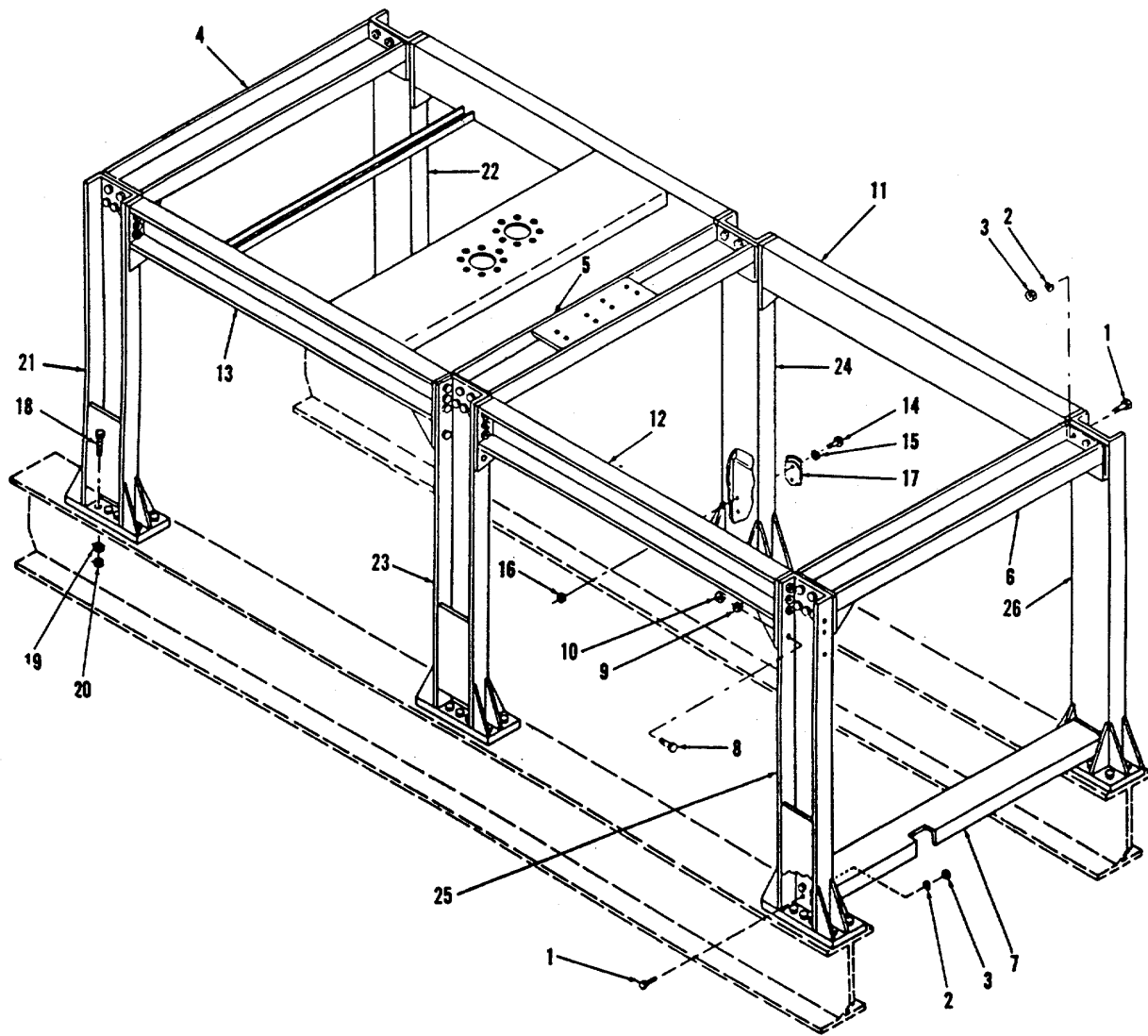

Figure 4-25. Document Compartment



LEGEND

- |     |               |     |               |
|-----|---------------|-----|---------------|
| 1.  | Screw         | 18. | Screw         |
| 2.  | Lockwasher    | 19. | Washer        |
| 3.  | Nut           | 20. | Nut           |
| 4.  | Support frame | 21. | Support frame |
| 5.  | Support frame | 22. | Support frame |
| 6.  | Support frame | 23. | Support frame |
| 7.  | Tie bar       | 24. | Support frame |
| 8.  | Screw         | 25. | Support frame |
| 9.  | Lockwasher    | 26. | Support frame |
| 10. | Nut           |     |               |
| 11. | Tie bar       |     |               |
| 12. | Tie bar       |     |               |
| 13. | Tie bar       |     |               |
| 14. | Screw         |     |               |
| 15. | Lockwasher    |     |               |
| 16. | Nut           |     |               |
| 17. | Step          |     |               |

Figure 4-26. Support Frame Assembly  
4-78

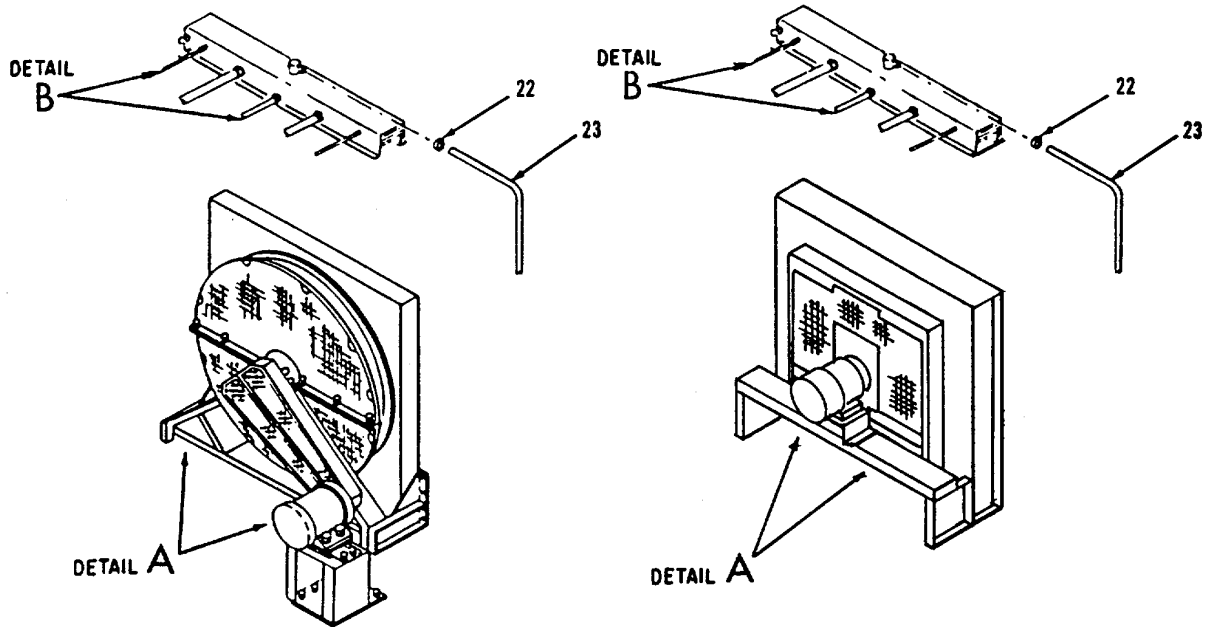

**CODE A**  
(SERIAL NOS. FZ00001 THRU FZ00064)

**CODE B**  
(SERIAL NOS. FZ09100 THRU FZ09150)

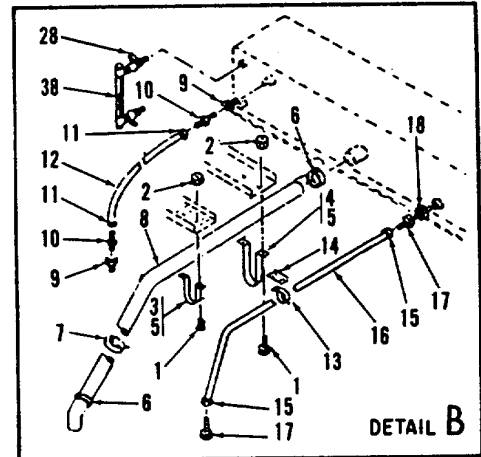
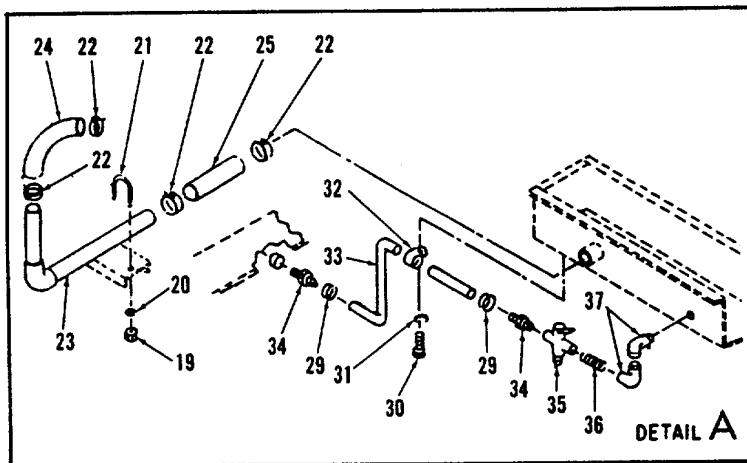

LEGEND

- |              |                     |                                      |
|--------------|---------------------|--------------------------------------|
| 1. Screw     | 14. Bracket         | 27. Hose                             |
| 2. Nut       | 15. Fitting         | 28. Valve (Code A Only)              |
| 3. Clamp     | 16. Hose            | 29. Clamp                            |
| 4. Clamp     | 17. Nipple          | 30. Screw                            |
| 5. Extrusion | 18. Reducer         | 31. Lockwasher                       |
| 6. Clamp     | 19. Nut             | 32. Clamp                            |
| 7. Clamp     | 20. Lockwasher      | 33. Hose                             |
| 8. Hose      | 21. U-bolt          | 34. Fitting                          |
| 9. Reducer   | 22. Clamp           | 35. Drain cock                       |
| 10. Nipple   | 23. Pipe connection | 36. Nipple                           |
| 11. Fitting  | 24. Hose            | 37. Elbow                            |
| 12. Hose     | 25. Hose            | 38. Sight indicator<br>(Code B only) |
| 13. Clamp    | 26. Clamp           |                                      |

Figure 4-27.

Radiator Assembly, Exploded View  
4-79

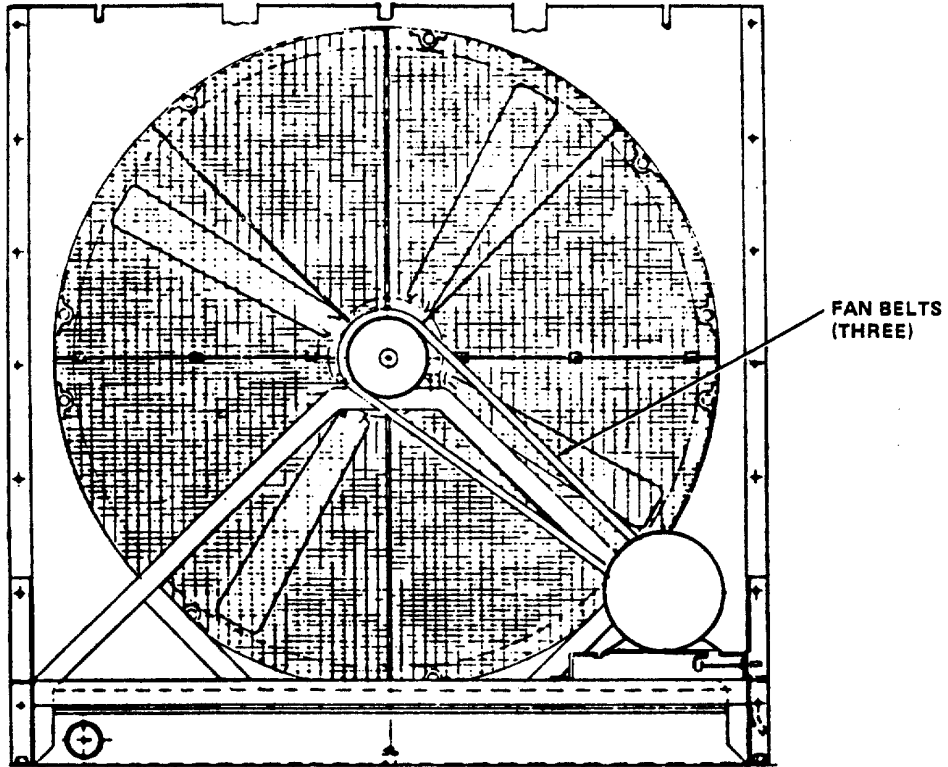

NOTE: FAN BELTS SHALL BE REPLACED AS A SET OF THREE.

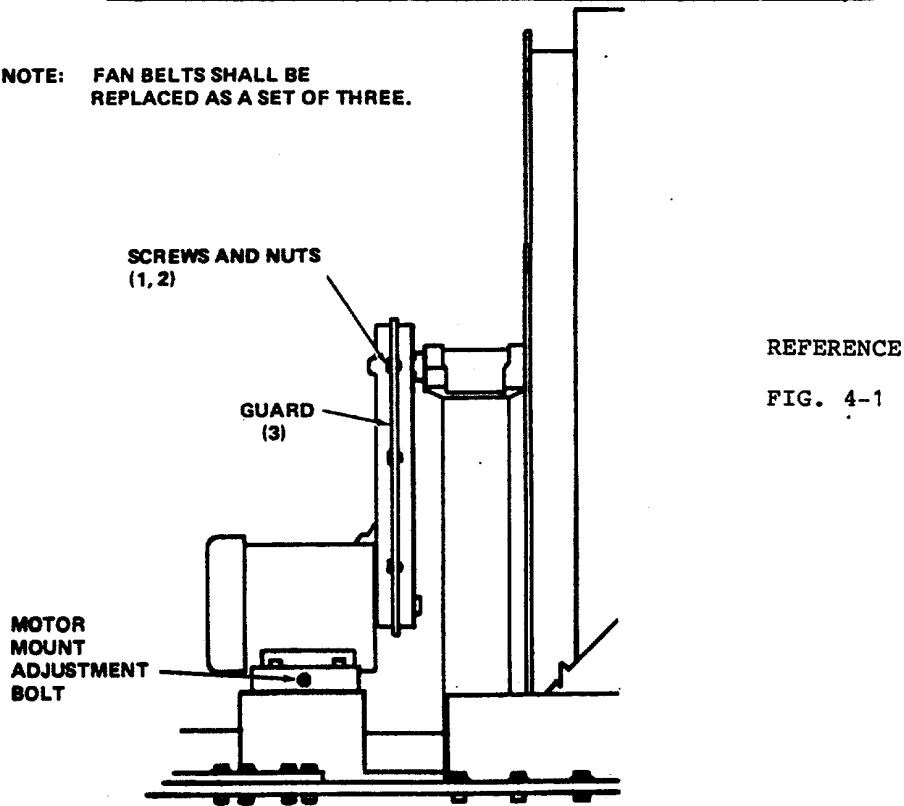

Figure 4-28. Fan Belt Adjustment and Replacement, Code A  
4-80

adjustment bolt (see figure 4-28) to increase belt tension.

#### NOTE

**All three belts should have same tension. If not, remove and replace belts as a set of three.**

- (4) Replace guard (3), screws (1), and nuts (2).
- c. Fan Belt Replacement (Code A). To remove fan belts proceed as follows:
- (1) Remove two halves of belt guard (3, figure 4-28) by removing six screws (1) and nuts (2).
  - (2) Loosen motor mount adjusting bolt and relieve tension on belts. Remove by manually rotating fan.
  - (3) Install new belts, and adjust for proper tension.
  - (4) Replace belt guard.
- d. Motor. Inspect motor for loose mounting, signs of overheating, or other damage. Run the generator set and determine that the motor is operating by observing that the fan is rotating. Check for excessive noise.
- e. Sight Indicator and Valves. (See figure 4-27)
- (1) Inspect Code B sight indicator (38) and Code A shut-off valves (28) for leakage, loose connection, or loose mounting.
  - (2) Inspect sight indicator for cracking.
- f. Hoses.
- (1) Inspect all hoses (8, 12, 16, 24, 25, 27, and 33) for loose mounting or loose connections, leakage, cracking, or rot.
  - (2) Replace hoses as follows:

#### CAUTION

**Be sure engine has been shut down sufficiently long to allow engine coolant to cool off before changing hoses. Loosen and then remove radiator cap.**

- (a) Drain coolant into clean container using coolant drain cock (see figure 4-2). Save coolant for reuse.
- (b) To remove hose (8), remove clamps (3, 4, 6, and 7). Remove hose (9) from radiator assembly.
- (c) To remove hose (12), unscrew fittings (11) from nipples (10).
- (d) To remove hose (16), remove clamp (13), unscrew fittings (15) from reducers (18).
- (e) To remove hose (24), remove clamps (22), then remove hose (24) from pipe connection (23).
- (f) To remove hose (25), remove clamps (22), then remove hose (25) from pipe connection (23) and then radiator assembly.
- (g) To remove overflow hose (27), remove clamp (26), then remove hose from radiator assembly.
- (h) To remove hose (33), remove clamps (29 and 32), then unscrew hose from fittings (34).
- (i) Install hose (33) by attaching hose (33) to fittings (34). Secure with clamps (29 and 32).
- (j) Install overflow hose (27) by attaching hose (27) to radiator assembly, then secure with clamp (26).
- (k) Install hose (25) by attaching hose (25) to radiator assembly, then to pipe connection (23). Secure with clamps (22).

- (l) Install hose (24) by attaching clamps (22) and securing to pipe connection (23).
- (m) Install hose (16) by attaching fittings (15) to reducers (18), then install clamp (13).
- (n) Install hose (12) by attaching fittings (11) to nipples (10).
- (o) Install hose (8) by attaching to radiator assembly. Secure with clamps (3, 4, 6, and 7).

### Section XVIII. MAINTENANCE OF FUEL LINES AND FITTINGS

4-50. FUEL LINES. The generator set fuel lines (figure 4-29) are hose assemblies connecting the fuel tank and fuel transfer pump, and the engine.

- a. Visually inspect all lines and fittings for leakage or deformity, signs of rot or physical damage. Inspect screen which is welded inside filler neck assembly (47) for tears or damage.
- b. Replace defective lines and fittings as follows:
  - (1) Remove lines by removing clamps supporting defective hose assemblies to the generator set.

- (2) Remove spring clamps, or unscrew assembly from adapters, tees, etc. as necessary.
- (3) Separate defective lines or fittings from assembly.
- (4) Install new lines or fittings onto assembly.
- (5) Install hose assemblies using spring clamps or attaching hardware (fittings).
- (6) Install clamps securing hose assembly to generator set.
- (7) Recycle fuel if not contaminated in any way.

### Section XIX. MAINTENANCE OF ENGINE PREHEAT

4-51. ENGINE PREHEAT. The engine preheat assembly (see figure 4-30) is mounted to the base assembly under the forward end of the engine. The preheat system maintains the engine in a preheated, ready-to-start condition by heating the coolant and oil. This requires an external power source.

- a. Inspection. Inspect thermostatic switch S30 (25, figure 4-30), heaters H101, H102, H103 (18) and (53) and heater power control contactor K109 (54, figure 4-12) for loose mounting, loose electrical connections, loose hose assemblies and general signs of overheating. Inspect hose assemblies for loose connections, leakage, wear or rotting.

b. Testing.

- (1) Thermostatic switch S30 (13, figure 4-30).
  - (a) Close both shutoff cocks (4).
  - (b) Install a temperature measuring instrument (thermocouple) as close to the thermostatic switch (13) as possible.
  - (c) Switch on heater system. Observe that heater system automatically turns off when temperature measuring



instrument reaches approximately 120°F ±5 (50°C ±2).

- (d) As the water begins to cool, note that heater automatically comes on at approximately 100°F ±5 (38°C ±2).
  - (e) If switch fails to meet above test, it should be replaced.
  - (f) Open both shutoff cocks.'
- (2) Heater H101, H102 and H103 (18 and 53, figure 4-30).
- (a) Place EXTERNAL POWER BREAKER and PREHEAT switch to the off position. (figure 2-10).
  - (b) Locate terminal board within heater electrical enclosure (40 figure 4-30) and remove wires X173H and X174H from terminal points 6 and 7. Isolate 12 gauge and 14 gauge wires from terminal point 7.
  - (c) Using an ohmmeter, check resistance between terminal point 4 and 12 gauge wire isolated from terminal point 7. Resistance should be 8.0 ohms. Resistance between terminal point 4 and 6 should also be 8.0 ohms. Resistance between terminal point 4 and 14 gauge wire isolated from terminal

point 7 should be 50 ohms. (Refer to Engine Accessories Wiring Diagram FO-11)

- (d) If the above tests are not met, one or more of the heater elements are defective and must be replaced.

c. Replacement.

**CAUTION**

**Shut off engine/generator set and allow sufficient time for engine coolant to cool before handling hoses and fittings. Use suitable containers to prevent loss of coolant. Switch off EXTERNAL POWER BREAKER.**

- (1) Close both shutoff cocks (4), drain coolant from preheat system by disconnecting heater hose going to highest point on engine and carefully lowering into suitable container.
- (2) To remove coolant heater assembly, remove the wires going to heater element (18) and (53). Remove heater coolant hoses. Remove four bolts, nuts and washers (34).
- (3) To remove oil heater, oil must first be drained from oil sump. Remove bell cap (38) then disconnect wires from end of heater element. Refill engine crankcase with oil once heating element has been replaced.
- (4) Open both shutoff cocks when coolant heater repair or replacement have been accomplished.

- 1. Screw
- 2. Nut
- 3. Clamp

- 4. Screw
- 5. Nut
- 6. Clamp

- 7. Clamp
- 8. Screw
- 9. Nut

LEGEND

- 10. Clamp bracket
- 11. Fitting
- 12. Hose

- 13. Elbow
- 14. Fitting
- 15. Hose

- 16. Elbow

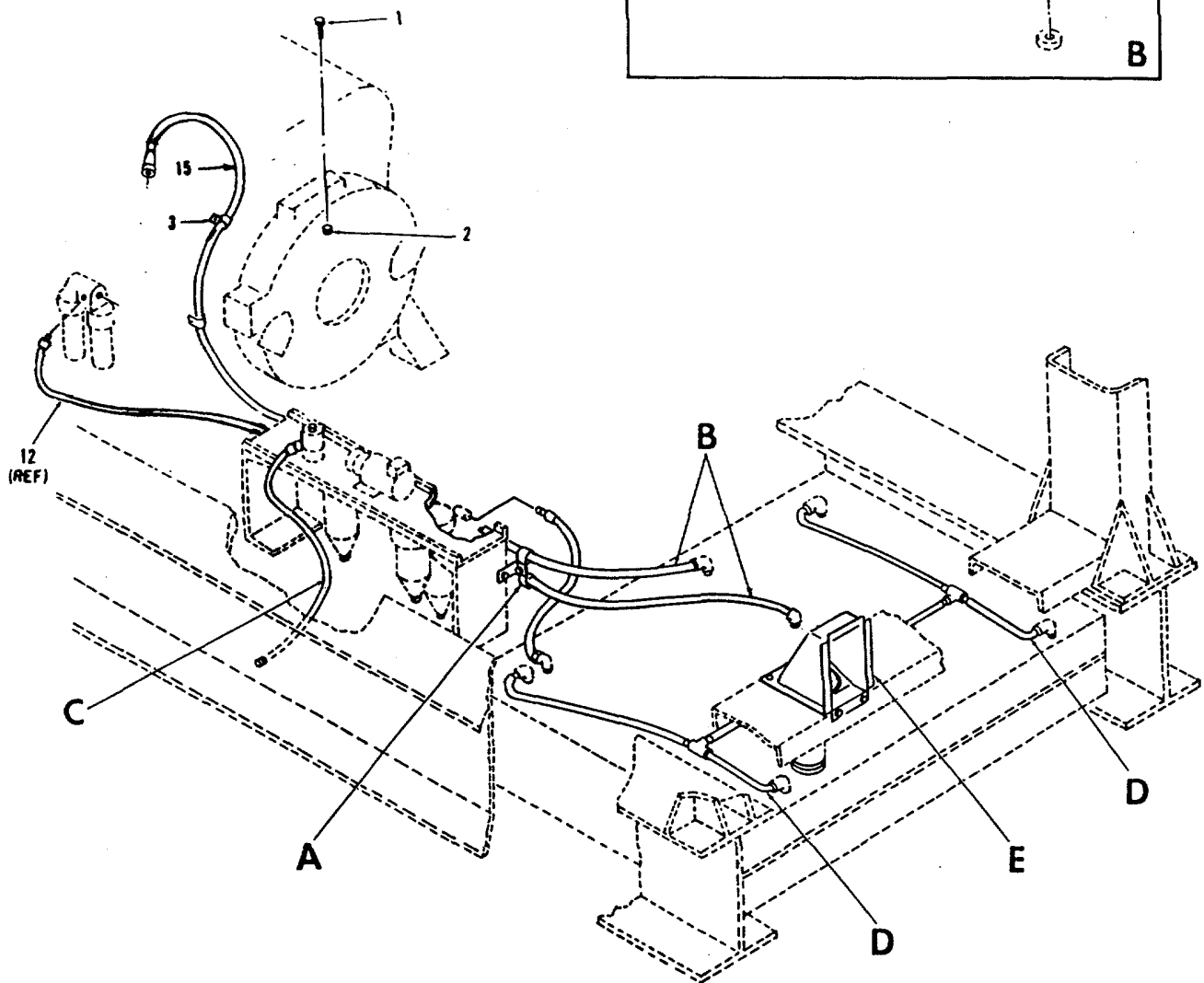
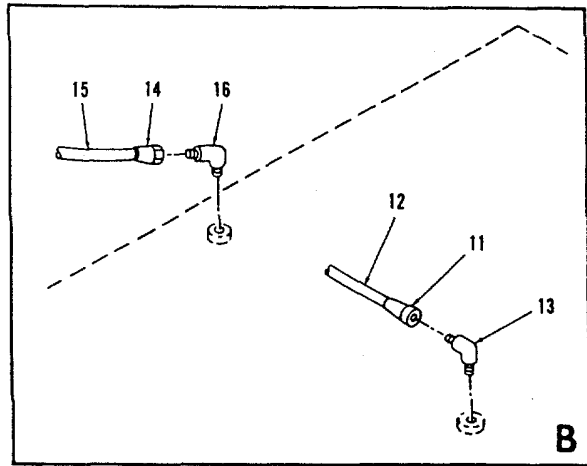
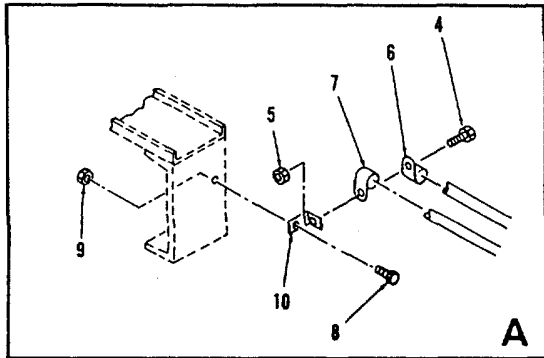

Figure 4-29. Fuel Lines (Sheet 1 of 2)

LEGEND

- |                      |                        |
|----------------------|------------------------|
| 17. Screw            | 48. Lockwasher         |
| 18. Nut              | 49. Lug                |
| 19. Clamp            | 50. Lug                |
| 20. Adapter          | 51. Wire               |
| 21. Hose             | 52. Bushing<br>reducer |
| 22. Fitting          |                        |
| 23. Hose             |                        |
| 24. Fitting          |                        |
| 25. Tee              |                        |
| 26. Clamp            |                        |
| 27. Hose             |                        |
| 28. Clamp            |                        |
| 29. Hose             |                        |
| 30. Clamp            |                        |
| 31. Hose             |                        |
| 32. Tee              |                        |
| 33. Clamp            |                        |
| 34. Hose             |                        |
| 35. Clamp            |                        |
| 36. Hose             |                        |
| 37. Clamp            |                        |
| 38. Hose             |                        |
| 39. Clamp            |                        |
| 40. Hose             |                        |
| 41. Cap              |                        |
| 42. Filler tube      |                        |
| 43. Screw            |                        |
| 44. Washer           |                        |
| 45. Lockwasher       |                        |
| 46. Nut              |                        |
| 47. Filler neck assy |                        |

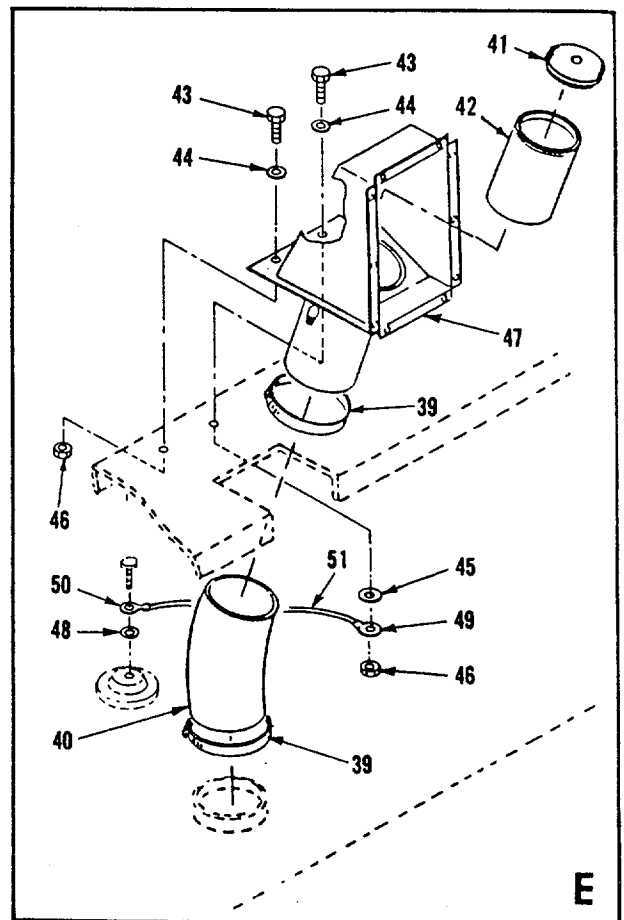
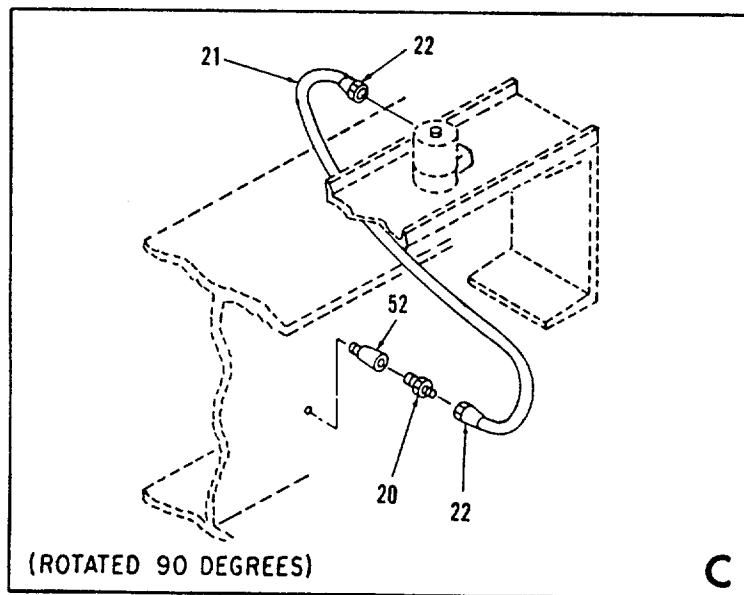
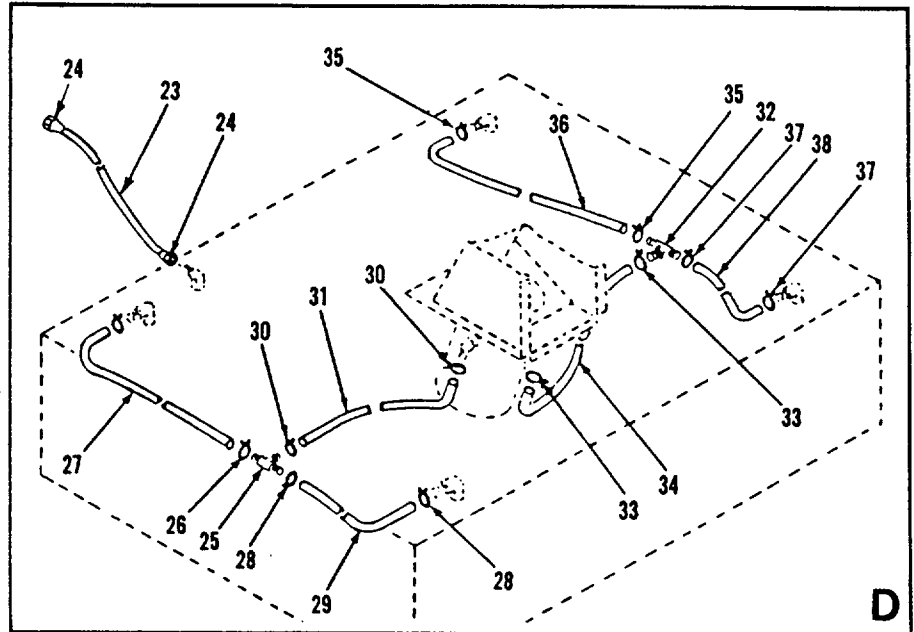
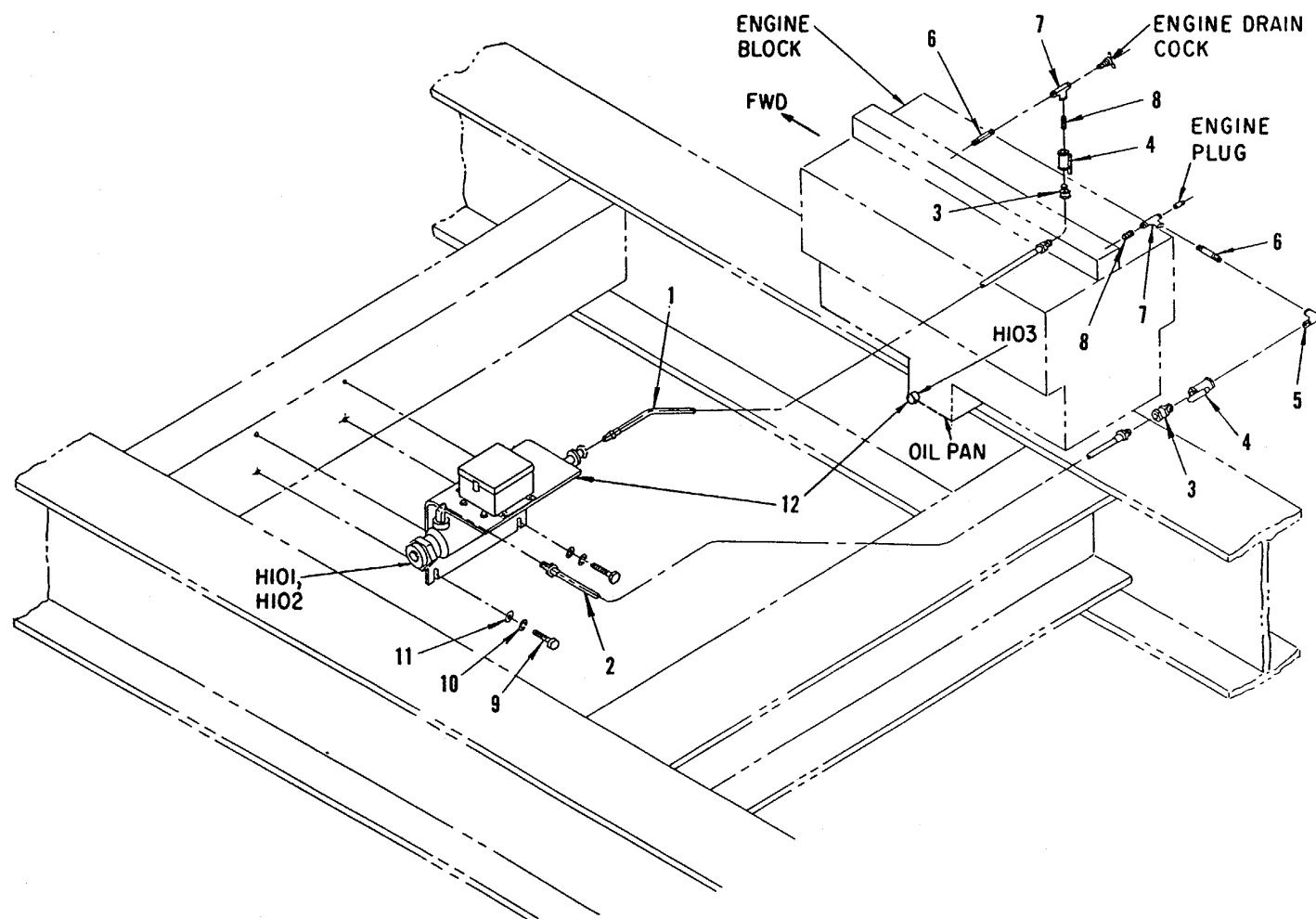

Figure 4-29. Fuel Lines (Sheet 2 of 2)



- 1. Hose
- 2. Hose
- 3. Adapter
- 4. Shutoff cock

- 5. Elbow
- 6. Nipple
- 7. Tee
- b. Nipple

- 9. Screw
- 10. Lockwasher
- 11. Washer
- 12. Heater assembly kit

Figure 4-30. Preheat Installation (Sheet 1 of 2)

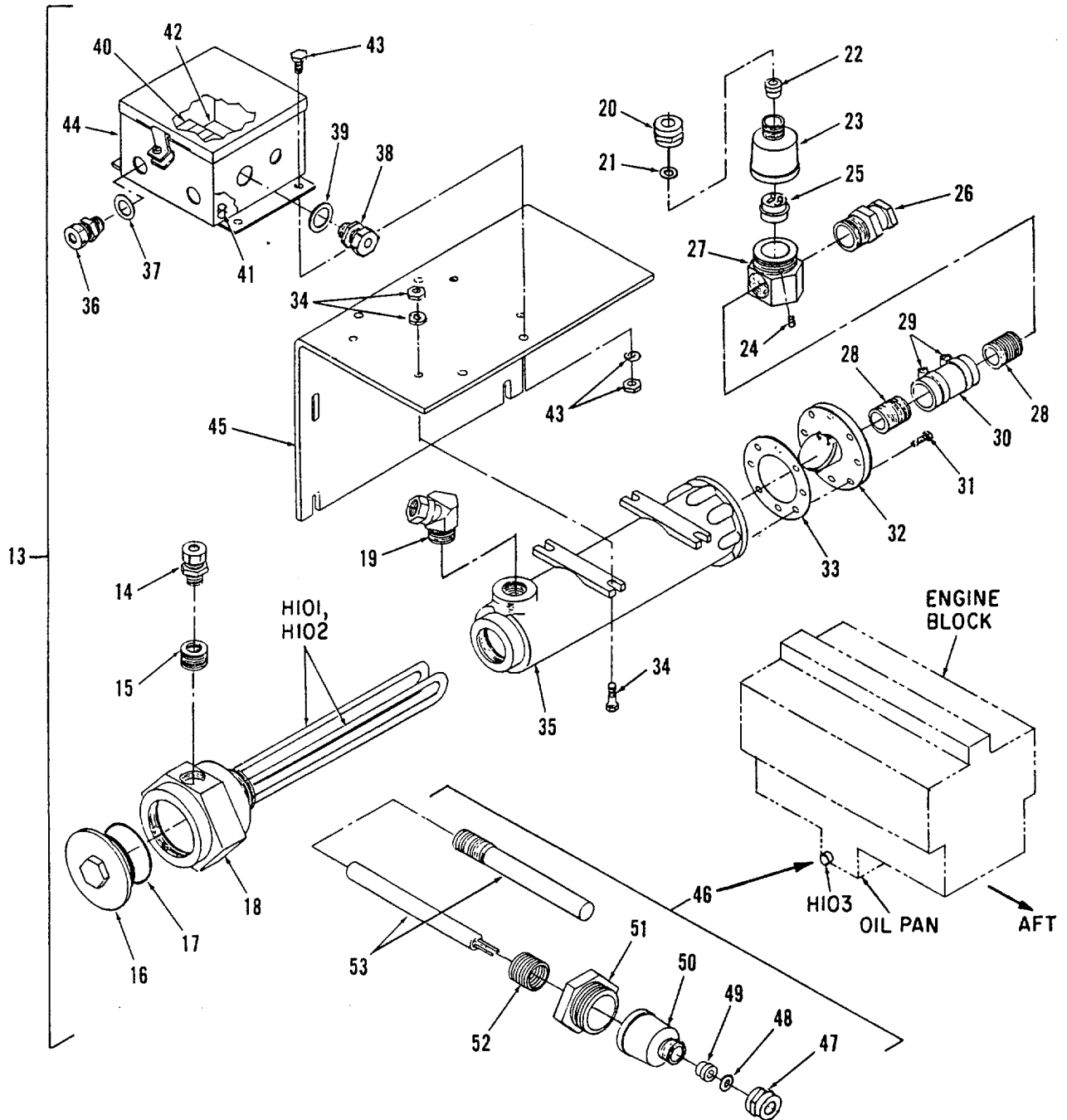

Figure 4-30. Preheat Installation (Heater) (Sheet 2 of 2)

LEGEND FOR FIGURE 4-30 (SHEET 2)

- |                              |                         |
|------------------------------|-------------------------|
| 13. Heater assy              | 34. Bolt assy           |
| 14. Cord grip                | 35. EB tank             |
| 15. Reducer                  | 36. Cord grip           |
| 16. Cover                    | 37. Seal ring           |
| 17. O-ring                   | 38. Cord grip           |
| 18. Heater element           | 39. Seal ring           |
| 19. Swivel adapter           | 40. Terminal block      |
| 20. Cap                      | 41. Ground lug          |
| 21. Washer                   | 42. Plate               |
| 22. Grommet                  | 43. Bolt assy           |
| 23. Cap                      | 44. Junction box        |
| 24. Set screw                | 45. Mounting plate      |
| 25. Sensing unit             | 46. Lub oil heater assy |
| 26. Swivel adapter           | 47. Cap                 |
| 27. Burr                     | 48. Washer              |
| 28. Nipple                   | 49. Grommet             |
| 29. Clamp                    | 50. Cap                 |
| 30. Hose                     | 51. Burr                |
| 31. Screw                    | 52. Reducer             |
| 32. EC flange and valve assy | 53. Heater element      |
| 33. Gasket                   |                         |

**Section XX. MAINTENANCE OF FUEL TRANSFER PUMP**

4-52. FUEL TRANSFER PUMP. The fuel transfer pump (figure 4-31) has a DC operated motor and is used to transfer fuel from an auxiliary source to the generator set fuel tank. Pumping is automatically controlled by a float level switch in the generator set fuel tank when the FUEL PUMP switch on engine control panel (see figure 2-1) is in the AUTO position. The pump (16, figure 4-31) is mounted on the support bracket (51) on the generator set base assembly.

a. Inspection.

- (1) Inspect pump for leaks, loose connections, dents, and cracks.
- (2) Remove fuel line from pump inlet connection and inspect filter assembly for accumulated dirt, cracks, breaks which would cause restriction to fuel flow.

- (3) Inspect the motor for overheating or other visible signs of damage.

b. Test. Transfer pump testing consists of an operational test as follows:

- (1) Place 24V DC CONTROL CIRCUIT BREAKER on generator panel to OFF, and FUEL PUMP switch on engine panel to OFF position.
- (2) Disconnect hose assembly connected to pump connector (10, figure 4-31).
- (3) Attach a length of hose of this connector and place in a container of adequate size.
- (4) Connect an external fuel supply to the fuel transfer pump connection on the outside of the base assembly.

- (5) If fuel tank is 1/2 full or more, jump out contactor K20 (33, figure 4-17) by momentarily connecting small terminal A to large terminal P140C with a jumper cable (see figure 4-32).
- (6) With 24V DC CONTROL CIRCUIT BREAKER set ON, and the FUEL PUMP switch in AUTO, check the flow of fuel. It should pump approximately 1 gallon per minute (3.8 l per minute). Set FUEL PUMP switch to OFF, flow should stop. Refer to next higher maintenance if flow rate is not met or pump fails to stop.

c. Service. None required.

#### 4-53. FILTER AND STRAINER. (See figure 4-31).

a. Removal.

- (1) Open drain cocks (23 and 29) on the filter and strainer assembly (22).
- (2) Drain the fuel into a suitable container.
- (3) Remove hose connections from elbows (8) and (11) and remove elbows.
- (4) Remove four screws (20) and lockwashers (21) securing filter and strainer assembly (22) to support bracket (51). Remove filter and strainer assembly (22).
- (5) Open drain cock (40) on

strainer assembly (39). (6) Drain the fuel into a suitable container.

- (7) Remove hose connections from elbows (8), remove elbows.
- (8) Remove four screws (37) and lockwashers (38) securing strainer assembly to support bracket (51). Remove strainer assembly (32).

b. Replacement.

- (1) Install filter and strainer assembly (22) on support bracket (51) with four screws (20) and lockwashers (21).
- (2) Attach two elbows (8) and (11) to filter and strainer assembly.
- (3) Attach hose connections to elbows.
- (4) Install strainer assembly (39) to support bracket (51) with four screws (37) and lockwashers (38).
- (5) Attach two elbows (8) to the strainer assembly.
- (6) Connect hose to elbows (8).
- (7) Close drain cocks (23, 29, and 40).

#### **NOTE**

**For filter and strainer servicing, refer to paragraph 3-15.**

## Section XXI. MAINTENANCE OF FUEL TANK ASSEMBLY

4-54. GENERAL. The fuel tank assembly (figure 4-33) is located at the rear end of the base assembly, under the control cubicle. It is equipped with two fuel level switches and one liquid level transmitter.

a. Inspection of Fittings. Inspect elbow fittings (1, 2, and 3) for leaks or obvious damage.

b. Replacement of Fittings. Remove fittings (1, 2, and 3) and install new fittings using sealing compound (MIL-S-7916C).

4-55. FUEL LEVEL SWITCH.

a. Test. (See figures 4-33 and 4-34.)

- (1) Inspect the wires to the switch for secure connection.
- (2) Inspect for loose terminals or other signs of damage.
- (3) Remove connector from switch (4, figure 4-33) and remove switch from fuel tank.
- (4) Connect ohmmeter (set on Rx1 scale) to pins A and B (figure 4-34). Move upper float to upper stop at top of the switch. Ohmmeter shall show open circuit (no continuity). Move upper float down to lower stop. Ohmmeter shall show closed circuit (continuity).
- (5) Connect ohmmeter to pins C and D. Move lower float to upper stop. Ohmmeter shall show no continuity. Move lower float down to lower stop. Ohmmeter shall show continuity.
- (6) Repeat test procedure (steps 3 through 5) with second fuel level switch.

### NOTE

**Switch part numbers are located on unit.**

(7) If switches are defective, replace them.

b. Replacement.

(1) Remove connector from switch and remove switch.

(2) Install switch in the tank using sealant compound and attach connector.

### NOTE

**Both fuel level switches are similar. Be sure to install in proper location on fuel tank.**

4-56. LIQUID QUANTITY TRANSMITTER. Remove liquid quantity transmitter in accordance with paragraph 4-56b prior to testing.

a. Test. Connect ohmmeter between case of transmitter and the transmitter connector pin as shown in figure 4-35. With sensing arm of transmitter in lowered position (A), ohmmeter shall read between 0.00 and 0.90 ohms and with sensing arm of transmitter in raised position (B), ohmmeter shall read between 29.8 and 31.3 ohms. Disconnect ohmmeter. Reinstall transmitter.

b. Replacement. (See figure 4-33.) Tag and disconnect wiring and remove transmitter by removing five screws (6) and transmitter (8), and gasket (7). Install transmitter on tank using sealing compound (MIL-S-7916C). Reinstall gasket (7), transmitter (8), and five screws (6). Connect wires by securely pushing pin on wire into connector receptacle.



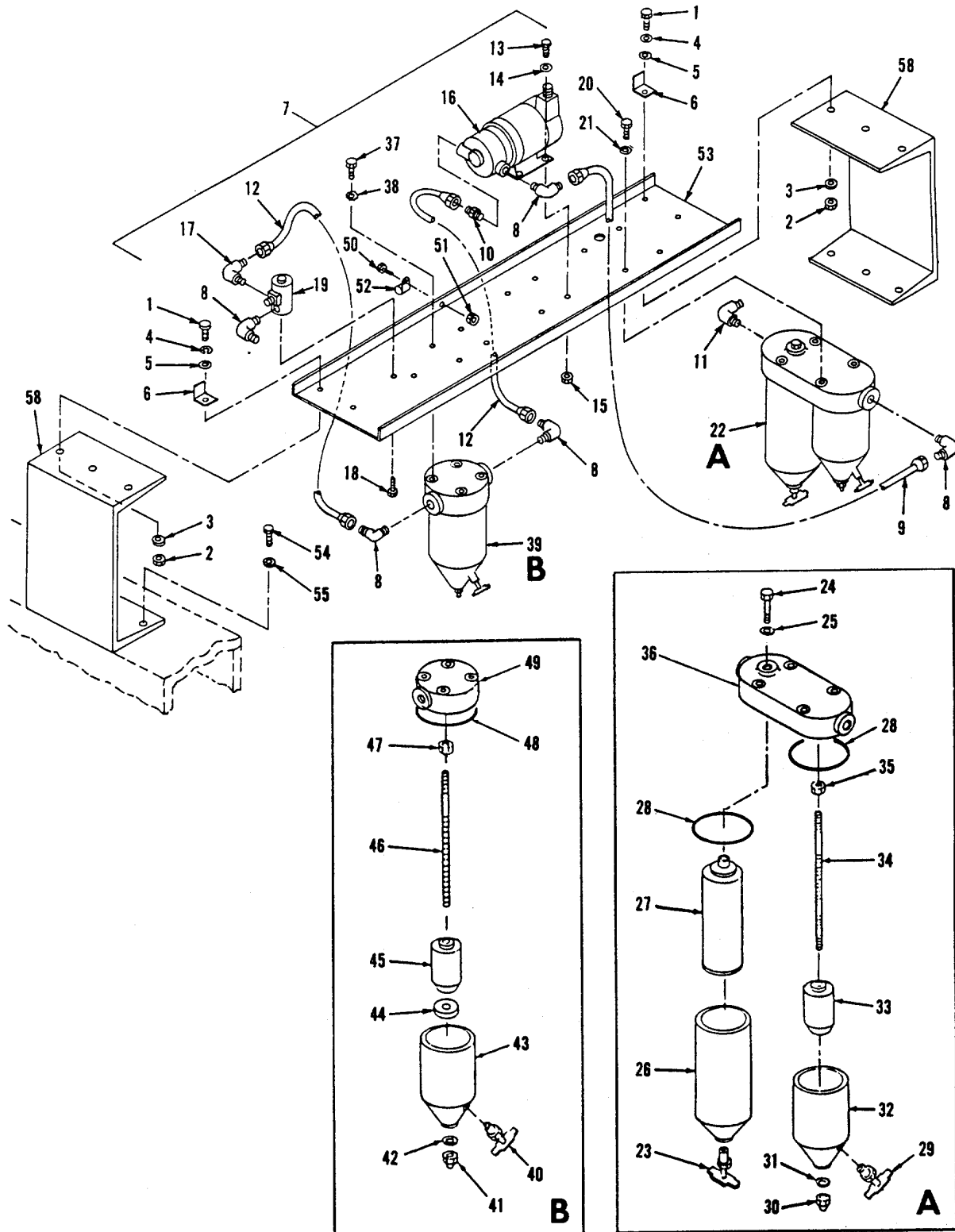

Figure 4-31. Fuel Transfer Pump Installation, Exploded View.

LEGEND FOR FIGURE 4-31.

- |                              |                            |
|------------------------------|----------------------------|
| 1. Screw                     | 30. Nut                    |
| 2. Nut                       | 31. Washer                 |
| 3. Bevel washer              | 32. Can                    |
| 4. Lockwasher                | 33. Strainer               |
| 5. Washer                    | 34. Rod assy               |
| 6. Bracket                   | 35. Nut                    |
| 7. Transfer pump-filter assy | 36. Filter-strainer heater |
| 8. Elbow                     | 37. Screw                  |
| 9. Hose                      | 38. Washer                 |
| 10. Connector                | 39. Washer                 |
| 11. Hose                     | 40. Drain cock             |
| 12. Hose                     | 41. Nut                    |
| 13. Screw                    | 42. Washer                 |
| 14. Washer                   | 43. Can                    |
| 15. Nut                      | 44. Retainer               |
| 16. Pump                     | 45. Strainer               |
| 17. Elbow                    | 46. Rod assy               |
| 18. Screw                    | 47. Nut                    |
| 19. Valve                    | 48. Gasket                 |
| 20. Screw                    | 49. Strainer heater        |
| 21. Lockwasher               | 50. Screw                  |
| 22. Filter-strainer assy     | 51. Nut                    |
| 23. Drain cock               | 52. Clamp                  |
| 24. Screw                    | 53. Bracket                |
| 25. Washer                   | 54. Screw                  |
| 26. Can                      | 55. Bevel washer           |
| 27. Filter element           | 56. Lockwasher             |
| 28. Gasket                   | 57. Nut                    |
| 29. Drain cock               | 58. Channel                |

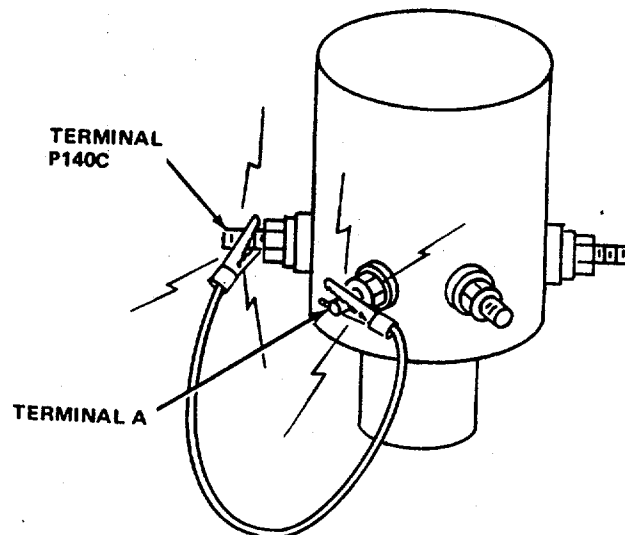
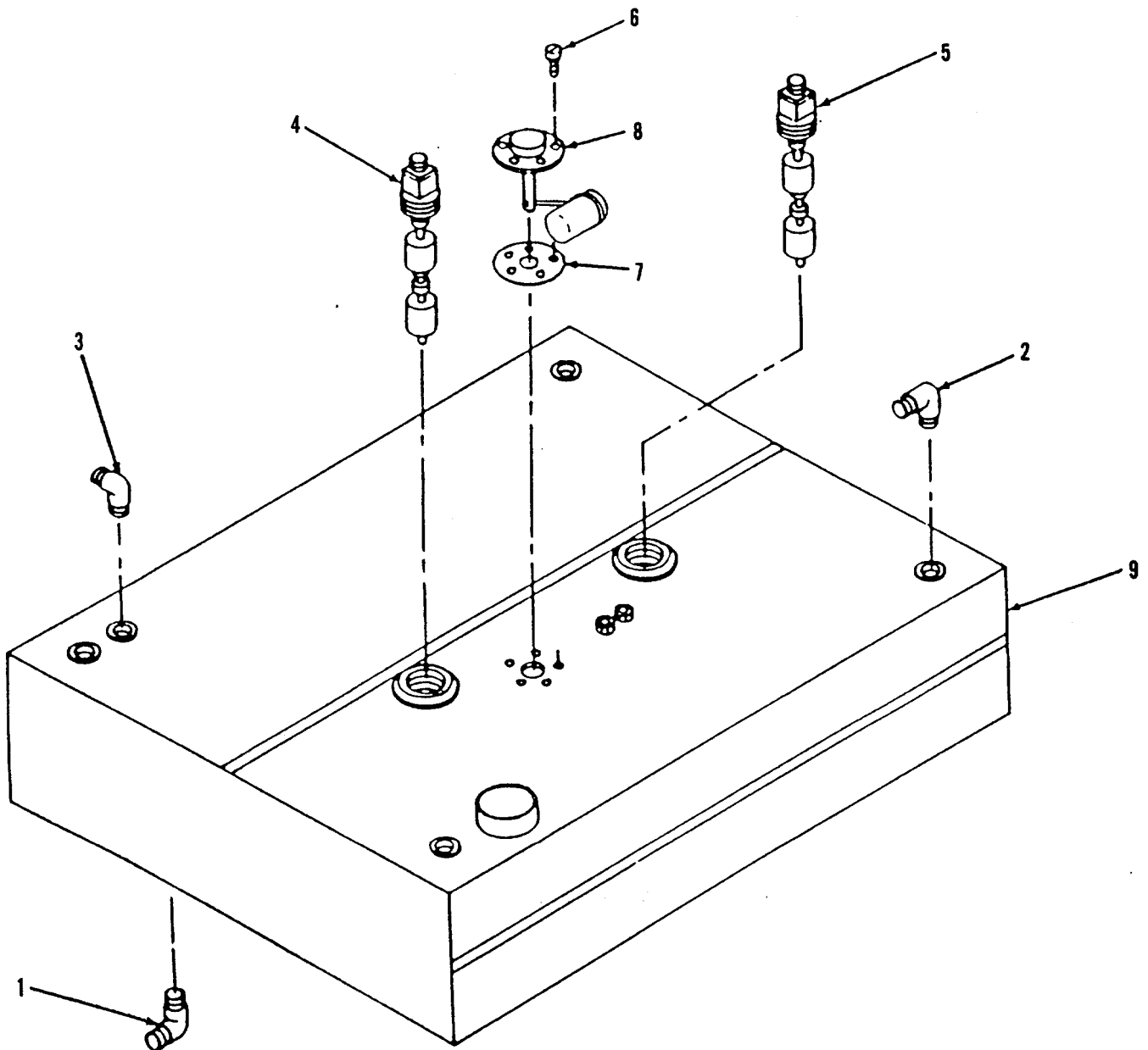

Figure 4-32. Fuel Transfer Pump Contactor K20



LEGEND

- |           |                |
|-----------|----------------|
| 1. Elbow  | 6. Screw       |
| 2. Elbow  | 7. Gasket      |
| 3. Elbow  | 8. Transmitter |
| 4. Switch | 9. Fuel tank   |
| 5. Switch |                |

Figure 4-33. Fuel Tank Assembly, Exploded View.

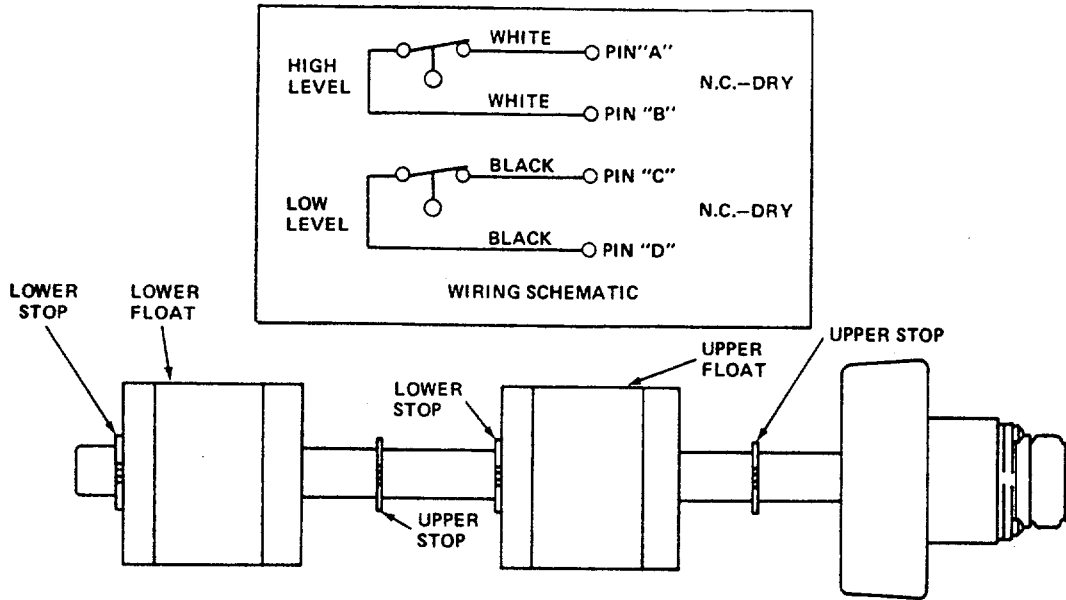

**NOTE: FLOAT TRAVEL FROM SWITCH OPENING  
TO SWITCH CLOSING TO BE 0.12 IN. (.31 CM)**

Figure 4-34. Fuel level Switch Test Data

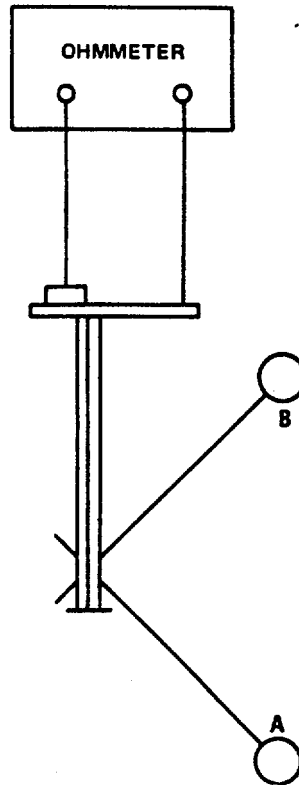

Figure 4-35. Liquid Quantity Transmitter  
4-94

## Section XXII. MAINTENANCE OF INTERCONNECTING ELECTRICAL WIRING HARNESS

4-57. GENERAL. This section contains information on interconnecting wiring harnesses of the engine generator and chassis. The wiring harnesses provide electrical interconnection between major assemblies of the generator set.

4-58. TEST AND REPLACEMENT. Proceed as follows:

### WARNING

**Set MAINTENANCE LOCKOUT switch to LOCKOUT. Disconnect negative cable from batteries. Remove external power by opening CB101 (120V RECEPTACLE BREAKER). Load terminals of generator set circuit breaker (CB2) may still be energized with bus voltage.**

a. Test. Perform continuity check, using ohmmeter between connecting points in the wiring harness. Check for short circuits between connector pins of the same receptacle or terminal board.

b. Repair.

(1) If a broken wire is accessible remove

sufficient insulation from each side of the break to allow a good connection of the bared ends by twisting them together. Solder the connection and wrap with electrical tape.

(2) If a wire is broken from a terminal lug, replace the lug. If a wire is broken from a connector, resolder and reassemble.

### WARNING

**Under no condition leave the bare connection exposed.**

(3) If a break in the wire is inaccessible within the wiring harness, disconnect it at both ends and tape both ends. Lace a new lead of the same gauge and insulation outside the harness and connect it to the proper terminals or pins. Properly tag both ends of all replacement wires.

## Section XXIII. MAINTENANCE OF GENERATOR AND RECONNECTION ASSEMBLY

4-59. GENERAL. The generator (figure 4-36) is a synchronous, brushless device with an integral exciter. It is directly driven from the engine shaft through a disc coupling to provide line voltages at any load between no load and rated load. The reconnection assembly allows reconnection of generator windings to give specified output voltage of 120/208 volts or 240/416 volts operation.

4-60. RECONNECTION BOARD AND BUSS. (See figure 4-36.) Inspect for cracks, breaks, corrosion, and loose mounting. If replacement is required, refer to next higher level of maintenance.

4-61. GENERATOR. Inspect for excessive heat

during normal operation, by checking for peeling paint, excessive noise, smoke, and abnormal odors. Refer to next higher level of maintenance if overheating exists.

4-62. BEARING. Inspect the generator bearing for signs of wear by checking for excessive unusual noise, smoke, and abnormal odors. If replacement is required, refer to higher level maintenance.

4-63. DRIVE PLATE ASSEMBLY. Inspect the drive plate assembly for distortion, excessive wear, and loose mounting. If replacement is required, refer to higher level maintenance.

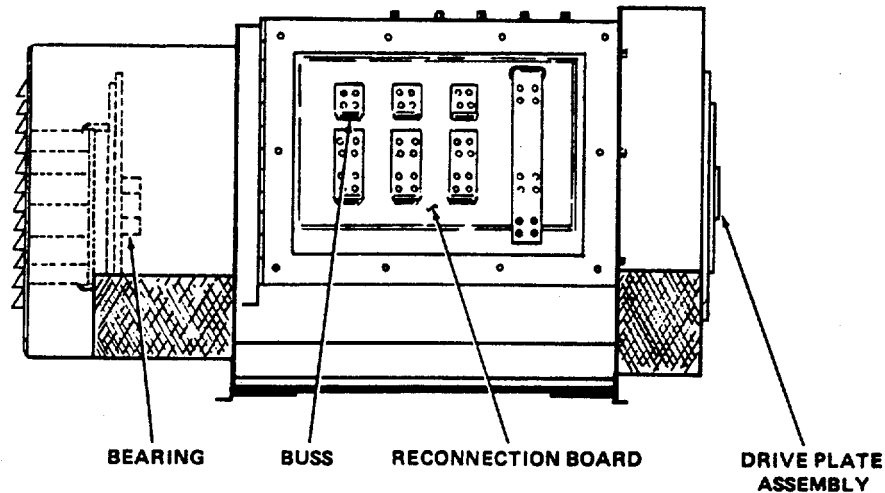

Figure 4-36. Generator and Reconnection Board

#### Section XXIV. MAINTENANCE OF ELECTRIC HYDRAULIC ACTUATOR

4-64. GENERAL. The electric hydraulic actuator (figure 4-37) is part of a governing system to control generator set speed, independently, in parallel, or with commercial power. It is mechanically coupled to the engine and electrically controlled by a load sharing circuit assembly.

- a. Inspection. Check all parts for wear, cracks, nicks, and corrosion. Check the electrical

connector for cracks or damage and wiring connections for breaks.

- b. Service. The electric hydraulic actuator has a reservoir (sump) containing engine oil. Refer to Lubrication Order, LO5-6115-593-12 and table 3-1 for proper oil. The sump is equipped with a dipstick. Check level and add oil, if necessary. Drain by removing drain plug.

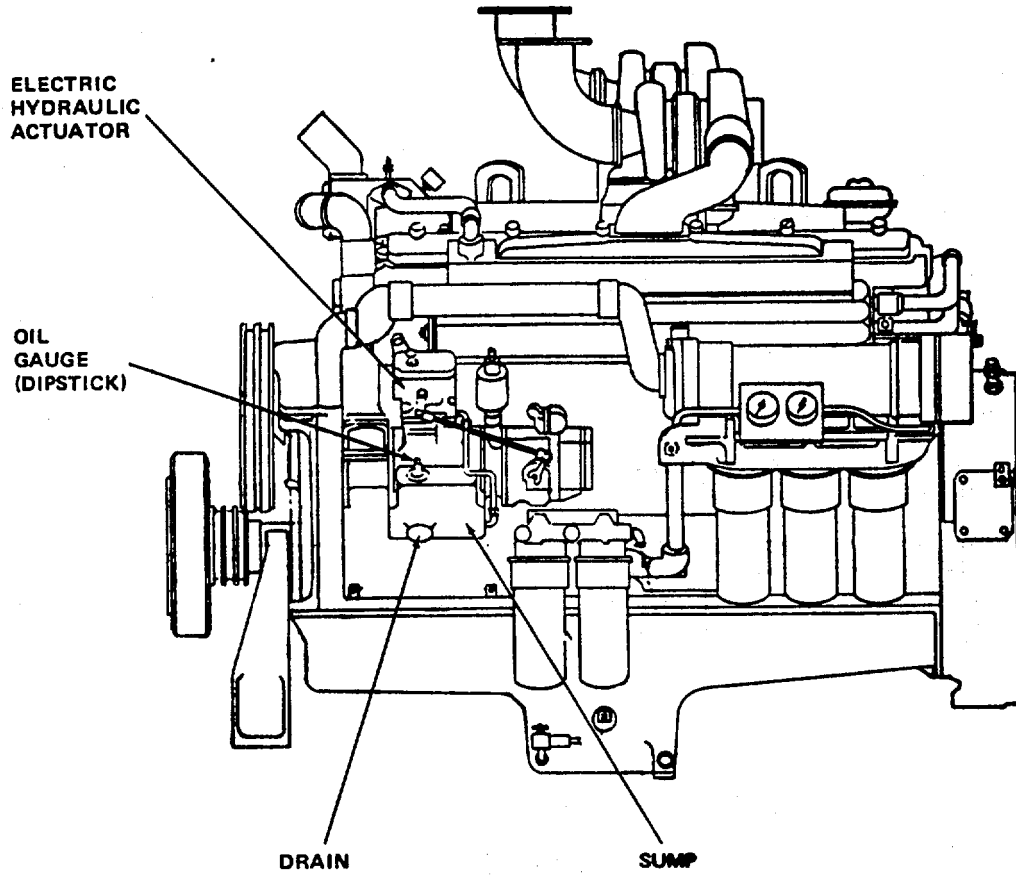

Figure 4-37. Electric Hydraulic Actuator  
4-97

## Section XXV. MAINTENANCE OF ETHER KIT

4-65. ETHER KIT. The ether kit (figure 4-38) contains a solenoid- actuated ether tank to feed ether into the engine intake manifold for cold condition starting. It is mounted on the right hand center support frame.

- a. Test. Refer to figure 4-39

### WARNING

**Ether is highly flammable fuel. Do not expose to open flame, lit cigarettes, or hot surfaces.**

- (1) Remove tube (1) from tee (5).
  - (2) Toggle START AID (13, figure 2-1) switch to ON position.
  - (3) Observe tee (5) for evidence of ether being ejected.
  - (4) Replace tube (1).
- b. Removal. Refer to figure 4-39.

- (1) Remove tank (6) by loosening clamp (10).
- (2) Disconnect tee (5) and electrical connector, and remove solenoid assembly (14) by removing two nuts (11) and lockwashers (17).

- (3) Remove ether line tubes on engine assembly by removing six clamps (3).

- c. Installation.

- (1) Attach ether line tubes on engine assembly with clamps (3).
- (2) Install solenoid assembly (14) on frame with two nuts (11) and washers (17).
- (3) Install tee (5) on solenoid assembly (14) and connect ether line tubes (1 and 2).
- (4) Reconnect electrical connector.
- (5) Install jet assemblies (4) in the engine intake manifold. Connect ether line tubes to jet assemblies.
- (6) Connect ether line tubes to tee (5).
- (7) Install ether tank (6) onto clamp bracket (9) with clamp (10).

- d. Repair. Repair the ether kit by replacement of worn or defective components.

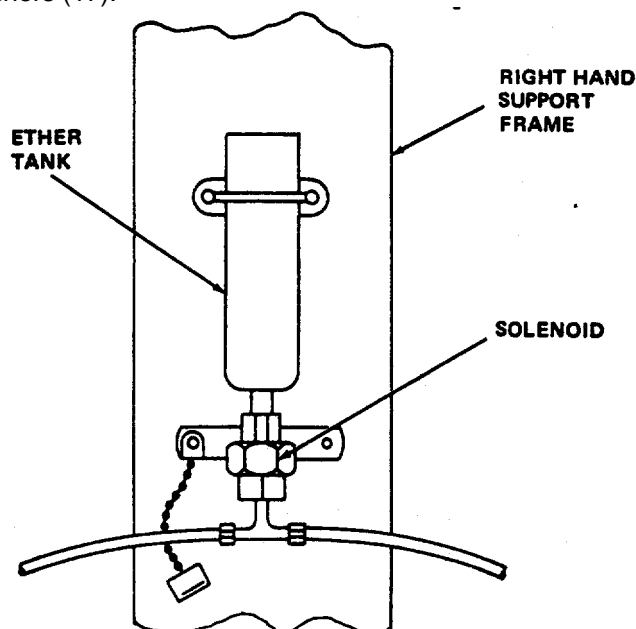

Figure 4-38. Ether Kit  
4-98



## Section XXVI. MAINTENANCE OF ENGINE ASSEMBLY

4-66. GENERAL. The engine provides mechanical power to drive generator. The diesel engine is a 12-cylinder, V-type, turbocharged, aftercooled type, rated at 750 hp at 1800 rpm. The engine air intake system consists of a precleaner with a replaceable filter. The engine is equipped with monitoring and control devices, lube oil cooler, and an independent governing system. See figure 4-40.

4-67. WATER PUMP BELT. (See figure 4-41)

### NOTE

**All generator sets with engine serial numbers 10605201 and higher are equipped with a new style water pump. Sets equipped with the new pump require no belt adjustments. The following procedure applies to serial number 10605201.**

- a. Adjustment. (1) Remove screws and lockwashers on front adjusting sheave.
  - (2) Turn engine over manually to roll belts outward on pulley as pulley sheaves are turned in to obtain desired belt tension. The engine can be turned manually as follows:
    - (a) Remove cotter pin from manual engine crank bolt.
    - (b) Push bolt toward generator to engage gear.
    - (c) Use a wrench to turn bolt.
  - (3) Turn front and rear adjusting sheaves while securing hub in stationary position to obtain desired belt tension.
  - (4) Lock front and rear adjusting sheaves in position with lockwashers and screws.

- (5) Check belt tension by applying pressure of the index finger at the center of the longest span of the belt. Deflection should be approximately 1 inch (25 mm).

b. Replacement. (See figure 4-41. )

- (1) To replace water pump belts, remove the screws and lockwashers which secure the adjusting sheaves to the fixed sheave.
- (2) Loosen the adjusting sheaves and remove belts.

### NOTE

**Always replace belts in complete sets to prevent early failure and provide efficient operation. Belt riding depth should not vary over 1/16 inch (1.59 mm) on new belt sets.**

- (3) Belts should not bottom on pulley grooves and should not protrude over 3/32 inch (2.4 mm) above top of edge of groove.
- (4) Install new water pump belts to pulleys and secure in position with the adjusting sheaves, lockwashers, and screws.
- (5) Adjust the water pump belt tension as described in paragraph a, above.

4-68. SERVICING DCA WATER FILTERS. (See figure 4-40. )

### NOTE

**New engines are shipped with a DCA pre-charge element. At first oil change (see Lubrication Order) replace pre-charge element with normal DCA Service Element. Replace filter element at each oil change. If coolant is drained and the coolant is replaced, install a DCA pre-charge element and repeat cycle. To test coolant corrosion inhibitor use Fleetguard DCA, Part Number 3300846-S, or Cummins Coolant, Part Number 3375 208, Test Kit.**

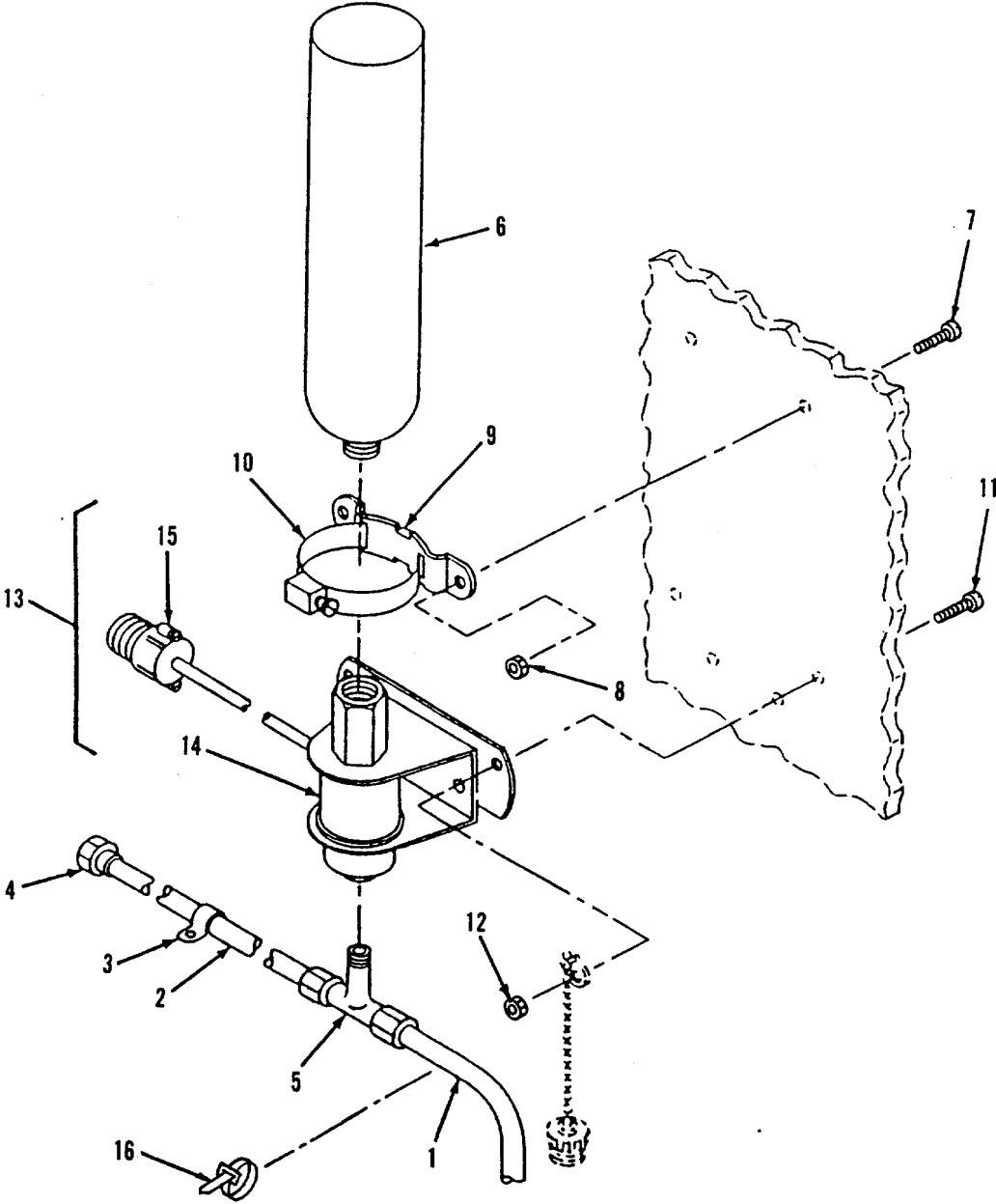

LEGEND

- |                  |                                 |
|------------------|---------------------------------|
| 1. Tube          | 10. Clamp                       |
| 2. Tube          | 11. Screw                       |
| 3. Clamp         | 12. Nut                         |
| 4. Jet assy      | 13. Solenoid and connector assy |
| 5. Tee           | 14. Solenoid assy               |
| 6. Tank          | 15. Connector                   |
| 7. Screw         | 16. Tiedown                     |
| 8. Nut           |                                 |
| 9. Clamp bracket |                                 |

Figure 4-39. Ether Installation  
4-100

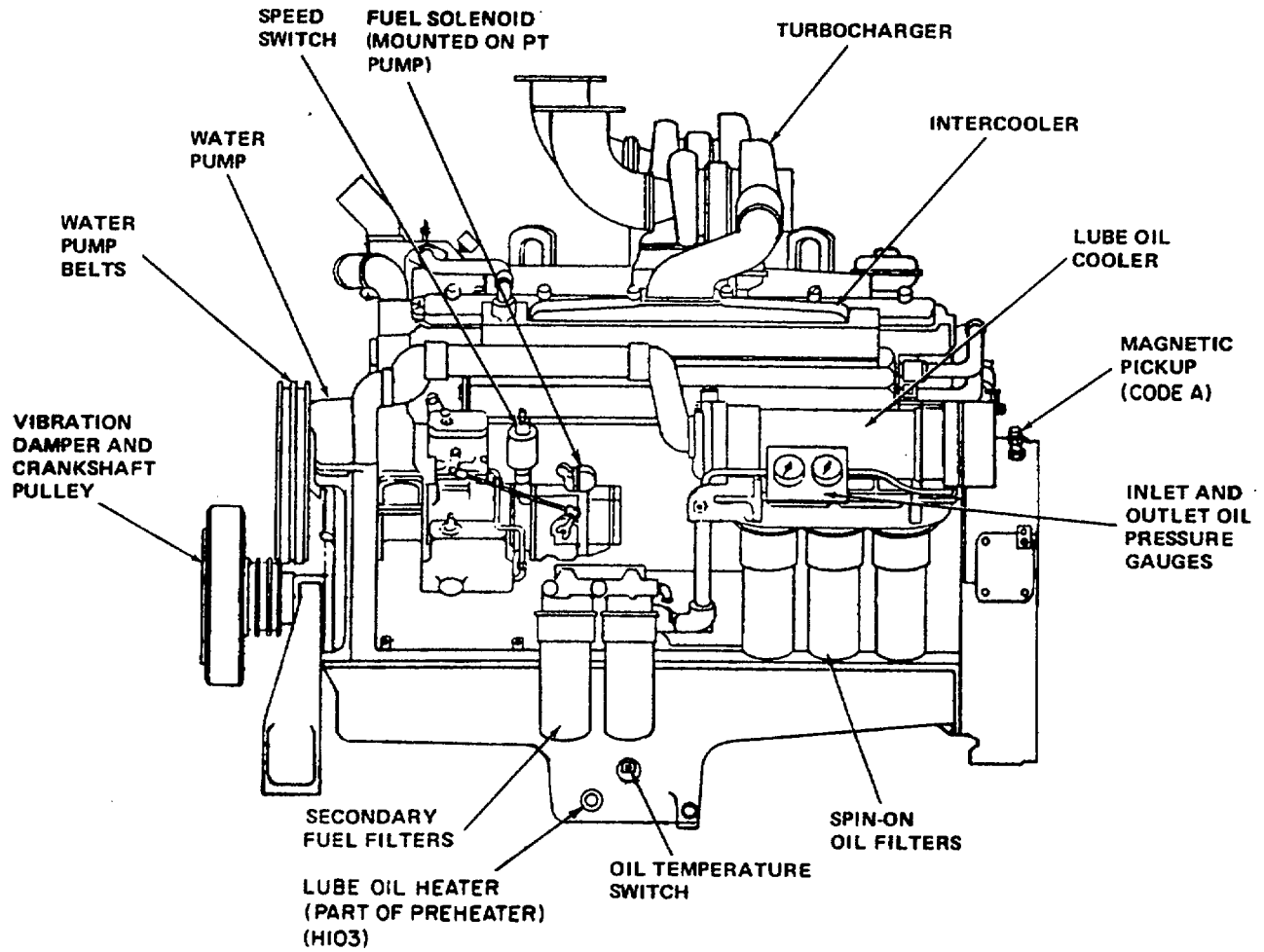

Figure 4-40. Engine Components (Sheet 1 of 2)  
4-101

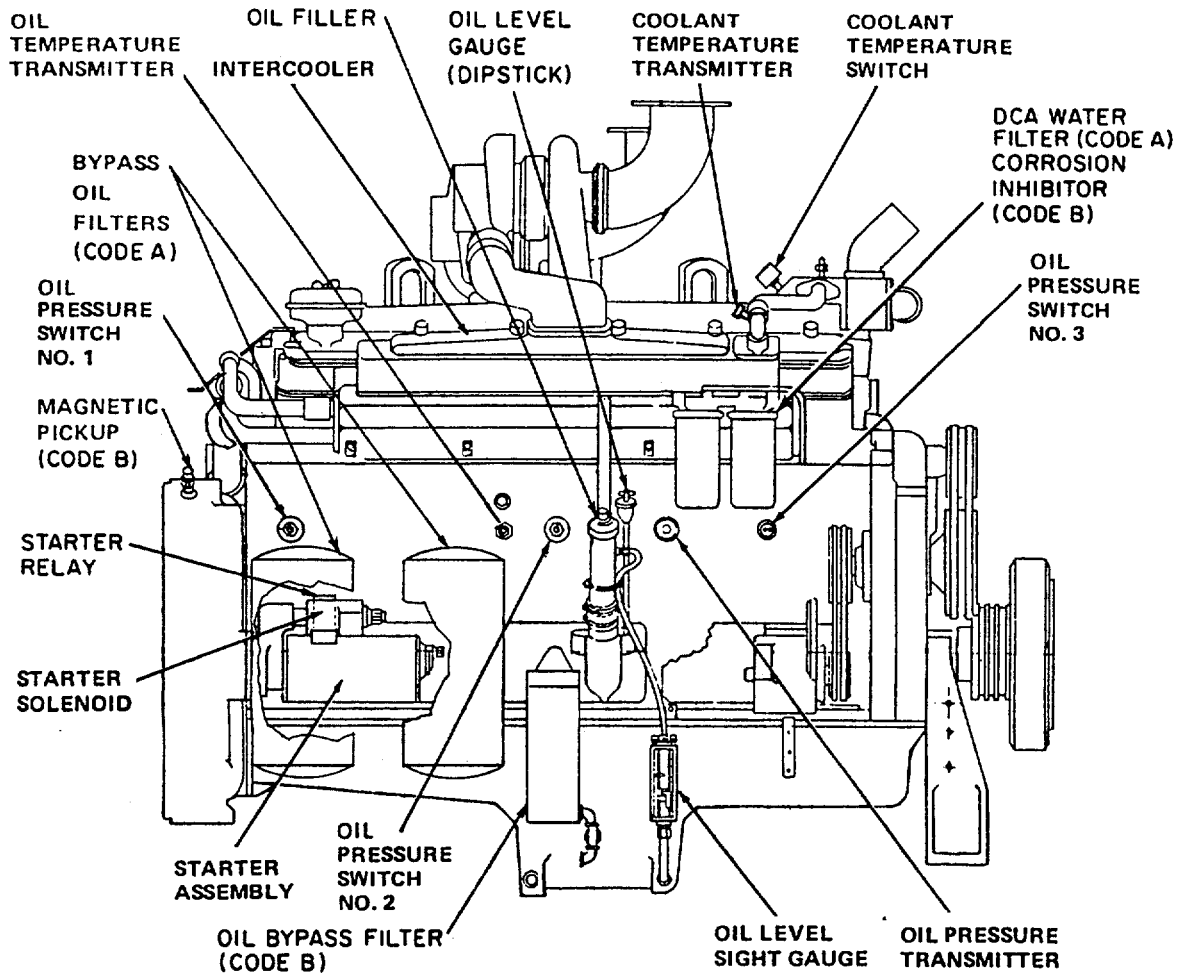

Figure 4-40. Engine Components (Sheet 2 of 2)  
4-102

- a. Drain coolant into clean container via coolant drain (see figure 4-2). Save coolant for reuse.
- b. Unscrew water filter from filter mounting head. Discard filter.
- c. Clean filter mounting head with solvent (see table 3-1). Dry with compressed air.
- d. Inspect filter mounting head for cracks and mutilated threads.
- e. Install new filter by screwing filter to filter mounting head.
- f. Replace coolant, then check coolant level; if low add proper coolant (see table 3-1).

4-69. SPEED SWITCH. (See figures 4-40 and 4-42.) The speed switch is driven by the engine camshaft. It provides overspeed protection and starter lockout protection. Testing of the speed switch requires a variable speed device and is performed by a higher level of maintenance. Replace the speed switch as follows:

a. Removal and Installation

- (1) Remove electrical cable to

connector (1, figure 4-42).

- (2) Unscrew switch from adapter (3), and remove switch (2). (3) Install switch (2) to adapter (3). (4) Connect electrical cable to switch connector (1).

b. Test (Static).

- (1) Remove electrical cable from connector (1, figure 4-42).
- (2) Using ohmmeter set to Rx1 scale, check that continuity exists between terminals A-B and H-G on mechanical type speed switch only.
- (3) With ohmmeter set to Rx1000 scale, check for infinite resistance at terminals A-C, D-E, and F-J, on mechanical type speed switch only.
- (4) Reconnect electrical cable to switch connector (1).
- (5) For additional tests refer to next higher level of maintenance.

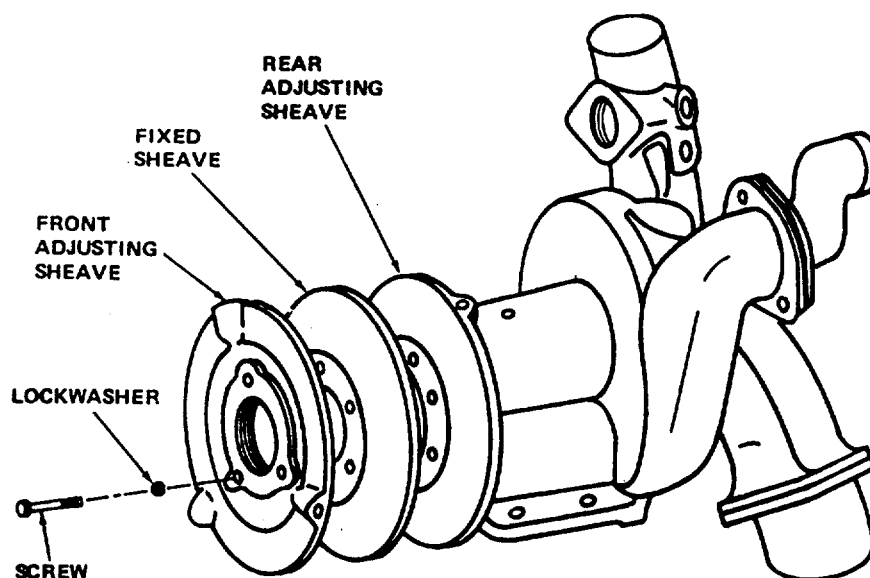
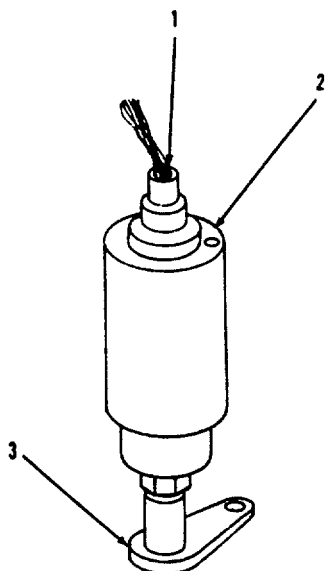

Figure 4-41. Water Pump Belt Adjustment  
4-103



LEGEND

- 1. Connector
- 2. Sped switch
- 3. Adapter

**Figure 4-42. Speed Switch**

h. Add oil as necessary.

4-71. **STARTER ASSEMBLY.** The starter assembly (figure 4-44) is a 24V DC clutch-type unit with a starter solenoid assembly.

a. **Test.** Testing the starter and starter solenoid is an operational test as follows:

- (1) Check that the battery is fully charged.
- (2) Check the battery connector and the terminals contact surfaces for corrosion.
- (3) Tighten battery connectors securely.
- (4) Check that all leads to the starter and the starter solenoid are tightened securely.
- (5) Operate the starter while observing starter motor operation. Refer to the starting instructions (figure 2-6) for starting the generator set.
- (6) If the starter solenoid emits an audible noise each time the MASTER SWITCH START-STOP is cycled into the START position, and the engine does not turn over, the starter assembly must be replaced.

b. **Inspection.** Visually inspect starter for loose wires, corrosion, or cracked housing. Brush inspection should be referred to next higher level of maintenance.

4-72. **OIL PRESSURE TRANSMITTER.** (See figure 4-40).

a. **Test.** (See figure 4-45).

- (1) Remove nut and washers and electrical lead from the threaded terminal.
- (2) Using an ohmmeter, measure resistance between transmitter screw terminal and ground. If measured resistance on the Rx1 scale is not between 227 and 257

4-70. **OIL LEVEL SIGHT GAUGE AND FILLER.** (See figure 4-43. ) Replace oil level sight gauge as follows:

- a. Remove clamp (8), then disconnect hose (9) from oil filler tube (7). Plug hole to prevent leakage.
- b. Drain oil from hose into a suitable container.
- c. Remove oil level sight gauge (1) by unscrewing fitting (10).
- d. Remove hose (9) from gauge (1).
- e. Install hose (9) onto gauge (1).
- f. Screw gauge (1) onto fitting (10). g. Remove plug and connect hose (9) to filler tube (7).

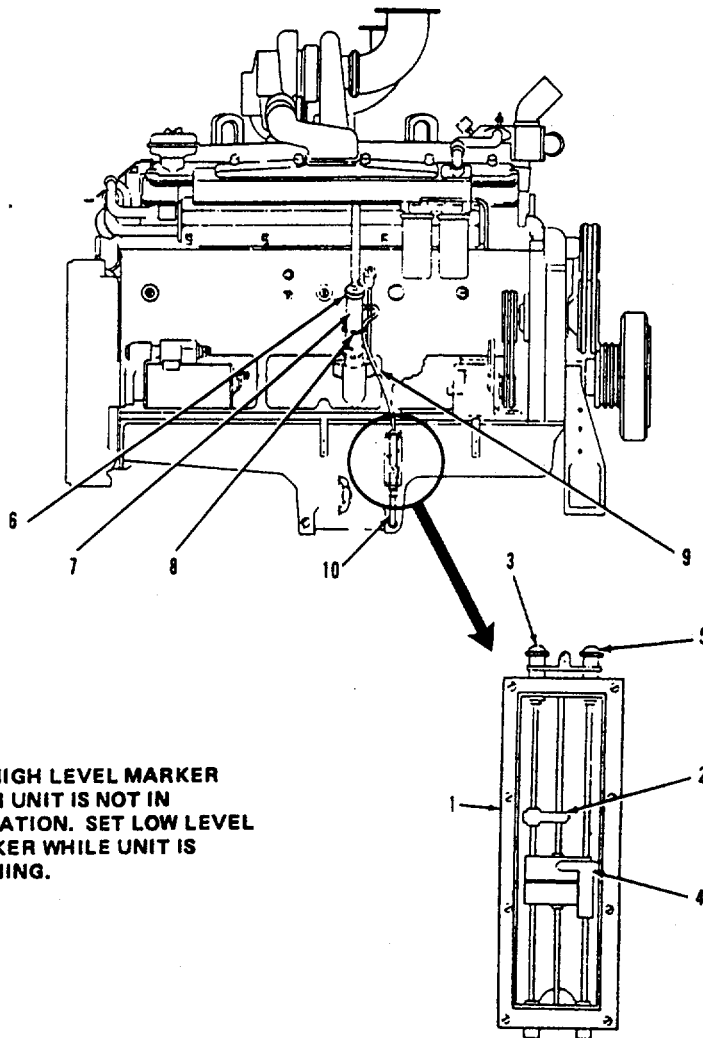

**NOTE:** SET HIGH LEVEL MARKER  
WHEN UNIT IS NOT IN  
OPERATION. SET LOW LEVEL  
MARKER WHILE UNIT IS  
RUNNING.

LEGEND

- |    |                       |     |                 |
|----|-----------------------|-----|-----------------|
| 1. | Oil level sight gauge | 6.  | Oil filler cap  |
| 2. | High level marker     | 7.  | Oil filler tube |
| 3. | High level adjust     | 8.  | Clamp           |
| 4. | Low level marker      | 9.  | Hose            |
| 5. | Low level adjust      | 10. | Fitting         |

Figure 4-43. Oil Level Sight Gauge and Filler

ohms, replace the transmitter. Crank engine to determine that resistance decreases to approximately 70 ohms. If resistance does not decrease, replace transmitter.

- b. Replacement. (See figure 4-45.)
- (1) Remove nut, washers, and lead from transmitter threaded terminal.
  - (2) Unscrew transmitter from engine block.
  - (3) Install transmitter onto engine block.
  - (4) Reconnect electrical lead using nut and washers.

**4-73. PRESSURE SWITCH.** (See figure 4-40.) There are three pressure switches labeled no. 1, 2, and 3 on figure 4-46.

- a. Inspection. Inspect pressure switches (see figure 4-46) for loose mounting, loose connection, dents, and leakage.
- b. Test OP1. (See figure 4-46 and FO-3.)
- (1) With generator set at shutdown and MAINTENANCE LOCKOUT switch set to OPERATION, connect multimeter (set to measure DC volts) from terminal 26 of TB6 to terminal 12 of TB9; multimeter should read 24V DC.
  - (2) Crank engine and observe multimeter; multimeter reading should drop to zero almost immediately.
- c. Test OP2. (See figure 4-46 and FO-3.)
- (1) With generator set at shutdown, connect an ohmmeter (set to Rx1 scale) from terminal 7 to terminal 12 of TB22; multimeter reading should be less than 1 ohm.
  - (2) As engine is being cranked, ohmmeter reading should jump to infinite ohms.

- d. Test OP3. (See figure 4-46 and FO-3.)
- (1) With generator set at shutdown, connect ohmmeter from terminal 18 of TB20 to any convenient ground connection; ohmmeter reading should be infinite ohms.
  - (2) Crank engine and observe ohmmeter; ohmmeter reading should drop to less than 1 ohm almost immediately.
- e. Replacement. (See figure 4-46.)
- (1) Disconnect leads from switch (1, 2, or 3).
  - (2) Unscrew switch (1 or 2) from engine block.
  - (3) For reassembly, screw switch into engine block and tighten to 20 foot-pounds (27 joules). Reconnect leads to switch.

**4-74. OIL FILTERS.** (See figure 4-47.)

- a. Spin-on Type Filters. Refer to paragraph 4-8 c for replacement of spin-on type oil filters.
- b. Bypass Oil Filters. (See figure 4-47.) Inspect filter case for dents, cracks, and oil leaks. If damaged, refer to higher maintenance.

**4-75. SECONDARY FUEL FILTER ELEMENT.**  
(See figure 4-40.)

- a. Service and replacement of the secondary fuel filter element is as follows (see figure 4-48).
- (1) Unscrew and remove the filter case and discard filter element and gasket.
  - (2) Inspect the filter case for dents and cracks that affect proper sealing when reinstalled. If damaged, replace unit.
  - (3) Clean filter case. Handle or store in manner to prevent out-of-round.
  - (4) Insert new element in filter case seating it securely.



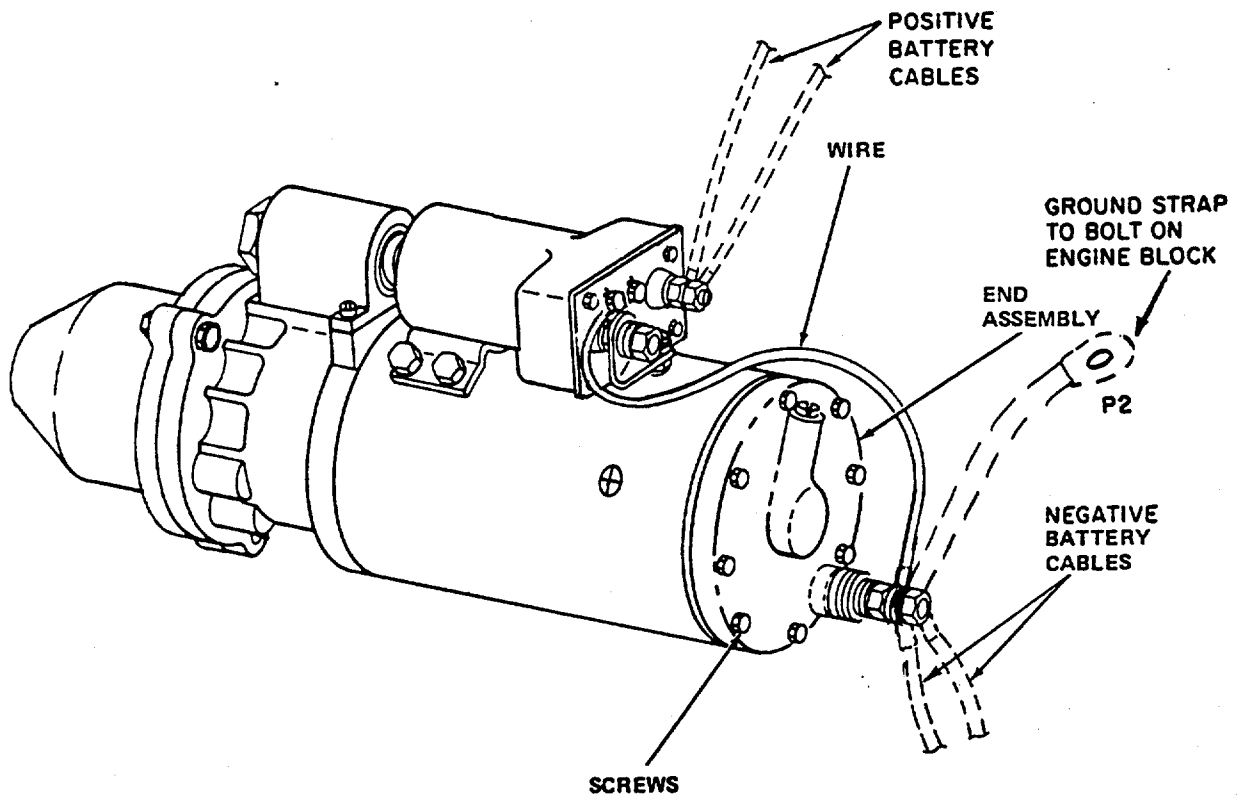

Figure 4-44. Starter Assembly.

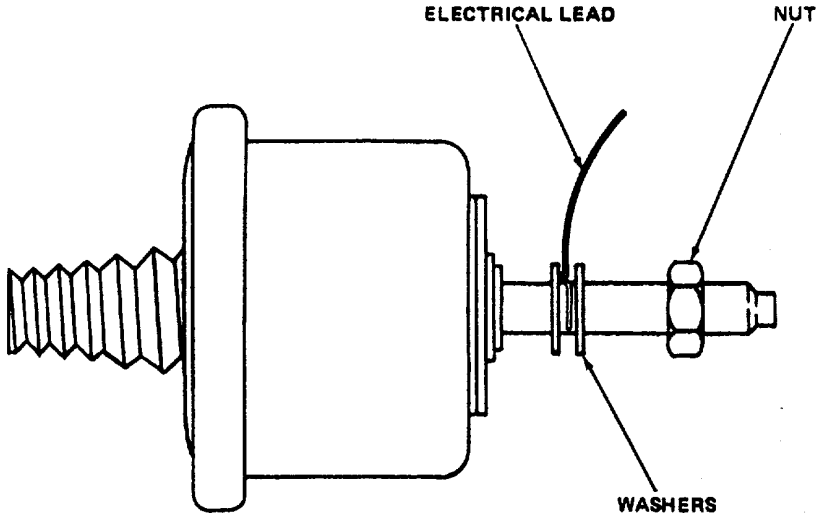

Figure 4-45. Oil Pressure Transmitter

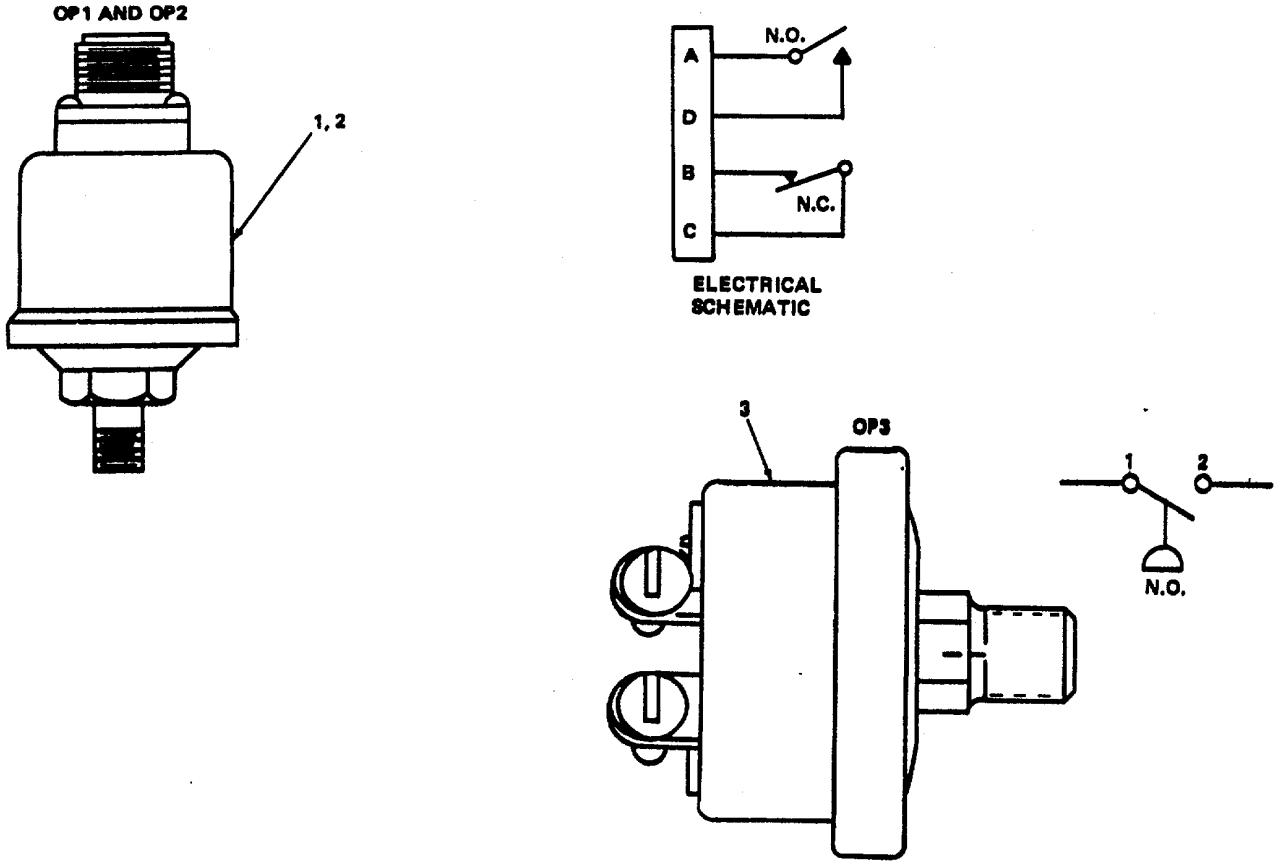

Figure 4-46. Pressure Switches

- (5) Fill filter assembly with fuel (see table 3-1).
- (6) Install new top gasket and position filter case to filter head. Tighten by hand until gasket touches filter head, then turn an additional one-half to three-fourths of a turn.
- (7) Check the fuel filter for leakage and be certain that the filter case and gasket are properly installed.

**4-76. LUBE OIL COOLER.** (See figure 4-40.)

- a. Inspection. (See figure 4-49.)

**CAUTION**

Engines which have encountered major types of failures, where excessive amounts of metal particles have circulated through the system, cannot be properly cleaned; therefore, replacement of oil cooler is mandatory.

Inspect the cooler housing (4), and all connections for cracks, leaks, dents, and breaks.

- b. Replacement.

- (1) Drain coolant into a clean container via coolant drain (see figure 4-2). Save coolant for reuse.
- (2) Drain lubricating oil by removing oil drain plug and opening engine oil drain valve. Collect oil in suitable container for reuse.
- (3) Unscrew oil filter assemblies (1).

- (4) Remove water inlet tube (2) from housing (4). Separate and discard gasket (3).
- (5) Remove water outlet connection (5). Separate and discard gasket (3).
- (6) Remove oil transfer tubes (6). Separate and discard gaskets (7).
- (7) Remove capscrews (8) and washers (9) to release cooler housing (4) from bracket (10). Separate and discard gaskets (11).
- (8) Install new gaskets (11).
- (9) Position cooler housing (4) onto bracket (10). Secure with capscrews (8) and washers (9).
- (10) Install new gaskets (7). Install oil transfer tubes (6).
- (11) Install new gaskets (3). Install water outlet connection (5) and water inlet tube (2) into housing (4).
- (12) Install oil filter assemblies (1).
- (13) Close engine oil drain valve.
- (14) Fill lubricating system with oil using oil filler tube (figure 4-40).
- (15) Run engine, check for leaks, recheck engine oil level; add oil (see table 3-1) as necessary to bring oil level to FULL mark on oil level gauge (dipstick).
- (16) Replace coolant, then check coolant level; if low add proper coolant (see table 3-1).

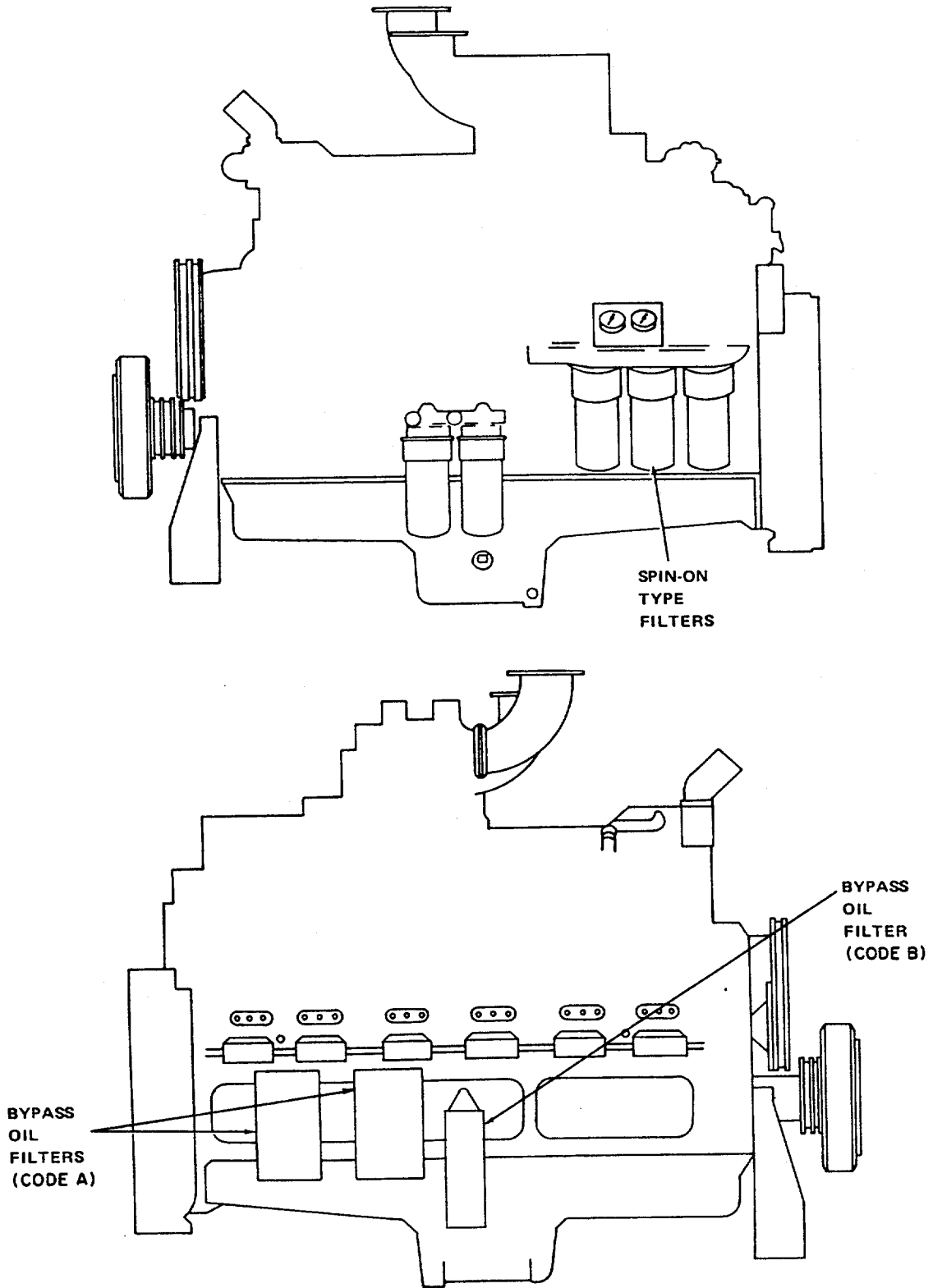

Figure 4-47. Oil Filters

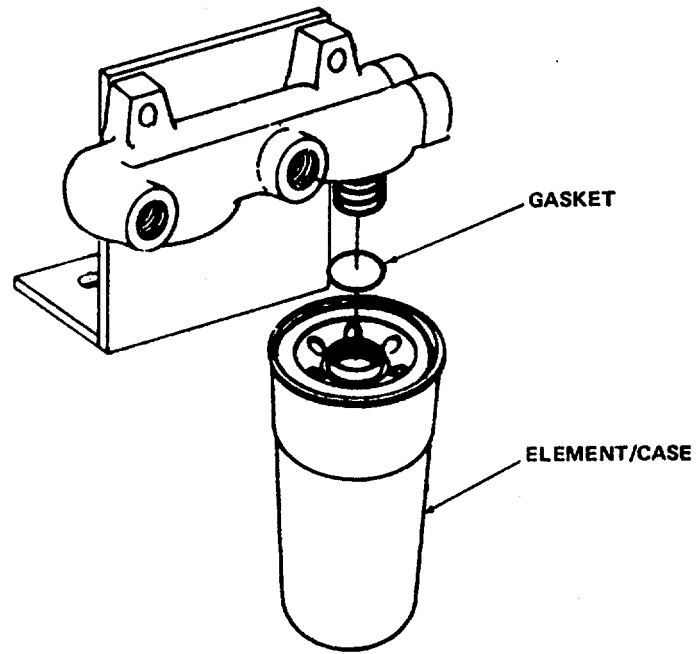
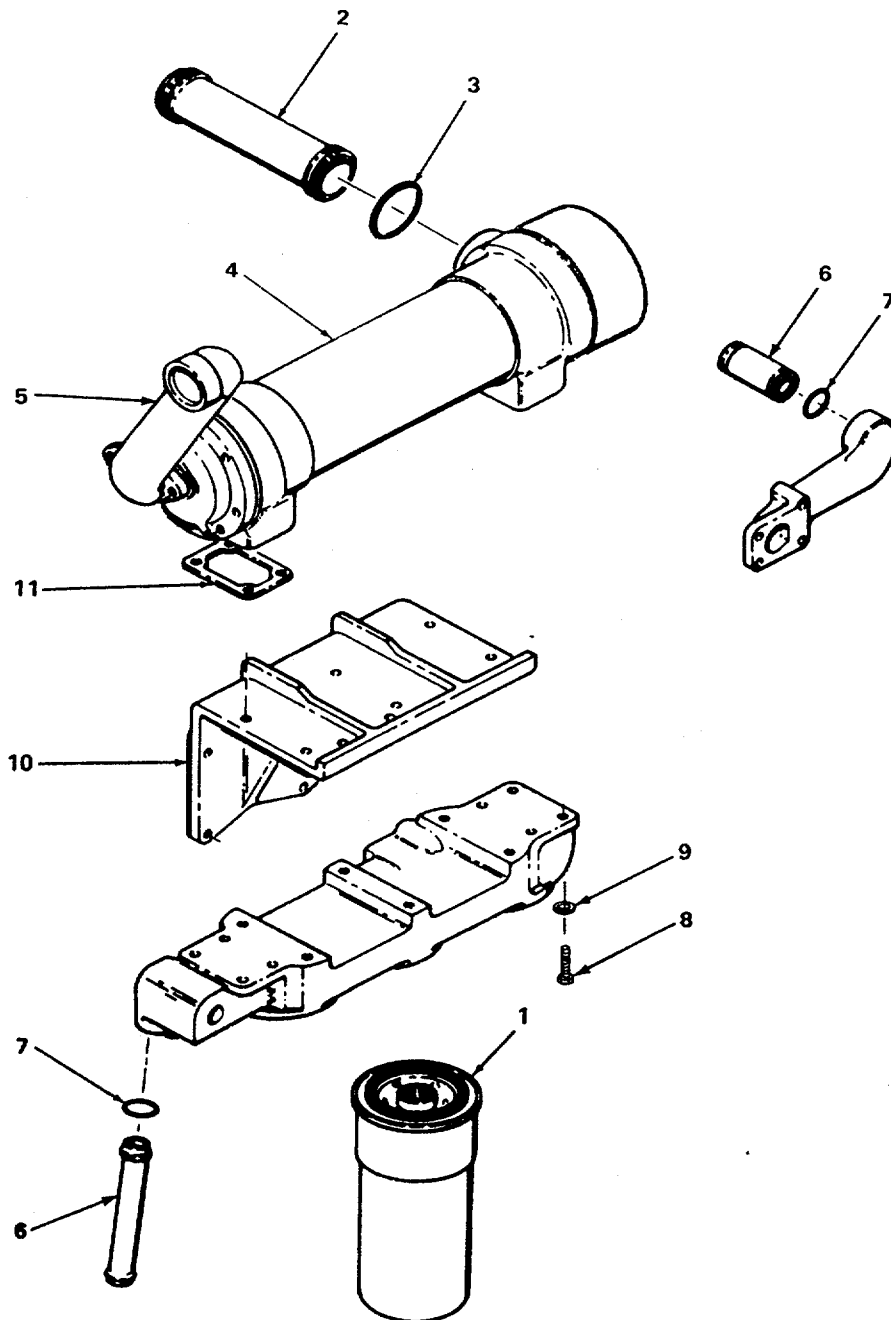

Figure 4-48. Secondary Fuel Filter



LEGEND

- |    |                   |     |           |
|----|-------------------|-----|-----------|
| 1. | Oil filter assy   | 7.  | Gasket    |
| 2. | Inlet tube        | 8.  | Cap screw |
| 3. | Gasket            | 9.  | Washer    |
| 4. | Cooler housing    | 10. | Bracket   |
| 5. | Outlet connection | 11. | Gasket    |
| 6. | Tubes             |     |           |

Figure 4-49. Lube Oil Cooler

**4-77. INJECTOR.** (See figure 4-50.)

- a. Inspection. Inspect injector for looseness and signs of leakage or smoking.
- b. Replacement.

**CAUTION**

Cleanliness is extremely important when working with fuel injectors. Injection nozzle service troubles are, in most instances, caused by dirt. Use clean paper on the work bench and place components in a container of clean diesel fuel as they are removed.

- (1) Remove rocker housing cover (7, figure 4-59) by removing bolts (5) and washers (4).
- (2) Remove rocker arm housing (8) by lifting straight up. Mark its position for best fit during reassembly.
- (3) Remove screws (1, figure 4-50), clamp (2), and link (3).

**CAUTION**

Use care when removing injectors to prevent damage to the tip.

- (4) Remove injector from cylinder head using an injector puller or by using two small pry bars, or by using a slide hammer with an adapter.
- (5) Tag and number injectors by cylinder from which they were moved.
- (6) Refer to next higher level of maintenance for injector testing, repair, and calibration.
- (7) Position injector in cylinder head.
- (8) Install capscrew (1), clamp (2), and link (3). Tighten capscrews to 11 to 12 foot-pounds

(15 to 16 joules) increments of 4 foot-pounds (5 joules).

- (9) Refer to paragraph 4-87 and adjust rocker arm associated with fuel injector being replaced.
- (10) Install rocker arm housing (see figure 4-59).
- (11) Install gear case cover (7, figure 4-59) using bolts (5) and washers (4).

**4-78. TURBOCHARGER.** (See figure 4-40.)

- a. Inspection. (See figure 4-51.)

- (1) Operate engine at approximate rated output and listen for unusual turbocharger noise and check for excessive black smoke. Do not mistake whine heard during rundown for one that indicates impeller shaft bearing failure during operation. Other unusual noises can result from improper clearance between turbine impeller and turbine housing. If such noises are heard, replace turbocharger. For repair of turbo charger, refer to next higher level of maintenance.
- (2) Inspect for an accumulation of dirt on the compressor impeller vanes and in the compressor housing.
- (3) Clean the turbocharger and surrounding area with cleaning solvent, Federal Specification P-D-680, Type II.
- (4) Loosen the clamps which secure air hose to the turbocharger and remove the hose from the turbocharger. Remove air hose from air cleaner outlet to turbocharger inlet.
- (5) Inspect the turbocharger compressor wheel and compressor housing for dirt. If the coating of dirt is light and even, cleaning the compressor wheel is not necessary. An uneven buildup of dirt will disturb the balance of rotating parts and lead to failure of the turbocharger. If the coating

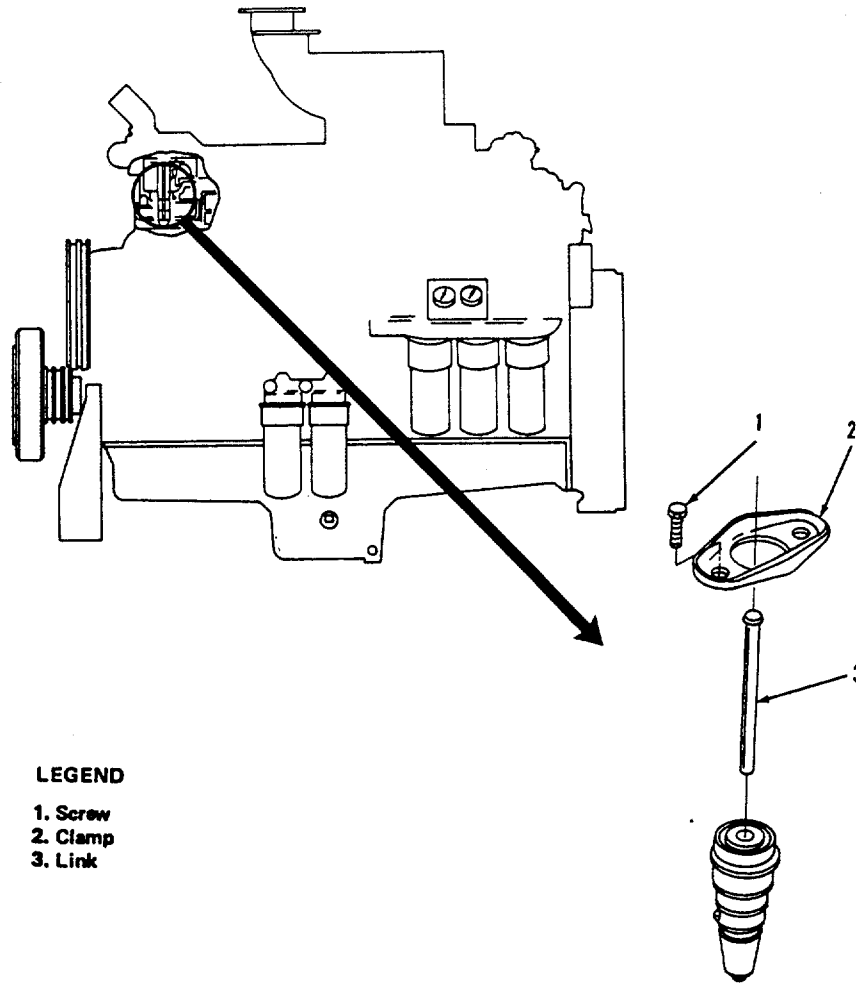

**LEGEND**  
1. Screw  
2. Clamp  
3. Link

Figure 4-50. Fuel Injector



LEGEND

1. Clamp
2. Hose
3. Screw
4. Lockwasher
5. Washer
6. Support
7. Elbow
8. Adapter
9. Hose
10. Elbow
11. Adapter
12. Clamp
13. Hose
14. Elbow
15. Hose
16. Clamp
17. Hose
18. Clamp
19. Nuts
20. Mounting stud
21. Turbocharger
22. Exhaust elbow
23. Gasket

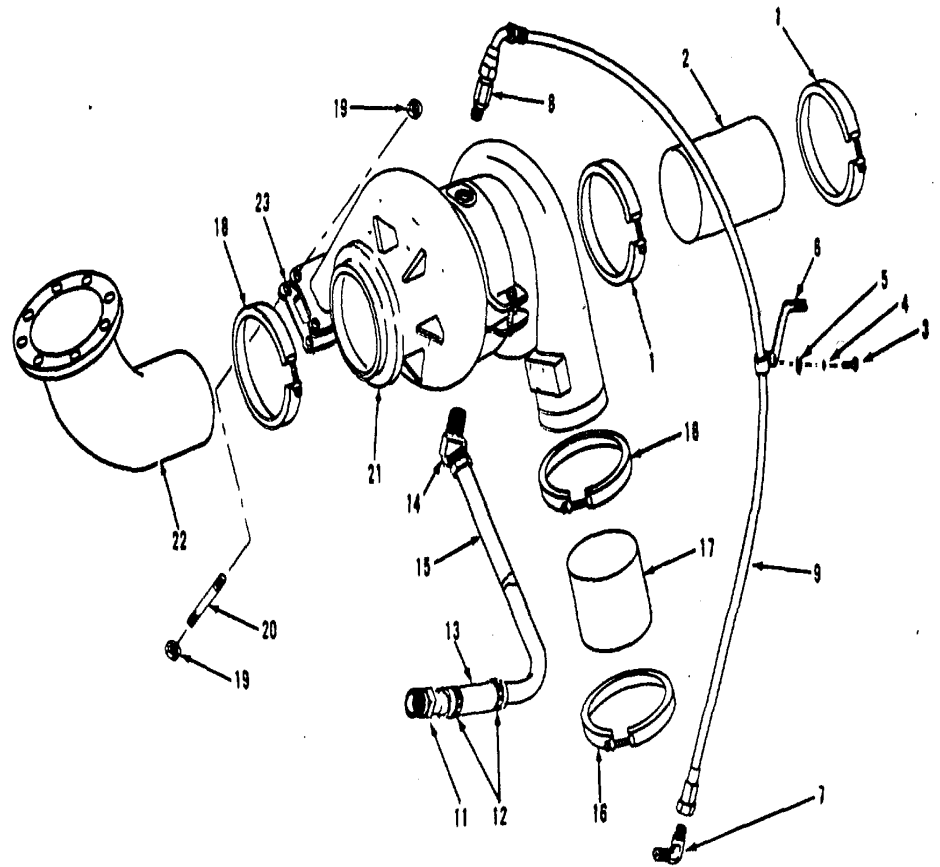

Figure 4-51. Turbocharger

of dirt is uneven, excessive, or approaching the appearance of a layer which might flake off, cleaning is necessary. If this cannot be cleaned satisfactorily, replace turbocharger.

(6) Replace hoses and clamps.

b. Replacement.

- (1) Disconnect and remove oil inlet line (15) and elbow (14). Plug line to minimize leakage.
- (2) Disconnect and remove oil return line (9) and adapter (8). Plug line to minimize leakage.
- (3) Loosen clamps (1, 16, and 18). Remove hoses (2 and 17).
- (4) Remove nuts (19) which secure turbocharger to exhaust manifold.
- (5) Remove turbocharger by separating unit from exhaust elbow (22) and lifting clear of engine.

**CAUTION**

While turbocharger is off the engine, keep all intake and exhaust manifold openings covered. This will prevent foreign objects from accidentally getting into the manifolds and damaging the turbocharger or engine when the engine is again put into operation.

- (6) Position turbocharger on exhaust manifold. Slide onto exhaust elbow (22).
- (7) Secure turbocharger with nuts (19).
- (8) Install hoses (2 and 17).
- (9) Tighten all clamps (1, 16, and 18).
- (10) Connect oil return line (9) using adapter (8).

- (11) Connect oil inlet line (15) using elbow (14).

**4-79. WATER PUMP.** (See figure 4-40.)

NOTE

All generator sets with engine serial number 10605201 and higher are equipped with a new style water pump (with idler assembly). The new pump is removed in the same manner as the old pump.

a. Replacement of Water Pump. (See figure 4-52.)

- (1) Drain engine coolant.
- (2) Remove drive belts in accordance with paragraph 4-67 b.
- (3) Remove coolant hoses.
- (4) To remove water pump remove eight mounting bolts (on pumps not equipped with idler assemblies) or five mounting bolts (on pumps with idler assemblies).
- (5) Install water pump with mounting hardware.
- (6) Attach hoses.
- (7) Install and adjust belts in accordance with paragraph 4-67 b.
- (8) Refill engine coolant; refer to tables 3-1 and 4-1.

b. Inspection of Idler Assembly. Refer to figure 4-52 and visually inspect locator spring (14) and spring (15) for cracks or damage.

c. Replacement of Idler Assembly. After removing water pump in accordance with paragraph a, above, the idler assembly may be removed by removing four screws (1) and washers (2). Install new idler pulley assembly with four screws (1) and washers (2).

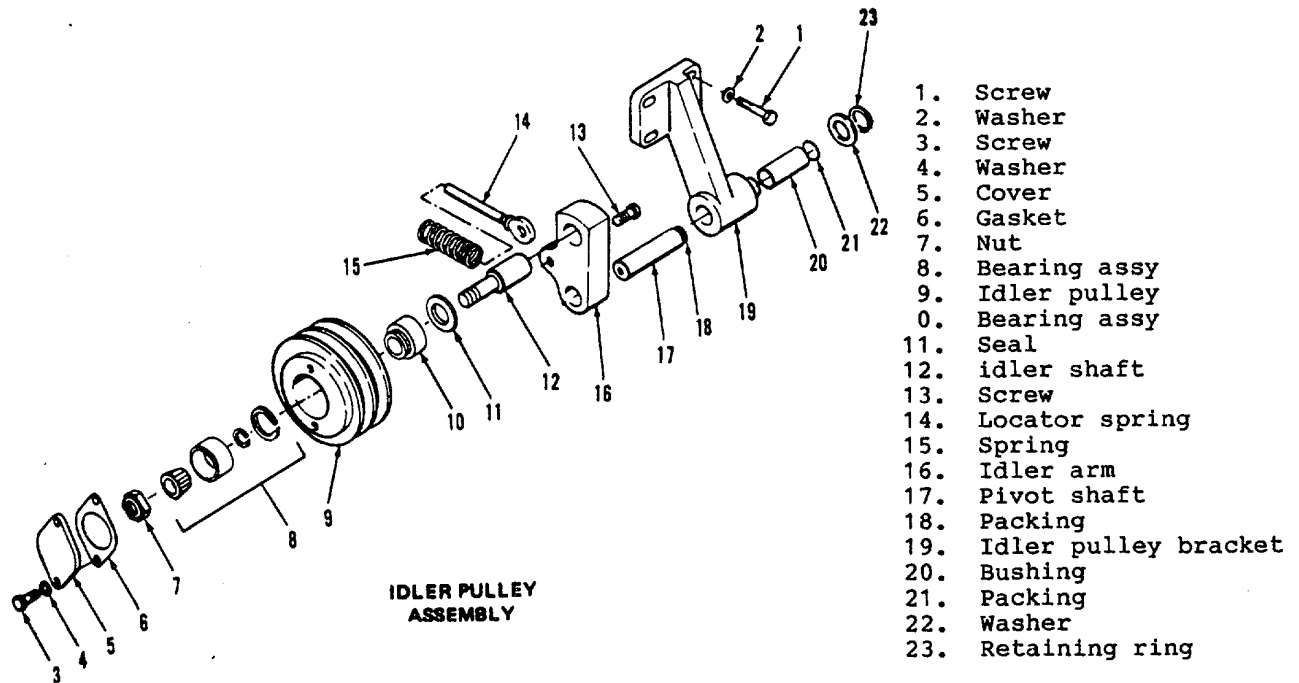
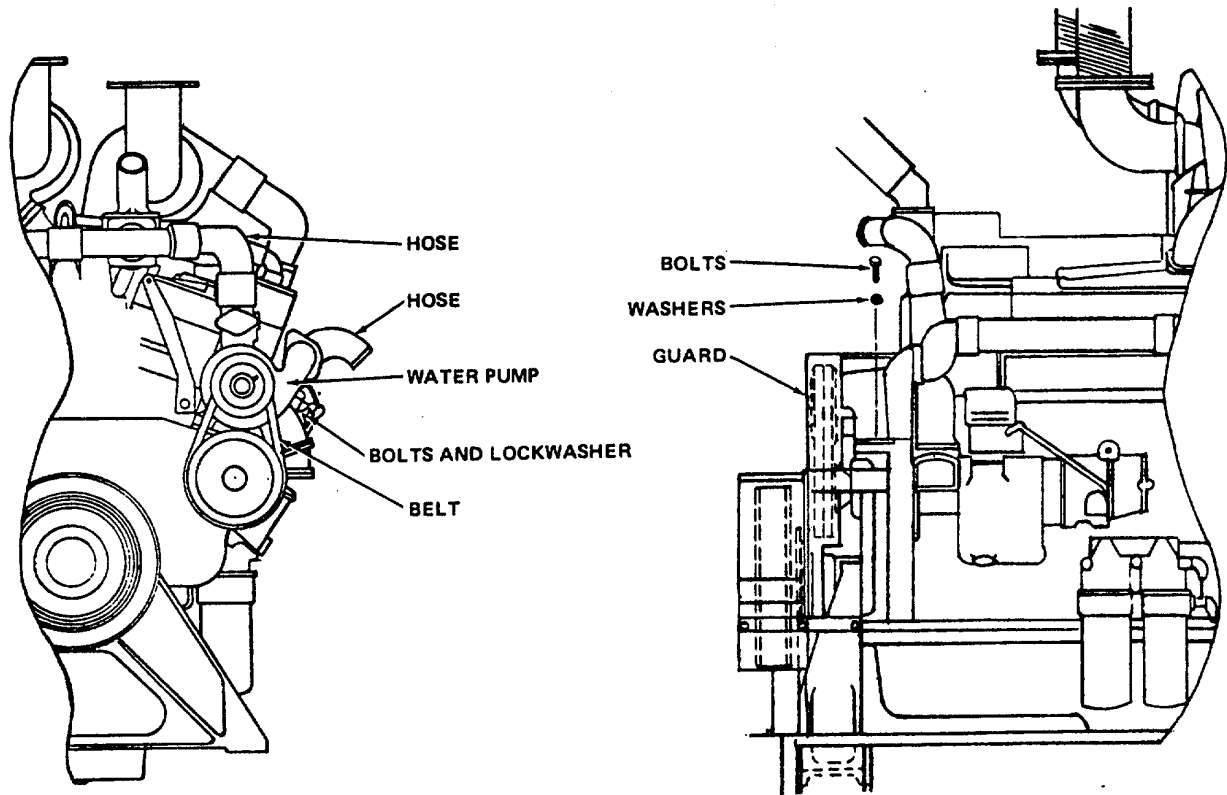

Figure 4-52. Water Pump and Idler Pulley Assembly

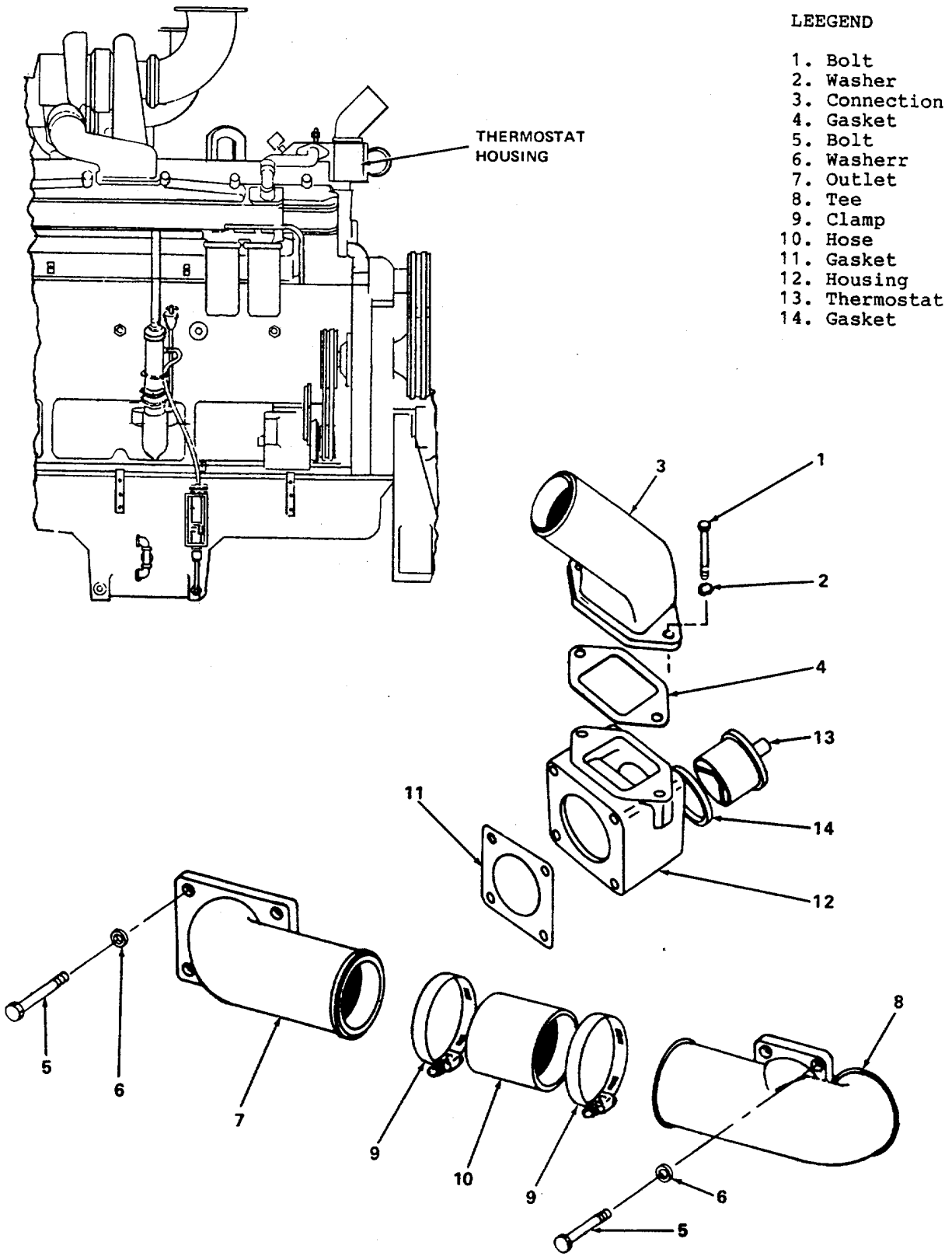

Figure 4-53. Thermostat Removal

**4-80. THERMOSTAT.** (See figure 4-53.) The thermostats are inside the thermostat housing mounted at the top front of the engine.

a. Removal. Drain coolant and remove assembly (figure 4-53) as follows:

- (1) Remove bolts (1), washers (2), connection (3), gasket (4), bolts (5), and washers (6).
- (2) Loosen clamps (9), then remove outlet (7), tee (8), hose (10), and gasket (11).
- (3) Remove thermostat (13) and gasket (14) from housing (12).

b. Test.

- (1) Suspend thermostat in a container of clean water. Thermostat must be completely immersed but not touching bottom of container.
- (2) Heat water gradually and stir so heat is evenly distributed.
- (3) Check temperature of water with reliable thermometer. Do not overheat. Observe thermostat as temperature increases. If the thermostat is functioning properly it should begin to open between 175 to 182°F (79 to 83° C) and be fully open at 205 F (96° C).
- (4) The thermostat is not adjustable. If it does not operate within the above limits, it should be replaced.
- (5) Install a new gasket (14) and thermostat (13) in housing (12). Be sure hole in thermostat is "up".
- (6) Install gasket (4), connection (3), washers (2), and bolts (1).

(7) Secure gasket (11) and outlet (7) with washers (6) and bolts (5). Attach hose (10) with one clamp (9). Attach tee (8) with remaining clamp (9) and secure with washers (6) and bolts (5).

(8) Refill cooling system; refer to tables 3-1 and 4-1.

**4-81. COOLANT TEMPERATURE TRANSMITTER .** (See figure 4-40.) To remove the coolant temperature transmitter, drain coolant into a suitable container by removing coolant drain plug and opening draincock. Refer to figure 4-54 and remove the nut, electrical lead, and washers; then unscrew the temperature transmitter from the water manifold.

a. Inspection. Inspect transmitter for corrosion and leakage, and ensure that the connection is secure. The transmitter is not repairable and replacement is necessary when it fails to operate. If the engine is not overheating and unit shuts down as though it were, or if the engine continues to operate when running hot, the transmitter should be removed and tested as a possible cause of trouble.

b. Test. The coolant temperature transmitter senses the temperature of the engine coolant to operate temperature indicator on control panel.

- (1) Suspend transmitter in a container of clean water. Transmitter should be inserted so that sensing element is completely immersed but connector end is out of water.
- (2) Set ohmmeter to Rx10 scale and connect ohmmeter between single conductor and case. Heat water gradually and stir so heat is evening distributed.
- (3) Check temperature of water with reliable thermometer. Do not overheat.

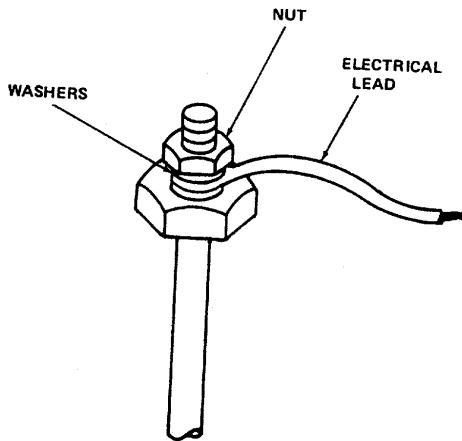

**Figure 4-54. Coolant Temperature Transmitter**

Observe ohmmeter as temperature increases. If the transmitter is functioning properly, the resistance should read  $143 \pm 14.5$  ohms at  $120^{\circ}\text{G}$  ( $49^{\circ}\text{C}$ ).

- (4) The transmitter is not repairable. If it does not indicate a resistance within the above range, it should be replaced.

c. Replacement.

- (1) Screw temperature transmitter into water manifold.
- (2) Connect wire with washers and nut.
- (3) Plug drain and close draincock.
- (4) Fill radiator with coolant in accordance with table 4-1.

**4-82. TEMPERATURE SWITCH.** (See figure 4-40.) The temperature switch senses engine coolant temperature. When coolant exceeds  $217 \pm 3^{\circ}\text{F}$  ( $103 \pm 2^{\circ}\text{C}$ ), the normally closed contacts open and the normally open contacts close. This action results in automatic shutdown of engine operation at coolant temperatures exceeding  $217 \pm 3^{\circ}\text{F}$  ( $103 \pm 2^{\circ}\text{C}$ ).

- a. Inspection. Inspect switch for corrosion and leakage, and ensure that the electrical connector is secure. The switch is not repairable and replacement is necessary when it fails to operate. If the engine is not overheating and the units shuts down as though it were, or if the engine continues to operate when running hot, the switch should be removed and tested as a possible cause of trouble.

- b. Removal. (See figure 4-55.) Loosen connector, pull wiring plug, and unscrew temperature switch from water manifold.

c. Test.

- (1) Connect ohmmeter set to Rx1 scale across switch contacts.
- (2) Suspend switch in a container of antifreeze. Switch should be inserted so that sensing element is completely immersed but connector end is out of antifreeze.
- (3) Heat antifreeze gradually and stir so heat is evenly distributed.
- (4) Check temperature of antifreeze with a reliable thermometer.
- (5) When antifreeze has reached  $214^{\circ}\text{F}$  ( $90^{\circ}\text{C}$ ), the switch should open and the ohmmeter should read less than 1 ohm.
- (6) Allow antifreeze to cool. As the temperature drops to below  $212^{\circ}\text{F}$  ( $89^{\circ}\text{C}$ ) the switch should close and the ohmmeter should read infinite ohms.
- (7) The switch is not repairable. If it does not operate within the above limits it should be replaced.

- b. **VIBRATION DAMPER AND CRACKSHAFT PULLEY.** (See figure 4-40.) The vibration damper and crankshaft pulley are mounted on the front end of the crankshaft. Inspect as follows:

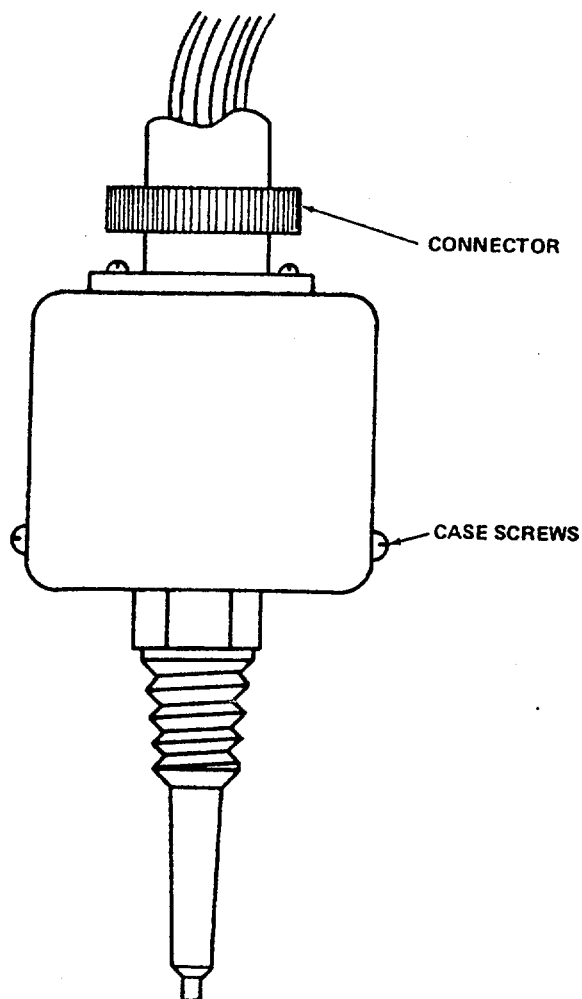

**Figure 4-55. Coolant Temperature Switch**

- d. Replacement. Screw temperature switch into water manifold. Connect electrical connector. Refill with coolant in accordance with table 4-1. Check for leakage, tighten if necessary.

4-83. **VIBRATION DAMPER AND CRANKSHAFT PULLEY.** (See figure 4-40.) The vibration damper and crankshaft pulley are mounted on the front end of the crankshaft. Inspect as follows:

- a. Inspect pulley belt grooves for step wear along sides and bottom of groove, indicating excessive wear.

- b. Inspect pulley belt grooves around total circumference of pulley for cracks or distortion.
- c. Inspect hub area for cracks.
- d. For replacement refer to next higher level of maintenance.

4-84. **INTERCOOLER.** (See figure 4-40.) The intercoolers are mounted on top of the engine on each side as shown in figure 4-40.

- a. Inspection. (See figure 4-56.)

- (1) Drain cooling system by opening drain plug and shut-off cock. Use suitable container to store coolant for reuse.
  - (2) Disconnect water connection tube (1) by loosening clamps (2), then separate hose (3) from outlet (4).
  - (3) Disconnect water transfer tube assembly (5) by loosening clamps (2) and separating transfer tubing (7) from hose (3). Remove bolt (8) and washers (9 and 10) to loosen tee (6). Remove bolt (11) and washer (12) to separate fitting (13) from intercooler (29). Remove assembly in one piece, or loosen clamps (2) to disassemble tubing into individual sections. Remove and discard gaskets (14 and 15).
  - (4) Remove air balance tube assembly (16) by removing bolts (17) and washers (18 and 19). Remove and discard gaskets (20). Remove assembly as one piece, or loosen clamps (2) to disassemble tubing into individual sections.
  - (5) Loosen clamp (23) securing air intake connection (24) to air hose (25).
  - (6) Remove bolts (26) and washers (27 and 28) to free intercooler (29) from engine.
  - (7) Mount intercooler (29) onto engine block using bolts (26) and washers (27 and 28).
  - (8) Secure air hose (25) to air intake connection (24) with clamp (23).
  - (9) Install air balance tube assembly (16) by replacing gaskets (20) and mounting tubing using bolts (17) and washers (18 and 19).
  - (10) Install water transfer tube assembly (5) by replacing gaskets (14 and 15), then mount tee (6) using bolt (8) and washers (9 and 10). Secure fitting (13) to intercooler (29) using bolt (11) and washer (12). Secure tubing (7) to hose (3) using clamp (2).
  - (11) Secure water connection tube (11) to outlet (4) using clamps (2).
  - (12) Close draincock and drain plug. Refill cooling system.
  - (13) Check all connections for security. Observe closely during first use after replacement for signs of leakage.
- 4-85. EXHAUST MANIFOLD. The exhaust manifold (figure 4-57) provides for the routing of the engine exhaust gases. Also, the exhaust gases serve as an input to the turbocharger.
- a. Inspection. Inspect the exhaust manifold for rust, loose mounting, cracks, and breaks.
  - b. Replacement.
    - (1) Refer to paragraph 4-78 and remove the turbocharger.
    - (2) Disconnect and plug fuel and oil lines as needed to facilitate removal.
    - (3) Remove fuel injection lines.
    - (4) Remove bolts (1, figure 4-57), washers (2) and spacers (3) attaching exhaust manifold to engine.
    - (5) Remove gaskets (4) and lift exhaust manifold from engine.
    - (6) Reinstall exhaust manifold with bolts (1), washers (2), and spacers (3). Use new gaskets (4). Replace injection lines and



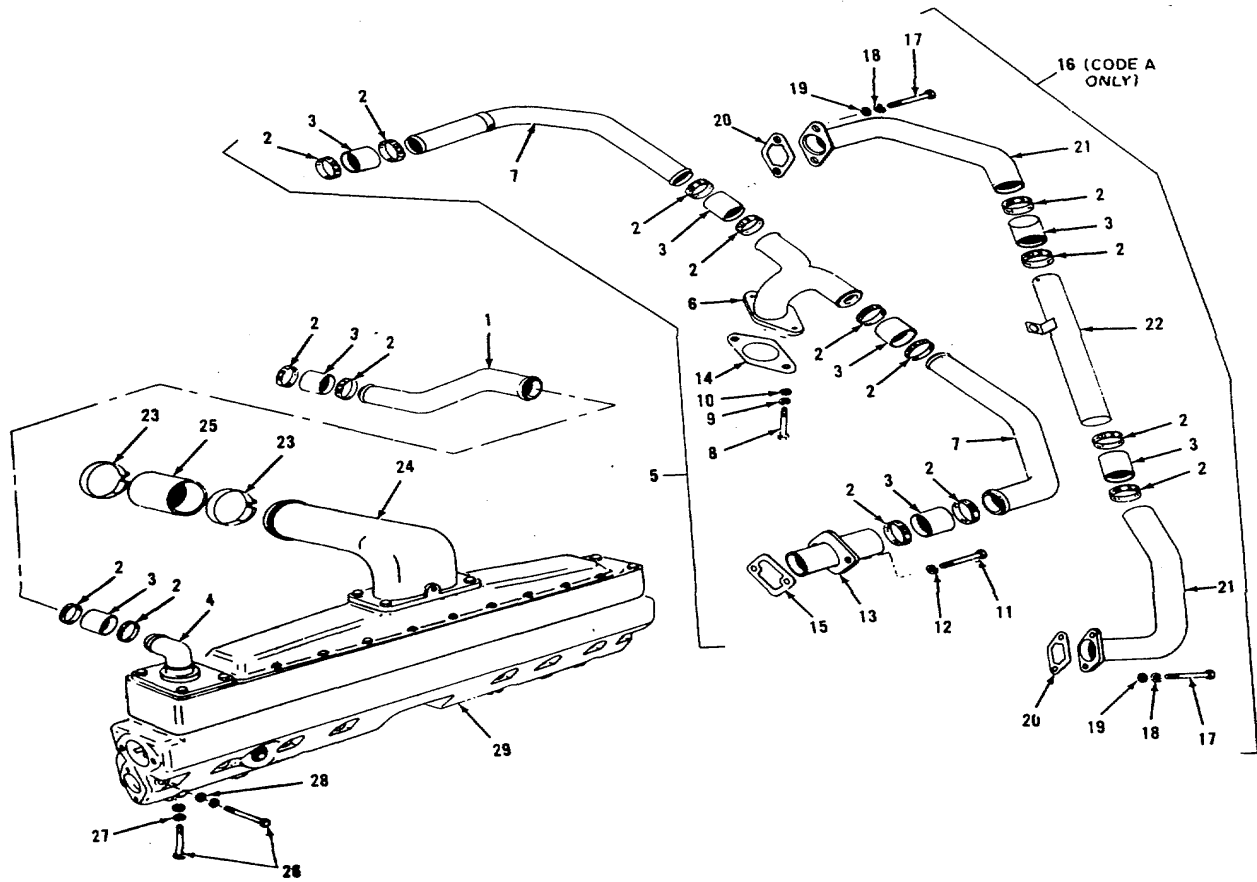

LEGEND

- |     |                       |     |                       |
|-----|-----------------------|-----|-----------------------|
| 1.  | Water connection tube | 16. | Air balance tube assy |
| 2.  | Clamp                 | 17. | Bolts                 |
| 3.  | Hose                  | 18. | Washer                |
| 4.  | Outlet                | 19. | Washer                |
| 5.  | Transfer tube assy    | 20. | Gasket                |
| 6.  | Transfer tee          | 21. | Air tube              |
| 7.  | Transfer tube         | 22. | Air tube              |
| 8.  | Bolt                  | 23. | Clamp                 |
| 9.  | Washer                | 24. | Air intake connection |
| 10. | Washer                | 25. | Air hose              |
| 11. | Bolt                  | 26. | Bolts                 |
| 12. | Washer                | 27. | Washer                |
| 13. | Fitting               | 28. | Washer                |
| 14. | Gasket                | 29. | Intercooler           |
| 15. | Gasket                |     |                       |

Figure 4-56. Intercooler

turbocharger (refer to paragraph 4-78). Torque bolts (1) to 25 foot-pounds (33 joules) in 8 foot-pound (11 joules) increments.

#### 4-86. WATER MANIFOLD.

- a. Inspection. Inspect water manifold (figure 4-58) for corrosion, leaks, loose bolts, dents, and cracks.
- b. Replacement.
  - (1) Disconnect water inlet and outlet connections.
  - (2) Remove bolts (1, figure 4-58) and washers (2).
  - (3) Remove clamps (3) and tube (4) with O-ring (5).
  - (4) Remove bolts (6) and washers (7). Remove O-rings (8) and lift out water manifold.
  - (5) Reinstall as follows:
    - (a) Install new O-rings (8).
    - (b) Attach tube (4) with new O-ring (5).

(c) Install clamp (3) with bolts (1) and washers (2).

(d) Attach water manifold to engine block with bolts (6) and washers (7). Install new O-rings (8).

4-87. **ROCKER ARM AND SHAFT ASSEMBLY.** The rocker arms are mounted on the rocker arm shaft which is supported by the rocker arm housing. The rocker arms are actuated by the pushrods and, in turn, operate the valves.

- a. Inspection. (See figure 4-59)

- (1) Remove gear case cover (7) and gasket (6) by removing bolts and washers (4).
- (2) Inspect adjusting screw (1) end of rocker arm (2) and shaft (3) for evidence of physical damage. Refer to next higher maintenance level for replacement of any damaged items.

#### NOTE

**Adjusting screw nut be replaced when more than 36 inch-pounds (4 joules) driving torque is required to turn screw.**

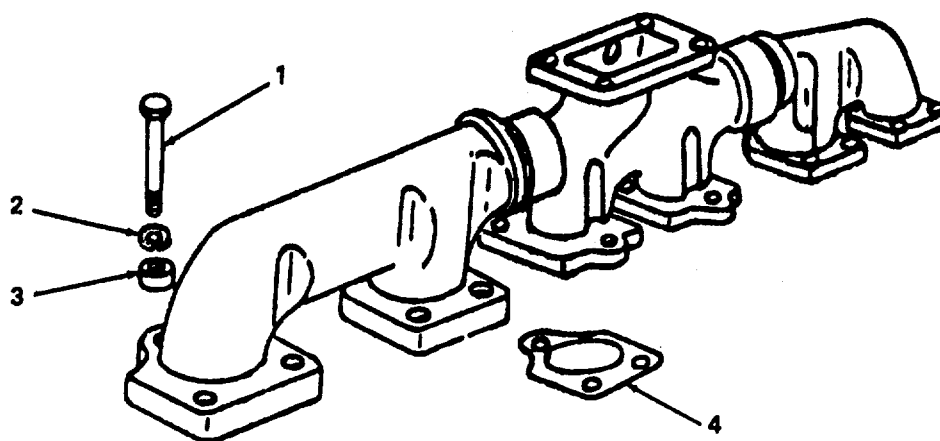

#### LEGEND

1. Bolt
2. Washer
3. Spacer
4. Gasket

Figure 4-57. Exhaust Manifold

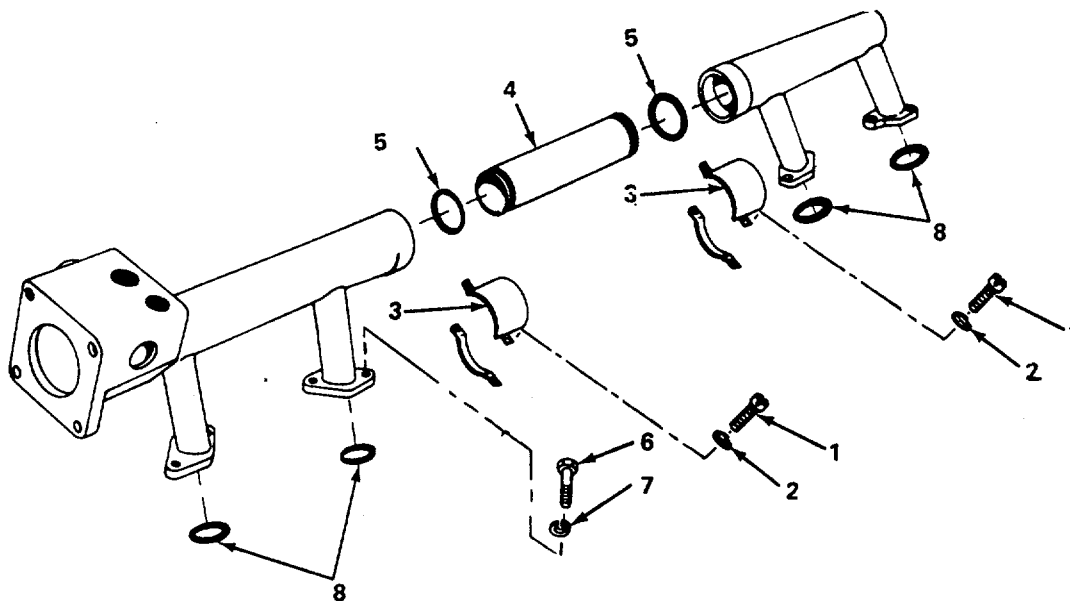

LEGEND

- |            |            |
|------------|------------|
| 1. Bolts   | 5. O-ring  |
| 2. Washers | 6. Bolts   |
| 3. Clamp   | 7. Washers |
| 4. Tube    | 8. O-rings |

**Figure 4-58. Water Manifold**

(3) Inspect end of rocker arm adjusting screw and end of rocker arms. If they are worn, the rocker arm assemblies must be replaced.

- b. Adjustment. (See Figure 4-59.) Correct clearance (valve lash) between end of intake valve stem, exhaust valve stem, and related rocker arms, is very important in diesel engine performance because of high compression developed within the cylinders. Insufficient valve lash will cause loss of compression, misfiring, and eventually lead to burning of valves and valve seats. Excessive valve lash will result in faulty engine operation, valve lifter

noise, and cause rapid wear on the valve operating mechanism. With engine normal operating temperature or 160° F (71°C) minimum, valve lash for both intake and exhaust valves is 0.014-0.027 inch (0.36-0.69 mm). Adjust injector tappet (the middle lever in each group of three levers) by loosening adjusting screw one turn. Using a torque wrench, tighten adjusting screw to 70 inch-pounds (7.96 joules) and tighten locknut to 40 to 45 ft.-pounds. After any mechanical work has been done that may have disturbed the valve lash adjustment, set valves "cold" at 0.018 inch (0.45 mm) clearance so engine can be run and allowed to warm to normal operating

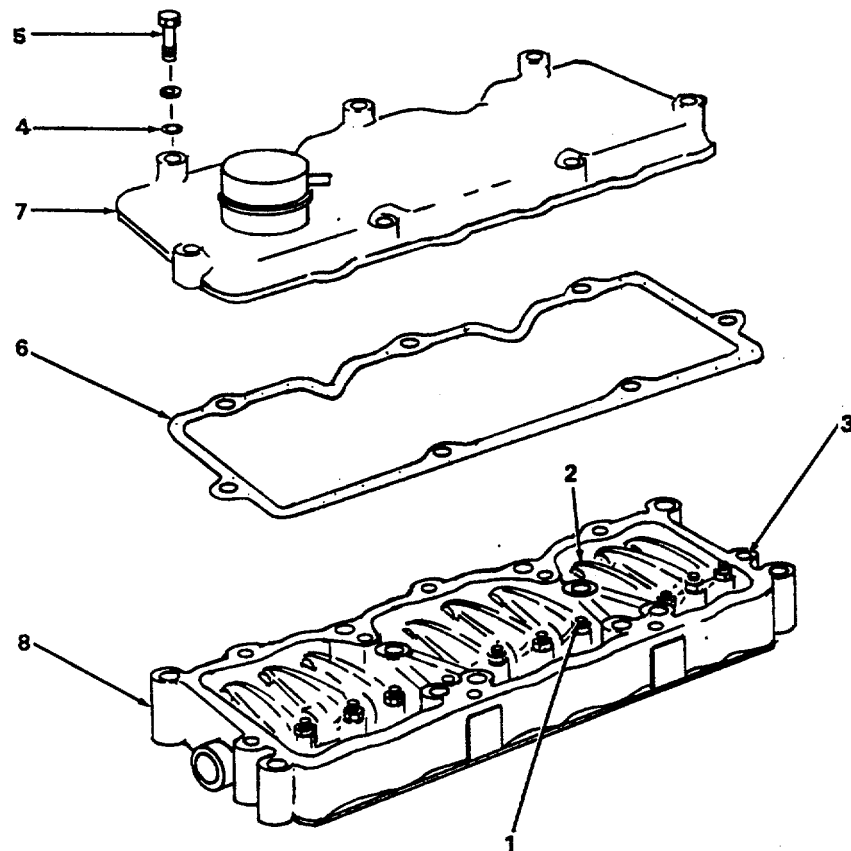
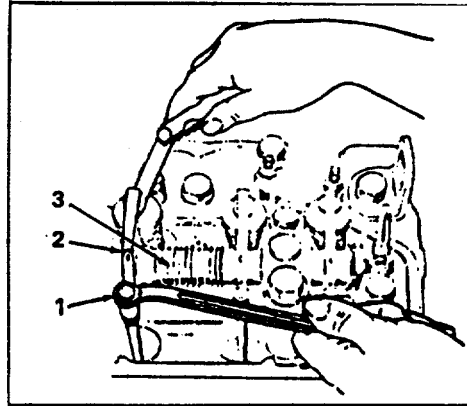

LEGEND

- |                    |                       |
|--------------------|-----------------------|
| 1. Adjusting screw | 5. Bolts              |
| 2. Rocker arm      | 6. Gasket             |
| 3. Shaft           | 7. Rocker housing     |
| 4. Washer          | 8. Rocker arm housing |

Figure 4-59. Rocker Arm and Shaft Assembly

temperature. After engine has warmed up to normal operating temperature, check valve lash again for proper clearance.

### CAUTION

After any mechanical work has been done that may have disturbed the valve lash adjustment, ensure the rocker arm adjusting screws are turned upward (counterclockwise) high enough to prevent rocker arms

and push rods from opening too far, the pistons, will strike the valves when the engine is turned over.

Observe the rocker arms of the opposite cylinder. Rotate crank- shaft until both rockers arms move simultaneously then continue for approximately 1/4 revolution. At this point, both valves are closed and valve lash may be adjusted.

## Section XXVII. MAINTENANCE OF BASE ASSEMBLY

**4-88. GENERAL.** This base assembly, figure 4-60, consists of a rigid frame skid base, fuel tank, and related components. The tank is recess-mounted in the skid base. The engine and generator are mounted on the skid base assembly.

### 4-89. INSPECTION.

- a. Inspect the skid base and frame assembly for rust, corrosion, breaks and loose hardware.
- b. Inspect the fuel tank for dents, cracks, or distortion.
- c. Inspect threaded holes in the base assembly for damaged threads.
- d. Inspect the oil and fuel drain plug and hoses between skid base and engine for leaks.
- e. Inspect ground studs for stripped threads and looseness.
- f. Inspect coolant and oil drain plugs for stripped threads, deformation, or leakage.

### 4-90. REPAIR.

#### a. Base Subassembly.

- (1) With stiff bristle brush, remove heavily concentrated grease and dirt.

(2) Clean the skid base with cleaning solvent, Federal Specification P-D-680.

(3) Repair cracks in skid base by welding or brazing. Fill or sand weld marks to an even finish.

(4) Repair threads in tapped holes by retapping.

(5) Repaint as necessary.

- b. Fuel Tank. Warning switches and transmitter must be removed before repairing fuel tank. Refer to paragraphs 4-55 and 4-56 for test and replacement of these items.

### NOTE

Whenever fittings are replaced on the fuel tank, use sealing compound (MIL-S07916C).

(1) Drain all fuel from tank. Flush inside of tank with steam under pressure. Rinse with hot water and detergent to remove flakes or other foreign matter.

(2) Fuel tank must withstand an internal pressure of 0.5 psi. Seal all tank openings, apply pressure, and check for leaks (use a leak test solution or soapy water). Should tank leak, weld in accordance with

MIL-W-8611 using wire per MIL-R-5031, Class 16. Paint tank or base assembly with MIL-T-704 Type A, semigloss, olive drab paint, color number X24087, if required.

**4-91. REPLACEMENT OF TERMINALS, FITTINGS AND HOSES.**

a. Removal.

- (1) Remove two ground terminals (5, figure 4-60), one on each side of base assembly by

removing two nuts (1 and 3) and washers (2 and 4).

- (2) Remove drain cock (12), hose assembly (6), elbow (9), coupling (10), and nipple (13).

b. Installation.

- (1) Install drain cock (12), nipple (13), coupling (10), elbow (9), and hose assembly (7).

- (2) Install two ground terminals (5) with nuts (1 and 3) and washers (2 and 4).

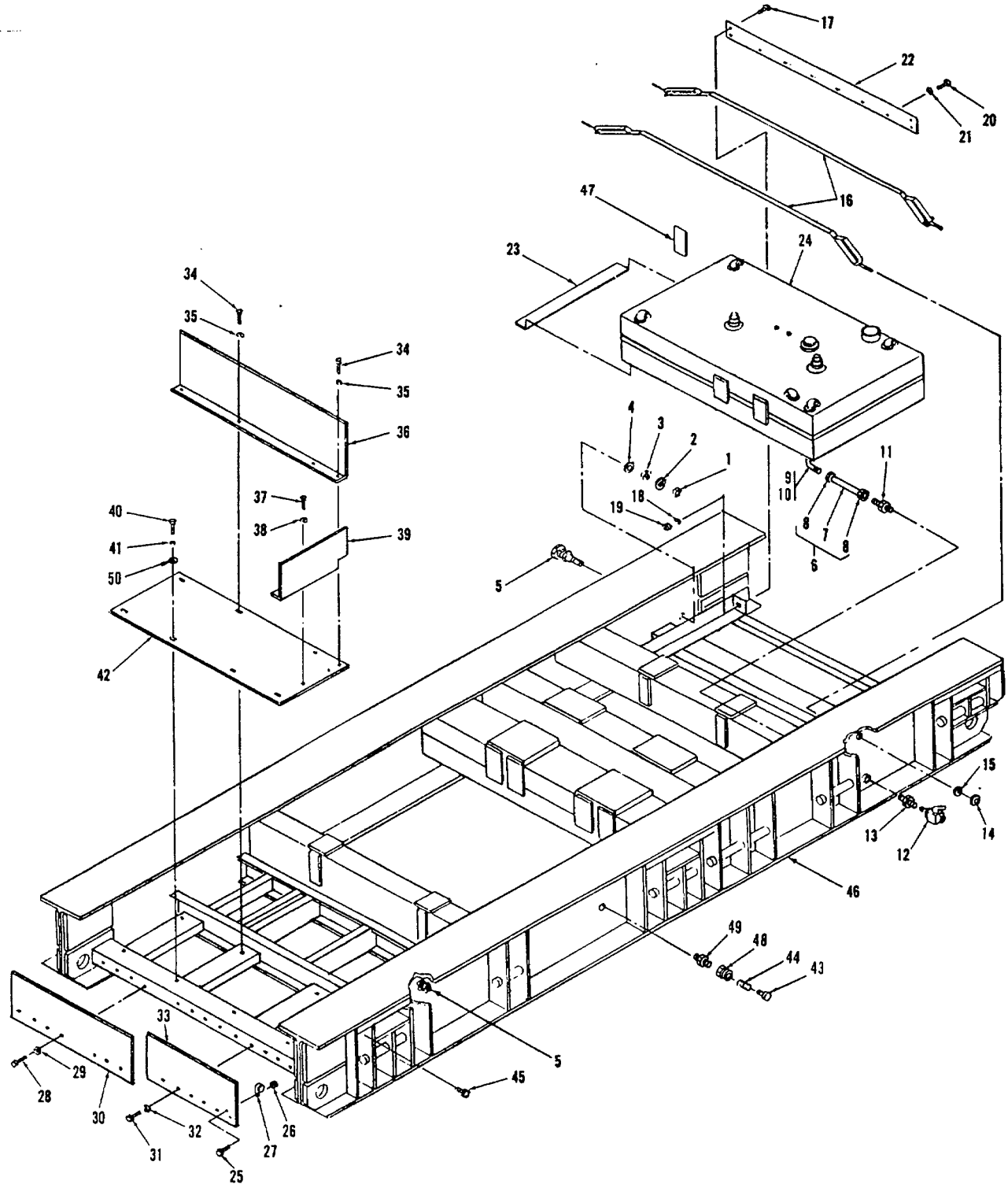

Figure 4-60. Base Assembly, Exploded View

LEGEND FOR FIGURE 4-60

- |     |                 |     |               |
|-----|-----------------|-----|---------------|
| 1.  | Nut             | 25. | Nut           |
| 2.  | Lockwasher      | 26. | Screw         |
| 3.  | Nut             | 27. | Plate         |
| 4.  | Lockwasher      | 28. | Screw         |
| 5.  | Ground terminal | 29. | Lockwasher    |
| 6.  | Hose assy       | 30. | Plate         |
| 7.  | Hose            | 31. | Screw         |
| 8.  | Fitting         | 32. | Lockwasher    |
| 9.  | Elbow           | 33. | Plate         |
| 10. | Pipe coupling   | 34. | Screw         |
| 11. | Nipple          | 35. | Lockwasher    |
| 12. | Drain cock      | 36. | Angle         |
| 13. | Nipple          | 37. | Screw         |
| 14. | Nut             | 38. | Lockwasher    |
| 15. | Washer          | 39. | Angle         |
| 16. | Strap           | 40. | Screw         |
| 17. | Screw           | 41. | Lockwasher    |
| 18. | Lockwasher      | 42. | Support plate |
| 19. | Nut             | 43. | Adapter       |
| 20. | Screw           | 44. | Plug          |
| 21. | Lockwasher      | 45. | Plug          |
| 22. | Brace           | 46. | Base          |
| 23. | Webbing         | 47. | Webbing       |
| 24. | Fuel tank assy  | 48. | Coupling      |
|     |                 | 49. | Nipple        |
|     |                 | 50. | Flat washer   |



4-92. BREATHER LINES AND FITTINGS.

(See figure 4-61.)

a. Inspection. Visually inspect all lines and fittings for security of attachment, deformity, and signs of physical damage.

b. Replacement.

- (1) Loosen clamps (29) and remove hose (28),
- (2) Loosen clamps (23). Remove clamps (24) by removing screws (25), washers (26), and nuts (27). Remove hose (22).
- (3) Remove brackets (7) and restore existing hardware.
- (4) Remove bracket (18) by removing screws (19), washers (20) and nuts (21).
- (5) Loosen clamps (17) and remove hose (16). Remove bracket (6) and restore existing hardware.
- (6) Remove mounting bracket (12) by removing two screws (13), washers (14), and nuts (15).
- (7) Disassemble adapters (10), elbows (9), and pipe nipple (11) from tee (8).
- (8) Remove clamps (24) by removing screws (25), washers (26), and nuts (27).
- (9) Loosen clamps (23) and remove hose (28).
- (10) Remove brackets (7) and restore existing hardware.

- (11) Remove nipple (5), nuts (4), screws (2), washers (3), and breather (1).
- (12) Install breather (1) onto panel with four screws (2), washers (3), and nuts (4). Install nipple (5).
- (13) Install one bracket (6) and three brackets (7) as shown in figure 4-49A using existing hardware.
- (14) Attach two elbows (9) to tee (8) using pipe compound. Install adapters (10) to elbow (9) using pipe compound. Install pipe nipple (11) on tee (8) using pipe compound.
- (15) Install mounting bracket (12) (over assembled tee) onto the support frame member using two screws (13), washers (14), and nuts (15).
- (16) Install 60-inch (150-cm) long hose (16) between breather (1) and pipe nipple (11) using two clamps (17).
- (17) Place bracket (18) over hose (16) and attach to bracket (18) with screw (19), washer (20), and nut (21).
- (18) Install 66-inch (165-cm) long hose (22) between adapter (10) and breather on engine (as shown) using two clamps (24) attached to brackets (7) with screws (25), washers (26) and nuts (27). Tighten two clamps (23) on hose.
- (19) Install 78-inch (195-cm) long hose (28) between adapter (10) and breather on engine (as shown) using two clamps (29).

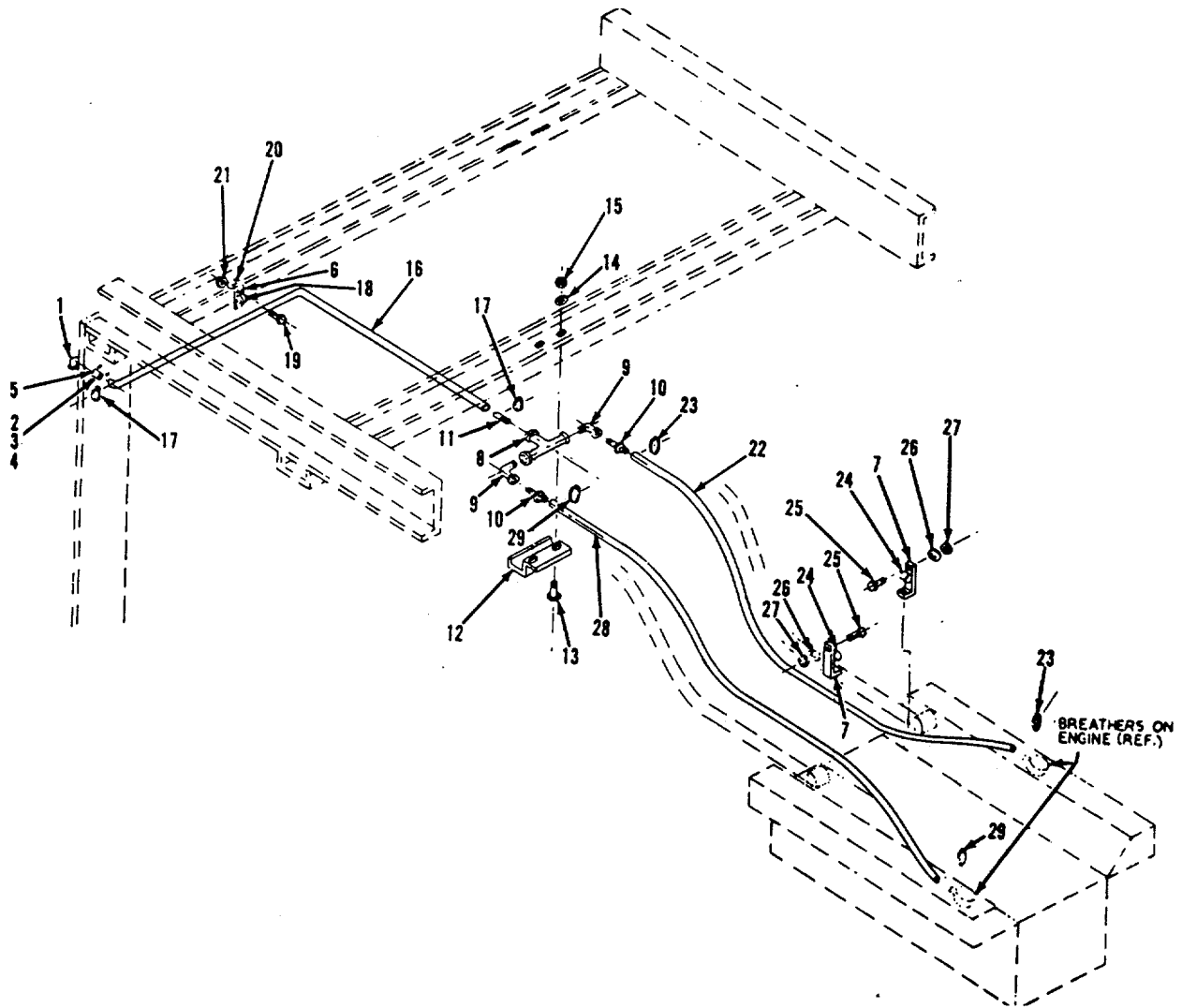

LEGEND

- |     |          |     |                        |     |                        |
|-----|----------|-----|------------------------|-----|------------------------|
| 1.  | Breather | 11. | Nipple                 | 21. | Nut                    |
| 2.  | Screw    | 12. | Bracket                | 22. | Hose (66 in.) (165 cm) |
| 3.  | Washer   | 13. | Screw                  | 23. | Clamp                  |
| 4.  | Nut      | 14. | Washer                 | 24. | Clamp                  |
| 5.  | Nipple   | 15. | Nut                    | 25. | Screw                  |
| 6.  | Bracket  | 16. | Hose (60 in.) (150 cm) | 26. | Washer                 |
| 7.  | Bracket  | 17. | Clamp                  | 27. | Nut                    |
| 8.  | Tee      | 18. | Bracket                | 28. | Hose (78 in.) (195 cm) |
| 9.  | Elbow    | 19. | Screw                  | 29. | Clamp                  |
| 10. | Adapter  |     |                        |     |                        |
| 20. | Washer   |     |                        |     |                        |

Figure 4-61. Breather Lines and Fittings

## CHAPTER 5

### AUXILIARY EQUIPMENT USED IN CONJUNCTION WITH THE GENERATOR SET

#### Section I. INTRODUCTION

5-1. Major auxiliary equipments for use with the generator set are the remote control module, the remote control cable and the automatic control module. Also

included as an auxiliary item is the generator set housing kit.

#### Section II. REMOTE CONTROL MODULE

5-2. GENERAL. The remote control module (figures 5-1, 5-2, and 5-3), when used with the remote control cable, allows remote starting and stopping, and monitoring control of the set from a location up to 100 feet (30) away. With minor exceptions, the remote control module is identical to the generator control panel; the remote control module contains a MASTER SWITCH, a START AID switch and a READY TO LOAD indicator lamp, and does not contain a clock, phase sequence indicator lights, or a 24V DC circuit breaker. The theory of operation for the remote control module is the same as that for the generator control panel as described in Chapter 1, Section III (with the above noted exceptions). When remote operation is required, the controls and indicators of the remote control module are connected in place of equivalent circuits in the generator set.

Allow approximately 24 inches (62 cm) clearance on all sides of the unit for access during operation and maintenance. See paragraph 2-10 for information on the connection procedures for the remote control module, FO-8 and FO-9 for wiring information, and FO-14 for a connection diagram.

5-4. LUBRICATION. The remote control module requires no lubrication.

5-5. PREVENTIVE MAINTENANCE CHECKS AND SERVICES (A, N, MC). To ensure that the remote control module is always ready for operation, inspect systematically so that defects may be discovered and corrected before they result in serious damage or failure. Perform the preventive maintenance checks and services in accordance with table 5-1. Air Force users shall refer to the applicable inspection manuals and work card sets in T.O. 35C2-3-series for periodic preventive maintenance requirements and table 5-1 for detailed procedures. Marine Corps users shall refer to the current issue of TM 11275-15/1.

5-3. INSTALLATION. The remote control module is a self-housed unit, suitable for either indoor or outdoor operation. The unit should be placed as level as possible, in a firm, dry, footing.

#### LEGEND FOR FIGURE 5-1

1. Screw	12. Plate assy	23. Dust Cap	34. Rivet
2. Nut	13. Screw	24. Dust Cap	35. Plate, wiring diagram
3. Seal	14. Lockwasher	25. Screw	36. Rivet
4. Door assy	15. Nut	26. Nut	37. Plate, wiring diagram
5. Screw	16. Angle	27. Screw	38. Door holder
6. Nut	17. Screw	28. Nut	39. Screw
7. Lockwasher	18. Lockwasher	29. Screw	40. Nut
8. Horn	19. Nut	30. Lockwasher	41. Clamp
9. Screw	20. Angle	31. Nut	42. Enclosure
10. Lockwasher	21. Screw	32. Clamp	
11. Nut	22. Nut	33. Harness assy	

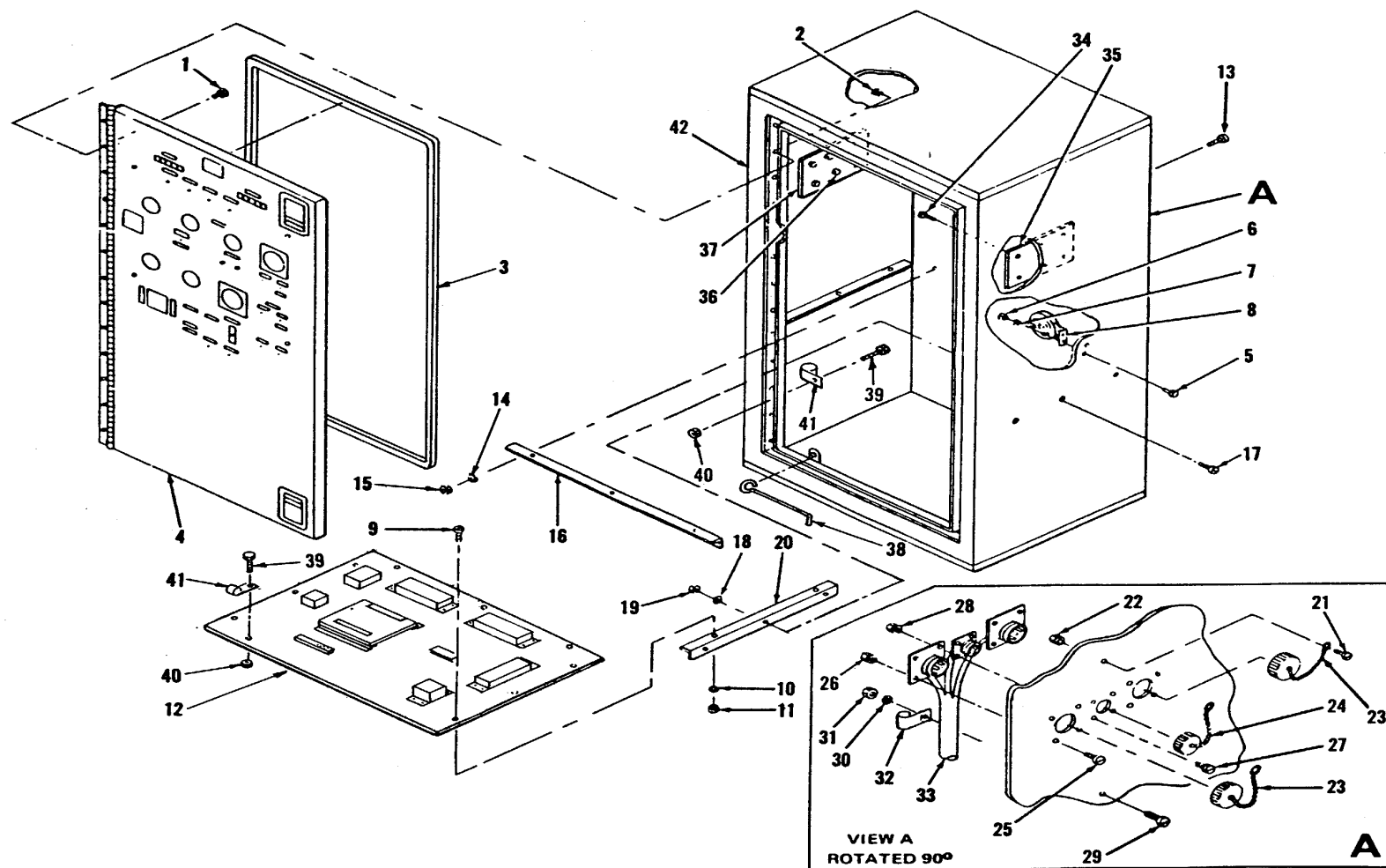

Figure 5-1. Remote Control Module

**Table 5-1. OPERATOR/CREW PREVENTIVE MAINTENANCE CHECKS AND SERVICES, REMOTE CONTROL MODULE.**

NOTE: Within designated interval, these checks are to be performed in the order listed.

B-Before

A-After

D-During

Item No.	INTERVAL			ITEMS TO BE INSPECTED	PROCEDURES CHECK FOR AND HAVE REPAIRED OR ADJUSTED AS NECESSARY	EQUIPMENT IS NOT READY/ AVAILABLE IF:
	B	D	A			
1	o			Remote Control Module	Inspect controls, gauges, lamps and instruments daily for damage, loose mounting or loose connections.	

**5-6. OPERATOR/CREW TROUBLESHOOTING.**

Table 5-2 contains troubleshooting information for use in correcting operating troubles which may develop in the generator set when used with the remote control module. Each malfunction is followed by a list of tests or inspections which will help to determine probable causes and corrective actions to take. Perform the tests or inspections and corrective actions in the order listed. Any trouble beyond the scope of crew level maintenance should be referred to the next higher (organizational) level of maintenance.

**NOTE**

Before referring to table 5-2, be sure that all applicable checks have been performed.

**5-7. OPERATOR/CREW MAINTENANCE OF THE REMOTE CONTROL MODULE.** This paragraph includes instructions to assist the operator/crew in maintaining the remote control module. If, during inspections, defective components are noted, refer to next higher level of maintenance for replacement or repair.

a. Inspection. Inspect components on the front panel, inside the enclosure, and on the mounting plate as follows:

- (1) Inspect all gauges, switches, and instruments on front panel for cracking or damage, loose mounting or loose connections.
- (2) Inspect the telephone jack (30, figure 2-14) for damage, loose mounting, or loose

connections.

- (3) Inspect the panel lamps (19, figure 2-14) for loose mounting or loose connections.
- (4) Inspect transformer (29, figure 5-2) for cracking or damage, loose mounting or loose connections.

b. Replacement.

- (1) Replace defective bulbs in lamp assemblies.
- (2) Replace defective telephone jack as follows:
  - (a) Tag and remove wires connected to the jack.
  - (b) Remove the hex nut and flatwasher attaching jack to panel, and remove jack.
  - (c) Install jack and secure with flatwasher and hex nut.
  - (d) Connect wires and remove wire tags.

**5-8. ORGANIZATIONAL TROUBLESHOOTING.**

Table 5-3 provides information for locating and correcting operating troubles which may develop in the generator set when used with the remote control module. Each malfunction is followed by a list of tests or inspections which will help to determine probable causes and corrective actions to take. Perform the tests or inspections and corrective actions in the order listed. Any trouble beyond the scope of

organizational maintenance shall be referred to the next higher level of maintenance.

relays (2 and 4, figure 5-2), and alarm horn (8, figure 5-1) for cracking or damage, loose mounting or loose connections.

5-9. ORGANIZATIONAL MAINTENANCE OF THE REMOTE CONTROL MODULE.

b. Test.

a. Inspection. Inspect transducer (26, figure 5-2),

(1) Test all SPST (single-pole,

**Table 5-2. Remote Control Module Troubleshooting  
(Operator/Crew Level)**

MALFUNCTION
TEST OR INSPECTION
CORRECTIVE ACTION

**WARNING**

**Death or injury may result if proper care is not taken while working with the various voltages in and around the generator set.**

**NOTE**

To determine whether it is the remote control module or the generator set that is malfunctioning operate or monitor the corresponding control or indicator on the generator set to see if the correct operation or indication is obtained. If operation or indication is correct, the remote control module is, most probably, at fault. If the generator set still does not operate properly it, most probably, is at fault (refer to paragraph 3-5 for appropriate troubleshooting procedures).

1. ENGINE GENERATOR SET SHUTS DOWN DUE TO HIGH COOLANT TEMPERATURE BUT HIGH COOLANT INDICATOR IS NOT ILLUMINATED.

Check bulb with ANNUNCIATOR TEST switch (16, figure 2-2).

If bulb is defective, replace bulb.

2. ENGINE GENERATOR SET SHUTS DOWN DUE TO HIGH LUBE TEMPERATURE BUT HIGH OIL TEMPERATURE INDICATOR IS NOT ILLUMINATED.

Check bulb with ANNUNCIATOR TEST switch (16, figure 2-2).

If bulb is defective, replace bulb.

**Table 5-2. Remote Control Module Troubleshooting  
(Operator/Crew Level)-Continued**

MALFUNCTION	TEST OR INSPECTION	CORRECTIVE ACTION
-------------	--------------------	-------------------

3. ENGINE GENERATOR SET SHUTS DOWN DUE TO LOW OIL PRESSURE BUT LOW OIL PRESSURE INDICATOR IS NOT ILLUMINATED.

Check bulb with ANNUNCIATOR TEST switch (16, figure 2-2).

If bulb is defective, replace bulb.

4. GENERATOR SET SHUTS DOWN DUE TO OVERSPEED CONDITION BUT OVERSPEED INDICATOR IS NOT ILLUMINATED.

Check bulb with ANNUNCIATOR TEST switch (15, figure 2-2).

If bulb is defective, replace bulb.

5. AN OVERVOLTAGE CONDITION EXISTS BUT OVERVOLTAGE INDICATOR IS NOT ILLUMINATED.

Check bulb with ANNUNCIATOR TEST switch (15, figure 2-2).

If bulb is defective, replace bulb.

6. AN UNDERVOLTAGE CONDITION EXISTS BUT UNDERVOLTAGE INDICATOR IS NOT ILLUMINATED.

Check bulb with ANNUNCIATOR TEST switch (15, figure 2-2).

If bulb is defective, replace bulb.

7. A REVERSE POWER TRIP CONDITION EXISTS BUT REVERSE POWER INDICATOR IS NOT ILLUMINATED.

Check bulb with ANNUNCIATOR TEST switch (15, figure 2-2).

If bulb is defective, replace bulb.

8. AN OVERLOAD CONDITION EXISTS BUT OVERLOAD INDICATOR IS NOT ILLUMINATED.

Check bulb with ANNUNCIATOR TEST switch (15, figure 2-2).

If bulb is defective, replace bulb.

9. A SHORT CIRCUIT CONDITION EXISTS BUT SHORT CIRCUIT INDICATOR IS NOT ILLUMINATED.

Check bulb with ANNUNCIATOR TEST switch (15, figure 2-2).

If bulb is defective, replace bulb.

**Table 5-2. Remote Control Module Troubleshooting  
(Operator/Crew Level)-Continued**

MALFUNCTION	TEST OR INSPECTION	CORRECTIVE ACTION
-------------	--------------------	-------------------

10. AMMETER DOES NOT INDICATE CORRECT CURRENT.

Set AMMETER select switch to each position and observe AMMETER indication.

If indication is incorrect in all positions of AMMETER select switch, the AMMETER is, most probably, at fault (refer to next higher level of maintenance for replacement).

If AMMETER indication is correct in at least one position, refer to next higher level of maintenance.

11. VOLTS AC METER DOES NOT INDICATE CORRECT VOLTAGE.

Set VOLTMETER select switch to each position and observe VOLTS AC meter indication.

If indication is incorrect in all positions of VOLTMETER select switch, the VOLT AC meter is, most probably, at fault (refer to next higher level of maintenance for replacement).

If VOLTS AC indication is correct in at least one position, refer to next higher level of maintenance.

single-throw) toggle switches as follows:

- |  |   |
|--|---|
| <ul style="list-style-type: none"> <li>(a) Operate toggle switch to the ON position.</li> <li>(b) At rear of the panel, remove one lead from the switch.</li> <li>(c) Using an ohmmeter (Rx1 scale), test switch for a closed circuit. If meter indicates an open circuit, replace switch.</li> <li>(d) Operate toggle switch to OFF position. Using an ohmmeter on Rx1 scale, test for open circuit. If meter indicates a closed circuit, replace switch.</li> </ul> <p>(2) Test all DPTT (double-pole, triple-throw) toggle switches as follows:</p> <ul style="list-style-type: none"> <li>(a) With switch in center (neutral) position,</li> </ul> | <ul style="list-style-type: none"> <li>check that contacts 1-2 and 5-6 have continuity. Ohmmeter should be set to R x 1 scale.</li> <li>(b) With switch in up (on) position, check that contacts 2-3 and 5-6 have continuity.</li> <li>(c) With switch in down (off) position, check that contacts 1-2 and 4-5 have continuity.</li> </ul> <p>(3) Activate ANNUNCIATOR TEST switch (16, figure 2-14) to energize the alarm horn. If alarm does not sound, test switch according to (1), above. If switch is not defective, connect 24V DC across terminals 1 and 2 of alarm horn. If horn does not sound, it is defective and should be replaced.</p> |
|--|---|



(4) Refer to paragraph 4-40 for test procedures for gauges. Note that the gauges on the remote control module are identical to those on the generator control panel.

c. Replacement.

(1) Replace gauges and switches on the front panel as follows:

- (a) Tag and remove wires to gauges and switches.
- (b) Remove mounting hardware to remove gauges and switches.

- (c) Install gauges and switches using mounting hardware.
- (d) Connect wires and remove wire tags.

(2) Replace alarm horn (8, figure 5-1) as follows:

- (a) Tag and disconnect wires to alarm horn.
- (b) Remove nut (6), washers (7), and screw (5) to remove horn (8).
- (c) Install horn (8) with screw (5), washer (7), and nut (6).
- (d) Connect wires and remove tags.

**Table 5-3. Remote Control Module Troubleshooting  
(Organizational Level)**

MALFUNCTION	TEST OR INSPECTION	CORRECTIVE ACTION
-------------	--------------------	-------------------

**WARNING**

**Death or injury may result if proper care is not taken while working with the various voltages in and around the remote control module.**

**1. GENERATOR SET DOES NOT START WHEN MASTER SWITCH IS MOVED TO START POSITION.**

Set 24V DC CONTROL CIRCUIT BREAKER to OFF and, using multimeter, check for continuity of MASTER SWITCH S1 in accordance with paragraph 5-9b(2).

Replace switch (see paragraph 5-9c), if defective.

**2. START AID SWITCH IS SET TO ON BUT GENERATOR DOES NOT START.**

Set 24V DC CONTROL CIRCUIT BREAKER (on generator control panel) to OFF, then, using a multimeter, check for continuity across the terminals of START AID SWITCH S2 as it is toggled to each position.

Replace switch (see paragraph 5-9c), if it does not read zero ohms in one position and infinite in the other position.

**Table 5-3. Remote Control Module Troubleshooting  
(Organizational Level)-Continued**

MALFUNCTION
TEST OR INSPECTION
CORRECTIVE ACTION

3. AUDIBLE ALARM (HORN) DOES NOT SOUND DURING FAULT CONDITION.

Step 1. Toggle ANNUNCIATOR RESET switch to RESET position.

If audible alarm (horn) still does not sound, check for 24 V DC (using multimeter) across 1 and 2 contacts of audible alarm AI (13, figure 5-2). If voltage is present, test AI (refer to paragraph 5-9b(3)).

If voltage is absent, proceed to next step.

Step 2. Using a multimeter, inspect for 24V DC across coil of relay K26.

If absent, proceed to next step. If present, inspect for 24V DC across contacts of K26. If this reading is zero volts, proceed to check and replace relay K25 (refer to next higher level of maintenance).

If this reading is 24V DC, inspect relay K26 (2, figure 5-3) and if replacement is required, refer to next higher level of maintenance.

Step 3. Using a multimeter, check for 24V DC across contacts 4 and 5 of ANNUNCIATOR TEST switch S13.

If voltage reading is zero, refer malfunction to next higher level of maintenance; specifically, the diodes associated with the energized fault circuit.

If voltage reading is 24V DC, set 24V DC CONTROL CIRCUIT BREAKER to OFF and check S13 for continuity as it is switched to its various positions. If replacement is required, refer to paragraph 5-9.

4. HERTZ METER READS INCORRECTLY.

Using a multimeter, note voltage at pins 1 and 2 on frequency converter A103 on generator control panel. Again, using multimeter check voltage at pins 1 and 2 of frequency converter A103 on remote control module.

If readings are the same, replace HERTZ meter M103 (refer to paragraph 5-9). If readings are not the same, refer replacement of A103 to next higher level of maintenance.

**Table 5-3. Remote Control Module Troubleshooting  
(Organizational Level)-Continued**

MALFUNCTION
TEST OR INSPECTION
CORRECTIVE ACTION

5. VOLTS AC METER DOES NOT INDICATE CORRECT VOLTAGE.

Disconnect cables to remote control module and, using a multimeter, check for continuity across the terminals of VOLTMETER select switch S101 as it is set to each position.

If multimeter does not read zero ohms when particular position is closed and infinite when open, the switch should be replaced.

6. AMMETER DOES NOT INDICATE CORRECT CURRENT.

If feasible, disconnect cables to remote control module and, using a multimeter, check for continuity across the terminals of AMMETER select switch S102 as it is set to each position.

If multimeter does not read zero ohms when particular position is closed and infinite when open, the switch should be replaced.

7. WHEN OPERATED, FREQ ADJ SWITCH DOES NOT AFFECT OUTPUT FREQUENCY OF GENERATOR SET.

Set 24V DC CONTROL CIRCUIT BREAKER (on generator control panel) to OFF and, using a multimeter, check for continuity across terminals of FREQ ADJ switch S5 as it is toggled to each position.

If switch does not read zero ohms in one position and infinite in the other it should be replaced.

8. WHEN OPERATED, VOLT ADJ SWITCH DOES NOT AFFECT OUTPUT VOLTAGE OF GENERATOR SET.

Set 24V DC CONTROL CIRCUIT BREAKER (on generator control panel) to OFF and, using a multimeter, check for continuity across terminals of VOLT ADJ switch S6 as it is toggled to each position.

If switch does not read zero ohms in one position and infinite in the other it should be replaced.

9. GENERATOR SETS DO NOT LOCK INTO OPERATION WHEN SWITCHED TO THIS MODE.

Set 24V DC CONTROL CIRCUIT BREAKER (on generator control panel) to OFF and, using a multimeter, check for continuity across the terminals of PARALLEL OPERATION switch S8 is toggled to this position.

If switch does not read zero ohms in one position and infinite in the other it should be replaced.

**Table 5-3. Remote Control Module Troubleshooting  
(Organizational Level)-Continued**

MALFUNCTION
TEST OR INSPECTION
CORRECTIVE ACTION

10. EMERGENCY SHUT-DOWN SWITCH IS SET TO ON POSITION BUT GENERATOR SET DOES NOT SHUT DOWN.

Set 24V DC CONTROL CIRCUIT BREAKER (on generator control panel) to OFF and, using a multimeter, check for continuity across the terminals of EMERGENCY SHUT DOWN switch S22 as it is toggled to each position.

If switch does not read zero ohms in one switch position and infinite in the other it should be replaced.

11. START AID SWITCH IS SET TO ON BUT GENERATOR SET DOES NOT START.

Set 24V DC CONTROL CIRCUIT BREAKER (on generator control panel) to OFF and, using a multimeter, check for continuity across the terminals of START AID switch S2 as it is toggled to each position.

If switch does not read zero ohms in one switch position and infinite in the other it should be replaced.

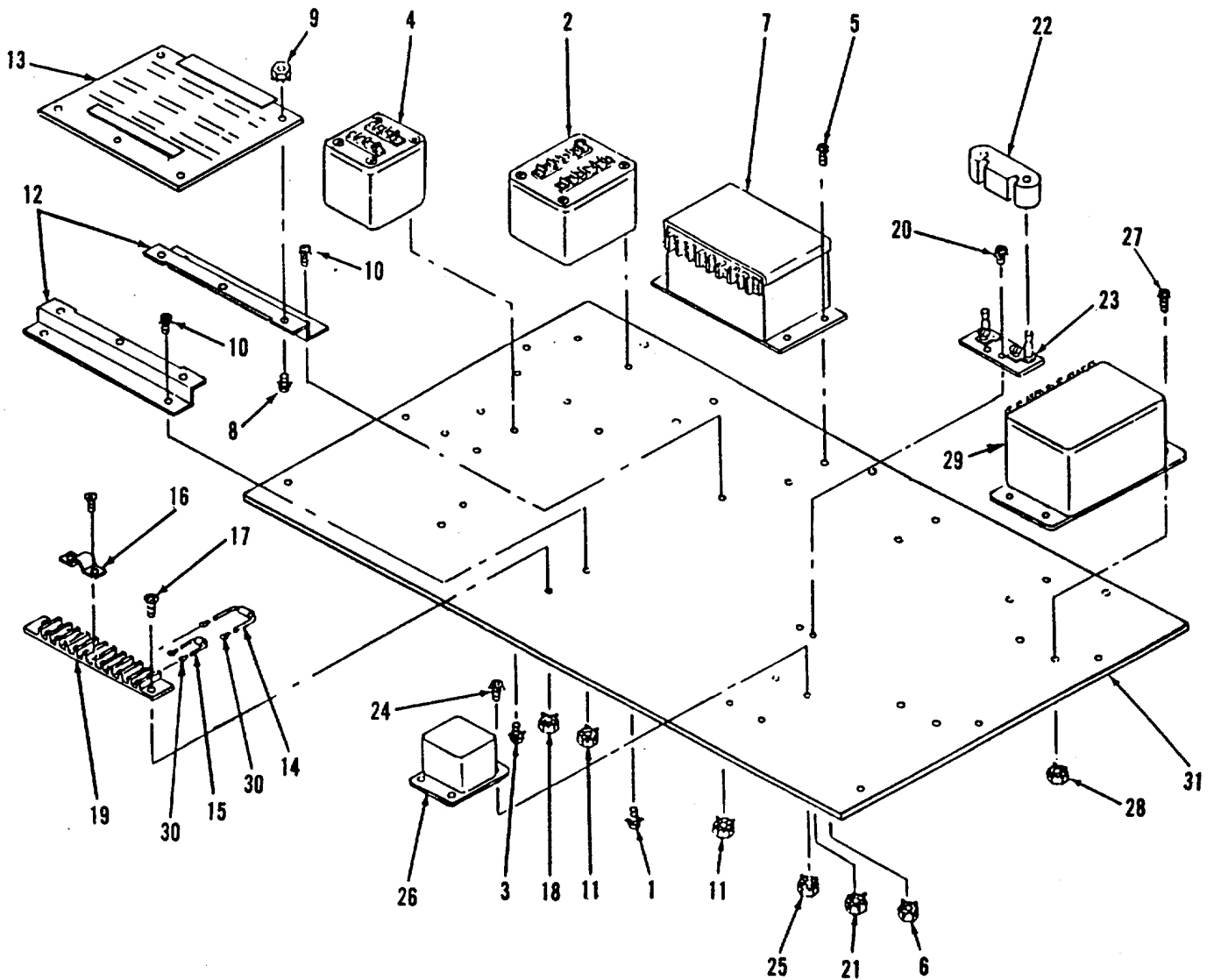

LEGEND

- |                         |                    |                    |
|-------------------------|--------------------|--------------------|
| 1. Screw                | 11. Nut            | 22. Terminal block |
| 2. Undervoltage relay   | 12. Bracket        | 23. Flasher        |
| 3. Screw                | 13. Annunciator    | 24. Screw          |
| 4. Underfrequency relay | 14. Resistor       | 25. Nut            |
| 5. Screw                | 15. Diode          | 26. Transducer     |
| 6. Nut                  | 16. Jumper         | 27. Screw          |
| 7. Converter            | 17. Screw          | 28. Nut            |
| 8. Screw                | 18. Nut            | 29. Transformer    |
| 9. Nut                  | 19. Terminal block | 30. Terminal lug   |
| 10. Screw               | 20. Screw          | 31. Plate          |
|                         | 21. Nut            |                    |

Figure 5-2. Remote Control Module, Plate Assembly

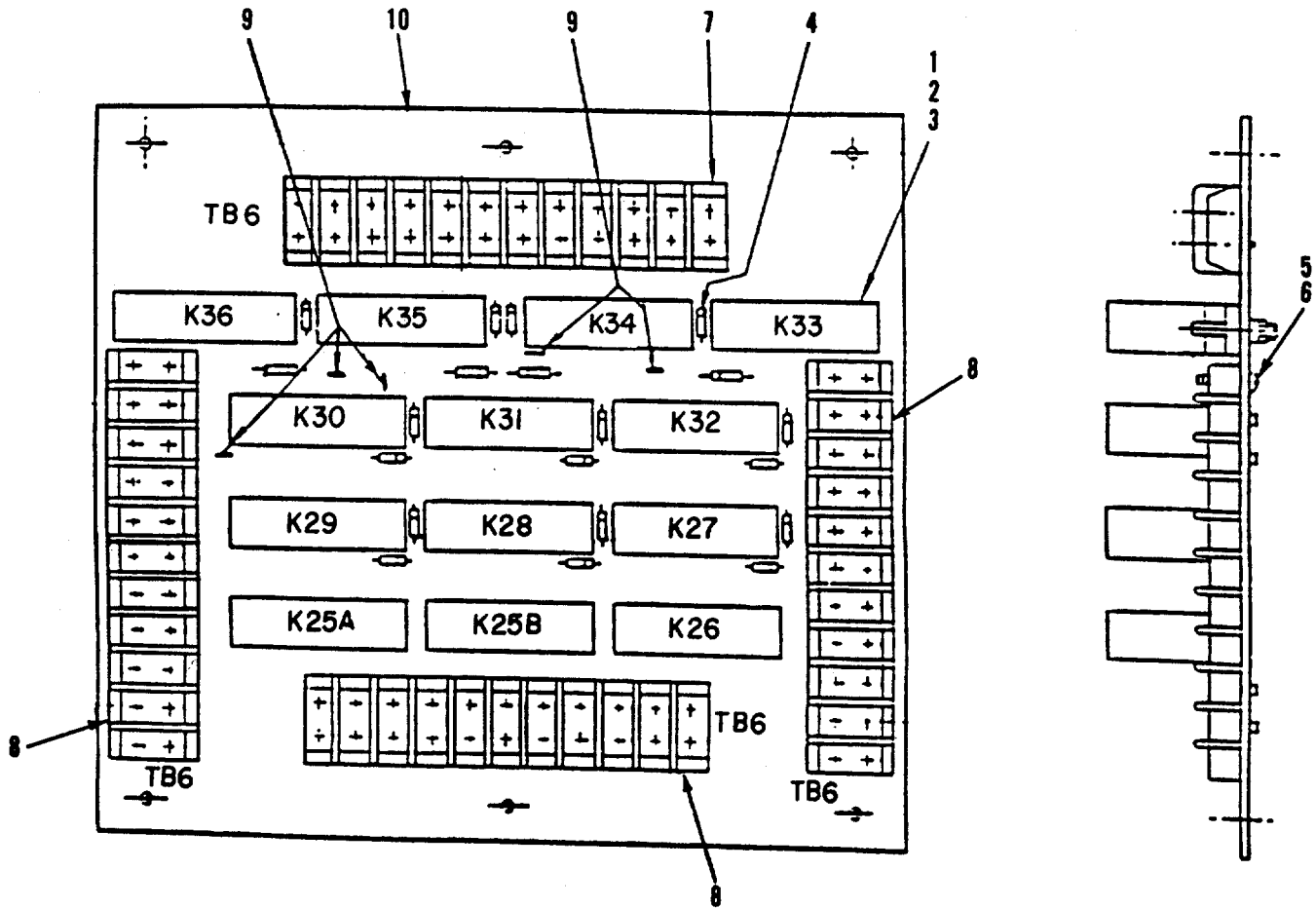

LEGEND

- |           |                           |
|-----------|---------------------------|
| 1. Screw  | 7. Terminal board         |
| 2. Relay  | 8. Terminal board         |
| 3. Socket | 9. Wire                   |
| 4. Diode  | 10. Printed circuit board |
| 5. Screw  |                           |
| 6. Nut    |                           |

Figure 5-3. Remote Control Module, Annunciator Control Assembly

### Section III. REMOTE CONTROL CABLE ASSEMBLY

5-10. GENERAL. The remote control cable assembly is used to connect the remote control module to the generator set. The cable assembly may be of any length

up to a maximum of 1000 feet (300 m). Refer to par. 2-10 for additional information.

### Section IV. AUTOMATIC CONTROL MODULE

5-12. GENERAL. The automatic control module can sense and initiate unattended sequence when an interruption or deviation in the normal 120V AC supply exceeds allowable values; start the generator sets; disable and energize circuit breakers, and exercise the automatic control system. The automatic control module is equipped with voltage and frequency sensing devices which are normally set for a voltage deviation of  $\pm 10$  percent and a frequency deviation of  $\pm 3$  percent, but can be reset as local conditions warrant.

5-13. FUNCTIONAL DESCRIPTION. (Ref. FO-12) The ACM is designed to automatically control up to four MEP-029A, 500 KW generator sets. The utility monitor circuit which includes a 120 VAC over/under voltage relay (27/59N), under frequency relay (81N-U), over frequency relay (81N-0), 1.5-15 second (adjustable) time delay relay (TD), 50/60Hz frequency select switch and a run relay (RR), continually monitors the 120 VAC utility voltage from the line side of the utility breaker.

When the utility power is normal, relays 27/59N, 81N-U and TD are energized (81N-0 will only energize during an over-frequency condition) and the normal power available lamp will be on.

If the utility power completely fails or voltage varies by more than  $\pm 10\%$  and/or frequency varies more than  $\pm 3\%$ , TD relay after a 1.5-15 second time delay will allow all generators to begin a start-up cycle providing the generators are in the automatic mode. Relays 27/59N, 81N-U, TD and RR deenergize allowing 24 volts D.C. to energize the K5 engine start circuit via normally closed contacts TD and RR through TB4-5, 6, 7, 8 through J3-B through the automatic position of the auto-trip-manual switch (S53) on each set. The utility breaker (located within user switchgear) will open via additional sets of RR contacts at TB3-17, 18 and 19.

As the generators run up to speed, each generator's

quality circuit (81G-0, 81G-U, 27/59G and CR) monitors the condition of their respective set. This circuit has identical voltage and frequency specifications as the utility monitor circuit in the ACM and is only completely functional if the generator set is in the automatic mode. As each generator satisfies its own quality circuit, control relay (CR) will energize and provide 120 VAC through J3-N to TB2-5, 6, 7, or 8 to its applicable MR relay (MR1, 2, 3, or 4) in the ACM. However, the first MR to be energized will lock out all other MR relays and also provide a closure to its generator circuit breaker control circuit via its applicable normally open contact (TB 3-1 through TB 3-8) through J3-D and J3-E. The first set to close its circuit breaker via MR will also energize its own breaker control relay (BCR) which now disconnects its synchronizer to electric governor (2301) connection which is no longer needed since this generator is already on line. Once all other units have satisfied their quality circuit and energized CR, their respective synchronizers will be energized via CR contacts at terminal one of the synchronizer. The fact that all other MR relays have locked out and synchronizers are now energized, enables the remaining units circuit breakers to be closed only when proper synchronization has taken place.

It should be noted that K106 sync check relay (N.O. contacts 5 and 6) is always in the circuit breaker closure circuit in series with MR closure contacts and/ or the synchronizer closure contacts. This will preclude any set circuit breaker closure, in automatic or manual unsynchronized.

As each set circuit breaker (CB2) closes, its' auxiliary contacts (CB2-5 will close allowing 120 V.A.C. via J3-P to TB2-9, 10, 11 or 12 to energize each sets respective BR1-BR4 relay. These BR relays along with the 24 VDC

available to LR1 (LRTD1) - LR4 (LRTD4) make up the prioritized feeder breaker control circuits. The first set to close to the bus will energize a BR relay which will always close LR1 (Load Relay) and its 2-20 second (adjust- able) time delay (LRTD1) secondly. Each LR and LRTD should control loads not to exceed 250KW each. LRTD's allow a time delay between load applications as to allow engine turbochargers to build up speed. LR1 relay will always be the first relay to energize on start-up and the last relay to de-energize when the sets are shut down. Therefore, it is classified as the #1 priority feeder breaker control. When LR1 relay energizes, it also prevents RR relay from being re-energized if utility power returns via LR1 normally closed contacts in series with RR relay coil. This allows all sets, which are in the automatic mode, to complete their start-up and parallel cycles regardless of utility power returning. As each remaining set is automatically synchronized and paralleled to the bus, the remaining LR and LRTD relays will energize in numerical order. The ACM has a 3 position rotary switch labeled "Instant", "Time Delay" (TD) and "No Return". This switch allows the user three options as to what will happen when the utility power returns after a failure. If the switch is in the "Instant" return position, immediately, when the utility power returns, the utility 120 VAC will be supplied through energized T.D. relay normally open contacts through S1 to TB2-1, 2, 3, and 4 to J3-C on all units, energizing the breaker trip relay (BTR) which will shunt trip each unit's circuit breaker (CB2). At this time, all BR, LR and LRTD relays de-energize causing the LR1 normally closed contact, in series with RR coil, to reclose allowing RR relay to re-energize, thereby allowing the utility breaker to close back to the load. In the "TD" position, a 3-30 minute (adjustable) time delay via UTR (Utility Trip Relay) allows a predetermined time delay after the utility power returns before the unit circuit breakers (CB2) are tripped. This insures utility power has returned to stay, avoiding unnecessary transfer and re-transfers of the utility breaker control. In the "no return" position, the generators will carry the load until switched off by the operator.

At the same instant when all units CB2's are tripped open via BTR, SDT (Shut Down Timer) begins a 300 second (adjustable) time out before de-energizing. The SDT relay allows the engines to continue to run and cool down after the load has been removed.

At the end of this time delay period, SDT N.O. contacts re-open, removing the 24 VDC to TB4-5, 6, 7, 8 and J3-B which in turn allows K5 relays to de-energize and stop all units.

This completes the automatic start and shutdown cycle of the generator set via the ACM.

5-14. INSTALLATION. The automatic control module is a self-housed unit, for indoor or outdoor operation. The unit should be placed as level as possible, on firm, dry, footing. Allow approximately 24 inches (62 cm) clearance on each side of the unit for access during operation and maintenance. See paragraph 2-11 for information on connecting the automatic control module, FO-12 for a schematic, and FO-15 for a connection diagram.

5-15. LUBRICATION. The automatic control module requires no lubrication.

5-16. PREVENTIVE MAINTENANCE CHECKS AND SERVICES (A, N, MC). To ensure that the automatic control module is always ready for operation, inspect systematically so that defects may be discovered and corrected before they result in serious damage or failure. Perform the preventive maintenance checks and services in accordance with table 5-4. Air Force users shall refer to the applicable inspection manuals and work card sets in T.O. 35C2-3- series for periodic preventive maintenance requirements and table 5-4 for detailed procedures. Marine Corps users shall refer to the current issue of TM 11275-15/1. See par. 2-11 and fig. 2-19 for operation.

5-17. OPERATOR/CREW TROUBLESHOOTING. Table 5-5 contains troubleshooting information for use in correcting operating troubles which may develop in the generator set when used with the automatic control module. Each malfunction is followed by a list of tests or inspections which will help to determine probable causes and corrective actions to take. Perform the tests or inspections and corrective actions in the order listed. Any trouble beyond the scope of crew level maintenance shall be referred to the next higher (organizational)



level of maintenance.

NOTE

Before referring to table 5-5, be sure that all applicable checks have been performed.

5-18. OPERATOR/CREW MAINTENANCE OF THE AUTOMATIC CONTROL MODULE. This paragraph provides instructions to assist the operator/crew in maintaining the automatic control module. If defective components are noted during inspection, refer to next higher level of maintenance for replacement or repair. (See figure 2-19).

- a. Inspection. Inspect NORMAL POWER AVAILABLE lamp for loose mounting or loose connections. Inspect relays for loose mounting or loose connections.
- b. Replacement. Replace defective bulb in lamp assembly.

5-19. ORGANIZATIONAL TROUBLESHOOTING. Table 5-6 provides information for locating and correcting operating troubles which may develop in the generator set when used with the automatic control module. Each malfunction is followed by a list of tests or inspections which will help to determine probable causes and corrective actions to take. Perform the tests or inspections and corrective actions in the order listed. Any trouble beyond the scope of organizational maintenance shall be referred to the next higher level of maintenance.

5-20. ORGANIZATIONAL MAINTENANCE OF THE AUTOMATIC CONTROL MODULE. (See figure 2-19).

- a. Inspection. Inspect the under/ over voltage device, underfrequency device, overfrequency device, relays, timers, switches, and fuseholders for loose mounting, loose wires, cracking, or damage. If components are damaged or

defective, and their replacement is beyond the scope of organizational maintenance, refer to the next higher level of maintenance.

- b. Testing the NO RETURN/TD RETURN/INSTANT RETURN Mode Selector Switch..

- (1) Test the mode selector switch S1 by tagging and removing wires, then removing switch from panel.
- (2) Refer to FO-12 sheet and connect one lead of ohmmeter (set on low scale) to the arm terminals 11 and 21) of the mode selector switch. Connect the other ohmmeter lead to the terminal set for that position. Meter should indicate continuity for the set of leads, no continuity for all others. Repeat this step for the other terminals (rotate switch to corresponding position). If switch indicates an open or intermittent contact on any of the closed switch positions, or a closed circuit on an open position, replace switch.
- (3) Install switch with mounting hardware and connect wires. Remove wire tags.

- c. Testing Toggle switch.

- (1) Test the toggle switch by tagging and removing wires.

NOTE

The FREQ SELECT 50 HZ/60 HZ switch S2 must be removed from the panel for testing.

- (2) Using an ohmmeter (Rx1 scale), close switch and check for continuity.

**Table 5-4. OPERATOR/CREW PREVENTIVE MAINTENANCE CHECKS AND SERVICES, AUTOMATIC CONTROL MODULE.**

NOTE: Within designated interval, these checks are to be performed in the order listed.

B-Before

A-After

D-During

Item No.	INTERVAL			ITEMS TO BE INSPECTED	PROCEDURES CHECK FOR AND HAVE REPAIRED OR ADJUSTED AS NECESSARY	EQUIPMENT IS NOT READY/ AVAILABLE IF:
	B	D	A			
1	o			Automatic Control Module	Inspect switches, fuses, relays and lamps daily for damage, loose mounting or loose connections.	

**Table 5-5. Automatic Control Module Troubleshooting (Operator/Crew Level)**

MALFUNCTION TEST OR INSPECTION CORRECTIVE ACTION
--

**WARNING**

**Death or injury may result if proper care is not taken while working with the various voltages in and around the generator set.**

1. GENERATOR SET DOES NOT START WHEN NORMAL POWER FAILS (SINGLE UNIT OPERATION, ACM WIRED PER INTERCONNECTION FOR SET #1)

Step 1. Remove and check DC fuses (F6, F7, F8 or F9) for continuity.

If fuse is not defective, proceed to next step.

If fuse is defective, replace with 5-ampere fuse of same type as original.

If generator set still does not start, recheck fuse.

If new fuse is blown, automatic control module troubleshooting should be referred to next higher level of maintenance.

**Table 5-5. Automatic Control Module Troubleshooting (Operator/Crew Level)-Continued**

MALFUNCTION
TEST OR INSPECTION
CORRECTIVE ACTION

Step 2. Connect a jumper wire between TB4-1 and TB4-5 on automatic control module.

If generator set starts, automatic control module is probably at fault. Refer automatic control module to next higher level of maintenance.

If generator set does not start, then it is most probably at fault (refer to paragraph 4-10).

**2. GENERATOR SET STARTS BUT OUTPUT DOES NOT CONNECT TO MAIN POWER BUSS WHEN NORMAL POWER FAILS (SINGLE UNIT OPERATION).**

Step 1. Check AC voltmeter and frequency meter on generator set or remote control module.

If voltage or frequency is out of tolerance, ( $\pm 3$  percent frequency,  $\pm 10$  percent voltage) then generator set is most probably at fault (refer to paragraph 4-10).

If voltage and frequency is within tolerances, proceed to next step.

Step 2. Connect a jumper wire across TB3-1 and TB3-2 (assuming generator in suspect is connected to set #1 terminals per ACM/GEN interconnection diagram).

If generator set output connects to main power buss, automatic control module is most likely at fault providing 120 V.A.C. is present at TB2-5. Refer automatic control module troubleshooting to next higher level of maintenance.

If generator set out put does not connect to main power buss, then generator set is most probably at fault (refer to paragraph 4-10).

**Table 5-6. Automatic Control Module Troubleshooting (Organizational Level)**

MALFUNCTION
TEST OR INSPECTION
CORRECTIVE ACTION

**1. GENERATOR SET DOES NOT START WHEN NORMAL POWER FREQUENCY GOES OUT OF TOLERANCE (SINGLE UNIT OPERATION).**

Table 5-6. Automatic Control Module Troubleshooting (Organizational Level)-Continued

MALFUNCTION
TEST OR INSPECTION
CORRECTIVE ACTION

**WARNING**

**Death or injury may result if proper care is not taken while working with the various voltages in and around the generator set.**

NOTE

The frequency of normal power is observable at the associated switchgear control.

Step 1. If frequency is over required rating and NORMAL POWER AVAILABLE indicator lamp is lit, inspect (using a multimeter set to measure AC) for 120 V AC across Overfrequency Device 81N-0 relay 7-5 contacts (figure 2-19).

If 120V AC is present, refer testing and replacement of 81N-0 relay to next higher level of maintenance.

If 120V AC is absent, refer testing and replacement of TD relay to next higher level of maintenance.

Step 2. If frequency is under required rating and NORMAL POWER AVAILABLE indicator lamp is lit, inspect (using a multimeter set to measure AC) for 120V AC across Underfrequency Device 81N-U relay 6-5 contacts (figure 2-19).

If 120V AC is present, refer testing and replacement of 81N-U relay to next higher level of maintenance.

If 120V AC is absent, refer testing and replacement of TD relay to next higher level of maintenance.

Step 3. If NORMAL POWER AVAILABLE indicator lamp is not lit, refer testing and replacement of Run Relay (RR) to next higher level of maintenance.

2. GENERATOR SET DOES NOT START WHEN NORMAL POWER VOLTAGE GOES OUT OF TOLERANCE.

NOTE

The voltage level of normal power is observable at the associated switchgear control.

**Table 5-6. Automatic Control Module Troubleshooting (Organizational Level)-Continued**

MALFUNCTION
TEST OR INSPECTION
CORRECTIVE ACTION

Step 1. If NORMAL POWER AVAILABLE indicator lamp is lit, inspect (using a multimeter set to measure AC) for 120V AC across Undervoltage Device 27/59N relay 6-5 contacts.

If 120V AC is present, refer testing and replacement of 27/59N relay to next higher level of maintenance.

If 120V AC is absent, refer testing and replacement of TD relay to next higher level of maintenance.

Step 2. If NORMAL POWER AVAILABLE indicator lamp is not lit, refer testing and replacement of RR relay to higher level of maintenance.

3. GENERATOR MAIN CIRCUIT BREAKER DOES NOT CLOSE DURING EMERGENCY SWITCHOVER (SINGLE UNIT OPERATION).

NOTE

Generator set operation is assumed to be normal.

Step 1. Using a multimeter (set to measure DC), inspect for 24V DC across TB3-1 and TB3-2.

If 24V DC is present, refer testing and replacement of MR relay to higher level of maintenance.

If 24V DC is absent, proceed to next step.

Step 2. Connect a jumper across TB4-1 and TB3-1.

4. GENERATOR OUTPUT DOES NOT CONNECT TO CRITICAL LOAD (LRI).

Using a multimeter (set to measure DC) check for 24V DC at coil of LR1 relay.

If present, refer to testing and replacement of LRI relay to next higher level of maintenance.

If absent connect a jumper from TB4-1 to R1 diode pack terminal 5.

If critical load is activated, refer testing and replacement of BR1 relay to next higher level of maintenance.

If jumper does not correct problem, remove jumper and refer testing and replacement of R1 diode pack assembly to next higher level of maintenance.

**Table 5-6. Automatic Control Module Troubleshooting (Organizational Level)-Continued**

MALFUNCTION	TEST OR INSPECTION	CORRECTIVE ACTION
-------------	--------------------	-------------------

**5. ADDITIONAL GENERATOR OUTPUTS DO NOT CONNECT LESSER PRIORITY FEEDER BREAKERS.**

Using a multimeter check for 24V DC at coil of LR2, 3 or 4 relays.

If present, refer to testing and replacement of LR2, 3 or 4 relays to next higher level of maintenance.

If absent connect a jumper from TB4-1 to R2 diode pack terminal 5 for checking LR2, or from TB4-1 to R2 diode pack terminal 2 for checking LR3.

If critical load is activated, refer testing and replacement of BR2, BR3 or BR4 relay to next higher level of maintenance.

If jumper does not correct problem, remove jumper and refer testing and replacement of R2 diode pack assembly to next higher level of maintenance.

**6. GENERATOR OUTPUT CONNECTS TO FEEDER LINES BUT FEEDER LINES 2, 4, 6 OR 8 ARE INOPERATIVE.**

Using a multimeter, check for 24V DC at LRTD1, 2, 3 or 4 whenever LR1, LR2, LR3 or LR4 is energized respectively.

If voltage is present refer testing and replacement of LRTD relays to next higher level of maintenance.

**Section V . HOUSING KIT**

5-21. GENERAL. The housing kit encloses the generator set and is removable to provide access for overhaul or replacement of major components. The housing is attached to the base assembly and the support frame assembly to provide a rain proof enclosure, and prevent rain, snow, or sand from entering the interior of the housing. With the housing kit installed, the generator set can be operated at ambient temperatures from 125°F (52°C) down to -25°F (-32°C). The housing doors allow access to the inside of the generator set. The shutter assembly at the radiator end of the generator set is automatically controlled and maintain correct operating temperatures for the

generator set. Major components of the housing kit include panels, doors, shutters, electrical harness, exhaust breather, and necessary hardware items for kit assembly.

Louver control relays K60 through K63, and fuses F61 thru F63 in External Power Box (figure 5-4) louver motor pilot switches S60 through S63, and louver motors B10 through B13 (capable of two way operation) control the four louver assemblies. When the engine starts each louver control relay energizes and 24 V DC is applied, by way of the louver motor pilot switches, to the louver motors and the louvers

open. Upon reaching their full-open position the louvers set the travel-limit switches to their opposite position, deactivating the louver motors. Louver operation at shutdown is exactly the same except that the motors operate in a reverse direction and 24V DC is applied through the normally closed contacts of the deenergized louver control relays.

The shutter assembly (there are two) is automatically operated by a hydraulic control assembly (figure 5-5) through which coolant is allowed to flow. With the engine cold, the spring-loaded shutters are held closed by the control assembly. As the coolant warms, the hydraulic medium (wax) melts. The control assembly relaxes its hold and allows the shutters to open. There is a direct correlation between coolant temperature and the extent of shutter opening.

5-22. **INSTALLATION.** The housing kit is installed by mounting its component sections directly onto the base assembly and the support frame assembly in the following sequence: door and shutter assembly, left side, front (radiator end), right side, rear, top, and electrical harness. Installation/assembly is normally performed at the Direct Support Maintenance level.

5-23. **LUBRICATION.** The housing kit door and shutter assemblies, access doors, and all moving parts require lubrication in accordance with the lubrication order LO5-6115-593-12. Army personnel shall refer to DA PAM 310-4 and Marine Corps personnel to SL-1-3 to ensure that the latest edition of the lubrication order (LO) is being used.

5-24. **PREVENTIVE MAINTENANCE CHECKS AND SERVICES (A, N, MC).** To ensure that the housing kit is always ready for operation, inspect systematically so that defects may be discovered and corrected before they result in serious damage or failure. Perform the preventive maintenance checks and services in accordance with table 5-7. Air Force users shall refer to the applicable inspection manuals and work card sets in T.O. 35C2-3-series for periodic maintenance requirements and table 5-7 for detailed procedures. Marine Corps users shall refer to the current issue of TM 11275-15/1.

5-25. **ORGANIZATIONAL TROUBLESHOOTING.** Table 5-8 contains information for locating and correcting operating troubles which may develop in the generator set when equipped with the housing kit. Each malfunction is followed by a list of tests or inspections to determine probable causes and corrective actions. Perform the tests or inspections and corrective actions in the order listed. Any trouble beyond the scope of organizational maintenance shall be referred to the next higher level of maintenance.

5-26. **ORGANIZATIONAL MAINTENANCE OF THE HOUSING KIT.**

a. Inspection. (See figure 5-5.)

- (1) Inspect the louvers, door panels, and front grille for cracks, loose mounting, loose or missing hardware, rust or corrosion.
- (2) Inspect the weather stripping around each door assembly for peeling of adhesive backing, excessive wear, rot, or damage.
- (3) Inspect all connectors in the wiring harness for damaged threads, and bent, loose, or missing pins. Check all connections for security and condition. Check all wiring for defective or worn insulation.

**WARNING**

**Set MAINTENANCE LOCKOUT switch to LOCKOUT. Disconnect negative cable from batteries. Remove external power by opening CB101 (120V RECEPTACLE BREAKER). Load terminals of generator set circuit breaker (CB2) may still be energized with the bus voltage.**

- b. Test. Refer to FO-17 and perform a continuity check of the harness assembly using an ohmmeter between connecting points in the wiring harness. Check for short circuits between connector pins of the same receptacle, plug, or terminal board.

**Table 5-7. OPERATOR/CREW PREVENTIVE MAINTENANCE CHECKS AND SERVICES, HOUSING KIT.**

NOTE: Within designated interval, these checks are to be performed in the order listed.

B-Before  
D-During

A-After

Item No.	INTERVAL			ITEMS TO BE INSPECTED	PROCEDURES CHECK FOR AND HAVE REPAIRED OR ADJUSTED AS NECESSARY	EQUIPMENT IS NOT READY/ AVAILABLE IF:
	B	D	A			
1	o			Weather Stripping	Excessive wear, rot or damage. Inspect for breaks, cracks, loose mounting, loose or missing hardware, corrosion, or rust.	

**Table 5-8. Housing Kit Troubleshooting**

<p>MALFUNCTION TEST INSPECTION CORRECTIVE ACTION</p>
--

1. LOUVERS FAIL TO OPERATE PROPERLY.

Observe if one or all louvers fail to operate.

If all louvers fail to operate, check wiring harness between louver circuits and 24V DC buss.

If only one louver fails to operate, refer testing and replacement of relay (K60 through K63), limit switches (S60 through S63), and motors (B10 through B13) associated with malfunctioning louver (refer to next higher level of maintenance).

2. RADIATOR SHUTTER FAILS TO OPERATE.

Visually inspect shutter assembly for broken springs, jammed shutters, and leaking coolant or hydraulic fluid at control assembly. Refer to paragraph 5-33 for housing kit maintenance procedure.

c. Repair of Harness Assembly.

(1) If a broken wire is accessible, remove sufficient insulation from each side of the break to allow a good connection of the bared ends by twisting them together. Solder the connection and wrap with electrical tape.

(2) If a wire is broken from a terminal lug, replace the lug. If a wire is broken from a connector, resolder and reassemble.

**CAUTION**

Under no condition leave the bare connection exposed.



- (3) If a break in the wire is inaccessible within the wiring harness, disconnect it at both ends and tape both ends. Lace a new lead of the same gauge and insulation outside the harness and connect it to the proper terminals or pins. Properly tag both ends of all replacement wires.

from a small (six-inch) section of the new stripping and pressing into place. Peel off additional backing as necessary, and continue to press stripping into place until completed.

NOTE

d. Replacement.

Do not "patch" one section of stripping on any component panel. Replace the all weather stripping around any panel.

- (1) Weather stripping. If weather stripping is damaged, rotten or defective, remove by peeling stripping off the panel or access door. Lightly scrape metal to remove any pieces of stripping which remain. Install fresh weather stripping by removing backing

- (2) Harness assembly. If 30 percent of the harness wires are defective, refer to next higher level of maintenance for replacement.

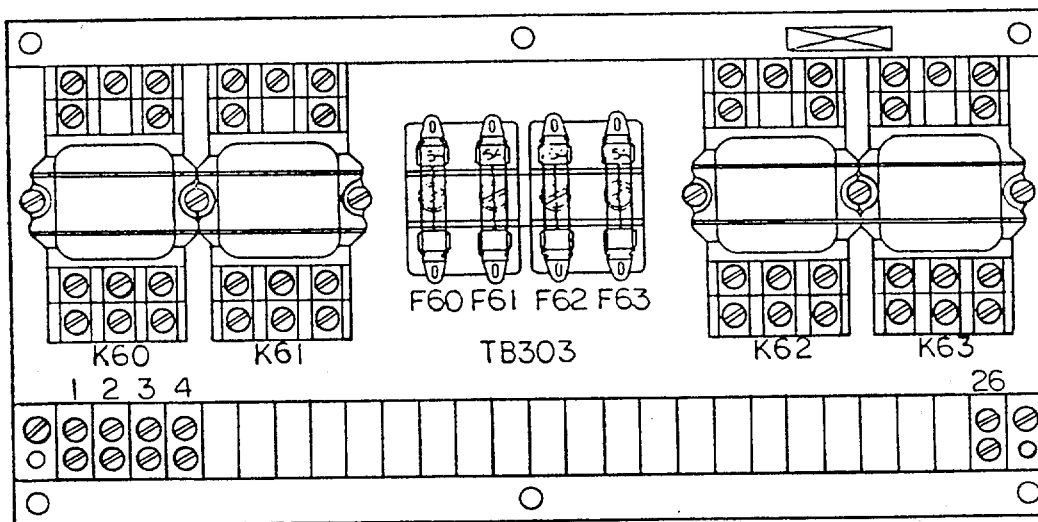

Figure 5-4. Actuator Control Relay Assembly

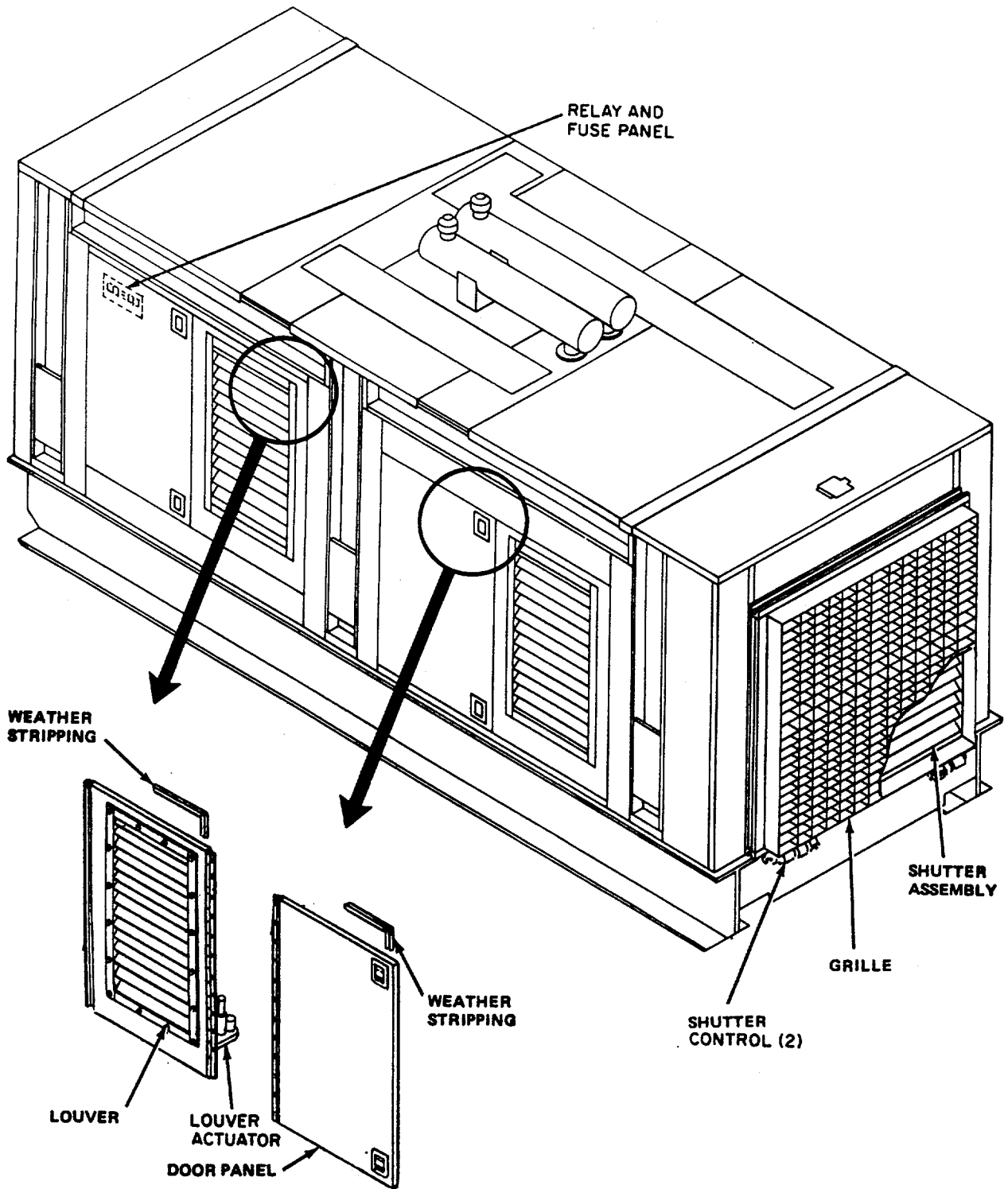

Figure 5-5. Housing Kit, Installed on Generator Set.

## APPENDIX A

### REFERENCES

- |      |  |  |
|------|--|--|
| A-1. | Fire Protection<br>TB 5-4200-200-10  | Hand Portable Fire Extinguishers Approved by Army Users.   |
| A-2. | Lubrication<br>C9100-IL<br>L0-5-6115-593-12<br>LI-6115-12/1  | Identification List for Fuels, Lubricants, Oils and Waxes.<br><br>Lubrication Order  |
| A-3. | Painting<br>T.O. 35-1-3<br><br>TM 43-0139  | Painting and Marking of USAF Aerospace Ground Equipment.<br><br>Painting Instructions for Field Use.   |
| A-4. | Radio Suppression<br>MIL-STD-461<br><br>TM 11-483  | Radio Interference Suppression<br><br>Radio Interference Suppression   |
| A-5. | Maintenance<br>T.O. 00-25-225<br><br>T.O. 00-25-234<br><br>T.O. 1-1-1<br><br>T.O. 1-1-2<br><br>T.O. 1-1A-14<br><br>T.O. 35-1-75<br><br>T.O. 35-1-11<br><br>T.O. 35-1-12<br><br>T.O. 35-1-26<br><br>T.O. 35-1-524<br><br>TB 750-651 | Repair of External Power Cables, Aerospace Ground Equipment.<br><br>General Shop Practice Requirements for the Repair, Maintenance and Test of Electrical Equipment.<br><br>Cleaning of Aerospace Equipment.<br><br>Corrosion Control and Treatment for Aerospace Equipment.<br><br>Installation Practices for Aircraft Electric and Electronic Wiring.<br><br>General Maintenance practices.<br><br>Organization, Intermediate and Depot Level Maintenance for FSC 6115 Non-Airborne Equipment.<br><br>Components and Procedures for Cleaning Aerospace Ground Equipment.<br><br>Repair/Replacement Criteria for FSC 6115 Aerospace Ground Equipment.<br><br>USAF Equipment Registration Number System Applicable to FSC 6115 Equipment.<br><br>Use of Antifreeze Solutions and Cleaning Compounds in Engine Cooling Systems. |

APPENDIX A - CONTINUED

REFERENCES

- |      |  |  |   |
|------|--|--|---|
| A-5. | Maintenance (cont'd)<br>DA Pam 738-750<br><br>TM5-6115-593-12<br>T.O. 35C2-3-463-1<br>NAVFAC P-8-631-12<br><br>TM5-6115-593-34<br>T.O. 35C2-463-2<br>NAVFAC P-8-631-34<br><br>TM5-6115-593-24P<br>NAVFAC P-8-631-24P<br>TM9-6140-200-14<br>T.O. 35C2-3-463-4 |  | The Army Maintenance Management System (TAMMS).<br>Operator/Crew and Organizational Maintenance Manual.<br><br>Intermediate (Field) (Direct and General Support) and Depot Level Maintenance Manual.<br><br>Organizational, Intermediate (Field) (Direct and General Support) and Depot Maintenance Repair Parts and Special Tools List.  |
| A-6. | Shipment and Storage<br>T.O. 35-1-4<br><br>T.O. 38-1-5<br><br>TB 740-97-2<br><br>TM 38-250   |  | Processing and Inspection of Aerospace Ground Equipment for Storage and Shipment.<br><br>Processing and Inspection of Non-Mounted, Non-Aircraft Gasoline and Diesel Engines for Storage and Shipment.<br><br>Preservation of USAMEC Mechanical Equipment for Shipment and Storage.<br><br>Packaging and Materials Handling, Preparation of Hazardous Materials for Military Air Shipment. |
| A-7. | Destruction of Material<br>TM 750-244-3  |  | Procedures for Destruction of Equipment to Prevent Enemy Use.   |
| A-8. | Radioactive Material<br>TB 750-248   |  | Instructions for Safe Handling, Maintenance, Storage, and Disposal of Radioactive Commodities Managed by U.S. Army Mobility Equipment Command.  |

## APPENDIX B

### BASIC ISSUE ITEM LIST AND ITEMS TROOP INSTALLED OR AUTHORIZED LIST

#### Section I. INTRODUCTION

B-1. SCOPE. This appendix lists integral components of and basic issue items for the 500 KW 50/60 HZ DOD generator set to help you inventory items required for safe and efficient operation.

B-2. GENERAL. This component of end item list is divided into the following sections:

- a. Section II. Integral Components of the End Item. These items, when assembled, comprise the 500 KW 50/60 HZ DOD generator set and must accompany it whenever it is transferred or turned in. The illustrations will help you identify these items.
- b. Section III. Basic Issue Items. These items are furnished with 500 KW 50/60 HZ DOD generator set and must accompany the generator set when transferred between accountable officers. This manual is your authority to requisition replacement BII.
- c. Section IV. Troop Installed or Authorized List. These items are authorized on and as required basis. This manual is your authority to requisition troop installed or authorized items.

B-3. EXPLANATION OF COLUMNS.

(1) Illustration. This column is divided as follows:

- (a) Figure number. Indicates the figure number of the illustration on which the item is shown.
- (b) Item Number: The number used to identify item called out in the illustration.

(2) National Stock Number. Indicates the

national stock number assigned to the item and which will be used for requisitioning.

- (3) Part Number. Indicates the primary number used by the manufacturer, which controls the design and characteristics of the item by means of its engineering drawing, specifications, standards and inspection requirements to identify an item or range of items.
- (4) Description. Indicates the Federal item name and, if required, a minimum description to identify the item.
- (5) Location. The physical location of each item listed is given in this column. The lists are designed to inventory all items in one area of the major item before moving on to an adjacent area.
- (6) Usable On Code. Usable on codes are included to help you identify which component items are used on the different models. Items in the enclosed lists are used on all models of the 500 KW 50/60 HZ DOD generator set model MEP 029A.
- (7) Quantity Required (QTY Reqd.). This column lists the quantity of each item required for a complete major item.
- (8) Quantity. This column is left blank for use during an inventory. Under the RCV'D column list the quantity you actually receive on your major item. The date columns are for your use when you inventory the major item at a later date; such as for shipment to another site.

**Section II. INTEGRAL COMPONENTS OF END ITEM**

(1) ILLUSTRATION		(2) NATIONAL STOCK NUMBER	(3) PART NO.	(4) DESCRIPTION	(5) LOCATION	(6) USABLE ON CODE	(7) QTY REQD	(8) QUANTITY			
(a) FIGURE NO.	(b) ITEM NO.							RCV'D	DATE	DATE	DATE

**Section III. BASIC ISSUE ITEMS**

(1) ILLUSTRATION		(2) NATIONAL STOCK NUMBER	(3) PART NO.	(4) DESCRIPTION	(5) LOCATION	(6) USABLE ON CODE	(7) QTY REQD	(8) QUANTITY				
(a) FIGURE NO.	(b) ITEM NO.							RCV'D	DATE	DATE	DATE	
B-1	1	5120-01- 013-1676	MS28741 16-2880 (96906)	Hose Fuel Aux			1					
B-1	2		76-11418 (30554)	Sling Assy			2					
B-1	3				Hammer, Slide			1				
B-1	4			13228E3 384	Cable, Ground			1				

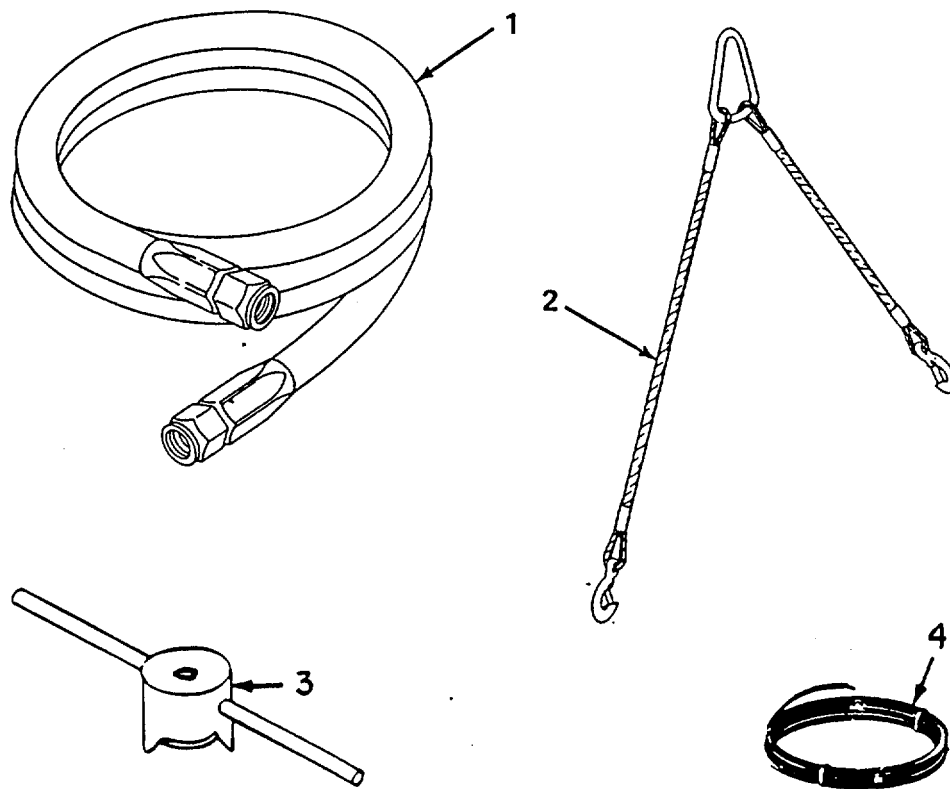

Figure B-1. Basic Issue Items

Section IV. TROOP INSTALLED OR AUTHORIZED LIST

(1) SMR CODE	(2) NATIONAL STOCK NUMBER	(3) DESCRIPTION	(4) UNIT OF MEASURE	(5) QUANTITY AUTHORIZED
PAC	5975-00-878-3791	Rod, Ground, Assy	EA	1
PAC	4210-00-555-8837	Extinguisher  Fire, MONOBROMOTRI- FLUOROMETHANE, with Bracket, Operating Temperature Range- Minus 50°F to plus 120°F	EA	1
PAC	4210-00-708-0031	Replacement Cylinder for 4210- 00-555-8837	EA	1

## APPENDIX C

### MAINTENANCE ALLOCATION CHART

#### Section I. INTRODUCTION

##### C-1. GENERAL.

- a. This section provides a general explanation of all maintenance and repair functions authorized at various maintenance levels.
- b. Section II designates overall responsibility for the performance of maintenance functions on the identified end item or component. The implementation of the maintenance functions upon the end item or component will be consistent with the assigned maintenance functions.
- c. Section III lists the tools and test equipment required for each maintenance function as referenced from Section II.
- d. Section IV contains supplemental instructions, explanatory notes and/or illustrations required for a particular maintenance function.

(A through K) and indicates the lowest maintenance category authorized to perform these functions. The symbol designations for the various maintenance categories are as follows:

- C - Operator or Crew
- O - Organizational maintenance
- F - Direct support maintenance
- H - General support maintenance
- D - Depot maintenance

The maintenance functions are defined as follows:

- A - Inspect. To determine serviceability of an item by comparing its physical, mechanical, and electrical characteristics with established standards.
- B - Test. To verify service-ability and to detect electrical or mechanical failure by use of test equipment.
- C - Service. To clean, to preserve, to charge, and to add fuel, lubricants, cooling agents, and air. If it is desired that elements, such as painting and lubricating, be defined separately, they may be so listed.
- D - Adjust. To rectify to the extent necessary to bring into proper operating range.
- E - Align. To adjust specified variable elements of an item to bring to optimum performance.
- F - Calibrate. To determine the corrections to be made in the readings of instruments or test equipment used in precise measurement. Consists of the comparison

##### C-2. EXPLANATION OF COLUMNS IN SECTION II.

- a. Group Number. Column 1. The assembly group is a numerical group assigned to each assembly in a top down breakdown sequence. The applicable assembly groups are listed on the MAC in disassembly sequence beginning with the first assembly removed in a top down disassembly sequence.
- b. Assembly Group. Column 2. The column contains a brief description of the components of each assembly group.
- c. Maintenance Functions. Column 3. This column lists the various maintenance functions



of two instruments, one of which is a certified standard of known accuracy, to detect and adjust any discrepancy in the accuracy of the instrument being compared with the certified standard.

- G - Install. To set up for use in an operational environment such as an emplacement, site, or vehicle.
- H - Replace. To replace unserviceable items with serviceable like items.
- I - Repair. Those maintenance operations necessary to restore an item to serviceable condition through correction of material damage or a specific failure. Repair may be accomplished at each category of maintenance.
- C-3. J - Overhaul. Normally, the highest degree of maintenance performed by the Army in order to minimize time work in process is consistent with quality and economy of operation. It consists of that maintenance necessary to restore an item to completely serviceable condition as prescribed by maintenance standards in technical publications for each item of equipment. Overhaul normally does not return an item to like new, zero mileage, or zero hour condition.
- C-4. K - Rebuild. The highest degree of material maintenance. It consists of restoring equipment as nearly as possible to new conditions in accordance with original manufacturing standards. Rebuild is performed only when required by operational considerations or other paramount factors and then only at the depot maintenance category. Rebuild reduces the zero the hours or miles the equipment, or component thereof, has been in use.

- d. Symbols. The uppercase letter placed in the appropriate column indicates the lowest level at which that particular maintenance function is to be performed.
- e. Tools and Equipment. Column 4. This column is provided for referencing by code, the special tools and test equipment (Section III) required to perform the maintenance functions.
- f. Remarks. Column 5. This column is provided for referencing by code, the remarks (Section IV) pertinent to the maintenance functions.

#### EXPLANATION OF COLUMNS IN SECTION III.

- a. Reference Code. This column consists of a number and a letter separated by a dash. The number references the T and TE requirements column on the MAC. The letter represents the specific maintenance function the item is to be used with. The letter is representative of columns A through K on the MAC.
- b. Maintenance Category. This column shows the lowest level of maintenance authorized to use the special tool or test equipment.
- c. Nomenclature. This column lists the name or identification of the tool or test equipment.
- d. Tool Number. This column lists the manufacturer's code and part number, or National Stock Number of tools and test equipment.

#### EXPLANATION OF COLUMNS IN SECTION IV.

- a. Reference Code. This column consists of two letters separated by a dash, both of which are references to Section II. The first letter references column 5 and the second letter references a maintenance function, column, A through K.

b. Remarks. This column lists information pertinent to the maintenance function being performed, as indicated on the MAC, Section II.

**SECTION II. MAINTENANCE ALLOCATION CHART**

(1) G R O U P  N O	(2) A S S E M B L Y G R O U P	(3) M A I N T E N A N C E F U N C T I O N S										(4) T O O L S  A N D  E Q U I P - M E N T	(5) R E M A R K S	
		A	B	C	D	E	F	G	H	I	J			K
		I N S P E C T	T E S T	S E R V I C E	A D J U S T	A L I G N	C A L I B R A T E	I N S T A L L	R E P L A C E	R E P A I R	O V E R H A U L			R E B U I L D
01	BATTERIES & RELATED ITEMS												1-B	
	Cables	C						O	O					A, B
	Batteries	C	O	O				O	O				C	
02	MUFFLER, EXHAUST												2-B&I 3-B&I	
	Muffler	C						O						A
	Gaskets	C						O						A
	Exhaust & Rain Cap	C						O					A	
03	EXTERNAL POWER BOX ASSY													
	Control Panel	O							O				A, D	
	Receptacles	C						O					A	
	CB (CB101)	C	O					O					A, E	
	Switch, Pre-Heat (S105)	C	O					O					A, C	
	Circuit Breakers	C	O					O					A, E	
	Plate & Sleeve Assy	C						O					A	
	Contractors, HTR (K107) (K109)	O	O					O	F				A, E	
	Transfer Cont (K108)	O	O					O	F				A	
	Contactor, Motor (K120)	O	F					F	F				E	
	Weather Stripping, Seals	O						O					A	
	Harness Assy		O					F	O				A, K	

SECTION II. MAINTENANCE ALLOCATION CHART (Cont)

(1) G R O U P  N O	(2) A S S E M B L Y G R O U P	(3) M A I N T E N A N C E F U N C T I O N S										(4) T O O L S  A N D  E Q U I P - M E N T	(5) R E M A R K S	
		A	B	C	D	E	F	G	H	I	J			K
		I N S P E C T	T E S T	S E R V I C E	A D J U S T	A L I G N	C A L I B R A T E	I N S T A L L	R E P L A C E	R E P A I R	O V E R H A U L			R E B U I L D
04	AC & DC CONTROL BOX ASSY												2-B&I 3-B&I	
	Control Panel	O						O	O					A
	Recept (J104-J109)	C						O						A
	Circuit Breaker CB103	C	O					O						A
	Conv, AC (J103)	C						O						A
	Switches	C	O					O						A
	Harness Assy		O					F	O					A, K
	Relays	O	F					F						A, E
	Weather Stripping, Seals	O						O						A
	Battery Charger (BCI)	F	F					F	F					A, D, E
	Diodes, Resistors, Capacitors		F					F						E
	Governor (A106)	F	F		F			F	F					A, K
	Circuit Cards		F					F	F					A, E, K
	Potentiometer, Manual	C	O					O						A
	Voltage Regulator	F	F					F	H					A, D, F, K
	Short Plug	C	O					O						A, E
	Shunt, DC amp	C	O					F						A, F
	Potentiometer, Motor Driven	O	F					F	H					A, F
05	CONTROL CUBICLE												2-B&I 3-B&I	
	Transducer, Elect. Signal	O	F					F						A, K
	Horn, Alarm		F					F						A
	Transformers	C	F					F						A

SECTION II. MAINTENANCE ALLOCATION CHART (Cont)

(1) G R O U P  N O	(2) A S S E M B L Y G R O U P	(3) M A I N T E N A N C E F U N C T I O N S										(4) T O O L S  A N D  E Q U I P - M E N T	(5) R E M A R K S		
		A	B	C	D	E	F	G	H	I	J			K	
		I N S P E C T	T E S T	S E R V I C E	A D J U S T	A L I G N	C A L I B R A T E	I N S T A L L	R E P L A C E	R E P A I R	O V E R H A U L			R E B U I L D	
	CONTROL CUBICLE (Continued)														
	Annunciator Control Assy	F							F	F					F
	Relays	O	F		F				F						A
	Diodes, Resistors, Capacitors		F						F						E
	Flashing Circuit, PC (FCI)		F						F						F
	Time Delay Module (TD2)	O	F						F	F					A, G
	Gauges and Instruments	C							O						A, K
	Digital Clock		F						F						F
	Switches	C							O						A
	Harness Assy		O						F	O					A, K
	Lamps	C							C						A
	Synchroscope	F	F						F						A
	Circuit BKR	C	O						O						A, E
	Telephone Jack	C							O						A
06	AIR CLEANER ASSY	C	C	O					O						A
	Air Shut-Off Valve	O	O						O						A, F
	Element	C							O						A
	Indicator	C							O						A
	Ducts and Hoses	O							O						A
07	TOOL BOX ASSY								O	O					H

SECTION II. MAINTENANCE ALLOCATION CHART (Cont)

(1) G R O U P  N O	(2) A S S E M B L Y G R O U P	(3) M A I N T E N A N C E F U N C T I O N S										(4) T O O L S  A N D  E Q U I P - M E N T	(5) R E M A R K S					
		A	B	C	D	E	F	G	H	I	J			K				
		I N S P E C T	T E S T	S E R V I C E	A D J U S T	A L I G N	C A L I B R A T E	I N S T A L L	R E P L A C E	R E P A I R	O V E R H A U L			R E B U I L D				
08	DOCUMENT COMP								O	O							A	
09	SUPPORT FRAME ASSY																	A
	Tie Bars		O							F								
	Support Frame, Frt		O							F								
	Support Frame, Center		O							F								
	Support Frame, Rear		O							F								
10	RADIATOR ASSY																	
	Radiator		C	F	C					F	F				4-B 5-B			A
	Indicator, Sight Valve		O							F								
	Hoses		O							O								
	Belt, Fan		C			O				O								
	Motor		O	F						F	F							
	Fan and Bearing		F							F								
11	FUEL LINE AND FITTINGS		C							O								A
12	ENGINE PREHEAT																	
	Switch, Thermo		O	O						O								A
	Heater, Coolant		O	O						O								A, E
	Heater, Lube		O	O						O								A, E
	Valves, Ball			F						F								F
	Hose and Fittings		O							O								A
	Junction Box		F							F								A, E

SECTION II. MAINTENANCE ALLOCATION CHART (Cont)

(1) G R O U P  N O	(2) A S S E M B L Y G R O U P	(3) M A I N T E N A N C E F U N C T I O N S										(4) T O O L S  A N D  E Q U I P - M E N T	(5) R E M A R K S	
		A	B	C	D	E	F	G	H	I	J			K
		I N S P E C T	T E S T	S E R V I C E	A D J U S T	A L I G N	C A L I B R A T E	I N S T A L L	R E P L A C E	R E P A I R	O V E R H A U L			R E B U I L D
13	FUEL TRANSFER PUMP													
	Pump	O	O	O				F	F					A
	Solenoid Valve		F					F						F
	Filter & Strainer	C		C				O						A
	Strainer	C		C				O						A
14	FUEL TANK ASSY													
	Level Switch, Fuel	C	O					O						F
	Transmitter	C	O					O						F
	Fittings	O						O						A
15	INTERCONNECTING ELECTRICAL HARNESS	C	O					F	O				2-B&I	E, K
16	GENERATOR & RECONNECTION ASSY													
	Harness and Cable	F						F	F					A, K
	Reconnection Board	O						F						A, K
	Switch, Limit		F					F						E
	Bus Bar	O						F						A
	Current Transformer	F	F					F						A, K
	Generator	O	F					F	F	H	D			A, R
	Permanent Magnet Stator & Frame Assy	F	F					F						A, K
	Permanent Magnet Rotor Assy	F	F					F	D	D				A, R
	Rectifier Rotating	F	F					F	F					A, K

SECTION II. MAINTENANCE ALLOCATION CHART (Cont)

(1) G R O U P  N O	(2) A S S E M B L Y G R O U P	(3) M A I N T E N A N C E F U N C T I O N S										(4) T O O L S  A N D  E Q U I P - M E N T	(5) R E M A R K S	
		A	B	C	D	E	F	G	H	I	J			K
		I N S P E C T	T E S T	S E R V I C E	A D J U S T	A L I G N	C A L I B R A T E	I N S T A L L	R E P L A C E	R E P A I R	O V E R H A U L			R E B U I L D
16	GENERATOR & RECONNECTION ASSY (Continued)													
	Bearing		O						F					A, K
	Drive Plate Assy		O						F					A, K
	Fan		F						F					A, K
	Rotor Assy		F	F					F	D		D		A, K
	Exciter Stator		F	F					F	D		D		A, K
	Exciter Armature		F	F					F	D		D		A, K
	Frame & Stator Combination		F	F					F	D		D		A, K
17	ACTUATOR, ELECTRIC HYDRAULIC		C	F	O	F			F	F	H			A, K
18	ETHER KIT		C	O	C				O	O				A, F
19	ENGINE ASSY													
	Engine		O	F	C	F			F	H	H			A, K
	Belt, Water Pump		C			O			O					A, K
	Filters, Water				O									I
	Speed Switch and Drive													
	Speed Switch		C	O		F			O	F				A
	Adapter		C						F					A
	Tach Drive		F						F	F			6-I	A

SECTION II. MAINTENANCE ALLOCATION CHART (Cont)

(1) G R O U P  N O	(2) A S S E M B L Y G R O U P	(3) M A I N T E N A N C E F U N C T I O N S										(4) T O O L S  A N D  E Q U I P - M E N T	(5) R E M A R K S		
		A	B	C	D	E	F	G	H	I	J			K	
		I N S P E C T	T E S T	S E R V I C E	A D J U S T	A L I G N	C A L I B R A T E	I N S T A L L	R E P L A C E	R E P A I R	O V E R H A U L			R E B U I L D	
19	ENGINE ASSY (Continued)														
	Oil Level Sight Gauge and Filler	C							O						A
	Starter Assy	C	O						F	F	H				A
	Brushes	F							F						A
	Solenoid Starter		O						F	F					
	Armature Starter		F						F	F					
	Drive Starter	F	F						F	F					A
	Field Assembly	F	F						F	F					A
	OIL FILTER AND SENSORS														
	Xmtr, Pressure	C	O						O						A
	Xmtr, coolant	C	O						O						A
	Switch, Pressure	O	O						O						A
	Switch, Temperature	O	O						O						A
	Filter, Element, Oil (Spin-on)	C		C					O						A
	Filter, Oil, Bypass	C		O					F						A
	Secondary Fuel Filter Element (Spin-on)	C		O					O						A
	Lube Oil Cooler	O	F						O	F					A
	Breather, Lines & Fittings	O							O						A
	Relief Valve	F	F						F	F					A



SECTION II. MAINTENANCE ALLOCATION CHART (Cont)

(1) G R O U P  N O	(2) A S S E M B L Y G R O U P	(3) M A I N T E N A N C E F U N C T I O N S										(4) T O O L S  A N D  E Q U I P - M E N T	(5) R E M A R K S	
		A	B	C	D	E	F	G	H	I	J			K
		I N S P E C T	T E S T	S E R V I C E	A D J U S T	A L I G N	C A L I B R A T E	I N S T A L L	R E P L A C E	R E P A I R	O V E R H A U L			R E B U I L D
19	OIL FILTER AND SENSORS (Continued)													
	Injector	O	F		F				O	F			7-B&I 8-B&I 9-B&I 10-B&I 11-B&I 12-I 13-I	A, K
	Pump, Fuel Injection	C	F	F	O				F	H	H	D	14-B, I &J 15-B, I &J 16-I&J 17-I&J	A, J, K
	Turbocharger	O							O	F				A, K
	WATER PUMP	C							O	F			18-1	A, K
	THERMOSTAT AND HOUSING													
	Thermostat			O					O					F, K
	Xmtr, Temperature	C	O						O					A
	Switch, Temperature	O	O						O					A
	Damper, Vibration & Crankshaft Pulley	O							F					A
	Idler Pulley Assembly	O							O					A
	Intercooler	O							O					A, K
	Exhaust Manifold	O							O					A, K
	Water Manifold	O							O					A, K
	Engine Front Support	F							F					A
	Oil Pan Assembly	C							F	F				A
	Oil Pump	H	H						H	H				A, F

SECTION II. MAINTENANCE ALLOCATION CHART (Cont)

(1) G R O U P  N O	(2) A S S E M B L Y G R O U P	(3) M A I N T E N A N C E F U N C T I O N S										(4) T O O L S  A N D  E Q U I P - M E N T	(5) R E M A R K S	
		A	B	C	D	E	F	G	H	I	J			K
		I N S P E C T	T E S T	S E R V I C E	A D J U S T	A L I G N	C A L I B R A T E	I N S T A L L	R E P L A C E	R E P A I R	O V E R H A U L			R E B U I L D
19	(Continued)													
	FLYWHEEL HOUSING, VIBRATION DAMPER AND CRANKSHAFT PULLEY													
	Flywheel Assembly													
	Ring Gear	H						H						A, K
	Flywheel	H						H						A, K
	Vibration Damper and Crankshaft Pulley	C						H						
	Housing	H						H						A
	Timing Gear and Cover	H						H						A, K
	CYLINDER HEAD AND VALVE OPERATING MECHANISM													
	Rocker Arm Shaft Assy	O						F	F					A, K
	Rocker Arm Assembly	O		O				F					19-D	A, K
	Pushrod & Tappet	F						F						A, K
	Cylinder Head Assy	F						F	F	H	D		20-I 21-I 22-J 23-J 24-I&J 25-J 26-J 27-A, I, &J	A, K
	Valve Intake and Exhaust	F	F		O			F	F					A, K
	Spring Valve	F	F					F						A, K
	Seats Intake and Exhaust Valves	F						H						A, K
	Valve Spring	F						H						A, K

SECTION II. MAINTENANCE ALLOCATION CHART (Cont)

(1) G R O U P  N O	(2) A S S E M B L Y G R O U P	(3) M A I N T E N A N C E F U N C T I O N S										(4) T O O L S  A N D  E Q U I P - M E N T	(5) R E M A R K S				
		A	B	C	D	E	F	G	H	I	J			K			
		I N S P E C T	T E S T	S E R V I C E	A D J U S T	A L I G N	C A L I B R A T E	I N S T A L L	R E P L A C E	R E P A I R	O V E R H A U L			R E B U I L D			
19	(Continued) CYLINDER HEAD AND VALVE OPERATING MECHANISM (Continued)																
	Head, Cylinder		F						H			H	D				A, K
	Lifters, Valve		H						H								A, K
	Camshaft		H						H								A, K
	PISTON AND RINGS																
	Piston Pin		H						H								A, K
	Connecting Rod		H						H								A, K
	Rod Bearing		H						H								A, K
	Piston Rings		H						H								A, K
	Piston		H						H								A, K
	CRANKSHAFT AND BLOCK																
	Cylinder Sleeves		H						H								A, K
	Main Bearings		H						H								A, K
	Crankshaft		H						H								A, K
	Bushing, Camshaft		H						H								A, K
	Cylinder Block		H						H	H	H	D					A, K
20	BASE ASSY																
	Skid Base		O							F							A, H
	Terminals & Fittings		O						O								
	Hoses		O						O								A
21	REMOTE CABLE ASSY		F						F	F							A

SECTION II. MAINTENANCE ALLOCATION CHART (Cont)

(1) G R O U P  N O	(2) A S S E M B L Y G R O U P	(3) M A I N T E N A N C E F U N C T I O N S										(4) T O O L S  A N D  E Q U I P - M E N T	(5) R E M A R K S	
		A	B	C	D	E	F	G	H	I	J			K
		I N S P E C T	T E S T	S E R V I C E	A D J U S T	A L I G N	C A L I B R A T E	I N S T A L L	R E P L A C E	R E P A I R	O V E R H A U L			R E B U I L D
22	REMOTE CONTROL MODULE												2-B&I 3-B&I	
	Transducer, Elect Signal	O	F						F					A, K
	Gauges & Instruments	C	O						O					A, K
	Transformers	D	F						F					A
	Switches	C	O						O					A
	Diodes, Capacitors, Resistors		F						F					A
	Lamps	C							C					A
	Time Delay Module		F						F	F				A
	Synchroscope	F	F						F					A
	Telephone Jack	C												A
	Annunciator Control Assy		F						F	F				A
	Relays	O	F						F					A
	Horn, Alarm	O	O						O					A
	Flashing Circuit (PC)		F						F					A
23	AUTOMATIC CONTROL MODULE												2-B&I 3-B&I	
	U/O Voltage Device	O	F			F			F					A
	U/F Device	O	F			F			F					A
	O/F Device	O	F			F			F					A
	Time Delay Relay	O	F			F			F					A
	Lamps	C							C					A
	Relays	O	F						F					A

SECTION II. MAINTENANCE ALLOCATION CHART (Cont)

(1) G R O U P  N O	(2) A S S E M B L Y G R O U P	(3) M A I N T E N A N C E F U N C T I O N S										(4) T O O L S  A N D  E Q U I P - M E N T	(5) R E M A R K S	
		A	B	C	D	E	F	G	H	I	J			K
		I N S P E C T	T E S T	S E R V I C E	A D J U S T	A L I G N	C A L I B R A T E	I N S T A L L	R E P L A C E	R E P A I R	O V E R H A U L			R E B U I L D
23	AUTOMATIC CONTROL MODULE (Continued)												2-B&I 3-B&I	
	Switches	O	O						O					A, E
	Fuses		O						O					E
	Fuse Holder	O							F					A
	Synchronizer	O	F						F	F				A
	Rectifiers	C	F						F					A
24	PARALLEL CABLE ASSEMBLIES	F							F	F				A
25	HOUSING KIT	O			F			F	F	F				A
	Weather Stripping, Seals	O							O					A
	Actuators, Louver		F		F				F					F
	Switches, Limit		F						F					E
	Relays		F						F					E
	Shutter Assy	F			F				F					F
	Harness Assy	O	O						F	O				A E

SECTION II. MAINTENANCE ALLOCATION CHART (Cont)

(1) G R O U P  N O	(2) ASSEMBLY GROUP	(3) MAINTENANCE FUNCTIONS										(4) TOOLS AND EQUIP- MENT	(5) REMARKS		
		A	B	C	D	E	F	G	H	I	J			K	
		I N S P E C T	T E S T	S E R V I C E	A D J U S T	A L I G N	C A L I B R A T E	I N S T A L L	R E P L A C E	R E P A I R	O V E R H A U L			R E B U I L D	
26	PARTS KITS														
	Gasket Set, Engine							F							
	Gasket Set, Cylinder Head							F							
	Gasket Set, AFC Fuel Pump							F							
	Kit, Cylinder Sleeve								H						
	Kit, Starter								F						
	Kit, Starter Relay								F						
	Kit, Brush, Electric								F						
	Kit, Starter Solenoid								F						

Section III. TOOLS, TEST AND SUPPORT EQUIPMENT REQUIREMENT

REFERENCE CODE	MAINTENANCE CATEGORY	NOMENCLATURE	NSN
1-B	O	Tester, Battery, Electrolyte solution	6630-00-171-5126
2-B & I	O	Ohmmeter	6624-00-581-2466
3-B & I	F	Multimeter	6625-00-553-0142
4-B	C	Tester, Antifreeze solution	6630-00-247-2968
5-B	F	Tester, Radiator pressure	
6-I	F	Oil Seal Assembly Tool	
7-B & I	F	Test Stand, Injector	
8-B & I	F	Plunger Extension	
9-B & I	F	Tester, Injector leakage	
10-B & I	F	Tester, Spray angle	
11-B * I	F	Holding Fixture	
12-1	F	Retainer Wrench	
13-1	F	Crowfoot Wrench	
14-B, I & J	F	Test Stand, Fuel pump	
15-B, I & J	F	Spring Adjusting Tool	
16-I & J	H	Blockplate, Gear Pump	
17-I & J	H	Ream Fixture	
18-1	F	Puller	
19-D	O	Gage, Thickness	5210-00-221-1999
20-I	F	Holding Tool, Injector	
21-I	F	Testing, Hydrostatic	
22-J	H	Cutter Set	
23-J	H	Cutter Seat	
24-I & J	F	Adapter Wrench	
25-J	H	Grinding Machine, Valve face	4910-00-540-4679
26-J	H	Grinding Kit, Valve seat	4910-00-473-6437
27-A, I & J	F	Micrometers, Inside and outside	

**Section IV. REMARKS**

Ref. Code	Remarks
A	Visual inspection
B	Repaired by fabricating new tables
C	Hydrometer test
D	Repair by replacement of components
E	Continuity test
F	Operational test
G	Repair by replacing defective component
H	Repair by straightening and welding
I	Service by replacement
J	Adjust on engine or using test stand



**APPENDIX D  
ADDITIONAL AUTHORIZATION LIST**

**Section I. INTRODUCTION**

- D-1. **SCOPE.** This appendix lists additional items you are authorized and which may be required for operation of the 500 KW 50/60 HZ DOD generator set used in support of communications systems.
- D-2. **GENERAL.** This list identifies items that do not have to accompany the 500 KW 50/60 HZ DOD generator set and that do not have to be turned in with it. This manual is your authorization to requisition these items as required.
- D-3. **EXPLANATION OF LISTING.** National stock numbers, descriptions, and quantities are provided to help you identify and request the additional items you require to support equipment.

**Section II. ADDITIONAL AUTHORIZATION LIST**

(1) NATIONAL STOCK NUMBER	(2) DESCRIPTION PART NUMBER & FSCM                      USABLE ON CODE	(3) U/M	(4) QTY AUTH
	Remote Control Cable Assy 76-11025 (30554)	EA	1
	Remote Control Module 76-11339 (30554)	EA	1
	Automatic Control Module 691031-001 (30554)	EA	1
	Housing Kit 76-11000 (30554)	EA	1

INDEX

Subject	Paragraph, Figure, Table, Number
A	
AC-DC CONTROL BOX	
Circuit Breaker	
Inspect.....	3-10a
Test .....	4-29a
Replace.....	4-29b
Control Panel	
Inspect.....	4-28b
Replace .....	4-28e
Repair .....	4-28d
Convenience Receptacle, AC (J103)	
Inspect.....	3-10b
Replace .....	4-30
Harness Assembly	
Test .....	4-38b
Repair .....	4-38c
Potentiometer, Manual	
Inspect .....	3-10a
Test .....	4-33a
.....	4-34a
Replace.....	4-33b
.....	4-34b
Potentiometer, Motor Driven	
Inspect.....	4-35
Receptacle (J04-J109)	
Inspect .....	3-10b
Replace .....	4-30
Relays	
Inspect .....	4-37
Short Plug	
Inspect .....	3-10b
Test .....	4-31a
Replace.....	4-31b
Shunt, DC Amp	
Inspect.....	3-10a
Test .....	4-36a
Switch	
Inspect .....	3-10a
Test .....	4-32a
Replace .....	4-32b
ACTUATOR, ELECTRIC HYDRAULIC	
Inspect.....	4-64a
Service .....	4-64b
ADMINISTRATIVE STORAGE.....	1-7
AIR CLEANER	
Inspect.....	3-12a
Service.....	4-42b
Replace .....	4-42e
Air Shut Off Valve	
Inspect .....	4-43a
Test .....	4-43b
Replace.....	4-43c
Ducts and Hoses	
Inspect .....	4-44a
Replace .....	4-44b

INDEX-Continued

Subject	Paragraph, Figure, Table, Number
A-Continued	
Element	
Inspect.....	3-12c
Replace .....	4-42c
Indicator	
Inspect.....	3-12b
Replace .....	4-42d
AUTOMATIC CONTROL MODULE	
Component Inspection .....	5-20a
Mode Selector Switch Test.....	5-20b
Toggle Switch Test .....	5-20c
B	
BASE ASSEMBLY	
Inspect.....	4-89
Replace .....	4-90
Hoses	
Inspect.....	4-89d
Replace .....	4-91
Terminals and Fittings	
Inspect.....	4-89e
Replace .....	4-91
BATTERIES AND RELATED ITEMS	
Batteries	
Inspect.....	3-7a
Test .....	4-16a
Service .....	3-7b
Install.....	4-16b
Replace .....	4-16b
Cables	
Inspect.....	3-7a
Replace .....	4-14a
Repair.....	4-14b
C	
CONTROL CUBICLE	
Circuit Breaker	
Inspect.....	3-11a
Test .....	4-40b
Replace .....	4-40q
Gauges and Instruments	
Inspect.....	3-11a
Replace .....	4-40q
Harness Assembly	
Test .....	4-41b
Repair.....	4-41c
Lamps	
Inspect.....	3-11a
Replace .....	3-11b

INDEX-Continued

Subject	Paragraph, Figure, Table, Number
C-Continued	
Relays	
Inspect.....	4-40a
Switches	
Inspect.....	3-11a
Replace .....	4-40q
Telephone Jack	
Inspect.....	3-11a
Replace .....	3-11b
Time Delay Module (TD2)	
Inspect.....	4-40a
Transducer, Electrical Signal	
Inspect.....	4-40a
Transformers	
Inspect.....	3-11a
D	
DESTRUCTION OF ARMY MATERIEL.....	1-6
DISMANTLING FOR MOVEMENT.....	4-5
DOCUMENT COMPARTMENT	
Replace .....	3-11a
Repair.....	4-40q
E	
ENGINE ASSEMBLY	
Belt, Water Pump	
Inspect.....	3-20a
Adjust .....	4-67a
Replace .....	4-67b
Cylinder Head and Valve Operating Mechanism	
Rocker Arm Assembly	
Inspect.....	4-87a
Adjustment .....	4-87b
Rocker Arm Shaft Assembly	
Inspect.....	4-87a
Filters, Water	
Service .....	4-68
Injector	
Inspect.....	4-77a
Replace .....	4-77b
Lube Oil Cooler	
Inspect.....	4-76a
Replace .....	4-76b
Oil Filters and Sensors	
Breather, Lines and Fittings	
Inspect.....	4-92a
Replace .....	4-92b
Filter, Element, Oil (Spin-on)	
Inspect.....	4-20
Service .....	4-8c
Replace .....	4-74a

INDEX-Continued

Subject	Paragraph, Figure, Table, Number
E-Continued	
Filter, Oil, Bypass	
Inspect .....	4-74b
Service .....	4-8c
Oil Level Gauge and Filler	
Inspect.....	3-20d
Replace .....	4-70
Switch, Pressure	
Inspect.....	4-73a
Test .....	4-73b
Replace .....	4-73e
Transmitter, Pressure	
Inspect.....	3-20j
Test .....	4-72a
Replace .....	4-72b
Pump, Fuel Injector	
Inspect.....	3-20i
Secondary Fuel Filter Element (Spin-on)	
Inspect.....	3-20h
Service .....	3-20m
Replace .....	4-75a
Solenoid Starter	
Test .....	4-71
Speed Switch and Drive	
Adapter	
Inspect .....	3-20b
Speed Switch	
Inspect.....	3-20a
Test .....	4-69b
Replace .....	4-69
Starter Assembly	
Inspect.....	3-20e
Test .....	4-71a
Thermostat and Housing	
Damper, Vibration and Crankshaft Pulley	
Inspect.....	4-83a
Exhaust Manifold	
Inspect. ....	4-85a
Replace.....	4-85b
Idler Pulley Assembly	
Inspect 4-79b	
Replace.....	4-79c
Intercooler	
Inspect 4-84a	
Replace.....	4-84b
Oil Pan Assembly	
Inspect.....	3-20k
Switch, Temperature	
Inspect.....	4-82a
Test .....	4-82c
Replace .....	4-82d
Thermostat	
Test .....	4-80a
Water Manifold	
Inspect.....	4-86a
Replace .....	4-86b

INDEX-Continued

Subject	Paragraph, Figure, Table, Number
E-Continued	
Transmitter, Temperature	
Inspect.....	3-20j
Test.....	4-81a
Replace.....	4-81b
Turbocharger	
Inspect.....	4-78a
Replace.....	4-78b
Water Pump	
Inspect.....	3-20a
Replace.....	4-79a
ENGINE PREHEAT	
Heater (H101 and H102)	
Inspect.....	4-51a
Test.....	4-51b
Replace.....	4-51c
Hose and Fittings	
Inspect.....	4-51a
Replace.....	4-51c
Switch, Thermo Immersion (S30)	
Inspect.....	4-51a
Test.....	4-51b
Replace.....	4-51c
EQUIPMENT CONVERSION.....	4-4
ETHER KIT	
Inspect.....	3-19a
Test.....	4-65a
Service.....	3-19b
Replace.....	4-65d
Repair.....	4-65d
EXTERNAL POWER ASSEMBLY	
Circuit Breaker (CB101)	
Inspect.....	3-9
Test.....	4-20a
Replace.....	4-20b
Circuit Breakers	
Inspect.....	3-9
Test.....	4-24a
Replace.....	4-20
Contactors, Heater (K107) and (K109)	
Inspect.....	4-23a
Test.....	4-23b
Replace.....	4-23c
Control Panel	
Inspect.....	4-19a
Repair.....	4-19c
Harness Assembly	
Test.....	4-27a
Repair.....	4-27c
Plate and Sleeve Assembly	
Inspect.....	3-9
Replace.....	4-25
Receptacles	
Inspect.....	3-9
Replace.....	4-21

INDEX-Continued

Subject

Paragraph,  
Figure, Table,  
Number

E-Continued

Switch, Pre-Heat (S105)	
Inspect.....	3-9
Test.....	4-22a
Replace.....	4-22b
Transfer Contactor (K108)	
Inspect.....	4-23a
Test.....	4-23b
Replace.....	4-23c
Weather Stripping, Seals	
Inspect.....	4-26a
Replace.....	4-26b

F

FUEL LINE AND FITTINGS

Inspect.....	3-14
Replace.....	4-50b

FUEL TANK ASSEMBLY

Fittings	
Inspect.....	4-54a
Replace.....	4-54b
Level Switch, Fuel	
Inspect.....	3-16a
Test.....	4-55a
Replace.....	4-55b
Transmitter	
Inspect.....	3-16b
Test.....	4-56a
Replace.....	4-56b

FUEL TRANSFER PUMP

Filter and Strainer	
Inspect.....	3-15a
Service.....	3-15b
Replace.....	4-53b
Pump	
Inspect.....	4-52a
Test.....	4-52b
Strainer	
Inspect.....	3-15a
Service.....	3-15b
Replace.....	4-53b

G

GENERATOR AND RECONNECTION ASSEMBLY

Bearing	
Inspect.....	4-62
Buss Bar	
Inspect.....	4-60
Drive Plate Assembly	
Inspect.....	4-63

INDEX-Continued

Subject

Paragraph,  
Figure, Table,  
Number

G-Continued

Generator	
Inspect.....	4-61
Reconnection Board	
Inspect.....	4-60

H

HOUSING KIT

Harness Assembly	
Inspect.....	5-26a
Test.....	5-26b
Repair.....	5-26c
Weather Stripping, Seals	
Inspect.....	5-26a
Replace.....	5-26d

I

INSTALLATION OF THE GENERATOR SET .....	4-3
INTERCONNECTING ELECTRICAL HARNESS	
Inspect.....	3-17
Test.....	4-58a
Repair.....	4-58b

L

LEVELS OF MAINTENANCE ACCOMPLISHMENT.....	1-5
LUBRICATION INSTRUCTIONS.....	F3-1b

M

MAINTENANCE FORMS AND RECORDS .....	1-3
MUFFLER, EXHAUST	
Exhaust and Rain Cap	
Inspect.....	3-8
Replace.....	4-18
Gaskets	
Inspect.....	3-8
Replace.....	4-18
Muffler	
Inspect.....	3-18a
Replace.....	4-18

N

NORMAL OPERATING CONDITIONS	
Starting.....	2-4
Stopping.....	2-5



INDEX-Continued

Subject

Paragraph,  
Figure, Table,  
Number

O

OPERATING PROCEDURES

Emergency Operation .....	2-6b
Emergency Stopping.....	2-5c
Exercise of Engine on Standby .....	2-7
Operation with Housing Kit.....	2-9
	F2-9
	F2-10
	F2-11
	F2-12
Operation with Remote Control Module and Cable .....	2-10
	F2-14
	F2-15
	F2-16
	F2-17
	F2-18
Operation with Automatic Control Module .....	2-11
Parallel Operation .....	2-12
	F2-19
	F2-20
	F2-21
Preparation for Starting.....	2-4a
	F2-5
Single Engine Generator Set Operation .....	2-6a
	F2-8
Starting .....	2-4b
	F2-6
Stopping.....	2-5a
	F2-17
Stopping by Safety Devices .....	2-5b
Operation Under Unusual Conditions	
Cold Weather.....	2-13
Dusty or Sandy Areas .....	2-15
Emergency Operation on JP5 Fuel .....	2-20
Extreme Heat.....	2-14
High Altitudes .....	2-18
Salt Water Areas .....	2-17
Snow .....	2-19
Rainy or Humid Conditions .....	2-16

P

PREPARATION FOR SHIPMENT AND STORAGE .....	1-8
PREVENTIVE MAINTENANCE CHECKS AND SERVICES	
PREVENTIVE MAINTENANCE CHECKS AND SERVICES	
Operator/Crew .....	T3-2
Organizational .....	T4-2
Remote Control Module .....	T5-1
Automatic Control Module.....	T5-4
Housing Kit .....	T5-7

INDEX-Continued

Subject	Paragraph, Figure, Table, Number
R	
RADIATOR ASSEMBLY	
Belt, Fan	
Inspect.....	3-13a
Adjust.....	4-49a
Replace.....	4-49b
Hoses	
Inspect.....	4-49e
Replace.....	4-49e
Indicator, Sight Valve	
Inspect.....	4-49d
Motor	
Inspect.....	4-49c
Radiator	
Inspect.....	3-13a
Service.....	3-13b
RADIO INTERFERENCE SUPPRESSION.....	4-11
REMOTE CONTROL MODULE	
Gauges and Instruments	
Inspect.....	5-7a
Test.....	5-9a(4)
Replace.....	3-13b
Horn, Alarm	
Inspect.....	5-9a
Test.....	5-9b
Replace.....	5-9c
Lamps	
Inspect.....	5-7a
Replace.....	5-7b
Relays	
Inspect.....	5-9a
Switches	
Inspect.....	5-9a
Test.....	5-9b
Replace.....	5-9c
Telephone Jack	
Inspect.....	5-7a
Replace.....	5-7b
Transformers	
Inspect.....	5-7a
Transducer, Electrical Signal	
Inspect.....	5-9a
REPORTING OF ERRORS.....	1-4
S	
STANDBY SERVICE.....	2-7
SUPPORT FRAME ASSEMBLY	
Support Frame, Center	
Inspect.....	4-48
Support Frame, Front	
Inspect.....	4-48
Support Frame, Rear	
Inspect.....	4-48
Tie Bars	
Inspect.....	4-48

INDEX-Continued

Subject	Paragraph, Figure, Table, Number
T	
TABULATED DATA .....	1-10
TOOL BOX ASSEMBLY	
Replace .....	4-45a
Repair .....	4-45b
TROUBLESHOOTING	
Operator/Crew .....	T3-3a
Organizational .....	T4-3b
Remote Control Module, Operator/Crew .....	T5-2a
Remote Control Module, Organizational.....	T5-3
Automatic Control Module, Operator/Crew .....	T5-5
Automatic Control Module, Organizational .....	T5-6
Housing Kit .....	T5-8
U	
UNLOADING THE GENERATOR SET.....	4-1

FOR CONTINUATION OF SCHEMATIC SEE SHEET 2

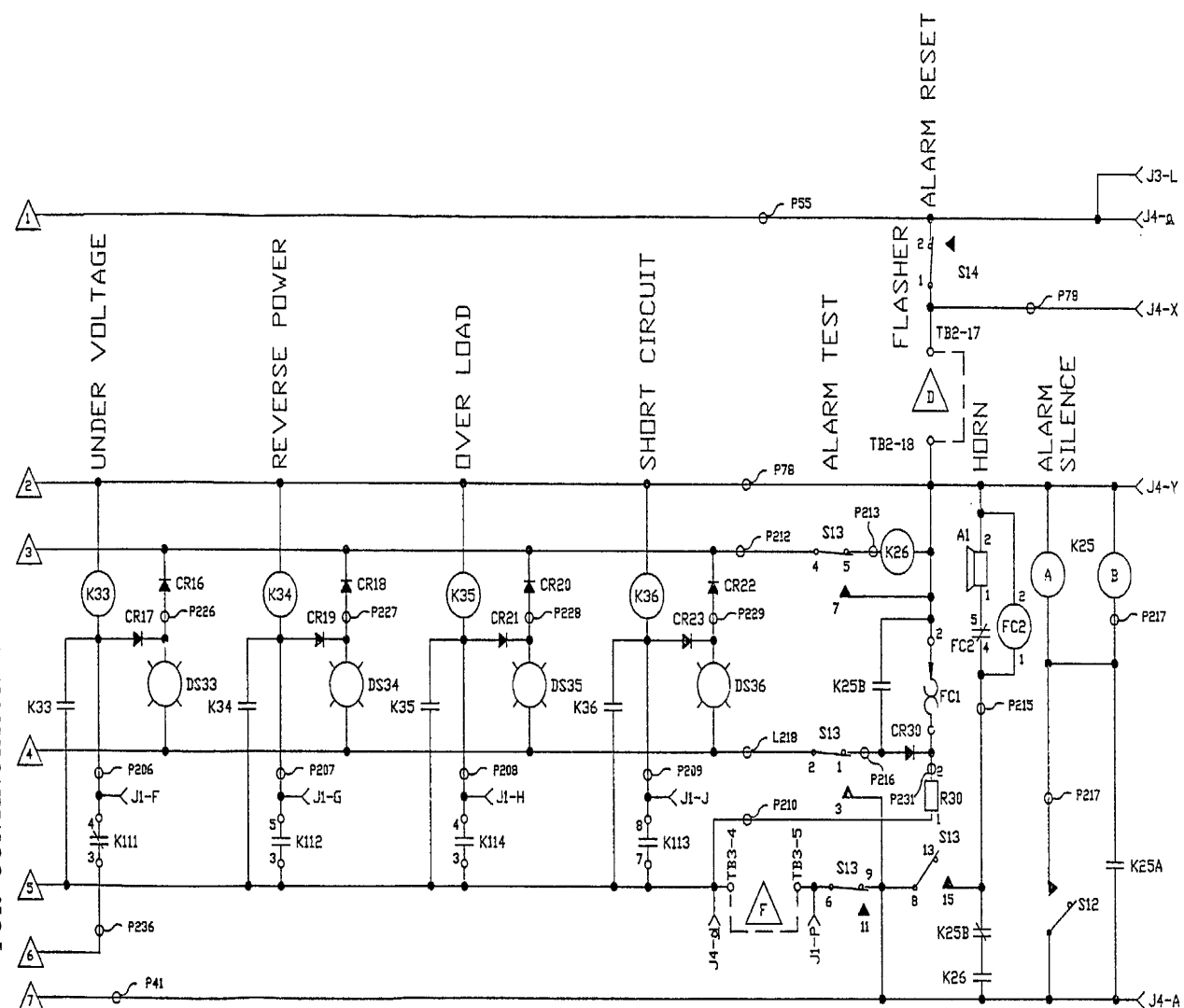

NOTES:

1. INTERPRET DWG PER DOD-STD-100.
2. JUMPERS SEE A THRU F ATE TO BE REMOVED WHEN REMOTE CONTROL BOX IS INSTALLED INTO SYSTEM
3. MOVE JUMPER L ON TB20 FROM POINT 1 RO POINT 2 WHEN BATTERY CHARGER NOT ENGAGED IN STBY.
4. THIS CIRCUIT IS USED ONLY WHEN GENERATOR SET IS ENCLOSED WITH LOUVERED DOORS.
5. J1, J2 J4 ARE REMOTE CONTROL BOX CONNECTIONS.
6. J3 AUTOMATIC CONTROL MODULE BOX CONNECTIONS.
7. FOR DC TROUBLE SHOOTING DIAGRAM SEE DWG 76-11436.
8. REMOVE JUMPER FOR 60 HZ OPERATION WHEN REMOTE CONTROL BOX IS INSTALLED INTO SYSTE.,.

DESIGNATION

IDENTIFYING LEGEND

DESIGNATION

IDENTIFYING LEGEND

1. A1	ANNUNCIATOR AUDIBLE ALARM	60. M1	OIL PRESSURE GAGE
2. A106	GOV CONTROLLER (SPEED CONT)	61. M2	OIL TEMP GAGE
3. B1	FUEL TRANSFER PUMP MOTOR	62. M3	WATER TEMP GAGE
4. B2	STARTER MOTOR	63. M4	FUEL LEVEL GAGE
5. BC1	BATTERY CHARGER	64. M5	ELLAPSED TIME METER
6. B4,5	MOTOR OPERATED POTS	65. M20	DC VOLTMETER
7. B10-13	LOUVER MOTORS	66. M21	DC AMMETER
8. BCR	RELAY, BREAKER CLOSE	67. M111	DIGITAL CLOCK
9. BTR	RELAY, BREAKER TRIP	68. MT1,2,3,4	TRANSMITTERS FOR GAUGES
10. BT1-BT4	BATTERY		
11. CB1	DC POWER BREAKER	69. OPI,2	OIL PRESS SWITCH
12. CB2	AC BUS POWER (MOTOR OPERATED) BREAKER	70.	OP3 OIL PRESS SWITCH (AIR POX SOL LOCKOUT)
13. CR	DIODES	71. OT1,2	OIL TEMP SWITCH
14. C101	FILTER CAPACITOR		
		72. R1,2,3	VOLT DROPPING RESISTORS (GAUGES)
		73. R30	RESISTOR, FLASHER BURDEN
15. DS1	INDICATOR, FUEL PUMP 'ON'		
16. DS2 3,4,5,10,11	PANEL LIGHTS		
17. DS6	INDICATOR, CB2 POWER BREAKER 'CLOSED'	74. S1	START/STOP SWITCH
18. DS7	INDICATOR, PARALLEL CIRCUIT 'ON'	75. S2	PRIMING SWITCH, ETHER
19. DS27-36	INDICATORS, FAULT	76. S3	SWITCH, MAIN BUS CIRCUIT BKR, ON/Or F (C12)-
20. DS41	INDICATOR PHASE 1,2,3	77. S5	MANUAL FREQ ADJUST SWITCH
21. DS42	INDICATOR, PHASE 1,3,2	78. S6	MANUAL VOLT ADJUST SWITCH
22. DS50	INDICATOR BATTLE SHORT 'ON'	79. S7	BATTLE SHORT SWITCH
23. DS51	INDICATOR OVERCRANK	80. S8	PARALLELING SWITCH
		81. S9	FUEL TRANSFER SWITCH OFF-AUTO
		82. S11	PANEL LIGHT SWITCH
		83. S12	ALARM SILENCE SWITCH
24. ETHER AID	STARTING AID SOLENOID	85. S13	ANNUNCIATOR TEST SWITCH
25. F60,61,62,63	FUSE	86. S20	MAINT SW (DC POWER LOCKOUT)
26. FC1	FLASHER	87. S21	FREQ SELECT SW (50/60 HZ OP)
27. FC2	FLASHER-ANNUNCIATOR AUDIBLE ALARM	88. S22	EMERGENCY STOP SWITCH
28. FL1,2,3,4	FUEL LEVEL SWITCHES	89. S49	SECONDS TIME ADJUST (CLOCK)
29. K1	RELAY, RUN STOP (6 PDT)	90. S50	MINUTES TIME ADJUST (CLOCK)
30. K3	RELAY, CRANKING	91. S51	HOURS TIME ADJUST (CLOCK)
31. K5	START/RUN/STOP PILOT	93. S53	AUTO/TRIP /MAN SWITCH
32. K5	RELAY, TIMING CRANK DISCONNECT	94. S60-63	LOUVER MOTOR PILOT SWITCH
33. K8	RELAY, LOW FUEL SHUTDOWN	95. SRM	SYNCHRONIZING RELAY
34. K19	RELAY, TIMING OVERCRANK SHUTDOWN	96 SS1,2,3	SPEED SWITCH
35. K20	RELAY, FUEL TRANSFER PUMP	97. SHUNT	D.C. AMMETER
36. K21	RELAY, EMERGENCY STOP		
37. K22	RELAY, MAIN CIRCUIT BKR CONTROL (CB2-PILOT)		
38. K23	RELAY, PARALLEL CONTROL (6PDT)	98. TD1	TIME DELAY ASSY (30 SEC DELAY 'ON')
39. K24	RELAY, ETHER AID CONTROL	99. TD2	TIME DELAY ASSY (5 SEC DELAY 'ON')
40. K25	RELAY, ALARM SILENCE CONTROL	100. TD3	TIME DELAY ASSY (5 SEC DELAY 'ON' a 5 SEC DELAY 'OFF')
41. K26	RELAY, ALARM 'ON' ARMING		
42. K27-K36	RELAY, FAULT INDICATOR		
43. K40	RELAY, FREQ SELECT	101. WT1,2	WATER TEMP SWITCH
44. K50	RELAY, BATTLE SHORT CONTROL		
45. K52	RELAY, ANNUNCIATOR DELAY		
46. K54	RELAY, DC POWER PILOT		
47. K60-63	RELAY, LOUVER CONTROL ASSY (TB303)		
48. K102	RELAY, OVER VOLTAGE SENSING		
49. K103-1,-2	RELAY, PHASE SEQUENCE		
50. K106	RELAY, SYNC CHECK		
51. K111	RELAY, UNDER VOLTAGE SENSING		
52. K112	RELAY, REVERSE POWER SENSING		
53. K113	RELAY, SHORT CIRCUIT SENSING		
54. K114	RELAY, OVERLOAD SENSING		
55. K130	RELAY, PARALLEL LINES (TP510)		
56. L1	FUEL SOLENOID, (ENGINE)		
57. L2,L22	AIR 80X SHUT-DOWN SOLENOID		
58. L3	FUEL SOLENOID (FUEL TRANSFER PUMP)		
59. L4	STARTER SOLENOID		

FOR CONTINUATION OF SCHEMATIC SEE SHEET 3

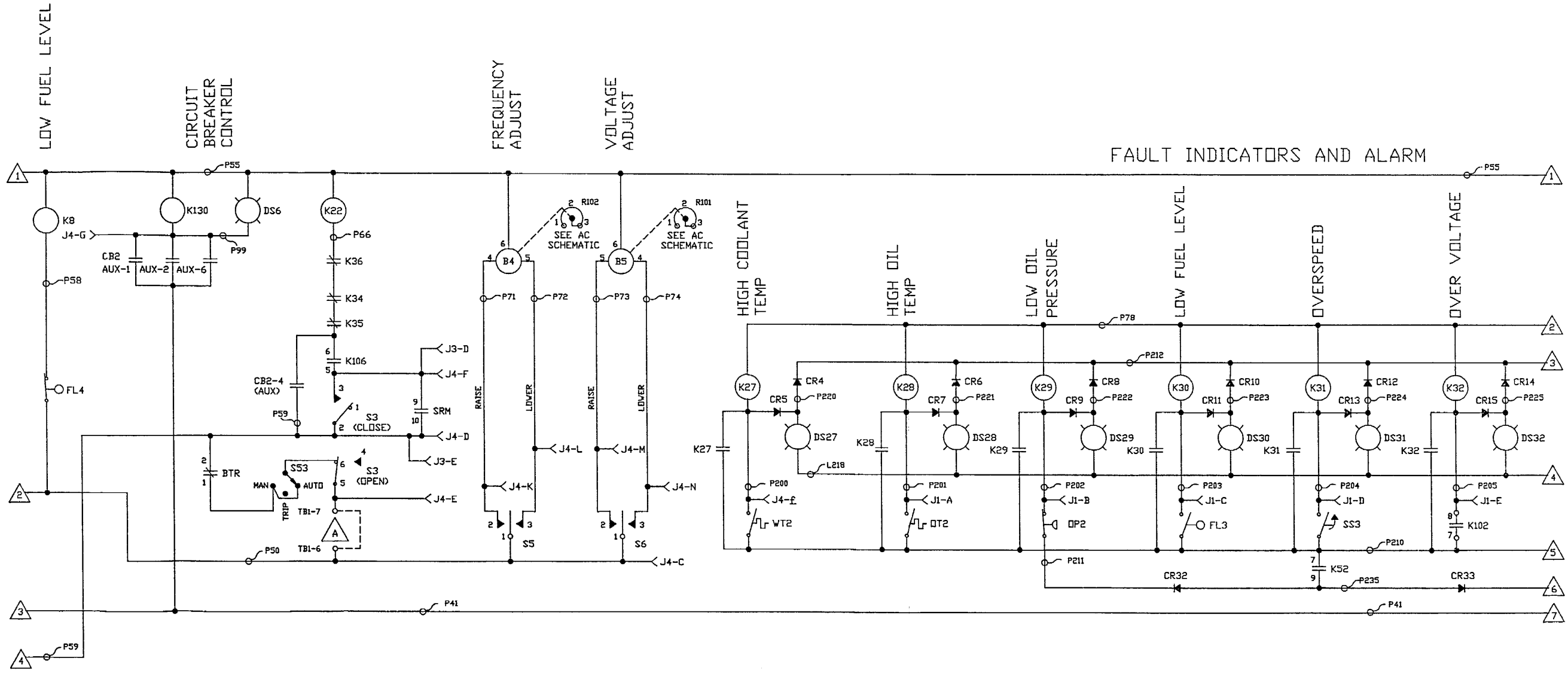

FOR CONTINUATION OF SCHEMATIC SEE SHEET 1



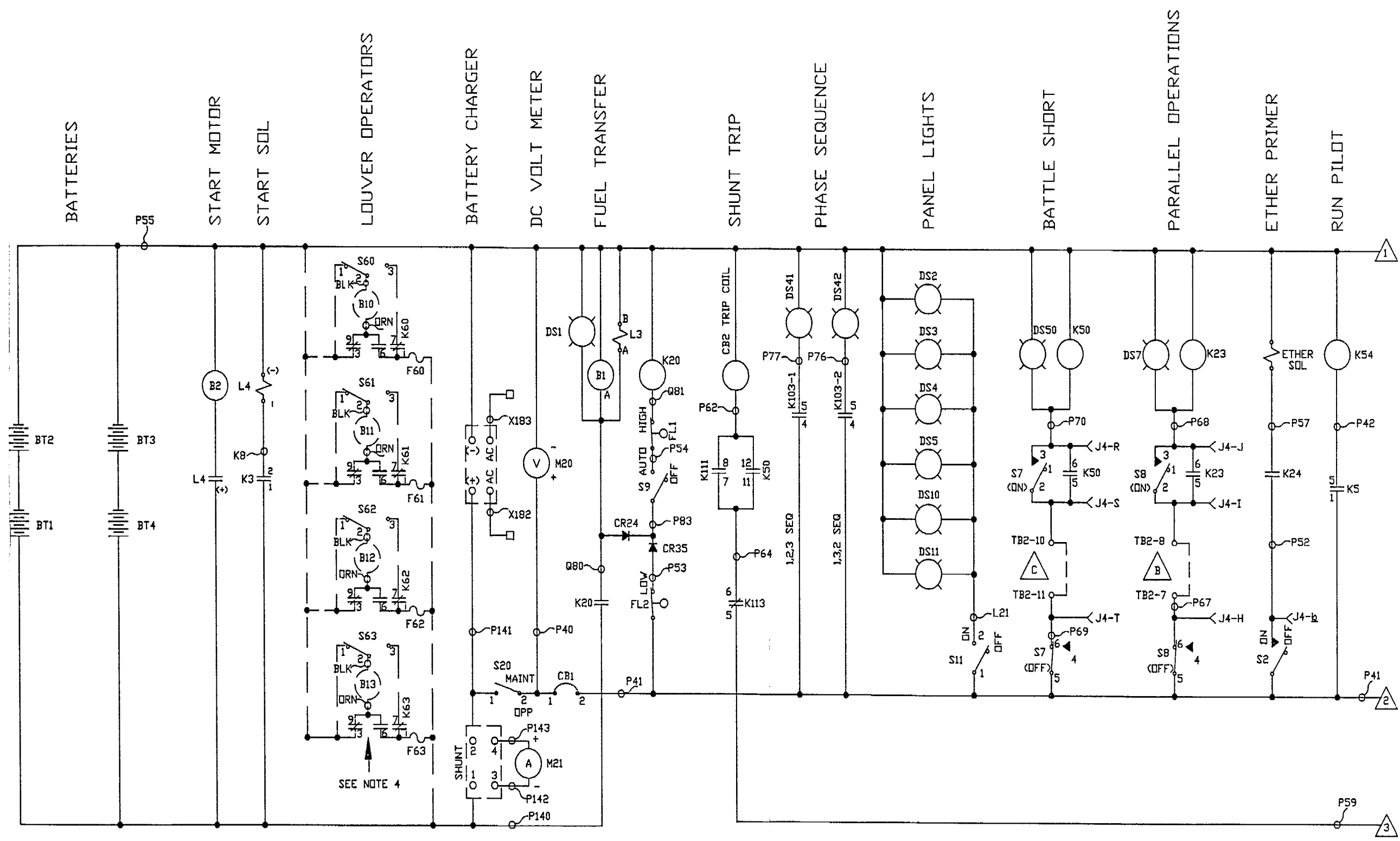

FOR CONTINUATION OF SCHEMATIC SEE SHEET 3

FO-1 DC Schematic (Sheet 4 of 4)

FP-7/(FP-8 blank)

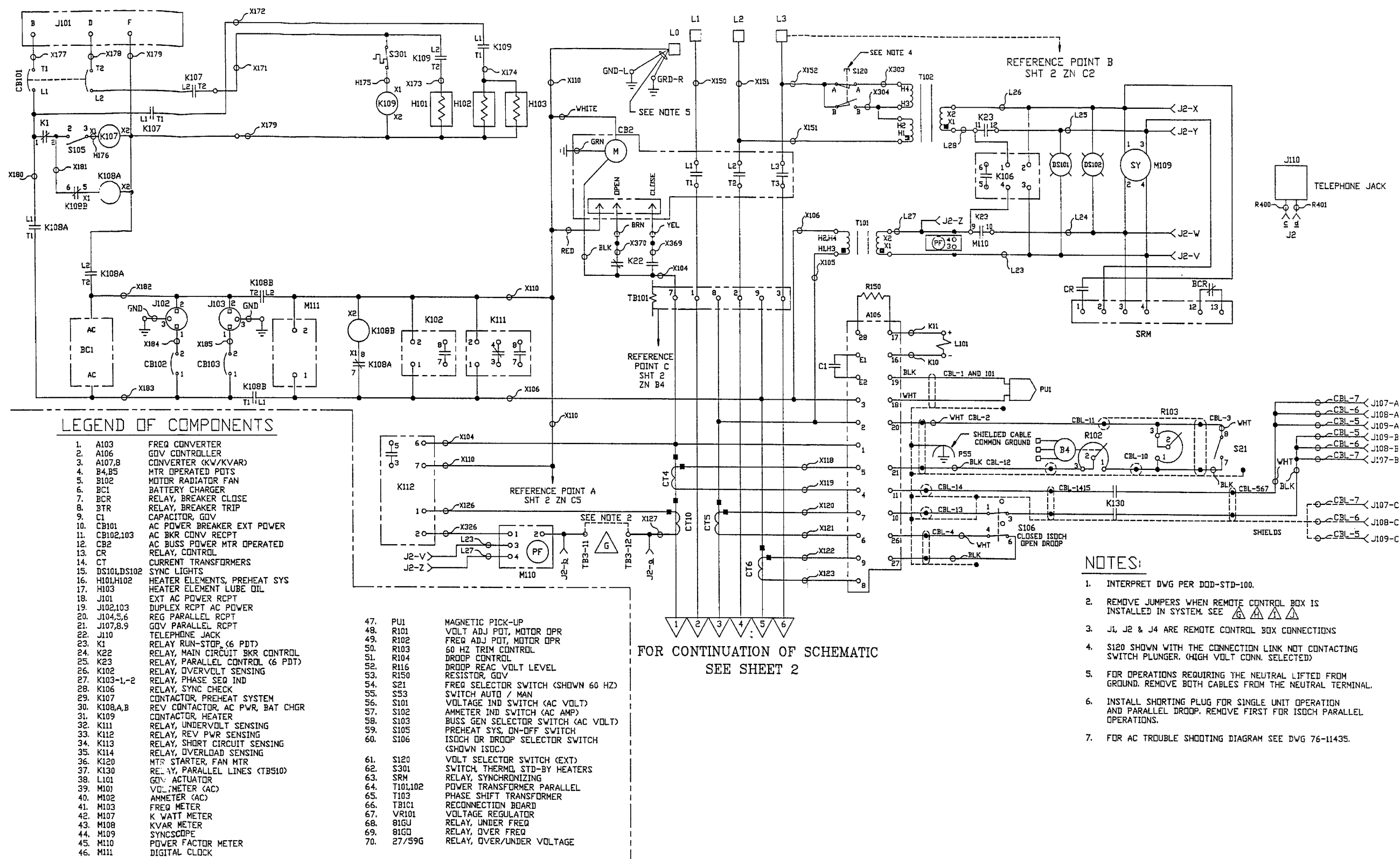

FO-2 AC Schematic (Sheet 1 of 2)

FP-9/(FP-10 blank)



FOR CONTINUATION OF SCHEMATIC  
SEE SHEET 1

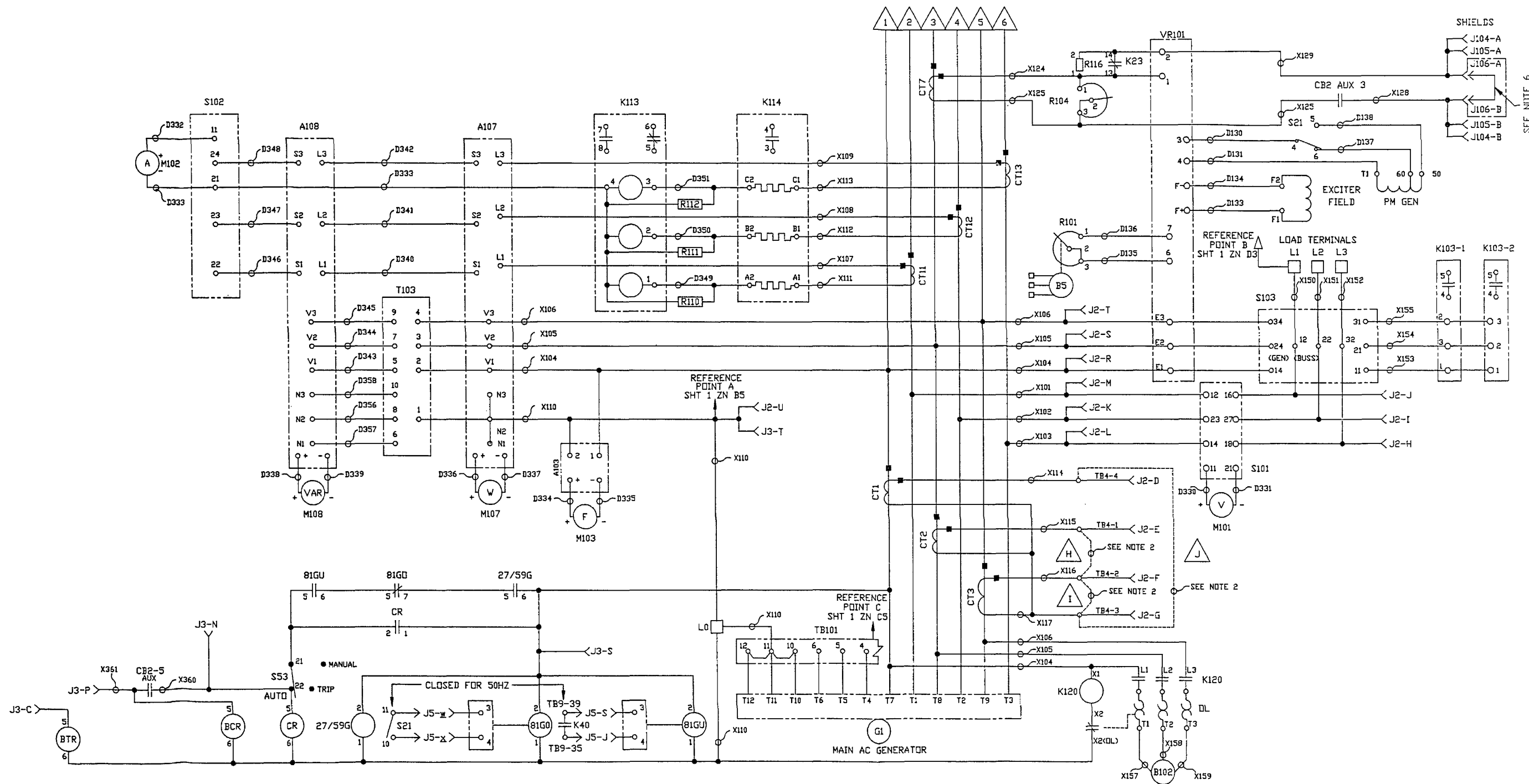

FO-2 AC Schematic (Sheet 2 of 2)

FP-11/(FP-12 blank)

FOR CONTINUATION OF SCHEMATIC SEE SHEET 2

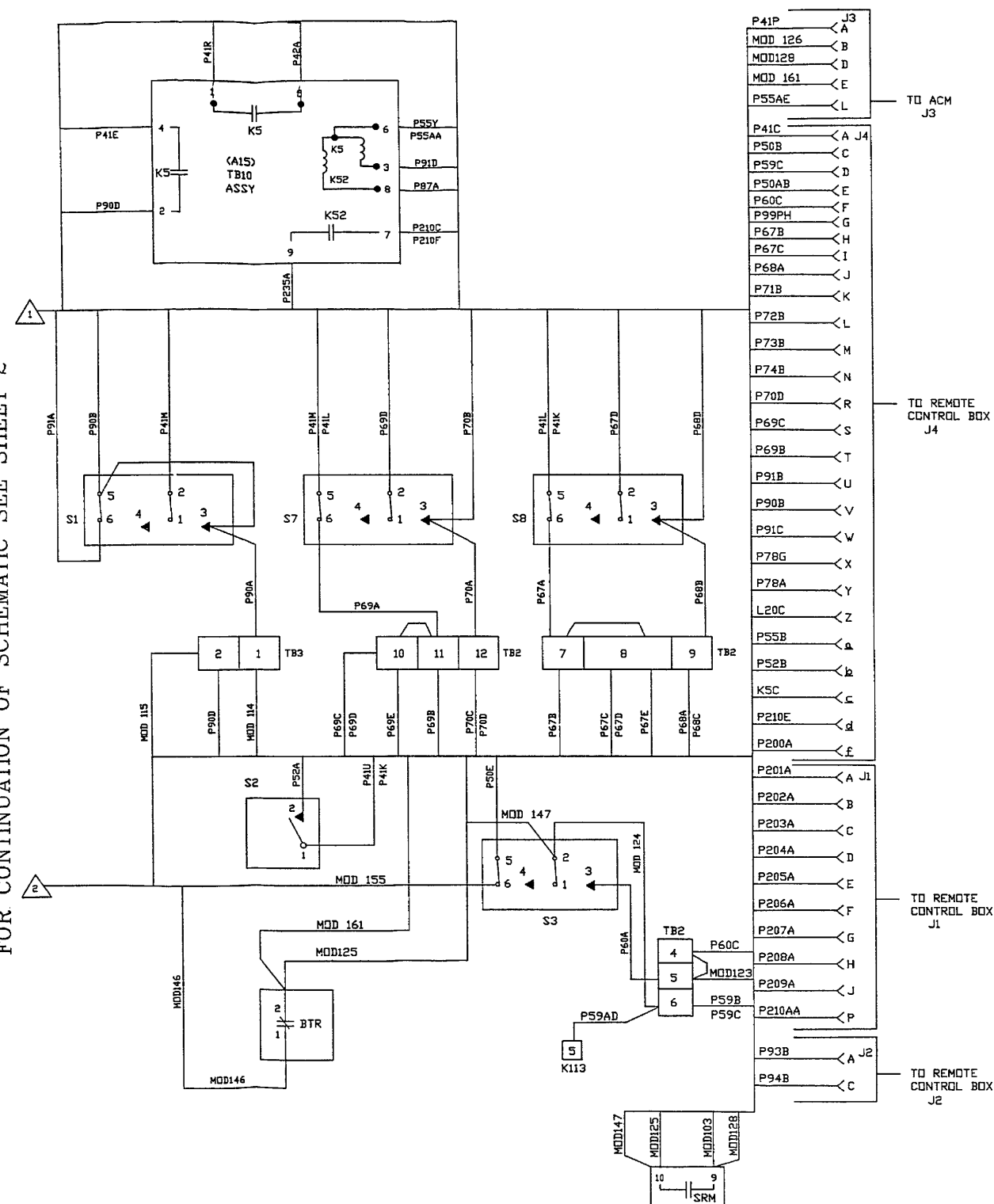

FO-3 DC Wiring Diagram (Sheet 1 of 5)

FP-13/(FP-14 blank)

LEGEND OF COMPONENTS

1.	AI	ANNUNCIATOR AUDIBLE ALARM		
2.	A106	GOVERNOR CONTROLLER (SPEED CONTROL)		
3.	BC1	BATTERY CHARGER		
4.	BTI-4	BATTERIES		
5.	BTR	RELAY, BREAKER TRIP		
6.	B1	FUEL TRANSFER PUMP MOTOR		
7.	B2	STARTER MOTOR		
8.	B4	MOTOR OPERATOR, FREQ CONTROL	70.	M1
9.	B5	MOTOR OPERATOR, VOLTAGE CONTROL	71.	M2
10.	B10-13	LOUVER MOTORS	72.	M3
			73.	M4
			74.	M5
			75.	M20
			76.	M21
			77.	MT1
			78.	MT2
			79.	MT3
			80.	MT4
			81.	M111
			82.	OP1
			83.	OP2
			84.	OP3
			85.	OT1
			86.	OT2
			87.	R1,2,3
			88.	R30
			89.	SHUNT
			90.	SRM
			91.	S1
			92.	S2
			93.	S3
			94.	S5
			95.	S6
			96.	S7
			97.	S8
			98.	S9
			99.	S12
			100.	S12
			101.	S12
			102.	S12
			103.	S20
			104.	S21
			105.	S22
			106.	S49
			107.	S50
			108.	S51
			109.	S52
			110.	S51,2,3
			111.	S53
			112.	S50-63
			113.	TB6
			114.	TB9
			115.	TB10
			116.	TB303
			117.	TD1
			118.	TD2
			119.	TD3
			120.	WT1
			121.	WT2
			122.	81GU
			123.	FC2

NOTES:

1. INTERPRET DWG PER DOD-STD-100.
2. ITEMS NO. 10, 25, 29, a 116 FOR HOUSED UNIT ONLY.
3. REMOVE JUMPER FOR 60HZ OPERATION WHEN REMOTE CONTROL BOX
4. FOR D.C. SCHEMATIC DIAGRAM SEE DWG 76-11245.

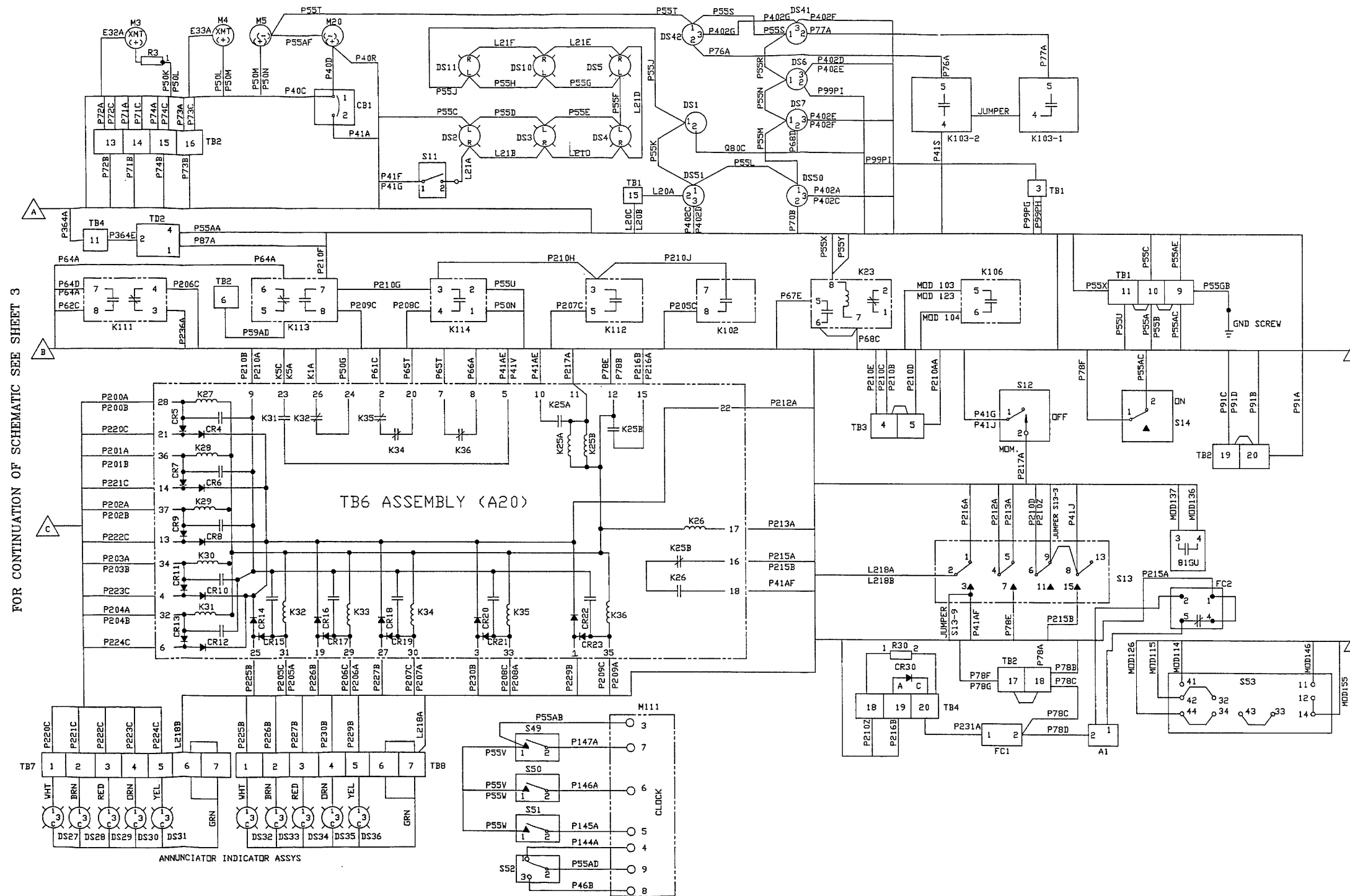

FO-3 DC Wiring Diagram (Sheet 2 of 5)

FP-15/(FP-16 blank)

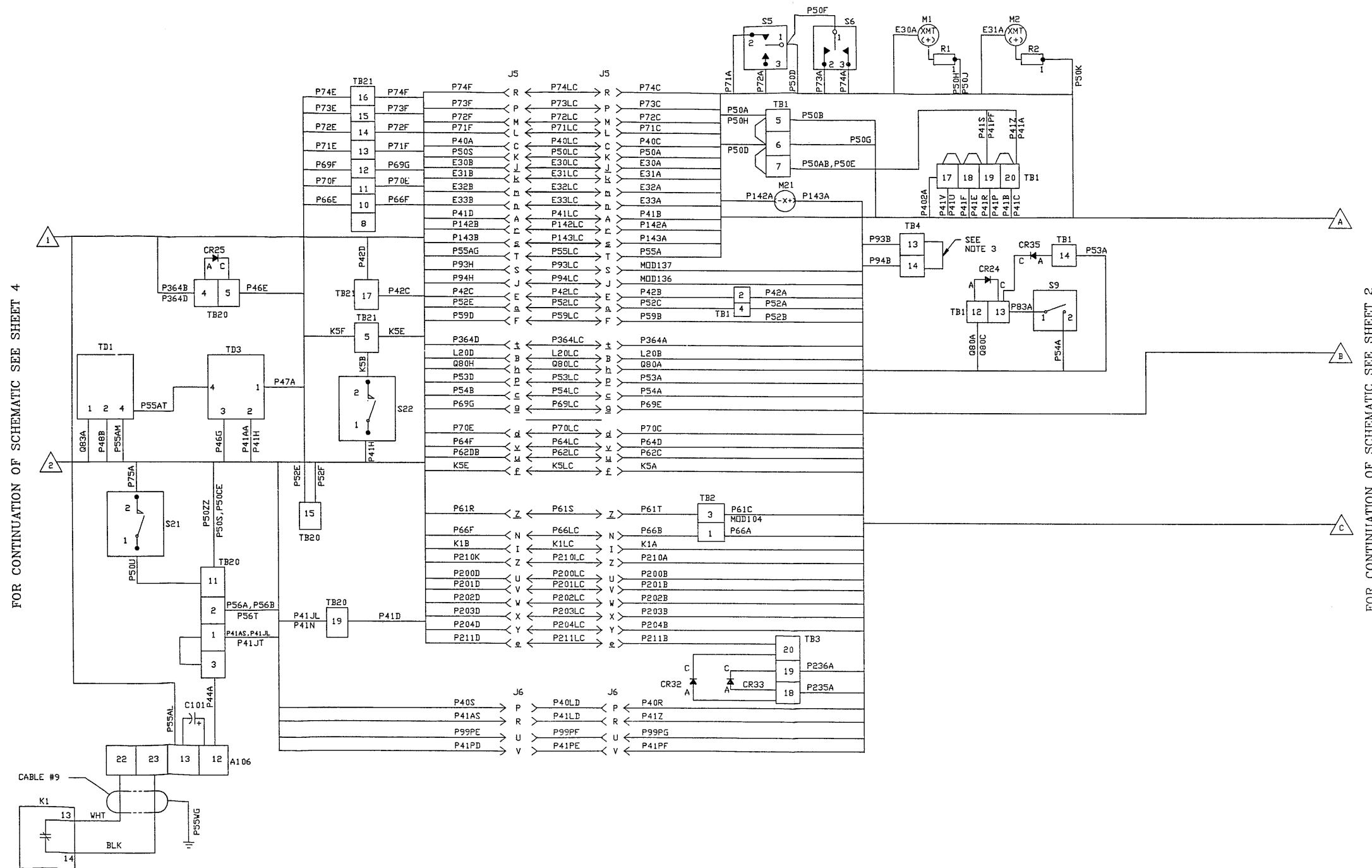

FO-3 DC Wiring Diagram (Sheet 3 of 5)  
FP-17/(FP-18 blank)

FOR CONTINUATION OF SCHEMATIC SEE SHEET 4

FOR CONTINUATION OF SCHEMATIC SEE SHEET 2

FOR CONTINUATION OF SCHEMATIC SEE SHEET 5

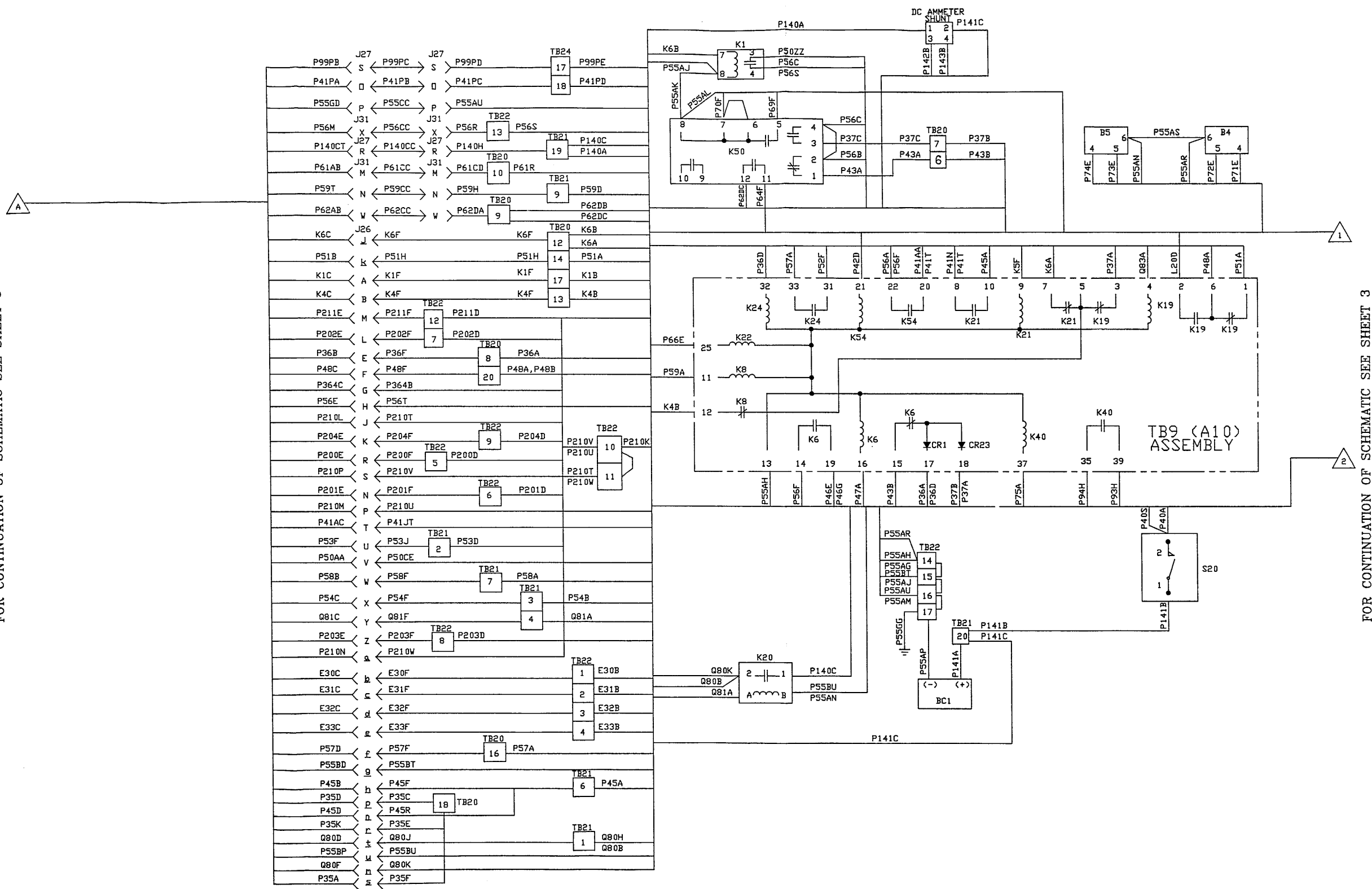

FOR CONTINUATION OF SCHEMATIC SEE SHEET 3

FO-3 DC Wiring Diagram (Sheet 4 of 5)

FP-19/(FP-20 blank)

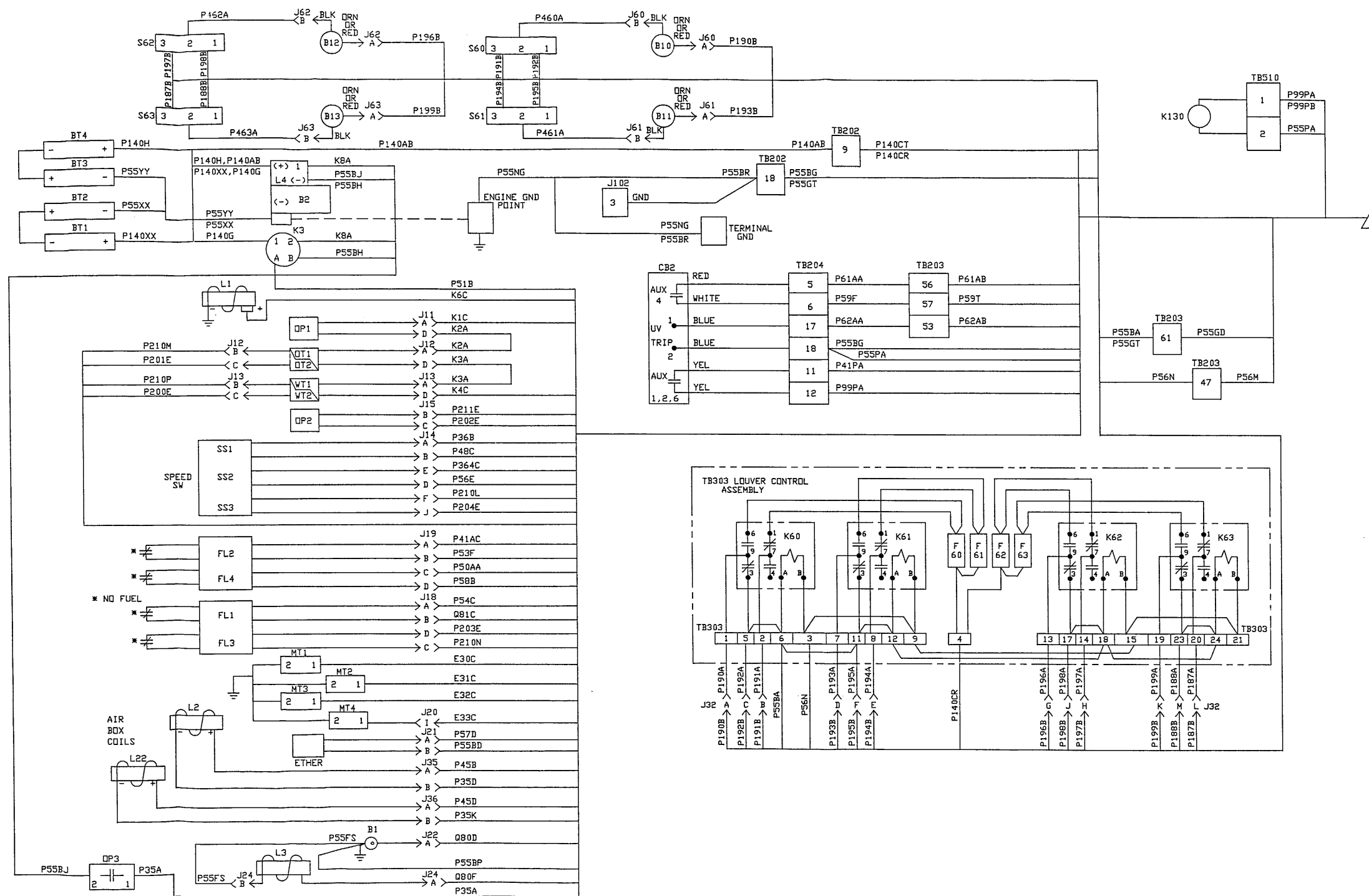

FOR CONTINUATION OF SCHEMATIC SEE SHEET 4

FO-3 DC Wiring Diagram (Sheet 5 of 5)

FP-21/(FP-22 blank)

FOR CONTINUATION OF SCHEMATIC SEE SHEET 2

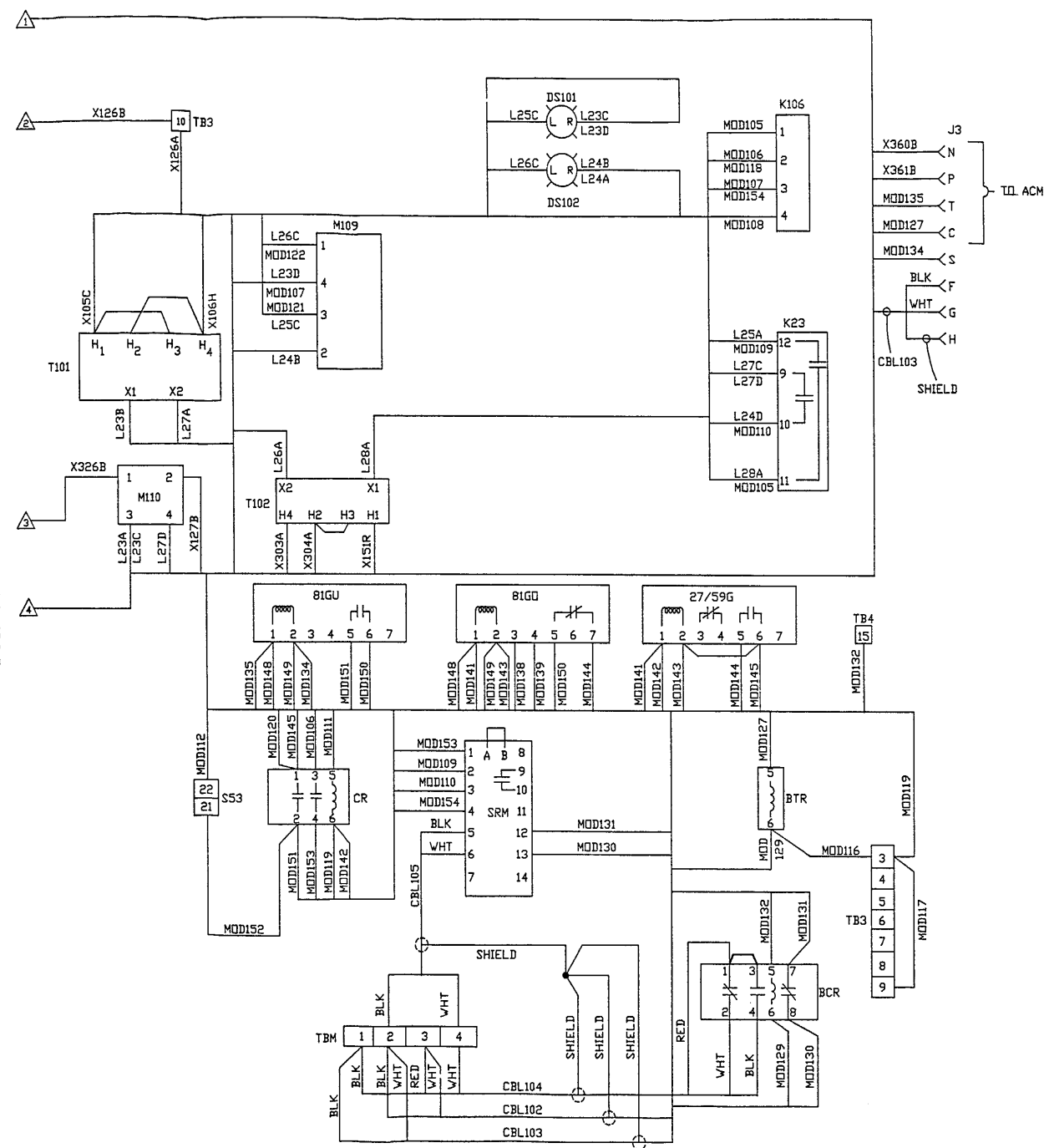

LEGEND OF COMPONENTS

- |     |               |  |     |          |  |
|-----|---------------|--|-----|----------|--|
| 1.  | A103          | CONVERTER, FREQUENCY   | 45. | L101     | GOVERNOR ACTUATOR  |
| 2.  | A106          | GOVERNOR CONTROL UNIT  | 46. | M101     | VOLTMETER  |
| 3.  | A107          | CONVERTER - KW   | 47. | M102     | AMMETER  |
| 4.  | A108          | CONVERTER, KVAR  | 48. | M103     | FREQUENCY METER  |
| 5.  | BC1           | BATTERY CHARGER  | 49. | M107     | KW METER   |
| 6.  | BCR           | RELAY, BREAKER CLOSE   | 50. | M108     | KVAR METER   |
| 7.  | BTR           | RELAY, BREAKER TRIP  | 51. | M109     | SYNCHROSCOPE   |
| 8.  | B4            | MOTOR OPERATED POT, FREQ CONTROL   | 52. | M110     | POWER FACTOR METER   |
| 9.  | B5            | MOTOR OPERATED POT, VOLTAGE CONTROL  | 53. | M111     | DIGITAL CLOCK  |
| 10. | B102          | RADIATOR FAN MOTOR   | 54. | PM       | PERM. MAG GEN. VR101 POWER   |
| 11. | CB2           | CIRCUIT BRKR MAIN AC MOTOR OPERATED  | 55. | PU1      | MAGNETIC PICKUP  |
| 12. | CB101         | CIRCUIT BRKR COMMERCIAL POWER IN   | 56. | R101     | VOLTAGE ADJ POT  |
| 13. | CB102-103     | CIRCUIT BRKR CONVENIENCE RCPT  | 57. | R102     | FREQ ADJ POT   |
| 14. | CR            | RELAY, CONTROL   | 58. | R103     | 50 HZ ADJ POT  |
| 15. | CT1,2,3       | CURRENT XFMR FOR REMOTE' THERMAL WATT CONVERTER OVERLOAD RELAY SHORT CIRCUIT RELAY | 59. | R104     | DROOP ADJ POT  |
|     |               |  | 60. | R116     | DROOP REACTIVE VOLTAGE LEVEL   |
| 16. | CT4,5,6       | CURRENT XFMR FOR GOVERNOR CONTROL  | 61. | R150     | RESISTOR, GOV  |
| 17. | CT7           | CURRENT XFMR FOR CROSS-CURRENT SENSING   | 62. | SRM      | SYNCHRONIZING RELAY  |
| 18. | CT10          | CURRENT XFMR FOR POWER FACTOR METER & REVERSE POWER RELAY SELECTOR SWITCH          | 63. | S21      | FREQ SELECTOR SWITCH   |
|     |               |  | 64. | 553      | AUTO/TRIP/MAN SWITCH   |
| 19. | CT11,12,13    | CURRENT XFMR FOR UNIT INSTRUMENTATION L OVERLOAD & SHORT CKT RELAYS                | 65. | 5101     | VOLTMETER SWITCH   |
|     |               |  | 66. | S102     | AMMETER SWITCH   |
| 20. | C1            | CAPACITOR, GOV   | 67. | S103     | VOLTAGE SELECTOR SWITCH' BUS/GEN                                     |
| 21. | DS101,102     | LIGHT, SYNCHRONIZING   | 68. | S105     | PREHEAT SELECTDR SWITCH  |
| 22. | G1            | GENERATOR, MAIN  | 69. | S106     | ISOCHRONOUS OR DROOP   |
| 23. | H101,102      | HEATERS PREHEAT SYS.   | 70. | S120     | VOLTAGE SELECT CONTROL BUSS POWER                                    |
| 24. | H103          | LUBE OIL HEATER  | 71. | S301     | THERMOSTAT, PREHEAT  |
| 25. | J101          | RCPT EXTERNAL POWER  | 72. | TB       | TERMINAL BOARDS  |
| 26. | J102,103      | CONVENIENCE RCPT   | 73. | TBM      | TERMINAL BOARD   |
| 27. | J104,105,106  | RCPT REACTIVE PARALLELING  | 74. | TB101    | VOLTAGE RECONNECTION BOARD   |
| 28. | J107,108,109  | RCPT GOV. PARALLELING  | 75. | TB107    | RESISTOR NETWORK CURRENT SUMMATION-OVERLOAD SHORT CIRCUIT RELAY ASSY |
| 29. | J110          | TELEPHONE JACK   | 76. | T101,102 | POWER XFMR PARALLEL  |
| 30. | K1            | RELAY, RUN/STOP  | 77. | T103     | PHASE SHIFT XFMR   |
| 31. | K22           | RELAY, CB2 PILOT   | 78. | VR101    | VOLTAGE REGULATOR  |
| 32. | K23           | RELAY, PARALLELING CONTROL   | 79. | 81GU     | UNDER FREQ RELAY   |
| 33. | K102          | RELAY, OVERVOLTAGE SENSING   | 80. | 81GU     | OVER FREQ RELAY  |
| 34. | K103-1,K103-2 | RELAY, PHASE SEQUENCE  | 81. | 27/59G   | OVER/UNDER VOLTAGE RELAY   |
| 35. | K106          | SYNC CHECK RELAY   |     |          |  |
| 36. | K107          | CONTACTOR, PREHEAT POWER   |     |          |  |
| 37. | K108A,B       | REVERSING CONTACTOR, BATTERY CHARGE POWER  |     |          |  |
| 38. | K109          | CONTACTOR, HEATERS   |     |          |  |
| 39. | K111          | RELAY, UNDERVOLTAGE SENSING  |     |          |  |
| 40. | K112          | RELAY, REVERSE POWER   |     |          |  |
| 41. | K113          | RELAY, SHORT CIRCUIT   |     |          |  |
| 42. | K114          | RELAY, OVERLOAD  |     |          |  |
| 43. | K120          | FAN MOTOR STARTER  |     |          |  |
| 44. | K130          | RELAY, PARALLEL LINES (TB510)  |     |          |  |

NOTES

- REMOVE JUMPERS FROM TB3-11 & TB3-12, TB4-1 & TB4-2, TB4-2 & TB4-3 TB4-3 a TB4-4, IN CONTROL BOX, WHEN REMOTE CONTROL BOX IS INSTALLED IN SYSTEM.
- INTERPRET DWG PER DOD-STD-100.
- FOR A.C. SCHEMATIC DIAGRAM SEE DWG 76-11243.

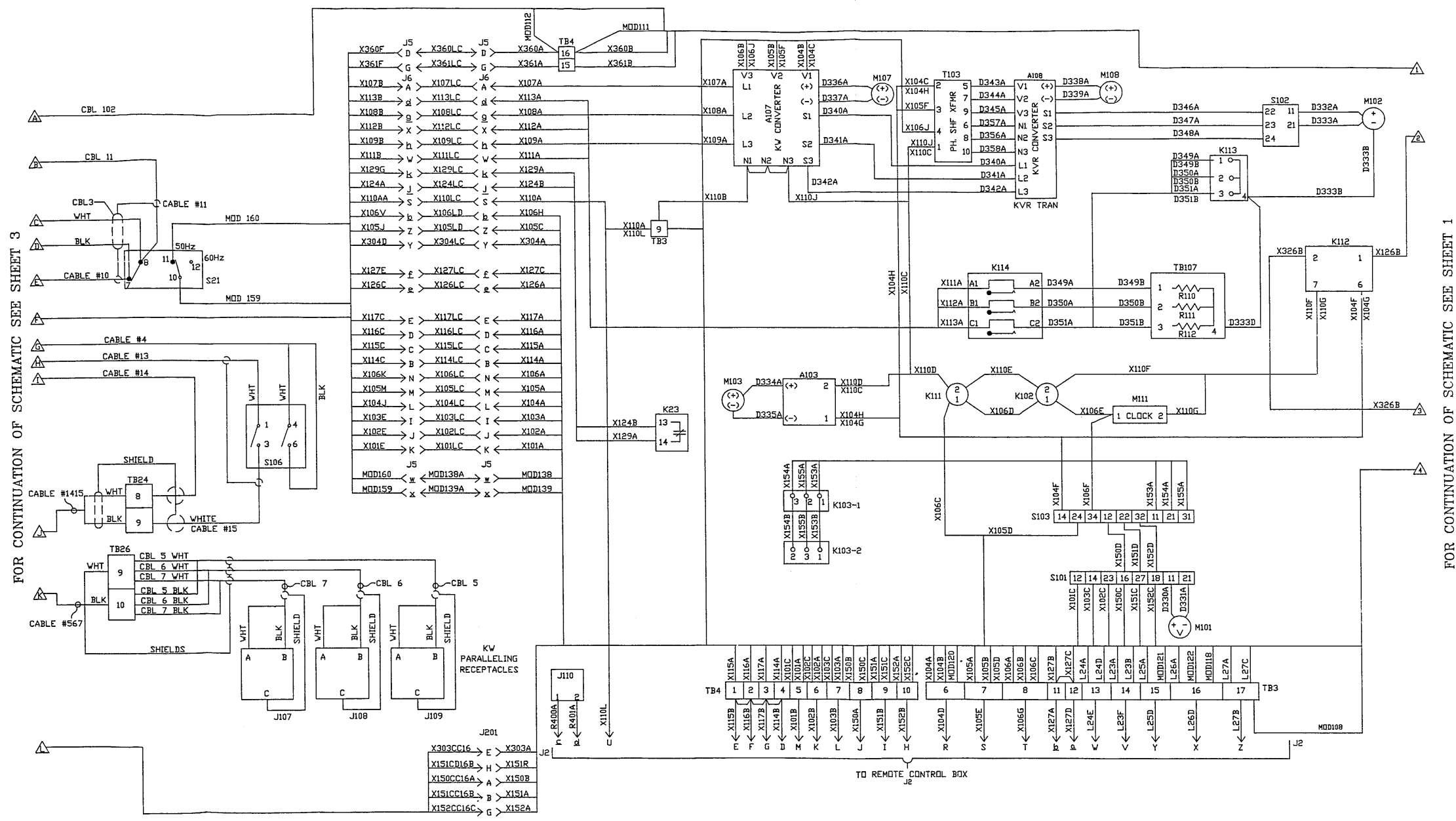

FOR CONTINUATION OF SCHEMATIC SEE SHEET 3

FOR CONTINUATION OF SCHEMATIC SEE SHEET 1

FO-4 AC Wiring Diagram (Sheet 2 of 4)

FP-25 / (FP-26 blank)



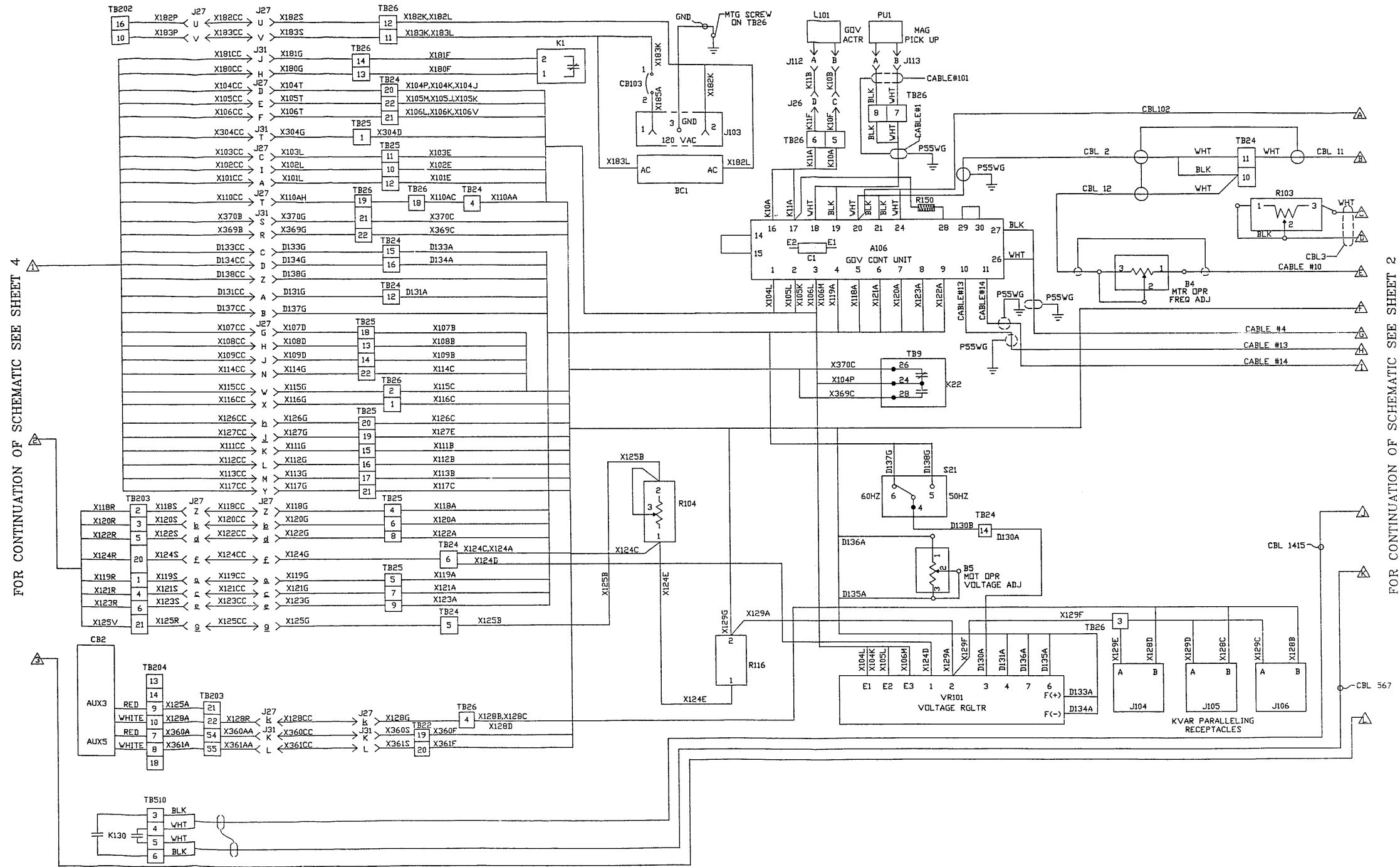

FOR CONTINUATION OF SCHEMATIC SEE SHEET 4

FOR CONTINUATION OF SCHEMATIC SEE SHEET 2

FO-4 AC Wiring Diagram (Sheet 3 of 4)

FP-27 / (FP-28 blank)

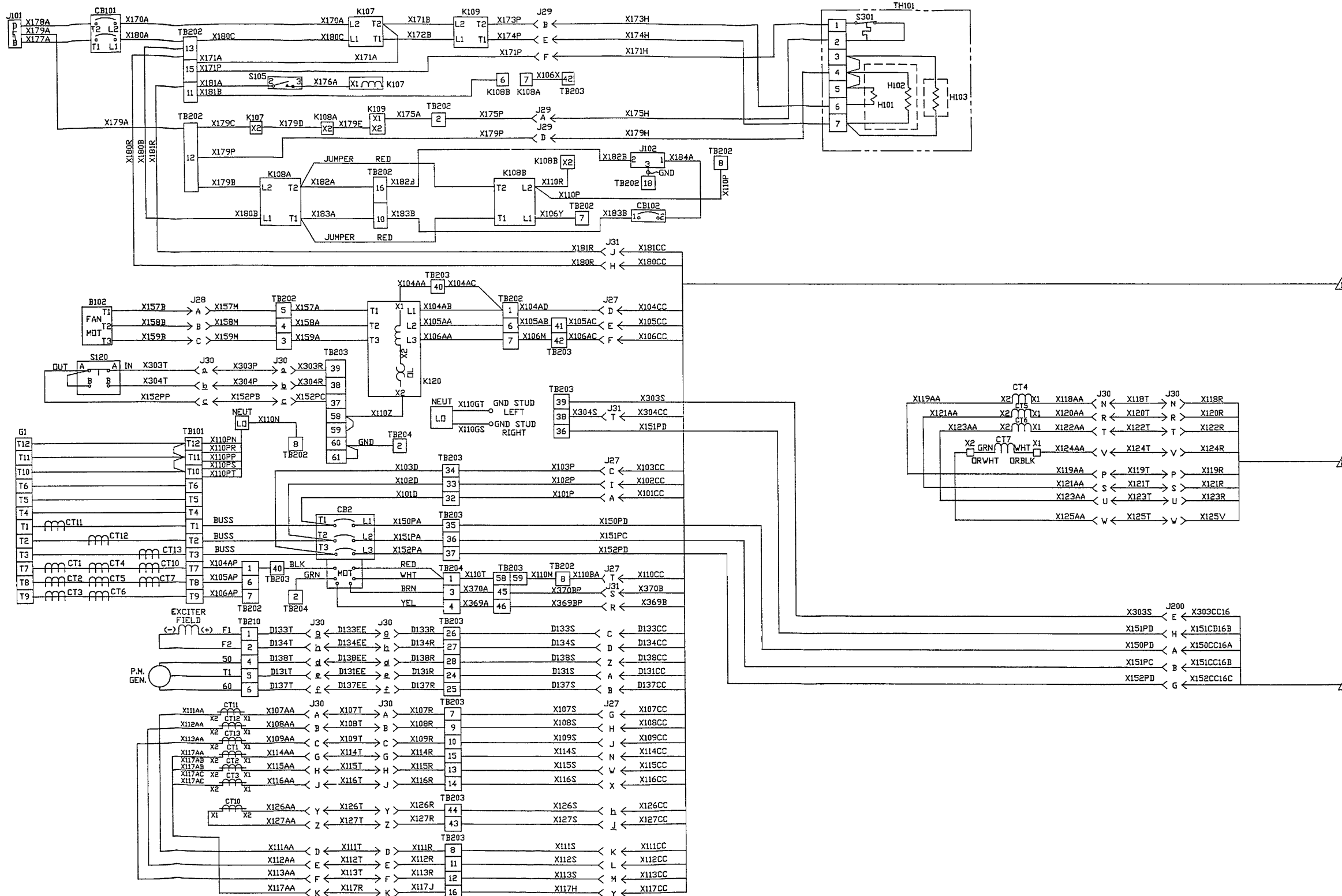

FOR CONTINUATION OF SCHEMATIC SEE SHEET 3

FO-4 AC Wiring Diagram (Sheet 4 of 4)

FP-29 / (FP-30 blank)

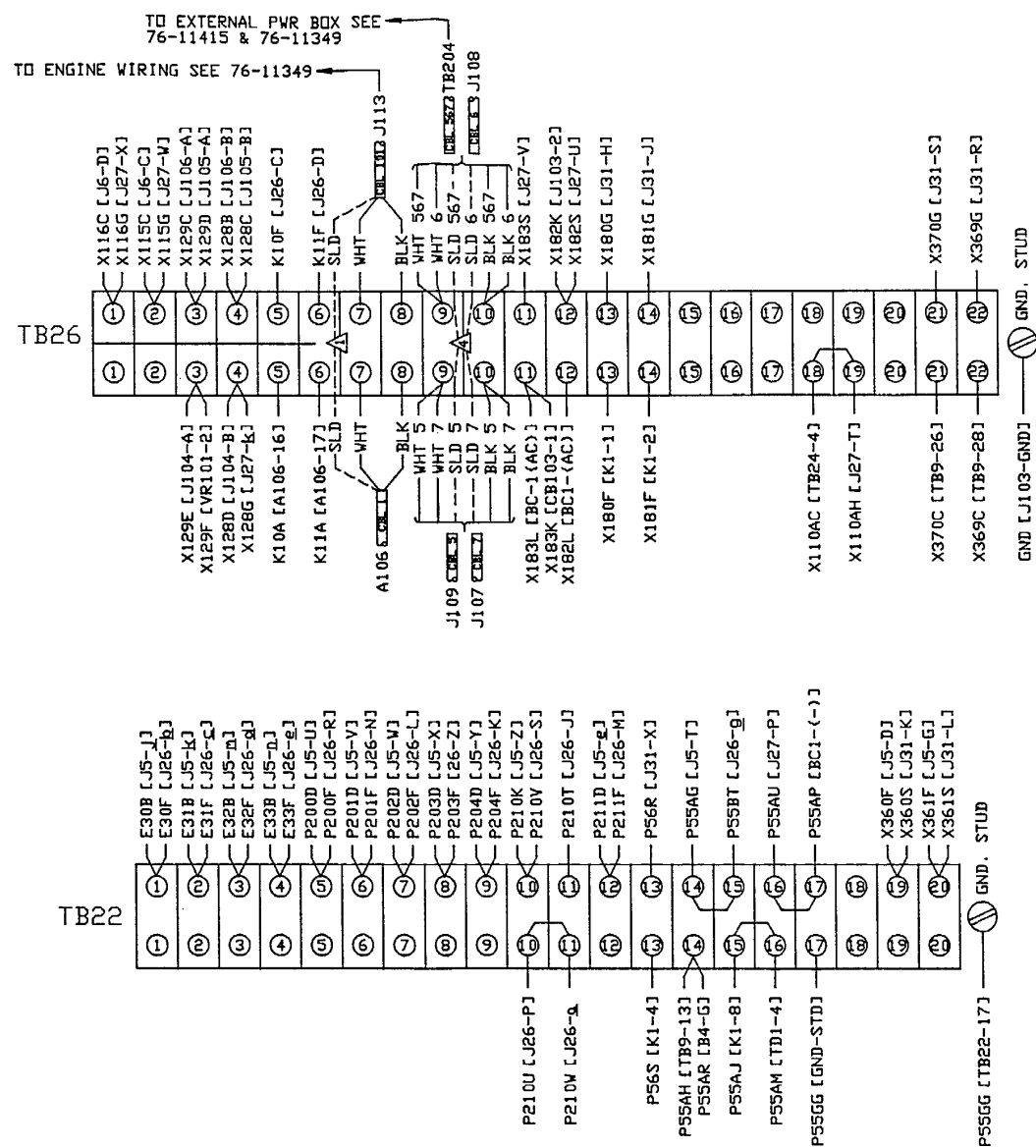
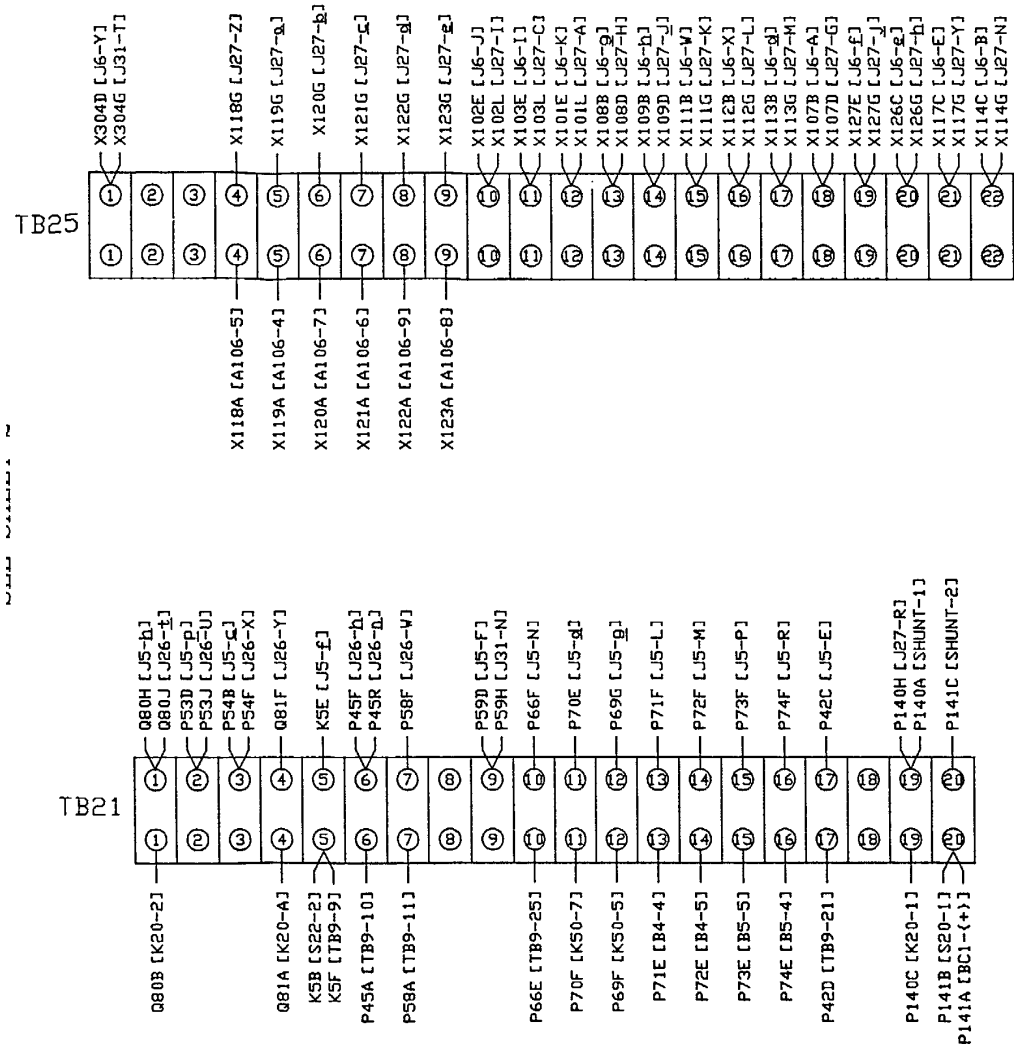

UPPER BACK PANEL

FO-5 AC / DC Control Box (Sheet 1 of 4)

FP-31 / (FP 32 blank)

NOTES:

1. INTERPRET DWG. PER DOD-STD-100
2. FOR ELECTRICAL SCHEMATIC SEE 76-11243 & 76-11245
3. FOR HARNESS ASSY SEE DWG. 76-11384
4. FOR TERMINAL BLOCK JUMPERS AND CR25 SEE DWG. 76-11327

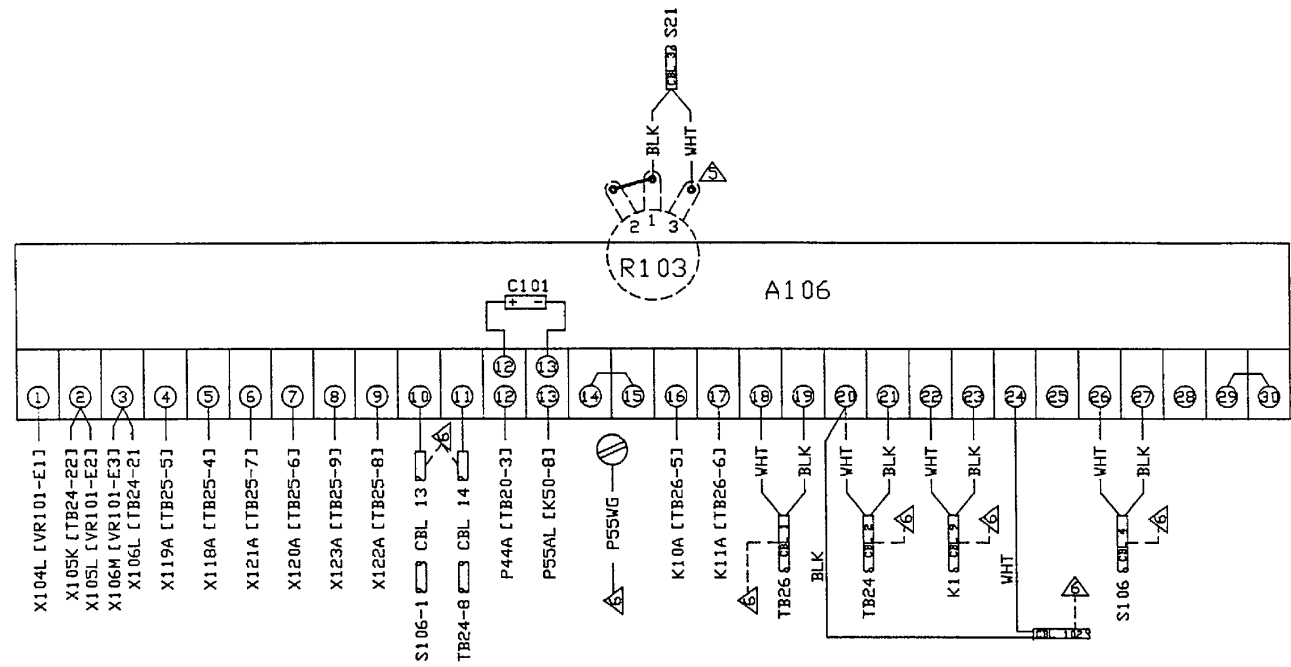
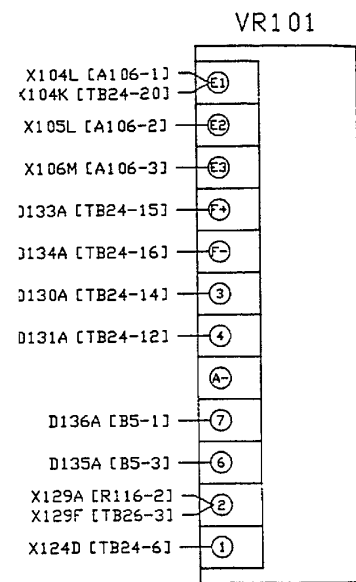

LOWER BACK PANEL

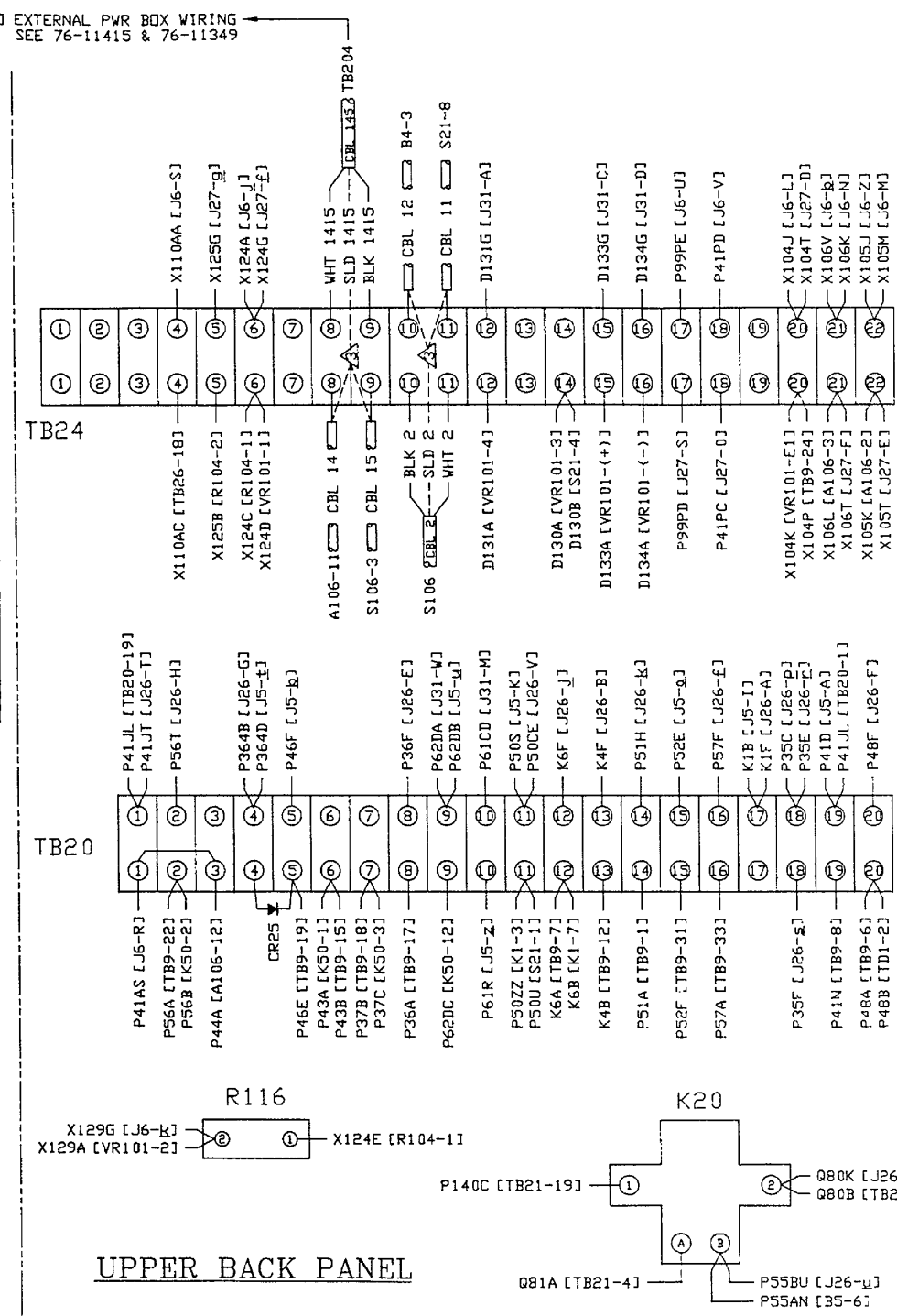
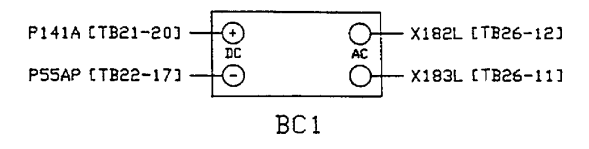

UPPER BACK PANEL

FOR CONTINUATION OF UPPER BACK PANEL SEE SHEET 1

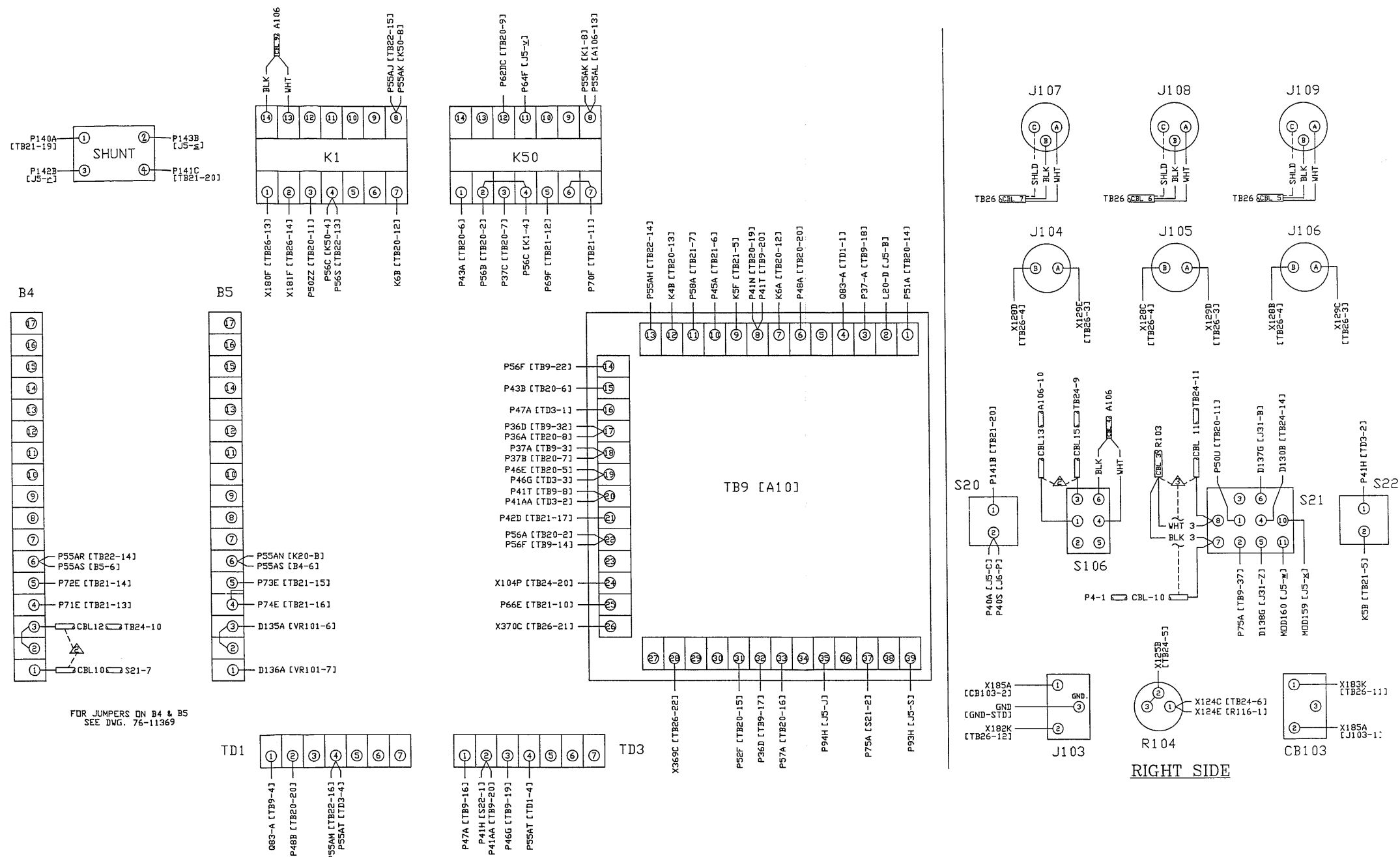

SHELF

FO-5 AC / DC Control Box (Sheet 3 of 4)

FP-35 / (FP-36 blank)

RIGHT SIDE

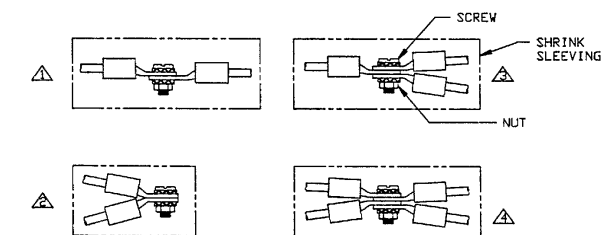
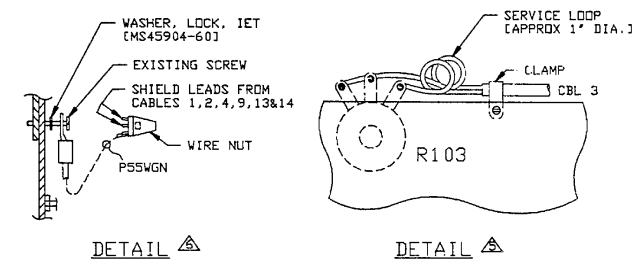
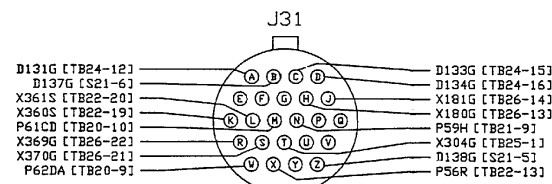
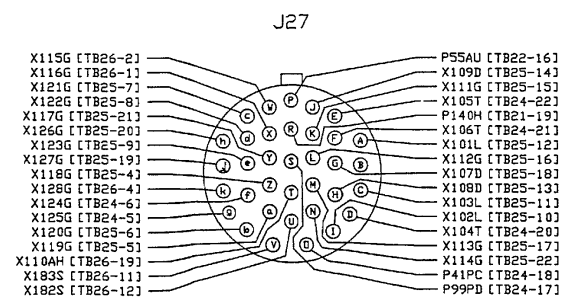
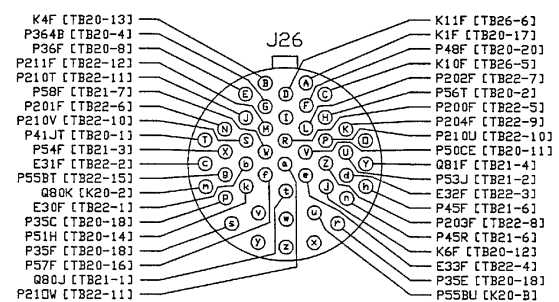
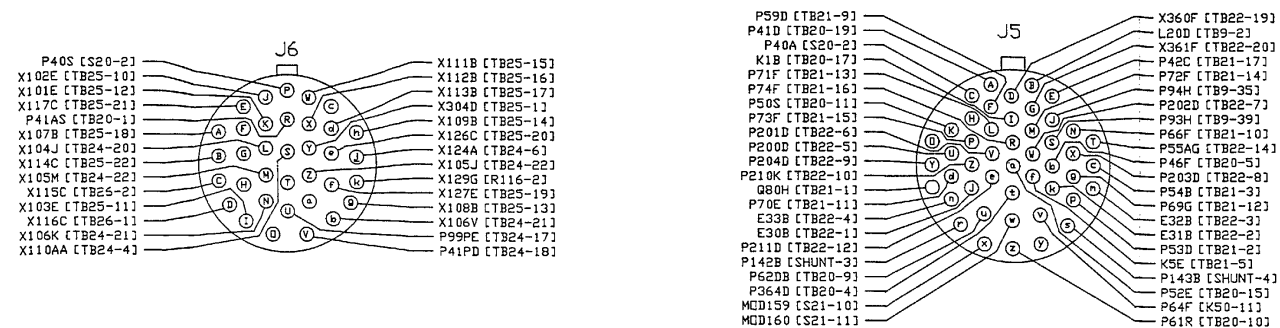

DETAILS FOR CONNECTING SHIELDS

LEFT WALL

FO-5 AC / DC Control Box (Sheet 4 of 4)

FP-37/(FP-38 blank)

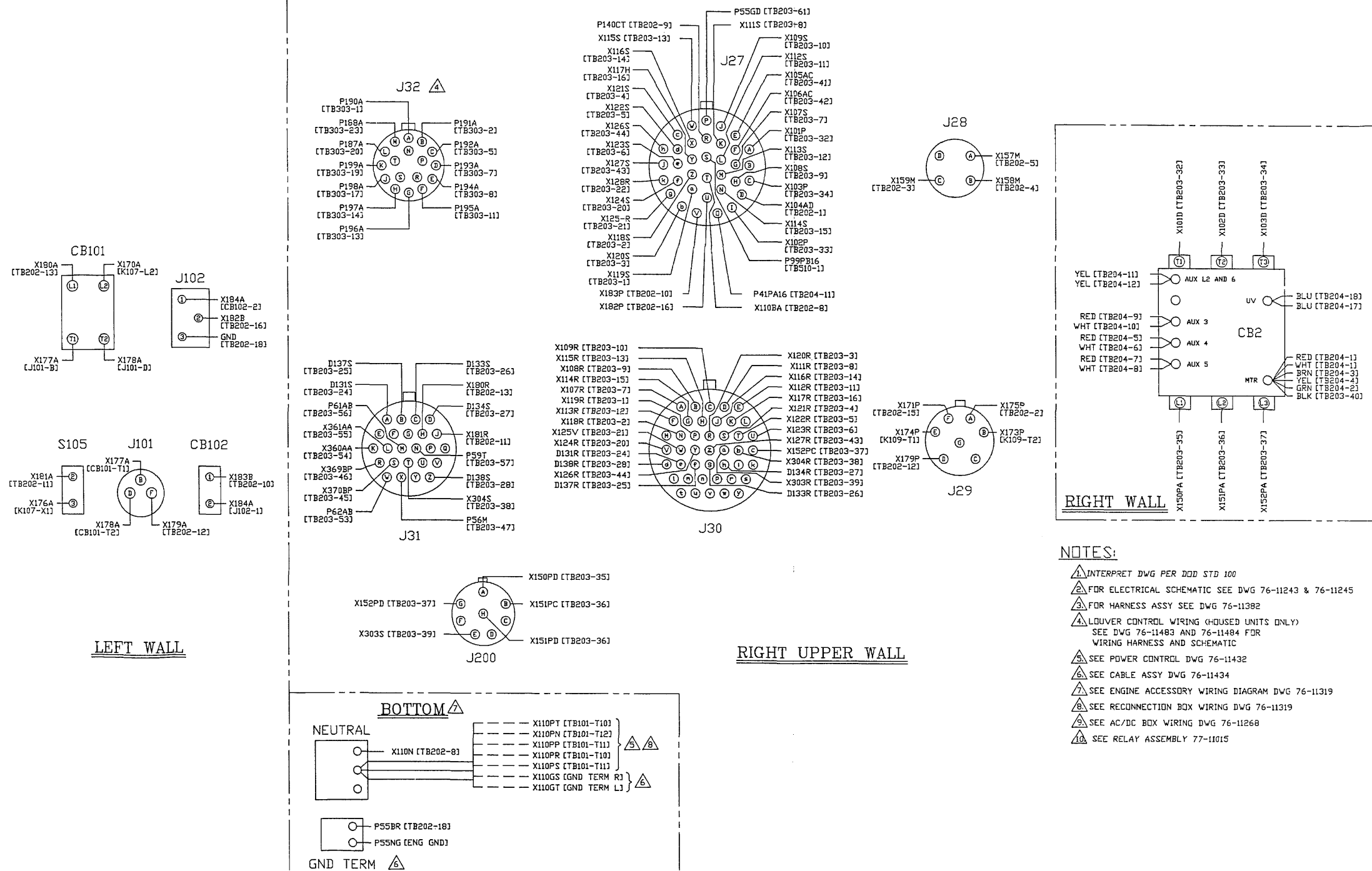

FO-6 External Power Box Wiring Diagram (Sheet 1 of 3)

FP-39/(FP-40 blank)

FOR CONTINUATION OF BACK PANEL SEE SHEET 3

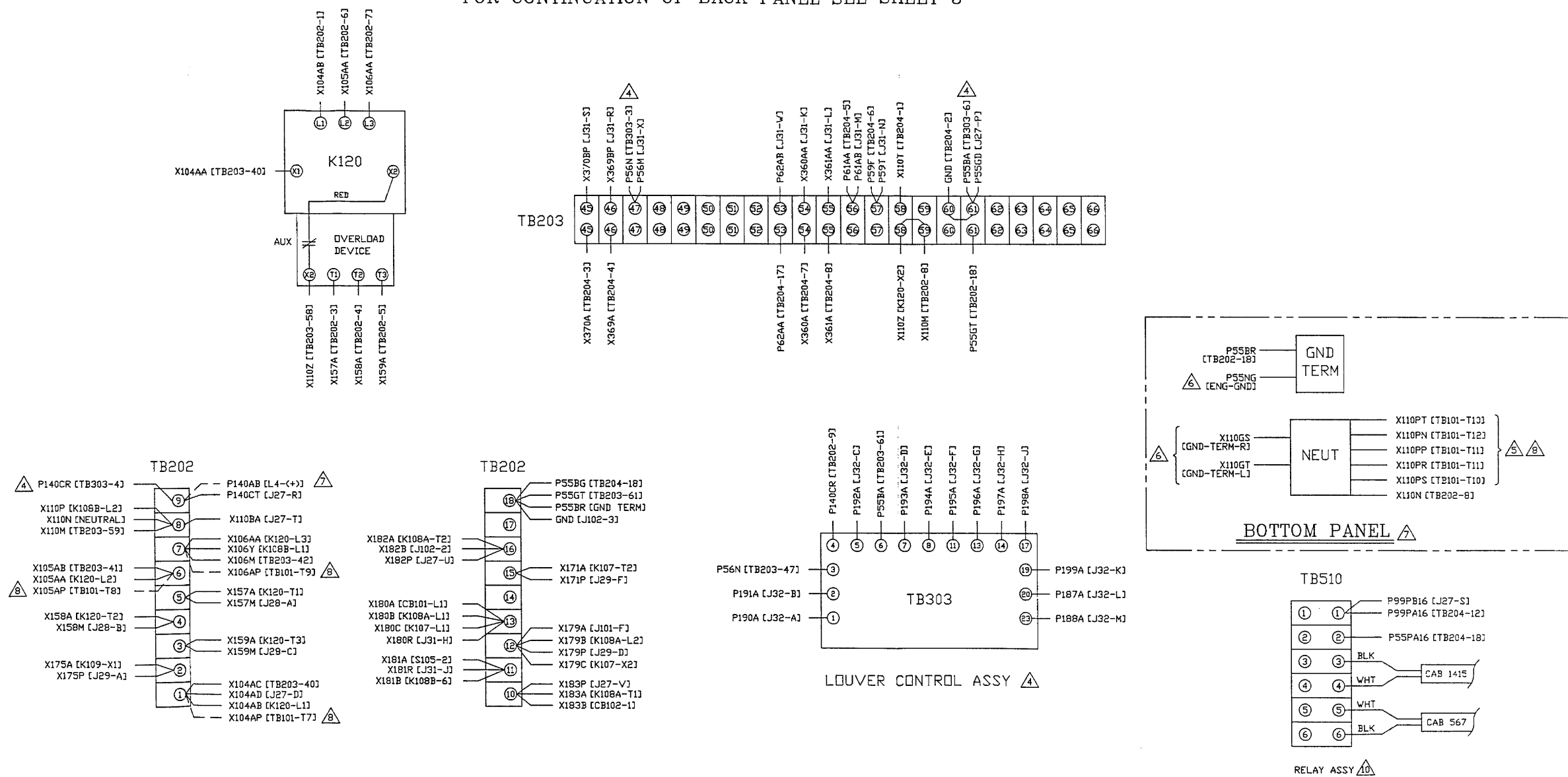

BACK PANEL

FO-6 External Power Box Wiring Diagram (Sheet 2 of 3)

FP-41/(FP-42 blank)



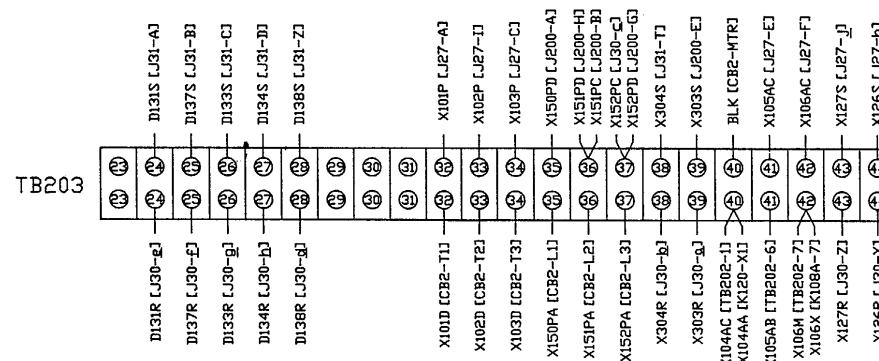
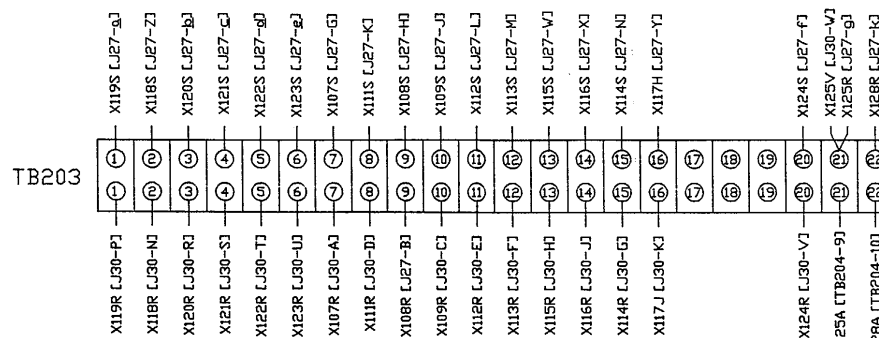
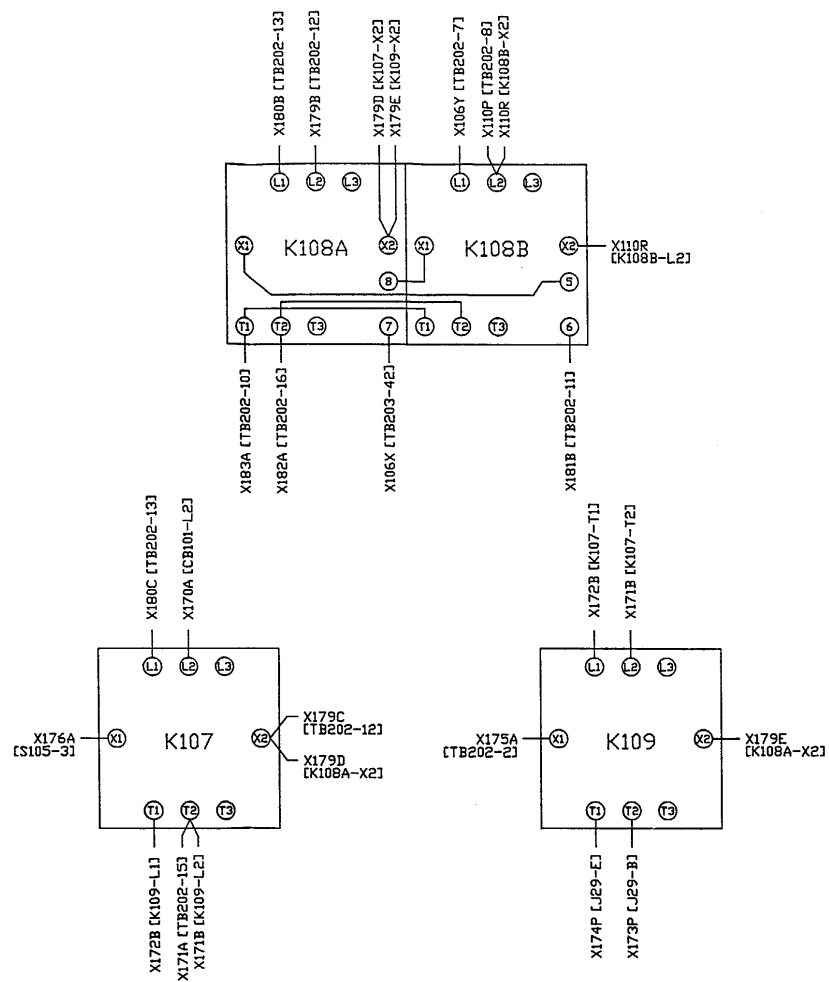

BACK PANEL

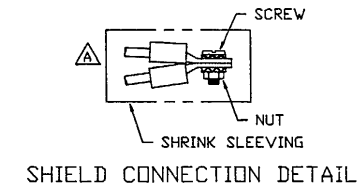
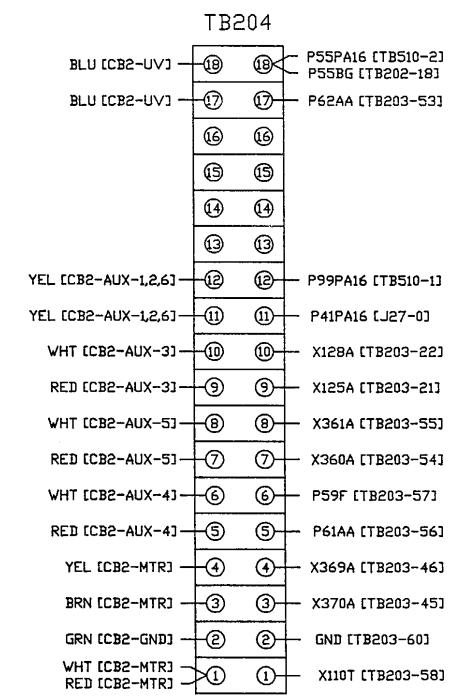

FO-6 External Power Box Wiring Diagram (Sheet 3 of 3)

FP-43/(FP-44 blank)

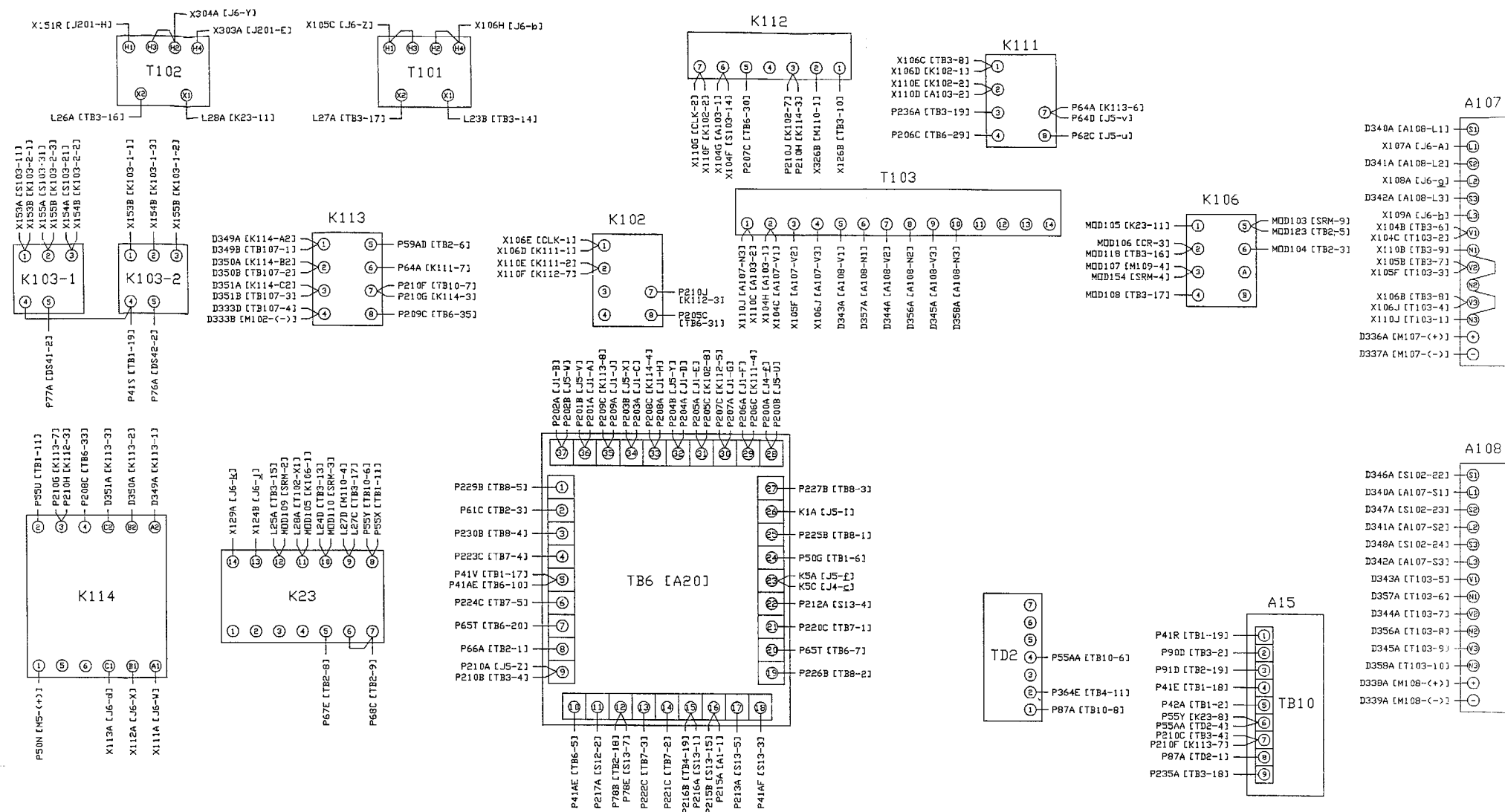

- NOTES:**
1. INTERPRET DWG PER DDD STD 100
  2. FOR ELECTRICAL SCHEMATIC SEE DWG 76-11245
  3. FOR HARNESS ASSY SEE DWG 76-11390
  4. FOR BOX ASSY DWG SEE 76-11318
  5. FOR ENGINE PANEL ASSY SEE 76-11378
  6. FOR GENERATOR PANEL ASSY SEE 76-11379

**FO-7 Unit Control Box Wiring Diagram (Sheet 1 of 4)**  
**FP-45/(FP-46 blank)**

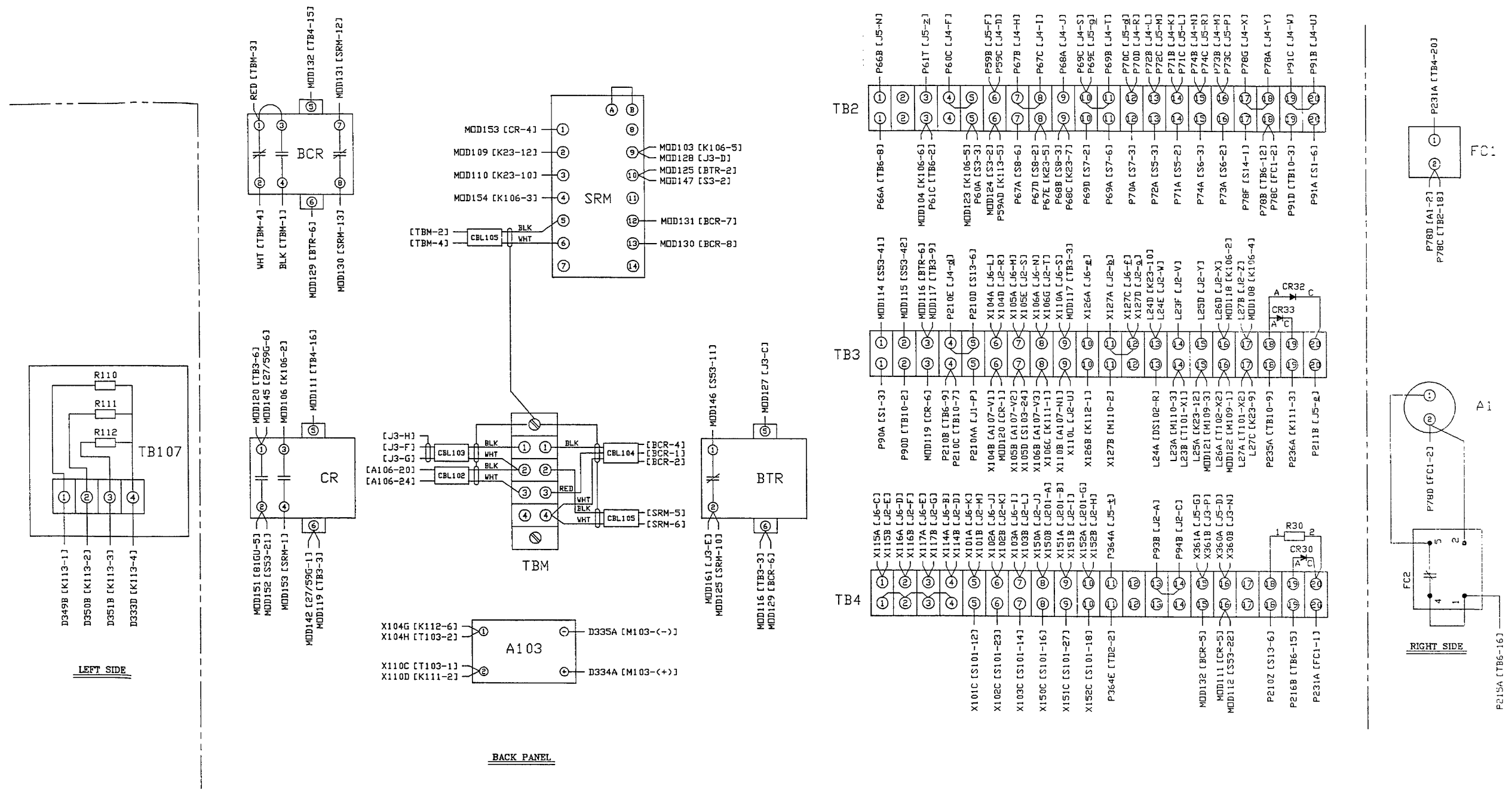

FO-7 Unit Control Box Wiring Diagram (Sheet 2 of 4)  
FP-47/(FP-48 blank)

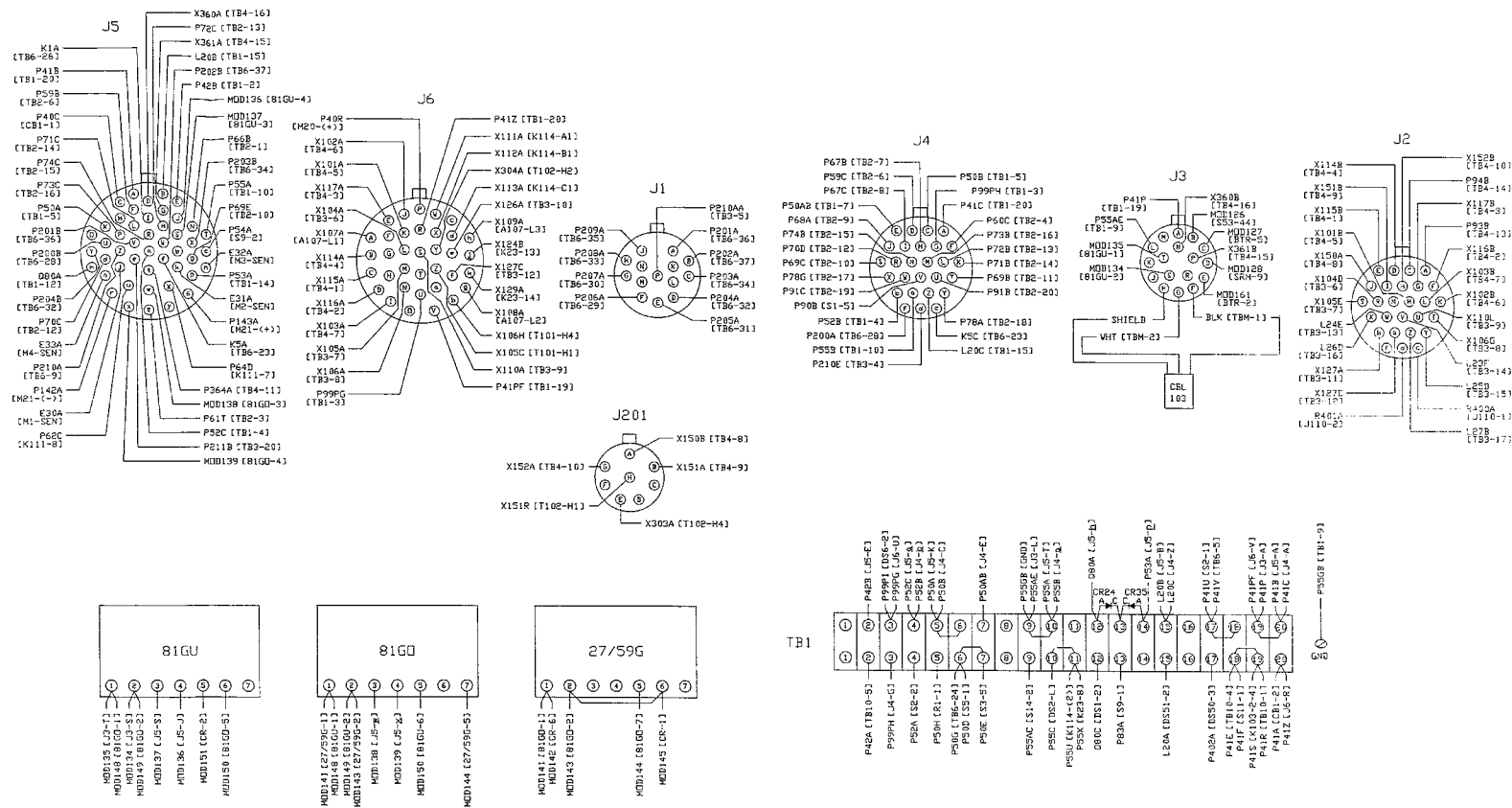

FOR CONTINUATION OF BACK PANEL SEE SHEET 2

FO-7. Unit Control Box Wiring Diagram (Sheet 3 of 4)

FP-49/(FP-50 blank)



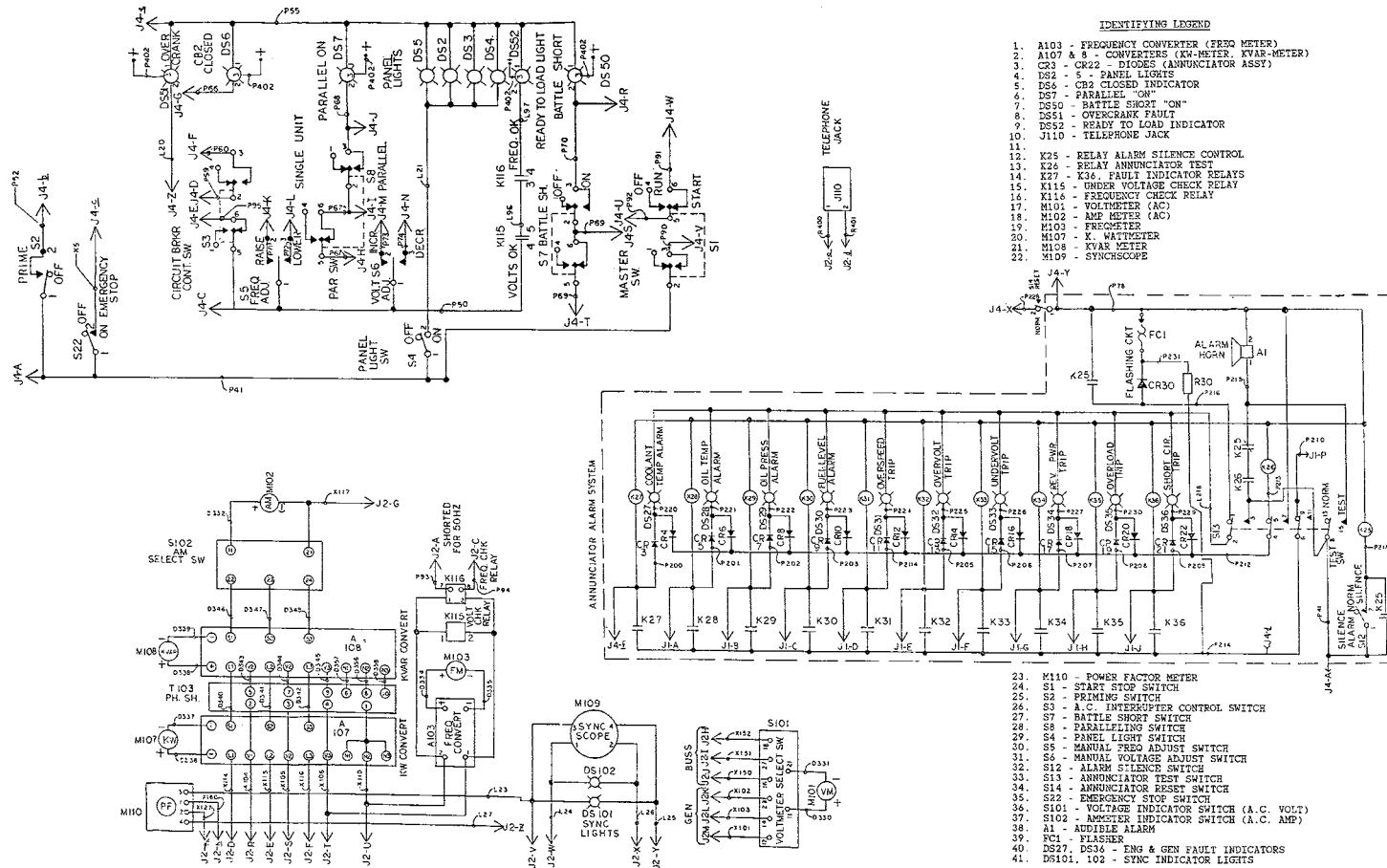

FO-8. Remote Control Module Schematic

FP-53/(FP-54 blank)

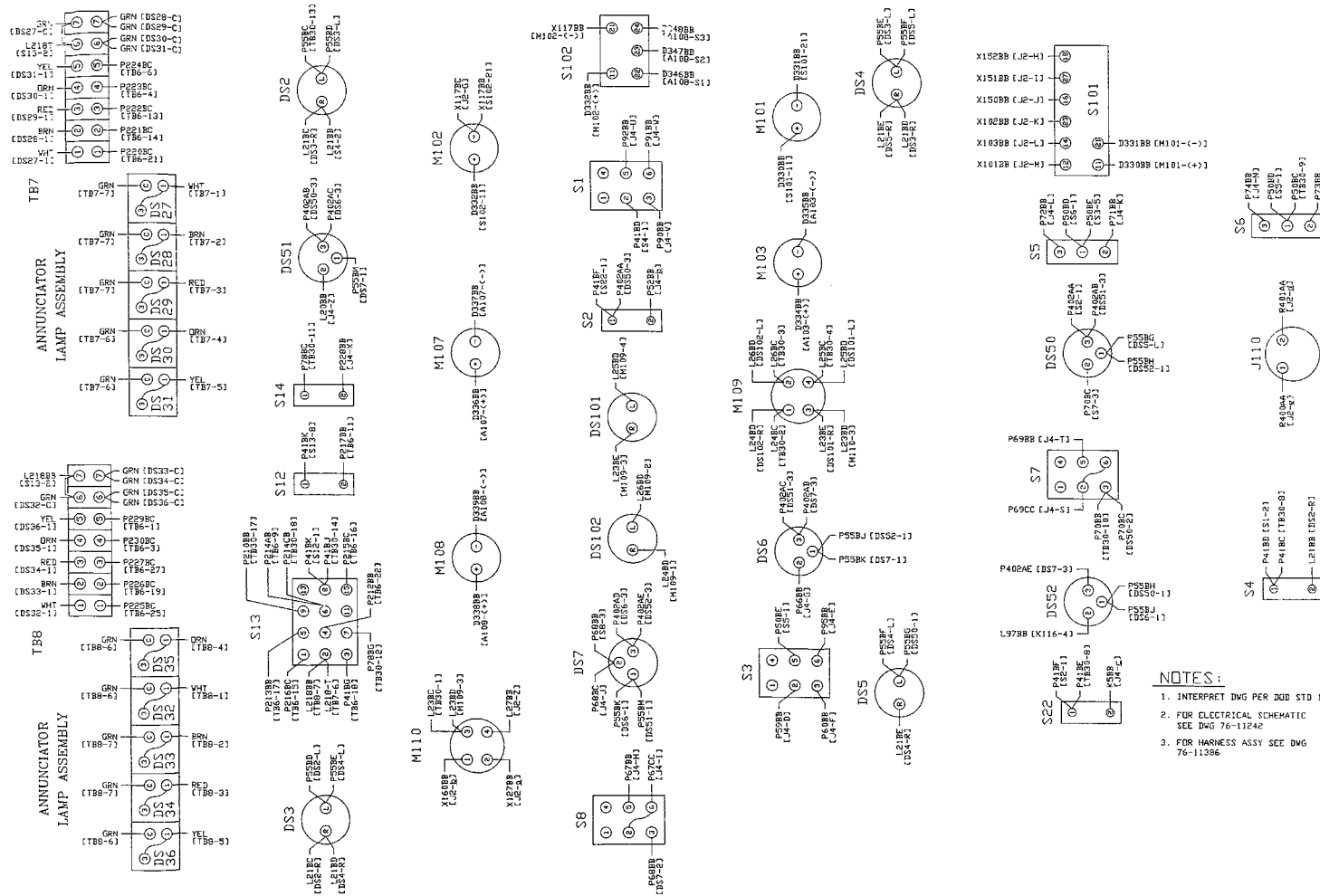

FO-9. Remote Control Module Wiring Diagram (Sheet 1 of 2)

FP-55/(FP-56 blank)

NOTES:

1. INTERPRET DWG PER DOD STD 100
2. FOR ELECTRICAL SCHEMATIC SEE DWG 76-11242
3. FOR HARNESS ASSY SEE DWG 76-11386

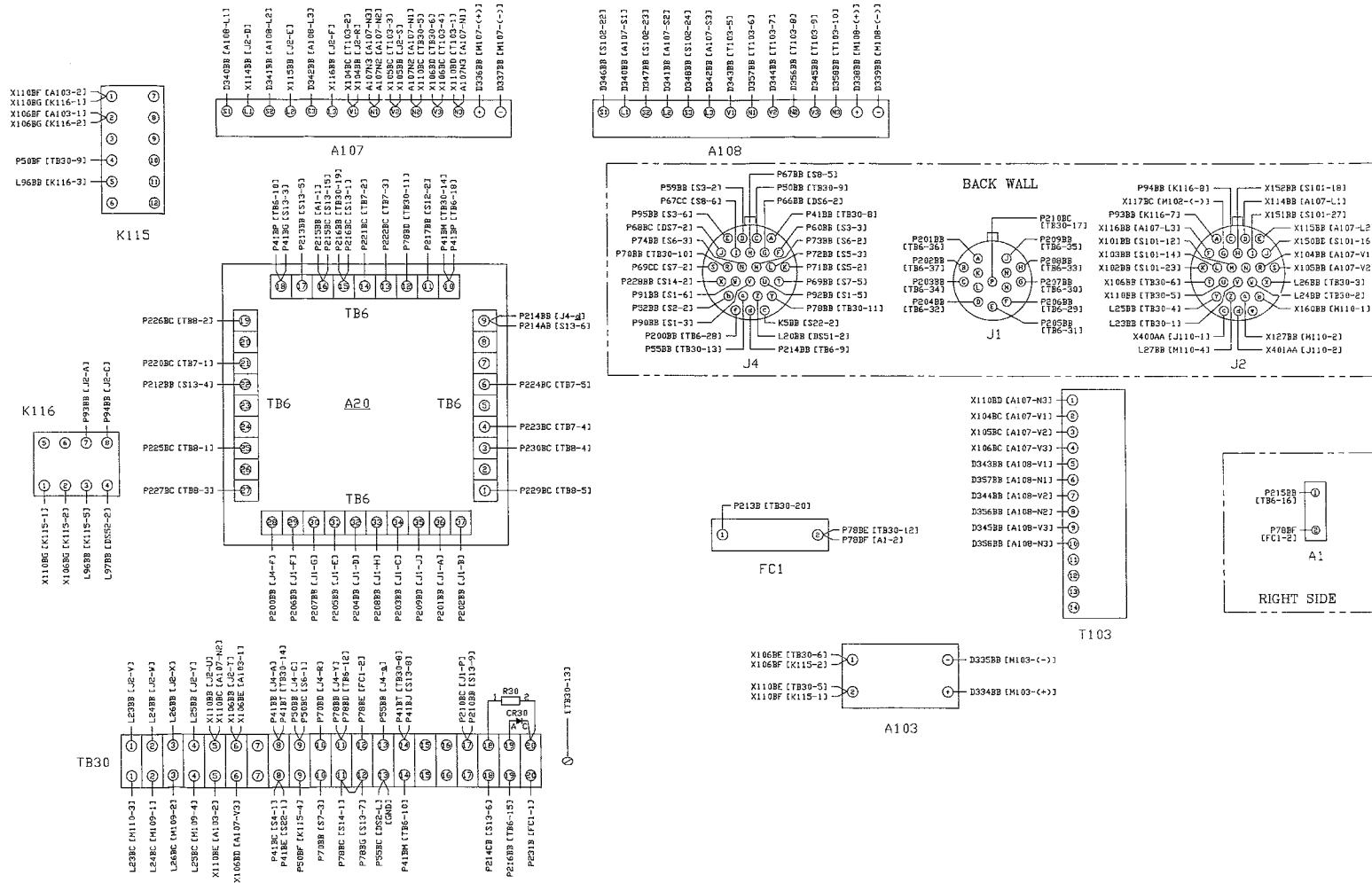

FO-9. Remote Control Module Wiring Diagram (Sheet 2 of 2)

FP-57/(FP-58 blank)



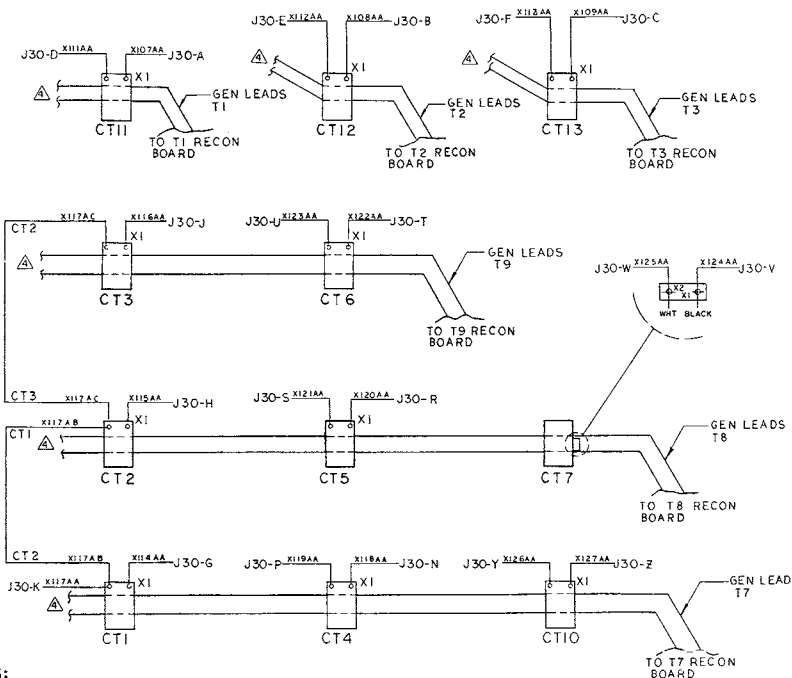
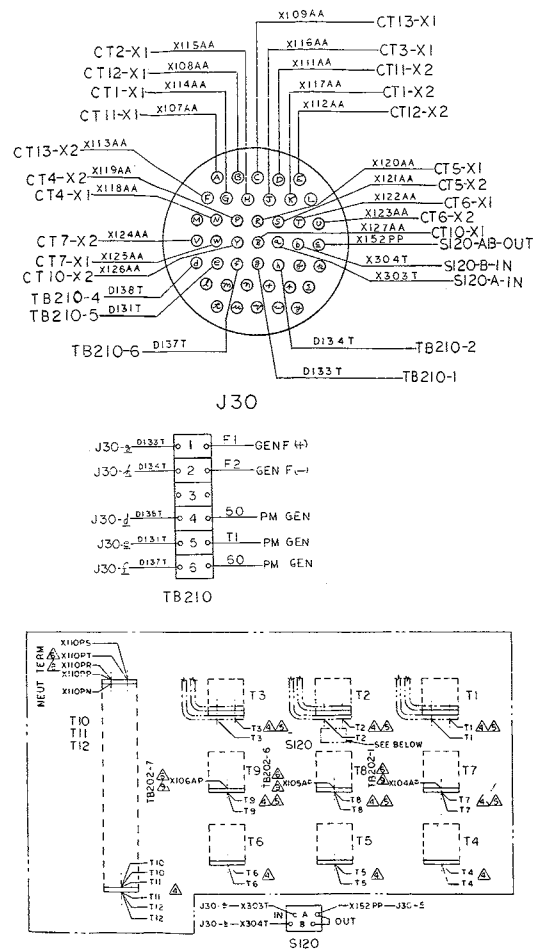

- NOTES:**
- ⚠ FOR ELECTRICAL SCHEMATIC SEE FO-2.
  - ⚠ FOR HARNESS DWG SEE FO 10-7, INTERMEDIATE (FIELD) (DIRECT AND GENERAL SUPPORT) AND DEPOT MAINTENANCE MANUAL.
  - ⚠ SEE CURRENT TRANSFORMER WIRING ABOVE.
  - ⚠ SEE EXTERNAL BOX WIRING FO-7.
  - ⚠ SEE ENGINE ACCESSORY WIRING FO-11.
  - ⚠ SEE POWER CABLE DWG FO 10-18, INTERMEDIATE (FIELD) (DIRECT AND GENERAL SUPPORT) MAINTENANCE MANUAL.
  - ⚠ SEE AC HARNESS DWG FO 10-3, INTERMEDIATE (FIELD) (DIRECT AND GENERAL SUPPORT) AND DEPOT MAINTENANCE MANUAL.

FO-10. Generator Reconnection Box Wiring Diagram

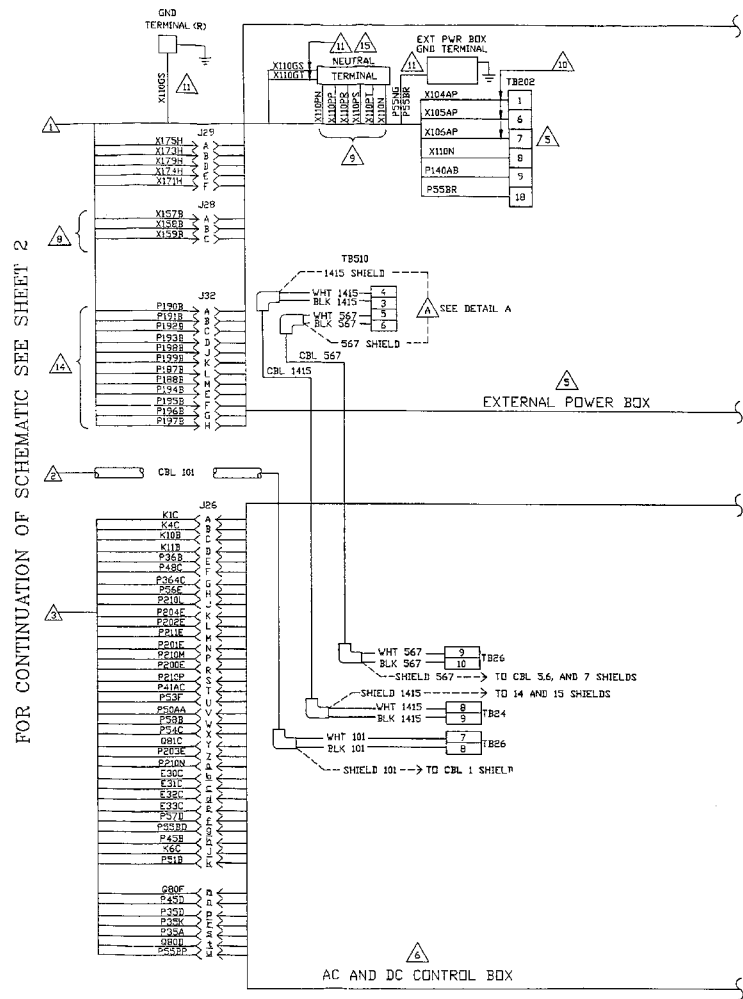

FOR CONTINUATION OF SCHEMATIC SEE SHEET 2

- ▲ INTERPRET DWG PER DOD-STD-100
- ▲ GROUND STRAP FURNISHED BY ENGINE MFG (SHOWN FOR REF)
- ▲ IT IS RECOMMENDED THAT THE TORQUE USED TO TIGHTEN THE TERMINAL NUT SHALL NOT EXCEED 20 INCH-POUNDS WHEN LUG IS ATTACHED TO MT2 AND MT3
- ▲ SEE ELECTRICAL HARNESS INSTALLATION DWG 76-11449
- ▲ SEE EXTERNAL POWER BOX WIRING DIAGRAM 76-11415
- ▲ SEE AC/DC CONTROL BOX WIRING DIAGRAM 76-11269
- ▲ SEE RECONNECTION BOX WIRING DIAGRAM 76-11319
- ▲ SEE AUX POWER HARNESS DRAWING 76-11430
- ▲ SEE POWER CABLE DWG 76-11432
- ▲ SEE A/C POWER HARNESS 76-11433
- ▲ SEE CABLE ASSY 76-11434
- ▲ SEE BATTERY CABLE DWGS 76-11422, 76-11423 AND 76-11424
- ▲ FOR ENGINE ACCESSORY HARNESS SEE DWG 76-11425
- ▲ FOR HOUSING UNITS ONLY SEE LOUVER HARNESS ASSY DWG 76-11429 AND SCHEMATIC 76-11483
- ▲ FOR UNGROUNDING NEUTRAL OPERATIONS REMOVE X1100S AND X1100T WIRES FROM THE NEUTRAL TERMINAL
- ▲ THIS WIRE SHOWN FOR REFERENCE SEE DWG 76-11391
- ▲ SEE ENGINE ASSY DWG 76-11063
- ▲ USE MOTOR NAME PLATE TO CONNECT MOTOR VOLTAGE TO LOW VOLTAGE CONNECTION (208V)

FO-11. Engine Accessories Wiring Diagram (Sheet 1 of 2)

FP-61/(FP-62 blank)

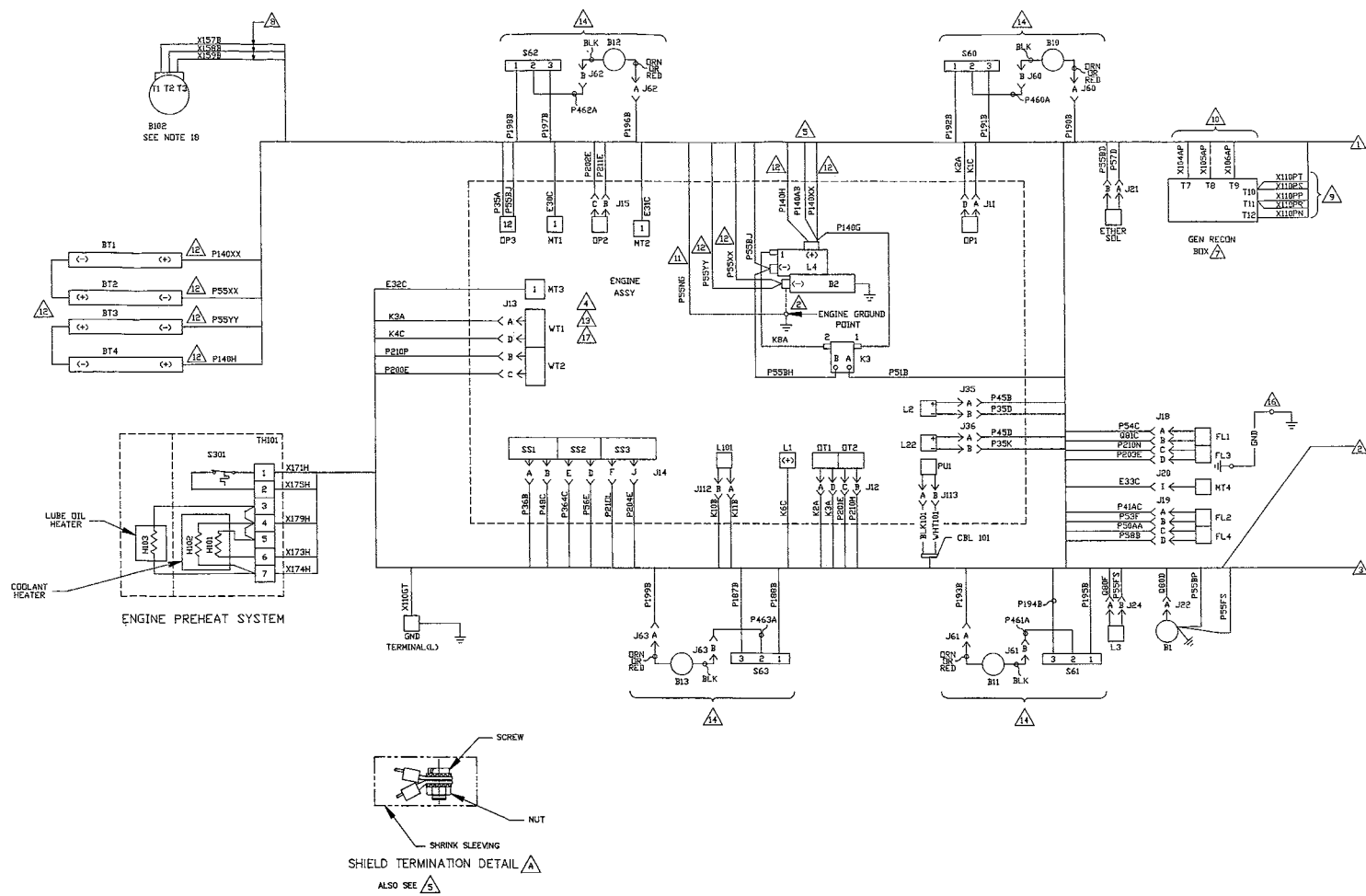

FO-11. Engine Accessories Wiring Diagram (Sheet 2of 2)

FP-63/(FP-64 blank)

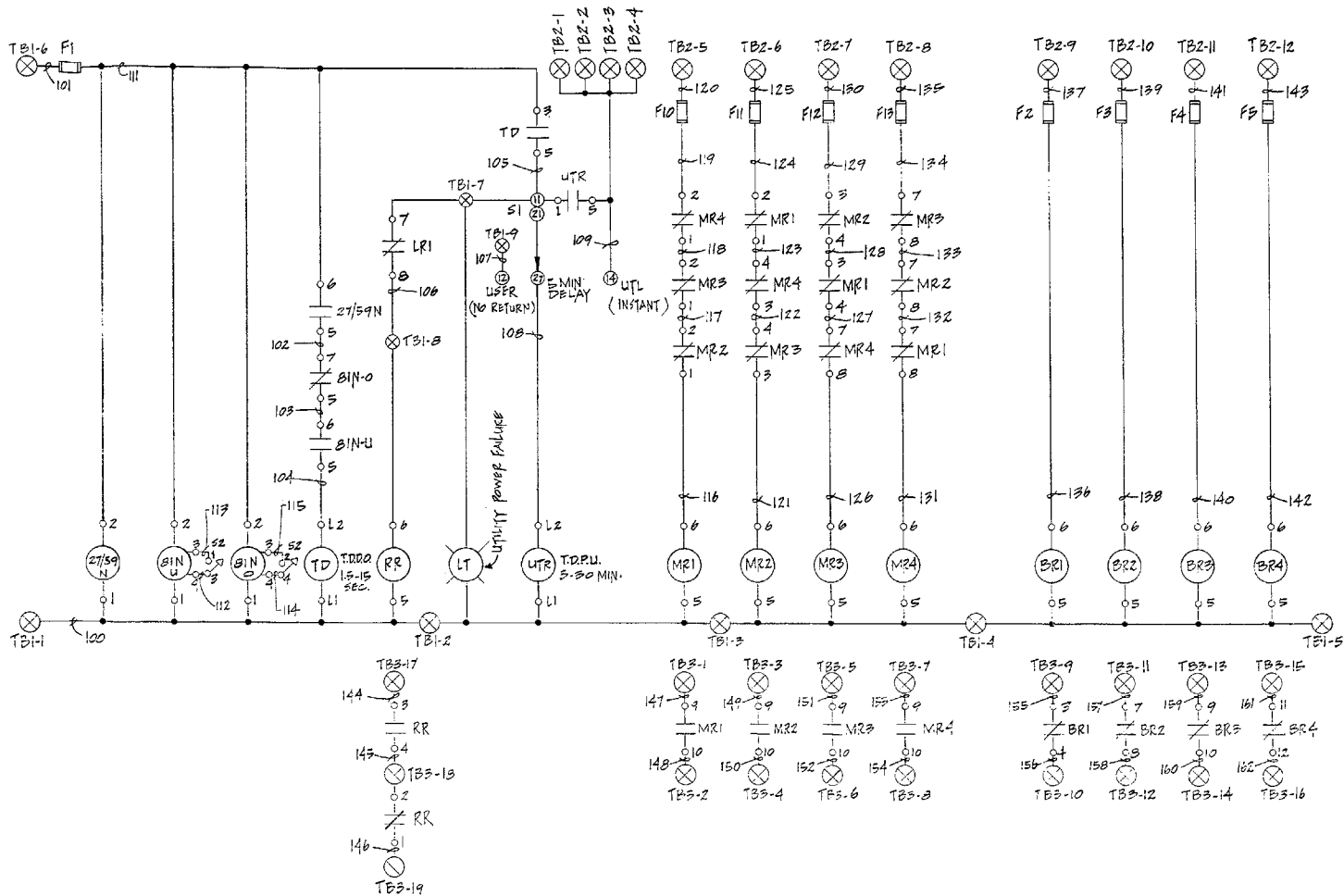

FO-12. Automatic Control Module AC Schematic (Sheet 1 of 2)

FP-65/(FP-66 blank)

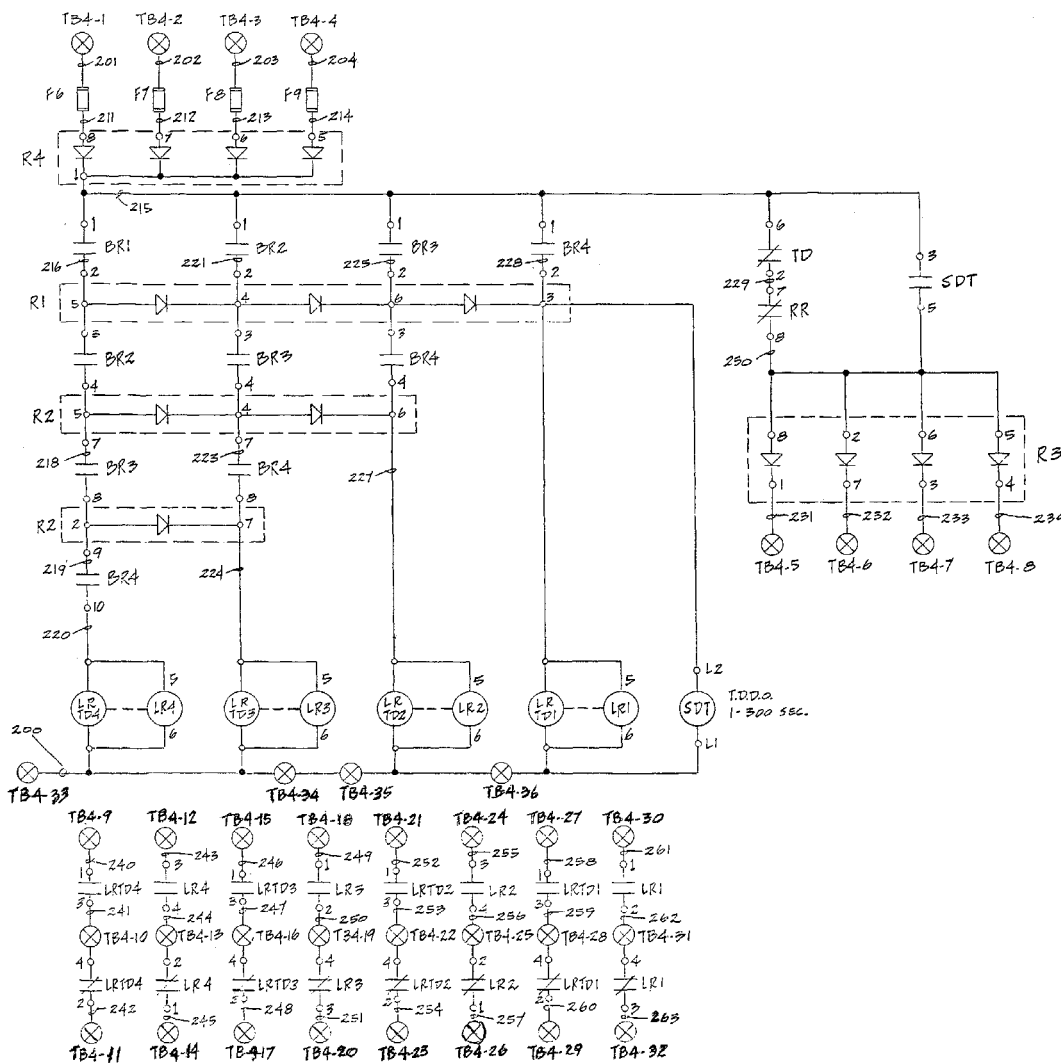

FO-12. Automatic Control Module AC Schematic (Sheet 2 of 2)  
FP-67/(FP-68 blank)

BACK PANEL

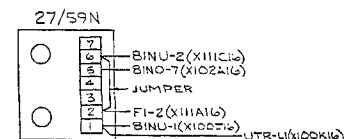
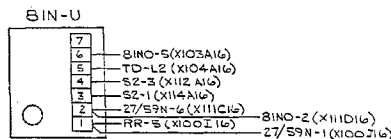
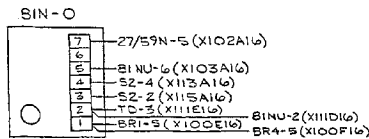
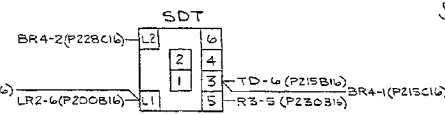
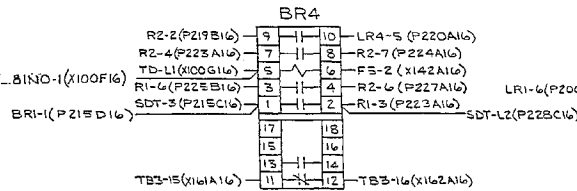
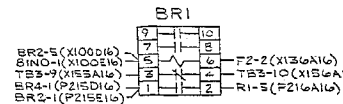
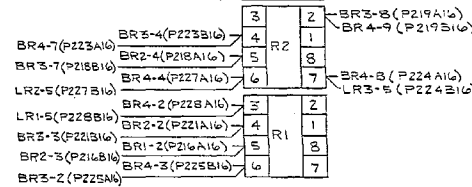
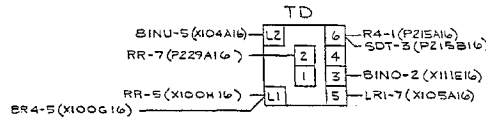
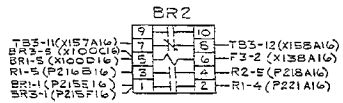
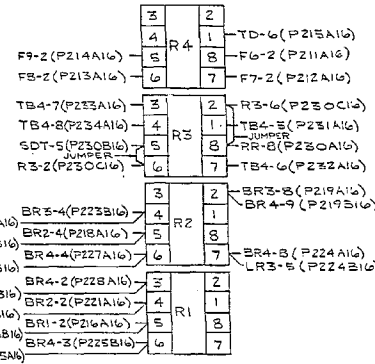
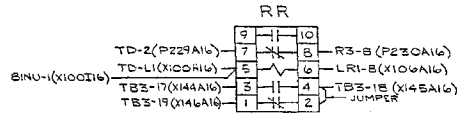
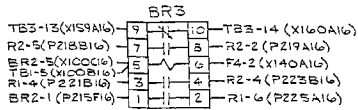

(CONTINUED ON SHEET 2)

- NOTES:
1. FOR A.C. SCHEMATIC SEE FO-12.1
  2. FOR D.C. SCHEMATIC SEE FO-12.2
  3. COIL VOLTAGE :-  
A) 24-VDC FOR ALL LR RELAYS  
B) 110/120VAC FOR ALL BR, MR & RR RELAYS

CONTINUED FROM SHEET 1

BACK PANEL

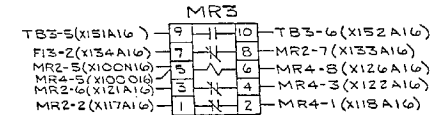
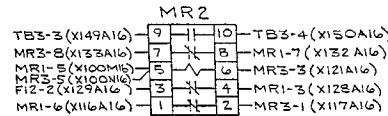
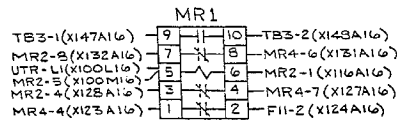
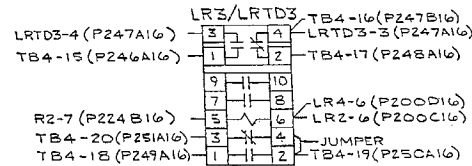
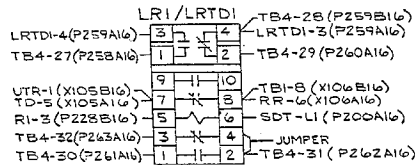
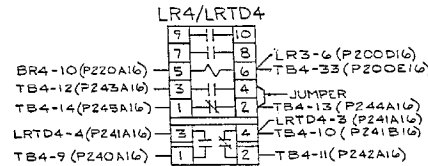
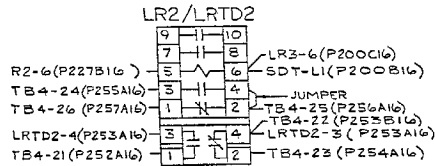
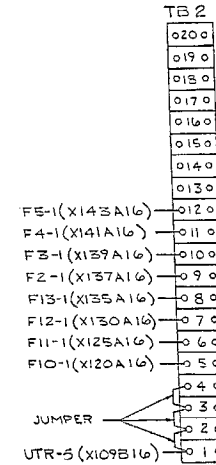
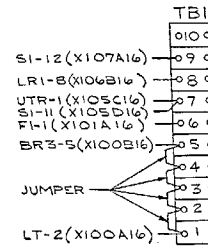
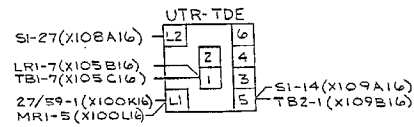

FO-13. Automatic Control Module Wiring Diagram(Sheet 2 of 3)

FP-71/(FP-72 blank)

(CONTINUED ON SHEET 13)

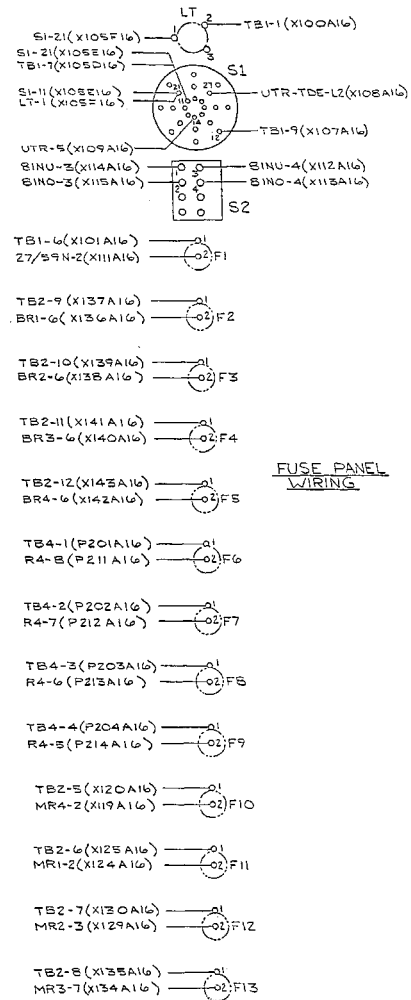

FUSE PANEL  
WIRING

CONTINUED FROM SHEET 2  
BACK PANEL

TB3	
RR-1(X146A16)	0200
RR-4(X145A16)	0190
RR-3(X144A16)	0180
BR4-12(X162A16)	0170
BR4-11(X161A16)	0160
BR3-10(X160A16)	0150
BR3-9(X159A16)	0140
BR2-8(X158A16)	0130
BR2-7(X157A16)	0120
BR1-4(X156A16)	0110
BR1-3(X155A16)	0100
MR4-10(X154A16)	0090
MR4-9(X153A16)	0080
MR3-10(X152A16)	0070
MR3-9(X151A16)	0060
MR2-10(X150A16)	0050
MR2-9(X149A16)	0040
MR1-10(X148A16)	0030
MR1-9(X147A16)	0020

MR4	
TE3-7(X153A16)	0110
MR1-4(X127A16)	0100
MR3-5(X100016)	0090
MR3-4(X122A16)	0080
MR3-2(X118A16)	0070

TE3-8(X154A16)	0100
MR3-6(X126A16)	0090
MR1-8(X131A16)	0080
MR1-1(X123A16)	0070
F10-2(X119A16)	0060

TB4	
0400	
0390	
0380	
0370	
0360	
0350	
0340	
0330	
0320	
0310	
0300	
0290	
0280	
0270	
0260	
0250	
0240	
0230	
0220	
0210	
0200	
0190	
0180	
0170	
0160	
0150	
0140	
0130	
0120	
0110	
0100	
0090	
0080	
0070	
0060	
0050	
0040	
0030	
0020	
0010	

FO-13. Automatic Control Module Wiring Diagram (Sheet 3 of 3)  
FP-73/(FP-74 blank)



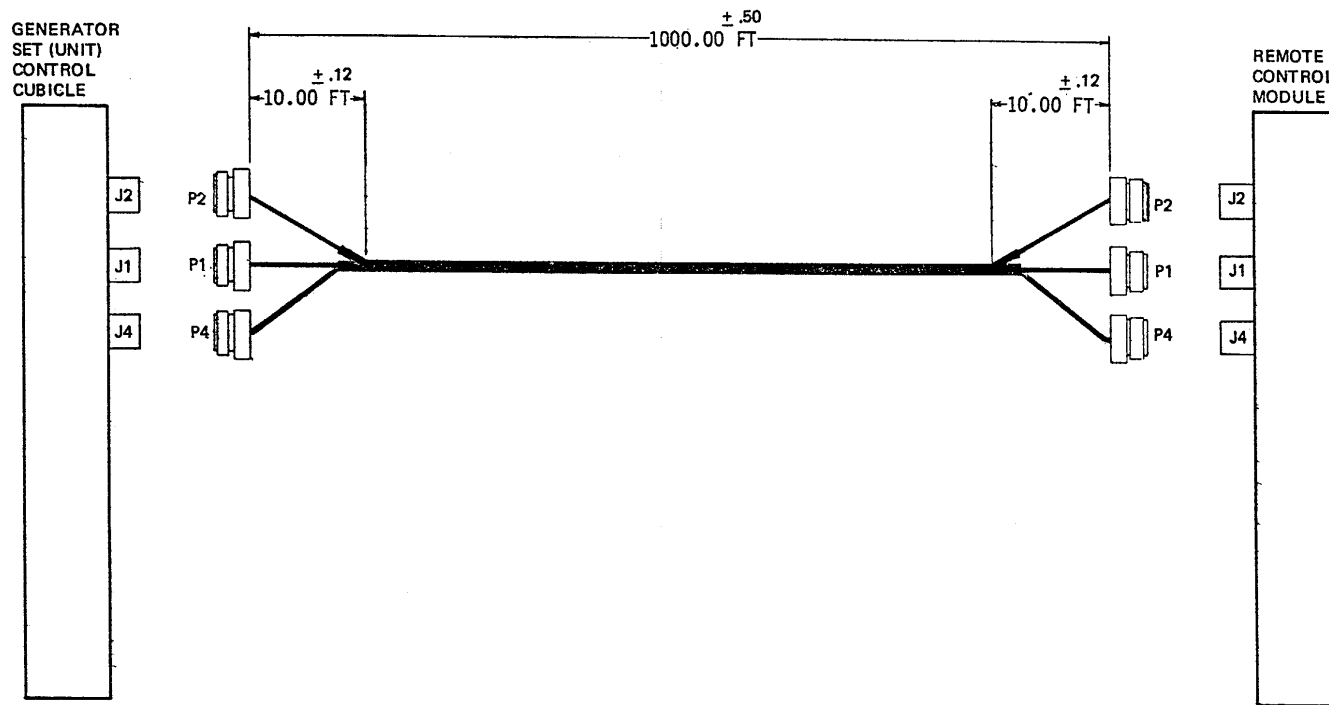

FO-14. Remote Control Module Interconnect Wiring Diagram

FP-75/(FP-76 blank)

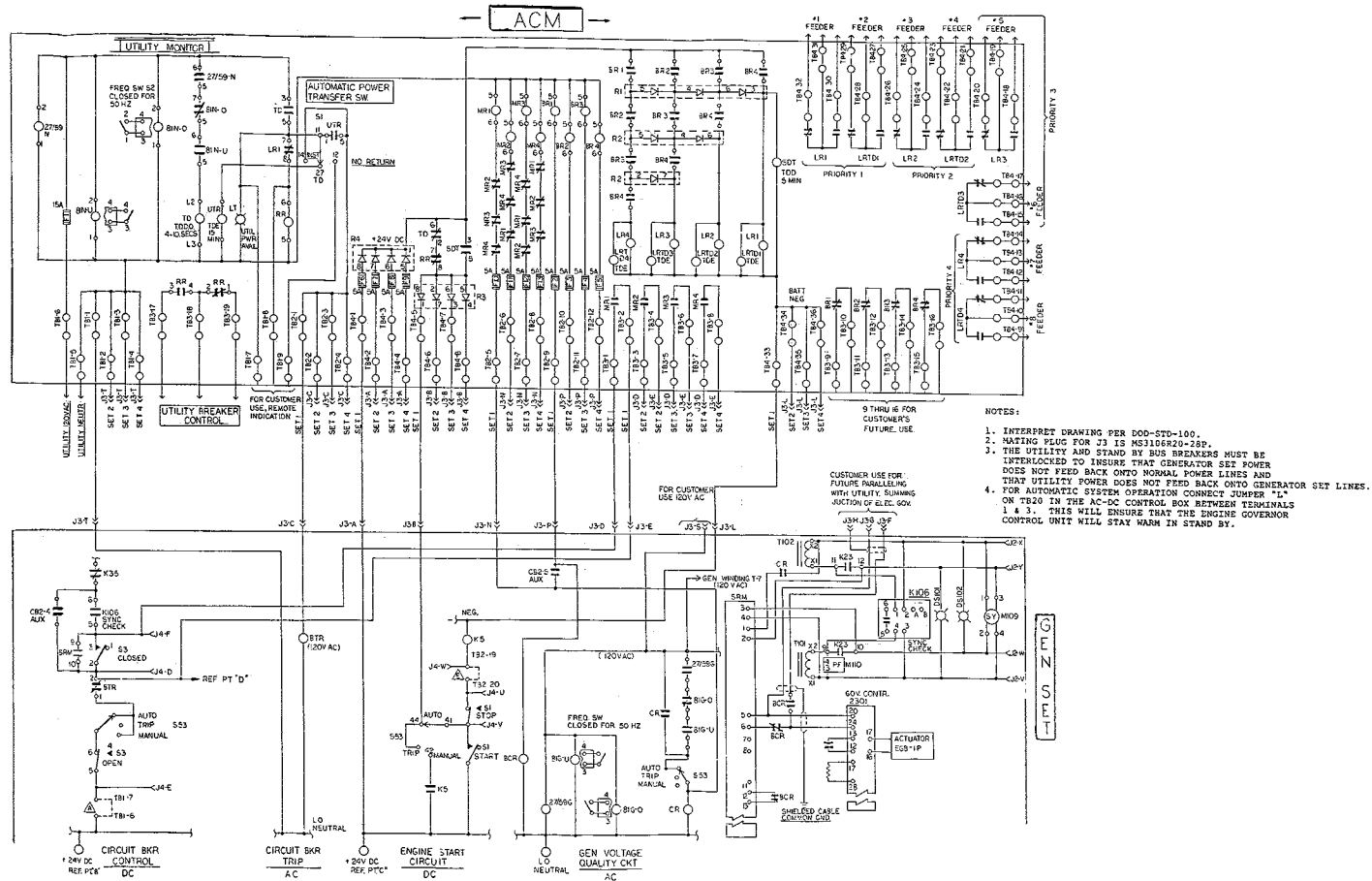

FO-15. Automatic Control Module Interconnect Wiring Diagram

FP-77/(FP-78 blank)

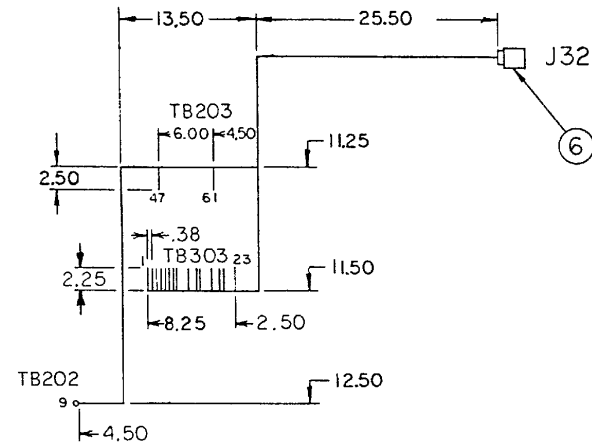

NOTES:

1. ALL WIRES SHALL BE NEATLY LACED INTO HARNESS THROUGH THE USE OF SELF-LOCKING STRAPS FIND NO 5 LACING STRAPS SHALL BE LOCATED AT EACH WIRE BREAKOUT AND PERIODIC INTERVALS NOT TO EXCEED THREE INCHES
2. SOLDERING SHALL BE DONE IN ACCORDANCE WITH REQUIREMENT 5 OF MIL-STD-454
3. WIRING NUMBERS SHALL BE IN ACCORDANCE WITH MIL-W-5088 EXCEPT THAT LENGTH BETWEEN ADJACENT GROUPS OF NUMBERS SHALL NOT EXCEED THREE INCHES
4. FOR WIRING INFORMATION SEE FO-6.

WIRE NO	SIZE	LENGTH	MKG COLOR	FROM	END PREP	TO	END PREP
P100A1G	16	63.00	RED	TB303-1	(2)	J32-A	SOLDER
P101A1G	16	63.00	RED	TB303-2	(2)	J32-B	SOLDER
P102A1G	16	62.00	RED	TB303-5	(2)	J32-C	SOLDER
P103A1G	16	62.00	RED	TB303-7	(2)	J32-D	SOLDER
P104A1G	16	62.00	RED	TB303-8	(2)	J32-E	SOLDER
P105A1G	16	60.00	RED	TB303-11	(2)	J32-F	SOLDER
P106A1G	16	59.00	RED	TB303-13	(2)	J32-G	SOLDER
P107A1G	16	59.00	RED	TB303-14	(2)	J32-H	SOLDER
P108A1G	16	58.00	RED	TB303-17	(2)	J32-J	SOLDER
P109A1G	16	58.00	RED	TB303-19	(2)	J32-K	SOLDER
P107A1G	16	58.00	RED	TB303-20	(2)	J32-L	SOLDER
P108A1G	16	56.00	RED	TB303-23	(2)	J32-M	SOLDER
P140CR12	12	65.00	RED	TB303-4	(7)	TB202-9	(1)
P56N1G	16	37.00	RED	TB303-3	(2)	TB203-47	(2)
P55B12	12	32.00	RED	TB303-6	(7)	TB203-61	(7)

8			M5086/2-12-9	A R	WIRE AWG#12	MIL-W-5086/2	
7		B	71-4924	3	TERMINAL LUG	MIL-T-7928	
6			MS3102R-20-29S	1	CONNECTOR		
5			MS3367-1-9	A R	TIE WRAP		
4			SN60WRAP 2	A R	SOLDER	QQ-S-571	SEE NOTE 2
3			M5086/2-16-9	A R	WIRE AWG#16	MIL-W-5086/2	
2			MS25036-106	14	TERMINAL LUG	MIL-T-7928	
1			MS25036-157	1	TERMINAL LUG	MIL-T-7928	
FIND NO	SYM	CODE IDENT	DWG SIZE	PART OR IDENTIFYING NO	QTY REQD	NOMENCLATURE OR DESCRIPTION	SPECIFICATION MATERIAL

LIST OF MATERIALS

FO-16. Louver Control Schematic  
FP-79/(FP-80 blank)

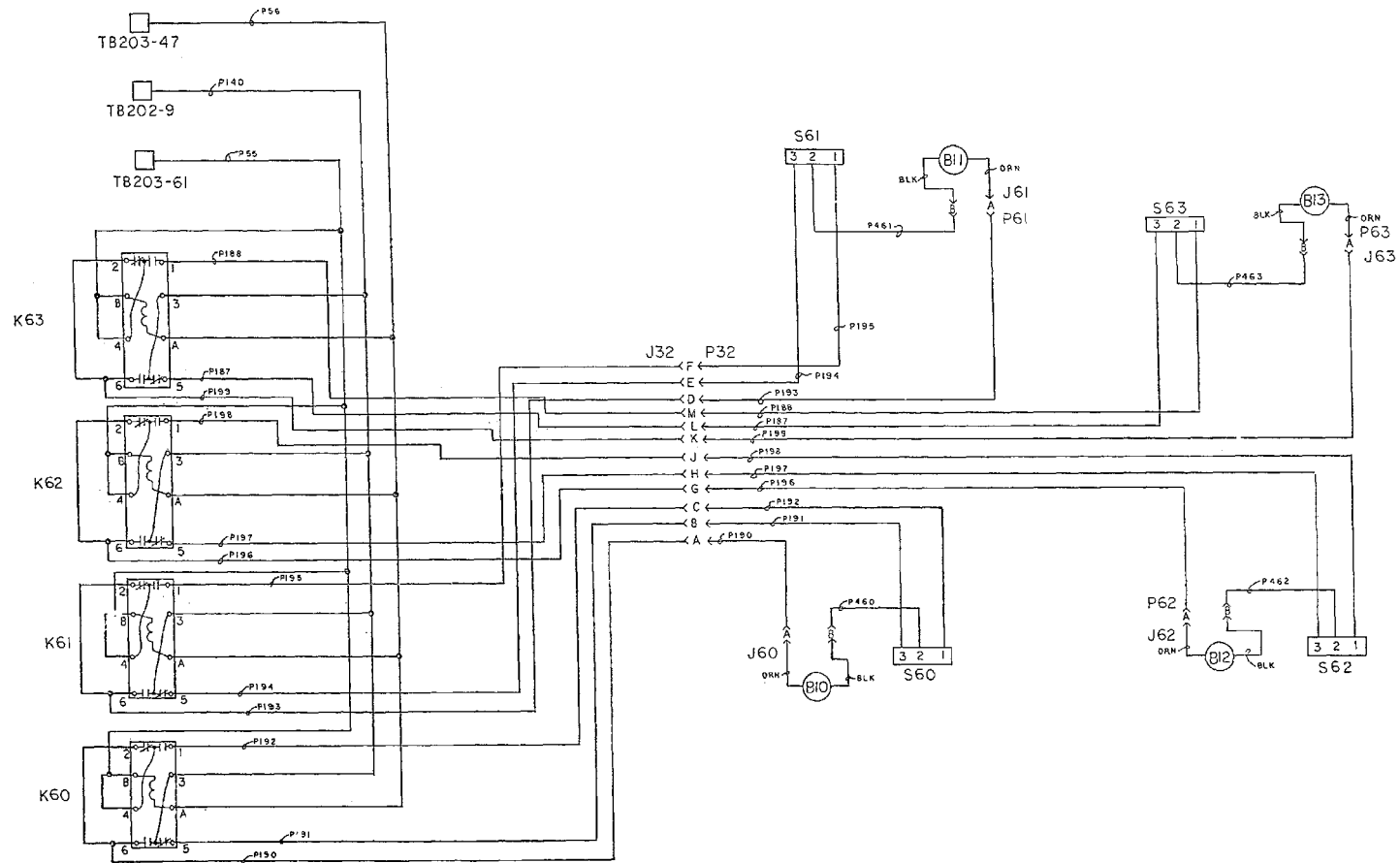

FO-17. Louver Control Schematic

FP-81/(FP-82 blank)

By Order of the Secretaries of the Army and the Air Force:

Official:

**THOMAS F. SIKORA**

*Brigadier General, United States Army  
The Adjutant General*

**CARL E. VUONO**  
*General, United States Army  
Chief of Staff*

Official:

**ALFRED G. HANSEN**

*General, USAF, Commander, Air Force  
Logistics Command*

**LARRY D. WELCH**, *General USAF  
Chief of Staff*

DISTRIBUTION:

To be distributed in accordance with DA Form 12-25E, 0865).

RECOMMENDED CHANGES TO EQUIPMENT TECHNICAL PUBLICATIONS

 <p style="font-size: small; margin: 0;"><i>THEN...JOT DOWN THE DOPE ABOUT IT ON THIS FORM. CAREFULLY TEAR IT OUT, FOLD IT AND DROP IT IN THE MAIL.</i></p>		SOMETHING WRONG WITH PUBLICATION	
		FROM: (PRINT YOUR UNIT'S COMPLETE ADDRESS)	
		DATE SENT	
PUBLICATION NUMBER		PUBLICATION DATE	PUBLICATION TITLE
IN THIS SPACE, TELL WHAT IS WRONG AND WHAT SHOULD BE DONE ABOUT IT.			
BE EXACT PIN-POINT WHERE IT IS			
PAGE NO.	PARA-GRAPH	FIGURE NO.	TABLE NO.
PRINTED NAME, GRADE OR TITLE AND TELEPHONE NUMBER		SIGN HERE	

## The Metric System and Equivalents

### Linear Measure

1 centimeter = 10 millimeters = .39 inch  
 1 decimeter = 10 centimeters = 3.94 inches  
 1 meter = 10 decimeters = 39.37 inches  
 1 dekameter = 10 meters = 32.8 feet  
 1 hectometer = 10 dekameters = 328.08 feet  
 1 kilometer = 10 hectometers = 3,280.8 feet

### Weights

1 centigram = 10 milligrams = .15 grain  
 1 decigram = 10 centigrams = 1.54 grains  
 1 gram = 10 decigrams = .035 ounce  
 1 decagram = 10 grams = .35 ounce  
 1 hectogram = 10 decagrams = 3.52 ounces  
 1 kilogram = 10 hectograms = 2.2 pounds  
 1 quintal = 100 kilograms = 220.46 pounds  
 1 metric ton = 10 quintals = 1.1 short tons

### Liquid Measure

1 centiliter = 10 milliliters = .34 fl. ounce  
 1 deciliter = 10 centiliters = 3.38 fl. ounces  
 1 liter = 10 deciliters = 33.81 fl. ounces  
 1 dekaliter = 10 liters = 2.64 gallons  
 1 hectoliter = 10 dekaliters = 26.42 gallons  
 1 kiloliter = 10 hectoliters = 264.18 gallons

### Square Measure

1 sq. centimeter = 100 sq. millimeters = .155 sq. inch  
 1 sq. decimeter = 100 sq. centimeters = 15.5 sq. inches  
 1 sq. meter (centare) = 100 sq. decimeters = 10.76 sq. feet  
 1 sq. dekameter (are) = 100 sq. meters = 1,076.4 sq. feet  
 1 sq. hectometer (hectare) = 100 sq. dekameters = 2.47 acres  
 1 sq. kilometer = 100 sq. hectometers = .386 sq. mile

### Cubic Measure

1 cu. centimeter = 1000 cu. millimeters = .06 cu. inch  
 1 cu. decimeter = 1000 cu. centimeters = 61.02 cu. inches  
 1 cu. meter = 1000 cu. decimeters = 35.31 cu. feet

## Approximate Conversion Factors

<i>To change</i>	<i>To</i>	<i>Multiply by</i>	<i>To change</i>	<i>To</i>	<i>Multiply by</i>
inches	centimeters	2.540	ounce-inches	Newton-meters	.007062
feet	meters	.305	centimeters	inches	.394
yards	meters	.914	meters	feet	3.280
miles	kilometers	1.609	meters	yards	1.094
square inches	square centimeters	6.451	kilometers	miles	.621
square feet	square meters	.093	square centimeters	square inches	.155
square yards	square meters	.836	square meters	square feet	10.764
square miles	square kilometers	2.590	square meters	square yards	1.196
acres	square hectometers	.405	square kilometers	square miles	.386
cubic feet	cubic meters	.028	square hectometers	acres	2.471
cubic yards	cubic meters	.765	cubic meters	cubic feet	35.315
fluid ounces	milliliters	29.573	cubic meters	cubic yards	1.308
pints	liters	.473	milliliters	fluid ounces	.034
quarts	liters	.946	liters	pints	2.113
gallons	liters	3.785	liters	quarts	1.057
ounces	grams	28.349	liters	gallons	.264
pounds	kilograms	.454	grams	ounces	.035
short tons	metric tons	.907	kilograms	pounds	2.205
pound-feet	Newton-meters	1.356	metric tons	short tons	1.102
pound-inches	Newton-meters	.11296			

## Temperature (Exact)

°F	Fahrenheit temperature	5/9 (after subtracting 32)	Celsius temperature	°C
----	---------------------------	-------------------------------	------------------------	----

