

1 bd
4 U113
TM
1944

TM 11-2250

WAR DEPARTMENT TECHNICAL MANUAL

U.S. Dept. of Army

REEL EQUIPMENT CE-11

UNIVERSITY OF CALIFORNIA
LIBRARY
FEB 25 1944

WAR DEPARTMENT • 18 JANUARY 1944

WAR DEPARTMENT TECHNICAL MANUAL

TM 11-2250

REEL
EQUIPMENT
CE-11



WAR DEPARTMENT • 18 JANUARY 1944

United States Government Printing Office
Washington 1944

WAR DEPARTMENT,
WASHINGTON 25, D. C., 18 January 1944.

TM 11-2250, Reel Equipment CE-11, is published for the information and guidance of all concerned.

[A. G. 300.7 (9 Oct 43).]

BY ORDER OF THE SECRETARY OF WAR:

G. C. MARSHALL,
Chief of Staff.

OFFICIAL:

J. A. ULIO,
Major General,
The Adjutant General.

DISTRIBUTION:

Bn and H 7 (5); IC 3, 7, 11 (10).
(For explanation of symbols see FM 21-6.)

II

U113
-2

DESTRUCTION NOTICE

TM 1112250
1944



WHY—To prevent the enemy from using or salvaging this equipment for his benefit.

WHEN—When ordered by your commander or when you are in immediate danger of capture.

HOW—1. Smash—Use sledges, axes, hand axes, pickaxes, hammers, crowbars, heavy tools.
2. Cut—Use axes, hand axes, machetes, etc.
3. Burn—Use gasoline, kerosene, oil, flame-throwers, incendiary grenades, etc.
4. Explosives—Use firearms, grenades, TNT, etc.
5. Disposal—Bury in slit trenches, fox holes, other holes. Throw in streams. Scatter.
6. USE ANYTHING IMMEDIATELY AVAILABLE FOR DESTRUCTION OF THIS EQUIPMENT.

WHAT—1. Smash hand-set, transmitter, receiver, capacitors, and test clips.
2. Cut hand-set cord, carrying straps, and wire.
3. Bend or break spool, handles, axle, and crank.
4. Burn wire, straps, and cord.
5. Bury or scatter any or all of the above pieces after breaking or burning.

DESTROY EVERYTHING

M558570

III

CONTENTS

SECTION I. Description.	Paragraph	Page
General.....	1	1
Reel Unit RL-39.....	2	2
Handset TS-10-(*).....	3	2
Weights and dimensions.....	4	4
 II. Operation.		
Assembly.....	5	4
Use.....	6	4
 III. Functioning of parts.		
Sound - powered transmitter and receiver, Handset TS- 10-(*).....	7	8
 IV. Maintenance.		
Determining circuit failures in Handset TS-10-(*).....	8	10
Lubrication of Reel Unit RL-39.....	9	11
Cleaning bearings.....	10	11
Repairing Reel Unit RL-39..	11	12
 V. Supplementary data.		
Table of replaceable parts....	12	12

Section I

Description

1. GENERAL. Reel Equipment CE-11 is a lightweight portable unit designed to be carried by one man. It consists of Reel Unit RL-39 and Handset TS-10-(*),¹ which is a sound-powered telephone. The equipment is used primarily by the Infantry for laying and recovering Assault Wire W-130-(*), over short distances. The handset cord is equipped with two test clips that can be connected to two terminals on the wire spool at any time during wire-laying operations. The reel end of the wire is connected to these terminals at all times. With this arrangement, communication can be established with the base installation at the convenience of the operator, without the uncertainty of a bad connection or the necessity for cutting the insulation of the wire.

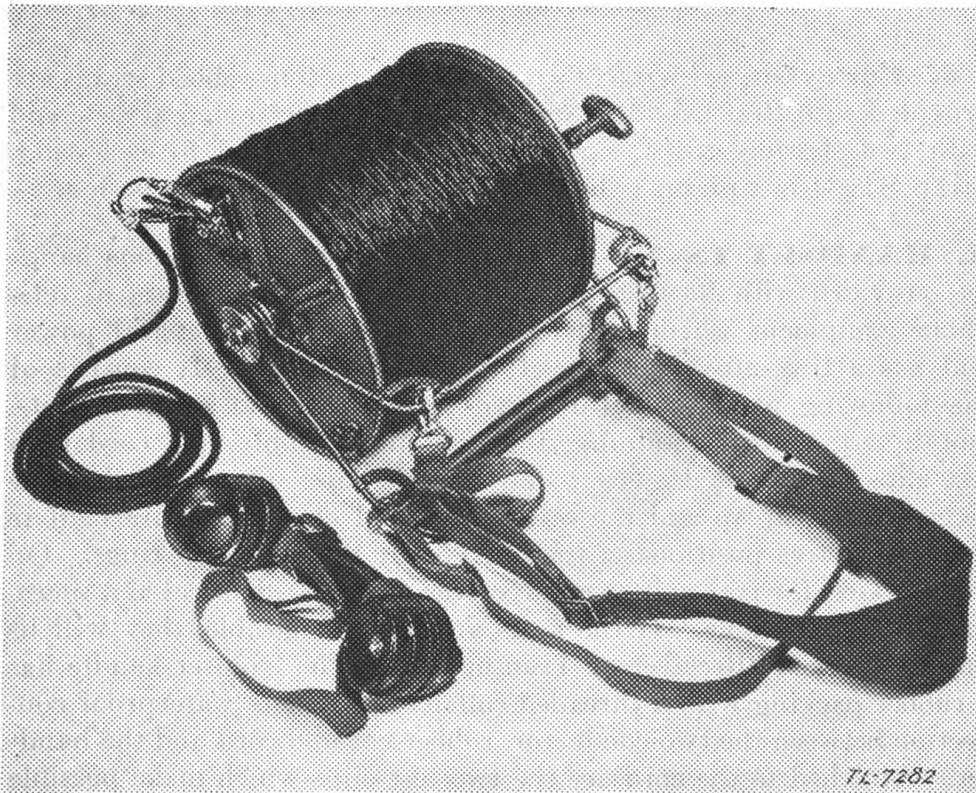

Figure 1. Reel Equipment CE-11.

¹ In this manual the symbol (*) refers to all models of specified equipment.

2. REEL UNIT RL-39. a. Spool DR-8. The wire spool is a steel drum, 9 inches in diameter and about 8 inches wide. It holds approximately $\frac{1}{4}$ mile of twisted-pair assault wire. Mounted on one side of the spool is a terminal plate fitted with two brass thumb nut terminals. A hole in the spool flange, directly below the terminal plate, permits the reel end of the wire to be connected to these terminals.

b. Handle assembly. The handles are made of two U-shaped steel rods, with a loop formed at each end to encircle the bearing assembly. Steel braces are riveted across the corners of both handles to hold the snaps of the carrying straps in position. The bearing assembly consists of a brass housing containing a steel center with a square hole. The two bearings support the axle and spool, and rotate freely when wire is payed out or when the crank is used to rewind the wire.

c. Axle and crank. The axle is a steel shaft, $\frac{5}{16}$ inch square and 11 $\frac{11}{16}$ inches long. Attached to one end is a crank consisting of a lever arm and a cast-iron knob. The arm and knob are joined together by a brass spindle, and the complete crank is rivited to the axle. A cotter pin in the open end of the axle permits the complete assembly to be removed from the handles. If this pin is misplaced or lost, the spare, which is carried in the back of the level arm (fig. 7), will be used.

d. Carrying straps. Two adjustable, cotton-webbed straps are provided with Reel Unit RL-39. Strap ST-35 has a ring at each end with two shorter straps, equipped with snaps, sewed to each ring. Strap ST-34 is a plain, 1- by 38-inch strap, with snaps at both ends.

3. HANDSET TS-10-(*). The sound-powered telephone handset, provided with Reel Equipment CE-11, is a complete set of telephone equipment which is independent of external electrical power and has a transmission range of from 3 to 5 miles. It consists of the following parts: sound-powered transmitter and receiver units, mouthpiece, earcap, retaining rings, handle assembly, and cord with test clips attached. Figure 2 shows the handset disassembled. The receiver and earcap and the transmitter and mouthpiece are held in their respective positions in the handset by the clamping rings. On some models the transmitter and receiver units are identical and therefore interchangeable. If the units are interchangeable, they will be plainly marked "Receiver or Transmitter." The handset handle has a rubber packing with a threaded collar to provide a waterproof connection between the two-conductor, rubber-covered cord and the handset. Attached to the cord are the two test clips which make possible the quick, sure connection between handset and wire spool. Carrying

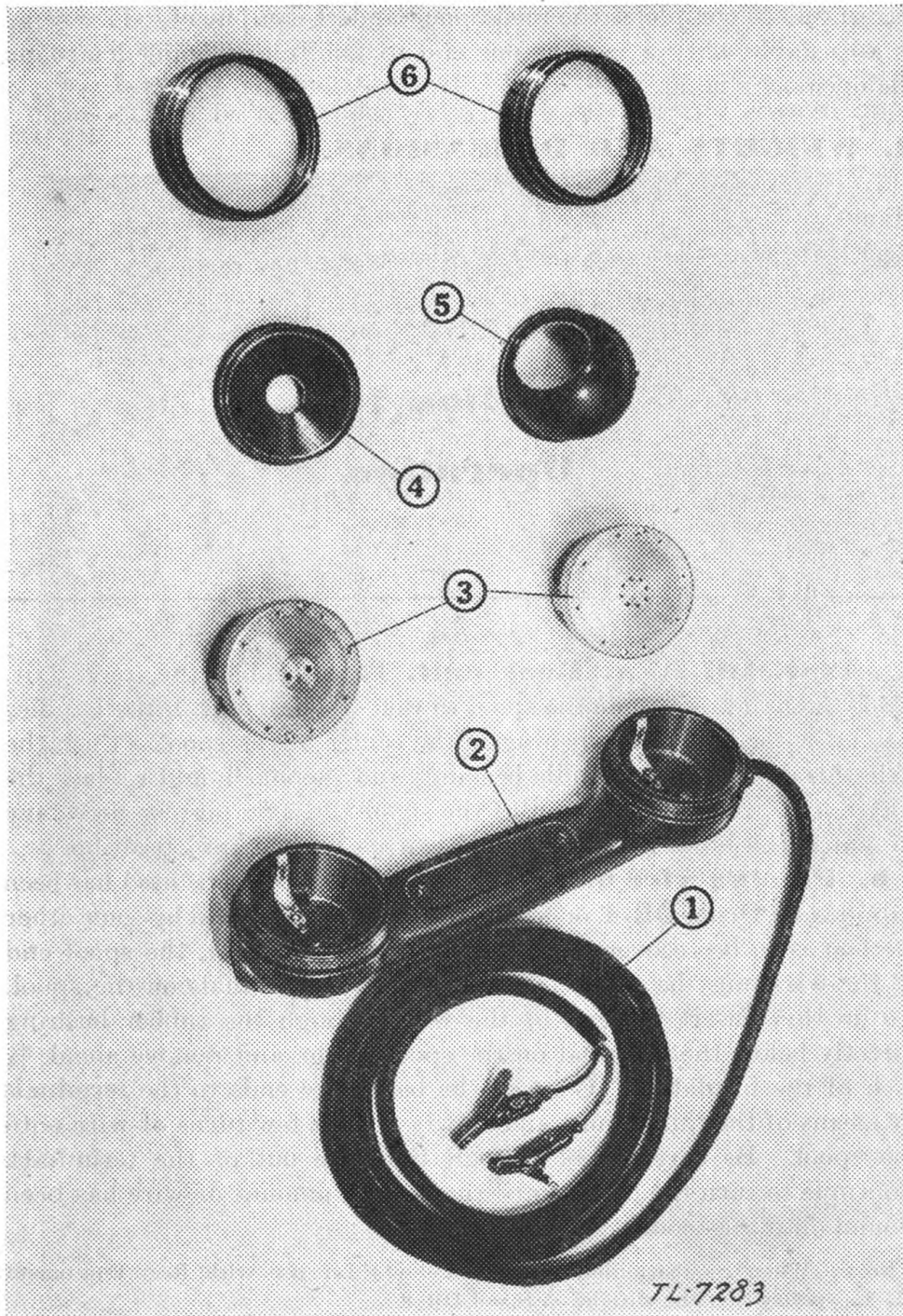

- | | |
|------------------------------------|---------------------|
| 1. Cord assembly. | 4. Earcap. |
| 2. Handle. | 5. Mouthpiece. |
| 3. Transmitter and receiver units. | 6. Retaining rings. |

Figure 2. Handset TS-10-(*), disassembled.

Strap ST-33 completes the telephone handset equipment. This strap is adjustable, with a loop at one end to facilitate placing it around the operator's neck.

4. WEIGHTS AND DIMENSIONS.

<i>Components</i>	<i>Weight</i>	<i>Dimensions (inches)</i>
Handset TS-10-(*)	25 ounces	9 $\frac{1}{4}$ by 3 $\frac{1}{2}$
Reel Unit RL-39	17 pounds, with wire	14 by 10

Section II

Operation

5. ASSEMBLY. a. Reel unit. To assemble the reel unit, place the handles astride the spool so that the bearings in the handles line up with the square opening in the center of the spool. Push the axle through both the handle bearings and the spool, and replace the cotter pin. A slight rotation of the spool and axle may be necessary to match the holes before the axle can be pushed into position.

b. Placing wire on spool. When the wire to be used has been supplied on Drum DR-4, or when wire that has been laid by some other method is to be recovered on Reel Equipment CE-11, the spool end of the wire must be connected to the pair of terminals on the spool. To do this, insert the end of the wire through the rubber bushing directly below the terminal on the spool flange and remove about $\frac{3}{4}$ inch of the insulation. Connect the bare wire ends to the terminals by means of the thumb nuts and slowly wind a few turns of wire onto the spool. Be careful not to pull the wire out of the terminals. Continue to turn the crank until the desired amount of wire has been wound onto the spool.

NOTE.—When requisitioning Wire W-130-(*) for use with Reel Equipment CE-11, specify that the wire be on Spool DR-8.

6. USE. a. General. The wire communication provided by Reel Equipment CE-11 is used primarily to supplement messenger and visual signal communication. It may also be used when standard field telephones are not available. The unit makes the laying or recovering of several hundred yards of wire a comparatively simple operation. Technically trained personnel are not needed to operate

the unit, and the average soldier can be taught the proper method of use in a very short time.

b. Laying wire. In laying wire, the straps are not necessary. They should be unsnapped from the reel unit and secured on the



Figure 3. Laying wire with Reel Equipment CE-11.

operator's person in such a way that they will not be lost. With the handles of the reel unit brought together and held in one hand, the unit can be carried at the side (fig. 3). As the operator walks toward his objective, the spool rotates freely, allowing the wire to unwind. If, when operating in forward areas, it is necessary to crawl toward the



Figure 4. Recovering wire with Reel Equipment CE-11.



Figure 5. Using sound-powered Handset TS-10-() with Reel Equipment CE-11.*

objective, the spool can be pulled, wheelbarrow fashion, with the wire unwinding as the spool rolls over the ground.

c. Recovering wire. To recover wire with Reel Equipment CE-11, the straps are necessary and must be attached to the reel unit. Prepare the equipment for mounting by snapping the ends of the Carrying Strap ST-35 to the handles. The loop in the strap can then be placed over the operator's head, so that the weight of the reel is supported on the shoulders. To prevent the equipment from swinging, attach Strap ST-34 to the lower handle with the strap passing

around the waist. With the reel equipment carried as described (fig. 4), the spool is held away from the body by the lower handle, allowing free rotation of the drum. The operator thus has one hand free to turn the crank as he walks in the direction of the wire, and one hand to guide the wire evenly onto the spool. The speed of recovery is determined by the speed with which the operator turns the crank. An alternate method for recovering wire when the operator cannot expose himself is to hold the reel unit by the handles without the straps and take in the wire from a crouched position. This is a much slower method and should be used only when the normal method is impracticable.

d. Use of the sound-powered telephone. The reel unit operator may at any time establish communication with the rear by clipping the test clips of the handset cord to the spool terminals (fig. 5). It must be remembered, however, that the sound-powered telephone has no provision for signaling other than by voice. The starting end of the line must therefore be monitored continually to insure immediate contact between the operator and the base installation. The telephone equipment at the starting end of the wire may be another sound-powered handset, or a local battery (magneto) telephone, such as the standard field Telephone EE-8-(*). These are the only types of telephone equipment that will work properly with the sound-powered telephone.

Section III

Functioning of Parts

7. SOUND-POWERED TRANSMITTER AND RECEIVER, HANDSET TS-10-(*). **a. General.** Each transmitter unit is a generator of electrical energy, and derives its power solely from the sound waves set up by the spoken word. Each receiver unit is capable of converting the electrical energy output of a transmitter to a sound-level output sufficient to reproduce intelligible speech. Both the transmitter and receiver units have a permanent magnet with two pole pieces, an armature, and a coil. The armature is mounted on a pivot within the coil, and the armature-coil assembly in turn is mounted between the pole pieces of the magnet. Since the complete assembly is very delicately adjusted, repairs should be at-

tempted only by experienced signal repair personnel equipped with the proper tools.

b. Principle of transmission. Sound waves striking on the diaphragm of the transmitter unit cause the diaphragm and armature, which is polarized by the field of the permanent magnet, to vibrate. This vibration results in a change in polarity of the armature, which causes a voltage to be induced in the coil. The resulting voice current is then transmitted over the line. When acoustical power drives the diaphragm downward (fig. 6), the right-hand end of the pivoted armature approaches the north pole of the magnet and the left-hand end approaches the south pole. This causes the passage of a magnetic flux from the right-hand north pole through the armature to the left-hand south pole. When the diaphragm moves upward, the left-hand end of the armature approaches the north pole and the right-hand end approaches the south pole, causing the passage of a magnetic flux from the left-hand north pole through the armature to the right-hand south pole. This reversal of direction of flux in the armature causes

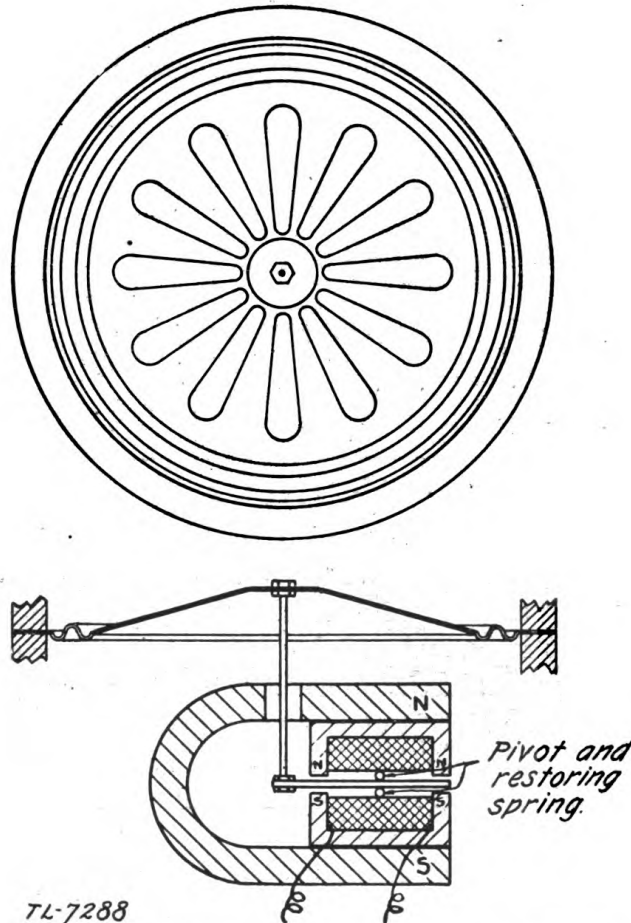

Figure 6. Schematic drawing of a sound-powered transmitter and receiver unit.

the voltage to be induced in the winding which surrounds the armature.

c. Principle of reception. Alternating current flowing in the coil of the receiver brings about variations in the magnetization of the armature. This variation in magnetism causes the armature to vibrate. The diaphragm vibrates simultaneously with the armature because of the mechanical link between the two parts. The vibrations of the diaphragm produce sound waves which are perceptible to the ear. When the alternating current from the distant telephone is applied to the winding of the receiver, the armature is magnetized. When the current is in such direction that a north pole is induced at the right-hand end of the armature and a south pole at the left-hand end, the right-hand end of the armature moves downward and the left-hand end moves upward, driving the diaphragm upward. When the current changes in direction, the poles in the armature reverse and cause the diaphragm to move downward.

d. Capacitors. Capacitors of 0.05- μ f capacity are provided in the transmitting and receiving circuits to improve the frequency response and thereby increase speech intelligibility. They are tubular or flat in construction, and are mounted either in the handset handle or directly on the transmitter and receiver units.

Section IV

Maintenance

8. DETERMINING CIRCUIT FAILURES IN HANDSET

TS-10-(*). **a. Method of testing.** Trouble in the transmitting or receiving circuit can be localized by connecting the handset to a telephone that is known to be serviceable. Transmit from the handset to the serviceable telephone and from the serviceable telephone to the handset. Both the receiver and transmitter are quickly and easily tested by this method. Trouble in the handset should be rare, and disassembly should not be undertaken unless the trouble is definitely located in the handset.

b. No transmission. If the preceding test indicates trouble in the transmitter circuit of the handset, unscrew the transmitter retaining ring, remove the mouthpiece and transmitter unit, and check all wires and terminals for breaks, loose connections, corrosion, etc. If

the trouble is localized in the transmitter unit itself, replace it with a new one.

c. No reception. For receiver trouble, follow the same procedure as that described in *b* above.

9. LUBRICATION OF REEL UNIT RL-39. A few drops of oil, SAE No. 30, should be placed monthly in the small oil fittings (fig. 7) in each bearing of the reel unit handles and in the oilhole of the crank handle.

10. CLEANING BEARINGS. To clean the bearing bushing, remove the axle from the handles and unscrew the four flathead machine screws on the inner side of each bearing bushing. The retaining disk can then be removed and the bearing bushing made accessible for cleaning with a solvent and a piece of cotton waste. When reassembling the bearing bushing, make sure that the sides containing the machine screws are facing each other, with the oil cups on the outside. Put a few drops of oil in each oil cup after the unit has been completely reassembled.

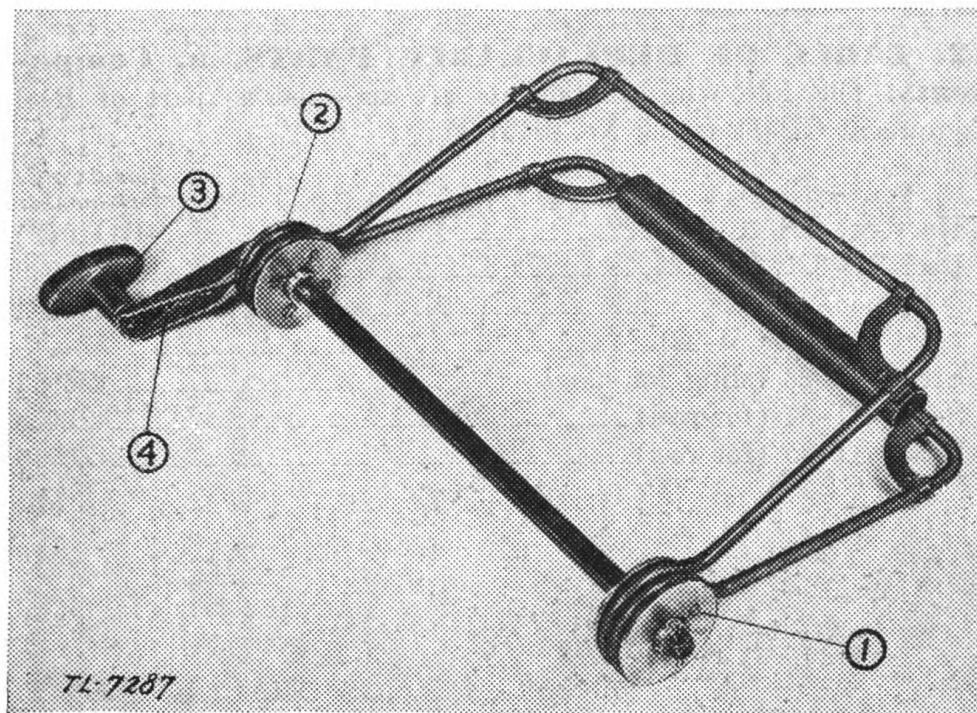

- 1 and 2. Bearing oil cups.
- 3. Crank oilhole.
- 4. Spare cotter pin.

Figure 7. Handle and axle assembly of Reel Unit RL-39, showing lubrication and spare cotter pin.

11. REPAIRING REEL UNIT RL-39. **a.** Drums, handles, cranks, and axles that are bent, cracked, or broken in field use, can be repaired by the use of the acetylene blowtorch for heating, welding, and brazing the various parts. Reel sets can usually be repaired and returned to use regardless of the extent of the damage.

b. Webbed carrying straps can be repaired at shops by sewing or splicing, and by adding new webbing and parts when necessary.

c. After repair, reel sets should be refinished with olive-drab paint in order to provide protection from rust.

Section V

Supplementary Data

12. TABLE OF REPLACEABLE PARTS. **a. Components.** The following components are supplied as part of Reel Equipment CE-11 (stock No. 6H6111):

<i>Nomenclature</i>	<i>Signal Corps stock number</i>
1 Hand-set TS-10- (*) -----	4B1110(*)
1 Reel RL-39 -----	6H3039
1 Spool DR-8 -----	6H7108-1
1 Connector M-221 -----	-----
1 Strap ST-33 (sling for hand-set) -----	4Z6933
1 Strap ST-34 (for reel) -----	4Z6934
1 Strap ST-35 (for reel) -----	4Z6935

b. Replaceable parts list for Hand-set TS-10-C, G, H, and K.

Signal Corps stock No.	Name	Description	Function	Manufacturer	Manufacturer's drawing No.
4B1110C/22.1	Cap, receiver, for TS-10-C, H, K.	Molded earpiece.	Acoustical system	AE ¹	D-67324.
4B1110G/22	Cap, receiver, for TS-10-G.	do.	do.	RCA ²	K84778-1.
3Z1137	Clip TL-137	Test; with prick point and spring.	Hand-set to terminal connection.		
3E4058	Cord	6-ft, 2-conductor, tinsel.	Cord for hand-set.	AE	H-47807 det. 12.
4B1110C/39	Gasket, coverplate.	Rubber gasket.	Dust and moisture seal on hand-set handle plate.		
4B1110C/40	Grommet, gland nut	Rubber grommet.	Part of watertight cord to hand-set connection.	AE	D6721-B.
4B1110G/9	Guard, cord for TS-10-G.	Spring cord guard.	Protects cord.	RCA	K-841841-2.
4B1110C/24	Handle for TS-10-C, H, K.	Hand-set handle with capacitor.	Holds receiver and transmitter units.	AE	GD-52134-A.
4B1110G/24	Handle for TS-10-G.	do.	do.	RCA	P-712697-504 and K85591-504.
4B1110C/5	Mouthpiece for TS-10-C, H, K.	Molded mouthpiece.	Acoustical system	AE	D-38805.
4B1110G/5	Mouthpiece for TS-10-G.	do.	do.	RCA	K-845777-1.
4B1110C/9	Nut, gland.	Collar nut.	Holds grommet in place.	AE	CH-699919 det. 9.
4B1110C/38	Plate, cover.	Hand-set handle plate.	Covers opening in hand-set handle.	AE	D-780006B.
4B1110/1	Receiver unit for TS-10-C, H, K.	Sound-powered receiver unit.	Receiver circuit.	AE	CH-69919 assembly 7.
4B3059	Receiver unit for TS-10-G.	do.	do.	RCA	P-171460-501.
4B111DC/6	Ring, clamping for TS-10-C, H, K.	Metal retaining ring.	Holds receiver and transmitter units in place.	AE	GH-76040 det. 3.
4B1110G/6	Ring, clamping for TS-10-G.	Fiber retaining ring.	do.	RCA	K-841840-5.

¹ Automatic Electric Co., Chicago, Ill.
² Radio Corporation of America, Camden, N. J.

Signal Corps stock No.	Name	Description	Function	Manufacturer	Manufacturer's drawing No.
6L6440-4.52	Screw, machine	Machine screw No. 4-40, 1/4-inch OHB ³ , black enameled.	Holds cover plate		
6L6440-3.4	Screw, machine	Machine screw No. 4-40, 1/16-inch, FHB ⁴ , nickeled.	Wiring terminals		
3Z9929	Terminal TM-29	Spade clip	Terminating wire		
3Z9930	Terminal TM-30	do	do		
3Z10189	Terminal TM-189	do	do		
4B1110C/3	Transmitter unit for TS-10-C, H, K.	Sound - powered transmitter unit.	Transmitter circuit	AE	GH-69919 assem- blv 2.
4B9859	Transmitter unit for TS-10-G.	do	do	RCA	P-171460-502.

³ Oval head binding.
⁴ Fillister head binding.



