

TM 11-5815-281-12

DEPARTMENT OF THE ARMY TECHNICAL MANUAL

OPERATOR AND ORGANIZATIONAL
MAINTENANCE MANUAL

DISTRIBUTOR-TRANSMITTER
SET, TELETYPEWRITER
AN/GGC-9



*HEADQUARTERS, DEPARTMENT OF THE ARMY
23 FEBRUARY 1962*

WARNING

DANGEROUS VOLTAGES EXIST IN THIS EQUIPMENT

Be careful when working on the 115-volt ac motor circuit, the signal line circuits, and 120-volt dc power supply circuit. Serious injury or death may result from contact with these circuits. Turn off the power and discharge all high-voltage capacitors before making any connections or replacing any parts inside the equipment.

DON'T TAKE CHANCES!

Technical Manual
 No. 11-5815-281-12

HEADQUARTERS,
 DEPARTMENT OF THE ARMY
 WASHINGTON 25, D. C., 23 February 1962

DISTRIBUTOR-TRANSMITTER SET, TELETYPEWRITER AN/GGC-9

		Paragraph	Page
CHAPTER	1. INTRODUCTION		
Section	I. General	1,2	3
	II. Description and data	3-13	3
CHAPTER	2. INSTALLATION		
Section	I. Service upon receipt of equipment	14-16	10
	II. Preliminary installation procedures	17-21	12
	III. Preliminary adjustment and lubrication procedures	22-29	17
	IV. Installation and lineup	30-34	22
CHAPTER	3. OPERATING INSTRUCTIONS		
Section	I. Operator's controls and indicators	35-37	25
	II. Operation	38, 39	28
CHAPTER	4. ORGANIZATIONAL MAINTENANCE		
Section	I. Operator's maintenance instructions	40-42	30
	II. Organizational maintenance instructions	43-47	33
CHAPTER	5. SHIPMENT AND LIMITED STORAGE AND DEMOLITION TO PREVENT ENEMY USE		
Section	I. Shipment and limited storage	48, 49	35
	II. Demolition of materiel to prevent enemy use	50, 51	35
APPENDIX	I. MAINTENANCE ALLOCATION		37
	II. BASIC ISSUE ITEMS LIST		42
INDEX			45

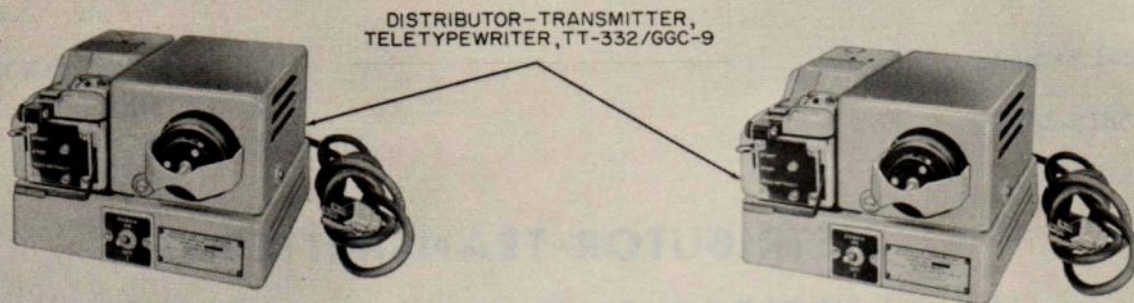

DISTRIBUTOR-TRANSMITTER,
TELETYPEWRITER, TT-332/GGC-9

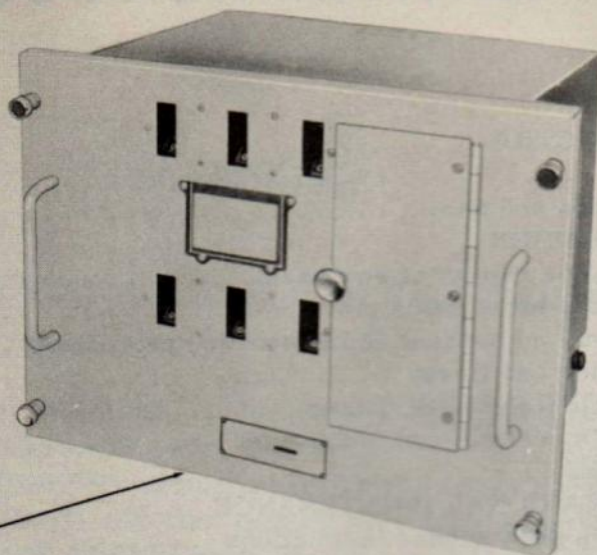

NUMBERING UNIT,
TELETYPEWRITER,
MESSAGE, MX-3650/GGC-9

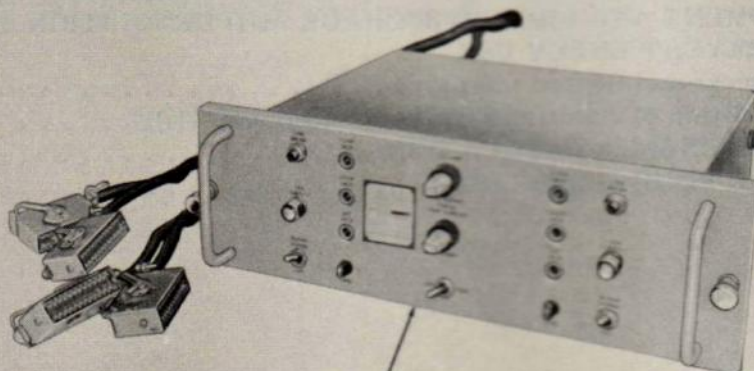

CONTROL,
DISTRIBUTOR-TRANSMITTER,
TELETYPEWRITER, C-3873/GGC-9

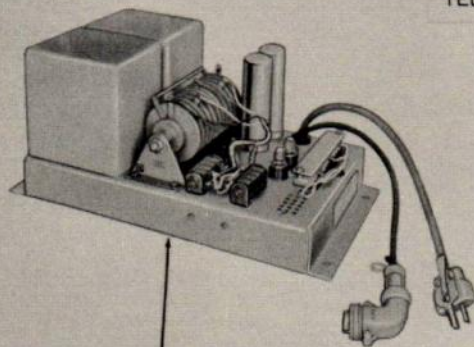

POWER SUPPLY, PP-3131/GGC-9

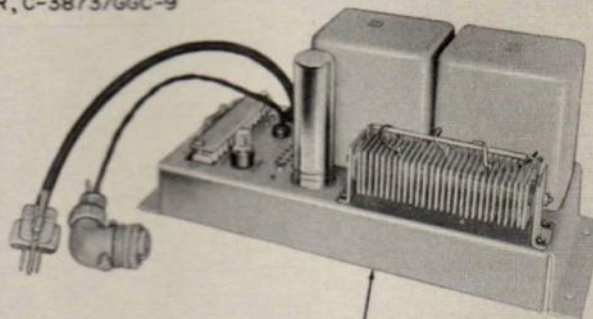

POWER SUPPLY, PP-1801/FG

TM5815-281-12-1

Figure 1. Distributor-Transmitter Set, Teletypewriter AN/GGC-9,
less cable assemblies and running spares.

CHAPTER 1

INTRODUCTION

Section I. GENERAL

1. Scope

This manual describes Distributor-Transmitter Set, Teletypewriter AN/GGC-9 and covers its installation, operation, and organizational maintenance. It includes normal operating procedures, cleaning and inspection of the equipment, and replacement of parts available to first and second echelon maintenance personnel.

2. Forms and Records

a. Unsatisfactory Equipment Reports. Fill out and forward DA Form 468 (Unsatisfactory Equipment Report) as specified in AR 700-38.

b. Report of Damaged or Improper Shipment. Fill out and forward DD Form 6 (Report of Damaged or Improper Shipment) as prescribed in AR 700-58 (Army).

c. Preventive Maintenance Forms (fig. 26 and 27). Prepare DA Form 11-252

(Maintenance Check List for Signal Equipment (Teletypewriter)) in accordance with instructions on the form.

d. Parts List Form. Fill out and forward DA Form 2028 (Recommended Changes to DA Technical Manual Parts Lists or Supply Manual 7, 8, or 9), direct to the Commanding Officer, U. S. Army Signal Materiel Support Agency, ATTN: SIGMS-MLM, Fort Monmouth, N. J. to recommend changes in, or to comment on, Basic Issue Items List or Repair Parts and Special Tools Lists.

e. Comments on Manual. Forward all other comments on this publication direct to the Commanding Officer, U. S. Army Signal Materiel Support Agency, ATTN: SIGMS-PA2d, Fort Monmouth, N. J.

f. Index of Equipment Publications. Refer to DA Pamphlet 310-4 to determine what Changes to, or revisions of, this publication are current.

Section II. DESCRIPTION AND DATA

3. Purpose and Use

a. Distributor-Transmitter Set, Teletypewriter AN/GGC-9 transmits teletypewriter messages from perforated tape. It also transmits message identification and processing information consisting of channel designating letters, message numbers, and message processing information for either automatic or semiautomatic teletypewriter switching systems.

b. The AN/GGC-9 is used in mobile communications centers. The MX-3650/GGC-9 and the C-3873/GGC-9 are usually rack mounted. The two TT-322/GGC-9's, the PP-3131/GGC-9, and the PP-1801/FG are usually mounted on shelves. Each TT-322/GGC-9 is associated with a separate

signal line circuit. Gear sets for 60- and 100-word per minute (wpm) are supplied with the set. Gear sets for 66- or 75-wpm may be obtained through normal supply channels.

4. Technical Characteristics

a. Distributor-Transmitter Set, Teletypewriter AN/GGC-9.

Power input requirement . . . Approx 4 amperes, 105- to 125-volt, 50- to 60-cycle, single-phase, ac.

Signaling code . . . Five-unit, start-stop; stop impulse length equals start impulse length multiplied by 1.42.

Type of signals . . Neutral (20 or 60 ma).
 Speed:
 Operations 368.1, 404^a, 460^a, or
 per minute 600.
 Words per 60,66^a, 75^a, or 100.
 minute
 Total weight of 133-1/2 lb.
 components

b. Distributor-Transmitter, Teletypewriter TT-322/GGC-9.

Motor type Series-governed.
 Motor speed 3,600 rpm.
 Tape width 7/8 and 11/16 inch.
 Power 105- to 125-volt, 50-
 requirement to 60-cycle, single-
 phase, ac input.
 Transmitted Less than 5 percent.
 signal bias

c. Numbering Unit Teletypewriter Message MX-3650/GGC-9.

Numbering range . 001 to 999.
 Power input 48-volt dc.
 requirement

d. Control, Distributor-Transmitter, Teletypewriter C-3873/GGC-9.

Power input 48-volt dc (filtered
 requirement and unfiltered); 120-
 volt dc; and 105- to
 125-volt ac.

Number of lines Two.
 served

e. Power Supply PP-3131/GGC-9.

Power input 105- to 125-volt, 50-
 requirement to 60-cycle, single-
 phase, ac.

Output 48-volt unfiltered dc;
 48-volt filtered dc;
 150-volt filtered dc.

f. Power Supply PP-1801/FG.

Power input 105- to 125-volt, 50-
 requirement to 60-cycle, single-
 phase, ac.

Output 120-volt filtered dc.

5. Components of Distributor-Transmitter Set, Teletypewriter AN/GGC-9.

a. Components.

Quantity	Item	Height (in.)	Depth (in.)	Width (in.)	Unit weight (lb)
2	Distributor-Transmitter, Teletypewriter TT-322/GGC-9	6-1/2	11-1/2	9-1/2	19-1/2
1	Numbering Unit, Teletypewriter, Message MX-3650/GGC-9	12-1/2	14	17-1/2	31
1	Control, Distributor-Transmitter, Teletypewriter C-3873/GGC-9	5-1/2	14	17-1/2	26
1	Power Supply PP-3131/GGC-9	7	15-1/2	8-1/4	33-1/2
1	Power Supply PP-1801/FG	6-1/2	6	15	23-1/2
1	Cable Assembly, Special Purpose, Electrical, Branched CX-7640/GGC-9				
1	Cable Assembly, Power, Electrical, Branched CX-7641/GGC-9				
2	Cable Assembly, Special Purpose, Electrical CX-7642/GGC-9				
1	Cable Assembly, Power, Electrical CX-7643/U				
2	TM 11-5815-281-12				
1 set	Running spares (b below)				

b. Running Spares.

Quantity	Item
15	Fuse, 1.6 ampere, 115 v
5	Fuse, 2 ampere, 125 v
5	Fuse, 0.3 ampere, 250 v
1	Worm, 100 wpm
1	Worm gear, 100 wpm

^aSpare gear sets for this operational speed must be separately procured.

6. Common Names

To avoid continuous repetition of nomenclature throughout the manual, common names have been assigned to the items listed below:

Item	Common name
Distributor-Transmitter Set, Teletypewriter AN/GGC-9	Distributor set

Item	Common name
Distributor-Transmitter, Teletypewriter TT-322/GGC-9	Transmitter
Numbering Unit, Teletypewriter, Message MX-3650/GGC-9	Numbering base
Control, Distributor-Transmitter, Teletypewriter C-3873/GGC-9	Control base
Power Supply PP-3131/GGC-9	48-volt power supply
Power Supply PP-1801/FG	120-volt power supply

vertical, racks. The power supplies and transmitters have holes for mounting to suitable horizontal surfaces.

8. Description of Distributor-Transmitter, Teletypewriter TT-322/GGC-9.

(fig. 2)

Distributor-Transmitter, Teletypewriter TT-322/GGC-9 consists of a mounting base, a transmitter mechanism, and a motor. The transmitter mechanism is mounted on the left of the mounting base and is enclosed with dust covers. The controls are at the front of the transmitter. The motor is mounted on the right of the mounting base and has a louvered dust cover. The governor portion of the motor extends through the front of the dust cover to permit convenient motor speed adjustment. A control switch is on the front of the mounting base. The dust covers and base are painted light gray.

7. Description of Distributor-Transmitter Set, Teletypewriter AN/GGC-9

(fig. 1)

The distributor set consists of two Distributor-Transmitters, Teletypewriter TT-322/GGC-9; one Numbering Unit, Teletypewriter, Message MX-3650/GGC-9; one Control, Distributor-Transmitter, Teletypewriter C-3873/GGC-9; one Power Supply PP-3131/GGC-9; and one Power Supply PP-1801/FG. The transmitters, numbering base, and control base are enclosed to prevent dirt from entering the operating mechanisms. The numbering and control bases are usually mounted in

9. Description of Numbering Unit, Teletypewriter, Message MX-3650/GGC-9.

(fig. 3)

Numbering Unit, Teletypewriter.

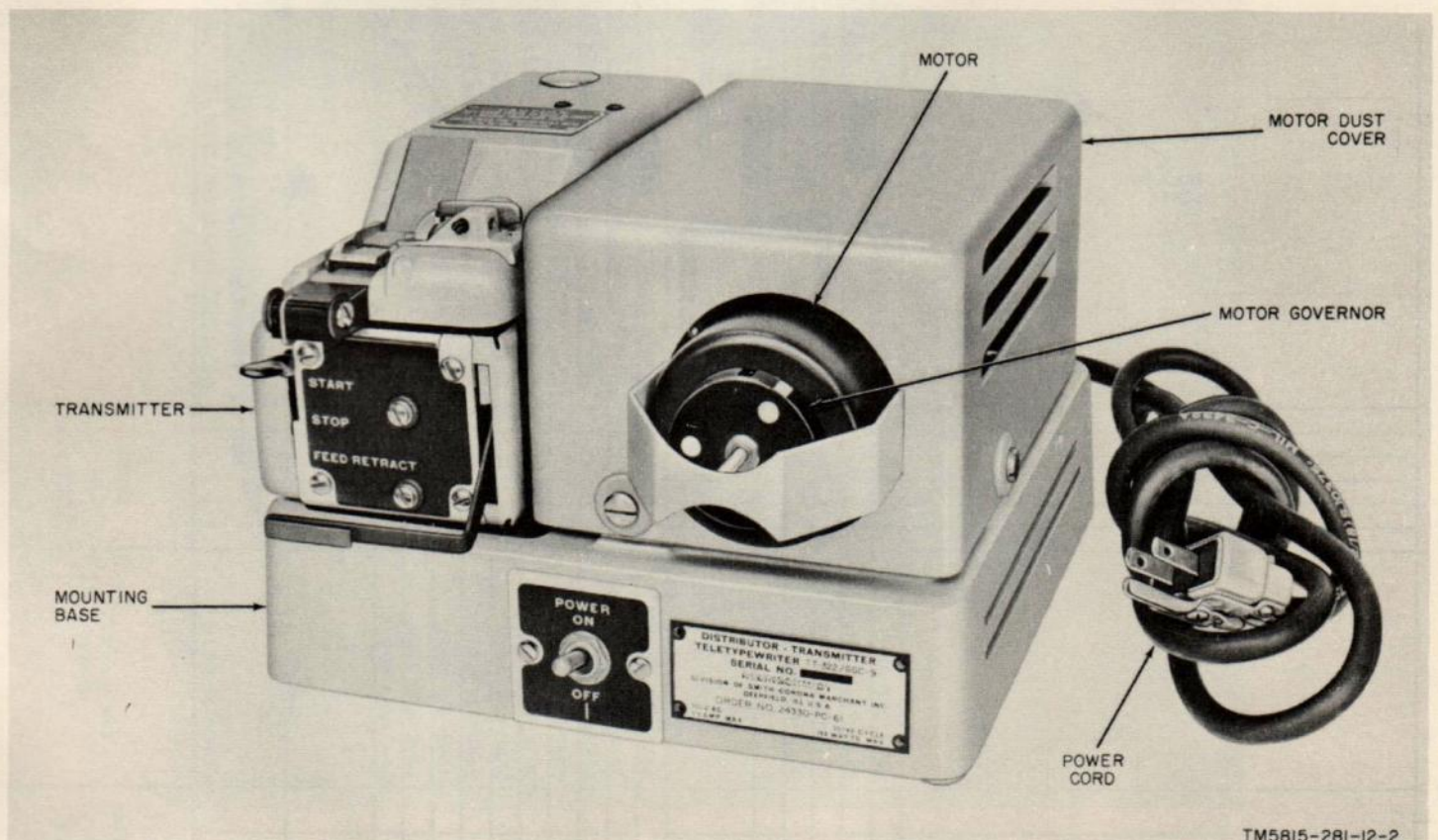

Figure 2. Distributor-Transmitter, Teletypewriter TT-322/GGC-9.

Message MX-3650/GGC-9 is equipped with four captive mounting screws and two handles at the front for rack mounting. The front panel has two horizontal sets of message number indicator openings. A door on the front panel protects the numbering controls from accidental operation. Four plugs at the rear of the numbering base facilitate cable connections.

10. Description of Control, Distributor-Transmitter, Teletypewriter C-3873/GGC-9.

(fig. 4)

Control, Distributor-Transmitter, Teletypewriter C-3873/GGC is equipped with two captive mounting screws and two handles at the front for rack mounting. The switches, controls, and fuses for the equipment are mounted on the front panel. Signal line terminals and the cables and jacks required for interconnection to the associated components are mounted on the rear panel.

11. Description of Power Supply PP-3131/GGC-9.

(fig. 5)

Power Supply PP-3131/GGC-9 consists of a transformer, and inductor, rectifiers, capacitors, fuses, and a terminal board mounted on a formed, sheet-metal base. Other components are mounted within the base. A power cord and an output cord are provided for input and output connections.

12. Description of Power Supply PP-1801/FG

(fig. 6)

Power Supply PP-1801/FG consists of a transformer, inductor, rectifier, capacitor, fuse, and terminal board mounted on a formed, sheet-metal base. Other components are mounted within the base. A power cord and an output cord are provided for input and output connections.

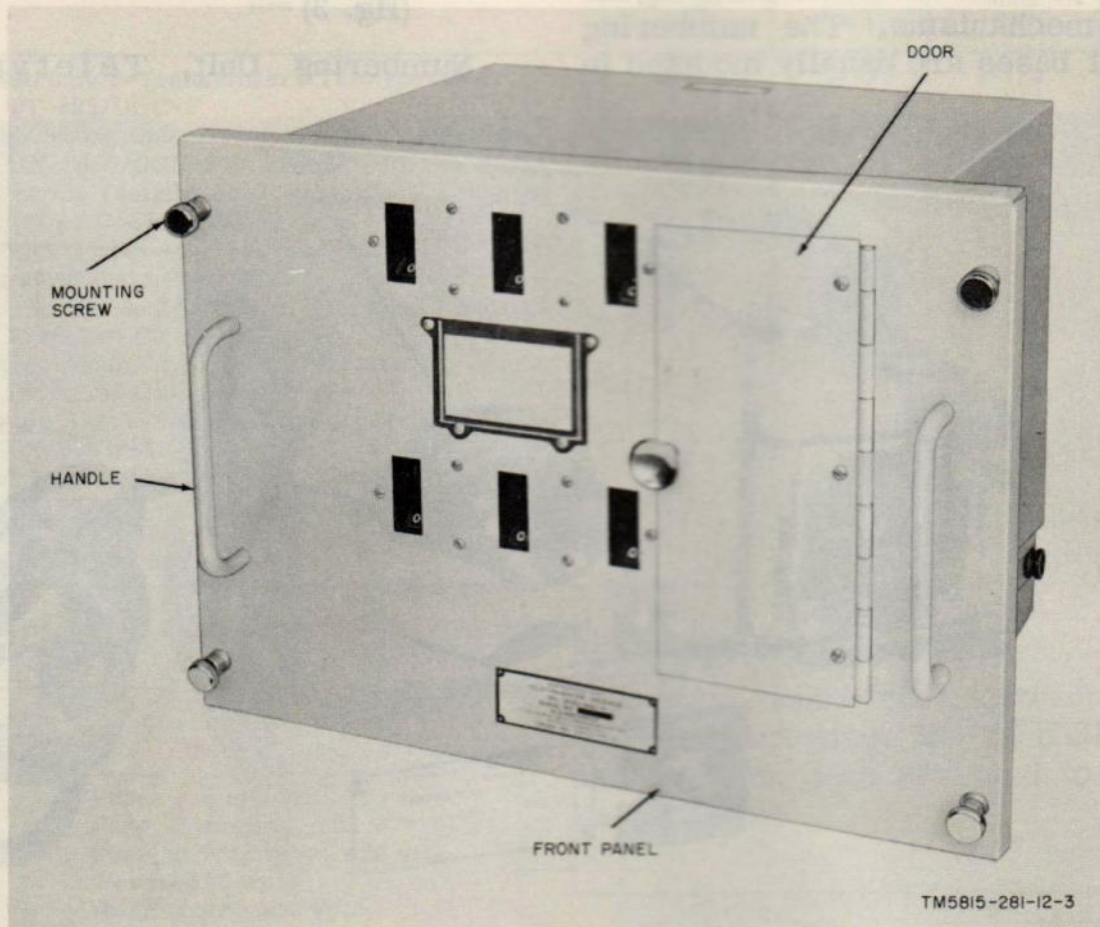

Figure 3. Numbering Unit, Teletypewriter, Message, MX-3650/GGC-9.

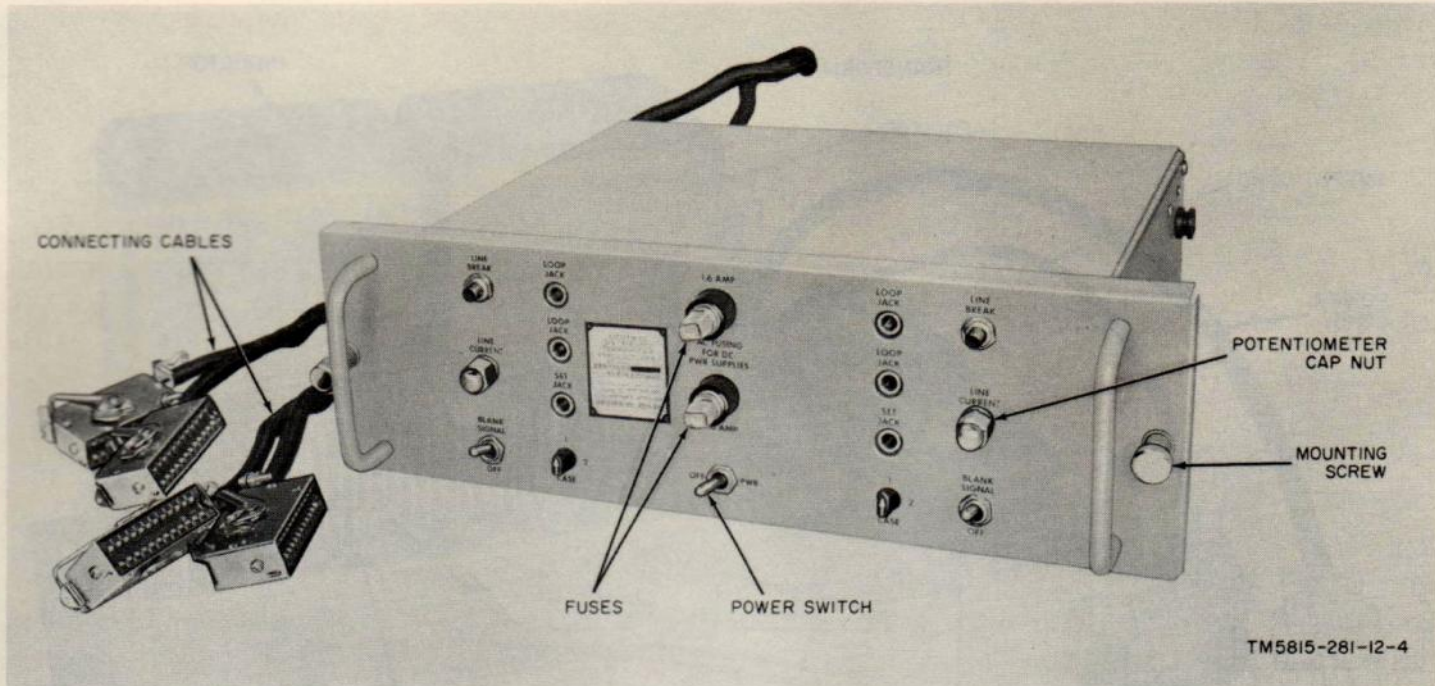

Figure 4. Control, Distributor-Transmitter, Teletypewriter C-3873/GGC-9.

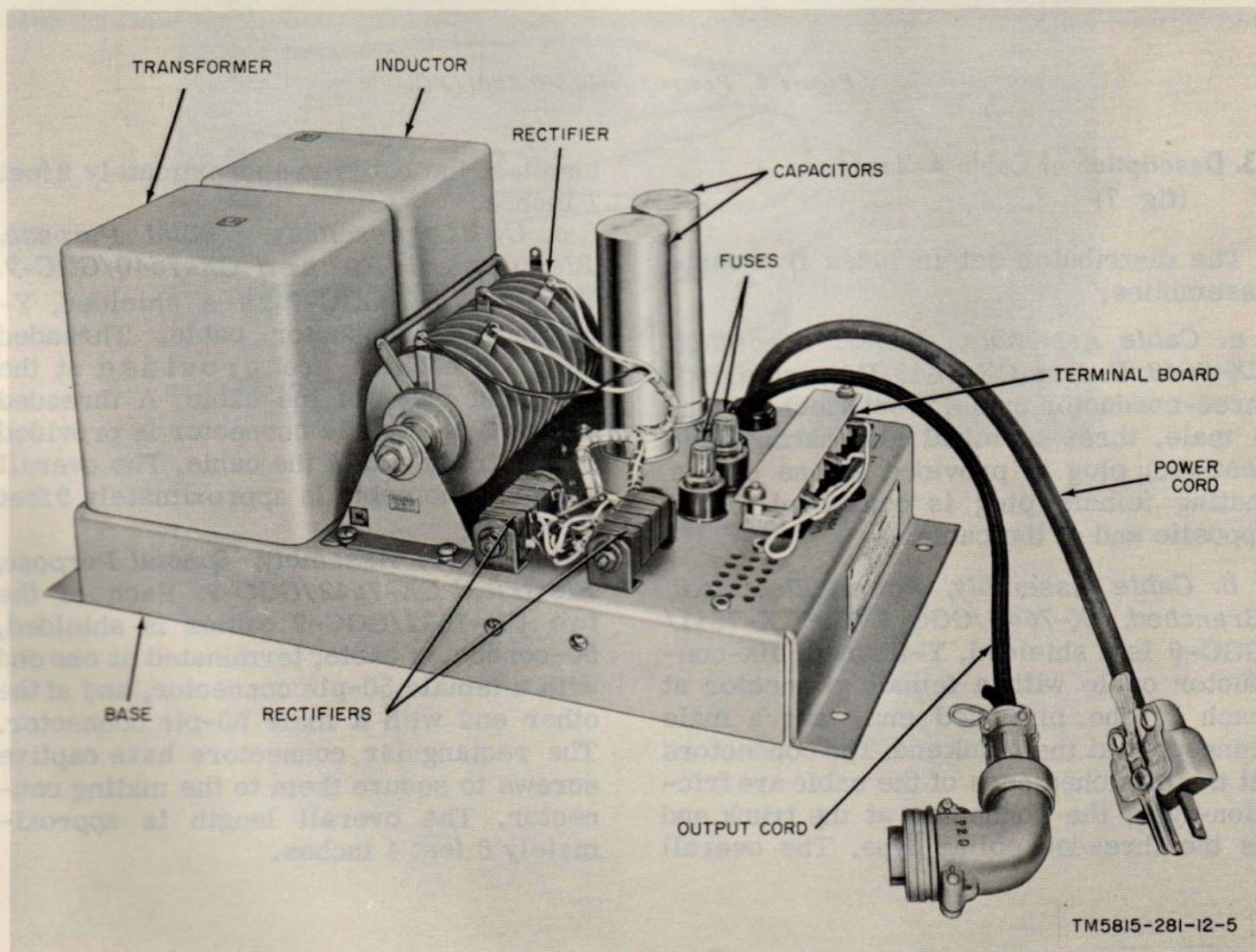
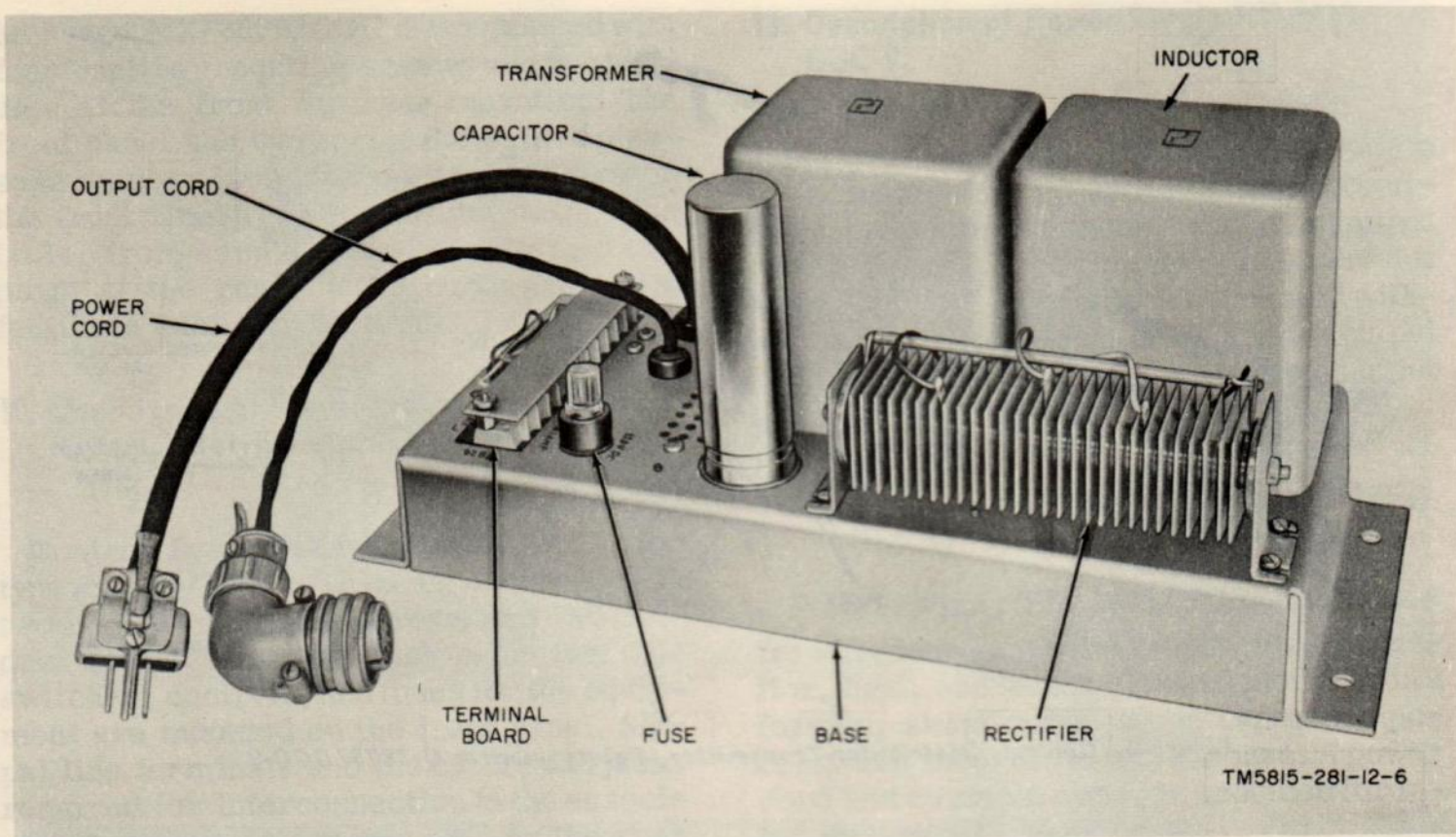

Figure 5. Power Supply PP-3131/GGC-9.



TM5815-281-12-6

Figure 6. Power Supply PP-1801/FG.

13. Description of Cable Assemblies (fig. 7)

The distributor set includes five cable assemblies.

a. *Cable Assembly, Power, Electrical CX-7643/U.* The CX-7643/U is a shielded, three-conductor cable, 7 feet 3 inches long. A male, three-terminal alternating-current (ac) plug is provided at one end; a mating female plug is connected to the opposite end of the cable.

b. *Cable Assembly, Power, Electrical, Branched, CX-7641/GGC-9.* The CX-7641/GGC-9 is a shielded, Y-formed, six-conductor cable with a female connector at each of the branched ends and a male connector at the trunk end. The connectors at the branched ends of the cable are friction-type; the connector at the trunk end is the threaded collar type. The overall

length of the cable is approximately 9 feet 7 inches.

c. *Cable Assembly, Special Purpose, Electrical, Branched CX-7640/GGC-9.* The CX-7640/GGC-9 is a shielded, Y-formed, 11-conductor cable. Threaded male connectors are provided at the branched ends of the cable. A threaded collar-type, female connector is provided at the trunk end of the cable. The overall length of the cable is approximately 9 feet 7 inches.

d. *Cable, Assembly, Special Purpose, Electrical CX-7642/GGC-9.* Each of the two CX-7642/GGC-9 cables is shielded, 50-conductor cable, terminated at one end with a female 50-pin connector, and at the other end with a male 50-pin connector. The rectangular connectors have captive screws to secure them to the mating connector. The overall length is approximately 6 feet 4 inches.

CHAPTER 2 INSTALLATION

Section I. SERVICE UPON RECEIPT OF EQUIPMENT

Note: The information in this chapter is located by installation personnel only.

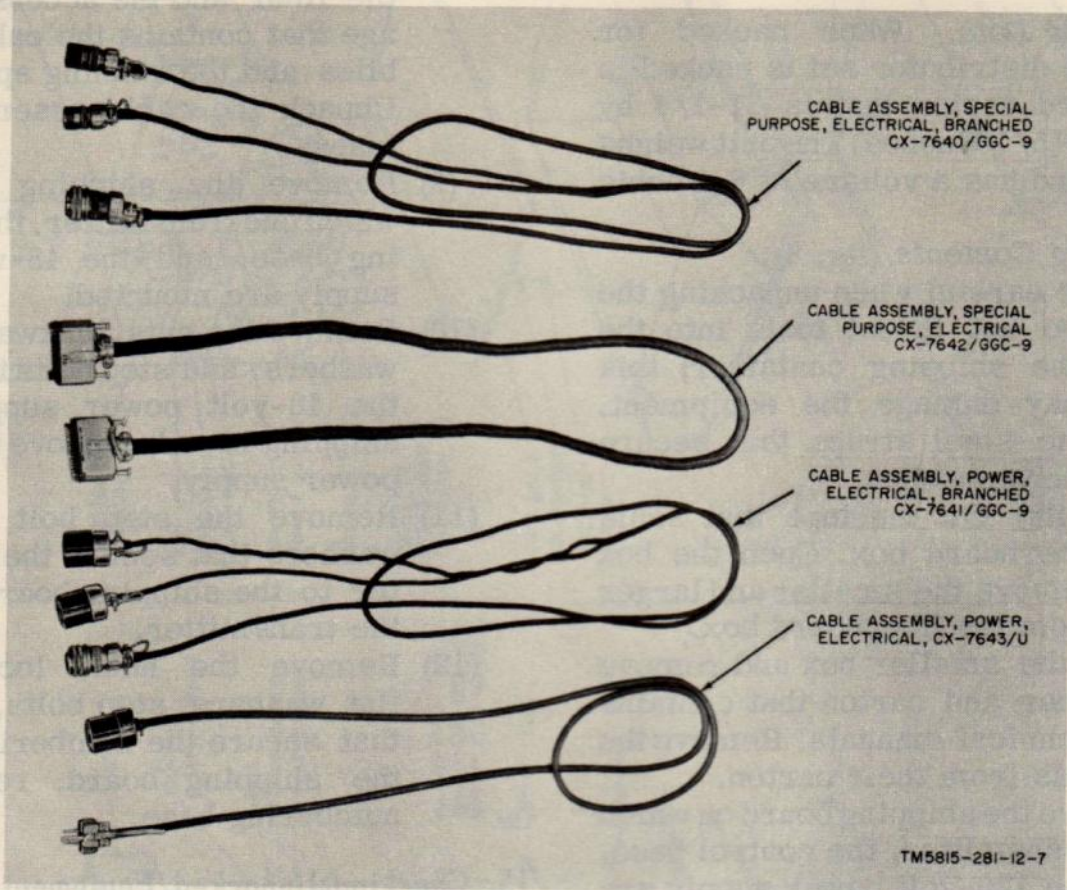

Figure 7. Cable assemblies.

CHAPTER 2

INSTALLATION

Section I. SERVICE UPON RECEIPT OF EQUIPMENT

Note: The information in this chapter is for use by installation personnel only.

14. Unpacking

a. Packaging Data. When packed for shipment, the distributor set is packed in one fiberboard carton that is 31-1/4 by 20-3/4 by 21-15/16 inches. The unit weighs 165 pounds and has a volume of 8.4 cubic feet.

b. Removing Contents (fig. 8).

Caution: Be careful when unpacking the equipment. Do not thrust tools into the interior of the shipping container; this procedure may damage the equipment.

- (1) Cut the steel straps that secure the fiberboard box.
- (2) Carefully cut the tape that seals the fiberboard box. Open the box and remove the smaller and larger box from the fiberboard box.
- (3) Open the smaller box and remove the liner and carton that contains the technical manuals. Remove the manuals from their carton.
- (4) Remove the shipping board on which one transmitter, the control base, and the 120-volt power supply are mounted.
- (5) Remove the nuts, lockwashers, flat washers, and step bolts that secure the 120-volt power supply to the shipping board; remove the 120-volt power supply.
- (6) Remove the step bolts and lockwashers that secure the transmitter to the shipping board; remove the transmitter.
- (7) Remove the nuts, lockwashers, flat washers, step bolts, and clips that secure the control base to the shipping board. Lift the control base from the shipping board and remove the protective paper from the jacks on the ends of the cables.
- (8) Open the larger box and remove

the liner and the accessory package that contains the cable assemblies and the running spare fuses. Unpack the cable assemblies and fuses.

- (9) Remove the shipping board on which one transmitter, the numbering base, and the 48-volt power supply are mounted.
- (10) Remove the nuts, lockwashers, flat washers, and step bolts that secure the 48-volt power supply to the shipping board; remove the 48-volt power supply.
- (11) Remove the step bolt and lockwashers that secure the transmitter to the shipping board; remove the transmitter.
- (12) Remove the nuts, lockwashers, flat washers, step bolts, and clips that secure the numbering base to the shipping board; remove the numbering base.

15. Checking Unpacked Equipment

Check the equipment against the table of components (para 5) or the basic issue item list (appx II). The list indicates the accessories, attachments, and component assemblies which constitute the complete equipment.

16. Siting

Consider the following when selecting a site for the distributor set:

- a.* A space of at least 30 inches in front of the distributor set is required for operation of the set.
- b.* A 105- to 125-volt, 50- to 60-cycle, alternating-current source is required for operation of the equipment.
- c.* Adequate lighting is required for both day and night operation.

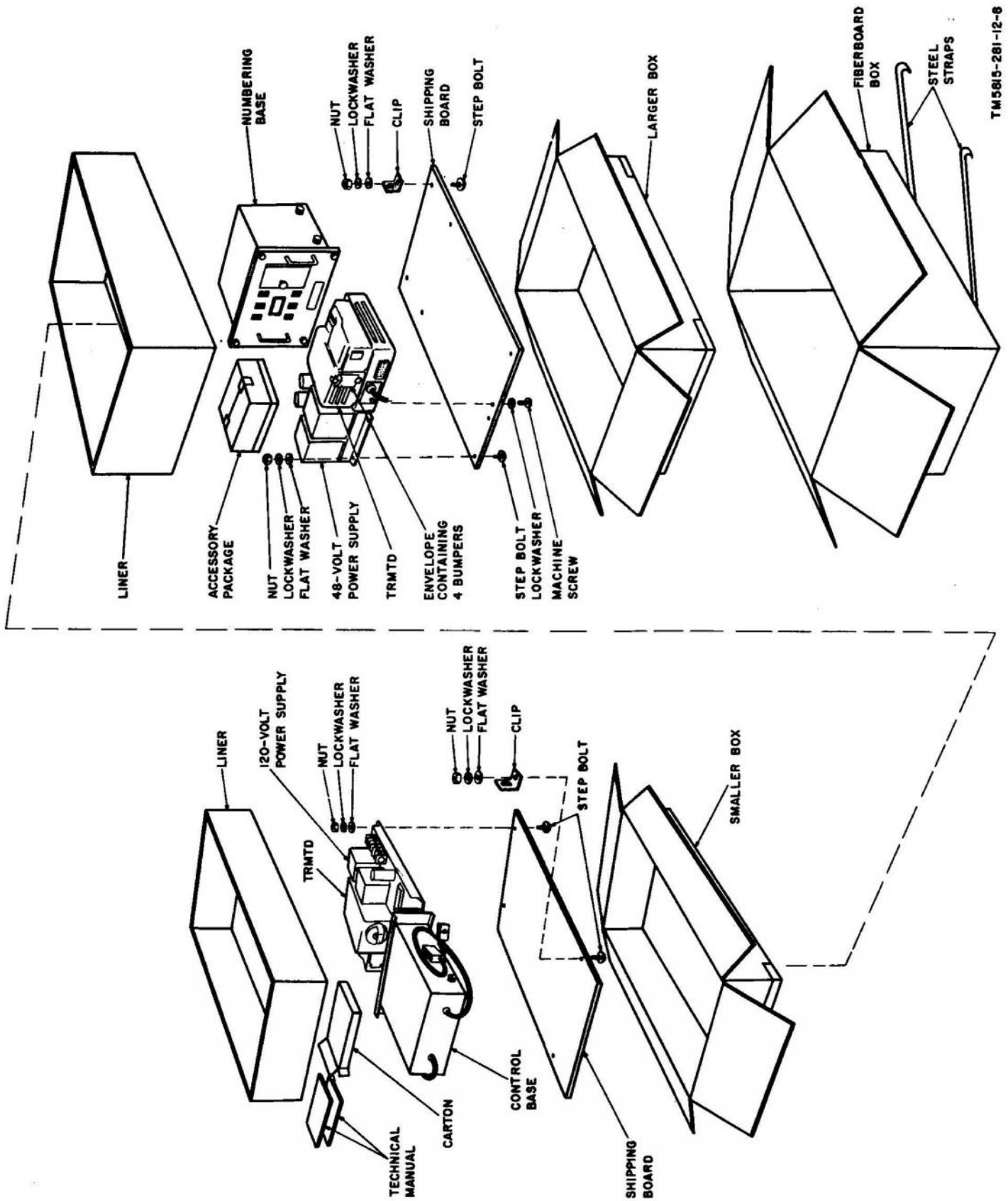

TM5815-281-12-8

Figure 8. Distributor set packed for shipment.

Section II. PRELIMINARY INSTALLATION PROCEDURES

17. Tools, Test Equipment, and Materials

The following tools, test equipment, and materials are required for installation of the distributor set but are not furnished as part of the set:

- a. Tool Equipment TE-50-B.
- b. Multimeter TS-352/U.
- c. A teletypewriter receiver, preferable a page printer equipped with a telephone-type plug for a signal connection.
- d. The only material required is Oil, Lubricating, Federal stock No. 9150-K60-4297.

18. Assembly of Components (fig. 9)

a. The numbering base and control base are designed to be mounted in a vertical-type metal rack. To mount these units, position them on the rack and secure them by tightening the captive screws on the front panels.

b. The power supplies are designed to be base mounted with four mounting screws. They are normally mounted in a horizontal

position. Insert the screws from the top downward into the base.

c. The transmitter bases are provided with tapped mounting holes to secure the unit to a table or shelf. Insert the screws from under the table or shelf upward into the mounting holes in the transmitter base. If the installation does not require the transmitters to be anchored, install the four rubber bumpers provided with the equipment.

19. Interunit Cable Connections

All plugs and jacks on the components are clearly identified as indicated in figure 10. Connect each numbered plug to its like-numbered jack. Jacks J1 through J4 should be secured to their mating plugs as shown in figure 11.

20. Fuse Check

The distributor set is shipped with fuses installed. Check the value of each of the fuses listed in the chart below before applying power.

Component	Circuit	Fuse symbol	Fuse rating		Reference illustration
			Amp	Volts	
Control base	48-volt power supply ac input	F5	1.6	115	12
Control base	120-volt power supply ac input	F4	1.6	115	12
48-volt power supply	Unfiltered output	F1	2	125	13
48-volt power supply	Filtered output	F2	2	125	13
120-volt power supply	120-volt output	F3	0.3	250v	14
Transmitter	Motor circuit	F1	1.6	115	15
Transmitter	Motor circuit	F2	1.6	115	15

21. Ground and Power Connections

a. *Ground Connections.* Connect a wire lead from an unpainted portion of the control base to a low-resistance ground connection.

b. *48-Volt Power Supply Adjustment.* Adjust the 48-volt power supply transformer taps and connect power to the distributor set as follows:

- (1) Set the POWER switch of the transmitter (fig. 2) to OFF.

- (2) Set the control base power switch (fig. 4) to OFF.
- (3) Use a voltmeter and check the voltage at the ac source.
- (4) Remove the cover from terminal board TB25 (fig. 13) on the 48-volt power supply. Check to see that the white ac line voltage on the terminal board is connected to the terminal (105, 115, or 125) that corresponds most closely to the voltage reading obtained as

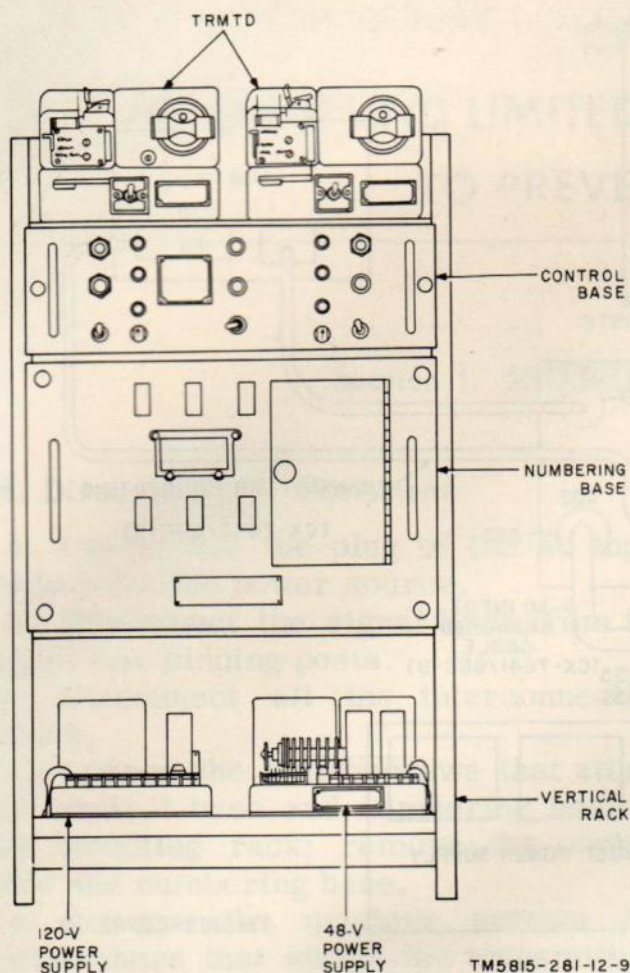

Figure 9. Typical distributor set installation.

instructed in (3) above. If the voltage reading is midway between two of these readings, connect the white lead to the higher-numbered terminal.

- (5) Insert the plug of the ac input cable on the control base (fig. 10) into the ac power source. Set the control base power switch at PWR (fig. 4), to energize the 48-volt power supply.
- (6) Disconnect jack J29 from plug P29. Check the direct-current (dc) output across pins F and G of plug P29. The correct no-load output reading is 54 volts. If adjustment is necessary, turn the power switch on the control base to OFF before adjusting the output ((7) and (8) below).
- (7) The dc output is adjustable. *Coarse* adjustments are made by moving the yellow lead connected to 79, 72,

or 65 of TB25. *Fine* adjustments are made by moving the position of the yellow-white lead connected to 8, 6, 4, 2, or \pm of TB25. Adjust the position of the leads, as required, to obtain the output nearest the desired output of 54 volts.

- (8) After an adjustment, turn the power switch on the control base to PWR and recheck the output across pins F and G of plug P29. If necessary, turn the power switch on the control base to OFF and readjust.

Warning: Turn the power switch on the control base to OFF each time a transformer tap of the 48-volt power supply is adjusted. Failure to take this precaution may result in a severe electrical shock.

- (9) Replace the cover on terminal board TB25. Reconnect jack J29 to plug P29.

c. *120-Volt Power Supply Adjustment.* Adjust the 120-volt power supply transformer taps as follows:

- (1) Remove the cover from terminal board TB26 (fig. 14) on the 120-volt power supply.
- (2) Move the power switch of the control base to the PWR position.
- (3) Remove jack J55 from plug P55 and check the ac voltage output across the terminals of jack J55. Leave the jack disconnected from the plug while adjusting the primary transformer lead.
- (4) Check to see that the white (primary) lead on terminal board TB26 is connected to the terminal (105, 115, or 125) that corresponds most closely to the ac power source reading obtained as instructed in (3) above. Reconnect if necessary. If the reading falls at the midpoint between two readings, connect the lead to the higher-numbered terminal.
- (5) Connect jack J55 to plug P55 and disconnect jack J32 from plug P32. Use a voltmeter and check to see that the dc output of the power supply across terminals A and B of plug P32 is 120 volts. If the reading

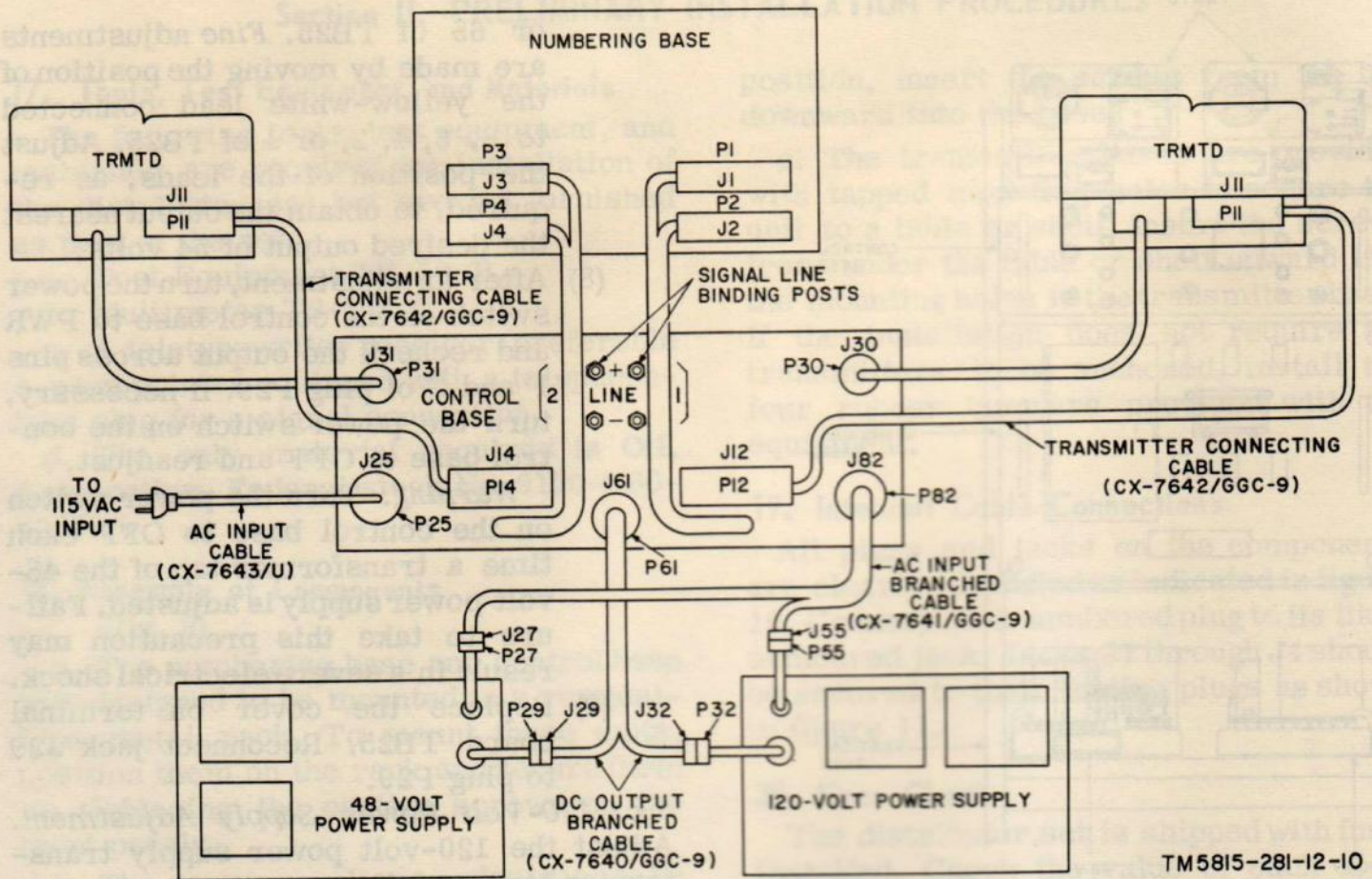

TM5815-281-12-10

Figure 10. Distributor-Transmitter Set, Teletypewriter AN/GGC-9, cabling diagram.

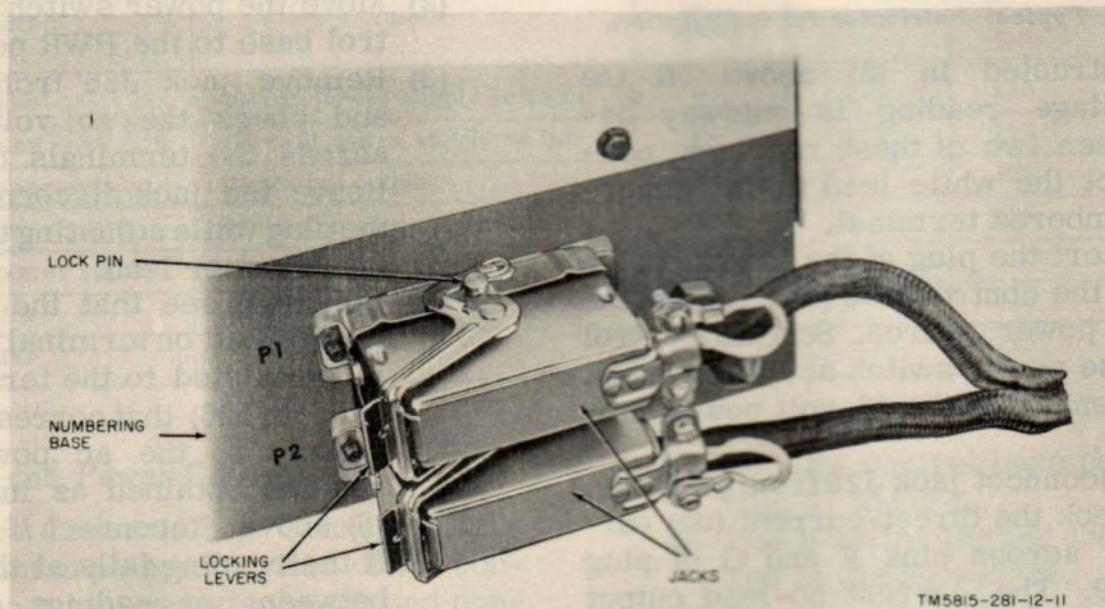

TM5815-281-12-11

Figure 11. Interconnecting jacks, locking device.

is not 120 volts, turn the power switch on the control base to OFF and move the black-green lead connected to the coarse adjustment terminal (160, 170, or 180) of TB26. Move the black-green lead to a

higher-numbered terminal to increase the voltage output; move the lead to a lower-numbered terminal to decrease the voltage output.

(6) Turn the power switch on the

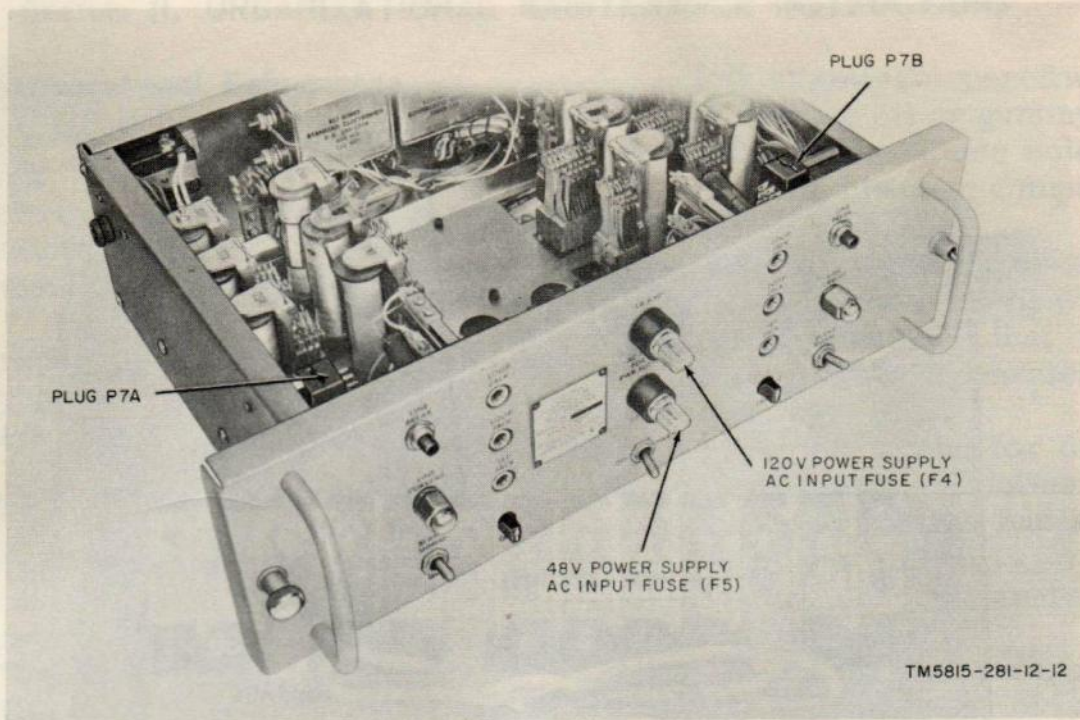

Figure 12. Control base fuse locations.

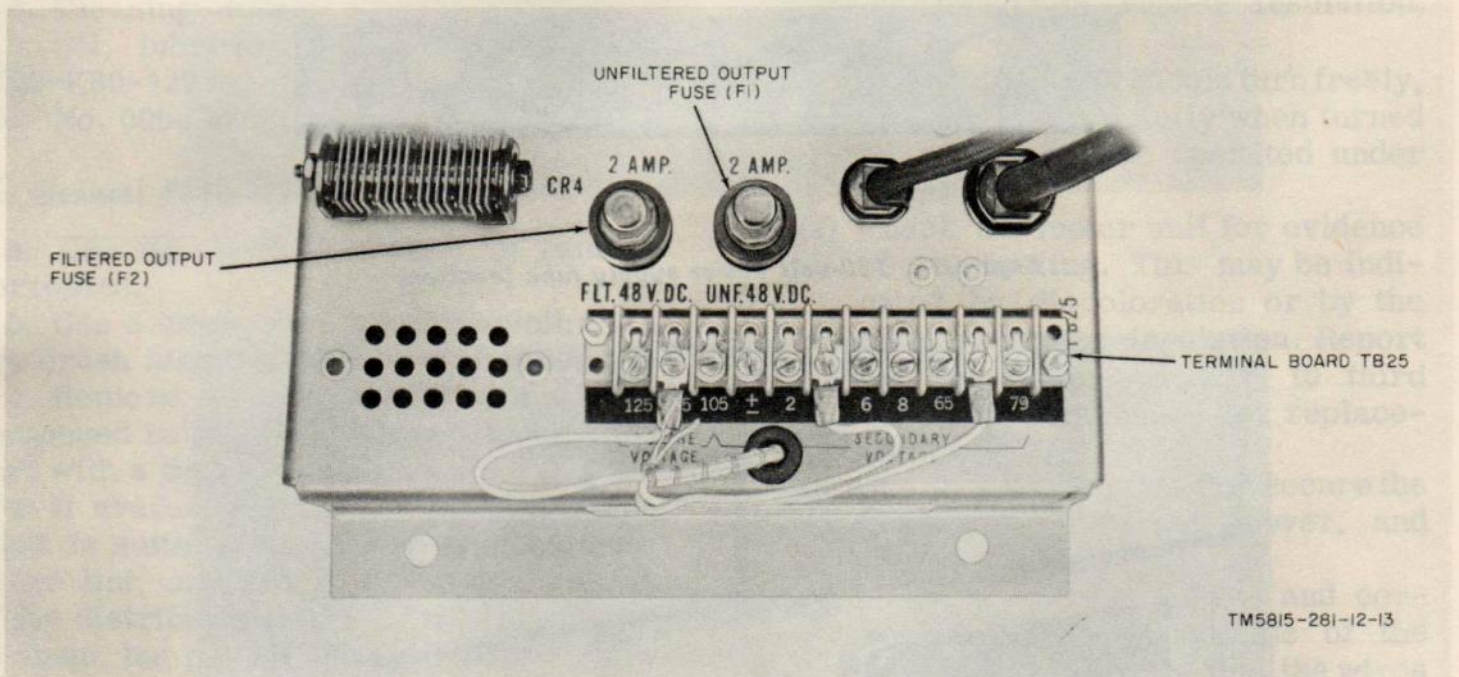

Figure 13. 48-volt power supply fuse locations.

control base to PWR and recheck the output across terminals A and B of plug P32. If necessary, operate the power switch on the control base to OFF and move the yellow-violet lead connected to the fine adjustment terminal (\pm , 2, 4, 6, or 8) on TB26 to secure the correct no-load output of 120 volts.

Warning: Turn the power switch on the control base to OFF before adjusting the position of a transformer tap of the 120-volt power supply. Failure to observe this precaution may result in severe electrical shock.

- (7) Replace the cover on terminal board TB26 and reconnect jack J32 and plug P32.

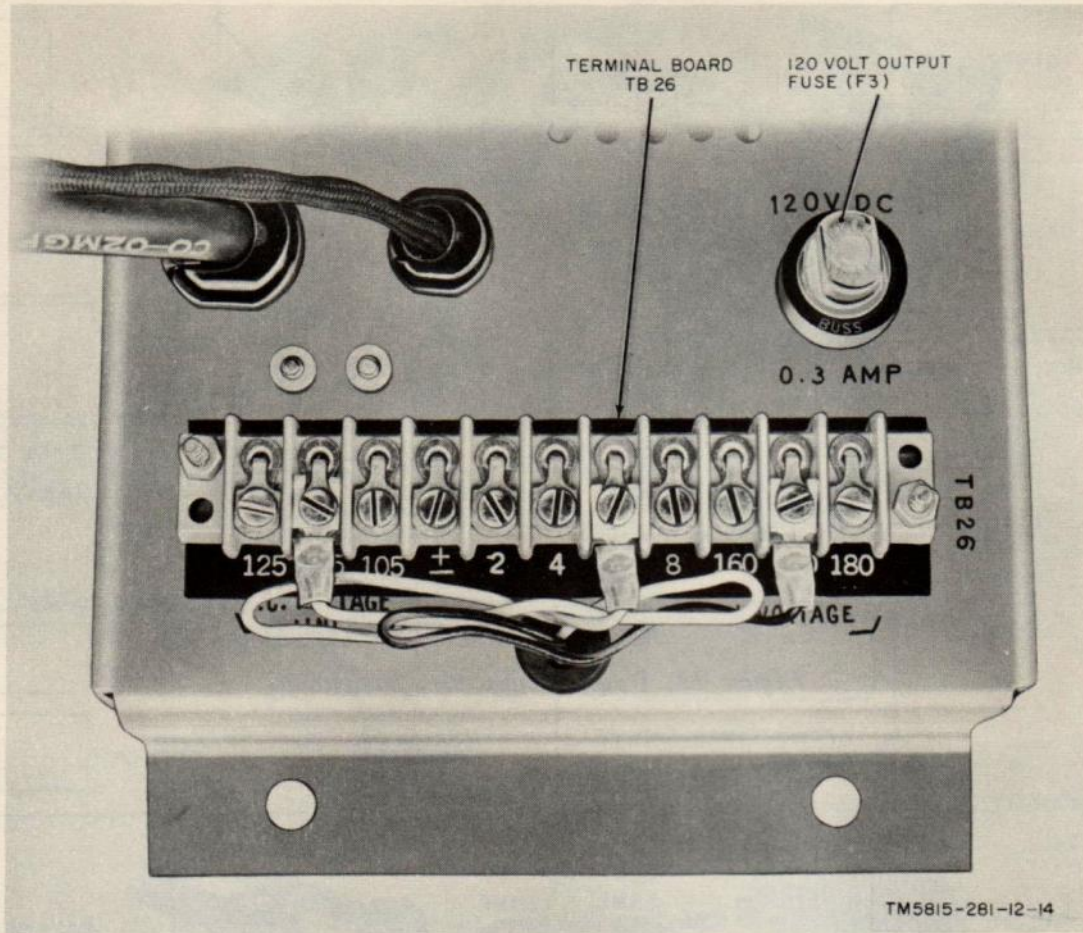

Figure 14. 120-volt power supply fuse location.

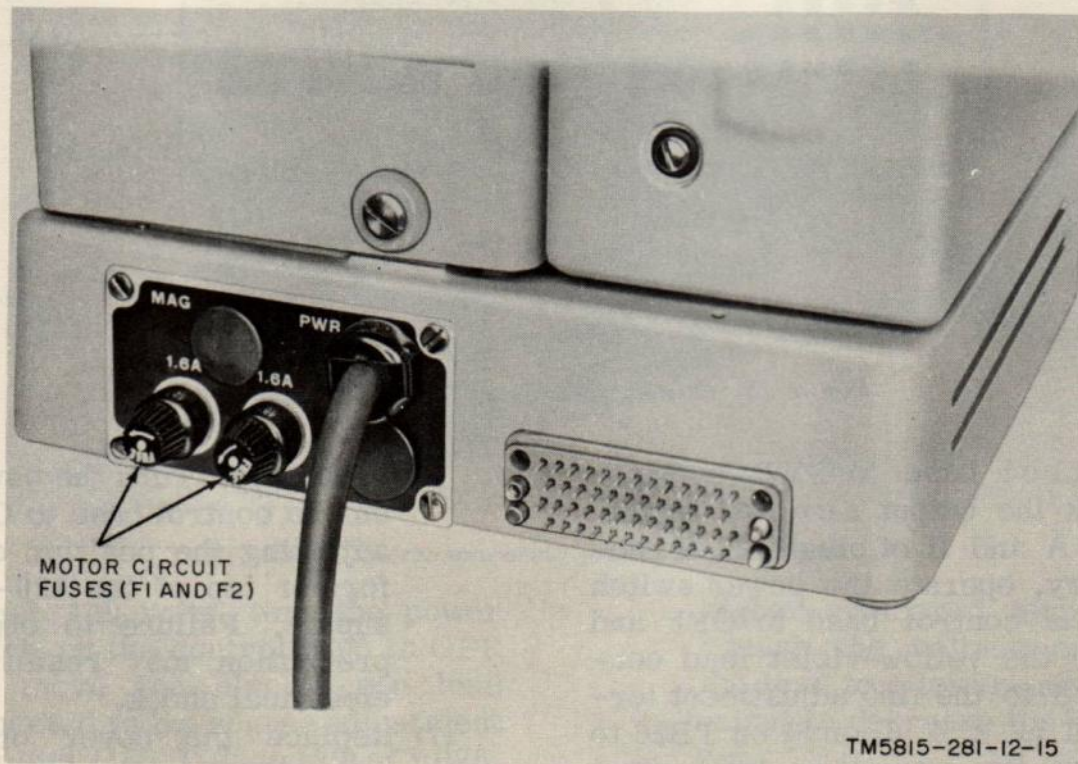

Figure 15. Transmitter fuse locations.

Section III. PRELIMINARY ADJUSTMENT AND LUBRICATION PROCEDURES

22. Extent of Preliminary Checks and Adjustments

This section covers checks and adjustments that must be made before the equipment can be operated or installed in a working circuit. A preliminary adjustment of the motor speed should be made before adjustment of the friction clutches.

23. Motor Speed Adjustment (fig. 16)

With the equipment connected (para 19) and the power switch on the control base at PWR adjust the motor speed of each transmitter as follows:

- a. Move the POWER switch on the transmitter to ON. The motor should operate.
- b. Strike a shuttered 180-vibration-per-second (vps) tuning fork gently against the palm of the hand to start it vibrating.
- c. Observe the spots on the rotating target wheel of the series-governed motor

through the vibrating shutter on the end of the tuning fork. If the white spots on the target wheel appear stationary, no adjustment is necessary. If the white spots appear to move clockwise (motor speed too fast), pull the end of the motor-governor adjustment worm outward. Hold it out until the apparent clockwise motion of the target spots as viewed through the vibrating shutter, practically stops. To avoid overadjustment, release the motor-governor adjustment worm slightly before the target spots come to a complete standstill.

d. If the spots appear to move counter-clockwise (motor speed too slow), push the end of the motor-governor adjustment worm inward until the apparent motion of the target spots, as viewed through the vibrating shutter, practically stops. To avoid overadjustment, release the motor-governor adjustment worm slightly before the target spots come to a complete standstill.

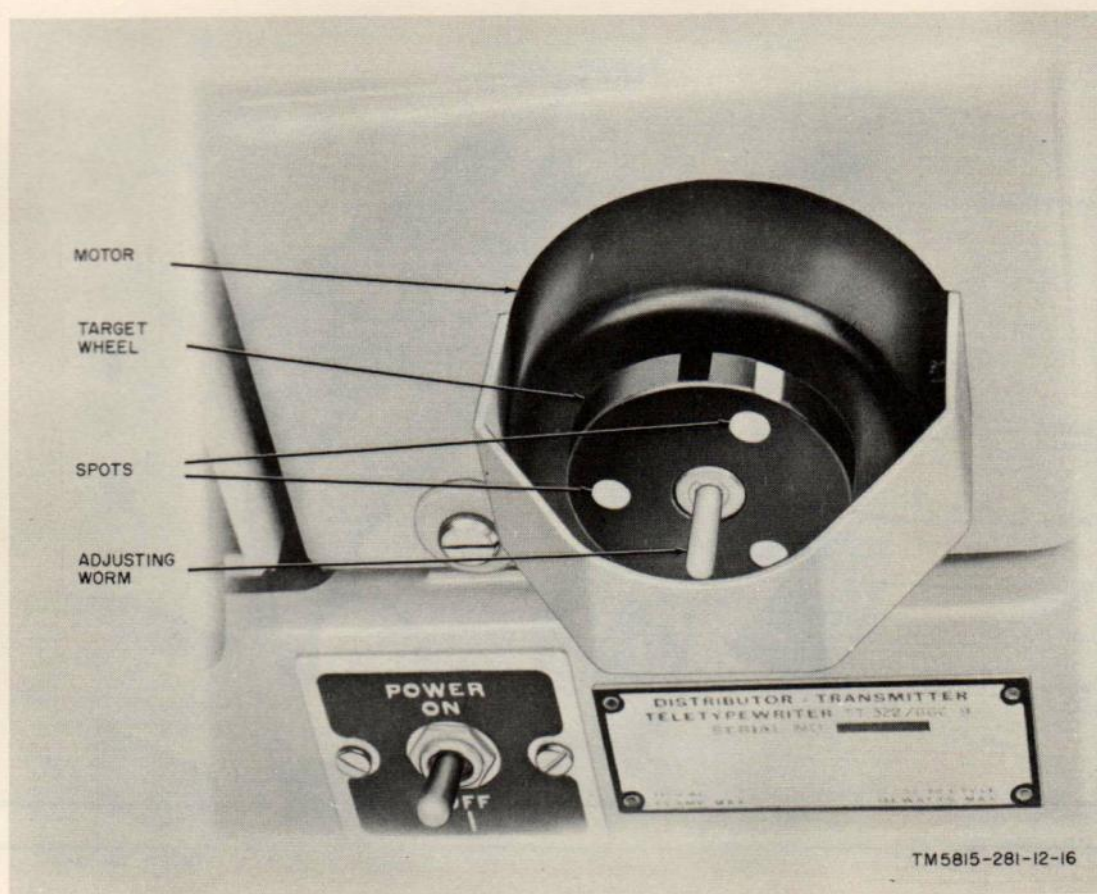

Figure 16. Motor-governor adjustment.

24. Lubrication of Friction Clutches

a. *Recommended Lubricants.* The recommended lubricant for the equipment is Oil, Lubricating, FSN 9150-K60-4297.

b. *Lubrication.* Remove the three shoulder screws that secure the motor dust cover on the transmitter; remove the dust cover. Apply 10 to 15 drops of oil on each felt washer (fig. 17) in the friction clutch assemblies. Wipe off any excess oil with a cloth.

25. Friction Clutch Adjustment (fig. 18)

a. *Requirement.* Enough tension should be applied to the friction clutch to insure complete and proper rotation of the transmitter camshaft assembly.

b. *Method of Checking.* Insert a message tape into the transmitter as for normal transmission. Operate the stop-start lever from the STOP to the START position and back to STOP several times and check the requirement, then allow the transmitter to run continuously and recheck the requirement.

c. *Adjustment.* Loosen the machine screws in the friction adjusting collar. Turn the collar to decrease the tension of the friction clutch spring until the transmitter camshaft does not rotate properly. Turn the collar of the friction clutch in the opposite direction until the clutch does operate properly. Turn the collar another one-half to three-quarter turn tighter. Tighten the machine screws. Recheck the requirement.

26. Strapping for Channel Designating Letters

The numbering base will automatically transmit three channel designating letters for each channel when the correct straps are installed on plug P7A associated with transmitter A and plug P7B associated with transmitter B. The channel designating letters are used to identify the message at the receiving station. Any three letters of the alphabet may be transmitted, as required. Strap the plugs individually following the procedure outlined below:

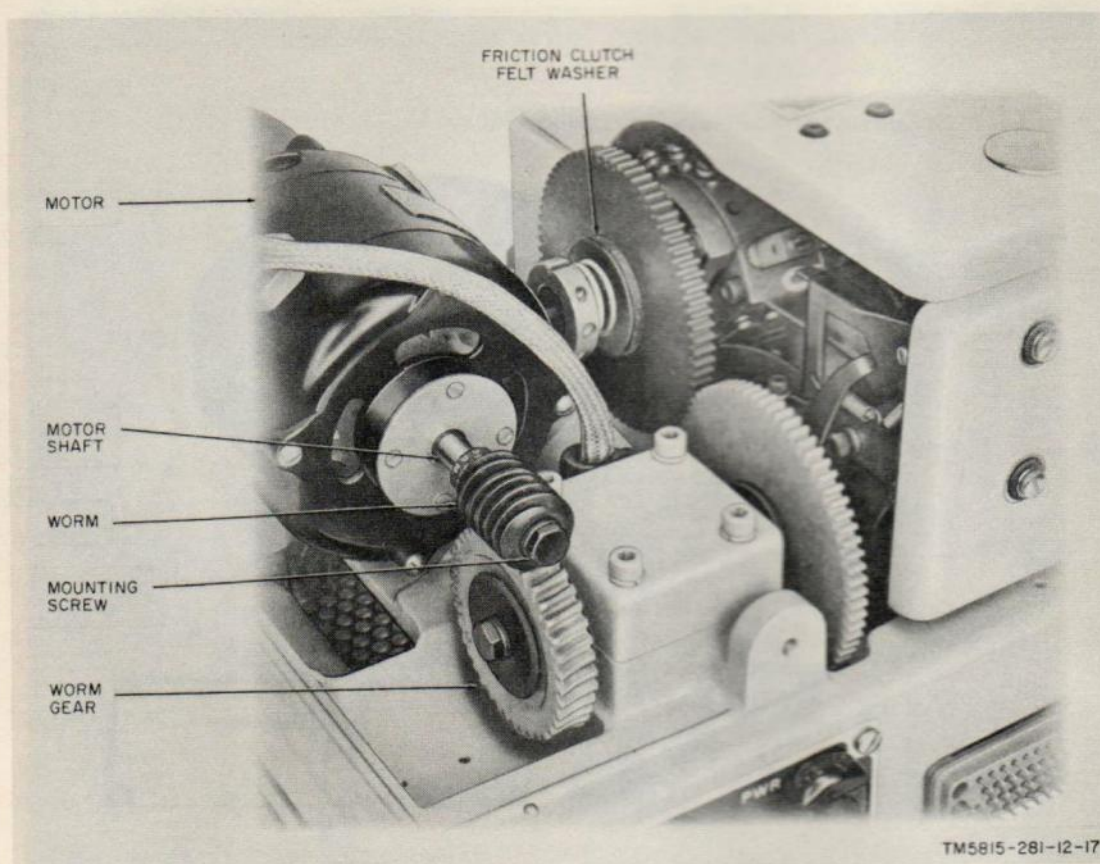

Figure 17. Friction clutch assembly and drive gear set.

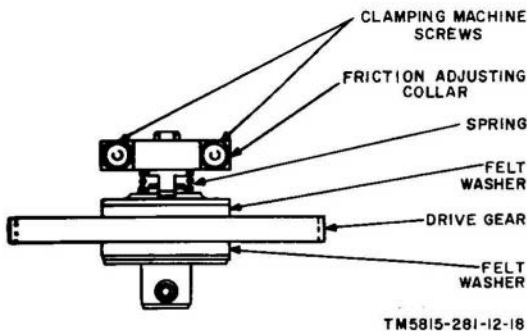

Figure 18. Friction clutch adjustment.

a. Remove the machine screws that secure the top plate to the control base; remove the top plate.

b. Remove plug P7A or P7B, as applicable. Notice the physical location and numbering of the pins.

c. Prepare a chart similar to that shown below for each plug to be wired.

Pins	Impulses				
	1	2	3	4	5
Common terminal	0	4	8	12	16
First channel designating letter	1	5	9	13	17
Second channel designating letter	2	6	10	14	18
Third channel designating letter	3	7	11	15	19

d. Determine the channel designating letters assigned to the transmitter.

e. Refer to the teletypewriter code chart in figure 19 and determine the sequence of marking and spacing impulses for each channel designating letter.

f. Place an X through each box in the chart that corresponds to a marking impulse for each channel designating letter as determined in e above.

g. Connect a wire between the common terminal (0, 4, 8, 12, or 16) in each vertical row and each pin designated for a marking impulse in the same vertical row.

h. The chart below and the plug wired in figure 20 are arranged for the channel designating letters R, B, and I.

Pins	Impulses				
	1	2	3	4	5
Common terminal	0	4	8	12	16
First channel designating letter	1	X	9	X	17
Second channel designating letter	X	6	10	X	X
Third channel designating letter	3	X	X	15	19

i. Replace the plug on its mating receptacle (fig. 12).

j. Replace the top plate and secure with the machine screws previously removed.

27. Changing the Operating Speed (fig. 17)

a. The distributor set has the 60-word-per-minute gears installed. Gears for 100 wpm are mounted on studs inside the transmitter motor dust cover. The two transmitter units can be operated at either the same speeds or at different speeds, as required, since each operates independently on its own signal line.

b. To change the operating speed, change the drive gear set of the transmitter as follows:

- (1) Remove the three shoulder screws that secure the motor dust cover to the transmitter; remove the dust cover.
- (2) Disconnect the ac plug to prevent the motor of the transmitter from starting while the drive gear set is being changed.
- (3) Grasp the target wheel on the motor and hold it firmly while loosening the screw that holds the worm on the motor shaft. Continue to hold the target wheel and loosen the screw that holds the worm gear to the power shaft.
- (4) Remove the screw and lockwasher that hold the worm to the motor shaft and pull the worm from the shaft.
- (5) Remove the screw and lockwasher that hold the worm gear to the power shaft and remove the worm gear.

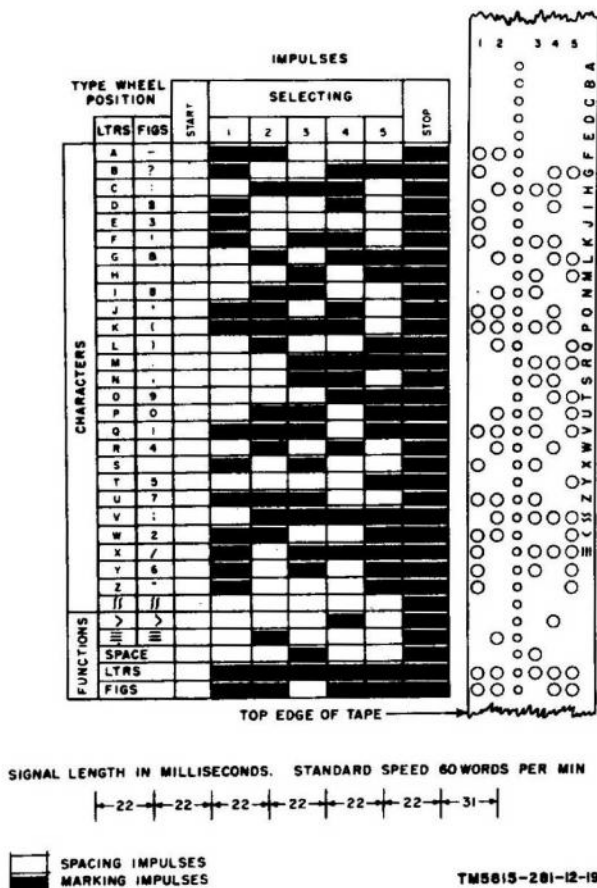

Figure 19. Stop-start, five-unit code chart.

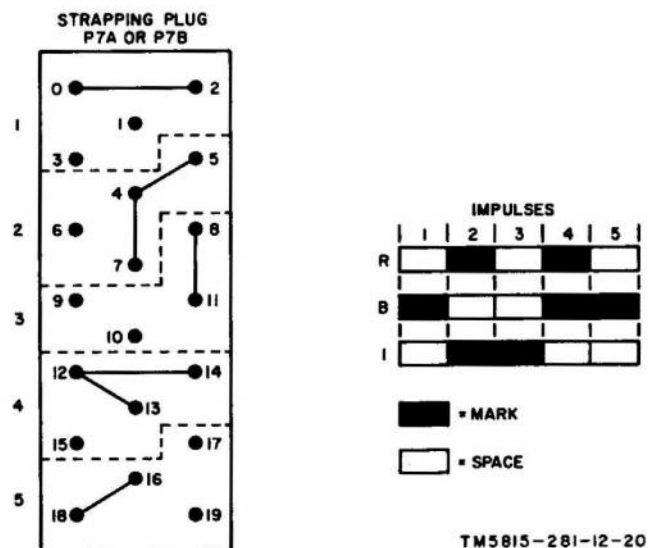

Figure 20. Channel-designating letters RBI strapped into plug P7A or P7B.

- (6) Remove the cotter pins that hold the replacement drive gear set to the studs inside the transmitter motor dust cover; remove the gears. Position the worm gear of the new

drive gear set on the power shaft. Make sure it engages the gear keys on the shaft. Secure by installing the screw and lockwasher.

- (7) Position the worm of the new drive gear set on the motor shaft. If necessary, loosen the motor mounting screws to get proper clearance to mount the worm. Secure the worm with a screw and lockwasher.
- (8) Position the motor so that just perceptible backlash exists between the gears. Make sure there is no binding between the gears.
- (9) Install the removed drive gear set in the stud in the transmitter motor dust cover. Install the dust cover on the transmitter motor; insert the ac plug into its associated jack.

28. Preparation for Local Testing

- a. Make sure the power switch (fig. 4) on the control base is at OFF.
- b. Connect a milliammeter (adjusted to read on the 100-milliampere (ma) scale) across the + and - terminals of LINE 1.
- c. Connect a good teletypewriter receiver (preferably a page printer), that supplies its own bias current, into either LOOP JACK on the left side of the front panel of the control base.
- d. Remove the capnut from the shaft of the LINE CURRENT potentiometer at the left front of the control base. Turn the potentiometer shaft fully counterclockwise.
- e. Move the power switch of the control base to PWR. With the multimeter connected across the LINE 1 output terminals, turn the potentiometer shaft clockwise until the milliammeter reads 20 or 60 ma, depending on which will be used on the signal line. Install the capnut on the potentiometer shaft.

f. Move the power switch to OFF. Disconnect the meter from the LINE 1 output terminals and replace it with an electrical strap to hold the signal line closed during the equipment check.

g. Repeat the instructions in b through f above, to adjust the line current for

LINE 2; use the LINE CURRENT potentiometer and one of the LOOP JACK positions on the right front of the control base.

h. Obtain several message tapes containing the following test message:

THE QUICK BROWN FOX JUMPED OVER THE LAZY DOG'S BACK 12345-67890, letters shift, carriage return, line feed, figures shift and all remaining upper-case characters.

29. Local Tests

Note: The items listed in the *Corrective measures* column in the chart below are only for the use of the installer.

After setting up the equipment (para 28), check the operation of the distributor set in the sequence listed in the chart below. Start the test with transmitter A and repeat the operations for transmitter B. After completing the test remove the straps from across the LINE 1 and LINE 2 output terminals.

Item No.	Item	Action or condition	Normal indications	Corrective measures
1	Power switch on control base (fig. 24).	Operate to PWR -----	None-----	None.
2	CASE switch. -----	Operate to 1 -----	None-----	None.
3	BLANK SIGNAL-OFF switch.	Operate to OFF -----	None-----	None.
4	POWER switch on transmitter (fig. 22).	Operate to ON-----	Transmitter motors start.	Check fuses F1 and F2; check power source connections. Examine motor commutator for cleanliness. Check brushes.
5	Message numbering reset switch on numbering base (fig. 23).	Move to RESET and release.	Message numbering indicators step to 000 if not already there.	Check numbering reset circuit.
6	Stop-start lever on transmitter ^a .	Move from FEED RETRACT to STOP.	Feed claw engages tape feed holes.	Check lever linkage and tape-out lever linkage.
7	Stop-start lever on transmitter.	Move from STOP to START and to FEED RETRACT.	Feed claw is moved out of engagement with feed holes.	Check lever linkage and tape-out lever linkage.
8	Message tape.	Insert in transmitter and move lever from FEED RETRACT to STOP.	Feed claw engages tape feed holes.	Check lever linkage.
9	Stop-start lever on transmitter.	Move to START.	Transmitter starts transmitting 13 character message identification followed by the information on the message tape.	Check distributor clutch magnet, reader clutch magnet, and associated circuits.
10	Teletypewriter receiver.	Check start-of-message indicator.	Should be five blank code groups.	Check circuits associated with case switch.
11	Teletypewriter receiver.	Check channel-designating letters on received message.	Three letters should be assigned for associated transmitter.	Check strapping of plug P7.
12	Teletypewriter receiver.	Check message number on received message.	Message number should be 001.	Check numbering stepping switch circuits.
13	Teletypewriter receiver.	Check accuracy of received message.	Text of message agrees with transmitted tape.	Check distributor and reader contacts of TRMTD.
14	Message numbering indication.	Check reading.	Upper indicators should read 001; lower 000.	Check numbering circuits.
15	Repeat items No. 8 through 14.	Check message numbering indicator reading.	Upper indicators should read 002; lower 000.	Check numbering circuits.
16	CASE switch -----	Operate to 2. -----	None-----	None.
17	BLANK SIGNAL-OFF switch.	Move to BLANK SIGNAL --	None-----	None.

Item No.	Item	Action or condition	Normal indications	Corrective measures
18	Message tape.	Insert in transmitter and move stop-start lever to START; run until message is completed.	Transmitter sends message identification information; then tape message.	Check distributor clutch magnet, reader clutch magnet, and associated circuits.
19	Teletypewriter receiver.	Check start of message indicator.	Should read "BLANK" Z, C, Z, C.	Check associated circuits through CASE switch (S10 or S11 as applicable).
20	Teletypewriter receiver.	Check text for accuracy.	Should record message text without error.	Check transmitter contacts.
21	Teletypewriter receiver.	Check for the receipt of blank code groups at the end of the message.	Teletypewriter will cycle through blank function without printing.	Check blank signal mechanism and circuit.
22	LINE BREAK switch on control base.	Press -----	Teletypewriter receiver should run open.	Check circuit through LINE BREAK switch.
23	Numbering base FORWARD STEP switches.	Depress UNITS, TENS, and HUNDREDS switches.	Associated message numbering indicator should step once for each operation of switch.	Check numbering stepping switch circuits.
24	Numbering base message numbering reset switch.	Operate to RESET -----	Three associated message numbering indicators should step to 000.	Check numbering stepping switch circuit.
25	Repeat items No. 1 through 24 with transmitter B (connected to jack J14); use components associated with that unit.	Same as items No. 1 through 24.	Same as items No. 1 through 24.	Same as items No. 1 through 24.

Section IV. INSTALLATION AND LINEUP

30. Equipment Application

The components of Distributor-Transmitter Set, Teletypewriter AN/GGC-9 are designed to operate on two signal lines on a duplex, transmit only basis. The transmitter connected to jack J12 on the control base transmits to LINE 1 and the transmitter connect to jack J14 transmits to LINE 2. Paragraphs 31 through 33 contain detailed procedures to install the equipment on the signal circuits.

31. Installation Options

Subparagraphs a through c below list the various installation options of the distributor set. The controls described are on the front panel of the control base (fig. 24). One set of controls is provided for each transmitter; the set on the left is associated with the transmitter connected to jack J12 on the rear of the control base. This transmitter transmits to LINE 1. The

set of controls on the right is associated with the transmitter connected to jack J14 on the rear of the control base. This transmits to LINE 2.

a. *Local Current Supply Option.* The distributor set normally supplies line current for 20- to 60-ma operation on the signal line for both transmitters. The change from one line current level to the other is made by adjusting the associated LINE CURRENT potentiometer (fig. 24). A separate potentiometer is provided for each of the two signal lines and the potentiometers are individually adjusted to meet the requirements of the separate circuits.

b. *External Current Supply Option.* The AN/GGC-9 may be used with an external current supply furnished on either both lines or on a single line. Three methods of modifying the equipment are described below. The first procedure prepares the equipment for use when both transmitters (A and B) are to be used with an external

source of signal line current. The second procedure prepares the equipment for external battery supplied to transmitter A with transmitter B furnishing line current locally. The third procedure described the necessary modification to prepare transmitter B for an external line current supply with transmitter A furnishing line current locally (a above).

(1) *External current supplied on both lines.*

- (a) Disconnect jacks J32 and J55 (fig. 10). This completely removes the 120-volt power supply from the equipment.
- (b) Remove the bottom cover from the control base.
- (c) Install a strap between terminals 6 and 7 of terminal board TB1 to complete both signal circuits.
- (d) Replace the bottom cover on the control base.

(2) *External current supply for transmitter A only.*

- (a) Move the power switch on the control base to OFF.
- (b) Remove the bottom cover from the control base.
- (c) Loosen the screw that secures a gray-green lead and an orange-black lead to terminal 7 of terminal TB1.
- (d) Remove the gray-green lead and tighten the screw on terminal 7.
- (e) Connect the gray-green lead to the terminal screw which fastens two red-black leads on terminal 6 of TB1.
- (f) Replace the bottom cover on the control base.
- (g) Position the power switch of the control base to PWR.

(3) *External current supply for transmitter B only.*

- (a) Move the power switch on the control base to OFF.
- (b) Remove the bottom cover from the control base.
- (c) Loosen the screw that secures a single gray-green lead to terminal 7 of terminal board TB1.
- (d) Disconnect the gray-green lead from its terminal and reconnect

it with the *single red-black* lead on terminal 6 of TB1.

- (e) Replace the bottom cover on the control base.
- (f) Position the power switch of the control base to PWR.

c. *Case Switch Option.* The type of receiving equipment used to receive the messages from the distributor set will determine the option to be used. If the receiver is a normal teletypewriter tributary, move the CASE switch to 1, so that the start-of-message indicator consists of five successive blanks. If the receiver is a part of Automatic Switching Center AN/FGC-30 or similar equipment, move the CASE switch to 2, so that the start-of-message indicator consists of one blank code group followed by the code groups for ZCZC.

d. *Blank Signal Switch Option.* If a predetermined number of blank signals are to be transmitted automatically at the end of each message to facilitate tape handling at the receiving station, move the BLANK SIGNAL-OFF switch to BLANK SIGNAL. If the receiving equipment is a page printer, or if the receiving equipment does not require the transmission of blank signals at the end of each message, move the BLANK SIGNAL-OFF switch to OFF.

32. Adjusting Number of Blank Signals Transmitted

The blank signal counter mechanism has an adjustable range from 10 to 80. If more or less blank signals are to be transmitted automatically at the end of each message, remove the dummy plug from the hole in the top rear of the transmitter and adjust the blank signal counter mechanism as follows:

a. To transmit fewer blank signals after a message, rotate the counter indexing ratchet (fig. 21) towards the rear of the transmitter. Count the clicks caused as the detent engages each ratchet tooth. Each click reduces by two the number of blanks that will be transmitted. Reduce the number as desired.

b. To transmit more blank signals after a message, use a small screwdriver to move the detent out of engagement with the

counter indexing ratchet. Rotate the ratchet toward the front of the transmitter. Watch the lines on the side of the counter indexing ratchet. When the ratchet is moved the equivalent of one of the spaces between the lines on the side of the ratchet, the number of blank spaces the unit will transmit is increased by 10. Release the detent.

33. Signal Line Connections

(fig. 10)

Connect the signal lines to the LINE 1 and LINE 2 terminal posts at the rear of the control base. Transmitter A connected

to jack J12 is associated with LINE 1. Transmitter B connected to jack J14 is associated with LINE 2.

34. Circuit Lineup

For best operation, adjust the distributor set to meet the conditions of the signal lines. Circuit lineup for the distributor set consists of adjusting the line current to the required level. Before the equipment is installed on the line, the installer must know what signal line current is required and the operation speed to be used.

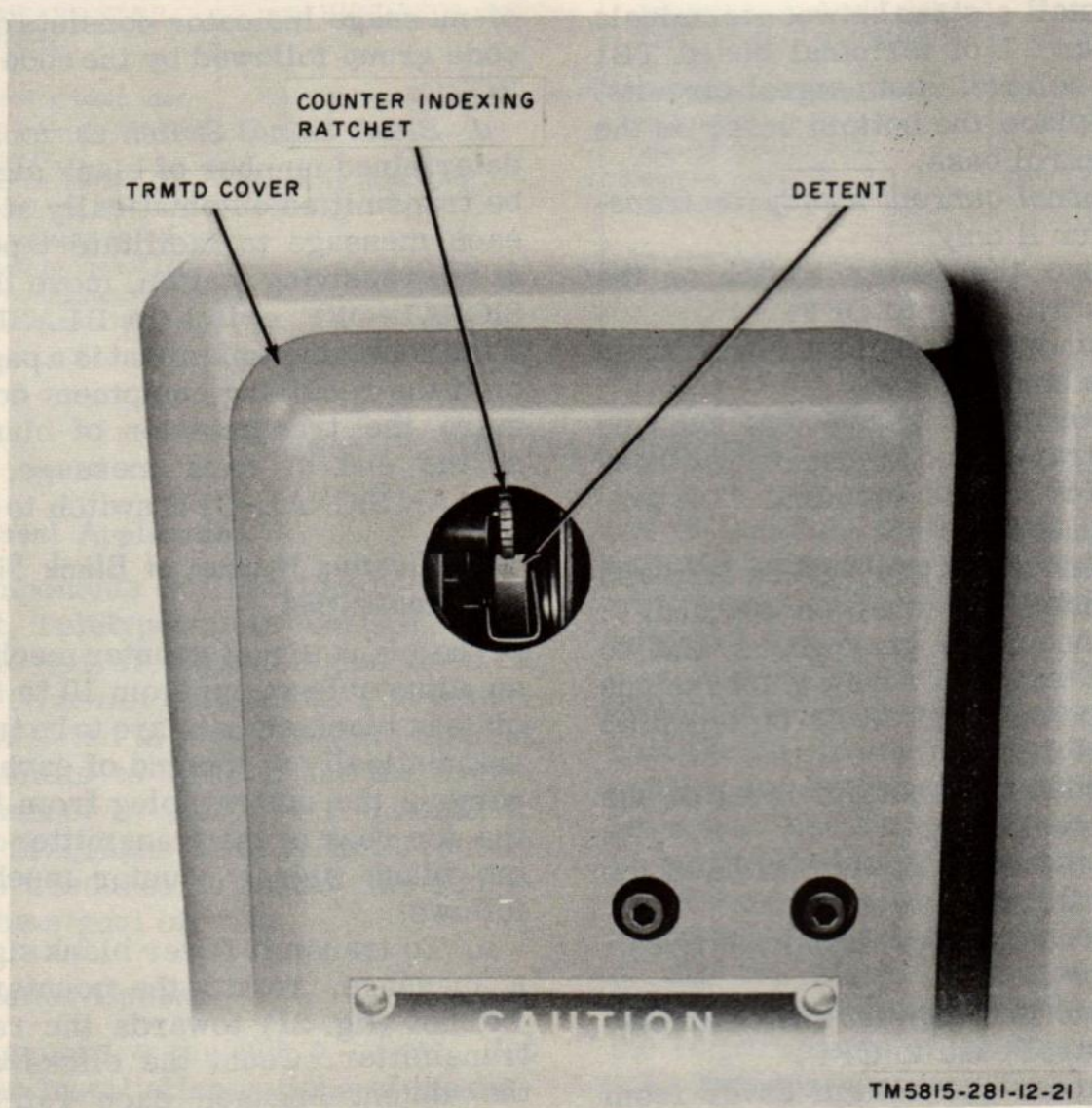

Figure 21. Blank signal counter mechanism adjustment points.

CHAPTER 3

OPERATING INSTRUCTIONS

Section I. OPERATOR'S CONTROLS AND INDICATORS

35. Distributor-Transmitter, Teletypewriter TT-322-GGC-9 Controls (fig. 22)

Control	Function	
POWER switch -----	<i>Sw pos</i>	<i>Action</i>
	ON OFF	Closes ac circuit to operate transmitter motor. Opens ac circuit to stop transmitter motor.
Stop-start lever -----	<i>Pos</i>	<i>Action</i>
	FEED RE-TRACT	Lowers feed pins to permit message tape to be inserted and conditions equipment to send 13-character message identification information before transmitting text of message.
	STOP	Stops transmission. (tape feed pins engage feed holes.)
Tape cover latch -----	START	Starts transmission.
Tight-tape lever -----	Releases tape cover to permit message tape to be removed. When tape binds or becomes taut, lever raises and stops transmission.	

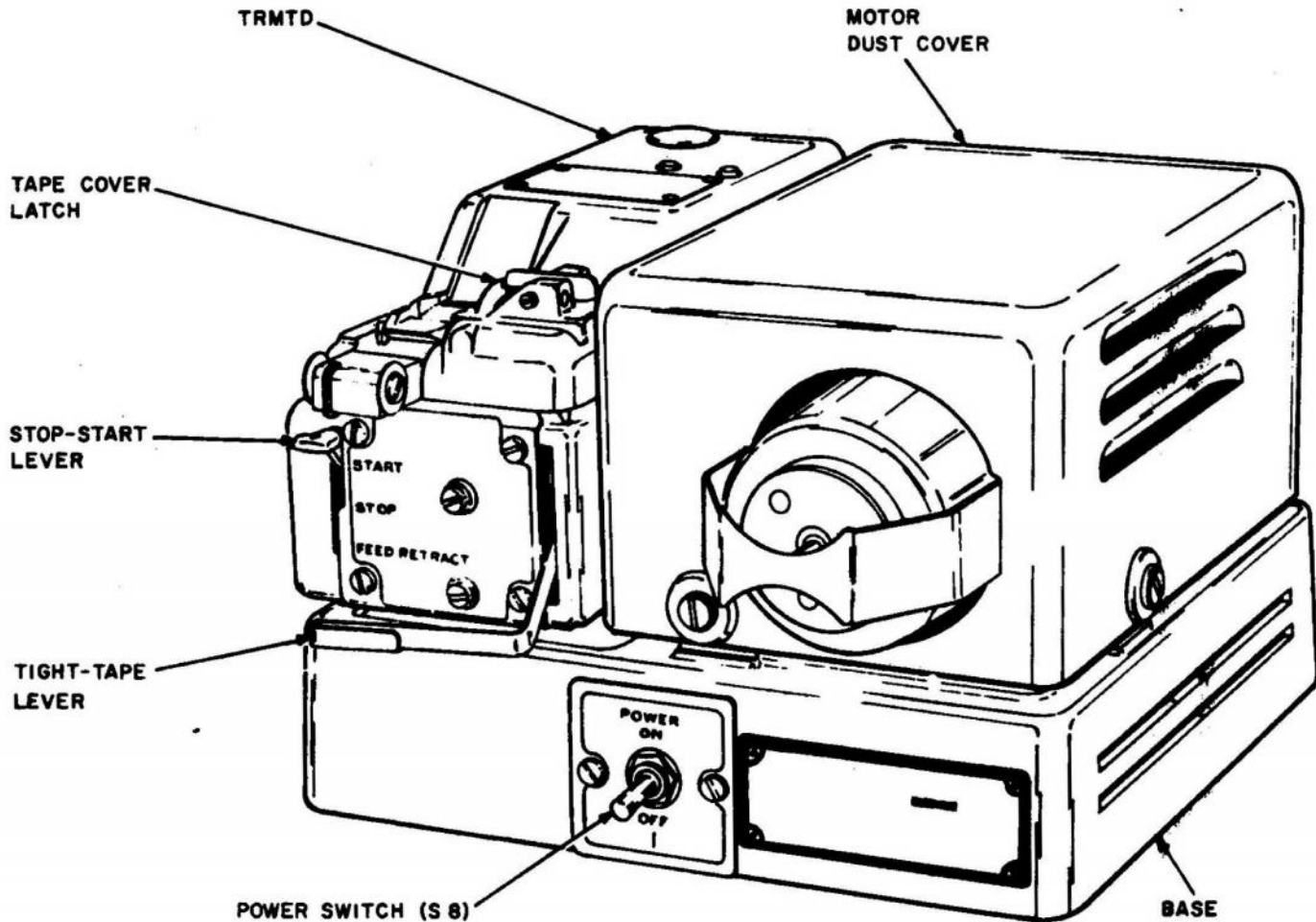

TM5815-281-12-12-22

Figure 22. Transmitter controls.

36. Numbering Unit, Teletypewriter, Message MX-3650/GGC-9 Controls

(fig. 23)

Two sets of message numbering controls are provided on the numbering base. The upper set of controls and the upper set of

message numbering indicators are associated with transmitter A which transmits to LINE 1. The lower set of controls and the lower set of message numbering indicators are associated with transmitter B which transmits to LINE 2.

Control or indicator	Function								
Message numbering reset -----	<table border="0"> <tr> <td style="text-align: center;"><i>Sw pos</i></td> <td style="text-align: center;"><i>Action</i></td> </tr> <tr> <td>Midposition</td> <td>Permits automatic transmission of start-of-message indicator, channel-designating letters, and message number.</td> </tr> <tr> <td>RESET</td> <td>Returns message numbering indicator dials to zero.</td> </tr> <tr> <td>OFF</td> <td>Prevents transmission of 13-character message identification information. (A removable mechanical stop is provided to prevent switch from being accidentally moved to this position.)</td> </tr> </table>	<i>Sw pos</i>	<i>Action</i>	Midposition	Permits automatic transmission of start-of-message indicator, channel-designating letters, and message number.	RESET	Returns message numbering indicator dials to zero.	OFF	Prevents transmission of 13-character message identification information. (A removable mechanical stop is provided to prevent switch from being accidentally moved to this position.)
<i>Sw pos</i>	<i>Action</i>								
Midposition	Permits automatic transmission of start-of-message indicator, channel-designating letters, and message number.								
RESET	Returns message numbering indicator dials to zero.								
OFF	Prevents transmission of 13-character message identification information. (A removable mechanical stop is provided to prevent switch from being accidentally moved to this position.)								
FORWARD STEP switches: UNITS, TENS, and HUNDREDS Message numbering indicators -----	<p>Each switch advances its associated message numbering indicator one unit each time the switch is depressed.</p> <p>Indicates the number of the message being transmitted.</p>								

37. Control, Distributor-Transmitter, Teletypewriter C-3873/GGC-9 Controls

(fig. 24)

Two sets of controls are provided on the control base. The set on the left of the front panel is associated with transmitter A and

LINE 1. The set of controls on the right of the front panel is associated with transmitter B and LINE 2. The fuses and the power switch in the center of the front panel are connected into the circuits to the power supplies that provide line current and control power for the entire unit.

Control	Function						
LINE BREAK switch -----	When depressed, opens signal line. In normal position, holds signal circuit closed.						
Power switch -----	<table border="0"> <tr> <td style="text-align: center;"><i>Sw pos</i></td> <td style="text-align: center;"><i>Action</i></td> </tr> <tr> <td>PWR</td> <td>Closes ac circuit to power supplies and to the transmitters.</td> </tr> <tr> <td>OFF</td> <td>Opens ac circuits to components, to prevent equipment operation.</td> </tr> </table>	<i>Sw pos</i>	<i>Action</i>	PWR	Closes ac circuit to power supplies and to the transmitters.	OFF	Opens ac circuits to components, to prevent equipment operation.
<i>Sw pos</i>	<i>Action</i>						
PWR	Closes ac circuit to power supplies and to the transmitters.						
OFF	Opens ac circuits to components, to prevent equipment operation.						

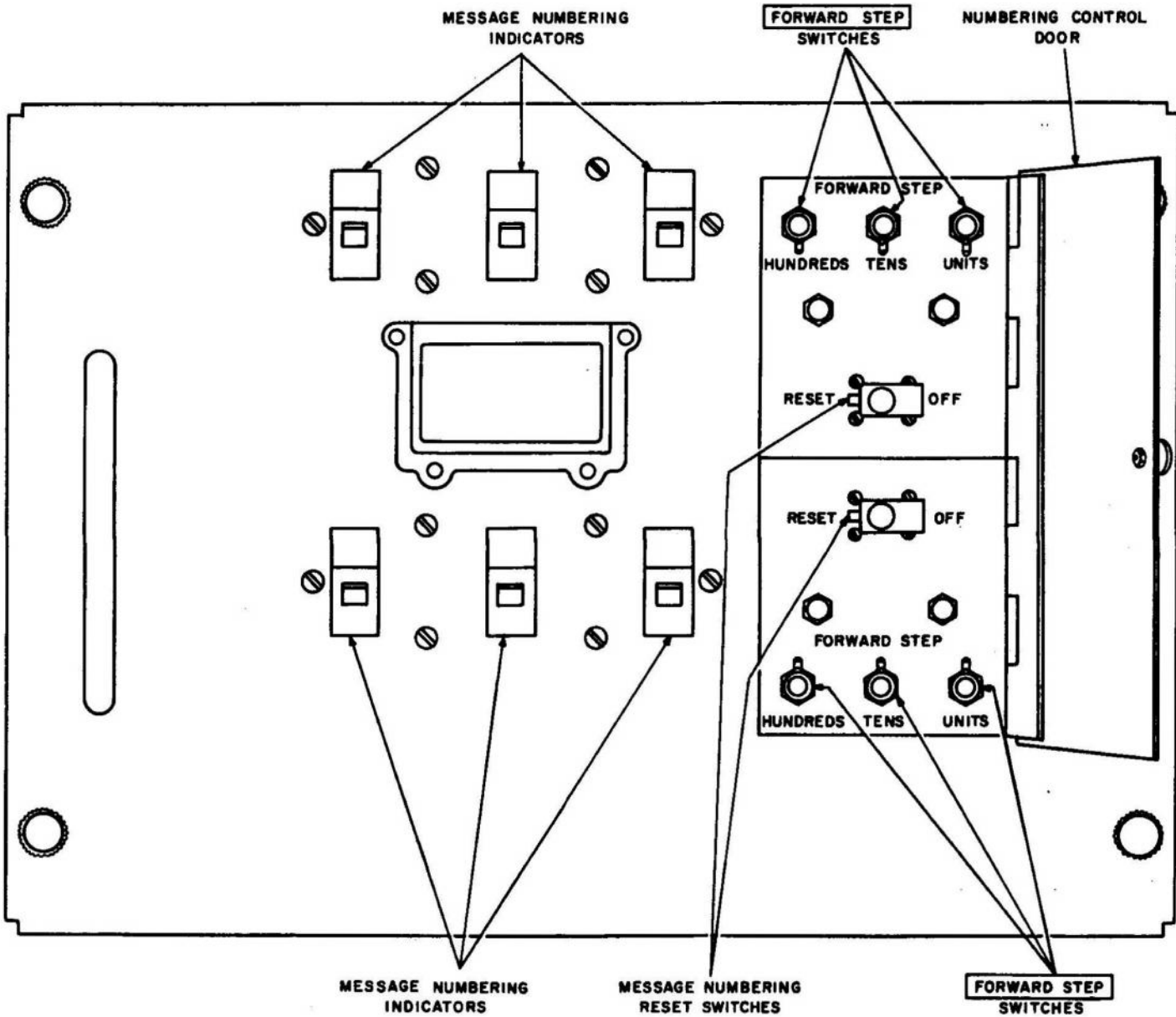

TM5815-281-12-23

Figure 23. Numbering base controls.

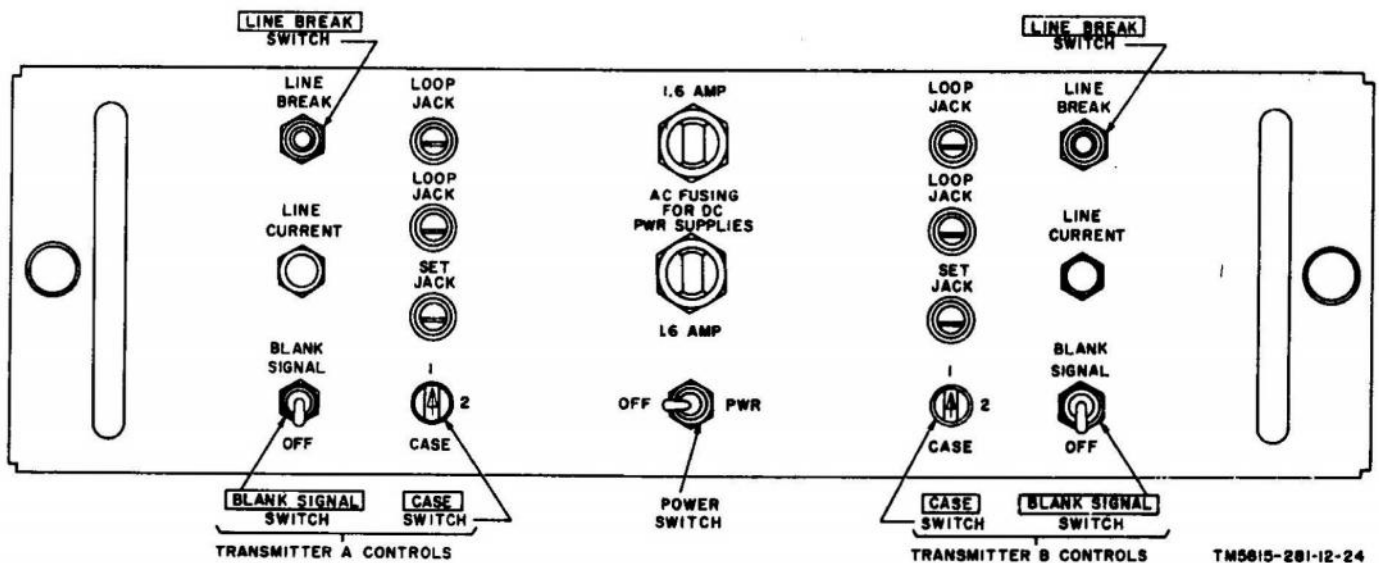

TM5815-281-12-24

Figure 24. Control base controls.

Section II. OPERATION

38. Starting and Stopping Procedures

a. Starting.

- (1) Move the power switch (fig. 24) on the control base to PWR.
- (2) Move the POWER switch on the transmitter to ON.
- (3) Operate the message numbering reset switches (fig. 23), if the counting mechanism is to be set to zero.

b. Stopping.

- (1) Set the POWER switch on the transmitter (fig. 22) to OFF.
- (2) Move the power switch (fig. 24) on the control base to OFF.

c. *Emergency Stopping Procedure.* Operate the power switch (fig. 24) on the control base to OFF.

39. Operating Procedure

a. Move the POWER switch (fig. 22) on the transmitter to ON.

b. Insert a message tape into the transmitter as follows:

- (1) Move the stop-start lever to FEED RETRACT.
- (2) Press the tape cover closed; it will latch in the closed position.
- (3) Slide the message tape into the slot under the tape cover, so that the printing is up and to the left (fig. 25).
- (4) Align the arrow on the tape guide with the first printed letter to be transmitted. Make sure the message tape feed holes are properly aligned with the pins of the tape feed claw.

- (5) Move the stop-start lever to STOP. Apply a slight forward and then a rearward pull on the message tape to make sure the feed pins have properly engaged the feed holes.
- (6) Insert the tape into the slot of the tight-tape lever.

c. Move the stop-start lever to START. The transmitter will transmit the 13-character message identification information. The message tape will then move through the transmitter and the text of the message will be transmitted.

d. To stop the transmission of a message briefly, before its completion, operate the stop-start lever to STOP. Message transmission may then be resumed by operating the stop-start lever to START.

Note: If the stop-start lever is brought down into the FEED RETRACT position, another 13-character message identification information group will be added when the message is continued.

e. If a tangle in the message tape stops transmission by raising the tight-tape lever, untangle the tape and allow the tight-tape lever to move down to its normal position; transmission will resume.

f. As the end of the message tape enters the transmitter it is sensed by the end-of-tape lever and stops transmission. However, if the BLANK SIGNAL-OFF switch is at BLANK SIGNAL, the preset number of blank signals will be transmitted after the end of tape is sensed; transmission then will cease.

g. After the message is transmitted, remove the tape from the transmitter and operate its POWER switch to OFF.

Section I. OPERATOR'S MAINTENANCE INSTRUCTIONS

1. Steps of Operator's Maintenance

Operator's maintenance is limited to external inspection and cleaning of the components of the Distributor-Transmitter Set, Cryptewriter AV/GC-8. Any malfunctions of the equipment should be reported to the maintenance personnel.

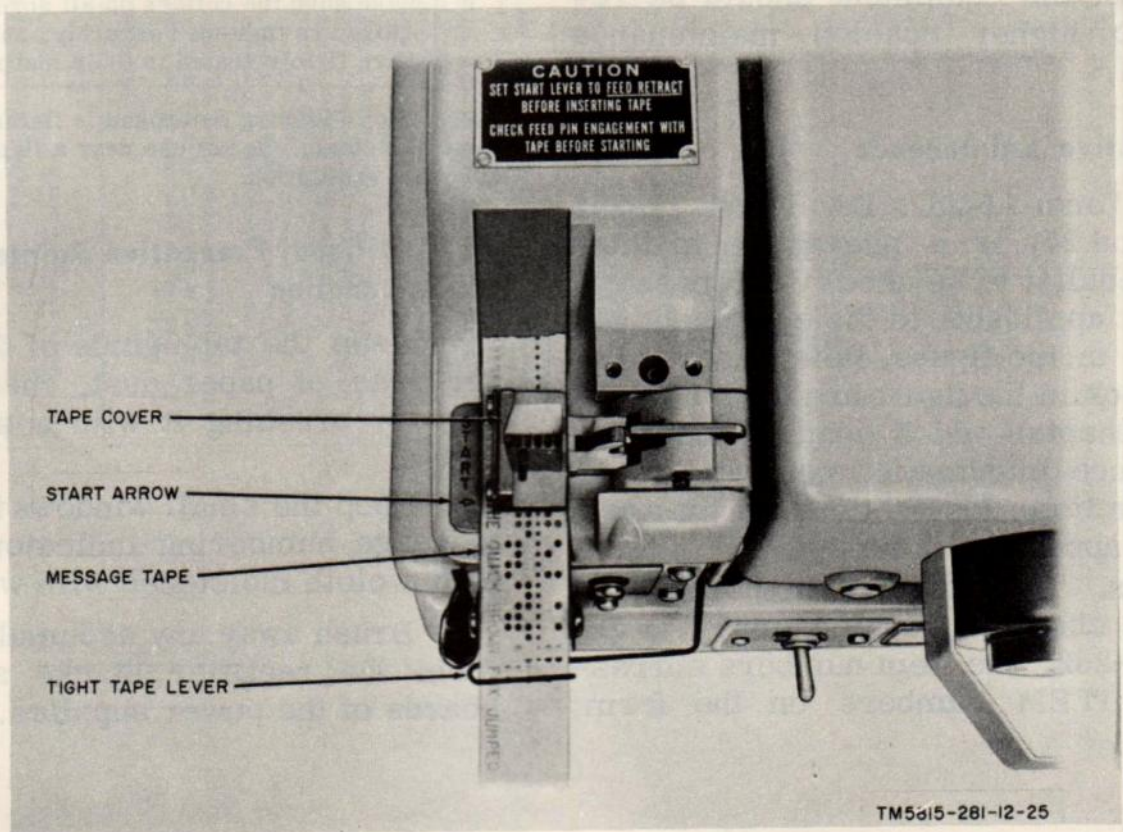

Figure 25. Message tape positioned in transmitter.

CHAPTER 4

ORGANIZATIONAL MAINTENANCE

Section I. OPERATOR'S MAINTENANCE INSTRUCTIONS

40. Scope of Operator's Maintenance

Operator's maintenance is limited to external inspection and cleaning of the components of the Distributor-Transmitter Set, Teletypewriter AN/GGC-9. Any malfunction of the equipment should be reported to higher echelon maintenance personnel.

41. Preventive Maintenance

a. *DA Form 11-252.* DA Form 11-252 (fig. 26 and 27) is a preventive maintenance checklist to be used by the operator. Items not applicable to the equipment are lined out in the figure. References in the ITEM block in the figure are to paragraphs in this chapter which contain additional maintenance information pertinent to the particular item. Instructions for the use of the form appear on the form.

b. *Items.* The information shown in the following chart is supplementary to DA Form 11-252. The item numbers correspond to ITEM numbers on the form.

Item	Maintenance procedure
2	If necessary, wet a cloth with Cleaning Compound (Federal stock No. 7930-395-9542) and clean the parts; then wipe the parts with a clean, dry cloth.
6	Make sure the collars on all screw-type connectors are tightened securely, and that all plugs are firmly seated in their mating jacks.

Warning: Cleaning compound is flammable and its fumes are toxic. Do not use near a flame. Provide adequate ventilation.

42. Additional Preventive Maintenance Information

a. Keep the tape guide of the transmitter free of paper dust, chad, and other dirt by brushing it with a small bristle brush.

b. Keep the small windows in front of the message numbering indicator dials clean with a cloth moistened with water.

c. Brush away any accumulations of dirt from the rectifier stacks and terminal boards of the power supplies.

**MAINTENANCE CHECK LIST FOR SIGNAL EQUIPMENT
TELETYPEWRITER**
(AR 750-625)

EQUIPMENT NOMENCLATURE

**DISTRIBUTOR - TRANSMITTER SET,
TELETYPEWRITER AN/GGC-9**

EQUIPMENT SERIAL NUMBER

123

INSTRUCTIONS

This form may be used for a period of one month by using the correct dates and weeks of the month. It is to be used as a Preventive Maintenance check list for Signal equipment in actual use, or for a check on equipment prior to issue.

1. For detailed Preventive Maintenance instructions see:
 - a. The Technical Manual (in TM 11 series) for the equipment.
(See DA Pamphlet Number 310-4)
 - b. The Supply Bulletin (SB 11-100 series) for the equipment.
(See DA Pamphlet Number 310-4)
 - c. The Department of the Army Lubrication Order.
(See DA Pamphlet Number 310-4)
2. The following action will be taken by either the Communications Officer/Chief for 1st echelon, or the Inspector for higher echelon:
 - a. Enter Equipment Nomenclature and Serial Number.
 - b. Strike out items that do not apply to the equipment.
3. Operator/Inspector will enter in the columns entitled **CONDITION**, on the proper line, a notation regarding the condition, using symbols specified under **LEGEND**.
4. After operator completes each daily inspection he will initial over the appropriate dates under "Daily Condition for Month", then return form to his supervisor.

FOLD

TYPE OF INSPECTION

OPER- ATOR	2ND ECH- ELON	DATE	SIGNATURE
✓		6 JAN 62	<i>Peter D. Quinn</i>

DA FORM 11-252
MAY 57
REPLACES DA FORMS 11-282, 1 OCT 58; 11-289, 11-292, AND 11-293; WHICH ARE OBSOLETE.

Figure 26. DA Form 11-252, pages 1 and 4.

LEGEND for marking conditions: Satisfactory, Y. Adjustment, Repair or Replacement required, X. Defect corrected, (X).		DAILY CONDITION FOR MONTH OF <i>Jan 1962</i>																														
		DAILY																														
NO.	DAILY ITEM	CONDITION EACH WEEK					ADDITIONAL ITEMS FOR 2D AND 3D ECHELON INSPECTIONS	CONDITION																								
		1ST	2D	3D	4TH	5TH																										
1.	CHECK FOR NORMAL OPERATION OF EQUIPMENT. BE ALERT FOR ANY UNUSUAL PERFORMANCE OR CONDITION.	✓	✓	✓	✓	✓	16. CLEAN THE TYPE ROLLERS.	2D ECH- ELON																								
2.	CLEAN DIRT, OIL AND MOISTURE FROM THE EXPOSED SURFACES OF THE TELETYPEWRITER AND COVER.	✓	✓	✓	✓	✓	17. CLEAN THE KEYS AND CHECK FOR BROKEN, MISSING, LOOSE, OR UNUSABLE KEYS.																									
3.	INSPECT ALL EXTERNAL SWITCHES FOR PROPER MECHANICAL ACTION, FREEDOM OF MOVEMENT AND POSITIVE ACTION.	✓	✓	✓	✓	✓	18. CLEAN USED TUBES AND INSULATE RE-PLACE MISSING OR TYPING POSITION IF REQUIRED.																									
4.	EMPTY CHAD BOXES ON REPERFORATORS AND CHECK BY OPERATOR THAT CHAD BOXES ARE FREE OF OBSTRUCTIONS.	✓	✓	✓	✓	✓	19. INSPECT GENERAL CONDITION OF LUBRICATION AND LUBRICATE AS REQUIRED IN ACCORDANCE WITH APPLICABLE LUBRICATION INSTRUCTIONS. PARA 24																									
WEEKLY		18	19	20	21	22	23	24	25	26	27	28	29	30	31																	
5.	CLEAN THE INSIDE AND OUTSIDE OF TRAMMEL RAILS—INSPECT FOR BROKEN GRINDING LATCHES, HANDLES AND EQUIPMENT SUPPORTS OR BRACKETS.	✓	✓	✓	✓	✓	20. CLEAN EXCESS OIL, GREASE AND DIRT FROM MECHANICAL ASSEMBLAGES, GEARS, SHAFTS, FRAMES, ETC.																									
6.	INSPECT EXTERNAL CABLES AND CORDS FOR CUTS OR GOUGED JACKETS, FRAYING, BAD BRUISES OR KINKS AND BROKEN PLUGS OR CONNECTORS.	✓	✓	✓	✓	✓	21. PERFORM ANY ADJUSTMENT REQUIRED AS A RESULT OF CLEANING, LUBRICATION OR NORMAL WEAR.																									
7.	INSPECT EXTERNAL BINDING POSTS AND TERMINAL BLOCKS FOR CRACKS, BREAKS, DIRT, LOOSE SCREWS, LOOSE CONNECTIONS AND MOUNTINGS.	✓	✓	✓	✓	✓	22. INSPECT FOR FREE MOVEMENT OF ALL MOVING PARTS: SENT, BROKEN, DISTORTED OR WORN SHAFTS, GEARS, CAMS, SPRINGS, CLUTCHES, BUSHINGS AND BEARINGS.																									
ADDITIONAL ITEMS FOR 2D AND 3D ECHELON INSPECTIONS																																
8.	INSPECT FOR, AND TIGHTEN, ANY LOOSE SCREWS, NUTS OR BOLTS ON THE COVER OR TRAMMEL RAILS. CHECK FOR BROKEN CATCHES, LATCHES, HANDLES, HINGES AND MOUNTINGS.						23. GRABBER BRACKET AND CHECK THE SUBMOUNTING ASSEMBLY.																									
9.	INSPECT COVER WINDOWS FOR CRACKS, BREAKAGE, OR OTHER DAMAGE.						24. CHECK THAT THE BRUNING ON PAGE PRINTERS IS UNALIGNMENT FREE FULLY AND THAT THE CHARACTERS ARE FULLY PRINTED AND FULLY BRUNED—CHECK THAT THE CHARACTERS ARE FULLY PRINTED ON TYPING REPERFORATORS.																									
10.	INSPECT ALL ELECTRICAL PLUGS AND RECEPTACLES FOR BREAKAGE, FIRM SEATING, PROPER CONTACT, CORROSION AND GREASE OR OIL DEPOSITS. CLEAN IF REQUIRED.						25. CHECK THE TAPES OF TYPING AND NON-TYPING REPERFORATORS AND PERFORATORS FOR CLEAN BRUNING OF CODE AND FEED HOLES.																									
11.	INSPECT CABLES, CORDS AND WIRING FOR CUT OR GOUGED JACKETING, KINKS, BAD BRUISES OR FRAYING.						IF DEFICIENCIES NOTED ARE NOT CORRECTED DURING THE INSPECTION, INDICATE ACTION TAKEN FOR CORRECTION. (Continue on page 4, if more space is needed)																									
12.	INSPECT BINDING POSTS AND TERMINAL BLOCKS FOR CRACKS, BREAKS, DIRT AND LOOSE CONNECTIONS.																															
13.	INSPECT FOR LOOSE MOUNTING SCREWS AND NUTS ON PARTS OR BRACKETS.																															
14.	INSPECT ALL SWITCHES FOR BINDING, FREEDOM OF MOVEMENT AND POSITIVE ACTION.																															
15.	INSPECT MOTOR AND GOVERNOR FOR WORN BRUSHES AND CONTACTS. CLEAN IF REQUIRED.																															

Figure 27. DA Form 11-252, pages 2 and 3.

Section II. ORGANIZATIONAL MAINTENANCE INSTRUCTIONS

43. Scope of Organizational Maintenance

This section covers second echelon maintenance of Distributor-Transmitter Set, Teletypewriter AN/GGC-9, and consists of the following:

- a. Replacement of defective fuses (para 20).
- b. Visual inspection (para 43).
- c. Cleaning (para 46).
- d. Preventive maintenance (para 47).

44. Tools and Materials Required

Only a screwdriver and the following commonly available materials are required for organizational maintenance of Distributor-Transmitter Set, Teletypewriter AN/GGC-9:

- a. Cleaning Compound (Federal stock No. 7930-395-9542).
- b. Cleaning cloth.
- c. Oil, lubricating (Federal stock No. 9150-K60-4297).
- d. No. 0000 sandpaper.

45. General Cleaning Instructions

- a. Use No. 0000 sandpaper to remove corrosion.
- b. Use a clean, dry, lint-free cloth and a dry brush for most cleaning purposes.
- c. Remove deposits of oil with a cloth dampened in cleaning compound. Wipe the part with a dry cloth.
- d. If available, vacuum cleaning equipment is suitable for removing loose dust, paper lint, and dirt from the components of the distributor set. Compressed air may be used, but pressure must be kept below 60 pounds per square inch to prevent equipment damage.

46. Preventive Maintenance of Distributor Set Components

a. Dust Covers and Cover Panels.

- (1) Inspect dust covers and component cover panels. Look for dents, marred painted surfaces, or other damage.
- (2) Clean the outer surfaces of dust covers and panels with a piece of

cloth slightly dampened with water. To remove oil or gummy deposits on the surfaces, use a cloth moistened with cleaning compound.

b. Bases.

- (1) Clean the bases thoroughly with a cloth and sash brush. Wipe off all deposits of oil that may have dropped from mechanical assemblies.
- (2) Check the wiring for cracked or deteriorated insulation and for kinks and strains caused by improper placement.
- (3) Tighten loose fasteners, clamps, and connections.
- (4) Wipe all oil and grease from the outer insulation of cords and cables.

Caution: Never use cleaning compound on rubber insulation.

c. Motors.

- (1) The motor shaft should turn freely, smoothly, and quietly when turned by hand or when operated under power.
- (2) Check the motor unit for evidence of overheating. This may be indicated by discoloration or by the odor of burned insulation. Report an overheated motor to third echelon maintenance for replacement.
- (3) See that the screws that secure the governor, governor cover, and target wheel are tight.
- (4) Remove all dirt, dust, and corrosion from the outside of the motor. Check to see that the wires leading to the motor are intact.

d. Transmitters.

- (1) Look for loose or missing external screws, bolts and electrical connections; frayed or broken wire insulation, and oil-soaked wiring and insulation.
- (2) Blow out or brush away any dirt, paper, or dust that has accumulated in the external parts of the sensing mechanism or tape feed mechanism.

e. Power Supplies.

- (1) Inspect the power supplies for loose connections and mounting screws. Tighten all loose screws, bolts, nuts, and cable clamps. Solder any loose or broken connections. Check the condition of the flexible transformer taps.
- (2) Use a suitable brush, cheesecloth, and a vacuum cleaner to remove dust and dirt. Remove oily and gummy deposits with a cloth dampened with cleaning compound. Remove all rust spots. Repaint all chipped, scratched, or worn metal surfaces.

f. Cords, Cables, and Wiring.

Caution: Do not allow oil or cleaning compound to come into contact with rubber insulation. Oil or cleaning compound causes rubber deterioration.

- (1) Check all external wiring for cracked or deteriorated insulation. Look for frayed or cut insulation at connecting or support points, kinks, or strains caused by improper placement.
- (2) Tighten all loose connectors, fasteners, and wiring connections. Repair loose or broken connections. Remove corrosion, rust, dirt, or dust from ground connections. Be sure the outer insulation

cover on cords and cables is wiped clean.

- (3) See that the wiring is arranged so that it does not interfere with the operation of mechanical parts. Resolder loose connections and replace worn or damaged wiring.

g. Terminal Boards.

- (1) Inspect terminal boards for cracks, breaks, and loose connections. Check for broken or stripped screws and threads, dirt and corrosion. Tighten loose screws, lugs, and mounting bolts. Be careful not to strip the threads by exerting too much force. Solder loose or broken connections.
- (2) Remove moisture with a dry cloth. Brush off dirt and dust. Remove oil or gummy deposits from terminal boards with a cloth moistened with cleaning compound.

47. Visual Inspection

When the equipment fails to perform properly, check all of the items listed below.

- a. Wrong setting of switches and controls (para 37).
- b. Worn, broken, or disconnected cable connectors.
- c. Indicator lamps glowing in fuse caps.
- d. Ground connections.

CHAPTER 5

SHIPMENT AND LIMITED STORAGE AND DEMOLITION TO PREVENT ENEMY USE

Section I. SHIPMENT AND LIMITED STORAGE

48. Disassembly of Equipment

a. Disconnect the plug of the ac input cable from the power source.

b. Disconnect the signal lines from the signal line binding posts.

c. Disconnect all the interconnecting cables.

d. Loosen the thumbscrews that attach the control base and numbering base to the mounting rack; remove the control base and numbering base.

e. Remove the machine screws and lockwashers that attach the transmitters to the mounting base; remove the transmitters.

f. Remove the screws, nuts, and lockwashers that secure the power supplies to the mounting rack; remove the power supplies.

49. Repackaging of Distributor-Transmitter Set, Teletypewriter AN/GGC-9 for Shipment or Limited Storage

Note: The AN/GGC-9 components are normally installed in mobile communication centers. The equipment usually will remain in the operating position during movement and will be sheltered in the same position during limited storage. The following

information is supplied only for those occasions when the components are to be removed and stored as a set.

The exact procedure for repackaging depends on the material available and the conditions under which the equipment is to be shipped or stored. Wrap and tape all multiple connection plugs to prevent the pins from being bent or damaged during shipment or storage.

a. *Material Requirements.* The following materials are required for packaging the distributor set. For stock numbers of materials, consult SB 38-100.

Material	Quantity	Size
Shipping boards	2	31" x 20" x 1/2"
Fiberboard carton	1	32" x 21" x 22"
Fiberboard carton	1	31-1/2" x 20-1/2" x 13"
Fiberboard carton	1	31-1/2" x 20-1/2" x 8-1/2"
Corrugated cardboard	36 sq ft	
Adhesive tape	50 ft	2 inch width
Waterproof tape	20 ft	2 inch width
Filler material	15 lb	

b. *Packaging.* Repackage the distributor set using the original packaging (fig. 8) as a guide.

Section II. DEMOLITION OF MATERIEL TO PREVENT ENEMY USE

50. Authority for Demolition

Demolition of the equipment will be accomplished only upon the order of the commander. The destruction procedures outlined in paragraph 51 will be used to prevent further use of the equipment.

51. Methods of Destruction

Use any of the following methods to destroy the equipment:

a. *Smash.* Smash all controls, relays, clutch magnets, switches, capacitors, transformers, castings, shafts, gears,

and bearings; use sledges, axes, hand-axes, pickaxes, hammers, or crowbars.

b. Cut. Cut the ac input cable and all interconnecting cables and all base wiring; use axes, cutting pliers, bayonets, or machetes.

Warning: Be extremely careful with explosives and incendiary devices. Use these items only when the need is urgent.

c. Burn. Burn all cords, cables, wiring

diagrams, technical manuals, and relays; use gasoline, kerosene, oil, flame-throwers, or incendiary grenades.

d. Bend. Bend covers, operating levers, and bases.

e. Explode. If explosives are necessary, use firearms, grenades, or TNT.

f. Dispose. Bury or scatter the destroyed parts in slit trenches, foxholes, or throw them into streams.

APPENDIX I

MAINTENANCE ALLOCATION

Section I. INTRODUCTION

1. General

a. This appendix assigns maintenance functions to be performed on components, assemblies, and subassemblies by the lowest appropriate maintenance echelon.

b. Columns in the maintenance allocation chart are as follows:

- (1) *Part or component.* This column shows only the nomenclature or standard item name. Additional descriptive data is included only where clarification is necessary to identify the component. Components, assemblies, and subassemblies are listed in top-down order. That is, the assemblies which are part of a component are listed immediately below that component and the subassemblies which are part of an assembly. Each generation break-down (components, assemblies, or subassemblies) are listed in disassembly order or alphabetical order.
- (2) *Maintenance function.* This column indicates the various maintenance functions allocated to the echelons.
 - (a) *Service.* To clean, to preserve, and to replenish lubricants.
 - (b) *Adjust.* To regulate periodically to prevent malfunction.
 - (c) *Inspect.* To verify serviceability and to detect incipient electrical or mechanical failure by scrutiny.
 - (d) *Test.* To verify serviceability and to detect incipient electrical or mechanical failure by use of special equipment such as gages, meters, etc.
 - (e) *Replace.* To substitute serviceable components, assemblies, or subassemblies, for un-

serviceable components, assemblies, or subassemblies.

- (f) *Repair.* To restore an item to serviceable conditions through correction of a specific failure or unserviceable condition. This function includes but is not limited to welding, grinding, riveting, straightening, and replacement of parts other than the trial and error replacement of running spare type items such as fuses, lamps, or electron tubes.
- (g) *Align.* To adjust two or more components of an electrical system so that their functions are properly synchronized.
- (h) *Calibrate.* To determine, check, or rectify the graduation of an instrument, weapon, or weapons system, or components of a weapons system.
- (i) *Overhaul.* To restore an item to completely serviceable condition as prescribed by serviceability standards developed and published by heads of technical services. This is accomplished through employment of the technique of "Inspect and Repair Only as Necessary" (IROAN). Maximum utilization of diagnostic and test equipment is combined with minimum disassembly of the item during the overhaul process.
- (j) *Rebuild.* To restore an item to a standard as near as possible to original or new condition in appearance, performance, and life expectancy. This is accomplished through the maintenance technique of complete disassembly of the item, inspection of all parts or components, repair or

replacement of worn or unserviceable elements using original manufacturing tolerances and/or specifications and subsequent reassembly of the item.

- (3) *1st, 2d, 3d, 4th, 5th echelon.* The symbol X indicates the echelon responsible for performing that particular maintenance operation, but does not necessarily indicate that repair parts will be stocked at that level. Echelons higher than the echelon marked by X are authorized to perform the indicated operation.
- (4) *Tools required.* This column indicates codes assigned to each individual tool equipment, test equipment, and maintenance equipment referenced. The grouping of codes in this column of the maintenance allocation chart indicates the tool, test, and maintenance equipment required to perform the maintenance function.
- (5) *Remarks.* Entries in this column will be utilized when necessary

to clarify any of the data cited in the preceding columns.

c. Columns in the allocation of tools for maintenance functions are as follows:

- (1) *Tools required for maintenance functions.* This column lists tools, test, and maintenance equipment required to perform the maintenance functions.
- (2) *1st, 2d, 3d, 4th, 5th echelon.* The dagger (†) symbol indicates the echelons normally allocated the facility.
- (3) *Tool code.* This column lists the tool code assigned.

2. Maintenance by Using Organizations

When this equipment is used by signal services organizations organic to theatre headquarters or communication zones to provide theatre communications, those maintenance functions allocated up to and including fourth echelon are authorized to the organization operating this equipment.

Section II. MAINTENANCE ALLOCATION CHART

(1) PART OR COMPONENT	(2) MAINTENANCE FUNCTION	(3) 1ST ECH.	(4) 2ND ECH.	(5) 3RD ECH.	(6) 4TH ECH.	(7) 5TH ECH.	(8) TOOLS REQUIRED	(9) REMARKS
DISTRIBUTOR-TRANSMITTER SET, TELETYPEWRITER AN/GCC-9	service	X		X			6	External parts Interior parts Motor speed
	adjust	X		X			2,4,6,7	All adjustments
	inspect	X		X			6,7	External parts Interior parts
				X			1,2,4,5,6,7	Performs resistance, voltage and current measurements to determine condition of equipment circuits
					X		1,2,3,4,5,6,7	Performs all tests required to insure equipment returned to user meets minimum mechanical visual electrical and operational requirements as set forth in F.E.T.P.
CABLE ASSEMBLY, SPECIAL PURPOSE, ELECTRICAL, BRANCHED CX-7640/GCC-9	overhaul						6,7	
	replace			X				
	repair			X			6,7	
CABLE ASSEMBLY, POWER ELECTRICAL, BRANCHED CX-7641/GCC-9	replace			X				
	repair			X			6,7	
CABLE ASSEMBLY, SPECIAL PURPOSE, ELECTRICAL CX-7642/GCC-9	replace			X				
	repair				X		6,7	

(i) PART OR COMPONENT	(j) MAINTENANCE FUNCTION	(k) 1ST ECH.	(l) 2ND ECH.	(m) 3RD ECH.	(n) 4TH ECH.	(o) 5TH ECH.	(p) TOOLS REQUIRED	(q) REMARKS
AN/GCC-9 (continued)								
CABLE ASSEMBLY, POWER, ELECTRICAL CX-7643/0	replace			X			6, 7	
	repair			X			6, 7	
CONTROL, DISTRIBUTOR-TRANSMITTER, TELETYPEWRITER C-3873/GCC-9	repair			X			6, 7	
	rebuild				X		1, 2, 3, 4, 5, 6, 7	
	overhaul				X		1, 2, 3, 4, 5, 6, 7	
DISTRIBUTOR-TRANSMITTER, TELETYPEWRITER TT-322/GCC-9	repair			X			6, 7	
	rebuild				X		1, 2, 3, 4, 5, 6, 7	
	overhaul				X		1, 2, 3, 4, 5, 6, 7	
GOVERNOR ASSEMBLY	replace			X			6, 7	
	repair			X			6, 7	
MOTOR, UNIVERSAL, GOVERNED	replace			X			6, 7	
	rebuild				X		6, 7	
	overhaul				X		6, 7	
NUMBERING UNIT, TELETYPEWRITER MESSAGE MX-3650/GCC-9	repair			X			6, 7	
	rebuild				X		1, 2, 3, 4, 5, 6, 7	
	overhaul				X		1, 2, 3, 4, 5, 6, 7	
POWER SUPPLY PP-1801/FG	replace			X			6, 7	See separate MAC
POWER SUPPLY PP-3131/GCC-9	replace			X			6, 7	
	rebuild				X		1, 2, 3, 4, 5, 6, 7	
	overhaul				X		1, 2, 3, 4, 5, 6, 7	

AN/GCC-9

APPENDIX II

BASIC ISSUE ITEMS LIST

Section I. INTRODUCTION

1. General

This appendix lists items supplied for initial operation and for running spares. The list includes tools, accessories, parts, and material issued as part of the major end item. The list includes all items authorized for basic operator maintenance of the equipment. End items of equipment are issued on the basis of allowances prescribed in equipment authorization tables and other documents that are a basis for requisitioning.

2. Columns

- a. *Source, Maintenance, and Recoverability Code.* Not used.
- b. *Federal Stock Number.* This column lists the 11-digit Federal stock number.
- c. *Designation by Model.* Not used.
- d. *Description.* Nomenclature or the standard item name and brief identifying data for each item are listed in this column. When requisitioning, enter the nomenclature and description.
- e. *Unit of Issue.* The unit of issue is

each unless otherwise indicated and is the supply term by which the individual item is counted for procurement, storage, requisitioning, allowances, and issue purposes.

f. *Expendability.* Nonexpendable items are indicated by NX. Expendable items are not annotated.

g. *Quantity Authorized.* Under "Items Comprising an Operable Equipment", the column lists the quantity of items supplied for the initial operation of the equipment. Under "Running Spares and Accessory Items", the quantities listed are those issued initially with the equipment as spare parts. The quantities are authorized to be kept on hand by the operator for maintenance of the equipment.

h. *Illustrations.* The "Item No." column lists the reference designations that appear on the part in the equipment. These same designations are also used on any illustrations of the equipment. The numbers in the "Figure No." column refer to the illustrations where the part is shown.

Section II. FUNCTIONAL PARTS LIST

(1)	(2)	(3)	(4)	(5)	(6)	(7)	(8)	
SOURCE MAINTENANCE AND RECOVERABILITY CODE	FEDERAL STOCK NUMBER	DESIGNATION BY MODEL	DESCRIPTION	UNIT OF ISSUE	EXPENDABILITY	QUANTITY AUTHORIZED	ILLUSTRATIONS	
							FIGURE NO	ITEM NO
	5815-892-3434		DISTRIBUTOR-TRANSMITTER SET, TELETYPEWRITER AN/GCC-9: 7.42 unit code; 5 channels; accepts 7/8 in w and 11/16 in w fully punched tape; series governed motor; 60 and 100 wpm; 106 to 125v ac, 60 cyc, single ph				1	
			ITEMS COMPRISING AN OPERABLE EQUIPMENT					
	Ord thru AGC		TECHNICAL MANUAL: TM 11-5815-281-12			2		
	5995-876-4269		CABLE ASSEMBLY, POWER, ELECTRICAL, BRANCHED CX-7641/GCC-9			1	7	
	5995-823-2947		CABLE ASSEMBLY, POWER, ELECTRICAL CX-7643/U			1	7	
	5995-876-4270		CABLE ASSEMBLY, SPECIAL PURPOSE, ELECTRICAL BRANCHED CX-7640/GCC-9			1	7	
	5995-823-2953		CABLE ASSEMBLY, SPECIAL PURPOSE, ELECTRICAL CX-7642/GCC-9			2	7	
	5815-856-3908		CONTROL, DISTRIBUTOR-TRANSMITTER, TELETYPEWRITER C-38Y3/GCC-9			NX	4	
	5815-892-3435		DISTRIBUTOR-TRANSMITTER, TELETYPEWRITER TT-322/GCC-9			NX	2	
	5815-856-3909		NUMBERING UNIT, TELETYPEWRITER MESSAGE MX-3650/GCC-9			NX	3	
	5815-842-6442		POWER SUPPLY PP-1801/FG			NX	6	
	5815-823-2956		POWER SUPPLY PP-3131/GCC-9			NX	5	
			DISTRIBUTOR-TRANSMITTER, TELETYPEWRITER TT-322/GCC-9					
			DISTRIBUTOR-TRANSMITTER, TELETYPEWRITER TT-322/GCC-9 (BASIC COMPONENT)			NX	2	
	5815-697-7889		GEAR, WORM: (60 wpm): Kleinschmidt part No. 52106			2	17	52105
	5815-834-3010		GEAR, WORM (100 wpm): Kleinschmidt part No. 52108			1	17	52108
	5815-697-7890		GEAR, WORMWHEEL: (60 wpm): Kleinschmidt part No. 52106A			2	17	52106A
	5815-834-3011		GEAR, WORMWHEEL: (100 wpm): Kleinschmidt part No. 52109A			1	17	52109A

(1) SOURCE MAINTENANCE, AND RECOVERABILITY CODE	(2) FEDERAL STOCK NUMBER	(3) DESIGNATION BY MODEL	(4) DESCRIPTION	(5) UNIT OF ISSUE	(6) EXPENDABILITY	(7) QUANTITY AUTHORIZED	(8) ILLUSTRATIONS	
							FIGURE NO	ITEM NO
			AN/GGC-9 (continued)					
			RUNNING SPARES AND ACCESSORY ITEMS					
			DISTRIBUTOR-TRANSMITTER SET, TELETYPEWRITER AN/GGC-9					
			GROUP 1 DISTRIBUTOR-TRANSMITTER, TELETYPEWRITER TT-322/GGC-9					
	5920-224-5269		FUSE, CARTRIDGE: 1.6 amp; Littlefuse part No. 31301.6			10	10	15
			GROUP 2 NUMBERING UNIT, TELETYPEWRITER MESSAGE, MX-3650/GGC-9					
			NO PARTS AUTHORIZED FOR STORAGE AT FIRST ECHELON					
			GROUP 3 CONTROL, DISTRIBUTOR-TRANSMITTER C-3A73/GGC-9					
	5920-224-5269		FUSE, CARTRIDGE: 1.6 amp; Littlefuse part No. 31301.6			5	5	12
			GROUP 4 POWER SUPPLY PP-3131/GGC-9					
	5920-295-7013		FUSE, CARTRIDGE: INDICATING: 2A; MIL type F02G2R00A			5	5	13

AN/GGC-9

INDEX

	Paragraph	Page		Paragraph	Page
Adjustment:			Description	8	5
48-volt power supply	21b	12	Technical characteristics	4b	4
Motor speed	23	17	Distributor-Transmitter Set, Teletypewriter AN/GGC-9:		
Number of blank signals transmitted	32	23	Description	7	5
120-volt power supply	21c	13	Repackaging for shipment or limited storage	49	35
Transmitter friction clutch	25	18	Technical characteristics	4a	4
Application, equipment	30	22	Dust covers and cover panels	46a	33
Assemblies, cable	13	8	Equipment application	30	22
Assembly of components	18	12	Localizer tests:		
Bases, distributor set	46b	33	List	29	21
Cable assemblies	13	8	Preparation	28	20
Changing operating speed of transmitter	27	19	Forms and records:		
Checking unpacked equipment	15	10	Comments on manual	2e	3
Circuit lineup	34	24	DA Form 11-252	41a	30
Comments on manual	2e	3	Parts list forms	2d	3
Common names	6	4	Preventive maintenance forms	2c	3
Components	5a, 18	4-12	Report of damaged or improper shipment	2b	3
Connections:			Unsatisfactory equipment reports	2a	3
Ground and power	21	12	Friction clutches:		
Interunit cable	19	12	Adjustment	25	18
Signal line	33	24	Lubrication	24	18
Control, Distributor-Transmitter, Teletypewriter C-3873/GGC-9:			Method of checking	25b	18
Controls and indicators	37	26	Requirement	25a	18
Description	10	6	Fuse check	20	12
Technical characteristics	4d	4	Ground and power connections:		
Controls and indicators:			48-volt power supply adjustment ..	21b	12
Control, Distributor-Transmitter, Teletypewriter C-3873/GGC-9 ..	37	26	Ground connections	21a	12
Distributor-Transmitter, Teletypewriter TT-322/GGC-9	35	25	120-volt power supply adjustment ..	21c	13
Numbering Unit, Teletypewriter Message MX-3650/GGC-9	36	26	Indicators:		
Cords, cables, and wiring	46f	34	Control, Distributor-Transmitter, Teletypewriter C-3873/GGC-9 ..	37	26
Demolition of materiel:			Distributor-Transmitter, Teletypewriter, TT-322/GGC-9	35	25
Authority for demolition	50	35	Numbering Unit, Teletypewriter, Message MX-3650/GGC-9	36	26
Methods of destruction	51	35	Inspection, organizational maintenance	47	34
Description:			Installation options:		
Cable assemblies	13	8	Blank signal-off option	31c	23
Power, Electrical CX-7643/U ..	13a	8	Case switch option	31b	22
Power, Electrical, Branched CX-7641/GGC-9	13b	8	Line current option	31a	22
Special Purpose, Electrical CX-7642/GGC-9	13d	8	Interunit cable connections	19	12
Special Purpose, Electrical, Branched CX-7640/GGC-9 ..	13c	8	Lineup, circuit	34	24
Control, Distributor-Transmitter, Teletypewriter C-3873/GGC-9 ..	10	6	Lubrication, friction clutches	24	18
Distributor-Transmitter Set, Teletypewriter AN/GGC-9	7	5	Methods of destruction:		
Distributor-Transmitter, Teletypewriter TT-322/GGC-9	8	5	Bend	51d	36
Numbering Unit, Teletypewriter, Message MX-3650/GGC-9	9	5	Burn	51c	36
Power Supply PP-1801/FG	12	6	Cut	51b	36
Power Supply PP-3131/GGC-9	11	6	Disposed	51f	36
Disassembly of equipment	48	35	Exploded	51e	36
Distributor set components, preventive maintenance	46	33	Smash	51a	35
Distributor-Transmitter, Teletypewriter TT-322/GGC-9:			Motor, distributor set	46c	33
Controls and indicators	35	25	Motor speed adjustment	23	17
			Numbering Unit, Teletypewriter, Message MX-3650/GGC-9:		
			Controls and indicators	36	26
			Description	9	5
			Technical characteristics	4c	4
			Operating procedure:		
			Starting and stopping procedures ..	38	28

	Paragraph	Page		Paragraph	Page
Usual conditions	39	28	Report of damaged or improper shipment.....	2b	3
Organizational maintenance, preventive maintenance.....	41	30	Unsatisfactory equipment reports .	2a	3
Special tools, materials, and test equipment required	40	30	Repackaging of Distributor-Transmitter Set, Teletypewriter AN/GGC-9	49	35
Organizational maintenance instructions:			Report of damaged or improper shipment.....	2b	3
General cleaning instructions	45	33	Running spares	5b	4
Scope of organizational maintenance	43	33	Scope:		
Tools and materials required	44	33	Manual	1	3
Parts list form.....	2d	3	Organizational maintenance instructions	43	33
Power supplies, distributor set	6e	34	Service upon receipt of equipment:		
Power supply adjustment:			Checking unpacked equipment	15	10
48-volt	21b	12	Siting	16	10
120-volt	21c	13	Unpacking	14	10
Power Supply PP-3131/GGC-9:			Signal line connections	33	24
Description	11	6	Siting.....	16	10
Technical characteristics	4e	4	Special tools, organizational maintenance	40	30
Power Supply PP-1801/FG:			Starting and stopping procedures:		
Description	12	6	Emergency stopping	38c	28
Technical characteristics	4f	4	Starting	38a	28
Preliminary adjustment and lubrication:			Stopping.....	38b	28
Changing operating speed of transmitter	27	19	Technical characteristics:		
Extent.....	22	17	Control, Distributor-Transmitter, Teletypewriter C-3873/GGC-9 ..	4d	4
Localizer tests	29	21	Distributor-Transmitter Set, Teletypewriter AN/GGC-9	4a	3
Lubrication of friction clutches ...	24	18	Distributor-Transmitter Set, Teletypewriter TT-322/GGC-9..	4b	4
Motor speed adjustment	23	17	Numbering Unit, Teletypewriter, Message MX-3650/GGC-9	4c	4
Preparation for local testing	28	20	Power Supply PP-1801/FG	4f	4
Transmitter friction clutch adjustment.....	25	18	Power Supply PP-3131/GGC-9	4e	4
Wiring in channel designations ...	26	18	Terminal boards	46g	34
Preventive maintenance:			Test equipment and material	17	12
DA Form 11-252	41a	30	Test equipment, organizational maintenance	40	30
Distributor set components	46	33	Transmitters, distributor set	46d	34
Bases	46b	33	Tools	17	12
Cords, cables, and wiring	46f	34	Tools and materials required, organizational maintenance instructions...	44	33
Dust covers and cover panels .	46a	33	Unpacking:		
Motor	46c	33	Packaging	14a	10
Power supplies	46e	33	Removing contents	14b	10
Terminal boards	46g	34	Unsatisfactory equipment reports	2a	3
Transmitters	46d	33	Wiring in channel designations	26	18
Preventive maintenance forms	2c	3			
Purpose	3	3			
Records and forms:					
Comments on manual	2e	3			
Parts list form	2d	3			
Preventive maintenance forms	2c	3			

By Order of Secretary of the Army:

G. H. DECKER,
General, United States Army,
Chief of Staff.

Official:

J. C. LAMBERT,
Major General, United States Army,
The Adjutant General.

Distribution:

Active Army:

DASA (6)
USASA (2)
CNGB (1)
Tech Stf, DA (1) except
CSigO (14)
Tech Stf Bd (1)
USCONARC (5)
USAARTYBD (1)
USAARMBD (2)
USAIB (1)
USARADB (2)
USAABELCTBD (1)
USAAVNBD (1)
USAATBD (1)
ARADCOM (2)
ARADCOM, Rgn (2)
OS Maj Comd (3)
OS Base Comd (2)
LOGCOMD (2)
MDW (1)
Armies (2)
Corps (2)
Instl (2)
Fort Monmouth (63)
USATC AD (2)
USATC Armor (2)
USATC Engr (2)
USATC FA (2)
USATC Inf (2)
USAOMC (3)
Svc Colleges (2)
Br Svc Sch (2)
GENDEP (2) except
Atlanta GENDEP (none)
Sig Sec, GENDEP (5)
Sig Dep (12)

WRAMC (1)
USA Trans Tml Comd (1)
Army Tml (1)
POE (1)
OSA (1)
USAEPG (2)
AFIP (1)
AMS (1)
Army Pictorial Cen (2)
EMC (1)
Yuma Test Sta (2)
USACA (3)
USASSA (20)
USASSAMRO (1)
USASEA (1)
USA Caribbean Sig Agcy (1)
USA Sig Msl Spt Agcy (13)
Sig Fld Maint Shops (3)
USA Corps (3)
JBUSMC (2)
Def Log Svc Cen (1)
Units org under fol TOE
(2 Copies each UNOINDC)
11-7
11-16
11-57
11-97
11-117
11-155
11-157
11-500 (AA-AE) (4)
11-557
11-587
11-592
11-597

NG: State AG (3).

USAR: None.

For explanation of abbreviations used, see AR 320-50.

TM 11-5815-281-12 DISTRIBUTOR-TRANSMITTER SET, TELETYPEWRITER AN/GGC-9 - 1962