

**UNIT, INTERMEDIATE DIRECT SUPPORT
AND GENERAL SUPPORT
MAINTENANCE MANUAL**

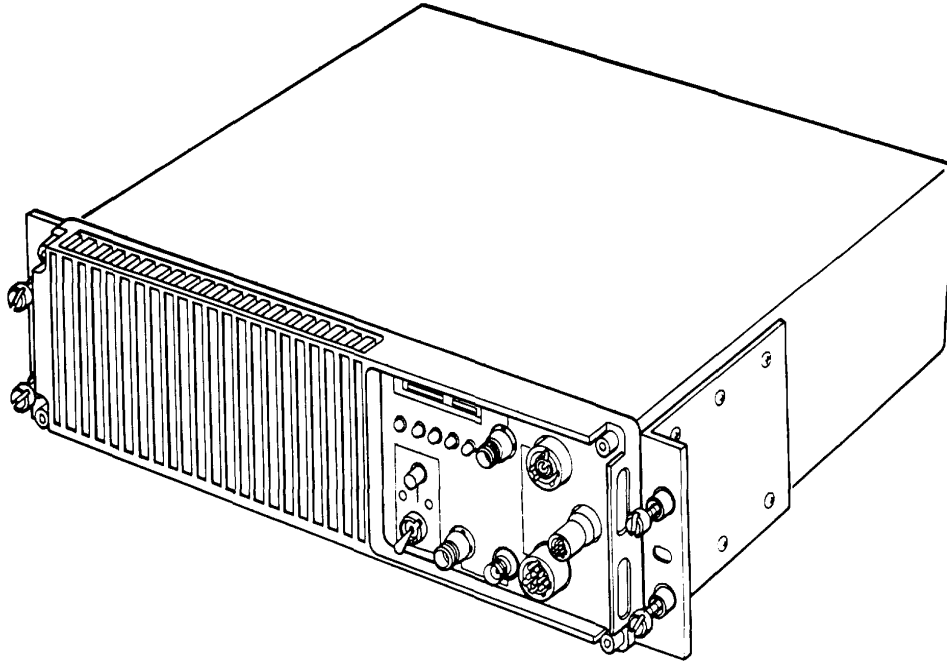

**TUNER,
PRE/POST SELECTOR
TN-612/G
(NSN 5895-01-205-0877)**

HOW TO USE THIS MANUAL	iii
EQUIPMENT DESCRIPTION AND DATA	1-3
UNIT MAINTENANCE	2-1
INTERMEDIATE DIRECT SUPPORT AND GENERAL SUPPORT MAINTENANCE	3-1
APPENDICES	A-1
SUBJECT INDEX	Index-1



5

SAFETY STEPS TO FOLLOW IF SOMEONE IS THE VICTIM OF ELECTRICAL SHOCK

1

DO NOT TRY TO PULL OR GRAB THE INDIVIDUAL

2

IF POSSIBLE, TURN OFF THE ELECTRICAL POWER

3

IF YOU CANNOT TURN OFF THE ELECTRICAL POWER, PULL, PUSH OR LIFT THE PERSON TO SAFETY USING A DRY WOODEN POLE OR A DRY ROPE OR SOME OTHER INSULATING MATERIAL

4

SEND FOR HELP AS SOON AS POSSIBLE

5

AFTER THE INJURED PERSON IS FREE OF CONTACT WITH THE SOURCE OF ELECTRICAL SHOCK, MOVE THE PERSON A SHORT DISTANCE AWAY AND IMMEDIATELY START ARTIFICIAL RESUSCITATION

WARNING

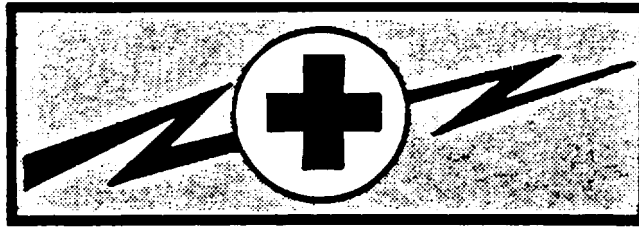

HIGH VOLTAGE

is used in the operation of this equipment

DEATH ON CONTACT

may result if personnel fail to observe safety precautions

Never work on electronic equipment unless there is another person nearby who is familiar with the operation and hazards of the equipment and who is competent in administering first aid. When technicians are aided by operators, they must be warned about dangerous areas.

Whenever possible, the power supply to the equipment must be shut off before beginning work on the equipment. Take particular care to ground every capacitor likely to hold a dangerous potential. When working inside the equipment, after the power has been turned off, always ground every part before touching it.

Be careful not to contact high-voltage connections or 120 volt ac input connections when installing or operating this equipment.

Whenever the nature of the operation permits, keep one hand away from the equipment to reduce the hazard of current flowing through the body.

WARNING: DO NOT BE MISLED BY THE TERM "LOW VOLTAGE". POTENTIALS AS LOW AS 50 VOLTS MAY CAUSE DEATH UNDER ADVERSE CONDITIONS.

For Artificial Respiration, refer to FM 21-11. Air Force personnel refer to AFOSH 127-50 and AFOSH 127-66, Chapter 10.

WARNING

RF RADIATION HAZARD



Dangerous RF power levels exist on and around the antenna during operation. Do not stand closer than 40 inches (1.0 meter) to the antenna when the transmitter is operating. Failure to heed this warning may result in death or serious injury.

WARNING

Turn off all equipment power before using TRICHLOROTRIFLUOROETHANE. Provide adequate ventilation while using TRICHLOROTRIFLUOROETHANE. Avoid prolonged breathing of the fumes and vapor. Do not use solvent near heat or open flames; the products decomposed are toxic and irritating. Because TRICHLOROTRIFLUOROETHANE dissolves natural oils, avoid prolonged contact with the skin. When needed, use gloves that the solvent cannot penetrate. If the solvent is taken internally, consult a physician immediately.

CAUTION



The Pre/Post Selector contains certain static-sensitive solid state devices that are subject to damage from electrostatic discharge (ESD). Effective control of electrostatic discharge is maintained only through continuous strict observance of the following maintenance procedures:

- Any maintenance requiring disassembly of the equipment must be performed at an approved work station. The work station must include a grounded surface and grounded wrist strap, in accordance with DOD-HDBK-263.
- All maintenance personnel must have completed training in the handling of static-sensitive devices before working on this equipment. Maintenance personnel must wear the grounded wrist strap and be at an approved work station when performing maintenance.
- The static-sensitive subassemblies or circuit cards must be stored in approved electrostatic-free material when not installed in the equipment.

D

Technical Manual
 No. 11-5895-1305-24
 Technical Manual
 No. EE020-HJ-MMI-010/W110-TN612G
 Technical Order
 TO 31R2-4-572-2

Washington, DC, 15 May 1989

UNIT, INTERMEDIATE DIRECT SUPPORT AND
 GENERAL SUPPORT MAINTENANCE MANUAL

TUNING UNIT, PRE/POST SELECTOR
 TN-612/G
 (NSN 5895-01-205-0877)

REPORTING ERRORS AND RECOMMENDING IMPROVEMENTS

You can help improve this manual. If you find any mistakes or if you know of a way to improve the procedures, please let us know. Mail your letter, DA Form 2028 (Recommended Changes to Publications and Blank Forms) or DA Form 2028-2 located in back of this manual direct to: Commander, US Army Communications-Electronics Command and Fort Monmouth, ATTN: AMSEL-LC-ME-PS, Fort Monmouth, New Jersey 07703-5000.

For Air Force, submit AFTO Form 22 (Technical Order System Publication Improvement Report and Reply) in accordance with paragraph 6-5, Section VI, T.O. 00-5-1. Forward direct to prime SM-ALC/MMEDT McClellan AFB, CA 95652-5609.

For Navy, mail comments to the Commander, Space and Naval Warfare Systems Command, ATTN: SPAWAR 003-242, Washington, DC 20363-5100

In either case a reply will be furnished direct to you.

		<u>Page</u>
	HOW TO USE THIS MANUAL	iii
CHAPTER	1. INTRODUCTION	1-1
Section	I. General Information	1-1
	II. Equipment Description and Data	1-3
	III. Principles of Operation	1-9
CHAPTER	2. UNIT MAINTENANCE	2-1
Section	I. Repair Parts, Special Tools; Test, Measurement, and Diagnostic Equipment (TMDE); and Support Equipment	2-1

	Page
II. Service Upon Receipt	2-1
III. Preventive Maintenance Checks and Services (PMCS)	2-2
IV. Unit Troubleshooting.....	2-4
V. Unit Maintenance	2-4
VI. Preparation for Storage or Shipment.....	2-6
CHAPTER 3. INTERMEDIATE DIRECT SUPPORT AND GENERAL SUPPORT MAINTENANCE.....	3-1
Section I. Repair Parts, Special Tools; Test, Measurement, and Diagnostic Equipment (TMDE); and Support Equipment.....	3-1
II. Intermediate General Support Troubleshooting.....	3-2
III. Intermediate General Support Maintenance.....	3-55
APPENDIX A. REFERENCES	A-1
APPENDIX B. MAINTENANCE ALLOCATION CHART.....	B-1
APPENDIX C. EXPENDABLE/DURABLE SUPPLIES AND MATERIALS LIST.....	C-1
GLOSSARY	GLOSSARY-1
Section I. Abbreviations and Acronyms.....	GLOSSARY-1
Section II. Definition of Unusual Terms.....	GLOSSARY-4
SUBJECT INDEX.....	INDEX-1
FOLDOUTS	
Functional Block Diagram	FOLDOUT-1
Test Point Locations.....	FOLDOUT-2
Chassis A2A15 Schematic Diagram.....	FOLDOUT-3
Chassis A2A15 Parts Location Diagram	FOLDOUT-4

HOW TO USE THIS MANUAL

- The front cover index identifies frequently used information. Each item is boxed and identified by topic and page number.
- The first page containing the information you are looking for has a black box on the edge of the page.
- Bend the manual in half and follow the margin index to the page with the black edge marker.
- Topics in the table of contents which are the same as topics on the front cover are also boxed.
- A complete alphabetical subject index is located in the back of the manual. Use the index to locate specific information.
- The glossary contains an explanation of technical terms and acronyms.

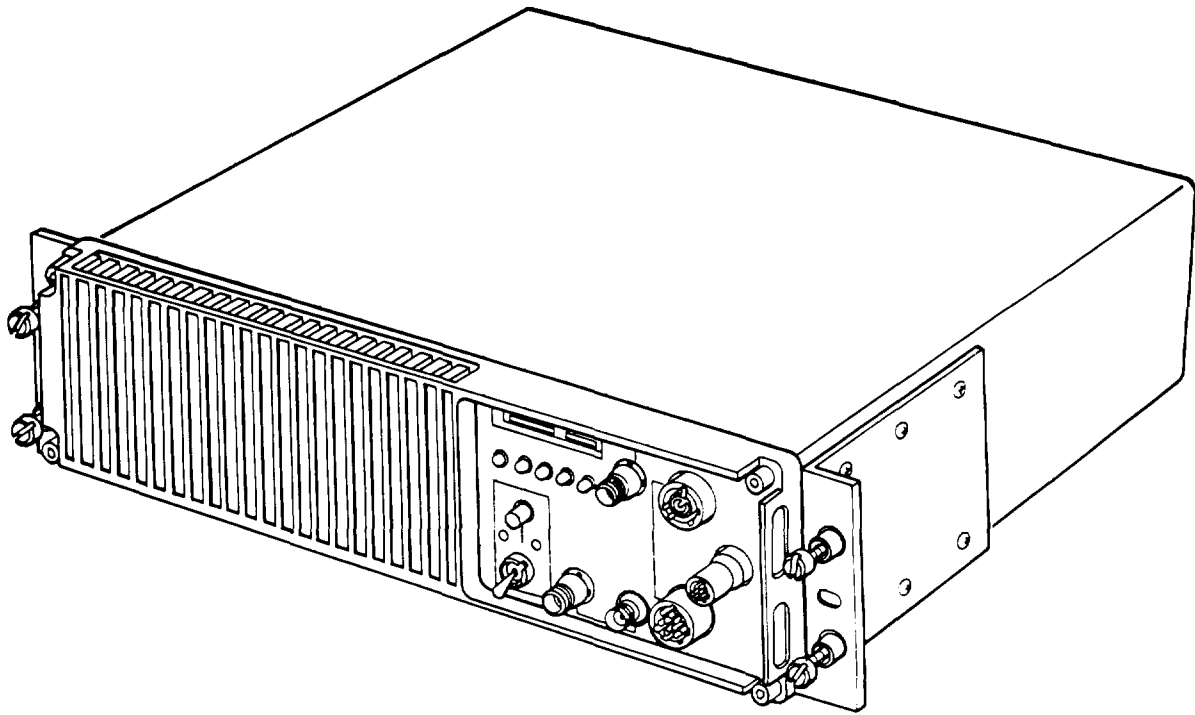

TN-612/G PRE/POST SELECTOR TUNING UNIT

**CHAPTER 1
INTRODUCTION**

<u>Subject</u>	<u>Page</u>
Equipment Description and Data	1-3
General Information	1-1
Principles of Operation	1-9

Section I. GENERAL INFORMATION

1-1. SCOPE

- a. Type of Manual. Unit, Intermediate Direct Support, and General Support Maintenance.
- b. Model Number and Equipment Name. Tuning Unit, Pre/Post Selector TN-612/G.

c. Purpose of Equipment. The Pre/Post Selector is composed of a set of tunable filters controlled by a microprocessor. In the transmit mode it is connected between the RT-1512/G and Power Amplifier AM-7296/G. It reduces the wide band noise and interference. In the receive mode, it is connected between the Antenna and Receiver. It increases selectivity and reduces noise and interference signals.

d. Maintenance Category Cross-Reference. Army maintenance categories are referenced in this manual. Navy and Air Force personnel will contact their same-level maintenance group. Refer to the following cross-reference list.

<u>Army</u>	<u>Navy</u>	<u>Air Force</u>
Unit	Organizational	Organizational

1-2. MAINTENANCE FORMS, RECORDS, AND REPORTS

a. Reports of Maintenance and Unsatisfactory Equipment. Department of the Army forms and procedures used for equipment maintenance will be those prescribed by DA Pam 738-750, as contained in Maintenance Management Update. Air Force personnel will use AFR 66-1 for maintenance reporting and TO 00-35D-54 for unsatisfactory equipment reporting. Navy personnel will report maintenance performed utilizing the Maintenance Data Collection Subsystem (MDCS) IAW OPNAVINST 4790.4A, and unsatisfactory material/conditions utilizing the PMS Feedback Report.

1-2. MAINTENANCE FORMS, RECORDS, AND REPORTS (Cont.)

b. Report of Packaging and Handling Deficiencies. Fill out and forward SF 364 (Report of Discrepancy (ROD)) as prescribed in AR 735-11-2/DLAR 4140.55/SECNAVINST 4355.18/AFR 400-54/MCO 4430.3J.

c. Transportation Discrepancy Report (TDR) (SF 361). Fill out and forward Transportation Discrepancy Report (TDR) (SF 361) as prescribed in AR 55-38/NAVSUPINST 4610.33C/AFR 75-18/MCO P4610.19D/DLAR 4500.15.

1-3. CONSOLIDATED INDEX OF PUBLICATIONS AND BLANK FORMS

a. Army. Refer to the latest issue of DA Pam 25-30 to determine whether there are new editions, changes, or additional publications pertaining to the equipment.

b. Navy. Navy personnel refer to NAVSUP 2002.

c. Air Force. For technical publications, Air Force personnel refer to Numerical Index and Requirement Table (NI & RT). For non-technical publications refer to AFR 0-2. For forms, refer to AFR 0-9.

1-4. REPORTING EQUIPMENT IMPROVEMENT RECOMMENDATIONS (FIR)

a. Army. If your equipment needs improvement, let us know. Send us an EIR. You, the user, are the only one who can tell us what you don't like about your equipment. Let us know why you don't like the design or performance. Put it on an SF 368 (Product Quality Deficiency Report). Mail it to: Commander, US Army Communications-Electronics Command and Fort Monmouth, ATTN: AMSEL-PA-MA-D, Fort Monmouth, New Jersey 07703-5000. We'll send you a reply.

b. Navy. Navy personnel are encouraged to submit EIRs through their local Beneficial Suggestion Program.

c. Air Force. Air Force personnel are encouraged to submit EIRs in accordance with AFR 900-4.

1-5. DESTRUCTION OF MATERIEL TO PREVENT ENEMY USE

a. Army. Destroy the AM-7301/GRC-215 Power Amplifier in accordance with the procedures in TM 750-244-2 to prevent enemy use.

b. Navy. Navy personnel will comply with the Local Command Material Destruction Plan.

c. Air Force. Air Force personnel comply with TM 750-244-2 or the Local Emergency Destruction Plan.

1-6. PREPARATION FOR STORAGE OR SHIPMENT

a. Army. Before placing equipment into administrative storage, insure that equipment is operational. If operational, put into storage using appropriate corrosion control techniques. When removing from storage, again perform operational tests and UNIT PMCS, (if available) to determine mission capability.

b. Navy. Refer to NAVSUP PUB 503.

c. Air Force. Refer to AFM 66-267 (storage) and AFR 67-31 (shipment).

1-7.OFFICIAL NOMENCLATURE, NAMES, AND DESIGNATIONS

COMMON NAME	OFFICIAL NOMENCLATURE
Pre/Post Selector (PPS)	Tuning Unit, Pre/Post Selector TN-612/G P/N A3023760
Case	Housing Assembly, AI, P/N A3026049
Chassis	Chassis Assembly, A2, P/N A3031346
Front Panel	Front Panel, A2A1, P/N A3031144
Microprocessor Module	Microprocessor Module, A2A2, P/N A3026053
Overload Module	Overload Module, A2A3, P/N A3026054
PTT and Override Control Module	PTT and Override Control Module, A2A4, P/N A3026055
RF/RX Amplifier Module	RF/RX Amplifier Assy, A2A5, P/N A3026056
Power Supply Module	Power Supply Module, A2A100, P/N A3026057
Chassis	Chassis Assembly, A2A15, P/N A3031088

Section II. EQUIPMENT DESCRIPTION AND DATA

1-8.EQUIPMENT CHARACTERISTICS, CAPABILITIES, AND FEATURES

- Increases selectivity and reduces noise in Receive (RX) mode.
- Incorporates built-in-test (BIT) circuits for self diagnosis.
- Modular construction.
- Fully solid state.
- Automatic tuning (from frequency codes of associated receiver).

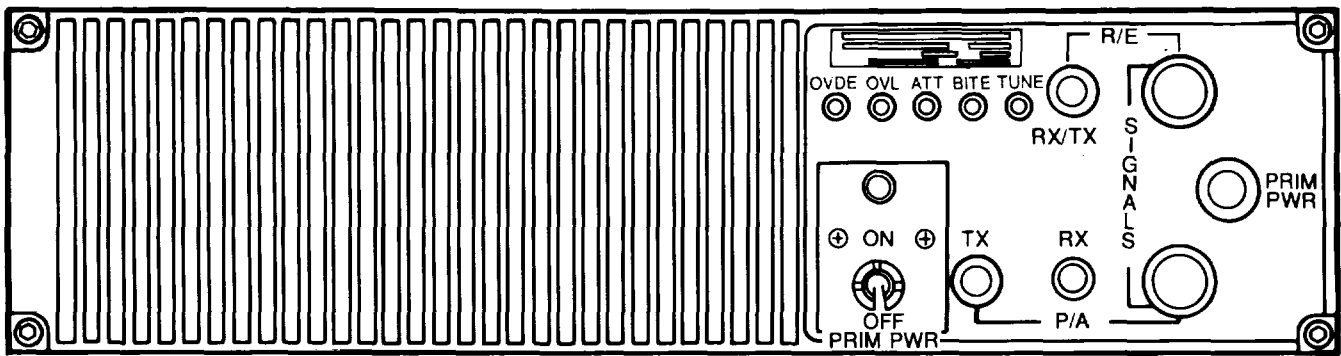

PRE/POST SELECTOR FRONT PANEL

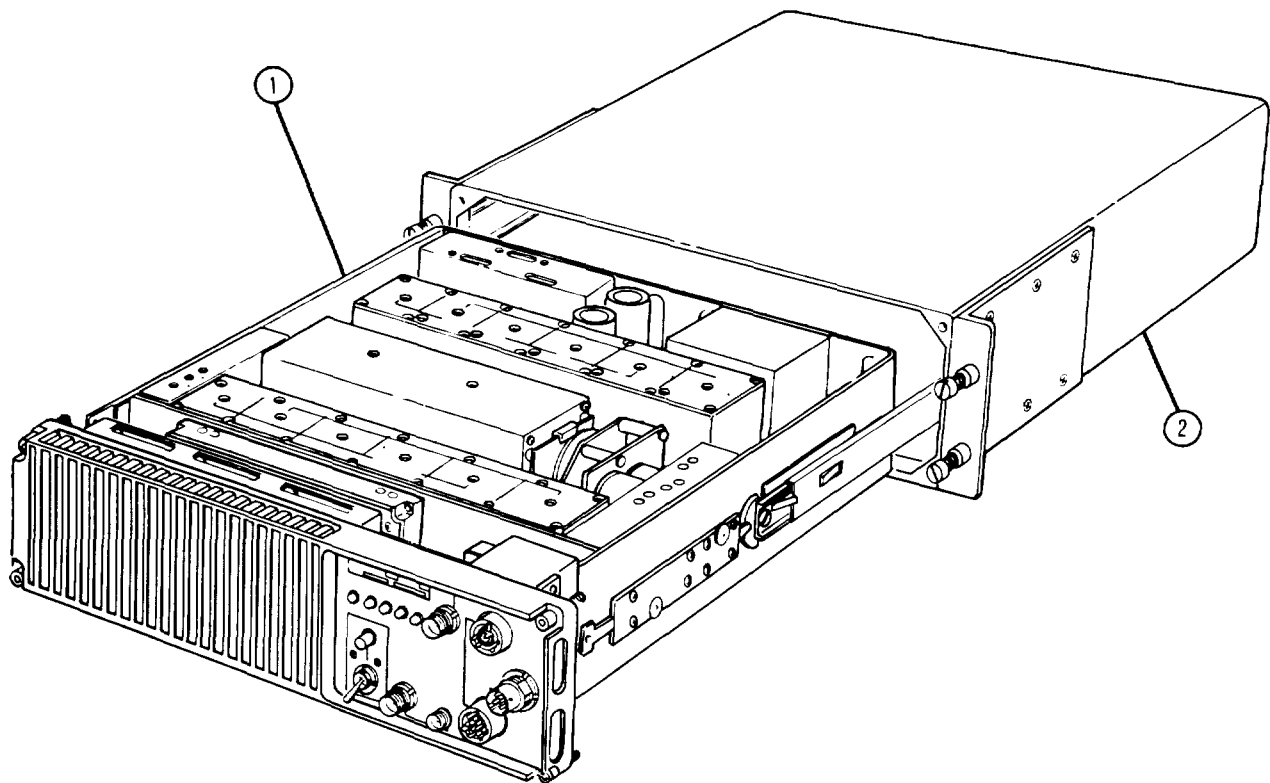

NOTE

For description and purpose of front panel controls, refer to operator TM for the system.

Chassis (A2). Houses Microprocessor, RF/RX Amplifier, Power Supply, Overload, PTT & Override Control modules; front panel and chassis components.

Housing Assembly (A1). Houses entire chassis and its components.

1-9. LOCATION AND DESCRIPTION OF MAJOR COMPONENTS (Cont.)

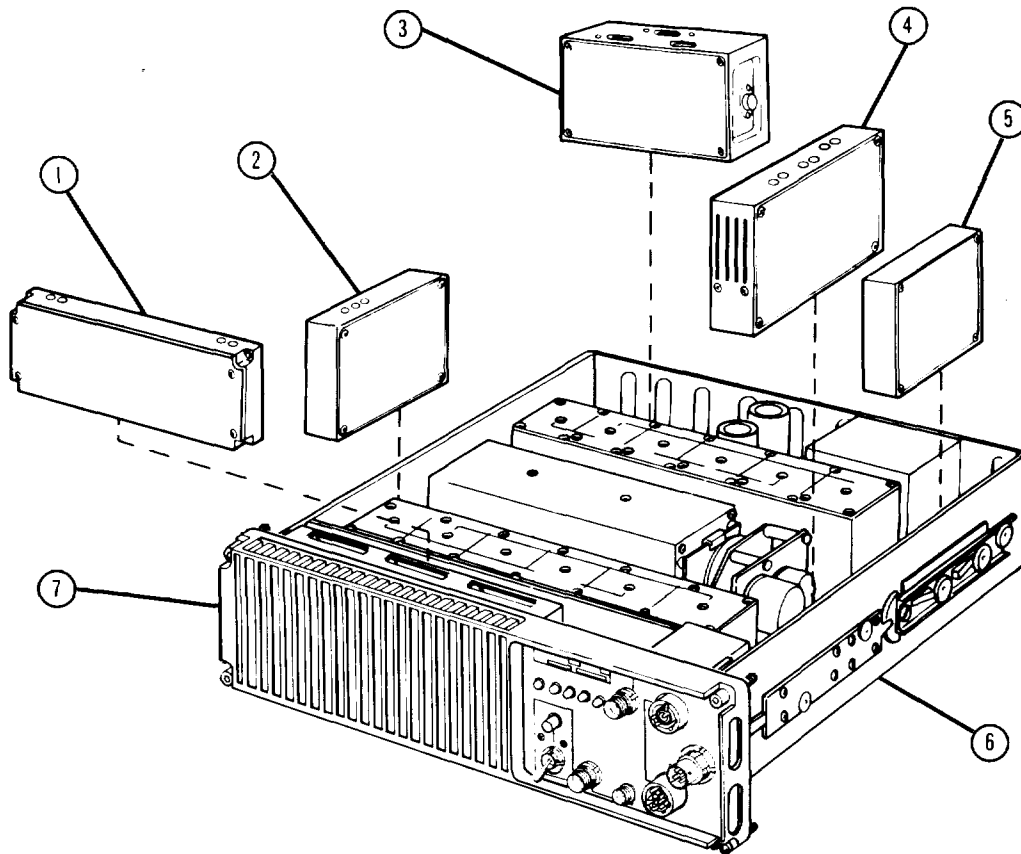

Microprocessor Module (A2A2). Controls the tuning sequence.

RF/RX Amplifier Assy (A2A5). Compensates for filter attenuation in RX mode. Provides routing (switching) for transit signal

Power Supply Module (A2A10). Provides supply voltages and includes BITE circuit.

Overload Module (A2A3). In RX mode, it protects the input circuit when the input RF voltage exceeds 40 Vrms; attenuates input signal in excess of 2 Vrms.

PTT and Override Control Module (A2A4). Bypasses the filter during frequency-hopping operations.

Chassis (A2A15). Houses filter and power supply components, RF Connections, relays, variable capacitors, and drive motor.

Front Panel (A2A1). Houses the RF/TX amplifier, the indicator lamps, and external connectors.

1-10. IDENTIFICATION AND INSTRUCTION PLATES

The identification plate is located on the front panel as shown below.

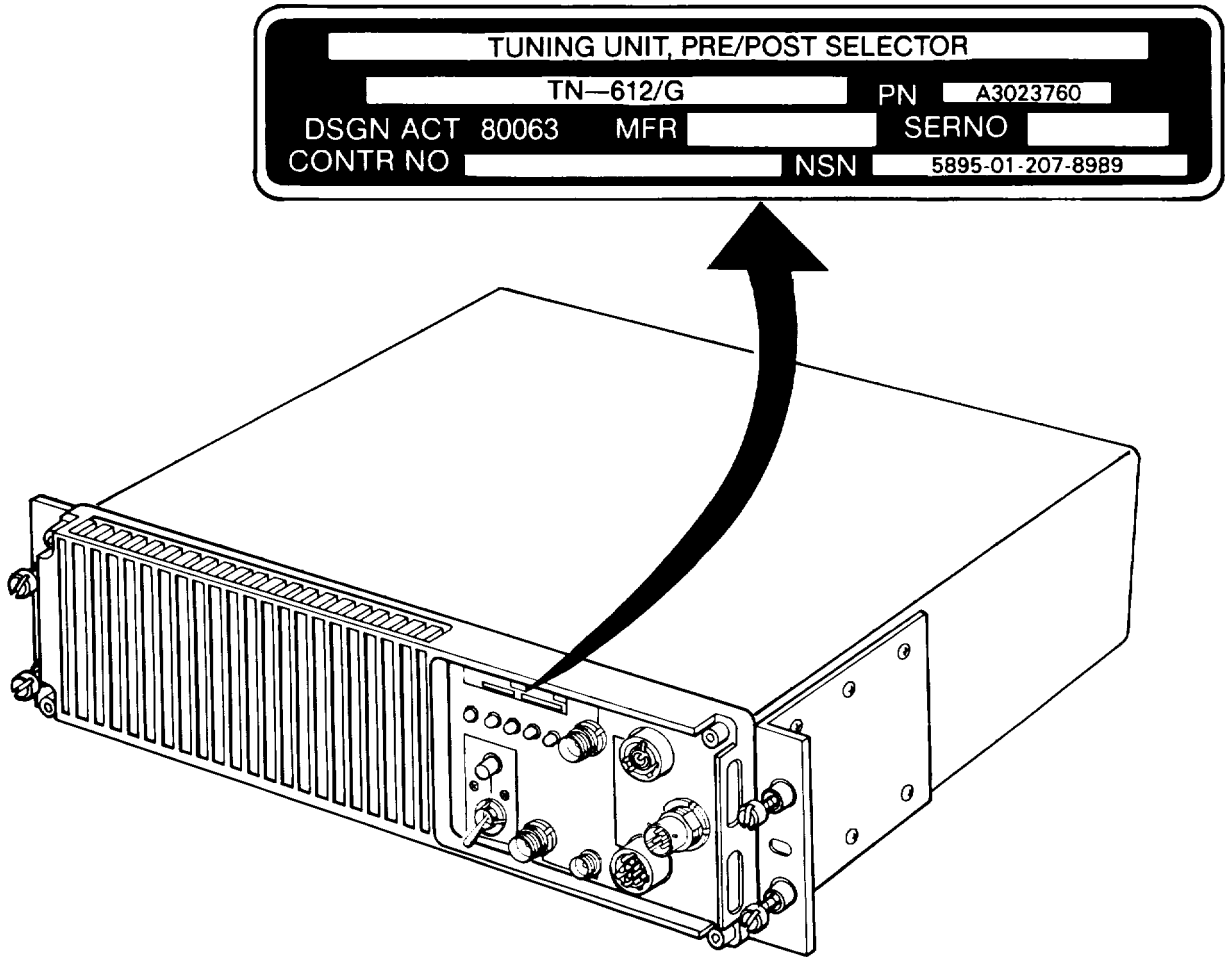

1-11. EQUIPMENT DATA

a. Electrical Characteristics:

Frequency Range	2 to 29.9999 MHz
Tuning Accuracy	± 0.5% of tuned frequency
RF In/Out Impedance	50-Ohm unbalanced (VSWR < 2.5:1)
Input Power	115 Vac (+5% -15%) (97.25-120.75 Vac) 47 to 400 Hz single phase
Tuning Time	< 4 seconds

TX Mode:

Overall Gain	8.5 to 11.5 dB (in frequency range)
Input Level	+14.5 to +21.5 dBm in the temperature range from -21 to 70 ^o C
3rd Order IM	< 40 dB below PEP during two-tone test
Harmonics	70 dB below output power
Power Consumption	120 W max

RX Mode:

Overall Gain	0 to 3 dB
Noise Figure	< 15 dB
Input Protection	At 40 Vrms, RF is switched to 50-Ohm load. Withstands signals and atmos- pheric disturbances up to 500 V peak.
RF Selectivity	-3 dB at ±1% off tuned frequency -30 dB at ±5% off tuned frequency -50 dB at +10% off tuned frequency -60 dB at -10% off tuned frequency
Power Consumption	50 W max

b. Physical Characteristics:

Width	17.36 in.
Height	4.4 in.
Depth	16.77 in.
Weight	39.7 lb.

1-12. SAFETY, CARE AND HANDLING

CAUTION

Prior to removing or installing a component, ensure that power to the Pre/Post Selector has been turned off. Cables disconnected with voltage present may arc or short. This can produce damage to the connector.

Make all cable connections by hand. Do not use tools. When tools are used to make connections, connectors may be over tightened and damage to the connector and pins may occur.

CAUTION

The Pre/Post Selector contains certain static-sensitive solid state devices which are subject to damage from electrostatic discharge (ESD). Effective control of electrostatic discharge is maintained only through continuous strict observance of the following maintenance procedures:

- Any maintenance requiring disassembly of the equipment must be performed at an approved work station. The work station must include a grounded surface and grounded wrist strap in accordance with DOD-HDBK-263.
- All maintenance personnel must have completed training in the handling of static-sensitive devices before working on this equipment. Maintenance personnel must wear the grounded wrist strap and be at an approved work station when performing maintenance.
- The static sensitive subassemblies or circuit cards must be stored in approved electrostatic free material when not installed in the equipment.

Section III. PRINCIPLES OF OPERATION

1-13. FUNCTIONAL DESCRIPTION OF PRE/POST SELECTOR

a. Pre/Post Selector is part of a complete 400 W transceiver system installed in the Communications Terminal AN/TRC-179(V) 1, 2, & 3 and AN/FRC-180(V) 1 & 2.

b. It is a tunable, 2 to 30 MHz, band-pass filter automatically tuned to a 10 kHz bandwidth for the selected RX/TX frequency. Tuning is obtained by connecting suitable inductors and adjusting variable capacitors according to the frequency value coming from the associated receiver or receiver-transmitter.

c. The Pre/Post Selector is connected between the exciter (RT-1512/G) and the power amplifier (AM-7296/G) in the transmit (TX) mode. It is designed to provide RF selectivity and improve performance of the associated HF transmitter by reducing wide band noise and interference. In the receive (RX) mode, it is connected between the RF receiver output jack of the power amplifier (AM-7296/G) and the receiver (R2322/G) or receiver portion of RT-1512/G. It is designed to improve RF selectivity of the associated receiver and reduce noise and interference signals. Foldout FO-1 shows a block diagram of the unit.

d. The Pre/Post Selector is composed of seven functional assemblies:

- Chassis
- Front Panel
- Microprocessor Module
- Overload Module
- PTT and Override Control Module
- RF/RX Amplifier Module
- Power Supply Module

e. In RX mode (normal operation), the receive signal is applied to the front panel at J4 (RX). It is processed through a surge arrestor in the front panel and then routed to the overload module. The overload module samples the rms voltage level of the signal. When the signal is over 40 Vrms, the overload module connects it to a 50-Ohm load. When the signal exceeds 2 to 5 Vrms, the module attenuates it 20 dB and then sends it to the HF tunable filter. The filter output is sent to the RF/RX amplifier where it is amplified to make up for any filter loss (0 to +3 dB across the PPS). The receive signal is then sent to the front panel connector J3 (RX OUT) to be cabled to the receiver.

1-13.FUNCTIONAL DESCRIPTION OF PRE/POST SELECTOR (Cont.)

f. In RX mode (ECCM operation), the override control circuit in the PTT and override control module activates a relay that allows the signal to bypass the HF filters and then pass through the RF/RX amplifier (no amplification by module) to be sent to the J3 connector, RX OUT.

g. In TX mode (normal operation), the signal from the RT is applied to TX input jack J3 and to the RF/RX amplifier. The signal follows a straight-through path once again, and is routed to the TX amplifier mounted on the front panel. The TX amplifier amplifies the signal 10 dB and sends it to the overload Module. The overload module is passive to the TX signal and routes it to the HF filters and then to the RF/RX amplifier. The signal follows a path straight-through the RF/RX Amplifier and is sent to TX OUT jack J5. From there it is cabled to the power amplifier.

h. In TX mode (ECCM), the signal bypasses the HF filters in the same manner as RX mode (ECCM operation).

1-14. FUNCTIONAL DESCRIPTION OF MAJOR COMPONENTS

a. Chassis (A2A15). The chassis houses the filter and power supply components, RF relays, variable capacitors, and drive motor. Auxiliary circuits such as motor controls, and relay drivers are also located on the chassis.

b. Front Panel (A2A1). The front panel houses the TX amplifier module, which provides for 10 dB amplification of RT-1512/G output signals. It also provides mounting for lamp indicators, connectors, and primary power circuit breaker (PRIM PWR).

c. Microprocessor Module (A2A2). The microprocessor controls the tuning sequence. Its input is the binary coded decimal (BCD) frequency code from the RT. A frequency change pulse (FCP) starts the tuning sequence by causing the power supply module to provide +5 Vdc tune voltage to the modules that require it.

d. Overload Module (A2A3). An overload circuit connects the receive signal to a 50-Ohm load every time it exceeds 40 Vrms. The same signal is attenuated (attenuation control is activated by the RX/RF amplifier) by 20 dB if it exceeds 2 to 5 Vrms.

e. PTT and Override Control Module (A2A4). A circuit is provided which controls the signal path to the HF tuneable filter. When an override signal is received from the RT (in ECCM operation) the RX or TX signal is routed around the HF tuneable filter and a straight-through path in the RF/RX amplifier is provided.

1-13. FUNCTIONAL DESCRIPTION OF MAJOR COMPONENTS (Cont.)

f. RF/RX Amplifier Module (A2A5). The receive signal from the antenna is amplified in the RF amplifier module to compensate for filter attenuation. There is also a signal-level sensing circuit that provides the attenuation activation signal for the overload module in conditions of high signal-level input.

g. Power Supply Module (A2A10O). The power supply module provides dc operating voltages (+24 Vdc, +12 Vdc, +5 Vdc, and a +5 Vdc Tune voltage) from the primary ac input power. The internal power supply energizes the RX or TX circuits according to the mode selected. It contains a BITE circuit that monitors the +5 Vdc. Whenever there is a fault with the + 5 Vdc supply, the BITE circuit lights the front panel BITE LED, which provides a visual indication of a fault. Also, the antenna is switched to a 50-Ohm resistor by the overload module.

1-11/(1-12 BLANK)

**CHAPTER 2
UNIT MAINTENANCE**

<u>Subject</u>	<u>Page</u>
Preparation for Storage or Shipment	2-6
Preventive Maintenance Checks and Services (PMCS)	2-2
Repair Parts, Special Tools; Test, Measurement, and Diagnostic Equipment (TMDE); and Support Equipment.....	2-1
Service Upon Receipt	2-2
Unit Maintenance	2-4
Unit Troubleshooting	2-4

Section I. REPAIR PARTS, SPECIAL TOOLS; TEST, MEASUREMENT, AND
DIAGNOSTIC EQUIPMENT (TMDE); AND SUPPORT EQUIPMENT

2-1. COMMON TOOLS AND EQUIPMENT

- a. Army. For authorized common tools and equipment, refer to the Modified Table of Organization and Equipment (MTOE) applicable to your unit.
- b. Navy. Navy personnel refer to applicable Tables of Allowance (TA).
- c. Air Force. Air Force personnel refer to applicable Tables of Allowance (TA).

2-2. SPECIAL TOOLS, TMDE, AND SUPPORT EQUIPMENT

Special tools, TMDE, and support equipment and their purposes are listed in the Maintenance Allocation Chart, Appendix B.

2-3. REPAIR PARTS

Repair parts used during Unit maintenance are listed and illustrated in the repair parts and special tools list located in TM 11-5895-1305-24P (Army), EE020-HJ-MMI-010/W110-TN612G (Navy), and TO 31R2-4-572-2 (Air Force).

Section II. SERVICE UPON RECEIPT

2-4. UNPACKING

There are no special procedures for unpacking the Pre/Post Selector. Avoid damaging the container during the unpacking operation; return the empty container to established supply channels or return an unserviceable Pre/Post Selector in it. Use normal care in handling electronic equipment. Prevent damage to exterior controls and indicators. Avoid jarring the unit during removal.

2-5. CHECKING UNPACKED EQUIPMENT

a. Inspect the equipment for damage incurred during shipment. If the equipment has been damaged, report the damage on SF-364, Report of Discrepancy (ROD).

b. Check the equipment against the packing slip to see if the shipment is complete. Report all discrepancies in accordance with the instructions of DA Pam 738-750.

c. Refer to DA Pam 25-30 to see if your equipment has had any Modification Work Orders (MWO) applied.

2-6. PRELIMINARY SERVICING AND ADJUSTMENT OF EQUIPMENT

- Check all front panel connectors for broken, bent or missing pins.
- Check all front panel mounted switches, lamps or other hardware for damage.

Section III. PREVENTIVE MAINTENANCE CHECKS AND SERVICES (PMCS)

2-7. GENERAL

Preventive maintenance procedures help maintain the equipment in a serviceable condition. They include items to be checked and procedures for checking them. The checks and services described in the PMCS table outline inspections that are to be made at specific monthly (M) and quarterly (Q) intervals.

a. Routine Checks. The following items are not listed in the PMCS table. Defects that can be found by these checks should be reported and corrected when found.

- Cleaning and dusting.
- Checking for frayed or loose cables.
- Covering unused receptacles.
- Checking for loose nuts, bolts, and screws.

2-7. GENERAL (Cont.)

b. Explanation of Columns.

- (1) Item Number Column. This column is used as a source of item numbers for the TM Number Column on DA Form 2404, Equipment Inspection and Maintenance Worksheet, in recording results of PMCS.
- (2) Interval column. This column specifies the frequency of the check, M for Monthly checks and Q for Quarterly checks.
- (3) Item to be inspected column. This column specifies the item to be checked.
- (4) Procedures Column. This column describes the procedure by which the check is to be performed.

c Instructions for Reporting and Correcting Deficiencies. If your equipment does not perform as required, refer to the trouble- shooting procedures within this chapter. Report any malfunctions or failures on proper DA Form 2404, or refer to DA Pam 738-750.

NOTE

If your equipment must be in operation all the time, only do items that can be checked and serviced without disturbing operation. Make the complete checks and services when the equipment can be shut down.

2-8.UNIT PMCS TABLE

PREVENTIVE MAINTENANCE CHECKS AND SERVICES

Item No.	Interval		Item To Be Inspected	Procedures
	M	Q		
1	•		End item equipments	Inspect for completeness
2	•		Communications equipment performance	Initiate terminal off-line BIT by applying power to TN-612/G. If BIT fails, refer to troubleshooting procedures in Section IV, Chapter 2

Section IV. UNIT TROUBLESHOOTING

2-9. GENERAL

Troubleshooting at the Unit level is limited to observing both system off-line indications and system error messages and BIT to check the operation of the Pre/Post Selector. Its operational checkout is performed while the unit is installed in the system. Refer to TM 11-5895-1218-12 or TM 11-5895-1219-12 (Army), EE150-LQ-OMI-010/WIIO-TRC179VI or EE150-LR-OMI-010/WIIO-TRC179V2 (Navy), or TO 31R2-2TRC179-21 or TO 31R2-2TRC179-1 (Air Force) for that checkout in the system. If equipment failure is indicated, proceed to Unit Maintenance below.

Section V. UNIT MAINTENANCE

2-10. GENERAL

Unit Maintenance is limited to replacing the front panel lamp and the Pre/Post Selector if the BIT testing with the unit installed in the system indicates a failure.

2-11. REMOVAL OR REPLACEMENT OF PRE/POST SELECTOR

Refer to TM 11-5895-1218-12 or TM 11-5895-1219-12 (Army), EE150-LQ-OMI-010/WIIO-TRC179VI or EE150-LR-OMI-010/WIIO-TRC179V2 (Navy), or TO 31R2-2TRC179-21 or TO 31R2-2TRC179-1 (Air Force) for removal and replacement procedures for the Pre/Post Selector when installed in the terminal.

2-12. REPLACEMENT OF PRIMARY POWER (PRIM PWR) LAMP

INITIAL SETUP

<u>Test Equipment</u>	<u>Equipment Conditions</u>
None	Pre/Post Selector input power cable disconnected from PRIM PWR connector.
<u>Tools</u>	<u>Material/Parts</u>
None	Lamp, A2AIDS1, P/N MS3338-6839

WARNING

HIGH VOLTAGE is used in the operation of this equipment. DEATH ON CONTACT may result if personnel fail to observe safety precautions. Learn the areas containing high voltage in this piece of equipment. Be careful not to contact high-voltage connections when testing this equipment.

REMOVE PRIM PWR LAMP

- STEP 1. Unscrew the PRIM PWR lamp cap
- STEP 2. Remove lamp from lamp cap.

REPLACE PRIM PWR LAMP

- STEP 1. Install new lamp in lamp cap.
- STEP 2. Reinstall PRIM PWR lamp cap
- STEP 3. Reconnect input power cable to PRIM PWR connector.

2-12. REPLACEMENT OF PRIM PWR LAMP (Cont.)

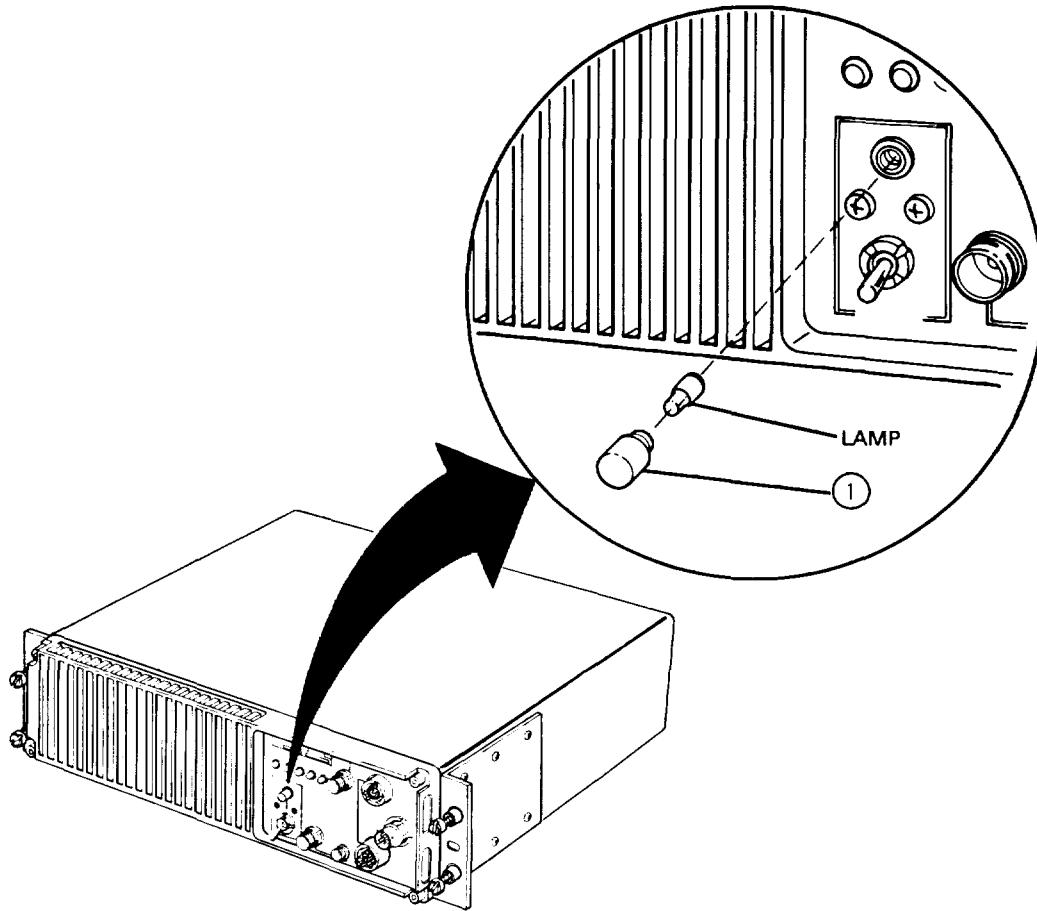

Section VI. PREPARATION FOR STORAGE OR SHIPMENT

2-13. GENERAL

- a. Army. Refer to paragraph 1-6a for administrative storage.
- b. Navy. Refer to NAVSUP PUB 503.
- c. Air Force. Refer to AFM 66-267 (storage) and AFR 67-31 (shipment)

2-14. MARKING

The marking on the exterior of the container shall be in accordance with MIL-STD-129H.

**CHAPTER 3
INTERMEDIATE DIRECT SUPPORT AND
GENERAL SUPPORT MAINTENANCE**

NOTE

Intermediate Direct Support is not allocated for the
Pre/Post Selector.

<u>Subject</u>	<u>Page</u>
Intermediate General Support Maintenance	3-55
Intermediate General Support Troubleshooting	3-2
Repair Parts, Special Tools, Test, Measurement, and Diagnostic Equipment (TMDE); and Support Equipment.....	3-1

Section I. REPAIR PARTS, SPECIAL TOOLS; TEST, MEASUREMENT,
AND DIAGNOSTIC EQUIPMENT (TMDE); AND SUPPORT EQUIPMENT

3-1. COMMON TOOLS AND EQUIPMENT

- a. Army. For authorized common tools and equipment, refer to the Modified Table of Organization and Equipment (MTOE) applicable to your unit.
- b. Navy. Navy personnel refer to applicable Table of Allowances (TA).
- c. Air Force. Air Force personnel refer to applicable Table of Allowances (TA).

3-2. SPECIAL TOOLS, TMDE, AND SUPPORT EQUIPMENT

Special tools, TMDE, and support equipment and their purposes are listed in the Maintenance Allocation Chart (MAC), Appendix B.

3-3. REPAIR PARTS

Repair Parts used during intermediate general support maintenance are listed and illustrated in TM 11-5895-1305-24P (Army), EE020-HJ-MMI-010/W110-TN612G (Navy), and TO 31R2-4-572-2 (Air Force).

Section II. INTERMEDIATE GENERAL SUPPORT TROUBLESHOOTING

3-4. GENERAL

a. The following troubleshooting procedures will help technicians at the intermediate general support maintenance level to isolate a fault to the defective module and to related power supply components mounted on the chassis.

b. Test Set TS-4247/G. This test fixture, shown below, provides the necessary power control commands, and panel lamp status indicators when testing the TN-612/G. The test fixture includes cables W3, W17, and W18. For complete operating and maintenance instructions refer to TM 11-6625-3220-14&P.

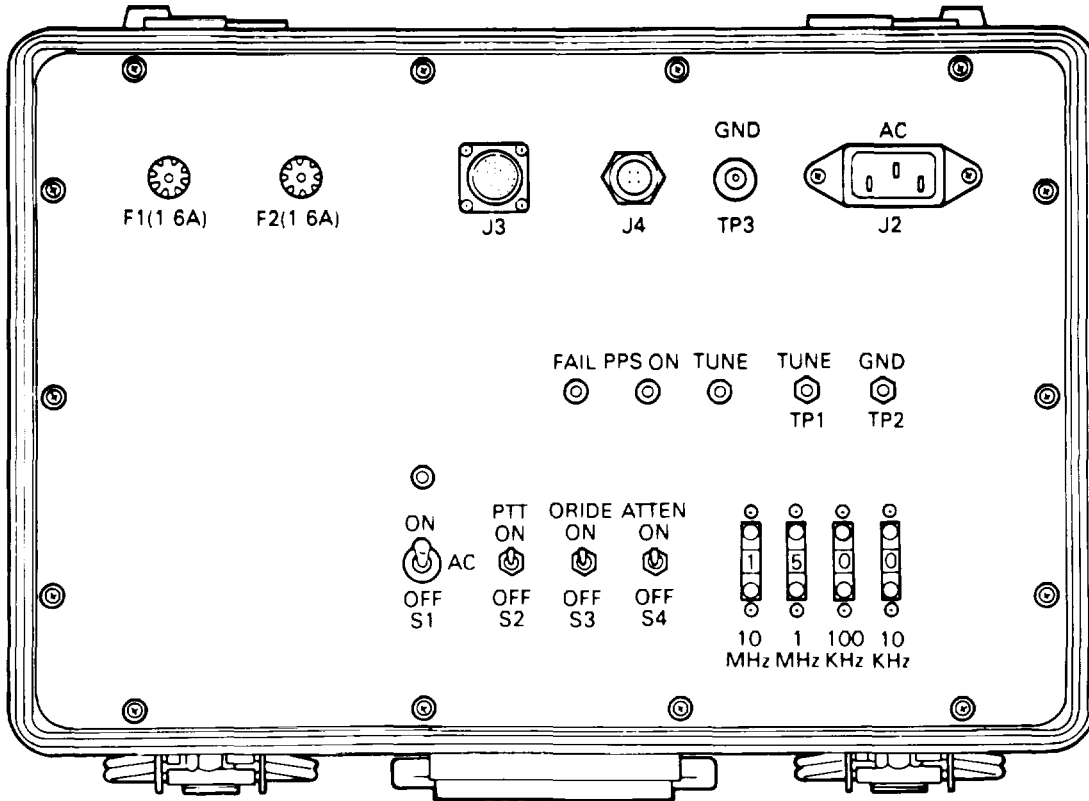

TEST SET, PRE-POST SELECTOR TS-4247/G (FRONT PANEL)
(Commonly referred to as Test Fixture)

3-5. OPERATIONAL CHECK OF PRE/POST SELECTOR

a. Built-in-Test (BIT)

INITIAL SETUP

Test Equipment	Equipment Condition
Test Set, Pre-Post Selector TS-4247/G	Pre/Post Selector connected to test fixture, as shown. PPS PRIM PWR switch off. Test fixture switches S1 to S4 set to OFF.

WARNING

HIGH VOLTAGE is used in the operation of this equipment. DEATH ON CONTACT may result if personnel fail to observe safety precautions. Learn the areas containing high voltage in this piece of equipment. Be careful not to contact high-voltage connections when performing tests.

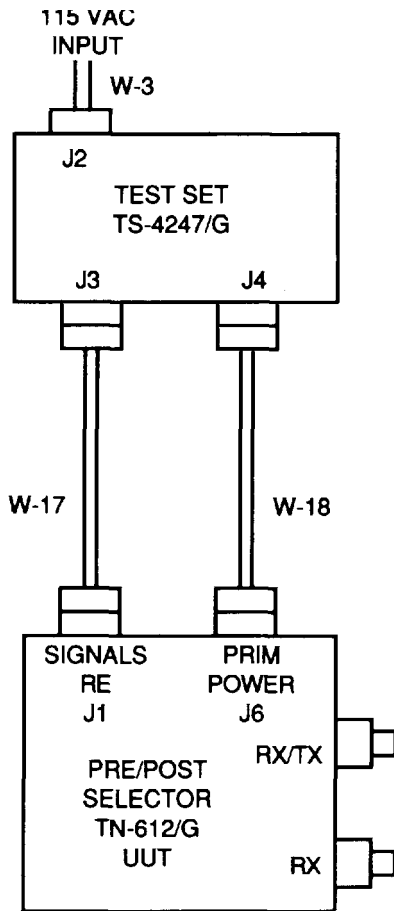

3-5. OPERATIONAL CHECK OF PRE/POST SELECTOR

a. Built-in-Test (BIT)

INITIAL SETUP

Test Equipment	Equipment Condition
Test Set, Pre-Post Selector TS-4247/G	Pre/Post Selector connected to test fixture, as shown. PPS PRIM PWR switch off. Test fixture switches S1 to S4 set to OFF.

WARNING

HIGH VOLTAGE is used in the operation of this equipment. DEATH ON CONTACT may result if personnel fail to observe safety precautions. Learn the areas containing high voltage in this piece of equipment. Be careful not to contact high-voltage connections when performing tests.

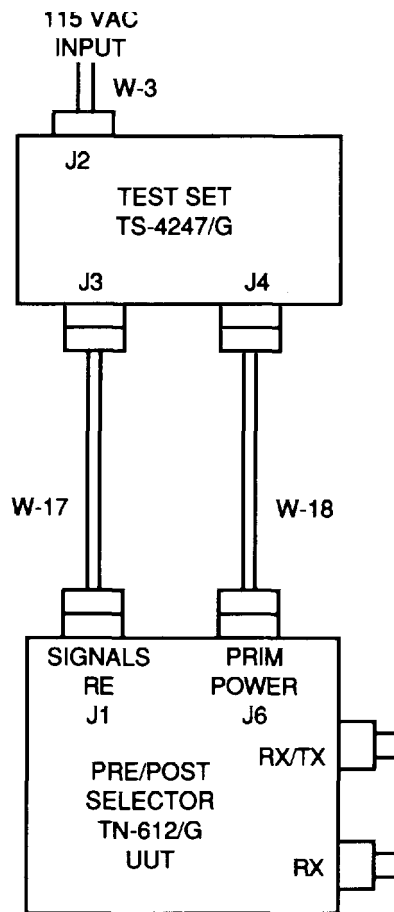

3-5. OPERATIONAL CHECK OF PRE/POST SELECTOR (Cont.)

a. Built-in-Test (BIT) (Cont.)

- STEP 1. Connect power cable W-3 to test fixture J2.
- STEP 2. Connect W-17 between PPS J1 (SIGNALS RE) and test fixture J3.
- STEP 3. Connect W-18 between PPS J6 (PRIM PWR) and test fixture J4.
- STEP 4. Connect other end of power cable to 115 Vac outlet.
- STEP 5. Set test fixture ac power switch (S1) to ON.
- STEP 6. Select 10.55 MHz on test fixture.
- STEP 7. Set PPS PRIM PWR switch to ON. Off-line BIT is initiated when power is applied. If the PPS fails to power up, the BITE LED lights, or the PPS PRIM PWR lamp is ON, even when PRIM PWR switch is OFF, refer to Symptom Index, para. 3-7.
- STEP 8. Switch test fixture override switch (S3) to ORIDE ON. The OVDE LED (green) should light. If LED does not light, refer to Symptom Index, para 3-7.
- STEP 9. Select frequency 15.25 MHz on the test set. With the ORIDE switch (S3) in ORIDE ON position, the TUNE LED (yellow) should not light on the PPS front panel.
- STEP 10. Switch test fixture S3 to OFF. Select 1.99 MHz on test fixture. The BITE LED (red) should light, the TUNE and OVL may also light.
- STEP 11. Set PPS PRIM POWER switch to off.
- STEP 12. Set test fixture power switch (S1) to OFF.
- STEP 13. Remove test cables W-17 and W-18 from the PPS.

3-5. OPERATIONAL CHECK OF PRE/POST SELECTOR (Cont.)

b. Power Supply Assembly

INITIAL SETUP

Test Equipment

Test Set, Pre-Post Selector
TS-4247/G
Digital Multimeter, AN/USM-486

Tools

Tool Kit, TK-17
Workstation, Static

Equipment Condition

PPS chassis extended or removed
from case (para. 3-6).
PPS connected to test fixture, as
shown.
BIT procedure in para 3-5a
complete.
All Power switches off.

WARNING

HIGH VOLTAGE is used in the operation of this equipment. DEATH ON CONTACT may result if personnel fail to observe safety precautions. Learn the areas containing high voltage in this piece of equipment. Be careful not to contact high-voltage connections when performing tests.

CAUTION

This equipment contains components that are sensitive to damage by electrostatic discharge (ESD). Improper handling will result in component and assembly failure. Use extreme care when handling. Refer to DOD-HDBK-263 for proper handling procedures.

- STEP 1. Connect power cable W-3 to test fixture J2.
- STEP 2. Connect W-17 between PPS J1 (SIGNALS RE) and test fixture J3.
- STEP 3. Connect W-18 between PPS J6 (PRIM PWR) and test fixture J4.
- STEP 4. Connect other end of power cable to 115 Vac outlet.
- STEP 5. Set test fixture power switch (S1) to ON.
- STEP 6. Turn PPS PRIM PWR switch to ON.

3-5. OPERATIONAL CHECK OF PRE/POST SELECTOR (Cont.)

b. Power Supply Assembly (Cont.)

STEP 7. Connect DMM common lead to TP2 on test set. Connect DMM to proper test points on the PPS Power Supply to measure the following voltages under test conditions. Any incorrect or missing voltage indicates a fault in the module. Refer to para. 3-26 for module replacement. If module replacement does not correct fault, the PPS chassis is defective and must be repaired.

- TP 1 : +4.75 to +5.25 Vdc
- TP 2 : +17.1 to +18.9 Vdc
- TP 14: +26.6 to +29.4 Vdc

STEP 8. Set PPS PRIM PWR to OFF.

STEP 9. Set test fixture power switch S1 to off.

STEP 10. Disconnect all cables.

STEP 11. If power supply replacement does not repair the problem, the PPS chassis is defective.

NOTE

The PPS must be put back together and tested after each corrective action has been completed.

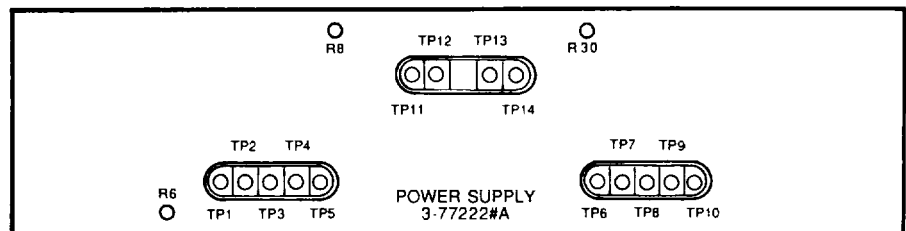
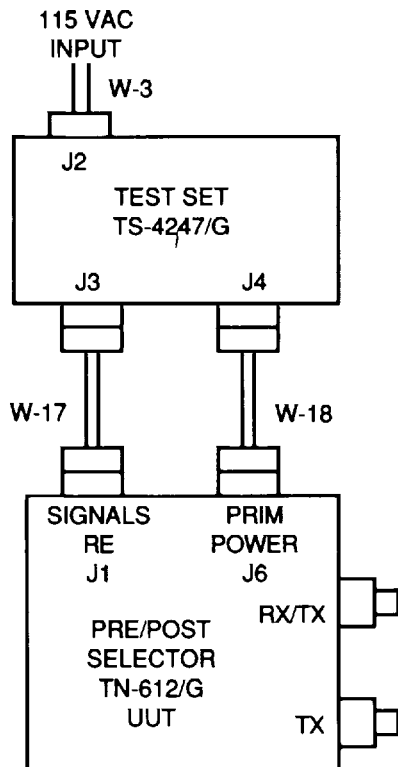

**POWER SUPPLY MODULE
TEST POINTS**

3-5. OPERATIONAL CHECK OF PRE/POST SELECTOR (Cont.)

c. Measurement of Overall Gain

INITIAL SETUP

Test Equipment

Equipment Condition

Test Set, Pre-Post Selector
 TS-4247/G
 Power Amplifier, AM-7353/G
 Attenuator, Bird 8323
 Attenuator, Bird 8322
 Power Meter, AN/USM-491
 Signal Generator, SG-1170/U
 Adapter, Pomona Type 3844A, (2 each)
 Adapter, UG-201A/U, (4 each)
 Adapter, UG-1034/U
 Test Cable, RG-58, BNC-to-BNC (5 each)

Refer to Initial Test Setup
 Allow 15 minute warmup time.

WARNING

HIGH VOLTAGE is used in the operation of this equipment. DEATH ON CONTACT may result if personnel fail to observe safety precautions. Learn the areas containing high voltage in this piece of equipment. Be careful not to contact high-voltage connections when performing tests.

CAUTION

This equipment contains components that are sensitive to damage by electrostatic discharge (ESD). Improper handling will result in component and assembly failure. Use extreme care when handling. Refer to DOD-HDBK-263 for proper handling procedures.

STEP 1. Set test fixture switches as follows:

PTT(S2) to OFF
 ORIDE (S3) to OFF
 ATTEN (S4) to OFF
 AC(S1) to OFF
 Frequency to 2.87 MHz.

3-5. OPERATIONAL CHECK OF PRE/POST SELECTOR (Cont.)

c. Measurement of Overall Gain (Cont.)

WARNING

Do not exceed 0 dBm output on signal generator or permanent damage to TN-612/G may result.

STEP 2. Connect equipment as shown in initial test setup illustration. Set equipment and UUT power to ON. Set AN/USM-491 to measure 17 dBm. Set SG-1170/U frequency to 2.87 MHz, output signal control to -10 dBm. Adjust vernier on SG-1170/U until a measurement of 17 dBm is obtained on the AN/USM-491.

NOTE

Do not change the SG-1170/G output setting in the following steps.

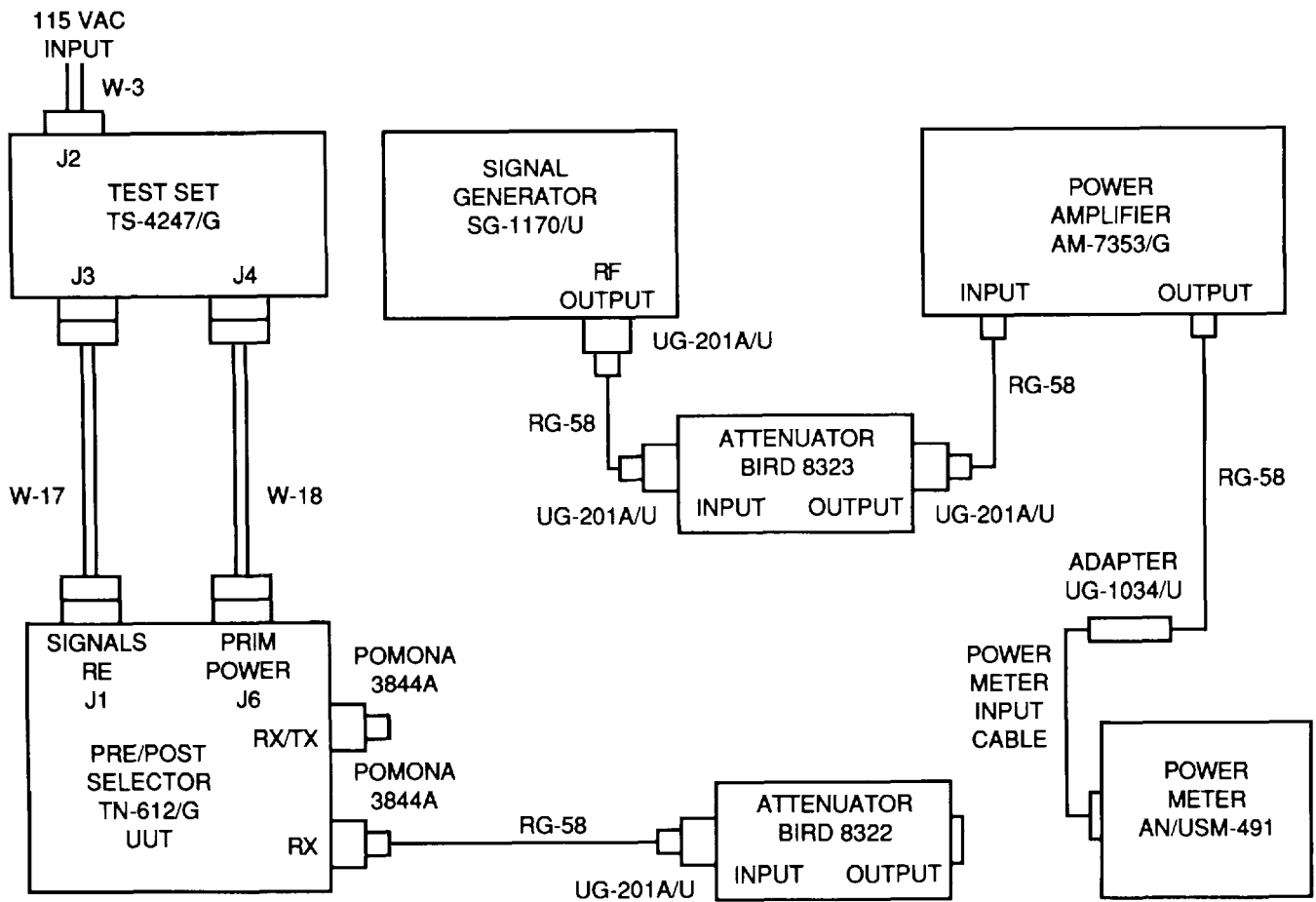

INITIAL TEST SETUP

3-5. OPERATIONAL CHECK OF PRE/POST SELECTOR (Cont.)

c. Measurement of Overall Gain (Cont.)

STEP 3. Set SG-1170 power to OFF. Connect equipment as shown in measurement test setup.

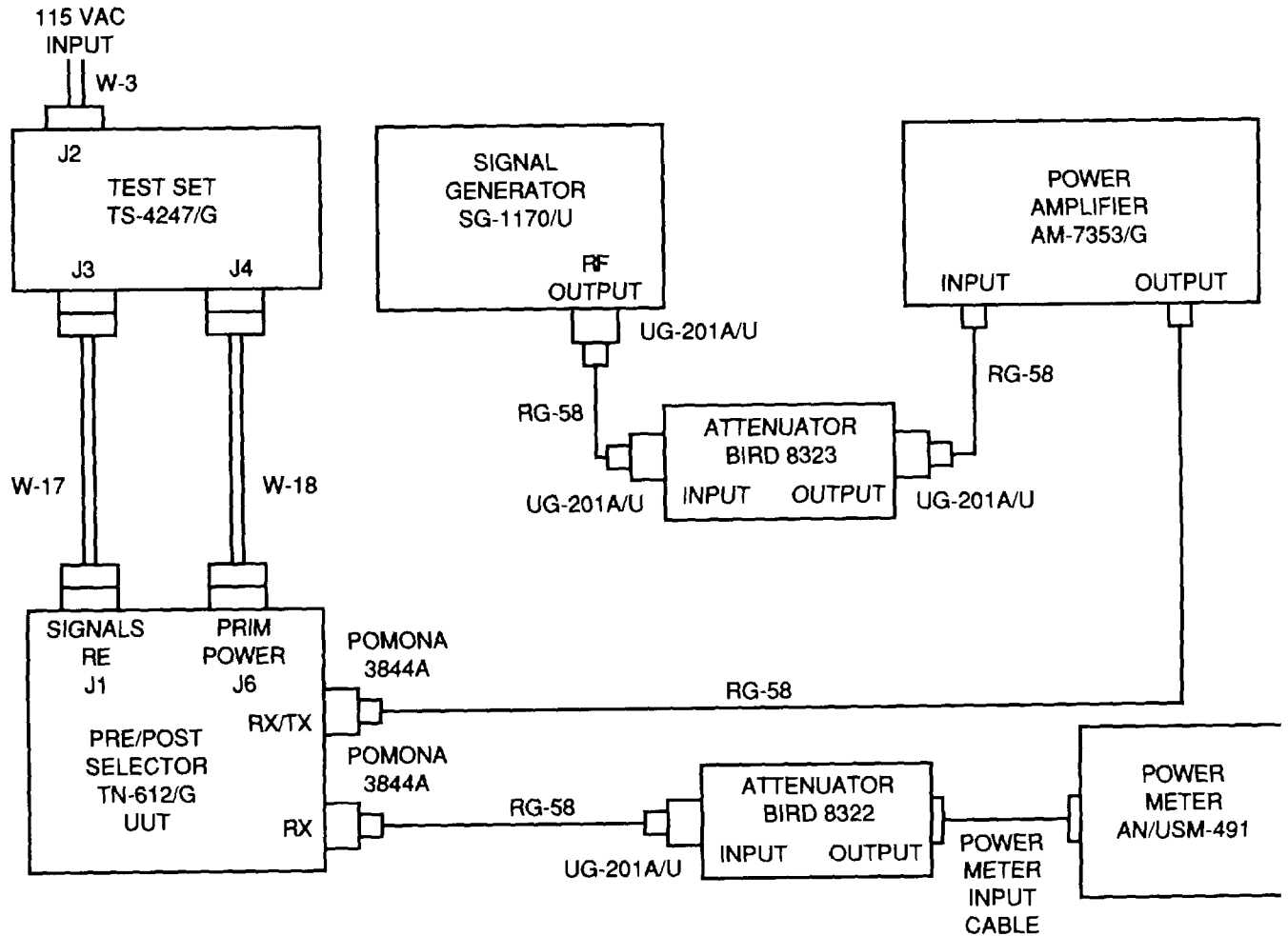

MEASUREMENT TEST SETUP

3-5. OPERATIONAL CHECK OF PRE/POST SELECTOR (Cont.)

c. Measurement of Overall Gain (Cont.)

STEP 4. Set SG-1170/U power to ON.

STEP 5. Set test fixture PTT switch (S2) to ON.

STEP 6. Power meter should indicate -3 dBm (-1.5 to -4.5 dBm) or, 0.50 mW (0.35 to 0.71 mW).

STEP 7. Set test fixture PTT switch S2 and SG-1170/U to OFF.

NOTE

Anytime a frequency change is made on the PPS test fixture, the tune LED on the PPS front panel should light. If it does not light, refer to Symptom Index, para. 3-7.

STEP 8. Repeat steps 2 through 7 above and substitute the following frequencies in steps 1 and 2: 5.62 MHz, 11.25 MHz, 22.50 MHz, and 29.99 MHz. If overall gain measurements are correct, go to para 3-5d. If measurements are incorrect, refer to para 3-7 for troubleshooting procedures.

3-5. OPERATIONAL CHECK OF PRE/POST SELECTOR (Cont.)

d. Measurement of Insertion Loss

INITIAL SETUP

Test Equipment

Equipment Condition

Test Set, Pre-Post Selector TS-4247/G
 Test Cable, RG-58, BNC-to-BNC,
 (2 each)
 Adapter, Pomona Type 3844A, (2 each)
 Tracking Generator, SG-1122/U
 Spectrum Analyzer, IP-1216(P)/GR
 Plug-in IF, PL-1388/U
 Plug-in RF, PL-1399/U

Refer to Initial Test Setup
 Allow 15 minute warmup time.

Tools

Workstation, Static

WARNING

HIGH VOLTAGE is used in the operation of this equipment. DEATH ON CONTACT may result if personnel fail to observe safety precautions. Learn the areas containing high voltage in this piece of equipment. Be careful not to contact high-voltage connections when performing tests.

CAUTION

This equipment contains components that are sensitive to damage by electrostatic discharge (ESD). Improper handling will result in component and assembly failure. Use extreme care when handling. Refer to DOD-HDBK-263 for proper handling procedures.

3-5. OPERATIONAL CHECK OF PRE/POST SELECTOR (Cont.)

d. Measurement of Insertion Loss (Cont.)

STEP 1. Set test fixture switches as follows:

- PTT(S2) to OFF
- ORIDE (S3) to OFF
- ATTEN (S4) to OFF
- AC(S1) to OFF
- Frequency to 2.87 MHz.

STEP 2. Turn power on at the test equipment, test fixture and UUT.

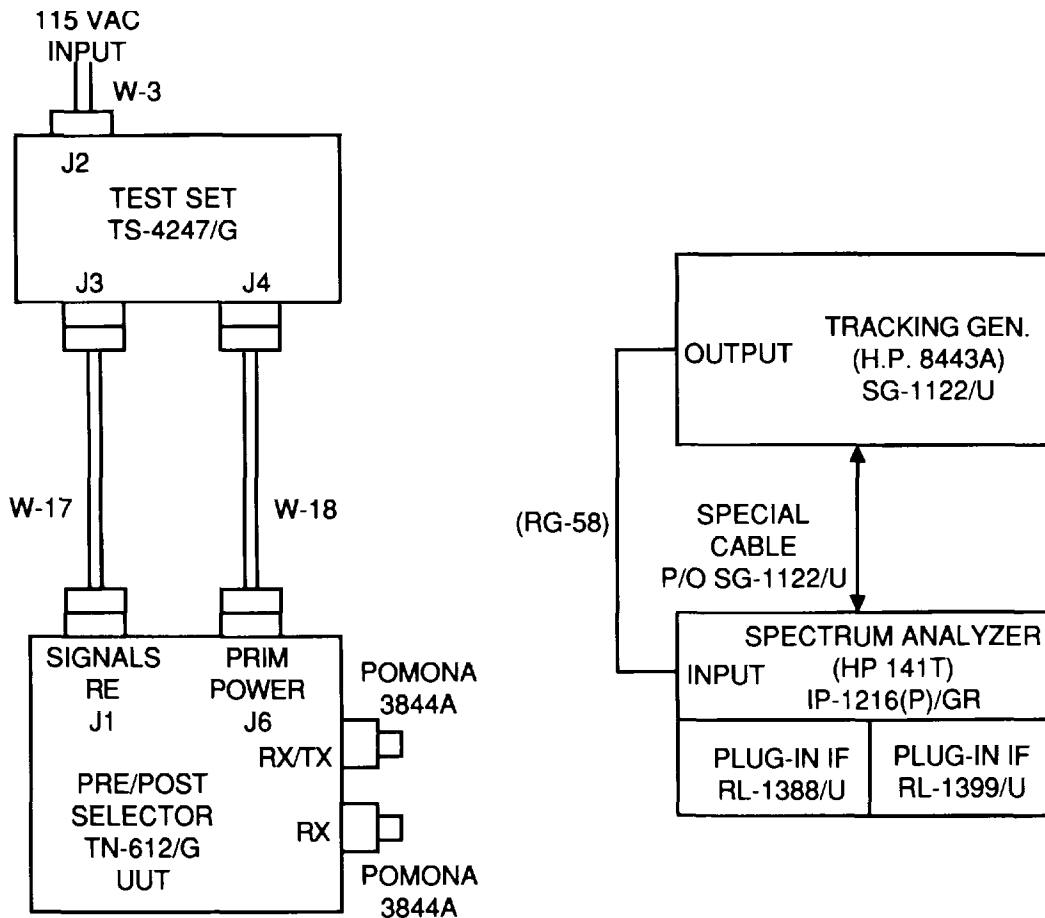

INITIAL REFERENCE TEST SETUP

STEP 3. Set spectrum analyzer and tracking generator as follows:

Tracking Generator:

- | | |
|----------------------|---|
| Mode: | Marker |
| Resolution: | 1 kHz |
| Marker Position: | 25 MHz (not critical, can be left for last setting) |
| Function: | Track Analyzer |
| RF Output Level dBm: | -15 dBm |

3-5. OPERATIONAL CHECK OF PRE/POST SELECTOR (Cont.)

d. Measurement of Insertion Loss (Cont.)

Spectrum Analyzer:

RF section
 Range MHz: 0-110
 Frequency: 15 MHz
 Bandwidth: 10 KHz
 Scan Width: 5 MHz (PER DIVISION)
 ZERO-PER DIVISION-
 0-100 MHz switch: (PER DIVISION)
 Input Attenuation: 0 Db

IF section

Base Line Clipper: fully ccw
 Scantime per Division: 0.1 seconds
 Video Filter: OFF
 Scan Mode: INT
 Scan Trigger: Auto
 Log Ref Level: -10 dBm
 Linear Sensitivity: 0 dBm
 10 dB LOG/2 dB LOG
 Linear Switch: 2 dB LOG position

DISPLAY section

Writing Speed: Engage the STANDARD button

(now the 25 MHz marker can easily be set)

STEP 4. Store the reference trace on the spectrum analyzer. This can be done by adjusting the PERSISTENCE control fully clockwise and adjusting the INTENSITY and FOCUS controls to obtain a suitably defined trace. The ERASE control may have to be used several times while adjusting the trace.

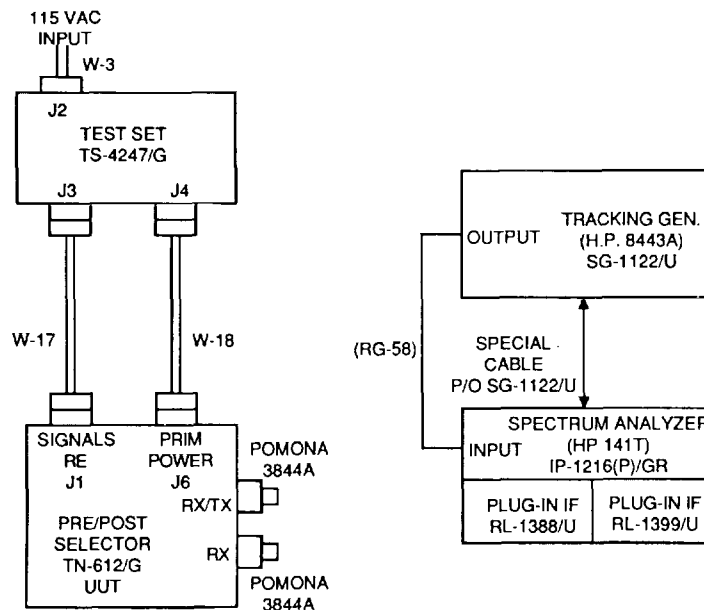

INITIAL REFERENCE TEST SETUP

3-5. OPERATIONAL CHECK OF PRE/POST SELECTOR (Cont.)

d. Measurement of Insertion Loss (Cont.)

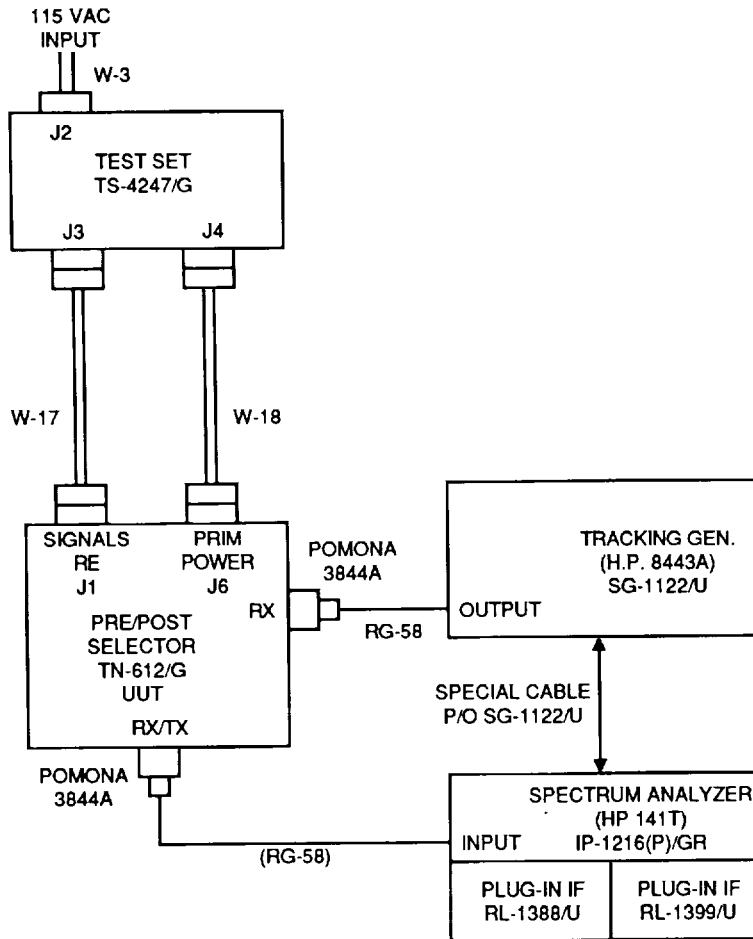

INSERTION LOSS TEST SETUP

- STEP 5. Connect the test equipment as shown in INSERTION LOSS TEST SETUP.
- STEP 6. Allow the spectrum analyzer to mark 2.87 MHz (the INTENSITY may have to be increased slightly) and change frequency of the test fixture to 5.62 MHz. Allowing the analyzer sufficient time (5 to 10 seconds) to mark the frequencies, change the test fixture frequency to 12.5 MHz, 17.5 MHz, 22.5 MHz, and 29.99 MHz.
- STEP 7. Compare the test frequency markers (amplitude peaks) to the reference level. All markers should be within 0 to +3 dB of the reference level (the display is 2.0 dB per division).
- STEP 8. If measurements do not fall within the specified limits, refer to the Symptom Index, para. 3-7.

3-5. OPERATIONAL CHECK OF PRE/POST SELECTOR (Cont.)

e. Measurement of Insertion Loss in Override Condition

INITIAL SETUP

Test Equipment

Test Set, Pre-Post Selector TS-4247/G
 Test Cable, RG-58, BNC-to-BNC, (2 each)
 Adapter, Pomona Type 3844A, (2 each)
 Tracking Generator, SG-1122/U
 Spectrum Analyzer, IP-1216(P)/GR
 Plug-in IF, PL-1388/U
 Plug-in RF, PL-1399/U

Equipment Condition

Refer to Initial Test Setup
 Allow 15 minute warmup time.

Tools

Workstation, Static

WARNING

HIGH VOLTAGE is used in the operation of this equipment. DEATH ON CONTACT may result if personnel fail to observe safety precautions. Learn the areas containing high voltage in this piece of equipment. Be careful not to contact high-voltage connections when performing tests.

CAUTION

This equipment contains components that are sensitive to damage by electrostatic discharge (ESD). Improper handling will result in component and assembly failure. Use extreme care when handling. Refer to DOD-HDBK-263 for proper handling procedures.

3-5. OPERATIONAL CHECK OF PRE/POST SELECTOR (Cont.)

e. Measurement of Insertion Loss in Override Condition (Cont.)

STEP 1. Set test fixture switches as follows:

- PTT(S2) to OFF
- ORIDE (S3) to ON
- ATTEN (S4) to OFF
- AC(SI) to OFF
- Frequency to 2.87 MHz.

STEP 2. Turn power on at the test equipment, test fixture and UUT.

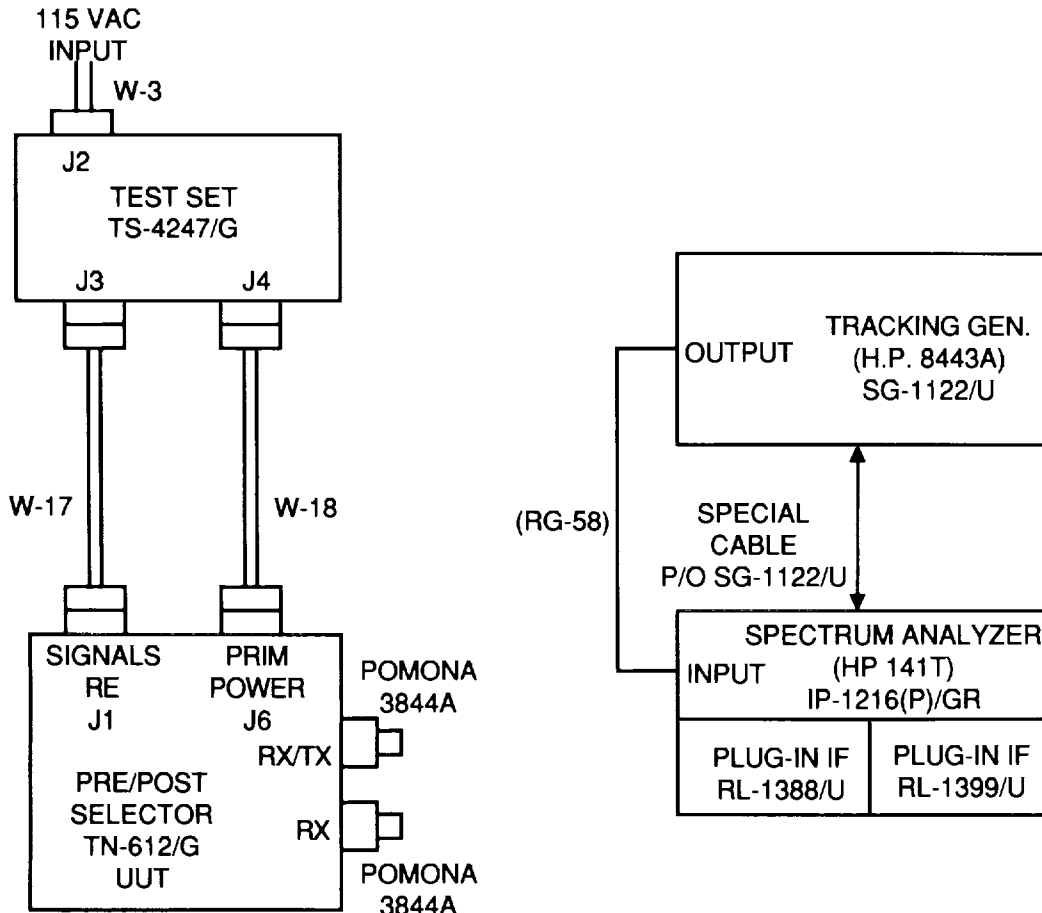

REFERENCE TEST SETUP

STEP 3. Set spectrum analyzer and tracking generator as follows:

Tracking Generator:

- | | |
|----------------------|---|
| Mode: | Marker |
| Resolution: | 1 kHz |
| Marker Position: | 25 MHz (not critical, can be left for last setting) |
| Function: | Track Analyzer |
| RF Output Level dBm: | -15 dBm |

3-5. OPERATIONAL CHECK OF PRE/POST SELECTOR (Cont.)

e. Measurement of Insertion Loss in Override Condition (Cont.)

Spectrum Analyzer:

RF section
 Range MHz: 0-110
 Frequency: 15 MHz
 Bandwidth: 10 KHz
 Scan Width: 5 MHz (PER DIVISION)
 ZERO-PER DIVISION-
 0-100 MHz switch: (PER DIVISION)
 Input Attenuation: 0 dB

IF section

Base Line Clipper: fully ccw
 Scantime per Division: 0.1 seconds
 Video Filter: OFF
 Scan Mode: INT
 Scan Trigger: Auto
 Log Ref Level: -10 dBm
 Linear Sensitivity: 0 dBm
 10 dB LOG/2 dB LOG
 Linear Switch: 2 dB LOG position

DISPLAY section

Writing Speed: Engage the STANDARD button

(now the 25 MHz marker can easily be set)

STEP 4. Store the reference trace on the spectrum analyzer. This can be done by adjusting the PERSISTENCE control fully clockwise and adjusting the INTENSITY and FOCUS controls to obtain a suitably defined trace. The ERASE control may have to be used several times while adjusting the trace.

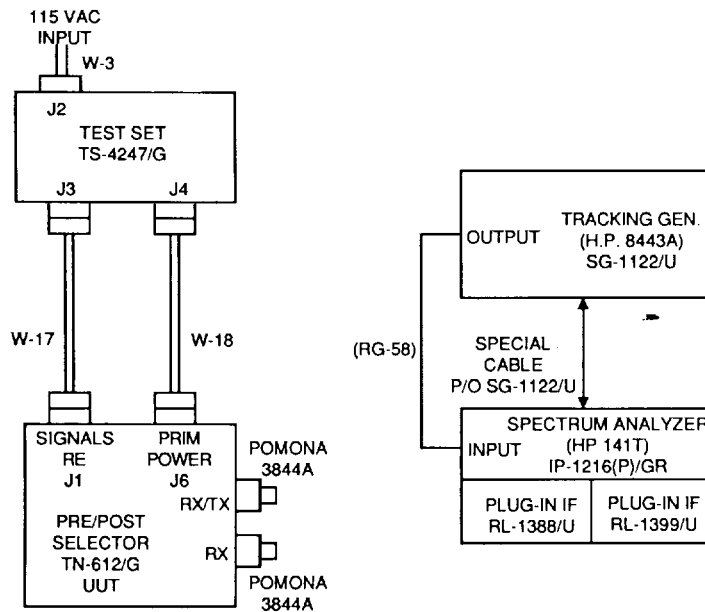

3-5. OPERATIONAL CHECK OF PRE/POST SELECTOR (Cont.)

e. Measurement of Insertion Loss in Override Condition (Cont.)

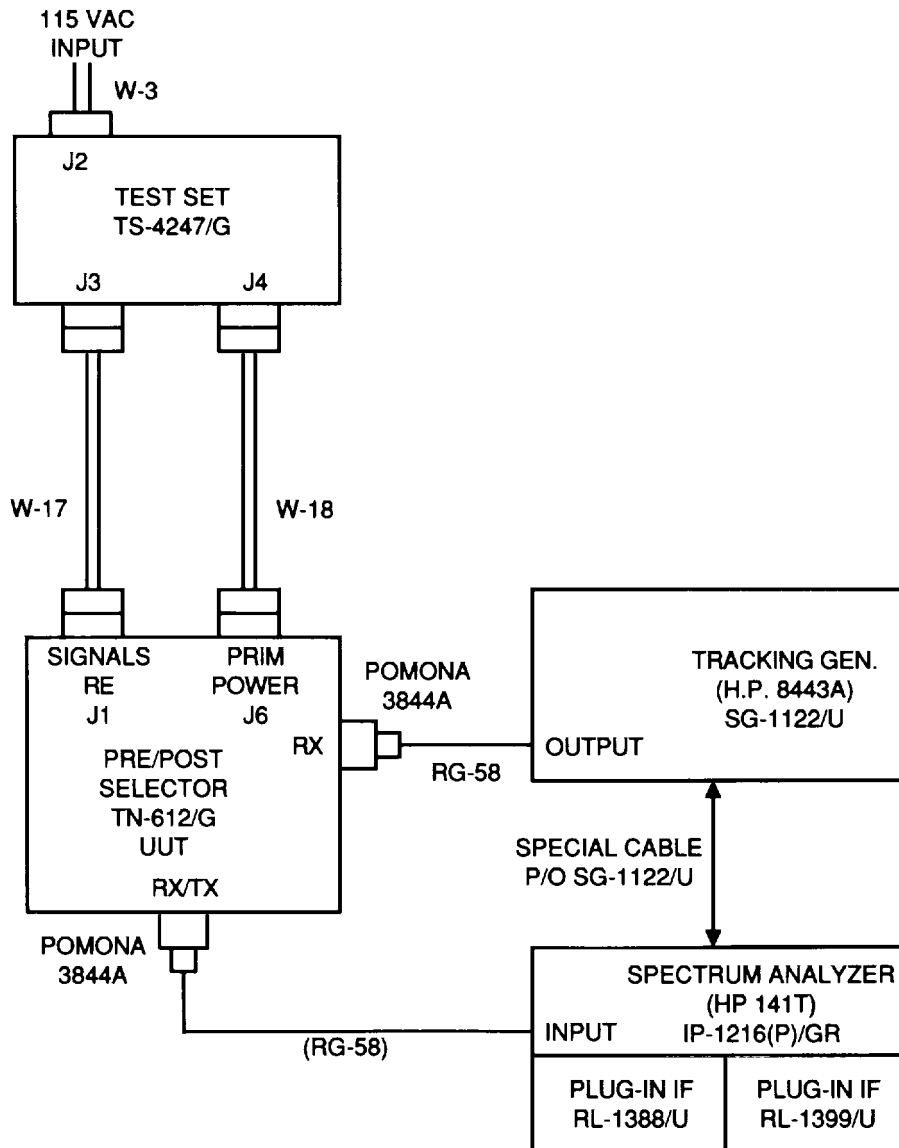

INSERTION LOSS IN OVERRIDE CONDITION TEST SETUP

STEP 5. Connect the test set-up as shown in INSERTION LOSS IN OVERRIDE CONDITION TEST SETUP. Compare the reference level with the insertion loss level. The insertion loss trace should be within -0.5 to -2.5 dB of the reference level. NOTE: The spectrum analyzer was set up to display 2.0 Db per division.

STEP 6. If the measurement does not fall within the specified limits, refer to the Symptom Index, para 3-7. If the measurement is within specified limits, operational check is completed.

3-6. EXTENDING CHASSIS FOR TROUBLESHOOTING PROCEDURES

INITIAL SET-UP

Tools

Tool Kit, TK-17

Equipment Condition

Power OFF.
All cables disconnected from PPS front panel.

Perform the following preliminary step-by-step procedures to remove/install PPS Chassis, perform PPS (BIT), and interconnect the PPS Power Supply Assembly to the Power Supply Test Fixture. Fault-isolate Pre/Post Selector to faulty LRUs by performing the overload check, tuning filter attenuation check, and RF attenuator check.

Extend Chassis:

- STEP 1. Use a 5mm hexagonal wrench to remove the 4 front panel mounting screws .
- STEP 2. Slide front panel and chassis out of case until slide rail locks lock.

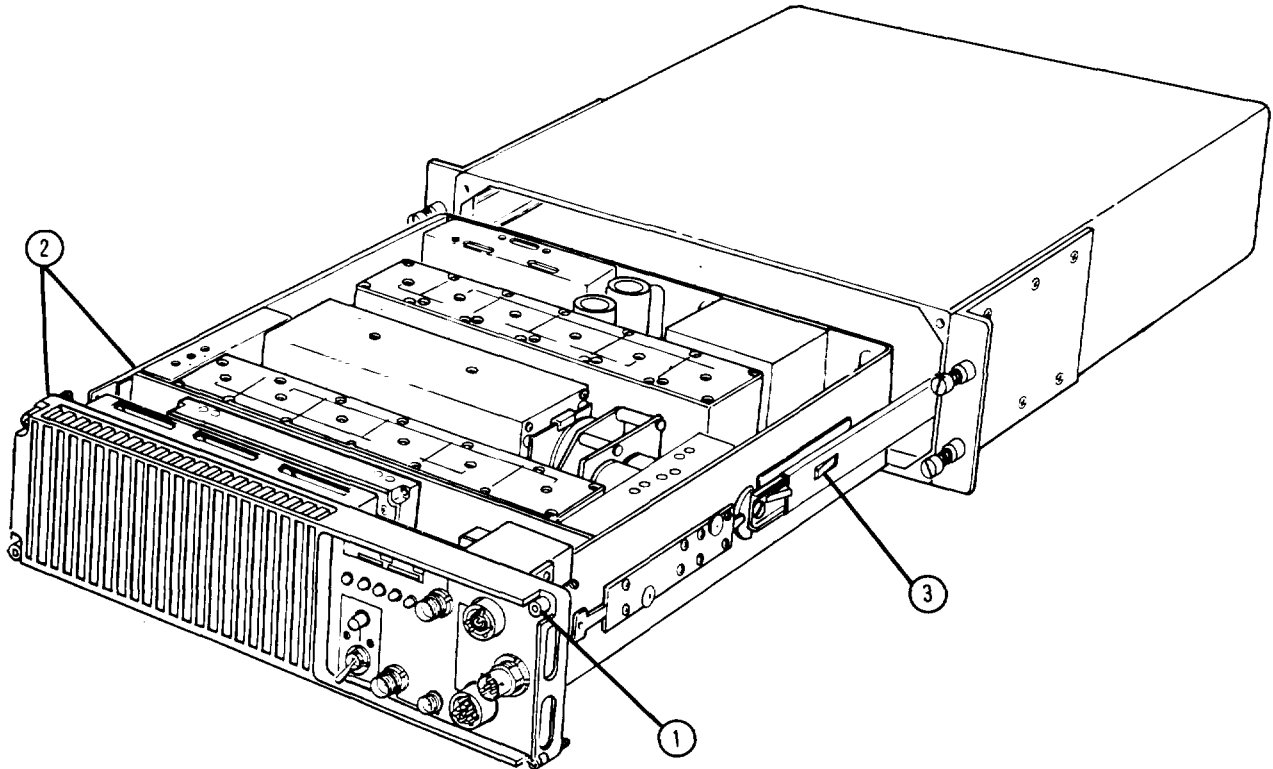

3-6. EXTENDING CHASSIS FOR TROUBLESHOOTING PROCEDURES (Cont.)

Secure Chassis:

STEP 1. Depress slide rail locks , and push front panel and chassis into PPS case.

STEP 2. Install, and use a 5mm hexagonal wrench to tighten, the 4 front panel mounting screws .

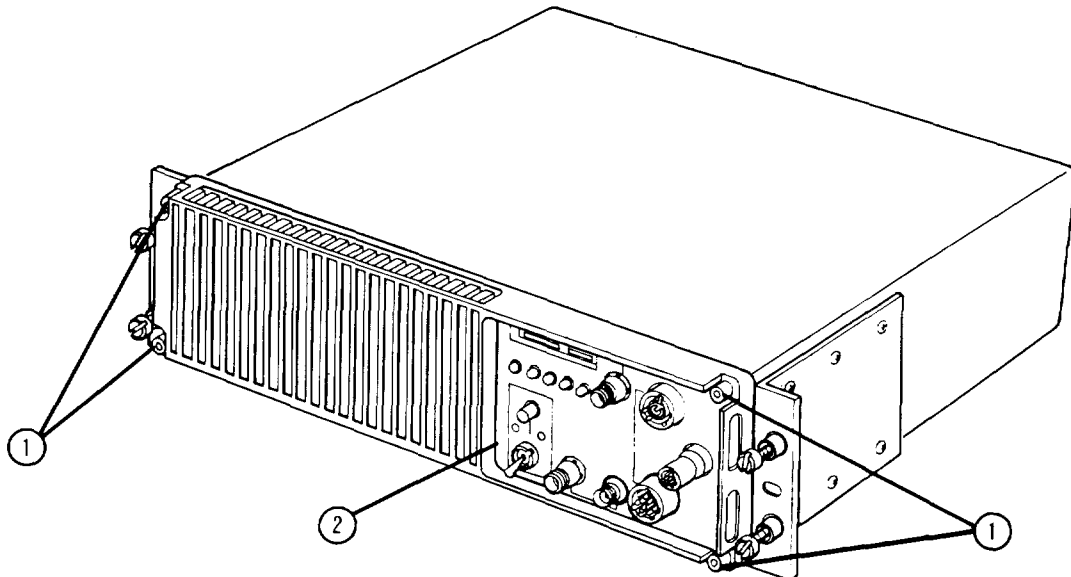
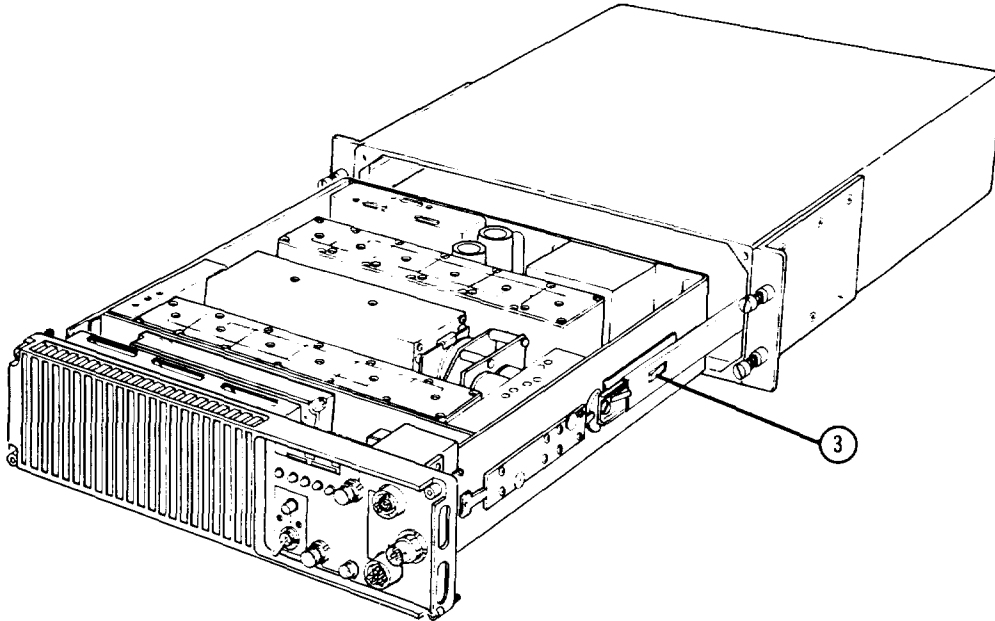

3-7. SYMPTOM INDEX

SYMPTOM	PARAGRAPH
With power cable connected to primary power, PRIM PWR lamp is always on; does not depend on switch position	3-9
Circuit breaker closes but PRIM PWR lamp remains off	3-10
PRIM PWR circuit breaker trips when PRIM PWR switch is set to ON; Pre/Post Selector is inoperative, whether PRIM PWR circuit breaker is ON or OFF	3-11
Overload (OVL) lamp is always on; BIT, TUNE, ATT lamps off	3-12
Override (OVDE) lamp always on	3-13
Attenuator (ATT) lamp always on	3-14
BITE lamp on	3-15
Override (OVDE) lamp does not light when the test fixture OVDE switch is set to ON	3-16
TUNE lamp does not light when frequency is changed	3-17
TUNE lamp lights when a frequency change is made in override condition	3-18
Insertion loss in Rx condition too high	3-19
Insertion loss in Rx override condition too high.....	3-20
Overall gain too low in Tx condition	3-21
BITE lamp does not light when an out-of-range frequency is selected.....	3-22

3-8. FLOW CHARTS AND HOW TO USE THEM

Flow charts make troubleshooting easier and give maintenance personnel a clear path to follow.

To use the flow chart, begin at START symbol and follow the path indicated by the arrow. Perform the task given in the symbol block and then follow the arrow to the next block. At the decision symbol be sure to follow the correct path indicated by YES or NO.

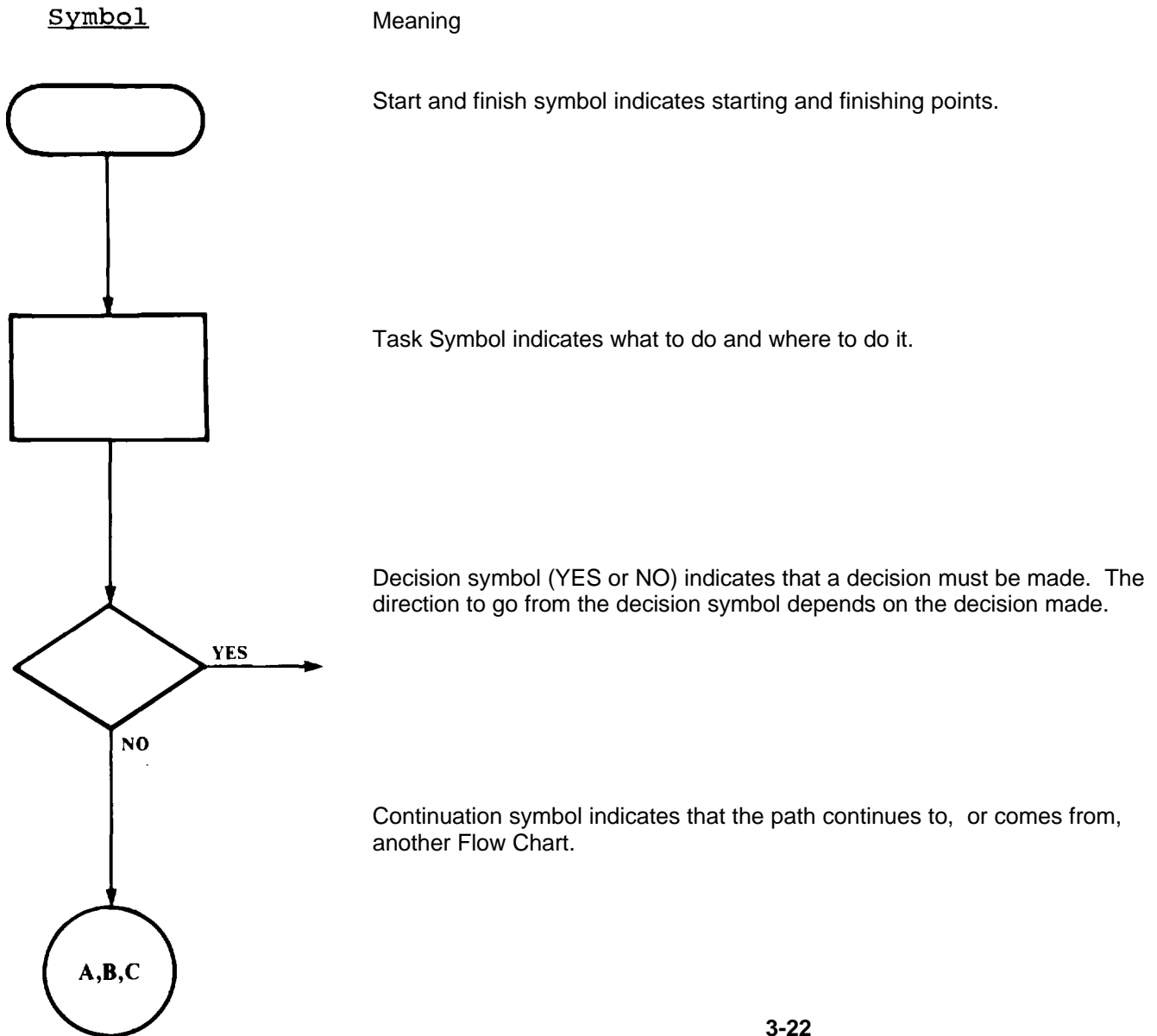

3-22

3-9. WITH POWER CABLE CONNECTED TO PRIMARY POWER, PRIM PWR LAMP IS ALWAYS ON; DOES NOT DEPEND ON SWITCH POSITION

INITIAL SETUP

Test Equipment

Equipment Condition

Test Set, TS-4247/G

Pre/Post Selector connected to

test fixture, as shown below.
Test fixture power on.

Tools

Tool Kit TK-17
Workstation, Static

WARNING

HIGH VOLTAGE is used in the operation of this equipment. DEATH ON CONTACT may result if personnel fail to observe safety precautions. Learn the areas containing high voltage in this piece of equipment. Be careful not to contact high-voltage connections when performing tests.

CAUTION

This equipment contains components that are sensitive to damage by electrostatic discharge (ESD). Improper handling will result in component and assembly failure. Use extreme care when handling. Refer to DOD-HDBK-263 for proper handling procedures.

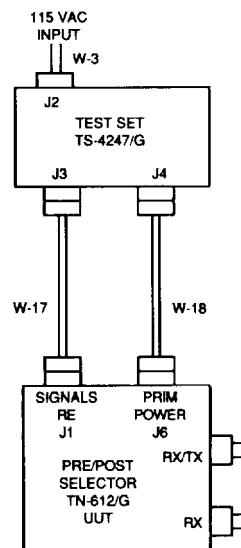

STEP 1. Defective circuit breaker, replace front panel, (para. 3-24).

STEP 2. Apply power and verify proper operation of circuit breaker.

3-10. PRIM PWR/CIRCUIT BREAKER ACTIVATES BUT PRIM PWR LAMP
REMAINS OFF

INITIAL SETUP

Test Equipment

Multimeter, Digital AN/USM-486
Test Set, TS-4247/G

Tools

Tool Kit, TK-17

Equipment Condition

Pre/Post Selector removed from
case (para 3-6).
Bottom cover removed (para 3-25).
Pre/Post Selector connected to
test fixture, as shown below.

WARNING

HIGH VOLTAGE is used in the operation of this equipment. DEATH ON CONTACT may result if personnel fail to observe safety precautions. Learn the areas containing high voltage in this piece of equipment. Be careful not to contact high-voltage connections when performing tests.

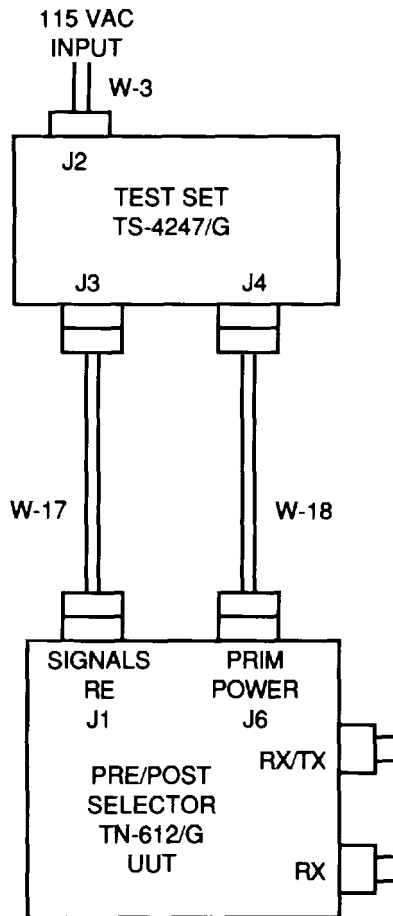

3-10. CIRCUIT BREAKER CLOSSES BUT PRIM PWR LAMP REMAINS OFF (Cont.)

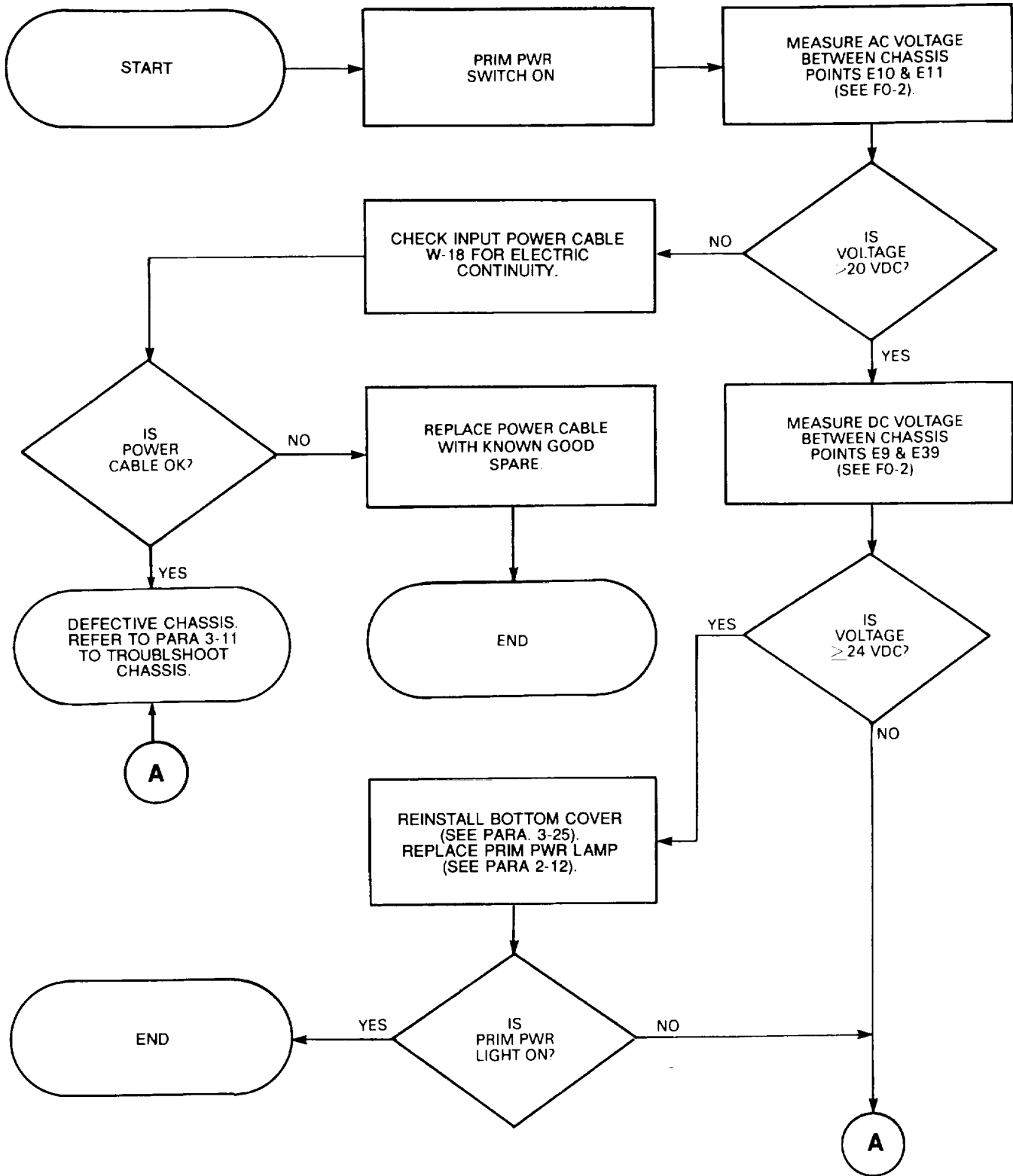

3-11. PRIM PWR CIRCUIT BREAKER TRIPS WHEN PRIM PWR SWITCH IS SET TO ON; PRE/POST SELECTOR IS INOPERATIVE, WHETHER PRIM PWR CIRCUIT BREAKER IS ON OR OFF.

INITIAL SETUP

Test Equipment

Test Set, TS-4247/G
 Digital Multimeter, AN/USM-486

Tools

Tool Kit, TK-17

Equipment Condition

Pre/Post Selector removed from case (para 3-6).
 Pre/Post Selector bottom cover removed (para 3-25).
 Pre/Post Selector connected to test fixture, as shown below.

WARNING

HIGH VOLTAGE is used in the operation of this equipment. DEATH ON CONTACT may result if personnel fail to observe safety precautions. Learn the areas containing high voltage in this piece of equipment. Be careful not to contact high-voltage connections when performing tests.

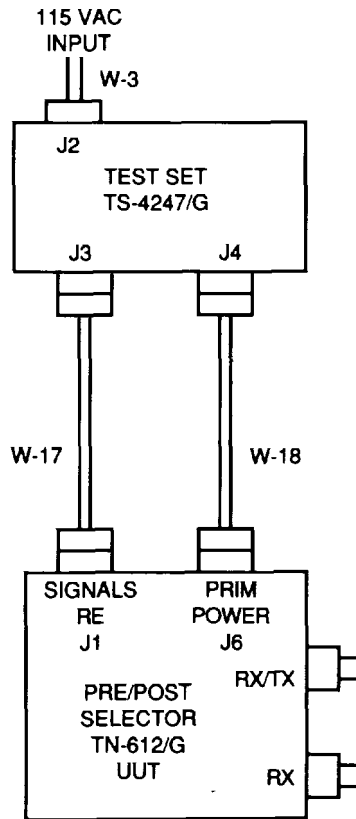

3-11. PRIM PWR CIRCUIT BREAKER TRIPS WHEN PRIM PWR SWITCH IS SET TO ON; PRE/POST SELECTOR IS INOPERATIVE, WHETHER PRIM PWR CIRCUIT BREAKER IS ON OR OFF (Cont.)

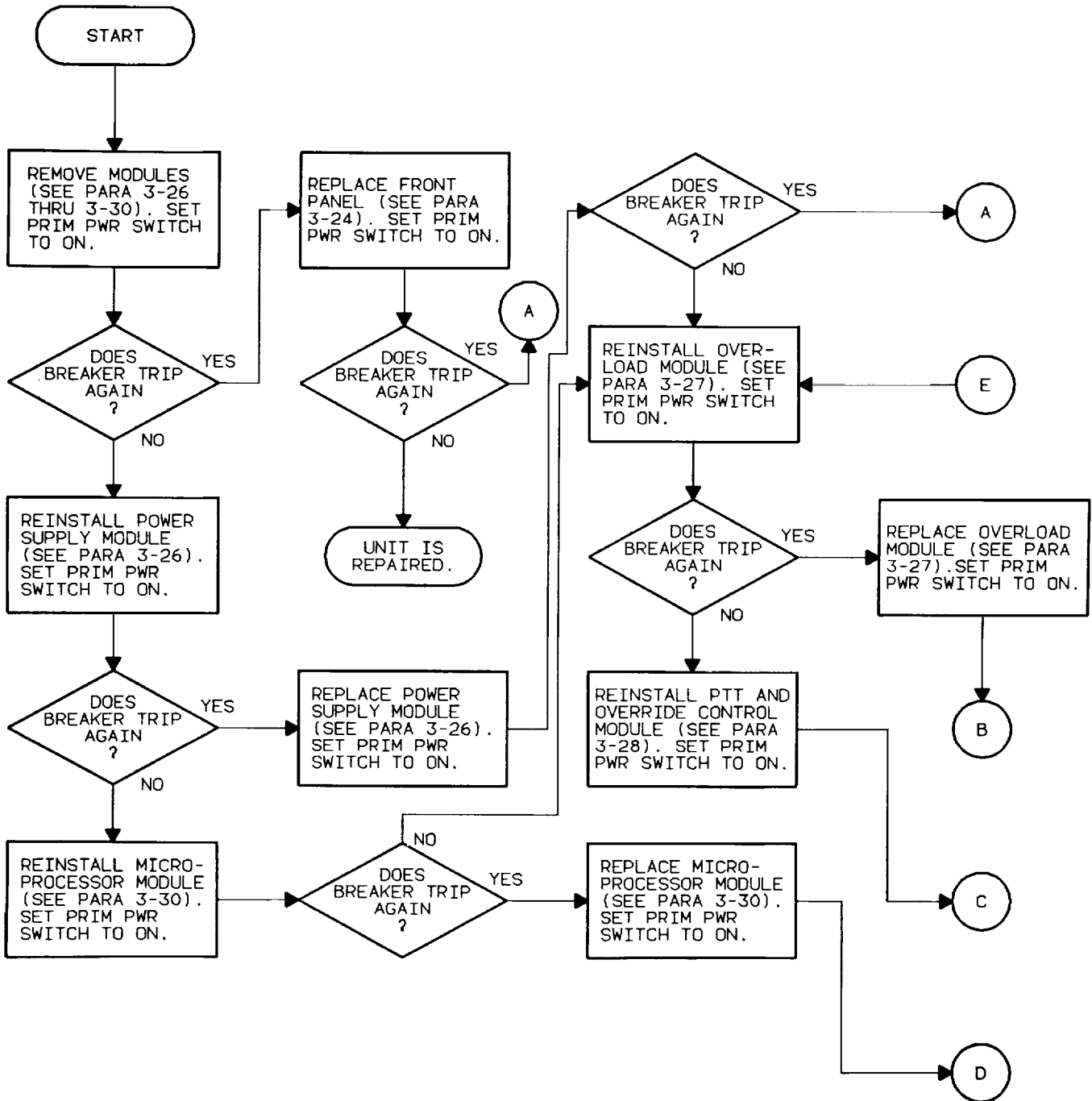

3-11. PRIM PWR CIRCUIT BREAKER TRIPS WHEN PRIM PWR SWITCH IS SET TO ON; PRE/POST SELECTOR IS INOPERATIVE, WHETHER PRIM PWR CIRCUIT BREAKER IS ON OR OFF (Cont.)

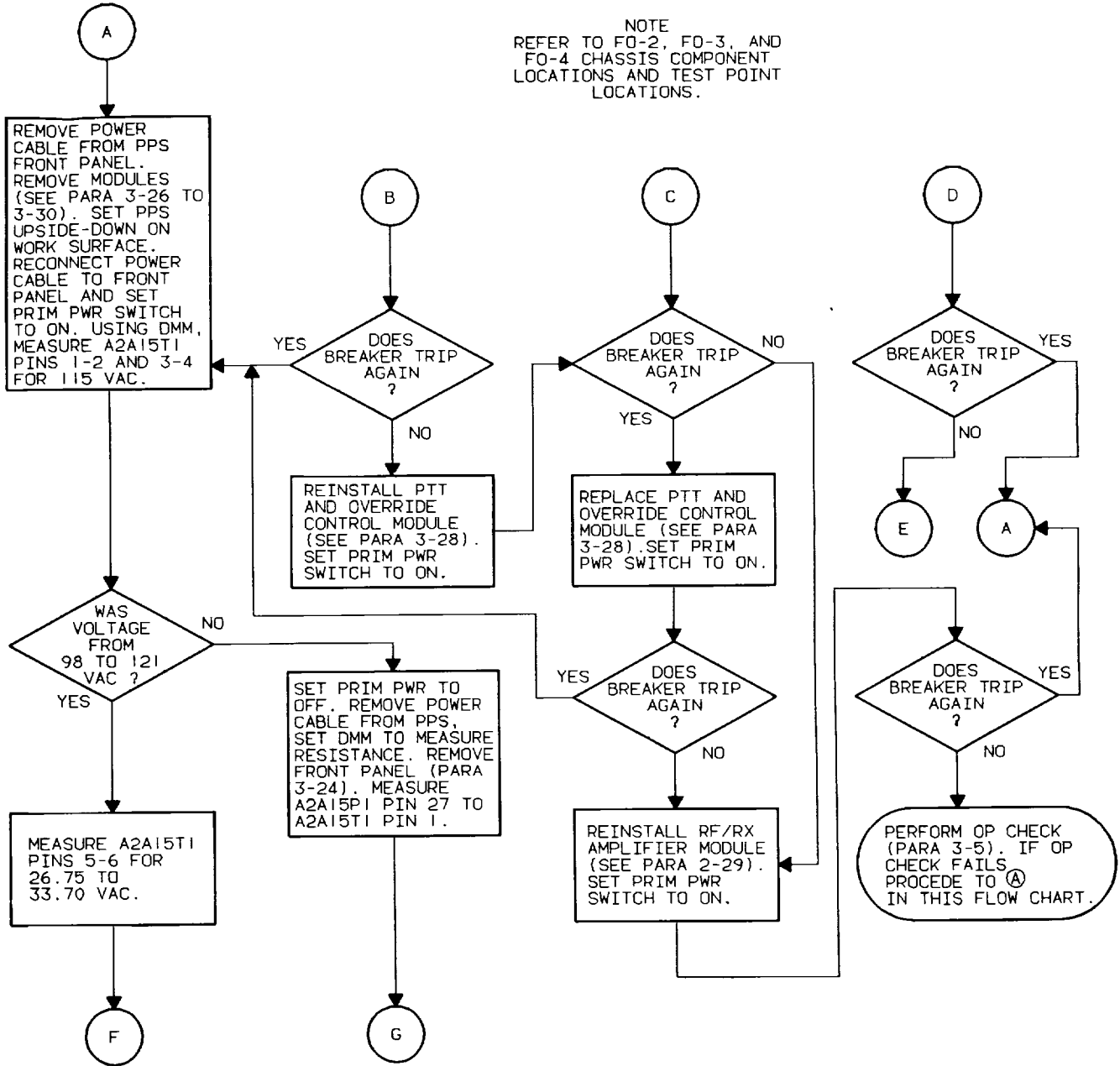

3-11. PRIM PWR CIRCUIT BREAKER TRIPS WHEN PRIM PWR SWITCH IS SET TO ON; PRE/POST SELECTOR IS INOPERATIVE, WHETHER PRIM PWR CIRCUIT BREAKER IS ON OR OFF (Cont.)

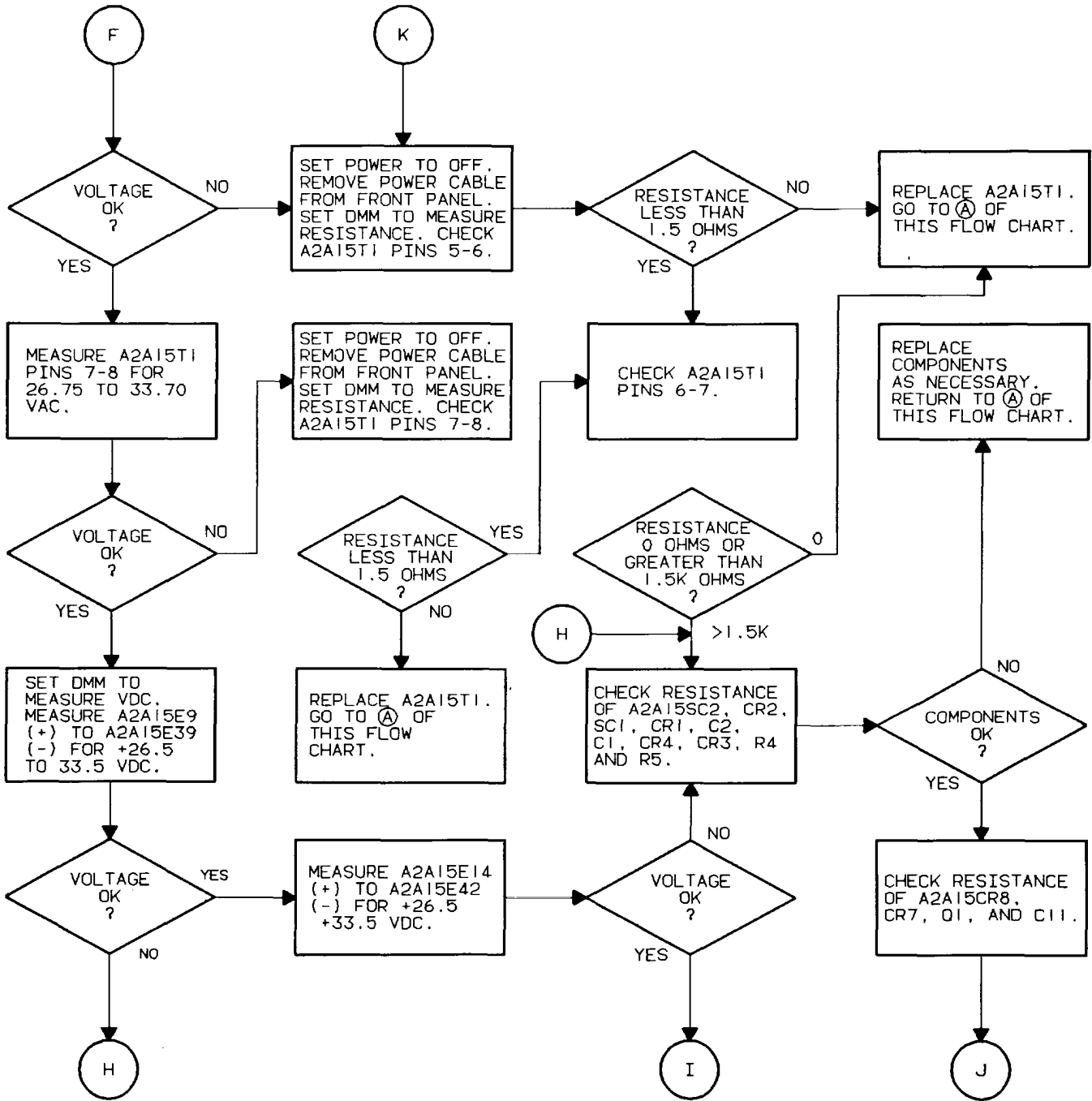

3-11. PRIM PWR CIRCUIT BREAKER TRIPS WHEN PRIM PWR SWITCH IS SET TO ON; PRE/POST SELECTOR IS INOPERATIVE, WHETHER PRIM PWR CIRCUIT BREAKER IS ON OR OFF (Cont.)

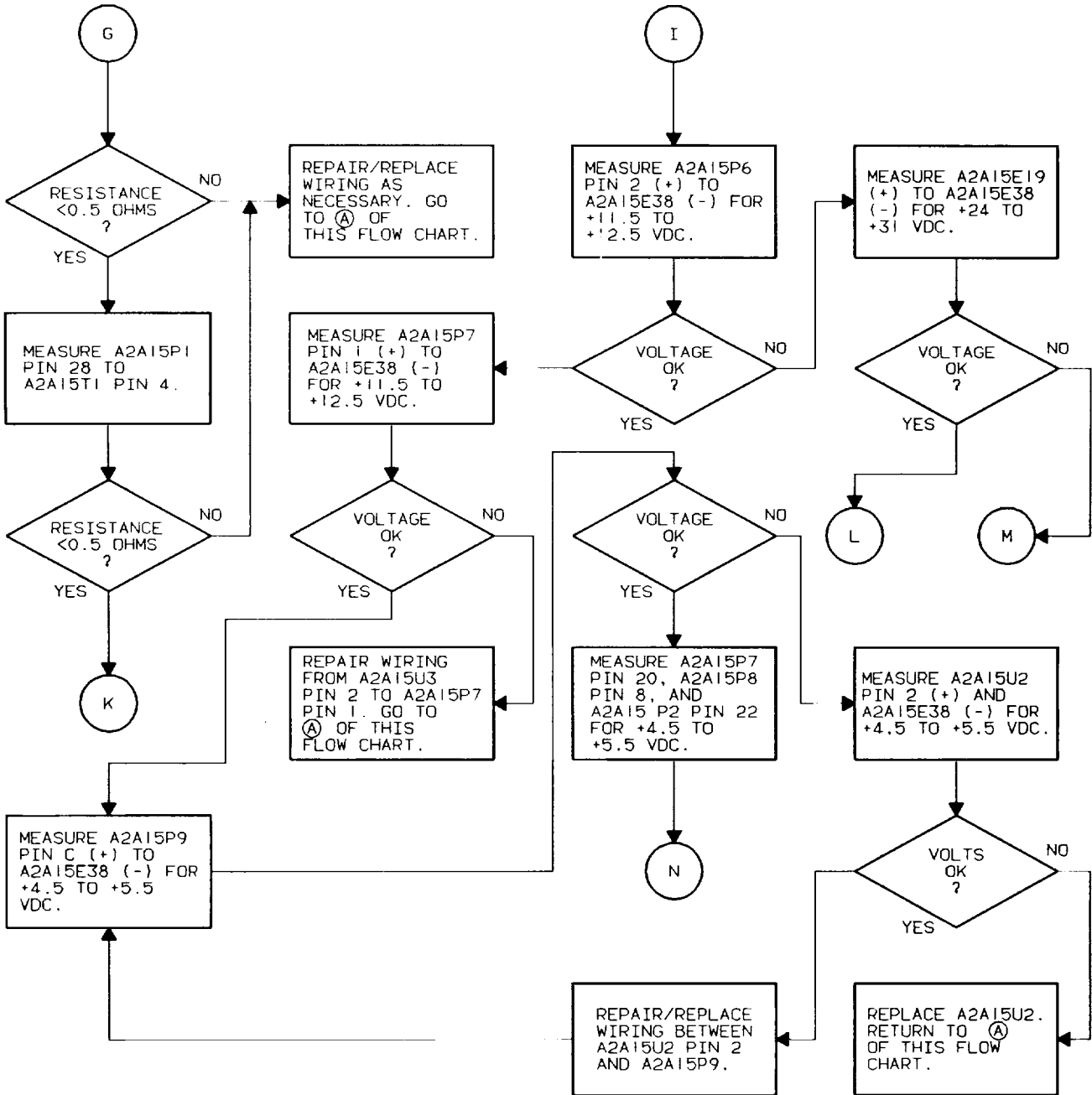

3-11. PRIM PWR CIRCUIT BREAKER TRIPS WHEN PRIM PWR SWITCH IS SET TO ON; PRE/POST SELECTOR IS INOPERATIVE, WHETHER PRIM PWR CIRCUIT BREAKER IS ON OR OFF (Cont.)

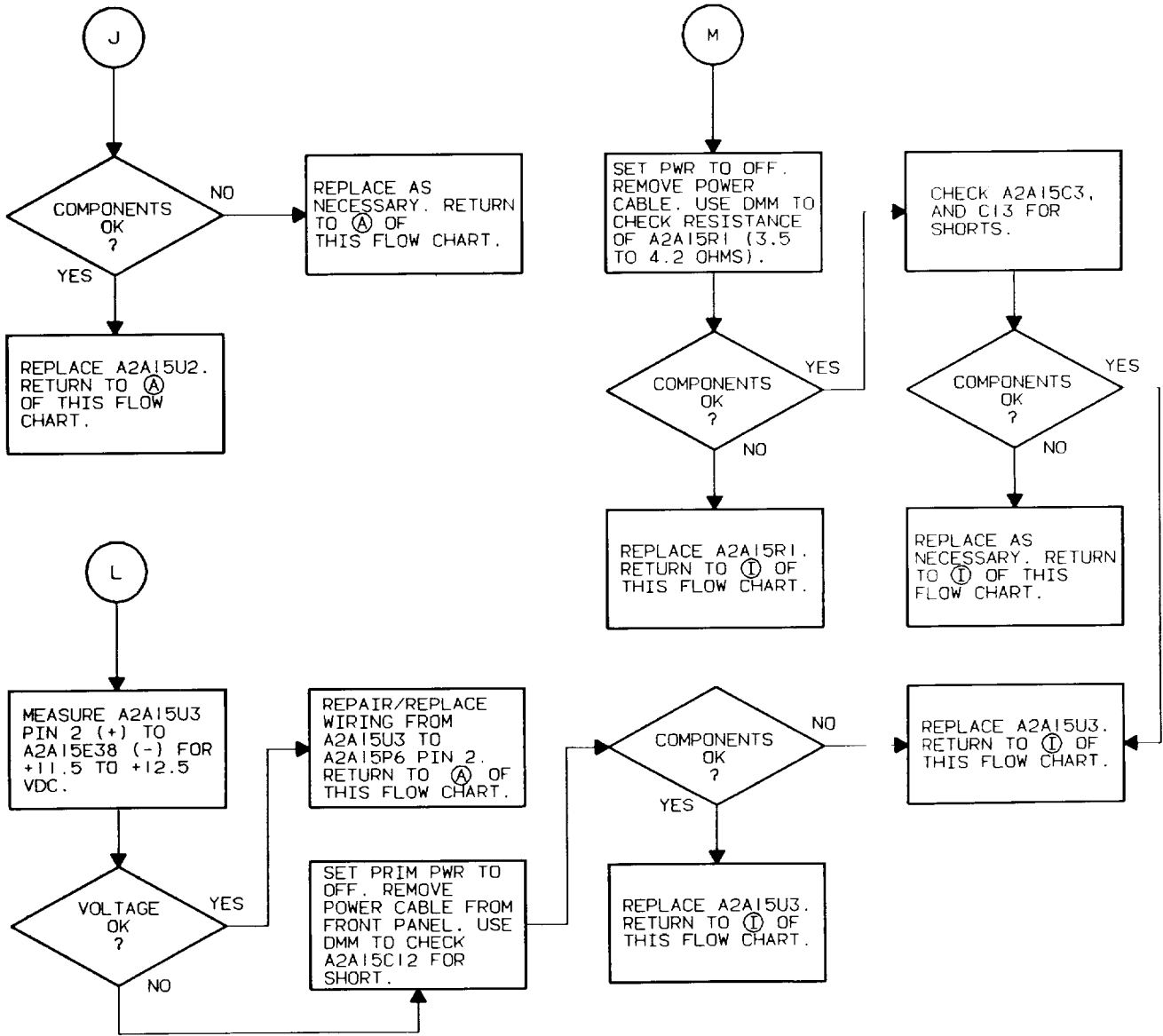

3-11. PRIM PWR CIRCUIT BREAKER TRIPS WHEN PRIM PWR SWITCH IS SET TO ON; PRE/POST SELECTOR IS INOPERATIVE, WHETHER PRIM PWR CIRCUIT BREAKER IS ON OR OFF (Cont.)

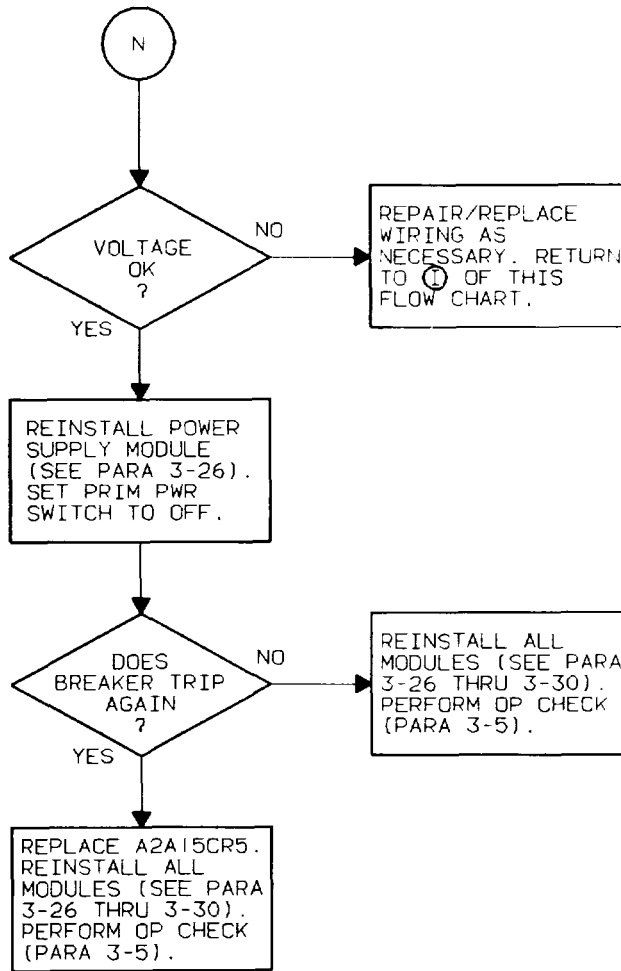

3-12. OVERLOAD (OVL) LAMP ALWAYS ON; TUNE, BITE, ATT LAMPS OFF

INITIAL SETUP

Test Equipment

Test Set, TS-4247/G

Tools

Tool Kit, TK-17

Equipment Condition

Pre/Post Selector connected to test fixture, as shown below.

WARNING

HIGH VOLTAGE is used in the operation of this equipment. DEATH ON CONTACT may result if personnel fail to observe safety precautions. Learn the areas containing high voltage in this piece of equipment. Be careful not to contact high-voltage connections when performing tests.

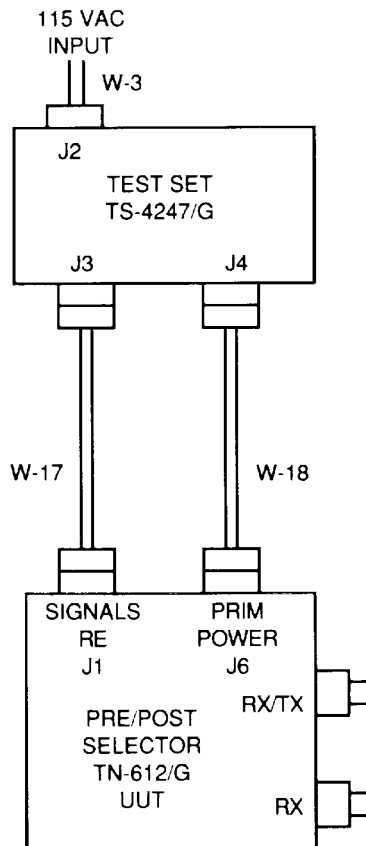

Replace defective overload module (para. 3-27).

3-13. OVERRIDE (OVDE) LAMP ALWAYS ON

INITIAL SETUP

Test Equipment

Test Set, TS-4247/G
test fixture, as shown below.
Tools

Equipment Condition

Pre/Post Selector connected to

Tool Kit, TK-17

WARNING

HIGH VOLTAGE is used in the operation of this equipment. DEATH ON CONTACT may result if personnel fail to observe safety precautions. Learn the areas containing high voltage in this piece of equipment. Be careful not to contact high-voltage connections when performing tests.

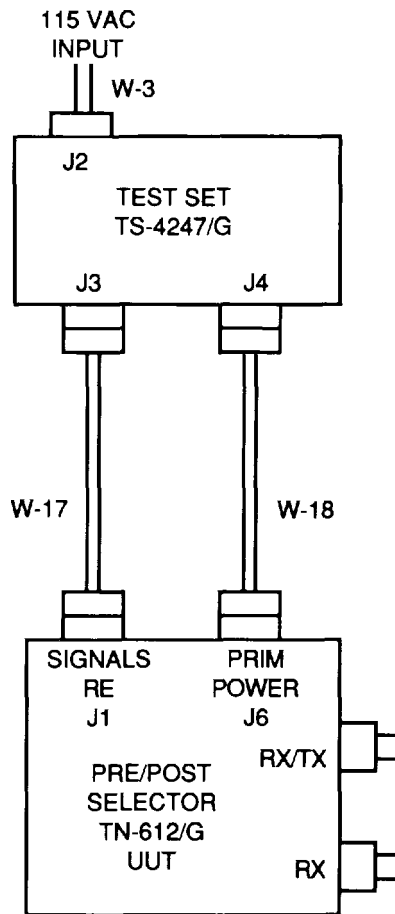

Replace defective PTT and override control module (para. 3-28).

3-14. ATTENUATOR (ATT) LAMP ALWAYS ON

INITIAL SETUP

Test Equipment

Equipment Condition

Test Set, TS-4247/G
test fixture, as shown below.
Tools

Pre/Post Selector connected to

Tool Kit, TK-17

WARNING

HIGH VOLTAGE is used in the operation of this equipment. DEATH ON CONTACT may result if personnel fail to observe safety precautions. Learn the areas containing high voltage in this piece of equipment. Be careful not to contact high-voltage connections when performing tests.

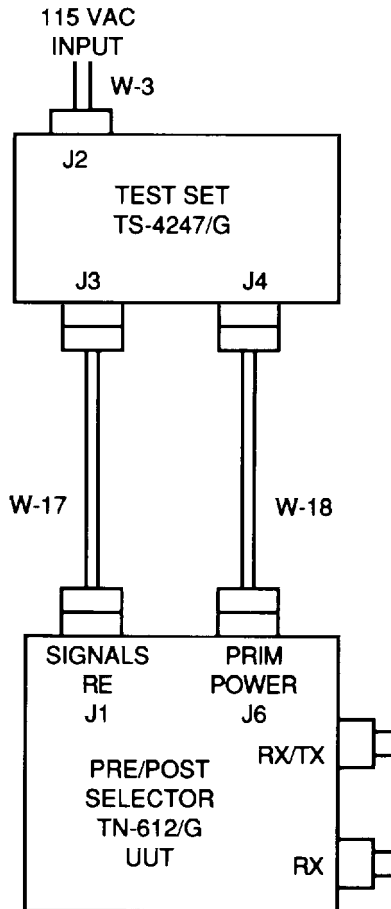

Replace defective RF/RX amplifier module (para. 3-28).

3-15. BITE LAMP ON

INITIAL SETUP

Test Equipment

Test Set, TS-4247/G

Tools

Tool Kit, TK-17

Equipment Condition

Pre/Post Selector removed from case (para 3-6).

Pre/Post Selector connected to test fixture, as shown below.
BIT complete.

WARNING

HIGH VOLTAGE is used in the operation of this equipment. DEATH ON CONTACT may result if personnel fail to observe safety precautions. Learn the areas containing high voltage in this piece of equipment. Be careful not to contact high-voltage connections when performing tests.

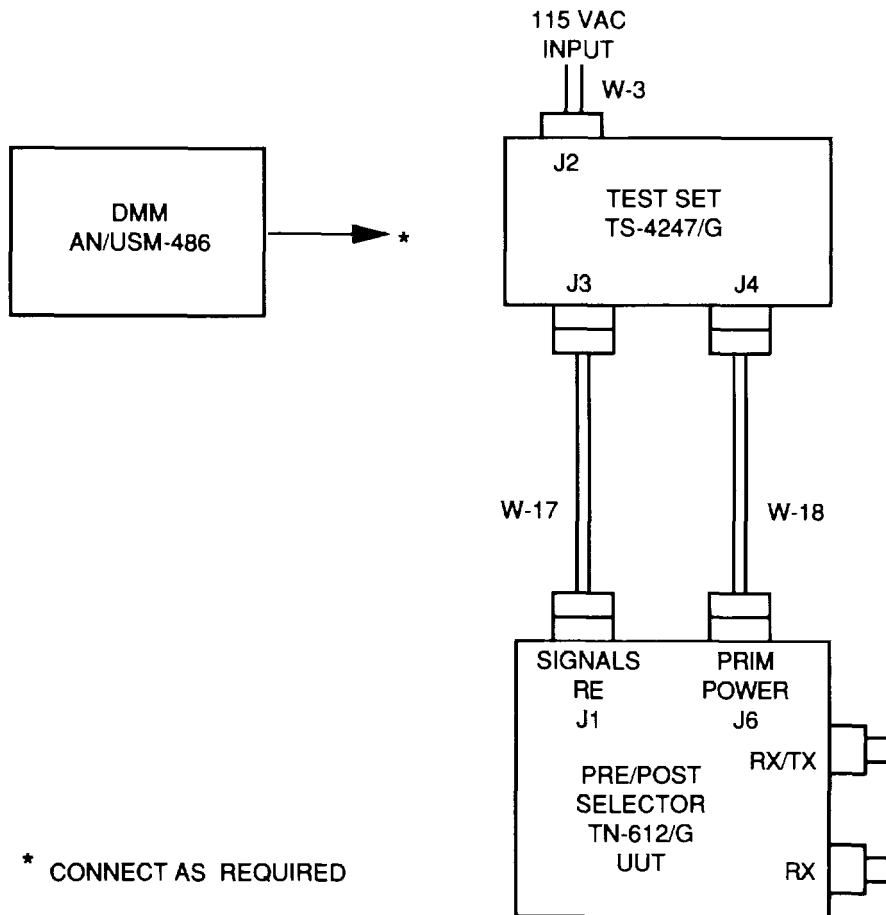

3-15. BITE LAMP ON (Cont.)

STEP 1. Set test fixture switches as follows:

PTT (S2) to OFF ATTEN (S4) to OFF
 AC (S1) to OFF ORIDE (S3) to OFF

STEP 2. Set power on at test fixture and Pre/Post Selector.

STEP 3. Select a frequency on test fixture in the 2 to 30 MHz band.

STEP 4. Wait until the TUNE lamp goes off.

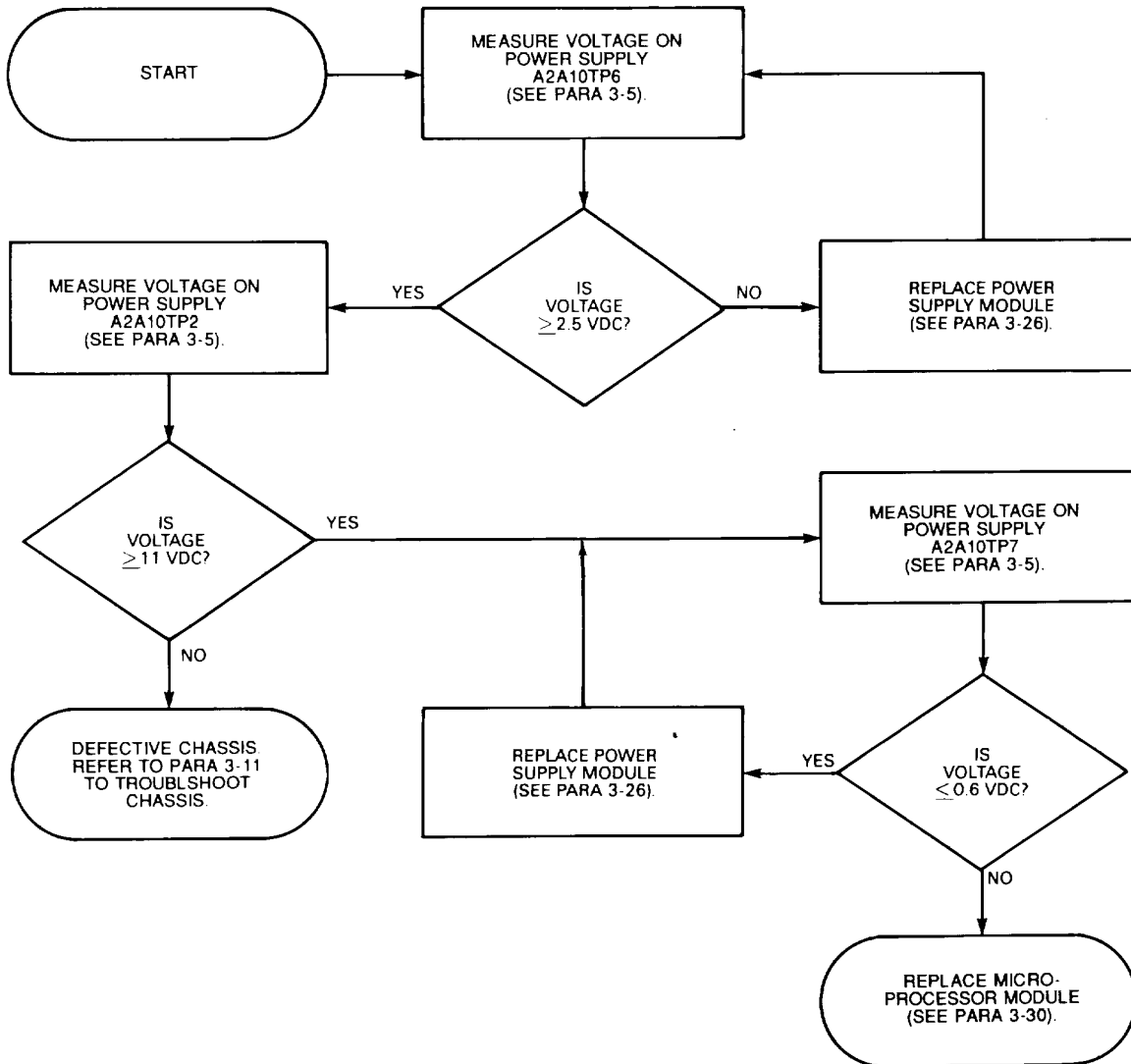

NOTE

Tuning lasts about 5 seconds starting from a frequency change. Observe lamps during this period.

3-16. OVERRIDE (OVDE) LAMP DOES NOT LIGHT WHEN THE TEST FIXTURE OVDE SWITCH IS SET TO ON

INITIAL SETUP

Test Equipment

Test Set, TS-4247/G
Multimeter, Digital AN/USM-486

Tools

Tool Kit, TK-17

Equipment Condition

Pre/Post Selector removed from case (para 3-6).
Pre/Post Selector connected to test fixture, as shown below.
BIT complete.

WARNING

HIGH VOLTAGE is used in the operation of this equipment. DEATH ON CONTACT may result if personnel fail to observe safety precautions. Learn the areas containing high voltage in this piece of equipment. Be careful not to contact high-voltage connections when performing tests.

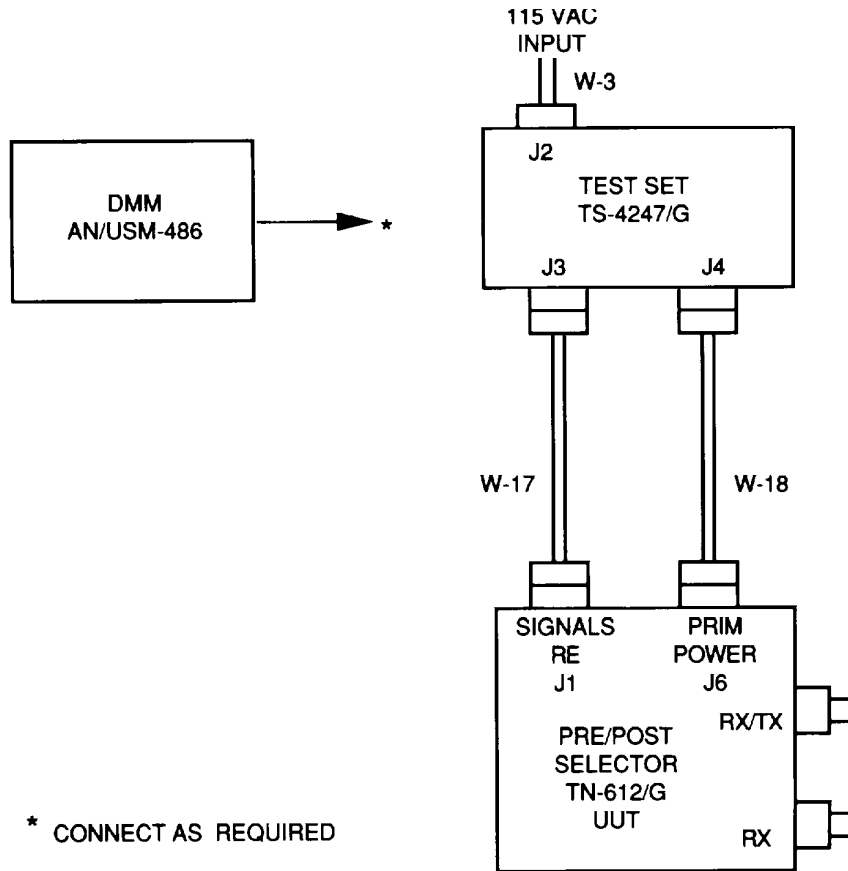

3-16. OVERRIDE (OVDE) LAMP DOES NOT LIGHT WHEN THE TEST FIXTURE OVDE SWITCH IS SET TO ON (Cont.)

STEP 1. Set test fixture switches as follows:

PTT (S2) to OFF ORIDE (S3) to OFF
 ATTEN (S4) to OFF AC (S1) to OFF

STEP 2. Turn power on at the test fixture and Pre/Post Selector.

STEP 3. Select a frequency on test fixture in the 2 to 30 MHz band.

STEP 4. Wait until the test fixture TUNE lamp goes off.

STEP 5. Set the test fixture PPS ORIDE switch (S3) to ON.

STEP 6. Follow the indications of the flow chart.

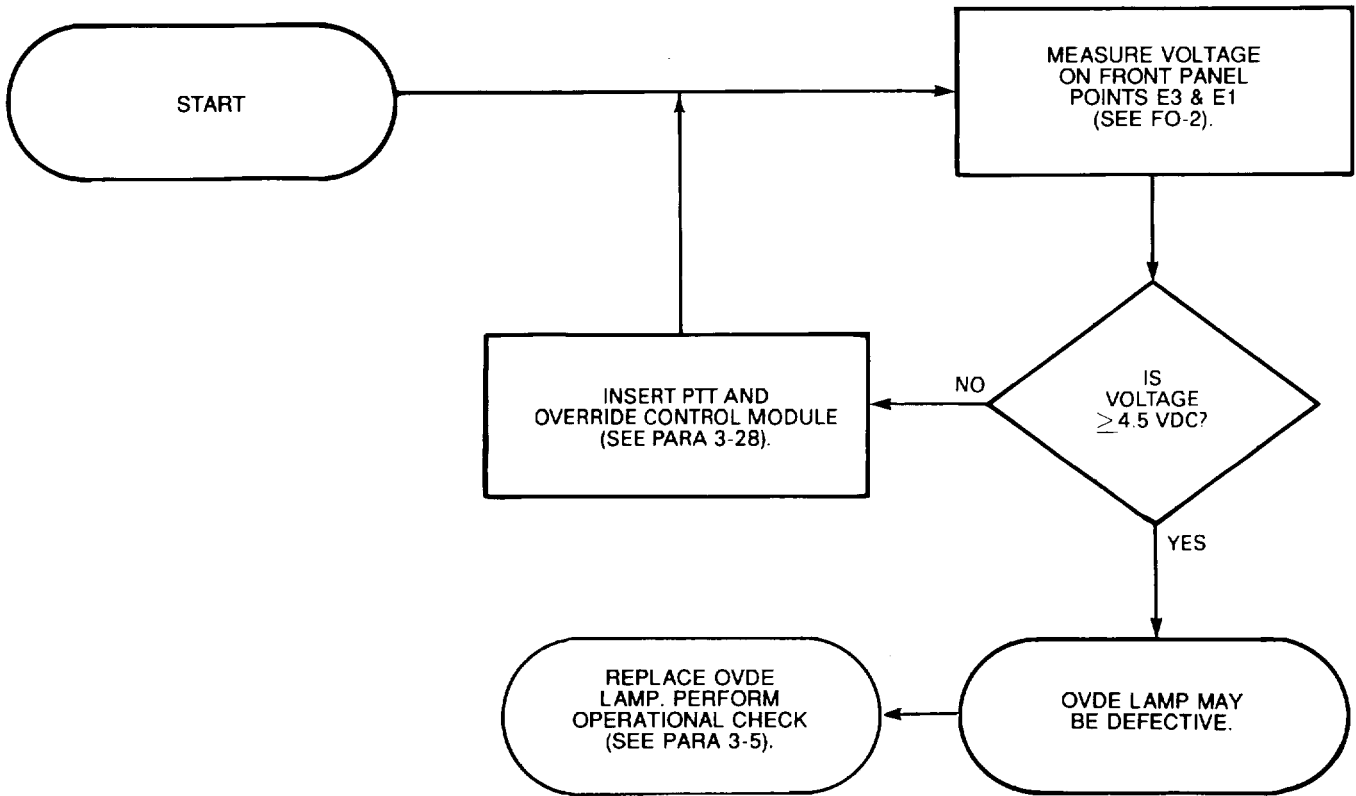

NOTE

Tuning lasts about 5 seconds starting from a frequency change. Observe lamps during this period.

3-17. TUNE LAMP DOES NOT LIGHT WHEN FREQUENCY IS CHANGED.

INITIAL SETUP

Test Equipment

Test Set, TS-4247/G

Tools

Tool Kit, TK-17

Equipment Condition

Pre/Post Selector connected to test fixture, as shown below.

WARNING

HIGH VOLTAGE is used in the operation of this equipment. DEATH ON CONTACT may result if personnel fail to observe safety precautions. Learn the areas containing high voltage in this piece of equipment. Be careful not to contact high-voltage connections when performing tests.

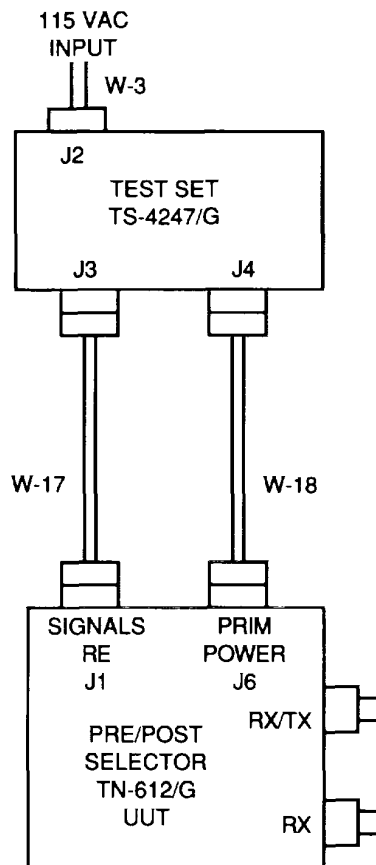

3-17. TUNE LAMP DOES NOT LIGHT WHEN FREQUENCY IS CHANGED (Cont.)

STEP 1. Set Test Fixture switches as follows:

PTT (S2) to OFF	ORIDE (S3) to OFF
ATTEN (S4) to OFF	AC (S1) to OFF

STEP 2. Turn power on at test fixture and Pre/Post Selector.

STEP 3. Select 10 MHz frequency on TS-4247/G.

STEP 4. Wait for 10 seconds.

STEP 5. Change one digit of the selected frequency.

STEP 6. Follow the indications of the flow chart below.

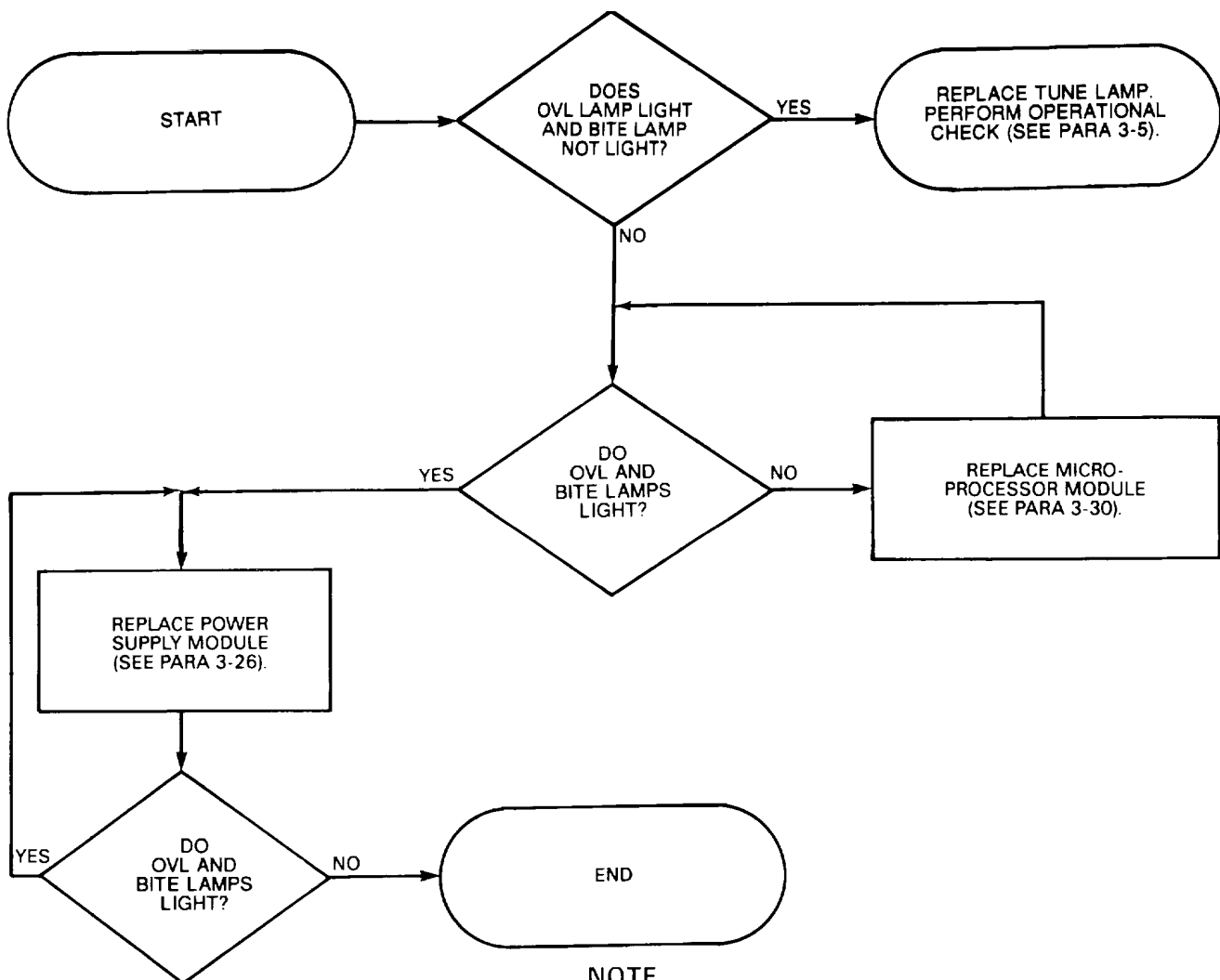

NOTE

Tuning lasts about 5 seconds starting from a frequency change. Observe lamps during this period.

3-18. TUNE LAMP LIGHTS WHEN A FREQUENCY CHANGE IS MADE IN OVERRIDE CONDITION

INITIAL SETUP

Test Equipment

Test Set, TS-4247/G
 Multimeter, Digital AN/USM-486

Tools

Tool Kit, TK-17

Equipment Condition

Bottom cover removed,
 (para 3-25).
 Pre/Post Selector connected to
 test fixture, as shown below.
 BIT complete.

WARNING

HIGH VOLTAGE is used in the operation of this equipment. DEATH ON CONTACT may result if personnel fail to observe safety precautions. Learn the areas containing high voltage in this piece of equipment. Be careful not to contact high-voltage connections when performing tests.

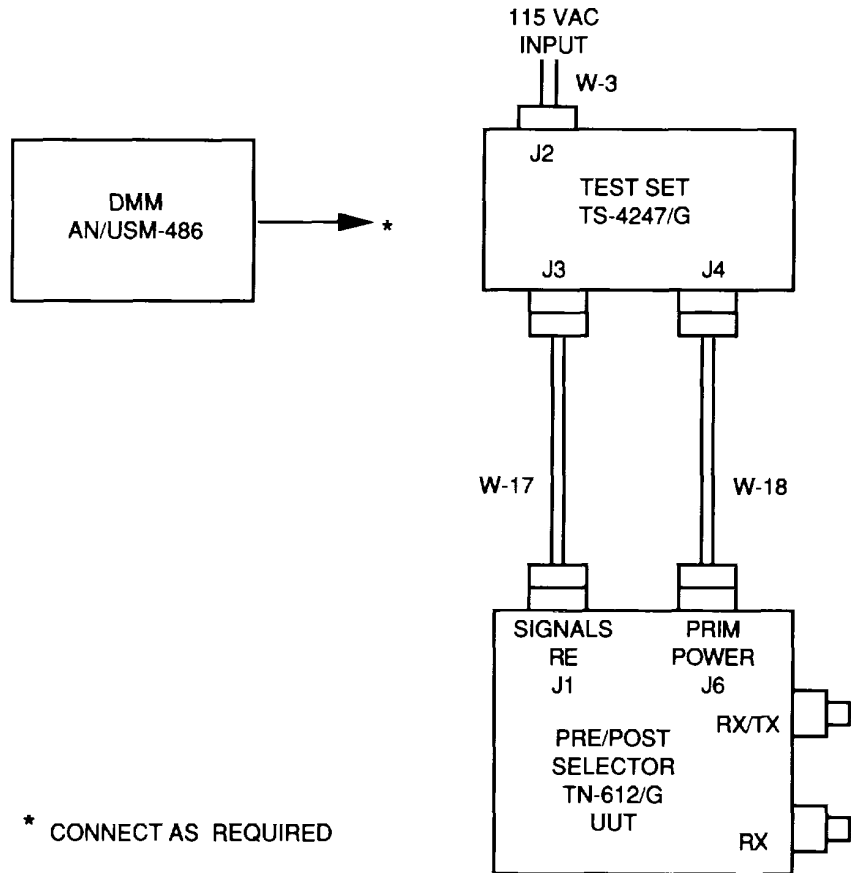

3-18. TUNE LAMP LIGHTS WHEN A FREQUENCY CHANGE IS MADE IN OVERRIDE CONDITION (Cont.)

STEP 1. Set test fixture switches as follows:

PTT (S2) to OFF	ORIDE (S3) to OFF
ATTEN (S4) to OFF	AC (S1) to OFF

STEP 2. Turn power on at the test fixture and Pre/Post Selector.

STEP 3. Select 10 MHz frequency on TS-4247/G.

STEP 4. Wait 10 seconds.

STEP 5. Set test fixture PPS ORIDE (S3) switch to ON.

STEP 6. Follow the indications of the flow chart below.

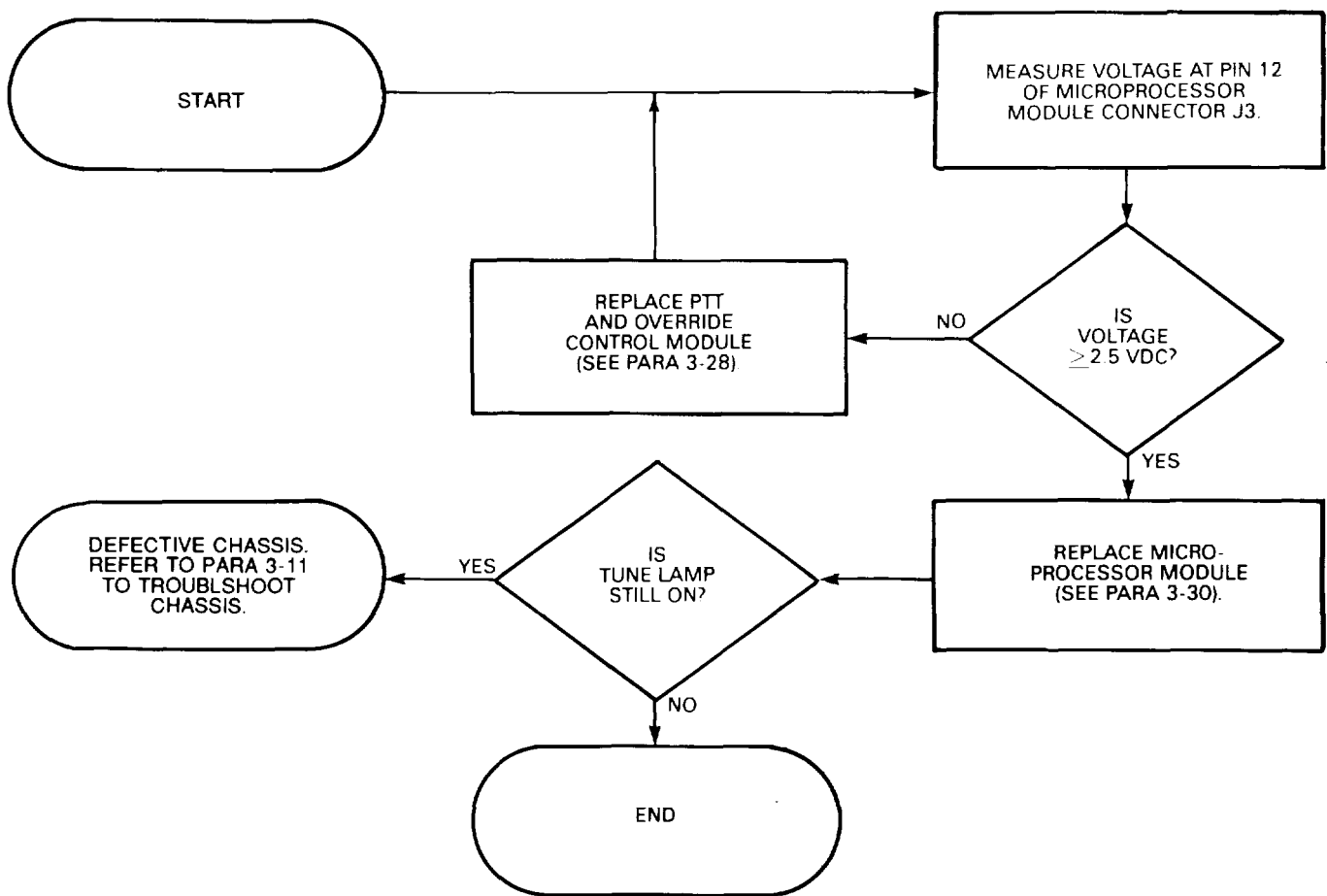

3-19. INSERTION LOSS IN RX CONDITION TOO HIGH

INITIAL SETUP

Test Equipment

Test Set, Pre-Post Selector TS-4247/G
Test Cable, RG-58, BNC-to-BNC,
(2 each)
Adapter, Pomona Type 3844A, (2 each)
Tracking Generator, SG-1122/U
Spectrum Analyzer, IP-1216(P)/GR
Plug-in IF, PL-1388/U
Plug-in RF, PL-1399/U

Equipment Condition

Refer to Initial Test Setup
Allow 15 minute warmup time.

Tools

Workstation, Static

WARNING

HIGH VOLTAGE is used in the operation of this equipment. DEATH ON CONTACT may result if personnel fail to observe safety precautions. Learn the areas containing high voltage in this piece of equipment. Be careful not to contact high-voltage connections when performing tests.

CAUTION

This equipment contains components that are sensitive to damage by electrostatic discharge (ESD). Improper handling will result in component and assembly failure. Use extreme care when handling. Refer to DOD-HDBK-263 for proper handling procedures.

3-19. INSERTION LOSS IN RX CONDITION TOO HIGH (Cont.)

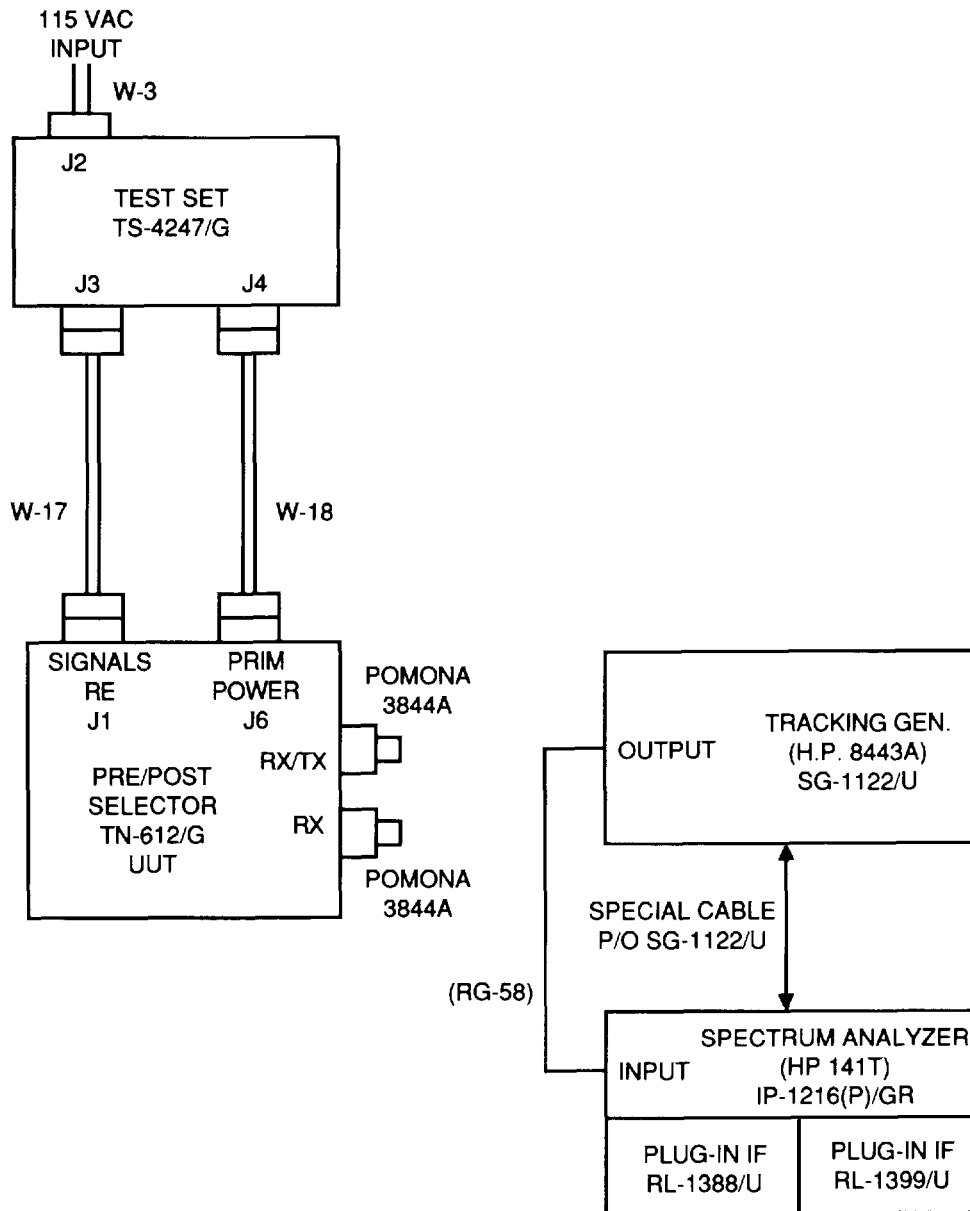

3-19. INSERTION LOSS IN RX CONDITION TOO HIGH (Cont.)

STEP 1. Perform the operational checks of para 3-5d.

STEP 2. Follow the indications of the flow chart below.

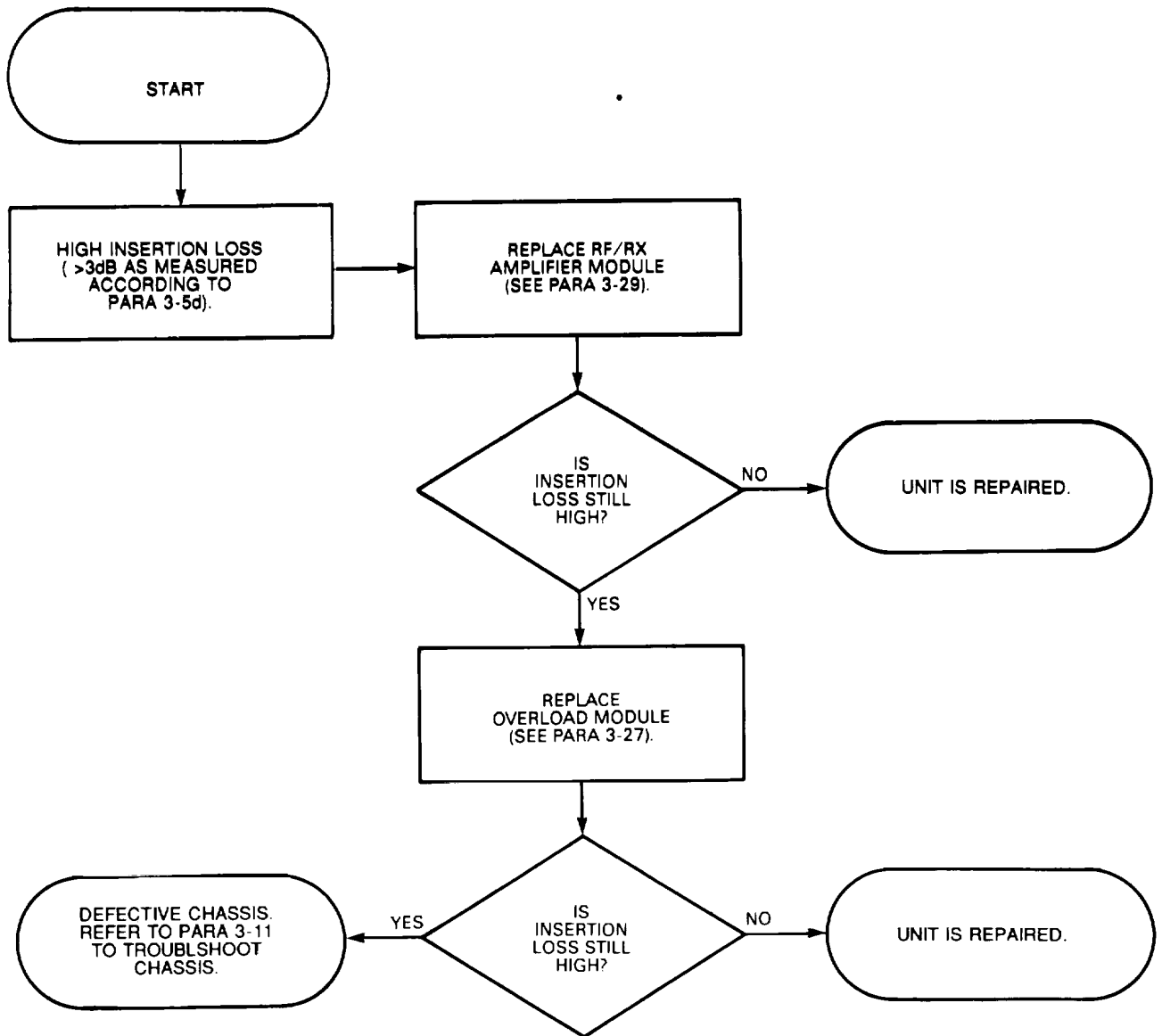

3-20. INSERTION LOSS IN RX OVERRIDE CONDITION TOO HIGH.

INITIAL SETUP

Test Equipment

Test Set, Pre-Post Selector TS-4247/G
Test Cable, RG-58, BNC-to-BNC, (2 each)
Adapter, Pomona Type 3844A, (2 each)
Tracking Generator, SG-1122/U
Spectrum Analyzer, IP-1216(P)/GR
Plug-in IF, PL-1388/U
Plug-in RF, PL-1399/U

Equipment Condition

Refer to Initial Test Setup
Allow 15 minute warmup time.

Tools

Workstation, Static

WARNING

HIGH VOLTAGE is used in the operation of this equipment. DEATH ON CONTACT may result if personnel fail to observe safety precautions. Learn the areas containing high voltage in this piece of equipment. Be careful not to contact high-voltage connections when performing tests.

CAUTION

This equipment contains components that are sensitive to damage by electrostatic discharge (ESD). Improper handling will result in component and assembly failure. Use extreme care when handling. Refer to DOD-HDBK-263 for proper handling procedures.

3-20. INSERTION LOSS IN RX OVERRIDE CONDITION TOO HIGH (Cont.)

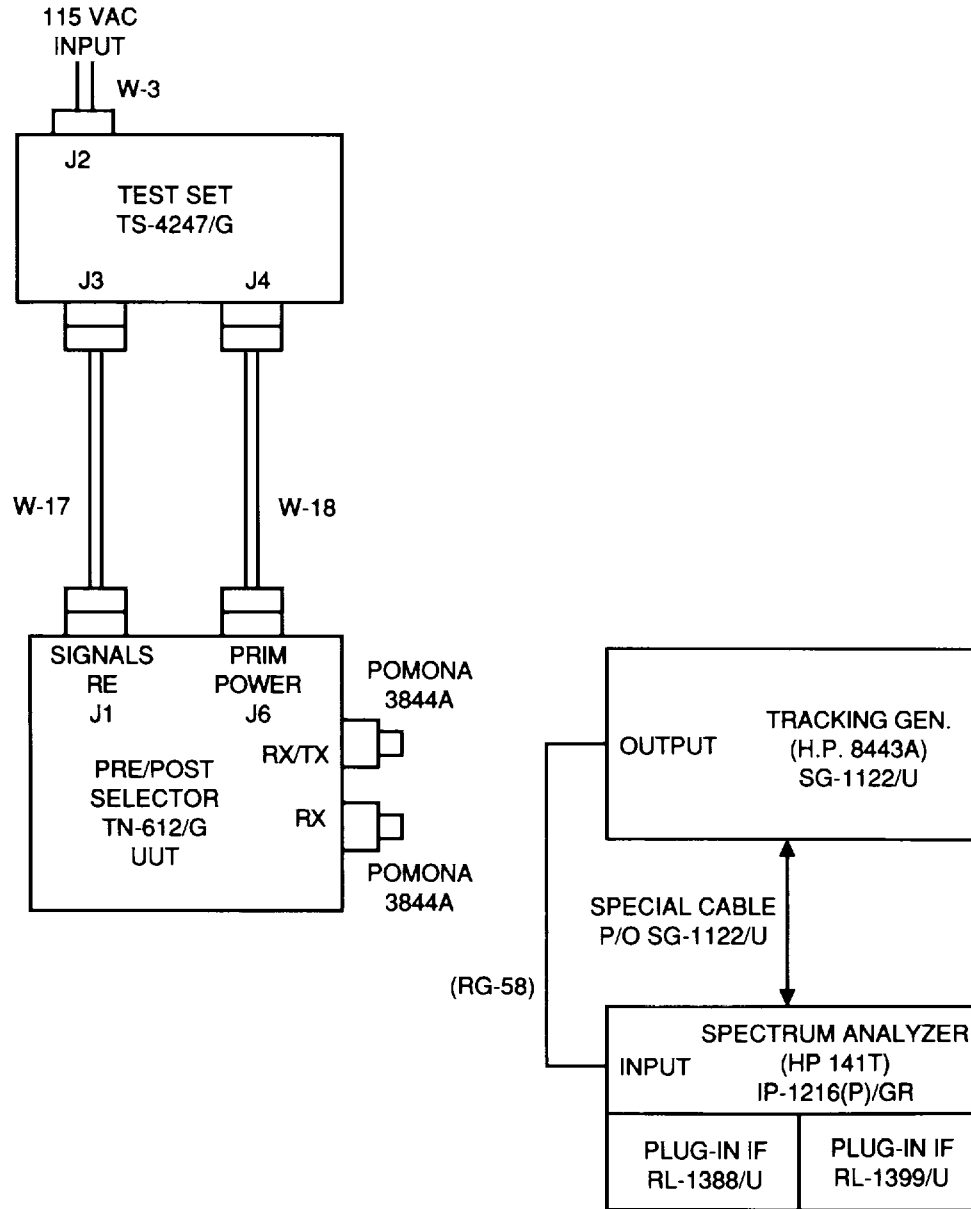

3-20. INSERTION LOSS IN RX OVERRIDE CONDITION TOO HIGH (Cont.)

STEP 1. Perform the operational checks of para 3-5e.

STEP 2. Follow the indications of the flow chart below.

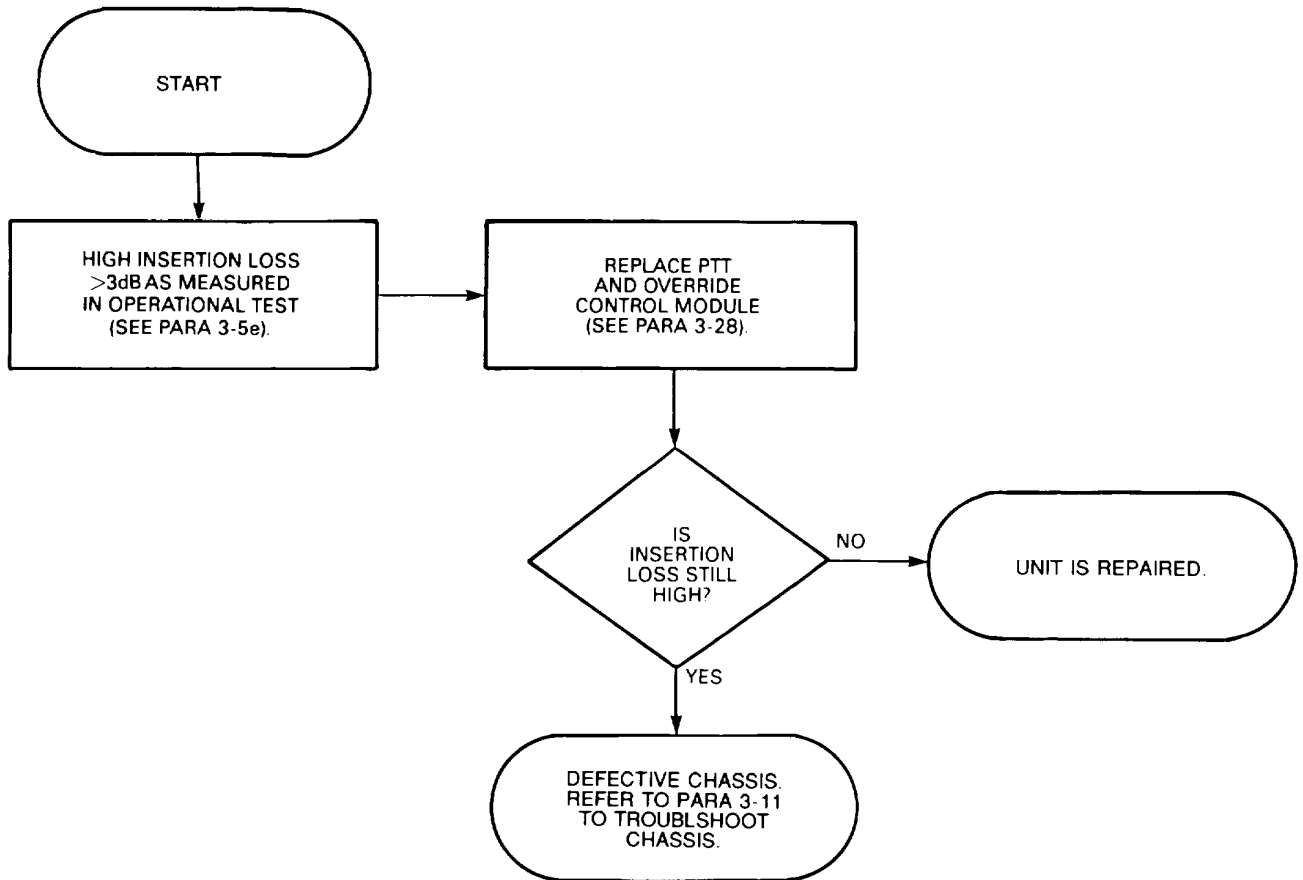

3-21. OVERALL GAIN TOO LOW IN TX CONDITION

INITIAL SETUP

Test Equipment

Test Set, Pre-Post Selector
TS-4247/G
Power Amplifier, AM-7353/G
Attenuator, Bird 8323
Attenuator, Bird 8322
Power Meter, AN/USM-491
Signal Generator, SG-1170/U
Adapter, Pomona Type 3844A, (2 each)
Adapter, UG-201A/U, (4 each)
Adapter, UG-1034/G
Test Cable, RG-58, BNC-to-BNC (4 each)

Equipment Condition

Refer to Initial Test Setup
Allow 15 minute warmup time.

WARNING

HIGH VOLTAGE is used in the operation of this equipment. DEATH ON CONTACT may result if personnel fail to observe safety precautions. Learn the areas containing high voltage in this piece of equipment. Be careful not to contact high-voltage connections when performing tests.

CAUTION

This equipment contains components that are sensitive to damage by electrostatic discharge (ESD). Improper handling will result in component and assembly failure. Use extreme care when handling. Refer to DOD-HDBK-263 for proper handling procedures.

3-21. OVERALL GAIN TOO LOW IN TX CONDITION (Cont.)

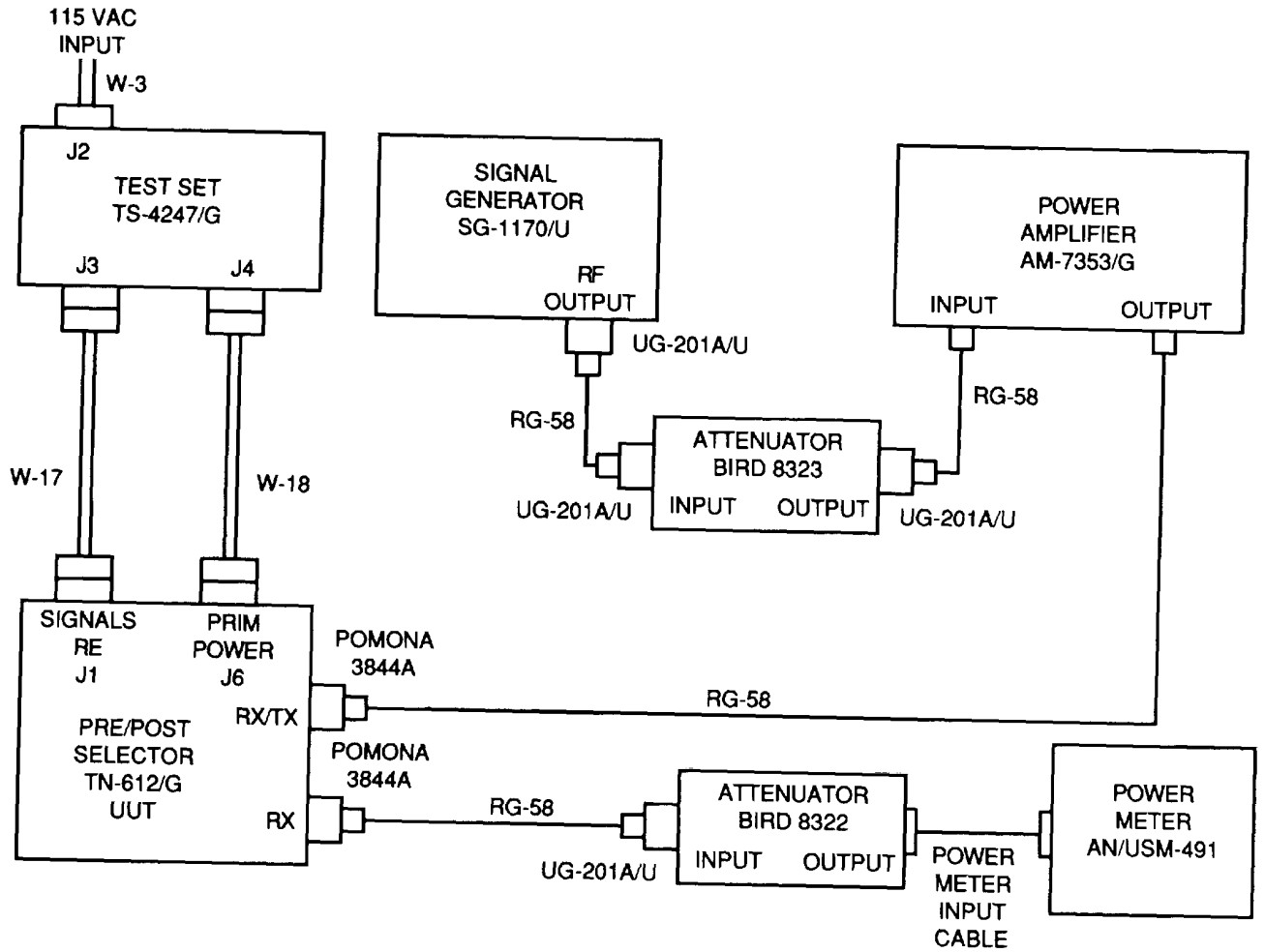

3-21. OVERALL GAIN TOO LOW IN TX CONDITION (Cont.)

STEP 1. Perform operational checks of para 3-5c.

STEP 2. Follow the indications of the flow chart below.

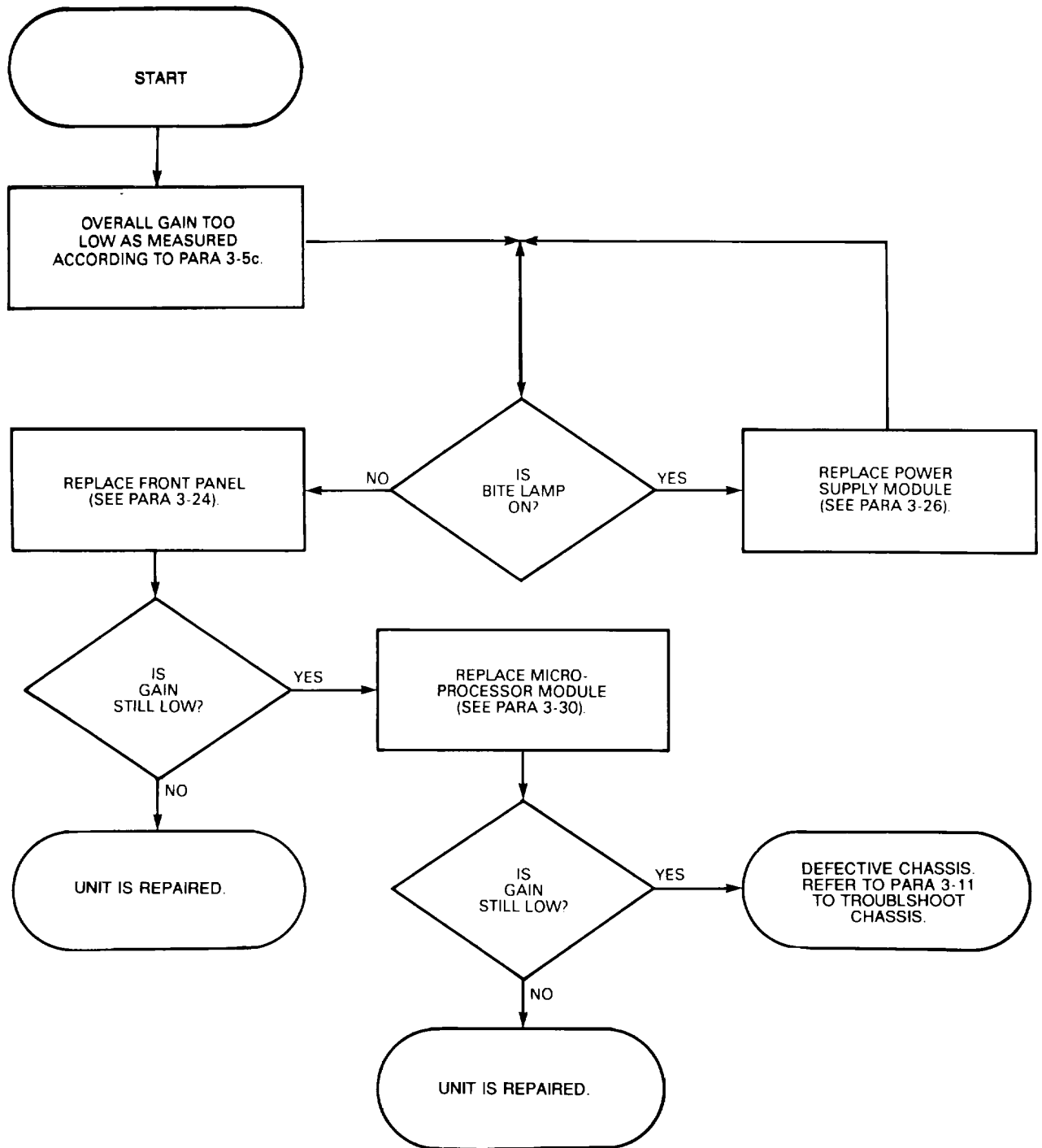

3-22. BITE LAMP DOES NOT LIGHT WHEN AN OUT-OF-RANGE FREQUENCY IS SELECTED

INITIAL SETUP

Test Equipment

Test Set, TS-4247/G
Multimeter, Digital AN/USM-486

Tools

Tool Kit TK-17

Equipment Condition

Pre/Post Selector removed from case (para. 3-6).
Pre/Post Selector connected to test fixture, as shown below.

WARNING

HIGH VOLTAGE is used in the operation of this equipment.-DEATH ON CONTACT may result if personnel fail to observe safety precautions. Learn the areas containing high voltage in this piece of equipment. Be careful not to contact high-voltage connections when performing tests.

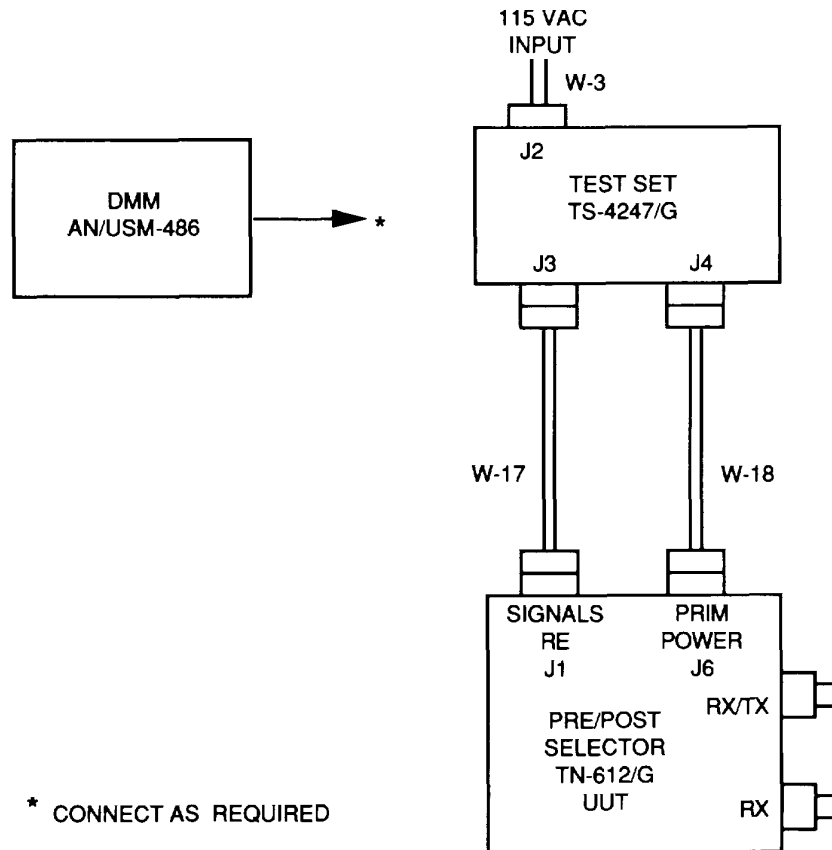

3-22. BITE LAMP DOES NOT LIGHT WHEN AN OUT-OF-RANGE FREQUENCY IS SELECTED (Cont)

- STEP 1. Set test fixture as follows:
 PTT (S2) to OFFORIDE (S3) to OFF
 ATTEN (S4) to OFFAC (S1) to OFF
- STEP 2.. Turn chassis 90° with front panel down.
- STEP 3. Turn power on at the test fixture and UUT.
- STEP 4. Select 1 MHz frequency.
- STEP 5. Follow the indications of the flow chart below.

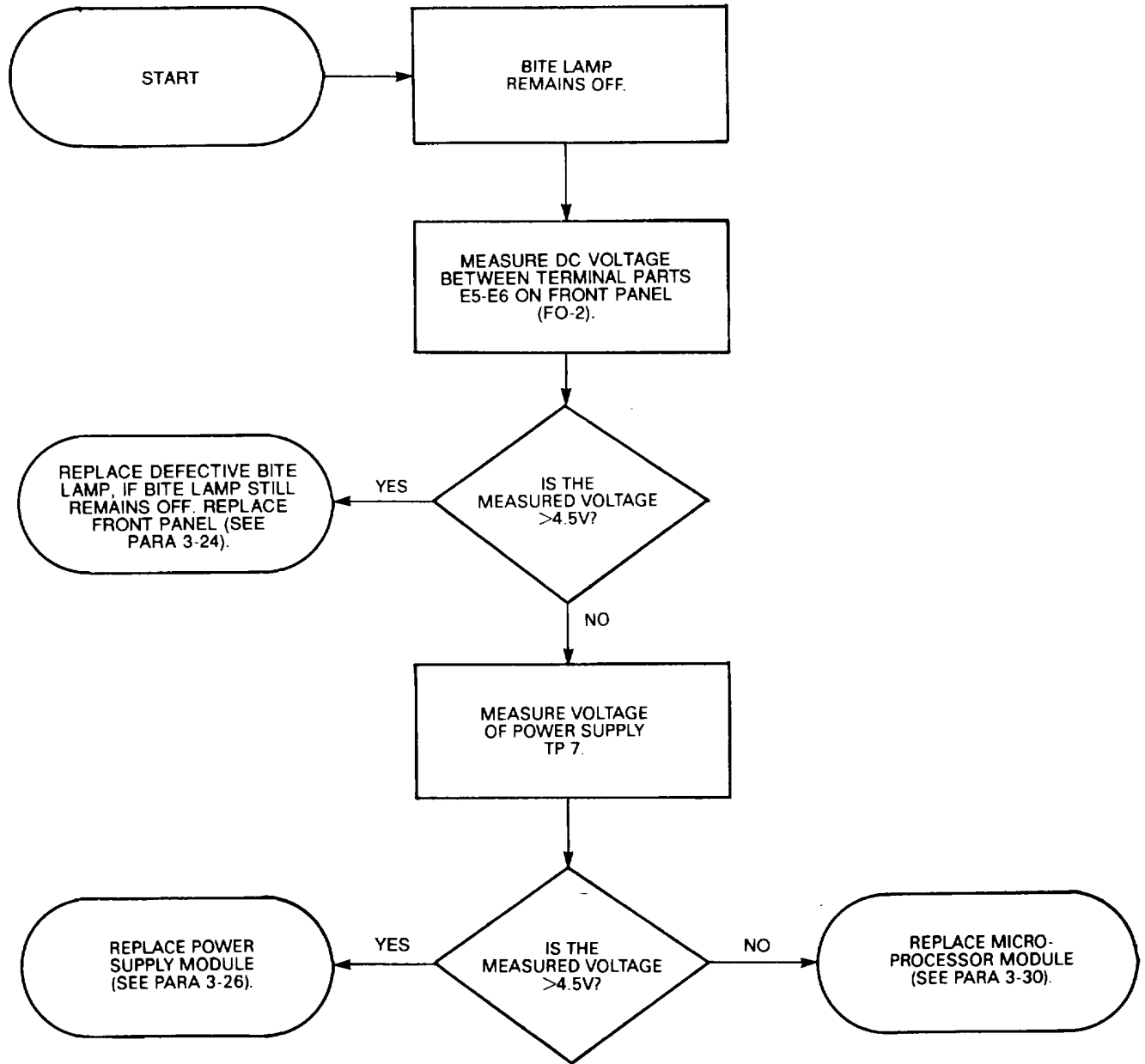

Section III. INTERMEDIATE GENERAL SUPPORT MAINTENANCE

3-23. GENERAL

Maintenance at the intermediate general support level includes replacing defective modules. To facilitate maintenance of the Pre/Post Selector, removal and replacement procedures are provided.

After replacing a faulty module, perform the self-test (BIT) and the functional test (para. 3-5) to ensure proper operation of the pre/post selector.

3-55/(3-56 BLANK)

3-24. REPLACEMENT OF FRONT PANEL (A2A1)

INITIAL SETUP

Tools

Tool Kit, TK-17
Workstation, static

Equipment Conditions

PPS PRIM PWR switch off and all cables removed.

Material/Parts

Front Panel, A2A1, P/N A3026052

CAUTION

This equipment contains components that are sensitive to damage by electrostatic discharge (ESD). Improper handling will result in component and assembly failure. Use extreme care when handling. Refer to DOD-HDBK-263 for proper handling procedures.

3-24. REPLACEMENT OF FRONT PANEL (A2A1) (Cont.)

REMOVE FRONT PANEL

STEP 1. Refer to para. 3-6 to extend unit into locked position on slides.

NOTE

After removing the 4 screws in STEP 1, the front panel will be held in place only by the 2 connectors joining the front panel to the chassis.

STEP 2. Use a cross-point screwdriver to remove the 4 screws , lock washers , and flat washers that secure the front panel to the chassis .

STEP 3. Separate the front panel by pulling the front panel straight away from the chassis.

REPLACE FRONT PANEL

NOTE

When positioning the front panel onto the chassis, take care to ensure that the connectors properly align and seat to prevent connector pin damage.

STEP 1. Position the front panel on the chassis .Replace, and use a cross-point screwdriver to tighten, the 4 screws , lock washers , and flat washers .

STEP 2. Refer to para. 3-6 to replace unit in case, and para. 3-5 to perform operational check of UUT.

STEP 3. Set PRIM PWR switch to ON. Verify UUT is operational by observing that the BIT light does not come on.

3-24. REPLACEMENT OF FRONT PANEL (Cont.)

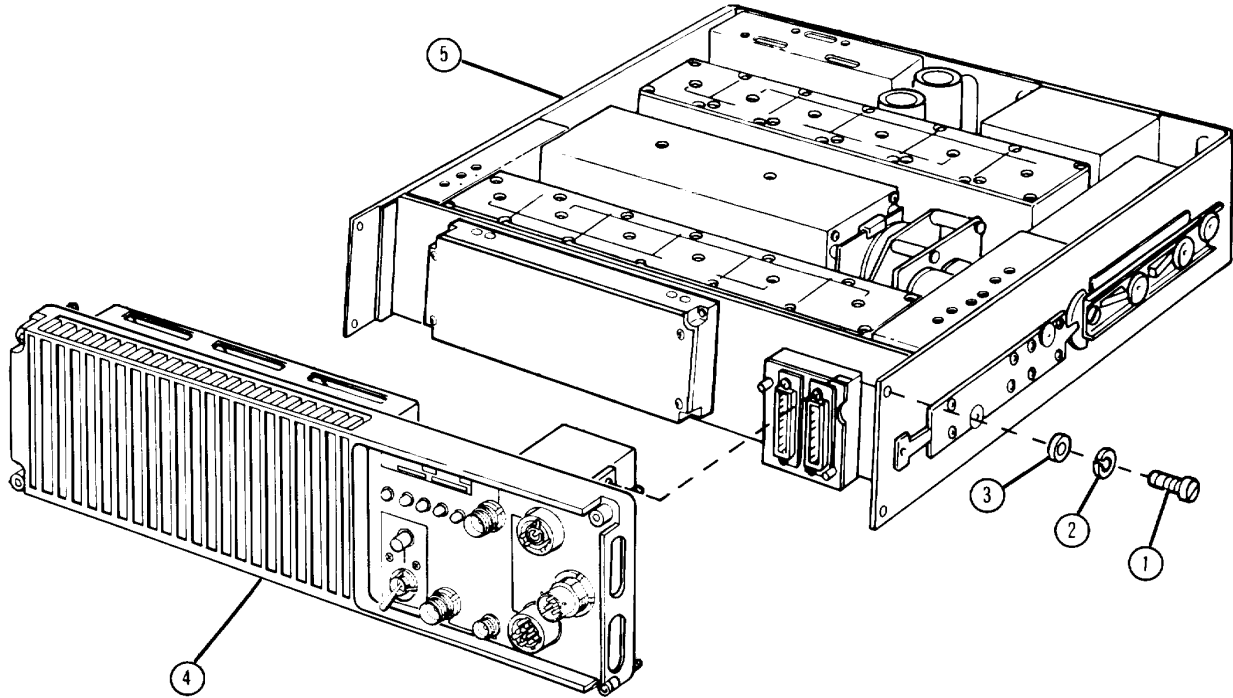

3-25. REMOVAL OF BOTTOM COVER

INITIAL SETUP

Tools

Tool Kit, TK-17

Equipment Conditions

Pre/Post Selector extended from case,
(para. 3-6).

REMOVAL OF BOTTOM COVER

STEP 1. Pull locking levers on unit sides and turn the chassis 90° with front panel up.

STEP 2. Use a cross-point screwdriver to remove 11 screws that secure the fiber-glass plate on bottom of chassis.

REPLACEMENT OF BOTTOM COVER

STEP 1. Position fiber-glass plate and use a cross-point screwdriver to tighten 11 screws .

STEP 2. Return chassis to normal position.

REMOVAL OF BOTTOM COVER (Cont.)

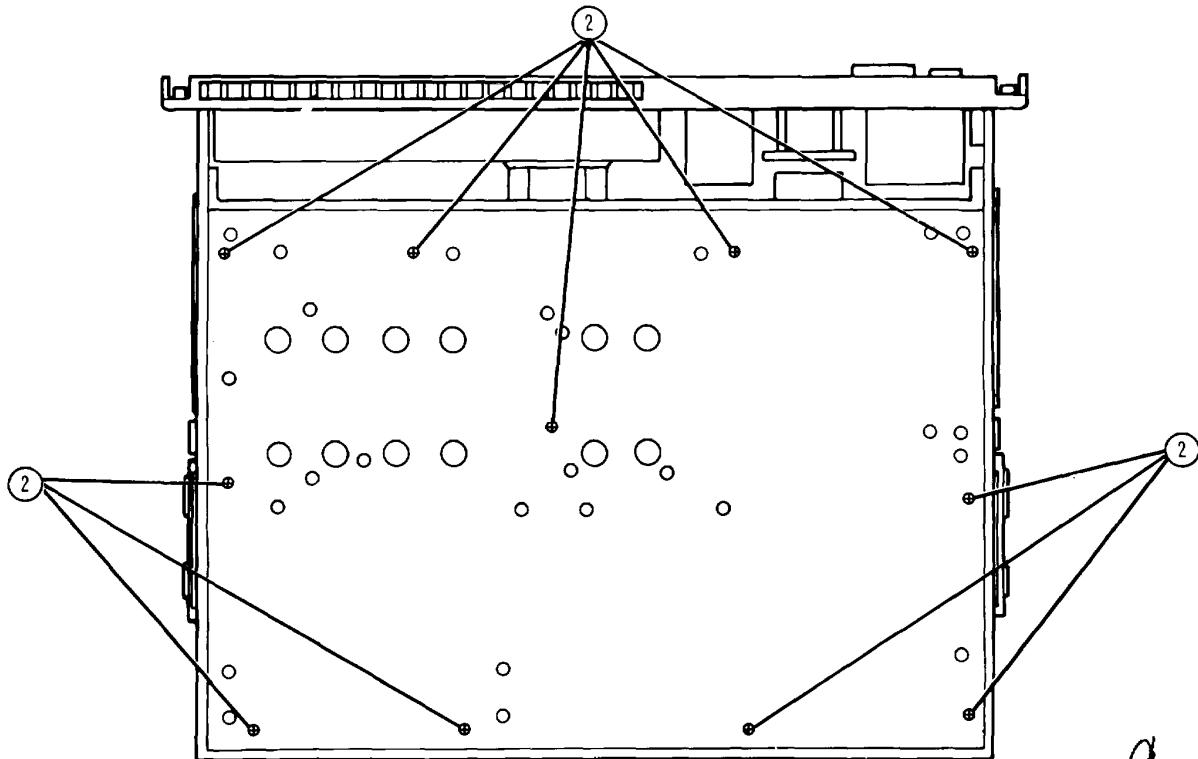
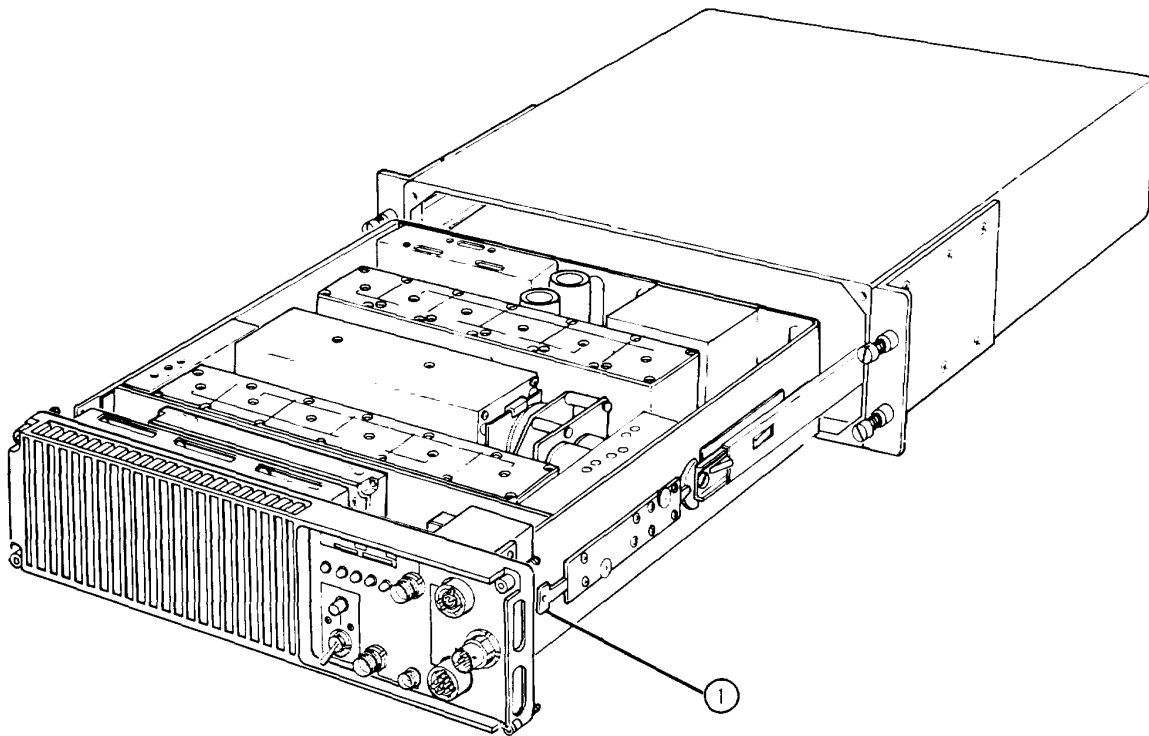

009

3-26. REPLACEMENT OF POWER SUPPLY (A2A10)

INITIAL SETUP

Tools

Tool Kit, TK-17
Workstation, Static

Equipment Conditions

PPS PRIM PWR switch off and all cables removed.

Material/Parts

Power Supply Module, A2A10, P/N A3026057

CAUTION

This equipment contains components that are sensitive to damage by electrostatic discharge (ESD). Improper handling will result in component and assembly failure. Use extreme care when handling. Refer to DOD-HDBK-263 for proper handling procedures.

REMOVE POWER SUPPLY

STEP 1. Refer to para. 3-6 to remove unit from case.

CAUTION

Read STEP 2 and STEP 3 prior to performing either step to prevent possible damage to Pre/Post Selector or the Power Supply Module.

STEP 2. With the unit laying top-down on a flat surface, use a the bottom of the unit (these screws are accessible cross-point screwdriver to loosen 4 captive-screws on through the protective cover). Use the screwdriver to press on each screw while lifting the rear of the unit slightly off the flat surface to disconnect the Power Supply Module from the chassis .

STEP 3. Carefully lift unit high enough to remove Power Supply Module from beneath the unit.

REPLACE POWER SUPPLY MODULE

STEP 1. With unit laying top-up on a flat surface, position the Power Supply Module on the chassis and press gently to ensure that the connector pins properly engage.

3-26. REPLACEMENT OF POWER SUPPLY (A2A10) (Cont.)

REPLACE POWER SUPPLY (Cont.)

STEP 2. Carefully, to prevent the Power Supply Module from falling out of the chassis, turn the unit over and use a cross-point screwdriver to tighten the 4 captive-screws (that secure the Power Supply Module to the chassis.

STEP 3. Refer to para. 3-6 to replace unit in case, and para. 3-5 to perform operational check of UUT.

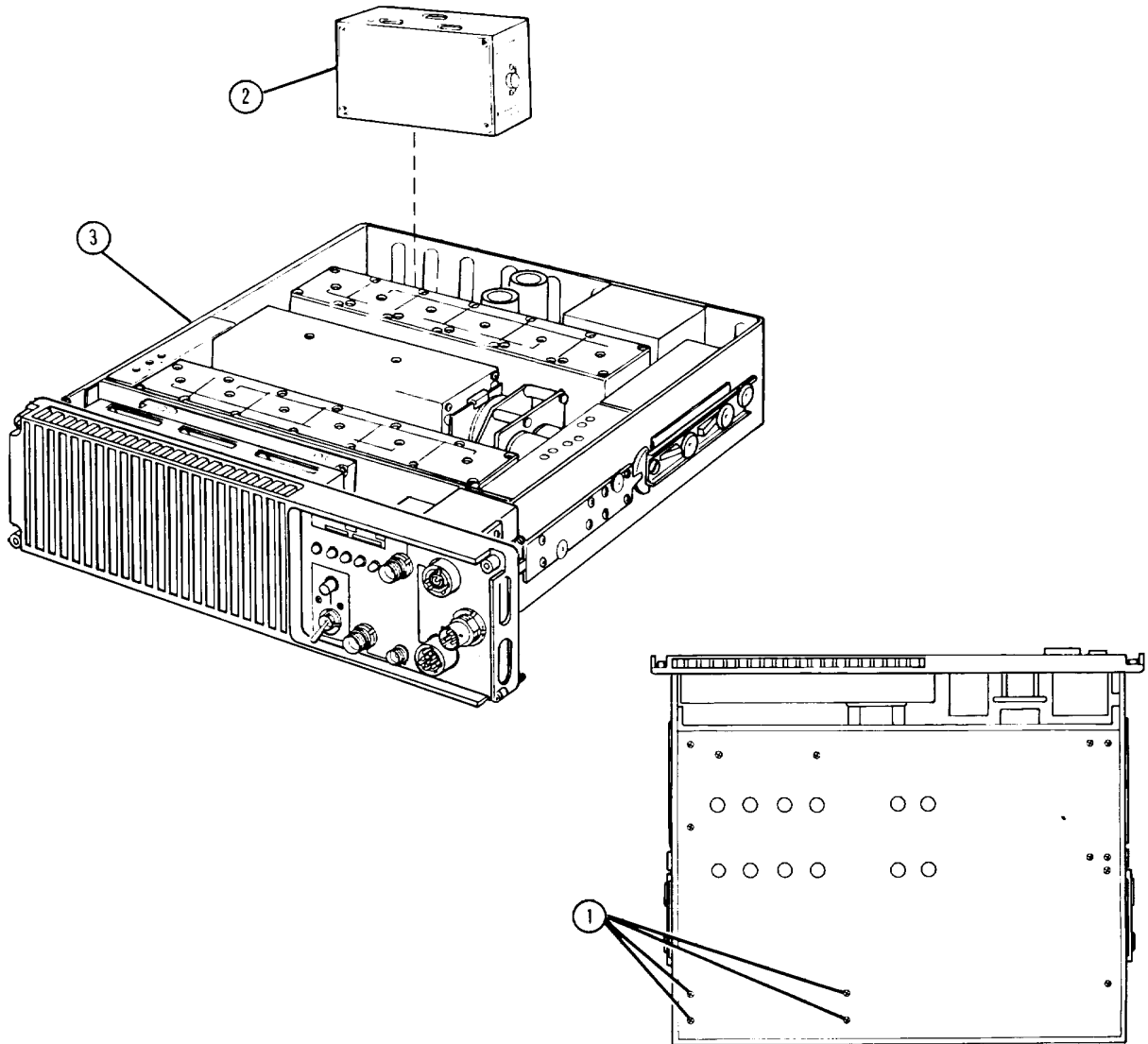

3-27. REPLACEMENT OF OVERLOAD MODULE (A2A3)

INITIAL SETUP

Tools

Tool Kit, TK-17
Workstation, Static

Equipment Conditions

PPS PRIM PWR switch off and all cables removed.

Material/Parts

Overload Module, A2A3, P/N A3026054

CAUTION

This equipment contains components that are sensitive to damage by electrostatic discharge (ESD). Improper handling will result in component and assembly failure. Use extreme care when handling. Refer to DOD-HDBK-263 for proper handling procedures.

REMOVE OVERLOAD MODULE

STEP 1. Refer to para. 3-6 to remove unit from case.

CAUTION

Read STEP 2 and STEP 3 prior to performing either step to prevent possible damage to Pre/Post Selector or the Overload Module.

STEP 2. With the unit laying top-down on a flat surface, use a cross-point screwdriver to loosen 4 captive-screws on the bottom of the unit (these screws are accessible through the protective cover). Use the screwdriver to press on each screw while lifting the rear of the unit slightly off the flat surface to disconnect the Overload Module from the chassis

STEP 3. Carefully lift unit high enough to remove the Overload Module from beneath the unit.

REPLACE OVERLOAD MODULE

STEP 1. With unit laying top up on a flat surface, position the Overload Module on the Chassis and press gently to ensure the connector pins properly engage.

3-27. REPLACEMENT OF OVERLOAD MODULE (A2A3) (Cont.)

REPLACE OVERLOAD MODULE (Cont.)

STEP 2. Carefully, to prevent the Overload Module from falling out of the chassis, turn the unit over and use a cross-point screwdriver to tighten the 4 captive-screws (that secure the Overload Module to the chassis.

STEP 3. Refer to para. 3-6 to replace unit in case, and para. 3-5 to perform operational check of UUT.

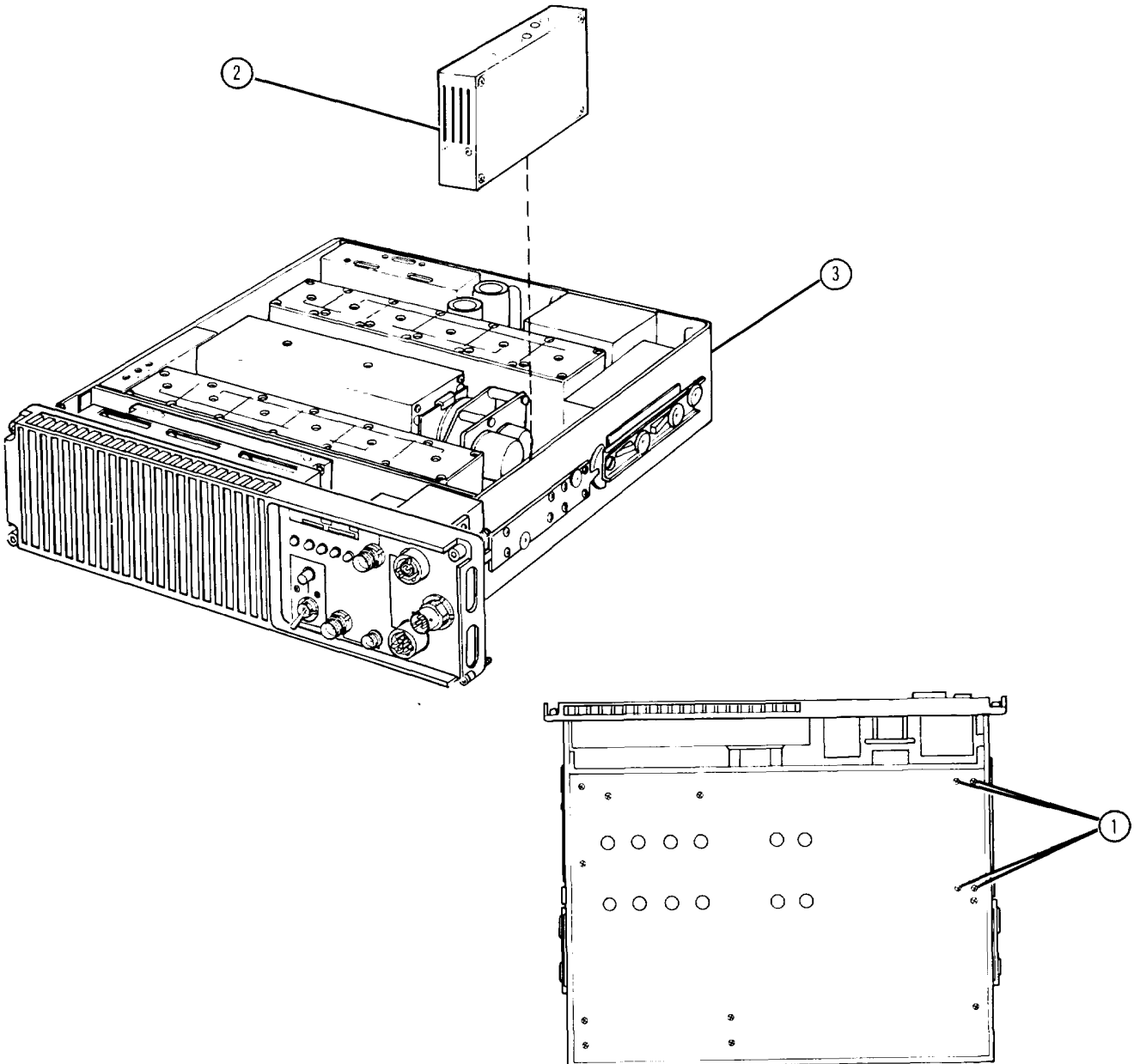

3-28. REPLACEMENT OF PTT AND OVERRIDE CONTROL MODULE (A2A4)

INITIAL SETUP

Tools

Tool Kit, TK-17
Workstation, Static

Equipment Conditions

PPS PRIM PWR switch off and all cables removed.

Material/Parts

PTT and Override Control Module, A2A4, P/N A3026055

CAUTION

This equipment contains components that are sensitive to damage by electrostatic discharge (ESD). Improper handling will result in component and assembly failure. Use extreme care when handling. Refer to DOD-HDBK-263 for proper handling procedures.

REMOVE PTT AND OVERRIDE CONTROL MODULE

STEP 1. Refer to para. 3-6 to remove unit from case.

CAUTION

Read STEP 2 and STEP 3 prior to performing either step to prevent possible damage to Pre/Post Selector or the PTT and Override Control Module.

STEP 2. With the unit laying top-down on a flat surface, use a cross-point screwdriver to loosen 2 captive-screws on the bottom of the unit (these screws are accessible through the protective cover). Use the screwdriver to press on each screw while lifting the rear of the unit slightly off the flat surface to disconnect the PTT and Override Control Module from the chassis.

STEP 3. Carefully lift unit high enough to remove the PTT and Override Control Module from beneath the unit.

REPLACE PTT AND OVERRIDE CONTROL

STEP 1. With unit laying top-up on a flat surface, position the PTT and Override Control Module on the chassis and press gently to ensure the connector pins properly engage.

3-66

3-28. REPLACEMENT OF PTT AND OVERRIDE CONTROL MODULE (A2A4) (Cont.)

REPLACE PTT AND OVERRIDE CONTROL (Cont.)

STEP 2. Carefully, to prevent the PTT and Override Control Module from falling out of the chassis, turn the unit over and use a cross-point screwdriver to tighten the 2 captive screws that secure the module to the chassis.

STEP 3. Refer to para. 3-6 to replace unit in case, and para. 3-5 to perform operational check of UUT.

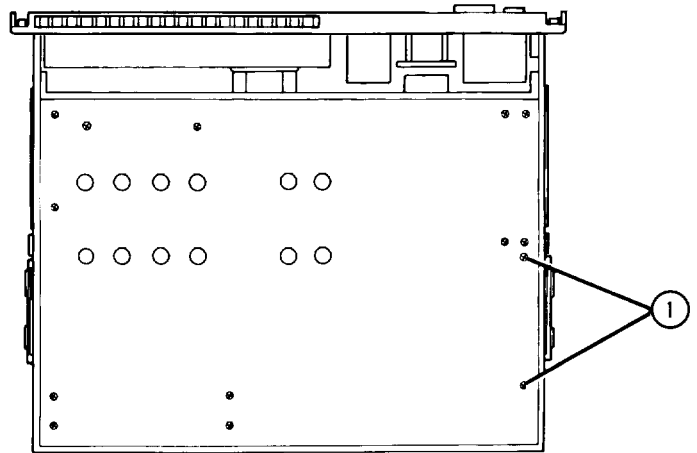
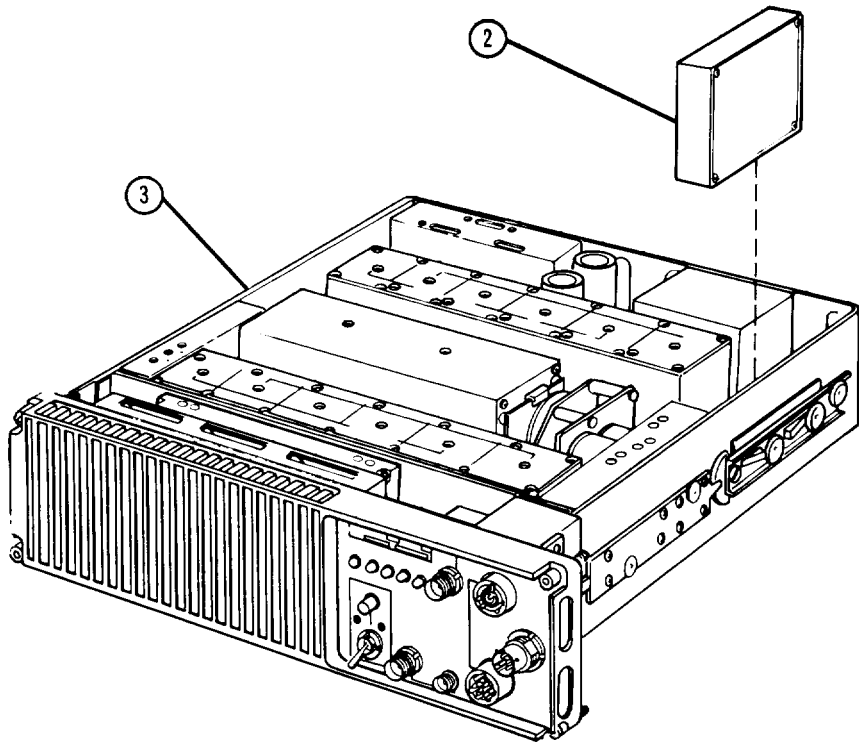

3-29. REPLACEMENT OF RF/RX AMPLIFIER MODULE (A2A5)

INITIAL SETUP

Tools

Tool Kit, TK-17
Workstation, Static

Equipment Conditions

PPS PRIM PWR switch off and all cables removed.

Material/Parts

RF/RX Amplifier Module, A2A5, P/N A3026056

CAUTION

This equipment contains components that are sensitive to damage by electrostatic discharge (ESD). Improper handling will result in component and assembly failure. Use extreme care when handling. Refer to DOD-HDBK-263 for proper handling procedures.

REMOVE RF/RX AMPLIFIER MODULE

STEP 1. Refer to para. 3-6 to remove unit from case.

CAUTION

Read STEP 2 and STEP 3 prior to performing either step prevent possible damage to Pre/Post Selector or the RF/RX Amplifier Module.

STEP 2. With the unit laying top down on a flat surface, use a cross-point screwdriver to loosen 2 captive screws on the bottom of the unit (these screws are accessible through the protective cover). Use the screwdriver to press on each screw while lifting the rear of the unit slightly off the flat surface to disconnect the RF/RX Amplifier Module from the chassis.

STEP 3. Carefully lift unit high enough to remove the RF/RX Amplifier Module from beneath the unit.

REPLACE RF/RX AMPLIFIER

STEP 1. With unit laying top-up on a flat surface, position the RF/RX Amplifier Module on the chassis and press gently to ensure the connector pins properly engage.

3-29. REPLACEMENT OF RF/RX AMPLIFIER MODULE (A2A5) (Cont.)

REPLACE RF/RX AMPLIFIER (Cont.)

STEP 2. Carefully, to prevent the RF/RX Amplifier Module from falling out of the chassis, turn the unit over and use a cross-point screwdriver to tighten the 2 captive screws O that secure the RF/RX Amplifier Module to the chassis.

STEP 3. Refer to para. 3-6 to replace unit in case, and para. 3-5 to perform operational check of UUT.

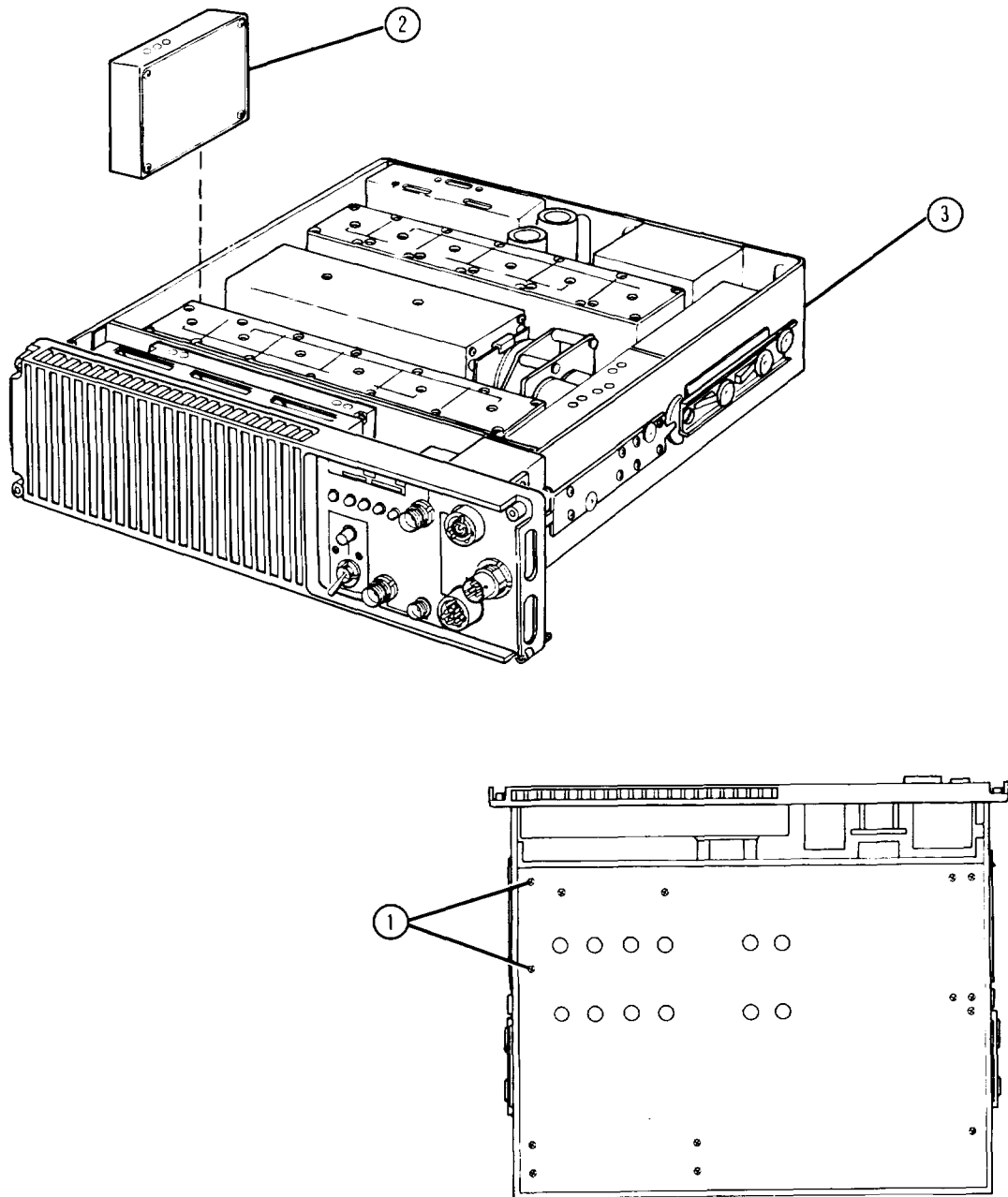

3-30. REPLACEMENT OF MICROPROCESSOR MODULE (A2A2)

INITIAL SETUP

Tools

Tool Kit, TK-17
Workstation, Static

Equipment Conditions

PPS PRIM PWR switch off and all cables removed.

Material/Parts

Microprocessor Module, A2A2, P/N A3026053

CAUTION

This equipment contains components that are sensitive to damage by electrostatic discharge (ESD). Improper handling will result in component and assembly failure. Use extreme care when handling. Refer to DOD-HDBK-263 for proper handling procedures.

REMOVE MICROPROCESSOR MODULE

STEP 1. Refer to para. 3-6 to extend unit into locked position on slides.

STEP 2. Refer to para 3-24, steps 1 through 3, to remove front panel.

STEP 3. Locate Microprocessor Module , and use a flat-blade screwdriver to loosen, then remove, the 4 screws and washers .

STEP 4. Lift and remove the Microprocessor Module from the chassis

REPLACE MICROPROCESSOR MODULE

STEP 1. Aline Microprocessor Module with guide pins and seat module onto chassis 3 .

STEP 2. Install, and use a flat-blade screwdriver to tighten, the 4 screws and washers .

STEP 3. Refer to paragraph 3-24 to reinstall front panel.

STEP 4. Refer to para. 3-6 to replace unit in case, and para. 3-5 to perform operational check of UUT.

3-30. REPLACEMENT OF MICROPROCESSOR MODULE (A2A2) (Cont.)

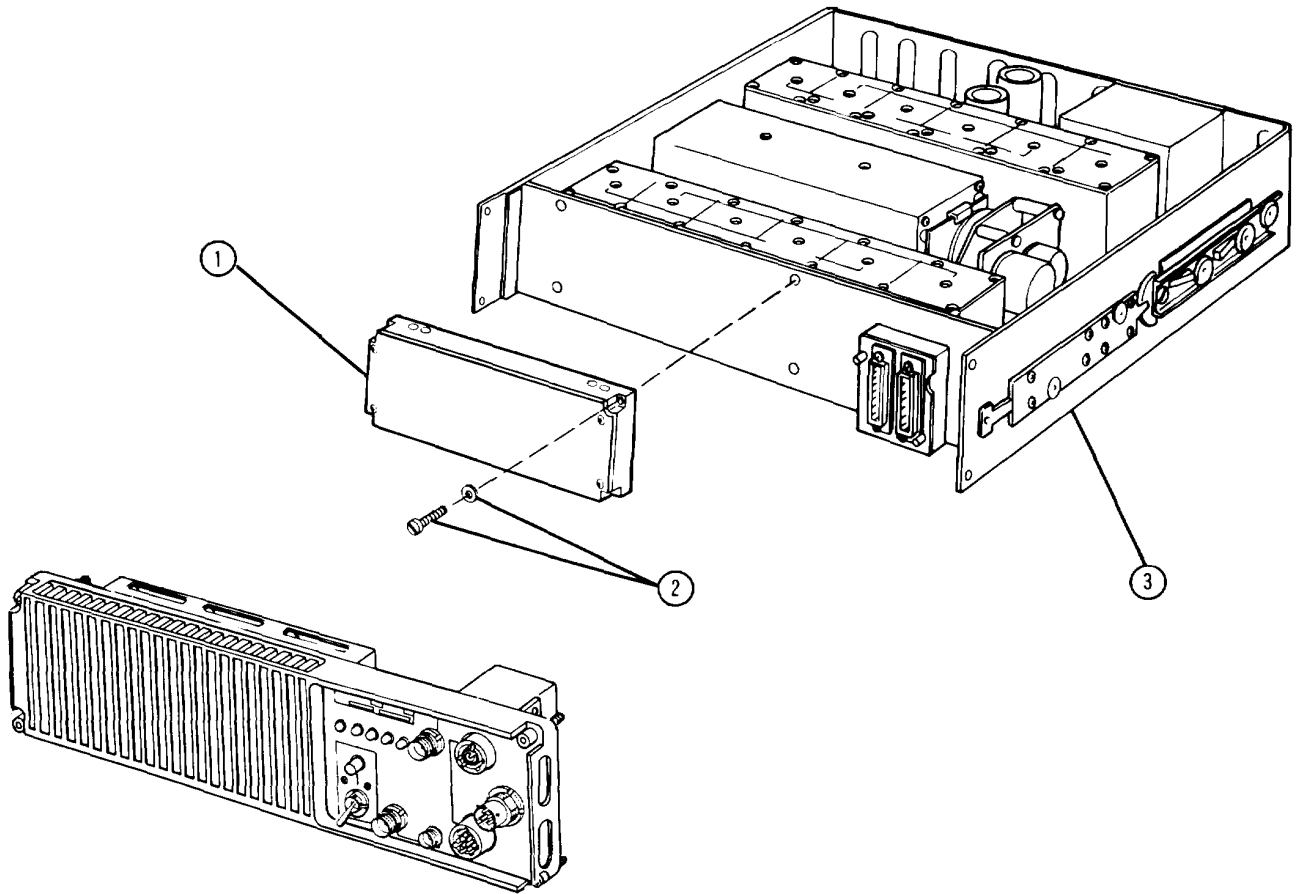

3-71/(3-72 BLANK)

**APPENDIX A
REFERENCES**

A-1. SCOPE

This Appendix lists all technical manuals required for Maintenance of Pre/Post Selector TN-612/G.

A-2. PUBLICATIONS

Consolidated Index of Army Publications and Blank Forms	DA Pam 25-30
Field Instructions for Painting and Preserving Electronics Command Equipment Including Camouflage Pattern Painting of Electrical Equipment Shelters	TB 43-0118
Numerical Index of Departmental Forms	AF REG 0-9
Numerical Index of Standard and Recurring Air Force Publications	AF REG 0-2
Operator's and Unit Maintenance Manual for Communications Terminal AN/TRC-179(V) 1 (NSN 5895-01-156-0411)	TM 11-5895-1218-12/ Navy EE150-LQ-OMI-010/W110-TRC179V1/ Air Force TO 31R2-2TRC179-1
Operator's and Unit Maintenance Manual for Communications Terminal AN/TRC-179(V)2 (NSN 5895-01-156-0412)	TM 11-5895-1219-12/ Navy EE150-LR-OMI-010/W110-TRC179V2/ Air Force TO 31R2-2TRC179-1
Operator, Unit, Intermediate Direct Support and General Support Maintenance Manual including Repair Parts and Special Tools List for Test Set, Pre/Post Selector TS-4247/G (NSN 6625-01-267-4403)	TM 11-6625-3220-14&P/ Navy ET800-CC-OMP-010/TS4247G/ Air Force TO 33D7-19-5-1

Painting and Preservation Supplies Available for
Field Use of Electronics Command Equipment SB 11-573

Procedures for Destruction of Electronics Materiel to Prevent Enemy
Use (Electronics Command) TM 750-244-2

Safety Measures to be Observed When Installing
and Using Whip Antennas, Field Type Masts
Towers and Antennas and Metal Poles that are
Used With Communications, Radar, and Direction
Finder Equipment TB 43-0129

The Army Maintenance Management System
(TAMMS) DA Pam 738-750

Unit, Intermediate Direct Support and General
Support Maintenance Repair Parts and
Special Tools List (Including Depot
Maintenance Repair Parts and Special Tools)
for Tuning Unit, Pre/Post Selector TN-612/G
(NSN 5985-01-205-0877) TM 11-5895-1305-24P/
EE020-HJ-PLD-010/W110-TN612G/
TO 31R2-4-572-4

**APPENDIX B
MAINTENANCE ALLOCATION CHART**

Section I. INTRODUCTION

B-1. GENERAL

This appendix provides a summary of the maintenance operation for Tuning Unit, Pre/Post Selector TN-612/G. It authorizes levels of maintenance for specific maintenance functions on repairable items and components and the tools and equipment required to perform each function. This appendix may be used as an aid in planning maintenance operations.

B-2. MAINTENANCE FUNCTION

Maintenance functions will be limited to and defined as follows:

- a. Inspect. To determine the serviceability of an item by comparing its physical, mechanical, and/or electrical characteristics with established standards through examination.
- b. Test. To verify serviceability and to detect incipient failure by measuring the mechanical or electrical characteristics of an item and comparing those characteristics with prescribed standards.
- c. Service. Operations required periodically to keep an item in proper operating condition, i.e., to clean (decontaminate), to preserve, to drain, to paint, or to replenish fuel, lubricate, hydraulic fluids, or compressed air supplies.
- d. Adjust. To maintain, with prescribed limits, by bringing into proper or exact position, or by setting the operating characteristics to the specified parameters.
- e. Aline. To adjust specified variable elements of an item to bring about optimum or desired performance.
- f. Calibrate. To determine and cause corrections to be made or to be adjusted on instruments or test measuring and diagnostic equipment used in precision measurement. Consists of comparisons of two instruments, one of which is a certified standard of known accuracy, to detect and adjust any discrepancy in the accuracy of the instrument being compared.
- g. Install. The act of emplacing, seating, or fixing into position an item, part, module (component or assembly) in a manner to allow the proper functioning of the equipment or system.
- h. Replace. The act of substituting a serviceable like type part,

subassembly, or module (component or assembly) for an unserviceable counterpart.

- i. Repair. The application of maintenance services (inspect, test, service, adjust, align, calibrate, replace) or other maintenance actions (welding, grinding, riveting, straightening, facing, remachining, or resurfacing) to restore serviceability to an item by correcting specific damage, fault, malfunction, or failure in a part, subassembly, module (component or assembly), end item, or system.
- l. Overhaul. That maintenance effort (service/action) necessary to restore an item to a completely serviceable/operational condition as prescribed by maintenance standards (i.e., DMWR) in appropriate technical publications. Overhaul is normally the highest degree of maintenance performed by the Army. Overhaul does not normally return an item to like new condition.
- k. Rebuild. Consists of those services/actions necessary for the restoration of unserviceable equipment to a like new condition in accordance with original manufacturing standards. Rebuild is the highest degree of material maintenance applied to Army equipment. The rebuild operation includes the act of returning to zero those age measurements (hours, miles, etc.) considered in classifying Army equipment/components.

B-3. COLUMN ENTRIES (SECT. II)

a. Column 1, Group Number. Column 1 lists group numbers, the purpose of which is to identify components, assemblies, subassemblies, and modules with the next higher assembly.

b. Column 2, Component/Assembly. Column 2 contains the noun names of components, assemblies, subassemblies, and modules for which maintenance is authorized.

c. Column 3, Maintenance Functions. Column 3 lists the functions to be performed on the item listed in column 2. When items are listed without maintenance functions, it is solely for purpose of having the group numbers in the MAC and RPSTL coincide.

d. Column 4, Maintenance Level. Column 4 specifies, by the listing of a work time figure in the appropriate subcolumn(s), the lowest level of maintenance authorized to perform the function listed in column 3. This figure represents the active time required to perform that maintenance function at the indicated level of maintenance. If the number or complexity of the tasks within the listed maintenance function vary at different maintenance levels, appropriate work time figures will be shown for each category. The number of task-hours specified by the work time figure represents the average time required to restore an item (assembly, subassembly, component, module, end item or system) to a serviceable condition under typical field operating conditions. This time includes preparation time, troubleshooting time, and quality assurance/quality control time in addition to the time required to perform the specific tasks identified for the maintenance functions authorized in the maintenance allocation chart.

Subcolumns of column 4 are as follows:

UNIT

- C - Operator/Crew
- O - Organizational/Unit

INTERMEDIATE

- F - Direct Support
- H - General Support
- L - Special Repair Activity (SRA)

DEPOT

- D - Depot

e. Column 5, Tools and Equipment. Column 5 specifies by code, those common tool sets (not individual tools) and special tools, test, and support equipment required to perform the designated function.

f. Column 6, Remarks. Column 6 contains an alphabetic code which leads to the remark in section IV, Remarks, which is pertinent to the item opposite the particular code.

B-4. TOOL AND TEST EQUIPMENT REQUIREMENTS (SECT. III)

a. Tool or Test Equipment Reference Code. The numbers in this column coincide with the numbers used in the tools and equipment column of the MAC. The numbers indicate the applicable tool or test equipment for the maintenance functions.

b. Maintenance Level. The codes in this column indicate the maintenance level allocated the tool or test equipment.

c. Nomenclature. This column lists the noun name and nomenclature of the tools and test equipment required to perform the maintenance functions.

d. National/NATO Stock Number. This column lists the National/NATO stock number of the specific tool or test equipment.

e. Tool Number. This column lists the manufactures part number of the tool followed by the Federal Supply Code for manufactures (5 digit) in parentheses.

B-5. REMARKS (SECT. IV)

a. Reference Code. This code refers to the appropriate item in section II, column 6.

b. Remarks. This column provides the required explanatory information necessary to clarify items appearing in section II.

**SECTION II. MAINTENANCE ALLOCATION CHART
FOR
TUNER UNIT, P/P SELECTOR TN-612/G**

(1) GROUP NUMBER	(2) COMPONENT ASSEMBLY	(3) MAINTENANCE FUNCTION	(4) MAINTENANCE LEVEL					(5) TOOLS AND EQUIPMENT	(6) REMARKS
			C	O	F	H	D		
00	TUNING UNIT, PRE/POST SELECTOR TN-612/G (A3023760)	REPLACE TEST TEST TEST REPAIR REPAIR REPAIR OVERHAUL		0.1 0.1 0.1		1.0 L(3.0) 1.0 L(2.5)	40.0	1 2-5,7-20 TBD 1 6,14 TBD TBD	A B C,D D,E,G K C,D D,E,G
01	HOUSING ASSEMBLY AI (A3026049)	REPAIR				0.5	6		
02	CHASSIS ASSEMBLY A2 (A3031346)	REPLACE REPAIR REPAIR		0.1		1.0 L(2.5)	1	L F F	
0201	CHASSIS ASSEMBLY A2A15 (A3031088)	TEST TEST REPAIR REPAIR				1.0 L(1.5) 1.0 L(1.0)	2,11,14,18 TBD 6,14 TBD	D,F D,F,G D,F,J D,F,G,H	
020101	COIL CASE ASSEMBLY A2A15A6 (A3030955)	REPAIR				L(0.5)		F,G	
020102	COIL CASE ASSEMBLY A2A15A6 (A3030955)	REPAIR				L(0.5)		F,G	
020103	SENSOR ASSEMBLY AZA15AB AZA15A7 (A3030959)	REPAIR				L(0.5)		F,G	
02010301	CCA (A3031244)	REPAIR				L(0.5)		F,G	
020104	CCA #2 AZA15A1Z (A3031231)	REPAIR				L(0.5)		F,G	
020105	CCA #1 AZA15A11 (A3030963)	REPAIR				L(0.5)		F,G	
020106	CONNECTION ASSEMBLY (A3030964)	REPAIR				L(0.5)		F,G	
020107	CONNECTION ASSEMBLY A2A15A13 (A3026549-1)	REPAIR				L(0.5)		F,G	
020108	VARIABLE ASSEMBLY AZA15A14 (A3026549-2)	REPAIR				L(0.5)		F,G	
0202	FRONT PANEL A2A1 (A3031144)	REPLACE TEST REPAIR REPAIR				0.1 L(1.5) 0.5 L(1.0)	6,14 TBD 6 TBD	D D,G D,F,M D,G,H	
020201	CCA AZA1AI (A3031046)	REPAIR				L(1.0)		F,G	
0203	MICROPROCESSOR MODULE A2A2 (A3026053)	REPLACE TEST REPAIR				0.1 L(1.5) L(1.0)	6,14 TBD TBD	D D,G D,G,H	

SECTION II. MAINTENANCE ALLOCATION CHART
FOR
TM-612/G

(1) GROUP NUMBER	(2) COMPONENT ASSEMBLY	(3) MAINTENANCE FUNCTION	(4) MAINTENANCE LEVEL					(5) TOOLS AND EQUIPMENT	(6) REMARKS
			C	O	F	H	D		
020301	CCA A2A2A1 (A3026558)	REPAIR				L(1.0)			F,G
0204	OVERLOAD MOOULE A2A3 (A3026054)	REPLACE TEST REPAIR				0.1 L(1.5) L(1.0)	6,14 TBD TBD		D D,G D,G,H
020401	CCA A2A3A1 (A3026558)	REPAIR				L(1.0)			F,G
0205	PTT/OVERRIDE CONTROL MODULE AZA4 (A3026055)	REPLACE TEST REPAIR				0.1 L(1.5) L(1.0)	6,14 TBD TBD		D D,G D,G,H
020501	CCA AZA4A1 (A3026187)	REPAIR				L(1.0)			F,G
0206	RF/RX AMPLIFIER ASSY A2A5 (A3026056)	REPLACE TEST REPAIR				0.1 L(1.5) L(1.0)	6,14 TBD TBD		D D,G D,G,H
020601	CCA A2A5A1 (A3026562)	REPAIR				L(1.0)			F
0207	POWER SUPPLY MODULE A2A10 (A3026057)	REPLACE TEST REPAIR				0.1 L(0.7) L(1.0)	6,14 TBD TBD		D D,G D,G,H
020701	P.S. CCA #1 AZA1OAI (A3030843)	REPAIR				L(1.0)			F,G
020702	P.S. CCA #2 A2A1OAZ (A3026564)	REPAIR				L(1.0)			F,G

**SECTION III. TOOL AND TEST EQUIPMENT REQUIREMENTS
FOR
TUNER UNIT, P/P SELECTOR TN-612/G**

TOOL OR TEST EQUIPMENT REF CODE	MAINTENANCE CATEGORY	NOMENCLATURE	NATIONAL/NATO STOCK NUMBER	TOOL NUMBER
1	O	KEY SET SOCKET HEAD (METRIC)	5120-00-112-9599	
2	H	MULTIMETER, DIGITAL AN/USM-486	6625-01-145-2430	FLUKE 8050A-01
3	H	POWER METER AN/USM-491	6625-01-191-7679	BOONTON 4200-6E
4	H	SIGNAL GENERATOR SG-1170/U	6625-01-120-3501	WAVETEK 3001-608
5	H	GENERATOR, TRACKING SG-1122/U	6625-00-155-5990	HP 8443A
6	H	TOOL KIT, ELEC. TK-17 (INCL. METRIC)	5180-01-195-0855	JENSEN JTK-17RM
7	H	SPECTRUM ANALYZER IP-1216(P)/GR	6625-01-424-4370	HP 141T
8	H	POWER AMPLIFIER AM-7353/G	5895-01-255-4151	ENI 325LA
9	H	TEST SET, PRE/POST SELECTOR TS-4247/G	6625-01-267-4403	MX-900152-801
10	H	ATTENUATOR 100W, 30dB, 50 Ohms	5895-01-286-7278	BIRD 8323
11	H	OSCILLOSCOPE AN/USM-488	6625-01-187-7847	TEK 2235L
12	H	PLUG-IN I.F. PL-1388/U	6625-00-431-9339	HP 8552B
13	H	PLUG-IN R.F. PL-1399/U	6625-00-432-5055	HP 8553B
14	H	WORK STATION, STATIC	4940-01-087-3458	3M-8021
15	H	TEST CABLE, RG-58 BNC to BNC (4 ea.)	5995-00-724-4232	ITT PAMONA 2249-C-48
16	H	ADAPTER, BNC to TNC (2 ea.)	5935-00-701-2215	PAMONA 3844A
17	H	ADAPTER, UG-ZO1/A BNC to N (5 ea.)	5935-00-259-0205	
18	H	KIT, TEST LEAD (FOR FLUKE)	6625-00-444-4041	
19	H	ATTENUATOR, 200 W, 30 dB, 50 Ohms	5985-00-763-8025	BIRD 8322
20	H	ADAPTER, UG-1034/G BNC to N	5935-00-204-5098	M55339/01 -00001

SECTION IV. REMARKS

TUNER UNIT, P/P SELECTOR TN-612/G

REFERENCE CODE	REMARKS
A	HOUSING ASSEMBLY/CASE WILL REMAIN IN RACK.REPLACE CHASSIS ASSY A2. CASE OF REPLACEMENT PRE/POST SELECTOR WILL BE USED AS A SHIPPING CONTAINER.
B	BUILT-IN-TEST (BIT).TESTED AS PART OF NEXT HIGHER ASSEMBLY.
C	INTERMEDIATE MAINTENANCE FAULT ISOLATES AND REPLACES THE FOLLOWING SUBASSEMBLIES: FRONT PANEL ASSEMBLY A2A1, MICROPROCESSOR MODULE A2A2, OVERLOAD MODULE A2A3, PTT/OVERRIDE MODULE A2A4, RF/RX AMP ASSY A2A5 AND PS MODULE A2A10. GENERAL SUPPORT ALSO PERFORMS QUALITY TEST, AND REPLACES CHASSIS MOUNTED COMPONENTS AND FRONT PANEL INDICATOR LAMPS.
D	ELECTROSTATIC SENSITIVE COMPONENTS.
E	SRA REPAIRS/TESTS SUBASSEMBLIES AND DOES COMPLETE CHASSIS REPAIR, INCLUDING MECHANICAL ASSEMBLIES.
F	REPAIR/TESTED AS PART OF NEXT HIGHER ASSEMBLY.
G	SPECIALIZED REPAIR ACTIVITY (SRA).NOTE: INITIAL SRA REPAIR WILL BE PERFORMED BY CONTRACTOR. RETURN DEFECTIVE UNIT(S) TO DEPOT.
H	REPAIR TO PIECE PART LEVEL.
I	CONTRACTOR REPAIR.
J	G.S. REPLACES CHASSIS MOUNTED COMPONENTS.
K	REPLACES FRONT INDICATOR LAMP AND DEFECTIVE CHASSIS ASSEMBLY, A2. PPS CASE/HOUSING ASSY WILL REMAIN IN THE RACK. CASE OF REPLACEMENT PPS WILL BE USED AS A SHIPPING CONTAINER.
L	SEE RELATED NOTE A UNDER GROUP 00.
M	REPLACES FRONT PANEL STATUS INDICATOR LAMPS.

B-7/(B-8 BLANK)

**APPENDIX C
EXPENDABLE/DURABLE SUPPLIES
AND MATERIALS LIST**

Section I. INTRODUCTION

C-1. SCOPE

This appendix lists expendable supplies and materials you will need to operate and maintain Tuning Unit, Pre/Post Selector TN-612/G. These items are authorized to you by CTA 50-970, Expendable items (except medical, class V, repair parts, and heraldic items).

C-2. EXPLANATION OF COLUMNS

a. Column (1), Item Number. This number is assigned to the entry in the listing and is referenced in the narrative instructions to identify the material (e.g. use cleaning compound, item 1, appendix C).

b. Column (2), Level. This column identifies the lowest level of maintenance that requires the listed item.

- C - Operator/Crew
- O - Organizational/Unit
- F - Direct Support/Intermediate Direct Support
- H - General Support/Intermediate General Support
- L - Special Repair Activity

c. Column (3), National Stock Number. This is the national stock number assigned to the item; use it to request or requisition the item.

d. Column (4), Description. Indicates the federal item name and, if required, a description to identify the item. The last line for each item indicates the Federal Supply Code for Manufacturers (FSCM) in parentheses, if applicable.

e. Column (5), Unit of Measurement (U/M). Indicates the measure used in performing the actual maintenance function. This measure is expressed by a two-character abbreviation (e.g., ea, in, pr). If the unit of measure differs from the unit of issue, requisition the lowest unit of issue that will satisfy your requirements.

Section II. EXPENDABLE/DURABLE SUPPLIES AND MATERIALS LIST

(1) Number	(2) Level	(3)	(4)	(5) National Number	Description	U/M
1	0				6850-00-105-3084 ROETHANE OT620 (81348)	TRICHLOROTRIFLUO oz
2	H				8040-00-843-0802 SILICONE (81349)	ADHESIVE/SEALANT oz
3	H				8030-00-823-7927 (81349)	LOCKING COMPOUND
	oz					

**GLOSSARY
OF ABBREVIATIONS, ACRONYMS
AND UNUSUAL TERMS**

Section I. ABBREVIATIONS AND ACRONYMS

A

AC Alternating Current
ANT Antenna
ATT Attenuator

B

BCD Binary Coded Decimal
BIT Built-In Test
BITE Built-In Test Equipment

C

CCA Circuit Card Assembly

D

dB Decibel
dBm Decibel measured in milliwatts
dc Direct Current

E

ECCM Electronic Counter Counter-Measures
EMI Electromagnetic Interference
EMP Electromagnetic Pulse

F

FCP Frequency Change Pulse
FO Fold Out
Freq Frequency

G

Gnd Ground

H

Hex Hexagonal
HF High Frequency
Hz Hertz

I

IF Intermediate Frequency
IM Intermodulation

K

Kg Kilogram

L

Lbs Pounds

M

MAC Maintenance Allocation Chart

Max Maximum

Mhz Megahertz

MIL STD Military Standard

mm Millimeter

MTOE Modified Table of Organizational Equipment

O

OVDE Override

OVL Overload

P

PEP Peak Envelope Power

PMCS Preventive Maintenance Checks and Services

PRIM Primary

PWR Power

R

Rcvr Receiver

RF Radio Frequency

RPSTL Repair Parts and Special Tools List

Rx Receive(r)

S

SCR Silicon Controlled Rectifier

SRA Special Repair Activity

SRU Shop Replaceable Unit

SWR Standing-Wave Ratio

T

TA Table of Allowances
TB Technical Bulletin
TMDE Test, Measurement, and Diagnostic Equipment
Tx Transmit(ter)

U

UUT Unit Under Test

V

V Voltage
V Voltage
VAC Voltage Alternating Current
Vdc Voltage Direct Connect
Vol Volume
Vol Volume
Vrms Voltage, Root Mean Square
VSWR Voltage Standing Wave Ratio

W

W Watt(s)

X

Xmtr Transmitter

Section II. DEFINITION OF UNUSUAL TERMS

BITE INDICATOR LAMP - indicator lamp on Front Panel controlled by BITE for failure indication

BITE CIRCUIT - Circuit which is part of power supply module and monitors and controls important system functions

CHASSIS - Assembly which houses modules and components

DS - Designation for an indicator lamp

DUMMY LOAD - Resistive load used for test purposes instead of antenna

FAILURE SIGNAL - Failure signals are generated by the BITE Module in case of system malfunction

FILTER - Circuit which filters operating frequency in a required range

GND - Ground potential

INDICATOR LAMP - Failure indication lamp on the Front Panel which is controlled by the BITE Module

HARMONICS - Waves at a frequency being multiple of that of a base frequency

OPERATING CONDITION - Condition in which the Pre/Post Selector Unit is connected to all system units (normal condition)

RX - Receive

RX/TX - Receive/Transmit

RX/TX VOLTAGE CONTROL SIGNAL - Signal from BITE Module which controls the Voltage Regulator to provide +26 Vdc/Tx and +5 Vdc/Tx

SHIELD - Ground potential for shielded cable

TEST FIXTURE - Equipment for testing the Pre/Post Selector Unit in test condition

TEST CONDITION - Condition in which the Pre/Post Selector Unit is only connected to test equipment and operating voltage instead of to system units

Third (3rd) Order IM - The third harmonic of the operational frequency produced by harmonic generation in the internal circuitry.

TX - Transmit

SUBJECT INDEX

<u>Subject</u>	<u>Paragraph</u>
Appendix A	A-1
Appendix B	B-1
Appendix C	C-1
B	
Built-in-Test (BIT) of Pre/Post Selector.....	3-5
C	
Capabilities	1-8
Cautions	1-12
Characteristics	1-8
Common Tools and Equipment	2-1, 3-1
Consolidated Index of Publications and Blank Forms	1-3
D	
Description of Major Components	1-9
Destruction of Materiel to Prevent Enemy Use	1-5
E	
Equipment Characteristics, Capabilities, and Features	1-8
Equipment Data	1-11
Equipment Improvements	1-4
Expendable Supplies and Materials List	C-1
F	
Features.....	1-8
Flow Charts and How To Use Them	3-8
Functional Description.....	1-13, 1-14
Functional Description of Major Components	1-14
Functional Description of Pre/Post Selector.....	1-13
Functional Test Power Supply Assembly.....	3-5b

SUBJECT INDEX - (Cont.)

<u>Subject</u>	<u>Paragraph</u>
H	
How to Use This Manual	iii
Identification Plates.....	1-10
Intermediate General Support Maintenance, General.....	3-22
Intermediate General Support Troubleshooting, General.....	3-4
L	
Location and Description of Major Components.....	1-9
M	
Maintenance Allocation Chart.....	APPENDIX B
Maintenance Forms, Records, and Reports.....	1-2
Marking.....	2-14
Measurement of Insertion Loss	3-5
Measurement of Insertion Loss in Override Condition	3-5
Measurement of Overall Gain	3-5
O	
Official Nomenclature, Names, and Designations.1-7	
Operational Test-Measurement of Insertion Loss.....	3-5
Operational Test-Measurement of Insertion Loss in Override Condition	3-5
Operational Test-Measurement of Overall Gain	3-5
P	
Physical Characteristics	1-11
Power Supply Assembly on Pre/Post Selector Test Fixture	3-5
Preliminary Servicing of Equipment	2-6
Preliminary Troubleshooting Procedures.....	3-6
Preparation for Shipment	1-6
Preparation for Shipment, General.....	2-13
Preparation for Storage.....	1-6
Preparation for Storage, General.....	2-13
Publications	APPENDIX A

SUBJECT INDEX - (Cont.)

<u>Subject</u>	<u>Paragraph</u>
R	
Remove Pre/Post Selector	2-11
Repair Parts	2-3, 3-3
Replacement of Bottom Cover	3-25
Replacement of Chassis.....	3-31
Replacement of Front Panel.	3-24
Replacement of Front Panel Lamps	2-12
Replacement of Microprocessor Module	3-30
Replacement of Overload Module	3-27
Replacement of Power Supply	3-26
Replacement of Pre/Post Selector	2-11
Replacement of PRIM PWR Lamp	2-12
Replacement of PTT and Override Control Module	3-28
Replacement of RF/RX Amplifier Module	3-29
Reporting Equipment Improvement Recommendations	1-4
Reporting Recommendations	1-4
S	
Safety, Care, and Handling	1-12
Scope	1-1
Special Tools and Equipment.....	2-2
Special Tools, TMDE, and Support Equipment.....	2-2, 3-2
Symptom Index	3-7
T	
Technical Characteristics	1-11
U	
Unit PMCS Table	2-8
Unit Troubleshooting, General.....	2-9
Unpacking.....	2-4
W	
Warning	Pages B, C, D

By Order of the Secretary of the Army:

Official:

CARL E. VUONO
General, United States Army
Chief of Staff

WILLIAM J. MEEHAN II
Brigadier General, United States Army
The Adjutant General

Distribution:

To be distributed in accordance with special list.

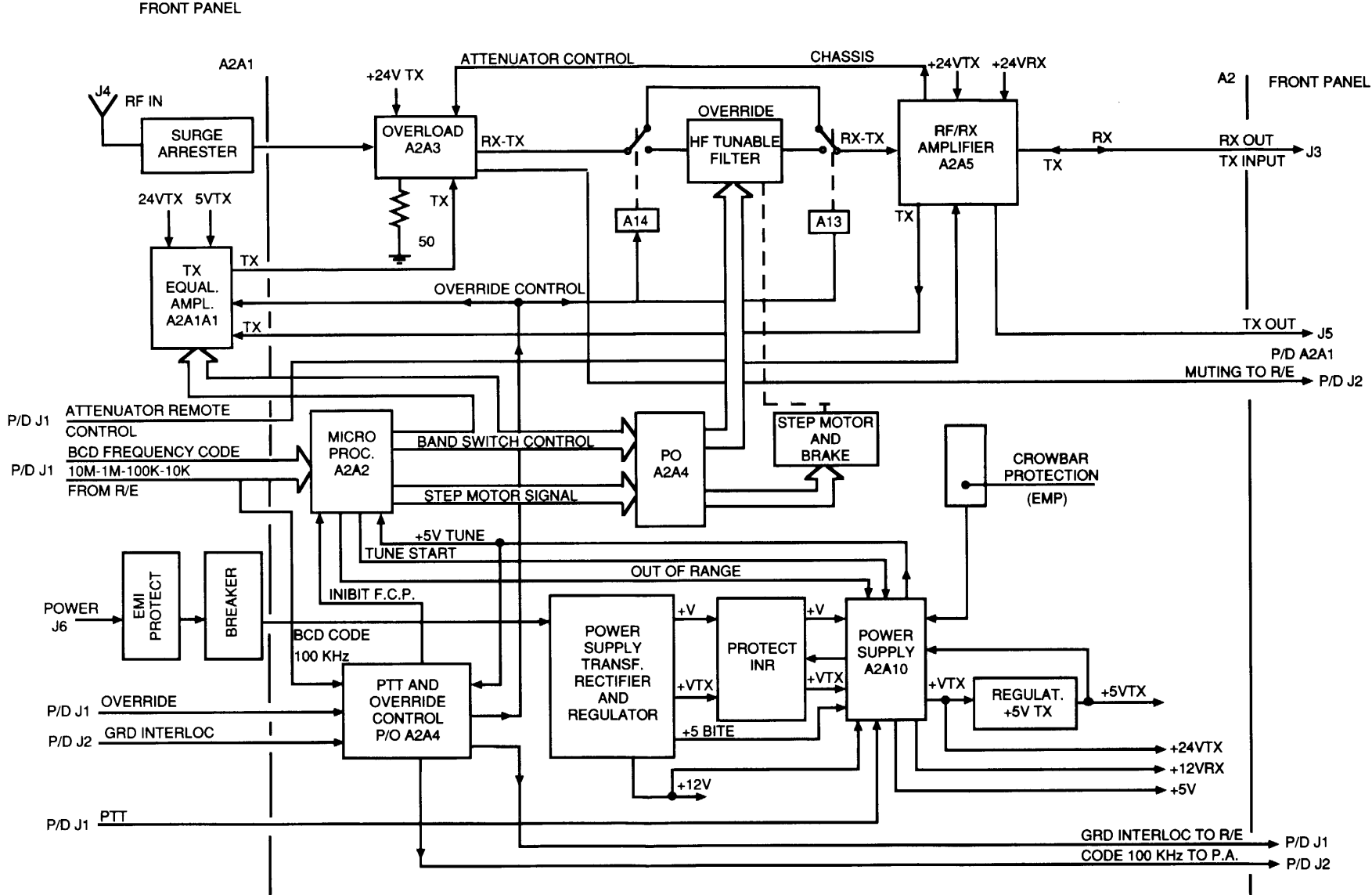

CEONA-001

FO-1. Pre-Post Selector Tn-612/G Functional Block Diagram

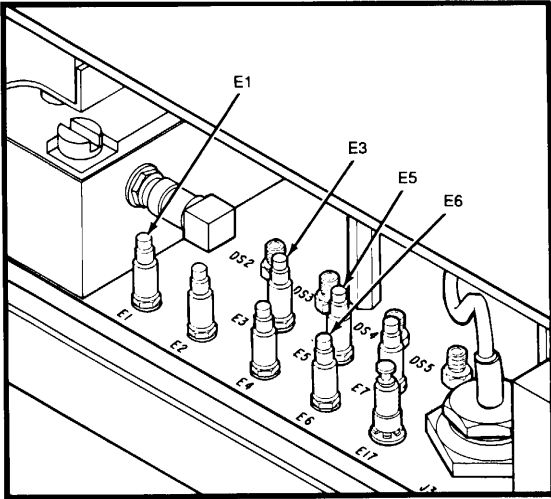
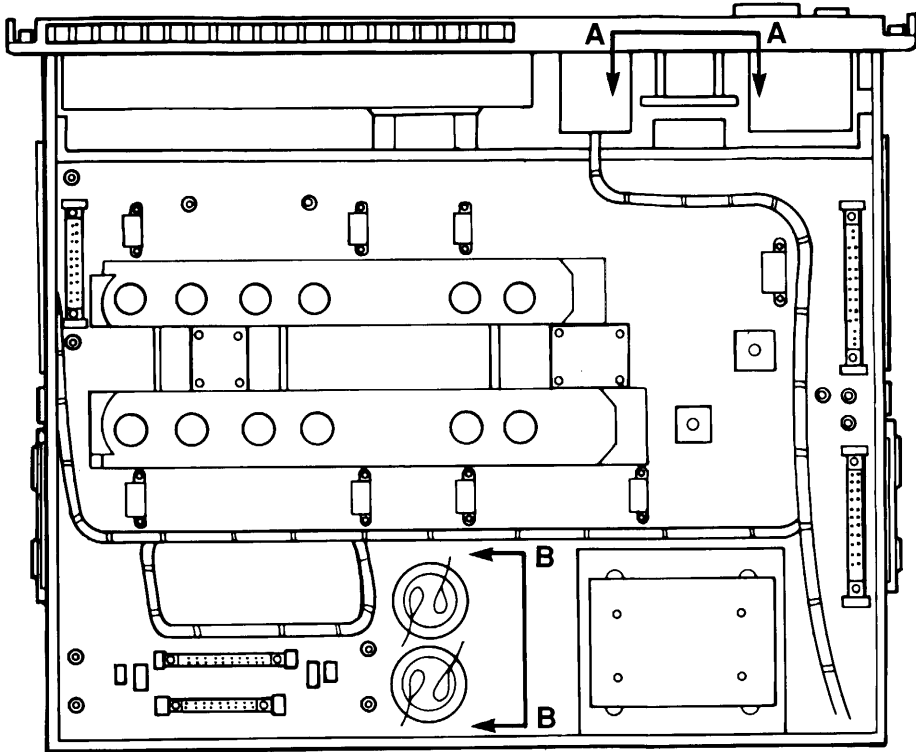

VIEW A

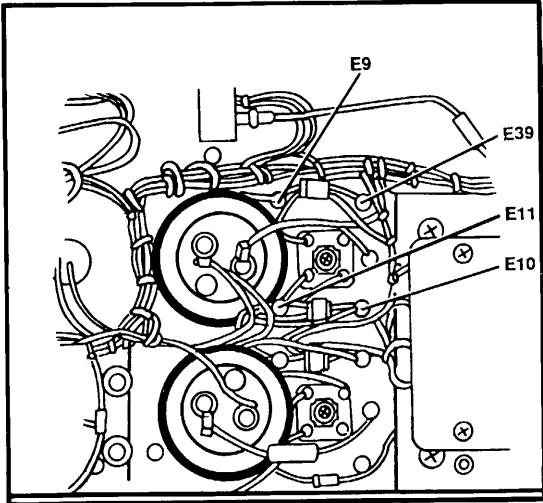

VIEW B

CEONA-002

FO-2. Pre-Post Selector Tn-612/G Test Point Location Diagram

INTEGRATED CIRCUIT TABLE		
REFERENCE DESIGNATION	SECOND TAGGING LINE SYMBOL	PART NUMBER
U1 (ML1), U2 (ML2)	M1	A3026796-1
U3 (ML3)	M2	A3026796-3

CROSS REFERENCE TABLE			
REF DES	ASSEMBLY NUMBER	PRINTED WIRING BOARD	SCHEMATIC NUMBER
A1	A3031144	NA	A3026698
A2	A3026053	NA	A3026692 A3030942
A3	A3026054	NA	A3026101 A3030938
A4	A3026055	NA	A3026694 A3030941
A5	A3026056	NA	A3026695
A6	A3030955	NA	A3026691
A7	A3030959	NA	A3026691
A8	A3031244	NA	A3031233
A9	A3026538	NA	A3026691
A10	A3026057	NA	A3031058/ A3026697
A11	A3030964	A3030951	A3026691
A12	A3030963	A3030952	A3026691
A13	A3026549-1	NA	A3026699
A14	A3026549-2	NA	A3026700

REFERENCE DESIGNATION	
HIGHEST USED	NOT USED
A14 C43 CR16 CV1 CW9 E53 J10 K20 O10 R5 SC2 T1 U3	CR6
A1 A3031144	
J2	
A2 A3026053	
J3	J1, 2
A3 A3026054	
J4	J1 THRU J3
A4 A3026055	
J5	J1 THRU J4
A5 A3026056	
J6	J1 THRU J5
A6 A3030955	
C6 L6 P4	

A7 A3030959	
C6 L6 P4	
A8 A3031244	
PI	
A9 A3026538	
B1 PI	
A10 A3026057	
J8 Q2	J1 THRU J6
A11 A3030964	
C4 E12	
A12 A3030963	
C4 E12	
A13 A3026549-1	
C2 CR1 E2 K1 P6	
A14 A3026549-2	
C2 CR1 E2 K1 P6	

NOTES:

- 1.0 GENERAL:
 - 1.1 CHARACTERS UNDERLINED DENOTE LOWER CASE.
- 2.0 SPECIFIC:
 - 2.1 UNLESS OTHERWISE SPECIFIED:
 - RESISTANCE VALUES ARE IN OHMS.
 - RESISTORS ARE 1%, 5W.
 - CAPACITANCE VALUES ARE IN MICROFARADS.
 - VOLTAGES ARE DC.
 - DIODES AND/OR TRANSISTORS ARE JANTX TYPE.
 - 2.2 PARTIAL REFERENCE DESIGNATIONS ARE SHOWN:
 - FOR COMPLETE DESIGNATION PREFIX WITH UNIT DESIGNATION A2A15.
 - 2.3 PART NUMBER A3026776.
 - 2.4 PART NUMBER A3026779-1.
 - 2.5 PART NUMBER A3026780-1.
 - 2.6 PART NUMBER A3026783-2.
 - 2.7 PART NUMBER A3026791.
 - 2.8 PART NUMBER A3030877.
 - 2.9 FOR CONTINUATION OF CIRCUIT SEE SCHEMATIC A3026691.
 - 2.10 REFERENCE:
 - ASSEMBLY NUMBER A3031088.

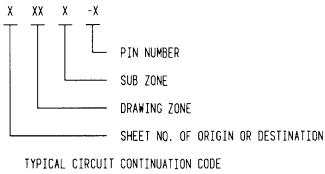

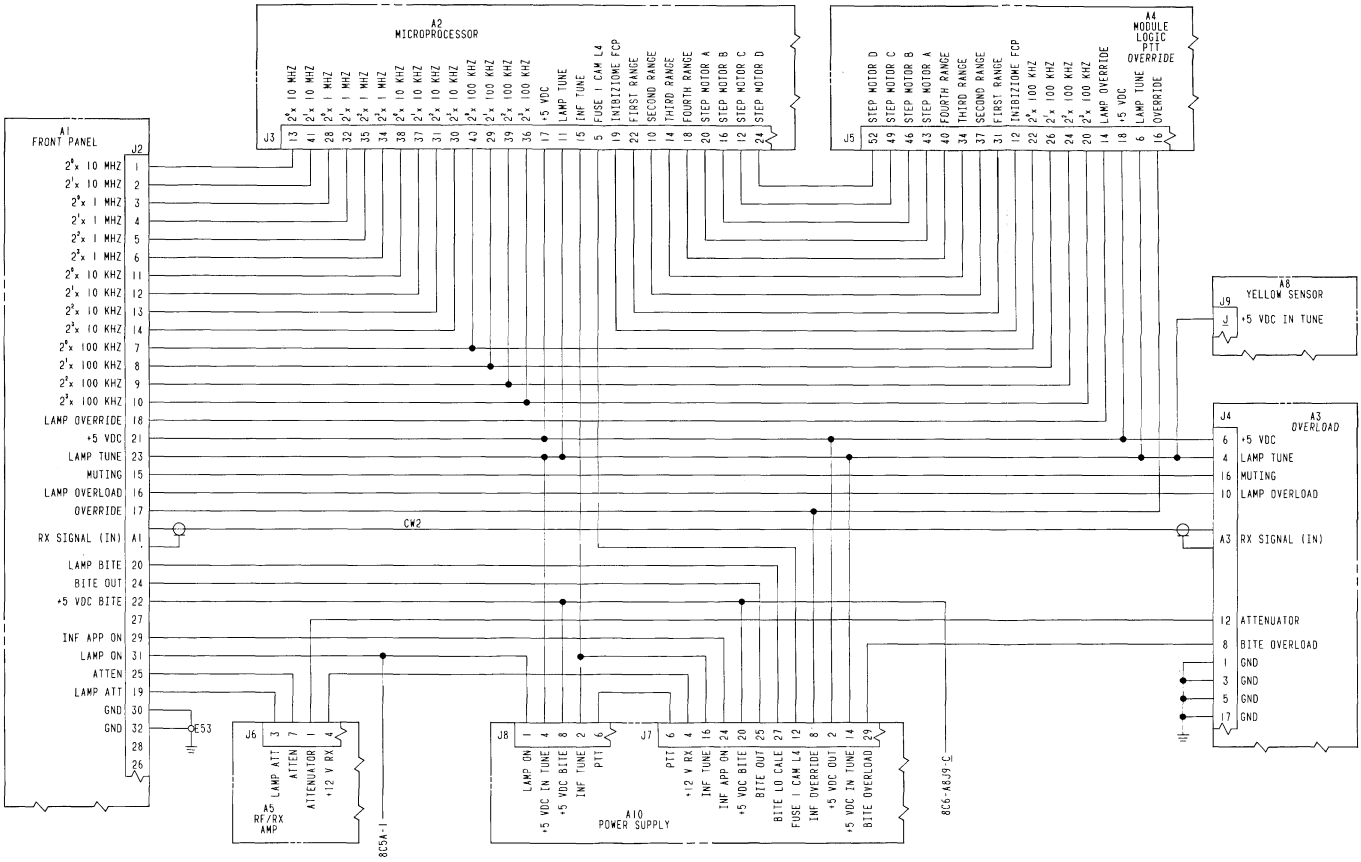

FO-3. Chassis A2A15 Schematic Diagram (Sheet 2 of 9)

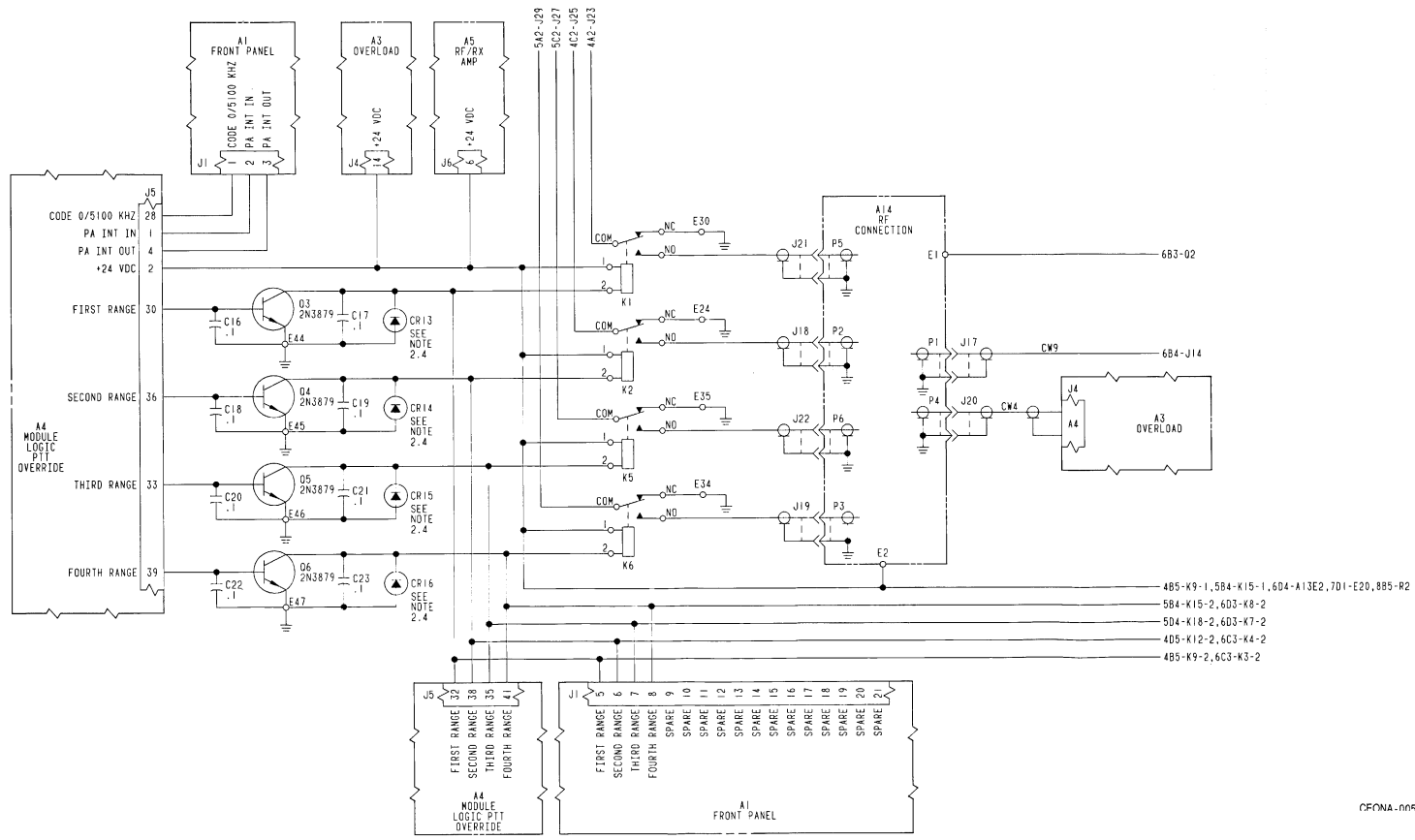

CFONA-005

FO-3. Chassis A2A15 Schematic Diagram (Sheet 3 of 9)

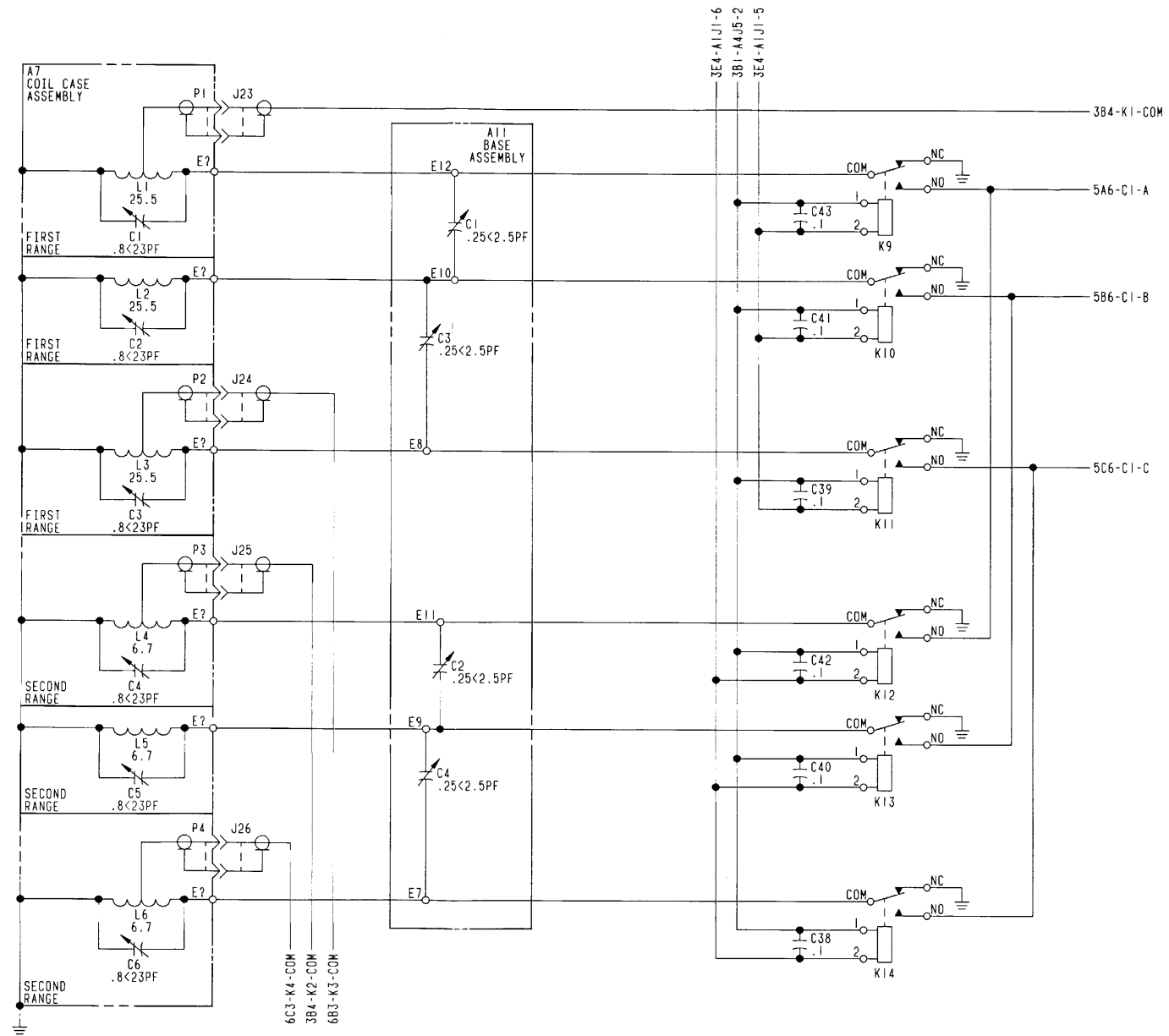

FO-3. Chassis A2A15 Schematic Diagram (Sheet 4 of 9)

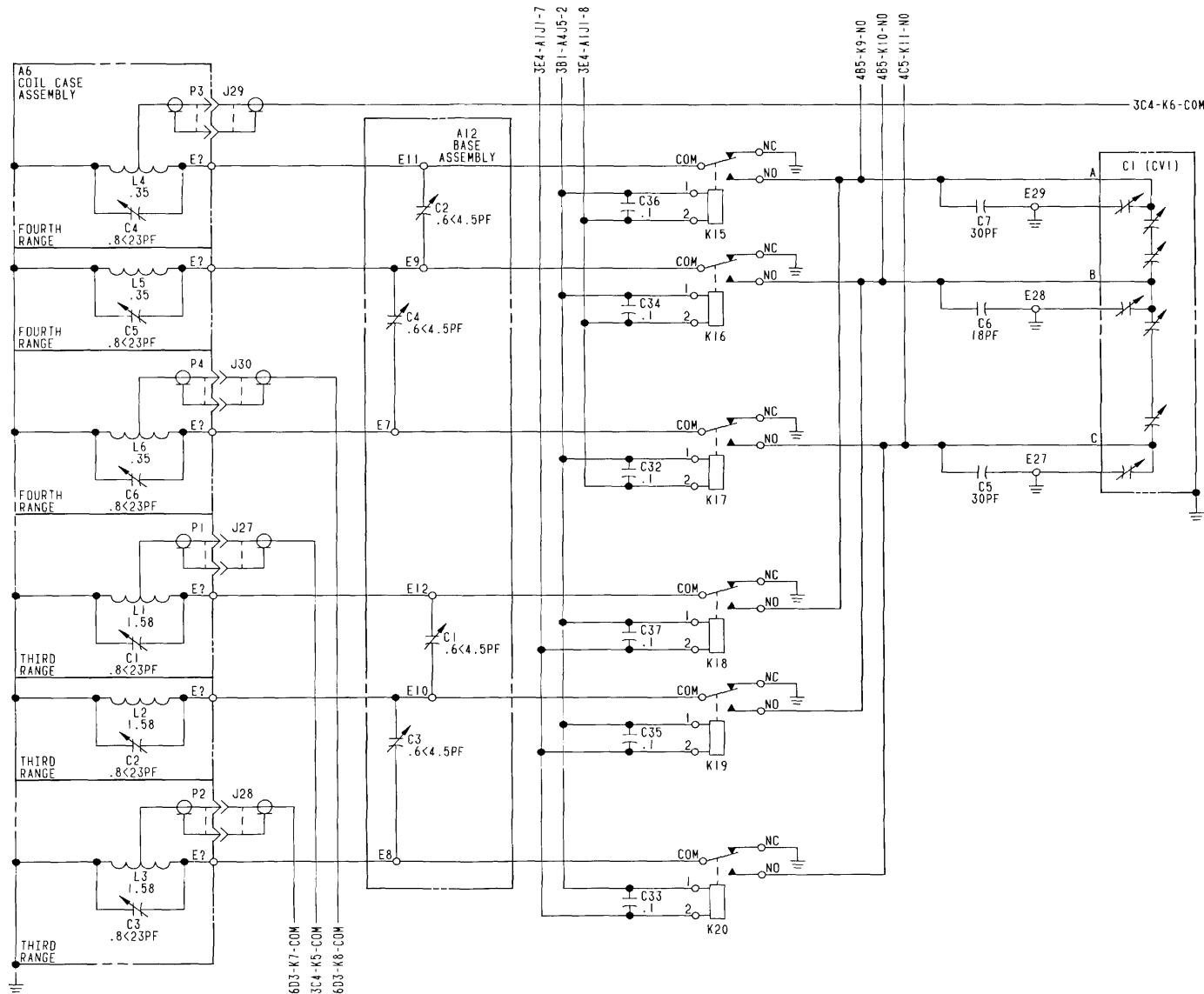

FO-3 Chassis A2A15 Schematic Diagram (Sheet 5 of 9)

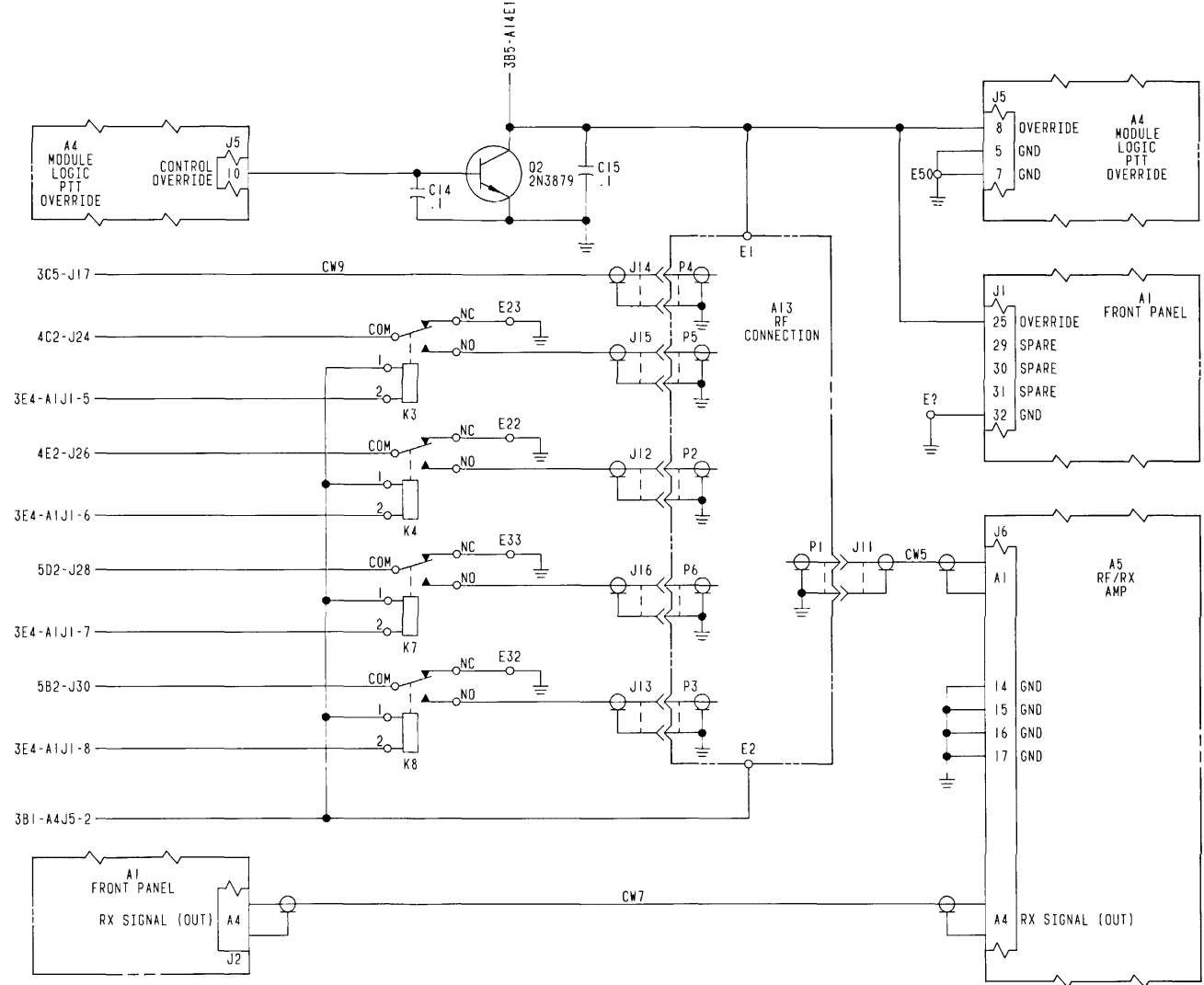

CEONA-008

FO-3 Chassis A2A15 Schematic Diagram (Sheet 6 of 9)

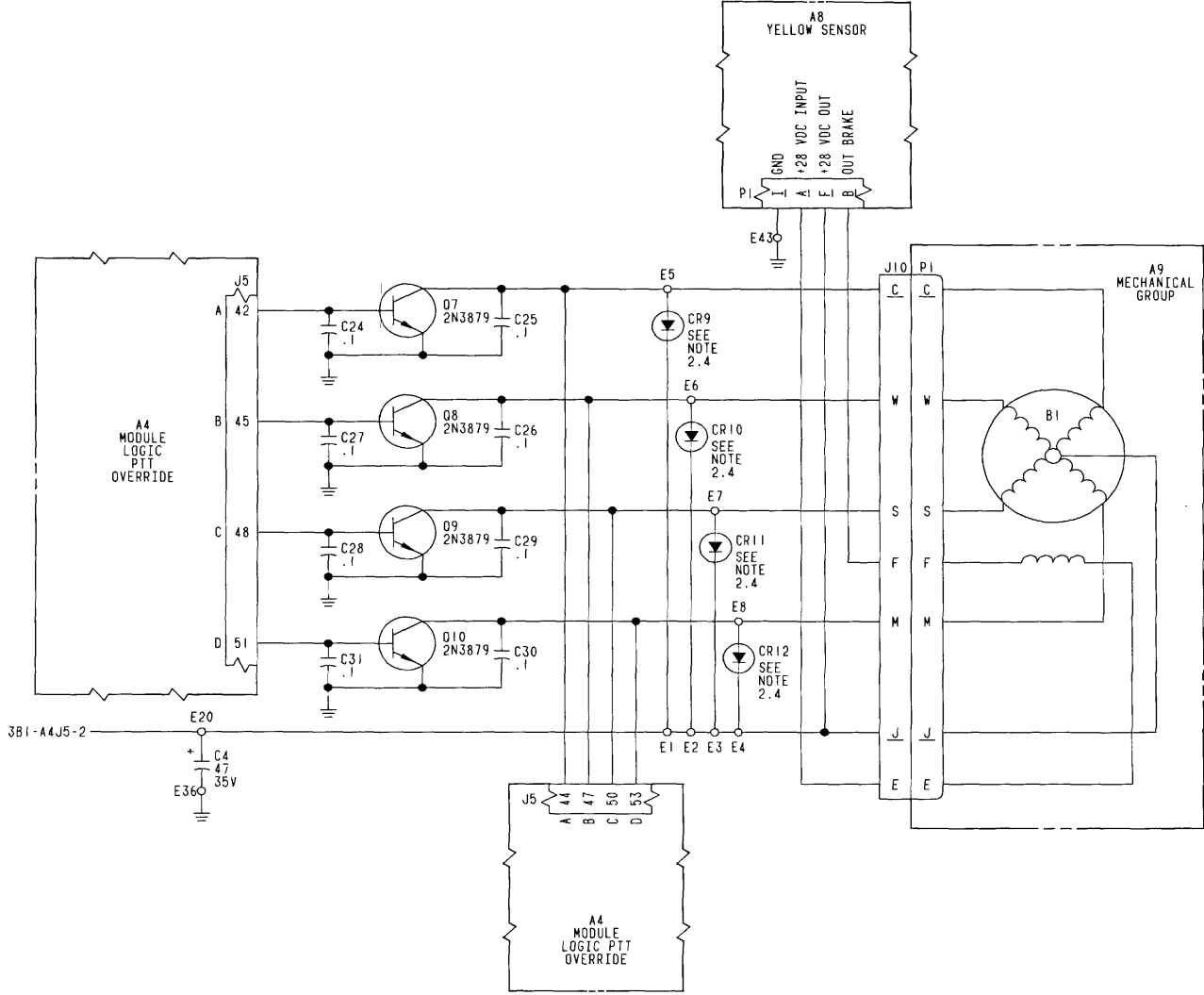

CEONA-009

FO-3 Chassis A2A15 Schematic Diagram (Sheet 7 of 9)

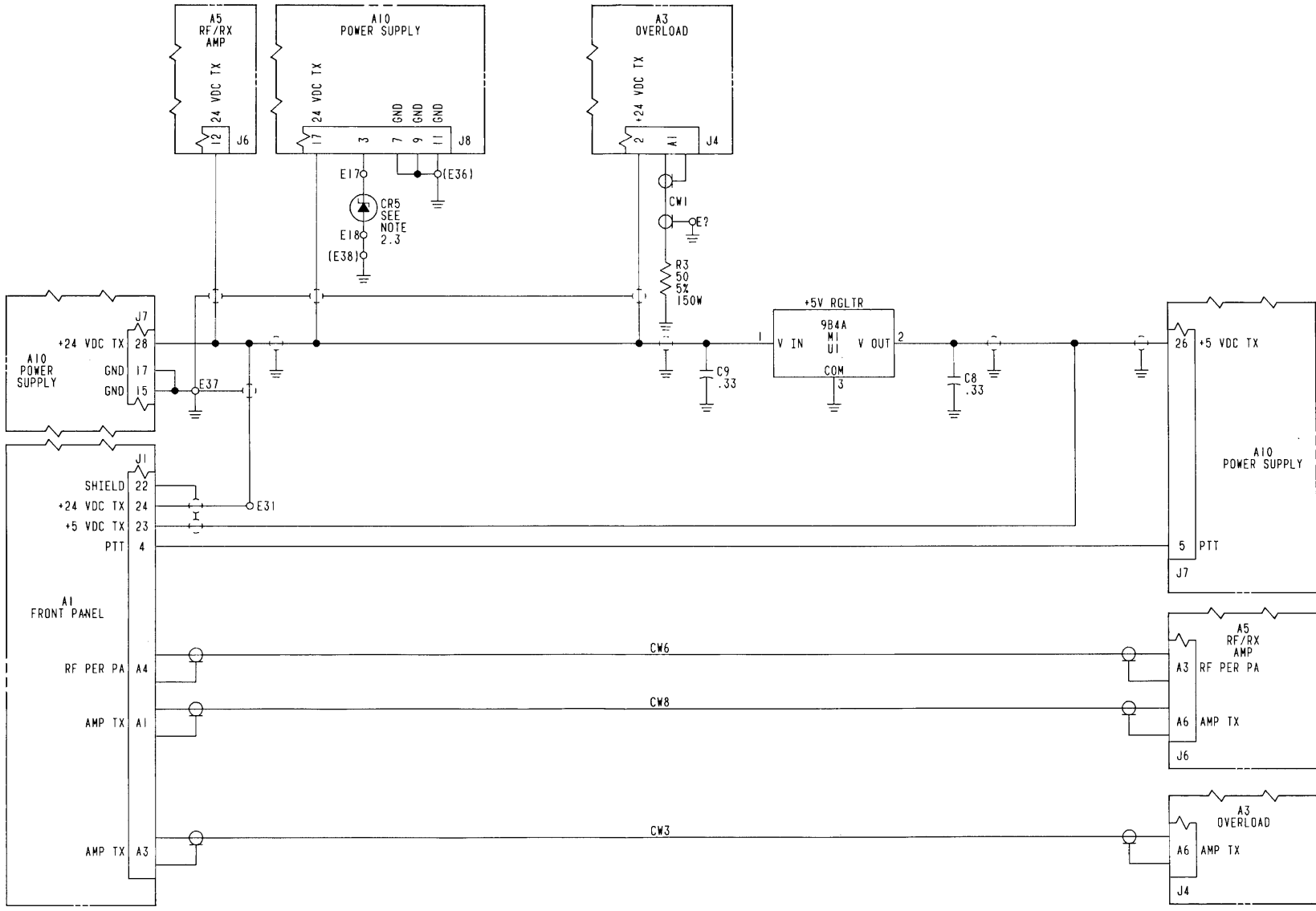

CFONA-011

FO-3 Chassis A2A15 Schematic Diagram (Sheet 9 of 9)

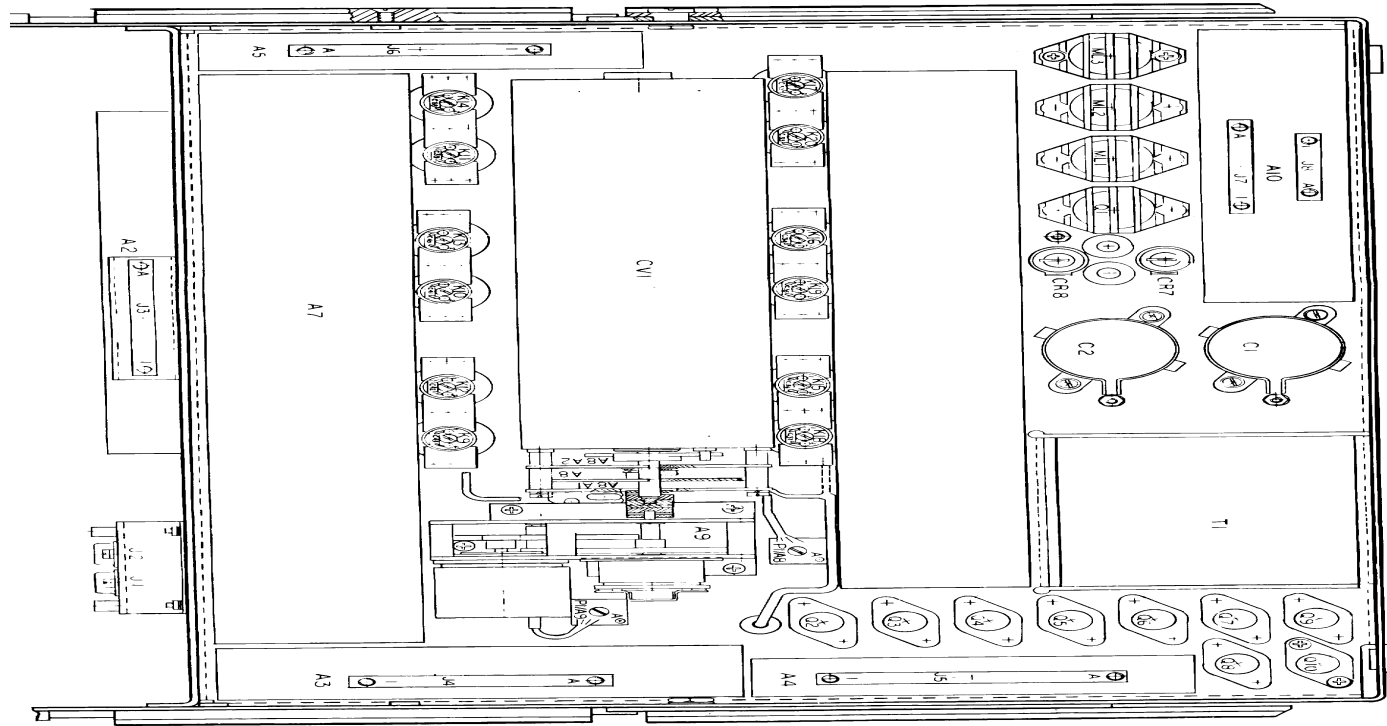

This page only for NON-SOFTWARE-related TM errors/improvements.

RECOMMENDED CHANGES TO EQUIPMENT TECHNICAL PUBLICATIONS

SOMETHING WRONG WITH THIS PUBLICATION?



THEN...JOT DOWN THE DOPE ABOUT IT ON THIS FORM. CAREFULLY TEAR IT OUT. FOLD IT AND DROP IT IN THE MAIL.

FROM: (PRINT YOUR UNIT'S COMPLETE ADDRESS)

DATE SENT

PUBLICATION NUMBER

PUBLICATION DATE

PUBLICATION TITLE

BE EXACT PIN-POINT WHERE IT IS

IN THIS SPACE TELL WHAT IS WRONG AND WHAT SHOULD BE DONE ABOUT IT:

PAGE NO.	PARA-GRAPH	FIGURE NO.	TABLE NO.
----------	------------	------------	-----------

TEAR ALONG PERFORATED LINE

PRINTED NAME GRADE OR TITLE AND TELEPHONE NUMBER

SIGN HERE

