

TECHNICAL MANUAL
OPERATOR'S MANUAL

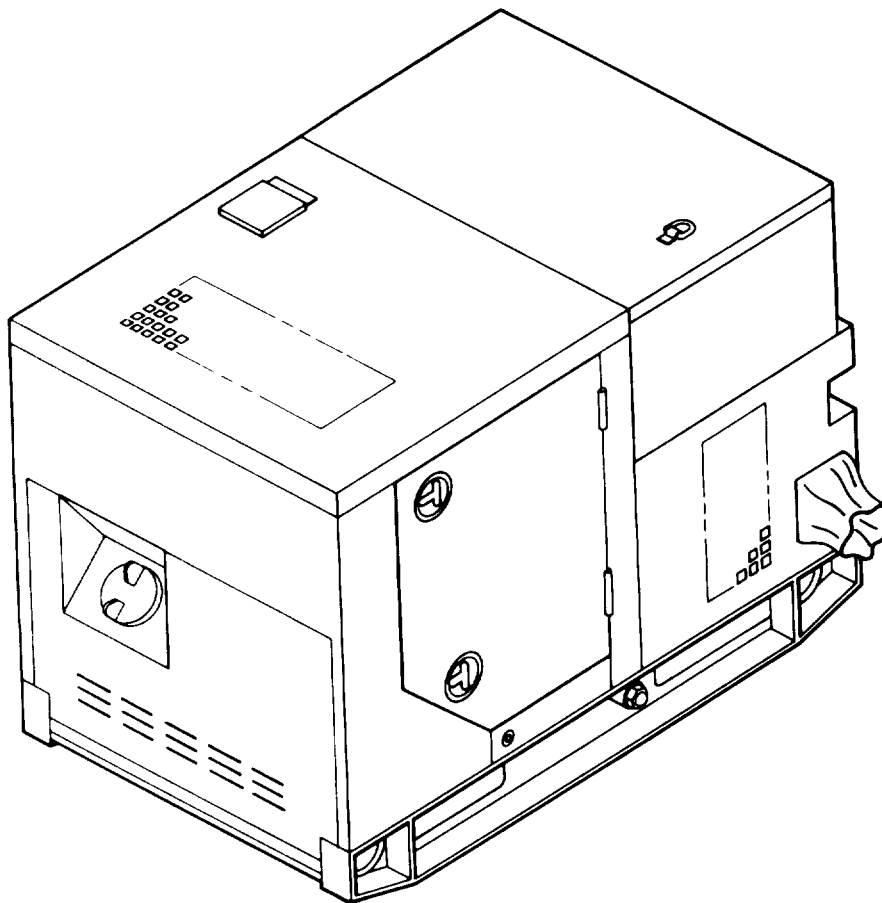

GENERATOR SET
SKID MOUNTED, TACTICAL QUIET
5 KW, 60 AND 400 HZ
MEP-802A (60 HZ) 6115-01-274-7387
MEP-812A (400 HZ) 6115-01-274-7391

EQUIPMENT
DESCRIPTION
PAGE 1-5

OPERATING
INSTRUCTIONS
PAGE 2-1

PREVENTIVE
MAINTENANCE
PAGE 2-8

LUBRICATION
INSTRUCTIONS
PAGE 3-1

TROUBLESHOOTING
PROCEDURES
PAGE 3-1

MAINTENANCE
PROCEDURES
PAGE 3-10

INDEX
PAGE 1-1

DISTRIBUTION STATEMENT A : Approved for public release; distribution is unlimited.

HEADQUARTERS, DEPARTMENTS OF THE ARMY AND AIR FORCE

30 DECEMBER 1992

CHANGE
NO. 2

HEADQUARTERS, DEPARTMENTS OF
THE ARMY AND AIR FORCE
WASHINGTON, D.C., 30 October 1996

Operator Manual

**GENERATOR SET, SKID MOUNTED, TACTICAL QUIET
5 KW, 60 AND 400 HZ
MEP-802A (60HZ) 6115-01-274-7387
MEP-812A (400HZ) 6115-01-274-7391**

DISTRIBUTION STATEMENT A: Approved for public release; distribution is unlimited

TM 9-6115-641-10/TO 35C2-3-456-11, 30 December 1992, is changed as follows:

1. Remove and insert pages as indicated below. New or changed text material is indicated by a vertical bar in the margin. An illustration change is indicated by a miniature pointing hand.

Remove pages	Insert pages
i through iv	i through iv
1-7 through 1-10	1-7 through 1-10
2-5 and 2-6	2-5-and 2-6
2-15 and 2-16	2-15 and 2-16
2-25 trough 2-30	2-25 through 2-30
-----	2-30.1/(2-30.2 blank)
2-35/(2-36 blank)	2-35 and 2-36
3-9 and 3-10	3-9 and 3-10

2. Retain this sheet in front of manual for reference purposes.

By Order of the Secretaries of the Army and Air Force:

DENNIS J. REIMER
General, United States Army
Chief of Staff

Official:

JOEL B. HUDSON
Administrative Assistant to the
Secretary of the Army
02944

RONALD R. FOGELMAN
General, USAF
Chief of Staff

HENRY VICCELLIO, JR.
General, USAF
Commander, Air Force Materiel Command

DISTRIBUTION:

To be distributed in accordance with DA Form 12-25-E, block no. 5241, requirements for TM 9-6115-641-10.

CHANGE
NO. 1

HEADQUARTERS, DEPARTMENTS OF
THE ARMY AND THE AIR FORCE
WASHINGTON, D.C., 30 AUGUST 1995

Operator's Manual

GENERATOR SET, SKID MOUNTED, TACTICAL QUIET
5 KW, 60 AND 400 HZ
MEP-802A (60HZ) 6115-01-274-7387
MEP-812A (400HZ) 6115-01-274-7391

DISTRIBUTION STATEMENT A: Approved for public release; distribution is unlimited

TM 9-6115-641-10/TO35C2-3-456-11, 30 December 1992, is changed as follows:

1. Remove and insert pages as indicated below. New or changed text material is indicated by a vertical bar in the margin. An illustration change is indicated by a miniature pointing hand.

Remove pages

1-9 through 1-14
2-9 and 2-10
2-19 and 2-20
2-33 and 2-34
3-7 and 3-8

Insert pages

1-9 through 1-14
2-9 and 2-10
2-19 and 2-20
2-33 and 2-34
3-7 and 3-8

2. Retain this sheet in front of manual for reference purposes.

C1

By Order of the Secretary of the Army:

Official:



JOEL B. HUDSON

*Acting Administrative Assistant to the
Secretary of the Army*

00839

DENNIS J. REIMER
*General, United States Army
Chief of Staff*

RONALD R. FOGELMAN
*General, USAF
Chief of Staff*

HENRY VICCELLIO JR.
*General, USAF
Commander, Air Force Material Command*

DISTRIBUTION:

To be distributed in accordance with DA Form 12-25-E, block no. 5241, requirements for TM 9-6115-641-10.

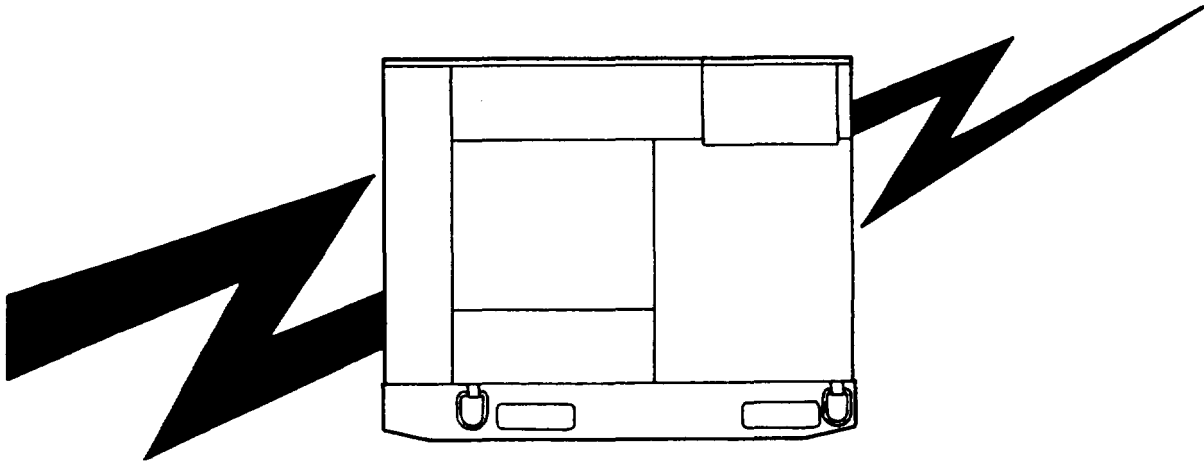

WARNING

High voltage is produced when this generator set is in operation. Improper operation could result in personal injury or death.

WARNING

Never attempt to start the generator set if it is not properly grounded. Failure to observe this warning could result in serious injury or death by electrocution.

WARNING

Never attempt to connect or disconnect load cables while the generator is running. Failure to observe this warning could result in severe personal injury or death by electrocution.

WARNING

DC voltages are present at generator set electrical components even with generator set shut down. Avoid grounding self when touching any electrical components. Failure to observe this warning can result in personal injury.

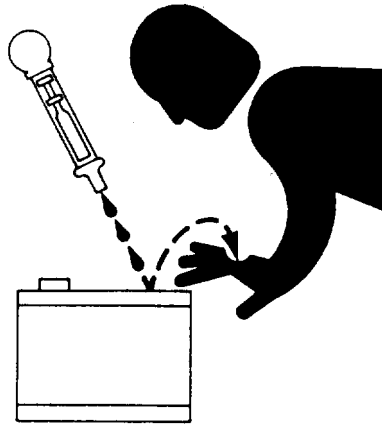

WARNING

Battery acid will cause burns to unprotected skin.

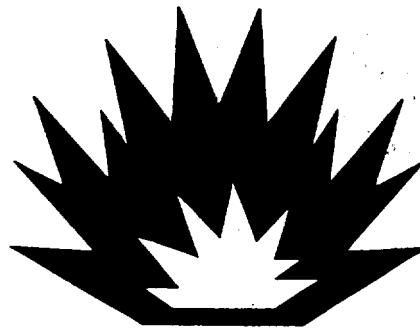

WARNING

The fuels in this generator set are highly explosive. Do not smoke or use open flame when performing maintenance. Flames and explosion could result in severe personal injury or death.

WARNING

Hot fueling of generators while they are operating presents a safety hazard and should not be attempted. Hot engine surfaces and sparks produced from the engine and generator circuitry are possible sources of ignition. Failure to observe this warning could cause severe personal injury or death may result.

WARNING

Batteries give off flammable gas. Do not smoke or use open flame when performing maintenance. Flames and explosion could result in personal injury or death.

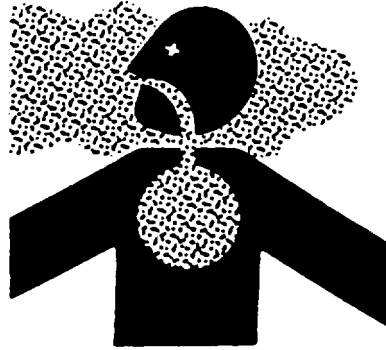

WARNING

Exhaust discharge contains deadly gases. Do not operate generator set in enclosed area unless exhaust discharge is properly vented outside. Severe personal injury or death due to carbon monoxide poisoning could result.



WARNING

Liquids under pressure are generated as a result of operation of the generator set. High pressure leaks could cause severe personal injury or death.



WARNING

With any access door open, the noise level of this generator set when operating could cause hearing damage. Hearing protection must be worn when working near the generator set while running.

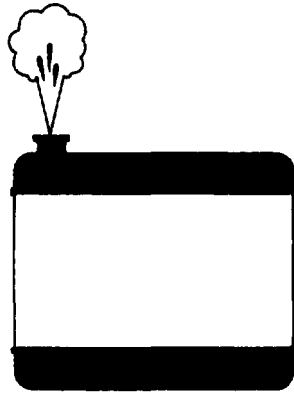

WARNING

Cooling system operates at high temperatures. Personal injury or death from burns or scalding could result from contact with high pressure steam and/or liquid.



WARNING

Avoid contacting metal items with bare skin in extreme cold weather. Failure to observe this warning can result in personal injury.

FOR FIRST AID REFER TO FM 21-11.

TECHNICAL MANUAL
NO. 9-6115-641-10

HEADQUARTERS
DEPARTMENT OF THE ARMY AND AIR FORCE
WASHINGTON, D.C., 30 DECEMBER 1992

Operator's Manual

**GENERATOR SET, SKID MOUNTED, TACTICAL QUIET
5 KW, 60 AND 400 HZ
MEP-802A (60 HZ) 6115-01-274-7387
MEP-812A (400 HZ) 6115-01-274-7391**

Distribution Statement A: Approved for public release; distribution is unlimited.

REPORTING OF ERRORS AND RECOMMENDING IMPROVEMENTS

You can help improve this manual. If you find any mistakes or if you know of a way to improve the procedures, please let us know.

(A): Mail your letter or DA Form 2028 (Recommended Changes to Publications and Blank Forms), or DA Form 2028-2 located in the back of this manual directly to: Commander, US Army Aviation and Troop Command, ATTN: AMSAT-I-MP, 4300 Goodfellow Blvd., St. Louis, MO 63120-1798. You may also submit your recommended changes by E-mail directly to <mpmt%avma28@st-louis-emh7.army.mil>. Instructions for sending an electronic 2028 may be found at the back of this publication immediately preceding the hard copy 2028.

(F): Air Force - AFTO Form 22 directly to: Commander, Sacramento Air Logistics Center, ATTN: TILBA, McClellan AFB, CA 95652-5990.

A reply will be furnished directly to you.

TABLE OF CONTENTS

	Page
HOW TO USE THIS MANUAL	v
CHAPTER 1 INTRODUCTION	1-1
Section I. General Information	1-1
Section II. <u>Equipment Description</u>	1-4
Section III. Technical Principles of Operation	1-11
CHAPTER 2 <u>OPERATING INSTRUCTIONS</u>	2-1
Section I. Description and Use of Operator's Controls and Indicators	2-1
Section II. <u>Preventive Maintenance Checks and Services (PMCS)</u>	2-8
Section III. Operation Under Usual Conditions	2-16
Section IV. Operation Under Unusual Conditions	2-31
CHAPTER 3 MAINTENANCE INSTRUCTIONS.....	3-1
Section I. <u>Lubricating Instructions</u>	3-1
Section II. <u>Troubleshooting</u>	3-1
Symptom Index.....	3-2
Section III. <u>Maintenance Procedures</u>	3-10
APPENDIX A REFERENCES	A-1
APPENDIX B COMPONENTS OF END ITEM (COEI) AND BASIC ISSUE ITEMS (BII) LISTS	B-1
APPENDIX C ADDITIONAL AUTHORIZATION LIST (AAL).....	C-1
APPENDIX D EXPENDABLE/DURABLE SUPPLIES AND MATERIALS LIST (EDSML)	D-1
<u>INDEX</u>	I-1

LIST OF ILLUSTRATIONS

Figure	Title	Page
1-1	Generator Set, 5kW, Tactical Quiet	1-2
1-2	Generator Set Components.....	1-5
1-3	Engine Starting System.....	1-11
1-4	Fuel System.....	1-12
1-5	Engine Cooling System	1-13
1-6	Engine Lubrication System.....	1-14
1-7	Air Intake and Exhaust System.....	1-15
1-8	Output Supply System.....	1-15
2-1	Operator's Controls and Indicators.....	2-2
2-2	Malfunction Indicator Panel	2-5
2-3	Frequency Adjust Control.....	2-7
2-4	Grounding Connections.....	2-17
2-5	Installation of Load Cables	2-19
2-6	Operating Instructions Plates (Front and Right Side).....	2-24
2-7	Operating Instructions Plates (Rear and Left Side)	2-25
2-8	Operating Instructions Plate	2-26
2-9	Generator Set Identification Plate	2-26
2-9A	Generator Set Identification Plate	2-27
2-10	Set Rating Identification Plate.....	2-27
2-11	Voltage Connection Caution Plate	2-28
2-12	Grounding Stud Plate	2-28
2-13	NATO Slave receptacle Plate	2-28
2-14	Diagnostics Plate	2-28
2-15	Convenience Receptacle Plate.....	2-28
2-16	External Fuel Supply Plate	2-28
2-17	Battery Connection Instruction Plate.....	2-29
2-18	Generator Identification Plate	2-29
2-19	Frequency Adjust Plate	2-30
2-20	Lifting and Tiedown Diagram Plate	2-30
2-21	Fuel System Diagram Plate.....	2-30.1
3-1	Air Cleaner Element Replacement.....	3-11
3-2	Draining Fuel Filter/Water Separator	3-15

LIST OF TABLES

Table	Title	Page
1-1	Leading Particulars	1-7
2-1	Control Panel Controls and Indicators	2-3
2-2	Malfunction Indicator Panel	2-6
2-3	Frequency Adjust Control	2-7
2-4	Operator Preventive Maintenance Checks and Services.....	2-9
2-5	Load Terminal, AC Voltage Reconnection Switch and AM-VM Transfer Switch Selection	2-18
3-1	Troubleshooting	3-3
3-2	Coolant	3-13
3-3	Diesel Fuel.....	3-14

HOW TO USE THIS MANUAL

In this manual (TM 9-6115-641-10) , paragraphs are underlined and the sections and chapters appear in capital letters. The location of additional material that must be referenced is clearly marked. Drawings in this text are located as close as possible to their references.

Chapter 1 - Introduction. Chapter 1 contains general information, equipment description and technical principles of operation.

Chapter 2, - Operating Instructions. Chapter 2 contains a description of generator set operation controls and indicators. The control panel assembly is illustrated and each control and indicator is described in a follow-on table. Operating procedures which include Preventive Maintenance Checks and Services (PMCS) and operation under usual and unusual conditions are detailed.

Chapter 3 - Maintenance. Chapter 3 lists maintenance procedures authorized at the operator level, and troubleshooting procedures used to recognize generator set malfunctions, the test or inspections, and their corrective action. An index of generator set failure symptoms will help guide you to the appropriate troubleshooting chart.

Appendices.

Appendix A is a list of the other publications referenced by this manual. Included are other manuals which should be used with this operator's manual.

Appendix B is the Components of End Item (COEI) and Basic Issue Items (BII) Lists.

Appendix C is the Additional Authorization List (AAL) .

Appendix D is the Expendable/Durable Supplies and Materials List (EDSML).

Index. The index contains key technical manual subjects arranged in alphabetical order. If you require information on a specific subject (i.e., starting), but you are not sure where to look, use the index to locate specific page.

CHAPTER 1

INTRODUCTION

SECTION I. GENERAL INFORMATION

1-1 SCOPE.

1-1.1 Type of Manual. This manual contains operation and operator maintenance instructions for the Tactical Quiet (TQ), 5 kW 60 and 400 Hz Generator Sets (FIGURE 1-1), herein referred to as generator set. Included are descriptions of major components and their functions in relation to other components.

1-1.2 Model Numbers and Equipment Names.

<u>Model Number</u>	<u>Equipment Name</u>
MEP-802A	Generator Set, Skid Mounted, Diesel Powered, Tactical Quiet 5 kW 60 Hz.
MEP-812A	Generator Set, Skid Mounted, Diesel Powered, Tactical Quiet 5 kW 400 Hz.

1-1.3 Purpose of Equipment. The generator set provides tactical quiet AC power. The generator set is easily transported, operated, and maintained.

1-2 MAINTENANCE FORMS AND RECORDS.

1-2.1 (A) Department of the Army forms and procedures used for equipment maintenance will

be those prescribed by DA PAM 738-750, The Army Maintenance Management System (TAMMS).

1-2.2 (F) Maintenance Forms and Records maintained by the Air Force are prescribed in AFR 66-1 and the applicable TO 00-20 Series Technical Orders.

1-2.3 (N) Navy users should refer to their service peculiar directives to determine the applicable maintenance forms and records to be used.

1-3 REPORTING EQUIPMENT IMPROVEMENT RECOMMENDATIONS (EIR).

1-3.1 If your generator set needs improvement, let us know. Send us an EIR. You, the user, are the only one who can tell us what you don't like about your equipment. Let us know why you don't like the design or performance. We will send you a reply.

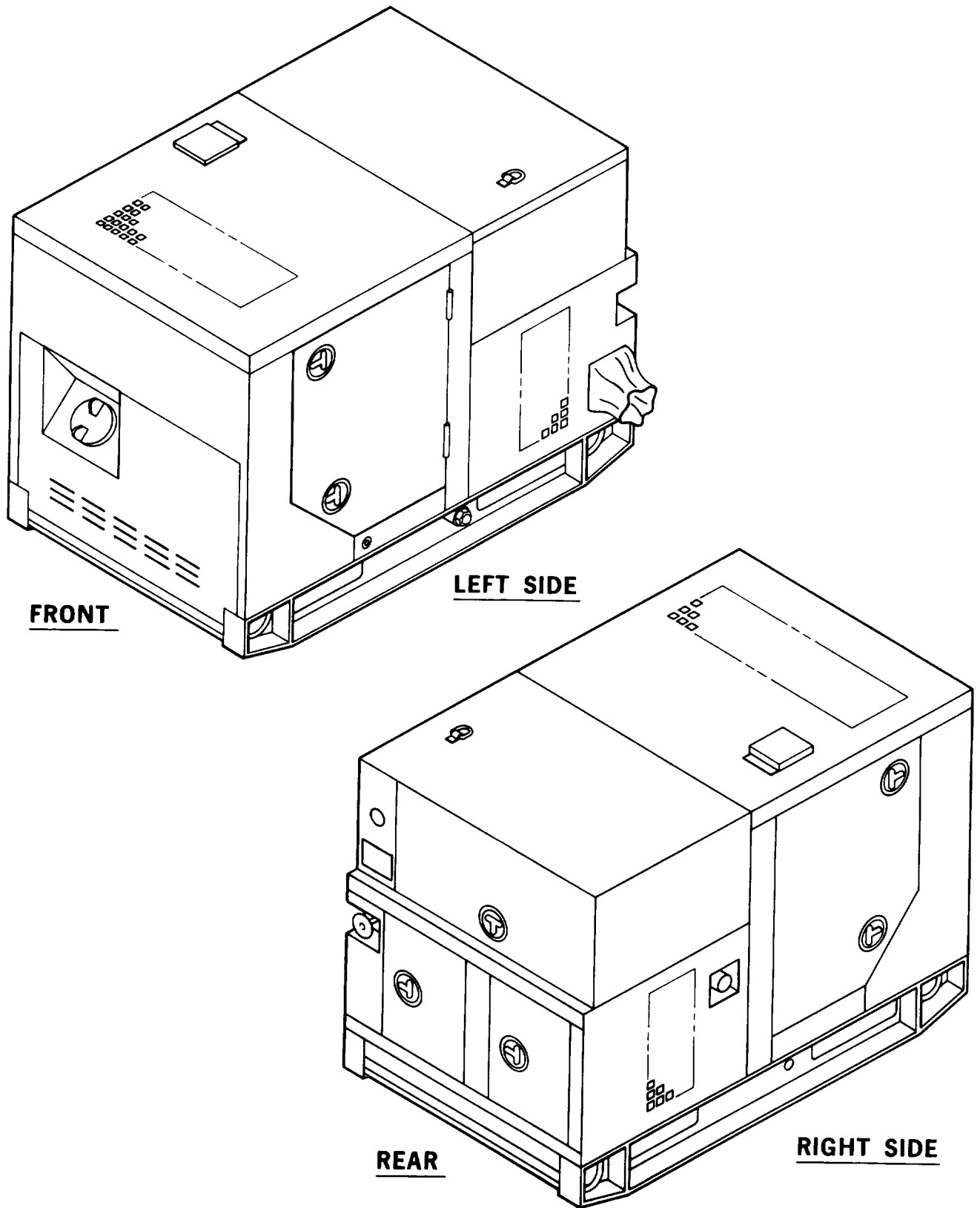

FIGURE 1-1. Generator Set, 5 kw, Tactical Quiet

1-3.2 (A) Put it on an SF 368 (Quality Deficiency Report) . EIRs should be mailed directly to:

Commander
US Army Aviation and Troop Command
ATTN: AMSAT-I-MDC
4300 Goodfellow Blvd.
St. Louis, MO 63120-1798

1-3.3 (N) Put it on applicable Navy form and mail it directly to:

Naval Construction Battalion
Center
Attn: Code 157 Civil
Engineer
Support Office (CESO)
Port Hueneme,
CA 93043-5000

1-3.4 (F) Quality Deficiency Reports (QDR)/Material Deficiency Reports (MDR) shall be sent by electronic message to SMALC-CA//TILE//.

1-4 WARRANTY INFORMATION.

The generator sets, models MEP-802A and MEP-812A, are warranted by Libby Corporation for a period of 36 months or 1800 operating hours, whichever occurs first. Refer to Warranty Technical Bulletin TB 9-6115-641-24. The warranty starts on the date found in block 23, DA Form 2408-9, in the logbook.

Report all defects in material or workmanship to your supervisor, who will take appropriate action through your Unit Maintenance Shop.

1-5 LIST OF ABBREVIATIONS.

The following list of abbreviations consists of those special or unique abbreviations that are not contained in MIL-STD-12 and do not conflict with those in MIL-STD-12.

<u>Abbreviation</u>	<u>Description</u>
KPA	Kilopascal
KVA	Kilovolt-ampere
kW	Kilowatt
CTA	Common Table of Allowance
MTOE	Modified Table of Organization and Equipment
NATO	North Atlantic Treaty Organization
JTA	Joint Table of Allowances

SECTION II. EQUIPMENT DESCRIPTION

1-6 EQUIPMENT CHARACTERISTICS, CAPABILITIES AND FEATURES.

The generator sets, models MEP-802A and MEP-812A (FIGURE 1-2), are fully enclosed, self-contained, skid-mounted, portable units. They are equipped with controls, instruments and accessories necessary for operation. The generator sets consist of a diesel engine, brushless generator, excitation system, speed governing system, fuel system, 24 VDC starting system, control system and fault system.

NOTE

All locations (FIGURE 1-2) referenced in FIGURE 1-2 are given facing the control box side (rear) of the generator set.

1-7 LOCATION AND DESCRIPTION OF MAJOR COMPONENTS.

1-7.1 Engine (6). The generator is powered by a two cylinder, four cycle, fuel injected, naturally-aspirated, liquid-cooled diesel engine which occupies the front half of the generator set. The engine is also equipped with a fuel filter/water separator, oil filter, and an air cleaner assembly. Protection devices automatically stop the engine during conditions of high coolant temperature, low oil pressure, no fuel, and over-voltage.

1-7.2 Radiator (9). The of the generator set. It acts as a heat exchanger for the engine coolant.

1-7.3 Muffler (12). The muffler and exhaust tubing are connected to the exhaust manifold on the engine. The exhaust exits from the top of the generator set housing. Gases are exhausted upward.

1-7.4 Starter (15). The starter is located on the right side of the engine. The electric starter mechanically engages the engine flywheel in order to start the diesel engine.

1-7.5 Battery Charging Alternator (14). The battery charging alternator is located on the right side of the engine. It is capable of maintaining the batteries in a state of full charge in addition to providing the required 24 VDC control power.

1-7.6 Batteries (7). Two batteries are required, one on each side of the generator set. The batteries are electrolyte serviceable, lead acid, 12 volt type, connected in series. After starting, the generator set is capable of operating with batteries removed. A fuse and a diode, located behind the control panel assembly, protects the generator set if the batteries are incorrectly connected.

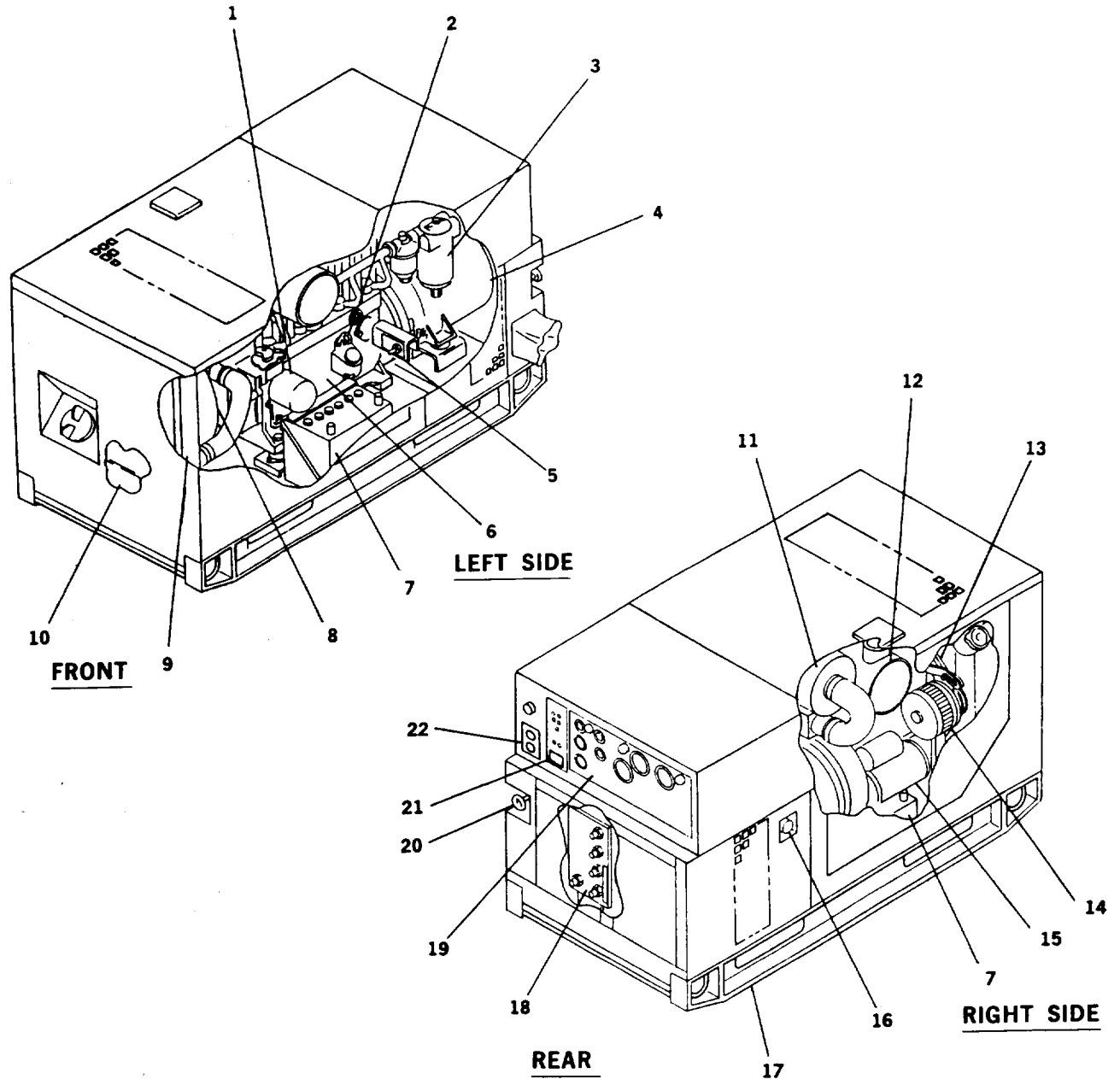

- | | | | |
|----|-----------------------------|----|-----------------------------|
| 1 | Oil Filter | 12 | Muffler |
| 2 | Dipstick | 13 | Fan Belt |
| 3 | Fuel Filter/Water Separator | 14 | Battery Charging Alternator |
| 4 | AC Generator | 15 | Starter |
| 5 | Dead Crank Switch | 16 | NATO Slave Receptacle |
| 6 | Engine | 17 | Skid Base |
| 7 | Batteries | 18 | Load Output Terminal Board |
| 8 | Water Pump | 19 | Control Panel Assembly |
| 9 | Radiator | 20 | Frequency Adjust Control |
| 10 | Fuel Tank | 21 | Malunction indicator Panel |
| 11 | Air Cleaner Assembly | 22 | Convenience Receptacle |

FIGURE 1-2. Generator Set Components

1-7.7 Air Cleaner Assembly (11). The air cleaner assembly is located on the right side behind the engine. It consists of a dry-type, disposable air filter element made of paper and canister. The air cleaner assembly features a dust collector which traps large dust particles. The air cleaner assembly has a restriction indicator which will indicate red when the air filter element requires servicing.

1-7.8 Fuel Tank (10). The 5 gallon (18.9 liters) fuel tank is located in the front of the generator set below the engine and between the skid base side members. The fuel tank is a fuel reservoir and has sufficient capacity to enable the generator set to operate for at least 8 hours without refueling.

1-7.9 AC Generator (4). The AC generator is a single bearing, drip-proof, synchronous, brushless, three phase, fan-cooled generator. The generator is coupled directly to the rear of the diesel engine.

1-7.10 Load Output Terminal Board (18). The load output terminal board is located on the right side (rear) of the generator set. Four output terminals located on the board. They are marked L1, L2, L3 and LO. A fifth terminal, marked GND, is located next to the output terminals and serves as equipment ground for the generator set. A removable, solid copper bar is connected between the LO and GND terminals.

1-7.11 Control Panel Assembly (19)- The generator set control panel assembly is located at the rear of the generator set and contains controls and instruments for operating the engine and the generator.

1-7.12 Malfunction Indicator Panel (21). The malfunction indicator panel is located to the left of the control panel assembly. It indicates malfunctions of the generator set components.

1-7.13 NATO Slave Receptacle (16). The NATO slave receptacle is located on the right side (rear) of the generator set. It is used for slave starting.

1-7.14 Skid Base (17). The skid base supports the generator set. It has fork lift access openings and cross members for short distance movement. The skid base has provisions in the bottom for installation of the generator set on a trailer.

1-7.15 Fuel Filter/Water Separator (3). The fuel filter/water separator is located to the rear of the engine compartment on the left side. The element removes impurities and water from the diesel fuel.

1-7.16 Dipstick (2). The dipstick is located in the engine compartment on the left side. The dipstick shows the lubricating oil level in the engine crankcase.

1-7.17 Oil Filter (1). The oil filter is located in the engine compartment on the left side. The filter removes impurities from the engine lubricating oil.

1-7.18 Fan Belt (13). The fan belt is located in the engine compartment on the front of the engine. The belt drives the fan, water pump and battery charging alternator.

1-7.19 Water Pump (8). The water pump is located in the engine compartment on the front of the engine. The pump circulates the engine coolant through the engine block and the radiator.

1-7.20 Dead Crank Switch (5). The Dead Crank switch is located in the engine compartment on the left side. For maintenance purposes the switch allows the engine to be cranked without starting.

1-7.21 Convenience Receptacle (22). The convenience receptacle is a 10 Amp, 120 VAC receptacle used to operate small plug in type equipment. It is protected by a Ground Fault Circuit Interrupter located below the malfunction indicator (1-7.12), an overload circuit breaker located inside the control box, and an in-line fuse on generator sets, contract number DAAK01-88-D-D080. The convenience receptacle power is available at all times during operation of the generator set.

1-7.22 Frequency Adjust Control (20). The Frequency adjust control is located at the rear left side of generator set. It is used to adjust the generator frequency output

1-8 DIFFERENCES BETWEEN MODELS. The differences between models of the generator sets covered in this manual are as follows:

Model MEP-802A is equipped with a 60 Hz generator.

Model MEP-812A is equipped with a 400 Hz generator.

1-9 EQUIPMENT DATA. For a list of Leading Particulars refer to TABLE 1-1

Table 1-1. Leading Particulars

1.	Generator Set:	
	Model Numbers	
	5 kW 60 Hz Tactical Quiet	MEP-802A
	5 kW 400 Hz Tactical Quiet	MEP-812A
	National Stock Numbers	
	5 kW 60 Hz Tactical Quiet	NSN 6115-01-274-7387
	5 kW 400 Hz Tactical Quiet	NSN 6115-01-274-7391
	Overall Length	
	MEP-802A	50.6 in. (128.6 cm)
	MEP-812A	50.6 in. (128.6 cm)

Table 1-1. Leading Particulars - continued

1.	Generator Set - continued	
	Overall Width	
	MEP-802A	32 in. (81.28 cm)
	MEP-812A	32 in. (81.28 cm)
	Overall Height	
	MEP-802A	37 in. (93.98 cm)
	MEP-812A	37 in. (93.98 cm)
	Dry Weights (less Basic Issue Items)	
	MEP-802A	800 lb. (362.8 kg.)
	MEP-812A	825 lb. (374.2 kg.)
	Wet Weights	
	MEP-802A	868 lb. (393.7 kg.)
	MEP-812A	878 lb. (398.2 kg.)
2.	Engine:	
	Manufacturer	Onan
	Model	DN2M
	Type	Naturally-aspirated, two cylinder four cycle diesel
	Displacement	57 cu. in. (0.9 liters)
	Altitude Degradation, 4000 ft (1220 m) to 8000 (2440 m)	3.5% per 1000 ft (305 m)
	Firing Order	1,2
	Cold Weather Starting Aid System Use	When temperature is +40°F (4°C) or below
	Valve Tappet Clearance Adjustment	None Required
3.	Cooling System:	
	Type	Pressurized radiator and pump
	Capacity	6.2 qts. (5.9 liters)
	Normal Operating Temperature	170-200°F (77-93°C)
	Temperature Indicating System	
	Voltage Rating	24 VDC
4.	Lubricating System:	
	Type	Full flow, circulating pressure
	Oil Pump Type	Positive displacement gear

Table 1-1. Leading Particulars - continued

4.	Lubricating System - Continued:	
	Normal Operating Pressure	25-60 psi (172-414 kPa)
	Oil Filter Type	Full flow, spin-on, replaceable element
	Lubricating System Capacity	3.2 qts. (3.0 liters)
	Pressure Indicating System	
	Voltage Rating	24 VDC
5.	Fuel System:	
	Type of Fuel	DF-1, DF-2, DF-A, JP4, JP5, JP8
	Fuel Tank Capacity	5 gal. (18.9 liters)
	Fuel Consumption Rate:	60 Hz: .55 gal. (2.1 liters) per hour 400 Hz: .61 gal. (2.3 liters) per hour
	Auxiliary Fuel Pump:	
	Voltage Rating	24 VDC
	Delivery Pressure	5.0-6.5 psi (34.5-65.5 kPa) range
	Fuel Level Switch:	
	Type	Float
	Current	3.0 amp at 6 to 32 VDC
6.	Engine Starting System:	
	Batteries	Two 12 volt, connected in series
	Starter:	
	Manufacturer	Onan
	Model	191-1550
	Voltage Rating	24 VDC
	Drive Type	Gear Reduction
	Battery Charging Alternator:	
	Manufacturer	Prestolite
	Models	8EM3005CA and 8MR3005CA
	Rating	18 amps at 24 VDC
	Protective Fuse	30 amps
7.	AC Generator:	
	Manufacturer	Onan

Table 1-1. Leading Particulars - Continued

7. AC Generator - Continued:		
Type	MEP-802A Rotating field synchronous	MEP-812A Rotating field synchronous
Load Capacity	5kW	5kW
Current Ratings:		
120/240 volt connection	60 Hz: 26 amps	400 Hz: 26 amps
120/208 volt connection	17 amps	17 amps
120 volt connection	52 amps	52 amps
Power Factor	0.8	0.8
Cooling	Fan cooled	Fan cooled
Drive Type	direct coupling	direct coupling
Duty Classification	continuous	continuous
8. Protection Devices:		
Low Oil Pressure Switch:		
Trip Pressure		15 ± 3 psi (103.4 ± 20.7 kPa)
Voltage Rating		24 VDC
Current Rating		5 amps
Coolant High Temperature Switch:		
Trip Temperature		225 ± 5° F (107 + 3°C)
Voltage Rating		12-120 VDC
Current Rating		2 amps
Overvoltage:		
Trip Point Conditions		153 ± 3 VAC for no less than 200 milliseconds (120 VAC coil winding)
Trip Point		No more than 1.25 seconds after trip conditions exist

SECTION III . TECHNICAL PRINCIPLES OF OPERATION

1-10 INTRODUCTION.

This section contains functional descriptions of the generator set and explains how the controls and indicators interact with the system.

1-11 ENGINE STARTING SYSTEM.

The Engine Starting System (FIGURE 1-3), consists of two 12-volt batteries connected in series, a starter, a 24 volt battery charging alternator, a magnetic pickup (for sensing engine speed) and the related switches and relays required for control of the starting system. For engine cranking, battery power is supplied to the starter motor through the starter solenoid which in turn is controlled by the cranking relay. The starter then engages the engine flywheel causing the engine to turn over. For engine starting, the DEAD CRANK switch must be in the NORMAL position, the DC Control power circuit breaker must be pushed in, the EMERGENCY STOP SWITCH must be in the OUT position, and the MASTER SWITCH is moved to the START position. The cranking relay is then controlled by a circuit consisting of the crank disconnect relay and crank disconnect switch. As the engine accelerates to the preset speed (sensed by the magnetic pickup), the crank disconnect switch opens and de-energizes the cranking relay to stop and disengage the starter. The starting sequence may also be stopped by moving the MASTER SWITCH to OFF. The engine may be cranked without starting by use of the DEAD CRANK switch. With the DEAD CRANK switch in the CRANK position, the cranking relay, starter solenoid and starter motor are energized without activating any other starting or control function.

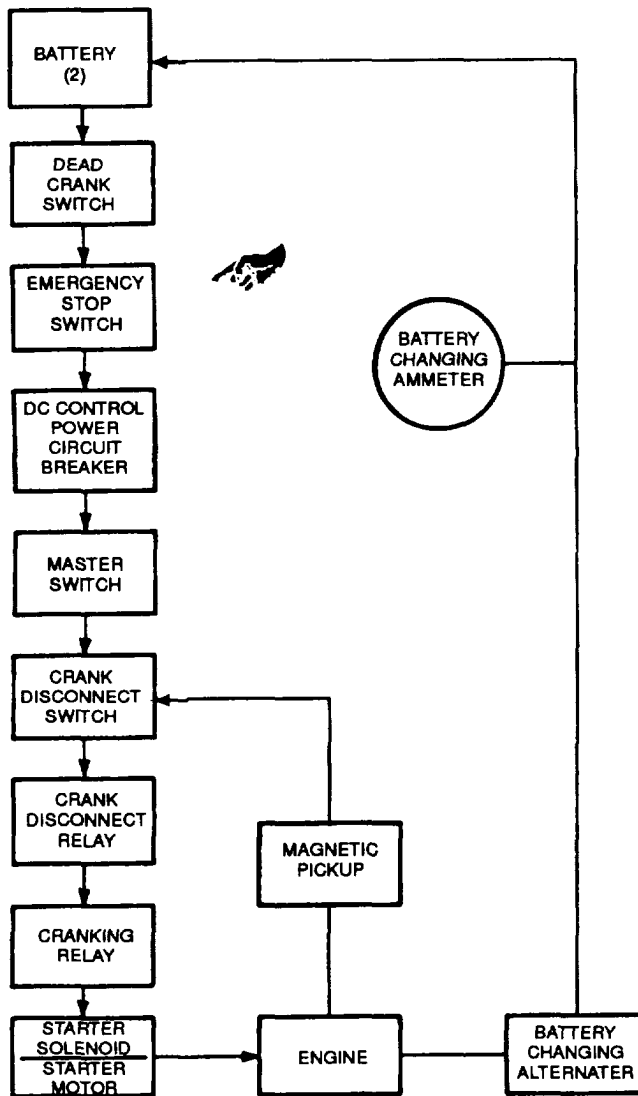

Figure 1-3. Engine Starting System

The batteries are charged by the battery charging alternator that is belt driven by the engine. Generator set control system power is also supplied by the battery charging alternator. The BATTERY CHARGE ammeter indicates the charge/discharge rate of the batteries, from -10 AMPS to +20 AMPS, in 5 AMPS increments. Normal operating indication depends on the state of charge in the batteries. A low charge, such as exists immediately after engine starting, will cause a high reading (needle moves toward CHARGE area). When the charge in the batteries has been restored, the indicator moves near zero, 0.

1-12 FUEL SYSTEM.

The Fuel System (FIGURE 1-4), consists of piping, fuel tank, fuel filter, electrically driven transfer pump, fuel

filter/water separator, two injection pumps and two injectors, one for each cylinder. Fuel is drawn from the fuel tank by the transfer pump when the MASTER SWITCH is in the PRIME & RUN position. After reaching the transfer pump, fuel passes through a fuel filter/water separator where water and small impurities are removed. The fuel then goes to the injection pumps where it is pressurized and pushed into the injectors. Through the injectors fuel enters the diesel engine combustion chamber, where it is mixed with air and ignited. The fuel that is not used is returned to the fuel tank via an excess fuel return line.

The Auxiliary Fuel System consists of an external fuel supply, fuel filter piping, a 24 VDC auxiliary fuel pump and a fuel level float switch. When the MASTER SWITCH is set on PRIME & RUN AUX FUEL it actuates the auxiliary fuel pump and transfers fuel from the external

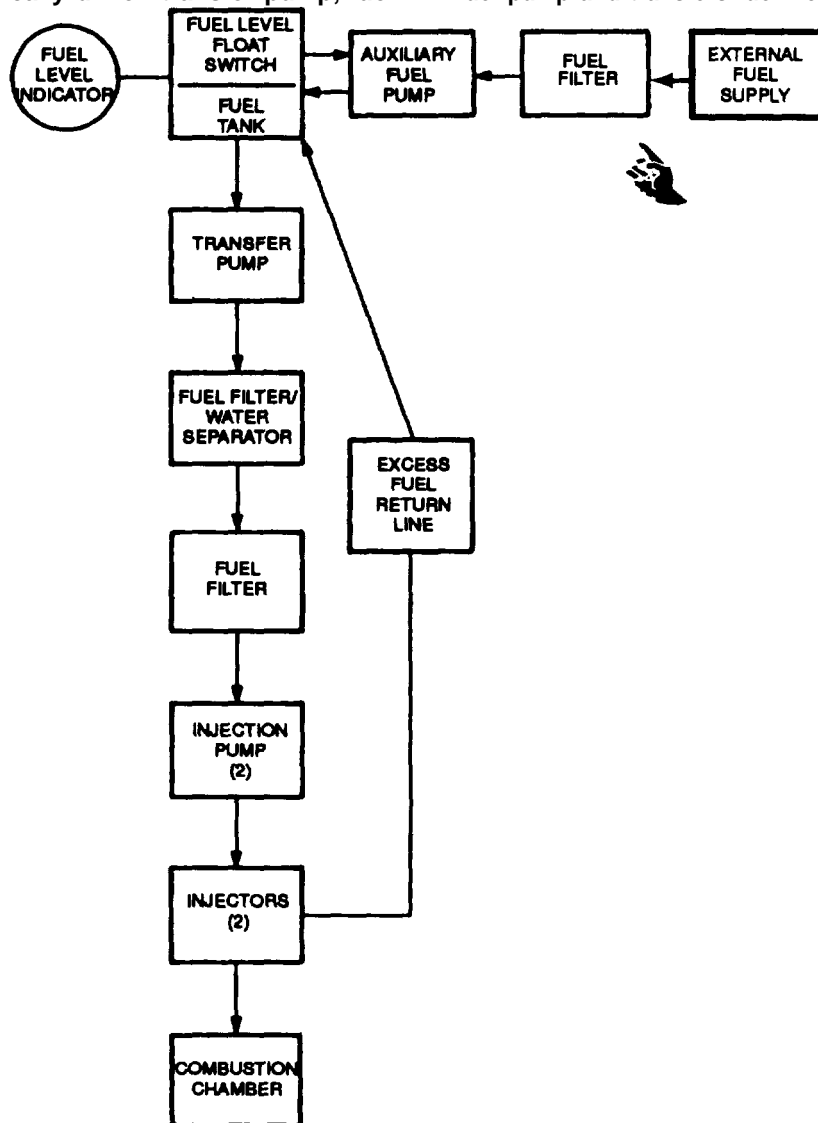

Figure 1-4. Fuel System

fuel supply to the generator fuel tank. The fuel level float switch shuts off the auxiliary fuel pump when the generator fuel tank is full and reactivates the pump as the level drops. The FUEL LEVEL indicator indicates fuel level of generator fuel tank from (E) empty to (F) full in quarter tank increments.

1-13 ENGINE COOLING SYSTEM.

1-13.1 The Engine Cooling System (FIGURE 1-5) consists of a radiator, hoses, thermostat, water pump, a belt driven fan, and cooling jackets. The water pump forces coolant through passages (cooling jackets) in the engine block and cylinder head where the coolant absorbs heat from the engine. When the engine reaches normal operating temperature, the thermostat opens and the heated coolant flows through the upper radiator hose assembly into the radiator. The cooling fan circulates air through the radiator where the coolant temperature is reduced.

1-13.2 A coolant high temperature switch provides automatic shut down in the event that coolant temperature exceeds $225 \pm 5^\circ\text{F}$ ($107 \pm 3^\circ\text{C}$). The COOLANT TEMP indicator indicates the engine coolant temperature, from 120°F to 240°F (48°C to 115°C).

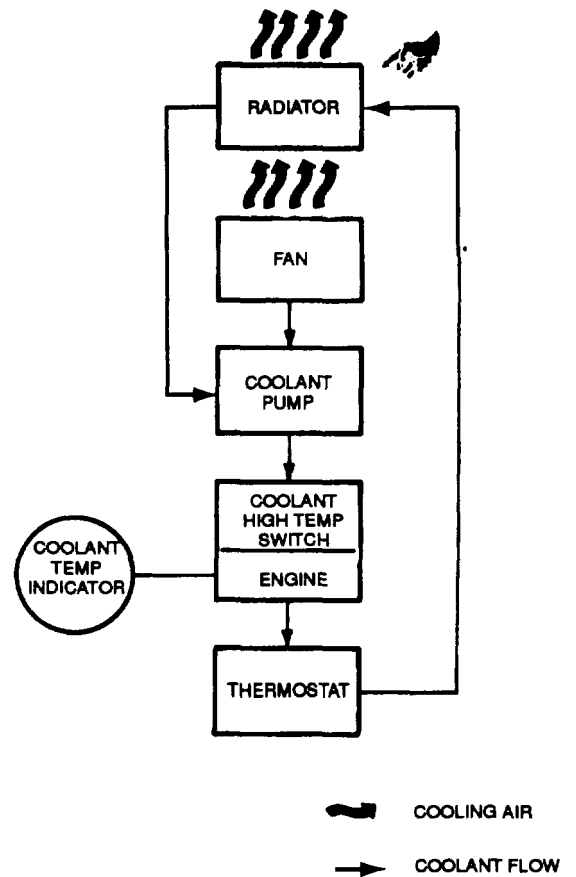

Figure 1-5. Engine Cooling System

1-14 **LUBRICATION SYSTEM.**

The Lubrication System (FIGURE 1-6) consists of an oil sump, dipstick pump, oil pressure sender, and filter. The oil sump is a reservoir for engine lubricating oil. The dipstick indicates oil level in the sump. A pump draws oil from the sump and through a screen removing large impurities. The oil then passes through a spin-on type filter where small impurities are removed. From the filter, oil enters the engine and is distributed to the engine's internal moving parts.

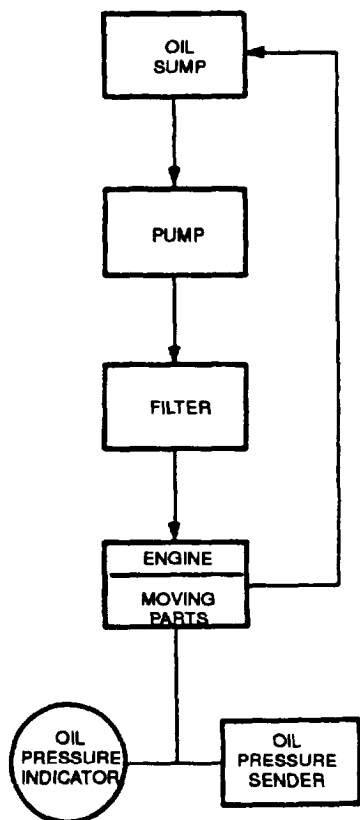

Figure 1-6. Engine Lubrication System

After passing through the engine, the oil returns to the oil sump. The OIL PRESSURE indicator indicates oil pressure sensed by the oil pressure sender in the engine. The engine will shut off automatically if the oil pressure drops to a dangerously low level. The oil level can be checked when the engine is not operating.

1-15 **AIR INTAKE AND EXHAUST SYSTEM.**

1-15.1 The Air intake and Exhaust System(FIGURE 1-7), consists of an air cleaner assembly, intake manifold, exhaust manifold and muffler. Ambient air is drawn into the air cleaner assembly where it passes through the air cleaner element.

Airborne dirt is removed and trapped in the element. A restriction indicator, located on the air cleaner assembly housing, displays red when the air cleaner element should be serviced. Filtered air is drawn out of the air cleaner assembly through air intake tubes to the air intake manifold where it passes into the engine and is mixed with fuel from the injectors.

1-15.2 The engine exhaust gases are expelled into the exhaust manifold. The exhaust manifold channels the gases into the muffler that deadens the sound of the exhaust gases. The gases pass from the muffler through the muffler outlet and are vented upward from the generator set housing.

1-15.3 Cold outside temperatures make starting the engine difficult. To improve engine starting, a cold weather starting aid has been provided that features two preheaters. The preheater warm up the air intake manifold when the MASTER SWITCH is in the PREHEAT position.

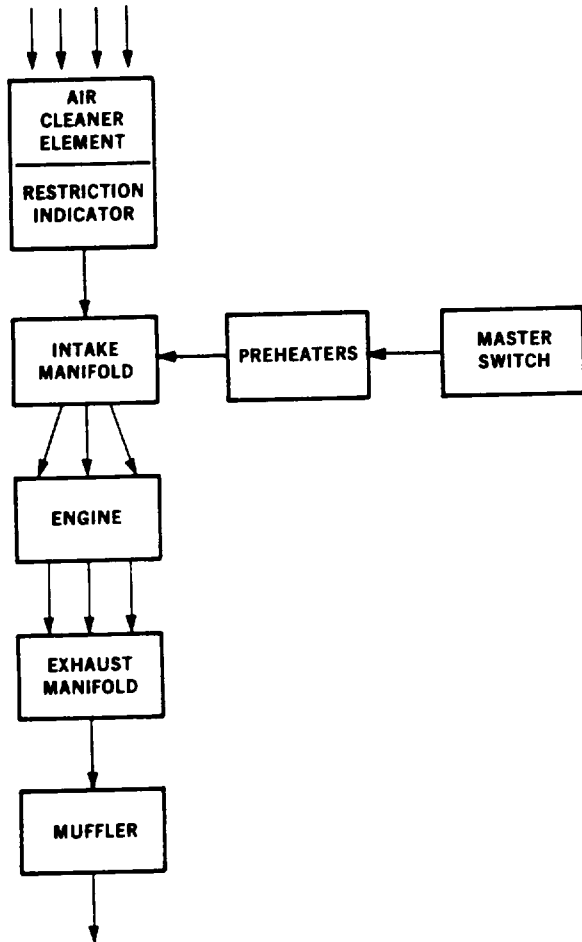

FIGURE 1-7. Air Intake and Exhaust system

1-16 OUTPUT SUPPLY SYSTEM.

1-16.1 The Output Supply System (FIGURE 1-8) consists primarily of the generator, the output load terminal board, the AC voltage reconnection switch, AM-VM transfer switch and the AC circuit interrupter relay.

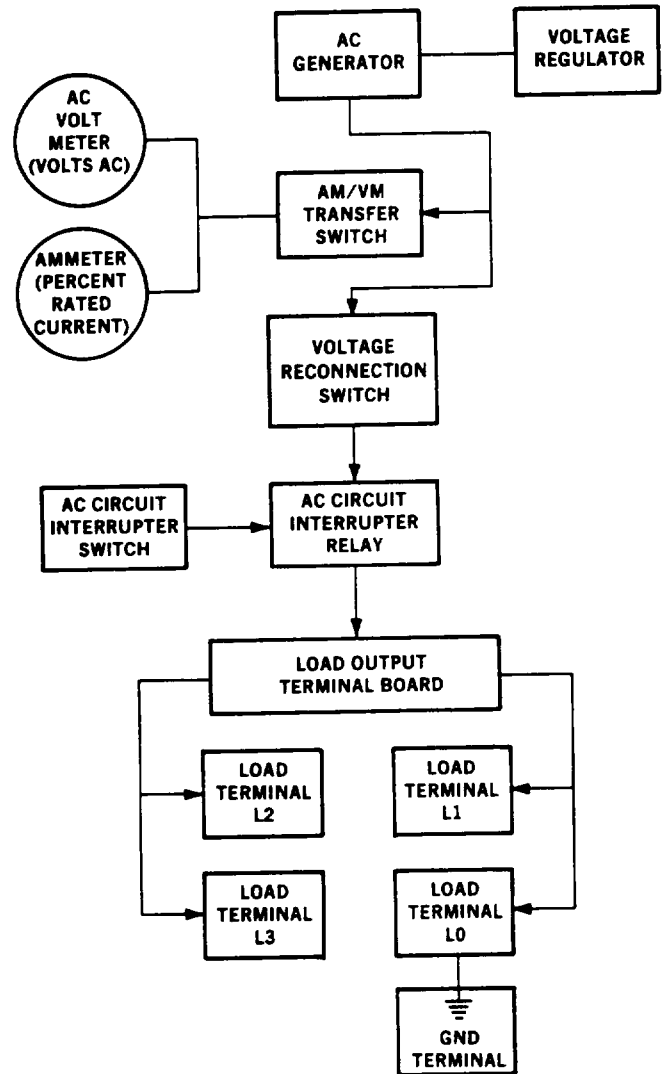

FIGURE 1-8. output supply system

Power created by the generator is supplied through the voltage reconnection switch and the AC circuit interrupter relay to the output load terminals on the output load terminal board.

The voltage reconnection switch allows configuration of the generator set for the following voltage ranges:

120-volt, single phase, 2 wire.

120/240-volt, single phase, 3 wire and

120/208-volt, 3-phase, 4 wire.

1-16.2 The AC CIRCUIT INTERRUPTER switch closes and opens the AC circuit interrupter relay. This enables or interrupts the power flow between the voltage reconnection switch and the output load terminals. The AC circuit interrupter relay is also opened automatically during any of the specified set faults. The voltage regulator senses AC generator output voltage and provides control voltage to the AC generator exciter to maintain the desired AC generator output voltage. The position of the AM-VM transfer switch selects the output load terminals from which current and voltage are measured and are indicated on the ammeter (PERCENT RATED CURRENT) and AC volt meter (VOLTS AC) .

CHAPTER 2

OPERATING INSTRUCTIONS

**SECTION I. DESCRIPTION AND USE OF OPERATOR'S
CONTROLS AND INDICATORS**

2-1 GENERAL.

This section describes and illustrates the controls and indicators to ensure proper operation of the generator set.

2-2 CONTROL PANEL ASSEMBLY.

The control panel assembly contains most of the operating controls and indicators for the generator set. FIGURE 2-1 shows the control panel assembly layout and TABLE 2-1 describes each control and indicator.

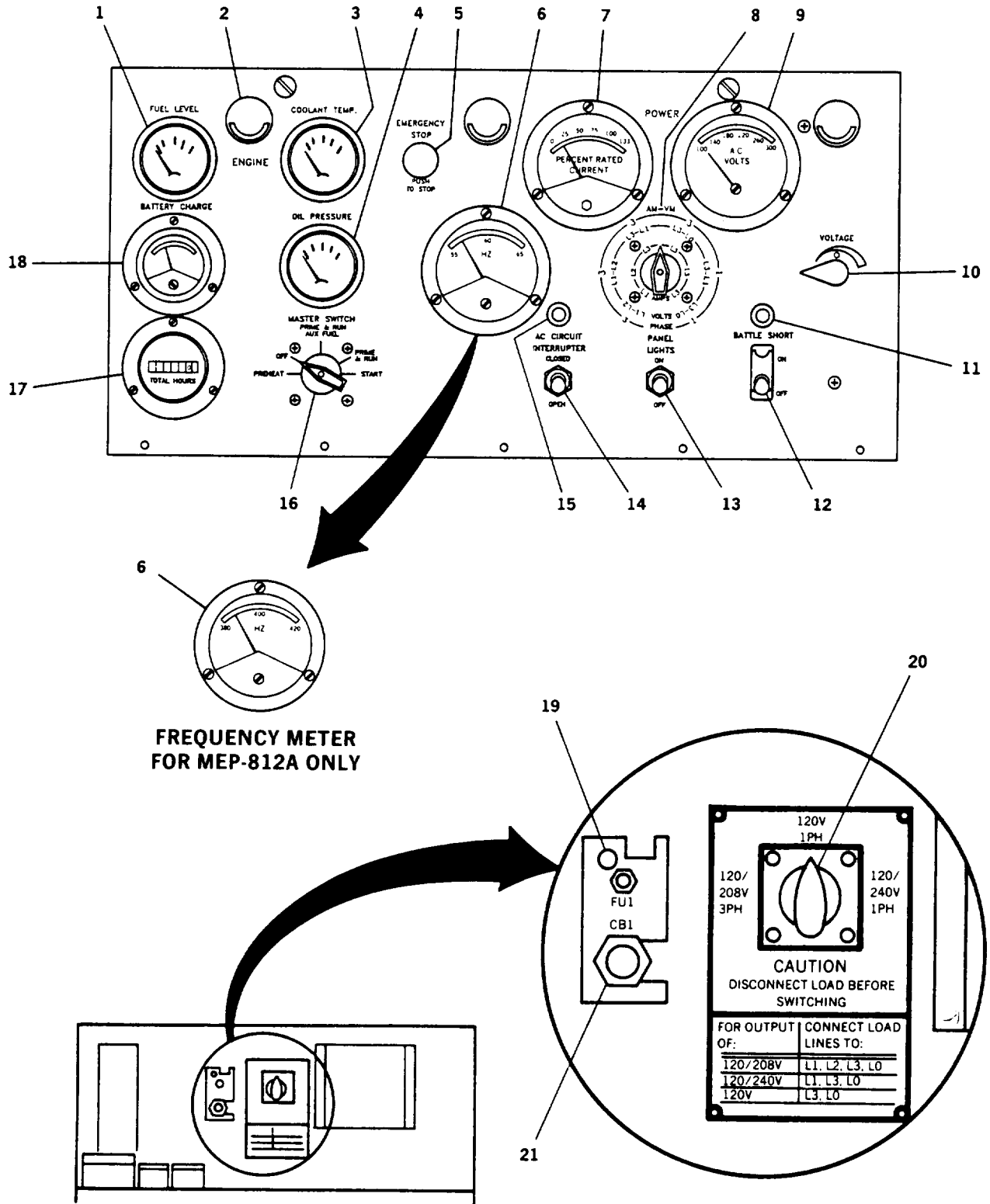

FIGURE 2-1. Operator's Controls and Indicators

TABLE 2-1. Control Panel Controls and Indicators

Key	Control or Indicator	Function																					
1	FUEL LEVEL indicator	Indicates fuel level.																					
2	Panel lights	Illuminates control panel.																					
3	COOLANT TEMP. indicator	Indicates engine coolant temperature.																					
4	OIL PRESSURE indicator	Indicates oil pressure.																					
5	EMERGENCY STOP pushbutton	Shuts down generator set.																					
6	FREQUENCY meter (HERTZ)	Indicates generator set output frequency.																					
7	Ammeter (PERCENT RATED CURRENT)	Indicates generator set load current as a percent of rated current.																					
8	AM-VM transfer switch	<p>Allows selection of current and voltage readings between output load terminals as follows:</p> <table style="margin-left: auto; margin-right: auto; border-collapse: collapse;"> <thead> <tr> <th style="text-align: left; padding: 5px;">Switch Position</th> <th style="text-align: left; padding: 5px;"><u>Voltage</u></th> <th style="text-align: left; padding: 5px;"><u>Current</u></th> </tr> </thead> <tbody> <tr> <td style="padding: 5px;">L1-L2 (3 Phase</td> <td style="padding: 5px;">L1-L2</td> <td style="padding: 5px;">L1</td> </tr> <tr> <td style="padding: 5px;">L2-L3 (3 Phase</td> <td style="padding: 5px;">L2-L3</td> <td style="padding: 5px;">L2</td> </tr> <tr> <td style="padding: 5px;">L3-L1 (3 Phase)</td> <td style="padding: 5px;">L3-L1</td> <td style="padding: 5px;">L3</td> </tr> <tr> <td style="padding: 5px;">L3-LO (3 Phase)</td> <td style="padding: 5px;">L3-LO</td> <td style="padding: 5px;">L3</td> </tr> <tr> <td style="padding: 5px;">L3-L1 (1 Phase)</td> <td style="padding: 5px;">L3-LO</td> <td style="padding: 5px;">L3</td> </tr> <tr> <td style="padding: 5px;">L3-LO (1 Phase)</td> <td style="padding: 5px;">L3-LO</td> <td style="padding: 5px;">L3</td> </tr> </tbody> </table>	Switch Position	<u>Voltage</u>	<u>Current</u>	L1-L2 (3 Phase	L1-L2	L1	L2-L3 (3 Phase	L2-L3	L2	L3-L1 (3 Phase)	L3-L1	L3	L3-LO (3 Phase)	L3-LO	L3	L3-L1 (1 Phase)	L3-LO	L3	L3-LO (1 Phase)	L3-LO	L3
Switch Position	<u>Voltage</u>	<u>Current</u>																					
L1-L2 (3 Phase	L1-L2	L1																					
L2-L3 (3 Phase	L2-L3	L2																					
L3-L1 (3 Phase)	L3-L1	L3																					
L3-LO (3 Phase)	L3-LO	L3																					
L3-L1 (1 Phase)	L3-LO	L3																					
L3-LO (1 Phase)	L3-LO	L3																					
9	AC Voltmeter (VOLTS AC)	Indicates output voltage of generator set.																					
10	VOLTAGE adjust potentiometer	Adjusts generator set voltage.																					
11	BATTLE SHORT light	Amber light indicates battle short switch on.																					

TABLE 2-1. Control Panel Controls and Indicators - Continued

Key	Control or Indicator	Function
12	BATTLE SHORT switch	Bypasses protective devices.
13	PANEL LIGHTS switch	Activates or deactivates panel lights.
14	AC CIRCUIT INTERRUPTER switch	Opens and closes AC circuit interrupter relay.
15	AC CIRCUIT INTERRUPTER light	Green light indicates AC circuit interrupter relay is closed.
16	MASTER SWITCH	<p>PREHEAT - Energizes heater plugs.</p> <p>OFF - Deenergizes all circuits, except panel lights.</p> <p>PRIME & RUN AUX FUEL - Energizes generator set run circuits with fuel pump operating and with auxiliary fuel pump system activated.</p> <p>PRIME & RUN - Energizes generator set run circuits with fuel pump operating and auxiliary fuel system deenergized.</p> <p>START - Energizes starter.</p>
17	Time meter (TOTAL HOURS)	Indicates total engine operating hours.
18	BATTERY CHARGE ammeter	Indicates charge/discharge rate of batteries.
19	DC CONTROL POWER circuit breaker (CB1) (located behind control panel)	Energizes or deenergizes DC circuits.
20	AC Voltage Reconnection Switch (located behind control panel)	Selects 120/208 VAC, three-phase; 120 VAC, single phase; or 120/240 VAC, single phase output at load terminal board.
21	BATTERY CHARGER FUSE (FU1) (located behind control panel)	Protects battery charging alternator.

2-3 MALFUNCTION INDICATOR PANEL.

The malfunction indicator panel (FIGURE 2-2) is located to the left of the control panel. It contains a

series of lights which indicate a generator set failure or abnormal operating condition. TABLE 2-2 describes each indicator light.

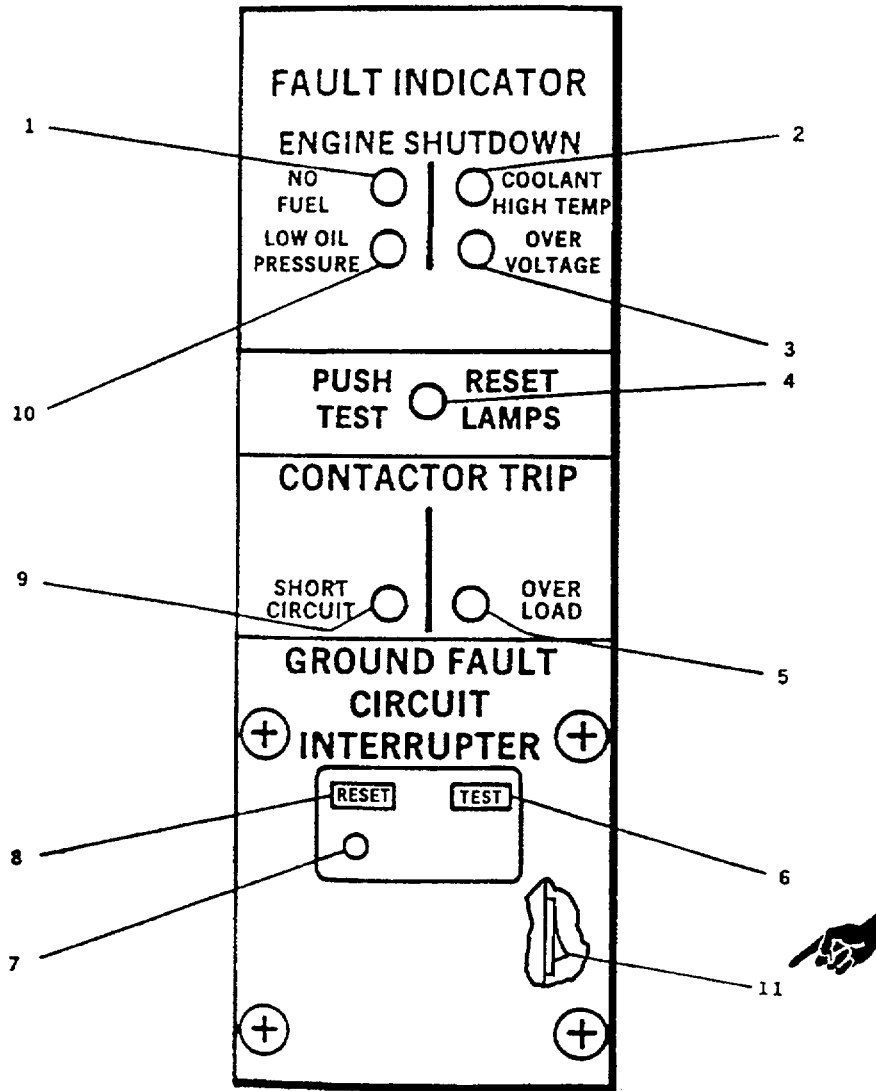

Figure 2-2. Malfunction Indicator Panel

Table 2-2. Malfunction Indicator Panel

Key	Control or Indicator	Function
1	NO FUEL indicator	Lights when fuel level in fuel tank is below preset level.
2	COOLANT HIGH TEMP indicator	Lights when engine coolant temperature exceeds $225^{\circ} \pm 5^{\circ}$ F ($107^{\circ} \pm 3^{\circ}$ F).
3	OVERVOLTAGE indicator	Lights when voltage in 120 volt generator coil exceeds 153 ± 3 volts.
4	PUSH TEST RESET LAMPS	Tests and resets fault indicator lamps.
5	OVER LOAD indicator	Lights when current in any phase exceeds 110 percent of rated current.
6	GROUND FAULT CIRCUIT INTERRUPTER TEST pushbutton	Tests Ground Fault Circuit Interrupter.
7	Ground Fault Circuit Interrupter indicator	Mechanically trips red indicator, at ground fault condition in circuit of convenience receptacle.
8	Ground Fault Circuit Interrupter PUSH TO TEST Pushbutton	Depress to reset Ground Fault Circuit Interrupter after test or ground fault has occurred.
9	SHORT CIRCUIT indicator	Lights when generator set output in any phase exceeds 425 ± 25 percent of rated current.
10	LOW OIL PRESSURE indicator	Lights when engine lubrication systems pressure is less than 15 ± 3 psi (103.4 ± 20.7 kPa) during engine operation.
11	Convenience Receptacle Overload Circuit Breaker (10-amp in-line fuse on generator sets, contract number DAAK01-88-D-D080)	Circuit breaker trips on when load on convenience receptacle exceeds 10 amps (fuse blows on generator sets, contract number DAAK01-88-D-D080).

2-4 FREQUENCY ADJUST CONTROL.

The frequency adjust control (FIGURE 2-3), is to the left and below the control panel. Table 2-3 describes each part and its function.

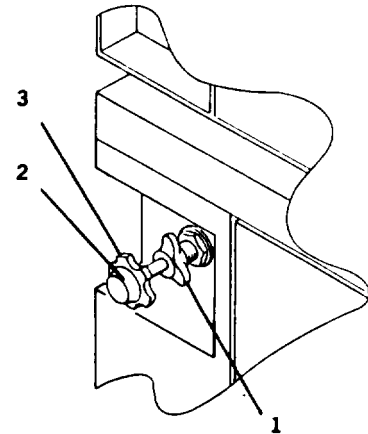

FIGURE 2-3. Frequency Adjust Control

TABLE 2-3. Frequency Adjust Control

Key	Control	Function
1	Locking Ring	Turn locking ring counterclockwise to unlock frequency adjust control. Turn locking ring clockwise to lock frequency adjust control at desired setting.
2	Frequency adjust button	Press frequency adjust button and pull frequency adjust knob to increase frequency. Press frequency adjust button and push frequency adjust knob to decrease frequency. This enables a rapid adjustment of frequency.
3	Frequency adjust knob	Turn knob clockwise to increase frequency and counterclockwise to decrease frequency. This provides a fine adjustment in frequency.

SECTION II. PREVENTIVE MAINTENANCE CHECKS AND SERVICES (PMCS)

2-5 GENERAL. To ensure that the generator set is ready for operation at all times, it must be inspected so that defects can be discovered and corrected before they result in serious damage or failure.

2-5.1 Before You Operate. Always keep in mind the CAUTIONS and WARNINGS. Perform your before (B) PMCS.

2-5.2 While You Operate. Always keep in mind the CAUTIONS and WARNINGS. Perform your during (D) PMCS.

2-5.3 After You Operate. Be sure to perform your after (A) PMCS.

2-5.4 If Your Equipment Fails to Operate. If your equipment does not perform as required, refer to Chapter 3 under Troubleshooting for possible problems. Report any malfunctions or failures on the proper DA Form 2404, or refer to DA PAM 738-750.

2-6 PMCS PROCEDURES.

NOTE

For general location of the items to be inspected in TABLE 2-4, refer to FIGURE 1-2 and FIGURE 2-1.

2-6.1 Purpose of PMCS Table. Your Preventive Maintenance Checks and Services (TABLE 2-4) list the inspections and care of your equipment required to keep it in good operating condition.

2-6.2 Purpose of Service Intervals. The interval column of your PMCS table tells you when to do a certain check or service.

2-6.3 Special Instructions. The following guidelines have been provided to help you in classifying leaks observed while performing PMCS.

Class I. Seepage of fluid (as indicated by wetness or discoloration) not great enough to form drops.

Class II. Leakage of fluid great enough to form drops but not enough to cause drops to drip from item being checked/inspected.

Class III. Leakage of fluid great enough to form drops that fall from the item being checked/inspected.

CAUTION

Equipment operation is allowable with minor oil and coolant leakage (Class I or II) and is able to perform its combat missions (refer to DA PAM 738-750).

Of course, you must consider the fluid capacity in the item/system being checked/inspected. When in doubt, notify the next higher level of maintenance.

When operating with Class I or Class II leaks, continue to check fluid levels as required in your PMCS.

All leaks should be reported to the next higher level of maintenance.

d. Procedures Column The procedures column of your PMCS table tells you how to do the required checks and services. Carefully follow these instructions. If you do not have the tools, or the procedures indicate, complete a DA FORM 2404 and submit it to the next higher level of maintenance.

e. The "Equipment is not ready/available if". This column tells you when and why the generator set cannot be used.

NOTE

The terms "ready/available" and "mission capable", refer to the same status: Generator set is on hand and is able to perform its combat missions, refer to DA PAM 738-750.

f. Reporting and Correcting Deficiencies. If your generator set does not perform as required, refer to Chapter 3 under Troubleshooting for possible problems. Report any malfunctions or failures on DA Form 2404, refer to DA PAM 738-750.

g. Removal of Assemblies/Equipment to Perform PMCS. There is no requirement to remove assemblies/equipment prior to performing the PMCS.

NOTE

The generator set can be operated continuously at anyload from no load up to and including rated load; However, at light loads (less than 25% of set rating) an oily residue (unburned fuel oil) may occasionally be noticed in the exhaust system outlet and around connection joints in the exhaust system. This residue is caused by the inability of the fuel injection system to consistently meter the small amount of fuel required to operate at these low load levels and is not a defect in the fuel system. The oily residue could affect engine performance and create a cosmetic problem on and around the generator set. Operation at rated load will burn off this oily residue. The length of time required at rated load depends on the amount of residue. The muffler may also need to be removed and cleaned if excessive build up occurs. This oily residue can be prevented by increasing the electrical load on the set.

2-6 PMCS PROCEDURES

Table 2-4. Operator Preventive Maintenance Checks and Services

Item Number	Interval	Location	Procedure	Not Fully Mission Capable if:
		Item to be Check/Service		
1	Before	Generator Set Exterior	<p>NOTE</p> <p>If the equipment must be kept in continuous operation, check and service only those items that can be checked and serviced without disrupting operations. Complete all checks and services when equipment is shut down.</p> <p>Check door panels, hinges, and latches for damage, loose, or corroded items. Inspect air intake and exhaust grills for debris.</p> <p>Check to ensure identification plates are secure.</p> <p>Inspect skid base for cracks and/or are corrosion.</p> <p>inspect to ensure acoustical materials, located in the grill areas and under the engine, are secure, damaged, or missing.</p> <p>WARNING</p> <p>With any access door open while the generator set is in operation, the noise level may cause hearing damage. To avoid hearing damage, hearing protection should be worn.</p>	<p>Cannot secure door.</p> <p>Skid base is cracked or shows signs of structural damage.</p>
		Housing		
		Identification Plates		
		Skid Base		
4	Before	Acoustical Materials		
		Engine Assembly		

2-6 **PMCS PROCEDURES - Continued.**

Table 2-4. Operator Preventive Maintenance Checks and Services - Continued

Item Number	Interval	Location	Procedure	Not Fully Mission Capable if:
		Item to be Check/Service		
			WARNING	
5	Before	Engine Assembly	Inspect for loose, damaged, or missing hardware.	Any loose, damaged, or missing hardware.
6	Before	Fuel System	Inspect for leaks, damage, loose, or missing hardware.	Any fuel leaks, damage, loose or missing parts.
7	Before	Fuel Filter/Water Separator	Inspect for leaks, cracks, damage, proper mounting, loose or missing parts. Drain water from fuel filter/water separator. Ref (3-3.6.2)	Any fuel leak Water not drained.
8	Before	Lubrication System	Inspect for leaks, damage, loose or missing parts. Inspect oil level. Inspect for contamination.	Class III leaks, damage, loose or missing parts. oil level is low. Oil shows signs of contamination.
		Cooling System	WARNING	
			WARNING Cooling system operates at high temperatures. Personal injury or death from burns or scalding can result from contact with high pressure steam and/or liquid.	
9	Before	Radiator	Inspect for leaks, damage, loose or missing parts.	Class III leaks of missing radiator cap.
10	Before	Hoses	Inspect for leaks, cracks, or missing parts.	Class III leaks or missing dampers or hoses.
11	Before	Cooling Fan	Inspect for obstruction, damage, or looseness. Inspect for unusual noise in fan area.	Damaged or loose. Unusual noise from area.
12	Before	Fan Belt	Inspect for cracks, fraying, or looseness.	Broken or missing belt.
13	Before	Overflow Bottle	Inspect for proper mounting, leaks, or missing hardware.	Class III leaks or missing hardware.

2-6 PMCS PROCEDURES - Continued.

TABLE 2-4. Operator Preventive Maintenance Checks and Services - Continued

Item Number	Internal	Location	Procedure	Not Fully Mission Capable if:
		Item to be Check/Service		
		Exhaust/ Intake System		
			<u>WARNING</u> Exhaust discharge contains deadly gases. DO NOT operate generator set in an enclosed areas unless exhaust discharge is vented outside. Severe personal injury or death due to carbon monoxide poisoning could occur.	
14	Before	Exhaust System	Inspect for leaks, corrosion, and missing parts.	Leaks, damaged, or missing parts.
15	Before	Air Cleaner Assembly	Inspect for loose, damage, or missing parts Inspect restriction indicator for clogged air cleaner element.	Loose or missing parts. Clogged air cleaner element.
		Grounding Rod Assembly		
			<u>WARNING</u> NEVER attempt to start the generator set if it is not properly grounded. Personal injury or death due to electrocution may result.	
16	Before	Ground Rod Cable and Connections	Inspect for damage, corrosion, and loose connections.	Damaged, corroded or loose connections

2-6 PMCS PROCEDURES - Continued.

TABLE 2-4. Operator Preventive Maintenance Checks and Services - Continued

Item Number	Interval	Location	Procedure	Not Fully Mission Capable if:
		Item to be Check/Service		
		Electrical System		
			<u>WARNING</u> Battery Acid can cause burns to unprotected skin. Batteries give off a flammable gas. DO NOT smoke or use open flame when performing maintenance. Flames and explosion could result in severe personal injury or death. DC voltage is present at generator set electrical components even with generator set shut down. Avoid grounding self when in contact with electrical components. Personal injury or death due to electrocution could result.	
17	Before	Batteries	Inspect electrolyte level.	Electrolyte is below battery plates.
18	Before	Battery Cables	Inspect for corrosion, damage, loose connections, or missing parts.	Damaged, loose, or missing parts.
19	Before	Output Box Assembly	Inspect cables for damage or loose connections. Inspect output terminals for damage or missing hardware.	Damaged, loose, or missing parts. Damaged or missing hardware.
		<u>Control Box Assembly</u>		
20	Before	Controls and Indicators	Inspect for damage or missing parts.	Damaged or missing parts.
			<u>WARNING</u> High voltage is produced when this generator set is in operation. Personal injury or death due to electrocution could result.	
21	Before	Control Box Harness	Inspect for damage and looseness.	Damaged or loose.

2-6 PMCS PROCEDURES - Continued.

TABLE 2-4. Operator Preventive Maintenance Checks and Services - Continued

Item Number	Interval	Location	Procedure	Not Fully Mission Capable if:
		Item to be Check/Service		
22	During	Generator Set Exterior	<p>NOTE</p> <p>If The equipment must be kept in continuous operation, check and service only those items that can be checked and serviced without disrupting operations. Complete all checks and services when equipment is shut down.</p> <p>Check door panels, hinges, and latches for damage, loose, or corroded items.</p> <p>WARNING</p> <p>With any access door open while the generator set is in operation, the noise level may cause hearing damage. To avoid hearing damage, hearing protection should be worn.</p> <p>WARNING</p> <p>The fuels used in this generator set are highly explosive. DO NOT smoke or use open flame when performing maintenance. Flames and explosion can occur resulting in severe injury or death.</p>	Cannot secure door.
		Housing		
		Engine Assembly		
23	During	Engine Assembly	Inspect for loose, damaged, or missing hardware.	Any loose, damaged, or missing hardware.
24	During	Fuel System	Inspect for leaks, damage, loose, or missing hardware.	Any fuel leaks, damage, loose or missing parts.
25	During	Lubrication System	Inspect for leaks, damage, loose or missing parts.	Class III leaks, damage, loose or missing parts.
			Inspect oil level. Inspect for contamination.	Oil level is low. Oil shows signs of contamination.

2-6 PMCS PROCEDURES - Continued.

TABLE 2-4. Operator Preventive Maintenance Checks and Services - Continued

Item Number	Interval	Location	Procedure	Not Fully Mission Capable if:
		Item to be Check/Service		
26	During	Cooling System	Inspect for obstruction, damage, or looseness. Inspect for unusual noise in fan area.	Damaged or loose. Unusual noise from area.
		Cooling Fan		
27	During	Overflow Bottle	Inspect for proper mounting, leaks, or missing hardware.	Class III leaks or missing hardware,
28	During	Grounding Rod Assembly	Inspect for damage, corrosion, and loose connections.	Damaged, corroded, or loose connections.
		Ground Rod Cable and Connections		
29	During	Control Box Assembly	<p style="text-align: center;">WARNING</p> <p style="text-align: center;">High voltage is produced when this generator set is in operation. Personal injury or death due to electrocution could result.</p>	Indicators are not operating properly.
		Controls and Indicators		
30	After	Generator Set Exterior	<p style="text-align: center;">NOTE</p> <p style="text-align: center;">If The equipment must be kept in service continuous operation, check and only those items that can be checked and serviced without disrupting operations. Complete all checks and services when equipment is shut down.</p>	Cannot secure door.
		Housing		
31	After	Identification Plates	Check to ensure identification plates are secure	
32	After	Skid Base	Inspect skid base for cracks and/or corrosion.	Skid base is cracked or shows signs of structural damage.

2-6 PMCS PROCEDURES - Continued.

TABLE 2-4. Operator Preventive Maintenance Checks and Services - Continued

Item No.	Interval	Location	Procedure	Not Fully Mission Capable if:
		Item to Check/Service		
			<p>WARNING The fuels used in this generator set are highly explosive. DO NOT smoke or use open flame when performing maintenance. Flames and explosion can occur resulting in severe injury or death.</p>	
33	After	Engine Assembly	Inspect for loose, damaged, or missing hardware.	Loose, damaged, or missing hardware.
34	After	Fuel System	Inspect for leaks, damage, loose, or missing hardware.	Any fuel leaks, damage, loose or missing parts.
35	After	Fuel Filter/ Water Separator	Inspect for leaks, cracks, damage, proper mounting, loose or missing parts. Drain water.	Any fuel leaks. Water not drained.
36	After	Lubrication System <u>Cooling System.</u>	Inspect for leaks, damage, loose or missing parts. Inspect oil level. Inspect for contamination.	Class III leaks, damage, loose or missing parts. Oil level is low. Oil shows signs of contamination.
			<p>WARNING Cooling system operates at high temperatures. Personal injury or death from burns or scalding can result from contact with high pressure steam and/or liquid.</p>	
37	After	Radiator	Inspect for leaks, damage, loose or missing parts.	Class III leaks or missing radiator cap.
38	After	Hoses	Inspect for leaks, cracks, or missing parts.	Class III leaks or missing clamps or hoses.
39	After	Fan Belt <u>Control Box Assembly</u>	Inspect for cracks fraying, or looseness.	Broken or missing belt.
40	After	Controls and Indicators	Inspect for damaged or missing parts.	Damaged or missing parts.

SECTION III. OPERATION UNDER USUAL CONDITIONS

2-7 GENERAL. This section provides information and guidance for generator set operation under normal conditions, refer to FM 20-31.

2-8 ASSEMBLY AND PREPARATION FOR USE.

2-8.1 Installation of Ground Rod.

WARNING

Do not operate the generator set until it has been connected to a suitable ground. Serious injury or death can result from operating an ungrounded generator set.

- a. Insert ground cable (2, FIGURE 2-4) through slot on load output terminal board terminal marked GND (1). Tighten terminal nut.
- b. Connect coupling (5) to ground rod (4) and screw driving stud (3) into coupling (5). Make sure that driving stud (3) seats on ground rod (4).
- c. Drive ground rod into ground until coupling is just above surface.
- d. Remove driving stud and install another section of ground rod.

- e. Install another coupling (5) and driving stud (3). Drive ground rod down until new coupling is just above ground surface.
- f. Repeat steps d and e until ground rod has been driven eight feet or deeper, providing an effective ground.
- g. Connect clamp (6) and ground cable (2) to ground rod (4) and tighten clamp screw.

2-8.2 Installation of Load Cables.

WARNING

Never attempt to connect or disconnect load cables while the generator set is running. Failure to observe this warning could result in severe personal injury or death by electrocution.

CAUTION

Do not connect the load cables to the convenience receptacle. Failure to observe this caution can result in damage to the generator set.

- a. Shutdown generator set.

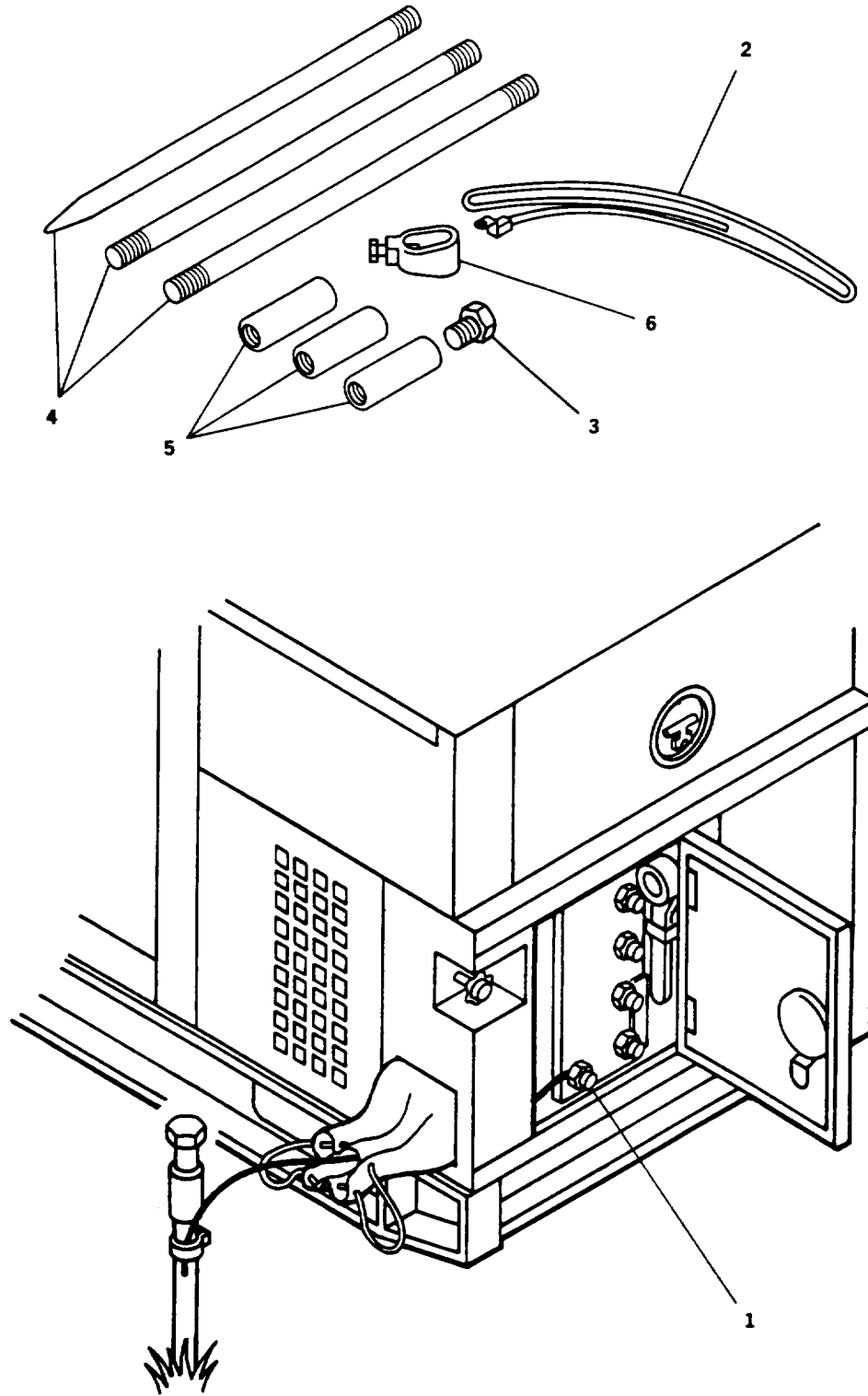

FIGURE 2-4. Grounding Connections

CAUTION

When using single phase connections, always attempt to balance loads between terminals (do not connect all loads between one terminal and LO). Failure to observe this caution can result in damage to generator set.

- b. Select required output terminals from TABLE 2-5.
- c. Open output load terminal door.
- d. Using terminal nut wrench (3, FIGURE 2-5) loosen terminal nuts (1) on terminals (2) selected in Step b.
- e. Insert ends of load cables through load cable exit. Then insert ends of cables into slots of load terminal studs (2).
- f. Tighten load terminal nuts (1).
- g. Secure wrench (3) in bracket inside load terminal door, and close door.

TABLE 2-5. Load Terminal, AC Voltage Reconnection Switch and AM-VM Transfer Switch Selection

RECONNECTION SWITCH POSITION	TERMINALS	AM-VM TRANSFER SWITCH POSITION	VOLTAGE READING	CURRENT READING (TERMINAL)
120/208V 3PH	L 1 , L 2 , L3, LO	L1-L2 3 PHASE	208 VOLTS	L1
		L2-L3 3 PHASE	208 VOLTS	L2
		L3-L1 3 PHASE	208 VOLTS	L3
		L3-LO 3 PHASE	120 VOLTS	L3
120V 1PH	L3-LO	L3-LO 1PHASE	120 VOLTS	L3
120/240V 1PH	L3-L1 L3-LO OR L1-LO	L3-L1 1PHASE	240 VOLTS	L3
		L3-LO 1 PHASE	120 VOLTS	L3
		L1-LO 1 PHASE	120 VOLTS	L1

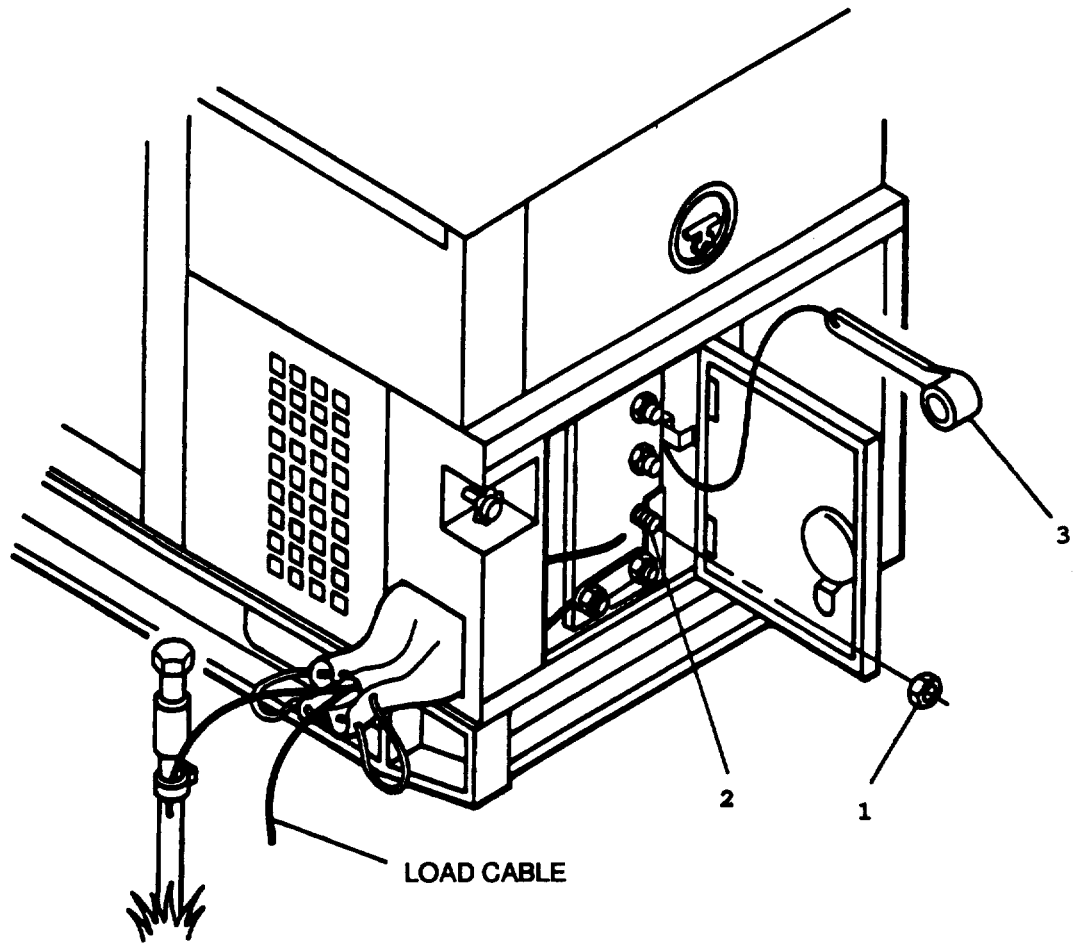

Figure 2-5. Installation of Load Cables

2-9 INITIAL ADJUSTMENTS. DAILY CHECKS AND SELF TEST.

2-9.1 Perform all before (B) PMCS, refer to TABLE 2-4.

2-9.2 Initial Adjustments

- a. Place DEAD CRANK switch in NORMAL position.
- b. Push DC CONTROL POWER circuit breaker in.
- c. Ensure AC voltage reconnection switch is positioned to match voltage requirements.
- d. Place AM-VM transfer switch in a position corresponding to output terminal load connections, refer to TABLE 2-1.
- e. Pull out emergency stop switch.
- f. Place PARALLEL UNIT switch in UNIT position.

2-9.3 Self Test

- a. Place MASTER SWITCH to PRIME AND RUN position.

- b. Push PRESS TO TEST pushbutton on malfunction indicator panel. Ensure all indicator lights are lit. When PRESS TO TEST pushbutton is released, all lights should go out.
- c. Press BATTLE SHORT press to test light on the control panel assembly. Ensure indicator light is lit. When press to test light is released, light should go out.
- d. Press AC CIRCUIT INTERRUPTER press to test light on the control panel assembly. Ensure indicator light is lit. When press to test light is released light should go out.

2-10 **OPERATING PROCEDURE.**

WARNING

High voltage is produced when this generator set is in operation. Personal injury or death due to electrocution could result.

WARNING

Exhaust discharge contains deadly gases. Do not operate the generator set in enclosed areas unless exhaust discharge is properly vented outside. Severe personal injury or death due to carbon monoxide poisoning could result.

2-10.1 Starting Procedure.

WARNING

Never attempt to start the generator set if it has not been properly grounded. Failure to observe this warning could result in serious injury or death by electrocution.

CAUTION

Do not crank engine in excess of fifteen seconds. Allow starter to cool at least fifteen seconds between attempted starts. Failure to observe this caution could result in damage to the starter.

NOTE

At temperatures below 40°F (4°C) it may be necessary to use the Cold Weather Starting Aid.

NOTE

Ensure all generator set access doors, except control panel access door, are closed.

- a. In cold weather conditions, place MASTER SWITCH to PREHEAT position for approximately 30 seconds.
- b. Rotate MASTER SWITCH to START position.
- c. Hold MASTER SWITCH in START position until oil pressure reaches at least 25 psi (172 kPa), voltage has increased to its approximate rated value, and engine has reached stable operating speed.
- d. Release MASTER SWITCH to PRIME AND RUN position.
- e. If operating with an auxiliary fuel source, rotate MASTER SWITCH to PRIME AND RUN AUX FUEL position.

NOTE

Under normal conditions warm up engine without load for five minutes. (If required, load can be applied immediately.)

- f. Check COOLANT TEMP [170 - 200°F (77-93° C)] and OIL PRESSURE [25-60 psi (172-414 kPa)] indicators for normal readings.
- g. Using VOLTAGE adjust potentiometer (FIGURE 2-1) and Frequency Adjust Control (FIGURE 2-3), adjust voltage and frequency to rated values.
- h. Press GROUND FAULT CIRCUIT INTERRUPTER TEST pushbutton. Ensure indicator window is clear. Press RESET pushbutton and ensure indicator is red.
- i. Place AC CIRCUIT INTERRUPTER switch to CLOSED position.
- j. Ensure frequency and voltage are still at required values. Adjust if necessary.
- k. Rotate AM-VM transfer switch to each phase position while observing ammeter (PERCENT RATED CURRENT meter). If more than rated load is indicated in any phase, reduce load.

WARNING

High voltage is produced when this generator set is in operation. Improper operation could result in personal injury or death.

WARNING

With any access door open, the noise level of this generator set when operating could cause hearing damage. Hearing protection must be worn when working near the generator set while running.

- l. Perform all DURING (D) OPERATION PMCS requirements in accordance with TABLE 2-4.

2-10.2 **Stopping Procedure.**

- a. Place AC CIRCUIT INTERRUPTER switch in OPEN position.
- b. Allow generator set to operate five minutes with no load applied.
- c. Place MASTER SWITCH in OFF position.
- d. Perform all AFTER OPERATION (A) PMCS requirements in accordance with TABLE 2-4.

- e. Place DEAD CRANK switch to OFF position.

2-11 PREPARATION FOR MOVEMENT.

- a. Shut down generator set. Refer to paragraph 2-10.2.
- b. Disconnect load cables.
- c. When using auxiliary fuel line, disconnect line, drain excess fuel from line and store line in storage box.
- d. Disconnect ground cable and remove ground rods. Store ground rod in holding clip on right side of skid base. Store cable and couplings in storage box.

- e. Secure all generator set access doors and panels.

- f. For initial set up after movement, refer to paragraph 2-8 for assembly and preparation for use.

2-12 OPERATING INSTRUCTIONS AND DATA PLATES.

There are identification and instruction plates on the generator set. FIGURE 2-6 through 2-20 show the location and contents of each plate on the generator set.

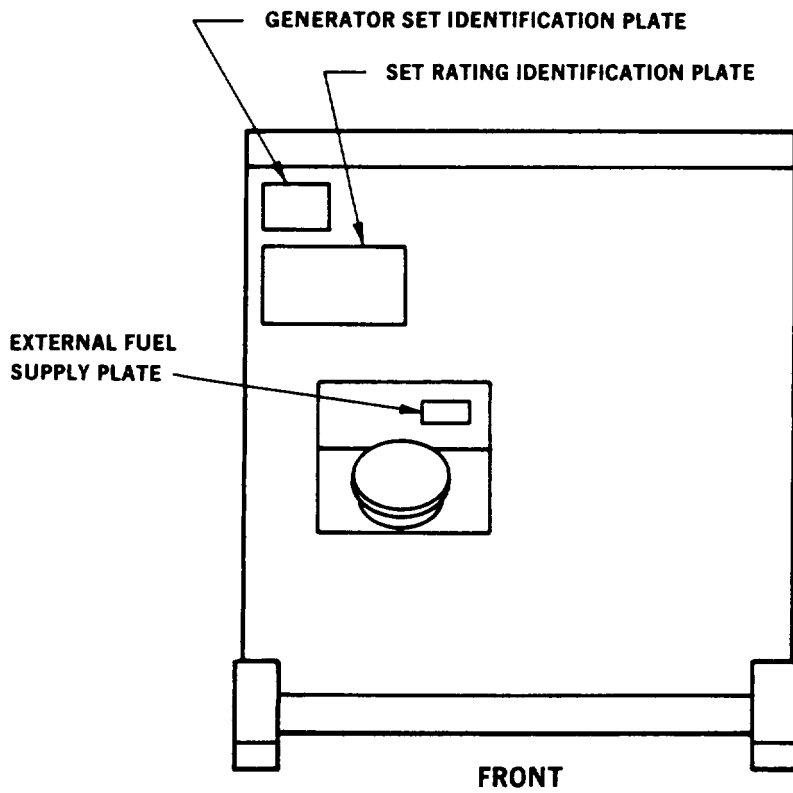
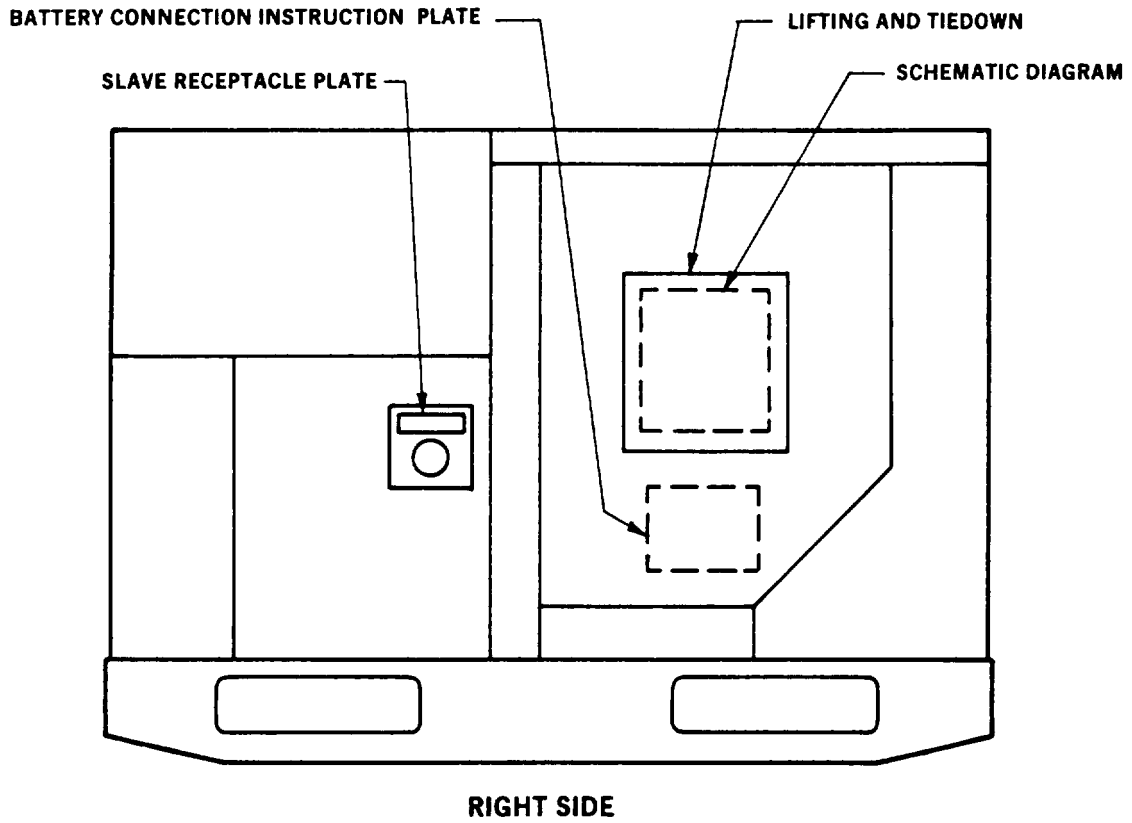

FIGURE 2-6. Operating Instructions Plates (Front and Right Side)

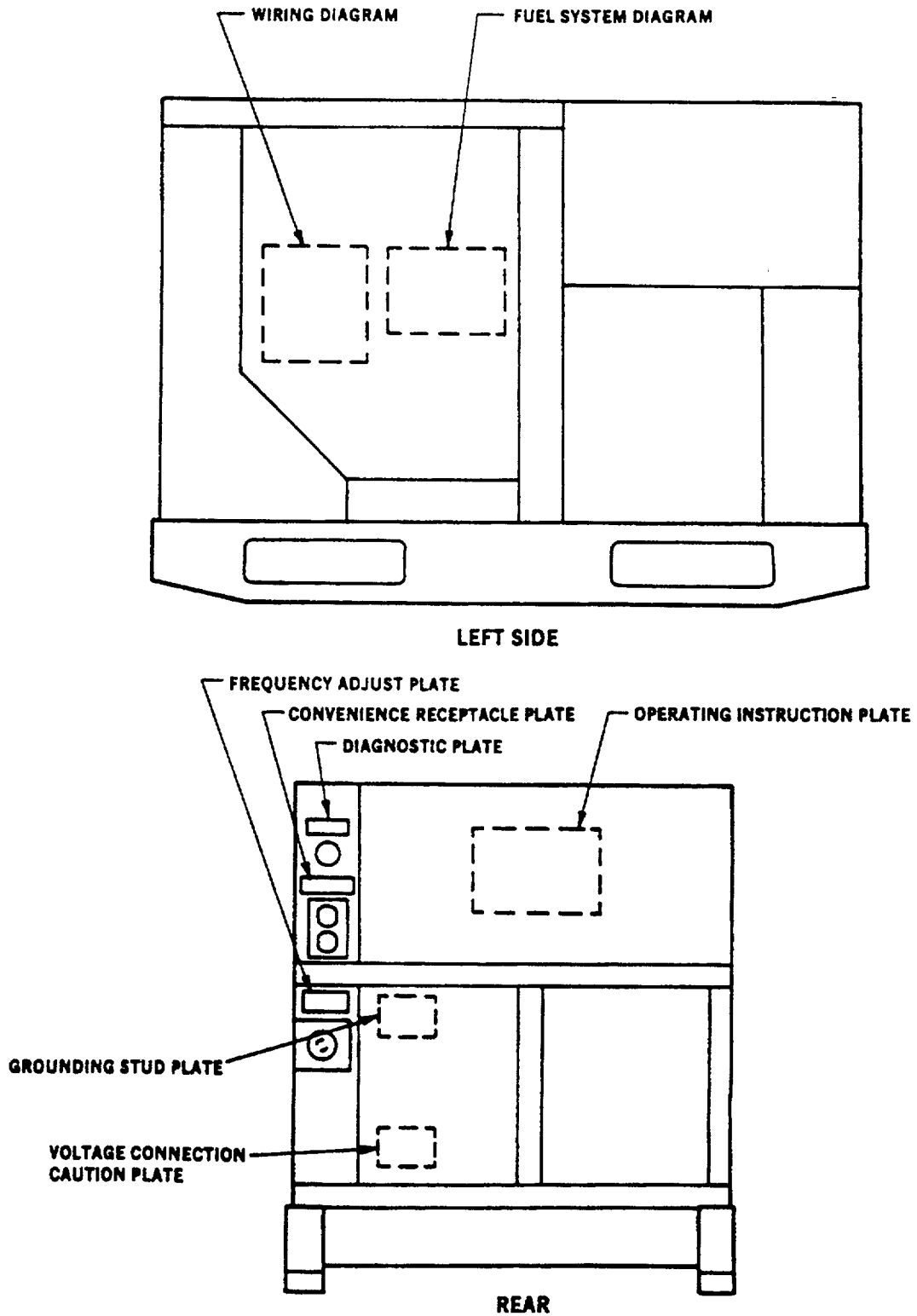

Figure 2-7. Operating Instructions Plates (Rear and Left side)

OPERATING INSTRUCTIONS

WARNING:

- A. TO AVOID SHOCK HAZARD SET FRAME MUST BE GROUNDED. CONNECT WIRE, NO. 8 WIRE OR LARGER FROM GROUND TERMINAL (GND) TO EARTH GROUND.
- B. BATTERY NEGATIVE TERMINAL IS CONNECTED TO GROUND.
- C. IDLING OF THE ENGINE AT SPEEDS LOWER THAN THOSE ATTAINABLE THROUGH THE CONTROLS MAY RESULT IN DAMAGE TO ELECTRICAL COMPONENTS.

1. **PRESTART CHECKS**
 - A. CHECK RADATOR COOLANT, ENGINE LUBE OIL, FUEL, AND BATTERY ELECTROLYTE LEVEL.
 - B. CHECK FUEL-WATER SEPARATOR. DRAIN WATER IF PRESENT.
 - C. PLACE CONTROL SWITCHES TO OFF OR EQUIVALENT POSITION.
2. **NORMAL START (TEMPERATURE ABOVE -25° F)**
 - A. CRANK THE ENGINE BY PLACING THE MASTER SWITCH IN THE START POSITION. DO NOT CRANK FOR CONTINUOUS PERIODS LONGER THAN 15 SECONDS.
 - B. AT TEMPERATURES BELOW APPROXIMATELY 40° F IT MAY BE NECESSARY TO USE THE AIR INTAKE MANIFOLD HEATER. HOLD THE MASTER SWITCH IN THE PRE-HEAT POSITION FOR APPROXIMATELY 30 SECONDS PRIOR TO STEP C.
3. **STOPPING THE SET**
 - A. REMOVE LOAD BY PLACING THE AC CIRCUIT INTERRUPTER SWITCH IN OPEN POSITION.
 - B. STOP UNIT BY PLACING MASTER SWITCH IN OFF POSITION.
4. REFER TO APPLICABLE TECHNICAL MANUAL FOR ADDITIONAL INFORMATION ON MAINTENANCE AND TROUBLESHOOTING PROCEDURES.

SERVICE INSTRUCTIONS

FUEL AND OIL			COOLANT	
AMBIENT TEMPERATURE	DIESEL FUEL	LUBRICATING OIL	AMBIENT TEMPERATURE	RADATOR COOLANT
+20° F TO +120° F	W-F-800 OR DF-2	ML-L-2104C OE H00-30	+40° F TO +120° F	WATER ML-A-5300B
0° F TO +20° F	W-F-800 OR DF-1	ML-L-2104C OE H00-10	-25° F TO +120° F	WATER ML-A-46153
-25° F TO 0° F	W-F-800 OR DF-1	ML-L-46187	-25° F TO +120° F	WATER ML-A-11755
-25° F TO 0° F	W-F-800 OR DF-A	ML-L-46187		

SYSTEM CAPACITY

FUEL TANK	LUBRICATING OIL			COOLING SYSTEM	
	CRANKCASE	FILTERS	RADATOR AND OVERFLOW	BLOCK	
	FULL	LOW	CAPACITY		
5	3.2	2.4	.28	5.0	2.2
GALLONS	QTS.	QTS.	QTS.	QTS.	QTS.

NOTE: FOR OPERATION USING JFA, JFS, OR JPS FUEL REFER TO APPLICABLE OPERATING INSTRUCTION MANUAL.

30554-88-20066

Figure 2-8. Operating Instructions Plate

US DEPARTMENT OF DEFENSE NATO STANDARD OTAN

GENERATOR SET DIESEL ENGINE 5KW 60HZ

MODEL MEP-802A NSN 6115-01-274-7387

SER NO RZB REG NO.

TM 9-6115-641-10 NAVFAC 9-6115-641-10

TO 35C2-3-456-11 TM -

VOLTS 120V 1PH, 120/240V 1PH, 120/208V 3PH

AMPS 52, 26, 17 PF 0.8

DRY WT 800 LB LG 50.6 IN W 32 IN HGT 37 IN

DATE MFD CONTR NO DAAK01-88-D-0080

WARRANTY DATE INSP

MFD BY LIBBY CORP INSP STAMP

30554-88-20063-01

US DEPARTMENT OF DEFENSE NATO STANDARD OTAN

GENERATOR SET DIESEL ENGINE 5KW 400HZ

MODEL MEP-812A NSN 6115-01-274-7391

SER NO RZB REG NO.

TM 9-6115-641-10 NAVFAC 9-6115-641-10

TO 35C2-3-456-11 TM -

VOLTS 120V 1PH, 120/240V 1PH, 120/208V 3PH

AMPS 52, 26, 17 PF 0.8

DRY WT 825 LB LG 50.6 IN W 32 IN HGT 37 IN

DATE MFD CONTR NO DAAK01-88-D-0080

WARRANTY DATE INSP

MFD BY LIBBY CORP INSP STAMP

30554-88-20063-02

Figure 2-9. Generator Set Identification Plate

US DEPARTMENT OF DEFENSE
NATO STANDARD OTAN

GENERATOR SET DIESEL ENGINE 5KW 60HZ

MODEL MEP-802A NSN 6115-01-274-7387
SER NO FZ REG NO. _____
TM 9-6115-641-10 NAVFAC 9-6115-641-10
TO 35C2-3-456-11 TM -

VOLTS 120V 1PH, 120/240V 1PH,
120/208V 3PH

AMPS 52, 26, 17 PF 0.8

DRY WT 800(LB) LG 50.6(IN) W 32(IN) HGT 37(IN)

DATE MFD _____ CONTR NO DAAK01-94-D-0036
WARRANTY _____ DATE INSP _____

MFD BY FERMONT DIV INSP STAMP _____

30554-88-20063-01

US DEPARTMENT OF DEFENSE
NATO STANDARD OTAN

GENERATOR SET DIESEL ENGINE 5KW 400HZ

MODEL MEP-812A NSN 6115-01-274-7391
SER NO FZ REG NO. _____
TM 9-6115-641-10 NAVFAC 9-6115-641-10
TO 35C2-3-456-11 TM -

VOLTS 120V 1PH, 120/240V 1PH,
120/208V 3PH

AMPS 52, 26, 17 PF 0.8

DRY WT 825(LB) LG 50.6(IN) W 32(IN) HGT 37(IN)

DATE MFD _____ CONTR NO DAAK01-94-D-0036
WARRANTY _____ DATE INSP _____

MFD BY FERMONT DIV INSP STAMP _____

30554-88-20063-02

Figure 2-9A. Generator Set Identification Plate

GENERATOR SET, DIESEL FUELED
TACTICAL QUIET
MODE III (60 HERTZ), SIZE 5 (5 KW)

KW CAPACITY			PF	FREQ	FUEL	OUTPUT VOLTAGE	VOLTAGE ADJUST RANGE	PHASE	CURRENT CAPACITY AMPS
120 DEG F S/L	95 DEG F 4000 FT	95 DEG F 8000 FT							
5.0	5.0	4.3	.80	60	DF1/DF2/DFA	120/208	205-220	3	17
5.0	5.0	4.3	.80	60	DF1/DF2/DFA	120/240	228-252	1	26
5.0	5.0	4.3	.80	60	DF1/DF2/DFA	120	114-126	1	52
5.0	5.0	4.3	.80	60	JPS/JPB	120/208	205-220	3	17
5.0	5.0	4.3	.80	60	JPS/JPB	120/240	228-252	1	26
5.0	5.0	4.3	.80	60	JPS/JPB	120	114-126	1	52
KW CAPACITY			PF	FREQ	FUEL	OUTPUT VOLTAGE	VOLTAGE ADJUST RANGE	PHASE	CURRENT CAPACITY AMPS
100 DEG F S/L	100 DEG F 3000 FT								
4.2	4.2	-	.80	60	JP4	120/208	205-220	3	14
4.2	4.2	-	.80	60	JP4	120/240	228-252	1	21
4.2	4.2	-	.80	60	JP4	120	114-126	1	43

30554-88-20160-01

GENERATOR SET, DIESEL FUELED
TACTICAL QUIET
MODE II (400 HERTZ), SIZE 5 (5 KW)

KW CAPACITY			PF	FREQ	FUEL	OUTPUT VOLTAGE	VOLTAGE ADJUST RANGE	PHASE	CURRENT CAPACITY AMPS
120 DEG F S/L	95 DEG F 4000 FT	95 DEG F 8000 FT							
5.0	5.0	4.3	.80	400	DF1/DF2/DFA	120/208	205-220	3	17
5.0	5.0	4.3	.80	400	DF1/DF2/DFA	120/240	228-252	1	26
5.0	5.0	4.3	.80	400	DF1/DF2/DFA	120	114-126	1	52
5.0	5.0	4.3	.80	400	JPS/JPB	120/208	205-220	3	17
5.0	5.0	4.3	.80	400	JPS/JPB	120/240	228-252	1	26
5.0	5.0	4.3	.80	400	JPS/JPB	120	114-126	1	52
KW CAPACITY			PF	FREQ	FUEL	OUTPUT VOLTAGE	VOLTAGE ADJUST RANGE	PHASE	CURRENT CAPACITY AMPS
100 DEG F S/L	100 DEG F 3000 FT								
4.2	4.2	-	.80	400	JP4	120/208	205-220	3	14
4.2	4.2	-	.80	400	JP4	120/240	228-252	1	21
4.2	4.2	-	.80	400	JP4	120	114-126	1	43

30554-88-20160-02

Figure 2-10. Set Rating Identification Plate

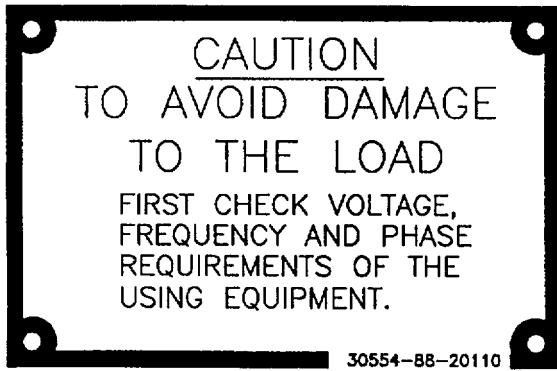

Figure 2-11. Voltage Connection Caution Plate

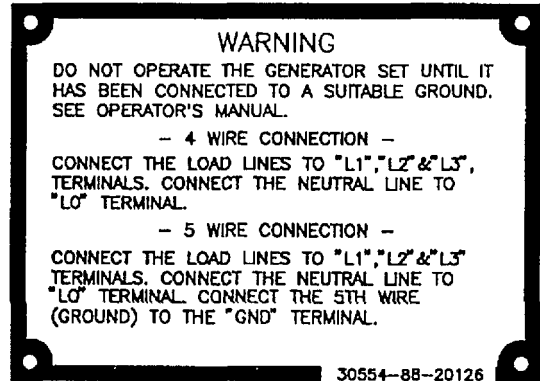

Figure 2-12. Grounding Stud Plate



Figure 2-13. NATO Slave Receptacle Plate

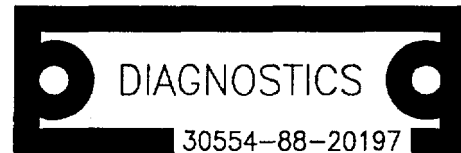

Figure 2-14. Diagnostics Plate

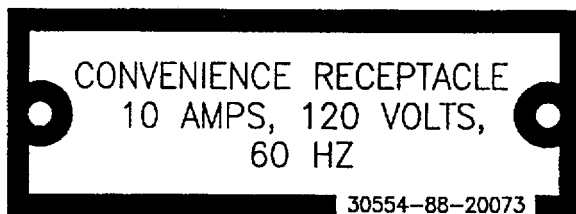

Figure 2-15. Convenience Receptacle Plate



Figure 2-16. External Fuel Plate Supply

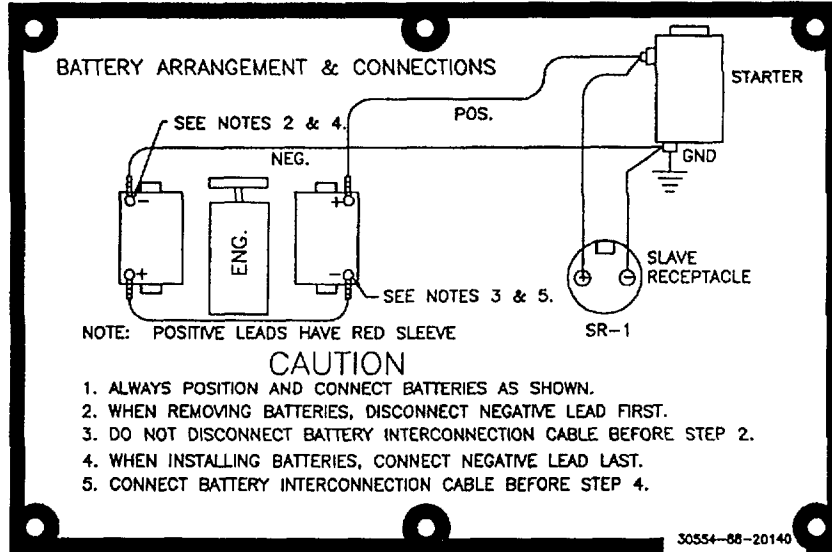

Figure 2-17. Battery Connection Instruction Plate

US DEPARTMENT OF DEFENSE	
NOM	GENERATOR, ALTERNATING CURRENT, SYNCHRONOUS BRUSHLESS
MAKE	MILITARY DESIGN
MODEL	88-20038
SER NO.	NO OF WIRES 12
VOLTS 120V	AMPS 17.4/8.7
KW 5	KVA 6.25 PF 0.8
HERTZ 60	PH 1, 3 RPM 1800
MFD BY ONAN CORPORATION	
30554-88-20064-01	

US DEPARTMENT OF DEFENSE	
NOM	GENERATOR, ALTERNATING CURRENT, SYNCHRONOUS BRUSHLESS
MAKE	MILITARY DESIGN
MODEL	88-20039
SER NO.	NO OF WIRES 12
VOLTS 120V	AMPS 17.4/8.7
KW 5	KVA 6.25 PF 0.8
HERTZ 400	PH 1, 3 RPM 2000
MFD BY ONAN CORPORATION	
30554-88-20064-02	

Figure 2-18. Generator Identification Plate

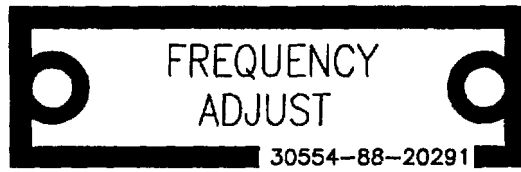

Figure 2-19. Frequency Adjust Plate

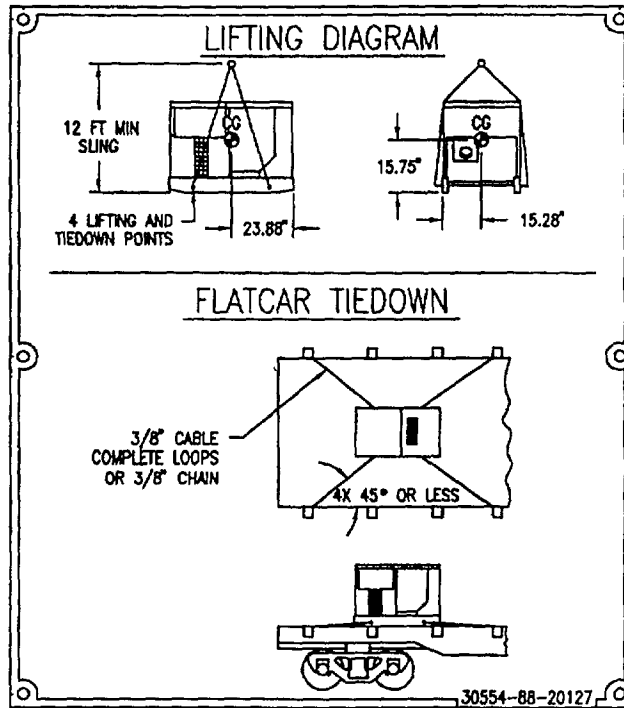

Figure 2-20. Lifting and Tiedown Diagram Plate

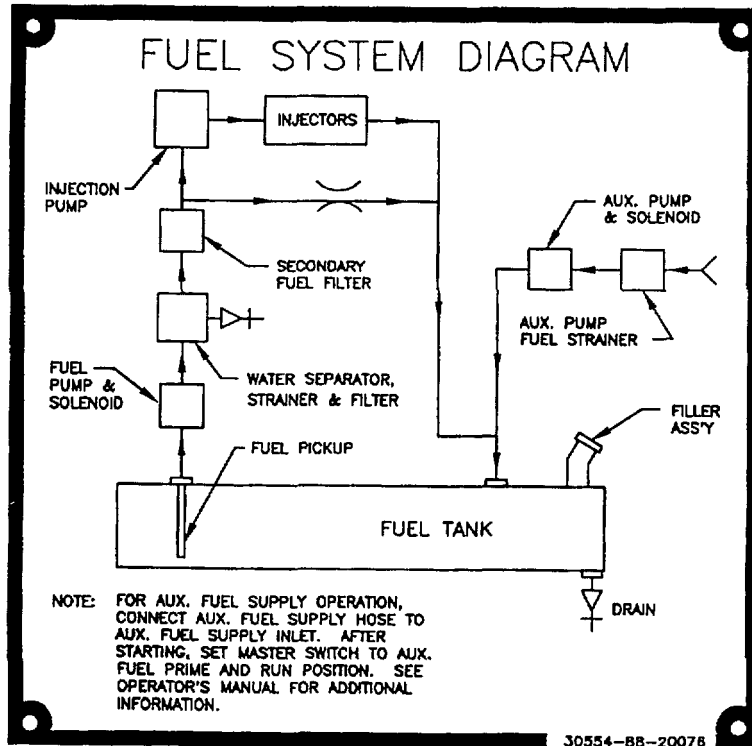

Figure 2-21. Fuel System Diagram Plate

SECTION IV. OPERATION UNDER UNUSUAL CONDITIONS

2-13 OPERATION IN EXTREME COLD
WEATHER BELOW -25°F
(-31°C).

The generator set operates in ambient temperatures as low as -25°F (-31°C) without special winterization equipment. To ensure satisfactory operation under extreme cold weather the following steps must be taken:

WARNING

Avoid contacting metal items with bare skin in extreme cold weather. Failure to observe this warning can cause personal injury.

- a. Keep generator set and surrounding area as free of ice and snow as practical.
- b. Keep fuel tank full to protect against moisture, condensation and accumulation of water.
- c. Ensure that proper grade diesel fuel is used.
- d. Keep batteries free from corrosion and in a well charged condition.

2-14 OPERATION IN EXTREME HEAT
ABOVE 120°F (49°C).

- a. Check vents and radiator air passages frequently for obstructions.
- b. Check coolant temperature indicator frequently for any indication of overheating.
- c. Allow sufficient space for fuel expansion when filling fuel tank.
- d. Keep generator clean and free of dirt. Clean obstructions from generator intake and outlet screens.
- e. Clean external surface of engine when generator set is not operating.

2-15 OPERATION IN DUSTY OR
SANDY AREAS.

- a. If possible, provide a shelter for generator set. Use available natural barriers to shield generator set from blowing dust or sand.
- b. Wet down dusty and sandy surface areas around generator set frequently if water is available.

- c. Keep all access doors closed, as much as possible, to prevent entry of dust and sand into housing assembly.
- d. Wipe dust and sand frequently from the generator set external surface and components. Wash exterior surfaces frequently with clean water when generator set is not operating.
- e. Service engine air cleaner assembly frequently to compensate for intake of additional dust or sand. Refer to Paragraph 3-3.3.2.
- f. Drain sediment frequently from fuel filter/water separator. When servicing fuel tank be careful to prevent dust or sand from entering fuel tank.
- g. Change engine oil and oil filter frequently.
- h. Store oil and fuel in dust-free containers.
- i. Ensure that generator set ground connections are free of dust and sand and connections are tight before starting the unit.

2-16

OPERATION UNDER RAINY OR HUMID CONDITIONS.

CAUTION

Failure to remove waterproof material before operating generator set could result in equipment damage.

- a. If possible, provide a shelter for generator set. Cover generator set with canvas or other waterproof material when it is not being operated.
- b. Provide adequate drainage to prevent water from accumulating on operation site.
- c. Keep all generator set access doors closed, as much as possible, to prevent entry of water into housing assembly.
- d. Drain water frequently from fuel filter/water separator.

WARNING

DC voltages are present at generator set electrical components even with generator set shutdown. Avoid grounding yourself when touching electrical components. Failure to follow this warning can result in personal injury.

- e. Remove moisture from generator set components before and after each operating period.
- f. Keep fuel tank full to protect against moisture, condensation and accumulation of water.

2-17 **OPERATION IN SALT WATER AREAS.**

CAUTION

Failure to remove waterproof material before operating generator set could result in equipment damage.

- a. If possible, provide a shelter for the generator set. Locate generator set so that radiator faces into prevailing winds. Use natural barriers or, if possible, construct a barrier to protect generator set from salt water. Cover generator set with canvas or other waterproof material when it is not being operated.
- b. Keep all generator access doors dosed, as much as possible, to prevent entry of salt water into housing assembly.
- c. Wash exterior surfaces frequently with dean water when generator set is not operating.
- d. Check wiring connections for corrosion and wire insulation for signs of deterioration.

2-18 **OPERATION AT HIGH ALTITUDES.**

The generator set will operate at elevations up to 4000 feet (1219.1 meters) above sea level without special adjustment or reduction in load. At elevations greater than 4000 feet (1219.1 meters) above sea level, the kilowatt rating is reduced approximately 3.5 percent for each additional 1000 feet (304.8 meters).

2-19 NATO SLAVE RECEPTACLE START OPERATION.

2-19.1 **General.** The NATO slave receptacle can be used to start the generator set when batteries are discharged.

2-19.2 NATO Slave Emergency Starting Procedure.

- a. Connect one end of NATO slave cable to fully charged 24 VDC system and other end to discharged generator set's NATO slave receptacle. start discharged generator set.
- b. Refer to Paragraph 2-10 for engine starting procedures.
- c. Remove NATO slave cable after generator set Starts.

2-20 EMERGENCY STOPPING.

2-20.1 **General.** Depressing the EMERGENCY STOP pushbutton will stop the generator set.

NOTE

The generator set cannot be restarted without resetting the EMERGENCY STOP pushbutton and turning MASTER SWITCH to OFF position.

2-21 OPERATION USING BATTLE SHORT SWITCH.

CAUTION

Continued operation using the BATTLE SHORT switch can result in damage to the generator set.

NOTE

If any emergency situation requires continued operation of the generator set, the BATTLE SHORT switch is used to override all the safety devices except the short circuit devices, and EMERGENCY STOP function.

NOTE

BATTLE SHORT switch must be OFF to start generator set.

- a. Start generator set if set is not running. Refer to paragraph 2-10.
- b. Lift cover on BATTLE SHORT switch and position switch to ON.

2-22 OPERATION WHILE IN CONTAMINATED AREAS.

The generator set is capable of being operated by personnel wearing nuclear, biological, or chemical (NBC) protective clothing without special tools or supporting equipment. Refer to FM 3-5, NBC Decontamination for information on decontamination procedures. Specific procedures for the generator set are the following:

a. Control panel indicators sealing gasket, rubber sleeves, and rope draw cords at output terminal access ports, control panel door gaskets, access door gaskets, rubber tubing, and belts within the engine compartment, coverings for electrical conduits, external water drain tubing, and retaining cords for slave receptacle covers will absorb and retain chemical agents. Replacement of these items is the recommended method of decontamination.

b. Lubricants, fuel, coolant, or battery fluids may be present on the external surfaces of the generator set or components due to leaks or normal operation. These fluids will absorb NBC agents. The preferred method of decontamination is removal of these fluids using conventional decontamination methods in accordance with FM 3-5.

c. Continued decontamination of external generator set surfaces with supertropical bleach (STB)/decontamination solution number 2 (DS2) will degrade clear plastic indicator coverings to a point where reading indicators will become impossible. This problem will become more evident for soldiers wearing protective masks. Therefore, the use of STB or DS2 decontamination in these areas should be minimized. Indicators should be decontaminated with warm soapy water.

d. External surfaces of the control panel assembly that are marked with painted or stamped lettering will not withstand repeated decontamination with STB or DS2 without degradation of this lettering. Therefore, the recommended method of decontamination for these areas is with warm soapy water.

e. Areas that will entrap contaminants, making efficient decontamination extremely difficult, include the following:

- (1) Exposed heads of screws.
- (2) Areas adjacent to and behind exposed wiring conduits.
- (3) Hinged areas or access doors.
- (4) Retaining chains for external receptacle covers.
- (5) Areas around the tie-down/lifting rings, crevices around access doors, external screens covering ventilation areas, the external oil drain valve, and areas adjacent to the external fuel drain valve.

(6) Areas behind knobs and switches on the control panel, externally mounted equipment specification data plates, external receptacle covers, access doors, access door locking mechanisms, recessed wells for access door handles, fuel cap, load terminal board, slave receptacles, and frequency adjustment controls.

Replacements of these items, if available, is the preferred method of decontamination. Conventional methods of decontamination should be used on these areas, while stressing the importance of thoroughness and the probability of some degree of continuing contact and vapor hazard.

f. In an NBC contaminated environment, the generator set should be operated with all access doors closed to reduce the effects of contamination.

g. The use of overhead shelters or chemical protective covers is recommended as an additional means of protection against contamination in accordance with FM 3-5. However, if using covers, care should be taken to provide adequate space for air flow and exhaust.

h. For additional NBC information, refer to FM 3-3 and FM 3-4. Other services use applicable publications for NBC.

2-23 USE OF THE CONVENIENCE RECEPTACLE.

WARNING

Power is available when the main contactor is open. Avoid accidental contact. Failure to observe this warning can result in severe personal injury or death by electrocution.

CAUTION

The maximum power rating for the convenience receptacle is 10 Amps. Continuous operation above 10 Amps can result in damage to the generator set.

- a. Start the generator set if it is not operating. Refer to para. 2-10.
- b. Ensure the load does not exceed the maximum rating.
- c. Reset the Ground Fault Circuit Interrupter.
- d. Plug appropriate connector into convenience receptacle.

CHAPTER 3

MAINTENANCE INSTRUCTIONS

SECTION I. LUBRICATION INSTRUCTIONS

3-1 LUBRICATION ORDER.

Refer to LO 9-6115-641-12
for lubrication information.

SECTION II. TROUBLESHOOTING

3-2 GENERAL.

This section lists common malfunctions you may find during operation of the generator set. You should perform the tests/inspections and corrective actions in the order listed.

This manual cannot list all malfunctions that may occur, nor all tests or inspections and corrective actions. If a malfunction is not listed or is not corrected by listed corrective actions, notify your supervisor.

NOTE

Air Force users may perform maintenance only as authorized.

SYMPTOM INDEX

Troubleshooting
 Procedure
 Page

COOLING SYSTEM

COOLANT TEMPERATuRE Indicator indicates
 engine overheating 3 - 6

ELECTRICAL SYSTEM

BATTERY CHARGE ammeter
 Shows low or no charge 3 - 7
 Shows excessive charge 3 - 7

AC VOLTMETER (VOLTS AC)
 Indicates low voltage 3 - 8
 Indicates correct voltage but frequency
 meter (HERTZ) is off scale 3 - 8
 Voltage fluctuates 3 - 8

FREQUENCY meter (HERTZ)
 Frequency fluctuates 3 - 8

AC CIRCUIT INTERRUPTER
 Light fails to light when AC CIRCUIT
 INTERRUPTER switch is closed 3 - 9

ENGINE

Fails to crank 3 - 3
 Cranks but fails to start 3 - 3
 Stops when MASTER SWITCH is released
 from START position 3 - 3
 Stops suddenly 3 - 4
 Runs erratically or misfires 3 - 4
 Does not develop full power 3 - 4
 Knocks 3 - 5

EXHAUST SYSTEM

Blue or white exhaust smoke 3 - 5
 Black exhaust smoke 3 - 5

LUBRICATING SYSTEM

Low oil pressure 3 - 6

TABLE 3-1. Troubleshooting

MALFUNCTION	TEST OR INSPECTION	CORRECTIVE ACTION
-------------	--------------------	-------------------

1. Engine fails to crank.

Step 1. Check that DEAD CRANK switch is in the NORMAL position.
Place switch in NORMAL position.

Step 2. Check that DC CONTROL POWER circuit breaker is energized (in) .
If DC CONTROL POWER circuit breaker is deenergized (out), go to Step 3.

Step 3. Defect in Engine Starting/Electrical System.
Check battery connections. If loose or corroded, notify next higher maintenance level.

2. Engine cranks but fails to start.

Step 1. Cold ambient temperature.
If ambient temperature is below 40°F (4°C) turn MASTER SWITCH to PREHEAT position for a maximum of 30 seconds prior to cranking engine, refer to paragraph 2-10.1.

Step 2. Check for dirty air cleaner element.
Service air cleaner assembly, refer to paragraph 3-3.3.2.

Step 3. Check for dirty fuel filter/water separator.
Service fuel filter/water separator, refer to paragraph 3-3.6.2. If engine still fails to start, notify next higher maintenance level.

3. Engine starts but stops when MASTER SWITCH is released from START position.

Step 1. Check for proper starting procedure.
Hold MASTER SWITCH in START position until 25 psi (172 kPa) is reached, refer to paragraph 2-10.1.

TABLE 3-1. Troubleshooting - Continued

MALFUNCTION	TEST OR INSPECTION	CORRECTIVE ACTION
	Step 2.	Check to see if any FAULT INDICATOR lights are lit. NO FUEL light is lit, refer to paragraph 3-3.5.1. If any other lights are lit, notify next higher maintenance level.
4. Engine stops suddenly.		
	Step 1.	Check to see if any FAULT INDICATOR lights are lit. NO FUEL light is lit, refer to paragraph 3-3.5.1. If any other lights are lit, go to step 2.
	Step 2.	Check that DC CONTROL POWER circuit breaker is energized (in) . If DC CONTROL POWER circuit breaker is deenergized (out) , notify next higher maintenance level.
5. Engine runs erratically or misfires.		
	Step 1.	Check for dirty air cleaner element. service air cleaner assembly, refer to paragraph 3-3.3.2.
	Step 2.	Check for contaminated fuel. Service fuel filter/water separator, refer to paragraph 3-3.6.2.
	Step 3.	Check for improper type of fuel. If improper fuel is suspected, refer to TABLE 3-3, notify next higher maintenance level.
6. Engine does not develop full power.		
	Step 1.	Check for dirty air cleaner element. Service air cleaner assembly, refer to paragraph 3-3.3.2.
	Step 2.	Check for contaminated fuel. Service fuel filter/water separator, refer to paragraph 3-3.6.2.

TABLE 3-1. Troubleshooting - Continued

MALFUNCTION	TEST OR INSPECTION	CORRECTIVE ACTION
	Step 3.	Check for restricted exhaust system. Make sure exhaust opening is free from obstructions. If no obstructions are found, notify next higher maintenance level.
	Step 4.	Check for improper type of fuel. If improper type of fuel is suspected, refer to TABLE 3-3, notify next higher maintenance level.
7.	Engine knocks.	
	Step 1.	Check for low lubrication oil level. If necessary add oil, refer to LO 9-6115-641-12.
	Step 2.	Check for loose parts or foreign objects in engine compartment. If no loose parts or foreign objects are found, go to Step 3.
	Step 3.	Check for improper type of fuel. If improper type of fuel is suspected, refer to TABLE 3-3, notify next higher maintenance level.
8.	Blue or white exhaust smoke.	
		Check for improper type of fuel. If improper type of fuel is suspected, refer to TABLE 3-3, notify next higher maintenance level.
9.	Black exhaust smoke.	
	Step 1.	Check for improper type of fuel. If improper type of fuel is suspected, refer to TABLE 3-3, notify next higher maintenance level.
	Step 2.	Check for dirty air cleaner element. Service air cleaner assembly, refer to paragraph 3-3.3.2.

TABLE 3-1. Troubleshooting - Continued

MALFUNCTION

TEST OR INSPECTION

CORRECTIVE ACTION

- Step 3. Check for generator set overload.
Check for generator set overload by checking the ammeter (PERCENT RATED CURRENT) on the control panel assembly, refer to FIGURE 2-1. If unable to adjust, notify next higher maintenance level.

10. Low oil pressure.

- Step 1. Check for low lubrication oil level.
If necessary add oil, refer to LO 9-6115-641-12.
- Step 2. Check for high coolant temperature, above 200°F (93°C), refer to FIGURE 2-1.
If coolant temperature is high, go to Step 3.
- Step 3. Check coolant level.
If low, add coolant, refer to paragraph 3-3-4.2.
If full, go to Step 4.
- Step 4. Check for obstruction in air intake system.
If obstructions are found, remove debris. If no obstructions are found, go to Step 5.
- Step 5. Check for loose fan belt.
If loose, notify next higher maintenance level.

11. COOLANT TEMPERATURE indicator indicates engine overheating.

- Step 1. Check for generator set overload.
Check for generator set overload by checking the ammeter (PERCENT RATED CURRENT) on-the control panel assembly, refer to FIGURE 2-1. If unable to adjust, notify next higher maintenance level.
- Step 2. Check coolant level.
If low, add coolant, refer to paragraph 3-3.4.2.
If full, go to Step 3.
- Step 3. Check for low lubrication oil level.
If necessary add oil, refer to LO 9-6115-641-12.
If full, go to Step 4.

Table 3-1. Troubleshooting - Continued

MALFUNCTION	TEST OR INSPECTION	CORRECTIVE ACTION
	Step 4. Check for obstruction in air intake system.	If obstructions are found, remove debris. If no obstructions are found, go to Step 5.
	Step 5. Check for loose fan belt.	If loose, notify next higher maintenance level.
12. BATTERY CAGE ammeter shows low or no charge.		
	Step 1. Check BATTERY CHARGER FUSE.	If BATTERY CHARGER FUSE (FIGURE 2-1) is blown, notify next higher maintenance level.
	Step 2. Check fan belt.	If fan belt is loose, notify next higher maintenance level.
	Step 3. Check for loose or broken wires.	Check for loose or broken wires at the back of the battery charging alternator (FIGURE 1-2) and BATTERY CHARGE ammeter (FIGURE 2-1). If wires are loose or broken, notify next higher maintenance level.
13. BATTERY CHARGE ammeter shows excessive charging after prolonged operation.		
	Step 1. Check batteries for low electrolyte level.	If low refer to paragraph 3-3.2.2. If level is correct, go to step 2.
	Step 2. Check battery connections.	If loose or corroded, notify next higher maintenance level.

Table 3-1. Troubleshooting - Continued

MALFUNCTION

TEST OR INSPECTION

CORRECTIVE ACTION

14. AC voltmeter (VOLTS AC) Indicates low voltage.

Step 1. Check that AM-VM transfer switch position corresponds to readings on the AC voltmeter (VOLTS AC), refer to TABLE 2-5.
Set VOLTAGE adjust potentiometer.

Step 2. Check for loose or broken wires at back of AM-VM transfer switch, VOLTAGE adjust potentiometer, and AC voltmeter (VOLTS AC).
If wires are loose or broken, notify next higher maintenance level.

15. AC voltmeter (VOLTS AC) Indicates correct voltage, but frequency meter (HERTZ) is off scale.

Step 1. Check FREQUENCY adjust control.
Set FREQUENCY adjust control.

Step 2. Check for loose or broken wires at back of FREQUENCY adjust control.
If wires are loose or broken, notify next higher maintenance level.

16. AC voltmeter (VOLTS AC) fluctuates

Check back of AC voltmeter (VOLTS AC) for loose or broken wires.
If wires are loose or broken, notify next higher maintenance level.

17. Frequency meter (HERTZ) fluctuates

Check back of frequency meter (HERTZ) for loose or broken wires.
If wires are loose or broken, notify next higher maintenance level.

TABLE 3-1. Troubleshooting - Continued

MALFUNCTION	TEST OR INSPECTION	CORRECTIVE ACTION
18.	AC CIRCUIT INTERRUPTER light fails to light when AC CIRCUIT INTERRUPTER switch is closed.	<p>Step 1. TEST AC CIRCUIT INTERRUPTER light by depressing. If light fails to light, refer to next higher maintenance level.</p> <p>Step 2. Check load cables for proper connection. For proper connection of the load cables, refer to paragraph 2-8.2. If correct go to Step 3.</p> <p>Step 3. Ensure load does not exceed generator rating. Decrease load, if load is correct, refer to next higher maintenance level.</p>
19.	No voltage at the Convenience Receptacle.	<p>Step 1. Open control panel and inspect circuit breaker on side of Ground Fault Circuit Interrupter device. If tripped, reset device. Check fuse on black wire of Ground Fault Circuit Interrupter for generator sets, contract number DAAK01-88-D-D080.</p> <p>Step 2. Check reset button for red band. If red band is visible, push reset button. If Ground Fault Circuit Interrupter can not be reset, refer to next higher maintenance level.</p>

SECTION III. MAINTENANCE PROCEDURES

3-3 GENERATOR SET INSPECTION AND SERVICE.

WARNING

3-3.1 Introduction. This section contains operator maintenance procedures. Deficiencies noted during inspection which are beyond the maintenance scope of the operator shall be reported to next higher maintenance level.

Batteries give off flammable gas. Do not smoke or use open flame when performing maintenance. Flames and explosion could result in personal injury or death.

3-3.2 Batteries.

- d. Remove battery caps.

WARNING

Battery Acid can cause burns to unprotected skin.

CAUTION

Electrolyte level must cover battery plates in all cells. Failure to observe this caution can cause damage to the battery.

WARNING

Batteries give off flammable gas. Do not smoke or use open flame when performing maintenance. Flames and explosion could result in personal injury or death.

NOTE

Electrolyte level should be at bottom of each cap cylinder.

3-3.2.1 Inspection.

- a. Shut down generator set, refer to paragraph 2-10.2.
- b. Open engine access door.
- c. Inspect for damaged battery case, corrosion, or damaged and loose connections on terminal cable, and damaged or missing battery caps.

- e. Inspect electrolyte level.
- f. Perform service procedures if required.
- g. Install battery caps.
- h. Close engine access door.

3-3.2.2 Service.

- a. Shut down generator set, refer to paragraph 2-10.2.
- b. Open engine access door.

WARNING

Batteries give off flammable gas. Do not smoke or use open flame when performing maintenance. Flames and explosion could result in severe personal injury or death.

- c. Remove battery caps.

NOTE

Electrolyte level should be at bottom of each cap cylinder.

- d. Add distilled water to each battery cell as required.
- e. Replace battery caps.
- f. Close engine access door.
- g. If necessary contact next higher maintenance level to clean or replace batteries or battery terminals.

3-3.3 Air Cleaner Assembly (FIGURE 3-1).

3-3.3.1 Inspection.

- a. Shut down generator set, refer to paragraph 2-10.2.
- b. Open left side engine access door.
- c. Inspect air cleaner housing (5, FIGURE 3-1) for dents,

corrosion, missing hardware and other damage.

- d. Open right side engine access door and inspect air cleaner restriction indicator for indication of a clogged air cleaner element.
- e. Close engine access door.

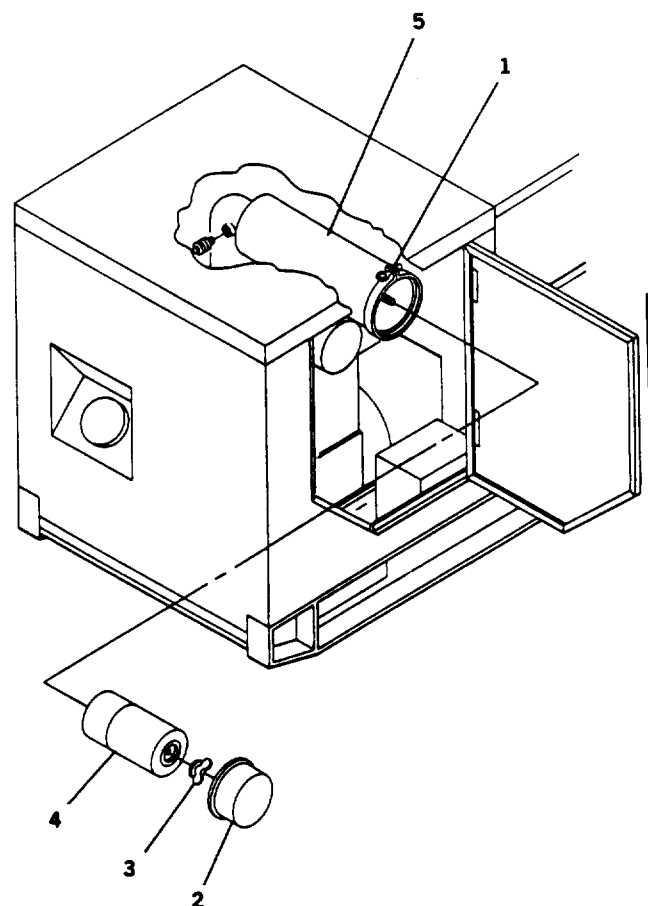

FIGURE 3-1. Air Cleaner Element Replacement

3-3.3.2 Service.

- a. Shut down generator set. Refer to paragraph 2-10.2.
- b. Open left side engine access door.
- c. Loosen wing nut clamp (1, FIGURE 3-1) and remove end cap (2) on air cleaner housing (5).
- d. Remove wing nut (3) and air cleaner element (4). If fouled, discard air cleaner element.
- e. Inspect inside of air cleaner housing (5) for debris. Wipe air cleaner housing interior with clean lint-free cloth.
- f. Install air cleaner element (4), wing nut (3), end cap (2) and tighten wing nut (1).
- g. Close engine compartment access door.

WARNING

Cooling system operates at high temperatures. Personal injury or death from burns or scalding could result from contact with high pressure steam and/or liquid.

- c. Check radiator for dirt, leaves, insects, etc. blocking air flow.
- d. Check radiator and hoses for leaks, loose connections, loose mounting, corrosion, chafing and missing parts.
- e. Check coolant level in coolant recovery (overflow) bottle.
- f. Close engine compartment access doors.

3-3.4.2 Service.

WARNING

Cooling system operates at high temperatures. Personal injury or death from burns or scalding could result from contact with high pressure steam and/or liquid.

3-3.4 Cooling Svstem.

3-3.4.1 Inspection.

- a. Shut down generator set. Refer to paragraph 2-10.2.
- b. Open both engine access doors.

- a. Shut down generator set. Refer to paragraph 2-10.2.
- b. Open right side engine access door.
- c. Remove coolant recovery (overflow) bottle cap.
- d. Fill coolant recovery (overflow) bottle to HOT line if coolant is hot or to COLD line if coolant is cold, with proper coolant/antifreeze in accordance with Table 3-2.
- e. Install coolant recovery (overflow) bottle cap. Close right side engine access door.

TABLE 3-2. Coolant

COOLANT		
AMBIENT TEMPERATURE	RADIATOR COOLANT	RATIO
+40°F TO +120°F (+4°C TO +49°C)	Water: MIL-A-53009 Inhibitor, Corrosion	35:1
-25°F TO +120°F (-32°C TO +49°C)	Water: MIL-A-46153 Antifreeze	1:1
-25°F TO +120°F (-32°C TO +49°C)	MIL-A-11755 Antifreeze	NA

3-3.5 Service Fuel Tank.

CAUTION

3-3.5.1 Service.

WARNING

The fuels in this generator set are highly explosive. Do not smoke or use open flame when performing maintenance. Flames and explosion could result in severe personal injury or death.

Use only specified diesel fuel to service the fuel tank, refer to TABLE 3-3. Otherwise, equipment damage could result, if improper fuel is used.

- a. Shut down generator set. Refer to Paragraph 2-10.2.

TABLE 3-3. Diesel Fuel

FUEL	
AMBIENT TEMPERATURE	DIESEL FUEL
+20°F TO +120°F (7°C TO +49°C)	VV-F-800 GRADE DF-2 JP4, JP5, JP8
0°F TO +20°F (17°C TO +7°C)	VV-F-800 GRADE DF-1 JP4, JP5, JP8
-25°F TO 0°F (-32°C To -17°C)	VV-F-800 GRADE DF-1
-25°F TO 0°F (-32°C To -17°C)	VV-F-800 GRADE DF-A

b. Remove fuel cap.

c. Remove strainer, clean as necessary and reinstall.

NOTE

Fuel tank holds 5 gallons (18.9 liters).

d. Add diesel fuel to fuel tank.

e. Install fuel cap.

c. Inspect fuel filter/water separator assembly (Figure 3-2) for proper mounting, cracks, dents, leaks, loose fuel lines and other damage.

d. Close left engine access door.

3-3.6.2 Service.

a. Shut down generator set, refer to paragraph 2-10.2.

b. Rotate MASTER SWITCH to prime and run.

c. Open left side engine access door.

d. Open fuel drain cock (1, FIGURE 3-2) on fuel filter/water separator housing (2) and drain contaminants into a suitable container.

3-3.6 Fuel Filter/Water Separator (FIGURE 3-2).

3-3.6.1 Inspection.

a. Shut down generator set. Refer to paragraph 2-10.2.

b. Open left side engine access door.

- e. Close drain cock (1).
- f. Close left side engine access door.
- g. Rotate MASTER SWITCH to OFF.

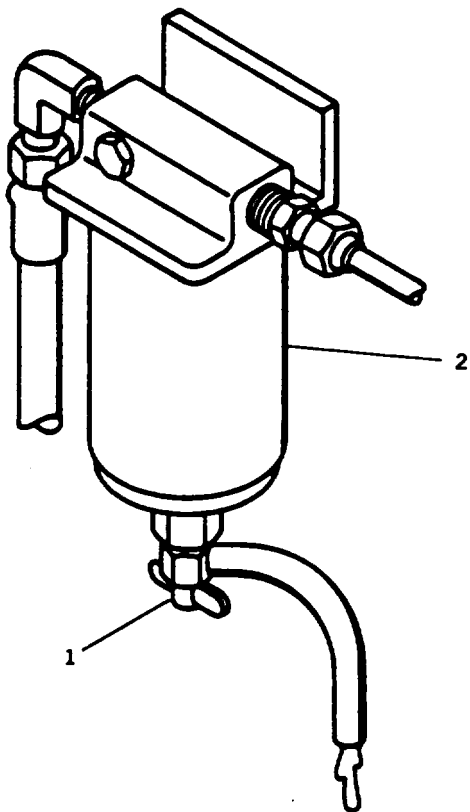

FIGURE 3-2. Draining Fuel Filter/Water Separator

3-3.7 Lubrication System.

3-3.7.1 Inspection.

- a. Shut down generator set. Refer to paragraph 2-10.2.
- b. Open both engine access doors.
- c. Inspect engine assembly for oil leaks.
- d. Check for damage, proper mounting, or missing parts.
- e. Check engine crankcase oil level. Refer to LO 9-6115-641-12.
- f. Close both engine access doors.

3-3.7.2 Service.

- a. Shut down generator set. Refer to paragraph 2-10.2.
- b. Open left engine access door.
- c. Remove oil filler cap.
- d. Add oil to engine crankcase. Refer to LO 9-6115-641-12.
- e. Install oil filler cap.
- f. Close left engine access door.

APPENDIX A

REFERENCES

A-1 SCOPE.

This appendix lists all forms, field manuals, technical manuals and miscellaneous publications referenced in this manual.

A-2 FORMS.

Recommending Improvements to Technical Publications	AFTO Form 22
Equipment Inspection and Maintenance Worksheet	DA Form 2404
Equipment Control Log	DA Form 2408-9
Quality Deficiency Report	SF 368
Recommended Changes to Equipment Technical Publications	DA Form 2028-2
Recommended Changes to Publications and Blank Forms	DA Form 2028

A-3 FIELD MANUALS.

Electric Power Generation in the Field	FM 20-31
First Aid	FM 21-11
NBC Contamination Avoidance	FM 3-3
NBC Decontamination	FM 3-5
NBC Protection	FM 3-4

A-4 TECHNICAL MANUALS.

Marine Corps Forms	TM 4700-15/1
------------------------------	--------------

A-5 MISCELLANEOUS PUBLICATIONS.

Air Force Maintenance Forms and Records	AFR 66-1
The Army Maintenance Management System (TAMMS)	DA PAM 738-750
Lubrication Order	LO 9-6115-641-12
Military Standard Abbreviations	MIL-STD-12
Warranty Technical Bulletin	TB 9-6115-641-24

APPENDIX B
COMPONENTS OF END ITEM AND BASIC ISSUE ITEMS LISTS

SECTION I. INTRODUCTION

B-1 SCOPE.

This appendix lists components of end item and basic issue items for the generator set to help you inventory items required for safe and efficient operation.

B-2 GENERAL.

The Components of End Item and Basic Issue Items Lists are divided into the following sections:

a. Section II. Components of End Item. This listing is for informational purposes only, and is not authority to requisition replacements. These items are part of the end item, but are removed and separately packaged for transportation or shipment. As part of the end item, these items must be with the end item whenever it is issued or transferred between property accounts. Illustrations are furnished to assist you in identifying the items.

b. Section III. Basic Issue Items (BII). These are the minimum essential items required to place the generator set in operation, to operate it, and to perform emergency repairs. Although shipped separately packaged, BII must be with the generator set during operation and whenever it is transferred between property accounts. The illustrations will assist you with hard-to-identify items. This manual is your authority to request/requisition replacement BII, based on TOE/MTOE authorization of the end item.

B-3 EXPLANATION OF COLUMNS.

The following provides an explanation of columns found in the tabular listing:

a. Column (1) - Illustration Number (Illus Number). This column indicates the number of the illustration in which the item is shown.

b. column (2) - National Stock Number. Indicates the National Stock Number assigned to the item and will be used for requisitioning purposes.

APPENDIX B

c. column (3) - Description. Indicates the Federal item name and, if required, a minimum description to identify and locate the item. The last line for each item indicates the commercial and Government Entity (CAGE) code (in parentheses) followed by the part number. Usable on code identifies the specific type of generator set (50/60 or 400 Hz) to which the BII applies. However, there are no BII which are specific to either the 50/60 or 400 Hz generator sets.

d. column (4) - Unit of Measure (U/M). Indicates the measure used in performing the actual operational/maintenance function. This measure is expressed by a two-character alphabetical abbreviation (e.g., ea, in, pr).

e. column (5) - Quantity required (Qty reqd). Indicates the quantity of the item authorized to be used with/on the equipment.

SECTION II. COMPENTS OF END ITEM LIST

NONE

APPENDIX B

**ARMY TM 9-6115-641-10
AIR FORCE TO 35C2-3-456-11**

TECHNICAL MANUAL
OPERATOR'S MANUAL

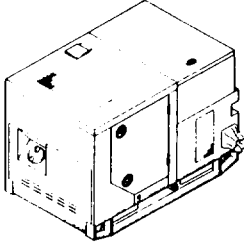

**GENERATOR SET,
SKID MOUNTED, TACTICAL QUIET**

5 kW, 60 AND 400 Hz
MEP-802A (60 Hz) 6115-01-274-7387
MEP-812A (400 Hz) 6115-01-274-7381

PUBLISHED UNDER THE AUTHORITY OF THE
DEPARTMENTS OF THE ARMY
AND THE AIR FORCE

BROWN DRAFT
DEPARTMENT OF THE ARMY TECHNICAL BULLETIN

WARRANTY PROGRAM
FOR

GENERATOR SET TACTICAL QUIET
5 kW, 60/400 Hz
MEP-802A AND MEP-812A

Headquarters, Department of the Army, Washington, D. C.

REPORTING ERRORS AND RECOMMENDING IMPROVEMENTS

You can help improve this manual. If you find any mistakes or if you know of a way to improve the procedures, please let us know.

Mail your letter, DA Form 2028 (Recommended Changes to Publications and Blank Forms), or DA Form 2028-1 located in back of this bulletin direct to:

Commander
U.S. Army Troop Support Command
ATTN: AMSTB-NHTS
4300 Goodfellow Blvd.
St. Louis, MO 63120-1798

A reply will be furnished to you.

LUBRICATION ORDER **LO 9-6115-641-12**

**GENERATOR SET, SKID MOUNTED,
TACTICAL QUIET 5 kW, 60/400 Hz**

DOD MODEL CLASS HERTZ NSN
MEP-802A TACTICAL QUIET 60 6115-01-274-7387
MEP-812A TACTICAL QUIET 400 6115-01-274-7391

Reference TM 9-6115-641-10

Intervals (on-condition or hard time) and the related man-hour times are based on normal operation. The man-hour time specified is the time you need to do all the services prescribed for a particular interval. On-condition (OC) oil sample intervals shall be applied unless changed by the Army Oil Analysis Program (AOAP) laboratory. Change the hard time interval if your lubricants are contaminated or if you are operating the equipment under severe operating conditions, including lower-than-normal operating hours. The hard time interval may be extended during periods of low activity. If extended, a check of oil condition is required. If necessary, the hard time interval will be applied in the event AOAP laboratory support is not available.

Reporting errors and recommending improvements. You can help improve this manual. If you find any mistakes or if you know of a way to improve the procedures, please let us know. Mail your letter or DA Form 2028 (Recommended Changes to Publications and Blank Forms) direct to:

Commander, U.S. Army Troop Support Command, ATTN: AMSTB-NHTS, 4300 Goodfellow Boulevard, St. Louis, MO 63120-1798. A reply will be furnished to you.

Lubricate points indicated by arrowhead on both sides of equipment.

The lowest level of maintenance authorized to lubricate a point is Unit Maintenance (U).

NOTE:

- FOR OPERATION OF EQUIPMENT IN COLD TEMPERATURES BELOW -10°F (-23°C), remove lubricants prescribed in the key for temperatures above -10°F (-23°C). Clean parts with 200 cleaning solvent. Re-lubricate with lubricants specified in the key for temperatures 0°F to -45°F.
- OIL FILTER. After installing filter, fill drainage, service, cooling, fuel, and shock housing for main and glow engine, check crankcase oil level, and bring to full level. Oil filter replacement interval shall align with on-condition AOAP

CAR 1 OF 1

SECTION III . BASIC ISSUE ITEMS					
(1) Illus Number	(2) National Stock Number	(3) Description Cage and Part Number	Usable On Code	(4) U/M	(5) Qty reqd
1		TECHNICAL MANUAL, TM 9-6115-641-10		EA	1
2		LUBRICATION ORDER, LO 9-6115-641-12		EA	1
3		WARRANTY TECHNICAL BULLETIN TB 9-6115-641-24		EA	1

APPENDIX C
ADDITIONAL AUTHORIZATION LIST

SECTION I. INTRODUCTION

C-1 SCOPE.

This appendix lists additional items you are authorized for the support of the generator set.

C-2 GENERAL.

This list identifies items that do not have to accompany the generator set and that do not have to be turned in with it. These items are all authorized to you by CTA, MTOE, TDA, or JTA.

C-3 EXPLANATION OF LISTING.

National stock numbers, descriptions, and quantities are provided to help you identify and request the additional-items you require to support this equipment. The items are listed in alphabetical sequence by item name under the type document (i.e., CTA, MTOE, TDA, or JTA which authorizes the item(s) to you.

SECTION II. ADDITIONAL AUTHORIZATION LIST

(1) NATIONAL STOCK NUMBER	(2) DESCRIPTION CAGE & PART NUMBER USABLE ON CODE	(3) U/M	(4) QTY AUTH
2910-00-066-1235	ADAPTER, CONTAINER (97403) 13211E7541	EA	1
7240-00-222-3088	CAN, GASOLINE, MILITARY (80372) 42-D-1280	EA	1
4210-00-270-4512	EXTINGUISHER, FIRE, CARBON DIOXIDE (81348) O-E-910	EA	1
5120-01-013-1676	SLIDE HAMMER, GROUND (97403) 13226E7741	EA	1
7240-00-177-6154	SPOUT, CAN, FLEXIBLE (81349) MIL-S-1285	EA	1

APPENDIX D

EXPENDABLE/DURABLE SUPPLIES AND MATERIALS LIST (EDSML)

SECTION I. INTRODUCTION

D-1 SCOPE.

This appendix lists expendable/durable supplies and materials you will need to operate and maintain the generator set. This listing is for informational purposes only and is not authority to requisition the listed items. These items are authorized to you by CTA 50-970, Expendable/Durable Items (except Medical, Class V, Repair Parts, and Heraldic Items), or CTA 8-100, Army Medical Department Expendable/Durable Items.

D-2 EXPLANATION OF COLUMNS.

a. Column (1) - Item Number. This number is assigned to the entry in the listing and is referenced in the narrative instructions to identify the material (e.g., "Use cleaning compound, item 5. Appx. D").

b. Column (2) - Level. This column identifies the lowest level of maintenance that requires the listed item.

c. column (3) - National Stock Number. This is the National Stock Number assigned to the item; use it to request or requisition the item.

d. column (4) - Description. Indicates the Federal item name and, if required, a description to identify the item. The last line for each item indicates the Commercial and Government Entity (CAGE) code in parentheses () followed by the part number.

e. Column (5) - Unit of Measure (U/M). Indicates the measure used in performing the actual maintenance function. This measure is expressed by a two-character alphabetical abbreviation (e.g., ea, in, pr). If the unit of measure differs from the unit of issue, requisition the lowest unit of issue that will satisfy your requirements.

APPENDIX D

(1) ITEM NUMBER	(2) LEVEL	(3) NATIONAL STOCK NUMBER	(4) DESCRIPTION	(5) U/M
1	c	7920-01-338-3329	CLOTH, CLEANING	EA
2	c	6850-00-181-7929	ANTIFREEZE (81349) MIL-A-46153	GL
3	c	6810-00-107-1510	WATER, DISTILLED	GL
4	c	9150-00-189-6727	LUBRICATING OIL, ENG (81349) MIL-L-2104, OEA HDO 10	QT
5	c	9150-01-152-4117	LUBRICATING OIL, ENG (81349) MIL-L-2104, OEA HDO 15/40	QT

INDEX

Subject	Page
A	
Abbreviations, List of	1-3
AC Generator, Location of	1-6
Additional Authorization List	C-1
After You Operate PMCS	2-8
Air Cleaner Assembly, Inspection and Servicing of	3-11
Air Cleaner Assembly, Location of	1-6
Air Cleaner Element, Replacement of	3-12
Air Intake and Exhaust System, Description of	1-14
Alternator, Location of	1-4
Assembly and Preparation for Use	2-16
B	
Batteries, Inspection and Servicing of	3-10
Batteries, Location of	1-4
Battle Short Switch, Use of	2-34
Before You Operate PMCS	2-8
C	
Components of End Item and Basic Issue Items	B-1
Control Panel, Description of	2-1
Control Panel Assembly, Location of	1-6
Controls and Indicators	2-3
Convenience Receptacle, Location of	1-7
Coolant Specifications	3-13
Cooling System, Inspection and Servicing of	3-12
D	
Daily Checks	2-20
Dead Crank Switch, Location of	1-7
Dipstick, Location of	1-6
Description and Use of Operator's Controls and Indicators	2-1
Diesel Fuel Specifications	3-14
Differences Between Models	1-7
E	
Emergency Stopping	2-34
Engine, Location of	1-4
Engine, Servicing Lube Oil	3-15

INDEX (CONTINUED)

Subject Page

E (CONTINUED)

Engine Cooling System, Description of	1-13
Engine Lubrication System, Description of	1-14
Engine Starting System, Description of	1-11
Equipment Characteristics, Capabilities and Features . .	1-4
Equipment Data	1-7
Equipment Description	1-4
Equipment is Not Ready/Available If	2-9
Expendable/Durable Supplies and Materials List	D-1

F

Fan Belt, Location of	1-7
Frequency Adjust Control, Description of	2-7
Frequency Adjust Control, Location of	1-7
Fuel Filter/Water Separator, Location of	1-6
Fuel Filter/Water Separator, Servicing of	3-14
Fuel Specifications	3-14
Fuel System, Description of	1-12
Fuel Tank, Location of	1-6
Fuel Tank, Servicing	3-13

G

General Information	1-1
Generator Set Inspection and Service	3-10
Grounding Rod, Installation of	2-16

H, I, J

How to Use This Manual	V
If Your Equipment Fails to Operate	2-8
Initial Adjustments	2-20
Installation of Grounding Rod	2-16
Installation of Load Cables	2-16

K, L

Leading Particulars	1-7
Leakage Definitions for Operators PMCS.	2-8
List of Abbreviations	1-3
Load Cables, Installation of	2-16
Load Output Terminal Board	1-6
Location and Description of Major Components	1-4
Lubrication Instructions	3-1

INDEX (CONTINUED)

Subject	Page
---------	------

K,L (CONTINUED)

Lubrication System, Description of	1-14
Lubrication System, Inspection and Servicing of	3-15

M, N

Maintenance Forms and Records	1-1
Maintenance Procedures	3-10
Malfunction Indicator Panel, Location of	1-6
Malfunction Indicator Panel, Description of	2-5
Model Numbers and Equipment Names	1-1
Muffler, Location of	1-4

O

Oil, Engine, Checking and Adding	3-15
Oil Filter, Location of	1-7
Operating Instructions	2-1
Operating Instructions on plates	2-23
Operating Procedures	2-20
Operation at High Altitudes	2-33
Operation in Dusty or Sandy Areas	2-31
Operation in Extreme Cold Weather (-25°F [-31°C])	2-31
Operation in Extreme Heat Above 120°F (48.8°C)	2-31
Operation in Salt Water Areas	2-33
Operation Under Rainy or Humid Conditions	2-32
Operation Under Unusual Conditions	2-31
Operation Under Usual Conditions	2-16
Operation Using Battle Short Switch	2-34
Operation While Contaminated	2-35
Output Supply System, Description of	1-15

P, Q

PMCS Procedures	2-8
PMCS Table	2-10
Preparation for Movement	2-23
Preventive Maintenance Checks and Services (PMCS)	2-8
Purpose of Equipment	1-1

INDEX (CONTINUED)

Subject	Page
R	
Radiator, Location of	1-4
References	A-1
Reporting and Correcting Deficiencies	2-9
Reporting Equipment Improvement Recommendations (EIR)	1-1
S	
Scope of Technical Manual	1-1
Self Test	2-20
Servicing	3-10
Skid Base, Location of	1-6
Slave Receptacle, Location of	1-6
Slave Starting Procedures	2-34
Starter, Location of	1-4
Starting Procedure	2-21
Stopping Procedure	2-22
Symptom Index, Troubleshooting	3-2
T	
Technical Principles of Operation	1-11
Troubleshooting	3-1
Type of Manual	1-1
U, V, W	
Voltage Reconnection Terminal Board, Location of	2-4
Warranty Information	1-3
Water Pump, Location of	1-7
While You Operate PMCS	2-8

X, Y, Z

By Order of the Secretaries of the Army and Air Force:

Official:

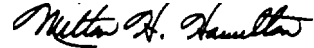

MILTON H. HAMILTON
*Administrative Assistant to the
Secretary of the Army*
03557

GORDON R. SULLIVAN
*General, United States Army
Chief of Staff*

MERRILL A. McPEAK
*General, USAF
Chief of Staff*

Official:

RONALD W. YATES
*General, USAF
Commander Air Force Materiel Command*

DISTRIBUTION:

To be distributed in accordance with DA Form 12-25-E, block no. 5241, requirements for TM 9-6115-641-10.

These are the instructions for sending an electronic 2028

The following format must be used if submitting an electronic 2028. The subject line must be exactly the same and all fields must be included; however only the following fields are mandatory: 1, 3, 4, 5, 6, 7, 8, 9, 10, 13, 15, 16, 17, and 27.

From: "Whoever <whoever@avma27.army.mil>
To: mpmt%avma28@st-louis-emh7.army.mil

Subject: DA Form 2028

1. From: Joe Smith
2. Unit: home
3. Address: 4300 Park
4. City: Hometown
5. St: MO
6. zip: 77777
7. Date Sent: 19-OCT-93
8. Pub no: 55-2840-229-23
9. Pub Title: TM
10. Publication Date: 04-JUL-85
11. Change Number: 7
12. Submitter Rank: MSG
13. Submitter FName: Joe
14. Submitter MName: T
15. Submitter LName: Smith
16. Submitter Phone: 123-123-1234
17. Problem: 1
18. Page: 2
19. Paragraph: 3
20. Line: 4
21. NSN: 5
22. Reference: 6
23. Figure: 7
24. Title: 8
25. Item: 9
26. Total: 123
27. Text:

This is the text for the problem before line 27.

RECOMMENDED CHANGES TO EQUIPMENT TECHNICAL PUBLICATIONS



THEN... JOT DOWN THE DOPE ABOUT IT ON THIS FORM. CAREFULLY TEAR IT OUT, FOLD IT AND DROP IT IN THE MAIL!

SOMETHING WRONG WITH THIS PUBLICATION?

FROM (PRINT YOUR UNIT'S COMPLETE ADDRESS)

PFC JOHN DOE
COA, 3d ENGINEER BN
FT. LEONARDWOOD, MD 63108

DATE SENT

PUBLICATION NUMBER
TM 9-6115-641-10

PUBLICATION DATE
30 DEC 92

PUBLICATION TITLE Generator Set, Skid Mounted Tactical Quiet, 5KW, 60 and 400 HZ

BE EXACT PIN-POINT WHERE IT IS

PAGE NO	PARA-GRAPH	FIGURE NO	TABLE NO
6	2-1 a		
81		4-3	
125	line 20		

IN THIS SPACE TELL WHAT IS WRONG AND WHAT SHOULD BE DONE ABOUT IT:

In line 6 of paragraph 2-1a the manual states the engine has 6 cylinders. The engine on my set only has 4 cylinders. Change the manual to show 4 cylinders.

Callout 16 on figure 4-3 is pointing at a bolt. In key to figure 4-3, item 16 is called a shim. Please correct one or the other.

I ordered a gasket, item 19 on figure B-16 by NSN 2910-00-762-3001. I got a gasket but it doesn't fit. Supply says I got what I ordered, so the NSN is wrong. Please give me a good NSN

PRINTED NAME GRADE OR TITLE AND TELEPHONE NUMBER

JOHN DOE, PFC (268) 317-7111

SIGN HERE

JOHN DOE

DA FORM 2028-2
1 JUL 79

PREVIOUS EDITIONS ARE OBSOLETE
DRSTS-M Overprint 1, 1 Nov 80

P.S.—IF YOUR OUTFIT WANTS TO KNOW ABOUT YOUR RECOMMENDATION MAKE A CARBON COPY OF THIS AND GIVE IT TO YOUR HEADQUARTERS

TEAR ALONG PERFORATED LINE

FILL IN YOUR
UNITS ADDRESS



FOLD BACK

DEPARTMENT OF THE ARMY

OFFICAL BUSINESS

COMMANDER
U.S. ARMY AVIATION AND TROOP COMMAND
ATTN: AMSAT-I-MTS
4300 GOODFELLOW BOULEVARD
ST. LOUIS, MO 63120-1798

TEAR ALONG PERFORATED LINE

RECOMMENDED CHANGES TO EQUIPMENT TECHNICAL PUBLICATIONS



SOMETHING WRONG WITH THIS PUBLICATION?

THEN... JOT DOWN THE DOPE ABOUT IT ON THIS FORM. CAREFULLY TEAR IT OUT. FOLD IT AND DROP IT IN THE MAIL!

FROM: (PRINT YOUR UNIT'S COMPLETE ADDRESS)

DATE SENT

PUBLICATION NUMBER
TM 9-6115-641-10

PUBLICATION DATE
30 DEC 92

PUBLICATION TITLE Generator Set, Skid Mounted Tactical Quiet, 5KW, 60 and 400 HZ

BE EXACT PIN-POINT WHERE IT IS

IN THIS SPACE TELL WHAT IS WRONG AND WHAT SHOULD BE DONE ABOUT IT:

PAGE NO	PARA-GRAPH	FIGURE NO	TABLE NO
---------	------------	-----------	----------

TEAR ALONG PERFORATED LINE

PRINTED NAME, GRADE OR TITLE, AND TELEPHONE NUMBER

SIGN HERE

DA FORM 2028-2
1 JUL 79

PREVIOUS EDITIONS ARE OBSOLETE.
DRSTS-M Overprint 2, 1 Nov 80.

PS --IF YOUR OUTFIT WANTS TO KNOW ABOUT YOUR RECOMMENDATION MAKE A CARBON COPY OF THIS AND GIVE IT TO YOUR HEADQUARTERS

FILL IN YOUR
UNITS ADDRESS



FOLD BACK

DEPARTMENT OF THE ARMY

OFFICAL BUSINESS

COMMANDER
U.S. ARMY AVIATION AND TROOP COMMAND
ATTN: AMSAT-I-MTS
4300 GOODFELLOW BOULEVARD
ST. LOUIS, MO 63120-1798

TEAR ALONG PERFORATED LINE

The Metric System and Equivalents

Linear Measure

1 centimeter = 10 millimeters = .39 inch
 1 decimeter = 10 centimeters = 3.94 inches
 1 meter = 10 decimeters = 39.37 inches
 1 dekameter = 10 meters = 32.8 feet
 1 hectometer = 10 dekameters = 328.08 feet
 1 kilometer = 10 hectometers = 3,280.8 feet

Weights

1 centigram = 10 milligrams = .15 grain
 1 decigram = 10 centigrams = 1.54 grains
 1 gram = 10 decigrams = .035 ounce
 1 dekagram = 10 grams = .35 ounce
 1 hectogram = 10 dekagrams = 3.52 ounces
 1 kilogram = 10 hectograms = 2.2 pounds
 1 quintal = 100 kilograms = 220.46 pounds
 1 metric ton = 10 quintals = 1.1 short tons

Liquid Measure

1 centiliter = 10 milliliters = .34 fl. ounce
 1 deciliter = 10 centiliters = 3.38 fl. ounces
 1 liter = 10 deciliters = 33.81 fl. ounces
 1 dekaliter = 10 liters = 2.64 gallons
 1 hectoliter = 10 dekaliters = 26.42 gallons
 1 kiloliter = 10 hectoliters = 264.18 gallons

Square Measure

1 sq. centimeter = 100 sq. millimeters = .155 sq. inch
 1 sq. decimeter = 100 sq. centimeters = 15.5 sq. inches
 1 sq. meter (centare) = 100 sq. decimeters = 10.76 sq. feet
 1 sq. dekameter (are) = 100 sq. meters = 1,076.4 sq. feet
 1 sq. hectometer (hectare) = 100 sq. dekameters = 2.47 acres
 1 sq. kilometer = 100 sq. hectometers = .386 sq. mile

Cubic Measure

1 cu. centimeter = 1000 cu. millimeters = .06 cu. inch
 1 cu. decimeter = 1000 cu. centimeters = 61.02 cu. inches
 1 cu. meter = 1000 cu. decimeters = 35.31 cu. feet

Approximate Conversion Factors

To change	To	Multiply by	To change	To	Multiply by
inches	centimeters	2.540	ounce-inches	newton-meters	.007062
feet	meters	.305	centimeters	inches	.394
yards	meters	.914	meters	feet	3.280
miles	kilometers	1.609	meters	yards	1.094
square inches	square centimeters	6.451	kilometers	miles	.621
square feet	square meters	.093	square centimeters	square inches	.155
square yards	square meters	.836	square meters	square feet	10.764
square miles	square kilometers	2.590	square meters	square yards	1.196
acres	square hectometers	.405	square kilometers	square miles	.386
cubic feet	cubic meters	.028	square hectometers	acres	2.471
cubic yards	cubic meters	.765	cubic meters	cubic feet	35.315
fluid ounces	milliliters	29.573	cubic meters	cubic yards	1.308
pints	liters	.473	milliliters	fluid ounces	.034
quarts	liters	.946	liters	pints	2.113
gallons	liters	3.785	liters	quarts	1.057
ounces	grams	28.349	liters	gallons	.264
pounds	kilograms	.454	grams	ounces	.035
short tons	metric tons	.907	kilograms	pounds	2.205
pound-feet	newton-meters	1.356	metric tons	short tons	1.102
pound-inches	newton-meters	.11296			

Temperature (Exact)

°F	Fahrenheit temperature	5/9 (after subtracting 32)	Celsius temperature	°C
----	------------------------	----------------------------	---------------------	----

ARMY TM 9-6115-641-10
AIR FORCE TO 35C2-3-456-11

PIN: 071025: 002