



CONFIDENTIAL  
RESTRICTED

TM 9-802

WAR DEPARTMENT

TECHNICAL MANUAL

TRUCK, AMPHIBIAN, 2½-TON,  
6 x 6, GMC DUKW-353

OCTOBER 15, 1942

DECLASSIFIED

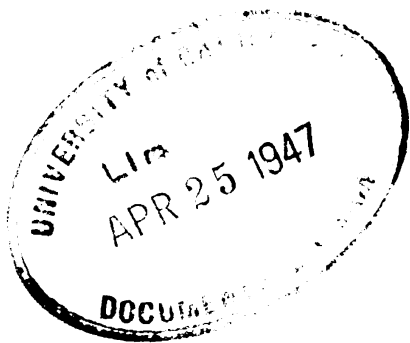



**RESTRICTED**

**TECHNICAL MANUAL**  
**No. 9-802**

**WAR DEPARTMENT**  
**Washington, October 15, 1942**

**TRUCK, AMPHIBIAN, 2½-TON, 6 x 6**

Prepared under the direction of  
 the Chief of Ordnance  
 (with the cooperation of the Yellow Truck and Coach  
 Manufacturing Company)

1112  
 2  
 TM 9-802  
 1942  
 X X

**CONTENTS**

**PART I—Operating Instructions**

SECTION		Paragraphs	Pages
I:	Introduction.....	1-3	2
II:	General Description and Characteristics.....	4-7	3-9
III:	Controls and Operations.....	8-24	10-57
IV:	Armament.....	25-27	58
V:	Preventive Maintenance and Inspection.....	28-41	59-68
VI:	Lubrication.....	42-45	69-75
VII:	Care and Preservation.....	46-53	76-79
VIII:	Tools and Equipment.....	54-57	80-81
IX:	Decontamination.....	58-61	82-84

**Part II—Organizational Instructions**

X:	General Information on Maintenance.....	62-66	85-94
XI:	Special Tools.....	-67	95-96
XII:	Organizational Spare Parts and Accessories.....	68-69	97
XIII:	Axle—Front Driving.....	70-79	98-109
XIV:	Axle—Rear Driving.....	80-87	110-115
XV:	Brake System.....	88-105	116-151
XVI:	Clutch.....	106-113	152-163
XVII:	Cooling System.....	114-124	164-174
XVIII:	Electrical System—Wiring.....	125-129	175-183
XIX:	Electrical System—Starting Motor and Battery.....	130-139	184-191
XX:	Electrical System—Ignition.....	140-150	192-202
XXI:	Electrical System—Generator and Control.....	151-159	203-210
XXII:	Electrical System—Lighting.....	160-171	211-221
XXIII:	Electrical System—Accessories.....	172-174	222-225
XXIV:	Engine.....	175-187	226-257
XXV:	Exhaust System.....	188-191	258-262
XXVI:	Frame.....	192-193	263
XXVII:	Fuel System.....	194-208	264-277
XXVIII:	Hull and Associated Parts.....	209-218	278-297
XXIX:	Instruments and Gauges.....	219-221	298-303
XXX:	Propeller Shafts, Driving Axle.....	222-228	304-317
XXXI:	Water Propeller and Drive.....	229-240	318-327
XXXII:	Spring Suspension.....	241-250	328-337
XXXIII:	Steering System.....	251-259	338-349
XXXIV:	Take-Off, Transmission Power.....	260-264	350-352
XXXV:	Transfer Case, Driving Axle.....	265-272	353-360
XXXVI:	Transmission.....	273-279	361-367
XXXVII:	Wheels, Hubs, Bearings and Tires.....	280-290	368-381
XXXVIII:	Winch.....	291-299	382-391
XXXIX:	References.....	300-301	392
	INDEX.....		393

**PART I**  
**OPERATING INSTRUCTIONS**

**Section I**

**INTRODUCTION**

	<b>Paragraph</b>
Purpose and scope .....	1
Content and arrangement of the manual.....	2
References .....	3

**1. PURPOSE AND SCOPE**

TM 9-802 dated October 15, 1942, is intended to serve temporarily (pending the publication of a revision now in preparation which will be wider in scope) to give information and guidance to the personnel of the using arms charged with the operation and maintenance of this materiel.

**2. CONTENT AND ARRANGEMENT OF THE MANUAL**

Sections I through IX contain information chiefly for the guidance of operating personnel. Sections X through XXXVIII contain information intended chiefly for the guidance of personnel doing maintenance work.

**3. REFERENCES**

Section XXXIX lists all Standard Nomenclature Lists, Technical Manuals, and other publications for the material described herein.

Section II

**GENERAL DESCRIPTION AND CHARACTERISTICS**

	Paragraph
General description .....	4
Identification .....	5
Characteristics .....	6
Tabulated data .....	7

**4. GENERAL DESCRIPTION (Figs. 1 and 2)**

a. Vehicle described in this manual is known as Truck, Amphibi-an, 6x6, DUKW-353, and is designed for amphibious service—opera-tion on land or water. Vehicle has automotive characteristics of a 6 x 6 conventional truck, and in addition is equipped with an integral water-tight hull designed in such a manner that truck chassis and drive units are attached to and in body of hull. For land operation, vehicle utilizes six driving wheels driven by conventional six cylinder valve-in-head engine through transmission, transfer case, and prop-eller shafts. For water operation, vehicle is propelled with a water propeller powered from engine through transmission and a water propeller transfer case. As a truck, front wheels are steered with conventional steering gear assembly. When operating in water, ve-hicle is steered with combined use of front wheels and a rudder which is interconnected to and operated by the steering gear column.

**5. IDENTIFICATION**

a. Vehicle may be identified by six driving wheels, “boat” shaped body or hull, and low silhouette cab and cargo compartment. Springs and driving axles are attached to bottom of hull and suspend in water when in use as a boat. Water propeller and rudder are mounted in tunnel at rear.

**b. Identification Plates**

(1) **Vehicle serial number plates.** Vehicle serial number plate, Fig. 3, includes vehicle nomenclature, model, pay load, etc., as shown in illustrations.

(2) **Publication plates.** Publication plate, Fig. 4, gives the TM number of the technical manual and parts list to use with these ve-hicles.

(3) **Engine serial number.** Engine serial number plate, Fig. 5, is mounted on left-hand side of engine lower part of cylinder block and includes information as shown in illustrations.

**6. CHARACTERISTICS**

**a. Hull Structure**

(1) Welded steel hull is built to accept chassis frame and power

TRUCK, AMPHIBIAN, 2½-TON, 6 x 6

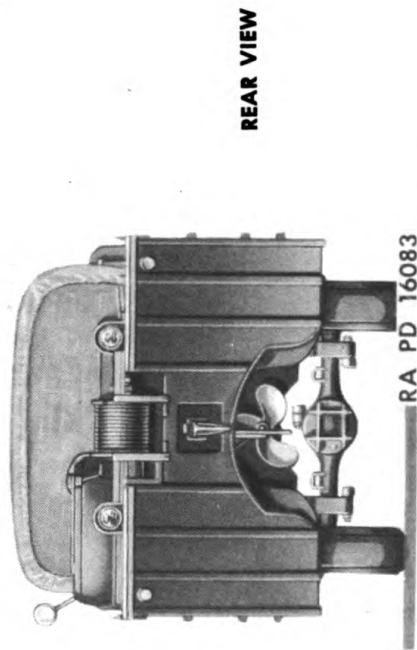
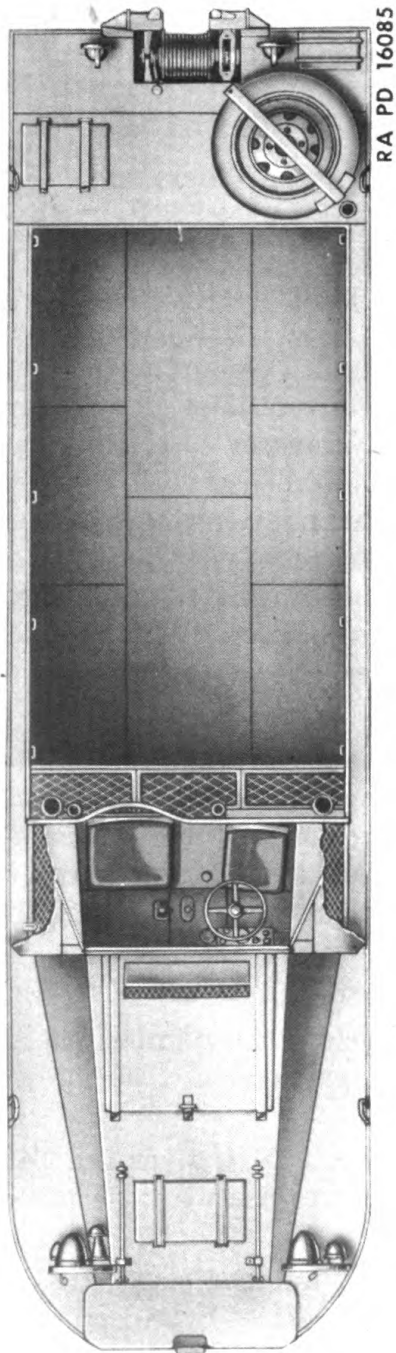
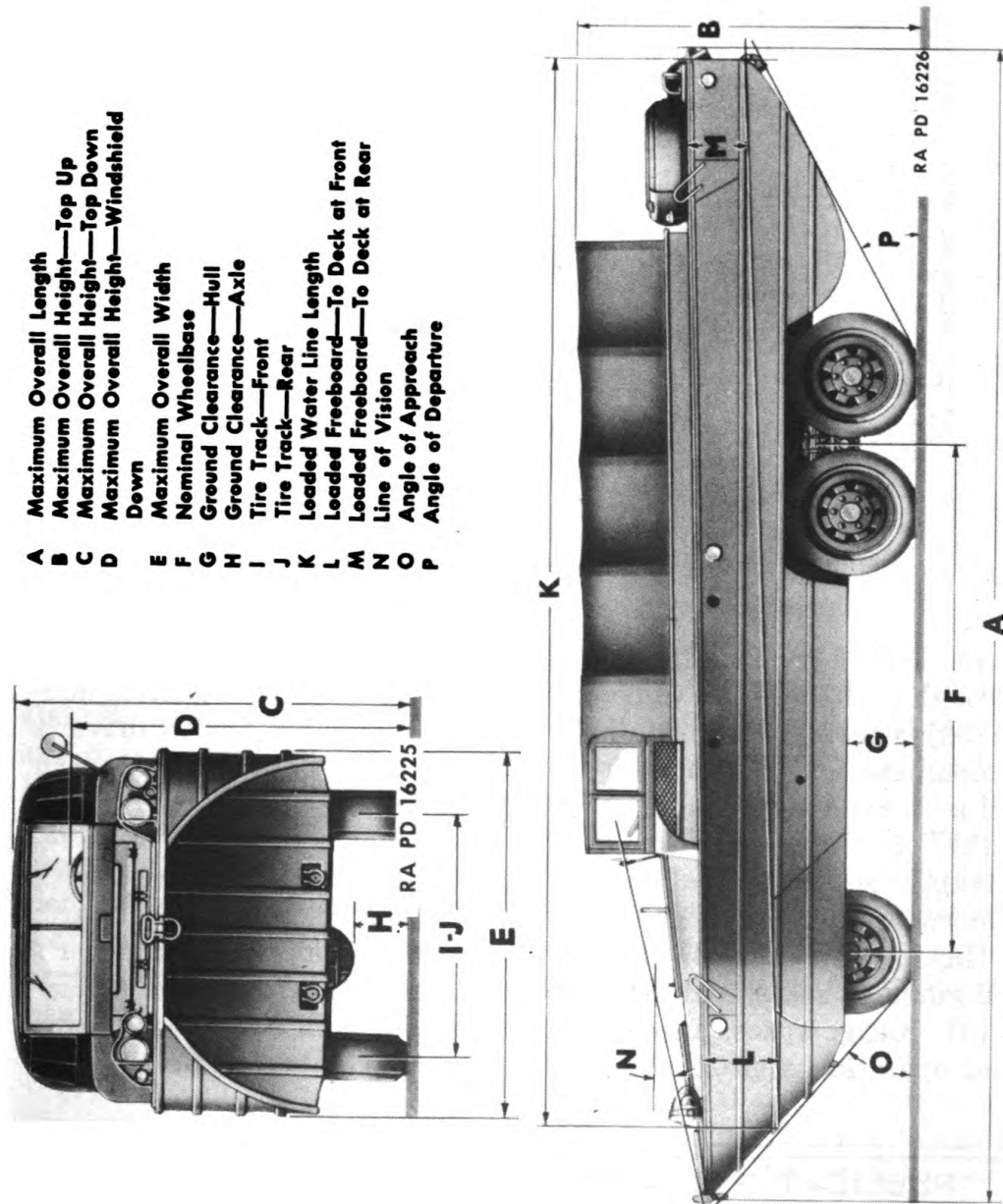

Figure 1—Plan and Rear View of Vehicle

**GENERAL DESCRIPTION AND CHARACTERISTICS**



- A Maximum Overall Length
- B Maximum Overall Height—Top Up
- C Maximum Overall Height—Top Down
- D Maximum Overall Height—Windshield Down
- E Maximum Overall Width
- F Nominal Wheelbase
- G Ground Clearance—Hull
- H Ground Clearance—Axle
- I Tire Track—Front
- J Tire Track—Rear
- K Loaded Water Line Length
- L Loaded Freeboard—To Deck at Front
- M Loaded Freeboard—To Deck at Rear
- N Line of Vision
- O Angle of Approach
- P Angle of Departure

**Figure 2—Front and Side View of Vehicle Showing Dimensions**



**TRUCK, AMPHIBIAN, 2 1/2-TON, 6 x 6**

NOMENCLATURE - AMPHIBIAN TRUCK 2 1/2 TON 6 X 6	
SUPPLY ARM OR SERVICE MAINTAINING TRUCK	
ORDNANCE DEPARTMENT	
MAKE GENERAL MOTORS TRUCK MODEL DUKW 353	
SERIAL NO. <input type="text"/>	DEL. DATE <input type="text"/>
GROSS WEIGHT <input type="text"/>	LBS.
MAXIMUM PAYLOAD <input type="text"/>	5000 LBS.
MAXIMUM TRAILER LOAD <input type="text"/>	LBS.
RECOMMENDED BY MANUFACTURER	
OCTANE RATING OF GASOLINE <input type="text"/>	70 MIN
OIL ABOVE FREEZING <input type="text"/>	SAE 30
OIL BELOW FREEZING <input type="text"/>	10 W
YELLOW TRUCK & COACH MFG. CO.	
PONTIAC MICHIGAN	

RA PD 16222

**Figure 3—Vehicle Serial Number (Nomenclature)**

plant. Spring suspension and driving axles are attached to and through bottom of hull to frame with bolts and attaching parts adequately sealed at hull. The hull is decked forward of open driver's compartment, to rear of rear wheels, and along both sides. A crash rail is installed all around hull at deck height.

(2) Two-man cab or driver's compartment is open type with removable canvas top and open back. Compartment is equipped with removable curtains at each side. Windshield folds either forward, or tilts upward and outward. Compartment is equipped with driver's and gunner's seats, with entrance from the rear or over side.

(3) Cargo space, provided at rear of cab, will accommodate for land operation approximately 25 men and equipment or approxi-

PUBLICATIONS APPLYING TO THIS VEHICLE	
OPERATORS MANUAL	TM 9-802
MAINTENANCE MANUAL	TM 9-1802
PARTS LIST	SNL G-501

RA PD 16234

**Figure 4—Publications Plate**

## GENERAL DESCRIPTION AND CHARACTERISTICS

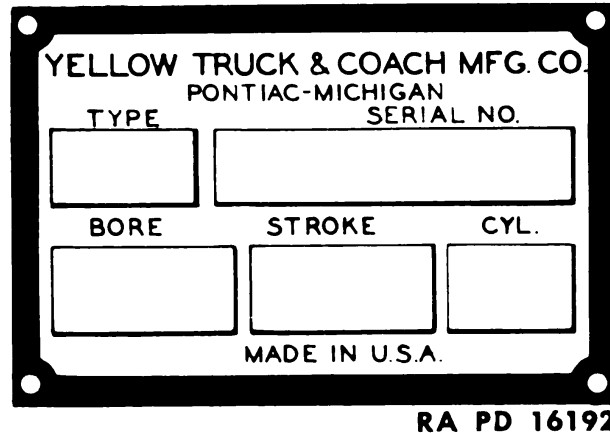

**Figure 5—Engine Serial Number Plate**

mately 5000 lbs. pay-load. Hatches in rear deck and floor provide access to tool and storage holds, also rudder operating mechanism and rear winch shaft. Two hatches in bow permit access to engine, accessories, and forward compartment.

**b. Power Plant and Transmission**

(1) Engine, mounted on frame and accessible through main hatch in front deck, is six-cylinder, valve-in-head type with 269.5 cu. in. piston displacement. Power plant is removable through hatch.

(2) Main transmission has five speeds forward and one reverse with direct drive in fourth and over drive in fifth. Power take-off for tire pump and winch is mounted on left side of transmission.

(3) Two-speed transfer case permits drive of rear axles, or front and rear axles, depending upon position of manual shift levers. Axles are driven through conventional propeller shafts and universal joints, which operate in water-tight housings.

(4) Water propeller transfer case, mounted in drive line between transmission and transfer case, permits engagement or disengagement of water propeller. Water propeller is driven through propeller shafts and universal joints. Shafting is equipped with marine type stuffing box to prevent water leakage where it passes through hull into propeller tunnel.

**c. Miscellaneous**

(1) **Winch.** Shaft driven winch, mounted at rear, is driven by transmission power take-off. Winch is controlled by shift lever in cab and jaw clutch on winch. Chocks and guides for front or rear operation of winch cable are provided on hull.

(2) **Bilge pumps.** 60-gallon per minute self-priming rotary pump, power driven by water propeller shaft, is connected through manually controlled selector manifold to the four lowest parts of hull. 160-gallon per minute centrifugal pump, also power driven by water propeller shaft, discharges from main part of hull when bilge water exceeds capacity of rotary pump. 50-gallon per minute hand pump is furnished for emergency use.

**TRUCK, AMPHIBIAN, 2½-TON, 6 x 6**

**7. TABULATED DATA**

a. Refer to Fig. 2 for dimensional illustration.

b. Table

(1) General

Maximum over-all length.....	372	inches
Maximum over-all height—top up.....	106	inches
top down .....	98	inches
windshield down ....	85	inches
Maximum over-all width .....	96	inches
Nominal wheel base.....	164	inches
Ground clearance .....	18½	inches
Tire track—front .....	65¾	inches
rear .....	63¾	inches
Loaded water line length.....	344	inches
Loaded freeboard—to deck—front.....	23	inches
Loaded freeboard—to deck—rear.....	18	inches
Loaded freeboard—to coaming—front and rear..	28	inches
Loaded draft—to front wheels.....	44	inches
Loaded draft—to rear wheels.....	49	inches
Cargo space—to top of coaming.....	180	cu. ft.
28" deep front, 23" deep rear, 82" wide, 149" long.		
Cargo space under tarpaulin bows.....	364	cu. ft.
Center of bows 54" above floor front.		
Center of bows 48" above floor rear.		
Crew (operating) .....	1	
Tire size—11.00/18—10 ply Desert type.		

(2) Weights (approx.)

Chassis, hull, fuel, oil, and water.....	13,000	lbs.
Equipment .....	600	lbs.
Total weight fully equipped.....	13,600	lbs.
Driver .....	200	lbs.
Cargo .....	5,000	lbs.
Total weight with load.....	18,800	lbs.

(3) Capacities

Cooling systems .....	20	qts.
Engine crankcase oil.....	Refill 10 qts.—Dry	11 qts.
Transmission .....	11	pts.
Transfer case .....	4	pts.
Water propeller transfer case.....	1	pt.
Axle differential (front and forward rear—each)....	13	pts.
Axle differential (rearward rear).....	10	pts.
Fuel tank .....	40	gals.
Oil bath air cleaner.....	1	qt.

(4) Engine specifications

Type .....	Valve-in-head
------------	---------------

**GENERAL DESCRIPTION AND CHARACTERISTICS**

Number of cylinders ..... 6  
 Bore ..... 3-25/32 inches  
 Stroke ..... 4 inches  
 Piston displacement ..... 269.5  
 Weight (without accessories) ..... 525 lbs.

**(5) Maneuverability**

Minimum turning circle diameter (land)  
 (a) Left turn ..... 72 feet  
 (b) Right turn ..... 70 feet  
 Minimum turning circle diameter (water)  
 (a) Left turn ..... 42 feet  
 (b) Right turn ..... 39 feet  
 Angle of approach ..... 38 degrees  
 Angle of departure ..... 261½ degrees  
 Vertical object ..... 18 inches  
 Maximum grade descending ability ..... 60%  
 Maximum grade ascending ability ..... 60%  
 Land cruising range without refueling—5,000# load—  
 (average conditions) @ 35 m.p.h. .... 400 miles  
 Maximum allowable land speed ..... 50 m.p.h.  
 Maximum water speed ..... 6.4 m.p.h.

**(6) Performance**

**Acceleration (land)**

From standstill to 5 m.p.h. in High first 1.2 secs.  
 From standstill to 10 m.p.h. in High second 3.3 secs.  
 From 20 m.p.h. to 40 m.p.h. in High fourth 29.0 secs.

**Maximum land speed @ 2,750 engine r.p.m.**

	Low	High
Reverse .....	3 m.p.h.	7 m.p.h.
First .....	3 m.p.h.	7 m.p.h.
Second .....	5 m.p.h.	11 m.p.h.
Third .....	10 m.p.h.	22 m.p.h.
Fourth (direct) .....	18 m.p.h.	40 m.p.h.
Fifth (over-drive) .....	22 m.p.h.	50 m.p.h.
Max. governed speed .....		50 m.p.h. @ 2750 engine r.p.m.

**Maximum water speed (5,000# load, full throttle—smooth water)**

	Speed
Second (full throttle) .....	6.4 m.p.h.
Third (full throttle) .....	5.4 m.p.h.
Third (one-quarter throttle) .....	4.2 m.p.h.

Fourth and fifth—(over-drive) transmission is not used when operating water propeller.

Section III

**CONTROLS AND OPERATION**

	Paragraph
Driver's general instructions .....	8
Trouble-shooting .....	9
Vehicle nomenclature and terms.....	10
Oil, gas and water supply.....	11
Instruments, switches and gauges .....	12
Vehicle operating controls .....	13
Prestarting and before operation preventive maintenance....	14
Starting vehicle—on land .....	15
Driving vehicle—on land .....	16
Stopping vehicle—on land .....	17
Starting—water operation .....	18
Launching—water operation .....	19
Operation in water .....	20
Landing from water .....	21
Anchoring, mooring, and towing.....	22
Emergency expedients .....	23
Winch operation—land and water.....	24

**8. DRIVER'S GENERAL INSTRUCTIONS**

**a. General.** Information and instructions outlined in this section embrace not only the essential factors of driving this vehicle on land as a conventional truck, but also include unique and important instructions for operation of vehicle in amphibious service. Operation of an amphibious vehicle of this type requires basic training in truck driving, together with a knowledge of water operation fundamentals.

**b. Land Operation.** Driving the vehicle as a "land" truck requires the knowledge of all the fundamentals of operating a conventional 6 x 6 truck. In addition, the driver must take into consideration certain characteristics of this vehicle. In addition, driver should consider special characteristics of the vehicle such as width, height, length, front and rear overhangs, visibility and weight.

**c. Water Operation.** Experience as a driver of a 6 x 6 truck is the basis of amphibious service training; however, operating personnel should be familiar with instructions applicable to water operation before attempting to operate the vehicle in water.

**d. Caution and Instruction Plates.** Various caution and instruction plates are placed in driver's compartment. These plates are illustrated in Figs. 6 and 7.



**CONTROLS AND OPERATION**

**AUX. COOLING AIR INTAKE**  
 CONTROL AT CENTER OF DASH  
 PUSH DOWN TO OPEN

OPEN WHEN POSSIBLE TO HELP  
 ENGINE COOLING WHENEVER ENGINE  
 TEMPERATURE IS ABOVE 170°

**CAUTION** ALWAYS CLOSE TO KEEP  
 ENGINE DRY DURING ROUGH WATER  
 OR STEEP WATER ENTRY

RA PD 16235

AUXILIARY AIR INTAKE INSTRUCTION PLATE

**MAXIMUM PERMISSIBLE ROAD SPEEDS  
 IN THE FOLLOWING GEAR POSITIONS**

TRANSMISSION IN	TRANSFER CASE AUX. RANGE IN	
	HIGH RANGE	LOW RANGE
OVERDRIVE	50	22
DIRECT	40	18
THIRD	22	10
SECOND	11	5
FIRST	7	3
REVERSE	7	3

BASED ON 2750 R.P.M. MAX. ENGINE SPEED

RA PD 16236

MAXIMUM SPEED CAUTION PLATE

**TO ENGAGE MARINE PROPELLER - DEPRESS  
 CLUTCH & FOOT BRAKE - THEN PULL UP CONTROL**

USE ALL WHEELS, ENTERING & LEAVING WATER  
 DISENGAGE WHEELS FOR MAX. WATER PERFORMANCE

APPROX. LOADED SMOOTH WATER PERFORMANCE  
 2ND GEAR, FULL THROTTLE - 6.4 M.P.H. - 0.8 M. P. GAL.  
 3RD GEAR, FULL THROTTLE - 5.4 M.P.H. - 1.4 M. P. GAL.  
 3RD GEAR, 1/4 THROTTLE - 4.2 M.P.H. - 2.3 M. P. GAL.

MAX. REVERSE, FULL THROTTLE, ALL WHEELS, HI-RANGE

**CAUTION-DISENGAGE PROPELLER WHEN OUT  
 OF WATER** EXCEPT IF PUMPING BILGE - THEN ONLY  
 WITH TRANSMISSION IN SECOND GEAR

RA PD 16237

WATER PROPELLER INSTRUCTION PLATE

**Figure 6—Caution and Instruction Plates**

**TRUCK, AMPHIBIAN, 2 1/2-TON, 6 x 6**

<p><b>WINCHING CAUTIONS</b></p> <p>WHEN WINCHING <u>THIS VEHICLE</u> ALWAYS ASSIST WINCH WITH WHEELS IN LOWEST GEAR AS CABLE COMES TIGHT.</p> <p>WHEN POSSIBLE INCREASE PULLING POWER BY DOUBLING CABLE WITH SNATCH BLOCKS.</p> <p>ALWAYS KEEP CABLE WOUND TIGHTLY AND EVENLY. KEEP CABLE WELL PROTECTED WITH GREASE &amp; WINCH COVER.</p> <p>SHEAR PIN AND SPARES ARE BELOW REAR DECK NEAR WINCH.</p>	<p><b>ENGAGE FRONT AXLE</b> FOR ALL OFF THE ROAD &amp; WATER OPERATIONS, ALSO STEEP GRADES, HEAVY PULLING, SNOW &amp; ICE.</p> <p><b>DISENGAGE FRONT AXLE</b> FOR ALL FAVORABLE LAND OPERATIONS</p> <table border="1" style="width: 100%; border-collapse: collapse;"> <tr> <th style="width: 25%;">WINCH</th> <th style="width: 25%;">TRANSMISSION</th> <th style="width: 25%;">TRANSFER CASE</th> </tr> <tr> <td style="text-align: center;"> <p>(H) WIND LOOSE CABLE</p> <p>○ N</p> <p>(L) HEAVY PULLING</p> <p>○ N</p> <p>(R) UNWIND CABLE</p> </td> <td style="text-align: center;"> <p>(2) (5) (R)</p> <p>— (N) —</p> <p>(3) (4) (1)</p> </td> <td style="text-align: center;"> <table border="1" style="width: 100%; border-collapse: collapse;"> <tr> <th style="width: 50%;">AUX. RANGE</th> <th style="width: 50%;">FRONT AXLE</th> </tr> <tr> <td style="text-align: center;">● LOW</td> <td style="text-align: center;">● IN</td> </tr> <tr> <td style="text-align: center;">○ N</td> <td style="text-align: center;">○ OUT</td> </tr> <tr> <td style="text-align: center;">● HIGH</td> <td></td> </tr> </table> </td> </tr> </table>	WINCH	TRANSMISSION	TRANSFER CASE	<p>(H) WIND LOOSE CABLE</p> <p>○ N</p> <p>(L) HEAVY PULLING</p> <p>○ N</p> <p>(R) UNWIND CABLE</p>	<p>(2) (5) (R)</p> <p>— (N) —</p> <p>(3) (4) (1)</p>	<table border="1" style="width: 100%; border-collapse: collapse;"> <tr> <th style="width: 50%;">AUX. RANGE</th> <th style="width: 50%;">FRONT AXLE</th> </tr> <tr> <td style="text-align: center;">● LOW</td> <td style="text-align: center;">● IN</td> </tr> <tr> <td style="text-align: center;">○ N</td> <td style="text-align: center;">○ OUT</td> </tr> <tr> <td style="text-align: center;">● HIGH</td> <td></td> </tr> </table>	AUX. RANGE	FRONT AXLE	● LOW	● IN	○ N	○ OUT	● HIGH	
WINCH	TRANSMISSION	TRANSFER CASE													
<p>(H) WIND LOOSE CABLE</p> <p>○ N</p> <p>(L) HEAVY PULLING</p> <p>○ N</p> <p>(R) UNWIND CABLE</p>	<p>(2) (5) (R)</p> <p>— (N) —</p> <p>(3) (4) (1)</p>	<table border="1" style="width: 100%; border-collapse: collapse;"> <tr> <th style="width: 50%;">AUX. RANGE</th> <th style="width: 50%;">FRONT AXLE</th> </tr> <tr> <td style="text-align: center;">● LOW</td> <td style="text-align: center;">● IN</td> </tr> <tr> <td style="text-align: center;">○ N</td> <td style="text-align: center;">○ OUT</td> </tr> <tr> <td style="text-align: center;">● HIGH</td> <td></td> </tr> </table>	AUX. RANGE	FRONT AXLE	● LOW	● IN	○ N	○ OUT	● HIGH						
AUX. RANGE	FRONT AXLE														
● LOW	● IN														
○ N	○ OUT														
● HIGH															

RA PD 16239

WINCH, TRANSMISSION AND TRANSFER CASE INSTRUCTION PLATE

<p><b>BILGE PUMP MANIFOLD VALVES</b> PULL UP TO OPEN</p> <table border="1" style="width: 100%; border-collapse: collapse;"> <tr> <th style="width: 12.5%;">LEFT REAR</th> <th style="width: 12.5%;">CENTER</th> <th style="width: 12.5%;">MANIFOLD DRAIN</th> <th style="width: 12.5%;">FRONT</th> <th style="width: 12.5%;">RIGHT REAR</th> </tr> </table> <p>TO PUMP - OPEN ONLY ONE VALVE AT A TIME NORMALLY CENTER COMPARTMENT</p> <p><b>COLD WEATHER CAUTION</b> OPEN HOT AIR DISCHARGE TO BILGE, PUMP EACH LINE DRY, THEN OPEN ALL FIVE VALVES. BE SURE THAT MANIFOLD DRAIN, ALSO PERMANENT DRAIN HOLE IN CENTRIFUGAL PUMP ARE NOT CLOGGED</p> <p><b>TO DRAIN ENGINE COOLING SYSTEM</b> REMOVE RADIATOR CAP AND OPEN THE FOLLOWING THREE PETCOCKS:          ONE ON LEFT REAR SIDE OF ENGINE          ONE ON FRONT OF RADIATOR CORE          ONE ON BOTTOM OF SURGE TANK</p>	LEFT REAR	CENTER	MANIFOLD DRAIN	FRONT	RIGHT REAR	<p><b>TIRE PRESSURES</b></p> <p>REDUCE PRESSURE TO CROSS SOFT GROUND OR SAND          INCREASE PRESSURE FOR HARD GROUND OPERATION          ALWAYS KEEP ALL TIRES AT EQUAL PRESSURE          BEFORE WATER ENTRY SET TIRES FOR ESTIMATED CONDITIONS AT NEXT LANDING - IF UNCERTAIN, REDUCE TO 12#</p> <p><b>RECOMMENDED PRESSURES FOR 10 PLY 1100-18 DESERT TIRE</b></p> <table border="1" style="width: 100%; border-collapse: collapse;"> <thead> <tr> <th style="width: 50%;">TYPE OF OPERATION</th> <th style="width: 10%;">TIRE PRESS.</th> <th style="width: 15%;">MAX. SAFE SPEED</th> <th style="width: 25%;">MAX. SAFE DISTANCE</th> </tr> </thead> <tbody> <tr> <td>HARD SURFACES ONLY</td> <td>40#</td> <td>50 M.P.H.</td> <td>UNLIMITED</td> </tr> <tr> <td>AMPHIBIOUS - FAVORABLE LANDING SITE</td> <td>30#</td> <td>40 M.P.H.</td> <td>30 MILES</td> </tr> <tr> <td>AMPHIBIOUS - UNFAVORABLE LANDING SITE</td> <td>22#</td> <td>30 M.P.H.</td> <td>10 MILES</td> </tr> <tr> <td>SOFT SAND OR UNCERTAIN LANDING SITE</td> <td>12#</td> <td colspan="2">INFLATE ON REACHING HARD GROUND</td> </tr> </tbody> </table> <p><b>TO ENGAGE TIRE PUMP</b>          DEPRESS CLUTCH, SHIFT TRANSFER CASE TO NEUTRAL, THEN PULL UP CONTROL &amp; RELEASE CLUTCH          RUN ENGINE HALF SPEED ONLY FOR MAXIMUM PUMP OUTPUT  <b>CAUTION</b> - DRAIN AIR TANK AFTER PUMPING AND IN COLD WEATHER</p>	TYPE OF OPERATION	TIRE PRESS.	MAX. SAFE SPEED	MAX. SAFE DISTANCE	HARD SURFACES ONLY	40#	50 M.P.H.	UNLIMITED	AMPHIBIOUS - FAVORABLE LANDING SITE	30#	40 M.P.H.	30 MILES	AMPHIBIOUS - UNFAVORABLE LANDING SITE	22#	30 M.P.H.	10 MILES	SOFT SAND OR UNCERTAIN LANDING SITE	12#	INFLATE ON REACHING HARD GROUND	
LEFT REAR	CENTER	MANIFOLD DRAIN	FRONT	RIGHT REAR																						
TYPE OF OPERATION	TIRE PRESS.	MAX. SAFE SPEED	MAX. SAFE DISTANCE																							
HARD SURFACES ONLY	40#	50 M.P.H.	UNLIMITED																							
AMPHIBIOUS - FAVORABLE LANDING SITE	30#	40 M.P.H.	30 MILES																							
AMPHIBIOUS - UNFAVORABLE LANDING SITE	22#	30 M.P.H.	10 MILES																							
SOFT SAND OR UNCERTAIN LANDING SITE	12#	INFLATE ON REACHING HARD GROUND																								

RA PD 16238

BILGE PUMP AND TIRE PRESSURE INSTRUCTION PLATE

Figure 7—Caution and Instruction Plates

**CONTROLS AND OPERATION**

**9. TROUBLE-SHOOTING**

a. Trouble-shooting tables included in other sections of this manual should be thoroughly studied by driver and crew. These tables will enable the crew to recognize even gradual changes in the mechanical condition of various units, and will thus encourage corrective service before failure. Knowledge of various trouble symptoms, causes, and remedies will enable driver and crew to apply emergency measures when operating under critical and adverse conditions.

**10. VEHICLE NOMENCLATURE AND TERMS**

a. There are many parts of an amphibious truck which are different than those generally encountered on a "land" truck. In addition, terms are employed in the operation of vehicle in water which are not generally used when operating vehicle as a truck. Wherever possible, use of marine terms when describing various component parts of vehicle have been avoided. However, in some instances, nomenclature generally applied to a boat must necessarily be used, particularly when describing water propeller, bilges, rudder, etc. Reference should be made to Fig. 8.

c. **Definition of Terms.** Following table defines various operating terms and nomenclature used in describing vehicle and its operation throughout this manual.

<b>Name or Term</b>	<b>Definition</b>
Aft . . . . .	At, toward, or near stern or rear of vehicle.
Answer the helm . . . . .	Respond to the steering apparatus.
Anchor . . . . .	An instrument, generally equipped with two hooks or flukes, which is used to anchor or hold vehicle in one place in water.
Ballast . . . . .	Heavy material generally placed in hold of boat to improve stability.
Beam . . . . .	The extreme width of boat at its widest part.
Bow . . . . .	The forward part of a boat or vehicle.
Bilge . . . . .	The bottom of hull or boat.
Breast line . . . . .	A line running directly across at front or rear as used when towing or mooring alongside.
Bulkhead . . . . .	A partition or wall separating compartments.
Chocks . . . . .	A guide for ropes or cables.
Coaming . . . . .	A raised section, generally around openings, to prevent entry of water.
Dock . . . . .	A landing place for boats.
Draft . . . . .	The distance from the surface of the water to the deepest part of boat, or vehicle, when floating.
Fairlead . . . . .	A ring serving as a guide for rope or cable.



TRUCK, AMPHIBIAN, 2½-TON, 6 x 6

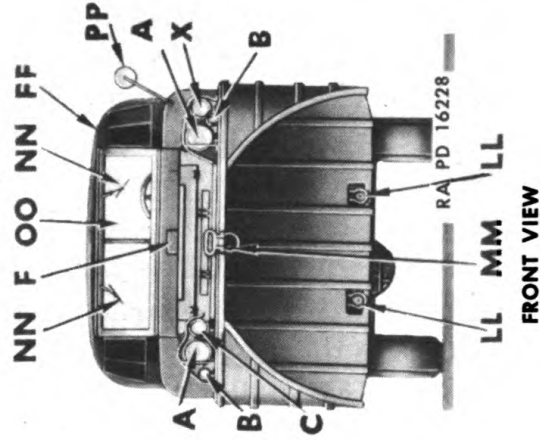
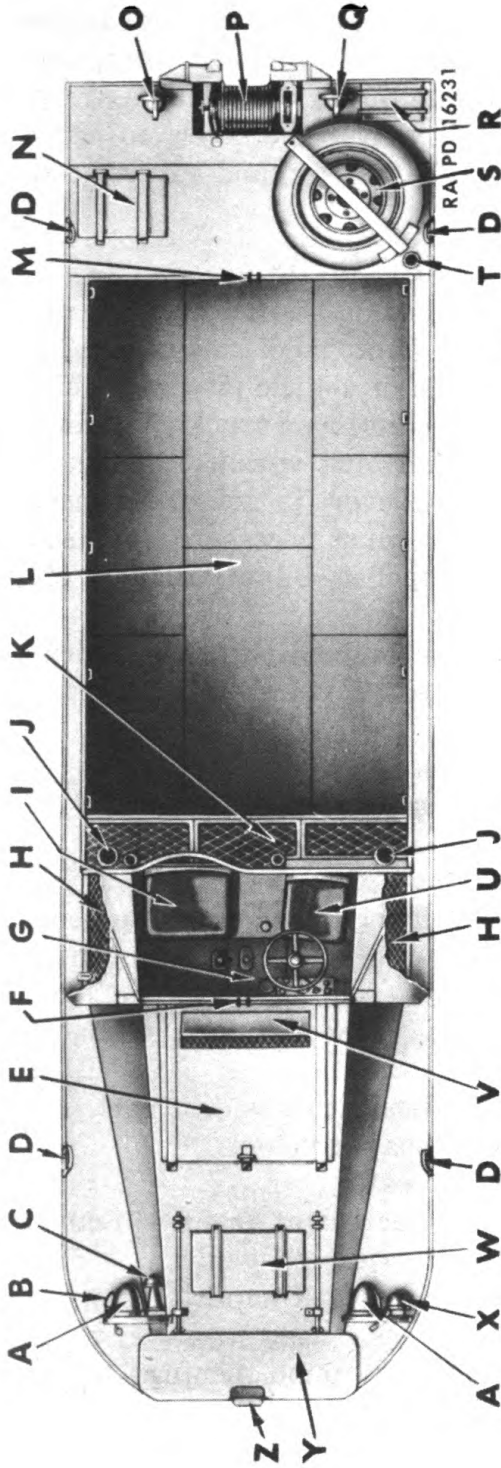

FRONT VIEW

- A Head Lamp
- B Blackout Marker Lamp
- C Horn
- D Lifting Eye
- E Engine Compartment Hatch Cover
- F Winch Cable Guide (in Windshield Lower Panel)
- G Driver's Compartment
- H Air Exhaust Grille
- I Assistant Driver's Seat
- J Fire Extinguisher
- K Air Intake Grilles
- L Cargo Compartment
- M Winch Cable Guide (in Cargo Compartment Rear Bulkhead)
- N Stern Compartment Hatch Cover
- O Rear R.H. Combination Blackout Stop and Tail Light
- P Winch
- Q Rear L.H. Combination Blackout Tail and Service Stop and Tail Light
- R Tool Compartment Hatch Cover
- S Spare Wheel, Tire and Carrier
- T Fuel Tank Filler Neck
- U Driver's Seat
- V Auxiliary Air Intake
- W Bow Compartment Hatch Cover
- X Blackout Driving Light
- Y Surf Coaming
- Z Winch Cable Guide (at Front of Bow)

Generated on 2013-07-22 08:35 GMT / http://hdl.handle.net/2027/uc1.b3243762  
 Public Domain, Google-digitized / http://www.hathitrust.org/access\_use#pd-google

CONTROLS AND OPERATION

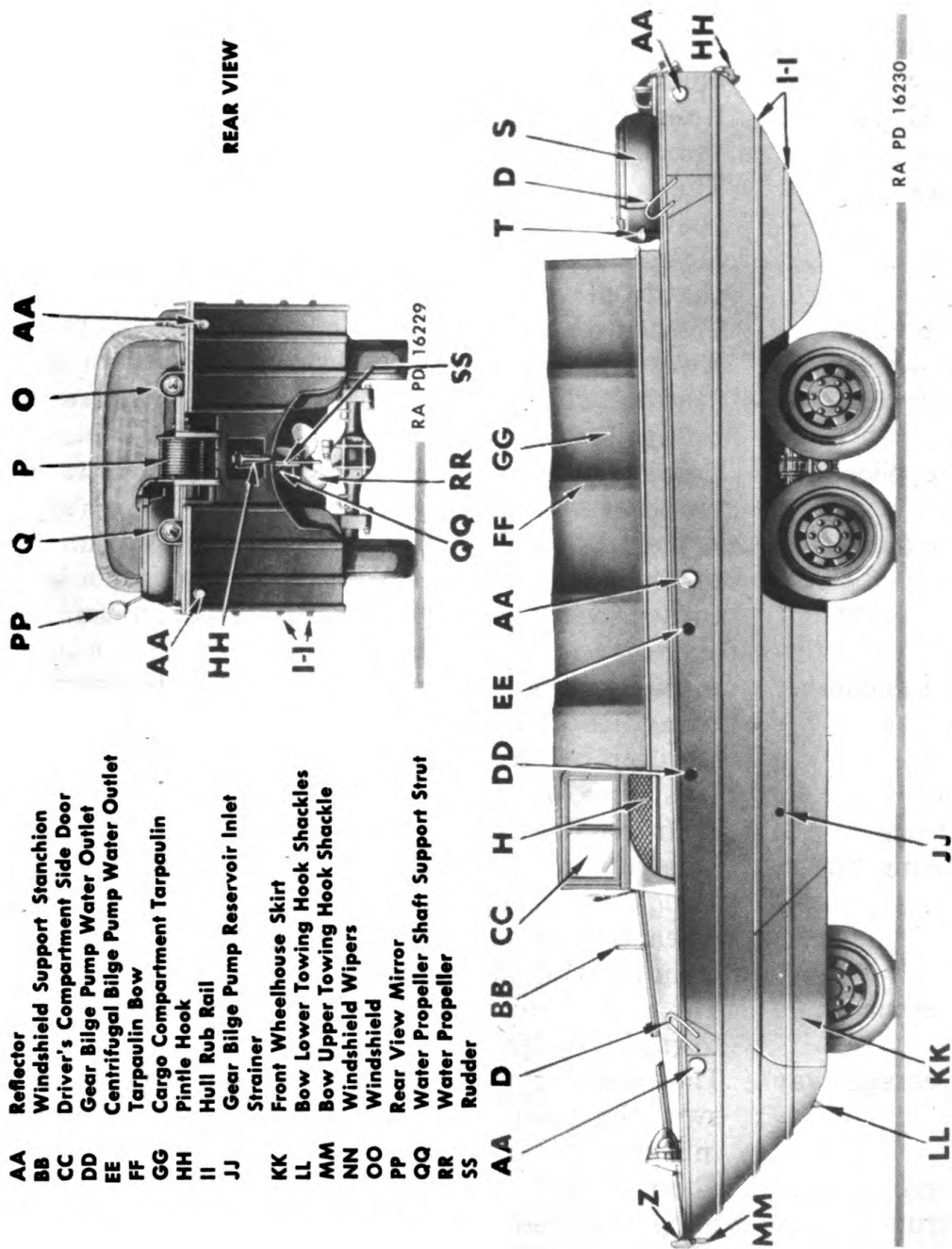

Figure 8—Location of Various Parts on Vehicle



**TRUCK, AMPHIBIAN, 2 1/2-TON, 6 x 6**

Name or Term	Definition
Fenders . . . . .	A cushion to protect side of vehicle when coming alongside of another vehicle, ship, or dock.
Hatch . . . . .	A cover of an opening in the deck, generally hinged and latched.
Helm . . . . .	The apparatus by which a ship is steered, the rudder and steering wheel.
Hold . . . . .	Interior of vehicle hull below floor or deck—space for cargo—below decks.
Hull . . . . .	The body of vehicle or that part which forms the boat.
Lee . . . . .	Means opposed to weather or the side opposite to that from which the wind blows, the sheltered side.
Moor . . . . .	To secure a vessel or vehicle.
Off-shore . . . . .	Away from the shore.
Port . . . . .	The left side of ship looking from stern (rear) toward bow (front).
Propeller tunnel .	Concave opening at rear of vehicle in which water propeller and rudder are mounted.
Rudder . . . . .	A piece hinged vertically near vehicle's stern. Interconnected with steering gear so that when it is turned, vehicle turns in same direction (water operation only).
Sea anchor . . . . .	A bulky object let down into water to form a "drag" to deter movement in water. Used when too deep to anchor in normal manner.
Sheer . . . . .	To swerve, or turn.
Secure . . . . .	To fasten down.
Spring line . . . . .	Line running diagonally from front or rear of one vehicle to opposite end of another, generally used when towing another vehicle alongside in water, or in mooring alongside vessel or dock.
Starboard . . . . .	The right side of ship looking from stern (rear) toward bow (front).
Steerage way . . .	The rate of motion sufficient to make a vessel answer the helm, or permit the steering of vehicle in water.
Stern . . . . .	The rear part of a boat or vehicle.
Strut . . . . .	Support—used as describing "V" type support which holds water propeller in alignment.
Stuffing box . . . .	Device to prevent leakage at a shaft—such as water propeller shaft or rudder post.
Transfer case, water propeller .	An auxiliary gear case or power take-off mounted between transmission and water propeller shafting

**CONTROLS AND OPERATION**

Name or Term	Definition
	to permit engagement and disengagement of water propeller.
Wake . . . . .	The track left by a vessel in the water.
Water propeller .	Propeller (sometimes referred to as a "wheel" or "screw"), located at rear under hull, is driven through shafts by transmission to propel vehicle through water.
Wheel . . . . .	Used as describing a water propeller, or the steering wheel of a boat.

**11. OIL, GAS, AND WATER SUPPLY**

**a. Crankcase Oil**

(1) Crankcase oil filler neck (Fig. 9), mounted on right-hand side of engine, is accessible after engine compartment hatch is raised. Lubricant capacity of crankcase, type of lubricant recommended, and filling, draining, and flushing intervals are outlined in Section VI, "Lubrication."

(2) Oil filler dip stick (Fig. 9), mounted on right-hand side of engine, is also accessible after engine compartment hatch is raised. Lower portion of dip stick is graduated showing relative oil level of crankcase. Dip stick should be pulled out, lower portion wiped off with a clean cloth, reinserted to its limit, then pulled out again for correct reading. Oil level of crankcase will be indicated on graduated portion of gauge or dip stick. Crankcase oil should be kept up to the "full" mark.

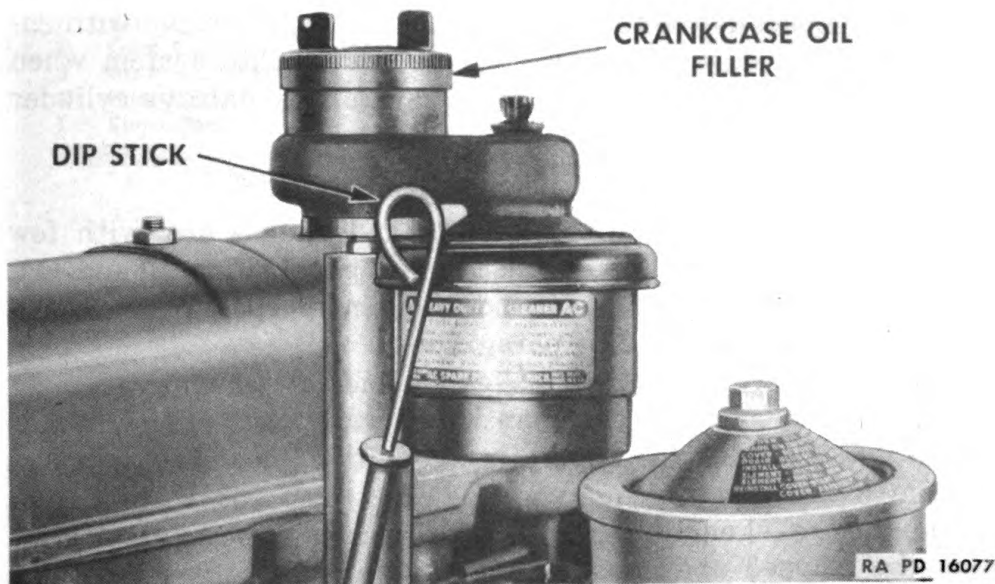

**Figure 9—Crankcase Oil Filler and Dip Stick**

**TRUCK, AMPHIBIAN, 2½-TON, 6 x 6****b. Fuel Supply**

(1) **Octane rating.** For best performance, gasoline with an octane rating of 70 or above should be used. Instruction plate is placed on engine valve cover. Fuel with an octane rating with less than that recommended necessitates the readjustment of ignition timing and, as a general rule, engine performance will be affected.

(2) Fuel tank filler neck is located at rear of vehicle on left-hand side. **CAUTION:** When replenishing fuel tank, same precaution should be taken as when filling fuel tank on a conventional truck. Supply filler hose should be properly grounded to prevent static sparks and care should be taken to prevent entrance of dirt or water into fuel tank.

(3) **Important:** If any fuel has been spilled into compartments of hull, these compartments must be thoroughly cleaned and all fumes evacuated before attempting to start engine. As a matter of precaution, engine compartment hatch should be raised and compartment ventilated before and after engine operation.

**c. Cooling System Supply**

(1) The basis of coolant for engine cooling system is fresh, clean water to which should be added inhibitors (rust preventives) and anti-freeze solutions (at temperature below 32°F.). **Do not use salt water in cooling system except in extreme emergency** — then drain and flush when fresh water is available.

(2) Radiator filler cap is accessible after engine compartment hatch has been raised. This cap is conventional notch type and care should be taken when removing it if engine is hot.

(3) If engine overheats from lack of water, do not add cold water immediately. Radiator should only be filled after boiling has ceased and engine cooled down, then add water slowly, preferably with engine running. Cold water should not be poured into system when engine is hot as such change in temperature may damage cylinder head and block.

**12. INSTRUMENTS, SWITCHES, AND GAUGES**

a. Operating instruments, switches, and gauges are, with few exceptions as noted, mounted on instrument panel (Figs. 10 and 11), located directly in front of driver. Location and purpose of these controls are outlined in succeeding paragraphs.

b. **Temperature Gauge.** This gauge indicates temperature of water in cooling system (not quantity of water in system). Water temperature depends upon operating conditions, load, etc. Normal operating temperature range should be between 160°F. to 185°F. If temperature should reach 212°F. (generally boiling), engine should be stopped and cause of overheating determined and cor-



**CONTROLS AND OPERATION**

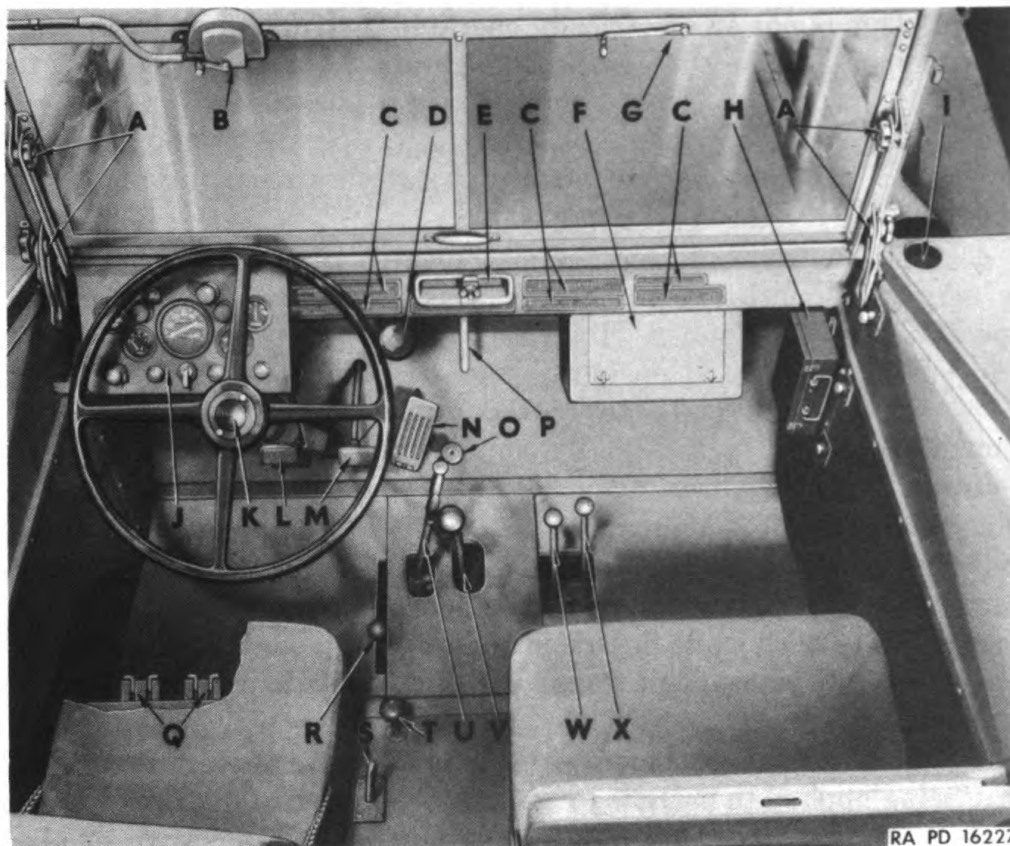

**Figure 10—Driver's Compartment**

- |   |  |
|---|--|
| <b>A</b> Windshield Regulators          | <b>M</b> Brake Pedal                     |
| <b>B</b> Left Hand Windshield Wiper     | <b>N</b> Accelerator Pedal               |
| <b>C</b> Caution and Instruction Plates | <b>O</b> Starter Button                  |
| <b>D</b> Flash Light                    | <b>P</b> Air Scoop Regulator             |
| <b>E</b> Winch Cable Guide              | <b>Q</b> Bilge Pump Valve Control Levers |
| <b>F</b> Map Compartment                | <b>R</b> Winch Control Lever             |
| <b>G</b> Right Hand Windshield Wiper    | <b>S</b> Tire Pump Control Lever         |
| <b>H</b> First Aid Kit                  | <b>T</b> Marine Propeller Control Lever  |
| <b>I</b> Front Clamp for Gun Mount      | <b>U</b> Hand Brake Lever                |
| <b>J</b> Instrument Panel               | <b>V</b> Gear Shift Lever                |
| <b>K</b> Horn Button                    | <b>W</b> Transfer Case Control Lever     |
| <b>L</b> Clutch Pedal                   | <b>X</b> Front Axle Shift Lever          |

**TRUCK, AMPHIBIAN, 2½-TON, 6 x 6**

rected. This is not an electrically operated instrument and will indicate temperature of the cooling system at all times from 100°F. to 220°F.

**c. Fuel Gauge.** Fuel gauge, electrically operated, indicates level of gasoline in fuel tank and is only operative when ignition switch is turned on.

**d. Speedometer.** Speedometer indicates road speed of vehicle in miles per hour. The instrument records total number of miles operated and "trip" miles. "Trip" indicator can be cleared by turning knurled button located on under side of speedometer head. Do not allow vehicle road speed to exceed maximum permissible speeds shown on plate, Fig. 7. This instrument will not indicate miles per hour operation in water, nor total miles operated in water.

**e. Oil Pressure Gauge.** Oil pressure gauge on instrument panel indicates pressure of engine lubrication oil. Pressure reading may vary according to operating conditions. However, if oil pressure should fall to zero while engine is running, stop engine immediately and determine cause. **This gauge does not indicate amount of oil in crankcase.**

**f. Ammeter** on instrument panel indicates rate of electric current flow being applied to battery by generator, or rate of discharge from battery. At low engine speeds, needle may show a negative or discharge reading.

**g. Ignition Switch.** Ignition switch is lever type and handle must be turned "on" before engine can be started. Do not allow switch to remain turned "on" with engine not running except when making necessary tests.

**h. Choke Button.** Choke button (marked "choke") should only be pulled out far enough to allow engine to run smoothly during warm-up period and should be allowed to return to "open" position as soon as possible after engine is started. Return spring on choke linkage returns choke valve to open position when control button is released.

**i. Throttle Button.** Throttle button (marked "throttle") on instrument panel may be used for starting engine or to set throttle at a sustained speed. Button can be pulled out in varying degrees, accelerating engine from idling speed to maximum governed speed.

**j. Main Light Switch.** Main light switch (Fig. 12), located on instrument panel, is a four-position push-pull type switch which controls both service and blackout head lamps, service and blackout stop and tail lamps. Switch is equipped with a circuit breaker type fuse which automatically opens light circuit when a short occurs and automatically closes circuit when thermostatic element in circuit breaker cools off. Switch operates in the following manner:



## CONTROLS AND OPERATION

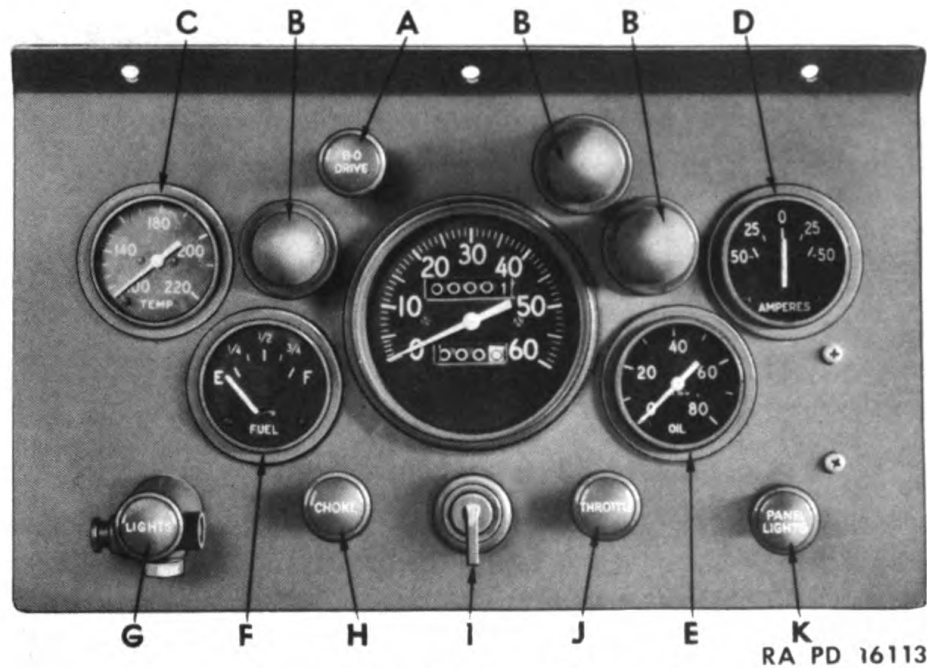

Figure 11—Instrument Panel

- |  |                                       |
|--|---------------------------------------|
| <b>A</b> Blackout Driving Light Switch | <b>G</b> Main Light Switch            |
| <b>B</b> Panel Lights                  | <b>H</b> Choke Control Button         |
| <b>C</b> Temperature Gauge             | <b>I</b> Ignition Switch              |
| <b>D</b> Ammeter                       | <b>J</b> Hand Throttle Control Button |
| <b>E</b> Oil Gauge                     | <b>K</b> Panel Light Switch           |
| <b>F</b> Fuel Gauge                    |                                       |

(1) **Off position.** When switch control button is pushed completely in, all lights, both service and blackout, are turned off. Blackout and service stop lights cannot be operated with switch in this position.

(2) **Blackout position.** When switch button is pulled to first stage, blackout head lamps and blackout stop and tail lamps are energized. Button is locked in place with automatic plunger type lock when pulled to this position.

(3) **Service position.** Switch locking button at left of switch body must be depressed before switch button can be pulled to second stage or service position. When switch is in service position, service head lamps, service stop and tail lamps, and instrument panel lights are energized.

(4) **Service stop light position.** When switch button is pulled completely out, service stop lights may be operated for daylight service.

**k. Blackout Driving Light Switch.** Blackout driving light switch, located on instrument panel (marked "B.O. Drive"), energizes blackout driving light which is installed adjacent to left-hand service head lamp. This driving light, which is a shielded type, is used in addition to the standard blackout head lamps when additional illu-

**TRUCK, AMPHIBIAN, 2½-TON, 6 x 6**

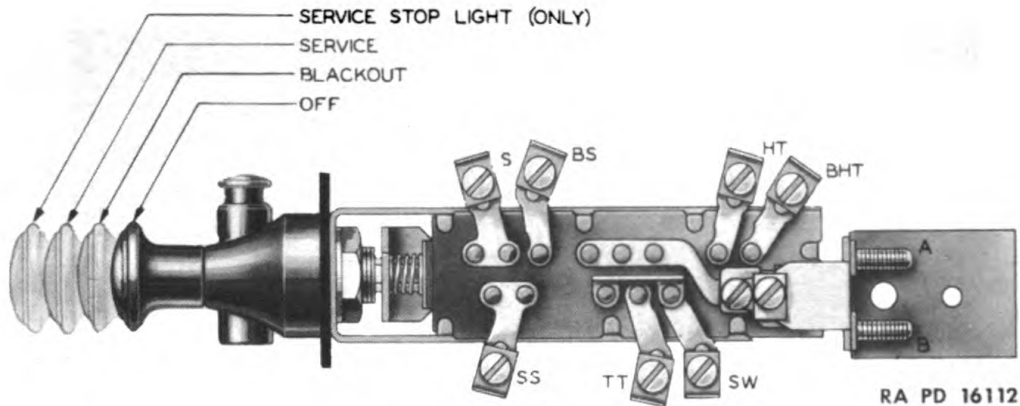

**Figure 12—Main Light Switch**

mination is necessary during blackout conditions. Blackout driving light switch will not energize lamp until main light switch is in first stage or blackout position as previously explained.

**l. Panel Light Switch.** Panel light switch, located on instrument panel (marked "Panel") is a push-pull type and energizes instrument panel lights after main light switch is placed in second or service position as previously explained.

**m. -Starter Control Lever.** Engine starter is operated by stepping down on pedal (accessible to driver's right foot). Initial movement of pedal engages starter pinion with flywheel teeth. Further movement completes electrical circuit between battery and starter, causing starter to rotate, thus cranking engine. When engine starts, foot should be removed from pedal immediately. **CAUTION:** Do not step on pedal when engine is running.

**n. Windshield Wiper Control.** Vacuum windshield wiper is mounted on left side of windshield. Control button is provided for operation of this wiper as shown in Fig. 10. Button is pulled out to turn windshield wiper on, and pushed in to turn wiper off. A hand operated wiper is mounted on right-hand section of windshield.

**13. VEHICLE OPERATING CONTROLS**

**a.** Vehicle operating controls are located in driver's compartment (Fig. 10). Location and purpose of these controls are described in succeeding paragraphs. Actual operation of each control under various conditions is explained in respective operation paragraphs.

**b. Carbureter Control**

(1) Accelerator pedal (accessible to driver's right foot) is used to accelerate or decelerate engine, depending upon degree pedal is depressed or released. When pedal is completely released, engine will operate at idling speed. Acceleration from idling to governed speed is obtained by degree pedal is pressed down. Corresponding degree of deceleration is obtained by releasing pedal.



## CONTROLS AND OPERATION

(2) Hand primer, located on right-hand side of engine just above fuel pump, is used to prime carbureter when vehicle has been standing for long periods of time or has been drained of fuel.

**c. Clutch Control.** Clutch pedal, accessible to driver's left foot, engages and disengages clutch. Depressing clutch pedal disengages engine from transmission so that transmission gears may be shifted.

**d. Transmission Control**

(1) Transmission shift lever, accessible to driver's right hand, is used to select various gear ratios or speeds provided in transmission. Transmission provides five speeds forward and one reverse. All transmission speeds are used in conjunction with transfer case when wheels are operated. In addition to transmitting speed and power to driving wheels and water propeller, transmission also transmits power to winch and air pump through interconnected power take-off.

**e. Transfer Case Control.** Transfer case shift lever is used to shift transfer case into high, neutral, or low speeds as required to operate wheels. Arrangement of this lever is such that low range cannot be used until front axle is in engaged position. Transfer case is not used to operate water propeller.

**f. Front Axle Engagement.** Front axle declutching lever is used to engage and disengage front axle drive. This lever has only two positions, namely "in" and "out." Front axle must be engaged (lever in "in" position) before transfer case can be shifted into "low" position. After front axle has been engaged, transfer case may be shifted into either high or low range.

**g. Steering Control**

(1) **Front wheels.** Front wheels are turned or steered by means of conventional steering gear assembly which is interconnected to front axle steering knuckles and tie rod with drag link.

(2) **Rudder.** Vehicle is steered during water operation by means of a rudder mounted at stern just to the rear of water propeller. Movement of steering wheel is transmitted through steering column to cables interconnected with rudder.

**h. Service Brake Control.** Service brake pedal, accessible to and operated by driver's right foot, controls application and release of vacuum hydraulic operated brake shoes at each wheel. Driver applies pressure to pedal to actuate brakes as desired. Release of brakes is correspondingly as rapid as foot pressure on pedal is released.

**i. Hand Brake Control**

(1) Manually operated hand brake lever, located to right of driver, is used to control application of brake band assembly mounted on transfer case. This brake system operates directly on transfer case output shaft, transmitting braking effort to wheels through

**TRUCK, AMPHIBIAN, 2½-TON, 6 x 6**

propeller shafts. Hand brake should not be used to brake vehicle during normal road operation. Primary purpose of this brake is to hold vehicle in parked position or to assist in bringing it to an emergency stop. When lever is pulled back, spring loaded latch will lock the lever in applied position.

**j. Winch Controls.** Power take-off shifting lever is used when necessary to operate winch. There are three operating positions, "low," "reverse," and "high," with neutral positions between. Refer to Para. 24 for operation of winch.

**k. Tire Pump Control.** Air compressor is driven by chain from power take-off auxiliary drive shaft. Pump is placed in engagement by means of a shift lever, which has two operating positions, "in" and "out." Clutch must be disengaged before tire pump shift lever is placed into "in" position.

**l. Water Propeller Control**

(1) Water propeller shift lever is used to engage or disengage gears in an auxiliary transfer case connected to rear of main transmission. Water propeller is engaged when lever is pulled up and disengaged when lever is pushed down. Clutch must be disengaged before water propeller lever is placed into engaged or disengaged position.

(2) Speed of water propeller is determined by selection of transmission gears. For normal operation, transmission should be placed directly into second speed for forward operation or into reverse for reversing operation. Water propeller should be engaged only when vehicle is operating in water. **Use of propeller on land, except for bilge pumping or brief testing, should always be avoided.**

**m. Bilge Pump Control**

(1) Bilge pumping system comprises two mechanically operated bilge pumps, a system of piping to various compartments, and manifold valve arrangement which permits independent pumping of various compartments by one pump.

(2) Gear type pump, located under driver's compartment, is driven with belt by water propeller drive shaft and operates when water propeller operates. This pump provides positive suction from the front, center, left rear, or right rear compartments as selected at the control valves.

(3) Four valve handles are provided to permit pumping of the compartments serviced by this bilge pump. The compartments can only be pumped out one at a time depending upon the selection at control valves. For normal operation when leaks are not apparent in other compartments, the middle control valve should be opened, as this compartment is most apt to require the use of bilge pump.

## CONTROLS AND OPERATION

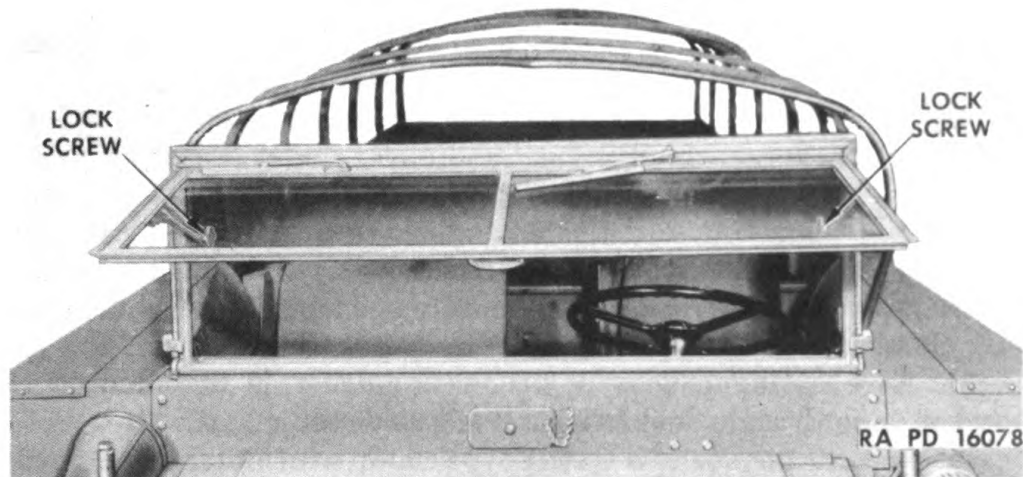

**Figure 13—Windshield in Tilted Position**

(4) A centrifugal emergency bilge pump is located below the cargo floor boards and is operated by chain drive from the water propeller drive shaft. This pump services the main (middle) section of the bilge only and as a general rule will not operate until the water is about 5 inches deep in this compartment.

(5) In addition to mechanically operated bilge pumps, a hand operated bilge pump is provided. This pump is stowed on right-hand front deck of vehicle.

**n. Miscellaneous Controls**

(1) **Windshield positioning.** Windshield can be placed in two positions, tilted or completely lowered. Fig. 13 shows windshield in tilted position. Two adjusting nuts, one on each side as shown in illustration, must be loosened before windshield can be placed in tilted position. Windshield can then be locked with nuts at desired

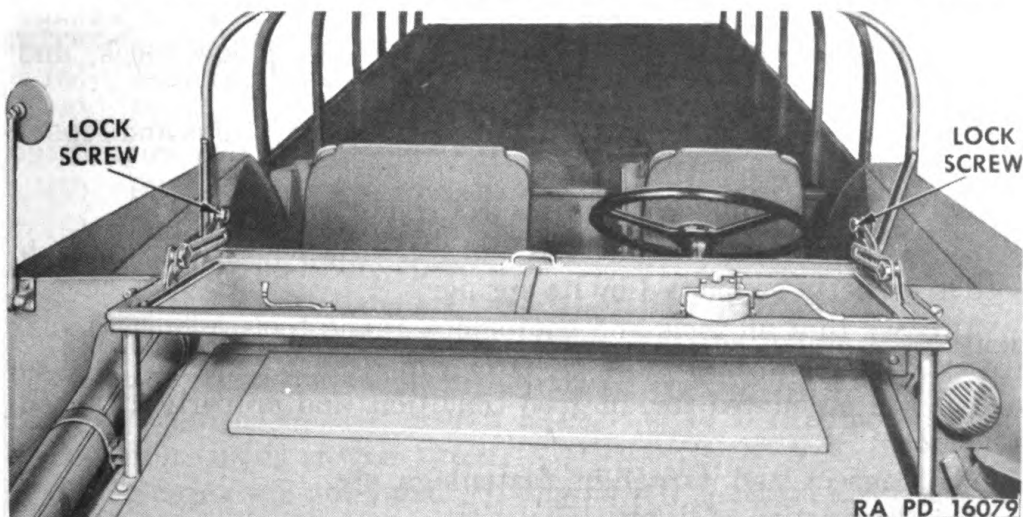

**Figure 14—Windshield in Lowered Position**



**TRUCK, AMPHIBIAN, 2½-TON, 6 x 6**

point. Fig. 14 shows windshield in completely lowered position. Adjusting nuts on both sides, as shown, must be loosened to lower windshield to supports which are attached to forward deck.

(2) **Auxiliary air intake.** Auxiliary air intake is opened or shut by means of a lever which is located directly under center of windshield. When lever is pushed down and forward, intake is opened, permitting additional intake of air into engine compartment. This intake is used primarily when vehicle is completely covered with tarpaulin, also in extremely hot weather, generally reducing engine temperature about 10 degrees.

(3) **Fire extinguishers.** A fire extinguisher is mounted in a bracket on both right and left-hand sides to rear of each air outlet. Mounting lock consists of a spring type clamp which must be opened before extinguisher can be removed. Extinguisher is operated by turning a handle to left, then working up and down like a pump. Best results will be obtained by directing stream of liquid at base of flame.

(4) **Surf coaming.** Purpose of surf coaming at the bow of vehicle is to minimize water washing over bow, particularly in rough sea or when heavily loaded. Surf coaming can be raised and lowered by two bars which are held in open or closed position by screw locks on front deck.

(5) **Hatch controls.** All hatch covers are secured down to compartments with screw type latches. Hatches are equipped with seals and, when properly secured, will prevent water from entering into various compartments.

#### 14. PRESTARTING AND BEFORE OPERATION PREVENTIVE MAINTENANCE

##### a. Before Starting Engine—Vehicle Exterior

(1) Look on ground under vehicle for evidence of oil leakage from axle housings, steering knuckle housings, pillow block, and steering gear.

(2) Inspect steering drag link and tie rod connections and report excessive looseness.

(3) Check tire inflation and inspect condition of tires.

(4) Inspect condition of brake lines at all wheels. See that each hose is properly supported by its spring.

(5) See that all tools and equipment (hand tools, pioneer tools, fire extinguishers, first aid kits, etc.) which have been assigned to vehicle are accounted for, in good condition, and properly attached to vehicle.

(6) Inspect load, tarpaulin, fastenings, etc.

(7) Test action of lights.

(8) Check windshield wiper blade and hose.



**CONTROLS AND OPERATION**

(9) Replenish fuel in tank. Do not fill tank entirely to top of filler neck.

**b. Before Starting Engine—Vehicle Interior**

(1) Inspection for possible oil leakage from transmission, power take-off, water propeller transfer case, and axle transfer case should be made if cargo condition permits access to these units.

**c. Before Starting Engine—In Engine Compartment**

(1) Remove filler cap at radiator and replenish water if low. Water level should not have changed since preceding inspection; if so, look for leaks around radiator core and connections.

(2) Inspect fan belt; see that it is in place and properly adjusted.

(3) Check engine oil level and condition of oil. If there has been any change in oil level, look for leaks in oil lines. If water or other foreign matter is found in oil, report condition.

(4) Inspect fuel lines and connections at carbureter, fuel filter, and fuel pump for leaks.

(5) Inspect condition of all exposed electrical wiring and connections. All connections should be clean and dry.

(6) Observe general condition of engine accessories, including carbureter air cleaner and cover, generator, starter, ignition shield, etc.

**15. STARTING VEHICLE ON LAND****a. Starting the Engine**

(1) Place transmission shift lever in "neutral." (All shift levers should be in neutral or "out" position.)

(2) Pull hand brake lever straight back and lock in applied position.

(3) Pull out hand throttle button about  $\frac{1}{2}$ ". This is not necessary if engine is warm.

(4) Hold choke button out about half-way if engine is cold. In extremely cold weather, choke button may be held completely out.

(5) Turn ignition switch to "on" position.

(6) Push clutch pedal down to disengage clutch and hold down until engine starts.

(7) Push starter lever down. Release lever when engine starts.

(8) Make necessary hand throttle and choke adjustments to obtain even engine idling speed.

**b. Starting Hints**

(1) **Operating starting motor.** The starting motor should not be engaged for periods longer than 10 to 15 seconds. After starter has been engaged without results, a period of 10 to 15 seconds should elapse before using starter again.

(2) **Engine will not start.** If engine will not start after reasonable cranking, do not continue to use starting motor until reason for failure is determined and corrected.

**TRUCK, AMPHIBIAN, 2½-TON, 6 x 6**

(3) **Starter fails to crank.** If starter fails to crank or cranks slowly, and battery is known to be in good condition, report starting motor failure to proper authority, then use hand cranking method.

**c. Hand Cranking.** A cranking gear is mounted on propeller shaft at rear of water propeller transfer case. Hand crank engine in following manner:

- (1) Place transmission in first speed.
- (2) Place transfer case lever in neutral position.
- (3) Engage water propeller.
- (4) Check rear of vehicle to make sure propeller is clear.
- (5) Insert flat end of cranking bar in cog of cranking gear. Standing with back to right side of vehicle, pull sharply on cranking bar and turn engine over one or two times before turning ignition switch on.

(6) Pull hand throttle out about ½".

(7) Hold (or block, if only driver is attending vehicle) choke button out about ½". If choke has been used during repeated efforts with starting motor, it will not be necessary to use choke when hand cranking.

(8) Turn ignition switch on. Pull sharply on cranking bar. **CAUTION:** Do not push on cranking bar to start engine.

(9) When engine starts, immediately step on clutch, disengage water propeller, then place transmission in neutral. Do not run water propeller for any length of time unless vehicle is in water.

(10) If engine does not start in five or six crankings, reference should be made to "Trouble-Shooting" table in Section XXIV, "Engine," to determine cause of engine failure.

**d. Towing to Start.** Engine may be started by towing vehicle in following manner (engine can be started by towing with vehicle only on land, **not in water**).

(1) Tow chain or line should be of sufficient length to permit maneuverability of both vehicles.

(2) In **towed vehicle**, advance throttle about ½". Pull choke out part way, if not previously used.

(3) Place transmission in fourth (fifth if traction is difficult).

(4) Place transfer case in "high."

(5) Front axle should not be engaged.

(6) Turn on ignition switch.

(7) While being towed for the first 100 feet, disengage clutch.

(8) When towed vehicle speed reaches approximately 10 m.p.h., slowly engage clutch.

(9) Disengage clutch immediately after engine starts.

**e. Cold Weather Starting.** Starting engine in cold weather should not prove difficult, providing various cold weather preparations have been made. Reference should be made to Section VI,

## CONTROLS AND OPERATION

“Lubrication,” for proper lubricants recommended for use in cold temperatures. Precautions and routine maintenance operations itemized in Section XVII, “Cooling System,” and Section XIX, “Starting Motor and Battery,” should be followed.

### f. Warming Up Engine

(1) After engine has been started, engine should be permitted to go through a short “warm-up” period whenever conditions permit. This warm-up period provides the driver an opportunity to observe and check performance of engine before the vehicle is placed under way.

(2) After engine is running smoothly, listen for any unusual noises—sharp knocks, clattering, etc. Report any unusual noises immediately to proper authority.

(3) **Temperature gauge.** Cooling temperature should slowly rise until operating temperature of approximately 165°F. is reached. No prescribed time can be allotted during which temperature should reach normal as atmospheric temperature, length of time engine has been idle, etc., determine this period of “warm-up.” However, if temperature rises sharply above normal up to boiling (212°F.), engine should immediately be stopped, overheating cause determined and corrected.

(4) **Oil Pressure gauge.** When engine first starts, consistency of oil may cause a sharp rise in the oil pressure reading on gauge. As engine warms up, oil pressure should recede slowly to normal. The pressure readings may fluctuate as engine speed increases or decreases. A sudden drop or erratic fluctuation of oil pressure indicates trouble. Engine should be immediately stopped, and condition investigated. **Oil pressure gauge does not indicate quantity of oil in crankcase.**

(5) **Ammeter.** Ammeter on instrument panel indicates charging activity of generating system. Ammeter may or may not show “charge” or plus (+) reading when engine is first started. As a general rule, ammeter will show charge as engine speed is increased, depending upon amount starting motor has drained battery. Ammeter should not show excessive discharge during warm-up period.

## 16. DRIVING VEHICLE ON LAND

a. General controls used in land operation are grouped in driver’s compartment, and their locations and purposes have been explained previously. Succeeding paragraphs briefly outline fundamental requisites for efficient operation of vehicle on land.

b. During operation accomplish procedure outlined in Para 33.

### c. Transfer Case and Front Axle Shift Combinations

(1) Vehicle may be driven by rear axles **only**, or by front and rear axles. Front axle **cannot** be driven independently.

**TRUCK, AMPHIBIAN, 2 1/2 -TON, 6 x 6**

(2) **Rear axles driving only.** Transfer case may be operated in "high" ("H") only. Front axle declutching lever must be in "OUT" position. Transfer case cannot be operated in "low" ("L" on shift plate) when **only** rear axles are driving.

(3) **Front and rear axles driving.** Front axle declutching lever must be in "IN" position. Transfer case cannot be placed into "low" position until front axle lever is placed into "IN" position. After front axle has been engaged, transfer case can be operated in either "high" or "low" position.

(4) **Auxiliary drives.** When using transmission to operate winch or water propeller, front and rear axles may be driven at same time with transfer case levers in positions as previously explained.

**d. Shifting Transmission from Low to High Speeds**

(1) With transfer case in position for axle drive, transmission shift from first to fifth can be accomplished in successive stages as follows:

(a) Depress clutch pedal and release accelerator pedal.

(b) Place transmission shift lever from neutral into first speed position.

(c) Slowly release pressure on clutch pedal and at same time slowly depress accelerator pedal.

(d) After engagement is made, accelerate engine until road speed is increased to approximately that indicated on plate (Fig. 7).

**Note:** Recommended maximum road speeds at various transmission ratios differ with transfer operated in "low" and "high".

(e) After necessary road speed has been obtained in first speed, release accelerator pedal, depress clutch pedal, and place transmission into second speed position.

(f) Release clutch pedal and accelerate to proper road speed, and repeat operations (a) through (e) for third, fourth and fifth speeds in successive stages.

(g) Fourth speed ratio is "direct" and is generally used for normal operations on average roads. Fifth speed is "over-drive" and is generally used to attain maximum "no-load" speed on good roads.

**e. Shifting Transmission from High to Low Speeds**

(1) Transmission should always be shifted into next lower speed before engine starts to labor, or vehicle speed is materially decreased. The need for "down-shifting" is generally apparent when ascending a steep grade or when more power is needed to pull on rough terrain, or in muck or sand. As a precautionary measure, the same ratio used to ascend a grade should be used when descending. "Double-clutch" procedures recommended for shift from high to lower transmission speeds are as follows:

## CONTROLS AND OPERATION

- (a) Depress clutch pedal and release accelerator pedal at same instant.
- (b) Move transmission shift lever into "neutral" ("N").
- (c) Release clutch pedal and accelerate engine momentarily to synchronize gears.
- (d) Depress clutch pedal again and move transmission shift lever into next lower speed. Do not use force on lever, "feel" it into position.
- (e) Release clutch pedal and accelerate engine to desired speed.
- (f) Transmission may be shifted successively into all next lower speeds in same manner.

### f. Transmission Reverse Shift

- (1) Vehicle must first be brought to a dead stop before transmission can be placed into reverse position in following manner:
  - (a) Push clutch pedal down to disengage clutch.
  - (b) Move shift lever as far as possible to the right, then toward front to reverse ("R") position.
  - (c) Release clutch pedal and accelerate engine to desired road speed.

### g. Front Axle Engagement

- (1) Engage front axle only in off-the-road operations, on steep grades, or during hard pulling. Front axle should not be engaged when operating on average roads under normal conditions.
- (2) Front axle can be engaged or disengaged at any vehicle speeds. It can be disengaged only when transfer case is in neutral or high range. Use of clutch is not necessary; however, this use tends to free up operation of lever. Considerable pressure may be necessary to disengage front axle declutching lever; however, this condition does not indicate any trouble.

### h. Transfer Case Shift—High to Low

- (1) This shift should be made while vehicle is still on hard ground and before difficult terrain is encountered. Front axle must be engaged before transfer case can be operated in "low" range.
- (2) Place front axle declutching lever into "IN" position.
- (3) Depress clutch pedal and move transfer case shift lever into "neutral" ("N") position.
- (4) Release clutch pedal and accelerate engine (approximately double that of vehicle speed).
- (5) Depress clutch pedal again and move transfer case shift lever forward into "low" position. Do not use excessive pressure.
- (6) Release clutch and accelerate engine to desired speed.

### i. Transfer Case Shift—Low to High

- (1) This shift may be accomplished regardless of vehicle speed.



**TRUCK, AMPHIBIAN, 2 1/2 -TON, 6 x 6**

(2) Depress clutch pedal and move shift lever into neutral ("N") position.

(3) Release clutch pedal and accelerate engine to synchronize with vehicle speed.

(4) Depress clutch pedal again, then move transfer case shift lever into high ("H") position. Accelerate engine to desired speed.

**j. Steering**

(1) Vehicle is steered in same manner as employed when driving conventional 6 x 6 truck. Rudder linkage is permanently linked to steering gear column; however, rudder action does not interfere with steering on land. Consideration must be taken of vehicle's width and turning diameters when making a turn. Refer to Para. 7 for turning diameter specifications.

**k. Operating on Grades**

(1) **Ascending grades.** Always shift into lower transmission speeds before engine begins to labor. This can be accomplished most successfully when vehicle still has sufficient momentum to permit changing gears without bringing vehicle to a stop. Front axle should be engaged when going up steep grades.

(2) **Descending grades.** Always shift into lower transmission speed. This will permit engine to act as a brake to assist in controlling vehicle speed. Do not permit the vehicle to exceed maximum road speeds in any gear when driving down grades. Excessive engine speeds developed under such conditions are harmful to engine.

(3) **CAUTION:** When shifting to a lower gear at any rate of vehicle speed, make sure that engine speed is synchronized with vehicle speed before clutch is engaged. If clutch is engaged at time engine is operating at lower than relative road speed, drive line parts may be damaged.

**1. Operating on Rough Terrain**

(1) Always engage front axle in off-the-road operation, on steep grades, and during hard pulling in sand, mud or clay.

(2) Do not attempt to "jump" vehicle out of deep sand, mud or clay. Never permit wheels to "dig." When vehicle progress stops, declutch immediately, then reverse slowly for several feet or until another start can be made. Go forward slowly again and declutch immediately before wheels start digging. It may be necessary to repeat this procedure several times to make a track, if possible, in the sand or mud. If progress cannot be made by using this procedure, winch should be used to assist vehicle out of the mud or sand before it becomes mired.

(3) Before attempting to operate in soft sand, reduce pressure of tires to approximately 15 lbs. Tires should be reinflated to recommended pressure before operation on solid ground.

**CONTROLS AND OPERATION****17. STOPPING VEHICLE ON LAND****a. Checking Vehicle Speed**

- (1) Release accelerator pedal.
- (2) Depress brake pedal slowly and evenly until vehicle is checked to desired speed.
- (3) Do not "fan" pedal, but apply even pressure. This will permit engine to assist in checking speed.

**b. Normal Vehicle Stop**

- (1) At the approach of a normal stop, release accelerator pedal, then check vehicle speed by even pressure on brake pedal.
- (2) Depress clutch pedal and move transmission shift lever into neutral ("N").
- (3) Increase pressure on brake pedal to bring vehicle to slow even stop.
- (4) Apply hand brake to park vehicle.
- (5) Place transfer case shift lever into neutral position. Place front axle declutching lever into "out" position.

**c. At the Halt**

- (1) Bring vehicle to normal stop (Para. 17b.).
- (2) Turn ignition switch off.
- (3) Turn all lights off.
- (4) Make inspections as outlined in Para. 34.

**18. STARTING—WATER OPERATION****a. Before Water Operation Preventive Maintenance**

- (1) This procedure is provided, and should be performed in addition to all items shown under "Pre-starting and Before Operation" (Para. 14).
- (2) **Exterior—vehicle on land**
  - (a) Inspect water propeller and see that it is securely mounted on shaft.
  - (b) Remove all foreign matter such as weeds, dirt, etc., from propeller and shaft.
  - (c) Check fit of water propeller rear shafting in rear "out-board" bearing. Report if excessively loose.
  - (d) Lubricate water propeller shaft rear "out-board" bearing, as specified in Section VI, "Lubrication."
  - (e) Inspect rudder and shaft. Rudder should be 3 degrees to the left with front wheels straight ahead. Report looseness of rudder on shaft.
  - (f) Look for loose or missing bolts at all points of attachment of chassis units to hull.
  - (g) Inspect all exterior hull panels for possible damage during land operation which may have resulted in penetration of panels.
  - (h) Make a careful and thorough examination of "bellows"

**TRUCK, AMPHIBIAN, 2½-TON, 6 x 6**

type seals at each end of propeller shaft housings under vehicle. See that clamp rings are securely tightened. Report the slightest evidence of damage or defective bellows. If these parts are damaged or in any way defective, do not allow vehicle to enter water until new parts are obtained and properly installed.

(1) Inspect all breather tubes on axles and pillow block. Report if damaged.

(j) Inspect all drain plugs on bottom and sides of hull. See that these plugs are securely tightened in place.

**(3) Interior—vehicle on land**

(a) Open all hatch covers and thoroughly ventilate interior of hull and bilge compartment.

(b) Inspect bilge compartments. Note and report presence of fuel or oil fumes which may be an indication of leakage from the various lines or units.

(c) Test action of bilge pumps and operation of control valves. Refer to Para. 18c. **Bilge compartment should be thoroughly pumped out and then cleaned of all leaves, paper, sand, dirt, twigs, or other foreign matter.**

(d) Check gear type bilge pump drive belt for proper tension.

(e) Inspect condition of and tension of driving chain at centrifugal type bilge pump.

(f) See that tools and equipment that have been assigned to vehicle are accounted for, in good condition, and securely attached.

(g) Check condition of leather flap valve and plunger in the hand bilge pump. Check condition of emergency buckets.

(h) Inspect hatch gaskets and seals and see that hatches are closed and securely locked.

(i) If rough operation is anticipated, cargo cover should be tightened securely on all sides and cargo secured in place.

(j) Check rudder control cable, pulleys and linkage. Report excessive play in cable.

**(4) Interior—after vehicle enters water**

(a) If conditions permit, inspect water propeller shaft, stuffing box and rudder shaft. If these show any indication of excessive leaking, gland nuts should be tightened. Do not set gland nuts extremely tight as this will cause overheating of stuffing box. A slight seepage of water through stuffing box may be considered normal.

(b) Inspect interior of hull for water leaks. Special attention should be given to hull seams, especially propeller tunnel.

**b. Starting Engine**

(1) Starting engine preparatory to entering water, embraces all instructions outlined in Paras. 15a. through f.

(2) If engine is to be started while vehicle is afloat, instructions as outlined in Para. 15 should be used, with the exception of Para.

## CONTROLS AND OPERATION

15d., "Towing to Start." Engine cannot be started by towing vehicle in water.

c. **Testing Bilge Pumps.** It is a good practice to test operation of bilge pumps before entering water. This is not necessary, however, if water operation is intermittent. If time permits, make following test.

(1) Pour three or four pails full of water into each compartment. Water should be just high enough to cover suction end of bilge pipes. Middle compartment will require more. Vehicle should be placed so that the rear end is lower than front.

(2) Make certain that transfer case shift lever is in neutral position.

(3) Depress clutch pedal, place water propeller shift lever in engaged position (pull up), then place transmission directly into second forward speed.

(4) Release clutch pedal and accelerate engine to about  $\frac{1}{2}$  full throttle. Open one bilge control valve at a time until that particular compartment is dry. **Note: Only one valve should be opened at a time.** Watch bilge discharge from outlet on left side of hull near driver.

(5) After test is made, decelerate engine, depress clutch pedal, place transmission shift lever into neutral, then disengage water propeller.

(6) **CAUTION:** When operating water propeller on land, make certain that no one is near stern of vehicle as a safety precaution. Water propeller is not guarded and will inflict serious injury upon contact. Do not operate water propeller on land for any length of time.

## 19. LAUNCHING—WATER OPERATION

a. As a general rule, vehicle will enter water from land. This necessitates use of driving axles. Other conditions may necessitate entry of vehicle into water from ship's side which may not require use of driving axles.

### b. Preparatory Operations

(1) All hatches, cargo and equipment must be thoroughly secured before entering water. Auxiliary air intake should be closed.

(2) Inspect terrain at point of entry to determine transmission gear ratio required for entering water. If soft sand is present at either point of entry, or is expected at any future landing point, all tires should be deflated to approximately 15 lbs.

(3) Engine should be thoroughly warmed up, and oil, gas and water supply checked and replenished, if necessary.

(4) If steep water entry, rough sea, or heavy load is anticipated, raise surf coaming at bow of vehicle.



**TRUCK, AMPHIBIAN, 2 1/2-TON, 6 x 6****c. Entry From Land**

(1) Select, if possible, a gradual slope into water. If necessary to make entry over rough, mucky, or rocky terrain, take into consideration the vehicle's approach and departure angles and ground clearance. (Refer to Para. 7.)

(2) For normal water entry, vehicle enters with only wheels driving as follows:

(a) Place front axle declutching lever into engaged position, transmission shift lever into second speed, and transfer case shift lever into high range.

(3) Accelerate as required when going into water and continue at required speed until vehicle is afloat.

(4) Immediately after vehicle is afloat, accomplish following operations.

(a) Decelerate engine.

(b) Depress clutch pedal.

(c) Step on foot brake pedal **hard** to stop wheels from rotating.

(d) Place transmission shift lever directly into second forward speed position.

(e) Place water propeller shift lever into engaged position (pull up).

(f) Release clutch pedal and accelerate engine rapidly at the same time to desired speed.

(g) If vehicle is well out into water and there seems to be no necessity for use of driving wheels, step on clutch momentarily and place transfer case shift lever into neutral position. It is not necessary to disengage front axle, as front axle drive will be needed when landing vehicle.

(h) **Note:** Operation from (a) through (g) should be accomplished in order stated and as quickly as possible. Do not force any of the shift levers into mesh with extreme pressure but rather "feel" them into engagement.

(i) After water propeller is engaged, best operation is full throttle with transmission in second forward speed.

(5) If entering into a heavy surf, strong current, or when maximum speed is desired, water propeller may be operated, as well as the driving wheels, when vehicle enters water, as follows:

(a) Stop vehicle with brakes before attempting to make water propeller shift.

(b) Depress clutch pedal and place water propeller into engaged position, transmission into second speed, front axle declutching lever engaged position, and transfer case into high.

**d. Starting From Ship Side Or Pier**

(1) If vehicle is to be swung from a ship for entry to water, make

## CONTROLS AND OPERATION

certain that engine is warmed up and operating as vehicle is placed into water. After vehicle has been launched and mooring lines cast off, water propeller should be immediately engaged with transmission in second speed.

(2) In pulling away from ship's side or pier, push front of vehicle outward and avoid turning front away sharply. If sharp turn away from pier or ship is made, back of vehicle will tend to swerve toward pier or ship and cause possible damage. If possible when leaving the side of a vessel or pier, push vehicle well out into water before starting water propeller.

(3) Always use fenders (bumpers) at the side of vehicle when alongside of a vessel or a pier.

### 20. OPERATION IN WATER

a. **General.** No set rules can be established for operating or driving vehicle in water. Various conditions require different operation procedures. A thorough knowledge of steering in water, water propeller drive system, and bilge pump system, together with knowledge of various emergency expedients, is essential. Recommendations and instructions given in succeeding sub-paragraphs have been compiled from actual experience. These instructions should be thoroughly studied and understood. The instructions include only operation under average conditions. Reference should be made to Para. 23, "Emergency Expedients" for any out-of-the-ordinary conditions which may be encountered.

#### b. Forward Steering

(1) Rudder of vehicle by which it is steered in water is mounted near stern. This rudder is operated or turned by cables attached to conventional steering gear column. As rudder is attached near stern, normal forward steering is obtained by forcing stern the opposite way from desired forward turn. **Driver, however, turns steering wheel in a conventional automotive manner.**

(2) Water steering requires more turning of steering wheel than is generally used when operating on land. While rudder responds quickly to motion of steering wheel, the vehicle's response is not as rapid as experienced on land. It is therefore necessary to anticipate any turns when operating in water. This is particularly necessary when steering in rough water.

(3) When holding a straight course in rough water, driver must try to anticipate the action of waves by turning steering wheel ahead of time. In this way, sheering or swerving from the desired course can be minimized. If vehicle is allowed to start swerving, it will take considerable effort to bring it back to its course.

(4) Bear in mind that under extremely adverse sea conditions, reduction of speed will reduce trouble from waves. When landing be-

**TRUCK, AMPHIBIAN, 2½-TON, 6 x 6**

fore heavy surf, steer absolutely square in front of waves and reduce speed as wave crest approaches stern.

(5) When operating at less than top speed, bear in mind that enough vehicle speed should be maintained to provide steering way. If necessary to reduce speed of vehicle to point where rudder will not steer vehicle, occasional short spurts of engine should be made to drive enough water against rudder to provide desired steering. When approaching shore in rough water, make all speed possible between waves and also as soon as driving wheels touch bottom.

(6) When steering close to an object in water, remember that stern has a tendency to swerve toward an object when vehicle is steered away from it.

**c. Steering in Reverse**

(1) Reverse steering in water under average conditions, requires approximately same technique as used when reversing "land" vehicle. When operating in strong winds and rough water, however, reverse steering will be uncertain. The most satisfactory reverse steering can be secured by forcing stern in desired direction while still driving ahead. This starts stern of vehicle turning and as propeller is placed into reverse, this turn will generally be maintained.

(2) Always place all wheels in driving position (high range) as they will materially assist in power and steering of vehicle in reverse.

**d. Forward Driving.** Water propeller can be engaged in second speed—full throttle, third speed—full throttle, or third speed— $\frac{1}{4}$  throttle. Maximum speed on water is attained in second speed—full throttle (See Marine Propeller instruction plate—Fig. 6). When third speed is used either at full throttle or  $\frac{1}{4}$  throttle, speed on water is reduced, however, fuel mileage is increased as itemized on instruction plate, Fig. 6. Third speed— $\frac{1}{4}$  throttle is obtained in following manner:

(1) Disengage water propeller and engage rear wheels high range. Set hand throttle until speedometer registers 12 m.p.h. (rear wheels operating and turning freely in water).

(2) With hand throttle remaining in position for 12 m.p.h., rear wheel operation in water, disengage rear wheels (transfer case into neutral), then engage water propeller and operate at same throttle setting.

**e. Disengaging Or Engaging Water Propeller.** If necessary to disengage or engage water propeller while operating in water, following operations should be accomplished:

(1) Depress clutch pedal and decelerate engine.

(2) Push down on water propeller shift lever to disengage or pull up to engage and release clutch.

**f. Reversing.** It is impossible to make a quick stop with vehicle in water. Bear in mind that vehicle brakes have no effect when afloat. Reversing propeller is the only method of stopping in water. When necessary to reverse in water, water propeller and driving wheels (high range) should be reversed. Driver must foresee a stop

## CONTROLS AND OPERATION

or a condition where reversing is necessary. When such conditions are apparent, reverse vehicle in following manner:

- (1) Depress clutch pedal and decelerate engine.
- (2) Make sure that front axle declutching lever is into "IN" position, then place transfer case into "high" range.
- (3) While holding clutch pedal in depressed position, place transmission lever into reverse.
- (4) Release clutch pedal and accelerate engine to full throttle (governed speed).
- (5) After vehicle speed is checked to point of control, reduce speed as necessary to maneuver properly.

### g. Pumping Bilges

(1) As explained in Para. 13m., "Bilge Pump Control," the mechanical bilge pumping system consists of two bilge pumps operated by water propeller shafting. These pumps operate only when water propeller is in engaged position.

(2) As the pumping of various compartments in hull depends upon the position of shut-off valves, it is important that attention be given to alternate pumping of all compartments while operating in water. **Remember:** All valves must be closed except the one which controls compartment to be pumped. It is a practical plan to alternate control valves every few minutes during operation in calm water to permit clearing of bilge compartments of any water which may seep in from normal operation. Under average operating conditions, the valve controlling pumping of center compartment should be left open for longer periods of time.

(3) When operating in rough water, note where vehicle is "shipping" water and operate bilge pump control valves accordingly. Reference should be made to Para. 23, "Emergency Expedients" for pumping of bilges under emergency conditions.

## 21. LANDING FROM WATER

a. A general rule to remember when landing, is that **all driving wheels** should be operating **before** land is approached. A gradual slope from water should be selected, if possible. Also avoid, if possible, landing through mud, clay, or thick weed patches. Weeds may tend to entangle water propeller.

### b. Approaching Land

(1) Various water and wind conditions must be taken into consideration when approaching land. Under normal conditions where swift current, wind and rough water are not present, approach should be made in following manner:

(a) When approaching land, the driving wheels should be engaged a considerable distance before reaching shallow water. (This is particularly important when approaching land in rough water.) Place driving wheels into engagement by depressing clutch, placing front axle declutching lever into "in" position, and placing transfer case into desired (generally "low") range.

(b) Continue to operate full throttle with propeller and wheels until wheels are grounded. After wheels are grounded and vehicle is



**TRUCK, AMPHIBIAN, 2 1/2-TON, 6 x 6**

well out of water, **water propeller must** be disengaged, and transmission and transfer case shift lever placed into suitable driving positions.

**c. Approach In Swift Current.** If landing must be made in a swift current, start making approach well above point of departure. Come in toward shore at approximately a 45 degree angle. After front wheels ground, stern of vehicle will tend to swing down with the current. In extreme cases, it may be necessary to come in at a closer angle than 45 degrees.

**d. After Landing**

(1) If conditions permit after landing, bilges should be completely pumped out as explained in Para. 18c., "Testing Bilge Pumps." A large quantity of water inside vehicle adds considerably to weight and should be pumped out before operating on rough terrain. Also, when conditions permit, accomplish the operations itemized in Section V, "Preventive Maintenance and Inspection" pertaining to "after-water operation."

**22. ANCHORING, MOORING AND TOWING****a. Anchoring**

(1) Anchor, stowed in bow compartment, is used with interconnecting winch cable or other lines to hold vehicle to bottom. When anchor bottoms, flukes or points of anchor, fasten to bottom, thus holding vehicle stationary.

(2) Do not fasten anchor shackle to winch cable hook. Remove anchor shackle bolt, and fasten shackle into chain ring. Install bolt and tighten. Remember the anchor **must** be fastened securely to line or cable **before** dropping it overboard.

(3) As anchoring is generally necessary under emergency conditions, all available line and cable should be connected to anchor, as the longest line will provide safest anchoring.

(4) Under emergency conditions, any bulky, heavy object can be used as an anchor, such as spare tire and wheel, etc.

(5) If unable to bottom anchor in extremely deep water, additional bulky object can be let down into the water. The tarpaulin, with enough ballast in it to keep it under water, can be used. This type of "sea anchor" will reduce drifting.

**b. Mooring.** In extremely rough weather, avoid mooring alongside a dock or vessel; however, if necessary to moor, long mooring lines should be used to reduce strain. Bow or front of vehicle should head into current unless wind is stronger than current, in which case head bow into wind. Fig. 15 illustrates method of mooring vehicle to dock with the use of breast lines at front and rear, and spring lines from front and rear of vehicle to dock as shown. These lines should hold vehicle without pulling against dock. It is necessary however, to

## CONTROLS AND OPERATION

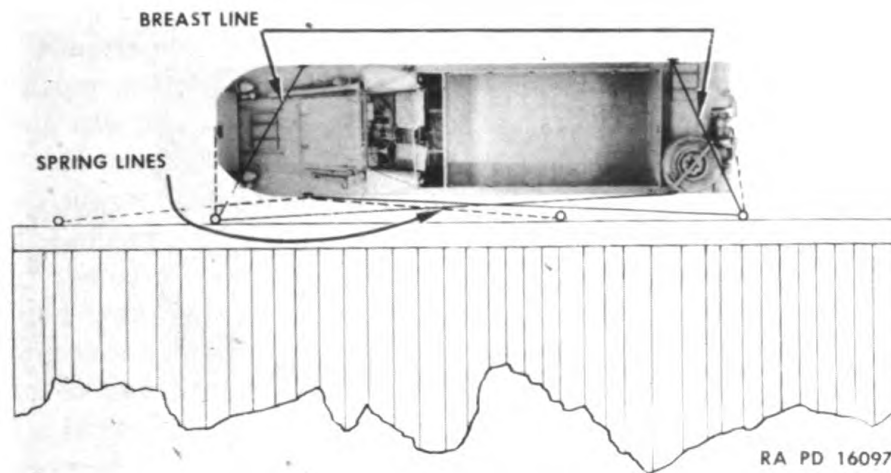

**Figure 15—Method of Mooring Vehicle**

take into consideration rise and fall of tide when mooring. Line should be lengthened or shortened as necessary to meet conditions.

**c. Towing**

(1) There are two methods which are commonly used when towing in water; towed vehicle at stern and towed vehicle alongside of towing unit. **Important: Always drop tow before attempting to land. Winch towed vehicle out of water [see (4) (c)].**

(2) **Towing Attachments.** For towing purposes in the water, each vehicle is equipped with a tow hook anchor shackle at the front (just under bow winch cable guide), pintle hook at rear (just below winch), and two lifting eyes on right and left side.

(3) **Towing vehicle at stern (Fig. 16).** Tow cable should be attached securely to rear pintle hook on towing vehicle or direct from winch, and to bow tow hook anchor shackle on towed vehicle. Tow cable should be approximately 100 feet long to permit maneuverability of both vehicles. When operating in rough water, the longest possible tow line should be used. When approaching bank, towed vehicle should not be too close to towing unit. Slack tow cable so that towing vehicle can make landing without added load, then land other vehicle with winch. Steer towed vehicle directly behind front vehicle.

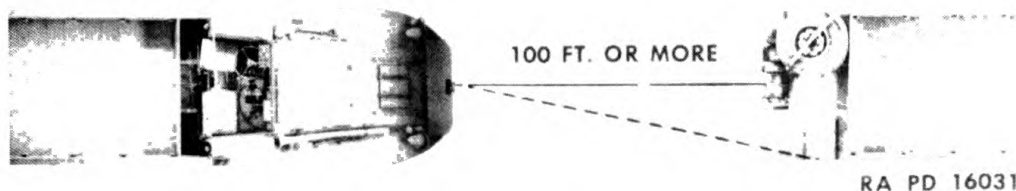

**Figure 16—Method of Towing at Stern**

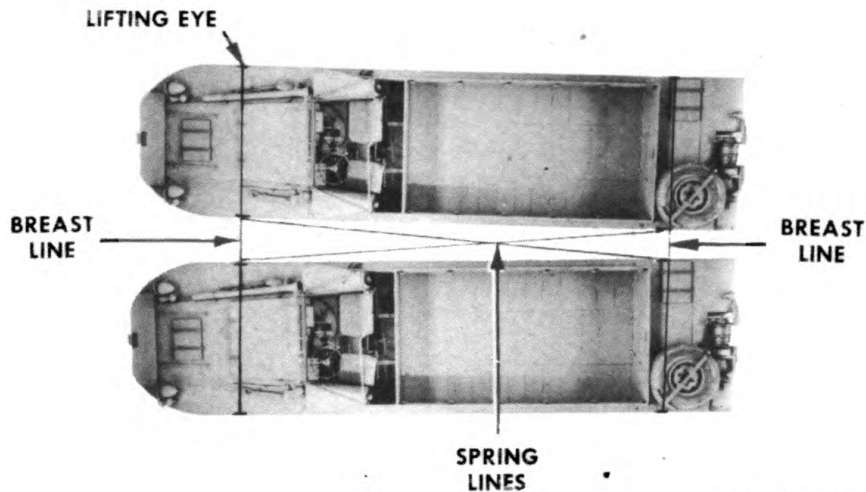

**TRUCK, AMPHIBIAN, 2½-TON, 6 x 6**

RA PD 16081

**Figure 17—Method of Towing Alongside**

(4) **Towing vehicle alongside (Fig. 17).** In smooth water, when considerable maneuvering is necessary, it is advisable to tow another unit from alongside. Ample fenders (bumpers) should be used between the two units. The two units should be moored together as follows:

(a) Illustration in Fig. 17 shows use of “breast” and “spring” lines when towing or maneuvering alongside. Breast lines at front and rear should extend from outside lifting eye of one unit to the outside lifting eye of other unit. Spring lines should extend from inside, front lifting eye of one unit to the inside rear lifting eye of another.

(b) The two units should not be too close together. Distance between the two units should vary between 1½ feet to 4 feet. The greater distance to be used if any waves might be encountered. The bow ends should be approximately one foot farther apart than the sterns, so that action of water will tend to keep units safely apart.

(c) All towing lines and cables should be thoroughly wrapped with canvas or rags where they pass through cable guide, anchor shackles, and pintle hooks or where rubbing occurs. **Extreme care should be taken to prevent lines from becoming entangled in water propeller or rudder.**

**23. EMERGENCY EXPEDIENTS**

a. **General.** Conditions which require emergency measures may be encountered in water operations. These conditions, together with probable expedients, are itemized in succeeding paragraphs and should be thoroughly studied by operating crew. The crew should bear in mind, that emergency expedients should be applied as simultaneously as possible, rather than attempting to accomplish them

## CONTROLS AND OPERATION

one at a time. In emergencies, every known expedient should be accomplished quickly.

**b. Emergency Steering.** If steering cable breaks or rudder jams, preventing operation of rudder, one of three methods of emergency steering can be used.

(1) If only driver is in vehicle, stop water propeller, open stern compartment hatch, and secure rudder tiller so that rudder is in straight ahead position. After rudder is secured, place all wheels into "high" transfer case range, water propeller shaft lever in "in" position, and transmission in second speed. Operate at full throttle and steering can be obtained with front wheels. Steering with wheels will not be as responsive as with rudder.

(2) If two are in crew, center wheels in straight-ahead position and have second member of crew steer vehicle with tiller in stern compartment.

(3) If rudder is damaged and wedged at an angle, making it impossible to hold course, rudder shaft must be disconnected in stern compartment and rudder dropped through bottom of vehicle. Removal of rudder is explained in Section XXXIII, "Steering System," Para. 259. After rudder has been removed and hole plugged, vehicle can be steered with front wheels. All wheels high range and water propeller second speed.

**c. Water Propeller Fails.** If water propeller is rendered inoperative, some progress can be made by using all wheels in "high" transfer case range, and third transmission speed full throttle. Water propeller should be disengaged. Under extremely favorable conditions, speed will be approximately 2 m.p.h.

**d. Power Fails.** If engine fails and vehicle is near shore, shovels and tarpaulin bows, floor boards, etc. will make useful paddles. If impossible to paddle against off-shore wind or current, anchor vehicle until assistance arrives.

**e. Pumping Bilge**

(1) The two mechanical bilge pumps will service bilges under all normal conditions. If for any reason water propeller cannot be operated or flooding condition cannot be reduced with mechanical bilge pumps alone, use hand bilge pump and, if necessary, buckets, helmets, and any other articles suitable for bailing. To prime hand pump, hold overboard so that water will be forced up through bottom.

(2) If necessary to use mechanical bilge pumps without water propeller operating (due to damaged propeller or if serving as a stationary pontoon), disconnect water propeller shafting to rear of pump drives.

**f. Hull Penetrations**

(1) Penetrations above water line should be plugged with wooden



**TRUCK, AMPHIBIAN, 2 1/2-TON, 6 x 6**

plugs or rags, etc. Start plug from outside and pull in through hole.

(2) Penetrations below water line may also be plugged with wooden plugs, or rags, etc. Where possible, start plugs or rags through holes from outside of hull. Pressure of water will assist in keeping plug in place. If penetration is just below water line, shifting cargo to opposite side or end may bring hole above water line.

**g. Rough Weather**

(1) When operating in rough weather in water, action of vehicle is sometimes unpredictable. Various hints in the succeeding subparagraphs should be studied and applied when necessary as conditions arise.

(2) In strong winds and rough water, steering in reverse will be uncertain. When reversing, stern can be best controlled by giving vehicle occasional forward spurts to force the stern in the desired direction.

(3) When vehicle is completely covered with cargo tarpaulin and entrance flaps are closed, engine must receive its air through auxiliary air intake. However, in rough water, this can be opened only between waves. Cargo entrance flap should be kept open on the side away from wind. If it is necessary to go through heavy surf, all openings can be kept tight a few minutes, but should be opened as soon as possible to cool engine.

(4) When running through a heavy surf, it is particularly important that back and sides of cargo cover be absolutely tight.

(5) All cargo should be thoroughly secured before operation in rough water.

(6) In extremely rough sea from ahead, shift movable weights toward stern to help keep bow above waves, and to reduce tendency for propeller to jump out.

**24. WINCH OPERATION—LAND AND WATER**

**a.** Knowledge of winch operation, conditions under which winch may be used, and rigging methods are important when operating this vehicle in amphibious service. Winch, rear mounted, is used to assist vehicle and other units under many varied conditions. Reference should also be made to Section XXXVIII, "Winch" for mechanical maintenance instructions on winch mechanism.

**b. Operation Controls**

(1) **Power take-off lever.** Winch is driven by power take-off at left side of transmission. Engagement for pulling or hoisting is through power take-off shift lever located in cab (Fig. 10). This lever has three operating positions; low, reverse, and high with neutral positions in between. Hinge locking plate, attached to floor board beside lever, provides positive means of locking lever into neutral position (between reverse and low). This arrangement will prevent

## CONTROLS AND OPERATION

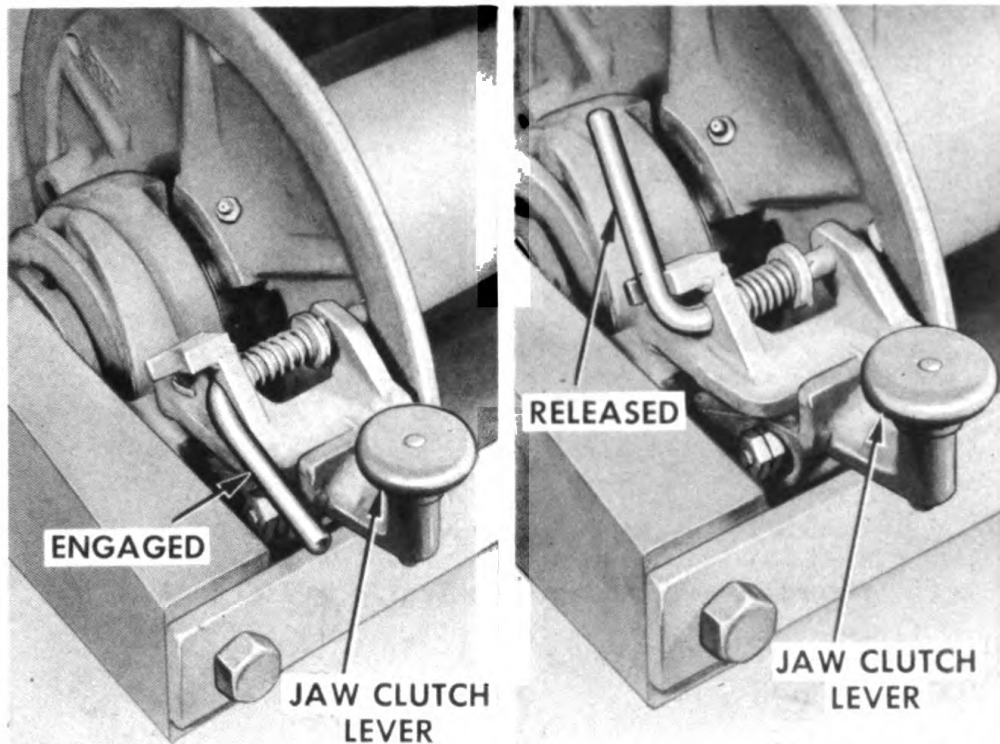

RA PD 16114

**Figure 18—Winch Sliding Jaw Clutch Lever and Drum Flange Lock**

accidental engagement of power take-off. An automatic safety brake on worm shaft will sustain load while lever is being shifted into various operating positions.

(2) **Sliding jaw clutch.** Sliding jaw clutch at winch mechanism. Fig. 18, is used to engage and disengage winch drum. When sliding jaw clutch handle is placed into disengaged position, winch cable can be pulled out by hand. Sliding jaw clutch must be engaged to permit operation of winch under power.

(3) **Drum flange lock.** The drum flange lock (Fig. 18) is mount-

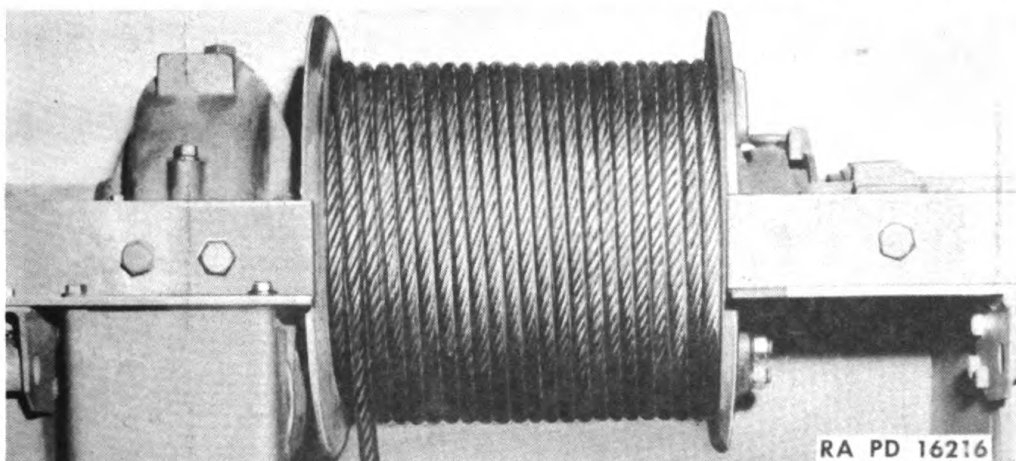

**Figure 19—Cable Should Be Wound Evenly on Drum**

CONTROLS AND OPERATION

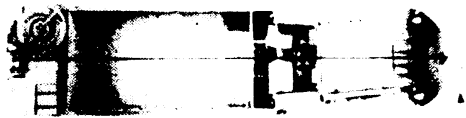

6 TO 70 FEET

SEE FIGURE 30

▶ SEE FIGURE 34

RA PD 16035

**Figure 23—Winching from Front, 6 to 70 Feet**



100 TO 120 FEET

SEE FIGURE 31

▶ SEE FIGURE 33

RA PD 16036

**Figure 24—Winching from Front, 100 to 120 Feet**

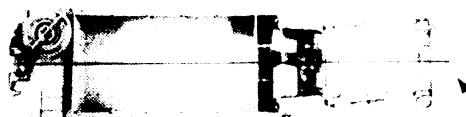

200 TO 250 FEET

SEE FIGURE 28, 29 OR 40

▶ SEE FIGURE 32

RA PD 16037

**Figure 25—Winching from Front, 200 to 250 Feet**



**TRUCK, AMPHIBIAN, 2 1/2-TON, 6 x 6**

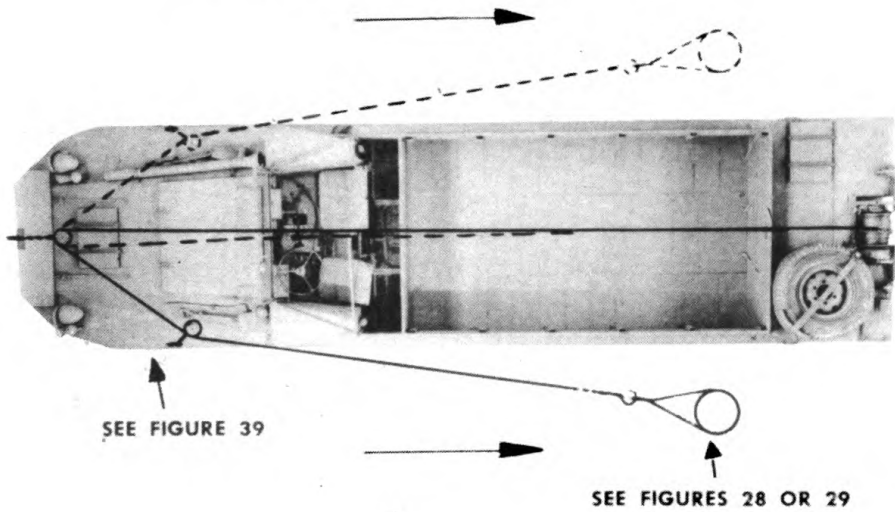

RA PD 16038

**Figure 26—Short Hitch, Winching from Front**

ed to sliding jaw clutch handle mechanism. This lock, which is spring loaded, engages one of several holes in the winch drum when sliding jaw clutch is in released position. This mechanism prevents cable from unwinding from drum while vehicle is under way. Flange lock handle must be raised up and disengaged from the drum before sliding jaw clutch can be engaged with drum. Disengaged position of flange lock handle is shown in Fig. 18.

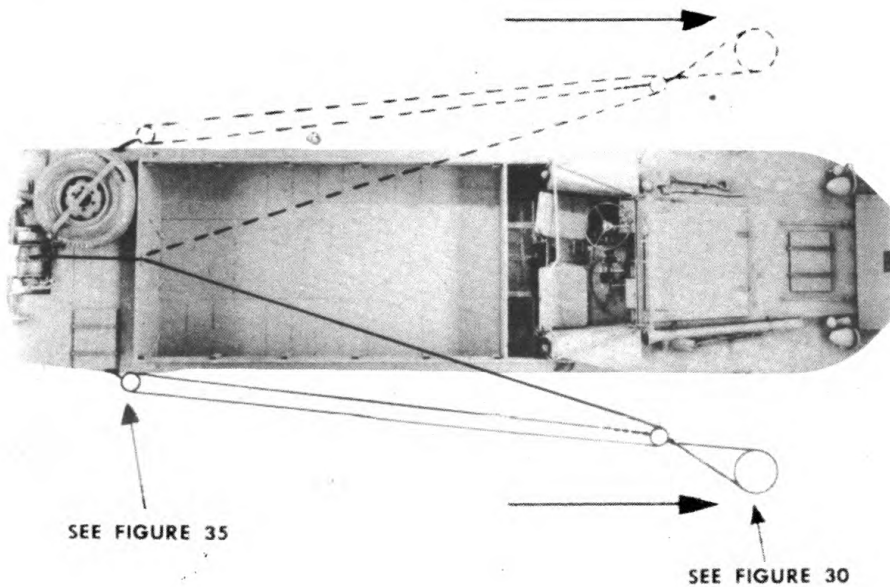

RA PD 16039

**Figure 27—Short Hitch, Winching from Rear**



**CONTROLS AND OPERATION**



RA PD 16064

**Figure 28—Emergency Hitch Around Tree with Cable as used in Figures 22 and 25**

**c. Operating Cycle**

(1) **To hook on.** Place sliding jaw clutch lever into relaxed position. Pull up and release drum flange lock handle. Pull off enough cable to make hook-up.



RA PD 16065

**Figure 29—Correct Hitch Around Tree with Chain as used in Figures 22, 25 and 26**



**TRUCK, AMPHIBIAN, 2 1/2-TON, 6 x 6**

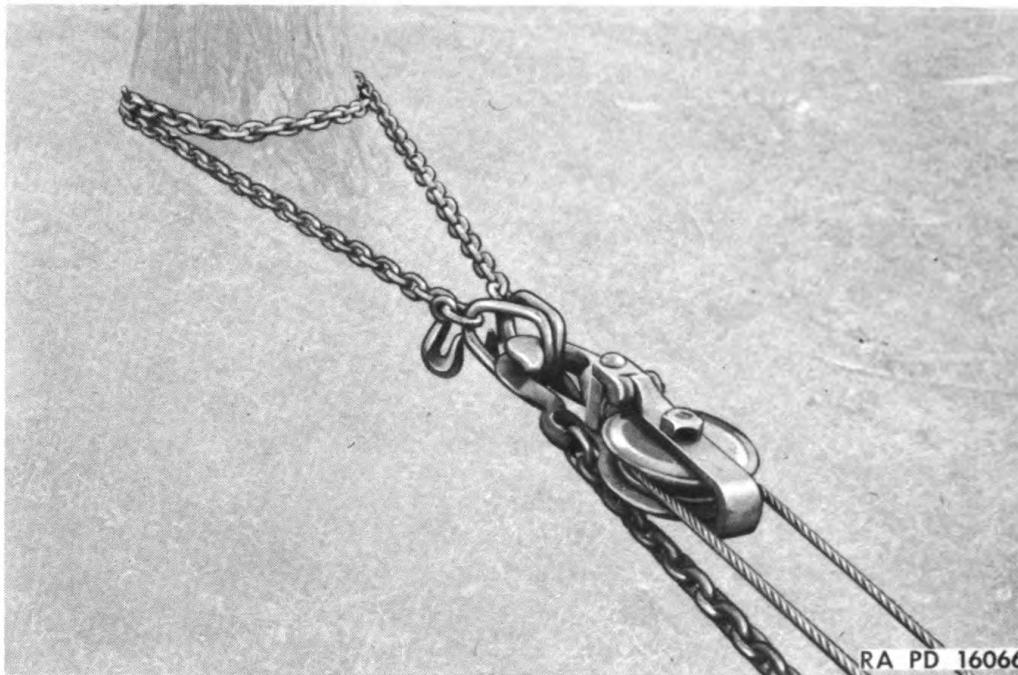

**Figure 30—Rigging at Tree with Snatch Block and Chain as used in Figures 20, 23 and 27**

(2) **To pull (wind in).** Place sliding jaw clutch lever into engaged position, depress engine clutch pedal, shift power take-off lever into low position if load is heavy, or high position to take slack or if load is extremely light, then release engine clutch pedal.

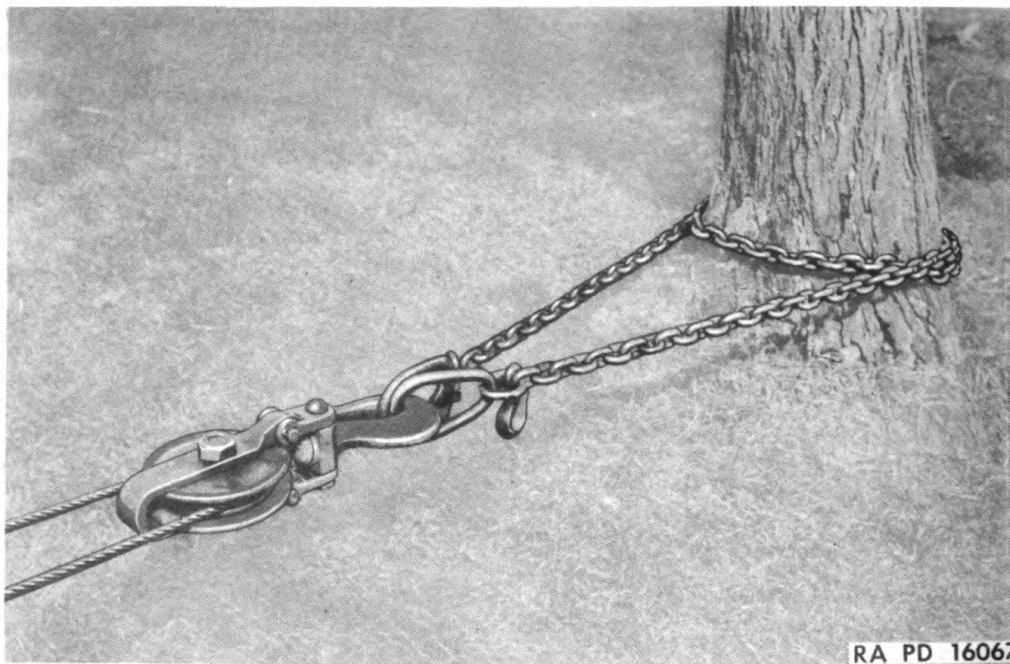

**Figure 31—Rigging at Tree with Snatch Block as used in Figures 21 and 24**

## CONTROLS AND OPERATION

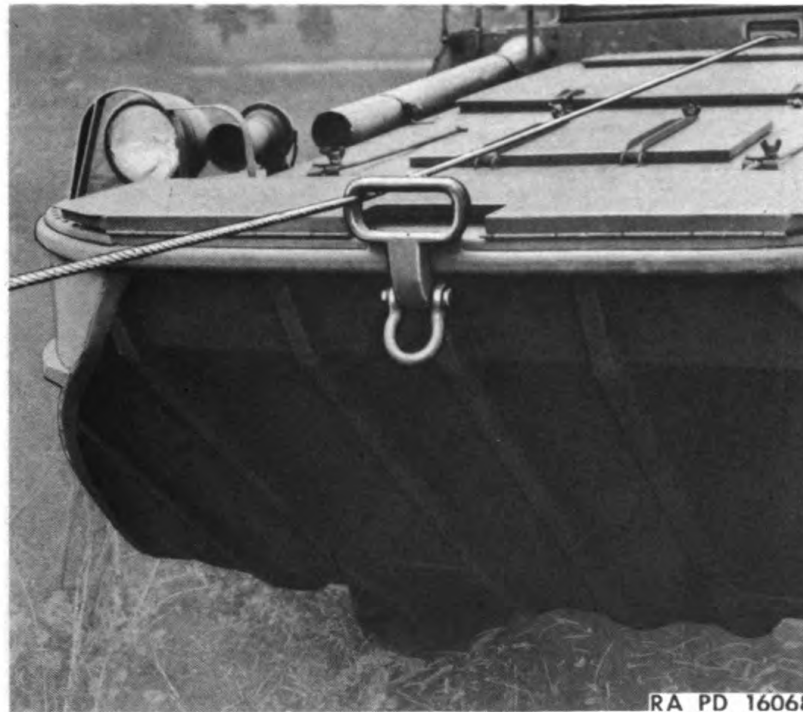

**Figure 32—Winch Rigging as used in Figure 25**

(3) **To stop.** Depress engine clutch pedal and shift take-off lever into neutral position.

(4) **To lower (pay out).** Depress engine clutch pedal and shift power take-off lever into reverse.

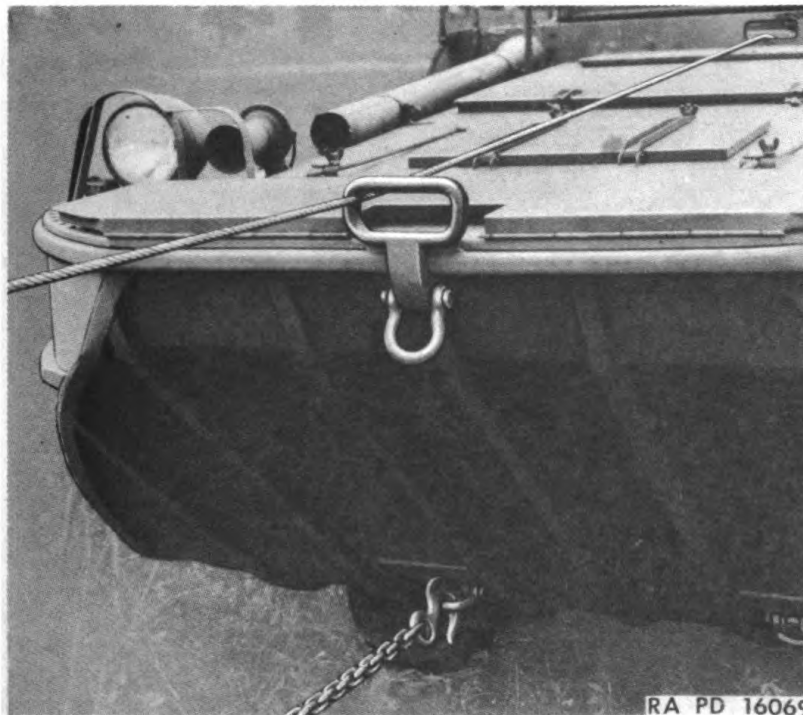

**Figure 33—Winch Rigging as used in Figure 24**



**TRUCK, AMPHIBIAN, 2½-TON, 6 x 6**

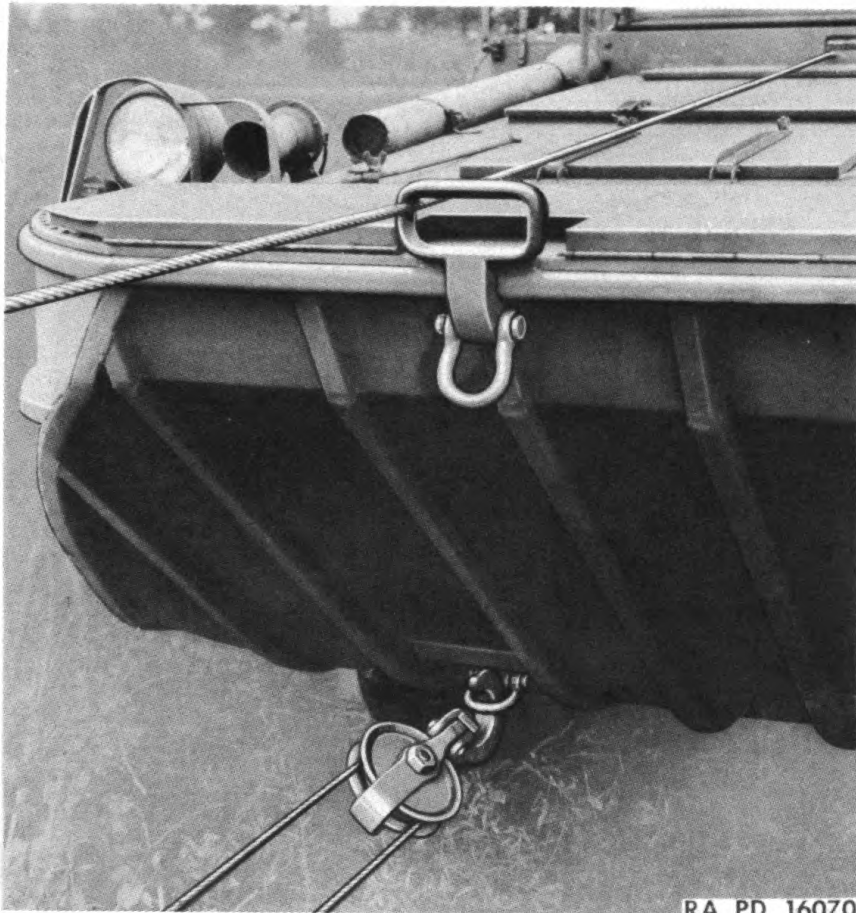

RA PD 16070

**Figure 34—Winch Rigging as used in Figure 23**

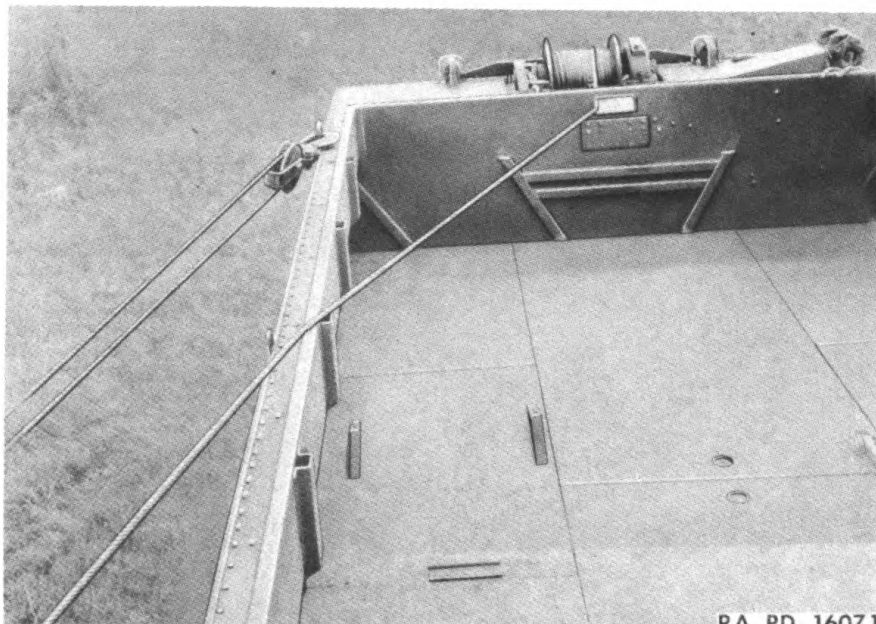

RA PD 16071

**Figure 35—Winch Rigging as used in Figure 27**



**CONTROLS AND OPERATION**

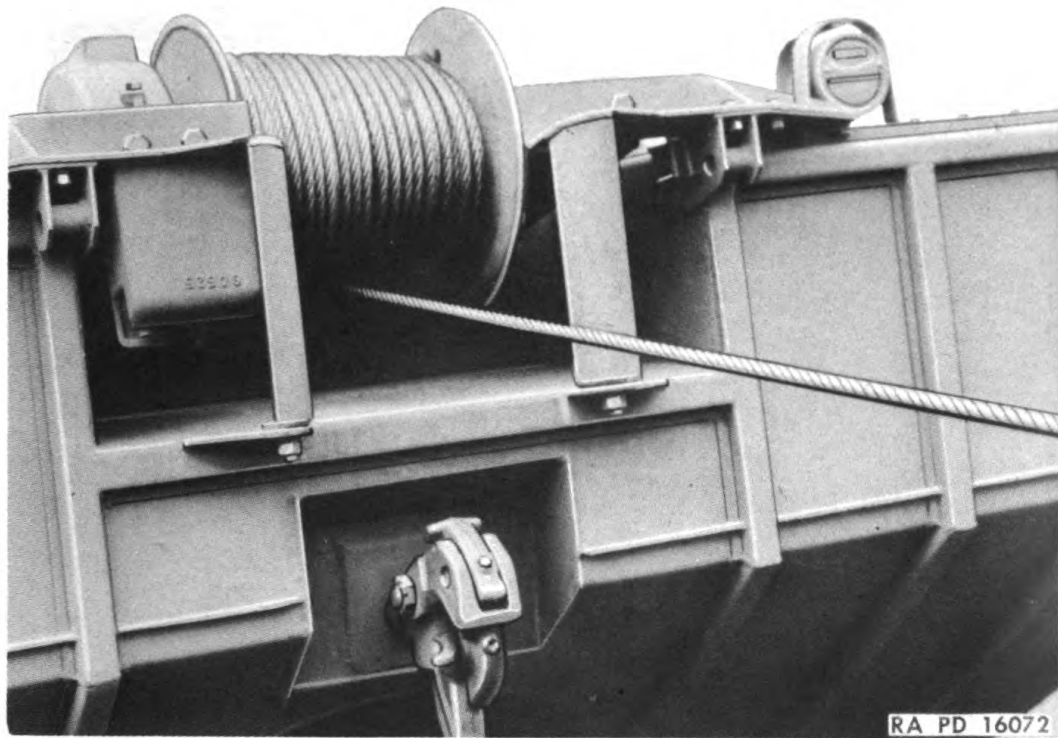

**Figure 36—Winch Rigging as used in Figure 22**

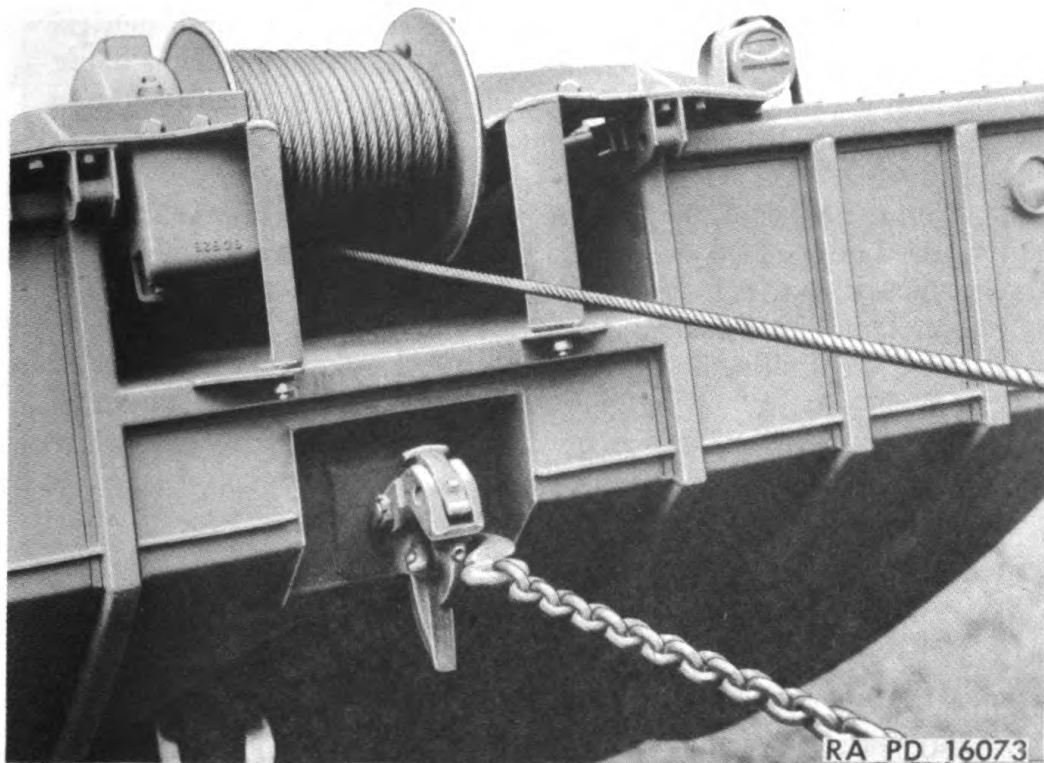

**Figure 37—Winch Rigging as used in Figure 21**

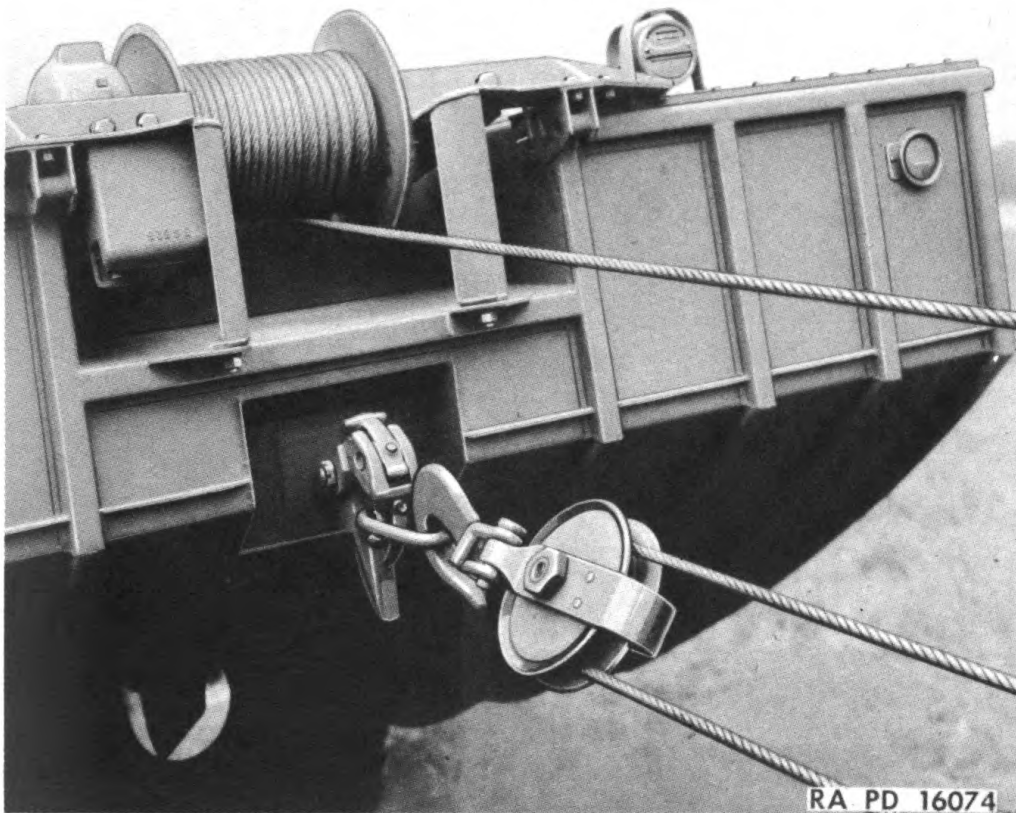
**TRUCK, AMPHIBIAN, 2½-TON, 6 x 6****Figure 38—Winch Rigging as used in Figure 20**

(5) **Winch not in use.** Power take-off lever must be in neutral position. Hinge locking plate must be in place to prevent lever being thrown into gear accidentally. Winch sliding jaw clutch should be in disengaged position with drum flange lock in engaged position (handle down).

**d. Pulling Speeds.** Winch pulling speeds are based on maximum engine speed of 1000 r.p.m. which should not be exceeded when using winch. Operating winch faster than this engine speed will result in excessive strains and probable failure of parts.

**e. Wind In (Pulling) Speed Shift.**

(1) The "wind in" or pulling speeds (low and high) are obtained by moving power take-off shift lever to engage proper gearing. Use high speed position for handling light loads or lower speed position for heavy loads. Do not race engine when winching, especially when winch is pulling a light load or when winding in cable with no load.

(2) **Important.** When winching this vehicle, always assist winch with wheels as cable becomes tight, using transmission in first (or reverse for backpulls) and transfer case auxiliary range in "low."

**f. Pay Out (Lowering) Speed Shift.** Two methods may be used for "paying out" winch cable.



**CONTROLS AND OPERATION**

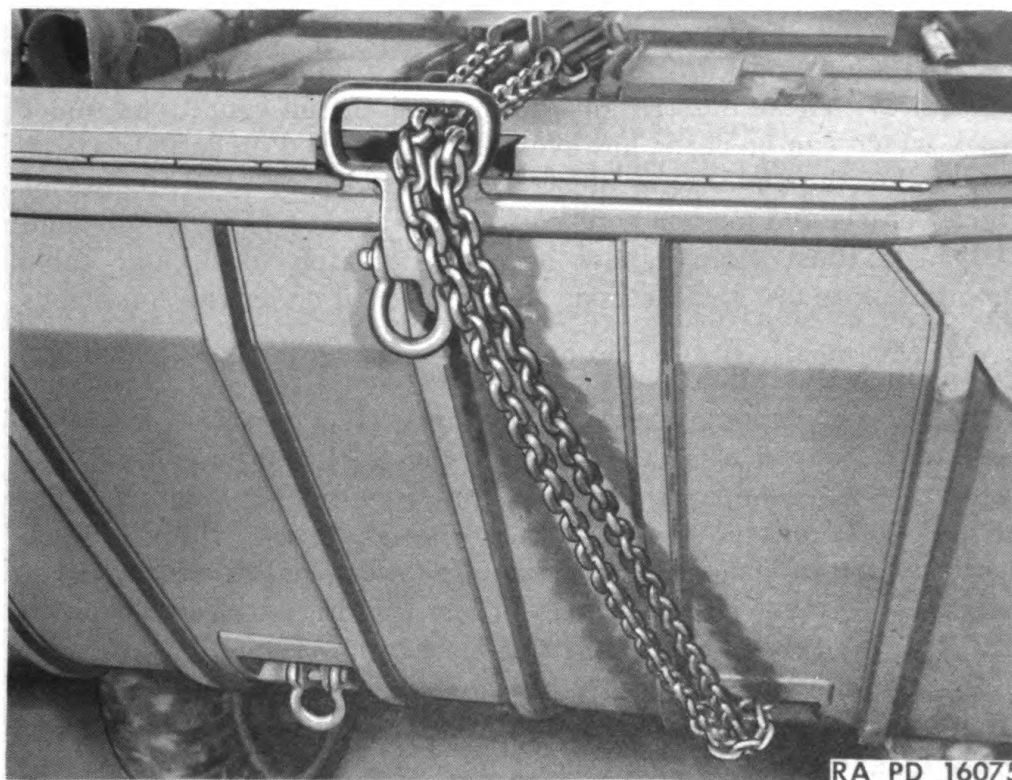
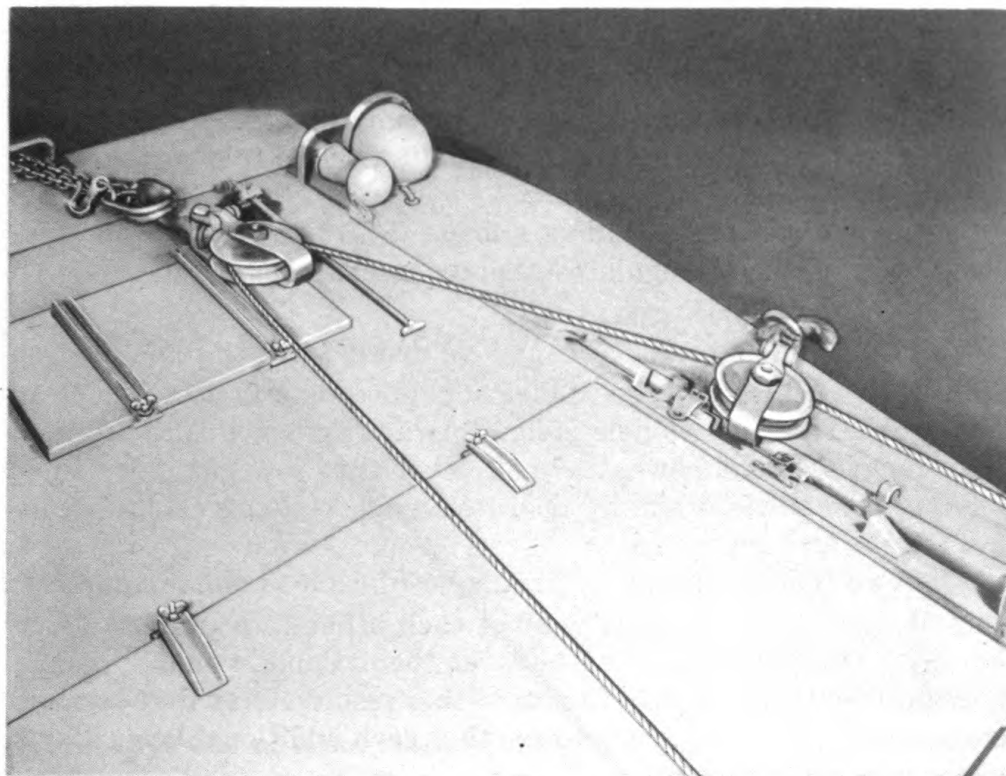

RA PD 16075

**Figure 39—Winch Rigging as used in Figure 26**

**TRUCK, AMPHIBIAN, 2½-TON, 6 x 6**

(1) **Not under load.** Place sliding jaw clutch into disengaged position with drum flange lock lever raised up in locked disengaged position. Pay out speed depends upon the amount of pull applied to rope. Drag brake on drum flange will automatically keep drum from spinning and cable unwinding too rapidly. Care should be taken not to kink cable.

(2) **When winch is handling a load.** Shift power take-off lever into reverse gear and regulate speed by accelerating engine.

**g. Winding Cable**

(1) Cable should not be wound on drum without some load on cable. If no load is available, cable should be properly attached to an anchor or a tree, and vehicle pulled forward by winch. (Sliding jaw clutch engaged and power take-off lever into low.) A very light pressure on vehicle brake by operator while winding cable will insure a tight and neat wind.

(2) **Caution.** Winding on first layer of cable is most important. Coils of cable must be tight against each other to prevent coils on next layer from pressing down between them. Cable should be wound on drum evenly and slowly to obtain this result. After first layer is wound evenly, it is necessary to see that each additional layer starts back across drum properly.

**h. Rigging Under Various Conditions.** Several examples of winch rigging under various conditions are illustrated in Figs. 20 through 27. These illustrations do not present all conditions under which winch can be used; however, they are based on actual experience under the conditions illustrated. Methods of attachments of winch vehicle and anchor points are illustrated in Figs. 28 through 40. These illustrations show necessary snatch block and cable combination to use and methods should be used under the conditions shown.

**i. Winch Operation Hints and Precautions**

(1) **Use of driving wheels with winch.** If a vehicle is assisting itself with its own winch, all driving wheels should be utilized. Always start wheels operating the instant winch cable starts to take the load. In other words, do not start driving wheels if there is slack in winch cable. When driving wheels are used to assist winch operation, make certain that winch is in low (pulling), transmission in 1st speed (or reverse) and transfer case in low range.

(2) **Sand anchor.** Use of sand anchor is illustrated in Fig. 40. After winch cable attachment has been made to anchor shackle, points of anchor should be guided into sand or ground as shown, holding it steady as winch takes up slack and drives flukes or points of anchor into sand. If driver is operating alone, anchor points can be started into the ground before driver starts to operate winch. If sand



## CONTROLS AND OPERATION



RA PD 16076

**Figure 40—Use of Sand Anchor, May be used in Manner Shown in Figures 22 and 25**

or ground is soft, anchor can be thrown out and will dig into ground, in many instances, when load is put on winch cable.

(3) Bear in mind that winch will be more powerful with all the cable off of the drum before it starts to operate. Under many conditions, this is not possible. However, the best procedure to use is to pay out as much cable from the winch drum as possible before starting the pull.

(4) Cable guides in the hull permit winch cable to be pulled straight into winch drum when winching from the front. However, when winching from the rear, this straight pull cannot be obtained under some conditions. If it is necessary to pull at an angle from the rear, all free cable should be guided evenly onto the drum as the winch winds in.

**Section IV**  
**ARMAMENT**

	<b>Paragraph</b>
General .....	25
Gun mount .....	26
Gun mount supports .....	27

**25. GENERAL**

a. Provision has been made on the hull for the mounting of standard ring type gun mount and machine gun.

**26. GUN MOUNT**

a. When gun mount is installed on vehicle, machine gun is operated by gunner located to right of driver.

**27. GUN MOUNT SUPPORTS**

a. Three supports or sockets are provided at right front corner, right rear corner, and center rear of driver's compartment. These gun mount supports are clamp type and hold the legs of mount securely when clamp and "U" bolts are tightened.

Section V

**PREVENTIVE MAINTENANCE AND INSPECTION**

	<b>Paragraph</b>
Purpose and scope.....	28
Preventive maintenance and inspection terms.....	29
Placing new or used vehicle into service.....	30
Pre-starting and before operation inspection and preventive maintenance .....	31
Before water operation inspection.....	32
Inspection during operation.....	33
Inspection at the halt.....	34
Inspection after water operation.....	35
Inspection after land operation.....	36
Weekly inspection and preventive maintenance.....	37
Monthly inspection and preventive maintenance.....	38
Semi-annual inspection and preventive maintenance.....	39
Seasonal and temperature changes.....	40
Long-term storage .....	41

**28. PURPOSE AND SCOPE**

a. Inspection and preventive maintenance procedures and operations outlined in this section provide an opportunity for crew and Using Arms maintenance personnel to replenish essential operating materials, to detect by audible, visual or manual inspection improper functioning of operating units and systems, and to make minor adjustments on parts subject to wear during normal operation. Its outstanding purpose is to eliminate the element of neglect which is too often responsible for sudden, unexpected failure of vehicle operation.

**29. PREVENTIVE MAINTENANCE AND INSPECTION TERMS**

a. Various terms are used when describing inspection and preventive maintenance operations. Using Arms maintenance personnel should familiarize themselves with these terms.

**30. PLACING NEW OR USED VEHICLE INTO SERVICE**

a. If a used or new vehicle is being placed into service, accomplish general inspection operations included in Paras. 31 and 32.

**31. PRE-STARTING AND BEFORE OPERATION INSPECTION AND PREVENTIVE MAINTENANCE**

a. Purpose of this pre-starting and before operation inspection and preventive maintenance procedure is to be sure that condition of the vehicle has not changed since the after-operation inspections were performed. While these procedures are of a routine nature, the driver and crew should bear in mind that such inspections are important from standpoint of vehicle performance and crew safety dur-

**TRUCK, AMPHIBIAN, 2 1/2-TON, 6 x 6**

ing operation. By being thoroughly familiar with recommended procedures, crew can go through these inspections almost automatically and in a few minutes' time size up general condition of vehicle.

b. As pre-starting and before operation preventive maintenance procedures are of vital interest to driver, these procedures are listed in Para. 14, Section III, "Controls and Operation."

**32. BEFORE WATER OPERATION INSPECTION**

a. As before water operation preventive maintenance procedures are of vital interest to driver, these procedures are listed in Para. 18, Section III, "Controls and Operation."

**33. INSPECTION DURING OPERATION**

a. In preventive maintenance, it is the attention to little things that count—such as unusual noises or odors and slight irregularities in vehicle performance. Taking necessary steps to correct any defects that develop completes the preventive procedure. While vehicle is in motion, a good driver listens for any sounds which may be a sign of trouble. He knows and watches for the odor of an overheated generator, overheated brakes, boiling anti-freeze, fuel vapor from a leaky fuel system or other such signs of trouble. Every time he uses brakes, shifts gears, changes speeds, or turns, he considers it a test and notes any unsatisfactory or unusual performance. Only under emergency condition should the vehicle be operated after indications of trouble have been observed.

b. During Land and Water Operation listen for such noises as the following which usually indicate the trouble specified.

- (1) Squeaks in engine—Generator or water pump trouble.
- (2) Engine Knocks—An alert driver can do much to avoid serious damage to engine by investigating and reporting the first signs of engine knocks.
- (3) Spark ping—Not serious during acceleration.
- (4) Hissing sound—Escape of steam due to overheating.
- (5) Excessive grinding noises under floor boards—Transmission, power take-off, or transfer case trouble.
- (6) Excessive heavy vibration in and beneath vehicle—Loose propeller shaft mounting, bent propeller shaft or worn universal joint.
- (7) Instruments—Glance frequently at instrument panel gauges and observe engine temperature, oil pressure, ammeter action and fuel supply.
- (8) Transmission and transfer case gears should shift without excessive effort or noise.
- (9) Note and report excessive play or looseness in steering mechanism or in rudder action.



## PREVENTIVE MAINTENANCE AND INSPECTION

(10) Note and report inefficient action of clutch. Clutch pedal should have approximately 2½" free travel.

(11) Performance—Be on the alert for lack of power or any other condition which may indicate engine trouble. In this way the alert driver can avoid a complete breakdown. Always stop vehicle before trouble stops engine and the condition will be easier to correct.

c. During Operation—On Land Only.—In **addition** to the foregoing items under **b**, the following inspection procedure is provided for land operation only.

(1) If a continuous hum develops in wheels it may be due to improper wheel bearing adjustment and should be investigated and reported.

(2) If squealing of tires occurs on turns and sharp curves it is an indication of improper tire inflation and excessive speed and should be corrected.

(3) If any sound comes from axles, it may be an indication of improperly adjusted or worn axle gears and should be investigated and reported.

(4) Steering—First sign of pulling to one side or the other may indicate the need for tire inflation or repair. Note and report inefficient action of brakes.

d. During Operation—On Water Only.—In addition to the foregoing items for land and water operation under **b**, the following procedure applies during water operation only. If there is a possibility of vehicle remaining in water for periods of 24 hours or more, it is essential that procedures in "Before Operation," "At Halt," and "After Operation" be accomplished.

(1) Make periodic inspection of each bilge compartment, if possible, to determine possibility of excessive leaks or inability of bilge pumps to keep compartments empty. Be alert to operation of bilge pumps and note exhaust of large quantities of water which may be an indication of damage to any section of hull and the need for immediate landing for repair.

(2) Note excessive vibration which may be an indication of looseness of water propeller, shaft and bearings.

(3) Keep air intake grilles and auxiliary intake open when possible to permit maximum cooling.

### 34. INSPECTION AT HALT

a. Some troubles are difficult to identify during operation due to location of units in the various hull sections. The driver should take advantage of every halt to locate and identify anything that might cause failure during operation. Driver should immediately report any conditions that he cannot handle. All inspection operations in this section apply during land operation only except those given under **e**.

**TRUCK, AMPHIBIAN, 2½-TON, 6 x 6**

**b. Driver's Compartment**

- (1) Hand brake should hold vehicle while at halt.
- (2) Instruments and gauges should show a normal reading.

**c. Exterior**

- (1) Note and report excessive temperature of brake drums or wheel hubs.
- (2) Inspect steering mechanism carefully. Report tie rod or drag link connections that are excessively loose.
- (3) Check tire inflation and condition of tires.
- (4) Examine driving axles for lubricant leaks and note temperature.
- (5) Check load, tarpaulin, fastenings, etc.

**d. In Vehicle**

- (1) Look for lubricant leaks and note excessive temperatures of all accessible driving units.

**e. In Engine Compartment—Engine Stopped**

- (1) Remove radiator cap and replenish water if low.
- (2) Inspect radiator core and connections for leaks.
- (3) Inspect fan belt and check its adjustment.
- (4) Check engine oil level and condition of the oil.

**35. INSPECTION AFTER WATER OPERATION**

**a.** Inspections after water operation are necessary to make sure that the vehicle is in a satisfactory condition for immediate operation either on land or in water. Unless immediate return to water operation is anticipated, the "daily after operation" inspection operation in Para. 36 should be accomplished.

**b. After Operation—Vehicle in Water.** Before vehicle is landed, if conditions permit, a thorough inspection should be made to determine existence of leaks throughout hull, inefficiency of bilge pumps or defects in driving mechanism.

**c. After Water Operation—Vehicle on Land—Note:** Items (1) to (9) may be omitted if immediate return to water operation is anticipated.

(1) Open all hatches and note existence of fuel or oil fumes which may indicate leakage from the various units.

(2) Before stopping engine, operate bilge pump controls to remove all water from bilge compartment.

(3) Wash vehicle inside and out with fresh water if possible. All compartments should be partially filled with clean water and then pumped out through pumping system.

(4) Inspect flexible brake hose all wheels. See that they are properly supported by their springs and report if hose has been damaged during water operation.

## PREVENTIVE MAINTENANCE AND INSPECTION

(5) Inspect all breather tubes from axles and pillow blocks and report if damaged during water operation.

(6) Check tire inflation. See that tires are in good condition and properly inflated for land operation.

(7) Remove seaweed or any other foreign matter which may have become wound around water propeller, shafting, rudder, exposed axle propeller shaft, or under structure.

(8) Inspect bellows type seals at each end of propeller shaft housings. These seals should be replaced if damaged in any way.

(9) Inspect water propeller and mounting. Lubricate water propeller shaft rear bearing.

(10) After a period of water operation, and unless immediate return to water operation is anticipated, it is recommended that a small quantity of lubricant be drained from axle housings and carefully examined to determine possibility of water having entered axles. If water is apparent, all lubricant should be drained from axles and units should be flushed and refilled with proper lubricant.

(11) Lubricate all points which are accessible from exterior of vehicle. (Refer to Section VI, "Lubrication".)

### 36. INSPECTION AFTER LAND OPERATION

a. This procedure is particularly important after either land or water operation because at this time the driver inspects and tests various units and systems to find any defects that may have developed during the previous operation. The driver should correct any conditions found and report those that he cannot handle. These inspections, while comparable to those itemized under "Pre-Starting and Before Operation" should be more thorough. Inspection operations should be followed up with necessary maintenance or service operations. This procedure should never be entirely omitted even in extreme tactical situations but may be reduced to the bare fundamental services. When performing these operations, driver should remember and consider any irregularities noticed during the day's operation.

#### b. In Driver's Compartment—Before Stopping Engine

(1) Hand brake lever ratchet should keep lever in applied position and brakes should hold.

(2) See if engine idles smoothly and investigate any unusual noises or conditions noticed during operation.

(3) See if engine temperature is normal.

(4) See if oil pressure is normal.

(5) Ammeter should show no excessive discharge or charge. Reading should be close to 0 at idling speed.

(6) Note approximate amount of fuel required to refill tank and replenish if necessary.

**TRUCK, AMPHIBIAN, 2½-TON, 6 x 6****c. In Engine Compartment**

(1) Raise engine hatch and note the presence of excessive fumes which might indicate leaks in the exhaust system, fuel and oil lines or in the hull.

(2) Note and report excessive engine vibration.

(3) Note and report excessive looseness or rubbing of fan belt on pulley.

(4) Inspect carbureter control linkage.

(5) Inspect electrical wiring and connections. All connections should be clean, tight and dry.

(6) Inspect fuel and oil lines and report leaks.

(7) Inspect mounting of engine accessories such as starter, generator, fuel pump, carbureter, etc.

(8) Remove radiator cap and replenish water if needed. Remove cap carefully to avoid danger of escaping steam pressure. If considerable water is required to replenish system, look for leaks in radiator core, water lines and connections.

(9) Check engine oil level and condition of the oil.

(10) Check oil level in carbureter air cleaner and crankcase breather. Rub fingers through oil to detect dirt. If cleaners are dirty, service according to instructions.

**d. In Vehicle**

(1) Open hatch covers and remove floor boards. Notice unusual odors which might indicate leakage of fuel or oils from the various units.

(2) Examine rudder control, cable and linkage.

(3) Inspect transmission and power take-off for lubricant leaks and note temperature.

(4) Inspect water propeller transfer case for lubricant leaks.

(5) Inspect axle drive transfer case for lubricant leaks.

(6) Inspect stuffing boxes at propeller shafts and rudder control shafts. See that stuffing box hose is in good condition.

(7) Examine axle propeller shaft housing seals at hull.

(8) Inspect mounting of water propeller transfer case, propeller shaft center bearings and pillow block.

**e. Under Vehicle**

(1) Inspect steering gear drag link and tie rod and steering arms. Actually handle these parts in order to determine excessive looseness.

(2) Examine hull at points of mounting of steering gear, frame, spring brackets, axle brackets, etc., to see that attaching bolts and nuts are present and tight. Observe necessity for adding sealing compound at these points.

(3) Look for lubricant leaks from axle housings, steering knuckle housings, steering gear and pillow block.



## PREVENTIVE MAINTENANCE AND INSPECTION

(4) Remove all foreign matter such as nails, glass, stones, or weeds from tires. Replace any missing valve caps and check for improperly locked valve stems which may indicate pulling of valve stem on tube as a result of operating tires when soft.

(5) Examine springs and suspensions for broken springs, loose or missing rebound clips.

(6) Check brake lines for leaks. See that springs and clips which support flexible brake hose are tight and in proper position. Report torn or defective hose.

(7) Remove foreign matter from around exposed propeller shafting. Tighten loose universal joint bolts.

(8) Check wheel and axle shaft flange nuts. Report damaged or missing rims, bolts, nuts, or other attaching parts.

(9) Place hand cautiously on each brake drum and wheel hub and note temperature. All drums should be approximately same temperature. Report wheel hubs that are too hot to touch with hand as this may indicate lack of lubricant, damaged or improperly adjusted bearings or brakes.

(10) Report all damaged, loose or missing sheet metal parts such as hull sections which have been penetrated, loose or missing hatches, etc.

(11) See that winch cable is tight and evenly wound; if not, rewind cable. Report defective cable. Check shear pin and spares under rear deck.

(12) Test action of lights and switches if assignment permits use of lights. If lamps are loose, tighten them. Report broken brackets and cracked lenses.

(13) Inspect load, tarpaulin and fastenings. Make sure that load is in good condition and properly secured.

(14) Check all tools and equipment which have been assigned to vehicle and see that they are in good condition and properly located.

### 37. WEEKLY INSPECTION AND PREVENTIVE MAINTENANCE

a. Weekly preventive maintenance procedure is general adjustment and inspection routine which requires the performance of adjustments to offset the effect of normal wear throughout the vehicle as well as other maintenance operations necessary, to restore vehicle to proper operating condition. Following procedure should be performed with vehicle on land.

#### b. In Vehicle

(1) Check clutch pedal free travel. The amount of free travel of clutch pedal before clutch starts to disengage should be approximately 2½ inches. Inspect and report defective clutch action.

**TRUCK, AMPHIBIAN, 2½-TON, 6 x 6**

(2) Inspect vehicle controls and report excessive looseness in rods and levers.

(3) Inspect hydraulic brake lines and check connections.

(4) Inspect general condition of inside of hull and bilge compartments. Clean thoroughly and report damaged, loose or missing parts.

(5) Clean top of battery and terminals with clean water or with solution of water and baking soda. Tighten terminals at each end of ground cable and at each end of battery to starting motor cable. Remove battery filler plugs. Use a hydrometer and check specific gravity of each battery cell. If electrolyte is not well over top of plates, add distilled water or report condition so that distilled water may be added. Never use salt water in battery.

(6) Check and service engine oil and oil filter as required.

(7) Remove ignition system shield cover and inspect and service spark plugs, distributor breaker points, and ignition high and low tension cables as required. Check all wiring and connections.

(8) Inspect and service engine air cleaner and crankcase ventilator breather as required.

(9) Check mounting bolts of all units within the hull. This should include starting motor, generator carbureter, engine, power take-off, water propeller transfer case, axle transfer case, propeller shaft universal joints, bilge pumps, tire pump, etc.

(10) Check gear type bilge pump drive belt and centrifugal type bilge pump drive chain. Service as required.

(11) Inspect all units within hull for oil and fuel leaks. If leakage occurs at oil seals, report condition.

(12) Remove level plugs from transmission, transfer cases and steering gear. Be sure lubricant is at the correct level. Service as required. Be sure to replace plugs.

(13) Flush interior of vehicle with plenty of clean, fresh water. Use bilge pumps to drain various compartments and observe action of bilge pump during this operation.

(14) Check winch operation and inspect condition of winch, cable and drive shaft. Check winch lubrication.

(15) See that all tools and equipment which have been assigned to vehicle are accounted for, in good condition, and properly installed in their correct location. This should include hand tools, pioneer tools, fire extinguishers, first aid kits, sand anchor, tow chain, etc.

**c. Exterior**

(1) Inspect hatch covers and attaching parts. Examine hatch cover seals and repair or report those found defective.

(2) Remove level plugs from all drive axles and from steering knuckles and see that lubricant is at correct level. Service as required. If water operation has been experienced during preceding week, it is

## PREVENTIVE MAINTENANCE AND INSPECTION

recommended that a small quantity of lubricant be drained from each of these units and oil be carefully examined to determine possible water content. If water is found, unit should be drained, flushed, and refilled with proper lubricant. Be sure to replace plugs.

(3) Check all mounting bolts used for attachment of chassis units to hull. If loose or missing bolts are found, these points should be well caulked with sealing compound before tightening or replacing. Tighten axle flange and wheel nuts.

(4) Completely wash outside of vehicle.

(5) Inflate tires to correct pressure.

(6) Examine all structural sections of hull and report loose or missing parts, or conditions which require welding.

(7) Inspect shock absorber linkage and mounting. Check for leakage of fluid from shock absorbers.

(8) Inspect bellows type seals at each end of propeller shaft housings and replace these parts if damaged or defective. Tighten seal clamp ring screws.

(9) Inspect all points of spring suspension such as shackles, brackets, "U" bolts, clips, etc.

(10) Carefully check steering gear drag link and tie rod connections and report excessive looseness.

(11) Check wheel bearing adjustment.

(12) Check wheel and axle shaft flange nuts.

### 38. MONTHLY INSPECTION PREVENTIVE MAINTENANCE

a. Purpose of this inspection interval is to perform lubrication inspection and maintenance services that will offset normal wear and eliminate any conditions which may interfere with dependable operation during forthcoming months. Driver should accompany vehicle and assist in procedure when possible or provide a suitable report of vehicle operating conditions.

b. No set routine or mileage can be established for this interval until experience has pointed out necessity of establishing specific mileage service. All the operations itemized in other inspection intervals should be accomplished in a more detailed and thorough manner, and followed up with maintenance or service operations.

### 39. SEMI-ANNUAL INSPECTION AND PREVENTIVE MAINTENANCE

a. Purpose of this inspection interval is to provide an opportunity for replacement, repair, or rebuild of major units which may prove by past service experience to be necessary. Operations at this interval should include, in a more detailed and thorough manner, the operations which are generally accomplished at the weekly and monthly inspection intervals. An established mileage interval may be set up in

**TRUCK, AMPHIBIAN, 2 1/2-TON, 6 x 6**

lieu of semi-annual period, after service performance has proven necessity of such action.

b. Semi-annual inspection and preventive maintenance interval provides an opportunity to make various seasonable adjustments if necessary, as well as analyzing the service performance of vehicle during foregoing six months.

**40. SEASONAL AND TEMPERATURE CHANGES**

**a. From Above Freezing To Below Freezing**

- (1) Add anti-freeze to cooling system.
- (2) Test and add anti-freeze as required during operation.
- (3) Use lubricants specified for climatic and operating conditions.
- (4) Keep battery fully charged. Remember that at a gravity lower than 1160 batteries will freeze at 2° F.
- (5) Keep moisture out of fuel system.
- (6) Take necessary precautions to see that engine is operated at normal operating temperature.
- (7) Use a more volatile gasoline.
- (8) Adjust exhaust manifold heat control valve and adjust carbureter.

**b. From Below Freezing To Above Freezing**

- (1) Remove anti-freeze from cooling system and flush the system.
- (2) Use lubricant specified for climate.
- (3) Adjust exhaust manifold heat control valve and carbureter.

**c. Icing Conditions**

- (1) Drive at slower speeds. Stop vehicle frequently and inspect all controls, as slush freezing on bottom of vehicle will interfere with vehicle control.
- (2) Remove sleet from windshield.
- (3) Remove slush and mud from controls when parking vehicle.
- (4) Do not set hand brake when parking. Do not park in water which may freeze.

**41. PREPARING VEHICLE FOR LONG-TERM STORAGE**

a. If for any reason vehicles must be placed in storage for a long period of time, it is important that precautions be taken to make sure that the vehicle will be in good condition for operation when required.



Section VI  
**LUBRICATION**

	Paragraph
General .....	42
Lubrication guide .....	43
Points to be serviced and/or lubricated by ordnance maintenance personnel .....	44
Reports and records .....	45

**42. GENERAL**

The following lubrication instructions for Truck, Amphibian, 2½-ton, 6 x 6, DUKW, are published for the information and guidance of all concerned, and supersede all previous instructions. Materiel must be lubricated in accordance with the latest instructions contained in Technical Manuals and or Ordnance Field Service Bulletins.

**43. LUBRICATION GUIDE**

Lubrication instructions for all points to be serviced by the using arm are shown in the Lubrication Guide which specifies the types of lubricants required and the intervals at which they are to be applied. The following lubrication instructions contain the same information as the guide. Guides from which data is reproduced are 10 x 15 in. laminated charts which are part of the accessory equipment of each piece of materiel. Data contained in the lubrication guides is taken from TM's and is binding on using troops.

**44. POINTS TO BE SERVICED AND OR LUBRICATED BY  
ORDNANCE MAINTENANCE PERSONNEL**

a. **Starter outboard bearing.** Every 5,000 miles, remove starter and lubricate outboard bearing through oiler with OIL, engine, crankcase grade.

**45. REPORTS AND RECORDS**

a. **Reports.** If lubrication instructions are closely followed, proper lubricants used, and satisfactory results are not obtained, a report will be made to the ordnance officer responsible for the maintenance of the materiel.

b. **Records.** A complete record of lubrication servicing will be kept for the materiel.

TRUCK, AMPHIBIAN, 2 1/2-TON, 6 x 6

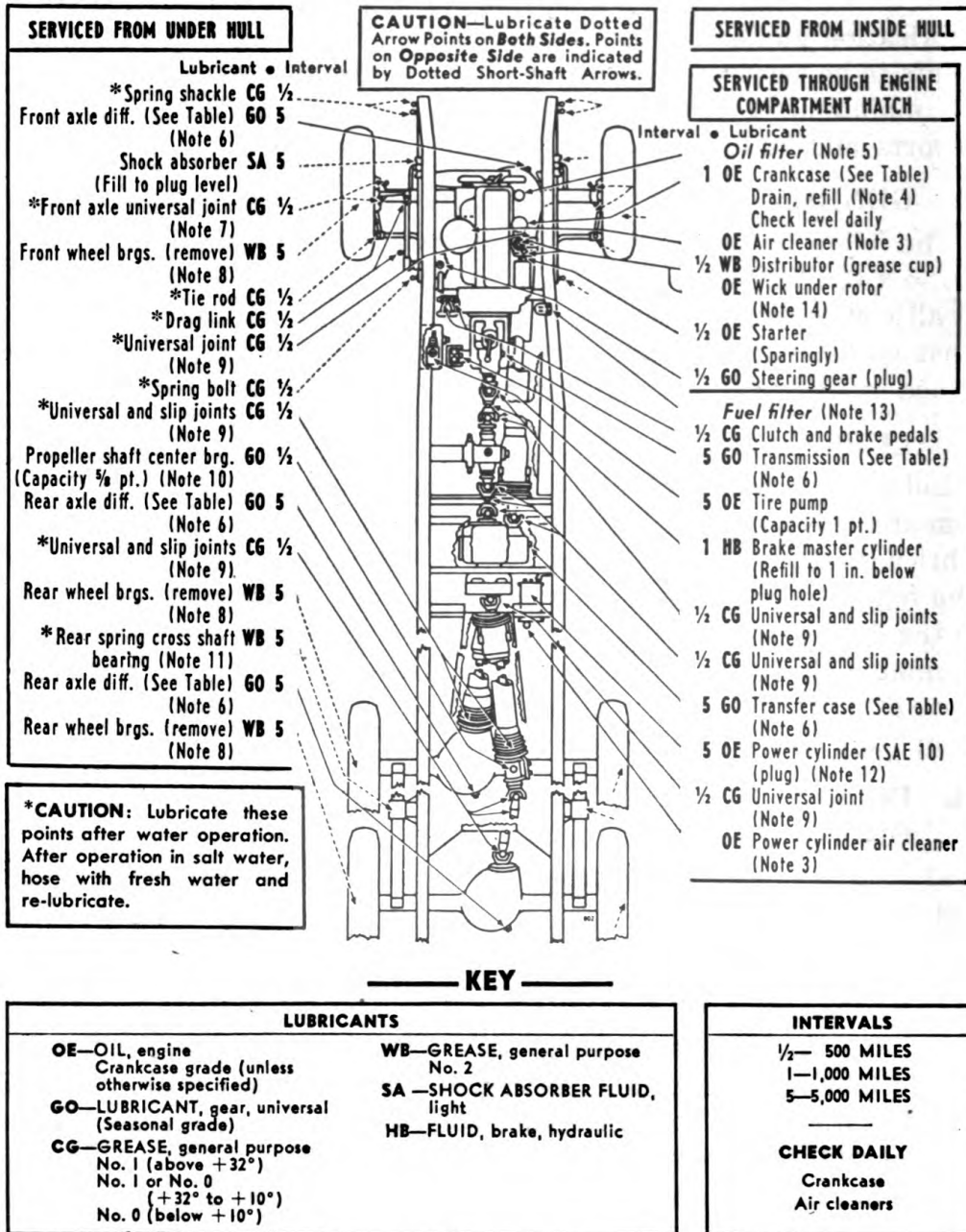

**SERVICED FROM UNDER HULL**

- Lubricant • Interval
- \*Spring shackle CG 1/2
  - Front axle diff. (See Table) GO 5  
(Note 6)
  - Shock absorber SA 5  
(Fill to plug level)
  - \*Front axle universal joint CG 1/2  
(Note 7)
  - Front wheel brgs. (remove) WB 5  
(Note 8)
  - \*Tie rod CG 1/2
  - \*Drag link CG 1/2
  - \*Universal joint CG 1/2  
(Note 9)
  - \*Spring bolt CG 1/2
  - \*Universal and slip joints CG 1/2  
(Note 9)
  - Propeller shaft center brg. GO 1/2  
(Capacity 3/8 pt.) (Note 10)
  - Rear axle diff. (See Table) GO 5  
(Note 6)
  - \*Universal and slip joints CG 1/2  
(Note 9)
  - Rear wheel brgs. (remove) WB 5  
(Note 8)
  - \*Rear spring cross shaft bearing (Note 11) WB 5
  - Rear axle diff. (See Table) GO 5  
(Note 6)
  - Rear wheel brgs. (remove) WB 5  
(Note 8)

**\*CAUTION:** Lubricate these points after water operation. After operation in salt water, hose with fresh water and re-lubricate.

**CAUTION**—Lubricate Dotted Arrow Points on Both Sides. Points on Opposite Side are indicated by Dotted Short-Shaft Arrows.

**SERVICED FROM INSIDE HULL**

**SERVICED THROUGH ENGINE COMPARTMENT HATCH**

- Interval • Lubricant
- Oil filter (Note 5)
  - 1 OE Crankcase (See Table)  
Drain, refill (Note 4)  
Check level daily
  - OE Air cleaner (Note 3)
  - 1/2 WB Distributor (grease cup)
  - OE Wick under rotor  
(Note 14)
  - 1/2 OE Starter  
(Sparingly)
  - 1/2 GO Steering gear (plug)
  - Fuel filter (Note 13)
  - 1/2 CG Clutch and brake pedals
  - 5 GO Transmission (See Table)  
(Note 6)
  - 5 OE Tire pump  
(Capacity 1 pt.)
  - 1 HB Brake master cylinder  
(Refill to 1 in. below  
plug hole)
  - 1/2 CG Universal and slip joints  
(Note 9)
  - 1/2 CG Universal and slip joints  
(Note 9)
  - 5 GO Transfer case (See Table)  
(Note 6)
  - 5 OE Power cylinder (SAE 10)  
(plug) (Note 12)
  - 1/2 CG Universal joint  
(Note 9)
  - OE Power cylinder air cleaner  
(Note 3)

**KEY**

LUBRICANTS	
OE—OIL, engine Crankcase grade (unless otherwise specified)	WB—GREASE, general purpose No. 2
GO—LUBRICANT, gear, universal (Seasonal grade)	SA —SHOCK ABSORBER FLUID, light
CG—GREASE, general purpose No. 1 (above +32°) No. 1 or No. 0 (+32° to +10°) No. 0 (below +10°)	HB—FLUID, brake, hydraulic

INTERVALS
1/2— 500 MILES
1—1,000 MILES
5—5,000 MILES
<b>CHECK DAILY</b>
Crankcase
Air cleaners

RA PD 16062

Generated on 2013-07-25 08:50 GMT / http://hdl.handle.net/2027/uc1.b3243762  
Public Domain, Google-digitized / http://www.hathitrust.org/access\_use#pd-google

**LUBRICATION**

**NOTE—All points are serviced from INSIDE HULL, unless otherwise specified.**

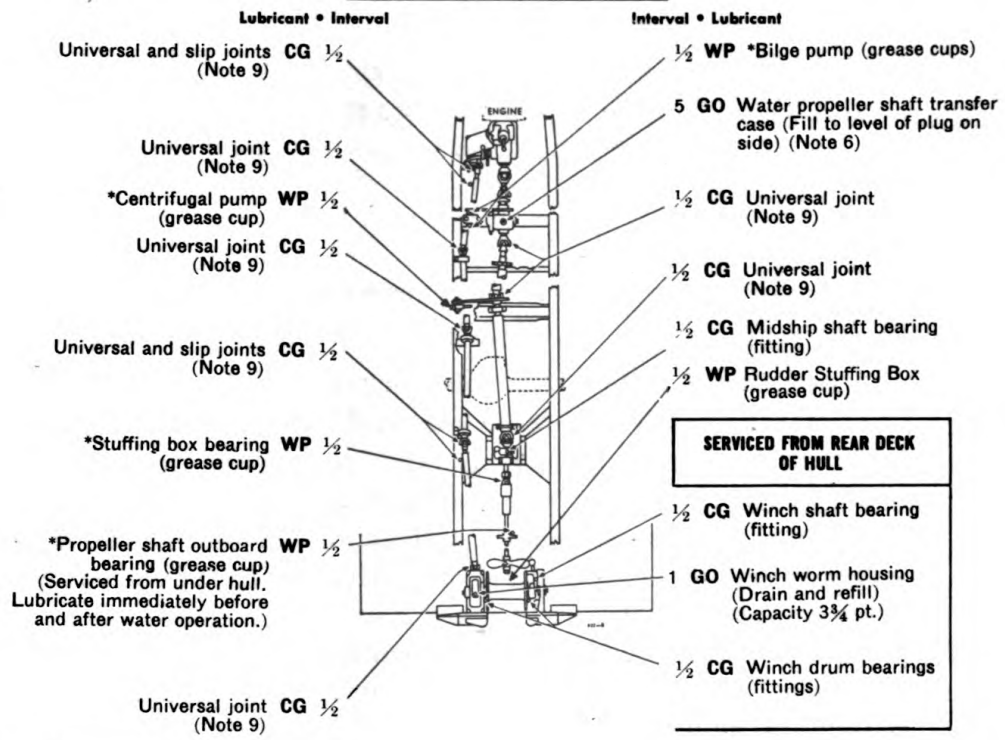

**\*CAUTION:** Lubricate these points after every water operation.

**— KEY —**

LUBRICANTS	
WP—No. 4 GREASE, water pump	CG—GREASE, general purpose No. 1 (above +32°) No. 1 or No. 0 (+32° to +10°) No. 0 (below +10°)

INTERVALS
1/2— 500 MILES
1—1,000 MILES
5—5,000 MILES

RA PD 16063

**Figure 42—Lubrication Guide**

Generated on 2013-07-25 08:49 GMT / http://hdl.handle.net/2027/uc1.b3243762  
Public Domain, Google-digitized / http://www.hathitrust.org/access\_use#pd-google

**TRUCK, AMPHIBIAN, 2½-TON, 6 x 6**

**TABLE OF CAPACITIES AND LUBRICANTS TO BE USED**

	Capacity (Approx.)	Above +32°	+32° to +10°	+10° to -10°	Below -10°
Crankcase (refill) . . . . .	10 qt.	OE SAE 30	OE SAE 30	OE SAE 10	
Transmission	11 pt.				
Transfer Case	4 pt.				
Water Propeller Transfer Case	1 pt.		GO		
Front and For- ward Rear Axle	13 pt.	GO SAE 90	SAE 90 or 80	GO SAE 80	Refer to OFSB 6-11
Rearward Rear Axle Diff.	10 pt.				

**NOTES**

**Additional Lubrication and Service Instructions  
on Individual Units and Parts**

- FITTINGS.** Clean before applying lubricant. Lubricate until new lubricant is forced from the bearing, unless otherwise specified. Lubricate chassis points and universal joints as soon after water operation as possible. Also, always lubricate chassis points after washing truck.
- INTERVALS** indicated are for normal service. For extreme conditions of speed, heat, sand, mud, snow, rough roads, dust, etc., reduce interval by ⅓ or ½, or more if conditions warrant.
- AIR CLEANERS.** **Engine air cleaner.** Daily, check level and refill oil reservoir to bead level with OIL, engine, crankcase grade. Every 100 to 1,000 miles, depending on operating conditions, drain, clean and refill. Every 2,000 miles, also remove air cleaner and wash all parts. **Crankcase breather.** Every 1,000 miles, or oftener if necessary, remove crankcase breather, clean and reoil with OIL, engine, crankcase grade. **Power cylinder air cleaner.** Every 5,000 miles, or oftener if necessary, remove cylinder air intake cylinder, wash filter element in SOLVENT, dry-cleaning, dip in OIL, engine, seasonal grade, and reassemble. Proper maintenance of air cleaners is essential to prolonged engine life.
- CRANKCASE.** Drain only when engine is hot. Refill to FULL mark on gauge. Run engine a few minutes and recheck oil level. If oil filter element is changed, one additional quart will be required. Drain plug is reached through plug hole in bottom of



## LUBRICATION

hull. CAUTION: Be sure pressure gauge indicates oil is circulating. See Table.

5. **OIL FILTER.** Every 1,000 miles, drain filter through drain plug. Every 3,000 miles, remove, inspect and install new element if necessary. Every 8,000 miles, or less if oil becomes dirty, install new element. After renewing element, refill crankcase to FULL mark on gauge. Run engine a few minutes and recheck oil level.
6. **GEAR CASES.** Weekly, check level with truck on level ground and, if necessary, add lubricant to correct level; also make visual inspection for leakage and report leakage to ordnance maintenance personnel. Keep lubricant in differentials to level of lower filler plug. Vents located on front and both rear axles are extended by means of a flexible hose, to inside of hull. Make sure vents are not clogged. Drain, flush and refill at end of first 1,000 miles; thereafter as indicated at points on chart. When draining, drain immediately after operation. Plug holes are provided in bottom of hull through which drain plugs for transmission and transfer case may be reached.
7. **FRONT AXLE UNIVERSAL JOINTS.** Remove plug at top, lubricate through lower fitting until lubricant is visible at top plug hole. Replace plug.
8. **WHEEL BEARINGS (Front and rear).** Remove wheel, clean and repack bearings only. To clean and pack wheel bearings properly, they must be removed from the hub. Follow the procedure below:
  - a. **Front wheel bearings.**
    - (1) Remove the bearings from the hub and wash them in SOLVENT, dry-cleaning, until all the old lubricant is removed from both inside and outside of cage.
    - (2) Lay them aside to dry and wash the inside of the hub with SOLVENT, dry-cleaning.
    - (3) When bearings are thoroughly dry, pack the races with GREASE, general purpose No. 2, and reassemble in hub. To satisfactorily pack a bearing it is necessary to knead lubricant into space between the cage and inner race. Do not apply any lubricant to the inside of the hub. The lubricant packed in the bearing races is sufficient to provide lubrication until the next service period. An excess may result in leakage of the lubricant into the brake drum.
    - (4) Replace wheel and tighten adjusting nut until wheel binds. Back off the nut until wheel turns freely without side play. Lock adjusting nut into position.

**TRUCK, AMPHIBIAN, 2½-TON, 6 x 6**

**b. Rear wheel bearings.** Rear axle is full-floating type and axle shaft must be removed to adjust wheel bearings.

(1) Unscrew axle shaft flange stud nuts which hold axle, remove axle shaft, oil seal and retainer.

(2) Release two lock nuts which hold bearings.

(3) Clean and pack bearings, using same procedure as for front wheel bearings above.

(4) Replace bearings and tighten inner lock nut until wheel binds. Back off nut  $\frac{1}{8}$  turn, or sufficiently to permit wheel to turn freely without side play.

(5) Replace second lock nut, tighten and test adjustment.

(6) Insert axle shaft in housing and make final test for adjustment. New oil seals must be used after axle has been disassembled for lubrication or repair. **CAUTION:** Stud nuts used to hold the wheel to the hub must not be lubricated.

9. **UNIVERSAL JOINTS AND SLIP JOINTS.** Apply GREASE, general purpose, seasonal grade, to joint until it overflows at relief valve, and to slip joint until lubricant is forced from end of slip joint. Universal and slip joints used on winch drive shaft are not provided with vents. Use hand gun to prevent damage to joint seals. On the front axle and forward rear axle, the universal joints are encased in large water-tight tubes and are covered by large rubber bellows where joints are connected to axle housing. These must be removed to lubricate these joints and splines. When lubricating, allow surplus lubricant to remain on joints before installing bellows.
10. **PROPELLER SHAFT CENTER BEARING.** Mounted on top of forward rear axle and reached from under hull. Lubricate through plug hole on top of unit with LUBRICANT, gear, universal, seasonal grade, to level of plug on side of unit.
11. **REAR SPRING CROSS SHAFT BEARINGS.** Every 5,000 miles, remove rear spring cross shaft seats and bearings, clean and repack with  $\frac{1}{2}$  pt. GREASE, general purpose No. 2.
12. **POWER CYLINDER.** Every 5,000 miles, remove plugs on top and at front of cylinder and lubricate with about one teaspoonful of OIL, engine, SAE 10.
13. **FUEL FILTER.** Every few days, remove drain plug to drain accumulated dirt. Remove element as necessary and wash in SOLVENT, dry-cleaning. **Caution: Do not drain into hull.**
14. **DISTRIBUTOR.** Every 500 miles refill grease cup with GREASE, general purpose No. 2, turn cup one full turn. Apply

**LUBRICATION**

few drops OIL, engine, crankcase grade to wick under rotor. Wipe breaker cam lightly with GREASE, general purpose, seasonal grade, and lubricate breaker arm pivot with OIL, engine, crankcase grade, sparingly.

15. **FRONT AND REAR SPRINGS.** Every 500 miles, paint sides with GREASE, graphite, light.
16. **OIL CAN POINTS.** Every 500 miles, lubricate spark and throttle control rod ends, sliding surface of winch jaw clutch, rudder steering cable pulleys, rudder control rod ends, pintle hook, all yokes and clevises, hinges, latches, etc., with OIL, engine, crankcase grade.
17. **POINTS REQUIRING NO PERIODIC LUBRICATION SERVICE.** Fan, water pump, generator, clutch pilot bearing, clutch release bearing, clutch shaft splines, steering column upper bearing, clutch shift fork ball stud, winch drive shaft support bearings, water propeller shaft drive center bearing, shock absorber links, power take-off.
18. **MANIFOLD HEAT CONTROL.** Every 500 miles, apply GREASE, graphite, light, to intake manifold gate valve, to prevent rusting.
19. **PINTLE HOOK SPRING.** Every 5,000 miles pack with water pump grease.

Section VII

**CARE AND PRESERVATION**

	Paragraph
Records .....	46
Cleaning .....	47
Paint .....	48
Preparing for painting .....	49
Painting metal surfaces.....	50
Paint as a camouflage .....	51
Remove paint .....	52
Painting lubricating devices .....	53

**46. RECORDS**

a. **Use.** An accurate record must be kept of each motor vehicle issued by the Ordnance Department. For this purpose the Ordnance Motor Book (0.0. Form No. 7255), generally called "Log Book," is issued with each vehicle and must accompany it at all times. This book furnishes a complete record of the vehicle from which valuable information concerning operation and maintenance costs, etc., is obtained and organization commanders must insist that correct entries be made. This book will habitually be kept in a canvas cover to prevent its being injured or soiled.

b. **Assignment Record.** The page bearing a record of assignment must be destroyed prior to entering the combat zone. All other references which may be posted regarding the identity of the organization must also be deleted.

**47. CLEANING**

a. Grit, dirt, and mud are the sources of greater wear to a vehicle. If deposits of dirt and grit are allowed to accumulate, particles will soon find their way into bearing surfaces, causing unnecessary wear, and if the condition is not remedied, will soon cause serious difficulty. When removing engine parts or any other unit, in making repairs and replacements, or if, in the course of inspection, working joints or bearing surfaces are to be exposed, all dirt and grit that might find its way to the exposed surfaces must first be carefully removed. The tools must be clean, and care must always be taken to eliminate the possibilities of brushing dirt or grit into the opening with the sleeve or other part of the clothing. To cut oil-soaked dirt and grit, hardened grit, or road oil, use dry cleaning solvent applied with cloths (not waste) or a brush. Care should be taken to keep water from the power unit, as it might interfere with proper ignition and carburetion. Detailed information on cleaning is included in TM 9-850.

b. Oil holes which have become clogged should be opened with a piece of wire. Wood should never be used for this purpose, as splinters



## CARE AND PRESERVATION

are likely to break off and permanently clog the passages. Particular care should be taken to clean and decontaminate vehicles that have been caught in a gas attack. See Section X, DECONTAMINATION, for details of this operation.

### 48. PAINT

a. Ordnance material is painted before issue to the using arms and one or more maintenance coats per year will ordinarily be ample for protection. With but few exceptions this material will be painted with ENAMEL, synthetic, olive drab, lusterless. The enamel may be applied over old coats of tung oil enamel and oil paint previously issued by the Ordnance Department if the old coat is in satisfactory condition for repainting.

b. Paints and enamels are usually issued ready for use and are applied by brush or spray. They may be brushed on satisfactorily when used unthinned in the original package consistency or when thinned no more than 5% by volume with THINNER. The enamel will spray satisfactorily when thinned with 15% by volume of THINNER, (linseed oil must not be used as a thinner since it will impart a luster not desired in this enamel). If sprayed, it dries hard enough for repainting within 1/2 hour and dries hard in 16 hours.

c. Complete information on painting is contained in TM 9-850.

### 49. PREPARATION FOR PAINTING

a. If the base coat on the material is in poor condition, it is more desirable to strip the old paint from the surface than to use sanding and touch-up methods. After stripping, it will then be necessary to apply a primer coat.

b. PRIMER ground, synthetic, should be used on wood as a base coat for synthetic enamel. It may be applied either by brushing or spraying. It will brush satisfactorily as received or after the addition of not more than 5% by volume of THINNER. It will be dry enough to touch in 30 minutes, and hard in 5 to 7 hours. For spraying, it may be thinned with not more than 15% by volume of THINNER. Lacquers must not be applied to the PRIMER, ground, synthetic, within less than 48 hours.

c. PRIMER, synthetic, rust inhibiting, for bare metal, should be used on metal as a base coat. Its use and application are similar to that outlined in paragraph (b) above.

d. The success of a job of painting depends partly on the selection of a suitable paint, but also largely upon the care used in preparing the surface prior to painting. All parts to be painted should be free from rust, dirt, grease, kerosene, oil, and alkali and must be dry.

### 50. PAINTING METAL SURFACES

a. If metal parts are in need of cleaning, they should be washed in

**TRUCK, AMPHIBIAN, 2½-TON, 6 x 6**

a liquid solution consisting of ½ pound of SODA ASH in 8 quarts of warm water, or an equivalent solution, then rinsed in clear water and wiped thoroughly dry. Wood parts in need of cleaning should be treated in the same manner, but the alkaline solution must not be left on for more than a few minutes and the surfaces should be wiped dry as soon as they are washed clean. When artillery or automotive equipment is in fair condition and only marred in spots, the bad places should be touched with ENAMEL, synthetic, olive drab, lusterless and permitted to dry. The whole surface will then be sandpapered with PAPER, flint No. 1 and a finish coat of ENAMEL, synthetic, olive drab, lusterless applied and allowed to dry thoroughly before the material is used. If the equipment is in bad condition, all parts should be thoroughly sanded with PAPER, flint No. 2, or equivalent, given a coat of PRIMER, ground, synthetic, and permitted to dry for at least 16 hours. They will then be sandpapered with PAPER, flint No. 00, wiped free from dust and dirt, and final coat of ENAMEL, synthetic, olive drab, lusterless applied and allowed to dry thoroughly before the material is used.

**51. PAINT AS A CAMOUFLAGE**

a. Camouflage is now a major consideration in painting Ordnance vehicles, with rust prevention secondary. The camouflage plan at present employed utilizes three factors: color, gloss, and stenciling.

**(1) Color**

Vehicles are painted with ENAMEL, synthetic, olive drab, lusterless, which was chosen to blend in reasonably well with the average landscape.

**(2) Gloss**

The new lusterless enamel makes a vehicle difficult to see from the air or from relatively great distances over land. A vehicle painted with ordinary glossy paint can be detected more easily and at greater distance.

**(3) Stenciling**

White stencil numbers on vehicles have been eliminated because they can be photographed from the air. A blue drab stencil enamel is now used which cannot be so photographed. It is illegible to the eye at distances exceeding 75 feet.

**(4) Preserving camouflage**

(a) Continued friction or rubbing must be avoided, as it will smooth the surface and produce a gloss. Care should be taken to see that washing is done entirely with a sponge or a soft rag. The surface should never be rubbed or wiped, except while wet, or a gloss will develop.

## CARE AND PRESERVATION

(b) It is not desirable that vehicles, painted with lusterless enamel, be kept as clean as vehicles were kept when glossy paint was used. A small amount of dust increases the camouflage value. Grease spots should be removed with SOLVENT, dry cleaning. Whatever portion of the spot cannot be so removed should be allowed to remain.

(c) Continued friction of wax-treated tarpaulins on the sides of a vehicle will also produce a gloss, which should be removed with SOLVENT, dry cleaning.

(d) Tests indicate that repainting with olive drab paint will be necessary once yearly, with blue drab paint twice yearly.

### 52. REMOVING PAINT

a. After repeated paintings, the paint may become so thick as to crack and scale off in places, presenting an unsightly appearance. If such is the case, remove the old paint by use of a lime-and-lye solution (see TM 9-850 for details) or REMOVER, paint and varnish. It is important that every trace of lye or other paint remover be completely rinsed off and that the equipment be perfectly dry before repainting is attempted. It is preferable that the use of lye solutions be limited to iron or steel parts. If used on wood, the lye solution must not be allowed to remain on the surface for more than a minute before being thoroughly rinsed off and the surface wiped with rags. Crevices or cracks in wood should be filled with putty and the wood sandpapered before refinishing. The surfaces thus prepared should be painted according to directions.

b. Be sure all rust is removed before painting procedures are followed.

### 53. PAINTING LUBRICATING DEVICES

a. Oil cups, grease fittings, oil holes, and similar lubricating devices, as well as a circle about three-fourths of an inch in diameter at each point of lubrication will be painted with ENAMEL, red, water resisting, in order that they may be readily located.

Section VIII

**VEHICLE EQUIPMENT**

	Paragraph
Vehicle tools .....	54
Pioneer tools .....	55
Equipment .....	56
Care of tools and equipment.....	57

**54. VEHICLE TOOLS**

a. Following vehicle tools are stored in stern compartment:

Bag, Tool (1)	Screwdriver 6" (1)
Bar, Side Ring Removal (1) (Tire Rim)	Tool, Rim Side Ring (Tire Rim)
Gun, Lubrication (1)	Wrench, Adjustable (3 auto)
Hammer, 1 lb. Ball Pein (1)	Wrench, Adjustable End (12 crescent)
Handle, Wheel Nut Wrench (1)	Wrench, Double End (723) (1)
Jack and Handle (1)	Wrench, Double End (27S) (1)
Lever, Hand Crank (1)	Wrench, Double End (28S) (1)
Pliers, 6" Combination (1)	Wrench, Double End (731A) (1)
Screwdriver, #1 X-recess (1)	Wrench, Double End (#25 heavy type) (1)
Screwdriver, #2 X-recess (1)	Wrench, Spark Plug (1)
Screwdriver, #3 X-recess (1)	Wrench, Wheel Bearing Nut (1)
Screwdriver, #4 X-recess (1)	

**55. PIONEER TOOLS**

a. Following pioneer tools are stowed on the deck of hull:

Single Bit Axe (1) "D" Handle Shovels (2) Pick Mattock (1)

**56. EQUIPMENT**

a. Items listed below are carried inside vehicle and fastened in the most convenient available spaces:

Assembly, Anchor (1)	Extinguisher, Fire (2)
Assembly, Heavy Duty Snatch Block (2)	Gauges, Tire (attached to hose) (2)
Assembly, Rope (2)	Hose, Tire Inflation (2)
Assembly, Utility Tow Chain (1)	Kit, First Aid (1)
Book, Instruction (1)	Light, Flash (1)
Buckets, Canvas (2)	Pump, Hand Bilge (1)
Can, Oil (1)	Shear Pins, Winch (10)
Cord, Sash (100 ft.)	Sponges (2)
	Boat Hook (1)

**57. CARE OF TOOLS AND EQUIPMENT**

a. Before and after extensive water operation of tools and equipment which have been or will be subjected to water, should be thor-



**VEHICLE EQUIPMENT**

oughly lubricated and/or cleaned, as salt water has a deteriorating effect on material.

---

**Important:** Tools and equipment mounted in and on this vehicle must be kept in good condition, as they are vital to the successful and safe operation of vehicle.

---

Section IX

**DECONTAMINATION**

	Paragraph
Protective measures .....	58
Cleaning .....	59
Decontamination .....	60
Special precaution for automotive material .....	61

**58. PROTECTIVE MEASURES**

a. When material is in constant danger of gas attack, unpainted metal parts will be lightly coated with engine oil. Instruments are included among the items to be protected by oil from chemical clouds or chemical shells, but ammunition is excluded. Care will be taken that the oil does not touch the optical parts of instruments or leather or canvas fittings. Material not in use will be protected with covers as far as possible. Ammunition will be kept in sealed container.

b. Ordinary fabrics offer practically no protection against mustard gas or lewisite. Rubber and oilcloth, for example, will be penetrated within a short time. The longer the period during which they are exposed, the greater the danger of wearing these articles. Rubber boots worn in an area contaminated with mustard gas may offer a grave danger to men who wear them several days after the bombardment. Impermeable clothing will resist penetration more than an hour, but should not be worn longer than this.

**59. CLEANING**

a. All unpainted metal parts of material that have been exposed to any gas except mustard and lewisite must be cleaned as soon as possible with SOLVENT, dry cleaning, or ALCOHOL, and wiped dry. All parts should then be coated with engine oil.

b. Ammunition which has been exposed to gas must be thoroughly cleaned before it can be fired. To clean ammunition use AGENT, decontaminating, noncorrosive, or if this is not available, strong soap and cool water. After cleaning, wipe all ammunition dry with clean rags. **Do not use dry powdered AGENT, decontaminating (chloride of lime) (used for decontaminating certain types of material on or near ammunition supplies), as flaming occurs through the use of chloride of lime on liquid mustard.**

**60. DECONTAMINATION**

a. For the removal of liquid chemicals (mustard, lewisite, etc.) from material, the following steps should be taken:

**b. Protective Measures**

(1) For all of these operations a complete suit of impermeable clothing and a service gas mask will be worn. Immediately after removal of the suit, a thorough bath with soap and water (preferably

## DECONTAMINATION

hot) must be taken. If any skin areas have come in contact with mustard, if even a very small drop of mustard gets into the eye, or if the vapor of mustard has been inhaled, it is imperative that complete first aid measures be given within 20 to 30 minutes after exposure. First aid instructions are given in TM 9-850 and FM 21-40.

(2) Garments exposed to mustard will be decontaminated. If the impermeable clothing has been exposed to vapor only, it may be decontaminated by hanging in the open air; preferably in sunlight, for several days. It may also be cleaned by steaming for two hours. If the impermeable clothing has been contaminated with liquid mustard, steaming for six to eight hours will be required. Various kinds of steaming devices can be improvised from materials available in the field.

### (c) Procedure

(1) Commence by freeing material of dirt through the use of sticks, rags, etc., which must be burned or buried immediately after this operation.

(2) If the surface of the material is coated with grease or heavy oil, this grease or oil should be removed before decontamination is begun. SOLVENT dry cleaning, or other available solvents for oil should be used with rags attached to ends of sticks.

(3) Decontaminate the painted surfaces of the material with bleaching solution made by mixing one part AGENT, decontaminating (chloride of lime), with one part water. This solution should be swabbed over all surfaces. Wash off thoroughly with water, then dry and oil all surfaces.

(4) All unpainted metal parts and instruments exposed to mustard or lewisite must be decontaminated with AGENT, decontaminating, noncorrosive, mixed one part solid to fifteen parts solvent (ACETYLENE TETRACHLORIDE). If this is not available, use warm water and soap. Bleaching solution must not be used, because of its corrosive action. Instrument lenses may be cleaned only with PAPER lens tissue, using a small amount of alcohol, ethyl. Coat all metal surfaces lightly with engine oil.

(5) In the event AGENT, decontaminating (chloride of lime) is not available, material may be temporarily cleaned with large volumes of hot water. However, mustard lying in joints or in leather or canvas webbing is not removed by this procedure and will remain a constant source of danger until the material can be properly decontaminated. All mustard washed from material in this manner lies unchanged on the ground necessitating that the contaminated area be plainly marked with warning signs before abandonment.

(6) The cleaning or decontaminating of material contaminated with lewisite will wash arsenic compounds into the soil, poisoning

**TRUCK, AMPHIBIAN, 2 1/2 -TON, 6 x 6**

many water supplies in the locality for either men or animals.

(7) Leather or canvas webbing that has been contaminated should be scrubbed thoroughly with bleaching solution. In the event this treatment is insufficient, it may be necessary to burn or bury such material.

(8) Detailed information on decontamination is contained in FM 21-40, TM 9-850, and TC 38, 1941, Decontamination.

**61. SPECIAL PRECAUTIONS FOR AUTOMOTIVE MATERIAL**

a. When vehicles have been subjected to gas attack with the engine running, the air cleaner should be serviced by removing the oil, flushing with SOLVENT dry cleaning, and refilling with the proper grade of oil.

b. Instrument panels should be cleaned in the same manner as outlined for instruments.

c. Contaminated seat cushions will be discarded.

d. Washing the compartments thoroughly with bleaching solution is the most that can be done in the field. Operators should constantly be on the alert, when running under conditions of high temperature, for slow vaporization of the mustard or lewisite.

e. Exterior surfaces of vehicles will be decontaminated with bleaching solution. Repainting may be necessary after this operation.



PART II

ORGANIZATIONAL INSTRUCTIONS.

Section X

GENERAL INFORMATION ON MAINTENANCE

	Paragraph
Scope of maintenance operations . . . . .	62
Definition of maintenance terms . . . . .	63
Allocation of maintenance operations . . . . .	64
Maintenance accessibility . . . . .	65
Accessibility operations . . . . .	66

62. SCOPE OF MAINTENANCE OPERATIONS

a. Scope of maintenance operations by vehicle crews and maintenance personnel of Using Arms are determined by ease with which project can be accomplished, amount of time available, weather conditions, concealment, shelter, proximity of hostile fire, equipment, parts available, and skill of personnel. Since all these factors are variable, no exact system of procedure can be prescribed or followed.

b. All maintenance operations within scope of Using Arms maintenance facilities are primarily based on two factors: (1) sufficient time to do job, and (2) facilities necessary to do job. Absence of any one of these factors necessarily places maintenance operation in the next highest echelon.

63. DEFINITION OF MAINTENANCE TERMS

a. Definition of maintenance terms used in succeeding "Allocation of Maintenance Operations" table are as follows:

(1) **Service**, consists of cleaning, lubricating, tightening bolts and nuts, and making external adjustments of sub-assemblies or assemblies and controls.

(2) **Replace**, consists of removing part, sub-assembly or assembly from vehicle and replacing it with a new or reconditioned or rebuilt part, sub-assembly, or assembly, whichever the case may be.

(3) **Repair**, consists of making repairs to, or replacing of the part, sub-assembly, or assembly that can be accomplished without completely disassembling the sub-assembly or assembly and does not require heavy welding or riveting, fitting and or aligning.

(4) **Rebuild**, consists of completely reconditioning and placing in serviceable condition any unserviceable part, sub-assembly, or assembly of the motor vehicle including welding, riveting, machining, fitting, aligning, assembling, and testing.

**TRUCK, AMPHIBIAN, 2½-TON, 6 x 6**

NOTE: The using arm personnel is authorized to remove and reinstall front and rear axles, an engine, transmission or transfer case assembly. However, the replacement of front and rear axles, an engine, transmission or transfer case assembly with **another** front or rear axle, engine, transmission or transfer case assembly, **must not be done by Using Arms unless authorization is received from Ordnance personnel.**

**64. ALLOCATION OF MAINTENANCE OPERATIONS**

a. Following table designates operations allocated to Using Arms maintenance personnel.

b. Table

Manual Section and Unit	Operation
<b>Armament (Section IV)</b>	
Gun Mount .....	Service and Replace
Machine Gun .....	Service and Replace
<b>Preventive Maintenance and Inspection (Section V)</b>	
Chassis and Hull .....	Check, Tighten Bolts, Etc.
<b>Lubrication (Section VI)</b>	
Chassis .....	General Lubrication
<b>Care and Preservation (Section VII)</b>	
Chassis and Hull .....	General Cleaning and Painting
<b>Tools and Equipment (Section VIII)</b>	
Vehicle Tools .....	Service and Replace
Pioneer Tools .....	Service and Replace
Equipment .....	Service and Replace
<b>Front Driving Axles (Section XIII)</b>	
Front Driving Axle Assembly	
(Para. 63a. Note) .....	Service and Replace
Caster and Camber .....	Check
Turning Angle .....	Check and Adjust
Toe-in .....	Check and Adjust
<b>Rear Driving Axles (Section XIV)</b>	
Forward Rear Axle Assembly	
(Para. 63a. Note) .....	Service and Replace
Rearward Rear Axle Assembly	
(Para. 63a. Note) .....	Service and Replace
Axle Shaft .....	Replace
<b>Brake System (Section XV)</b>	
Power System .....	Test and Service
Brake Shoes .....	Service
Brake Assemblies .....	Service and Replace
Brake Pedal and Linkage .....	Service and Replace

**GENERAL INFORMATION ON MAINTENANCE**

<b>Manual Section and Unit</b>	<b>Operation</b>
Master Cylinder Assembly . . . . .	Service and Replace
Hydrovac Assembly . . . . .	Service and Replace
Check Valve Assembly . . . . .	Service and Replace
Hydraulic and Vacuum Lines . . . . .	Service and Replace
Hand Brake Assembly . . . . .	Service and Replace
Hand Brake Linkage . . . . .	Service and Replace
<b>Clutch (Section XVI)</b>	
Clutch Assembly . . . . .	Service and Replace
Clutch Pedal and Linkage . . . . .	Service and Replace
<b>Cooling System (Section XVII)</b>	
System . . . . .	Drain, Clean and Flush
Radiator . . . . .	Service and Replace
Fan and Belts . . . . .	Service and Replace
Water Pump . . . . .	Replace
<b>Electrical System, Wiring (Section XVIII)</b>	
Wiring Harnesses, Wires and Junction Boxes . . . . .	Service and Replace
<b>Electrical System, Starting Motor and Battery (Section XIX)</b>	
Battery . . . . .	Service and Replace
Starting Motor Assembly . . . . .	Service and Replace
<b>Electrical System, Ignition System (Section XX)</b>	
Distributor Assembly . . . . .	Service and Replace
Spark Plugs . . . . .	Service and Replace
Ignition Coil . . . . .	Replace
High and Low Tension Wires . . . . .	Service and Replace
<b>Electrical System, Generator and Control (Section XXI)</b>	
Generator . . . . .	Service and Replace
Regulator . . . . .	Replace
<b>Electrical System, Lighting (Section XXII)</b>	
Head Lamp (service) Assembly . . . . .	Service and Replace
Blackout Driving Lamp Assembly . . . . .	Service and Replace
Blackout Marker Lamp Assemblies . . . . .	Service and Replace
B. O. and Service Stop and Tail Lamp Assemblies . . . . .	Service and Replace
Panel Lamps . . . . .	Replace
Switches . . . . .	Service and Replace
<b>Electrical System, Accessories (Section XXIII)</b>	
Radio Noise Suppression Units . . . . .	Service and Replace
Horn Assembly . . . . .	Service and Replace
<b>Engine (Section XXIV)</b>	
Engine Basic Assembly (Para. 63a, Note) . . . . .	Service and Replace
Cylinder Head and Valve Mechanism . . . . .	Service and Replace

**TRUCK, AMPHIBIAN, 2 1/2-TON, 6 x 6**

<b>Manual Section and Unit</b>	<b>Operation</b>
Oil Pan .....	Service and Replace
Oil Pump .....	Replace
Oil Filter .....	Service and Replace
Crankcase Ventilator System .....	Service and Replace
Manifolds .....	Replace
<b>Exhaust System (Section XXV)</b>	
Manifold and Pipes .....	Service and Replace
Manifold Connections .....	Service and Replace
<b>Frame (Section XXVI)</b>	
Frame Assembly .....	Service
<b>Fuel System (Section XXVII)</b>	
Air Cleaner .....	Service and Replace
Fuel Filter .....	Service and Replace
Fuel Pump .....	Service and Replace
Carburetor .....	Service and Replace
Governor .....	Replace
Fuel Tank .....	Service and Replace
Fuel Lines .....	Service and Replace
<b>Hull and Associated Parts (Section XXVIII)</b>	
Gear Bilge Pump Assembly .....	Service and Replace
Centrifugal Bilge Pump Assembly .....	Service and Replace
Bilge Pump Pipes and Control .....	Service and Replace
Hull Deck Plates, Hatches, and Bulkheads .....	Service and Replace
Windshield Assembly .....	Service and Replace
Tarpaulin and Curtains .....	Service and Replace
<b>Instruments and Gauges (Section XXIX)</b>	
Instrument Panel Assembly .....	Service and Replace
<b>Driving Axle Propeller Shafts (Section XXX)</b>	
Propeller Shaft Assemblies .....	Service and Replace
Propeller Shaft Seals .....	Service and Replace
Propeller Shaft Pillow Block Assy .....	Service and Replace
<b>Water Propeller and Drive (Section XXXI)</b>	
Propeller Shafts and U Joints .....	Service and Replace
Transfer Case .....	Service and Replace
Water Propeller .....	Service and Replace
Water Propeller Strut Bearing .....	Service
Water Propeller Stuffing Box .....	Service and Replace
<b>Spring Suspension (Section XXXII)</b>	
Front and Rear Spring Assemblies .....	Service and Replace
Torque Rods .....	Replace
Shock Absorbers .....	Service and Replace
Spring Seat Assemblies .....	Service and Replace



**GENERAL INFORMATION ON MAINTENANCE**

<b>Manual Section and Unit</b>	<b>Operation</b>
<b>Steering System (Section XXXIII)</b>	
Steering Gear Assembly .....	Service and Replace
Rudder and Linkage .....	Service and Replace
<b>Power Take-off (Section XXXIV)</b>	
Power Take-off Assembly .....	Service and Replace
<b>Driving Axle Transfer Case (Section XXXV)</b>	
Transfer Case Assembly	
(Para. 63a. Note) .....	Service and Replace
<b>Transmission (Section XXXVI)</b>	
Transmission Assembly	
(Para. 63a. Note) .....	Service and Replace
<b>Wheels, Hubs, Bearings, and Tires (Section XXXVII)</b>	
Wheels .....	Service and Replace
Hubs and Bearings .....	Service and Replace
Tires and Rims .....	Service and Replace
<b>Winch (Section XXXVIII)</b>	
Winch Assembly .....	Service and Replace
Winch Controls .....	Service and Replace
Winch Drive Shafts .....	Service and Replace

**65. MAINTENANCE ACCESSIBILITY**

a. Design and purpose of this vehicle necessarily conceals operating units and parts. Purpose of this section is to designate accessibility of such units or parts, and to explain operations necessary to gain access to important vehicle units which require servicing or maintenance. Accessibility table and operations do not include parts of vehicle which are readily accessible and are not concealed beyond conventional automotive practice.

b. Table below alphabetically lists concealed units, with accessibility points (Fig. 43) and reference to operations (Para. 66) required to gain access to units.

**66. ACCESSIBILITY OPERATIONS**

**a. Bow Hatch Cover**

(1) Loosen wing nuts on two hold-down bolts so bolts can be disengaged from cover clamps.

(2) Raise hatch cover at forward edge to open.

(3) Do not force cover open more than hinges permit.

**b. Engine Compartment Hatch Cover.** If access greater than provided by hatch is desired, complete bow deck can be removed by taking out bolts along all edges and disconnecting radiator supports from within engine compartment. However, this procedure is not recommended. Power plant can be removed through engine compartment hatch.

TRUCK, AMPHIBIAN, 2 1/2-TON, 6 x 6

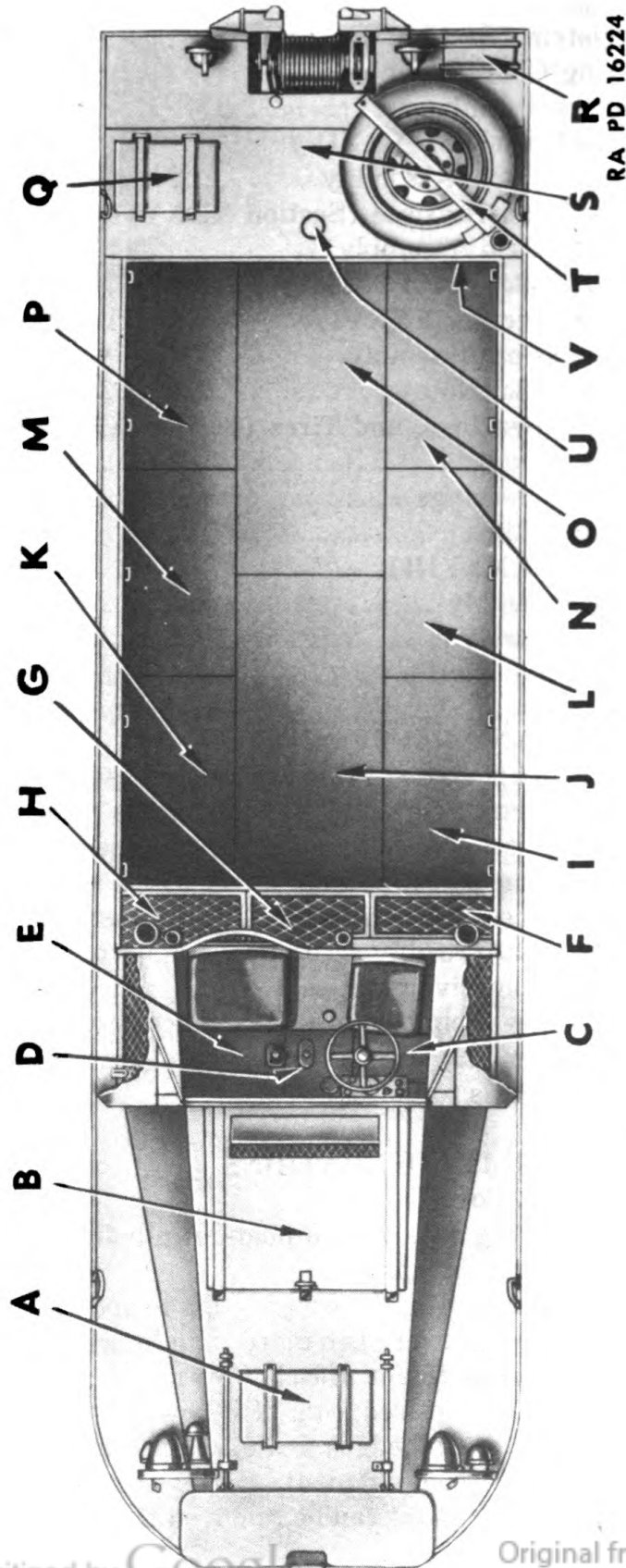

Figure 43—Accessibility Chart  
(See Pages 93 and 94)

**GENERAL INFORMATION ON MAINTENANCE**

Unit	Fig. 43 Letter	Paragraph
Air Cleaner (Engine).....	B	66-b
Air Exhaust Ducts.....	A	66-a
Battery.....	B	66-b
Bearing, Water Prop. Center Shaft Front.....	J	66-f
Bearing, Water Prop. Shaft Thrust.....	O	66-f
Bilge Pump (Gear Type).....	F	66-e
Front Intake Strainer and Hose.....	B	66-b
Discharge Pipe Drain.....	F	66-e
Discharge Pipe Hose Connection.....	F	66-e
Drive Belt Adjustment.....	F	66-e
Drive Belt and Hose Connections.....	G	66-e
Hose Connections.....	C, F	66-c, e, f
Left and Right Rear Intake Pipes Conn. Hoses.....	J	66-f
Left Rear Intake Strainer and Hose.....	N	66-f
Midship Intake Strainer and Hose.....	J	66-f
Reservoir, Inlet Hose and Strainer.....	C, F	66-c, e
Right Rear Intake Strainer and Hose.....	P	66-f
Valves.....	C, F	66-c, e
Valve Controls.....	C	66-c
Bilge Pump (Centrifugal Type).....		
Discharge Pipe and Hose.....	I	66-f
Drive Chain Adjustment.....	J	66-f
Drive Chain and Intake Strainer.....	J	66-f
Brake Line Connections.....	J	66-f
Brake Line Connections (Through Hull).....	O	66-f
Brake Master Cylinder.....	C	66-c
Brake Master Cylinder Filler Plug.....	C	66-c
Brake Pedal Linkage.....	C	66-c
Brake Vacuum System (At Engine).....	B	66-b
Carbureter.....	B	66-b
Clutch Controls.....	C	66-c
Clutch Inspection Hole Cover.....	D	66-d
Cranking Sprocket, Engine (On Water Prop. Shaft).....	G	66-e
Dimmer Switch in Toe Board.....	B	66-b
Distributor.....	B	66-b
Engine and Accessories.....	B	66-b
Engine Mounting Insulators (Front and Rear).....	B	66-b
Engine Oil Drain Plug.....		
Remove Access Plug in Hull Bottom.....		66-l
Engine Oil Filler.....	B	66-b
Engine Oil Filter.....	B	66-b
Engine Water Drain Cock.....	B	66-b
Exhaust Pipes (At Engine).....	A	66-a
Exhaust Pipe Connections (At Engine).....	B	66-b
Fan and Drive.....	B	66-b
Fan Belt Adjustment.....	B	66-b
Frame Mounting Bolts.....	B, J, N, P	66-b, f
Fuel Filter.....	B	66-b
Fuel Gauge Tank Unit (Removal).....	T, S	66-h, i
Fuel Lines at Tank.....	Q	66-g
Fuel Line Union at Rear Bulkhead.....	O	66-f
Fuel Pump.....	B	66-b
Fuel Shut-off Cock.....	B	66-b
Fuel Tank (Removal).....	T, S	66-h, i
Fuel Tank Drain Cock and Hose (Through Hole in Bulkhead).....	N	66-f
Fuel Tank Mounting Strap Bolt Nuts (Through Hole in Bulkhead).....	N	66-f
Gear Shift Lever.....	D	66-d
Generator.....	B	66-b
Hand Brake and Control Linkage (At Main Transfer Case).....	J	66-f
Hand Brake Controls (Forward End).....	D	66-d
Hydrovac Brake Unit (All Service Points).....	J	66-f
Junction Blocks (Wiring).....	B	66-b
Muffler.....	A	66-a
Pintle Hook (Removal).....	Q	66-g
Power Take-off Unit.....	C	66-c

**TRUCK, AMPHIBIAN, 2 1/2-TON, 6 x 6**

Fig. 43

Unit	Letter	Paragraph
Propeller Shaft Front Joint, Forward Rear Axle	J	66-f
Propeller Shaft Front Joint, Rearward Rear Axle	J	66-f
Propeller Shaft Front Joint, Water Propeller Front	G	66-e
Propeller Shaft Rear Joint, Water Propeller Front	J	66-f
Propeller Shaft Rear Joint, Water Propeller Center	O	66-f
Propeller Shaft, Transmission to Water Propeller Transfer Case	D	66-d
Propeller Shaft, Water Propeller Transfer Case to Main Transfer Case	G	66-e
Radiator Drain Cock (Remove Plug on Bulkhead)	A	66-a
Radiator Filler Cap	B	66-b
Radiator Fittings and Mountings	B	66-b
Radiator Overflow Tank and Drain	B	66-b
Radio Interference Noise Suppression Units	B	66-b
Rudder Cable and Front Guide	A	66-a
Rudder Shaft, Control Linkage and Cables	Q	66-g
Rudder Shaft Upper Nut	U	66-k
Seal, Forward Rear Axle Prop. Shaft Housing (Front)	J	66-f
Seal, Front Axle Prop. Shaft Housing (Rear)	G	66-e
Seal, Rearward Rear Axle Prop. Shaft Housing (Front)	J	66-f
Speedometer Drive Shaft and Adapter (At Main Transfer Case)	G	66-e
Stabilizer Rod, Power Plant (Forward End)	C	66-c
Stabilizer Rod, Power Plant (Rear End)	G	66-e
Starting Motor	B	66-b
Starting Motor Control Linkage	D	66-d
Starting Gear and Rudder Cable	B	66-b
Stuffing Box, Rudder	Q	66-g
Stuffing Box, Water Propeller Shaft	O	66-f
Tire Pump Air Tank Drain Cock	F	66-e
Tire Pump Air Tank Safety Valve and Lines	C, F	66-c, e
Tire Pump Control Linkage	C, D, G	66-c, d, e
Tire Pump Drive (At Power Take-off)	C	66-c
Tire Pump Drive and Adjustment	D	66-d
Tools and Equipment	Q, R	66-j
Transfer Case Controls, Main (Forward End)	D, E	66-d, c
Transfer Case Controls, Main (Rear End)	G	66-e
Transfer Case Drain and Filler Plugs, Water Propeller	G	66-e
Transfer Case Drain Plug, Main, Remove Access Plug in Hull Bottom		66-l
Transfer Case Filler Plug, Main	G	66-e
Transfer Case, Main (Front Side and Top)	G	66-e
Transfer Case, Main (Rear Side and Top)	J	66-f
Transfer Case, Water Propeller (Front Side)	D	66-d
Transfer Case, Water Propeller (Rear Side)	G	66-e
Transmission	D	66-d
Transmission Drain Plug, Remove Access Plug in Hull Bottom		66-l
Transmission Filler Plug	E	66-c
Voltage Regulator	B	66-b
Water Propeller Controls	D	66-d
Winch Control Linkage	C	66-c
Winch Drive Shaft Bearing (Center)	O	66-f
Winch Drive Shaft Bearing (Forward)	J	66-f
Winch Drive Shaft Bearing (Rear)	O	66-f
Winch Front Drive Shaft Front Joint	C	66-c
Winch Front Drive Shaft Rear Joint	J	66-f
Winch Front Intermediate Drive Shaft Front Joint	J	66-f
Winch Front Intermediate Drive Shaft Rear Joint	O	66-f
Winch Mounting Studs and Bolt	Q	66-g
Winch Rear Drive Shaft Front Joint	O	66-f
Winch Rear Drive Shaft Rear Joint and Stop Collar	Q	66-g
Winch Rear Drive Shaft Shear Pin	Q	66-g
Winch Rear Intermediate Drive Shaft Front Joint	O	66-f
Winch Rear Intermediate Drive Shaft Rear Joint	O	66-f
Wiring Harness	B	66-b
Wiring Junction Blocks (Front Lights)	A	66-a
Wiring to Rear Lights	Q	66-g



## GENERAL INFORMATION ON MAINTENANCE

(1) Loosen wing nuts on three hold-down bolts so bolts can be disengaged from cover clamps.

(2) Raise hatch cover at forward edge to open.

(3) With hatch cover opened as far as possible, secure in opened position with hold-up chain.

**c. Driver's Compartment Floor Left or Right Sections.** Both left and right floor sections of driver's compartment are attached to supports in the same manner.

(1) Remove five x-recess flat head screws from floor section; two in front edge, two in rear edge, and one in outer edge.

(2) Lift section of floor to clear control levers, etc., and remove from vehicle.

**d. Driver's Compartment Floor Center Section**

(1) Remove four x-recess flat head screws from floor section, one from each corner.

(2) Lift section of floor to clear control levers, etc., and remove from vehicle.

**e. Air Intake Grille Sections**

(1) Grille sections, left, center and right are not attached to supports in any way.

(2) Lift grille section off supports and remove from vehicle.

**f. Cargo Compartment Floor Sections**

(1) Floor sections as shown in Fig. 43 are not attached to supports. Any section can be removed without disturbing remaining sections.

(2) Shift cargo off floor section to be removed.

(3) Using hand holes provided in floor section, lift section and remove from vehicle.

**g. Stern Compartment Hatch Cover**

(1) Loosen wing nuts on two hold-down bolts so bolts can be disengaged from cover clamps.

(2) Raise hatch cover at forward edge to open.

(3) Do not force cover open more than hinges permit.

**h. Spare Wheel and Tire**

(1) Loosen hex nut on tire carrier hold-down bolt sufficiently to disengage hook at lower end of bolt from eye bolt.

(2) Swing hold-down strap assembly up and toward front of vehicle to free wheel and tire.

(3) Slide wheel and tire toward rear of vehicle to clear guard and lift wheel and tire off from stern deck.

**i. Stern Deck Plate**

(1) Remove spare wheel and tire as directed in Item **h.** above.

(2) Remove bolts attaching deck plate to supports along each edge and to three reinforcing members.

**TRUCK, AMPHIBIAN, 2 1/2-TON, 6 x 6**

(3) Remove fuel tank filler cap from filler neck and disconnect chain which attaches cap.

(4) Loosen rubber seal between filler neck and stern deck plate and slide seal upward to remove from filler neck.

(5) Stern deck plate is now completely loosened and may be lifted up to clear fuel tank filler neck at left end and removed from vehicle.

**j. Tool Compartment Hatch Cover**

(1) Loosen wing nut on hold-down bolt so bolt can be disengaged from cover clamp.

(2) Raise hatch cover at right edge to open.

(3) Do not force cover open more than hinges permit.

**k. Rudder Shaft Nut Access Cover.** Access cover is provided to permit removal of nut at upper end of rudder shaft. This is necessary whenever rudder is to be removed in an emergency or for replacement.

(1) Remove screws attaching cover to stern deck plate and remove cover.

**l. Access Plugs.** Access plugs are provided in bottom of hull below engine crankcase drain plug, transmission drain plug and main transfer case drain plug. When access plugs are removed, drain plugs can be unscrewed and units drained.

(1) Using a suitable tool, unscrew access plug beneath unit to be drained.

(2) When installing plug be sure that plug is tightened securely to prevent leakage into hull. Use waterproof grease on plug threads.

**Section XI**  
**SPECIAL TOOLS**

**67. MAINTENANCE SPECIAL TOOLS**

a. Following list itemizes special tools employed in the maintenance of this vehicle. Tools such as listed, or their equivalent, are recommended.

<b>Mfg's Symbol</b>	<b>Mfg's Tool No.</b>	<b>Name</b>
TSA	T-1000	Micro-Liner Set
KM	J-1665	Tie-Rod Bushing Tool
KM	KMO-347	Tie-Rod Bushing Reamer
CSM	CS-1033	Brake Cylinder Gauge
BRE	B-120	Brake Lining Grinder
CSM	CS-1032	Bleeder Pressure Tank
KM	J-747	Brake Bleeder Hose
CSM	CS-1038	Wheel Cylinder Clamp
KM	KMO-142	Brake Spring Pliers
KM	KMO-3	Brake Tubing Cutter
KM	J-1885	Double Lap Flaring Tool Set
KM	K-411	Clutch Aligning Arbor
KM	J-164	Pilot Bearing Remover
KM	J-1895	Clutch Housing Pilot Hole Dial Indicator
KM	K-410	Pilot Bearing Driver
CSM	CS-1036	Water Pump Pulley Puller
AEE	F-131	Tester Battery
AEE	F-8	Volt Meter (Low Reading)
AEE	13	Timing Light
AEE	23	Timing Light
AEE	G-3	Tension Scale
STT	MT-1000	Torque Wrench
KM	J-2341	Bilge Pump Packing Nut Spanner (Centrifugal)
KM	J-2342	Bilge Pump Packing Nut Wrench (Gear)
KM	J-2345	Oil Seal Pillow Block Replacer (Both Ends)
KM	J-2344-A	Pillow Block Bearing Cup Replacer
KM	J-2343	Pillow Block Bearing Cone Replacer
KM	J-2344-B	Pillow Block Bearing Cup Remover
KM	J-1714	Flange Puller
KM	J-1714	Flange Puller
KM	J-2361	Propeller Puller
KM	J-2310	Shackle Pin Puller
STT	MT-1000	Torque Wrench
KM	J-544-A	Tension Scale
KM	J-1376-G	Pitman Arm Puller
KM	J-1663	Adjusting Nut Wrench

**TRUCK, AMPHIBIAN, 2 1/2-TON, 6 x 6**

<b>Mfg's Symbol</b>	<b>Mfg's Tool No.</b>	<b>Name</b>
KM	J-1660-3	Bearing Cup Driver Handle
KM	J-2347	Front Hub Oil and Water Seal Driver
KM	J-870	Rear Wheel Bearing Nut Wrench
KM	J-872-1	Rear Wheel Outer Bearing Race Tool
KM	J-872-4	Rear Wheel Inner Bearing Race Replacer
KM	J-2346	Rear Hub Oil and Water Seal Driver
AHB	T-300	Bearing Lubricator



Section XII

**ORGANIZATION SPARE PARTS AND ACCESSORIES**

	<b>Paragraph</b>
Organization spare parts .....	68
Accessories .....	69

**68. ORGANIZATION SPARE PARTS**

a. A set of organization spare parts is supplied to the Using Arms for field replacement of those parts most likely to become broken, worn or otherwise unserviceable. The set is kept complete by requisitioning new parts for those used. Organization spare parts are listed in pertinent SNL's.

b. Care of organization spare parts is covered in the section of this manual entitled "Care and Preservation."

**69. ACCESSORIES**

a. Accessories include tools and equipment required for such disassembling and assembling as the Using Arms is authorized to perform, and for the cleaning and preservation of the gun carriage, sighting and fire control equipment, ammunition, etc. They also include chests, covers, tool rolls, and other items necessary to protect the material when it is not in use, or when traveling. Accessories should not be used for purposes other than as prescribed, and when not in use should be properly stored.

b. There are a number of accessories whose names or general characteristics indicate their use. Others, embodying special features having special uses, are described below:

- (1) **Bilge pump**, hand for use in emergency—stowed on right-hand front deck.
- (2) **Tire pump**, driven from auxiliary power take-off.

Section XIII

**AXLE, FRONT DRIVING**

	Paragraph
Description .....	70
Operation .....	71
Trouble-shooting .....	72
Preventive maintenance and inspection .....	73
Front wheel alignment .....	74
Front axle assembly replacement.....	75
Axle shaft and universal joint assembly replacement.....	76
Steering knuckle bearing replacement .....	77
Differential and carrier assembly replacement .....	78
Tie rod replacement .....	79

**70. DESCRIPTION**

a. Front axle is a single reduction, spiral beveled driving unit with full-floating axle shafts for universal joints on each shaft at the steering knuckle. Axle assembly is mounted on semi-elliptic springs.

**71. OPERATION**

a. Power is transmitted from main transfer case to front axle by tubular propeller shaft enclosed in metal housing. Housing is attached at hull end by a hinge and rubber bellows type seals are used at each end. A shift lever is provided in cab to permit driver to engage and disengage the front axle at main transfer case. Detailed instructions covering front axle engagement and disengagement are given in "Controls and Operation" section of this book.

**72. TROUBLE SHOOTING**

a. In most cases, an unusual noise is the first indication of improper functioning of axle driving units. Since the differential and pinion assemblies are the same in both front and rear axles the information on these parts given under "Trouble-Shooting" in Para. 82, Section XIV, applies equally to the front axle and is not repeated in this section. Front wheel alignment, condition of housing, and condition of steering knuckle assemblies have major effects on steering and on front tire wear. These conditions are generally applicable only when vehicle is used in land operation. The most common difficulties, their cause, and the probable remedies are given in the following table.

**b. Trouble-Shooting Table**

Symptom and Probable Cause	Probable Remedy	Refer to Paragraph
(1) <b>Wandering</b>		
(a) Steering gear or linkage adjustment incorrect.	Adjust	255

**AXLE, FRONT DRIVING**

<b>Symptom and Probable Cause</b>	<b>Probable Remedy</b>	<b>Refer to Paragraph</b>
(b) Spring mounting incorrect or spring broken.	Correct mounting or replace spring . . . . .	245
(c) Axle housing twisted or bent causing unequal or insufficient caster.	Replace complete axle assembly . . . . .	75
(d) Front wheel bearings out of adjustment.	Adjust bearings . . . . .	284
<b>(2) Vehicle pulls to one side</b>		
(a) Tires inflated incorrectly.	Inflate to proper pressure . . . . .	288
(b) Diameters of front tires unequal.	Install tires having same diameters . . . . .	280
(c) Camber angles not equal.	Adjust wheel bearings, or replace axle assembly, whichever is necessary . . . . .	75-284
<b>(3) Shimmy</b>		
(a) Tire inflation pressure low or uneven.	Inflate to proper pressure . . . . .	288
(b) Hub, wheel and tire assemblies unbalanced or wheels bent.	Balance or replace assemblies . . . . .	283
(c) Shock absorbers not functioning correctly.	Refill or replace . . . . .	249
(d) Excessive caster (especially if shimmy occurs at low speeds).	Tighten spring U-bolts, replace springs, or replace axle assembly, whichever is necessary . . . . .	75-245
(e) Wheel bearings loose or worn.	Adjust or replace as necessary . . . . .	284
<b>(4) Hard steering</b>		
(a) Tires underinflated.	Inflate to correct pressure . . . . .	288
(b) Lack of lubrication.	Lubricate tie rod bolts, steering gear and drag link . . . . .	Sec. VI
(c) Spring U-bolts loose or spring broken causing misalignment of front wheels.	Tighten bolts or replace springs as found necessary . . . . .	245
(d) Axle shaft universal joint assemblies improperly lubricated.	Lubricate . . . . .	Sec. VI

**TRUCK, AMPHIBIAN, 2½-TON, 6 x 6**

Symptom and Probable Cause	Probable Remedy	Refer to Paragraph
(e) Steering gear adjustment incorrect.	Adjust steering gear.	255
(5) Uneven tire wear		
(a) Wheel alignment incorrect.	Inspect all wheel alignment factors and adjust or replace any defective parts . . . . .	74
(b) Tires inflated improperly.	Inflate to correct pressure . . . . .	288

**73. PREVENTIVE MAINTENANCE AND INSPECTION**

a. Regular preventive maintenance and inspection operations as outlined in Section V, "Preventive Maintenance and Inspection," should be accomplished at the intervals indicated. Regular inspection of the front axle unit is essential to obtain maximum service. This is particularly necessary for front wheel alignment.

b. Lubrication of front axle unit is important, particularly after water operation. Reference should be made to Section VI, "Lubrication," for type of lubricant, lubrication intervals, and method of draining and flushing differential carrier.

c. When making inspection of the front axle unit, consideration should be taken of other alignment units such as brakes, steering gear, etc. Functions in these related units will affect front axle operation.

**74. FRONT WHEEL ALIGNMENT**

a. Front wheel alignment has a major effect on steering from the standpoint of control, ease of steering and safety. Front wheel misalignment also is a major cause of premature and uneven tire wear. The factors involved in front wheel alignment, which apply to the vehicle described in this manual, are caster, camber, toe-in and turning angle.

**b. Caster**

(1) Caster is the inclination of the center-line through upper and lower steering knuckle trunnions towards rear of vehicle, and is measured in degrees (dimension "L" in Fig. 44). The correct caster angle for this vehicle is 1½ to 2 degrees. There is no adjustment for this dimension. An accurate determination of caster angle requires use of special instruments such as shown in Fig. 45, for example. Follow instructions of instrument manufacturer in making measurement.

(2) If axle caster angle is found to be less than 1½ degrees or more than 2 degrees, it is probably the result of loose, sagging or broken springs, or of a twisted axle housing. Inspect springs and



**AXLE, FRONT DRIVING**

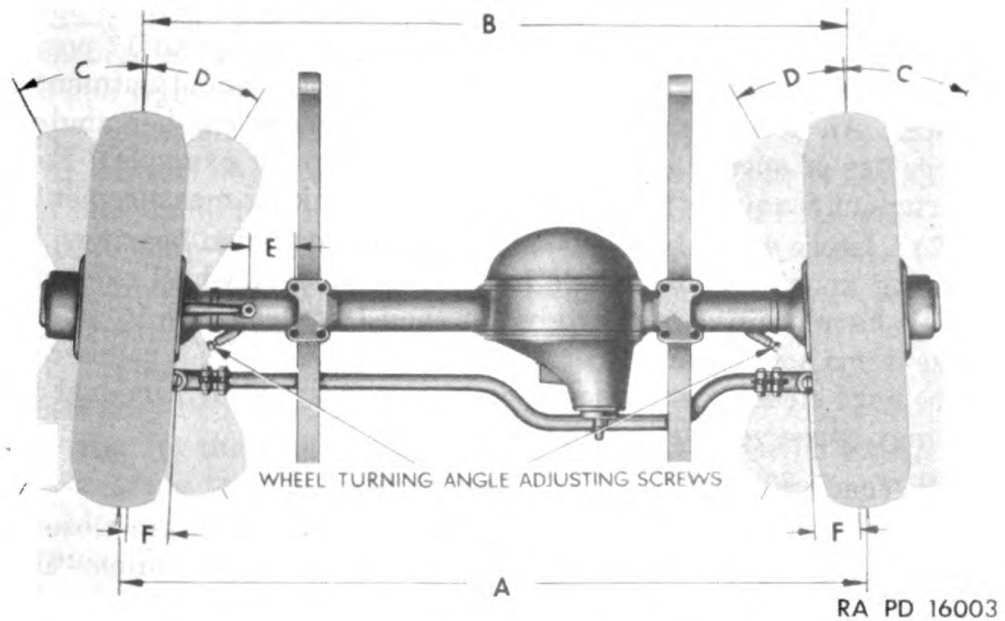
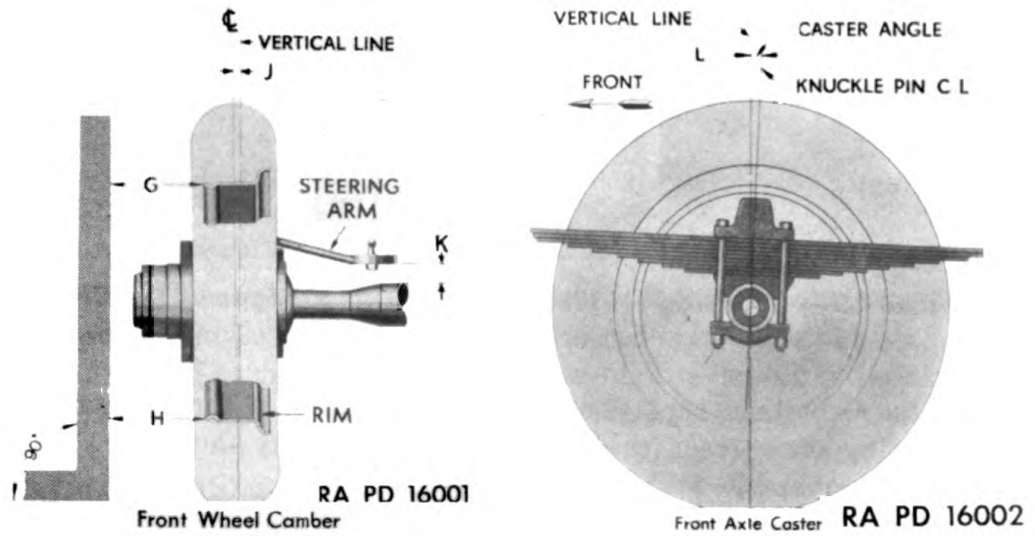

- |  |  |
|--|--|
| <b>A</b> Minus <b>B</b> Toe-In                                 | <b>F</b> Backing Plate to Center Line of Tie-Rod Yoke Bolt |
| <b>C</b> Turning Angle (Inside)                                | <b>H</b> Minus <b>G</b> Wheel Camber (inches)              |
| <b>D</b> Turning Angle (Outside)                               | <b>J</b> Wheel Camber (Degrees)                            |
| <b>E</b> Center Line of Steering Arm Ball to Outside of Spring | <b>K</b> Bottom of Steering Arm to Top of Axle Housing     |
|  | <b>L</b> Caster Angle (Degrees)                            |

**Figure 44—Front Wheel Alignment Chart**

## TRUCK, AMPHIBIAN, 2½-TON, 6 x 6

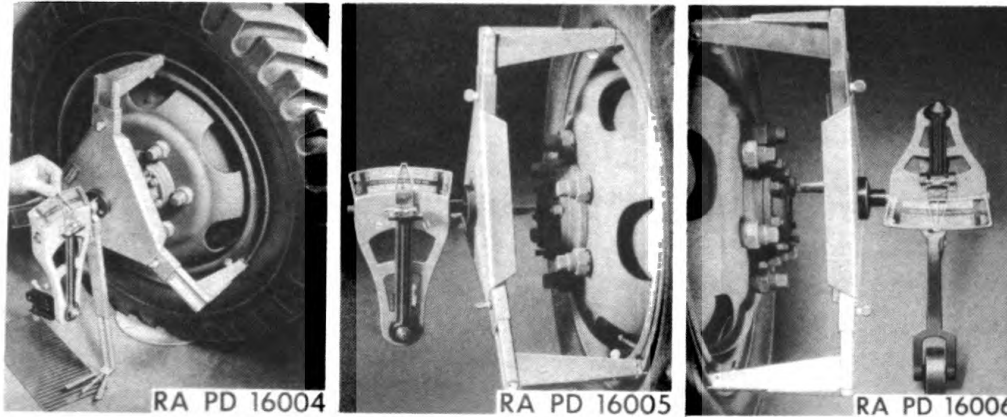

**Figure 45—Checking Caster Angle**      **Figure 46—Checking Camber**      **Figure 47—Checking Toe-In**

tighten U-bolts or replace springs as necessary. If springs and spring mounting are correct, the complete axle assembly should be replaced.

#### c. Camber

(1) Camber is the sidewise inclination of the front wheels. Positive camber is outward inclination of wheels as viewed from front of vehicle, that is, the wheels are farther apart at the top than at the bottom (dimensions "H" minus "G" in Fig. 44). Negative camber is inward inclination of wheels as viewed from front of vehicle. Correct camber angle for front wheels on this vehicle is  $\frac{1}{2}^{\circ}$  to  $1^{\circ}$  positive with wheels in straight ahead position. There is no adjustment for camber. An accurate determination of the wheel camber angle requires use of special instruments (see Fig. 46 for example). Follow instrument manufacturer's instructions in taking measurement.

(2) Loose wheel bearings, loose knuckle trunnion bearings, bent steering knuckle or bent axle housing will affect wheel camber. If wheels have positive camber greater than  $1^{\circ}$  or less than  $\frac{1}{2}^{\circ}$ , inspect these items and adjust or replace as required. Incorrect camber may cause hard steering and uneven or excessive tire wear. Unequal camber may cause vehicle to pull to one side.

#### d. Toe-In

(1) Toe-in is the amount by which front wheels are closer together at the front than at the rear (dimensions "A" minus "B" in Fig. 44). Correct toe-in for this vehicle is 0" to  $\frac{3}{16}$ " measured at wheel rims or 0" to  $\frac{1}{4}$ " measured at centers of tire tread. An adjustable tie-rod, connecting the two steering knuckles, is used to adjust toe-in. An instrument or gauge designed for the purpose should be used to obtain an accurate toe-in measurement, following instrument manufacturer's instructions. (See Fig. 47.) Loose wheel bearings, worn bushings in steering knuckle support, damaged wheels, bent steering knuckle, bent axle housing or a bent or improperly adjusted

## AXLE, FRONT DRIVING

tie-rod will affect toe-in. If toe-in is found to be incorrect adjust wheel bearings as instructed in Para. 284 or replace wheels if damaged, before adjusting tie-rod to correct toe-in. Always check castor and camber angles after adjusting tie-rod. The tie-rod has finer threads (16 per inch) on left-hand end than on right end (12 per inch). By making adjustment at both ends of tie-rod, a fine degree of toe-in adjustment can be made.

### e. Toe-In Adjustment Procedure

(1) Inflate tires to correct pressure (40 lbs.) and place vehicle on smooth, level surface with front wheels in straight-ahead position. Remove cotter pin, nut and tie-rod bolt from each steering knuckle support and remove each tie-rod yoke from steering knuckle supports. Remove clamp bolts and key from each tie-rod yoke. Screw yokes onto or off of tie-rod as required to correct toe-in. Toe-in will be increased about  $\frac{1}{8}$ " by backing right-hand yoke (coarse threads) one turn towards end of rod and turning left-hand yoke (fine threads) one turn further onto tie-rod. Reversing this process will decrease toe-in by the same amount.

(2) After adjusting yokes, connect tie-rod to each steering knuckle, putting each tie-rod bolt in place. It is not necessary to replace nuts until final adjustment has been made. Measure toe-in and readjust tie-rod, if necessary, until toe-in is between 0" and  $\frac{3}{16}$ " (measured at wheels rims). When final adjustment is complete, install and tighten tie-rod bolt nuts until they are snug, then back off  $\frac{1}{3}$  to  $\frac{1}{2}$  a turn and install new cotter pins.

(3) Insert key at each tie-rod yoke clamp with hole in key aligned with one clamp bolt hole, insert clamp bolt (two at each yoke) and tighten clamp bolt nuts, using new lockwashers. Lubricate tie-rod bolts as instructed on lubrication chart for this vehicle.

### f. Turning Angle

(1) The turning angle is the maximum angle through which wheels may be turned from the straight-ahead position. This angle is greater for the inside wheel than the outside wheel on a turn. The correct angle for the inside wheel is  $28^{\circ}$  to  $29^{\circ}$  (dimension "C" in Fig. 44) and the angle for the outside wheel is  $24^{\circ}-15'$  to  $25^{\circ}-6'$  (dimension "D" in Fig. 44). Stop screws on axle housing are provided for each wheel to limit the angle through which the inside wheel can turn (angle "C" in Fig. 44).

### g. Turning Angle Adjustment Procedure

(1) Turn wheels to extreme left position. Adjust stop screw until angle "C" is correct for left wheel in accordance with "Specifications." Use an accurate turning angle instrument to obtain correct angle, following instrument manufacturer's instructions.

(2) With wheels in position giving correct reading for angle



**TRUCK, AMPHIBIAN, 2 1/2-TON, 6 x 6**

“C” on left wheel check angle “D” for right wheel. If this angle is incorrect toe-out on turns will be incorrect. Bent, loose or twisted tie-rod may cause this condition.

(3) Tack-weld or braze stop screw to housing when angle is set correctly.

(4) Adjust angle “C” for right-hand wheel by turning wheels to extreme right and repeating operations given for left-hand turning angle.

**75. FRONT AXLE ASSEMBLY REPLACEMENT**

a. Front axle assembly may be removed as a complete unit by first supporting front end of vehicle on blocks, removing fender skirts and wheels, and disconnecting brake connections, shock absorbers, steering gear drag link, axle propeller shaft, and springs from axles.

**b. Removal Procedure****(1) Remove fender skirts and wheels**

Remove the two bolts attaching each fender skirt to hull and remove the skirts. Install dolly jack under front axle differential housing and raise front axle high enough to permit removal of wheels. Remove front wheels.

**(2) Support front end of vehicle on blocks**

Install blocks under hull back of front axle, placing blocks in a position where they will support entire front end weight safely and without damage to hull. Blocks must be high enough to permit withdrawal of axle assembly on dolly jack. When blocks are in place, lower jack until hull rests on blocks and all axle weight is on jack. Disconnect brake connections at fittings at hull. Instructions given in Para. 102 must be followed explicitly.

**(3) Disconnect shock absorbers and drag link**

Remove nut from pin attaching lower end of shock absorber link to eye-bolt at spring bumper block and remove tapered pin. Remove cotter pin from ball stud in steering arm at left-hand knuckle. Loosen nut on ball stud until top of nut is beyond threaded end of stud. Tap nut to loosen tapered stud from arm, remove nut and then remove stud from arm.

**(4) Disconnect axle propeller shaft housing and shaft**

Disconnect rubber bellows at axle end of housing from differential carrier as instructed in Para. 225. Disconnect propeller shaft at axle drive pinion as instructed in Para. 226.

**(5) Remove axle**

Remove nuts from “U” bolts at each spring and remove “U” bolts. Lower axle on dolly jack and withdraw from underneath chassis.



## AXLE, FRONT DRIVING

### c. Installation Procedure

#### (1) Attach axle assembly to springs

Place complete front axle assembly on dolly jack and move into position under vehicle. Raise assembly into position against springs, being certain spring center bolt heads enter holes in axle spring pads. Install spring "U" bolts, spring bumper plate and shock absorber eye bolt and plate. Tighten "U" bolt nuts.

#### (2) Connect shock absorbers and brake lines

Insert tapered link pin through lower end of shock absorber link and link eye bolt, install nut on pin, and tighten nut at each shock absorber. Connect brake flexible tubing at hull connections and bleed front brakes in accordance with instructions in Para. 93.

#### (3) Connect drag link, shaft and propeller shaft housing

Install drag link tapered ball stud in steering arm at left end of axle, put nut on stud and tighten securely. Lock nut in place with new cotter pin. Attach propeller shaft at axle drive pinion as instructed in Para. 226. Attach housing and seal at axle differential carrier as instructed in Para. 225.

#### (4) Inspect axle for lubrication

Inspect differential housing and universal joints. Add or replace lubricant as required in accordance with lubrication chart for this vehicle.

#### (5) Inspect front wheel alignment

Check all front wheel alignment factors in accordance with instructions in Para. 74 in this section.

### 76. AXLE SHAFT AND UNIVERSAL JOINT ASSEMBLY REPLACEMENT

a. Axle shaft and universal joint assemblies may be removed without removing complete axle assembly from vehicle. However, it is necessary to remove wheel, hub, brake shoes and anchor plate assembly, anchor plate spacer, hub inner oil deflector, brake dust shield and steering knuckle. Notify Ordnance Personnel.

### 77. STEERING KNUCKLE BEARING REPLACEMENT

a. Replacement and adjustment of steering knuckle trunnion bearings requires removal of axle shaft and universal joint assemblies, housing outer end seal (seal attached to inner side of steering knuckle support), tie-rod and steering knuckle trunnions.

After extensive salt water operations, inspection should be made of lubricant in trunnion bearing housing. Remove lubrication fitting (Fig. 48) and examine lubricant. If oil shows presence of salt water, trunnion bearings should be removed, washed, and assembly thor-

**TRUCK, AMPHIBIAN, 2 1/2-TON, 6 x 6**

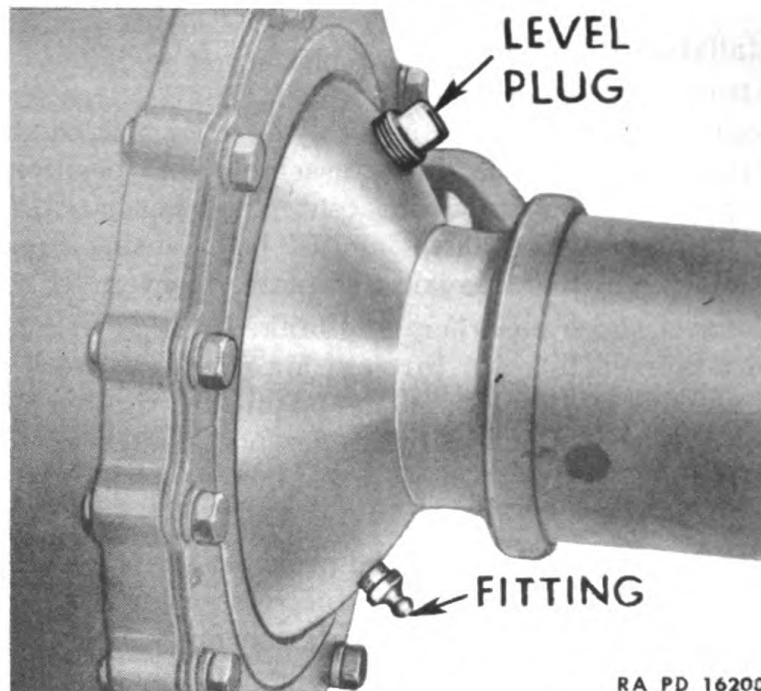

RA PD 16200

**Figure 48—Oil Level Plug and Fitting at Front Axle Universal**

oughly lubricated. Notify Ordnance. Fig. 49 shows construction of shaft and universal joint assembly.

**78. DIFFERENTIAL AND CARRIER ASSEMBLY REPLACEMENT**

a. The differential and carrier assembly may be removed only as a complete assembly. Both axle shaft and universal joint assemblies must be removed, tie-rod must be removed and the axle propeller shaft and propeller shaft housing must be disconnected before carrier can be removed. Notify Ordnance Personnel.

**79. TIE-ROD REPLACEMENT**

a. Tie-rod and tie-rod yokes may be removed from vehicle by removing tie-rod bolts from steering knuckle supports. No other parts are affected. See Fig. 51.

**b. Removal Procedure**

**(1) Disconnect tie-rod**

Remove cotter pin and nut from tie-rod bolt at each steering knuckle support. Drive out each bolt and pull tie-rod yokes off knuckle supports.

**(2) Inspect knuckle support bushings**

Inspect bushing in each knuckle support and replace if worn or scored excessively. The inside diameter of this bushing should be 0.7495"-0.7505" and there should be 0.0005" to 0.0025" clearance between tie-rod bolt and bushing. If necessary to replace bushing, proceed as follows:

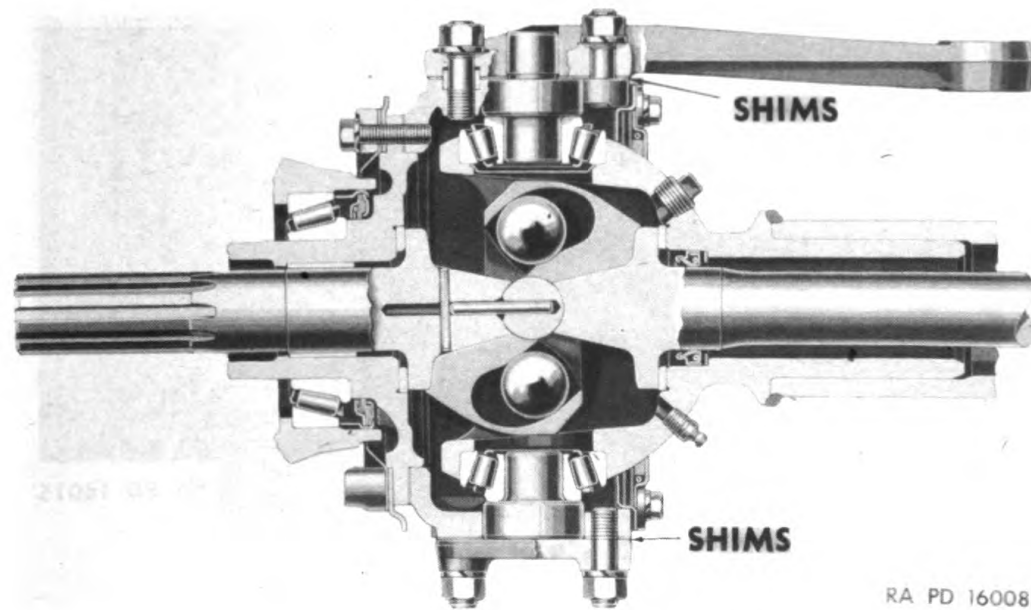
**AXLE, FRONT DRIVING**

RA PD 16008

**Figure 49—Steering Knuckle and Universal Joint Assembly**

(a) Drive old bushing out of knuckle support with special driver KMJ-1665 as shown in Fig. 52.

(b) Install new bushing with same tool.

(c) With bushing in place, ream to size with reamer KM-347.

**(3) Inspect tie-rod and yokes**

Examine rod for evidence of bending or twisting. Check condition of threads at ends of rod and in yokes. Inspect bolt holes

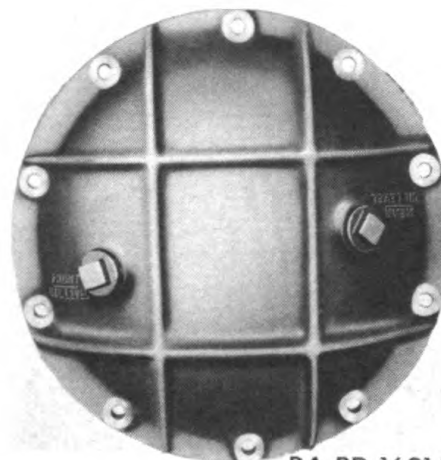

RA PD 16014

**Figure 50—Install Cover in Position shown on Front Axle**



**TRUCK, AMPHIBIAN, 2½-TON, 6 x 6**

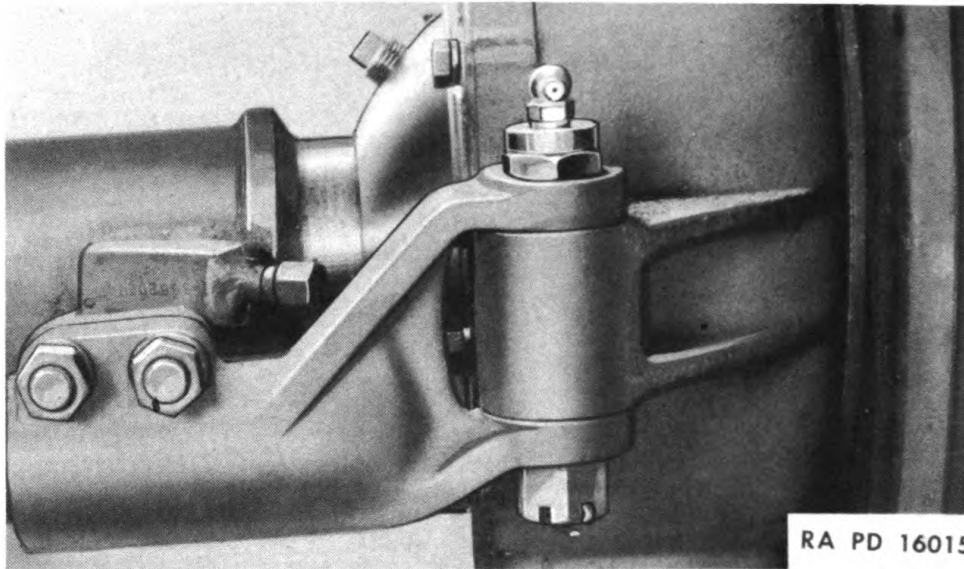

**Figure 51—Tie-Rod End Construction**

in yokes. Use new parts in place of any that are damaged or worn excessively.

**c. Installation Procedure**

**(1) Install tie-rod**

Place tie-rod in position with yokes on steering knuckle supports. Lubricate bushings and install tie-rod bolts.

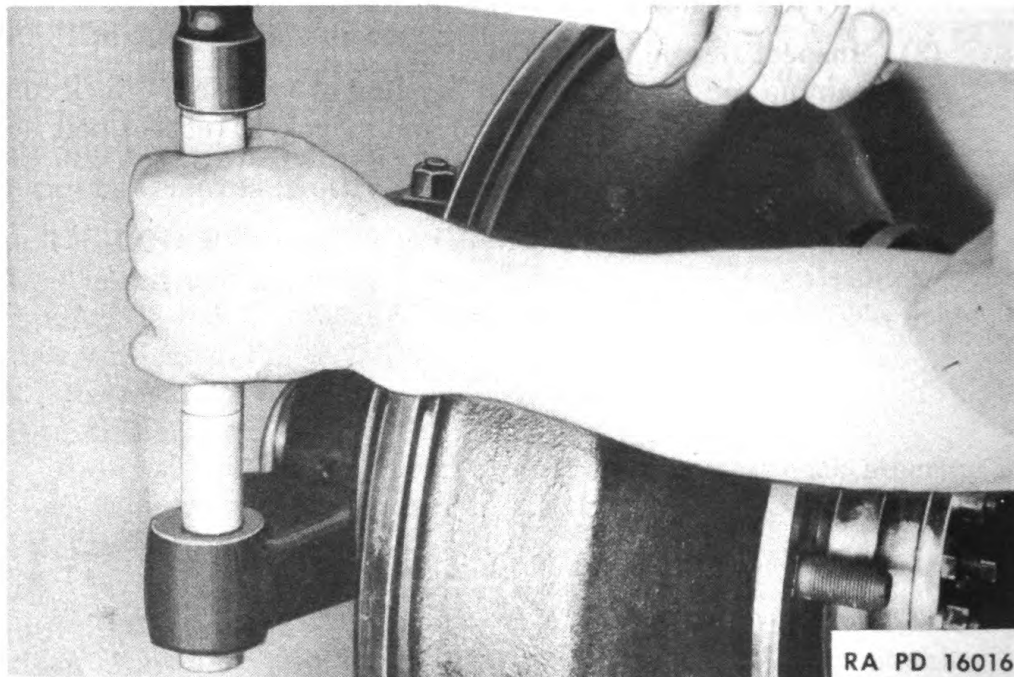

**Figure 52—Typical Method of Removing and Installing Tie-Rod Bushing**



**AXLE, FRONT DRIVING****(2) Adjust front wheel toe-in**

Check toe-in, adjust tie-rod as instructed in Para. 74 in this section.

Section XIV

**AXLE, REAR DRIVING**

	Paragraph
Description .....	80
Operation .....	81
Trouble-shooting .....	82
Preventive maintenance and inspection.....	83
Rear axle assembly replacement.....	84
Axle cover replacement .....	85
Axle shaft replacement .....	86
Differential and carrier assembly replacement .....	87

**80. DESCRIPTION**

a. Two single reduction spiral bevel, full floating driving axles are used on this vehicle. All driving and braking load is taken by rubber bushed torque rods, three between each axle and vehicle frame. Vehicle weight and load is supported by inverted semi-elliptic springs attached at centers to seats on ends of trunnion cross shaft and with ends resting free on axle housings.

**81. OPERATION**

b. Power is transmitted from main transfer case to forward rear axle by a single tubular propeller shaft. Power to rearward rear axle is transmitted from transfer case to a pillow block on top of forward rear axle housing and thence to rearward rear axle by another propeller shaft. Propeller shafts to forward rear axle and to pillow block are enclosed in metal housings, hinged at one end to hull bulkhead and with rubber bellows-type seals at each end.

**82. TROUBLE-SHOOTING**

a. An unusual noise is usually the first evidence of improper functioning of driving axle parts. Occasionally, noises which seem to come from rear axles may be caused by some other unit, such as transfer case or transmission. Also, improper tire inflation or uneven tire wear may be the cause of a noise which seems to come from the axle. Common symptoms of axle difficulties and probable remedies are tabulated in the following paragraph. The table applies, in general, to land operation only.

**b. Trouble-Shooting Table**

Symptom and Probable Cause	Probable Remedy	Refer to Paragraph
<b>(1) Continuous axle noise</b>		
(a) Tires improperly inflated or tread worn unevenly. (Check by driving vehicle on soft, unfinished road surface and if this stops noise, noise is	Inflate tires to correct pressure (40 lbs.) or	

Generated on 2013-07-25 14:01 GMT / http://hdl.handle.net/2027/uc1.b3243762  
Public Domain, Google-digitized / http://www.hathitrust.org/access\_use#pd-google

**AXLE, REAR DRIVING**

Symptom and Probable Cause	Probable Remedy	Refer to Paragraph
being caused by tires and not by axle).	replace if tread is worn unevenly . . . . .	288
(b) Wheel bearings worn, out of adjustment, or in need of lubrication.	Replace, adjust or lubricate wheel bearings, as found necessary . . . . .	286
(c) Differential bearings or gears worn or out of adjustment.	Replace complete differential and carrier assembly (Notify Ordnance)	
(d) Insufficient or improper lubricant in differential housing.	Clean out differential housing and lubricate . . . . .	Sec. VI
<b>(2) Axle Noise On Drive Only Or On Coast Only</b>		
(a) Differential pinion and ring gear out of adjustment or worn excessively.	Replace differential and carrier assembly (Notify Ordnance)	
<b>(3) Excessive Back Lash In Axle Driving Parts</b>		
(a) Axle shaft flange screws loose or holes in flange worn.	Tighten flange screws or replace axle shaft, whichever is found necessary . . . . .	86
(b) Ring gear and pinion out of adjustment or worn excessively, differential side gear or pinion thrust washers worn.	Replace differential and carrier assembly (Notify Ordnance)	

**83. PREVENTIVE MAINTENANCE AND INSPECTION**

a. Operations itemized in Section V, "Preventive Maintenance and Inspection" at intervals indicated, should be accomplished on both forward and rearward rear axles.

b. Reference should be made to preventive maintenance and inspection operations which pertain to other allied units such as wheels, brakes, propeller shafts, etc. when accomplishing inspection operations on rear axle units.

c. Reference to Section VI, "Lubrication" for type of lubricant, lubrication intervals and methods of draining and flushing differential carrier.

**84. REAR AXLE ASSEMBLY REPLACEMENT**

a. Removal of either of the two rear axles requires supporting vehicle at rear on jacks or blocks, supporting axle to be removed

## TRUCK, AMPHIBIAN, 2 1/2-TON, 6 x 6

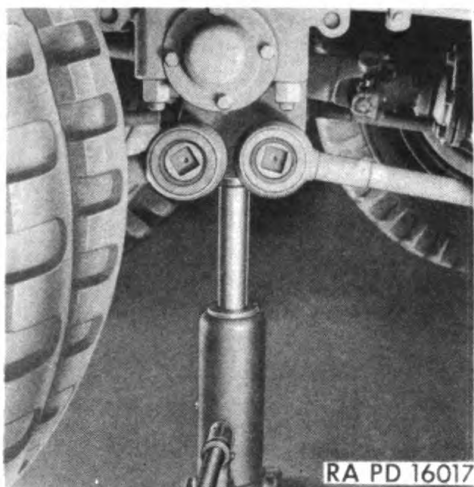

**Figure 53—Method used in Jacking Up Rear End**

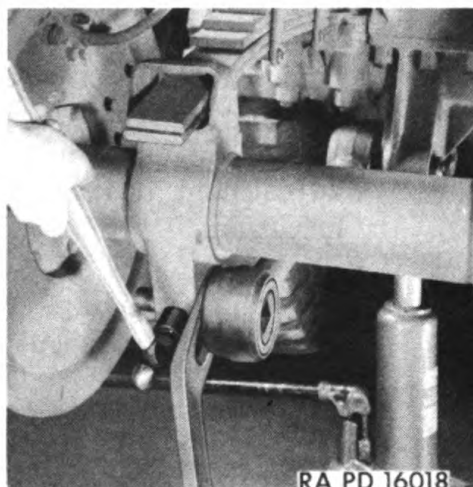

**Figure 54—Disconnecting Torque Rods from Axle**

on a suitable dolly or jack, disconnecting attaching parts, moving axle away from ends of springs and withdrawing sidewise from underneath vehicle.

**b. Removal Procedure (Figs. 53 and 54)**

**(1) Jack up rear end of vehicle**

Install jacks under each axle trunnion cross shaft brackets and raise rear of vehicle until all load is removed from rear springs. (See Fig. 53 for example.) Then support axle to be removed on dolly or suitable jack and raise jack until all axle weight is on jack. Be sure dolly or jack is located to permit withdrawal of axle after disconnecting.

**(2) Remove wheels**

Follow instructions given in Para. 283.

**(3) Disconnect brake lines**

Disconnect forward rear axle brake wheel cylinder flexible connections at hull.

**(4) Remove pillow block**

Note: This operation applies only to forward rear axle removal. Remove the 4 bolts and washers which attach pillow block to bracket on forward rear axle housing and support pillow block so that joints and propeller shaft housing will not be damaged.

**(5) Disconnect axle propeller shaft**

At forward rear axle, disconnect propeller shaft housing and propeller shaft at axle differential carrier as explained in Para. 226. At rearward rear axle, disconnect propeller shaft at differential as explained in Para. 226.

**(6) Disconnect torque rods**

Remove nuts and washers from the three torque rod ends at



## AXLE, REAR DRIVING

brackets on axle housing and force torque rod pins out of brackets. Strike each bracket sharply with a heavy hammer to start the pins while prying with claw bar. (See Fig. 54 for example.)

### (7) Remove axle assembly

With axle resting on dolly jack, move forward or rearward until end of springs are out of brackets on axle housing. Then lower dolly jack and withdraw axle assembly sidewise from underneath vehicle.

### c. Installation Procedure

#### (1) Place axle assembly in position under vehicle

Set complete axle assembly on dolly jack and roll into approximate position under vehicle. Raise assembly on dolly jack until ends of springs are in line with brackets on top of axle housing. Then move dolly jack and axle into position with spring ends in housing brackets.

#### (2) Connect torque rods

Clean all grease or oil from torque rod end pins and see that rubber bushings are clean and free from dirt or grease. Connect the torque rods to axle by inserting torque rod pins in axle brackets. Connect the two lower rods, forcing torque rod and pins into place solidly, using a heavy hammer and block of wood. Install nut and new lockwasher on each lower torque rod and pin and tighten solidly. Install upper torque rod in a similar manner.

#### (3) Connect axle propeller shaft

At forward rear axle, connect propeller shaft and propeller shaft housing at differential carrier as explained in Para. 226. At rearward rear axle connect propeller shaft at differential pinion as explained in Para. 226.

#### (4) Attach pillow block

Note: This operation applies only to forward rear axle installation.

Mount pillow block on bracket at top of forward rear axle housing and insert screws, using new lockwashers. Tighten screws securely.

#### (5) Connect brake lines

Attach brake cylinder flexible connections at hull connection and bleed brakes. Follow instructions given in Paras. 93 and 102.

#### (6) Replace wheels and remove jacks

Install wheels as instructed in Para. 283.

Lower dolly jack under forward rear axle and remove. Lower jacks under cross shaft trunnion brackets and remove.

TRUCK, RAPHAEL, 7 1/2-TON, 6x6

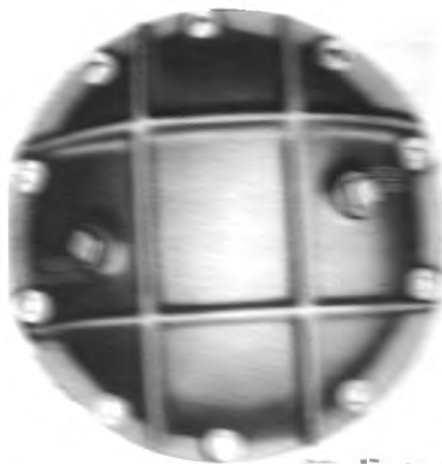

TRUCK, RAPHAEL, 7 1/2-TON, 6x6

- 1. **TRUCK, RAPHAEL, 7 1/2-TON, 6x6**  
 This is a 7 1/2-ton, 6x6 truck with a 100-inch wheelbase. It is equipped with a 250-hp engine and a 5-speed manual transmission. The truck is in good condition and is ready for service.
- 2. **TRUCK, RAPHAEL, 7 1/2-TON, 6x6**  
 This is a 7 1/2-ton, 6x6 truck with a 100-inch wheelbase. It is equipped with a 250-hp engine and a 5-speed manual transmission. The truck is in good condition and is ready for service.
- 3. **TRUCK, RAPHAEL, 7 1/2-TON, 6x6**  
 This is a 7 1/2-ton, 6x6 truck with a 100-inch wheelbase. It is equipped with a 250-hp engine and a 5-speed manual transmission. The truck is in good condition and is ready for service.
- 4. **TRUCK, RAPHAEL, 7 1/2-TON, 6x6**  
 This is a 7 1/2-ton, 6x6 truck with a 100-inch wheelbase. It is equipped with a 250-hp engine and a 5-speed manual transmission. The truck is in good condition and is ready for service.
- 5. **TRUCK, RAPHAEL, 7 1/2-TON, 6x6**  
 This is a 7 1/2-ton, 6x6 truck with a 100-inch wheelbase. It is equipped with a 250-hp engine and a 5-speed manual transmission. The truck is in good condition and is ready for service.

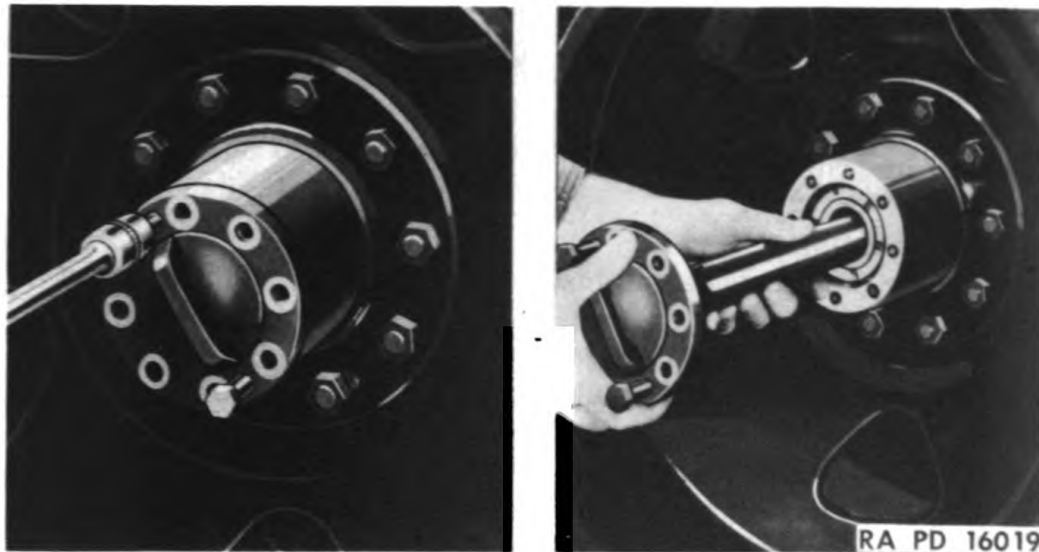
**AXLE, REAR DRIVING****Figure 56—Removing Axle Shaft****c. Installation Procedure****(1) Install axle shaft**

Be certain shaft, flange and hub surfaces are clean. Place a new shaft flange gasket on shaft and insert splined end of shaft in axle housing and into splined differential side gears. With new lock plate in position, install the eight shaft flange cap screws and tighten alternately until all are tight. Bend tangs of lock plate against screw heads.

**87. DIFFERENTIAL AND CARRIER ASSEMBLY REPLACEMENT**

**a.** Replacement of differential and carrier assembly is beyond scope of Using Arms personnel. Refer to Ordnance Personnel.

Section XV

**BRAKES**

	Paragraph
General description .....	88
Operation .....	89
Trouble-shooting .....	90
Preventive maintenance and inspection.....	91
Power system tests .....	92
Bleeding hydraulic brake system.....	93
Service brake shoe adjustments.....	94
Front brake assembly replacement.....	95
Rear brake assembly replacement.....	96
Brake pedal and bracket replacement.....	97
Master cylinder replacement .....	98
Hydrovac replacement .....	99
Hydrovac air cleaner replacement.....	100
Vacuum check valve replacement.....	101
Hydraulic lines and flexible hose replacement.....	102
Hand brake adjustment .....	103
Hand brake band and drum replacement.....	104
Hand brake lever and linkage replacement.....	105

**88. GENERAL DESCRIPTION**

**a. Service Brake System (Fig. 57).** Service or foot brake system is vacuum assisted hydraulic type and operates brake shoes at all six wheels. Units used in this system include brake pedal, pedal linkage, master cylinder, wheel cylinders, Hydrovac unit (power cylinder, relay valve and hydraulic slave cylinder), vacuum check valve, vacuum and hydraulic lines.

**b. Hand Brake System.** Brake band is external contracting type. Hand brake system operates brake band at rear of transfer case through linkage connected with hand brake lever located within easy reach of operator. System consists of hand brake lever, brake band and lining assembly, brake drum, and connecting linkage.

**89. OPERATION**

**a. Service Brakes**

(1) Application or operation of service brakes is dependent upon the function of two systems—hydraulic and vacuum. These two systems are interconnected in such a manner that hydraulic pressure actuates relay valve which controls vacuum and atmosphere in power cylinder.

**(2) Hydraulic system**

The primary or actual brake operating system consists of a master



**BRAKES**

cylinder, one wheel cylinder at each wheel, Hydrovac slave cylinder, and connecting hydraulic hose or lines. Master cylinder is operated through brake pedal and connecting linkage. Briefly, the hydraulic system employs the principle of pressing a column of fluid with which the wheel cylinder pistons are operated to force brake shoes against brake drums.

**(3) Vacuum system**

The secondary, or assisting system, consists of a Hydrovac unit (relay valve, power cylinder and hydraulic slave cylinder), check valve and interconnecting tubing and lines. This system utilizes engine manifold vacuum and atmosphere to operate power cylinder, which assists driver in building up sufficient hydraulic pressure necessary to apply brakes. Movement of power cylinder pistons, controlled by vacuum and atmosphere, forces fluid from hydraulic slave cylinder into brake lines and to each wheel cylinder. As brakes are released, hydraulic pressure at relay valve drops, shutting off atmospheric pressure in power cylinder and opens both sides of cylinder pistons to vacuum, and brakes are released by return springs.

**b. Hand Brake.** When applying hand brake, lever located at left of transmission gear shift lever is moved rearward. This movement is transmitted to brake band, located at rear of transfer case, through pull rod and applies brake by drawing brake band and lining assembly tightly against brake drum. When brakes are released, lever is moved forward and, with the assistance of return springs, lining is released from brake drum.

**90. TROUBLE-SHOOTING**

**a.** Brake system defects are usually reflected by one or more of the symptoms outlined in table following. Whenever brake defects are encountered, it should be borne in mind that cause for this condition is sometimes due to misadjustment or failure to properly service other units. Failure of brakes to function properly is sometimes caused by improper wheel bearing adjustment, loose spring clips, and axle misalignment. When servicing brake system, refer to "Trouble-Shooting" charts covering closely associated units such as wheels, axles, springs, etc.

**b. Table**

Symptom and Probable Cause	Probable Remedy	Refer to Paragraph
<b>(1) Excessive pedal pressure and poor stop:</b>		
(a) Brake shoes improperly adjusted.	Readjust . . . . .	94
(b) Relay valve not functioning.	Replace Hydrovac . .	99
(c) Power cylinder not functioning.	Replace Hydrovac . .	99

TRUCK, AMPHIBIAN, 2 1/2 -TON, 6 x 6

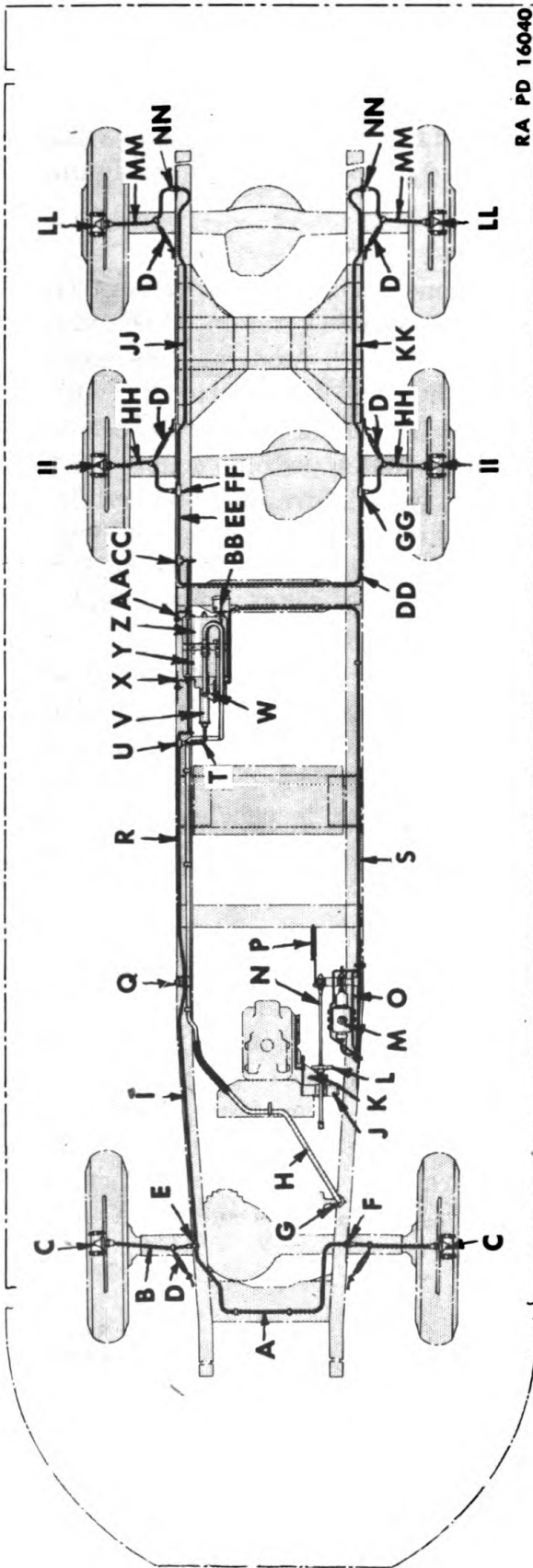

Figure 57—General Arrangement of Brake Units, Controls, Hydraulic and Brake Lines

- |    |   |    |  |
|----|---|----|--|
| A  | Hydraulic Line                              | CC | Hydraulic Line Tee                         |
| B  | Flexible Hose, Front Wheel                  | DD | Hydraulic Line, Tee to Tee                 |
| C  | Wheel Cylinder, Front Wheel                 | EE | Hydraulic Line, Tee to Tee                 |
| D  | Flexible Hose Suspension Spring             | FF | Hydraulic Line Tee, Right Forward          |
| E  | Hydraulic Line Tee, Front Wheel             | GG | Wheel                                      |
| F  | Flexible Hose to Hydraulic Line Connection  | HH | Hydraulic Line Tee, Left Forward Wheel     |
| G  | Check Valve                                 | II | Flexible Hose, Forward Rear Wheels         |
| H  | Vacuum Line                                 | JJ | Wheel Cylinder, Forward Rear Wheels        |
| I  | Hydraulic Line, Shut-off Cock to Tee        | KK | Hydraulic Line, Tee to Flexible Hose       |
| J  | Pedal Shaft                                 | LL | Hydraulic Line, Tee to Flexible Hose       |
| K  | Pedal Bracket                               | MM | Wheel Cylinder, Rearward Rear              |
| L  | Brake Pedal                                 | NN | Wheels                                     |
| M  | Master Cylinder                             |    | Flexible Hose, Rearward Rear Wheels        |
| N  | Linkage Pull Rod                            |    | Flexible Hose to Hydraulic Line Connection |
| O  | Master Cylinder and Bracket Assembly        |    |  |
| P  | Linkage Return Spring                       |    |  |
| Q  | Shut-off Cock                               |    |  |
| R  | Hydraulic Line, Tee to Shut-off Cock        |    |  |
| S  | Hydraulic Line, Master Cylinder to Hydrovac |    |  |
| T  | Hydraulic Line, Slave Cylinder to Tee       |    |  |
| U  | Hydraulic Line Tee                          |    |  |
| V  | Hydrovac Slave Cylinder                     |    |  |
| W  | Hydrovac Relay Valve                        |    |  |
| X  | Hydrovac Mounting Bracket, Front            |    |  |
| Y  | Hydrovac Assembly                           |    |  |
| Z  | Hydrovac Power Cylinder                     |    |  |
| AA | Hydrovac Mounting Bracket, Rear             |    |  |
| BB | Hydrovac Air Cleaner                        |    |  |

**BRAKES**

Symptom and Probable Cause	Probable Remedy	Refer to Paragraph
(d) Leak in vacuum system.	Tighten all connections . . . . .	92
(e) Brake linkage improperly adjusted.	Adjust . . . . .	98
(f) Improper linings.	Replace shoe and lining . . . . .	95-96
(g) Check valve not functioning.	Clean or replace . . . . .	101
(h) Dirty Hydrovac air cleaner.	Clean or replace . . . . .	100
(i) Grease soaked linings.	Replace shoe and lining . . . . .	95-96
(j) Shoe twisted or sprung.	Replace shoe and lining . . . . .	95-96
(k) Shoe anchor twisted or sprung.	Replace shoe anchor . . . . .	95-96
(l) Improper brake fluid.	Bleed and refill . . . . .	93
(m) Obstructed brake line.	Replace . . . . .	102
<b>(2) Pedal goes to floor board</b>		
(a) Normal lining wear.	Readjust . . . . .	94
(b) Excessive lining wear.	Replace shoe and lining . . . . .	95-96
(c) Low fluid level in master cylinder.	Refill . . . . .	93
(d) Air trapped in hydraulic system.	Bleed entire system . . . . .	93
(e) Hydraulic fluid leak.	Tighten or replace connections. Replace defective units . . . . .	102
(f) Brake shoes improperly adjusted.	Readjust . . . . .	94
<b>(3) Noisy brakes</b>		
(a) Shoe twisted or sprung.	Replace shoe and lining . . . . .	95-96
(b) Shoe anchor twisted or sprung.	Replace shoe anchor . . . . .	95-96
(c) Dirty linings.	Replace shoe and lining . . . . .	95-96
(d) Loose lining rivets.	Replace shoe and lining . . . . .	95-96
(e) Drums distorted.	Replace hub and drum . . . . .	95-96
(f) Improper linings.	Replace shoe and lining . . . . .	95-96

**TRUCK, AMPHIBIAN, 2 1/2-TON, 6 x 6**

Symptom and Probable Cause	Probable Remedy	Refer to Paragraph
<b>(4) Springy, spongy pedal action</b>		
(a) Air in hydraulic system.	Bleed entire system.	93
(b) Improper brake fluid.	Use recommended fluid .....	93
(c) Brake shoes improperly adjusted.	Readjust .....	94
<b>(5) Truck pulls to one side</b>		
(a) Grease soaked linings.	Replace shoe and lining .....	95-96
(b) Brake shoes improperly adjusted.	Readjust .....	95-96
(c) Loose anchor.	Tighten .....	95-96
(d) Wheel bearings improperly adjusted.	Readjust .....	284-286
(e) Tires not properly inflate.	Inflate .....	288
(f) Loose spring clips.	Tighten .....	245-247
(g) Improper linings.	Replace shoe and lining .....	95-96
<b>(6) One brake drags</b>		
(a) Weak or broken brake shoe return springs.	Replace .....	95-96
(b) Brake anchor pins tight.	Clean or replace ....	95-96
(c) Brake shoes improperly adjusted.	Readjust .....	94
(d) Wheel bearings improperly adjusted.	Readjust .....	284-286
(e) Defective wheel cylinder piston cups.	Replace wheel cylinder .....	95-96
(f) Obstructed brake line.	Replace .....	102
(g) Grease soaked lining.	Replace shoe and lining .....	95-96
<b>(7) All brakes drag</b>		
(a) Brake linkage improperly adjusted.	Readjust .....	98
(b) Weak or broken return springs.	Replace .....	95-96
(c) Mineral oil in hydraulic system.	Bleed and refill entire system .....	93
(d) Defective master cylinder check valve.	Replace master cylinder .....	98
(e) Defective Hydrovac slave cylinder check valve.	Replace Hydrovac ..	99
<b>(8) Severe brake with light pedal pressure</b>		



**BRAKES**

Symptom and Probable Cause	Probable Remedy	Refer to Paragraph
(a) Brake shoes improperly adjusted.	Readjust . . . . .	94
(b) Brake linkage improperly adjusted.	Readjust . . . . .	98
(c) Loose brake shoe anchor.	Tighten . . . . .	95-96
(d) Improper linings.	Replace shoe and lining . . . . .	95-96
(e) Grease soaked linings.	Replace shoe and lining . . . . .	95-96

**91. PREVENTIVE MAINTENANCE AND INSPECTION**

a. During the course of normal operation conditions may become apparent which indicate that satisfactory brake efficiency is not being obtained. If brake system is thoroughly inspected and tested at regular intervals cause for these conditions can usually be avoided. These indications are usually apparent when excessive pedal pressure is necessary to apply brakes, also when light pedal pressure results in severe or uneven application. Also refer to "Trouble-Shooting" in Para. 90b., for other symptoms and causes.

**b. Inspection Procedure**

(1) **Vacuum leaks.** It is important that all vacuum lines and connections be tight to prevent entrance of atmosphere, otherwise the efficiency of the complete braking system is seriously affected. It should be borne in mind when making tests that at no place in the system can any greater vacuum be obtained than exists in the intake manifold. Therefore, it is important that the test first be made at this point in order to determine the actual manifold vacuum. Refer to Para. 92b.(2) for method of testing for manifold vacuum.

(2) **Master cylinder fluid level.** Hydraulic fluid level in master cylinder should be checked at regular intervals to determine that supply tank is full. If fluid level is allowed to become low, air may enter system and cause one or more of the conditions outlined under "Trouble-Shooting" in Para. 90b. Fluid should be kept to within 3/8" to 1/2" of filler cap.

(3) **Hydraulic fluid leaks.** Brake lines and flexible hose should be carefully inspected for any evidence of hydraulic fluid leakage. Leaks can usually be detected visually if adjacent parts appear to be oily. However, continued low level of hydraulic fluid in master cylinder is usually an indication that system is leaking at some point, possibly at the wheel cylinder, where it is not visible.

(4) **Overheating.** Whenever brake shoes are not properly adjusted, excessive heat may be generated at brake drums. All drums should be approximately same temperature. However, an abnormally cool drum usually indicates that the brakes on that particular wheel are not functioning properly and may not be adjusted evenly with

**TRUCK, AMPHIBIAN, 2 1/2-TON, 6 x 6**

the other wheels. **Note:** If an overheated condition is found, this should not be confused with the possibility that the wheel bearings may not be properly adjusted. Refer to Paras. 284 and 286 for proper method of adjusting wheel bearings.

(5) **Master cylinder adjustment.** Check clearance between master cylinder inner lever and stop screw. This dimension should be .020". If inspection indicates that adjustment is necessary this can be performed as described in Para. 98c.(4).

(6) **Hand brake adjustment.** Inspect hand brake linkage, brake lining and drum. Check lining to drum clearance and, if necessary, make adjustment as directed in Para. 103b.

(7) **Brake pedal adjustment.** Check clearance between brake pedal and toe board. Brake pedal should just touch toe board in released position. If pedal strikes heavily against toe board this indicates that master cylinder may not be fully released. Adjust as directed in Para. 98c.(5).

(8) **Inspect vacuum line hose.** Carefully inspect vacuum line hose for spongy and porous condition. If any indications are apparent that hose may leak they should be replaced. Keep hose clamps tight.

**92. POWER SYSTEM TESTS**

a. Regular periodic tests should be made to determine if hydraulic and vacuum systems are functioning as a complete unit. If either one of these systems is not working properly the complete braking system will be so seriously affected that proper brake efficiency will be impossible until corrective measures have been made.

**b. Check Valve and Vacuum Line Test Procedure****(1) Install vacuum gauge**

Remove hose clamps attaching vacuum line to Hydrovac center plate tee. Attach vacuum gauge to end of vacuum line so that no leaks exist at this point. Start engine and note vacuum gauge reading which, if no leaks exist, will be manifold vacuum.

**(2) Stop engine**

Turn off ignition switch to stop engine. Observe rate of vacuum drop. If vacuum drops more than 1" every 15 seconds this indicates that vacuum check valve is not seating properly or that vacuum line is leaking at one of the connections. Inspect and tighten all connections or replace vacuum valve as directed in Para. 101. When satisfactory results have been obtained remove vacuum gauge. Reconnect vacuum line to center plate tee being careful to tighten connection so that there are no leaks.

**c. Power Cylinder and Relay Valve Test Procedure****(1) Connect vacuum gauges**

Remove pipe plug at rear of power cylinder and attach vacuum gauge. Remove pipe plug at center plate and attach vacuum

## BRAKES

gauge. Connections must be tight so that there are no leaks at these points. Start engine and note vacuum gauge readings. Vacuum reading at both gauges should be same as at manifold in Para. 92b. If same reading cannot be obtained, it indicates that leaks exist, possibly at vacuum line connections.

**(2) Stop engine**

Turn off ignition switch to stop engine and note rate of vacuum drop. If rate of drop is more than 2" every 15 seconds, when vacuum lines and check valve tests are satisfactory, it indicates that leaks exist in Hydrovac unit and complete unit should be replaced.

**(3) Apply brakes**

Start engine and apply brakes. Vacuum gauge at center plate should still register manifold vacuum while gauge at rear of power cylinder will drop to zero. Stop engine and note rate of vacuum drop at gauge on center plate. If rate of vacuum drop is more than 1" every 15 seconds, it indicates that vacuum and atmospheric relay valves or power cylinder piston seals are defective and entire unit should be replaced. Remove vacuum gauges at center plate and at rear of power cylinder. Replace pipe plugs and tighten securely.

**d. Hydraulic Slave Cylinder Test Procedure**

**(1) Deplete vacuum**

With engine stopped make a few applications of brakes to deplete any vacuum which might be present in Hydrovac power cylinder or vacuum lines. Remove bleeder screw at any one of the wheels. Install 2000# hydraulic pressure gauge in bleed hole and tighten connection securely.

**(2) Apply brakes**

While engine is still stopped apply brakes and note hydraulic pressure at gauge. This will denote that brake fluid is passing through Hydrovac slave cylinder, which makes it possible to apply brakes in case of Hydrovac failure. This hydraulic pressure is the output of the brake master cylinder.

**(3) Start engine with brakes applied**

With brake pedal held in same position start engine and note increase of hydraulic pressure. If hydraulic pressure increases approximately 800# this indicates that Hydrovac slave cylinder is functioning satisfactorily on application.

**(4) Release brakes**

Release foot brake pedal quickly and note drop of hydraulic pressure at gauge. If pressure returns to near "0" immediately it indicates that slave cylinder valve is functioning satisfac-

**TRUCK, AMPHIBIAN, 2½-TON, 6 x 6**

torily. Remove hydraulic gauge attached at wheel bleeder screw. Install bleeder screw and tighten securely.

**93. BLEEDING HYDRAULIC BRAKE SYSTEM**

a. Whenever any service operations make it necessary to disconnect hydraulic lines or when any conditions outlined under "Trouble-Shooting" are evident, it is necessary to bleed entire brake system. Bleeder screw is used at each wheel cylinder, also three bleed screws are used at Hydrovac unit. When bleeding Hydrovac, it is especially important that screws be bled in their proper order "D", "E" and "F" as illustrated in Fig. 69. Two bleeding systems are used—pressure and manual. Procedure of these two methods are described in Paras. c and d, following.

b. **Brake Fluid.** When necessary to add brake fluid, only Delco Super No. 9 or Wagner Lockheed 21 hydraulic fluid should be used. Mineral fluids will cause rubber parts to swell or otherwise deteriorate, necessitating premature replacement of all brake units where rubber parts are used.

**c. Pressure Bleeding Procedure****(1) Connect master cylinder**

Remove five screws attaching left hand driver's floor board to support and lift floor board out of vehicle. Remove filler cap from master cylinder. When using pressure tank, No. CSM-CS-1032, make sure fluid level is up to pet cock above outlet and that tank has 10 to 20 lbs. air pressure before starting bleeding operation. Connect bleeding tank hose to master cylinder filler cap opening, using proper size fitting.

**(2) Connect bleeder tube (Fig. 58)**

Remove cap screw and lockwasher at wheel cylinder or Hydrovac bleeder screw. Attach bleeder tube, No. KM-J-747, in end of bleeder screw. Place opposite end of bleeder tube in suitable container which should have sufficient fluid to cover end of tube.

**(3) Bleeding operation (Fig. 58)**

Note air pressure in tank, which should be 10 to 20 lbs. and fluid level should be above shut-off valve. Open shut-off cock at bottom of tank. Open bleeder valve screw  $\frac{3}{4}$  turn in counter-clockwise and watch flow at end of bleeder hose. Close bleeder valve tightly as soon as air bubbles stop and fluid comes out in solid stream. Remove bleeder hose and install cap screw and lockwasher. Repeat this operation at all six wheels, also at three Hydrovac screws. Remove bleeder hose attached to master cylinder filler cap. Reinstall floor board and attach to supports with five screws.

d. **Manual Bleeding Procedure.** Manual bleeding requires filling



**BRAKES**

**Figure 58—Typical Method of Bleeding Wheel Cylinders**

master cylinder and pumping brake pedal to force fluid through lines to expel air from system. Operations necessary for manual bleeding are same as explained under pressure bleeding, except use of tanks. It is advisable to refill master cylinder after bleeding each point as air may be taken into system unless master cylinder is kept full.

#### **94. SERVICE BRAKE SHOE ADJUSTMENTS**

a. Whenever symptoms outlined under "Trouble-Shooting" in Paragraph 94, or when inspection reveals necessity, through adjustment of service brake shoes should be made, refer also to master adjustments in Para. 98c. At intervals, dependent upon type of operation, it will be necessary to readjust brake shoes. These adjustments are to compensate for normal wear of linings and should be made when necessity is indicated.

##### **b. Front Brake Adjustment (Fig. 59)**

###### **(1) Check wheel bearing adjustment**

Jack up end of axle and check wheel bearing adjustment as directed in Para. 284. Proper brake shoe adjustment cannot be obtained unless wheel bearings are correctly adjusted.

###### **(2) Adjust shoes**

Remove 2 adjusting hole covers on backing plate at each side of hydraulic flexible line connection. Insert screw driver or adjusting tool through hole in backing plate until tool engages notches on wheel cylinder adjusting cap. Turn adjusting cap in clockwise direction, when looking at end of cylinder, until lining

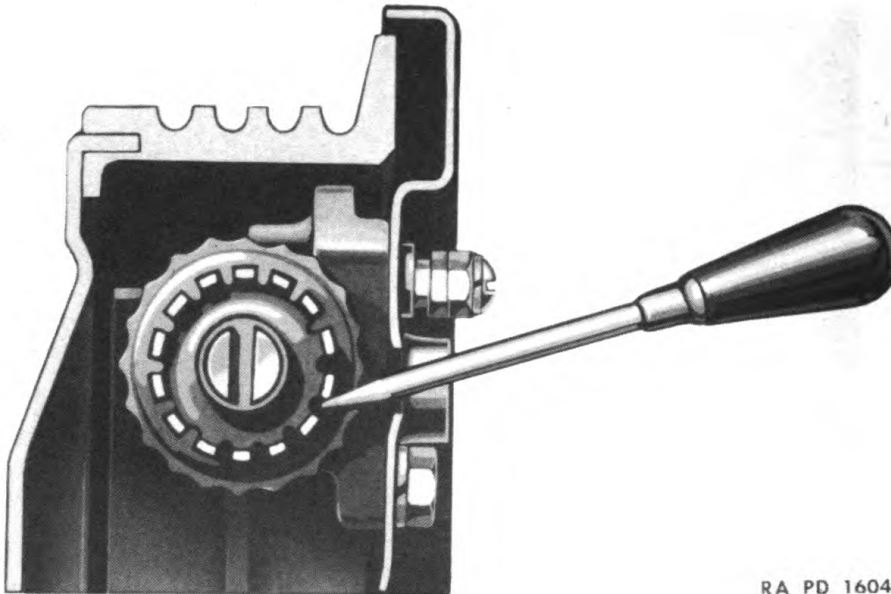
**TRUCK, AMPHIBIAN, 2½-TON, 6 x 6**

RA PD 16042

**Figure 59—Adjust Front Brakes by Turning Wheel Cylinder Cap with Screwdriver or Adjusting Tool Inserted through Openings in Brake Dust Shield**

causes a slight drag on drum as wheel is turned by hand. Back off adjusting cap four notches to provide proper running clearance between brake lining and brake drum. Repeat foregoing operations at all four brake shoes on front axle.

**(3) Install adjusting hole covers**

Replace adjusting hole covers over each adjusting hole in backing plate. Use of these covers prevents entrance of dirt at these points. Lower wheel to ground by removing jack from underneath axle.

**c. Rear Brake Adjustment (Fig. 60)**

**(1) Check wheel bearing adjustment**

Jack up end of axle and check wheel bearing adjustment as directed in Para. 286. Proper brake shoe adjustment cannot be obtained unless wheel bearings are correctly adjusted.

**(2) Adjust brake shoes**

Use wrench on hex head adjusting pinion shaft as shown in Fig. 60. Turn adjusters in clockwise direction until lining causes slight drag against brake drum as wheel is turned by hand. Back off adjuster  $\frac{3}{4}$  of a turn which will provide proper running clearance between brake lining and brake drum. There are two adjusters at each wheel. Adjust all four brake shoes equally on each axle. Lower wheel to ground by removing jack from underneath axle.

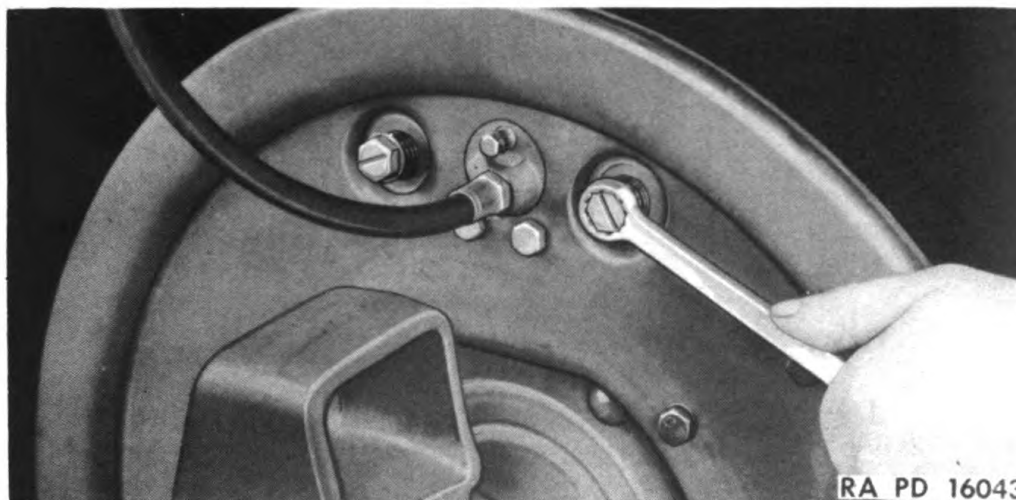

**BRAKES**

**Figure 60—Adjust Rear Brakes by Turning Pinion Studs in Clockwise Direction as Indicated by Arrows**

**95. FRONT BRAKE ASSEMBLY REPLACEMENT**

a. Instructions in this paragraph include replacement of all component parts of front brake assembly. If only necessary to replace specific parts follow instructions outlined as follows (Fig. 61).

**(1) Hub and brake drum replacement**

Follow instructions in Paras. 95b.—(1) through (3) for removal and 95c.—(5) through (8), except (6) for installation.

**(2) Brake shoes and linings replacement**

Follow instructions in Paras. 95b.—(1) through (5) for removal and 95c.—(3) through (8), except (6) for installation.

**(3) Wheel cylinder replacement**

Follow instructions in Paras. 95b.—(1) through (6) except (5) for removal and 95c.—(2) through (8), except (3) for installation.

**(4) Brake anchor plate replacement**

Follow instructions in Paras. 95b.—(1) through (7) for removal and 95c.—(1) through (8) for installation.

**(5) Brake dust shield replacement**

Follow all instructions in Paras. 99b. for removal and 99c. for installation.

**b. Removal Procedure****(1) Jack up axle**

Set brakes by moving hand brake lever rearward as far as possible. Place jack under axle and lift until wheel is clear of ground. Remove wheel stud nuts and remove wheel from hub.

**(2) Remove drive flange**

Bend lips of lock plate away from bolt heads and remove eight

**TRUCK, AMPHIBIAN, 2 1/2-TON, 6 x 6**

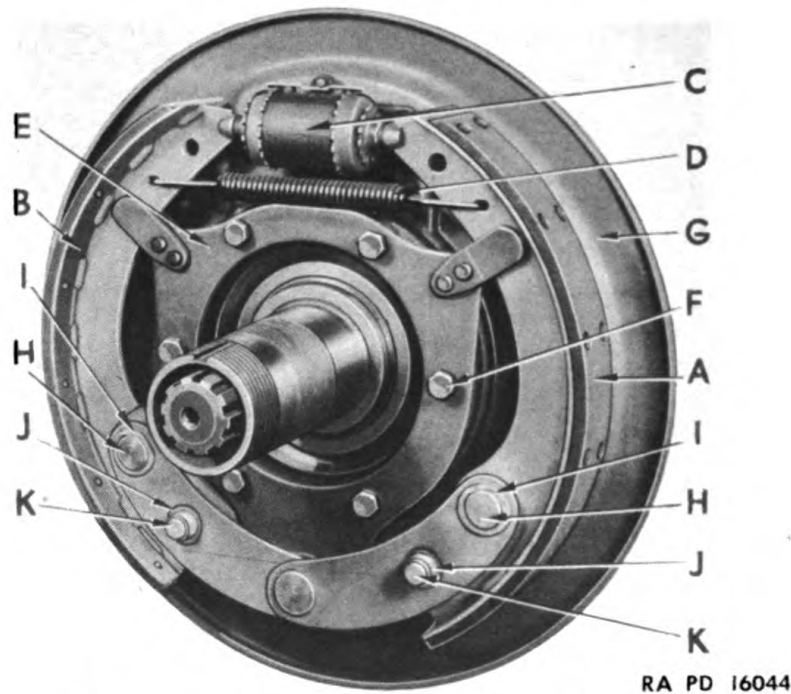

**Figure 61—Front Brakes (L.H. Shown)**

- |                                       |                                     |
|---------------------------------------|-------------------------------------|
| <b>A</b> Brake Shoe and Lining, Rear  | <b>G</b> Brake Dust Shield          |
| <b>B</b> Brake Shoe and Lining, Front | <b>H</b> Articulating Link Pin      |
| <b>C</b> Wheel Cylinder               | <b>I</b> Articulating Link Pin Lock |
| <b>D</b> Brake Shoe Return Spring     | <b>J</b> Friction Spring            |
| <b>E</b> Brake Anchor Plate           | <b>K</b> Friction Spring Pin        |
| <b>F</b> Anchor Plate Screw           | <b>L</b> Anchor Pin                 |

cap screws attaching flange to hub. Remove flange and gasket.

**(3) Remove hub and drum**

Bend lips of lock plate up from flats of lock nut. Remove lock nut, lock plate, adjusting nut and washer. Pull hub and drum assembly straight out to remove from axle, outer bearing cone will also be removed at this time.

**(4) Install wheel cylinder clamp (Fig. 62)**

Place CSM-CS-1038 clamp over ends of wheel cylinder to keep cylinder parts intact. Refer to Fig. 62 for method of installing clamp. Use KM-KMO-142 brake shoe return spring pliers to remove spring from brake shoes in manner shown.

**(5) Remove brake shoes**

Remove anchor pin lock, using screw driver and hammer in manner illustrated in Fig. 63. Remove anchor pin attaching links to brake anchor. Shoe and lining assembly with links can now be completely removed.

**(6) Remove wheel cylinder**

Remove two cap screws and lockwashers attaching wheel cylinder to brake dust shield. Pull cylinder from dust shield and



## BRAKES

turn cylinder from flexible hose without twisting hose. See Fig. 64.

### (7) Remove brake anchor plate and dust shield

Remove six cap screws and lockwashers attaching anchor plate to spacer. Anchor plate can now be completely removed. Remove twelve cap screws and lockwashers holding spacer, oil deflector and dust shield to steering knuckle. Spacer, oil deflector and dust shield can now be completely removed.

### c. Installation Procedure

#### (1) Install dust shield and anchor plate

Locate dust shield in place against steering knuckle with flanged edge outward and wheel cylinder opening at top. Replace oil deflector and spacer against dust shield and install twelve cap screws with lockwashers. Tighten cap screws securely. Locate anchor plate against spacer with guide plates at top and offset at anchor end toward dust shield. Install six cap screws with lockwashers. Tighten cap screws securely.

#### (2) Install wheel cylinder

Thread flexible hose through wheel cylinder opening in dust shield and attach wheel cylinder using gasket between hose and cylinder. Tighten cylinder on hose securely. Do not twist hose during tightening. Attach cylinder to dust shield using two cap screws and lockwashers. Tighten screws securely.

#### (3) Install brake shoes

Attach brake shoe with links to anchor using anchor pin. Both forward and reverse shoe and linings are alike; however, reverse assembly uses links which are offset so that they are wider at anchor end than at shoe end. Be sure shoes are installed in their correct location. Install new lock in anchor pin groove in such a manner that lock engages groove all around.

#### (4) Install brake shoe return spring

Attach one end of return spring through hole in brake shoe and use KM-KMO-142 special pliers to attach opposite end of spring to other shoe as illustrated in Fig. 62. During installation of spring note that shoes seat in wheel cylinder adjusting screw slot. Remove CSM-CS-1038 wheel cylinder clamp placed over ends of cylinder at time of removal.

#### (5) Install hub, drum and wheels

Install hub and drum and adjust wheel bearings as directed in Para. 284. Install wheels on hubs and replace hub stud nuts. Tighten nuts evenly and alternately until tight. Again check wheel bearing adjustment.

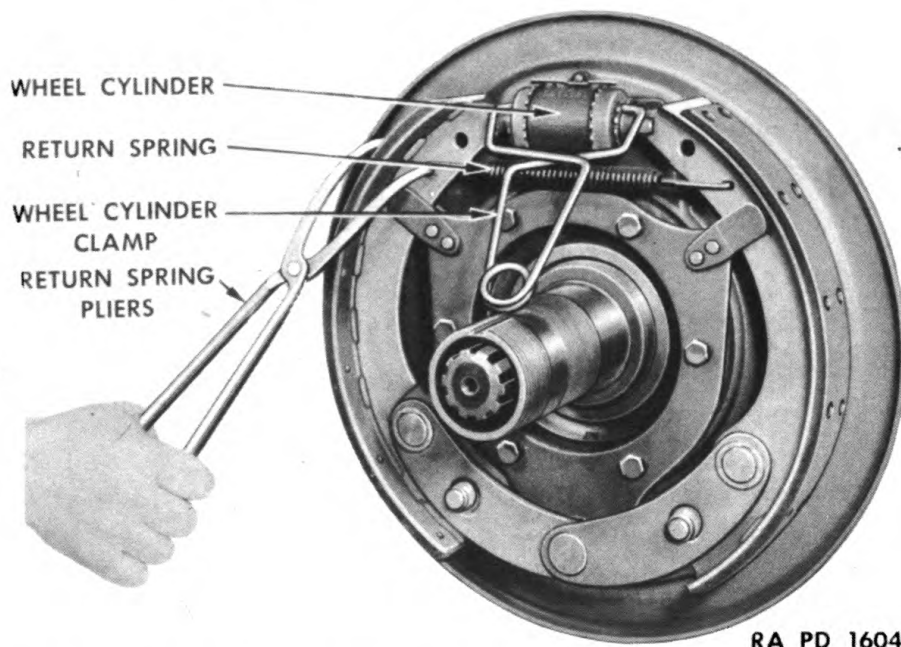
**TRUCK, AMPHIBIAN, 2 1/2-TON, 6 x 6**

RA PD 16045

**Figure 62—Installation of Wheel Cylinder Clamp and Use of Brake Shoe Return Spring Pliers**

**(6) Bleed brake system**

Entire brake system must be bled after any units have been removed which necessitates disconnecting brake lines.

**(7) Adjust brakes**

Adjust brake shoes as directed in Para. 94b.

**(8) True-up brake lining**

Whenever brake shoe and linings have been renewed, or when new hub and drum assemblies have been installed, it is of utmost importance that brakes be carefully adjusted. Maximum braking efficiency can be obtained immediately if linings are properly centralized in relation to axle spindle. Brake lining surface must also be true in relation to face of brake drum before 100% brake efficiency can be obtained. Brake lining trueing unit similar to one illustrated in Fig. 65, when used according to instructions accompanying unit, provides maximum contact between lining and drum. Use of this unit eliminates necessity of second adjustment after new brake linings have been broken in. Further need of adjusting brakes after hub and drum are installed for use of dummy drum, is eliminated as linings can be trued to exact brake drum dimensions by measuring drum with micrometer as shown in Fig. 66.

**96. REAR BRAKE ASSEMBLY REPLACEMENT**

- a. Instructions in this paragraph include replacement of all com-

**BRAKES**

ponent parts of rear brake assembly. If only necessary to replace specific parts instructions outlined as follows (Fig. 67).

**(1) Hub and brake drum replacement**

Follow instructions in Paras. 96b.—(1) through (3) for removal and 96c.—(5) through (9), except (7), for installation.

**(2) Brake shoes and linings replacement**

Follow instructions in Paras. 96b.—(1) through (5) for removal and 96c.—(3) through (9) for installation.

**(3) Wheel cylinder replacement**

Follow instructions in Paras. 96b.—(1) through (6), except (5), for removal and 96c.—(2) through (8), except (3), for installation.

**(4) Brake anchor plate and dust shield replacement**

Follow instructions in Paras. 96c.—(1) through (7) for removal and 96c.—(1) through (8), for replacement.

**b. Removal Procedure****(1) Jack up axle**

Set brakes by moving hand brake lever rearward as far as possible. Place jack under axle and lift until wheel is clear of ground. Remove wheel stud nuts and remove wheels from hub.

**(2) Remove axle shafts**

Bend locking plate lips away from head of cap screws and remove eight cap screws attaching axle shaft flange to hub. Remove axle shaft and gasket by pulling straight out from axle.

**(3) Remove hub and drum**

Bend lips of lock plate up from flats of lock nut. Remove lock nut, lock plate, adjusting nut and washer. Pull hub and drum assembly straight out to remove from axle, outer bearing cone will also be removed at this time.

**(4) Install wheel cylinder clamp**

Place CSM-CS-1038 clamp over ends of wheel cylinder to keep cylinder parts intact. Refer to Fig. 62 for method of installing clamp. Use KM-KMO-142 brake shoe return spring pliers to remove spring from brake shoes in manner shown in Fig. 62.

**(5) Remove brake shoes**

Remove anchor pin lock, using screwdriver and hammer in manner illustrated in Fig. 63. Remove anchor pin attaching links to brake anchor. Shoe and lining assembly with links can now be completely removed.

**(6) Remove wheel cylinder (Fig. 64)**

Remove two cap screws and lockwashers attaching wheel cylinder to brake dust shield. Pull cylinder from dust shield and turn cylinder from flexible hose without twisting hose.

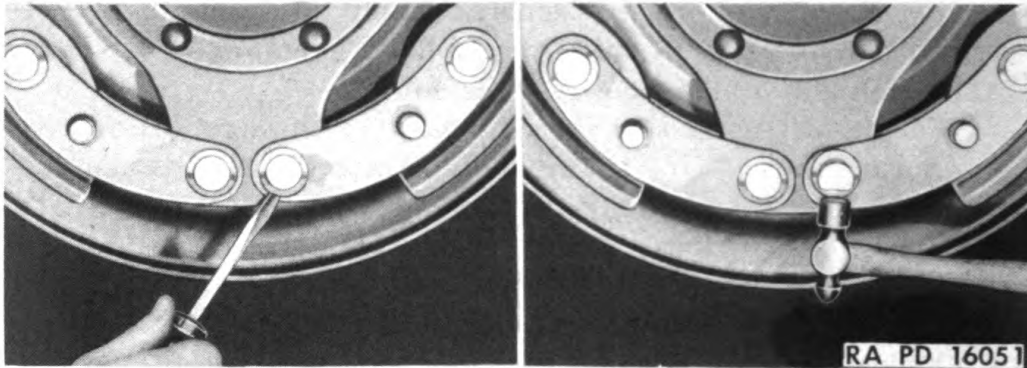

**TRUCK, AMPHIBIAN, 2½-TON, 6 x 6**

**Figure 63—Remove Brake Shoe Anchor Pin Locks with Screwdriver and Hammer**

**(7) Remove brake anchor plate and dust shield**

Remove six nuts, lockwashers and bolts attaching anchor plate and dust shield to axle housing flange. Anchor plate and dust shield can now be completely removed.

**c. Installation Procedure**

**(1) Install dust shield and anchor plate**

Locate dust shield in place against steering knuckle with flanged edge outward and wheel cylinder opening at top. Place anchor plate against dust shield with offset at anchor end toward outside. Install six bolts, lockwashers and nuts. Tighten nuts alternately and evenly until tight.

**(2) Install wheel cylinder**

Thread flexible hose through wheel cylinder opening in dust shield and attach wheel cylinder, using gasket between hose and cylinder. Tighten cylinder on hose securely. Do not twist hose during tightening. Attach cylinder to dust shield using two cap screws and lockwashers. Tighten screws securely.

**(3) Install brake shoes**

Attach brake shoe with links to anchor using anchor pin. Forward and rearward shoe and lining assemblies are alike and can be installed in either position. Install new lock in anchor pin groove in such a manner that lock engages groove all around.

**(4) Install brake shoe return spring**

Attach one end of return spring through hole in brake shoe and use KM-KMO-142 special pliers to attach opposite end of spring to other shoe as illustrated in Fig. 62. During installation of spring note that shoes seat in wheel cylinder adjusting screw slot. Remove CSM-CS-1038 wheel cylinder clamp placed over ends of cylinder at time of removal.



## BRAKES

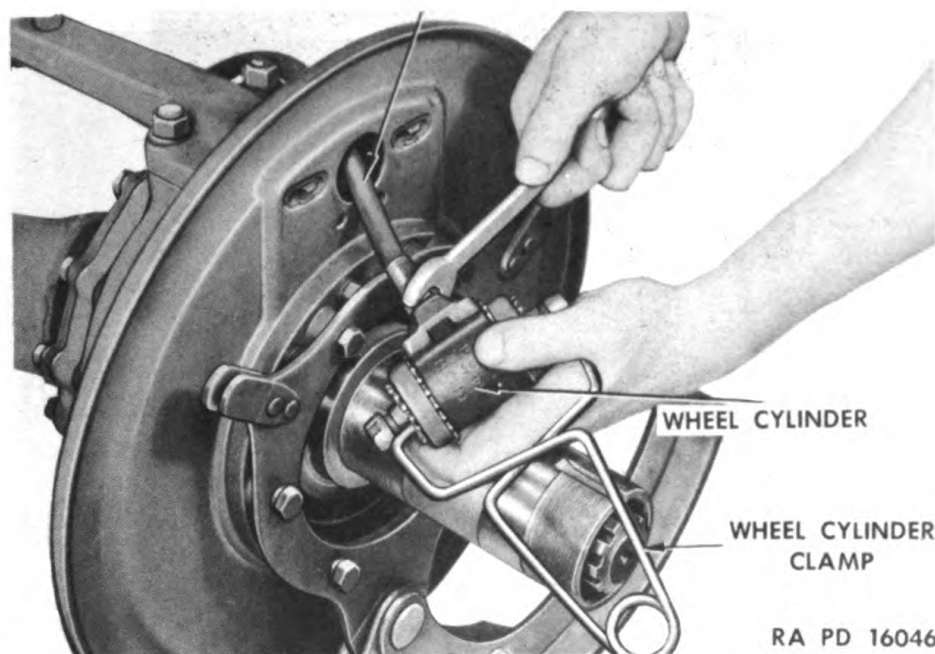

**Figure 64—Removing Brake Flexible Hose from Wheel Cylinder**

**(5) Install hub and drum**

Install hub and drum and adjust wheel bearings as directed in Para. 286.

**(6) Install wheels**

Install inner wheel over hub studs and replace inner nut. Tighten nuts evenly and alternately until tight. Install outer wheel over inner nuts and replace outer nuts. Tighten nuts evenly and alternately until tight.

**(7) Bleed brake system**

Entire brake system must be bled after any units have been removed which necessitates disconnecting brake lines. Adjust brake shoes as directed in Para. 94.

**(8) Install axle shafts**

Place gasket against clamping surface of flange and insert shaft through hub and into axle housing. Turn shaft as necessary to mate shaft and side gear splines. Install cap screws using lock plate under head of screws. Tighten screws evenly and alternately until tight. Bend lips of lock plate against head of cap screws.

**(9) Grind Lining**

Use of brake lining grinder, described in Para. 95, is recommended when shoe and linings have been replaced.

### 97. BRAKE PEDAL AND BRACKET REPLACEMENT

- a. Removal of brake pedal or bracket is not generally necessary,

**TRUCK, AMPHIBIAN, 2½-TON, 6 x 6**

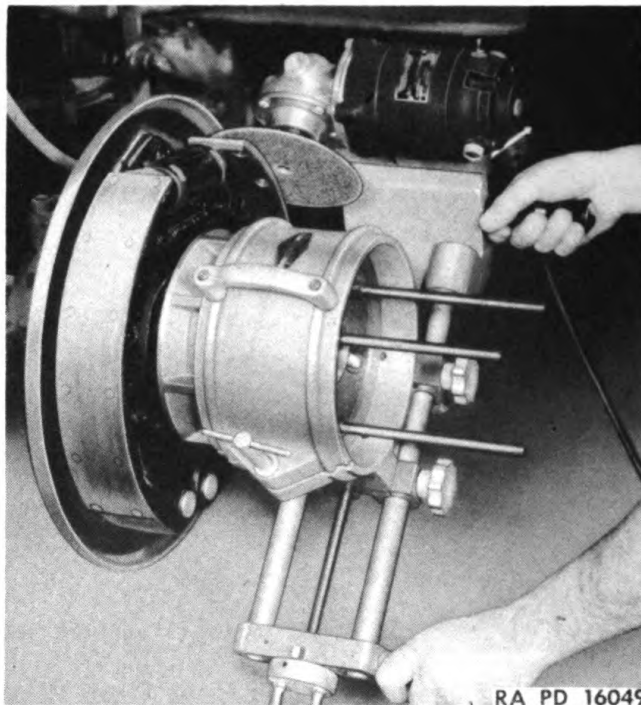

**Figure 65—Application of Brake Lining Grinder for Trueing Surface of Brake Lining in Relation to Axle Spindle**

except when removing power plant or when replacing pedal bushing.

**b. Removal Procedure**

**(1) Remove floor board**

Remove five screws attaching left hand driver's floor board to supports and lift floor board out of the vehicle. Remove screws attaching metal plate to toe board around clutch and brake pedal. Remove metal plate.

**(2) Disconnect clutch and brake pedal linkage**

Remove cotter pin and clevis pin attaching pull rod to brake pedal. Disconnect and remove clutch pedal linkage by removing cotter pin and washer attaching bell crank to idler shaft.

**(3) Remove clutch and brake pedals**

Remove retainer spring at outer end of pedal shaft. Remove nut, lockwasher and bolt attaching pedal shaft to mounting bracket. Move shaft to left and out of mounting bracket, pedal can be removed as shaft is removed from bracket. Remove three cap screws and lockwashers attaching bracket to transmission case and clutch housing. Bracket can now be completely removed.

**c. Installation Procedure**

**(1) Install clutch and brake pedal bracket**

Locate bracket in its correct position and install three cap screws and lockwashers. Tighten cap screws securely.



**BRAKES**

**Figure 66—Use of Micrometer to Measure Brake Drum Diameter When Using Lining Grinder**

**(2) Install clutch and brake pedals**

Place clutch pedal on cross shaft and start plain end of cross shaft into left-hand boss of pedal bracket. Place brake pedal between two bosses on bracket and shove cross shaft through brake pedal and into right-hand bracket boss. Turn shaft to line up shaft groove with clamp bolt holes. Install bolt, lock-washer and nut. Tighten nut securely. Replace retainer spring in groove at outer end of pedal shaft.

**(3) Install clutch pedal linkage**

Install clutch pedal linkage and readjust clutch as directed in Para. 110.

**(4) Install brake pedal pull rod**

Install clevis pin and cotter pin attaching rod to brake pedal. Check clearance between toe board and pedal and readjust, if necessary, as directed in Para. 98c. (5).

**(5) Install metal toe plate and floor board**

Install metal plate around steering column and pedals on toe board and tighten screws. Install floor board and attach to support using five screws. Tighten screws securely.

**98. MASTER CYLINDER REPLACEMENT**

a. Brake master cylinder is located between two supporting brackets which are attached to left-hand frame side rail by bolts

**TRUCK, AMPHIBIAN, 2 1/2-TON, 6 x 6**

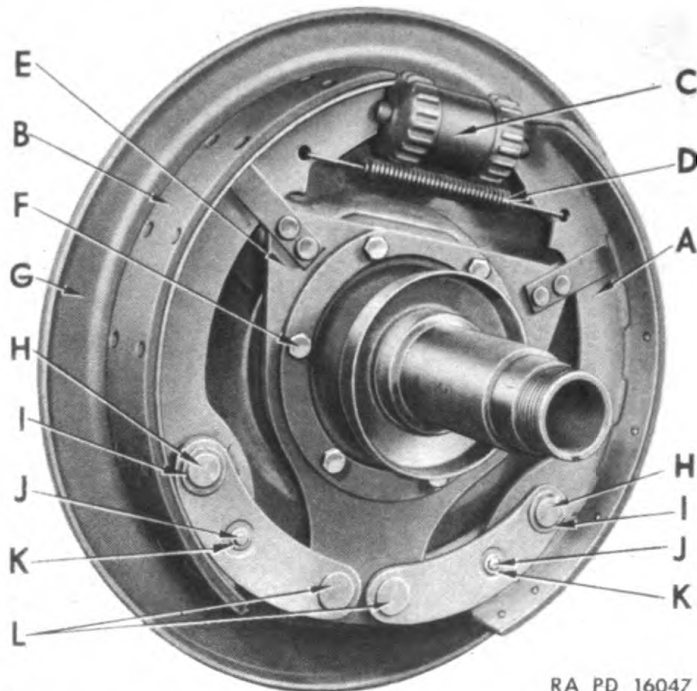

RA PD 16047

**Figure 67—Rear Brakes (L.H. Shown)**

- |                                       |                                     |
|---------------------------------------|-------------------------------------|
| <b>A</b> Brake Shoe and Lining, Rear  | <b>G</b> Brake Dust Shield          |
| <b>B</b> Brake Shoe and Lining, Front | <b>H</b> Articulating Link Pin      |
| <b>C</b> Wheel Cylinder               | <b>I</b> Articulating Link Pin Lock |
| <b>D</b> Brake Shoe Return Spring     | <b>J</b> Friction Pin               |
| <b>E</b> Brake Anchor Plate           | <b>K</b> Friction Pin Lock          |
| <b>F</b> Anchor Plate Screw           | <b>L</b> Anchor Pin                 |

**b. Removal Procedure (Fig. 68)**

**(1) Remove left-hand floor board**

Remove 4 screws and lift out left-hand floor board. Disconnect hydraulic line at front of brake master cylinder.

**(2) Disconnect pedal rod and return spring**

Disconnect pedal return spring extension at clevis pin eye. Remove cotter pin and clevis pin connecting pull rod adjustable yoke to cross shaft inner operating lever.

**(3) Remove master cylinder and brackets**

Remove 4 nuts, lockwashers and bolts attaching brackets to frame side rail. Assembly of master cylinder, brackets, cross shaft and levers can now be completely removed.

**c. Installation Procedure (Fig. 68)**

**(1) Install master cylinder and brackets**

Install master cylinder and bracket assembly inside left-hand frame side rail. Replace four bolts through frame side rail and brackets. Replace lockwashers and nuts on bolts and tighten nuts securely.



## BRAKES

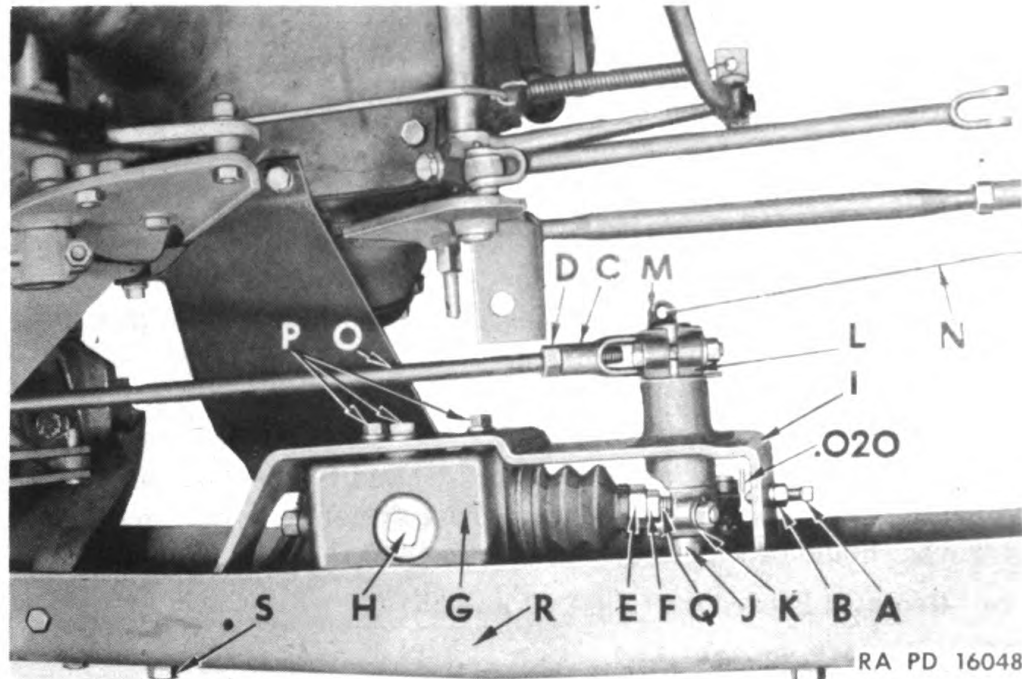

**Figure 68—Brake Master Cylinder Mounting Brackets and Linkage Assembly**

<b>A</b>	Stop Screw	<b>K</b>	Shaft Lever, Outer
<b>B</b>	Stop Screw Lock Nut	<b>L</b>	Shaft Lever, Inner
<b>C</b>	Pedal Rod Adjustable Yoke	<b>M</b>	Clevis Pin
<b>D</b>	Adjustable Yoke Lock Nut	<b>N</b>	Return Spring Extension
<b>E</b>	Master Cylinder Push Rod	<b>O</b>	Pedal Pull Rod
<b>F</b>	Push Rod Lock Nut	<b>P</b>	Cap Screw, Bracket to Master Cylinder
<b>G</b>	Brake Master Cylinder	<b>Q</b>	Push Rod Yoke
<b>H</b>	Master Cylinder Filler Cap	<b>R</b>	Frame Side Rail
<b>I</b>	Master Cylinder Brackets	<b>S</b>	Bracket to Frame Screws
<b>J</b>	Lever Shaft		

**(2) Install hydraulic line**

Attach hydraulic line to front of master cylinder. Tighten fitting securely to prevent leakage of hydraulic fluid.

**(3) Adjust master cylinder push rod**

Loosen push rod to yoke lock nut. Turn push rod (Fig. 68) until end of rod just contacts piston when in released position. Piston is fully released when rear end contacts stop plate at rear end of master cylinder barrel. If piston is not allowed to return to fully released position, piston cup will cover fluid by-pass hole in master cylinder, thereby preventing fluid entering master cylinder barrel on return stroke.

**(4) Measure stop screw to shaft inner lever clearance (Fig. 68)**

Clearance between end of stop screw and shaft inner lever must be .020". Loosen lock nut and turn stop screw in direction necessary to obtain this dimension. Tighten lock nut when adjustment is completed.

**TRUCK, AMPHIBIAN, 2½-TON, 6 x 6**

**(5) Adjust pedal pull rod length (Fig. 68)**

Loosen adjustable yoke lock nut and turn yoke to line up holes in yoke and inner lever so that clevis pin can be easily installed, with pedal in released position.

**(6) Attach pedal rod and return spring**

Attach pedal rod adjustable yoke to master cylinder inner lever using clevis pin and cotter pin. Attach return spring to clevis pin and at frame cross member. Entire brake system must be bled as directed in Para. 93.

**9. HYDROVAC REPLACEMENT**

**a.** Hydrovac unit is attached to right-hand frame side rail (Fig. 4) behind transfer case. Whenever power system test indicates that hydrovac should be replaced, it is necessary to remove complete unit.

**b. Removal Procedure (Figs. 57 and 69)**

**(1) Remove vacuum line**

Use screwdriver and loosen hose clamp screws attaching vacuum line to inlet "tee." Slide hose back on line and off "tee."

**(2) Disconnect hydraulic inlet and outlet lines**

Disconnect hydraulic outlet line at front end of slave cylinder, also inlet line (master cylinder to Hydrovac) at side of slave cylinder housing.

**(3) Disconnect Hydrovac**

Remove 2 nuts attaching Hydrovac to rear support bracket. Remove two bolts, nuts and lockwashers attaching front bracket to inside of frame side rail. Hydrovac assembly with front bracket can now be completely removed from vehicle.

**c. Installation Procedure (Figs. 57 and 69)**

**(1) Replace Hydrovac**

Replace Hydrovac in vehicle with slave cylinder toward front and vacuum line "tee" on top. Insert 2 clamp studs through holes in rear bracket and install 2 nuts. Place 2 bolts through frame side rail and front bracket using lockwashers and nuts. Tighten front bracket bolt nuts securely, also tighten 2 nuts at rear bracket.

**(2) Attach lines**

Attach hydraulic inlet line (master cylinder to Hydrovac) to inside of slave cylinder housing. Attach outlet line (to wheel cylinders) to end of slave cylinder. Tighten fittings securely to prevent hydraulic fluid leaks. Attach vacuum line to "tee" at

**BRAKES**

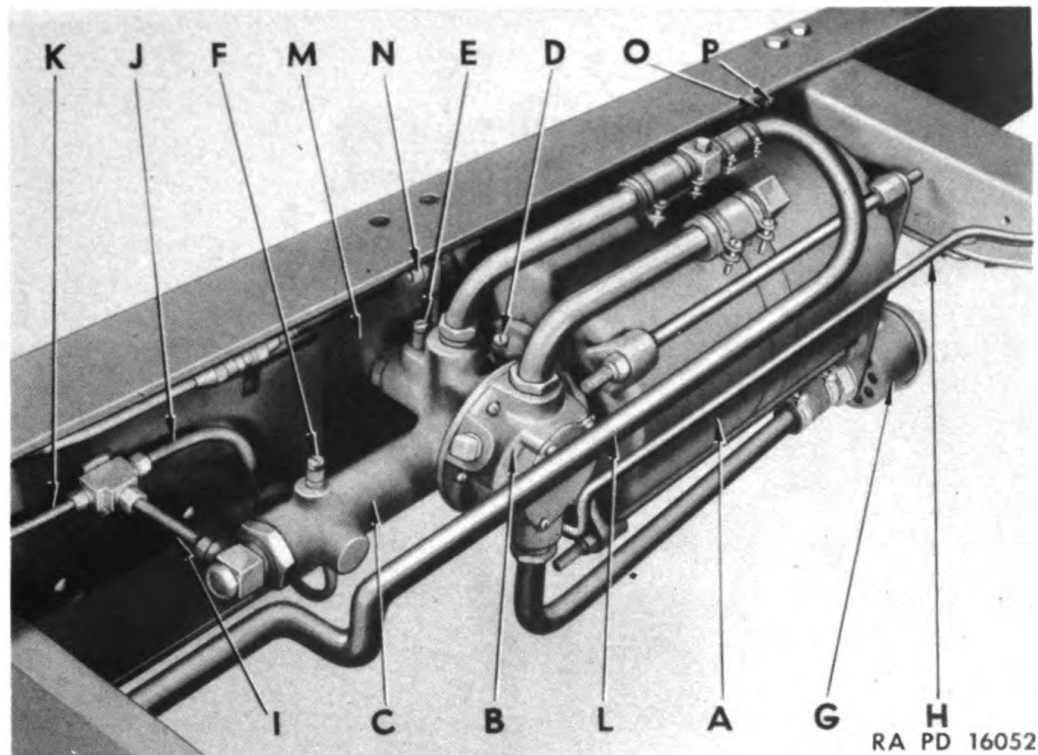

**Figure 69—Brake Hydrovac Unit, Air Cleaner, Vacuum and Hydraulic Lines Installation**

- |   |   |
|---|---|
| <b>A</b> Hydrovac Power Cylinder            | <b>I</b> Hydraulic Line, To Wheel Cylinders       |
| <b>B</b> Hydrovac Relay Valve               | <b>J</b> Hydraulic Line, To Rear Wheel Cylinders  |
| <b>C</b> Hydrovac Slave Cylinder            | <b>K</b> Hydraulic Line, To Front Wheel Cylinders |
| <b>D</b> Bleeder Screw No. 1                | <b>L</b> Vacuum Line, To Manifold                 |
| <b>E</b> Bleeder Screw No. 2                | <b>M</b> Mounting Bracket, Front                  |
| <b>F</b> Bleeder Screw No. 3                | <b>N</b> Mounting Bracket Nut                     |
| <b>G</b> Air Cleaner                        | <b>O</b> Mounting Bracket, Rear                   |
| <b>H</b> Hydraulic Line, To Master Cylinder | <b>P</b> Mounting Bracket Nut                     |

Hydrovac center plate using rubber hose and 2 hose clamps. Tighten clamps securely to prevent atmospheric leak.

**(3) Bleed brake system**

When Hydrovac has been installed, it is necessary to bleed entire brake system as directed in Para. 93.

**100. HYDROVAC AIR CLEANER REPLACEMENT**

**a. Air cleaner (Fig. 70) is attached to Hydrovac unit as illustrated in Fig. 69. Air entering power cylinder through relay valve is filtered by curled hair within air cleaner. Air passing through curled hair cleaning element which is oiled, is cleaned thus preventing dirt from reaching relay valve and power cylinder.**

**b. Removal Procedure**

**(1) Remove hose**

Loosen two hose clamp bolts and slide hose back on tube.



**TRUCK, AMPHIBIAN, 2½-TON, 6 x 6**

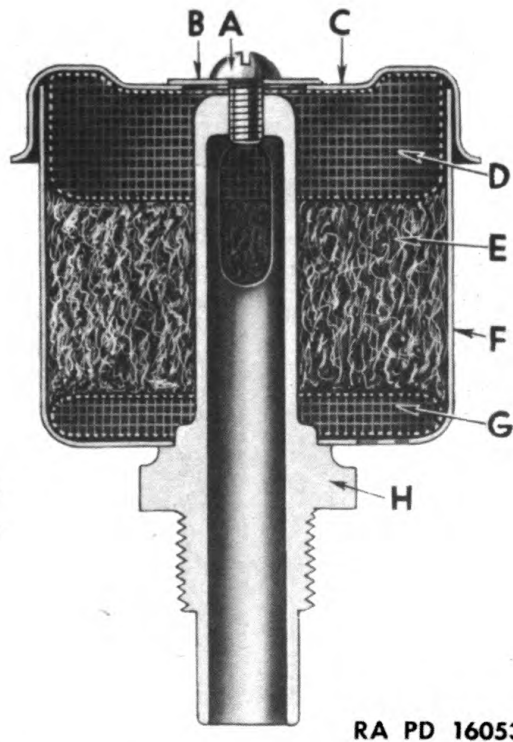

RA PD 16053

**Figure 70—Sectional View of Hydrovac Cleaner**

- |                             |                              |
|-----------------------------|------------------------------|
| <b>A</b> Cover Screw        | <b>E</b> Curled Hair Element |
| <b>B</b> Cover Screw Washer | <b>F</b> Shell               |
| <b>C</b> Shell Cover        | <b>G</b> Inner Screw         |
| <b>D</b> Outer Screw        | <b>H</b> Center Stem         |

**(2) Remove air cleaner**

Remove nut and lockwasher attaching air cleaner to bracket at rear of power cylinder shell. Cleaner can now be completely removed.

**c. Cleaning Air Cleaner**

**(1) Disassemble air cleaner**

Remove screw and flat washer holding cover to shell. Remove cover, outer screen, curled hair, inner screen, and stem from shell.

**(2) Cleaning**

Place all parts in Solvent, dry cleaner, loosen accumulated dirt. Blow all parts dry with compressed air, after deposits of dirt have been removed. Saturate curled hair in light engine oil and allow surplus to drain off.

**(3) Reassemble air cleaner**

Place stem through hole in shell and install inner (small) screen in bottom of shell. Place oiled curled hair evenly around



## BRAKES

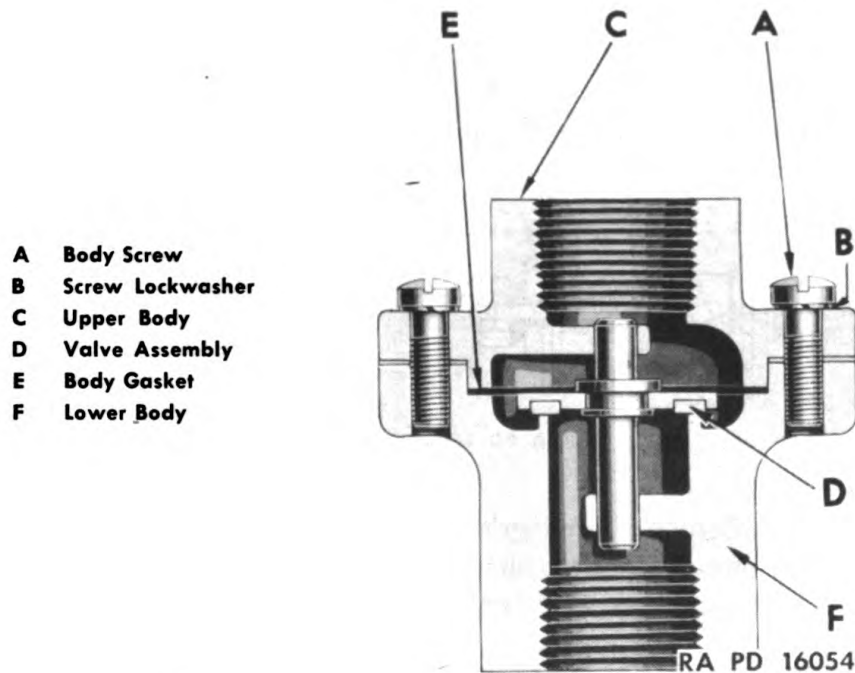

**Figure 71—Sectional View of Vacuum Check Valve**

stem inside shell. Place outer (large) screen inside shell with edge of screen toward cover. Replace cover and secure in place with flat washer and screw.

### d. Installation Procedure

#### (1) Install air cleaner

Place stem of air cleaner through mounting bracket and install lockwasher and nut. Tighten nut securely.

#### (2) Install hose

Slide hose and clamps rearward until hose is over stem. Locate clamps near ends of hose and tighten clamp bolts securely.

## 101. VACUUM CHECK VALVE REPLACEMENT

a. Whenever tests indicate that check valve is not seating properly, unit should be removed and cleaned or replaced.

### b. Removal Procedure

#### (1) Remove vacuum tube connections and valve

Use wrench to disconnect tube nut from elbow at bottom of check valve. Remove elbow from bottom of check valve. Remove check valve from special elbow fitting attached to manifold. Valve is threaded to fitting.

## TRUCK, AMPHIBIAN, 2½-TON, 6 x 6

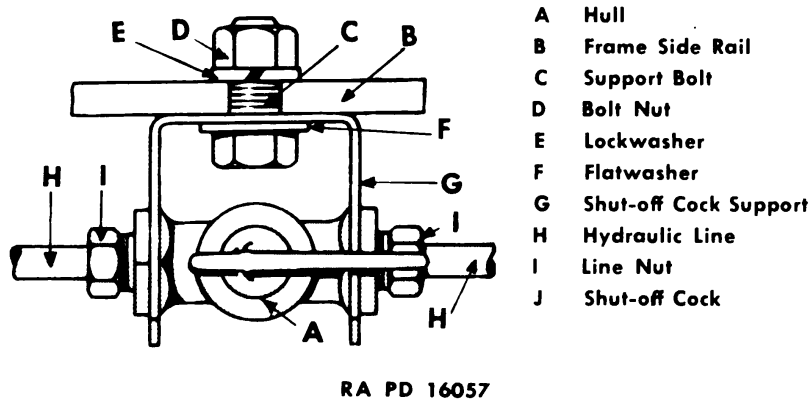

**Figure 72—Hydraulic Line Connection and Front Wheel Shut-Off Cock**

**c. Cleaning Check Valve (Fig. 71)**

**(1) Disassemble check valve**

Use screwdriver to remove four screws and lockwashers attaching upper and lower halves of body together. Separate two halves of valve body. Check valve can now be lifted from lower half of valve body.

**(2) Cleaning valve seat**

Use steel wool to clean up valve seat in lower half of valve body. Steel wool is only used to remove any slight imperfections or foreign deposits.

**(3) Inspect valve and reassemble**

Inspect and clean stem of valve, also guide in lower half of valve body. Inspect rubber seal at valve and if deteriorated or worn replace with new part. Place long end of valve stem into guide in lower valve housing. Place gasket between two halves of valve body. Place two halves of valve body together and install cap screws and lockwashers. Tighten screws evenly and alternately.

**d. Installation Procedure**

**(1) Install check valve**

Thread check valve to special elbow fitting attached to manifold. Tighten securely to prevent atmospheric leaks. Thread elbow into bottom of valve and tighten securely. Attach tube nut to elbow and tighten securely.

**BRAKES**

- A Flexible Hose
- B Seal Washer
- C Rubber Seal
- D Hull
- E Frame Side Rail
- F Shakeproof Lockwasher
- G Lock Nut
- H Line Nut
- I Hydraulic Line
- J Line Tee
- K Tee Gasket
- L Tee Bolt

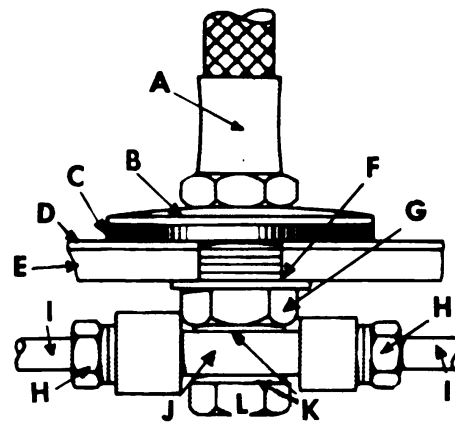

RA PD 16056

**Figure 73—Hydraulic Line and Flexible Hose Tee Connection at Right Front and Forward Rear Wheels**

**102. HYDRAULIC LINES AND FLEXIBLE HOSE REPLACEMENT**

a. Location of hydraulic lines and flexible hose, used between master cylinder, Hydrovac unit and wheel cylinders, are shown in Fig. 57.

b. **Hydraulic Lines or Tubing.** Hydraulic lines are special metal tubing manufactured to withstand high pressure. Whenever neces-

- A Hose, Flexible
- B Washer, Seal
- C Seal, Rubber
- D Hull
- E Rail, Frame Side
- F Lockwasher, Shakeproof
- G Nut, Lock
- H Nut, Line
- I Line, Hydraulic

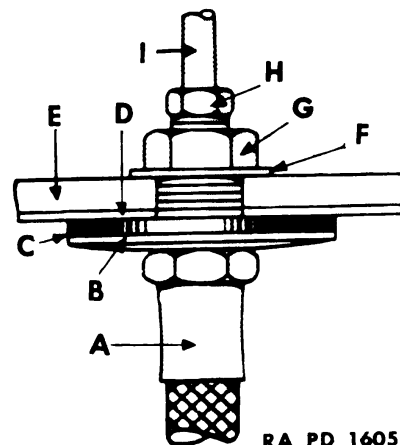

RA PD 16055

**Figure 74—Hydraulic Line and Flexible Hose Connection at Left Front and Rearward Rear Wheels**

TRUCK, AMPHIBIAN, 2 1/2 -TON, 6 x 6

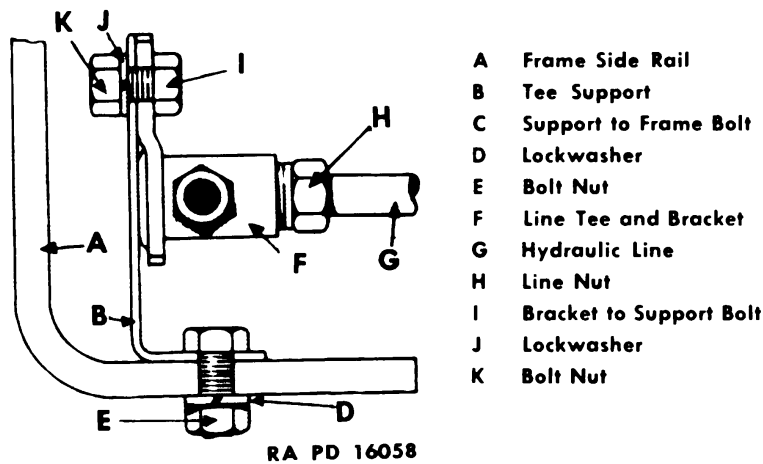

**Figure 75—Hydraulic Line Connections and Tee Mounting near Hydrovac Unit**

sary to replace any of these lines, it is important that this special tubing be used, as ordinary tubing is not satisfactory.

c. **Flexible Hose.** Flexible hose, used between each wheel cylinder and hull or frame connections, is special flexible type, made especially for this purpose.

d. **Front Wheel Shut-Off Cock.** Shut-off cock, located opposite transmission inside left-hand frame side rail, is provided to shut off hydraulic fluid to front wheel cylinders. If flexible hose or hydraulic line should become damaged, cock can be closed, and rear brakes only will continue to function.

- (1) **Remove flexible hose—right front and forward rear wheels**  
Remove bolt inside frame side rail attaching “tee” to flexible hose connection. Remove lock nut attaching flexible hose to frame side rail. Draw hose out of hull and frame from outside and remove hose from wheel cylinder (Fig. 73).
- (2) **Remove flexible hose—left front and rearward rear wheels**  
Remove tubing nut attaching hydraulic line or tubing to end of flexible hose inside frame side rail. Remove nut and gasket inside frame side rail attaching flexible hose to frame side rail. Draw hose out of hull and frame from outside and remove hose from wheel cylinder (Fig. 74).



**BRAKES****(3) Remove hydraulic lines or tubing**

Removal of all hydraulic lines is same except that some use more frame clips than others, therefore following removal instructions apply to all lines. Remove fitting nut at each end so that line is removed from "tee" or other fitting. Remove nut, lockwasher and bolt attaching clip to frame side rail or cross member. Line with clips and fitting nuts can now be completely removed.

**f. Tube Cutting and Flaring (Figs. 76, 77 and 78).** When tube assembly is not available, it will be necessary to cut tube to proper length and flare ends to fit couplings. Tubing that is not properly flared will leak and cause brakes to be ineffective. Cut and flare tubing in following manner:

(1) Cut the tubing to the desired length, using KM-KMO-3 special tube cutter to prevent flattening. Square off the end with a fine-cut mill file, then ream the sharp edges with reamer blade provided on the tube cutter.

(2) Place new compression coupling nuts on tubing. Dip end of tubing to be flared in Hydraulic Brake Fluid. This lubrication results in a better formation of the flare. Loosen clamping nuts on KMJ-1885 flaring tool, and insert tubing in channel of the die until it bears against the stop pin. Fig. 76.

(3) Tighten clamping nuts by hand and place fixture in a bench vise. Then tighten down clamping nuts firmly with a wrench and remove stop pin from the die. The tubing is now firmly gripped in die and ready for the first flare-forming operation.

(4) Using the flare-forming tool having the concave die, insert forming tool in die and strike firm blows, with a hammer, until shoulder of the tool contacts top of the die. Fig. 77.

(5) Next, use flare-forming tool having 45-degree die at its lower end. Insert tool in die and strike firm blows, with a hammer, until shoulder of tool contacts top of the die Fig. 78.

**g. Installation Procedure****(1) Install hydraulic lines or tubing**

Locate line in its correct position and attach fitting nuts to proper "tee" or flexible hose connections. Attach line to frame side rail or cross member using clip, bolt, lockwasher and nut. During installation, be sure that line is not crushed or bent sharply, as this will restrict flow of hydraulic fluid and prevent efficient operation of brakes.

**(2) Install flexible hose—left front and rearward rear wheels**

Thread flexible hose into wheel cylinder, using gasket between

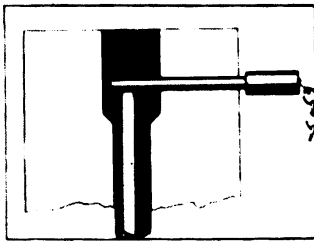
**TRUCK, AMPHIBIAN, 2½-TON, 6 x 6**

**Figure 76—Install Tubing to Depth of Stop Pin as Shown**

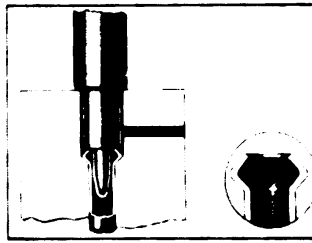

**Figure 77—First Flaring Operation Using Tool with Concave Die**

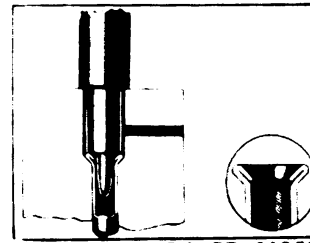

**Figure 78—Finish Flaring Operation Using Tool with 45 Degree Die**

RA PD 16059

hose connection and wheel cylinder. Tighten hose securely to eliminate possibility of leaks. Pass opposite end of hose through spring support clip. Place seal washer and rubber seal over opposite end of hose connection and insert end of hose connection through hull and frame. Install flat washer, lockwasher and nut on hose connection and tighten nut securely. Do not twist hose during tightening. Attach hydraulic line to end of flexible hose by threading line nut inside of flexible hose connection. Tighten nut securely to eliminate possibility of leaks.

- (3) **Install flexible hose—right front and forward rear wheels**  
Thread flexible hose into wheel cylinder, using gasket between hose connection and wheel cylinder. Tighten hose securely to eliminate possibility of leaks. Pass opposite end of hose through spring support clip. Place seal washer and rubber seal over opposite end of hose connection and insert end of hose connection through hull and frame. Install flat washer, lockwasher and nut on hose connection and tighten nut securely. Do not twist hose during tightening. Insert cap screw through tee and thread into flexible hose connection, using gasket under head of screw, also between tee and connection. Tighten cap screw securely to eliminate possibility of leaks.

### 103. HAND BRAKE ADJUSTMENT

a. Whenever new or relined brake band has been installed, or when brake fails to hold, it indicates that lining to drum clearance should be adjusted.

#### b. Adjustment Procedure

##### (1) Remove floor board

Remove cargo compartment center forward floor board by removing screws attaching floor board to supports. Set hand

## BRAKES

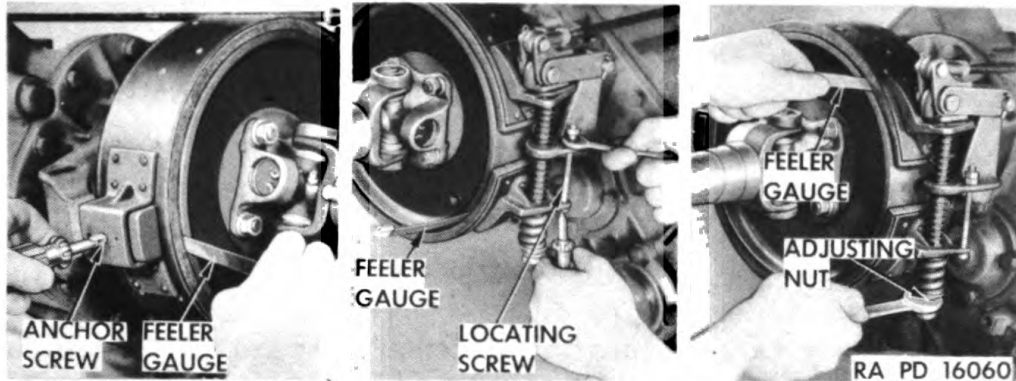

**Figure 79—Adjust Hand Brake Lining to Drum at Anchor by Turning Anchor Screw and Check Clearance with Feeler Gauge**

**Figure 80—Adjust Hand Brake Lining to Drum at Bottom by Turning Locating Screw and Check Clearance with Feeler Gauge**

**Figure 81—Adjust Hand Brake Lining to Drum at Top by Turning Adjusting Ball Nut and Check Clearance with Feeler Gauge**

brake lever in fully released position by moving lever as far forward as possible.

**(2) Adjust anchor screw**

Remove lock wire through anchor screw slot. Turn anchor screw as necessary to obtain .010"-.015" clearance between lining and drum with feeler gauge as shown Fig. 79. Thread lock wire through band anchor bracket and slot in anchor screw, twist ends of wire to prevent anchor screw turning.

**(3) Adjust locating screw**

Loosen lock nut on locating screw. Use screwdriver in slotted head of locating screw to prevent screw turning, while adjusting nut is turned to obtain .020" clearance between lining and drum as shown in Fig. 80. Tighten lock nut when proper adjustment has been obtained.

**(4) Adjust adjusting bolt**

Loosen lock nut at lower end of adjuster bolt. Turn adjusting nut to obtain .020" clearance between lining and drum as shown in Fig. 81. Tighten lock nut when proper adjustment has been obtained.

**(5) Adjust pull rod**

Remove cotter pin and clevis pin attaching adjustable yoke to cam levers. Loosen adjustable yoke lock nut. Turn yoke as necessary to line up holes in yoke and cam levers. Attach ad-

**TRUCK, AMPHIBIAN, 2½-TON, 6 x 6**

justable yoke to cam levers using clevis pin and cotter pin. Tighten adjustable yoke lock nut. Install forward center floor board and attach to supports with screws.

**104. HAND BRAKE BAND AND DRUM REPLACEMENT**

a. Hand brake drum and band with lining are located at rear of transfer case. Either band with lining, or drum, can be replaced without necessitating removal of other unit.

**b. Brake Band Removal Procedure (Fig. 82)****(1) Remove floor board**

Remove cargo compartment center forward floor board by removing screws attaching floor board to supports. Remove cotter pins and clevis pins attaching spacer links to brake support and adjusting bolt.

**(2) Remove adjusting bolt**

Use wrench to remove lock nut and adjusting nut from lower end of adjusting bolt. Lockwasher, flat washer and compression spring can now be removed from lower end of adjusting bolt. Lift bolt straight up as two release springs and cam shoe are removed.

**(3) Remove locating and anchor screw**

Use wrench to remove two nuts from locating screw so that screw can be lowered and removed. Use pliers to cut anchor screw lock wire. Remove anchor screw from anchor and band anchor bracket.

**(4) Remove band and lining**

Brake band and lining assembly must now be pulled toward rear to remove from brake support. When band has been removed, anchor screw spring can also be removed.

**c. Installing Brake Band****(1) Install brake band**

Place anchor screw spring in left-hand support while brake band and lining assembly is being moved forward and over anchor.

**(2) Install anchor and locating screws**

Thread anchor screw through band anchor and into support anchor. Anchor screw is only temporarily installed at this time. Pass locating screw through holes in brake band lower bracket and support. Temporarily thread two nuts on locating screw.

**(3) Install adjusting bolt**

Place cam shoe on adjusting bolt. Pass threaded end of adjusting bolt downward through band upper bracket, upper release spring, support, lower release spring and band lower



**BRAKES**

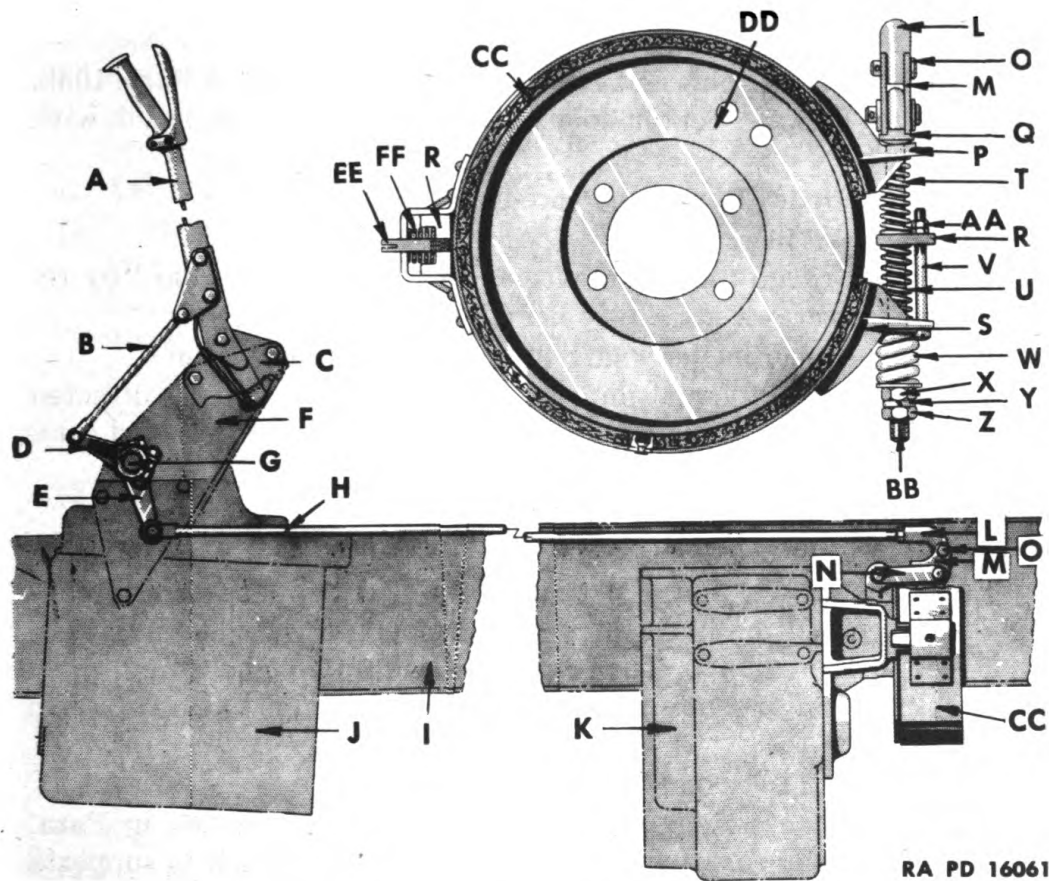

RA PD 16061

**Figure 82—Hand Brake Lever, Mountings, Linkage, Band and Lining, and Drum Installation**

- |   |                          |    |                       |
|---|--------------------------|----|-----------------------|
| A | Hand Brake Lever         | Q  | Cam Shoe              |
| B | Lever to Cross Shaft Rod | R  | Band Support          |
| C | Lever Sector             | S  | Band Lower Bracket    |
| D | Operating Lever, L.H.    | T  | Release Spring, Upper |
| E | Operating Lever, R.H.    | U  | Release Spring, Lower |
| F | Lever Bracket            | V  | Locating Screw        |
| G | Cross Shaft              | W  | Compression Spring    |
| H | Brake Pull Rod           | X  | Adjusting Nut         |
| I | Frame Side Rail          | Y  | Lockwasher            |
| J | Transmission             | Z  | Lock Nut              |
| K | Transfer Case            | AA | Adjusting Nut         |
| L | Adjustable Yoke          | BB | Adjusting Bolt        |
| M | Cam Lever                | CC | Brake Band and Lining |
| N | Spacer Link              | DD | Brake Drum            |
| O | Clevis Pin               | EE | Anchor Screw          |
| P | Band Upper Bracket       | FF | Anchor Spring         |

bracket. Place compression spring, flat washer and adjusting nuts on lower end of adjusting bolt.

**(4) Install clevis pins**

Place spacer link at each side of spacer eye and attach with clevis pin. Attach spacer links to adjusting bolt eye and cam levers by passing clevis pin through spacer links, cam levers

**TRUCK, AMPHIBIAN, 2 1/2-TON, 6 x 6**

and adjusting bolt loop. Install cotter pin in each clevis pin eye.

**(5) Adjust brake band**

Adjust brake lining to drum clearance as directed in Para. 103b. Install forward center floor board and attach to supports with screws.

**d. Brake Drum Removal Procedure****(1) Remove floor board**

Remove cargo compartment center forward floor board by removing screws attaching floor board to supports.

**(2) Remove propeller shaft universal joint and drum**

Disconnect universal joint at rear of transfer case as directed in Para. 226. Brake drum can now be moved to rear and completely removed.

**e. Brake Drum Installation Procedure****(1) Install brake drum and shaft**

Clean bolting surfaces on both sides of drum. Place drum in its correct position inside of lining and push forward against universal joint flange. Turn drum to line up bolt holes and push bolts through drum holes. Install propeller shaft as directed in Para. 226.

**(2) Adjust brake band**

Make brake lining to drum adjustment as directed in Para. 103b. Install forward center floor board and attach to supports with screws.

**105. HAND BRAKE LEVER AND LINKAGE REPLACEMENT**

a. Hand brake lever and control rod to brake band can be removed without disturbing mounting brackets. When necessary to remove lever mountings, it is of course necessary that lever be removed first.

**b. Removal Procedure****(1) Remove floor boards and hand lever**

Remove three driver's compartment floor boards. Remove cotter pins and clevis pins attaching pull rod to hand brake lever and cross shaft lever. Remove bolt nuts attaching sector to support bracket. Remove sector and lever assembly from support bracket.

**(2) Remove cross shaft**

Remove clamp bolt and nut attaching right-hand lever to cross shaft. Drive shaft to left to remove from lever and support brackets. Remove left-hand lever from cross shaft by removing clamp bolt, nut and lockwasher.

**(2) Remove left- and right-hand support brackets**

Remove three cap screws and lockwashers attaching left-hand

**BRAKES**

cross shaft support bracket to transmission. Lift bracket up to remove completely. Remove two cap screws and lockwashers, also nut and lockwasher attaching right-hand cross shaft support bracket to transmission. Remove bracket from stud and lift bracket out completely.

**c. Installation Procedure****(1) Install right- and left-hand support brackets**

Place support bracket in position with stud through lower hole. Install stud nut and lockwasher, also two cap screws and lockwashers. Tighten cap screws and stud nut. Place support bracket in position with forward edge of bracket between transmission case and pedal bracket. Install three cap screws and lockwashers. Tighten cap screws securely.

**(2) Install cross shaft**

Install short lever (3" hole centers) on shaft using Woodruff key and clamp bolt with nut and lockwasher. Place shaft through left- and right-hand support brackets. Install right-hand lever (3½" hole centers) on shaft using Woodruff key and clamp bolt with nut and lockwasher.

**(3) Install hand brake lever**

Attach lever and sector assembly to left-hand support bracket with two bolts, nuts and lockwashers. Spacers are used over bolts between support bracket and sector.

**(4) Attach pull rods**

Use clevis pins and cotter pins to attach short pull rod between hand brake lever and cross shaft left-hand lever. Attach brake band pull rod to cross shaft right-hand lever using clevis pin and cotter pin. Adjust pull rod as directed in Para. 103b. Install three driver's compartment floor boards.

**CAUTION**

1. After water operation, wet brake linings may cause uncertain brake action.
2. Linings used on this vehicle minimize swelling in water which could cause brakes to lock if shoes are adjusted too close.

Section XVI

**CLUTCH**

	Paragraph
General description .....	106
Operation .....	107
Trouble-shooting .....	108
Preventive maintenance and inspection.....	109
Adjustment for facing wear.....	110
Release mechanism replacement.....	111
Retracting spring replacement.....	112
Clutch, pilot bearing and housing replacement.....	113

**106. GENERAL DESCRIPTION**

a. Clutch used in this vehicle is single plate, dry disc type with a single dish-shaped diaphragm type pressure spring. Clutch release mechanism consists of clutch pedal, release fork, and release bearing. Clutch pedal is mounted on shaft and is connected to release fork through linkage as shown in Fig. 83. Release fork is ball stud mounted in clutch housing. Inner end of fork engages groove in release sleeve for actuation of release bearing. Release bearing is of the sealed type, prelubricated at assembly and does not require further lubrication throughout the life of the bearing.

b. Clutch pilot bearing is an oil-sealed type which fits in recess of crankshaft and provides a pilot for clutch shaft of transmission. This bearing needs attention only when clutch is removed from vehicle.

**107. OPERATION**

a. Action of clutch is illustrated in Fig. 84 which shows relative positions of parts when clutch is “engaged” and “disengaged.” Note that when engaged, clutch disc is contacting face of flywheel, being firmly held in this position by clutch pressure plate—which, in turn, is forced toward flywheel by pressure exerted upon it by the diaphragm spring. With clutch in this engaged position, engine and transmission are connected. Pressing down on clutch pedal disengages clutch, thus severing connection between engine and transmission.

**108. TROUBLE-SHOOTING**

a. Clutch is designed for maximum efficiency and long life and with reasonable care, no operating difficulty should be encountered. Natural wear will occur, however, and must be compensated for, and in this connection, cause of unsatisfactory operation may be determined by referring to the following.



**CLUTCH**

**b. Table**

Symptom and Probable Cause	Probable Remedy	Refer to Paragraph
<b>(1) Clutch slippage</b>		
(a) Facings worn.	Replace driven disc assembly . . . . .	113
(b) Improper adjustment — no pedal free travel.	Adjust pedal free travel	110
(c) Grease on facings.	Replace driven disc assembly . . . . .	113
(d) Release bearing sleeve seized on clutch shaft.	Replace and lubricate.	111
(e) Clutch disc hub binding on splines.	Replace and lubricate.	113
(f) Insufficient spring tension.	Replace clutch assembly . . . . .	113
<b>(2) Clutch grabbing or chattering</b>		
(a) Clutch not being operated properly.	Road test with driver	
(b) Facings oil or grease soaked.	Replace driven disc assembly . . . . .	113
(c) Worn splines on clutch shaft or in hub.	Replace transmission or driven disc . . . . .	113
(d) Facings loose on driven disc.	Replace driven disc . . . . .	113
(e) Loose engine mountings.	Inspect and tighten . . . . .	183
(f) Any excessive looseness throughout drive line.	Inspect transmission clutch shaft. Inspect propeller shaft universal joints and splines. Inspect differential gear splines. Inspect axle shaft mounting and splines.	
(g) Pressure plate or flywheel scored or rough.	Replace clutch assembly or flywheel . . . . .	113
(h) Loose power plant stabilizer rod.	Tighten . . . . .	277
<b>(3) Rattling</b>		
(a) Weak retracting springs.	Replace springs . . . . .	112
(b) Excessive clearance at driving lugs.	Replace cover or clutch assembly . . . . .	113
(c) Release fork loose on ball stud.	Replace ball stud . . . . .	111

**TRUCK, AMPHIBIAN, 2½-TON, 6 x 6**

Symptom and Probable Cause	Probable Remedy	Refer to Paragraph
(d) Clutch operating lever loose on shaft.	Replace operating lever	111
(e) Pedal pull back spring disconnected.	Connect spring	..... 111

**109. PREVENTIVE MAINTENANCE AND INSPECTION**

a. Operations itemized in Section V, "Preventive Maintenance and Inspection" at intervals indicated, should be accomplished on clutch system.

b. The most important preventive maintenance operation is to check and adjust clutch linkage to compensate for normal wear of clutch facings. This procedure is explained in Para. 110.

**110. ADJUSTING FOR FACING WEAR**

a. Adjustment for facing wear is accomplished by regulating the amount of free clutch pedal travel. This amount of travel is the distance clutch pedal moves before causing release bearing to contact fingers of diaphragm spring. As facings wear, fingers of diaphragm spring move toward release bearing, thus reducing clearance at this point and at the same time lessening clutch pedal travel.

**b. Clutch Pedal Free Travel Adjustment Procedure. (Refer to Fig. 83)**

**(1) Remove floor board in driver's compartment**

Remove left-hand floor board in driver's compartment.

**(2) Adjust pedal linkage**

Loosen check nut on adjusting link at release lever. Turn adjusting nut in or out, as may be required, to obtain 2½" free travel of foot pedal before clutch starts to release. Free pedal travel should be checked with finger on pedal and not with foot, as this adjustment is very sensitive. With 2½" pedal free travel definitely established, turn up check nut firmly against adjusting nut to prevent adjustment from coming loose.

**111. RELEASE MECHANISM REPLACEMENT**

a. Clutch pedal, linkage, and release fork may be replaced without disturbing any major units. However release bearing cannot be replaced until after transmission is removed.

**b. Clutch Pedal Removal Procedure**

**(1) Remove left-hand floor and toe board**

Remove left-hand floor and toe board.

**(2) Disconnect clutch control linkage**

Disconnect connecting link at clutch operating lever by removing cotter and clevis pin.

## CLUTCH

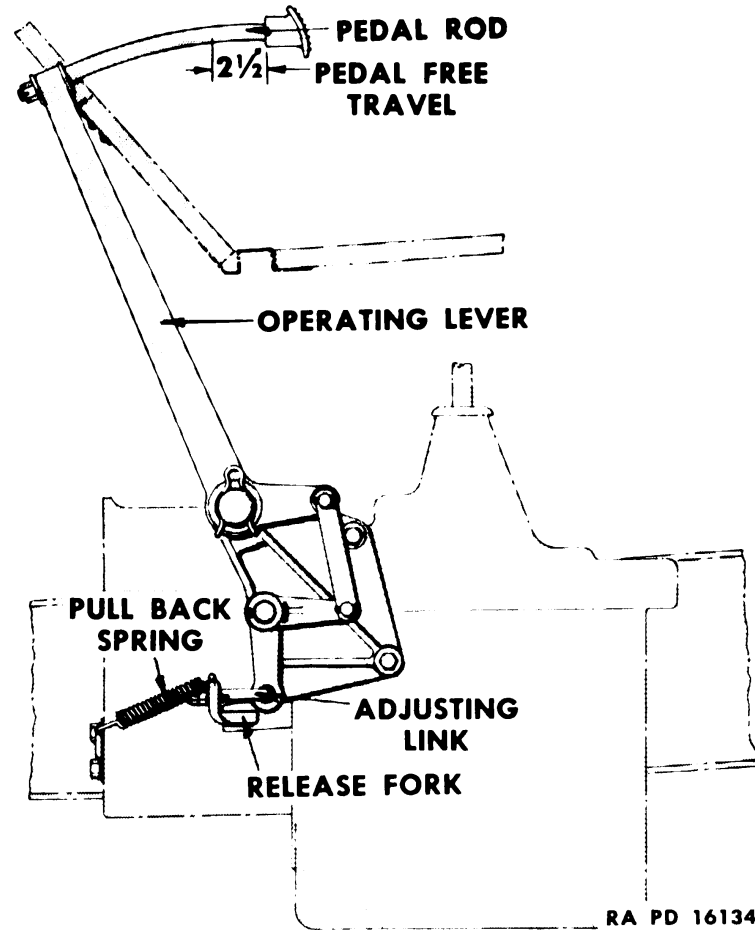

**Figure 83—Clutch Pedal and Linkage**

**(3) Remove clutch pedal**

Disassemble clutch pedal rod and operating lever by removing cotter pin and nut at end of pedal rod. Remove hair pin lock at end of pedal shaft, then remove clutch operating lever.

**c. Clutch Pedal Installation Procedure**

**(1) Install clutch pedal on shaft**

Place clutch operating lever over end of shaft. Install hair pin lock at end of pedal shaft, then insert pedal rod in hole at end of operating lever and secure with nut and cotter pin.

**(2) Connect linkage**

Attach clutch connecting link to operating lever using clevis pin and new cotter pin. Check pedal free travel and adjust as outlined in Para. 110 if free travel is not  $2\frac{1}{2}$ ".

## TRUCK, AMPHIBIAN, 2½-TON, 6 x 6

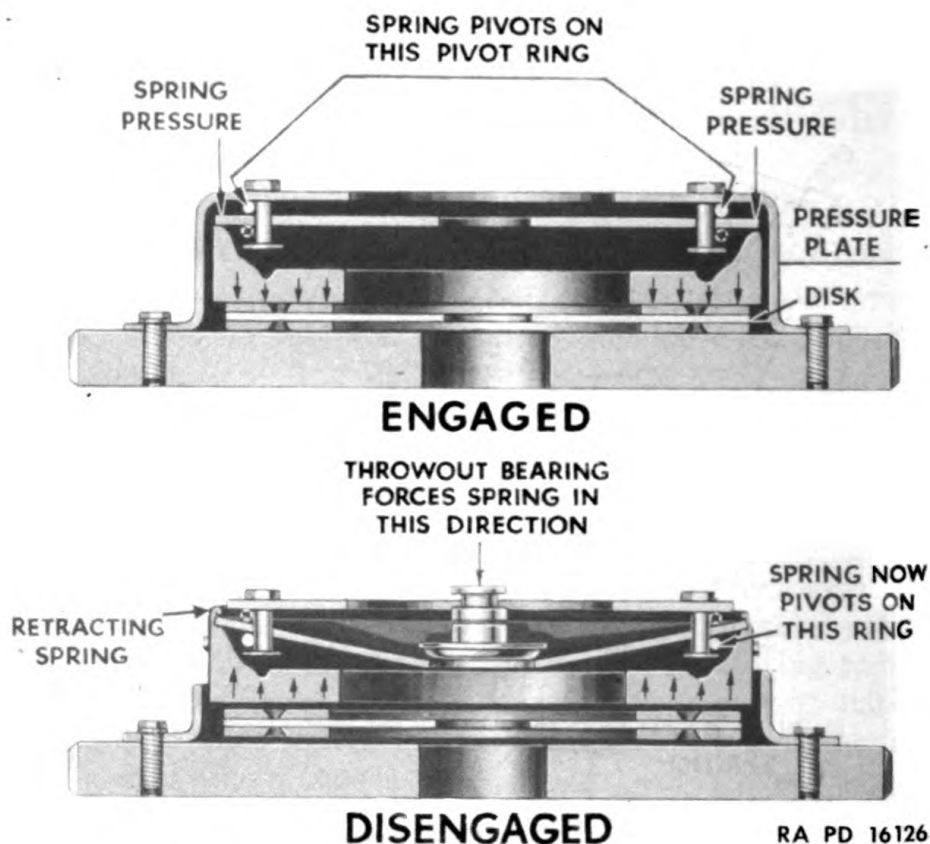

**Figure 84—Engaged and Disengaged Positions**

**d. Clutch Release Fork Removal Procedure**

**(1) Remove clutch housing under pan**

Remove 4 cross recess screws which attach clutch housing under pan to clutch housing and remove pan.

**(2) Remove clutch release fork and ball stud assembly**

Disconnect clutch release fork from clutch linkage by removing two nuts at the end of adjusting link. Loosen and remove release fork ball stud from inner side of clutch housing, using a ¾" offset open end wrench. Disconnect clutch pull back spring from release fork and remove fork and ball stud assembly from clutch housing. Lift ball stud retainer spring out of fork and withdraw ball stud.

**e. Release Fork Installation Procedure**

**(i) Install ball stud**

Pack ball seat in fork with high melting point lubricant as specified in Section VI, "Lubrication" and install ball stud and retainer spring. Be sure to place ends of ball retainer spring downward so that spring will be completely seated in grooves in fork.



**CLUTCH****(2) Reinstall fork and ball stud assembly in clutch housing**

Install fork and ball stud assembly, using care to see that fingers at inner end of fork are in groove of release bearing sleeve, then thread ball stud into support and make sure ball and stud support are drawn up tightly.

**(3) Connect clutch pedal linkage (Fig. 83)**

Attach clutch pedal adjusting link to release fork, using adjusting nut and connect pull back spring. Adjust clutch pedal free travel as instructed in Para. 110, and install check nut.

**f. Release Bearing Removal Procedure****(1) Remove transmission**

Remove transmission as directed in Para. 279.

**(2) Remove release bearing and support assembly**

Lift release bearing and support assembly from hardened buttons of release fork. Release bearing should not be removed from support as these two items are not serviced separately.

**g. Release Bearing Installation Procedure****(1) Lubricate release fork groove in bearing support**

Apply a moderate supply of high melting point lubricant (see Section VI "Lubrication" for specifications) to release fork groove in release bearing support assembly but do not lubricate bearing as this bearing is prelubricated at assembly.

**(2) Install release bearing and support assembly**

Place release bearing support in release fork making sure that hardened buttons at end of fork enter groove in support. Line inner race of bearing up with splines in clutch driven disc hub and install transmission as directed in Para. 279.

**112. RETRACTING SPRING REPLACEMENT**

a. Replacement of cover retracting springs can be accomplished without removing clutch assembly from vehicle in the following manner.

**b. Retracting Spring Removal Procedure****(1) Remove floor boards and under pan**

Remove floor boards in driver's compartment. Remove 4 cross recess head screws which attach clutch under pan to clutch housing and remove part.

**(2) Remove retracting springs**

Rotate flywheel until retracting spring is visible and remove bolt which attaches retracting spring to pressure plate and remove spring as illustrated in Fig. 85. Repeat this operation until all three retracting springs are removed.

TRUCK, AMPHIBIAN, 2 1/2-TON, 6 x 6

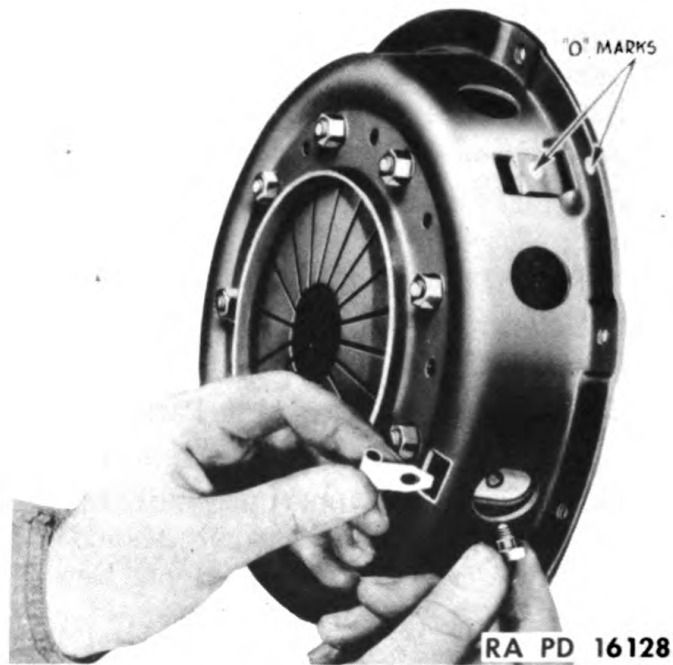
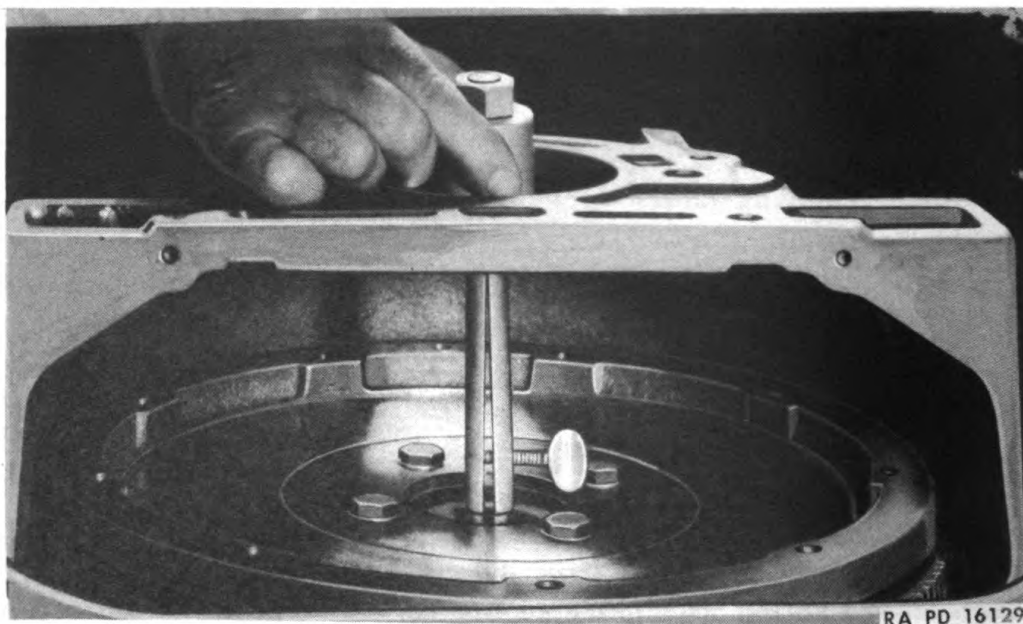

**Figure 85—Removing Retracting Springs**

**c. Retracting Spring Installation Procedure**

**(1) Install retractor spring**

Insert retractor spring in hole in cover as illustrated in Fig. 85 and secure to pressure plate, using special bolt and shake

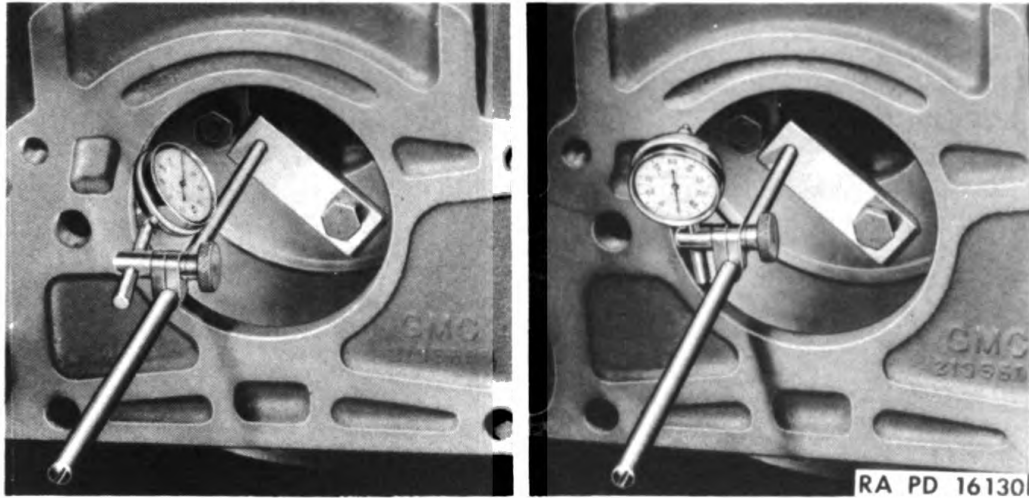

**Figure 86—Removing Pilot Bearing**

**CLUTCH**

**Figure 87—Clutch Pilot Hole Run-Out and Squareness of Clutch Housing Rear Face**

proof lockwasher. Attach clutch under pan to clutch housing, using 4 cross recess head screws and lockwashers.

### 113. CLUTCH, PILOT BEARING AND HOUSING REPLACEMENT

a. Clutch cannot be removed from engine without first removing transmission. Removal of clutch or transmission does not necessitate removal of engine from vehicle; however, the two lower transmission to clutch housing retaining bolts are accessible only from inside of clutch housing after clutch housing lower pan is removed and maximum accessibility, safety and efficiency of the work to be performed will be obtained if complete power plant is removed from vehicle. Instructions for removal of transmission only are outlined in Para. 279. Instructions for removal of complete power plant are contained in Para. 183.

b. Following procedures cover the replacement of clutch, pilot bearing and clutch housing; however, clutch housing replacement should not be attempted unless proper facilities for checking alignment of housing and flywheel are available.

#### c. Clutch Removal Procedure

##### (1) Remove transmission

Remove transmission as directed in Para. 279.

##### (2) Remove release fork and ball stud assembly

Disconnect clutch release fork from clutch linkage by removing two nuts at the end of adjusting link. Loosen and remove release fork ball stud from inner side of clutch housing, using



## TRUCK, AMPHIBIAN, 2½-TON, 6 x 6

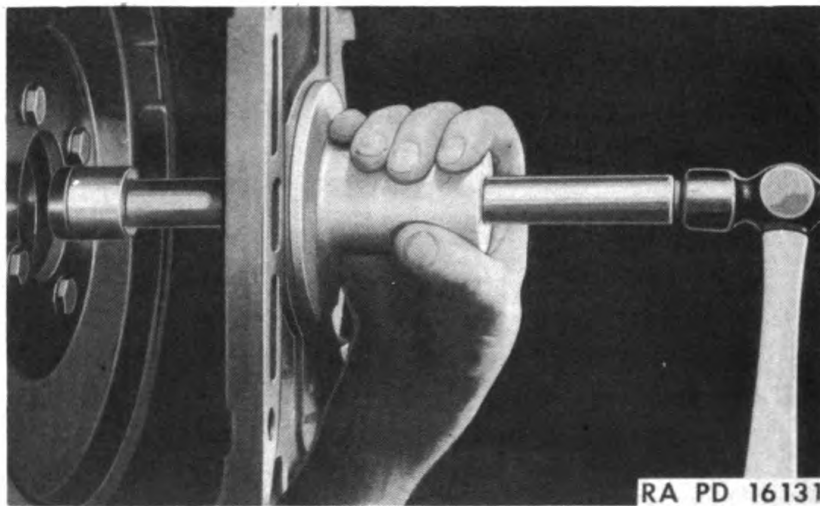

**Figure 88—Replacing Pilot Bearing**

a ¾" offset open end wrench. Disconnect clutch pull back spring from release fork and remove fork and ball stud assembly from clutch housing.

**(3) Remove clutch**

Insert clutch shaft of correct size or Clutch Aligning Arbor KM-K-411 into driven disc hub and loosen the nine clutch cover to flywheel bolts one at a time until diaphragm spring pressure is fully released. Then completely remove all mounting bolts, withdraw aligning arbor and lower clutch assembly.

**d. Pilot Bearing Removal Procedure**

**(1) Remove clutch assembly**

Remove clutch assembly as directed in Para. 113c.

**(2) Remove pilot bearing**

Use pilot bearing remover KM-J-164 as illustrated in Fig. 86 in the following manner to remove pilot bearing. Adjust puller with thumb screw until fingers on puller are closed. Insert puller through center of bearing as far as it will go. Tighten thumb screw to spread fingers of puller behind bearing and slide weight sharply against stop nut on puller shaft several times to remove bearing.

**e. Clutch Housing Removal Procedure**

**(1) Remove starter cross shaft and brackets**

Remove starter as directed in Para. 138. Remove pin which attaches accelerator control bell crank to cross shaft bracket and remove bell crank. Disconnect oil pressure gauge line at bracket by loosening flange nut. Remove two bolts at each cross shaft bracket and remove cross shaft and brackets.



**CLUTCH**

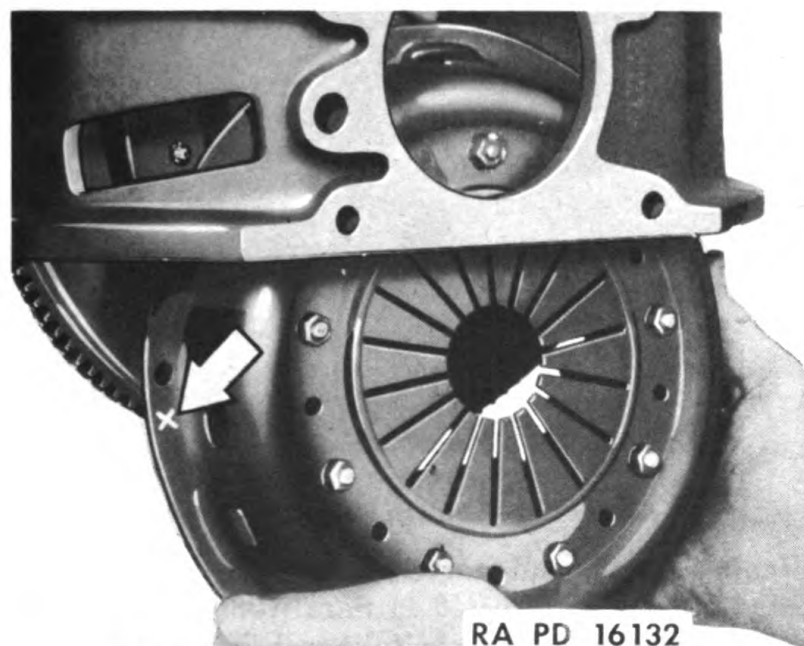

**Figure 89—Installing Clutch Assembly**

**(2) Remove clutch housing**

Disconnect hydrovac vacuum line at manifold and remove vacuum line and clip from housing inspection hole cover bolt. Remove two cross recess screws which attach extension plate to front of clutch housing and six bolts which attach housing to engine and remove housing.

**f. Clutch Housing Installation Procedure**

**(1) Attach housing to engine**

Place housing over dowels and bolt clutch housing to engine using shakeproof lockwashers under the heads of the six mounting bolts. Attach extension plate to front of housing using two cross recess screws.

**(2) Check run-out of pilot hole**

Attach dial indicator mounting bracket (tool KM-J-1895) to flywheel with a flywheel mounting bolt as illustrated in Figure 87. Place dial indicator feeler tip so that it is in contact with inner surface of pilot hole. Rotate flywheel and note reading on dial indicator. If reading exceeds .010" housing must be replaced.

**(3) Check squareness of rear face of housing**

Repeat operation for checking run-out of pilot hole except that dial indicator feeler tip must be resting on machine surface of housing approximately 1/4" from edge of pilot hole. If reading exceeds .007" housing must be replaced.

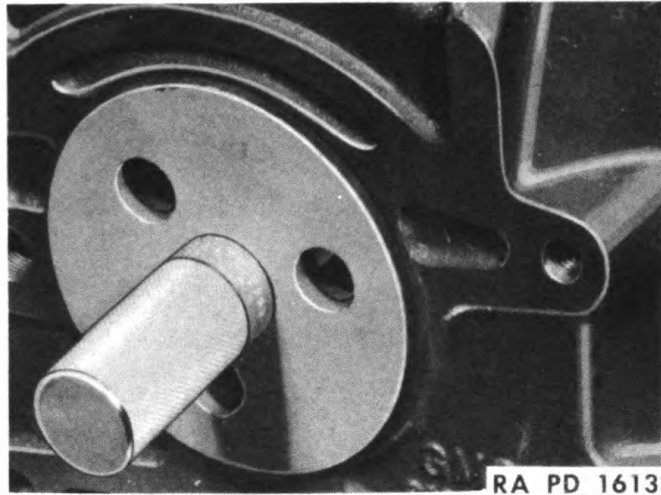
**TRUCK, AMPHIBIAN, 2½-TON, 6 x 6****Figure 90—Clutch Aligning Arbor****(4) Install starter and starter linkage**

Install starter as directed in Para. 138. Attach starter cross shaft to housing with two bolts at each bracket. Install accelerator control bell crank on left-hand bracket and replace cotter pin. Connect hydrovac vacuum line to manifold and attach line to housing with clip at inspection cover bolt.

**g. Pilot Bearing Installation Procedure**

Great care must be exercised to provide correct bearing installation. When bearing is installed, it must be in exact alignment with pilot hole in clutch housing. Use pilot bearing driver KM-K-410 as illustrated in Fig. 88 to install bearing.

**(1) Lubricate and install bearing**

Apply lubricant to balls and races before installing bearing. Refer to Section VI, "Lubrication," for proper lubricant. Position bearing on end of driver. Place tool and bearing in pilot hole of clutch housing then move handle forward until bearing begins to enter hole in crankshaft (Fig. 88). Tap end of handle with a light hammer until bearing is properly seated.

**h. Clutch Installation Procedure.** The use of Clutch Aligning Arbor KM-K-411 is recommended to properly center clutch disc during installation of clutch cover.

**(1) Locate "X" mark on flywheel**

Crank engine with starter (or hand crank if engine is out of vehicle) until "X" mark on flywheel is visible from underside of housing.

**(2) Install clutch assembly**

Place clutch disc, cover and pressure plate assembly against flywheel and rotate cover until "X" mark on cover (shown in Fig. 89) registers with "X" mark on flywheel. Insert Clutch Align-

**CLUTCH**

ing Arbor KM-K-411 (Fig. 90) in clutch disc and install bolts which attach cover to flywheel. Each bolt should be tightened gradually, a turn at a time, to prevent distortion of cover as spring pressure is taken up.

(3) **Install clutch release fork and linkage**

Install release fork and linkage as directed in Para. 111e.

(4) **Install transmission**

Install transmission as outlined in Para. 279.



Section XVII

**COOLING SYSTEM**

	Paragraph
General description .....	114
Operation .....	115
Trouble-shooting .....	116
Preventive maintenance and inspection.....	117
Draining, cleaning, flushing and refilling.....	118
Cold weather preparation.....	119
Fan and belt maintenance.....	120
Radiator replacement .....	121
Thermostat replacement .....	122
Water pump replacement .....	123
Temperature gauge replacement .....	124

**114. GENERAL DESCRIPTION**

a. Units which comprise cooling system are: radiator, overflow tank, water pump, thermostat, thermostat by-pass, temperature indicator, water temperature control tube, filler caps and the tubes and fittings connecting radiator with engine and water pump. These units cooperate, when given proper maintenance, to automatically control engine operating temperature.

**115. OPERATION**

a. **General.** Water is drawn from bottom of radiator by action of water pump and is force-circulated through passages and water jackets in engine and returned, through upper connections, to radiator where it is cooled by action of fan blowing air through radiator core. Fan draws air through intake grille, located just to rear of driver's compartment floor, forces air through shroud and radiator core, through exhaust ducts and out air exhaust grille. Air, for operation of vehicle with tarpaulin installed is taken in through auxiliary air intake. Refer to Fig. 91.

b. **Overflow Tank.** Overflow tank is provided to take surge of cooling liquid from engine into radiator upper tank whenever vehicle is brought to a sudden stop or engine is suddenly accelerated.

c. **Thermostat.** Thermostat restricts flow through radiator thereby accelerating normal operating temperature of engine. Thermostat automatically opens in gradual stages, beginning at approximately 160°. Thermostat is fully opened at approximately 185°. A by-pass is provided around thermostat and radiator to allow circulation of cooling liquid throughout engine and water pump whenever thermostat is closed. Temperature indicator is driver's guide to



**COOLING SYSTEM**

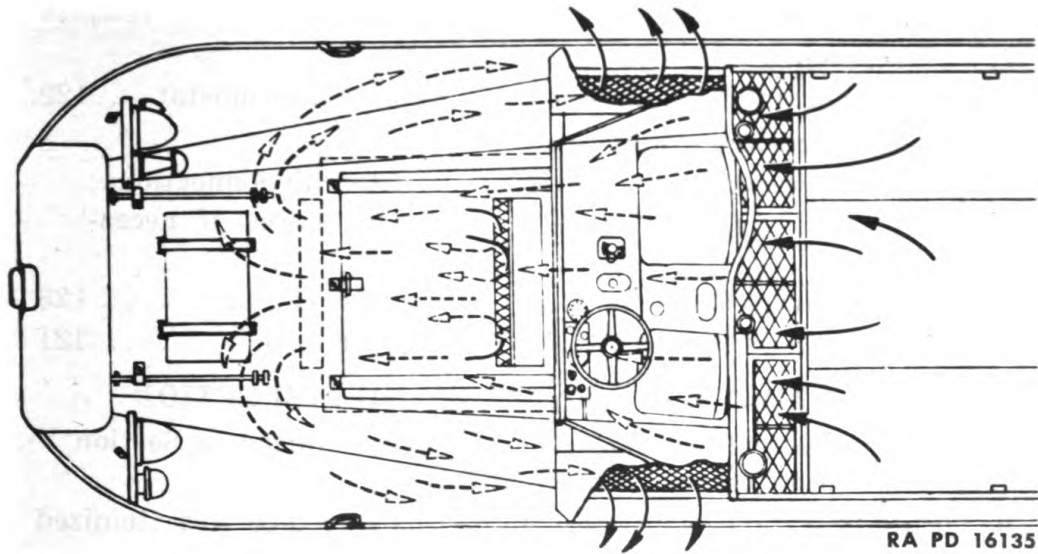

**Figure 91—Cooling Air Circulation**

proper operation of cooling system. It provides constant indication of engine temperature.

**d. Filler Caps.** Two filler caps are provided in system, a conventional sealing cap at radiator and a pressure type cap at overflow tank. **Caution:** Do not exchange the position of these caps. Pressure type cap must be on overflow tank. Radiator cap is a conventional type sealing cap and must be kept in place when vehicle is in operation.

(1) **Overflow tank sealing cap (Fig. 92).** This cap incorporates a spring loaded valve which maintains a pressure of  $3\frac{1}{4}$  to  $4\frac{1}{4}$  pounds in cooling system when engine has reached normal operating temperature. This increase in pressure raises boiling point of cooling liquid and permits a slightly higher operating temperature which results in improved engine performance and economy without the danger of over-heating.

**116. TROUBLE-SHOOTING**

Symptom and Probable Cause	Probable Remedy	Refer to Paragraph
(1) <b>Overheating</b>		
(a) Lack of cooling liquid	Refill system.	
(b) Fan belt loose or bottoming in pulleys.	Adjust or replace belt.	120
(c) Thermostat remains closed.	Replace thermostat	122
(d) Water pump inoperative.	Replace water pump	123
(e) Cooling system clogged.	Clean entire system	118
(f) Incorrect ignition timing.	Retime ignition	145
(g) Brakes dragging.	Adjust brakes properly.	94

**TRUCK, AMPHIBIAN, 2½-TON, 6 x 6**

Symptom and Probable Cause	Probable Remedy	Refer to Paragraph
(2) <b>Overcooling</b>		
(a) Thermostat remains open.	Replace thermostat	...122
(3) <b>Loss of cooling liquid</b>		
(a) Defective hose connections.	Tighten all connections; replace hoses if necessary.	
(b) Defective water pump.	Replace pump	.....123
(c) Leaks in radiator core.	Replace core	.....121

**117. PREVENTIVE MAINTENANCE AND INSPECTION**

- a. Preventive maintenance operations as itemized in Section V should be accomplished at intervals indicated.
- b. Important phases of preventive maintenance are itemized under Paras. 118, 119 and 120 of this section.

**118. DRAINING, CLEANING, FLUSHING AND REFILLING**

a. **General.** Entire cooling system should be cleaned at least twice each year—more often if inspection reveals unusual accumulations of rust and scale. This service should always be performed before and after using anti-freeze solution. Wherever cooling system is to be completely drained, be sure radiator, overflow tank and cylinder block are empty. Three drain cocks are provided for this purpose. If system is drained and not refilled immediately, a suitable tag should be marked “No water in cooling system” and attached to steering wheel.

**b. Draining Procedure**

(1) **Open engine compartment hatch cover**

Loosen engine compartment hatch cover hold-down bolt wing nuts and open hatch cover, securing it in raised position with hold-up chain. Remove radiator and overflow tank filler caps.

(2) **Drain overflow tank and cylinder block**

Unscrew overflow tank drain cock, located at bottom of tank, and cylinder block drain cock, located at left rear side of engine.

(3) **Open bow compartment hatch cover**

Loosen bow compartment hatch cover hold-down bolt wing nuts and open hatch cover. Remove snap plug located at upper right-hand corner of bow compartment bulkhead (between frame side rails) and unscrew radiator drain cock.

**c. Cleaning and Flushing Procedure**

(1) **Drain system**

Run engine at idling speed to stir up loose rust, then drain

## COOLING SYSTEM

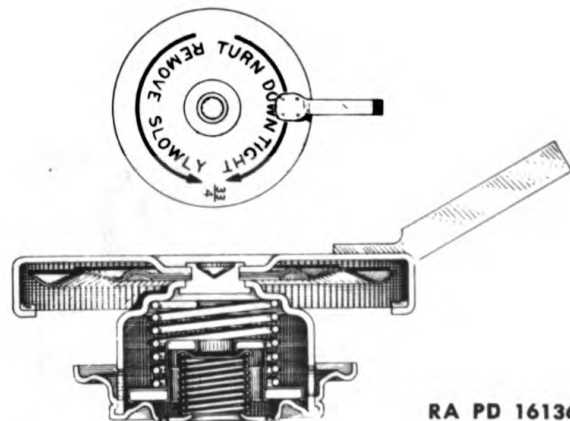

RA PD 16136

**Figure 92—Overflow Tank Cap**

system as described in Para. 118b. Close radiator, overflow tank and cylinder block drain cocks.

**(2) Put cleaner in radiator and refill system**

Pour a suitable cleaner into radiator and fill system with water. (If a commercial cleaner is to be used, follow cleaner manufacturer's instructions for cleaning and neutralizing system, in addition to those given in this paragraph.) Replace radiator and overflow tank filler caps.

**(3) Heat solution**

Run engine to heat solution to approximately  $180^{\circ}$  but **do not allow to boil** (cover radiator core if necessary to attain  $180^{\circ}$ ). Continue to run engine at least 30 minutes. Stop engine and after a few minutes, thoroughly drain system. Close drain cocks and fill system with water, installing filler caps. Run engine until warmed up then drain system again. Refill system as described in Para. 118.

**(4) Pressure flushing. Note:** In the event pressure flushing is employed, the following precautions must be taken:

(a) Remove thermostat as described in Para. 122. Flush radiator and cylinder block separately—flush radiator first to allow engine to cool off. Be sure radiator filler cap is in place. Loosen hose clamp and open engine to radiator inlet hose. Loosen hose clamp and open radiator to water pump connection hose. Attach pressure gun to bottom of radiator, forcing water out top. Use radiator hose to attach gun and to direct flow of water from radiator. Attach pressure gun to cylinder head connection on engine, forcing water out radiator to water pump connection. Follow instructions of flushing gun manufacturer in addition to above precautions.



**TRUCK, AMPHIBIAN, 2½-TON, 6 x 6**

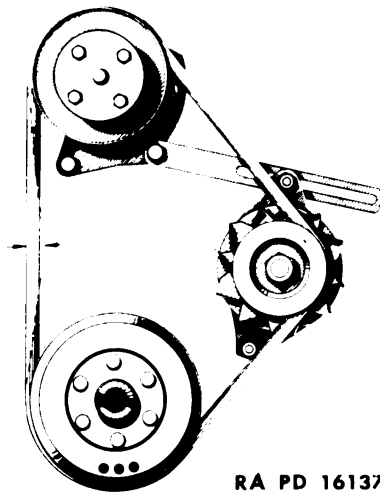

**Figure 93—Fan Belt Adjustment**

**d. Refilling Procedure**

**(1) Close drain cocks and refill**

Close radiator drain cock and install snap plug in bow compartment bulkhead. Close bow compartment hatch cover and secure with two hold-down bolt wing nuts. Close overflow tank and cylinder block drain cocks and fill cooling system through radiator filler neck. **Caution:** Use clean, soft water. Avoid use of water that contains alkali, or other substances that promote the accumulation of scale and rust. **Do not use salt water.**

**(2) Replace filler caps and close engine compartment hatch cover.**

Replace radiator and overflow tank filler caps—Sealing cap on radiator and pressure cap on overflow tank. **This is important** for proper operation of cooling system. Close engine compartment hatch cover and secure.

**119. COLD WEATHER PREPARATIONS**

**a. General.** In order to obtain greatest efficiency and carefree operation of vehicle during cold weather, a systematic inspection and servicing procedure such as outlined in Para. 118 should be diligently performed.

**b. Coolant.** Cooling liquid must be protected against freezing when vehicle is operating in atmospheric temperature below 32°F. There are three general types of anti-freeze commercially available which may be used to prepare anti-freeze solutions satisfactorily for use in cooling system. These substances are commonly known as denatured alcohol, methanol (synthetic wood alcohol) and ethylene glycol.



## COOLING SYSTEM

(1) **Alcohol and methanol.** Alcohol and methanol are subject to evaporation and therefore require frequent testing and adding of anti-freeze to provide protection for the lowest anticipated temperature.

(2) **Ethylene glycol.** Ethylene glycol requires a very well maintained cooling system. If used in a leakproof system, usually no additions of anti-freeze are required. Due to its high boiling point, only water is lost by evaporation.

(3) **Other anti-freeze agents.** Solutions containing salt, magnesium chloride, sodium silicate, kerosene, or other oils, are not satisfactory for use in cooling system.

### c. Cold Weather Procedure

#### (1) Test cooling solution

During cold weather operation, the cooling solution must be tested frequently to determine strength of anti-freeze. A testing device should be used in strict accordance with instructions provided by the manufacturer for testing particular type of anti-freeze used. Do not use different types of anti-freeze in the same cooling system. Following chart lists correct amount of each type of anti-freeze to be used.

### ANTI-FREEZE CHART

20-Quart Capacity  
(Amounts in Quarts)

Temperature	Alcohol	Methanol	Ethylene Glycol
+10°F.	6½	5	5
0°F.	7½	6½	7
-10°F.	9	7½	8
-20°F.	10	9	9
-30°F.	13	10	10

#### (2) Thaw out cooling system

In the event cooling system becomes frozen and a heated garage is not available, hold cover against core and run engine slowly until system is thawed out. If cooling solution becomes frozen solid, place vehicle in a heated garage until ice is completely thawed out and, under no circumstances should engine be run while in this condition.

## 120. FAN AND BELT MAINTENANCE

a. **Fan Belt Adjustment Procedure.** Fan is mounted to water pump pulley and is driven by belt from crankshaft in connection with

**TRUCK, AMPHIBIAN, 2½-TON, 6 x 6**

generator. Belt must be kept at proper tension in order to obtain efficiency of these units and to obtain maximum life of belt. Fan and belt are accessible through engine compartment hatch cover opening.

**(1) Loosen generator mounting**

Loosen two generator to mounting bracket bolt nuts and then loosen generator to adjusting arm bolt.

**(2) Position generator**

Move generator towards or away from engine as necessary to obtain correct belt tension. A light pressure on belt at a point midway between crankshaft and water pump pulley must cause a ½" to ¾" deflection as shown in Fig. 93. **Do not adjust belt too tight.** Tighten generator to adjusting arm bolt and then tighten two generator to mounting bracket bolt nuts.

**b. Fan Belt Removal Procedure****(1) Loosen generator mounting**

Loosen two generator to mounting bracket bolt nuts and then loosen generator to adjusting arm bolt. Move generator towards engine as far as it will go. Remove belt from generator pulley, water pump pulley and crankshaft pulley, then remove belt over fan blade.

**c. Fan Belt Installation Procedure****(1) Install belt**

Thread fan belt over fan blades and place over water pump, crankshaft, and generator pulleys. Refer to Para. a. for adjustment procedure. Check clearance between blades and shroud.

**d. Fan Replacement Procedure**

(1) Remove four fan to water pump bolts and remove fan and spacer. Install in reverse order.

**121. RADIATOR REPLACEMENT**

**a. General (Figs. 94 and 95).** Radiator, fan shroud and overflow tank may be readily removed through engine compartment hatch cover opening independently of each other. Radiator to side support bolts are accessible through bow compartment hatch cover.

**b. Removal Procedure****(1) Drain cooling system**

Follow procedure given in Para. 118.

**(2) Remove radiator connections**

Loosen radiator upper and lower connection hose clamp screws and remove upper and lower hoses from radiator, also disconnect radiator to overflow tank pipe at tank drain cock. Remove two radiator overflow pipe clip screws and remove clips.

## COOLING SYSTEM

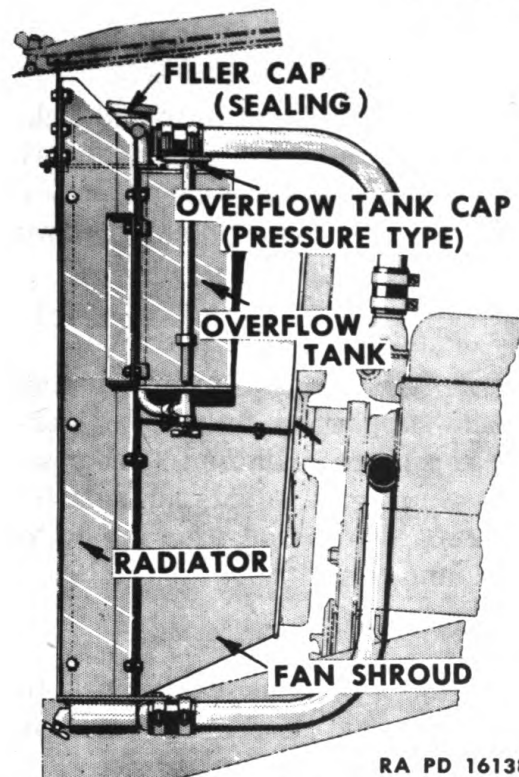

RA PD 16138

Figure 94—Radiator Installation

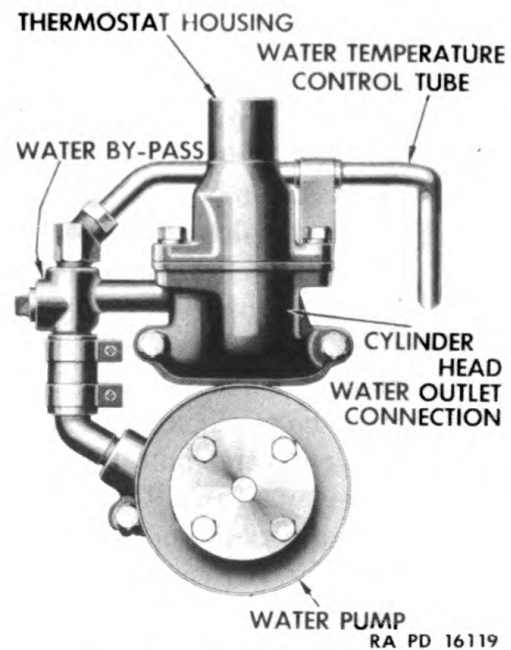

RA PD 16119

Figure 95—Front View of Water Temperature Control Installation

## (3) Remove radiator

Through bow compartment, remove six (3 each side) radiator to side supports bolt nuts and lockwashers and remove bolts. Raise radiator straight up and remove from vehicle through engine compartment hatch cover opening. Take particular notice that radiator to deck support seal is not lost.

## c. Radiator Installation Procedure

## (1) Replace seals

Make sure fan shroud to radiator upper and lower felts, also radiator to deck support seal, are in good condition and in place. Replace if necessary.

## (2) Install radiator

Carefully bend radiator mounting flanges in toward radiator just enough to allow flanges to clear side supports, and carefully lower radiator into position. From bow compartment install six (3 each side) radiator to side support bolts, lockwashers and nuts. Connect radiator overflow pipe to overflow tank drain cock and install clips and screws. Also install upper and lower connection hoses to radiator and tighten four clamp screws securely.

## (3) Refill cooling system

Follow procedure given in Para. 118.

**TRUCK, AMPHIBIAN, 2½-TON, 6 x 6**

**d. Fan Shroud Removal Procedure**

**(1) Remove shroud bolts**

Remove four upper shroud to lower shroud bolt nuts and lockwashers and remove bolts. Remove eight shroud to side support bolt nuts and lockwashers and remove bolts. Remove upper shroud from vehicle then remove lower shroud. Do not lose two shroud to radiator felts.

**e. Fan Shroud Installation Procedure**

**(1) Install shrouds**

Place lower shroud to radiator felt in position and install lower shroud, securing it to side support by four bolts, lockwashers and nuts. Place upper shroud to radiator felt in position and install upper shroud, securing it to side support by four bolts, lockwashers and nuts. Also install four upper to lower shroud bolts, lockwashers and nuts.

**f. Overflow Tank Removal Procedure**

**(3) Drain tank and disconnect**

Remove pressure type cap and unscrew tank drain cock to drain any coolant that might be in tank. Disconnect radiator overflow pipe at tank drain cock. Remove four tank to side support bolt nuts, and lockwashers and remove bolt. Remove tank from vehicle.

**g. Overflow Tank Installation Procedure**

**(1) Install tank**

Place tank in position on side support and install four tank to support bolts, lockwashers and nuts. Connect radiator overflow pipe to tank drain cock. Replace tank filler cap. This is the pressure type cap.

**122. THERMOSTAT REPLACEMENT**

**a. General.** Engine thermostat is located at cylinder head water outlet. No adjustments or repairs can be made on thermostat and if operation of cooling system indicates unit as unsatisfactory, new unit must be installed.

**b. Removal Procedure**

**(1) Drain radiator**

Loosen two bow compartment hatch cover hold-down bolt wing nuts and open hatch cover. Remove snap plug in bow compartment bulkhead and unscrew radiator drain cock and drain radiator. Loosen two engine compartment hatch cover hold-down bolt wing nuts and open hatch cover, securing it in raised position with hold-up chain.

**(2) Remove housing**

Loosen radiator upper connection hose clamp screws and remove hose from thermostat housing. Remove two thermostat



## COOLING SYSTEM

housing to water outlet connection bolts and remove thermostat housing. Raise thermostat unit from water outlet connection.

### c. Testing Procedure

(1) Place thermostat in a container of water that may be heated.

(2) Place a suitable thermometer (one that will register at least 185°) in the water so that temperature of water will be indicated.

(3) Heat water gradually and watch operation of thermostat. Thermostat should start to open at approximately 160° and be fully opened at approximately 185°. In the event operation of thermostat is not satisfactory, discard and use one known to operate properly.

### d. Installation Procedure

#### (1) Install thermostat

Place thermostat in position in cylinder head water outlet connection. Place new thermostat housing to outlet connection gasket in position and assemble thermostat housing to outlet connection. Install two thermostat housing to outlet connection bolts with lockwashers, assembling water temperature control tube clip to left-hand bolt.

#### (2) Install hose

Install radiator upper connection hose over thermostat housing and tighten two hose clamp screws securely.

#### (3) Refill radiator

Close radiator chain cock, install snap plug in bulkhead and close bow compartment hatch cover, securing it with hold-down bolts and refill radiator. Close engine compartment hatch cover and secure with hold-down bolts.

## 123. WATER PUMP REPLACEMENT

**a. Water Pump Removal Procedure.** Water pump may be removed from vehicle, through engine compartment hatch cover opening.

#### (1) Drain cooling system

Follow procedure given in Para. 118.

#### (2) Remove fan and belt

Follow procedure given in Para. 120. Remove four fan to water pump pulley bolts and remove fan and spacer.

#### (3) Remove connection

Loosen two radiator to water pump hose clamp screws, at water pump, and remove hose from water pump. Loosen two by-pass elbow hose clamp screws and remove hose from by-pass tee. Remove four water pump to cylinder block bolts and re-

**TRUCK, AMPHIBIAN, 2½-TON, 6 x 6**

move water pump from vehicle. Do not loose water pump to cylinder block gasket.

**b. Water Pump Installation Procedure**

**(1) Assemble pump to engine**

Place a new water pump to cylinder block gasket in position, then place water pump in position on engine.

**(2) Install mounting bolts**

Install 17/8" bolt with lockwasher in water pump bolt hole just above water inlet and tighten finger tight. Then install remaining three bolts with lockwashers, assembling fuel and oil lines clip and generator adjusting arm. Tighten all four bolts securely.

**(3) Install connection**

Install by-pass elbow hose to tee and tighten hose clamp screws. Install radiator to water pump hose to water pump inlet and tighten hose clamp screws.

**(4) Install fan and belt**

Place spacer and fan in position on water pump and install four bolts with lockwasher. Follow procedure given in Para. 120.

**(5) Fill cooling system**

Follow procedure given in Para. 118.

**124. TEMPERATURE GAUGE REPLACEMENT**

**a. General.** Temperature gauge, capillary tube and thermal unit are fabricated as an assembly. No provisions are made to repair this assembly. In event gauge functions improperly, replace unit.

**b. Replacement Procedure.** Follow instructions given in Para. 221.

Section XVIII

**ELECTRICAL SYSTEM—WIRING**

	Paragraph
General .....	125
Preventive maintenance and inspection.....	126
Circuits .....	127
Electrical check-up .....	128
Harness replacement .....	129

**125. GENERAL**

a. Electrical system of this vehicle is 6-volt; with wires adequately marked with various "tracer" colors (Fig. 96), and grouped, whenever practical, in wiring individual harnesses. Connection points at junction blocks, terminals, and instruments are plainly marked, when necessary, for accessibility and accuracy when making electrical connection.

b. Wiring group describes the general care and maintenance of wiring and harnesses. In addition to general wiring instructions, procedures necessary to accomplish a general tune-up of system are also described. Units used in various other electrical systems are described in their individual sections as follows:

- |                         |                       |
|-------------------------|-----------------------|
| Starting Motor—Sec. XIX | Blackout Lamps—       |
| Battery—Sec. XIX        | Sec. XXII             |
| Distributor—Sec. XX     | Main Light Switch—    |
| Ignition Coil—Sec. XX   | Sec. XXII             |
| Spark Plugs—Sec. XX     | Horn—Sec. XXIII       |
| Condenser—Sec. XX       | Fuel Gauge—Sec. XXIII |
| Generator—Sec. XXI      | Radio Suppression     |
| Regulator—Sec. XXI      | Filters—Sec. XXIII    |
| Head Lamps—Sec. XXII    | Radio Suppression     |
| Tail Lamps—Sec. XXII    | Condensers—Sec. XXIII |
| Stop Lamps—Sec. XXII    |                       |

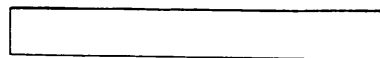

PLAIN



SINGLE TRACER



CHECK



SINGLE CROSS TRACER

RA PD 16142

**Fig. 96—Wire Tracer Patterns**





**ELECTRICAL SYSTEM—WIRING**

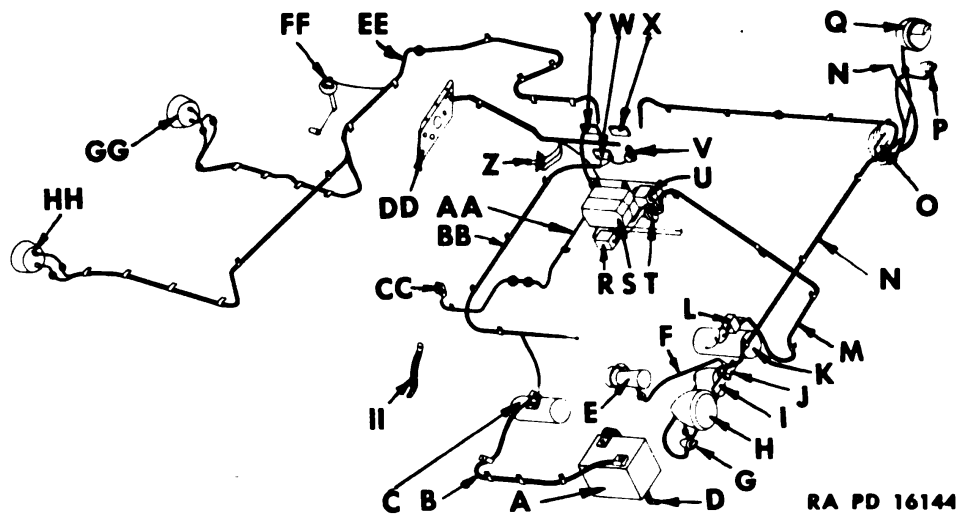

**Figure 98—Wiring Harness Diagram**

- |   |   |
|---|---|
| <b>A</b> Battery                        | <b>T</b> Field Circuit Filter                       |
| <b>B</b> Battery to Starter Cable       | <b>U</b> Armature Circuit Filter                    |
| <b>C</b> Starting Motor                 | <b>V</b> Horn Circuit Filter                        |
| <b>D</b> Battery Ground Cable           | <b>W</b> Junction Block, 3 Post                     |
| <b>E</b> Horn                           | <b>X</b> Junction Block, Front                      |
| <b>F</b> Horn to Junction Block Harness | <b>Y</b> Junction Block, Rear                       |
| <b>G</b> Blackout Marker Lamp           | <b>Z</b> Headlamp Dimmer Switch                     |
| <b>H</b> Headlamp, R.H.                 | <b>AA</b> Junc. Block to Stop Switch Harness        |
| <b>I</b> Headlamp Junction Block        | <b>BB</b> Junc. Block to Coil and Starter Harness   |
| <b>J</b> Horn Junction Block            | <b>CC</b> Stop Switch                               |
| <b>K</b> Generator                      | <b>DD</b> Instrument Panel                          |
| <b>L</b> Armature Filter                | <b>EE</b> Junc. Block to Stop and Tail Lamp Harness |
| <b>M</b> Generator to Regulator Harness | <b>FF</b> Fuel Tank Gauge                           |
| <b>N</b> Headlamp Harness               | <b>GG</b> Blackout Tail Service Stop and Tail Lamp  |
| <b>O</b> Headlamp Junction Block        | <b>HH</b> Blackout Stop and Tail Lamp               |
| <b>P</b> Blackout Marker Lamp           | <b>II</b> Ground Strap                              |
| <b>Q</b> Blackout Driving Lamp          |   |
| <b>R</b> Battery Circuit Filter         |   |
| <b>S</b> Regulator                      |   |

**126. PREVENTIVE MAINTENANCE AND INSPECTION**

a. **Connections.** Wiring terminals and connections at junctions and units should be inspected regularly. These connections must be kept absolutely tight at all times. Bear in mind: a clean and tight electrical connection is a good connection.

b. **Splices.** If a splice is made in a line, solder must be used to bond the splice. Insulating tape should be used profusely to protect all bare wires.

c. **Clips and Grommets.** Examine and tighten all harness clips at regular intervals. If rubber grommets show signs of deterioration, replace immediately with new parts.

d. **Fire and Water.** If vehicle is flooded, or has been subjected to fire, wiring harnesses should be replaced with new assemblies, as well as all other wire which may be damaged.

TRUCK, AMPHIBIAN, 2 1/2-TON, 6 x 6

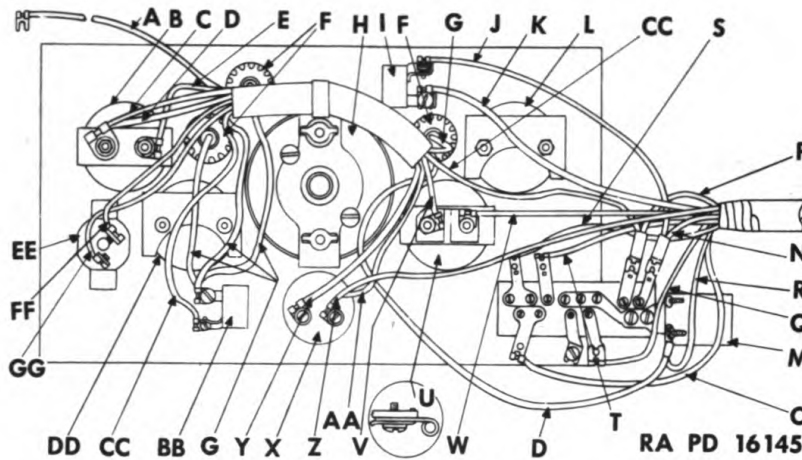

Figure 99—Instrument Panel Wiring Connections

- |   |                            |    |                           |
|---|----------------------------|----|---------------------------|
| A | No. 16 Black, White Tr.    | R  | No. 8 Yellow, B           |
| B | Ammeter                    | S  | No. 16 Red, Black Tr.—S   |
| C | No. 14 Green               | T  | No. 16 Black, Red Tr.—BS  |
| D | No. 8 Yellow               | U  | Gas Gauge                 |
| E | No. 8 Red                  | V  | No. 16 White, Red Tr.     |
| F | Panel Light                | W  | No. 16 Green              |
| G | No. 16 Green, Black Ch.    | X  | Ignition Switch           |
| H | Speedometer                | Y  | No. 14 Green              |
| I | B.O. Driving Light Switch  | Z  | No. 14 Green              |
| J | No. 16 White, Black Tr.    | AA | No. 16 White, Red Tr.     |
| K | No. 16 White, Black Tr.    | BB | Panel Light Switch        |
| L | Temperature Gauge          | CC | No. 16 Black, Green Tr.   |
| M | Light Switch               | DD | Oil Pressure Gauge        |
| N | No. 16 White, BHT          | EE | Gas Gauge Circuit Breaker |
| O | No. 16 Black, Red Ch.—SS   | FF | No. 16 White, Red Tr.     |
| P | No. 12 Black, Green Tr.—HT | GG | No. 16 White, Red. Tr.    |
| Q | No. 16 Red, SW             |    |                           |

127. CIRCUITS

a. Each wire in electrical system is of a specific size. Insulation of each wire is of a distinctive color or pattern of colors to aid in recognizing wires in various circuits. Chart, Fig. 96, illustrates patterns used in system.

b. Circuit diagram, Fig. 97, illustrates, in a schematic manner, the various electrical circuits throughout vehicle electrical system. Testing for continuity of circuit can be readily made with conventional test light or buzzer test equipment of any electrical unit or system. If circuit diagram is followed accurately, a point-to-point test can be made of any circuit to establish circuit continuity.

c. Several wiring harnesses are used on vehicles, as illustrated in Fig. 98. These harnesses contain wires to various units and junction blocks. Each harness may be removed as an assembly from the vehicle. The assemblies are well insulated with heavy loom, and are held in place by clips to prevent chafing. Rubber grommets are used where harnesses extend through bulkheads or sheet metal. Location of various harnesses are itemized in following paragraphs.

**ELECTRICAL SYSTEM—WIRING**

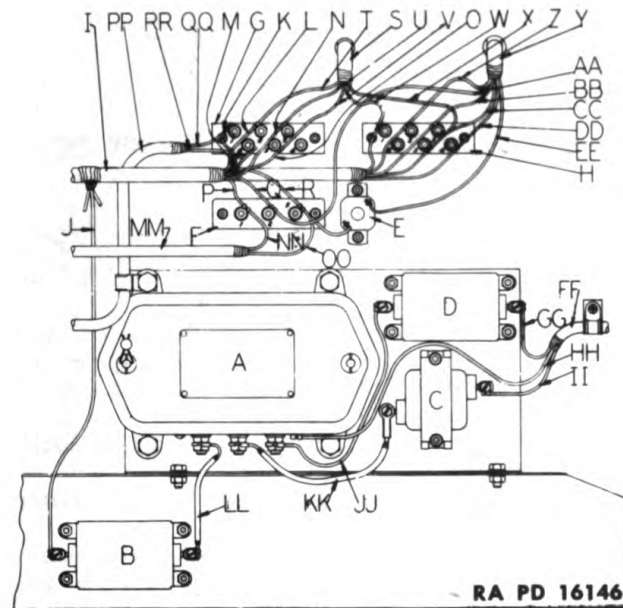

**Figure 100—Regulator Filters and Junction Block Connections**

- |                                     |  |
|-------------------------------------|--|
| <b>A</b> Regulator                  | <b>X</b> No. 14 White                                |
| <b>B</b> Battery Circuit Filter     | <b>Y</b> Head Lamp Harness                           |
| <b>C</b> Field Circuit Filter       | <b>Z</b> No. 16 White-Black Tr.                      |
| <b>D</b> Armature Circuit Filter    | <b>AA</b> No. 16 Black                               |
| <b>E</b> Horn Circuit Breaker       | <b>BB</b> No. 14 White-Green Tr.                     |
| <b>F</b> Junction Block, 3 Post     | <b>CC</b> No. 16 White                               |
| <b>G</b> Junction Block, Front      | <b>DD</b> No. 12 White-Black Cr. Tr.                 |
| <b>H</b> Junction Block, Rear       | <b>EE</b> No. 16 Tan-Red and Black Cr. Tr.           |
| <b>I</b> Instrument Panel Harness   | <b>FF</b> Generator, Regulator and Filter Harness    |
| <b>J</b> No. 8 Yellow               | <b>GG</b> No. 8 Tan-Red and Black Cr. Tr.            |
| <b>K</b> No. 16 Red                 | <b>HH</b> No. 14 Black                               |
| <b>L</b> No. 16 Green               | <b>II</b> No. 14 Black-Red Ch.                       |
| <b>M</b> No. 16 Black-Red Ch.       | <b>JJ</b> No. 8 Tan-Red and Black Cr. Tr.            |
| <b>N</b> No. 16 Red-Black Tr.       | <b>KK</b> No. 14 Black-Red Ch.                       |
| <b>O</b> No. 16 Black-Red Tr.       | <b>LL</b> No. 8 Yellow                               |
| <b>P</b> No. 14 Green               | <b>MM</b> Junction Block to Coil and Starter Harness |
| <b>Q</b> No. 16 Black-White Tr.     | <b>NN</b> No. 14 Green                               |
| <b>R</b> No. 8 Red                  | <b>OO</b> No. 8 Red                                  |
| <b>S</b> Stop and Tail Lamp Harness | <b>PP</b> Junction Block to Stop Switch Harness      |
| <b>T</b> No. 16 Green               | <b>QQ</b> No. 16 Red                                 |
| <b>U</b> No. 16 Red-Black Tr.       | <b>RR</b> No. 16 Black-Red Ch.                       |
| <b>V</b> No. 16 Black-Red Tr.       |  |
| <b>W</b> No. 16 Black-Green Tr.     |  |

Wires and connections of each harness are listed in Figs. 101 through 106.

**d. Instrument Panel and Regulator Connections.** Figs. 99 and 100 illustrate connections at instrument panel, and at regulator. Further details regarding these connections will be found in Section XXIX and Section XXI, respectively.

**e. Instrument Panel Harness (Fig. 101).** This harness extends from junction blocks through toe board and to instrument panel.

**f. Junction Block to Coil and Starter Harness (Fig. 102).** This



TRUCK, AMPHIBIAN, 2½-TON, 6 x 6

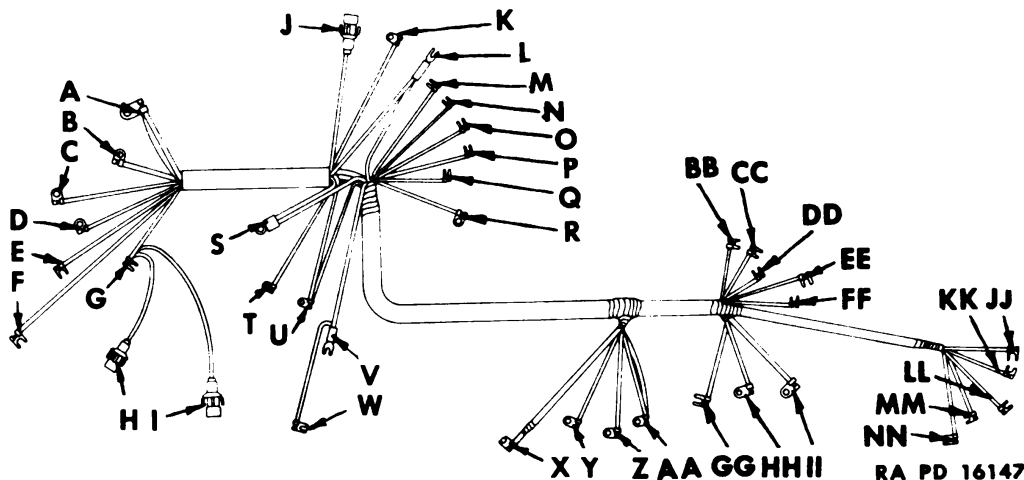

Figure 101—Instrument Panel Wiring Harness

Instrument Panel	Terminal	Instrument Panel	Terminal
A No. 14 Green	Ammeter	V No. 16 White	
B No. 8 Yellow		W No. 16 White,	
C No. 16 White, Red Tr.	Ammeter	Black Tr.	Light Sw. "BHT"
D No. 16 White, Red Tr.		No. 16 White, Black Tr.	B.O. Sw.
E No. 16 Black,		Battery Circuit Filter	
Green Tr.	Panel Lights Sw.	X No. 8 Yellow	
F No. 16 Black, White Tr.	Horn	Dimmer Switch	
G No. 16 Green,		Y No. 12 White, Black Ch. Tr.	
Black Ch. (3)	Panel Light Sw.	Z No. 14 White, Green Tr.	
H No. 16 Green, Black Ch.	Dash Lamp	AA No. 12 and No. 16 Black,	
I No. 16 Green, Black Ch.	Dash Lamp	Green Tr.	Bat.
J No. 16 Green, Black Ch.	Dash Lamp	Junction Block, Rear	
K No. 14 Green	Ign. Sw. Feed	BB No. 16 Red	1
L No. 12 and No. 16 Black,		CC No. 16 Green	2
Green Tr.	Light Sw. "HT"	DD No. 16 Black-Red Ch.	6
M No. 16 White, Black, Tr.	B.O. Sw.	EE No. 16 Red-Black Tr.	3
N No. 16 Red, Black Tr.	Light Sw. "S"	FF No. 16 Black-Red Tr.	5
O No. 16 Black, Red Tr.	Light Sw. "BS"	Junction Block, 3 Post	
P No. 16 Black, Red. Ch.	Light Sw. "SS"	GG No. 16 Black-White Tr.	2
Q No. 16 Red.	Light Sw. "SW"	HH No. 14 Green	1
R No. 16 Green	Gas Gauge	II No. 8 Red	3
S No. 8 Yellow	Light Sw. Feed	Junction Block, Front	
T No. 16 White,		JJ No. 16 Black-Green Tr.	1
Red Tr.	Gas Gauge (Ign.)	KK No. 16 White	5
U No. 16 White, Red Tr.	Ign. Sw.	LL No. 12 White-Black Cr. Tr.	4
No. 14 Green		MM No. 16 White-Black Tr.	2
		NN No. 14 White, Green Tr.	3

harness connects coil and starter switch to junction blocks and extends along under side of toe board. Horn to junction block harness extends from horn through forward deck and under deck to junction block.

g. **Junction Block to Stop Switch Harness (Fig. 103).** This harness extends from junction block over top of wheelhouse and along left-hand frame side rail to stop lamp switch.

h. **Head Lamp Harness (Fig. 104).** This harness extends from junction blocks through bulkhead and forward along top of floor channel and under forward deck to lamp junction blocks.



**ELECTRICAL SYSTEM—WIRING**

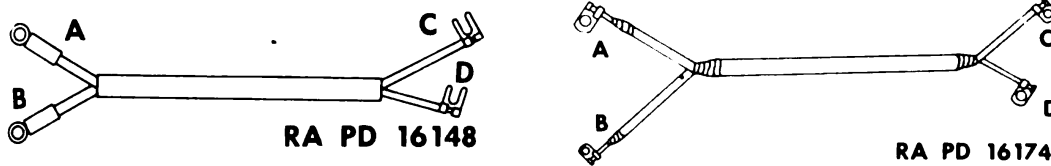

**Figure 102—Horn, and Coil and Starter Harnesses**

HORN TO JUNCTION BLOCK		JUNCTION BLOCK TO COIL AND STARTER	
	Horn		Starter Switch
A	No. 16 Tan-Red and Black Cr. Tr.	A	No. 8 Red
B	No. 16 Black		Ignition Shield Terminal
	Junction Block	B	No. 14 Green
C	No. 16 Tan-Red and Black Cr. Tr.		Junction Block, 3 Post
D	No. 16 Black	C	No. 8 Red
		D	No. 14 Green
			Terminal
			3
			1

i. **Generator to Regulator and Filter Harness (Fig. 105).** This harness connects generator, at left side of engine, with regulator and filter at inside of left-hand engine room bulkhead.

j. **Stop and Tail Lamp Harness (Fig. 106).** This harness extends from junction blocks through bulkhead and rearward along under side of left-hand coaming and under rear deck to stop and tail lamps.

**128. ELECTRICAL CHECK-UP**

a. Electrical check-up is the orderly process of checking vehicle electrical equipment to determine if it is functioning properly. In addition, if it is not, to return equipment to new condition so that new vehicle performance is restored. A comprehensive analysis of electrical system must include checks on battery, starting motor, generator, regulator, distributor, coil, spark plugs, and all wiring.

b. Reference should be made to all other Electrical System sections and maintenance instructions as itemized accomplished.

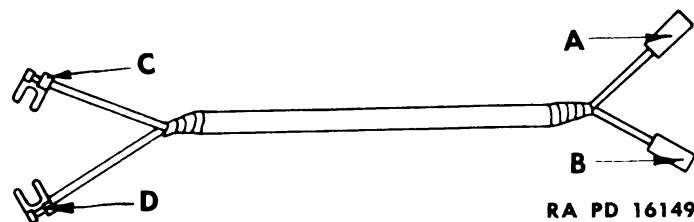

**Figure 103—Junction Block to Stop Switch Wiring Harness**

Stop Switch		Junction Block, Rear	
A	No. 16 Red	C	No. 16 Red
B	No. 16 Black-Red Ch.	D	No. 16 Black-Red Ch.
			Terminal
			1
			6

TRUCK, AMPHIBIAN, 2 1/2-TON, 6 x 6

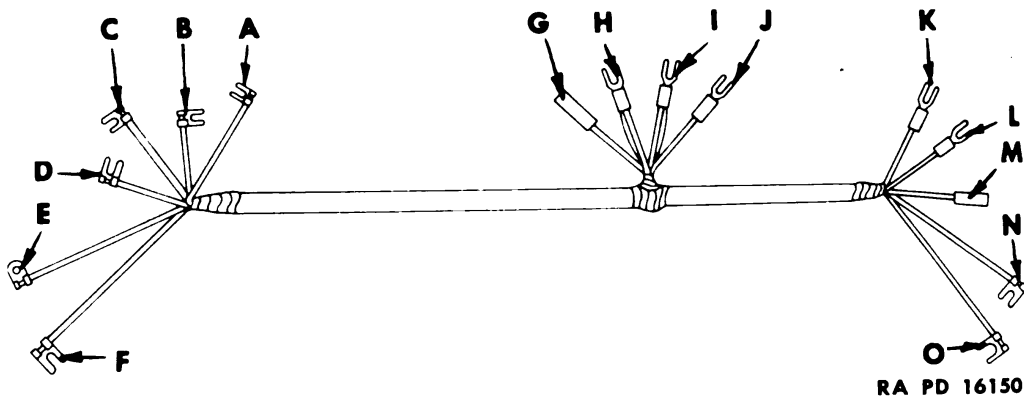

Figure 104—Headlamp Wiring Harness

Junction Block, Front		Terminal	Terminal
A	No. 12 White, Black Cr. Tr.	4	H No. 12 White-Black Cr. Tr. . . . High Beam
B	No. 14 White-Green Tr.	3	No. 14 White-Black Cr. Tr.
C	No. 16 White	5	I No. 14 White-Green Tr. . . . Low Beam
D	No. 16 White-Black Tr.	2	No. 16 White-Green Tr.
E	No. 16 Tan-Red and Black Cr. Tr.		J No. 16 White-Black Tr. . . . Blackout
	Horn Circuit Breaker		R. H. Headlamp Junction
	Junction Block, 3 Post		K No. 14 White-Black Cr. Tr. . . High Beam
F	No. 16 Black	2	L No. 16 White-Green Tr. . . . Low Beam
	L. H. Marker		M No. 16 White . . . . . Connector
G	No. 16 White	Connector	Horn Junction Block
	L. H. Headlamp Junction		N No. 16 Tan
			O No. 16 Black

129. HARNESS REPLACEMENT

a. Location of various wiring harnesses, used on this vehicle, are illustrated diagrammatically in Fig. 98. Individual harnesses are illustrated in Figs. 101 through 106.

b. **Removal.** Tabulation of wire size and color, also junctions, are shown in individual harness illustrations. When removing harness disconnect wires from each unit terminal or junction, as shown

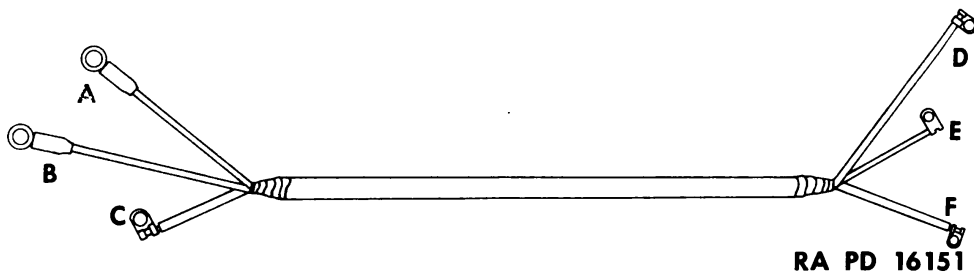

Figure 105—Generator to Regulator and Filter Wiring Harness

Generator	Terminal	Regulator	Terminal
A	No. 14 Black . . . . . Ground	D	No. 14 Black . . . . . Ground
B	No. 14 Black-Red Ch. . . . . Field		Field Filter
C	No. 8 Tan-Red and Black Cr. Tr. . . . Filter	E	No. 14 Black-Red Ch. . . . . Gen. Armature Filter
		F	No. 8 Tan-Red and Black Cr. Tr.

ELECTRICAL SYSTEM — WIRING

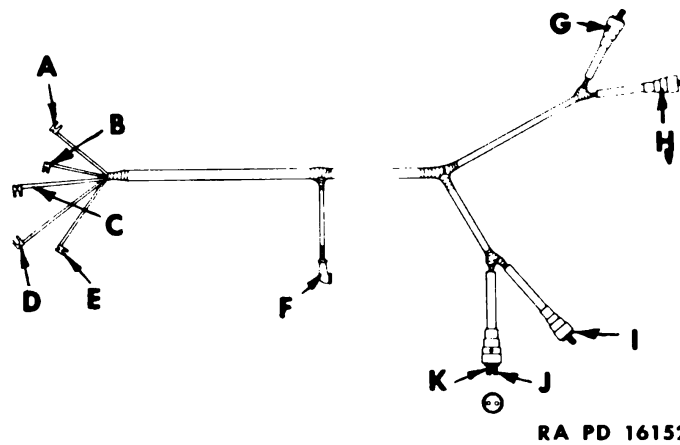

Figure 106—Stop and Tail Lamp Wiring Harness

	<b>Junction Block, Rear</b>	<b>Terminal</b>		<b>R. H. Blackout Stop</b>	<b>Terminal</b>
A	No. 16 Black-Red Tr. ....	5	G	No. 16 Black-Red Tr. ....	Connector
B	No. 16 Red-Black Tr. ....	3		R. H. Blackout Stop	
C	No. 16 Green ....	2	H	No. 16 White ....	Connector
	<b>Junction Block, Front</b>			L. H. Blackout Tail	
D	No. 14 White ....	5	I	No. 16 White ....	Connector
E	No. 16 Black-Green Tr. ....	1		L. H. Stop and Tail Lamp Connector	
	<b>Fuel Tank Gauge Unit</b>		J	No. 16 Red-Black Tr. ....	Stop
F	No. 16 Green		K	No. 16 Black-Green Tr. ....	Tail

under individual illustrations. Remove clips attaching harness to supports, bulkhead, etc. When wires and clips have been removed and disconnected, harness can be completely removed as an assembly.

c. **Installation.** Install harness in its correct location, being sure it is threaded through grommets at bulkheads. Install clips attaching harness to supports, bulkheads, etc. Fig. 98 shows approximate location of all clips and grommets. Select wire size and color, as shown under individual harnesses, and attach to unit terminals or junctions specified. Tighten all terminals securely. Bear in mind: a clean and tight electrical connection is a good connection.

## Section XIX

**ELECTRICAL SYSTEM—STARTING MOTOR AND BATTERY**

	Paragraph
General description .....	130
Operation .....	131
Trouble-shooting .....	132
Preventive maintenance and inspection .....	133
Battery maintenance .....	134
Line voltage tests .....	135
Battery replacement .....	136
Starter switch replacement .....	137
Starting motor replacement .....	138
Starting motor control linkage replacement .....	139

**130. GENERAL DESCRIPTION**

a. Starting system consists of battery, starting motor, control linkage and interconnecting cables between battery and starting motor. Starting motor is attached to right-hand side of clutch housing and is equipped with an over-running clutch drive which is manually shifted into engagement with flywheel. Starting motor switch, attached to top of starting motor, completes electrical circuit between battery and starting motor, when starter is being used. Battery is 6 volt type and is located at right side of engine. Electrical energy stored in battery is used primarily to supply current for operation of starting motor. The battery consists of three cells connected in series, giving a terminal voltage of six volts. Each cell is made up of an acid-proof compartment in which two groups of plates, positive and negative, are immersed in electrolyte, a solution of sulphuric acid and water.

**131. OPERATION**

a. Starting motor and battery are connected to each other by cables. Starting motor is controlled by foot pedal, which opens and closes starter switch contact points, thereby controlling electrical circuit between battery and starting motor.

b. **Starting Motor (Fig. 107).** When starter pedal button is depressed, initial movement of shift lever pushes drive unit rearward to engage pinion teeth with flywheel ring gear teeth. Upper end of shift lever engages starting switch button after pinion has fully engaged flywheel gear, or when spring is sufficiently compressed to force pinion into mesh as soon as armature rotates. When engine has started, action of over-running clutch on starting motor shaft releases starter pinion from flywheel teeth.

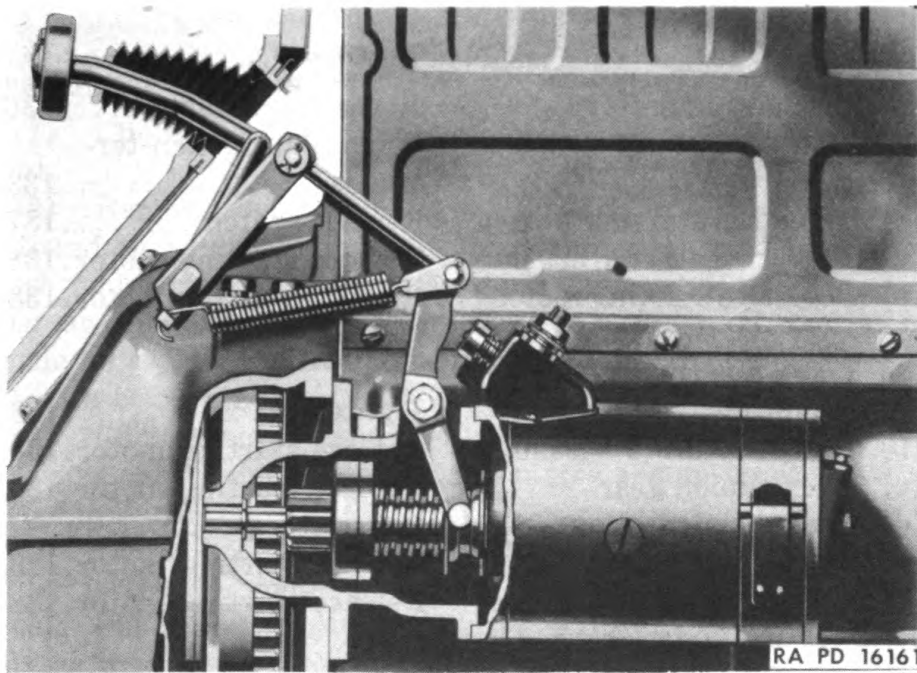

**ELECTRICAL SYSTEM—STARTING MOTOR AND BATTERY****Figure 107—Starting Motor Installation**

After pedal is released by driver, spring on starter shaft and return spring attached to shaft lever returns starting mechanism to off position.

**c. Battery.** Battery is an electro-chemical device for storing electrical energy and when properly used, has two major functions. The first function is to govern, directly or indirectly, the voltage of vehicle's electrical system. The second function is to provide electrical energy to starting motor and ignition circuit while engine is being started. Battery also supplies energy, under limited conditions, to lights and other electrical accessories.

**132. TROUBLE-SHOOTING**

**a.** When diagnosing trouble symptoms in starting motor systems, three factors must be taken into consideration. These are (1) condition of battery, (2) condition of cable and terminals, or continuity of electric circuit, and (3) mechanical and electrical condition of starting motor unit.

**b.** If engine fails to start after repeated and satisfactory operations of starting motor, cause of failure of engine to start cannot be attributed to starting motor system, but to other functioning systems of engine such as ignition, fuel, etc. Reference should be made to other "Trouble-Shooting" tables in this manual to determine cause of engine failure.

**TRUCK, AMPHIBIAN, 2½-TON, 6 x 6**

**c. Table**

**(1) Starter will not operate**

Symptom and Probable Cause	Probable Remedy	Refer to Paragraph
(a) Discharged battery	Recharge or replace . . .	136
(b) Loose terminals	Clean and tighten terminals . . . . .	133
(c) Defective starting switch	Replace switch . . . . .	137
(d) Defective starter brushes	Replace starting motor .	138
(e) Defective starting motor	Replace starting motor .	138
<b>(2) Noisy starting motor</b>		
(a) Loose starting motor mounting	Tighten . . . . .	133
(b) Defective drive assembly	Replace starting motor .	138
(c) Worn pinion gear	Replace starting motor .	138
(d) Lack of lubrication	Lubricate . . . . .	Sec. VI
(e) Worn commutator	Replace starting motor .	138
(f) Worn bushings	Replace starting motor .	138
<b>(3) Over and under charged battery</b>		
(a) Incorrect voltage adjustments	Replace . . . . .	158
<b>(4) Slow starting motor speed</b>		
(a) Discharged battery	Recharge or replace . . .	136
(b) Loose terminals	Clean and tighten terminals . . . . .	134
(c) Worn brushes	Replace starting motor .	138
(d) Sticking brushes	Replace starting motor .	138
(e) Dirty or worn commutator	Replace starting motor .	138
(f) Armature rubbing field coils	Replace starting motor .	138
<b>(5) Discharged battery</b>		
(a) Loose or dirty terminals	Clean and tighten . . . . .	133
(b) Excessive resistance in cables	Check line voltage . . . . .	135
(c) Generator not charging	Replace generator . . . . .	159
(d) Battery cells shorted	Replace battery . . . . .	136
(e) Dry battery cells	Replenish water . . . . .	134
<b>(6) Over-heated battery</b>		
(a) Incorrect regulator adjustment	Replace . . . . .	158

**133. PREVENTIVE MAINTENANCE AND INSPECTION**

a. At regular intervals following inspections should be made of starting system. During severe operations, such as extreme cold or hot weather, inspection intervals should be more frequent.

b. **Battery.** Inspection, tests and battery maintenance are out-

**ELECTRICAL SYSTEM—STARTING MOTOR AND BATTERY**

lined in Para. 134 following. Importance of properly maintaining battery cannot be over-emphasized as the complete starting system will fail if battery is not in proper condition.

**c. Starting Motor**

(1) Check starting motor mounting bolts to be sure they are tight.

(2) Remove cover band and inspect condition of commutator and if found to be dirty, place strip of number 00 sandpaper between brush and commutator while armature is revolving. If this fails to clean up commutator, or if commutator is badly worn, starting motor should be replaced. After polishing operation, dust should be blown out with compressed air.

(3) Remove cover band and inspect condition of brushes. If appreciable wear is evident, starting motor should be replaced as directed in Para. 138.

(4) Check and, if necessary, tighten screws attaching starter switch to starting motor housing.

(5) Check and, if necessary, tighten terminal stud nut attaching battery to switch cable, also ammeter to switch wire.

(6) If any indications are evident that contact points are not closing, switch should be replaced as directed in Para. 137.

**134. BATTERY MAINTENANCE**

a. Complete test should be made of starting motor circuit at regular intervals to determine condition of various units. Symptoms and probable causes of starting system difficulties are outlined in Para. 132. Other electrical units such as generator and regulator are sometimes contributing factors to battery failure. Therefore, reference should always be made to trouble-shooting charts covering these units.

(1) **Check water level.** Remove 3 filler caps and check level of water in each cell. Water level should be approximately  $\frac{3}{8}$ " above cell plates. During cold weather water should only be added just before run. Use only pure distilled water when necessary to add.

(2) **Check battery terminals.** Inspect condition of battery terminals and if found to be corroded, remove and clean with solution of ammonia and water. Coat cable terminals and battery post with petrolatum. Install terminal on post and tighten clamp nut securely.

(3) **Cell test.** Use an accurate reading hydrometer and check each cell of battery for specific gravity of battery solution. Full charged battery should test between 1.260 and 1.300. If reading is below 1.225 battery should be replaced. Freezing point of electrolyte depends on its specific gravity or condition of battery charge. Following table gives freezing temperature of battery solution at various specific gravities.



**TRUCK, AMPHIBIAN, 2½-TON, 6 x 6**

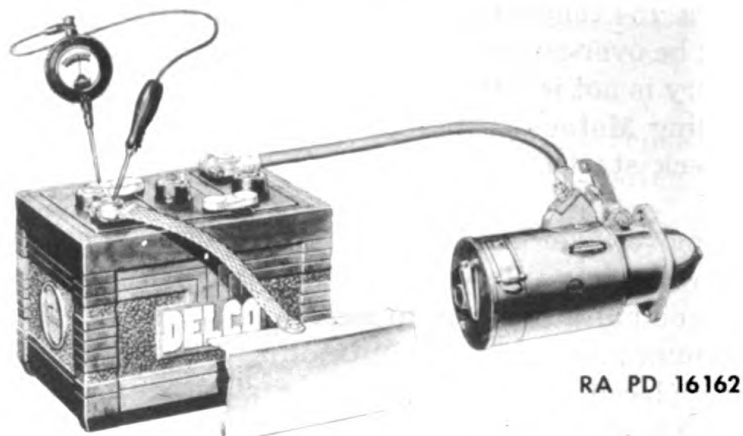

**Figure 108—Check Battery Cell Voltage with Starting Motor Operating**

**Freezing Temperature vs. Specific Gravity**

Specific Gravity	Freez. Temp. Deg. F.	Specific Gravity	Freez. Temp. Deg. F.
1100	+18	1220	—31
1120	+14	1240	—51
1140	+ 8	1260	—75
1160	+ 2	1280	—92
1180	— 6	1300	—95
1200	—17		

(4) **Cell voltage test.** With ignition switch off or high tension lead removed from ignition coil, operate starting motor and quickly check each cell of battery with AEE-F8 low reading voltmeter in manner shown in Fig. 108. If voltage falls below 1.7 volts at 80°F. or if there is a difference between cell readings of more than 1/10 volt, battery is at fault and should be replaced.

**135. LINE VOLTAGE TEST**

a. Check cable leads and connections to determine if they are in good condition without excessive resistance. Excessive resistance produces abnormal voltage drop which may lower voltage at starting motor to such a low value that normal operation of starting motor will not be obtained. Abnormal voltage drop can be detected with a low reading voltmeter. Notify Ordnance Maintenance Personnel.

**136. BATTERY REPLACEMENT**

a. Ordinarily it is only necessary to remove battery when inspection or tests reveal that it must be replaced or recharged.

**b. Removal Procedure**

**(1) Remove cable**

Loosen three thumb screws and lift engine room hatch cover.



**ELECTRICAL SYSTEM—STARTING MOTOR AND BATTERY**

Attach hold-up chain to hold hatch cover open. Loosen positive and negative cable clamp bolt nuts and lift cable terminals from battery posts.

**(2) Remove upper tray**

Remove two wing nuts holding upper tray over top of battery. Lift upper tray from battery. Use battery lifter strap and raise battery from lower tray. Do not tip battery during removal as electrolyte fluid may be spilled from battery.

**c. Installation Procedure****(1) Install battery**

Select battery and test each cell as directed in Para. 134. Use battery lifter strap on terminals and lower battery into place on lower tray. Positive terminal of battery must be toward front. Install upper tray over battery with rods at each end through holes in tray. Install wing nut on each stud and tighten securely.

**(2) Install cables**

Clean clamping surface of battery and cable terminals. Install positive and negative cables to battery terminals and tighten clamp bolts nuts (negative grounded). Coat terminals with petrolatum to prevent corrosion. Lower hatch cover and tighten three thumb screws holding hatch cover in place.

**137. STARTER SWITCH REPLACEMENT****a. Removal Procedure****(1) Disconnect cables**

Loosen three wing nuts on hold-down bolts and lift engine room hatch cover. Attach hold-up chain to hold hatch cover open. Remove starter switch terminal nut, two cables and condenser wire. Tape terminal on end of battery cable to prevent discharge of battery if cable should come in contact with metal.

**(2) Remove switch and condenser**

Remove two screws and lockwashers attaching switch to starting motor housing. Remove condenser and starter switch.

**b. Installation Procedure****(1) Install switch and condenser**

Use two screws and lockwashers to attach starter switch and condenser to starting motor housing. Tighten screws securely. Install ammeter cable, battery cable, and condenser pig tail wire over starter switch terminal. Replace lockwasher and nut. Tighten nut securely. Remove hold-up chain and lower hatch cover. Tighten three wing nuts on hold-down bolts holding hatch cover in place.

**TRUCK, AMPHIBIAN, 2 1/2-TON, 6 x 6**

**138. STARTING MOTOR REPLACEMENT**

a. Starting motor must be removed to lubricate inboard bearing (see Section VI).

**b. Replacement Procedure**

**(1) Lift engine room hatch cover**

Loosen three wing nuts on hold-down bolts and lift engine room hatch cover. Attach hold-up chain to hold hatch cover open. Remove fuel filter as directed in Para. 200. Remove battery ground cable to prevent accidental discharge of battery. Remove nut and lockwasher attaching ammeter, battery and condenser cables to starter switch terminal and remove cables.

**(2) Disconnect linkage**

Remove linkage return spring. Remove cotter pin, return spring clip and clevis pin attaching linkage rod to shift lever. Remove bolt, stud nut and lockwashers attaching starting motor to clutch housing. Starting motor can now be moved forward to complete removal procedure.

**c. Installation Procedure**

**(1) Install starting motor**

Locate starting motor in its correct position with starter switch on top. Temporarily install lockwasher and cap screw also lockwasher and nut attaching starter to clutch housing. Tighten nut and cap screw evenly and alternately until tight.

**(2) Connect linkage and cables**

Install clevis pin attaching linkage rod to shift lever and install return spring clip and cotter pin. Attach return spring to clip and linkage cross shaft. Attach ammeter, battery and condenser cables to starter switch stud and install lockwasher and nut. Tighten nut securely. Attach ground cable at battery and tighten securely. Install fuel filter as directed in Para. 200. Remove hold-up chain and lower hatch. Tighten three wing nuts on hold-down bolts holding hatch in place.

**139. STARTING MOTOR CONTROL LINKAGE REPLACEMENT**

a. Removal of starting control linkage is only necessary when linkage has become bent or otherwise damaged.

**b. Removal Procedure**

**(1) Remove linkage**

Loosen three wing nuts on hold-down bolts and lift engine room hatch. Attach hold-up chain to hold hatch open. Disconnect return spring at rear. Remove cotter pin spring clip and clevis pin attaching linkage to starter shift lever. Remove cotter pin and clevis pin attaching panel rod to cross shaft. Pedal can now be lifted up through toeboard. Remove four cap screws (two

**ELECTRICAL SYSTEM—STARTING MOTOR AND BATTERY**

each side) attaching linkage brackets to top of clutch housing. Linkage assembly can now be completely removed.

**c. Replacement Procedure****(1) Install linkage**

Install linkage on clutch housing and replace four cap screws and lockwashers attaching linkage brackets to clutch housing. Insert pedal rod through toe board and attach to linkage using clevis pin and cotter pin. Attach linkage rod to starter shift lever using clevis pin. Install spring clip over clevis pin and install cotter pin. Attach return spring to clip and linkage cross shaft. Remove hold-up chain and lower hatch. Tighten three wing nuts on hold-down bolts holding hatch in place.

Section XX

**ELECTRICAL SYSTEM—IGNITION**

	Paragraph
General description .....	140
Operation .....	141
Trouble-shooting .....	142
Preventive maintenance and inspection.....	143
Distributor maintenance .....	144
Ignition timing .....	145
Spark plug maintenance .....	146
High and low tension wire maintenance.....	147
Distributor replacement .....	148
Condenser and point replacement.....	149
Ignition coil replacement.....	150

**140. GENERAL DESCRIPTION**

a. Ignition system comprises ignition switch, source of electrical energy (battery or generator), ignition coil, condenser, distributor, low and high tension wiring, and spark plugs. All of these factors combine to produce electrical energy of sufficiently high voltage to ignite fuel vapors in engine combustion chambers.

b. **Distributor.** The distributor mounted on right-hand side of engine is equipped with centrifugal type of spark control. The unit is driven from camshaft by spiral cut gears. Lower end of distributor shaft is tongued and engages slot on upper end of oil pump shaft to drive oil pump. (See Fig. 109.)

c. **Ignition Coil.** Ignition coil is oil-filled and hermetically sealed to prevent entrance of moisture. High tension terminal is protected by a porcelain insulator which has high resistance to leakage across its surface and is not damaged by electrical leakage which might occur. Purpose of ignition coil is to transform energy from low voltage source (battery or generator) into energy at sufficiently high voltage to jump gap at spark plug.

d. **Spark Plugs.** Spark plugs are the medium by which high tension voltage is converted into a spark in combustion chamber of engine.

e. **Condenser.** The condenser is mounted in body of distributor and is connected across distributor points. The purpose of condenser is to reduce distributor point arc by its ability or capacity to store up electrical energy.

f. **Low and High Tension Wire.** Low tension wires are those in the primary circuit, while high tension wires are those in secondary circuit. (See Fig. 110.)

**141. OPERATION**

a. Distributor including condenser, ignition coil and spark plugs



**ELECTRICAL SYSTEM—IGNITION**

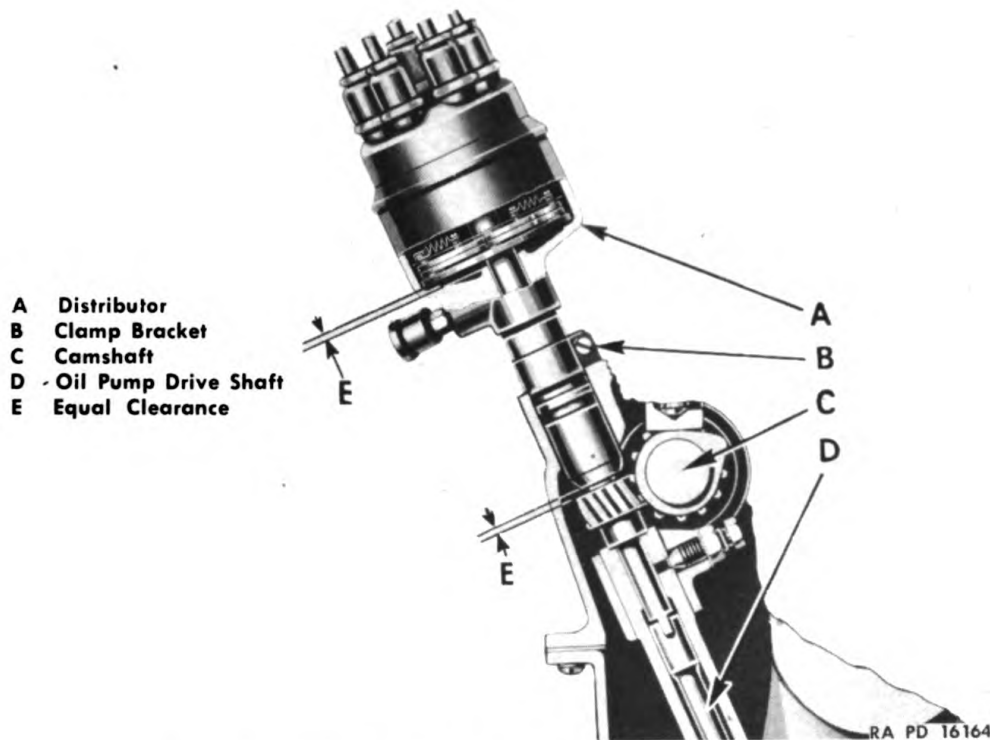

**Figure 109—Distributor Installation**

are connected by high and low tension wiring to form the ignition system or circuit.

**b. Distributor**

(1) The distributor is a mechanical unit designed to assist in induction of primary voltage to secondary voltage (point mechanism) to distribute high voltage current in correct sequence to spark plugs (rotor and cap), and to vary spark automatically to provide efficient operation of engine (centrifugal control).

**c. Ignition Coil**

(1) Ignition coil is made up of two windings or circuits—primary and secondary. When contact points in distributor close, current from generator or battery flows through primary circuit, creating a magnetic field around windings and core. When distributor points open, current in primary circuit does not stop flowing instantly but flows into condenser which is connected in parallel with points. Condenser action causes quick collapse of magnetic field which induces a voltage in primary as well as in secondary windings. This voltage increases until it is sufficiently high to produce a spark at spark plug.

**d. Spark Plug.** Six spark plugs are used, one for each engine cylinder, to deliver spark to combustion chamber. Plugs are connected to distributor by insulated cables which carry secondary current from ignition coil.

TRUCK, AMPHIBIAN, 2 1/2-TON, 6 x 6

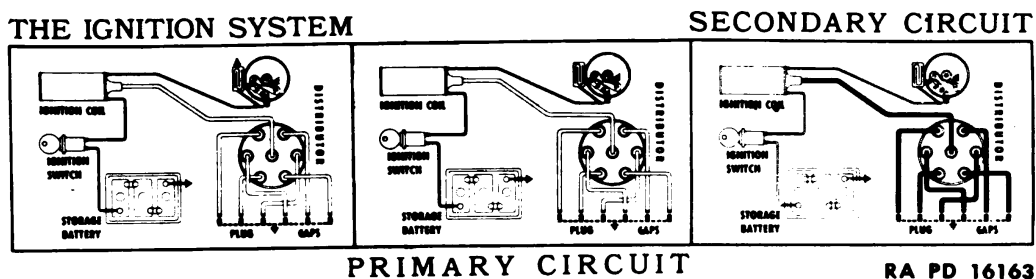

Figure 110—Typical Ignition System Circuits

e. **Condenser.** Purpose of condenser is to reduce distributor point arc by its ability or capacity to store up electrical energy until released by action of distributor points.

142. TROUBLE-SHOOTING

a. When diagnosing any ignition system trouble, the mechanic should visualize ignition wiring diagram and keep in mind fundamental action of the two ignition circuits, primary and secondary. (See Fig. 110.) The checker must also bear in mind symptoms usually attributed to defects in ignition circuits are in some instances occasioned by defects in other engine operating systems.

b. There are some symptoms that can be visually and audibly detected which definitely point to defects in ignition systems; however, other engine operating systems should have routine checks before deciding that ignition system is at fault. See Para. 177 for engine "Trouble-Shooting."

c. Table following itemizes symptoms, causes and probable remedies of trouble that may be experienced with ignition system.

Symptom and Probable Cause	Probable Remedy	Refer to Paragraph
(1) <b>Lack of power—overheating</b>		
(a) Late timing	Adjust . . . . .	145
(2) <b>Back firing</b>		
(a) Crossed spark plug cable	Correct . . . . .	146
(b) Cracked or leaded distributor cap	Replace . . . . .	149
(3) <b>Missing at high speed—under load</b>		
(a) Incorrect spark plug gap	Adjust . . . . .	146
(b) Distributor point tension weak	Replace . . . . .	149
(c) Incorrect distributor point gap	Adjust . . . . .	144
(d) Defective spark plug	Replace . . . . .	146
(e) Defective coil	Replace . . . . .	150

**ELECTRICAL SYSTEM—IGNITION**

*Clean* HIGH TENSION CLIPS  
AND SOCKETS



RA PD 16169

**Figure 111—Cleaning Distributor Cap Socket**

Symptom and Probable Cause	Probable Remedy	Refer to Paragraph
(f) Defective condenser	Replace . . . . .	149
<b>(4) Pre-ignition</b>		
(a) Incorrect type spark plugs	Replace . . . . .	146
<b>(5) Excessive "ping" under load or high speed</b>		
(a) Incorrect manual advance	Adjust . . . . .	145

**143. PREVENTIVE MAINTENANCE AND INSPECTION**

a. Entire ignition system should not only be inspected at regular intervals, but preventive maintenance operations should be performed on various units to keep system operating efficiently. Only by an orderly process of inspection of various units and accomplishment of necessary maintenance and adjustments can ignition system be expected to perform efficiently.

b. Preventive maintenance includes operations on distributor, ignition timing, spark plugs, and wires. Detailed instructions on maintenance on these units are described under respective paragraphs in this section.

**144. DISTRIBUTOR MAINTENANCE**

a. Distributor maintenance procedures embrace cleaning and inspection of cap and rotor, point adjustment, and adjusting timing.

b. **Clean Cap and Rotor.** Distributor cap should be removed and thoroughly cleaned inside and out. Inspect thoroughly for any presence of cracks. Use a small, round brush to thoroughly clean wire sockets as illustrated in Fig. 111.

**c. Adjusting Points**

**(1) Remove distributor cap and rotor**

Remove ignition shield cover as directed in Para. 172. Remove distributor cap and rotor.

**(2) Crank engine**

Remove air intake center grille behind driver's seat. Place transmission in fourth speed, then engage water propeller. Do not turn ignition switch on. Use cranking bar on propeller shaft



**TRUCK, AMPHIBIAN, 2½-TON, 6 x 6**

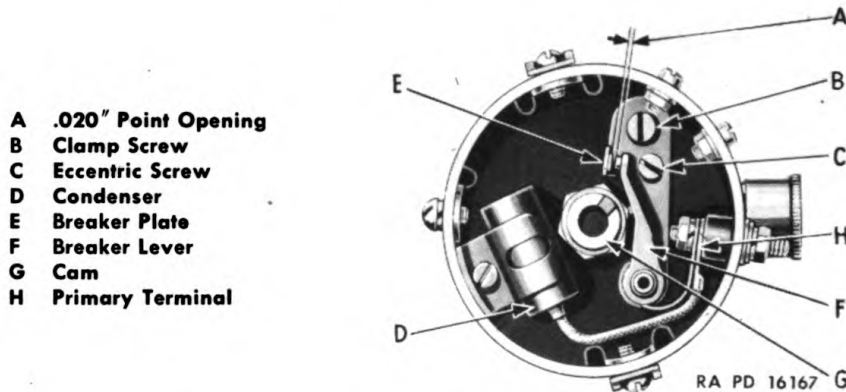

**Figure 112—Distributor with Cap and Rotor Removed**

sprocket and turn until distributor breaker lever fibre is on high point of one of the distributor shaft cams. Disengage water propeller.

**(3) Adjust points**

Loosen clamp screw and turn eccentric screw until point opening is .020". See Fig. 112. Tighten clamp screw and again measure point opening to be sure it has not been changed during tightening.

**(4) Replace distributor rotor and cap**

Replace distributor rotor and cap.

**(5) Install ignition shield cover**

Install ignition shield cover as directed in Para. 172.

**(6) Install air intake center grille**

Install air intake center grille.

**145. IGNITION TIMING**

**a.** Importance of proper ignition timing cannot be over-emphasized, since performance of vehicle will be seriously affected if ignition system in general, particularly ignition timing is not properly adjusted.

**b. Initial Timing.** Whenever distributor has been replaced it is necessary that ignition system be retimed. Procedure for initial timing is as follows:

**(1) Crank engine**

Remove air intake center grille behind driver's seat. Place transmission in fourth speed, then engage water propeller. Do not turn ignition switch on. Use cranking bar on sprocket and turn until No. 1 piston is in firing position; at this point note if pointer on flywheel housing registers with timing mark on flywheel. See Fig. 113. Disengage water propeller.

**(2) Mark distributor**

Locate No. 1 spark plug terminal on distributor cap. Place cap in position on distributor housing and mark housing in rela-



## ELECTRICAL SYSTEM—IGNITION

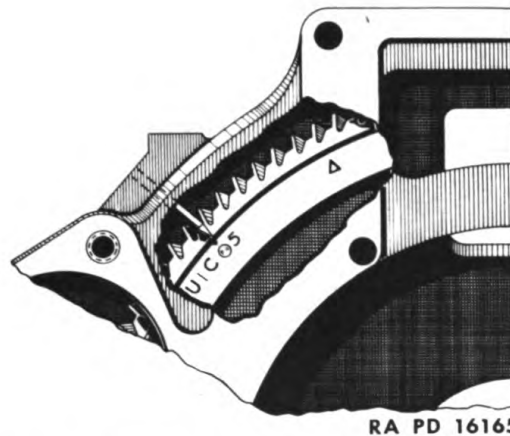

**Figure 113—Flywheel Marking for Ignition Timing**

tion to cap mark, so that location of No. 1 terminal will be known when cap is removed.

(3) **Install distributor**

Install distributor in its proper location as directed in Para. 148.

(4) **Set manual adjustment (Fig. 114)**

Locate manual adjustment bracket so that mark on block is midway between "A" advance and "R" retard. Tighten cap screw holding bracket to block.

(5) **Timing**

Turn distributor housing counterclockwise until points are closed. Rotate housing clockwise until points just begin to open—with rotor pointing to mark on housing. Tighten bracket clamp bolt and make further timing check as described in Para. 145.

**c. Ignition Timing Check.** Whenever distributor has been removed, it is necessary to check ignition timing when distributor is installed. Use of a timing light is recommended for this operation; however, a test lamp may also be used.

(1) **Timing light procedure**

(a) Loosen cap screw and set manual control bracket at midpoint.

(b) Attach one lead of timing light to No. 1 spark plug terminal and other lead to convenient ground.

(c) Start engine and run at idling speed.

(d) Hold light close to peephole in flywheel housing. Note position of flywheel marking (steel ball) in relation to pointer. See Fig. 113.

(e) If these two points (pointer and steel ball) are more than  $\frac{1}{16}$ " apart, distributor timing should be adjusted.

(f) Loosen clamp bolt (Fig. 114) and turn distributor housing until steel ball indexes with pointer.

Original from  
UNIVERSITY OF CALIFORNIA

**TRUCK, AMPHIBIAN, 2½-TON, 6 x 6****Figure 114—Distributor Manual Advance Adjustment**

(g) Tighten clamp bolt and check timing again.

**(2) Test lamp procedure**

(a) Connect one lead of test lamp to distributor primary terminal at side of housing and other lead to convenient ground.

(b) Remove center grille at rear of driver's seat. Place transmission in fourth speed, then engage water propeller. Use cranking bar on propeller shaft sprocket to turn engine over.

(c) Crank engine very slowly until No. 1 spark plug is about to fire. Continue to crank very slowly and stop at exact instant test lamp lights. Disengage water propeller.

(d) Check location of pointer in relation to flywheel marking. See Fig. 113. If pointer is within  $\frac{1}{16}$ " of steel ball, timing may be considered as satisfactory.

(e) If necessary, loosen clamp bolt (Fig. 114) and turn distributor housing until steel ball indexes with pointer when engine is turned over again.

(f) Tighten clamp bolt and check timing again.

**d. Manual advance.** In addition to automatic advance control, manual advance, Fig. 114, is provided with which initial setting may be varied to suit quality of fuel used. Bear in mind that advance specifications on this distributor are determined after careful test and with the use of high grade fuel. Because of various grades of fuel which may be used, slight readjustment of initial setting may be necessary to obtain satisfactory engine performance and fuel economy.

**(1) Road test**

In order to determine setting of manual advance for maximum performance of engine, a road test should be made, using the same grade of fuel as will be used in service. Engine should be thoroughly warmed up to operating temperature. Manual advance should be set to provide smooth engine performance with



## ELECTRICAL SYSTEM—IGNITION



**Figure 115—Installing Spark Plug Cables—Distributor Cap**

a slight “ping” under full throttle at comparatively low vehicle speed. Bear in mind, that this setting may vary on different vehicles and that several tests should be made to determine the exact border-line between effortless engine performance and that which produces an excessive degree of “clatter” or “ping.”

(2) **Adjustment (Fig. 114)**

Loosen cap screw attaching distributor clamp to cylinder block. Move bracket toward cylinder block to retard spark or in opposite direction to advance spark. Tighten cap screw and road test.

### 146. SPARK PLUG MAINTENANCE

a. Proper maintenance of spark plugs is the first and probably the most important question in maintaining the ignition system.

b. **Spark Plug Gap.** Setting gap in spark plug is a **Precision Operation** and should be treated as such. Proper gap provides .025" clearance between side electrode and center electrode. When regapping is necessary, bend side electrode only—not center electrode. It is not only necessary to set gap to proper dimension, but all plugs should have same dimension. Use a standard round feeler gauge.

c. **Replacement Procedure**

(1) **Remove ignition shield cover**

Remove ignition shield cover as directed in Para. 172.

(2) **Remove spark plug wires**

Remove spark plug wires and suppressors from spark plugs.

(3) **Remove spark plugs**

Use a spark plug wrench when removing plugs. Ordinary wrenches may crack or damage porcelain.

d. **Installation Procedure**

(1) **Install spark plugs**

Use new gasket and thread plug into cylinder head with

**TRUCK, AMPHIBIAN, 2½-TON, 6 x 6**

gers. Use spark plug wrench and tighten plug until it "bottoms," then turn one-quarter to one-half turn until firm.

**(2) Install spark plug wires**

Select wires carefully to be sure they are installed to correct plug. Correct firing order is 1-5-3-6-2-4. Be sure wires form good connection in suppressors, also are fully seated in distributor cap. Refer to Fig. 125 for proper method of installing spark plug wires through rings to prevent wires contacting ignition shield.

**(3) Install ignition shield cover**

Install ignition shield cover as directed in Para. 172.

**147. HIGH AND LOW TENSION WIRE MAINTENANCE**

a. Low and high tension wires between coil, distributor and spark plugs are all contained within ignition shield; therefore, wires are protected against moisture.

b. **Inspection.** Frequent inspection should be made of wiring and those showing evidence of failure should be replaced. Wires which have become cracked due to heat or are oil soaked and swollen should be replaced.

**148. DISTRIBUTOR REPLACEMENT**

a. When inspection or tests reveal that distributor should be replaced proceed as outlined in following paragraphs.

**b. Removal Procedure**

**(1) Remove ignition shield cover**

Remove ignition shield cover as directed in Para. 172.

**(2) Remove wires**

Lift six spark plug and secondary wire from distributor cap. Loosen terminal nut at side of housing and remove primary cable.

**(3) Remove grease cup**

Remove distributor shaft grease cup from housing. Grease cup is located under ignition shield.

**(4) Remove distributor**

Note position of rotor so that replacement can be installed in same position. Loosen clamp bracket bolt and lift distributor straight up. Do not rotate engine while distributor is removed.

**c. Installation Procedure**

**(1) Install distributor**

Turn rotor to position noted at time of removal. Insert distributor through bracket and into crankcase. Turn distributor shaft as necessary to mesh tongued end of shaft with oil pump shaft. Primary terminal on distributor housing should be toward rear of engine, when distributor is in correct running positions. It



**ELECTRICAL SYSTEM—IGNITION**

is important that slight clearance be maintained between upper and lower end of housing at points shown in Fig. 109. When distributor is first placed in operating position, lower end of housing will contact drive gear. Before tightening clamp place fingers under housing and thumb on drive shaft. While holding down, raise housing  $\frac{1}{2}$ ". Be sure to equalize clearance at top and bottom. Tighten clamp bolt while distributor is held in position.

**(2) Install grease cup**

Install grease cup in distributor housing. Grease cup is located under ignition shield.

**(3) Install wires**

Connect spark plug wires to distributor cap in their proper sequence, starting with No. 1 wire which must be in firing position when piston is in firing position. Attach primary wire to terminal at side of distributor housing.

**(4) Retime ignition**

Retime ignition as directed in Para. 145.

**(5) Install ignition shield cover**

Install ignition shield cover as directed in Para. 172.

**149. CONDENSER AND POINT REPLACEMENT****a. Removal Procedure****(1) Remove ignition shield cover**

Procedure for removing ignition shield cover is outlined in Para. 172.

**(2) Remove distributor cap**

Lift six spark plug and secondary wire from cap. Remove two spring clamps attaching cap to housing and lift cap from housing.

**(3) Remove rotor**

Lift rotor from drive shaft.

**(4) Remove condenser**

Loosen primary terminal nut inside housing and lift condenser pig-tail wire from terminal. Remove screw attaching condenser bracket to breaker plate support.

**(5) Remove distributor points (Fig. 112)**

Loosen primary terminal nut inside housing. Lift breaker lever from breaker plate. Remove breaker point clamp screw and lift breaker plate out.

**b. Installation Procedure****(1) Install distributor points**

Place breaker plate in its proper location, with eccentric screw through hole in plate. Install clamp screw through breaker and into plate support. Install breaker lever over breaker plate stud

**TRUCK, AMPHIBIAN, 2 1/2-TON, 6 x 6**

and attach tension spring under primary terminal lockwasher. Tighten terminal nut and clamp screw. Adjust contact point opening as directed in Para. 144.

**(2) Install condenser**

Place condenser in its proper location and attach bracket to breaker plate support using cap screw. Place pig-tail wire between breaker lever spring and insulator. Tighten cap screw and terminal stud nut securely.

**(3) Install rotor**

Place rotor over end of drive shaft and turn until it seats into groove of shaft.

**(4) Install distributor cap**

Locate cap in its correct position on housing and secure with two cap springs. Replace spark plug and primary wires in cap sockets. Be sure wires are fully seated in sockets. Replace ignition shield cover.

**150. IGNITION COIL REPLACEMENT**

a. Ignition coil is mounted inside ignition system shield near distributor.

**b. Removal Procedure**

**(1) Remove ignition shield cover**

Remove ignition shield cover as described in Para. 172.

**(2) Remove ignition coil**

Remove nuts and lockwashers at terminals and remove two wires. Remove two cap screws and shakeproof lockwashers attaching coil bracket to shield. Lift coil up and remove secondary wire from socket at bottom of coil.

**c. Installation Procedure**

**(1) Install coil**

Insert primary wire firmly into socket at bottom coil. Replace two cap screws and lockwashers attaching coil bracket to inside of ignition shield. Tighten cap screws securely. Attach distributor terminal wire (#14 Tan-Red and Black Cr. Tr.) to negative terminal and wire (#14 Green) to positive terminal. Tighten nuts securely.

**(2) Install ignition shield cover**

Install ignition shield cover as directed in Para. 172.

Section XXI

**ELECTRICAL SYSTEM—GENERATOR AND CONTROLS**

	Paragraph
General description .....	151
Operation .....	152
Trouble-shooting .....	153
Preventive maintenance and inspection .....	154
System operation tests .....	155
Regulator maintenance .....	156
Generator maintenance .....	157
Regulator replacement .....	158
Generator replacement .....	159

**151. GENERAL DESCRIPTION**

**a. General.** Generator and control system comprises generator, three-unit regulator, battery, ammeter, and connecting wires. Purpose of system is to keep battery fully charged and to furnish, when engine speeds permit, current for ignition, lighting system, and other electrical accessories. Only generator and regulator are covered in this section, refer to other electrical sections for information covering other electrical units.

**b. Generator.** Generator is shunt-wound, two brush type mounted on left-side of engine and driven with belt by crankshaft in conjunction with water pump. Generator is cooled by air drawn through openings in end of generator by fan mounted behind drive pulley. Air scoop mounted at rear of generator aids in directing flow of air through generator.

**c. Regulator.** Regulator is three-unit type containing cutout relay, voltage regulator and current regulator. The regulator is mounted on left-hand engine compartment partition.

**152. OPERATION**

**a.** Generating system consists of generator, regulator and wiring. Generator is located at left front side of engine as shown in Fig. 116. Regulator is attached to left-hand engine compartment partition as shown in Fig. 117. Filters and condensers used in connection with radio suppression are described in Para. 172.

**b. Generator.** Generator is driven by engine crankshaft with belt in conjunction with water pump and fan. As speed of engine reaches a predetermined point, action of generator creates electrical current which, limited by setting and specifications of regulator unit, charges battery and furnishes current to vehicle electrical systems.

**TRUCK, AMPHIBIAN, 2 1/2-TON, 6 x 6**

**c. Regulator**

(1) The regulating units automatically open and close circuit between generator and battery as needs require, controls maximum generator ampere output, and controls generator voltage output. Each unit performs the following functions.

(a) **Cut-out relay.** Cut-out relay automatically closes circuit between generator and battery when generator voltage rises above that of battery, and automatically opens circuit between generator and battery when generator voltage falls below that of battery.

(b) **Voltage regulator.** Voltage regulator controls generator voltage and does not allow it to rise above a value determined by voltage regulator setting.

(c) **Current regulator.** Current regulator controls maximum generator output (amperage) and does not allow output to exceed value by current regulator setting.

**153. TROUBLE-SHOOTING**

a. The symptoms, causes and remedies of trouble, which may be experienced in generating system, are listed in following paragraphs.

<b>Symptom and Probable Cause</b>	<b>Probable Remedy</b>	<b>Refer to Paragraph</b>
<b>(1) Fully charged battery and high charging rate</b>		
(a) Voltage regulator out of adjustment	Notify Ordnance	
(b) Defective voltage regulator	Replace regulator . . . . .	158
(c) Shorted generator field	Replace generator . . . . .	159
(d) Poor generator to regulator ground	Clean and tighten . . . . .	154
<b>(2) Low battery and low or no charging rate</b>		
(a) Wiring damaged	Correct or Replace . . . . .	154
(b) Voltage regulator out of adjustment	Notify Ordnance	
(c) Current regulator out of adjustment	Notify Ordnance	
(d) Dirty regulator points	Notify Ordnance	
(e) Defective generator	Replace . . . . .	159
(f) Cut-out relay out of adjustment	Notify Ordnance	
<b>(3) Noisy generator</b>		
(a) Belt tension	Adjust . . . . .	120
(b) Defective bearings	Replace generator . . . . .	159
(c) Brushes not seating	Reseat . . . . .	157
(d) Armature rubbing field coils	Replace generator . . . . .	159



**ELECTRICAL SYSTEM—GENERATOR AND CONTROLS****154. PREVENTIVE MAINTENANCE AND INSPECTION**

a. Generator and regulator units require periodic inspection and maintenance operations to keep system at peak efficiency. Detailed maintenance instructions are described under respective paragraphs of this group.

**b. Generator****(1) Drive belt tension**

Check generator drive belt tension. Correct adjustment provides  $\frac{1}{2}$ " to  $\frac{3}{4}$ " belt deflection at center of belt. Low belt tension will cause a reduced and unsteady output. Excessive belt tension will cause rapid wear on belt and generator bearing. Adjust belt as described in Para. 120 if it is frayed or worn.

**(2) Brushes**

Remove cover band and check brushes for worn condition and if necessary replace as directed in Para. 157. Check pig-tail lead connections to be sure they are tight. Install cover band.

**(3) Brush spring tension**

Remove cover band and check brush spring tension. Excessive spring tension will cause commutator and brushes to wear rapidly. Low spring tension will cause a reduced generator output and arcing, and burning of commutator and brushes. Check brush spring tension as directed in Para. 157.

**(4) Inspect commutator**

Remove cover band and inspect commutator. If dirty, clean as directed in Para. 157. If commutator is rough, out-of-round, or has high mica remove generator as directed in Para. 159.

**(5) Mounting**

Check mounting bracket to engine cap screws, tighten if necessary. Check generator to bracket bolts and tighten nuts if loose. If necessary, tighten adjusting arm to generator cap screw.

**c. Regulator****(1) Wiring**

Tighten all wiring connections and, if necessary, remove and clean terminals. Check wiring for evidence of insulation cracks or other failure. Replace, if necessary.

**(2) Ammeter**

Observe action of ammeter and if erratic locate trouble and correct. Tighten ammeter terminals.

**(3) Regulator cover gasket**

Remove regulator cover and examine gasket. If gasket is cracked replace with new part.

TRUCK, AMPHIBIAN, 2½-TON, 6 x 6

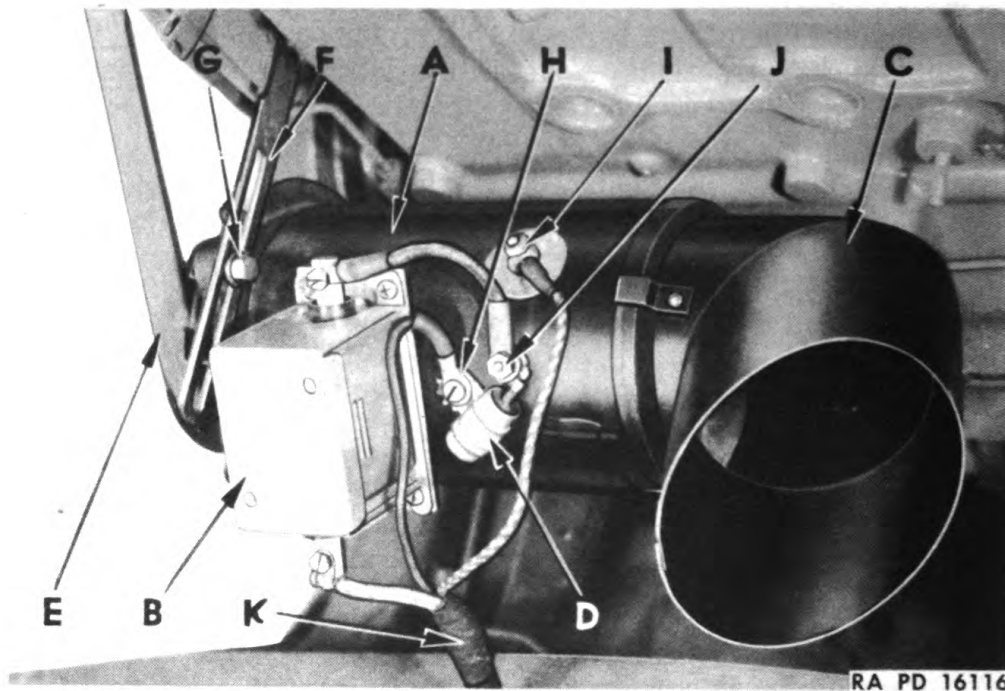

Figure 116—Generator, Filter and Drive Belt Installation

A	Generator	G	Adjusting Arm Screw
B	Armature Filter	H	Armature Terminal
C	Air Intake Scoop	I	Field Terminal
D	Condenser	J	Ground Terminal
E	Drive Belt	K	Generator to Regulator Wiring Harness
F	Drive Belt Adjusting Arm		

### 155. SYSTEM OPERATION TESTS

a. To properly localize system difficulties requires the use of special instruments and skilled personnel. Notify Ordnance Maintenance Personnel.

### 156. REGULATOR MAINTENANCE

a. Proper regulator adjustments cannot be obtained without the use of special tools and skilled personnel. Notify Ordnance Maintenance Personnel.

### 157. GENERATOR MAINTENANCE

a. If generator is not functioning properly, following adjustments or repairs may be made without removing generator from vehicle.

b. **Adjust Drive Belt.** Method of adjusting drive belt is described in Para. 120. If inspection indicates that replacement is advisable refer to Para. 159 for procedure.

#### c. Brushes

##### (1) Removal

Remove cover band. Remove screw attaching brush pig-tail to brush holder. Lift brush tension arm and remove brush.



**ELECTRICAL SYSTEM—GENERATOR AND CONTROLS**

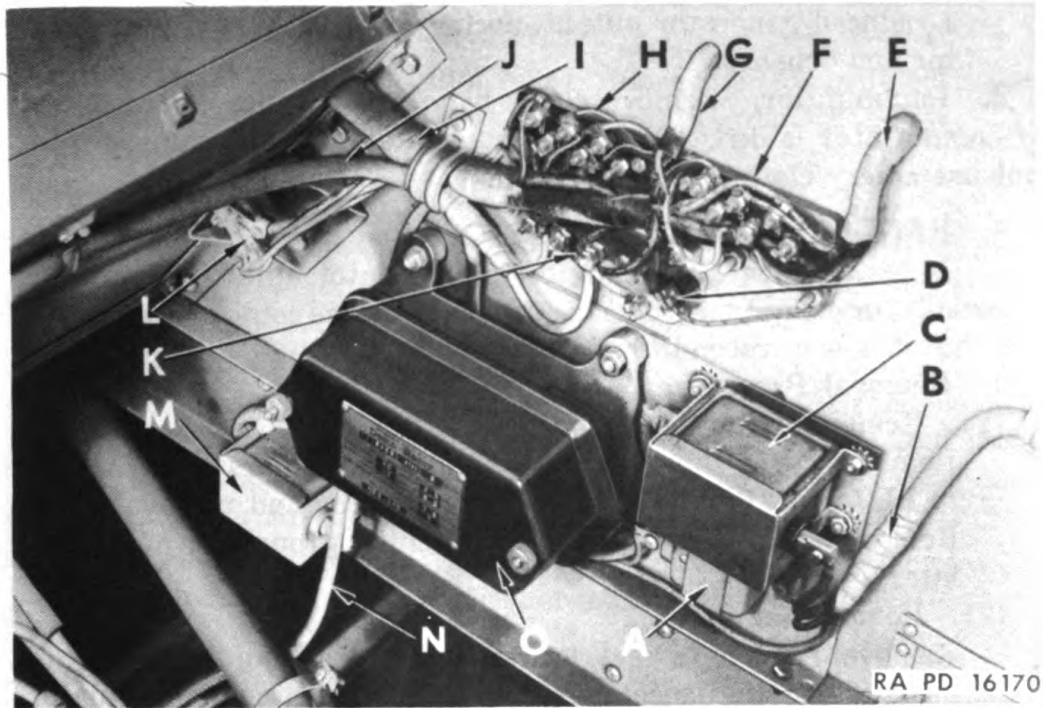

**Figure 117—Regulator, Filters, Junction Blocks and Wiring Harness Installation**

- |   |  |
|---|--|
| <b>A</b> Field Circuit Filter                             | <b>I</b> Instrument Panel Wiring Harness                   |
| <b>B</b> Generator to Regulator and Filter Wiring Harness | <b>J</b> Junction Block to Coil and Starter Wiring Harness |
| <b>C</b> Armature Circuit Filter                          | <b>K</b> Three Post Junction Block                         |
| <b>D</b> Horn Circuit Breaker                             | <b>L</b> Head Lamp Dimmer Switch                           |
| <b>E</b> Head Lamp Wiring Harness                         | <b>M</b> Battery Circuit Filter                            |
| <b>F</b> Front Junction Block                             | <b>N</b> Junction Block to Stop Switch Wiring Harness      |
| <b>G</b> Stop and Tail Lamp Harness                       | <b>O</b> Regulator   |
| <b>H</b> Rear Junction Block                              |  |

**(2) Installation**

Raise brush tension arm and install brush into brush holder and lower tension arm against top of brush. Attach brush pigtail to brush holder using screw. Tighten screw securely.

**(3) Seating**

Brushes must be seated by use of a "bedding" stone. With generator operating at medium speed, press stone firmly against commutator and move it back and forth along commutator to cover area contacted by brushes. Brushes should seat satisfactorily in a short period. Blow generator out with compressed air, after using stone, to remove all particles of abrasive. **Do not use emery cloth or sandpaper to seat brushes.**

**(4) Tension**

Carefully check brush spring tension, Tool No. AEE-G-3, which should be 25 ozs. Excessive spring tension will cause commutator and brushes to wear rapidly. Low spring tension will cause

**TRUCK, AMPHIBIAN, 2½-TON, 6 x 6**

a reduced generator output, arcing and burning of commutator and brushes.

d. **Commutator.** Remove cover band and inspect commutator. If commutator is dirty clean with a strip of No. 00 sandpaper. **Do not use emery cloth.** Blow out all dust with compressed air.

**158. REGULATOR REPLACEMENT**

a. If tests indicate that any of the regulator units are damaged internally, or cannot be properly adjusted, replace complete unit with one that is new or reconditioned.

**b. Removal Procedure****(1) Remove wires**

Remove three knurled nuts and lockwashers at "ARM," "FLD" and "BAT" terminals on regulator and remove wires. Remove screw and lockwasher attaching ground wire to regulator.

**(2) Remove regulator**

Remove four nuts and lockwashers attaching regulator to bracket and engine compartment bulkhead. Remove regulator from four bolts. Note that fibre washers are used under regulator legs, between regulator and bracket.

**c. Installation Procedure****(1) Install regulator**

Place fibre washer over each of the four bolts. Install regulator over bolts and attach with lockwashers and nuts. Install regulator with terminals down. Tighten nuts securely.

**(2) Install wires**

Remove knurled nuts and lockwashers, also ground screw. Place wires on terminals as follows:

- (a) "ARM"; No. 8 Tan—Red and Black Cross Tracer
- (b) "FLD"; No. 14 Black and Red Check
- (c) "BAT"; No. 8 Yellow
- (d) "Ground"; No. 14 Black

Tighten knurled nuts and ground screw securely.

**(3) Polarity**

If generator or regulator have been disconnected for repair or adjustment purposes, generator should be polarized after units are reconnected, and **before engine is started.** Reversed polarity will cause regulator points to vibrate excessively and burn. Make certain that generator is correctly polarized by **momentarily** connecting a jumper lead between "Bat" terminal and "Arm" terminal **before starting the engine.** This allows a momentary surge of battery current to generator which automatically gives generator the correct polarity with respect to battery it is to charge.



**ELECTRICAL SYSTEM—GENERATOR AND CONTROLS****159. GENERATOR REPLACEMENT**

a. When tests or inspection reveal that generator is defective or not operating properly complete unit should be replaced.

**b. Removal Procedure****(1) Disconnect wires**

Remove nut, lockwasher and wire at "FLD" terminal on generator. Remove nut, lockwasher, condenser pig-tail and armature wire at "ARM" terminal on generator.

**(2) Remove filter and condenser**

Remove screw, two lockwashers, ground wire and condenser at generator ground terminal. Remove two screws and four lockwashers attaching filter to generator housing. Lay filter and condenser aside.

**(3) Loosen drive belt**

Remove cap screw, lockwasher and flat washer attaching generator to adjusting arm.

**(4) Remove generator**

Remove two nuts, lockwashers and bolts attaching generator to support bracket. Generator can now be lifted up to complete removal.

**c. Installation Procedure****(1) Install generator**

Lower generator into place and install two bolts (one each end) through generator mounting and bracket. Install lockwashers and nuts to bolts and draw up temporarily.

**(2) Install drive belt**

Place belt in grooves of fan pulley, crankshaft pulley and generator pulley. Attach generator to adjusting arm using flat washer, lockwasher and cap screw. Adjust belt tension as directed in Para. 120. Make final tightening of mounting bolt nuts.

**(3) Install filter and condenser**

Install filter to generator housing using two screws. Shakeproof lockwashers must be used between generator housing and filter, also under head of screw. (See Fig. 125, Para. 172.) Install condenser bracket and ground wire (No. 10 black) to generator housing using screw with shakeproof lockwashers next to generator housing and under head of screw.

**(4) Connect wires**

Attach condenser pig-tail wire and armature wire (No. 10 Black) to "ARM" terminal on generator. Attach field wire (No. 14 black and red check) to "FLD" terminal on generator. Tighten terminal stud nuts securely.

**TRUCK, AMPHIBIAN, 2½-TON, 6 x 6****(5) Polarity**

If generator or regulator have been disconnected for repair or adjustment purposes, generator should be polarized after units are reconnected, and **before engine is started**. Reversed polarity will cause regulator points to vibrate excessively and burn. Make certain that generator is correctly polarized by **momentarily** connecting a jumper lead between "Bat" terminal and "Arm" terminal **before starting the engine**. This allows a momentary surge of battery current to generator which automatically gives generator the correct polarity with respect to battery it is to charge.

Section XXII

**ELECTRICAL SYSTEM—LIGHTING**

	Paragraph
General description .....	160
Operation .....	161
Trouble-shooting .....	162
Preventive maintenance and inspection .....	163
Head lamp adjustment .....	164
Blackout driving lamp adjustment .....	165
Head lamps replacement .....	166
Blackout driving lamp replacement .....	167
Blackout marker lamps replacement .....	168
Blackout and service stop and tail lamps replacement .....	169
Instrument panel lamps replacement .....	170
Replacement of switches .....	171

**160. GENERAL DESCRIPTION**

a. Lighting system consists of service head lamps, blackout driving lamp, blackout marker lamps; service and blackout tail and stop lamps, instrument panel lamps and actuating switches.

b. **Head Lamps.** Service head lamps, mounted on right and left corners of bow deck, are double filament "sealed beam" type. These lamps are illuminated when main light switch is in service position. Action of dimmer switch controls upper and lower beams.

c. **Blackout Driving Lamp.** Blackout driving lamp is mounted on bow deck at left of left head lamp. Lamp is controlled with a push-pull type switch in instrument panel (marked "BO Drive") after main light switch is placed in blackout position. This lamp furnishes a diffused light beam to permit limited illumination for driving under blackout conditions.

d. **Blackout Marker Lamps.** Blackout marker lamps are mounted on bow deck at side of each head lamp, and are illuminated only when main light switch is in blackout position. Due to construction of lamp, light beam is not visible from above. Purpose of lights is to mark location of vehicle from in front. Lamps incorporate a specially designed lens and a colored filter which diffuses light beam.

**e. Service and Blackout Tail and Stop Lamps**

(1) Tail and stop lamps consist of two units: left-hand rear lamp, located on stern deck at left of winch, incorporates a combination service stop and tail light in the upper portion and blackout tail light in the lower portion; right-hand rear lamp, located on stern deck at right of winch, incorporates a blackout stop lamp in

**TRUCK, AMPHIBIAN, 2½-TON, 6 x 6**



**Figure 118—Lighting System Fuse**

the upper portion and a blackout tail light in the lower portion.

(2) The lens on each blackout tail lamp is designed to produce two beams. These two beams are directed so that when one vehicle is following another at a specified safe distance, the two beams merge into a single beam. Thus, a driver is able to maintain the proper distance between vehicles when driving under blackout conditions. The beam of the blackout stop and tail lights is diffused so that the light beam is not visible from above.

**f. Instrument Panel Lamps.** Three snap-in type lights are mounted in instrument panel and illuminate instruments and gauges in instrument panel. Beam of each light is shielded with a metal cover.

### 161. OPERATION

**a. Lighting system operating switches** include main light switch, blackout driving light switch, and panel light switch on instrument panel; dimmer switch at left of clutch pedal; stop light switch mounted on master cylinder. Operation of main, blackout driving and panel switches is described in Para. 12.

### 162. TROUBLE-SHOOTING

**a. General Procedure.** If any lamp in system fails to light when proper switch is turned on following general procedure applies:

- (1) Be sure battery is fully charged.
- (2) Be sure proper switch or switches are turned on.
- (3) Check for burned out bulb and replace as required.
- (4) Check and test wiring circuit for shorts.
- (5) Replace switch if test proves it is to be inoperative.

**b. Main Light Switch Fuse. (Fig. 118).** In the event circuit is broken by action of thermal fuse, light switch should be turned off immediately and cause of short in system determined and corrected.

**c. Stop Lamp Switch.** If stop lights fail to function, even after bulbs and circuit have been checked and tested, trouble may be in switch mounted at hydraulic master cylinder.



## ELECTRICAL SYSTEM—LIGHTING

### 163. PREVENTIVE MAINTENANCE AND INSPECTION

a. Preventive maintenance and inspection operations as outlined in Section V, "Preventive Maintenance and Inspection" should be accomplished according to the intervals stated.

b. For maximum illumination from lamps in system it is imperative that regular attention be given to the following operations:

(1) **Lamp bulbs and wiring.** Lamp bulbs must not be blackened and proper voltage must be maintained at the bulb. Low battery, loose or dirty electrical contacts in wiring system, and poor ground all contribute to a decrease in voltage. Check wiring and connections regularly and keep battery properly charged. Be sure battery is charged sufficiently and that wiring between generator and battery is in good condition. When bulb burns out replace bulb or sealed unit.

(2) **Clean lamp lenses.** Dirty lenses absorb a large amount of light and, therefore, decrease light output. Lenses are easily cleaned with water or liquid glass cleaner. Inside of sealed beam unit lenses cannot be cleaned because lens is sealed to reflector.

(3) **Aiming adjustment.** The difference of a few degrees in the aiming adjustment of head lamps or blackout driving lamp will determine the effectiveness of the light beam. The aiming adjustment of these lamps should be checked periodically or whenever the light beam is ineffective.

(4) **Replace sprung or bent reflectors.** A sprung or bent reflector will distort light beam, making it impossible to correctly aim or direct light beam. The only remedy is to replace reflector or sealed unit.

c. **Stop Lamp Switch Test.** If stop lamps do not illuminate upon application of brake foot pedal, make sure that bulbs are not burned out before testing switch. Also check wiring for short. Test switch mounted on hydraulic master cylinder under center section of driver's compartment floor boards as follows:

(1) Connect short lead of a voltmeter to each terminal of switch.

(2) With brakes off, voltmeter should read battery voltage.

(3) With brakes applied, reading should be "O."

(4) If switch does not check correctly in either test, replace with new unit. Switch is threaded into master cylinder unit and can be unscrewed after disconnecting wiring.

### 164. HEAD LAMP ADJUSTMENT

a. Upper Beam—upper beam should only be used on highway or water when no approaching vehicles are near. Upper beam illumi-

**TRUCK, AMPHIBIAN, 2 1/2-TON, 6 x 6**

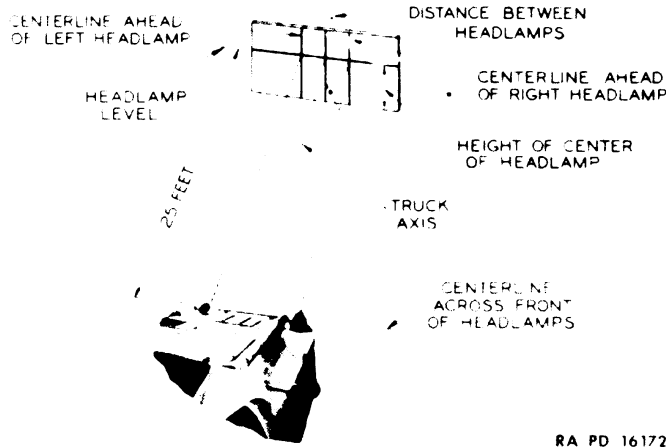

**Figure 119—Head Lamp Aiming Chart**

nates area considerably farther ahead than low beam. However, it also casts the light beam higher, which interferes with an approaching driver's vision.

b. Lower Beam — lower or depressed beam should always be used when approaching another vehicle and when driving in well lighted areas. The depressed beam will furnish adequate light to permit safe passing of approaching vehicle. Lower beam is obtained by depressing dimmer switch (left of clutch pedal).

c. Aiming adjustment operations must be done accurately to assure effective head light beams. When aiming head lamps, light beam may seem distorted. This condition is usually caused by a sprung reflector which requires replacement of sealed beam unit. Any reflector may be sprung or dented by careless handling.

d. Aiming Adjustment Procedure. Head lamps can be adjusted quickly and accurately with a head lamp tester; however, if this

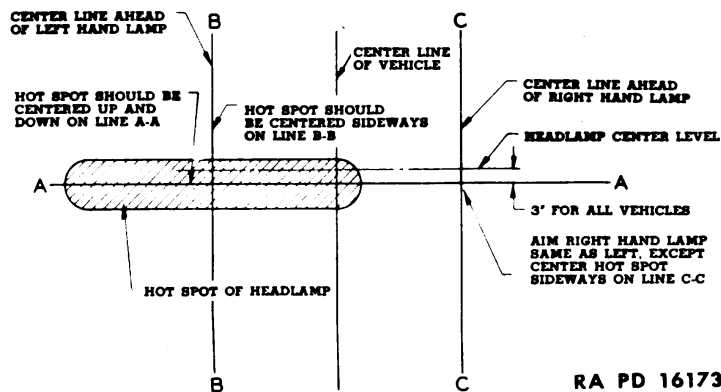

RA PD 16173

**Figure 120—Head Lamp Aiming Pattern**

**ELECTRICAL SYSTEM—LIGHTING**

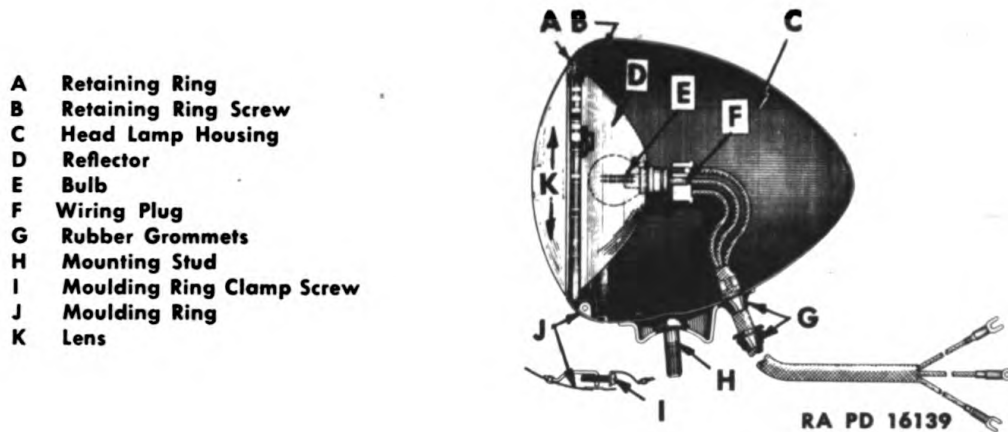

**Figure 121—Head Lamp Assembly**

equipment is not available, adjustment can be made as follows:

(1) Place vehicle on level floor so that head lamps are 25 feet from a smooth vertical surface, preferably of light color. A wall or door is suitable. Center line of the vehicle should be perpendicular to the surface.

(2) Draw a horizontal line on vertical surface at height of lamp center, as shown in Fig. 119. Locate points on this horizontal line on which projected center line of vehicle intersects. Measure distance between lamp centers and divide this distance equally on either side of center mark. Then draw two vertical lines directly ahead of each lamp center as shown.

(3) Switch on high or bright beam in head lamps and cover one lamp while adjusting other.

(4) Loosen support nut inside bow compartment and aim lamp so that beam pattern registers with horizontal and vertical lines as shown in Fig. 120. Then tighten nut securely, taking care not to change location of beam pattern on vertical surface.

(5) After lamp is aligned, cover its beam and proceed in same manner with opposite lamp.

**165. BLACKOUT DRIVING LAMP ADJUSTMENT**

a. Blackout driving lamp is adjustable horizontally but not vertically. It is necessary to adjust aim of light beam so beam illuminates as much of the area as possible directly ahead of vehicle.

**b. Aiming Adjustment Procedure**

(1) Turn on blackout driving light beam. Loosen lamp mounting

**TRUCK, AMPHIBIAN, 2½-TON, 6 x 6**

stud nut at bracket above deck plate sufficiently to turn lamp horizontally but not enough to break circuit ground and extinguish light. Turn lamp horizontally so light beam will illuminate as much as possible of area directly ahead of vehicle. Tighten lamp mounting stud nut securely without changing adjusted position of lamp.

**166. HEAD LAMP REPLACEMENT****a. Head Lamp Assembly Removal (Fig. 121)**

(1) Open bow hatch cover. Loosen wing nuts on hold-down bolts, swing bolts away from cover clamps and raise cover. From inside bow compartment, disconnect wiring at junction block terminals and remove mounting stud nut at each lamp.

(2) Loosen rubber grommet from bow deck plate so wiring can be pulled through plate. Lift each head lamp to free mounting stud from hole in mounting plate and remove lamp.

**b. Head Lamp Assembly Installation—(Fig. 121.)**

(1) Put each head lamp into position with mounting stud inserted through hole in mounting plate. Thread wiring through hole in deck plate and press rubber grommet into place in plate.

(2) Connect wiring carefully to junction block terminals as shown in wiring diagram in Section XVIII, "Electrical System—Wiring." Install mounting stud nut at each lamp mounting stud inside bow compartment and then adjust head lamp aiming as outlined under Para. 164. Close bow hatch cover, swing hold-down bolts to engage cover clamps and tighten wing nuts on hold-down bolts.

**c. Head Lamp Sealed Beam Unit Removal.** Whenever bulb of either head lamp burns out it is necessary to replace complete sealed beam unit. Sealed beam unit is made up of lamp lens, reflector and bulb element sealed together in a unit. Removal procedure is as follows.

(1) Remove moulding clamp screw at bottom of lamp lens and remove moulding ring. Remove three screws which attach sealed beam unit retaining ring to lamp housing and remove ring. Pull sealed beam unit out of housing and disconnect prongs of bulb from wiring plug. (Refer to Fig. 121.)

**d. Head Lamp Sealed Beam Unit Installation**

(1) Insert prongs of sealed beam unit bulb in wiring plug and place sealed beam unit in position in lamp housing. Install sealed beam unit retaining ring and attach with three screws to lamp housing. Install moulding ring, clip engaging slot at top of lamp housing, and clamp screw located at bottom of lamp housing and lens. Tighten clamp screw.



**ELECTRICAL SYSTEM—LIGHTING****167. BLACKOUT DRIVING LAMP REPLACEMENT**

**a. Blackout Driving Lamp Assembly Removal—(Fig. 122).** Driving lamp is mounted on a separate bracket which is attached to bow deck plate. Lamp can be removed without loosening bracket from deck plate.

(1) Open bow compartment hatch cover. Loosen wing nuts on hold-down bolts, swing bolts to disengage cover clamps and open hatch cover. Disconnect wires to driving lamp at junction block terminals inside bow compartment. Loosen rubber grommet from bow deck plate so wiring can be pulled through plate. Unscrew lock nut from lamp mounting stud at mounting bracket and remove lamp.

**b. Blackout Driving Lamp Assembly Installation—(Fig. 122).**

(1) Put lamp assembly in position with mounting stud through mounting bracket and install lock nut and washer. Thread wiring through hole in deck plate and press rubber grommet into place in plate.

(2) Connect wiring carefully to junction block terminals as shown in wiring diagram in Section XVIII, "Electrical System—Wiring." Adjust blackout driving lamp aiming.

(3) Close bow hatch cover, swing hold-down bolts to engage cover clamps and tighten wing nuts on hold-down bolts securely.

**c. Blackout Driving Lamp Sealed Beam Unit Removal.** Whenever bulb of driving lamp burns out it is necessary to replace complete sealed beam unit. Sealed beam unit consists of lens, reflector, bulb element and beam visor sealed together in a unit. Removal procedure is as follows: Refer to Fig. 122.

(1) Remove moulding ring retaining screw at bottom of lamp, pull out ring and sealed beam unit at bottom of lamp and raise upward to free clip at top of housing.

(2) With back side of reflector exposed, use a screwdriver to loosen spring clips and retaining ring which hold sealed beam unit in moulding ring. Then remove sealed beam unit from ring.

(3) Pull connecting prongs of bulb from wiring plug and remove screw to disconnect ground wire.

**d. Blackout Driving Lamp Sealed Beam Unit Installation**

(1) Connect ground wire to ground clip on sealed beam unit with screw and insert prongs of bulb in wiring plug.

(2) Place sealed beam unit into position in moulding ring, put retaining ring in place over reflector and complete assembly by using screwdriver to force three retaining ring springs under flange of moulding ring.

(3) Install sealed beam unit and rings assembly in lamp housing, moulding ring clip engaging slot at top of lamp housing, and install moulding ring retaining screw.

TRUCK, AMPHIBIAN, 2½-TON, 6 x 6

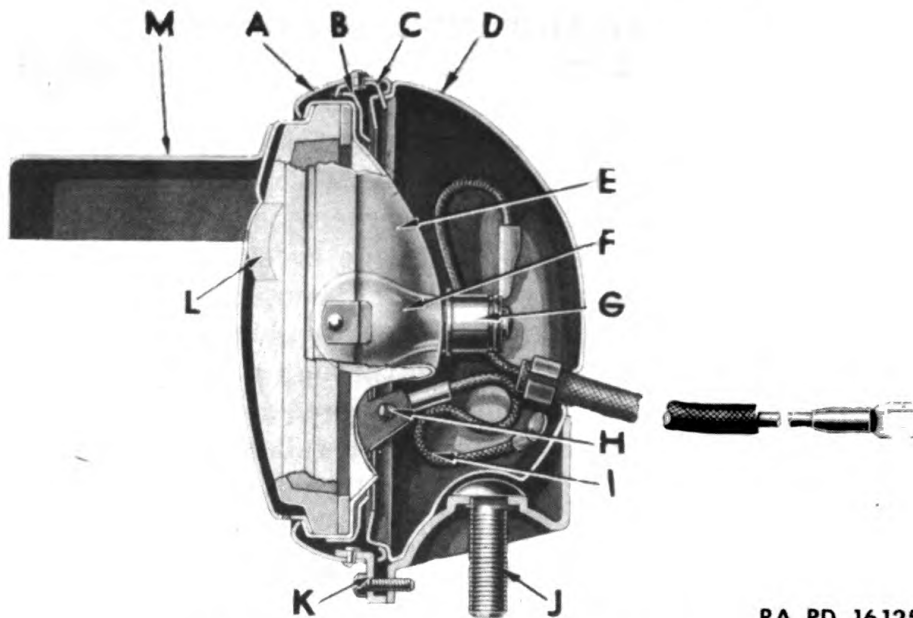

RA PD 16125

Figure 122—Blackout Driving Light

- |   |                        |   |                               |
|---|------------------------|---|-------------------------------|
| A | Moulding Ring          | H | Ground Wire Screw             |
| B | Retaining Ring         | I | Ground Wire                   |
| C | Moulding Ring Top Clip | J | Lamp Mounting Stud            |
| D | Lamp Housing           | K | Moulding Ring Retaining Screw |
| E | Reflector              | L | Lens                          |
| F | Bulb Element           | M | Beam Visor                    |
| G | Wiring Plug            |   |                               |

168. BLACKOUT MARKER LAMPS REPLACEMENT

a. Blackout Marker Lamps Removal—(Fig. 123).

(1) Open bow compartment hatch cover. Loosen wing nuts on hold-down bolts, swing bolts to disengage cover clamps and raise hatch cover to open. Disconnect wiring at connector and remove nut from mounting stud under each lamp from inside bow compartment. Then lift each lamp to clear mounting stud at deck plate and remove.

b. Blackout Marker Lamps Installation

(1) Put lamp assembly in position with wiring and mounting stud through hole in deck plate and position locating dowel on lamp bracket in dowel hole in deck plate. Screw locking nut on mounting stud, tighten securely, and plug wire into connector at each lamp.

c. Blackout Marker Lamp Bulb And Lens Removal—(Fig. 123).

(1) Remove retaining screw and twist lens and cover to loosen lock rivet at top. Then remove lens and cover assembly from lamp housing.

Remove bulb from socket in housing.

d. Blackout Marker Lamp Bulb And Lens Installation

(1) Install bulb in socket in lamp housing. Put lens and cover

**ELECTRICAL SYSTEM—LIGHTING**

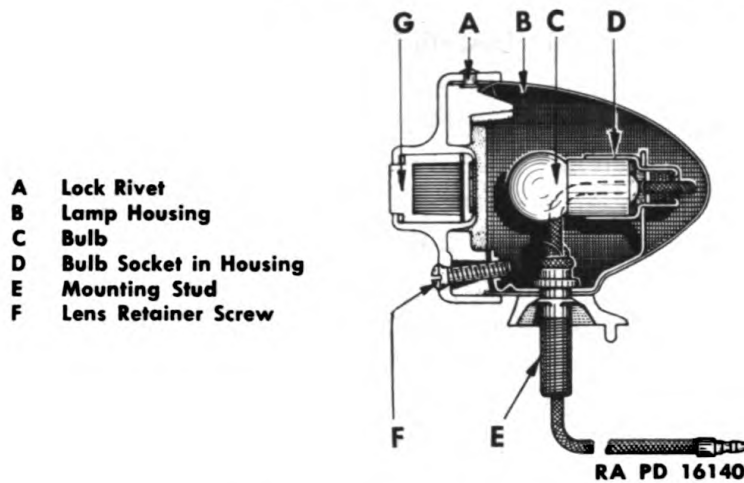

**Figure 123—Blackout Marker Lamp**

in place on lamp housing. Engage lock rivet in hole in top of housing, twist cover and lens to lock the rivet in housing and install retaining screw.

**169. BLACKOUT AND SERVICE STOP AND TAIL LAMPS REPLACEMENT**

**a. Complete Lamp Assembly Removal—(Fig. 124).** Removal procedure for both rear lamps is identical.

(1) Disconnect wiring at connectors located at back of lamp above stern deck rear plate. Remove nuts from two mounting studs at back of lamp and pull lamp clear of mounting bracket.

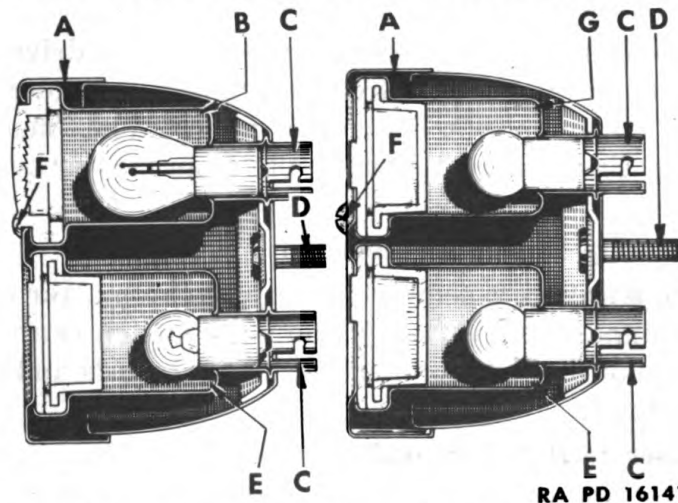

**Figure 124—Blackout and Service Stop and Tail Lamp**

- |   |                                   |
|---|-----------------------------------|
| <b>A</b> Bulb and Lens Unit Cover         | <b>E</b> Blackout Tail Light Unit |
| <b>B</b> Service Stop and Tail Light Unit | <b>F</b> Cover Screw              |
| <b>C</b> Bulb Socket in Housing           | <b>G</b> Blackout Stop Lamp Unit  |
| <b>D</b> Mounting Stud                    |                                   |



**TRUCK, AMPHIBIAN, 2½-TON, 6 x 6**

**b. Complete Lamp Assembly Installation**

(1) Put lamp in position against mounting bracket with mounting studs through holes in bracket and install nuts on studs; tightening securely. Connect wiring at connectors at rear of lamp. Be sure to connect wiring properly. Refer to Section XVIII, "Electrical System—Wiring" for correct wiring hook-up.

**c. Bulb And Lens Unit Removal—(Fig. 124).** Bulb is soldered to the lens retainer, and retainer is crimped over lens and fitter to make a unit assembly. When bulb is burned out, it is necessary to replace this complete unit. This applies to both rear lamps.

(1) Remove bulb and lens unit cover attaching screws and remove cover. Pull burned out unit out of socket in lamp housing.

**d. Bulb And Lens Unit Installation**

(1) Install bulb and lens unit in lamp housing inserting bulb into socket in housing. Put bulb and lens unit cover in place on lamp housing and install attaching screws.

**170. INSTRUMENT PANEL LAMPS REPLACEMENT**

**a.** These lamps are mounted in instrument panel and replacement procedure is detailed in Para. 221.

**171. REPLACEMENT OF SWITCHES**

**a.** Replacement procedures for main light switch, blackout driving light switch and instrument panel lamps switch are detailed in Para. 221.

**b. Stop Lamp Switch Removal**

(1) Remove four screws and center section of driver's compartment floor boards for access to hydraulic master cylinder. Disconnect two wires to stop lamp switch at switch mounted into master cylinder outlet fitting. Unscrew switch assembly from master cylinder outlet fitting.

**c. Stop Lamp Switch Installation**

(1) Screw switch assembly into hydraulic master cylinder outlet fitting. Connect two wires to stop lamp switch terminals. Install center section of driver's compartment floor boards and fasten down with four screws.

**d. Dimmer Switch Removal**

(1) Open engine compartment hatch cover. Loosen wing nuts on hold-down bolts, swing bolts away from cover clamps, raise cover and fasten in open position with hold-up chain.

(2) Disconnect wiring at switch terminals at switch mounted in driver's compartment lower toe-board. Remove two screws which



**ELECTRICAL SYSTEM—LIGHTING**

attach switch to toe-board and withdraw switch from hole in toe-board.

**e. Dimmer Switch Installation**

(1) Install switch in hole in toe-board and attach with two screws. Connect wiring to switch terminals. Refer to Section XVIII, "Electrical System—Wiring" for proper attachment of wires.

(2) Close engine compartment hatch cover. Unfasten hold-up chain, lower hatch cover, swing hold-down bolts to engage cover clamps and tighten wing nuts securely.

**IMPORTANT**

After rough water operation, check each lamp, and if necessary remove beam unit and drain water from bodies. Check condition of wires, grommets, and connections. Wipe wires dry if necessary. Make certain that grommets are providing a tight seal where wires pass through deck and lamp body.

Section XXIII

**ELECTRICAL ACCESSORIES**

	Paragraph
Radio noise interference suppression.....	172
Fuel gauge .....	173
Horn .....	174

**172. RADIO NOISE INTERFERENCE SUPPRESSION**

a. Radio interference noise suppression (radio suppression) is the suppression of noise disturbances from the electrical system of the vehicle which would interfere with proper reception of radio signals, or permit detection of vehicle location, by highly sensitive receivers.

b. The sources of electrical noise interference may be basically divided into three groups—**Ignition System**, including coil, distributor and spark plugs—**Generating System**, including generator and regulator—and **Wiring**.

c. Radio frequency waves given off by these three groups during operation of electrical system of vehicle are actually radiated or broadcast as radio waves, or signals, that interfere with any receiving apparatus that may be operating in the vehicle or in its vicinity. Radio interference noise suppression, therefore, involves the suppressing of these waves **at their sources**—or confining them within an area where they cannot be picked up by the antenna of a radio-equipped vehicle.

d. Suppression is accomplished by the use of spark plug suppressors, ignition shield, filters and condensers. In addition to the use of these special units, shakeproof lockwashers are used when mounting filters, condensers, regulator and associated parts.

e. **Testing.** Procedure for testing radio suppression units requires the use of special instruments and skilled personnel. Notify Ordnance Maintenance Personnel when radio receiving or sending difficulties are encountered.

**f. Filter and Condenser Replacement**

**(1) Removal**

When removing filters or condensers, note carefully location of shakeproof lockwashers so that they can be installed in same location when reassembling.

**(2) Installation**

When installing filters or condensers it is extremely important that shakeproof lockwashers be used under head of cap screws and under nuts also between unit and part to which it is being attached. Mountings and terminals must be tight to provide a good tight connection and mounting. Refer to Fig. 125 for location of filters and condensers.

**ELECTRICAL ACCESSORIES**

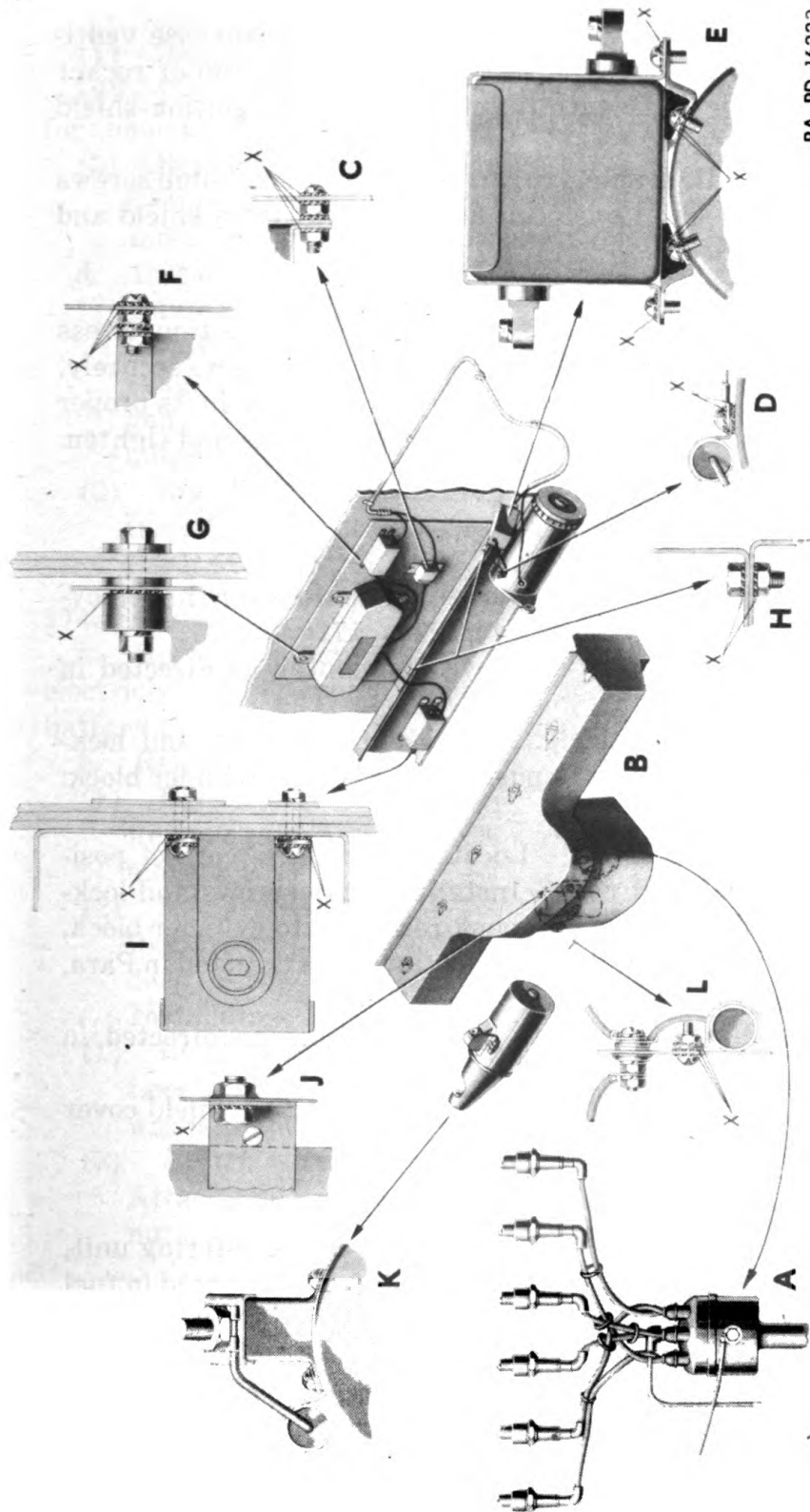

RA PD 16223

**Figure 125—Radio Noise Suppression Units Installation**

- |                                |                           |                           |
|--------------------------------|---------------------------|---------------------------|
| A Spark Plug Wires             | E Generator Filter        | I Battery Circuit Filter  |
| B Ignition Shield              | F Armature Filter         | J Ignition Coil           |
| C Field Circuit Filter         | G Regulator               | K Starter Condenser       |
| D Generator Armature Condenser | H Regulator Bracket       | L Ignition Coil Condenser |
|                                | X = Shakeproof Lockwasher |                           |

**TRUCK, AMPHIBIAN, 2½-TON, 6 x 6**

**g. Ignition Shield Cover Replacement**

**(1) Removal procedure**

(a) **Loosen valve rocker arm cover.** Loosen crankcase ventilator tube nut at manifold. Remove two stud nuts at top of rocker arm cover. Lift cover sufficiently to clear flange on ignition shield cover.

(b) **Remove ignition shield cover.** Remove four thumb screws attaching cover to shield. Cover can now be lifted from shield and completely removed.

**(2) Installation procedure**

(a) Install ignition shield cover in its proper position. Press down in place and install four thumb screws. Tighten screws securely.

(b) **Install valve rocker arm cover.** Locate cover in its proper position with studs through holes in cover. Install nuts and tighten. Install and tighten crankcase ventilator tube connection.

**h. Ignition Shield Replacement**

**(1) Removal procedure**

(a) **Remove ignition shield cover.** Instructions for the removal of ignition shield cover are outlined in Para. 172g.

(b) **Remove distributor.** Remove distributor as directed in Para. 148.

(c) **Remove ignition shield.** Remove five screws and lockwashers attaching shield to valve push rod cover and cylinder block.

**(2) Installation procedure**

(a) **Install ignition shield** Locate shield in its correct position against valve push rod cover. Install five cap screws and lockwashers attaching shield and valve push rod cover to cylinder block.

(b) **Install distributor.** Install distributor as directed in Para. 148.

(c) **Ignition timing.** Adjust ignition timing as directed in Para. 145.

(d) **Install ignition shield cover.** Install ignition shield cover as directed in Para. 172g.

**173. FUEL GAUGE**

a. Fuel gauge system consists of two units, the registering unit, mounted on instrument panel, and tank unit, which is mounted in fuel tank. As shown on general wiring section of this book, circuit for this system passes through ignition switch. Various positions of tank unit float arm will cut in resistance, permitting current to flow to a calibrated gauge, thereby registering quantity of fuel in tank. Refer to wiring section of this book for electrical circuit between tank unit and instrument panel gauge.

b. **Testing.** Procedure for testing fuel gauge units and wiring



**ELECTRICAL ACCESSORIES**

requires special instruments and skilled personnel. Notify Ordnance when system fails or does not register accurately.

**c. Removal procedure**

- (1) Removal of instrument panel gauge is described in Para. 221.
- (2) Remove spare wheel and stern deck front plate. Procedure for removal of these parts is fully described in Para. 66.
- (3) **Remove fuel tank gauge**

Remove wire terminal nut and remove wire. Remove five screws and lockwashers attaching gauge to tank. Lift gauge from tank.

**d. Installation Procedure****(1) Install fuel tank gauge**

Install gauge through tank opening, using new gasket between gauge and tank. Install five screws and lockwashers attaching gauge to tank. Tighten screws securely. Attach wire to terminal and tighten nut securely.

**(2) Install stern deck front plate and spare wheel**

Installation procedure for these parts is fully described in Para. 66.

**174. HORN**

a. Horn is mounted on right-hand side of forward deck and is electric vibrating type. Current for operation of horn is supplied by battery through wiring as shown in Fig. 97.

**b. Removal Procedure****(1) Disconnect wires**

Remove nuts and lockwashers attaching wires to horn and remove wires.

**(2) Remove horn**

Remove two nuts, lockwashers and bolts attaching horn to deck bracket and remove horn from bracket.

**c. Installation Procedure****(1) Install horn**

Locate horn in place on bracket and install two bolts, lockwashers and nuts. Tighten nuts securely.

**(2) Attach wires**

Attach two wires to horn terminals and install lockwashers and nuts. Tighten terminal nuts securely.

**Section XXIV**

**ENGINE**

	<b>Paragraph</b>
General description.....	175
Engine accessories.....	176
Operation trouble-shooting.....	177
Mechanical trouble-shooting.....	178
Preventive maintenance and inspection.....	179
Engine tune-up.....	180
Valve mechanism maintenance.....	181
Oil filter service.....	182
Power plant replacement.....	183
Oil pan replacement.....	184
Oil pump replacement.....	185
Manifold replacement.....	186
Crankcase ventilator maintenance.....	187

**175. GENERAL DESCRIPTION**

**a.** Engine is six cylinder, valve-in-head type conventionally mounted in the chassis and accessible for removal and service purposes through an engine compartment hatch. General data on the engine is itemized in Para. 7.

**176. ENGINE ACCESSORIES**

**a.** This section of the manual covers only the basic engine and does not describe any of the engine accessories such as carbureter, water pump, ignition system or generating system. Following list or index itemizes sections of the manual describing various engine accessory units.

**b. Accessory Section Index**

<b>System</b>	<b>Section</b>
Clutch.....	XVI
Fan, water pump, and radiator.....	XVII
Electrical wiring.....	XVIII
Starting motor and battery.....	XIX
Ignition system.....	XX
Generator and control.....	XXI
Exhaust system.....	XXV
Carbureter, air cleaner, fuel pump and fuel filter.....	XXVII

**177. OPERATION TROUBLE-SHOOTING**

**a.** In general, operating troubles on engine power plant are caused not only by mechanical deficiencies of the engine mechanism proper but by some malfunctions in allied accessory systems of the engine. There are generally two kinds of trouble-shooting charts which apply to the operating of an engine power plant. One trouble-shooting chart will cover temporary starting failures or operating deficiencies. The

**ENGINE**

other chart (Para. 178), covers malfunctions of mechanical components of the engine proper. Symptoms and causes itemized in both charts may overlap somewhat; however, as a general rule, the operation trouble chart (Para. 177 g) will be used by driver and crew while the mechanical trouble chart (Para. 178) will be used by maintenance personnel to determine causes of mechanical failures.

**b. Operation Trouble-Shooting Table.** Engine operating trouble may be classified under three general conditions. These are, (1) failure to start, (2) misfiring, and (3) uneven running. Chart, Fig. 126, shows systematic analysis to determine which condition in Table applies.

Symptom and Probable Cause	Probable Remedy	Refer to Paragraph
<b>CONDITION NO. 1</b>		
<b>Engine Will Not Start—No Spark</b>		
<b>(1) Ammeter shows no discharge (zero reading)</b>		
(a) Ignition switch partly turned on	Turn on full . . . . .	12
(b) Defective ignition switch	Replace ignition switch . . . . .	221
(c) Loose connections on ignition switch	Check and tighten connections . . . . .	221
(d) Primary wire from ignition to coil or from coil to distributor broke, or connection loose	Repair and tighten . .	147
(e) Breaker points excessively burned or pitted	Clean and adjust or replace . . . . .	144
(f) Breaker points in distributor not closing	Adjust or replace . . .	144
(g) Ignition coil primary windings open	Replace coil . . . . .	150
(h) Loose connection from starter to ignition switch	Clean and tighten connections . . . . .	221
<b>(2) Normal ammeter reading</b>		
(a) High tension wire from coil to distributor broken or grounded	Repair or replace . . .	150
(b) Defective ignition coil or condenser	Install new part . . . .	149-150

**TRUCK, AMPHIBIAN, 2 1/2-TON, 6 x 6**  
**ENGINE FAILS TO START—MISFIRES—OR RUNS UNEVENLY**

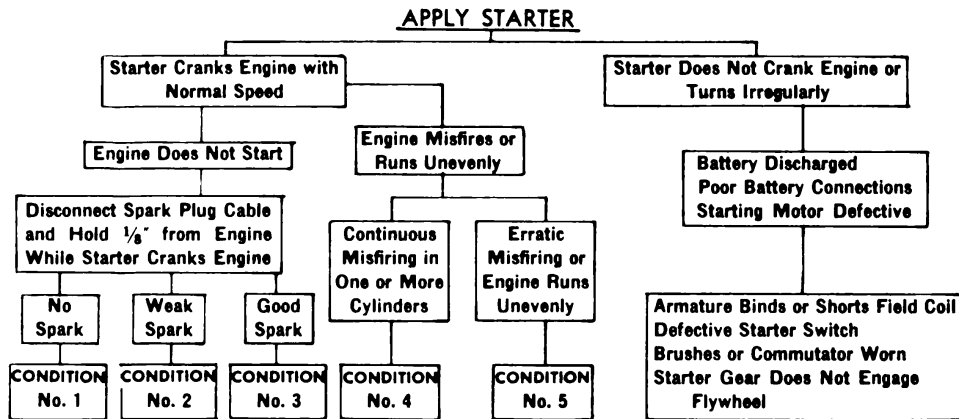

**Figure 126—Operation Trouble-Shooting Chart**

Symptom and Probable Cause	Probable Remedy	Refer to Paragraph
(c) Defective distributor rotor or distributor cap	Install new part. . . . .	144
(d) High tension wires wet	Dry thoroughly. . . . .	147
(e) Spark plug wires distributor cap terminal ends corroded or loose in distributor cap	Clean or replace. . . . .	147
<b>(3) Ammeter indicates abnormal discharge</b>		
(a) Indicates that a "short" exists between ammeter and ignition coil	Repair or replace. . . . .	129
(b) In event of shorted primary circuit "short" may exist in distributor	Check distributor. . . . .	144
(c) Points not opening	Adjust or replace. . . . .	144
(d) Condenser "shorted"	Install new condenser	149
(e) Primary winding in ignition coil "shorted"	Install new coil. . . . .	150
(f) Breaker point arm in distributor grounded	Adjust or replace. . . . .	144
(g) Wire from ignition switch to ignition coil "shorted" or grounded	Repair or replace. . . . .	129

**CONDITION NO. 2**

**Engine Will Not Start—Weak Spark**

**(1) Weak spark**

- (a) Distributor points badly burned or pitted Clean or replace. . . . . 144



**ENGINE**

Symptom and Probable Cause	Probable Remedy	Refer to Paragraph
(b) Defective distributor condenser	Install new condenser	149
(c) Defective ignition coil	Replace coil . . . . .	150
(d) Loose connections throughout circuit causing "Voltage Drop"	Check and tighten . . .	127
(e) High tension (secondary) wires defective or wet	Dry or replace . . . . .	147
(f) Defective distributor cap	Install new cap . . . . .	144
(g) Defective distributor rotor or broken distributor brush	Install new rotor . . . .	144

**CONDITION NO. 3**

**Engine Will Not Start—Good Spark**

(1) Fuel tank empty	Fill tank	
(2) Carbureter contains dirt and water	Remove and clean . . .	204
(3) Carbureter flooded through excessive use of choke	Do not attempt to start motor for five minutes. When another attempt is made, do not use choke	
(4) Choke control not operating	Check linkage . . . . .	206
(5) Fuel does not reach carbureter	Check fuel tank—add fuel	
(6) Fuel lines clogged	Remove and clean . . .	208
(7) Fuel filter clogged	Remove and clean . . .	200
(8) Fuel pump defective	Replace . . . . .	202
(9) Check fuel lines, fuel filter and fuel pump (in extremely cold weather) for ice	Remove and clean . . . . .	200, 201, 208

**CONDITION NO. 4**

**Engine Misfires**

(1) Continuous misfiring in one or more cylinders	Check spark plugs . . .	146
---	-------------------------	-----

**TRUCK, AMPHIBIAN, 2½-TON, 6 x 6**

Symptom and Probable Cause	Probable Remedy	Refer to Paragraph
(a) Is proper type plug used?	Check engine tune up	180
(b) Dirty spark plugs	Clean and adjust; use feeler gauge.....	146
(c) If spark plug porcelain is very white	Plug too hot, use colder plug.....	146
(d) If plug is light brown, plug is correct	Replace with same type	146
(e) If plug is black or oily, plug is too cold	Use hotter plug	146
(f) If porcelain body is cracked	Replace.....	146
(g) High tension wires leaking through cracked insulation	Replace.....	147
(h) Distributor cap defective	Replace.....	144
(i) Insufficient or uneven compression in one or more cylinders	Test.....	180

**CONDITION NO. 5**

**Engine Runs Unevenly**

<b>(1) Erratic misfiring at idling speeds</b>		
(a) Faulty spark plugs	Replace.....	146
(b) Spark gap too wide	Adjust.....	145
(c) Ignition coil and condenser defective	Install new parts....	149, 150
(d) Distributor breaker points sticking, defective, or improperly adjusted	Adjust or replace....	144
(e) Valves sticking open	Replace.....	181
(f) Weak valve springs	Replace.....	181
(g) Broken valve head	Replace.....	181
(h) Valve springs broken	Replace.....	181
(i) Defective cylinder head gasket	Replace gasket.....	181
(j) Uneven cylinder compression	Service.....	180

**ENGINE**

Symptom and Probable Cause	Probable Remedy	Refer to Paragraph
<b>(2) Uneven engine operation at high speed</b>		
(a) Breaker points adjusted too wide	Adjust.....	144
(b) Weakened distributor breaker arm tension springs	Replace.....	144
(c) Incorrect type spark plugs	Replace.....	146
(d) Cracked cylinder head	Replace.....	181
(e) Cracked cylinder block	Notify Ordnance	
(f) For reasons given under Condition No. 4		
(g) For reasons given under Condition No. 3		

**178. MECHANICAL TROUBLE-SHOOTING**

a. The following trouble-shooting table covers in general, symptoms and causes of failures within the engine such as connecting rods, pistons, etc.

Symptom and Probable Cause	Probable Remedy	Refer to Paragraph
<b>b. Mechanical Trouble-Shooting Chart</b>		
<b>(1) Poor compression</b>		
(a) incorrect valve lash	Adjust.....	181
(b) Worn valves and seats	Notify Ordnance	
(c) Valve stems or lifters sticking	Notify Ordnance	
(d) Valve stems or guides worn	Notify Ordnance	
(e) Valve springs weak or broken	Install new parts . . . .	181
(f) Cylinder head leaking	Install new gasket and tighten cylinder head	181
(g) Piston rings worn, broken or stuck	Notify Ordnance	
(h) Pistons worn	Notify Ordnance	
(i) Piston ring grooves worn	Notify Ordnance	
(j) Cylinder scored or excessively worn	Notify Ordnance	
<b>(2) Excessive fuel consumption</b>		
(a) Poor driving practices	Investigate and correct—test vehicle in actual operation	

**TRUCK, AMPHIBIAN, 2 1/2-TON, 6 x 6**

Symptom and Probable Cause	Probable Remedy	Refer to Paragraph
<b>(3) Lack of power</b>		
(a) Motor overheating	Check cooling system	118
(b) Faulty compression	Tune-up engine . . . . .	180
(c) Faulty ignition system	Service . . . . .	142
(d) Air cleaner clogged	Service . . . . .	199
<b>(4) Valves sticking</b>		
(a) Incorrect valve lash	Readjust . . . . .	181
(b) Insufficient clearance between valve stem or guide	Notify Ordnance	
(c) Valve springs weak or broken	Replace . . . . .	181
(d) Valve stems scored or dirty	Clean . . . . .	181
(e) Valve lifters sticking	Notify Ordnance	
(f) Use of fuel with high gum content	Use correct fuel	
<b>(5) Burned valves and seats</b>		
(a) Improper valve lash	Readjust . . . . .	181
(b) Weak valve springs	Install new springs . .	181
(c) Excessive carbon deposits at valve	Clean and service . . .	181
(d) Valves sticking in guides	Notify Ordnance	
(e) Valve head ground too thin	Notify Ordnance	
(f) Valve seats too narrow	Notify Ordnance	
(g) Too lean a fuel mixture	Adjust carbureter . . .	203
(h) Overheating	Check cooling system	118
(i) Valve lifter sticking, holding valve open	Notify Ordnance	
(j) Overspeeding	Correct poor driving practices . . . . .	16
<b>(6) Noisy valves</b>		
(a) Valve lash incorrectly adjusted	Readjust . . . . .	181
(b) Worn rocker arm face and valve stem	Notify Ordnance	
(c) Valves loose in guide	Notify Ordnance	
(d) Weak valve springs	Install new springs . .	181
(e) Valves sticking	Refer to "Valve Sticking" (4)	



**ENGINE**

Symptom and Probable Cause	Probable Remedy	Refer to Paragraph
<b>(7) Excessive oil consumption</b>		
(a) Piston rings broken, worn, or stuck	Notify Ordnance	
(b) Piston rings improperly fitted	Notify Ordnance	
(c) Piston ring slots clogged with carbon	Notify Ordnance	
(d) Cylinder bore out of round or excessively tapered	Notify Ordnance	
(e) Cylinder bore scored or badly worn	Notify Ordnance	
(f) Crankshaft and connecting rod bearings worn	Notify Ordnance	
(g) Overheating	Check cooling system	18
(h) Improper grade and viscosity of oil	Use correct lubricant.	Sect VI
(i) Oil level too high	Use correct amount.	Sect VI
(j) Oil leaks at gaskets and seals	Notify Ordnance	
(k) Overspeeding engine	Correct poor driving practices . . . . .	16
(l) Unnecessary and excessive driving in low gear ranges on level ground	Correct poor driving practices . . . . .	16
<b>(8) Popping, spitting and spark knock</b>		
(a) Inferior grade of fuel	Use correct fuel	
(b) Spark advanced too far	Adjust . . . . .	145
(c) Carburetor improperly adjusted	Adjust . . . . .	203
(d) Valve lash adjusted too close	Readjust . . . . .	181
(e) Excessive carbon deposits	Remove cylinder head and clean . . . . .	181
(f) Weak valve springs	Install new springs . . .	181
(g) Valves not seating properly—overheated	Notify Ordnance	
(h) Piston rings in poor condition	Notify Ordnance	
(i) Heat control valve improperly adjusted	Adjust . . . . .	186

Generated on 2013-07-29 08:40 GMT / http://hdl.handle.net/2027/uc1.b3243762  
Public Domain, Google-digitized / http://www.hathitrust.org/access\_use#pd-google

**TRUCK, AMPHIBIAN, 2 1/2-TON, 6 x 6**

Symptom and Probable Cause	Probable Remedy	Refer to Paragraph
<b>(9) Low oil pressure</b>		
(a) Improper grade and viscosity of oil	Use correct lubricant.	Sect VI
(b) Oil pressure relief valve stuck	Clean, test spring, replace. Notify Ordnance	
(c) Oil pump screen clogged	Remove and clean thoroughly.	184
(d) Excessive crankshaft and connecting rod bearing clearance	Notify Ordnance	
(e) Excessive oil pump gear to housing clearance	Install new assembly.	185
(f) Defective oil gauge	Replace.	221
<b>(10) Excessive cylinder and piston wear</b>		
(a) Lack of oil	Add oil.	Sect VI
(b) Dirty oil	Drain, flush and refill	Sect VI
(c) Improper grade and viscosity of oil	Use correct lubricant.	Sect VI
(d) Overheating	Check cooling system	118
(e) Pistons and rods improperly installed	Notify Ordnance	
(f) Piston rings not properly fitted	Notify Ordnance	
(g) Piston rings stuck or broken	Notify Ordnance	
(h) Air cleaner neglected	Service.	199
(i) Carbureter fuel mixture too rich	Readjust.	203
(j) Overspeeding engine particularly when cold	Correct poor driving practices.	16
(k) Excessive crankcase oil dilution	Service crankcase ventilating system more frequently.	187
<b>(11) Connecting rod bearing failure</b>		
(a) Lack of oil	Add oil.	Sect VI
(b) Low oil pressure	Refer to Item (9)	
(c) Improper grade and viscosity of oil	Use correct lubricant.	Sect VI
(d) Crankshaft surface rough	Notify Ordnance	

**ENGINE**

<b>Symptom and Probable Cause</b>	<b>Probable Remedy</b>	<b>Refer to Paragraph</b>
(e) Restricted oil passages	Notify Ordnance	
(f) Bearings worn or sprung	Notify Ordnance	
(g) Bearings improperly fitted	Notify Ordnance	
(h) Bearing loose in connecting rod and cap	Notify Ordnance	
(i) Connecting rod out of alignment	Notify Ordnance	
(j) Excessive crankcase dilution	Service crankcase ventilating system more frequently.....	187
<b>(12) Overheating</b>		
(a) Inefficient cooling system	Check cooling system	118
(b) Improper grade and viscosity of oil	Use correct lubricant.	Sect VI
(c) Fuel mixture too lean	Adjust carbureter....	203
(d) Air cleaner restricted	Service.....	199
(e) Ignition system faulty	Check and service....	144
(f) Ignition timing incorrect	Tune-up engine.....	180
<b>(13) Crankshaft bearing failure</b>		
(a) Lack of oil	Add oil.....	Sect VI
(b) Low oil pressure	Refer to Item (9)	
(c) Improper grade and viscosity of oil	Use correct lubricant.	Sect VI
(d) Crankshaft bearing journal worn or out of round	Notify Ordnance	
(e) Crankshaft oil passage restricted	Notify Ordnance	
(f) Bearings worn or sprung	Notify Ordnance	
(g) Bearings improperly fitted	Notify Ordnance	
(h) Bearings loose in crankshaft bearing support and cap	Notify Ordnance	
(i) Crankshaft or bearings out of alignment	Notify Ordnance	
(j) Excessive crankcase dilution	Service crankcase ventilating system more frequently.....	187

**TRUCK, AMPHIBIAN, 2 1/2 -TON, 6 x 6****179. PREVENTIVE MAINTENANCE AND INSPECTION**

a. Inspection and preventive maintenance operations generally accomplished on an engine power plant embrace all inspection procedure itemized for the engine accessory or related units. Reference should be made to Section V, "Preventive Maintenance and Inspection" for all operations pertaining to engine and its accessories and should be accomplished at the intervals designated.

**180. ENGINE TUNE-UP**

a. The tune-up cycle is an inspection and adjustment procedure for each individual unit in the ignition and fuel systems. Periodic tune-up cycle chart as illustrated in Fig. 127 should be followed if satisfactory performance and continuous operation are to be obtained. Satisfactory results from engine tune-up operations cannot be expected if a systematic procedure is not adhered to. Performing tune-up operations in the order given, and carefully following factory-recommended clearances and specifications, satisfactory results will be obtained. In order to satisfactorily perform all the following operations, regular tune-up equipment, such as compression gauge, vacuum gauge, voltmeter, ammeter, timing light, etc., are necessary.

b. **Compression Test.** Before starting with tune-up procedure, a test of engine compression should be made, for an engine without fairly even compression in all cylinders cannot be successfully tuned. Compression pressure depends upon cranking speeds, engine temperature, compression ratio and the condition of the engine. If the reading indicated by the compression is reasonably high and uniform for all cylinders, compression pressure may be considered normal. Make compression test in the following manner:

- (1) Remove ignition shield.
- (2) Turn ignition switch "off," pull hand throttle all the way out. Remove all spark plugs from engine
- (3) Insert compression gauge in spark plug hole in one engine and crank engine a few turns with starting motor. Note highest compression gauge reading while engine is being cranked. Perform same operation at each cylinder and record reading.
- (4) Compression reading of approximately 110 pounds per cylinder is desirable. A variation within approximately five (5) pounds limit is normal. If compression is too low, the cause (either piston rings, valves, or cylinder head gasket) should be checked and corrected. Loss of compression through piston rings can be detected by pouring a liberal quantity of oil through spark plug hole on top of piston, allow



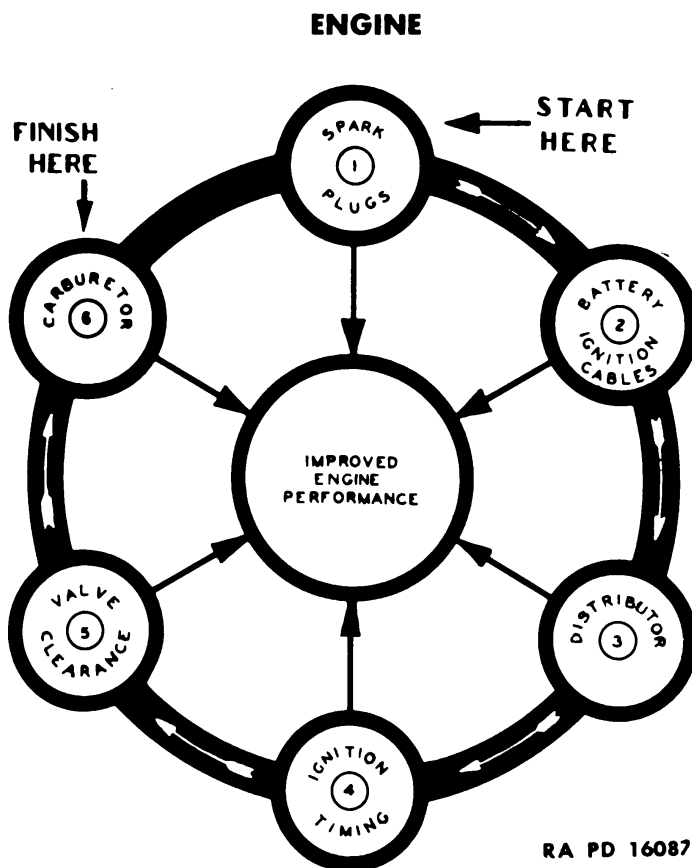

**Figure 127—Engine Tune-Up Cycle Chart**

enough time for oil to spread around piston and proceed with second compression test reading. If compression increases materially in cylinder so treated, it indicates a defective piston seal. An extremely low reading in two adjacent cylinders might indicate a leaky cylinder head gasket, or defective valve seating.

**c. Engine Tune-up Procedure (Fig. 127)**

Item	Operation	Refer to Paragraph
(1) <b>Spark plugs</b> . . . . .	Service spark plugs . . . . .	146
(2) <b>Battery and ignition cables</b> . . . . .	Service cables . . . . .	134
(a) <b>Battery</b> . . . . .	Service battery . . . . .	134
(3) <b>Distributor</b>		
(a) <b>Distributor</b> . . . . .	Clean and inspect distributor cap . . . . .	144
(b) <b>Rotor</b> . . . . .	Remove and clean rotor . . . . .	144
(c) <b>Breaker points</b> . . . . .	Inspect, clean, and adjust . . . . .	144
(d) <b>Condenser</b> . . . . .	Inspect and tighten connections . . . . .	149
(4) <b>Ignition timing</b> . . . . .	Check and adjust . . . . .	145
(5) <b>Valve lash</b> . . . . .	Check and adjust . . . . .	181
(6) <b>Carbureter</b>		
(a) <b>Carbureter</b> . . . . .	Check carbureter adjustment . . . . .	203
(b) <b>Fuel filter</b> . . . . .	Check and service . . . . .	200

**TRUCK, AMPHIBIAN, 2 1/2 -TON, 6 x 6**

Item	Operation	Refer to Paragraph
(c) Air cleaner.....	Service.....	199
(d) Fuel pump.....	Service.....	201
(e) Fuel lines.....	Inspect and service.....	208
(f) Fuel tank.....	Inspect.....	207

**181. VALVE MECHANISM MAINTENANCE**

**a.** Valve mechanism maintenance embraces lashing or adjusting of intake and exhaust valves; periodic tightening of cylinder head bolts; removal of cylinder head and valve mechanism. Procedures which follow include all of these maintenance operations in logical sequence.

**b. Valve Lash.** Adjusting valve lash or clearance between intake and exhaust stems and respective rocker arm, is a procedure which should be accomplished periodically or as conditions demand. Clearance at exhaust and intake valves is .012 inch with engine warm. Adjust valves in following manner:

**(1) Warm up engine**

Before proceeding with valve lash adjustment, engine must be thoroughly warmed up to normalize expansion of valve operating parts. After normal engine operating temperatures have been reached (approximately after 15 minutes), allow engine to idle in slow and proceed with valve lash adjustment operation.

**(2) Remove valve cover**

Disconnect crankcase ventilating tube at valve cover and remove two valve cover retaining bolt nuts. Remove valve cover.

**(3) Adjust valve clearance (Fig. 128)**

Loosen valve rocker arm ball stud nut and insert .012 inch feeler gauge between rocker arm and valve. Adjust rocker arm ball stud until proper clearance is indicated by feeler gauge. After proper clearance has been obtained, tighten rocker ball stud nut, then check with feeler gauge again to make sure adjustment has not been altered while tightening nut. Repeat these operations at all valves.

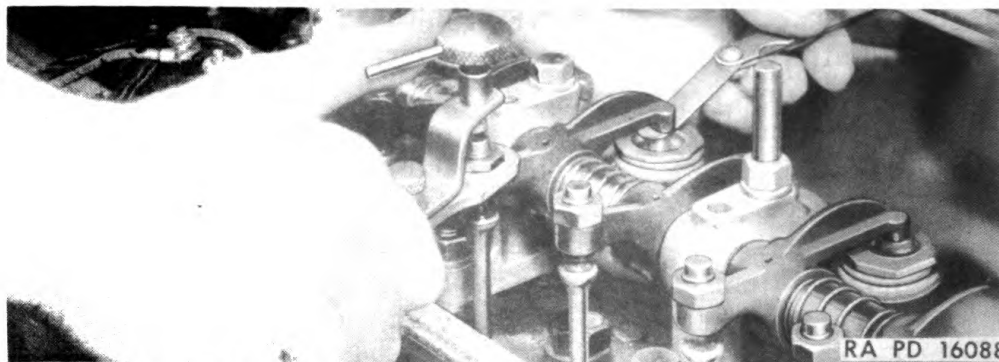

**Figure 128—Valve lash should be adjusted with engine at normal operating temperatures**

ENGINE

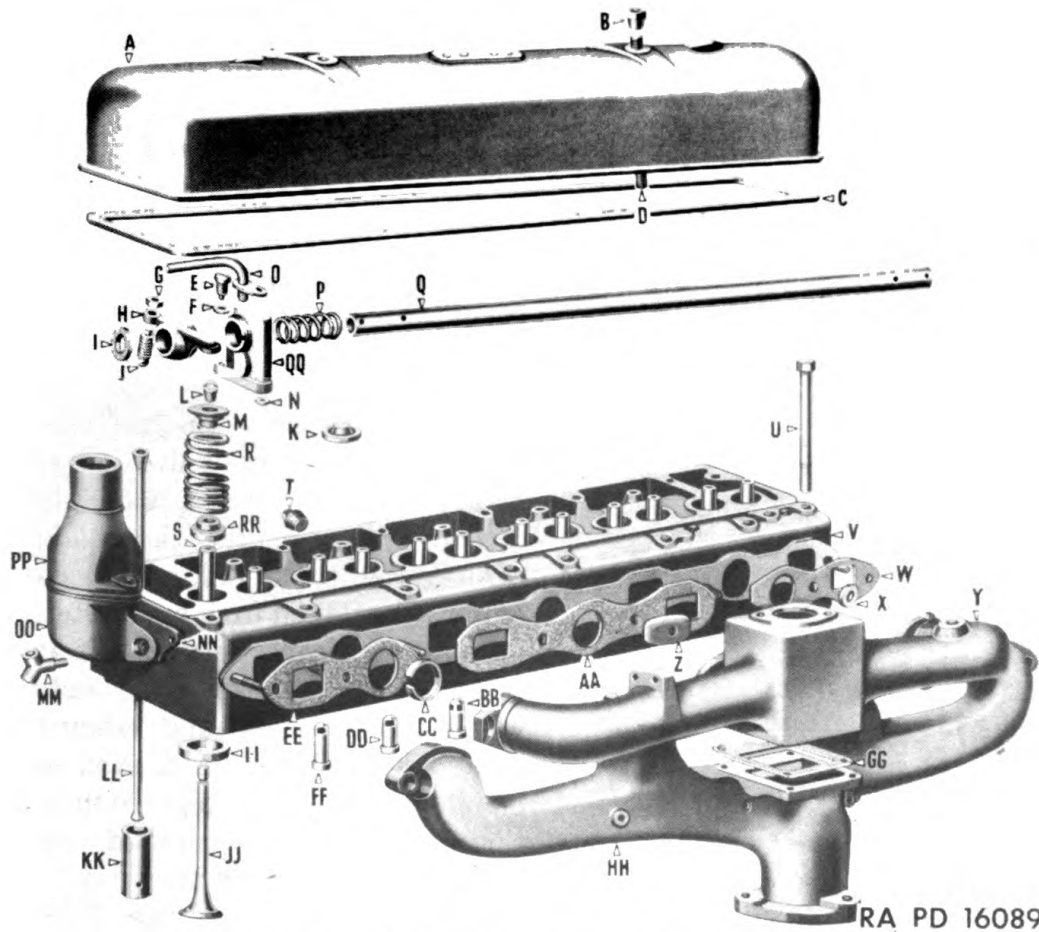

Figure 129—Cylinder Head and Component Parts

A Valve Cover	L Valve Key	X Manifold Washer	II Valve Insert
B Cover Nut	M Spring Retainer	Y Intake Manifold	JJ Valve
C Cover Gasket	N Pipe Gasket	Z Manifold Clamp	KK Valve Lifter
D Cover Stud	O Overflow Pipe	AA Manifold Gasket	LL Valve Push Rod
E Locating Screw	P Rocker Shaft Spring	BB Water Nozzle	MM Oil Inlet
F Nut	Q Rocker Arm Shaft	CC Manifold Pilot	NN Housing
G Adj. Screw Nut	R Valve Spring	DD Water Nozzle	OO Thermostat
H Rocker Arm	S Valve Stem Guide	EE Manifold Gasket	Housing
I Washer	T Plug	FF Water Nozzle	PP Water Outlet
J Adjusting Screw	U Cylinder Head Bolt	GG Manifold Gasket	QQ Shaft Bracket
K Oil Shield—Intake Only	V Cylinder Head	HH Exhaust Manifold	RR Spring Seat
	W Manifold Gasket		

(4) Install valve cover

Install valve cover, making certain that valve cover gasket is in correct position and is not mutilated in any manner. Install the two valve cover stud nuts and connect crankcase ventilating tube.

c. **Cylinder Head and Valve Mechanism Assembly Removal (Figs. 129 and 130).** It is necessary to remove cylinder head and valve mechanism assembly in order to replace valves, springs and recondition valves and seats. Complete cylinder head assembly can be removed as a unit without disturbing water pump, fan or other engine accessories except manifolds and ignition coil, as described in following operations.



## TRUCK, AMPHIBIAN, 2½-TON, 6 x 6

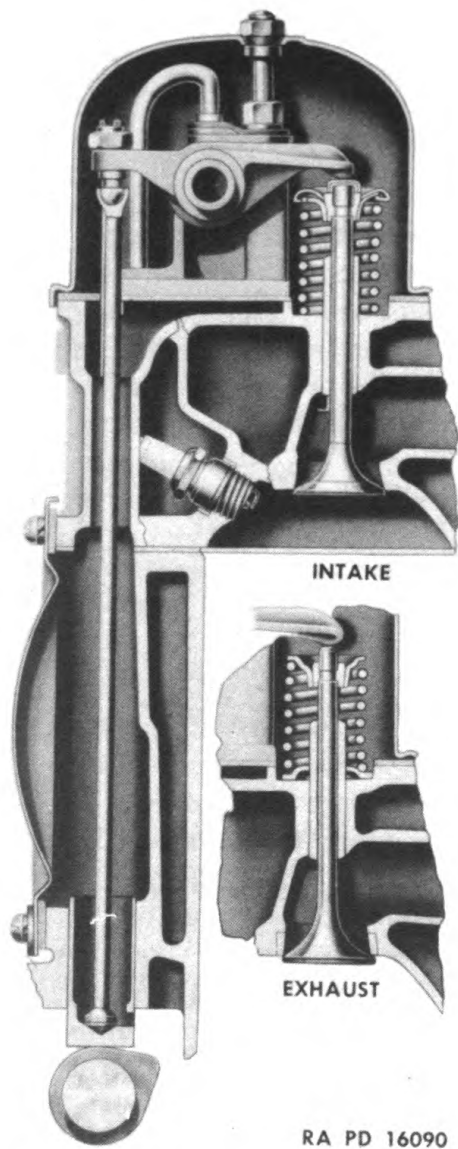

**Figure 130—Valve Mechanism**

- (1) Drain water from radiator and cylinder block. (Refer to Para. 118). Disconnect steam relief tube at cylinder head. Also disconnect water outlet fitting (remove 2 mounting bolts). Disconnect windshield wiper line hose, also brake power cylinder vacuum line from intake manifold (below check valve).
- (2) Disconnect crankcase ventilation tube from valve cover fitting, and at intake manifold fitting. Disconnect fuel line, hand throttle rod, choke rod, and accelerator throttle rod from carbureter. Remove air cleaner (clamp bolt at carbureter). Remove stud nuts which attach intake and exhaust manifold to cylinder head, exhaust manifold to exhaust pipe connections, then remove manifold and carbureter, etc., as an assembly.
- (3) Disconnect oil line from filter at front of cylinder head, also oil pressure gauge line at cylinder head. Disconnect temperature thermal unit line at fitting in cylinder head. Remove crankcase oil filler tube and breather assembly (2 clamp bolts). Disconnect and remove oil filter and attaching bracket (2 clamp bolts and oil line at bottom).
- (4) Remove radio suppression shield. Disconnect ignition cables at spark plugs.
- (5) Remove ignition coil from bracket.
- (6) Remove oil filter and filter tube to block bracket.
- (7) Remove valve push rod cover. Remove valve rocker arm and shaft as a complete assembly. Lift valve push rods out of engine. Remove cylinder head to block bolts and carefully lift cylinder head off block.

**d. Installing Cylinder Head Assembly**

- (1) Before installing cylinder head and valve assembly, make sure



## ENGINE

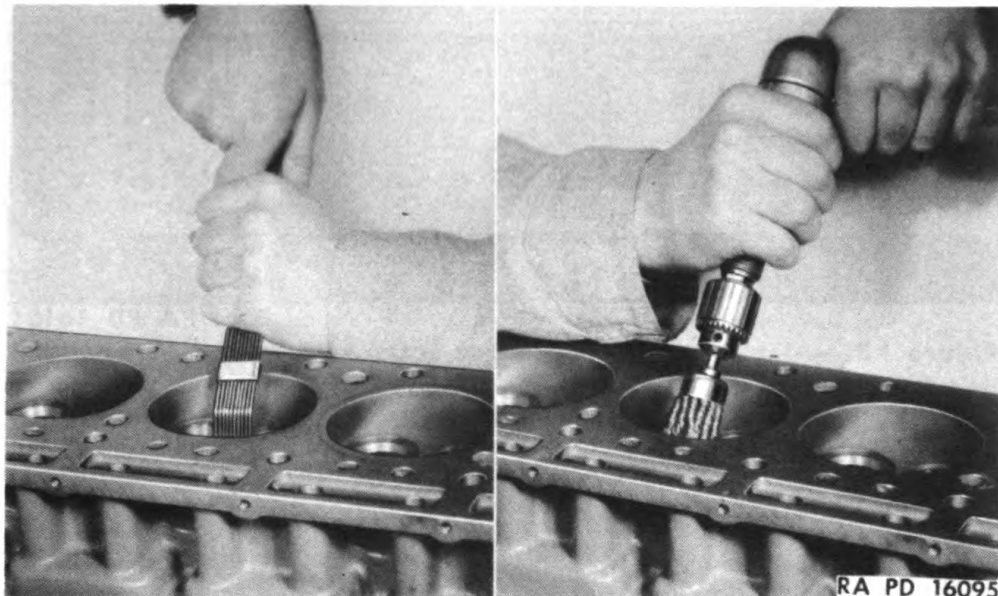

**Figure 131—Typical Method of Cleaning Cylinder Head**

that the head and block are clean and free from carbon and dirt.

(2) Always use a new gasket. Be sure that gasket is installed with side marked "top" toward cylinder head.

(3) Place cylinder head assembly in place and install bolts.

(4) Tighten cylinder head bolts in the order shown in Fig. 132. A suitable torque wrench should be used to obtain uniform tightening of the cylinder head bolts (Fig. 133). Use torque wrench the factory recommends. Torque is 60-70 ft. lbs. Tighten bolts while cylinder head is cold. After making final connections, run engine until normal operating temperatures are obtained and give bolts a final tightening with torque wrench.

(5) Valve push rods should not be inserted until after cylinder head is remounted on block. This is necessary to avoid damaging push rods.

(6) **IMPORTANT:** Uniform tightening of cylinder head bolts is essential for trouble-free operation. Under or over-tightening of these bolts should be avoided, as it frequently results in distortion of cylinder head, water leaks, blown cylinder head gaskets, and usually leads to serious engine difficulty.

(7) Install valve rocker arm and shaft as complete assembly.

(8) Install valve push rod cover and gasket.

(9) Install oil filter and filler tube bracket.

(10) Install ignition coil on bracket with shakeproof lockwashers.

(11) Connect ignition wires to spark plugs.

(12) Install radio suppression shield.

(13) Install oil filter and bracket assembly and oil connection at bottom of filter.

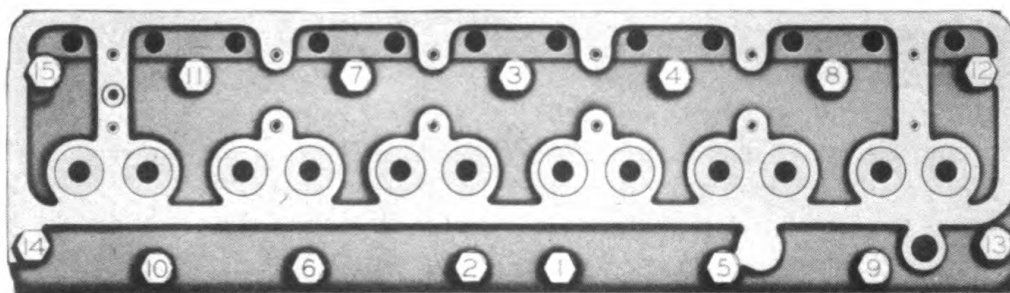
**TRUCK, AMPHIBIAN, 2½-TON, 6 x 6**

RA PD 16101

**Figure 132—Tighten Cylinder Head Bolts with Torque Wrench in Sequence Shown**

- (14) Install crankcase oil filler tube and breather assembly to bracket.
- (15) Insert and thread temperature thermal unit in cylinder head.
- (16) Connect oil lines at front of head.
- (17) Install new intake and exhaust manifold gaskets with manifold and carburetor assembly.
- (18) Connect gas line, hand throttle rod, choke rod and foot feed throttle rod.
- (19) Connect windshield wiper line, and brake power cylinder vacuum line to intake manifold.
- (20) Fill radiator.
- (21) Service and install air cleaner (Para. 199), warm up engine and check tightness of cylinder head bolts.
- (22) Lash valves (Para. 118).
- (23) Install valve rocker arm pan with gasket (with 2 valve cover retaining nuts).
- (24) Connect crankcase ventilator tube to valve rocker arm pan fitting and at manifold fitting.

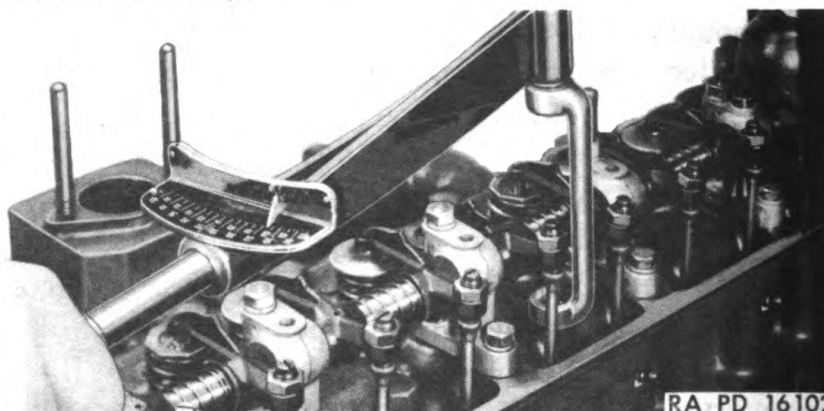

RA PD 16102

**Figure 133—Use of Torque Wrench on Cylinder Head Bolts**



**ENGINE**

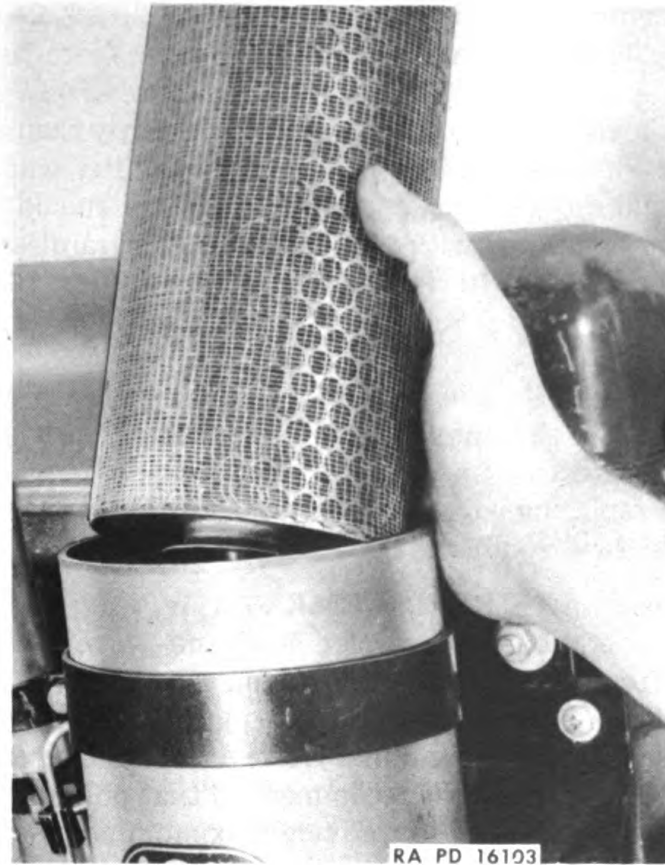
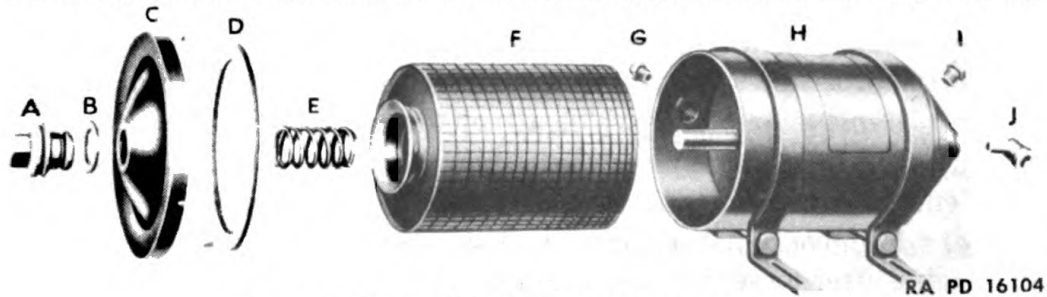

**Figure 134—Replacing Oil Filter Element**

**182. OIL FILTER SERVICE**

**a.** A replaceable element type filter is used. Part of the oil passing through the valve rocker shaft oil line is directed through the oil filter where foreign elements are absorbed. Oil filtered in this manner is then returned directly to engine oil pan through oil pump mounting.

**b.** The most positive assurance of a continuous and efficient function of the oil filter is a periodic inspection and frequent replacement of the filtering element. Oil filter element changing periods are directly related



**Figure 135—Oil Filter Component Parts**

- |                               |                             |                          |
|-------------------------------|-----------------------------|--------------------------|
| <b>A</b> Oil Filter Cover Nut | <b>E</b> Oil Filter Spring  | <b>H</b> Oil Filter Body |
| <b>B</b> Cover Nut Gasket     | <b>F</b> Oil Filter Element | <b>I</b> Drain Plug      |
| <b>C</b> Filter Cover         | <b>G</b> Inlet Fitting      | <b>J</b> Outlet Fitting  |
| <b>D</b> Filter Cover Gasket  |                             |                          |

**TRUCK, AMPHIBIAN, 2½-TON, 6 x 6**

to the oil changing periods, type and quality of oil used, severity of and type of engine operation. It is, therefore, impossible to recommend a definite mileage period that will meet all types of service. Vehicles operating in dusty areas require renewals more frequently than those which operate under normal conditions. While the oil filter will adequately remove dust and dirt entering the oil, the element should be replaced before it becomes clogged with these substances, regardless of mileage.

**c. Oil Filter Element Replacement Procedure (Figs. 134 and 135)**

(1) Unscrew nut which retains cover and remove cover, gasket and spring.

(2) Drain oil filter housing to remove solid matter and water which may have settled in the sump located in the bottom of housing.

(3) Replace element if necessary.

(4) Before replacing cover and gasket, carefully inspect gasket and see that it is in good condition.

**183. POWER PLANT REPLACEMENT (Fig. 136)**

**a.** Service operations on cylinder head and valve mechanism can be performed from within engine compartment with engine hatch cover raised. Engine compartment provides adequate accessibility for service on fuel, electrical, and cooling units. However, for those services which require removal of oil pan, it is recommended that power plant be completely removed from vehicle to provide maximum accessibility, safety and efficiency of the service to be performed.

**b. Removal Procedure.** The following procedure provides for the removal of engine clutch and transmission through engine hatch. In this connection, it should be noted that the procedure outlined does not require removal of radiator, steering gear, transmission, or power take-off. The sequence of the following operations may be changed to conform with local conditions.

**(1) Remove radiator shroud and connections**

(a) Raise engine hatch cover and clamp it securely against windshield.

(b) Remove four bolts and nuts which attach upper and lower shroud sections, then remove eight bolts and nuts which hold end section to radiator side support and remove both sections of shroud.

(c) Remove four bolts which attach fan to pulley and remove fan.

(d) Drain cooling system by removing drain cocks at right-hand lower end of radiator and at left-hand rear side of cylinder block.

(e) Remove radiator upper and lower hose connections at radiator and engine after loosening hose clamps.

**(2) Remove fuel filter**

Disconnect fuel lines running to and from filter by loosening flange nuts. Remove two bolts which attach filter to frame bracket and remove filter.

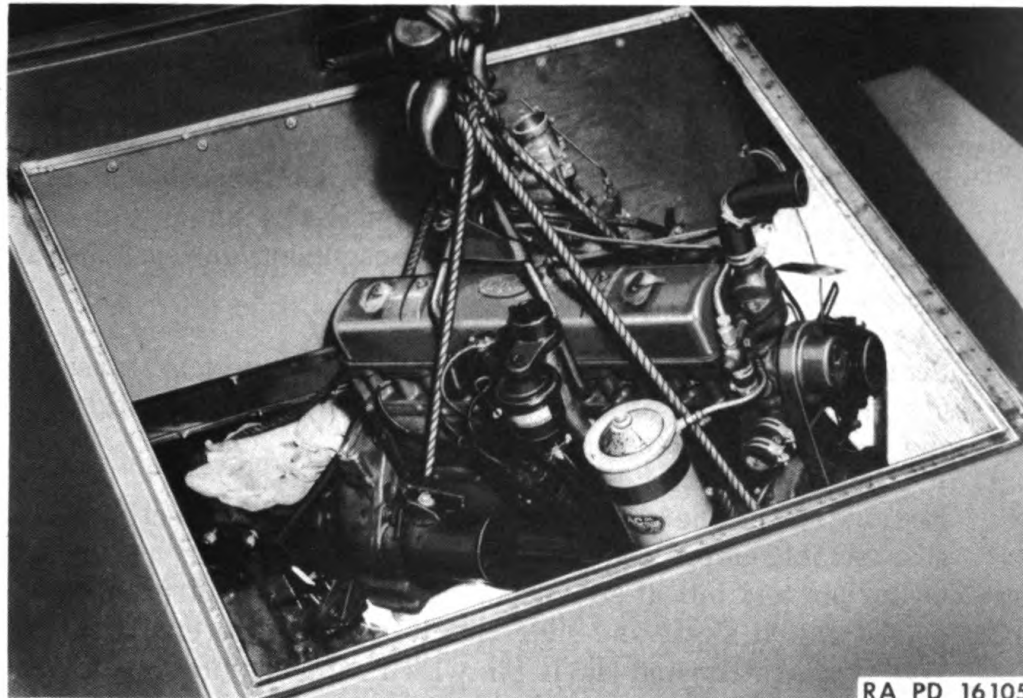

**ENGINE**

RA PD 16105

**Figure 136—Engine Removal****(3) Disconnect starting motor cable**

Remove battery ground strap from battery terminal to prevent accidental discharge of battery. Remove nut and lockwasher attaching ammeter and condenser wires and battery cable to starter switch terminal and remove wires and cable.

**(4) Disconnect carburetor controls**

Disconnect accelerator control rod from bell crank at end of starter cross shaft by removing cotter pin. Disconnect throttle and choke control cables from carburetor. Remove air cleaner to avoid damage during removal and place a cover over carburetor to prevent entrance of dirt.

**(5) Disconnect gauge and electrical fittings from left-hand side of engine**

(a) Unscrew engine temperature gauge thermal unit retaining nut at cylinder head and remove thermal unit.

(b) Disconnect oil gauge flexible hose at toe board, using two wrenches to prevent twisting of hose.

(c) Disconnect horn wire at horn by removing screw.

(d) Disconnect generator and regulator wire harness at junction block.

(e) Disconnect windshield wiper hose at intake manifold tube.

**(6) Disconnect exhaust pipe**

Remove 3 bolts and nuts from flange attaching exhaust pipe to manifold and pull exhaust pipe away from engine.

**TRUCK, AMPHIBIAN, 2½-TON, 6 x 6**

- (7) **Remove floor boards in driver's compartment**  
Remove the 3 floor board sections in driver's compartment to gain access to engine rear accessory units.
- (8) **Disconnect tire pump**  
Remove two lower nuts from tire pump front support bolts and remove chain. Place wire or rope around tire pump and seat riser to hold tire pump away from transmission during removal procedure.
- (9) **Remove power take-off support**  
Remove 4 bolts which attach power take-off support to transmission and power take-off (two bolts at upper side of power take-off and two bolts at transmission).
- (10) **Remove clutch and brake pedal and support**  
Remove cotter and clevis pin from clutch pedal connecting link. Disassemble clutch pedal rod and operating lever by removing cotter pin and nut at end of pedal rod. Remove hairpin lock at end of clutch shaft and slide clutch operating lever off shaft. Withdraw cotter and clevis pin which attaches brake pedal to brake rod. Remove two bolts which attach pedal support to transmission and two bolts which attach support to clutch housing, then remove support and brake pedal.
- (11) **Remove hand brake lever cross shaft**  
Disconnect hand brake control rod at cross shaft lever by removing cotter and clevis pin. Remove retaining bolts and nuts attaching cross shaft brackets to transmission (one bolt on left side and two bolts and one nut on right side) and remove cross shaft, lever and brackets as an assembly. This assembly can be removed intact by tilting right-hand bracket to clear lower stud on right-hand side of transmission.
- (12) **Remove water propeller control lever, cross shaft and brackets**  
Disconnect water propeller transfer case control rods at cross shaft lever by removing cotter and clevis pins. Disconnect winch control lever at power take-off by removing cotter and clevis pin, then remove cotter pin from winch control lever to transmission stud and remove lever. Remove cotter and clevis pin attaching power plant stabilizer rod to water propeller control cross shaft left-hand bracket. Remove hairpin lock at right-hand end of cross shaft and remove left-hand bracket cross shaft and lever as an assembly after nut and winch control lever to transmission stud is removed. Remove one remaining nut which attaches right-hand bracket to transmission and remove bracket.
- (13) **Remove transmission to transfer case propeller shaft**  
Remove four bolts and nuts from flanges at each end of propeller shaft, loosen slip joint dust sleeve, slide shaft into slip joint until yoke clevis flange bolts and remove propeller shaft.

**ENGINE****(14) Disconnect units at clutch housing**

Disconnect Hydrovac vacuum line at right side of clutch housing by loosening clamp bolt and pulling hose off end of line. Disconnect starter button rod at cross shaft by removing cotter and clevis pin.

**(15) Disconnect winch drive shaft from power take-off**

Loosen set screw in power take-off yoke, then lift stop collar (snap ring) out of grooves in shaft splines and slide ring back on shaft. Remove yoke from power take-off shaft using a lead hammer to start yoke.

**(16) Remove transmission cover**

Remove eight bolts which attach transmission cover to transmission case and remove cover and gear shift lever as an assembly. Cover transmission with a clean cloth to prevent entrance of dirt.

**(17) Remove engine support bolts**

Remove bolts in front support and left and right-hand rear support and recheck engine compartment carefully to make sure all lines and connections between power plant and hull have been disconnected.

**(18) Remove power plant**

Install suitable engine lifter hooks and attach chain falls. As an added safety factor and to offset the hazard of engine slipping due to the extreme angles at which it is removed, it is recommended that heavy rope be used in addition to engine lifter hooks, then proceed as follows:

(a) Raise engine a few inches and move it slightly forward to clear engine mounting brackets.

(b) Move rear end of power plant toward right-hand side of engine compartment to permit power take-off to clear steering gear housing. At the same time, raise front of engine upward into hatch opening.

(c) With engine at the approximate angle illustrated in Fig. 165, continue to lift front of engine upward through hatch opening and hold rear of power plant down until it clears toe boards.

(d) Lift power plant out through hatch opening.

**c. Power Plant Installation Procedure.** It is important that power plant assembly be given a thorough inspection before it is installed in vehicle as many items are then more accessible. The following items should be replaced (by Ordnance). If they show the slightest sign of wear: engine oil pump, crankshaft rear oil seal, clutch facings, pressure plate, diaphragm spring, retracting springs, release bearing, and clutch pilot bearing. Transmission cover must be taken off before installing power plant through engine compartment hatch opening.



**TRUCK, AMPHIBIAN, 2½-TON, 6 x 6**

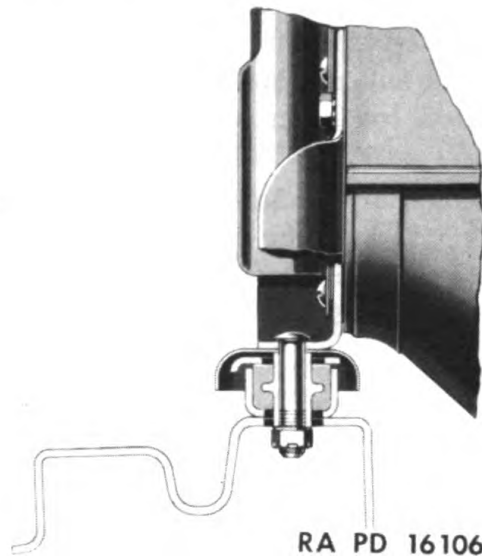

**Figure 137—Engine Front Mounting**

**(1) Inspect engine mounting insulators**

Inspect engine mounting insulators and replace if they are oil soaked. Install oil shields over insulators in positions as shown in Figs. 137 and 138.

**(2) Place power plant in vehicle**

(a) With engine at the approximate angle illustrated in Fig. 136, lower power plant into engine compartment and hold rear of power plant down until transmission clears toe boards.

(b) Move power plant back until mounting brackets are over insulators and install and tighten mounting bolts.

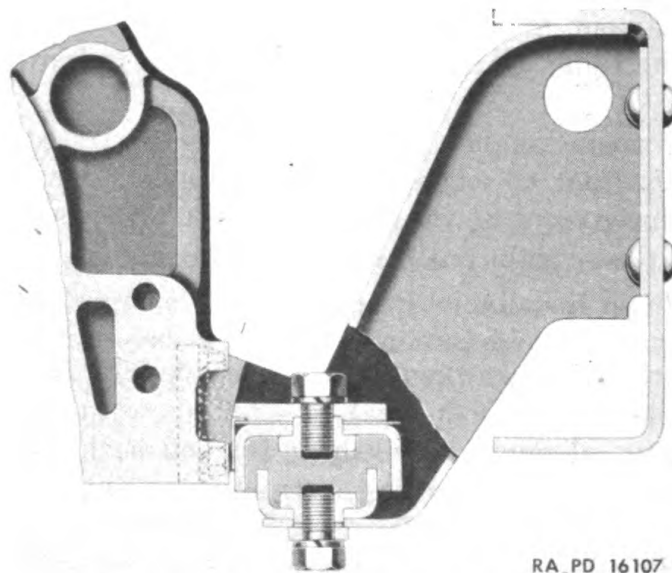

**Figure 138—Engine Rear Mounting**

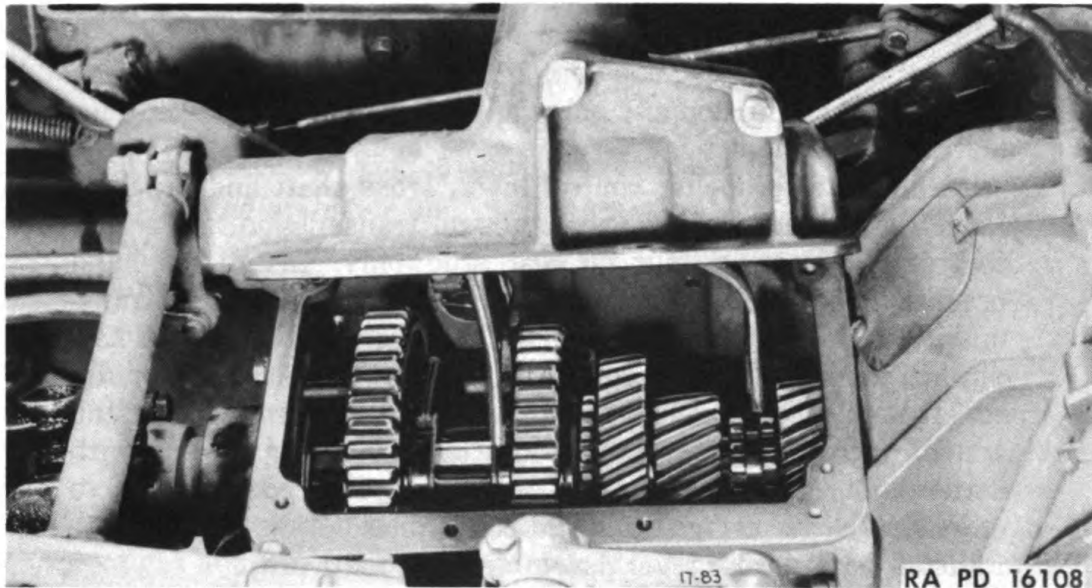

**ENGINE**

**Figure 139—Installing Transmission Cover**

**(3) Install transmission cover**

Inspect transmission to see that no foreign material is in case and perform the following operations with utmost cleanliness:

(a) Line up three sliding gears making sure gears are placed in neutral position. See Fig. 139. Place shift lever in neutral position. When shift lever is in neutral position, shift forks and shift lug will be in a straight line opposite each other.

(b) Place gasket on top of transmission and install cover, making sure two shifting forks engage collars on sliding gears. First and reverse rocker arm must also engage rocker lug which is fitted to left-hand shift rail in cover.

(c) Install eight bolts which attach cover to transmission, placing engine ground strap under head of forward left-hand bolt. Check shift lever operation in all positions. If lever does not work properly, remove cover and investigate source of trouble.

**(4) Attach winch drive shaft to power take-off**

Start yoke over power take-off output shaft and slide forward into position. Tighten set screw in yoke and place snap ring in groove in shaft splines.

**(5) Install parts accessible from driver's compartment**

(a) Connect Hydrovac vacuum lines at right of clutch housing with hose provided and tighten hose clamp bolts.

(b) Attach starter button rod to cross shaft using cotter and clevis pin.

(c) Place accelerator control rod in bell crank at end of starter cross shaft and insert new cotter pin.

**TRUCK, AMPHIBIAN, 2 1/2 -TON, 6 x 6**

- (6) **Install transmission to transfer case propeller shaft**  
Loosen slip joint dust cap and install propeller shaft between flanges on transmission and transfer case, install and tighten four bolts and nuts at flanges.
- (7) **Install water propeller control lever, cross shaft and brackets**  
Place right hand bracket over studs on transmission and secure to transmission with nut on rear stud only. Install left-hand bracket, cross shaft and lever as an assembly and attach to transmission with winch control lever to transmission stud. Install hair pin lock at right end of shaft. Attach power plant stabilizer rod to left-hand bracket and adjust as directed in Para. 277. Install winch control lever over stud and attach to power take-off with cotter and clevis pin. Connect water propeller control rods to cross shaft lever using cotter and clevis pins.
- (8) **Install hand brake lever assembly**  
Place hand brake lever assembly over stud on transmission and install bolt in upper rear hole in left side and two bolts and one nut on right side of transmission. Connect hand brake control rod to cross shaft lever using cotter and clevis pin.
- (9) **Install clutch and brake pedal and support**  
Attach support and brake pedal to transmission and clutch housing using two bolts at transmission and two bolts at clutch housing. Slide clutch pedal over end of shaft and install hair pin lock. Connect clutch and brake pedal controls rods to pedals using cotter and clevis pins. Connect brake pedal pull-back spring between pedal and extension from water propeller transfer case support.
- (10) **Install power take-off support**  
Bolt power take-off support to power take-off and transmission using two bolts at each end of support.
- (11) **Connect tire pump**  
Attach tire pump support to water propeller control cross shaft bracket and adjust chain as directed in Para. 290.
- (12) **Connect exhaust pipe**  
Be sure new gasket and gasket flange between exhaust pipe flange and manifold are in place and install three bolts and nuts which attach flange to manifold.
- (13) **Connect accessories on left hand side of engine**  
The following items are accessible from engine hatch opening:
- (a) Place thermal unit of water temperature gauge in opening in cylinder head and tighten retaining nut securely.
  - (b) Connect windshield wiper hose to intake manifold tube.
  - (c) Refer to wiring diagram in Section XVIII and connect generator and regulator wire at junction block.
  - (d) Connect horn wire to horn.



## ENGINE

(e) Connect oil gauge flexible line at toe board using two wrenches to prevent twisting of line.

(f) Connect throttle and choke cables at carbureter.

**(14) Connect accessories on right side of engine**

(a) Place ammeter and condenser wires and battery cable over starting switch terminal stud and install lockwasher and nut.

(b) Attach fuel filter to frame bracket using two bolts, connect lines running to and from filter and tighten flange nuts securely.

**(15) Install radiator shroud and connections**

Attach fan to pulley using four bolts and lockwashers. Connect upper and lower radiator hoses to engine and radiator and tighten hose clamp bolts. Install drain cocks and fill cooling system with water or anti-freeze and see that all connections are tight and free from leaks. Attach lower radiator shroud section to radiator side support, then install upper section and bolt the two sections together.

**(16) Check radio interference noise suppression connections**

Refer to Para. 172 and make sure that all items of radio noise suppression are installed.

### 184. OIL PAN REPLACEMENT

a. Purpose of oil pan is to act as a reservoir to hold and receive oil as it circulates and lubricates engine internally. It acts as a sump from which oil pump draws its oil to distribute and circulates through the engine. Baffle plates are provided at fixed points to prevent surge of oil. Oil enters oil pump through a covered basket-shaped fine-mesh screen. Screen is covered by an inverted cup which prevents surge of

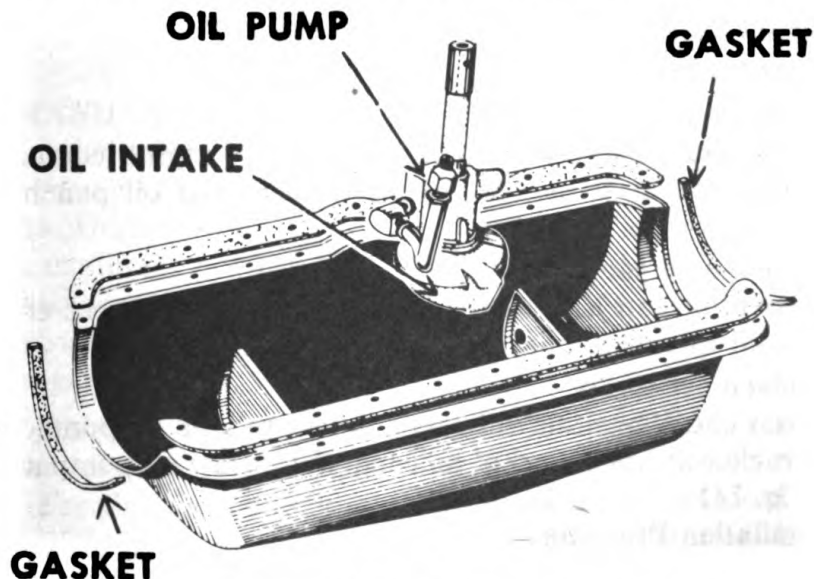

Figure 140—Oil Pan and Components

**TRUCK, AMPHIBIAN, 2½-TON, 6 x 6**

oil exposing suction tube to air. Whenever oil pan is removed for cleaning purposes, oil intake screen should also be removed and cleaned.

**b. Removal Procedure (Fig. 140)****(1) Remove engine assembly**

Remove power plant as directed in Para. 183.

**(2) Remove oil pan screws**

Make certain that oil pan is thoroughly drained of oil before removing oil pan attaching screws. Remove oil pan attaching screws and pull oil pan from crankcase. Oil intake screen may be readily removed for cleaning purposes by detaching retaining wire from cover. Clean inside of oil pan thoroughly and scrape off all gaskets from crankcase and oil pan. Do not overlook oil pan gaskets which are retained in front, and rear main bearing cap.

**b. Installation Procedures****(1) Install gaskets**

Use a small amount of shellac to hold gaskets securely on under side of block. Do not place gasket directly on oil pan. Install side gaskets first, then install end pieces of cork in groove of bearing caps (Fig. 140).

**(2) Install oil pan**

Place oil pan in position and insert a few screws to hold pan in place. Insert and tighten remainder of screws. Make certain that oil pan is placed on crankcase squarely and that all screws are thoroughly tightened.

**185. OIL PUMP REPLACEMENT**

**a.** The oil pump is a gear type pump and is mounted in the left-hand side of engine and is accessible for servicing (screen) and replacement only after the oil pan is removed.

**b. Removal Procedure****(1) Remove engine**

Engine assembly must be removed from engine compartment hatch as directed in Para. 183. Make certain that oil pan has been completely drained of oil.

**(2) Remove oil pan**

Remove oil pan as directed in Para. 184. Disconnect crankcase main oil line at crankcase as shown in Fig. 141.

**(3) Loosen set screw**

Loosen check nut and set screw which retains oil pump housing to bracket at upper end of housing. Withdraw oil pump as shown in Fig. 141.

**c. Installation Procedure****(1) Inspect oil intake screen**

Before installing oil pump assembly, make certain that mesh



## ENGINE

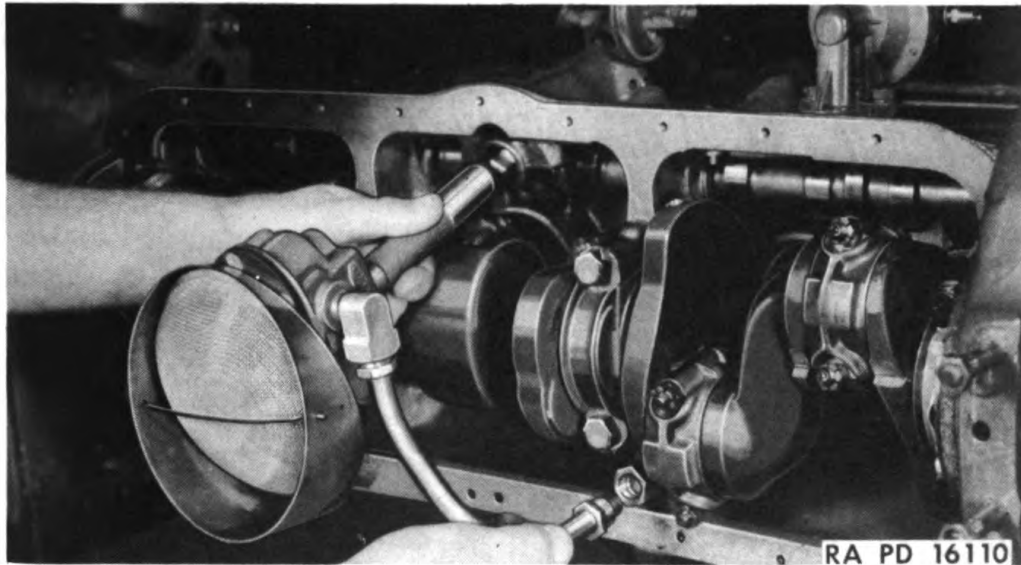

**Figure 141—Remove Oil Pump and Oil Line as an Assembly**

intake screen is thoroughly cleaned. Screen may be readily removed by detaching retaining wire on cover and withdrawing.

(2) **Install oil pump assembly**

Install oil pump assembly in place as shown in Fig. 141. Do not tighten set screw excessively, as this may cause distributor shaft to bind. Make certain set screw lock nut is tight. Install oil pan as directed in Para. 184.

(5) **Install engine assembly**

Install engine assembly into chassis as directed in Para. 183. Fill crankcase with proper lubricant as indicated in Section VI, "Lubrication." Check oil level at dip stick and if all connections are made, test oil pressure at gauge with engine running.

## 186. MANIFOLD REPLACEMENT

a. Intake and exhaust manifolds are each a one-piece casting and are mounted on the cylinder head with pilot rings, gaskets, studs, and nuts which provide a uniform assembly attachment group. The exhaust manifold provides a channel through which the residue gases and excess heat are carried away from the engine. The intake manifold provides, and acts as a mode of heating and feeding the vaporized fuel to the engine.

b. **Manifold Heat Control Valve.** The most important adjustments in connection with maintaining proper manifold temperatures consist of setting the manifold heat control valve for seasonal operation. The manifold heat control valve as shown in Fig. 142 consists of a lever and butterfly valve located in exhaust manifold. This butterfly valve directs and controls the volume of hot exhaust gases through the heat

## TRUCK, AMPHIBIAN, 2½-TON, 6 x 6

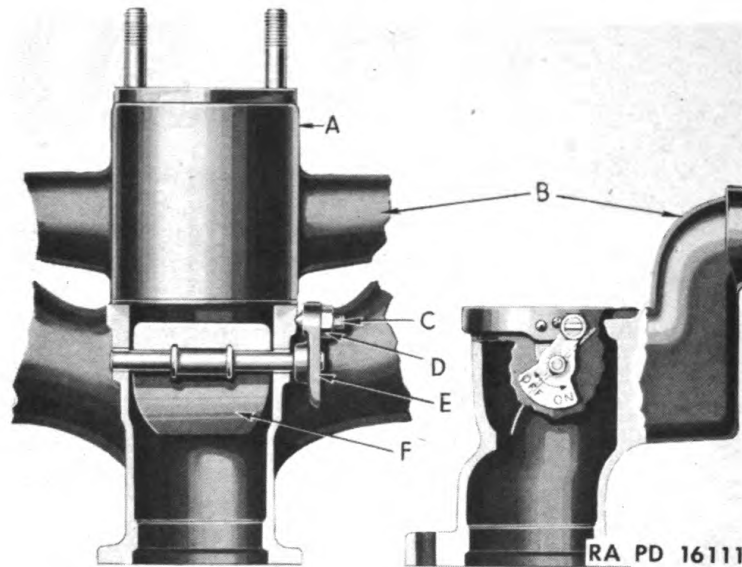

**Figure 142—Manifold Heat Control**

<b>A</b>	<b>Intake Manifold</b>	<b>D</b>	<b>Lock Nut</b>
<b>B</b>	<b>Exhaust Manifold</b>	<b>E</b>	<b>Lever</b>
<b>C</b>	<b>Slot Headed Screw</b>	<b>F</b>	<b>Valve</b>

chamber of the intake manifold; thereby aids in fuel vaporization for maximum economy.

**c. Manifold Heat Control Adjustments (Fig. 142).** During normal operation in cold weather, valve should be open in "ON" position. Operations during cold weather with heavy loads, at high speeds, or on rough terrain, valve should be in "MEDIUM" position. This position should also be used during mild weather operation with small loads and low speeds. For warm weather, or during mild weather with heavy loads at high speeds, valve should be closed in "OFF" position. Adjust in following manner:

(1) Loosen lock nut. Loosen set screw. Move lever to desired position. Tighten screw into recess in manifold and tighten lock nut.

**e. Manifold Removal Procedure.** The intake and exhaust manifolds are removed as a unit, after component parts have been disconnected.

(1) Remove air cleaner from top of carbureter.

(2) Disconnect hand throttle rod, accelerator throttle rod, and choke rod. Disconnect crankcase ventilator tube from valve rocker arm pan. Disconnect crankcase ventilator tube from crankcase ventilator valve adapter. Unscrew ventilator valve from intake manifold valve adapter.

(3) Disconnect vacuum brake line from intake manifold adapter. Remove adapter from intake manifold. Remove 3 bolt nuts from exhaust pipe flange to exhaust manifold.



## ENGINE

(4) Remove eight hex. nuts, four manifold washers, and four manifold clamps. Remove three pilot rings out of cylinder head block intake parts. Remove two nuts from studs that extend through flanges extending out on engine side of intake manifold.

(5) Remove two cap screws extending from bottom of butterfly chamber of exhaust manifold through exhaust manifold and anchor in bottom of intake manifold fuel chamber. Separate exhaust and intake manifolds. Clean and inspect.

(6) Remove all gaskets from cylinder head ports, between exhaust manifold and heat chamber of intake manifold, also clean pilot rings and scrape carbon out of pilot ring seats.

### f. Manifold Installation Procedure

(1) Install new gaskets and assemble intake and exhaust manifolds (2 cap screws and 2 stud nuts). Install pilot rings in intake ports of cylinder head and install new gaskets. Carefully lift manifold assembly into place and install the four manifold washers and nuts hand tight and proceed to install manifold clamps and stud nuts. Tighten all manifold stud nuts in a uniform manner to avoid leaks and heat distortion.

(2) Install inside sleeve and gasket between exhaust pipe flange and exhaust manifold. Couple exhaust manifold and exhaust pipe flange with three bolts and nuts tightened in uniform manner. Install adapter at intake manifold.

(3) Connect vacuum brake line to intake manifold adapter. Screw ventilator valve to intake manifold adapter. Connect crankcase ventilator tube to ventilator valve adapter. Connect ventilator tube to valve rocker arm pan.

(4) Connect choke rod, accelerator rod, hand throttle rod. Install air cleaner. Check all stud nuts and line connections.

## 187. CRANKCASE VENTILATION MAINTENANCE

a. Ventilation of the crankcase and removal of fuel and water vapors within crankcase are accomplished by circulation of air actuated by vacuum. Air is drawn into crankcase breather filter at oil filler tube and after circulating through engine, is drawn upward and out of the engine through valve rocker arm cover by the intake manifold vacuum. The manifold vacuum tube is connected to a fitting at center of intake manifold and contains a spring loaded plunger type valve which acts as a restriction for vapor flow (Fig. 143).

b. Under normal operating conditions, the tube and restriction valve unit of the crankcase ventilating system should be disconnected and thoroughly cleaned, intervals depending upon type of service. The breather, which cleans the air by filtering of dust and dirt particles, requires more frequent attention. This is an oil bath type which should be serviced at the same intervals as carburetor air cleaner.

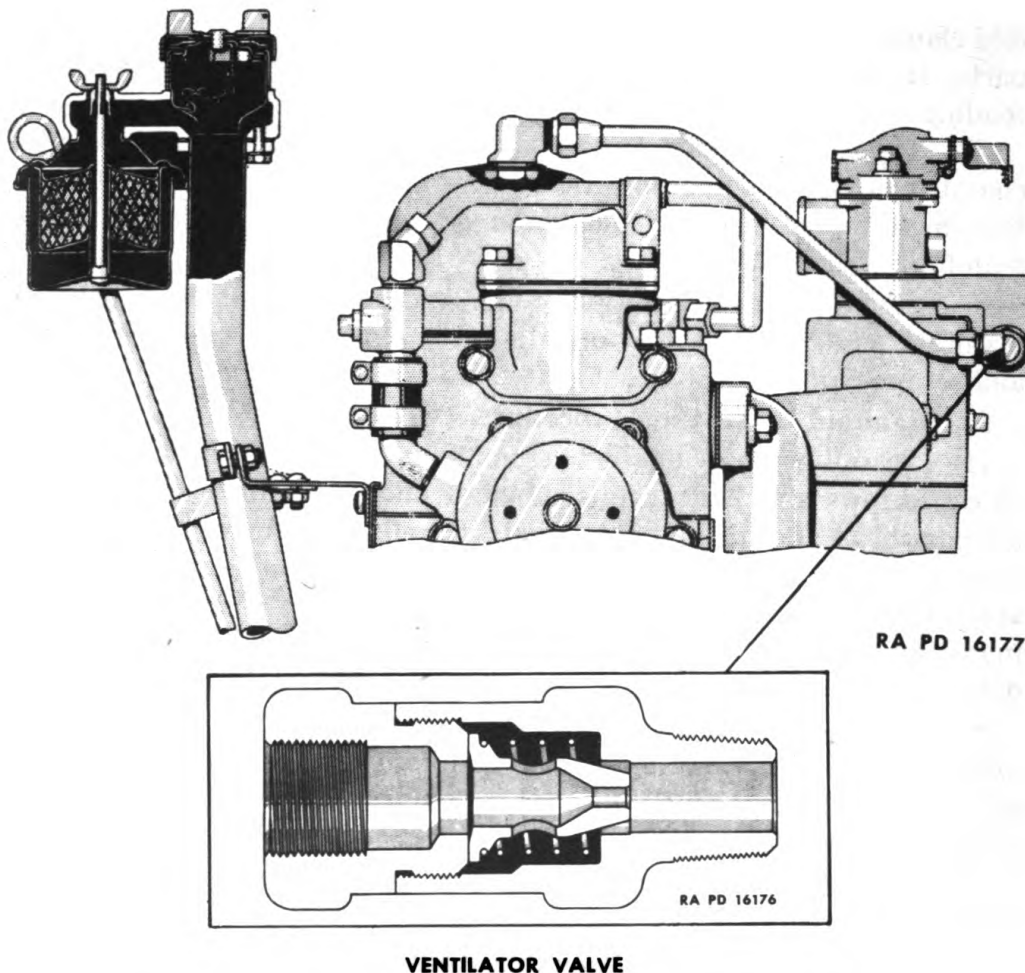
**TRUCK, AMPHIBIAN, 2½-TON, 6 x 6****VENTILATOR VALVE****Figure 143—Crankcase Ventilator Installation****c. Crankcase Ventilating Tube and Valve Service**

(1) Disconnect tube at valve rocker arms cover fitting and at valve adapter. Remove valve from manifold adapter. Disassemble valve, clean thoroughly with suitable cleaning fluid, and dry with compressed air.

(2) Install valve in manifold adapter. Connect tube to valve. Connect tube to valve rocker arm cover and tighten all connections.

**d. Crankcase Breather Service (Fig. 144)**

(1) Remove wing nut from side of breather adapter at crankcase oil filler tube. Remove filter element from breather.

(2) Wash filter element with suitable cleaning fluid until all foreign matter has been removed. Clean oil reservoir thoroughly by washing in suitable cleaning fluid until it is thoroughly cleaned. Wipe reservoir dry with a clean cloth and fill to "oil level" with engine oil as directed in Section VI, "Lubrication."



**ENGINE**



**Figure 144—Cleaning Breather Cleaner**

(3) Blow filter element dry with compressed air. Do not use extremely high air pressure, as mesh will become compressed and filter element will be unsatisfactory for further use. Dip filter element in engine oil (See Section VI, "Lubrication") and allow surplus to drain out. Reinstall breather adapter and tighten wing nut securely.

Section XXV

**EXHAUST SYSTEM**

	<b>Paragraph</b>
General description .....	188
Trouble-shooting .....	189
Inspection and preventive maintenance .....	190
Replacement of component parts .....	191

**188. DESCRIPTION**

a. Exhaust system is designed primarily to carry exhaust fumes from engine through muffler, which is designed to deaden engine combustion noise, and from muffler through tail pipe to carry all fumes outside and away from vehicle. Exhaust pipe is attached to engine manifold, with gasket and seal clamp, and extends into muffler mounted in the front bow compartment. Muffler tail pipe extends through right-hand air outlet tunnel and exhausts outside to right of air outlet grille. Purpose of this mounting is to provide cooling of muffler and piping by air exhausted from engine compartment.

**189. TROUBLE-SHOOTING**

a. Operator can readily detect any trouble in exhaust system by any unusual noise in hull bow compartment or engine compartment, by unusual loud combustion sound, or by odor of exhaust fumes. **Carbon monoxide gas, carried in the exhaust fumes from any gasoline motor, is odorless and tasteless and the only warning operator has of its possible presence is the odor of exhaust fumes, however, this warning is not always given. At the first evidence of exhaust fumes, immediate inspection of all parts of system should be made.**

**b. Table**

Symptom and Probable Cause	Probable Remedy	Refer to Paragraph
<b>(1) Exhaust fume odor</b>		
(a) Muffler blown or leaking	Replace muffler .....	191
(b) Exhaust pipe connections leaking	Tighten connections ....	191
(c) Manifold leaking	Tighten or replace.....	191
<b>(2) Excessive combustion noise</b>		
(a) Muffler blown	Replace muffler .....	191
(b) Exhaust pipe connections loose	Tighten connections ....	191
(c) Manifold loose or gasket blown	Tighten or replace.....	191
<b>(3) Parts rattling</b>		
(a) Muffler mountings loose	Tighten support straps..	191

**EXHAUST SYSTEM**

Symptom and Probable Cause	Probable Remedy	Refer to Paragraph
(b) Exhaust pipe connections loose	Tighten all attaching parts . . . . .	191

**190. PREVENTIVE MAINTENANCE AND INSPECTION**

a. Daily and periodic inspection and preventive maintenance periods, as outlined in Section V, "Inspection and Preventive Maintenance," should be followed.

b. Before any inspection or maintenance is accomplished on the exhaust system, bow compartment and engine compartment hatches should be raised and compartments thoroughly ventilated.

c. Daily inspection should be made of condition of muffler in front bow compartment, and muffler clamp tightened if necessary.

d. At periodic intervals, inspection should be made of exhaust pipe to manifold connections at engine. If gasket or seals show any signs of leaks, new parts should be installed.

e. Inspection should be made of exhaust pipe and muffler, particularly after any extended water operations. If any of the pipes or muffler show signs of corrosion or rust, these parts should be immediately replaced.

f. **CAUTION:** Engine should not be run while mechanic is in bow compartment. After new parts have been replaced in exhaust system, a check should be made of all flange and mounting bolts after engine has been run for a few minutes. Bow compartment should be aired before this check is made.

**191. REPLACEMENT OF COMPONENT PARTS (Fig. 145)**

a. Exhaust system consists of five distinct units—exhaust tail pipe shield assembly, muffler to tail pipe shield pipe, muffler assembly, bulkhead seal to muffler pipe, and exhaust manifold to bulkhead seal pipe. Any one of these five component parts may be removed or installed separately.

**b. Removal Procedure**

**(1) Open bow and engine compartment hatches**

Open bow and engine compartment hatches and allow time for thorough ventilation before entering.

**(2) Remove exhaust tail pipe shield assembly**

The exhaust tail pipe shield assembly is designed to protect operator from accidental contact with hot exhaust pipe and is located at right-hand air outlet. Remove by withdrawing 4 screws which attach shield to hull.

**(3) Remove tail pipe**

Remove 2 nuts and lockwashers from bolts holding flange

TRUCK, AMPHIBIAN, 2 1/2-TON, 6 x 6

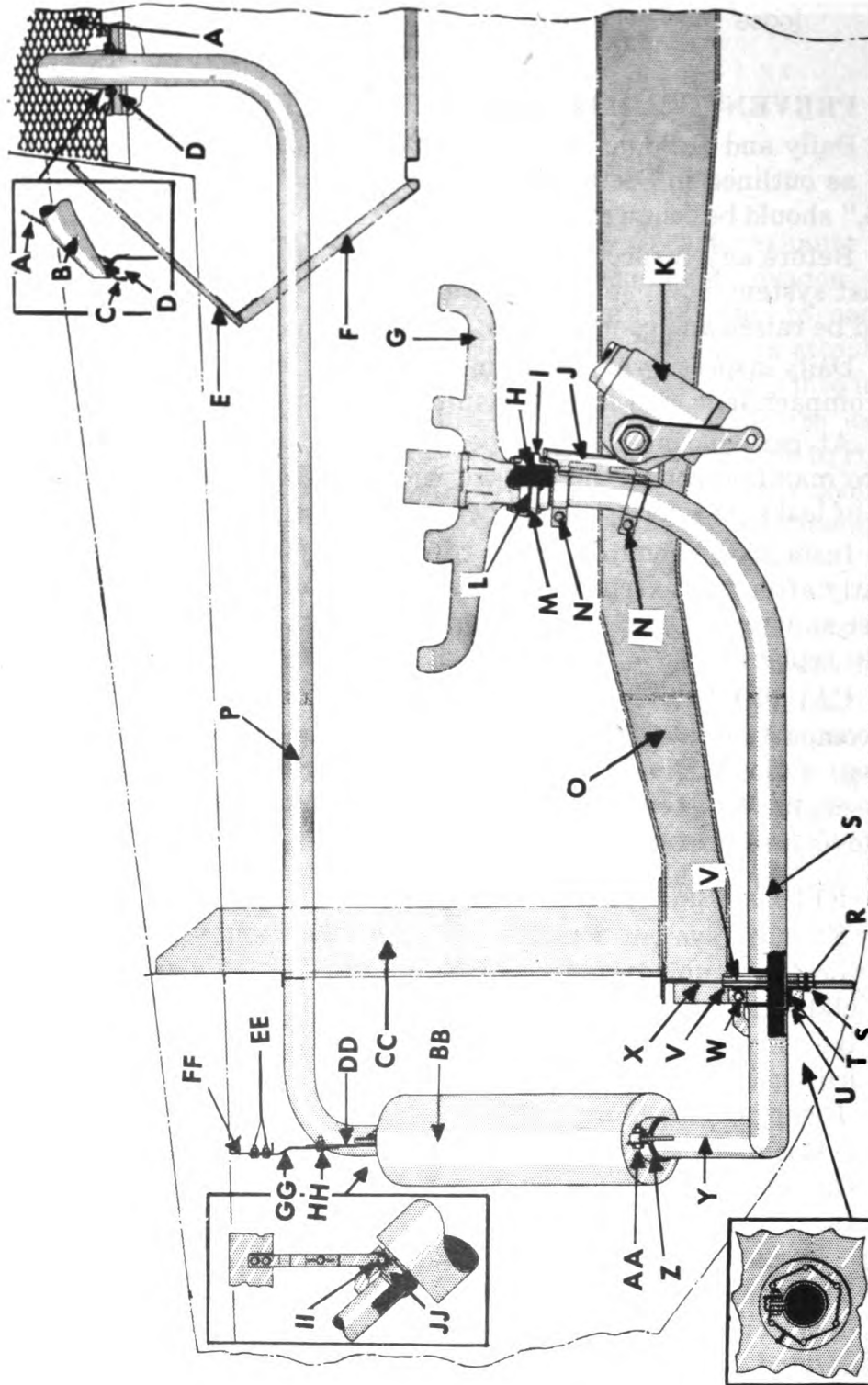

Figure 145—Exhaust System Installation (Captions on page 261)



**EXHAUST SYSTEM***(Captions for Fig. 145.)*

<b>A</b>	<b>Air Exhaust Grille</b>	<b>S</b>	<b>Bulkhead Seal Bolt</b>
<b>B</b>	<b>Outlet End, Exhaust Tail Pipe</b>	<b>T</b>	<b>Exhaust Pipe Clamp</b>
<b>C</b>	<b>Surf Coaming</b>	<b>U</b>	<b>Bulkhead Seal Flange</b>
<b>D</b>	<b>Exhaust Tail Pipe to Coaming Bolt</b>	<b>V</b>	<b>Seal Anti-Squeak</b>
<b>E</b>	<b>Upper Toe Board</b>	<b>W</b>	<b>Exhaust Pipe Clamp Bolt</b>
<b>F</b>	<b>Lower Toe Board</b>	<b>X</b>	<b>Bow Compartment Bulkhead</b>
<b>G</b>	<b>Exhaust Manifold</b>	<b>Y</b>	<b>Bulkhead Seal to Muffler Exhaust Pipe</b>
<b>H</b>	<b>Exhaust Pipe Sleeve</b>	<b>Z</b>	<b>Exhaust Pipe to Muffler Clamp</b>
<b>I</b>	<b>Exhaust Pipe Flange</b>	<b>AA</b>	<b>Clamp Bolt</b>
<b>J</b>	<b>Steering Gear Heat Shield</b>	<b>BB</b>	<b>Muffler</b>
<b>K</b>	<b>Steering Gear Housing</b>	<b>CC</b>	<b>Radiator Side Supports</b>
<b>L</b>	<b>Exhaust Pipe Gasket</b>	<b>DD</b>	<b>Muffler Lower Support Strap</b>
<b>M</b>	<b>Flange Seal</b>	<b>EE</b>	<b>Upper Strap to Deck Channel Bolt</b>
<b>N</b>	<b>Heat Shield Clamp and Bolt</b>	<b>FF</b>	<b>Deck Support Channel</b>
<b>O</b>	<b>Frame Side Rail</b>	<b>GG</b>	<b>Muffler Upper Support Strap</b>
<b>P</b>	<b>Exhaust Tail Pipe</b>	<b>HH</b>	<b>Upper to Lower Support Strap Bolt</b>
<b>Q</b>	<b>Manifold to Bulkhead Exhaust Pipe</b>	<b>II</b>	<b>Clamp Bolt</b>
<b>R</b>	<b>Bulkhead Seal Plate</b>	<b>JJ</b>	<b>Exhaust Tail Pipe to Muffler Clamp</b>

welded on tail pipe, to coaming. Inside bow compartment, remove tail pipe to muffler, clamp, bolt nut and lockwasher. Tail pipe can now be removed by first withdrawing exhaust end of pipe from outlet opening in hull, into bow compartment.

**(4) Remove muffler**

While in bow compartment, remove muffler to exhaust pipe clamp bolt, washer and nut. Remove muffler lower support strap to muffler upper support strap bolt, nut and lockwasher. Remove muffler to tail pipe clamp, bolt, nut and washer. Muffler can then be withdrawn from bow compartment.

**(5) Remove bulkhead to muffler exhaust pipe**

Remove exhaust pipe to bulkhead seal flange clamp which is held in place with bolt, nut and washer. Remove muffler to exhaust pipe clamp held by bolt, nut and lockwasher. This exhaust pipe can now be withdrawn through bow compartment cover.

**(6) Remove exhaust pipe shield**

The exhaust pipe shield is attached to exhaust pipe at left of steering column with two clamp bolts, nuts and washers, and must be removed before engine to bulkhead exhaust pipe can be removed.

**(7) Remove engine to bulkhead seal pipe**

To gain access to these parts, it is necessary to enter engine compartment on left-hand side of engine. Remove 3 exhaust pipe to manifold flange bolts, nuts and lock nuts. When this flange is loosened, flange gasket and seal may be removed. Remove lock wire and 6 nuts from exhaust pipe to bulkhead seal assembly. Exhaust pipe can now be removed through engine compartment hatch.

**c. Installation Procedure****(1) Replace engine to bulkhead seal pipe**

After ventilating engine compartment, enter through engine compartment hatch. Place flange gasket and seal in exhaust

**TRUCK, AMPHIBIAN, 2 1/2-TON, 6 x 6**

manifold and attach pipe to exhaust manifold with three flange bolts, nuts and lock nuts. Attach pipe to bulkhead seal assembly with 6 nuts and wire lock with new wire.

**(2) Replace exhaust pipe shield**

Attach exhaust pipe shield to exhaust pipe at left of steering column with 2 clamp bolts, nuts and washers.

**(3) Replace bulkhead to muffler exhaust pipe**

Ventilate bulkhead compartment before entering. Attach pipe to bulkhead seal with seal flange clamp, clamp bolt nut and washer. Attach to muffler with muffler to exhaust pipe clamp, clamp bolt nut and washer.

**(4) Replace muffler**

Attach muffler to exhaust pipe with bulkhead seal to muffler clamp, bolt, nut and washer. Attach muffler to tail pipe with tail pipe to muffler clamp, bolt nut and washer. Replace muffler lower strap to muffler upper support strap bolt, nut and lock-washer.

**(5) Replace exhaust tail pipe**

Insert exhaust end of tail pipe through opening in hull located in right side of hull just below air outlet grille opening. Hold in position by partially tightening 2 nuts and washers on tail pipe to coaming flange. Attach to muffler with tail pipe to muffler clamp, bolt nut and washer. Tighten 2 nuts in tail pipe to coaming flange.

Section XXVI

**FRAME**

	Paragraph
General description .....	192
Maintenance of frame.....	193

**192. GENERAL DESCRIPTION**

a. The frame is the structural center of the vehicle—for, in addition to carrying load, it furnishes support for the hull, power plant and drive system and undercarriage.

b. Frame, similar in most respects to frame of a conventional truck, consists of two longitudinal channel side rails connected by crossmembers. Crossmembers which support transfer cases are bolted to facilitate transfer case replacement. However, all other crossmembers are riveted to side rails.

**193. MAINTENANCE OF FRAME**

a. Due to the design of frame and its location inside hull, very little service attention is required on frame proper. However, it is important that bolts and nuts which attach frame to hull structure and spring suspensions be inspected and tightened regularly.

b. **Spring Suspension Mounting Bolts.** Bolts and nuts which attach brackets and shackles of front spring and rear axle trunnion bracket assembly and reinforcing plates to frame pass through hull. Consequently caulking compound must be used around bolts to prevent leakage during water operation. Heads of bolts are accessible from inside of hull, and nuts are accessible from wheelhouses on outside of vehicle.

c. **Frame to Hull Mounting Bolts.** Frame is bolted to inside of hull at the following points: bow compartment bulkhead at extreme front end of frame; front end of cargo compartment floor supports at midship section of frame; and, rear end of cargo compartment floor supports at rear of frame.

**Section XXVII**  
**FUEL SYSTEM**

	<b>Paragraph</b>
Description.....	194
Operation of system.....	195
Trouble-shooting.....	196
Preventive maintenance and inspection.....	197
Fuel leaks.....	198
Air cleaner service.....	199
Fuel filter service.....	200
Fuel pump service.....	201
Fuel pump replacement.....	202
Carbureter adjustments.....	203
Carbureter replacement.....	204
Governor replacement.....	205
Control linkage replacement.....	206
Fuel tank replacement.....	207
Fuel line replacement.....	208

**194. DESCRIPTION**

**a. General.** Fuel system on this vehicle comprises fuel tank, interconnecting lines, fuel filter, fuel pump, carbureter, governor, air cleaner, and control linkage. In addition to these units, an electrically controlled fuel gauge system is provided. Reference should be made to Section XXIII, "Electrical Accessories," for replacement of fuel gauge units. All units of fuel system with the exception of fuel tank and lines are accessible through engine compartment after hatch cover has been opened. Accessibility of fuel tank is through stern compartment hatch cover.

**195. OPERATION**

**a. Fuel Supply.** Fuel supply, stored in fuel tank, is drawn through fuel filter by action of fuel pump mounted at engine. Fuel pump forces fuel, as required, into carbureter where it is properly mixed with air to provide correct fuel vapors at varying speeds.

**b. Air Intake.** Air passes into carbureter through an oil-bath type air cleaner mounted on carbureter.

**196. TROUBLE-SHOOTING**

**a.** Many symptoms which might indicate fuel system trouble are in reality due to faulty ignition. Before making any extensive adjustments or repairs on fuel system, the ignition system should be thoroughly checked. Reference should be made to Para. 142.



**FUEL SYSTEM**

Symptom and Probable Cause	Probable Remedy	Refer to Paragraph
<b>(1) Excessive fuel consumption</b>		
(a) Dirty air cleaner.	Service air cleaner. . . . .	199
(b) Improper carbureter adjustment.	Adjust idler screw. . . . .	203
	Adjust choke control. . . . .	203
	Internal—Replace. . . . .	204
(c) Fuel leaks in fuel lines.	Tighten connections. . . . .	198
	Replace lines. . . . .	208
(d) Fuel leak at carbureter.	Tighten cover to body screws.	No Reference
(e) Fuel leak at fuel pump.	Tighten knurled nut at top of fuel bowl. . . . .	
(f) Fuel leaks at fuel filter.	Replace bowl gasket. . . . .	201
	Tighten cover bolt at top of filter. . . . .	200
	Tighten drain plug. . . . .	200
	Replace bowl to cover gasket.	200
	Ventilate compartment. . . . .	198
(g) Fuel leak in fuel tank.	Replace tank. . . . .	207
	Ventilate compartment. . . . .	198
(h) Engine not properly timed.	Check timing. . . . .	145
(i) Improper engine temperature.	Check cooling system. . . . .	116
(j) Vehicle overloaded.	Load to rated capacity. . . . .	7
(k) Tire under-inflated.	Inflate to proper pressure. . . . .	288
(l) Brakes dragging.	Adjust brakes. . . . .	94
(m) Controls frozen.	Free up and lubricate choke and throttle valve shafts and accelerator linkage. . . . .	206
	Replace carbureter. . . . .	204
(n) Carbureter parts worn.	Replace carbureter. . . . .	204
<b>(2) Fast idling</b>		
(a) Improper throttle control adjustment.	Adjust control wire at carbureter. . . . .	203
	Adjust control wire housing clamp at carbureter. . . . .	203
(b) Throttle control frozen.	Free up and lubricate throttle control linkage. . . . .	206
(c) Improper return spring.	Replace accelerator return spring. . . . .	206
<b>(3) Engine will not idle</b>		
(a) Throttle plate closing too far.	Adjust throttle stop screw. . . . .	203

**TRUCK, AMPHIBIAN, 2 1/2-TON, 6 x 6**

Symptom and Probable Cause	Probable Remedy	Refer to Paragraph
(b) Improper fuel mixture.	Adjust idling screw . . . . .	203
<b>(4) Low fuel pressure</b>		
(a) Air leaks.	Tighten all fuel line connections . . . . .	208
	Tighten fuel pump bowl knurled nut . . . . .	201
	Tighten fuel filter cover bolt.	200
(b) Fuel pump diaphragm broken.	Replace fuel pump . . . . .	202
(c) Fuel pump valves leaking.	Replace pump . . . . .	202
(d) Fuel pump linkage worn.	Replace pump . . . . .	202
<b>(5) Engine "stumbles" on acceleration</b>		
(a) Carbureter not properly functioning.	Replace carbureter . . . . .	204

**197. PREVENTIVE MAINTENANCE AND INSPECTION**

a. Reference should be made to pre-starting preventive maintenance procedures as described in Para. 14 and other preventive maintenance and inspection instructions as described in Section V, "Preventive Maintenance and Inspection."

b. One of the most important preventive maintenance operations is the daily checking of all fuel connections as well as servicing of fuel units such as fuel filter, pump and air cleaner at intervals indicated in Section V, "Preventive Maintenance and Inspection." Servicing instructions on these various fuel units are itemized in respective paragraphs of this section.

**198. FUEL LEAKS**

a. **Important: Fuel tank, lines, filter, fuel pump, and carbureter are located in enclosed compartments in the hull. Whenever leaks occur at any one of these units or fuel has been spilled into compartment, resultant vapors create a safety hazard. Maintenance of all fuel connections to prevent fuel leaks is extremely important. Careless spilling of any fuel into compartment must be avoided.**

b. **Ventilating Compartments. All compartments which contain any fuel units should be thoroughly ventilated, before and after operation. If fuel fumes are detected at any time, complete ventilation of compartment should be immediately made. Do not carry open flame into any compartments at any time.**

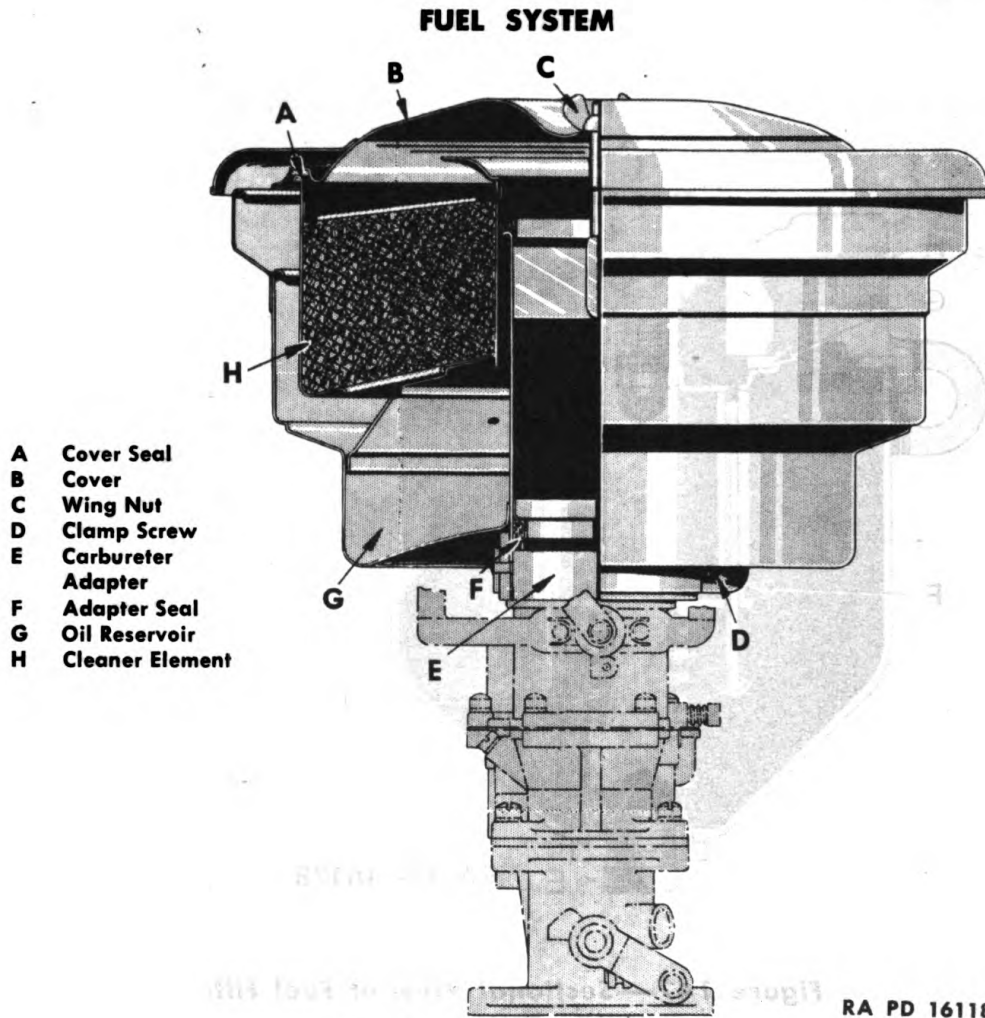

**Figure 146—Air Cleaner**

**199. AIR CLEANER SERVICE (Refer to Fig. 146)**

a. Oil bath air cleaner is mounted directly to top of carbureter and is designed to remove dust and dirt from entering carbureter. Air entering cleaner passes into oil chamber. Due to impact and sudden reversal of air flow, most all dirt in air is thrown into oil and settles into bottom of cleaner. Partially cleaned air passes through a dense oil wetted mesh where remaining dust is trapped. This dust and dirt is loaded with minute particles of abrasive which, if permitted to enter engine, cause rapid wear of moving parts, resulting in loss of power and increased oil and fuel consumption.

b. Importance of keeping air cleaner in proper condition should be impressed upon those responsible for mechanical upkeep of engine. Air cleaner must be cleaned at regular intervals. Under adverse conditions, after extensive operation on dusty or sandy terrain, unit should be cleaned every day. In event vehicle operates in dust storm areas, cleaner should be cleaned immediately after such storms occur.



## TRUCK, AMPHIBIAN, 2½-TON, 6 x 6

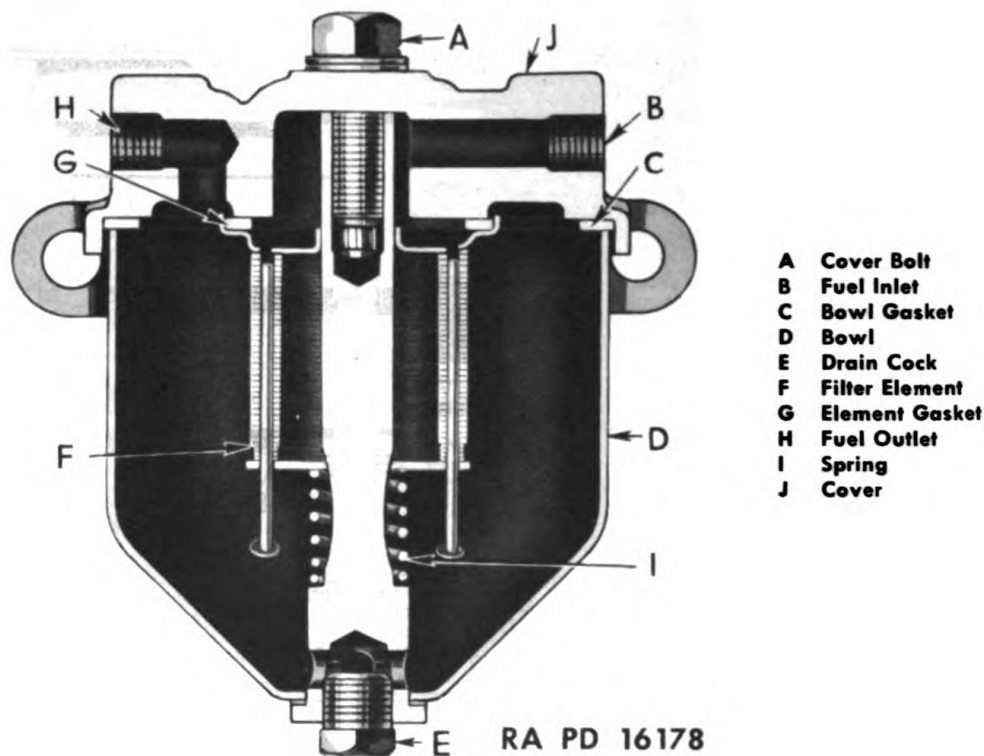

**Figure 147—Sectional View of Fuel Filter**

**c. Cleaning Procedure**

**(1) Remove air cleaner assembly**

Loosen clamp bolt which clamps throat of air cleaner to carbureter. Air cleaner assembly may then be lifted from top of carbureter. Remove wing nut at center of top cover so that cover can be taken off. Lift element from cleaner body.

**(2) Clean filter element**

Clean filter element thoroughly by flushing in a pan of suitable cleaning fluid. This operation should be repeated until all dirt has been removed. Blow filter dry and clean with air pressure. Do not use extremely high pressure, as mesh will become compressed and render vehicle unsatisfactory for further use. Dip element into clean engine oil and allow surplus to drain off. Wash reservoir in suitable cleaning fluid and wipe out with clean cloth.

**(3) Fill with oil and replace**

Fill to oil level stamped on inside of cleaner body, using oil as specified in Section VI, "Lubrication." Replace filter element into body of cleaner and install cover. Make sure that cork gasket in cover is in good condition and forms a seal. Install wing nut and tighten securely. Replace air cleaner assembly on carbureter.



## FUEL SYSTEM

Examine air cleaner to carburetor adapter seal in cleaner body and replace if damaged. Check adapter edge and make sure it is not distorted or bent, but will fit properly against seal when cleaner is placed over adapter. Press down on cleaner cover to compress adapter seal and hold unit while tightening clamp bolt.

### 200. FUEL FILTER SERVICE (Refer to Fig. 147)

a. Fuel filter is mounted on right-hand frame side rail between fuel tank and fuel pump and is accessible in engine compartment. Fuel filter should be serviced at regular intervals.

#### b. Procedure

##### (1) Remove and disassemble filter

Disconnect filter inlet and outlet lines by unscrewing flange nuts. Remove two filter mounting bolts. After cover bowl at top of filter is removed, cover may be withdrawn. Filter element and spring may then be stripped off of bowl stem. Remove drain plug from bowl stem.

##### (2) Clean and inspect

After disassembly, element should be thoroughly cleaned of all foreign matter. Use a reliable cleaning solution and be sure all particles are removed from between discs of element. Inspect gaskets for cuts and replace if necessary.

##### (3) Assemble and install fuel filter

Place element spring over stem in filter bowl, then element over stem in filter bowl, compressing spring. Assemble cover to bowl, making sure gaskets are in correct position. Install hex head cover bolt and tighten sufficiently to prevent filter leaking. Install drain plug and tighten securely. Place filter in position on mounting bracket and install two mounting bolts. Connect inlet and outlet fuel line connections. Tighten nuts securely.

### 201. FUEL PUMP SERVICE

a. Fuel pump, located at right-hand side of engine, is a diaphragm type mechanically operated from camshaft. In addition to camshaft operation while engine is running, pump is equipped with hand operated lever which may be used to pump an initial supply of fuel into carburetor in case vehicle has run out of fuel or carburetor bowl has been emptied for any reason.

b. **Servicing Fuel Pump.** At periodic intervals, fuel pump filter bowl should be removed and thoroughly cleaned of all sediment. This can be accomplished by unscrewing bowl clamp knurled nut at top of bowl. Filter bowl can then be withdrawn from pump and thoroughly cleaned. Filter screen should be replaced.

c. **Fuel Pump Test.** Fuel pump may be given capacity and pressure test to determine whether or not it is functioning properly. These two tests are separate and distinct from each other and must be made

**TRUCK, AMPHIBIAN, 2½-TON, 6 x 6**

with pump mounted on engine. Test should be made before pump is overhauled, or replace with another assembly to determine condition of unit.

**(1) Capacity test**

It is necessary in making this test, to determine only that sufficient amount of fuel is flowing. This may be accomplished by disconnecting fuel pump to carbureter line and attaching a suitable bleeder hose to fuel pump outlet so that fuel may be caught in a container. With outlet or bleeder hose at carbureter level or slightly higher, flow of fuel should be approximately one pint in not over one minute operation of engine at 2000 to 2500 rpm.

**(2) Pressure test**

Pressure test can be obtained with a standard fuel pump pressure gauge attached to outlet of fuel pump. Pressure should be 3¾ pounds maximum in lowest idling speed of engine.

(3) If tests do not show a pressure to exceed maximum (3¾ lbs.) and at least the minimum flow in capacity, fuel pump operation can be considered as normal.

**202. FUEL PUMP REPLACEMENT****a. Removal**

(1) Close shut-off cock at fuel filter and disconnect fuel pump fuel lines. Remove two bolts which attach fuel pump to bracket and remove assembly.

**b. Installation**

(1) Place fuel pump in position in engine. Install mounting studs, making sure hollow stud is in correct place for oil filter return line.

(2) Connect oil filter return line to mounting stud. Connect fuel pump inlet and outlet line. Open shut-off valve at fuel filter. After connections are made, make fuel pump tests as previously described.

**203. CARBURETER ADJUSTMENTS**

**a.** All fuel mixture adjustments, except idling, are determined by calibration of various jets and can only be changed by disassembling carbureter and installing different jets. Choke and hand throttle control adjustments at carbureter must be carefully maintained in order to obtain maximum engine performance.

**b. Idling Mixture Adjustment**

(1) Before adjusting idling mixture, warm up engine so that intake manifold is at least warm to the hand (120° F. or higher). Slow engine down to idling speed.

(2) Turn idling screw clockwise for richer mixture or counterclockwise for leaner mixture. Turn idling screw until engine runs smoothly. Regulation of idling mixture in no way affects function of carbureter at higher speeds.

## FUEL SYSTEM

### c. Idling Speed Adjustment

(1) Adjust idling speed at stop screw on throttle lever until desired speed is obtained.

### d. Choke Control Adjustment Procedure

#### (1) Adjust choke

Tighten choke wire lock nut, behind instrument panel. Loosen trunnion set screw at carburetor end of choke wire. Adjust choke button until there is  $\frac{1}{16}$ " clearance between button and instrument panel. Open carburetor choke valve (air shutter) to its fully opened position, that is, valve should be in a vertical position, then tighten trunnion set screw securely. Tighten wire housing clamp sufficiently to hold housing securely.

### e. Hand Throttle Control Adjustment Procedure

#### (1) Adjust hand throttle

Tighten throttle wire lock nut, behind instrument panel. Push in throttle button all the way. Loosen control wire stop collar set screw and adjust collar so there is  $\frac{1}{4}$ " clearance between lever and stop collar. Tighten collar set screw securely. Tighten wire housing clamp sufficiently to hold housing securely.

## 204. CARBURETER REPLACEMENT

### a. Removal Procedure

#### (1) Remove air cleaner

Remove air cleaner as described in Para. 199.

#### (2) Disconnect choke control and hand throttle

Loosen control wire clip screw at carburetor end of flexible housing and loosen carburetor choke lever swivel screw. Pull choke control wire from carburetor. Remove collar or stop at carburetor end of hand throttle control wire and loosen control wire clip screw. Remove throttle control wire from carburetor.

#### (3) Close shut-off cock and disconnect line

Close fuel line shut-off cock at fuel filter. Place suitable container below carburetor to catch fuel drainage and disconnect carburetor fuel line at carburetor by unscrewing flange nut. Remove 2 carburetor-to-intake-manifold stud nuts and lockwashers and remove carburetor from vehicle.

### b. Installation Procedure

#### (1) Install carburetor

Place carburetor in position over intake manifold studs and install 2 stud lockwashers and nuts. Place fuel pump to carburetor fuel line in position in carburetor fitting and install flange nut. Open shut-off cock at fuel filter.

#### (2) Attach hand throttle control.

Thread hand throttle control wire and flexible housing through throttle control wire clip at carburetor and install end of wire

**TRUCK, AMPHIBIAN, 2 1/2-TON, 6 x 6**

through hole in carbureter rod. Fasten end of flexible housing by tightening clip set screw securely. Place throttle control collar on end of wire and tighten set screw securely. For adjustment of hand throttle control, refer to Para. 203.

**(3) Attach choke control**

Thread choke control flexible housing and wire through control clip at carbureter and insert wire through swivel. Fasten end of flexible housing by tightening clip set screw securely. Tighten swivel set screw securely. For adjustment of choke control, refer to Para. 203. Install air cleaner as described in Para. 199.

**205. GOVERNOR REPLACEMENT****a. Removal Procedure****(1) Remove governor**

Remove carbureter as described in Para. 204. Lift governor off carbureter stud.

**b. Installation Procedure****(1) Install governor**

Install governor to manifold gasket over carbureter stud. Place governor over carbureter stud in such a manner that arrow indicating carbureter side is upward. Install governor to carbureter gasket over carbureter stud in such a position to allow vacuum to by-pass through governor for operation of carbureter power jet piston. Be sure this gasket is in good condition and that vacuum openings are not obstructed. Install carbureter and air cleaner as described in Paras. 199 and 204.

**206. CONTROL LINKAGE REPLACEMENT (Refer to Fig. 148)**

a. Instructions given here are for replacement of accelerator and control linkage, progressively beginning with accelerator pedal. However, these parts as well as choke and hand throttle controls may be replaced individually if so desired.

**b. Carbureter Choke Control Removal Procedure****(1) Remove choke control**

Follow instructions given in Para. 221.

**c. Hand Throttle Control Removal Procedure****(1) Remove throttle control**

Follow instructions given in Para. 221.

**d. Accelerator Control Removal Procedure****(1) Remove pedal**

Working in driver's compartment, remove cotter pin and clevis pin from pedal to toe board bracket. From under side of accelerator pedal remove cotter and washer from pedal to idler lever rod. Accelerator pedal can now be removed.



FUEL SYSTEM

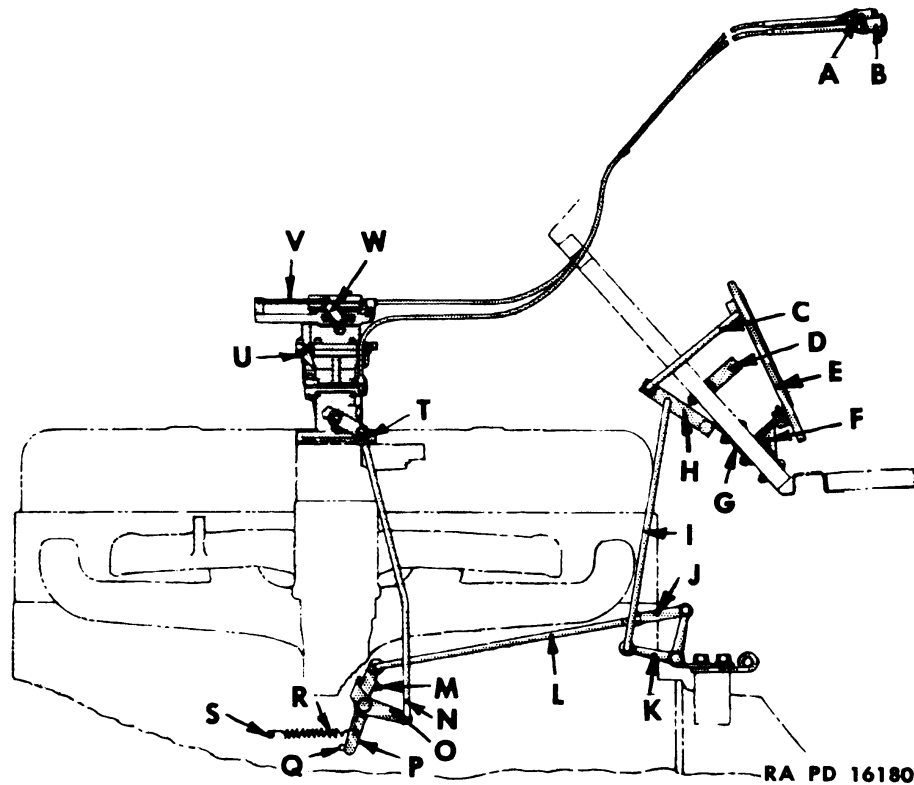

Figure 148—Accelerator, Throttle and Choke Control

- |   |  |   |  |
|---|--|---|--|
| A | Choke Control Button                                       | M | Carbureter Control Lever (cast) Adjusting Screw                                |
| B | Hand Throttle Control Button                               | N | Carbureter Control Lever to Carbureter Rod                                     |
| C | Accelerator Pedal to Idler Lever Rod                       | O | Carbureter Control Lever (formed)  |
| D | Accelerator Pedal Stop Bracket                             | P | Carbureter Control Lever (cast)  |
| E | Accelerator Pedal  | Q | Carbureter Control Lever (cast) Stop Pin                                       |
| F | Accelerator Pedal Bracket                                  | R | Return Spring (2 used) one attached to formed lever—one attached to cast lever |
| G | Idler Lever Bracket  | S | Return Spring Pin  |
| H | Idler Lever  | T | Hand Throttle Stop Collar  |
| I | Idler Lever to Bell Crank Rod                              | U | Carbureter   |
| J | Bell Crank to Carbureter Control Lever Rod Adjustable Yoke | V | Choke Control Return Spring  |
| K | Bell Crank   | W | Choke Control Trunnion Block   |
| L | Bell Crank to Carbureter Control Lever                     |   |  |

- (2) **Remove pedal to idler lever rod**  
In engine compartment, remove rod cotter pin and washer at idler lever and remove rod.
- (3) **Remove idler lever**  
Remove idler lever to bell crank rod cotter pin and washer at idler lever, then remove idler lever to bracket pin cotter pin and washer and remove idler lever.
- (4) **Remove accelerator pedal and idler lever brackets**  
On under side of toe board, remove three nuts and washers fastening idler lever bracket to toe board and remove bracket. In driver's compartment, remove pedal bracket by withdrawing bolts from toe board.

**TRUCK, AMPHIBIAN, 2 1/2-TON, 6 x 6**

- (5) **Remove idler lever to bell crank rod**  
Remove cotter pin and washer from end of rod at bell crank and remove rod.
- (6) **Remove bell crank**  
Remove bell crank to carbureter control lever rod adjustable yoke cotter and clevis pin at bell crank, then remove bell crank to bracket cotter pin, washer and clevis pin and remove bell crank.
- (7) **Remove bell crank to carbureter control lever rod**  
Remove cotter pin and washer from rod at carbureter control lever and remove rod.
- (8) **Remove carbureter control levers (at cylinder block)**  
Remove control lever outer (lighter) return spring from end of cast control lever. Then remove control lever inner (heavier) return spring from formed control lever. Remove cotter from lower end of control lever to carbureter rod and remove rod from formed control lever. Remove nut and washer from control lever mounting stud and remove both control levers.
- (9) **Remove carbureter control lever to carbureter rod**  
Loosen set screw in hand throttle control wire trunnion block and remove block from wire. Withdraw wire from end of rod and remove rod from carbureter lever.
- e. Accelerator Control Installation Procedure**
- (1) **Install carbureter control lever to carbureter rod**  
Install rod through control lever from engine side. Insert hand throttle control wire through end of rod and install trunnion block, tightening screw securely. Refer to Para. 203 for hand throttle adjustment.
- (2) **Install carbureter control levers (at cylinder block)**  
Place cast control lever in position in formed control lever with extension pointing downward. Assemble both levers to mounting stud and install plain washer, lockwasher and nut. Hook return spring over cylinder block pin, heavier spring on inside, then hook heavy spring into formed control lever and lighter spring into cast control lever. Adjust cast control lever adjusting screw to provide approximately 1/8" clearance between end of screw and formed lever. Tighten lock nut.
- (3) **Install bell crank to carbureter control lever rod**  
Insert bent end of rod through upper end of cast control lever and fasten with washer and cotter pin. Rod must not bind. Be sure it is installed so that it will work freely.
- (4) **Install bell crank**  
Install bell crank to left-hand side of bell crank bracket with clevis pin, washer and cotter pin. Do not attach carbureter control lever to bell crank rod, to bell crank at this time.

## FUEL SYSTEM

### (5) Install accelerator pedal and idler lever brackets

In driver's compartment, attach accelerator pedal bracket to toe board by inserting two bolts through bracket and through two lower bolt holes in toe board. Then insert third bolt with washer in upper bolt hole in toe board. In engine compartment install lockwasher and nut on lower bolt. Then place idler lever bracket in position on upper bolts and secure with two lockwashers and nuts.

### (6) Install idler lever

Assemble idler lever to left-hand side of idler lever bracket and secure with washer and cotter pin.

### (7) Install idler lever to bell crank rod

Position ends of rods in center hole of idler lever and in opening of lower arm of bell crank in such a manner that rod will work freely and not bind. End of rod to which washer is welded must be at bell crank.

### (8) Install accelerator pedal

In driver's compartment attach pedal to toe board bracket with pin, washer and cotter pin.

### (9) Install accelerator pedal to idler lever rod

Attach ends of rod to pedal and idler lever with washer and cotter pin at either end in such a manner that rod will travel through toe board freely.

### (10) Adjust bell crank to carbureter control lever rod yoke

With accelerator pedal at full throttle position (laying on stop bracket), open carbureter throttle to full throttle position by forcing lower end of cast carbureter control lever toward rear of vehicle, over-ruling return spring. With cast control lever in this position adjust rod adjustable yoke so pin holes in yoke line up with opening in end of upper arm of bell crank. Install clevis pin and cotter and tighten yoke lock nut.

## 207. FUEL TANK REPLACEMENT (Refer to Fig. 149)

### a. Fuel Tank Removal Procedure

(1) CAUTION: Before starting removal operation, fuel tank must be drained. This is accomplished by removing filler cap, opening drain cock in fuel tank drain holes, and removing drain hose coupling plug. Fuel should be drained into a suitable container.

### (2) Remove fuel tank

Remove spare wheel and tire hold-down clamp bolt nut, then raise clamp and lift off spare rim and tire. Remove stern deck plate according to instructions given in Para. 66. Disconnect wire at fuel tank gauge terminal, fuel line hose at top of fuel tank by loosening flange nut, and fuel tank drain hose by

TRUCK, AMPHIBIAN, 2 1/2-TON, 6 x 6

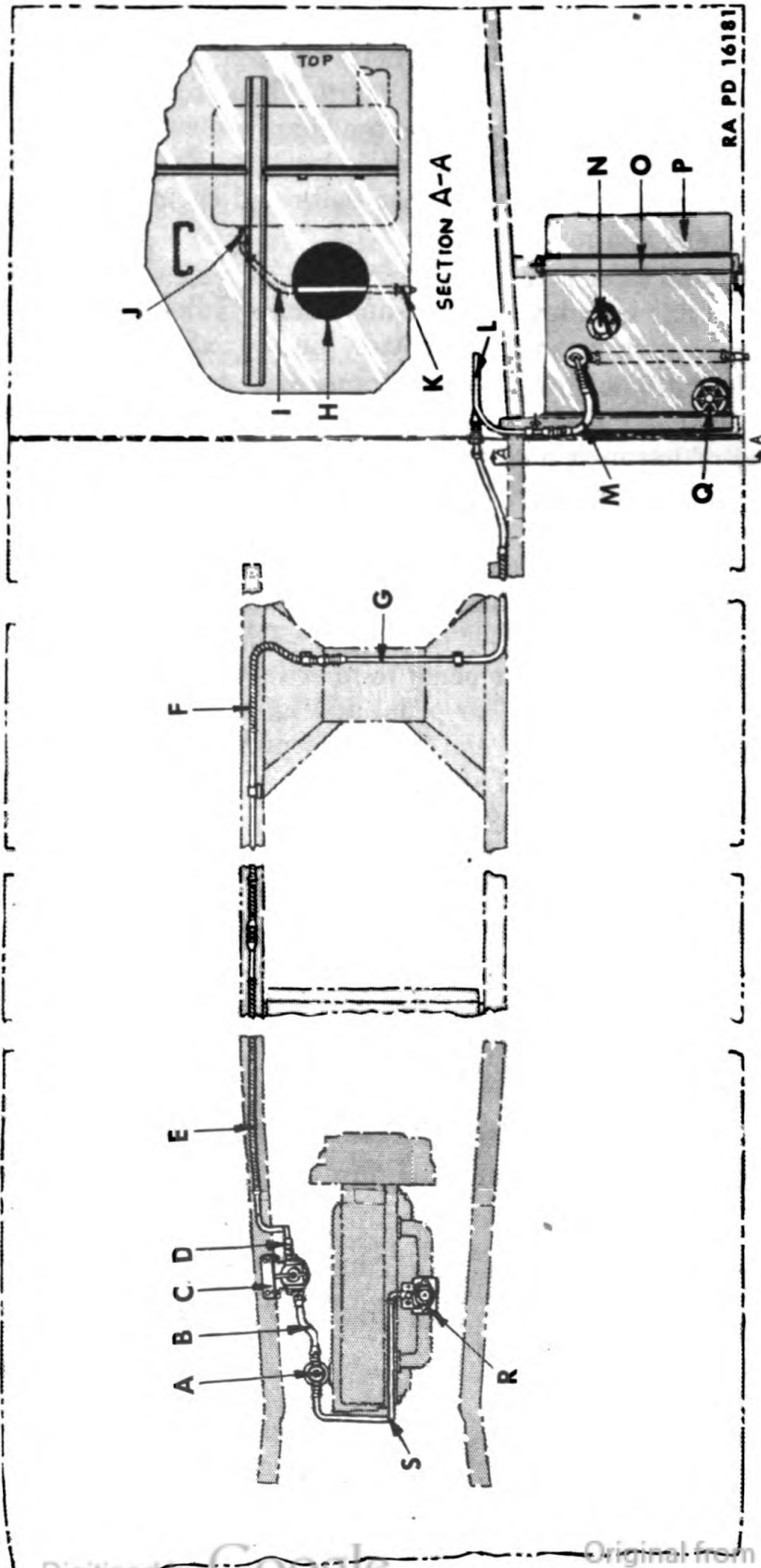

Figure 149—Fuel Tank and Lines (See Page 277 for Captions)



**FUEL SYSTEM**

(Caption for Fig. 149)

<b>A</b> Fuel Pump	<b>J</b> Fuel Tank Drain Cock
<b>B</b> Fuel Filter to Fuel Pump Flexible Hose	<b>K</b> Drain Tube Hull Opening Connection Plug
<b>C</b> Fuel Filter	<b>L</b> Hose to Bulkhead Connection Fuel Line
<b>D</b> Fuel Line Shut-off Cock	<b>M</b> Fuel Tank Flexible Hose
<b>E</b> Frame Connection to Fuel Filter Fuel Line	<b>N</b> Fuel Gauge Tank Unit
<b>F</b> Crossmember to Frame Connections Fuel Line	<b>O</b> Fuel Tank Support Strap
<b>G</b> Bulkhead to Crossmember Connection Fuel Line	<b>P</b> Fuel Tank
<b>H</b> Fuel Tank Drain Cock Hand Hole	<b>Q</b> Fuel Tank Filler Cap
<b>I</b> Fuel Tank Drain Tube	<b>R</b> Carbureter
	<b>S</b> Fuel Pump to Carbureter Fuel Line

loosening hose clamp bolt at fuel tank. Remove nuts from 2 fuel tank strap "T" bolts and remove tank from vehicle.

**b. Fuel Tank Installation Procedure**

**(1) Install fuel tank**

Place fuel tank in position on fuel tank supports and secure by installing two "T" bolt nuts. Install fuel tank drain hose on tank connection and tighten hose clamp bolt. Close drain cock and install drain hose coupling plug. Connect fuel line hose to top of fuel tank, tightening flange nut securely. Connect wire to fuel tank gauge unit terminal. Replace stern deck plate according to instructions given in Para. 66. Place spare wheel and tire in position on deck plate and secure with clamp bolt and nut.

**208. FUEL LINE REPLACEMENT (Refer to Fig. 149)**

**a.** Special metal fuel lines, covered with protective looms, where necessary, extend between fuel tank and carbureter. Flexible hose is provided between fuel tank and stern compartment bulkhead also between fuel filter and fuel pump to eliminate possibility of fuel line breakage. A shut-off cock is provided at fuel filter for convenience when performing service operations on system. A drain hose extends between fuel tank and hull side opening for draining tank. Drain cock at tank must be closed and coupling plug at hull installed at all times except when draining tank.

**b. Fuel Line Removal.** Fuel lines are securely fastened in position with clips and may be readily removed or installed. Refer to Para. 66, for accessibility to various fuel lines and connections.

**CAUTION**

Do not spill fuel in hull. Use containers and rags under fuel unit being serviced.

Section XXVIII

**HULL AND ASSOCIATED PARTS**

	Paragraph
General description .....	209
Trouble-shooting .....	210
Preventive maintenance and inspection.....	211
Gear bilge pump adjustment.....	212
Centrifugal bilge pump adjustment.....	213
Hull component parts replacement .....	214
Tarpaulin and curtains replacement .....	215
Windshield and wipers replacement .....	216
Gear bilge pump, drive, controls and piping replacement... ..	217
Centrifugal bilge pump, drive and piping replacement.....	218

**209. GENERAL DESCRIPTION**

**a. Hull Construction**

(1) Hull is constructed of steel plates, angles and channels which are welded, riveted and bolted together to form a unit structure. Interior of hull is divided into sections or compartments by bulkheads and panels welded and bolted in place. Metal deck plates and compartment wood floor boards are supported on support angles and channels. Bulkheads, panels, supports, deck plates and floor boards are all installed after chassis frame (as a separate unit) is installed and properly bolted down to bottom of hull.

**b. Hull Compartments**

(1) Driver's and cargo compartments are open at top or covered with tarpaulin. Bow, engine and stern compartments are covered by steel deck plates and hatch covers. Hatch covers are water tight when closed and properly clamped down. Refer to Fig. 43 in Section X for locations.

(2) Accessibility for maintenance and servicing of units located in compartments and covered by floor boards, etc., is fully described in Paras. 65 and 66.

**c. Bilge Pumps**

(1) Bilge pumps are used to pump water out of hull. Three types of pumps are provided in vehicles: a belt driven gear type pump; a chain driven centrifugal pump; and a hand pump. The first two pumps are described in this group, while use of hand pump is outlined in "Controls and Operation," Section III.

**d. Gear Bilge Pump System**

(1) Gear bilge pump is mounted on chassis frame side rail on an adjustable bracket which is located approximately under driver's seat. Pump is belt driven from a pulley on water propeller drive shaft and pump operates constantly whenever water propeller is

**HULL AND ASSOCIATED PARTS**

engaged. Pump intake is connected to a system of pipes and control valves which enable driver to pump water from any one of four compartments (bow, midship, left rear, right rear). Since pump is gear type, it must not be run without some water passing through pump at all times. A water reservoir is provided in system and connected to inlet strainer at hull exterior with a small inlet pipe. Inlet pipe provides a constant supply of water to pump whenever vehicle is in the water.

(2) Water is discharged through an outlet in side of hull (above water level). This outlet is connected to pump outlet by pipe and connecting hoses. A drain cock is provided at lowest point in outlet pipe so that pump and lines can be drained immediately after operation in freezing weather.

**e. Centrifugal Bilge Pump System**

(1) Centrifugal type bilge pump is mounted on chassis frame side rail on an adjustable bracket. Pump is located below front center section of cargo compartment. A chain drives pump from a sprocket on water propeller drive shaft. Pump operates whenever water propeller is engaged. A single intake strainer is connected directly to pump intake. Depth of water must be approximately 5 inches in hull before intake strainer is submerged and water will be pumped out. Water is discharged through an outlet in side of hull (above water level). This outlet is connected to pump outlet by pipes and connecting hoses.

**210. TROUBLE-SHOOTING**

a. Hull leaks, inoperative bilge pumps and failure of vacuum windshield wiper are the extent of items related directly to this group. "Trouble-Shooting Table" below covers these troubles while troubles pertaining to all other units are listed in their respective sections.

**b. Trouble-Shooting Table**

Symptom and Probable Cause	Probable Remedy	Refer to Paragraph
(1) <b>Hull leakage</b>		
(a) Penetration	Plug holes preferably from outside hull . . . . .	23
(b) Improper attachment of tarpaulin	Fasten tarpaulin down snugly to keep out water	215
(c) Hatch covers loose or seals in poor condition	Check cover seals and tighten cover clamp bolts. . .	214
(d) Welded joints torn or split	Notify Ordnance	
(e) Axle propeller shaft housings seals leaking	Tighten or replace seals	228

**TRUCK, AMPHIBIAN, 2½-TON, 6 x 6**

Symptom and Probable Cause	Probable Remedy	Refer to Paragraph
(f) Water propeller shaft stuffing box leaking.	Adjust or replace packing . . . . .	233
(g) Rudder stuffing box leaking	Adjust or replace packing . . . . .	257
(h) Drain plugs in hull for engine, transmission and main transfer case loose	Tighten drain plugs . . . . .	66
(i) Steering gear mountings through hull leaking	Tighten mountings or repair as necessary . . . . .	255
(j) Spring shackle bracket mounting bolts through hull and frame leaking	Tighten bolts after applying caulking compound . . . . .	193
<b>(2) Gear bilge pump inoperative or inefficient</b>		
(a) Drive belt slipping or broken	Tighten or replace belt . . . . .	212
(b) Intake strainers plugged	Clean strainers and hull bottom . . . . .	211
(c) Intake control valves leaking or stuck	Clean valves or replace as necessary . . . . .	217
(d) Hose connections in pipe system leaking	Tighten hose clamps or replace hose . . . . .	217
(e) Pump shaft packing leaking excessively	Adjust or replace packing . . . . .	212
(f) Pump worn	Replace pump . . . . .	217
<b>(3) Centrifugal bilge pump inoperative or inefficient</b>		
(a) Drive chain broken or off sprocket	Replace drive chain and adjust . . . . .	218
(b) Intake strainer plugged	Clean strainer and hull bottom . . . . .	211
(c) Hose connections in pipe system leaking	Tighten hose clamps or replace hose . . . . .	218
(d) Pump shaft packing leaking excessively	Adjust or replace packing . . . . .	213
<b>(4) Vacuum windshield wiper inoperative</b>		
(a) Leak in vacuum line	Check vacuum line for leaks and tighten all connections	
(b) Hose kinked	Replace hose	
(c) Tubing or fittings plugged	Clean tubing and fittings	
(d) Wiper motor parts worn	Replace wiper motor . . . . .	216

**211. PREVENTIVE MAINTENANCE AND INSPECTION**

a. Preventive maintenance operations as itemized in Section V, "Preventive Maintenance and Inspection," should be accomplished at intervals indicated.



## HULL AND ASSOCIATED PARTS

b. One of the most important phases of preventive maintenance on the hull and associated parts, is proper cleaning of the bilges before and after water operation. These bilges should be thoroughly washed and wiped out and all dirt leaves, etc., removed. At regular intervals, bilge pump intake strainers should be examined and cleaned if necessary.

c. Hatch covers are adequately sealed; however, these seals should be examined at regular intervals and replaced if necessary.

d. During cold weather, particular care should be taken to thoroughly drain bilges if vehicle is going to be stored or standing idle. Pet cock drain on bottom of manifold must be open and clear. This pet cock is accessible after left section of air intake grille is opened. Check drain in centrifugal pump.

### 212. GEAR BILGE PUMP ADJUSTMENT

a. Gear bilge pump has two necessary adjustments which should be checked regularly and adjusted as necessary.

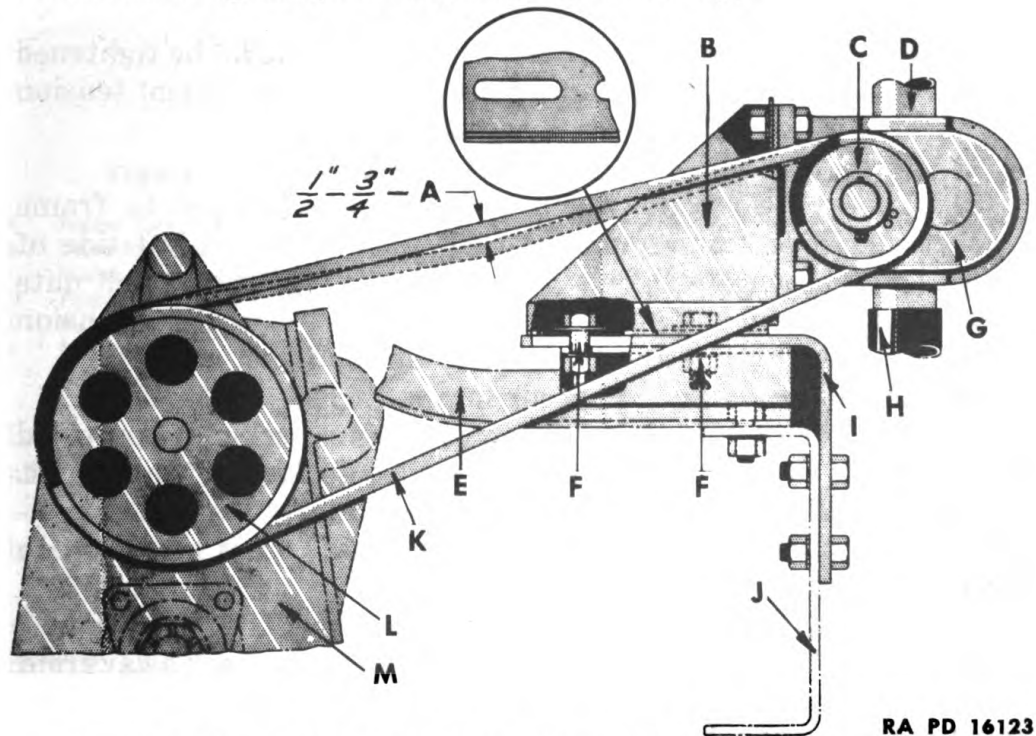

RA PD 16123

**Figure 150—Gear Bilge Pump Mounting and Drive Adjustment**

- |          |  |          |                                      |
|----------|--|----------|--------------------------------------|
| <b>A</b> | <b>Belt Tension Adjustment</b>                     | <b>G</b> | <b>Gear Type Bilge Pump</b>          |
| <b>B</b> | <b>Pump Bracket</b>                                | <b>H</b> | <b>Bilge Pump Outlet</b>             |
| <b>C</b> | <b>Driven Pulley</b>                               | <b>I</b> | <b>Frame Bracket</b>                 |
| <b>D</b> | <b>Bilge Pump Intake</b>                           | <b>J</b> | <b>Frame Side Rail</b>               |
| <b>E</b> | <b>Water Propeller Transfer Case Upper Support</b> | <b>K</b> | <b>Drive Belt</b>                    |
| <b>F</b> | <b>Pump Mounting Bracket Bolts</b>                 | <b>L</b> | <b>Drive Pulley</b>                  |
|          |  | <b>M</b> | <b>Water Propeller Transfer Case</b> |

**TRUCK, AMPHIBIAN, 2½-TON, 6 x 6**

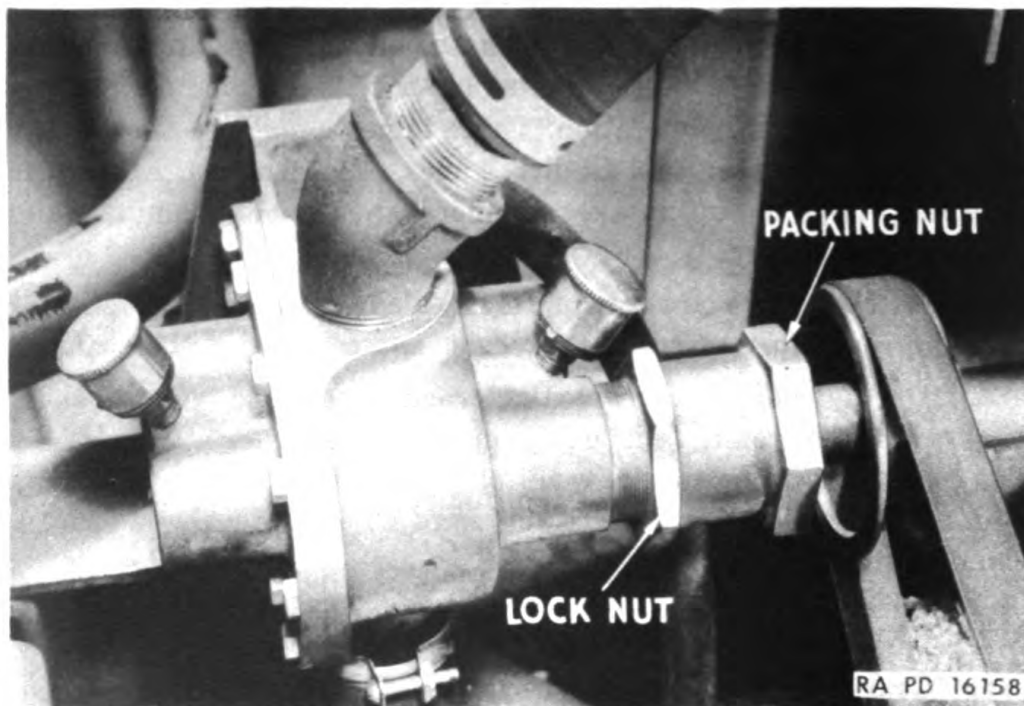

**Figure 151—Gear Bilge Pump Packing Adjustment**

**b. Gear Bilge Pump Drive Belt.** Drive belt should be tightened whenever inspection shows that belt does not have sufficient tension as indicated in Fig. 150. Proceed as follows:

(1) Remove center section of air intake grille.

(2) Loosen two bolts which mount pump bracket to frame bracket and slide pump and mounting bracket toward left side of vehicle to take up slack in belt. Tighten mounting bracket bolt nuts while holding pump and bracket in new position. Check belt tension as indicated in Fig. 150 and readjust if tension is not correct.

(3) Install center section of air intake grille.

**b. Gear Bilge Pump Drive Shaft Packing.** Packing is provided around pump shaft at pulley end to prevent leakage at this point. Packing should be tightened whenever an excessive amount of leakage occurs around shaft. A small amount of leakage is necessary to prevent overheating of shaft. Refer to Fig. 151.

(1) Remove center section of air intake grille.

(2) Loosen lock nut with wrench KM-J-2342 and back away from packing nut a few turns. Tighten packing nut until leakage is reduced but not entirely stopped. Tighten lock nut against packing nut securely.

(3) Install center section of air intake grille.

**213. CENTRIFUGAL BILGE PUMP ADJUSTMENT**

**a.** Centrifugal bilge pump has two necessary adjustments which should be checked regularly and adjusted as necessary.



HULL AND ASSOCIATED PARTS

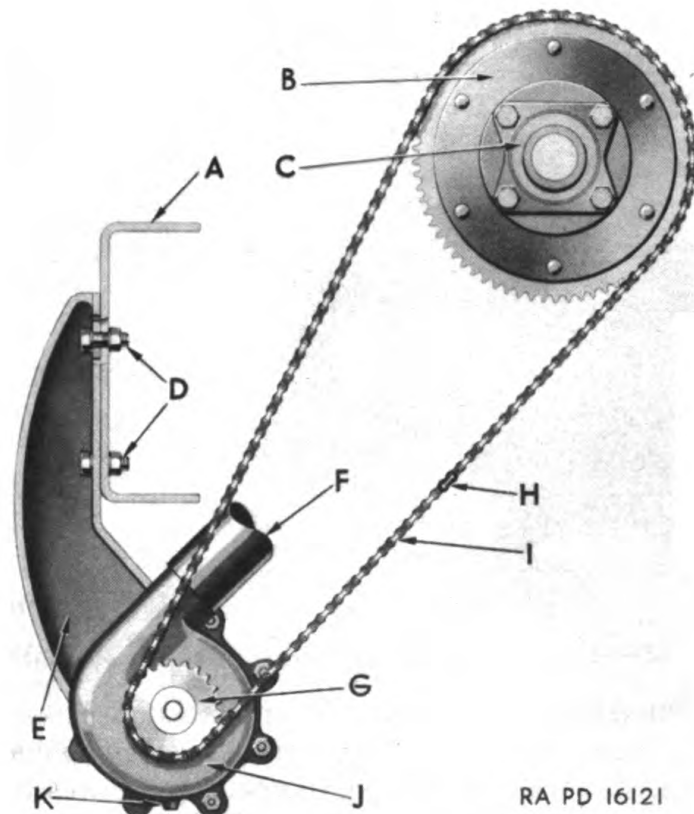

**Figure 152—Centrifugal Bilge Pump Drive Adjustment**

- |                                      |                                  |
|--------------------------------------|----------------------------------|
| <b>A</b> Frame Side Rail             | <b>G</b> Driven Gear             |
| <b>B</b> Drive Sprocket              | <b>H</b> Drive Chain Master Link |
| <b>C</b> Water Propeller Shaft Yoke  | <b>I</b> Drive Chain             |
| <b>D</b> Pump Mounting Bracket Bolts | <b>J</b> Centrifugal Bilge Pump  |
| <b>E</b> Pump Mounting Bracket       | <b>K</b> Drain Hole              |
| <b>F</b> Pump Outlet                 |                                  |

**b. Centrifugal Bilge Pump Drive Chain.** Whenever drive chain is too loose causing chain to slap or chain to ride off pulleys, chain should be adjusted. Refer to Fig. 152.

(1) Remove front center section of cargo compartment floor boards.

(2) Loosen two bolts attaching pump mounting bracket to frame side rail. Nuts on these bolts are accessible in frame channel as shown in Fig. 152.

(3) Slide pump mounting bracket downward in relation to frame side rail to tighten drive chain. This movement is permitted by elongated holes in pump mounting bracket.

(4) Tighten two bracket to frame rail mounting bolts with pump held in new position to take up slack in chain.

(5) If movement of pump mounting bracket is not sufficient to tighten chain, then chain must be shortened by removing links.

(6) Install front center section of floor board.

**TRUCK, AMPHIBIAN, 2½-TON, 6 x 6**

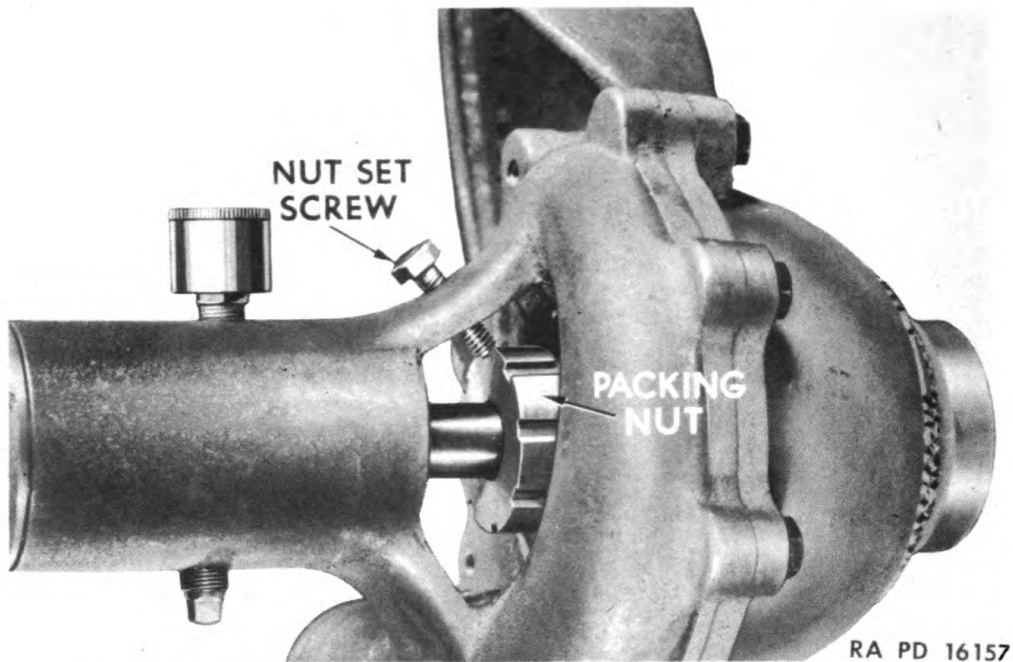

**Figure 153—Centrifugal Bilge Pump Packing Adjustments**

**b. Centrifugal Bilge Pump Drive Shaft Packing.** Packing around pump shaft in pump housing is provided to prevent leakage at this point. Packing should be tightened whenever an excessive amount of leakage occurs around shaft. Refer to Fig. 153.

(1) Remove front center section of cargo compartment floor board. Lift by hand holes provided in floor board.

(2) Loosen lock screw shown in Fig. 153 sufficiently to permit tightening of packing nut. Tighten packing nut with wrench KM-J-2341 until leakage is reduced but not entirely stopped. Tighten lock screw so that it engages notch in packing nut.

(3) Install front center section of cargo compartment floor board.

## **214. HULL COMPONENT PARTS REPLACEMENT**

**a. Hatch Covers and Seals Removal.** All hatch covers are hinged to deck and clamped in a closed position in a similar manner. Likewise, hatch cover seals are installed the same under all hatch covers.

(1) Loosen wing nuts on hold-down bolts so bolts can be disengaged from cover clamp as when opening hatch covers.

(2) Remove two cotter pins from each hatch cover hinge pin and drive out hinge pin.

(3) Clamps, bolt retainers and hinge halves are welded to hatch cover and deck plates. If clamps, bolt retainers or hinge halves must be removed, welded joint must be broken.

(4) Remove felt seal strips from channel shaped retainers attached to hatch cover or deck plate by starting removal of strip at



## HULL AND ASSOCIATED PARTS

one end with a sharp pointed tool and pulling seal out by hand. Carefully note how ends of seal strips are jointed or lapped.

### b. Hatch Covers and Seals Installation

(1) Install felt seal strips in channel-shaped retainer on hatch cover or deck plate in proper lengths to assure water-tight joints. Feed strips into retainers by pinching edges together while inserting strip in retainer.

(2) If clamps, bolt retainers or hinge halves are to be installed, place parts in proper position and weld in place.

(3) Place hatch cover in position over hatch opening so hinge halves are in alignment and install hinge pins. Insert cotter pins in hinge pins. Close hatch cover. Swing hold-down bolts into position on cover clamps and tighten wing nuts to clamp cover securely.

**c. Cargo Compartment Front Bulkhead Removal.** Removal of this bulkhead facilitates replacement of main transfer case.

(1) Remove front sections of cargo compartment floor boards to expose forward end of longitudinal floor supports.

(2) Remove two bolts and nuts attaching longitudinal floor supports to bulkhead. Remove bolts and nuts attaching each end of bulkhead to hull sides. Raise upward to remove bulkhead from vehicle.

### d. Cargo Compartment Front Bulkhead Installation

(1) Place bulkhead in position and install bolts and nuts attaching each end of bulkhead to hull sides.

(2) Align cargo compartment longitudinal floor supports with bolt holes in lower edge of bulkhead. Install bolts and nuts which attach floor supports to bulkhead. Put front sections of cargo compartment floor boards in place.

**e. Stern Deck Front Plate Removal.** Stern compartment may be entered through hatch in stern deck plate. However, removal of fuel tank or replacement of fuel gauge tank unit requires removal of stern deck front plate. Before this plate can be removed, spare tire must be taken off. Refer to Para. 66 for complete instructions on removal of wheel and tire, as well as stern deck plate.

### f. Stern Deck Front Plate Installation

(1) With hatch cover to right side of vehicle, place stern deck plate in position on stern deck supports. Fuel tank filler neck must be inserted through hole in deck plate as plate is put in position.

(2) Slide rubber seal over end of filler neck and fit into position between filler neck and deck plate. Attach fuel tank filler cap chain in filler neck and screw cap in place.

(3) Install bolts around outer edge of stern deck plate and through plate into reinforcing members to secure plate firmly to deck supports.

(4) With spare wheel and tire carrier strap in raised position, lay

**TRUCK, AMPHIBIAN, 2½-TON, 6 x 6**

spare wheel and tire flat on stern deck plate and locate properly against guard. Close carrier strap down over spare tire and engage hook on lower end of hold-down bolt in eye bolt in stern plate. Tighten nut on hold-down bolt to clamp spare wheel and tire securely.

**g. Bow Deck Surf Coaming Removal.** Bow deck surf coaming is attached to hull by two hinges on lower edge. Surf coaming may be held in either a raised or lowered position by brace rods at each end connected between upper edge of surf coaming and clamp brackets on bow deck.

(1) Loosen wing nuts on surf coaming brace clamp bolts and disengage bolts from clamp plates. Swing hinged clamp plates so coaming braces may be lifted out of clamp brackets.

(2) Loosen wing nuts on bow deck hatch cover hold-down bolts, disengage bolts from cover clamps and open hatch cover.

(3) Enter bow compartment to gain access to bolt nuts on under side of bow deck which attach surf coaming hinge to deck plate. Remove bolt nuts and bolts. Complete surf coaming assembly, including braces, is now loose and can be removed from vehicle.

**h. Bow Deck Surf Coaming Installation**

(1) Place surf coaming assembly in position on front end of bow deck and align holes in hinges with holes in deck plate.

(2) Install eight bolts through hinges and deck plate. Put nuts on hinge bolts from inside bow compartment and tighten securely. Close bow compartment hatch cover. Engage cover clamps with hold-down bolts and tighten wing nuts to clamp hatch cover in closed position.

(3) Place surf coaming braces in clamp brackets, swing hinged clamp plates over braces, engage end of each clamp plate with clamp bolt and tighten wing nut securely.

**i. Pintle Hook Removal.** Pintle hook is mounted through rear end of hull and removal must be accomplished from inside stern compartment. Refer to Fig. 154.

(1) Loosen wing nuts on stern compartment hatch cover hold-down bolts, disengage bolts from cover clamps and open hatch cover.

(2) After entering stern compartment, remove six bolts which attach pintle hook end cover to inner end of housing in stern bulkhead. Remove cover and gasket. Remove cotter pin, large nut and flat washer from end of pintle hook shaft.

(3) Slide retainer plate and gasket off spring outer sleeve. Slide spring outer sleeve, spring, and spring inner sleeve off end of pintle shaft.

(4) Assistant at rear of vehicle may then pull pintle hook outward from hull to clear end of shaft.

## HULL AND ASSOCIATED PARTS

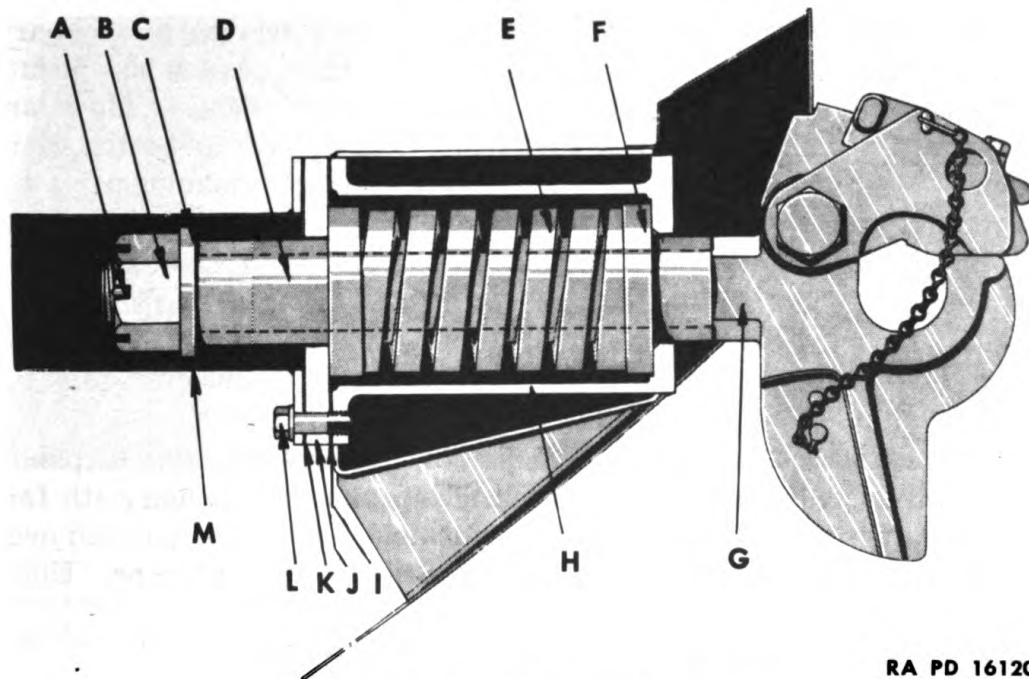

RA PD 16120

Figure 154—Pintle Hook Installation

A	Cotter Pin	H	Housing in Hull
B	Pintle Shaft Nut	I	Retainer Plate Gasket
C	Flat Washer	J	Retainer Plate
D	Spring Outer Sleeve	K	End Cover Gasket
E	Pintle Spring	L	End Cover Bolt
F	Spring Inner Sleeve	M	End Cover
G	Pintle Assembly		

## j. Pintle Hook Installation (Fig. 154).

(1) Insert end of pintle hook shaft through hole in rear end of hull from outside vehicle. While hook is held in position against hull by assistant, enter stern compartment and slide spring inner sleeve, spring, and spring outer sleeve over end of pintle shaft.

(2) Assemble inner gasket and retainer plate over end of spring outer sleeve. Install flat washer over end of pintle shaft and thread large nut on shaft. Tighten nut sufficiently to hold coil spring under slight tension to eliminate rattles. Then install cotter pin.

(3) Place outer gasket and end cover in position against retainer plate and housing in rear bulkhead and install six attaching bolts, tightening securely to prevent leakage around gaskets.

## 215. TARPAULIN AND CURTAINS REPLACEMENT

a. Driver's and cargo compartments are completely enclosed when all sections of tarpaulins and curtains are in place and properly fastened down. Covering is installed in sections so one section, or a combination of sections, can be installed or removed separately. Sections of tarpaulins and curtains and points of attachment are listed on page 288.



**TRUCK, AMPHIBIAN, 2 1/2 -TON, 6 x 6**

**b. Cargo Compartment Bows.** Five bows over cargo compartment support cargo compartment tarpaulin. Ends of each bow fit into metal pockets on inner side of compartment surf coaming. Bows are not fastened and can be lifted out readily. Each bow can be disassembled into four parts by removing bolts and nuts holding parts together.

**c. Driver's Compartment Bow.** A tubular metal bow is mounted in support clamps attached to side of hull behind driver's seat and gun support. Bow serves as rear support for driver's compartment tarpaulin. Bow is a one-piece unit but can be lifted out of clamps for removal after loosening clamp bolts.

**d. Driver's Compartment Tarpaulin.** A one-piece flat tarpaulin is used over driver's compartment. Tarpaulin is attached with fasteners at front edge along top of windshield. Rear edge is pulled over metal bow at back of compartment and held down by ropes. Untie ropes and loosen front fasteners to remove tarpaulin.

**e. Driver's Compartment Hinged Side Curtains.** Curtains with plastic glass and metal frames are hinged at forward end to side posts of windshield support frame. Curtains are provided with catches which hold them closed against metal bow behind driver's seat. Curtains and tarpaulin over compartment overlap to enclose top and sides of compartment. Removal can be accomplished by opening curtains wide and raising to disengage hinge rod ends from brackets.

**f. Cargo Compartment Tarpaulin.** A one-piece tarpaulin is spread over five supporting bows above cargo compartment. Tarpaulin is fitted with straps and buckles spaced to attach to bows at top. These straps serve to fasten tarpaulin to bows along center of top. Sides of tarpaulin are fastened to eyes attached to surf coaming along sides of compartment with tie ropes. Ends of tarpaulin extend over front and rear bows and are pulled tight and tied to bulkheads with draw ropes.

**g. Driver's Compartment Tarpaulin Extension.** This extension tarpaulin is used to cover air intake between driver's compartment and cargo compartment. Front edge of extension is attached to tarpaulin over driver's compartment with straps and buckles. Rear edge extends over first bow in cargo compartment. Tie ropes at each rear corner of extension stretch it tight over cargo compartment bow and tie to eyes suitably located in side surf coamings. Side flaps attached to extension tarpaulin can be rolled up to permit air to enter air intake. These side flaps should be lowered and fastened down only when vehicle is traveling in extremely rough water. Engine cooling is decreased considerably when air intake is completely enclosed.

**h. Cargo Compartment End Curtains.** Each end of cargo com-



**HULL AND ASSOCIATED PARTS**

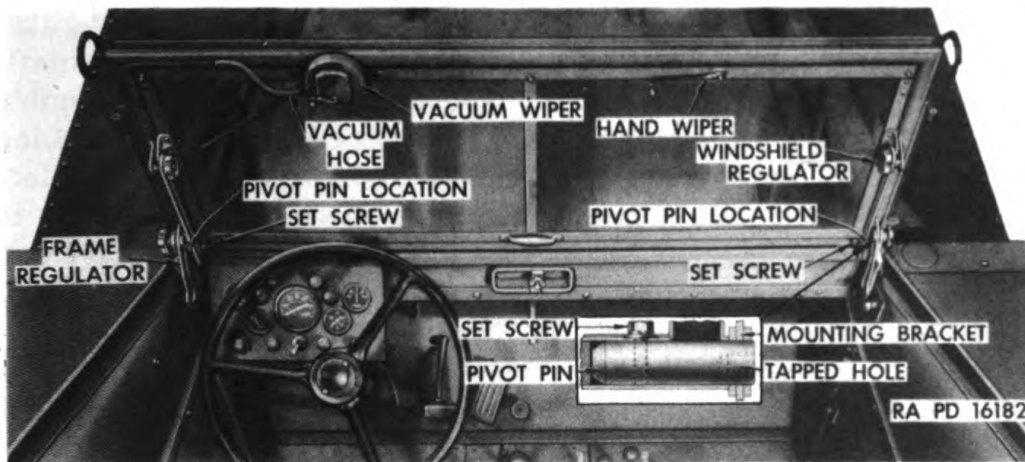

**Figure 155—Windshield Mounting and Wipers**

partment is fitted with an end curtain which is attached to front and rear bows respectively. Curtains hang straight down and are tied to cargo compartment bulkheads with ropes in lower edge.

**216. WINDSHIELD AND WIPERS REPLACEMENT**

**a. Left Windshield Wiper Removal.** This vacuum operated wiper is mounted to top of windshield frame and connected to vacuum tube by a rubber hose. Refer to Fig. 155.

(1) Disconnect hose at vacuum tube near wiper motor on rear side of windshield. Unscrew wiper arm lock nut from end of wiper shaft at front side of windshield and remove washer and wiper arm. Remove one screw from each side of wiper motor. These screws attach wiper motor to windshield frame. Pull wiper motor away from windshield until shaft clears frame.

**b. Left Windshield Wiper Installation**

(1) Insert motor shaft through hole in windshield frame at rear side of windshield and attach motor to frame with two screws. Assemble wiper arm on end of motor shaft from front side of windshield and attach with lock nut and washer. Connect vacuum hose between vacuum line and motor.

**c. Right Windshield Wiper Removal.** Right windshield wiper is mounted in top of windshield frame at right side and is hand operated. Refer to Fig. 155.

(1) Unscrew lock nut which attaches handle on rear side of windshield and remove operating handle.

(2) Pull wiper arm and shaft away from front side of windshield until shaft clears hole in frame.

**d. Right Windshield Wiper Installation**

(1) Insert wiper arm shaft through windshield frame from front side of windshield.

**TRUCK, AMPHIBIAN, 2½-TON, 6 x 6**

(2) Put operating handle on end of shaft from rear side of windshield and clamp in place by installing lock nut.

**e. Windshield Glass Removal.** Glass and glass frame assembly can be removed from tubular supporting frame without loosening tubular frame mountings. Refer to Fig. 155.

(1) At front side of windshield near top use a screwdriver to bend left end of hinge open. At rear side of windshield remove two thumb screws from regulator adjusting arm clamp bolts at each end of windshield. Disconnect vacuum hose at left wiper motor.

(2) Swing glass and frame assembly outward at bottom to clear tubular support frame. Then slide glass and frame to left from front side of windshield. Movement will disengage portion of hinge connected to glass frame from portion of hinge connected to tubular support frame. Remove glass and frame to suitable bench or table.

(3) Remove three crown nuts and bolts attaching top section of glass frame to rest of frame and pull off top section or channel. Remove glass from right and left sections of frame and clean all frame channels thoroughly.

**f. Windshield Glass Installation**

(1) Brush inside of frame channels with soap solution or rub with paraffin to facilitate glass installation.

(2) Place strip of rubber filler over edge of new glass and slide frame in place over rubber filler and glass. Fit filler strip at corners of glass as necessary.

(3) Install second section of glass in same manner.

(4) Put top section of frame over top edge of glass sections and install three bolts and crown nuts. Replace glass and frame assembly in tubular support frame on vehicle by sliding hinge sections together from left end (from front side) of support frame. Bend end of hinge to lock windshield in position.

(5) Close windshield and fit regulator adjusting arms over adjusting clamp bolts at each end of windshield. Then install thumb screws and tighten to clamp windshield in closed position.

**g. Windshield and Tubular Support Frame Removal.** Complete windshield and tubular support frame can be removed as an assembly. Refer to Fig. 155.

(1) Remove thumb screws from regulator adjusting arm clamp bolts at each end of windshield and remove clamp bolts and washers. This permits windshield and tubular support frame to be tipped forward at top and supported on stanchions in deck plate.

(2) Remove pivot pin set screws in bottom tube of support frame (near each end). Refer to inset in Fig. 187.

(3) Screw a bolt into tapped hole in each pivot pin at each end of bottom tube of support frame to assist in pulling pin. Then re-

## HULL AND ASSOCIATED PARTS

move two pivot pins. Complete windshield glass and tubular support frame is now loose and can be lifted off from vehicle.

### **h. Windshield and Tubular Support Frame Installation**

(1) Put complete assembly in position on vehicle and line up holes in bottom tube with holes in support brackets.

(2) Slide pivot pins into hole through each bracket and into frame bottom tube. Refer to inset in Fig. 155. Set screw holes in pins must line up with set screw holes in frame tube.

(3) Install set screws in bottom tube to hold pivot pins in place. Raise forward edge of windshield to vertical position so that slot in each regulator adjusting arm is aligned with hole in each support bracket.

(4) Install adjusting arm clamp bolts through regulator adjusting arms and bolt brackets, using washers in correct position. Put on thumb screws and tighten to clamp tubular support frame and windshield in an upright position.

## **217. GEAR BILGE PUMP, DRIVE, CONTROLS AND PIPING REPLACEMENT**

**a. Gear Bilge Pump and Drive Removal.** Pump drive consists of a drive belt, a drive pulley at front side of water propeller transfer case, and a driven pulley on pump shaft. Pump is mounted on chassis frame side rail on an adjustable bracket located below driver's seat. Refer to Fig. 150.

(1) Remove left and center sections of air intake grille for access to pump and drive.

(2) Loosen bolts clamping hose clamps at pump inlet and outlet and disconnect hoses at these two points.

(3) Remove two pump mounting bracket bolts, nuts and washers. Move pump sufficiently to take drive belt off pulleys, lift pump off frame bracket, and remove through air intake grille opening.

(4) Loosen set screw in driven pulley on pump shaft and remove pulley and key.

(5) Remove cotter pin and nut which lock drive pulley on water propeller transfer case shaft and, utilizing tapped holes in pulley, attach suitable puller and remove pulley and Woodruff key.

### **b. Gear Bilge Pump and Drive Installation**

(1) Assemble drive pulley and Woodruff key on end of shaft at front side of water propeller transfer case. Tap pulley lightly with a soft hammer near hub to drive on shaft. Install large nut, tighten securely and insert cotter pin.

(2) Assemble driven pulley and key on end of pump shaft and tighten set screw securely.

(3) Put pump and mounting bracket in position on frame bracket and install two mounting bolts, washers and nuts loosely. Connect



TRUCK, AMPHIBIAN, 2 1/2-TON, 6 x 6

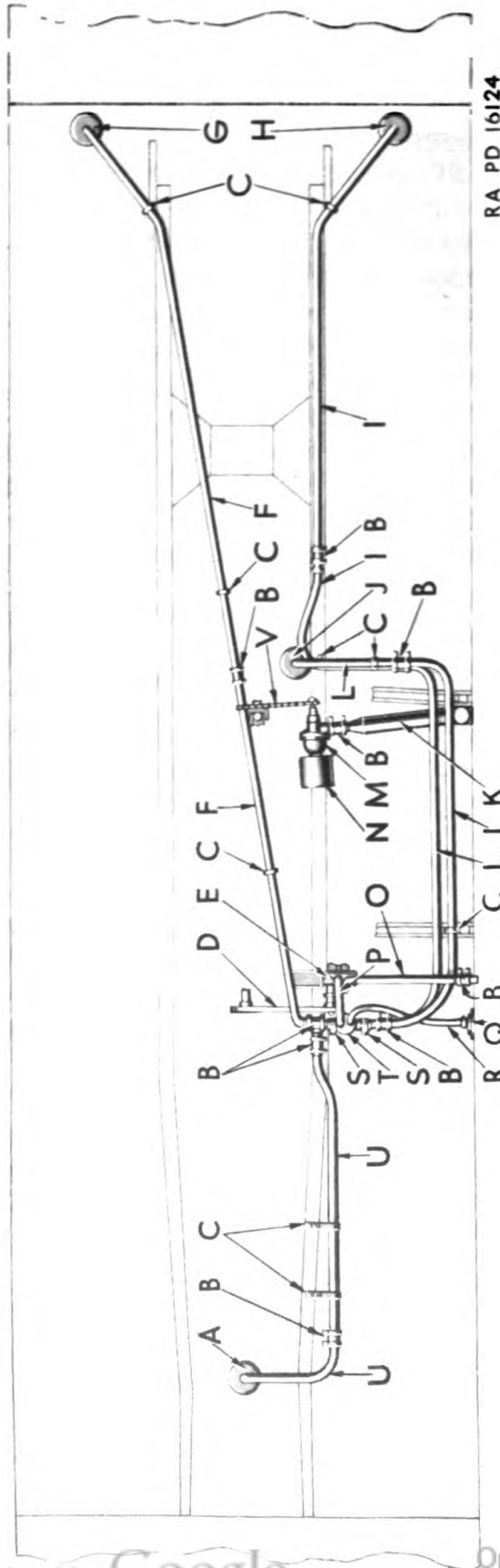

Figure 156—Bilge Pumps, Pipes and Control Installation

- |   |  |   |                                 |
|---|--|---|---------------------------------|
| A | Front Compartment Intake Strainer      | P | Gear Bilge Pump Intake Pipe     |
| B | Hose Connections                       | Q | Reservoir Inlet Strainer        |
| C | Pipe Clamps or Clips                   | R | Reservoir Inlet Hose            |
| D | Gear Pump Drive Belt                   | S | Gear Pump System Control Valves |
| E | Gear Bilge Pump                        | T | Gear Pump System Reservoir      |
| F | Right Rear Compartment Intake Pipes    | U | Front Compartment Intake Pipes  |
| G | Right Rear Compartment Intake Strainer | V | Centrifugal Pump Drive Chain    |
| H | Left Rear Compartment Intake Strainer  |   |                                 |
| I | Left Rear Compartment Intake Pipe      |   |                                 |
| J | Mid-ship Compartment Intake Strainer   |   |                                 |
| K | Centrifugal Pump Discharge Pipe        |   |                                 |
| L | Mid-ship Compartment Intake Pipe       |   |                                 |
| M | Centrifugal Bilge Pump                 |   |                                 |
| N | Centrifugal Pump Intake Strainer       |   |                                 |
| O | Gear Bilge Pump Discharge Pipe         |   |                                 |

RA PD 16124



**HULL AND ASSOCIATED PARTS**

hoses at pump inlet and outlet and tighten hose clamp bolts securely.

(4) Place pump drive belt over both pulleys. Slide pump and mounting bracket toward left side of vehicle to take up slack in belt. Belt tension should be as shown in Fig. 150. With belt tension correct, tighten two mounting bracket bolts to clamp pump in adjusted position.

(5) Install left and center sections of air intake grille.

**c. Gear Bilge Pump Piping, Valves and Controls Removal.** Gear bilge pump piping is installed in vehicle as shown in Fig. 156. Fig. 188 shows control valves for gear bilge pump system. Before removal of system or any portion thereof is attempted position of units should be studied. Fig. 156 shows relative positions of units, hose connections and attaching clips. If complete system is to be removed, maximum accessibility is attained by opening engine compartment hatch cover and removing all floor boards and air intake grilles.

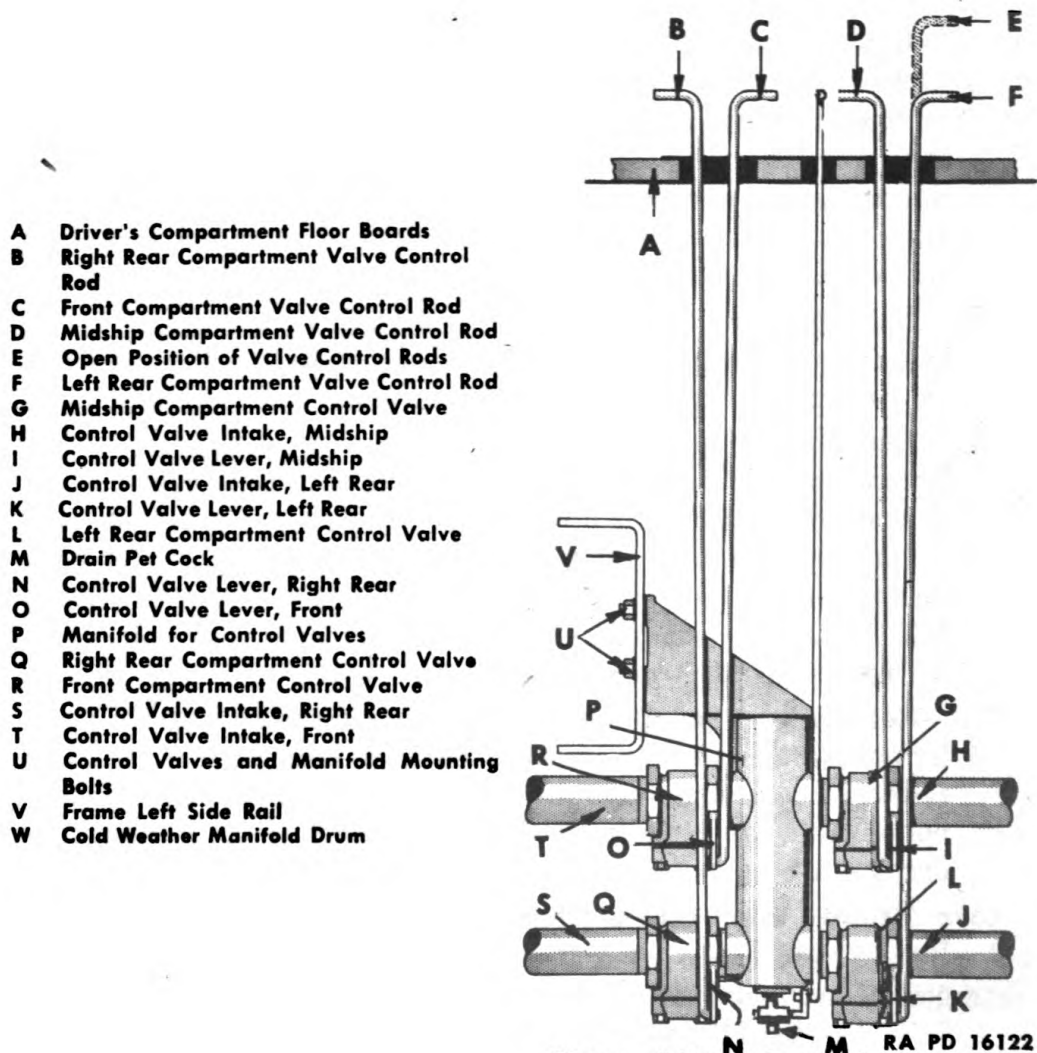

- A Driver's Compartment Floor Boards
- B Right Rear Compartment Valve Control Rod
- C Front Compartment Valve Control Rod
- D Midship Compartment Valve Control Rod
- E Open Position of Valve Control Rods
- F Left Rear Compartment Valve Control Rod
- G Midship Compartment Control Valve
- H Control Valve Intake, Midship
- I Control Valve Lever, Midship
- J Control Valve Intake, Left Rear
- K Control Valve Lever, Left Rear
- L Left Rear Compartment Control Valve
- M Drain Pet Cock
- N Control Valve Lever, Right Rear
- O Control Valve Lever, Front
- P Manifold for Control Valves
- Q Right Rear Compartment Control Valve
- R Front Compartment Control Valve
- S Control Valve Intake, Right Rear
- T Control Valve Intake, Front
- U Control Valves and Manifold Mounting Bolts
- V Frame Left Side Rail
- W Cold Weather Manifold Drum

**Figure 157—Controls for Gear Bilge Pump Valves**

**TRUCK, AMPHIBIAN, 2 1/2-TON, 6 x 6**

For removal of separate units of system, refer to Para. 66 for accessibility.

**(1) Remove front compartment intake pipes and strainer**

Disconnect two hose connections: one in engine compartment, and one near control valve under driver's seat. Loosen two clips located as shown in illustration, Fig. 156. Remove two sections of intake pipe and strainer.

**(2) Remove midship compartment intake pipes and strainer**

Disconnect two hose connections: one at front of left rear wheelhouse, and one near control valve under driver's seat. Loosen three clamps located as shown in Fig. 156. Remove two sections of intake pipe and strainer.

**(3) Remove left rear compartment intake pipes and strainer**

Disconnect three hose connections: two near left rear wheelhouse, and one near control valve under driver's seat. Remove four clamps and clips located as shown in Fig. 156. Remove three sections of intake pipe and strainer.

**(4) Remove right rear compartment intake pipes and strainer**

Disconnect two hose connections — one near center of cargo compartment, one near control valve under driver's seat. Remove three clips attaching pipes to frame side rail and floor supports. Remove two sections of intake pipe and strainer.

**(5) Remove pump discharge pipe**

Disconnect two hose connections: one at hull outlet, and one at bottom of gear bilge pump. Remove curved section of pipe.

**(6) Remove gear pump reservoir and pipes**

Remove driver's seat by removing bolts attaching seat bottom to seat box. Disconnect hose connection between reservoir outlet and pump intake inside driver's seat box. Disconnect hose connection between bottom of reservoir and control valve manifold. Unfasten reservoir inlet hose at bottom of reservoir. Then lift reservoir up through seat box to remove.

**(7) Remove gear pump valves and rods (Refer to Fig. 157)**

Remove cotter pins from lower ends of four control rods and remove rods. Remove four control valve bracket mounting bolts, nuts and washers. Valves, manifold and mounting bracket are now loose and can be removed as an assembly.

**(8) Remove reservoir inlet hose and strainer**

Remove six bolts, nuts and washers attaching inner half of strainer (including screen) to outer half which is welded to side of hull. Strainer is located inside of hull, below and at left of driver's seat. Remove inner half of strainer with hose assembled, as well as gasket between halves of strainer.

## HULL AND ASSOCIATED PARTS

### d. Gear Bilge Pump Piping, Valves and Controls Installation

#### (1) Install gear pump valves and rods (Refer to Fig. 157)

Place valves, manifold and mounting bracket assembly in position against frame left side rail and install four mounting bolts, nuts and washers. Install ends of four control rods through valve levers as shown in illustration and insert cotter pins.

#### (2) Install gear pump reservoir and pipes

Put reservoir assembly in place through hole in seat box bottom and connect outlet pipe to gear bilge pump intake with connecting hose. Install connecting hose between bottom of reservoir and control valves manifold. Place driver's seat on seat box and install bolts attaching seat bottom to seat box.

#### (3) Install reservoir inlet hose and strainer

Place inner half of strainer (including screen) in position against outer half of strainer which is welded to side of hull below and at left of driver's seat. Put new gasket in place between halves of strainer, install six bolts, nuts and washers and tighten securely. Connect hose between inner half of strainer and inlet at bottom of reservoir with hose clamps.

#### (4) Install pump discharge pipe

Place curved section of pipe in position between pump outlet and hull outlet. Install connecting hoses at each end of pipe. Be sure drain cock at low point of pipe is shut off.

#### (5) Install right rear compartment intake pipes and strainer

Place two sections of intake pipes and strainer in proper location Fig. 156. Install two pipe connecting hoses, one near center of cargo compartment and one near control valve under driver's seat. Assemble three clips attaching pipes.

#### (6) Install left rear compartment intake pipes and strainer

Place three sections of intake pipes and strainers in proper location as indicated by Fig. 156. Install three pipe connecting hoses: two near left rear wheelhouse, and one near control valve under driver's seat. Assemble four clamps and clips located as illustrated in Fig. 156.

#### (7) Install midship compartment intake pipes and strainer

Place two sections of intake pipe and strainer in proper location as indicated by Fig. 156. Install two pipe connecting hoses: one at front of left rear wheel house; and one near control valve under driver's seat. Assemble three clamps located as shown in Fig. 156.

**TRUCK, AMPHIBIAN, 2½-TON, 6 x 6****(8) Install front compartment intake pipes and strainer**

Place two sections of intake pipes and strainer in proper location as indicated in Fig. 156. Install two pipe connecting hoses: one in engine compartment, and one near control valve under driver's seat. Assemble two clamps located as shown in Fig. 156.

**(9) Install floor boards and air intake grille**

Install all sections of driver's compartment and cargo compartment floor boards which were removed for accessibility to pipe system units. Also install sections of air intake grille which were removed. Close engine compartment hatch cover, swing hold-down bolts into position in cover clamps and tighten wing nuts to clamp cover securely.

**218. CENTRIFUGAL BILGE PUMP, DRIVE AND PIPING REPLACEMENT**

**a. Centrifugal Bilge Pump and Drive Removal.** Pump drive consists of a drive chain, a drive sprocket in water propeller drive line, and a driven gear on bilge pump shaft. Pump is mounted on chassis frame side rail on an adjustable bracket below front center section of cargo compartment. Refer to Fig. 152.

(1) Remove left front and front center sections of cargo compartment floor board.

(2) Loosen hose clamp at pump outlet and disconnect hose.

(3) Remove two pump mounting bolts, nuts and washers. Move pump sufficiently to remove drive chain from gears, and lift pump and bracket upward to remove.

(4) Loosen set screw in driven gear on pump shaft and remove pulley and key. Pump intake strainer is attached directly to pump intake and is removed with pump. Remove intake strainer from pump by loosening set screw and pulling off strainer assembly.

(5) Disassemble master link in drive chain in order to remove chain from around drive sprocket and drive shaft. Drive sprocket is mounted between flanges at rear of front water propeller drive shaft and front of intermediate water propeller drive shaft. Removal of sprocket is described in Para. 237.

**b. Centrifugal Bilge Pump and Drive Installation.**

(1) Install drive sprocket in water propeller drive line as described in Para. 237. Fit drive chain in place on teeth of drive sprocket and assemble master link in chain.

(2) Assemble driven gear and key on end of pump shaft and tighten set screw securely. Install intake strainer on pump intake and tighten set screw.

(3) Put pump and mounting bracket in position on frame side



**HULL AND ASSOCIATED PARTS**

rail and install two mounting bolts, nuts and washers loosely. Connect hose at pump outlet and tighten hose clamp bolts.

(4) Lift pump and bracket upward sufficiently to put drive chain in position over teeth of driven gear. Then slide pump and mounting bracket downward to take up slack in drive chain. Do not adjust chain too tightly. Tighten two pump mounting bracket bolts to clamp pump in adjusted position.

(5) Install left front and front center sections of cargo compartment floor boards.

**c. Centrifugal Bilge Pump Pipe Removal.** Since the only pump intake strainer is attached directly to pump intake, pipe system consists of discharge pipe only. Refer to Fig. 156.

(1) Remove left front section of cargo compartment floor boards.

(2) Loosen hose clamps and disconnect hoses at bilge pump outlet and upper end of lower discharge pipe.

(3) Lower discharge pipe is now loose and can be removed. Upper discharge pipe is welded to side of hull and outlet fitting in hull and cannot be removed.

**d. Centrifugal Bilge Pump Pipe Installation**

(1) Put lower discharge pipe in position between centrifugal pump outlet and upper discharge pipe.

(2) Install connecting hose and clamps at each end of pipe and tighten clamp bolts securely.

(3) Install left front section of cargo compartment floor boards.

**PRIMING PUMPS**

Pour about gallon of water in pump outlets while propeller is driving pumps, then disengage clutch momentarily, allowing priming water to flow back into pumps. Engage clutch and accelerate engine to pump as desired.

Section XXIX

**INSTRUMENTS AND GAUGES**

	Paragraph
Description .....	219
Instrument panel assembly replacement.....	220
Instrument and gauge replacement .....	221

**219. DESCRIPTION**

a. Instruments and gauges, as illustrated in Fig. 158, are installed in a cluster in instrument panel, mounted on left side of windshield lower panel forward of steering column. The instrument panel, with all instruments and gauges, can be removed or installed as complete assembly, or each instrument or gauge can be removed and installed separately.

**220. INSTRUMENT PANEL ASSEMBLY REPLACEMENT**

**a. Instrument Panel Removal**

(1) **Caution:** Before attempting any maintenance or repair on instrument and gauges, disconnect at least one terminal at battery.

(2) In engine compartment remove temperature gauge thermal plug from engine fitting and remove throttle and choke wires from carburetor. In driver's compartment, back of instrument panel, re-

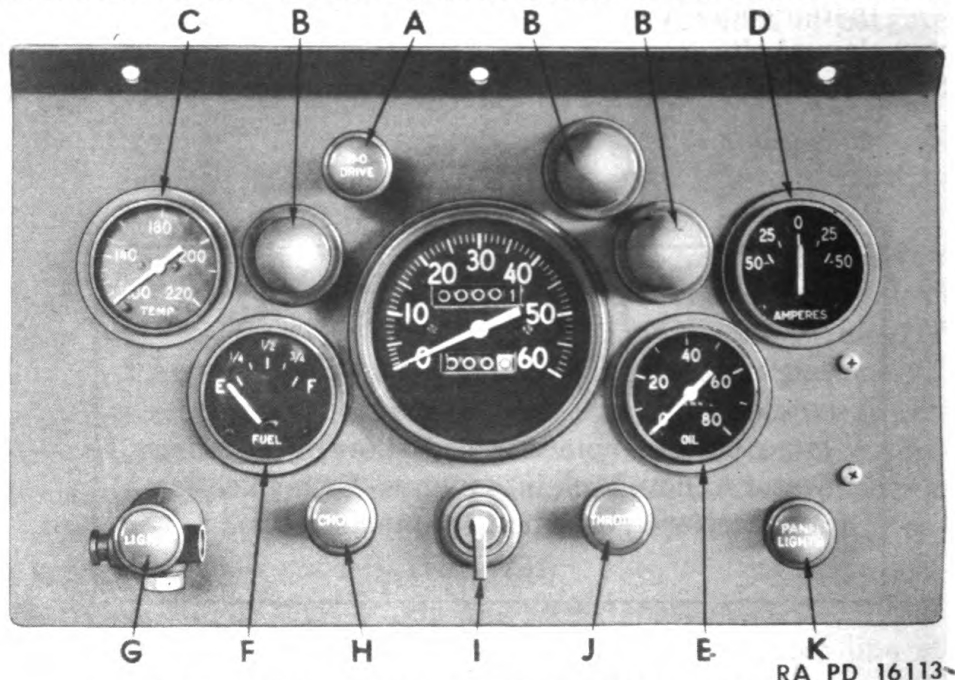

**Figure 158—Front View of Instrument Panel**

- |   |                               |   |                              |
|---|-------------------------------|---|------------------------------|
| A | Blackout Driving Light Switch | G | Main Light Switch            |
| B | Panel Lights                  | H | Choke Control Button         |
| C | Temperature Gauge             | I | Ignition Switch              |
| D | Ammeter                       | J | Hand Throttle Control Button |
| E | Oil Gauge                     | K | Panel Light Switch           |
| F | Fuel Gauge                    |   |                              |

## INSTRUMENTS AND GAUGES

move all terminal connections from terminal on back of instruments and gauges.

(3) Remove thumb screw from top of speedometer bracket and remove wiring harness clip. Remove nut and wiring harness clip from left-hand bolt of ammeter gauge bracket. Disconnect oil gauge flexible line from back of oil pressure gauge by backing off flange nut.

(4) Remove bolt nut and washer from instrument panel to steering column brace. Remove 3 bolts, nuts and lockwashers attaching instrument panel to windshield lower panel assembly.

(5) Remove instrument panel assembly by withdrawing temperature gauge terminal unit, hand choke control wire and flexible housing, and throttle control wire and flexible housing through openings in upper toe board.

### b. Instrument Panel Installation

(1) In driver's compartment place panel in position in windshield lower panel assembly, and fasten with 3 bolts, nuts and lockwashers. Fasten instrument panel to steering column brace with bolt, washer and nut.

(2) On back of instrument panel attach wiring harness clip to top bolt of speedometer bracket with thumb nut. Fasten wiring harness to left bolt of ammeter bracket with clip, washer and nut.

(3) Attach electric wiring to instrument and gauge terminals following carefully details as shown in Fig. 99 (Section XVIII). Be sure that wires as identified by tracer color are attached to terminals designated in diagram.

(4) Connect oil gauge flexible line to back of oil pressure gauge with flange nut. Connect speedometer driving cable to back of speedometer head with flange nut.

(5) Thread choke control wire and flexible cable, throttle control wire and flexible cable and temperature control terminal plug through proper openings in upper toe board.

(6) In engine compartment place temperature gauge terminal plug in connection in engine and fasten with attaching nut.

(7) Insert end of hand throttle control wire and flexible housing through clip at carbureter. Thread end of wire through end of carbureter rod. Fasten end of control flexible housing securely in clip at carbureter by tightening clip clamp bolt.

(8) Place throttle control collar on end of throttle control wire and fasten with set screw. For adjustment of throttle control see Para. 203.

(9) Thread end of choke control wire and flexible housing through clip at carbureter, continuing end of wire through choke control lever. Fasten end of flexible housing in clip with set screw.

**TRUCK, AMPHIBIAN, 2½-TON, 6 x 6**

Tighten end of wire in choke control lever at carbureter with set screw. For choke control adjustment see Para. 203.

**221. INSTRUMENT AND GAUGE REPLACEMENT**

**a. Caution:** Before attempting any replacement of instruments or gauges, disconnect one terminal wire at battery, otherwise serious damage might result.

**b. Speedometer Head Removal**

(1) Remove driving cable from back of speedometer head by unscrewing swivel nut. Remove 2 wing nuts from speedometer head bolts. Remove wiring harness clip from upper speedometer head bolt. Remove speedometer clamp off speedometer head bolts. Remove speedometer head by pushing from back to front instrument panel.

**c. Speedometer Head Installation**

(1) Place speedometer head in position in instrument panel by pressing in from front of instrument panel. On back of instrument panel place speedometer head bracket in two bolts in speedometer head and fasten with washer and wing nut on lower bolt.

(2) Place wiring harness clip on upper speedometer head bolt and secure with washer and wing nut. Attach driving cable to center connection on speedometer head with swivel nut.

**d. Speedometer Driving Cable Removal**

(1) In driver's compartment, at back of instrument panel, remove speedometer driving cable from speedometer head by unscrewing swivel nut at center connection on speedometer head. Remove cable to dash clip, bolt, nut and washer. Remove cable to dash grommet and remove grommet from speedometer driving cable.

(2) In engine compartment remove cable to transmission clip, bolt, nut and washer. Remove cable to master cylinder clip, bolt, nut and washer. Remove cable to second cross member, clip, bolt, nut and washer. Unscrew swivel nut attaching cable assembly to speedometer gear on left side transfer case. Withdraw speedometer driving cable through upper toe board into engine compartment.

**e. Speedometer Driving Cable Installation**

(1) In engine compartment, thread end of speedometer driving cable having smaller swivel nut, through upper toe board to instrument panel. Insert end of driving cable into end of drive gear in left side of transfer case and tighten swivel nut securely.

(2) Attach cable to transmission clip, bolt nut and lockwasher. Attach cable to second cross member, clip, bolt, nut and lockwasher. Attach cable to master cylinder, clip, bolt, nut and lockwasher.

(3) In driver's compartment place cable to dash grommet on cable and force into position in upper toe board. Attach cable to speedometer head with swivel nut. Attach cable to dash, clip, bolt, nut and lockwasher.



**INSTRUMENTS AND GAUGES****f. Ammeter Removal**

(1) Remove nuts and wiring harness clip from left-hand ammeter clamp bolt. Remove nut and wire terminal from right-hand ammeter clamp bolt. Remove nut and washer from right ammeter clamp bolt and remove ammeter clamp.

(2) Remove ammeter gauge from instrument panel by pushing through, from back.

**g. Ammeter Installation**

(1) Place ammeter gauge in position in instrument panel by pressing in from front of panel. On back of instrument panel place ammeter clamp on 2 bolts in ammeter gauge and fasten with nut and washer on right bolt. Place harness wiring clip in right bolt and fasten with nut and washer. Place wire terminal on right bolt and fasten with nut and washer.

**h. Fuel Gauge Removal**

(1) Remove 2 nuts from 2 fuel gauge clamp bolts. Remove wire terminals from 2 bolts. Remove nut and washer from each of 2 fuel gauge clamp bolts and remove fuel gauge clamp. Remove fuel gauge from instrument panel by pressing through from back.

**i. Fuel Gauge Installation**

(1) Place fuel gauge in position in instrument panel by pressing in from front of panel. Place fuel gauge clamp on 2 bolts in back of fuel gauge and attach with nut and washer on each bolt. Place terminal wires on each bolt and fasten with nut to each bolt.

**j. Ignition Switch Removal**

(1) Remove 2 screws attaching 2 wire terminals at back of ignition switch. Using combination pliers, remove knurl nut from ignition switch post in front of instrument panel. Remove ignition switch by pushing switch through panel from front.

**k. Ignition Switch Installation**

(1) Place ignition switch in position in instrument panel by pushing in from back. On front of instrument panel, place knurl nut over switch post and tighten with combination pliers. Attach two wires to two terminals in back of switch.

**l. Main Light Switch Removal**

(1) Remove 7 terminal wires attached to back of main light switch with 7 screws. At front of instrument panel loosen set screw holding knob to switch post and remove knob.

(2) Loosen hex locking nut on under side of switch housing.

(3) Compress switch locking plunger until housing will slip off switch post easily and remove housing. Remove lock nut and washer from switch post and remove main light switch assembly by pressing through from front of instrument panel.

**TRUCK, AMPHIBIAN, 2 1/2-TON, 6 x 6****m. Main Light Switch Installation**

(1) Insert main light switch through instrument panel from back and attach at front with lock nut and washer.

(2) Working from front of instrument panel, place switch housing over switch post. Compress switch locking plunger until housing slips over post freely. Press housing firmly against face of instrument panel and fasten by tightening hex locking nut in under side of housing. At back of instrument panel attach 7 wires to terminals on switch with attaching screws. Terminals on switch are lettered. Wires are identified by tracer color. Refer to Section XVIII.

**n. B. O. or Panel Light Switch Removal**

(1) Remove 2 terminal wires from back of B. O. driving switch held by two screws. Loosen set screw holding knob to switch post and remove knob.

(2) Remove nut and lockwasher from switch post. Remove switch from instrument panel by pushing through from front.

**o. B. O. or Panel Light Switch Installation**

(1) Insert switch into position in instrument panel board from back, fastening at front of panel with washer and lock nut. Place knob on switch post and fasten with set screw. Attach 2 wires to 2 terminals at back of switch.

**p. Temperature Gauge Removal**

(1) **Caution:** Do not attempt to disconnect capillary tube or seal from back of temperature gauge. Remove temperature gauge thermal plug from engine fitting by unscrewing nut at engine fitting.

(2) Remove 2 nuts at back of temperature gauge clamp plate and remove clamp plate. Remove temperature gauge by withdrawing gauge and capillary tube through upper toe board and instrument panel.

**q. Temperature Gauge Installation**

(1) Thread capillary tube through instrument panel and place gauge in position in instrument panel. Place temperature gauge clamp on two bolts of temperature gauge and fasten with 2 nuts.

(2) Thread capillary tube into engine compartment through opening in upper toe board. In engine compartment insert thermal plug into engine fitting and tighten holding nut.

**r. Instrument Panel Light Removal.** All three instrument panel lights are of the "button" type and can be removed by the following procedure:

(1) Remove panel light shield, located over light in instrument panel, by inserting point of screwdriver under rim of shield and giving screwdriver light twist. Remove instrument light unit by inserting point of screwdriver between rim of unit and light shield bracket, on back of instrument panel, and give screwdriver light twist.

## INSTRUMENTS AND GAUGES

### s. Instrument Panel Lights Installation

(1) Install instrument panel light shield by inserting light shield extension into panel from back of panel and "snapping" shield into place on front of panel. Install instrument panel light unit by "snapping" light unit into light shield extension on back of instrument panels.

### t. Hand Throttle Control Removal

(1) In engine compartment loosen screw in collar on end of hand throttle control wire and remove collar. Loosen control wire clip screw at carbureter. Loosen clip screw holding throttle wire flexible housing in throttle control wire clip at carbureter. Remove nut and lockwasher on back of throttle control assembly at instrument panel. Pull throttle control assembly out through instrument panel.

### u. Hand Throttle Control Installation

(1) Thread control wire and flexible housing through opening in instrument panel, sliding washer and lock nut over control wire and flexible housing as it is moved through panel.

(2) Fasten throttle control assembly to back of instrument panel with lockwasher and nut. Thread wire and flexible housing through upper toe board into engine compartment. In engine compartment thread wire and flexible housing through clip at carbureter, continuing flexible wire through end of carbureter rod. Attach end of flexible housing at clip at carbureter with bolt, nut and washer.

(3) Place stop collar on an end of flexible wire and fasten with set screw. For adjustment of stop collar on hand throttle control see Para. 203.

### w. Hand Choke Control Removal

(1) Loosen screw at carbureter choke lever swivel. Loosen control wire clip screw at carbureter end of flexible tubing. On back of instrument panel remove nut and lockwasher from hand choke control assembly.

(2) Remove hand choke control assembly by withdrawing through instrument panel.

### x. Hand Choke Control Installation

(1) Thread control wire and flexible housing through opening in instrument panel, sliding lockwasher and nut over control wire and flexible housing as it is moved through panel. Fasten hand choke assembly to back of instrument panel with lockwasher and nut.

(2) Thread control wire and flexible housing through hole in upper toe board into engine compartment. In engine compartment thread flexible wire and housing through clip at carbureter, continuing flexible wire through choke lever swivel.

(3) Attach end of flexible housing to clip at carbureter with set screw. Attach end of wire in choke lever swivel. For adjustment of the end choke control see Para. 203.

Section XXX

**PROPELLER SHAFTS, DRIVING AXLE**

	Paragraph
Description .....	222
Trouble-shooting .....	223
Inspection and preventive maintenance.....	224
Propeller shaft housing assembly replacement.....	225
Propeller shaft assembly replacement.....	226
Pillow block assembly replacement.....	227
Propeller shaft housing seal replacement.....	228

**222. DESCRIPTION**

**a. Propeller shaft assemblies. (Fig. 159).** A total of six propeller shaft assemblies are used in transmitting power between main transmission and the three driving axles. Each shaft assembly consists of either a tubular or solid shaft with a slip joint to permit lengthwise movement, and with universal joints at each end to permit movement at right angles to the shaft.

**b. Propeller shaft housing assemblies.** The propeller shaft assemblies connecting main transfer case to front axle, to forward rear axle, and to pillow block are each encased in a separate tubular metal housing (Refer to Fig. 159). Each housing is attached at one end to outside of hull by a hinge and synthetic rubber bellows and, at other end, to axle differential carrier or pillow block by a support and synthetic rubber bellows. These housings, with bellows type seals at each end, are required to prevent leakage of water into hull. No housing is used at propeller shaft between pillow block and rearward rear axle.

**223. TROUBLE-SHOOTING**

**a. General.** Unusual noises or vibrations are generally the first indication of improper conditions in driving axle propeller shaft assemblies. However, before replacing a propeller shaft, be certain that noise or vibration is being caused by propeller shaft and not by loose hatches, grilles, floorboards, etc. Failure of propeller shaft or housing seals will be evidenced by water leakage during water operation.

**b. Trouble-Shooting Table**

Symptom and Probable Cause	Probable Remedy	Refer to Paragraph
(1) <b>Excessive noise or vibration</b>		
(a) Pillow block attaching screws loose.	Tighten screws .....	227
(b) Universal joint yokes on ends of shaft assemblies not in same plane.	Disconnect shaft at slip joint and reassemble with yokes in same plane.....	226
(c) Universal joints require lubrication.	Lubricate joints .....	Section VI



PROPELLER SHAFTS, DRIVING AXLES

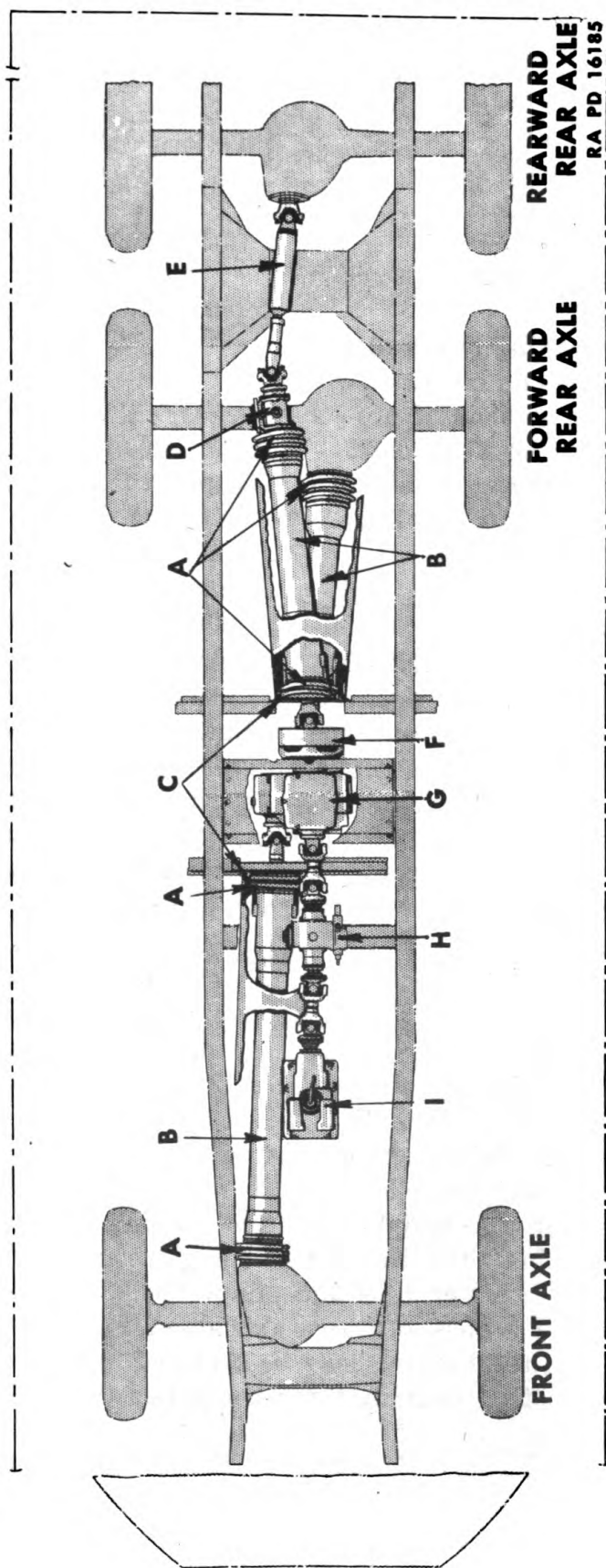

Figure 159—Arrangement of Axle Propeller Shafts and Housing

- |   |                              |   |                          |   |                               |
|---|------------------------------|---|--------------------------|---|-------------------------------|
| A | Propeller Shaft Housing Seal | D | Pillow Block             | G | Main Transfer Case            |
| B | Propeller Shaft Housing      | E | Propeller Shaft Assembly | H | Water Propeller Transfer Case |
| C | Hull Bulkheads               | F | Hand Brake               | I | Transmission                  |

**TRUCK, AMPHIBIAN, 2 1/2 -TON, 6 x 6**

Symptom and Probable Cause	Probable Remedy	Refer to Paragraph
(d) Universal joint bearings or trunnions worn.	Replace shaft assembly . . .	226
(e) Propeller shaft sprung.	Replace shaft assembly . . .	226
(f) Pillow block bearings out of adjustment.	Adjust bearings . . . . .	227
(g) Pillow block bearings worn excessively.	Replace bearings . . . . .	227
<b>(2) Water leaking into hull</b>		
(a) Clamp rings on bellows type seals at ends of propeller shaft housing loose.	Tighten clamps . . . . .	228
(b) Seal retainer ring at bulkhead ends of housings loose.	Tighten the 12 nuts on each of the three retainer rings . . . . .	228
(c) Seal punctured.	Replace defective seal . . .	228
(d) Housing damaged.	Replace defective housing	225

**224. PREVENTIVE MAINTENANCE AND INSPECTION**

a. Operations itemized in Section V, "Preventive Maintenance and Inspection" should be accomplished at intervals indicated. One of the most important items in preventive maintenance of propeller shafts is a periodic inspection of propeller shaft seals at the housing. In addition to propeller shaft, flange bolts and universal joints should be checked at regular intervals and attaching bolts tightened.

**225. PROPELLER SHAFT HOUSING ASSEMBLY REPLACEMENT**

a. **General.** Replacement of the propeller shaft housing assemblies between transfer case and front axle or between transfer case and forward rear axle requires disconnecting housing hinge, removal of clamps at the bellows type seals at each end of the housing, sliding housing assembly into hull as far as possible, loosening baffle on propeller shaft, disconnecting housing support from differential carrier, disconnecting propeller shaft at universal joint at axle pinion shaft, dropping axle end of shaft and housing downwards away from axle, and then withdrawing housing assembly. To remove housing between transfer case and pillow block it is necessary to jack up rear end of vehicle until rear axle assembly hangs free. With axle hanging free the housing may be replaced by following a procedure similar to that described for the other two axle propeller shaft housings.

**b. Removal Procedure (Housing To Front Axle Or To Forward Rear Axle)**

**(1) Disconnect hinge from housing**

Remove the three cap screws and washers from hinge at hous-

## PROPELLER SHAFTS, DRIVING AXLES

ing. One screw is located at bottom of housing and one is located at each side of housing.

(2) **Loosen housing seal clamp rings**

Remove screw from clamp at end of rubber bellows on propeller shaft housing and remove the clamp.

(3) **Slide housing into hull**

Work housing assembly away from axle and through hole in bulkhead into the hull as far as possible. Do not pinch or damage seal at hull end during this operation. Pull seal at axle end off of housing.

(4) **Disconnect universal joint**

Remove the four nuts and lockwashers from the two "U" bolts (Fig. 160) at the universal joint at axle pinion. Push "U" bolts out of flange, thus disconnecting propeller shaft. Do not drop needle bearings from ends of the joint when "U" bolts are removed. Wrap a piece of tape around the trunnion to hold bearings in place after "U" bolts are removed.

(5) **Move baffle on propeller shaft**

Loosen bolts on baffle near yoke at axle end of propeller shaft and slide baffle along propeller shaft, away from axle end.

(6) **Disconnect housing support**

Remove the four cap screws and washers attaching housing support and pinion bearing cap to axle differential carrier. Do not remove the two remaining cap screws which hold only the bearing cap.

(7) **Remove housing assembly**

When preceding operation is completed drop housing and propeller shaft down at axle end so housing may be pulled forward out of hull. Remove housing assembly from vehicle.

**c. Installation Procedure (Housing To Front Axle Or To Forward Rear Axle)**

(1) **Place housing over shaft**

Slide housing over propeller shaft from axle end. Be sure end with hinge screw tapping plates are towards hull and reinforcing channel is at bottom. Slide housing through rubber bellows at hull and on through hole in hull as far as possible.

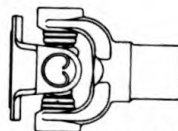
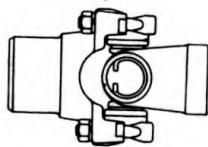

RA PD 16186

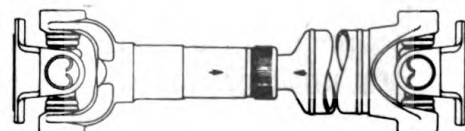

RA PD 16187

**Figure 160—Universal Joints**

**Figure 161—Slip Joints**



**TRUCK, AMPHIBIAN, 2½-TON, 6 x 6****(2) Connect housing support**

Raise end of propeller shaft and housing assembly into position with housing support over end of propeller shaft. Then attach the support to the differential carrier with the four cap screws. Use new lockwashers and tighten screws. Be sure end of shaft is inside ringed end of support before screws are installed because there is not enough free movement at shaft slip joint to permit moving shaft into alignment with axle pinion after support is installed.

**(3) Connect universal joint**

Remove tape or wrapping holding the needle bearing assemblies to the universal joint trunnions and hold bearings in place with fingers. Move shaft into position so that bearing cages seat in yoke on differential pinion shaft. Then install the two "U" bolts. Use new lockwashers and tighten nuts on the "U" bolts.

**(4) Tighten baffle on propeller shaft**

Move baffle on propeller shaft close to end of shaft and tighten the two bolts to hold it firmly in position.

**(5) Connect hinge to housing**

Draw housing over ring on housing support at differential carrier and slide it fore or aft as necessary until holes in tapping plates at each side and bottom will line up with corresponding holes in hinge. Use new lockwashers, install the three screws and tighten.

**(6) Connect seals to housing**

Work rubber bellows onto axle end of housing until straight portion of bellows is past ring crimped in housing. Work bellows at opposite end into similar position and install clamp ring. To install clamp ring, wrap ring strap around straight portion of bellows on housing so edge of strap is beyond crimp in housing. Slip free end of strap through slot in nut and pull strap tight with a pair of pliers, then bend down flat. Tighten clamp screw.

**d. Removal Procedure (Housing To Pillow Block)****(1) Jack up rear end of vehicle**

Block front wheels and install jacks under spring trunnion cross shaft brackets. Raise vehicle on jacks until axle assemblies hang free. Be certain jacks are installed so that they cannot slip or permit vehicle to fall. Vehicle must be jacked up until wheels are clear of ground to permit removal of the housing from the housing support on front end of pillow block.

**(2) Remove housing assembly**

Proceed with instructions given in Para. 225b., operations (1),



**PROPELLER SHAFTS, DRIVING AXLES**

(2), (3), (4) and (7) except that end of housing is raised and housing removed over top of axle housing.

**e. Installation Procedure****(1) Install housing assembly**

Proceed as instructed in Para. 225a., operations (1), (3), (5) and (6).

**(2) Remove jacks.** Lower vehicle on jacks and remove the jacks and the blocks from front wheels.**226. PROPELLER SHAFT ASSEMBLY REPLACEMENT**

**a. General.** Propeller shaft assemblies between water propeller transfer case and either the transmission or main transfer case may be removed by removing floor boards and disconnecting flanges at universal joints. Removal of shafts from main transfer case to front axle, forward rear axle and pillow block require removal of floor boards, disconnecting universal joints and disconnecting propeller shaft housings. Shaft between pillow block and rearward rear axle may be removed by disconnecting universal joints at each end of this shaft.

**b. Removal Procedure.** Shafts between water propeller transfer case and either the transmission or the main transfer case.

**(1) Remove floor boards**

To remove shaft assembly to front of water propeller transfer case remove center and left section of driver's compartment floor boards. Four screws attach center section and five attach left-hand section. Shaft to rear of water propeller transfer case can be removed after center section of air intake grille behind driver's seat is removed.

**(2) Disconnect universal joint flanges**

Disconnect universal joint flanges from companion flanges. Remove four nuts, washers and bolts from universal joint flanges at each end of propeller shaft assembly.

**(3) Remove propeller shaft assembly**

Separate flanges on the propeller shaft assembly from companion flanges by pushing shaft together at slip joint. Then lift shaft assembly out of vehicle.

**c. Installation Procedure.** Shaft between water propeller transfer case and either the transmission or the main transfer case.

**(1) Inspect before installing**

Each shaft assembly has a splined slip joint. (See Fig. 161 and 162.) When the two parts of the shaft are assembled at the slip joint the propeller shaft yokes at each end must be in the same plane. Marks on the male and female portion of the slip joint must be in line. If the marks are not in line, loosen the dust cap on female portion of joint, pull shaft apart at joint and

**TRUCK, AMPHIBIAN, 2 1/2-TON, 6 x 6**

reassemble with marks in line. Be certain splines are lubricated and oil seal in dust cap is not damaged. After joint is reassembled so marks are in line tighten the dust cap finger-tight.

**(2) Install shaft assembly**

Place shaft assembly in position between companion flanges on transmission and water propeller transfer case (or main transfer case and water propeller transfer). The slip joint grease fitting should be towards front of vehicle. Insert four bolts through each companion flange and universal joint flange, install new lockwashers, and tighten alternate nuts until all are drawn up securely.

**(3) Replace floor boards or grille**

Install left and center section of driver's compartment floor boards or center section of air intake grille, whichever was removed. Attach left-hand floor board with five screws and center floor board with four screws. The center section of air intake grille is not fastened in place.

**d. Removal Procedure. Shafts between main transfer case and front axle, forward rear axle, or pillow block.****(1) Remove cargo compartment floor board**

Lift out front center section of cargo compartment floor boards to permit access to universal joints at the main transfer case.

**(2) Disconnect shaft from main transfer case**

Remove nuts and washers from "U" bolts attaching companion flange on transfer case shaft to universal joint trunnion on propeller shaft for either the front or forward rear axle. Wrap tape around trunnion to hold needle bearing assemblies in place after the "U" bolts are removed. Disconnect shaft between transfer case and pillow block by removing four bolts connecting companion flange and shaft universal joint flange at transfer case.

**(3) Remove propeller shaft assembly**

Disconnect propeller shaft housing and universal joint from axle or pillow block as instructed in Para. 225. Do not withdraw the housing assembly from vehicle. Withdraw propeller shaft assembly from housing, pulling it out from axle end of housing.

**e. Installation Procedure. Shafts between main transfer case and front axle, forward rear axle, or pillow block.****(1) Inspect before installing**

Be certain shaft slip joint is assembled so yokes at each end of assembly are in the same plane. See instructions in Para. 226c., operation (1).

## PROPELLER SHAFTS, DRIVING AXLES

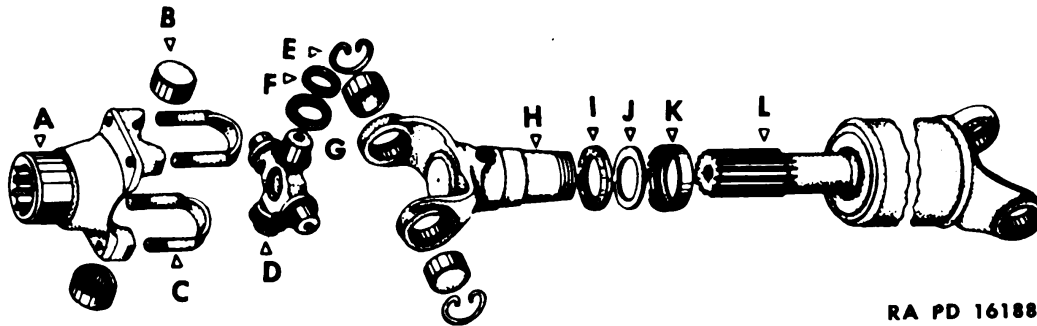

RA PD 16188

**Figure 162—Disassembled view of propeller shaft and universal joint assembly as used between main transfer case and front axle, main transfer case and forward rear axle, or pillow block and rearward rear axle**

A	Flange	H	Yoke, Sleeve
B	Assembly, Trunnion Bearing	I	Seal, Dust
C	"U" Bolt	J	Washer, Split
D	Journal	K	Cap, Dust
E	Ring, Bearing Snap Lock	L	Shaft and Yoke
F	Gasket		
G	Retainer, Gasket		

(2) **Install propeller shaft assembly**

Install propeller shaft through propeller shaft housing with slip joint end of shaft assembly towards transfer case. Then connect universal joint at axle or pillow block and replace propeller shaft housing as instructed in Para. 225.

(3) **Connect shaft to transfer case**

Attach universal joint at transfer case end of propeller shaft to flange on transfer case shaft. Follow instructions in Para. 225c., operation (3) for front or forward rear axle propeller shaft. Attach flange on front universal joint of propeller shaft between pillow block and main transfer case to flange on transfer case shaft with four bolts, nuts and lockwashers, tightening alternate nuts.

(4) **Replace cargo compartment floor board**

Set cargo compartment floor board in place in cargo compartment.

**f. Removal Procedure. Propeller shaft assembly between pillow block and rearward rear axle.**

(1) **Disconnect universal joints**

Remove the four nuts and lockwashers from the two "U" bolts which hold universal joint trunnions to flanges at pillow block and at rearward rear axle. Drive out the "U" bolts, being careful not to drop the needle bearing assemblies from trunnions.

(2) **Remove shaft assembly**

Shorten shaft by moving shaft together at slip joint, thus separating universal joints from flanges. Remove shaft assem-

**TRUCK, AMPHIBIAN, 2½-TON, 6 x 6**

bly from vehicle and wrap tape around trunnions to hold universal joint needle bearings in place.

**g. Installation Procedure. Propeller shaft assembly between pillow block and rearward rear axle.**

**(1) Inspect before installing**

Be certain shaft slip joint is assembled so yokes at each end of assembly are in same plane. Follow instructions given in Para. 226c., operation (1).

**(2) Install propeller shaft assembly**

Place shaft assembly in position between flanges on rear of pillow block and on rearward rear axle drive pinion. Slip joint end of shaft must be towards pillow block. Remove tape or wrapping holding bearings on universal joint trunnion at one end of shaft, holding bearings in place with fingers. Insert the two "U" bolts connecting trunnion to companion flange, install new lockwashers and place nuts on "U" bolts. Tighten alternate nuts. Then repeat this procedure at opposite end of shaft assembly.

**227. PILLOW BLOCK ASSEMBLY REPLACEMENT**

**a. General.** Removal of pillow block assembly requires disconnecting propeller shaft housing and propeller shaft from front end of pillow block, disconnecting propeller shaft from rear of pillow block and removing four cap screws which attach pillow block to bracket on top of forward rear axle housing.

**b. Removal Procedure. (Pillow Block Assembly)**

**(1) Disconnect propeller shaft and housing from front end of pillow block**

Follow procedure given in Para. 225d.

**(2) Disconnect propeller shaft from rear of pillow block**

Follow instructions in Para. 226f., disconnecting shaft at pillow block end only.

**(3) Remove pillow block**

Remove four cap screws and lockwashers which attach pillow block to bracket on housing and remove the pillow block assembly from the vehicle.

**c. Oil Seal Replacement (See Fig. 163).**

**(1) Mount pillow block in vise**

Clean any dirt or grease from outside of pillow block assembly and mount assembly in vise.

**(2) Remove propeller shaft flanges**

Remove cotter pin and nut from each end of pillow block shaft and pull propeller shaft flanges off of shaft with flange puller KMJ-1714. Remove keys at each end of shaft and, at rear end,



## PROPELLER SHAFTS, DRIVING AXLES

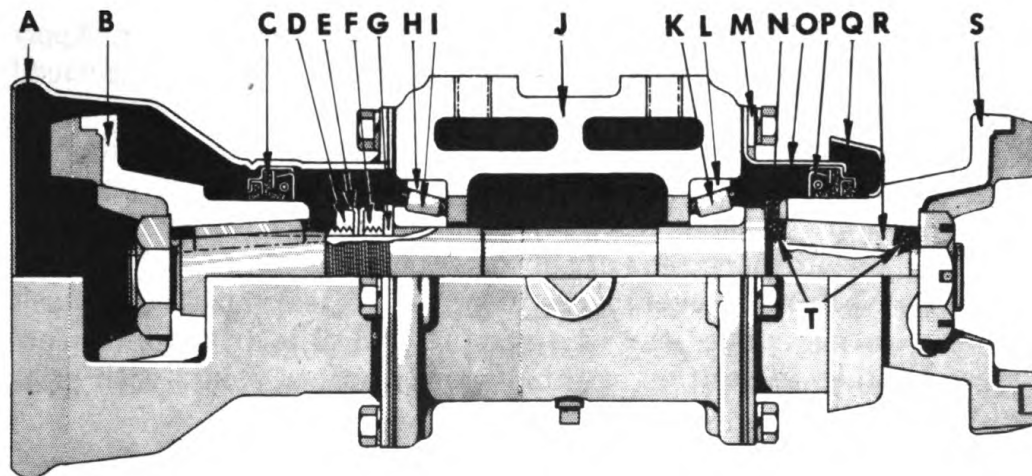

RA PD 16189

Figure 163—Pillow Block Assembly

<b>A</b>	<b>Propeller Shaft Support Housing</b>	<b>K</b>	<b>Rear Bearing Cone</b>
<b>B</b>	<b>Propeller Shaft Flange</b>	<b>L</b>	<b>Rear Bearing Cup</b>
<b>C</b>	<b>Oil Seal Assembly</b>	<b>M</b>	<b>Spacer</b>
<b>D</b>	<b>Adjusting Nut Lock Nut</b>	<b>N</b>	<b>Felt Washer</b>
<b>E</b>	<b>Adjusting Nut and Locknut Locks</b>	<b>O</b>	<b>Pillow Block Rear Cover</b>
<b>F</b>	<b>Adjusting Nut</b>	<b>P</b>	<b>Oil Seal Assembly</b>
<b>G</b>	<b>Adjusting Nut Washer</b>	<b>Q</b>	<b>Dust Shield</b>
<b>H</b>	<b>Front Bearing Cup</b>	<b>R</b>	<b>Key</b>
<b>I</b>	<b>Front Bearing Cone</b>	<b>S</b>	<b>Propeller Shaft Flange</b>
<b>J</b>	<b>Pillow Block</b>	<b>T</b>	<b>Cork Seals</b>

remove the two cork seals from keyway and the felt washer from shaft.

**(3) Remove propeller shaft housing support**

Remove the six cap screws and lockwashers which attach housing support to front end of pillow block. Then remove the housing support and oil seal as an assembly.

**(4) Remove rear cover and oil seal assembly**

Remove six cap screws and washers at rear of pillow block. Then, remove the spacer and the cover and oil seal assembly.

**(5) Replace oil seals**

One spring loaded type seal is located in the propeller shaft housing support at front of pillow block and one is located in cover at rear of pillow block. Both are staked in place with a prick punch at assembly. To replace either seal proceed as follows:

- (a) Drive seal out of housing support or rear cover using oil seal replacer tool KM-J-2345.
- (b) Clean up prick punch marks used to retain seals, using a small file. Be sure surface is smooth and clean before installing new seal.

**TRUCK, AMPHIBIAN, 2½-TON, 6 x 6**

- (c) Apply a coat of sealing compound to outside surface of seal where it will contact housing support or cover. Apply thin, smooth coat, being very careful that no compound gets on the sealing surface itself.
- (d) Install seal in housing support or in rear cover using replacer tool KM-J-2345. When installing seal in propeller shaft housing support, small diameter of seal must be towards large end of support. When installing seal in pillow block rear cover, large diameter of seal must be towards large, flanged end of cover. After seal is driven into place stake in position at three equally spaced points with prick punch.

**d. Pillow Block Shaft and Bearing Replacement****(1) Remove bearing adjusting nut**

While propeller shaft housing support and pillow block rear cover are removed for seal replacement (see c. above), bearings and shaft should be removed for inspection. Bend tangs of lockwashers away from bearing lock nut and adjusting nut on pillow block shaft. Then remove lock nut, both lockwashers, adjusting nut and adjusting nut washer.

**(2) Remove pillow block shaft**

Tap front end of shaft with soft-faced hammer, driving shaft out through rear of pillow block. Front bearing cone is a loose fit on shaft and will remain in cup. Rear bearing cone is a press fit on shaft and will remain on shaft. Both bearing cups are pressed in housing.

**(3) Remove bearings**

Lift front bearing cone from cup in pillow block. Remove rear bearing cone with bearing puller. Clean and inspect bearing cups in pillow block but do not remove unless damaged or worn excessively. If necessary, drive cups out of ends of block with brass drift or driver KM-J-2344B. Tap alternately on opposite sides of cup so cup will come out without becoming cocked in housing.

**(4) Clean bearings**

Clean and inspect bearings as follows:

- (a) Soak in suitable cleaning fluid such as clean gasoline.
- (b) Remove from fluid and strike larger side of bearing flat against a wood block to knock out heavier particles of dirt.
- (c) Blow bearings clean and dry with compressed air, directing air across bearings. Be careful not to spin bearings.
- (d) Rotate bearings slowly by hand, and inspect rollers and races for defects and excessive wear.
- (e) After inspection, dip bearings in engine oil and wrap in clean cloth.

**PROPELLER SHAFTS, DRIVING AXLES****(5) Install bearings**

If bearing cups were removed, drive one cup into each end of housing with bearing driver KM-J-2344A until seated solidly in housing. Lubricate and install rear bearing cone on pillow block shaft using bearing driver KM-J-2343. Drive bearing solidly against shoulder on shaft.

**(6) Install shaft and adjust bearings**

With rear bearing cone in place on shaft, install shaft from rear of pillow block. Lubricate and install front bearing cone over front end of shaft, sliding into place in front bearing cup. Install adjusting nut washer and adjusting nut on shaft. If rear bearing cone was removed from shaft, or if either of the cups were removed from pillow block, tighten adjusting nut solidly to be certain all bearings are seated properly. Then back nut off just enough to permit shaft to spin in bearings. There must be no perceptible end play, however, when bearings are in final adjustment install two new adjusting nut lockwashers and replace adjusting nut lock nut. Tighten locknut, being careful not to change bearing adjustment. Check to be certain shaft has no end play but still turns freely after tightening lock nut. Then bend tangs of locks over flats on nuts.

**(7) Install propeller shaft housing support**

Place new gasket on front end of pillow block and install the propeller shaft housing support and oil seal assembly on front end of pillow block. (Bellows type housing seal must be in place on support before support is attached to pillow block.) Attach with six cap screws using new lockwashers and tightening screws securely.

**(8) Install pillow block rear cover**

Place new gasket on rear of pillow block, install the cover and oil seal assembly and the spacer. Attach to pillow block with six cap screws, using new lockwashers and tightening screws securely. Be certain spacer is installed between cover flange and lockwashers. (See Fig. 163.)

**(9) Install propeller shaft flanges**

Install new felt washer at rear end of shaft. Place keys in keyways at each end of shaft. Apply sealing compound to keyways from end of key to end of shaft; press new cork seals into keyways. Cover corks with compound. Install propeller shaft flange at each end of shaft, sliding hub of flange through oil seal very carefully. Be certain outer portion of seal is not damaged or doubled back while installing the flange. Install flange nuts at each end of shaft, tighten solid and lock in place with new cotter pin.

**TRUCK, AMPHIBIAN, 2 1/2-TON, 6 x 6**

**e. Installation Procedure (Pillow Block Assembly)**

**(1) Install pillow block**

Mount pillow block on left side of bracket on top of forward rear axle with propeller shaft housing support towards front of vehicle. Attach with four cap screws using new lockwashers.

**(2) Connect propeller shaft at rear of pillow block**

Connect universal joint on front end of rearward rear axle propeller shaft to flange at rear of block. (See Para. 226g.)

**(3) Connect propeller shaft and propeller shaft housing at front of pillow block**

Connect universal joint yoke on rear of propeller shaft between transfer case and pillow block to flange at front end of pillow block and connect the propeller shaft housing. Para. 225e.

**228. PROPELLER SHAFT HOUSING SEAL REPLACEMENT**

**a. General.** Replacement of rubber bellows type seals at axle or pillow block end of propeller shaft housings requires disconnecting housings and universal joints at axle or pillow block ends and removing clamp ring from housing support. Replacement of seals at bulkhead end of housings requires removing housings from vehicle and removing seal retainer rings which attach seals to bulkheads.

**b. Removal Procedure. Seals at Front or Forward Rear Axle**

**(1) Disconnect housing and propeller shaft**

For seal at front axle or forward rear axle follow instructions in Para. 225b., operation (1) through (6). Do not remove housing assembly from vehicle.

**(2) Disconnect seal**

Remove screw from clamp ring attaching seal to differential carrier, remove clamp, and pull seal away from carrier.

**c. Installation Procedure. Seal at Front or Forward Rear Axle**

**(1) Connect seal to axle**

Work large end of seal onto flange of axle drive pinion bearing cap. Wrap clamp ring strap around straight portion of bellows at bearing cap flange. Slip free end of strap through slot in nut and pull strap tight with a pair of pliers, then bend free end down flat. Install clamp screw and draw up tight.

**(2) Connect propeller shaft and housing**

Install housing support, and connect propeller shaft and propeller shaft housing at axle as instructed in Para. 225c.

**d. Removal Procedure. Seal at Pillow Block**

**(1) Disconnect housing and propeller shaft**

Disconnect propeller shaft housing and propeller shaft from pillow block assembly in accordance with instructions in Para. 225d., but do not remove housing from vehicle.

**(2) Remove housing support**

Remove propeller shaft yoke from front of pillow block shaft



**PROPELLER SHAFTS, DRIVING AXLES**

and remove propeller shaft housing support and seal assembly from front of pillow block as instructed in Para. 227c.

**(3) Remove seal from housing support**

Remove clamp from seal at rear of housing support. Then work small end of seal over flange on rear of housing support and remove the seal.

**e. Installation Procedure. Seal at Pillow Block****(1) Install seal on housing support**

Install seal from flanged end of propeller shaft housing support with large end of seal towards large end of support. Work small end of seal over flange on end of support. Then install clamp ring. See Para. 228c., operation (1).

**(2) Install housing support on pillow block**

Replace housing support and seal assembly on front end of pillow block and install propeller shaft yoke on front end of pillow block shaft as instructed in Para. 227d., operation (7).

**(3) Connect housing and propeller shaft**

Connect propeller shaft universal joint at front of pillow block and replace propeller shaft housing as instructed in Para. 225e.

**f. Removal Procedure. Seals at Bulkhead****(1) Remove propeller shaft housing**

To remove any of the three propeller shaft housing to hull bulkhead seals, remove the propeller shaft housing assembly as instructed in Para. 225. It is not necessary to disconnect propeller shaft at main transfer case end.

**(2) Remove seal retainer ring and seal**

Lift out front center section of cargo compartment floor boards and remove the twelve nuts and lockwashers from studs on housing seal retainer ring. While still inside hull push on studs to loosen retainer ring from seal. Then remove retainer ring and seal from outside of hull bulkhead.

**g. Installation Procedure. Seals at Bulkhead****(1) Install seal retainer ring on seal**

Push flanged end of seal through the retainer ring with ring studs facing away from seal. Move ring into position on seal with studs through stud holes in seal.

**(2) Install seal on hull bulkhead**

Place seal in position on outside of hull bulkhead with retainer studs in holes in bulkhead. Install nuts and new lockwashers on studs from inside of vehicle tighten all nuts finger tight, then draw up nuts on opposite sides alternately until all are tightened evenly.

**(3) Replace housing assembly**

Install shaft housing assembly as instructed in Para. 225.

Section XXXI

**WATER PROPELLER AND DRIVE**

	Paragraph
General description .....	229
Operation .....	230
Trouble-shooting .....	231
Preventive maintenance and inspection.....	232
Stuffing box maintenance .....	233
Oil seal replacement .....	234
Transfer case replacement .....	235
Control linkage replacement .....	236
Propeller shafts replacement .....	237
Thrust bearing assembly replacement .....	238
Water propeller replacement .....	239
Strut bearing replacement .....	240

**229. GENERAL DESCRIPTION**

a. Water propeller and drive includes water propeller transfer case, propeller shafts, thrust bearing at rear axle trunnion cross-member, stuffing box, strut bearing, and water propeller. Location of the various units is shown in Fig. 164.

b. **Water Propeller Transfer Case.** Water propeller transfer case, essentially a split propeller shaft power take-off, consists of a case, gears and output shafts for transfer of power to main transfer case, gear type bilge pump, and water propeller.

c. **Thrust Bearing Assembly.** Thrust bearing assembly consists of a double row ball bearing, two retainers, two spring loaded oil seals, a housing, and a threaded bearing cap. The two retainers are held in housing by bearing cap and a bolt. Outer surface of retainers and inner surfaces of housing are spherical in shape to provide a means of aligning thrust bearing with water propeller shaft strut bearing. The bolt in housing is provided to clamp retainers in position after bearings are in alignment.

d. **Stuffing Box.** Stuffing box assembly around rear water propeller shaft consists of a housing, two bushings, a packing nut, a lock nut and a woven graphite cord packing.

**230. OPERATION**

a. Water propeller may be engaged or disengaged by raising or lowering control lever knob at right of driver's seat. Control rod is connected to shifter shaft in cover of water propeller transfer case through cross shaft and linkage mounted at rear of transmission. Drive for water propeller is taken from upper rear flange of transfer case through propeller shafts to propeller. Driving thrust is taken by collar, which is held to shaft with two tapered pins,

**WATER PROPELLER AND DRIVE**

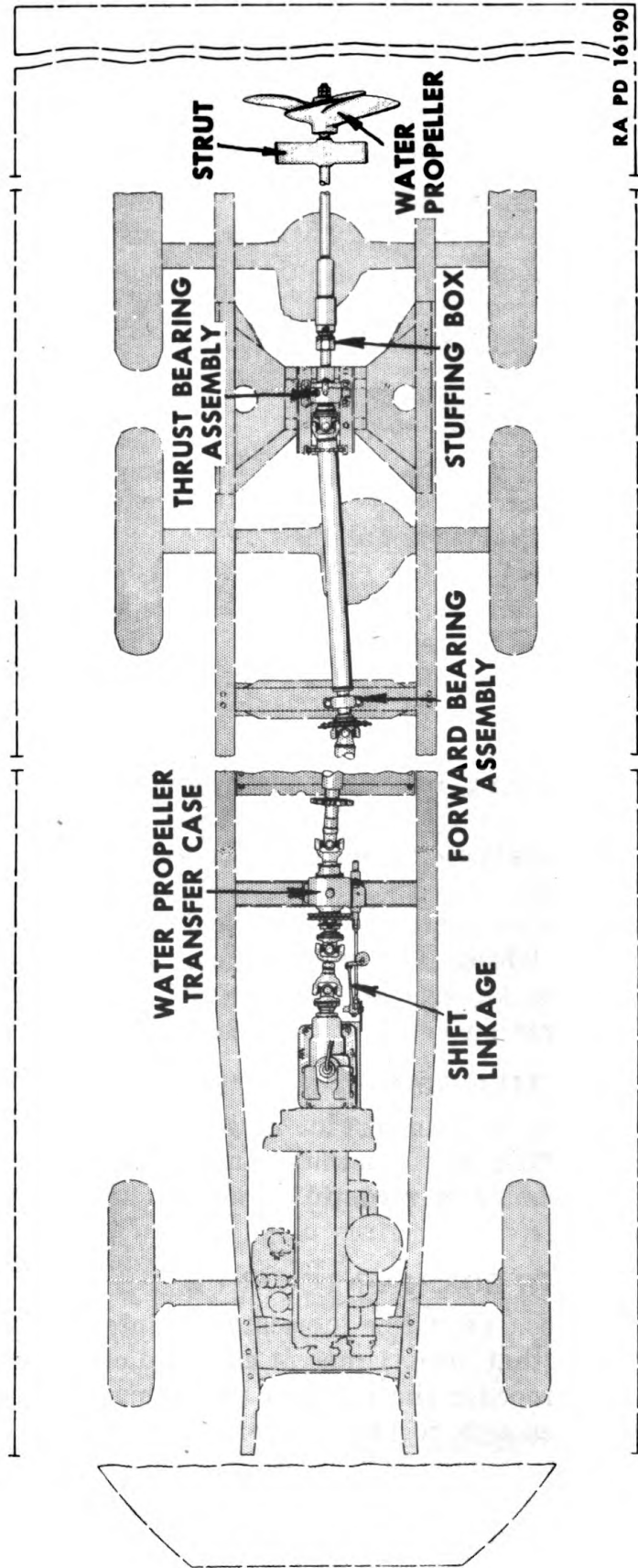

**Figure 164—Water Propeller and Drive Installation**

**TRUCK, AMPHIBIAN, 2 1/2-TON, 6 x 6**

and thrust bearing assembly. Transfer case is connected directly to transmission and all transmission ratios are available although it is recommended that no speed higher than third be used.

**231. TROUBLE-SHOOTING**

a. Operating difficulties encountered in water propeller and drive will most likely be confined to noisy operations of transfer case and propeller shafts, excessive vibration in propeller shafts or hard shifting of transfer case.

**(1) Excessive vibration or noise in propeller shafts**

Symptom and Probable Cause	Probable Remedy	Refer to Paragraph
(a) Water propeller bent or loose	Replace or tighten . . . . .	239
(b) Strut bearing worn	Replace bearing . . . . .	240
(c) Thrust bearing not aligned with strut bearing	Adjust bearing . . . . .	238
(d) Drive shafts sprung	Replace shafts . . . . .	237
(e) Universal joints worn or lacking lubrication	Replace shafts . . . . .	237
(f) Bearing support bolts loose	Tighten bolts and nuts. . . . .	238

**(2) Hard shifting**

(a) Poor driving practices	Follow recommended procedure . . . . .	16
(b) Cross shaft seized in brackets	Inspect, clean and lubricate . . . . .	236
(c) Control rods sprung	Replace rods . . . . .	236

**(3) Loss of lubricant in transfer case**

(a) Worn or damaged oil seals	Notify Ordnance	
(b) Damaged gaskets	Replace gaskets . . . . .	234

**232. PREVENTIVE MAINTENANCE AND INSPECTION**

a. Two of the most important inspection and maintenance procedures are stuffing box adjustment and inspection of water propeller. Reference should be made to Paras. 233 and 239 for details on these procedures.

**233. STUFFING BOX MAINTENANCE**

a. Stuffing box should be lubricated at intervals as directed in Section VI. See that hose clamps at each end of hose between stuffing box and propeller shaft tunnel are tight. Packing nut should be kept tight enough to prevent serious water leaks but not so tight as to cause stuffing box to become overheated.

**b. Adjustment Procedure (Fig. 165).**

**(1) Adjust stuffing box**

Raise one edge of rear center section of cargo compartment



## WATER PROPELLER AND DRIVE

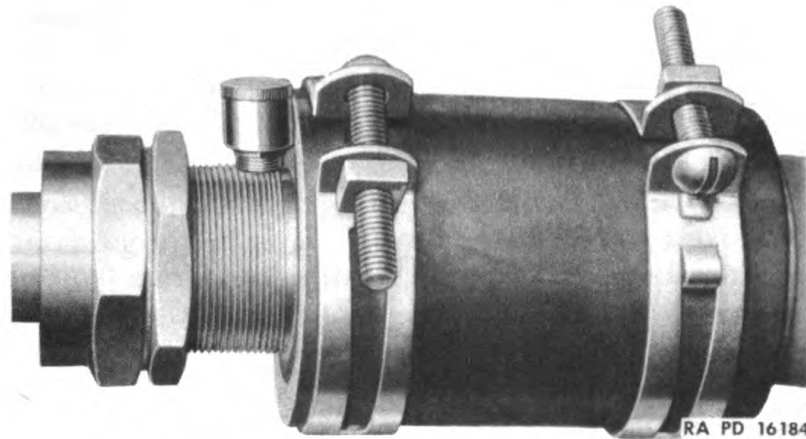

**Figure 165—Water Propeller Stuffing Box**

floor board and slide board over side boards in order to gain access to stuffing box. Loosen lock nut, tighten packing nut 1/6 turn, and tighten lock nut. If leak does not stop, wait a few minutes and turn nut 1/6 turn more. When limit of adjustment is reached (packing nut bottoms on stuffing box housing) back off packing nut until it is free of stuffing box and replace the packing.

### 234. OIL SEAL REPLACEMENT

a. Oil seals at each end of the lower shafts of the water propeller transfer case may be replaced after propeller shaft flanges and bearing retainers are removed. Oil seals at upper shaft are accessible after pulley and yoke at each end of shaft are removed.

b. Thrust bearing oil seals replacement cannot be accomplished until intermediate propeller shaft is removed and thrust bearing assembly is removed from shaft.

c. Notify Ordnance maintenance personnel.

### 235. TRANSFER CASE REPLACEMENT

a. Water propeller transfer case may be lifted out of vehicle through air intake grille opening after propeller shafts, shift control rod and bilge pump belt are removed.

#### b. Removal Procedure

##### (1) Remove center section floor board and air intake grille

Remove center section of driver's floor board and air intake grille in order to gain access to transmission to transfer case propeller shaft.

##### (2) Remove propeller shafts from water propeller transfer case to transmission and main transfer case

(a) Loosen dust cap at slip joint. Remove four bolts and nuts from flanges at each end of propeller shaft. Separate flanges by pushing shaft together at slip joint and lift propeller shaft out of vehicle.

**TRUCK, AMPHIBIAN, 2 1/2-TON, 6 x 6**

**(3) Remove forward water propeller shaft**

Remove shaft as directed in Para. 237b.

**(4) Remove belt from bilge pump drive pulley**

Loosen two pump mounting bracket bolts and slide pump and mounting bracket toward center of vehicle to slacken belt. Then remove drive belt.

**(5) Remove transfer case**

Disconnect water propeller control rod from shifter shaft in cover of transfer case by removing cotter and clevis pin. Remove two bolts and nuts which attach transfer case to lower support and one bolt at upper support then lift transfer case out through air intake grille opening.

**c. Transfer Case Installation Procedure**

**(1) Install transfer case**

Place transfer case between flanges of lower support and install two bolts and nuts which attach case to support. Then install bolt which attaches case to upper support. Connect water propeller control rod to shifter shaft using a cotter and clevis pin.

**(2) Install propeller shafts**

Push lower propeller shafts together at slip joint and place in position. Install and tighten four bolts and nuts in flanges at each end of shaft then tighten dust cap at slip joint. Install forward water propeller as directed in Para. 237c.

**(3) Install belt over bilge pump drive pulley**

Install and adjust bilge pump drive belt as directed in Para. 212.

**236. CONTROL LINKAGE REPLACEMENT**

a. Water propeller transfer case control linkage is accessible after center section of driver's compartment floor board is removed. Control linkage is not adjustable and any bent or distorted parts should be replaced.

**b. Linkage Removal Procedure**

**(1) Remove shifter shaft control rod**

Disconnect control rod at shifter shaft and cross shaft shift lever by removing cotter and clevis pins, then remove rod.

**(2) Remove cross shaft and shift lever**

Loosen clamp bolt in shift lever and move lever towards center of vehicle far enough to expose key in shaft. Remove key and shaft hairpin locks at inner and outer sides of left-hand bracket and remove shaft.

**(3) Disconnect power plant stabilizer rod**

Disconnect power plant stabilizer rod at left-hand cross shaft bracket by removing cotter and clevis pin.

## WATER PROPELLER AND DRIVE

### (4) Remove cross shaft brackets

Disconnect winch control lever at power take-off shifter shaft by removing cotter and clevis pin. Remove cotter pin at end of winch control lever to transmission stud and remove lever and stud. Remove nut which attaches left-hand bracket to transmission and slide bracket off stud. Remove two nuts attaching right-hand bracket to transmission, loosen hand brake cross shaft brackets, and remove water propeller cross shaft bracket.

### c. Linkage Installation Procedure

#### (1) Install cross shaft brackets

Place right-hand bracket over forward stud under hand brake cross shaft bracket and install stud nuts. Install left-hand bracket and secure to transmission with nut over forward stud and winch control lever to transmission stud. Place winch control lever over stud and attach to power take-off with cotter and clevis pin. Attach power plant stabilizer rod to left-hand bracket with cotter and clevis pins.

#### (2) Install cross shaft and shift lever

Start shaft through right-hand bracket with keyway end of shaft towards center of vehicle. Insert key in shaft, install shift lever and insert shaft in left-hand bracket when key in shaft and keyway in lever are in alignment. Install hairpin locks in grooves at right-hand end of shaft and tighten clamp bolt in lever when lever is centered over key. Attach control rod to shifter shaft at transfer case and short arm of shift lever on cross shaft with clevis pins and secure with new cotter pins.

## 237. PROPELLER SHAFT REPLACEMENT

a. Forward, intermediate, and rear sections of propeller shaft may be replaced independently; however, it is necessary to unbolt bearing assemblies from frame before intermediate and rear shafts can be removed.

### b. Forward Propeller Shaft Removal Procedure

#### (1) Disconnect rear yoke

Remove four bolts which hold rearward yoke and bilge pump drive sprocket to forward flange of intermediate shaft.

#### (2) Remove bilge pump drive sprocket

Slide shaft forward as far as possible to separate yoke and flange and remove bilge pump drive sprocket. Raise rear end of shaft high enough to clear forward bearing and pull shaft out of transfer case.

**TRUCK, AMPHIBIAN, 2½-TON, 6 x 6****c. Forward Propeller Shaft Installation Procedure****(1) Install propeller shaft**

Inspect machined surface of yoke at forward end of shaft to be certain it is free from nicks or burrs which would impair efficiency of transfer case oil seal. Place yoke over splines of upper transfer case shaft and slide yoke onto shaft as far as possible.

**(2) Install bilge pump drive sprocket**

Place rear yoke of shaft in approximate operating position and insert bilge pump drive sprocket. See that shoulder on sprocket enters groove in flange of intermediate shaft and install four bolts through yoke, sprocket and flanges. Replace lockwashers and tighten nuts to draw yoke and flange together.

**d. Intermediate Propeller Shaft Removal Procedure****(1) Disconnect forward bearing assembly from crossmember**

Remove two bolts and nuts which attach forward bearing assembly to frame crossmember.

**(2) Disconnect forward flange**

Remove four bolts and nuts which attach forward flange to bilge pump drive sprocket and yoke of intermediate shaft. Slide intermediate shaft forward and remove bilge pump drive sprocket.

**(3) Remove propeller shaft guard**

Remove two nuts on underside of trunnion crossmember which attach propeller shaft guard to crossmember and remove guard.

**(4) Remove propeller shaft**

Remove four bolts and nuts which attach rear yoke to flange at front of rear shaft, move shaft forward far enough to separate flange and yoke and lift propeller shaft and forward bearing assembly out of vehicle.

**e. Intermediate Propeller Shaft Installation Procedure****(1) Install propeller shaft**

Place propeller shaft in position with forward bearing assembly on shaft and bolt rear yoke to flange of rear shaft using four bolts, nuts and lockwashers.

**(2) Connect forward flange**

Align forward flange of shaft with yoke at rear of intermediate shaft and insert bilge pump drive sprocket. See that shoulder on sprocket enters groove in flange and install four bolts through yoke, sprocket and flange. Replace lockwashers and tighten nuts to draw yoke and flange together.

**(3) Attach forward bearing to crossmember**

Install two bolts, nuts and lockwashers which attach forward



## WATER PROPELLER AND DRIVE

bearing to crossmember. Insert propeller shaft guard through hole in trunnion crossmember and install lower nuts and lock-washers.

### f. Rear Propeller Shaft Removal Procedure

#### (1) Remove water propeller

Remove water propeller as directed in Para. 239b.

#### (2) Remove thrust bearing assembly

Remove thrust bearing assembly as directed in Para. 238b.

#### (3) Disconnect hose at stuffing box

Remove clamp bolt and clamp which attaches hose to rear end of stuffing box (see Fig. 165).

#### (4) Remove propeller shaft

Move intermediate shaft towards left side of vehicle and pull rear shaft straight forward approximately fifteen inches to remove shaft from strut bearing. Then raise end of shaft slightly and withdraw from tunnel.

### g. Rear Propeller Shaft Installation Procedure

#### (1) Install propeller shaft

Inspect machined surface of shaft collar to see that it is free from nicks or burrs which might impair efficiency of thrust bearing oil seal. Start threaded end of shaft through hose connection at tunnel. Use care when inserting shaft through strut bearing to see that threads do not scratch bearing and slide shaft to its approximate operating position.

#### (2) Install thrust bearing and water propeller

Install thrust bearing assembly as directed in Para. 238c. Install water propeller as directed in Para. 239c.

## 238. THRUST BEARING ASSEMBLY REPLACEMENT

a. Thrust bearing assembly replacement can be accomplished after rear flange of intermediate propeller shaft is disconnected. It is particularly important that bearing be adjusted as outlined in Para. 238c, after bearing assembly is installed.

### b. Thrust Bearing Assembly Removal Procedure

#### (1) Disconnect intermediate propeller shaft

(a) Remove two bolts attaching forward bearing to crossmember and remove guard at rear of intermediate shaft.

(b) Remove four bolts and nuts which attach rear yoke to flange, move shaft forward far enough to separate flange and yoke and move shaft toward left side of vehicle.

#### (2) Remove rear shaft flange

Withdraw cotter pin and remove flange retaining nut using 1½" socket wrench. Remove flange using puller KM-J-1714 to pull flange off shaft.

**TRUCK, AMPHIBIAN, 2½-TON, 6 x 6****(3) Remove thrust bearing assembly**

Remove four bolts attaching assembly to crossmember and slide assembly off shaft.

**c. Thrust Bearing Assembly Installation Procedure****(1) Loosen bearing retaining cap**

Unscrew bearing retainer set screw and loosen bearing retainer cap and bolt in upper side of housing. This is done to allow thrust bearing to align itself with strut bearing when assembly is placed on shaft.

**(2) Install bearing assembly**

Slide assembly over shaft until bearing strikes shaft collar and then install flange at end of shaft and draw flange retaining nut up tight and lock with new cotter pin.

**(3) Adjust bearing**

Tighten bearing retainer cap until tight, then back off one full notch and lock with set screw in top of housing. Install and tighten set screw lock nut. Turn retainer positioning bolt (in upper portion of housing) down tight and install four bolts, lockwashers, and nuts which attach bearing assembly to crossmember.

**(4) Connect intermediate propeller shaft**

Connect yoke and flange at rear end of shaft using four bolts, lockwashers and nuts and then bolt forward bearing support to crossmember.

**239. WATER PROPELLER REPLACEMENT**

**a.** Water propeller replacement is recommended whenever propeller is bent or distorted as any irregularity in surface of propeller will seriously affect its operation. Instructions as outlined below should be followed carefully when installing a new or reconditioned propeller.

**b. Water Propeller Removal Procedure****(1) Remove retaining nut**

Withdraw cotter pin at end of shaft and remove lock nut and retaining nut.

**(2) Install puller**

Install puller (Tool KM-J-2361) over propeller as shown in Fig. 166.

**(3) Remove propeller**

Tighten three nuts on bolts extending through puller plate alternately one turn at a time until propeller can be pulled off easily.

**c. Water Propeller Installation Procedure****(1) Check fit of propeller key and install propeller**

See that propeller key is a slip fit in keyways in shaft and pro-

## WATER PROPELLER AND DRIVE

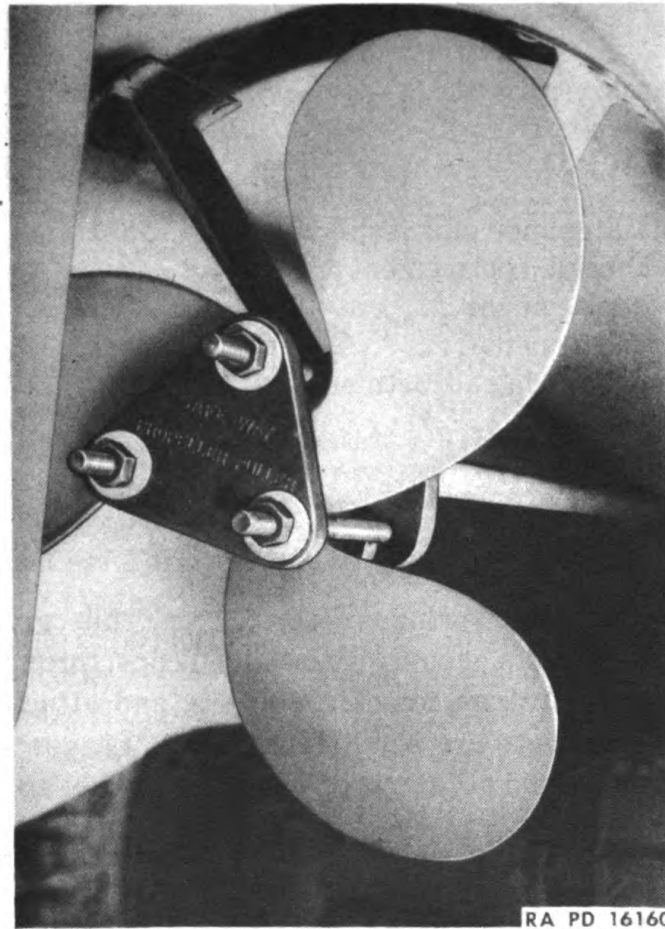

**Figure 166—Removing Water Propeller**

propeller hub. Measure distance key extends out of shaft and depth of keyway in propeller hub. There should be .010" clearance between top of key and bottom of hub keyway to make sure propeller seats on shaft and not the key. Start water propeller over end of shaft with keyways in shaft and in hub aligned, then slide propeller on shaft as far as possible. Insert key in keyway and move key and propeller into position by installing retaining nut. Tighten nut until propeller is seated on tapered portion of shaft and install lock nut and cotter pin.

### 240. STRUT BEARING REPLACEMENT

a. Strut bearing is a babbitt bearing, poured with shaft assembled in place. Replacement of bearing is necessary whenever shaft is loose in strut.

b. Replacement procedure should not be attempted by the Using Arms Maintenance Personnel as this procedure is beyond the scope of their operations.

Section XXXII

**SPRING SUSPENSION**

	Paragraph
Description .....	241
Trouble-shooting .....	242
Preventive maintenance and inspection.....	243
Front spring shackle replacement.....	244
Front spring replacement .....	245
Rear spring replacement .....	246
Rear spring seat bearing adjustment .....	247
Torque rod replacement .....	248
Shock absorber maintenance .....	249
Shock absorber replacement .....	250

**241. GENERAL DESCRIPTION**

a. Front and rear springs described in this group include shackles, brackets, bolts, mountings, rebound clips, torque rod mounting parts for rear springs, shock absorbers, and attachments. The front and rear springs are semi-elliptic type. Leaves are held together by four rebound clips and properly located on spring seat by means of center bolt.

b. **Springs.** Top leaf of front springs has an eye formed at each end into which a bronze bushing is pressed. Third leaf is also wrapped around eye. Front end of spring is mounted in shackle, while rear end of spring is supported in stationary bracket. Rear springs are inverted semi-elliptic type with center of spring held to spring seat by two "U" bolts. Spring seat is carried on trunnion cross shaft by tapered roller bearings. Ends of spring ride on axle housing and are free to slide forward and backward to permit spring to lengthen and shorten under load compression and rebound action.

c. **Shock Absorbers.** Used in this vehicle at front springs only are a heavy duty double acting type interconnecting frame and axle.

**242. TROUBLE-SHOOTING**

Symptom and Probable Cause	Probable Remedy	Refer to Paragraph
<b>a. Hard Riding</b>		
(1) Insufficient lubrication	Lubricate .....	Sect. VI
(2) Bolts in shackle or bracket frozen	Remove and clean or replace .....	244
(3) Vehicle overloaded	Load to rated capacity....	7
(4) Uneven load distribution	Correct loading practice.	



**SPRING SUSPENSION**

Symptom and Probable Cause	Probable Remedy	Refer to Paragraph
<b>b. Over flexible</b>		
(1) Over lubrication	Refer to lubrication Sect. VI	
(2) Lack of fluid in shock absorbers	Refill to proper level Sect. VI	
(3) Shock absorber not operating	Replace . . . . .	250
(4) Rebound clips loose or displaced	Locate and tighten	
<b>c. Excessive Noise</b>		
(1) Worn bolts and bushings in shackles	Replace . . . . .	244
(2) Worn shackles	Replace . . . . .	244
(3) Loose front spring mounting bolts	Tighten or replace . . . . .	243
(4) Rear spring seat bearings loose	Adjust . . . . .	247
<b>d. Spring Leaf Failures</b>		
(1) Vehicle overload	Load to rated capacity . . .	7
(2) Rebound clips loose	Adjust and tighten	
(3) Shackle and spring pins frozen	Remove and clean . . . . .	244
(4) Grabbing clutch	Replace clutch . . . . .	113
(5) Grabbing brakes	Adjust . . . . .	94

**243. PREVENTIVE MAINTENANCE AND INSPECTION**

**a.** Following spring maintenance items are important:

(1) Front spring shackles should be drawn up tight enough to take up all play caused by wear. Shackles should not be drawn up too tight, to prevent free action of shackle bolt or pin. Draw up nuts as tightly as possible, then back off one half turn to prevent binding. Always use new cotter pins full size of hole.

(2) Spring center bolts should be kept tight at all times.

(3) Mounting bolts holding front spring axle and rear spring "U" bolts should be kept tight under normal spring load.

(4) Rebound clips should be drawn up tight enough to hold leaves in alignment without restricting free movement of leaves.

(5) Lubrication of spring shackles and brackets should be performed periodically and particularly after extensive water operation. Refer to Section VI, "Lubrication."

(6) When springs have lost most of resiliency or elastic properties, it is advisable to replace them with new ones, rather than attempt to restore spring camber by heating, bending and tempering.

(7) Rubber bushings at end of torque rods should be kept clean and free from oils and greases.

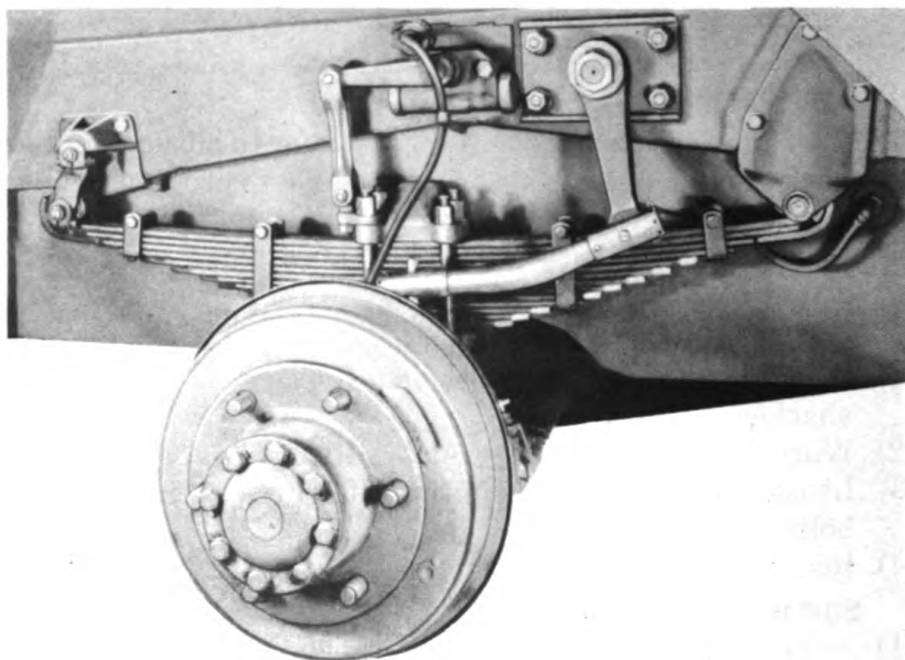
**TRUCK, AMPHIBIAN, 2½-TON, 6 x 6**

RA PD 16193

**Figure 167—Front Spring Installation****244. FRONT SPRING SHACKLE REPLACEMENT****a. Removal Procedure (Figs. 167, 168, and 169)****(1) Hoist up front end**

Jack up or hoist front end of vehicle until spring tension is completely relieved. Block rear wheels to keep vehicle from rolling.

**(2) Remove clamp bolts and shackle pins**

Shackle shown in Fig. 168, remove shackle pin clamp bolts, nuts, lockwashers. Adjust tool KM-J-2310 as shown in Fig. 169 and proceed to remove shackle pins. Grease fittings should be removed and shackle pins cleaned and inspected.

**b. Installation Procedure****(1) Install shackle and pins**

Shackle pins should be cleaned and inspected. A lead hammer should be used to drive shackle pins in place. Be certain that clamp bolt holes are in proper alignment.

**(2) Install grease fittings and clamp bolts**

Make certain that the grease channel is not clogged and that the grease fittings have been cleaned before threading grease fittings in shackle pins. Clamp bolts should be lubricated with a couple of drops of engine oil before inserting into place. Be certain that clamp bolt hole in shackle, and clamp bolt groove in shackle pins are in proper alignment before inserting clamp bolts in place. Tighten clamp bolts using lockwashers, nuts.

**SPRING SUSPENSION**

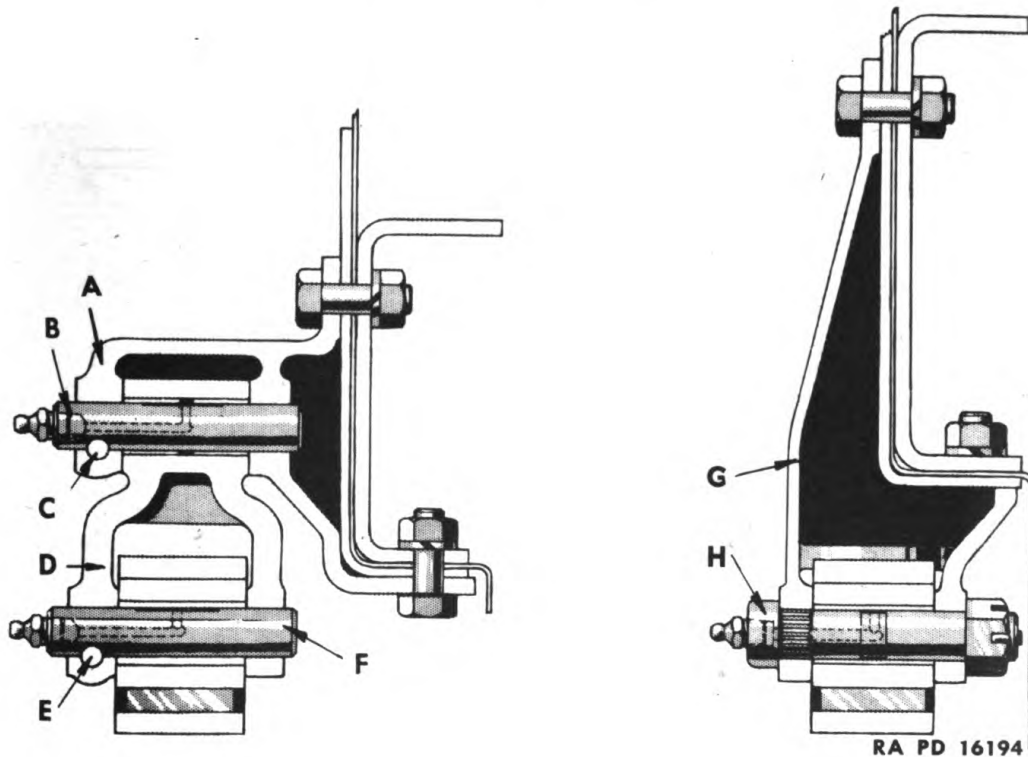

**Figure 168—Front Spring Shackle and Bracket**

- |          |   |          |                                       |
|----------|---|----------|---------------------------------------|
| <b>A</b> | <b>Front Spring Front Bracket</b>       | <b>E</b> | <b>Shackle Pin Clamp Bolt</b>         |
| <b>B</b> | <b>Front Spring Front Shackle Pin</b>   | <b>F</b> | <b>Front Spring Front Shackle Pin</b> |
| <b>C</b> | <b>Shackle Pin Clamp Bolt</b>           | <b>G</b> | <b>Front Spring Rear Bracket</b>      |
| <b>D</b> | <b>Front Spring Shackle and Bushing</b> | <b>H</b> | <b>Front Spring Rear Pin</b>          |

**245. FRONT SPRING REPLACEMENT**

**a. Removal Procedure**

(1) Remove four spring seat nuts. This operation will remove spacer plate holding spring to seat and disconnect shock absorber link.

(2) Remove spring shackle pin. Follow instructions in Para. 244 for removal of spring shackle pins.

(3) Remove cotter pin and slotted hex nut, and use tool KM-J-2310 to remove bolt. Remove spring assembly.

**b. Installation Procedure**

(1) Rear spring bracket bolt should have grease channel cleaned and inspected. Be certain the knurled shoulder of bolt is in alignment when inserting in place. Use lead hammer to drive bolt in place if necessary. Thread slotted hex nut on bolt and align cotter pin hole. Insert full size cotter pin. Install shackle pin and clamp bolt as described in Para. 244b.

(2) Place mounting spacer block in position, insert "U" bolts into place. Place shock absorber link in position and thread nuts on "U" bolts. Lower vehicle.



**TRUCK, AMPHIBIAN, 2 1/2-TON, 6 x 6**

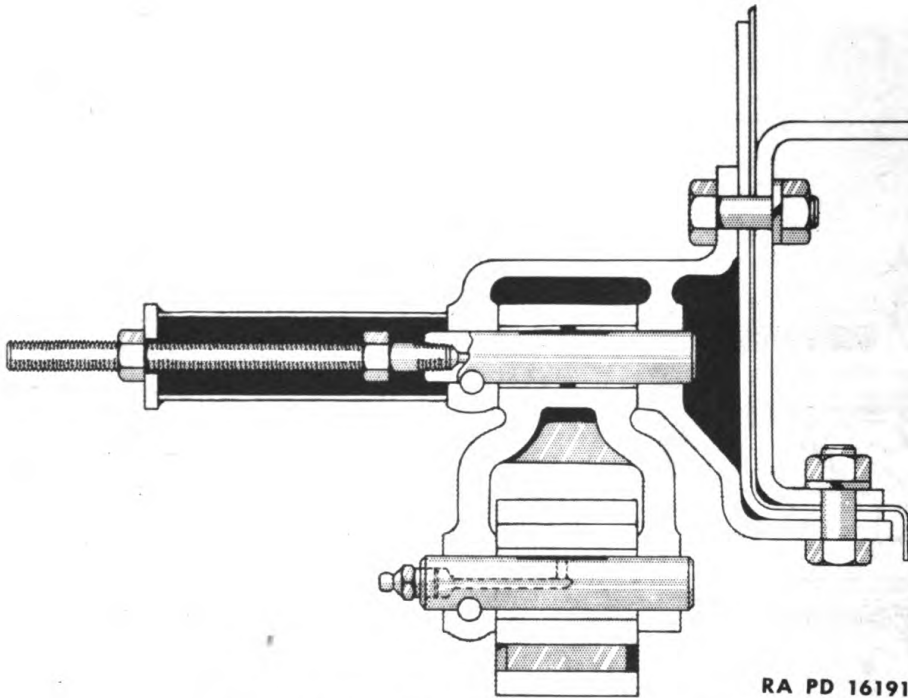

**Figure 169—Shackle Pin Removal**

**246. REAR SPRING REPLACEMENT**

a. **Rear Spring Removal Procedure (Fig. 170).** Rear springs should be periodically inspected and adjusted. To do this properly, springs should be removed from chassis as follows:

**(1) Raise vehicle and disconnect springs**

Place jack under cross shaft to frame bracket and raise to relieve spring tension. Remove four nuts on "U" bolts and remove "U" bolts and spacer block. Loosen spring seat clamping bolts. Slide spring back in its seat until front end can be lifted

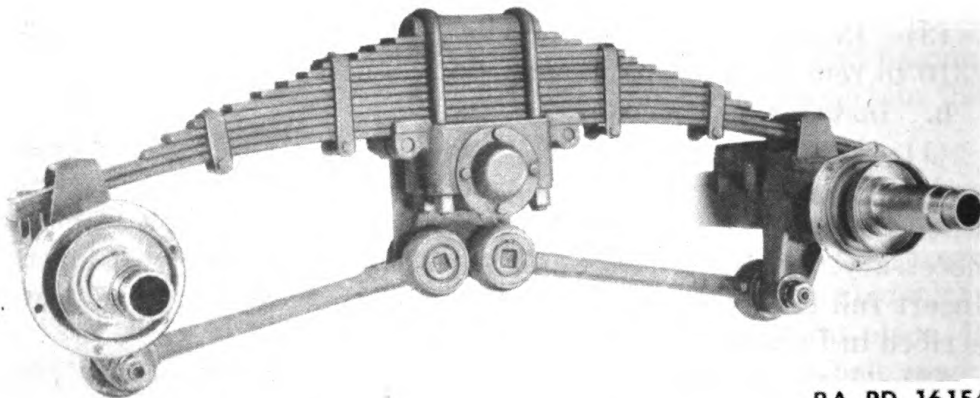

**Figure 170—Rear Spring Installation**



**SPRING SUSPENSION**

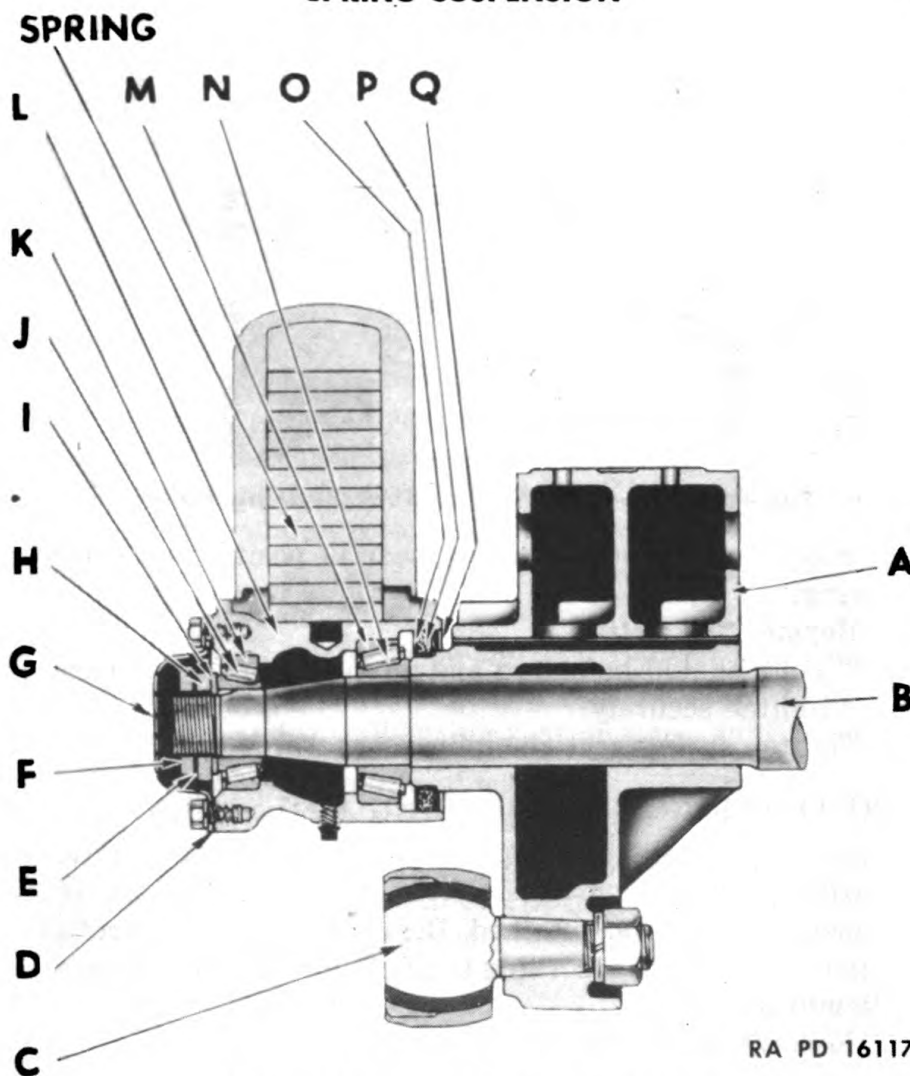

RA PD 16117

**Figure 171—Rear Spring Seat**

- |          |   |          |                               |
|----------|---|----------|-------------------------------|
| <b>A</b> | <b>Frame Trunnion Bracket and Stud Assembly</b> | <b>I</b> | <b>Adjusting Washer</b>       |
| <b>B</b> | <b>Cross Shaft Assembly</b>                     | <b>J</b> | <b>Outer Bearing Cone</b>     |
| <b>C</b> | <b>Upper Torque Rod</b>                         | <b>K</b> | <b>Outer Bearing Clip</b>     |
| <b>D</b> | <b>Spring Seat Cap Gasket</b>                   | <b>L</b> | <b>Spring Seat</b>            |
| <b>E</b> | <b>Adjusting Lock Nut</b>                       | <b>M</b> | <b>Inner Bearing Cap</b>      |
| <b>F</b> | <b>Locking Nut</b>                              | <b>N</b> | <b>Inner Bearing Cone</b>     |
| <b>G</b> | <b>Spring Seat Cap</b>                          | <b>O</b> | <b>Oil Seal Washer</b>        |
| <b>H</b> | <b>Adjusting Nut</b>                            | <b>P</b> | <b>Oil Seal Felt</b>          |
|          |   | <b>Q</b> | <b>Oil Seal Felt Retainer</b> |

out of bracket on forward axle. Pull spring forward until rear end clears bracket on rearward axle.

**b. Rear Spring Installation Procedure.** Installation of rear spring may usually be accomplished without changing position of rear axles.

**(1) Install spring**

Place end of spring in bracket on forward rear axle and slide spring in its seat until rear of spring will clear bracket on rearward axle. Slide spring toward rear until center bolt drops into

**TRUCK, AMPHIBIAN, 2½-TON, 6 x 6**

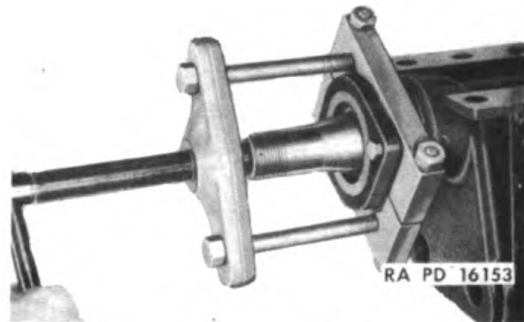

**Figure 172—Rear Spring Seat Bearing Puller**

recess in spring seat. Place spacer in position on top leaf of spring.

**(2) Replace "U" bolts**

"U" bolts should be placed and aligned properly—thread nuts and tighten securely.

**(3) Tighten spring seat clamping cap screws.**

**247. REAR SPRING SEAT BEARING ADJUSTMENT**

**a.** Rear spring seat bearings (Fig. 171) must be removed and packed with fresh lubricant as directed in Section VI if satisfactory spring operation is to be obtained. Bearings should be carefully adjusted upon reassembly according to the following procedure:

**b. Removal**

**(1) Remove spring and bearing cap**

Remove spring as outlined in Para. 246a. Remove bearing cap and gasket taking out four cap screws.

**(2) Remove adjusting and locking nuts**

Straighten tongues of adjusting nut lock and remove locking nut, adjusting nut lock, adjusting nut, and adjusting nut washer. Remove spring seat together with outer bearing cone, and cup, and inner bearing cup.

**(3) Remove inner bearing cone and seal**

With rear spring seat bearing puller (Fig. 172), remove inner bearing cone. Remove oil seal parts.

**(4) Inspect and lubricate**

Wash bearing cones and cups thoroughly with kerosene or Diesel fuel, and after wiping clean, inspect them carefully.

**(a)** If surface of cups or bearing rollers are pitted, they should be replaced. A pitted one is one in which small particles have broken out, leaving small jagged depressions.

**(b)** Bearings used in spring seats roll back and forth as vehicle passes over uneven terrain, but bearing rollers always return to same

## SPRING SUSPENSION

relative position in cups. In fact, bearing rollers rest in this one position most of the time. Polished lines appear on bearing cups, showing "resting" position of the rollers. These lines are spaced according to distance between lines of contact of each roller. These lines are not harmful and bearings should not be replaced unless surfaces of cups are actually pitted or broken.

(c) Inspect seals for damage resulting from handling during assembling or disassembling and for sand or mud inside of seal. Replace seals when these conditions exist. Soak bearings in engine oil, shake off excess, and pack by squeezing chassis grease in behind the rollers and smoothing the grease with the surfaces of the rollers. Apply a small amount of grease to the shaft between the bearings so as to form a dam should the grease in the bearings soften enough to flow.

(1) **Install oil seals**

Install oil seal felt retainer, oil seal felt, oil seal washer, and install inner bearing cone. Lubricate bearings then place in spring seat and install spring seat on cross shaft end.

(2) **Install adjusting nut and washer**

Place adjusting nut washer, and adjusting nut (inner) over end of cross shaft and with suitable wrench, pull adjusting nut up to approximate adjustment. Spring seat should be oscillated while tightening to prevent grease from being squeezed out from under bearing rollers.

(3) **Install dummy bearing cap**

A dummy bearing cap (with nut of convenient size brazed on face of dummy bearing cap) is to be installed on face of spring seat with two attaching cap screws. Put torque wrench on brazed nut and test effort required to move spring seat. This force should be 20 to 25 ft. lbs.

(4) **Remove dummy cap and adjust**

Remove dummy cap and tighten or loosen adjusting nut to obtain the 20 to 25 lbs. testing effort at the tightest place while rocking spring seat. If torque wrench and dummy cap are not available, an alternate method of testing bearing adjustment can be used. Bolt a 2 ft. bar to face of spring seat and measure bearing drag with spring scale at end of bar. Reading of scale should be from 10 to 12 lbs. if bearing adjustment is correct.

(5) **Install bearing cap**

When adjusting nut is tightened properly, replace adjusting nut lock and locking nut (outer). Tighten locking nut securely. Test adjustment once more to see that it has not been changed and correct if necessary. Bend tangs of adjusting nut lock over



## TRUCK, AMPHIBIAN, 2½-TON, 6 x 6

flats of adjusting nut and locking nut. Replace bearing cap and four cap screws and replace spring—refer to Para. 246.

### 248. TORQUE ROD REPLACEMENT

a. Torque rods, three on each side, connect rear axles to frame. Lower rods connect axles to cross shaft brackets whereas upper rods extend from axle housings to brackets which are bolted through hull and trunnion crossmember. Both ends of torque rods are rubber bushed to ball pin which has tapered mounting stud. Tapered studs must be kept tight at all times. Rubber bushing in ends of rods require no special attention, except that they should be sprayed with rubber preserving fluid to prevent cracking or deterioration of rubber.

#### b. Torque Rod Removal

(1) Place jacks under spring seats and raise until tension is off springs. Remove nuts from torque rods—force torque rod pins out of brackets. To start pin insert a claw bar between bracket and hub of torque arm at axle. Strike bottom of bracket sharply with a heavy hammer while prying with claw bar. Do not pry too hard or rubber bushing in torque rod will be damaged. Proceed to remove upper ends of torque rods in same manner.

#### c. Torque Rod Installation

(1) Clean all grease or oil from torque rod pins, and see that rubber bushings are clean and free from oil, grease or dirt. Insert torque rods in axle brackets. The two lower rods on each axle should be installed before top torque rods are installed. **Force torque rod studs in firmly**, using block of wood and a heavy hammer. Then install lock-washers and nuts. Tighten securely, lower and remove jacks.

### 249. SHOCK ABSORBER MAINTENANCE

a. Absorber units do not require special attention, except periodical inspection and tightening of links and checking of fluid levels in housings. Use suitable shock absorber fluid and check level at periodic intervals. Before proceeding with operation on shock absorber, lubricate vehicle spring pins and shackles. See that tire pressure does not exceed pressure as recommended. Smoother operation is obtained only when shackles operate freely and tires are not over inflated.

#### b. Shock Absorber Inspection

(1) Disconnect link from axle and pull shock absorber arm down. If arm drops easily partway and then stops and continues moving down slowly the rest of the way, there is not enough fluid in shock absorber. Clean shock absorber thoroughly and remove filler plug. Then fill with shock absorber fluid. Use fluid gun.



## SPRING SUSPENSION

### c. Shock Absorber Test

(1) Replace filler plug and move shock absorber arm up and down several times to work fluid into piston cylinder. Then inject additional fluid to fill reservoir. To provide necessary air space in shock absorber, allow fluid to escape down to bottom edge of filler plug hole before replacing plug. Replace cap gaskets wherever necessary. Shock absorber packing washers which have been operating with fluid below proper level may become worn and cause leaks around shaft. Leaks of this nature can only be corrected by replacing shock absorbers.

## 250. SHOCK ABSORBER REPLACEMENT

### a. Removal

(1) Disconnect link from shock absorber arm. Remove bolts which hold shock absorber to frame and remove shock absorber.

### b. Installation

(1) Bolt shock absorber to frame and connect link between shock absorber and spring seat. When installation is complete, check all screws and nuts. If necessary paint absorbers and fittings. Check tire pressure, keep spring pins well lubricated and spring bolts and shackles free.

Section XXXIII  
**STEERING SYSTEM**

	Paragraph
General description.....	251
Operation.....	252
Trouble-shooting.....	253
Preventive maintenance and inspection.....	254
Steering gear adjustment.....	255
Drag link adjustment.....	256
Rudder stuffing box and linkage adjustment.....	257
Steering gear replacement.....	258
Rudder and linkage replacement.....	259

**251. GENERAL DESCRIPTION**

a. Steering mechanism in this vehicle comprises two systems which are interconnected. Steering wheel and gear, drag link and tie rod constitute land operation system; whereas, steering wheel and gear, cable, rudder linkage and rudder comprise water operation system. Steering gear is recirculating ball type. This description refers to balls which serve as contact between worm and worm nut.

b. **Rudder Cable Spool (Fig. 173).** Rudder cable spool is held to lower end of worm shaft with shear pin. Approximately 50 lbs. pull at steering wheel rim is required to brake this shear pin. Rudder cable is placed in groove in center of spool and retained by a clamp and two bolts.

**252. OPERATION**

When steering wheel is turned, movement is transmitted through worm, worm nut, and sector shaft inside steering gear through pitman arm and then through drag link and steering arm to front wheels. Movement of the steering wheel also causes rudder cable spool on worm shaft to turn and wind rudder control cable, thus actuating rudder through linkage. Refer to Section III, "Controls and Operation" for detailed instructions regarding steering on both land and in water.

**253. TROUBLE-SHOOTING**

a. Proper operation of steering system is closely related to other units in vehicle. Hence, whenever diagnosing steering difficulties other relative factors must also be checked. A symptom indicating steering trouble may also be evidence of difficulty in other units; i.e., front axle alignment, front axle suspension, tire inflation, wheel and tire mounting, frame alignment and brakes. Symptoms which indicate possible trouble in steering system are listed below with probable cause, probable remedy and references to paragraphs in which remedies are explained.

**STEERING SYSTEM**

**b. Trouble-Shooting**

Symptom and Probable Cause	Probable Remedy	Refer to Paragraph
<b>(1) Hard steering</b>		
(a) Worm bearings or sector gear lash too tight.	Check and adjust worm bearings and sector gear lash.....	255
(b) Drag link ends adjusted too tight.	Check and adjust correctly.	256
(c) Misalignment in steering gear mountings causing binding.	Adjust mountings.....	255
(d) Bent drag link or pitman arm caused binding.	Straighten part, if practical, or replace.....	258
(e) Lack of lubrication at drag link ends or in gear housing.	Lubricate as required. (Sect.) VI	
(f) Worn parts in steering gear and drag link causing binding.	Replace assembly or drag link.....	258
(g) Rudder cable too tight or cable off pulley.	Adjust rudder cable.....	259
(h) Misalignment of front end of front axle parts worn.	Align front end and replace worn parts.....	74
(i) Tires under-inflated.	Inflate tires.....	288
<b>(2) Wander or lack of steering control</b>		
(a) Worm bearings or sector gear lash too loose.	Check and adjust worm bearings, and sector gear lash.....	255
(b) Drag link ends worn or adjusted too loose.	Adjust if possible, or replace.....	256
(c) Steering gear mountings loose.	Adjust and tighten mountings.....	255
(d) Worn parts in steering gear. Play in gear after adjusted.	Replace assembly.....	258
(e) Pitman arm loose on sector shaft.	Tighten pitman arm lock nut.....	258
(f) Steering linkage adjusted too tight causing driver to over-steer.	Adjust worm bearings, sector gear lash or drag link ends as necessary.....	255
(g) Rudder cable too loose.	Adjust rudder cable.....	257
(h) Misalignment of front end or front axle parts worn.	Align front end and replace worn parts.....	74

**TRUCK, AMPHIBIAN, 2½-TON, 6 x 6**

Symptom and Probable Cause	Probable Remedy	Refer to Paragraph
<b>(3) Road shock transmitted to steering wheel</b>		
(a) Steering drag link ends adjusted too tight.	Check and adjust correctly.....	256
(b) Worm bearings or sector gear too tight.	Check and adjust worm bearings and sector gear lash.....	255
(c) Looseness and misalignment of front end parts.	Tighten parts and align front end.....	74
(d) Pounding caused by loose wheel bearings or tires unbalanced.	Adjust bearings.....	284
<b>(4) Unequal turning radius to right and left</b>		
(a) Drag link bent.	Straighten part, if practical, or replace.....	258
(b) Steering knuckle stop screws broken, worn, or improperly adjusted.	Adjust or replace stops...	74
(c) Rudder cable improperly adjusted.	Adjust rudder linkage...	257

**254. PREVENTIVE MAINTENANCE AND INSPECTION**

- a. Preventive maintenance and inspection operations as outlined in Section V should be accomplished according to the intervals stated.
- b. One of the most important inspection and maintenance procedures is the adjustment of worm and sector shaft bearings as directed in Para. 255.

**255. STEERING GEAR ADJUSTMENT**

a. There are three adjustments necessary for correct steering gear operation. Worm bearing adjustment, outlined in Para. 255b.; sector gear lash adjustment, Para. 255c. and steering gear mounting adjustment, Para. 255d. Steering gear adjustment procedure is outlined for steering gear in vehicle. However if gear is out of vehicle adjustment should be made with gear in a vise as adjustment points are much more accessible.

**b. Worm Bearing Adjustment Procedure**

**(1) Disconnect steering gear linkage**

If steering gear is to be adjusted in vehicle remove cotter pin from rudder cable rear center guide clevis pin (see Fig. 173), and remove clevis pin and pulley, thereby providing slack in cable. Pin is accessible from inside stern compartment after hatch cover is raised. Turn steering wheel to right and to left as far as possible to draw all slack in cable into engine compartment. Discon-



**STEERING SYSTEM**

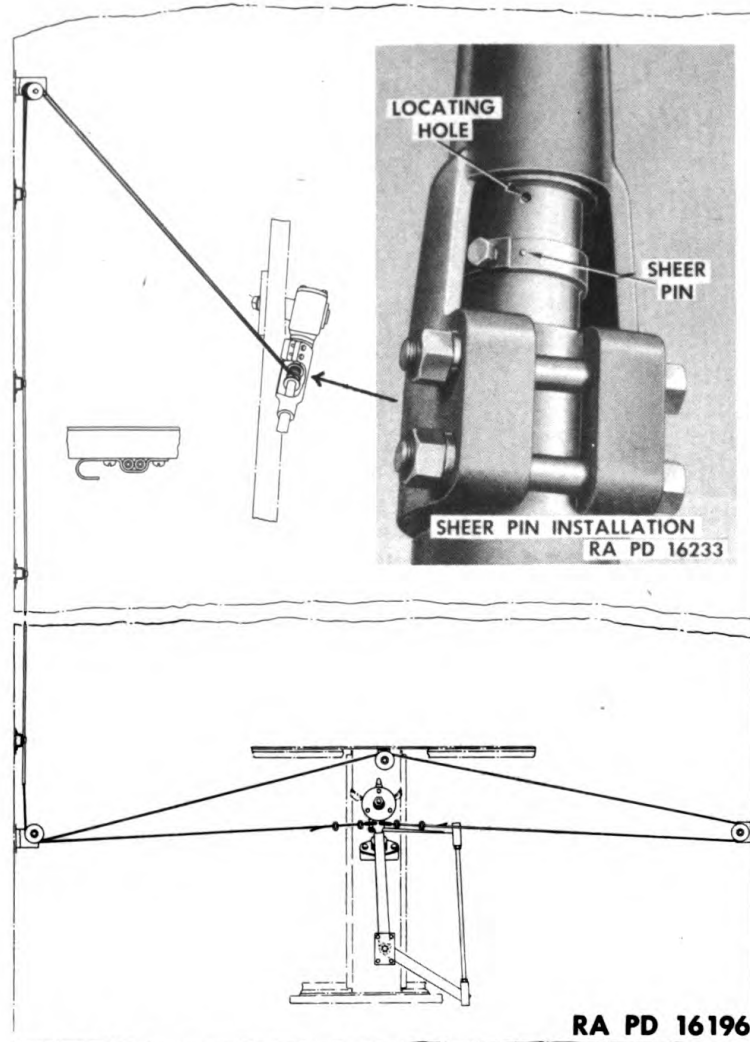

**Figure 173—Plain View of Rudder Linkage**

nect steering gear drag link from pitman arm by removing cotter pin and nut from ball stud.

- (2) **Loosen steering column to prevent binding of shaft**  
Loosen steering column at bracket extending from windshield lower panel by removing bolt and nut attaching steering column to windshield panel bracket. Tighten bolts clamping steering gear housing flange to vehicle under structure.
- (3) **Relieve load on worm bearings**  
Loosen lash adjuster lock nut and turn lash adjuster counter-clockwise a few turns (Fig. 174).
- (4) **Measure pull required to keep steering wheel in motion**  
Turn steering wheel gently either right or left as far as it will go—then back about one turn. **Caution: Approach end of gear travel cautiously with linkage disconnected as worm nut in unit may be damaged.** Use a spring scale KM-J-544A to measure pull r

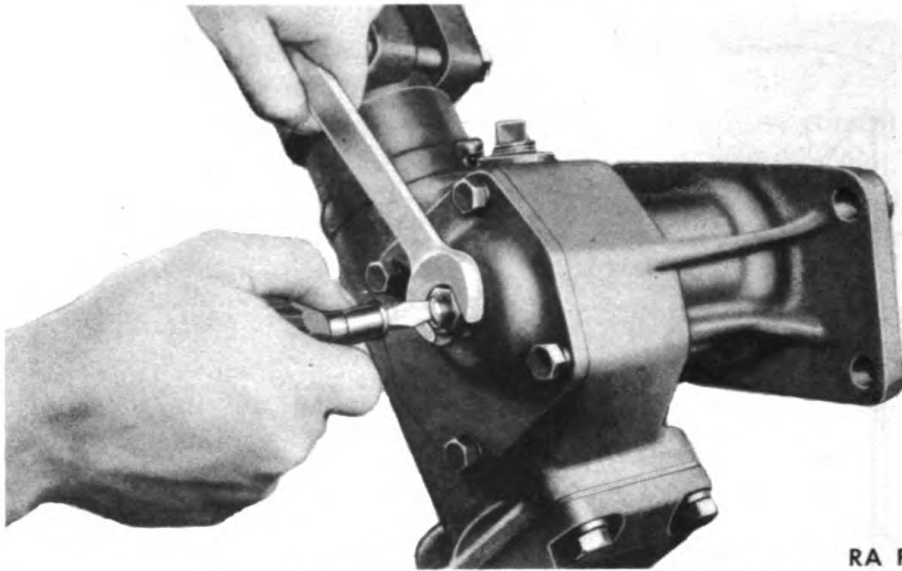
**TRUCK, AMPHIBIAN, 2½-TON, 6 x 6**

RA PD 16156

**Figure 174—Adjusting Sector Gear Lash**

quired to keep steering wheel in motion. Scale should be used at rim of steering wheel with a line through length of scale at right angle to spoke of wheel. (See Fig. 175.) If pull required to keep wheel moving is not between 1 and 1½ pounds, worm bearing adjustment is required.

**(5) Adjust worm bearings (Fig. 176)**

Remove four end cover bolts and end cover. Take out as many shims as required to eliminate all worm shaft end play when end cover is reinstalled and bolts fully tightened.

**(6) Recheck steering wheel rim pull**

Check pull required to keep steering wheel in motion as outlined in Operation (4). Readjust if necessary to obtain proper pull. If adjustment is correct and gear feels lumpy when turning, bearings are damaged and gear must be replaced.

**c. Sector Gear Lash Adjustment Procedure (Fig. 174)****(1) Disconnect steering gear linkage**

Performs operations 1 and 2 under "Worm Bearing Adjustment Procedure," Para. 255b.

**(2) Determine center position of steering gear**

Center steering gear by turning steering wheel from right to left extreme, being careful to approach end positions cautiously, meanwhile counting number of turns. Then rotate wheel back exactly half way. If gear is in center position, round head pins in rim of steering wheel will be at top.

**(3) Check steering wheel rim pull**

Tighten side cover bolts—then turn lash adjuster clockwise until there is no shaft end play or tooth lash. Check pull with spring scale at steering wheel rim as shown in Fig. 175, and measure



## STEERING SYSTEM

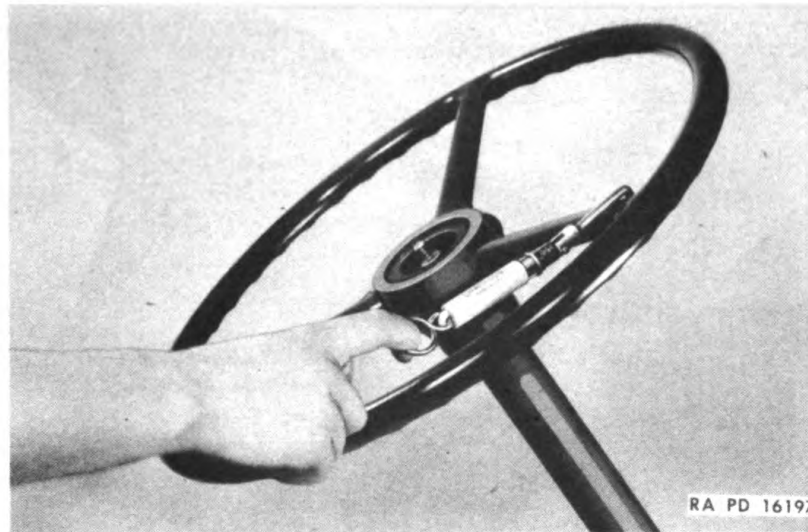

**Figure 175—Use Spring Scale to Check Adjustments**

greatest pull as wheel is pulled through center position. Readjust lash adjuster if pull of 2 to 2½ pounds is not obtained.

(4) **Recheck steering wheel rim pull**

Tighten lock nut and check pull again to be sure adjustment has not changed.

d. **Steering Gear Mounting Adjustment Procedure**

(1) **Loosen all steering gear mounting bolts**

Loosen steering gear housing to frame nuts and place sealing compound under heads of nuts.

(2) **Tighten steering column to brace bolt**

Be sure the three bolts attaching brace to lower windshield and instrument panels are tight, then connect steering column to brace and tighten bolt nut securely.

(3) **Tighten steering gear mounting bolts**

Tighten four bolts and nuts which attach gear housing flange to frame side rail. Upper front bolt should be tightened last as this bolt acts as a pivot to properly position steering gear.

(4) **Check steering wheel rim pull**

Check pull at steering wheel with spring scale as described under "Worm Bearing Adjustment Procedure" Para. 255b. and "Sector Gear Lash Adjustment Procedure" Para. 255c. after all mounting bolts are tight. If pull exceeds limits, cause must be located and corrected.

(5) **Connect steering gear linkage**

Attach drag link to pitman arm as outlined in Para. 258. Pull all slack in rudder cable into stern compartment and install rear center guide pulley using clevis pin and new cotter pin.

TRUCK, AMPHIBIAN, 2½-TON, 6 x 6

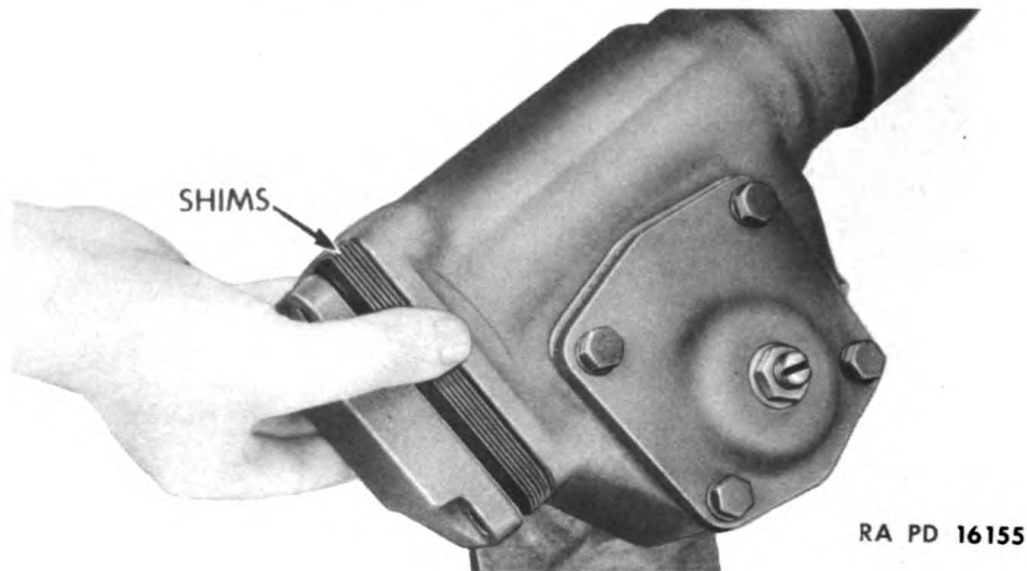

Figure 176—Adjust Worm Bearings

256. DRAG LINK ADJUSTMENT •

a. Ball sockets in drag link incorporate an automatic adjustment feature consisting of a pair of opposed wedge blocks and spring as shown in Fig. 177. Position of wedge blocks is indicated by round head pin projecting from side. Limit of automatic adjustment has been reached when pin head projects  $\frac{3}{8}$ " measured between socket body and underside of pin head. At this time manual adjustment by screw plug at end of socket is necessary.

b. Drag Link Ball Socket Adjustment Procedure

(1) Tighten ball socket joint

Remove cotter pin locking screw plug to drag link and turn plug tight against ball while holding wear indicator pin in tight.

(2) Adjust ball socket

Be sure ball ends are well lubricated before adjustment. Back off screw plug  $\frac{1}{2}$  to 1 turn and insert cotter pin. Ball joints must be

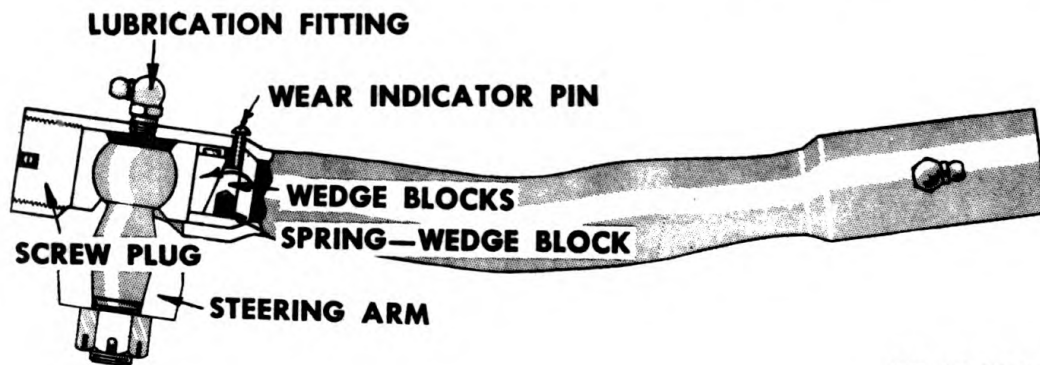
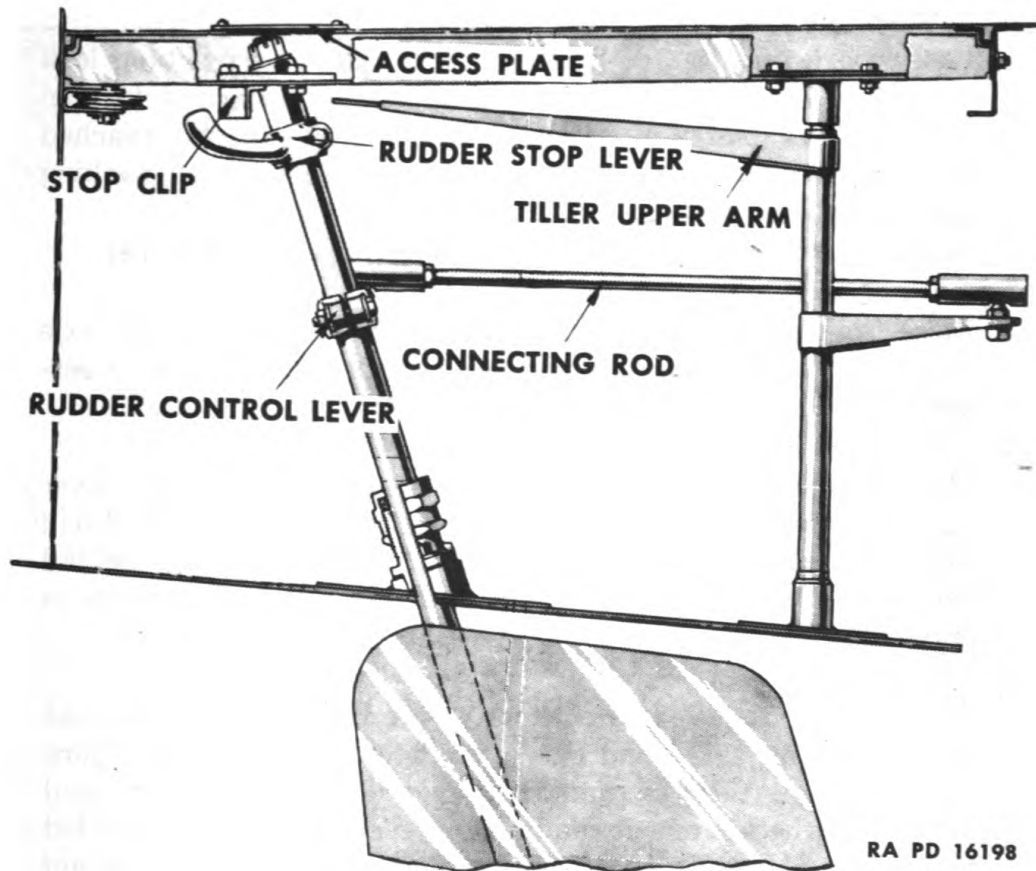

Figure 177—Steering Gear Drag Link



## STEERING SYSTEM



RA PD 16198

**Figure 178—Rudder Linkage at Stern**

tight enough to prevent end play and yet loose enough to allow free movement.

### 257. RUDDER STUFFING BOX AND LINKAGE ADJUSTMENT

a. Rudder stuffing box, rudder cable, and linkage must be correctly adjusted in order to provide proper steering on land as well as in water. Rudder stuffing box adjustment is accomplished by tightening or loosening packing nut at rudder stuffing box. Adjustment is required whenever large amount of water enters through the stuffing box or stuffing box becomes overheated. A small seepage of water is normal as this helps to control and lubricate stuffing box. Cable or linkage adjustment is required whenever cable sags or rudder does not have proper amount of movement to the right or to the left of straight-ahead position.

#### b. Rudder Stuffing Box Adjustment Procedure

##### (1) Raise stern compartment hatch cover

Raise stern compartment hatch cover and enter stern compartment to gain access to stuffing box.

Original from  
UNIVERSITY OF CALIFORNIA

**TRUCK, AMPHIBIAN, 2½-TON, 6 x 6**

(2) **Adjust stuffing box**

Loosen lock nut, tighten packing nut 1 6 turn and tighten lock nut. If leak is not corrected, wait a few minutes and tighten packing nut 1 6 turn more. When limit of adjustment is reached (packing nut button on stuffing box housing) back off packing nut and replace packing.

c. **Rudder Linkage Adjustment Procedure (Figs. 173 and 178)**

(1) **Adjust steering knuckle stop screws**

Raise front end of vehicle and place supports behind front axle in manner to permit front wheels to hang freely and adjust steering knuckle stop screws as outlined in Para. 74g.

(2) **Adjust connecting rod length**

Measure length of connecting rod between rudder control lever and tiller shaft lower arm. If distance between center lines of ball sockets at each end of rod is not 21<sup>3</sup>/<sub>4</sub>" loosen lock nuts behind ball socket assemblies and turn rod until this dimension is obtained.

(3) **Check cable position**

Two men are required to efficiently perform this operation, one at the steering wheel and one in the stern compartment. Turn steering wheel to maximum right and left turn positions and determine whether or not rudder stop lever contacts clips welded to bottom of rudder shaft support channel. **Lever should not contact stop clips.** If stop lever hits either clip, cable clamps must be loosened and cable adjusted until there is approximately equal amounts of clearance between lever and each clip when rudder is in extreme right and left turn position.

**258. STEERING GEAR REPLACEMENT**

a. Steering gear replacement is required whenever steering gear operation feels "lumpy" after worm and sector gear bearings have been properly adjusted. Steering gear may be removed through toe board closure plate opening after mounting bolts, linkage and plate in toe board have been removed.

b. **Steering Gear Removal Procedure**

(1) **Disconnect steering column at instrument panel**

Remove horn wire terminal from steering column and remove bolt and nut which attaches steering column to bracket which extends from lower windshield panel.

(2) **Remove closure plates in toe board**

Remove 10 screws which attach three sections of closure plate to toe board and remove plates.

(3) **Disconnect steering linkage**

Disconnect steering drag link from pitman arm by removing

## STEERING SYSTEM

cotter pin and nut from ball stud. Remove pitman arm nut and then pitman arm, using puller KM-J 1376-G.

(4) **Disconnect rudder control cable**

Enter stern compartment through hatch cover opening and remove 2 clamps which holds end of left-hand cable. Remove cable from thimble. Pull disconnected cable end through loom at the side of vehicle, until the end is in engine compartment. Remove 2 bolts which attach cable clamp to rudder cable spool and unwind cable from spool.

(5) **Remove steering gear assembly**

Remove 4 bolts and nuts which attach steering gear housing flange to frame and lift steering gear through closure plate opening in toe board and remove from vehicle.

c. **Steering Gear Installation Procedure**

(1) **Install steering gear**

Lower steering gear through closure plate opening in toe board into position against frame side rail. Place cork gasket between flange and frame side rail. Insert 4 mounting bolts through flange and side rail and place channel plate in position against outside of hull and install nuts and lockwashers, using a liberal amount of sealing compound under heads of nuts. Do not tighten mounting bolts at this time.

(2) **Tighten steering gear mounting**

Be sure the 3 bolts attaching steering column brace to lower windshield and instrument panels are tightened, then connect steering column to brace by installing bolt through column in brace. Install lockwasher nut and tighten nut securely. Tighten 4 mounting bolt nuts which attach steering gear housing flange to frame side rail. Upper front bolt nut should be tightened last, as this bolt acts as a pivot to properly position steering gear assembly.

(3) **Install steering gear linkage**

Install pitman arm on serrated end of sector shaft with flat section of pitman arm and shaft matched and draw pitman arm up tight on sector shaft with nut and lockwasher, using a wrench with sufficient leverage to fully tighten nut.

(4) **Install rudder cable**

Thread cable through loom and side of hull and attach cable to tiller upper arm as directed in Para. 259.

(5) **Install horn wire terminal**

Attach horn wire terminal to steering column and install closure plates in toe board.

(6) **Test and adjust steering gear**

Test and adjust steering gear as directed in Para. 255, then assemble drag link to pitman arm.

**TRUCK, AMPHIBIAN, 2 1/2-TON, 6 x 6****259. RUDDER AND LINKAGE REPLACEMENT**

a. Replacement of rudder can be accomplished without disturbing any major units in vehicle. Rudder shaft and linkage is accessible from inside of stern compartment.

**b. Rudder Removal Procedure (Fig. 178)****(1) Loosen stop lever and rudder control lever**

Withdraw cotter pin at rudder shaft end of connecting rod and unscrew ball socket adjusting screw and disconnect rod from rudder control lever. Loosen clamp bolt nuts in rudder stop and control levers and move levers downward until keys which position levers on shaft are exposed and remove keys.

**(2) Loosen rudder stuffing box**

Loosen lock nut and back off packing nut one or more turns to be sure shaft will slip through stuffing box.

**(3) Remove rudder and shaft**

Remove round plate in front portion of stern deck front plate to gain access to rudder shaft nut. Withdraw cotter pin and remove nut. Lower rudder and shaft and remove from underside of vehicle.

**c. Rudder Installation Procedure (Fig. 178)****(1) Install rudder**

Insert rudder shaft in stuffing box from underside of vehicle. Place rudder control lever and stop lever over shaft and insert shaft in upper support and install shaft nut. Draw nut up tight, insert new cotter pin in hole and bend flat over nut.

**(2) Position stop lever and rudder control lever**

Insert key in upper shaft keyway and slide rudder stop lever over key and tighten clamp bolt. Insert key in keyway in middle of shaft and slide control lever over key and tighten clamp bolt.

**(3) Adjust rudder stuffing box**

Adjust rudder stuffing box as directed in Para. 257b.

**d. Cable Removal Procedure****(1) Disconnect cable from tiller upper arm**

Remove tape and loosen four clamps holding ends of cable in tiller upper arm; then draw cable ends out of thimbles.

**(2) Remove cable from steering column spool**

Pull cable out of loom at left side of hull into engine compartment. Remove two bolts which attach cable clamp to spool and unwind cable.

**e. Cable Installation Procedure****(1) Prepare cable for installation**

Lay out full length of cable in a straight line to be sure there are no kinks or twists. Double one end back to within eight feet of the other end and mark the center of the loop.



**STEERING SYSTEM**

- (2) **Prepare steering column spool for installation of cable**  
Remove horn button, spring, and steering wheel retaining nut. Then remove steering wheel using puller KM-J-452-G. Remove bolt which attaches steering column jacket to bracket which extends from lower windshield panel. Remove two clamp bolts which attach spool housing to steering gear and slide housing up far enough to clear rudder spool.
- (3) **Install cable on spool**  
Raise front of vehicle until both front wheels clear the ground and turn wheels to extreme right turn position. Place cable in groove in center of spool and install cable clamp with long end of cable started over upper portion of spool. Roll short end of cable into a compact ball and move wheels to "straight ahead" position. Movement of wheels will wind long end of cable on upper portion of spool. At the same time, short end of cable will wind backwards on lower part of spool and must be unwound by hand (cable being in a ball facilitates unwinding). With wheels still in "straight ahead" position wind two and a half coils of the short cable around lower part of spool in the direction in which cable is clamped on spool.
- (4) **Insert cable ends in loom at left side of vehicle (Fig. 173)**  
Start long length of cable through flap at side of hull and place cable in upper pulley and slide through upper loom to stern compartment pulley. Place short end of cable over lower pulley and pass through lower loom to pulley in stern compartment.
- (5) **Attach spool housing to steering gear**  
Slide spool housing down over steering gear and hold cables together so they will pass through slot in housing. Rotate housing so cables are centered in opening of housing and install and tighten clamp bolts.
- (6) **Attach cable to tiller arm**  
Connect short end of cable directly to tiller arm. Pass long length of cable around stern compartment center guide pulley, then over stern compartment right-hand guide assembly pulley and adjust as directed in Para. 257c. **Do not kink cable.**
- f. Rudder Cable Spool Shear Pin Replacement Procedure**
- (1) **Remove broken shear pin**  
Start rod or nail  $\frac{1}{8}$  inch in diameter in locating hole in spool (see Fig. 123) and turn steering wheel until rod or nail falls through hole, then drive pieces of pin out with  $\frac{3}{32}$ " diameter drift.
- (2) **Install new shear pin**  
Be sure locating holes in worm shaft and rudder are in proper alignment and press new pin in shear pin hole.

Section XXXIV

**TAKE-OFF, TRANSMISSION POWER**

	Paragraph
General description .....	260
Operation .....	261
Trouble-shooting .....	262
Preventive maintenance and inspection.....	263
Power take-off replacement .....	264

**260. GENERAL DESCRIPTION**

a. Power take-off furnished in this vehicle is a dual two-speed reverse type. There are two output shafts at the rear of power take-off; lower shaft for driving winch propeller shaft and upper shaft for driving tire pump. Both drive units are equipped with shifter shafts which will permit tire pump and winch to be operated independently. Power take-off is attached to transmission with 6 studs and nuts.

**261. OPERATION**

a. Power take-off drive gear meshes with reverse idler gear in transmission which makes it possible to operate power take-off, regardless of which gear position in main transmission is placed in. Two speeds forward and one speed reverse for the winch drive shaft are obtained when any one of the three gears on the power take-off main shaft mesh with power take-off drive gear. Tire pump drive is obtained whenever jaw clutch connecting power take-off drive shaft and main shaft is engaged.

**262. TROUBLE-SHOOTING**

a. Any operating difficulties occurring with power take-off would most likely be confined to noisy operation shifting difficulties. Probable cause and probable remedies are shown in the trouble-shooting table below.

**b. Trouble-Shooting Table**

Symptom and Probable Cause	Probable Remedy	Refer to Paragraph
<b>(1) Power take-off noise</b>		
(a) Lubricant of not proper viscosity or insufficient	Check quality and quantity of oil in transmission .....	Sec. VI
(b) Power take-off mounting nuts loose	Tighten nuts .....	264
(c) Gears worn excessively	Replace power take-off assembly .....	264
(d) Incorrect number of gaskets between transmission and power take-off	Install correct number of gaskets .....	264

**TAKE-OFF TRANSMISSION POWER**

<b>Symptom and Probable Cause</b>	<b>Probable Remedy</b>	<b>Refer to Paragraph</b>
(2) <b>Hard to shift gears</b>		
(a) Lubricant too heavy	Drain transmission and fill with correct grade	Sec. VI
(b) Clash ends of gear teeth burred	Replace assembly . . . . .	264
(c) Paint or foreign matter on shift rails	Clean shift rails . . . . .	263

**263. PREVENTIVE MAINTENANCE AND INSPECTION**

- a. Preventive maintenance and inspection operations as outlined in Section V, should be accomplished according to intervals stated.
- b. Power take-off does not require any adjustments if it is properly installed on transmission; however, it is imperative that shifter shafts be kept free from any paint or foreign material, as shifter shafts must pass freely through oil seals if shifting is to be accomplished in regular manner. It is recommended that shafts be cleaned with a suitable cleaning fluid at the regular preventive maintenance operations.

**264. POWER TAKE-OFF REPLACEMENT**

a. Power take-off may be replaced without disturbing transmission mounting after winch drive shaft and tire pump chain are disconnected. It is recommended that forward left-hand floor boards of cargo compartment be removed and replacement operations be performed by mechanic lying on his side on the bottom of the hull under the frame side rail.

**b. Power Take-Off Removal Procedure**

- (1) **Drain transmission**  
Remove drain plug to transmission and allow lubricant to drain while performing succeeding operations.
- (2) **Disconnect tire pump chain**  
Disconnect tire pump chain.
- (3) **Disconnect winch drive shaft**  
Back off set screw which holds yoke of drive shaft to power take-off output shaft and drive yoke off shaft.
- (4) **Disconnect tire pump and winch control rods**  
Remove cotter and clevis pins attaching winch control and tire pump control rods to ends of shifter shafts and disconnect rods.
- (5) **Remove power take-off**  
Place support under power take-off unit so that it will not be damaged in accidental dropping during removal. Remove 2 bolts attaching power take-off support to transmission, then remove the 6 stud nuts attaching power take-off to transmis-

**TRUCK, AMPHIBIAN, 2 1/2-TON, 6 x 6**

sion and lower power take-off. The number of gaskets used between power take-off and transmission should be noted, as the same number should be used during installation operations. Place a cover or cloth over transmission opening to prevent entry of dirt during time power take-off is disconnected.

**c. Power Take-Off Installation Procedure.** Before installing power take-off units, inspect transmission to see that no dirt or foreign material has entered while power take-off was removed.

**(1) Install power take-off**

Attach power take-off to transmission, making sure that same number of gaskets that were removed are installed. Draw up the 6 stud nuts evenly and tightly and install two power take-off support bolts which hold power take-off support to transmission.

**(2) Connect tire pump and winch control rods**

Connect tire pump and winch control rods to ends of shifter shafts, using clevis pins and new cotter pins.

**(3) Connect winch drive shaft**

Place key in lower output shaft and slide yoke of drive shaft over power take-off output shaft, making sure that key and keyway are in line. When yoke is properly positioned, tighten set screw in yoke.

**(4) Install tire pump chain**

Install tire pump chain over sprockets at tire pump and winch upper output shaft.

**(5) Refill transmission with lubricant**

Install transmission drain plug and fill transmission to proper level with lubricant as directed in Section VI.



Section XXXV

**TRANSFER CASE, DRIVING AXLE**

	Paragraph
General description .....	265
Operation .....	266
Trouble-shooting .....	267
Preventive maintenance and inspection.....	268
Control linkage adjustments.....	269
Oil seal replacement.....	270
Transfer case assembly replacement.....	271
Control linkage replacement.....	272

**265. GENERAL DESCRIPTION**

a. Main transfer case, essentially a two-speed auxiliary unit, consists of a case, gears and output shafts for transfer of power to each of the three driving axles. It is located between the frame side rails behind water propeller transfer case and is driven by transmission through propeller shafts. Spring-loaded type oil seals are used at front of mainshaft, rear of main drive gear, driven shaft and front axle drive shaft. Seals used in shifter shafts in transfer case are felt type held in place by retainers.

**266. OPERATION**

a. Shifting of transfer case gears is accomplished manually through levers and rods (see Fig. 179) to transfer case shifter shafts to which are attached shift forks for actual gear engagement.

b. High and low ranges are obtainable for both front and rear axle drive. However, front axle must be engaged before transfer case can be shifted into low range. Instructions for control of transfer case during vehicle operation are outlined in Section III, "Controls and Operations."

**267. TROUBLE-SHOOTING**

a. Any operating trouble occurring in main transfer case will most likely be confined to noisy operation and shifting difficulties. The following are the symptoms, probable causes and remedies for difficulties which may occur.

**b. Trouble-Shooting Table**

Symptom and Probable Cause	Probable Remedy	Refer to Paragraph
<b>(1) Hard shifting</b>		
(a) Poor driving practices	Follow recommended practices .....	16
(b) Levers seized on shaft	Inspect, clean and lubricate .....	269
<b>(2) Slips out of gear</b>		
(a) Shifter shaft ball spring, weak or broken	Replace spring .....	269

TRUCK, AMPHIBIAN, 2½-TON, 6 x 6

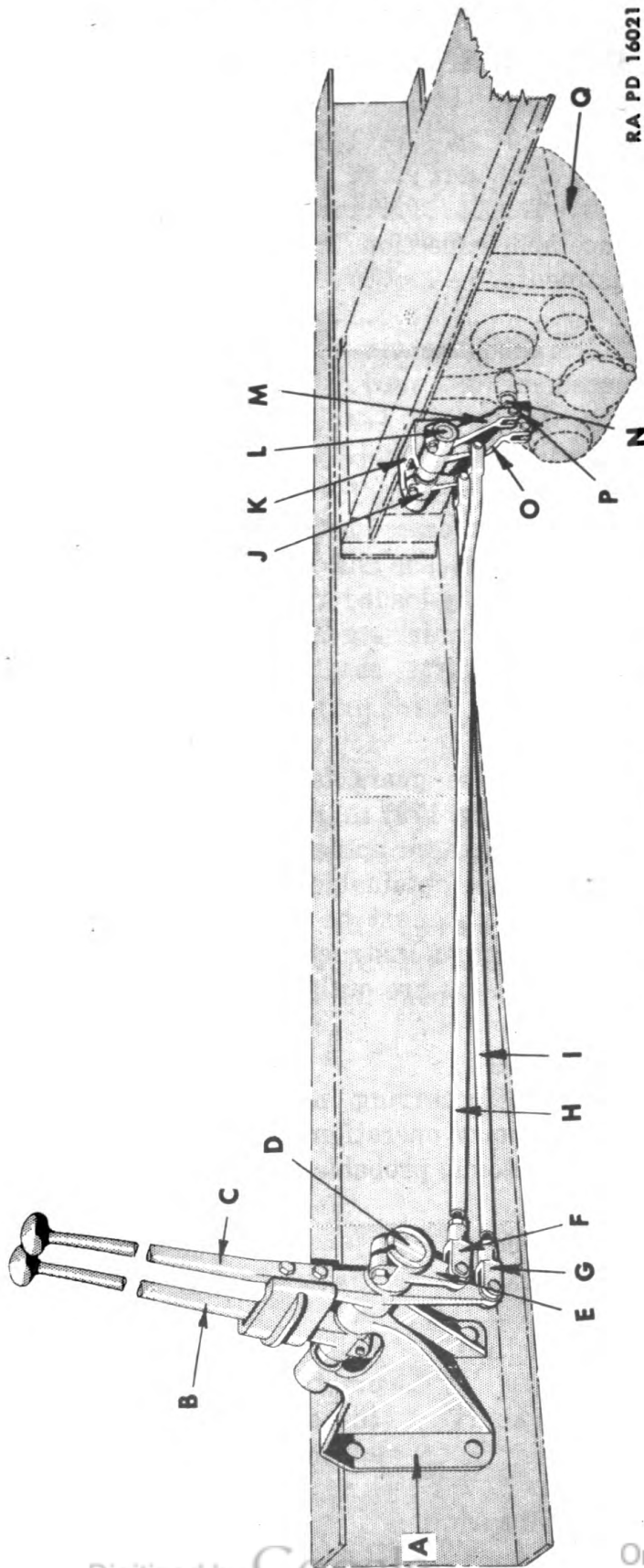

RA PD 16021

Fig. 179—Transfer Case Controls

- |   |   |   |  |   |                                |
|---|---|---|--|---|--------------------------------|
| A | Control Lever Bracket                       | G | High and Low Control Rod Adjustable Yoke | M | Rear Cross Shaft               |
| B | Declutching Control Lever                   | H | Declutching Control Rod                  | N | Inner High and Low Shift Lever |
| C | High and Low Control Lever                  | I | High and Low Control Rod                 | O | Rear Declutching Control Lever |
| D | Control Lever Shaft                         | J | Outer High and Low Shift Lever           | P | Declutching Shifter Shaft      |
| E | Declutching Control Shaft Lower Inner Lever | K | Rear Cross Shaft Bracket                 | Q | Transfer Case                  |
| F | Declutching Control Rod Adjustable Yoke     | L | High and Low Shifter Shaft               |   |                                |

**TRANSFER CASE, DRIVING AXLE**

Symptom and Probable Cause	Probable Remedy	Refer to Paragraph
(b) Gears not fully engaged	Adjust control linkage.	269
<b>(3) Excessive noise</b>		
(a) Insufficient lubricant	Add lubricant as required . . . . .	Section VI
(b) Lubricant of incorrect viscosity	Change or refill . . . . .	Section VI
(c) Gears or bearings worn	Replace assembly . . . . .	271
<b>(4) Loss of lubricant</b>		
(a) Worn or damaged seals	Replace seals . . . . . (Notify Ordnance)	
(b) Damaged gaskets	Replace gaskets . . . . . (Notify Ordnance)	

**268. PREVENTIVE MAINTENANCE AND INSPECTION**

a. **Intervals and Routine.** Daily and periodic intervals and routine outlined in Section V, "Preventive Maintenance and Inspection," should be accomplished on transfer case and controls.

b. **Lubrication.** Pertinent information on proper lubrication of transfer case will be found in Section VI, "Lubrication."

**269. CONTROL LINKAGE ADJUSTMENTS (Fig. 179)**

a. Control lever adjustment must be maintained to provide proper gear engagement in transfer case. Adjustment of declutching control lever is necessary when shifter shaft poppet ball does not seat in shifter shaft at shaft support. Need for adjustment of high and low speed control lever is indicated when shifter shaft poppet ball does not seat in shifter shaft at shaft support or when clearance between control lever and bracket on declutching control lever is excessive.

**b. Front Axle Declutching Control Lever Adjustment Procedure**

**(1) Determine poppet ball seat positions**

Remove floor boards in driver's and cargo compartment to gain access to controls. Remove cotter at clevis pin which attaches declutching control rod to front axle declutching control shaft lower inner lever. Move shifter shaft in and out of transfer case to be sure that poppet ball is entering depressions in shaft for engaged and disengaged positions. Leave shaft in "out" or disengaged position.

**(2) Position hand control lever**

Note position of control lever as it should be slightly forward of an upright or vertical position. When front axle declutching control lever is in this position, clevis pin at front of declutching control rod should line up with hole in declutching control shaft lower inner lever.

**TRUCK, AMPHIBIAN, 2 1/2-TON, 6 x 6****(3) Adjust length of declutching control rod**

Be sure that shifter shaft in transfer case remains in disengaged position. Line up hole in adjustable yoke at end of declutching control rod with hole in control shaft lower inner lever. Loosen lock nut behind adjustable yoke and turn yoke as necessary to line up holes in yoke and control lever. Replace clevis pin and cotter pin and be sure yoke lock nut is again tightened.

**c. High and Low Control Lever Adjustment Procedure (Fig. 179)****(1) Determine poppet ball seat positions**

Remove floor boards in driver's and cargo compartment to gain access to controls. Remove cotter and clevis pin attaching high and low control rod to lower end of control lever. Move shifter shaft in and out of transfer case and locate poppet spring seats in shifter shaft. Leave shaft in neutral position. This is between high and low.

**(2) Position hand control lever**

Place declutching control lever in disengaged position and set high and low speed control lever so that 1/8" clearance exists between high and low speed lever and bracket on declutching control lever.

**(3) Adjust length of control rod**

If clevis pin holes in adjustable yoke of control rod and lower end of control lever do not line up, loosen adjustable yoke lock nut and turn yoke as necessary to line up holes. Replace clevis pin and cotter pin and be sure yoke lock nut is again tightened.

**270. OIL SEAL REPLACEMENT**

a. It is not necessary to remove or disassemble transfer case in order to replace seals at front end of mainshaft, forward rear axle drive shaft or front axle drive shaft. These seals are accessible after drive shaft flanges and bearing retainers have been removed. Oil seal at rearward rear axle drive shaft requires partial disassembly. Shifter shaft oil seals are accessible after shifter shaft support is removed from transfer case. Notify Ordnance.

**271. TRANSFER CASE ASSEMBLY REPLACEMENT**

a. It will be necessary to remove floor boards in driver's compartment, air intake grille, cargo compartment front bulkhead and first sections of cargo compartment floor in order to remove main transfer case. (Figs. 179 and 180.)

**b. Removal Procedure****(1) Remove floor boards in driver's and cargo compartment**

Remove floor boards in driver's compartment, air intake grille and front section of cargo compartment floor. Remove cargo



**TRANSFER CASE, DRIVING AXLE**

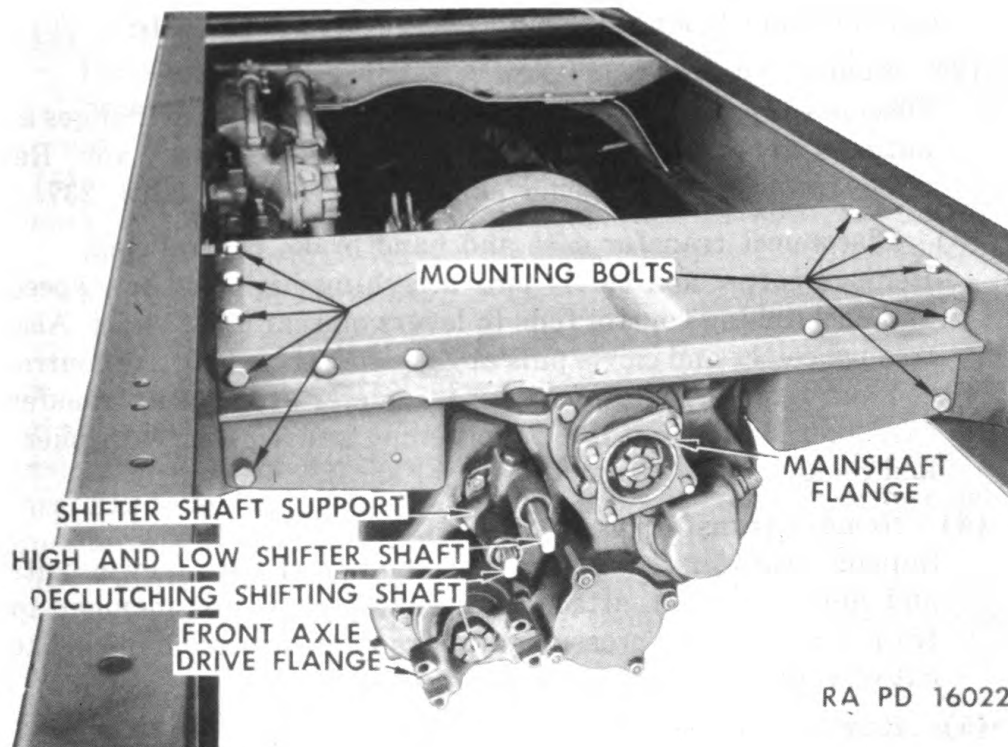

RA PD 16022

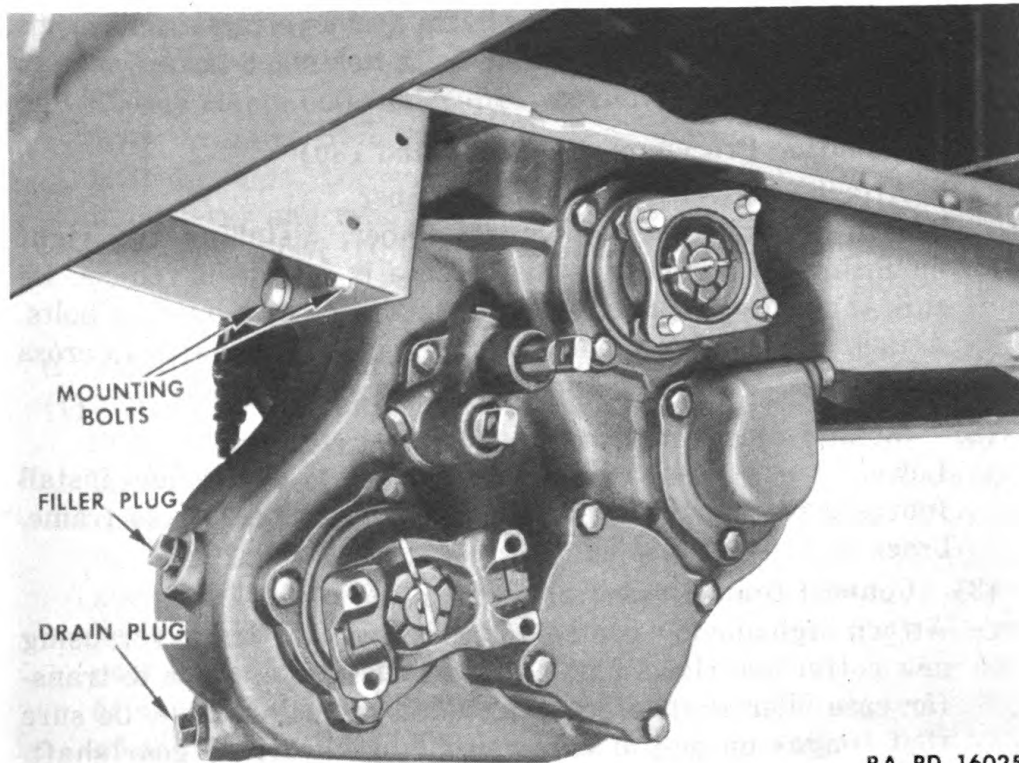

RA PD 16025

**Fig. 180—Transfer Case Installation**

**TRUCK, AMPHIBIAN, 2½-TON, 6 x 6**

compartment front bulkhead as outlined in Para. 214c.

**(2) Remove shafts**

Disconnect propeller shafts at the four transfer case flanges as outlined in Section XXX, "Propeller Shaft, Driving Axle." Remove front water propeller shaft as directed in Para. 237.

**(3) Disconnect transfer case and hand brake control rods**

Remove cotter and clevis pins attaching high and low speed and declutching control rods to levers on rear cross shaft. Also remove cotter and clevis pins at each end of hand brake control rod and remove rod. Remove speedometer cable from transfer case idler shaft front cap by loosening knurled nut with pliers and removing cable from drive gear shaft.

**(4) Remove transfer case**

Support transfer case and remove bolts and nuts (seven bolts and nuts per side) attaching transfer case crossmember to frame bracket. Lift crossmember, transfer case and hand brake out of vehicle as an assembly.

**(5) Remove crossmember from transfer case**

Crossmember and cross shaft may be removed from transfer case after cross shaft levers are disconnected from high and low and declutching shifter shafts (remove cotter and clevis pins) and the eight mounting bolts holding transfer case to crossmember are removed.

**c. Installation Procedure (Figs. 179 and 180)****(1) Attach transfer case to crossmember**

Attach transfer case to crossmember, installing the eight mounting bolts before transfer case is placed in vehicle. Be sure that lock plates are used under heads of mounting bolts. Attach high and low and declutching shifter shafts to cross shaft levers with clevis pins, using new cotter pins.

**(2) Install transfer case in vehicle**

Lower transfer case and crossmember into vehicle and install fourteen bolts and nuts which attach crossmember to frame bracket.

**(3) Connect control rods**

Attach high and low control rod to rear cross shaft lever, using new cotter and clevis pin. Replace speedometer cable to transfer case idler shaft front cap. When replacing cable, be sure that tongue on end of cable meshes with driven gear shaft. Attach declutching control rod to cross shaft lever with clevis pin and new cotter. Replace hand brake control rod and attach to hand brake and hand brake lever with clevis pins.

### TRANSFER CASE, DRIVING AXLE

**(4) Install propeller shafts**

Install water propeller shaft as directed in Para. 237. Connect propeller shafts at four flanges of transfer case as instructed in Section XXX, "Propeller Shafts, Driving Axles."

**(5) Prepare transfer case for operation**

When transfer case has been completely installed, it should be filled to level plug with recommended lubricant. Adjust controls as directed in Para. 269.

### 272. CONTROL LINKAGE REPLACEMENT

**a.** Transfer case control levers under driver's compartment floor and shift levers on cross shaft at transfer case can be replaced independently. Control lever replacement procedures are itemized in Para. 272 b. and c. Cross shaft and bracket at transfer replacement procedures are outlined in Para. 272 d. and e.

**b. Control Lever Removal Procedure (Fig. 179)**

Remove floor boards in driver's compartment to gain access to controls.

**(1) Disconnect upper and lower levers**

Remove two bolts and nuts which attach each upper control lever to its respective lower lever.

**(2) Remove lower levers from shaft**

Disconnect high and low and declutching control rods from levers on control shaft by taking out cotter and clevis pins. Loosen clamp bolt in declutching control lower lever and drive lever towards frame and remove Woodruff key which holds lever to shaft. Loosen clamp bolt in declutching control shaft inner lever and remove lever. Remove key from end of shaft and push shaft (towards outside of frame) out of frame bracket. Strip declutching and high and low control levers from shaft as it is removed from bracket.

**c. Control Lever Installation Procedure (Fig. 179)**

**(1) Install lower control levers on shaft**

Start control lever shaft through outer bracket bushing with keyway end towards center of vehicle. Then place declutching control lower lever on shaft with stop pad towards center of vehicle. Tap Woodruff key into keyway near center of shaft and push shaft into its approximate position as lever and shaft key are matched. Place high and low speed lower control lever over end of shaft, then tap Woodruff key into keyway near end of shaft. Place declutching control shaft inner lever over end of shaft. Install and tighten lever clamp bolt when lever and inner end of shaft are even. When shaft is properly located in bracket and both lower shifting levers are free, tighten clamp bolt in declutching control lower outer lever.

**TRUCK, AMPHIBIAN, 2 1/2-TON, 6 x 6****(2) Install upper control levers**

Connect upper and lower control levers, using two bolts, nuts and lockwashers per lever.

**(3) Connect control rods**

Attach control rods to lower control levers, using clevis pins and new cotter pins. If new parts have been installed or if length of control rods has been changed, readjust as directed in Para. 269.

**d. Rear Cross Shaft and Bracket Removal Procedure (Figs. 179 and 180)****(1) Disconnect outer high and low shift lever**

Lift center section of air intake grille to gain access to rear cross shaft. Disconnect high and low control rod from outer shift lever by taking out the cotter pin and clevis pin. Loosen clamp bolt in lever and push lever towards right side of vehicle until Woodruff key is exposed. Then remove key.

**(2) Remove cross shaft bracket**

Remove three bolts and nuts attaching cross shaft bracket to crossmember and slide bracket, outer high and low shift lever and declutching lever off shaft. Shaft may be withdrawn from high and low shift lever after clamp bolt is loosened.

**e. Cross Shaft Installation Procedure (Figs. 179 and 180)****(1) Install cross shaft bracket and outer lever**

Attach cross shaft bracket to crossmember, using three bolts and nuts. Start cross shaft through bracket outer bushing with keyway end towards center of vehicle. Then place outer high and low shift lever on shaft with stop pad towards end of bushing. Tap Woodruff key into keyway near center of shaft and push shaft into its approximate location as lever and shaft key are matched.

**(2) Install inner high and low shift and declutching levers**

Place rear declutching control lever over end of shaft. Then tap Woodruff key into keyway near end of shaft. Place inner high and low shift lever over end of shaft, being careful to align key and keyway. Install and tighten lever clamp bolt when high and low shift lever and inner end of shaft are even. When cross shaft is properly positioned in bracket and both levers are free, tighten clamp bolt in outer high and low shift lever.

**(3) Connect control rods**

Attach control rods to cross shaft levers, using clevis pins and new cotter pins. If new parts have been installed or if length of control rods has been changed, readjust as directed in Para. 269.



Section XXXVI  
**TRANSMISSION**

	Paragraph
General description .....	273
Operation .....	274
Trouble-shooting .....	275
Preventive maintenance and inspection.....	276
Power plant mounting adjustment.....	277
Oil seal replacement .....	278
Assembly replacement .....	279

**273. GENERAL DESCRIPTION**

a. Transmission is attached to rear face of clutch housing by four bolts held by lockwashers. In addition, two lower mounting bolts are secured by a length of wire threaded through the heads of the bolts.

b. Complete power plant assembly (engine, clutch, and transmission) is held rigidly in place by means of a stabilizing rod as illustrated in Fig. 181.

**274. OPERATION**

a. Transmission provides five speeds forward and one reverse. Power is transferred directly through transmission in fourth speed providing a 1 to 1 ratio; whereas, in fifth speed and all other speeds including reverse, the power is directed through gears of various sizes to provide the desired gear ratio.

b. Transmission gears are shifted manually by conventional gear shift lever to obtain the correct gear ratio for all operating conditions. Shifting lever positions and instructions for transmission operation are outlined in Section III, "Controls and Operation," Para. 16.

**275. TROUBLE-SHOOTING**

a. Noises which seem to come from the transmission may actually originate in some other part of the chassis; therefore, before any mechanical work is performed on transmission a thorough check should be made, by riding with driver if possible, to determine actual source of noise. **Note:** Noise may actually be in drive line—due to worn needle bearings, universal joints loose, out of alignment or out of balance.

**TRUCK, AMPHIBIAN, 2½-TON, 6 x 6**

**b. Trouble-Shooting Table**

**(1) Excessive noise**

Symptom and Probable Cause	Probable Remedy	Refer to Paragraph
(a) Insufficient lubricant.	Add lubricant as required . . . . .	Sect. VI
(b) Lubricant of incorrect viscosity.	Change or refill . . . . .	Sect. VI
(c) Gears or bearings worn or loose on shafts.	Replace assembly . . . . .	279

**(2) Hard shifting**

(a) Clutch does not release.	Adjust clutch pedal . . . . .	110
(b) Shift lever binds in transmission cover.	Lubricate lever ball . . . . .	Sect. VI
(c) Shifter shafts scored.	Replace assembly . . . . .	279

**(3) Slips out of gear**

(a) Weak or broken shift shaft poppet springs.	Replace assembly . . . . .	279
(b) Excessively worn gears.	Replace assembly . . . . .	279
(c) Shifting fork bent.	Replace assembly . . . . .	279

**276. PREVENTIVE MAINTENANCE AND INSPECTION**

a. Preventive maintenance and inspection operations as outlined in Section V, "Preventive Maintenance and Inspection," should be accomplished according to the intervals stated.

b. One of the most important inspection and maintenance procedures is lubrication of the unit. Reference should be made to Section VI, "Lubrication," for type of lubricant, intervals, and methods of cleaning and flushing unit.

c. At regular intervals, try movement of shift lever in each of the shifting positions. This test is more readily accomplished when vehicle is in motion, as it will level any tendency of gears to slip out of mesh. If hard shifting is encountered, need for corrective service is indicated.

**277. POWER PLANT MOUNTING ADJUSTMENT**

a. Power plant stabilizer rod, connected from water propeller control cross shaft bracket on left side of transmission to water propeller transfer case lower support, limits forward movement of power plant. This rod must be adjusted whenever transmission or stabilizer rod is removed.

**b. Adjustment Procedure (Fig. 181)**

**(1) Install stabilizer rod**

Place stabilizer rod in position as shown in Fig. 181 and insert clevis pin through fixed yoke and bracket on water propeller transfer case lower support.

## TRANSMISSION

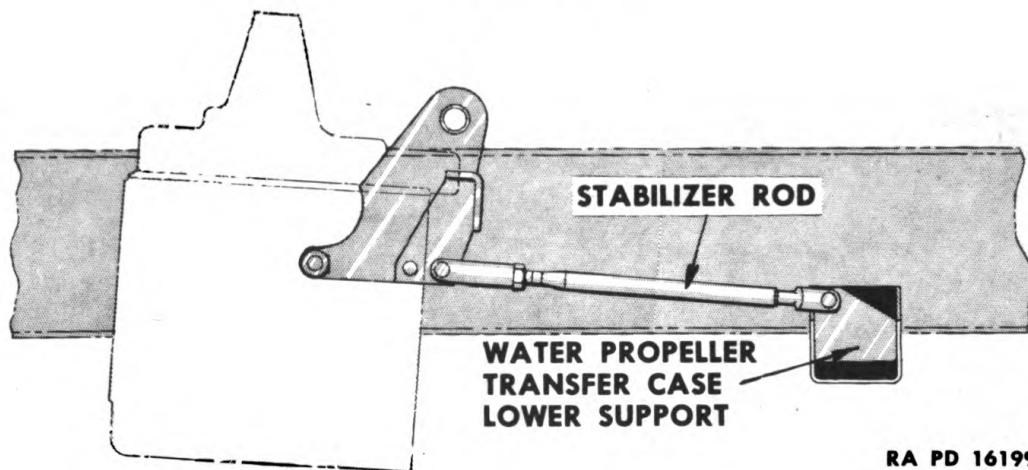

**Fig. 181—Power Plant Stabilizer Rod**

### (2) Adjust Rod

Turn adjustable yoke at transmission end of rod until hole in yoke is in line with hole in transmission bracket. Install cotter pins in both clevis pins and tighten adjustable yoke lock nut.

### 278. OIL SEAL REPLACEMENT

a. Oil seal at rear of transmission main shaft is replaceable after propeller shaft between water propeller transfer case and transmission, propeller shaft flange, and bearing retainer at rear of main shaft are removed. Notify Ordnance.

### 279. TRANSMISSION ASSEMBLY REPLACEMENT

a. Transmission may be removed from vehicle without removing engine; however, it is recommended that engine and transmission be removed as a unit whenever engine removal equipment is available. Following instructions cover removal of transmission from engine only. Refer to Para. 183 for complete power plant removal instructions.

#### b. Removal Procedure (Fig. 182)

##### (1) Drain transmission

Remove the three sections of floor board in driver's compartment after bolts holding boards to supports are removed. Remove drain plug in bottom of hull which is located at rear left-hand corner of transmission. Remove transmission drain plug and allow lubricant to drain while performing remainder of operations.

##### (2) Disconnect tire pump

Remove two upper nuts from tire pump front support bolt and remove chain from tire pump sprocket. Place wire or rope around tire pump and seat riser to hold tire pump away from transmission during removal procedure.



TRUCK, AMPHIBIAN, 2½-TON, 6 x 6

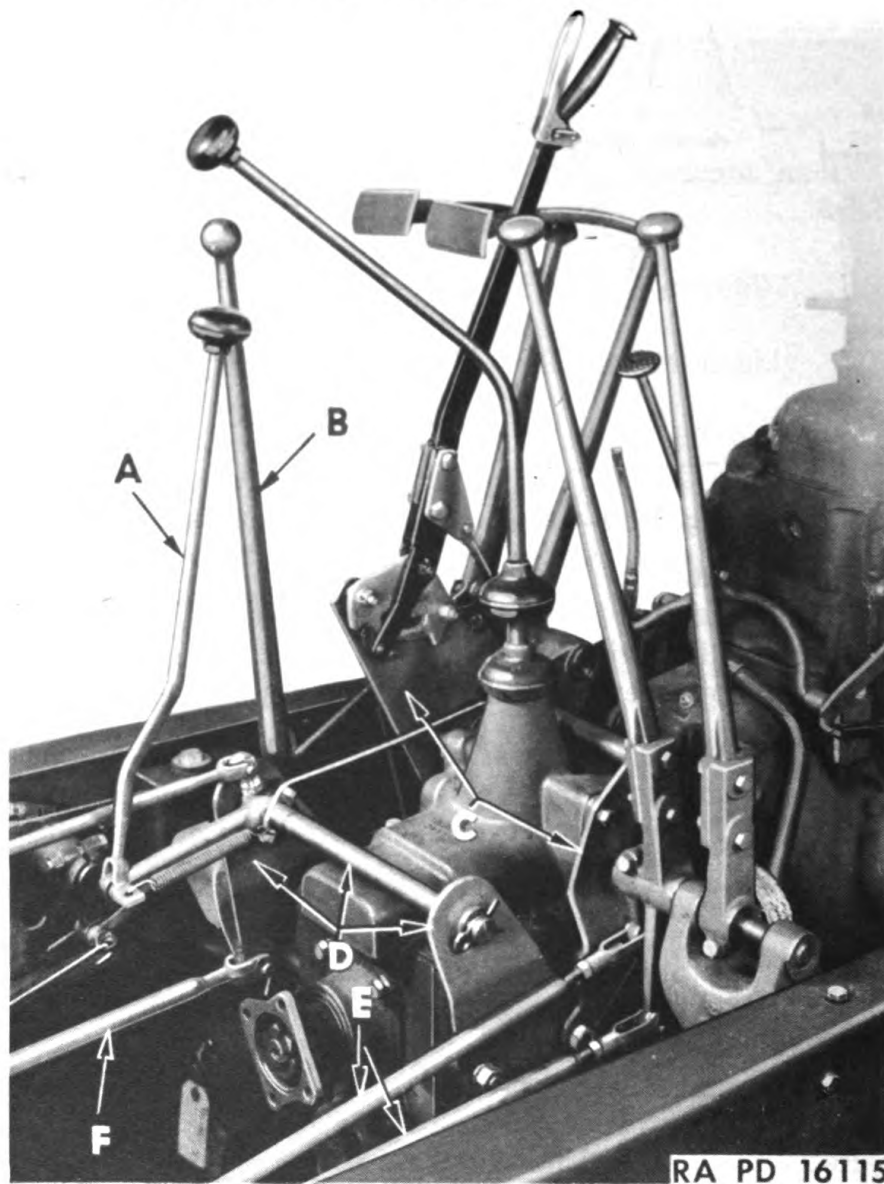

**Fig. 182—Transmission Installation**

- |  |   |
|--|---|
| <b>A</b> Water Propeller Control Rod           | <b>D</b> Water Propeller Control Cross Shaft and Brackets |
| <b>B</b> Winch Control Lever                   | <b>E</b> Main Transfer Case Control Rods                  |
| <b>C</b> Hand Brake Lever Cross Shaft Brackets | <b>F</b> Power Plant Stabilizer Rod                       |

**(3) Remove power take-off support**

Remove four bolts which attach power take-off support to transmission and power take-off (two bolts at power take-off and two bolts at transmission), and remove support.

**(4) Remove clutch and brake pedal and support**

Remove cotter and clevis pin from clutch pedal connecting link. Disassemble clutch pedal rod and operating lever by removing cotter pin and nut at end of pedal rod. Remove hairpin lock at end of clutch shaft and slide clutch operating lever off shaft.



## TRANSMISSION

Withdraw cotter and clevis pin which attaches brake pedal to brake rod. Remove two bolts which attach pedal support to transmission and two bolts which attach support to clutch housing, then remove support and brake pedal.

**(5) Remove hand brake lever cross shaft**

Disconnect hand brake control rod at cross shaft lever by removing cotter and clevis pin. Remove remaining bolts and nuts attaching cross shaft brackets to transmission (one bolt on left side and two bolts and one nut on right side) and remove cross shaft, lever and brackets as an assembly. This assembly can be removed intact by tilting right hand bracket to clear lower stud on right hand side of transmission.

**(6) Remove water propeller control lever cross shaft and brackets**

Disconnect water propeller transfer case control rods at cross shaft lever by removing cotter and clevis pins. Disconnect winch control lever at power take-off by removing cotter and clevis pin, then remove cotter pin from winch control lever to transmission stud and remove lever. Remove cotter and clevis pin attaching power plant stabilizer rod to water propeller control cross shaft left-hand bracket. Remove forward nut which attaches left-hand bracket to transmission, winch control lever to transmission stud and hair pin lock from right-hand end of shaft, then take off left-hand bracket, lever and shaft as an assembly. Remove one remaining nut which attaches right-hand bracket to transmission and slide bracket off studs.

**(7) Remove transmission to transfer case propeller shaft**

Remove propeller shaft between transmission and water propeller transfer case by removing four bolts and nuts from flanges at each end of propeller shaft.

**(8) Remove power take-off**

Remove nuts from six studs which hold power take-off to transmission and remove power take-off. Use care to see that gaskets between power take-off and transmission are not lost as the same number must be reinstalled to provide proper meshing of power take-off gear.

**(9) Remove transmission**

Remove bolts in engine rear supports and loosen bolt in front support; then raise rear of engine approximately four inches. Place blocks between rear supports and engine in such a manner that they will not pull out when transmission is removed. Remove four cross recess head screws which attach clutch housing lower pan to clutch housing. Cut wire which locks two

**TRUCK, AMPHIBIAN, 2½-TON, 6 x 6**

lower transmission mounting bolts and remove bolts (bolts may be removed by using a  $\frac{3}{4}$ " end wrench). Support transmission securely and remove two upper mounting bolts which attach transmission to clutch housing. Pull transmission straight back until shaft is clear of clutch hub. **Do not let weight of transmission rest on clutch disc or disc may be sprung or distorted, seriously affecting clutch operation.** When shaft is clear of clutch hub, turn transmission 90 degrees and lift out through floor board opening.

**c. Installation Procedure****(1) Place transmission in vehicle**

Inspect clutch release bearing and support assembly and replace if assembly shows any indication of wear, as release bearing and support cannot be replaced unless transmission is removed. Be certain that hardened buttons of release fork are in groove of release bearing support before transmission is placed in vehicle. (Refer to Para. 111.) Place transmission in vehicle being particularly careful not to permit assembly to get out of alignment with clutch driven disc hub. Transmission must be supported until the four mounting bolts are installed. Install two upper bolts first using new lockwashers under heads of bolts. Install two lower transmission bolts (in clutch housing) using new lockwashers and pass lockwire through heads of bolts after they have been tightened securely.

**(2) Replace lower clutch housing pan**

Attach lower clutch housing pan to clutch housing with four cross recess screws. Remove blocks (used to support engine during transmission removal) from between engine and engine supports and install and tighten engine support bolts.

**(3) Attach power take-off to transmission**

Before attaching power take-off to transmission, check the contact of meshing gears as directed in Para. 264. When proper mesh is obtained, install six stud nuts and tighten securely.

**(4) Install transmission to transfer case propeller shaft**

Reinstall propeller shaft between transmission and water propeller transfer case and tighten four flange bolt nuts at each end.

**(5) Install water propeller control lever cross shaft and bracket**

Place right hand cross shaft bracket over transmission studs and secure to transmission by installing rear nut. Reinstall left-hand bracket lever and cross shaft as an assembly. Secure with nut on forward stud and winch control lever to transmission stud. Install hairpin lock at end of cross shaft. Attach water propeller transfer control rods to cross shaft lever with cotter

## TRANSMISSION

and clevis pins. Place winch control lever over stud and hold in place with washer and cotter pin. Connect winch control lever to power take-off by installing cotter and clevis pin. Attach power plant stabilizer rod to water propeller control cross shaft left hand bracket and adjust as directed in Para. 277.

**(6) Install hand brake lever and cross shaft**

Place cross shaft lever bracket assembly on transmission and install bolt in upper rear hole on left side. Install bolts in upper holes on right-hand side and nut over stud. (Remaining bolts on left-hand side should not be installed until power take-off support and clutch and brake pedal support is installed.) Connect hand brake control rod to cross shaft lever with clevis and cotter pin.

**(7) Install clutch and brake pedal and support**

Attach clutch and brake pedal support to transmission and clutch housing by installing the two bolts which attach support to clutch housing and one bolt to transmission through support upper hole. Install clutch operating lever on shaft and secure with hairpin lock on end of shaft. Connect clutch and brake pedal control rod to their respective pedals using cotter and clevis pins.

**(8) Install power take-off support**

Attach power take-off support to transmission and power take-off using two bolts at each end of support.

**(9) Connect tire pump**

Place drive chain over sprockets at power take-off and tire pump and attach tire pump front support to bracket on water propeller control cross shaft left-hand bracket. Refer to Para. 290 for tire pump chain adjustment.

**(10) Prepare transmission for service**

Remove filler plug and add lubricant to transmission as directed in Section VI, "Lubrication." Install floor boards in driver's compartment.

Section XXXVII

**WHEELS, HUBS, BEARINGS AND TIRES**

	Paragraph
Description .....	280
Trouble-shooting .....	281
Preventive maintenance and inspection .....	282
Wheel maintenance .....	283
Front hub bearing adjustment.....	284
Front hub and bearing replacement.....	285
Rear hub bearing adjustment.....	286
Rear hub and bearing replacement.....	287
Tire maintenance .....	288
Mounting and dismounting tires.....	289
Tire pump, lines and tank maintenance.....	290

**280. DESCRIPTION**

**a. Wheels.** Single wheels are used on each axle of vehicle. Front wheels are attached directly to front hubs by six serrated bolts in flanges on hubs. Each rear wheel is attached to a wheel spacer by six studs and the spacer is attached to flange on hub by six separate bolts. Budd type nuts are used at each bolt or stud. Tires are 11.00/18 10-ply Military Desert type with tube and bead lock. Tires are held on each wheel rim by a single split lock ring and the hinged type bead lock. A spare tire and wheel assembly is mounted on top of deck at left rear corner of vehicle.

**b. Hubs.** Front hubs are mounted on opposed tapered roller bearings on spindles of steering knuckles and rear hubs are mounted on opposed barrel type roller bearings on tubular ends of rear axle housings. Each axle shaft drive flange is attached to hub by eight cap screws. Each front brake drum is attached to inner side of flange on hub by the six wheel bolts and each rear drum is attached to hub by the six bolts which attach wheel spacer to hub.

**c. Tire Pump.** A two-cylinder, air-cooled air compressor, chain driven from power take-off, is located just below driver's seat. Air is discharged into a storage tank which is connected, by copper tubing, to air hoses at each side of vehicle. Hoses, with fittings for inflating tires, are hung on brackets inside hull at each side just above air intake grille. Pump is controlled manually by a shift lever near right rear of driver's seat. To put pump in operation, disengage clutch, pull up on shift lever and engage clutch. To stop pump, disengage clutch, push down on lever and engage clutch.

**281. TROUBLE-SHOOTING**

**a. General**—Excessive or uneven tire wear or hard steering are



**WHEELS, HUBS, BEARINGS AND TIRES**

usually indications of improper tire maintenance or hub bearing adjustment. Noise from tire pump drive chain is usually the result of improper drive chain adjustment.

**b. Trouble-Shooting Table**

Symptom and Probable Cause	Probable Remedy	Refer to Paragraph
<b>(1) Excessive or uneven tire wear</b>		
(a) Tires improperly inflated.	Inflate to 40 pounds.	288
(b) Wheel bent or not mounted correctly on hub.	Replace wheel or remount . . . . .	289
(c) Brakes grab.	Adjust brakes . . . . .	94
(d) Front wheels out of alignment.	Check alignment and adjust, or replace axle assembly as found necessary. . . . .	74
<b>(2) Hard steering</b>		
(a) Tires underinflated.	Inflate to 40 pounds.	288
(b) Steering gear adjusted too tight.	Adjust steering gear	255
(c) Front wheels out of alignment.	Check alignment and adjust or replace axle assembly as found necessary. . . . .	74
<b>(3) Wheels pounding</b>		
(a) Hub bearings loose.	Adjust . . . . .	284-286
<b>(4) Vehicle pulls to one side</b>		
(a) Uneven tire pressure.	Inflate all tires to 40 pounds . . . . .	288
(b) Wheel bearings out of adjustment.	Adjust bearings .	284-286
(c) Brakes adjusted improperly.	Adjust brakes . . . . .	94
<b>(5) Shimmy</b>		
(a) Tires not inflated correctly.	Inflate all tires correctly . . . . .	288
(b) Tires worn unevenly.	Replace tires . . . . .	289
(c) Front hub bearings loose.	Adjust bearings . . . . .	284
(d) Wheel bent or mounted incorrectly.	Replace wheel or install correctly . . . . .	289
(e) Wheel assembly out of balance.	Replace wheel and tire assembly . . . . .	289
<b>(6) Tire pump drive chain noisy</b>		
(a) Chain too loose.	Adjust chain . . . . .	290
<b>(7) Excessive wear on tire pump drive chain or sprockets</b>		
(a) Chain too tight.	Adjust chain . . . . .	290

**TRUCK, AMPHIBIAN, 2½-TON, 6 x 6**

**282. PREVENTIVE MAINTENANCE AND INSPECTION**

a. **General**—Preventive maintenance and inspection procedure pertaining to tires, wheels, hub bearings and tire pump should be carried out in accordance with instructions given in Section V, "Preventive Maintenance and Inspection." Regular lubrication with proper lubricant, in correct quantity, and at specified periods as outlined in Section VI, "Lubrication," is essential to trouble-free operation of hub bearings and of tire pump.

b. **Maintenance and Inspection Procedure.**—Maintenance and inspection procedure covering wheels, front hub bearings, rear hub bearings, tires, and tire pump is covered in succeeding paragraphs.

**283. WHEEL MAINTENANCE**

a. **General.** It is essential that wheel bolt nuts be kept tight at all times. During first 500 to 1000 miles operation tighten nuts daily and after this period inspect nuts for tightness at regular periods. It is especially important that tightness of bolt nuts be checked immediately after operation in water.

b. **Front Wheel Bolt Tightening Procedure**

(1) **Tighten stud nuts**

Remove the bolt, nut and washer at each lower corner of front fender skirt and remove the skirts. Use wrench and wrench handle supplied with vehicle tool kit and tighten opposite nuts alternately until all are drawn up wrench tight. Never use an extension on wrench handle.

(2) **Replace fender skirts**

Insert top of fender skirt in groove in hull and attach to hull with one bolt, lockwasher and nut at each lower corner.

c. **Rear Wheel Bolt Tightening Procedure**

(1) **Tighten wheel spacer bolts (See Fig. 183)**

Use wrench and wrench handle supplied with vehicle tool kit and **TIGHTEN THE SIX SPACER NUTS** (square-headed type) **FIRST**. Tighten opposite nuts alternately until all are wrench tight. Do not use extension on wrench handle.

(2) **Tighten wheel nuts**

After all spacer nuts are tight, tighten the six wheel nuts (hex head nuts) until all are wrench tight.

**284. FRONT HUB BEARING ADJUSTMENT (See Fig. 184)**

a. **General.** Check adjustment of wheel bearings at regular inspection periods by raising wheels from ground and checking side-wise movement of wheels. Use a long bar under tire and determine amount of movement of inner side of brake drum relative to brake dust shield. When bearings are in proper adjustment, movement will be barely perceptible. If movement is excessive or if wheels do not turn freely, adjust bearings. Be certain brakes do not drag.

**WHEELS, HUBS, BEARINGS AND TIRES**

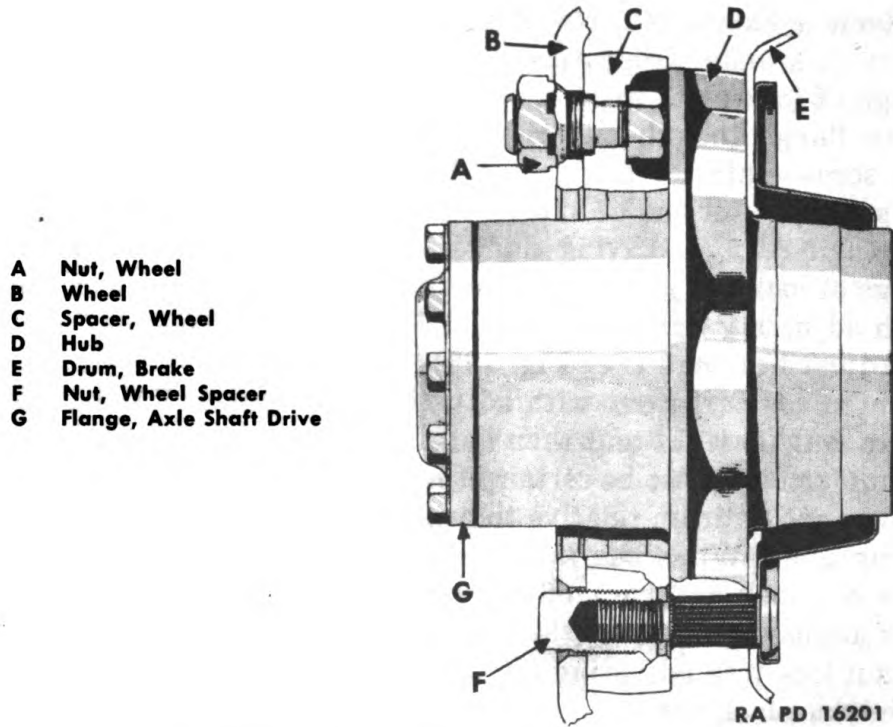

**Figure 183—Rear Wheel and Wheel Spacer Installations**

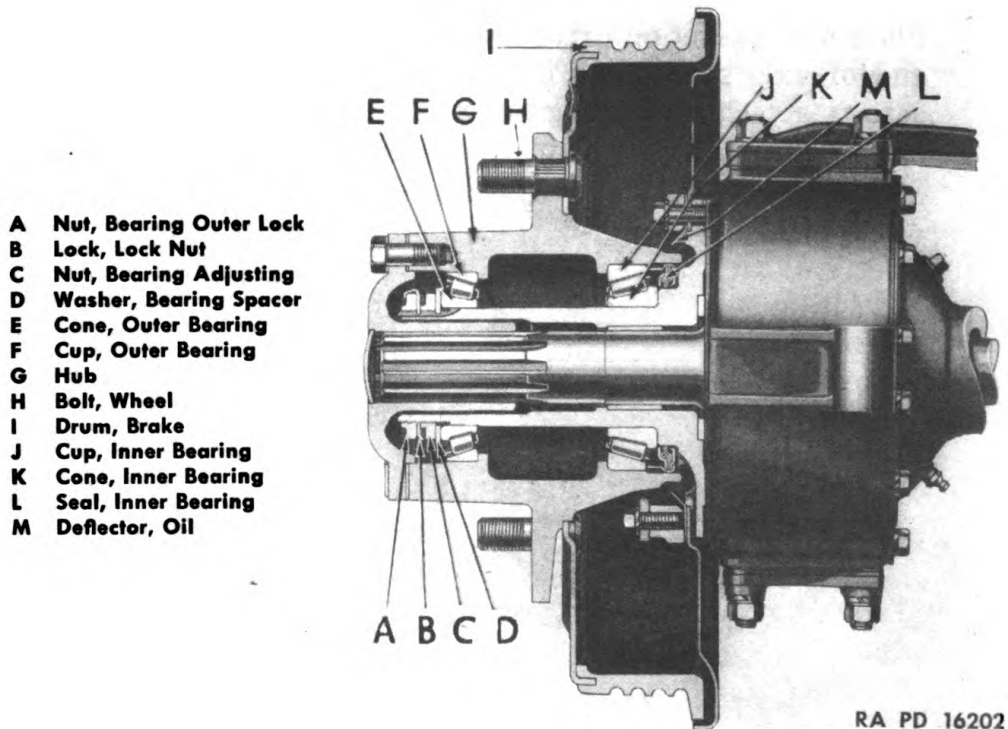

**Figure 184—Front Hub Cross-Section**



## TRUCK, AMPHIBIAN, 2½-TON, 6 x 6

**b. Adjustment Procedure—Front Hub Bearings****(1) Remove axle shaft drive flange**

Place jack under front axle and raise wheels off ground. Bend tangs of lock plate away from heads of cap screws attaching drive flange to hub and remove the cap screws. Screw  $\frac{7}{8}$ " cap screws into the two tapped holes in flange and pull flange off splined outer end of axle shaft by turning screws alternately. Then remove driving flange, lock ring and gasket. Bend tangs of lock nut lock away from lock nut and remove lock nut with adjusting nut wrench KM-J-1663. Then remove nut lock.

**(2) Adjust bearings (See Fig. 185)**

Tighten adjusting nut with adjusting nut wrench KM-J-1663. Draw nut up tight and then back off at least one-eighth of a turn. Turn wheel to be certain it rotates freely. Check sidewise movement of drum relative to brake dust shield (see a. in this paragraph). When bearings are in proper adjustment, install new nut lock and back off adjusting nut until short tang on lock aligns with nearest slot in adjusting nut. Bend short tangs of nut lock into adjusting nut slots.

**(3) Replace lock nut**

Install lock nut and tighten with wrench KM-J-1663. Check bearing adjustment (a. in this paragraph). If adjustment is correct, bend long tangs on nut lock over into slots on lock nut.

**(4) Install axle shaft drive flange**

Place new gasket on drive flange and replace flange on splined end of axle shaft. Use new screw lock ring and install cap screws attaching driving flange to hub. Install fender skirts and attach with two bolts, nuts and new lockwashers. Lower jack and remove.

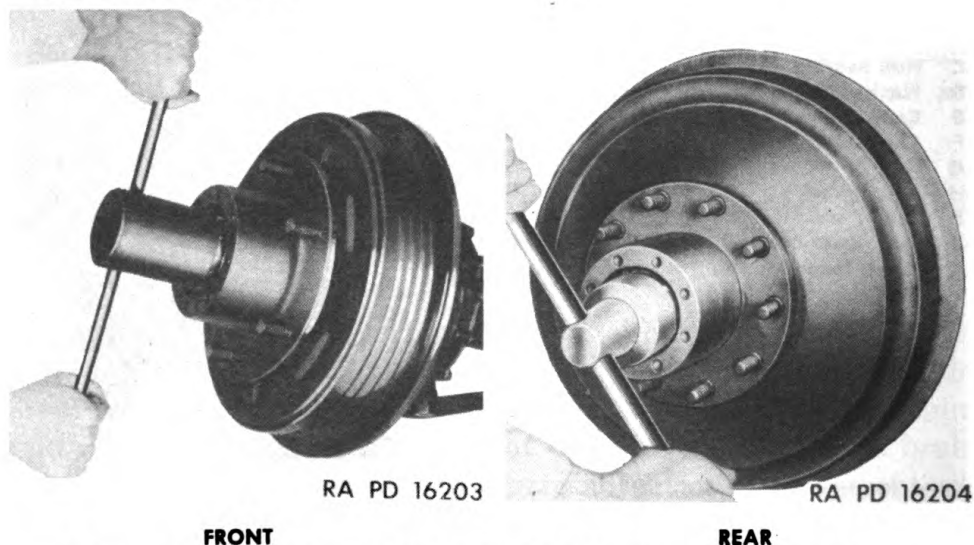

**Figure 185—Typical Method of Adjusting Hub Bearings**



**WHEELS, HUBS, BEARINGS AND TIRES****285. FRONT HUB AND BEARING REPLACEMENT**

**a. General.** Hub and bearing replacement requires removing wheels, axle shaft driving flange bearing adjusting nut and lock and pulling hub and drum assembly off steering knuckle spindle.

**b. Removal Procedure****(1) Remove wheels and disconnect hub**

Remove wheel and tire assembly as instructed in Para. 289. Then remove shaft driving flange, bearing lock nut, nut lock and adjusting nut. (See instructions in Para. 284.)

**(2) Remove hub and drum**

Remove bearing spacing washer and outer bearing cone. Then pull the hub and drum assembly off steering knuckle spindle. Both bearing cups, inner bearing cone and inner oil seal will remain in hub.

**c. Oil Seal and Bearing Replacement****(1) Remove oil seal**

If inner bearing cone, cup or inner oil seal are to be replaced, or if inner bearing is to be lubricated, remove oil seal with screw driver. This seal is a light press fit in hub and should not be removed unless necessary because it cannot be removed without being damaged.

**(2) Remove bearings**

Lift inner bearing cone out of inner race. Inspect both bearing cups and, if pitted or worn excessively, remove, using a drift from inner side. Clean bearings as follows:

(a) First soak parts in Solvent, dry cleaning fluid, and use clean stiff brush to loosen all particles of old lubricant.

(b) Remove from fluid and strike larger side of bearing flat against a wood block to knock out heavier particles of dirt.

(c) Blow bearings clean and dry with compressed air, directing air across bearings. Be careful not to spin bearings.

(d) Rotate bearing slowly by hand, and inspect rollers and race for defects and excessive wear. NEVER spin bearings while dry.

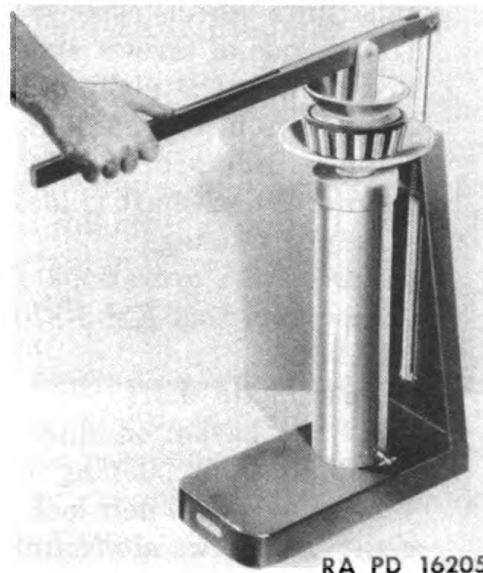

**Figure 185.—Bearing Lubricator**

**TRUCK, AMPHIBIAN, 2 1/2-TON, 6 x 6****(3) Install bearing cups**

Install inner and outer bearing cups in hub with wide side of cup inwards. Drive into place with driver KM-J-1660-3. Hub bearings should be lubricated at regular intervals as explained in Section VI, "Lubrication." **Never pack hubs with lubricant nor force grease into bearings or hubs through pipe plugs.** Always remove bearings and clean as instructed above. Then pack by hand or use special lubricator (see Fig. 186).

**(4) Install inner cone and oil seal**

Install inner bearing cone in inner cup and install new oil seal at inner end of hub. Be certain seal is installed with flexible sealing portion of seal assembly outwards (away from bearing). Drive seal into place, using special seal driver KM-J-2347.

**(5) Install hub and outer cone**

Push hub and drum assembly into place on knuckle spindle and install outer bearing cup.

**(6) Adjust hub bearings**

Install bearing spacer washer and adjust bearings as instructed in Para. 284. Replace nut lock, lock nut and drive flange as instructed in Para. 284. Replace wheel and tire assemblies and tighten wheel nuts. See Para. 283. Lower and remove jack.

**286. REAR HUB BEARING ADJUSTMENT (See Fig. 187)**

**a. General.** Follow instructions in Para. 284a. to determine need for bearing adjustment.

**b. Adjustment Procedure—Rear Hub Bearings****(1) Remove axle shaft**

Place jack under axle on which bearings are to be adjusted and raise until wheels clear ground. Bend tangs of lock plate away from heads of screws attaching axle shaft drive flange to hub and remove the eight cap screws and lock plate. Insert two  $\frac{7}{16}$ " screws in tapped holes in flange and pull shaft out of differential side gear hub by drawing up alternately on the two screws. When shaft is loosened, withdraw from axle housing.

**(2) Adjust bearings**

Proceed with operations (2), (3) and (4) under Para. 284b. except that tool KM-J-870 is used at rear wheels instead of KM-J-1663.

**(3) Install axle shaft**

Place new gasket on inner side of shaft drive flange and install axle in housing, pushing inner end into splined differential side gear hub. Install new lock plate and attach flange to hub with eight cap screws alternately until all are tightened to a torque of 95 to 115 foot-pounds. Lower and remove jack from under vehicle.



**WHEELS, HUBS, BEARINGS AND TIRES**

- A** Assembly, Bearing Lock Nut and Seal  
**B** Lock, Lock Nut  
**C** Nut, Bearing Adjusting  
**D** Washer, Thrust  
**E** Cone, Outer Bearing  
**F** Cup, Outer Bearing  
**G** Ring, Outer Bearing Snap  
**H** Hub  
**I** Bolt, Wheel Spacer  
**J** Drum, Brake  
**K** Cup, Inner Bearing  
**L** Cone, Inner Bearing  
**M** Seal, Inner Bearing  
**N** Deflector, Oil

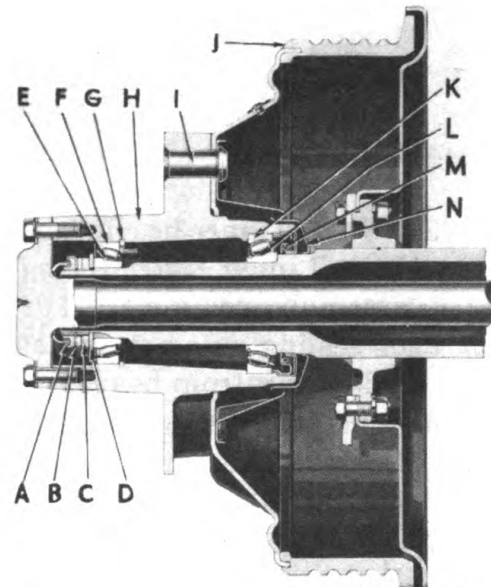

RA PD 16206

**Figure 187—Rear Hub Cross Section****287. REAR HUB AND BEARING REPLACEMENT**

**a. General.** Hub and bearing replacement requires removing wheel, axle shaft, bearing lock nut, nut lock, adjusting nut and bearing spacing washer and then withdrawing hub and drum assembly from axle. It is not necessary to remove the wheel spacer from drum.

**b. Removal Procedure****(1) Remove wheel and disconnect hub**

Remove wheel and tire assembly from wheel spacer on hub as instructed in Para. 289. Then remove axle shaft, bearing lock nut, lock and adjusting nut using wrench KM-J-870.

**(2) Remove hub and drum**

Remove bearing spacing washer and outer bearing cone. Then pull hub and drum off end of axle housing. Both bearing cups, inner bearing cone, inner oil seal, wheel spacer, brake drum and oil deflector inside brake drum will come off with hub. Oil deflector on axle housing will remain in place on housing.

**c. Oil Seal and Bearing Replacement****(1) Remove oil seal and bearings**

Remove inner oil seal, inner bearing cone and both bearing cups (if necessary) in accordance with instructions in Para. 285c. Be especially careful when removing outer bearing cup that drift is used against bearing cup and not against snap ring in housing. Do not remove snap ring.

**(2) Clean bearings**

Follow instructions in Para. 285c. operation (2).

**TRUCK, AMPHIBIAN, 2 1/2-TON, 6 x 6****(3) Install bearing cups**

Install inner and outer bearing cups in hub with wide side of race inwards. Drive into place solidly with driver KM-J-872-1 at outer cup and KM-J-872-4 at inner cup.

**(4) Lubricate bearings**

Follow procedure as outlined in Para. 285c. operation (3).

**(5) Install inner bearing cone and oil seal**

Install inner bearing cone in bearing cup. Install new oil seal assembly, using special driver KM-J-2346. Be sure leather side of sealing assembly is towards bearing (i.e., synthetic rubber side away from bearing).

**(6) Install hub and outer cone**

Push hub and drum assembly into place on end of axle housing and install outer bearing cone in outer bearing cup.

**(7) Adjust hub bearing**

Follow instructions in Para. 285c. operation (2).

**(8) Install wheels**

Replace wheel and tire assembly as instructed in Para. 289. Lower and remove jack.

**288. TIRE MAINTENANCE**

**a. General.** Safe and economical operation of this vehicle requires systematic tire maintenance. Since vehicle is designed to operate on both land and water, it may be necessary to operate with tires in an under-inflated condition to obtain sufficient traction to cross a sandy or muddy beach. Under such a condition, tires may be deflated as much as necessary to obtain required traction. Air pressure in tires should be forty pounds per square inch for operation on land, however, and a tire pump with air hoses is provided in vehicle so that tires may be re-inflated as soon as road surface conditions will permit. Regular inspection and maintenance as described in next two paragraphs is essential to safe and economical tire service.

**b. Tire Inspection Procedure****(1) Inspect tire daily**

Examine tire casing and remove all foreign matter such as nails, glass, stones, etc. Replace any missing valve caps. Replace tire if cut badly. If front tires are wearing unevenly, check wheel alignment as instructed in Para. 74.

**(2) Gauge tires**

Check tire inflation pressure daily with an accurate gauge. Note any excessive pressure loss and determine cause of such loss before using tire again. Always use same pressure gauge to eliminate error resulting from differences between gauges. Be certain that all tires are inflated to same pressure.



**WHEELS, HUBS, BEARINGS AND TIRES**

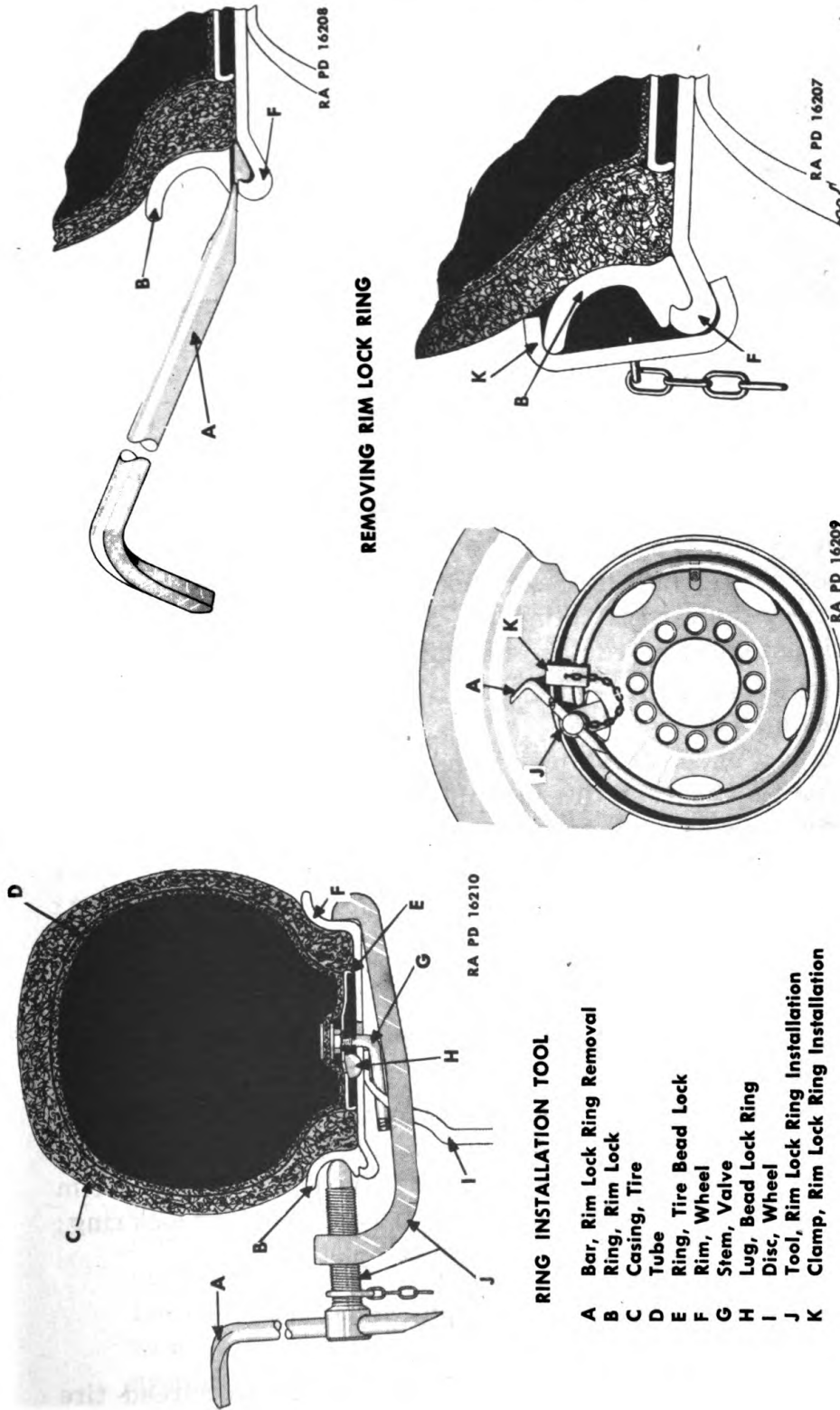

**RING INSTALLATION TOOL**

- A Bar, Rim Lock Ring Removal
- B Ring, Rim Lock
- C Casing, Tire
- D Tube
- E Ring, Tire Bead Lock
- F Rim, Wheel
- G Stem, Valve
- H Lug, Bead Lock Ring
- I Disc, Wheel
- J Tool, Rim Lock Ring Installation
- K Clamp, Rim Lock Ring Installation

**Figure 188—Tire Installation and Installation Tools**

## TRUCK, AMPHIBIAN, 2½-TON, 6 x 6

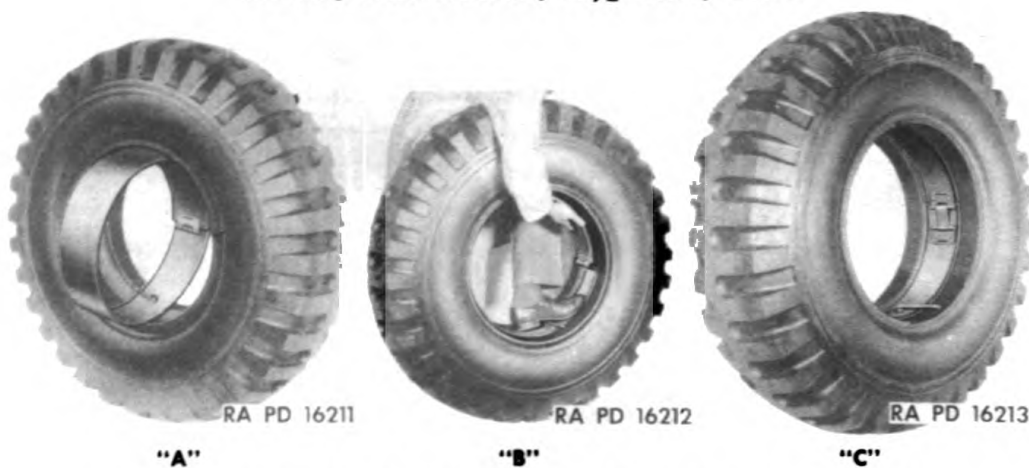

**Figure 189—Typical Method of Installing Bead Lock**

### 289. DISMOUNTING AND MOUNTING TIRES

a. **General.** Dismounting tire requires removing wheel from hub, removing tire lock ring from wheel rim, sliding tire and bead lock ring off rim, removing bead lock ring and tube from casing. Mounting tire requires installing tube and bead lock ring in casing, placing this assembly on rim and installing lock ring on rim.

#### b. Wheel Removal Procedure

##### (1) Jack up axle

Place jack under axle housing and raise tire off ground.

##### (2) Remove wheel and tire assembly

At front wheels, remove fender skirt by removing bolt, nut and washer at each lower corner of skirt, then remove the six hex head nuts holding wheel disc to hub and remove the wheel. At rear wheels remove the six hex head nuts to remove wheel but do not remove the square-headed nuts holding wheel spacer to hub.

#### c. Tire Removal Procedure (See Figs. 188 and 189)

##### (1) Remove tire lock ring

Remove valve core to completely deflate tire. Use lock ring removing bar supplied with vehicle tool kit. Insert straight end of bar in notch in lock ring near split. Pry lock ring out of rim and insert hook end of removing bar between rim and lock ring; then pry and work ring out of rim completely.

##### (2) Remove tire from rim

Pull tire and bead lock ring assembly off wheel rim.

##### (3) Remove bead lock and tube

Reinstall valve core and inflate tube enough to spread tire beads. Use lock ring removing bar to pry up on bead lock at a point about 8 inches from hinge. This will collapse bead lock to the limit which hinge will permit. Turn complete bead lock ring assembly around in tire (see Fig. 189-A) to provide necessary

**WHEELS, HUBS, BEARINGS AND TIRES**

clearance at valve stem as bead lock is removed from casing. Deflate tube and remove from casing.

**d. Tire Installation Procedure****(1) Install tube in casing**

Install inner tube in tire casing and inflate enough to hold tube in casing.

**(2) Install bead lock**

With bead lock ring collapsed at hinge, insert valve stem through hole in bead lock ring and install ring inside tire with plane of ring at 90 degrees to plane of tire (see Fig. 189-A for example). Collapse and press bead lock ring into tire until part of ring directly opposite valve stem opening is centered between beads of tire. Inflate tube sufficiently to spread beads of tire apart about the same amount as width of tire bead lock. Turn bead lock ring around in tire from its position at 90 degrees to plane of tire (Fig. 189-A) to a position in same plane as tire (Fig. 189-B), working ring into position between beads of tire. Turn the ring in the direction which will bring lug (not shown in Fig. 189) on ring near valve stem, directly under horizontal portion of valve stem after bead lock is in position. Deflate tube entirely, hold one end of lock in place with one foot and jerk other end up quickly with both hands (Fig. 189-C) until hinge snaps into place. Inspect bead lock and be certain that it is centered properly so that its edges are below edges of tire beads all the way around on both sides.

**(3) Install tire on rim**

Slip tire and bead lock ring assembly over wheel rim with valve stem pointing outwards. Be sure that the lug on bead lock ring engages valve stem slot in wheel rim.

**(4) Install tire lock ring**

Install tire lock ring tool through hole in tire ring so that hook end of tool engages inside of wheel rim. Then, place end of tire lock ring in position on tire rim with split near screw end of tool. Place end of tool screw against lock ring and force lock ring into position in rim by tightening up on screw. Use ring removal bar as handle for screw. Place clamp (on chain attached to screw) around rim and ring to hold ring in position. Back off on screw, remove tool and move it to the next hole in wheel disc. Force ring into position at this point. Move clamp around on ring to a point near the end of screw. Remove the tool and proceed with this series of operations until the entire lock ring is in position on rim.

**(5) Inflate tire**

Inflate tire to forty pounds pressure.



**TRUCK, AMPHIBIAN, 2½-TON, 6 x 6**

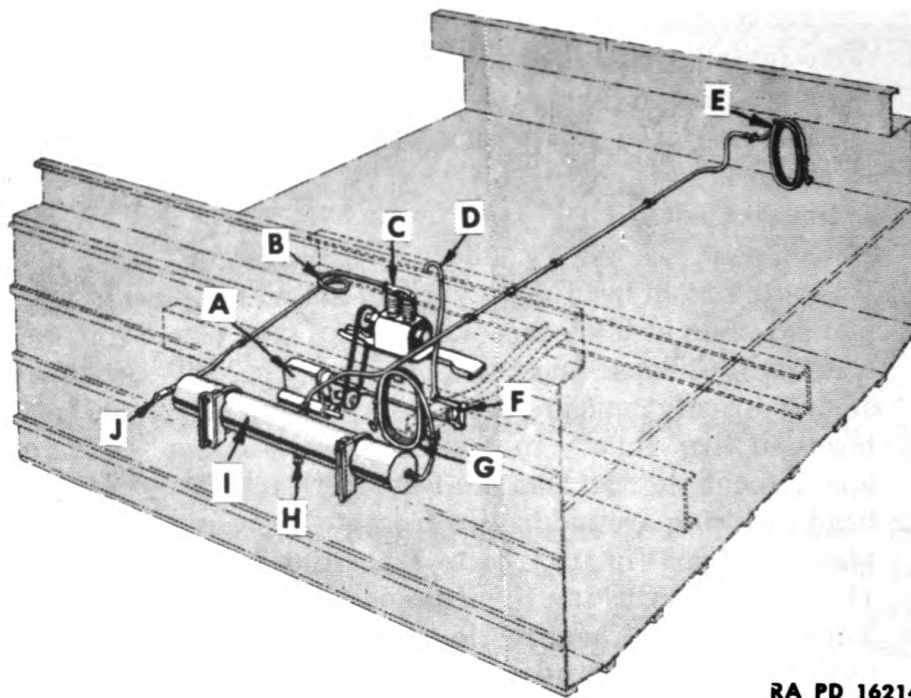

RA PD 16214

**Figure 190—Tire Pump, Tank and Lines Installation**

- |   |                             |   |                             |
|---|-----------------------------|---|-----------------------------|
| A | Power Take-Off              | F | Bell Crank, Control Rod     |
| B | Coil, Cooling               | G | Hose, Tire Inflation (L.H.) |
| C | Discharge, Tire Pump        | H | Cock, Air Tank Drain        |
| D | Rod, Tire Pump Shift        | I | Tank, Air                   |
| E | Hose, Tire Inflation (R.H.) | J | Valve, Air Tank Safety      |

**(6) Install wheel and tire assembly**

Place wheel and tire assembly on wheel bolts on hub. Install the six nuts on wheel bolts and tighten opposite nuts alternately until all are tight. (See Para. 283.) At front wheels, replace fender skirts. Lower and remove jack.

**290. TIRE PUMP, LINES AND TANK MAINTENANCE**

a. **General.** Replacement of tire pump, air tank or lines is beyond the scope of the Using Arms Personnel. If pump becomes inoperative refer to Ordnance. However, inspection and maintenance operations given under b. and c. in this paragraph should be performed regularly. (See Fig. 190 for installation.)

**b. Drain Cock Operation**

**(1) Drain air tank daily**

Drain cock is located at bottom of tank. With air in tank under pressure, open drain cock wide and blow out all moisture from tank every day. Then close cock. It is important to blow tank down daily, especially during cold weather.



**WHEELS, HUBS, BEARINGS, AND TIRES**

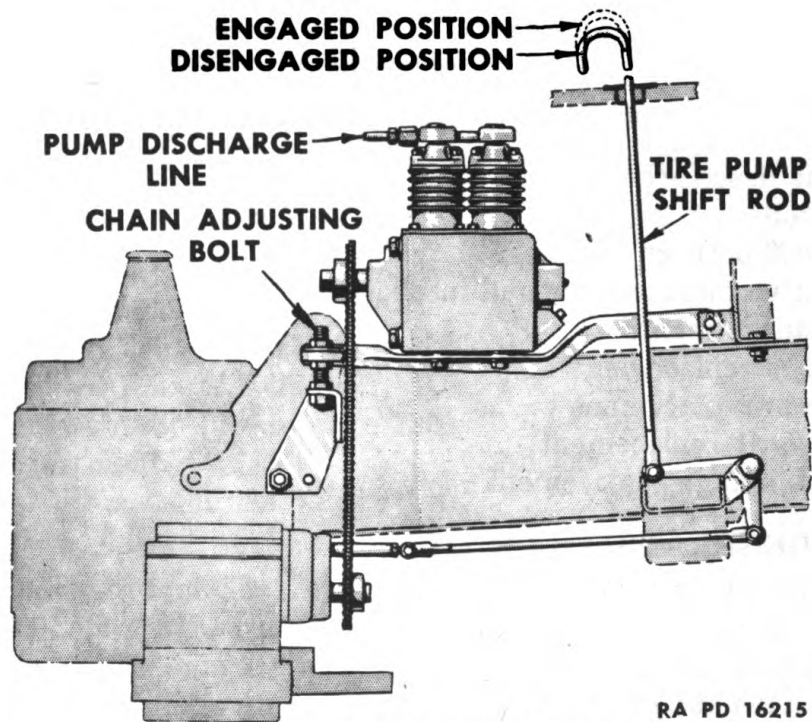

RA PD 16215

**Figure 191—Tire Pump Mounting**

**c. Pump Drive Chain Adjustment**

**(1) Inspect chain and sprockets**

If chain is noisy while pump is in operation, or if inspection reveals excessive wear on chain or sprockets, chain should be adjusted. A very loose chain may be noisy. A tight chain will cause excessive wear.

**(2) Adjust chain (see Fig. 191)**

With pump control lever in disengaged position, rotate pump by hand, noting carefully whether chain becomes tight at any position during a complete revolution of pump sprocket. To adjust chain, loosen top nut on adjusting bolt and screw the nut at under side of pump support bracket upwards to tighten chain, or downwards to loosen chain. When chain is in proper adjustment, it should not be tight during any part of a revolution and yet it should not be loose enough to be sloppy at any position. After chain is adjusted properly, tighten top nut on adjusting bolt.

Section XXXVIII

**WINCH**

	<b>Paragraph</b>
General description .....	291
Operation .....	292
Trouble-shooting .....	293
Preventive maintenance and inspection.....	294
Brake adjustments .....	295
Assembly replacement .....	296
Shear pin replacement .....	297
Drive shaft replacement .....	298
Control linkage replacement .....	299

**291. GENERAL DESCRIPTION**

a. Winch is worm driven, horizontal drum type, mounted in pocket of stern compartment. It is equipped with a manually operated sliding jaw clutch to engage or disengage drum with drum shaft; a drum flange drag brake which bears against flange of drum when sliding jaw clutch is disengaged and is designed to keep drum from overrunning cable when cable is being withdrawn from drum by hand; a drum flange lock which is designed to lock drum from revolving when clutch is disengaged, thereby preventing cable from unwinding due to motion of vehicle; and an automatic wrap type brake on worm shaft designed to hold load at any position winch has placed it when, for any reason, power has been cut off.

**292. OPERATION**

**a. Drive**

(1) Power for operation is provided through power take-off mounted on left-hand side of transmission which is connected to winch worm shaft by drive shafts. A shear pin is provided in drive shaft yoke at worm shaft. Shear pin is designed to shear when winch is loaded beyond capacity, thereby preventing severe strains on winch or driving parts. Rear drive shaft incorporates a stop collar, located at rearward end, which prevents shaft from sliding forward and off winch worm shaft, if and when shear pin is broken. **CAUTION:** Always use a shear pin furnished—never use a substitute. A substitute may result in expensive replacement of parts. Spare shear pins are located in stern compartment. Refer to Para. 24 for operation instructions.

**293. TROUBLE-SHOOTING**

a. If, upon following instructions on use of winch given in Para. 24, winch fails to operate smoothly and without excessive noise, consult the following table:

**WINCH**

**b. Trouble-Shooting Chart**

Symptom and Probable Cause	Probable Remedy	Refer to Paragraph
<b>(1) Winch fails to operate when shifted into gear</b>		
(a) Drum flange lock engaged with drum	Disengage . . . . .	24
(b) Sliding jaw clutch in disengaged position	Engage . . . . .	24
(c) Shear pin sheared off	Install new pin . . . . .	297
<b>(2) Winch fails to hold load</b>		
(a) Automatic brake out of adjustment	Adjust . . . . .	295
(b) Automatic brake lining worn out	Replace unit . . . . .	296
<b>(3) Excessive heat at worm shaft housing</b>		
(a) Automatic brake adjusted too tight	Adjust . . . . .	295
(b) Incorrect type of lining being used	Replace unit . . . . .	296
<b>(4) Winch drum overruns cable when cable is being pulled out by hand</b>		
(a) Drag brake at winch drum out of adjustment	Adjust . . . . .	295
<b>(5) Noisy operation</b>		
(a) Insufficient lubricant in worm shaft housing	Fill housing to level plug on side of housing . . . . .	Sect. VI
(b) Insufficient lubricant at drum shaft	Lubricate . . . . .	Sect. VI

**294. PREVENTIVE MAINTENANCE AND INSPECTION**

**a.** Operations itemized in Section V, "Inspection and Preventive Maintenance," and intervals should be accomplished on winch and control mechanism.

**b.** Reference should be made to Section VI, "Lubrication," for type of lubricant, lubrication intervals, and method of filling and draining.

**c.** Winch cable should be kept in the best condition and should be inspected at periodic intervals for rust and frayed condition. Winch cable should have an application of grease (see Section VI, "Lubrication") to prevent it from rusting. In addition, the cable should be wound evenly on the drum as described in Para. 24.

**d.** Whenever necessity requires, as indicated by test, drag brake and automatic brake should be adjusted. See instructions in Para.

**295.**

TRUCK, AMPHIBIAN, 2½-TON, 6 x 6

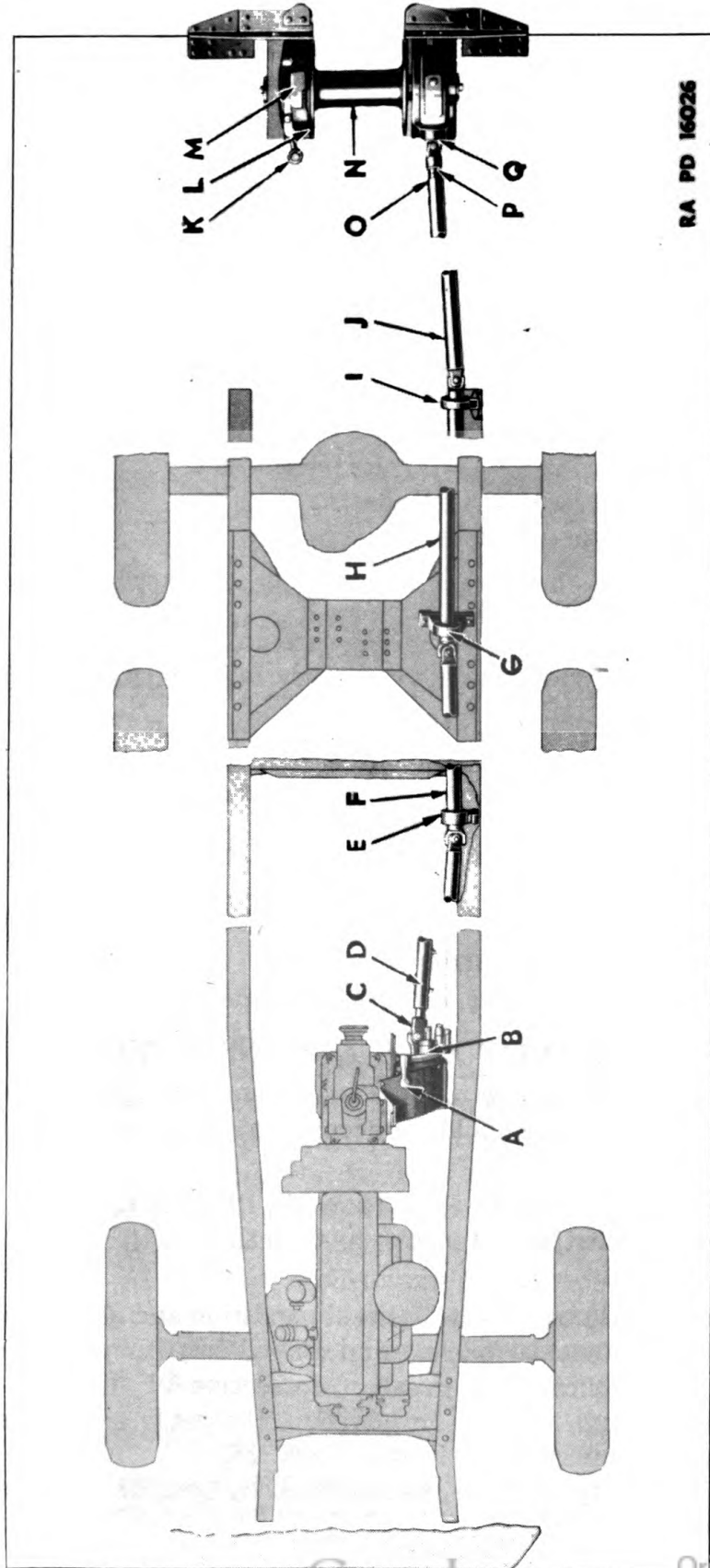

RA PD 16026

Figure 192—Winch Installation

- A Lever, Winch Control Shift
- B Take-Off, Power
- C Joint, Front Slip
- D Shaft, Front Drive
- E Bearing, Front Center
- F Shaft, Front Intermediate Drive
- G Bearing, Center, Center
- H Shaft, Rear Intermediate Drive
- I Bearing, Rear Center
- J Shaft, Rear Drive
- K Handle, Sliding Jaw Clutch
- L Brake, Drag
- M Clutch, Sliding Jaw
- N Drum, Winch
- O Joint, Rear Slip
- P Collar, Stop (Snap Ring)
- Q Shear Pin Location



WINCH

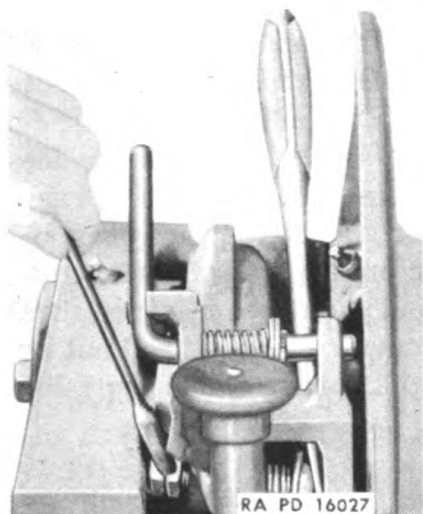

**Figure 193—Drag Brake Adjustment**

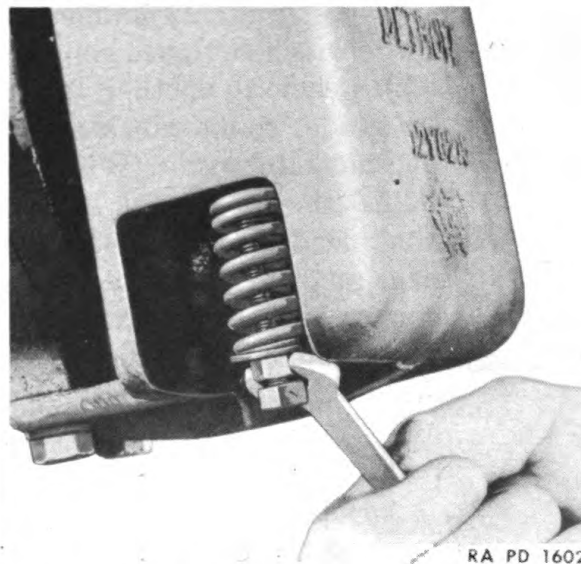

**Figure 194—Automatic Brake Adjustment**

**295. BRAKE ADJUSTMENTS**

a. Adjustment instructions given here have to do with operating winch—not mechanical adjustments required when overhauling or making repairs. Two adjustments are required and are made as follows:

b. **Drag Brake Adjustment.** Adjustment of drag brake is required when drum spins or overruns cable when it is being pulled from drum by hand.

(1) **Disengage sliding jaw clutch**

Move shift yoke handle as far to right as it will go, thus completely freeing drag brake from side of drum flange.

(2) **Pry tension bolt away from brake**

Use screwdriver or similar wedge between drag brake and head of tension bolt and pry bolt away from brake. This will move bolt enough to get wrenches on lock nut and adjusting nut at other end of bolt.

(3) **Adjust brake**

Hold adjusting nut with wrench and back off lock nut. Turn up adjusting nut one full turn, then remove wedge for determining if sufficient brake has been obtained; if not, repeat the process. Complete adjustment by turning lock nut up tight against adjusting nut.

c. **Automatic Brake Adjustment.** Need for adjustment of automatic brake is required in the event brake fails to hold load at any

**TRUCK, AMPHIBIAN, 2 1/2-TON, 6 x 6**

position winch has placed it when power is cut off from winch. One method of determining whether or not this brake requires adjustment is as follows:

**(1) Check brake adjustment**

Place winch equipped vehicle at the top of a steep grade. Fasten winch cable to another vehicle at bottom of grade. Pull vehicle up grade, using winch only. After a reasonable haul, depress engine clutch pedal. Winch will stop pulling and vehicle being pulled should not roll backward. In the event brake does not hold, need for adjustment is indicated. CAUTION: Brake may heat up even though it is properly adjusted; however, if hand cannot be held on brake cover on account of heat, this indicates that brake is too tight and should be loosened. Brake is designed to hold load and, if properly adjusted, will not become hot. Excessive heat indicates that brake should be relined or replaced.

**(2) Adjust brake**

Back off adjusting lock nut, then tighten adjusting nut 1/2 turn. Reset lock nut tight against adjusting nut.

**(3) Recheck adjustment of brake**

Check operation of brake as described above.

**296. ASSEMBLY REPLACEMENT**

a. Winch assembly may be removed from vehicle by removing bolts securing it to supports and hull and by removing shear pin at forward end of winch shaft. No other units need be removed.

**b. Removal Procedure****(1) Remove rope guard**

Suspend unit securely in chain fall or other suitable means so that unit may be lifted and swung clear of vehicle. Remove left-hand rope guard to lower support bolt nut and lockwasher and remove bolt.

**(2) Remove support angle bolts**

Remove five left-hand rear support angle to bracket bolt nuts and lockwashers and remove bolts. (It is not necessary to remove right-hand rope guard to support angle bolts.)

**(3) Remove end frame rear bolt**

Remove winch end frame to right-hand rear support angle bolt nut and lockwasher, and remove bolt.

**(4) Remove end frame front bolt**

Open stern compartment hatch cover for access to winch end frame to hull bolt, hull to worm shaft housing studs and shear pin. Remove winch end frame to hull bolt nut and lockwasher and remove bolt.

**WINCH****(5) Remove shaft housing studs**

Remove two hull to winch worm shaft housing studs with lockwashers. Remove winch worm shaft to drive shaft shear pin cotter and drive out shear pin. Swing left end of unit clear of hull and remove from vehicle.

**(6) Remove left-hand rope guard**

Remove left-hand rope guard and support angle to brake cover studs with lockwashers, and two support angle to worm shaft housing studs with lockwashers. This operation is necessary as this assembly must be assembled to unit being installed in vehicle.

**c. Installation Procedure****(1) Install left-hand rope guard**

Assemble left-hand rope guard and support angle assembly that has been removed from replaced unit to replacement unit by installing two support angle to brake cover studs with lockwashers, and two support angle to worm shaft housing studs with lockwashers. Using chain fall or other suitable means, lift winch unit and swing into position in vehicle guiding winch worm shaft into drive shaft yoke.

**(2) Install rear support angle**

Attach left-hand rear support angle to bracket by installing five bolts, lockwashers and nuts. Attach left-hand rope guard to lower support by installing bolt, lockwasher and nut.

**(3) Install end frame front and rear bolts**

Install right-hand rear support angle to winch end frame bolt, lockwasher and nut. Install winch end frame to hull bolt, lockwasher and nut.

**(4) Install shaft housing studs**

Install two hull to winch worm shaft housing studs with lockwashers.

**(5) Install shear pin**

Install drive shaft to worm shaft shear pin and cotter and close and secure stern compartment hatch cover.

**297. SHEAR PIN REPLACEMENT**

a. Winch drive shaft to worm shaft shear pin is accessible for replacement through stern compartment. A supply of spare shear pins with cotters are placed in a special mounting bracket located in stern compartment near winch worm shaft.

**b. Removal Procedure****(1) Move stop washer**

Loosen stern compartment hatch cover hold-down bolt wing nuts and open hatch cover. Raise winch drive shaft slip joint



TRUCK, AMPHIBIAN, 2½-TON, 6 x 6

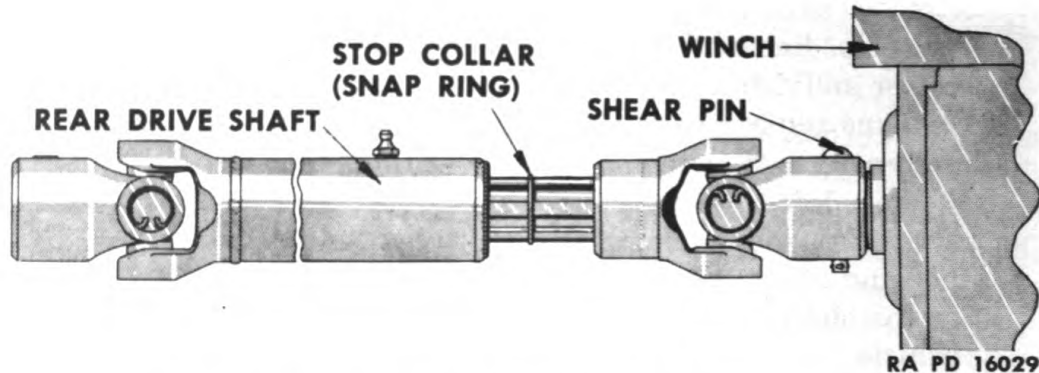

**Figure 195—Shear Pin and Stop Collar Installation**

stop washer (snap ring) from groove in shaft splines and move washer forward against tubular shaft.

(2) **Remove shear pin**

Move drive shaft rear universal joint forward on splines until rear yoke exposes shear pin hole in winch worm shaft. Using a suitable punch, drive portions of shear pin from worm shaft and from universal joint yoke.

c. **Installation Procedure**

(1) **Grease end of worm shaft**

Apply a coat of waterproof grease on forward end of winch worm shaft to prevent universal joint yoke seizing to worm shaft due to corrosion.

(2) **Position drive shaft**

Rotate propeller shaft so that shear pin hole in universal joint yoke lines up with shear pin hole in winch worm shaft.

(3) **Install shear pin**

Move universal joint rearward so that shear pin may be installed through universal joint and worm shaft. Install shear pin and secure with cotter pin. Move stop washer (snap ring) into position in groove in shaft splines. (Fig. 195). Close stern compartment hatch cover and secure with hold-down bolts. Tighten wing nuts securely.

**298. DRIVE SHAFT REPLACEMENT**

a. Winch drive shafts are located just inside of frame left-hand side rail. For definite information on accessibility of these shafts and their universal joints, refer to Para. 66. It is recommended that shafts are removed progressively starting at winch and working forward. To provide maximum accessibility for mechanic, it is also recommended that stern compartment hatch cover is opened; cargo compartment center and left front floor boards, and driver's compartment center and left-hand floor boards are removed.



## WINCH

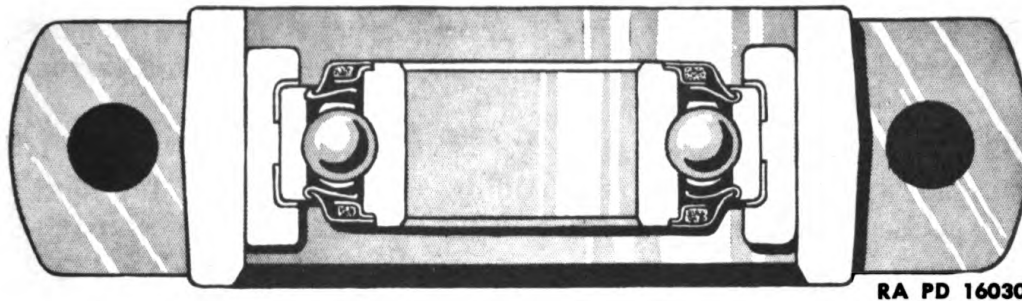

**Figure 196—Drive Shaft Center Bearing**

**b. Removal Procedure (Figs. 192 and 196)**

**(1) Move stop washer**

Lift rear drive shaft slip joint stop washer from its groove in shaft splines and move it along splines, towards front of vehicle, as far as it will go. Remove shear pin cotter and drive shear pin out of yoke, using a suitable punch.

**(2) Disconnect drive shaft from winch**

Move rear shaft "U" joint forward on shaft splines until "U" joint yoke is removed from winch worm shaft.

**(3) Remove rear intermediate drive shaft rear yoke**

Loosen set screw holding "U" joint yoke to rear end of rear intermediate shaft and remove yoke from shaft. Yoke is keyed to shaft. Do not lose key.

**(4) Remove rear drive shaft**

Remove rear shaft, from vehicle, through cargo compartment floor board opening.

**(5) Remove rear intermediate drive shaft**

Loosen set screw holding "U" joint yoke to front end of rear intermediate shaft, then remove two rear center bearing to support bolts and remove rear intermediate shaft with rear center bearing from vehicle. Center, center bearing and "U" joint yoke will remain in vehicle. Yoke is keyed to shaft. Do not lose key.

**(6) Remove center, center bearing**

Remove center bearing to frame bolt nuts, lockwashers and spacers and remove bolts; then remove bearing and upper spacer from vehicle. This will provide room for removal of front intermediate shaft.

**(7) Remove front intermediate drive shaft**

Loosen set screw holding "U" joint yoke to front end of front intermediate shaft and remove yoke from shaft. Yoke is keyed to shaft. (Do not lose key). Remove shaft from vehicle.

**TRUCK, AMPHIBIAN, 2½-TON, 6 x 6****(8) Remove front center bearing**

Remove two center bearing to frame bolt nuts and lockwashers and remove bolts and spacers. Then remove center bearing from vehicle.

**(9) Remove front drive shaft**

Move front shaft to rear pulling shaft off front "U" joint splines. Remove shaft from vehicle through cargo compartment floor board opening.

**(10) Remove front "U" joint**

Loosen set screw holding "U" joint yoke to power take-off shaft and remove "U" joint from shaft. Yoke is keyed to shaft. Do not lose key.

**(11) Remove rear center bearing from shaft**

In the event new rear intermediate shaft is replaced by new part, center bearing may be pressed or driven from shaft.

**c. Installation Procedure****(1) Install front "U" joint**

Place key in keyway and install front "U" joint yoke to power take-off shaft. Tighten yoke set screw securely.

**(2) Install front drive shaft**

Assemble front shaft over splines of front "U" joint in such a manner that "U" joint yokes on either end of shaft will be in same plane.

**(3) Place front center bearing**

Place front center bearing in position but do not attach to frame.

**(4) Install front intermediate drive shaft**

Place front intermediate shaft in position, inserting front end through frame crossmember, and install front center bearing on shaft. Then place key in keyway of shaft and install "U" joint yoke on shaft in such a manner that "U" joint yokes on either end of shaft will be in same plane. Tighten yoke set screw securely.

**(5) Attach front center bearing to frame**

Assemble spacers over bolts, insert bolts through bearing bracket and frame. Position spacers so bearing will be at proper angle to line up shaft and install bolt lockwashers and nuts. Tighten nuts securely.

**(6) Install rear intermediate drive shaft**

Press center, center bearing and rear center bearing on rear intermediate drive shaft and place drive shaft in position in vehicle. Place key in keyway at front end of shaft and install shaft in "U" joint yoke. Tighten set screw securely.

## WINCH

**(7) Attach center and rear center bearings to frame**

Install two center, center bearing to frame bolts in bearing bracket; position long spacer over bolts, so bearing will be at proper angle, and insert both through frame. Install two spacers, lockwashers and nuts to bolts and tighten nuts securely. Install two rear center bearing to frame bolts through bearing bracket and support and install lockwashers and nuts. Tighten nuts securely.

**(8) Install rear drive shaft**

Place rear drive shaft in position through cargo compartment floor board opening. Place key in keyway in rear end of rear intermediate shaft and install "U" joint yoke to shaft. "U" joint yokes on either end of shaft must be in same plane.

**(9) Assemble rear "U" joint to winch**

Compress rear shaft slip joint and install "U" joint rear yoke on winch worm shaft. Install stop washer (snap ring) in groove in "U" joint splines.

**(10) Install shear pin**

Follow procedure given in Para. 297.

**(11) Install floor boards and close stern compartment hatch cover**

## 299. CONTROL LINKAGE REPLACEMENT

a. Winch control lever and linkage is accessible for removal through driver's compartment left-hand floor board opening. Lever or link may be removed from vehicle by removing cotters and pins.

**b. Removal Procedure**

(1) Remove driver's compartment left-hand floor board.

(2) Remove control lever to link clevis pin cotter and washer and remove clevis pin.

(3) Remove control lever to transmission stud cotter pin and lever retainer washer and remove lever from stud.

(4) Remove link to power take-off shift shaft clevis pin cotter and washer and remove clevis pin.

(5) Remove link from vehicle.

**c. Installation Procedure**

(1) Place link in position over power take-off shift shaft and install pin through link and shift shaft, place plain washer over clevis pin; then install cotter pin.

(2) Assemble control lever over transmission stud.

(3) Place retainer washer over stud and install cotter pin.

(4) Place lower end of control lever in link and install clevis pin, washer and cotter pin.

(5) Replace floor board in driver's compartment.

Section XXXIX

REFERENCES

	Paragraph
Standard nomenclature lists . . . . .	300
Explanatory publications . . . . .	301

**300. STANDARD NOMENCLATURE LISTS**

- a. Cleaning, Preserving and Lubricating Materials . . . . . SNL K-1
- b. **Armament**
  - Gun, cal. .30, Browning M1919A4, fixed and flexible  
bow mounts . . . . . SNL A-6
  - Gun, submachine, cal. .45, Thompson, M1928A1 . . . . . SNL A-32
  - Gun, machine, cal. .50, Browning, M2, heavy barrel  
fixed and flexible and ground mounts . . . . . SNL A-39

**301. EXPLANATORY PUBLICATIONS**

- a. Cleaning, Preserving, and Lubricating Materials . . . . . TM 9-850
- b. **Maintenance and Inspection**
  - Technical Manual—Title . . . . . TM 9-1802
  - Echelon system of maintenance . . . . . TM 10-525
  - Fire prevention, safety precautions, accidents . . . . . TM 10-360
  - Motor transport inspection . . . . . TM 10-545
  - Sheet metal work, body, fender and radiator repairs. TM 10-450
- c. **Armament**
  - Gun, cal. .30, Browning, M1919A4 . . . . . FM 23-50
  - Gun, submachine, cal. .45, Thompson M1928A1 . . . . . FM 23-40
  - Browning Machine Gun, cal. .50, all types . . . . . TM 9-1225
- d. **Storage and Shipment**
  - Loading of mechanized and motorized army equip-  
ment on open top railroad equipment—Association  
of American Railroads Storage of Military Motor  
Vehicles . . . . . AR 850-10
- e. **Miscellaneous**
  - Automotive electricity . . . . . TM 10-580
  - Automotive lubrication . . . . . TM 10-540
  - Defense against chemical attack . . . . . FM 21-40
  - Electrical fundamentals . . . . . TM 1-455
  - Fuels and carburetion . . . . . TM 10-550
  - Motor transport . . . . . FM 25-10



## LIST OF ILLUSTRATIONS

Figure	Title	Page No.	Figure	Title	Page No.
<b>SECTION II</b>			<b>SECTION X</b>		
1	Left Side and Rear View of Vehicle	4	43	Accessibility Chart	90
2	Front and Side View of Vehicle Showing Dimensions	5	<b>SECTION XIII</b>		
3	Vehicle Serial Number (Nomenclature)	6	44	Front Wheel Alignment Chart	101
4	Publication Plate	6	45	Checking Caster Angle	102
5	Engine Number Serial Plate	7	46	Checking Camber	102
<b>SECTION III</b>			47	Checking Toe-In	102
6	Caution and Instruction Plates	11	48	Oil Level Plug and Fitting at Front Axle Universal	106
7	Caution and Instruction Plates	12	49	Steering Knuckle and U Joint Assembly	107
8	Location of Various Parts on Vehicles	15	50	Install Cover in Position Shown on Front Axle	107
9	Crankcase Oil Filler and Dip Stick	17	51	Tie-Rod End Construction	108
10	Driver's Compartment	19	52	Removing and Installing Tie-Rod Bushing	108
11	Instrument Panel	21	<b>SECTION XIV</b>		
12	Main Light Switch	22	53	Method Used in Jacking Up Rear End	112
13	Windshield in Tilted Position	25	54	Disconnecting Torque Rods from Axle	112
14	Windshield in Lowered Position	25	55	Rear Axle Cover	114
15	Method of Mooring Vehicles	41	56	Removing Axle Shaft	115
16	Method of Towing at Stern	41	<b>SECTION XV</b>		
17	Method of Towing Alongside	42	57	Arrangement of Brake Units; Controls and Lines	118
18	Winch Sliding Jaw Clutch Lever and Drum Flange Lock	45	58	Bleeding Wheel Cylinders	125
19	Cable Should Be Wound Evenly on Drum	45	59	Adjusting Front Brakes	126
20	Winching from Rear 6 to 100 Feet	46	60	Adjusting Rear Brakes	127
21	Winching from Rear 100 to 150 Feet	46	61	Front Brakes	128
22	Winching from Rear 200 to 300 Feet	46	62	Use of Wheel Cylinder Clamp and Brake Shoe Return Pliers	130
23	Winching from Front 6 to 70 Feet	47	63	Removing Brake Shoe Anchor Pin Locks	132
24	Winching from Front 100 to 200 Feet	47	64	Removing Flexible Hose from Wheel Cylinder	133
25	Winching from Front 200 to 250 Feet	47	65	Application of Brake Lining Grinder	134
26	Short Hitch, Winching from Front	48	66	Use of Micrometer to Measure Brake Drum Diameter	135
27	Short Hitch, Winching from Rear	48	67	Rear Brakes	136
28	Emergency Hitch Around Tree	49	68	Master Cylinder Brackets and Linkage	137
29	Correct Hitch Around Tree	49	69	Brake Hydrovac Unit	139
30	Rigging at Tree with Snatch Block and Chain	50	70	Hydrovac Cleaner	140
31	Rigging at Tree with Snatch Block	50	71	Vacuum Check Valve	141
32	Winch Rigging	51	72	Hydraulic Line Connection—Front Wheel	142
33	Winch Rigging	51	73	Hydraulic Line Connection—Right Rear Wheel	143
34	Winch Rigging	52	74	Hydraulic Line Connection—Left Rear Wheel	143
35	Winch Rigging	52	75	Hydraulic Line Connection—Hydrovac Unit	144
36	Winch Rigging	53	76	Installing Tube in Flaring Tool	146
37	Winch Rigging	53	77	First Flaring Operation	146
38	Winch Rigging	54	78	Finish Flaring Operation	146
39	Winch Rigging	55	79	Adjust Hand Brake Lining to Drum at Anchor	147
40	Use of Sand Anchor	57			
<b>SECTION VI</b>					
41	Lubrication Guide	70			
42	Lubrication Guide	71			

**TRUCK, AMPHIBIAN, 2 1/2 -TON, 6 x 6**

Figure	Title	Page No.	Figure	Title	Page No.
80	Adjust Hand Brake Lining to Drum at Bottom	147	<b>SECTION XXI</b>		
81	Adjust Hand Brake Lining to Drum at Top	147	116	Generator and Drive Belt Installation	206
82	Hand Brake Installation	149	117	Wiring Harness Installation	207
<b>SECTION XVI</b>			<b>SECTION XXII</b>		
83	Clutch Pedal and Linkage	155	118	Lighting System Fuse	212
84	Engaged and Disengaged Position	156	119	Head Lamp Aiming Chart	214
85	Removing Retracting Springs	158	120	Head Lamp Aiming Pattern	214
86	Removing Pilot Bearing	158	121	Head Lamp Assembly	215
87	Clutch Pilot Hole Run-Out	159	122	Blackout Driving Light	218
88	Replacing Pilot Bearing	160	123	Blackout Marker Lamp	219
89	Installing Clutch Assembly	161	124	Blackout and Service Stop and Tail Lamp	219
90	Clutch Aligning Arbor	162	<b>SECTION XXIII</b>		
91	Cooling Air Circulation	165	125	Radio Noise Suppression Units Installation	223
<b>SECTION XVII</b>			<b>SECTION XXIV</b>		
92	Overflow Tank Cap	167	126	Operation Trouble-Shooting Chart	228
93	Fan Belt Adjustment	168	127	Engine Tune-Up Cycle Chart	237
94	Radiator Installation	171	128	Valve Lash Adjustment	238
<b>SECTION XVIII</b>			129	Cylinder Head and Component Parts	239
95	Water Temperature Control Installation	171	130	Valve Mechanism	240
96	Wire Tracer Pattern	175	131	Cleaning Cylinder Head	241
97	General Electric Circuit Diagram	176	132	Tightening Cylinder Head Bolts	242
98	Wiring Harness Diagram	177	133	Use of Torque Wrench on Cylinder Head Bolts	242
99	Instrument Panel Wiring Connection	178	134	Replacing Oil Filter Element	243
100	Regulator Filter and Junction Block Connection	179	135	Oil Filter Component Parts	243
101	Instrument Panel Wiring Harness	180	136	Engine Removal	245
102	Horn and Coil and Starter Harnesses	181	137	Engine Front Mounting	248
103	Junction Block to Stop Switch Wiring Harness	181	138	Engine Rear Mounting	248
104	Headlamp Wiring Harness	182	139	Installing Transmission Cover	249
105	Generator to Regulator and Filter Wiring Harness	182	140	Oil Pan and Components	251
106	Stop and Tail Lamp Wiring Harness	183	141	Removing Oil Pump	253
<b>SECTION XIX</b>			142	Manifold Heat Control	254
107	Starting Motor Installation	185	143	Crankcase Ventilator Installation	256
108	Checking Battery Cell Voltage	188	144	Cleaning Breather Cleaner	257
<b>SECTION XX</b>			<b>SECTION XXV</b>		
109	Distributor Installation	193	145	Exhaust System Installation	260
110	Ignition System Circuits	194	<b>SECTION XXVII</b>		
111	Cleaning Distributor Cap Socket	195	146	Air Cleaner	267
112	Distributor with Cap and Rotor Removed	196	147	Sectional View of Fuel Filter	268
113	Flywheel Marking for Ignition Timing	197	148	Accelerator Throttle and Choke Control	273
114	Distributor Manual Advance Adjustment	198	149	Fuel Tank and Lines	276
115	Installing Spark Plug Cables	199	<b>SECTION XXVIII</b>		
			150	Gear Bilge Pump Adjustment	281
			151	Gear Bilge Pump Packing Adjustment	282
			152	Centrifugal Bilge Pump Drive Adjustment	283

**LIST OF ILLUSTRATIONS**

<b>Figure</b>	<b>Title</b>	<b>Page No.</b>	<b>Figure</b>	<b>Title</b>	<b>Page No.</b>
153	Centrifugal Bilge Pump Packing Adjustment . . . . .	284	<b>SECTION XXXIII</b>		
154	Pintle Hook Installation . . . . .	287	173	Plan View of Rudder Linkage . . . . .	341
155	Windshield Mounting and Wipers . . . . .	289	174	Adjusting Sector Gear Lash . . . . .	342
156	Bilge Pumps, Pipes and Controls Installation . . . . .	292	175	Using Spring Scale to Check Adjustment . . . . .	343
157	Controls for Gear Bilge Pump Valves . . . . .	293	176	Adjusting Worm Bearings . . . . .	344
<b>SECTION XXIX</b>			177	Steering Gear Drag Link . . . . .	344
158	Front View of Instrument Panel . . . . .	298	178	Rudder Linkage at Stern . . . . .	345
<b>SECTION XXX</b>			<b>SECTION XXXV</b>		
159	Axle Propeller Shafts and Housing . . . . .	305	179	Transfer Case Controls . . . . .	354
160	Universal Joints . . . . .	307	180	Transfer Case Installation . . . . .	357
161	Slip Joints . . . . .	307	<b>SECTION XXXVI</b>		
162	Propeller Shaft Disassembled View . . . . .	311	181	Power Plant Stabilizer Rod . . . . .	363
163	Pillow Block Assembly . . . . .	313	182	Transmission Installation . . . . .	364
<b>SECTION XXXI</b>			<b>SECTION XXXVII</b>		
164	Water Propeller and Drive Installation . . . . .	319	183	Rear Wheel and Wheel Spacer . . . . .	371
165	Water Propeller Stuffing Box . . . . .	321	184	Front Hub Cross Section . . . . .	371
166	Removing Water Propeller . . . . .	327	185	Adjusting Hub Bearings . . . . .	372
<b>SECTION XXXII</b>			186	Bearing Lubricator . . . . .	373
167	Front Spring Installation . . . . .	330	187	Rear Hub Cross Section . . . . .	375
168	Front Spring Shackle and Bracket . . . . .	331	188	Tire Installation . . . . .	377
169	Shackle Pin Removal . . . . .	332	189	Installing Bead Lock . . . . .	378
170	Rear Spring Installation . . . . .	332	190	Tire Pump, Tank and Lines . . . . .	380
171	Rear Spring Seat . . . . .	333	191	Tire Pump Mounting . . . . .	383
172	Rear Spring Seat Bearing Puller . . . . .	334	<b>SECTION XXXVIII</b>		
			192	Winch Installation . . . . .	384
			193	Drag Brake Adjustment . . . . .	385
			194	Automatic Brake Adjustment . . . . .	385
			195	Shear Pin and Stop Collar Installation . . . . .	388
			196	Drive Shaft Center Bearing . . . . .	389



TRUCK, AMPHIBIAN, 2 1/2-TON, 6 x 6

INDEX

A	Page No.	B—Cont'd	Page No.
Accessibility	89-92	Cleaning vacuum check valve	142
Accessibility operations	93	Foot pedal replacement	133
Adjustments		Front brake replacement	127
Bilge pump, centrifugal	282	Hand brake adjustment	146
Bilge pump, gear	281	Hand brake band and drum replacement	148
Blackout driving lamp	215	Hand brake lever and linkage replacement	150
Brakes	125, 146	Hydraulic lines replacement	143
Carbureter	270	Hydrovac replacement	138
Clutch facing wear	159	Hydrovac air cleaner replacement	139
Control linkage, axle transfer case	355	Master cylinder replacement	135
Distributor points	195	Power system tests	122
Drag link, steering	344	Preventive maintenance	121
Fan and generator belt	169	Rear brake replacement	130
Generator brushes	206	Service brake adjustments	125
Head lamp	213	Trouble shooting	117
Manifold heat control	254	Vacuum check valve replacement	141
Regulator	206	Brushes, generator	206
Rudder linkage	346		
Spark advance, manual	198	<b>C</b>	
Spark plug gap	199	Camber, front wheel	102
Spring seat bearing, rear	334	Carbureter adjustment	270
Stabilizer rod, power plant	362	Carbureter replacement	271
Steering gear	340	Care and preservation	76
Stuffing box		Caster, front wheel	100
Rudder	345	Clutch	152
Water propeller	320	Assembly replacement	159
Timing, ignition	196	Facing wear adjustment	154
Tire pump drive chain	381	Housing replacement	160
Valve lash	238	Pedal replacement	154
Winch brake	385	Pilot bearing replacement	160
Air cleaner service	267	Preventive maintenance	154
Alignment, front wheel	101-103	Release bearing replacement	157
Allocation of maintenance operations	86-89	Release fork replacement	156
Anti-freeze chart	169	Retracting spring replacement	157
Armament	58	Trouble shooting	152
Axle (See front or rear axle)		Coil replacement	202
Axle shaft and universal joint replacement, front	105	Cold weather preparation	168
Axle shaft replacement, rear	114	Condenser replacement, ignition system	201
<b>B</b>		Controls	
Battery	184	Air intake, auxiliary	26
Maintenance	187	Bilge pump	24
Operation	185	Brakes	23
Preventive maintenance	186	Carbureter	22
Replacement	188	Caution and instruction plates	11
Trouble shooting	185	Choke button	20
Bilge pump, centrifugal		Clutch	23
Adjustments	282	Driver's instructions	27
Replacement of units	296	Front axle	23
Bilge pump, gear		Starter control lever	22
Adjustments	281	Steering	23
Replacement of units	291	Throttle button	20
Blackout lights		Tire pump	24
Driving lamp adjustment	215	Transfer case, driving axle	23
Driving lamp replacement	217	Transmission	23
Marker lamp replacement	218	Water propeller	24
Stop and tail lamps replacement	219	Winch	24, 44
Switch replacement	301, 302	Windshield wiper	22
Brakes	116	Cooling system	164
Bleeding hydraulic system	124	Anti-freeze chart	169
Cleaning air cleaner	140	Cleaning and flushing	166



INDEX

C—Cont'd	Page No.	F	Page No.
Cold weather preparation . . . . .	168	Fan belt (See cooling system)	
Draining . . . . .	166	Filler cap, cooling system . . . . .	165
Fan belt adjustment . . . . .	169	Frame maintenance . . . . .	263
Fan belt replacement . . . . .	170	Front axle . . . . .	98
Preventive maintenance . . . . .	166	Alignment . . . . .	100
Radiator and shroud replacement . . . . .	170	Assembly replacement . . . . .	104
Refilling . . . . .	168	Axle shaft and universal joint re- placement . . . . .	105
Thermostat replacement . . . . .	172	Differential and carrier assembly replacement . . . . .	106
Trouble shooting . . . . .	165	Steering knuckle trunnion bearing replacement . . . . .	105
Water pump replacement . . . . .	173	Tie rod replacement . . . . .	106
Crankcase ventilation . . . . .	255	Trouble shooting . . . . .	98
Cylinder head replacement . . . . .	239	Front springs (See springs)	
<b>D</b>			
Data, tabulated (See tabulated data)		Fuel system . . . . .	264
Decontamination . . . . .	82	Air cleaner service . . . . .	267
Differential and carrier replacement		Carbureter adjustment . . . . .	270
Front axle . . . . .	106	Carbureter replacement . . . . .	271
Rear axle . . . . .	115	Control linkage replacement . . . . .	272
Dimmer switch replacement . . . . .	220	Filter service . . . . .	269
Distributor		Gauge . . . . .	20, 224
Maintenance . . . . .	195	Governor replacement . . . . .	272
Points adjustment . . . . .	195	Leaks . . . . .	266
Points replacement . . . . .	201	Line replacement . . . . .	277
Replacement . . . . .	200	Preventive maintenance . . . . .	266
Drag link, steering . . . . .	344	Pump replacement . . . . .	270
Draining cooling system . . . . .	166	Pump service . . . . .	269
Drive shaft replacement, winch . . . . .	388	Tank replacement . . . . .	275
Driving axle propeller shafts (See propeller shafts, driving axle)		Trouble shooting . . . . .	264
<b>E</b>			
Electrical accessories		<b>G</b>	
Fuel gauge . . . . .	224	Gauges (See instruments and gauges)	
Horn . . . . .	225	Generator . . . . .	203
Radio interference suppression		Belt adjustment . . . . .	169
Condenser replacement . . . . .	222	Brushes . . . . .	206
Filter replacement . . . . .	222	Polarity . . . . .	210
Ignition shield replacement . . . . .	223	Preventive maintenance . . . . .	205
Engine		Replacement . . . . .	209
Crankcase ventilation . . . . .	255	Trouble shooting . . . . .	204
Cylinder head replacement . . . . .	239	Governor replacement . . . . .	272
Hand cranking . . . . .	28	<b>H</b>	
Manifold heat control adjustment . . . . .	254	Hand brake (See brakes)	
Manifold replacement . . . . .	253	Hand cranking engine . . . . .	28
Oil filter service . . . . .	243	Hatch covers and seals . . . . .	284
Oil pan replacement . . . . .	251	Head lamp	
Oil pump replacement . . . . .	252	Adjustment . . . . .	213
Power plant replacement . . . . .	236	Assembly replacement . . . . .	216
Serial number plate . . . . .	3	Sealed beam unit replacement . . . . .	216
Starting . . . . .	27, 34	Horn . . . . .	225
Tabulated data . . . . .	8	Hubs . . . . .	368
Trouble shooting, mechanical . . . . .	231	Bearing adjustment	
Trouble shooting, operation . . . . .	227	Front hub . . . . .	370
Tune-up . . . . .	236	Rear hub . . . . .	374
Valve lash adjustment . . . . .	238	Preventive maintenance . . . . .	370
Equipment, miscellaneous . . . . .	80	Replacement of units	
Exhaust system . . . . .	258	Front hubs and bearings . . . . .	373
Preventive maintenance . . . . .	259	Rear hubs and bearings . . . . .	375
Trouble shooting . . . . .	258	Trouble shooting . . . . .	369
Replacement of units . . . . .	259	Hull and associated parts . . . . .	278
		Centrifugal bilge pump	
		Adjustment . . . . .	282
		Replacement of units . . . . .	296

TRUCK, AMPHIBIAN, 2 1/2-TON, 6 x 6

H—Cont'd	Page No.	L—Cont'd	Page No.
Front bulkhead replacement . . . . .	285	Stopping . . . . .	33
Gear bilge pump		Lighting . . . . .	211
Adjustment . . . . .	281	Blackout driving lamp	
Replacement of units . . . . .	291	Adjustment . . . . .	215
Hatch covers and seals . . . . .	284	Replacement . . . . .	217
Pintle hook replacement . . . . .	286	Blackout driving lamp switch re-	
Preventive maintenance . . . . .	280	placement . . . . .	302
Stern deck plate replacement . . . . .	285	Blackout marker lamps . . . . .	218
Surf coaming replacement . . . . .	286	Blackout and service stop and tail	
Tarpaulin and curtains . . . . .	287	lamps . . . . .	219
Trouble shooting . . . . .	279	Dimmer switch replacement . . . . .	220
Windshield and wipers . . . . .	289	Head lamp	
Windshield glass replacement . . . . .	290	Adjustment . . . . .	213
Windshield regulators . . . . .	25	Replacement . . . . .	216
Hydraulic lines replacement . . . . .	133	Instrument panel lamps replace-	
Hydrovac air cleaner . . . . .	139	ment . . . . .	302
Hydrovac replacement . . . . .	138	Instrument panel lamp switch re-	
		placement . . . . .	302
<b>I</b>		Main light switch	
Identification		Operation . . . . .	20
Engine number plate . . . . .	3	Replacement . . . . .	301
Publication plate . . . . .	3	Preventive maintenance . . . . .	213
Vehicle serial number plate . . . . .	3	Stop lamp switch replacement . . . . .	220
Ignition system . . . . .	192	Trouble shooting . . . . .	212
Adjusting distributor points . . . . .	195	Lubrication	
Checking ignition timing . . . . .	197	Capacities . . . . .	72
Coil replacement . . . . .	202	Guides . . . . .	70, 71
Condenser replacement . . . . .	201	<b>M</b>	
Distributor maintenance . . . . .	195	Main light switch	
Distributor replacement . . . . .	200	Operation . . . . .	20
Points replacement, distributor . . . . .	201	Replacement . . . . .	301
Spark advance, manual . . . . .	198	Maintenance	
Spark plug gap . . . . .	199	Accessibility . . . . .	89-92
Spark plug maintenance . . . . .	199	Accessibility operations . . . . .	93
Timing . . . . .	196	Allocation of operations . . . . .	86-89
Trouble shooting . . . . .	194	Definition of terms . . . . .	85
Inspection		Special tools . . . . .	95
After land operation . . . . .	63	Manifold replacement, engine . . . . .	253
After water operation . . . . .	62	Master cylinder replacement . . . . .	135
At halt . . . . .	61	<b>O</b>	
During operation . . . . .	60	Oil filter service . . . . .	243
Monthly . . . . .	67	Oil pan replacement . . . . .	251
Prestarting . . . . .	26	Oil pump replacement . . . . .	252
Semi-annual . . . . .	67	Oil seal replacement, water propeller	
Weekly . . . . .	65	shaft . . . . .	321
Instruments and gauges		Operation	
Ammeter . . . . .	20, 29	Hand cranking . . . . .	28
Blackout driving light switch . . . . .	21	Land (See land operation)	
Fuel gauge . . . . .	20	Prestarting inspection . . . . .	26
Ignition switch . . . . .	20	Starting engine . . . . .	27, 34
Main light switch . . . . .	20	Water (See water operation)	
Oil pressure gauge . . . . .	20, 29	Winch . . . . .	44
Panel replacement . . . . .	298	Organization spare parts . . . . .	97
Speedometer . . . . .	20	Overflow tank, radiator . . . . .	164
Speedometer cable replacement . . . . .	300	Overflow tank sealing cap . . . . .	165
Switch replacement (See lighting)		<b>P</b>	
Temperature gauge . . . . .	18, 19	Painting	
Unit replacement . . . . .	300	Camouflage . . . . .	78
Instrument panel lamps . . . . .	302	Lubrication devices . . . . .	79
<b>L</b>		Metal surfaces . . . . .	77
Land operation, vehicle . . . . .	29	Preparation for . . . . .	77
Grades . . . . .	32		
Rough terrain . . . . .	32		
Starting and driving . . . . .	29		

INDEX

P—Cont'd	Page No.	R—Cont'd	Page No.
Removing paint.....	79	Assembly replacement.....	111
Pilot bearing replacement, clutch...	160	Axle shaft replacement.....	114
Pintle hook replacement.....	286	Differential and carrier assembly replacement.....	115
Polarity, generator and regulator.....	208, 210	Trouble shooting.....	110
Power plant replacement.....	244	Rear springs (See springs)	
Preventive maintenance (Also see inspection)		Refilling cooling system.....	168
Air cleaner.....	267	Regulator.....	203
Battery.....	186, 187	Operation.....	204
Bilge pumps.....	280	Polarity.....	208
Brakes.....	121	Preventive maintenance.....	205, 206
Clutch.....	152	Replacement.....	208
Cooling system.....	166	Trouble shooting.....	204
Crankcase ventilation.....	255	Release bearing replacement, clutch	157
Distributor.....	195	Release fork replacement, clutch...	156
Engine.....	236	Retracting spring replacement, clutch	157
Exhaust system.....	259	Rudder and linkage replacement...	348
Frame.....	263	Rudder linkage adjustment.....	346
Fuel filter.....	269		
Fuel system.....	266	<b>S</b>	
Generator.....	205	Sealed beam unit replacement	
Hubs, wheel.....	370	Blackout driving lamp.....	217
Hull and associated parts.....	280	Head lamp.....	216
Lights.....	212	Shear pin replacement, winch.....	387
Oil filter.....	243	Shock absorber	
Propeller, water.....	326	Maintenance.....	336
Regulator.....	205	Replacement.....	337
Spark plugs.....	199	Spark plug gap.....	199
Springs.....	329	Springs.....	328
Starting motor.....	187	Front spring replacement.....	331
Steering.....	340	Front spring shackle replacement.	330
Stuffing box, water propeller.....	320	Preventive maintenance.....	329
Take-off, transmission power.....	351	Rear spring replacement.....	332
Tires.....	370, 376	Shock absorber maintenance.....	336
Transmission.....	362	Shock absorber replacement.....	337
Valve lash, engine.....	238	Spring seat bearing adjustment...	334
Wheels.....	370	Torque rod replacement.....	336
Winch.....	383	Trouble shooting.....	328
Wiring.....	177	Stabilizer rod adjustment.....	362
Propeller and shafts, water.....	318	Starting.....	27, 34
Control linkage replacement.....	322	Starting motor.....	184
Oil seal replacement.....	321	Control linkage replacement.....	190
Propeller replacement.....	326	Preventive maintenance.....	187
Shafts replacement.....	323	Replacement.....	190
Stuffing box adjustment.....	320	Switch replacement.....	189
Strut bearing replacement.....	327	Trouble shooting.....	185
Transfer case replacement.....	321	Steering.....	338
Trouble shooting.....	320	Drag link adjustment.....	344
Propeller replacement, water.....	326	Gear adjustment.....	340
Propeller shafts, driving axle.....	304	Gear replacement.....	346
Assembly replacement.....	309	Preventive maintenance.....	340
Housing replacement.....	306	Rudder and linkage replacement.	348
Housing seal replacement.....	316	Rudder linkage adjustment.....	346
Pillow block replacement.....	312	Shear pin replacement.....	349
Preventive maintenance.....	306	Stuffing box adjustment, rudder..	345
Trouble shooting.....	304	Trouble shooting.....	338
<b>R</b>		Steering knuckle trunion bearing replacement.....	105
Radiator (See cooling system)		Stern deck plate replacement.....	285
Radio interference suppression.....	222	Stop and tail lamps	
Condenser replacement.....	222	Replacement.....	219
Filter replacement.....	222	Switch testing.....	213
Ignition shield replacement.....	223	Switch replacement.....	226
Rear axle.....	110	Stuffing box adjustment	





**TRUCK, AMPHIBIAN, 2½-TON, 6 x 6**



6 TO 100 FEET

SEE FIGURE 30

SEE FIGURE 38

RA PD 16032

**Figure 20—Winching from Rear, 6 to 100 Feet**



100-150 FEET

SEE FIGURE 31

SEE FIGURE 37

RA PD 16033

**Figure 21—Winching from Rear, 100 to 150 Feet**



200-300 FEET

SEE FIGURES 28, 29, 40

SEE FIGURE 36

RA PD 16034

**Figure 22—Winching from Rear, 200 to 300 Feet**