

hd U113
12
TM
1944
UNIVERSITY OF CALIFORNIA
LIBRARY
APR 25 1944
DOCUMENTS DIVISION

TM 11-2541

WAR DEPARTMENT TECHNICAL MANUAL

U.S. Dept. of Army

SPEAK-O-PHONE
SOUND DETECTOR,
MODEL SDB

RESTRICTED. DISSEMINATION OF RESTRICTED MATTER.—The information contained in restricted documents and the essential characteristics of restricted material may be given to any person known to be in the service of the United States and to persons of undoubted loyalty and discretion who are cooperating in Government work, but will not be communicated to the public or to the press except by authorized military public relations agencies. (See also par. 23b, AR 380-5, 15 Mar 1944.)

WAR DEPARTMENT • 27 SEPTEMBER 1944

SPEAK-O-PHONE SOUND DETECTOR, MODEL SDB



WAR DEPARTMENT • 27 SEPTEMBER 1944

RESTRICTED. DISSEMINATION OF RESTRICTED MATTER.—The Information contained in restricted documents and the essential characteristics of restricted material may be given to any person known to be in the service of the United States and to persons of undoubted loyalty and discretion who are cooperating in Government work, but will not be communicated to the public or to the press except by authorized military public relations agencies. (See also par. 23b, AR 380-5, 15 Mar 1944.)

United States Government Printing Office

Washington : 1944

RESTRICTED

WAR DEPARTMENT,
WASHINGTON 25, D. C., 27 September 1944.

TM 11-2541, Speak-O-Phone Sound Detector, Model SDB, is published for the information and guidance of all concerned.

[A. G. 300.7 (27 July 44).]

BY ORDER OF THE SECRETARY OF WAR:

G. C. MARSHALL,
Chief of Staff.

OFFICIAL:

J. A. ULIO,
*Major General,
The Adjutant General.*

DISTRIBUTION:

Armies (Sig) (5); SvC (Sig) (5); Depts (Sig) (5); Def C (Sig) (2); D (2); IC 11 (5);
C of Tech Sv (2); Arm & Sv Boards (2); Gen & Sp Sv Schs (10); T of Opn (5); Base C (5); Sig C Depts (2); Gen Oversea SOS Depts (Sig Sec) (2); Sig C Labs (2); Sig C Rep Shs (2); PE (Sig) (2).
IC 11: T/O & E 11-77; 11-107; 11-127; 11-237; 11-287; 11-297; 11-587; 11-592; 11-597.
For explanation of symbols, see FM 21-6.

66113

T-4
1944
★ ★

RESTRICTED

TABLE OF CONTENTS

	<i>Paragraph</i>	<i>Page</i>
<i>SECTION I. Description.</i>		
Purpose.....	1	1
General.....	2	2
List of components, weights and dimensions.....	3	3
<i>II. Installation and operation.</i>		
Planting carbon microphone.....	4	4
Contact microphone.....	5	4
Direct telephone-line tap.....	6	5
Induction-coil telephone tap.....	7	5
<i>III. Functioning of parts.</i>		
Amplifier input channels.....	8	6
Vacuum tubes.....	9	6
Output channels.....	10	7
Power supply.....	11	7
<i>IV. Maintenance.</i>		
Service test.....	12	8
Removal of amplifier.....	13	8
Testing tubes.....	14	10
Voltage measurements.....	15	10
Voltage chart.....	16	10
Resistance measurements.....	17	11
<i>V. Supplementary data.</i>		
Maintenance Parts List for Speak-O-Phone Sound Detector, Model SDB...	18	12

M558407

III

RESTRICTED

DESTRUCTION NOTICE

WHY

To prevent the enemy from using or salvaging this equipment for his benefit.

WHEN

When ordered by your commander.

HOW

1. Smash—Use sledges, axes, handaxes, pickaxes, hammers, crowbars, heavy tools.
2. Cut—Use axes, handaxes, machetes.
3. Burn—Use gasoline, kerosene, oil, flame throwers, incendiary grenades.
4. Explosives—Use firearms, grenades, TNT.
5. Disposal—Bury in slit trenches, fox holes, other holes. Throw in streams. Scatter.

USE ANYTHING IMMEDIATELY AVAILABLE FOR DESTRUCTION OF THIS EQUIPMENT.

WHAT

1. Smash—Control panel, switches, vacuum tubes, batteries, microphones, headphones, induction coil, all parts in the amplifier, and carrying case.
2. Cut—All connecting cables and telephone wire in small pieces.
3. Burn—Pieces of carrying case and this technical manual.
4. Bury or scatter—All debris of the above parts.

DESTROY EVERYTHING

RESTRICTED

v

RESTRICTED

TL-92352



Figure 1. Speak-O-Phone Sound Detector, Model SDB, in carrying case.

RESTRICTED

SECTION I

DESCRIPTION

1. PURPOSE.

The Speak-O-Phone Sound Detector, Model SDB, enables the operator to listen to conversations without the knowledge of those speaking. The equipment is adapted for use under four different conditions, as follows:

a. When it is possible to "plant" a microphone in the room prior to the conversation taking place.

b. Where it is not possible to gain access to the room where conversations are taking place, but where a wall or panel of an adjoining room is available.

c. When it is desired to "listen in" on telephone conversations by a direct telephone-line tap.

d. When it is desired to "listen in" on a telephone-line by use of induction coil tapping, without actual wire connection.



Figure 2. Auxiliary components.

2. GENERAL.

a. The Speak-O-Phone Sound Detector (model SDB) (fig. 1) is a portable, battery-operated, three-stage, audio amplifier. It is contained in a carrying case which has three separate compartments (fig. 1), for amplifier, batteries, and auxiliary components respectively.

b. Two pairs of headphones (fig. 2) are provided for "listening in." There is also a recorder jack on the amplifier control panel (fig. 3), permitting everything that is heard to be recorded on a recorder. The recorder is not furnished as a part of the equipment.

3. LIST OF COMPONENTS, WEIGHTS, AND DIMENSIONS.

Quan	Component	Dimensions (in.)			Weight
		Length	Width	Height	
1-----	Speak-O-Phone Sound Detector, Model SDB, complete unit, including carrying case.	14½	11½-----	8¼	20 lb
1-----	Carrying case-----	14½	11½-----	8¼	5¾ lb
1-----	Amplifier unit with control panel.	10½	5½-----	6	4¾ lb
1-----	A battery-----	2⅞	1⅞-----	4	1 lb
1-----	B battery-----	2½	1⅞-----	4½	1.5 lb
1-----	C battery-----	2⅞	2⅞-----	3⅞	0.38 lb
2-----	Carbon microphones-----		2¼ (diam)-----	¾	6 oz
1-----	Contact microphone with 12-foot cable and connector.		2 (diam)-----	¾	6 oz
2-----	Thumb tacks-----	⅝	½ (diam)-----		
1-----	Nail-----	5			0.05 lb
1-----	Telephone induction coil with 12-foot cable and connector.	3⅞	⅞ (diam)-----		7 oz
2 pair-----	Headphones, with headband 10" x 1¼".		2 (diam)-----	¾	16 oz
2 reels-----	Wire, telephone, 50 foot-----				20 oz
2 boxes-----	Tacks, upholstery-----	⅞	¾ (diam)-----		0.26 lb
1 roll-----	Tape, friction, 5 foot-----		¾		0.06 lb
1-----	Screw driver-----	4½			0.05 lb

TL-92354

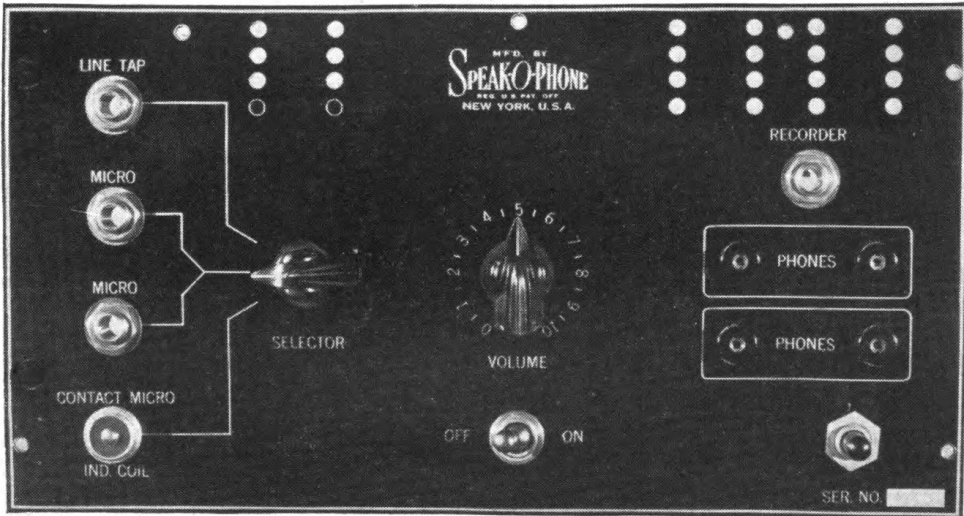

Figure 3. Amplifier control panel.

RESTRICTED

SECTION II

INSTALLATION AND OPERATION

4. PLANTING CARBON MICROPHONE.

If it is possible to gain access to the desired location prior to the conversation, install a carbon microphone. Either one or two microphones may be used at the same time, if desired; one each in two separate rooms, or both in the same room, if the acoustics, size of room, or amount of noise requires it.

a. Select a hiding place for the microphone as near as possible to the voices to be overheard. Suggested places of concealment are behind furniture, under desks, under tables, in draperies, or in any other convenient spot where the microphones can be hidden and the connecting line brought out to the sound detector with the least danger of discovery.

b. Place the microphone so that there is a slight opening in the covering material to carry the voice vibrations directly to the face of the microphone.

c. Connect the telephone wire (fig. 2) to the two microphone leads. Tape the connections, and tack down the wire leading to the sound detector.

d. Insert the phone plug on the end of the telephone wire into the sound detector input jack marked MICRO (fig. 3).

e. Set the selector knob (fig. 3) so that it points to MICRO.

f. Plug in headphones by inserting the phone tips into the two phone tip jacks (fig. 3) *within one etched rectangle* on the sound detector panel. If two sets of headphones are to be used, insert the second set of phone tips in the two phone tip jacks within the other etched rectangle.

g. Turn amplifier on by throwing the toggle switch (fig. 3) at the bottom of the panel to ON position.

h. Turn VOLUME control knob (fig. 3) clockwise until a voice near the microphone can be heard with sufficient volume and clarity over the headphones.

5. CONTACT MICROPHONE.

When it is not possible to gain access to the room where conversation is to take place, but a wall or panel in an adjoining room is available, use the contact microphone. This microphone is not as efficient as the carbon microphone, and it is used only when it is impossible to plant a carbon microphone in the desired location.

a. Mount the contact microphone against the door or wall of the room with two thumb tacks and the rubber band shown in figure 2. The microphone will not work if placed against a steel door or wall.

b. Screw the connector at the end of the microphone cable to the input connector (fig. 3) marked CONTACT MICRO on the sound detector panel.

c. Set the selector knob (fig. 3) to point toward CONTACT MICRO.

d. Plug in headphones, turn amplifier on, and, adjust the volume control knob as described in paragraph 4f, g, and h.

e. If sounds are not audible through normal use of this microphone, a special 5-inch nail is provided which may be driven into the wall until its tip rests on the plaster portion of the inner wall, but does not penetrate all the way through it.

f. Place the contact microphone against the head of the nail, fastening it in place by means of the two thumb tacks and the rubber band. The sound vibrations now will be picked up direct from the inner wall.

6. DIRECT TELEPHONE-LINE TAP.

a. Trace telephone line from subscriber's ringer box to a convenient location for tapping.

b. Scrape the insulation from one wire. Connect and tape the end of one wire of the twisted pair furnished with the set to the scraped portion of the subscriber's line. Follow the same procedure in preparing the second wire.

c. Plug into the input jack marked LINE TAP (fig. 3) on the sound detector panel.

d. Set the selector knob (fig. 3) to point toward LINE TAP.

e. Plug in headphones, turn on amplifier, and adjust the volume control knob as described in paragraph 4*f*, *g*, and *h*.

7. INDUCTION-COIL TELEPHONE TAP.

a. Place the induction coil (fig. 2) on the telephone ringer box; on the back of the wall to which the ringer box is attached; or between the twisted pair running out from the subscriber's telephone.

b. Screw connector at the other end of the induction coil cable onto the input connector (fig. 3) marked IND. COIL on the sound detector panel. This is the same connector to which the contact microphone is attached when used.

c. Turn the selector knob to point toward IND. COIL.

d. Plug in headphones, turn on amplifier, and adjust the volume control knob as described in paragraph 4*f*, *g*, and *h*.

e. It may be necessary to rotate the induction coil in order to find its most sensitive position, to provide a clear, undistorted tone with ample volume.

RESTRICTED

SECTION III

FUNCTIONING OF PARTS

8. AMPLIFIER INPUT CHANNELS.

a. Carbon Microphone Input (fig. 4). Two input jacks, J-2 and J-3, are provided for input from carbon microphones. Either one or two may be used depending on whether or not two microphones are required to satisfactorily cover the area of the room. The circuit is from the jacks, through the selector switch, SW-1, to the grid of the first amplifier stage.

TL-92355

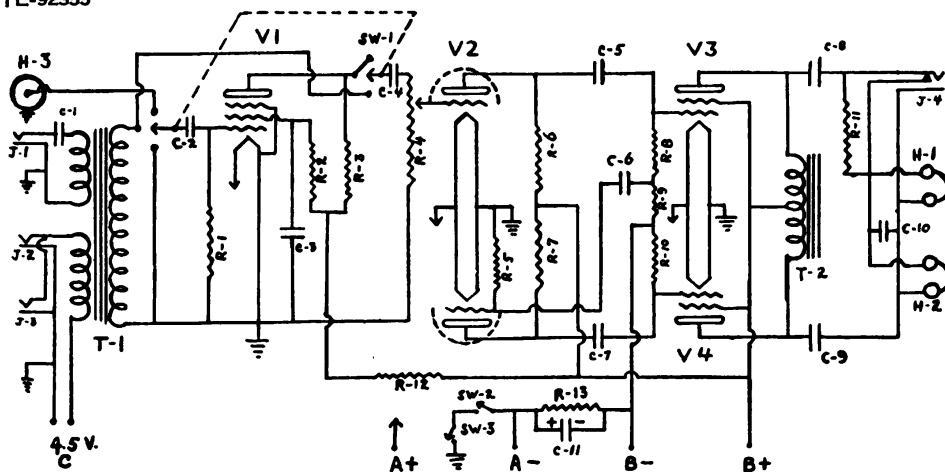

Figure 4. Amplifier, schematic diagram.

b. Contact Microphone and Induction Coil Input (fig. 4). A high-impedance input connector, H-3, is used for either contact microphone or induction coil applications. The circuit is from the connector, through the selector switch to the grid of the first amplifier stage.

c. Direct Telephone-line Tap Input (fig. 4). When a direct telephone-line tap is used the input is through a jack, J-1, the selector switch, to the grid of the second amplifier stage. Because the strength of this signal requires less amplification than the other applications, the first amplifier stage is bypassed.

d. Selector Switch. The selector switch (figs. 3 and 4) is a three-position switch which directs the path of the signal from the input jack being used to the grids of the first or second amplifier stages, according to the nature of the signal being received.

9. VACUUM TUBES.

a. First Audio Amplifier (fig. 4). The first audio amplifier is resistance coupled from the selector switch to the grid. The tube is a 1N5GT, a directly heated pentode. The grid connection is to a cap on the tube. The stage acts as a straight amplifier.

b. Phase Inverter (fig. 4). The second stage of the amplifier, a 1G6GT tube, is a duo-triode, which acts as a phase inverter to drive the output

stage. The first section of the tube drives the grid of V3, while the second section drives the grid of V4.

c. Power Output Stage (fig. 4). The power output stage consists of two 1LB4 tubes connected in push pull. The tubes are power amplifier pentodes, the suppressor grid being connected internally to the negative side of the filament.

d. Over-all Gain. Each of the tubes used in the amplifier is a high- μ tube. The gain of the amplifier unit is more than enough to bring out sufficient volume from the weakest signals at the input. When the carbon microphone is used, the only limit on the gain of the equipment is the noise in the room where the microphone is planted.

10. OUTPUT CHANNELS:

a. The output of the amplifier is arranged to feed into either one or two pairs of headphones, which plug into phone-tip jacks, H-1 and H-2 (fig. 4), on the panel.

b. An additional output jack, J-4, is provided for use with the crystal cutter of an accessory recorder, if it is desired to preserve a record of the conversation overheard. The accessory recorder is not a part of the equipment.

c. When a phone plug is inserted to the recorder jack, a 100,000-ohm resistor is put in series with the headphones; however, the full output is connected to the crystal cutter of a recorder.

11. POWER SUPPLY (fig. 4).

All power for the amplifier is provided by batteries.

a. A Battery. One and one-half volts direct current is provided for the filaments of the four tubes.

b. B Battery. Ninety volts direct current from the B battery provides plate and screen voltages for the tubes of the set.

c. C Battery. A $4\frac{1}{2}$ -volt battery connected across the carbon microphone section of the primary of the input transformer, provides the d-c voltage necessary for operation of the carbon microphones.

RESTRICTED
SECTION IV
MAINTENANCE

NOTE: Failure or unsatisfactory performance of equipment will be reported on W. D., A. G. O. Form No. 468. If this form is not available see TM 38-250.

12. SERVICE TEST.

Satisfactory operation depends largely on conditions outside the amplifier. Before concluding that the amplifier is at fault, check external connections and conditions.

- a. Make sure that the connections to the input jacks or amphenol connector are tight, and that contacts are not dirty.
- b. Check for short or open circuits in the lines between the planted microphones or the telephone tap and the amplifier.
- c. It is always possible that the planted microphone or telephone tap may be discovered by those whose conversation is being listened to and the equipment rendered useless.
- d. Check output connections to the headphones or recorder.
- e. Check battery voltage with a d-c voltmeter.

13. REMOVAL OF AMPLIFIER (figs. 5 and 6).

When it is necessary to remove the amplifier from its compartment in the carrying case, for inspection or repair, proceed as follows:

- a. Remove all connections from the amplifier panel.
- b. Remove the seven roundhead screws from the edge of the panel (fig. 1).

TL-92356

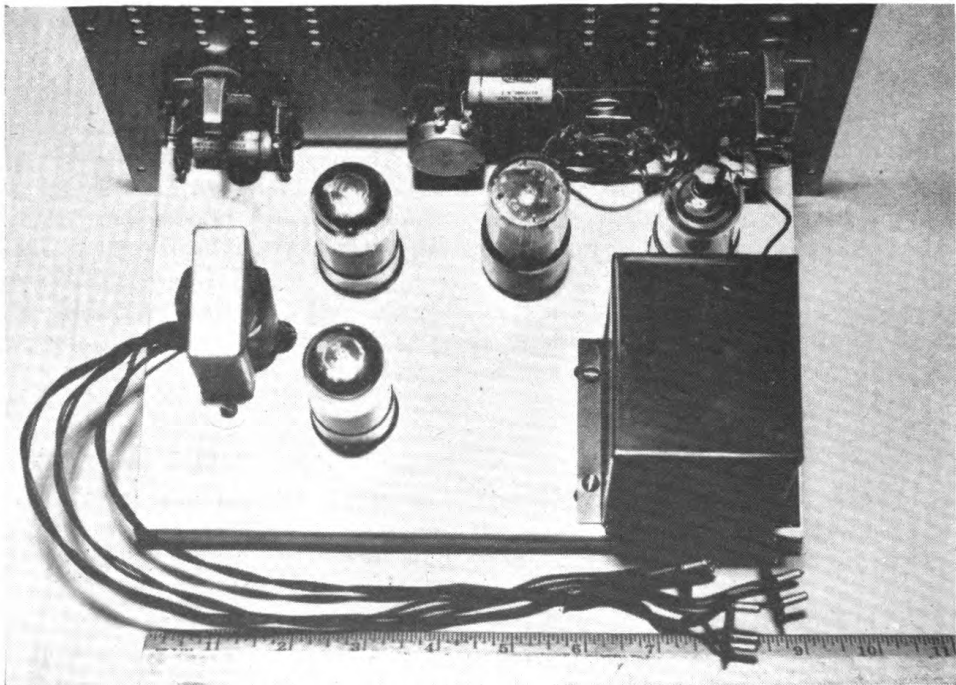

Figure 5. Amplifier, top of chassis and back of control panel.

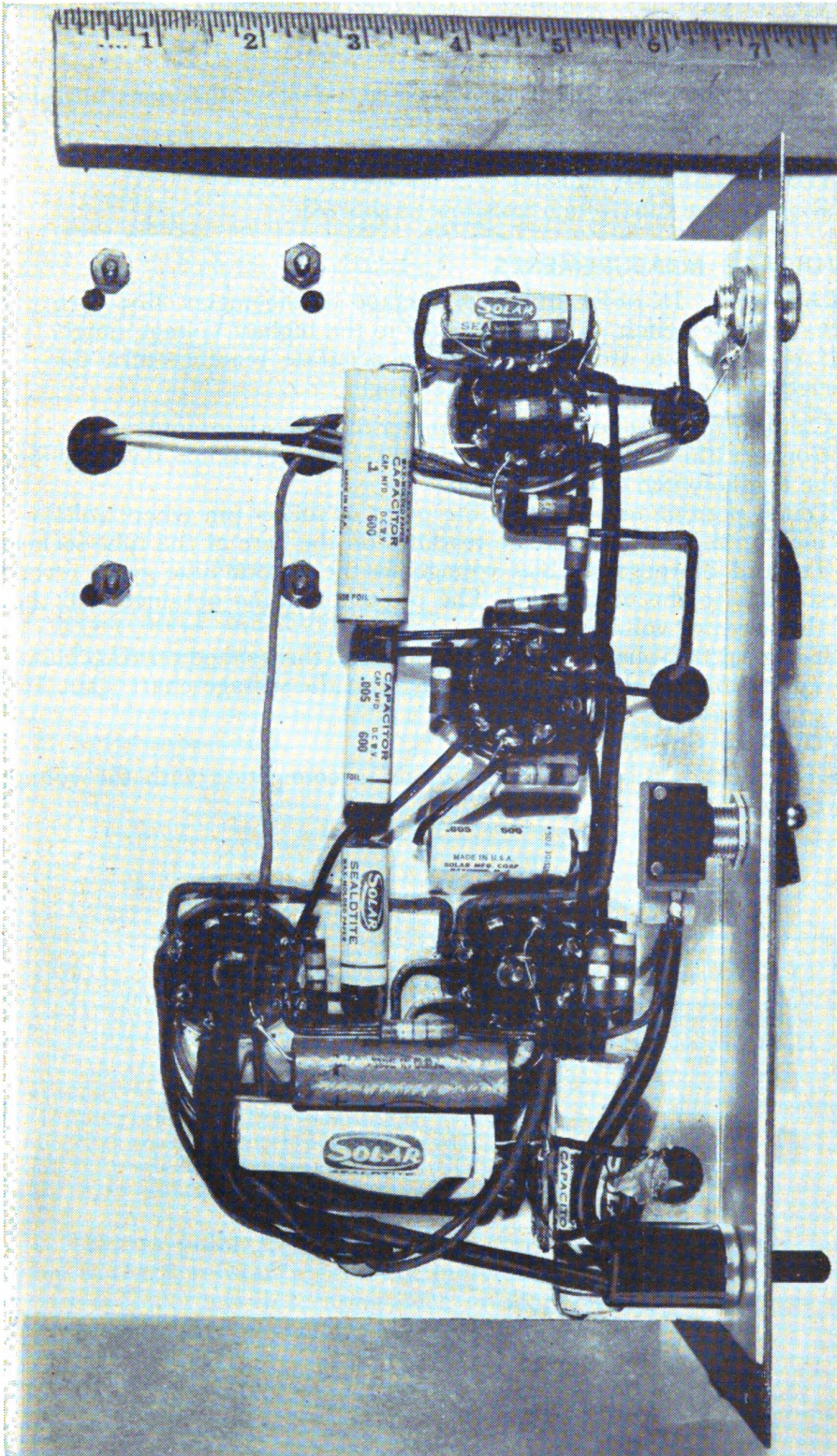

Figure 6: Amplifier, bottom of chassis.

- c. Disconnect the leads from the batteries (fig. 5).
- d. Lift the panel and amplifier chassis from the carrying case.

14. TESTING TUBES.

- a. Any standard tube tester may be used. Follow directions furnished with the tube tester.
- b. Remove the tubes from the amplifier.
- c. Test each tube for emission and for shorts.
- d. Replace any tube which tests low or shorted.

15. VOLTAGE MEASUREMENTS.

CAUTION: In order to avoid damage to the meter, first turn the selector switch on the voltmeter to the highest voltage range. If necessary, in order to obtain an accurate reading, turn the selector switch to a lower voltage range.

- a. Connect negative lead from voltmeter to a chassis ground.
- b. Connect the batteries to the proper connections on the amplifier, turn the toggle switch to ON position.
- c. Touch positive test probe to the point or socket pin where voltage is to be measured, and take voltage readings on the base of the tube sockets.
- d. To read the negative bias voltage on the output tube grids, reverse the test leads to the voltmeter. The positive reading obtained will then equal the negative voltage present.
- e. Using a 1,000-ohm per volt d-c voltmeter, the voltage readings should agree approximately with the values given in the voltage chart (par. 16).

16. VOLTAGE CHART.

See figure 7 for tube base designations in connection with the voltage chart below.

Tube		Pin No. 6	1	2	3	4	5	6	7	8
V1	1N5GT		¹ 60	1½	45	10			0	
V2	1G6GT			1½	60			60	0	¹ 90
V4	1LB4 (nr. panel)		1½	85	90			-7½		0
V3	1LB4 (nr. back)		1½	85	90		¹ 4½	-7½		0

¹ Connection point.

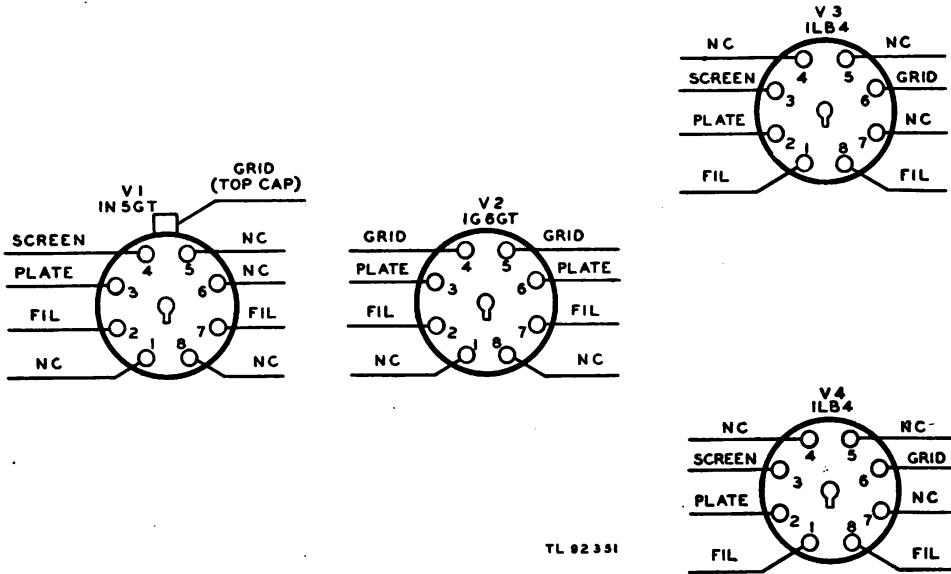

Figure 7. Amplifier, tube base designations.

17. RESISTANCE MEASUREMENTS.

a. Preliminary Steps. Remove the vacuum tubes, disconnect batteries, and make the resistance measurements indicated in the resistance chart below. Measure resistance from a chassis ground to the point indicated.

b. Resistance Chart.

Tube		Pin No.	1	2	3	4	5	6	7	8
V1	1N5GT		(*)	(*)	(*)	(*)	(*)	(*)	0	10-(1) 1100-(2) *(3)
V2	1G6GT		(*)	(*)	(*)	500,000	0(4)	(*)	0	(*)
V4	1LB4(nr.panel)		(*)	(*)	(*)	(*)	0	250,750	750	0
V3	1LB4(nr.back)		(*)	(*)	(*)	(*)	(*)	265,750	15,750	0

*Infinity.

- (1) With selector switch pointing to line tap.
- (2) With selector switch pointing to MICRO.
- (3) With selector switch pointing to CONTACT MICRO.
- (4) With volume control at 0.

c. Point-to-point Checks. Further resistance measurements may be taken to check resistance values of individual parts or circuits. This procedure is important in locating open or short circuits in the basic wiring and short-circuited capacitors.

RESTRICTED
SECTION V
SUPPLEMENTARY DATA

18. MAINTENANCE PARTS LIST FOR SPEAK-O-PHONE SOUND DETECTOR, MODEL SDB

Ref symbol	Signal Corps stock No.	Name of part and description	Quan per unit	Orgn stock	3d ech	4th ech	5th ech	Depot stock
---	3A31	BATTERY BA-31: portable; 4½-v; 3 "B" cells connected in series; screw and nut type terminals; 3⅞" high x 2¼"; 0.38 lb.	1	(*)	(*)	(*)	(*)	(*)
---	3A63	BATTERY BA-63: portable; 45-v; 22½-v tap; socket-type terminals; 30 "AA" cells; 4½" high x 1⅝" x 2½"; 1.5 lb.	2	(*)	(*)	(*)	(*)	(*)
---	3A65	BATTERY BA-65: portable; 1½-v; 4" "F" cells connected in parallel; socket-type terminals 4" high x 2⅞" x 1⅞"; 1 lb.	1	(*)	(*)	(*)	(*)	(*)
C-1, C-2, C-4, C-5, C-6, C-7, C-10.	3DA5-59	CAPACITOR: fixed; paper; tubular; single section; 5,000-mmf ± 25%; 600 v d-c (working); wax-mold seal; ⅜" diam x 1⅜" long; 0.023 lb; two 2" tinned No. 22 copper wire leads; Solar S-0215.	7	---	(*)	(*)	(*)	(*)
C-3, C-8, C-9	3DA100-109.2	CAPACITOR: fixed; paper; tubular; single section; 0.1 mf ± 25%; 200 v d-c (working); wax-mold seal; two 2" tinned No. 22 copper-wire leads; ½" diam x 1⅞" long; 0.05 lb; Solar S-0235.	3	---	(*)	(*)	(*)	(*)

C-11-----	3DB10-89-----	CAPACITOR: fixed; dryelectrolytic; tubular; single section; 10 mf $\pm 25\%$; 25 v dc (working); hermetically sealed in metal container in outside insulating tube; $1\frac{9}{32}$ " diam x $1\frac{11}{16}$ " long; two 3" tinned No. 20 copper-wire leads; 0.05 lb; Solar type M-010.	1	(*)	(*)	(*)	(*)
T-2-----	3C323-Z5G-----	CHOKER: output; center tapped; 3 color-coded leads (blue to blue, 550-ohms, red center tap); open frame; $1\frac{1}{8}$ " high x $1\frac{3}{8}$ " wide x $1\frac{11}{16}$ " long; two $\frac{1}{8}$ " mounting holes on $2\frac{3}{8}$ " mounting center; 0.53 lb; Electronic Transformer No. 87.	1	(*)	(*)	(*)	(*)
	3C1056-----	COIL: induction; telephone; iron core; waxsealed; in tubular container; d-c resistance 2,000-ohms approx; $3\frac{3}{8}$ " x $\frac{7}{8}$ " diam; 0.43 lb; Speak-O-Phone type 62B.	1	(*)	(*)	(*)	(*)
H-3-----	2Z7111.28-----	CONNECTOR: male; non-polarized; shielded straight-panel mount; chrome-plated brass body; tissue base laminated bakelite insulation; 1 center button contact, 1 outer coupling thread contact; $\frac{1}{4}$ " cord hole; $\frac{5}{8}$ " x $\frac{5}{8}$ " x $\frac{5}{8}$ "; with 1 swaged, 1 flat insulating washer and 1 hex locknut; Amphenol PC1M (chassis with coupling threads).	1	(*)	(*)	(*)	(*)
	2Z8671.23-----	CONNECTOR: female; straight; non-polarized; chrome-plated drawn brass; 1 center button contact, 1 outer coupling thread contact; $\frac{1}{4}$ " cord hole; $1\frac{5}{16}$ " long x $\frac{5}{8}$ " diam; 0.06 lb; Amphenol MC1F.	2	(*)	(*)	(*)	(*)

*Indicates stock available.

Ref symbol	Signal Corps stock No.	Name of part and description	Quan per unit	Orgn stock	3d ech	4th ech	5th ech	Depot stock
	2B1743/C1	COVER: microphone; rubber; moulded to fit carbon microphone; $2\frac{1}{4}$ " diam x $\frac{3}{4}$ "; 0.025 lb; Speak-O-Phone.	2		(*)	(*)	(*)	(*)
	2Z2724-1	GRID CAP: small receiving tube type; spring action; hot tinned; $\frac{7}{8}$ " long x $\frac{1}{16}$ " high x $\frac{3}{16}$ " wide; 0.002 lb; ICA grid cap 1551.	1		(*)	(*)	(*)	(*)
	2B971-2.1	HEADPHONES: magnetic; cloth-covered metal head bands; spring slide; 5' black braid cord; 18,000-ohms impedance; each phone $2\frac{1}{2}$ " diam x $\frac{3}{4}$ "; head-band $10\frac{1}{2}$ " x $1\frac{1}{4}$ "; 0.5 lb; Speak-O-Phone type 73.	2 pr		(*)	(*)	(*)	(*)
H-1, H-2	2ZK5576-5	JACK: pin; single contact; black plastic ring, $\frac{1}{16}$ " OD x $\frac{3}{16}$ " thick; with 1 insulating washer $\frac{1}{2}$ " OD; $\frac{1}{4}$ " hole with raised collar; 1 hex. nut for single hole mounting; overall size $\frac{7}{16}$ " x $\frac{7}{16}$ " x $\frac{7}{8}$ "; shank $\frac{1}{2}$ " long x $\frac{1}{4}$ " OD; 0.012 lb; ICA 889B.	4		(*)	(*)	(*)	(*)
J-1, J-2, J-3	2Z5595	JACK: headphone; open circuit; with 1 hex nickel-plated mounting nut and washer; 1 flat, 1 swedged insulating washer for $\frac{7}{16}$ " panel hole; $1\frac{1}{4}$ " x $\frac{3}{4}$ " x $1\frac{1}{4}$ "; shank $\frac{5}{16}$ " long x $\frac{3}{8}$ " OD; 0.015 lb; Utah No. 1 imp short jack.	3		(*)	(*)	(*)	(*)
J-4	2Z5598-8	JACK: headphone; closed circuit; with 1 hex nickel-plated mounting nut and washer; 1 flat; 1 swedged-insulating washer for $\frac{7}{16}$ " panel hole; $1\frac{1}{4}$ " x $\frac{3}{4}$ " x $1\frac{1}{4}$ "; shank $\frac{5}{16}$ " long x $\frac{3}{8}$ " OD; 0.02 lb; Utah No. 2A closed circuit imp short jack.	1		(*)	(*)	(*)	(*)

2Z5844	KNOB: bar pointer; black bakelite; setscrew type; with 1/4" brass insert; for 1/4" shaft; 1 1/4" long x 5/8" high x 3/4" wide; shaft hole 3/8" deep; 0.032 lb; ICA J274.	(*)	(*)	(*)	(*)	(*)
6L1440	NAIL: iron; common wire; 40-d	(*)	(*)	(*)	(*)	(*)
2B1743	MICROPHONE: crystal; high impedance; 1 1/4" chrome-plated brass cone; 1 1/4" chrome-plated brass cone; with 12' 175-OD rubber-covered shielded cable and Amphenol connector; 2" diam x 5/8"; 0.37 lb; Speak-O-Phone contact type 25X.	(*)	(*)	(*)	(*)	(*)
2B1744	MICROPHONE: carbon; no handle; 40-ohms approx; two 5" rubber-covered wire leads; 2 1/2" diam x 1 1/2"; 0.2 lb; Western Electric F1 xintr.	(*)	(*)	(*)	(*)	(*)
2Z7111.123	PLUG: male; straight; nonpolarized; bakelite body; 3/8" cord hole; 2 7/8" x 5/8" diam; 0.05 lb; ICA 24B.	(*)	(*)	(*)	(*)	(*)
2Z7113.47	PLUG: male; straight; large; 3-prong; fiber body; nicked-metal prongs 3/8" long; for 45-v "B" battery; 1 5/16" diam; 0.006 lb; JFD No. 701.	(*)	(*)	(*)	(*)	(*)
2Z3022-6	PLUG: male; straight; small; 2-prong; fiber body; nicked-metal prongs 3/8" long; for 1 1/2-v "A" battery; 5/8" diam; 0.003 lb; JFD No. 706.	(*)	(*)	(*)	(*)	(*)
R-4	POTENTIOMETER: carbon; single section; 500,000-ohms; 0.7 w; straight taper; 3 terminals; inclosed; with two 9/16" hex. nuts for mounting; 1 1/6" diam x 7/2" long; mounting bushing 3/8" diam x 3/8" long; shaft 1/4" diam x 3/8" from mounting bushing; 0.05 lb; Clarostat K-2856.	(*)	(*)	(*)	(*)	(*)

*Indicates stock available.

Ref symbol	Signal Corps stock No.	Name of part and description	Quan per unit	Orgn stock	3d ech	4th ech	5th ech	Depot stock
R-13	3RC21BE751J	RESISTOR: fixed; carbon; 750-ohms $\pm 10\%$; $\frac{1}{2}$ w; bakelite insulation; tubular; two $1\frac{1}{2}$ " No. 20 tinned-copper wire leads; $\frac{3}{16}$ " diam x $\frac{5}{8}$ " long; 0.003 lb; IRC type BT1/2.	1	---	(*)	(*)	(*)	(*)
R-9	3RC21BE153J	RESISTOR: fixed; carbon; 15,000-ohms; description same as R-13.	1	---	(*)	(*)	(*)	(*)
R-6, R-7	3RC21BE513J	RESISTOR: fixed; carbon; 50,000-ohms; description same as R-13.	2	---	(*)	(*)	(*)	(*)
R-11, R-12	3RC21BE104K	RESISTOR: fixed; carbon; 100,000-ohms; description same as R-13.	2	---	(*)	(*)	(*)	(*)
R-8, R-10	3RC21BE244K	RESISTOR: fixed; carbon; 250,000-ohms; description same as R-13.	2	---	(*)	(*)	(*)	(*)
R-3, R-5	3RC21BE514K	RESISTOR: fixed; carbon; 500,000-ohms; description same as R-13.	2	---	(*)	(*)	(*)	(*)
R-1	3RC21BE105K	RESISTOR: fixed; carbon; 1 megohm; description same as R-13.	1	---	(*)	(*)	(*)	(*)
R-2	3RC21BE275K	RESISTOR: fixed; carbon; 3 megohms; description same as R-13.	1	---	(*)	(*)	(*)	(*)
	6M18	RUBBER BAND: No. 18.	1	(*)	(*)	(*)	(*)	(*)
	2Z8799-137	SOCKET: amplifier tube; standard loctal; moulded-bakelite; retainer-ring mounting; mounting hole 1.172" diam; $1\frac{1}{2}$ " diam, $\frac{3}{4}$ " high; 0.025 lb; Amphenol 5-6.	2	---	(*)	(*)	(*)	(*)
	2Z8678.21	SOCKET: phase-inverter tube; standard loctal; moulded-bakelite; retainer-ring mounting; mounting hole 1.172" diam; $1\frac{1}{2}$ " diam, $\frac{3}{4}$ " high; 0.018 lb; Amphenol 78-8L.	2	---	(*)	(*)	(*)	(*)

SW-1	3Z9825-58.58	SWITCH: rotary; 2-circuit; 3-position; single-section; nonshorting; bakelite body; with two $\frac{9}{16}$ " hex. nuts and 1 lock washer, shaft $\frac{1}{8}$ " diam x $\frac{3}{8}$ " long; bushing $\frac{3}{8}$ " diam x $\frac{3}{8}$ " long; $1\frac{3}{4}$ " x $1\frac{1}{8}$ " x $1\frac{1}{2}$ "; 0.055 lb; Centralab T6882.	1	(*)	(*)	(*)
SW-2	3Z8935	SWITCH: toggle; SPST; 1-amp, 250-v; 3-amp, 125-v; non-shorting; nickel finish; bakelite insulation; bushing $\frac{9}{16}$ " diam x $\frac{7}{16}$ " long; $1\frac{3}{16}$ " x $\frac{1}{2}$ " x $1\frac{1}{4}$ "; 0.035 lb; ICA 1230.	1	(*)	(*)	(*)
SW-3	3Z9819-3	SWITCH: push-button; momentary; SPST; single-section; bakelite; cylindrical; 0.75-amp, 125-v; push-button $\frac{7}{8}$ " long x $\frac{1}{2}$ " diam; two 5" rubber-covered wire leads; 1" long x $\frac{5}{8}$ " diam; 0.13 lb; SM Chicago No. 179.	1	(*)	(*)	(*)
	6L32009-2	TACKS: upholstery; light; box of 50; $\frac{3}{8}$ " head diam x $\frac{9}{16}$ " point length; 0.13 lb.	1	(*)	(*)	(*)
	6L32009-1	TACKS: upholstery; dark; box of 50; $\frac{3}{8}$ " head diam x $\frac{9}{16}$ " point length; 0.13 lb.	1	(*)	(*)	(*)
T-1	2Z9631.154	TRANSFORMER: input; pri No. 1, 650-ohms; pri No. 2, 300-ohms; sec 1, 100 ohms; sealed in pitch; 6 colors coded leads; pri No. 1, green; pri No. 2, brown; sec, yellow; 4 mounting holes, $\frac{7}{8}$ " diam, on $1\frac{1}{8}$ " x $2\frac{1}{16}$ " mounting plate; $3'$ x $3'$ x $2\frac{3}{4}$; 1.25 lb; Electronic Transformer No. 350.	1	(*)	(*)	(*)
V1	2JIN5GT	TUBE: VT-146 (1N5GT); amplifier.	1	(*)	(*)	(*)
V2	2JIG6GT	TUBE: 1G6GT; phase inverter.	1	(*)	(*)	(*)
V3, V4	2JILB4	TUBE: 1LB4; output; amplifier.	2	(*)	(*)	(*)

*Indicates stock available.

Ref symbol	Signal Corps stock No.	Name of part and description	Quan per unit	Orgn stock	3d ech	4th ech	5th ech	Depot Stock
-----	1B822.59-----	WIRE: light brown-covered; twisted pair; No. 20 solid copper; rubber wall; cottons braid covering; one lead with tracer; 50-foot length; 0.5 lb; Bernbach Radio Co.	1	(*)	(*)	(*)	(*)	(*)
-----	1B117.1-----	WIRE: dark brown-covered; same description as 1B822.59.	1	(*)	(*)	(*)	(*)	(*)

*Indicates stock available.

