

1/4 bod
9113
TM
1944

TM 9-892

WAR DEPARTMENT TECHNICAL MANUAL

U.S. Dept of Army

10-TON PAYLOAD,
14-TON GROSS,

2-WHEEL STAKE AND
PLATFORM SEMITRAILER *and*
10-TON CONVERTER DOLLY

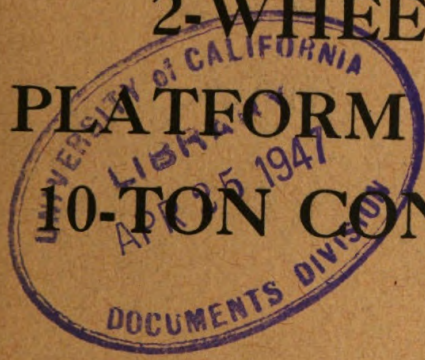

WAR DEPARTMENT

22 APRIL 1944

WAR DEPARTMENT TECHNICAL MANUAL

TM 9-892

**10-TON PAYLOAD,
14-TON GROSS,
2-WHEEL STAKE AND
PLATFORM SEMITRAILER *and*
10-TON CONVERTER DOLLY**



WAR DEPARTMENT

22 April 1944

WAR DEPARTMENT
Washington 25, D. C., 22 April 1944

TM 9-892, 10-ton Payload, 14-ton Gross, 2-wheel Stake and Platform Semitrailer and 10-ton Converter Dolly is published for the information and guidance of all concerned.

[A.G. 300.7 (18 Dec. 43)]

BY ORDER OF THE SECRETARY OF WAR:

G. C. MARSHALL,
Chief of Staff.

OFFICIAL:

J. A. ULIO,
Major General,
The Adjutant General.

DISTRIBUTION: X

U113

12

CONTENTS

TM 9-892

1944

PART ONE—GENERAL

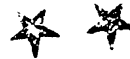

		Paragraphs	Pages
SECTION	I Introduction	1-2	4-5
	II Description and tabulated data	3-5	6-11
	III Vehicle stowage and special tools	6-8	11-12

PART TWO—OPERATING INSTRUCTIONS

SECTION	IV Semitrailer	9-12	13-16
	V Dolly	13-14	17-20

PART THREE—VEHICLE MAINTENANCE INSTRUCTIONS

SECTION	VI Lubrication	15-16	21-27
	VII First echelon preventive maintenance	17-21	27-32
	VIII Second echelon preventive maintenance	22	32-41
	IX Trouble shooting	23-30	42-47
	X Brake system	31-42	47-63
	XI Suspension	43-48	64-70
	XII Landing gear	49-53	70-74
	XIII Wheels, hubs, drums, and tires	54-61	74-81
	XIV Electric system	62-65	81-86
	XV Fifth wheel, pintle hook, lunette eye, and safety chains	66-70	86-89

PART FOUR—ORDNANCE MAINTENANCE INSTRUCTIONS

SECTION	XVI Internal brake assembly	71-77	90-94
	XVII Suspension	78-81	94-98
	XVIII Axle	82-87	99-102
	XIX Fifth wheel	88-92	102-106
	XX Semitrailer landing gear	93-96	107-112
	XXI Hubs, drums, and bearings ...	97-102	112-115
	XXII Body and frame	103-106	115-116

APPENDIX

SECTION	XXIII Shipment and temporary storage	107-109	117-120
REFERENCES		121-122
INDEX		123

**10-TON PAYLOAD, 14-TON GROSS, 2-WHEEL STAKE AND
PLATFORM SEMITRAILER AND 10-TON CONVERTER DOLLY**

PART ONE—GENERAL

Section I

INTRODUCTION

1. SCOPE.

a. This manual is published for the information and guidance of personnel to whom the equipment is assigned. This manual contains information on operation and maintenance of the 10-ton Payload, 14-ton Gross, 2-wheel Stake and Platform Semitrailer, and on the 10-ton Converter Dolly, as well as descriptions of the major units and their functions in relation to the other components of this vehicle.

b. This manual has the following arrangement: **NOTE:** *Where dolly maintenance operations are different from those of the semitrailer, mention is made of this fact in the paragraph covering the description of the component involved, and the differences covered in the maintenance procedure which follows the description.*

(1) Part One, General, contains description and data. It lists the tools and equipment carried on the vehicle.

(2) Part Two, Operating Instructions, contains instructions for the operation of the semitrailer and dolly, with description and location of the controls and instruments.

(3) Part Three, Vehicle Maintenance Instructions, contains information needed for the performance of the scheduled lubrication and preventive maintenance services, and instructions for maintenance operations which are the responsibility of the using organizations (first and second echelons).

(4) Part Four, Ordnance Maintenance Instructions, contains information for the guidance of the third and fourth echelons of maintenance. For ordnance maintenance information on the Bendix-Westinghouse air brakes, refer to TM 9-1827A.

(5) The Appendix contains instructions for shipment and limited storage, and is followed by a list of references including standard nomenclature lists, technical manuals, and other publications applicable to the vehicle.

2. RECORDS.

a. Forms and records applicable for use in performing prescribed operations are listed below with brief explanations of each.

(1) **STANDARD FORM No. 26, DRIVER'S REPORT—ACCIDENT, MOTOR TRANSPORTATION.** One copy of this form will be kept with the vehicle at all times. In case of an accident resulting in injury or property damage, it will be filled out by the driver on the spot or at his first opportunity.

INTRODUCTION

(2) **WAR DEPARTMENT FORM NO. 48, DRIVER'S TRIP TICKET AND PREVENTIVE MAINTENANCE SERVICE RECORD.** This form, properly executed, will be furnished to the driver when his vehicle is dispatched on nontactical missions. The driver and the official user of the vehicle will complete in detail appropriate parts of this form. These forms need not be issued for vehicles in convoy or on tactical missions. The reverse side of this form contains the driver's daily and weekly preventive maintenance service reminder schedule.

(3) **W.D., A.G.O. FORM NO. 478, MWO AND MAJOR UNIT ASSEMBLY REPLACEMENT RECORD.** This form will be used by all personnel completing a modification or major unit assembly replacement to record clearly the description of work completed, date, vehicle hours, and/or mileage, and MWO number or nomenclature of unit assembly. Personnel performing the operation will initial in the column provided. Minor repairs, parts, and accessory replacements will not be recorded.

(4) **W.D., A.G.O FORM NO. 6, DUTY ROSTER.** This form, slightly modified, will be used for scheduling and maintaining a record of vehicle maintenance operations. It may be used for lubrication records.

(5) **W.D., A.G.O. FORM NO. 461, PREVENTIVE MAINTENANCE SERVICE AND TECHNICAL INSPECTION WORK SHEET FOR WHEELED AND HALF-TRACK VEHICLES.** This form will be used for all 1,000-mile (monthly) and 6,000-mile (semiannual) maintenance services and all technical inspections performed on wheeled or half-track vehicles.

(6) **W.D., O.O. FORM NO. 7353, SPOT-CHECK INSPECTION REPORT FOR ALL MOTOR VEHICLES.** This form may be used by all commanding officers or their staff representatives in making spot-check inspections on all vehicles.

(7) **W.D., A.G.O. FORM NO. 468, UNSATISFACTORY EQUIPMENT RECORD.** This form will be used for reporting manufacturing, design, or operational defects in materiel with a view to improving and correcting such defects, and for use in recommending modifications of materiel. This form will not be used for reporting failures, isolated materiel defects, or malfunctions of materiel resulting from fair wear and tear or accidental damage, nor for the replacement, repair, or the issue of parts and equipment. It does not replace currently authorized operational or performance records.

(8) **W.D., O.O. FORM NO. 7370, EXCHANGE PART OR UNIT IDENTIFICATION TAG.** This tag, properly executed, may be used when exchanging unserviceable items for like serviceable assemblies, sub-assemblies, parts, vehicles, and tools.

10-TON PAYLOAD, 14-TON GROSS, 2-WHEEL STAKE AND PLATFORM SEMITRAILER AND 10-TON CONVERTER DOLLY

Section II

DESCRIPTION AND TABULATED DATA

3. DESCRIPTION.

a. **Semitrailer** (figs. 1 and 2). The 10-ton semitrailer, is a two-wheel, single-axle vehicle having dual tires. A vertical-type landing gear is provided at drop in frame to support the front of the semitrailer when it is disconnected from the towing vehicle or dolly. The body frame is built integral with the chassis. The racks can be removed to convert the trailer into a platform-type vehicle. The springs are of the semielliptic type. The rear ends of the main springs are mounted in shackles. The front ends are supported in stationary brackets. The semitrailer has an open top, and is provided with a tarpaulin. The brakes are actuated by air, and are of the internal-expanding type. The brakes are controlled by a foot or hand controller mounted in the towing vehicle. The semitrailer is towed by a tractor truck equipped with a fifth wheel. Both regular and blackout lights are provided.

b. **Dolly** (figs. 3 and 4). The dolly is used to convert the semitrailer into a four wheel trailer. The dolly is equipped with a fifth wheel for coupling the dolly to the semitrailer. The dolly is equipped with an A-type draw bar. A swivel-type lunette is provided at the front end of the draw bar for coupling to a pintle hook on towing vehicle. The dolly is not equipped with lights or brakes. A stiff-leg, fold-back landing gear is installed at the front of the draw bar. The landing gear keeps the dolly in a level position when disconnected from towing vehicle.

4. SEMITRAILER DATA.

a. **Physical Characteristics:**

Weight empty	9,430 lb
Maximum payload	10 ton
Height of racks	4 ft 0 in.
Height from ground to top of racks (empty)	8 ft 8 ³ / ₄ in.
Height from ground to top of racks (loaded)	8 ft 5 ³ / ₄ in.
Length over-all	25 ft 6 ⁵ / ₁₆ in.
Width over-all	7 ft 11 ³ / ₄ in.
Width inside	7 ft 5 ³ / ₄ in.
Ground clearance under rear axle	1 ft 4 in.
Ground clearance under landing gear wheels	1 ft 2 ¹ / ₂ in.

Tires:

Quantity (interchangeable with towing vehicle and dolly)	4
--	---

DESCRIPTION AND TABULATED DATA

RA PD 334359

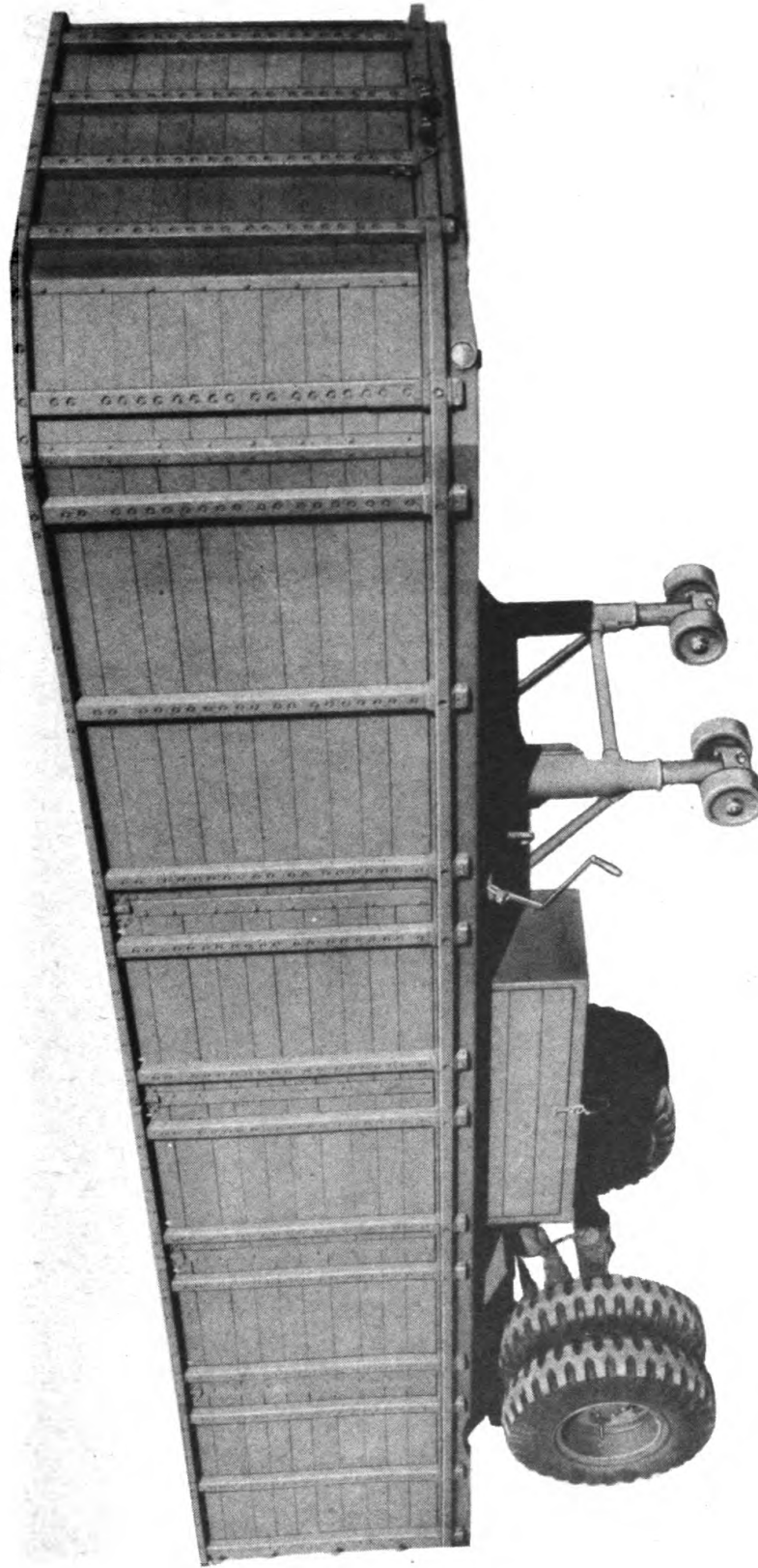

Figure 1—Semitrailer—Three-quarter Right Front View

TM 9-892

4

**10-TON PAYLOAD, 14-TON GROSS, 2-WHEEL STAKE AND
PLATFORM SEMITRAILER AND 10-TON CONVERTER DOLLY**

RA PD 334360

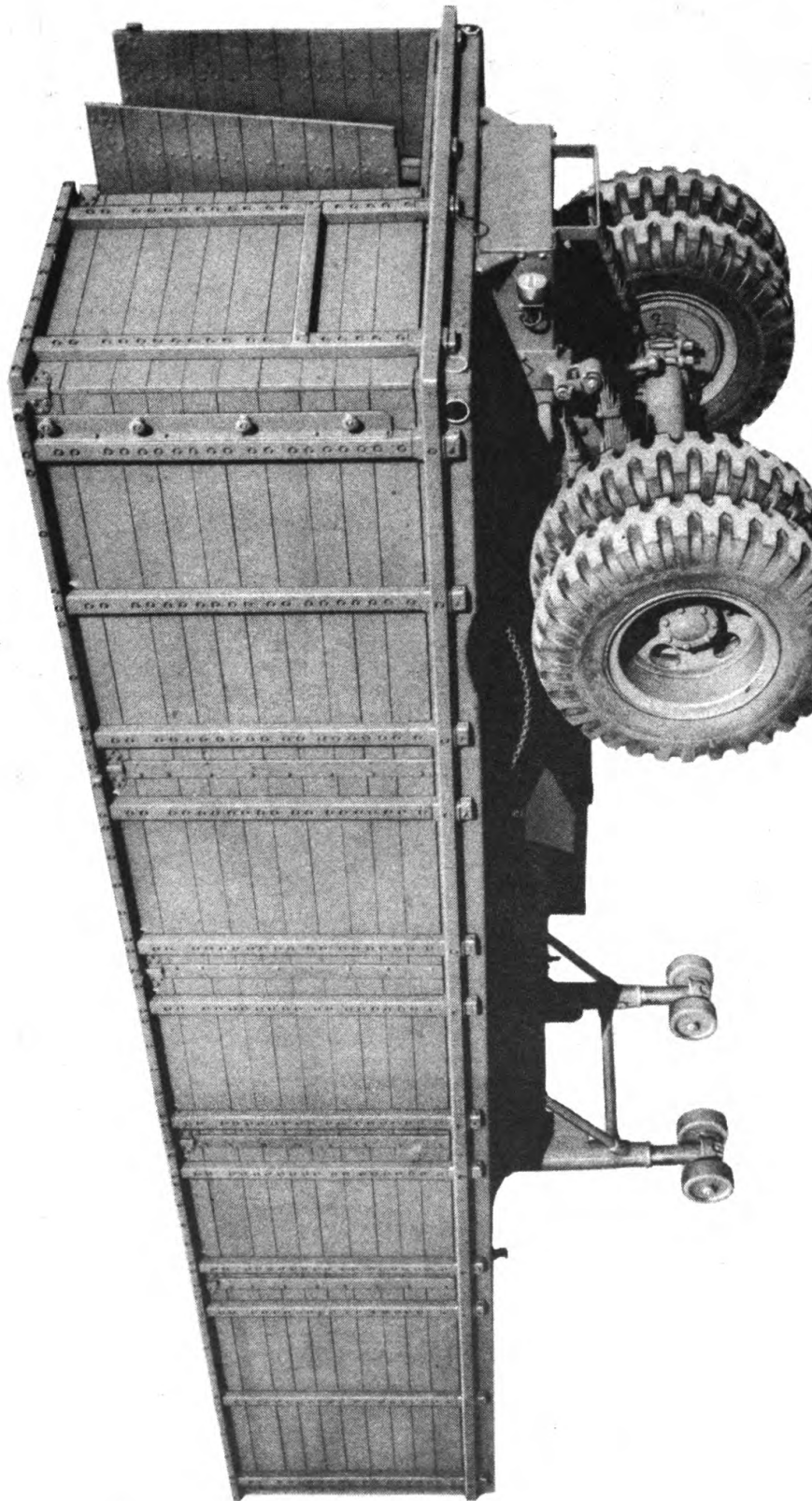

Figure 2—Semitrailer—Three-quarter Left Rear View

DESCRIPTION AND TABULATED DATA

RA PD 334362

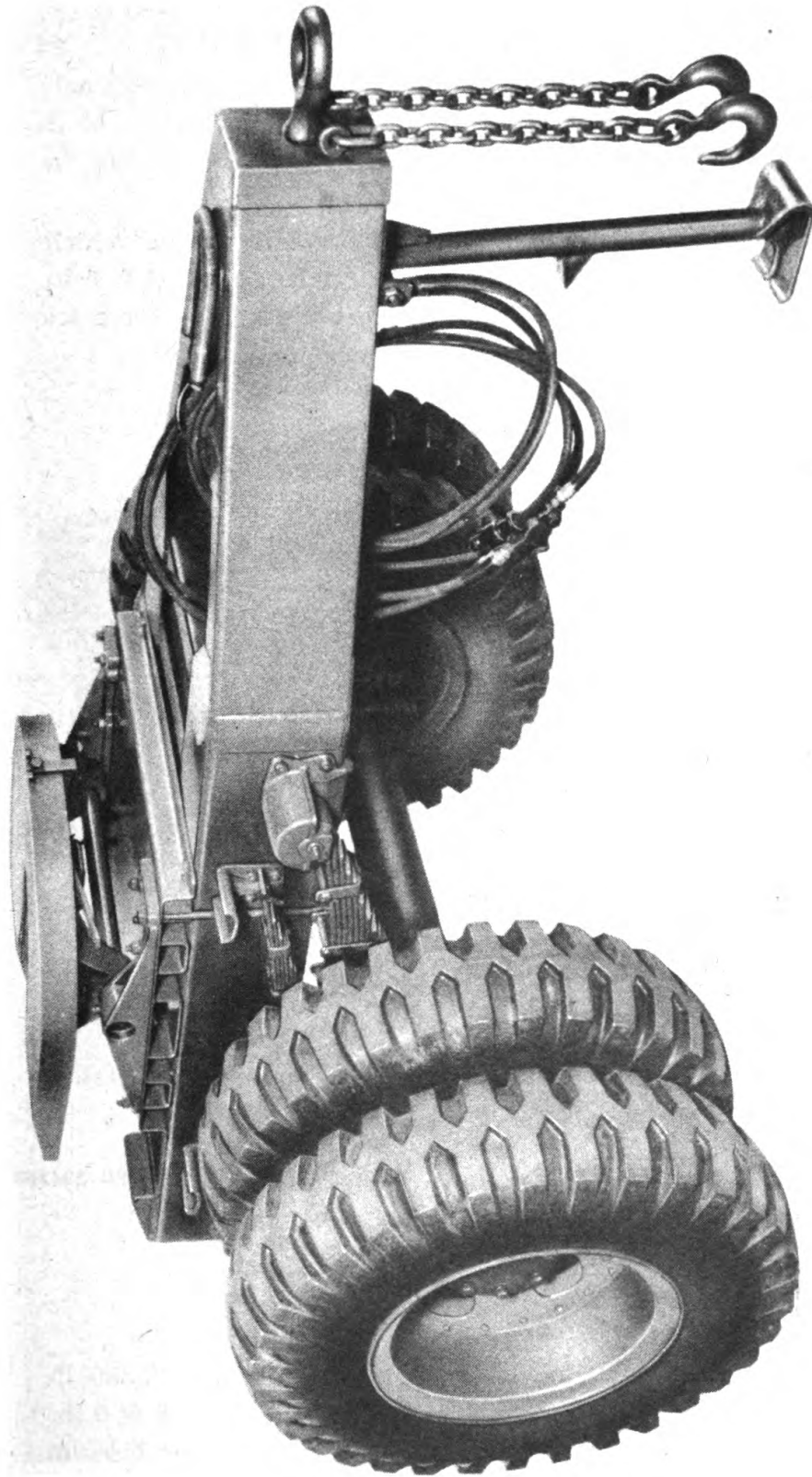

Figure 3—Dolly—Three-quarter Right Front View

TM 9-892
4-5

10-TON PAYLOAD, 14-TON GROSS, 2-WHEEL STAKE AND PLATFORM SEMITRAILER AND 10-TON CONVERTER DOLLY

Size 11.00/20
No. of plies 14
Type tread Mud and snow grip (nondirectional)
Air pressure 80 lb
Tread type 5 ft 10½ in.

b. Performance.

Allowable speed Same as towing vehicle
Turning radius 3 ft 6 in.
Towing vehicle 5-ton 4 x 2 tractor truck

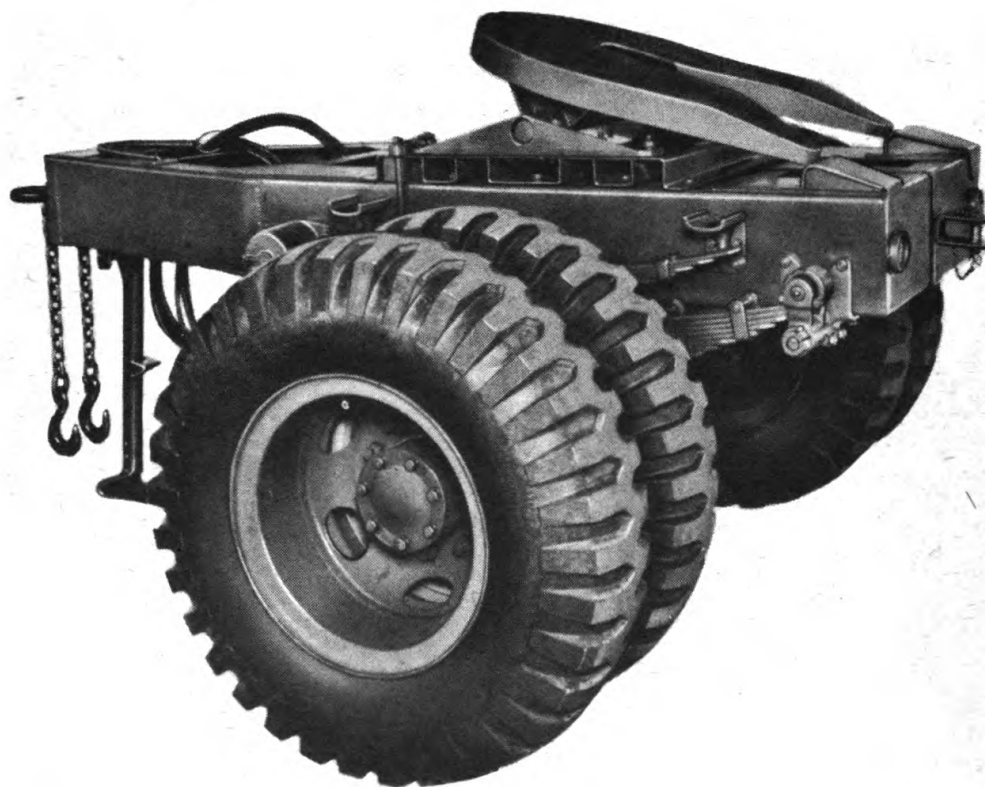

RA PD 334363

Figure 4—Dolly—Three-quarter Left Rear View

5. DOLLY DATA.

a. Physical Characteristics:

Weight over-all 3,380 lb
Length over-all 9 ft 6 in.
Width over-all 7 ft 11½ in.
Type fifth wheel A-O-106
Ground clearance under axle 1 ft 4 in.

DESCRIPTION AND TABULATED DATA

Tires:

Quantity (Interchangeable with semitrailer and towing vehicle)	4
Size	11.00/20
Type tread	Mud and snow grip (nondirectional)
No. of plies	14
Air pressure	80 lb
Tread	5 ft 10½ in.

Section III

VEHICLE STOWAGE AND SPECIAL TOOLS

6. PURPOSE.

a. The list in this section is for information only. It is not to be used as a basis for requisition. There are no tools provided for the dolly. The following equipment is provided on the semitrailer.

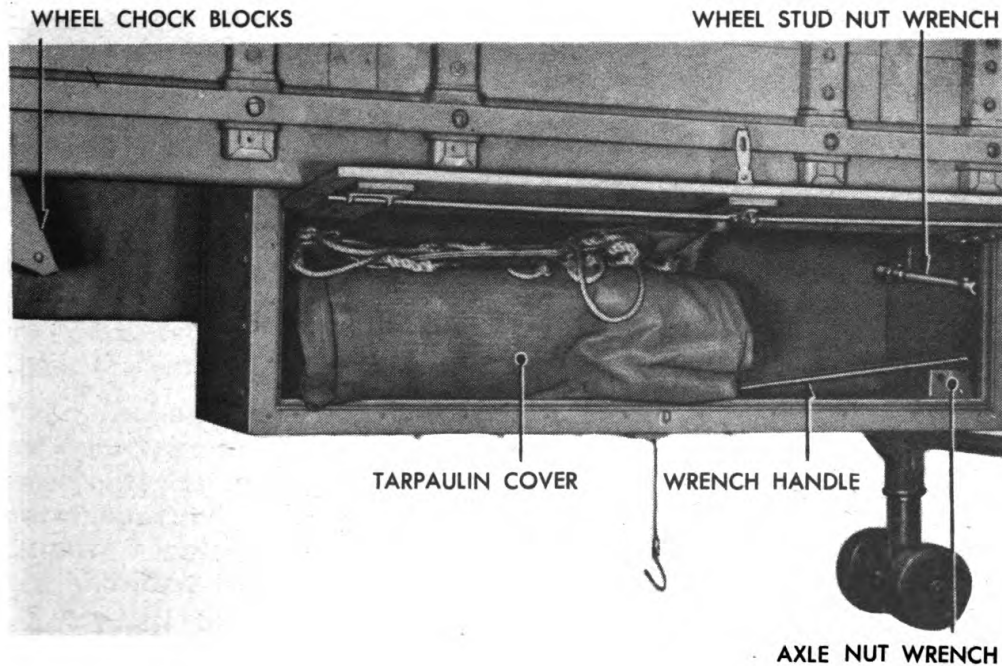

RA PD 334368

Figure 5—Tools and Equipment Stowage on the Vehicle

TM 9-892

7-8

**10-TON PAYLOAD, 14-TON GROSS, 2-WHEEL STAKE AND
PLATFORM SEMITRAILER AND 10-TON CONVERTER DOLLY**

7. VEHICLE STOWAGE.

a. On Vehicle Equipment (fig. 5).

Quantity per Vehicle	Item Name	Stowage Location
1	Tarpaulin, cover	Tool box
1	Wrench, axle nut	Tool box
1	Wrench, wheel stud nut	Tool box
1	Handle, wrench	Tool box
2	Chocks, wheel block	Tool box

8. SPECIAL TOOLS.

a. No special tools are required to maintain the semitrailer and dolly. The vehicles are towed by a tractor truck equipped with sufficient tools to accommodate all general care and maintenance. Therefore, the semitrailer tools have been kept to a minimum. Tools when not in use must be stored in the place or receptacles provided.

PART TWO—OPERATING INSTRUCTIONS

Section IV

SEMITRAILER

9. CONTROLS.

a. **Landing Gear** (fig. 6). The hand crank for the landing gear is held in the disengaged position on a hook which is attached to the operating shaft on the right side of the semitrailer toward the front. To operate, remove crank from hook and engage the crank on the crank shaft. Lowering the landing gear is accomplished by turning the crank clockwise, raising is accomplished by turning the crank counterclockwise. To disengage crank, pull the crank off the operating shaft, turn the crank in toward semitrailer body, and hang the crank on the hook. When raising the landing gear make sure the landing gear is raised to its maximum travel, so that the landing gear legs will not become damaged when traveling. When lowering landing gear make certain it is lowered as far as possible; this will eliminate the difficulty in backing towing vehicle under semitrailer when recoupling.

b. **Blackout Switch** (fig. 6). The blackout switch is located on the right side of the front crossmember directly below the rub rail. There is no off position on the switch. It is operated by means of a coin, key, or screwdriver, and is either at the blackout position or at the standard light position. The face of the switch has an arrow pointing to the blackout position. The flow of current is controlled at the towing vehicle.

c. **Coupling Brake Hose** (figs. 6 and 7). Remove the dummy couplings from both air lines. Hang the dummy couplers on the clips located at the side of front stake pockets. Couple the air hose tagged "SERVICE" which is attached to towing vehicle to the coupler on the right side of semitrailer tagged "SERVICE". Couple the air hose tagged "EMERGENCY" which is attached to the towing vehicle, to the coupler tagged "EMERGENCY" on left side of towing vehicle. Open the emergency and service line cut-out cocks at towing vehicle.

d. **Uncoupling Brake Hose**. Close the service and emergency cut-out cocks located on towing vehicle. Disconnect the service and emergency air hose from couplings on semitrailer. Hang the two air hoses on clips provided at rear of cab on towing vehicle. Install dummy couplers on the emergency and service couplers to prevent dirt and other foreign matter entering the brake system.

e. **Light Jumper Cable** (fig. 7). To connect light jumper cable, open cover and insert the jumper cable into light coupling socket located in center of front crossmember.

f. **Chock Blocks**. Two chock blocks are provided. One is located on the right side, and the other on the left side of semitrailer ahead

10-TON PAYLOAD, 14-TON GROSS, 2-WHEEL STAKE AND PLATFORM SEMITRAILER AND 10-TON CONVERTER DOLLY

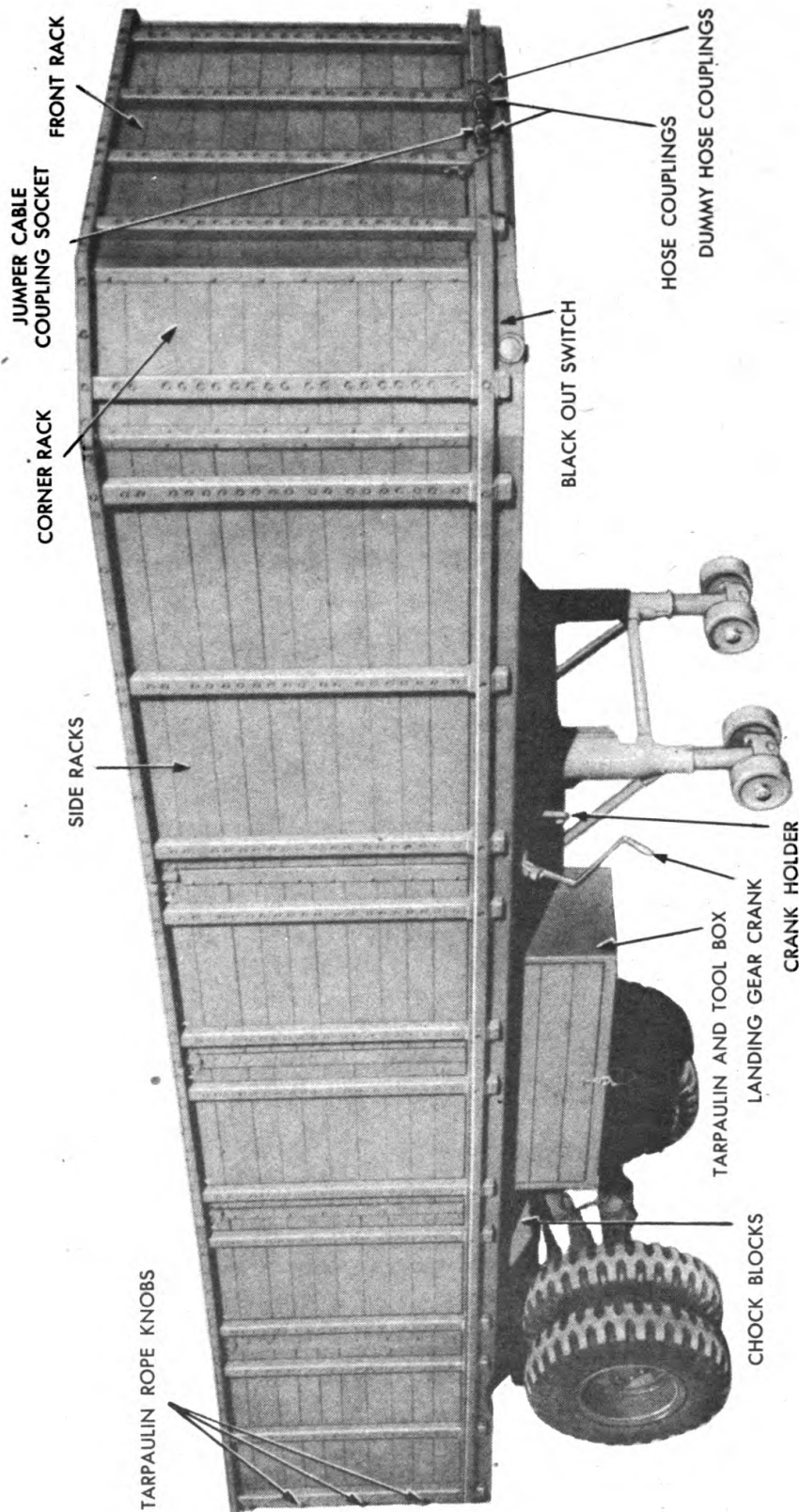

RA PD 334364

Figure 6—Semitrailer Controls

SEMITRAILER

of wheels. The blocks are attached to chains and are hung on hooks when not in use. The chock blocks are placed against tire when trailer is parked on a grade.

10. OPERATION.

a. Before-operation Service. Perform the services in paragraph 18 before operating the semitrailer.

b. Coupling Semitrailer to Towing Vehicle. Place chock blocks in back of tires. Make certain the fifth wheel is in the unlocked posi-

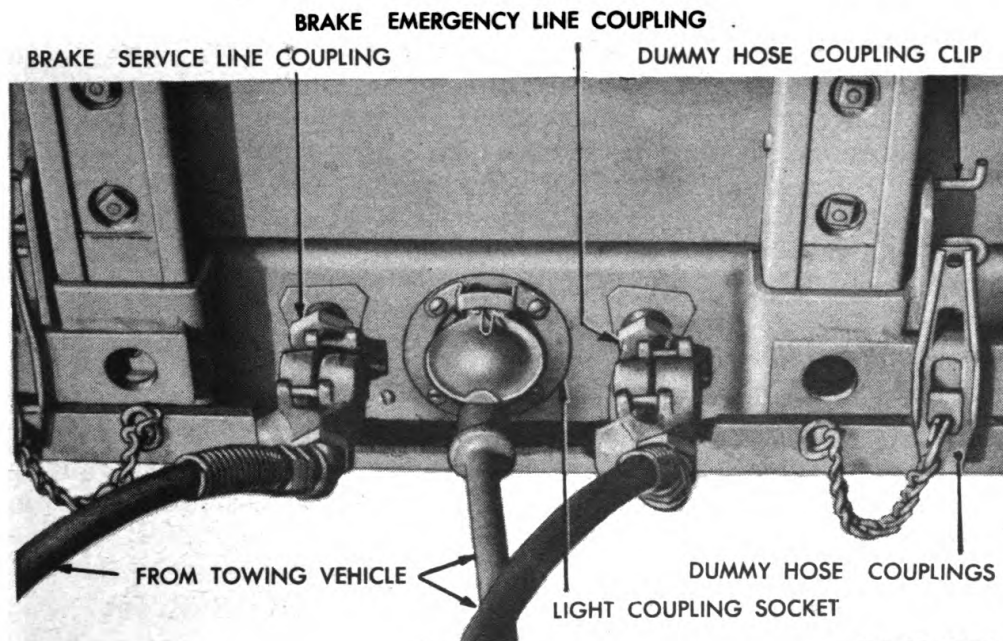

RA PD 334365

Figure 7—Brake Air Hose and Jumper Cable Coupled to Semitrailer

tion (fig. 9). Slowly back towing vehicle under the semitrailer so that the king pin which protrudes below the upper fifth wheel plate on the semitrailer is centered, or nearly so, with the jaws on fifth wheel of towing vehicle. Continue backing until the king pin locks into the fifth wheel. Couple brake air hose (par. 9 e). Couple light jumper cable (par. 9 e). Apply brake on semitrailer, and try pulling the semitrailer forward. If coupling is complete, movement of the semitrailer will be difficult. Remove the two chock blocks and hang them at underside of body. Wind up the landing gear until stop is reached (par. 9 a).

c. Driving. The truck and semitrailer combination is driven in much the same manner as the straight truck. When turning corners care should be taken to allow for the fact that the semitrailer wheels turn "inside" the turning circle of the truck. This is because the semitrailer truck is a hinged-in-the-middle unit. When making a

10-TON PAYLOAD, 14-TON GROSS, 2-WHEEL STAKE AND PLATFORM SEMITRAILER AND 10-TON CONVERTER DOLLY

right-hand turn at an intersection, continue forward to approximately the center of the cross road then cut your truck sharply to the right. When backing the semitrailer, the truck should be steered in the opposite direction to which it is desired that the trailer be turned.

d. Braking. The semitrailer brakes must be applied in coordination with the towing vehicle brakes. The semitrailer brakes must not be expected to carry the entire braking load. Such abuse will place excess strain on both the semitrailer and towing vehicle. The semitrailer brakes must be applied easily and released when they grab as a grabbing brake is not operating with maximum efficiency. Keep tires short of the skidding point. When parking trailer for an extended period of time, place the chock blocks against the tires.

e. Uncoupling Semitrailer from Towing Vehicle. Place chock blocks at the rear side of tires. Lower the landing gear as far as possible. Uncouple light jumper cable. Uncouple air line from emergency coupling. Uncoupling the emergency line automatically applies the brakes. Uncouple air hose from the service coupling. Place fifth wheel lock-lever in the unlocked position (fig. 9). Move the towing vehicle sharply forward to disengage the fifth wheel from the king pin and move the towing vehicle forward.

11. LOADING.

a. Proper load distribution is important to load riding, operating conditions, and life of the trailer. Distribute the load as equally as possible, and never load beyond rated capacity. With the load equally distributed, approximately 47 percent of the load is at the king pin and 53 percent on the semitrailer axle.

12. CONVERTING STAKE AND RACK TRAILER INTO PLATFORM TYPE TRAILER.

a. Removing Racks. Remove one gravity pin from bottom of the two center stake racks on right and left tailgate. Remove right tailgate rack, then left tailgate rack. Mark each of the remaining racks with a number on lower panel, also place a corresponding number directly below under body rub rail. *NOTE: It is very important that the racks be marked prior to removal, to facilitate re-assembly and to eliminate refitting.* Remove nut and lock washer from each of the carriage bolts holding rack stakes in pockets. With a long, tapered $\frac{3}{8}$ -inch punch tap the carriage bolts out of the rack stakes and brackets. Remove screws and carriage bolts from corner angles and metal strips between racks. With one man inside of trailer body holding the racks, tap up on rack stakes and lift out the racks.

b. Installing Racks. Install racks according to numerical markings, making certain the number placed on the racks corresponds with number placed on underside of rub rail. Secure rack to stake pockets using carriage bolt, nut, and lock washer. Secure rack corner angles and metal strips using screws and carriage bolts. Install tailgate racks.

Section V

DOLLY**13. CONTROLS.**

a. **Landing Gear** (figs. 8 and 34). The landing gear supports the front of the dolly when dolly is uncoupled from towing vehicle. A latch is provided on under side of first crossmember. This latch holds the landing gear in the "up" position. When lowering landing gear to the vertical position, with one hand holding the landing gear leg, pull out on the latch, lower the landing gear leg, and lock the landing gear in the vertical position.

b. **Combination Brake Jumper Hose and Light Jumper Cable Assembly** (fig. 8). The combination brake jumper hose and light cable assembly consists of two air hoses and one light jumper cable. The assembly is taped together and fastened to a bracket at front of dolly. A ring and suspension spring is provided to prevent the assembly from dragging and chafing.

(1) A ring is painted on each end of one air hose coupling to assist in quickly identifying the two ends of one hose, thus eliminating the time required to trace the lines, also prevents the possibility of hooking the air lines up wrong. When coupling the air hose make certain the couplings with the painted rings are matched to the tags on the semitrailer and the towing vehicle couplers, service to service, or emergency to emergency.

c. **Lunette Eye** (fig. 8). The lunette eye is used as a means of attaching the dolly to the pintle hook on the towing vehicle; when dolly is in tow behind another dolly the lunette eye is fastened to the shackle of the dolly.

d. **Pintle Hook** (fig. 8). The pintle hook is fastened to the rear crossmember and is used for pulling any light vehicle which is equipped with a hinged draw bar. The primary use of the pintle hook is for towing empty dollies. *NOTE: Do not couple loaded dolly and semitrailer combination to the dolly pintle hook.* The pintle hook is fully automatic. By backing the pintle hook against the lunette eye, instant and positive coupling is accomplished. A release lever is located on under side of pintle hook; when the release lever is moved forward, the pintle hook opens.

e. **Safety Chain** (fig. 8). The two safety chains are hooked to bull rings at each side of the towing vehicle to prevent loss of the load in tow should pintle hook become disengaged from the dolly. Couple the safety chains before moving dolly. When one dolly is towed behind another dolly the safety chains are fastened to the cross shaft.

f. **Fifth Wheel** (fig. 9). To uncouple the dolly from the semi-trailer, raise the plunger latch until stop is reached. Pull the operating handle toward the front of the dolly until you hear the latch drop in behind the lug on the plunger. This will hold the plunger

10-TON PAYLOAD, 14-TON GROSS, 2-WHEEL STAKE AND PLATFORM SEMITRAILER AND 10-TON CONVERTER DOLLY

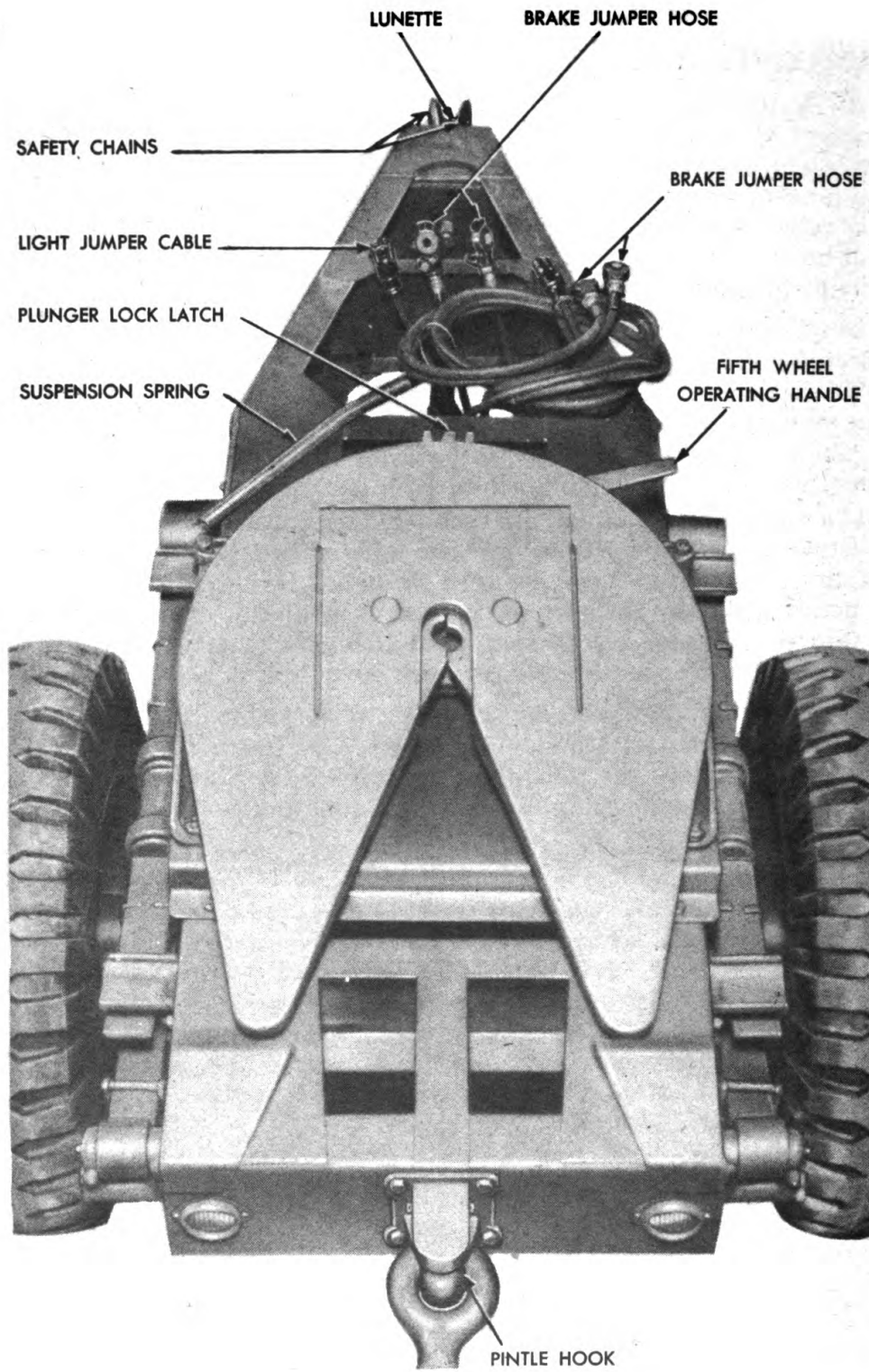

RA PD 334384

Figure 8—Dolly Controls

DOLLY

in the unlocked position until the king pin is withdrawn. During the withdrawal of the king pin the entire mechanism is cocked for recoupling. No other operation is necessary for recoupling.

14. OPERATION.

a. **Before-operation Service.** Perform the service in paragraph 18 before operating dolly.

b. **Coupling Dolly to Towing Vehicle.** Back the towing vehicle so that the pintle hook contacts the lunette eye at front of dolly. Open the pintle hook and place the lunette eye in pintle hook and lock the pintle hook. Fasten safety chains to bull ring at rear of towing vehicle. Raise dolly landing gear (par. 13 a).

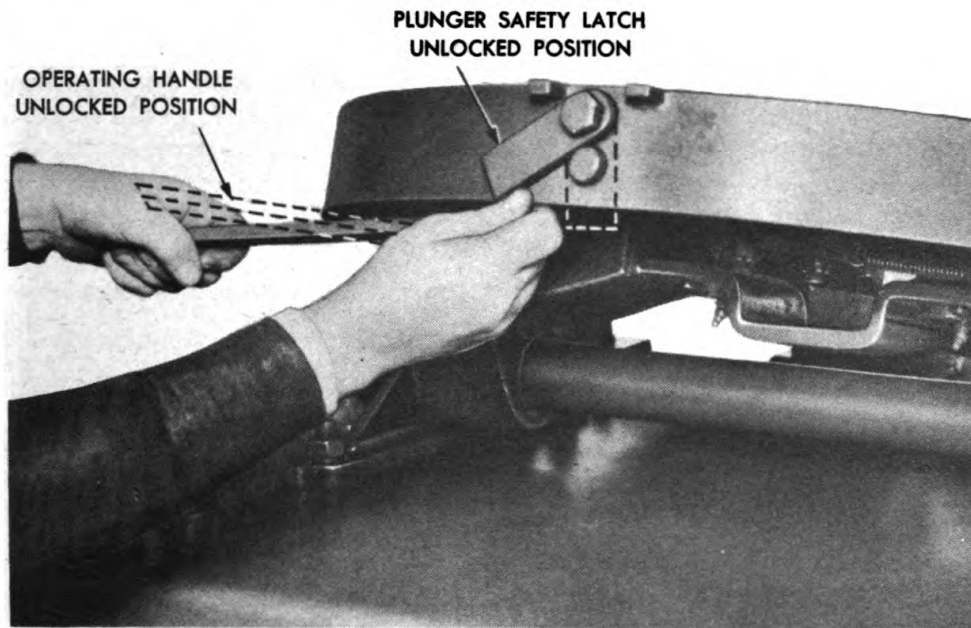

RA PD 334387

Figure 9—Fifth Wheel Operating Controls

c. **Coupling Dolly to Semitrailer.** Place chock block in back of tires on semitrailer. Make certain the fifth wheel is in the unlocked position (fig. 9). Slowly back dolly under the semitrailer so that the king pin which protrudes below the upper fifth wheel plate on the semitrailer is centered, or nearly so, with the jaws on fifth wheel on the dolly. Continue backing until the king pin locks into the fifth wheel. Couple brake air hose (par. 13 b). Couple light jumper cable (par. 13 b). Apply the brake on the semitrailer and try pulling the dolly forward. If coupling is complete, movement of the semitrailer will be difficult. Remove the two chock blocks and hang them on hooks at under side of body. Wind up the semitrailer landing gear until stop is reached (par. 9 a).

10-TON PAYLOAD, 14-TON GROSS, 2-WHEEL STAKE AND PLATFORM SEMITRAILER AND 10-TON CONVERTER DOLLY

d. **Uncoupling Dolly from Semitrailer.** Place chock blocks at the rear side of tires. Lower the landing gear on semitrailer as far as possible. Uncouple light jumper cable (par. 13 b). Uncouple air line from emergency coupling. When uncoupling the emergency line first this will automatically apply the semitrailer brakes. Uncouple air hose from the service coupling and attach the emergency and service line together to prevent dirt from entering the jumper hose. Unhook the hold-up spring. Place fifth wheel lock-lever in the unlocked position (fig. 9). Move the towing vehicle sharply forward to disengage the fifth wheel from the king pin and move the towing vehicle forward. When parking trailer for an extended period of time, place the chock blocks against the tires to prevent semitrailer from moving. **NOTE:** *Do not depend on the air brakes to hold the parked semitrailer. Air will eventually escape from the semitrailer brake system; causing the brakes to release.*

e. **Uncoupling Dolly from Towing Vehicle.** Pull out on plunger latch and lower the landing gear to a vertical position. Make certain the landing gear is locked in the vertical position to prevent the dolly from falling to the ground at the front. Uncouple safety chain from towing vehicle and open pintle hook. Lift the lunette out of the pintle hook and move towing vehicle forward.

PART THREE—VEHICLE MAINTENANCE INSTRUCTIONS

Section VI

LUBRICATION

15. LUBRICATION ORDER.

a. The Lubrication Order (fig. 10) prescribes lubrication maintenance for the 10-ton payload, 14-ton gross, 2-wheel stake and platform semitrailer.

b. The Lubrication Order (fig. 12) prescribes lubrication maintenance for 10-ton converter dolly.

c. Lubrication instructions on the Orders are binding on all echelons of maintenance and there shall be no deviations from these instructions.

d. Service intervals specified on the Orders are for normal operating conditions. Reduce these intervals under extreme conditions such as excessively high or low temperatures, prolonged periods of high speed, continued operation in sand or dust, immersion in water, or exposure to moisture, any one of which may quickly destroy the protective qualities of the lubricant and require servicing in order to prevent malfunctioning or damage to the materiel.

e. Lubricants are prescribed in the "Key" in accordance with three temperature ranges; above $+32^{\circ}\text{F}$, $+32^{\circ}\text{F}$ to 0°F , and below 0°F . Determine the time to change grades of lubricants by maintaining a close check on operation of the vehicle during the approach to changeover periods. Ordinarily it will be necessary to change grades of lubricants *only when air temperatures are consistently in the next higher or lower range*, unless malfunctioning occurs sooner due to lubricants being too thin or too heavy.

16. DETAILED LUBRICATION INSTRUCTIONS.

a. **Lubrication Equipment.** Operate lubricating guns carefully and in such manner as to insure a proper distribution of the lubricant. If lubrication fitting valves stick and prevent the entrance of lubricant, remove the fitting and determine cause. Replace broken or damaged lubricators.

b. Points of Application.

(1) Lubrication fittings, grease cups, oilers and oil holes are readily identifiable on the vehicle. Wipe clean such lubricators and the surrounding surface before lubricant is applied.

(2) Where relief valves are provided, apply new lubricant until the old lubricant is forced from the vent. Exceptions are specified in notes in subparagraph d below.

(3) Always wipe clean metal surfaces on which a film of lubricant must be maintained by manual application, before the film is renewed.

10-TON PAYLOAD, 14-TON GROSS, 2-WHEEL STAKE AND PLATFORM SEMITRAILER AND 10-TON CONVERTER DOLLY

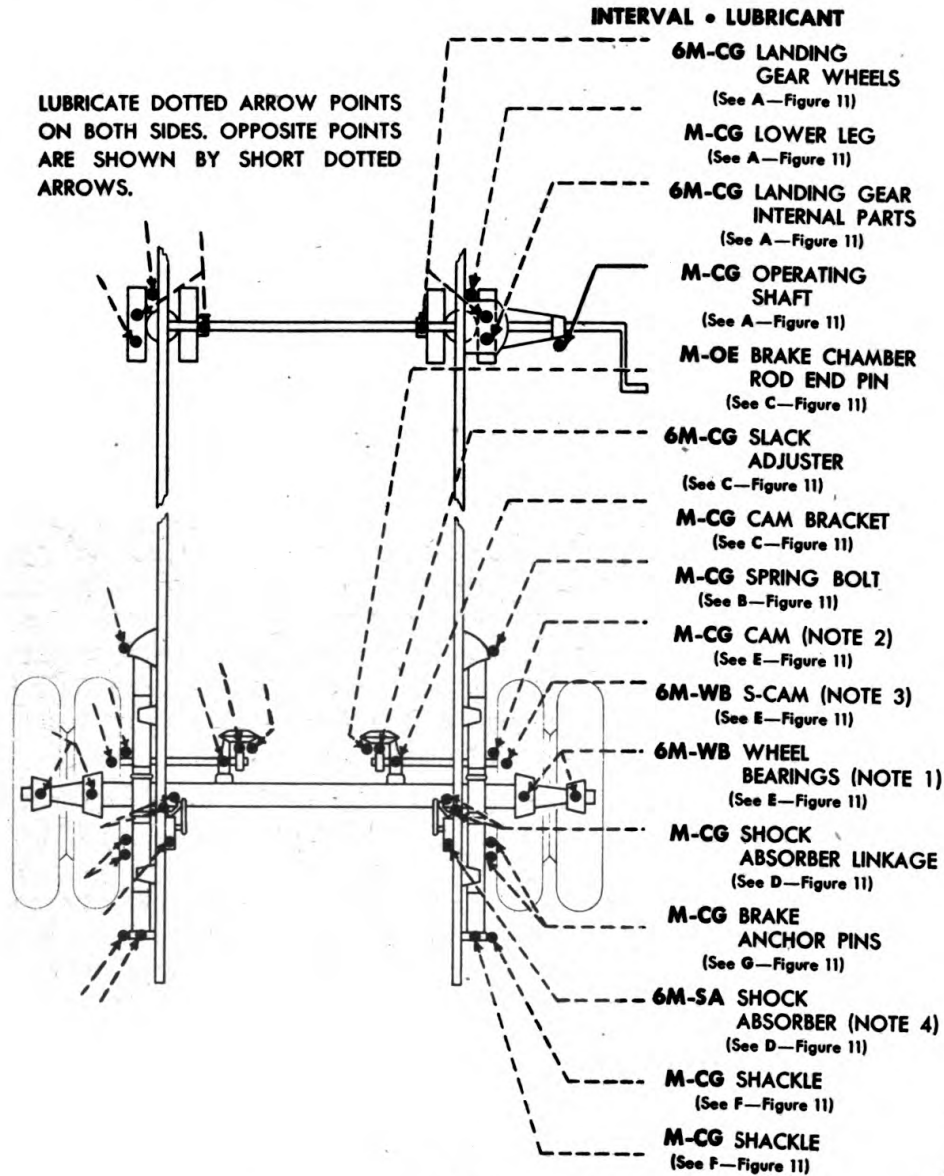

— KEY —

LUBRICANTS	LOWEST ANTICIPATED AIR TEMPERATURE			INTERVALS
OE—OIL, engine	above +32° F	+32° F to 0° F	below 0° F	M - Monthly 6M - 6 months
	OE SAE 30	OE SAE 10	PS	
CG—Grease, general purpose	CG No. 1	CG No. 0	CG No. 0	
WB—GREASE, general purpose No. 2—All temperatures				
SA—FLUID, shock-absorber, heavy—All temperatures				

RA PD 334367

Figure 10—Lubrication Order—Semitrailer

LUBRICATION

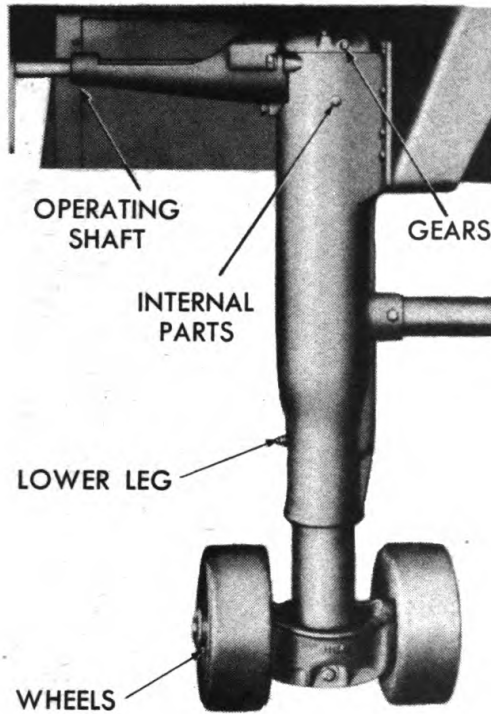

A—LANDING GEAR

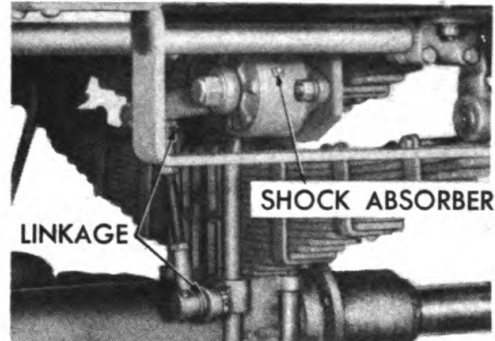

D—SHOCK ABSORBER

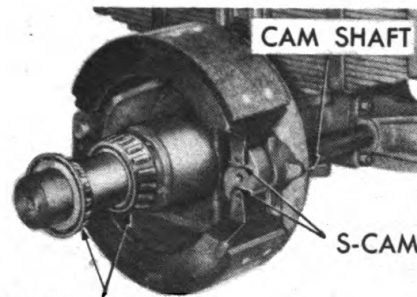

E—WHEEL BEARINGS AND S-CAM

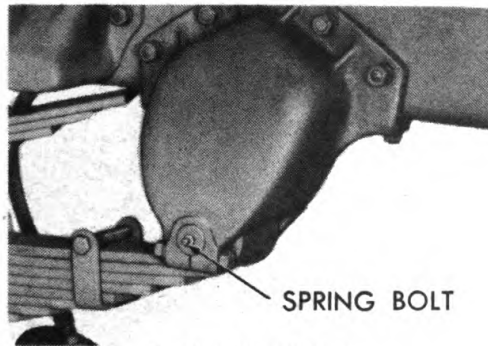

B—SUSPENSION

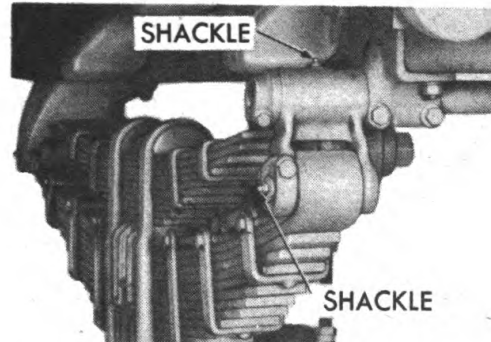

F—SUSPENSION

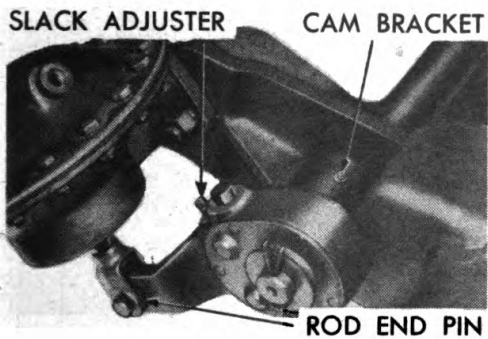

C—PARTS

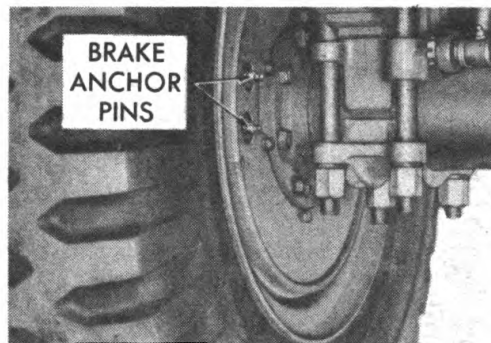

G—BRAKE ANCHOR PINS

RA PD 334371

Figure 11—Semitrailer Localized Lubrication Points

10-TON PAYLOAD, 14-TON GROSS, 2-WHEEL STAKE AND PLATFORM SEMITRAILER AND 10-TON CONVERTER DOLLY

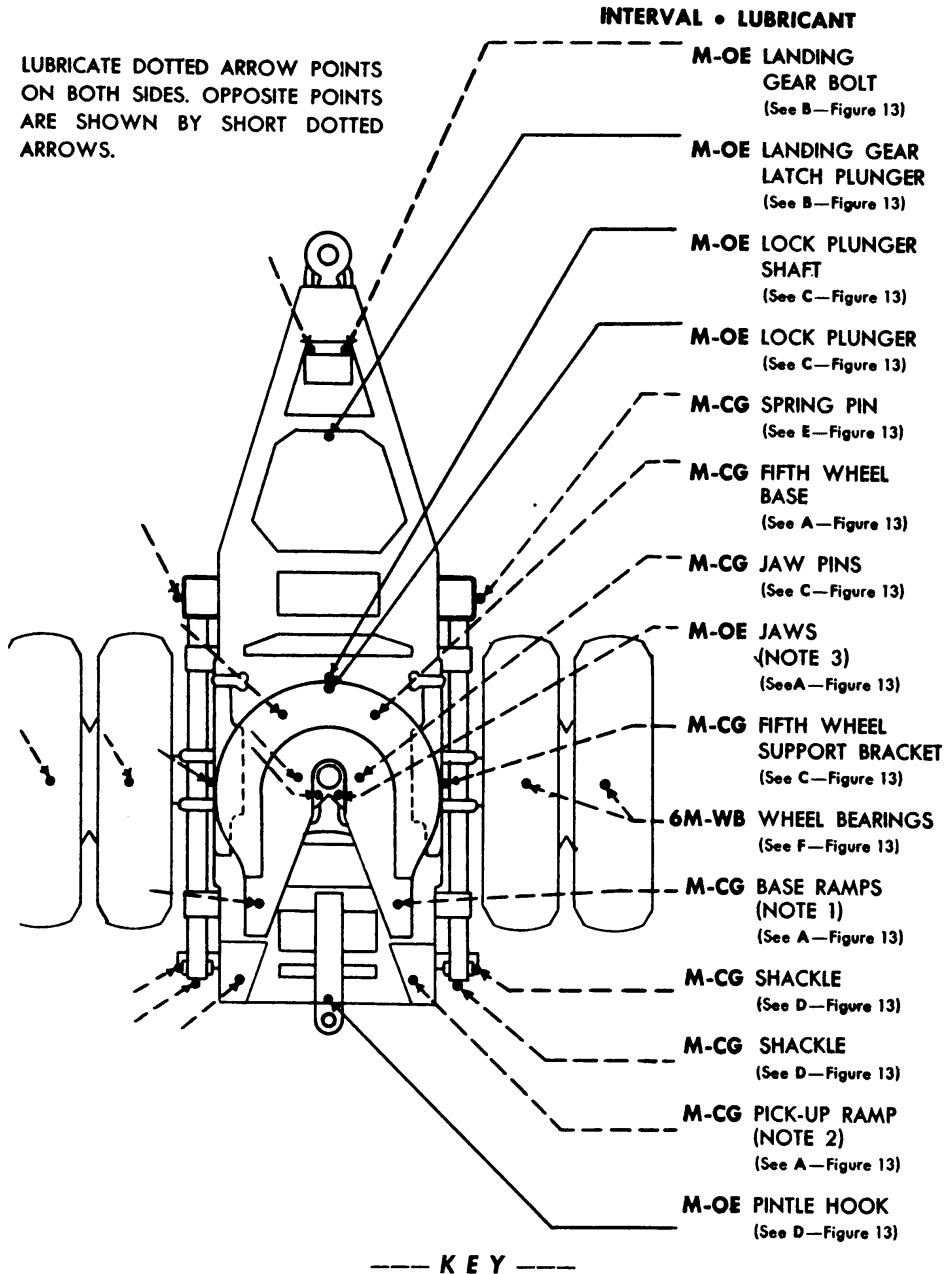

LUBRICANTS	LOWEST ANTICIPATED AIR TEMPERATURE			INTERVALS
OE—OIL, engine	above +32° F	+32° F to 0° F	below 0° F	M—Monthly 6M—6 months
	OE SAE 30	OE SAE 10	PS	
CG—Grease, general purpose	CG No. 1	CG No. 0	CG No. 0	
WB—GREASE, general purpose No. 2—All temperatures				

RA PD 334398

Figure 12—Dolly Lubrication Order

LUBRICATION

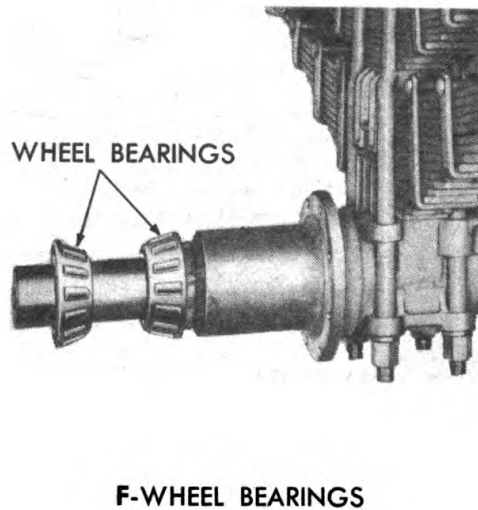
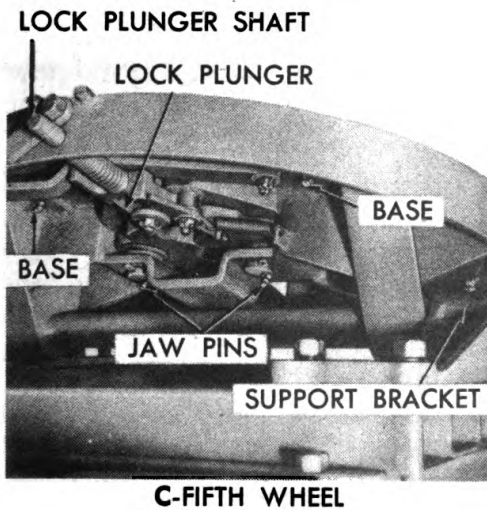
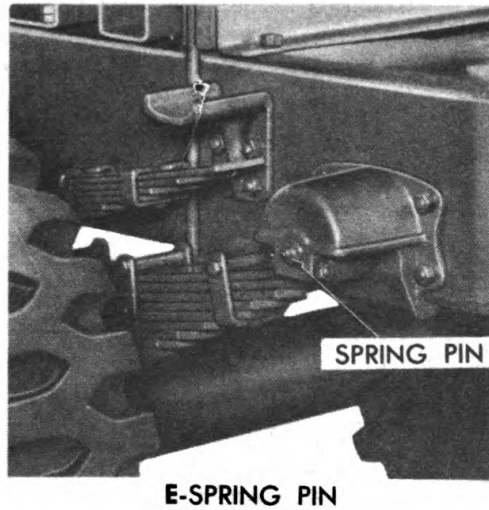
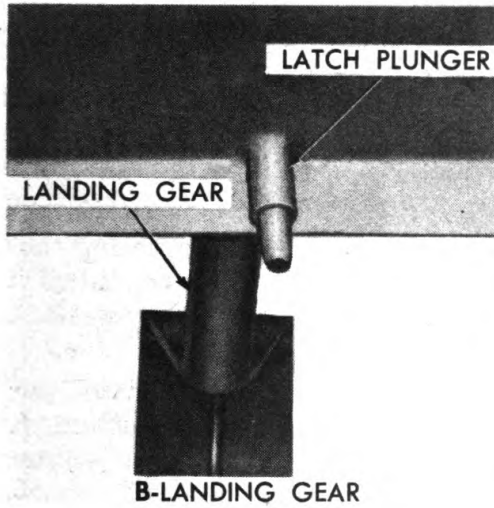
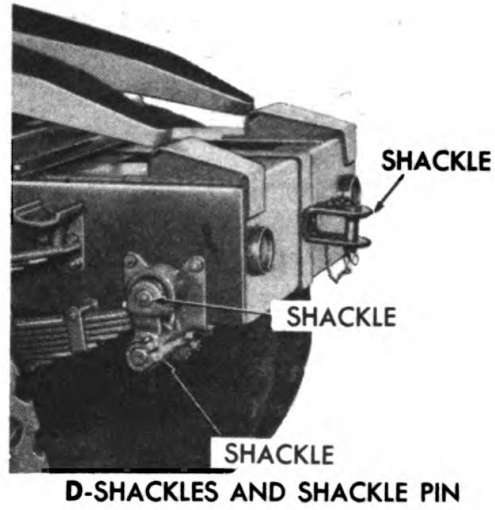
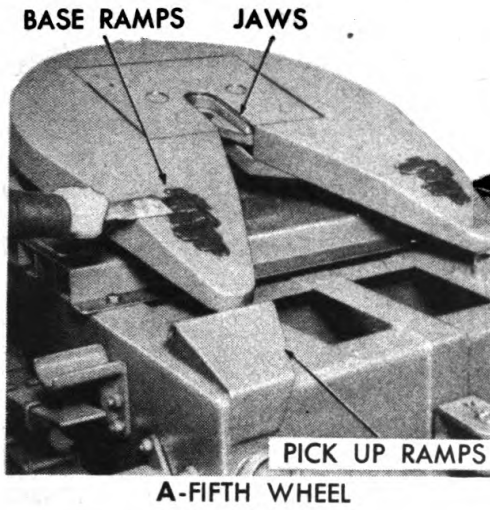

RA PD 334361

Figure 13—Dolly Localized Lubrication Points

10-TON PAYLOAD, 14-TON GROSS, 2-WHEEL STAKE AND PLATFORM SEMITRAILER AND 10-TON CONVERTER DOLLY

c. **Cleaning.** Use SOLVENT, dry-cleaning, or OIL, fuel, Diesel, to clean or wash all parts. Use of gasoline for this purpose is prohibited. After washing, dry all parts thoroughly before applying lubricant. If vehicle is to be washed, lubricate after washing.

d. **Semitrailer Notes on Individual Units and Parts** (fig. 11). The following instructions pertain to lubrication and service of individual units and parts. Note references in the Order (fig. 10) itself are to the step below having the corresponding number.

(1) **WHEEL BEARINGS.** Remove bearing cone assemblies from hub. Wash bearings, cones, spindle, and inside of hub, and dry thoroughly. Do not use compressed air. Inspect bearing races and replace if damaged. Wet the spindle and inside of hub and hub cap with GREASE, general purpose, No. 2 to a maximum thickness of $\frac{1}{16}$ inch only, to retard rust. Lubricate bearings with GREASE, general purpose, No. 2 with a packer, or by hand, kneading lubricant into all spaces in the bearing. Use extreme care to protect the bearings from dirt, and immediately reassemble and replace wheel. Do not fill hub or hub cap. The lubricant in the bearing is sufficient to provide lubrication until the next service period. Any excess might result in leakage into the drum. Adjust bearings in accordance with instructions in paragraph 56.

(2) **CAMSHAFT AND BRAKE ANCHOR PINS.** When lubricating these points care must be exercised in not over-lubricating. Over-lubricating will cause grease to flow on brake shoes thus causing faulty brakes.

(3) **S-CAM.** Coat top and bottom side of the S-cam with GREASE, general purpose, No. 2 when wheels are removed for wheel bearing lubrication. Do not allow grease to come in contact with the brake lining.

(4) **SHOCK ABSORBER.** To prevent particles of dirt from entering the shock absorber when refilling, clean all dirt from unit and from frame surrounding unit. Remove filler plug and inspect fluid level which should be at level of plug. If refilling is necessary, disconnect shock absorber link at axle end.

(a) Pump shock absorber arm up and down several times to dispel air trapped in the unit. Add fluid and repeat pumping. When the working chamber is properly filled, there will be uniform resistance and no "rubbery" feeling or lost motion. Refill chamber to level of filler plug. Install filler plug and connect shock absorber link at axle.

e. **Dolly Notes on Individual Units and Parts** (fig. 13). The following instructions pertain to lubrication and service of individual units and parts. Note references in Order (fig. 12) itself are to the step below having the corresponding number.

(1) **FIFTH WHEEL BASE, PICK-UP AND BASE RAMPS.** With dolly disconnected from semitrailer clean all sand, grit and other foreign

FIRST ECHELON PREVENTIVE MAINTENANCE

matter from surface. With a hand paddle, coat the entire surface of the base with GREASE, general purpose No. 1 above +32°F, or GREASE, general purpose, No. 0 below 32°F.

(2) FIFTH WHEEL JAWS. Lubricate the jaws and lock with OIL, engine, SAE 30, above +32°F, OIL, engine, SAE 10, +32°F to 0°F and OIL, lubricating, preservative, special, below 0°F, to permit easy operation of the lock lever handle.

Section VII

FIRST ECHELON PREVENTIVE MAINTENANCE

17. PURPOSE.

a. To ensure mechanical efficiency, it is necessary that the vehicle be systematically inspected at intervals each day it is operated, and weekly, so that defects may be discovered and corrected before they result in serious damage or failure. Certain scheduled maintenance services will be performed at these designated intervals. The services set forth in this section are those performed by driver or crew before operation, during operation, at halt, after operation and weekly.

b. Driver preventive maintenance services are listed on the back of Driver's Trip Ticket and Preventive Maintenance Service Record, W.D. Form No. 48, to cover vehicles of all types and models. Items peculiar to specific vehicles, but not listed on W.D. Form No. 48, are covered in manual procedures under the items to which they are related. Certain items listed on the form, that do not pertain to the vehicle, are eliminated from the procedures as written into the manual. Every organization must thoroughly school each driver in performing the maintenance procedures set forth in manuals whether or not they are listed specifically on W.D. Form No. 48.

c. The items listed on W.D. Form No. 48, that apply to this vehicle, are expanded in this manual to provide specific procedures for accomplishment of the inspections and services. These services are arranged to facilitate inspection and conserve the time of the driver, and are not necessarily in the same numerical order as shown on W.D. Form No. 48. The item numbers, however, are identical with those shown on that form.

d. The general inspection of each item applies also to any supporting member or connection, and generally includes a check to see whether or not the item is in good condition, correctly assembled, secure, or excessively worn.

e. The inspection for good condition is usually an external visual inspection to determine whether or not the unit is damaged beyond safe or serviceable limits. The term good condition is explained

10-TON PAYLOAD, 14-TON GROSS, 2-WHEEL STAKE AND PLATFORM SEMITRAILER AND 10-TON CONVERTER DOLLY

further by the following: Not bent or twisted, not chafed or burned, not broken or cracked, not bare or frayed, not dented or collapsed, not torn or cut.

f. The inspection of a unit to see that it is correctly assembled is usually an external visual inspection to see whether or not it is in its normal assembled position in the vehicle.

g. The inspection of a unit to determine if it is secure is usually an external visual examination, a hand-feel, wrench, or a pry-bar check for looseness. Such an inspection should include any brackets, lock washers, lock nuts, locking wires, or cotter pins used in assembly.

h. Excessively worn will be understood to mean worn close to, or beyond, serviceable limits, and likely to result in a failure if not replaced before the next scheduled inspection.

i. Any defects or unsatisfactory operation characteristics beyond the scope of the first echelon to correct must be reported at the earliest opportunity to the designated individual in authority.

18. BEFORE-OPERATION SERVICE.

a. This inspection schedule is designed primarily as a check to see that the vehicles have not been tampered with, or sabotaged since the After-operation Service was performed. Various combat conditions may have rendered the vehicles unsafe for operation and it is the duty of the driver to determine whether or not the vehicles are in condition to carry out any mission to which they are assigned. This operation will not be entirely omitted, even in extreme tactical situations.

b. **Procedures.** Before-operation Service consists of inspecting items listed below according to the procedure described, and correcting or reporting any deficiencies. Upon completion of the service, results should be reported promptly to the designated individual in authority.

(1) **ITEM 1, TAMPERING AND DAMAGE.** Look for any injury to trailer and dolly in general, its accessories and equipment caused by tampering or sabotage, collision, falling debris, or shell fire that may delay the vehicle, or cause it to fail, when it is put into operation.

(2) **ITEM 5, AIR BRAKE TANK AND AIR FILTERS.** Examine air brake reservoir tank, air lines, air filters, and connections for looseness or damage. Listen for air leaks. Drain water from tanks and close drain cock. Be sure truck to trailer air couplings are securely connected, or if not in use, that they are closed and properly supported.

(3) **ITEM 12, LIGHTS AND REFLECTORS.** Be sure that all switches operate and that all lamps burn (tactical situation permitting). See that all lights and reflectors are secure and that lenses are clean and undamaged.

FIRST ECHELON PREVENTIVE MAINTENANCE

(4) ITEM 13, WHEEL NUTS AND HUB CAP SCREWS. See that all trailer and dolly wheel mounting studs and nuts, and hub cap screws are present and secure.

(5) ITEM 14, TIRES. Inspect trailer and dolly tires for flats or low pressure. Whenever practicable, all tires should be gaged and inflated to 80 pounds.

(6) ITEM 15, SPRINGS AND SUSPENSIONS. Check the trailer and dolly springs to see whether they have abnormal sag, broken or shifting leaves, loose or missing rebound clips, eyebolts, U-bolts and shackles. Shock absorbers should be secure and not leaking. Linkage should not be worn or bent.

(7) ITEM 18, TOWING CONNECTIONS. Inspect all towing devices to see that they are in good condition and securely connected or mounted. Pay particular attention to pintle draw-bar and retraction spring. See that fifth wheel mechanism operates properly, and if connected to trailer, that pintle is securely locked, and that safety and check chains are fastened.

(8) ITEM 19, BODY, LOAD AND TARPAULINS. Inspect body for looseness and damage. See that ropes are lashed securely. Inspect tarpaulins for rips and holes and see that load is evenly distributed and secure. Make certain tailgate is installed and fastened.

(9) ITEM 25, DURING-OPERATION CHECK. The During-operation Service should start as soon as vehicle is put in motion.

19. DURING-OPERATION SERVICE.

a. While the vehicle is in motion, be on the alert for any unusual noise, such as rattles, knocks, squeals or hums that may indicate trouble. Observe if there is any abnormal sag, side sway, or drag that might indicate broken suspensions, disconnected towing or safety devices or dragging brakes.

b. **Procedures.** During-operation Services consists of observing items listed below according to the procedures following each item, and investigating any indications of serious trouble. Notice minor deficiencies to be corrected or reported at earliest opportunity, usually next scheduled halt.

(1) ITEM 27, BRAKES. Test trailer brakes independent of truck tractor brakes to be sure they are effective and operate without excessive pull to one side, chatter, or squealing.

(2) ITEM 34, RUNNING GEAR. Be on the alert for any unusual noise or unsatisfactory operating characteristics, of trailer or dolly wheels, suspension units, or mountings.

(3) ITEM 35, TRAILER BODY. Be on the alert for abnormal sagging, or tilting of trailer.

20. AT-HALT SERVICE.

a. At-halt Service may be regarded as minimum battle maintenance and should be performed under all tactical conditions even

10-TON PAYLOAD, 14-TON GROSS, 2-WHEEL STAKE AND PLATFORM SEMITRAILER AND 10-TON CONVERTER DOLLY

though more extensive maintenance service must be slighted, or omitted altogether.

b. Procedures. At-halt Service consists of investigating any deficiencies noted during operation, inspecting items listed below according to the procedures following the items, and correcting any deficiencies found. Upon completion of services, deficiencies not corrected should be reported promptly to higher authority.

(1) **ITEM 39, TEMPERATURES; HUBS, BRAKE DRUMS.** Place hand cautiously on each trailer and dolly drum and wheel hub to see whether it is abnormally hot.

(2) **ITEM 42, SPRINGS AND SUSPENSIONS.** Check trailer and dolly for broken or shifted spring coils or leaves, damaged or loose clips, U-bolts, eyebolts, shackles, shock absorber linkage.

(3) **ITEM 44, WHEEL NUTS AND HUB CAP SCREWS.** See that both dolly and trailer wheel rim, mounting and hub cap flange nuts and screws are present and secure.

(4) **ITEM 45, TIRES.** Examine dolly and trailer tires for under-inflation or damage. Remove foreign objects from treads and between duals. *NOTE: Tire air pressure increase during operation should not be reduced.*

(5) **ITEM 50, TOWING CONNECTIONS.** See that fifth wheel is in proper position and securely locked. Be sure electrical and air brake connections are fastened and that support springs hold lines so as to prevent chafing.

(6) **ITEM 51, BODY AND LOAD.** Inspect post clamps for good condition and security. Be sure trailer load is not shifting and is safe for travel.

(7) **ITEM 52, APPEARANCE AND GLASS.** Inspect exterior of vehicle for rusty and glossy spots. Clean all light and reflector glass and inspect for damage.

21. AFTER-OPERATION AND WEEKLY SERVICE.

a. After-operation servicing is particularly important because at this time the driver inspects his vehicles to detect any deficiencies that may have developed and corrects those he is permitted to handle. He should report promptly to the designated individual in authority the results of his inspection. If this schedule is performed thoroughly, the vehicles should be ready to roll again on a moment's notice. The Before-operation Service, with a few exceptions, is then necessary only to ascertain whether the vehicles are in the same condition in which they were left upon completion of the After-operation Service. The After-operation Service should never be entirely omitted even in extreme tactical situations, but may be reduced to the bare fundamental services outlined for the At-halt Service, if necessary.

b. Procedures. When performing the After-operation Service the driver must remember and consider any irregularities noticed during the day in the Before-operation, During-operation, and At-halt

FIRST ECHELON PREVENTIVE MAINTENANCE

Services. The After-operation Service consists of inspecting and servicing the following items. Those items of the After-operation that are marked by an asterisk (*) require additional weekly services, the procedures for which are indicated in step (b) of each applicable item.

(1) **ITEM 59, LIGHTS (LAMPS) AND REFLECTORS.** Clean all units, and inspect them for looseness and damage. If tactical situation permits, open and close light switches to be sure they operate properly and see if the lamps respond.

(2) **ITEM 64, ELECTRICAL WIRING.** Inspect all wiring connections and terminals for cleanliness, good insulation, and security. Make sure loom shielding is in correct position to protect wiring from chafing. Make a quick inspection of all accessible wiring for damage.

(3) **ITEM 68, *TIRES.**

(a) Examine both dolly and trailer tires, including spares, for damage and excessive wear. Remove objects lodged in treads and carcasses and from between duals. Check for low pressures, proper position of valve stems and presence of valve caps. Inflate to correct pressure, 80 pounds (maximum) cold.

(b) *Weekly.* Replace badly worn or otherwise unserviceable dolly and trailer tires. Serviceable tires which show abnormal wear should be rotated to other wheel positions. Apparent mechanical defects causing such wear should be reported for attention by higher echelon.

(4) **ITEM 69, *SPRINGS AND SUSPENSIONS.**

(a) Inspect springs for abnormal sag, broken or shifted leaves, and loose or missing rebound clips, eyebolts, U-bolts or shackles. Examine shock absorbers for looseness or damage.

(b) *Weekly.* Tighten U-bolts and rebound clips. Test hangers for loose mountings; tighten.

(5) **ITEM 73, LEAKS, GENERAL.** Look for grease leaks at wheel hub caps and around drums. Examine shock absorber bodies for fluid leaks.

(6) **ITEM 75, AIR BRAKE TANK AND AIR FILTERS.** Open tank drain-cock to drain water (condensation), temperature and situation permitting. Examine tank, air filters, and air line connections for looseness and damage. Make sure hose coupling packing ring is not cut, damaged, or excessively worn.

(7) **ITEM 77, *TOWING CONNECTIONS.**

(a) Inspect rear pintle and towing shackles for looseness, damage and excessive wear. Examine fifth wheel on dolly and king pin on trailer for wear or damage, and see that latching mechanism operates properly and locks securely.

(b) *Weekly.* Tighten all towing device mounting and assembly nuts securely. Test fifth wheel connecting and locking mechanism for proper operation. Examine pintle hook spring and draw bar for damage.

TM 9-892

21-22

10-TON PAYLOAD, 14-TON GROSS, 2-WHEEL STAKE AND PLATFORM SEMITRAILER AND 10-TON CONVERTER DOLLY

(8) **ITEM 78, BODY AND LOAD.** Examine body carefully for damaged, loose, or missing parts. If load is present, make sure it is evenly distributed, secure, and safe for travel.

(9) **ITEM 82, *TIGHTEN.**

(a) Tighten any dolly or trailer external assembly or mounting nuts or screws where inspection has indicated the necessity.

(b) *Weekly.* Tighten all dolly and trailer wheel rim, mounting, and axle flange nuts or cap screws; spring U-bolts, shackles and rebound clips; towing connections, or any other mounting or assembly nuts or screws indicated by inspection as necessary on a weekly or mileage basis.

(10) **ITEM 83, *LUBRICATE AS NEEDED (WEEKLY ONLY).** Lubricate dolly and trailer items such as shackles, hinges, latches, control linkage, frictional joints or clevises, and any point where inspection indicates the necessity, according to Lubrication Order instruction (par. 15).

(11) **ITEM 84, *CLEAN VEHICLE.**

(a) When trailer is not loaded, clean dirt and trash from inside of body.

(b) *Weekly.* Wash trailer, conditions permitting. When trailer is washed in a stream, or lake, care must be taken to keep water out of wheel bearings and brakes. When not convenient to wash vehicle, wipe off thoroughly. **CAUTION: Do not rub lusterless paint enough to create shine that would cause reflection.**

(12) **ITEM 85, *TOOLS AND EQUIPMENT.**

(a) Check semitrailer tools and equipment against stowage lists, paragraph 6, to be sure all items are present. See that they are in good condition and properly mounted or stowed.

(b) *Weekly.* Clean all tools and equipment of rust, dirt or excessive grease. Apply preservatives where necessary and possible. See that tools with cutting edges are sharp and properly protected, and that all items are properly and securely mounted or stowed.

Section VIII

SECOND ECHELON PREVENTIVE MAINTENANCE

22. SECOND ECHELON PREVENTIVE MAINTENANCE SERVICES.

a. Regular scheduled maintenance inspections and services are a preventive maintenance function of the using arm, and are the responsibility of commanders of operating organizations.

SECOND ECHELON PREVENTIVE MAINTENANCE

(1) **FREQUENCY.** The frequency of the preventive maintenance services outlined herein is considered a minimum requirement for normal operation of vehicles. Under unusual operating conditions such as extreme temperatures, dusty or sandy terrain, it may be necessary to perform certain maintenance services more frequently.

(2) **FIRST ECHELON PARTICIPATION.** The drivers should accompany their vehicles and assist the mechanics while periodic second echelon preventive maintenance services are performed. Ordinarily the driver should present the vehicle for a scheduled preventive maintenance service in a reasonably clean condition; that is, it should be dry and not caked with mud or grease to such an extent that inspection and servicing will be seriously hampered. However, the vehicle should not be washed or wiped thoroughly clean, since certain types of defects, such as cracks, leaks and loose or shifted parts or assemblies are more evident if the surfaces are slightly soiled or dusty.

(3) If instructions other than those which are contained in the general procedures in step 4, or the specific procedures in step 5, which follow, are required for the correct performance of a preventive maintenance service or for correction of a deficiency, other sections of the Vehicle Operator's Manual pertaining to the item involved, or a designated individual in authority, should be consulted.

(4) **GENERAL PROCEDURES.** These general procedures are basic instructions which are to be followed when performing the services on the items listed in the specific procedures. **NOTE:** *The second echelon personnel must be thoroughly trained in these procedures so that they will apply them automatically.*

(a) When new or overhauled subassemblies are installed to correct deficiencies, care should be taken to see that they are clean, correctly installed, properly lubricated and adjusted.

(b) When installing new lubricant retainer seals, a coating of the lubricant should be wiped over the sealing surface of the lip of the seal. When the new seal is a leather seal, it should be soaked in SAE 10 engine oil (warm if practicable) for at least 30 minutes. Then, the leather lip should be worked carefully by hand before installing the seal. The lip must not be scratched or marred.

(c) The general inspection of each item applies also to any supporting member or connection, and usually includes a check to see whether the item is in good condition, correctly assembled, secure, or excessively worn. The mechanics must be thoroughly trained in the following explanation of these terms.

1. The inspection for good condition is usually an external visual inspection to determine whether the unit is damaged beyond safe or serviceable limits. The term good condition is explained further by the following: Not bent or twisted, not chafed or burned, not broken or cracked, not bare or frayed, not dented or collapsed, not torn or cut.

10-TON PAYLOAD, 14-TON GROSS, 2-WHEEL STAKE AND PLATFORM SEMITRAILER AND 10-TON CONVERTER DOLLY

2. The inspection of a unit to see that it is correctly assembled is usually an external visual inspection to see whether it is in its normal assembled position in the vehicle.

3. The inspection of a unit to determine if it is secure is usually an external visual examination, a wrench, hand-feel, or a pry-bar check for looseness. Such an inspection should include any brackets, lock washers, lock nuts, locking wires, or cotter pins used in assembly.

4. Excessively worn will be understood to mean worn, close to or beyond serviceable limits, and likely to result in a failure if not replaced before the next scheduled inspection.

(d) *Special Services.* These are indicated by repeating the item numbers in the columns which show the interval at which the services are to be performed, and show that the parts or assemblies are to receive certain mandatory services. For example, an item number in one or both columns opposite a *Tighten* procedure, means that the actual tightening of the object must be performed. The special services include:

1. *Adjust.* Make all necessary adjustments in accordance with the pertinent section of the Vehicle Operator's Manual, special bulletins, or other current directives.

2. *Clean.* Clean units of the vehicle with dry-cleaning solvent to remove excess lubricant, dirt, and other foreign material. After the parts are cleaned, rinse them in clean solvent and dry them thoroughly. Take care to keep the parts clean until reassembled, and be certain to keep dry-cleaning solvent away from rubber or other material which it will damage. Clean the protective grease coating from new parts since this material is not usually a good lubricant.

3. *Special lubrication.* This applies either to lubrication operations that do not appear on the vehicle Lubrication Order and to items that do appear on the Order but should be performed in connection with the maintenance operations, if parts have to be disassembled for inspection or service.

4. *Service.* This usually consists of performing special operations, such as replenishing battery water, draining and refilling units with oil, and changing the oil filter cartridge.

5. *Tighten.* All tightening operations should be performed with sufficient wrench torque (force on the wrench handle) to tighten the unit according to good mechanical practice. Do not overtighten, as this may strip threads or cause distortion. Tightening will always be understood to include the correct installation of lock washers, lock nuts, and cotter pins provided to secure the tightening.

(e) When conditions make it difficult to perform the complete preventive maintenance procedures at one time, they can sometimes be handled in sections, planning to complete all operations within the week if possible. All available time at halts and in bivouac areas must be utilized if necessary to assure that maintenance operations

SECOND ECHELON PREVENTIVE MAINTENANCE

are completed. When limited by the tactical situation, items with special services in the columns should be given first consideration.

(f) The numbers of the preventive maintenance procedures that follow are identical with those outlined on W.D. A.G.O. Form No. 461, which is the Preventive Maintenance Service Work Sheet for Wheeled and Half-track Vehicles. Certain items on this work sheet that do not apply to this vehicle are not included in the procedures in this manual. In general, the numerical sequence of items on the work sheet is followed in the manual procedures, but in some instances there is deviation for conservation of the mechanic's time and effort.

(5) **SPECIFIC PROCEDURES.** Procedures for performing each item in the 1,000 miles (monthly) and 6,000 miles (6 month) maintenance procedures are described in the following chart. Each page of the chart has two columns at its left edge corresponding to the 6,000-mile and the 1,000-mile maintenance respectively. Very often it will be found that a particular procedure does not apply to both scheduled maintenances. In order to determine which procedure to follow, look down the column corresponding to the maintenance due, and wherever an item number appears perform the operation indicated opposite the number.

ROAD TEST

MAINTENANCE	
6,000 Mile	1,000 Mile
1	1
5	5
10	10
12	12

NOTE: *When the tactical situation does not permit a full road test, perform those items which require little or no movement of the vehicle. When a road test is possible, it should be for preferably 4 and not over 6 miles.*

Before-operation Inspection. Perform the Before-operation service as outlined in paragraph 18.

Brakes, Service and Emergency (Braking Effect, Side Pull, Noise, Chatter, Air Control). Test trailer brakes separately by use of hand control or foot treadle, on truck tractor, and observe if they are effective. Note any erratic action, side pull or noise that might indicate uneven brake shoe pressure, dirty linings or scored drums. Stop trailer on a reasonable incline, disconnect emergency line and observe if brakes automatically hold vehicle. Be sure application valves operate properly and close fully when pedal pressure or hand application lever is in released position.

Unusual Noises (Attachments, Body and Wheels). Be on the alert during road test for any noise that may indicate loose or damaged attachments mounted on vehicle. Listen particularly for indications of loose wheel mountings. With trailer connected and in motion, have assistant listen for any unusual noise on dolly and trailer from attachments, axles, suspension units, or wheels.

Air-brake System Leaks. Test trailer air brakes for leaks with air pressure at governed maximum. With all

10-TON PAYLOAD, 14-TON GROSS, 2-WHEEL STAKE AND PLATFORM SEMITRAILER AND 10-TON CONVERTER DOLLY

MAINTENANCE	
6,000 Mile	1,000 Mile
13	13
47	47
47	47

brakes applied and engine stopped, there should not be a noticeable drop in pressure within one minute. If any pressure drop occurs during this check, test system for leaks by soapsuds method.

Temperature (Brake Drums and Hubs). At completion of run, feel brake drums and hubs of both dolly and trailer for abnormally high temperatures.

MAINTENANCE OPERATIONS

Raise Vehicle and Block Safely

Tires and Rims (Valve Stems and Caps, Condition, Direction, Matching Spare Carrier). Inspect both dolly and trailer tires as follows:

VALVE STEMS AND CAPS. Observe if all valve stems are in good condition and in correct position, and if all valve caps are present and installed securely. Do not tighten with pliers.

CONDITION. Examine all tires for cuts, bruises, breaks, and blisters. Remove embedded glass, nails, and stones. Look for irregular tread wear, watching for any sign of flat spots, cupping, feather edges, and one-sided wear. Remove tires worn thin at center of tread (or other un-serviceable tires) and exchange for new or retreaded tires. Any mechanical deficiencies causing such conditions should be determined and corrected or reported. Wheel positions of tires with irregular wear should be changed to even up wear. Front tires, worn irregularly, should be moved to rear-wheel positions.

DIRECTION. Directional tires and non-directional tires should not be installed on same vehicle. Directional tires on trailer wheels should ordinarily be mounted so that the "V" of chevron will point down when viewed from the front.

MATCHING. With tires properly inflated, inspect them to see if they are matched according to over-all circumference and type of tread.

SPARE TIRE CARRIER. See whether spare tire carrier, if furnished, is in good condition and secure.

RIMS. All rims and their lock rings or flanges should be in good condition and secure.

TIGHTEN. Tighten all wheel mounting and hub flange nuts securely.

SERVE. With dolly and trailer tires properly inflated to 80 pounds (cool) check over-all circumference of all tires including spares. Select tires to be mounted on

SECOND ECHELON PREVENTIVE MAINTENANCE

MAINTENANCE	
6,000 Mile	1,000 Mile
48	
49	
49	

duals or on driving axles, so they will not have difference in over-all circumference exceeding the 3/4-inch limits specified in current directives and bulletins. Mount all dual tires with the larger tire outside. The valve stem on inner wheels should point out and valve stem on outer wheel should point in, and should be opposite each other. Spares must be matched properly and mounted for use on one of the road wheels at intervals not exceeding 90 days. A convenient time to do this is during these maintenance services. **CAUTION:** *After performing the tire-matching service, do not re-install wheels until wheel-bearing services are completed.*

Rear Brakes (Drums, Supports, Cams and Shafts). Inspect trailer brakes and service as follows: Remove wheels. **NOTE:** *On 6,000-mile maintenance several wheel bearing and brake items up to 52 are group services and overlap. Perform in best order for economy of time and orderly reassembly.*

DRUMS AND SUPPORTS. Clean dirt and grease from drums and supports keeping solvent away from linings. Examine drums and supports to see if they are in good condition, securely mounted and if drums are excessively worn or scored.

CAMS AND SHAFTS. See if cams and shafts, where they contact, are excessively worn; if camshafts operate freely in collar and if shafts and collars are worn.

TIGHTEN. Tighten brake support cap screws and hub to drum nuts securely.

49

Brake Shoes (Linings, Anchors and Springs). Examine trailer brake linings without removing drums through inspection holes, to see if they are so worn that rivet heads may contact drums within next 1,000 miles of operation. If vehicle has been operated in deep water, mud or loose sand, remove forward right trailer wheel and drum and examine lining for damage. If this lining must be replaced, remove all trailer and dolly wheels, check their brakes and service as necessary, being sure to clean, lubricate, and adjust all removed wheel bearings as described in paragraph 56.

49

ADJUST. Adjust trailer shoes by minor method, if necessary. With trailer rear wheels and drums removed, inspect linings to see if they are in good condition, tightly secured to brake shoes, in good wearing contact with drums, free of dirt or lubricant and not excessively worn. Also see if shoes are in good condition, properly secured to anchors, guides, and retracting springs, and that springs have sufficient tension to return shoes prop-

10-TON PAYLOAD, 14-TON GROSS, 2-WHEEL STAKE AND PLATFORM SEMITRAILER AND 10-TON CONVERTER DOLLY

MAINTENANCE	
6,000 Mile	1,000 Mile
52	52
	52
52	
52	
52	

erly to released position. Thickness of lining at most worn point should be enough for at least 1,000 miles of service before rivet heads are likely to contact drums.

CLEAN. Clean all dirt and grease from linings with wire brush, cloth, or compressed air.

ADJUST. After subsequent related items to 56 inclusive are completed, adjust shoes by minor method. If new linings have been installed, adjust by major method. Adjust slack adjusters so diaphragm push-rod travel is 3/4 inch minimum, 1 3/4 inches maximum.

52 **Wheels (Bearings, Seals, Flanges, and Nuts).** Inspect and service as follows:

52 **WHEELS.** Inspect dolly and trailer wheels to see if they are in good condition and secure.

BEARINGS AND SEALS. Check for looseness of wheel bearing adjustment. Revolve wheels and listen for evidence of dry or damaged bearings. Inspect around flanges and brake supports for lubricant leaks.

FLANGES AND NUTS. Note if flanges are in good condition, and if nuts are tightened securely.

52 **CLEAN.** Disassemble both dolly and trailer wheel bearings and oil seals. Clean thoroughly in dry-cleaning solvent and examine bearing cups and cones to see if they are in good condition; if machined surfaces they contact are in good condition and if there is any excessive wear.

52 **SPECIAL LUBRICATION.** When all of the related items are to the point where wheel bearings are to be reinstalled, lubricate bearings according to instructions on Lubrication Order and as follows: Take care to have all parts clean and dry, the hands clean, and use clean lubricant. The inside of the wheel hub, and hub cap or hub flange, and outside of spindle or axle shall be wetted only to a thickness of 1/16-inch minimum with lubricant to retard rusting. Bearing shall be either machine packed or hand packed by kneading lubricant into all spaces in the bearings. Coat the cups or outer races and the lips of the oil seals with lubricants and install new lubricant retainer seals if necessary. **CAUTION: Do not pack the large cavity in wheel hubs between wheel bearings with lubricant. To do so is to cause leakage past the seals.**

52 **ADJUST.** After lubricating dolly and trailer wheel bearings, reassemble hub and drum assemblies into place, and adjust wheel bearings correctly, according to paragraph 56, for dolly, and paragraph 56, for trailer.

SECOND ECHELON PREVENTIVE MAINTENANCE

MAINTENANCE		
6,000 Mile	1,000 Mile	
56	56	Springs (Clips, Leaves, U-Bolts, Hangers, and Shackles). See that they are in good condition, correctly assembled, and secure. Spring clips and bolts should be in place; spring leaves should not be shifted out of their correct position. This may be an indication of a sheared center bolt. Note whether the deflection of both springs are normal and approximately the same. Test the hangers and bolts for excessive wear by means of a pry bar.
56	56	TIGHTEN. Tighten all spring U-bolts securely and uniformly.
58	58	Shock Absorbers and Links. See that shock absorber bodies are secured to frame, that the links which connect their arms to the axle are in good condition and secure, and that there are no fluid leaks.
58		SERVE. Fill the shock absorber bodies with specified fluid. Work arms and repeat this operation until all air is expelled and the reservoir is full.
70	70	Air-Brake Reservoirs. Observe whether they are in good condition and secure. Open the drain cocks and drain off water.
80	80	Frame (Side and Crossmembers). Inspect frame, brackets, side rails, and crossmembers to see that they are in good condition, secure, and correctly alined. If the frame appears to be out of line, report the condition to proper authority.
81	81	Wiring, Conduits. Observe these items underneath the vehicle to see that they are in good condition, properly supported, connected, and secure.
83	83	Brake Lines (Fittings and Hose). Observe brake lines, fittings, and rear brake hose, underneath the vehicle and see that they are in good condition and secure.
85	85	Vehicle Lubrication. If due, lubricate all points of dolly and trailer in accordance with instructions in Lubrication Order, paragraphs 15 and 16, using only clean lubricant, and omitting items that have received special lubrication during this service. Replace missing or damaged grease fittings or plugs. Keep lubricant containers and dispensers covered except when withdrawing lubricant. Open any clogged passages or fitting holes until lubricant is properly delivered. Wipe off excess lubricant that might drip onto brakes, rubber parts, soil clothes or detract from vehicle's good appearance.

10-TON PAYLOAD, 14-TON GROSS, 2-WHEEL STAKE AND PLATFORM SEMITRAILER AND 10-TON CONVERTER DOLLY

MAINTENANCE	
6,000 Mile	1,000 Mile
88	88
88	
88	
89	
91	91
92	92
100	100
103	103

LOWER VEHICLE TO GROUND

Dolly Fifth Wheel. Examine fifth wheel unit on dolly to be sure it is in good condition and correctly assembled. Tighten all assembly and mounting nuts securely. Inspect all accessible friction surfaces, jaw and lock assemblies for good condition and excessive wear. If attached, disconnect trailer, clean base plate thoroughly, inspect for damage and relubricate according to instructions in Lubrication Order, paragraph 16. Inspect trailer king pin connection for good condition and excessive wear. Be sure ground check and safety chains are present and secure. Be sure locking jaws operate freely and lever latch locks securely.

88 **CLEAN.** Clean rocker and bed plate and king pin latch mechanism thoroughly of all grease and dirt and inspect for damage or excessive wear.

88 **SPECIAL LUBRICATION.** Apply a film of grease to fifth wheel top surface latch mechanism and king pin and all fittings. See paragraph 16, Lubrication Order.

89 **Tractor-to-Trailer Brake Hose, Wiring and Connections.** Observe brake hose or wiring to see that they are in good condition and securely fastened to clips, springs, or brackets so that they will not chafe or interfere with working parts. See that connecting fittings are in good condition, secure, and not excessively worn.

91 91 **Lamps (Lights).** Operate all trailer switches and note if lamps respond. Include stop and blackout lamps. Examine all trailer lights to see if they are in good condition and securely mounted and if lenses are dirty.

92 92 **Safety Reflectors.** See that they are all present, in good condition, clean, and secure.

100 100 **Body (Tailgate, Floor, Stakes, Sockets, Tarpaulin, and Stowage Compartments).** See that these items are in good condition and secure; that the tailgates are properly aligned and fasten securely; that the tarpaulin, ropes, and the metal hooks on the body are all present, in good condition and secure; and whether or not tailgate and stowage compartment door hinges and latches are adequately lubricated.

103 103 **Paint and Markings.** Examine the paint of entire vehicle to see that it is in good condition, paying particular attention to any bright spots in finish that might cause glare or reflection. Inspect vehicle markings and identification for legibility. Include identification plates.

SECOND ECHELON PREVENTIVE MAINTENANCE

MAINTENANCE		
6,000 Mile	1,000 Mils	
124	124	Tow Hitch (King Pin, Fifth Wheel Plates, Lunette, and Dolly Draw-bar). Note whether these items are in good condition, securely assembled and mounted, not excessively worn, and that the king pin and fifth wheel are adequately lubricated.
127	127	Supports or Landing Gear (Shafts, Wheels, Gears, and Crank). See that they are in good condition, correctly assembled, secure, and adequately lubricated, and whether the operation mechanism functions correctly to raise and lower the legs.
127	127	SPECIAL LUBRICATION. Apply chassis grease to all fittings. See Lubrication Orders (figs. 10 and 12).
127		TIGHTEN. Tighten all landing gear assembly and mounting bolts. Make certain cross tubing and braces are present, and tight.
128	128	Axles. Observe whether these axles are sprung or out of line, and that their attachments and mountings are secure.
TOOLS AND EQUIPMENT		
131	131	Tools and Equipment. Check all tools to make certain that they are present (see stowage list—pars. 6 and 8), and securely mounted or stowed. Make certain chock blocks and tarpaulin are stowed in their proper place, and in good condition.
135	135	Publications. Be sure vehicle manuals, Lubrication Orders, and Form No. 478 are present and properly stowed.
137	137	Tow (Dolly Safety Chain). Inspect to make certain they are in sound condition and properly fastened to the dolly. Make certain the grab hooks are not bent or distorted.
141	141	Modifications (MWO's Completed). Inspect dolly and trailer to be sure any modification work orders have been completed, and enter any MWO's or Major Unit Assembly Replacements made at time of this service on W.D., A.G.O. Form No. 478.
142	142	Final Road Test. Make a final road test rechecking items 5, 12, and 13. Confine this road test to the minimum distance necessary to make satisfactory observations. <i>NOTE: Correct or report all deficiencies found during final road test.</i>

**10-TON PAYLOAD, 14-TON GROSS, 2-WHEEL STAKE AND
PLATFORM SEMITRAILER AND 10-TON CONVERTER DOLLY****Section IX****TROUBLE SHOOTING****23. GENERAL.**

a. This section contains trouble shooting information and tests which can be made to help determine the causes of some of the troubles that may develop in use under average conditions. Each symptom of trouble given under the individual unit or system is followed by a list of possible causes of the trouble. The tests necessary to determine which one of the possible causes is responsible for the trouble are explained after each possible cause. Paragraphs 24, 27, and 30 apply to the semitrailer only. Paragraph 29 applies to the dolly only. Paragraphs 25, 26, and 28 apply to both the semitrailer and the dolly.

24. BRAKING SYSTEM.**a. No Brakes.**

(1) **SOURCE OF AIR SUPPLY SHUT OFF AT TOWING VEHICLE.** Open cut-out cocks at rear of towing vehicle.

(2) **AIR JUMPER HOSE BETWEEN TRUCK AND TRAILER NOT PROPERLY COUPLED.** Make certain air jumper hose tagged "Service" is coupled to connections on semitrailer tagged "Service." Service line is on the right side of semitrailer (par. 9 c).

(3) **LOW BRAKE LINE PRESSURE.** Check air pressure gage on towing vehicle. Pressure must not be below 60 pounds.

(4) **RESERVOIR DRAIN COCK OPEN.** Close drain cock on reservoir. Reservoir is located on crossmember ahead of axle.

b. One or More Brakes Running Hot.

(1) **IMPROPER ADJUSTMENT.** Adjust brakes (par. 38).

(2) **RELEASE SPRING BROKEN IN DRUM.** Replace spring (par. 41 c).

(3) **BINDING CAM, ANCHOR PINS, OR CHAMBER ROD END PIN.** Lubricate (par. 16).

(4) **BENT CHAMBER PUSH ROD.** Replace brake chamber (par. 33 b).

(5) **DRUM OUT OF ROUND.** Replace drum (par. 60 a).

c. Slow Brake Application or Slow Release.

(1) **LOW BRAKE LINE PRESSURE.** Check air supply at towing vehicle, refer to vehicle technical manual or TM 9-1827A.

(2) **EXCESSIVE TRAVEL IN CYLINDER PUSH ROD.** Adjust brakes (par. 32).

(3) **DIRTY AIR CLEANER.** Clean air cleaner (par. 36 e).

TROUBLE SHOOTING

(4) **RESTRICTION IN TUBING.** Look for kinked or dented tubing. Replace or repair (par. 37 d).

(5) **LACK OF LUBRICATION.** Lubricate anchor pin, cams, slack adjuster, mounting bracket, and chamber push rod pin (par. 16).

d. Drop in Air Pressure.

(1) **EXCESSIVE LEAKAGE IN RELAY EMERGENCY VALVE EXHAUST PORT.** Worn check valve body, replace relay emergency valve (par. 34 b), repair relay emergency valve, see TM 9-1827A.

(2) **AIR LEAKAGE AT TUBING CONNECTORS.** Tighten connector bodies and nut until leak disappears (par. 37).

(3) **EXCESSIVE LEAKAGE AT SERVICE LINE OR EMERGENCY LINE COUPLINGS.** Damaged packing ring in hose coupling. Replace hose coupling.

(4) **EXCESSIVE LEAKAGE AT SERVICE LINE COUPLING WHEN JUMPER HOSE IS DISCONNECTED.** Dirty or worn inlet valve, replace relay emergency valves (par. 34 b). Repair, see TM 9-1827A.

(5) **EXCESSIVE LEAKAGE AT EMERGENCY LINE COUPLING WHEN JUMPER HOSE IS DISCONNECTED.** Defective check valve disk or defective diaphragm. Replace relay emergency valves (par. 34 b). Repair, see TM 9-1827A.

e. Intermittent Brakes.

(1) **GREASE ON LINING.** Caused from overlubricating of anchor pins, camshaft or wheel bearing (par. 16). Replace lining (par. 41 c).

(2) **BRAKE OUT OF ADJUSTMENT.** Adjust brakes (par. 32).

(3) **SCORED BRAKE DRUM.** Replace drum (par. 60).

(4) **IMPROPER LINING.** Use specified lining.

(5) **WHEEL BEARINGS OUT OF ADJUSTMENT.** Adjust wheel bearing (par. 56 a).

f. Brakes Do Not Release.

(1) **BRAKE SYSTEM IMPROPERLY CONNECTED FROM TOWING VEHICLE.** Connect lines properly (par. 9 c).

(2) **BRAKE CONTROL IN THE APPLIED POSITION AT TOWING VEHICLE.** If semitrailer is coupled to towing vehicle place the control in the released position. If semitrailer is disconnected from towing vehicle open drain cock at reservoir.

(3) **RELAY EMERGENCY VALVE IN EMERGENCY POSITION.** Build up pressure in towing vehicle brake system, or open drain cock at reservoir.

(4) **CUT-OUT COCKS CLOSED ON TOWING VEHICLE.** Open cut-out cocks.

(5) **RESTRICTION IN TUBING OR HOSE.** Check all tubing and hose (par. 37).

TM 9-892

25-26

10-TON PAYLOAD, 14-TON GROSS, 2-WHEEL STAKE AND PLATFORM SEMITRAILER AND 10-TON CONVERTER DOLLY

25. SUSPENSION.

a. Shifted Spring Leaves.

- (1) **BROKEN SPRING CENTER BOLTS.** Replace spring center bolt (par. 78 b).
- (2) **CLIP BOLTS MISSING OR BROKEN.** Replace or repair (par. 78 b).
- (3) **LOOSE U-BOLTS.** Tighten U-bolts.

b. Uneven Riding.

- (1) **BROKEN SPRING LEAVES.** Replace spring leaves (par. 78 b).
- (2) **UNEVEN LOAD DISTRIBUTION.** Distribute load evenly.
- (3) **MAIN OR AUXILIARY SPRING HAS LOST ITS ARCH.** Replace main or auxiliary spring (pars. 44 and 45).
- (4) **SHOCK ABSORBER NOT FUNCTIONING PROPERLY.** Replace shock absorber (par. 48 d).

c. Excessive Noise.

- (1) **WORN PINS, BUSHING OR CROSS SHAFT.** Replace with new parts (par. 45).
- (2) **LOOSE SHACKLES, CROSS SHAFT CAPS, U-BOLTS, OR SPRING CLIPS.** Tighten.
- (3) **SHOCK ABSORBER LOOSE.** Tighten linkage and mounting bolts.

d. Over Flexible.

- (1) **BROKEN SPRING LEAVES.** Replace broken leaves (par. 78 b).
- (2) **OVERLUBRICATED.** Lubricate at time intervals specified in Lubrication Order (par. 16).
- (3) **LACK OF FLUID IN SHOCK ABSORBER.** Refill (par. 16).
- (4) **SHOCK ABSORBER NOT OPERATING.** Remove and inspect for broken parts (par. 48).
- (5) **SPRING LEAF CLIPS BROKEN.** Place leaves in alinement and install new clips (par. 78 b).

26. AXLE.

a. Semitrailer Wheels Not Tracking with Those of Dolly or Towing Vehicle.

- (1) **AXLE OUT OF ALINEMENT.** Place axle in alinement (par. 85).

b. Inner Tires Wearing More Rapidly Than Outer Tires.

- (1) **AXLE OUT OF CAMBER.** Check axle camber (par. 84), if not correct, replace axle (par. 46).
- (2) **BENT AXLE SPINDLE.** Check axle for bend (par. 83). Replace axle (par. 46).

c. Outer Tires Wearing More Rapidly than Inner Tires.

- (1) **Too much camber in axle.** Check camber (par. 84). Replace axle (par. 46).

TROUBLE SHOOTING

d. All Four Tires Wearing Uneven and Cupping.

- (1) **AXLE OUT OF ALINEMENT.** First check axle for bend (par. 83). Then place axle in alinement (par. 85).
- (2) **BENT AXLE.** Check axle for bend (par. 83). Replace axle (par. 46).

27. LANDING GEAR.

a. Operating Crank Hard to Turn.

- (1) **LACK OF LUBRICATION OR IMPROPER LUBRICANT USED.** Lubricant according to Lubrication Order (par. 16).
- (2) **BENT OPERATING SHAFT.** Replace or straighten (par. 50).
- (3) **LOWER LEG BENT CAUSING BIND IN FRAME BRACKET.** Replace lower leg (par. 94).
- (4) **BEVEL GEAR WORN.** Remove bevel gear cover from right and left frame bracket and inspect gears. Replace (par. 94 a (1)).
- (5) **SCREW BENT.** Disconnect bevel gear shaft. Operate first the right-hand assembly with crank, then turn the left-hand assembly with pipe wrench to determine which screw is bent. Replace bent screw (par. 94).

b. One or Both Support Leg Assemblies Do Not Respond When Turning Crank.

- (1) **BOLT MISSING IN OPERATING SHAFT OR IN BEVEL GEAR SHAFT.** Replace bolts.
- (2) **WOODRUFF KEY SHEARED IN BEVEL GEAR SHAFT.** Replace Woodruff key (par. 94).
- (3) **FEATHER KEY SHEARED IN SCREW.** Replace feather key (par. 94).

c. One Leg Higher Than the Other When In the Up Position.

- (1) **IMPROPER ADJUSTMENT.** Adjust lower leg (par. 50).

28. WHEELS, HUBS, AND TIRES.

a. Wobbly Wheel.

- (1) **LOOSE WHEEL STUD NUTS.** Tighten (par. 58 b).
- (2) **INNER OR OUTER WHEEL BEARINGS BURNED OUT.** Replace wheel bearings (par. 55).
- (3) **BENT AXLE.** Check axle for bend (par. 83).

b. Hot Hub.

- (1) **LACK OF LUBRICATION.** Lubricate (par. 16).
- (2) **DAMAGED BEARING OR CUP.** Replace bearing (par. 55), or bearing cup (par. 99 a).
- (3) **IMPROPER WHEEL BEARING ADJUSTMENT.** Adjust wheel bearings (par. 56).

c. Undue Tire Wear.

- (1) **OVER- OR UNDER-INFLATION.** Inflate tire to 80-pound pressure.

10-TON PAYLOAD, 14-TON GROSS, 2-WHEEL STAKE AND PLATFORM SEMITRAILER AND 10-TON CONVERTER DOLLY

(2) **OVERLOADING OR IMPROPER LOAD DISTRIBUTION.** Load to rated capacity or distribute load evenly.

(3) **TIRE TROUBLE.** See axle trouble shooting (par. 26).

d. Oil or Grease in Brake Drum or Outside of Wheel.

(1) **DEFECTIVE GREASE RETAINER.** Replace retainer (par. 59).

(2) **CRACKED HUB.** Replace hub (par. 57).

(3) **IMPROPER OR OVERLUBRICATION.** Relubricate (par. 16).

29. FIFTH WHEEL.

a. Excessive Lash or End Play Between Fifth Wheel and Semi-trailer.

(1) **JAWS WORN.** Replace the jaws (par. 90).

(2) **KING PIN ON UPPER FIFTH WHEEL PLATE EXCESSIVELY WORN.** Check the king pin (par. 106).

(3) **FIFTH WHEEL LOOSE IN ITS MOUNTINGS.** Tighten the two U-bolts and mounting bolts.

b. Uncoupling Difficulties.

(1) **PLUNGER LOCK BINDING IN JAWS.** At times difficulty may be encountered when uncoupling. This is no fault of the functional parts of the fifth wheel. The trouble lies in the fact that the semitrailer king pin is causing the plunger lock to bind. This is caused by the semitrailer and dolly being as far apart as possible without actually being uncoupled. All that is necessary to overcome the trouble is to apply a light pull on the lock lever and give the towing vehicle a rocking motion by first placing the towing vehicle in reverse and then forward.

(2) **BENT JAWS.** Replace the jaws (par. 90).

(3) **BENT OR DAMAGED PLUNGER LOCK.** Replace plunger (par. 90).

(4) **LACK OF LUBRICATION.** Lubricate jaw pins (par. 16), and place several drops of oil on plunger lock.

30. ELECTRICAL SYSTEM.

a. Lights Will Not Burn.

(1) **JUMPER CABLE NOT PLUGGED INTO TRAILER FROM TOWING VEHICLE.** Install jumper cable (par. 9 e).

(2) **LIGHT SWITCH AT TOWING VEHICLE IN THE "OFF" POSITION.** Turn switch on.

(3) **BATTERY AT TOWING VEHICLE NOT SUFFICIENTLY CHARGED.** Check battery on towing vehicle.

(4) **NO CURRENT FROM TOWING VEHICLE.** Check wiring on towing vehicle.

(5) **BROKEN OR DAMAGED WIRES.** Check wiring system for broken or damaged wires. Replace or repair.

TROUBLE SHOOTING

b. Dim Light.

- (1) **DIRTY OR CORRODED CONTACT BLADES IN COUPLING SOCKET OR JUMPER CABLE.** Clean the blades.
- (2) **DIRTY LENS.** Clean lens.
- (3) **BATTERY AT TOWING VEHICLE NOT SUFFICIENTLY CHARGED.** Check battery (TM 9-812).
- (4) **DIRTY OR CORRODED LAMP SOCKETS.** Remove lamp-unit and clean.

c. One of More Lights Will Not Burn.

- (1) **BURNED OUT LAMP UNIT.** Replace lamp unit (par. 63).
- (2) **BROKEN WIRE.** Check wires for damage. Replace or repair.
- (3) **DAMAGED LIGHT ASSEMBLY.** Replace light assembly (par. 63 c).
- (4) **DIRTY OR CORRODED LAMP SOCKET.** Remove lamp-unit and clean.

Section X

BRAKE SYSTEM

31. DESCRIPTION AND DATA.

a. Description. The brakes are of the heavy-duty, mechanical, internal-expanding, two-shoe, anchor-pin type, operating on the cam and lever principle. The S-type cams are integral with the camshafts. The cams are carried on bearings. The slack adjusters are of the 360-degree type, and permit rapid and proper adjustment of the brakes. The brakes actuated by two chambers which are mounted on the front side of the axle. Emergency breakaway features are built into the emergency relay valve which will allow air to pass into the brake chamber thus holding the trailer brakes for a limited time should the trailer break away from the towing vehicle. The brakes are controlled by a foot or hand control on the towing vehicle.

b. Tabulated Data.

Brakes:	
Make	Timken
Type	Two-shoe internal expanding
Size	17 ¹ / ₄ in. x 5 ¹ / ₂ in.
Operating pressure	Min 60 lb
Copper air lines	3/8 in. and 1/2 in. dia
Relay emergency valve	Bendix-Westinghouse

32. BRAKE ADJUSTMENT.

a. Jack Up Axle Assembly. Jack up wheel assembly until wheel clears ground. When jacking axle assembly, place jack under axle U-bolt cap to prevent jack from slipping.

10-TON PAYLOAD, 14-TON GROSS, 2-WHEEL STAKE AND PLATFORM SEMITRAILER AND 10-TON CONVERTER DOLLY

(1) **ADJUSTING BRAKE** (fig. 14). Turn adjusting screw on slack adjuster in a counterclockwise direction until wheel cannot be turned. Turn adjusting screw in a clockwise direction, about two notches or more, until wheel turns freely. Grasp the end of the push rod and slack adjuster and try pushing the push rod into the diaphragm. The travel of the push rod must not exceed $1\frac{3}{4}$ inches or be less than $\frac{3}{4}$ inch.

33. BRAKE CHAMBERS.

a. Description. The two brake chambers are mounted on a bracket which is mounted to the front side of the axle. The function

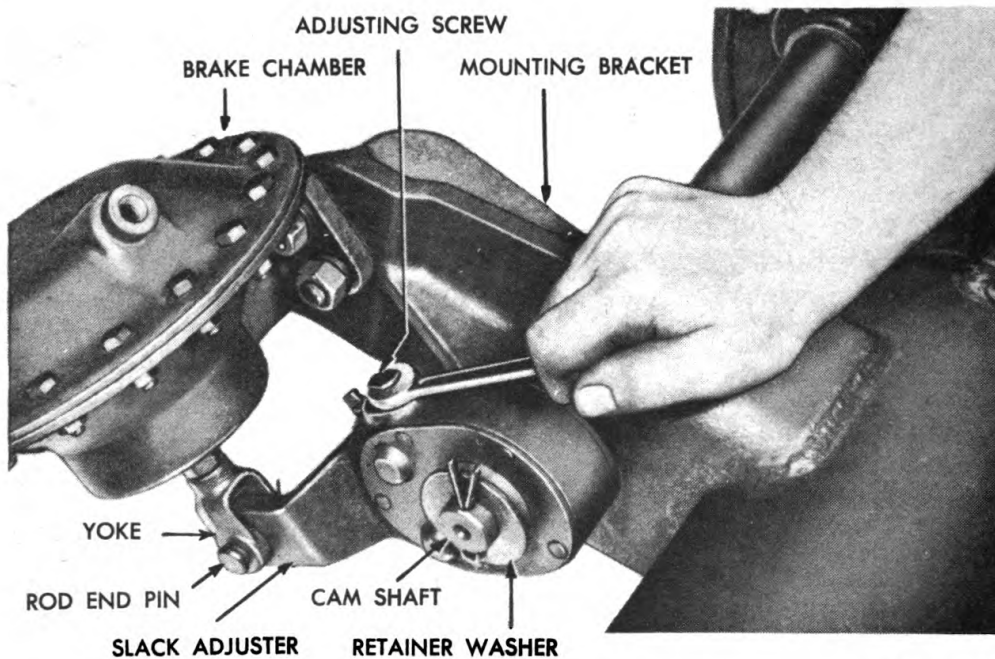

RA PD 334369

Figure 14—Brake Adjustment

of the brake chambers is to convert the energy of compressed air into the mechanical force necessary to expand the brake shoes against the brake drum and apply the brakes. Air pressure from the relay emergency valve enters the port at the top. The air is held in check by a diaphragm which moves the push rod forward to rotate the slack adjuster.

b. Removal (fig. 15). Place brake control in the released position. Screw connector nut from connector body. Pull the flexible air hose off connector body. Remove the cotter pin from rod end pin at slack adjuster. Drive out the rod end pin. Remove the four cap screws, four nuts and four lock washers holding brake chamber to mounting bracket and lift out the brake chamber. Remove connector body from brake chamber.

BRAKE SYSTEM

c. Installation (fig. 15).

(1) Place brake chamber in position on mounting bracket. Secure chamber to bracket using four cap screws, lock washers and nuts. Place a light film of grease over surface of rod end pin. Couple brake chamber to slack adjuster using the rod end pin and install cotter pin in rod end pin. Screw connector body into brake chamber making certain it is tight. Place flexible hose end over end of connector body and tighten connector nut. Give brakes minor brake adjustment (par. 32).

(2) **TEST FOR LEAKS.** Apply the brakes. Cover connector nut with soapy water. If leak is discovered, tighten the connector body and connector nut until leak disappears.

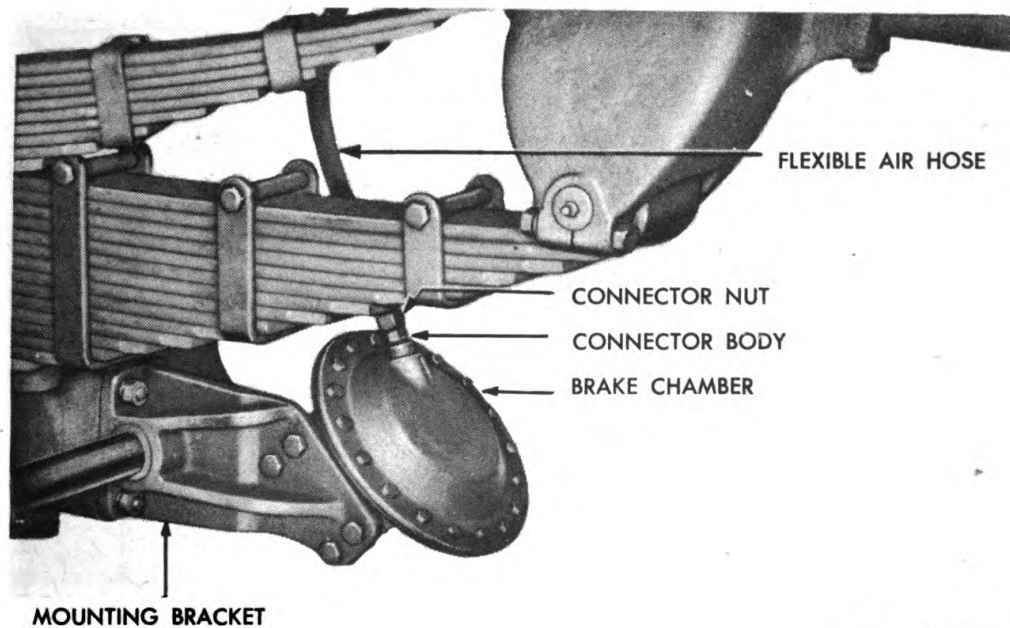

RA PD 334370

Figure 15—Brake Chamber

34. RELAY EMERGENCY VALVE (figs. 16 and 17).

a. Description. The relay emergency valve is located on rear side of channel crossmember near the rear axle. The relay emergency valve serves as a relay station to speed up the application or release of the trailer brakes and also provides a means of automatically applying the trailer brake in case the trailer should become accidentally disengaged from the towing vehicle. Its function is to operate so as to deliver and maintain the same air pressure in the trailer brake chambers is delivered by the control valve on the towing vehicle.

b. Removal (fig. 17). Shut off the air supply to trailer by closing the two cut-out cocks on towing vehicle. Open drain cock at bottom of reservoir tank allowing all air to drain from trailer brake system.

10-TON PAYLOAD, 14-TON GROSS, 2-WHEEL STAKE AND PLATFORM SEMITRAILER AND 10-TON CONVERTER DOLLY

RA PD 308602

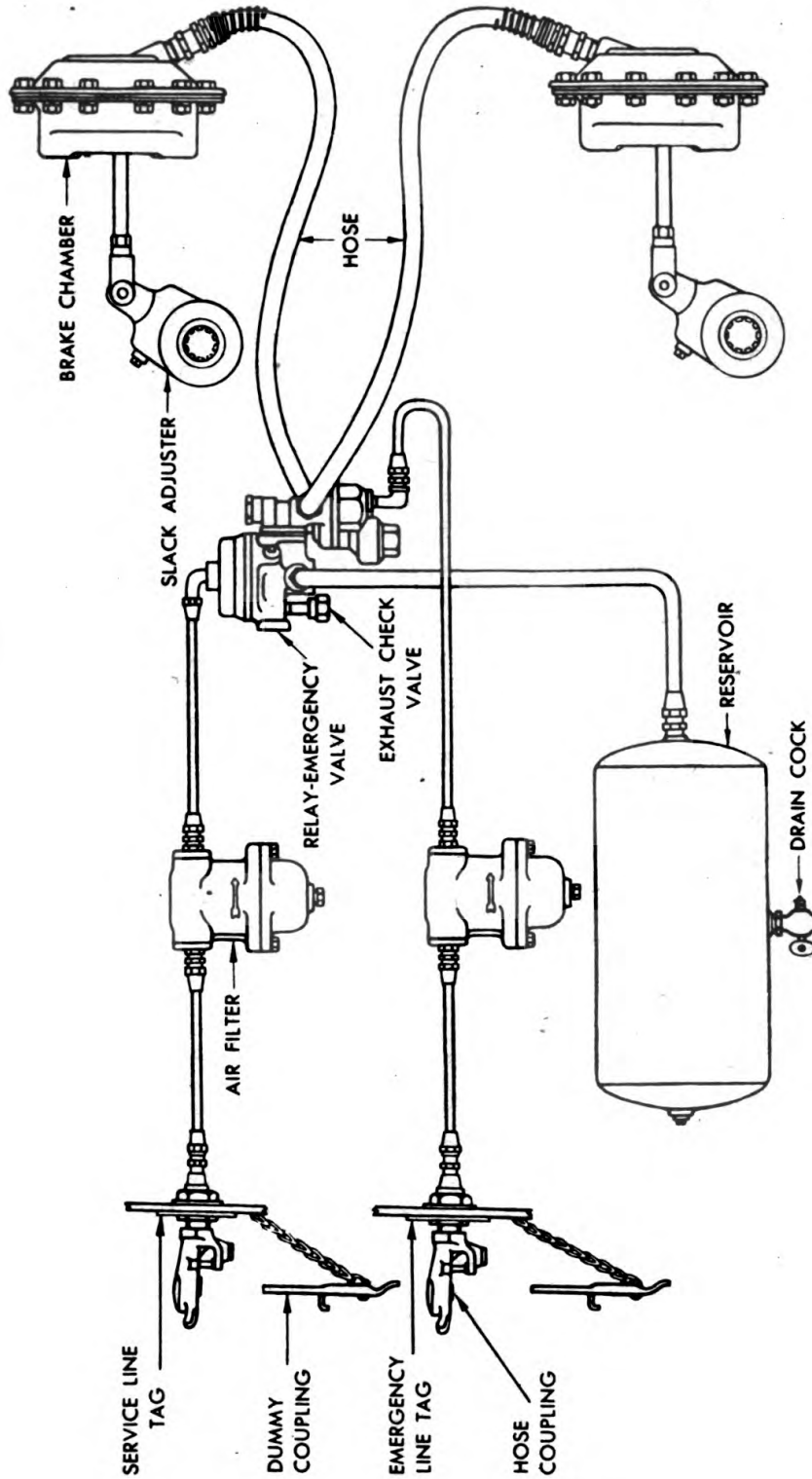
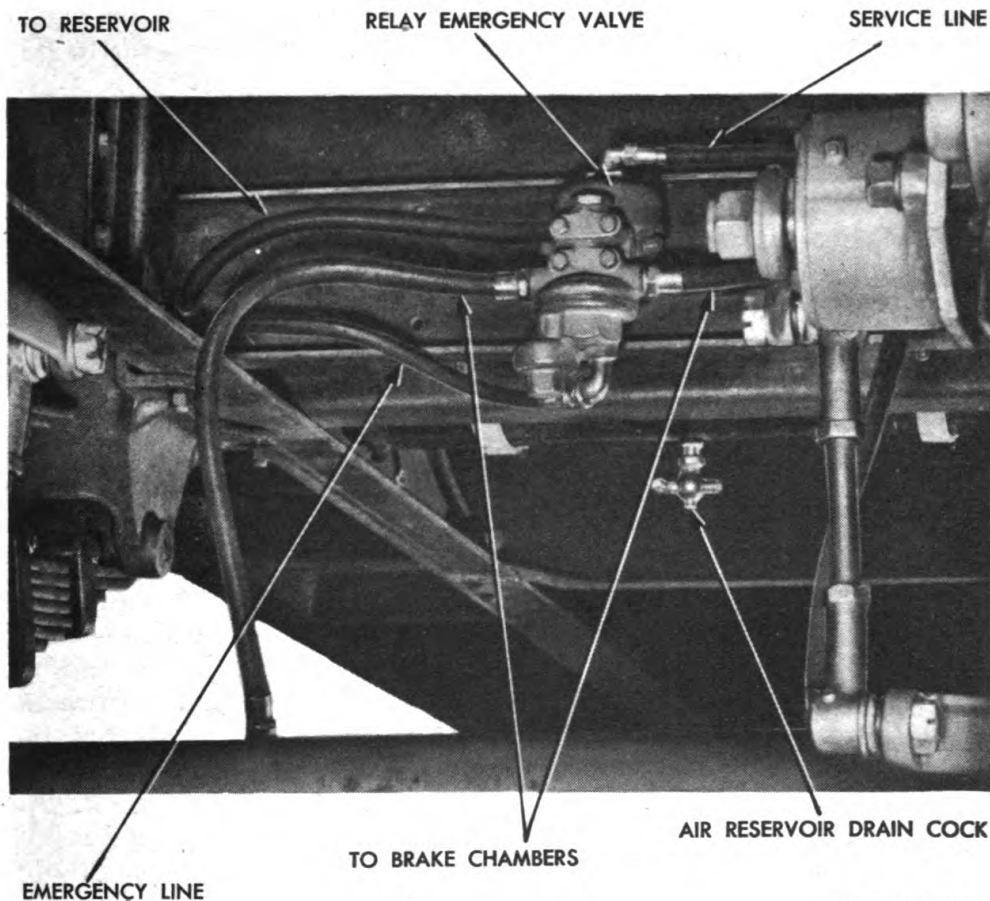

Figure 16—Brake System Diagram

BRAKE SYSTEM



RA PD 334372

Figure 17—Relay Emergency Valve

Remove tubing nut from tubing elbow at the service line. Remove tubing nut from tubing elbow at the emergency line. Disconnect the two flexible air lines leading to the brake chambers. Remove the tubing nut from the $\frac{1}{2}$ inch line that runs to the reservoir tank. Remove the two bolts holding relay emergency valve to crossmember and lift the valve out. Remove the three connector bodies. Remove the two elbows. **CAUTION:** *When screwing out the two elbows, use wrench against the unthreaded portion to prevent damage to the threads.*

c. Installation (fig. 17). Coat the threaded portion of all valve fittings with shellac. Screw the fittings into their proper ports in relay emergency valve. Secure the relay emergency valve to crossmember using two cap screws, two lock washers and two nuts. **NOTE:** *The word "top" is embossed on top of relay emergency valve. When installing valve make certain the word "top" is up.* Couple the two flexible hoses to connector body and tighten body nut. Couple service line to elbow at top and emergency line to elbow at bottom. Couple

10-TON PAYLOAD, 14-TON GROSS, 2-WHEEL STAKE AND PLATFORM SEMITRAILER AND 10-TON CONVERTER DOLLY

the 1/2-inch line to the 1/2-inch body. Close drain cock at bottom side of reservoir. Open the two cut-out cocks at towing vehicle. Test all fittings and connectors for leaks (par. 37 c).

35. AIR RESERVOIR.

a. Description. The reservoir is located on the channel cross-member ahead of the axle. Reservoir stores up a surplus supply of air for operation of relay emergency valve and brake chambers.

b. Removal. Close the two cut-out valves at rear of towing vehicle. Open drain cock at underside of reservoir and allow air to drain from trailer brake system. Remove the nut from tubing connector and remove connector body. Remove drain cock from underside of tank. Remove the two nuts, two lock washers, and two cap screws from mounting brackets. Spread the four reservoir mounting brackets open and pull the tank out. Remove connector body and pipe plug from tank.

c. Installation. Coat the threaded portion of pipe plug and connector body with shellac. Install the pipe plug into one end of the reservoir and the connector body into the opposite end and tighten. Place tank into position between the four mounting brackets making certain the drain cock port is at the bottom. Secure tank to the mounting brackets using two cap screws, two lock washers and two nuts. Install and tighten drain cock. Open drain cock. Open the two cut-out cocks at rear of towing vehicle. Allow the air to blow out of drain cock several seconds to permit all sand, dust or other foreign matter which may have accumulated in the tank to escape. Close drain cock and check for leaks. Cover drain cock, pipe plug, and tubing connector body with soapy water. Should bubbles appear, tighten the fittings until bubble disappears.

36. AIR CLEANER.

a. Description. Air cleaners are mounted ahead of axle near channeled crossmember. One cleaner is installed in emergency brake air line and the other in service brake line. Air cleaners consist of a metal screen mounted in a housing and are designed to prevent dirt, water and other foreign matter from entering the relay emergency valve. No. adjustment is required to maintain efficient functioning of cleaner. However, cleaner must be drained every 1,000 miles, disassembled, and thoroughly cleaned every 6,000 miles.

b. Draining Air Cleaner (fig. 18). Close the service and the emergency cut-out cocks at rear of towing vehicle. Remove drain plug from bottom of air cleaner. Open cut-out cocks at rear of towing vehicle and allow air to blow out of cleaner for several seconds. Close cut-out cocks, replace drain plug and open cut-out cocks.

c. Cleaning. Remove the two cap screws holding sediment bowl to body, remove strainer support and pull strainer out of body. Wash strainer in dry-cleaning solvent and install in body.

BRAKE SYSTEM

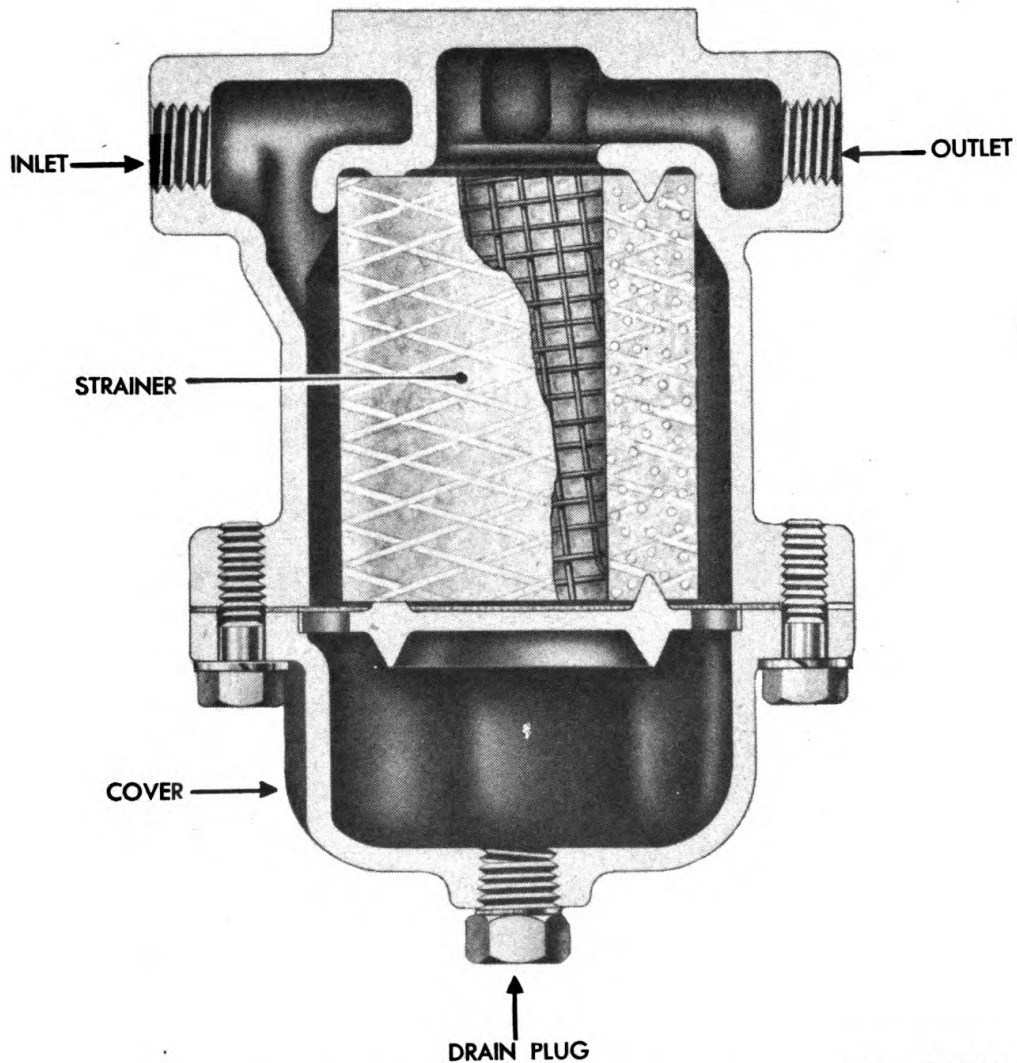

RA PD 308707

Figure 18—Air Cleaner—Sectional View

d. Removal. Shut off air supply at towing vehicle. Disconnect the two lines which lead into cleaner body. Remove the two connector bodies. Remove the two cap screws holding cleaner to mounting bracket and lift cleaner out.

e. Installation. Place cleaner in position on mounting brackets and install two cap screws, but do not tighten. Install the two connector bodies on the air cleaner. Couple the two air lines to the connector bodies and tighten the two cap screws holding cleaner to mounting bracket. Open cut-out valves at rear of towing vehicle and test tubing connectors for leaks using soapy water. Should leaks occur, tighten tube connector bodies and nuts. **NOTE:** *When installing air cleaner it is very important that the arrow embossed on the outer side be pointing toward the air line which runs to the rear of unit.* Open cut-out valves at rear of towing vehicle.

10-TON PAYLOAD, 14-TON GROSS, 2-WHEEL STAKE AND PLATFORM SEMITRAILER AND 10-TON CONVERTER DOLLY

37. LINES, TUBING AND CONNECTIONS.

a. **Description** (fig. 16). Two flexible air lines with couplings attached, are used between trailer and towing vehicle. Two flexible air lines are used between brake chambers and relay emergency valve. Balance of air lines are of $\frac{3}{8}$ -inch diameter tubing, except lines between air reservoirs and relay emergency valve, which are $\frac{1}{2}$ -inch diameter tubing.

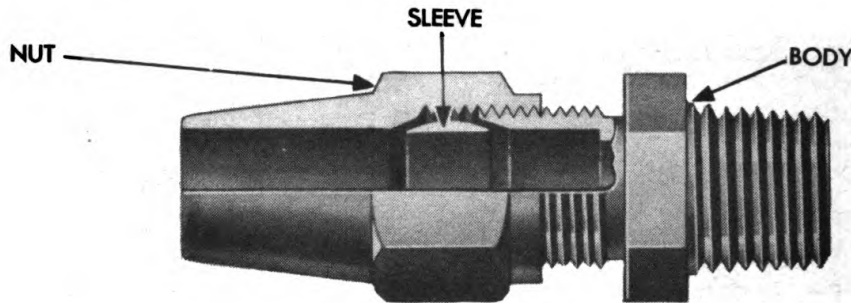

RA PD 308569

Figure 19—Tubing Connector—Sectional View

b. **Inspection.** If evidence is found indicating that brake chambers are not functioning properly, check all tubing lines for dents, kinks or other restrictions. Disconnect tubing lines and blow through the tubing, making certain that air passes through the tubing. Replace tubing if necessary.

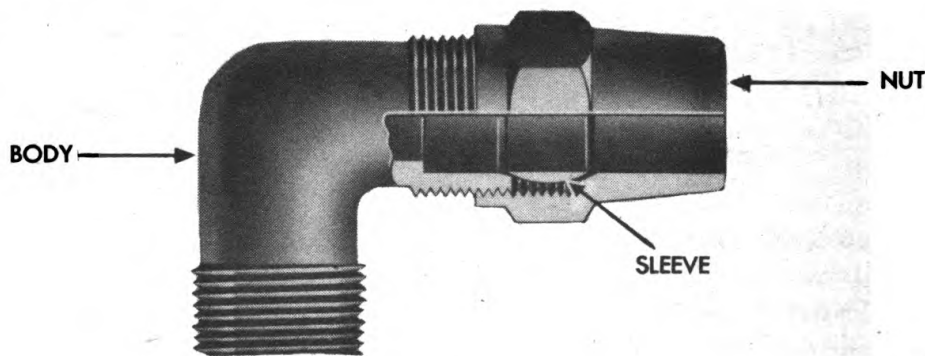

RA PD 308550

Figure 20—Tubing Elbow Connector—Sectional View

c. **Leakage Tests.** Place the brakes in the applied position with the minimum air pressure at 60 pounds. Coat all tubing lines and fittings with soapy water to test for leaks. Leakage is not permissible. Leakage at the tubing nut or body can be corrected by tightening. If this fails to correct the leakage, the tubing, tubing fitting, or both, must be replaced. If any leaks are found in the tubing, a new piece of tubing must be installed or a new piece of tubing spliced into the old tubing.

BRAKE SYSTEM

d. Removal (figs. 19 and 20). Close cut-out cocks at rear of towing vehicle. Open drain cocks at underside of air reservoir and allow all air to drain from trailer brake system. Remove the nuts from each end of damaged tubing. Pry open clips holding tubing to frame and pull tubing and loom out.

e. Installation. Thread copper tubing through loom and install the loom and tubing, forming it to fit the trailer frame. Install tubing connector nut on tubing and then place sleeve over tubing. Place end of tubing into tubing connector body, hold tubing firmly and straight in recess of connector body, and tighten the connector nut. **CAUTION:** *It is very important that care be used when bending*

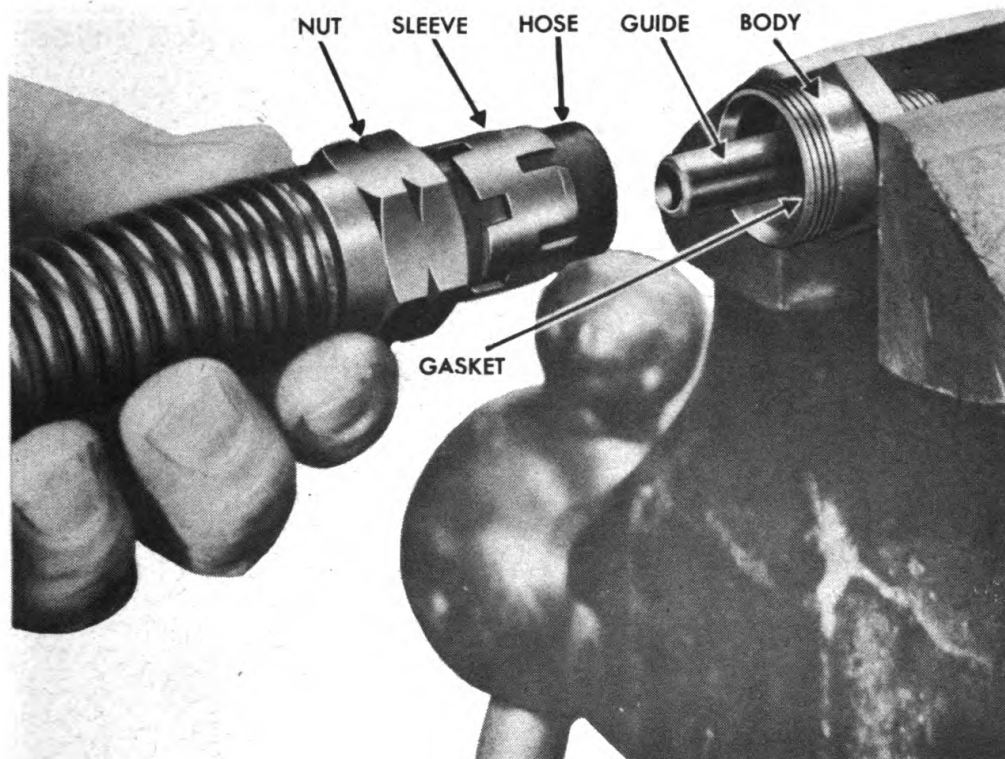

RA PD 308680

Figure 21—Placing Hose into Connector Body

and forming tubing to fit frame. A sharp bend will kink tubing and retard brake application and release. Keep dirt and other foreign matter out of tubing. When making a cut, use a tubing cutter, not a hack saw, as copper dust in tubing is detrimental to functional parts of relay emergency valve. When cutting tubing with a tube cutter, feed cutting wheel into the tubing, a very small amount with each complete rotation until the tube is cut. If the cutter is fed too rapidly, the end of tubing may become beveled inward, reducing the inside diameter of the tube. Make certain all lines are properly anchored to frame members, using tubing clips. When small portion of tubing becomes damaged, cut off the damaged section and replace, using standard 3/8-inch Westinghouse tubing union at each end of replace-

10-TON PAYLOAD, 14-TON GROSS, 2-WHEEL STAKE AND PLATFORM SEMITRAILER AND 10-TON CONVERTER DOLLY

ment tube. No attempt should be made to repair damaged $\frac{1}{2}$ -inch copper lines. Remove and replace with new lines. Close drain cock on reservoir. Open shut-off cocks at rear of towing vehicle. Check for leakage (par. 37 c).

38. AIR HOSE.

a. Description. Two air hoses are used between the brake chamber and the relay emergency valve. The hose has an outside diameter of $\frac{3}{4}$ inch and an inside diameter of $\frac{3}{8}$ inch. The hose is held to relay emergency valve and brake chamber by two connector assemblies.

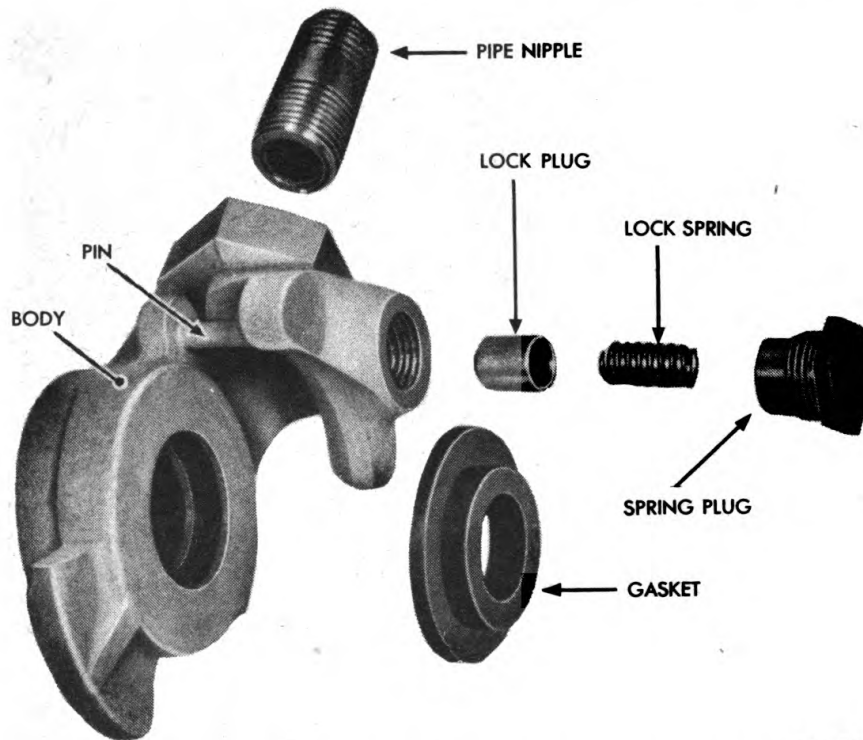

RA PD 308584

Figure 22—Hose Coupling—Disassembled

b. Removal. Remove nut from body of fitting at both ends and pull the hose assembly out of hose guide. Remove connector body from relay emergency valve and brake chamber but do not remove sleeve from hose. If a new piece of hose is to be installed, use a new sleeve.

c. Inspection. Inspect threads on connector body and nut, making certain they are in sound condition. Check hose for chafing, and other damage. If hose is damaged, replace with new hose discarding sleeve and gasket. Use spring, nut, and body again if not damaged.

d. Installation.

(1) Place spring guard and nut over end of hose with the nut toward end to be coupled. Place sleeve over end of hose, making

BRAKE SYSTEM

certain the bevel end of sleeve is toward the end of hose (fig. 21). Install connector body in relay emergency valve. Place gasket over end of hose guide in connector body with the protection cover toward the outer end and remove the protection cover. Shove the hose over hose guide making certain the hose is down into recess as far as it can go and secure the assembly to connector body.

(2) Install connector body in brake chamber and proceed as outlined in preceding step d. Test for leakage (par. 37 c).

39. HOSE COUPLINGS.

a. Description. Two hose couplings are used at the front of the trailer. One it attached to the emergency line and the other to the service line. Both hose couplings are identical in construction.



RA PD 308685

Figure 23—Installing Hose Coupling Gasket

b. Removal. With an adjustable wrench turn hose coupling counterclockwise and remove couplings.

c. Installation. Coat the threaded portion of the pipe or nipple with shellac. Install hose coupling on nipple or pipe and tighten coupling.

d. Replacing Gasket (figs. 22 and 23). Grasp the damaged coupling gasket with a pair of pliers and twist gasket out of coupling body. Scrape all rust and other foreign matter from hose coupling flange gasket groove. Partially collapse new gasket with the fingers

**10-TON PAYLOAD, 14-TON GROSS, 2-WHEEL STAKE AND
PLATFORM SEMITRAILER AND 10-TON CONVERTER DOLLY**

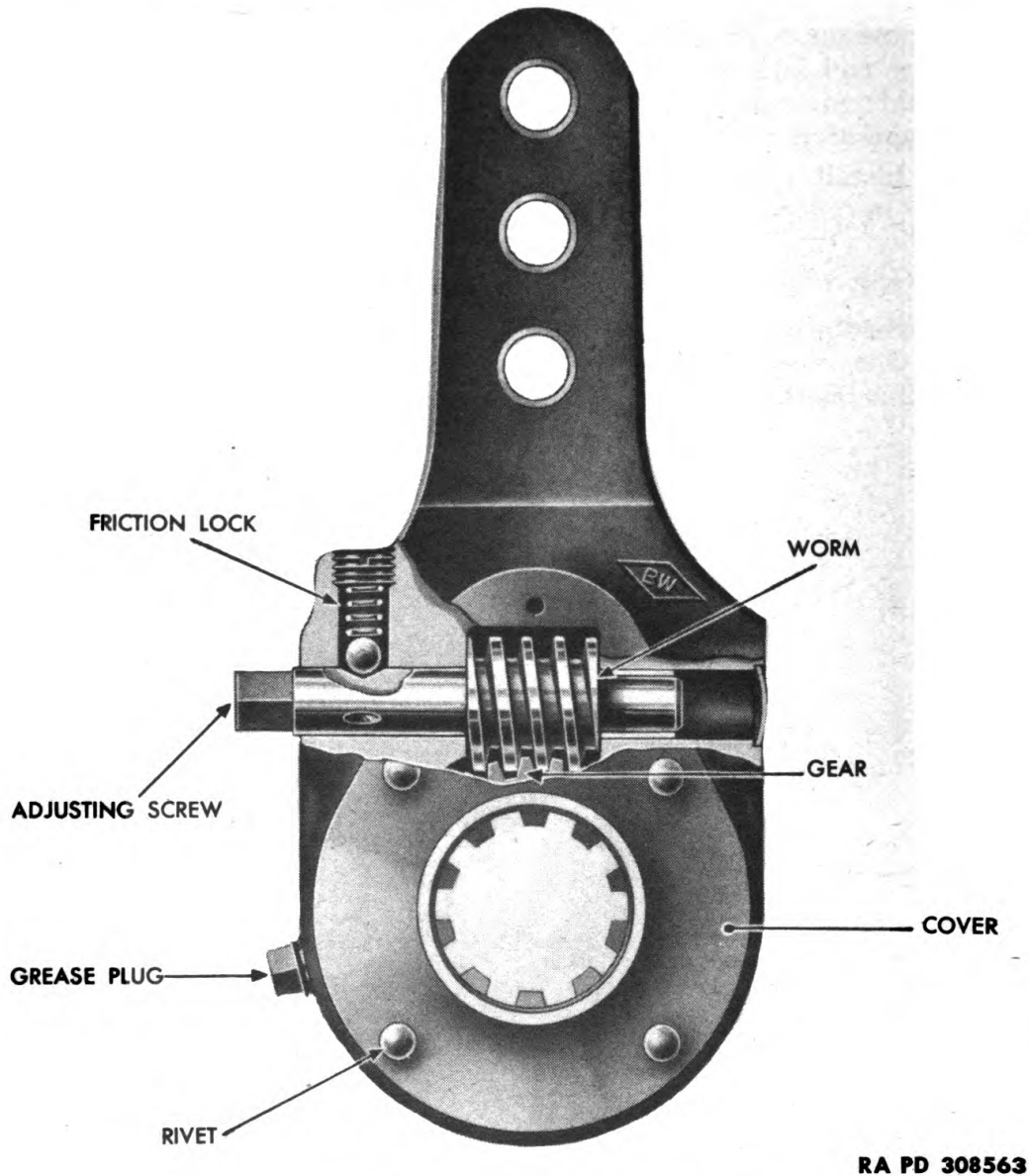

Figure 24—Slack Adjuster—Sectional View

and enter one side of gasket flange into the groove of the coupling. Push the gasket into place in coupling with a blunt screwdriver. Make certain the exposed face of the gasket is not distorted or twisted. Test for leakage (par. 37 e).

40. SLACK ADJUSTER.

a. **Description** (fig. 24). The slack adjuster acts as a brake lever and also provides a quick and easy method of adjusting brakes to compensate for brake lining wear. The slack adjuster is mounted on end of camshaft and is attached to the brake chamber. When the brakes are applied, air enters brake chamber. The slack adjuster

BRAKE SYSTEM

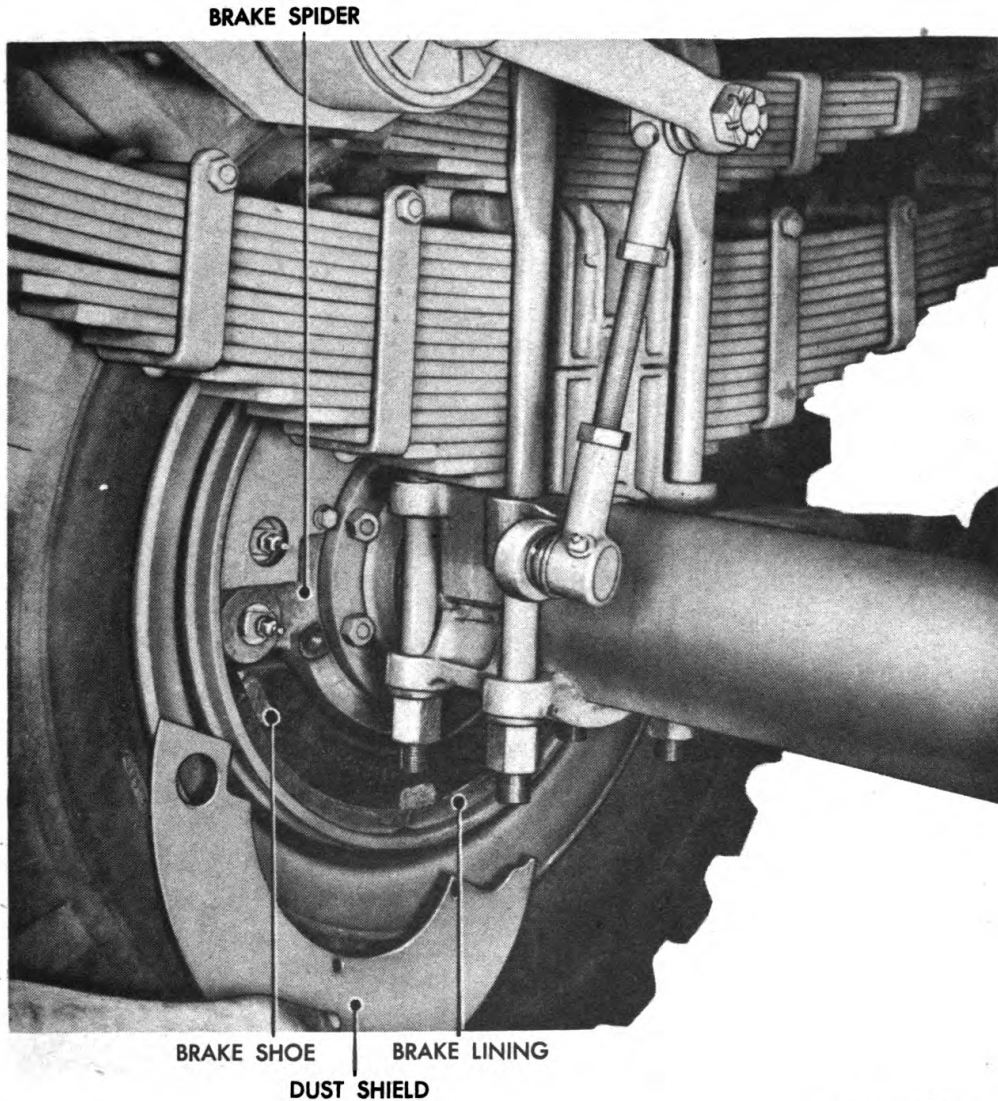

RA PD 334374

Figure 25—Inspecting Internal Brake

is moved forward rotating the camshaft, thus expanding the brake shoes.

b. Removal. Remove cotter pin from rod end pin and tap out end pin. Turn the adjusting screw on slack adjuster clockwise until the end of slack adjuster clears the yoke on end of chamber push rod. Remove cotter pin from end of camshaft, pull off the retainer washer and drive slack adjuster off camshaft. Pull off spacer washer.

c. Replacement. Place spacer washer over end of camshaft. Coat the splined surface of the camshaft with a light film of chassis lubricant and place slack adjuster on camshaft. When placing slack adjuster on camshaft make certain the spline in slack adjuster is in

**10-TON PAYLOAD, 14-TON GROSS, 2-WHEEL STAKE AND
PLATFORM SEMITRAILER AND 10-TON CONVERTER DOLLY**

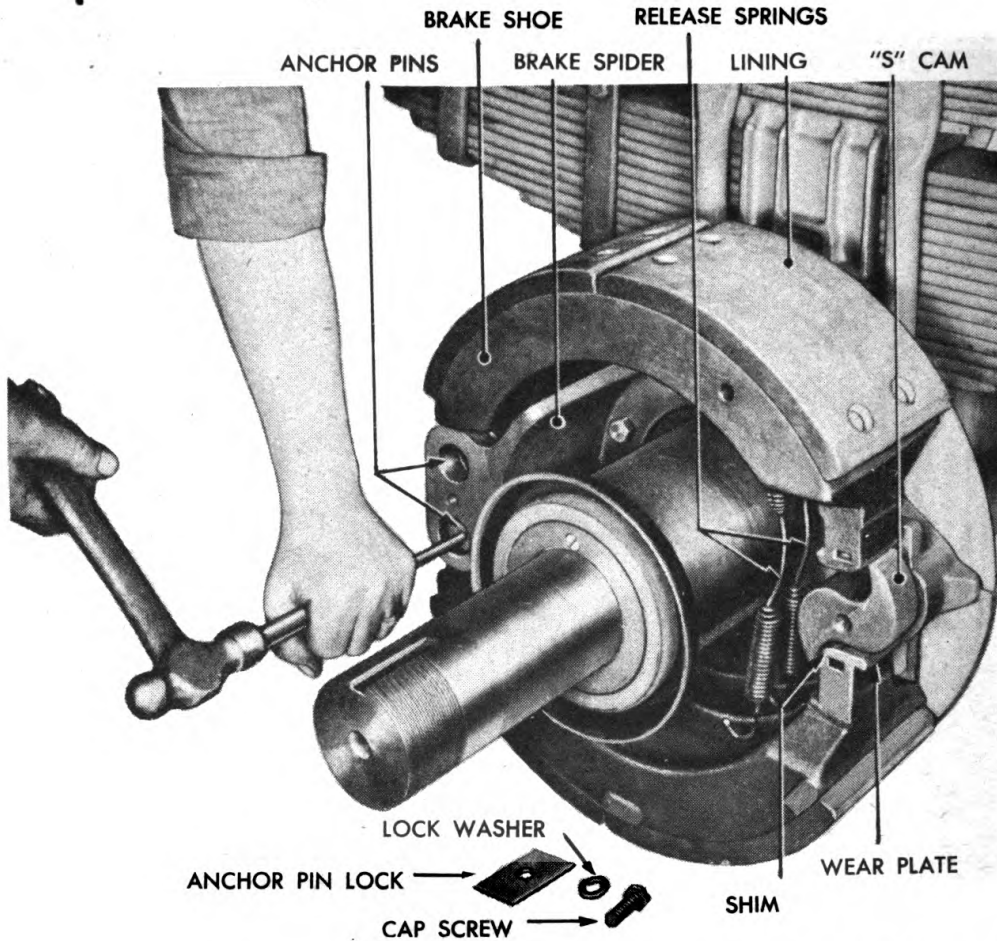

RA PD 334375

Figure 26—Removing Brake Anchor Pins

alignment with spline on camshaft. If slack adjuster is driven onto camshaft and the splines are not in alignment, the slack adjuster will become damaged. Place retainer washer next to slack adjuster and secure retainer washer and slack adjuster to the camshaft using cotter pin. Turn the adjusting screw on the slack adjuster until the arm is in alignment with yoke on chamber push rod. Coat the surface of the rod end pin with chassis lubricant, and install the pin into the yoke and slack adjuster. Install cotter pin in rod end pin.

41. BRAKE SHOE.

a. **Description.** The brake shoes are of the heavy-duty, mechanical, internal-expanding, two-shoe type. The shoes are operated by cam and lever principle. The anchor end of the shoes are equipped with bronze bushings. The cam end of the shoes is provided with a wear plate. Between the wear plate and the shoes, shims are provided

BRAKE SYSTEM

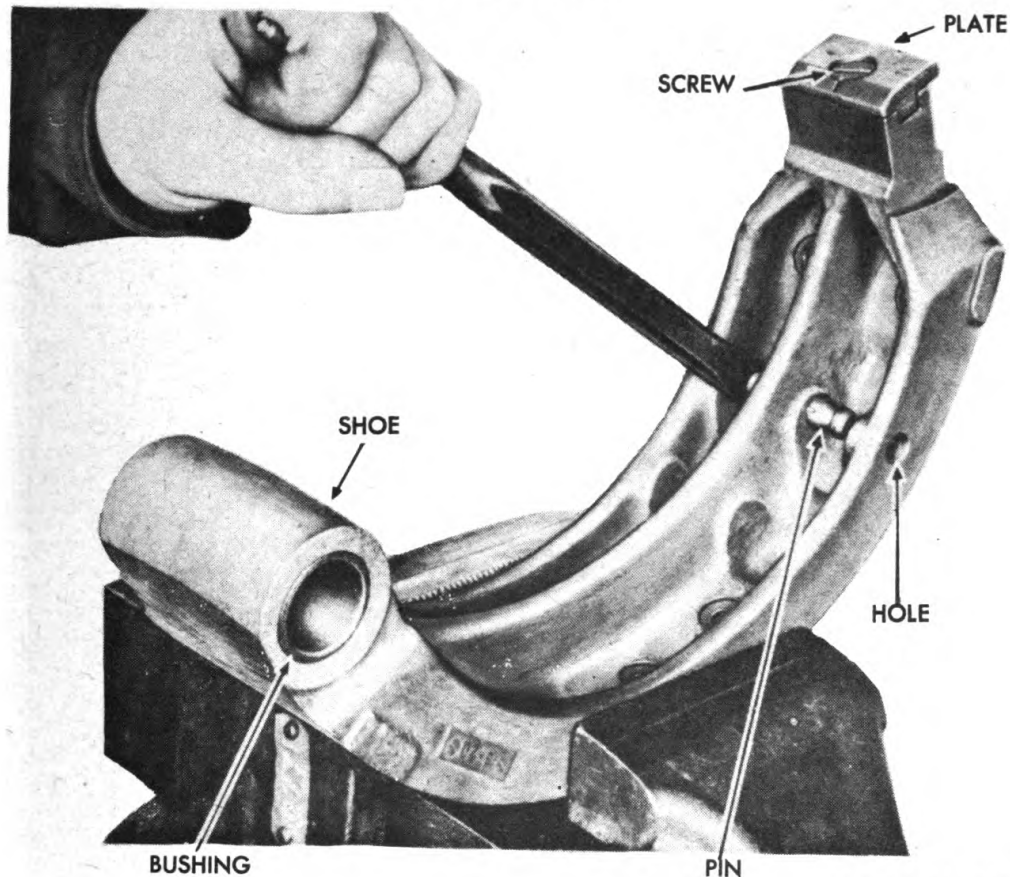

RA PD 334376

Figure 27—Removing Brake Spring Pin

to accommodate major brake adjustment. The shims are made in three thicknesses, $\frac{1}{64}$ inch, $\frac{1}{32}$ inch, and $\frac{1}{16}$ inch.

b. Inspection (fig. 25). The lining can be inspected for wear and broken or damaged internal parts without removing the wheel and hub assembly. This is accomplished by removing the three cap screws from dust shield, and lifting the dust shield off brake spider.

c. Removal (fig. 26).

(1) Remove wheel and hub assembly as one unit (par. 55 a). Remove cap screw and lock washer from brake anchor pin lock and tap out the lock between the two anchor pins. With a blunt end punch and hammer drive out the top anchor pin. Shove the top shoe toward the rear of trailer and lift the top shoe and the two release springs off the axle spider. Drive out the lower anchor pin and remove shoe. Remove spring pins (fig. 27).

(2) Remove eight screws, lock washers, and nuts holding lining to shoe (fig. 28).

d. Installation.

(1) Check brake lining for excessive wear and grease. Replace

10-TON PAYLOAD, 14-TON GROSS, 2-WHEEL STAKE AND PLATFORM SEMITRAILER AND 10-TON CONVERTER DOLLY

with new lining if necessary. If it is necessary to install new lining, replace the complete set of four lining blocks.

(2) Place lining in position on shoe and secure with eight screws, lock washers, and nuts. Place a light coat of general purpose grease No. 1 on surface of brake anchor pins. Install the spring pins. Place the lower shoe in position in brake spider. Aline the hole in brake shoe with the spider anchor pin hole. Install the anchor pin. **NOTE: Make certain anchor pins are installed with the lubrication fitting toward the outer side of the brake spider and the flat side of anchor**

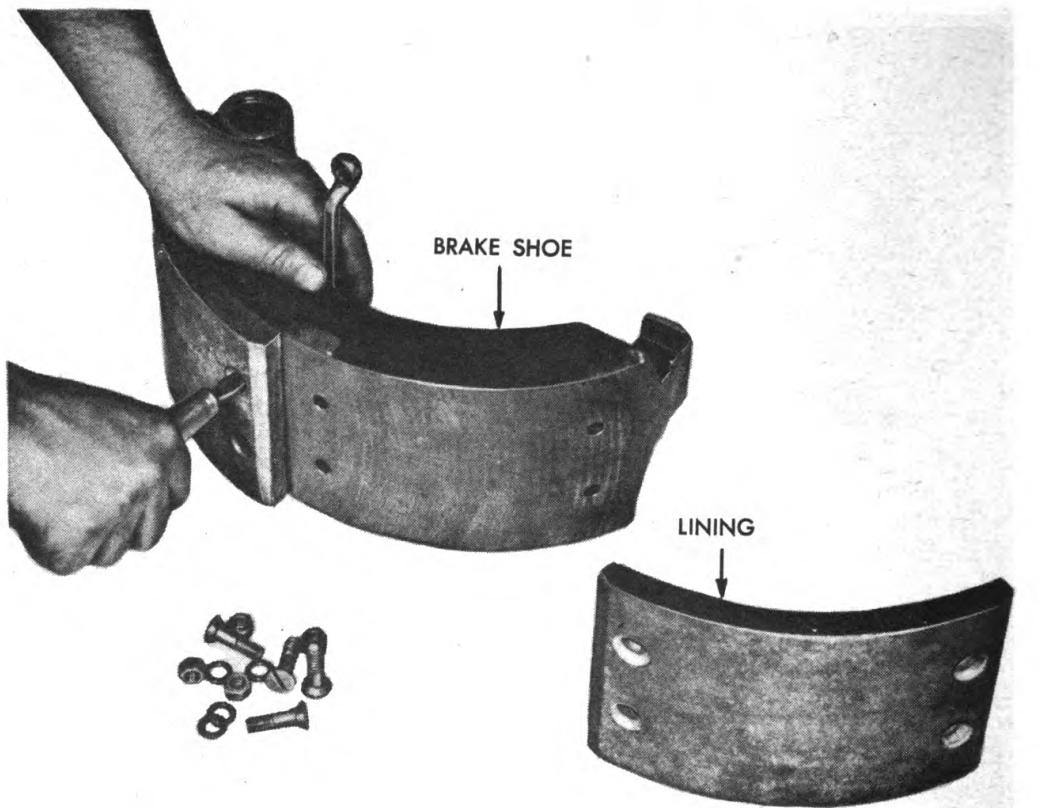

RA PD 334377

Figure 28—Removing Brake Lining

pin is down to accommodate the anchor pin lock. Hook the two release springs to spring pin on upper shoe. Place the shoe in position on brake spider. Move the shoe toward the rear of trailer so that the cam end of shoe will not rest on the cam. Couple the two release springs to the spring pin in lower shoe. Raise the cam end of shoe up, and rest the shoe on the cam. Aline hole in shoe with anchor pin hole and install the anchor pin (see preceding note). Secure anchor lock to brake spider and make certain that end of anchor pin lock is seated in the flat surface of anchor pins. Coat upper and lower surfaces of "S" portion of cam with general purpose grease. Remove

BRAKE SYSTEM

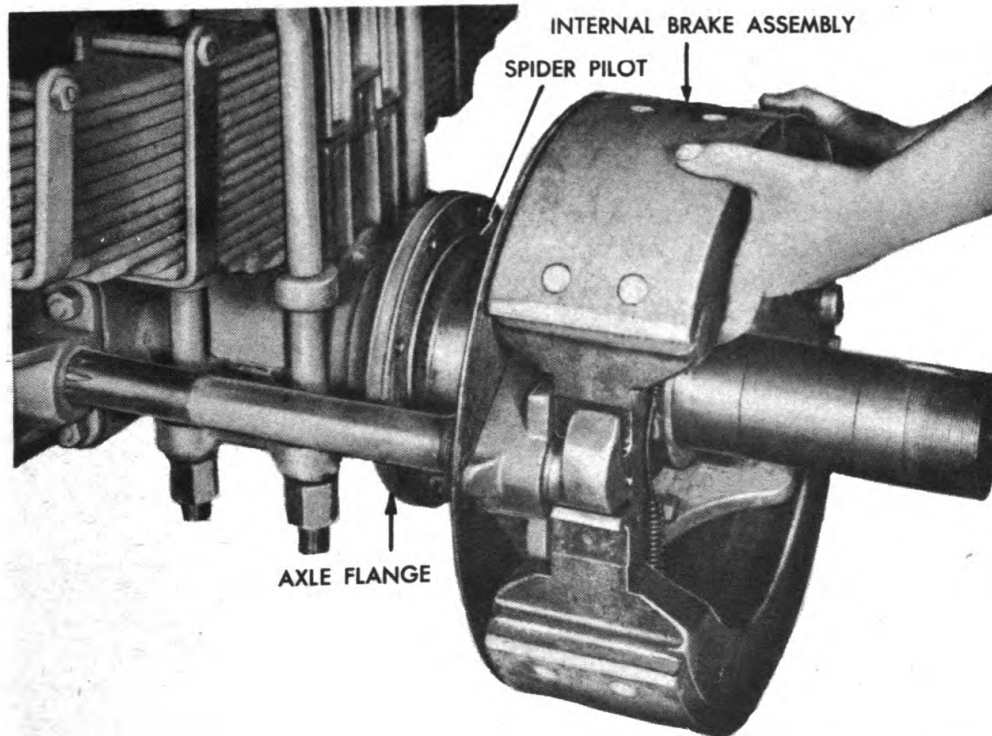

RA PD 334378

Figure 29—Removing Internal Brake Assembly

all burrs from lining and clean all grease, dust, and other foreign matter from brake drum. Install wheel and hub assembly as one unit (par. 55 b). Adjust brakes (par. 38).

42. INTERNAL BRAKE ASSEMBLY.

a. Removal (fig. 29). Remove slack adjuster (par. 40 b), wheel and hub assembly (par. 55 a), and the eight cap screws and nuts holding brake spider to axle flange. Lift the assembly off axle spindle using care not to damage the axle spindle threads.

b. Installation. Make certain the internal brake assembly is installed on the proper side. The cams are made in rights and lefts. Figure 29 illustrates the cam on the left side of semitrailer.

(1) Place internal brake assembly over axle spindle and shove the cam through the mounting bracket on axle. Install the internal brake assembly on pilot on axle flange and aline hole in axle flange with holes in brake spider. Secure the internal brake assembly to axle flange using eight cap screws and eight nuts. Tighten the cap screw nuts evenly to prevent cocking of brake spider on axle flange pilot. Place two center punch marks on each cap screw nut to prevent the nuts from working loose. Install slack adjuster (par. 40 c). Install wheel and hub assembly (par. 55 b). Adjust brake (par. 32).

10-TON PAYLOAD, 14-TON GROSS, 2-WHEEL STAKE AND PLATFORM SEMITRAILER AND 10-TON CONVERTER DOLLY

Section XI

SUSPENSION

43. DESCRIPTION (fig. 30).

a. **General.** The suspension is an assembly consisting of spring hangers, auxiliary spring brackets, cross shaft, auxiliary springs, main springs, shock absorbers and axle. The semitrailer frame is carried on the axle through the suspension assembly with the auxiliary spring brackets which are bolted to the frame side rails. The following maintenance instructions apply to both the semitrailer and dolly.

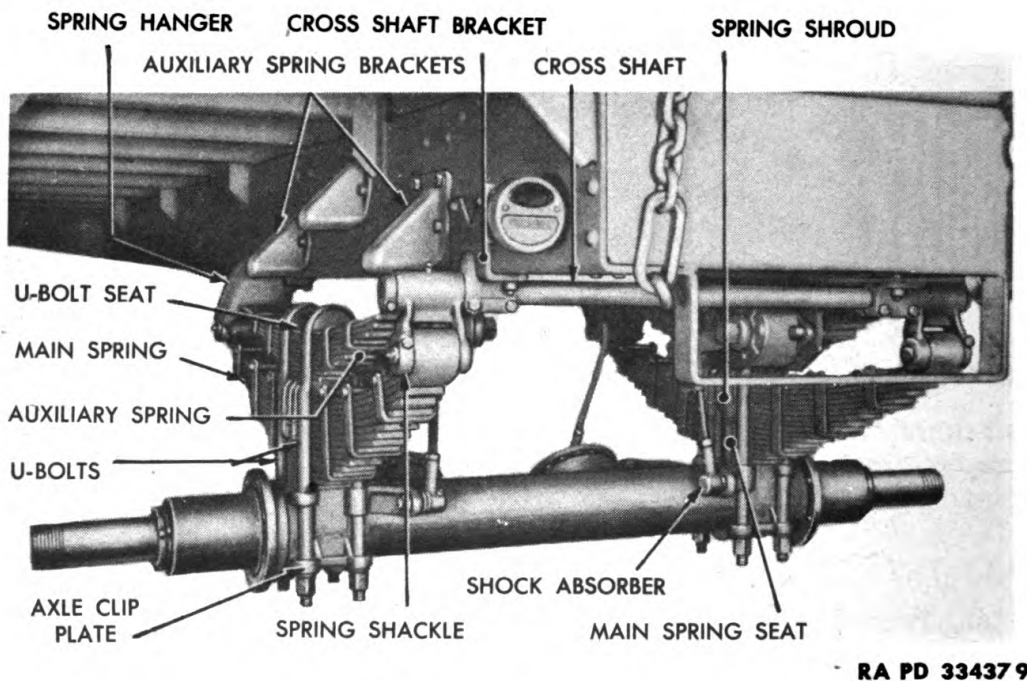

RA PD 334379

Figure 30—Semitrailer Suspension

b. **Springs.** The main spring is of the eye-type, anchored at the front hanger, and shackled to cross shaft at the rear. The springs are carried on bronze bushings and pins. The main spring consists of 16 leaves, spring center bolt, and 6 clips. The auxiliary spring consists of 10 leaves with the clips bent over the top leaf to eliminate clip spacers and bolts. The auxiliary spring and the main spring are bolted to the axle assembly with 2 U-bolts. The semitrailer main and auxiliary springs are interchangeable with towing vehicle springs. The dolly main spring is interchangeable with the semitrailer main spring.

c. **Axle.** The axle is of seamless steel tubular construction with solid steel spindles. The spring seats and shock absorber brackets are welded to the axle. The axle is cambered to prevent uneven wear of

SUSPENSION

the tires. The semitrailer axle can be used as a dolly axle. The dolly axle cannot be used as the semitrailer axle.

d. Shock Absorbers. Double-acting shock absorbers control the action of the springs. The shock absorber mechanism is bolted to the frame and the connecting links are attached to the axle at the rear side. The shock absorbers are interchangeable with the rear shock absorbers on towing vehicle. The dolly is not provided with shock absorbers.

44. MAIN SPRING.

a. Removal (fig. 30). Couple chain hoist to rear crossmember, or use blocking and jacks, and jack up the trailer frame until the weight of the frame is off the springs. When removing springs with jacks on blocking, make certain the block and jacks are placed where no slippage will take place (par. 47 a (1)). Remove four U-bolt nuts and lock washers. Tap the U-bolts up, using care not to damage the thread. Place a bar between the U-bolt seat and the U-bolts and pry the U-bolts out of main spring seat. Lift U-bolt seat off auxiliary spring and lift auxiliary spring off spring shroud. Remove one bolt from rear shackle and shackle pin and drive the pin out of shackle. Remove cap screw from front spring hanger bracket and pin, and drive out the pin. Tap the spring shackle toward rear of semitrailer and lift the main spring off the main spring seat. Remove auxiliary spring shroud.

b. Installation. If both main springs are being installed, before installing the main springs, insert a spring into each eye and place a straight board across the top of the pins. Measure the distance at the center bolt from board to bottom of spring to determine the arch. Install the spring with the greatest amount of arch on the right side (fig. 47).

(1) Place spring in position on main spring seat with the spring clip bolt nuts toward the tire. Make certain the spring center bolt is fully down into recess in main spring seat. Aline spring eye with hole in front spring hanger bracket by placing bar between the tire and the ground and prying the wheel in the direction desired.

(2) Remove lubricating fitting from spring pin. Coat the surface of spring pin with general purpose grease. Place the pin into spring hanger with the bolt groove down and in alinement with the pinch bolt hole in the spring hanger. Place a block of wood over spring pin and drive the pin into position. **CAUTION: Do not strike spring pin with steel hammer. They are of a hardened steel and chips may fly causing injury.** Install pinch bolt with the head toward front of vehicle. Install lubricating fitting.

(3) Tap spring shackle over spring eye. Aline shackle with spring eye by raising or lowering the hoisting facilities. Remove lubricating fitting from spring pin. Coat the surface of spring pin with general purpose grease. Place pin into shackle with the cap screw groove up and in alinement with cap screw hole in shackle. Place a block of wood over spring pin and drive the spring pin into shackle. Install

10-TON PAYLOAD, 14-TON GROSS, 2-WHEEL STAKE AND PLATFORM SEMITRAILER AND 10-TON CONVERTER DOLLY

pin bolt with the head toward front of vehicle. Install lock washer and nut and tighten.

(4) Place spring shroud over main spring. Place auxiliary spring on auxiliary spring chair making certain the spring center bolt is resting in recess in spring shroud. Place U-bolt seat on auxiliary spring with the hole over the spring center bolts. Install U-bolts. Install lock washer and nuts and tighten using a wrench with 36-inch minimum leverage. *NOTE: When tightening U-bolt nuts alternate from one to another to bring the auxiliary spring down evenly at both ends, thus maintaining the same distance between the auxiliary spring and the auxiliary spring brackets. Make certain auxiliary spring is in alinement with main spring.*

45. AUXILIARY SPRINGS.

a. Removal. Remove U-bolts, nuts, and lock washers. Tap up on U-bolts and pull the U-bolts out. Lift the U-bolt seat off auxiliary spring. Raise up on auxiliary spring and lift the spring out towards the rear of the vehicle.

b. Installation. Place auxiliary spring in position on spring shroud making certain the spring center bolt is seated in recess in spring shroud. Place U-bolt seat over auxiliary spring making certain the hole in center of U-bolt seat at underside is over the spring center bolt. Install U-bolts, lock washers, and nuts. Tighten nuts using a wrench with 36-inch minimum leverage, see note in paragraph 44.

46. AXLE.

a. Removal. Remove wheel and hub assembly as one unit from both axle spindles (par. 55 a). Remove the two connector nuts from the connector bodies at the brake chamber and pull the flexible hose off the brake chamber. Couple chain hoist to rear crossmember or use wood blocking and jacks to support the frame. Remove internal brake assemblies from both sides of axle (par. 42). Mark an "R" on the right-hand brake assembly, and an "L" on the left-hand brake. Remove four nuts and four lock washers from the four studs holding brake chamber mounting bracket to axle and lift off the brake chamber and mounting bracket as an assembly. Repeat the same operation on chamber mounting bracket on opposite side. Remove the eight chamber mounting bracket studs using a pipe wrench. Pull cotter pin from shock absorber arm, remove nut and pull the arm and link free of axle bracket. Place nut back on the shock absorber arm to prevent loss of spring and dust collars. Remove shock absorber from opposite side in the same manner. Place hub bearing adjusting nut on each spindle to prevent threads from becoming damaged. Place blocking or jack under axle. Remove the eight nuts and lock washers and U-bolts. Lower the axle to ground and remove axle. Remove the two screws holding grease retainer assembly to axle and remove grease retainer on opposite side in the same manner.

SUSPENSION

b. Installation.

(1) Lift the U-bolts off the spring assembly. Place axle in position under semitrailer frame making certain the shock absorber bracket is facing toward the rear of the vehicle. Raise the axle up until the axle contacts the main spring. Make certain the spring center bolt head which protrudes below the main spring is resting in the hole in the main spring chair. Place U-bolts in position over the spring assemblies. Install the lock washers and U-bolt nuts and tighten using a wrench with 36-inch minimum leverage. Install the 8 chamber mounting bracket studs using a pipe wrench. Secure chamber mounting bracket and brake chamber assembly to studs using 8 nuts and 8 lock washers. Install the brake assembly marked with an "R" on the right side. Install brake assembly marked with an "L" on the left side (par. 42 b). Secure the 2 grease retainer assemblies to axle spindle using 4 screws. Install wheel and hub assembly (par. 55 b (1)). Insert the flexible hoses in connector body at brake chamber and secure into position using connector nut. Remove nut from shock absorber arm and insert the arm into bracket on the axle. Install and tighten nut. Install cotter pin. Remove blocking, jacks and hoist. Check brake chamber connector for leaks (par 37 c). Adjust brakes (par. 32).

(2) Place brakes in the applied position and check the release. If brakes do not release rapidly the mounting bracket is causing the camshaft to bind. Loosen the nuts on the mounting bracket studs and tap the mounting bracket first to the right and then to the left, until the mounting bracket is in perfect alinement. Tighten stud nuts.

47. CROSS SHAFT.

a. Removal.

(1) Place ample blocking under rear crossmember to accommodate two jacks. Place the jacks on blocking directly under rivet heads of rear crossmember at both sides. Jack the trailer frame making certain jack cap contacts rivet head to prevent slippage.

(2) Remove nut and lock washer from cap screw in shackles. Drive out the two cap screws using a hammer and long tapered drift. Drive pin out of shackle and spring eye. If difficulty is encountered when driving out the two pins, raise or lower the jacks to relieve the tension.

(3) Remove the two pinch cap screws from the two cross shaft stud collars. Place a screwdriver into slot in the stud collars and turn them counterclockwise until removed. Tap shackle toward rear of vehicle and pull the shackles off the cross shaft.

(4) Remove four nuts and four lock washers from the underside of cross shaft bracket, with a long tapered $\frac{3}{8}$ -inch drift. Drive out the four cap screws. Drive a thin tapered chisel into slot on underside of the two cross shaft brackets to release bind. Tap out the cross shaft using care not to damage the threads.

**10-TON PAYLOAD, 14-TON GROSS, 2-WHEEL STAKE AND
PLATFORM SEMITRAILER AND 10-TON CONVERTER DOLLY**

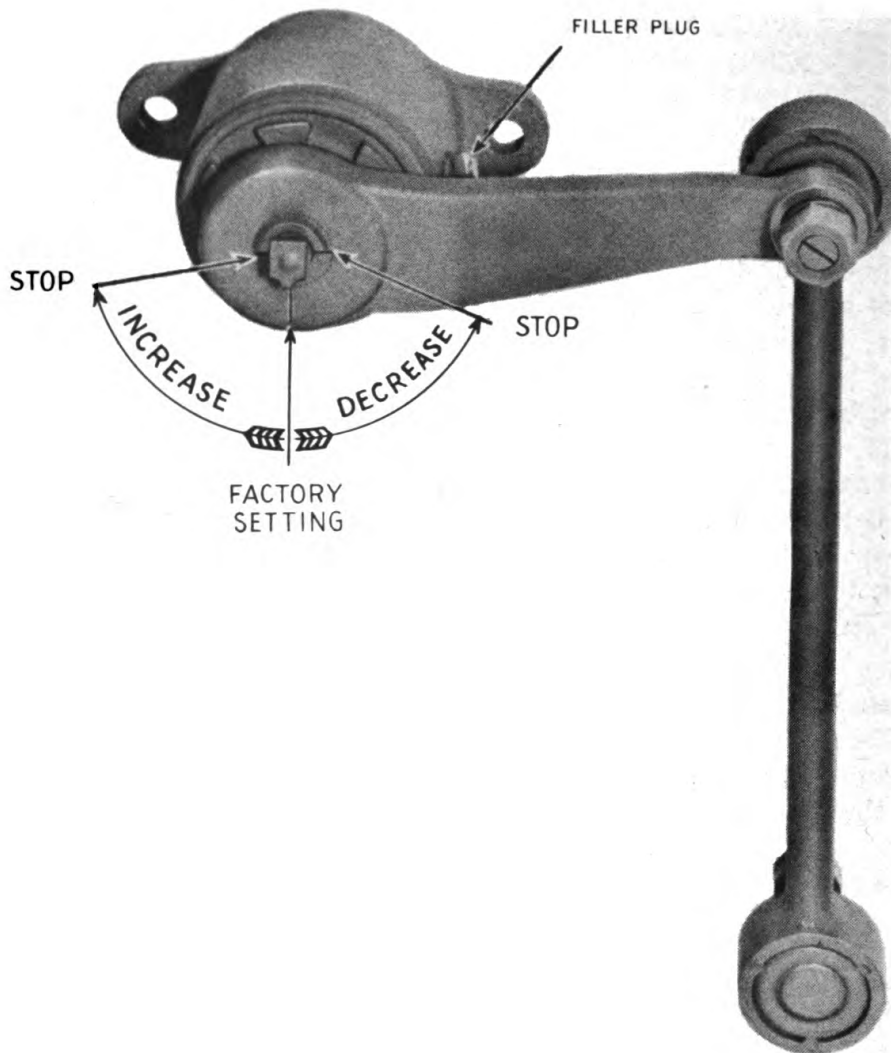

RA PD 18299

Figure 31—Shock Absorber Adjustment

b. Installation.

(1) Place a light film of general purpose grease No. 1 over the entire surface of the cross shaft. Place cross shaft into cross shaft mounting bracket making certain the four cap screw slots are in the "DOWN" position. Tap the cross shaft through the two mounting brackets until the cap screw slots are in alignment with the holes in underside of the cross shaft mounting brackets. Drive $\frac{3}{8}$ inch long tapered drift into mounting bracket to assist in properly aligning the slot in the cross shaft with the cap screw holes. If difficulty is en-

SUSPENSION

countered, turn the shaft to the desired position using a pipe wrench. Install the four cap screws, lock washers, and nuts.

(2) Place shackle on each end of cross shaft with the cap screw hole toward the outer side. Turn shackle down over spring eye. Raise or lower jack to aline pin hole in shackle with spring eye. Install the pin making certain the groove in pin is facing up. Install the two cap screws, lock washers, and nuts. Install the two cross shaft caps and tighten. Do not tighten the cross shaft too tight as tight cross shaft caps will retard free movement of the shackles. Install cap screw in shackle and tighten. Remove jacks and blocking. Lubricate shackles (par. 16).

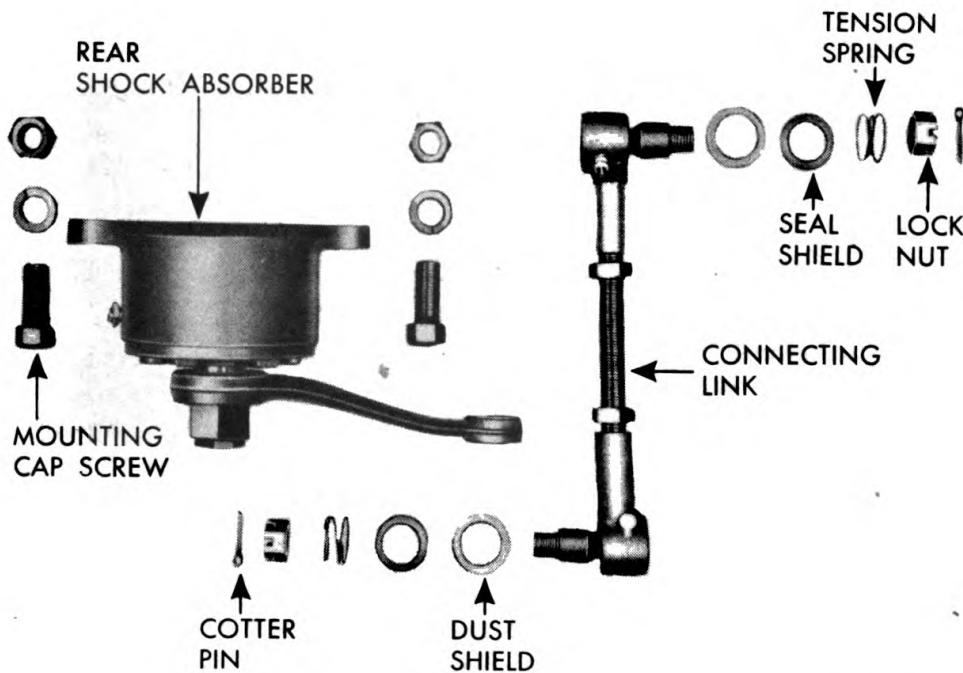

RA PD 323380

Figure 32—Shock Absorber and Connecting Links

48. SHOCK ABSORBER.

a. Description. Shock absorber controls the rebound action of the springs. The shock absorber mechanism is bolted to a mounting bracket on inner side of frame and the connecting links are attached to the spring plate. The links are provided with lubrication fittings.

b. Adjustment.

(1) The shock absorbers are adjusted at the factory to meet average riding conditions, and it is recommended that the factory setting be maintained. Adjustment can be made, however, to meet special operating conditions.

(2) Remove outer nut from shaft at the side of the housing (fig. 31). To increase the resistance of the shock absorber, the indi-

10-TON PAYLOAD, 14-TON GROSS, 2-WHEEL STAKE AND PLATFORM SEMITRAILER AND 10-TON CONVERTER DOLLY

cator is rotated clockwise. The indicator should not be turned more than $\frac{1}{8}$ inch at a time until satisfactory control is obtained. Do not adjust beyond shoulder stop.

c. Refilling.

(1) Clean all dirt and other foreign matter from unit to prevent particles of dirt from entering the mechanism. Remove filler plug, and inspect fluid level which must be at level of plug. Refill if necessary.

(2) Disconnect link at axle end. Pump arm up and down several times to dispel air trapped in the unit. Add fluid (par. 15) and repeat pumping. When the working chamber is properly filled, there will be uniform resistance and no rubbery feeling or lost motion. Refill chamber to level of filler plug, and install filler plug. Connect shock absorber link at axle end.

d. Removal (fig. 32). Remove cotter pin and nut from shock absorber link at axle end. Using copper hammer, tap tapered ball stud from U-bolt seat arm. Remove seal washer and spring from tapered ball stud. Remove two nuts and lock washers from two cap screws holding unit to frame mounting bracket.

e. Installation. Place shock absorber in position on frame mounting bracket, and install two cap screws, two lock washers, and two nuts. Place spring and seal washer on connecting link ball stud. Drive ball stud into position in U-bolt seat arm. Install nut and cotter pin.

Section XII

LANDING GEAR

49. DESCRIPTION.

a. Semitrailer landing gear is bolted to each side of the semitrailer main frame side rails at the drop. The landing gear is lowered prior to uncoupling the towing vehicle or dolly from the semitrailer. The operating crank is attached to the operating shaft on the right side. Gears are keyed to the operating shaft which mesh with gears on the end of the screw, thus lowering or raising the landing gear legs. Two wheels are provided at the end of each leg and the wheels are mounted on a truck. The truck is held to the leg by a pin which permits the wheels to move in a horizontal direction to accommodate uneven ground conditions.

b. The dolly landing gear is of a stiff leg fold-back type. The dolly landing gear holds the dolly in a level position when the dolly is disconnected from the semitrailer.

LANDING GEAR

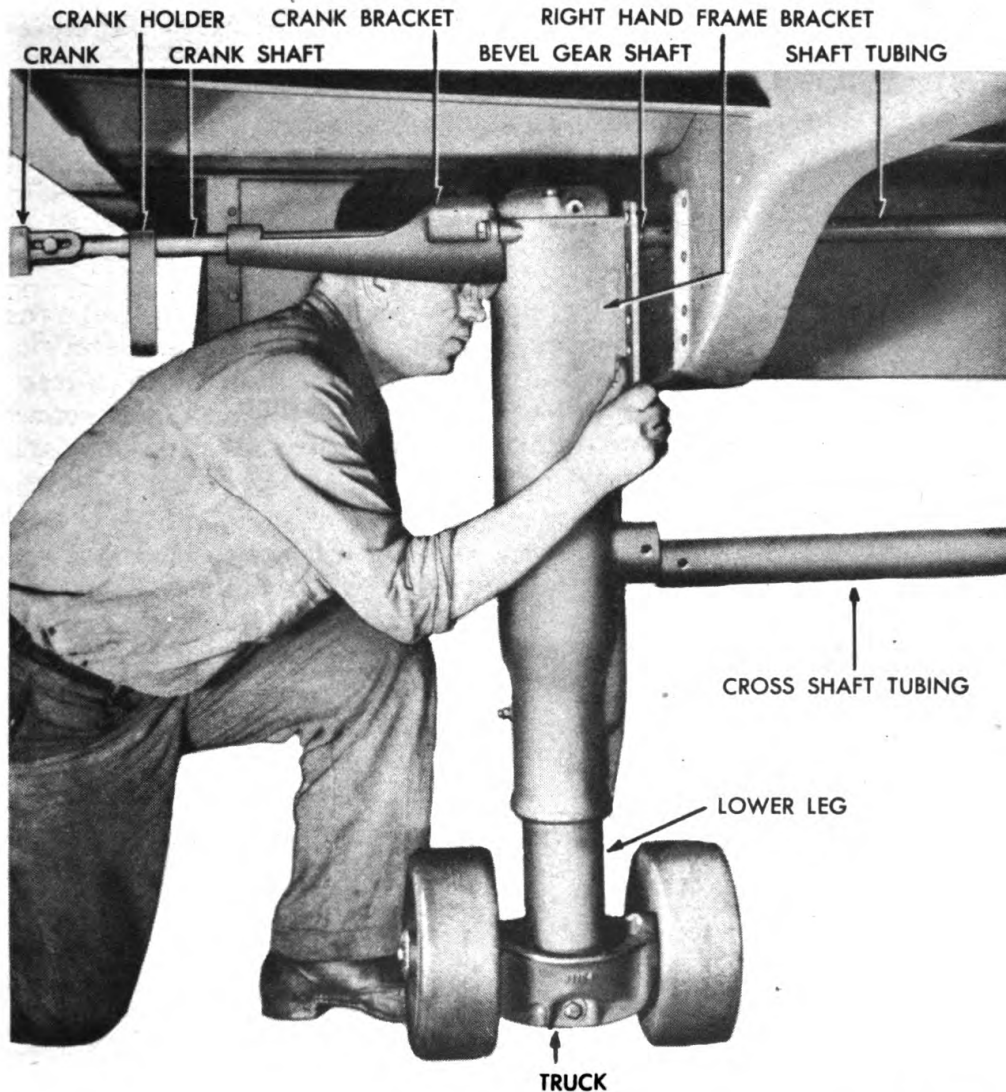

RA PD 334390

Figure 33—Removing Semitrailer Landing Gear Assembly

50. SEMITRAILER—RIGHT-HAND LANDING GEAR ASSEMBLY.

a. **Removal** (fig. 33). Do not remove any part of the landing gear assemblies unless the semitrailer is coupled to dolly or towing vehicle, or properly blocked up at front to prevent the semitrailer from falling on its nose.

(1) Remove cap screw and nut from crank and operating shaft. Pull the crank off operating shaft. Remove crank holder.

(2) Remove three cap screws and three lock washers from crank bracket. Pull crank bracket off crank shaft.

(3) Remove two cap screws, nuts and lock washers from crank

10-TON PAYLOAD, 14-TON GROSS, 2-WHEEL STAKE AND PLATFORM SEMITRAILER AND 10-TON CONVERTER DOLLY

shaft coupling. Pull the crank shaft and crank shaft coupling off the bevel gear shaft which protrudes from the frame bracket.

(4) Remove cap screw nut and lock washer from cross shaft tubing. Remove cap screw, nut and lock washer from back brace. Remove cap screw, nut and lock washer from bevel gear shaft tubing. Remove eight cap screws, nuts and lock washers holding the landing gear assembly to frame. Remove the assembly.

b. Installation.

(1) Place the assembly in position on the frame. Install cross shaft tubing into socket on housing. Place shaft tubing over bevel gear shaft. Install back brace into socket on housing. Aline holes in frame bracket with those in semitrailer frame. Install the eight cap screws, lock washers and nuts and tighten the nuts. Install cap screw, nut and lock washers in operating shaft tubing and back brace.

(2) Install crank brace using three cap screws and three lock washers. Place crank shaft through the crank bracket. Couple crank shaft to bevel gear shaft using coupling, two cap screws, two lock washers and two nuts. Place crank holder over crank shaft with the hook side toward rear of vehicle.

(3) Attach crank to operating shaft using cap screw and nut. Do not tighten cap screw. Tight cap screw will prevent free movement of the crank on the crank shaft. Place two punch marks on nut to prevent it from coming loose.

(4) Measure length of lower leg on landing gear at the opposite side. Turn crank until length of both legs are identical. Aline hole in bevel gear shaft with hole in shaft tubing. Secure shaft tubing to bevel gear shaft using cap screw, lock washer and nut.

51. SEMITRAILER—LEFT-HAND LANDING GEAR ASSEMBLY.

a. Removal. Block up front of semitrailer (par. 50 a). Remove cap screw nut and lock washer from cross shaft tubing. Remove cap screw, nut and lock washer from back bracket. Remove cap screw, nut and lock washer from shaft tubing. Remove eight cap screw nuts and lock washers holding the left-hand landing gear assembly to semitrailer frame. Lift the assembly out.

b. Installation. Adjust lower leg (par. 50). Place the assembly in position on frame and slip the operating shaft into operating shaft tubing. Secure the assembly to frame using six cap screws, six lock washers and nuts. Aline hole in operating shaft tubing with hole in operating shaft by turning the crank on the right side assembly and install cap screw, lock washer, and nut.

52. SEMITRAILER—TRUCK AND WHEEL ASSEMBLY.

a. Removal. Remove nuts and lock washers from cap screws that hold wheels to wheel truck. Remove cap screws and axle caps. Pull wheels off wheel truck. Remove cotter pin, nut, cap screw, and two

LANDING GEAR

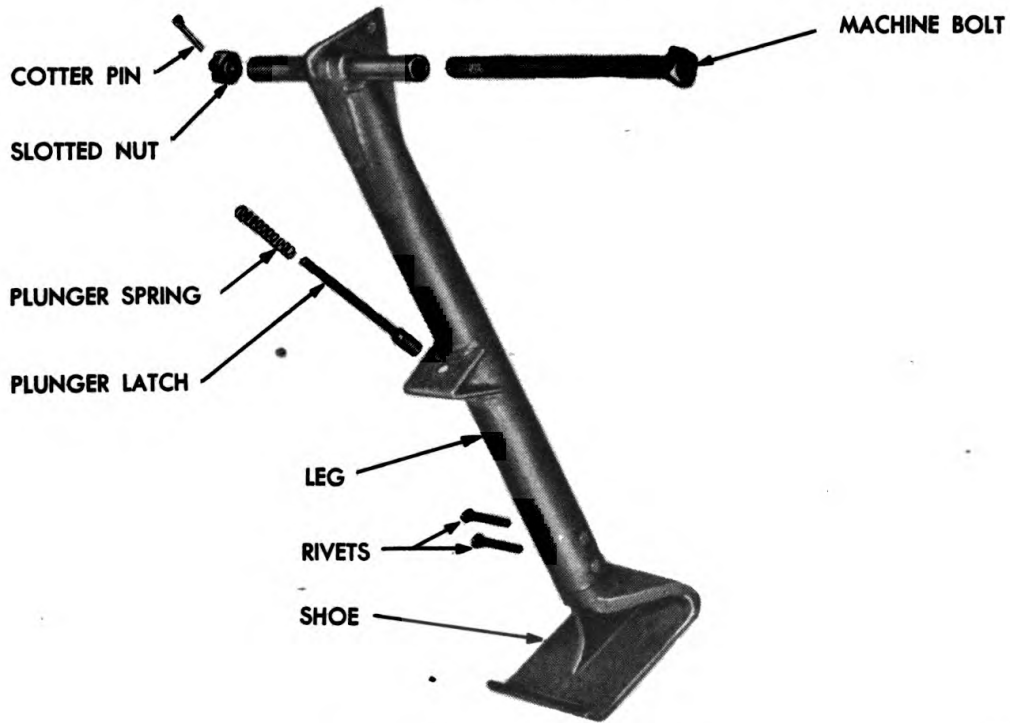

LANDING GEAR—EXPLODED VIEW

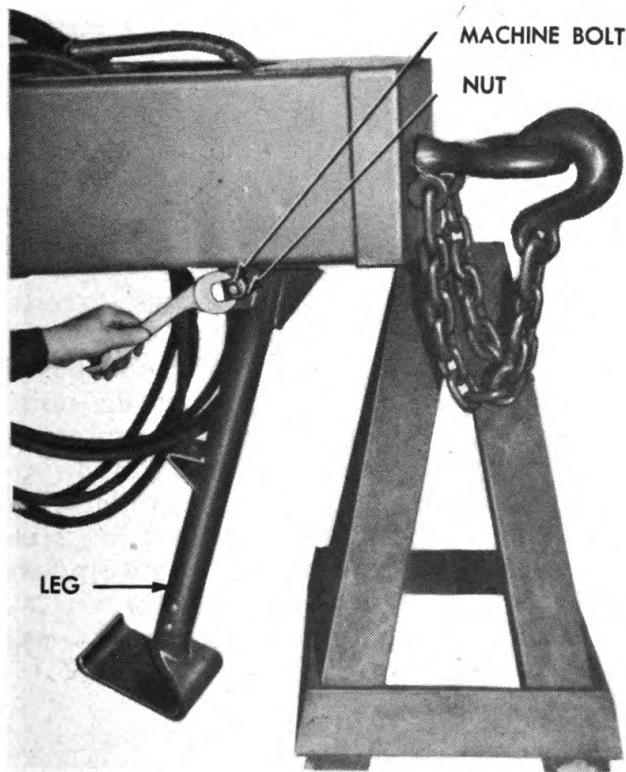

DOLLY LANDING GEAR

RA PD 334388

Figure 34—Dolly Landing Gear

TM 9-892

52-54

10-TON PAYLOAD, 14-TON GROSS, 2-WHEEL STAKE AND PLATFORM SEMITRAILER AND 10-TON CONVERTER DOLLY

plain washers from truck pin. Drive truck pin out of wheel truck and lower leg.

b. Installation. Place a light film of general purpose grease No. 1 over surface of truck pin. Place truck in position on lower leg. Aline hole in lower leg with hole in truck. Install truck pin. Secure truck pin to truck using two plain washers, cap screw, nut and cotter pin. Place a film of general purpose grease No. 1 over spindles on truck. Install wheels on truck spindles. Secure wheels to truck using axle caps, cap screw, lock washer, and nut.

53. DOLLY LANDING GEAR.

a. Removal (fig. 34). Couple lunette eye to pintle hook on towing vehicle or place a wood horse under A-frame of dolly draw bar. Remove cotter pin, nut, and plain washer from machine bolt holding landing gear to mounting brackets. Drive machine bolt out of mounting brackets and remove the landing gear.

b. Replacement. Place landing gear in position between the two mounting brackets of draw bar A-frame. Push the machine bolt through the mounting brackets and the eye in end of landing gear. Secure machine bolt to mounting brackets using plain washer, nut, and cotter.

Section XIII

WHEELS, HUBS, DRUMS, AND TIRES

54. DESCRIPTION AND TABULATED DATA.

a. Description. The wheels are of the ventilated pressed-steel type. Each wheel is fastened to the hub by a separate set of nuts. The stud nuts on the wheels on the right side have right-hand threads. The inner dual wheels are individually held to the hub by inner cap nuts. The outer wheel slips over the inner cap nuts and is independently held to hub by outer nuts. The wheels and tires on the dolly are identical to those on the semitrailer. The hub assembly is mounted on the axle spindles on tapered roller bearings. The drums are fastened to the inner end of wheel studs on the semitrailer. The hubs on the dolly are not equipped with drums, however, a collar is provided on the dolly wheel studs to take up the space between face of hub and stud nuts.

b. For maintenance and care of pneumatic tires refer to TM 31-200.

c. Data.

Wheels:

Make	Budd
Type	Ventilated disk
Number of studs	10

WHEELS, HUBS, DRUMS, AND TIRES



RA PD 334380

Figure 35—Removing Wheel and Hub Assembly

Tires:

Size 11:00 x 20
Number of plies 14
Type Mud and snow grip
Air pressure 80 lb

Bearings:

Make Timken
Size No. 596
Quantity 4

TM 9-892
54-56

10-TON PAYLOAD, 14-TON GROSS, 2-WHEEL STAKE AND PLATFORM SEMITRAILER AND 10-TON CONVERTER DOLLY

Cup:

Make Timken
Size No. 592-A
Quantity 4

55. WHEEL AND HUB ASSEMBLY.

a. Removal (fig. 35).

(1) Place jack under axle cap on side to be removed. Block opposite wheel to prevent trailer from moving. Place brakes in the released position. Raise jack until tires clear the ground. Place a greased board or plate under the dual wheels to serve as a skid. Lower jack until tires contact greased skid.

(2) Remove six cap screws and lock washers from hub cap. Remove hub cap and hub cap gasket. With axle nut wrench turn jam nut counterclockwise and remove jam nut from axle spindle. With the aid of a screwdriver, pull locking washer off axle spindle and turn adjusting nut counterclockwise. Remove the adjusting nut.

(3) Pull the wheel and hub assembly off axle spindle. Outer bearing will slide off the spindle with hub. Guard against permitting bearing to fall in the dirt. If wheel and hub assembly does not slide off spindle with a minimum amount of effort, decrease the diameter of brake shoes by turning adjusting screw on slack adjuster clockwise. Pull inner bearing off spindle. *NOTE: Wrap bearings in a cloth to prevent them from coming in contact with sand and other foreign matter.*

b. Installation.

(1) Inspect bearings and bearing cups for chips, pits and excessive wear. Check cups to make certain they are tight in hub bore. Inspect felt grease retainer for excessive wear or over-saturation. Replace felt if necessary (par. 59 a). Lubricate bearings (par. 16).

(2) Place one bearing on axle spindle. Place greased skid on ground under axle spindle. Roll wheel onto greased skid and adjust jack to aline center of hub with axle spindle. Shove the wheel and hub assembly on the spindle. Install outer bearing and adjusting nut. *CAUTION: Make certain adjusting nut is installed with the dowel toward outer side of hub.*

(3) Adjust bearings (par. 56 b). Install locking washer and jam nut. Secure hub cap and hub cap gasket to hub using six cap screws and six lock washers. Remove skid plate, jack and blocking.

56. BEARINGS.

a. Check Hub Bearing for Adjustment. Jack axle until tire clears ground. Test sidewise shake of wheel with hands or with a bar under tire. If bearings are correctly adjusted, shake of wheel will be just perceptible and wheel will turn freely with no drag. If bearing adjustment is too tight, bearings will become over-heated. Too loose

WHEELS, HUBS, DRUMS, AND TIRES

adjustment will cause pounding. Brakes must be in fully released position.

b. Adjustment. Jack axle until wheel clears the ground and rotate wheel to make certain it turns freely. Remove six cap screws and six lock washers from hub cap, and remove hub cap and hub cap gasket. With axle nut wrench turn jam nut counterclockwise and remove jam nut. Pull locking washer off axle spindle. Tighten adjusting nut using axle nut wrench until wheel binds and at the same time rotate wheel to make certain all surfaces are in contact. Then back adjusting nut off about $\frac{1}{6}$ turn, or more, if necessary, making sure wheel rotates freely. Check hub bearing for end play (par. 56 a).

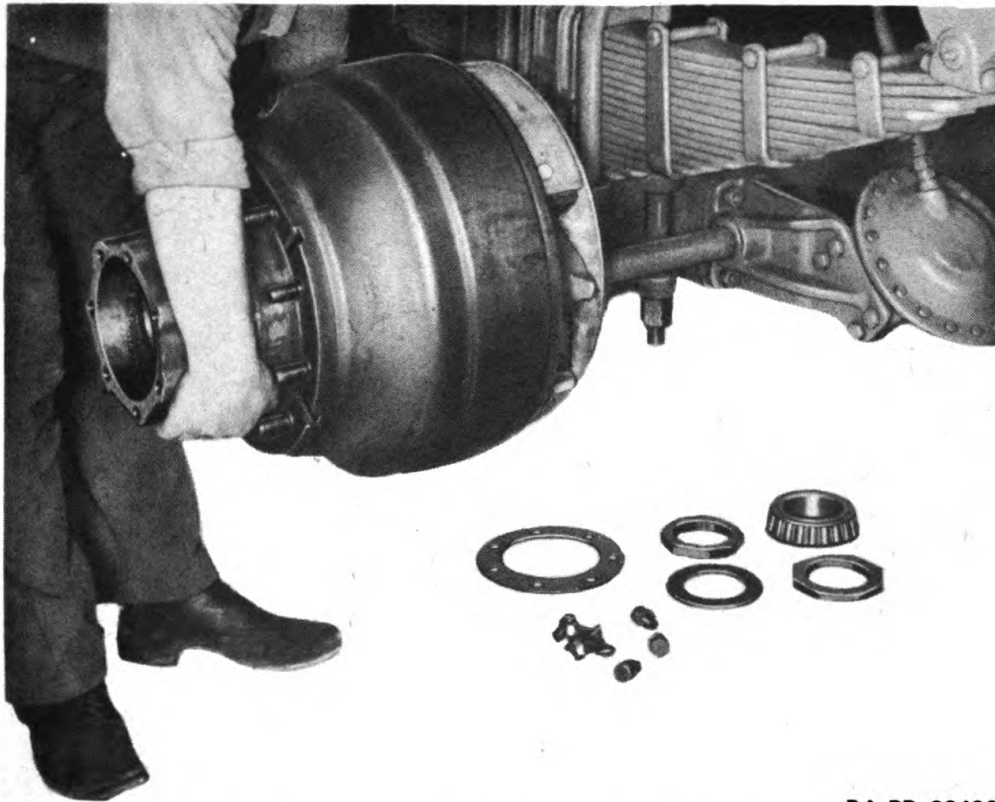

RA PD 334382

Figure 36—Removing Hub and Drum Assembly

Install locking washer, making certain hole in locking washer fits into dowel on adjusting nut, install jam nut and tighten. Secure hub cap and hub cap gasket to hub, using six cap screws and lock washers.

57. HUB AND DRUM ASSEMBLY.

a. Removal (fig. 36). Remove inner and outer wheel and tire assembly (par. 58 a). Remove jam nut (par. 55). Grasp the hub and drum assembly firmly with two hands and pull hub and drum assembly off spindle, using care not to allow outer bearing to fall in dirt. Do not allow drum to strike the threaded portion on axle spindle.

10-TON PAYLOAD, 14-TON GROSS, 2-WHEEL STAKE AND
PLATFORM SEMITRAILER AND 10-TON CONVERTER DOLLY

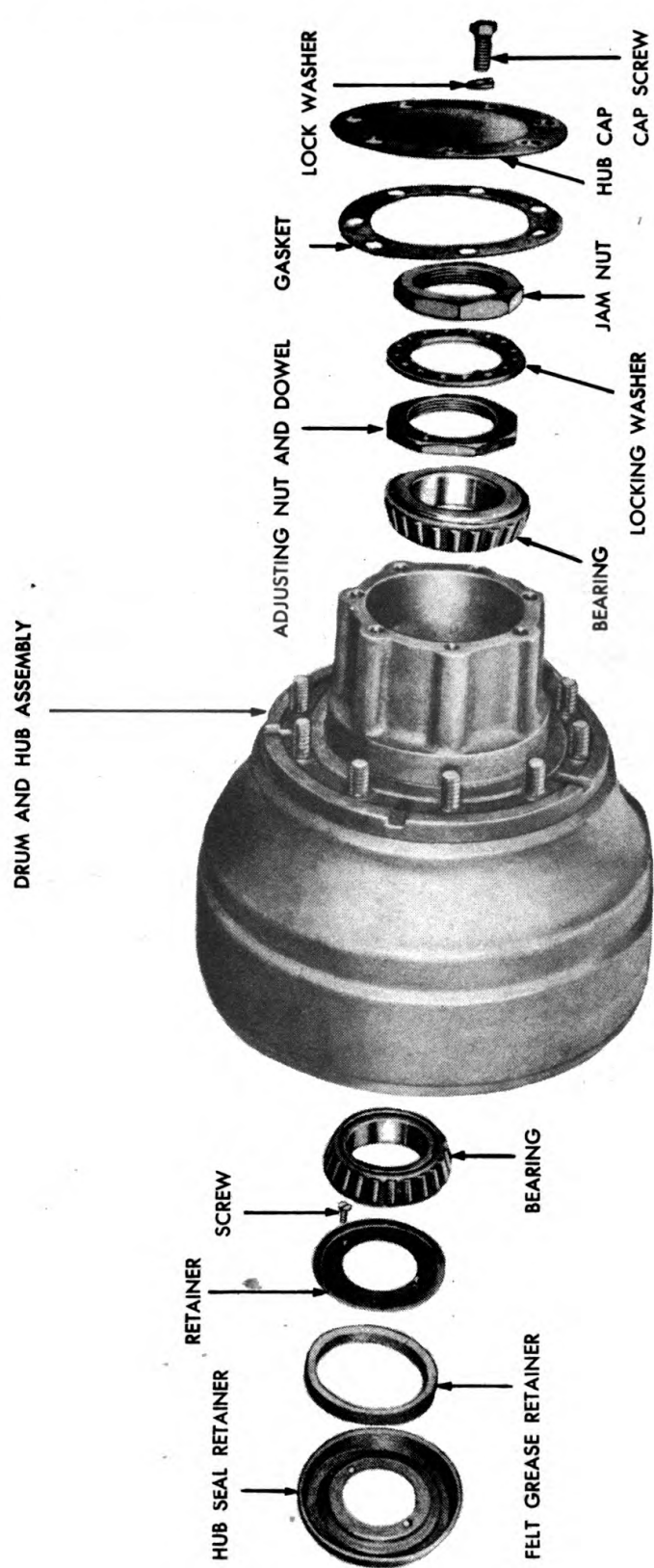

RA PD 334381

Figure 37—Assembly Sequence—Grease Retainer and Hub Internal Parts

Generated on 2013-08-06 12:33 GMT / http://hdl.handle.net/2027/uc1.b3243776
Public Domain, Google-digitized / http://www.hathitrust.org/access_use#pd-google

WHEELS, HUBS, DRUMS, AND TIRES

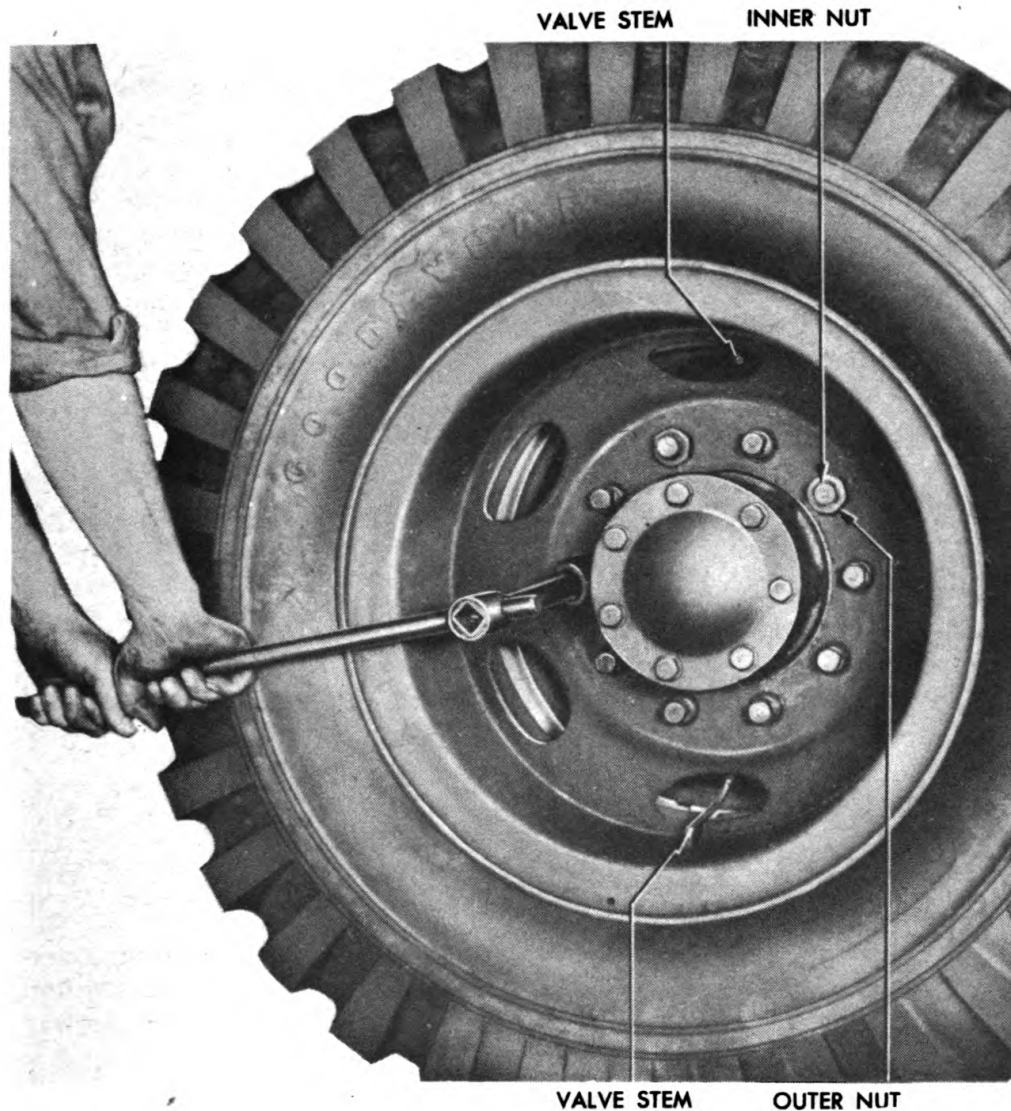

RA PD 334383

Figure 38—Installing Wheel on Hub

b. Installation (fig. 37). Inspect bearings and bearing cups for chips, pits, and excessive wear. Check cups to make certain they are tight in hub bore. Inspect felt grease retainer for excessive wear or oversaturation. Secure replacement if necessary (par. 59 a). Lubricate bearings (par. 16). Place one bearing on spindle. Adjust bearings (par. 56 b). Install inner and outer wheel and tire assembly (par. 58 b).

58. WHEEL AND TIRE ASSEMBLY.

a. Removal. With large end of wheel wrench loosen the 10 outer nuts from the inner nuts. Block the wheel on opposite side and jack

TM 9-892

58-61

10-TON PAYLOAD, 14-TON GROSS, 2-WHEEL STAKE AND PLATFORM SEMITRAILER AND 10-TON CONVERTER DOLLY

up the axle until wheel clears the ground. Continue removing outer nuts and lift the outer wheel and tire assembly off hub. Remove ten inner nuts using small end of wheel wrench and lift inner wheel and tire assembly off wheel studs.

b. Installation. Place inner wheel and tire assembly over wheel studs. Secure inner wheel to hub using ten inner nuts. **NOTE:** *Both inner and outer wheel stud nuts are marked with the letter "L" or "R" which indicate left- or right-hand threads. Make certain nuts with the letter "R" are used on the hub on the right side of vehicle, and studs with the letter "L" are used on the left side of vehicle.* Tighten inner nuts sufficiently to hold wheel firmly in position. Successively tighten opposite nuts to prevent cocking of wheel on hub pilot and studs. Place block under wheel and continue tightening.

(1) Mount outer wheel over inner nuts with valve stem located opposite the valve stem on inner wheel. This will provide ample room for inflation of tires. Install outer nuts making certain convex surface of nut contacts wheel. Successively tighten opposite nuts to prevent cocking of wheel on hub pilot and inner nuts. Place block under wheel and continue tightening. Remove blocking and jacks.

59. GREASE RETAINER.

a. Removal (fig. 37). Remove hub and wheel assembly as one unit (par. 58 a). Remove screws holding retainer assembly to axle assembly. Remove retainer from axle assembly, and pull felt off axle spindle.

b. Installation. Place felt over axle spindle. Place retainer over spindle. Align holes in retainer with those in the hub seal retainer and axle; install screws. Install wheel and hub assembly (par. 55 b).

60. DRUMS.

a. Removal. Remove wheel and hub assembly as one unit (par. 55 a). Remove 10 nuts holding grease slinger and drum to hub. Lift off grease slinger and drum.

b. Installation. Clean all rust and other foreign matter from drum pilot. Lean wheel and hub assembly at about a 70-degree angle. Place drum over studs. Place grease slinger over studs. Install nuts and tighten evenly to prevent drum from cocking on drum pilot. Place two punch marks on nut and stud to prevent nuts from coming loose. Install hub and drum assembly (57 b).

61. TIRES.

a. Removal. Remove tire and wheel assembly (par. 58 a) and remove valve cap and valve core allowing all air to escape from inner tube.

b. Demounting. Refer to TM 31-200.

WHEELS, HUBS, DRUMS, AND TIRES

c. **Mounting.** Refer to TM 31-200. Install valve core. Turn tire so the removable flange is down, and inflate to 80-pound pressure. **CAUTION:** *Never fully inflate tire with flange facing up. The flange may blow off causing serious injury.*

d. **Installation.** Install tire and wheel assembly (par. 58 b).

Section XIV

ELECTRIC SYSTEM

62. DESCRIPTION AND TABULATED DATA.

a. **Description.** The electrical diagram (fig. 39) illustrates all of the electrical circuits used on this vehicle. All electrical units are shown in their relative position. The electrical system consists of one combination service tail and blackout taillight, one combination blackout tail and blackout stop light, one blackout switch, coupling socket, one junction box, and three wiring harnesses. The flow of current is controlled at the light switch of the towing vehicle.

b. Data.

Service tail and blackout tail	QMC-08242-X
Blackout tail and blackout stop	QMC-08243-X
Blackout switch	QMC-08671-W
Coupling socket	Warner

63. LIGHTS.

a. **Description.** The combination blackout tail and blackout stop light is located on the right side near rear crossmember. The combination service tail and stop and blackout taillight is located on the left side near rear crossmember. The blackout design of both lights is such that when one truck is following a preceding trailer at a specified safe distance, the two beams will merge into a single highly visible light. To insure the accuracy of construction necessary to produce this effect, the lamps are soldered to the retainer and the lens and felts are crimped to the retainer to form a complete unit. When the lamp is burned out it is necessary to replace the complete sealed lamp-unit. Removal and installation procedure for both lights are identical.

b. Taillight Sealed-beam Unit.

(1) **REMOVAL.** Remove two screws from light door and remove door. Pull the two sealed-beam units out of light shell.

(2) **INSTALLATION.** Install sealed-beam units in their proper position (figs. 40 and 41). Place door in position. Secure door to light shell using two screws.

10-TON PAYLOAD, 14-TON GROSS, 2-WHEEL STAKE AND PLATFORM SEMITRAILER AND 10-TON CONVERTER DOLLY

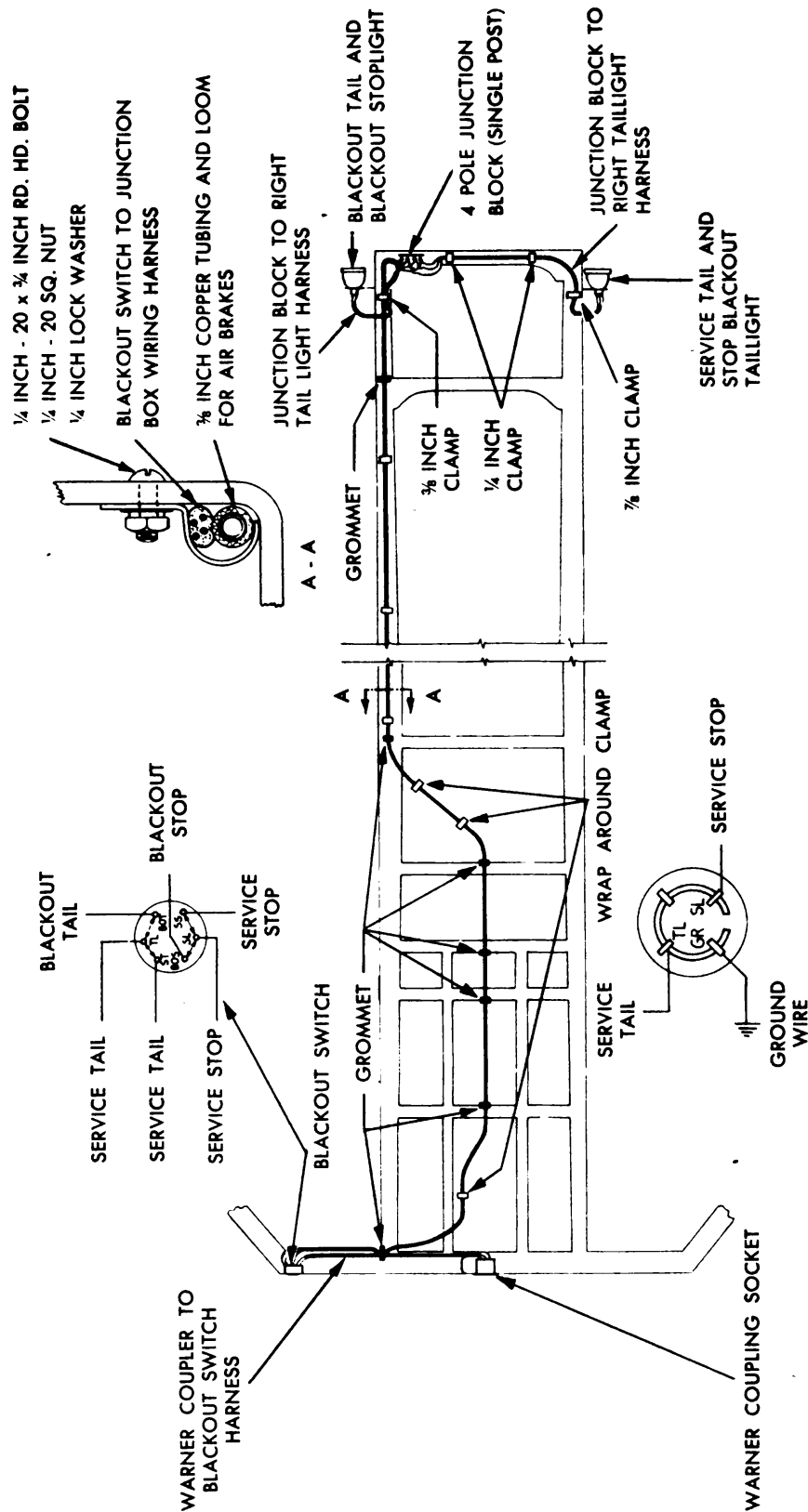

RA PD 334386

Figure 39 — Wiring Diagram

ELECTRIC SYSTEM

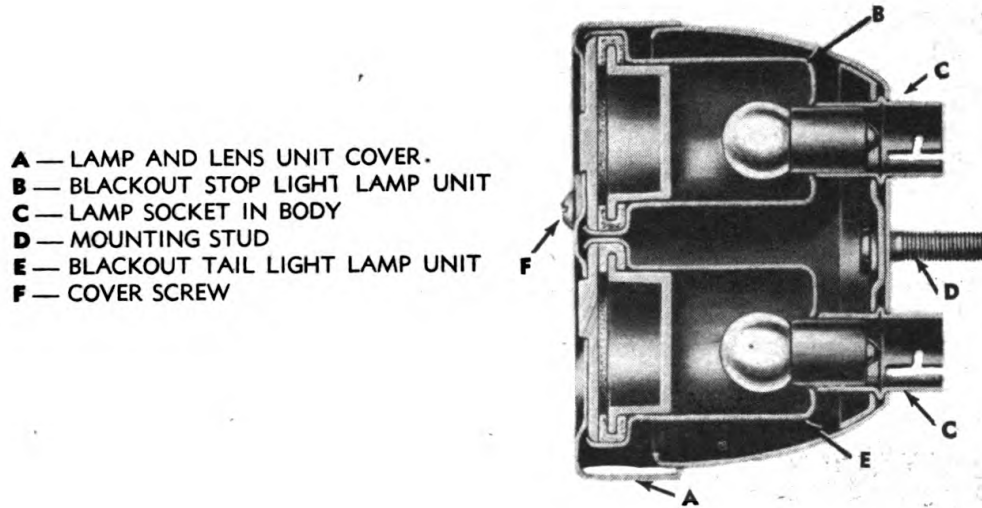

RA PD 64548

Figure 40—Combination Blackout Tail and Blackout Stop Light

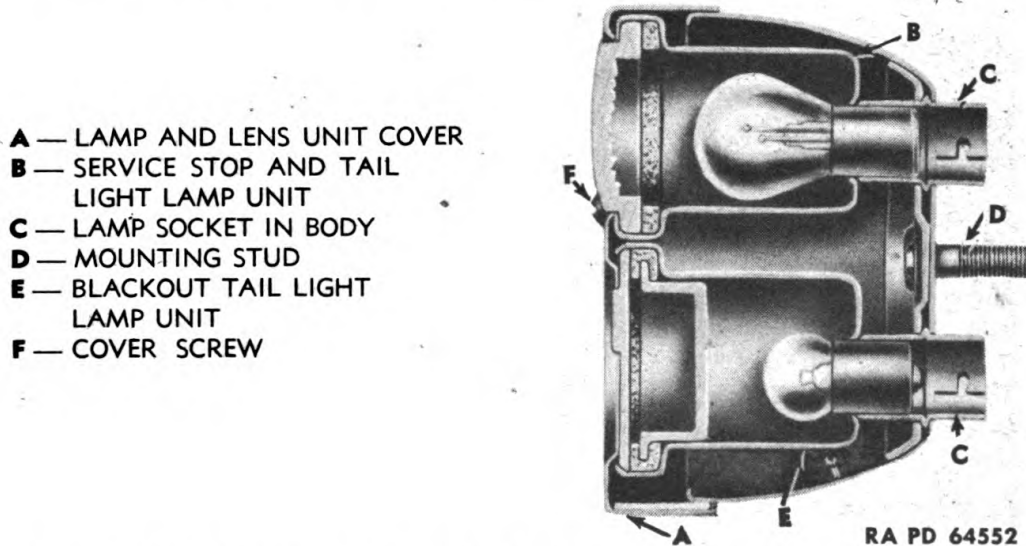

RA PD 64552

Figure 41—Combination Service Tail and Stop and Blackout Tail

c. Light Assembly.

(1) **REMOVAL.** Disconnect two leads from front side of body. Remove two nuts and two lock washers. Remove light assembly.

(2) **INSTALLATION.** Place light assembly into mounting bracket. Secure light assembly to mounting bracket using two lock washers and two nuts.

64. BLACKOUT SWITCH.

a. Description. The blackout switch is located on the right side of the front crossmember. The flow of current is supplied from the

TM 9-892
64-65

10-TON PAYLOAD, 14-TON GROSS, 2-WHEEL STAKE AND PLATFORM SEMITRAILER AND 10-TON CONVERTER DOLLY

towing vehicle, and controlled for the blackout lights by the blackout switch.

b. Removal. Remove three screws, three nuts, and three lock washers from cover on back of switch. Remove six wires from the six terminals. Pull wires out of switch body. Remove nut from front side of light and pull the switch out.

c. Installation. Place each wire into hole at side of switch body making certain grommet is installed in the hole of switch body. Secure each wire to its proper terminal. Each wire is of a different color. Base of each terminal is marked (fig. 42). Place the threaded

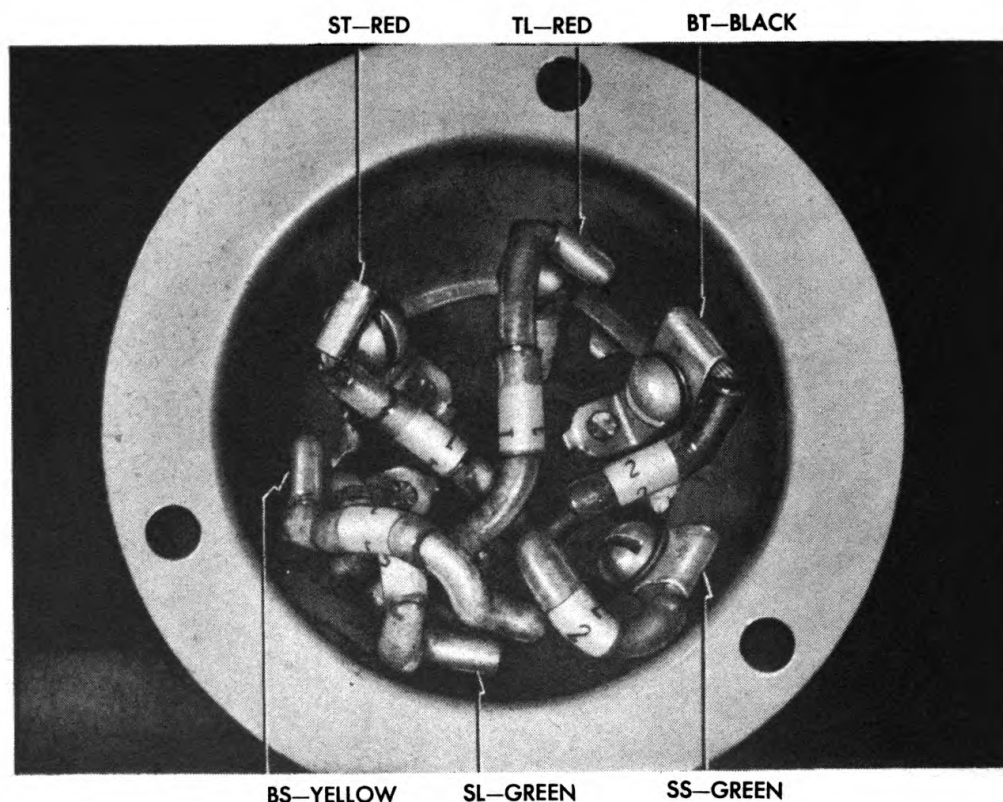

RA PD 334385

Figure 42—Rear View of Blackout Switch with Cover Removed

portion of the switch body into hole in front crossmember. Fasten switch to front crossmember using nut. Install cover plate. Secure cover plate to switch body using three screws, three lock washers and three nuts.

65. LIGHT COUPLING SOCKET.

a. Description. The coupling socket is located in the center of the front crossmember. The jumper cable is plugged into the coupling socket. Electric current is distributed to the various electrical units.

ELECTRIC SYSTEM

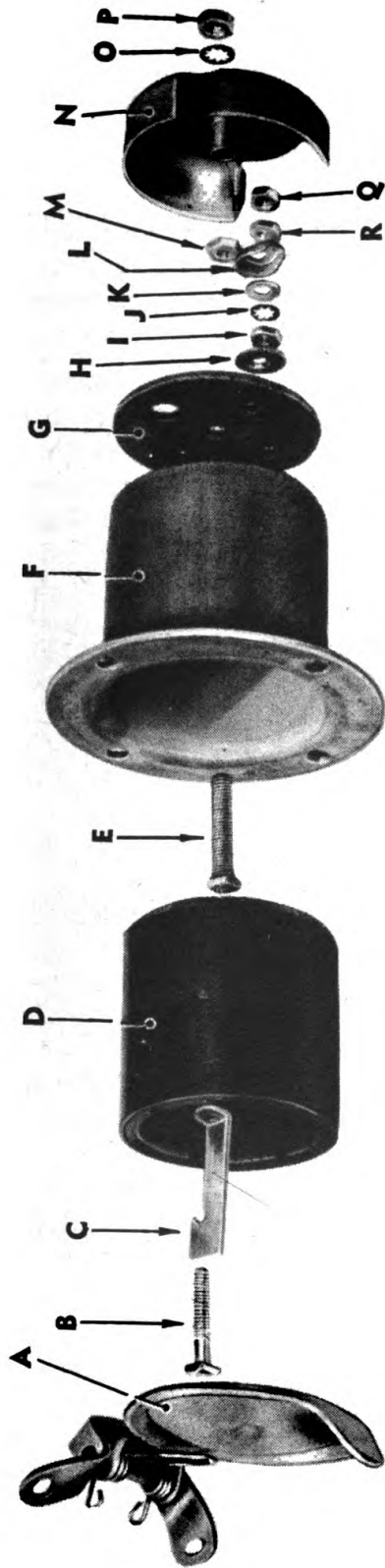

- A — COVER ASSEMBLY
- B — BOLT
- C — BLADE
- D — INSERT
- E — BOLT
- F — CASE
- G — INSULATOR
- H — WASHER
- I — NUT

- J — WASHER
- K — WASHER
- L — WASHER
- M — NUT
- N — CAP ASSEMBLY
- O — WASHER
- P — NUT
- Q — NUT
- R — NUT

RA PD 336423

Figure 43—Light Coupling Socket—Disassembled

**10-TON PAYLOAD, 14-TON GROSS, 2-WHEEL STAKE AND
PLATFORM SEMITRAILER AND 10-TON CONVERTER DOLLY**

from the coupling socket. A hole is provided in the semitrailer upper fifth wheel plate to permit ample room for maintenance service.

b. Removal (fig. 43). Uncouple dolly or towing vehicle from semitrailer (par. 10 b or 14 d). Reach through hole at underside of upper fifth wheel and remove nut and lock washer from cap. Pull cap off case. Remove the following parts of the three terminals which have wire attached: two nuts and cupped washer. Remove the three wires. Remove four screws and lock washers holding cover and coupling socket assembly to front crossmember. Remove coupling socket.

c. Installation. Place coupling through hole in center of front crossmember with the jumper cable alinement slot down. Install two screws in the two bottom holes in case flange. Place cover in position over the two top holes in case flange. Install two screws in cover and case flange. Secure the assembly to trailer frame using four lock washers and four nuts. Place wire on terminals. *NOTE: Each terminal is marked, "TL"—taillight, "SL"—stop light, "GR"—ground, or "BR"—brake. The terminal marked "BR" is not used (fig. 41).* Place cupped washer (L) over each terminal. Secure wire to terminals using nuts (R) and (Q).

Section XV

**FIFTH WHEEL, PINTLE HOOK, LUNETTE EYE,
AND SAFETY CHAINS**

66. DESCRIPTION.

a. Fifth Wheel. The fifth wheel is of a semiautomatic, two-jaw type. The jaws embrace the entire surface of the king pin when the dolly is coupled to the semitrailer. When the operating handle is pulled forward, a latch drops in behind the lung on the plunger. This holds the plunger in the unlatched position until the dolly is withdrawn during which operation the entire mechanism is cocked for recoupling. The fifth wheel mounted on the dolly is interchangeable with fifth wheel mounted on the towing vehicle.

b. Pintle Hook. The pintle hook is mounted on the rear crossmember of the dolly. It is of a semiautomatic design. The pintle hook is used as a means of coupling a vehicle to dolly which is to be towed behind the dolly.

c. Lunette Eye. The lunette eye is of the swivel-type and is fastened to the front end of the A-frame on dolly. The lunette eye is fastened to the pintle hook on the towing vehicle and the entire load is pulled from the lunette eye.

FIFTH WHEEL, PINTLE HOOK, LUNETTE EYE, AND SAFETY CHAINS

d. **Safety Chain.** The safety chain is held to the A-frame of the dolly at the extreme front by an eyebolt. Should the lunette eye in the dolly or the pintle hook on the towing vehicle let go, the safety chain will carry the load. The safety chain consists of twenty-one inches of $\frac{1}{2}$ inch chain. A hook is provided at end of chain and the opposite end of chain is fastened to an eyebolt.

67. FIFTH WHEEL.

a. **Removal (fig. 44).** Remove eight nuts and eight lock washers from the cap screws holding support bracket to mounting plate. Remove nuts and lock washers from cap screws in support bracket

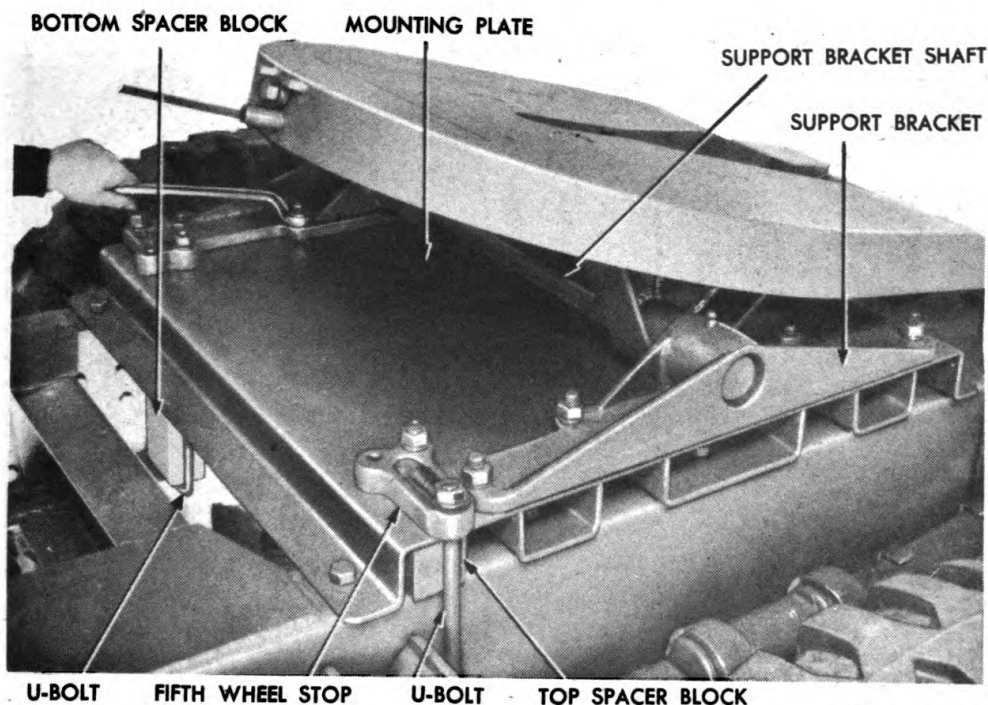

RA PD 334389

Figure 44—Removing Fifth Wheel

on the opposite side. Place a bar between support bracket shaft and the mounting plate and pry up on the support bracket shaft. Pull the two support brackets off the support bracket shaft. Lift the fifth wheel off the dolly.

b. **Installation.** Place one support bracket in position over holes in mounting plate on right side. Aline holes in support bracket with holes in mounting plates. Secure the support brackets to the mounting plate using eight cap screws, nuts and lock washers. Lift the fifth wheel onto mounting plate making certain the operating handle is toward the front of the dolly. With two men standing on dolly frame, lift the fifth wheel and enter support bracket shaft into support bracket bolted to the mounting plate. Place support bracket over

10-TON PAYLOAD, 14-TON GROSS, 2-WHEEL STAKE AND PLATFORM SEMITRAILER AND 10-TON CONVERTER DOLLY

support bracket shaft on left side. Aline holes in support bracket with holes in mounting plate and fasten support bracket to mounting plate using eight cap screws, nuts, and lock washers.

68. PINTLE HOOK.

a. Removal. Remove four nuts and four lock washers on inner side of rear crossmember and drive out the three cap screws. Remove the pintle hook.

b. Disassembly (fig. 44). Pull one cotter pin from the $\frac{7}{16}$ -inch pin located near top side of pintle hook main frame and drive out

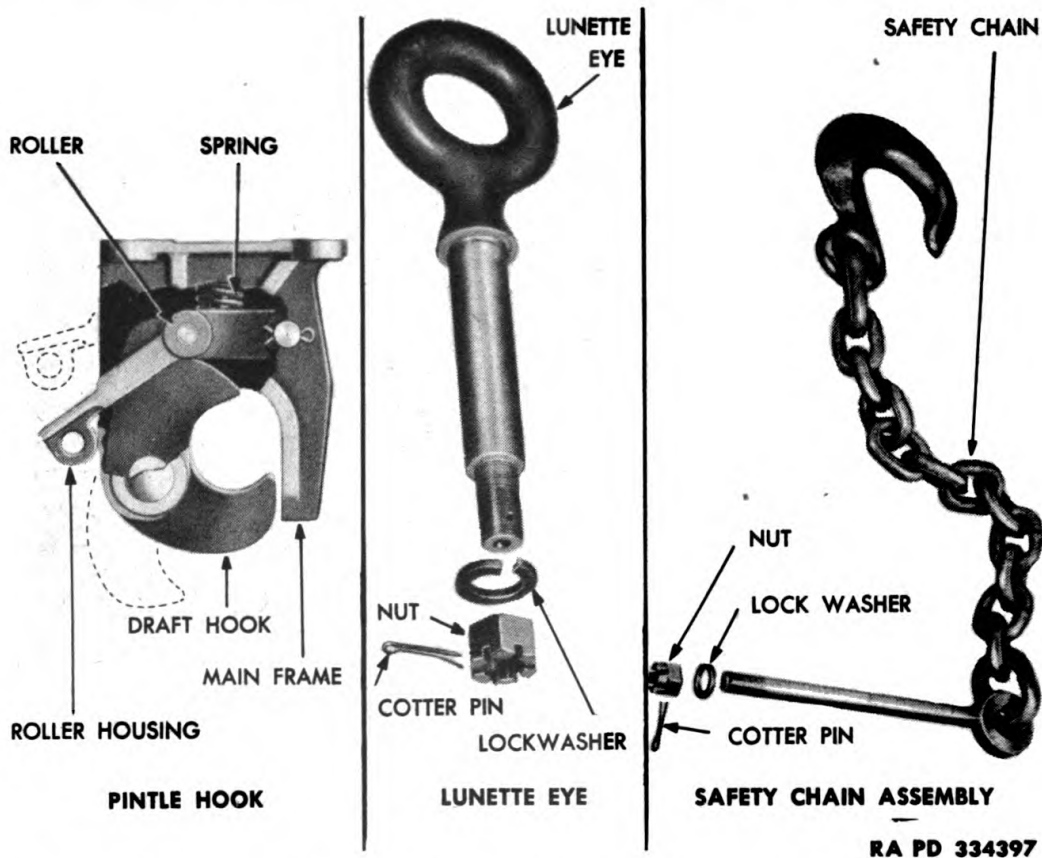

RA PD 334397

Figure 45—Shackles, Lunette Eye and Safety Chain—Disassembled

the $\frac{7}{16}$ -inch pin. Pull down on roller housing and remove the compression spring.

c. Assembly. Place compression spring into pintle hook main frame making certain the spring is seated in the cavity. Install the roller housing assembly with the spring guide toward the front of the main frame. With a screwdriver work the compression spring over the spring guide on the roller housing. Aline hole in roller housing with hole in main frame and install the $\frac{7}{16}$ -inch pin. Install the cotter pin. Place several drops of engine oil on the $\frac{7}{16}$ -inch pin and at the front side of the roller housing.

FIFTH WHEEL, PINTLE HOOK, LUNETTE EYE, AND SAFETY CHAINS

d. **Installation.** Locate pintle hook on dolly rear crossmember. Aline holes in pintle hook with holes in rear crossmember and secure in place using four $\frac{5}{8}$ -inch cap screws, nuts, and lock washers.

69. LUNETTE EYE.

a. **Removal** (fig. 44). Remove cotter pin from lunette eye at inner side of A-frame. Remove nut holding eye to A-frame. Remove washer and pull the lunette eye out of A-frame.

b. **Installation.** Coat the shaft portion of lunette eye with a light film of grease. Insert the eye in A-frame and install washer, nut and cotter pin.

70. SAFETY CHAIN.

a. **Removal** (fig. 44). Remove cotter pin, nut and lock washer from I-bolt which holds the assembly to dolly A-frame. Remove the safety chain.

b. **Installation.** Install I-bolt at end of safety chain in the hole at end of dolly A-frame. Fasten I-bolt using lock washer, nut, and cotter pin.

**10-TON PAYLOAD, 14-TON GROSS, 2-WHEEL STAKE AND
PLATFORM SEMITRAILER AND 10-TON CONVERTER DOLLY**

**PART FOUR—ORDNANCE MAINTENANCE
INSTRUCTIONS**

Section XVI

INTERNAL BRAKE ASSEMBLY

71. GENERAL.

a. **Description.** The complete braking system used on this vehicle is of the Bendix-Westinghouse design. All ordnance maintenance instructions will be found in TM 9-1827A with the exception of the internal brake assembly. Refer to TM 9-1827A for ordnance maintenance instructions on the following components of the brake system: slack adjuster, air filters, reservoir, relay emergency valve, and the brake chamber.

b. The dolly is not equipped with brakes.

72. DESCRIPTION AND DATA.

a. **Description.** The semitrailer is equipped with two internal brake assemblies. One internal brake assembly is bolted to the right side of the axle, and one assembly is bolted to the left side of the axle. The assemblies are right-hand and left-hand. All parts are interchangeable from one side to the other with the exception of the cams. The cams are right- and left-hand. Disassembly and assembly procedure for either of the internal brake assemblies are identical.

b. **Data.**

Make	Timken
Model	20103
Weight	94 lb
Diameter	17 $\frac{1}{4}$ in.
Width	5 $\frac{1}{2}$ in.

**73. DISASSEMBLY OF INTERNAL BRAKES INTO
SUBASSEMBLIES.**

a. **Remove Brake Shoes** (fig. 46). Remove six cap screws and lock washers holding two dust shields to brake spider. Remove lubrication fittings from brake anchor pins. Remove cap screw and lock washer from anchor pin lock. Tap anchor pin lock out of anchor pins. With a $\frac{5}{8}$ -inch punch, drive out the two anchor pins from the pin lock side. Lift out the brake return spring. Lift brake shoes off brake spider.

74. BRAKE SHOES.

a. **Cleaning.** Clean all parts, with the exception of the brake shoes, with dry-cleaning solvent. However, if the brake lining is dam-

INTERNAL BRAKE ASSEMBLY

aged or shows signs of excessive wear, the shoes may be cleaned in dry-cleaning solvent. If the lining is in good condition, steam clean the brake shoes.

b. Inspection. Inspect brake lining for excessive wear. If lining is worn down to screw heads, replace the lining. If lining is found to be oil soaked, replace lining. Inspect lining for excessive checking. Install brake anchor pin into brake anchor pin hole. Move the pin up and down to check for excessive wear in the pin and bushing. If movement of the pin is excessively loose, replace the anchor pins or brake shoe bushings, or both. Check wear plates for wear. If worn replace with shims to compensate for the wear.

c. Disassembly. Place shoe assembly in vise. Place bar between web in shoe and return spring pin. Pry the pin out (fig. 27). Remove 16 screws, lock washers, and nuts holding lining to shoes. Remove screw from wear plate. Remove wear plate and wear plate shim. Press out the 2 bushings.

d. Assembly.

(1) Press one shoe bushing into shoe with the end of bushing flush with the outer side of shoe. Turn shoe over and press the other bushing in using the same procedure. Ream bushings (par. 77).

(2) Install lining on brake shoe. Aline screw holes in lining with those in brake shoe. Secure lining to shoes using 16 flat head screws, lock washers and nuts. Place wear plate shim in position on cam end of shoe. Place wear plate over wear plate shim. Fasten the wear plate to shoe using screw, nut and cotter pin.

75. BRAKE SPIDER.

a. Disassembly. Remove locking wire from cam collar set screw. Remove cam collar set screw and pull cam collar off cam. Pull cam out of spider. Do not remove spider bushing unless worn excessively (par. 77). Remove lubrication fitting.

b. Cleaning and Inspection. Clean all parts in dry-cleaning solvent. Inspect bushing for excessive wear. Replace bushing if necessary.

c. Assembly. If bushing has been removed install new bushing. Drill a $\frac{1}{8}$ inch hole into bushing through the lubrication fitting. Coat inner side of spider bushing with general purpose grease. Place cam through spider. Cams are made in rights and lefts. When installing cam make certain the proper cam is used. Figure 26 illustrates right hand cam. Left hand cam has the "S" portion in reverse. Place cam collar over cam. Secure cam roller to cam using set screw. Place locking wire through hole in set screw. Wrap wire around cam collar and twist the two ends together.

76. ASSEMBLY OF SUBASSEMBLIES.

a. Place a light film of general purpose grease over surface of brake anchor pins and into the space between the two shoe bushings. Place

**10-TON PAYLOAD, 14-TON GROSS, 2-WHEEL STAKE AND
PLATFORM SEMITRAILER AND 10-TON CONVERTER DOLLY**

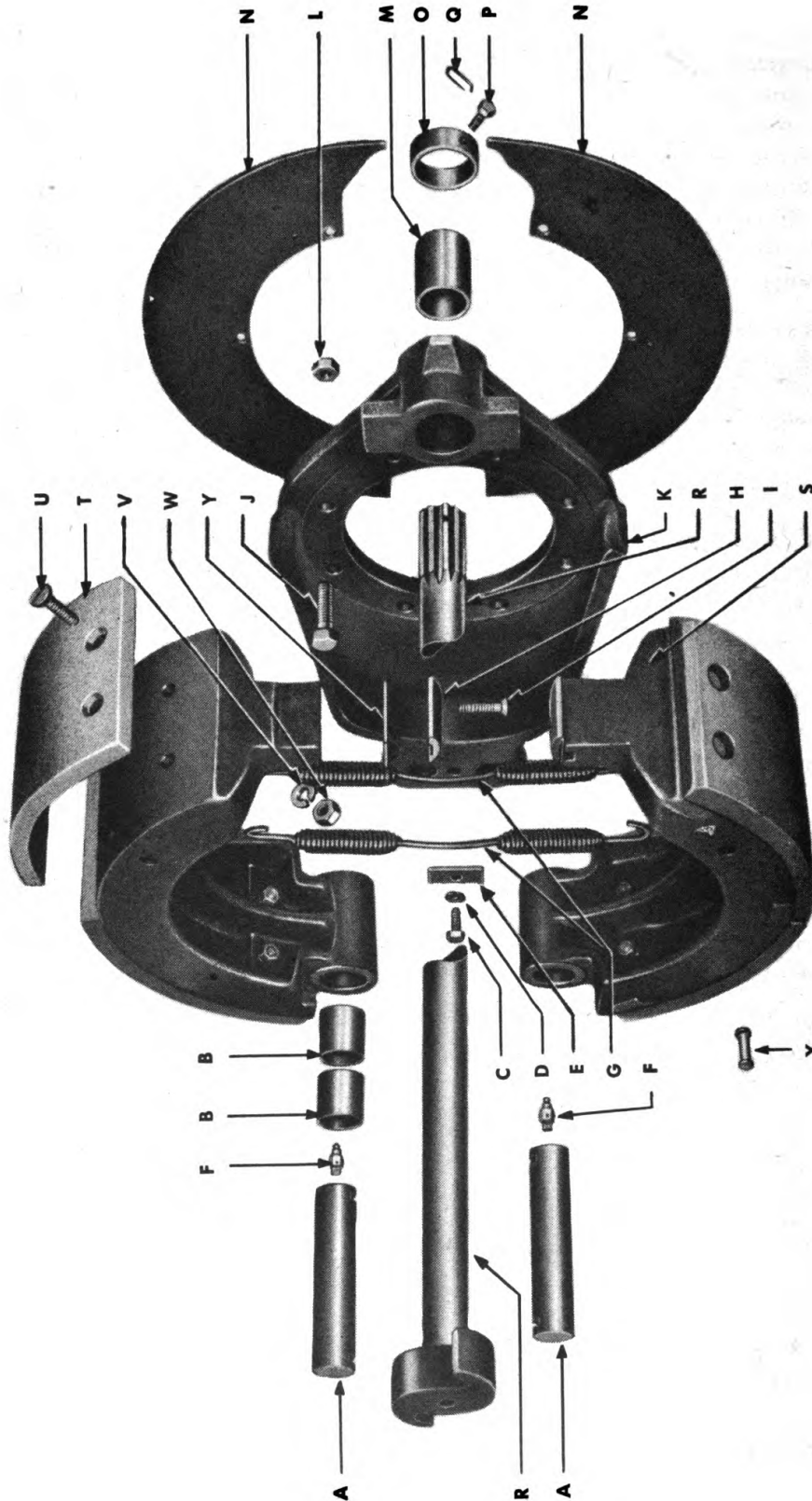

RA PD 334392

Figure 46—Internal Brake Assembly—Disassembled

INTERNAL BRAKE ASSEMBLY

A ANCHOR PINS	O CAM COLLAR
B SHOE BUSHINGS	P CAM COLLAR SET SCREW
C CAP SCREW	Q LOCKING WIRE
D LOCK WASHER	R BRAKE CAM
E ANCHOR PIN LOCK	S BRAKE SHOE
F LUBRICATION FITTING	T LINING
G BRAKE RETURN SPRING	U LINING SCREW
H WEAR PLATE	V LOCK WASHER
I WEAR PLATE SCREW	W NUT
J CAP SCREW	X RETURN SPRING PIN
K BRAKE SPIDER	Y WEAR PLATE SHIM 1/16 INCH THICK
L NUT	Y WEAR PLATE SHIM 1/32 INCH THICK
M SPIDER BUSHING	Y WEAR PLATE SHIM 1/64 INCH THICK
N DUST SHIELDS	

RA PD 334392B

Legend for Figure 46—Internal Brake Assembly—Disassembled

10-TON PAYLOAD, 14-TON GROSS, 2-WHEEL STAKE AND PLATFORM SEMITRAILER AND 10-TON CONVERTER DOLLY

lower shoe in position on brake spider. Aline hole in brake shoe with hole in brake spider. Insert brake anchor pin with the lubrication fitting cavity toward dust shield side. Tap spring pin into hole provided on side of brake shoe making certain end of spring pin projects out of each side of the center flange of brake shoe. Install spring pin in upper shoe in the same maner. Attach the two return springs to spring pin in upper shoe. Lower over brake spider. Couple the two return springs to spring pin in lower shoe. Aline anchor pin hole in brake shoe with hole in spider. Install brake anchor pin making certain lubrication fitting cavity is toward the dust shield side of spider. Anchor brake anchor pins in position using anchor plate, lock washer and cap screw. Install lubrication fitting in anchor pins. Fasten dust shields to brake spider using six cap screws and six lock washers.

77. FITS AND TOLERANCES.

a. Data.

	Max (inch)	Min (inch)	Replace Beyond (inch)	Material
Brake shoe bushing (outside diameter)	1.506	1.500	1.265	Bronze
Brake shoe bushing (ream diameter)	1.256	1.254		
Spider bushing (outside diameter)	1.636	When cam is extremely loose	Clevite No. 10 steel backing
Spider bushing (ream diameter)	1.509		
Brake anchor pin	1.250	1.248	1.235	Steel
Lining	0.75	0.25	Width 5½ in.

Section XVII

SUSPENSION

78. DESCRIPTION AND DATA.

a. Description.

(1) The suspension assembly consists of a main spring, auxiliary spring, cross shaft, shackles, and shock absorbers. The semitrailer and dolly frames are carried on the axle assembly through the suspension assembly.

SUSPENSION

(2) All maintenance instructions in this section apply to both the semitrailer and the dolly. The disassembly and assembly procedure is identical. However, all parts of the semitrailer suspension assembly are not interchangeable with the dolly suspension assembly.

(3) The shackles, pins, clips, U-bolts, shock absorbers, main spring, auxiliary springs, and cross shaft are interchangeable with the towing vehicle. All the above parts are interchangeable with the dolly with the exception of the auxiliary spring. The semitrailer auxiliary spring can be used on the towing vehicle but not on the dolly.

b. Data.

(1) MAIN SPRING.

Weight	200 lb
Length (from center to center at eye)	54 in.
Width	3 in.
Number of leaves	16
Thickness of leaves	$\frac{7}{16}$ in.

(2) AUXILIARY SPRING.

Weight	78 $\frac{1}{2}$ lb
Length	40 in.
Width	3 in.
Thickness of leaves	$\frac{5}{16}$ in.
Number of leaves	10

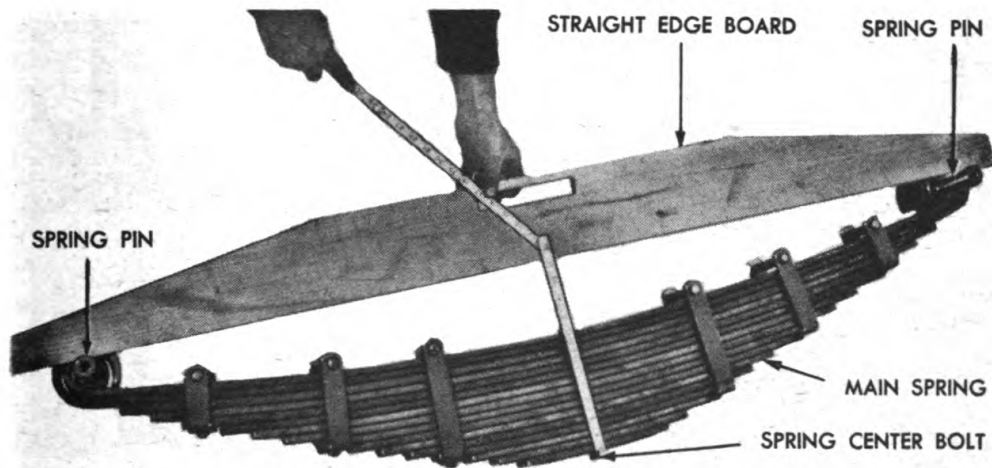

RA PD 334366

Figure 47—Checking Main Spring Arch

79. MAIN SPRING.

a. Cleaning and Inspection (fig. 47).

(1) Steam clean spring. Inspect spring for broken leaves. Check rebound clips for breakage or excessive wear. Check eye bushing for excessive wear by inserting shackle pin into spring eye and moving

10-TON PAYLOAD, 14-TON GROSS, 2-WHEEL STAKE AND PLATFORM SEMITRAILER AND 10-TON CONVERTER DOLLY

- A LUBRICATION FITTING
- B PIN
- C NUT
- D LOCK WASHER
- E FRONT SPRING HANGER BRACKET
- F CAP SCREW
- G AUXILIARY SPRING
- H AUXILIARY SPRING CLIP
- I CLIP RIVET
- J AUXILIARY SPRING BRACKET
- K U-BOLT SEAT
- L U-BOLT
- M SPRING CENTER BOLT
- N SPRING SHROUD
- O CROSS SHAFT STUD COLLAR
- P CROSS SHAFT
- Q CAP SCREW
- R CROSS SHAFT BRACKET
- S CAP SCREW
- T SPRING BUSHING
- U SHACKLE BUSHING
- V MAIN SPRING
- W AXLE CLIP PLATE
- X LOCK WASHER
- Y HIGH NUT
- Z BOLT
- AA RIVET
- AB MAIN SPRING CLIP
- AC NUT
- AD SPRING CENTER BOLT
- AE CLIP SPACER

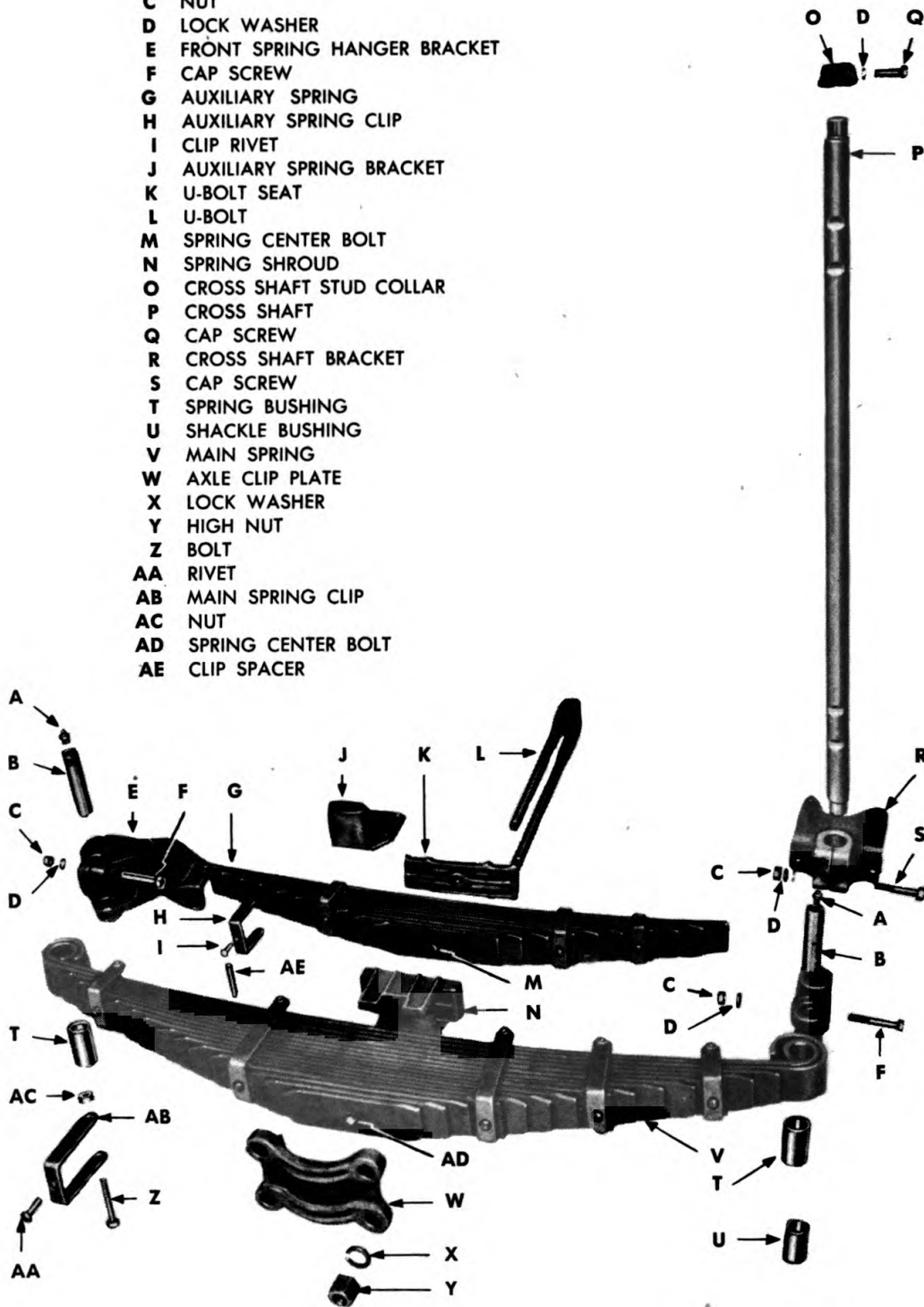

RA PD 334393

Figure 48—Suspension Assembly—Disassembled

SUSPENSION

shackle pin with a rocking motion. Replace shackle pin, bushing, or both, if worn excessively.

(2) When springs have lost some of their arch, resilience or elastic properties it is best to replace them with new ones. Any attempt at restoring spring camber or arch by heating, bending, and tempering is inadvisable, unless they are in the hands of a competent blacksmith. To check the arch of the main spring, first place a spring pin into each of the spring eyes with about one inch of the spring pin extending out of the spring eye. Place a straight board on top of the spring pins from eye to eye. Measure the distance from bottom of the board to the bottom of the last leaf (fig. 47). The arch must be within $\frac{5}{8}$ inch of the original arch (par. 80). Rearch or replace main spring if necessary.

b. Disassembly. Place spring across two wood horses. Place a C-clamp about three inches from spring center bolt and tighten the C-clamp. With a hand grinder, grind off the peened end of spring center bolt and remove nut from spring center bolt. With a $\frac{3}{8}$ x 10-inch steel rod, drive spring center bolt out of spring. Remove six nuts from the six rebound clips. Drive out the six rebound bolts and remove the rebound clip spacers. Remove the C-clamp from the spring.

c. Repair. Tap rebound clips with hammer to detect loose rivets. If rivets are loose, heat the head of the rivet with an acetylene torch and drive rivet from opposite side with a ball peen hammer until rivets are tight. Replace broken rebound clips by riveting new clips in position.

(1) **NOTE:** *Three different size rebound clips are used when installing new clips. Make certain the proper clip is used on the proper spring leaf (fig. 48).* If bushing is worn, press out the bushing. Install new bushing and ream (par. 80). With a wire brush remove all rust scale from top and bottom surface of each spring leaf.

d. Assembly. Place main leaf and wrap leaf assembly across two wood horses with the arch up. Continue building up the spring starting with the longest leaf and ending with the shortest leaf. Make certain each spring center bolt hole is in alignment with each other. Shove $\frac{7}{16}$ -inch rod down through the spring center bolt holes to make certain the holes are in alignment and that shifting of the leaves will not take place when C-clamp is installed. Install C-clamp and tighten, compressing the leaves. Remove the $\frac{7}{16}$ -inch rod from spring center bolt hole and install spring center bolt with the head toward bottom of spring. Install nut on spring center bolt and tighten. Peen the end of the bolt to prevent nut from becoming loose. Place clip spacer between each of the rebound clips. Secure spacer to clips using bolt and nut. Place two punch marks at end of bolts to prevent nut from coming loose.

80. AUXILIARY SPRING.

a. Cleaning and Inspection. Steam clean auxiliary spring. Inspect for broken leaves. Inspect rebound clips for breakage and loose rivets and replace or repair. Place straight board across top leaf of

TM 9-892**80-81****10-TON PAYLOAD, 14-TON GROSS, 2-WHEEL STAKE AND PLATFORM SEMITRAILER AND 10-TON CONVERTER DOLLY**

auxiliary spring. Measure the distance between bottom of board and bottom of last leaf. The arch must be within $\frac{5}{8}$ inch of the original arch (par. 80).

b. Disassembly. Install C-clamp near spring center bolt. Heat ends of rebound clips with an acetylene torch where they lap the top leaf. Spread the rebound clips open. Remove spring center bolt. Remove C-clamp.

c. Repair and Assembly. Tighten rebound clips (par. 78 c). Place longest leaf on bench with arch up. Continue building up the spring, ending with the shortest leaf. Aline spring center bolt holes by inserting a $\frac{7}{16}$ inch long tapered punch. Clamp the leaves together using a C-clamp. Install spring center bolt and nut. Peen end of nut to prevent loss. Remove C-clamp from center of spring and install it between the two rebound clips. Heat the ends of the rebound clips with an acetylene torch and bend them over the top leaf. Perform the same operation on opposite end of auxiliary springs.

81. FITS AND TOLERANCES.**a. Data.**

	Max (inch)	Min (inch)	Desired (inch)	Replace Beyond
Spring bushing (outside diameter)			1.5020	
Spring bushing (ream diameter)	1.253	1.249	1.250	1.2625
Shackle bushing (outside diameter)			1.5020	
Shackle bushing (ream diameter)	1.253	1.249	1.250	1.2625
Cross shaft (at outer ends)			1.250	When badly scored
Pin (spring)			1.250	1.875
Main spring arch (dolly and semitrailer)			10.6250	
Auxiliary spring arch (semitrailer)			4.5000	
Auxiliary spring arch (dolly)			5.6250	

b. Notes.

Auxiliary spring center bolt hole diameter, for $\frac{3}{8}$ -inch bolt.

Main spring center bolt hole diameter, for $\frac{7}{16}$ -inch bolt.

Section XVIII

AXLE

82. DESCRIPTION AND DATA.

a. Description. The maintenance instructions apply to the semi-trailer and the dolly. Both axles are similar in construction. The semi-trailer axle can be installed on the dolly. The dolly axle can be used on the semitrailer in an emergency only. The dolly axle is not equipped with a flange for bolting the internal brake assembly and no provisions have been made for attaching brake chambers. The axle is of a seamless tube construction with solid steel spindles pressed into the tubing.

b. Data.

Make	Liggett
Model (semitrailer)	20129
Model (dolly)	22102
Length	80 ³ / ₈ in.
Track	70 ¹ / ₂ in.

83. CHECKING AXLE FOR BEND.

a. Checking Axle for Bend (fig. 49). Checking axle for bend can be accomplished with the axle installed or removed from the semitrailer or dolly.

(1) Place axle gage in position on front side of axle with the single pronged end of the gage held firmly against the inner bearing surface. Adjust the double prongs on the opposite end of the gage

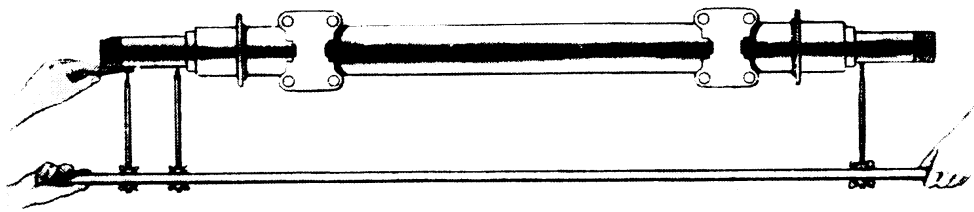

RA PD 334394

Figure 49—Checking Axle for Bend

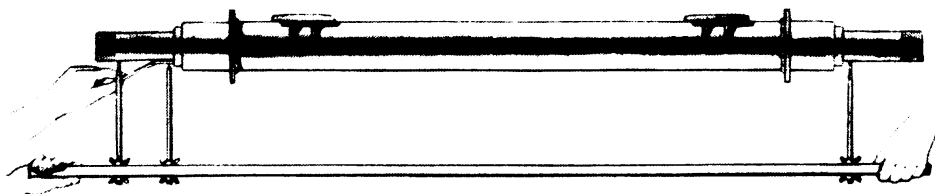

RA PD 334395

Figure 50—Checking Axle for Camber

10-TON PAYLOAD, 14-TON GROSS, 2-WHEEL STAKE AND PLATFORM SEMITRAILER AND 10-TON CONVERTER DOLLY

until they contact the inner and outer bearing surface. Move the gage over to the rear side of the axle. If either of the two prongs fail to make contact, a bent axle is indicated. Use a feeler gage to determine the amount of bend. If it is in excess of 0.002 inch, replace axle.

(2) If when checking both sides of one spindle it reveals no bend, turn the gage end for end and check the other spindle without disturbing the setting of the prongs. If there is clearance at either bearing surface, check with a feeler gage. If the prongs are in contact at both points, the axle is not bent.

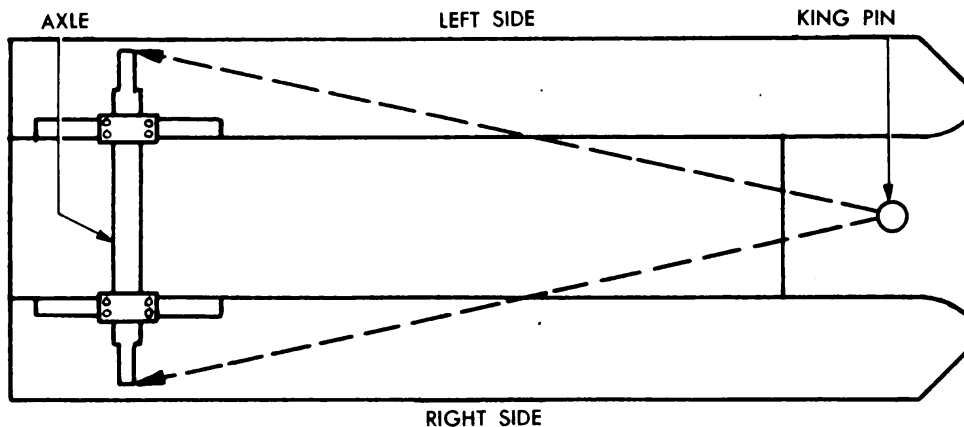

RA PD 334396

Figure 51—Semitrailer Axle Alinement Chart

84. CHECKING AXLE FOR CAMBER.

a. **Checking Axle for Camber** (fig. 50). Axle can be checked for camber installed or removed from the vehicle. When checking axle for camber, check for bend first and do not disturb the setting of the prongs. Prong settings established on a straight axle are a necessary factor in checking for camber. Place gage directly under axle. There must be clearance between inner prong and inner bearing surface. Using a feeler gage, check the clearance. Clearance must not be in excess of 0.1250 inch, nor less than 0.0600 inch. If clearance is not within these limits, replace axle. If axle camber is correct on one spindle, reverse gage and check the opposite spindle.

85. SEMITRAILER AXLE ALINEMENT.

a. **Checking Alinement** (fig. 51). Axle alinement must be checked with axle installed on vehicle. Couple hoist to rear of vehicle using a spread chain and remove the wheel and hub assembly as one unit (par. 55 a). Hoist vehicle and place two wood horses under axle between the U-bolt nuts. Lower chain hoist allowing vehicle to rest on the two horses. Using a steel tape, measure the distance from center of king pin to outer end of axle spindle at the left side. In the same manner take a measurement of the right side. The measurement

AXLE

on the right side should not be less than $\frac{1}{8}$ inch and no more than $\frac{1}{4}$ inch shorter than the left side. If axle is out of alinement place axle in alinement by following procedure in subparagraph **b** below.

b. Correcting Axle Alinement.

(1) The axle is properly placed in alinement at the time of construction. If axle is put out of alinement it is caused by broken, bent or worn parts of the suspension assembly.

(2) First make certain axle is not bent (par. 82 a).

(3) Check front spring hanger to make certain it is not bent, or the bolt holding hanger to side of frame is not loose.

(4) Check the main spring leaf and the wrap leaf to make certain it is not broken.

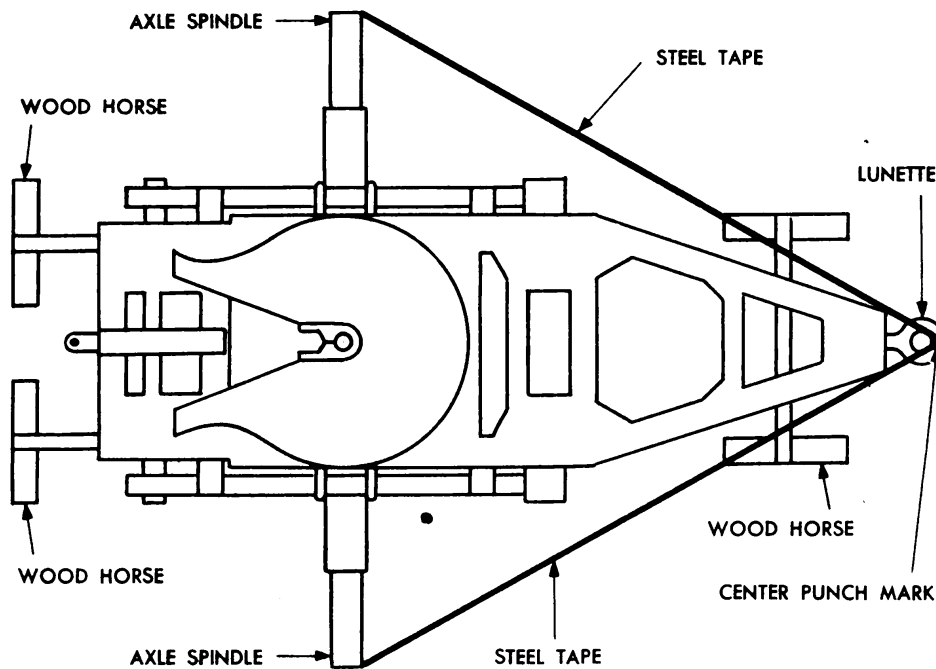

RA PD 335851

Figure 52—Dolly Axle Alinement Chart

(5) Place a crowbar between spring hanger and spring eye and pry up and down to detect excessive spring and shackle bushing wear. Rebush if necessary.

(6) Check the length of the two main springs to make certain they are the same length, or nearly so.

(7) Stand several feet back from the rear crossmember and sight down the main frame side rails and observe whether or not the frame is bent. If frame is bent, straighten, using heavy I-beam chains and jacks.

10-TON PAYLOAD, 14-TON GROSS, 2-WHEEL STAKE AND PLATFORM SEMITRAILER AND 10-TON CONVERTER DOLLY

86. DOLLY AXLE ALINEMENT.

a. **Checking Alinement** (fig. 52). Axle alinement must be checked with the axle installed on the dolly. Place a wood horse crosswise under A-frame about two feet from lunette eye. Couple chain hoist to rear crossmember and remove wheel and hub assembly as one unit (par. 55 a). Place two wood horses under axle allowing axle to rest on the two wood horses, but do not remove chain hoist. Place a center punch mark in the center of shaft on lunette eye. Using a steel tape, measure the distance from center punch mark to outer end of axle on both sides. Both measurements should be identical, or nearly so. A measurement of $\frac{1}{8}$ inch less on the right side is permissible. If the right-hand side is longer than the left side, correct axle alinement (par. 85 b).

87. FITS AND TOLERANCES.

a. Data.

Diameter of axle spindle bearing surface	3.7500
Length	80 $\frac{3}{8}$ in.
Spring centers	38 $\frac{7}{16}$ in.

Section XIX

FIFTH WHEEL

88. DESCRIPTION AND DATA.

a. **Description.** The fifth wheel serves as a means of coupling the dolly to the semitrailer. The fifth wheel on the dolly is interchangeable with the fifth wheel on the towing vehicle as an assembly. The parts are all interchangeable with the exception of the mounting plate, wood spacer blocks and the U-bolts. The fifth wheel base is mounted on two support brackets which permit horizontal movement.

b. Data.

Make	Dayton
Model	09100-Z
Weight	350 lb
Type	Two-jaw semiautomatic

89. CLEANING AND INSPECTION.

a. **Cleaning.** Steam clean the complete assembly.

b. **Inspection** (fig. 53).

(1) Place the fifth wheel on the floor with the top down. Pull the operating handle forward to the unlocked position, grasp the jaws firmly and try moving the jaws back and forward against the jaw

FIFTH WHEEL

pins. If movement of the jaws is excessive this indicates the pin hole or the jaw pins are worn. Replace the jaws, jaw pin, or both.

(2) Place the support brackets over the end of the support bracket shaft and test for excessive wear of the bushing in the support brackets and support shaft. Replace bushings in support brackets, or replace the support shaft, or both.

(3) Inspect the lock plunger spring and lock latch spring for breakage and loss of resilience. Replace spring if necessary.

(4) Move the operating handle forward to the unlocked position until plunger lock latch falls in behind the lug on the lock plunger. Trip the plunger lock latch with a screwdriver and check for free movement of the lock plunger shaft. If the lock plunger shaft does not move freely this indicates the plunger shaft is bent. Replace or straighten the lock plunger and shaft assembly.

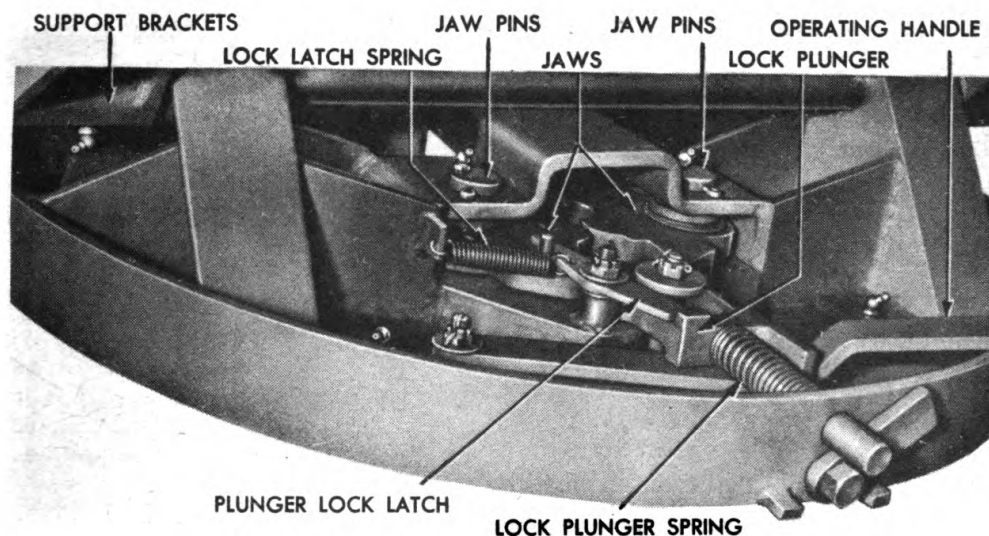

RA PD 335852

Figure 53—Fifth Wheel Jaw and Lock Mechanism

(5) Turn the fifth wheel over with the base up. Check the surface for gouged particles of metal which may protrude beyond the surface. Remove gouged particles with a hand grinder.

(6) Inspect all welds for cracks. Reweld where necessary.

90. DISASSEMBLY.

(1) Remove nut, lock washer and bolt from support shaft and base. With a blunt end bar and sledge hammer drive out the support shaft.

(2) Remove lubrication fitting from the two jaw pins. Pull cotter pins from the two jaw pins and with a blunt end punch drive out the jaw pins and remove the jaws and shim washers.

**10-TON PAYLOAD, 14-TON GROSS, 2-WHEEL STAKE AND
PLATFORM SEMITRAILER AND 10-TON CONVERTER DOLLY**

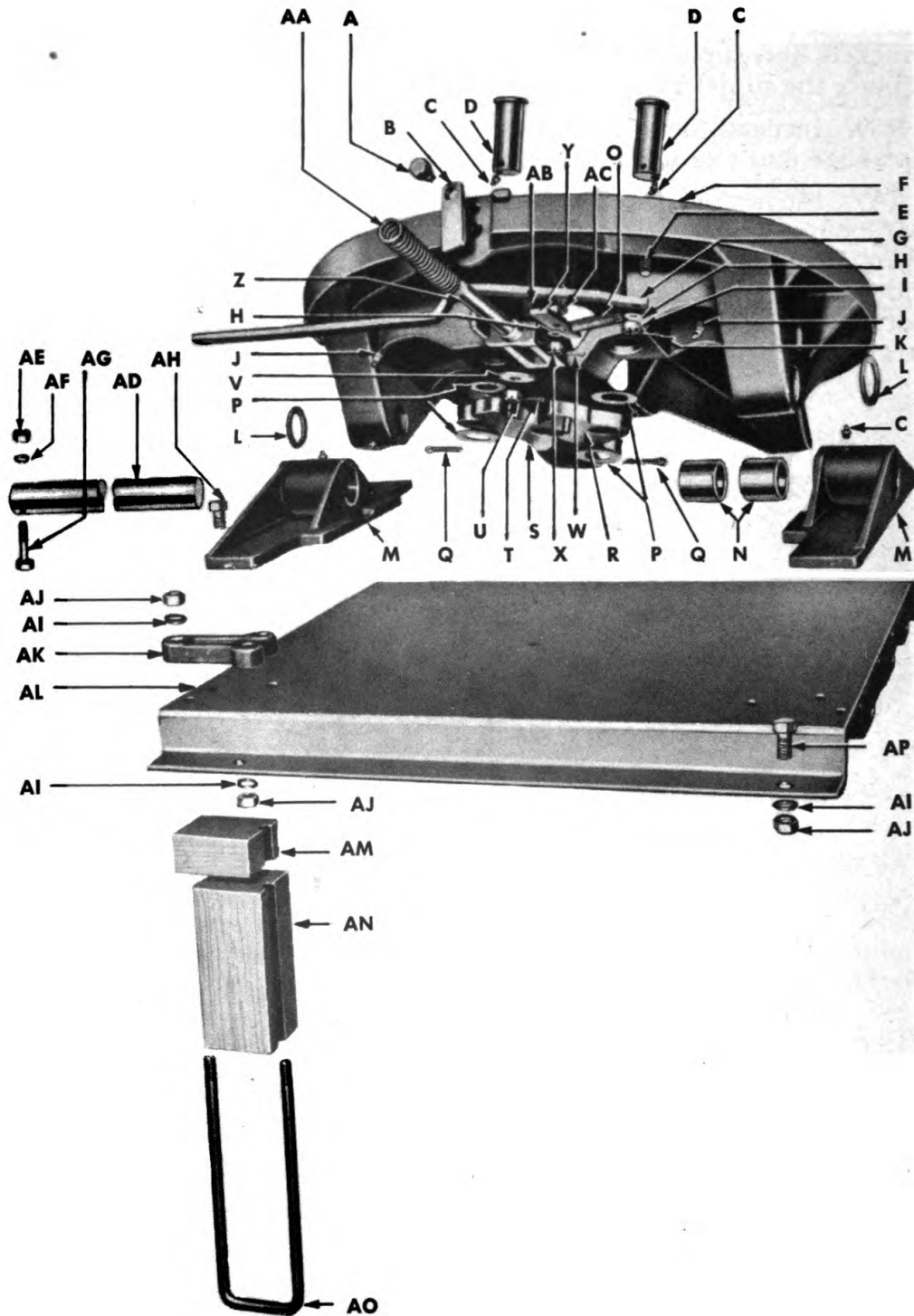

RA PD 335854

Figure 54—Fifth Wheel—Disassembled

FIFTH WHEEL

A SAFETY LATCH SCREW	V PLUNGER STUD WASHER
B SAFETY LATCH	W COTTER PIN
C LUBRICATION FITTING 90 DEGREE	X NUT
D JAW PIN	Y PLUNGER LOCK LATCH
E OPERATING HANDLE STUD	Z LOCK PLUNGER WITH SHAFT
F BASE	AA LOCK PLUNGER SPRING
G OPERATING HANDLE	AB PLUNGER STUD
H PLAIN WASHER	AC PLUNGER LOCK LATCH STUD
I NUT	AD SUPPORT BRACKET SHAFT
J LUBRICATION FITTING 67½ DEGREE	AE NUT
K COTTER PIN	AF LOCKWASHER
L SPECIAL WASHER (SHIM)	AG SHAFT BOLT
M SUPPORT BRACKET	AH CAP SCREW
N SUPPORT BRACKET BUSHINGS	AI NUT
O LATCH SPRING	AJ LOCKWASHER
P JAW PIN WASHERS	AK FIFTH WHEEL STOP
Q COTTER PIN	AL MOUNTING PLATE
R RIGHT HAND COUPLER JAW	AM TOP SPACER BLOCK
S LEFT HAND COUPLER JAW	AN BOTTOM SPACER BLOCK
T COTTER PIN	AO U-BOLT
U NUT	AP CAP SCREW

RA PD 335854B

Legend for Figure 54—Fifth Wheel—Disassembled

(3) Pull cotter pin from stud nut holding plunger lock latch to stud. Remove nut and lift the plunger lock latch off the stud. Uncouple lock latch spring and remove plunger lock latch.

(4) Remove cotter pin from stud nut holding lock plunger to stud. Remove nut from stud and lift off the plunger stud washer. Pull lock plunger toward rear of fifth wheel and remove the lock plunger and lock plunger spring.

(5) Remove screw from safety latch and remove the safety latch. Pull cotter pin from operating stud, remove stud nut, and lift operating handle off stud.

(6) If support bracket bushing is excessively worn remove by cutting down the sides of the bushing with a cape chisel.

91. ASSEMBLY.

a. Assembly (fig. 53).

(1) Place operating handle over operating handle stud and secure operating handle to stud using nut and cotter key. Do not tighten stud nut too tight. Operating handle must move freely.

(2) Place a light film of general purpose grease over surface of jaw pins. Place shim washer over the two jaw pin holes. Coat the top and bottom surface of right- and left-hand jaws with general purpose

10-TON PAYLOAD, 14-TON GROSS, 2-WHEEL STAKE AND PLATFORM SEMITRAILER AND 10-TON CONVERTER DOLLY

grease. Place the right-hand jaw and the left-hand jaw over the two jaw pin holes. *NOTE: The right-hand jaw can be distinguished from the left-hand jaw by the dowel pin located on lower side of the jaw.* Aline hole in jaws and shims with the jaw pin holes in the base. Drive in the two jaw pins and secure the jaw pins to base using two $\frac{3}{16}$ inch cotter pins.

(3) Coat the lock plunger with film of general purpose grease. Place lock plunger spring over shaft on lock plunger and insert the lock plunger into hole at front side of base and over the lock plunger stud. Coat the top and bottom surface of lock plunger washer with oil. Place the lock plunger washer over the lock plunger stud and secure washer to stud using nut and cotter key. Test the movement of the lock plunger by moving the lock plunger back and forth by hand. The lock plunger must move freely. Secure plunger safety latch to front side of base using safety latch screw.

(4) Coat the surface of support shaft with general purpose grease No. 1. A $\frac{3}{8}$ -inch hole is provided in one end of support shaft. Start the end with the hole into base from the left side and in such a manner as to have the hole in the support shaft in alinement with the hole in the base. Drive the support shaft into base. Aline hole in support shaft with hole in base by turning the support shaft with a pipe wrench. Install bolt, lock washer, and nut.

(5) If the bushings have been removed from the support brackets, press in new bushings and ream (par. 92). *NOTE: There must be $\frac{5}{8}$ -inch space between the two support bracket bushings after the bushings have been pressed into the support brackets.*

92. FITS AND TOLERANCES.

a. Data.	Max (inch)	Min (inch)	Desired (inch)	Replace Beyond
Support bracket bushings (outside diameter)	2.1265	2.1255		
Support bracket bushings (ream diameter)		2.001	2.003	Replace support bracket bushing if support bracket is extremely loose on support bracket shaft.
Support bracket shaft			2.0000	Replace when badly scored or when sup- port bracket becomes extremely loose.
Jaw pins			1.5000	Replace jaw pins or jaw when exces- sive slap is felt when dolly is coupled to semitrailer.
Jaw pin holes			1.5000	

Section XX

SEMITRAILER LANDING GEAR

93. DESCRIPTION AND DATA.

a. Description. The landing gear consist of two assemblies, right-hand and left-hand. The right-hand assembly is bolted to the right side of the semitrailer, and the left-hand assembly is bolted to the left side of semitrailer. The two assemblies are manually operated from one crank which is located on the right side of the semitrailer; the right- and left-hand assemblies are connected with a crank shaft and gear shafts, thus permitting both assemblies to retract and extend simultaneously. All parts are interchangeable from one assembly to another, with the exception of the frame brackets and the bevel gear shafts. The disassembly, assembly, cleaning, and inspection instructions apply to either the right- or left-hand assembly.

b. Data.

Make	Austin
Model	J1150-A
Height (extended)	3 ft 10 in.
Height (retracted)	2 ft 7 in.
Weight	289 lb

94. DISASSEMBLY.

a. Disassembly (fig. 56).

(1) Remove three cap screws and lock washers from bevel gear cover. Lift the bevel gear cover and gear cover gasket off the frame bracket.

(2) This paragraph applies to the right-hand assembly only. Remove three cap screws (U) and three lock washers from crank bracket (T). Remove two bolts, nuts and lock washers from crank shaft coupling (O) and lift the crank bracket and crank shaft off the frame bracket.

(3) Place a 3/8-inch drift punch in the bolt hole of the bevel gear shaft and turn the bevel gear shaft until stop is reached and the wheels are in the retracted position.

(4) Drive the bevel gear shaft (E) partly out of frame bracket or until Woodruff key is exposed. Remove Woodruff key and pull out the bevel gear shaft and lift the bevel gear (BG) out of the frame bracket.

(5) Remove cap screw (AT) and lock washer from guide key keeper plate (AS). Remove guide key keeper plate and guide key (AR). Remove jam nut from end of main operating screw and remove lock washer. Drive the bevel gear (BD) off main operating screw. Tap out the main screw feather key (AY). Turn the main operating screw (AX) out of the frame bracket. Pull lower leg out of the frame bracket.

(6) Remove bearing cone (BC). Do not remove bearing cup. The bearing cup is a pressed fit and will last the life of the hand gear.

**10-TON PAYLOAD, 14-TON GROSS, 2-WHEEL STAKE AND
PLATFORM SEMITRAILER AND 10-TON CONVERTER DOLLY**

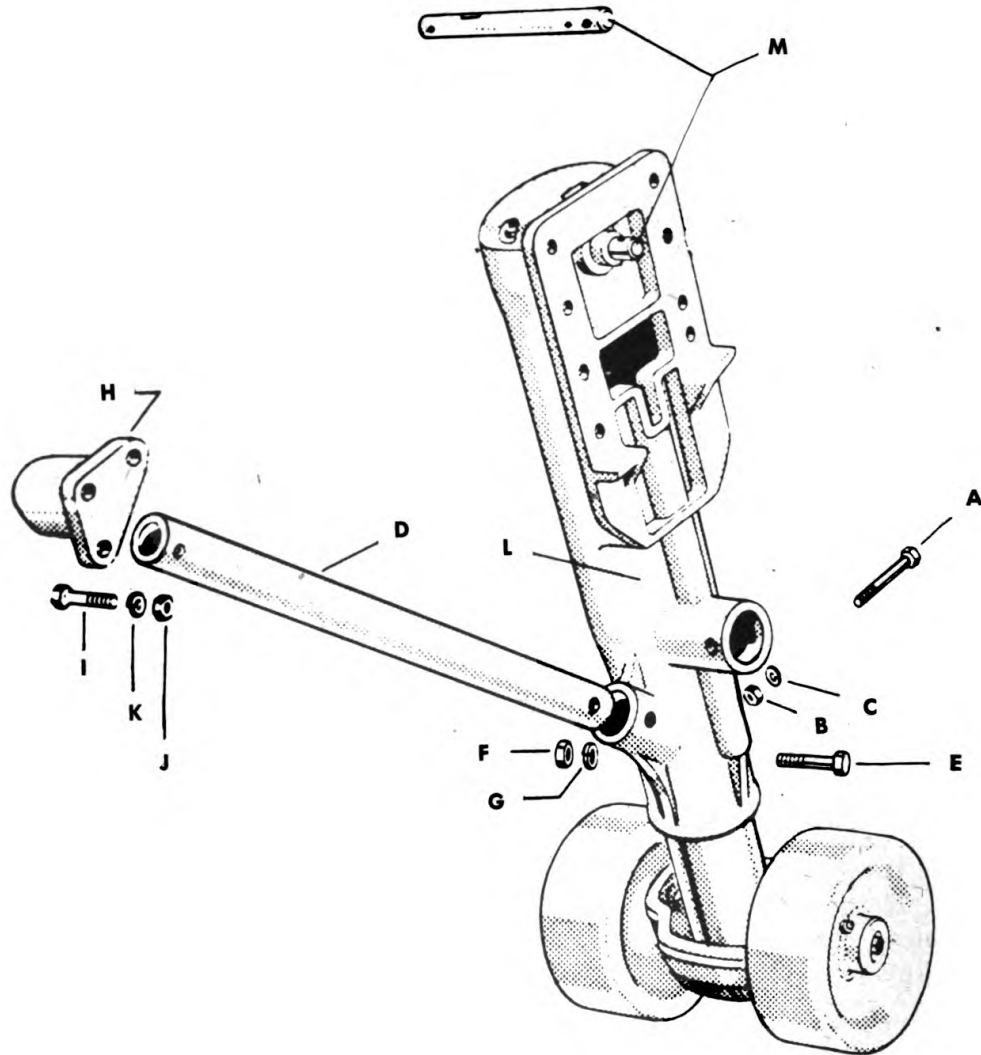

- A CROSS TUBE BOLT
- B NUT
- C LOCK WASHER
- D BACK BRACE
- E BOLT
- F NUT
- G LOCK WASHER

- H BACK BRACE BRACKET
- I BOLT
- J NUT
- K BACK BRACE BRACKET BOLT
LOCK WASHER
- L FRAME BRACKET
- M LEFT HAND BEVEL GEAR SHAFT

RA PD 335853

Figure 55—Left-hand Landing Gear Assembly

SEMITRAILER LANDING GEAR

Wipe the grease off bearing cup and inspect the cup for cracks. If the cup is cracked, pull the cup out. Remove thrust bearing (BA) and thrust washer (AZ). Place a screwdriver under end of retainer ring (AW), pry the retainer ring out of the lower leg and remove the main screw nut (AV).

(7) Remove wheel bolt and axle cap from the two truck spindles and pull off the two wheels. Remove cotter pin, nut and truck wheel washer from truck wheel bolt. Drive out the truck pin (AQ) and remove the truck connector (AL). Remove lubrication fittings, wheels, frame bracket and bevel gear cover.

95. CLEANING AND INSPECTION.

a. **Cleaning.** Steam clean all parts with the exception of the gear cover gasket.

b. **Inspection.** Inspect bevel gear shaft bushings for excessive wear, replace if necessary. Check crank bracket bushing for excessive wear and make certain the bushing is tight in the crank bracket and that bushing has not turned and closed the lubrication fitting hole. Check all bearings to make certain they are not chipped or damaged. Secure replacement if necessary. Inspect the thread of main operating screw for damage. If the threads are burred, dress up the threads using a file. Lay the main operating screw on a flat surface and roll the screw to detect for bend. If screw is bent, straighten or replace with new. Insert a $\frac{1}{8}$ -inch rod into the lubrication fitting holes to make certain the holes are open.

96. ASSEMBLY.

a. Assembly.

(1) If bevel gear shaft bushing (S) has been removed from frame bracket, press in new bushing and ream to 1 inch diameter. Press new bushing into crank bracket if the bushing has been removed and ream to 1 inch diameter. Drill $\frac{1}{8}$ -inch hole into crank bracket bushing through lubrication fitting hole to permit passage of lubricant.

(2) Place a light film of grease over truck spindles. Install wheel on truck spindle. Place axle cup (AG) over wheel bolt (AH). Place the wheel bolt through the hole in truck spindle and wheel truck spring (AK) over inner end of wheel bolt. Install lock washer and nut on wheel bolt and tighten the bolt. Install wheel on opposite truck spindle in the same manner.

(3) Place truck connector (AL) over end of lower leg (AE). Aline hole in lower leg with holes in connector truck (AL) and drive truck pin (AQ) through the leg and truck. Secure the truck pin to the truck connector using truck wheel bolt, truck wheel washer, nut and cotter pin. **NOTICE: Do not tighten wheel truck bolt too tight as the truck connector must move freely on the lower leg.**

(4) Place main screw nut (AV) into cavity at top of lower leg and lock the main screw in position using retainer ring (AW). If bearing cup (BB) has been removed, press in the bearing cup. Place thrust washer (AZ) over end of main operating screw. Place thrust

10-TON PAYLOAD, 14-TON GROSS, 2-WHEEL STAKE AND PLATFORM SEMITRAILER AND 10-TON CONVERTER DOLLY

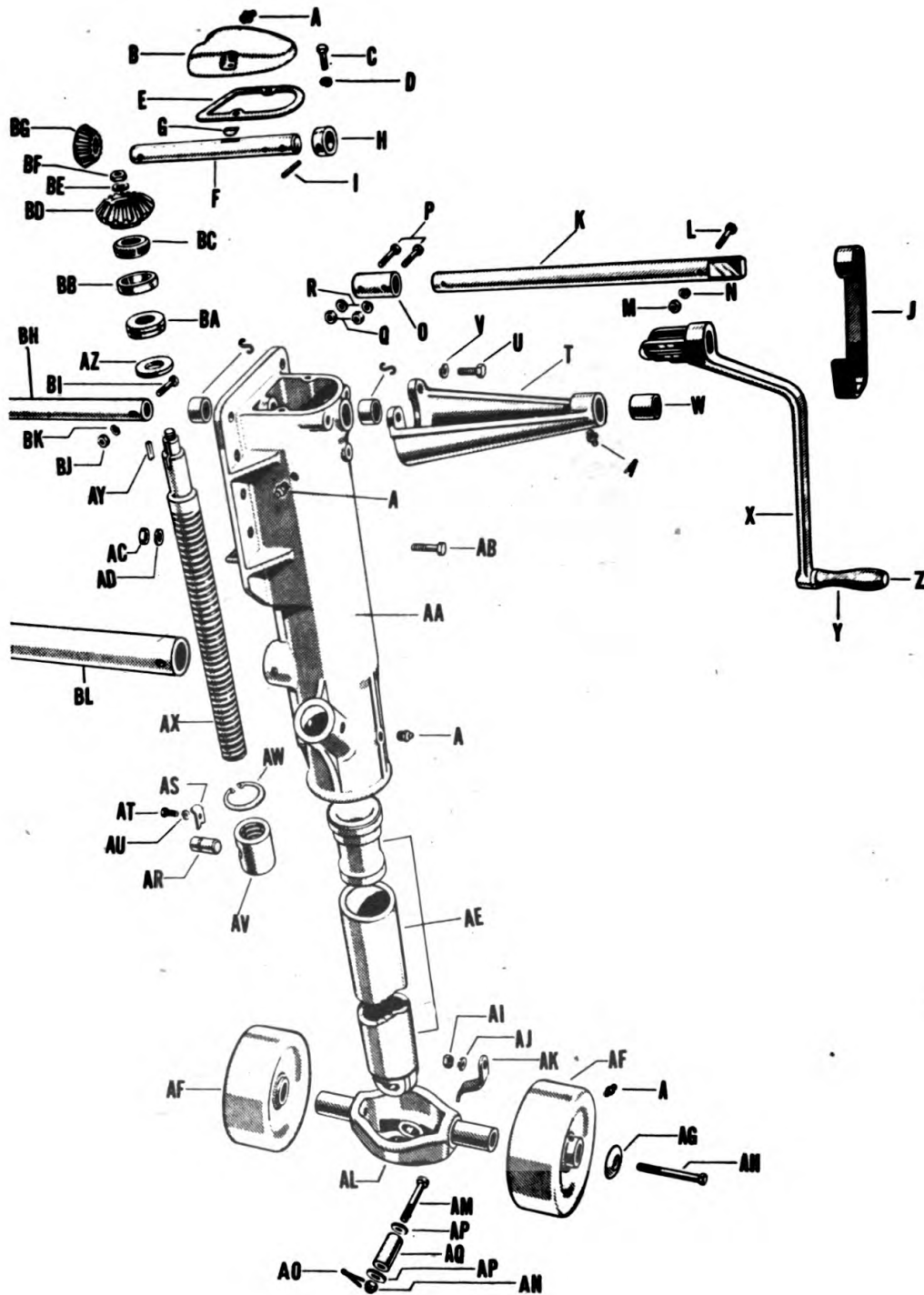

RA PD 334373

Figure 56—Right-hand Landing Gear Assembly—Disassembled

SEMITRAILER LANDING GEAR

A	ALEMITE FITTING	AG	AXLE CAP
B	BEVEL GEAR COVER	AH	WHEEL BOLT
C	CAP SCREW	AI	NUT
D	LOCK WASHER	AJ	LOCK WASHER
E	GEAR COVER GASKET	AK	WHEEL TRUCK SPRING
F	RIGHT HAND BEVEL GEAR SHAFT	AL	TRUCK, CONNECTOR
G	WOODRUFF KEY, NO. 15	AM	TRUCK WHEEL BOLT
H	BEVEL GEAR SHAFT COLLAR	AN	NUT
I	BEVEL GEAR SHAFT COLLAR PIN	AO	COTTER PIN
J	CRANK HOLDER	AP	WHEEL TRUCK WASHER BOLT
K	CRANK SHAFT	AQ	TRUCK PIN
L	CRANK HANDLE BOLT	AR	SCREW NUT GUIDE KEY
M	CRANK HANDLE NUT	AS	GUIDE KEY KEEPER PLATE
N	LOCK WASHER	AT	CAP SCREW
O	CRANKSHAFT COUPLING	AU	LOCK WASHER
P	CRANKSHAFT COUPLING BOLT	AV	MAIN SCREW NUT
Q	NUT	AW	RETAINING RING
R	PLAIN WASHER	AX	MAIN OPERATING SCREW
S	BEVEL GEAR SHAFT BUSHING	AY	MAIN SCREW FEATHER KEY
T	CRANK BRACKET	AZ	THRUST WASHER
U	CRANK BRACKET CAP SCREW	BA	THRUST BEARING
V	LOCK WASHER	BB	BEARING CUP
W	CRANK BRACKET BUSHING	BC	BEARING CONE
X	CRANK	BD	BEVEL GEAR
Y	CRANK HANDLE	BE	WASHER
Z	CRANK HANDLE RIVET	BF	JAM NUT
AA	RIGHT HAND BRACKET, FRAME	BG	BEVEL GEAR
AB	BOLT	BH	INTER-BEVEL GEAR SHAFT
AC	NUT	BI	BOLT
AD	LOCK WASHER	BJ	NUT
AE	LOWER LEG	BK	LOCK WASHER
AF	WHEEL	BL	CROSS TUBE

RA PD- 334373B

**Legend for Figure 56—Right-hand Landing Gear
Assembly—Disassembled**

bearing next to thrust washer and place the main operating screw into lower end of frame bracket. Install feather key (AY) into end of main operating screw. Install bevel gear on end of main operating screw and secure the bevel gear to main operating screw using lock washer and jam nut (BF).

(5) Place frame bracket over lower leg and turn the main operating screw into lower leg. Continue turning main operating screw until main screw nut is visible through hole on inner side of frame bracket. Install screw nut guide key (AR) into main screw nut and secure the screw nut guide to frame bracket using guide key keeper plate (AS), lock washer and nut.

(6) Install bevel gear shaft into frame bracket from the outer side and turn the bevel gear shaft so that the keyway is visible from top of frame bracket. Install Woodruff key into bevel gear shaft. Place bevel gear into frame bracket and aline the hole in bevel gear with hole in frame bracket. Aline Woodruff key with keyway in bevel gear and drive the bevel gear shaft into the bevel gear until the Woodruff key is in the center of the bevel gear, or nearly so.

10-TON PAYLOAD, 14-TON GROSS, 2-WHEEL STAKE AND PLATFORM SEMITRAILER AND 10-TON CONVERTER DOLLY

(7) Place bevel gear shaft collar (H) over inner end of bevel gear shaft. Secure the bevel gear shaft collar in position using pin (I). If the left-hand landing gear is being assembled, place a bevel gear shaft collar over both ends of the bevel gear shaft and secure the collar in position, using pin. Fasten crankshaft coupling to bevel gear shaft using one $\frac{3}{8}$ -inch bolt, nut and lock washer.

(8) Place bevel gear cover gasket over top of frame bracket. Place bevel gear cover over gasket and align holes in gear cover and gear cover gasket. Secure gear cover to frame bracket using four lock washers and four cap screws.

(9) Maintenance instructions in this paragraph apply to the right-hand landing gear assembly. Fasten crank bracket to right-hand frame bracket using three cap screws and three lock washers. Insert crankshaft through crank bracket and fasten end of crankshaft to coupling using $\frac{3}{8}$ -inch bolt, lock washer and nut.

(10) Install one lubrication fitting into bevel gear cover and one lubrication fitting into each of the two wheels. Install one lubrication fitting into top rear side and another in lower outside support bracket and lubricate the assembly (par. 15).

Section XXI**HUBS, DRUMS AND BEARINGS****97. DESCRIPTION AND DATA.**

a. Description. The dolly and semitrailer are equipped with two hub assemblies. As an assembly the hubs are rights and lefts. The hubs do not become rights and lefts until after the wheel studs are pressed into the hub. The hubs on the semitrailer are equipped with drums and the hubs on the dolly are equipped with a collar to take up the space on the hubs where a drum would normally fit. All component parts are interchangeable from dolly hubs to semitrailer hubs. The inner and outer wheel bearings are of the same size and are interchangeable from dolly to semitrailer and from right side to left side.

b. Data.

Weight (dolly)	33 lb
Weight (semitrailer)	79 lb
Bearing number (Timken)	596-A
Bearing cup (Timken)	592

98. CLEANING AND INSPECTION.

a. Cleaning. Steam clean the hub and drum assembly and wash bearing in dry-cleaning solvent.

HUBS, DRUMS AND BEARINGS

b. **Inspection.** Inspect drums for cracks and heat checks. Heat checking, unless severe, does not call for brake drum replacement. Reface or replace drum if necessary. Place a long punch down through hub and tap the cups to make certain the cups are tight in hub bore. If cups are loose replace hub or remachine (par. 100). Inspect wheel studs to make certain the studs are tight in the wheel stud holes and



RA PD 334391

Figure 57—Removing Bearing Cups

threads are not damaged. Replace or rethread studs if necessary. Inspect rollers in bearings for pits and chipped surfaces and replace if necessary. Check the cups for cracks, chips and pits. Replace if necessary.

99. DISASSEMBLY.

a. **Cups (fig. 57).** Place hub on end. Place a soft steel bar on inside shoulder of cup. Using a heavy hammer hit first one side of

**10-TON PAYLOAD, 14-TON GROSS, 2-WHEEL STAKE AND
PLATFORM SEMITRAILER AND 10-TON CONVERTER DOLLY**

the cup and then the other. Alternating in this manner makes the cup come out straight with the cup bore and danger of wedging the cup in the bore is minimized. Turn hub over and remove opposite cup in the same manner.

b. **Wheel Studs** (fig. 58). Place hub on side and insert wheel wrench handle in between the wheel studs to prevent wheel from moving. Remove 10 nuts from the 10 studs and lift grease slinger and drum off the wheel studs. Drive out the wheel studs using a copper or lead hammer or press them out. Dolly hubs are provided with a collar instead of a drum.

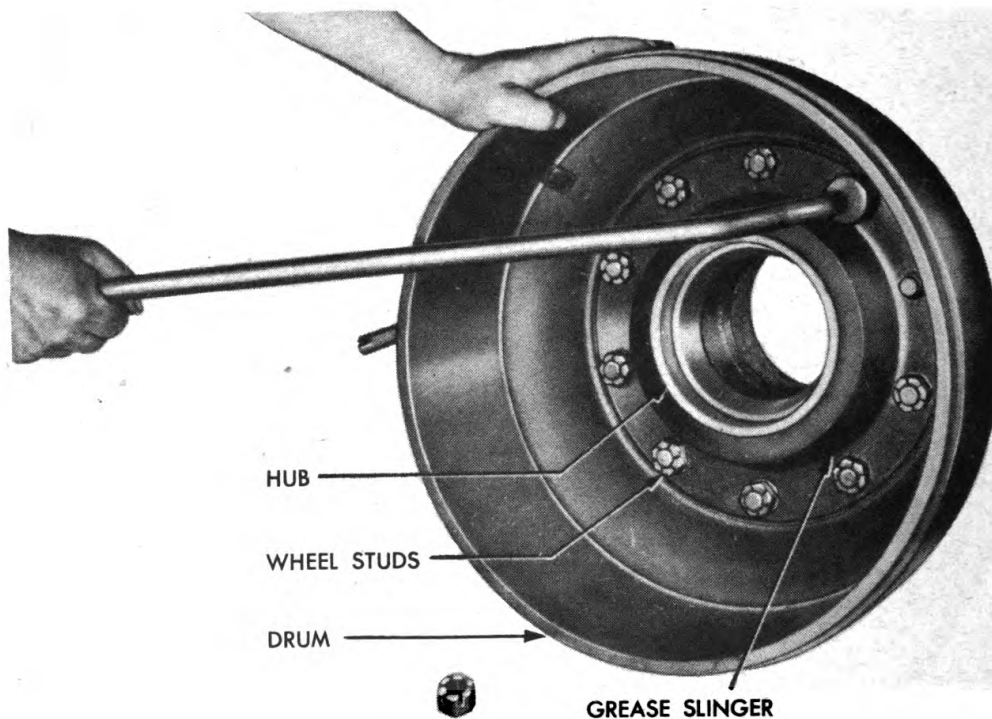

RA PD 335856

Figure 58—Removing Brake Drum

100. REPAIR.

a. **Hubs.** It is not necessary to discard hubs because of loose bearing cups. Braze about $\frac{1}{8}$ inch of bronze metal to the worn cup bore and machine cup to its original diameter (par. 102).

b. **Drums.** Scored, ruffed, and heat checked drums which are not true, may be machined to within 0.030 of their original diameter (par. 102). Replace drum when cracked or extremely out of round.

101. ASSEMBLY.

a. **Install Cups.** Start cup into hub with a copper hammer. Make certain the cup is square with the bore, and that smallest inside

HUBS, DRUMS AND BEARINGS

diameter of the cup is started into the bore. Press the cup in until stop is reached. Turn the hub over and press cup in from opposite side in the same manner. Inspect cups from inner side of hub to make certain the cups are down against the stop flange.

b. Install Studs. The studs come in right- and left-hand threads and are marked with an "R" indicating right-hand threads or with an "L" indicating left-hand threads. If the hub assembly is intended for the right side of the vehicle make certain the studs are all marked with the letter "R" or vice versa. Place studs into stud holes with the flat side of the studs in alinement with the groove in face of hub. Press the studs into hub until stop is reached.

c. Install Drum (fig. 58). If the hub assembly is intended for the dolly use a collar instead of a drum. Place hub on floor with drum pilot up. Clean all dust and other foreign matter from the surface of drum pilot. Place the drum over wheel studs, and grease slinger over the wheel studs next to the drum. Install the 10 nuts and tighten evenly to prevent cocking of drum on drum pilot.

102. FITS AND TOLERANCES.

a. Data.

	Max (inch)	Min (inch)	Replace Beyond
Brake drum (finished inside width) . . .	5.3437		
Brake drum (original inside diameter)	17.255	17.245	17.285
Hub (cup bore)	5.996	5.998	

Section XXII

BODY AND FRAME

103. DESCRIPTION.

a. The body frame consists of pressed steel members and is an integral part of the chassis. The body consists of 2 tailgates, 10 side racks, 2 corner racks and one front rack. The racks consist of ship-lap planking bolted to wood stakes. The rack stakes are seated in steel pockets and fastened to the pockets with carriage bolts. The flooring is made of hardwood. The floor is grooved to accommodate the skid irons which are screwed to the body crossmembers. The king pin is mounted in the upper fifth wheel plate and the pulling is done from the king pin.

104. RACKS.

a. Disassembly. Remove racks (par. 12). Place rack on two wood horses. Remove nut and carriage bolts holding stakes to boards. Remove stakes. Remove nuts and carriage bolts from rack fasteners. Remove screws from tarpaulin rub rail and lift the rail off.

**10-TON PAYLOAD, 14-TON GROSS, 2-WHEEL STAKE AND
PLATFORM SEMITRAILER AND 10-TON CONVERTER DOLLY**

b. **Assembly.** Install stakes into pockets on vehicle at the place where rack is to be used. Make stake 48 inches from the top of floor to the top of stake. Square up stakes and clamp a board across the top to hold the stakes in position. Start with the bottom board and continue bolting board into position.

105. FLOORING.

a. **Removal.** Remove the two tailgates. Remove carriage bolts holding scuff angle to rear crossmember. Remove screws from skid irons. Remove screws from floor planking. If floor planking is to be used when assembling, mark each plank to make certain it is used in its original position.

b. **Installation.** Place planking in position as marked, with the skid iron grooves up. Fasten planking to body crossmember using one self-tapping screw in the center of each plank at each crossmember. Place skid irons in position between the floor planking. Fasten skid irons to body crossmembers using round head self-tapping screws. Position scuff angle to floor and rear crossmembers. Fasten scuff angle to rear crossmember using carriage bolts.

106. KING PIN.

a. **Inspection.** Tap king pin with a hammer to detect whether or not the king pin is loose in the upper fifth wheel plate. If king pin is found to be loose remove floor and reweld. Check for excessive wear. The original diameter at the smallest place in the king pin is 2.000 inches plus or minus 0.005 inch. If this diameter is reduced by wear to 1.9325 inches, or less, it is advisable to replace the king pin. However, a king pin that may be worn beyond 1.9325 inches does not prevent operation of the vehicle. Inspect upper fifth wheel plate for gouged particles of metal which may protrude beyond the surface. Remove gouged particles with a hand grinder.

b. **Removal.** The king pin is located under body floor 34 inches back from the front and directly in the center. Remove the screws from the three center skid irons eight feet from the front. Place a bar under the skid irons and pry them up high enough to permit the operation of a hack saw. Cut off the three skid irons, and remove the three center planks. If it is necessary to cut the planks to remove them make the cuts in the center of the crossmembers and stagger the three cuts so that the cuts will come at two different crossmembers. With an acetylene cutting torch burn off all welds holding king pin to upper fifth wheel plate. Make certain all welds are removed and drive the king pin out of the plate from the underside using a sledge hammer. Grind all slag and excess weld from plate.

c. **Replacement.** Place king pin into hole from top side of upper fifth wheel plate, and weld into position using bare welding rods in the plug holes and coated rod on the flange. Place the flooring in position and screw to crossmember. Join the three skid irons, weld them together and install the skid iron screws.

APPENDIX

Section XXIII

SHIPMENT AND TEMPORARY STORAGE

107. GENERAL INSTRUCTIONS.

a. Preparation for domestic shipment of the vehicle is the same with the exception of minor added precautions as preparation for temporary storage. Preparation for shipment by rail includes instructions for loading the vehicle, blocking necessary to secure the vehicle on freight cars, and other information necessary to properly prepare the vehicle for domestic rail shipment. For more detailed information and for preparation for indefinite storage refer to AR 850-18.

108. PREPARATION FOR TEMPORARY STORAGE.

a. Vehicles to be prepared for temporary storage are those ready for immediate service but not used for less than 30 days. If vehicles are to be indefinitely stored after shipment by rail, they will be prepared for such storage at their destination.

b. If the vehicles are to be temporarily stored, take the following precautions.

(1) LUBRICATION. Lubricate the vehicle completely (par. 16).

(2) TIRES. Clean, inspect, and properly inflate all tires including spares. Replace with serviceable tires all tires requiring repairing or retreading. Do not store tired vehicles on floors, cinders, or other surfaces which are soaked with oil or grease. Wash off immediately any oil, grease, gasoline, or kerosene which comes in contact with tires under any circumstances.

(3) ROAD TEST. The preparation for limited storage will include a road test after the lubrication service to check on the general condition of the vehicle. Correct any defects noted in the vehicle operation before the vehicle is stored, or attach a tag in a conspicuous place, stating the repairs needed or describing the condition present. A written report of these items will then be made to the officer in charge.

(4) EXTERIOR OF VEHICLE. Remove rust appearing on any part of the vehicle exterior with flint paper. Repaint painted surfaces whenever necessary to protect wood or metal. Coat exposed polished metal surfaces susceptible to rust, such as winch cables and chains, with medium grade preservative lubricating oil. Close the tailgate. Leave rubber floor mats, when provided, in an unrolled position on the floor, not rolled or curled up.

(5) INSPECTION. Make a systematic inspection just before shipment or temporary storage to insure all above steps have been covered and that the vehicle is ready for operation on call. Make a list of all missing or damaged items and attach it in a conspicuous place. Refer to Before-operation Service (par. 18).

10-TON PAYLOAD, 14-TON GROSS, 2-WHEEL STAKE AND PLATFORM SEMITRAILER AND 10-TON CONVERTER DOLLY

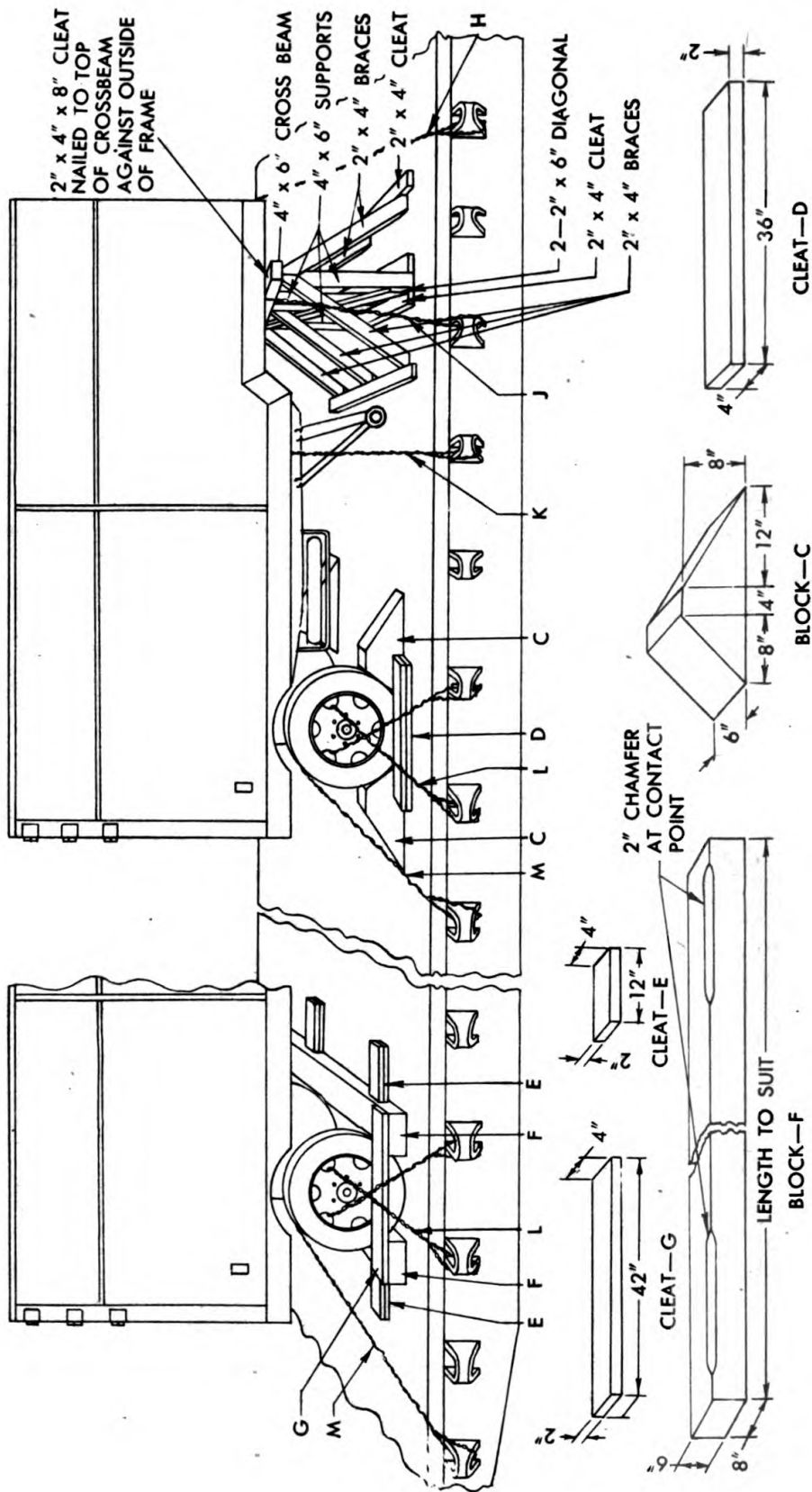

RA PD 318277

Figure 59—Blocking Requirements for Rail Shipment

SHIPMENT AND TEMPORARY STORAGE

(6) **BRAKES.** Release brakes and chock wheels.

c. Inspection in Limited Storage. Vehicles in limited storage will be inspected weekly for tire failures, evidence of vandalism, tampering, etc.

109. LOADING AND BLOCKING FOR RAIL SHIPMENT.

a. Preparation. In addition to the preparation described in paragraph 108 when ordnance vehicles are prepared for domestic shipment, the following preparation and precautions must be taken.

(1) **EXTERIOR.** Cover the body of the trailer with the canvas cover supplied as an accessory or available for use during rail shipment.

(2) **BRAKES.** The brakes must be released after the vehicle has been placed in position with a brake wheel clearance of at least 6 inches. The vehicles will be located on the car in such a manner as to prevent the car from carrying an unbalanced load.

(3) All cars containing ordnance vehicles must be placarded "DO NOT HUMP."

(4) Ordnance vehicles may be shipped on flat cars, end door box cars, side door cars, or drop end gondola cars, whichever type car is the most convenient.

b. Facilities for Loading. Whenever possible, load and unload vehicles from open cars, using permanent end ramps and spanning platforms. Movement from one flat car to another along the length of the train is made possible by cross-over plates or spanning platforms. If no permanent end ramp is available, an improvised ramp can be made from railroad ties. Vehicles may be loaded in gondola cars without drop ends by using a crane.

c. Securing Vehicles. In securing or blocking a vehicle, three motions, lengthwise, sidewise, and bouncing, must be prevented. Two methods for blocking vehicle on freight cars (fig. 59) are given below. **NOTE:** *All wheel blocking must be located against the outside wheel of the dual.*

(1) **FIRST METHOD (FRONT OF VEHICLE).** Position supporting frame to the rear of and against the kingpin so that crossbeam is at right angles to the trailer frame. Nail one cleat (2- x 4- x 8-in.) to the top of the crossbeam against the outside of the frame on each side, using four 40-penny nails for each cleat (fig. 59). Toe-nail the three supports (fig. 59) to the car floor using 40-penny nails. Toe-nail braces (fig. 59) and nail all cleats to the car floor with 40-penny nails.

(2) **FIRST METHOD (REAR OF VEHICLE).** Place one block "C" (fig. 59) at the front of each outside wheel and one at the rear of each outside wheel (four blocks "C" required). Nail the heel of the block to the car floor with five 40-penny nails, and nail the portion of the block under the tire to the car floor with two 40-penny nails. Place two cleats "D" (fig. 59) to the outside of each wheel (four cleats "D" required). Nail the lower cleat to the car floor with three 40-

10-TON PAYLOAD, 14-TON GROSS, 2-WHEEL STAKE AND PLATFORM SEMITRAILER AND 10-TON CONVERTER DOLLY

penny nails, and nail the top cleat to the cleat below with three 40-penny nails.

(3) **STRAPPING VEHICLE.** Secure vehicle in front "H" (fig. 59) and at the side "J" by strapping, consisting of four strands, two wrappings of No. 8 gage, black annealed wire, passed through the stake pockets of the trailer and secure at the stake pockets of the railroad car. *NOTE: Angularity from the stake pocket at front of trailer body to the stake pocket of the railroad car should be approximately 45 degrees. Strapping at the side of the trailer body should be at right angles to the car or at the closest stake pocket.* Secure center of vehicle "K" by strapping, passing wire around chassis frame and attaching at the closest stake pocket. Secure vehicle at axle "L" by passing wire through opposite openings in the wheels and attaching at the closest stake pocket of the car. Secure vehicle at the rear by passing wire through the spring shackles ("M", fig. 59) and attached at stake pockets of the car. *NOTE: Angularity of strapping at the rear should be approximately 45 degrees.*

(4) **SECOND METHOD (FRONT OF VEHICLE).** The front of the vehicle is blocked the same as in First Method (step (1) above).

(5) **SECOND METHOD (REAR OF VEHICLE).** Place one block "F" (fig. 59) across the front and one across the rear of the wheels. Blocks "F" must be at least as long as the over-all width of the vehicle at the car floor. Place cleats "G" against the outside face of the wheels on top of blocks "F". Nail cleats "G" to blocks "F" with 40-penny nails, using two nails at each end of cleat "G". Place cleats "E" against blocks "F", two to the front and two to the rear of each outside wheel. Nail each lower cleat to the car floor with three 40-penny nails, then nail each top cleat to the cleat below with three 40-penny nails.

(6) **STRAPPING VEHICLE.** Strapping is applied in the second method as in step (3) above.

d. Shipping Data.

Length of vehicle (over-all)	306 ⁵ / ₁₆ in.
Width of vehicle (over-all)	94 ³ / ₄ in.
Height of vehicle (over-all)	104 ³ / ₄ in.
Volume occupied per vehicle	1785 cu ft
Area of car floor occupied per vehicle	204 sq ft

REFERENCES

PUBLICATIONS INDEXES.

The following publications indexes should be consulted frequently for latest changes to or revisions of the publications given in this list of references and for new publications relating to materiel covered in this manual:

Introduction to Ordnance Catalog (explains SNL system)	ASF Cat ORD-1 IOC
Ordnance publications for supply index (index to SNL's)	ASF Cat ORD-2 OPSI
Index to ordnance publications (lists FM's, TM's, TC's, and TB's of interest to Ordnance Personnel, MWO's, OPSR's, BSD, S or SR's, OSSC's and OFSB's. Includes alphabetical listing of Ordnance major items with publications pertaining thereto)	OFSB 1-1
List of publications for training (lists MR's, MTP's, T/BA's, T/A's, and FM's, TM's and TR's concerning training)	FM 21-6
List of training films, film strips and film bulletins (lists TF's, FS's, and FB's by serial number and subject)	FM 21-7
Military training aids (lists graphic training aids, models, devices, and displays)	FM 21-8

STANDARD NOMENCLATURE LISTS.

Semitrailer, 10-ton payload, 14-ton gross, 2-wheel (2dt), stake and platform 1944 (w/dolly)	SNL G-676
Cleaning, preserving and lubricating materials; recoil fluids, special oils, and miscellaneous related items	SNL K-1
Soldering, brazing, and welding materials, gases, and related items	SNL K-2
Tool sets—motor transport	SNL N-19

EXPLANATORY PUBLICATIONS.

General.

Military motor vehicles	AR 850-15
Standard military motor vehicles	TM 9-2800

Maintenance and Repair.

Basic maintenance manual	TM 38-250
Chassis, body, and trailer units	TM 10-560
Lubrication of ordnance materiel	TM 9-2835

10-TON PAYLOAD, 14-TON GROSS, 2-WHEEL STAKE AND PLATFORM SEMITRAILER AND 10-TON CONVERTER DOLLY

- Motor vehicle inspections and preventive maintenance services TM 9-2810
- Maintenance and care of pneumatic tires and rubber treads TM 31-200
- Cleaning, preserving, lubricating and welding materials and similar items issued by the ordnance department TM 9-850

Protection of Materiel.

- Camouflage FM 5-20
- Explosives and demolitions FM 5-25
- Defense against chemical attack FM 21-40
- Decontamination of armored force vehicles..... FM 17-59
- Chemical decontamination, materials, and equipment TM 3-220

Storage and Shipment.

- Registration of motor vehicles AR 850-10
- Storage of motor vehicle equipment AR 850-18
- Ordnance storage and shipment chart, group G—
Major items OSSC-G
- Rules governing the loading of mechanized and motorized army equipment and major caliber guns for the United States Army and Navy, on open top equipment, are published by Operations and Maintenance Department of Association of American Railroads.

INDEX

	A	Page No.		Page No.
Adjustment			Brake chambers	
bearings		77	description	48
brake system		47	installation	49
shock absorber		69	removal	48
After-operation and weekly			Brake shoes	
service		30	assembly and disassembly	91
Air brake system			cleaning	90
after-operation and weekly			description	60
service		31	inspection	61, 91
before-operation service		28	maintenance operations	37
road test		35	removal and installation	61
Air cleaner			Brake spider, disassembly and	
description		52	assembly	91
draining and cleaning		52	Brake system	
removal and installation		53	adjustment	47
Air hose			air cleaner	52
description and inspection		56	air hose	56
removal and installation		56	air reservoir	52
Air reservoir, removal and			brake chamber	48
installation		52	brake shoe	60
Assembly			description and data	47
brake spider		91	during-operation service	29
fifth wheel		105	hose couplings	57
hubs, drums, and bearings		114	internal brake assembly	63
internal brake assembly		91	lines, tubing, and connections	54
pintle hook		88	maintenance operation	37
semitrailer landing gear		109	relay emergency valve	49
At-halt service		29	road test	35
Auxiliary springs, removal and			slack adjuster	58
installation		66	trouble shooting	42
Axle				
checking for bend		99	C	
checking for camber		100	Camber, checking for in axle	100
description and data		64, 99	Camshaft and brake anchor pins,	
dolly axle alinement		102	lubrication	26
fits and tolerances		102	Cleaning	
installation		67	air cleaner	52
removal		66	brake shoes	90
semitrailer axle alinement		100	fifth wheel	102
trouble shooting		44	hubs, drums, and bearings	112
	B		semitrailer landing gear	109
Before-operation service		28	Controls	
Blackout switch			dolly	17
description		13, 83	semitrailer	13
removal and installation		84	Coupling brake hose, description	13
Body and frame			Cross shaft	
description		115	installation	68
flooring		116	removal	67
king pin		116		
racks		115		

10-TON PAYLOAD, 14-TON GROSS, 2-WHEEL STAKE AND PLATFORM SEMITRAILER AND 10-TON CONVERTER DOLLY

	D	Page No.		E	Page No.
Data			Electric system		
axle		99	blackout switch		83
brake system		47	description and data		81
electrical system		81	light coupling socket		84
hubs, drums, and bearings		112	lights		81
internal brake assembly		90	trouble shooting		46
semitrailer landing gear		107			
tires and bearings		75	F		
wheels		74	Fifth wheel		
Description			assembly		105
air cleaner		52	cleaning and inspection		102
air hose		56	description and data ... 17, 86,		102
axle		99	disassembly		103
body and frame		115	fits and tolerances		106
brake shoe		60	maintenance operation		40
brake system		47	removal and installation		87
electric system		81	trouble shooting		46
fifth wheel	86,	102	First echelon preventive maintenance after-operation and		
hose couplings		57	weekly service		30
hubs, drums, and bearings		112	at-halt service		29
internal brake assembly		90	before-operation service		28
landing gear		70	during-operation service		29
lines, tubing and connections ..		54	Fits and tolerances		
semitrailer and dolly		6	axle		102
semitrailer landing gear		107	fifth wheel		106
slack adjuster		58	hubs, drums, and bearings		115
suspension		64	internal brake assembly		94
wheels, hubs, drums, and tires ..		74	suspension		98
Disassembly			G		
brake spider		91	Grease retainer, removal and		
fifth wheel		103	installation		80
hubs, drums, and bearings		113			
internal brake assembly		91	H		
pintle hook		88	Hose couplings		
semitrailer landing gear		107	description		57
Dolly			removal and installation		57
alinement of axle		102	Hub and drum assembly		
controls		17	installation		79
data		10	removal		77
description		6	Hubs, drums, and bearings		
operation		19	assembly		114
Dolly landing gear, removal and			cleaning		112
installation		74	description and data		112
During-operation service		29	disassembly		113
			fits and tolerances		115
			inspection		113
			repair		114

10-TON PAYLOAD, 14-TON GROSS, 2-WHEEL STAKE AND PLATFORM SEMITRAILER AND 10-TON CONVERTER DOLLY

S—Cont'd	Page No.		Page No.
Shock absorber		Tools and equipment, after-operation and weekly service	32
adjustment	69	Trouble shooting	
description	65, 69	axle	44
lubrication	26	braking system	42
maintenance operation	39	electrical system	46
removal and installation	70	fifth wheel	46
Slack adjuster		landing gear	45
description	58	suspension	44
removal and replacement	59	wheels, hubs, and tires	45
Springs and suspension			
after-operation and weekly service	31	V	
at-halt service	29	Vehicle stowage and special tools	12
before-operation service	28		
Stake and rack trailer, converting into platform trailer	16	W	
Suspension		Wheel bearings	
auxiliary springs	66, 97	lubrication	26
axle	66	maintenance operation	38
cross shaft	67	Wheels, hubs, drums, and tires	
description	64, 94	bearings	76
fits and tolerances	98	description and data	74
main spring	65, 95	drums	80
shock absorber	69	grease retainer	80
trouble shooting	44	hub and drum assembly	77
		tires	80
T		trouble shooting	45
Tires and rims		wheel and hub assembly	76
maintenance operations	36	wheel and tire assembly	79
preparation for temporary storage	117		