

DEPARTMENT OF THE ARMY  
TECHNICAL MANUAL  
DEPARTMENT OF THE AIR FORCE  
TECHNICAL ORDER

TM 5-6115-329-14

TO 35C2-3-440-1

---

**TECHNICAL MANUAL**

**OPERATOR, ORGANIZATIONAL, INTERMEDIATE (FIELD),  
(DIRECT SUPPORT AND GENERAL SUPPORT),  
AND DEPOT MAINTENANCE MANUAL**

**GENERATOR SETS, GASOLINE ENGINE  
DRIVEN, 0.5 KW (LESS ENGINE)**

<b><i>DOD</i></b>			
<b><i>MODEL</i></b>	<b><i>CLASS</i></b>	<b><i>HERTZ</i></b>	<b><i>NSN</i></b>
MEP-014A	UTILITY	60	6115-00-923-4469
MEP-019A	UTILITY	400	6115-00-940-7862
MEP-024A	UTILITY	28 VDC	6115-00-940-7867

---

HEADQUARTERS, DEPARTMENTS OF THE ARMY AND THE AIR FORCE  
OCTOBER 1977

## **WARNING**

Before starting engine or operating the generator set, insure that no loose bars, tools, or parts are lying in or on any part of the equipment, as they could cause serious damage to equipment or bodily injury to personnel.

Never wear loose clothing, or hanging appendages from person or clothing, while inspecting running engine or generator set.

Disconnect the spark plug cables prior to engine maintenance to prevent accidental starting and severe shock.

Before starting engine, insure that all operating levers and controls are in proper operating positions and the military engine units are properly supported.

Failure to do these things could result in damage to the engine and generator set.

Always provide metal-to-metal contact between fuel container and fuel tank, while refueling, to avoid igniting fuel vapors with a static spark.

Before refueling, insure that adequate fire fighting equipment is serviceable and is standing by for immediate use in event of fire or explosion.

During engine operation, proper fire fighting equipment should be serviceable and kept near in the event that fire is developed by electrostatic spark or detonation of the gas fumes.

Do not smoke or use an open flame in vicinity of these gasoline vapor hazards.

Do not refuel while engine is in operation.

Do not touch the ignition system harness during starting or while in operation.

Severe shocks or burns could result, and personnel maybe seriously injured.

Never touch engine or engine accessories with bare hands during operation, or before they have cooled sufficiently. Severe burns can be caused through carelessness.

If operating the generator set inside or indoors insure that proper ventilation is provided. Carbon monoxide fumes are a colorless, odorless and deadly gas. These agases could cause permanent brain damage or death, if highly concentrated in any certain area.

The symptoms are headache, dizziness, loss muscular control apparent drowsiness and coma.

If exposure symptoms exist, move afflicted person or personnel to properly ventilated area and provide artificial respiration, if necessary.

Dry cleaning solvent P-D-680, used to clean parts is potentially dangerous to personnel and property. Avoid repeated and prolonged skin contact. Do not use near open flame or excessive heat. Flash point of solvent is 100F. (38C. ) - 138F. (59C.).

The generator set must be properly grounded or possible electrocution of the operator could result.

Do not attempt to perform any maintenance on generator set while it is in operation. Voltage generated can cause death by electrocution.

Before servicing any part of the generator set, make certain that the Load Switch is OFF and the unit is NOT connected to an energized line. Severe electrical shock or death by electrocution may result.

CHANGE  
NO. 4

HEADQUARTERS  
DEPARTMENTS OF THE ARMY AND AIR FORCE  
WASHINGTON, D.C., 31 March 1993

Operator, Organizational, Intermediate (Field),  
(Direct Support and General Support),  
and Depot Maintenance Manual

GENERATOR SETS, GASOLINE ENGINE DRIVEN,  
0.5 KW (LESS ENGINE)

DOD MODEL	CLASS	HERTZ	NSN
MEP-114A	UTILITY	60	6115-00-923-4469
MEP-019A	UTILITY	400	6115-00-940-7862
MEP-024A	UTILITY	28VDC	6115-00-940-7867

DISTRIBUTION STATEMENT A: Approved for public release; distribution is unlimited.

TM 5-6115-329-14/TO 35C2-3-440-1, 11 October 1977, is changed as follows:

1. Remove and insert pages as indicated below. New or changed text material is indicated by a vertical bar in the margin. An illustration change is indicated by a miniature pointing hand.

Remove pages	Insert pages
3-7 and 3-8	3-7 and 3-8
4-13/(4-14 blank)	4-13/(4-14 blank)

2. Retain this sheet in front of manual for reference purposes.

TM 5-6115-329-14  
TO 35C2-3-440-1  
C 4

By Order of the Secretaries of the Army and Air Force:

Official:

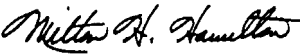
  
MILTON H. HAMILTON  
*Administrative Assistant to the  
Secretary of the Army*

04041

GORDON R. SULLIVAN  
*General, United States Army  
Chief of Staff*

Official:

MERRILL A. McPEAK  
*General, United States Air Force  
Chief of Staff*

RONALD W. YATES  
*General, United States Air Force  
Commander, Air Force Materiel Command*

DISTRIBUTION:

To be distributed in accordance with DA Form 12-25-E, block no. 0871, requirements for TM 5-6115-329-14.

CHANGE  
NO. 3

HEADQUARTERS,  
DEPARTMENTS OF THE ARMY AND AIR FORCE  
WASHINGTON, D.C., 24 October 1990

**Operator, Organizational, Intermediate (Field),  
(Direct Support and General Support),  
and Depot Maintenance Manual**

**GENERATOR SETS, GASOLINE ENGINE DRIVEN,  
0.5 KW (LESS ENGINE)**

<b>DOD MODEL</b>	<b>CLASS</b>	<b>HERTZ</b>	<b>NSN</b>
MEP-114A	UTILITY	60	6115-00-923-4469
MEP-019A	UTILITY	400	6115-00-940-7862
MEP-024A	UTILITY	28VDC	6115-00-940-7867

**Approved for public release; distribution is unlimited**

TM 5-6115-329-14/TO 35C2-3-440-1, 11 October 1977, is changed as follows:

1. Remove and insert pages as indicated below. New or changed text material is indicated by a vertical bar in the margin. An illustration change is indicated by a miniature pointing hand.

Remove pages

4-1 and 4-2  
B-1/B-2

Insert pages

4-1 and 4-2  
B-1/B-2

2. Retain this sheet in front of manual for reference purposes.

By Order of the Secretaries of the Army and Air Force):

**CARL E. VUONO**  
*General, United States Army*  
*Chief of Staff*

Official:

**THOMAS F. SIKORA**  
*Brigadier General, United States Army*  
*The Adjutant General*

**MICHAEL J. DUGAN**  
*General USAF*  
*Chief of Staff*

Official:

**CHARLES C. MCDONALD**  
*General, USAF*  
*Commander, Air Force Logistics Command*

DISTRIBUTION:

To be distributed in accordance with DA Form 12-25E, (qty rqr block no. 0871)

CHANGE }  
No. 2 }

HEADQUARTERS  
DEPARTMENTS OF THE ARMY AND AIR FORCE  
WASHINGTON, D.C., 19 June 1989

Operator, Organizational, Intermediate  
(Field), (Direct Support and General Support),  
and Depot Maintenance Manual

GENERATOR SETS, GASOLINE ENGINE DRIVEN,  
0.5 KW (LESS ENGINE)

DOD MODEL	CLASS	HERTZ	NSN
MEP-014A	UTILITY	60	6115-00-923-4469
MEP-019A	UTILITY	400	6115-00-940-7862
MEP-024A	UTILITY	28VDC	6115-00-940-7867

TM 5-6115-329-14/TO35C2-3-440-1, 11 October 1977, is changed as follows:

1. Remove and insert pages as indicated below. New or changed text material is indicated by a vertical bar in the margin. An illustration change is indicated by a miniature pointing hand.

Remove pages	Insert pages
2-3 and 2-4	2-3 and 2-4
4-39 and 4-40	4-39 and 4-40
4-45 and 4-46	4-45 and 4-46
---	4-46.1/4-46.2

2. Retain this sheet in front of manual for reference purposes.

**By Order of the Secretaries of the Army and the Air Force:**

**CARL E. VUONO**  
*General, United States Army*  
*Chief of Staff*

Official:

**WILLIAM J. MEEHAN, II**  
*Brigadier General, United States Army*  
*The Adjutant General*

Official:

**ALFRED G. HANSEN**  
*General, USAF, Commander, Air Force*  
*Logistics Command*

**LARRY D. WELCH**, *General USAF*  
*Chief of Staff*

**DISTRIBUTION:**

To be distributed in accordance with DA Form 12-25A, Operator, Unit, Direct Support and General Support Maintenance requirements for Generator Set, Gas Driven, 120/240V, 0.5KW, 1PH, (60HZ AC: MEP-014A; 400HZ AC: MEP-019A; 28V DC: MEP 024A).





CHANGE

No. 1

HEADQUARTERS  
DEPARTMENT OF THE ARMY,  
AND AIR FORCE  
WASHINGTON, D.C. 2 June 1986

**OPERATOR, ORGANIZATIONAL, INTERMEDIATE  
(FIELD), (DIRECT SUPPORT AND GENERAL SUPPORT),  
AND DEPOT MAINTENANCE MANUAL**

**GENERATOR SETS, GASOLINE ENGINE DRIVEN,  
0.5 KW (LESS ENGINE)**

<i>DOD</i>				
<i>MODEL</i>	<i>CLASS</i>	<i>HERTZ</i>		<i>NSN</i>
MEP-014A	UTILITY	60		6115-00-923-4469
MEP-019A	UTILITY	400		6115-00-940-7862
MEP-024A	UTILITY	28VDC		6115-00-940-7867

TM 5-6115-329-14/TO 35C2-3-440-1, 11 October 1977, is changed as follows:

1. Remove and insert pages as indicated below.

	Remove pages	Insert Pages
Table of Contents	iii and iv	iii and iv
Chapter 2	2-3 thru 2-6	2-3 thru 2-6
Chapter 3	3-5 thru 3-8	3-5 thru 3-8
Chapter 4	4-11 thru 4-14	4-11 thru 4-13

2. New or changed text material is indicated by a vertical bar in the margin. An illustration change is indicated by a miniature pointing hand.
3. Retain these sheets in front of manual for reference purposes.

By Order of the Secretaries of the Army and the Air Force:

Official:

**JOHN A. WICKHAM, JR.**  
*General, United States Army*  
*Chief of Staff*

**R. L. DILWORTH**  
*Brigadier General, United States Army*  
*The Adjutant General*

Official:

**CHARLES A. GABRIEL**  
*General, USAF*  
*Chief of Staff*

**EARL T. O'LOUGHLIN**  
*General, USAF, Commander*  
*Air Force Logistics Command*

Distribution:

To be distributed in accordance with DA Form 12-25A, Operator, Organizational Direct Support and General Support Maintenance requirements for Generator Set, Gas Driven, 120/240V, 0.5KW, 1PH, (60HZ AC: MEP-014A; 400HZ AC: MEP-019A; 28V DC: MEP 024A) (TM 5-6115-329 Series)

**HEADQUARTERS  
DEPARTMENTS OF THE ARMY AND AIR FORCE  
WASHINGTON, DC, 11 October 1977**

**OPERATOR, ORGANIZATIONAL, INTERMEDIATE  
(FIELD), (DIRECT SUPPORT AND GENERAL SUPPORT),  
AND DEPOT MAINTENANCE MANUAL**

**GENERATOR SETS, GASOLINE ENGINE DRIVEN,  
0.5 KW (LESS ENGINE)**

<i><b>DOD</b></i>				<i><b>NSN</b></i>
<i><b>MODEL</b></i>	<i><b>CLASS</b></i>	<i><b>HERTZ</b></i>		
MEP-014A	UTILITY	60		6115-00-923-4469
MEP-019A	UTILITY	400		6115-00-940-7862
MEP-024A	UTILITY	28VDC		6115-00-940-7867

***Table of Contents***

		Paragraph	Page
CHAPTER	1. <b>INTRODUCTION</b>		
Section	I. General .....	1-1	1-1
Section	II. Description and Data .....	1-9	1-2
CHAPTER	2. <b>OPERATING INSTRUCTIONS</b>		
Section	I. Operating Procedures .....	2-1	2-1
Section	II. Operation Under Unusual Conditions .....	2-3	2-6
CHAPTER	3. <b>OPERATOR/CREW MAINTENANCE INSTRUCTIONS</b>		
Section	I. Consumable Operating and Maintenance Supplies .....	3-1	3-1
Section	II. Lubrication Instructions .....	3-3	3-2
Section	III. Preventive Maintenance Checks and Services .....	3-5	3-5
Section	IV. Troubleshooting .....	3-6	3-8
Section	V. Operator/Crew Maintenance Instructions .....	3-8	3-11
CHAPTER	4. <b>ORGANIZATIONAL MAINTENANCE</b>		
Section	I. Service Upon Receipt of Equipment .....	4-1	4-1
Section	II. Movement to a New Worksite .....	4-5	4-11
Section	III. Repair Parts, Special Tools, Special Test, Management and Diagnostic Equipment (TMDE) and Special Support Equipment .....	4-7	4-11
Section	IV. Lubrication Instructions .....	4-9	4-12
Section	V. Preventive Maintenance Checks and Services (PMCS) .....	4-11	4-12
Section	VI. Troubleshooting .....	4-13	4-15
Section	VII. Radio Interference Suppression .....	4-17	4-37
Section	VIII. Maintenance of the Engine Assembly .....	4-20	4-39
Section	IX. Maintenance of the Frame Assembly .....	4-21	4-40
Section	X. Maintenance of the Control Panel Assembly .....	4-22	4-40
Section	XI. Maintenance of the Fuel System .....	4-32	4-46

\*This manual supersedes TM 5-6115-329-15, 26 June 1968, including all changes.

CHAPTER	5.	INTERMEDIATE (FIELD), (DIRECT AND GENERAL SUPPORT) AND DEPOT MAINTENANCE INSTRUCTIONS		
Section	I.	Repair Parts, Special Tools, Special Test, Measurement and Diagnostic Equipment (TMDE) and Special Support Equipment	5-1	5-1
Section	II.	Troubleshooting	5-4	5-2
Section	III.	General Maintenance	5-6	5-4
CHAPTER	6.	REMOVAL AND INSTALLATION OF MAJOR COMPONENTS		6-1
CHAPTER	7.	MAINTENANCE OF THE ENGINE ASSEMBLY		7-1
CHAPTER	8.	MAINTENANCE OF THE FRAME ASSEMBLY		8-1
CHAPTER	9.	MAINTENANCE OF THE CONTROL PANEL ASSEMBLY		
Section	I.	Panel Assembly	9-1	9-1
Section	II.	Capacitors	9-3	9-1
Section	III.	Voltage Regulator	9-6	9-4
Section	IV.	Terminal Board	9-7	9-4
Section	V.	Rectifiers	9-8	9-6
Section	VI.	Wiring Harness	9-9	9-8
Section	VII.	Shock Mounts	9-10	9-8
CHAPTER	10.	MAINTENANCE OF THE GENERATOR		10-1
CHAPTER	11.	GENERATOR SET TEST AND INSPECTION AFTER REPAIR OR OVERHAUL		
Section	I.	General Requirements	11-1	11-1
Section	II.	Inspection	11-2	11-1
Section	III.	Operational Tests	11-3	11-1
APPENDIX	A.	REFERENCES		A-1
	B.	BASIC ISSUE ITEMS LIST AND ITEMS TROOP INSTALLED OR AUTHORIZED		B-1
	C.	MAINTENANCE ALLOCATION CHART (FOR ARMY ONLY)		C-1
ALPHABETICAL		INDEX		I - 1

## List of Illustrations

Figure	Title	Page
1-1.	Generator Set, Model MEP-019A, Left Front, Three-Quarter View, with Shipping Dimensions	1-2
1-2.	Generator Set, Model MEP-019A, Right Rear, Three-Quarter View	1-3
1-3.	Generator Set, Model MEP-024A, Left Front, Three-Quarter View, with Shipping Dimensions	1-4
1-4.	Generator Set, Model MEP-024A, Right Rear, Three-Quarter View	1-5
1-5.	Generator Set, Model MEP-014A, Left Front, Three-Quarter View, with Shipping Dimensions	1-6
1-6.	Generator Set, Model MEP-014A, Right Rear, Three-Quarter View	1-7
1-7.	Wiring Diagram, Model MEP-014A	1-9
1-8.	Wiring Diagram, Model MEP-019A (Serial number range JB66-0001 thru JB66-4730)	1-10
1-9.	Wiring Diagram, Model MEP-019A (Serial number range SB71-0001 thru SB71-0177)	1-11
1-10.	Wiring Diagram, Model MEP-024A	1-12
2-1.	Controls and Instruments, Model MEP-014A	2-1
2-2.	Controls and Instruments, Model MEP-019A	2-2
2-3.	Controls and Instruments, Model MEP-024A	2-3
2-4.	Engine Controls	2-5
3-1.	Lubrication Order (Sheet 1 of 2)	3-3
3-1.	Lubrication Order (Sheet 2 of 2)	3-4
3-2.	Servicing Fuel Filter Assembly	3-11
3-3.	Fuel Tank Strainer, Removal and Installation	3-11
4-1.	Revetment - Top View	4-3
4-2.	Revetment - Side View	4-4
4-3.	Revetment - Isometric View	4-5
4-4.	Revetment - Perspective Without Roof	4-6
4-5.	Revetment - Front View	4-7
4-6.	Revetment - Left Side View	4-8
4-7.	Revetment, Exhaust Duct	4-9
4-8.	Equipment Conversion	4-10
4-9.	Types of Multimeters	4-15
4-10.	“Zeroing” the Multimeter (Sheet 1 of 3)	4-16
4-10.	“Zeroing” the Multimeter (Sheet 2 of 3)	4-17
4-10.	“Zeroing” the Multimeter (Sheet 3 of 3)	4-18
4-11.	TS-352 B/U Continuity Test	4-19
4-12.	Testing for Shorts	4-20
4-13.	Testing Resistance	4-20
4-14.	Reading the Ohm Scale	4-21
4-15.	DC Volts Scale (Sheet 1 of 3)	4-21
4-15.	DC Volts Scale (Sheet 2 of 3)	4-22
4-15.	DC Volts Scale (Sheet 3 of 3)	4-23
4-16.	Measuring DC Voltage	4-24
4-17.	Reading DC Voltage (Sheet 1 of 3)	4-24
4-17.	Reading DC Voltage (Sheet 2 of 3)	4-25
4-17.	Reading DC Voltage (Sheet 3 of 3)	4-25
4-18.	AC Volt Scale (Sheet 1 of 3)	4-26
4-18.	AC Volt Scale (Sheet 2 of 3)	4-26
4-18.	AC Volt Scale (Sheet 3 of 3)	4-27
4-19.	Measuring AC Voltage	4-28
4-20.	Reading AC Voltage	4-28
4-21.	Rheostat, AC Voltmeter, Load Switch and 120/240V Switch, Removal and Installation (Model MEP-014A)	4-31
4-22.	Rheostat, AC Voltmeter, Load Switch and 120/240V Switch, Removal and Installation (Model MEP-019A)	4-32
4-23.	DC Voltmeter, Rheostat and Percent Load Meter, Removal and Installation (Model MEP-024A)	4-33
4-24.	Radio Interference Suppression Components (Sheet 1 of 2)	4-37
4-24.	Radio Interference Suppression Components (Sheet 2 of 2)	4-38
4-25.	Radio Interference Suppression Components, Removal and Installation	4-39
4-26.	Load Switch, Removal and Installation (Model MEP-014A and MEP-024A)	4-42
4-27.	Duplex Receptacle, 120 Volts, AC, Removal and Installation (Model MEP-014A)	4-43
4-28.	Terminal Load and Terminal Block Assembly, Removal and Installation	4-44
4-29.	Control Panel Ground Strap and Fuel Tank Grounding Strap, Removal and Installation	4-46
4-30.	Fuel Tank, Selector Valve and Fuel Strainer, Removal and Installation	4-47
4-31.	Fuel Strainer, Disassembly and Reassembly	4-48

Figure	Title	Page
5-1.	Specially Designed Tool .....	
6-1.	Frame Assembly and Shock Mounts, Removal and Installation .....	6-2
6-2.	Control Panel Assembly, Removal and Installation .....	6-3
6-3.	Control Panel Bracket and Fuel Tank Bracket, Removal and Installation .....	6-4
6-4.	Generator, Removal and Installation, Exploded View .....	6-5
9-1.	Radio Interference Suppression Components, Removal and Installation (Sheet 1 of 2) .....	9-2
9-1.	Radio Interference Suppression Components, Removal and Installation (Sheet 2 of 2) .....	9-3
9-2.	Voltage Regulator, Removal and Installation .....	9-4
9-3.	Terminal Board Assembly, Removal and Installation (Sheet 1 of 2) .....	9-5
9-3.	Terminal Board Assembly, Removal and Installation (Sheet 2 of 2) .....	9-6
9-4.	Rectifier, Removal and Installation .....	9-7
9-5.	Shock Mount, Removal and Installation .....	9-9

***List of Tables***

Table	Title	Page
2-1.	Controls and Instruments .....	2-4
3-1.	Maintenance and Operating Supplies .....	3-1
3-2.	Preventive Maintenance Checks and Services .....	3-7
3-3.	Troubleshooting .....	3-9
4-1.	Preventive Maintenance Checks and Services .....	4-13
4-2.	Organizational Troubleshooting .....	4-30
5-1.	Fabricated Tools and Equipment .....	5-1
5-2.	Intermediate (Field), (Direct and General Support) and Depot Maintenance Troubleshooting .....	5-3
11-1.	Visual and Operational Inspection .....	11-2

# CHAPTER 1

## INTRODUCTION

---

### Section I. GENERAL

#### 1-1. Scope

This manual is for your use in operating and maintaining the DOD Generator Set, 0.5 KW, Model MEP-014A, MEP-019A and MEP-024A. The contents of the manual will be followed if in conflict with the contents of any referenced document.

#### 1-2. Limited Applicability

Some portions of this publication are not applicable to all services. These portions are prefixed to indicate the services to which they pertain: (A) for Army, (F) for Air Force, and (N) for Navy. Portions not prefixed are applicable to all services.

#### 1-3. Maintenance Forms and Records

*a.* (A) Maintenance forms and records used by Army personnel are prescribed by TM 38-750.

*b.* (F) Maintenance forms and records used by Air Force personnel are prescribed in AFM 66-1 and the applicable 00-20 Series Technical Orders.

*c.* (N) Navy users should refer to their service peculiar directives to determine applicable maintenance forms and records to be used.

#### 1-4. Reporting of Errors

Reporting of errors, omissions, and recommendations for improvement of this publication by the individual use is encouraged. Reports should be submitted as follows:

*a.* (A) Army - DA Form 2028 or 2028-2 directly to: Commander, US Army Troop Support & Aviation Materiel Readiness Command, ATTN: DRSTS-MTPS, 4300 Goodfellow Boulevard, St. Louis, MO 63120.

*b.* (F) Air Force - AFTO Form 22 directly to: Commander, Sacramento Air Logistics Center, ATTN: MMST, McClelland Air Force Base, CA 95652, in accordance with TO 00-5-1.

*c.* (N) Navy - by letter directly to: Commanding

Office, US Navy, Ships Parts Control Center, ATTN: Code 783, Mechanicsburg, PA 17055.

#### 1-5. Levels of Maintenance Accomplishment

*a.* (A) Army users shall refer to the Maintenance Allocation Chart (MAC), for tasks and levels of maintenance to be performed.

*b.* (F) Air Force users shall accomplish maintenance at the user level consistent with their capability in accordance with policies established in AFM 66-1.

*c.* (N) Navy users shall determine their maintenance levels in accordance with their service directives.

#### 1-6. Destruction of Army Materiel to Prevent Enemy Use

(A) Refer to TM 750-244-3 for information to prevent enemy use.

#### 1-7. Administrative Storage (A, F)

*a.* Army users refer to TM 740-90-1, Administrative Storage, for instructions relative to administrative storage.

*b.* Air Force users refer to TO 35-1-4, Processing and Inspection of Aerospace Ground Equipment for Storage and Shipment, for instructions relative to administrative storage.

#### 1-8. Preparation for Shipment and Storage

*a.* (A) Army - Refer to TB 740-97-2 and TM 740-90-1.

*b.* (F) Air Force - Refer to TO 35-1-4 for end item generator sets and TO 38-1-5 for installed engine.

*c.* (N) Navy - Refer to individual service directives for requirements.

## Section II. DESCRIPTION AND DATA

### 1-9. Description

a. Generator Set. The generator set (figs. 1-1 through 1-6) is a portable unit consisting of a Military Standard 1-1/2 horsepower gasoline engine, model 1A08-3, directly coupled to a Military design generator, DOD Model MEP-014A (0.5 kilowatt, 120 or 240 volt, 60 Hertz generator), DOD Model MEP-019A (0.5 kilowatt, 120 or 240 volt, 400-Hertz a.c., generator) (except sets manufactured by Bucknell, contract DSA 400-71-C-6006, serial number

range SB71-0001 through SB71-0177 which are 400 Hz, 120 volt AC, single-phase only), or DOD Model MEP-024A (0.5 kilowatt, 28 volt, d.c., generator), and the necessary components and accessories required for a self-contained generating unit. The unit is cushioned with rubber mounts and is mounted in an aluminum tubular frame. It will operate at an angle of 15° (maximum) in any plane from horizontal. The generator set is radio suppressed.

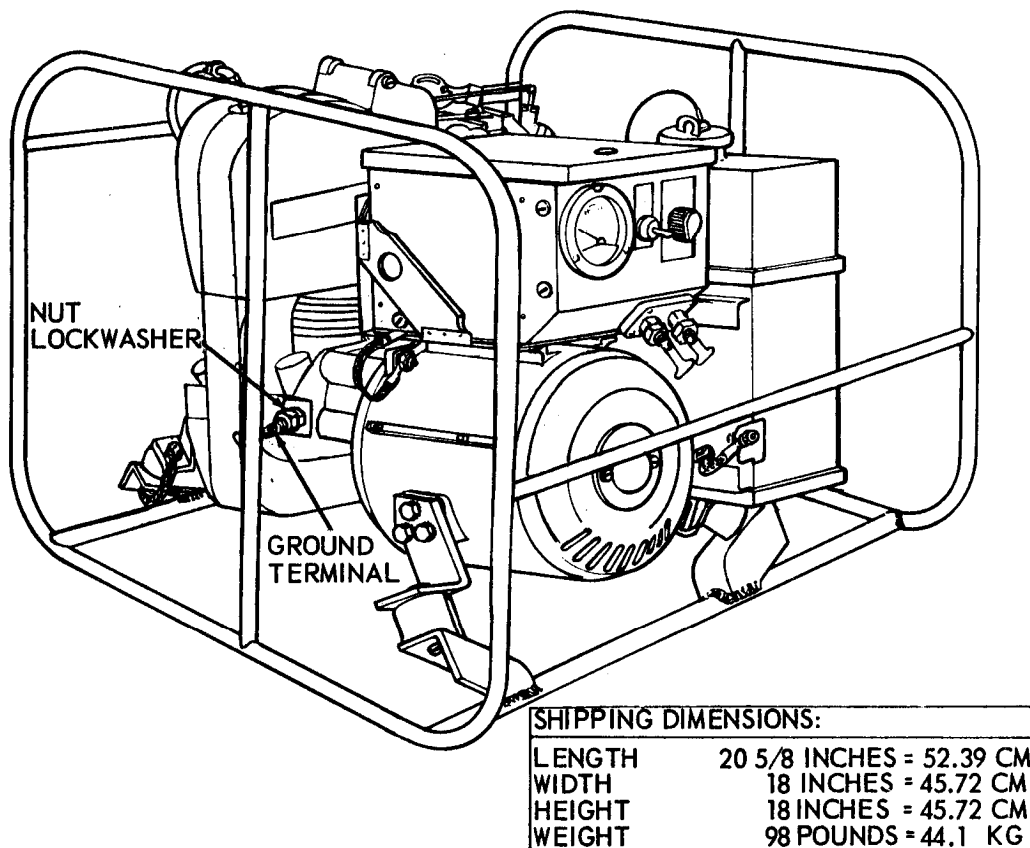

TS 6115-329-14/1-1

*Figure 1-1. Generator set, model MEP-019A, left-front, three-quarter view, with shipping dimensions.*



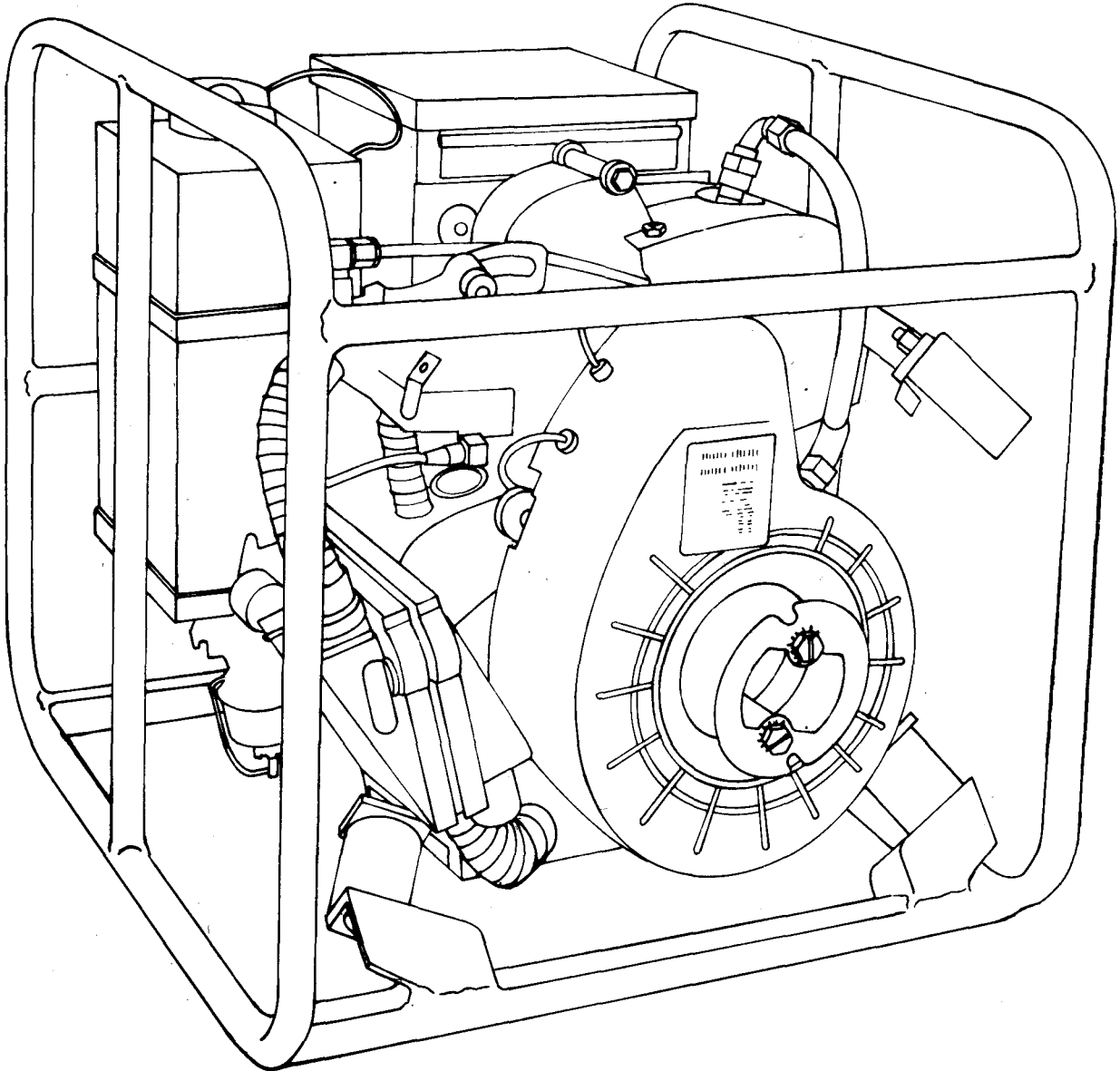

TS 6115-329-14/1-2

*Figure 1-2. Generator set, model MEP-019A, right rear, three-quarter view.*

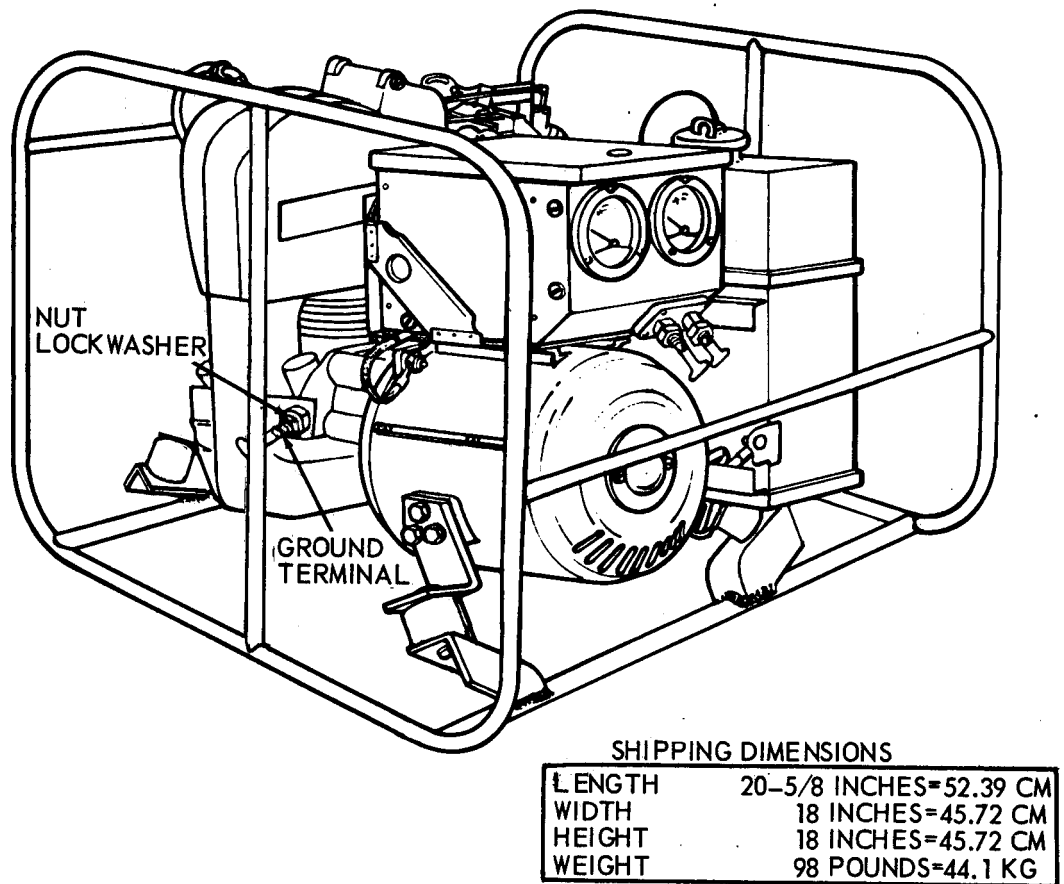

TS-6115-329-14/1-3

*Figure 1-3. Generator set, model MEP-024A, left front, three-quarter view, with shipping dimensions.*

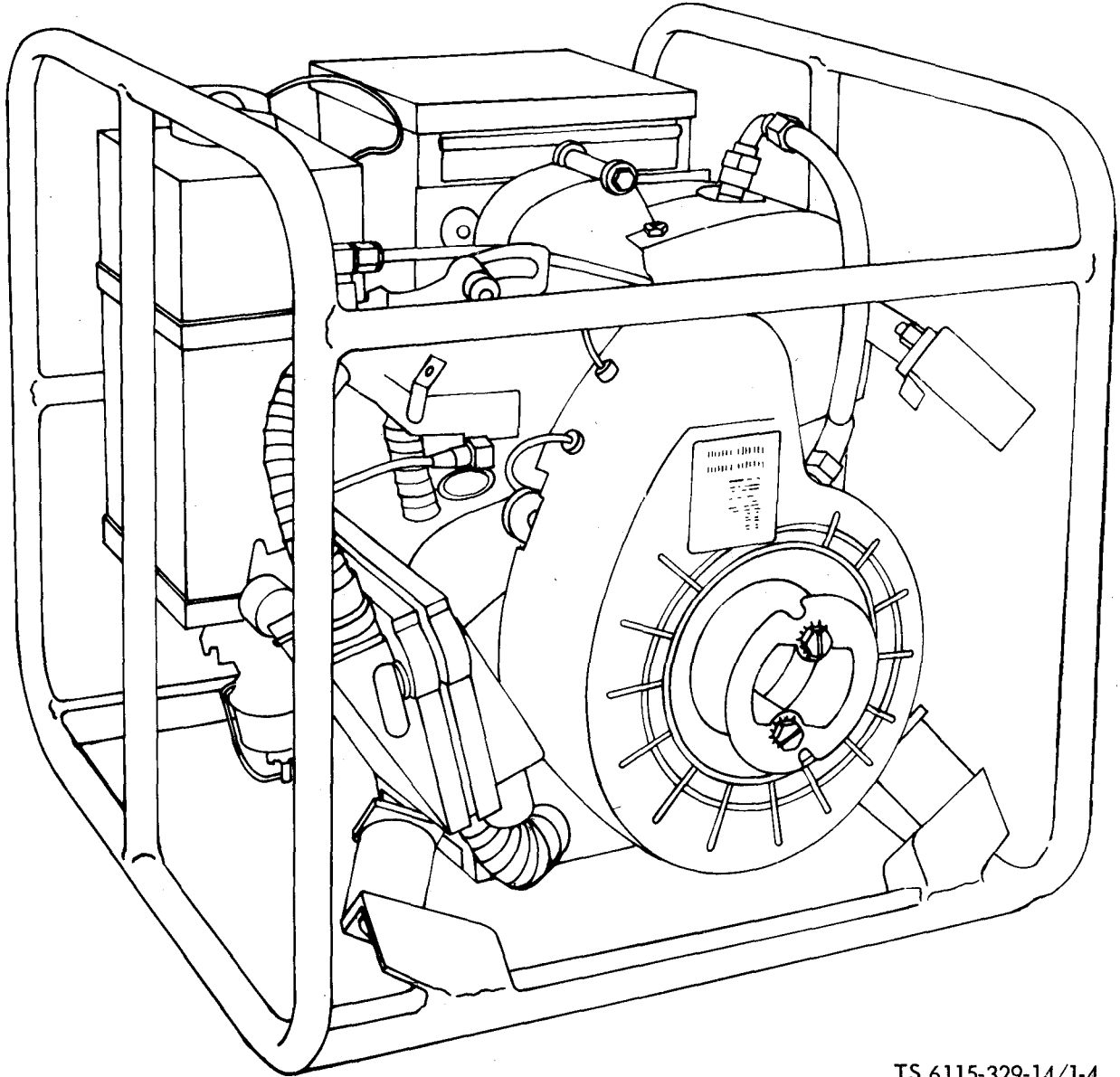

TS 6115-329-14/1-4

**Figure 1-4. Generator set, model MEP-024A, right rear, three-quarter view.**

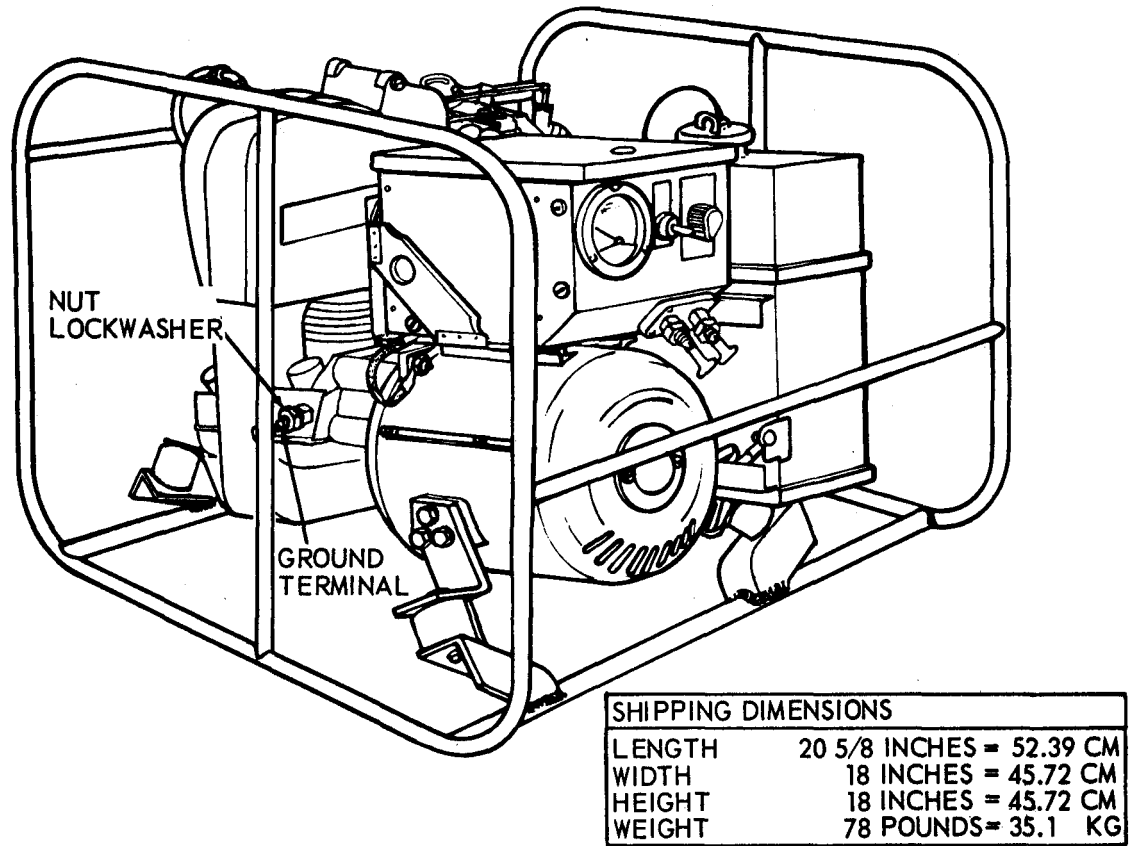

TS 6115-329-14/1-5

Figure 1-5. Generator set, model MEP-014A, left-front, three-quarter view, with shipping dimensions.

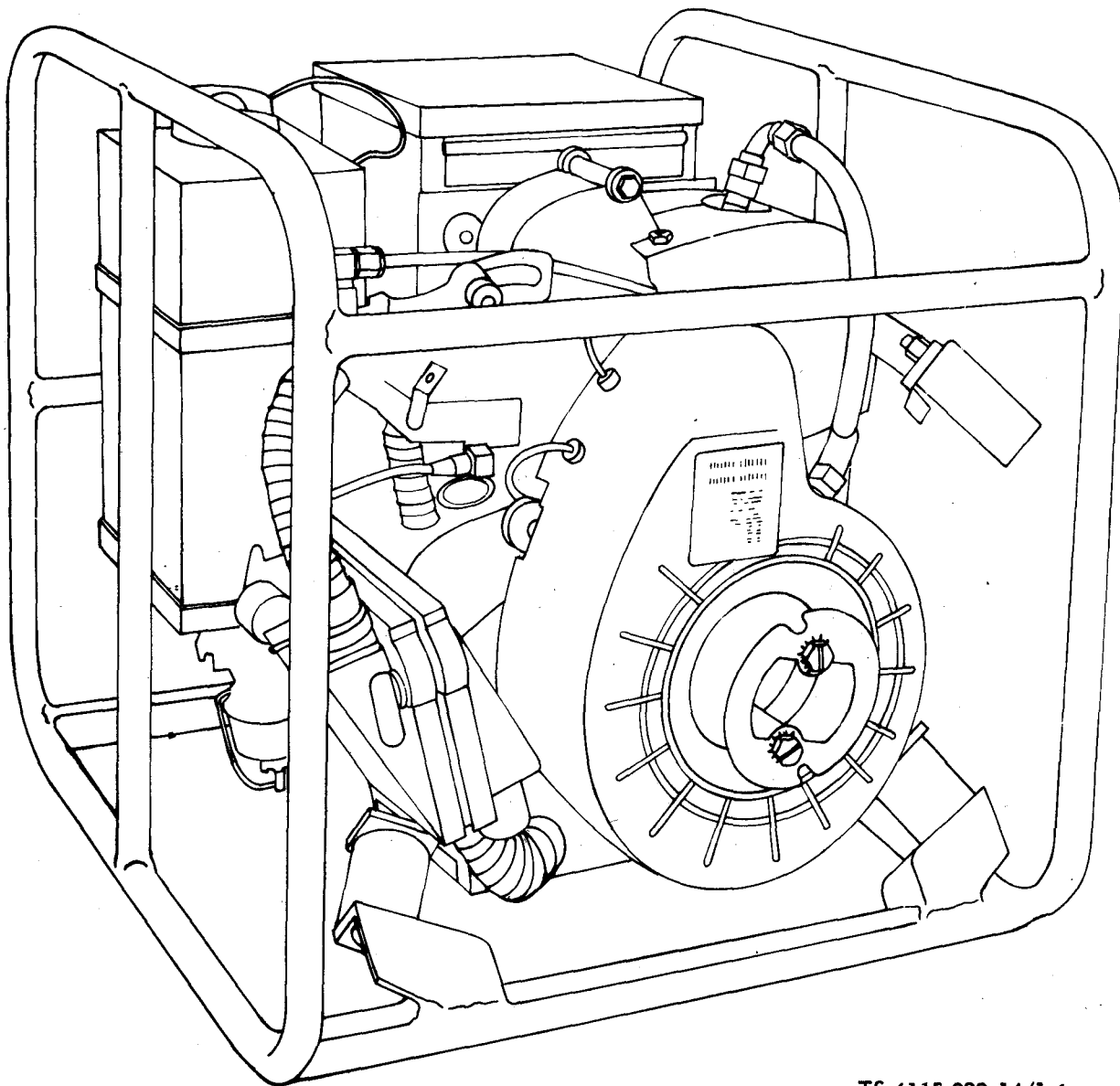

TS 6115-329-14/1-6

*Figure 1-6. Generator set, model MEP-014A, right-rear, three-quarter view.*

**b. Engine.** The Military Standard Engine (model 1A08-3) is a 4-stroke cycle, overhead valve, air-cooled engine. It is fully radio interference suppressed and fungus-proofed. This is a one-cylinder engine which develops 1-1/2 horsepower at 3,600 rpm. Refer to TM 5-2805-256-14 for additional information.

**1-10. Tabulated Data (Operator/Crew and Organizational Maintenance)**

**a. Identification.** The generator set has three major identification plates. They are an engine plate, a generator plate, and a generator set plate. The engine plate is mounted on the flywheel housing and indicates the make, model, serial number, stock number, and other pertinent maintenance data. The generator plate is mounted on the generator housing and indicates the type, National Stock Number, manufacturer, Serial number, KW rating, CPS, and power factor. The generator set plate is mounted on the right hand side panel of the control panel and indicates the manufacturer, type, serial number, and National Stock Number.

**b. Tabulated Data.**

(1) Generator set manufacturer:

NSN 6115-00-923-4469 Bogue Electric  
 NSN 6115-00-940-7862 Rett Electronics Inc.  
 NSN 6115-00-940-7867 Rett Electronics Inc.

<b>Model</b>	<b>Mode</b>	<b>Class</b>
MEP-014A	60 Hertz	Utility
MEP-019A	400 Hertz	Utility
MEP-024A	28 VDC	Utility
Operating temperature range	107°F - 65°F (42°C - 18°C)	
Voltage output	Model Mep-014A and MEP-019A, 120/240 VAC single phase, except serial number range SB710001 through SB710177 which are 120 VAC only Model MEP-024A, 28 VDC	
Power factor	1.0 (Metric)	
Capacities:		
Fuel System	1 gallon (3.8 liters)	
Lubricating oil	4/5 quart (0.76 liters) (Metric)	
Dimensions and Weights:		
(DOD models DOD MEP-019A and MEP-024A)		
Length	20-5/8 inches (52.3875 cm)	
Width	18 inches (45.72 cm)	
Height	18 inches (45.72 cm)	
Weight	98 pounds (44.1 kg) (Metric)	
(DOD model MEP-014A)		
Length	20-5/8 inches (52.3875 cm)	
Width	18 inches (45.72 cm)	
Height	18 inches (45.72 cm)	
Weight	78 pounds (35.1 kg)	

Specification	DOD model	
	MEP-014A	MIL-G-52732/1
	DOD model	
	MEP-019A	MIL-G-52732/2
	DOD model	
	MEP-024A	MIL-G-52732/3

**(2) Engine:**

Make	Military Standard Engine	
Model	1A08-3	
Type	4-Cycle, gasoline, overhead valve, air cooled	
Number of cylinders	1	
Bore	2.250 in. (5.715 cm)	
Stroke	2 in. (5.08 cm)	
Piston displacement	8 cu in. (131.12 cu cm)	
Compression ratio	6:1	
Horsepower at 3,600 r.p.m.	1.5	
Carburetor:		
Make	Military design	
Fuel Pump:		
Make	Military design	
Type	Diaphragm (Metric)	
Fuel pump outlet pressure	3.0 to 4.5 psi (0.2109 to 0.3163 kg per sq cm)	
Air Cleaner:		
Make	Military design	
Type	Dry	
Spark Plug:		
Make	Military Standard	
Type	Shielded	
Governor:		
Make	Military design	
Fuel Filter:		
Make	Military design	
Adjustments:		
Spark plug gap	0.028-0.033 in. (0.071-0.838 cm)	
Contact point gap	0.016-0.020 in. (0.040-0.050 cm)	
Valve tappet clearance (intake and exhaust)	0.007 in. to 0.009 in. (0.017 to 0.027 cm) cold	
Oil Capacity	1/2 qt (0.475 liters)	
Dimensions and Weights:		
Length	17-3/4 in. (45.08 cm)	
Width	17-3/4 in. (45.08 cm)	
Height	14-1/4 in. (36.19 cm)	
Weight	29 lbs. (13.15 kg)	

**(3) Fuel Strainer:**

Manufacturer	Imperial Eastman Corp.
Model	186J

**(4) Wiring Diagrams:**

DOD Model MEP-014A	Refer to Figure 1-7
DOD Model MEP-019A (Serial number range JB66-0001 thru JB66-4730)	Refer to Figure 1-8
DOD Model MEP-019A (serial number range SB71-0001 thru SB71-0177)	Refer to Figure 1-9
DOD Model MEP-024A	Refer to Figure 1-10

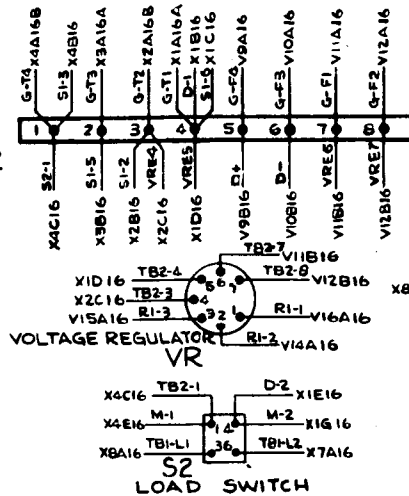
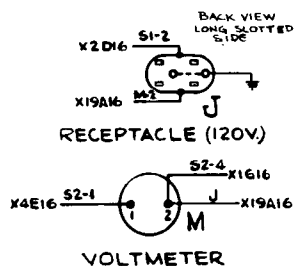
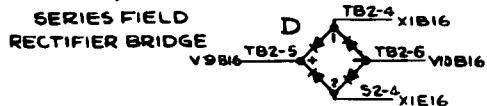
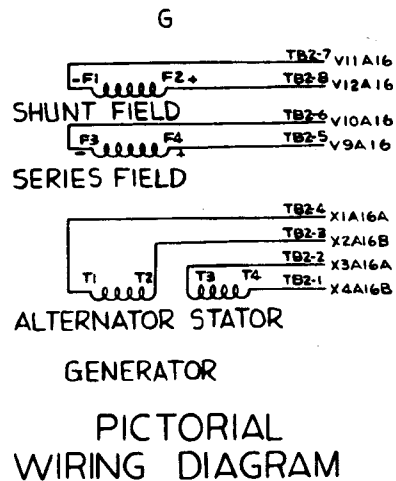

REFERENCE DESIGNATIONS	
C1	CAPACITOR (ISOLATED CASE)
D	SERIES FIELD BRIDGE
J	RECEPTACLE 120 VOLTS
M	VOLTMETER
R1	REGULATOR RHEOSTAT
S1	VOLTAGE SELECTOR SWITCH
S2	LOAD SWITCH
TB1	LOAD TERMINALS
TB2	TERMINAL STRIP
VR	VOLTAGE REGULATOR

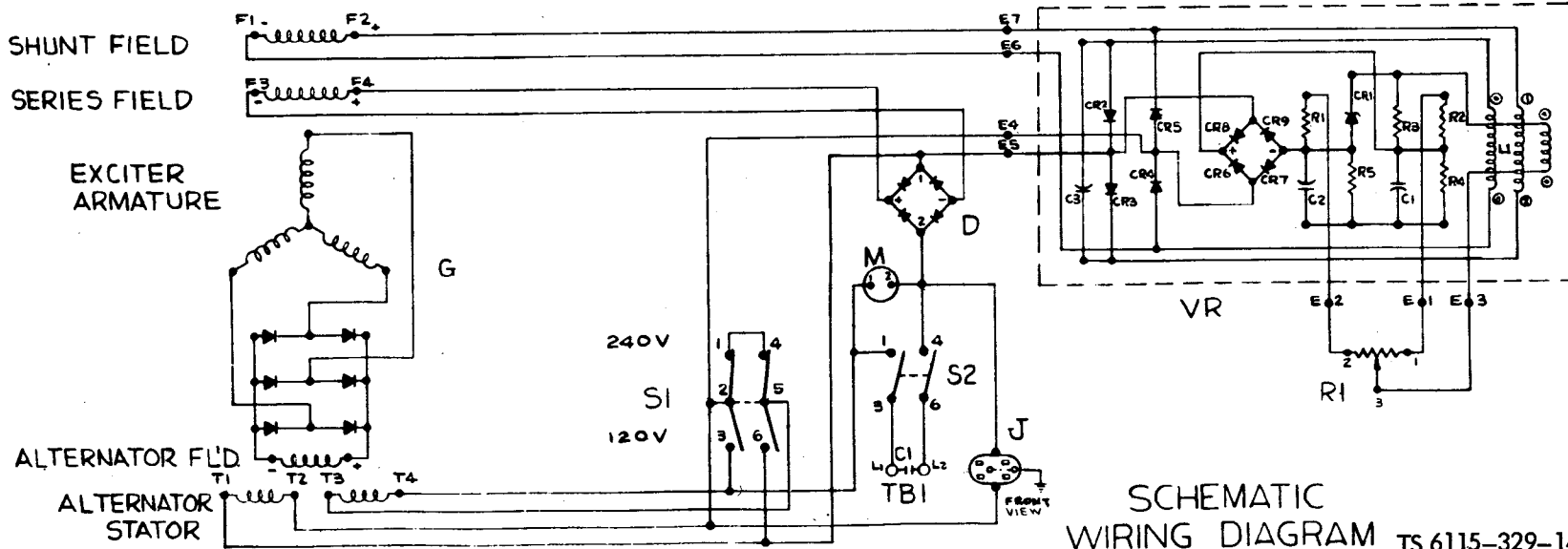
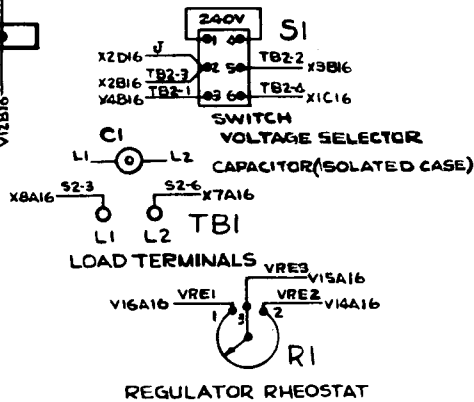
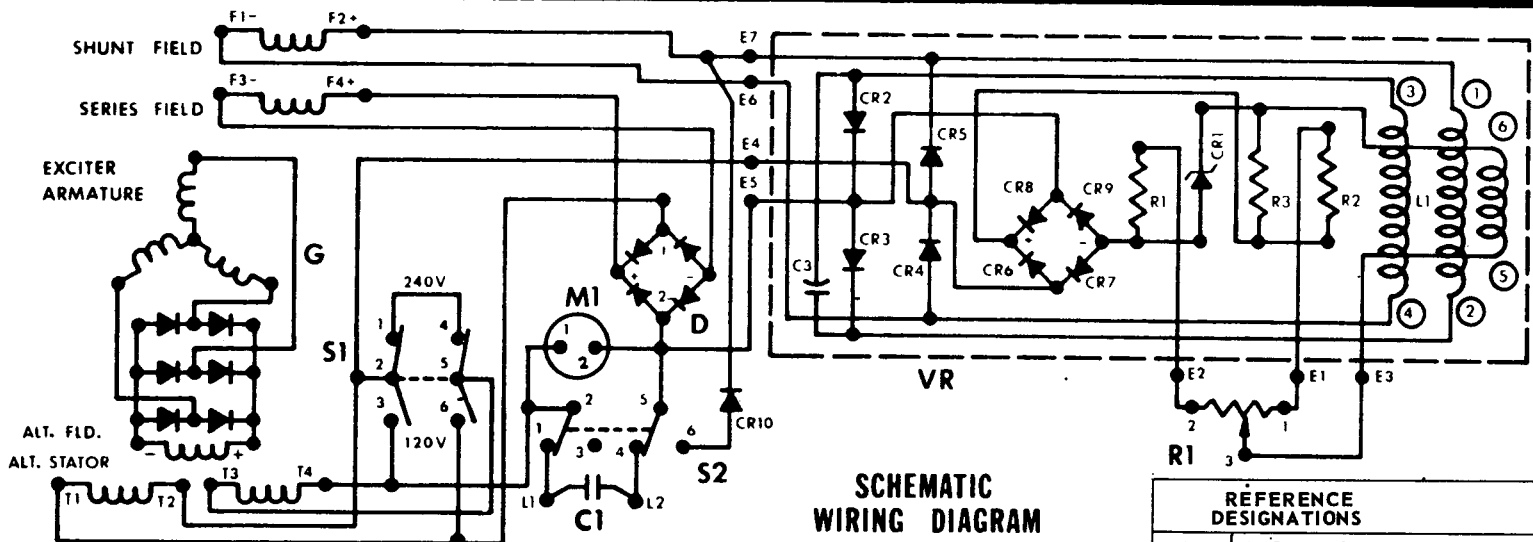
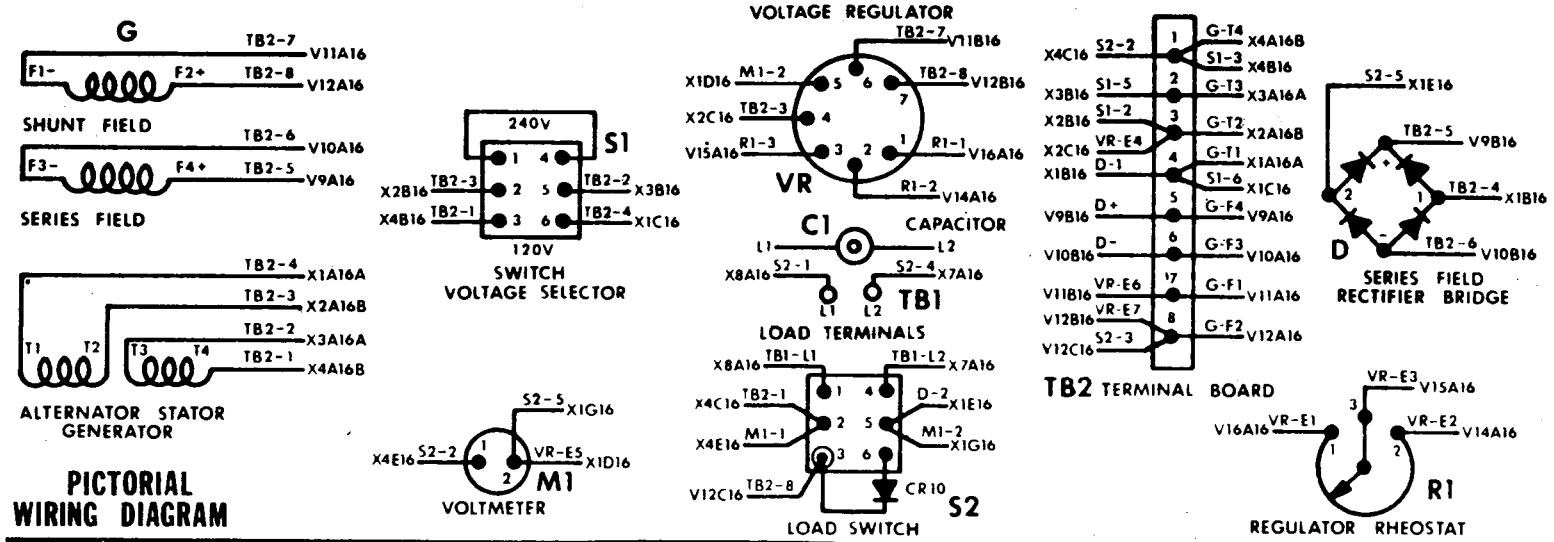

Figure 1-7. Wiring diagram, model MEP-014A.



REFERENCE DESIGNATIONS	
C1	CAPACITOR
D	SERIES FIELD BRIDGE
M1	VOLTMETER
R1	REGULATOR RHEOSTAT
S1	SWITCH, VOLTAGE SELECTOR
S2	LOAD SWITCH
TB1	LOAD TERMINALS
TB2	TERMINAL BOARD
VR	VOLTAGE REGULATOR

Figure 1-8. Wiring diagram, model MEP-019A (Serial number range JB66-0001 thru JB66-4730).



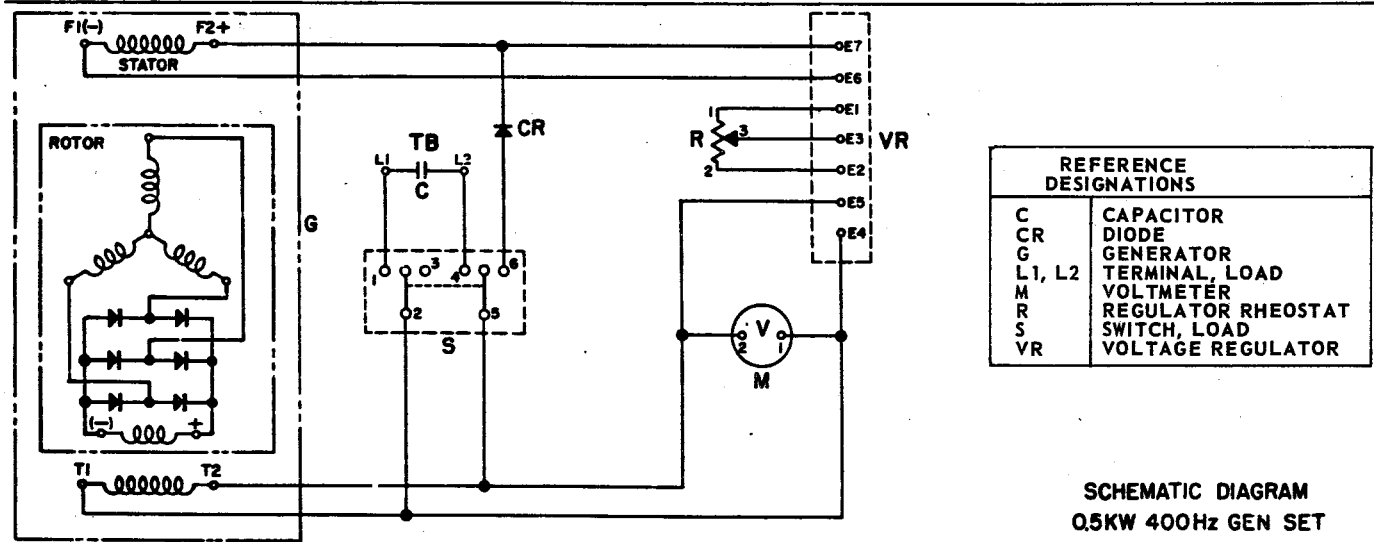
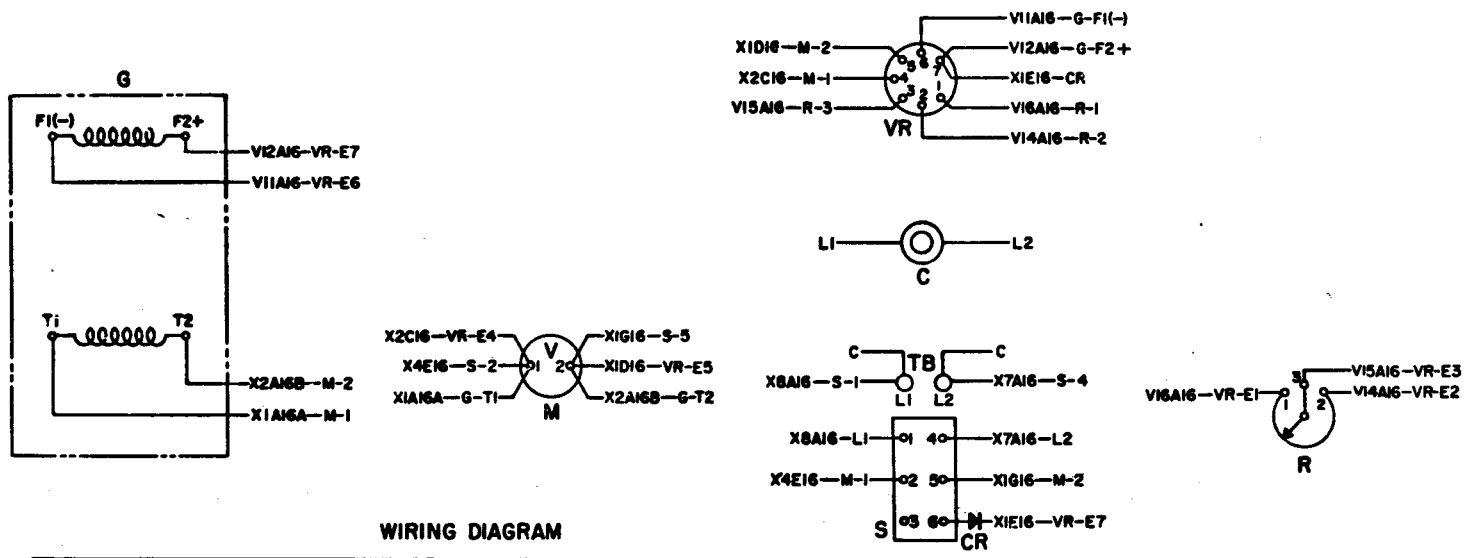

TS 6115-329-14/1-9

Figure 1-9. Wiring diagram, model MEP-019A (Serial number range SB71-0001 thru SB71-0177).

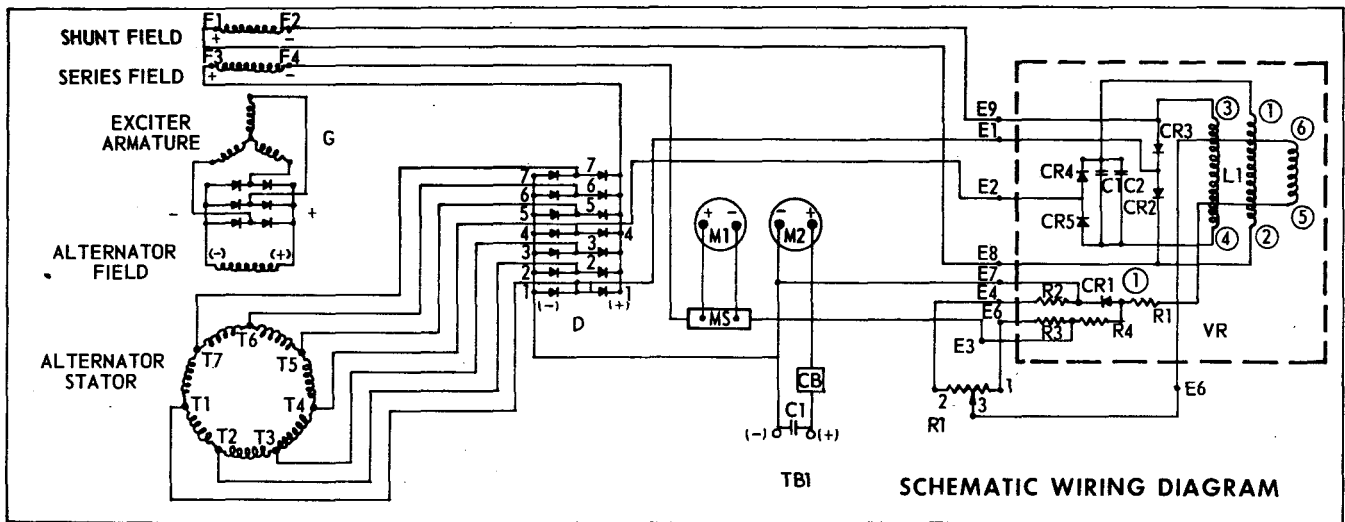
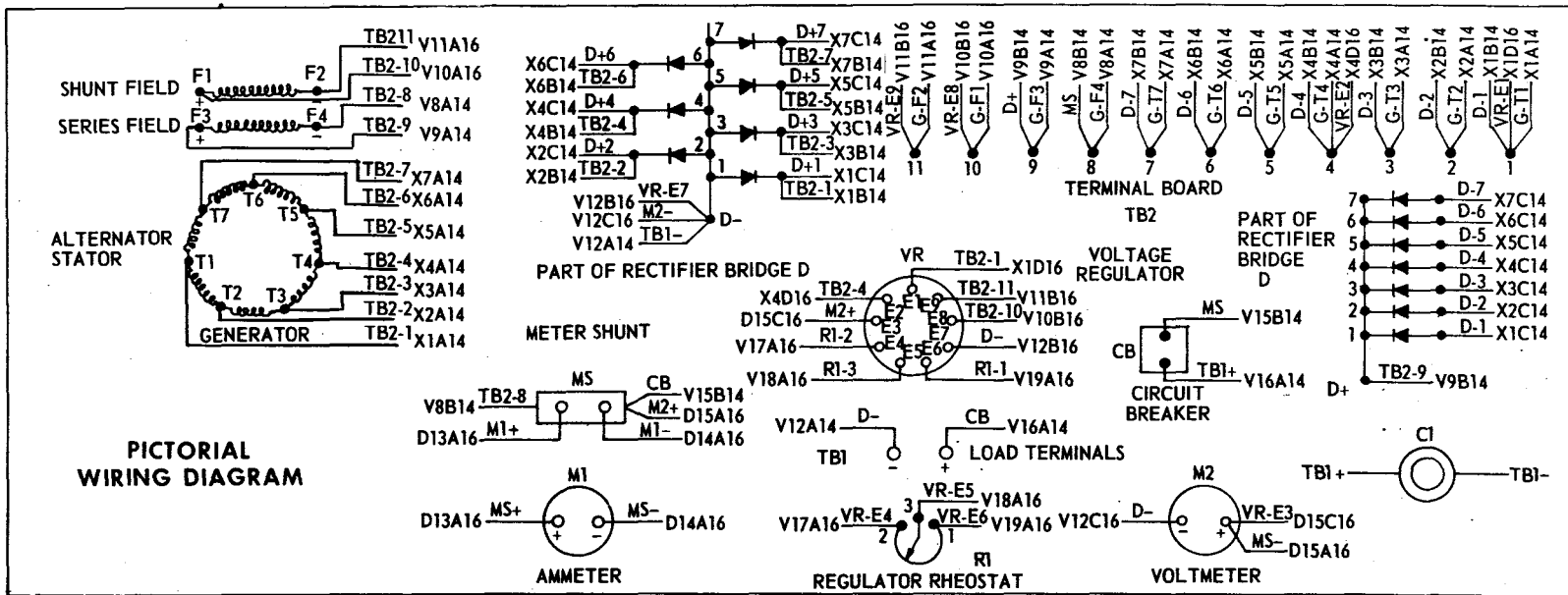

REFERENCE DESIGNATIONS	
CB	CIRCUIT BREAKER
C1	CAPACITOR
D	RECTIFIER BRIDGE
G	GENERATOR
MS	METER SHUNT
M1	AMMETER
M2	VOLTMETER
R1	REGULATOR RHEOSTAT
TB1	LOAD TERMINAL
TB2	TERMINAL BOARD
VR	VOLTAGE REGULATOR

Figure 1-10. Wiring diagram, model MEP-024A.

### 1-11. Tabulates Data (Intermediate and Depot Support Maintenance)

**a. General.** This paragraph contains all tabulated data relative to intermediate and depot maintenance of DOD models 1A08-3 Military standard engine and the DOD models MEP-014A, MEP-019A and MEP-024A generator sets.

#### **b. Generator Classification and Rating.**

Rating		0.5 KW
Voltage	DOD models MEP-014A and MEP-019A (except serial number range SB71-0001 through SB71 - 0177 which are 120 VAC only). DOD Model MEP-024A	120/240 VAC           28 VDC
Amperes	DOD models MEP-014A and MEP-019A DOD model MEP-024A	   4-17  17.86
Phase		1
Power factor		1.0
Frequency	DOD model MEP-014A DOD model MEP-019A DOD model MEP-024A	60 Hertz  400 Hertz  Fan
28 VDC Cooling		Sealed bearings
Lubrication		Continuous
Duty classification		Full
Degree of inclosure		Direct
Drive		Alternator
Type		167F (75C)
Temperature rise		10% for 10 minutes
Overspeed capacity		10 seconds at rated KW
Short circuit		3.5% deviation factor, maximum
Waveform		1% maximum
Terminal voltage deviation		

#### **c. Generator Stator Resistance Values.**

##### **.5KW-60HZ (SF 0.5 MD) Old Package 6115-00-935-8694**

Alternator Stator 13213E0005  
6.61 ohms + 10%, at 25°C between T1-T2 and T3-T4.  
Exciter Stator 13213E0072  
(1) Series field -.210 + 10%, ohms at 25°C  
(2) Shunt field - 455 + 10% ohms at 25°C

##### **.5KW-60Hz (MEP-014A) New Package 6115-00-932-4469**

Alternator Stator 13217E1787  
3.31 ohms + 10% between T1-T2 at 25°C  
Exciter Stator 13217E1795  
455 ohms + 10% at 25°C

##### **.5KW-28 VDC (DC 0.5 MD/28) Old Package 6115-00-917-7355**

Alternator Stator 13213E0109  
0.95 + 10% ohms at 25°C  
between T1-T2, T2-T3, T3-T4, T4-T5, T5-T6, T6-T7 and T7-T1  
Exciter Stator 13213E0111  
(1) Series field -.036 + 10% ohms at 25°C  
(2) Shunt field -38.0 + 10% ohms at 25°C

##### **.5KW-28 VDC (MEP-024A) New Package 6115-00-940-7867**

Alternator Stator 13213E0109  
0.95 + 10%, ohms at 25°C  
between T1-T2, T2-T3, T3-T4, T4-T5, T5-T6, T6-T7 and T7-T1  
Exciter Stator 13217E1756  
38.0 + 10% ohms at 25°C

##### **.5-40 OHZ (HF-0.5 MD) Old Package 6115-00-917-7354**

Alternator Stator 13213E0160  
2.2 + 10% ohms at 25°C (T1-T2)  
2.2 + 10% ohms at 25°C (T3-T3)  
Exciter Stator 13213E0167  
(1) Series field - 0.210 + 10% ohms at 25°C  
(2) Shunt field - 455 + 10% ohms at 25°C

##### **5-400Hz (MEP-019A) New Package 6115-00-940-7862.**

Alternator Stator 13217E1768  
1.1 + 10% ohms at 25°C  
Exciter Stator 13217E1765  
455 + 10% ohms at 25°C

#### **d. Nut and Bolt Torque Data.** Torque Weight Specifications (dry).

		(Metric)
Flywheel bolt nuts	240-300 in.-lb (42864.-53580. gr cm)	
Cylinder head nuts	140-155 in.-lb (25004.-27683. gr cm)	
Rocker arm adjusting screw lock nuts	44-55 in.-lb (7858.4-9823 gr cm)	
Intake manifold to cylinder head bolts	45-50 in.lb (8037.-8930. gr cm)	
Muffler to cylinder head nuts	60-85 in.-lb (10716.15181 gr cm)	
Spark plugs	275-300 in.-lb (49115.-53580 gr cm)	
Connecting rod bolts (with molykote on threads)	90-100 in. -lb (16074.-17860 gr cm)	
Oil pan capscrews	25-30 in.lb (4465.5358. gr cm)	
Bearing cap nuts	100-125 in.-lb (17860.-22325 gr cm)	
Fuel pump to crankcase bolts	45-50 in.-lb (7037.-8930 gr cm)	
Governor housing mounting screws	25-30 in.-lb (4465.-5358 gr cm)	
Carburetor to intake manifold	60-85 in.-lb (10716.-15181. gr cm)	
Generator shaft bolts	10-15 ft.-lb (1.383-2.s0745 kgm)	

***e. Engine Overhaul Data.***

Bore	2.25 in. (5.715 cm)
Stroke	2.00 in. (5.08 cm)
Compression ratio	6:1
Brake Horsepower:	
Model 1A08-3	1.50 at 3,600 rpm (revolutions per minute)
Cylinder compression minimum	90 psi (63279. kgs per sq meter)
Spark plug gap	0.028-0.033 (0.071-0.083 cm)
Magneto contact gap	0.016-0.020 (0.040-0.050 cm)
Carburetor float level	0.00-0.3 (0.00-0.762 cm) (from top of casting to top of float)
Fuel pump outlet pressure	3.0-4.5 psi (2109.3-3163.95 kgs per sq meter)
Valve tappet clearance (in-take & exhaust)	0.007 to 0.009 (0.017 to 0.022 cm) (cold)

**1-12. Differences Between Models**

Generator set, model MEP-019A, uses a gasoline engine driven, 0.5 kilowatt, 120/240 volt ac, 400 Hertz, single phase generator. The unit has a con-

trol panel assembly which includes an ac voltmeter, load On-Off flash switch, rheostat, and 120/240 V switch, except sets manufactured by Bucknell contract DSA-400-71-C-6006 serial number range SB710001 through SB710177 which are single voltage and have 120 volt 60 Hz capability only. Model MEP-014A uses a gasoline engine driven, 0.5 kilowatt, 120/240 volt ac, 60 Hertz, single phase generator. It has a control panel assembly which includes an ac voltmeter, load On-Off switch, rheostat, and a 120/240 V switch. Model MEP-024A uses a gasoline engine driven, 0.5 kilowatt, 28 volt dc generator. It has a control panel assembly which includes a percent load meter, voltmeter, load switch, and a rheostat.

**1-13. Orientation**

Throughout this manual, the use of the terms Right, Left, Front and Rear indicates directions from the view point of the operator as he faces the control panel of the unit.

## CHAPTER 2

### OPERATING INSTRUCTIONS

#### Section I. OPERATING PROCEDURES

##### 2-1. Operation of Equipment

Refer to paragraphs 2-2 c and d for starting instructions.

##### 2-2. Controls and Instruments

*a. Generator Controls and Instruments.* The purpose of generator controls and instruments and their normal reading are illustrated in figures 2-1, 2-2 and 2-3.

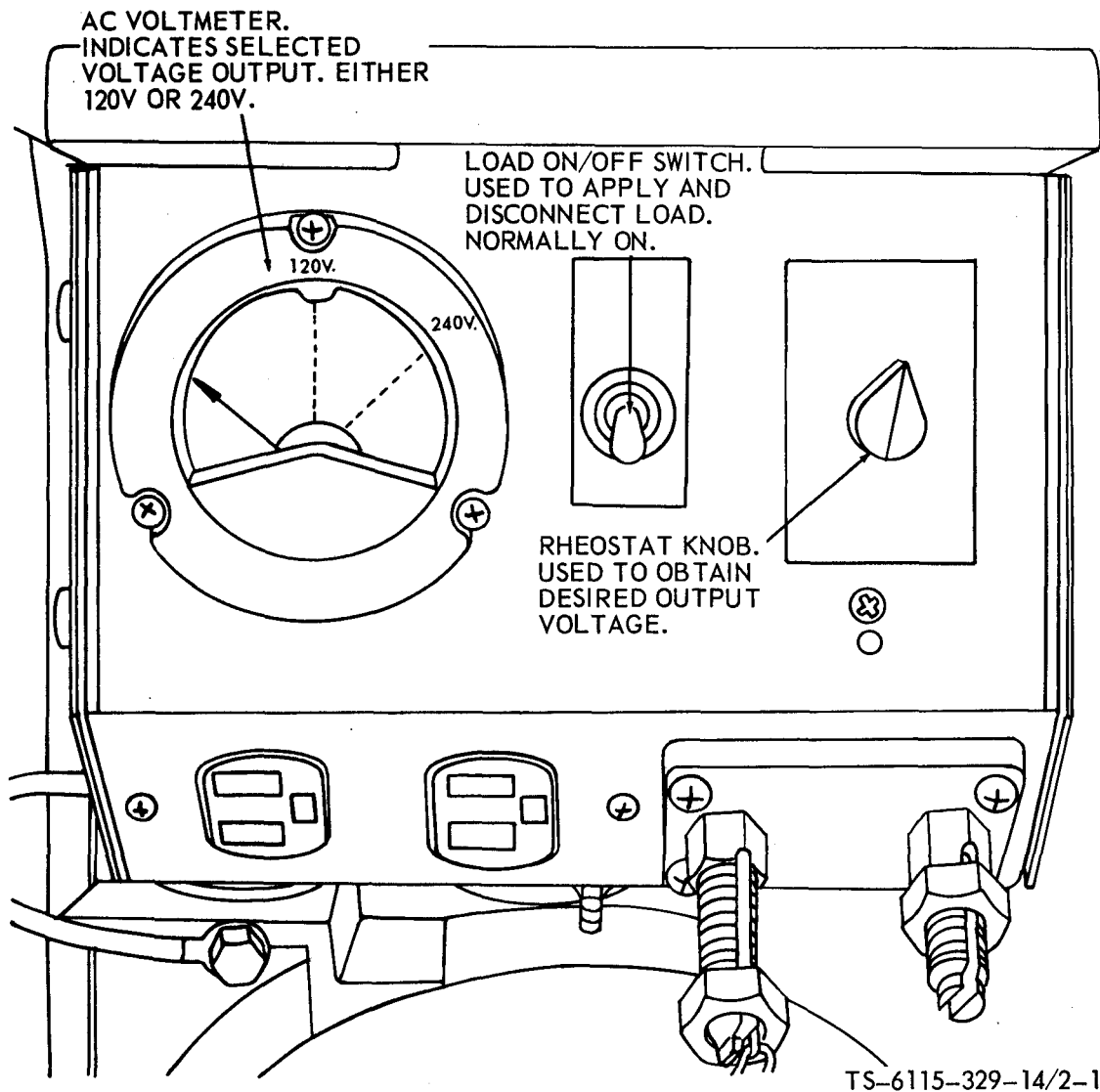
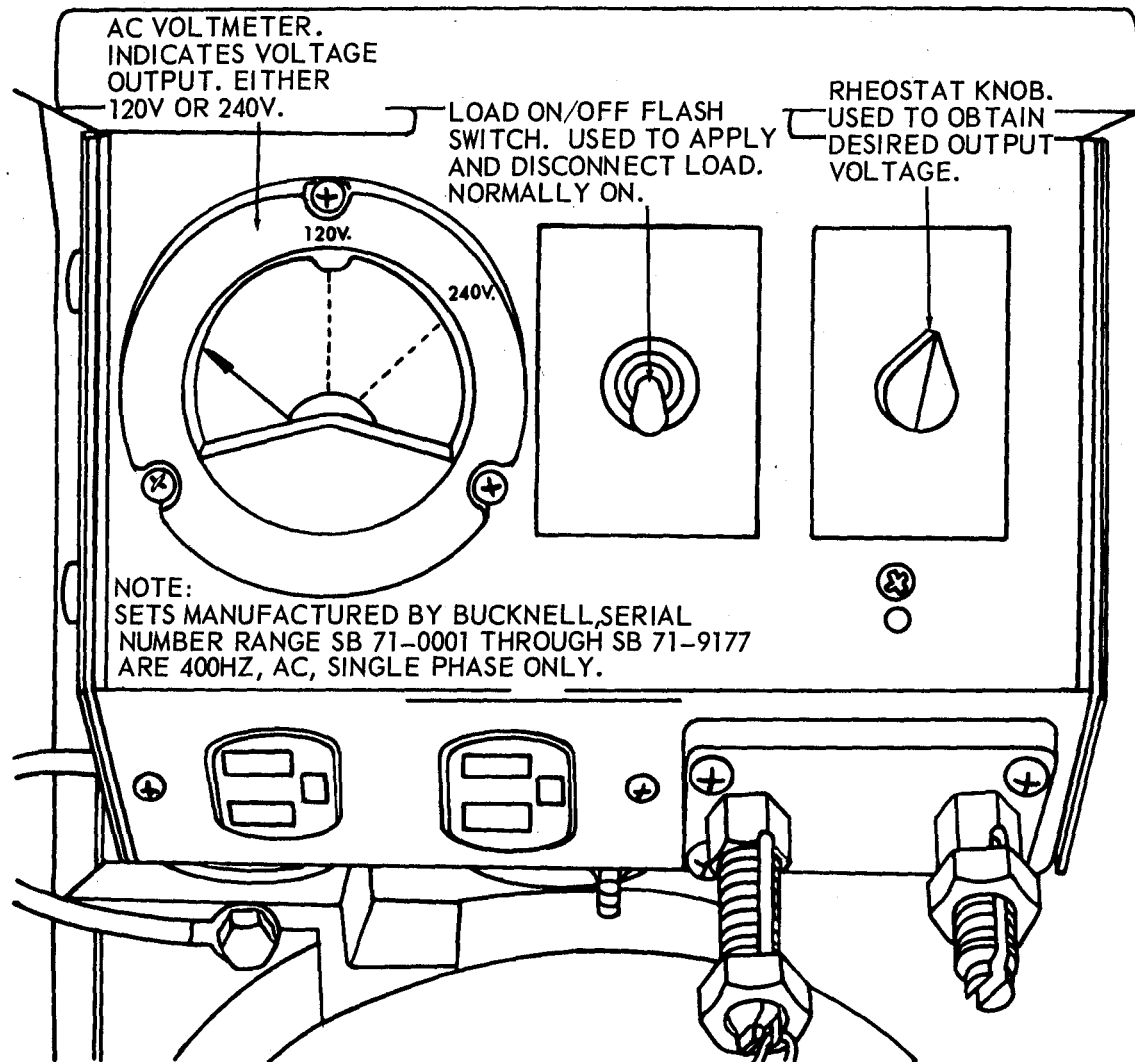
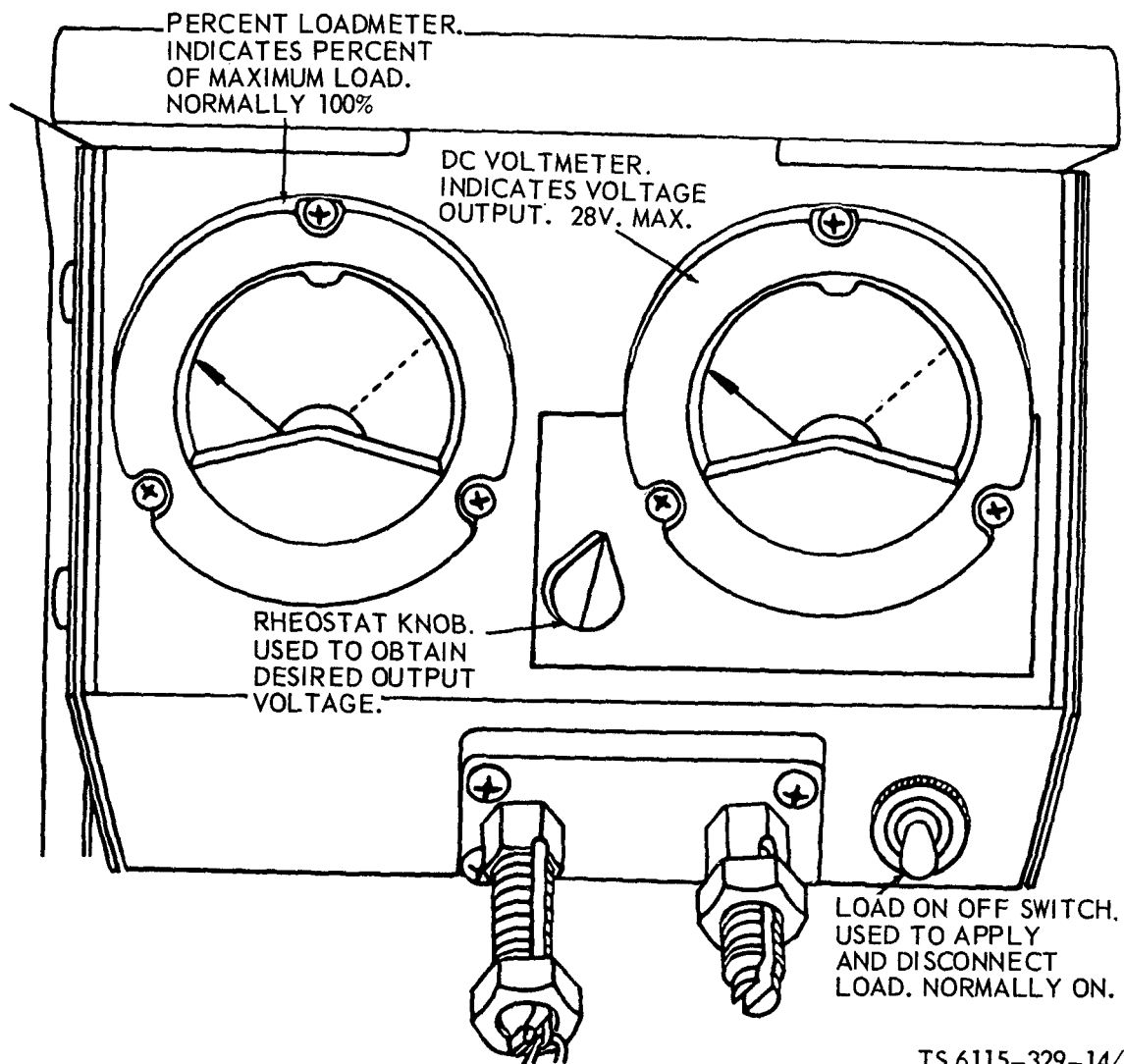

Figure 2-1. Controls and instruments, model MEP-014A.



TS 6115-329-14/2-2

Figure 2-2. Controls and instruments, model MEP-019A.



TS 6115-329-14/2-3

Figure 2-3. Controls and instruments, model MEP-024A.

Table 2-1 lists the nomenclature, model applicability, and use of the various controls and instru-

ments required for proper operation of the generator set.

Table 2-1. Controls and Instruments

Nomenclature	DOD Model	Use
AC Voltmeter	MEP-014A and MEP-019A	Indicates voltage output.
DC Voltmeter	MEP-024A	Indicates voltage output.
Load on/off switch	MEP-014A and MEP-024A	Used to apply and disconnect load.
Load on/off flash switch	MEP-019A	Used to apply and disconnect load.
Percent load meter	MEP-024A	Indicates percent of maximum load.
Rheostat knob	All	Used to obtain desired output voltage.

*b. Engine Controls and Instruments. Refer to TM 5-2805-256-14.*

**NOTE**

The operator must know to perform every operation of which the generator is capable. Paragraphs c and d give instructions on starting and stopping the generator set, basic motions of the generator set, and on coordinating basic motions for which the equipment is designed. Since nearly every job presents a different problem, the operator may have to vary given procedures to fit the individual job.

*c. Preparation for Starting*

(1) Perform the daily preventive maintenance checks and services (para. 3-5).

c. (2) Check for the presence of an operable fire extinguisher.

(3) Make ground and all desired load connections before starting engine.

**CAUTION**

**Place 120/240 V switch in desired position before starting models MEP-014A and MEP-019A (except sets manufactured by Bucknell serial number range SB71 - 0001 through SB71-0177 which have 120 volt capability only).**

*d. Starting.*

(1) Place LOAD ON-OFF FLASH switch (model MEP-019A), and LOAD ON/OFF switch (models MEP-014A and MEP-024A), in OFF position (fig. 2-1, 2-2 and 2-3).

(2) Rotate rheostat counterclockwise as far as it will go (fig. 2-1, 2-2 and 2-3).

**CAUTION**

**Unnecessary or excessive use of the choke can cause the lubricating oil to become diluted by gasoline.**

(3) Open fuel shutoff valve. Close the choke (move choke control lever away from flywheel) for starting cold engine. Open choke (move toward flywheel) gradually as engine starts and warms until choke is fully open (fig. 2-4).

(4) Place throttle control approximately 1/4 inch forward of the full idle position.

**WARNING**

**Serious eye injury can result from the starter rope knot. Wear eye protection when pull starting engine.**

(5) Place ignition switch in ON position (fig. 2-4).

(6) Wind starter rope around flange in clockwise direction. Pull rope briskly to start engine. When the engine has started, move the throttle control to the position that will allow the engine to operate at a smooth idle. Rotate the choke control clockwise until the choke is fully open and the engine will continue to run. Warm engine without load for 3-5 minutes.

(7) After engine warm-up, move the throttle to the full governed position.



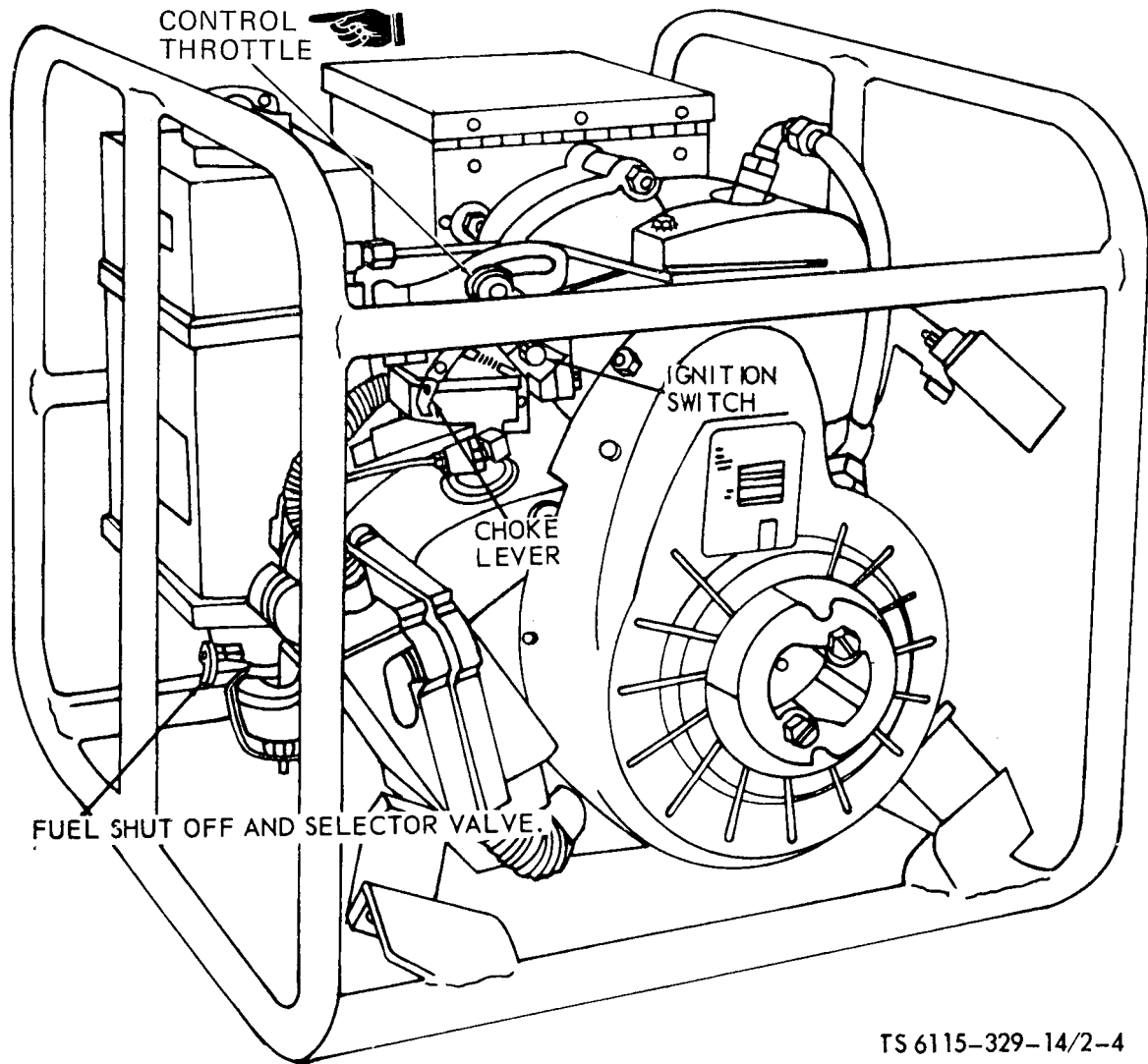

TS 6115-329-14/2-4

Figure 2-4. Engine controls.

- 8) On model MEP-019A only, place LOAD ON-OFF-FLASH switch in FLASH position. When engine has attained rated speed, observe panel meter for a voltage indication. Release switch when voltage reaches a minimum value of 100 volts.
- 9) If generator output voltage on model MEP-019A fails to develop after set has attained rated speed, and the LOAD ON-OFF-FLASH switch has been placed in FLASH position, field flashing from an external source will be required. The field is flashed by momentarily connecting a 12-volt DC source (with resistor of 20 ohms, 5 watts connected in series) to terminals 8 and 7 of TB 2 (fig. 1-8). Terminal 8 is positive with respect to terminal 7. The series resistor may be omitted if voltage polarity is strictly observed.

**CAUTION**

Reversing field flashing polarity from that indicated above will result

in the destruction of the voltage regulator, rendering the set inoperative.

*e. Stopping.*

- (1) Position LOAD ON/OFF switch (models MEP-014A and Mep-024A), or LOAD ON-OFF-FLASH switch (model MEP-019A) in OFF position (fig. 2-1,2-2 and 2-3).
- (2) Turn the voltage rheostat fully counterclockwise.
- (3) Run the engine at rated speed for 3-5 minutes to cool down the set.
- (4) Place ignition switch in OFF position (fig. 2-4).

## Section II. OPERATION UNDER UNUSUAL CONDITIONS

### 2-3. Operation in Extreme Cold (Below 0°F).

*a.* Keep fuel tank full to avoid condensation and freezing.

*b.* Service fuel filter often enough to prevent bursting from water sediment freezing in it.

*c.* Avoid accumulation of ice on generator set parts.

*d.* Operate set in location which is protected from chilling winds. This protection permits easier servicing and better performance.

*e.* Keep snow and ice out of the fuel supply to prevent carburetor jets from becoming plugged.

*f.* Avoid operating generator set for short periods. A minimum of 30 minutes operation is required to evaporate water caused by heating of cold metal parts.

*g.* Allow at least five minutes of continuous engine operation before applying load.

*h.* Lubricate in accordance with current lubrication order. Air Force personnel use the lubrication section of applicable TO 35C2-3-1-426 WC-series workcards.

*i.* Provide shelter or cover to protect unit when not in operation.

*j.* Engine (-25 to -65°F) (-32 to -53°C). Lubricate the engine in accordance with current lubrication order. Air Force personnel use the lubrication section of applicable TO 35C2-3-1-426 WC-series workcards. If practical, apply heat to the engine with a suitable torch (MIL-H-52112 type 1), Apply the heat by playing the torch flame back and forth over intake manifold, oil pan, valve covers, and air intake, until the engine cranks freely. Keep flame and heat from non-metallic parts of engine.

#### WARNING

**Do not let the heating torch flame come in contact with the fuel tank or fuel lines (the fuel line and fittings are plastic nylon); an explosion could occur, causing injury or death.**

#### CAUTION

**The heating torch generates sufficient heat to melt metal parts if the flame is held at one place for more than 30 seconds. Correct heating procedure is to play the flame back and forth over the components to be warmed. Take care**

**that the flame does not contact the spark plug cable, generator control box, or other non-metallic parts of the set.**

### 2-4. Operation in Extreme Heat

*a.* Keep generator set clean and free of dust.

*b.* Allow sufficient room around the generator set for air circulation.

*c.* Be sure engine shroud is not clogged with foreign matter.

*d.* Do not overload set.

### 2-5. Operation in Dusty or Sandy Areas

#### WARNING

**Clean all parts in a well-ventilated area. Avoid inhalation of solvent fumes and prolonged exposure of skin to cleaning solvent. Wash exposed skin thoroughly. Dry cleaning solvent (Fed. Spec. P-D-680) used to clean parts is potentially dangerous to personnel and property. Do not use near open flame or excessive heat. Flash point of solvent is 100° to 138°F. (39° to 59° C.).**

*a.* Shield the set from dust and sand.

*b.* Use a cloth dampened with dry cleaning solvent, Fed. Spec. P-D-680, to clean the set frequently.

*c.* Be sure engine shroud is not clogged with foreign matter.

*d.* Service air cleaner more often than normally required.

*e.* Prevent sand and dust from entering fuel tank.

*f.* Keep lubricants and lubrication equipment free of sand and dust.

### 2-6. Operation Under Rainy or Humid Conditions

*a.* Provide shelter for set if possible. If shelter is not available, use canvas cover for protection when unit is not in operation.

*b.* Keep water from entering fuel system.

*c.* Inspect fuel filter twice a day for accumulation of water.

d. Keep fuel tank as full as possible to prevent condensation of moisture inside.

**WARNING**

**The voltage of this set is dangerous to persons coming in contact with any part of electrical system, during operation. Severe, possibly fatal shock may result. This is especially true when the unit or surrounding area is damp or wet. In the event of an accident from electrical shock, SHUT DOWN the generator set at once. If the generator set cannot be shut down, free victim from the live conductor. Avoid direct contact with victim or live conductor. Use a dry broad, dry ropes, or any non-conductor to free victim. If the victim is unconscious apply artificial respiration and send for medical help.**

**2-7. Operation in Saltwater Areas**

a. Wipe down the generator set with clean fresh water at frequent intervals. Take care not to contaminate fuel system or damage electrical system with the water.

b. Use care to keep salt water from entering engine when adding oil.

c. Paint all exposed nonpolished surfaces. Coat exposed parts of polished steel with standard issue rust proofing material if available, or cover parts with a light coat of grease. Do not paint or grease exhaust manifold or muffler.

**2-8. Operation at High Altitude**

a. The generator set will operate full rated load at any elevation from sea level to 5,000 feet (150,000 cm) above sea level. However, maximum operating ambient temperature at 5,000 feet elevation is 107°F (42°C).

b. Operation at high elevation may require adjustment of carburetor for proper operation of unit. Refer to TM 52805-256-14, and TO 38G2-102-2.

c. The generator set is rated at 0.5 KW up to 5,000 feet altitude and 0.4 KW at 8,000 feet (240,000 cm) altitude. To calculate specific output capability above, 8,000 feet use the following formula:

$7\% \times \frac{\text{actual altitude} - 5,000}{1,000} \times 5,000 \text{ ft.}$

rating = derating factor

Example Solution for 13,000 feet (390,000 cm):

$0.07 \times \frac{13,000 - 5,000}{1,000} \text{ kw} = \text{derating}$

$0.07 \times 8 \times 0.5 \text{ kw} = 0.28 \text{ derating}$

$0.5 \text{ kw} - 0.28 \text{ kw} = 0.22 \text{ kw (derated power at 13,000 ft. )}$



## CHAPTER 3

# OPERATOR/CREW MAINTENANCE INSTRUCTIONS

### Section I. CONSUMABLE OPERATING AND MAINTENANCE SUPPLIES

#### 3-1 General

Table 3-1 lists the consumable operating and maintenance supplies required for operation and maintenance of the generator set.

#### 3-2. Explanation of Columns in the Tabular List of Consumable Operating and Maintenance Supplies

**a. Component Application Column (1).** This column identifies the component application of each maintenance or operating supply item.

**b. National Stock Number Column (2).** This column indicates the National Stock Number for the item and will be used for requisitioning purposes.

poses.

**c. Description, Column (3).** This column indicates the item and brief description.

**d. Quantity Required for Initial Operation, Column (4).** This column indicates the quantity of each maintenance or operating supply item required for initial operation of the equipment.

**e. Quantity Required for 8 Hours Operation Column (5).** This column indicates the estimated quantities required for an average eight hours of operation.

**f. Notes, Column (6).** This column indicates informative notes keyed to data appearing in a preceding column.

*Table 3-1. Maintenance and Operating Supplies*

(1)	(2)	(3)	(4)	(5)	(6)
COMPONENT APPLICATION	NATIONAL STOCK NO.	DESCRIPTION	QUANTITY REQUIRED F/INITIAL OPERATION	QUANTITY REQUIRED F/8 HRS OPERATION	NOTES
Crankcase  (1)		Oil, Lubricating 1 qt. (0.95 liters) can as follows:			(1) Includes quantity of oil to fill engine oil system as follows: 4/5 qt. (0.76 liters) crankcase. (2) See L05-2805-256-14 for grade application and replenishment intervals
	9150-00-265-9433	OE-30	4/5 qt. 0.76 liters	(2)	
	9150-00-265-9425	OE-10	4/5 qt. 0.76 liters	(2)	
Fuel, Tank (4)	9150-00-242-7602	OES Fuel, gasoline: Bulk as follows	1 gal 3.8 liters (4)	(2) 4 gal. 15.2 liters (5)	(4) Tank capacity.
	9130-00-160-1818	Gasoline, 91A Automotive combat			(5) Average fuel consumption is 0.50 gal (1.9 liters) per hour of continuous operation.
General Cleaning	6850-00-264-9037	Dry cleaning solvent Fed. Spec P-D-680	as required		

## Section II. LUBRICATION INSTRUCTIONS

### 3-3. General

*a.* This section contains a reproduction of the lubrication order and instructions which are supplemental to and not specifically covered in the lubrication order.

*b.* The lubrication order (LO 5-2805-256-12) shown as figure 3-1 is an exact reproduction of the approved lubrication order for the engine. Air Force personnel use the lubrication section of applicable TO 35C2-3-1-426 WC-series workcards.

**LUBRICATION ORDER**

**TO 38G2-102-2LC-1**

# L05-2805-256-12

(Supersedes L05-2805-256-12 dated 22 DEC 67)

## ENGINE, GASOLINE, 1-1/2 HP. MILITARY STANDARD MODELS

**(MODEL 1A08-1) (MODEL 1A08-2) (MODEL 1A08-3)**

Reference: FEDERAL SUPPLY CATALOG C9100-IL

Intervals are based on normal hours of operations. Adjust to compensate for abnormal operations and severe conditions. During inactive periods sufficient lubrication must be performed for adequate preservation.

Relubricate after washing.

Clean parts with SOLVENT, dry-clearing, or with OIL, fuel, Diesel. Dry before lubricating.

Drain crankcase when hot. Fill and check level.

FOLD

FOLD

LUBRICANT ● INTERVAL

INTERVAL ● LUBRICANT

Crankcase Fill and Level (Check level) (See key)

CAUTION: When OES oil is used the level will be checked more often.

OE HDO

8

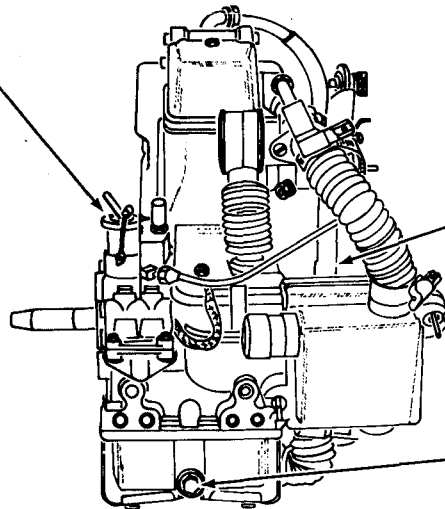

500

OE HDO Ignition Cam Wick (Sparingly)

50

Crankcase Drain (Drain and refill)

MODELS 1A08-3

TS 6115-329-14/3-1 (SHEET 1 OF 2)

Figure 3-1. Lubrication order (sheet 1 of 2).

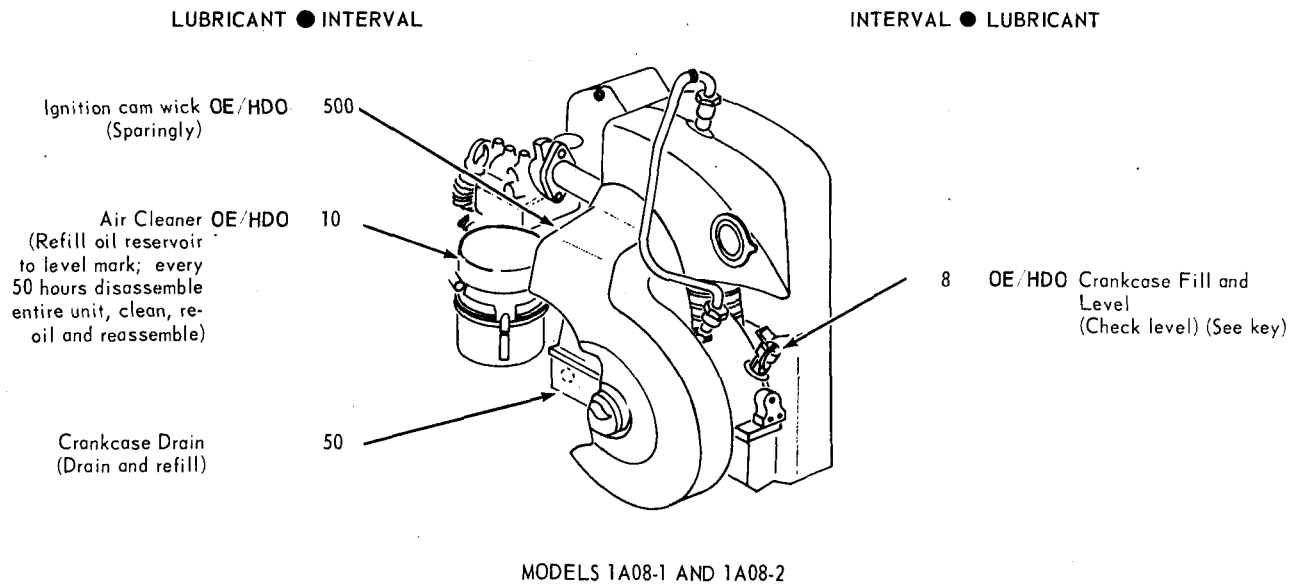

-KEY-

LUBRICANTS	CAPACITY	EXPECTED TEMPERATURES			INTERVALS
		Above +32° F	+40° F to -10° F	0° F to -65° F	
OE/HDO-LUBRICATING OIL, Engine					Intervals given are in hours of normal operation
Crankcase 1 1/2 HP	1/2 qt	OE/HDO 30	OE/HDO 10	OES	
• Air Cleaner-1 and -11 only	1/8 qt.				
OES-OIL, Engine, Sub-zero					

FOLD

FOLD

NOTES:

1. FOR OPERATION OF EQUIPMENT IN PROTRACTED COLD TEMPERATURES BELOW -10 F. Remove lubricants prescribed in the key for temperatures above -10 F.

2. LUBRICANTS. The following is a list of lubricants with the Military Symbols and applicable Specification numbers.  
OE/HDO MIL-L-2104C      OES MIL-L-10295

Copy of this Lubrication Order will remain with the equipment at all times; instructions contained herein are mandatory.

BY ORDER OF THE SECRETARIES OF THE ARMY AND THE AIR FORCE:

OFFICIAL:

PAUL E. SMITH  
Major General, United States Army  
The Adjutant General

BERNARD W. ROGERS  
General, United States Army  
Chief of Staff

OFFICIAL:

JAMIS E. SHIPARD, Colonel, USAF  
Director of Administration

DAVID C. JONIS, General, USAF  
Chief of Staff



### 3-4. Detailed Lubrication Information

**a. Care of Lubricants.** Keep lubricants in sealed containers and store in a clean dry place, away from external heat. Allow no dust, dirt or other foreign materials to mix with the lubricants.

NOTE

Lubrication equipment must be kept clean and ready for use.

**b. Instructions.** Proper lubrication is required to maintain longer engine life. Review lubrication order carefully, and adhere to the pertinent information and specification required. Apply lubricant specified on the lubrication order.

**c. Cleaning.** Before lubricating the equipment, wipe all lubrication points clean of dirt and grease

with a clean shop towel or equivalent.

NOTE

Keep all external parts not requiring lubrication clean from lubricants. After every external lubrication operation, remove any excess lubricant from the application points and wipe away the spilled lubricant. This prevents accumulation of foreign matter, dust and dirt, which would eventually clog or stop up the lubrication fittings or openings.

**d. OES Oil**

(1) Inspect the crankcase oil level frequently, as oil consumption can be expected to increase.

(2) The oil may require more frequent changing than usual because contamination, with sludge formations and dilution, will increase when the engine is operated under cold weather conditions.

## Section III. PREVENTIVE MAINTENANCE CHECKS AND SERVICES

### 3-5. General

a. To insure that the generator set is ready for operation at all times, it must be inspected systematically so defects may be discovered and corrected before they result in serious damage or failure. The necessary preventive maintenance checks and services that are to be performed by Operator/Crew personnel are listed and described in the following paragraph.

Defects discovered during operation will be noted for future correction. Stop operation immediately if a deficiency is noted which would damaged the equipment. All deficiencies and shortcomings will be recorded together with the corrective actions taken on the applicable form.

b. (A, N) Preventive Maintenance Checks and Services. Table 3-2 contains a tabulated listing of PMCS which shall be performed by the Operator/Crew personnel. The item numbers are listed consecutively and indicate the sequence of minimum requirements.

Equipment operation is allowable with minor leakage (Class I or II) . Of course, you must consider the fluid capacity of your generator set. When in doubt, notify your supervisor. When operating

with Class I or II leaks, continue to check fluid levels as required in your PMCS. Class III leaks should be reported to your supervisor or organizational maintenance.

c. Fluid Leakage. Leakage definitions for Operator/Crew PMCS shall be classified as follows:

Class I Seepage of fluid (as indicated by wetness or discoloration) not great enough to form drops.

Class II Leakage of fluid great enough to form drops but not enough to cause drops to drip from item being checked/inspected.

Class III Leakage of fluid great enough to form drops that full from the item being checked/inspected.



**Table 3-2. Preventative Maintenance Checks and Services**

ITEM NO.	B - BEFORE OPERATION			D - DURING OPERATION			A - AFTER OPERATION		
	INTERVAL			ITEM TO BE INSPECTED	PROCEDURES CHECK FOR AND HAVE REPAIRED OR ADJUSTED AS NECESSARY	EQUIPMENT IS NOT READY/ AVAILABLE IF:			
	B	D	A						
1	0		0	Generator Set	Inspect for fuel and oil leaks on and around engine. Inspect entire unit for bent, cracked, broken, loose, or missing parts. Check for proper grounding.	Fuel or oil leaks detected. Generator not properly grounded.			
	0				Inspect for cracked or broken welds				
2	0		0	Fuel Tank	Add fuel as required. Inspect for clogged vent cap or dirty tank screen.	Fuel tank leaking			
3	0		0	Oil Level Gage	Use oil level rod and measure the oil level in the crank case; add oil if necessary. Do not overfill. Refer to lubrication order (fig. 3-1) for proper grade of oil.				
4	0	0	0	Air Cleaner	Inspect for cleanliness and serviceability. Check restriction indicator. If red is visible, report to organizational maintenance.	Air cleaner is missing or unserviceable.			
5	0		0	Sparkplug and Cable	Inspect for loose installation.				
6		0		Voltmeter (DOD Models MEP-014A and MEP-019A)	Adjust rheostat to obtain selected voltage. If unable to obtain selected voltage, check for loose connections and tighten as necessary.	Voltage cannot be adjusted.			
7		0		Percent Load-meter (DOD Models MEP-024A only)	If the indicator fluctuates or indicates an overload condition, check for loose connections, then check the applied load.	Meter indication exceeds 125% of applied load. Meter inoperative.			
8			0	Fuel Filter	Inspect filter for accumulated dirt, water sediment, and leakage.	Filter leaking or missing.			

## **SECTION IV. TROUBLESHOOTING**

### **3-6. General**

*a.* This section contains troubleshooting information for locating and correcting operating troubles which may develop in the generator set. Each malfunction for an individual component, unit, or system is followed by a list of tests or inspections which will help you to determine probable causes and corrective actions to take. You should perform the test inspections and corrective actions in the order listed.

*b.* This manual cannot list all malfunctions that may occur, nor all test or inspections and corrective actions. If a malfunction is not listed or cannot be corrected by listed corrective actions, notify your supervisor.

### **3-7. TROUBLESHOOTING TABLE**

#### **NOTE**

Before you use this table, be sure you have performed all applicable operating checks

**Table 3-3. Troubleshooting**

---

**Malfunction**

**Test or Inspection**

**Corrective Action**

---

**ENGINE**

Refer to TM 5-2805-256-14 for engine troubleshooting.

**GENERATOR**

**WARNING**

Clean all parts in a well-ventilated area. Avoid inhalation of solvent fumes and prolonged exposure of skin to cleaning solvent. Wash exposed skin thoroughly. Dry cleaning solvent (Fed. Spec. P-D-680) used to clean parts is potentially dangerous to personnel and property. Do not use near open flame or excessive heat. Flash point of solvent is 100 ° to 138 °F. (38° to 59°C).

**1. GENERATOR FAILS TO BUILD UP RATED VOLTAGE**

**Step 1.** Inspect for loose connections or cable assemblies.

**Tighten loose connections.**

**Step 2.** Check rheostat for proper setting.

**Rotate rheostat clockwise to obtain selected voltage (either 120 V or 240 V) on A. C. voltmeter.**

**Step 3.** Check position of ON/OFF flash switch, (Model MEP-019A only).

**On 400 Hz (MEP-019A) model, position ON/OFF flash switch to flash. Observe voltmeter and position switch in ON position when voltage reaches desired output.**

**2. GENERATOR VOLTAGE FLUCTUATES**

**Step 1.** Inspect for loose terminal connections.

**Tighten loose terminal connections.**

**Step 2.** Check generator for overload.

**Reduce load.**

**3. GENERATOR OVERHEATS**

**Step 1.** Check generator for overload.

**Reduce load.**

**Step 2.** Inspect operating area for obstructions blocking proper ventilation.

**Remove obstructions.**

**Step 3.** Inspect generator for dirty condition.

---

*Table 3-3. Troubleshooting*

---

**Malfunction**

**Test or Inspection**

**Corrective Action**

---

**CAUTION**

Do not allow cleaning solvent to enter windings or to come into contact with insulation. Damage to the generator set will occur. Clean generator set using a clean wiping cloth dampened in cleaning solvent Fed. Spec. P-D-680.

**4. VOLTAGE DROPS UNDER LOAD**

Engine not delivering power.

**Refer to TM 5-2805-256-14/T0 38G2-102-2.**

---

## Section V. OPERATOR/CREW MAINTENANCE INSTRUCTIONS

### 3-8. General

Instructions in this section are published for the information and guidance of the operator/crew to maintain the generator set.

### 3-9. Engine

Refer to TM 5-2805-256-14/TO 38G2-102-2 for engine maintenance

### 3-10. Fuel System

**a. Fuel Tank.** Clean tank as required. Sand and paint rust spots and other exposed areas. Fill tank as required.

**b. Fuel Filter Assembly.** The fuel filter is a trap in the fuel line to catch water and other foreign matter and prevent it from reaching and clogging the carburetor. Refer to figure 3-2 for service instructions.

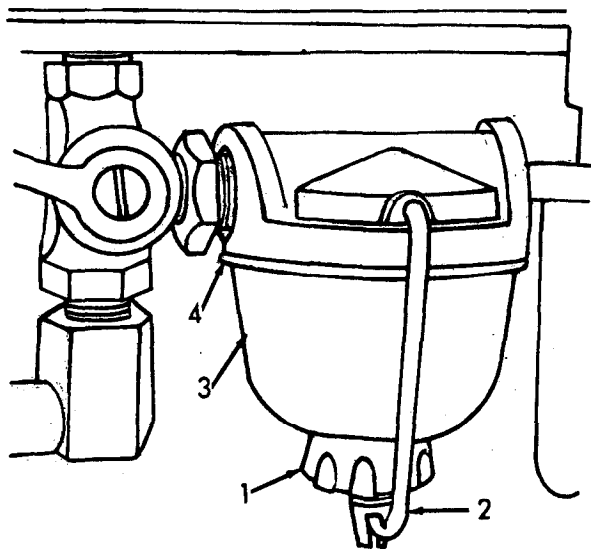

1. TURN KNURLED KNOB COUNTERCLOCKWISE.
2. SWING BAIL CLEAR OF BOWL.
3. REMOVE BOWL, EMPTY, AND CLEAN OF ANY FOREIGN MATTER.
4. REPLACE BROKEN GASKET.

TS 6115-329-14/3-2

Figure 3-2. Servicing fuel filter assembly.

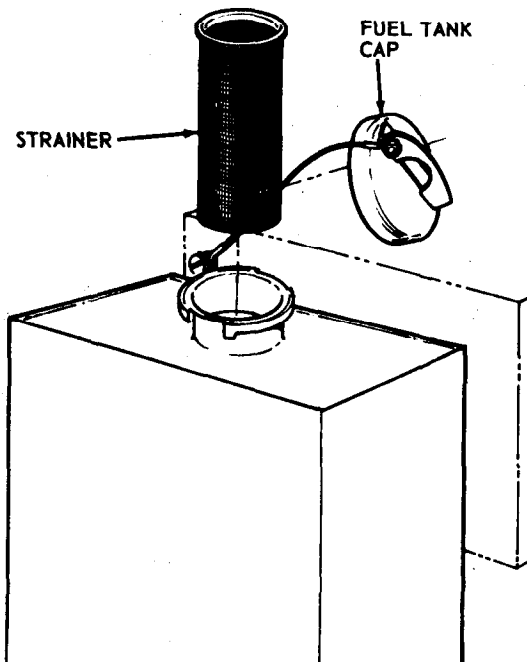

1. REMOVE FUEL TANK CAP.
2. LIFT STRAINER FROM FUEL TANK.
3. REVERSE STEPS 1 AND 2 TO INSTALL NEW STRAINER.

TS 6115-329-14/3-3

Figure 3-3. Fuel tank strainer, removal and installation.

**c. Fuel Tank Strainer.** Refer to figure 3-3 and replace unserviceable strainer.





## CHAPTER 4

### ORGANIZATIONAL MAINTENANCE

#### Section I. SERVICE UPON RECEIPT OF EQUIPMENT

##### 4-1. Inspecting and Servicing the Equipment

###### WARNING

**Clean all parts in a well-ventilated area. Avoid inhalation of solvent fumes and prolonged exposure of skin to cleaning solvent. Wash exposed skin thoroughly. Dry cleaning solvent (Fed. Spec. P-D-680) used to clean parts is potentially dangerous to personnel and property. Do not use near open flame or excessive heat. Flash point of solvent is 100° to 138°F. (38° to 59°C. ).**

###### a. Unpacking Equipment

(1) **General.** The equipment will be unpacked by the operator with assistance of organizational personnel.

(2) **Uncrating.** Remove any banding that is present. Observe necessary caution not to damage the generator set as it is unpacked.

###### (3) Removing Preservatives

(a) Remove tape used to seal all openings.

(b) Remove paper and other packing or cushioning material from all assemblies.

(c) Use dry cleaning solvent (Fed. Spec. P-D-680) to remove compound sprayed over metal surfaces. Remove rust and corrosion inhibitors.

(d) Depreserve engine per DA Form 2258.

###### b. Inspection

(1) Make positive identification of the nameplates on the generator set.

(2) Inspect the generator set thoroughly for cracks, rust, dents, and other damage which may have developed during shipment.

(3) Use the packing list and check the generator set and equipment to insure all items are accounted for, and are in working condition.

(4) Inspect for loose connections, loose or missing hardware on the generator set and the components.

(5) Crank the engine slowly with the starting rope to ensure all moving parts are free of restrictions.

(6) Correct all deficiencies. All deficiencies noted beyond the responsibility of organizational maintenance shall be reported to Direct Support maintenance.

###### c. Servicing.

(1) Use the current lubrication order to lubricate the generator set. Air Force personnel use the lubrication section of applicable TO 35C2-3-1-426 WC-series workcards.

(2) Inspect the air cleaner, clamps and hose connections. Tighten any loose clamps, and insure the air cleaner hoses are in working condition.

(3) Inspect the flywheel cover and accessories. Correct any sign of visual defects and secure loose mounting screws and nuts.

(4) Make a visual inspection on the carburetor, fuel lines, gasket, mounting screws, and exterior paint. Make these minor repairs immediately, or record and notify field maintenance.

(5) Inspect the governor, mounting screws, coverplate, shield, clamps, control rod housing, and the low tension cable assembly. Tighten any loose connections or screws.

(6) Inspect the magneto, coverplate, shield, and mounting screws. Tighten if loose, insure that parts are secure.

(7) Inspect the military engine fuel pump, fuel lines, mounting screws, clamps and nuts. Check the exterior painting for chips, cracks or discoloration. Repaint if necessary. Keep all fuel lines clear and intact.

(8) Check the fuel filter, input and output fuel lines and fittings. Insure that filter is secure and properly mounted.

(9) Check the starting rope assembly. Insure that the cutouts for rope are smooth, and are not bent, chipped, or full of burrs. Straighten where necessary, and remove burrs with emery cloth or file and repaint with proper touch-up paint.

(10) Make a visual inspection of the generator set and tighten any loose connections, clamps, nuts or screws. Correct any minor deficiency or repair. If minor repairs cannot be made at this time, make report to the supervisor and list the pertinent number of repairs, listing the part number and National Stock Number and its directly related serial number of DOD generator set.

## 4-2. Installation

*a. Location.* Avoid muddy, dusty, or sandy locations as an installation site, if possible. If it is necessary to install unit on soft ground, arrange a foundation of planks or other suitable material. Allow sufficient area around the generator set for easy access and adequate ventilation.

*b. Leveling.* See that the generator set is level positioned. The tilt, if any, must not exceed 15° in any place from horizontal.

*c. Indoor Installation.* Allow sufficient area around the unit for easy access and adequate ventilation.

### WARNING

Exhaust gases contain carbon monoxide which is a colorless, odorless, and deadly gas. Be sure the exhaust gases are piped to the outside atmosphere when operating in an enclosed area.

*d. Grounding.* Connect one end of ground wire to unit (figs. 1-1, 1-3 and 1-5). The wire should not be smaller than No. 6AWG. Connect the other end of the ground wire to a common service ground, or a steel, iron, or copper rod driven into the earth or to a buried metal plate at least two feet square. (Connect ground wire with ground clamp or solder it to ground). Ensure that all ground connections are securely tightened.

### WARNING

Never operate generator set unless it is grounded. Serious, or even fatal, injury can result from current generated by this unit.

### CAUTION

The United States Forestry Service requires that any engine driven equipment operating within National Forests or parks be provided with spark arresters for the avoidance of forest fires.

*e. Spark Arrester.* When a spark arrester is required, the installation procedure will be on the instruction sheet furnished with the spark arrester kit located on page B-1/(B-2 Blank).

## 4.3. Procedure for Constructing Revetment

*a. General.* This equipment is designed to operate in the open with unrestricted ventilation. In some situations it maybe necessary to operate the equipment from the protection of a revetment. This paragraph provides information on the construction of a revetment to protect the equipment should it become necessary.

*b. Dimensions.* The minimum allowable inside dimensions are shown in figures 4-1 and 4-2.

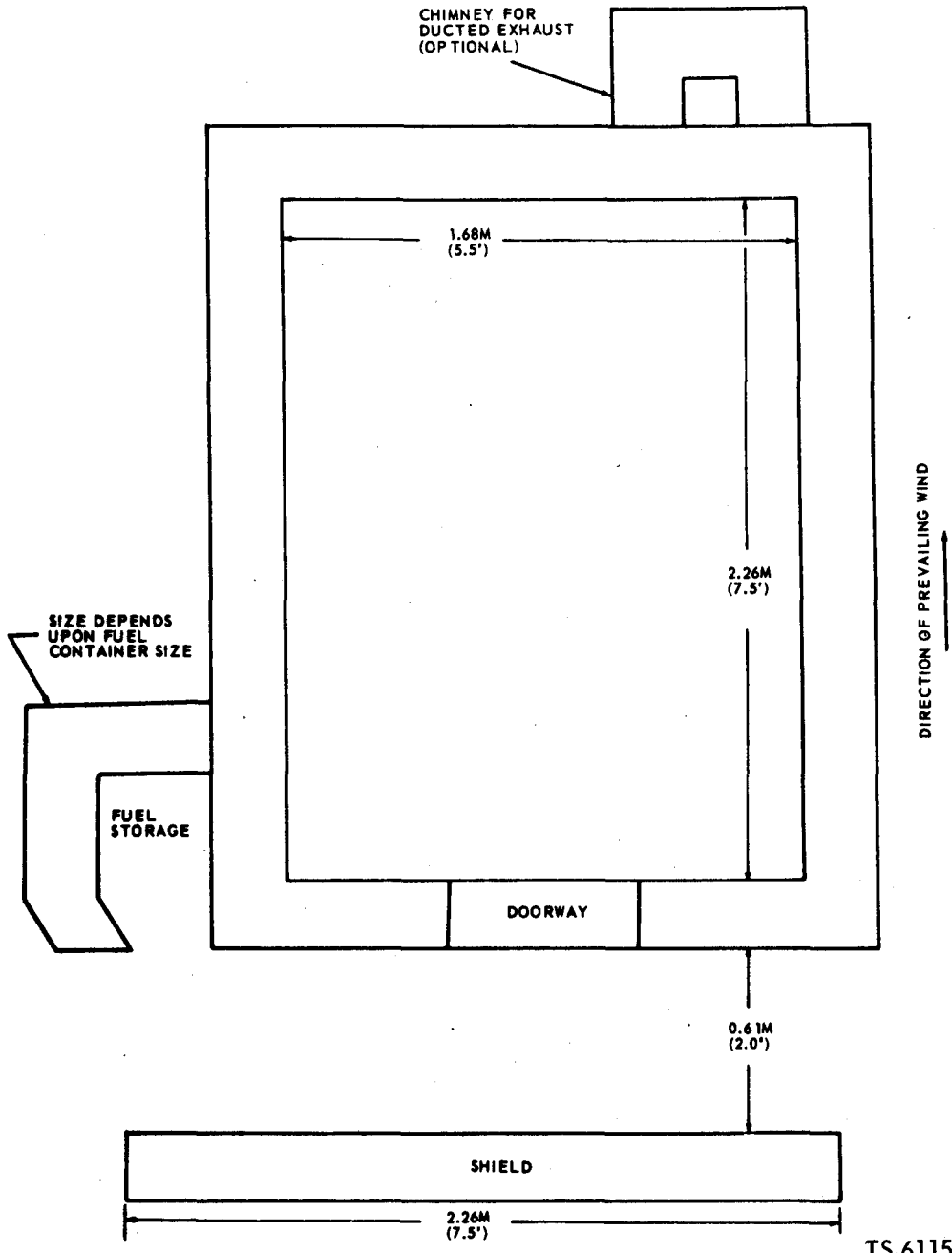

TS 6115-329-14/4-1

Figure 4-1. Revetment - top view.

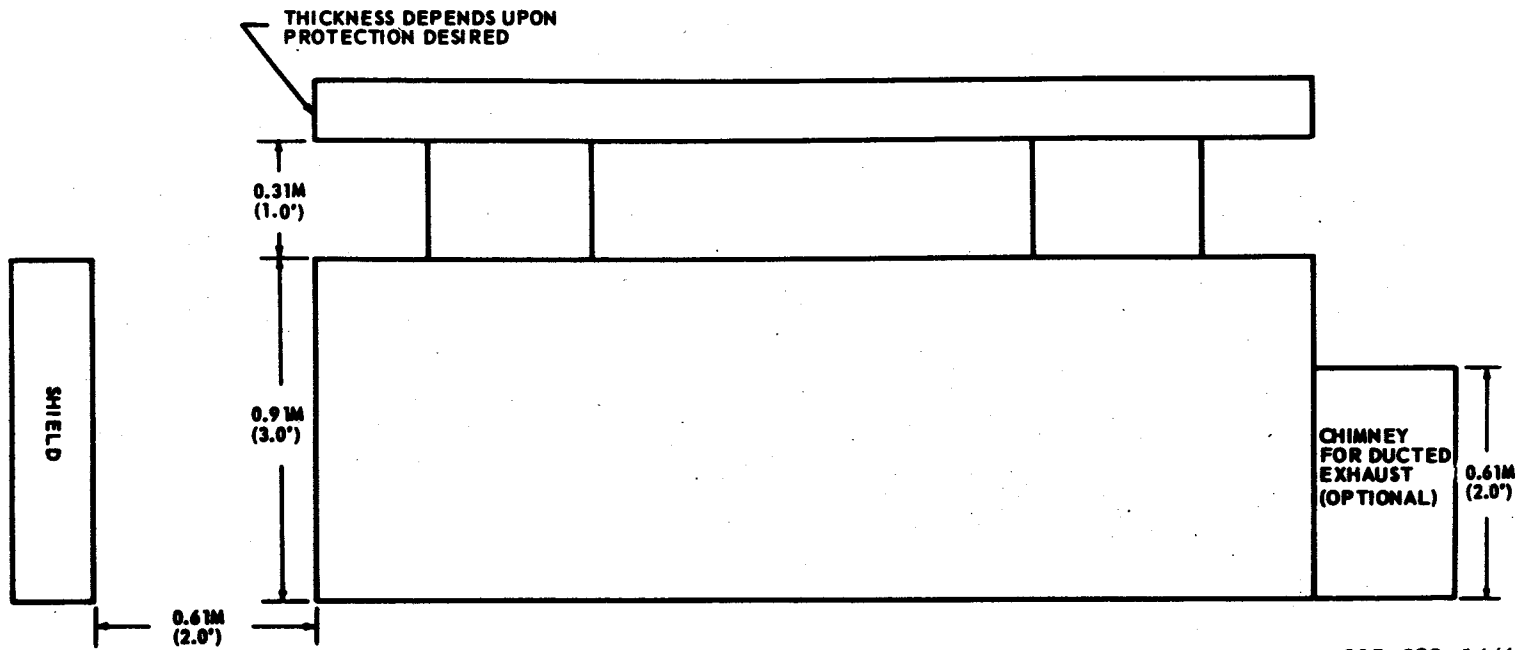
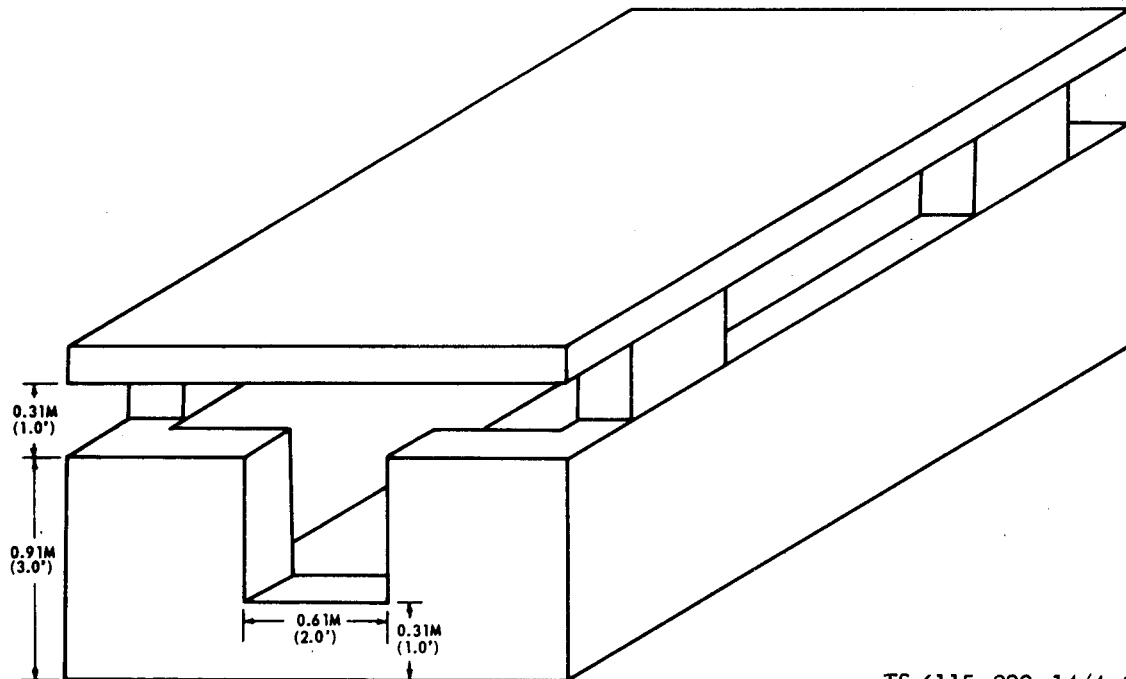

Figure 4-2. Revetment - side view.

TS 6115-329-14/4-2

The entrance shown in figure 4-3, into revetment should be 2.0 feet (0.61 meter) wide with a sill at the bottom no higher than 1.0 feet (0.31 meter). These minimum dimensions are based solely on consid-

erations of engine cooling and ventilation, allowing a minimum practicable amount of space for service and maintenance.



TS 6115-329-14/4-3

Figure 4-3. Revetment - isometric view.

**c. Foundation and Drainage.** If the generator set is attached to a shipping platform, this will provide an adequate foundation. Otherwise, use planks, timbers, logs, ammunition boxes, or other available material to prevent the skids from sinking into soft earth or sand. In no case, should the foundation exceed a height of six inches (15.24 cm) nor should the level of the generator set exceed a tilt of 15° in any direction. Drainage must be provided to insure run-off of water away from the generator set and out of the revetment through drain holes at inside ground level. Where there is no natural slope for the water to run away from the revetment, a sump and drainage trench must be provided outside of the revetment for each required drain hole.

**d. Wall Construction.** The walls of the revetment may be constructed with sandbags, ammunition boxes filled with sand or dirt, or any other material available. The wall height should not exceed 3.0 feet (0.91 meter) and should be constructed as shown in figures 4-3 and 4-4.

**e. Roof Construction.** The roof can be supported by any means possible, but should be 1.0 feet (0.31 meter) above the wall of the revetment and provide as much open space around the top as possible. Refer to figure 4-2, 4-3, 4-4, 4-5, and 4-6. The materials used in the roof construction consists of two pieces of lumber (4 inches by 4 inches) (10.16 cm) or logs (4 inches in diameter) about 10.0 feet (3.0 meters) long. Also needed are the necessary crosspieces of lumber, logs or steel planking to cover the entire roof as shown in figure 4-6. These cross pieces should be about 8.0 feet (2.44 meters) long. If the above materials are not readily available, any available material of a like nature may be used. The thickness of the roof (figs. 4-3 and 4-6) will depend upon the amount and type of protection desired. Caution should be taken when adding protection to the roof to insure that the roof is supported properly to carry the additional weight.

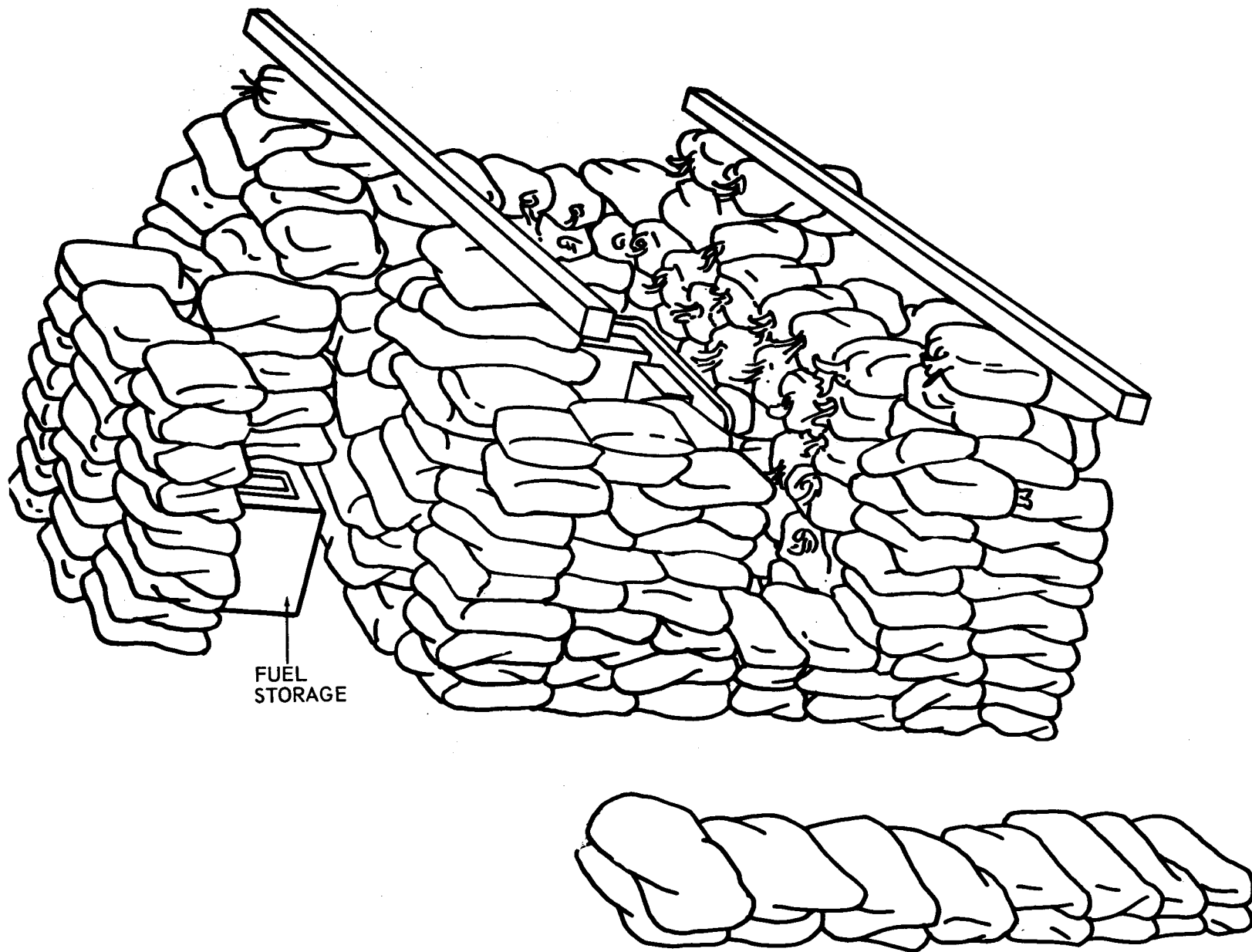

TS 6115-329-14/4-4

Figure 4-4. Revetment, persp. without roof.

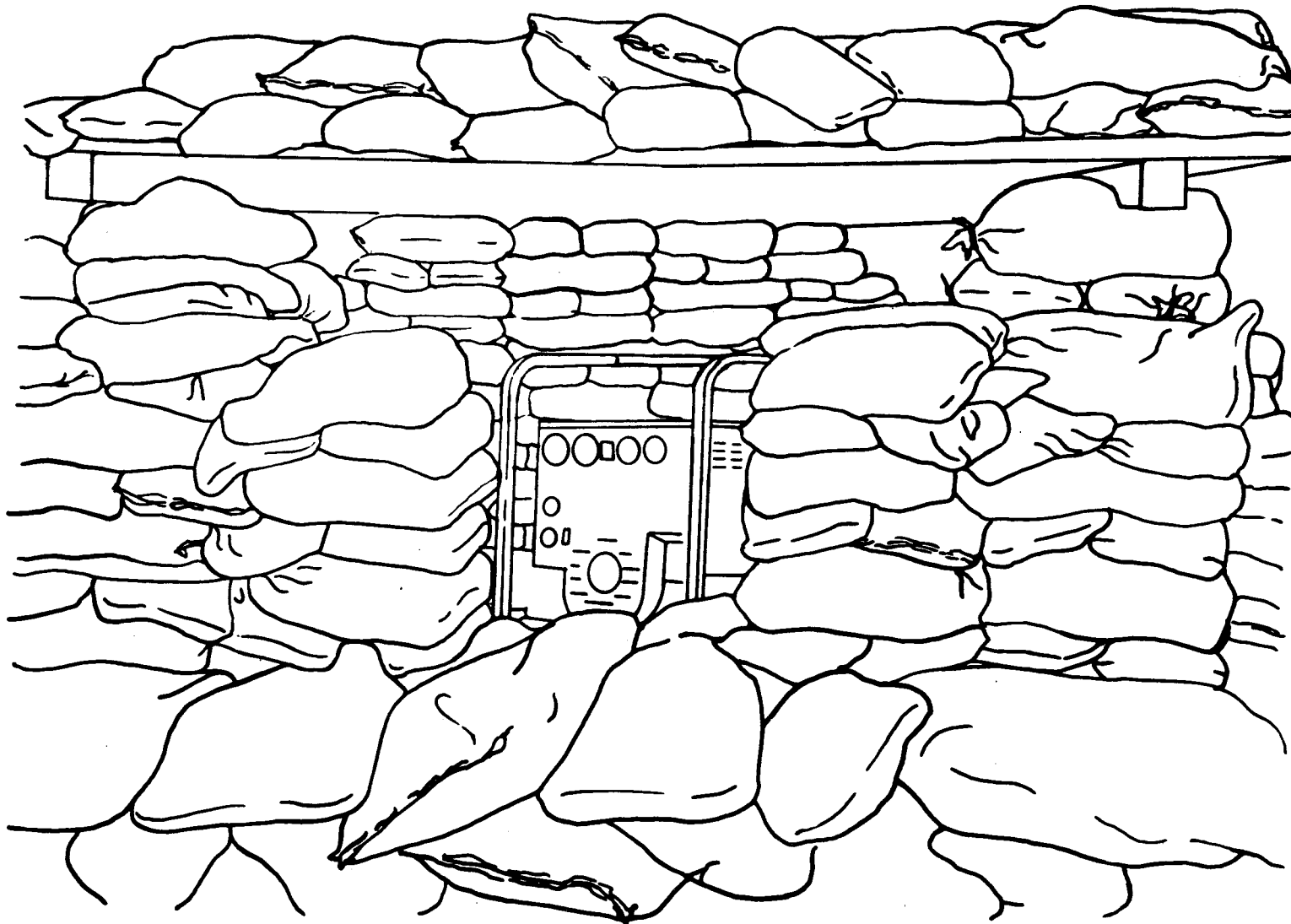

Figure 4-5. Revetment - front view.

TS 6115-329-14/4-5

TM 5-6115-329-14  
TO 35C2-3-440-1

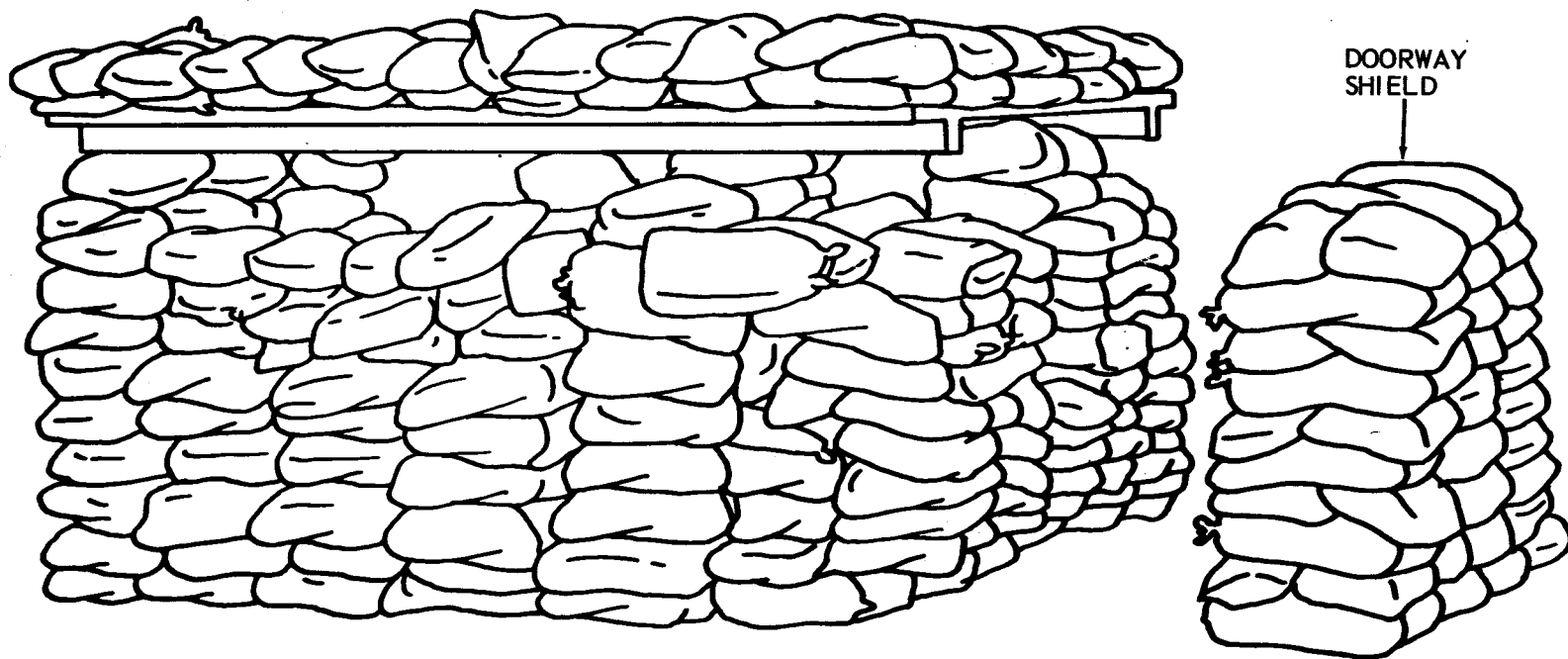

Figure 4-6. Revetment - left side view.



**f. Miscellaneous Construction.** A compartment should be constructed for fuel storage outside of the revetment as shown in figures 4-1 and 4-4. The size of the fuel storage area will depend upon the size of the fuel container being used. Since air temperatures within the revetment will build up considerably above the outside ambient temperature when the generator set is operating, always locate the fuel supply outside the revetment to minimize safety hazards associated with gasoline at high temperatures. For the same reason, it is recommended that the integral fuel tanks with which some generator sets are equipped, not be used. The exhaust from the generator set is to be ducted out of the revetment. The installation should be similar to that shown in figure 4-7. If flexible pipe is not avail-

able to use for an exhaust extension, a piece of exhaust pipe or any other similar material maybe utilized. The point at which the exhaust discharge goes through the revetment wall depends entirely upon the equipment that is available. The exhaust may or may not be discharged into an external chimney constructed as shown in figure 4-1. This chimney will aid in ducting the exhaust gases away from the revetment and will reduce the noise level. A revetment doorway shield must be constructed as shown in figures 4-1, 4-2, and 4-6. This shield is a wall, 3.0 feet (0.91 meters) high and 7.5 feet (2.26 meters) long, constructed in a manner similar to the revetment walls to prevent direct entrance of projectiles or fragments through the doorway into the revetment.

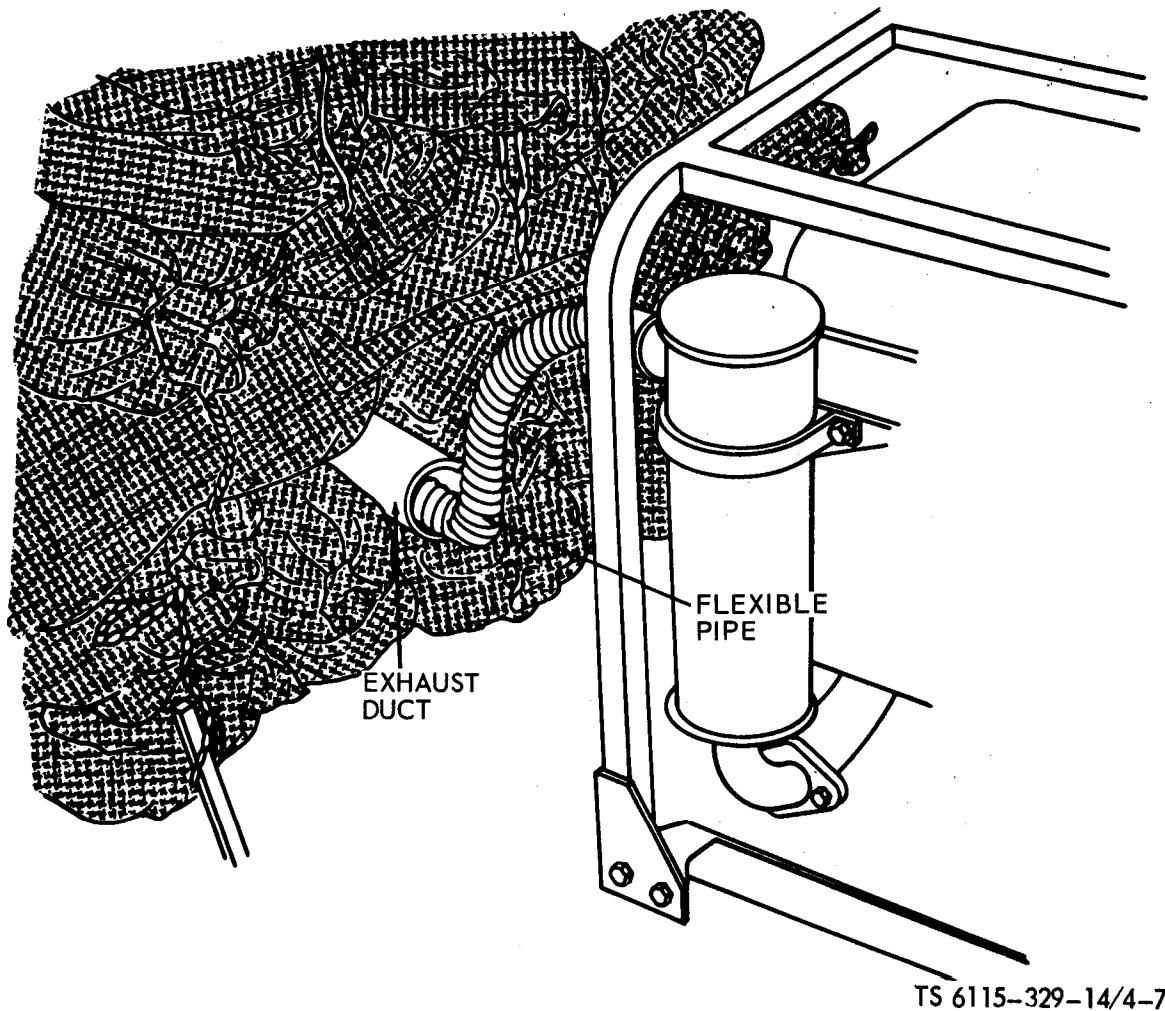
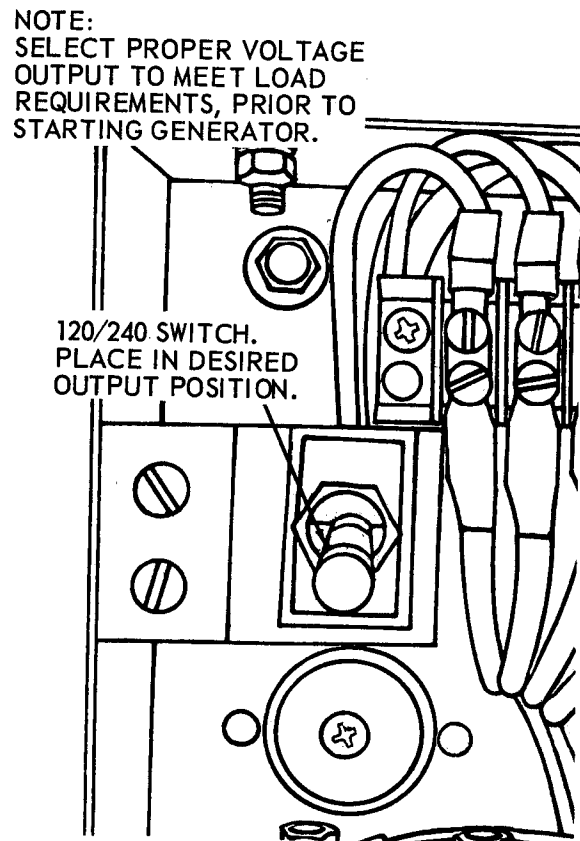

Figure 4-7. Revetment, exhaust duct.



TS 6115-329-14/4-8

Figure 4-8. Equipment conversion.

**g. Alignment Instructions.** When constructing the revetment, the orientation of the revetment will be such that its entrance is facing into the direction, of the prevailing wind (fig. 4-1). Each generator set will be located within the revetment so that its long axis is parallel to the long axis of the revetment and is centered within the revetment. In addition, the generator end will be towards the entrance. These instructions are very important and must be observed to obtain maximum ventilation and cooling benefits when operating in a revetment.

**h. Multiple Installations.** No more than one generator set will be installed within each revetment. Also, no other heat generating equipment will be placed in the revetment with a generator set.

#### 4-4. Voltage Selection

The generator set DOD models MEP-019A and MEP-014A have both 120 and 240 volt output capability, except sets manufactured by Bucknell, serial number range SB71-0001 through SB71-0177 which has 120 volt capability only. Refer to figure 4-8 for conversion instructions.

## Section II. MOVEMENT TO A NEW WORKSITE

### 4-5. Dismantling for Movement

With engine stopped, disconnect load and ground wires, fuel lines and exhaust extensions if used.

### 4-6. Reinstallation After Movement

Refer to paragraphs 4-2 and 4-3 g and h.

## Section III. REPAIR PARTS; SPECIAL TOOLS; SPECIAL TEST; MEASUREMENT AND DIAGNOSTIC EQUIPMENT (TMDE); AND SPECIAL SUPPORT EQUIPMENT

### 4-7. Tools and Equipment

**a. Generator.** No special tools or equipment are required by organizational maintenance personnel for maintenance of the generator set.

**b. Engine.** Refer to TM 5-2805-256-14/TO 38G2-102-2.

### 4-8. Maintenance Repair Parts

**a. Generator.** Repair parts and equipment are listed and illustrated in the repair parts and special tools list manual, TM 5-6115-329-24P/TO 35C2-3-440-4, covering organizational maintenance for this generator set.

**b. Engine.** Refer to TM 5-2805-256-24P/TO 38G2-102-4.

## Section IV. LUBRICATION INSTRUCTIONS

### 4-9. General

a. This section contains lubrication instructions which are supplemental to and not specifically covered in the lubrication order illustrated in figure 3-1. Army personnel should refer to DA Pam 310-4 to insure the latest edition of the LO is used. Air Force personnel use the lubrication section of applicable TO 35C2-3-1-426 WC-series workcards.

b. Carefully inspect the generator set to insure that proper specifications have been met as requested in the lubrication order.

#### NOTE

Proper preventive maintenance observation and adherence will prolong the life of the generator set.

### 4-10. Detailed Lubrication Information

Refer to TM 5-2805-256-14 for detailed lubrication information for the MIL-STD Engine model 1A08-3. Air Force personnel refer to TO 38G2-102-2.

## Section V. Preventive Maintenance Checks and Services (PMCS)

### 4-11. General

a. To insure that the generator set is ready for operation at all times, it must be inspected systematically so defects may be discovered and corrected before they result in serious damage or failure. The necessary preventive maintenance checks and services that are to be performed by organizational maintenance personnel are listed and described in the following paragraph. Defects discovered during operation will be noted for future correction. Stop operation immediately if a deficiency is noted which would damage the equipment. All deficiencies and shortcomings will be recorded together with the corrective actions taken on the applicable form. Air Force users shall refer to the applicable inspection manuals and work card sets in the TO35C2-3-1-426 WC series for periodic requirements.

**b. (A, N) Preventive Maintenance Checks and Services.** Table 4-1 contains a tabulated listing of

PMCS which shall be performed by organizational maintenance personnel. The item numbers are listed consecutively and indicate sequence of minimum requirements.

### 4-12. Preventive Maintenance Checks and Services

a. Preventive Maintenance is performed by organizational maintenance personnel at weekly and quarterly intervals. The quarterly interval will be equivalent to 3 calendar months or 250 hours of operation whichever comes first. All deficiencies which are beyond the capabilities of organizational maintenance must be reported to Direct Support Maintenance.

b. Table 4-1 contains a tabulated list of preventive maintenance checks and services which must be performed by organizational maintenance personnel.

Table 4-1. Preventive Maintenance Checks and Services

INTERVAL		W-WEEKLY (40 HRS) H-HOURLY	TOTAL M/H: 0.2 TOTAL M/H: 1.0
ORGANIZATION		INSPECTION PROCEDURES	WORK TIME M/H
W	H		
	0	LUBRICATING OIL Change oil every 50 hours of operation.	0.5
	0	FUEL FILTER Inspect fuel filter every 50 hours of operation. Clean as necessary (para 4-17 and fig. 4-7, TM 5-2805-256-14).	0.2
	0	<u>CAUTION</u> Do not clean air cleaner element in solvent. AIR CLEANER When red signal reaches service level, service the air cleaner element. (para 3-4, Table 3-1 and 3-2 TM 5-2805-256-14).	0.3

**ALL data on Page 4-14 is deleted.**



## Section VI. TROUBLESHOOTING

### 4-13. General Instructions For Use of Multimeters

*a. Introduction.* In electrical troubleshooting, the Simpson 160, the TS-352B/U, and the AN/URM-105 will do the same job. Therefore, your shop sets

may contain any one of these multimeters (fig. 4-9). Any of these three multimeters can be used to troubleshoot your equipment's electrical system. This section shows how.

**SIMPSON 160**  
NSN 6625-00-935-1333

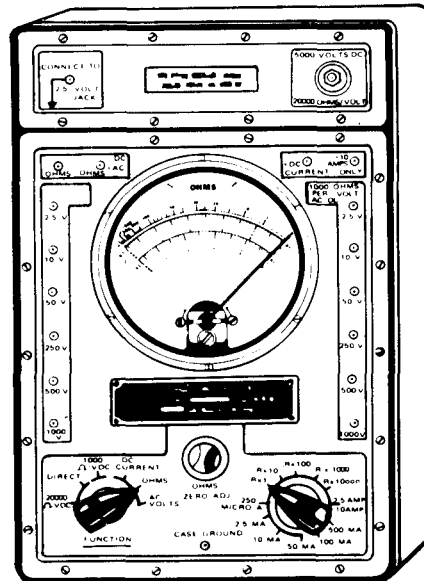
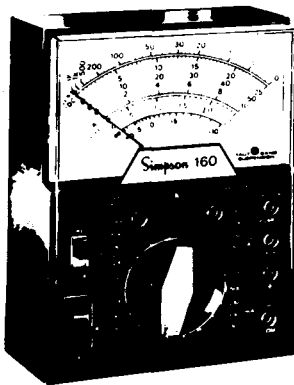

**TS-352B/U**  
NSN 6625-00-553-0142

**AN/URM-105**  
NSN 6625-00-999-6282

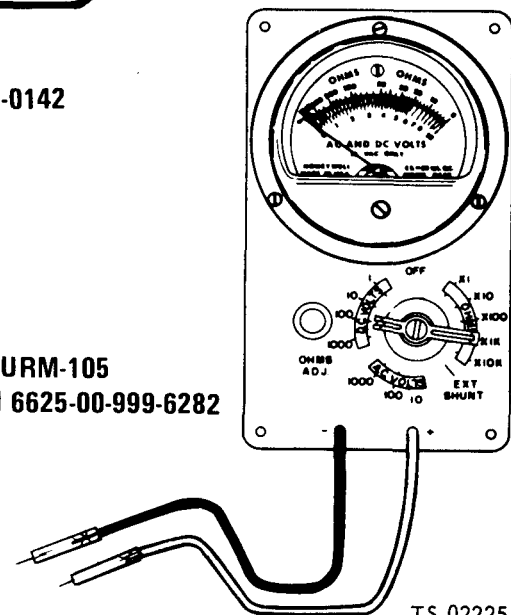

TS 022251

Figure 4-9. Types of multimeters.

NOTE

The Simpson 160 is only available in new shop sets as a substitute for the TS-352B/U or AN/URM-105.

**b. Using the Ohms Scale.** The ohms scale is used to make tests for continuity, shorts and re-

sistance.

**(1) "Zeroing" the Meter (Fig. 4-10).** The multimeter must be set up and "zeroed" before making these tests. Do the following steps that match the multimeter.

AN/URM-105

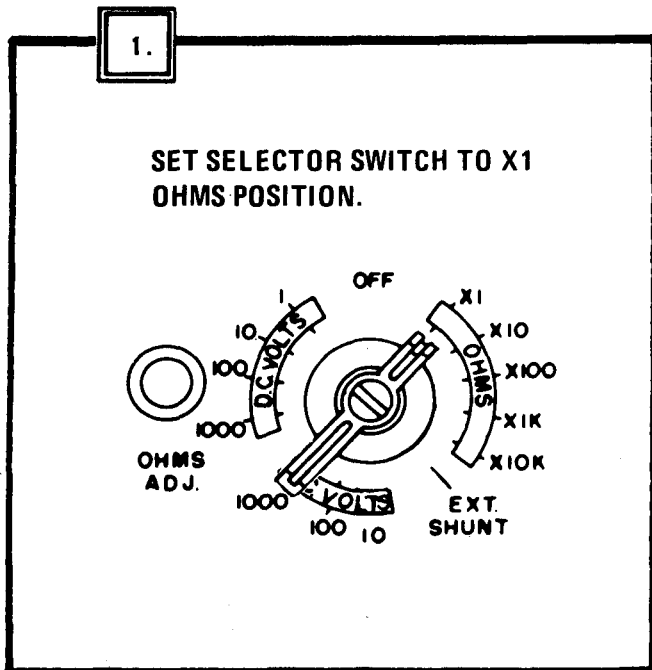

NOTE  
If the needle will not "zero", replace the batteries. If the needle still will not "zero" after replacing the batteries, turn the meter in for repair.

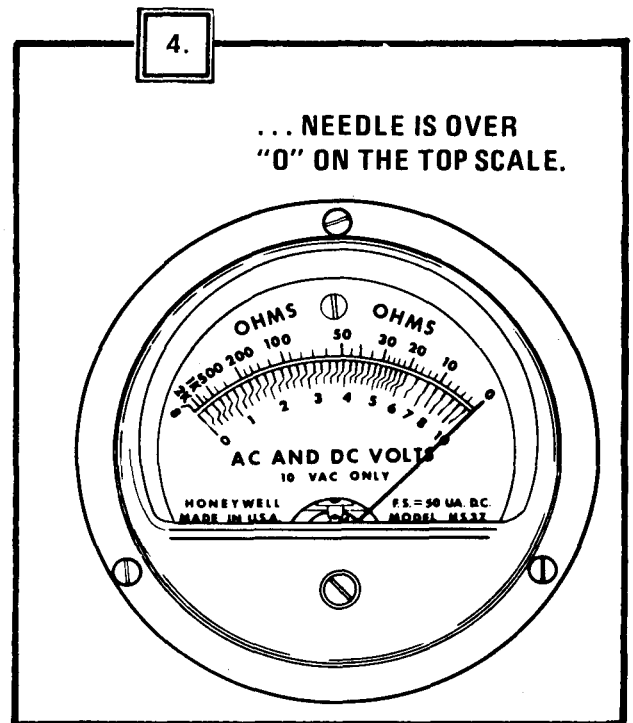
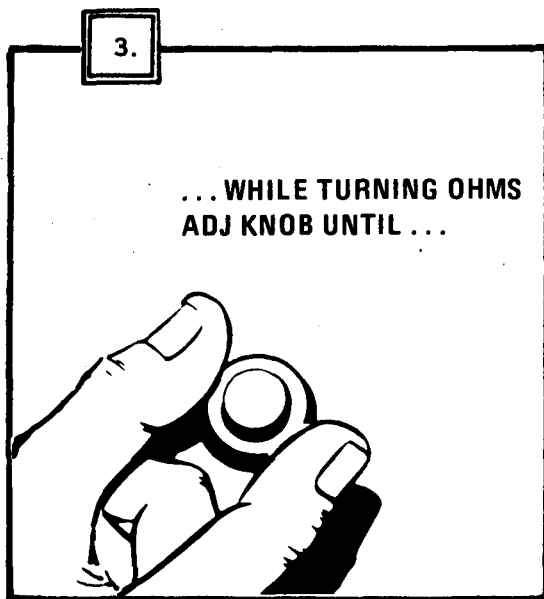
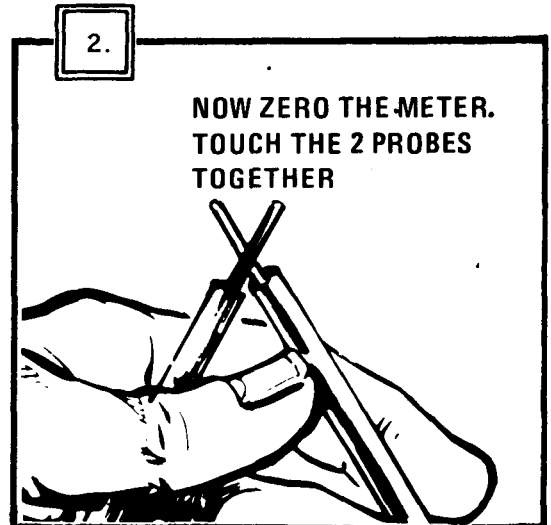
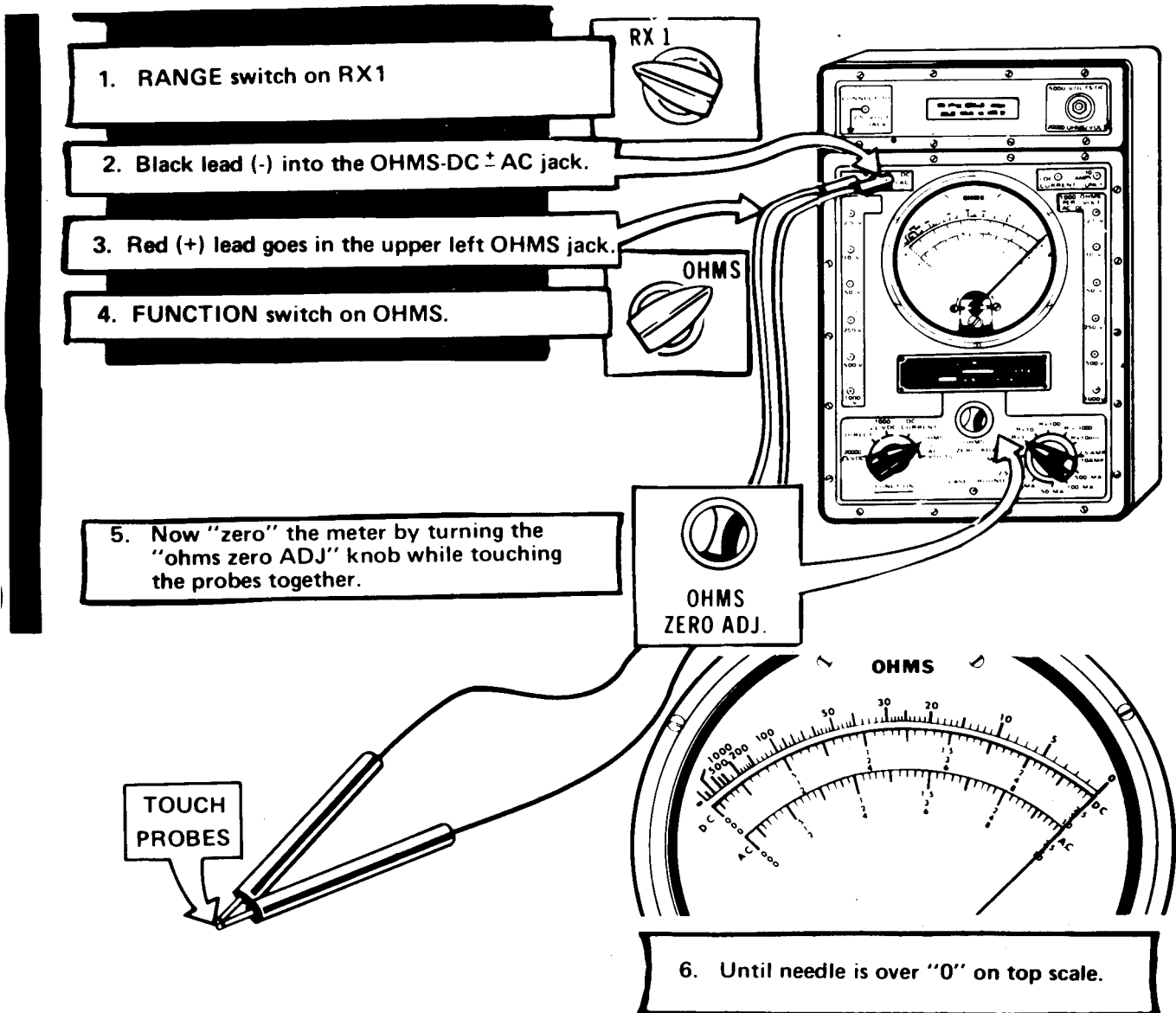

Figure 4-10. "Zeroing" the multimeter (sheet 1 of 3).

TS 022252



TS-352B/U



TS 02253

NOTE

If the needle will not "zero", replace the batteries. If the needle still will not "zero" after replacing the batteries, turn the meter in for repair.

Figure 4-10. "Zeroing" the multimeter (sheet 2 of 3).

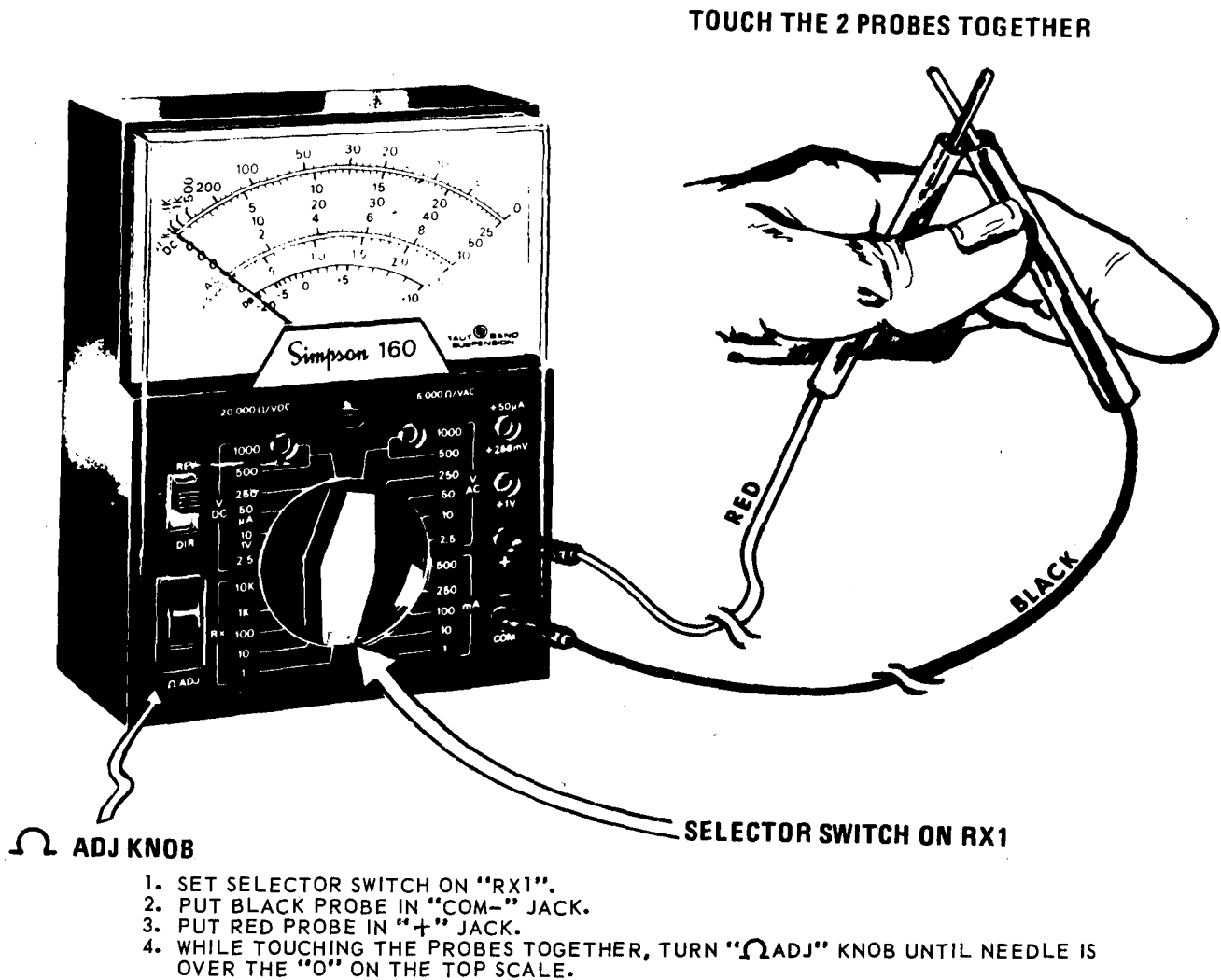

TS 022254

Figure 4-10. "Zeroing" the multimeter (sheet 3 of 3).

**NOTE**

If the needle will not "zero", replace the batteries. If the needle still will not "zero" after replacing the batteries, turn the meter in for repair.

**(2) Continuity Tests.** Continuity tests are made to check for breaks in a circuit (such as the switch, light bulb, or electrical cable) (Fig. 4-11). To make a continuity check, do the following steps:

**(a)** Set up and "zero" the multimeter (fig. 4-10).

**CAUTION**

**Failure to do the following step can damage the multimeter.**

**(b)** Disconnect the circuit being tested. To be safe, disconnect the battery ground strap.

**(c)** Connect the meter probes to both terminals of the circuit being tested. (The TS-352B/U is illustrated (fig. 4-11, but the probes are connected to the circuit the same way with all three multimeters).

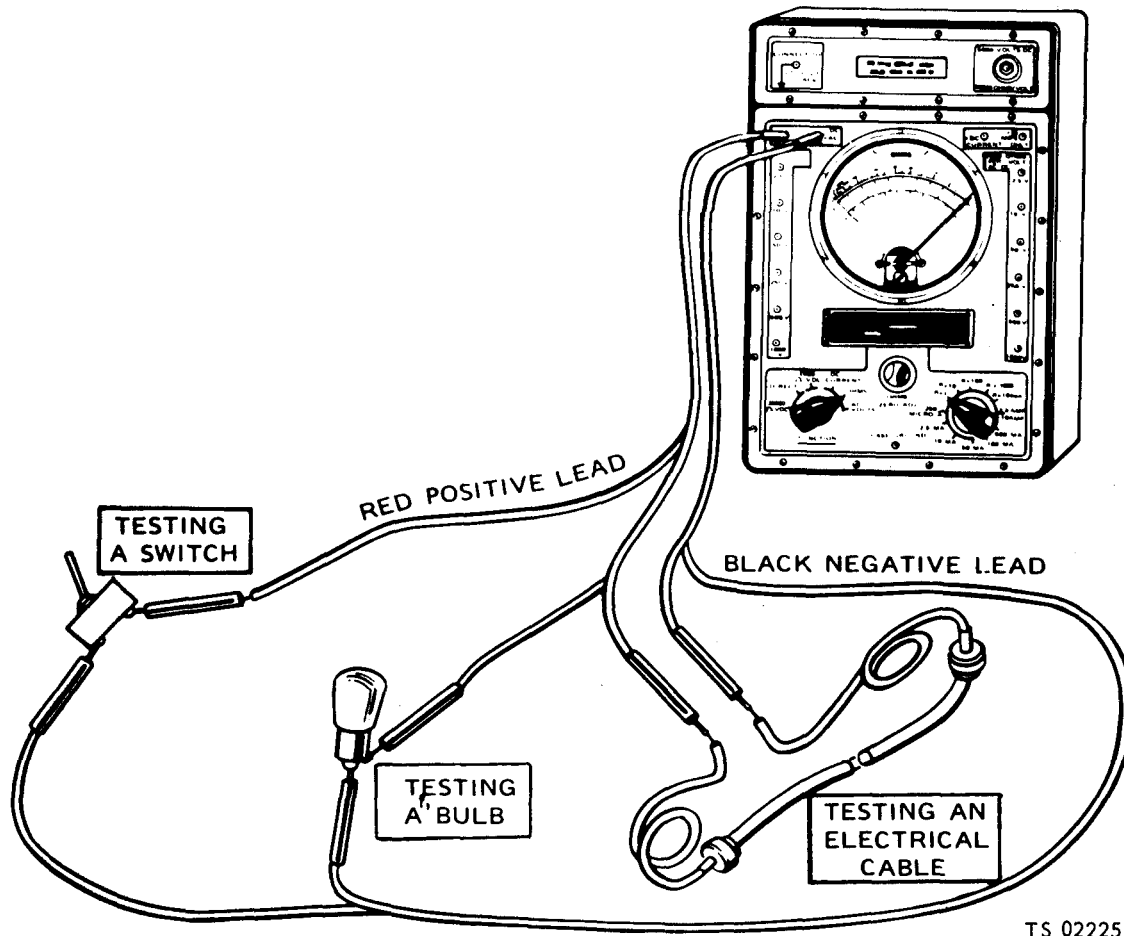

TS 022255

Figure 4-11. TS-352B/U continuity test.

(d) Look at the meter needle.

1. If the needle swings to the far right over the "o" on the top scale (on all three multimeters), the circuit has continuity.

2. If the needle doesn't move, the circuit is open (broken).

3. If the needle jumps or flickers there is a loose connection in the circuit being tested.

(3) **Testing for Shorts.** A short (or short circuit) occurs when two circuits that should not be connected have metal to metal contact with each other. A short also occurs when a circuit that should not touch ground has metal to metal contact with

ground. To check for shorts, do the following steps:  
(a) Set up and "zero" the multimeter (fig. 4-10).

**CAUTION**

**Failure to do the following step can damage the multimeter.**

(b) Disconnect the circuit being tested. To be safe, disconnect the battery ground strap.

(c) With all three multimeters, connect one probe to one circuit and the other probe to the other circuit or ground (if checking for a short to ground). The example below (fig. 4-12) shows a check to see if wire "A" is shorted to wire "B" in the wiring harness.

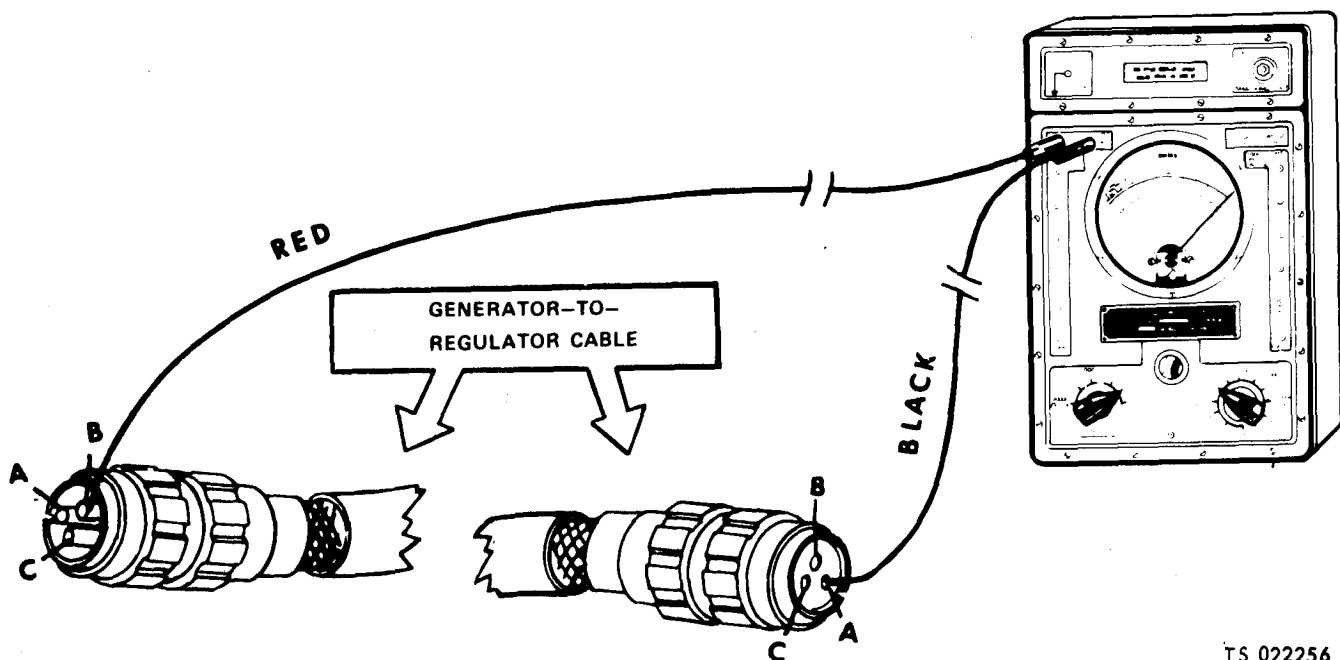

Figure 4-12. Testing for shorts.

TS 022256

(d) Look at the needle.

1. If the needle swings to the far right over the "0" on the top scale (on all three multimeters), the circuits are shorted.

2. If the needle doesn't move, the circuits are not shorted.

3. If the needle jumps or flickers, the circuits are occasionally shorted.

(4) **Testing Resistance.** To measure resistance in a circuit, do the following steps:

(a) Set up and "zero" the multimeter (fig. 4-10).

**CAUTION**

Failure to do the following step can damage the multimeter.

(b) Disconnect the circuit being tested. To be safe, disconnect the battery ground strap.

(c) If the test in this manual calls for an "ohms range" different than "RX1" or "X1", set the selector switch to that range (such as "RX10" or "X10").

**NOTE**

"Zero" the meter whenever you change ranges.

(d) With all three multimeters, connect the probes across the circuit or item to be measured. The example (fig. 4-13) shows measuring the resistance of a temperature sending unit.

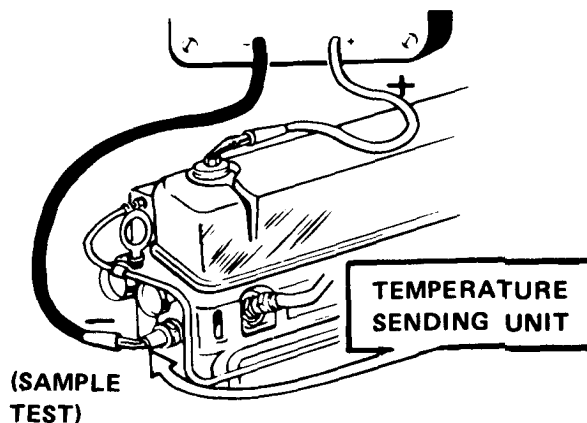

(SAMPLE TEST)

TEMPERATURE SENDING UNIT

TS 022257

Figure 4-13. Testing resistance.

(e) **Read the Meter.** If the meter switch is on the "RX1" or "X1" range, the reading is taken directly from the top scale. If the meter switch is on a different range, multiply the reading on the scale according to the table below.

Ohms Switch Setting	You Do
X1 or RX1	Read number on scale
X10 or RX10	Multiply reading by 10
X100 or RX100	Multiply reading by 100
X1K or RX1K	Multiply reading by 1,000
X10K or RX10K	Multiply reading by 10,000
	(Remember: K = 1,000)

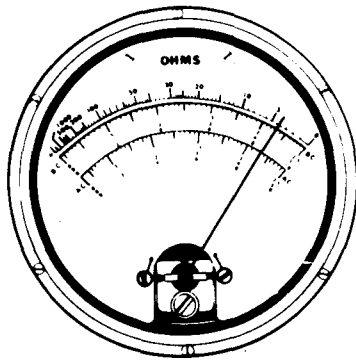

TS-352 B/U

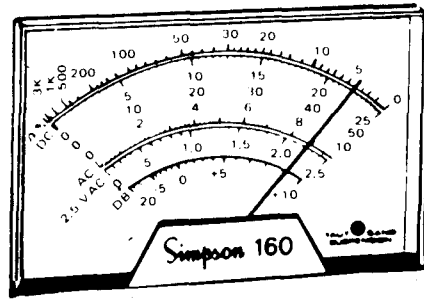

SIMPSON 160

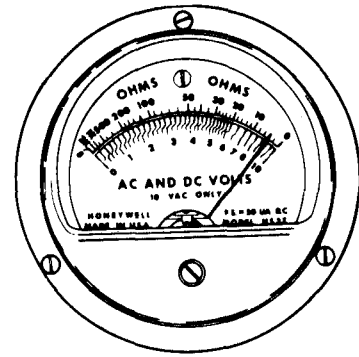

AN/URM-105

OHMS SWITCH SETTING

X1 OR RX1  
X10 OR RX10  
X100 OR RX100

READING

4 OHMS  
40 OHMS  
400 OHMS

TS 022258

Figure 4-14. Reading the ohm scale.

c. **Using the DC Volts Scale (Fig. 4-15).** The DC volts scale is used to measure all voltages on the equipment except the 115 AC voltage.

DC voltage, do the following steps that match the multimeter you have:

(1) Before using the multimeter to measure

(a) **AN/URM-105.** Set meter switch to DC volts range given in TM. (To measure 24 volts DC, set switch on "100 DC VOLTS" range).

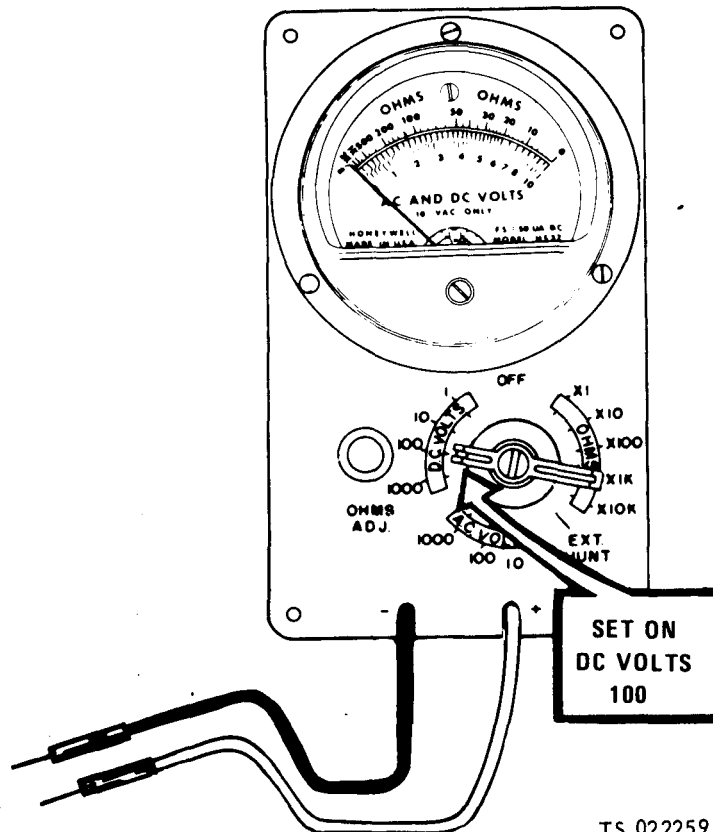

TS 022259

Figure 4-15. DC volts scale (sheet 1 of 3).

(b) TS-352B/U

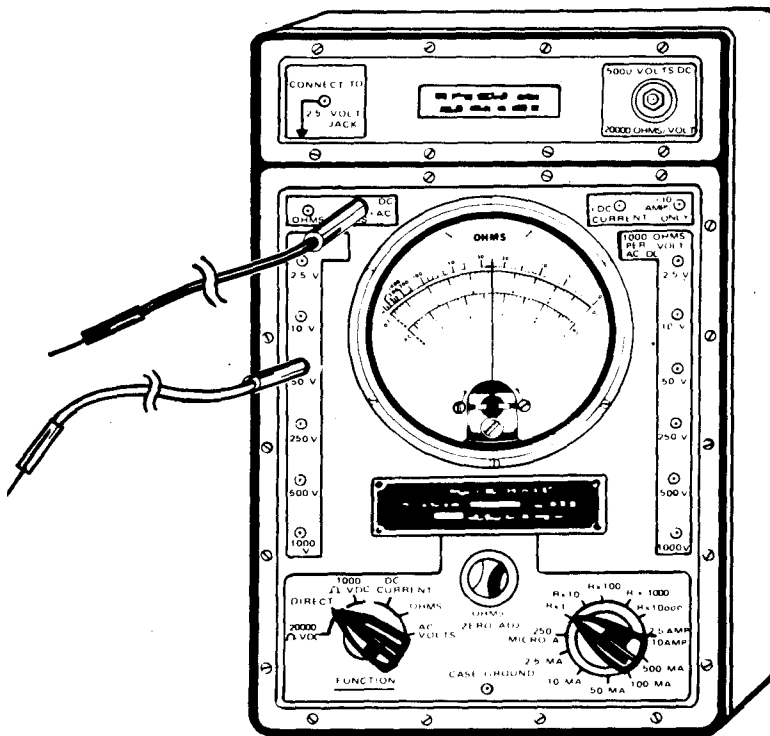
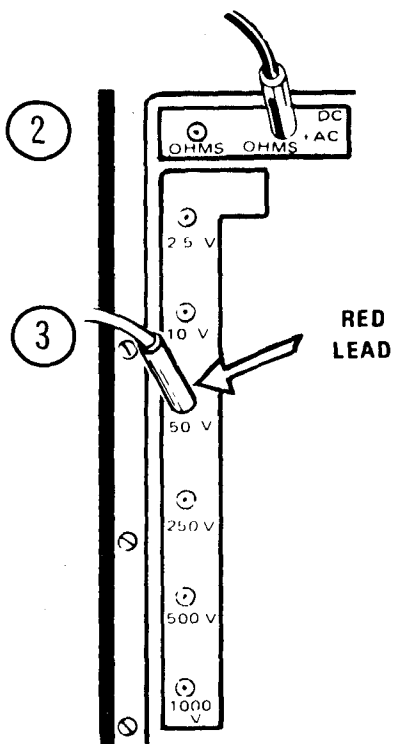
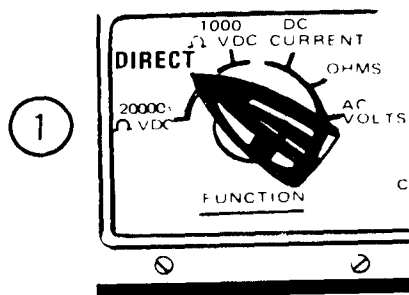

A

B

TS 022260

Figure 4-15. DC volts scale (sheet 2 of 3).

1. Set FUNCTION switch to "DIRECT". (RANGE switch can be at any position).
2. Put black lead in "-DC/+AC/OHMS" jack.
3. To measure 24 volts DC, plug red lead

into "50V" jack on left side of meter. (If measuring less than 10 volts DC, use "10V" jack. If measuring less than 2.5 volts DC, use "2.5V" jack).

(c) **Simpson 160**

1. Connect black lead to "COM-" jack.
2. Connect red lead to "+" jack.

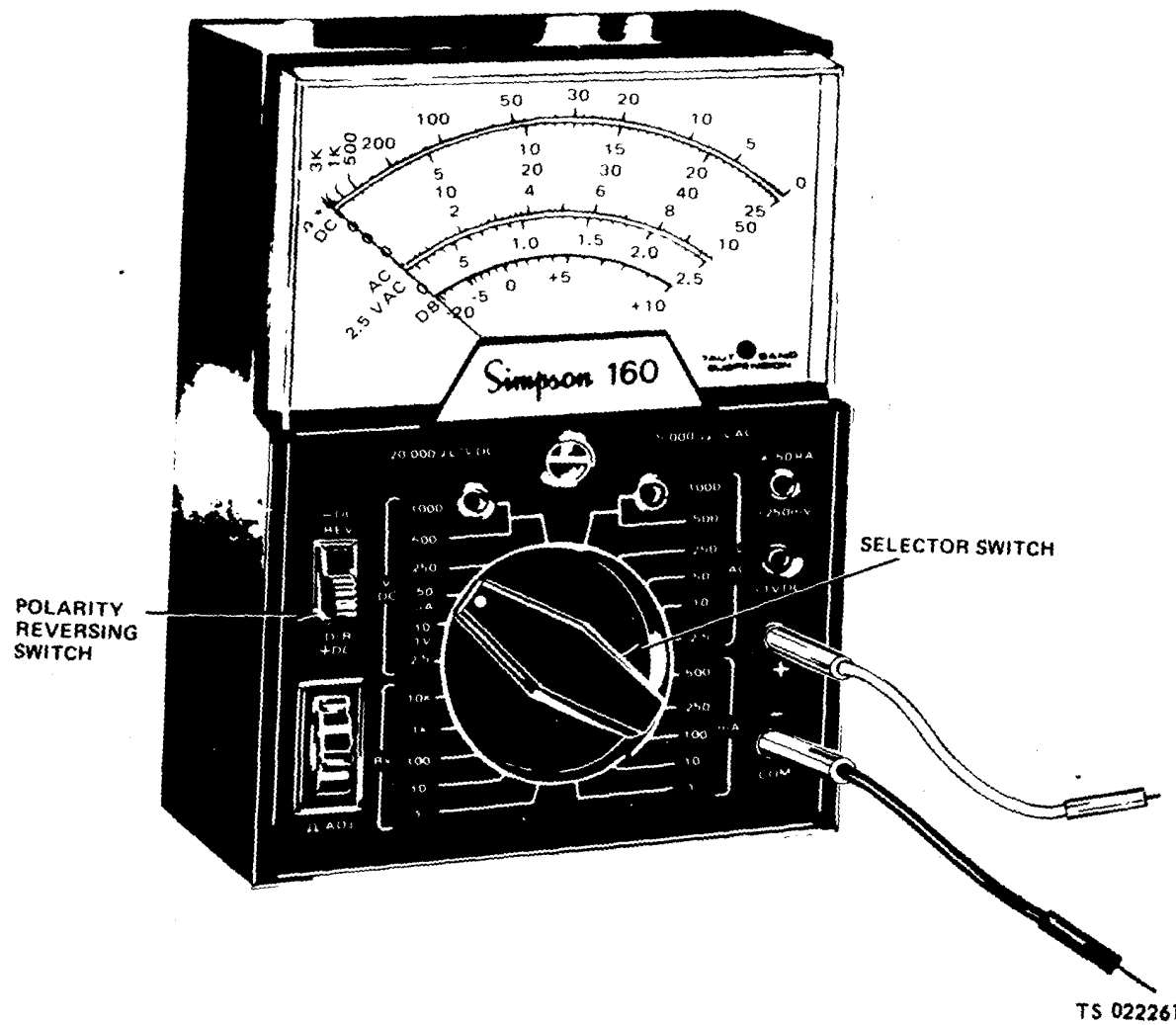

Figure 4-15. DC volts scale (sheet 3 of 3).

3. To measure 24 volts DC, set selector switch to "V/DC 50" position. (If measuring less than 10 volts DC, set selector switch to "V/DC 10" position. If measuring less than 2.5 volts DC, set selector switch to "V/DC 2.5" position).

4. Set polarity reversing switch to the "DC" position.

(2) To measure DC volts, do the following steps:

(a) Set up multimeter (paragraph (1)

above).

NOTE

If you are unsure of the voltage to be measured on the equipment, always start on the highest range. This will protect the meter.

(b) With all three multimeters, connect the red probe to the positive (+) side of the circuit and the black probe to the negative (-) side. The example (fig. 4-16) shows 24 volts DC being measured across the batteries.

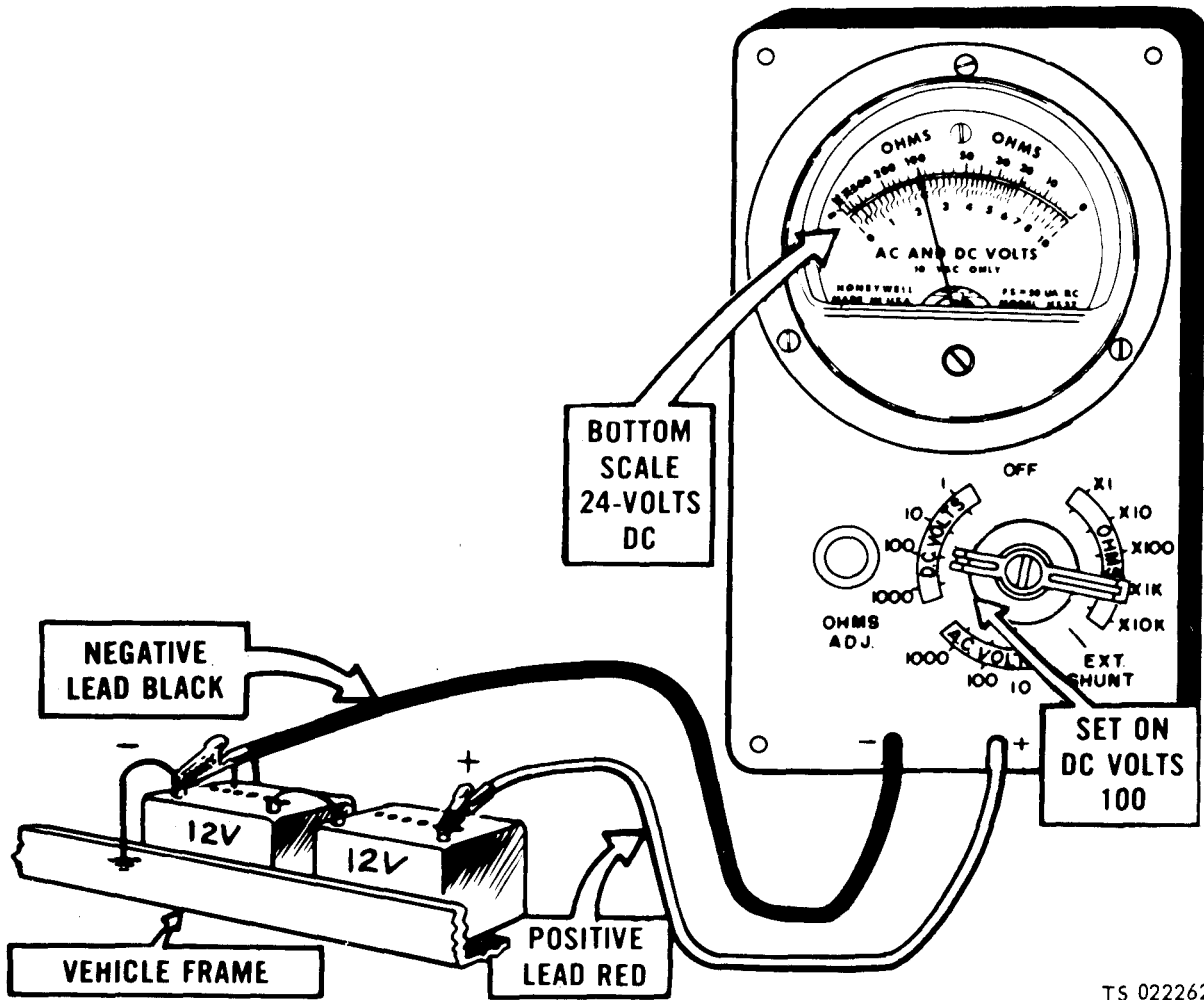

Figure 4-16. Measuring DC voltage.

(c) **Read the Meter.** (The example (fig.4-17) show how to read all three multimeters). If the needle tries to move off scale to the left, reverse the probes on the circuit.

1. **Simpson 160.** Read the "DC" volts scale for the range the selector switch is set at.

Switch Setting	Scale
V/DC 50	0-50
V/DC 10	0-10
V/DC 2.5	0-25 (and divide by 10)

Thus, the meter (fig. 4-17, sheet 1 of 3) is showing the following readings:

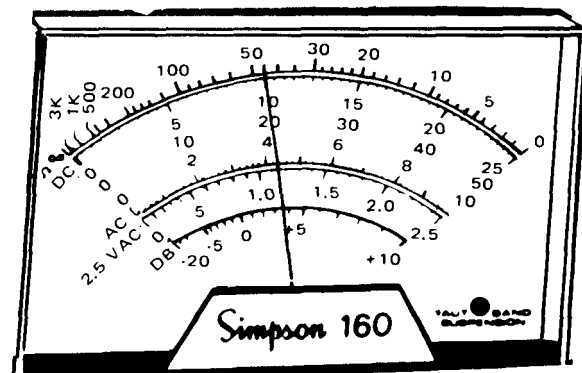

SWITCH SETTING	READING
V/DC 50	20 VOLTS DC
V/DC 10	4 VOLTS DC
V/DC 2.5	1 VOLT DC

TS 022263

Figure 4-17. Reading DC voltage (sheet 1 of 3).



2. *TS-352B/U*. Read the "DC" volts scale for the range the red lead is plugged in at.

Range	Scale
50V	0-5 (and multiply by 10)
10V	0-10
2.5V	0-2.5

Thus, the meter (fig. 4-17, sheet 2 of 3) is showing the following readings:

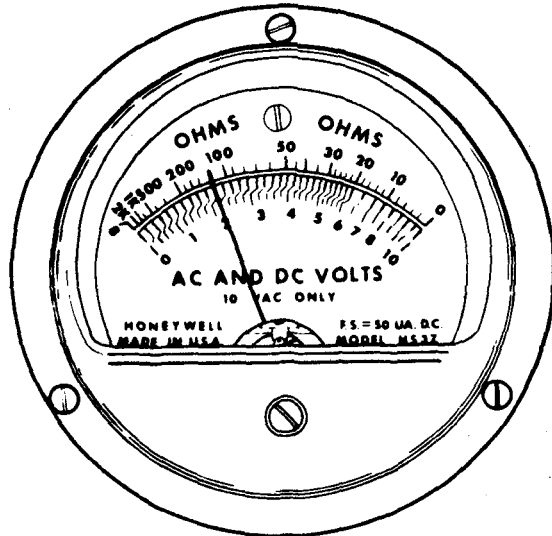

<u>SWITCH SETTING</u>	<u>READING</u>
100 DC VOLTS	20 VOLTS DC
10 DC VOLTS	2 VOLTS DC
1 DC VOLT	.2 VOLTS DC

TS 022265

Figure 4-17. Reading DC voltage (sheet 2 of 3).

3. *AN/URM-105*. Read the upper, black, straight-lined portion of the "AC and DC volts" scale for the range the selector is set at.

Switch Setting	Scale
1000 DC Volts	0-10 (and multiply by 100)
100 DC Volts	0-10 (and multiply by 10)
10 DC Volts	0-10
1 DC Volt	0-10 (and divide by 10)

Thus, the meter (fig. 4-17, sheet 3 of 3) is showing the following readings:

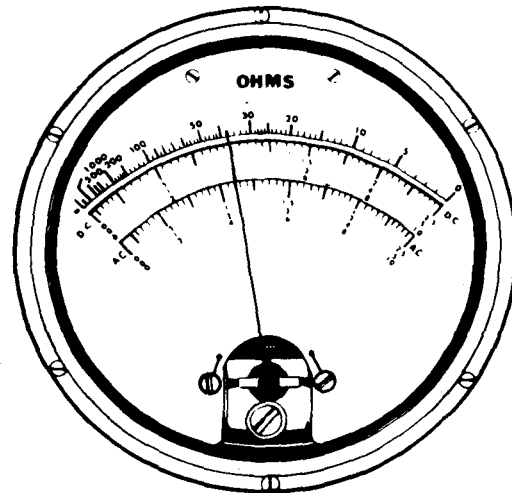

<u>RANGE</u>	<u>READING</u>
50V	20 VOLTS DC
10V	4 VOLTS DC
2.5V	1 VOLT DC

TS 022264

Figure 4-17. Reading DC voltage (sheet 3 of 3).

d. If the AC Volts Scale is Used. The AC volts scale is used to measure the 115 AC voltage.

(1) Before using the multimeter to measure 115 AC voltage, do the following steps that match the multimeter you have. Refer to figure 4-18.

(a) *AN/URM-105*. Set meter switch to "1000 AC volts".

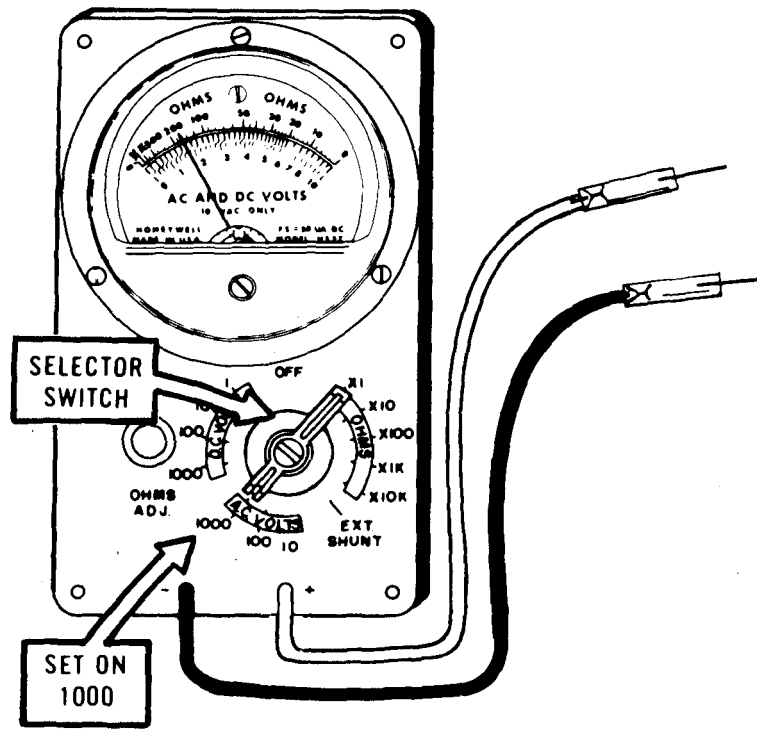

TS 022266

Figure 4-18. AC volt scale (sheet 1 of 3).

(b) TS-352B/U.

1. Set "FUNCTION" switch to "AC volts".  
("RANGE" switch can be at any setting). (A, fig. 4-18,  
sheet 1 of 3).

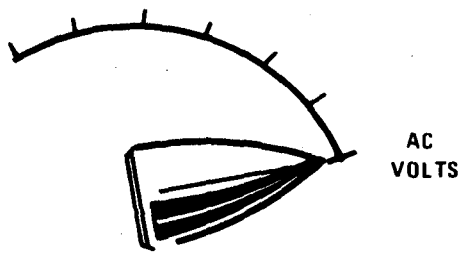

A

TS 018947

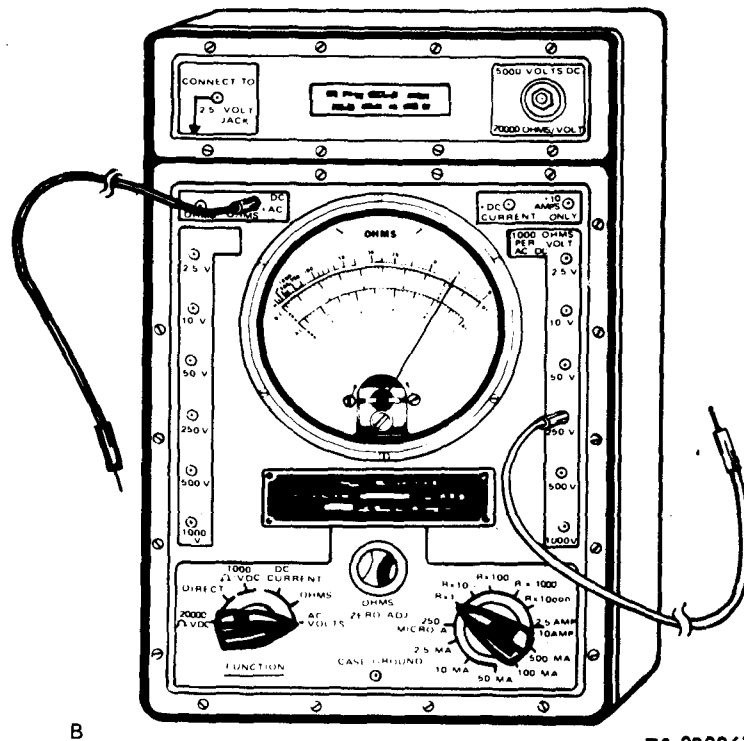

B

TS 022267

Figure 4-18. AC volts scale (sheet 2 of 3).

2. Put black lead in "-DC/+AC/OHMS" jack (B, fig. 4-18, sheet 2 of 3).
3. Put red lead in "250V" jack on right side of meter.

**(c) Simpson 160**

1. Put black lead in "COM-" jack.
2. Put red lead in "+" jack.
3. Set selector switch to "V/AC 250"

position.

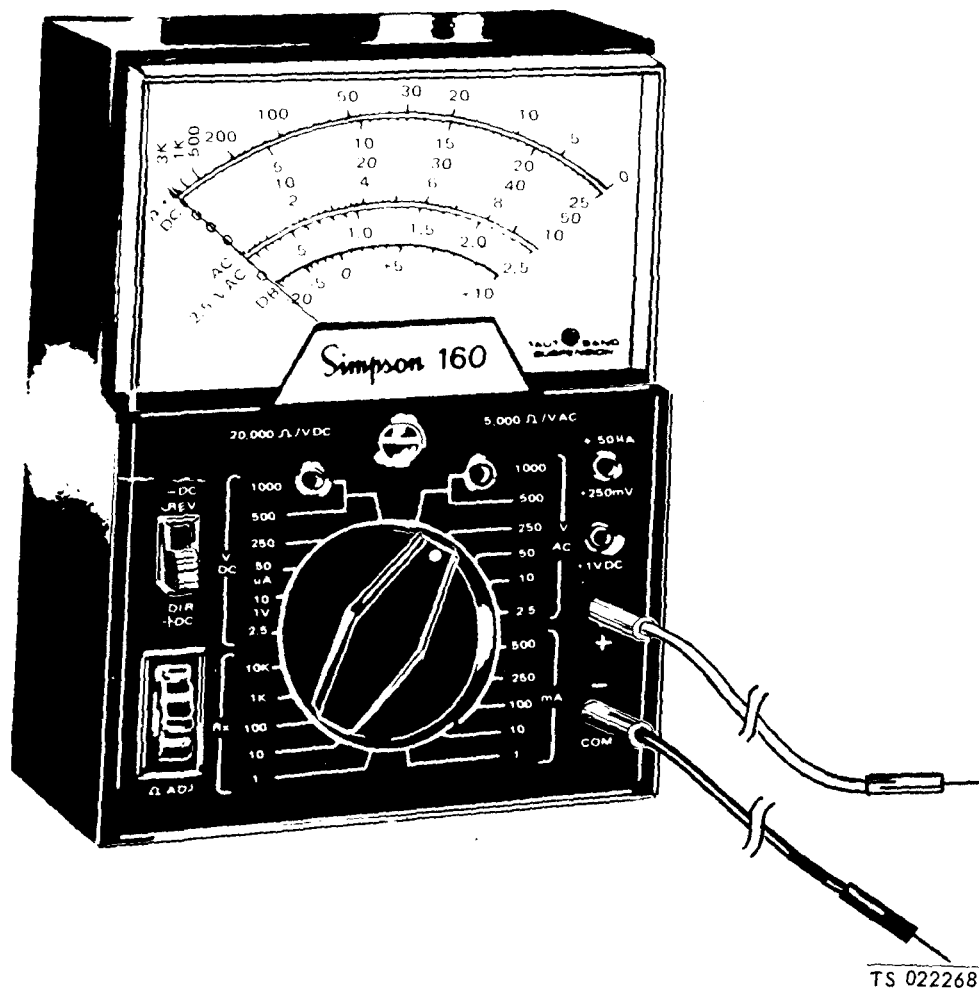
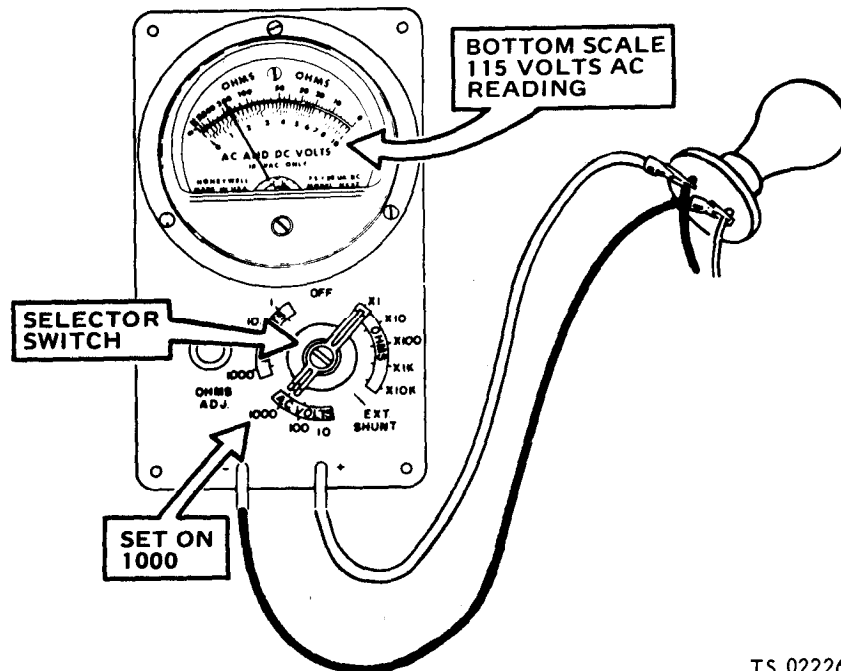

Figure 4-18. AC volt scale (sheet 3 of 3).

(2) To measure 115 AC voltage, do the follow-

- (a) Set up multimeter (fig. 4-18).
- (b) With all three multimeters, connect one

probe to one side of the circuit and the other probe to the other side, The example (fig. 4-19) shows 115 volts AC being measured across an AC light circuit.



TS 022269

Figure 4-19. Measuring AC voltage.

(c) Read meter on the "AC" scale, Figure 4-20 shows a reading of 115 volts on all meters.

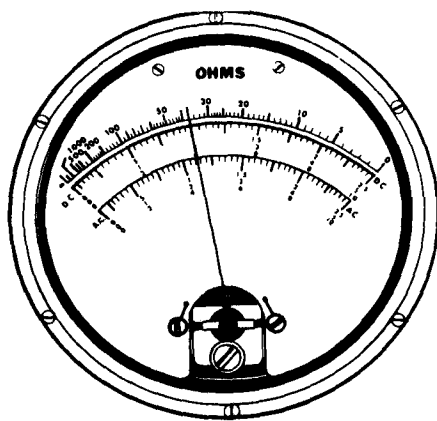

TS-352 B/U

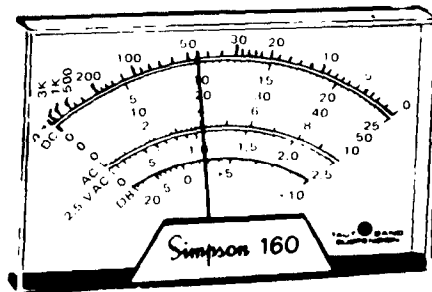

Simpson 160

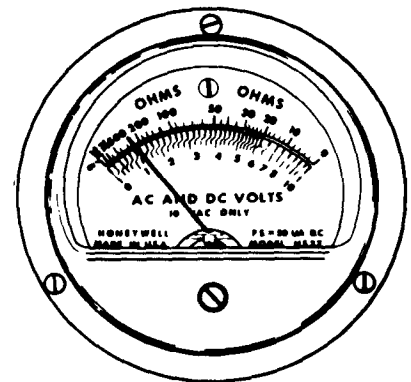

AN/URM-105

TS 022270

Figure 4-20. Reading AC voltage.

#### 4-14. General

**a.** This section contains troubleshooting information for locating and correcting most of the operating troubles which may develop in the generator set. Each malfunction for an individual component, unit, or system is followed by a list of tests or inspections which will help you to determine the

probable causes and corrective actions to take. You should perform the tests/inspections and corrective actions in the order listed.

**b.** This manual cannot list all malfunctions that may occur, nor all tests or inspections and corrective actions. If a malfunction is not listed or is not corrected by listed corrective actions, notify your supervisor.

## 4-15. Engine

Refer to TM 5-2805-256-14/TO 38G2-102-2 for troubleshooting information pertaining to the Military Standard Engine.

## 4-16. Troubleshooting Table

### NOTE

Before you use this table, be sure you have performed all applicable operating checks.

### WARNING

**Clean all parts in a well-ventilated area. Avoid inhalation of solvent fumes and prolonged exposure of skin to cleaning solvent. Wash exposed skin thoroughly. Dry cleaning solvent (Fed. Spec. P-D-680) used to clean parts is potentially dangerous to personnel and property. Do not use near open flame or excessive heat. Flash point of solvent is 100° to 138° F. (38° to 59° C.).**

*Table 4-2. Organizational Troubleshooting*

---

<b>Malfunction</b>	<b>Test or Inspection</b>	<b>Corrective Action</b>
--------------------	---------------------------	--------------------------

---

## 1. GENERATOR FAILS TO BUILD UP RATED VOLTAGE

- Step 1.** Inspect for loose connections or loose cable assemblies.  
**Tighten loose connections and cables.**
- Step 2.** Check rheostat for proper setting.  
**Rotate rheostat to obtain exact desired voltage on voltmeter.**
- Step 3.** Check for defective rheostat by rotating rheostat knob from right to left and left to right and observe voltmeter needle for respective increase or decrease in voltage.  
**Connect additional voltmeter to load terminals and take comparative readings to establish validity of set voltmeter. Visually inspect wire leads at rheostat for breaks or poor solder connections. Inspect rheostat for breaks or poor wiper contact. Refer to figure 4-21 for DOD model MEP-014A, figure 4-22 for DOD model MEP-019A and figure 4-23 for DOD model MEP-24A and the following instructions to replace a defective rheostat.**
- (1) Position LOAD ON/OFF switch (models MEP-014A and MEP-024A), or LOAD ON/OFF FLASH switch (model MEP-019A) in OFF position.
  - (2) Close fuel shutoff valve by rotating clockwise to shutoff fuel.
  - (3) Place ignition switch in OFF position.
  - (4) Disconnect power source.
  - (5) Tag and disconnect leads from rheostat. (Figures 4-21,4-22, or 4-23).
  - (6) Loosen setscrew securing rheostat knob to shaft and remove rheostat knob (Fig's 4-21,4-22, or 4-23).
  - (7) Remove nut securing rheostat to control panel and remove defective rheostat and discard.
  - (8) Install a new rheostat on control panel and secure with nut.
  - (9) Place rheostat knob over end of shaft and secure by tightening setscrew.
  - (10) Reconnect leads to rheostat.
  - (11) Reconnect power source.
  - (12) Place LOAD ON-OFF-FLASH switch (model MEP-019A), and LOAD ON/OFF switch (models MEP-014A and MEP-024A), in OFF position.
  - (13) Rotate rheostat counterclockwise as far as it will go.
  - (14) Open fuel shutoff valve. Close the choke (move choke control lever away from flywheel) for starting cold engine. Open choke (move toward flywheel) gradually as engine starts and warms until choke is fully open.
  - (15) Place ignition switch in ON position.
  - (16) Wind starter rope around starter flange in clockwise direction. Pull rope briskly to start engine.
  - (17) On model MEP-019A only, place LOAD-ON-OFF-FLASH switch in FLASH position. When engine has attained rated speed, observe panel meter for a voltage indication. Release switch when voltage reaches a minimum of 100 volts.
  - (18) If generator output voltage on model MEP-019A fails to develop after set has attained rated speed, and the LOAD ON-OFF-FLASH switch has been placed in FLASH position, field flashing from an external source will be required. The field is flashed by momentarily connecting a 12-volt DC source (with resistor of 20 ohms, 5 watts connected in series) to terminals 8 and 7 of TB 2 (fig 1-8). Terminal 8 is positive with respect to terminal 7. The series resistor may be omitted if voltage polarity is strictly observed.

### CAUTION

Reversing field flashing polarity from that indicated above will result in the destruction of the voltage regulator, rendering the set inoperative.

Table 4-2. Organizational Troubleshooting

Malfunction	Test or Inspection	Corrective Action
-------------	--------------------	-------------------

NOTE:  
TAG, DISCONNECT AND UNSOLDER  
ELECTRICAL LEADS AS NECESSARY.

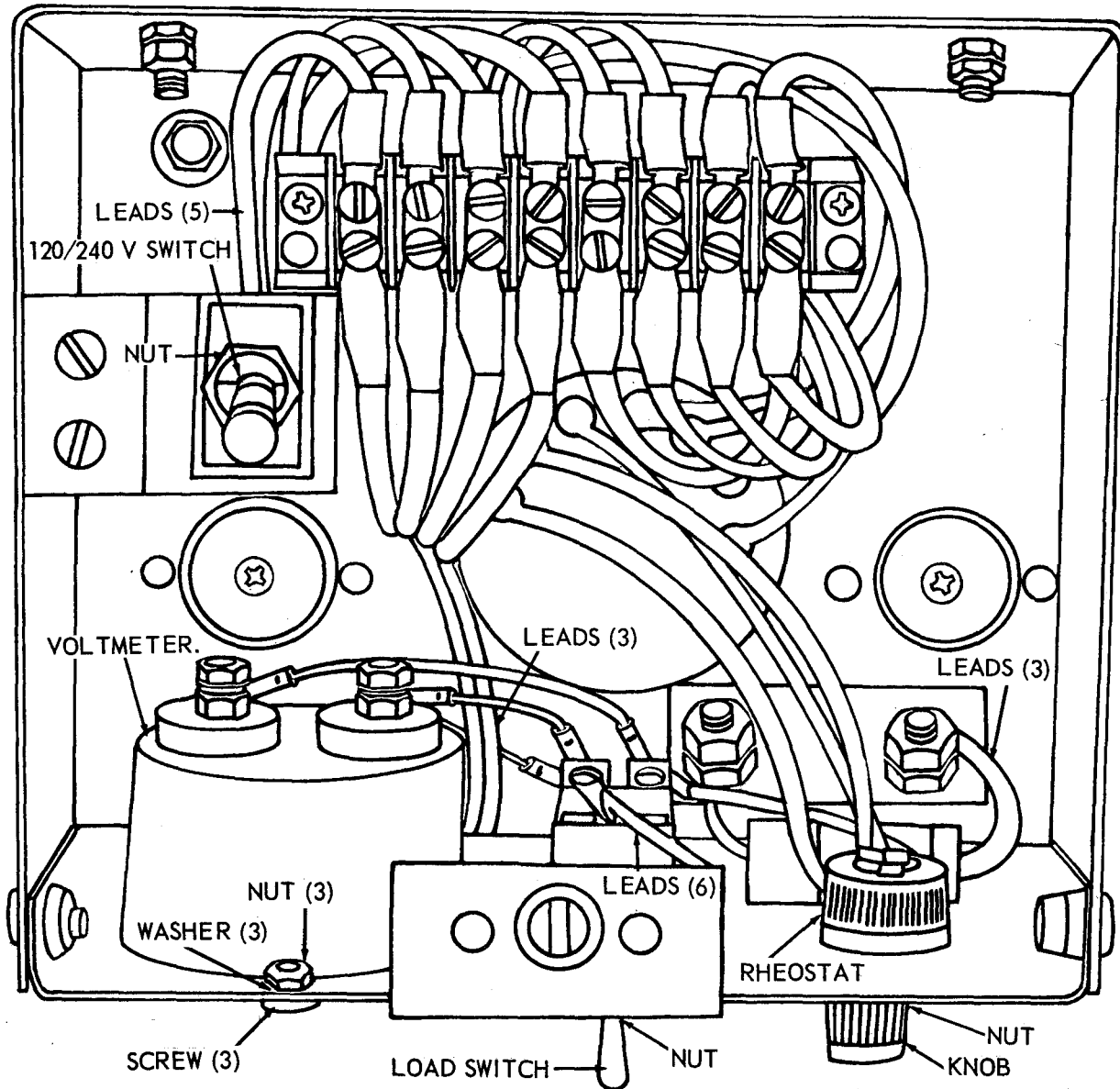

TS 6115-329-14/4-21

Figure 4-21. Rheostat, AC voltmeter, load switch, and 120/240 V switch, removal and installation (model MEP-014A)

Table 4-2. Organizational Troubleshooting

Malfunction	Test or Inspection	Corrective Action
-------------	--------------------	-------------------

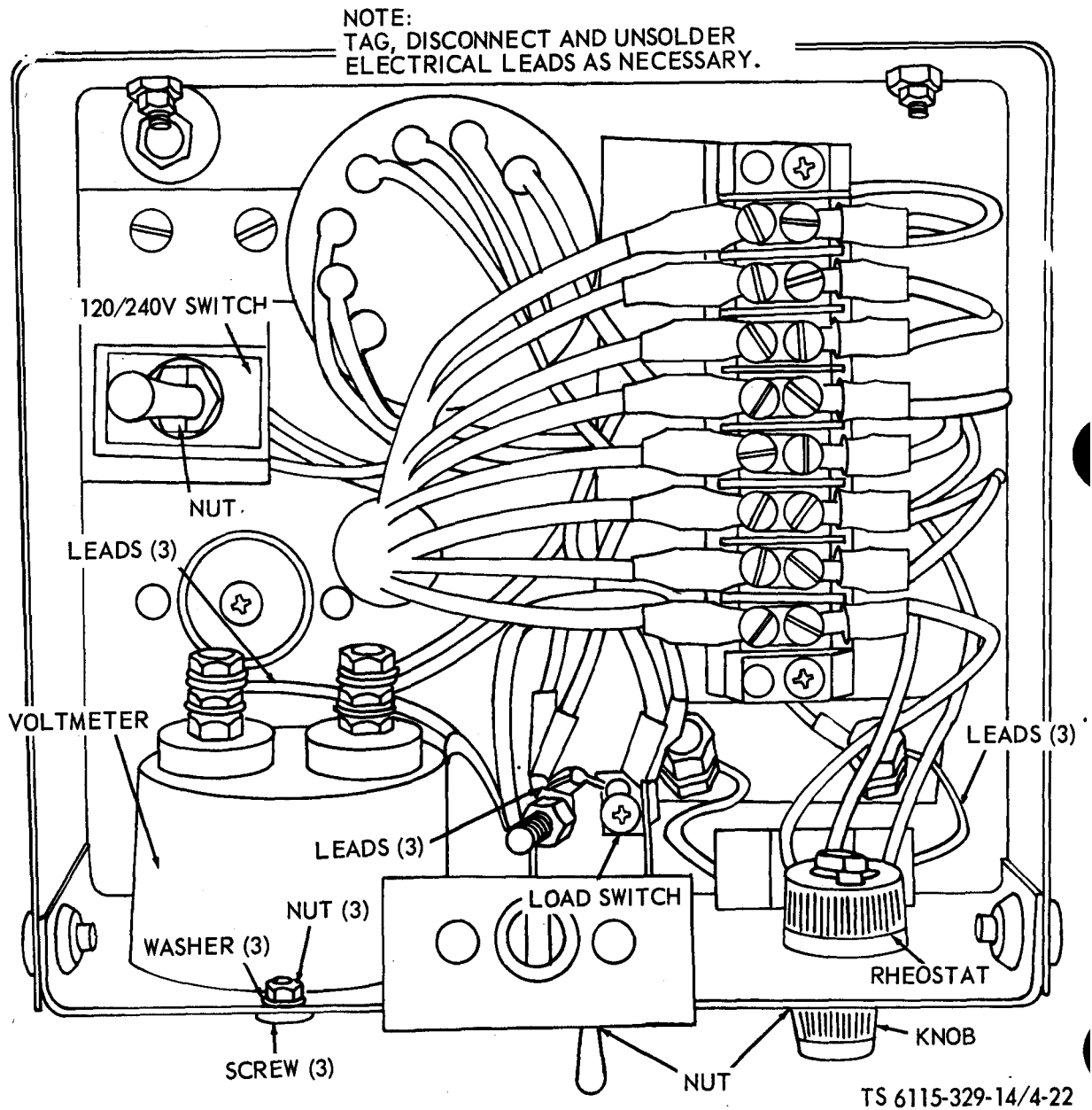
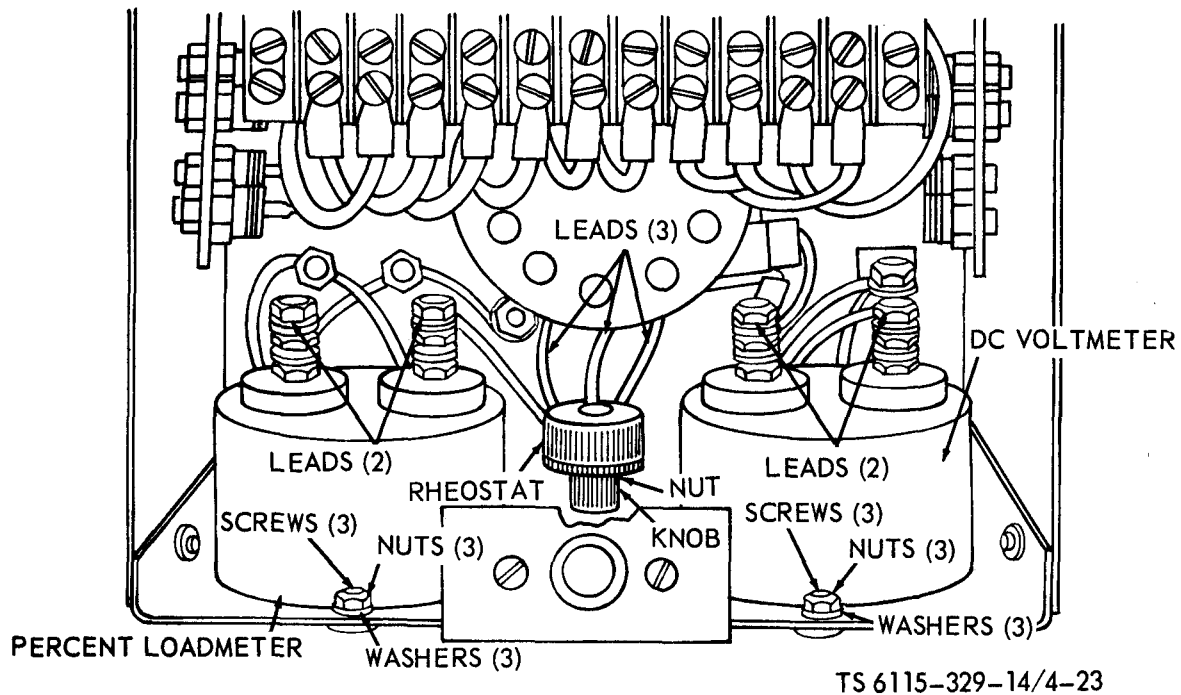

Figure 4-22. Rheostat, AC voltmeter, load switch and 120/240 V switch removal and installation (model MEP-019A)



**Table 4-2. Organizational Troubleshooting**

Malfunction	Test or Inspection	Corrective Action
-------------	--------------------	-------------------



**Figure 4-23. DC voltmeter, rheostat and percent load meter, removal and installation (model MEP-024A).**

- Step 4.** Check carburetor for proper adjustment. Refer to TM 5-2805-256-14/TO38G2-102-2.  
**Adjust carburetor. Refer to TM 5-2805-256-14/TO 38G2-102-2 for adjustment procedures.**
- Step 5.** Check governor for proper adjustment. Refer to TM 5-2805-256-14/TO 38G2-102-12 for adjustment procedures.  
**Adjust governor. Refer to TM 5-2805-256-14/TO 38G2-102-12 for adjustment procedures.**
- Step 6.** Check position of ON-OFF flash switch (model MEP-019A only).  
**On 400 Hz (MEP-019A) model, position ON-OFF flash switch to flash. Observe voltmeter and position switch in ON position when voltage reaches desired output.**

**2. GENERATOR VOLTAGE FLUCTUATES**

- Step 1.** Check for loose terminal connections.  
**Tighten connections.**
- Step 2.** Check generator for overload.  
**Reduce load.**
- Step 3.** Check engine for irregular operation.  
**Refer to TM 5-2805-256-14/TO 38G2-102-2.**
- Step 4.** Inspect governor for proper adjustment.  
**Refer to TM 5-2805-256-14/TO 38G2-102-2 for adjustment procedures.**
- Step 5.** Check for defective rheostat by rotating rheostat knob from right to left and left to right and observe voltmeter needle for fluctuation.

**Table 4-2. Organizational Troubleshooting**

<b>Malfunction</b>	<b>Test or Inspection</b>	<b>Corrective Action</b>
--------------------	---------------------------	--------------------------

Connect additional voltmeter to load terminals and take comparative readings to establish validity of generator set voltmeter. Refer to figure 4-21 for DOD model MEP-014A, figure 4-22 for MEP-019A and to figure 4-23 for model MEP-024A and the following instructions to replace a defective rheostat.

- (1) Position LOAD ON/OFF switch (models MEP-014A and MEP-024A), or LOAD ON-OFF FLASH switch (model MEP-019A) in OFF position.
- (2) Close fuel shutoff valve by rotating clockwise to shutoff fuel.
- (3) Place ignition switch in OFF position.
- (4) Disconnect power source.
- (5) Tag and disconnect leads from rheostat. (Figures 4-21, 4-22 or 4-23).
- (6) Loosen setscrew securing rheostat knob on shaft and remove rheostat knob. (Fig's 4-21,4-22 or 4-23).
- (7) Remove nut securing rheostat to control panel and remove defective rheostat and discard.
- (8) Install a new rheostat on control panel and secure with nut.
- (9) Place rheostat knob over end of shaft and secure by tightening setscrew.
- (10) Reconnect leads to rheostat.
- (11) Reconnect power source.
- (12) Place LOAD ON-OFF-FLASH switch (model MEP-019A), and LOAD ON/OFF switch (models MEP-014A and MEP-024A), in OFF position.
- (13) Rotate rheostat counterclockwise as far as it will go.
- (14) Open fuel shutoff valve. Close the choke (move choke control lever away from flywheel) for starting cold engine. Open choke (move toward flywheel) gradually as engine starts and warms until choke is fully open.
- (15) Place ignition switch in ON position.
- (16) Wind starter rope around starter flange in clockwise direction. Pull rope briskly to start engine.
- (17) On model MEP-019A only, place LOAD ON-OFF-FLASH switch in FLASH position. When engine has attained rated speed, observe panel meter for a voltage indication. Release switch when voltage reaches a minimum value of 100 volts.
- (18) If generator output voltage on model MEP-019A fails to develop after set has attained rated speed, and the LOAD ON-OFF-FLASH switch has been placed in FLASH position, field flashing from an external source will be required. The field is flashed by momentarily connecting a 12-volt DC source (with resistor of 20 ohms, 5 watts connected in series to terminals 8 and 7 of TB 2 (fig. 1-8). Terminal 8 is positive with respect to terminal 7. The series resistor may be omitted if voltage polarity is strictly observed.

**CAUTION**

**Reversing field flashing polarity from that indicated above will result in the destruction of the voltage regulator, rendering the set inoperative.**

### 3. GENERATOR OVERHEATS

- |                |  |
|----------------|--|
| <b>Step 1.</b> | Check generator for overloaded condition,<br>Reduce load.                                    |
| <b>Step 2.</b> | Inspect operating area for obstructions blocking proper ventilation.<br>Remove obstructions. |
| <b>Step 3.</b> | Inspect generator for dirty condition.   |

**CAUTION**

**Do not allow cleaning solvent to come into contact with generator windings or insulation. Damage to the generator may result.**

**Table 4-2. Organizational Troubleshooting**

---

**Malfunction**

**Test or Inspection**

**Corrective Action**

---

Clean generator with a clean cloth dampened in cleaning solvent Fed. Spec. P-D-680, and dry thoroughly.

**4. GENERATOR VOLTAGE TOO HIGH**

*Step 1.* Check for defective rheostat by rotating rheostat knob from right to left and from left to right and observe voltmeter needle for fluctuation.

Connect additional voltmeter to load terminals of generator set and take comparative readings to establish validity of generator set voltmeter. Refer to figure 4-21 for DOD model MEP-O14A, figure 4-22 for MEP-019A and to figure 4-23 for model MEP-024A and the following instructions to replace a defective rheostat.

- (1) Position LOAD ON/OFF switch (models MEP-014A and MEP-024A), or LOAD ON-OFF FLASH switch (model MEP-019A) in OFF position.
- (2) Close fuel shutoff valve by rotating clockwise to shutoff fuel.
- (3) Place ignition switch in OFF position.
- (4) Disconnect power source.
- (5) Tag and disconnect leads from rheostat. (Figures 4-21, 4-22 or 4-23).
- (6) Loosen setscrew securing rheostat knob on shaft and remove rheostat knob. (Fig's 4-21, 4-22 or 4-23).
- (7) Remove nut securing rheostat to control panel and remove defective rheostat and discard.
- (8) Install a new rheostat on control panel and secure with nut.
- (9) Place rheostat knob over end of shaft and secure by tightening setscrew.
- (10) Reconnect leads to rheostat.
- (11) Reconnect power source.
- (12) Place LOAD ON-OFF-FLASH switch (model MEP-019A), and LOAD ON/OFF switch (models MEP-014A And MEP-024A), in OFF position.
- (13) Rotate rheostat counter-clockwise as far as it will go.
- (14) open fuel shutoff valve. Close the choke (move choke control lever away from flywheel) for starting cold engine. open choke (move toward flywheel) gradually as engine starts and warms until choke is fully open.
- (15) Place ignition switch in ON position.
- (16) Wind starter rope around starter flange in clockwise direction. Pull rope briskly to start engine.
- (17) on model MEP-019A only, place LOAD ON-OFF-FLASH switch in FLASH position. When engine has attained rated speed, observe panel meter for a voltage indication. Release switch when voltage reaches a minimum value of 100 volts.
- (18) If generator output voltage on model MEP-019A fails to develop after set has attained rated speed, and the LOAD ON-OFF-FLASH switch has been placed in FLASH position, field flashing from an external source will be required. The field is flashed by momentarily connecting a 12-volt DC source (with resistor of 20 ohms, 5 watts connected in series) to terminal 8 and 7 of TB 2 (fig. 1-8). Terminal 8 is positive with respect to terminal 7. The series resistor may be omitted if voltage polarity is strictly observed.

**CAUTION**

**Reversing field flashing polarity from that indicated above will result in the destruction of the voltage regulator, rendering the set inoperative.**

*Step 2.* Check for defective voltmeter by rotating rheostat knob and observing needle for fluctuation.

Connect additional voltmeter to load terminals of generator set and take comparative readings to establish validity of generator set voltmeter. Refer to figure 4-21 for DOD model MEP-014A and figure 4-22 for model MEP-019A and to figure 4-23 for model MEP-024A and the following instructions to replace a defective voltmeter.

*Table 4-2. Organizational Troubleshooting*

**Malfunction**

**Test or Inspection**

**Corrective Action**

- (1) Position LOAD ON/OFF switch (models MEP-014A and MEP-024A), or LOAD ON-OFF-FLASH switch (model MEP-019A) in OFF position.
- (2) Close fuel shutoff valve by rotating clockwise to shutoff fuel.
- (3) Place ignition switch in OFF position.
- (4) Disconnect power source.
- (5) Tag and disconnect leads from voltmeter. (Figures 4-21, 4-22 or 4-23).
- (6) Remove nuts, washers and screws securing the voltmeter on the control panel and remove defective voltmeter and discard. (Fig's 4-21, 4-22 and 4-23).
- (7) Install a new voltmeter on control panel and secure with screws, washers and nuts.
- (8) Reconnect leads to voltmeter.
- (9) Reconnect power source.
- (10) Place LOAD ON-OFF-FLASH switch (model MEP-019A), and LOAD ON/OFF switch (models MEP-014A and MEP-024A), in OFF position.
- (11) Rotate rheostat counterclockwise as far as it will go.
- (12) Open fuel shutoff valve, Close the choke (move choke control lever away from flywheel) for starting cold engine. Open choke (move toward flywheel) gradually as engine starts and warms until choke is fully open.
- (13) Place ignition switch in ON position.
- (14) Wind starter rope around starter flange in clockwise direction. Pull rope briskly to start engine.
- (15) On model MEP-019A only, place LOAD ON-OFF-FLASH switch in FLASH position. When engine has attained rated speed, observe panel meter for a voltage indication. Release switch when voltage reaches a minimum of 100 volts.
- (16) If generator output voltage on model MEP-019A fails to develop after set has attained rated speed, and the LOAD ON-OFF-FLASH switch has been placed in FLASH position, field flashing from an external source will be required. The field is flashed by momentarily connecting a 12-volt DC source (with resistor of 20 ohms, 5 watts connected in series) to terminals 8 and 7 of TB 2 (fig. 1-8). Terminal 8 is positive with respect to terminal 7. The series resistor may be omitted if voltage polarity is strictly observed.

**CAUTION**

Reversing field flashing polarity from that indicated above will result in the destruction of the voltage regulator, rendering the set inoperative.

**5. VOLTAGE DROPS UNDER LOAD**

Check engine to insure it is delivering power.  
Refer to TM 5-2805-256-14/TO 38G-102-2.

Check external load source and verify load is within requirements of generator set.

## Section VII. RADIO INTERFERENCE SUPPRESSION

### 4-17. General

Radio interference suppression is attained by providing a low-resistance path to ground for stray currents. The methods used on the generator set include shielding the MIL-STD engine high-frequency and ignition wires, grounding the generator set frame with bonding straps, and using radio frequency filters composed of capacitors and resistors.

### 4-18. Interference Suppression Components

*a. Primary Suppression Components.* The primary suppression components are those whose primary function is to suppress radio interference. These components are described and located in figure 4-24.

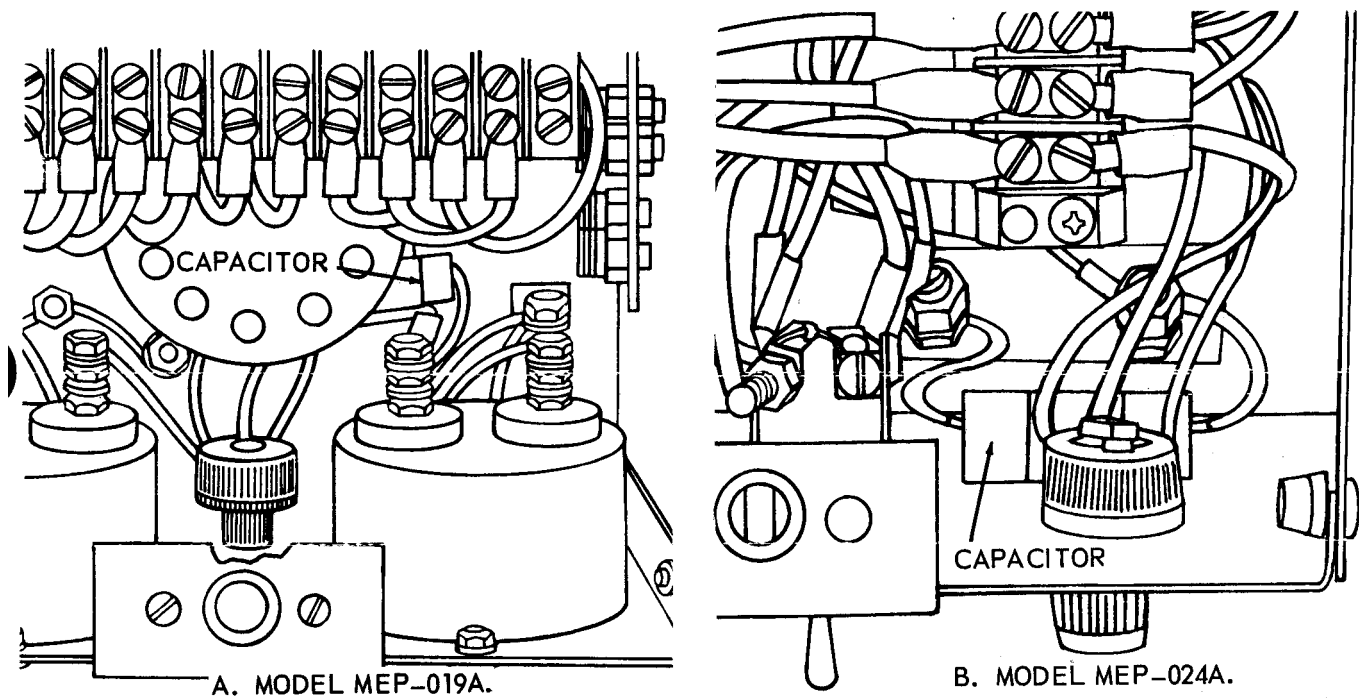

TS 6115-329-14/4-24 (Sheet 1 of 2)

Figure 4-24. Radio interference suppression components (sheet 1 of 2).

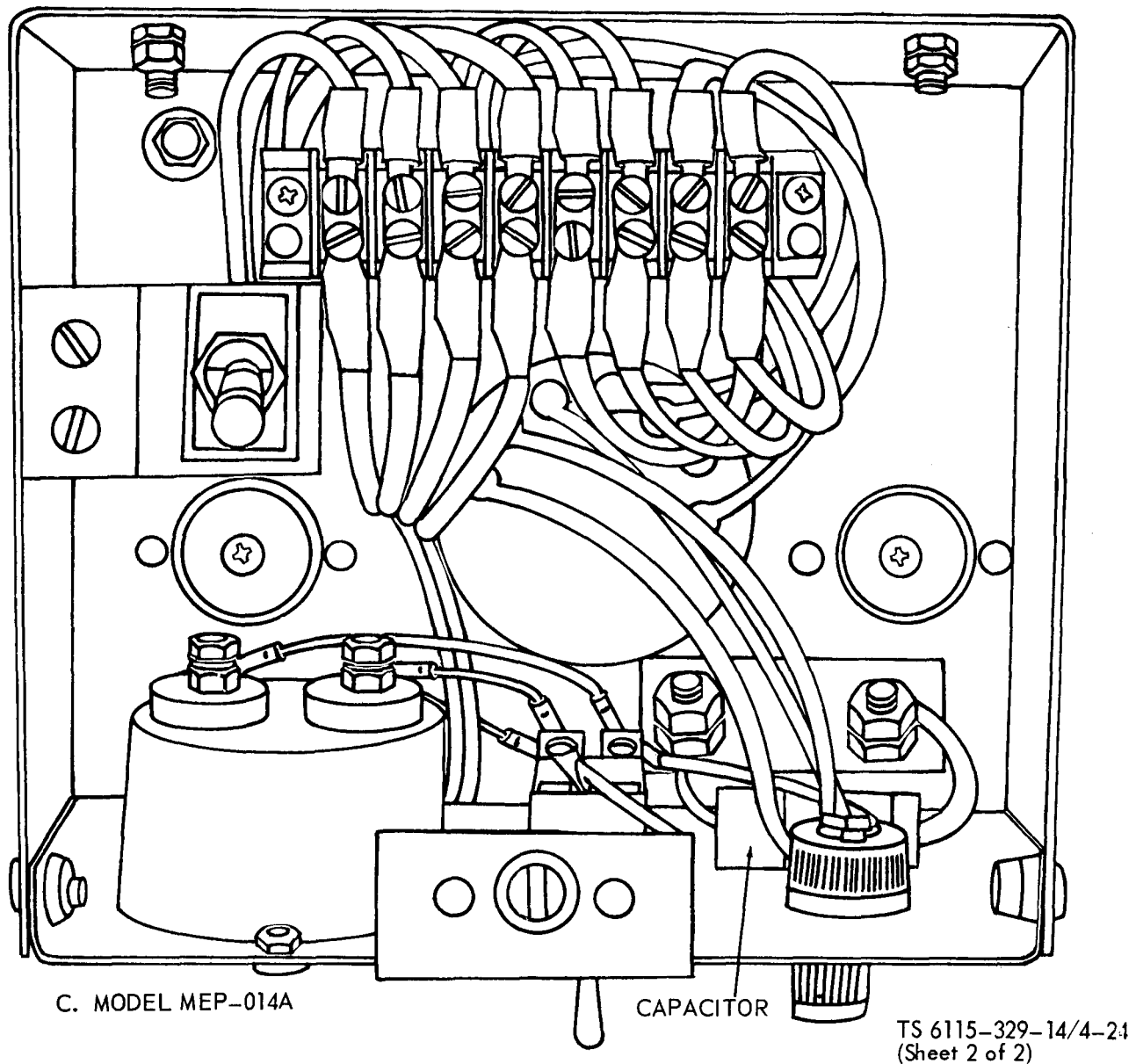

Figure 4-24. Radio interference suppression components (sheet 2 of 2).

**b. Secondary Suppression Components.** These components have radio interference suppression functions which are incidental or secondary to their primary function.

#### 4-19. Replacement of Suppression Components

**a. Removal.** Refer to figure 4-13 and the follow-

ing instructions to replace bonding straps and star washers.

##### (1) Fuel Tank Bonding Strap

**(a)** Remove nuts and lockwashers from the fuel tank bonding strap.

**(b)** Remove bonding strap.

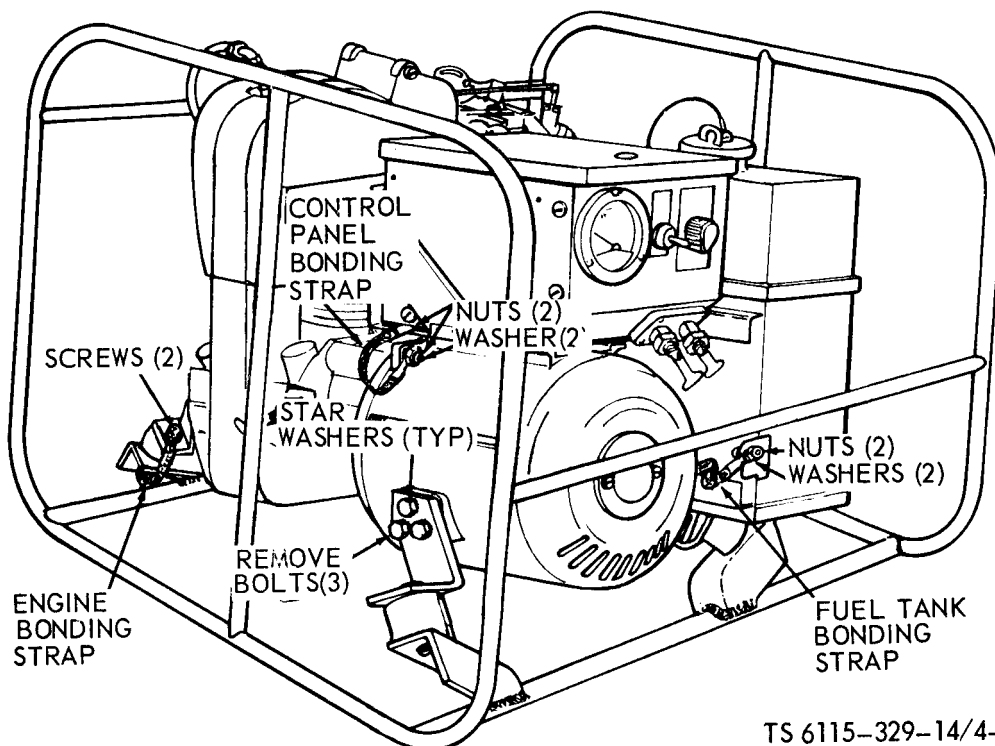

TS 6115-329-14/4-25

Figure 4-25. Radio interference suppression components, removal and installation.

**(2) Control Panel Bonding Strap**

(a) Remove nuts and lockwashers from the control panel bonding strap.

(b) Remove bonding strap.

**(3) Engine Bonding Strap**

(a) Remove screws from engine bonding strap.

(b) Remove bonding strap.

**b. Cleaning and Inspection.** Clean bonding straps with a clean cloth. Inspect for frayed or broken braid. Inspect mounting hardware for cracks, chips, or damaged threads.

**c. Repair.** Replace damaged or defective parts as required.

**d. Installation**

**(1) Engine Bonding Strap.** Secure engine bonding strap to bracket with screws.

**(2) Control Panel Bonding Strap.** Secure control panel bonding strap to generator housing and control panel with lockwashers and nuts.

**(3) Fuel Tank Bonding Strap.** Secure fuel tank bonding tank to frame and fuel tank with lockwashers and nuts.

**Section VIII. Maintenance of the Engine Assembly**

**4-20. Engine**

Refer to TM 5-2805-14/TO 38G2-102-2 for troubleshooting and maintenance instructions and to

LO 5-2805-256-12/TO 38G2-102-2LC-1 pertaining to the MIL-STD Engine Model 1A08-3.

## Section IX. Maintenance of the Frame Assembly

### 4-21. Ground Terminal

#### WARNING

**Clean all parts in a well-ventilated area. Avoid inhalation of solvent fumes and prolonged exposure of skin to cleaning solvent. Wash exposed skin thoroughly. Dry cleaning solvent (Fed. Spec. P-D-680) used to clean parts is potentially dangerous to personnel and property. Do not use near open flame or excessive heat, Flash point of solvent is 100° to 138° F. (38° to 59° C.).**

*a. Removal.* To remove the ground terminal (figs. 1-1,1-3, or 1-5), remove the nut and lock-washer and remove the ground terminal.

*b. Cleaning.* Clean the ground terminal and mounting hardware in cleaning solvent Fed. Spec. P-D-680, and dry thoroughly.

*c. Inspect.* Inspect the ground terminal and mounting hardware for stripped threads, cracks, breaks, burrs or other damage.

*d. Repair.* Replace a defective ground terminal.

*e. Installation.* Refer to figures 1-1, 1-3, or 1-5 and install the ground terminal with lockwasher and nut.

*f. Replace.* For fabrication procedures, see chapter 4, section X, Maintenance of Control Panel Assembly, paragraph 4-29.

## Section X. Maintenance of the Control Panel Assembly

### 4-22. Rheostat

*a. Removal.* Refer to figures 4-21, 4-22, or 4-23 and the following instructions and remove the rheostat.

(1) Tag and disconnect leads from rheostat.

(2) Loosen setscrew securing rheostat knob on shaft and remove rheostat knob.

(3) Remove nut securing the rheostat to the control panel.

(4) Remove rheostat.

*b. Cleaning.* Clean the rheostat with a clean lint free cloth.

*c. Inspection, Testing and Repair.* Inspect the rheostat for a cracked case, for evidence of overheating or other damage. Inspect knob for cracks or breaks. Ensure rheostat rotates without binding or sticking. Using a multimeter, check resistance across outer terminals of rheostat. Resistance should be approximately 5,000 ohms for the MEP-014A and MEP-019A sets and 500 ohms for the MEP-024A sets. Check resistance between center terminal and outer terminals of rheostat. Full rotation of wiper should indicate between 0 ohms and maximum ohms indicated above. Replace a defective rheostat.

*d. Installation.*

(1) Secure rheostat to control panel with nut.

(2) Place rheostat knob over end of shaft and secure by tightening setscrew.

(3) Reconnect leads.

### 4-23 Voltmeter

#### WARNING

**Clean all parts in a well-ventilated area. Avoid inhalation of solvent fumes and prolonged exposure of skin to cleaning solvent. Wash exposed skin thoroughly. Dry cleaning solvent (Fed. Spec. P-D-680) used to clean parts is potentially dangerous to personnel and property. Do not use near open flame or excessive heat. Flash point of solvent is 100° to 138° F. (38° to 59° C.).**

*a. Removal.* Refer to figures 4-21,4-22, or 4-23 and the following instructions and remove the voltmeter.

(1) Tag and disconnect leads from voltmeter.

(2) Remove nuts, lockwashers and screws securing the voltmeter to the control panel.

(3) Remove voltmeter.

*b. Cleaning.*

(1) Clean the voltmeter case with a clean cloth dampened in cleaning solvent Fed. Spec. P-D-680 and dry thoroughly.

(2) Clean glass using a clean cloth and a mild soap and water solution.

*c. Inspection. Testing and Repair.* Inspect glass for discoloration, chips, cracks or scratches. Inspect dial face for legibility. Inspect voltmeter



case for cracks, breaks, corroded terminals or other damage. Test as follows:

(1) **AC Voltmeter** - Apply known external AC voltage source to terminals of meter within range of full scale on meter and take comparative readings. Accuracy should be within + 2% (5 volts) of full scale at ambient temperature.

(2) **DC Voltmeter** - Apply known external DC voltage source within range of meter to terminals of meter and take comparative readings. Accuracy should be within + 2% of full scale at ambient temperature. Replace a defective voltmeter.

**d. Installation.**

(1) Secure voltmeter to the control panel with screws, lockwashers and nuts.

(2) Reconnect leads.

**4-24. DC Percent Loadmeter (DOD MODEL MEP-024A Only)**

**WARNING**

**Clean all parts in a well-ventilated area. Avoid inhalation of solvent fumes and prolonged exposure of skin to cleaning solvent. Wash exposed skin thoroughly. Dry cleaning solvent (Fed. Spec. P-D-680) used to clean parts is potentially dangerous to personnel and property. Do not use near open flame or excessive heat. Flash point of solvent is 100° to 138° F. (38° to 59° C.),**

**a. Removal.** Refer to figure 4-23 and the following instructions and remove the percent loadmeter.

(1) Tag and disconnect leads from the percent loadmeter.

(2) Remove nuts, lockwashers, and screws securing the percent loadmeter on the control panel.

(3) Remove the percent loadmeter.

**b. Cleaning.**

(1) Clean the percent loadmeter case with a clean cloth dampened in cleaning solvent, Fed. Spec. P-D-680, and dry thoroughly.

(2) Clean glass using a clean cloth and a mild soap and water solution.

**c. Inspection, Testing and Repair.** Inspect glass for discoloration, chips, cracks, or scratches. Inspect dial face for legibility. Inspect loadmeter case for cracks, breaks, corroded terminals or other damage. Test as follows: Apply 0-50 millivolts to terminals of current meter. Meter should indicate the following within + 2% of full scale at ambient temperature.

0°	=	0 m volt
25°	=	10 m volts
50°	=	20 m volts
75°	=	30 m volts
100°	=	40 m volts
125°	=	50 m volts

Replace a defective percent loadmeter.

**d. Installation.**

(1) Secure the percent loadmeter to the control panel with screws, lockwashers, and nuts.

(2) Reconnect leads.

**4-25. Load On/Off Switch (DOD MODELS MEP-014A and MEP-024A).**

**a. Removal.** Refer to figure 4-26 and the following instructions and remove the load switch.

(1) Tag and disconnect leads.

(2) Remove nut securing load ON/OFF switch to the control panel.

(3) Remove load ON/OFF switch.

**b. Cleaning.** Clean the load switch using a clean cloth.

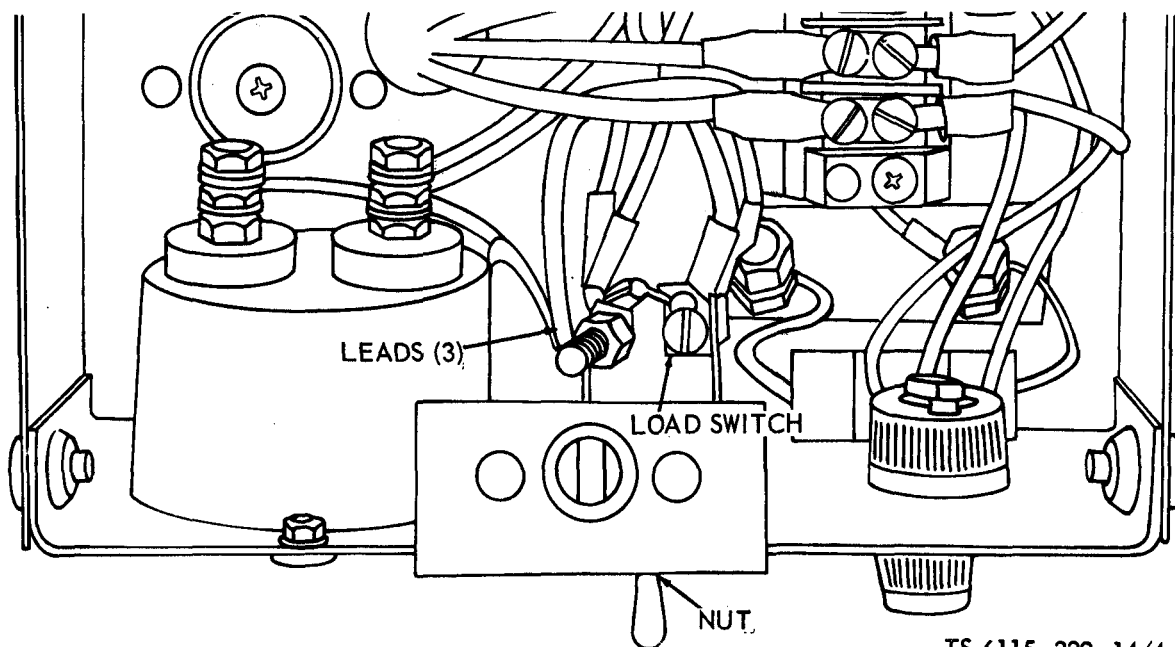

TS 6115-329-14/4-26

Figure 4-26. Load switch, removal and installation (model MEP-014A and MEP-024A).

**c. Inspection, Testing and Repair.** Inspect switch for cracks, breaks, corroded terminals or for evidence of overheating. Test as follows: Using a multimeter, check for continuity of the switch contacts.

**NOTE**

Movement of the switch mechanism is opposite to that of the toggle lever.

Replace a defective load switch.

**d. Installation.**

- (1) Secure load-ON-OFF-FLASH switch to control panel with nut.
- (2) Reconnect leads.

#### 4-26. Load-On-Off Flash Switch (Model MEP-019A)

**a. Removal.** Refer to figure 4-22 and the following instructions and remove the load-on-off flash switch.

- (1) Tag and disconnect leads from the load-ON-OFF-FLASH switch.
- (2) Remove nut securing the load-ON-OFF-FLASH switch.
- (3) Remove switch.

**b. Cleaning.** Clean the load-on-off flash switch using a clean cloth.

**c. Inspection, Testing and Repair.** Inspect the load-on-off flash switch for cracks, breaks, corroded terminals, or for evidence of overheating. Test as

follows: Using a multimeter, check for continuity of the switch contacts.

**NOTE**

Movement of the switch mechanism is opposite to that of the toggle lever.

Replace a defective switch.

**d. Installation.**

- (1) Secure load-ON-OFF-FLASH switch to control panel with nut.
- (2) Reconnect leads.

#### 4-27. Voltage Select Switch (MODEL MEP-014A and MEP-019A)

**a. Removal.** Refer to figure 4-21 or 4-22 and the following instructions and remove the voltage select switch.

- (1) Tag and disconnect leads from the voltage control switch.
- (2) Remove nut securing voltage control switch to control box.
- (3) Remove voltage control switch.

**b. Cleaning.** Clean the voltage select switch using a clean cloth.

**c. Inspection, Testing and Repair.** Inspect switch for a cracked case, evidence of overheating and other apparent damage. Test as follows: Using a multimeter, check for continuity of switch contacts.

NOTE

Movement of the switch mechanism is opposite to that of the toggle lever.

Replace a defective switch.

**d. Installation.**

- (1) Secure the voltage control switch to the control box with nut.
- (2) Reconnect leads.

**4-28. Duplex Receptacle, 120 Volts AC (MODEL MEP-014A)**

**a. Removal.** Refer to figure 4-27 and the following instructions and remove the duplex receptacle.

- (1) Lift cover, tag and disconnect leads from the duplex receptacle.
- (2) Remove screws securing duplex receptacle to the control box.
- (3) Remove duplex receptacle.

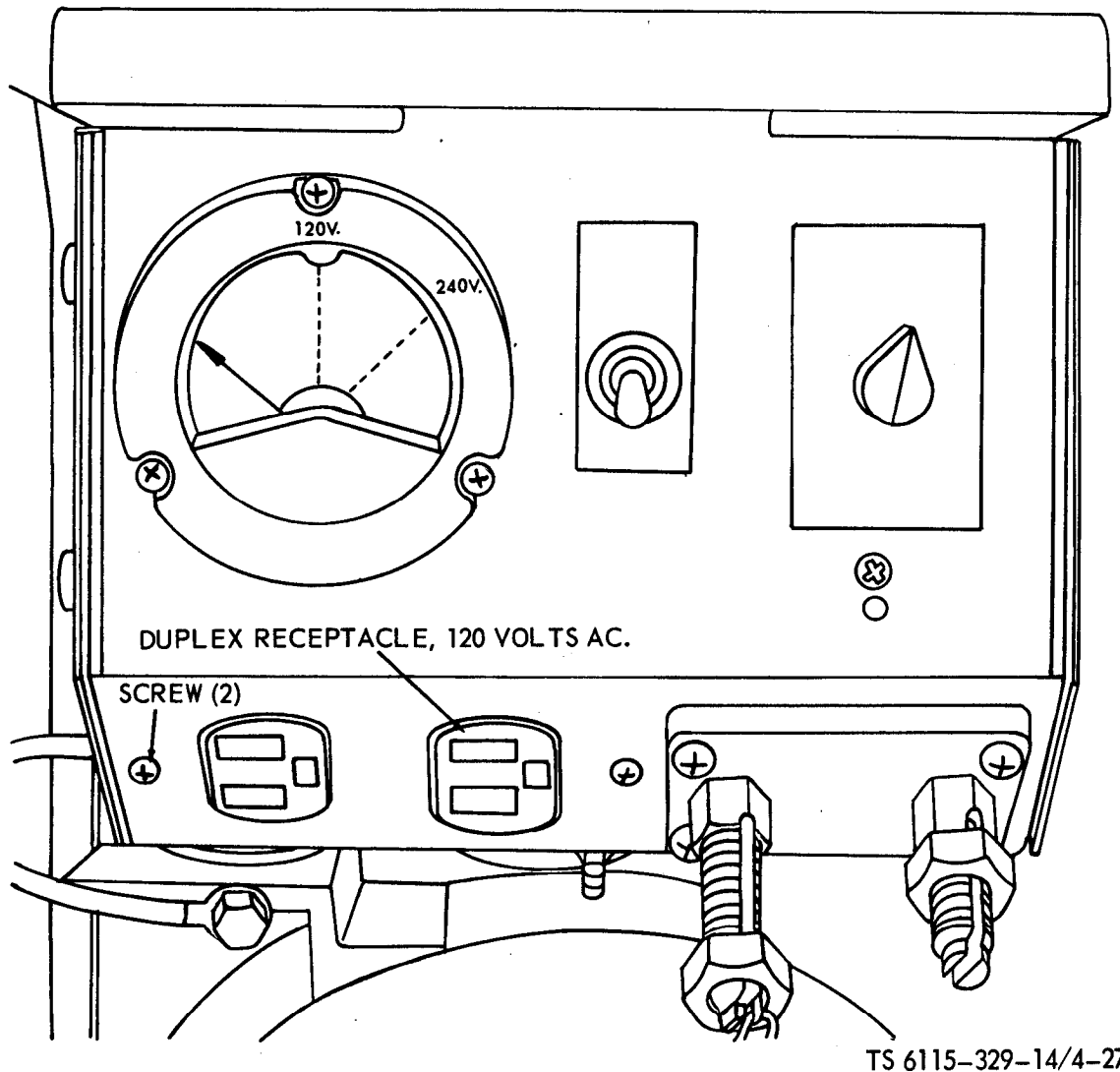

Figure 4-27. Duplex receptacle, 120 volts, AC, removal and installation (MODEL MEP-014A).

**b. Cleaning.** Clean the duplex receptacle using a clean cloth.

**c. Inspection, Testing and Repair.** Inspect the duplex receptacle for cracks, breaks, corroded terminals or other damage. Test as follows: Using a multimeter, check for continuity of each contact on

duplex receptacle. Replace a duplex receptacle if contacts opened during testing.

**d. Installation.**

- (1) Position duplex receptacle in place on control box and secure with screws.
- (2) Reconnect leads.

(3) Close cover.

#### 4-29. Terminal Load

**WARNING**

Clean all parts in a well-ventilated area. Avoid inhalation of solvent fumes and prolonged exposure of skin to cleaning solvent. Wash exposed skin thoroughly. Dry cleaning solvent (Fed. Spec. P-D-680) used to clean

parts is potentially dangerous to personnel and property. Do not use near open flame or excessive heat. Flash point of solvent is 100° to 138° F. (38° to 59° c.).

**a. Removal.** Refer to figure 4-28 and the following instructions and remove the terminal load.

(1) Lift cover, tag and disconnect leads.

(2) Remove nuts securing the terminal loads to the terminal load block.

(3) Remove the terminal loads.

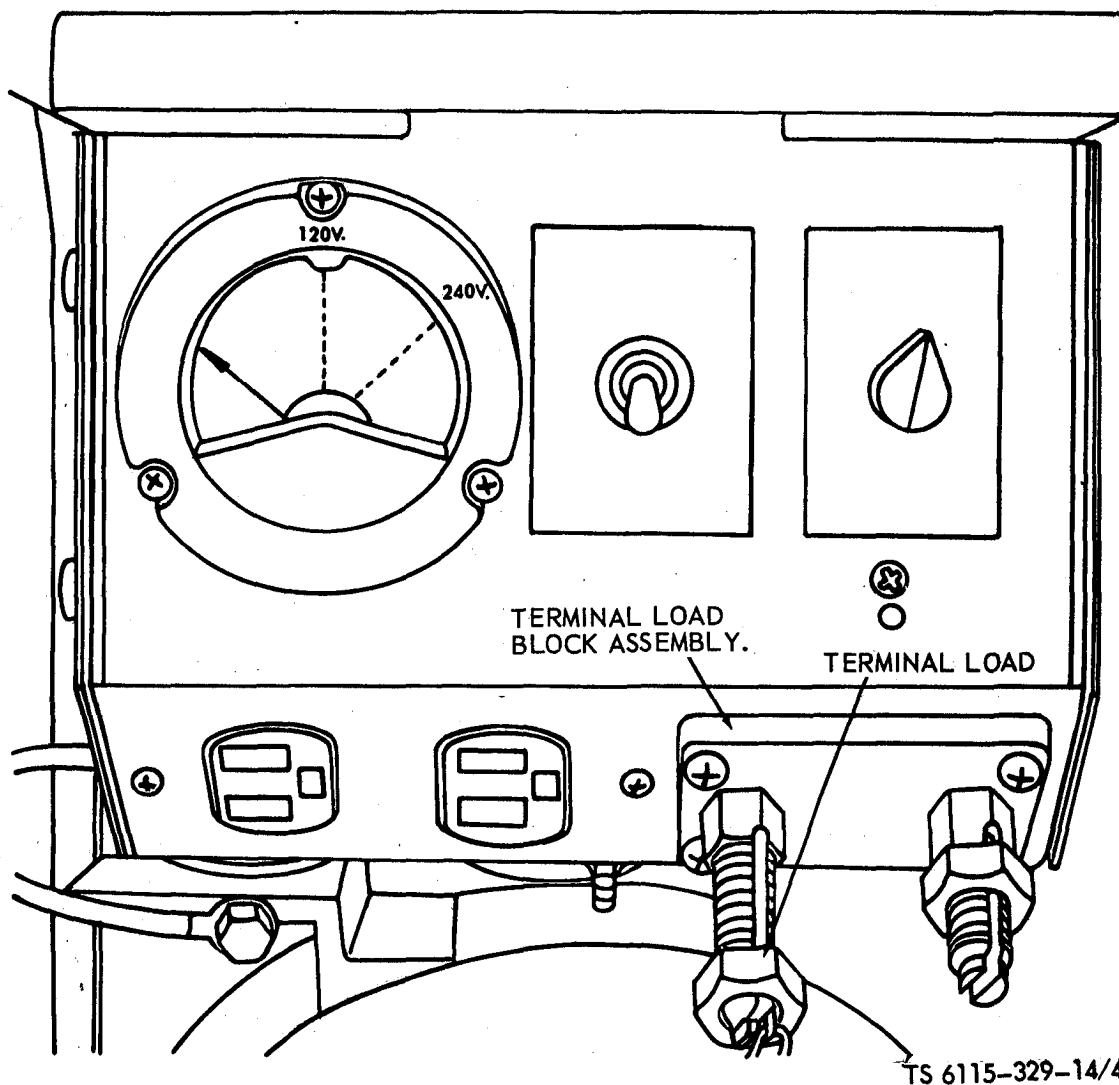

Figure 4-28. Terminal load and terminal block assembly, removal and installation.

**b. Cleaning.** Clean the load terminals with a clean cloth dampened in cleaning solvent, Fed. Spec. P-D-680, and dry thoroughly.

**c. Inspection and Repair.** Inspect load terminals for cracks, burrs, nicks, or damaged threads.

Replace damaged load terminal.

**d. Installation.**

(1) Secure the terminal loads to the terminal load block assembly with nuts.

- (2) Reconnect leads.
- (3) Close cover.

*a. Removal.* Refer to figure 4-28 and the following instructions and remove the terminal load block assembly.

*b. Replace.* Replace lost or broken terminal clip (Retainer, Safety clip). The terminal clip is a component of both the load terminal and the ground terminal. If the terminal clip is lost or broken, fabricate as follows.

(1) Requisition bulk wire NSN 9509-00-804-3814 (0.042 inch diameter) for the ground terminal (ground stud): Requisition bulk wire NSN 9505-01-049-0144 (0.050 inch diameter) for the load terminal.

(2) Cut off about 3 inches of the wire; short enough to keep the clips from touching another

terminal or the generator frame in the open or closed position.

(3) Slip the wire through the hole in the terminal.

(4) Hold the terminal as shown (Detail A, figure 4-28.1) and bend both ends of the wire straight up keeping the wire in as straight a line as you can with the terminal body.

(5) Bend the wire into back-to-back 90° angle (Detail B, figure 4-28.1) so that the legs of both angles are about one-half inch long.

(6) Bend the ends of each 90° angle down around into a U-shape (Detail C, figure 4-28.1) so that if done properly, the clip will hold the nut when it is unscrewed to install the cable (Detail D, figure 4-28.1).

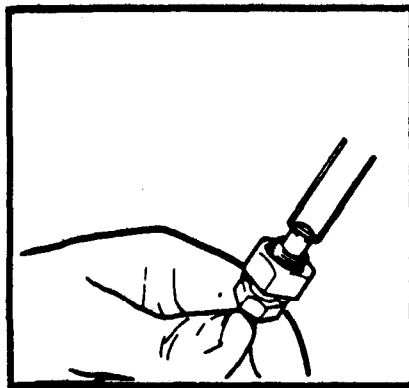

DETAIL A

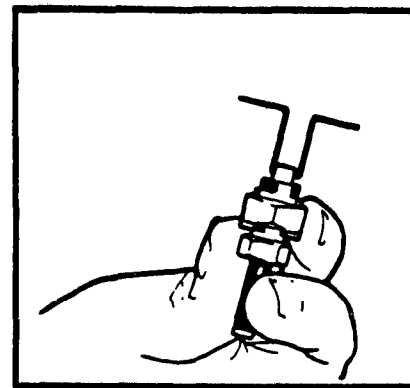

DETAIL B

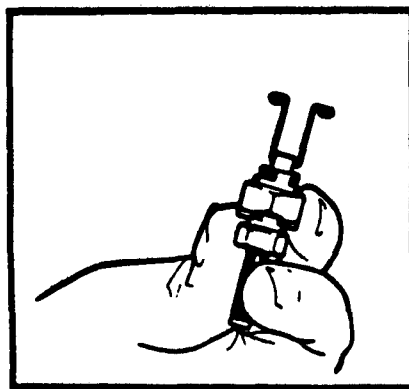

DETAIL C

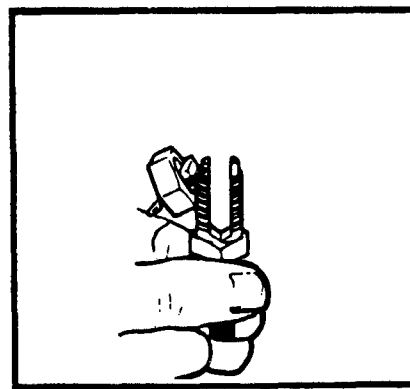

DETAIL D

Figure 4-28.1. Terminal Clip Replacement

#### 4-30. Terminal Load Block Assembly

##### WARNING

**Clean all parts in a well-ventilated area. Avoid inhalation of solvent fumes and prolonged exposure of skin to cleaning solvent. Wash exposed skin thoroughly. Dry cleaning solvent (Fed. Spec. P-D-680) used to clean parts is potentially dangerous to personnel and property. Do not use near open flame or excessive heat. Flash point of solvent is 100° to 138° F. (38° to 59° C.).**

- (1) Lift cover, tag and disconnect leads.
- (2) Remove nuts securing the terminal loads in the terminal load block assembly.
- (3) Remove terminal loads.
- (4) Remove screws securing the terminal load block assembly to the control box and remove terminal load block.

*b. Cleaning.* Clean the terminal load block assembly using a clean cloth dampened in cleaning solvent, Fed. Spec. P-D-680, and dry thoroughly.

*c. Inspection and Repair.* Inspect terminal load block assembly for cracks or breaks. Inspect mounting hardware for thread damage. Replace damaged terminal load block assembly.

*d. Installation.*

- (1) Secure terminal load block to the control box with screws.
- (2) Install terminal loads and secure with nuts.
- (3) Reconnect leads.
- (4) Close cover.

#### 4-31. Ground Strap

##### WARNING

**Clean all parts in a well-ventilated area. Avoid inhalation of solvent fumes and prolonged exposure of skin to cleaning solvent. Wash exposed skin thoroughly. Dry cleaning solvent (Fed. Spec. P-D-680) used to clean parts is potentially dangerous to personnel and property. Do not use near open flame or excessive heat. Flash point of solvent is 100° to 138° F. (38° to 59° C.).**

*a. Removal.* Refer to figure 4-29 and the following instructions and remove the control panel ground strap.

- (1) Remove nuts and lockwashers securing the control panel ground strap to the control box and the generator housing.
- (2) Remove ground strap.

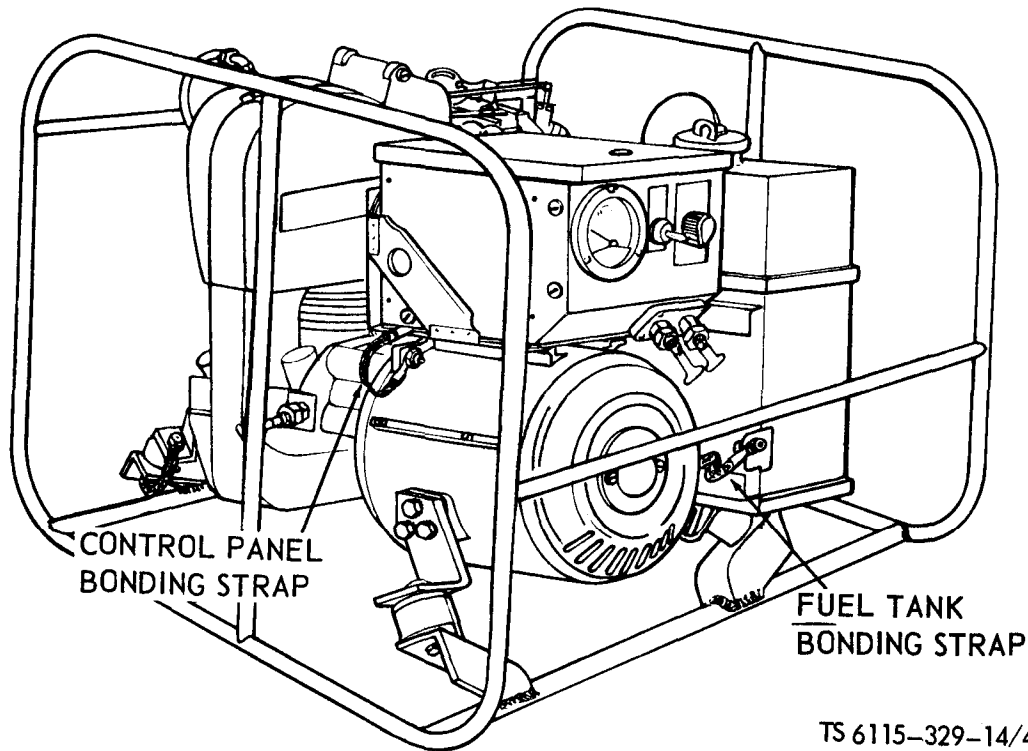

TS 6115-329-14/4-29

*Figure 4-29. Control panel ground strap and fuel tank grounding strap, removal and installation.*

**b. Cleaning.** Clean the ground strap in cleaning solvent, Fed. Spec. P-D-680, and dry thoroughly.

**c. Inspection and Repair.** Inspect ground strap for frayed or broken braid. Inspect mounting hardware for thread damage. Replace defective control panel ground strap.

**d. Installation.** Secure the control panel ground strap to the generator housing and the control box with lockwashers and nuts.

## Section XI. Maintenance of the Fuel System

### 4-32. Fuel Tank

#### WARNING

Clean all parts in a well-ventilated area. Avoid inhalation of solvent fumes and prolonged exposure of skin to cleaning solvent. Wash exposed skin thoroughly. Dry cleaning solvent (Fed. Spec. P-D-680) used to clean parts is potentially dangerous to personnel and property. Do not use near

open flame or excessive heat. Flash point of solvent is 100° to 138° F. (38° to 59° c.).

#### a. Removal.

- (1) Drain fuel tank.
- (2) Disconnect line (fig. 4-30).
- (3) Remove two screws.
- (4) Remove grounding strap (fig. 4-29).
- (5) Remove fuel tank (fig. 4-30).
- (6) Remove selector valve and fuel strainer from fuel tank.





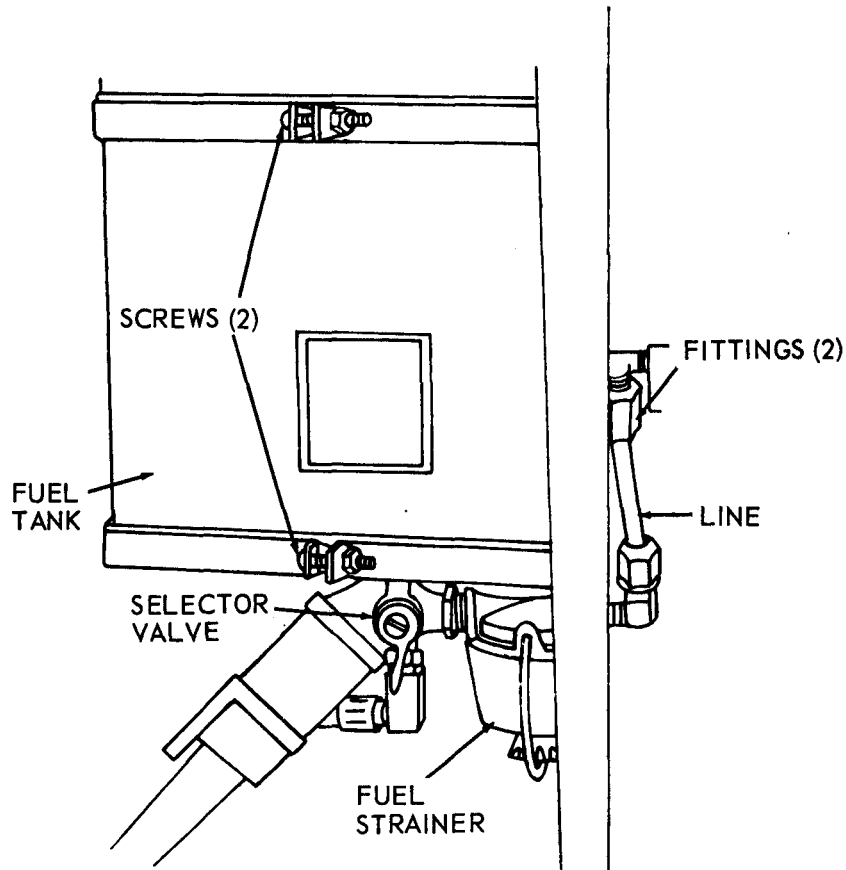

TS 6115-329-14/4-30

Figure 4-30. Fuel tank, selector valve and fuel strainer, removal and installation.

**b. Cleaning.** Clean exterior portion of fuel tank with a clean cloth dampened in cleaning solvent, Fed. Spec. P-D-680, and dry thoroughly.

**c. Inspection and Repair.** Inspect fuel tank for dents and for evidence of leaking. Replace defective fuel tank.

**d. Installation.**

- (1) Connect selector valve and fuel strainer to fuel tank (fig. 4-30).
- (2) Position fuel tank in straps and secure with two screws.
- (3) Reinstall line.
- (4) Attach grounding strap (fig. 4-29).

### 4-33. Cap and Chain Assembly (Fuel Tank)

**WARNING**

Clean all parts in a well-ventilated area. Avoid inhalation of solvent fumes and prolonged exposure of skin to cleaning solvent. Wash exposed skin thoroughly. Dry cleaning solvent (Fed. Spec. P-D-680) used to clean parts is potentially dangerous to personnel and property. Do not use near open flame or excessive heat. Flash point of solvent is 100° to 138° F. (38° to 59° C.).

**a. Removal.** Refer to figure 3-3 and the following instructions and remove the fuel tank cap and chain assembly.

(1) Remove screw securing the fuel tank cap chain to the control box.

(2) Unscrew cap from fuel tank.

**b. Cleaning.** Clean the chain and the metal portion of the fuel tank cap with a clean cloth dampened in cleaning solvent, Fed. Spec. P-D-680, and dry thoroughly.

**c. Inspection and Repair.** Inspect chain for worn or broken links. Inspect cap for burrs or nicks. Replace damaged or defective fuel tank cap or chain.

**d. Installation.**

(1) Secure fuel tank cap chain to the control box with screw.

(2) Install fuel tank cap onto fuel tank.

#### 4-34. Strainer (Fuel Tank)

##### WARNING

**Clean all parts in a well-ventilated area. Avoid inhalation of solvent fumes and prolonged exposure of skin to cleaning solvent. Wash exposed skin thoroughly. Dry cleaning solvent (Fed. Spec. P-D-680) used to clean parts is potentially dangerous to personnel and property. Do not use near open flame or excessive heat. Flash point of solvent is 100° to 138° F. (38° to 59° C.).**

**a. Removal.** Refer to figure 3-3 and the following instructions and remove the fuel tank strainer.

(1) Unscrew fuel tank cap from fuel tank.

(2) Lift strainer out of fuel tank.

**b. Cleaning.** Clean the fuel tank strainer with cleaning solvent, Fed. Spec. P-D-680, and dry with low pressure compressed air.

**c. Inspection and Repair.** Inspect the strainer for tears, punctures, or other damage. Replace defective strainer.

**d. Installation.**

(1) Position strainer in fuel tank.

(2) Install fuel tank cap on fuel tank.

#### 4-35. Fuel Strainer

##### WARNING

**Clean all parts in a well-ventilated area. Avoid inhalation of solvent fumes and prolonged exposure of skin to cleaning solvent. Wash exposed skin thoroughly. Dry cleaning solvent (Fed. Spec. P-D-680) used to clean parts is potentially dangerous to personnel and property. Do not use near open flame or excessive heat. Flash point of solvent is 100° to 138° F. (38° to 59° C.).**

**a. Removal.**

(1) Remove fuel tank (para. 4-32).

(2) Remove selector valve and fuel strainer from fuel tank (fig. 4-30).

(3) Remove selector valve from fuel strainer.

**b. Disassembly.**

(1) Turn knurled knob (1, fig. 4-31) counter-clockwise.

(2) Swing bail (2) clear of bowl.

(3) Remove bowl (3) and gasket (4) from head.

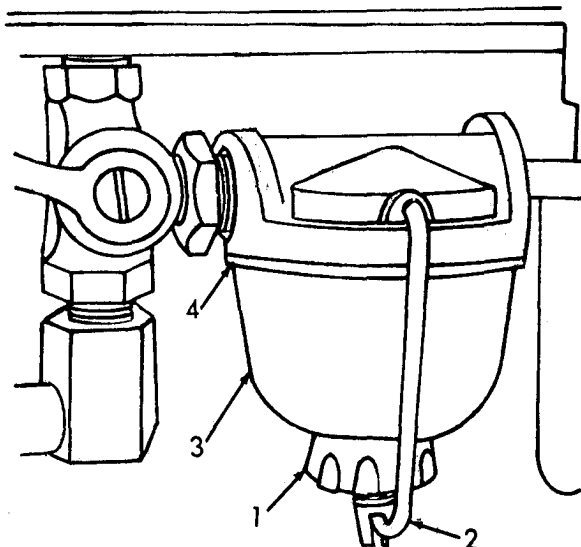

TS 6115-329-14/4-31

Figure 4-31. Fuel strainer, disassembly and reassembly.

**c. Cleaning.** Clean bowl in cleaning solvent, Fed. Spec. P-D-680, and dry thoroughly.

**d. Inspection and Repair.** Inspect strainer head and bowl for cracks and bail for distortion. Replace gasket and defective strainer.

**e. Assembly.**

(1) Position new gasket and bowl in place.

(2) Place bail in position and turn knurled nut clockwise to tighten.

**f. Installation.**

(1) Connect selector valve to fuel strainer (fig. 4-30).

(2) Install selector valve and fuel strainer on fuel tank.

(3) Install fuel tank (para. 4-32).

### 4-36. Selector Valve

**WARNING**

**Clean all parts in a well-ventilated area. Avoid inhalation of solvent fumes and prolonged exposure of skin to cleaning solvent. Wash exposed skin thoroughly. Dry cleaning solvent (Fed. Spec. P-D-680) used to clean parts is potentially dangerous to personnel and property. Do not use near open flame or excessive heat. Flash point of solvent is 100° to 138° F. (38° to 59° C.).**

**a. Removal.**

(1) Remove fuel tank (para. 4-32).

(2) Remove selector valve and fuel strainer from fuel tank (fig. 4-30).

(3) Remove selector valve from fuel strainer.

**b. Cleaning.** Clean the fuel selector valve in cleaning solvent, Fed. Spec. P-D-680, and dry thoroughly.

**c. Inspection and Repair.** Operate the selector valve handle and check for binding or sticking. Inspect valve for evidence of leaking. Replace defective valve.

**d. Installation.**

(1) Connect selector valve to fuel strainer (fig. 4-30).

(2) Install selector valve and fuel strainer on fuel tank.

(3) Install fuel tank (para. 4-32).

### 4-37. Fuel Line

**a. Removal.**

(1) Drain fuel tank.

(2) Refer to figure 4-30 and remove the fuel line.

**b. Cleaning.** Clean the fuel line with a clean cloth.

**c. Inspection and Repair.** Inspect line for dents, breaks, kinks or excessive bends that could cause fuel restriction. Inspect threaded parts for thread damage. Replace defective line assembly.

**d. Installation.** Refer to figure 4-30 and install the fuel line.



## CHAPTER 5

# INTERMEDIATE (FIELD), (DIRECT AND GENERAL SUPPORT) AND DEPOT MAINTENANCE INSTRUCTIONS

### Section I. REPAIR PARTS, SPECIAL TOOLS, TEST, MEASUREMENT AND DIAGNOSTIC EQUIPMENT (TMDE) AND SUPPORT EQUIPMENT

#### 5-1. Intermediate (Field), (Direct and General Support) and Depot Maintenance Repair Parts

**a. Generator.** Repair parts and equipment are listed and illustrated in TM 5-6115-329-24P/TO 35C2-3-440-4.

**b. Engine.** Refer to TM 5-2805-256-24P/TO 38G2-102-4 for repair parts and equipment pertaining to the MIL-STD engine Model 1A08-3.

#### 5-2. Special Tools and Equipment

**a. Generator.** There are no special tools or equipment needed by intermediate (field), (direct and general support) or depot maintenance personnel for performing maintenance on the generator set.

**b. Engine.** Refer to TM 5-2805-256-14/TO 38G2-102-2 for special tools and equipment needed by intermediate (field), (direct and general support) and depot maintenance personnel for performing maintenance on the MIL-STD engine Model 1A08-3.

*Table 5-1. Fabricated Tools and Equipment*

Nomenclature	Reference No. or NSN	Material Required
Rotor puller	Unknown	Steel

Item	Reference Paragraph	Use
Rotor puller	6-4	Pull rotor free of engine shaft.

#### 5-3. Fabricated Tools and Equipment

**Generator.** The specially designed tools and equipment illustrated and listed in Table 5-1 are for intermediate (field), (direct and general support) and depot maintenance personnel performing repair

or overhaul work on the generator set. Tools and equipment listed in Table 5-1 are not available for issue, but must be fabricated by qualified intermediate (field), (direct or general support) and depot maintenance personnel.

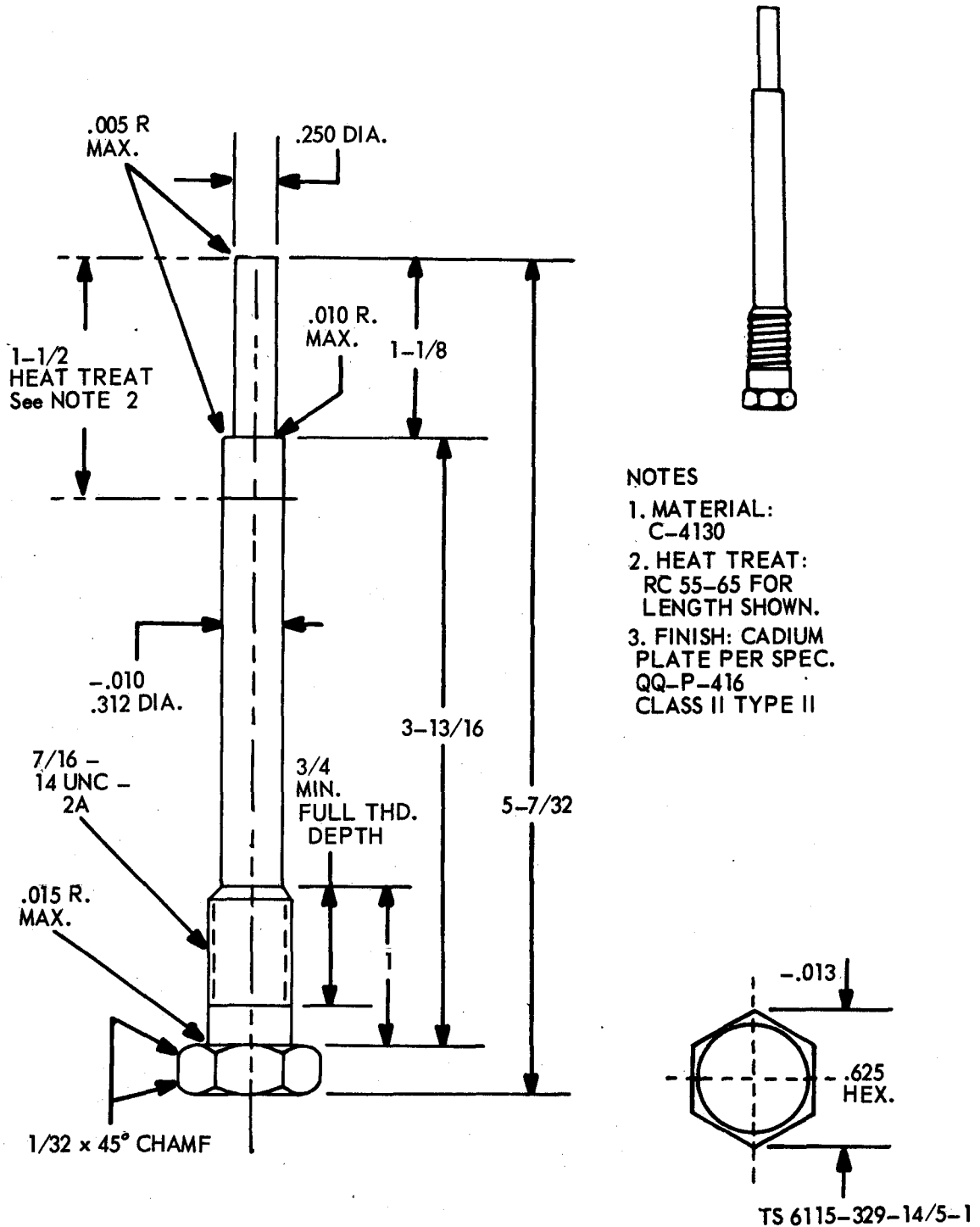

Figure 5-1. Specially designed tool.

## Section II. Troubleshooting

### 5-4. General

a. This section contains troubleshooting information for locating and correcting the operating troubles which may develop in the generator set.

Each malfunction for an individual component, unit, or system is followed by a list of test or inspections which will help you to determine the probable cause and corrective actions in the order

listed.

**b.** This manual cannot list all malfunctions that may occur, nor all tests or inspections and corrective actions. If a malfunction is not listed or is not corrected by listed corrective actions, notify your supervisor.

**c.** For engine troubleshooting, refer to TM 5-2805-256-14/TO 38G2-102-2.

## 5-5. Troubleshooting Table

NOTE

Before you use this table, be sure you have performed all applicable operating checks.

*Table 5-2. Intermediate (Field), (Direct and General Support) and Depot Maintenance Troubleshooting*

---

### Malfunction

Test or Inspection

Corrective Action

---

#### 1. GENERATOR FAILS TO BUILD UP RATED VOLTAGE

- Step 1.** Check for defective stator windings.  
**Refer to paragraph 10-3 and replace stator assembly.**
- Step 2.** Check for defective voltage regulator.  
**Refer to paragraph 9-6 and replace voltage regulator.**
- Step 3.** Test for defective rectifier assembly (para 9-8).  
**Refer to paragraph 9-8 and replace defective rectifier(s).**

#### 2. GENERATOR OVERHEATS

- Step 1.** Insure generator housing is tight on engine.  
**Refer to paragraph 10-3 and tighten generator housing mounting bolts.**
- Step 2.** Check for defective bearing.  
**Refer to paragraph 10-3 and replace defective bearing.**
- Step 3.** Check for defective stator.  
**Refer to paragraph 10-3 and replace defective stator.**

#### 3. GENERATOR OUTPUT VOLTAGE TOO HIGH

- Step 1.** Check for defective stator winding.  
**Refer to paragraph 10-3 and replace stator assembly.**
- Step 2.** Check for defective voltage regulator.  
**Refer to paragraph 9-6 and replace defective voltage regulator.**

#### 4. GENERATOR NOISY

- Step 1.** Check for defective generator outboard bearing.  
**Refer to paragraph 10-3 and replace defective outboard bearing.**

Table 5-2. Intermediate (Field), (Direct and General Support) and  
Depot Maintenance Troubleshooting (Cont'd)

---

**Malfunction**

**Test or Inspection**

**Corrective Action**

---

*Step 2.* Check for loose fan on rotor.

**Refer to paragraph 10-3 and tighten fan.**

**5. VOLTAGE FLUCTUATES**

*Step 1.* Check for defective voltage regulator.

**Refer to paragraph 9-6 and replace defective voltage regulator.**

*Step 2.* Check for defective stator windings.

**Refer to paragraph 10-3 and replace stator assembly.**

**6. VOLTAGE DROPS UNDER LOAD**

*Step 1.* Check for defective voltage regulator.

**Refer to paragraph 9-6 and replace defective voltage regulator.**

*Step 2.* Check for defective stator.

**Refer to paragraph 10-3 and replace defective stator.**

---

**Section III. GENERAL MAINTENANCE**

**5-6. General**

Refer to Chapters 3 and 4 for operator preventive maintenance checks and services and service the DOD generator set.

**5-7. General Disassembly Procedures**

*a.* Components to be repaired shall be disassembled to the extent required for complete serviceability.

*b.* Serviceable, precision, matched or mated parts shall be marked, handled and stored to preclude damage and to insure reassembly and installation in their matched and mated positions in the same assembly or component.

**5-8. General Repair and/or Replacement Criteria**

*a.* In-process inspection shall be performed on

each assembly, subassembly and component parts being repaired to insure strict adherence to criteria established by this manual.

*b.* Welding shall assure complete fusion and penetration and be in compliance with specifications and standards referenced herein.

**5-9. General Reassembly Procedures**

*a.* General precautions shall be adhered to during reassembly to insure that all internal parts have been properly installed and necessary tolerance checks performed.

*b.* Upon completion of reassembly, generator set shall be lubricated in accordance with Lubrication Order. Air Force personnel use the lubrication section of applicable TO 35C2-3-1-426 WC-series workcards.



## CHAPTER 6

# REMOVAL AND INSTALLATION OF MAJOR COMPONENTS

---

### 6-1. General

This chapter covers the removal and installation of the engine, control panel assembly, and main generator.

### 6-2. Engine Assembly

**a. Removal.** Refer to figures 6-1, 6-2, 6-3, and 6-4 and the following instructions for removal of the engine.

(1) Remove bolts from shock mounts securing the engine-generator in the carrying frame (fig. 6-1).

(2) Remove engine-generator from the frame assembly.

(3) Tag and disconnect leads from the terminal board (fig. 6-2).

(4) Tag and disconnect leads from the control panel assembly (fig. 6-2).

(5) Remove screw from ground strap.

(6) Remove screws, washers, and nuts securing the control box assembly to the control panel mounting bracket and remove the control box assembly (fig. 6-2).

(7) Disconnect the fuel line from the fuel pump (fig. 4-18).

(8) Remove screws and washers securing the upper and lower fuel tank brackets to the generator housing and remove brackets (fig. 6-3).

(9) Remove screws securing the control panel bracket to the generator housing (fig. 6-3) and remove bracket.

(10) Remove screws (1, fig. 6-4) from end cap (2) and remove end cap.

(11) Remove motor drive machine bolt (3).

(12) Remove nuts (4), bolts (5), and washers (6) securing the generator housing and stator (7) to

the engine end bell and remove housing and stator.  
(13) Remove bearing (8) from end of engine shaft.

(14) Insert special tool (Table 5-1) into out-board end of rotor and thread in until rotor assembly becomes free of shaft and remove rotor (9).

(15) Remove fan (10) from rotor.

(16) Remove bolts (11) securing engine end bell (12) to engine housing and remove end bell.

### **b. Installation.**

(1) Install engine end bell (12, fig. 6-4) to the engine housing with bolts (11).

(2) Thread fan (10) onto rotor (9) and install fan and rotor on engine shaft.

(3) Install bearing (8) on engine shaft.

(4) Position housing and stator (7) in place on end bell and secure with washers (6), screws (5) and nuts (4).

(5) Install motor drive machine bolt (3).

(6) Install end cap (2) to generator housing with screws (1).

(7) Install control panel mounting bracket on the generator housing (fig. 6-3).

(8) Install the lower and upper fuel tank brackets to the generator housing.

(9) Reconnect fuel line to the fuel pump (fig. 4-18).

(10) Position control box assembly in place on mounting bracket and attach with screws, washers, and nuts.

(11) Attach ground strap.

(12) Reconnect leads to control panel and terminal board (fig. 6-2).

(13) Secure engine-generator in carrying frame (fig. 6-1) by installing bolts into shock mounts.

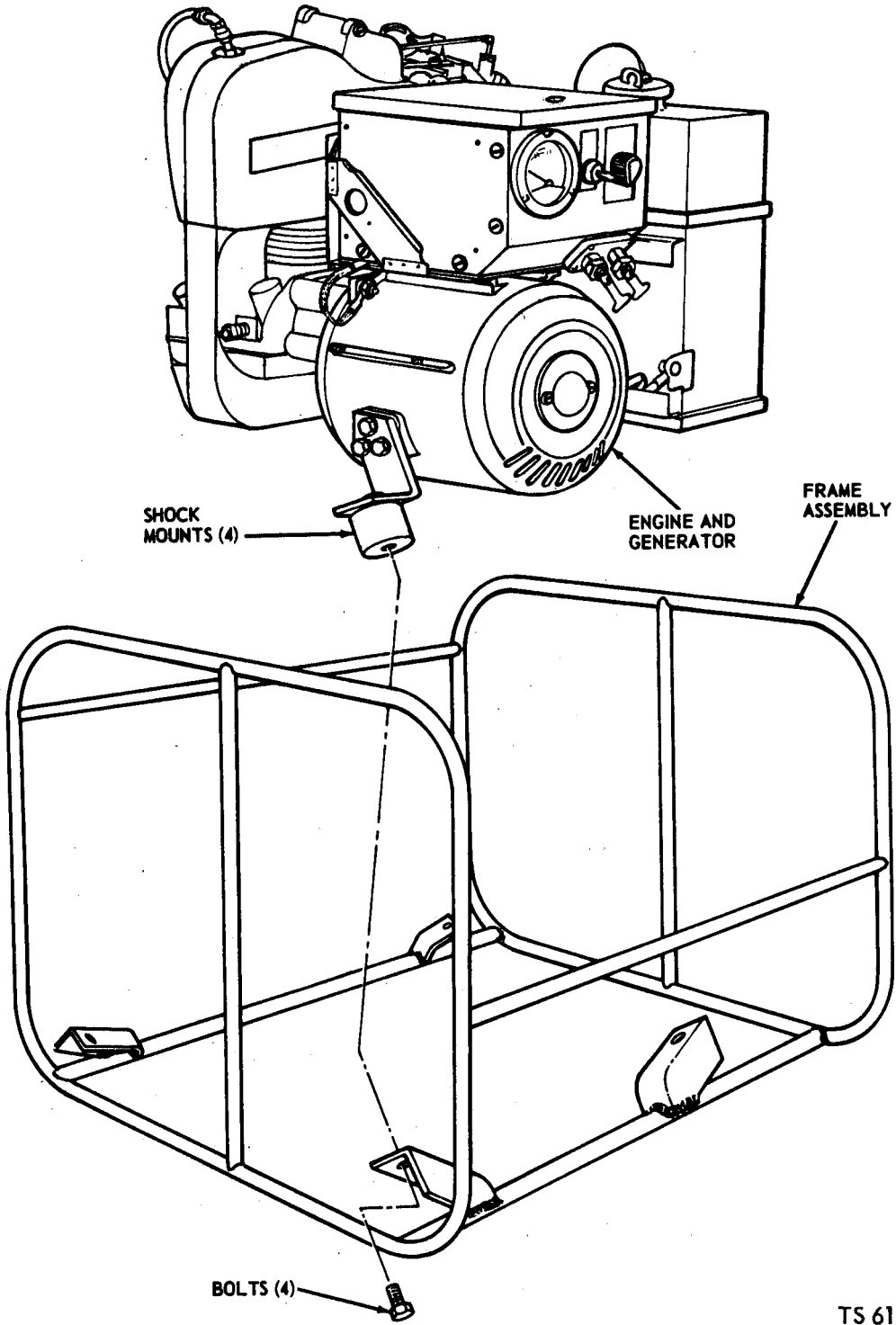

TS 6115-329-14/6-1

Figure 6-1. Frame assembly and shock mounts, removal and installation.

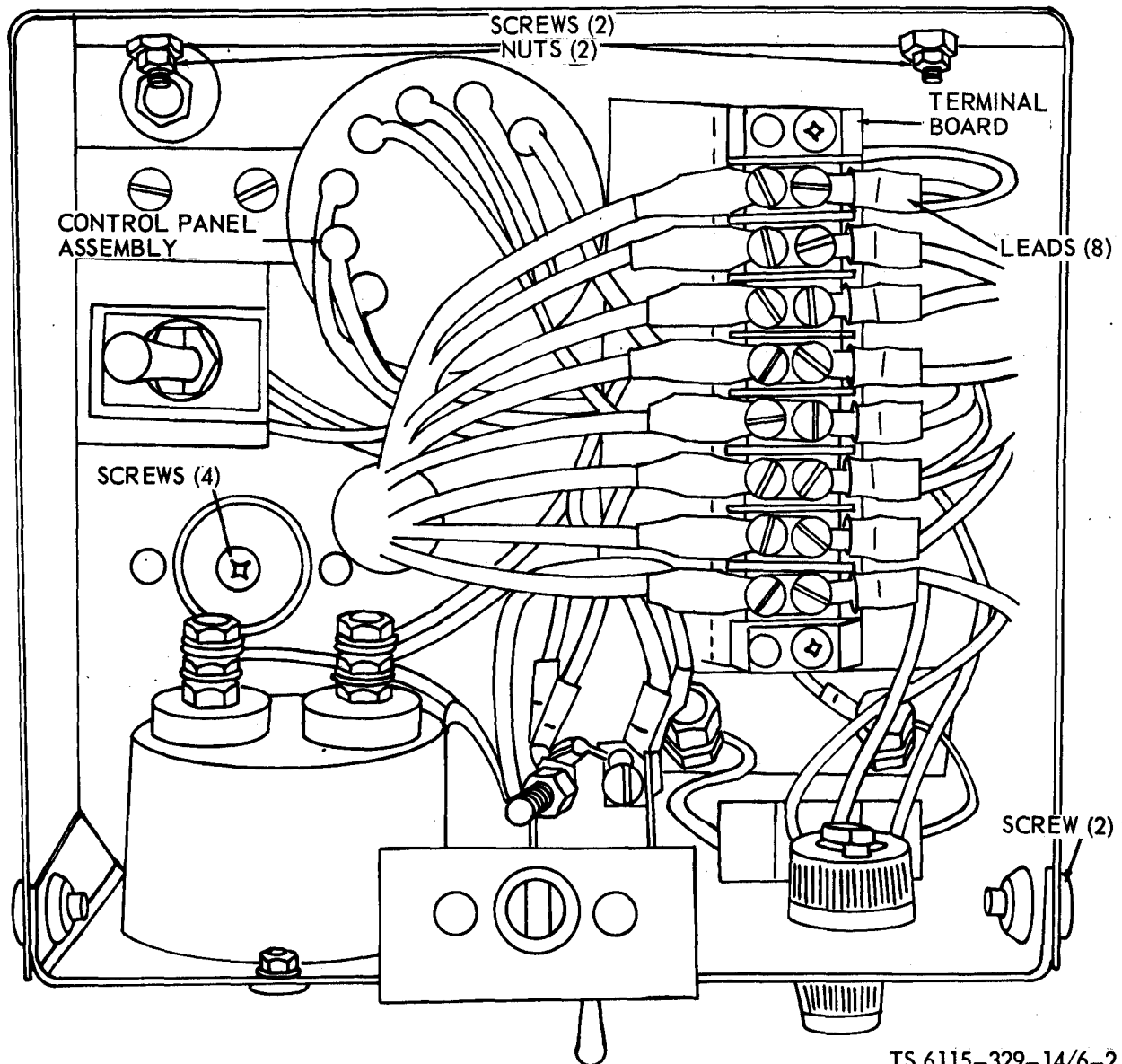
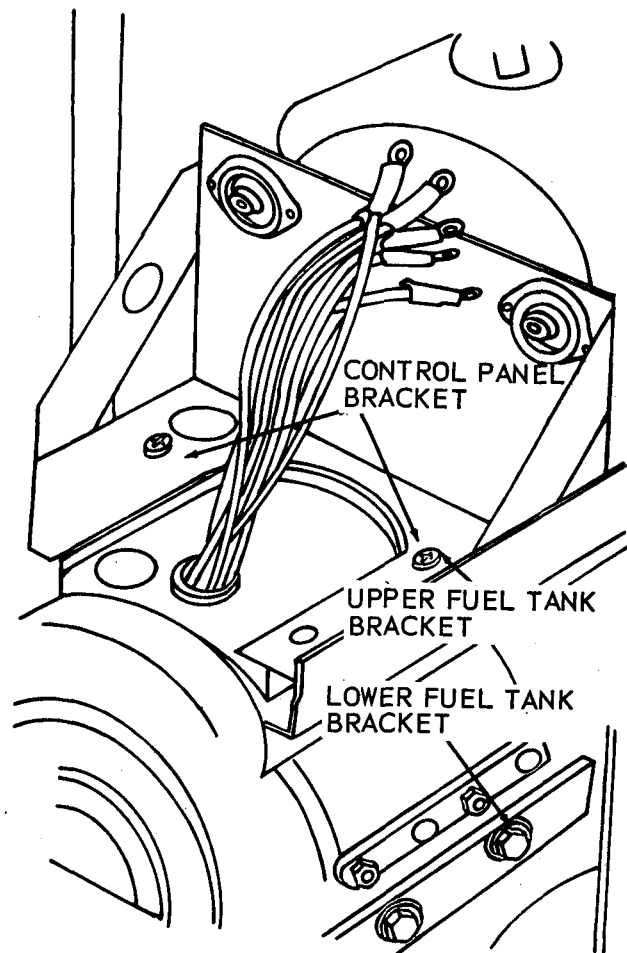
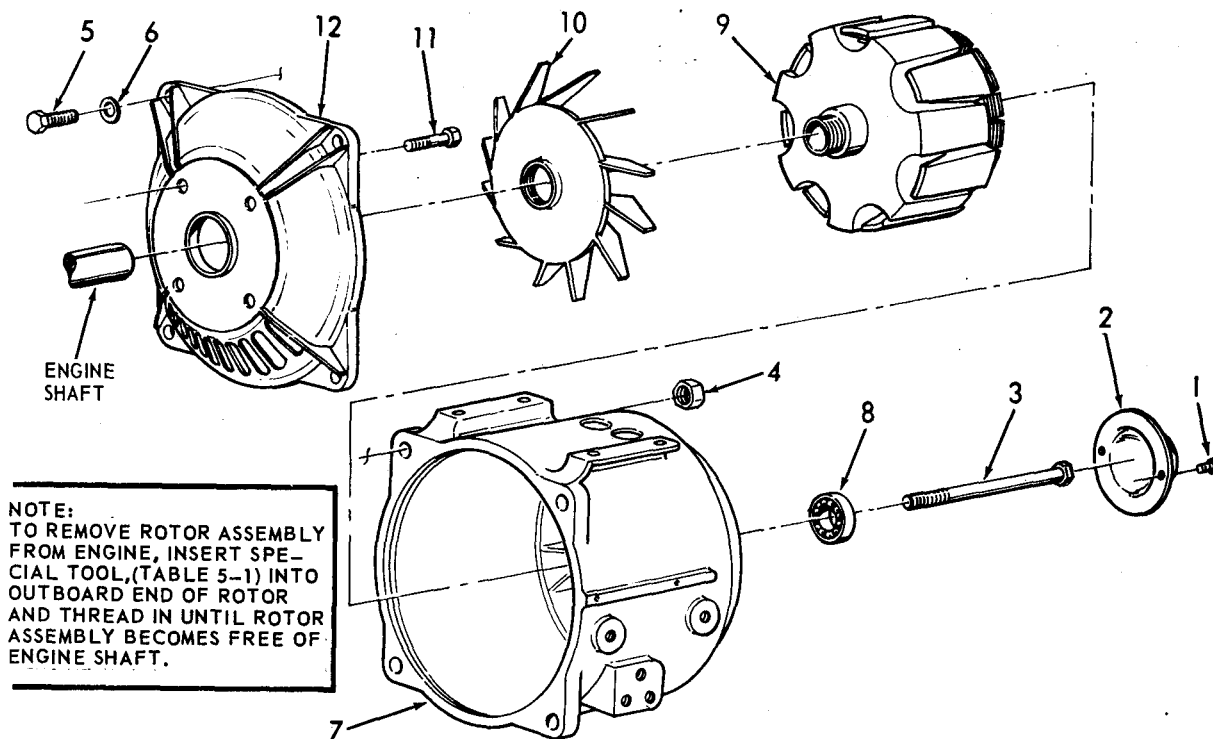

Figure 6-2. Control panel assembly, removal and installation.



TS 6115-329-14/6-3

Figure 6-3. Control panel bracket and fuel tank bracket, removal and installation.



TS 6115-329-14/6-4

1. Screw (2)
2. End cap
3. Bolt
4. Nut (4)
5. Bolt (4)
6. Washer (4)

7. Housing and stator
8. Bearing
9. Rotor
10. Fan
11. Bolt (4)
12. End bell

**Figure 6-4. Generator, removal and installation, exploded view.**

### 6-3. Control Panel Assembly

**a. Removal.** Refer to figure 6-2 and the following instructions to remove the control panel assembly.

- (1) Tag and disconnect leads from the terminal board (fig. 6-2).
- (2) Tag and disconnect leads from the control panel assembly (fig. 6-2).
- (3) Remove screw from ground strap.
- (4) Remove screws, washers, and nuts securing the control box assembly to the control panel mounting bracket and remove the control box assembly.

#### **b. Installation.**

- (1) Position control box assembly in place on mounting bracket and attach with screws, washers,

and nuts.

- (2) Attach ground strap.

(3) Reconnect leads to control panel and terminal board (fig. 6-2).

### 6-4. Generator

#### **a. Removal.**

- (1) Remove engine-generator from carrying frame (para 6-2a (1) and (2)).
- (2) Remove control panel assembly (para 6-3).
- (3) Disconnect fuel line from fuel pump (fig. 4-30).
- (4) Remove control panel bracket and fuel tank brackets from generator (fig. 6-3).
- (5) Remove screws (1, fig. 6-4) from end cap (2) and remove end cap.

- (6) Remove motor drive machine bolt (3).
- (7) Remove nuts (4), bolts (5), and washers (6) securing the generator housing and stator (7) to the engine end bell and remove housing and stator.
- (8) Remove bearing (8) from end of engine shaft.
- (9) Insert special tool (Table 5-1) into outboard end of rotor and thread until rotor assembly becomes free of shaft and remove rotor (9).
- (10) Remove fan (10) from rotor.
- (11) Remove bolts (11) securing engine end bell (12) to engine housing and remove end bell.

***b. Installation.***

- (1) Install engine end bell (12, fig. 6-4) to the engine housing with bolts (11).
- (2) Thread fan (10) onto rotor (9) and install fan and rotor on engine shaft.
- (3) Install bearing (8) on engine shaft.
- (4) Position housing and stator (7) in place on end bell and secure with washers (6), screws (5), and nuts (4).
- (5) Install motor drive machine bolt (3).
- (6) Install end cap (2) to generator housing with screws (1).
- (7) Refer to figure 6-3 and install control panel bracket and fuel tank bracket.
- (8) Attach fuel line (fig. 4-30).
- (9) Install control panel assembly (para 6-3).
- (10) Secure engine-generator assembly in carrying frame by installing bolts into shock mounts.

## CHAPTER 7

# MAINTENANCE OF THE ENGINE ASSEMBLY

---

### **7-1. General**

Refer to TM 5-2805-256-14/TO 38G2-102-2 for instructions pertaining to maintenance of the Mil-

itary Standard engine Model 1A08-3.





## CHAPTER 8

# MAINTENANCE OF THE FRAME ASSEMBLY

---

### 8-1. General

The frame assembly which is of welded tubular design, provides a means by which to move the generator set and also provides a housing to inclose the engine, main generator, generator control panel and fuel tank. Four (4) shock mounts are utilized to absorb vibration when the generator set is operating.

### 8-2. Frame

**WARNING**

**Clean all parts in a well-ventilated area. Avoid inhalation of solvent fumes and prolonged exposure of skin to cleaning solvent. Wash exposed skin thoroughly. Dry cleaning solvent (Fed. Spec. P-D-680) used to clean parts is potentially dangerous to personnel and property. Do not use near open flame or excessive heat. Flash point of solvent is 100° to 138°F. (38° to 59°C. ).**

**a. Removal.** Refer to figure 6-1 and the following instructions to remove the frame.

- (1) Remove bolts from shock mounts.
- (2) Remove engine-generator from carrying frame.

**b. Cleaning.** Clean the frame assembly using cleaning solvent, Fed. Spec. P-D-680, and dry thoroughly.

**c. Inspection and Repair.** Inspect frame assembly for cracks, dents, distortion, breaks, or for broken welds. Straighten distortion, weld cracks or

breaks and grind smooth. Replace a frame that is damaged beyond repair.

**d. Painting.** Spot paint or repaint frame assembly as required. Refer to TM 43-0139 for painting instructions. Air Force personnel refer to TO 35-1-3.

**e. Installation.**

- (1) Position engine-generator in carrying frame.
- (2) Secure by installing bolts into shock mounts.

### 8-3. Shock Mounts

**a. Removal.** Refer to figure 6-1 and the following instructions to remove the shock mounts.

- (1) Remove bolts from shock mounts securing engine-generator in carrying frame.
- (2) Remove engine-generator from carrying frame.
- (3) Remove bolts and washers securing shock mounts in mounting brackets.
- (4) Remove shock mounts.

**b. Cleaning.** Clean the shock mounts using a clean cloth.

**c. Inspection and Repair.** Inspect shock mounts for cracks, breaks, chunking, dry rot, missing rubber or for an oil soaked condition. Replace defective mounts.

**d. Installation.**

- (1) Secure shock mounts to mounting brackets with washers and bolts.
- (2) Position engine-generator in carrying frame and secure to frame by installing bolts into shock mounts.



## CHAPTER 9

# MAINTENANCE OF THE CONTROL PANEL ASSEMBLY

---

### Section I. PANEL ASSEMBLY

#### 9-1. General

The control panel assembly houses the necessary instruments and controls needed for the operation of the generator set. They include the voltage regulator, terminal board assembly, rectifiers, voltmeter, load switch, rheostat, duplex receptacle, terminal load, percent load meter (DOD model MEP-024A only), radio interference suppression components, and wiring. All components are accessible by raising the hinged panel.

#### 9-2. Panel Assembly

**WARNING**

**Clean all parts in a well-ventilated area. Avoid inhalation of solvent fumes and prolonged exposure of skin to cleaning solvent. Wash exposed skin thoroughly. Dry cleaning solvent (Fed. Spec. P-D-680) used to clean parts is potentially dangerous to personnel and property. Do not use near open flame or excessive heat. Flash point of solvent is 100° to 138°F. (38° to 59°C.).**

**a. Removal.** Refer to figure 6-2 and the following instructions to remove the control panel assembly.

(1) Tag and disconnect leads from the terminal board.

(2) Tag and disconnect leads from the control panel assembly.

(3) Remove screw from ground strap.

(4) Remove screws, washers, and nuts securing the control box assembly to the control panel mounting bracket and remove the control box assembly.

**b. Cleaning.**

(1) Clean the components of the control panel assembly using a clean lint-free cloth and dry low pressure compressed air.

(2) Clean control panel with a clean cloth dampened in cleaning solvent, Fed. Spec. P-D-680, and dry thoroughly.

**CAUTION**

**Do not allow cleaning solvent to come into contact with components of the control panel assembly.**

**c. Inspection and Repair.** Inspect control panel for dents, breaks, distortion, or other damage. Straighten dents and distortion. Replace a control panel damaged beyond repair.

**d. Installation.**

(1) Position control box assembly in place on mounting bracket and attach with screws, washers, and nuts.

(2) Attach ground strap.

(3) Reconnect leads to control panel and terminal board (fig. 6-2).

### Section II. CAPACITORS

#### 9-3. General

Refer to TM 11-483 for definitions, purposes, source and methods used to obtain proper radio suppression.

#### 9-4. Interference Suppression Components

The capacitor mounted in the control panel assembly is an isolated case, 0.1 microfarad, 600 volt, direct-current, 125° Centigrade capacitor.

#### 9-5. Replacement of Suppression Components

**a. Removal.**

(1) Refer to paragraph 9-2 a. and remove control panel assembly.

(2) Refer to figure 9-1 and the following instructions to remove radio interference suppression components.

(a) Tag leads.

(b) Remove nuts securing leads.

(c) Drill out rivet and remove capacitor.

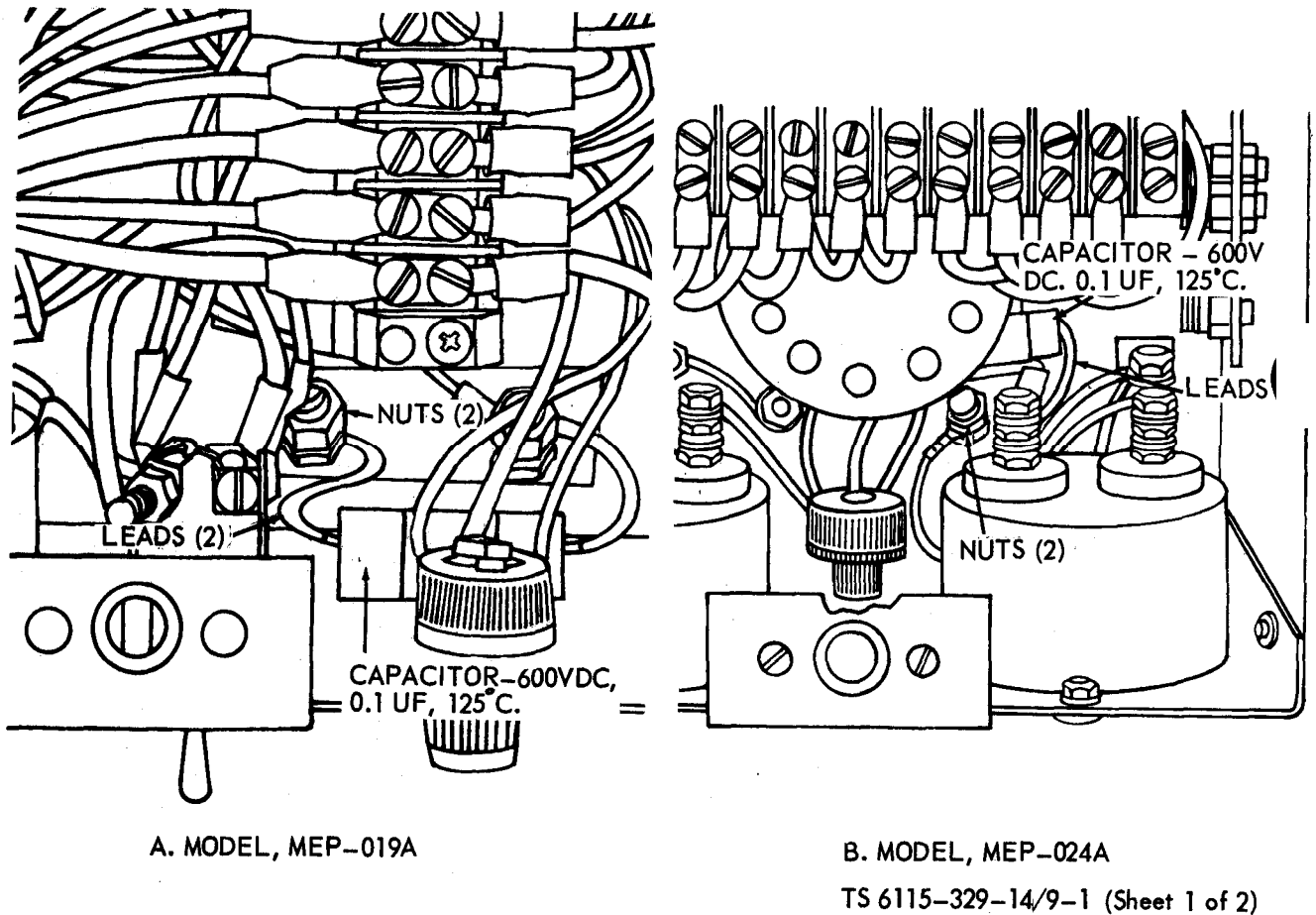
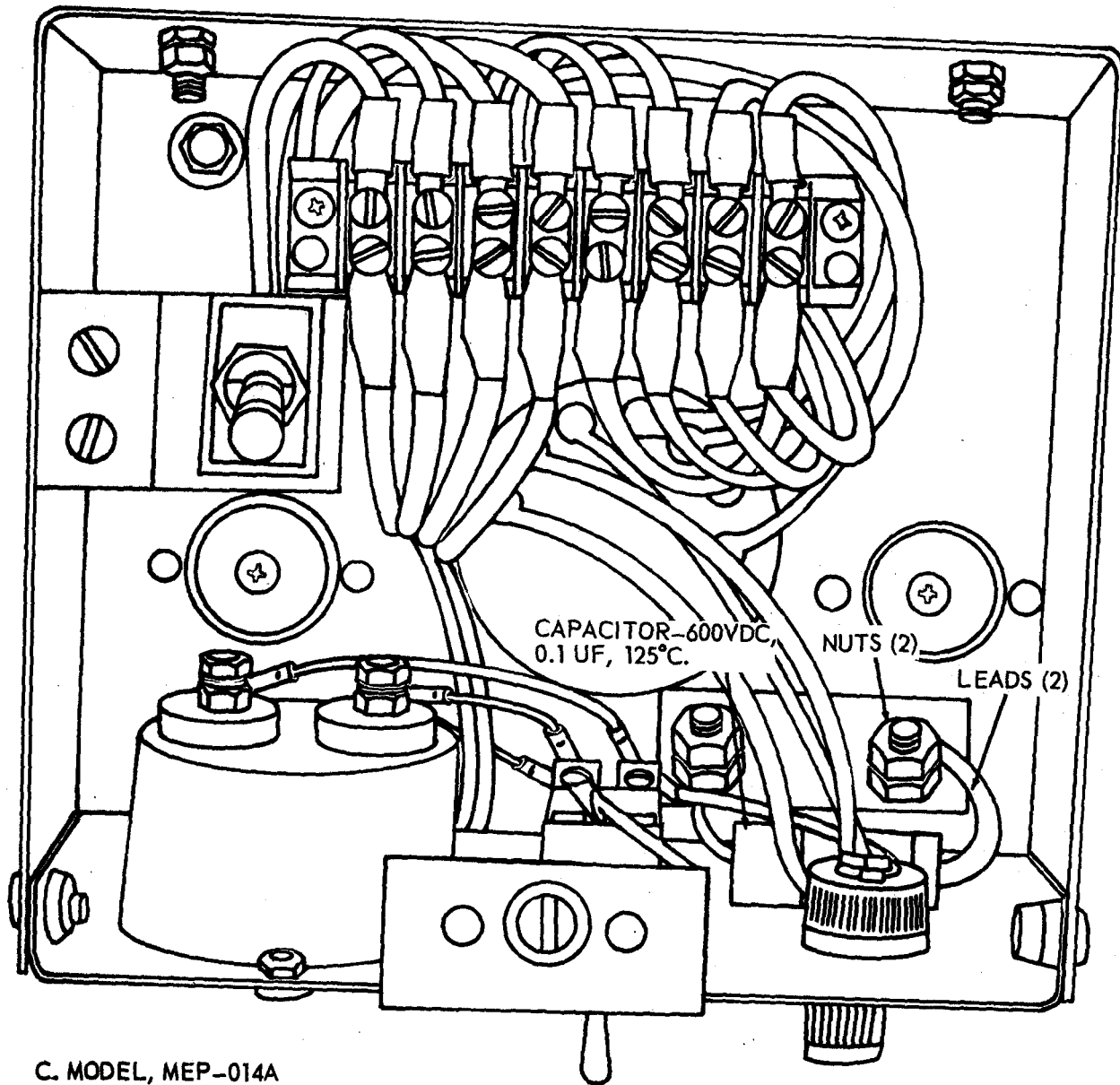

Figure 9-1. Radio interference suppression components, removal and installation (sheet 1 of 2).



C. MODEL, MEP-014A

TS 6115-329-14/9-1 (Sheet 2 of 2)

Figure 9-1. Radio interference suppression components, removal and installation, (sheet 2 of 2).

**b. Testing and Repair.** Test capacitor for leaks and shorts on a capacitor test. Replace defective capacitor.

**c. Installation.**

(1) Position capacitor in place and install riv-

et.

(2) Reconnect leads.

(3) Refer to paragraph 9-2 d. and install control panel assembly.

## Section III VOLTAGE REGULATOR

### 9-6. Voltage Regulator

#### a. Removal.

(1) Refer to paragraph 9-2 a. and remove control panel assembly.

(2) Refer to figure 9-2 and the following instructions to remove voltage regulator.

(a) Tag and disconnect leads from the voltage regulator.

(b) Remove nuts securing the voltage regulator in the control box.

(c) Remove voltage regulator.

**b. Cleaning.** Clean the voltage regulator housing using a clean lint-free cloth.

**c. Inspection and Repair.** Inspect voltage regulator for cracked housing and for evidence of overheating. Replace defective voltage regulator.

#### d. Installation.

(1) Position voltage regulator in place in the control box.

(2) Secure with nuts.

(3) Reconnect leads.

(4) Refer to paragraph 9-2 d. and install the control panel assembly.

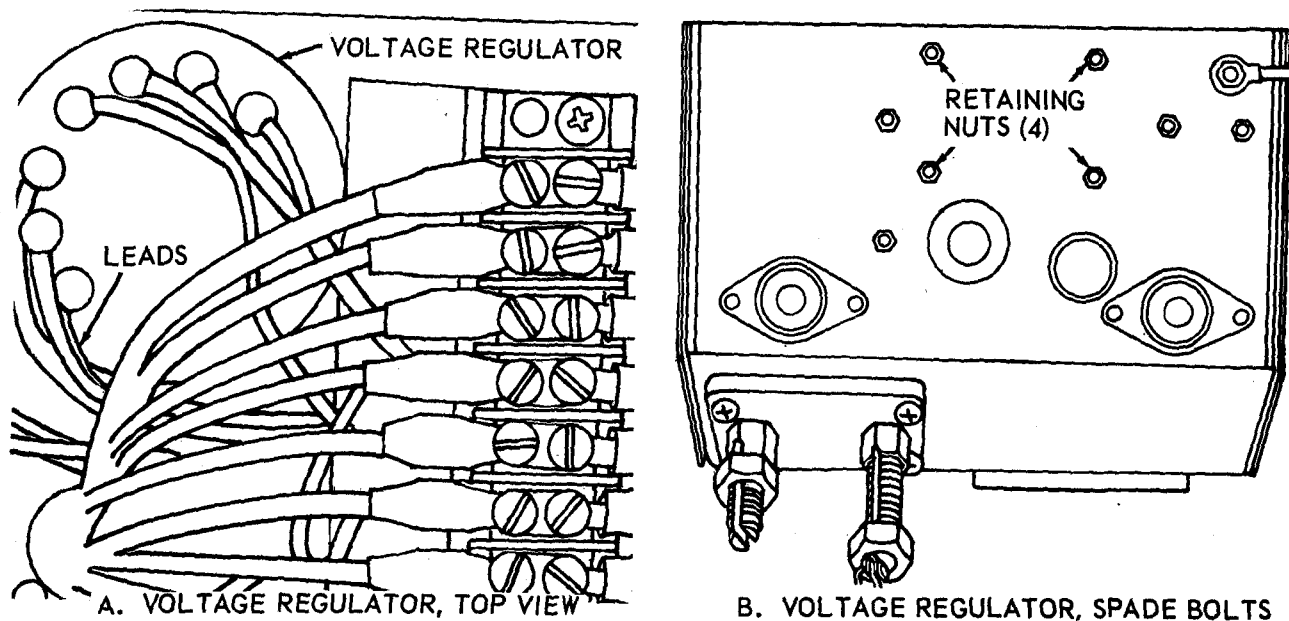

TS 6115-329-14/9-2

Figure 9-2. Voltage regulator, removal and installation.

## Section IV. TERMINAL BOARD

### 9-7. Terminal Board Assembly

**a. Removal.** Refer to figure 9-3 and the following instructions to remove terminal board assembly.

(1) Tag and disconnect leads from the termi-

nal board assembly.

(2) Remove screws securing the terminal board to the control box assembly.

(3) Remove terminal board.

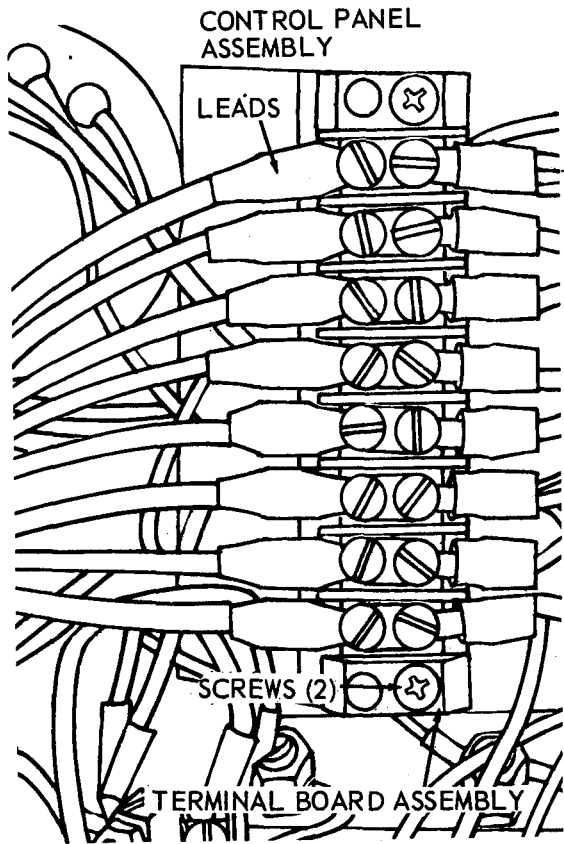

A. MODEL, MEP-019A

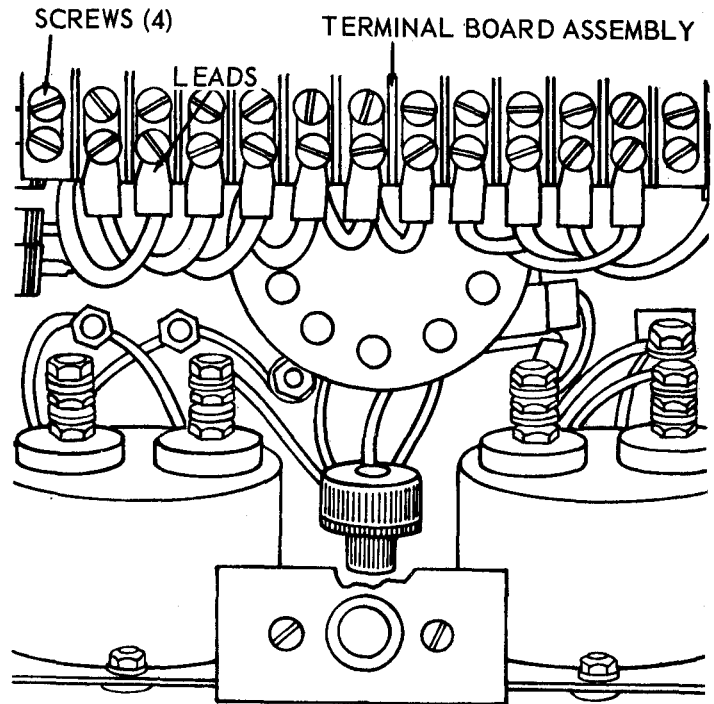

B. MODEL, MEP-024A

TS 6115-329-14/9-3 (Sheet 1 of 2)

Figure 9-3. Terminal board assembly, removal and installation (sheet 1 of 2).

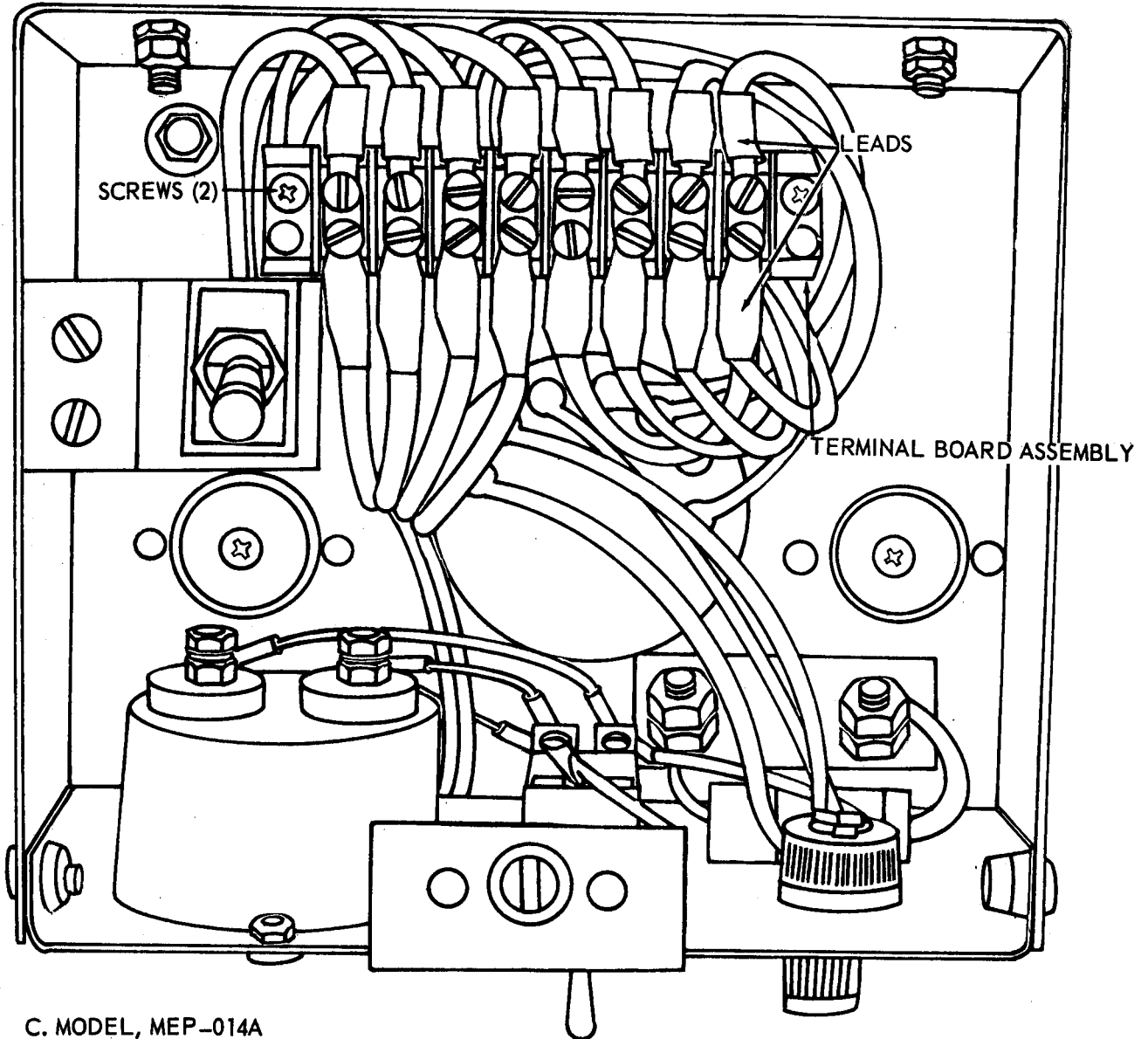

TS 6115-329-14/9-3 (Sheet 2 of 2)  
*Figure 9-3. Terminal board assembly, removal and installation (sheet 2 of 2).*

**b. Cleaning.** Clean the terminal board using a clean cloth and dry low pressure compressed air.

**c. Inspection and Repair.** Inspect terminal board for corroded terminals, cracks, breaks, or other damage. Replace defective terminal board.

**d. Installation.**

(1) Position terminal board in place and secure with screws.

(2) Reconnect leads to terminal board.

## Section V. RECTIFIER

### 9-8. Rectifier

**a. Removal.**

(1) Refer to paragraph 9-7 a. and remove terminal board assembly.

minal board assembly.

(2) Refer to figure 9-4 and the following instructions to remove rectifiers.



- (a) Tag and disconnect leads from rectifier.
- (b) Remove nut securing rectifier to the terminal board assembly mounting bracket.

- (c) Remove rectifier.
- (d) Remove other defective rectifier(s) in the same manner.

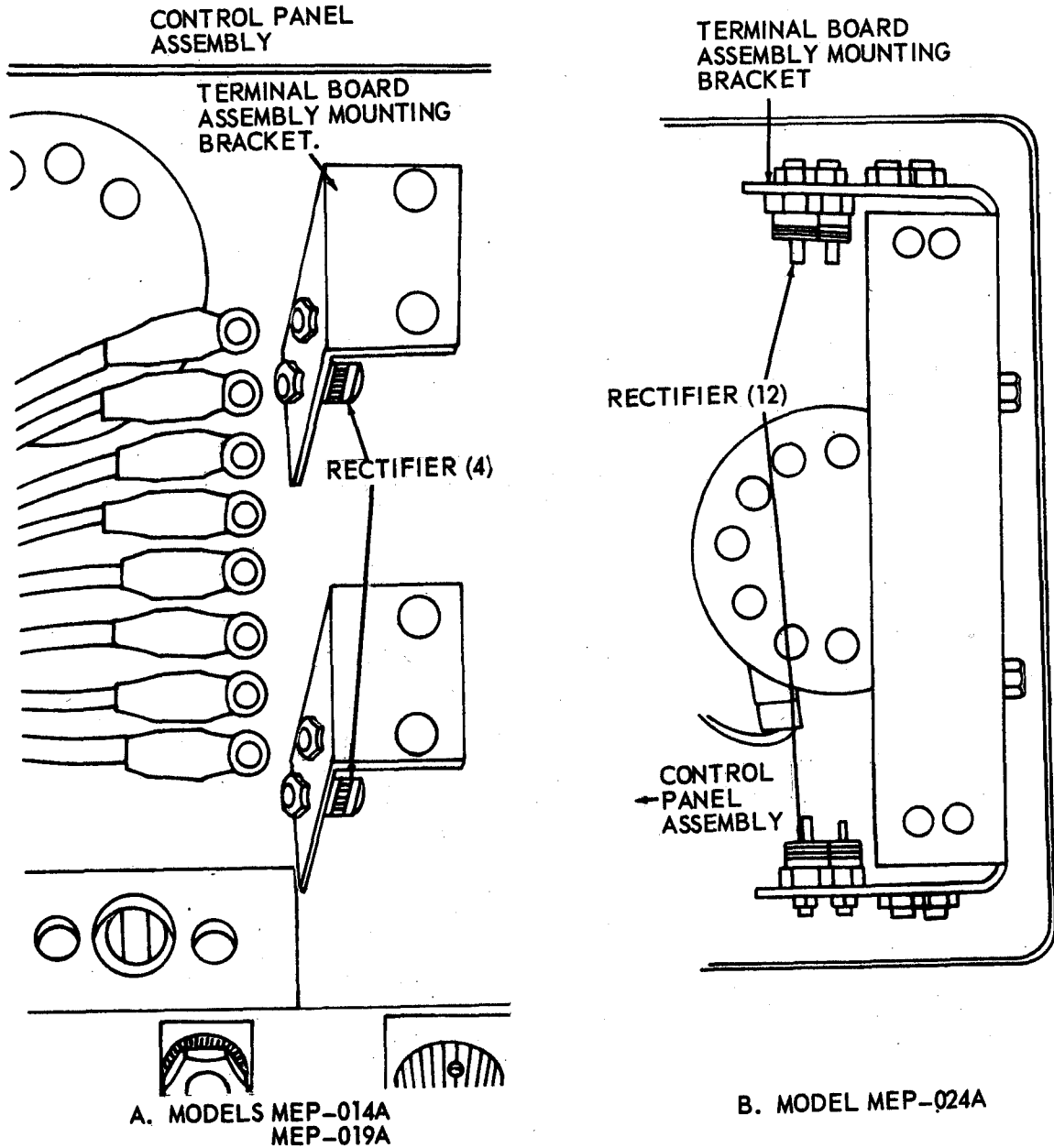

Figure 9-4. Rectifier, removal and installation.

**b. Cleaning.** Clean the rectifiers using a clean lint-free cloth and dry low pressure compressed air.

**c. Inspection and Repair.** Inspect rectifiers for cracks, breaks, and for evidence of overheating. Replace defective rectifier(s) as required.

**d. Installation.**

(1) Install rectifier to mounting bracket with nut.

(2) Reconnect leads.

(3) Refer to paragraph 9-7 d. and install terminal board assembly.

**e. Test.**

(1) Models MEP-019A and MEP-014A.

(a) Disconnect wires V9B16, X1B16, and

V10B16, from the terminal board.

(b) Check the front-to-back resistance ratio of each rectifier with an ohmmeter. Ratio should be at least 100,000/1 with the forward resistance being 10 ohms maximum.

(2) Model MEP-024A.

(a) Disconnect wires V9B14, X76B14, X5B14, X4B14, X3B14, X2B14, and X1B14 from the terminal board.

(b) Check the front-to-back resistance ratio of each rectifier with an ohmmeter. Ratio should be at least 100,000/1 with the forward resistance being 10 ohms maximum.

## Section VI. WIRING HARNESS

### 9-9. Wiring and Wire Harness

**a. General.** All of the generator set wiring can be identified by identification numbers on the wire.

**b. Testing and Replacement.** To test, disconnect both ends of the wire under test. Touch the probes of the multimeter to each end of the wire. If an open circuit is indicated, replace the wire. Al-

ways use a wire of at least equal size. Individual wires may be substituted for the defective wires in a wiring harness by running a new wire along side the harness. Tape, lace, or use plastic wire straps to secure the wire and make it an integral part of the harness.

## Section VII. SHOCK MOUNTS

### 9-10. Shock Mounts

**a. Removal.**

(1) Refer to paragraphs 4-22, 4-23, 4-25, 4-27, 4-29, 6-3, 9-6, 9-7, and 9-8 and remove the rheostat, voltmeter, load on/off switch, voltage control switch, terminal, load, control panel, voltage regulator, terminal board assembly and rectifiers.

(2) Refer to figure 9-5 and the following in-

structions to remove the shock mounts.

(a) Drill out rivets securing the control panel assembly shock mounts to the control panel.

(b) Remove shock mounts.

(c) Remove shock mounts from the control panel mounting bracket in the same manner.

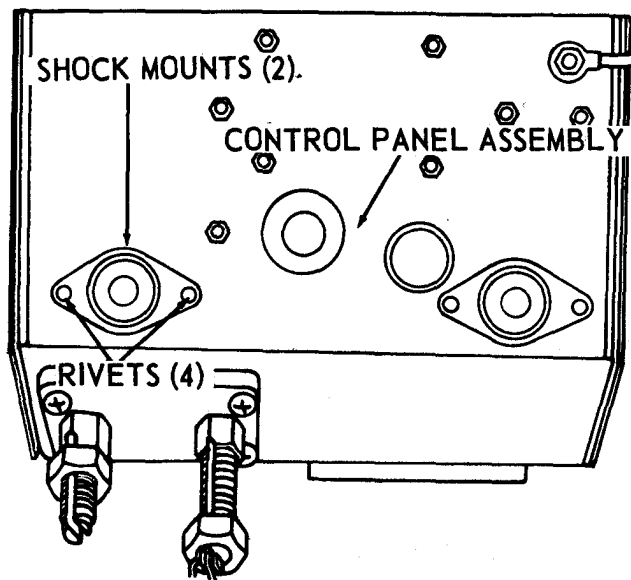

A. Shock Mounts, Control Panel.

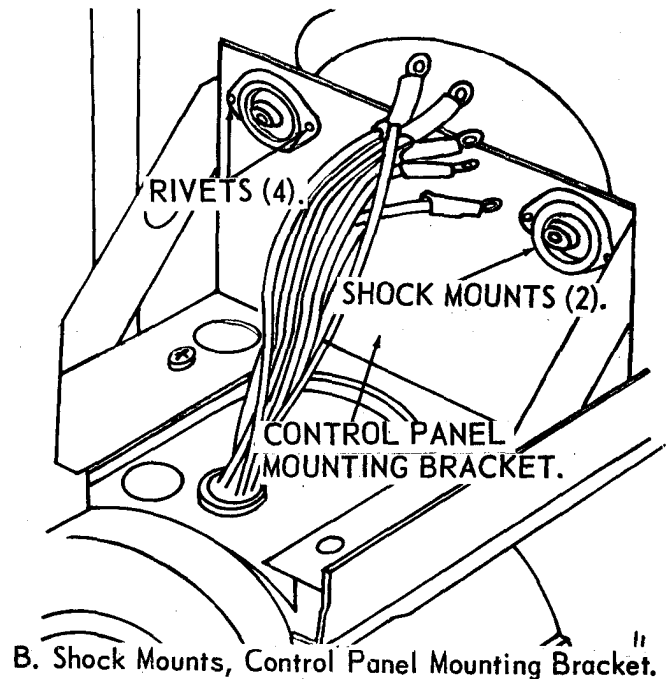

B. Shock Mounts, Control Panel Mounting Bracket.

TS 6115-329-14/9-5

Figure 9-5. Shock mount, removal and installation.

**b. Cleaning.** Clean shock mounts using a clean cloth and dry low pressure compressed air.

**c. Inspection and Repair.** Inspect shock mounts for cracks, breaks, chunking, dry rot or for an oil soaked condition. Replace shock mounts as required.

**d. Installation.**

(1) Position shock mounts in place on control panel.

(2) Install rivets.

(3) Install shock mounts on control panel mounting bracket in the same manner.

(4) Refer to paragraphs 9-8, 9-7, 9-6, 6-3, 4-29, 4-27, 4-25, 4-23, and 4-22 and install the rectifiers, terminal board assembly, voltage regulator, control panel, terminal load, voltage control switch, load on/off switch, voltmeter, and rheostat.



## CHAPTER 10

# MAINTENANCE OF THE GENERATOR

### 10-1. General

The generator housing is directly coupled to the Military Standard engine. The generator is a direct drive alternator type, single phase, fully inclosed with fan type cooling and sealed bearings.

### 10-2. On-Equipment Testing

On-Equipment electrical test procedures may provide a basis for determining the necessity and extent of generator repair. Take into consideration the test instrument used, test lead resistance, and the ambient temperature at the time of the test. If more precise measurements are required, use an instrument such as a Kelvin Balance or a Wheatstone Bridge and make comparative measurements between the suspected component and a like item that is known to be good.

### 10-3. Generator

#### WARNING

**Clean all parts in a well-ventilated area. Avoid inhalation of solvent fumes and prolonged exposure of skin to cleaning solvent. Wash exposed skin thoroughly. Dry cleaning solvent (Fed. Spec. P-D-680) used to clean parts is potentially dangerous to personnel and property. Do not use near open flame or excessive heat. Flash point of solvent is 100° to 138°F. (38° to 59°C.).**

#### *a. Removal and Disassembly.*

- (1) Remove engine-generator from carrying frame (para. 8-2).
- (2) Remove control panel assembly (para. 9-2).
- (3) Disconnect fuel line from fuel pump (fig. 4-30).
- (4) Remove screws securing control panel bracket to generator housing and remove bracket from generator (fig. 6-3).
- (5) Remove screws and washers securing the upper and lower fuel tank brackets to the generator housing and remove brackets.
- (6) Remove screws (1, fig. 6-4) from end cap

(2) and remove end cap.

(7) Remove motor drive machine bolt (3).

(8) Remove nuts (4), bolts (5), and washers (6) securing the generator housing and stator (7) to the engine end bell and remove housing and stator.

(9) Remove bearing (8) from end of engine shaft.

(10) Insert special tool (table 5-1) into out-board end of rotor and thread in until rotor assembly becomes free of shaft and remove rotor (9).

(11) Remove fan (10) from rotor.

(12) Remove bolts (11) securing engine end bell (12) to engine housing and remove end bell.

#### *b. Cleaning.*

(1) Clean the adapter, fan, and outside surface of the generator housing with a cloth dampened in cleaning solvent, Fed. Spec. P-D-680, and dry thoroughly.

(2) Clean stator and rotor using dry low pressure compressed air.

#### *c. Inspection and Repair.*

(1) Inspect bearing for a binding or sticking condition and for excessive wear. Replace defective bearing.

(2) Inspect adapter and fan for cracks or breaks. Replace defective adapter or fan.

(3) Inspect rotor and stator for damaged coils, faulty insulation and for evidence of overheating. Replace defective rotor or stator.

#### *d. Assembly and Installation.*

(1) Install engine end bell (12, fig. 6-4) to the engine housing with bolts (11).

(2) Thread fan (10) onto rotor (9) and install fan and rotor on engine shaft.

(3) Install bearing (8) on engine shaft.

(4) Position housing and stator (7) in place on end bell and secure with washers (6), screws (5), and nuts (4).

(5) Install motor drive machine bolt (3).

(6) Install end cap (2) to generator housing with screws (1).

(7) Install control panel mounting on the generator housing.

(8) Install the upper and lower fuel tank brackets to the generator housing.

(9) Attach fuel line (fig. 4-30).

(10) Install control panel assembly (para. 9-2).

(11) Install engine-generator in carrying frame.



# CHAPTER 11

## GENERATOR SET TEST AND INSPECTION AFTER REPAIR OR OVERHAUL

---

### Section I. GENERAL REQUIREMENTS

#### 11-1. General

The activity performing the repair or overhaul is responsible for the performance of all applicable test and inspections specified herein.

Activities performing maintenance on any portion of the generator set must perform those tests and inspection required by the applicable component or system repair instruction.

### Section II. INSPECTION

#### 11-2. Inspection

A complete visual inspection of the generator set shall be made after the generator set has been overhauled/repared in accordance with requirements contained in this manual or referenced. Attention shall be given to the following items:

**a.** Paint shall be uniform and free from runs, sags, blisters, peeling, overspray and other imperfections.

**b.** Data plates and decals shall be free of paint and overspray.

**c.** All gages must be free of dirt and moisture in the interior of the gage. Gage markings must be legible and glass must not be cracked or broken.

**d.** Controls and switches must operate freely.

**e.** Attaching hardware and fittings shall be installed and tight.

**f.** The general appearance of the generator set shall be in like new condition.

### Section III. OPERATIONAL TESTS

#### 11-3. Operational Testing

**a.** Using the visual and operational check list (Table 11-1) visually inspect and operationally test the generator set for a minimum of four hours as follows :

- (1) 1/4 Hour Warm Up.
- (2) 1 Hour 1/2 Load at .8 Power Factor.
- (3) 2-1/4 Hours Full Load at .8 Power Factor.
- (4) 1/4 Hour 125% Load at .8 Power Factor.
- (5) 1/4 Hour Idle.

**b.** During the test period the following operational checks will be made.

(1) The proper operation of all components under no load and full capacity load conditions.

(2) Proper function and adjustment of all instruments, controls and gages.

(3) Overheating, vibration and unusual noises.

(4) Record voltage, current, powerfactor, frequency and temperature readings at the above loads.

(5) Check operation of control and protective equipment while conducting the test run and when the test run periods are completed and the load gradually removed, shut down the unit, after the 1/4 hour idle period.

(6) Oil and fuel.

#### CAUTION

**If during the operational test excessive noise or vibration is observed or any overheating or malfunctions occur which may cause damage to the equipment, stop operation immediately until necessary repairs are made.**

(7) If the malfunction is minor and will not damage the unit, the tests may continue and defects corrected upon completion of tests.

(8) Inspect for proper functioning, com-

ponents which have been overhauled or repaired.

(9) Presence of one or more defects shall be cause for rejection until acceptable repair has been made. If repair is required to a major component, repeat the entire operational test.

**Table 11-1. Visual and Operational Inspection**

<b>Inspection Point</b>	<b>Condition</b>
1. Data Plates	<p><b>a.</b> Must be tightly affixed and legible.</p> <p><b>b.</b> Missing plates must be replaced.</p>
2. Overall	<p><b>a.</b> All fuel lines, wiring and covers shall be properly attached and in good condition.</p> <p><b>b.</b> All bolts and screws shall be of the proper size, have the required washers, and be securely tightened.</p> <p><b>c.</b> Grease fittings shall be undamaged.</p>
3. Items Troop Installed or Authorized	All items must be accounted for, and in condition comparable to new.
4. Engine	The engine must operate efficiently with no unusual noises and should show no signs of overheating during or after operating under full load for a period of one hour.
5. Fuel System	<p><b>a.</b> Fuel tank must be free of contamination and rust.</p> <p><b>b.</b> Fuel cap gasket must be in good condition and strainer must be clean.</p> <p><b>c.</b> Fuel lines must be secure and free of sharp bends.</p> <p><b>d.</b> There must be no evidence of leaks.</p>
6. Engine Electrical System	<p><b>a.</b> All wiring must be adequately insulated and securely fastened.</p> <p><b>b.</b> Cables shall be in comparable to new condition and wiring harness shall be securely attached.</p>
7. Control Box and Instruments	<p><b>a.</b> Control box shall be securely attached.</p> <p><b>b.</b> Gages shall be clean and legible.</p> <p><b>c.</b> Switches and controls shall operate freely.</p> <p><b>d.</b> Wiring and wiring harness shall be attached securely.</p>
8. Generator	<p><b>a.</b> Generator must be securely mounted and rotor shaft securely attached to the flywheel.</p> <p><b>b.</b> During operation, there shall be no excessive noise or vibration.</p> <p><b>c.</b> Conduct a load test to insure that the set is operable and that all meters are functioning properly.</p>



*Table 11-1. Visual and Operational Inspection (Cont'd)*

<b>Inspection Point</b>	<b>Condition</b>
9. Radio Interference Suppression	All interference suppression components shall be installed and securely fastened.
10. Frame and Components	<p><b>a.</b> The frame and shock mounts shall be securely attached, and shall support the generator and engine without buckling when raised, moved or skidded.</p> <p><b>b.</b> Welded parts shall be free from breaks or cracks at the weld.</p> <p><b>c.</b> All mounting brackets shall be securely attached.</p> <p><b>d.</b> Paint shall be as specified for all components of the generator set.</p>



## APPENDIX A

### REFERENCES

---

- A-1. Fire Protection**  
TM 5-4200-200-10 Hand Portable Fire Extinguishers Approved for Army Users.
- A-2. Lubrication**  
LO 5-2805-256-14 Engine, Gasoline: Military Standard.  
C 9100 IL Fuels, Lubricant, Oils and Waxes.  
TO 35C2-3-1-426WC-3-4-1 (F) Preventive Maintenance Workcards.
- A-3. Painting**  
TM 43-0139 Painting Instructions for Field Use.  
TO 35-1-3 (F) Painting and Marking of USAF AGE
- A-4. Radio Suppression**  
TM 11-483 Radio Interference Suppression.
- A-5. Shipment and Storage**  
TM 740-90-1 Administrative Storage of Equipment  
TB 740-93-2 Preservation of USATROSCOM Mechanical Equipment for Shipment and Storage.
- A-6. Maintenance**  
AFM 66-1 (F) AF Maintenance Management  
TM 5-764 Electric Motor and Generator Repair.  
TM 5-766 Electric Power Generator in the Field.  
TM 5-2805-256-14/TO 38G2-102-2 Engine, Gasoline: Military Standard (Models 1A08-3) 1-1/2 HP (Model 2A016-3) 3 HP.  
TM 5-2805-256-14P/TO 38G2-102-4 Operator, Organizational and Field Maintenance  
Repair Parts and Special Tools List.  
TM 38-750 Army Equipment Record Procedures.  
TM 5-6115-329-24P Organizational, Intermediate (Field), (Direct Support and General Support), and Depot Maintenance Repair Parts and Special Tools List.  
TO 35C2-3-1-426 (F) Inspection and Maintenance FSC-6115 Engine Driven AGE.



**APPENDIX B  
BASIC ISSUE ITEMS LIST AND ITEMS  
TROOP INSTALLED OR AUTHORIZED**

**Section I. INTRODUCTION**

**B-1. Scope**

This appendix lists Basic Issue Items, Items Troop Installed or authorized which accompany the DOD generator set and are required by the Crew/Operator for Operation, installation, or operator's maintenance.

**B-2. General**

This basic issue items, items troop installed or authorized list is divided into the following sections:

*a. Basic Issue Items List - Section II.* Not applicable.

*b. Item Troop Installed or Authorized List - Section III.* A list in alphabetical sequence of items which at the discretion of the unit commander may accompany the end item, but are NOT subject to be turned in with the end item.

**B-3. Explanation of Columns**

The following provides an explanation of columns in the tabular list of Basic Issue Items List, Section II, and Items Troop Installed or Authorized, Section III.

*a. Source, Maintenance and Recoverability Code(s) (SMR).* Not applicable.

*b. National Stock Number.* This column indicates the National stock number assigned to the item and will be used for requisitioning purposes.

*c. Description.* This column indicates the Federal item name and any additional description of the item required.

*d. Unit of Measure (U/M).* A two-character alphabetic abbreviation indicating the amount or quantity of the item upon which the allowances are based, e.g., ft, ea, pr, etc.

*e. Quantity Authorized (Items Troop Installed or Authorized Only).* This column indicates the quantity of the item authorized to be used with the equipment.

**Section III. ITEMS TROOP INSTALLED OR AUTHORIZED LIST**

(1) SMR Code	(2) National Stock Number	(3) Description	(4) Unit of Meas	(5) Qty Auth
		Ref No. & Mfr Code	Usable on Code	
	2910-00-066-1235	ADAPTER, DRUM	EA	1
	6115-00-990-8770	COVER, CANVAS	EA	1
	4210-00-555-8837	EXTINGUISHER, FIRE	EA	1
	4720-00-814-0321	HOSE ASSEMBLY, AUXILIARY	EA	1
	5975-00-878-3791	ROD ASSEMBLY, GROUND: 9 ft. 5/8 in. dia	EA	1
		(271 .5875 cm) 3 sections		
	2990-01-032-0755	ARRESTOR, SPARK, EXHAUST	EA	2
		13215E4080	97403	



## APPENDIX C

# MAINTENANCE ALLOCATION CHART (FOR ARMY ONLY)

---

### Section I. INTRODUCTION

#### C-1. General

**a.** This section provides a general explanation of all maintenance and repair functions authorized at various maintenance levels.

**b.** Section II designates overall responsibility for the performance of maintenance functions on the identified end item or component and the work measurement time required to perform the functions by the designated maintenance level. The implementation of the maintenance functions upon the end item or component will be consistent with the assigned maintenance functions.

**c.** Section III lists the tools and test equipment required for each maintenance function as referenced from Section II.

#### C-2. Explanation of Columns in Section II

**a. Column 1, Group Number.** Column 1 lists group numbers to identify related components, assemblies, subassemblies, and modules with their next higher assembly. The applicable groups are listed in the MAC in disassembly sequence beginning with the first group removed.

**b. Column 2, Component/Assembly.** This column contains the noun names of components, assemblies, subassemblies and modules for which maintenance is authorized.

**c. Column 3, Maintenance Functions.** This column lists the functions to be performed on the item listed in Column 2. The maintenance functions are defined as follows:

**(1) Inspect.** To determine serviceability of an item by comparing its physical, mechanical, and/or electrical characteristics with established standards through examination.

**(2) Test.** To verify serviceability and detect incipient failure by measuring the mechanical or electrical characteristics of an item and comparing those characteristics with prescribed standards.

**(3) Service.** Operating required periodically to keep an item in proper operating condition, i.e., to clean (decontaminate), to preserve, to drain, to paint, or to replenish fuel, lubricants, hydraulic flu-

ids, or compressed air supplies.

**(4) Adjust.** To maintain within prescribed limits, by bringing into proper or exact position, or by setting the operating characteristics to specified parameters.

**(5) Align.** To adjust specified variable elements of an item to bring about optimum or desired performance.

**(6) Calibrate.** To determine and cause corrections to be made or to be adjusted on instruments or test measuring and diagnostic equipments used in precision measurement. Consists of comparison of two instruments, one of which is a certified standard of known accuracy, to detect and adjust any discrepancy in the accuracy of the instrument being compared.

**(7) Install.** The act of emplacing, seating, or fixing into position an item, part or module (component or assembly) in a manner to allow the proper functioning of an equipment or system.

**(8) Replace.** The act of substituting a serviceable like type part, subassembly, or module (component or assembly) for an unserviceable counterpart.

**(9) Repair.** The application of maintenance services (inspect, test, service, adjust, align, calibrate, or replace) or other maintenance actions (welding, grinding, riveting, straightening, facing, remachining or resurfacing) to restore serviceability to an item by correcting specific damage, fault, malfunction, or failure in a part, subassembly, module (component or assembly), end item, or system.

**(10) Overhaul.** That maintenance effort (service/action) necessary to restore an item to a completely serviceable/operational condition as prescribed by maintenance standards (i.e., DMWR) in appropriate technical publications. Overhaul is normally the highest degree of maintenance performed by the Army. Overhaul does not normally return an item to a like new condition.

**(11) Rebuild.** Consists of those services/actions necessary for the restoration of unserviceable equipment to a like new condition in accordance

with original manufacturing standards. Rebuild is the highest degree of materiel maintenance applied to Army Equipment. The rebuild operation includes the act of returning to zero those age measurements (hours/miles, etc.) considered in classifying Army Equipment/Components.

**d. Column 4, Maintenance Category.** This column is made up of subcolumns for each category of maintenance. Work time figures are listed in these subcolumns for the lowest level of maintenance authorized to perform the function listed in Column 3. These figures indicate the average active time required to perform the maintenance function at the indicated category of maintenance under typical field operating conditions.

**e. Column 5, Tools and Equipment.** This column is provided for referencing by code, the common tool sets (not individual tools) special tools, test and support equipment required to perform the designated function.

### **C-3. Explanation of Columns in Section III**

**a. Column 1, Reference Code.** This column consists of an Arabic number listed in sequence from Column 5 of Section II. The number references the common tool sets, special tools and test equipment requirements.

**b. Column 2, Maintenance Category.** This column shows the lowest category of maintenance authorized to use the special tools or test equipment.

**c. Column 3, Nomenclature.** This column lists the name or identification of the common tool sets, special tools or test equipment.

**d. Column 4, National/NATO Stock No. (NSN).** This column is provided for the NSN of common tool sets, special tools and test equipment listed in the Nomenclature column.

**e. Column 5, Tool Number.** This column lists the manufacturer's code and part number of tools and test equipment.



**Section II. MAINTENANCE ALLOCATION CHART**

(1)	(2)	(3)	(4)			(5)	
GROUP NUMBER	COMPONENT/ASSEMBLY	MAINTENANCE FUNCTION	C	O	F	CATEGORY* H D	TOOLS AND EQUIPMENT
01	ENGINE ASSEMBLY						1-A
02	FRAME ASSEMBLY						
	Frame	Inspect			0.1		
		Replace			1.0		
		Repair			1.0		
	Shock mounts	Inspect			0.1		
		Replace			1.0		
	Ground Terminal			0.1			
		Replace		0.2			
03	CONTROL PANEL ASSY						
	Panel Assy	Inspect			0.2		
		Replace			1.0		
		Repair			2.0		
	Shock Mounts	Inspect			0.1		
		Replace			0.8		
	Rheostat	Inspect		0.1			
		Test		0.1			
		Replace		0.2			
	Voltage Meter	Inspect		0.1			
		Test		0.1			
		Replace		0.4			
	Load Meter, DC (DOD Model MEP-024A only)	Inspect		0.1			
		Test		0.1			
		Replace		0.4			
	Load Switch	Inspect		0.1			
		Test		0.1			
		Replace		0.2			
	Voltage Control Switch	Inspect		0.1			
		Test		0.1			
		Replace		0.5			
	Capacitors	Inspect			0.1		
		Replace			0.2		
	Connector Receptacle	Inspect		0.1			
		Replace		0.3			
	Terminal Load Block	Inspect		0.1			
		Replace		0.3			
	Wiring Harness	Inspect			0.1		
		Test		0.1			
		Replace			0.4		
		Repair		1.0			

\*SUBCOLUMNS ARE AS FOLLOWS:  
F-DIRECT SUPPORT;  
\*\*INDICATES WT/MH REQUIRED

C-OPERATOR/CREW;  
H-GENERAL SUPPORT;

O-ORGANIZATIONAL;  
D-DEPOT

**Section II. MAINTENANCE ALLOCATION CHART (Cont'd)**

(1)	(2)	(3)	(4)			(5)
GROUP NUMBER	COMPONENT/ASSEMBLY	MAINTENANCE FUNCTION	MAINTENANCE CATEGORY*			TOOLS AND EQUIPMENT
			C	O	F	
03	CONTROL PANEL ASSY (Cont'd)					
	Voltage Regulator	Inspect Test Replace			0.2 0.3 0.5	
	Rectifiers	Inspect Test Replace			0.3 0.1 1.0	
	Terminal Board	Inspect Replace		0.1 0.8		
	Ground Strap	Inspect Replace		0.1 0.3		
04	GENERATOR ASSEMBLY					2-A
	Rotor Assembly	Inspect Test Replace			0.4 0.2 1.0	
	Bearing	Inspect Replace			0.2 1.5	
	Cooling Fan	Inspect Replace			0.2 0.3	
	Housing Assembly	Inspect Replace			0.4 1.5	
	Stator Assembly	Inspect Test Replace			0.4 0.2 1.0	
05	FUEL SYSTEM					
	Tank	Inspect Replace		0.1 0.5		
	Cap & Chain Assembly	Inspect Replace		0.1 0.2		
	Strainer, Fuel Tank	Inspect Replace		0.1 0.1		
	Fuel Filter	Inspect Replace		0.1 0.4		
	Fuel Line	Inspect Replace		0.1 0.2		
	Valve, 3-way	Inspect Replace		0.1 0.4		
*SUBCOLUMNS ARE AS FOLLOWS:			C-OPERATOR/CREW			O-ORGANIZATIONAL;
F-DIRECT SUPPORT;			H-GENERAL SUPPORT;			D-DEPOT
**INDICATES WT/MH REQUIRED						

SECTION III

---

MAINTENANCE ALLOCATION CHART

SPECIAL TOOL AND SPECIAL TEST EQUIPMENT REQUIREMENTS

---

REFERENCE CODE	MAINTENANCE LEVEL	NOMENCLATURE	NATIONAL STOCK NO.	TOOL NUMBER
1-A	F	Refer to TM 5-2805-256-14 for engine special tools and special test equipment requirements. Engine model MIL-STD Model 1A08-3.		
2-A	F	See Paragraph 10-3, Chapter 10, and Table 5-1. No other special tools or test equipment required for listed generator sets.		

---



ALPHABETICAL INDEX

	Paragraph	Page
<b>A</b>		
Administrative Storage .....	1-7	1-1
<b>C</b>		
Cap and Chain Assy (Fuel Tank) .....	4-33	4-47
Cold Operation in Extreme .....	2-3	2-6
Consumable Operating and Maintenance Supplies .....	3-2	3-1
Controls and Instruments .....	2-2	2-1
<b>Control Panel Amy:</b> .....		
Removal and Instillation .....	6-3	6-5
Removal and Installation .....	9-2	9-1
<b>D</b>		
Data, Tabulated: .....		
Operator/Crew and Organizational Maintenance .....	1-10	1-8
Intermediate and Depot Support Maintenance .....	1-11	1-13
DC Percent Load Meter Maintenance .....	4-24	4-41
Description .....	1-9	1-2
Destruction of Army Materiel to Prevent Enemy Use .....	1-6	1-1
Detailed Lubrication Information: .....		
Operator .....	3-4	3-5
Organizational .....	4-10	4-12
Differences Between Models .....	1-12	1-14
Disassembly Procedures .....	5-7	5-4
Dismantling for Movement .....	4-5	4-11
Duplex Receptacle, 120 Volt AC .....	4-28	4-43
Dusty Area, Operation In .....	2-5	2-6
<b>E</b>		
Engine .....	3-9	3-11
Engine Assembly Removal and Installation .....	6-2	6-1
Engine Maintenance, Organizational .....	4-20	4-39
Engine Troubleshooting, Organizational .....	4-15	4-29
Equipment, Operation of .....	2-1	2-1
Errors, Reporting of .....	1-4	1-1
Explanation of Columns, Consumable Operating and Maintenance Supplies .....	3-2	3-1
<b>F</b>		
Fabricated Tools and Equipment .....	5-3	5-1
Forms and Records, Maintenance .....	1-3	1-1
Frame Assembly .....	8-2	8-1
Fuel Line .....	4-37	4-49
Fuel Strainer .....	4-35	4-48
<b>Fuel System</b> .....	3-10	3-11
Fuel Tank, Organizational Maintenance .....	4-32	4-46
<b>G</b>		
General: .....		
Instructions for Use of Multimeter .....	4-13	4-15
Lubrication Instructions, Operator .....	3-3	3-2
Lubrication Instructions, Organizational .....	4-9	4-12
Operator/Crew Maintenance Instructions .....	3-8	3-11
<b>Preventive Maintenance Checks and Services</b> .....		
Operator .....	3-5	3-5
Organizational .....	4-11,4-12	4-12
Radio Interference Suppression .....	4-17	4-37
Troubleshooting: .....		
<b>Operator</b> .....	3-6	3-8
Organizational .....	4-13	4-15
Intermediate (Field), (Direct and General Support) and Depot .....	5-4	5-2
Generator: .....		
Maintenance .....	10-3	10-1
Removal and Installation .....	6-4	6-5
Ground Strap .....	4-31	4-45
Ground Terminal Maintenance .....	4-21	4-40

**TM 5-6115-329-14**  
**TO 35C2-3-440-1**

	Paragraph	Page
Heat, Operation in Extreme .....	2-4	2-6
High Altitude, Operation .....	2-8	2-7
Humid Conditions, Operation Under .....	2-6	2-6
<b>I</b>		
Inspection, Generator Set .....	11-2	11-1
Inspecting and Servicing the Equipment .....	4-1	4-1
Installation .....	4-2	4-2
Instruments and Controls .....	2-2	2-1
Interference Suppression Components .....	4-18	4-37
Intermediate (Field, (Direct and General Support) and Depot Maintenance Repair Parts .....	5-1	5-1
<b>L</b>		
Levels of Maintenance Accomplishments .....	1-5	1-1
Limited Applicability .....	1-2	1-1
Load On/Off Flash Switch .....	4-26	4-42
Load On/Off Switch Maintenance .....	4-25	4-41
Lubrication Information, Detailed .....	3-4	3-5
<b>M</b>		
Maintenance: .....		
Accomplishment, Levels of .....	1-5	1-1
Forms and Records .....	1-3	1-1
Instructions, Operator/Crew .....	3-8	3-11
Repair Parts .....	4-8	4-11
Models, Differences Between .....	1-12	1-14
Movement: .....		
Dismantling for .....	4-5	4-11
Reinstallation After .....	4-6	4-11
Multimeters, Instruction for Use of .....	4-13	4-15
<b>O</b>		
On-Equipment Testing .....	10-2	10-1
Operation: .....		
At High Altitude .....	2-8	2-7
In Dusty or Sandy Areas .....	2-5	2-6
In Extreme Cold .....	2-3	2-6
In Extreme Heat .....	2-4	2-6
In Salt Water Areas .....	2-7	2-7
Of Equipment .....	2-1	2-1
Under Rainy or Humid Conditions .....	2-6	2-6
Operational Testing .....	11-3	11-1
Orientation .....	1-13	1-14
<b>P</b>		
Preparation for Shipment and Storage .....	1-8	1-1
Preventive Maintenance Checks and Services .....	3-5	3-5
Procedures for Constructing Revetments .....	4-3	4-2
<b>R</b>		
Rainy Conditions, Operation Under .....	2-6	2-6
Reassembly Procedures .....	5-9	5-4
Receptacle, Duplex 120 Volt DC .....	4-28	4-43
Rectifiers .....	9-8	9-6
Reinstallation After Movement .....	4-6	4-11
Repair and/or Replacement Criteria .....	5-8	5-4
Repair Parts, Intermediate (Field), (Direct and General Support) and Support .....	5-1	5-1
Repair Parts, Maintenance .....	4-8	4-11
Replacement of Suppression Components .....	4-19,9-5	4-38, 9-6
Reporting of Errors .....	1-4	1-1
Revetment Construction, Procedures for .....	4-3	4-2
Rheostat Maintenance .....	4-22	4-40
<b>S</b>		
Salt Water Area, Operation in .....	2-7	2-7
Sandy Area, Operation in .....	2-5	2-6
Scope .....	1-1	1-1
Selector Valve .....	4-36	4-49
Servicing and Inspecting the Equipment .....	4-1	4-1
Shock Mounts .....	8-3, 9-10	8-1, 9-8

**S(Cont)**

Shipment and Storage, Preparation for.....	1-8	1-1
Special Tools and Equipment.....	5-2	5-1
Storage: .....		
Administrative.....	1-7	1-1
Preparation for.....	1-8	1-1
Strainer, Fuel.....	4-35	4-48
Strainer, Fuel Tank.....	4-34	4-48
Strap, Ground.....	4-31	4-45
Switch: .....		
Load On/Off.....	4-25	4-41
Load On/Off Flash.....	4-26	
Voltage Select.....	4-27	

**T**

Table, Troubleshooting.....	3-7, 5-5	3-8, 5-3
Tabulated Data: .....		
Operator/Crew and Organizational Maintenance.....	1-10	1-8
Intermediate and Depot Support Maintenance.....	1-11	1-13
Consumable Operating and Maintenance Supplies Explanation of Columns.....	3-2	3-1
Terminal Board.....	9-7	9-4
Terminal Load.....	4-29	4-44
Terminal Load Block Assembly.....	4-30	4-45
Testing, On-Equipment.....	10-2	10-1
To Prevent Enemy Use, Destruction of Army Materiel.....	1-6	1-1
Tools and Equipment.....	4-7	4-11
Tools and Equipment, Fabrication.....	5-3	5-1
Troubleshooting: .....		
General.....	3-6	3-8
Intermediate (Field), (Direct and General Support) and Depot.....	5-4	5-2
Table.....	3-7, 5-5	3-8, 5-3

**V**

Valve, Selector.....	4-36	4-49
Voltage Regulator.....	9-6	9-4
Voltage Select Switch.....	4-27	4-42
Voltage Selection.....	4-4	4-10
Voltmeter Maintenance.....	4-23	4-40

**W**

Wiring Harness.....	9-9	9-8
---------------------	-----	-----





By Order of the Secretaries of the Army and the Air Force:

Official:

**BERNARD W. ROGERS**  
*General, United States Army*  
*Chief of Staff*

**J. C. PENNINGTON**  
*Brigadier General, United States Army*  
*The Adjutant General*

Official:

**DAVID C. JONES, General, USAF**  
*Chief of Staff*

**JAMES J. SHEPARD, Colonel, USAF**  
*Director of Administration*

Distribution:

To be distributed in accordance with DA Form 12-25D, Operator's maintenance requirements for Generator Set, Engine Driven: .5 KW 60 HZ, .5 KW 400 HZ.



# The Metric System and Equivalents

## Linear Measure

1 centimeter = 10 millimeters = .39 inch  
 1 decimeter = 10 centimeters = 3.94 inches  
 1 meter = 10 decimeters = 39.37 inches  
 1 dekameter = 10 meters = 32.8 feet  
 1 hectometer = 10 dekameters = 328.08 feet  
 1 kilometer = 10 hectometers = 3,280.8 feet

## Weights

1 centigram = 10 milligrams = .15 grain  
 1 decigram = 10 centigrams = 1.54 grains  
 1 gram = 10 decigrams = .035 ounce  
 1 dekagram = 10 grams = .35 ounce  
 1 hectogram = 10 dekagrams = 3.52 ounces  
 1 kilogram = 10 hectograms = 2.2 pounds  
 1 quintal = 100 kilograms = 220.46 pounds  
 1 metric ton = 10 quintals = 1.1 short tons

## Liquid Measure

1 centiliter = 10 milliliters = .34 fl. ounce  
 1 deciliter = 10 centiliters = 3.38 fl. ounces  
 1 liter = 10 deciliters = 38.82 fl. ounces  
 1 dekaliter = 10 liters = 2.64 gallons  
 1 hectoliter = 10 dekaliters = 26.42 gallons  
 1 kiloliter = 10 hectoliters = 264.18 gallons

## Square Measure

1 sq. centimeter = 100 sq. millimeters = .155 sq. inch  
 1 sq. decimeter = 100 sq. centimeters = 15.5 sq. inches  
 1 sq. meter (centare) = 100 sq. decimeters = 10.76 sq. feet  
 1 sq. dekameter (are) = 100 sq. meters = 1,076.4 sq. feet  
 1 sq. hectometer (hectare) = 100 sq. dekameters = 2.47 acres  
 1 sq. kilometer = 100 sq. hectometers = .386 sq. mile

## Cubic Measure

1 cu. centimeter = 1000 cu. millimeters = .06 cu. inch  
 1 cu. decimeter = 1000 cu. centimeters = 61.02 cu. inches  
 1 cu. meter = 1000 cu. decimeters = 35.31 cu. feet

## Approximate Conversion Factors

To change	To	Multiply by	To change	To	Multiply by
inches	centimeters	2.540	ounce-inches	newton-meters	.007062
feet	meters	.305	centimeters	inches	3.94
yards	meters	.914	meters	feet	3.280
miles	kilometers	1.609	meters	yards	1.094
square inches	square centimeters	6.451	kilometers	miles	.621
square feet	square meters	.093	square centimeters	square inches	.155
square yards	square meters	.836	square meters	square feet	10.764
square miles	square kilometers	2.590	square meters	square yards	1.196
acres	square hectometers	.405	square kilometers	square miles	.386
cubic feet	cubic meters	.028	square hectometers	acres	2.471
cubic yards	cubic meters	.765	cubic meters	cubic feet	35.315
fluid ounces	milliliters	29.573	cubic meters	cubic yards	1.308
pints	liters	.473	milliliters	fluid ounces	.034
quarts	liters	.946	liters	pints	2.113
gallons	liters	3.785	liters	quarts	1.057
ounces	grams	28.349	liters	gallons	.264
pounds	kilograms	.454	grams	ounces	.035
short tons	metric tons	.907	kilograms	pounds	2.205
pound-feet	newton-meters	1.365	metric tons	short tons	1.102
pound-inches	newton-meters	.11375			

## Temperature (Exact)

°F	Fahrenheit temperature	5/9 (after subtracting 32)	Celsius temperature	°C
----	------------------------	----------------------------	---------------------	----

TECHNICAL LIBRARY  
US ARMY ENGINEERING CENTER  
LEXINGTON, KY 40506