

D 101.11:  
11-2138/990

# TM 11-2138

DEPARTMENT OF THE ARMY TECHNICAL MANUAL

TERMINAL BOX

TA-125/GT

TELEPHONE REPEATING

COIL ASSEMBLY TA-145/GT

MAINTENANCE KIT

MX-842/GT

AND

SWITCHBOARD SIGNAL

TA-123/GT

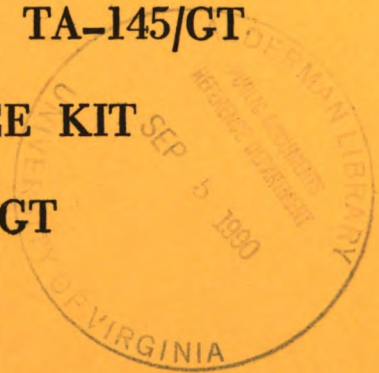

This copy is a reprint which includes current pages from Change 1.

DEPARTMENT OF THE ARMY • 25 JUNE 1952

AGO 4088B—June





CHANGE }  
NO. 1 }

HEADQUARTERS  
DEPARTMENT OF THE ARMY  
Washington, DC, 16 December 1983

**TERMINAL BOX TA-125/GT  
(NSN 5940-00-538-0777)  
TELEPHONE REPEATING COIL  
ASSEMBLY TA-145/GT  
(NSN 5950-00-378-5548)  
MAINTENANCE KIT MX-842/GT  
(NSN 5805-00-547-1075) AND  
SWITCHBOARD SIGNAL TA-123/GT**

TM 11-2138, 25 June 1952, is changed as follows:

*Cover.* The title is superseded as shown above.

*Page 1.* Delete paragraph 2 and substitute:

**2. Consolidated Index of Army Publications and Blank Forms**

Refer to the latest issue of DA Pam 310-1 to determine whether there are new editions, changes or additional publications pertaining to the equipment.

Add paragraphs 2-1, 2-2, 2-3, 2-4 and 2-5 after paragraph 2.

**2-1. Maintenance Forms, Records, and Reports**

*a. Reports of Maintenance and Unsatisfactory Equipment.* Department of the Army forms and procedures used for equipment maintenance will be those prescribed by TM 38-750, The Army Maintenance Management System (TAMMS).

*b. Report of Packaging and Handling Deficiencies.* Fill out and forward SF 364 (Report of Discrepancy (ROD)) as prescribed in AR 735-11-2/DLAR 4140.55/NAVMATINST 4355.73A/AFR 400-54/MCO 4430.3F.

*c. Discrepancy in Shipment Report (DISREP) (SF 361).* Fill out and forward Discrepancy in Shipment Report (DISREP) (SF 361) as prescribed in AR 55-38/NAVSUPINST 4610.33B/AFR 75-18/MCO P4610.19C/DLAR 4500.15.

## **2-2. Reporting Errors and Recommending Improvements**

You can help improve this manual. If you find any mistakes or if you know of a way to improve the procedures, please let us know. Mail your letter or DA Form 2028 (Recommended Changes to Publications and Blank Forms), direct to: Commander, US Army Communications-Electronics Command and Fort Monmouth, ATTN: DRSEL-ME-MP, Fort Monmouth, New Jersey 07703. In either case, a reply will be furnished direct to you.

## **2-3. Reporting Equipment Improvement Recommendations (EIR)**

If your equipment needs improvement, let us know. Send us an EIR. You, the user, are the only one who can tell us what you don't like about your equipment. Let us know why you don't like the design. Put it on an SF 368 (Quality Deficiency Report). Mail it to Commander, US Army Communications-Electronics Command and Fort Monmouth, ATTN: DRSEL-ME-MP, Fort Monmouth, New Jersey 07703. We'll send you a reply.

## **2-4. Administrative Storage**

Administrative Storage of equipment issued to and used by Army activities will have routine checks performed before storing. When removing the equipment from administrative storage the routine checks should be performed to assure operational readiness. Disassembly and repacking of equipment for shipment or limited storage are covered in Chapter 5 and TM 740-90-1.

## **2-5. Destruction of Army Electronics Materiel**

Destruction of Army electronics materiel to prevent enemy use shall be in accordance with TM 750-244-2.

*Page 14.* Delete Section II heading and substitute:

### **Section II. OPERATOR/CREW PREVENTIVE MAINTENANCE**

Paragraph 21. Delete paragraph 21 and substitute:

#### **21. General**

##### **NOTE**

Refer to TM 750-244-2 for proper procedures for destruction of this equipment to prevent enemy use.

*a.* Operator/crew preventive maintenance is the systematic care, servicing and inspection of equipment to prevent the occurrence of



trouble, to reduce downtime, and to maintain equipment in serviceable condition. To be sure that your equipment is always ready for your mission, you must do routine checks in b below.

b. Routine checks like CLEANING, PRESERVATION, DUSTING, WASHING, CHECKING FOR FRAYED CABLES, STOWING ITEMS NOT IN USE, COVERING UNUSED RECEPTACLES, CHECKING FOR LOOSE NUTS AND BOLTS AND CHECKING FOR COMPLETENESS are not listed as PMCS checks. They are things that you should do any time you see they must be done.

#### NOTE

When you are doing routine checks, keep in mind the warnings and cautions.

#### WARNINGS

- Adequate ventilation should be provided while using TRICHLOROTRIFLUOROETHANE. Prolonged breathing of vapor should be avoided. The solvent should not be used near heat or open flame; the products of decomposition are toxic and irritating. Since TRICHLOROTRIFLUOROETHANE dissolves natural oils, prolonged contact with skin should be avoided. When necessary, use gloves which the solvent cannot penetrate. If the solvent is taken internally, consult a physician immediately.
- Compressed air is dangerous and can cause serious bodily harm if protective means or methods are not observed to prevent a chip or particle (of whatever size) from being blown into the eyes or unbroken skin of the operator or other personnel. Goggles must be worn at all times while cleaning with compressed air. Compressed air shall not be used for cleaning purposes except where reduced to less than 29 pounds per square inch gage (psig) and then only with effective chip guarding and personnel protective equipment. Do not use compressed air to dry parts when trichlorotrifluoroethane has been used.

*Page 15.* Delete paragraph 22 and substitute:

#### **22. Operator/Crew Preventive Maintenance Checks and Services**

There are no scheduled operator/crew preventive maintenance checks and services on this equipment. The operator will perform routine checks. When a problem develops that is beyond the capabilities of the operator, the operator will advise organizational maintenance on DA Form 2404 and request assistance.

*Page 19.* Change Chapter 5 title to read "SHIPMENT AND LIMITED STORAGE."

Delete Section I and Section II headings.

Delete paragraph 29.

Page 20. Delete paragraph 30.

Page 21. Delete appendix I and substitute:

## APPENDIX I REFERENCES

---

Following is a list of applicable references available for Terminal Box TA-125/GT, Telephone Repeating Coil Assembly TA-145/GT, Maintenance Kit MX-842/GT and Switchboard Signal TA-123/GT.

AR 55-38	Reporting of Transportation Discrepancies in Shipment.
AR 735-11-2	Reporting of Item and Packaging Discrepancies.
DA Form 2028	Recommended Changes to Publications and Blank Forms.
DA Pam 310-1	Consolidated Index of Army Publications and Blank Forms.
SF Form 361	Discrepancies in Shipment Report (DISREP).
SF Form 364	Report of Discrepancy (ROD).
TB-SIG 222	Solder and Soldering.
TM 38-750	The Army Maintenance Management System (TAMMS).
TM 43-0139	Painting Instructions for Field Use.
TM 740-90-1	Administrative Storage of Equipment.
TM 750-244-2	Procedure for Destruction of Electronic Material to Prevent Enemy Use.

By Order of the Secretary of the Army:

**JOHN A. WICKHAM JR.**  
*General, United States Army*  
*Chief of Staff*

Official:

**ROBERT M. JOYCE**  
*Major General, United States Army*  
*The Adjutant General*

Distribution:

To be distributed in accordance with special list.



TERMINAL BOX  
TA-125/GT  
TELEPHONE REPEATING  
COIL ASSEMBLY TA-145/GT  
MAINTENANCE KIT  
MX-842/GT  
AND  
SWITCHBOARD SIGNAL  
TA-123/GT

---

DEPARTMENT OF THE ARMY

JUNE 1952

---

*United States Government Printing Office*  
*Washington: 1952*

DEPARTMENT OF THE ARMY  
WASHINGTON 25, D. C., 25 June 1952

TM 11-2138 is published for the information and guidance of all concerned.

[AG 413.42 (27 May 52)]

BY ORDER OF THE SECRETARY OF THE ARMY:

OFFICIAL: J. LAWTON COLLINS  
WM. E. BERGIN *Chief of Staff, United States Army*  
*Major General, USA*  
*The Adjutant General*

DISTRIBUTION:

Active Army:

Tech Svc (1); Tech Svc Bd (1); AFF Bd (ea Svc Test Sec) (1); AFF (5); AA Comd (2); OS Maj Comd (5); Base Comd (5); Log Comd (5); A (20); MDW (5); CHQ (2); FT (2); Sch (5) except 11 (25); Gen Dep (2); Dep 11 (20) except Sig Sec, Gen Dep (10); Tng Div (2); POE (10), OSD (2); Lab 11 (5); Mil Dist (3); 4th & 5th Ech Maint Shops 11 (3); Two (2) copies to each of the following T/O&E's: 11-107; 11-127; 11-500, CA, CB, CC, CD; 11-587; 11-592; 11-597.

NG: Same as Active Army except one copy to each unit.

ORC: Same as Active Army except one copy to each unit.

For explanation of distribution formula, see SR 310-90-1.

# CONTENTS

---

	<i>Paragraph</i>	<i>Page</i>
<b>CHAPTER 1. INTRODUCTION</b>		
<i>Section I.</i> General .....	1-2	1
<i>II.</i> Description and data .....	3-10	2
<b>CHAPTER 2. OPERATING INSTRUCTIONS</b>		
<i>Section I.</i> Service upon receipt of equipment .....	11, 12	10
<i>II.</i> Controls .....	13, 14	11
<i>III.</i> Installation and operation .....	15-18	11
<b>CHAPTER 3. MAINTENANCE INSTRUCTIONS</b>		
<i>Section I.</i> Lubrication and weatherproofing .....	19, 20	14
<i>II.</i> Preventive maintenance .....	21, 22	14
<b>CHAPTER 4. FIELD MAINTENANCE INSTRUCTIONS</b> .....	23-26	16
<b>5. SHIPMENT, LIMITED STORAGE, AND DEMOLITION TO PREVENT ENEMY USE.</b>		
<i>Section I.</i> Shipment and limited storage .....	27, 28	19
<i>II.</i> Demolition to prevent enemy use .....	29, 30	19
<b>APPENDIX I. REFERENCES</b> .....		21
<b>II. IDENTIFICATION TABLE OF PARTS</b> .....		25
<b>INDEX</b> .....		28





# CHAPTER 1

## INTRODUCTION

---

### Section I. GENERAL

#### 1. Scope

*a.* This technical manual is published for the guidance of all personnel to whom the equipment is issued. These instructions contain information on the installation, operation and maintenance of Terminal Box TA-125/GT; Telephone Repeating Coil Assembly TA-145/GT; Switchboard Signal TA-123/GT; and Maintenance Kit MX-842/GT. They apply only to these equipments.

*b.* Appendix I contains a list of current references, including supply catalogs, technical manuals, and other available publications applicable to the equipment. Appendix II contains an identification table of parts.

#### 2. Forms and Records

The following forms will be used for reporting unsatisfactory conditions of Army equipment and in performing preventive maintenance:

*a.* DD Form 6, Report of Damaged or Improper shipment, will be filled out and forwarded as prescribed in SR 745-45-5 (Army) and AFR 71-4 (Air Force).

*b.* DA Form 468, Unsatisfactory Equipment Report, will be filled out and forwarded to the Office of the Chief Signal Officer, as prescribed in SR 700-45-5.

*c.* AF Form 54, Unsatisfactory Report, will be filled out and forwarded to Commanding General, Air Matériel Command, Wright-Patterson Air Force Base, Dayton, Ohio, as prescribed in SR 700-45-5 and AFR 65-26.

*d.* Use other forms and records as authorized.

## Section II. DESCRIPTION AND DATA

### 3. Purpose and Use

The four equipments covered in this technical manual are used together. They provide a quick and easy method of monitoring, testing, and patching telephone, teletypewriter, and other circuits in forward field areas. The equipment also provides facilities so that simplex and phantom circuits may be established without disconnecting and reconnecting the wires. Terminal Box TA-125/GT is intended for use at small wireheads and test points when a weatherproof terminal is essential to provide uninterrupted service. It may be attached to any readily available vertical surface (such as a tree, post, or the side of a building). It will serve as a small main frame for Switchboards SB-22/PT and SB-86/P. Field wire and cable circuits then may be terminated on its binding posts and tested, monitored, patched, and simplexed or phantomed, as required, by the use of Maintenance Kit MX-842/GT and Telephone Repeating Coil Assembly TA-145/GT. Switchboard Signal TA-123/GT is intended for use at attended wireheads and test points so that a maintenance lineman may signal the attending personnel.

### 4. Application

This equipment may be applied to cable or field wire circuits in any forward combat area. It also is used in phase I of airborne operations. Its light weight and small size make it easily transportable; it may be dropped by parachute or carried by a descending paratrooper. The telephone repeater (TA-145/GT) is used with light weight, small field switchboards which are not provided with repeating coils. These equipments are used wherever rapid installation and servicing of field wire or cable circuits are required in forward combat areas.

### 5. Technical Characteristics

#### *a. Coil Assembly, Telephone Repeating TA 145/GT.*

D-c resistance, switchboard side . . . . .	75.2 ohms.
D-c resistance, line side . . . . .	91 ohms.
Impedance ratio . . . . .	1 to 1.

#### *b. Signal, Switchboard TA-123/GT.*

D-c resistance . . . . .	825 ohms $\pm$ 15.
A-c operating supply . . . . .	15 v, 20 cps.

## 6. Packaging Data

### *a. Packaging for Domestic Shipment.*

Case No.	Contents	Dimensions (in.)			Weight (lb)
		Width	Height	Depth	
1	Terminal Box TA-125/GT	6	2¾	14½	8.0
2	Coil Assembly, Telephone Repeating TA-145/GT.	6	2¾	14½	9.75
3	Maintenance Kit MX-842/GT.	6½	5½	1¾	.75

### *b. Packaging for Oversea Shipment.*

Case No.	Quantity	Contents	Dimensions (in.)			Weight (lb)	Vol. (cu ft)
			Height	Width	Depth		
1	16	Terminal Box	14¾	14¾	32¾	149	3.92
2	14	Coil Assembly, Telephone Repeating TA-145/GT.	13¾	15¾	27½	148	3.41
3	180	Maintenance Kit MX-842/GT.	16¾	26¾	36¾	144	8.95

## 7. Table of Components

Quantity	Name of component	Dimensions (in.)		
		Height	Width	Depth
1	Terminal Box TA-125/GT	2¾	5-11/16	14
1	Coil Assembly, Telephone Repeating TA-145/GT.	2¾	5-11/16	
1	Maintenance Kit MX-842/GT consisting of:	...	5¾	4¾
3	Signal, Switchboard TA-123/GT.	15/16	9/16	2-5/16
3	Cord Assembly, Electrical CX-1959/U.	...	...	16¾
2	Prod, Test MX-1315/U	2½	½	½

## 8. Description of Terminal Box TA-125/GT (figs. 1 and 2)

Terminal Box TA-125/GT is a small, light weight, weatherproof terminal box which contains 2 rows of binding posts and 2 rows of pin jacks.



*Figure 1. Terminal box, repeating coil assembly and maintenance kit, unopened.*

*a.* The cover is hinged at one end of the box and secured in the closed position by a spring-loaded latch at the other end. A circuit identification strip, mounted inside of the cover, provides a suitable writing surface for a lead pencil. Markings may be erased repeatedly without materially impairing the writing surface. The box is constructed with a rubber, or rubber-like, gasket inserted between the outer shell of the box and the metal backing which is riveted to the inside of the shell. The edge of the gasket protrudes above the edge of the box and is pressed firmly against the inner surface of the cover when it is closed. A row of 12 slots, on each side of the box, provides entrances for the wire pairs. The gasket is slit at each slot. When the cover is closed, its edges overlap the box far enough to cover the wire entrances and prevent moisture, dust, and other foreign matter from entering. Four D-rings and clips are provided, one on each corner, to facilitate mounting the box on any readily available vertical surface.

*b.* The terminal board is molded from a fungi-resistant insulating material and is mounted in the box by six machine screws. There are 48 binding post assemblies, arranged in 12 numbered pairs, on each side of the terminal board. The binding post pairs are designated by numbers (1 through 12) inscribed on the terminal board at the left of each pair. Corresponding pairs of binding posts, on opposite sides of the terminal board, bear the same num-

ber. The two topmost (diagonally adjacent) binding posts on each side of the terminal board are corresponding pairs (see circuit identification strip on inside of terminal box cover). The binding posts may be depressed to insert the bare end of a wire into spring-loaded jaws which firmly grip it. A row of 24 slotted lugs is located down the center of the terminal board. A screw driver may be inserted into any lug to operate the associated switch, which opens or closes the electrical connection between directly opposite binding posts. There are 48 pin jacks, arranged in 2 rows of 12 pairs on each side of the screw-driver-operated switches. The pin jack pairs are connected to their associated binding post pairs by bus-bars on the back of the terminal board.

## **9. Description of Coil Assembly, Telephone Repeating TA-145/GT** (figs. 1 and 2)

Telephone Repeating Coil Assembly TA-145/GT is a small, light weight, weatherproof unit consisting of a row of 12 pairs of binding posts, a row of pin jacks, and 4 repeating coils rectangular in shape and supported by brackets attached to the terminal board.

*a.* The box and cover are the same as described in paragraph 8*a*, except that the box for this unit has 12 slots on one side only.

*b.* The terminal board is molded from a fungi-resistant insulating material and is mounted in the box by 11 machine screws. There are 24 binding post assemblies, wired as 4 sets of 3 pairs each. The topmost two (diagonally adjacent) binding posts are designated SWBD; the next two binding posts are designated LINE; and the following two binding posts are designated, individually, TG and GND. The binding posts may be depressed to insert the bared end of a wire into spring-loaded jaws which firmly grip it. There are 24 pin jacks; each is connected to its associated binding post by a bus-bar on the back of the terminal board.

## **10. Description of Maintenance Kit MX-842/GT** (figs. 1 and 4)

Maintenance Kit MX-842/GT consists of two test prods, MX-1315/U; four Electrical Cord Assemblies CX-1959/U; three Switchboard Signals TA-123/GT; and one Carrying Case CY-1128/U.

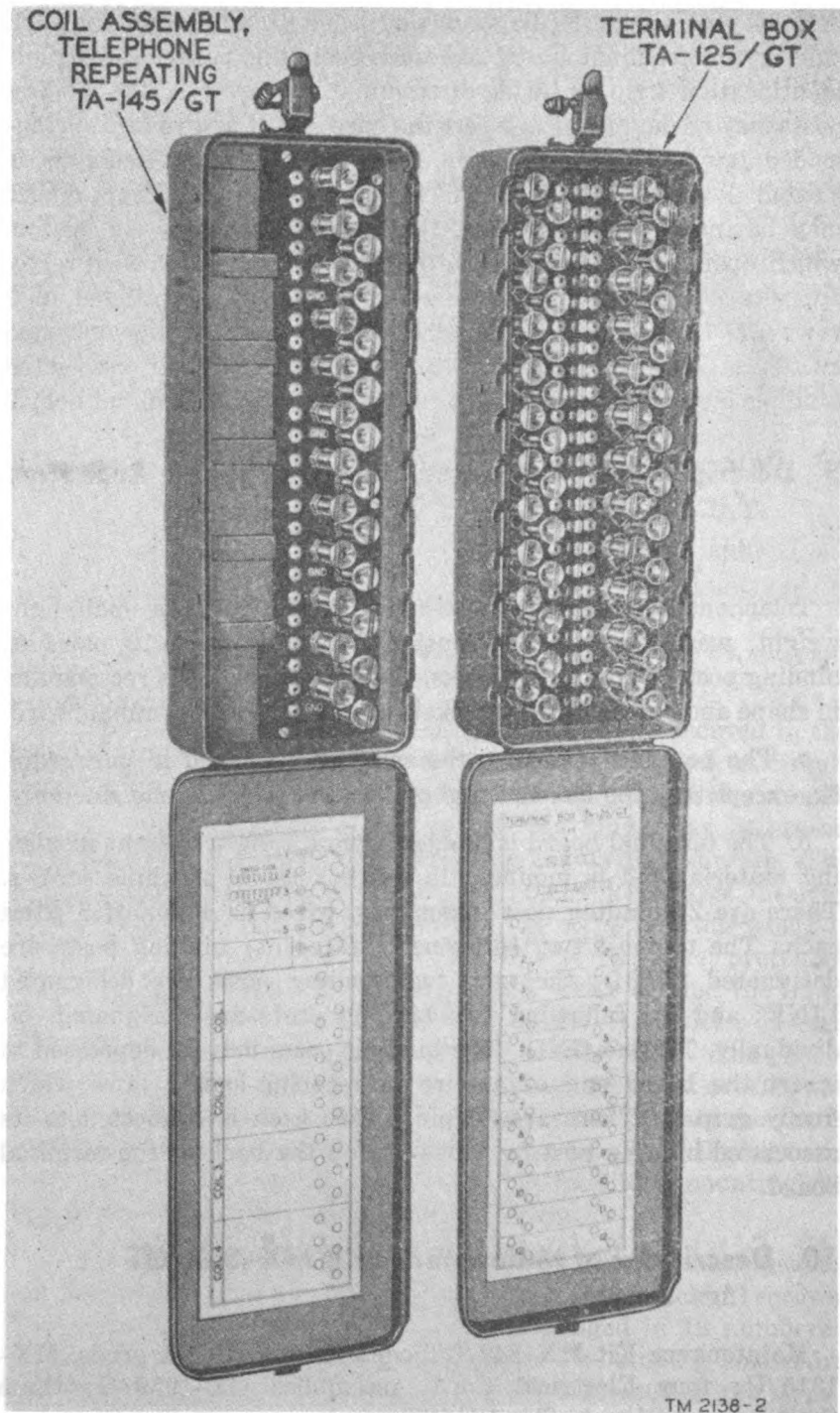

TM 2138-2

**Figure 2. Terminal Box TA-125/GT and Coil Assembly, Telephone Repeating TA-145/GT, with covers open.**



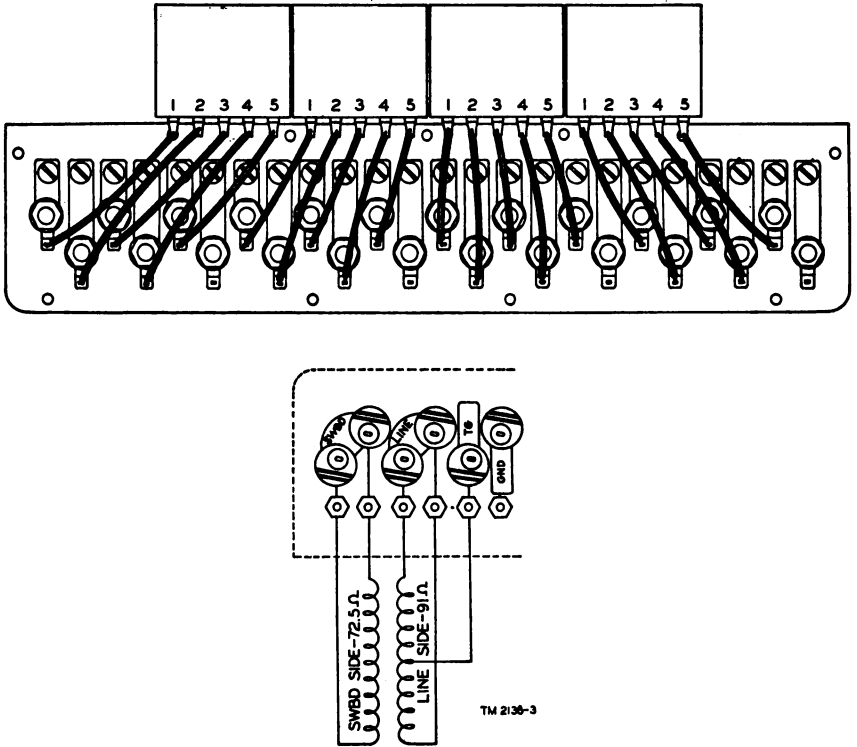
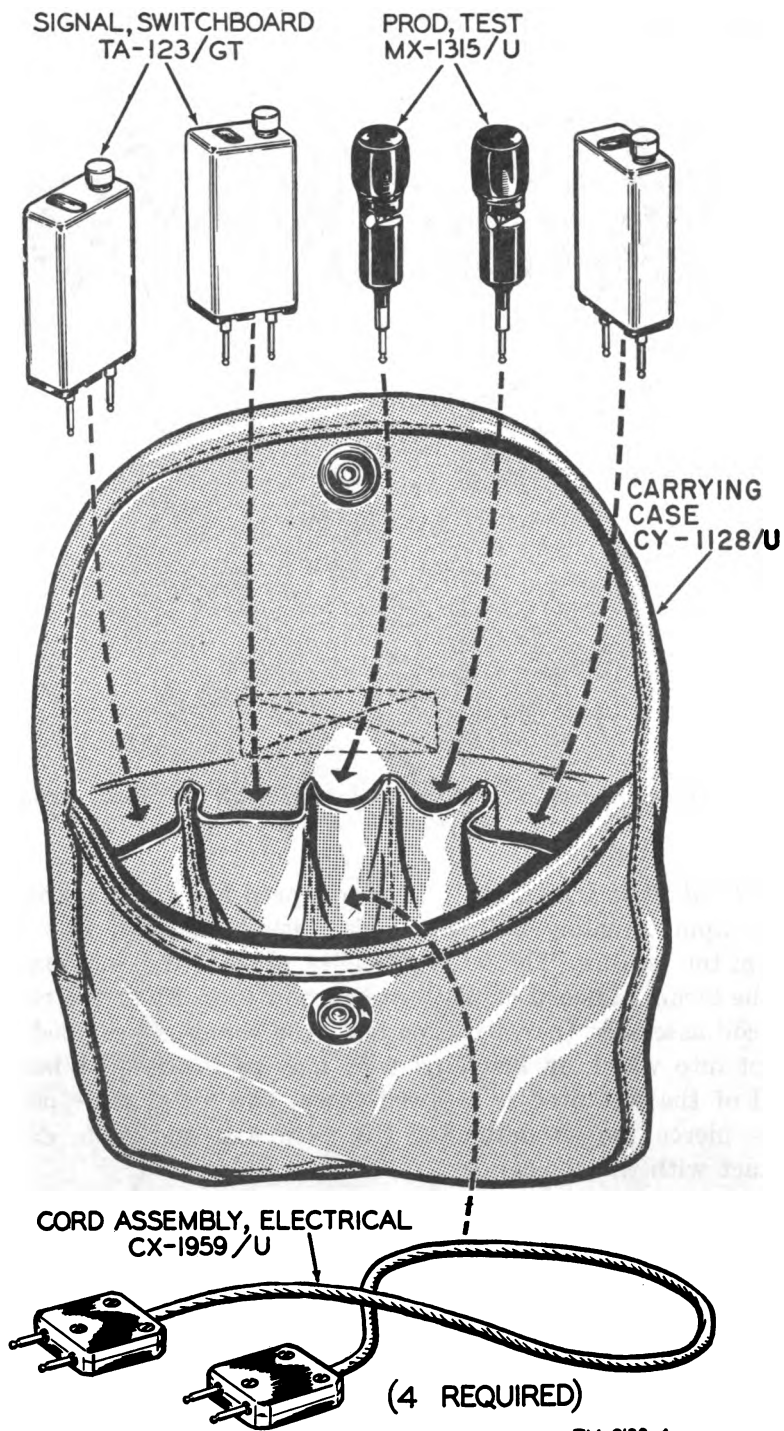

Figure 3. Coil Assembly, Telephone Repeating TA-145/GT, panel wiring and schematic diagram.

a. *Prod, Test MX-1315/U.* The test prod is a small cylindrical prod, approximately 2 inches long, entirely encased in rubber except the jackpin. The jackpin may be plugged into any pin jack on the terminal board of the terminal box (par. 8) or the repeating coil assembly (par. 9). The test prod shank is provided with a slot into which an insulated wire may be inserted. When the head of the test prod is screwed down, two metal pin-type contacts pierce the insulation of the wire and make the desired contact with the conductors.

b. *Cord Assembly, Electrical CX-1959/U.* The electrical cord assembly, commonly referred to as a patching cord, consists of a two-conductor cord with a jack plug assembly on each end. Each plug consists of a case and two jackpins. The jackpins may be plugged into a pair of pin jacks on the terminal board of the box (par. 8) or the repeating coil assembly (par. 9). Each plug of this cord assembly is provided with a jackpin identification mark on the case adjacent to the cord entrance.



TM 2138-4

Figure 4. Maintenance Kit MX-842/GT, with cover open.

c. *Signal, Switchboard TA-123/GT.* The switchboard signal consists of a small, rectangular-shaped case, with two jackpins at one end, and a reset button and transparent window at the other end. Internally, the switchboard signal contains a relay which actuates a metal flag signal. The metal flag signal presents either an olive-drab surface or a white surface to the transparent window to indicate whether ringing current is in the line (par. 17). The reset button provides for mechanically resetting the signal flag to show olive drab after it has been electrically operated to show white.

d. *Carrying Case CY-1128/U.* The carrying case is a canvas bag with a single-flap, snap-fastened cover and is provided with a hook for carrying it on the belt. The main compartment holds the four electrical cord assemblies, and five pockets across the inside of the back hold the three switchboard signals and the two test prods.

## CHAPTER 2

# OPERATING INSTRUCTIONS

---

### Section I. SERVICE UPON RECEIPT OF EQUIPMENT

#### 11. Unpacking New Equipment

*a.* Be very careful when uncrating and unpacking the equipment. Avoid thrusting tools into the interior of the shipping container. For oversea shipments, follow the instructions outlined in (1) through (8) below. For domestic shipments, follow the instructions outlined in (5) through (8) below.

- (1) Cut the metal straps from the box with a suitable cutting tool.
- (2) Remove the nails from the cover with a nail puller and take off the cover.
- (3) Carefully slit the water-resistant adhesive used to seal the waterproof bag inside the case.
- (4) Lift the packaged units from the wooden box.
- (5) Slit the overwrap around each unit and remove it.
- (6) Remove the moisture-vaporproof barrier and remove the inner package.
- (7) Slit the gummed kraft seal and remove the unit from the paper in which it is wrapped.
- (8) Return as much as possible of the packing material to the packing case for re-use.

*b.* Open each unit and check for any damage.

#### 12. Unpacking Used or Reconditioned Equipment

The unpacking procedure for used or reconditioned equipment is the same as that for new equipment. However, used or reconditioned equipment may be packed in quantities and combinations which differ from those of new equipment.

## Section II. CONTROLS

### 13. Terminal Box TA-125/GT and Coil Assembly, Telephone Repeating TA-145/GT

The terminal box and repeating coil assembly are interconnected manually. These units are used for interconnection only; therefore, they have no controls.

### 14. Maintenance Kit MX-842/GT

The Switchboard Signal TA-123/GT component of the maintenance kit is provided with a push button. After the signal flag has been operated electrically to show its white surface, the reset button must be pressed to reset the flag to the position which shows olive drab.

## Section III. INSTALLATION AND OPERATION

### 15. Installing Terminal Box TA-125/GT

*a.* Swing the D-rings out from the box. Drive four nails, screws, or hooks into any readily available and suitable vertical surface. Mount the terminal box by means of the D-rings on these facilities in a vertical position so that the hinge is at the bottom and the latch is at the top.

*b.* Release the latch and open the cover.

*c.* Bare the ends of a wire pair which is to be terminated at the terminal box.

*d.* Choose a pair of binding posts (par. 8*b*); depress one binding post and insert one wire (of the wire pair) into the opening in the top of the binding post; release the binding post and pull the inserted wire gently but firmly to see that it has been gripped by the internal jaws of the binding post. Repeat this procedure to connect the other wire (of the wire pair) to the other binding post of the binding-post pair.

*e.* If the wire pair of a line loop is terminated on one pair of binding posts, terminate the wire pair of an extension of that same loop on the correspondingly numbered binding-post pair on the other side of the terminal board.

*f.* If a loop circuit is to be closed, operate both screw-driver-

operated switches to the horizontal position. Each screw-driver-operated switch opens or closes a connection only between one binding post and the binding post directly opposite it.

*g.* Draw the connected pair tight and pull it into the adjacent slot in the edge of the box. Draw the pairs downward to the bottom of the slot. A slit in the gasket permits this operation.

*h.* Connect other wire pairs to the terminal board in the same manner.

## **16. Installing Coil Assembly, Telephone Repeating TA-145/GT**

*a.* Mount the repeating coil assembly in the same manner as, and as near as practicable to, the terminal box (par 15*a*).

*b.* Connections to individual binding posts are made by the same method used in connecting wires to the binding posts of the terminal box, but circuit connections differ. Proceed as directed in *c* below.

*c.* Refer to figure 3 which shows the terminal designations of the repeating coil assembly. (These designations are shown also on the circuit identification strip inside the cover.) Connect the wire pair from the switchboard to terminals 1 and 2 marked SWBD; connect the wire pair from the line to terminals 3 and 4; connect the line wire from the telegraph equipment to the terminal marked TG. Connect one end of a piece of field wire to the ground side of the telegraph equipment and connect the other end of this same wire to the terminal marked GND. Insert the bared end of another wire into the GND terminal *with the wire from the telegraph equipment* and make a suitable connection to ground with the other end of this wire (TM 11-358).

## **17. Using Maintenance Kit MX-842/GT with Terminal Box and Repeating Coils**

*a.* Set the flag of the switchboard signal to show olive drab by pressing the reset button. Plug the switchboard signal jack pins into the pin jacks of the line to be tested. If ringing current is present, a relay in the switchboard signal moves the flag so that a white surface shows through the transparent window. If the line is clear of ringing current, the flag will continue to show olive drab. When ringing current is present, a faint audible signal may be heard. If the ambient noise level is high enough to drown out the audible signal, it is sometimes possible to feel the vibrations

caused by ringing current by holding the switchboard signal between the thumb and forefinger.

b. To interconnect lines which have been previously connected to noncorresponding terminal pairs (pairs not directly opposite) of the terminal board or to a pair of terminals of the repeating coil assembly, operate both screw-driver-operated switches (of both of the lines to be interconnected) to the vertical position. Insert the jackpins on one end of Electrical Cord Assembly CX-1959/U into the pin jacks of one line. Insert the jackpins of the other end of the cord assembly into the pin jacks of the other line. Be sure that the second plug assembly is inserted so that corresponding sides of the lines are connected. (See jackpin identification mark on plug assembly case.)

c. The test prods will be used for purposes at the discretion of the user. To connect a wire to one of these test prods, unscrew the head of the test prod until the insulation-piercing pins have been withdrawn completely from the slot in the shank. Insert the wire into the slot; note that insulated wire may be used and that the test prod *need not* be connected to the *end* of a wire, if there is good reason to do otherwise. Screw the head of the test prod down tightly to force the insulation-piercing pins through the insulation and into firm contact with the wire. The test prod then may be inserted into any pin jack of either the terminal board or the repeating coil assembly.

d. Specific applications of this equipment to particular circuits must be worked out by the using personnel in accordance with the exigencies of the tactical situation. The proper application and use of this equipment require prior knowledge of the circuits with which it is to be used.

## 18. Use Under Unusual Conditions

The equipment described in this instruction book does not require special procedures for use under extremely hot, cold, or wet conditions. The overlapping covers on the terminal box and the repeating coil assembly protect the units from driving rain, but care should be taken to keep the equipment thoroughly dry. If moisture should freeze inside a binding post, it may become inoperable.



# CHAPTER 3

## MAINTENANCE INSTRUCTIONS

---

### Section I. LUBRICATION AND WEATHERPROOFING

#### 19. Lubrication

An occasional drop of any light lubricating oil on the hinges of the cover of Terminal Box TA-125/GT and Coil Assembly, Telephone Repeating TA-145/GT is all that is needed. No other lubrication is required.

#### 20. Weatherproofing

*a. General.* Signal Corps equipment, when operated under severe climatic conditions such as prevail in tropical, arctic, and desert regions, requires special treatment and maintenance. Fungus growth, insects, dust, corrosion, salt spray, excessive moisture, and extreme temperatures are harmful to most materials.

*b. Tropical Maintenance.* A special moistureproofing and fungi-proofing treatment has been devised, which, if properly applied, provides a reasonable degree of protection. This treatment is explained fully in TB SIG 13 and TB SIG 72.

*c. Winter Maintenance.* Special precautions necessary to prevent poor performance or total operational failure of equipment in extremely low temperatures are explained fully in TB SIG 66 and TB SIG 219.

*d. Desert Maintenance.* Special precautions necessary to prevent equipment failure in areas subject to extremely high temperatures, low humidity, and excessive sand and dust are explained fully in TB SIG 75.

### Section II. PREVENTIVE MAINTENANCE

#### 21. Definition of Preventive Maintenance

Preventive maintenance is work performed on equipment (usually when the equipment is not in use) to keep it in good

working condition so that break-down and needless interruptions in service will be kept to a minimum. Preventive maintenance differs from trouble shooting and repair since its object is to prevent certain troubles from occurring. See AR 750-5.

## 22. Preventive Maintenance Procedures

There are no specific preventive maintenance procedures required for this equipment. Be careful when using it, however, so that dirt or foreign matter will not accumulate in the equipment. Although the equipment is designed to exclude moisture under most conditions, it should be dried if it becomes wet, and kept clean.

- a. Use No. 0000 sandpaper to remove corrosion.
- b. Use a clean, dry, lint-free cloth, or a dry brush for cleaning.
  - (1) If necessary, except for electrical contacts, moisten or brush with Solvent, dry-cleaning (SD); then wipe the parts with a dry cloth.
  - (2) Clean electrical contacts with a cloth moistened with carbon tetrachloride; then wipe dry with a cloth.

***Caution:*** Repeated contact of carbon tetrachloride with the skin or prolonged breathing of the fumes is dangerous. Make sure adequate ventilation is provided.

- c. If available, dry compressed air may be used at line pressure not exceeding 60 psi (pounds per square inch) to remove dust from inaccessible places.

## CHAPTER 4

# FIELD MAINTENANCE INSTRUCTIONS

---

### 23. Inspection

At frequent intervals, visually inspect Terminal Box TA-125/GT, Telephone Repeating Coil Assembly TA-145/GT, and Maintenance Kit MX-142/GT for broken or cracked parts and excessive dirt or foreign matter lodged in the equipment. The interval of inspection depends on the conditions of usage of the equipment. Inspection should be more frequent during hard usage.

### 24. Disassembly

Repair of any of the parts of the equipment described in this manual is not practical. When defective parts are discovered by visual inspection, the parts must be replaced. Disassembly of replaceable parts is accomplished as follows:

*a. Terminal Box TA-125/GT (fig. 5).*

- (1) Unscrew the eight screws (1) and lift the panel assembly from the box.
- (2) Remove the binding post assemblies (2) by unscrewing the hexagonal nuts (3) and removing the lockwashers (4). Do not attempt to take the binding post assemblies apart.
- (3) Hold the jack screw (6) with a small open-end wrench and unscrew the jack housing (5) with a screw driver. Remove the jack spring (7) and bus-bar (8 or 8A).
- (4) The washer (9) is crimped in place. Force it off the end of the switch body (13) and remove the spring (10), contact (11), cam (12), and switch body (13) from the panel (14).

*b. Coil Assembly, Telephone Repeating TA-145/GT (fig. 6).*

- (1) The binding posts and jacks on the panel assembly are identical to the ones illustrated in figure 5 and are disassembled as described in *a* above.
- (2) Unscrew the 11 screws (1) to remove the panel assembly from the box. Five of these screws also hold the brackets (2) in place. Remove the brackets (2) and the coils (3).

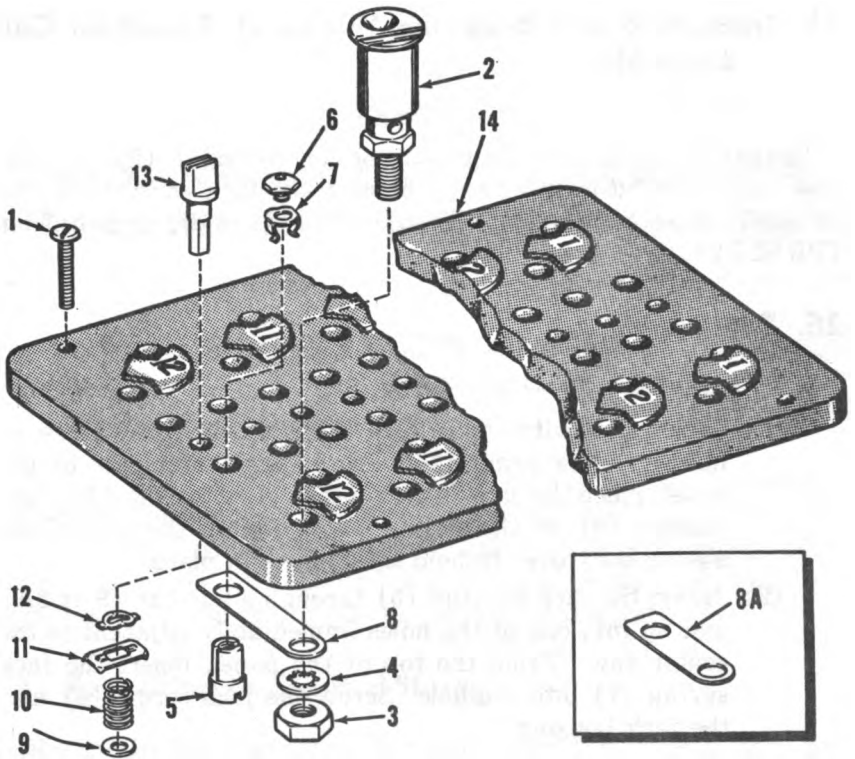

TM 2138-5

- |                                    |                      |                  |
|------------------------------------|----------------------|------------------|
| 1. Panel screws.                   | 6. Jack screw.       | 10. Spring.      |
| 2. Binding post assembly.          | 7. Jack spring.      | 11. Contact.     |
| 3. Hexagonal nut.                  | 8. Bus-bar (long).   | 12. Cam.         |
| 4. Lockwasher with internal teeth. | 8A. Bus-bar (short). | 13. Switch body. |
| 5. Jack housing.                   | 9. Washer.           | 14. Panel.       |

Figure 5. Terminal Box TA-125/GT, exploded view of panel assembly.

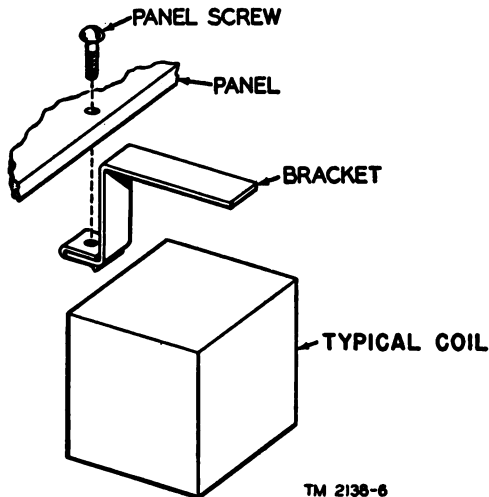

TM 2138-6

Figure 6. Coil Assembly, Telephone Repeating TA-145/GT, exploded view of coil and bracket.

## 25. Inspecting and Repairing Wiring of Repeating Coil Assembly

(fig. 3)

Inspect the wiring of the repeating coil assembly (fig. 3). Inspect the soldered terminals for a solid and firm contact. If the soldered contacts are not tight, remove the old solder and resolder (TB SIG 222).

## 26. Reassembly

### a. Terminal Box TA-125/GT (fig. 5).

- (1) Insert the switch body (13) into its hole (center row of holes) in the panel (14). From the under side of the panel, place the cam (12), contact (11), spring (10) and washer (9) on the switch body. Crimp the end of the switch body over to hold these parts in place.
- (2) Insert the jack housing (5) through a bus-bar (8 or 8A) and up into one of the holes immediately adjacent to the center row. From the top of the panel, insert the jack spring (7) into the hole. Screw the jack screw (6) into the jack housing.
- (3) Position the free end of the bus-bar (8 or 8A) over the hole into which the binding post (2) will go. Insert the binding post in the panel from the top; be sure it goes through the bus-bar and secure it in place with the lock-washer (4) and hexagonal nut (3). Position the binding posts so that the wire holes of each pair are next to each other as shown in figure 2.
- (4) Place the entire panel assembly into the box and secure it with eight screws (1).

### b. Coil Assembly, Telephone Repeating TA-145/GT (fig 6).

- (1) Position the four coils (3) along the right-hand side of the box.
- (2) Position the five brackets (2) over the coils; be sure the ends of the brackets engage the slots in the side of the box.

# CHAPTER 5

## SHIPMENT AND LIMITED STORAGE AND DEMOLITION TO PREVENT ENEMY USE

---

### Section I. SHIPMENT AND LIMITED STORAGE

#### 27. Preparation for Repacking

Do not disassemble this equipment for repacking. Disconnect all external leads; see that the equipment is dry; and close the covers of the terminal box and repeating coil assembly and latch them. Place the switchboard signals, test prods, and electrical cord assemblies in the canvas bag and close the cover.

#### 28. Repacking for Limited Storage

Repack in the original packages and packing cases, if they are available. If the original packing material is not available, repack the equipment in the quantities described in paragraph 6. Use the correct amount of desiccant to protect the equipment from moisture. Wrap the equipment in a waterproof barrier and seal the seams with a waterproofing compound or tape. Place the wrapped equipment in a corrugated cardboard box, or wrap it in corrugated cardboard material and place it in a wooden packing case. Allow 3 inches of space between the outside of the corrugated container and the inside of the wooden box. Pack this space with excelsior, or similar material. For more detailed information on packaging materials and procedures, refer to the packaging specifications listed in appendix I.

### Section II. DEMOLITION TO PREVENT ENEMY USE

#### 29. Methods of Demolition

*a. Smash.* Use sledges, axes, handaxes, pickaxes, hammers, crowbars, heavy tools.

*b. Cut.* Use axes, handaxes, matchetes.

*c. Burn.* Use gasoline, kerosene, oil, flame throwers, incendiary grenades.

*d. Explode.* Use firearms, grenades, TNT.

*e. Dispose.* Bury in slit trenches, fox holes, other holes. Throw in streams. Scatter.

*f. Other.* Use anything available for destruction of this equipment.

### **30. Destruction of Components**

When ordered by your commander, destroy all equipment to prevent its being used or salvaged by the enemy.

*a. Smash* (par. 29a) the cases, terminal boards, signal switchboards, binding posts, test prods, repeating coils.

*b. Cut* (par. 29b) all wires in the electrical circuits.

*c. Burn* (par. 29c) all instruction books, wires, circuit identification strips, canvas bag.

*d. Bury or scatter* (par. 28e) all remaining parts of the equipment.

*e. Destroy everything.*



# APPENDIX I

## REFERENCES

*Note.* For availability of items listed, check SR 310-20-3 for field manuals and JANAP's. Check SR 310-20-4 for technical manuals, technical bulletins, supply bulletins, modification work orders, and changes. Check SR 310-20-5 for Army regulations and special regulations.

---

### 1. Regulations

#### *a. Army.*

- AR 380-5      Safeguarding Military Information.  
AR 750-5      Maintenance Responsibilities and Shop Operation.

#### *b. Special.*

- SR 310-20-3      Index of Training Publications.  
SR 310-20-4      Index of Technical Manuals, Technical Regulations, Technical Bulletins, Supply Bulletins, Lubrication Orders, Modification Work Orders, Tables of Organization and Equipment, Reduction Tables, Tables of Allowances, Tables of Organization, and Tables of Equipment.  
SR 310-20-5      Index of Administrative Publications.  
SR 700-45-5      Unsatisfactory Equipment Report (Reports Control Symbol CSGLD-247).  
SR 745-45-5      } Report of Damaged or Improper Shipment  
AFR 71-4          } (Reports Control Symbols CSGLD-66 (Army), and AF-MC-U2 (Air Force)).

### 2. Supply Publications

- SB 11-47      Preparation and Submission of Requisitions for Signal Corps Supplies.  
SB 11-76      Signal Corps Kit and Materials for Moisture- and Fungi-Resistant Treatment.  
SB 38-5-3      List of Standard Lubricants, Hydraulic Fluids, Liquid Fuels and Preservative Materials Used by the Department of the Army.

### **3. Technical Manuals on Auxiliary Equipment and Test Equipment**

- TM 11-303 Test Sets I-56-C, -D, -H, and -J.
- TM 11-321 Test Set I-56-E.
- TM 11-358 Telegraph Control Office Set TC-3 and Switchboard BD-100.
- TM 11-680 Teletypewriter Circuits and Equipment. (Fundamentals).
- TM 11-2613 Voltohmmeter I-166.
- TM 11-2626 Test Units I-176, I-176-A, and I-176-B.

### **4. Painting, Preserving, Maintenance, and Lubrication**

- TB SIG 13 Moistureproofing and Fungiproofing Signal Corps Equipment.
- TB SIG 66 Winter Maintenance of Signal Equipment.
- TB SIG 69 Lubrication of Ground Signal Equipment.
- TB SIG 72 Tropical Maintenance of Ground Signal Equipment.
- TB SIG 75 Desert Maintenance of Ground Signal Equipment.
- TB SIG 123 Preventive Maintenance Practices for Ground Signal Equipment.
- TB SIG 222 Solder and Soldering.
- TM 9-2851 Painting Instructions for Field Use.

### **5. Decontamination**

- TM 3-220 Decontamination.

### **6. Packaging and Packing Information, Military (JAN) Specifications**

- JAN-B-121 Barrier-Materials; Greaseproof.
- JAN-C-149 (1) Compound, Protective, Strippable (Hot-Dipping).
- JAN-D-169 (4) Desiccants (Activated).
- JAN-P-100 Packaging and Packing for Overseas Shipment—General Specification.
- JAN-P-101 Packaging and Packing for Overseas Shipment—Adhesives, Water-Resistant, for Sealing Fiberboard Boxes.

- JAN-P-102 Packaging and Packing for Overseas Shipment—Composition Topcoating Materials, Bituminous.
- JAN-P-103(1) Packaging and Packing for Overseas Shipment—Boxes; Wood Cleated; Solid Fiberboard.
- JAN-P-104 Packaging and Packing for Overseas Shipment—Crates, Sheathed, Wood, Nailed.
- JAN-P-105A Packaging and Packing for Overseas Shipment—Boxes, Wood, Cleated, Plywood (for boxes whose weight of contents does not exceed 1,000 pounds).
- JAN-P-106A Packaging and Packing for Overseas Shipment—Boxes; Wood, Nailed (for weight of contents not in excess of 1,000 pounds).
- JAN-P-108(4) Packaging and Packing for Overseas Shipment—Boxes, Fiberboard (V-Board and W-Board), Exterior and Interior.
- JAN-P-109 Packaging and Packing for Overseas Shipment—Barrels, Tight.
- JAN-P-115(2) Packaging and Packing for Overseas Shipment—Compound, Sealing, Dipcoating.
- JAN-P-116(2) Packaging and Packing for Overseas Shipment—Preservation, Methods of.
- JAN-P-117(2) Packaging and Packing for Overseas Shipment—Bags, Interior Packaging.
- JAN-P-120(1) Packaging and Packing for Overseas Shipment—Carton, Folding, Paperboard.
- JAN-P-125(1) Packaging and Packing for Overseas Shipment—Barrier-Materials, Waterproof, Flexible.
- JAN-P-127(3) Packaging and Packing for Overseas Shipment—Tape, Adhesive, Pressure-Sensitive, Water Resistant.
- MIL-B-130A Barrier-Material, Paper, Noncorrosive.
- MIL-B-131A Barrier-Material; Water-Vaporproof, Flexible.
- JAN-P-132(1) Packaging and Packing for Overseas Shipment—Crates; Unsheathed, Wood; Nailed (for maximum net load of 2,500 pounds).
- JAN-P-133 Packaging and Packing for Overseas Shipment—Boxes, Set-up, Paperboard.

JAN-P-140      Packaging and Packing for Overseas Ship-  
ment—Adhesives, Water-Resistant, Case-  
Liner.

## 7. Other Publications

FM 24-5          Signal Communications.  
FM 24-20        Field Wire Technique.  
FM 72-20        Jungle Warfare.  
TB SIG 25        Preventive Maintenance of Power Cords.  
TB SIG 219      Operation of Signal Equipment at Low Tem-  
peratures.  
TB SIG 223      Field Expedients for Wire and Radio.



Fig. No.	Name of part and description	Function of part	Signal Corps stock No.
5	BUS BAR: long; flat metal strip-----	Connects binding posts to associated jacks.	4Z261-34
5	CONNECTOR RECEPTACLE: consisting of jack housing: metal, cylindrical w/internal threads. JACK ASSEMBLY, TELEPHONE: see connector receptacle.	Mounts jack spring and housing---	3Z3150A-6
5	NUT, PLAIN, HEXAGON: p/o connector receptacle.	Attaches binding post to panel-----	6L3504-28-7.10
5	NUT, SHEET SPRING: U-shaped; A9222-62-1-----	Grips panel mounting screws-----	6L2375-6
5	POST, BINDING: spring-loaded, wire-gripping jaws-----	Grips inserted wire to make a firm electrical contact.	3Z741-18.3
5	SCREW, TAPPING, THREAD FORMING: flat, slotted head; round; AN-530-6-10.	Attaches terminal board panel----	6L18206-10.1S
5	SWITCH ROTARY: consists of contact, cam, spring (helical), and washer.	Connects opposite bus bars-----	3Z9825-39.13
5	WASHER: internal tooth type; AN-986A-416B-----	Locks binding-post mounting nut in place.	6L72214-15

### 3. Coil Assembly, Telephone Repeating TA-145/GT

Except for the rotary switch, which is not a part hereof, the components of this equipment are identical with those listed for Terminal Box TA-125/GT in paragraph 2 of this appendix with the following additional items:

Fig. No.	Name of part and description	Function of part	Signal Corps stock No.
6	BRACKET, COIL, TELEPHONE REPEATING: Z-shaped metal.	Holds repeating coils in place.----	4Z2720-7

6	COIL, TELEPHONE REPEATING: rectangular w/five coded leads.	Provides for simplexing-----	3C1404-1
6	SCREW, TAPPING, THREAD FORMING: flat, slotted head; AN-530-6-8. BUS BAR, short; flat metal strip----- BUS BAR, long; flat metal strip-----	Mounts panel----- Connects binding post to adjacent jack (connector assembly). Connects binding post to adjacent jack (connector assembly).	6L7932-8.49 4Z261-35 4Z261-36

#### 4. Maintenance Kit MX-842/GT

Fig. No.	Name of part and description	Function of part	Signal Corps stock No.
4	CASE, MAINTENANCE KIT CY-1128/U: canvas; 5 pockets and main compartment inside.	Contains components of Kit and Signal, Switchboard TA-123/GT.	6F300-1128
4	CORD ASSEMBLY, ELECTRICAL CX-1959/U: two-conductor cord w/double pin-jack plug each end.	Provides for patching wire pairs connected to noncorresponding binding-post pairs.	3E5999-5.49
4	PROD, TEST MX-1315/U: cylindrical rubber covered shank; screw type head w/insulation-piercing pins.	Facilitates connection of test equipment.	3F3705-19.3
4	SIGNAL, SWITCHBOARD TA-123/GT-----	Provides visible signal to indicate that ringing current is on the line.	4C9639-123







