

DOCLC

TM 11-2700

WAR DEPARTMENT TECHNICAL MANUAL

AA
0
0
0
7
3
1
1
2
2
8



UC SOUTHERN REGIONAL LIBRARY FACILITY

INSTALLATION

OF RADIO AND INTERPHONE EQUIPMENT IN LIGHT TANK

M3A3

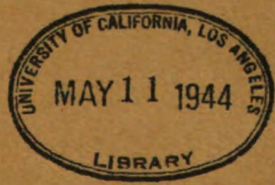

WAR DEPARTMENT • 18 MARCH 1944

Generated on 2016-03-24 14:00 GMT / http://hdl.handle.net/2027/uc1.aa0007311228

WAR DEPARTMENT,
WASHINGTON 25, D. C., 18 March 1944.

TM 11-2700, Installation of Radio and Interphone Equipment in Light Tank M3A3, is published for the information and guidance of all concerned.

[A. G. 300.7 (10 Feb 44).]

BY ORDER OF THE SECRETARY OF WAR:

G. C. MARSHALL,
Chief of Staff.

OFFICIAL:

J. A. ULIO,
*Major General,
The Adjutant General.*

DISTRIBUTION:

C and H 2, 17(5); IC and H 4-10, 18, 19, 44(5); IC 11(10).
(For explanation of symbols see FM 21-6.)

CONTENTS

SECTION I. RADIO SET SCR-506-(&).

	Paragraph	Page
Required parts	1	1
Location, assembly, and cording	2	2

II. RADIO SETS SCR-508-(&), SCR-528-(&), AND SCR-538-(&), AND ASSOCIATED INTERPHONE EQUIPMENT.

Required parts	3	3
Location, assembly, and cording	4	3

III. RADIO SET SCR-245-U.

Required parts	5	5
Location, assembly, and cording	6	6

APPENDIX. IGNITION NOISE SUPPRESSION IN LIGHT TANK M3A3		21
---	--	----

INSTALLATION
OF RADIO AND INTERPHONE
EQUIPMENT IN LIGHT TANK
M3A3



WAR DEPARTMENT

18 MARCH 1944

*United States Government Printing Office
Washington : 1944*

DESTRUCTION NOTICE

WHY—To prevent the enemy from using or salvaging this equipment for his benefit.

WHEN—When ordered by your commander.

HOW—1. Smash—Use sledges, axes, hand axes, pickaxes, hammers, crowbars, or other heavy tools.
2. Cut—Use axes, hand axes, or machetes.
3. Burn—Use gasoline, kerosene, oil, flame throwers, or incendiary grenades.
4. Explosives—Use firearms, grenades, or TNT.
5. Disposal—Bury in slit trenches, fox holes, or other holes. Throw in streams. Scatter.

USE ANYTHING IMMEDIATELY AVAILABLE FOR DESTRUCTION OF THIS EQUIPMENT

WHAT—1. Smash—All vacuum tubes, crystals, control dials, coupling coils, transformers, speakers in the receivers, external loudspeakers, microphones, headsets, dynamotors, and cable connectors.
2. Cut—All connecting wires, cording, and cabling.
3. Burn—All equipment, and all associated training, technical, and installation manuals.
4. Bury or scatter—All remains, after destroying their usefulness.

DESTROY EVERYTHING

SAFETY NOTICE

THIS EQUIPMENT USES HIGH VOLTAGES WHICH ARE DANGEROUS TO LIFE. OBSERVE ALL SAFETY PRECAUTIONS. MAKE NO ADJUSTMENTS INSIDE THE EQUIPMENT WITH THE POWER SWITCH ON. DO NOT OPERATE THE EQUIPMENT WITH THE SHIELDS REMOVED. DO NOT CONNECT POWER TO ANY UNIT OF THESE RADIO SETS UNTIL OPERATING INSTRUCTIONS HAVE BEEN READ COMPLETELY. TRANSMITTERS BC-653-(&) (IN RADIO SET SCR-506-(&)) AND BC-223-(&) (IN RADIO SET SCR-245-U) USE GRID BIAS KEYING WHICH DOES NOT REMOVE HIGH VOLTAGE WHEN KEY J-45 IS OPEN.

SECTION I

RADIO SET SCR-506-(E)

1. REQUIRED PARTS. Items necessary for the installation of Radio Set SCR-506-(E) in Light Tank M3A3 are listed below. Nomenclature followed by the symbol (E) is used to indicate any item of the equipment regardless of its model or procurement, except in the case of radio sets and interphone equipment, where it applies only to 12-volt models. Spare parts, instruction books, or Technical Manuals furnished with the equipment are not included.

Quantity	Stock No.	Item
1	2A224A	Antenna AN-24-A (auxiliary antenna).
2	6Z3147	Connector No. 61007 and Bondnut BL-50, Appleton Electric Co.
1	2Z2651-421	Clamp MC-421.
1	2Z2651-422	Clamp MC-422.
1	2Z2651-423	Clamp MC-423.
1	2Z2651-424	Clamp MC-424.
1	3E1307A-5.5	Cord CD-307-A, 65 inches long; for Headset HS-30-(E).
1	3E1314	Cord CD-314, for Loudspeaker LS-3.
1	3E1318	Cord CD-318, control cord for Microphone T-30-(E).
1	3E1604	Cord CD-604, 6 inches long, for Headset HS-30-(E).
1	2Z3367A	Cover BG-67, for Mast Base MP-37.
1	3H1640(E)	Dynamotor DM-40-(E), 12-volt, for Radio Receiver BC-652-(E), including spare parts.
1	3H1642(E)	Dynamotor DM-42-(E), 12-volt, for Radio Transmitter BC-653-(E), including spare parts.
1	2B830(E)	Headset HS-30-(E).
2	3G598	Insulator IN-98.
1		Hardware bag, containing nine machine screws, round head, No. 8, 32-inch by 1/4-inch; and nine lockwashers No. 8, standard.
1	3Z3445	Key J-45.
1	2Z6303.1	Loudspeaker LS-3.
1	2A2087	Mast Base MP-37.
1	2A2349	Mast Section MS-49.
1	2A2350	Mast Section MS-50.
1	2A2351	Mast Section MS-51.
1	2A2352	Mast Section MS-52.
1	2A2353	Mast Section MS-53.
1	2B1617(E)	Microphone T-17-(E).
1	2B1630(E)	Microphone T-30-(E).
1	2Z6721-253(E)	Mounting FT-253-(E), including two Cords CO-280 and spare parts.
1	2C4452(E)	Radio Receiver BC-652-(E), including tubes, crystal unit, and spare parts.
1	2C6530-653(E).	Radio Transmitter BC-653-(E), including tubes and spare parts.
1	2Z8056(E).	Roll BG-56-(E), for mast sections.
1	2C7978(E)	Switchbox BC-658-(E), with mounting screws.
8	1B146	Wire, W-146, for antenna and ground leads.

¹ Headset HS-18 may be substituted for Headset HS-30-(E), in which case Cord CD-604 will not be required.

² Mast Base MP-57 may be substituted for Mast Base MP-37.

2. LOCATION, ASSEMBLY, AND CORDING. a. General. Holes and brackets required for the installation of Radio Set SCR-506-($\&$) normally are located prior to delivery of Light Tank M3A3, and should not be relocated, nor should those on any radio part, unless absolutely necessary. Illustrations, installation methods, and any subsequent changes to this manual must be studied carefully before making an installation. Assembly and location of components of Radio Set SCR-506-($\&$) must be as shown in figure 4.

Caution: Light Tank M3A3 has a 12-volt electrical system. Before installing Radio Set SCR-506-($\&$), be sure that it is designed for a 12-volt installation.

b. Assembly and Installation. Components of the radio set should be installed as follows:

<i>Part and location</i>	<i>Method and materials</i>
Mast Base MP-37, rear of right sponson.	Assemble as shown in figure 1; locate as shown in figure 4.
Mast Sections MS-49 to MS-53, and Clamps MC-421 to MC-424, on Mast Base MP-37.	Screw mast sections together and secure with clamps. Then screw the antenna into the mast base. Mast sections must be carried in Roll BG-56-($\&$) when not in use.
Insulators IN-98, ceiling of right sponson.	Figure 4.
³ Mounting FT-253-($\&$), floor of right sponson.	Figure 4.
Dynamotor DM-40-($\&$), upper section of Radio Receiver BC-652-($\&$).	Remove the four screws on the front of the radio receiver panel and the one on the rear of the receiver case. Now remove the receiver chassis from the case. Fasten the dynamotor on the upper section of the chassis with the four snap slides, and connect it to the set with the lead and Plug PL-250. The receiver circuits will be automatically adjusted for 12-volt operation. Turn the name plate of the front panel to read 12-VOLT OPERATION. Replace the receiver chassis. ⁴
Dynamotor DM-42-($\&$), fuse panel housing of Radio Transmitter BC-653-($\&$).	Place the dynamotor below the fuse panel housing and fasten it in place with the five screws on the panel. (Connections are made automatically through the jacks at the rear of the dynamotor.) Remove the voltage regulator plate at the upper right of the transmitter and connect the six links for 12-volt operation by swinging the upper end of the links to the position nearer the transmitter. The outer side of the voltage indicator, above the dynamotor's red pilot light, should read 12 VOLTS.
Radio Transmitter BC-653-($\&$), on Mounting FT-253-($\&$).	Figure 4.
Radio Receiver BC-652-($\&$), on Mounting FT-253-($\&$).	Figure 4.
Switchbox BC-658-($\&$), on bracket in hull (fig. 4).	Plug the appropriate pair of attached cords to the radio set and the opposite pair to Interphone Control Box BC-606-($\&$) (a component of Radio Set SCR-508-($\&$), SCR-528-($\&$), and SCR-538-($\&$), as described in sec. II).
Headset HS-30-($\&$), Microphone T-30-($\&$), Key J-45, Loudspeaker LS-3, Cords CD-314 and CD-318.	Use Cords CD-307-A and CD-604 to connect Headset HS-30-($\&$) to Control Box BC-658-($\&$); and Cord CD-318 to connect Microphone T-30-($\&$) to the control box. Attach Loudspeaker LS-3 to the radio set with Cord CD-314.
Connectors No. 61007 and Bondnuts BL-50.	Install as shown in figure 4.

³ To prevent noisy reception while the vehicle is in motion, Mounting FT-253-($\&$) must make good electrical contact with the vehicle. The surface upon which the feet of the mounting rest must be thoroughly cleaned with emery cloth or sandpaper before the mounting is bolted in place. When the radio mounting shelf is not welded to the vehicle, the surfaces under the heads of all mounting bolts must be cleaned to insure good electrical contact between the mounting shelf and the vehicle frame.

⁴ Before returning the receiver chassis to the case, see that all vacuum tubes are firmly placed in the proper sockets, and that Crystal Unit DC-15-A has been installed.

SECTION II

RADIO SETS SCR-508-(&), SCR-528-(&), AND SCR-538-(&), AND ASSOCIATED INTERPHONE EQUIPMENT

3. REQUIRED PARTS. Items necessary for the installation of Radio Sets SCR-508-(&), SCR-528-(&), and SCR-538-(&) and associated interphone equipment in Light Tank M3A3 are listed below. Nomenclature followed by the symbol (&) is used to indicate any item of the equipment, regardless of its model or procurement, except in the case of radio sets and interphone equipment where it applies only to 12-volt models. Spare parts and instruction books or Technical Manuals furnished with the equipment are not included.

Quantity	Stock No.	Item
4	6Z3147	Connector No. 61007 and Bondnut BL-50, Appleton Electric Co.
4	3E1307A-5.5	Cord CD-307-A, 65 inches long; for Headset HS-30-(&).
4	3E1318	Cord CD-318.
¹ 4	3E1604	Cord CD-604.
32 feet	3E2213	Cordage CO-213.
1	2Z3400-108	Cover BG-108.
1	2Z2651-423	Clamp MC-423, for Mast Section MS-51.
1	2Z2651-424	Clamp MC-424, for Mast Section MS-52.
² 2	3H1634(&)	Dynamotor DM-34-(&), 12-volt, including spare parts.
³ 1	3H1635(&)	Dynamotor DM-35-(&), 12-volt, including spare parts.
⁴ 4	2B830(&)	Headset HS-30-(&).
1	3G601	Insulator IN-101.
⁴ 1	2C1617(&)	Interphone Amplifier BC-605-(&), including spare parts and tubes.
4	2C1738(&)	Interphone Control Box BC-606-(&).
⁵ 1	2A2088-48	Mast Base MP-48.
1	2A2351	Mast Section MS-51.
1	2A2352	Mast Section MS-52.
1	2A2353	Mast Section MS-53.
1	2B1617	Microphone T-17.
1	2B1630(&)	Microphone T-30-(&).
1	2Z6721-237(&)	Mounting FT-237-(&), including spare parts.
⁶ 1	2C4403(&)	Radio Receiver BC-603-(&), including spare parts and tubes.
⁷ 1	2C6494(&)	Radio Transmitter BC-604-(&), including spare parts, tubes, and crystals.
1	2Z8056(&)	Roll BG-56-(&).
18	3Z11038	Terminal lug, in cloth bag, for terminal boxes.
5 feet	1B128	Wire W-128.

4. LOCATION, ASSEMBLY, AND CORDING. a. General. Holes and brackets required for the installation of Radio Sets SCR-508-(&), SCR-528-(&), and SCR-538-(&), and associated interphone equipment, normally are located prior to delivery of Light Tank M3A3, and should not be relocated, nor should

¹ Headset HS-18 may be substituted for Headset HS-30-(&) and Cord CD-604.

² One only supplied with Radio Set SCR-528-(&).

³ None supplied with Radio Set SCR-538-(&).

⁴ Supplied only with Radio Set SCR-538-(&).

⁵ Mast Base MP-37 or MP-57 with Cover BG-67 may be substituted for Mast Base MP-48 and Cover BG-108.

⁶ Two supplied with Radio Set SCR-508-(&).

⁷ Not supplied with Radio Set SCR-538-(&).

those on any radio part, unless absolutely necessary. Illustrations, installation methods, and any subsequent changes to this manual must be studied carefully before making an installation. Assembly and location of components must be as shown in figure 6.

Caution: Light Tank M3A3 has a 12-volt electrical system. Before installing Radio Sets SCR-508-(&) SCR-528-(&), and SCR-538-(&), and associated interphone equipment, be sure that the models designed for 12-volt installations have been supplied.

b. Assembly and Installation. Components must be installed as follows:

<i>Part and location</i>	<i>Method and materials</i>
Mast Base MP-48, on mast base bracket attached on rear of turret bulge.	Study figure 5. Loosen screws 8 and 9, and remove assembly 7. Use Wire W-128 (internal lead) for assembly 6. Insert the tinned tip of Wire W-128 (item 6-B) fully into the slot and tighten the setscrew (item 9) firmly. Leave enough slack inside the stem (item 1) to permit full flexing of the mast base. Cut enough Wire W-128 to install the mast base on the mast base bracket (fig. 6).
Mast Sections MS-51, MS-52, and MS-53; and Clamps MC-423 and MC-424 on Mast Base MP-48.	Screw the mast sections together, and secure the sections with the clamps. Then screw the antenna into the mast base. When not in use, carry the mast sections in Roll BG-56-(&).
Insulator IN-101, through wall of turret bulge.	Figure 6.
Mounting FT-237-(&), on radio mounting shelf of turret bulge.	Figure 6.
Dynamotor DM-34-(&), in Receiver BC-603-(&).	Secure each dynamotor with the four screws provided.
Dynamotor DM-35-(&), in Transmitter BC-604-(&).	Secure the dynamotor with the four screws provided.
Radio Transmitter BC-604-(&), on Mounting FT-237-(&).	Figure 6.
Radio Receiver BC-603-(&), on Mounting FT-237-(&).	Figure 6.
Interphone Amplifier BC-605-(&), on Mounting FT-237-(&).	Figure 6.
Microphone-headset hooks, on spacers.	Figure 6.
Connectors No. 61007 and Bondnuts BL-50, on terminal boxes.	Figure 6.
Interphone Control Boxes BC-606-(&), on brackets.	Figure 6.
Microphones T-30-(&), Cords CD-318, Headsets HS-30-(&), Cords CD-307-A, and Cords CD-604.	Use Cords CD-307-A and CD-604 to connect Headsets HS-30-(&) to the Interphone Control Boxes BC-606-(&), and Cord CD-318 to connect Microphones T-30-(&) to control boxes.
Cover BG-108.	Place over Mast Base MP-48 when mast sections are not in use.
Cordage CO-213.	Before cutting Cordage CO-213, and wiring the equipment, check the installation of radio and interphone components in the tank. Skin insulation from ends of the cable, providing a soldered ground connection for both inner and outer shielding at each end. Tape the ends of all unused cable wires. Interconnect components as in figure 6. See figure 7 for wiring of Cordage CO-213 to Interphone Control Boxes BC-606-(&), Mounting FT-237-(&), and vehicle terminal boxes.

SECTION III

RADIO SET SCR-245-U

5. REQUIRED PARTS. Items necessary for the installation of Radio Set SCR-245-U in Light Tank M3A3 are listed below. Spare parts and instruction books or Technical Manuals furnished with the equipment are not included. Nomenclature followed by the symbol (&) is used to indicate any item of the equipment regardless of its model or procurement except in the case of radio sets and interphone equipment where it applies only to 12-volt models.

<i>Quantity</i>	<i>Stock No.</i>	<i>Item</i>	
1	2A224A	Antenna AN-24-A (auxiliary antenna).	
1	2Z1119A	Box BX-19-A (or Box BX-19), for receiver spare tubes.	
1	2Z1121	Box BX-21, for Boxes BX-19 and BX-20, headsets, and other material.	
1	2Z1856	Case CS-56, for transmitter tuning unit.	
2	3E1307A-5.5	Cord CD-307-A, 65 inches long; for Headset HS-30-(&).	
1	3E1318	Cord CD-318, for Microphone T-30-(&).	
1	3E1426	Cord CD-426, 24 inches long; connects Radio Transmitter BC-223-(&) to Dynamotor Unit PE-55.	
1	3E1355	Cord CD-355 18 inches long; connects Radio Receiver BC-312-(&) to Radio Transmitter BC-223-(&).	
1	2	3E1604	Cord CD-604.
1	3E2175A	Cord CO-175-A, 48 inches long; connects PE-55 to terminal box.	
1	2Z3367A	Cover BG-67-A (or Cover BG-67), for mast base.	
1	2Z3375A	Cover BG-75-A (or Cover BG-75), for Radio Receiver BC-312-(&).	
1	3H1357	Cover BG-77 (or Cover BG-77-A), for Dynamotor Unit PE-55.	
1	2Z3386	Cover BG-86 (or Cover BG-86-A), for Radio Transmitter BC-223-A.	
1	3H1855	Dynamotor Unit PE-55, including spare parts and accessories.	
1		Hardware, set of, including—	
		10 screws, machine, round head, No. 10-32 x 1", steel, galvanized.	
		10 elastic stopnuts, No. 10-32.	
		12 screws, machine, hexagonal head, 1/4"-20 x 1", steel, galvanized.	
		12 elastic stopnuts, 1/4"-20.	
		8 screws, machine, round head, No. 10-32 x 3/8", steel, galvanized.	
		8 lockwashers, No. 10 standard, steel, galvanized.	
		6 screws, machine, round head, No. 8-32 x 3/8", steel, galvanized.	
		6 lockwashers, No. 8, steel, galvanized.	
1	2	2B830(&)	Headset HS-30-(&).
3	3G586	Insulator IN-86 (two for auxiliary antenna, one for tying down mast sections).	
2	3G598	Insulator IN-98.	
1	3Z3445	Key J-45.	
1	2A2087	Mast Base MP-37.	
2	2A2349	Mast Section MS-49.	
2	2A2350	Mast Section MS-50.	
2	2A2351	Mast Section MS-51.	
2	2A2352	Mast Section MS-52.	

¹ Headset HS-18 may be substituted for Headset HS-30-(&) and Cord CD-604.

Quantity	Stock No.	Item
2	2A2353	Mast Section MS-53.
1	2B1617(&)	Microphone T-17-(&).
1	2B1630(&)	Microphone T-30-(&).
1	2Z6712	Mounting FT-172, snubber for Radio Transmitter BC-223-(&).
1	2Z6718	Mounting FT-178, snubber for Radio Receiver BC-312-(&).
1	2C4312(&).1	Radio Receiver BC-312-(&), including spare parts and accessories.
1	2C6223(&)	Radio Transmitter BC-223-(&), including spare parts and accessories.
1	2Z8056A	Roll BC-56-A, for mast sections.
50 ft	6Z7926	Rope RP-5, for auxiliary antenna and tying down mast sections.
1	2C8017(&)	Transmitter Tuning Unit TU-17-(&).
1	2C8018(&)	Transmitter Tuning Unit TU-18-(&).
15 ft	1B128	Wire W-128.

6. LOCATION, ASSEMBLY, AND CORDING. a. General. Holes and brackets required for the installation of Radio Set SCR-245-U normally are located prior to delivery of Light Tank M3A3, and should not be relocated, nor should those on any radio part, unless absolutely necessary. Illustrations, installation methods, and any subsequent changes to this manual must be studied carefully before making an installation. Assembly and location of components of Radio Set SCR-245-U must be as shown in figure 8.

Caution: Light Tank M3A3 has a 12-volt electrical system. Before installing Radio Set SCR-245-U, be sure that it is designed for a 12-volt installation.

b. Assembly and Installation. Components of the radio set should be installed as follows:

Part and location	Method and materials
Mast Base MP-37, in hole provided in roof of right sponson.	Assemble the mast base as follows (fig. 1): Place item 1 over hole in sponson. Place item 2 over item 1. Place item 3 over item 2. Insert item 4 through hole. Place item 5 over item 6 and insert through bottom of the hole in the roof of the right sponson. Place items 7 and 8 beneath item 6 and fasten entire assembly in place with items 9 and 10. Refer to figure 8 for termination of antenna lead before cutting wire.
Insulator IN-98.	Fasten to pads with the screws and washers provided as shown in figure 8.
Mounting FT-162, on floor of right sponson, left side;	Secure to sponson with the screws and stopnuts provided as shown in figure 8.
Mounting FT-173, on floor of right sponson, center; and	
Mounting FT-185, on floor of right sponson, right side.	
Mounting FT-178, on right sponson wall.	Remove receiver from the receiver cabinet and drill the cabinet as shown in figure 10. Position mounting as shown in figure 8. Assemble mounting as shown in figure 11, but <i>do not</i> mount retaining bracket until Cover BG-75 is installed.
Cover BG-75, on Radio Receiver BC-312-(&).	Replace receiver in its cabinet. Cut a slot in top of cover to admit retaining bracket of Mounting FT-178, and place cover over receiver cabinet. Then mount retaining bracket and complete assembly of Mounting FT-178.
Radio Receiver BC-312-(&), on Mounting FT-162.	Install receiver on Mounting FT-162, tighten thumbscrews, and lock in place with the snap slide catches.
Mounting FT-172, on right sponson wall.	Remove the tuning unit from the transmitter. Using the reinforcing plate (fig. 11) as a template, drill top of transmitter cabinet. Assemble Mounting FT-172 as shown in figure 11 and position as shown in figure 10.

* Mast Base MP-14, MP-14-A, or MP-57 may be substituted for Mast Base MP-37. Cover BC-67 or BC-67-A fits all four types.

* In all cases the serial number and order number of the Radio Transmitter BC-223-(&) must agree with that of transmitter tuning units. Transmitters and Transmitter tuning units should not be issued separately.

<i>Part and location</i>	<i>Method and materials</i>
Cover BG-86.	Cut a slot in the top of the cover to admit retaining bracket of Mounting FT-172 (see fig. 11), and place cover over transmitter cabinet before completing the assembly of Mounting FT-172.
Radio Transmitter BC-223-(&), on Mounting FT-173.	Place the transmitter on Mounting FT-173 and lock in position with snap slides.
Calibration charts.	Carried in side pocket of radio transmitter or mounted by drilling small holes in corners and securing in a convenient location with machine screws.
Dynamotor Unit PE-55, on Mounting FT-185 (fig. 8).	Place the dynamotor on mounting and lock in position with snap slides.
Cover BG-77.	Place over Dynamotor Unit PE-55.
Transmitter Tuning Units TU-17-(&) and TU-18-(&).	One unit to be carried in transmitter; unit not in use to be carried in Case CS-56.
Case CS-56.	Disposition left to discretion of using arms.
Mast Sections MS-49 to MS-53, on Mast Base MP-37.	Carry in Roll BG-56-A when not in use.
Roll BG-56-A.	For mast sections when not in use. Carry in convenient place in vehicle.
Cover BG-67.	To be placed over mast base when mast sections are not in use. (See fig. 8.)
Boxes BX-19 and BX-20.	Disposition left to discretion of using arms. Stow in Box BX-21 when not in use if Box BX-21 is carried in the vehicle.
Box BX-21.	Disposition left to the discretion of the using arms.
Headset HS-30-(&).	Plug Cord CD-307-A into jack of Radio Receiver BC-312-(&). Plug Cord CD-604 into Cord CD-307-A and connect Headset HS-30-(&) to Cord CD-604.
Microphone T-17-(&), and Key J-45.	Plug the cords attached to Microphone T-17-(&) and Key J-45 to the proper jacks in Radio Receiver BC-312-(&).
Crystal Holder FT-171-B with crystal.	To be carried in Transmitter Tuning Unit TU-17-(&) or TU-18-(&), according to frequency designated on holder.
Wire W-128 and screws, nuts, and other material.	Stow any excess material remaining after installation in Box BX-21.

c. Cording and Wiring Radio Set SCR-245-U. (1) Radio Set SCR-245-U should be corded and wired as shown in figure 8. Plug locks on the various cords must be tightened by hand, never with tools. Enough slack must be left in the cording and wiring connections to permit free motion of all units having shock mountings. Color codes specified must be followed.

(2) To prevent accidental shorts on the battery, do not connect the +12-volt and -12-volt leads of Cord CO-188-A connecting Dynamotor Unit PE-55 and the battery terminal block (in the terminal box) until all other connections have been completed. When installing Cord CO-188-A at the dynamotor end, it may be necessary to ream the entrance hole provided in the dynamotor housing. If necessary, it is also permissible to modify the dynamotor end of the cord by shortening the leads. Terminals must be resoldered to the leads before completing electrical connections when the leads are shortened.

(3) The antenna and ground connections should be made using wire W-128 as shown in figure 8. Ground connections from the transmitter and receiver should be as short as possible. Care should be taken to insure good electrical connection. All wire ends should be solder-tinned. All cords should be connected and draped in such a manner as not to interfere with the accessibility and operation of the radio equipment.

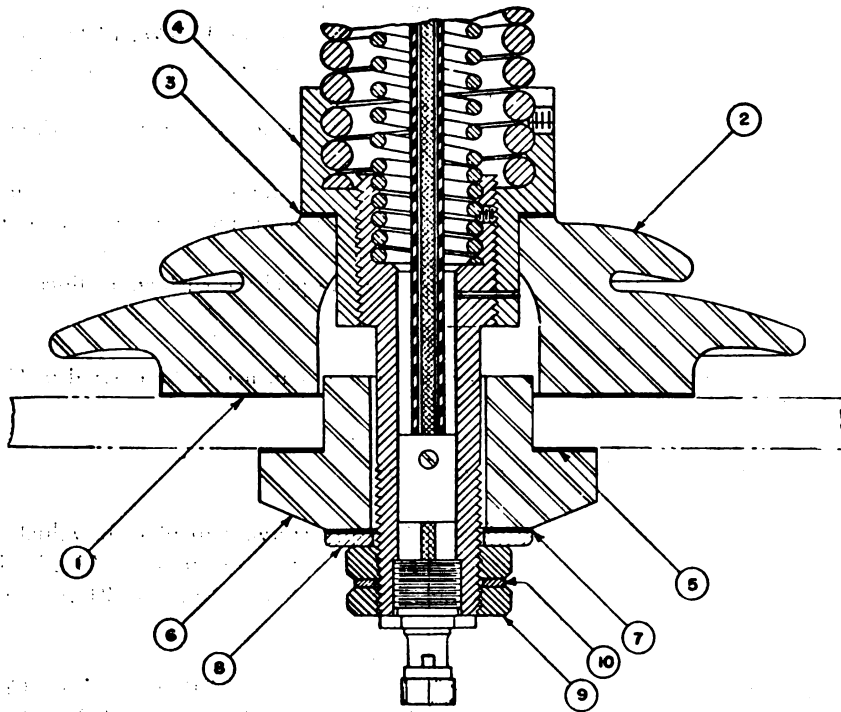

- ① - FIBER WASHER
- ② - PORCELAIN INSULATOR
- ③ - FABRIC WASHER
- ④ - SPRING RETAINER
- ⑤ - FIBER WASHER
- ⑥ - PORCELAIN INSULATOR
- ⑦ - FABRIC WASHER
- ⑧ - STEEL WASHER
- ⑨ - STEEL NUT
- ⑩ - LOCKWASHER

BASED ON
SC-D-1244-N

TL-7539

FIGURE 1. Mast Base MP-37, assembly for installation.

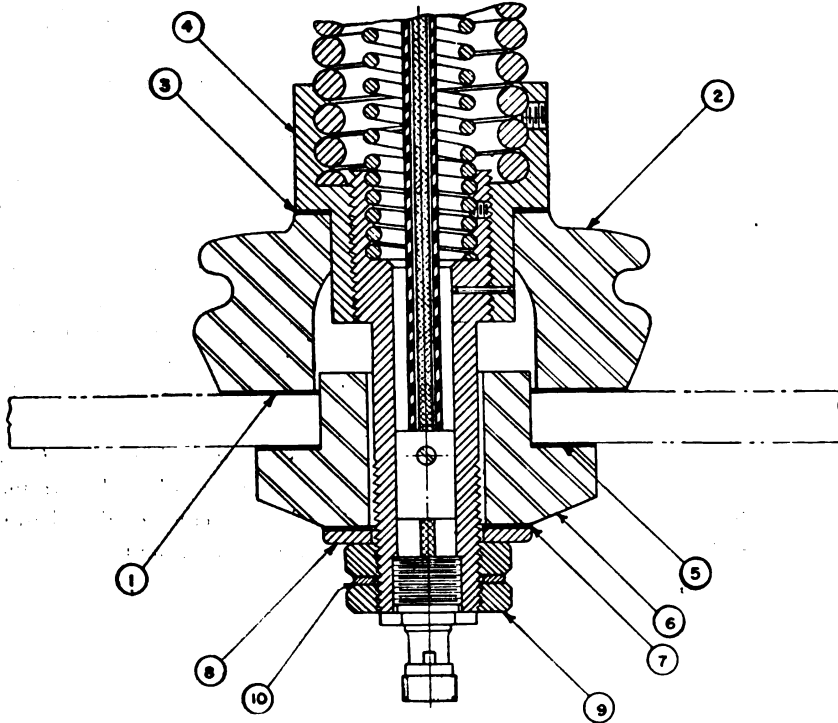

- ① - FIBER WASHER
- ② - PORCELAIN INSULATOR
- ③ - FABRIC WASHER
- ④ - SPRING RETAINER
- ⑤ - FIBER WASHER
- ⑥ - PORCELAIN INSULATOR
- ⑦ - FABRIC WASHER
- ⑧ - STEEL WASHER
- ⑨ - STEEL NUT
- ⑩ - LOCKWASHER

BASED ON
SC-D-1244-N

TL-7540

FIGURE 2. Mast Base MP-57, assembly for installation.

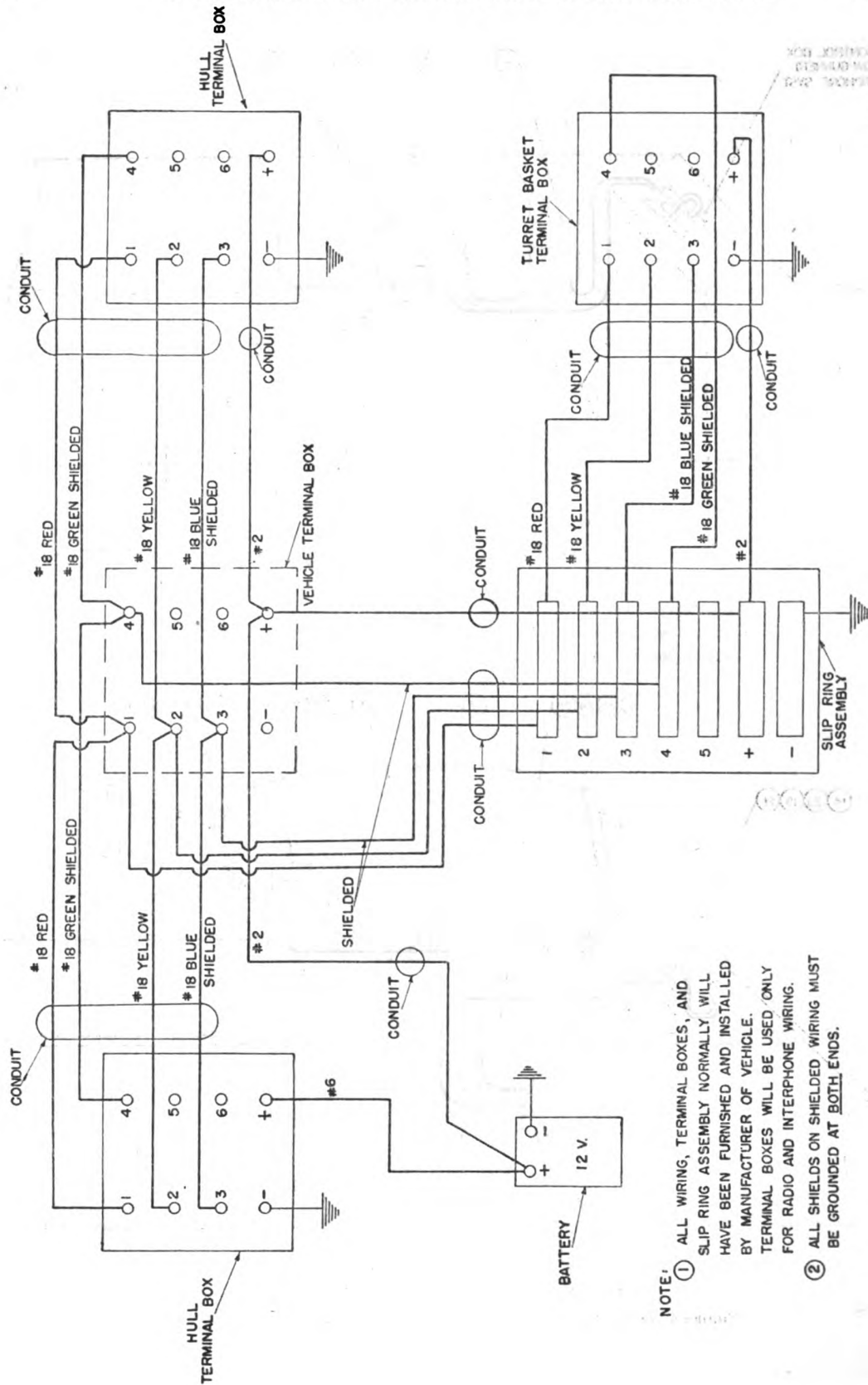

NOTE: ① ALL WIRING, TERMINAL BOXES, AND SLIP RING ASSEMBLY NORMALLY WILL HAVE BEEN FURNISHED AND INSTALLED BY MANUFACTURER OF VEHICLE. TERMINAL BOXES WILL BE USED ONLY FOR RADIO AND INTERPHONE WIRING.

② ALL SHIELDS ON SHIELDED WIRING MUST BE GROUNDED AT BOTH ENDS.

BASED ON SC-A-8558-A

FIGURE 3. Wiring diagram of slip rings and terminal boxes in Light Tank M3A3.

TL-7541

INTERPHONE CONTROL BOX
BC-606-(B) (BOW GUNNER)
(PART OF INTERPHONE SYST
SYSTEM)

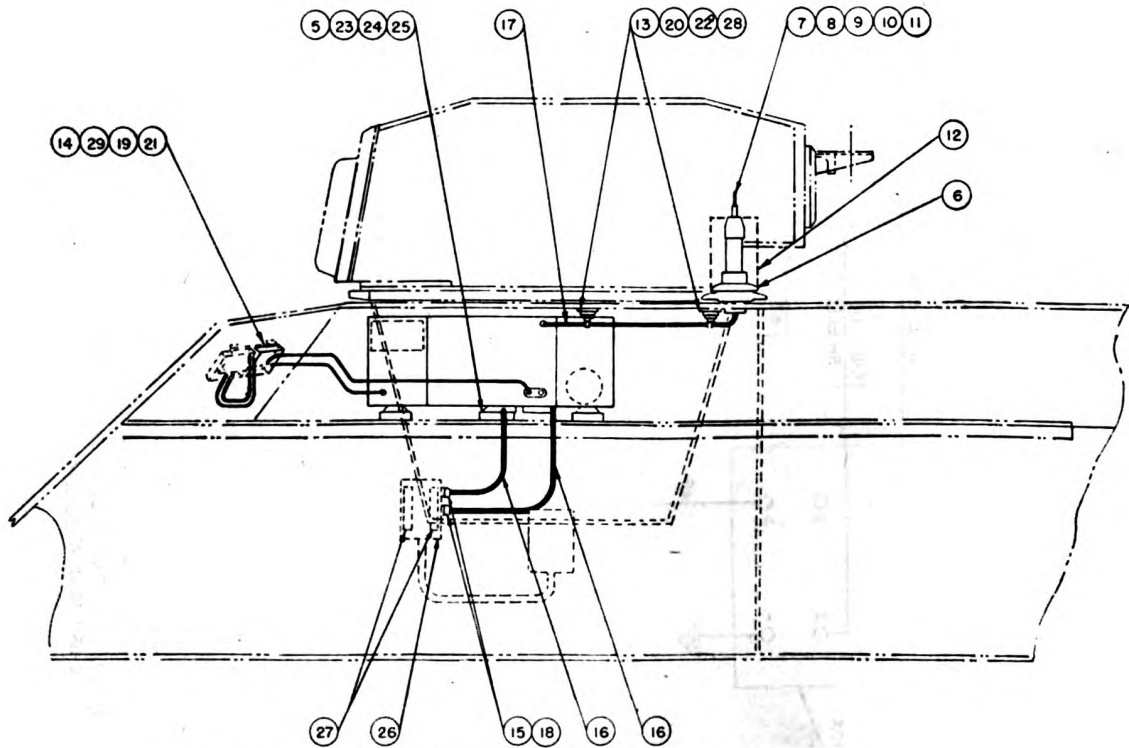
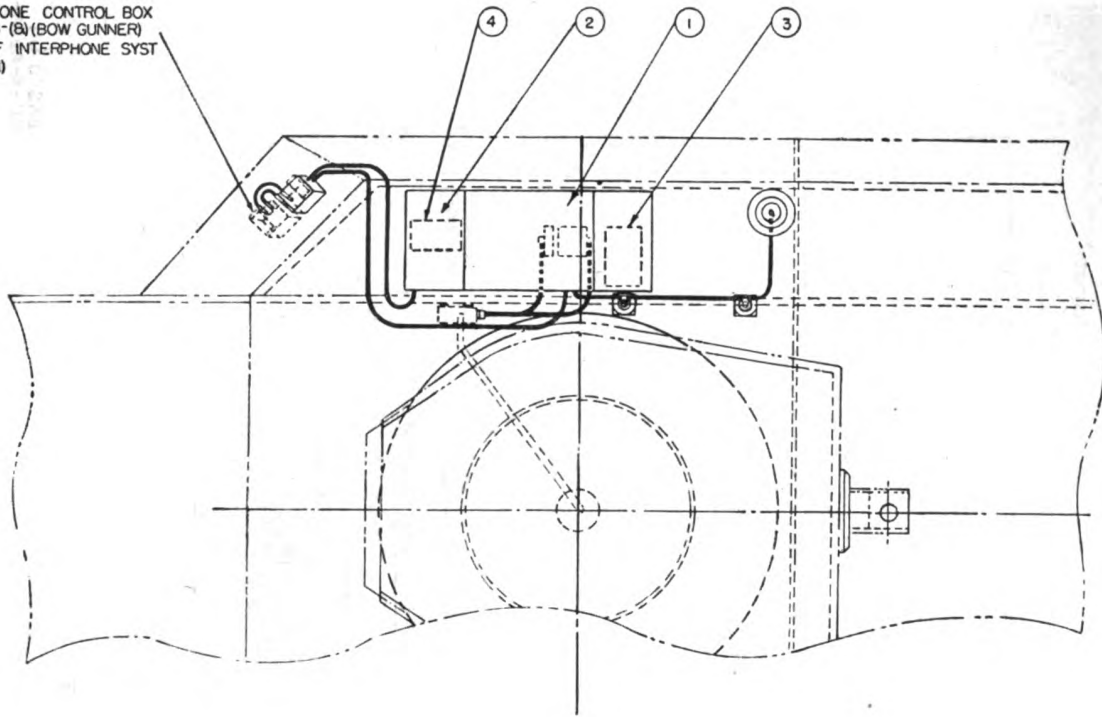

FIGURE 4. Installation of Radio Set SCR-506-(S) in Light Tank M3A3.

NOTE:

- 1- (26) TO (29) INCLUSIVE NORMALLY WILL HAVE BEEN FURNISHED AND INSTALLED BY VEHICLE MANUFACTURER.
- 2- ENDS OF WIRE (17) AFTER BEING CUT TO PROPER LENGTH, MUST BE TINNED FOR CONNECTION TO BINDING POST.
- 3- (19) (21) (23) (24) & (25) ARE FURNISHED WITH (5) & (14)
- 4- (20) AND (22) SHALL BE SUPPLIED AS PER PARTS LIST.
- 5- USE COVER BG-67 WHEN MAST SECTIONS ARE NOT INSTALLED.
- 6- CUT WIRE W-146 TO PROPER LENGTH AND TIN FOR ANTENNA CONNECTIONS.

ITEM NO.	NAME OF ITEM	QUAN REQ	TYPE NO.	REMARKS
(1)	RADIO TRANSMITTER	1	BC-653	
(2)	RADIO RECEIVER	2	BC-652	
(3)	DYNAMOTOR	1	DM-42	
(4)	DYNAMOTOR	1	DM-40	
(5)	MOUNTING	1	FT-253(B)	
(6)	MAST BASE	1	MP-37	
(7)	MAST SECTION	1	MS-49	WITH CLAMP MC-421
(8)	MAST SECTION	1	MS-50	WITH CLAMP MC-422
(9)	MAST SECTION	1	MS-51	WITH CLAMP MC-423
(10)	MAST SECTION	1	MS-52	WITH CLAMP MC-424
(11)	MAST SECTION	1	MS-53	
(12)	COVER	1	BG-67	
(13)	INSULATOR	2	IN-98	
(14)	SWITCHBOX	1	BC-658(B)	
(15)	APPLETON CONNECTOR	2		
(16)	CORD - CO-280			
(17)	WIRE - W-146			36" LONG
(18)	BOND NUT	2		
(19)	RD. HD. MACH. SCREW	3		
(20)	RD. HD. MACH. SCREW	6		
(21)	LOCKWASHER	3		
(22)	LOCKWASHER	6	SEE NOTE 3 & 4	
(23)	HEX. HD. MACH SCREW	12		
(24)	HEX. NUT	12		
(25)	LOCKWASHER	8		
(26)	TERMINAL BOX	1		
(27)	BRACKET	2	SEE NOTE 1	
(28)	PAD	2		
(29)	BRACKET	1		

TL-7542

BASED ON
SO-D-8888-D

FIGURE 4—Continued.

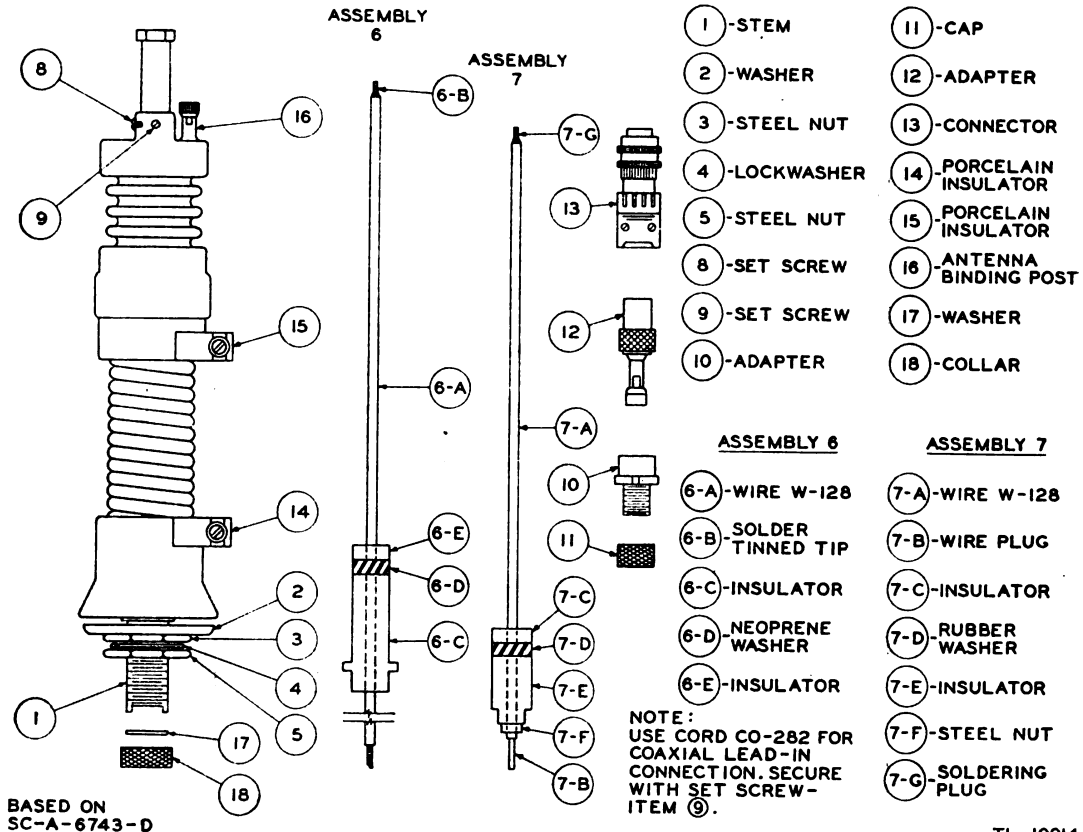

FIGURE 5. Mast Base MP-48, assembly for installation.

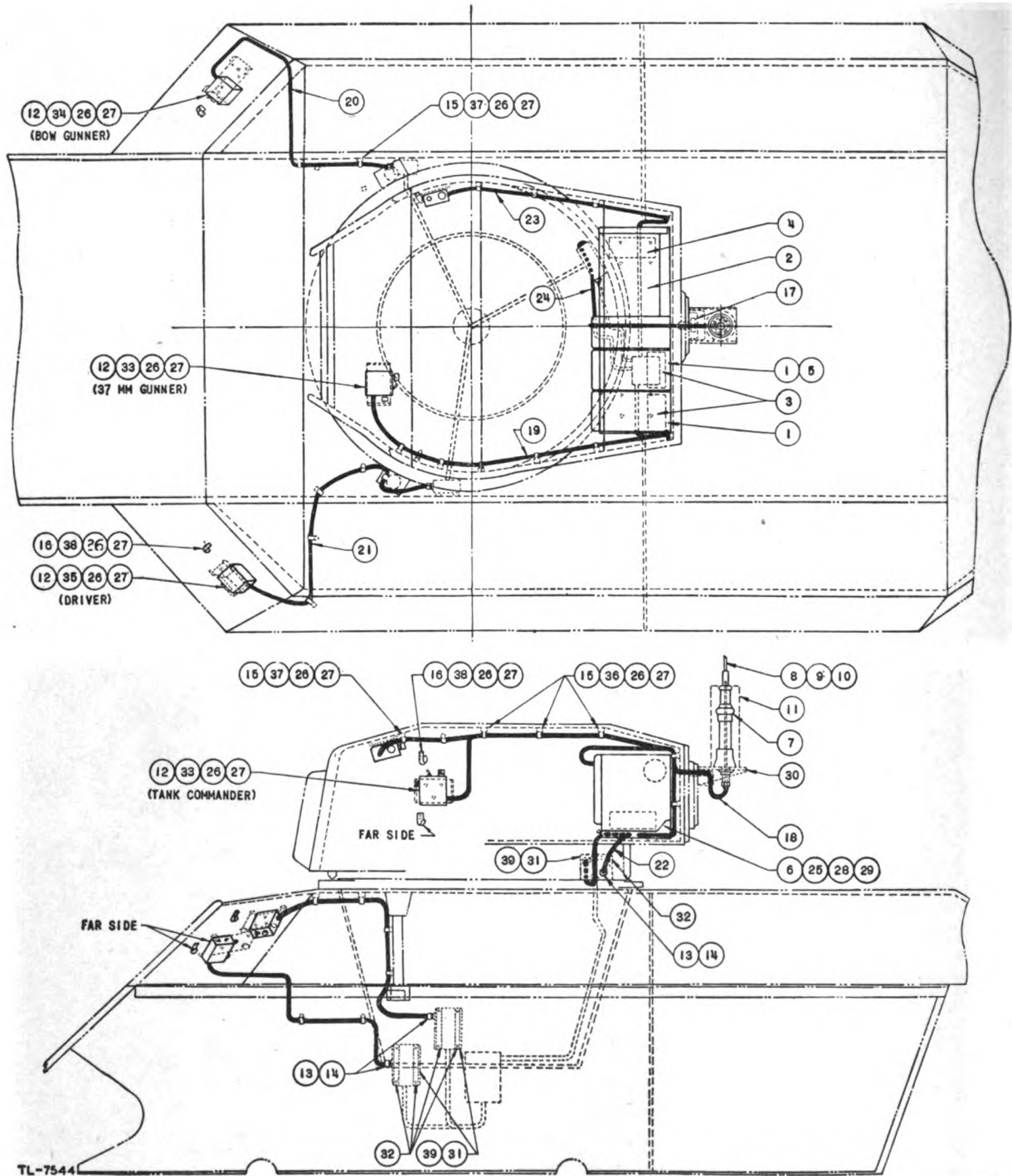

FIGURE 6. Installation of Radio Sets SCR-508-(S), SCR-528-(S), and SCR-538-(S), and associated interphone equipment in Light Tank M3A3.

RADIO SET COMPONENTS					
	TRANS BC-604-(A)	RECEIVER BC-603-(A)	INTER. AMPL. BC-605-(A)	12 VOLTS	
				DYNAMOTOR DM-35-(A)	DYNAMOTOR DM-34-(A)
RADIO SET SCR-508-(A)	1	2	-	1	2
RADIO SET SCR-528-(A)	1	1	-	1	1
RADIO SET SCR-538-(A)	-	1	1	-	2

- NOTE:
- FOR WIRING DIAGRAM OF RADIO SET SCR-508-(A), SCR-528-(A), OR SCR-538-(A) SEE FIGURE 7.
 - FOR WIRING OF SLIP RINGS AND TERMINAL BOXES SEE FIGURE 3.
 - FOR INSTALLATION OF RADIO SET SCR-508-(A), SEE FIGURE 4.
 - 80 TO 89 INCLUSIVE SHALL BE FURNISHED AND INSTALLED BY VEHICLE MANUFACTURER.
 - ENDS OF WIRE (8) AFTER BEING CUT TO PROPER LENGTH, SHALL BE TINED FOR CONNECTION TO BINDING POST.
 - 29, 29, AND 29 ARE FURNISHED WITH (6).
 - FOR ADDITIONAL COMPONENTS AND SPARE PARTS, SEE PARTS LIST.
 - 19, 19, 29 AND 29 ARE FURNISHED WITH (12).
 - CORDAGE LENGTHS GIVEN INCLUDE THE EXTRA LENGTH NECESSARY FOR CONNECTIONS.
 - DRIVER, BOW GUNNER, 37MM LOADER, AND 37MM GUNNER, SHALL EACH BE FURNISHED ONE HEAD-SET HS-30-(A) WITH CORD CD-307-A (56") AND CORD CD-604 AND ONE MICROPHONE TS-30-(A), WITH CORD CD-318.
 - USE COVER BG-108 WHEN MAST SECTIONS ARE NOT INSTALLED.

QTY. REQ.	NAME OF ITEM	ORDNANCE NO. OR MATERIAL	TYPE NO.	ITEM NO.	REMARKS
18.	TERMINAL LUG			39	
4.	SPACER	JA260934		38	
11.	SPACER	JA260933		37	
6.	SPACER	JA233905		36	
1.	BRACKET	JB183664		35	SEE NOTE # 4
1.	BRACKET	JA265574		34	
2.	BRACKET	JB262829		33	
6.	BRACKET	JA261175		32	
3.	TERMINAL BOX	JC76373		31	
1.	MAST BASE BRACKET	JC107653		30	
8.	HEX. HD. NUT			29	.5/16" - 24
8.	HEX. HD. MACH. SCREW	STEEL		28	.5/16" - 24 x 1 3/8" LONG
41	LOCKWASHER	ELECTRO.	SEE NOTE.	27	STD. FOR #8 SCREW
41	HD. MACH. SCREW	GALVANIZED	# 6 & # 8	26	JB-32x3/8" LONG
8.	LOCKWASHER			25	STD. FOR 5/16" SCREW
	CORD		CD-278	24	
	CORDAGE		CD-213	23	.103" LONG
	CORDAGE		CD-213	22	.32" LONG
	CORDAGE		CD-213	21	.76" LONG
	CORDAGE		CD-213	20	.58" LONG
	CORDAGE		CD-213	19	.94" LONG
	WIRE		JF-128	18	.28" LONG
1.	INSULATOR		IN-101	17	
4.	HOOK			16	
21.	CLAMP			15	
4.	BOND NUT			14	CAT. NO. BL-50
4.	APPLETON CONNECTOR			13	CAT. NO. 61007
4.	INTERPHONE CONTROL BOX	BC-606-(A)		12	
1.	COVER	BG-108		11	SEE NOTE 11
1.	MAST SECTION	MS-51		10	WITH CLAMP MC-423
1.	MAST SECTION	MS-52		9	WITH CLAMP MC-424
1.	MAST SECTION	MS-53		8	
1.	MAST BASE	MP-48		7	
1.	MOUNTING	FT-237-(A)		6	
	AMPLIFIER	BC-605-(A)		5	
	DYNAMOTOR	DM-35-(A)		4	
	DYNAMOTOR	DM-34-(A)		3	SEE TABLE OF COMPONENTS
	RADIO TRANSMITTER	BC-604-(A)		2	
	RADIO RECEIVER	BC-603-(A)		1	

BASED ON SC-D-8555-C

FIGURE 6—Continued.

(For figure 7, see back of manual.)

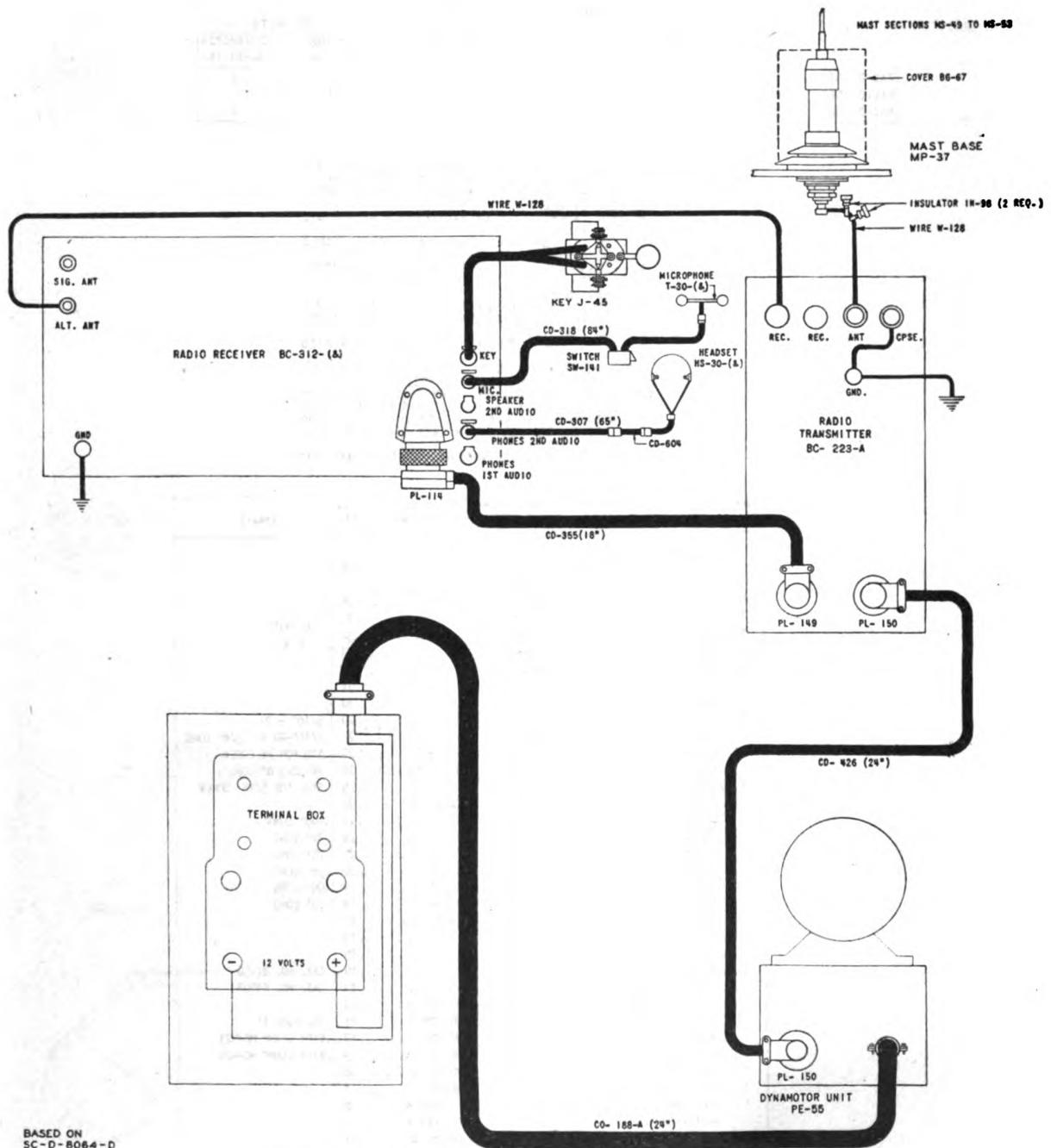

FIGURE 8. Installation of Radio Set SCR-245-U in Light Tank M3A3.

- NOTE:
1. WIRE N-128 SHALL BE CUT TO PROPER LENGTH. ENDS SHALL BE TINNED FOR ANTENNA AND GROUND CONNECTIONS.
 2. COVER 86-67 SHALL BE USED WHEN MAST SECTIONS ARE NOT INSTALLED.

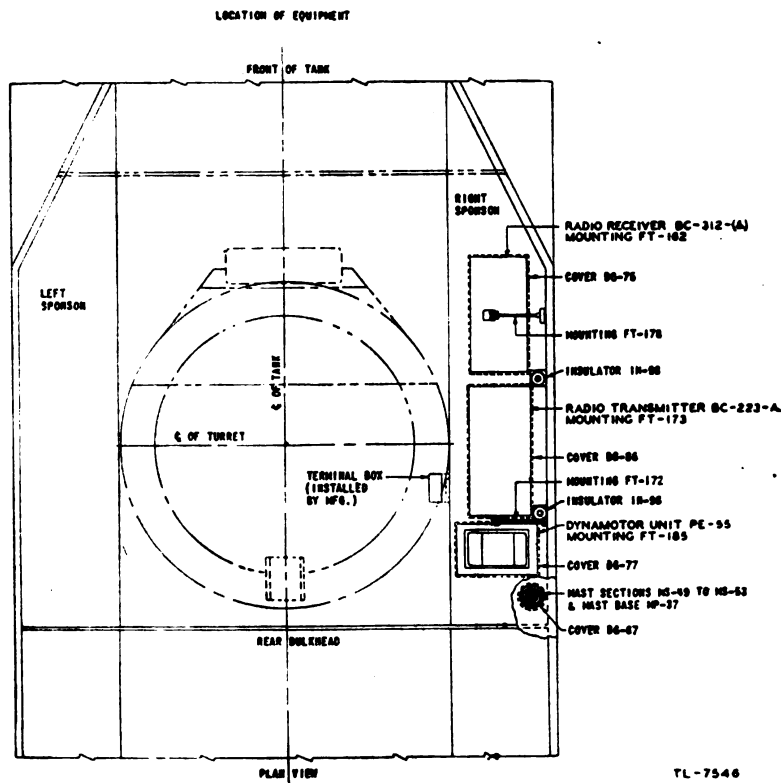
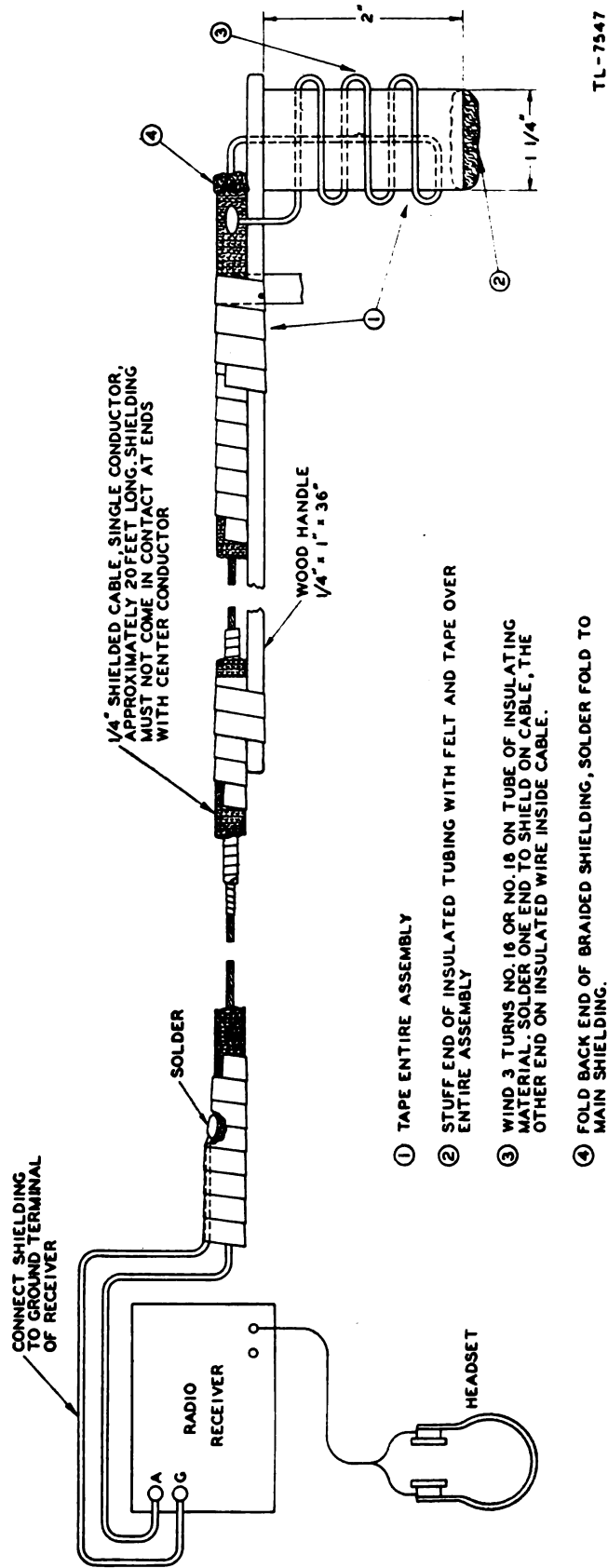

FIGURE 8—Continued.



TL-7547

FIGURE 9. Probe antenna.

Generated on 2016-03-24 14:09 GMT / http://hdl.handle.net/2027/uc1.aa0007311228
 Public Domain, Google-digitized / http://www.hathitrust.org/access_use#pd-google

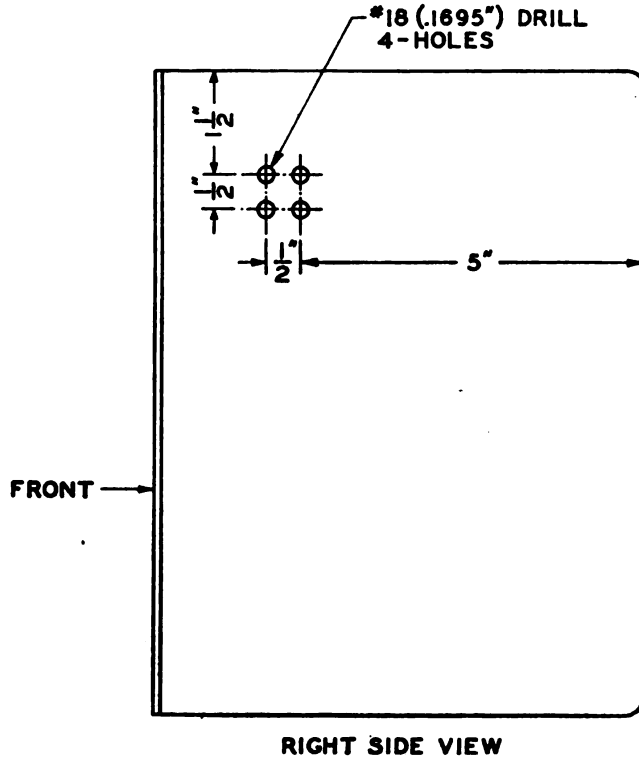

RIGHT SIDE VIEW
BASED ON SC-A-2894-B TL-9506

FIGURE 10. Drilling of Radio Receiver BC-312-(5) Box for Mounting FT-178.

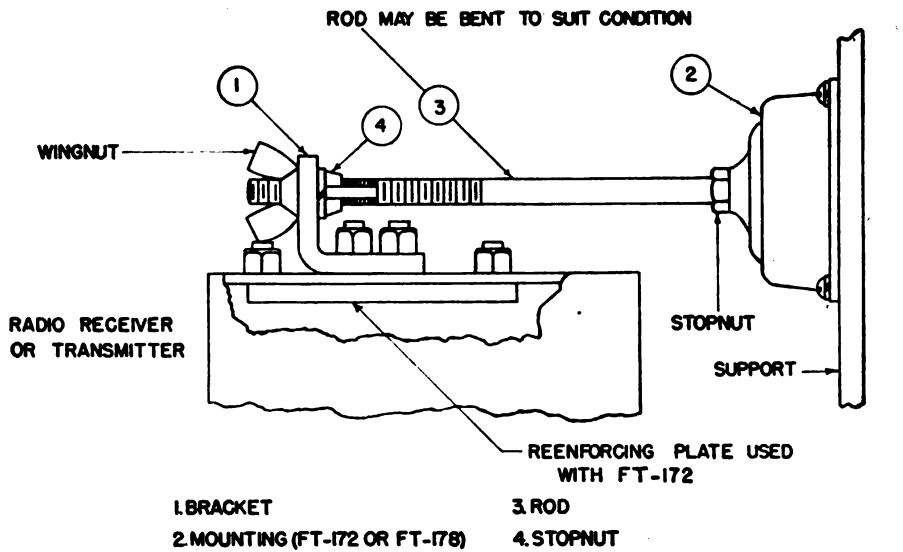

BASED ON
SC-A-4148-A

TL-10137

FIGURE 11. Assembly of Mounting FT-172 or FT-178.

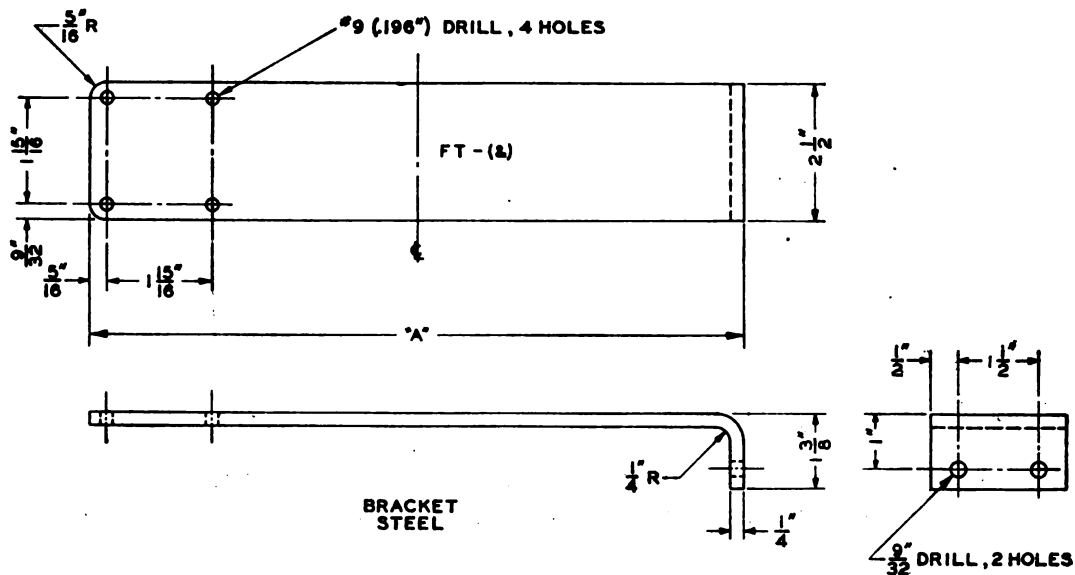

- ① FT-344 A=12 ³/₄" FOR MOUNTING FT-178 FOR RECEIVER BC-312-(&)
- ② FT-334 A=16 ⁵/₁₆" FOR MOUNTING FT-172 FOR TRANSMITTER BC-223-(&)
- ③ FT-364 A=23 ¹/₈" FOR MOUNTING FT-172 FOR TRANSMITTER BC-191-(&)

BASED ON
SC-A-5282-D

TL-10136

FIGURE 12. Bracket details for Mountings FT-172 and FT-178.

APPENDIX

IGNITION NOISE SUPPRESSION IN LIGHT TANK M3A3

1. GENERAL. Excessive ignition or other electrical noises may interfere with the operation of radio equipment in Light Tank M3A3. The Technical Manual issued with the tank will be helpful in locating the source of the noise since it describes the suppression systems used. Instructions for operating radio and interphone equipment used in Light Tank M3A3 should also be studied.

2. PROCEDURE. Locate and suppress ignition noise as follows:

a. Start the tank motor and turn on the radio receiver. Put the receiver sensitivity control at *maximum*. Then, listening to the receiver output with a headset, tune the receiver *slowly* over the entire range of frequencies to be used for communication.

b. When the frequency (or frequencies) with greatest noise level is found, turn off the vehicle engine. If interference persists, the source is outside the ignition system. If noise stops, the trouble is in the ignition system.

c. Start the engine again. Adjust the receiver sensitivity control until engine noises can be distinguished most easily from static, etc. Interference may then be identified as follows:

<i>Interference</i>	<i>Usual source</i>
Popping sounds; correspond to ignition firing, accelerate when engine is raced, stop when engine is turned off.	Ignition system.
Intermittent, clicking sound; lingers for several seconds when ignition is turned off.	Generator regulator.
Whining sound; varies with speed of engine; ceases only when generator stops rotating.	Generator.
Sparking, or continuous crackling noise.	Brushes and commutator of generator.

d. Interference from other electrical parts and circuits of the vehicle, such as panel gauges, heater fans, and, in vehicles with turrets, traversing motors and gyrostabilizers, can usually be identified by turning off the gauges, fans, or other suspected mechanisms, individually.

e. If the source of interference cannot be found by any of the preceding methods, connect a probe antenna (fig. 9) to the antenna terminal of the radio set. Move the loop of the probe antenna slowly over the various parts of the vehicle's electrical system. Keep the loop close to, but not in contact with, the part being examined. Interference-producing parts should be heard in the receiver.

f. Interference can generally be eliminated by cleaning, tightening, or replacing noise-producing parts. All suppressor and shielding components and all connections and grounding bonds should be examined, tightened, and the surfaces under them cleaned. This will assure good electrical contact between wires and terminals, and metal casings and the frame of the vehicles. (Insulated but ungrounded metal parts absorb and radiate electrical noises.)

g. If interference persists, suppressor components should be checked by substituting new ones. If a replacement is not available, disconnect the suspected component, and test capacitors, resistors, and chokes within it for opens, shorts, or other faults.

UC SOUTHERN REGIONAL LIBRARY FACILITY

AA 000 731 122 8

Generated on 2016-03-24 14:10 GMT / http://hdl.handle.net/2027/uc1.aa0007311228
Public Domain, Google-digitized / http://www.hathitrust.org/access#e#pat-google