

101.11:  
-5135-15/992

# TM 11-5135-15

DEPARTMENT OF THE ARMY TECHNICAL MANUAL

UNIVERSITY OF VIRGINIA  
ALDERMAN LIBRARY

JUN 12 1992

GOVERNMENT DOCUMENTS

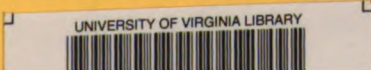
## RADIO SET CONTROL AN/GSA-7

This reprint includes all changes in effect at the time of publication; changes 4-6, 8 and 10.

HEADQUARTERS, DEPARTMENT OF THE ARMY

MAY 1958

Digitized by Google



## **WARNING**

### **DANGEROUS VOLTAGES EXIST IN THIS EQUIPMENT**

Be careful when working on 115-volt or 230-volt ac line connections or on the 120-volt dc B+ circuits. Serious injury or death may result from contact with these terminals.

### **RADIATION HAZARD**

Tube type OB2WA contains a small amount of radioactive material and is potentially hazardous. Contact qualified medical personnel immediately in case of an accidental cut from a broken tube. For further information, see TB SIG 225.

CHANGE }  
No. 4 }

HEADQUARTERS  
DEPARTMENT OF THE ARMY  
WASHINGTON, D.C., 12 May 1967

**RADIO SET CONTROL AN/GSA-7**

TM 11-5135-15, 7 May 1958, is changed as follows:

Page 4, paragraph 4 (as added by C 1, 12 Sep 61). Add the following after subparagraph c:

d. Remote Control Set AN/GSA-7 may be used in a radio-wire system containing a manual Telephone Switchboard SB-86/P when the equipment is interconnected (fig. 2.1 and 2.2) with manual Telephone Switchboard SB-22/PT.

Page 5, (as added by C 1, 12 Sep 61). Add figure 2.1 and 2.2 after figure 2.

Page 12, paragraph 11 (as added by C 1, 12 Sep 61).

Add the following after subparagraph j:  
j.1. Set the monitor switch to the T RADIO & MON position.

Delete subparagraph l (as changed by C 1, 12 Sep 61) and substitute:

l. Connect a jumper wire across the LINE terminals (fig. 7). Count the number of warning tones (beeps) heard in the handset. (The tone indicates that the transmitter is in use.) If the number of beeps is not approximately 12 per minute, remove the chassis from its case and adjust screwdriver adjustment R25 (fig. 3) until the desired number of beeps per minute is heard. Replace the chassis in its case. Remove the jumper wire from the LINE terminals.

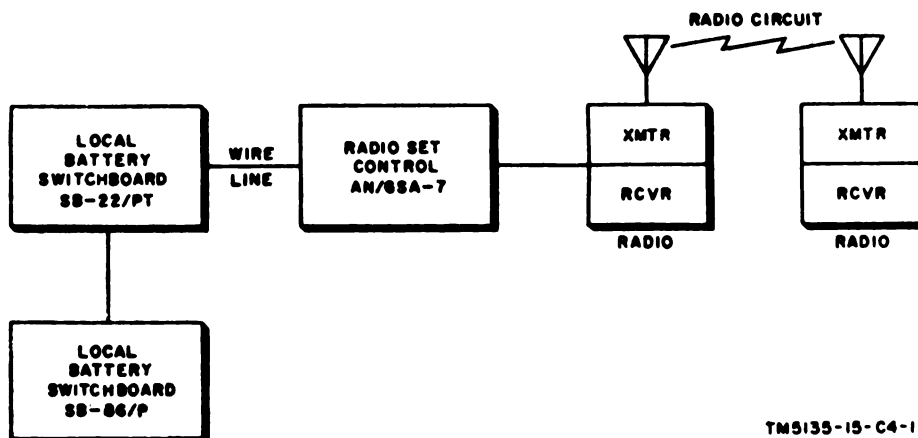
Page 13, paragraph 11.1 (as added by C 1, 12 Sep 61).

Add paragraph 11.1 after paragraph 11.

**11.1. Interconnection of SB-86/P and SB-22/PT**

To interconnect the SB-86/P and SB-22/PT for push-to-talk circuits, proceed as follows:

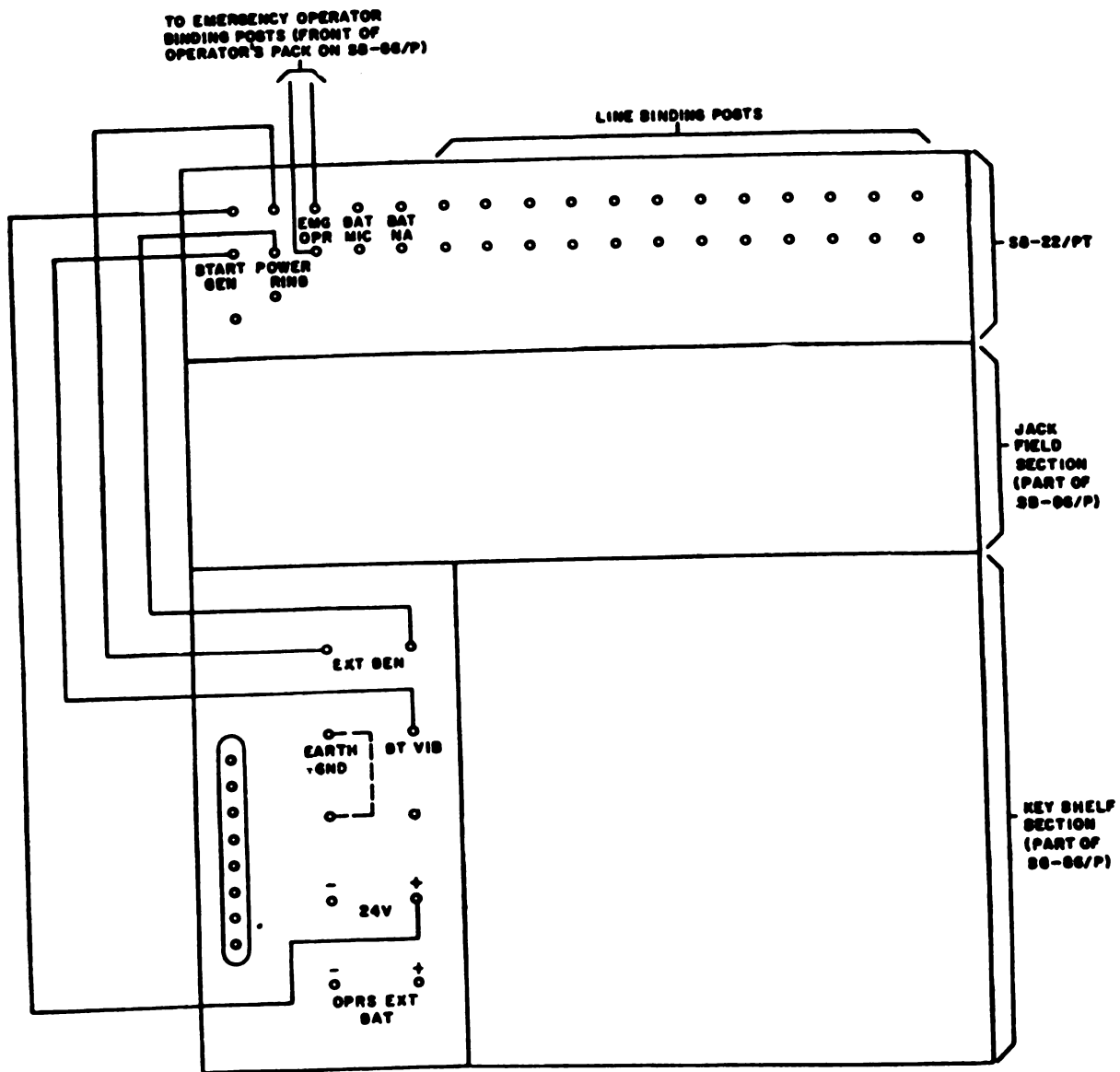
a. Lift the log plate from the top of the jack field section of the SB-86/P and position the SB-22/PT on top of the jack field section (fig. 2.2).



TM5135-15-C4-1

Figure 2.1. System application of Radio Set Control AN/GSA-7.

\*This change supersedes C 1, 12 September 1961; TM 11-5826-274-129, 11 May 1959; and TM 11-5826-274-359, 11 May 1959, including C 2, 28 September 1962.



TM5135-15-C4-2

Figure 2.2. Simplified cording diagram, showing connections between SB-86/P and SB-22/PT for push-to-talk radio circuits.

b. Hook the cover retaining loops on the SB-22/PT under the front catches on the jack field section. Tighten the cover retaining loops by turning the cover latches on the SB-22/PT.

c. Connect the emergency operator binding posts on the front of the SB-86/P to the EMG OPR binding posts at the rear of the SB-22/PT.

d. Connect the EXT GEN binding posts at the rear of the operator's pack in the SB-86/P

to the POWER RING posts at the rear of the SB-22/PT.

e. Connect one of the START GEN binding posts at the rear of the SB-22/PT to the ST VIB binding post at the rear of the operator's pack in the SB-86/P.

f. Connect the other START GEN binding post on the SB-22/PT to the +24V binding post at the rear of the operator's pack on the SB-86/P.



**g.** Connect the SB-22/PT operator's telephone set to the operator's telephone set receptacle on the front of the SB-22/PT.

**A.** Clamp the switch in the cord of the SB-22/PT operator's set to the side of the switchboard so that it can be conveniently reached by the operator. Place the operator's telephone set on the top of the SB-22/PT.

**i.** Connect the lines from the push-to-talk radio equipment to the line binding posts at the back of the SB-22/PT.

*Page 15, paragraph 13c (as added by C 1, 12 Sep 61).*

Add the following:

**c.1.** When the radio set control is used with the SB-86/P, proceed as follows:

- (1) Inform the calling party that a push-to-talk radio circuit is being used.
- (2) Remove the answering cord from the calling party's jack.
- (3) Insert the plug of one of the line pack cords (SB-22/PT) into the calling party's jack.
- (4) Insert the operator's cord (SB-22/PT) into the jack of the line pack being used.
- (5) Push the RING BACK-PWR RING FWD switch (SB-22/PT) to the RING BACK position.
- (6) Remove the operator's plug from the jack on the line pack (SB-22/PT) when the distant operator or party answers. The calling and the called parties can now talk.
- (7) When the calling and the called parties have finished talking, they will ring off and the signal associated with the cord (SB-22/PT) will turn white. Insert the operator's cord (SB-22/PT) into the jack associated with the cord (SB-22/PT) in use, and challenge the circuit.
- (8) Disconnect the line pack cord and the operator's cord when both parties have disconnected.

**c.2.** To extend calls received from the push-to-talk radio circuits connected to the SB-22/PT, proceed as follows:

- (1) Insert the operator's cord (SB-22/PT) into the jack associated with the signal indicating an incoming call.
- (2) Push the switch in the SB-22/PT operator's telephone set cord and answer the call.
- (3) Release the switch and listen for the desired number.
- (4) Insert the cord associated with the incoming signal (SB-22/PT) into the jack of the party (SB-86/P) requested by the calling party.
- (5) Operate the RING BACK-PWR-RING FWD switch (SB-22/PT) to the PWR RING FWD position.
- (6) Inform the called party that he is being called from a push-to-talk radio circuit.
- (7) Remove the operator's cord (SB-22/PT) from the calling party's jack after the called party answers. The calling and the called parties can now talk.
- (8) When the calling and the called parties have finished talking, they will ring off, and the signal associated with the cord (SB-22/PT) will turn white. Insert the operator's cord (SB-22/PT) into the jack associated with the cord (SB-22/PT) in use and challenge the circuit.
- (9) Disconnect the line pack cord and the operator's cord when both parties have disconnected.

**c.3.** When Radio Set Control AN/GSA-7 is used for radio transmission only, the radio receiver volume control should be adjusted to normal audio level output. Excessive audio levels may trigger the 20-cps ringing circuit and cause false ringing.

*Page 33, paragraph 34, chart.* Delete the chart and note and substitute the following:

Test equipment	Technical manual	Common name
Electronic Voltmeter ME-30B/U	TM 11-6625-320-35	Vacuum tube voltmeter.
Signal Generator SG-15/PCM	TM 11-2096	Signal generator.
Frequency Meter AN/TSM-16	TM 11-6625-218-12	Frequency meter.
Electron Tube Test Set TV-2/U	TM 11-6625-316-12	Tube tester.
Telephone Set TA-43/PT	TM 11-337	Field telephone.
Multimeter AN/URM-105	TM 11-6625-203-12	Multimeter.
Resistor, 150 ohm, 1 watt.		
Resistor, 2,000 ohm, 1 watt.		
Capacitor, 20 $\mu$ f.		
Connector U-79/U.		

Page 39, paragraph 40. Make the following changes:

Delete subparagraph *a* and substitute:

*a.* Connect the control unit to a 115- or 230-volt ac power source in accordance with paragraph 11*a*(2). Set the C.O. POWER switch to the EXT position and the monitor switch to the T RADIO & MON position.

Add subparagraphs *g* and *h* after subparagraph *f*.

*g.* Disconnect the control unit from the ac power source and connect it to the 22-30-volt dc power source in accordance with paragraph 11*a*(1).

*h.* Repeat the test described in *b* through *f* above.

Paragraph 41. Delete subparagraph *a* and substitute:

*a.* Connect the control unit to a 115- or 230-volt ac power source in accordance with paragraph 11*a*(2). Set the C.O. POWER switch to the EXT position and the monitor switch to the T RADIO & MON position.

Add subparagraphs *h* and *i* after subparagraph *g*.

*h.* Disconnect the control unit from the ac power source and connect it to the 22-30-volt dc power source in accordance with paragraph 11*a*(1).

*i.* Repeat the tests described in *b* through *g* above.

Page 43, appendix I. Add the following to the references.

TM 11-6625-251-15	Test Set TS-140/PCM, Signal Generators SG-15/PCM and SG-15A/PCM and Decibel Meters ME-22/PCM and ME-22A/PCM.
TM 11-5805-295-12P	Operator and Organizational Maintenance Repair Parts and Special Tools List and Maintenance Allocation Chart: Mountings MT-79/U and MT-79A/U.
TM 11-5805-295-35P	Field and Depot Maintenance Repair Parts and Special Tools List: Mountings MT-79/U and MT-79A/U.
TM 11-6625-203-12	Operator and Organizational Maintenance Manual: Multimeter AN/URM-105, Including Multimeter ME-77/U.
TM 11-6625-218-12	Organizational Maintenance Manual: Frequency Meter AN/TSM-16.
TM 11-6625-316-12	Operator and Organizational Maintenance Manual: Test Sets, Electron Tube TV-2/U, TV-2A/U, TV-2B/U, and TV-2C/U.
TM 11-6625-320-35	DS, GS, and Depot Maintenance Manual: Voltmeter, Meter ME-30A/U and Voltmeters, Electronic ME-30B/U and ME-30C/U.

Add appendixes II, III and IV after appendix I.

## APPENDIX II

### BASIC ISSUE ITEMS

#### Section I. INTRODUCTION

##### 1. General

This appendix lists items for Control, Radio Set AN/GSA 7, the component items comprising it, and the items which accompany it, or are required for installation, operation, or operator's maintenance.

##### 2. Explanation of Columns

An explanation of the columns in section II is given below.

*a. Source, Maintenance, and Recoverability Codes, Column 1.*

- (1) *Source code, column 1a.* The selection status and source for the listed item is noted here. The source codes used are:

Code	Explanation
P -----	Applies to repair parts which are stocked in or supplied from the GSA/DSA, or Army supply system, and authorized for use at indicated maintenance categories.
A -----	Applies to assemblies that are not procured or stocked as such but are made up of two or more units, each of which carry individual stock numbers and descriptions and are procured and stocked and can be assembled by units at indicated maintenance categories.

- (2) *Maintenance code, column 1b.* The lowest category of maintenance authorized to install the listed item is noted here. The maintenance codes used are as follows:

Code	Explanation
C -----	Operator/Crew
O -----	Organizational Maintenance

- (3) *Recoverability code, column 1c.* The information in this column indicates

whether unserviceable items should be returned for recovery or salvage. Recoverability code and its explanation are as follows:

*Notes.* When no code is indicated in the recoverability column, the part will be considered expendable.

Code	Explanation
R -----	Applies to repair parts and assemblies that are economically repairable at DSU and GSU activities and are normally furnished by supply on an exchange basis.

*b. Federal Stock Number, Column 2.* The Federal stock number for the item is indicated in this column.

*c. Description, Column 3.* The Federal item name, a five-digit manufacturer's code, and part number are included in this column.

*d. Unit of Issue, Column 4.* The unit used as a basis of issue (e.g. ea, pr, ft, yd, etc) is noted in this column.

*e. Quantity Incorporated in Unit Pack, Column 5.* Not used.

*f. Quantity Incorporated in Unit, Column 6.* The total quantity of the item used in the equipment is given in this column.

*g. Quantity Authorized, Column 7.* The total quantity of an item required to be on hand and necessary for the operation and maintenance of the equipment is given in this column.

*h. Illustration, Column 8.*

- (1) *Figure number, column 8a.* The number of the illustration in which the item is shown is indicated in this column.

- (2) *Item or symbol number, column 8b.*

The call out number used to reference the item in the illustration appears in this column.

<i>Code</i>	<i>Manufacturer's name</i>
15814	Daniels, C. R., Inc.
75915	Littlefuse, Inc.
76854	Oak Mfg. Co.
80063	Army Electronics Command Procurement and Production Directorate
81349	Military Specifications
81350	Joint Army-Navy Specifications

### 3. Federal Supply Codes

This paragraph lists the Federal supply code with the associated manufacturer's name.

SECTION II. BASIC ISSUE ITEMS LIST

(1)		BASIC ISSUE ITEMS LIST							(4)	(5)	(6)	(7)	(8)				
		SOURCE CD	MAINT. CD	REC. CODE	(2) FEDERAL STOCK NUMBER	(3) DESCRIPTION											
A	C					R	5820-543-1397	CONTROL, RADIO SET AM/OSM-7: Provides a means for interconnecting radio receivers or transmitters and receivers w/local battery telephone equipment on a push-to-talk basis. No attendant is necessary at the control equip, the radio transmitter is turned on and off automatically when needed by the wire equip user. (This item is nonrependable)						1	1	V1	V2
		1	2	3	4			5	6								
									ea			1	1				
									ea			1	1				
									ea			1	1				
									ea			1	1				
									ea			2	2				
									ea			1	1				
									ea			1	1				

(1)	BASIC ISSUE ITEMS LIST						(4)	(5)	(6)	(7)	(8)	
	SOURCE CD	MAINT. CD	REQ. CODE	(2)	(3)	ILLUSTRATIONS						
			FEDERAL STOCK NUMBER	DESCRIPTION	UNIT	QTY INC IN UNIT	QTY INC IN UNIT	QTY INC IN UNIT	QTY AUTH	FIGURE NUMBER	ITEM OR SYMBOL NUMBER	
				AN/GSA-7 (continued)								
				RUNNING SPARE ITEMS								
P 0			5910-754-6931	CAPACITOR, FIXED, ELECTROLYTIC: 81350; CE51C501G	ea	1	1	1	1	21	C1	
P 0			5910-377-1459	CAPACITOR, FIXED, ELECTROLYTIC: 81350; CE53C250N	ea	1	1	1	1	21	C11	
P 0			5960-262-3763	ELECTRON TUBE: 81349; 082WA	ea	1	1	1	1	21	V1	
P 0			5960-188-8515	ELECTRON TUBE: 81350; 6C4	ea	1	1	1	1	21	V6	
P 0			5960-262-0286	ELECTRON TUBE: 81350; 5651WA	ea	1	1	1	1	21	V5	
P 0			5960-188-6593	ELECTRON TUBE: 81350; 5696	ea	2	1	2	1	21	V3, V8	
P 0			5960-237-6917	ELECTRON TUBE: 81350; 5725/GA86M	ea	1	1	1	1	21	V4	
P 0			5960-262-0210	ELECTRON TUBE: 81350; 581WA	ea	2	1	2	1	21	V2, V7	
P 0			5920-142-7383	FUSE, CARTRIDGE: 81349; F02G1R00A	ea	1	1	1	5	7	F1	
P 0			5920-295-9602	FUSE, CARTRIDGE: 75915; 313001	ea	1	1	1	5	7	F2	
P 0			6130-583-3693	VIBRATOR, INTERRUPTER: 76954; 6578	ea	1	1	1	1	21	G1	
				NO ACCESSORIES, TOOLS OR TEST EQUIPMENT ARE TO BE ISSUED WITH THIS EQUIPMENT								
				NO BASIC ISSUE ITEMS ARE MOUNTED IN OR ON THIS EQUIPMENT								



# APPENDIX III

## MAINTENANCE ALLOCATION

---

### Section I. INTRODUCTION

#### 1. General

This appendix provides a summary of the maintenance operations covered in the equipment literature for Control, Radio Set AN/GSA-7. It authorizes categories of maintenance for specific maintenance functions on repairable items and components and the tools and equipment required to perform each function. This appendix may be used as an aid in planning maintenance operations.

#### 2. Explanation of Format for Maintenance Allocation Chart

*a. Group Number.* Not used.

*b. Component Assembly Nomenclature.* This column lists the item names of component units, assemblies, subassemblies, and modules on which maintenance is authorized.

*c. Maintenance Function.* This column indicates the maintenance category at which performance of the specific maintenance function is authorized. Authorization to perform a function at any category also includes authorization to perform that function at higher categories. The codes used represent the various maintenance categories as follows:

<i>Code</i>	<i>Maintenance Category</i>
C -----	Operator/Crew
O -----	Organizational Maintenance
F -----	Direct Support Maintenance
H -----	General Support Maintenance
D -----	Depot Maintenance

*d. Tools and Equipment.* The numbers appearing in this column refer to specific tools and equipment which are identified by these numbers in section III.

*e. Remarks.* Self-explanatory.

#### 3. Explanation of Format for Tool and Test Equipment Requirements

The columns in the tool and test equipment requirements chart are as follows:

*a. Tools and Equipment.* The numbers in this column coincide with the numbers used in the tools and equipment column of the MAC. The numbers indicate the applicable tool for the maintenance function.

*b. Maintenance Category.* The codes in this column indicate the maintenance category normally allocated the facility.

*c. Nomenclature.* This column lists tools, test, and maintenance equipment required to perform the maintenance functions.

*d. Federal Stock Number.* This column lists the Federal stock number.

*e. Tool Number.* Not used.

SECTION II. MAINTENANCE ALLOCATION CHART

MAINTENANCE ALLOCATION CHART																			
GROUP NUMBER	COMPONENT ASSEMBLY NOMENCLATURE	MAINTENANCE FUNCTIONS										REMARKS							
		INSPECT	TEST	SERVICE	ADJUST	ALIGN	CALIBRATE	INSTALL	REPLACE	REPAIR	OVERHAUL		REBUILD						
	CONTROL, RADIO SET AM/GSA-7	0																8	External, part seating of tubes V1 through V6, pluck out capacitors C1 and C11, pluck out vibrator G1, inspect for loose connections, inspect receptacles for bent or broken tips. Operational test Test tubes, voltages to determine condition of circuits; perform continuity tests. Test for trouble by sectionalizing and localizing trouble to component parts: test resistors, capacitors, transformers All tests External parts Internal parts Adjust jack contacts, tension of spring clips, warming tone control R-25, squelch circuit in radio receivers. All adjustments
			O	C														1 2,6	
				F														2,3,6	
				H	O													2,3,4,5,9	
					C			F										7 8	
								H										8 7 8 8	

SECTION III. TOOL AND TEST EQUIPMENT REQUIREMENTS

TOOL AND TEST EQUIPMENT REQUIREMENTS			
TOOLS AND EQUIPMENT	MAINTENANCE CATEGORY	NOMENCLATURE	FEDERAL STOCK NUMBER
1	H,D	AM/OSB-7 (continued)	
2	O,F,H,D	FREQUENCY METER AM/TKM-16	6685-542-1666
3	F,H,D	MULTIMETER AM/TKM-105	6685-581-2036
4	H,D	SHORT INSTRUMENT MULTIRANGE MX-147U	6685-578-5408
5	H,D	SIGNAL GENERATOR SG-15/TKM	6685-229-1087
6	O,F	TEST SET, ELECTRON TUBE TV-2/U	6685-699-0263
7	O	TEST SET, ELECTRON TUBE TV-7D/U	6685-820-0064
8	F,H,D	TOOL KIT, RADIO REPAIRMAN TK-115( )/U	5180-856-1578
9	H,D	TOOL KIT, RADIO AND RADIO REPAIRMAN TK-87/U	5180-691-4552
		VOLTMETER, METER MS-30	5805-407-4224

## APPENDIX IV

# ORGANIZATIONAL, DS, GS, AND DEPOT MAINTENANCE REPAIR PARTS

### Section I. INTRODUCTION

#### 1. General

This appendix contains a list of repair parts required for the performance of organizational maintenance and a list covering the corresponding requirements for direct support, general support, and depot maintenance for Control, Radio Set AN/GSA-7. Each group is arranged in alphabetical sequence.

*Notes.* No special tools, test, and support equipment are required.

#### 2. Explanation of Sections

This repair parts list is divided into sections:

a. *Prescribed Load Allowance List (PLA), Section II.* The PLA is a consolidated listing of repair parts allocated for initial stockage at organizational maintenance. This is a mandatory minimum stockage allowance.

b. *Repair Parts for Organizational Maintenance, Section III.* Repair parts authorized for organizational maintenance is included in this section.

c. *Repair Parts for DS, GS, and Depot Maintenance, Section IV.* This chart lists repair parts authorized for maintenance performance at direct support, general support, and depot.

d. *Federal Stock Number Index, Section V.* This is a cross-reference index of Federal stock numbers to illustrations by figure and item number.

#### 3. Explanation of Columns

An explanation of the columns in sections II through IV is given below.

a. *Source, Maintenance, and Recoverability Codes, Column 1, Sections III and IV.*

(1) *Source code, column 1a.* The selection status and source for the listed item is

noted here. Source codes and their explanations are as follows:

Code	Explanation
P -----	Applies to repair parts that are stocked in or supplied from the GSA/DSA, or Army supply system, and authorized for use at indicated maintenance categories.
A -----	Applies to assemblies that are not procured or stocked as such but are made up of two or more units, each of which carry individual stock numbers and descriptions and are procured and stocked and can be assembled by units at indicated maintenance categories.
X2 -----	Applies to repair parts which are not stocked. The indicated maintenance category requiring such repair parts will attempt to obtain them through cannibalization; if not obtainable through cannibalization, such repair parts will be requisitioned with supporting justification through normal supply channels.

(2) *Maintenance code, column 1b.* The lowest category of maintenance authorized to install the listed item is noted here.

Code	Explanation
C -----	Operator/crew
O -----	Organizational Maintenance
F -----	Direct Support Maintenance
H -----	General Support Maintenance

(3) *Recoverability code, column 1c.* The information in this column indicates whether unserviceable items should be returned for recovery salvage. Recoverability code and its explanation are as follows:

*Notes.* When no code is indicated in the recoverability column, the part will be considered expendable.

Code	Explanation
R	Applies to repair parts and assemblies which are economically repairable at DSU and GSU activities and normally are furnished by supply on an exchange basis.

*b. Federal Stock Number, Column 1, Section II; Column 2, Sections III and IV.* The Federal stock number for the item is indicated in this column.

*c. Description, Column 2, Section II; Column 3, Sections III and IV.* The Federal item name, five-digit manufacturer's code, and a part number are included in this column. For subsequent appearances of the same item, the manufacturer's code and part number are omitted. The original group in which the item first appeared is referenced in the list and will follow the item name, e.g., "RESISTOR, FIXED, COMPOSITION: See Group II.

*d. Unit of Issue, Column 4, Sections III and IV.* The unit used as a basis of issue (e.g. ea, pr, ft, yd, etc) is noted in this column.

*e. Quantity Incorporated in Unit Pack, Column 4, Section II; Column 5, Sections III and IV.* Not used.

*f. Quantity Incorporated in Unit, Column 6, Sections III and IV.* The quantity of repair parts in an assembly is given in this column.

*g. Maintenance Allowance, Column 3, Section II; Column 7, Sections III and IV.*

- (1) The allowance columns are divided into subcolumns. The total quantity of items authorized for the number of equipments supported is indicated in each subcolumn opposite the first appearance of each item. Subsequent appearances of the same item will have no entry in the allowance columns but will have a reference, in the description column, to the first appearance of the item. Items authorized for use as required but not for initial stockage are identified with an asterisk (\*) in the allowance column.
- (2) The quantitative allowances for organizational category of maintenance represents one initial prescribed load for a 15-day period for the number of equipments supported. Units and organizations authorized additional

prescribed loads will multiply the number of prescribed loads authorized by the quantity of repair parts reflected in the appropriate density column to obtain the total quantity of repair parts authorized.

- (3) Subsequent changes to organizational allowances will be limited as follows: No change in the range of items is authorized. If additional items are considered necessary, recommendation should be forwarded to Commanding General, U.S. Army Electronics Command, ATTN: AMSEL-MR-NMP-CM, Fort Monmouth, N.J., 07703; for exception or revision to the allowance list. Revisions to the range of items authorized will be made by the USA ECOM National Maintenance Point based upon engineering experience, demand data, or TAERS information.
- (4) The quantitative allowances for DS/GS categories of maintenance will represent initial stockage for a 30-day period for the number of equipments supported.

*h. One-Year Allowances Per 100 Equipments/Contingency Planning Purposes, Column 8, Section IV.* Opposite the first appearance of each item, the total quantity required for distribution and contingency planning purposes is indicated. The range of items indicates total quantities of all authorized items required to provide for adequate support of 100 equipments for one year.

*i. Illustration, Column 8, Section III; Column 10 Section IV.*

- (1) *Figure number, columns 8a and 10a.* The number of the illustration in which the item is shown is indicated in this column.
- (2) *Item of symbol number, columns 8b and 10b.* The callout number used to reference the item in the illustration is indicated in this column.

*j. Depot Maintenance Allowance Per 100 Equipments, Column 9, Section IV.* This column indicates the total quantity of each item authorized depot maintenance for 100 equipments. Subsequent appearances of the same

item will have no entry in this column, but will have a reference in the description column to the first appearance of the item.

#### 4. Location of Repair Parts

a. When the Federal stock number is unknown follow the procedures given in (1) through (4) below.

- (1) Locate the appropriate appendix of the repair parts list.
- (2) If the item or symbol number is available, locate the item by scrutiny of columns 8b and 10b of the repair parts list.
- (3) If the item, symbol, or figure number is not known check the description column (column 8) in the repair parts list to locate the part. The parts in this column are arranged in alphabetical order.
- (4) Locate the applicable illustration in this manual and note the figure number and item number. Use the repair parts listing and locate the figure

number and/or item number as noted on the illustration.

b. When the Federal stock number is known, use the repair part listing to find the part and the figure and item numbers as noted in the index of Federal stock numbers.

#### 5. Federal Supply Codes

This paragraph lists the Federal supply code and the associated manufacturer's name.

<i>Code number</i>	<i>Manufacturer's name</i>
00000 -----	Ordnance Corps.
01121 -----	Allen-Bradley Co.
06238 -----	Military Supply Standards
13499 -----	Collins Radio Co. Cedar Rapids Division
46384 -----	Penn Engineering and Mfg. Corp.
70779 -----	General Instrument Corp. Automatic Manufacturing Division
71400 -----	Bussmann Mfg. Division of McGraw-Edison Co.
75915 -----	Littlefuse, Inc.
80063 -----	Army Electronics Command Procurement and Production Directorate.
81348 -----	Federal Specifications.
81349 -----	Military Specifications.
81350 -----	Joint Army-Navy Specifications.
83330 -----	Smith, Herman H., Inc.
84171 -----	Arco Electronics, Inc.
96906 -----	Military Standard.



## SECTION II. PRESCRIBED LOAD ALLOWANCE LIST

PRESCRIBED LOAD ALLOWANCE						
(A) FEDERAL STOCK NUMBER	(B) DESCRIPTION	(C) 15-DAY ORG. MANT. ALLOWANCE				(D) QTY INC IN UN PK
		(1)	(2)	(3)	(4)	
		1-5	6-20	21-80	81-100	
	GROUP II FRONT PANEL ASSEMBLY ECOM DWG NO. SM-D-328361					
5325-622-5254	STUD, TURNLOCK, FASTENER: 80063; SM-B-328365	•	•	2	2	
5355-577-4084	KNOB: 80063; SM-C-328371	•	•	•	2	
5920-142-7383	FUSE, CARTRIDGE, FU-26: 71400; ACM	2	2	3	6	
5920-295-9602	FUSE, CARTRIDGE: 80063; SM-B-328393	2	2	3	6	
5920-523-1940	CAP, ELECTRICAL: 75915; 342006-5A-1	•	•	•	1	
5935-162-3087	COVER, ELECTRICAL CONNECTOR: 80063; SM-B-328370	•	•	•	1	
	GROUP III LOWER CHASSIS ASSEMBLY ECOM DWG NO. SM-D-328386					
5910-577-1459	CAPACITOR, FIXED, ELECTROLYTIC: 81349; CE53C25CM	•	•	•	2	
5910-754-6931	CAPACITOR, FIXED, ELECTROLYTIC: 81349; CE51C5010	•	•	•	2	
5960-188-6593	ELECTRON TUBE: 81349; 5696	3	9	22	42	
5960-262-0210	ELECTRON TUBE: 81349; 5814A	2	3	7	13	
5960-262-3763	ELECTRON TUBE: 81349; 082VA	2	2	4	8	
5960-686-8087	SHIELD, ELECTRON TUBE: 96906; MS-24233-5	•	•	•	1	
5960-686-8119	SHIELD, ELECTRON TUBE: 96906; MS-24233-1, type 1	•	•	•	1	
5960-729-8150	SHIELD, ELECTRON TUBE: 96906; MS-24233-3	•	•	•	1	
6130-583-3693	VIBRATOR, INTERRUPTER: 80063; SM-C-328394	•	•	•	2	
	GROUP IV UPPER CHASSIS ASSEMBLY ECOM DWG NO. SM-D-328443					
5960-188-8515	ELECTRON TUBE: 81349; 6C4	2	3	7	13	
5960-237-6917	ELECTRON TUBE: 81349; 5725	2	2	4	8	
5960-262-0286	ELECTRON TUBE: 81349; 5651WA	2	2	4	8	
5960-686-8085	SHIELD, ELECTRON TUBE: 96906; MS-24233-2	•	•	•	1	
	GROUP VI CABLE ASSEMBLIES					
5935-259-2545	PLUG, TIP: 83330; 108; (p/o W5)	•	•	•	1	
5935-518-9653	CONNECTOR, PLUG, ELECTRICAL: 81349; UP12CM (MS-91184-1); (p/o W1)	•	•	•	1	

SECTION III. REPAIR PARTS FOR ORGANIZATIONAL MAINTENANCE

SOURCE CD	MAINT. CD	REC. CODE	REPAIR PARTS FOR ORGANIZATIONAL MAINTENANCE		UNIT OF ISSUE	(6)			(7)			(8)						
			(2) FEDERAL STOCK NUMBER	(3) DESCRIPTION		(4) QTY INC IN UN PK	(5) QTY INC IN UN PK	(6) QTY INC IN UN PK	(7) 15 DAY ORG. MAINT. ALW.	(8) ILLUSTRATIONS	(A) FIGURE NUMBER	(B) ITEM OR SYMBOL NUMBER						
													(A) 1	(B) 2	(C) 3	(D) 4	(E) 5	(F) 6
A	C	R	5820-543-1397	CONTROL RADIO SET AN/USA-7: Provides a means for interconnecting radio receivers or transmitters and receivers w/local battery telephone equipment on a push-to-talk basis. No attendant is necessary at the control equip, the radio transmitter is turned on and off automatically when needed by wire equip user; 80063; SC-DL-328350 (This item is nonexpendable)	ea							1						
				GROUP I CHASSIS AND PANEL ASSEMBLY ECOM DNG NO. SM-C-328359														
				GROUP II FRONT PANEL ASSEMBLY ECOM DNG NO. SM-D-328361														
P	O		5920-523-1940	CAP, ELECTRICAL: 75915; 342006-5A-1	ea								1					
P	O		5935-162-3087	COVER, ELECTRICAL CONNECTOR: 80063; SM-B-328370	ea								1					
P	O		5920-142-7383	FUSE, CARTRIDGE, FU-26: 71400; ACM1	ea								6	7				
P	O		5920-295-9602	FUSE, CARTRIDGE: 80063; SM-B-328393	ea								3	6	7			
P	O		5355-577-4084	KNOB: 80063; SM-C-328371	ea									2				
P	O		5325-622-5254	STUD, TURNLOCK FASTENER: 80063; SM-B-328365	ea									2				
				GROUP III LOWER CHASSIS ASSEMBLY ECOM DNG NO. SM-D-328386														
P	O		5910-577-1459	CAPACITOR, FIXED, ELECTROLYTIC: 81349; CE53CE50M	ea									2	21			
P	O		5910-754-6931	CAPACITOR, FIXED, ELECTROLYTIC: 81349; CE51C501G	ea									2	21			
P	O		5960-262-3763	ELECTRON TUBE: 81349; 082VA	ea									4	8	21		
P	O		5960-188-6593	ELECTRON TUBE: 81349; 5696	ea									3	9	22	42	21

(1) SOURCE CD	(2) FEDERAL STOCK NUMBER	(3) DESCRIPTION						(4) UNIT OF ISSUE	(5) QTY INC IN LN PK	(6) IS DAY ORG. MAINT. ALW.	(7) ILLUSTRATIONS		
											FIGURE NUMBER	ITEM OR SYMBOL NUMBER	
													(8) FIGURE NUMBER
(10) MAINT. CD	(11) REC. CODE	(12) MODEL	(13) 1	(14) 2	(15) 3	(16) 4	(17) 5	(18) 6	(19) QTY INC IN LN PK	(20) QTY INC IN LN PK	(21) QTY INC IN LN PK		
P	0												
P	0	5960-262-0210	AM/GSA-7 (continued)										
P	0	5960-686-8119	ELECTRON TUBE: 81349; 581A									V2	
P	0	5960-729-8150	SHIELD, ELECTRON TUBE: 96906; MS-24233-1, type 1									21	V3
P	0	5960-686-8087	SHIELD, ELECTRON TUBE: 96906; MS-24233-3										V4
P	0	6130-583-3693	SHIELD, ELECTRON TUBE: 96906; MS-24233-5										V5
			VIBRATOR, INTERRUPTER: 80063; SM-C-32839A										V6
			GROUP IIIA LOWER CHASSIS SUBASSEMBLY ROOM DWG NO. SM-D-328401										V7
			GROUP IV UPPER CHASSIS ASSEMBLY ROOM DWG NO. SM-D-328443										V8
P	0	5960-188-8515	ELECTRON TUBE: 81349; 6C4										V9, V7
P	0	5960-262-0286	ELECTRON TUBE: 81349; 5651A										V4, V5
P	0	5960-237-6917	ELECTRON TUBE: 81349; 5T25										V4
P	0	5960-262-0210	ELECTRON TUBE: See Group III										V7
P	0	5960-188-6593	ELECTRON TUBE: See Group III										V8
P	0	5960-686-8085	SHIELD, ELECTRON TUBE: 96906; MS-24233-2										V6, V7
P	0	5960-686-8119	SHIELD, ELECTRON TUBE: See Group III										V4, V5
P	0	5960-686-8087	SHIELD, ELECTRON TUBE: See Group III										V1
			GROUP IVA UPPER CHASSIS SUBASSEMBLY ROOM DWG NO. SM-D-328449										V1

(1)		REPAIR PARTS FOR ORGANIZATIONAL MAINTENANCE				(2)	(3)	(4)	(5)	(6)	(7)				(8)	
											IS DAY ORG. MAINT. ALW.	QTY INC IN UNIT	QTY INC IN UNIT	QTY INC IN UNIT	QTY INC IN UNIT	FIGURE NUMBER
SOURCE CD	MAINT. CD	REC. CODE	FEDERAL STOCK NUMBER	MODEL	DESCRIPTION	UNIT OF MEASURE	QTY INC IN UNIT	QTY INC IN UNIT	QTY INC IN UNIT	QTY INC IN UNIT	QTY INC IN UNIT	FIGURE NUMBER	ITEM OR SYMBOL NUMBER			
P	0		9935-518-9653	1 2 3 4 5 6	RE/CBA-7 (continued) GROUP V CASE ASSEMBLY ROOM DWO NO. SM-D-36352 GROUP VI CABLE ASSEMBLIES CONNECTOR, FLUID, ELECTRICAL: 61349; UP120N (MS-9110A-1) (N/O VI) FLUID, STD: 83330; 108; (N/O 15)	00	1	•	•	•	•	•	1		70	
P	0		9935-859-8545			00	2	•	•	•	•	•	•	1		

SECTION IV. REPAIR PARTS FOR DS, OS, AND DEPOT MAINTENANCE

(1)	(2)	(3)	(4)	(5)	(6)	(7)							(8)	(9)		(10)
						30 DAY MAINT. ALW.								PER 100 HOUR	1 YR. ALW.	
MAINT. CD	FEDERAL STOCK NUMBER	DESCRIPTION	UNIT OF ISSUE	CITY IN PK	CITY IN UN	CITY IN UN	OS	OS	OS	OS	OS	OS	FIGURE NUMBER			ILLUSTRATIONS
OR																
A	5280-543-1397	CONTROL, RADIO SET AM/OSB-7: Provides a means for inter- connecting radio receivers or transmitters and receivers w/local battery telephone equipment on a push-to-talk basis No attendant is necessary at the control equip, the radio transmitter is turned on and off automatically when needed by wire equip user; 80063; SC-1L-328390 (this item is nonassemblable)	ea										1			
X2		GROUP I CHARIOTS AND PANEL ASSEMBLY ROOM Dwg NO. SM-C-328359	ea										1			
X2		COVER, BOTTOM: 80063; SM-C-328341	ea										1			
X2	5305-043-6638	PIN, KIMBE: 80063; SM-C-328328-3	ea										13			
X2	5305-989-7634	SCHEM, MACHINE: 96906; NR-35225-13	ea										4			
X2		SCHEM, MACHINE: 96906; NR-35207-263	ea										2			
X2		SCHEM, MACHINE: 96906; NR-35226-46	ea										2			
X2		SCHEM, KIT/LOK: 80063; SM-B-328342	ea										2			
X2	5310-193-7577	WASHER, LOCK: 96906; NR-35333-36	ea										1			

SOURCE CD	MAINT CD	REC. CODE	REPAIR PARTS FOR DIRECT SUPPORT, GENERAL SUPPORT, AND DEPOT MAINTENANCE											ILLUSTRATIONS																	
			(2) FEDERAL STOCK NUMBER		(3) DESCRIPTION											(4) QTY INC IN UN PK	(5) QTY INC IN UN UNIT	(7) 30 DAY MAINT. ALW.						(8) PER 100 EQUIP. CNTGTY	(9) DEPOT MAINT. ALW. PER 100 EQUIP. CNTGTY	(10) FIGURE NUMBER	(11) ITEM OR SYMBOL NUMBER				
			1	2	3	4	5	6	7	8	9	10	11	12	13			14	15	16	17										
XZ	P		5310-576-5752	AM/GSA-7 (continued)										4																	
				WASHER, LOCK: 96906; MB-35333-39										12																	
XZ	P			WASHER, LOCK: 96906; MB-35340-40																											
XZ	P			GROUP II FRONT PANEL ASSEMBLY ROOM IMG NO. SM-D-328361										1																	
P	O		5980-583-1940	MUSKING, SWITCH: 80063; SM-B-328369										1	*	*	2	*	*	*	*	*	2	*	*	2	*	*			
P	P		5910-721-2252	CAP, ELECTRICAL: 75915; 348006-5A-1										1	*	*	1	*	*	*	*	*	1	*	*	1	*	*	5	21	C2, C3
P	P		5935-201-3998	CAPACITOR, FILLED, PAPER DIELECTRIC: 80063; SM-B-328374										1	*	*	1	*	*	*	*	*	1	*	*	5	7	J2			
P	P		5935-583-8291	CONNECTOR, RECEPTACLE, ELECTRICAL: 81349; CS2020(1)(P)										2	*	*	2	*	*	*	*	*	2	*	*	8	7	J3, J4			
P	P		5935-549-2646	CONNECTOR, RECEPTACLE, ELECTRICAL U-79/U: 80063; SC-1L-99590										1	*	*	1	*	*	*	*	*	1	*	*	5	7	J5			
P	O		5935-162-3087	COVER, ELECTRICAL CONNECTOR: 80063; SM-B-328370										1	*	*	1	*	*	*	*	*	1	*	*	5	2				
P	O		5920-142-7383	FUSE, CARTRIDGE, FU-26: 71400; ACM1										1	2	6	11	2	2	2	2	2	2	2	2	130	50	F1			
P	O		5920-295-9602	FUSE, CARTRIDGE: 80063; SM-B-328393										1	2	6	4	2	2	2	2	2	2	2	2	130	50	F2			



(1) SOURCE CD	(1) MAINT. CD	(1) REC. CODE	(2) FEDERAL STOCK NUMBER		(3) DESCRIPTION						(4) UNIT OF ISSUE	(5) QTY INC IN UN PK	(6) QTY INC IN UNIT	(7) 30 DAY MAINT. ALW.						(8) PER ISO EQUIP. CTRCTY	(9) DEPOT MAINT. ALW. PER ISO EQUIP.	(10) ILLUSTRATIONS						
			(2) FEDERAL STOCK NUMBER	(2) MODEL	(7) DS	(7) CS	(7) TS	(7) CS	(7) TS	(7) CS				(7) TS	(7) CS	(7) TS	(10) FIGURE NUMBER	(10) ITEM OR SYMBOL NUMBER										
P	F		5980-356-2465		AIR/GSA-7 (continued)						ea		3	*	2	*	2	*	2	*	2	2	13	9		IX71, IX72		
X2	F				FUSIBLE: 80063; SM-B-328372 CASSET, PANEL: 80063; SM-C-32836A						ea		1															
P	O		5355-577-4084		KNOB: 80063; SM-C-328371						ea		3	*	2	*	2	*	2	*	2	*	2	13	9			
X2	F				NUT, FLAT, HEXAGONAL: 80063; SM-B-328383-3						ea		3															
X2	F				PLATE, IDENTIFICATION: 80063; SM-B-328367						ea		1															
X2	F				PLUG: 80063; SM-B-328366						ea		1															
P	F		5940-223-5293		POST BUILDING, U-106/U: 80063; SC-C-16495						ea		5	*	2	*	2	*	2	*	2	*	2	19	10	7		REL thru B5
P	F		5905-299-2046		REGISTER, FILMED, COMPOSITION: 81349; NC32071524						ea		1	*	*	*	*	*	*	*	*	*	1	5	5	21		REL
X2	F				SCREW, MACHINE: 96906; MS-35225-24						ea		1															
X2	F				SCREW, MACHINE: 96906; MS-35225-27						ea		2															
X2	F				SCREW, MACHINE: 96906; MS-35225-29						ea		1															
X2	F		5305-043-6638		SCREW, MACHINE: See Group I						ea		1															
X2	F				SCREW, W/LOCK: 80063; SM-B-328395						ea		3															
X2	F				SPACER: 80063; SM-B-328375						ea		1															
X2	F				STUD, DRIVE: 80063; SM-B-328368						ea		1															

SOURCE	MAINT. CD	REC. CODE	REPAIR PARTS FOR DIRECT SUPPORT, GENERAL SUPPORT, AND DEPOT MAINTENANCE						UNIT OF MEASUREMENT	(4) QTY INC IN UN PK	(5) QTY INC IN UN UNIT	(7) 30 DAY MAINT. ALW.						(8) PERCENTAGE OF STOCK	(9) DEPT. OR DIVISION	(10) ILLUSTRATIONS	
			FEDERAL STOCK NUMBER		MODEL		DESCRIPTION	QTY				DS	CS	TS	GS	MS	FIGURE NUMBER			ITEM OR SYMBOL NUMBER	
			1	2	3	4															5
P	0		5325-622-5254							6	•	2	•	2	•	2	27	12			
P	P		5930-583-2736							1	•	2	•	2	•	2	13	9	7	81	
P	P		5930-583-2735							1	•	•	•	•	•	•	10	7	7	83	
P	P		5930-577-0340							1	•	•	•	•	•	•	12	6	7	84	
P	P		5930-583-2734							1	•	•	•	•	•	•	15	10	7	82	
ZE	P		5940-159-1293							1											
ZE	P		5310-595-7237							4											
ZE	P		5310-534-2410							1											
ZE	P		5310-198-3724							2											
P	P		5910-537-5426							2	•	•	•	•	•	•	10	8	23	87, 88	
P	P		5910-667-4888							3	2	2	3	2	2	2	33	18	23	85, 86, 87	
P	P		5910-880-6114							1	•	•	•	•	•	•	10	7	23	86	

(1) SOURCE CD	(2) MAINT. CD	(3) REC. CODE	REPAIR PARTS FOR DIRECT SUPPORT, GENERAL SUPPORT, AND DEPOT MAINTENANCE										(4) UNIT OF ISSUE		(5) QTY INC IN UN PK	(6) 30 DAY MAINT. ALW. CB						(7) DS	(8) 1 YR. ALW. PER 100 EQUI. ENRGY	(9) DEPOT MAINT. ALW. PER 100 EQUI.	(10) ILLUSTRATIONS				
			(2) FEDERAL STOCK NUMBER	(3) DESCRIPTION						ea	ea	(7A) 1-20	(7B) 21-50	(7C) 51-100		(7D) 101-200	(7E) 201-300	(7F) 301-400	(7G) 401-500	(7H) 501-600	(7I) 601-700				(7J) 701-800	(7K) 801-900	(7L) 901-1000	(10A) FIGURE NUMBER	(10B) ITEM OR SYMBOL NUMBER
				1	2	3	4	5	6																				
P	O		5910-577-1459	AM/CBA-7 (continued) CAPACITOR, FIXED, ELECTROLYTIC: 81349; CE53C250M						ea	ea	1	*	2	2	2	2	2	2	2	2	2	19	8	21	C11			
P	O		5910-754-6931	CAPACITOR, FIXED, ELECTROLYTIC: 81349; CE51C501G						ea	ea	1	*	2	2	2	2	2	2	2	2	2	19	8	21	C1			
X2	F			CLAMP, ELECTRICAL: 80063; SM-B-328395-1						ea	ea	1	*																
P	O		5960-262-3763	ELECTRON TUBE: 81349; 0824A						ea	ea	1	3	9	16	2	2	4	187	100	21	21	100	21	21	V1			
P	O		5960-188-6593	ELECTRON TUBE: 81349; 5696						ea	ea	1	21	48	91	2	5	11	990	200	21	21	200	21	21	V3			
P	O		5960-262-0210	ELECTRON TUBE: 81349; 5814A						ea	ea	1	5	12	22	2	3	270	200	21	21	200	21	21	V2				
X2	F			NUT, FLAIN, HEXAGONAL: 80063; SM-B-328383-1						ea	ea	1	*																
X2	F			NUT, FLAIN, HEXAGONAL: 80063; SM-B-328383-2						ea	ea	2	*																
X2	F			NUT, FLAIN, HEXAGONAL: 51350; 102-128-6						ea	ea	1	*																
P	F		5905-230-9015	RESISTOR, FIXED, COMPOSITION: 81349; RC320PF20V						ea	ea	1	*	*	2	*	*	2	8	6	23	23	6	23	R5				
P	F		5905-279-1869	RESISTOR, FIXED, COMPOSITION: 81349; RC200PF121K						ea	ea	1	*	*	2	*	*	2	10	7	23	23	7	23	R9				
P	F		5905-279-1926	RESISTOR, FIXED, COMPOSITION: 81349; RC420PF241J						ea	ea	1	*	*	2	*	*	2	8	6	23	23	6	23	R13				
P	F		5905-221-8836	RESISTOR, FIXED, COMPOSITION: 81349; RC320PF621J						ea	ea	1	*	2	2	*	*	2	12	8	23	23	8	23	R7				
P	F		5905-256-0390	RESISTOR, FIXED, COMPOSITION: 81349; RC420PF681J						ea	ea	2	*	*	1	*	*	1	10	8	23	23	8	23	R3, R4				

REPAIR PARTS FOR DIRECT SUPPORT, GENERAL SUPPORT, AND DEPOT MAINTENANCE																				
(1) SOURCE	(2) MAINT. CODE	(3) REC. CODE	(4) FEDERAL STOCK NUMBER	(5) DESCRIPTION						(6) UNIT OF ISSUE	(7) QTY INC IN UN	(8) QTY INC IN UN PK	(9) 30 DAY MAINT. ALW.				(10) ILLUSTRATIONS			
				MODEL	1	2	3	4	5				6	7	8	9		10	11	12
										AM/GSA-7 (cont:raised)										
P	F		5905-279-2533	RESISTOR, FIXED, COMPOSITION: 81349; RC-32071223						ea	1	*	1	*	1	*	1	7	23	R2
P	F		5905-256-8352	RESISTOR, FIXED, COMPOSITION: 81349; RC-2071223						ea	1	*	2	*	2	*	2	8	23	R6
X2	F		5305-514-7506	SCREW, MACHINE: 96906; MS-35267-26						ea	2									
X2	F			SCREW, MACHINE: 96906; MS-35225-15						ea	6									
X2	F			SCREW, MACHINE: 96906; MS-35225-28						ea	1									
X2	F			SCREW, MACHINE: 96906; MS-35241-21						ea	4									
X2	F			SCREW, MACHINE: 96906; MS-35241-27						ea	2									
X2	F			SCREW, MACHINE: 96906; MS-35241-50						ea	1									
P	F		5961-978-7660	SEMICONDUCTOR DEVICE, DIODE: 81349; 1N540						ea	4	*	2	*	2	*	2	16	23	CRL thru C14
P	O		5960-686-8119	SHIELD, ELECTRON TUBE: 96906; MS-24233-1, type 1						ea	1	*	*	*	*	*	*	8	13	E3
P	O		5960-729-8150	SHIELD, ELECTRON TUBE: 96906; MS-24233-3						ea	1	*	*	*	*	*	*	5	12	B8
P	O		5960-686-8087	SHIELD, ELECTRON TUBE: 96906; MS-24233-5						ea	1	*	*	*	*	*	*	5	12	E2
X2	F			SPACER: 80063; SM-B-328396						ea	1									

(3) SOURCE CD	(2) MAINT. CD	(1) REC. CODE	(2) FEDERAL STOCK NUMBER		(3) DESCRIPTION	(4) UNIT OF ISSUE	(5) QTY INC IN UN	(6) QTY INC IN UN	(7) 30 DAY MAINT. ALW.						(8) PERIOD EQUIV. ALW. PER 100 EQUIV. DEPT. & MAIN. ALW. PER 100 EQUIV.	(9) ILLUSTRATIONS	
			(1) 2	(2) 3					(3) 4	(4) 5	(5) 6	(6) 1-20	(7) 21-50	(8) 51-100		(9) 1-20	(10) 21-50
X2	P				AM/CSA-7 (continued)	ea											
X2	P				SPACER, TUG: 80063; SN-B-328398	ea	2										
X2	P				STAND OFF: 80063; SN-B-328419-1	ea	2										
A	P	R			SUPPORT ASSEMBLY: 80063; SN-C-328397; (left hand lower)	ea	1										
X2	P				SUPPORT ASSEMBLY: 80063; SN-C-328398; (right hand lower)	ea	1										
X2	P				SUPPORT CHASSIS: 80063; SN-C-328355; (right hand lower)	ea	1										
X2	P				TERMINAL BOARD: 80063; SN-B-328436	ea	1										
P	O		6130-583-3693		VIBRATOR, INTERRUPTER: 80063; SN-C-328394	ea	1	1	2	2	2	2	16	11	21	G1	
X2	P				WASHER, FLAT: 81350; 10A-18-6L	ea	3										
X2	P				WASHER, LOCK: 96906; MS-35336-3	ea	4										
X2	P		5310-045-3299		WASHER, LOCK: 96906; MS-35338-42	ea	1										
X2	P		5310-198-3724		WASHER, LOCK: See Group II	ea	3										
X2	P		5310-534-2410		WASHER, LOCK: See Group II	ea	8										
P	P		5910-620-4727		GROUP IIIA LOWER CHASSIS SUBASSEMBLY ECON DMC NO. SN-D-328401	ea	1										C4
P	P		5910-667-4888		CAPACITOR, FIXED, ELECTROLYTIC: 80063; SN-C-328404 CAPACITOR, FIXED, PAPER ELECTRIC: See Group III	ea	2										C13, C15

SOURCE CD	MAINT. CD	REC. CODE	REPAIR PARTS FOR DIRECT SUPPORT, GENERAL SUPPORT, AND DEPOT MAINTENANCE										(m) ILLUSTRATIONS						
			(2) FEDERAL STOCK NUMBER	(3) DESCRIPTION	(4) UNIT OF ISSUE	(5) QTY INC IN UN PK	(7) 30 DAY MAINT. ALW.						(6) PER 100 EQUIP	DEPOT MAINT. ALW. PER 100 EQUIP	(c) FIGURE NUMBER	(n) ITEM OR SYMBOL NUMBER			
							(a) 1-2	(b) 3-4	(c) 5-6	(d) 7-8	(e) 9-10	(f) 11-12					(g) 13-14	(h) 15-16	
P	P		5910-583-1482	AM/GSA-7 (continued)	00	1	*	2	*	2	2	2	2	2	2	2	8	23	C10
P	P		5910-682-5249	CAPACITOR, FIXED, PAPER ELECTRIC: 80063; SM-B-328405	00	1	*	*	2	*	2	2	2	2	2	2	6	23	C9
P	P		5910-537-6388	CAPACITOR, FIXED, PAPER ELECTRIC: 80063; SM-B-328406	00	1	*	2	*	2	2	2	2	2	2	2	9	23	C17
P	P		5910-819-5745	CAPACITOR, FIXED, PAPER ELECTRIC: 81349; ON15BLOK	00	1	*	2	*	2	2	2	2	2	2	2	8	23	C14
P	P		5910-818-9758	CAPACITOR, FIXED, PAPER ELECTRIC: 81349; CPO5ALLEN72K3	00	1	2	2	3	2	2	2	2	2	2	2	19	23	C18
P	P		5999-583-5809	CRACK, RADIOPROJECT: 80063; SM-B-328492	00	2	*	*	2	*	2	*	*	2	2	10	4	23	L1, L2
XX	P			CLAMP ASSEMBLY: 80063; SM-B-328418 ORI	00	1													
XX	P			CLAMP ASSEMBLY: 80063; SM-B-328418 ORII	00	1													
XX	P			CLIP, VIBRATOR: 80063; SM-B-328415	00	1													
P	P		5915-688-5186	FILTER, BANDPASS: 80063; SM-B-328408	00	1	*	*	2	*	*	*	*	2	2	8	6	21	FL2
P	P		5915-583-4839	FILTER, RADIO INTERFERENCE: 80063; SM-C-328410	00	1	*	*	1	*	*	*	*	1	1	5	5	21	FL1
P	P		5805-581-9750	GENERATOR, KINING, MACHIE: 80063; SM-C-328407	00	1	*	*	2	*	*	*	*	2	2	10	8	21	02
XX	P			GROUND: 80063; SM-B-328416-2	00	1													



(1) SOURCE CD	(2) MAINT. CD	(3) REC. CODE	REPAIR PARTS FOR DIRECT SUPPORT, GENERAL SUPPORT, AND DEPOT MAINTENANCE						ILLUSTRATIONS							
			(2) FEDERAL STOCK NUMBER		(3) DESCRIPTION				(7) 30 DAY MAINT. ALW.			(6) PER 100 EQUIP. CENTRY	(6) 1 YR. ALW. PER 100 EQUIP. CENTRY	(6) DEPT. MAINT. ALW. PER 100 EQUIP. CENTRY	(6) FIGURE NUMBER	(6) ITEM OR SYMBOL NUMBER
					(4) UNIT OF ISSUE	(5) QTY INC IN UN PK	(6) QTY INC IN UN UNIT	(7) DB	(7) GB	(7) CS						
(1) MAINT. CD	(2) FEDERAL STOCK NUMBER	(3) REC. CODE	(4) UNIT OF ISSUE	(5) QTY INC IN UN PK	(6) QTY INC IN UN UNIT	(7) DB	(7) GB	(7) CS	(8) DB	(8) GB	(8) CS	(9) FIGURE NUMBER	(10) ITEM OR SYMBOL NUMBER			
X2	P															
X2	P															
X2	P															
X2	P															
X2	P															
X2	P															
X2	P															
X2	P															
P	P															
P	P															
P	P															
P	P															
P	P															

SOURCE CD	MAINT. CD	REC. CODE	REPAIR PARTS FOR DIRECT SUPPORT, GENERAL SUPPORT, AND DEPOT MAINTENANCE										(4) QTY INC IN UN PK	(5) QTY INC IN UN UNIT	(7) 30 DAY MAINT. ALW.						(8) PER 100 EQUIP	(9) DEPOT MAINT. ALW. PER 100 EQUIP.	(10) ILLUSTRATIONS	
			(2) FEDERAL STOCK NUMBER		(3) DESCRIPTION						DS				GS		(11) FIGURE NUMBER	(12) ITEM OR SYMBOL NUMBER						
			1	2	1	2	3	4	5	6	7	8			(13) T-20	(14) T-20			(15) 51-100	(16) 21-30			(17) 51-100	(18) 21-30
P	P		5905-185-6946		AM/GBA-7 (continued)						1	2	2	3	2	2	2	33	23	R12				
P	P		5905-279-2514		RESISTOR, FIXED, COMPOSITION: 01121; EM474						2	*	2	2	*	2	2	2	18	12	R8, R15			
P	P		5905-192-0390		RESISTOR, FIXED, COMPOSITION: 81349; RC20GF56AJ						1	*	2	2	*	2	2	19	13	23	R15			
P	P		5905-239-0569		RESISTOR, FIXED, COMPOSITION: 81349; RC20GF105J						2	*	2	2	*	2	2	13	10	23	R17, R18			
P	P		5905-279-1881		RESISTOR, FIXED, COMPOSITION: 81349; RC20GF225K						1	*	2	2	*	2	2	13	9	23	R16			
X2	P				SCREW, MACHINE: 96906; MS-35225-15						6													
X2	P				SCREW, MACHINE: 96906; MS-35225-28						8													
X2	P				SCREW, MACHINE: 96906; MS-35225-43						7													
X2	P				SCREW, MACHINE: 96906; MS-35267-27						3													
X2	P		5905-531-1625		SCREW, MACHINE: 81349; type 1, style 58						2													
P	P		5961-577-6214		SEMICONDUCTOR DEVICE, DIODE: 81349; 1J538						8	2	2	3	2	2	2	40	24	23	CR9 thru CR17			
P	P		5961-978-7660		SEMICONDUCTOR DEVICE, DIODE: See Group III						4										23	CR5 thru CR8		
P	P		5935-129-3081		SOCKET, ELECTRON TUBE: 80063; SM-B-328403						1	*	*	1	*	*	1	5	5	23	XG1			

(1) SOURCE CD	(2) MAINT. CD	(3) REC. CODE	(4) REPAIR PARTS FOR DIRECT SUPPORT, GENERAL SUPPORT, AND DEPOT MAINTENANCE		(5) DESCRIPTION			(6) UNIT OF ISSUE		(7) 30 DAY MAINT. ALW.		(8) PER 100 EQUIP. 1 YR. ALW. CNTGCT	(9) DEPOT MAINT. ALW. PER 100 EQUIP.	(10) ILLUSTRATIONS									
																(1) FEDERAL STOCK NUMBER	MODEL	QTY INC IN UN PK	QTY INC IN UN PK	DS	GS	FIGURE NUMBER	ITEM OR SYMBOL NUMBER
P	P		5935-260-5789			AN/GSA-7 (continued)	ee								XC1, XC11								
						SOCKET, ELECTRON TUBE: 81349; TS101P01		2	*	*	2	10	8	23									
P	P		5935-686-9955			SOCKET, ELECTRON TUBE: 81349; TS102P02	ee	2	*	*	2	13	10	23		XV1, XV3							
P	P		5935-160-1365			SOCKET, ELECTRON TUBE: 81349; TS103P01	ee	1	*	*	1	5	5	23		XV2							
X2	P					STAND OFF: 80063; SM-B-328419-2	ee	3															
X2	P					TERMINAL BOARD: 80063; SM-B-328409	ee	1															
X2	P					TERMINAL BOARD: 80063; SM-B-328412	ee	1															
X2	P		5940-926-0023			TERMINAL, STUD: 08288; MS-5940-8	ee	9															
X2	P		5940-847-3138			TERMINAL, LUG: 80063; SM-B-328377-1	ee	2															
X2	P					TERMINAL, LUG: 80063; SM-B-328377-2	ee	4															
P	P		5950-622-1983			TRANSFORMER, POWER, STEP-DOWN: 80063; SM-D-328413	ee	1	*	*	1	5	5	23		T1							
X2	P					WASHER, FLAT: 81350; 104-1S-6L	ee	3															
X2	P		5310-53A-2410			WASHER, LOCK: See Group II	ee	10															
X2	P		5310-198-3724			WASHER, LOCK: See Group II	ee	14															
X2	P		5310-045-3599			WASHER, LOCK: See Group III	ee	7															

SOURCE CD	MAINT. CD	REC. CODE	REPAIR PARTS FOR DIRECT SUPPORT, GENERAL SUPPORT, AND DEPOT MAINTENANCE										(10) ILLUSTRATIONS					
			(2) FEDERAL STOCK NUMBER	(3) DESCRIPTION						(7) 30 DAY MAINT. ALW.				(8) PERIODIC MAINT. ALW. PERIOD	(9) ALW. PERIOD			
1	2	3		4	5	6	DS (1)	DS (2)	DS (3)	DS (4)	GS (1)	GS (2)	GS (3)			(1A) FIGURE NUMBER	(1B) ITEM OR SYMBOL NUMBER	
P	II		5910-581-8278	AW/GSA-7 (continued) GROUP IV *SSTS ASSEMBLY ECON IMG NO. SM-D-320443 CAPACITOR, FIXED, MICA DIELECTRIC: 00000; 8499880; (p/o Oscillator Subassembly, Z1)						1	1-20	1-30	1-100	2	8	6	22	C35
P	II		5910-618-3290	CAPACITOR, FIXED, MICA DIELECTRIC: 81349; CM35E10303; (p/o Oscillator Subassembly, Z1)						1	1-20	1-30	1-100	2	8	6	22	C32
P	II		5910-683-8075	CAPACITOR, FIXED, MICA DIELECTRIC: 81349; CM30E10273; (p/o Oscillator Subassembly, Z1)						1	1-20	1-30	1-100	2	8	6	22	C33
P	II		5910-951-5192	CAPACITOR, FIXED, MICA DIELECTRIC: 81349; CM30711273; (p/o Oscillator Subassembly, Z1)						1	1-20	1-30	1-100	2	8	6	22	C33
P	II		5910-951-7071	CAPACITOR, FIXED, MICA DIELECTRIC: 81349; CM30715273; (p/o Oscillator Subassembly, Z1)						1	1-20	1-30	1-100	2	8	6	22	C33
P	II		5910-951-8636	CAPACITOR, FIXED, MICA DIELECTRIC: 81349; CM30718273; (p/o Oscillator Subassembly, Z1)						1	1-20	1-30	1-100	2	8	6	22	C33
P	II		5910-951-7073	CAPACITOR, FIXED, MICA DIELECTRIC: 81349; CM30720273; (p/o Oscillator Subassembly, Z1)						2	1-20	1-30	1-100	2	13	9	22	C33, C34

(1) SOURCE	(2) MAINT. CD	(3) REC. CODE	REPAIR PARTS FOR DIRECT SUPPORT, GENERAL SUPPORT, AND DEPOT MAINTENANCE										(4) UNIT OF ISSUE	(5) QTY INC IN UN PK	(6) QTY INC IN UN	(7) 30 DAY MAINT. ALW.						(8) PER 100 EQUIP. CNTGY	(9) 1 YR. ALW. PER 100 EQUIP.	(10) ILLUSTRATIONS	
			(2) FEDERAL STOCK NUMBER	(3) DESCRIPTION					(17) DS	(18) 1-20	(19) 21-30	(20) 31-100				(21) 100 GS	(22) 1-20	(23) 21-30	(24) 31-100	(25) 100	(26) FIGURE NUMBER			(27) ITEM OR SYMBOL NUMBER	
				1	2	3	4	5																	6
P	II		5910-883-4552	AM/GSA-7 (continued) CAPACITOR, FIXED, MICA DIELECTRIC: 81349; CM30272JF3; (p/o Oscillator Subassembly, Z1)						*	*	*	*	*	*	*	2	8	6	22	C34				
P	II		5910-802-0534	OR CAPACITOR, FIXED, MICA DIELECTRIC: 81349; BMCS300302J03; (p/o Oscillator Subassembly, Z1)						*	*	*	*	*	*	*	*	2	8	6	22	C34			
P	II		5910-060-6372	OR CAPACITOR, FIXED, MICA DIELECTRIC: 81349; CM30732J03; (p/o Oscillator Subassembly, Z1)						*	*	*	*	*	*	*	*	2	8	6	22	C34			
P	II		5910-565-3213	OR CAPACITOR, FIXED, MICA DIELECTRIC: 84171; CM30K362P; (p/o Oscillator Subassembly, Z1)						*	*	*	*	*	*	*	*	2	8	6	22	C34			
P	II		5910-76-1281	CAPACITOR, FIXED, MICA DIELECTRIC: 81349; CM3570352J; (p/o Oscillator Subassembly, Z1)						*	*	*	*	*	*	*	*	2	8	6	22	C34			
P	P		5910-820-6114	CAPACITOR, FIXED, PAPER DIELECTRIC: See Group III						*	*	*	*	*	*	*	*	2	8	6	22	C39			
P	P		5910-818-9758	CAPACITOR, FIXED, PAPER DIELECTRIC: See Group IIIA						*	*	*	*	*	*	*	*	2	8	6	22	C20, C26, C27			
X2	P			CLAMP, ELECTRICAL: 80063; SN-B-328395-2																					
X2	P			COIL, OSCILLATOR, TANK: 80063; SN-B-328454; (p/o Oscillator Subassembly, Z1)																					

(1) SOURCE CD	(2) MAINT. CD	(3) REC. CODE	(4) REPAIR PARTS FOR DIRECT SUPPORT, GENERAL SUPPORT, AND DEPOT MAINTENANCE			(5) DESCRIPTION	(6) QTY INC		(7) 30 DAY MAINT. ALW.				(8) PERCENTAGE OF EQUIP. MAINTENANCE CENTER	(9) DEPT ALW. EQUIP.	(10) ILLUSTRATIONS								
			UNIT OF ISSUE	LN	PK		DS	GS	DS	GS	FIGURE NUMBER	ITEM OR SYMBOL NUMBER											
															(A)	(B)	(C)	(D)	(E)	(F)			
P	0					AM/OMA-7 (continued)																	
P	0					5960-188-8515																	V6
P	0					5960-262-0286																	V5
P	0					5960-237-6917																	V4
P	0					5960-262-0210																	V7
P	0					5960-188-6593																	V8
P	P					5820-625-7085																	Z1
P	P					5905-185-6580																	R34
P	P					5905-171-1999																	R40
P	P					5905-114-2476																	R23
P	P					5905-279-1876																	R41
P	P					5905-192-0649																	R35
X2	P					5905-043-6638																	
X2	P																						
X2	P																						
P	0					5960-686-8085																	B6, E7

(1) SOURCE CD	(2) FEDERAL STOCK NUMBER	(3) DESCRIPTION						(4) UNIT OF ISSUE	(5) QTY INC IN UN PK	(6) QTY INC IN UN UNIT	(7) 30 DAY MAINT. ALW.						(8) 1 YR. ALW PERIOD EQUIV. CNTGTY	(9) DEFOT MAINT ALW. PERIOD EQUIV. 100 EQUIV.	(10) ILLUSTRATIONS	
		MODEL		IND	CD	DS	GS				DS	GS	DS	GS	FIGURE NUMBER	ITEM OR SYMBOL NUMBER				
		1	2																3	4
P O	5960-686-8119						AN/GSA-7 (continued)	ea										B4, B5		
P O	5960-686-8087						SHIELD, ELECTRON TUBE: See Group III SHIELD, ELECTRON TUBE: See Group III	ea										B1		
A F R							SUPPORT ASSEMBLY: 80063; SN-C-328444; (right hand upper)	ea												
A F R							SUPPORT ASSEMBLY: 80063; SN-C-328445; (left hand upper)	ea												
X2 F	5940-926-0023						TERMINAL, STUD: See Group IIIA	ea												
X2 F							WASHER, FLAT: 81350; 104-18-62	ea												
X2 F	5310-534-2410						WASHER, LOCK: See Group II	ea												
X2 F							WASHER, LOCK: 96906; MS-33336-3 GROUP IVA UPPER CHASSIS SUBASSEMBLY ECON DNG NO. SN-D-328449	ea												
X2 F							BRACKET: 80063; SN-B-328432	ea										C31		
P F	5910-537-6328						CAPACITOR, FIXED, MICA DIELECTRIC: See Group IIIA	ea												
P F	5910-583-0605						CAPACITOR, FIXED, PAPER DIELECTRIC: 80063; SN-B-328432	ea										C23		
P F	5910-667-4888						CAPACITOR, FIXED, PAPER DIELECTRIC: See Group III	ea										C24, C29, C38		
P F	5910-187-1763						CAPACITOR, FIXED, PAPER DIELECTRIC: 81349; CP55B1E405K	ea										C19, C25, C30		

(1) SOURCE CD	(2) MAINT. CD	(3) REQ. CODE	REPAIR PARTS FOR DIRECT SUPPORT, GENERAL SUPPORT, AND DEPOT MAINTENANCE												(10) ILLUSTRATIONS		
			(4) UNIT OF ISSUE	(5) QTY INC IN UN PK	(7) 30 DAY MAINT. ALW.						(8) 1 YR. ALW. PERCENTAGE	(9) DEPOT MAINT. ALW. EQUIV.					
					(a) 1-20	(b) 21-30	(c) 31-100	(d) 1-20	(e) 21-30	(f) 31-100			(g) FIGURE NUMBER	(h) ITEM OR SYMBOL NUMBER			
			(3) DESCRIPTION														
			(2) FEDERAL STOCK NUMBER						(1) MODEL								
P	P		5910-126-999A													21	C22
P	P		5910-668-4902													21	C28
P	P		5910-620-4727													21	C21
X2	P																
X2	P																
X2	P																
P	P		6240-295-1368													22	F6
X2	P		5310-679-5532														
X2	P																
X2	P																
X2	P																
X2	P																
X2	P																
X2	P																





(1) SOURCE CD	(2) MAINT. CD	(3) REC. CODE	REPAIR PARTS FOR DIRECT SUPPORT, GENERAL SUPPORT, AND DEPOT MAINTENANCE										(4) UNIT OF ISSUE	(5) QTY INC IN UN PK	(6) QTY INC IN UNIT	(7) 30 DAY MAINT. AL.W.						(8) PER 100 EQUIP. CTRCY ALW. PER 100 EQUIP.	(9) ILLUSTRATIONS		
			(1) FEDERAL STOCK NUMBER			(2) MODEL			(3) DESCRIPTION			DS				GS	SI-100	T-20	SI-100	T-20	SI-100		T-20	(A) FIGURE NUMBER	(B) ITEM OR SYMBOL NUMBER
			1	2	3	4	5	6	7	8	9														
P	P		5905-192-0660									AM/GBA-7 (continued)	ee	1	*	*	*	*	*	*	2	8	6	R30	
P	P		5905-249-9491									RESISTOR, FIXED, COMPOSITION: 13499; RA41B2	ee	2	*	2	*	2	*	2	2	19	14	R21, R32	
P	P		5905-279-2519									RESISTOR, FIXED, COMPOSITION: 81349; RC20GF274K	ee	1	*	2	*	2	*	2	2	12	8	R24	
P	P		5905-279-1883									RESISTOR, FIXED, COMPOSITION: 81349; RC20GF334J	ee	1	*	*	1	*	*	1	5	5	5	R27	
P	P		5905-279-2514									RESISTOR, FIXED, COMPOSITION: 81349; RC20GF335J	ee	1	*	*	*	*	*	*	1	5	5	R26	
P	P		5905-279-1881									RESISTOR, FIXED, COMPOSITION: See Group IIIA	ee	1	*	*	*	*	*	*	*	22	22	R42	
P	P		5905-185-6946									RESISTOR, FIXED, COMPOSITION: See Group IIIA	ee	3	*	*	*	*	*	*	*	22	22	R37, R39, R45	
P	P		5905-192-0390									RESISTOR, FIXED, COMPOSITION: See Group IIIA	ee	1	*	*	*	*	*	*	*	22	22	R43	
P	P		5905-279-2553									RESISTOR, FIXED, COMPOSITION: See Group III	ee	1	*	*	*	*	*	*	*	22	22	R20	
P	P		5905-617-6484									RESISTOR, VARIABLE: 81349; RVAR15SA505B	ee	1	*	2	*	2	*	2	2	12	8	R25	
X2	P											SCREW, MACHINE: 96906; MS-35225-15	ee	10											
X2	P											SCREW, MACHINE: 96906; MS-35225-43	ee	14											
X2	P											SCREW, MACHINE: 96906; MS-35267-27	ee	4											

(1) SOURCE CD	(1) MAINT. CD	(1) REC. CODE	REPAIR PARTS FOR DIRECT SUPPORT, GENERAL SUPPORT, AND DEPOT MAINTENANCE										(7) 30 DAY MAINT. ALW.		(6) PER 100 EQUIP. 1 YR. ALW. CNTGY	(6) DEPOT MAINT. PER 100 EQUIP.	(10) ILLUSTRATIONS		
			(2) FEDERAL STOCK NUMBER	(3) DESCRIPTION	(4) UNIT OF ISSUE	(5) QTY INC IN UN PK	(6) QTY INC IN UN UNIT	DS			GS			(7a) FIGURE NUMBER			(7b) ITEM OR SYMBOL NUMBER		
								(7c) T-80	(7c) 2T-90	(7c) 5T-100	(7d) T-80	(7d) 2T-90	(7d) 5T-100						
				AV/CSA-7 (continued)															
X2	F		5935-686-9955	SCREEN, MACHINE: 81350; 100-68A-8	ea													22	XV4, XV5, XV6, XV8
P	F		5935-160-1365	SOCKET, ELECTRON TUBE: See Group IIIA	ea													22	XV7
X2	F		5940-847-3138	SOCKET, ELECTRON TUBE: See Group IIIA	ea														
X2	F			STANDOFF: 80063; SM-B-328419-2	ea														
X2	F			TERMINAL, IUG: See Group IIIA	ea														
X2	F			TERMINAL, LUG: 80063;	ea														
X2	F			TERMINAL, LUG: 80063;	ea														
X2	F			SM-B-328377-2	ea														
X2	F			TERMINAL, LUG: 80063;	ea														
X2	F			SM-B-328422-1	ea														
X2	F			STUD, CAMLOC: 80063;	ea														
X2	F			SM-B-328422-1	ea														
X2	F			SUPPORT CHASSIS: 80063;	ea														
X2	F			SM-C-328472	ea														
X2	F			SUPPORT CHASSIS: 80063;	ea														
X2	F			SM-C-328474	ea														
X2	F			TERMINAL BOARD: 80063;	ea														
X2	F			SM-B-328463	ea														
X2	F			TERMINAL BOARD: 80063;	ea														
X2	F			SM-C-328468	ea														
X2	F		5940-926-0023	TERMINAL, STUD: See Group IIIA	ea														
P	F		5950-577-3063	TRANSFORMER, AUDIOFREQUENCY: 80063; SM-D-328459	ea													7 21	T2

REPAIR PARTS FOR DIRECT SUPPORT, GENERAL SUPPORT, AND DEPOT MAINTENANCE															
(1) SOURCE	(2) MAINT. CD	(3) REC. CODE	(4) FEDERAL STOCK NUMBER	(5) DESCRIPTION						(6) QTY INC IN UN	(7) 30 DAY MAINT. ALW.	(8) 1 YR. ALW. PERIOD EQUIV. CTRGY	(9) DEPOT MAINT. ALLOW. PERIOD EQUIV.	(10) ILLUSTRATIONS	
				1	2	3	4	5	6					(A) FIGURE NUMBER	(B) ITEM OR SYMBOL NUMBER
X2	F							AI/CBA-7 (continued)							
X2	F							WASHER, FLAT: 81350; 10A-1S-8L	7						
X2	F							WASHER, INSULATOR: 80063; SM-B-328367	1						
X2	F							WASHER, LOCK: 80063; SM-B-328382	1						
X2	F		5310-198-3724					WASHER, LOCK: See Group II	9						
X2	F		5310-534-2410					WASHER, LOCK: See Group II	13						
X2	F		5310-045-3299					WASHER, LOCK: See Group III	12						
X2	F							GROUP V CASE ASSEMBLY ECON DMG NO. SM-D-328352	1						
X2	F							CASE: 80063; SM-D-328353	6						
X2	F							PTH, ASSEMBLY: 80063; SM-B-328354	4						
X2	F							ROLL PTH: 80063; SM-B-328355	3						
P	F		6145-220-9392					GROUP VI CABLE ASSEMBLIES	3						
P	F		6145-112-8681					CABLE, SPECIAL PURPOSE, ELECTRICAL: WM-594/U: 80063; SC-A-46897A	3						
P	F		6145-112-8618					CABLE, POWER, ELECTRICAL: 81348; JCS90, type 4, (p/o 45)	4						
P	F							CABLE, POWER, ELECTRICAL: 81349; CO-ORDINATE (2/16) 0405; (p/o VI and 12)	15						

(1) SOURCE CD	(2) MAINT. CD	(3) REC. CODE	REPAIR PARTS FOR DIRECT SUPPORT, GENERAL SUPPORT, AND DEPOT MAINTENANCE										(4) UNIT OF ISSUE	(5) QTY INC IN UN PK	(7) 30 DAY MAINT. ALW.						(8) PER 100 EQUIP. CNTGTY	(9) DEPT MAINT. ALW. PER 100 EQUIP.	(10) ILLUSTRATIONS	
			(2) FEDERAL STOCK NUMBER	(3) DESCRIPTION						(6) QTY INC IN UN	DS				GS		(6) QTY INC IN UN	(6) FIGURE NUMBER	(6) ITEM OR SYMBOL NUMBER					
				1	2	3	4	5	6		(7) DS	(7) GS												
P	P		6145-542-6098	AW/CSA-7 (continued)						6	1	0	0	0	0	0	0	0	0					
P	P		5935-898-9055	CABLE, SPECIAL PURPOSE, ELECTRICAL: 81349; W4-709/U; (p/o V3 and W4)						1	0	0	0	0	0	0	0	0	0	0				
P	P		5935-283-2950	CONNECTOR, PLUG, ELECTRICAL U-230/U; 80063; SC-A-4697A						3	0	0	0	0	0	0	0	0	0	0		P5, P6		
P	P		5935-283-2884	CONNECTOR, PLUG, ELECTRICAL: 81349; U-77/U; (p/o V3)						3	0	0	0	0	0	0	0	0	0	0		P3, P4		
P	P		5935-518-9653	CONNECTOR, PLUG, ELECTRICAL: 81349; U-76/U; (p/o V3 and CX-74/U)						1	0	0	0	0	0	0	0	0	0	0		P6		
P	P		5935-552-4120	CONNECTOR, PLUG, ELECTRICAL: 81349; U7120M17; (p/o V1)						1	0	0	0	0	0	0	0	0	0	0		P7		
P	P		5935-201-3143	CONNECTOR, PLUG, ELECTRICAL: 81349; CS-1320(1)(8)(0.425); (p/o V1)						2	0	0	0	0	0	0	0	0	0	0				
P	P		5935-258-9974	CONNECTOR, RECEPTACLE, ELECTRICAL 80063; SN-C-328397-2						1	0	0	0	0	0	0	0	0	0	0	0		P1	
P	P		5935-201-3992	CONNECTOR, RECEPTACLE, ELECTRICAL: 80063; SN-C-328397-1						1	0	0	0	0	0	0	0	0	0	0	0		J1	
P	P		5935-259-2545	PLUG, TIP: 83330; 108; (p/o V5)						2	0	0	0	0	0	0	0	0	0	0				

## SECTION V. FEDERAL STOCK NUMBER INDEX

INDEX - FEDERAL STOCK NUMBER CROSS REFERENCE TO  
FIGURE AND ITEM NUMBER OR REFERENCE SYMBOL

STOCK NO.	FIGURE NO.	ITEM NO. REF. SYMBOL	STOCK NO.	FIGURE NO.	ITEM NO. REF. SYMBOL
5805-581-9750	21	R2	5905-279-2553	23	R2
5820-625-7085	25	Z1		22	R20
5905-114-2478	22	R23	5905-279-3497	22	R46
5905-120-1174	22	R38	5905-279-3500	22	R31
5905-171-1986	22	R26, R36, R47	5905-279-3504	23	R19
5905-171-1999	22	R40	5905-299-1971	22	R44
5905-171-2005	22	R22	5905-299-2046	21	R1
5905-185-6580	22	R34	5905-617-6484	3	R25
5905-185-6946	23	R12	5910-060-6372	22	C34
	22	R37, R39, R45	5910-126-9594	21	C22
5905-186-3008	22	R33	5910-187-1763	21	C19, C25, C30
5905-192-0390	23	R15	5910-537-5426	23	C7, C8
	22	R43	5910-537-6328	22	C31
5905-192-0649	22	R35		23	C17
	23	R14	5910-565-3213	22	C34
5905-192-0660	22	R30	5910-577-1459	21	C11
5905-195-6300	23	R10, R11	5910-581-8278	22	C35
5905-195-6817	22	R29	5910-583-0625	21	C23
5905-221-8836	23	R7	5910-583-4482	23	C10
5905-230-9015	23	R5	5910-620-4727	21	C21
5905-239-0569	23	R17, R18		25	C4
5905-249-9491	22	R21, R32	5910-622-5249	23	C9
5905-256-0390	23	R3, R4	5910-667-4888	23	C5, C6, C12, C13,
5905-256-8352	23	R6		22	C15
5905-279-1869	23	R9	5910-668-4902	21	C24, C29, C38
5905-279-1876	22	R41	5910-721-2252	21	C28
5905-279-1881	22	R42	5910-754-6931	21	C2, C3
	23	R16	5910-764-1281	22	C1
5905-279-1883	22	R27	5910-802-0534	22	C34
5905-279-1926	23	R13	5910-802-0534	22	C34
5905-279-2514	22	R28	5910-818-3290	22	C32
	23	R8, R15	5910-818-9758	23	C18
5905-279-2519	22	R24		22	C20, C26, C27
			5910-819-5745	23	C14

**INDEX — FEDERAL STOCK NUMBER CROSS REFERENCE TO  
FIGURE AND ITEM NUMBER OR REFERENCE SYMBOL**

STOCK NO.	FIGURE NO.	ITEM NO. REF. SYMBOL	STOCK NO.	FIGURE NO.	ITEM NO. REF. SYMBOL
5910-820-6114	22 23	C39 C16	5945-583-8180	21	K2
5910-883-4552	22	C34	5950-577-3063	21	T2
5910-883-8075	22	C33	5950-583-4488	21	L3
5910-951-5192	22	C33	5950-622-1983	23	T1
5910-951-7071	22	C33	5960-188-6593	21	V3, V8
5910-951-7073	22	C33, C34	5960-188-8515	21	V6
5910-951-8636	22	C33	5960-237-6917	21	V4
5915-583-4839	21	FL1	5960-262-0210	21	V2, V7
5915-628-5186	21	FL2	5960-262-0286	21	V5
5920-142-7383	7	F1	5960-262-3763	21	V1
5920-295-9602	7	F2	5961-577-6214	23	CR9 thru CR17
5930-577-0340	7	84	5961-978-7660	23	CR1 thru CR4, CR5 thru CR8
5930-583-2734	7	82	5999-583-5809	23	L1, L2
5930-583-2735	7	83	6130-583-3693	21	G1
5930-583-2736	7	81	6240-295-1368	22	B6
5935-129-3081	23	XC1			
5935-160-1365	23 22	XV2 XV7			
5935-201-3952	21	J1			
5935-201-3998	7	J2			
5935-258-9974	21	F1			
5935-260-5789	23	XC1, XC11			
5935-549-2646	7	J5			
5935-583-8291	7	J3, J4			
5935-686-9955	23 22	XV1, XV3 XV4, XV5, XV6, XV8			
5940-223-5293	7	E1 thru E5			
5945-577-2923	21	K3			
5945-583-7514	21	K5			
5945-583-7519	23	K1			
5945-583-7558	21	K4			

By Order of the Secretary of the Army:

**HAROLD K. JOHNSON,**  
*General, United States Army,*  
*Chief of Staff.*

**Official:**

**KENNETH G. WICKHAM,**  
*Major General, United States Army,*  
*The Adjutant General.*

**Distribution:**

*Active Army:*

USASA (2)  
CNGB (1)  
OCC-E (7)  
Dir/Trans (1)  
CofEngrs (1)  
TSG (1)  
CofSptS (1)  
USAARENBD (2)  
USAAESWBD (5)  
USACDCEA (1)  
USACDCCBRA (1)  
USACDCCEA (1)  
USACDCCEA Ft Huachuca (1)  
USACDCOA (1)  
USACDCQMA (1)  
USACDCTA (1)  
USACDCARMA (1)  
USACDCAVNA (1)  
USACDCARTYA (1)  
USACDCSWA (1)  
USACDCADA (1)  
USAMC (5)  
USCONARC (5)  
ARADCOM (5)  
ARADCOM Rgn (2)  
OS Maj Comd (4)  
LOGCOMD (2)  
USAMICOM (4)  
USASTRATCOM (4)  
USAESC (70)  
MDW (1)  
Armies (2) except  
  Eight (5)  
1st Cav Div (5)  
Corps (2)  
USAC (3)  
507th USASA Gp (5)  
508th USASA Gp (5)  
318th USASA Bn (5)  
319th USASA Bn (5)  
177th USASA Co (5)  
182nd USASA Co (5)  
183rd USASA Co (5)  
184th USASA Co (5)  
Svc Colleges (2)  
USASCS (5)

USASESCS (5)  
USAADS (10)  
USAAMS (10)  
USAARMS (2)  
USAIS (2)  
USAES (2)  
USATC Armor (2)  
USATC Engr (2)  
USATC Inf (2)  
USASTC (2)  
WRAMC (1)  
Army Pic Can (2)  
USACDCEC (10)  
Instl (2) except  
  Fort Hancock (4)  
  Fort Gordon (10)  
  Fort Huachuca (10)  
  WSMR (5)  
  Fort Carson (25)  
  Fort Knox (12)  
Army Dep (2) except  
  LBAD (14)  
  SAAD (30)  
  TOAD (14)  
  LEAD (7)  
  SHAD (3)  
  NAAD (5)  
  SVAD (5)  
  CHAD (3)  
  ATAD (10)  
GENDEPS (2)  
Sig Sec GENDEPS (5)  
Sig Dep (12)  
Sig FLDMS (2)  
AMS (1)  
USAERDAA (2)  
USAERDAW (13)  
USACRREL (2)  
Units Org under fol TOE:  
  (2 cys each)  
  5-617  
  6-185  
  6-186  
  6-300  
  6-345  
  6-346



6-385	11-127
6-386	11-155
6-405	11-157
6-406	11-158
6-415	11-500 (AA-AC)
6-416	11-587
6-435	11-592
6-436	11-597
6-445	17
6-575	17-100
6-576	17-102
6-577	32-56
7	32-57
7-100	32-68
7-102	32-500
11-7	37
11-8	37-100
11-38	37-102
11-57	44-85
11-58	44-86
11-85	44-53b
11-87	44-536
11-97	57
11-98	57-100
11-117	

**NG:** State AG (3); units—same as active Army except allowance is one (1) copy per unit.

**USAR:** None.

For explanation of abbreviations used, see AR 320-50.



CHANGE }  
No. 5 }

HEADQUARTERS  
DEPARTMENT OF THE ARMY  
WASHINGTON, D. C., 16 January, 1970

## RADIO SET CONTROL AN/GSA-7

TM 11-5135-15, 7 May 1958 is changed as follows:

### Note

The parenthetical reference to previous changes (*example*: page 1 of C 3) indicates that pertinent information was published in that change.

*Page 3* (page 1 of C 3). Delete paragraph 1.1 and substitute:

#### 1.1 Indexes of Publications

*a. DA Pam 310-4.* Refer to the latest issue of DA Pam 310-4 to determine whether there are any new editions, changes, or additional publications pertaining to the equipment.

*b. DA Pam 310-7.* Refer to the latest issue of DA Pam 310-7 to determine whether there are any modification work orders (MWO's) pertaining to the equipment.

*Page 3* (page 2 of C 3). Delete paragraph 2 and substitute:

#### 2. Forms and Records

*a. Reports of Maintenance and Unsatisfactory Equipment.* Use equipment forms and records in

accordance with instructions in TM 38-750.

*b. Report of Packaging and Handling Deficiencies.* Fill out and forward DD Forms 6 (Report of Packaging and Handling Deficiencies) as prescribed in AR 700-58 (Army), NAVSANDA Publications 378 (Navy), and AFR 71-4 (Air Force).

*c. Discrepancy in Shipment Report (DISREP) SF 361.* Fill out and forward Discrepancy in Shipment Report (DISREP) (SF 361) as prescribed in AR 55-38 (Army), NAVSUP Pub 459 (Navy), AFM 75-34 (Air Force), and MCO P46-10.19 (Marine Corps).

*d. Reporting of Equipment Manual Improvements.* Reporting of errors, omissions, and recommendations for improving this publication by the individual user is encouraged. Reports should be submitted on DA Form 2028 (Recommended Changes to Publications) and forwarded direct to Commanding General, U.S. Army Electronics Command, ATTN: AMSEL-ME-NMP-AD, Fort Monmouth, N.J. 07703.

*Page 40.* Add chapter 5.1 after chapter 5.

## CHAPTER 5.1

### DEPOT OVERHAUL STANDARDS

#### 41.1 Applicability of Depot Overhaul Standards

The tests outlined in this chapter are designed to measure the performance capability of a repaired radio set control. Radio set controls that are to be returned to stock should meet the standards given in these tests.

#### 41.2 Applicable References

*a. Repair Standards.* Applicable procedures of the depots performing this test and the general

standards for repaired electronic equipment given in TB SIG 355-1, TB SIG 355-2, and TB SIG 355-3, form a part of the requirements for testing this equipment.

*b. Technical Publication.* This manual is the only technical publication applicable to the equipment (refer to DA Pam 310-4 for changes in force):

*c. Modification Work Orders.* Perform all modification work orders applicable to this equipment before making the tests specified. DA Pam 310-7 lists all applicable MWO's.

### 41.3. Additional Equipment Required

In addition to the test equipment in the maintenance allocation chart (MAC), the following equipment is required:

Item	Federal Stock Number	Quantity
Telephone Set TA-312/PT	5805-543-0012	1
Handset H-33B/PT	5965-163-9947	1
Multimeter, TS-352/U	6625-242-5023	1
Oscilloscope OS-8A/U	6625-643-1740	1
Audio Oscillator TS-421/U	6625-669-0228	1
Stopwatch	6645-719-8950	1
Frequency Counter AN/USM-207	6625-911-6368	1
Power Supply 0-30V DC Electro Model NF (or equivalent).	NSN	1
Resistor, noninductive 150 ohms ±5% 2W.	NSN	
Resistor, noninductive 2000 ohms ±5% 2W.	NSN	1
Resistor, noninductive 600 ohms ±5% 2W.	NSN	1
Capacitor, 20 MFD fixed Electrolytic 150 vdc.	NSN	1

### 41.4. General Test Requirements

When a repaired equipment is being tested, perform tests in sequence and comply with preparatory instructions.

a. *Scope of Tests.* The following tests will be performed to assure the acceptability of repaired radio set controls for return to stock:

- (1) Physical test and inspection.
- (2) Electrical tests.
- (3) Operational tests.

b. *Initial Conditions.*

- (1) Perform all tests at room temperature.
- (2) Properly ground all equipment before making power connections.

### 41.5 Physical Test and Inspection

The equipment must meet the mechanical and visual requirements specified in inspection standards TB SIG 355-1, -2, and -3.

### 41.6 Electrical Tests

a. *Output Level—1600 Cycles* (fig. 24.1)

- (1) Connect a 150-ohm resistor across pins C and E of RADIO receptacle J3 or J4 (fig. 7)
- (2) Connect the ME-30A/U and the AN/USM-207 across the 150-ohm resistor.
- (3) Position the C. O. POWER switch to EXT. and the RADIO & MON switch (fig. 7) to T RADIO and MON.
- (4) Position the OFF-AC-DC switch to AC and apply 110 VAC to pins C and A of POWER receptacle J2.

(5) With the TS-421/U connected to the LINE terminals, apply a 20 cps signal at a level of 20 volts plus or minus 2 volts.

(6) The ME-30A/U must indicate between 0.1 and 0.2 volt.

(7) The AN/USM-207 must indicate 1600 cycles plus or minus 20 cps. The 1600 cycle signal must be prolonged for at least 2 seconds after the TS-421/U is turned off.

(8) Position the OFF-AC-DC switch to OFF and disconnect the 110 VAC source from the AN/GSA-7.

(9) Apply 26 volts dc plus or minus 2.0 volts to terminals D (+) and B (-) of POWER receptacle J2 and position the OFF-AC-DC switch to DC.

(10) Repeat (5) through (8) above except in (8) disconnect the 26 VDC source instead of the 110 VAC source.

(11) Turn the POWER SELECT switch to 230 V. Apply 230 VAC, to terminals C and A of the AN/GSA-7 POWER receptacle J2 and position the OFF-AC-DC switch to AC.

#### CAUTION

Never apply 230 VAC source to the AN/GSA-7 with the POWER SELECT switch in the 115V position.

(12) Repeat (5) through (8) above except in (8) disconnect the 230 VAC source instead of the 110 VAC source.

(13) Disconnect the 150-ohm resistor and the test equipment from the AN/GSA-7.

(14) Turn the POWER SELECT switch to 115V and apply 115 VAC, 60 cps to terminals C and A of POWER receptacle J2 for the remaining tests.

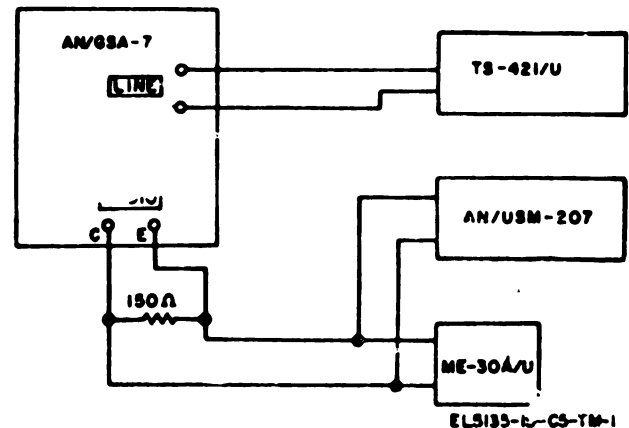


Fig. 24.1 Output level test, 1600 cycles.

**b. Output Level—20 Cycles (fig. 24.2).**

(1) Connect a 20 MFD capacitor in series with a 2000-ohm resistor across the LINE terminals.

(2) Connect the ME-30A/U and the OS-8A/U vertical input across the 2000-ohm resistor.

(3) Position the OFF-AC-DC switch to AC.

(4) Connect the SG-15/PCM to terminals A and B of RADIO receptacle J3 or J4. Adjust the SG-15/PCM to a frequency of 1600 cycles plus or minus 30 cycles at an output level of -20 dbm (77.5 millivolts rms).

(5) With the TS-421/U and the AN/USM-207 connected to the horizontal input of the OS-8A/U, adjust the TS-421/U for a 1 to 1 ratio. Lissajous pattern on the OS-8A/U. The output frequency indicated on the AN/USM-207 must be 20 cycles plus or minus 2 cycles.

(6) The output voltage across the 2000-ohm resistor as indicated on the ME-30A/U must be greater than 40 volts rms.

(7) Disconnect the SG-15/PCM and hold the RADIO & MON switch in the RTEL position. The indication on the ME-30A/U must be greater than 40 volts rms.

(8) Position the OFF-AC-DC switch to OFF. Disconnect the capacitor, resistor and the test equipment from the AN/GSA-7.

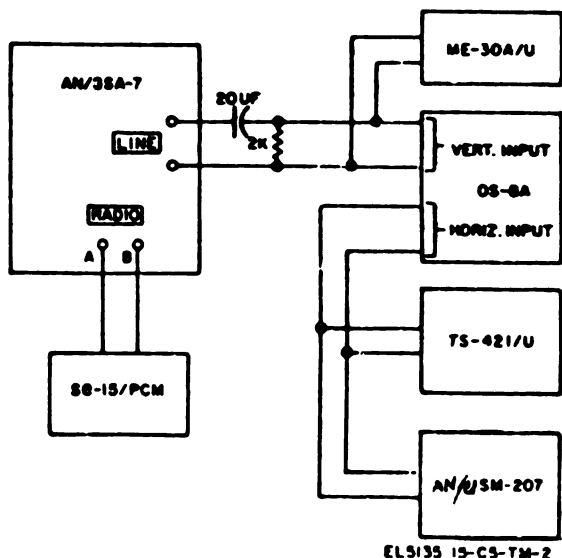


Figure 24.2 Output level test, 20 cycles.

**c. Loss From Line Terminals to RADIO Receptacles (Pins C and E).**

(1) Connect a 150-ohm resistor across pins C and E of RADIO receptacle J3 or J4.

(2) Connect the ME-30A/U across the 150-

ohm resistor.

(3) Connect the TS-421/U across the LINE terminals and position the OFF-AC-DC switch to AC.

(4) Adjust the TS-421/U to a frequency of 1000 cycles at a level of 0 db. Record the ME-30A/U indication for reference.

(5) The loss must not exceed 3 db when the TS-421/U is adjusted from 300 to 3500 cycles.

(6) Disconnect the 150-ohm resistor and the test equipment from the AN/GSA-7.

(7) Position the OFF-AC-DC switch to OFF.

**d. Loss From RADIO Receptacle (Pins A and B) LINE Terminals.**

(1) Connect a 600-ohm resistor and the ME-30A/U across the LINE terminals.

(2) Connect the SG-15/PCM across pins A and B of RADIO receptacle J3 or J4.

(3) Position the OFF-AC-DC switch to AC and the RADIO & MON-TEL switch to T.

(4) Adjust the SG-15/PCM to a frequency of 1000 cycles at a level of 0 db. Record the ME-30A/U indication for reference.

(5) The loss must not exceed 1.5 db when the SG-15/PCM is adjusted from 300 to 3500 cycles.

(6) Position the OFF-AC-DC switch to OFF. Disconnect the 600-ohm resistor and the test equipment from the AN/GSA-7.

**e. Warning Device Test.**

(1) Short the LINE terminals and connect the H-33B/PT to the PHONE receptacle.

(2) Position the RADIO & MON-TEL SWITCH to T RADIO & MON and the OFF-AC-DC switch to ON.

(3) Between 11 and 13 beeps per minute must be heard in the H-33B/PT.

(4) Position the OFF-AC-DC switch to OFF. Remove the short from the LINE terminals and disconnect the H-33B/PT.

**f. Carrier Operated Relay Test.**

(1) Connect a jumper between the CARR. OP terminal and the GND terminal.

(2) Position the switches as follows:

C.O. POWER to INT.

RADIO & MON-TEL to

OFF-AC-DC to AC.

(3) The resistance across the LINE terminals, as measured by the TS-352(\*)/U, must be 70 ohms plus or minus 20 ohms.

(4) Position the C. O. POWER switch to EXT. and remove the jumper between the CARR. OP and the GND terminals.

(5) Connect a 16 VDC plus or minus 1 VDC source to CARR. OP. terminal (-) and AUX terminal (+).

(6) The resistance across the LINE terminals, as measured by the TS-352(\*)/U must be 70 ohms plus or minus 20 ohms.

(7) Disconnect the 16 VDC source from the AN/GSA-7 and position the OFF-AC-DC switch to OFF.

#### **41.7 Operation Tests**

##### ***a. External Ringing Test Within Radio Set Control AN/GSA-7.***

(1) Connect Telephone TA-312/PT to the LINE terminals and position the OFF-AC-DC switch to AC.

(2) Hold the RADIO & MON-TEL SWITCH in the R TEL position for several seconds and then release it.

(8) The RADIO & MON-TEL switch will return to the T TEL position and the telephone will ring.

##### ***b. Local Switchboard Communication Test Through Radio Set Control AN/GSA-7.***

(1) Connect the H-33B/PT to the PHONE receptacle.

(2) Insure that the RADIO & MON-TEL switch is positioned to T TEL.

(3) Voice communication between the H-33B/PT and the TA-312/PT must be clear and intelligible.

##### ***c. Radio Communication Test Through Radio Set Control AN/GSA-7.***

(1) Position the RADIO & MON-TEL switch to RADIO & MON T.

(2) Voice communication between the H-33B/PT and the TA-312/PT must be clear and intelligible.

**By Order of the Secretary of the Army:**

**Official:**

**KENNETH G. WICKHAM,  
Major General, United States Army,  
The Adjutant General.**

**W. C. WESTMORELAND,  
General, United States Army,  
Chief of Staff.**

**Distribution:**

To be distributed in accordance with DA Form 12-51 (qty rqr Block #241), Operator requirements for AN/GSA-7 Radio Set Control.

Change }  
No. 6 }

HEADQUARTERS  
DEPARTMENT OF THE ARMY  
Washington, D.C., 23 April 1973

**RADIO SET CONTROL AN/GSA-7**

TM 11-5135-15, 7 May 1958, is changed as follows:

Page 3, paragraph 1b. Delete subparagraph b and substitute the following:

b. Appendixes in this manual include the following:

- (1) Appendix I, References.
- (2) Appendix II (BIIL). (Deleted per this change.)
- (3) Appendix III, Maintenance Allocation Chart (Change No. 4).
- (4) Appendix IV, Organizational, DS, GS, and Depot Maintenance Repair Parts and Special Tools List (RPSTL) (Change No. 4).

Paragraph 2d, next to last line. Change "ATTN: AMSEL-ME-NMP-AD" to ATTN: AMSEL-MA-CR.

Page 4, paragraph 4b.1. Add the following after the last sentence: Such an external ringing facility is Oscillator, Audio Frequency 0-574/GRC (fig. 4.1, para 8d).

Page 6. Delete paragraph 6 and substitute new paragraph 6:

**6. Components of AN/GSA-7.**

a. Operating Components (fig. 1).

Federal stock No.	Item	Dimensions (in.)			Weight (lb)
		Height	Width	Length	
5820-543-1397	Control, Radio Set AN/GSA-7; includes 1 each of following: Control unit	9	7 1/4	12 7/8	27.5
8105-543-1397	Bag, cotton duck: 15814; A-5725		8 1/2	16 1/2	
5995-578-6906	Cable Assembly, Power, Electrical, W1: 80063; SC-DL-328498.			84	2
5995-578-7902	Cable Assembly, Special Purpose Electrical, W2 and W3: 80063; SC-C-75348			30	2
5995-578-6705	Cable Assembly, Power, Electrical, W5: 80063; SC-D-162340			84	2
5995-578-6907	Cable Assembly, Power, Electrical, W4: 80063; SC-DL-328496.			84	2
5995-985-7561	Cable Assembly, Special Purpose, Electrical CX-7474/U: 80063; SC-DL-350796.			30	1
5805-186-9464	Mounting MT-791/U or MT-791A/U: 80063; SC-C-42670. TM 11-5135-15. Running Spares (b below).	3 7/8	8 3/4	12 3/4	11.8

*b. Running Spares.*

Federal stock No	Item	Figure
5960-624-4718	Electron tube: OB2WA (for Va)(1 ea)	21
5960-557-6780	Electron tube: 6C4WA (for V6)(1 ea)	21
5960-262-0286	Electron tube: 5651WA (for V5)(1 ea)	21
5960-188-6593	Electron tube: 5696 (for V3, V8)(1 ea)	21
5960-134-6064	Electron tube: 5725/6AS6W (for V4)(1 ea)	21
5960-262-0210	Electron tube: 5814A (for V2, V7)(1 ea)	21
5920-280-8342	Fuse, cartridge: F02G1ROOA (5 ea)	7(F1)
5920-284-9220	Fuse, cartridge: Slo-Bl0 (5 ea)	7(F2)

Page 9, paragraph 7d. Add the following subparagraph (5):

(5) Cable assembly CX-7474/U (fig. 6.1) is used for connection to such radios as following:

(a) Receiver-transmitters of AN/VRC-12 series radios (TM 11-5820-401-12).

(b) Radio Sets AN/VRC-53, AN/VRC-64, AN/GRC-125, and AN/GRC-160 (TM 11-5820-498-12).

(c) Radio Set AN/PRC-25 (TM 11-5820-398-12).

(d) Radio Set AN/PRC-77 (TM 11-5820-667-12).

Paragraph 8. Add the following subparagraph d:

d. Oscillator, Audio Frequency 0-574/GRA (fig. 4.1) is required when the distant radio in the system is not connected to a AN/GSA-7 (para 13.1). Add figure 4.1 after paragraph 8.



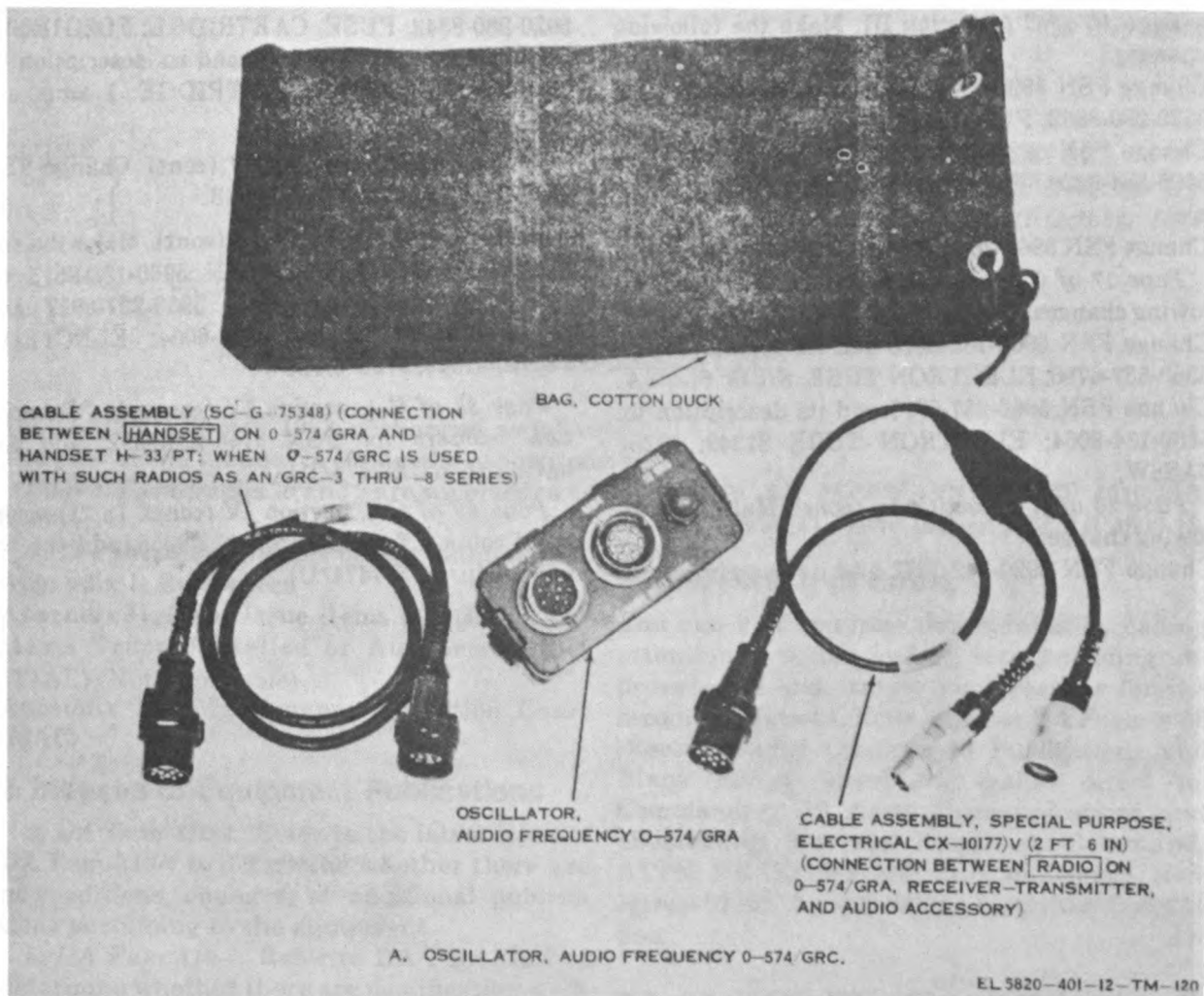


Figure 4.1. Oscillator, Audio Frequency 0-574/GR, components.

Page 10, paragraph 10a.1. Change the second sentence to read: If the packing slip is not available, check the equipment against the components listings in paragraph 6.

Page 12, paragraph 11h.1. Add the following after the last sentence: Refer to paragraph 13.1 for additional information applicable to the CX-7474/U.

Page 15. Add the following paragraph after paragraph 13:

### 13.1. Connections and Operating Procedures with Certain Radio Sets

Connections and operating procedures using the AN/GSA-7, CX-7474/U (para 11h.1; fig. 6.1), and 0-574/GR (para 8d; fig. 4.1) in conjunction with

certain radio sets is provided in the technical manuals listed for the radio sets in paragraph 7d(5).

Page 4 of C3, paragraph 16.1a, Warning. Change the warning to read as follows: **Warning:** The fumes of cleaning agent, Trichloroethane are toxic. Provide enough ventilation while it is being used. Do not use near an open flame. Trichloroethane is not flammable, but exposure to the open flame converts the fumes to a highly toxic and dangerous gas.

Paragraph 16.2b(1). Change subparagraph (1) to read as follows: (1) Trichloroethane (FSN 6810-292-9625; 1 qt).

Pages 5 through 8 of C 4, appendix II. Delete appendix II. (Refer to paragraph 6 for components listing.)

*Page 16 of C 4, section III. Make the following changes:*

Change FSN 5920-142-7383 and its description to: 5920-280-8342, FUSE, CARTRIDGE: FO2G1R00A.

Change FSN 5920-295-9602 and its description to: 5920-284-9220; FUSE CARTRIDGE: 1 amp, slo- blo.

Change FSN 5960-262-3763 to: 5960-624-4718.

*Page 17 of C 4, section III (cont). Make the fol- lowing changes:*

Change FSN 5960-188-8515 and its description to: 5960-557-6780; ELECTRON TUBE: 81349; 6C4WA.

Change FSN 5960-237-6917 and its description to: 5960-134-6064; ELECTRON TUBE 81349; 5725/ 6AS6W.

*Page 20 of C 4, section IV (cont). Make the fol- lowing changes:*

Change FSN 5920-142-7383 and its description to:

5920-280-8342; FUSE, CARTRIDGE: FO2G1R00A. Change FSN 5920-295-9602 and its description to: 5920-284-9220; FUSE, CARTRIDGE: 1 amp, slo- blo.

*Page 23 of C 4, section IV (cont) Change FSN 5960-262-3763 to: 5960-624-4718.*

*Page 32 of C 4, section IV (cont). Make the fol- lowing changes: Change FSN 5960-188-8515 to: 5960-557-6780. Change FSN 5960-237-6917 and its description to: 5960-134-6064; ELECTRON TUBE: 81349; 5725/6AS6W.*

*Page 38 of C 4, section IV (cont). In "Descrip- tion" column for FSN 6145-220-9392, add fol- lowing: (p/o CX-7474/U).*

*Page 39 of C 4, section IV (cont). In "Descrip- tion" column for FSN 5935-892-9055, add the fol- lowing: (p/o CX-7474/U).*

By order of the Secretary of the Army:

Official:

VERNE L. BOWERS

*Major General, United States Army*

*The Adjutant General*

CREIGHTON W. ABRAMS  
*General, United States Army*  
*Chief of Staff*

Distribution:

To be distributed in accordance with DA Form 12-51, (qty rqr block no. 241) Operator maintenance re- quirements for AN/GSA-7.

CHANGE }  
No. 8 }

HEADQUARTERS  
DEPARTMENT OF THE ARMY  
WASHINGTON, DC 31 October 1978

**RADIO SET CONTROL AN/GSA-7  
(NSN 5820-00-543-1397)**

TM 11-5135-15, 7 May 1958, is changed as follows:  
The title of the manual is changed as shown above.

Page 3. Paragraphs 1b and 2 are superseded as follows:

- b. The three appendixes of this manual are:  
Appendix I, References  
Appendix II, Basic Issue Items List (BIIL) and Items Troop Installed or Authorized List (ITIAL) (Not applicable)  
Appendix III, Maintenance Allocation Chart (MAC)

**2. Indexes of Equipment Publications**

a. *DA Pam 310-4*. Refer to the latest issue of DA Pam 310-4 to determine whether there are new editions, changes, or additional publications pertaining to the equipment.

b. *DA Pam 310-7*. Refer to DA Pam 310-7 to determine whether there are modification work orders (MWO's) pertaining to the equipment.

Page 4. Paragraphs 2.1, 2.2, 2.3, 2.4, and 2.5 are added after paragraph 2.

**2.1. Forms and Records**

a. *Reports of Maintenance and Unsatisfactory Equipment*. Maintenance forms, records, and reports which are to be used by maintenance personnel at all maintenance levels are listed in and prescribed by TM 38-750.

b. *Report of Packaging and Handling Deficiencies*. Fill out and forward DD Form 6 (Packaging Improvement Report) as prescribed in AR700-58/NAVSUPINST 4030.29/AFR 71-13/MCO P4030.29A, and DLAR 4145.8.

c. *Discrepancy in Shipment Report (DISREP) (SF 361)*. Fill out and forward Discrepancy in Shipment Report (DISREP) (SF 361) as pre-

scribed in AR 55-38/NAVSUPINST 4610.33B/AFR 75-18/MCO P4610.19C and DLAR 4500.15.

**2.2. Reporting of Errors**

You can help improve this manual by calling attention to errors and by recommending improvements and stating your reasons for the recommendations. Your letter or DA Form 2028 (Recommended Changes to Publications and Blank Forms) should be mailed direct to: Commander, US Army Communications and Electronics Materiel Readiness Command, ATTN: DRSEL-ME-MQ, Fort Monmouth, New Jersey 07703. A reply will be furnished direct to you.

**2.3. Administrative Storage**

For procedures, forms and records, and inspections required during administrative storage of this equipment, refer to TM 740-90-1.

**2.4. Destruction of Army Electronics Materiel**

Demolition and destruction of electronic equipment will be under the direction of the commander and in accordance with TM 750-244-2.

**2.5. Reporting Equipment Improvement Recommendations (EIR)**

EIR's will be prepared using Standard Form 368, Quality Deficiency Report. Instructions for preparing EIR's are provided in TM 38-750, The Army Maintenance Management System.

\*This Change supersedes C 7, 13 August 1975.

EIR's should be mailed direct to Commander, US Army Communications and Electronics Materiel Readiness Command, ATTN: DRSEL-ME-MQ, Fort Monmouth, NJ 07703. A reply will be furnished direct to you.

Page 6, paragraph 6, chart, line 3. Change "8105-543-1397" to read "8105-00-543-7837".

After paragraph 6, add:

#### NOTE

For requisitioning purposes, the Federal stock number must be converted to the National stock number by adding "-00-" after the Federal stock classification (FSC) code (first four digits); for example, FSN 8105-543-7837 converts to NSN 8105-00-543-7837.

Page 45. Appendix III is superseded as follows:

## APPENDIX III MAINTENANCE ALLOCATION

### Section I. INTRODUCTION

#### III-1. General

This appendix provides a summary of the maintenance operations for MD-700(P)/G. It authorizes categories of maintenance for specific maintenance functions on repairable items and components and the tools and equipment required to perform each function. This appendix may be used as an aid in planning maintenance operations.

#### III-2. Maintenance Function

Maintenance functions will be limited to and defined as follows:

*a. Inspect.* To determine the serviceability of an item by comparing its physical, mechanical, and/or electrical characteristics with established standards through examination.

*b. Test.* To verify serviceability and to detect incipient failure by measuring the mechanical or electrical characteristics of an item and comparing those characteristics with prescribed standards.

*c. Service.* Operations required periodically to keep an item in proper operating condition, i.e., to clean (decontaminate), to preserve, to drain, to paint, or to replenish fuel, lubricants, hydraulic fluids, or compressed air supplies.

*d. Adjust.* To maintain, within prescribed limits, by bringing into proper or exact position, or by setting the operating characteristics to the specified parameters.

*e. Align.* To adjust specified variable elements of an item to bring about optimum or desired performance.

*f. Calibrate.* To determine and cause corrections to be made or to be adjusted on instruments or test measuring and diagnostic equipments used in precision measurement. Consists of comparisons of two instruments, one of which is a certified standard of known accuracy, to detect and adjust any discrepancy in the accuracy of the instrument being compared.

*g. Install.* The act of emplacing, seating, or fixing into position an item, part, module (component or assembly) in a manner to allow the proper functioning of the equipment or system.

*h. Replace.* The act of substituting a serviceable like type part, subassembly, or module (component or assembly) for an unserviceable counterpart.

*i. Repair.* The application of maintenance services (inspect, test, service, adjust, align, calibrate, replace) or other maintenance actions (welding, grinding, riveting, straightening, facing, remachining, or resurfacing) to restore serviceability to an item by correcting specific damage, fault, malfunction, or failure in a part, subassembly, module (component or assembly), end item, or system.

*j. Overhaul.* That maintenance effort (service/action) necessary to restore an item to a completely serviceable/operational condition as prescribed by maintenance standards (i.e., DMWR) in appropriate technical publications. Overhaul is normally the highest degree of

maintenance performed by the Army. Overhaul does not normally return an item to like new condition.

*k. Rebuild.* Consists of those services/actions necessary for the restoration of unserviceable equipment to a like new condition in accordance with original manufacturing standards. Rebuild is the highest degree of materiel maintenance applied to Army equipment. The rebuild operation includes the act of returning to zero those age measurements (hours, miles, etc.) considered in classifying Army equipments/components.

### III-3. Column Entries

*a. Column 1, Group Number.* Column 1 lists group numbers, the purpose of which is to identify components, assemblies, subassemblies, and modules with the next higher assembly.

*b. Column 2, Component/Assembly.* Column 2 contains the noun names of components, assemblies, subassemblies, and modules for which maintenance is authorized.

*c. Column 3, Maintenance Functions.* Column 3 lists the functions to be performed on the item listed in column 2. When items are listed without maintenance functions, it is solely for purpose of having the group numbers in the MAC and RPSTL coincide.

*d. Column 4, Maintenance Category.* Column 4 specifies, by the listing of a "worktime" figure in the appropriate subcolumn(s), the lowest level of maintenance authorized to perform the function listed in column 3. This figure represents the active time required to perform that maintenance function at the indicated category of maintenance. If the number or complexity of the tasks within the listed maintenance function vary at different maintenance categories, appropriate "worktime" figures will be shown for each category. The number of task-hours specified by the "worktime" figure represents the average time required to restore an item (assembly, subassembly, component, module, end item or system) to a serviceable condition under typical field operating conditions. This time includes preparation time, troubleshooting time, and quality assurance/quality control time

in addition to the time required to perform the specific tasks identified for the maintenance functions authorized in the maintenance allocation chart. Subcolumns of column 4 are as follows:

- C — Operator/Crew
- O — Organizational
- F — Direct Support
- H — General Support
- D — Depot

*e. Column 5, Tools and Equipment.* Column 5 specifies by code, those common tool sets (not individual tools) and special tools, test, and support equipment required to perform the designated function.

*f. Column 6, Remarks.* Column 6 contains an alphabetic code which leads to the remark in section IV, Remarks, which is pertinent to the item opposite the particular code.

### III-4. Tool and Test Equipment Requirements (Sec III)

*a. Tool or Test Equipment Reference Code.* The numbers in this column coincide with the numbers used in the tools and equipment column of the MAC. The numbers indicate the applicable tool or test equipment for the maintenance functions.

*b. Maintenance Category.* The codes in this column indicate the maintenance category allocated the tool or test equipment.

*c. Nomenclature.* This column lists the noun name and nomenclature of the tools and test equipment required to perform the maintenance functions.

*d. National/NATO Stock Number.* This column lists the National/NATO stock number of the specific tool or test equipment.

*e. Tool Number.* This column lists the manufacturer's part number of the tool followed by the Federal Supply Code for manufacturers (5-digit) in parentheses.

### III-5. Remarks (Sec IV)

*a. Reference Code.* This code refers to the appropriate item in section II, column 6.

*b. Remarks.* This column provides the required explanatory information necessary to clarify items appearing in section II.

**SECTION II MAINTENANCE ALLOCATION CHART  
FOR  
RADIO SET AM/GSA-7**

(1) GROUP NUMBER	(2) COMPONENT/ASSEMBLY	(3) MAINTENANCE FUNCTION	(4) MAINTENANCE CATEGORY					(5) TOOLS AND EQPT.	(6) REMARKS
			C	O	F	H	D		
00	Radio Set Control AM/GSA-7	Inspect		0.1				8	
		Service		0.1				1,3	
		Test		0.3				1,2,3,8	
		Test			1.0			8	
01	Chassis and Panel Assembly	Replace		0.1				8	
		Repair			2.0			2 thru 9	
		Inspect			0.1			8	
		Test			0.5			2 thru 7	
0101	Front Panel Assembly	Repair			1.0			2 thru 7, 9	
		Inspect			0.2			8	
		Test			0.5			2 thru 7	
0102	Lower Chassis Assembly	Repair			1.5			2 thru 7, 9	
		Inspect			0.1			8	
		Test			0.5			2 thru 7	
010201	Lower Chassis Sub-Assembly	Repair			1.5			2 thru 7, 9	
		Inspect			0.1			8	
		Test			0.8			2 thru 7	
0103	Upper Chassis Assembly	Repair			1.0			2 thru 7, 9	
		Inspect			0.2			8	
		Test			0.5			2 thru 7	
010301	Upper Chassis Sub-Assembly	Repair			1.2			2 thru 7, 9	
		Inspect			0.2			8	
		Test			0.2			2 thru 7	
02	Cable Assembly, Power, Electrical	Repair			0.5			1,8	
		Inspect			0.2			8	
		Test			0.2			1,8	
03	Cable Assembly, Power, Electrical	Repair			0.5			1,8	
		Inspect			0.1			8	
		Test			0.2			1,8	
04	Cable Assembly SC-C-75348-2-101-8	Repair			0.5			1,8	
		Inspect			0.1			8	
		Test			0.2			1,8	
05	Cable Assembly SC-D-162340	Repair			0.5			1,8	
		Inspect			0.1			8	
		Test			0.2			1,8	
06	Mounting MT-791/U or MT-791A/U (See TM 11-5805-295-14P)	Repair			0.5			1,8	
		Inspect			0.1			8	
		Test			0.2			1,8	

**SECTION III TOOL AND TEST EQUIPMENT REQUIREMENTS  
FOR  
RADIO SET CONTROL AN/GSA-7**

TOOL OR TEST EQUIPMENT REF CODE	MAINTENANCE CATEGORY	NOMENCLATURE	NATIONAL/NATO STOCK NUMBER	TOOL NUMBER
1	O	MULTIMETER ME-77/U	6625-00-284-0854	
2	O,F,N,D	TELEPHONE SET TA-312/PT	5805-00-543-0012	
3	O,F,N,D	TUBE TESTER TV-7D/U	6625-00-820-0064	
4	F,N,D	AUDIO OSCILLATOR TS-302/U	6625-00-151-7479	
5	F,N,D	VOLTMETER ME-30/U	6625-00-643-1670	
6	F,N,D	SIGNAL GENERATOR SG-15/PCM	6625-00-225-1087	
7	F,N,D	COUNTER AN/USM-207A	6625-00-044-3228	
8	O,F,N,D	TOOL KIT, ELECTRONIC EQUIPMENT TX-101/CBQ	5180-00-064-5178	
9	F,N,D	TOOL KIT, ELECTRONIC EQUIPMENT TX-105/C	5180-00-610-8177	

By Order of the Secretary of the Army:

**BERNARD W. ROGERS**  
*General, United States Army*  
*Chief of Staff*

Official:

**J. C. PENNINGTON**  
*Brigadier General, United States Army*  
*The Adjutant General*

Distribution:

*Active Army:*

HISA (Ft Monmouth) (26)	
USAINSCOM (2)	29-610
COE (1)	(1 copy each)
TSG (1)	6-185
USAARENBD (1)	6-186
DARCOM (1)	6-300
TRADOC (2)	6-405
OS Maj Comd (4)	6-406
TECOM (2)	6-435
USACC (4)	6-436
MDW (1)	6-445
Armies (2)	6-575
Corps (2)	6-576
Svc Colleges (1)	6-577
USASIGS (5)	7
USAADS (2)	7-100
USAFAS (2)	7-102
USAARMS (2)	11-38
USAIS (2)	11-85
USAES (2)	11-87
USAICS (3)	11-97
MAAG (1)	11-98
USARMIS (1)	11-117
USAERDAA (1)	11-127
USAERDAW (1)	11-500(AA-AC)
Ft Gordon (10)	17
Ft Huachuca (10)	17-100
Ft Carson (5)	17-102
Army Dep (1) except	32-56
LBAD (14)	32-57
SAAD (30)	32-500
TOAD (14)	37
SHAD (3)	37-100
Ft Gillem (10)	37-102
USA Dep (1)	44-85
Sig Sec USA Dep (1)	44-86
Ft Richardson (CERCOM Ofc) (2)	44-535
Units org under fol TOE:	44-536
(2 copies each)	57
29-207	57-100

NG: State AG (3); Units — None

USAR: None

For explanation of abbreviations used. see AR 310-50.



CHANGE }  
NO. 10 }

HEADQUARTERS  
DEPARTMENT OF THE ARMY  
Washington, DC, 12 December 1983

## RADIO SET CONTROL AN/GSA-7 (NSN 5820-00-543-1397)

TM 11-5135-15, 7 May 1958, is changed as follows:

*Inside front cover.* Delete the "RADIATION HAZARD" notice and substitute:

### RADIATION HAZARDS



STD-RW-2

Ni 63  
Co 60

Tube types OB2WA and 5651 used in the AN/GSA-7 contain radioactive material. These tubes are potentially hazardous when broken; see qualified medical personnel and the Safety Director if you are exposed to or cut by broken tubes. Use extreme care when replacing these tubes (par. 20c) and follow safety procedures in their storage and disposal (par. 20.1).

Never place a radioactive tube in your pocket.

Use extreme care not to break radioactive tubes while handling them.

Never remove radioactive tubes from cartons until ready to use them.

Refer to paragraph 20.1 on handling, storage, and disposal of radioactive material.

*Page 3.* Delete paragraph 1-1 and substitute:

\*This change supersedes C3, 24 October 1963 and C9, 22 November 1979.

**1.1. Consolidated Index of Army Publications and Blank Forms**

Refer to the latest issue of DA Pam 310-1 to determine whether there are new editions, changes or additional publications pertaining to the equipment.

Delete paragraphs 2, 2.1, 2.2, 2.3 and 2.4 and substitute:

**2. Maintenance Forms, Records, and Reports**

*a. Reports of Maintenance and Unsatisfactory Equipment.* Department of the Army forms and procedures used for equipment maintenance will be those prescribed by TM 38-750, The Army Maintenance Management System.

*b. Report of Packaging and Handling Deficiencies.* Fill out and forward SF 364 (Report of Discrepancy (ROD)) as prescribed in AR 735-11-2/DLAR 4140.55/NAVMATINST 4355.73A/AFR 400-54/MCO 4430.3F.

*c. Discrepancy in Shipment Report (DISREP) (SF 361).* Fill out and forward Discrepancy in Shipment Report (DISREP) (SF 361) as prescribed in AR 55-38/NAVSUPINST 4610.33C/AFR 75-18/MCO P4610.19D/DLAR 4500.15.

**2.1. Reporting Errors and Recommending Improvements**

You can help improve this manual. If you find any mistakes or if you know of a way to improve the procedures, please let us know. Mail your letter or DA Form 2028 (Recommended Changes to Publications and Blank Forms) direct to: Commander, US Army Communications-Electronics Command and Fort Monmouth, ATTN: DRSEL-ME-MP, Fort Monmouth, New Jersey 07703. In either case, a reply will be furnished direct to you.

**2.2. Reporting Equipment Improvement Recommendations (EIR)**

If your radio set control needs improvement, let us know. Send us an EIR. You, the user, are the only one who can tell us what you don't like about your equipment. Let us know why you don't like the design. Put it on an SF 368 (Quality Deficiency Report). Mail it to Commander, US Army Communications-Electronics Command and Fort Monmouth, ATTN: DRSEL-ME-MP, Fort Monmouth, New Jersey 07703. We'll send you a reply.

**2.3. Administrative Storage**

Administrative Storage of equipment issued to and used by Army activities will have preventive maintenance performed in accordance with the PMCS charts before storing. When removing the equipment from administrative storage the PMCS should be performed to assure operational readiness. Disassembly and repacking of equipment for shipment or limited storage are covered in chapter 6 and TM 740-90-1.

**2.4. Destruction of Army Electronics Materiel**

Destruction of Army electronics materiel to prevent enemy use shall be in accordance with TM 750-244-2.

Delete paragraph 2.5.

Page 4, paragraph 4b. Add subparagraph b.1 after subparagraph b.

*b.1.* When Receiver-Transmitter, Radio RT-246/VRC or Receiver-Transmitter, Radio RT-524/VRC is used to call the telephone equipment, an external ring facility must be used to generate the 1,600-cps ring signal. Such an external ringing facility is Oscillator, Audio Frequency O-574/GRC (fig. 4.1, para 8d).

Page 6, paragraph 5. Add the following to the technical characteristics chart:

**WARNING**

Tube types OB2WA and 5651 are used in this equipment. These tubes contain radioactive material and are potentially hazardous when broken. The type and quantity of radioactivity are listed below.

Tube type	Isotope	Quantity (microcuries)
OB2WA	Ni 63	0.01-.05
	or	
5651	Co 60	0.0067
	Co 60	0.0067

Page 10, paragraph 10. Delete subparagraph a, a.1. and a.2., and substitute:

*a.* Inspect the equipment for damage incurred during shipment. If the equipment has been damaged, report the damage on SF 364 (para 2).

a.1. See that the equipment is complete as listed on the packing slip. If the packing slip is not available, check the equipment against the components listings in paragraph 6. Report all discrepancies in accordance with TM 38-750. Shortage of a minor assembly or part that does not affect proper functioning of the equipment should not prevent use of the equipment.

a.2. If the equipment has been used or reconditioned, see whether it has been modified, the modification work order (MWO) number will appear on the front panel near the nomenclature plate. Check to see whether the MWO number (if any) and appropriate notations concerning the modification have been entered in the equipment manual.

#### NOTE

Current MWO's applicable to the equipment are listed in DA Pam 310-1.

Page 12. Delete subparagraph 11h.1 and substitute:

h.1. To transmit and receive through Receiver-Transmitter, Radio RT-246/VRC or Receiver-Transmitter, Radio RT-524/VRC, Cable Assembly, Special Purpose, Electrical CX-7474/U (figs. 6.1 and 23.1) is used to adapt RADIO receptacle J3 or J4 on the AN/GSA-7 to the RETRANSMIT R/W connector on the RT-246/VRC or RT-524/VRC. Refer to paragraph 13.1 for additional information applicable to the CX-7474/U.

Add figure 6.1 after figure 6.



TM5135-15-C3-2

Figure 6.1. Cable, Assembly, Special Purpose, Electrical CX-7474/U.

Page 16. Change chapter 3 heading to "MAINTENANCE." Section I. Delete section I including figures 8 and 9 and substitute:

### Section I. OPERATOR/CREW PREVENTIVE MAINTENANCE CHECKS AND SERVICES

#### 14. General

##### NOTE

Refer to TM 750-244-2 for proper procedures for destruction of this equipment to prevent enemy use.

a. Operator/crew preventive maintenance is the systematic care, servicing and inspection of equipment to prevent the occurrence of trouble,

to reduce downtime, and to maintain equipment in serviceable condition. To be sure that your AN/GSA-7 is always ready for your mission, you must do scheduled preventive maintenance checks and services (PMCS).

(1) BEFORE OPERATION, perform your B PMCS to be sure that your equipment is ready to go.

(2) When an item of equipment is reinstalled after removal, for any reason, perform the necessary B PMCS to be sure the item meets the readiness reporting criteria.

(3) Use the ITEM NO. column in the PMCS table to get the number to be used in the TM ITEM NO. column on DA Form 2404 (Equipment Inspection and Maintenance Worksheet) when you fill out the form.

b. Routine checks like CLEANING, DUSTING, WASHING, CHECKING FOR FRAYED CABLES, STOWING ITEMS NOT IN USE, COVERING UNUSED RECEPTACLES, AND CHECKING FOR LOOSE NUTS AND BOLTS are not listed as PMCS checks. They are things that you should do any time you see they must be done. If you find a routine check like one of those listed in your PMCS, it is because other operators reported problems with this item.

**NOTE**

When you are doing any PMCS or routine checks, keep in mind the warnings and cautions.

**WARNINGS**

- Adequate ventilation should be provided while using TRICHLOROTRIFLUOROETHANE. Prolonged breathing of vapor should be avoided. The solvent should not be used near heat or open flame; the products of decomposition are toxic and irritating. Since TRICHLOROTRIFLUOROETHANE dissolves natural oils, prolonged contact with skin should be avoided. When necessary, use gloves which the solvent cannot penetrate. If the solvent is taken internally, consult a physician immediately.
- Compressed air is dangerous and can cause serious bodily harm if protective means or methods are not observed to prevent a chip or particle (of whatever size) from being blown into the eyes or

unbroken skin of the operator or other personnel. Goggles must be worn at all times while cleaning with compressed air. Compressed air shall not be used for cleaning purposes except where reduced to less than 29 pounds per square inch gage (psig) and then only with effective chip guarding and personnel protective equipment. Do not use compressed air to dry parts when trichlorotrifluoroethane has been used.

**NOTES**

The PROCEDURES column in your PMCS charts instruct how to perform the required checks and services. Carefully follow these instructions and, if tools are needed or the chart so instructs, get organizational maintenance to do the necessary work.

If your equipment must be in operation all the time, check those items that can be checked and serviced without disturbing operation. Make the complete checks and services when the equipment can be shut down.

c. Deficiencies that cannot be corrected must be reported to higher category maintenance personnel. Records and reports of preventive maintenance must be made in accordance with procedures given in TM 38-750.

**15. Operator/Crew Preventive Maintenance Checks and Services**

Perform before operation PMCS if you are operating the item for the first time.

**NOTE**

The checks in the interval column are to be performed in the order listed.

**16. Operator/Crew Preventive Maintenance Checks and Services Chart**

B — Before

Item No.	Interval	Item to be Inspected	Procedures — Check for and have repaired or adjusted as necessary	Equipment is not Ready/Available If:
	B			
1	•	Mission Essential Equipment	Check for completeness and satisfactory condition of the equipment. Report missing items.	Available equipment is insufficient to support the combat mission.
2	*	AN/GSA-7	Perform operational checks as described in paragraph 19.	Does not produce ringing signal.

\*Do this check before each deployment to a mission location. This will permit any existing problems to be corrected before the mission starts. The check does not need to be done again until redeployment.

**16.1. Cleaning**

Inspect the exterior of the equipment. The exterior surfaces should be clean, and free of dust, dirt, grease, and fungus.

a. Remove dust and loose dirt with a clean soft cloth.

**WARNING**

Adequate ventilation should be provided while using TRICHLOROTRIFLUOROETHANE. Prolonged breathing of vapor should be avoided. The solvent should not be used near heat or open flame; the products of decomposition are toxic and irritating. Since TRICHLOROTRIFLUOROETHANE dissolves natural oils,

prolonged contact with skin should be avoided. When necessary, use gloves which the solvent cannot penetrate. If the solvent is taken internally, consult a physician immediately.

b. Remove grease, fungus, and ground-in dirt from the cases; use a cloth dampened (not wet) with trichlorotrifluoroethane.

c. Remove dust or dirt from plugs and jacks with a brush.

d. Clean the front panel and control knobs; use a soft clean cloth. If dirt is difficult to remove, dampen the cloth with water; mild soap may be used for more effective cleaning.

Add section 1.1 after section 1.

**Section 1.1. ORGANIZATIONAL PREVENTIVE/MAINTENANCE CHECKS AND SERVICES**

**16.2. Tools, Materials, and Test Equipment Required**

A list of parts authorized for organizational maintenance appears in TM 11-5820-274-12P. The tools, materials, and test equipment required for organizational maintenance are listed below.

a. *Tools.* All the tools required are contained in Tool Kit, Electronic Equipment TK-101/G (NSN 5180-00-064-5178).

b. *Materials.*

(1) Cleaning solution — Trichlorotrifluoroethane (NSN 6850-00-105-3084).

(2) Cleaning cloth.

c. *Test Equipment.*

(1) Multimeter AN/URM-105.

(2) Test Set, Electron Tube TV-7/U.

**16.3. Organizational Preventive Maintenance**

Organizational preventive maintenance procedures are designed to help maintain equipment in serviceable condition. They include items to be checked and how to check them. These checks and services, described in paragraph 4-3, outline inspections that are to be made at specific monthly (M) intervals.

**16.4. Organizational Preventive Maintenance Checks and Services Chart**

M — Monthly

Item No.	Interval	Item to be Inspected	Procedures
	M		
1	•	AN/GSA-7	Perform operation check as described in paragraph 19.

**16.5. Touchup Painting Instructions**

Remove rust and corrosion from metal surfaces by lightly sanding them with fine sandpaper. Brush two thin coats of paint on the bare metal to protect it from further corrosion. Refer to the applicable cleaning and refinishing practices specified in TM 43-0139.

Page 20, paragraph 20. Add paragraph 20.1 after paragraph 20.

**20.1. Handling, Storage, and Disposal of Radioactive Material**

Follow the procedures for safe handling, storage, and disposal of radioactive materials as directed by:

a. TB-43-0197, Instructions for Safe Handling Maintenance, Storage and Disposal of Radioactive Items Managed by US Army Armament Materiel Readiness Command.

b. AR 40-37, Radioactive Materials Licensing and Control for Medical Purposes.

Page 23. Figure No. 11. Add NOTE 1: R37 value selected to provide at least a 2-second continuation of 1600 Hz signal after ringing signal ceases.

Adjacent to R37, add: NOTE 1.

Page 38. Add figure 23.1 after figure 23.

Page 40. Paragraph 41.7a. Change subparagraph (2) to read:

(2) Hold the RADIO & MON-TEL SWITCH in the R TEL position for several seconds. The telephone will ring.

Change subparagraph (3) to read:

(3) The RADIO & MON-TEL SWITCH will return to the T TEL position. The telephone will stop ringing.

Facing page 40. Figure no. 25. After note 5, add:

6. R37 value selected to provide at least a 2-second continuation of 1600 Hz signal after ringing signal ceases.

Adjacent to R37, add: NOTE 6.

Page 41. Change the title of chapter 6 to "SHIPMENT AND LIMITED STORAGE".

Page 42. Delete section II in its entirety.

Page 43. Delete appendix I and substitute:

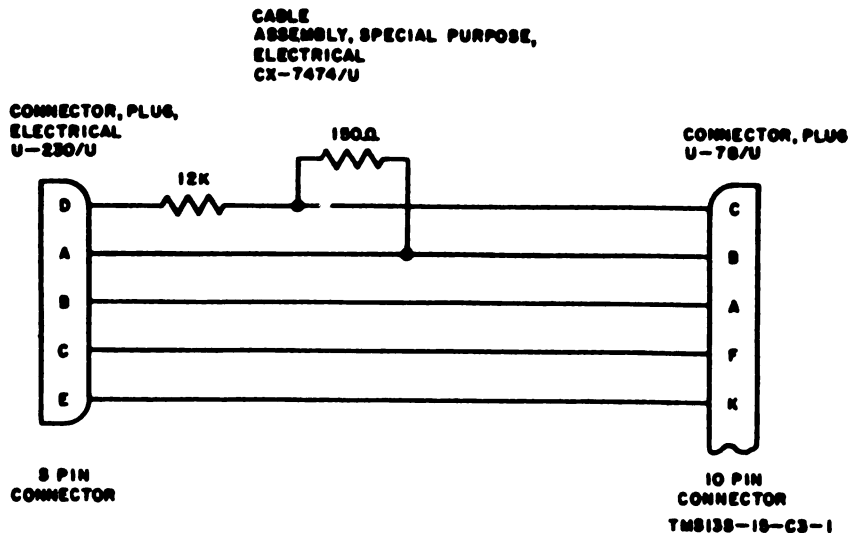


Figure 23.1. Cable assembly, special purpose, electrical CX-7474/U, wiring diagram.

## APPENDIX I REFERENCES

- AR 40-37  
DA Pam 310-1  
TB 43-0197
- TM 11-5805-295-14P
- TM 11-5820-274-24P
- TM 11-5820-401-10-1
- TM 11-5820-401-12
- TM 11-6625-203-12
- TM 11-6625-218-12  
TM 11-6625-251-15
- TM 11-6625-274-12
- TM 11-6625-316-12
- TM 11-6625-320-35
- TM 38-750  
TM 43-0139  
TM 740-90-1  
TM 750-244-2
- Licensing and Control of Radioactive Materials for Medical Purposes. Consolidated Index of Army Publications and Blank Forms. Instructions for Safe Handling, Maintenance, Storage and Disposal of Radioactive Items Managed by US Army Armament Materiel Readiness Command.
- Operators, Organizational, DS and GS Maintenance Repair Parts and Special Tools Lists (Including Depot Maintenance Repair Parts and Special Tools) for Mountings MT-791/U and MT-791A/U (NSN 5805-00-186-9464).
- Organizational, DS and GS Maintenance Repair Parts and Special Tools Lists (Including Depot Maintenance Repair Parts and Special Tools) for Radio Set Control AN/GSA-7 (NSN 5820-00-543-1397).
- Operators Manual: Radio Sets AN/VRC-12 (NSN 5820-00-223-7412), AN/VRC-43 (5820-00-223-7415), AN/VRC-44 (5820-00-223-7417), AN/VRC-45 (5820-00-223-7418), AN/VRC-46 (5820-00-223-7433), AN/VRC-47 (5820-00-223-7434), AN/VRC-48 (5820-00-223-7435) and AN/VRC-49 (5820-00-223-7437) (Used without an Intercom System).
- Operators and Organizational Maintenance Manual for Radio Sets AN/VRC-12 (NSN 5820-00-223-7412), AN/VRC-43 (5820-00-223-7415), AN/VRC-44 (5820-00-223-7417), AN/VRC-45 (5820-00-223-7418), AN/VRC-46 (5820-00-223-7433), AN/VRC-47 (5820-00-223-7434), AN/VRC-48 (5820-00-223-7435) and AN/VRC-49 (5820-00-223-7437) (Used without an Intercom System).
- Operators and Organizational Maintenance: Multimeter AN/URM-105 and AN/URM-105C (Including Multimeter ME-77/U and ME-77C/U).
- Organizational Maintenance Manual for Frequency Meter AN/TSM-16.
- Organizational, DS, GS and Depot Maintenance Manual: Test Set TS-140/PCM, Signal Generators SG-15/PCM and SG-15A/PCM and Decibel Meters ME-22/PCM and ME-22A/PCM.
- Operators and Organizational Maintenance Manual for Test Sets, Electron Tube TV-7/U, TV-7A/U, TV-7B/U (NSN 6625-00-376-4939) and TV-7D/U (6625-00-820-0064).
- Operators and Organizational Maintenance Manual: Test Sets, Electron Tube TV-2/U, TV-2A/U, TV-2B/U, and TV-2C/U.
- DS, GS, and Depot Maintenance Manual: Voltmeter, Meter ME-30A/U and Voltmeters, Electronic ME-30B/U and ME-30C/U.
- The Army Maintenance Management System (TAMMS).
- Painting Instructions for Field Use.
- Administrative Storage of Equipment.
- Procedure for Destruction of Electronics Materiel to Prevent Enemy Use.

By Order of the Secretary of the Army:

JOHN A. WICKHAM JR.  
*General, United States Army*  
*Chief of Staff*

Official:

ROBERT M. JOYCE  
*Major General, United States Army*  
*The Adjutant General*

DISTRIBUTION:

To be distributed in accordance with DA Form 12-51A, Operator's  
Maintenance requirements for AN/GSA-7.



## RADIO SET CONTROL AN/GSA-7

### CHAPTER 1. INTRODUCTION

#### Section I. General.

	Para- graph	Page
Scope.....	1	3
Forms and records.....	2	3
II. Description and data.		
Purpose and use.....	3	4
System application.....	4	4
Technical characteristics.....	5	4
Components of Radio Set Control AN/GSA-7.....	6	6
Description.....	7	6
Additional equipment required.....	8	9

### CHAPTER 2. INSTALLATION AND OPERATION

#### Section I. Service upon receipt of equipment.

Unpacking.....	9	10
Checking unpacked equipment.....	10	10
Installation.....	11	10
II. Operating instructions.		
Operating controls.....	12	13
Operating procedures.....	13	13

### CHAPTER 3. ORGANIZATIONAL MAINTENANCE

#### Section I. Preventive maintenance.

Tools, materials, and test equipment required.....	14	16
Preventive maintenance techniques.....	15	16
Use of preventive maintenance form.....	16	16

#### II. Troubleshooting at organizational maintenance level.

Extent of instructions.....	17	19
Visual inspection.....	18	19
Equipment performance checklist.....	19	19
Tube testing techniques.....	20	20

### CHAPTER 4. THEORY

General.....	21	21
Local telephone ring circuit.....	22	21
Ring radio circuits.....	23	22
Transfer relay K4 circuits.....	24	23
Transmit circuits.....	25	24
Warning tone and ring radio oscillator.....	26	24
Gate generator and gated amplifier.....	27	25
Receive circuits.....	28	27
Carrier operated relay K2.....	29	27
Monitor at radio set control.....	30	27
Power supply.....	31	28

### CHAPTER 5. FIELD MAINTENANCE

#### Section I. General troubleshooting techniques.

General instructions.....	32	30
Troubleshooting procedures.....	33	30
Test equipment required.....	34	33

#### II. Troubleshooting.

Checking filament and B+ circuits for shorts.....	35	33
Localizing troubles.....	36	34
Dc resistances of transformers and coils.....	37	35

#### III. Repairs.

General parts replacement techniques.....	38	39
Disassembly.....	39	39

<b>CHAPTER 5. FIELD MAINTENANCE—Continued</b>		
Section IV. Final testing.		
Check of 1,600-cps output level.....	40	39
Check of 20-cps output level.....	41	39
<b>CHAPTER 6. SHIPMENT AND LIMITED STORAGE AND DEMOLITION TO PREVENT ENEMY USE</b>		
Section I. Shipment and limited storage.		
Disassembly of equipment.....	42	41
Repackaging for shipment or limited storage.....	43	41
Section II. Demolition of material to prevent enemy use.		
Authority for demolition.....	44	42
Methods of destruction.....	45	42
<b>APPENDIX</b>		
I. REFERENCES.....		43
II. MAINTENANCE ALLOCATION CHART.....		45

# CHAPTER 1

## INTRODUCTION

### Section I. GENERAL

#### 1. Scope

a. This manual describes Radio Set Control AN/GSA-7 (fig. 1) and covers its installation, operation, theory, organizational and field maintenance, and repair. In this manual, Radio Set Control AN/GSA-7 is also referred to as radio set control.

b. The two appendixes of this manual are—  
Appendix I, References

Appendix II, Maintenance Allocation Chart

c. The repair parts and special tool lists will be published separately.

#### 2. Forms and Records

a. *Unsatisfactory Equipment Reports.* Fill out and forward DA Form 468 (Unsatisfactory Equipment Report) to Commanding Officer, U. S. Army Signal Equipment Support Agency, Fort Monmouth, N. J., as prescribed in AR 700-38.

b. *Report of Damaged or Improper Shipment.* Fill out and forward DD Form 6 (Report of Damaged or Improper Shipment), as prescribed in AR 700-58 (Army).

c. *Preventive Maintenance Form.* Prepare DA Form 11-238 (Maintenance Check List for Sig-

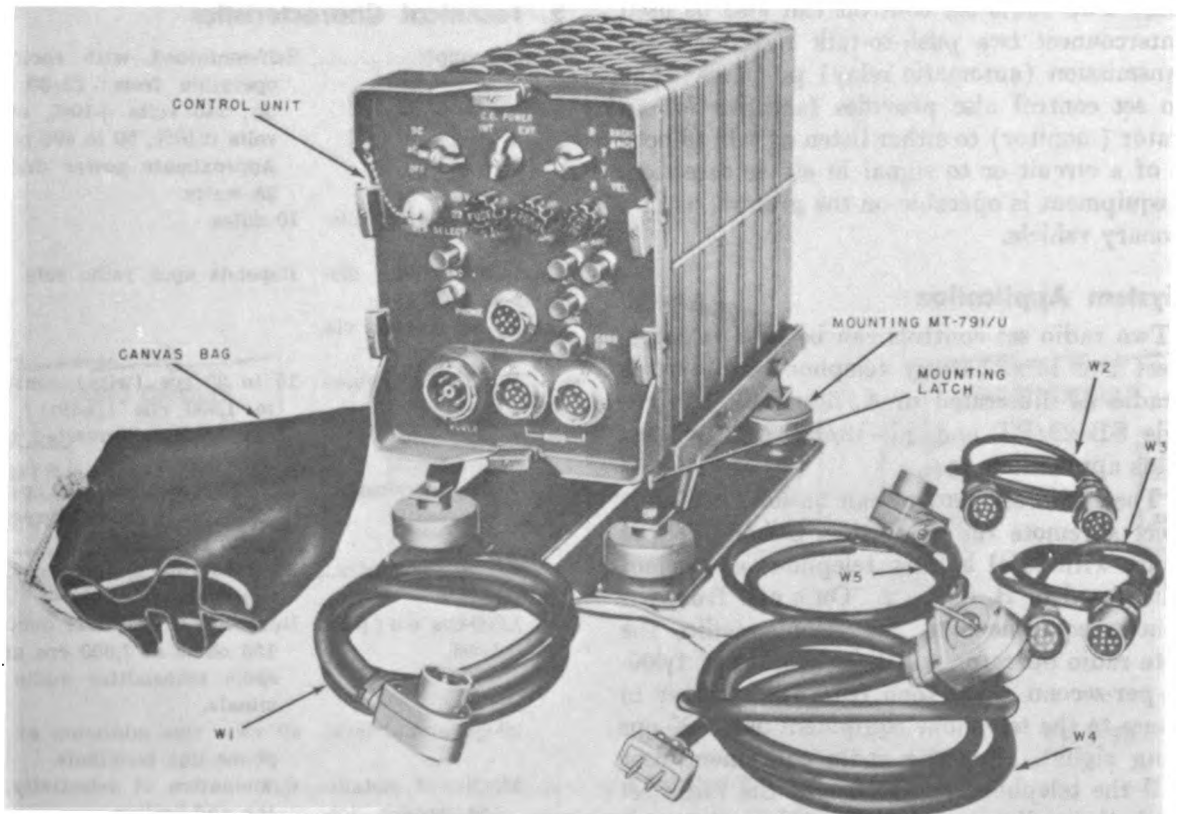


Figure 1. Radio Set Control AN/GSA-7.

nal Equipment (Sound Equipment, Radio, Direction Finding, Radar, Carrier, Radiosonde and Television)) (figs. 8 and 9) in accordance with instructions on the form.

*d. Parts List Form.* Forward DA Form 2028 (Recommended Changes to DA Technical Manual Parts Lists or Supply Manuals 7, 8, and 9) directly to the Commanding Officer, U. S. Army

Signal Equipment Support Agency, Fort Monmouth, N. J. Use for comments on parts listings in appendix II and the repair parts and special tool lists.

*e. Comments on Manual.* Forward all other comments on this publication directly to the Commanding Officer, U. S. Army Signal Publications Agency, Fort Monmouth, N. J.

## Section II. DESCRIPTION AND DATA

### 3. Purpose and Use

Radio Set Control AN/GSA-7 is a small lightweight electronic switching device for use in integrated wire-radio systems. It is also used to interconnect radio transceivers, or transmitters and receivers, with local battery telephone equipment on a push-to-talk basis. After the radio set control is connected and power is applied to it and to the radio, no attendant is necessary. The associated radio transmitter is turned on and off automatically by the wire equipment user. The radio set control can be used in wire-to-wire (via radio), wire-to-radio, or radio-to-wire communication. Two radio set controls can also be used to interconnect two push-to-talk radio sets for retransmission (automatic relay) purposes. The radio set control also provides facilities for an operator (monitor) to either listen or talk to both ends of a circuit or to signal in either direction. The equipment is operable on the ground, or in a stationary vehicle.

### 4. System Application

*a.* Two radio set controls can be used to interconnect two local battery telephone equipments via radio as illustrated in A, figure 2. Switchboards SB-22/PT and SB-18/PT can be used for this application.

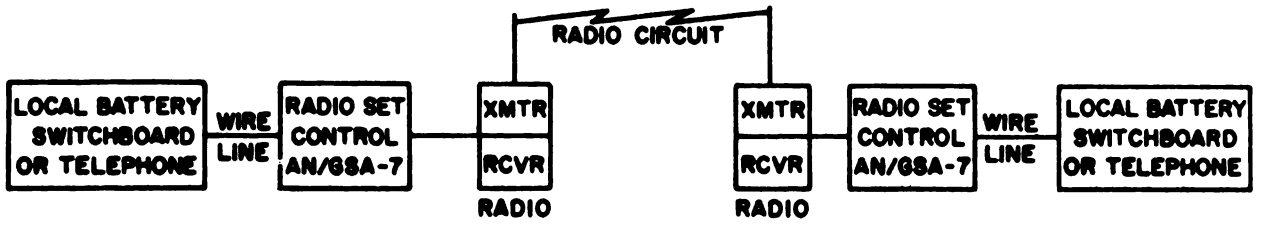
*b.* The radio set control can be used to interconnect a remote radio location, either fixed or moving, with local battery telephone equipment as illustrated in B, figure 2. On a call from the telephone equipment to the remote radio, the remote radio operator will hear a burst of 1,600-cycle-per-second (cps) tone from his receiver in response to the telephone equipment user's 20-cps ringing signal. For the radio equipment user to call the telephone equipment of the radio set control, the radio station transmitter must emit a burst of 1,600-cps tone. When using radio transmitters in the Radio Transmitter RT-

66/GRC, -67/GRC, and -68/GRC series, this can be accomplished by momentarily holding the transmitter DIAL LIGHT-RING switch in the RING position.

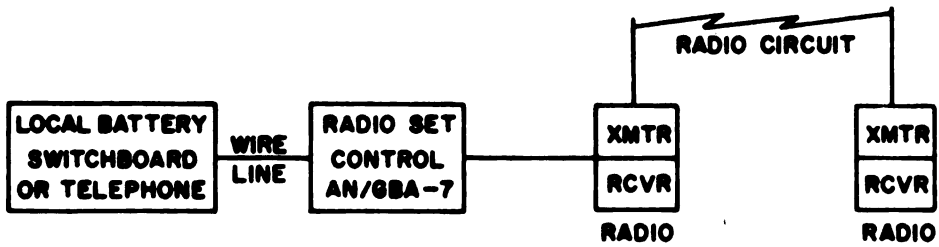
*c.* Two radio set controls may be used for retransmission purposes as illustrated in C, figure 2. Each radio receiver must have either a carrier-operated relay or direct current (dc) voltage output when receiving a radio frequency (RF) carrier to enable the radio set control to retransmit messages from the receiver of one radio set to the transmitter of the other radio set.

### 5. Technical Characteristics

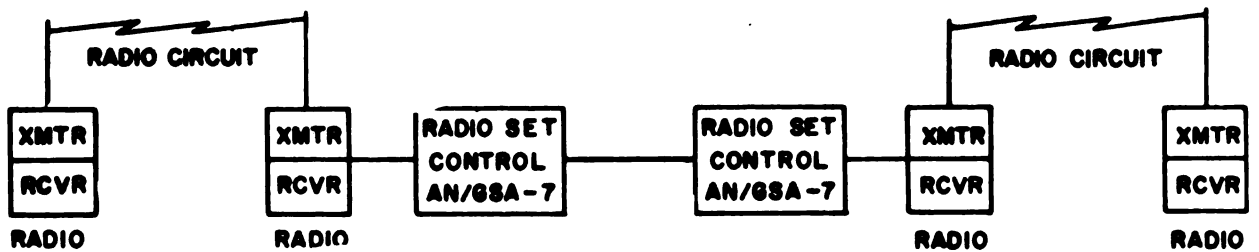
Power supply-----	Self-contained, with choice of operation from: 22-30 volts dc; 115 volts +10%, or 230 volts ±10%, 50 to 400 cps ac. Approximate power drain is 25 watts.
Maximum wire distance.	10 miles.
Maximum radio distance.	Depends upon radio sets used.
Means of ringing via radio:	
Ringing frequencies.	15 to 25 cps (wire) converted to 1,600 cps (radio); 1,600 cps (radio) converted to 20 cps (wire).
1,600-cps sensitivity.	-20 dbm of 1,600 ±30 cps into 600 ohms at the radio receiver audio terminals.
20-cps sensitivity--	20 volts rms applied to LINE terminals.
1,600-cps output level.	Between -6 and -11 dbm into 150 ohms at 1,600 cps at the radio transmitter audio terminals.
20-cps output level.	40 volts rms minimum at telephone line terminals.
Means of obtaining speech immunity in 1,600-cycle receiving circuit.	Combination of selectivity, delay, and limiter.



A



B



C

TM 5135-15-2

Figure 2. System applications of Radio Set Control AN/GSA-7.

Terminal impedances:  
 Telephone line input. 600 ohms balanced.  
 Input from radio receiver. 600 ohms unbalanced with one side grounded.  
 Output to radio transmitter. 150 ohms unbalanced with one side grounded.  
 Frequency response. 300 to 3,500 cps.  
 Requirements for carrier-operated relay or carrier-operated voltage in radio receiver. Needed only when retransmission is contemplated.

Warning device. 2,000-cps beep every 5 seconds while radio transmitter is on the air.  
 Weight (control unit with mounting). 39 pounds.

## 6. Components of Radio Set Control AN/GSA-7

a. *Components.* The components of Radio Set Control AN/GSA-7 are listed in the following table:

Quantity	Components	Height (in.)	Width (in.)	Length (in.)	Unit weight (lb)
1	Control unit	9	7 $\frac{1}{2}$	12 $\frac{1}{2}$	27.5
1	Mounting MT-791/U	3 $\frac{1}{2}$	8 $\frac{1}{2}$	12 $\frac{1}{2}$	11.8
1	Canvas bag		8 $\frac{1}{2}$	16 $\frac{1}{2}$	
2	Audio cable (W2, W3)			30	1
1	Ac power cable (W4)			84	2
1	Dc power cable (W1)			84	2
1	Auxiliary control cable (W5)			36	1
5	$\frac{1}{8}$ -24 bolts (w/nuts)			1 $\frac{1}{2}$	
5	$\frac{1}{8}$ -24 bolts w/nuts			$\frac{1}{2}$	
5	Lock washers				
5	Flat washers				
1 set	Running spares (b below)				3
2	Technical Manual 11-5135-15				.5
<b>Total</b>					<b>50.3</b>

b. *Running Spares.* The group of running spares supplied with each radio set control is listed below—

Quantity	Item
5	Fuses, cartridge, 1 amp 250 v, type F02G1R00A.
5	Fuses, cartridge, 1 amp 125 v, time-delay, type Littelfuse 313001.
1	Tube 6C4.
1	Tube 5725/6A88W.
1	Tube 5696.
1	Tube 5814A.
1	Tube 5651.
1	Tube 0B2WA.
5	Vibrators, 24 v dc.

## 7. Description

a. The control unit is completely self-contained as illustrated in figure 1. It is a compact, lightweight panel-and-chassis assembly with an immersion-proof outer case. The front panel mounts

the operating controls, cable connectors, and binding posts and is recessed to prevent damage to the controls by impact. The panel-chassis assembly is attached to the case with six wing-type, spring-loaded Dzus fasteners. Channel rails are attached to the bottom of the case so that the unit may be secured to Mounting MT-791/U in vehicular installations. The case is secured to the mount by a latch under the front panel (fig. 6).

b. Monitoring facilities are provided by means of a 10-pin audio connector which can accommodate a handset. A switch controls the choice of telephone or radio monitoring and will ring radio or telephone.

c. Figure 3 shows the control unit (top view) with the case removed. The interior is made up of two chassis, one upper level and one lower level. The lower level chassis is secured to the front panel, and the upper level chassis is attached to the lower with a piano-type hinge, two Camloc fasteners (accessible through the holes

ir

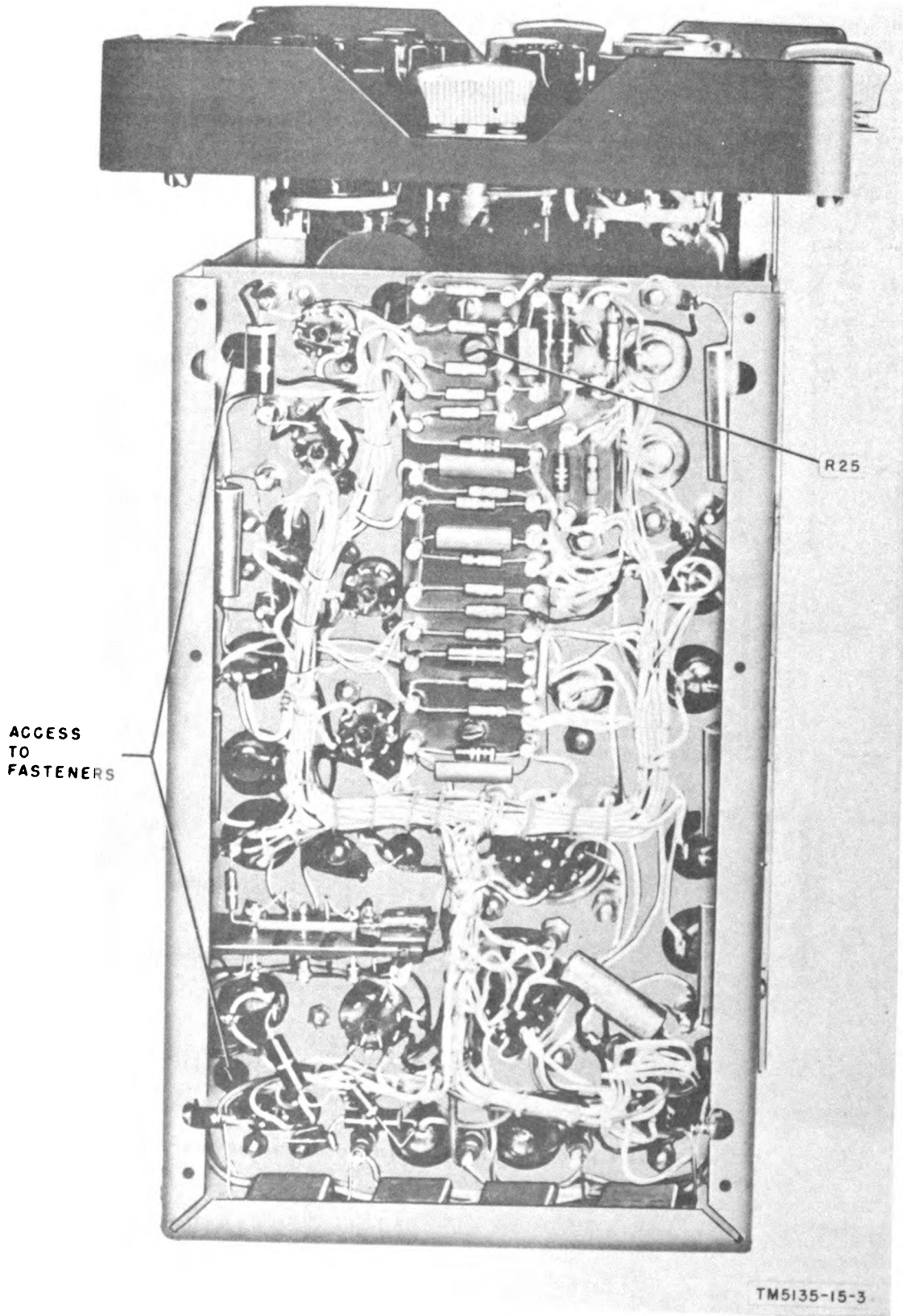
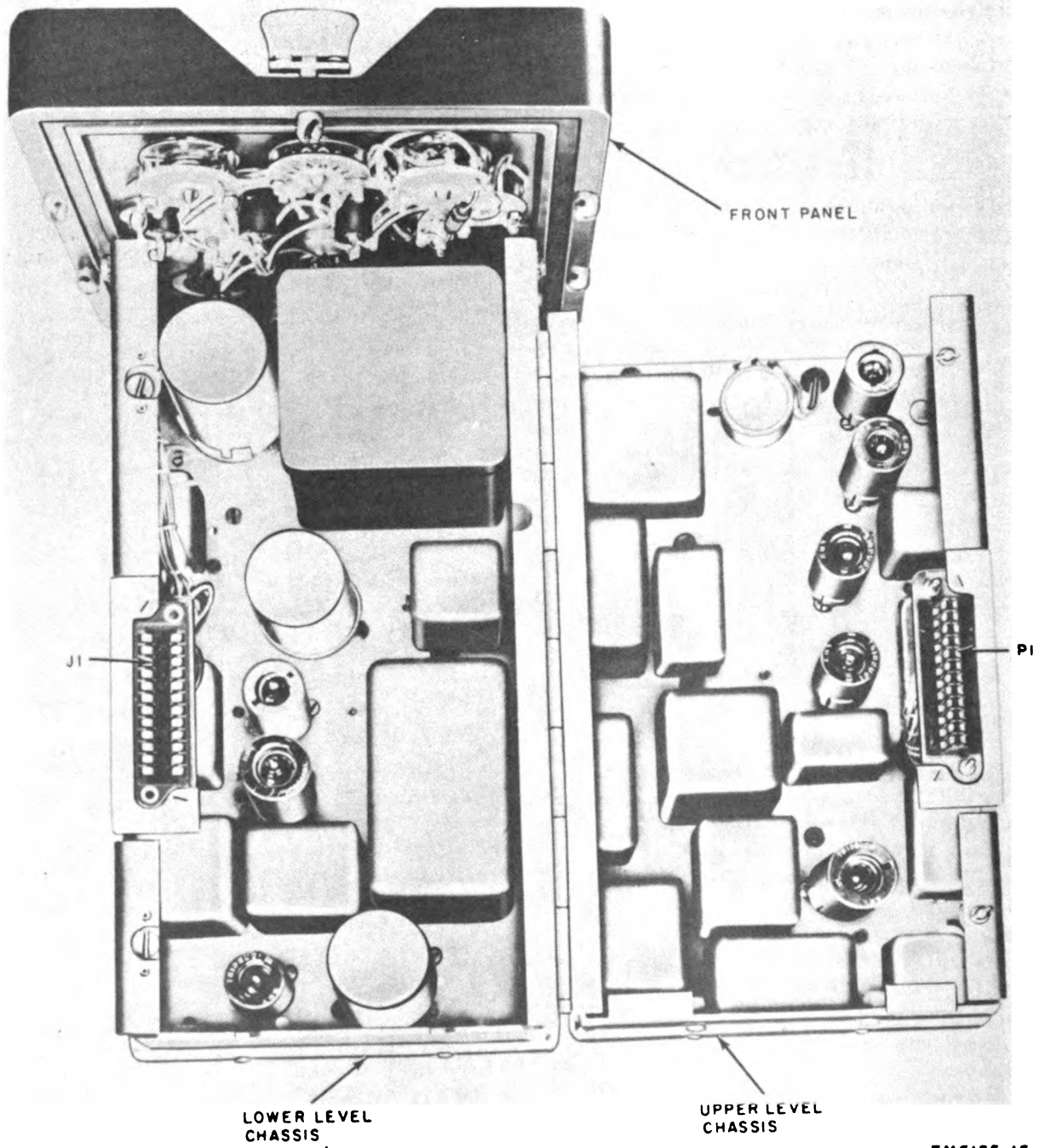


Figure 3. Control unit, case removed, top view.



TM5135-15-4

Figure 4. Control unit, upper level chassis swung open.



indicated), and two screws on the backplate. When the two fasteners are unlocked and the two screws are loosened, the two chassis can be separated as shown in figure 4. Electrical connections between the two chassis are made by the 24-contact receptacle and plug, J1 and P1.

*d.* There are five cables which connect to the front panel—

- (1) Dc power cable W1, for connection to a 24-volt dc source through POWER receptacle.
- (2) Ac power cable W4, for connection to a 115- or 230-volt, 50 to 400 cps ac power source through POWER receptacle.
- (3) Signal cables W2 and W3 which connect to the RADIO receptacles.

- (4) Auxiliary control cable W5 which connects to CARR. OP. and AUX binding posts for operation of the carrier operate relay when required for retransmission purposes.

## **8. Additional Equipment Required**

The following handset, not supplied with the radio set control, and one of the indicated power sources are required for operation of Radio Set Control AN/GSA-7.

- a.* Handset H-33/PT or equivalent.
- b.* Power source, 115 volts or 230 volts ac, 50 to 400 cps.
- c.* Power source, 24 volts dc.

## CHAPTER 2

### INSTALLATION AND OPERATION

#### Section I. SERVICE UPON RECEIPT OF EQUIPMENT

#### 9. Unpacking

*a. Packaging Data.* When packaged for shipment, the components of Radio Set Control AN/GSA-7 are placed in corrugated cardboard cartons and four radio set controls are packed in a wooden packing case. The wooden case is 30 inches by 30 inches by 22 inches high. The total weight is approximately 235 pounds. Figure 5 shows typical packaging. Each radio set control, when packaged, is in a single container 13 inches high by 13 inches wide by 18 inches long. The package weighs 55 pounds.

*b. Removing Contents.* Perform all the steps outlined below when unpacking equipment contained in wooden boxes (fig. 5).

- (1) Cut and fold back the metal straps.
- (2) Remove the nails from the top and one side of the box with a nail puller. Remove the top and one side. Do not attempt to pry them off because the equipment may become damaged.
- (3) Open the carton and remove the two technical manuals, the control unit on its mount, and the spare parts carton. The spare parts carton contains the running spares (par. 6b), a small bag of nuts and bolts, and a canvas bag (fig. 1) with cables W1 through W5.

#### 10. Checking Unpacked Equipment

*a.* Check the equipment received against the list of components (par. 6a).

*b.* Check for damage to the exterior of the equipment.

*c.* Remove the case by turning each of the six Dzus fasteners  $\frac{1}{4}$  turn counterclockwise and pulling the chassis from the case.

*d.* Insert a screwdriver into the two access holes (fig. 3) and turn each of the two fasteners  $\frac{1}{4}$  turn counterclockwise.

*e.* Loosen the two screws on the backplate.

*f.* Open the two chassis to the position shown in figure 4 and be sure that all tubes and plug-in components are properly seated in their sockets. Inspect for damage.

*g.* If no damage is evident, reassemble the equipment.

*h.* Check the cables for kinks, cuts, or fraying.

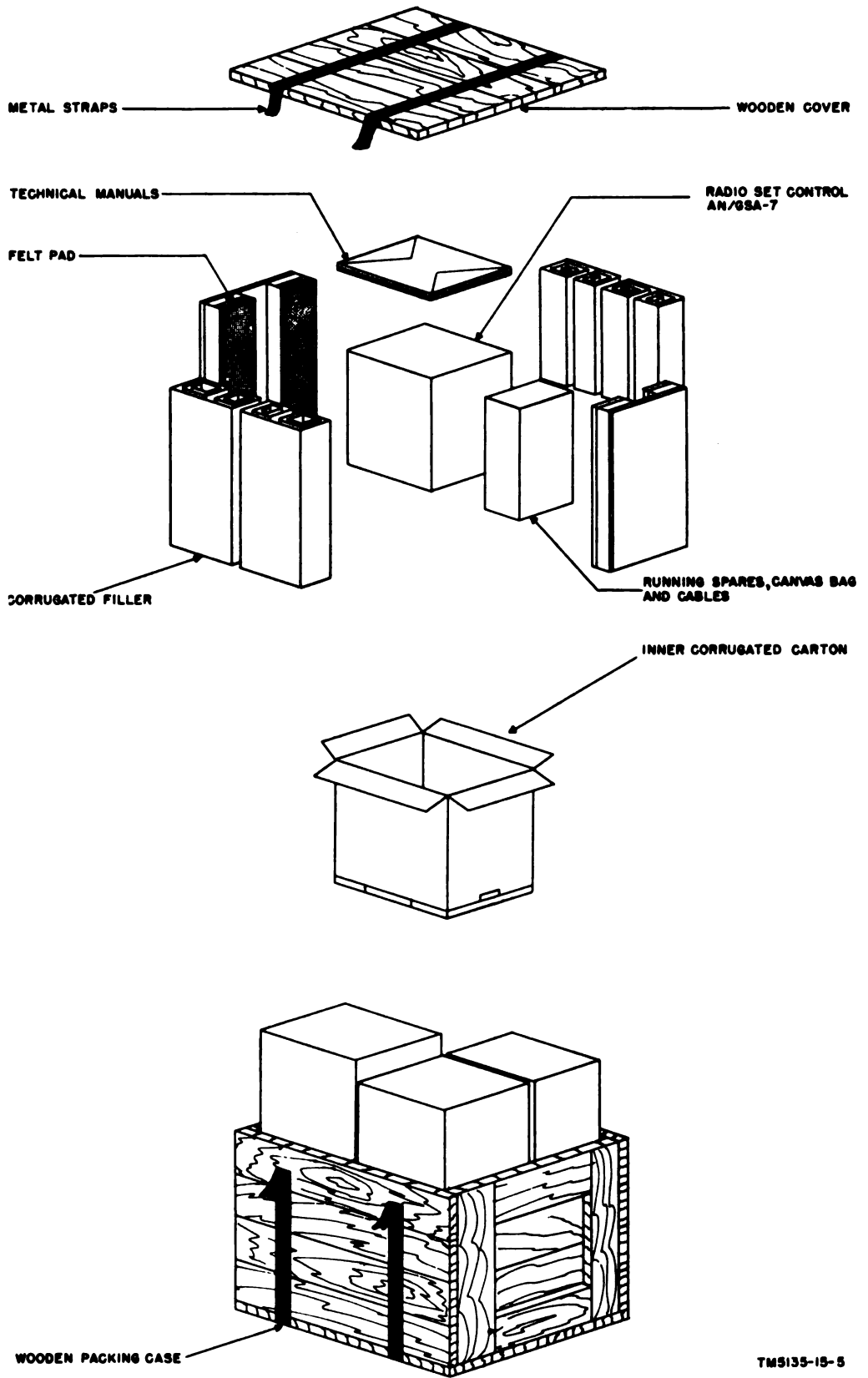
#### 11. Installation

The installation site depends on the location of the radio set with which the radio set control is to be employed. It must be located immediately adjacent to the radio set so that the signal cables (30 inches in length) can be connected to the radio set.

*a.* Determine the type of power available and connect the equipment as follows:

- (1) For 24-volt dc operation, connect the dc power cable (W1) to the POWER receptacle. The black lead is *negative* and the white lead is *positive*.
- (2) For ac operation, remove the protective cap from the 115V-230V POWER SELECT switch. With a screw driver, turn the switch counterclockwise for 115-volt operation or clockwise for 230-volt operation. Connect the ac power cable (W4) to the POWER receptacle and to the power source.

**Warning:** Never connect the radio set control to a 230-volt source with the POWER SELECT switch in the 115V position.



TM5135-15-5

Figure 5. Unpacking Radio Set Control AN/GSA-7.

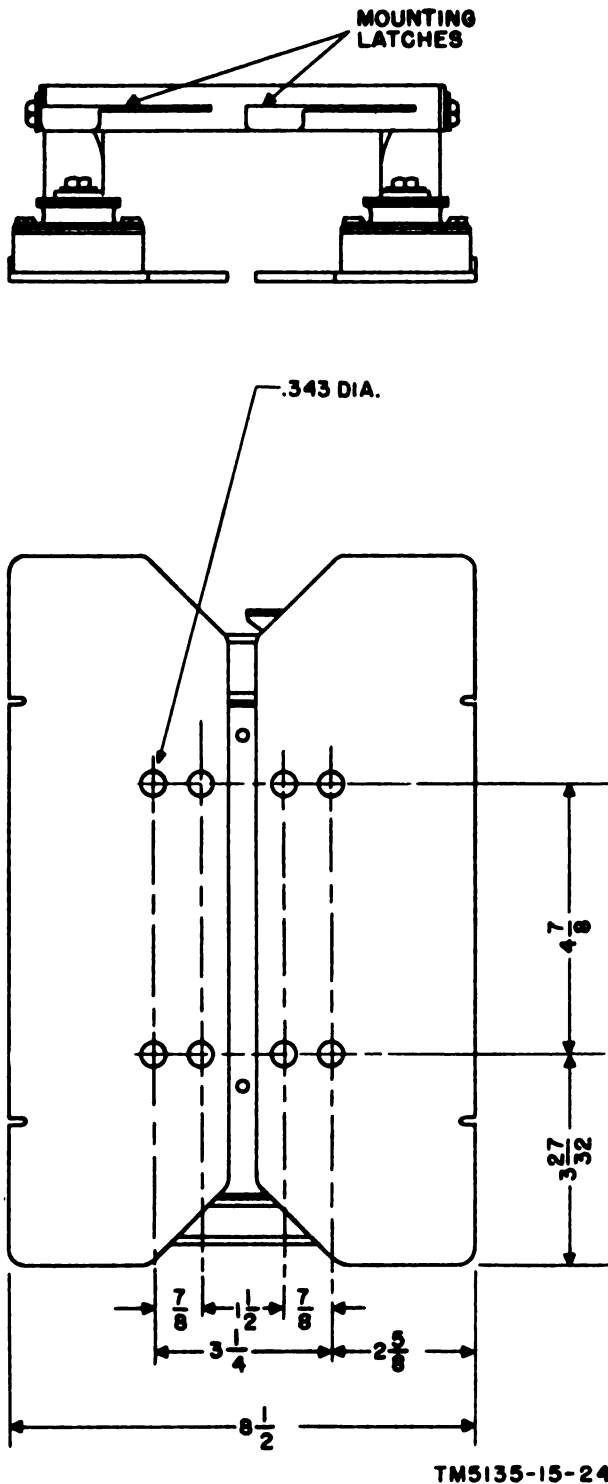


Figure 6. Mounting MT-791/U, mounting hole locations.

b. Locate the equipment so that the signal connecting cables can be plugged into the radio set.  
 c. To remove the control unit from Mounting MT-791/U, pull the mounting latches (fig. 6) for-

ward, release the control unit and lift it from the mount.

d. Use the mounting as a template or use the dimensions of figure 6 to mark the positions of the mounting holes. Eight holes are provided but only four need be used.

e. Drill the holes and fasten the mounting with four of the  $\frac{5}{16}$  by 24,  $\frac{3}{4}$ - or  $1\frac{1}{4}$ -inch long nuts and bolts provided.

f. Replace the control unit on the mounting and re-engage the mounting latches by pushing them back into place.

g. Establish normal radio contact with the desired remote station. Adjust the receiver squelch circuit for normal operation.

h. Connect either one or two signal cables (W2 or W3) from the RADIO receptacles to the radio set. For equipments with a separate receiver and transmitter, connect one signal cable to the transmitter and one to the receiver. (The two radio receptacles and the cables are identical and are wired in parallel.)

i. Set the C. O. POWER (carrier-operated power) switch to the proper position in accordance with the following:

- (1) If the radio receiver contains a carrier-operated relay and also makes use of the 10-pin audio connector, no additional connections need be made to the radio set control. Set the C. O. POWER switch to the INT. position.
- (2) If the radio receiver (for example, radio sets of the standardized AN/GRC-3 to -8 series) does not contain a carrier-operated relay but provides a carrier-operated voltage, connect auxiliary control cable W5 to the AUX and CARR. OP. terminal posts. Connect the other end to the 9 pin REC-TR receptacle on the front panel of the radio set. Set the C. O. POWER switch to EXT.
- (3) If retransmission is not contemplated, the position of the C. O. POWER switch is immaterial. Carrier-operated relay K2 in the radio set control has no function when retransmission is not contemplated.

j. Set the DC-AC-OFF switch to either the AC or DC position, depending on the power source.

k. Connect Handset H-33/PT to the PHONE connector.

l. Press the handset switch and count the number of warning tones (beeps) per minute. Approx-

mately 12 beeps per minute should be heard. If the number of beeps per minute is incorrect, remove the chassis from the case and, with a screw driver, adjust R25 (fig. 3) to the proper setting. Replace the chassis.

m. Connect the incoming telephone wires to the binding posts marked LINE. When the other end of the incoming telephone line is terminated at a Switchboard SB-22/PT or another radio set control (C, fig. 2), it is necessary to pole the line

properly. If the transmitter operates continuously (beeps heard in the handset with the monitor switch in the RADIO & MON position), the line is improperly poled or a short exists in the telephone line. When this occurs, interchange the LINE wires. If the transmitter operates continuously with LINE wires poled either way, check for a short caused by wire damage or by presence of a telephone instrument in the operated condition or CB (common battery) position.

## Section II. OPERATING INSTRUCTIONS

### 12. Operating Controls

(fig. 7)

The POWER SELECT and C. O. POWER switches are set to their proper positions during installation (par. 11a and i) and are left in those positions as long as the radio set control is used with the same power source and associated radio equipments. The operating controls and their functions are listed in the following chart:

Control	Function
OFF-AC-DC switch.	<i>Position</i> OFF <i>Function</i> Disconnects all power from the radio set control.
	AC      Connects the ac primary source to the input circuits.
	DC      Connects 24-volt dc power source to input circuits.
Monitor switch.	Premits ringing and communication with either the local telephone equipment (via telephone line) or remote station (via radio). Switch must be held to remain in either R position.
R RADIO & MON	<i>Position</i> R RADIO & MON <i>Function</i> Causes associated transmitter to send a 1,600-cps ringing signal.
	T RADIO & MON      With handset connected to PHONE receptacle, permits normal push-to-talk operation over the radio system.
	R TEL      Rings to local telephone switchboard via telephone line.
	T TEL      Permits conversing to local telephone switchboard.

### 13. Operating Procedures

a. Before Radio Set Control AN/GSA-7 is operated normally, the system should be checked out by the operator in the following manner:

- (1) Turn on the equipment by rotating the DC-AC-OFF switch to the AC position if the primary source is ac or to the DC position if the primary source is dc. In the DC position, a vibration will be felt when the hand is held against the case. This is due to operation of the power vibrator.
- (2) After allowing the equipment to warm up for a minute, hold the monitor switch in the R TEL position for several seconds and then release. The switch will return to the T TEL position. This causes a 20-cps ringing signal to be sent to the equipment at the end of the wire line. Communication with the local telephone equipment user is accomplished through the handset.
- (3) After communication with the local telephone equipment user has been established, contact the remote operator by radio. This is done by holding monitor switch S4 in the R RADIO & MON position for several seconds. The switch when released will return to the T RADIO & MON position. Two-way communication with the remote operator is then maintained by normal push-to-talk procedure. Allow the transmitter filaments to warm up for a second or two after the handset push-to-talk switch has been closed, before speaking. (This assumes that both radio sets are on and operating properly and that any telephone circuits at the remote station are complete.) Leave the monitor switch in the T RADIO & MON position.

b. When the above procedure has been completed, intercommunication via radio between the

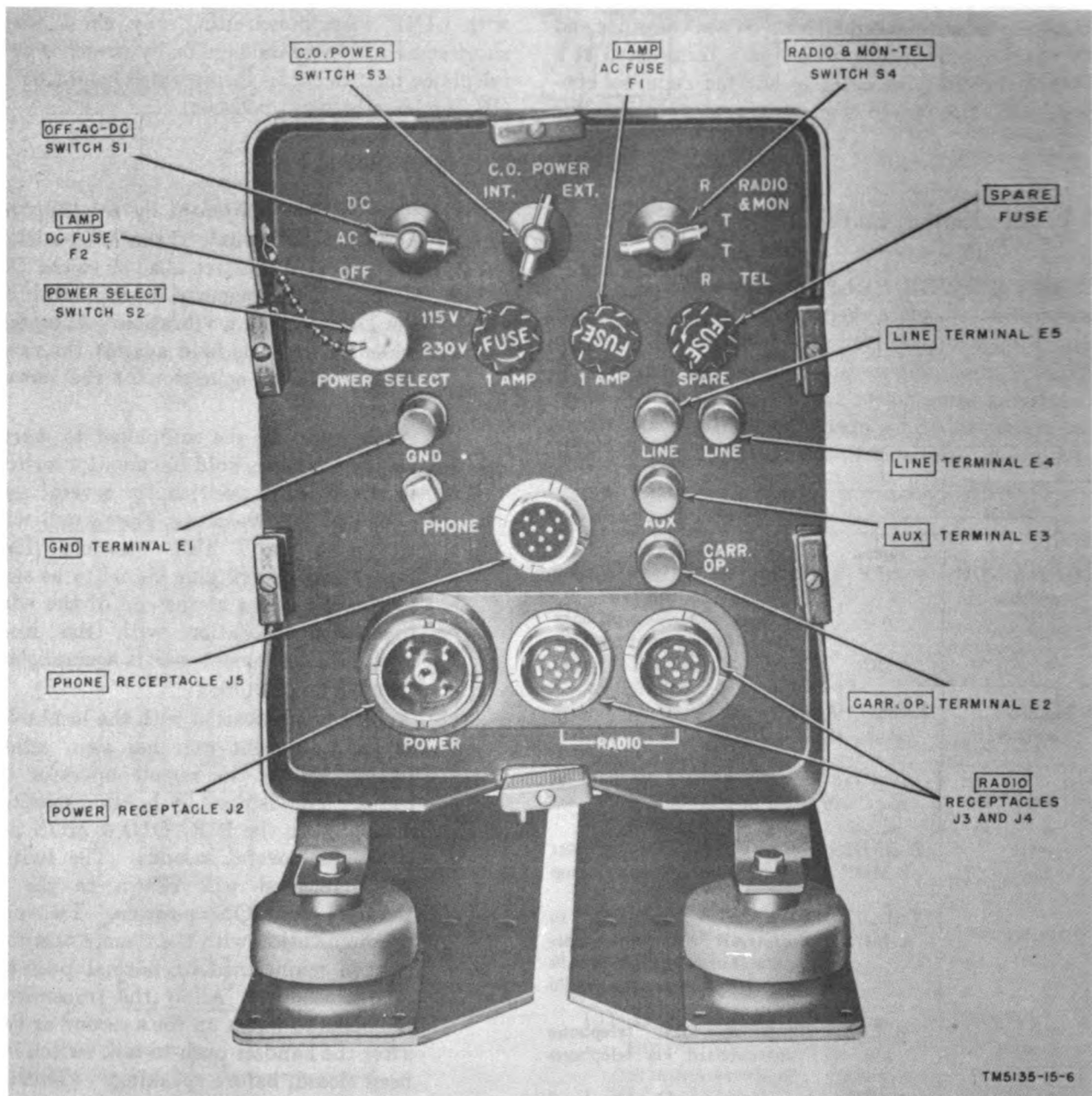


Figure 7. Control unit, front panel.

telephone equipment users (or communication between a radio station and telephone equipment) is automatically maintained when normal ringing and push-to-talk procedures are employed.

*c.* When the radio set control is used as a link in the communications system, the wire equipment users must use push-to-talk procedure. The presence or absence of a dc closure on the line determines whether the radio transmitters are turned on or off.

- (1) When using Telephone Set TA-43/PT (or TA-312/PT) with its switch in the local battery (LB) position, a closure is automatically placed on the line when the handset switch is pressed.
- (2) The switch on the operator's headset of Switchboard SB-22/PT places a closure on the line when it is depressed to its furthest position.

- (3) When using Telephone EE-8, a closure may be placed across the line or removed from the line by the hook switch when the telephone is in the CB (common battery) position. The hook switch at the telephone must be depressed in the standby condition, otherwise the radio transmitter will be held operated. For Telephone EE-8 to operate in the same manner as Telephone Set TA-43/PT, use Handset H-100/U (Federal stock #5965-223-4744) and place the LB-CB switch in the neutral or middle position to avoid a line closure caused by the EE-8 ringer (LB) or the holding coil (CB).

*d.* Before turning the equipment off, notify the remote and local switchboard operators and then rotate the OFF-AC-DC switch to the OFF position.

## CHAPTER 3

### ORGANIZATIONAL MAINTENANCE

---

#### Section I. PREVENTIVE MAINTENANCE

#### 14. Tools, Materials, and Test Equipment Required

The tools, materials, and test equipment required for organizational maintenance are listed below.

*a. Tools.* Tool Equipment TE-41.

*b. Materials.*

(1) Cleaning Compound (Federal stock No. 7930-395-9542).

(2) Cleaning cloth.

*c. Test Equipment.*

(1) Multimeter ME-77/U.

(2) Electron Tube Test Set TV-7/U.

#### 15. Preventive Maintenance Techniques

*a.* Use No. 000 sandpaper to remove corrosion.

*b.* Use a clean, dry, lint-free cloth or a dry brush for cleaning. If necessary, wipe the parts, including electrical contacts, with a cloth moistened with Cleaning Compound; dry them with a clean cloth.

**Caution:** Cleaning Compound is flammable and its fumes are toxic. Do not use near a flame; provide adequate ventilation.

#### 16. Use of Preventive Maintenance Form

DA Form 11-238 (figs. 8 and 9) is a preventive maintenance checklist to be used by the operator

and the unit repairman. Items 1 through 4 are checked daily and items 5 through 12 are checked weekly by the operator. Items not applicable to the equipment are lined out in the figures. References in the ITEM block in the figure are to paragraphs that contain additional maintenance information about the particular item. Instructions for use appear on the form.

*a. First Echelon Items (fig. 9).*

Item No.	Maintenance procedure
3	Check the spring-return action of the spring-loaded monitor switch.
10	Check connections at binding posts for tightness and for frayed wire strands.

*b. Second and Third Echelon Items (figs. 8 and 9).*

Item No.	Maintenance procedure
15	Check seating of tubes, V1 through V8, pluck-out capacitors C1 and C11 (fig. 21), pluck-out vibrator G1.
25	Check the rubber gasket at the rear of the front panel for cracks or poor sealing.



<p><b>ADDITIONAL ITEMS FOR 2D AND 3D ECHELON INSPECTIONS</b></p> <p>26. <del>.....</del></p> <p>27. CHECK FOR NORMAL OPERATION.      PAR. 13      ✓</p> <p>28. <del>.....</del></p>	<p style="text-align: center;"><b>MAINTENANCE CHECK LIST FOR SIGNAL EQUIPMENT</b>  <b>SOUND EQUIPMENT, RADIO, DIRECTION FINDING</b>  <b>RADAR, CARRIER, RADIOSONDE AND TELEVISION</b>  <small>(AR 790-623)</small></p> <hr/> <p style="text-align: center;"><b>EQUIPMENT NOMENCLATURE</b>  <b>RADIO SET CONTROL AN/GSA - 7</b></p> <hr/> <p style="text-align: center;"><b>EQUIPMENT SERIAL NUMBER</b>      <b>398</b></p> <hr/> <p style="text-align: center;"><b>INSTRUCTIONS</b></p> <p>This form may be used for a period of one month by using the correct dates and weeks of the month. It is to be used as a Preventive Maintenance check list for Signal equipment in actual use, or for a check on equipment prior to issue.</p> <ol style="list-style-type: none"> <li>1. For detailed Preventive Maintenance instructions see:       <ol style="list-style-type: none"> <li>a. The Technical Manual (in TM 11 series) for the equipment. (See DA Pamphlet Number 310-4)</li> <li>b. The Supply Bulletin (SB 11-100 series) for the equipment. (See DA Pamphlet Number 310-4)</li> <li>c. The Department of the Army Lubrication Order. (See DA Pamphlet Number 310-4)</li> </ol> </li> <li>2. The following action will be taken by either the Communications Officer/Chief for 1st echelon, or the Inspector for Higher echelon:       <ol style="list-style-type: none"> <li>a. Issue Equipment Nomenclature and Serial Number.</li> <li>b. Strike out items that do not apply to the equipment.</li> </ol> </li> <li>3. Operator/Inspector will enter in the column entitled <b>CONDITION</b>, on the proper line, a notation regarding the condition, using symbols specified under <b>LEGEND</b>.</li> <li>4. After operator completes each daily inspection he will initial over the appropriate dates under "Daily Condition for Month", then return form to his supervisor.</li> </ol>
---	---

TYPE OF INSPECTION		
OPERATOR	DATE	SIGNATURE
✓	May 5	Jay R Ham, Cpl
✓	May 12	Jay R Ham, Cpl
✓	May 15	Roy J. Barrie Jr/Sgt

**DA FORM 11-238**  
REV. 11-50, 11-52, 11-53, 11-54, 11-55, 11-56, 11-57, 11-58, 11-59, 11-60, 11-61, 11-62, 11-63, 11-64, 11-65, 11-66, 11-67, 11-68, 11-69, 11-70, 11-71, 11-72, 11-73, 11-74, 11-75, 11-76, 11-77, 11-78, 11-79, 11-80, 11-81, 11-82, 11-83, 11-84, 11-85, 11-86, 11-87, 11-88, 11-89, 11-90, 11-91, 11-92, 11-93, 11-94, 11-95, 11-96, 11-97, 11-98, 11-99, 11-100, 11-101, 11-102, 11-103, 11-104, 11-105, 11-106, 11-107, 11-108, 11-109, 11-110, 11-111, 11-112, 11-113, 11-114, 11-115, 11-116, 11-117, 11-118, 11-119, 11-120, 11-121, 11-122, 11-123, 11-124, 11-125, 11-126, 11-127, 11-128, 11-129, 11-130, 11-131, 11-132, 11-133, 11-134, 11-135, 11-136, 11-137, 11-138, 11-139, 11-140, 11-141, 11-142, 11-143, 11-144, 11-145, 11-146, 11-147, 11-148, 11-149, 11-150, 11-151, 11-152, 11-153, 11-154, 11-155, 11-156, 11-157, 11-158, 11-159, 11-160, 11-161, 11-162, 11-163, 11-164, 11-165, 11-166, 11-167, 11-168, 11-169, 11-170, 11-171, 11-172, 11-173, 11-174, 11-175, 11-176, 11-177, 11-178, 11-179, 11-180, 11-181, 11-182, 11-183, 11-184, 11-185, 11-186, 11-187, 11-188, 11-189, 11-190, 11-191, 11-192, 11-193, 11-194, 11-195, 11-196, 11-197, 11-198, 11-199, 11-200, 11-201, 11-202, 11-203, 11-204, 11-205, 11-206, 11-207, 11-208, 11-209, 11-210, 11-211, 11-212, 11-213, 11-214, 11-215, 11-216, 11-217, 11-218, 11-219, 11-220, 11-221, 11-222, 11-223, 11-224, 11-225, 11-226, 11-227, 11-228, 11-229, 11-230, 11-231, 11-232, 11-233, 11-234, 11-235, 11-236, 11-237, 11-238, 11-239, 11-240, 11-241, 11-242, 11-243, 11-244, 11-245, 11-246, 11-247, 11-248, 11-249, 11-250, 11-251, 11-252, 11-253, 11-254, 11-255, 11-256, 11-257, 11-258, 11-259, 11-260, 11-261, 11-262, 11-263, 11-264, 11-265, 11-266, 11-267, 11-268, 11-269, 11-270, 11-271, 11-272, 11-273, 11-274, 11-275, 11-276, 11-277, 11-278, 11-279, 11-280, 11-281, 11-282, 11-283, 11-284, 11-285, 11-286, 11-287, 11-288, 11-289, 11-290, 11-291, 11-292, 11-293, 11-294, 11-295, 11-296, 11-297, 11-298, 11-299, 11-300, 11-301, 11-302, 11-303, 11-304, 11-305, 11-306, 11-307, 11-308, 11-309, 11-310, 11-311, 11-312, 11-313, 11-314, 11-315, 11-316, 11-317, 11-318, 11-319, 11-320, 11-321, 11-322, 11-323, 11-324, 11-325, 11-326, 11-327, 11-328, 11-329, 11-330, 11-331, 11-332, 11-333, 11-334, 11-335, 11-336, 11-337, 11-338, 11-339, 11-340, 11-341, 11-342, 11-343, 11-344, 11-345, 11-346, 11-347, 11-348, 11-349, 11-350, 11-351, 11-352, 11-353, 11-354, 11-355, 11-356, 11-357, 11-358, 11-359, 11-360, 11-361, 11-362, 11-363, 11-364, 11-365, 11-366, 11-367, 11-368, 11-369, 11-370, 11-371, 11-372, 11-373, 11-374, 11-375, 11-376, 11-377, 11-378, 11-379, 11-380, 11-381, 11-382, 11-383, 11-384, 11-385, 11-386, 11-387, 11-388, 11-389, 11-390, 11-391, 11-392, 11-393, 11-394, 11-395, 11-396, 11-397, 11-398, 11-399, 11-400, 11-401, 11-402, 11-403, 11-404, 11-405, 11-406, 11-407, 11-408, 11-409, 11-410, 11-411, 11-412, 11-413, 11-414, 11-415, 11-416, 11-417, 11-418, 11-419, 11-420, 11-421, 11-422, 11-423, 11-424, 11-425, 11-426, 11-427, 11-428, 11-429, 11-430, 11-431, 11-432, 11-433, 11-434, 11-435, 11-436, 11-437, 11-438, 11-439, 11-440, 11-441, 11-442, 11-443, 11-444, 11-445, 11-446, 11-447, 11-448, 11-449, 11-450, 11-451, 11-452, 11-453, 11-454, 11-455, 11-456, 11-457, 11-458, 11-459, 11-460, 11-461, 11-462, 11-463, 11-464, 11-465, 11-466, 11-467, 11-468, 11-469, 11-470, 11-471, 11-472, 11-473, 11-474, 11-475, 11-476, 11-477, 11-478, 11-479, 11-480, 11-481, 11-482, 11-483, 11-484, 11-485, 11-486, 11-487, 11-488, 11-489, 11-490, 11-491, 11-492, 11-493, 11-494, 11-495, 11-496, 11-497, 11-498, 11-499, 11-500, 11-501, 11-502, 11-503, 11-504, 11-505, 11-506, 11-507, 11-508, 11-509, 11-510, 11-511, 11-512, 11-513, 11-514, 11-515, 11-516, 11-517, 11-518, 11-519, 11-520, 11-521, 11-522, 11-523, 11-524, 11-525, 11-526, 11-527, 11-528, 11-529, 11-530, 11-531, 11-532, 11-533, 11-534, 11-535, 11-536, 11-537, 11-538, 11-539, 11-540, 11-541, 11-542, 11-543, 11-544, 11-545, 11-546, 11-547, 11-548, 11-549, 11-550, 11-551, 11-552, 11-553, 11-554, 11-555, 11-556, 11-557, 11-558, 11-559, 11-560, 11-561, 11-562, 11-563, 11-564, 11-565, 11-566, 11-567, 11-568, 11-569, 11-570, 11-571, 11-572, 11-573, 11-574, 11-575, 11-576, 11-577, 11-578, 11-579, 11-580, 11-581, 11-582, 11-583, 11-584, 11-585, 11-586, 11-587, 11-588, 11-589, 11-590, 11-591, 11-592, 11-593, 11-594, 11-595, 11-596, 11-597, 11-598, 11-599, 11-600, 11-601, 11-602, 11-603, 11-604, 11-605, 11-606, 11-607, 11-608, 11-609, 11-610, 11-611, 11-612, 11-613, 11-614, 11-615, 11-616, 11-617, 11-618, 11-619, 11-620, 11-621, 11-622, 11-623, 11-624, 11-625, 11-626, 11-627, 11-628, 11-629, 11-630, 11-631, 11-632, 11-633, 11-634, 11-635, 11-636, 11-637, 11-638, 11-639, 11-640, 11-641, 11-642, 11-643, 11-644, 11-645, 11-646, 11-647, 11-648, 11-649, 11-650, 11-651, 11-652, 11-653, 11-654, 11-655, 11-656, 11-657, 11-658, 11-659, 11-660, 11-661, 11-662, 11-663, 11-664, 11-665, 11-666, 11-667, 11-668, 11-669, 11-670, 11-671, 11-672, 11-673, 11-674, 11-675, 11-676, 11-677, 11-678, 11-679, 11-680, 11-681, 11-682, 11-683, 11-684, 11-685, 11-686, 11-687, 11-688, 11-689, 11-690, 11-691, 11-692, 11-693, 11-694, 11-695, 11-696, 11-697, 11-698, 11-699, 11-700, 11-701, 11-702, 11-703, 11-704, 11-705, 11-706, 11-707, 11-708, 11-709, 11-710, 11-711, 11-712, 11-713, 11-714, 11-715, 11-716, 11-717, 11-718, 11-719, 11-720, 11-721, 11-722, 11-723, 11-724, 11-725, 11-726, 11-727, 11-728, 11-729, 11-730, 11-731, 11-732, 11-733, 11-734, 11-735, 11-736, 11-737, 11-738, 11-739, 11-740, 11-741, 11-742, 11-743, 11-744, 11-745, 11-746, 11-747, 11-748, 11-749, 11-750, 11-751, 11-752, 11-753, 11-754, 11-755, 11-756, 11-757, 11-758, 11-759, 11-760, 11-761, 11-762, 11-763, 11-764, 11-765, 11-766, 11-767, 11-768, 11-769, 11-770, 11-771, 11-772, 11-773, 11-774, 11-775, 11-776, 11-777, 11-778, 11-779, 11-780, 11-781, 11-782, 11-783, 11-784, 11-785, 11-786, 11-787, 11-788, 11-789, 11-790, 11-791, 11-792, 11-793, 11-794, 11-795, 11-796, 11-797, 11-798, 11-799, 11-800, 11-801, 11-802, 11-803, 11-804, 11-805, 11-806, 11-807, 11-808, 11-809, 11-810, 11-811, 11-812, 11-813, 11-814, 11-815, 11-816, 11-817, 11-818, 11-819, 11-820, 11-821, 11-822, 11-823, 11-824, 11-825, 11-826, 11-827, 11-828, 11-829, 11-830, 11-831, 11-832, 11-833, 11-834, 11-835, 11-836, 11-837, 11-838, 11-839, 11-840, 11-841, 11-842, 11-843, 11-844, 11-845, 11-846, 11-847, 11-848, 11-849, 11-850, 11-851, 11-852, 11-853, 11-854, 11-855, 11-856, 11-857, 11-858, 11-859, 11-860, 11-861, 11-862, 11-863, 11-864, 11-865, 11-866, 11-867, 11-868, 11-869, 11-870, 11-871, 11-872, 11-873, 11-874, 11-875, 11-876, 11-877, 11-878, 11-879, 11-880, 11-881, 11-882, 11-883, 11-884, 11-885, 11-886, 11-887, 11-888, 11-889, 11-890, 11-891, 11-892, 11-893, 11-894, 11-895, 11-896, 11-897, 11-898, 11-899, 11-900, 11-901, 11-902, 11-903, 11-904, 11-905, 11-906, 11-907, 11-908, 11-909, 11-910, 11-911, 11-912, 11-913, 11-914, 11-915, 11-916, 11-917, 11-918, 11-919, 11-920, 11-921, 11-922, 11-923, 11-924, 11-925, 11-926, 11-927, 11-928, 11-929, 11-930, 11-931, 11-932, 11-933, 11-934, 11-935, 11-936, 11-937, 11-938, 11-939, 11-940, 11-941, 11-942, 11-943, 11-944, 11-945, 11-946, 11-947, 11-948, 11-949, 11-950, 11-951, 11-952, 11-953, 11-954, 11-955, 11-956, 11-957, 11-958, 11-959, 11-960, 11-961, 11-962, 11-963, 11-964, 11-965, 11-966, 11-967, 11-968, 11-969, 11-970, 11-971, 11-972, 11-973, 11-974, 11-975, 11-976, 11-977, 11-978, 11-979, 11-980, 11-981, 11-982, 11-983, 11-984, 11-985, 11-986, 11-987, 11-988, 11-989, 11-990, 11-991, 11-992, 11-993, 11-994, 11-995, 11-996, 11-997, 11-998, 11-999, 1200

TM 5135-15-7

Figure 8. DA Form 11-238, pages 1 and 4.

LEGEND for marking conditions: Satisfactory, ✓. Adjustment, Repair or Replacement required, X. Defect corrected, (X).		DAILY CONDITION FOR MONTH OF																																							
		DAILY																															2D								
		NO.	ITEM	17	18	19	20	21	22	23	24	25	26	27	28	29	30	31	16	17	18	19	20	21	22	23	24	25	26	27	28	29	30	31	2D	3D	ECH-ELON				
		✓	✓	✓	✓	✓	✓	✓	✓	✓	✓	✓	✓	✓	✓	✓	✓	✓	✓	✓	✓	✓	✓	✓	✓	✓	✓	✓	✓	✓	✓	✓	✓	✓	✓	✓					
	1. COMPLETENESS AND GENERAL CONDITION OF EQUIPMENT. (Reference equipment operating manual, wire, cables, microphones, tubes, spare parts, technical manual).																																								
	2. CLEAN DIRT AND MOISTURE FROM ANTERNA, MICROPHONE, HEADSETS, MESS, JACKS, PLUGS, COMPONENT PANELS.																																								
	3. CHECK FOR NORMAL OPERATION OF EQUIPMENT. BE ALERT FOR UNUSUAL OPERATION OR CONDITION.																																								
	4. CHECK FOR NORMAL OPERATION OF EQUIPMENT. BE ALERT FOR UNUSUAL OPERATION OR CONDITION.																																								
		WEEKLY			CONDITION EACH WEEK			PAR. 13			ADDITIONAL ITEMS FOR 2D AND 3D ECH ELON INSPECTIONS																											CONDITION			
	5. CLEAN AND POLISH EXTERIORS OF CASES, BATTERIES, MOUNTS, ANTENNAS, HEADSETS.		9H																																				✓		
	6. INSPECT CASES, MOUNTS, ANTENNAS, HEADSETS AND EXPOSED METAL SURFACES FOR RUST, CORROSION.		9H																																					✓	
	7. INSPECT CORDS, CABLE, WIRE, SHOCK MOUNTS FOR CUTS, KINKS, BREAKS, PRAYING, UNDUCE STRAIN.		9H																																					✓	
	8. CHECK CONNECTIONS AND CONNECTION POINTS FOR LOOSENESS, CORROSION, SHORTS.																																							✓	
	9. INSPECT KEYS, SWITCHES AND SWITCHES FOR CORROSION, WEAR, CLEANING.																																							✓	
	10. INSPECT ACCESSIBLE ITEMS FOR LOOSENESS: SWITCHES, KNOBS, JACKS, CONNECTORS, HEADSET COMPONENTS, MICROPHONE, MICROPHONE MOUNTING.		9H																																					✓	
	11. CHECK TERMINALS AND CONNECTIONS FOR CORROSION, LOOSENESS, CLEANING.																																							✓	
	12. INSPECT STORAGE BATTERIES FOR CORROSION, WEAR, CLEANING.																																							✓	
		WEEKLY			CONDITION EACH WEEK			PAR. 13			ADDITIONAL ITEMS FOR 2D AND 3D ECH ELON INSPECTIONS																											CONDITION			
	13. INSPECT BATTERIES AND BATTERIES FOR CORROSION, WEAR, CLEANING.																																								✓
	14. CHECK TERMINALS AND CONNECTIONS FOR CORROSION, WEAR, CLEANING, DAMAGED GASKETS, CRACKS.																																								✓
		WEEKLY			CONDITION EACH WEEK			PAR. 13			ADDITIONAL ITEMS FOR 2D AND 3D ECH ELON INSPECTIONS																											CONDITION			
	15. INSPECT SEATING OF READILY ACCESSIBLE PLUGS - OUT ITEMS: TUBES, BATTERIES, FUSES, BATTERIES, CONNECTIONS, VIBRATORS, PLUGS, JACKS.																																								✓
	16. INSPECT RELAYS AND CONTACTS FOR LOOSE MOUNTINGS, BATTERIES AND BATTERIES FOR CORROSION, WEAR, CLEANING, CRACKS, DISCOLORATION.																																								✓
	17. INSPECT WINDINGS AND BATTERIES FOR CORROSION, WEAR, CLEANING, CRACKS, DISCOLORATION.																																								✓
	18. INSPECT RESISTORS, BUSHINGS AND INSULATORS FOR CRACKS, CRIPPLING, BLISTERING, MOISTURE, DISCOLORATION.																																								✓
	19. CLEAN AND TIGHTEN SWITCHES, BATTERIES, BATTERIES, BATTERIES, RELAY CASES AND INTERIORS OF CHASSIS AND BATTERIES NOT READILY ACCESSIBLE.																																								✓
	20. INSPECT TERMINALS AND BATTERIES FOR CORROSION, WEAR, CLEANING.																																								✓
	21. INSPECT TERMINALS OF LARGE FIXED CAPACITORS AND RESISTORS FOR DIRT, CORROSION, LOOSE CONTACTS.																																								✓
	22. INSPECT TRANSFORMERS, BATTERIES, BATTERIES AND RHEOSTATS FOR OVERHEATING AND OIL LEAKAGE.																																								✓
	23. INSPECT BATTERIES AND BATTERIES FOR CORROSION, WEAR, CLEANING.																																								✓
	24. INSPECT BATTERIES AND BATTERIES FOR CORROSION, WEAR, CLEANING.																																								✓
	25. INSPECT WATERPROOF GASKETS FOR LEAKS, WORN OR LOOSE PARTS.																																								✓

## Section II. TROUBLESHOOTING AT ORGANIZATIONAL MAINTENANCE LEVEL

### 17. Extent of Instructions

a. Organizational troubleshooting techniques are limited to replacing a faulty plug-in part or locating obvious troubles in cables or components.

b. The troubleshooting techniques are presented in two general procedures, the visual inspection and the use of the equipment performance check list (pars. 18 and 19). Perform these checks after the overall system trouble has been localized to the radio set control.

### 18. Visual Inspection

Failure of the radio set control to operate properly may be caused by an easily overlooked mechanical or electrical fault. When it fails to perform properly, turn off the power and check for the following:

- a. Burned-out fuse.
- b. Broken or defective LINE binding posts.
- c. Incorrect switch setting.
- d. Loose or corroded line wire connections to the binding posts.
- e. Dirt, corrosion, or moisture between binding posts which may cause a partial short-circuit between them and greatly reduce the efficiency of

the line when transferring signal and control voltages.

f. Worn or broken cables and connectors.

g. Defective or improperly installed capacitors C1 or C11 or vibrator G1.

h. Defective handset (cable, connector, push-to-talk switch, dirty diaphragm).

### 19. Equipment Performance Check List

a. *General.* The equipment performance check list helps the unit repairman locate and correct troubles. Repairs are limited to plug-in parts. All corrective measures that the second-echelon repairman can perform are given in the corrective measures column.

b. *Procedure.* Place the radio set control in operation as a link in the communication system (par. 13). After the equipment has warmed up, perform the steps below in the order given. Observe the operation and perform any corrective measures necessary. If the corrective measures do not fix the equipment, troubleshooting by higher echelon is required. Note on the repair tag how the equipment performed and what corrective measures were taken.

	Step	Action or condition	Normal indications	Corrective measures
START OPERATE STOP	1	If operating from 24-volt dc source, set S1 to DC position.	Vibrations from power vibrator should be felt when hand is held against case.	Check slo-blo fuse F2, plug-in vibrator G1, power input cable (W1), connection to J2.
	2	If operating from ac power, set S1 to AC (switch S2 set to proper voltage)	Filaments of tubes should be lighted (only visible after removing case).	Check fuse F1, ac power cable (W4), connection to J2.
	3	Crank ringing generator of field telephone.	Radio xmtr should turn on and stay on for approximately 1-10 seconds after cranking ceases.	Check to see that monitor switch is in T RADIO & MON position; check tubes V8 and V6; cable to xmtr (W2 and/or W3).
	4	Operate push-to-talk switch of field telephone or handset.	A 1,600-cps note should be heard in the handset. Xmtr should turn on and remain on as long as switch is operated.	Check tubes V7 and V4, handset. Higher echelon repair is required.
	5	Request operator at remote equipment to send a ringing signal (1,600 cps) via radio.	2,000-cps warning tone (beep) should be heard at field phone and in handset at a rate of 12 beeps per minute. Field phone should ring . . . . .	Check tubes V5, V7. Adjust R25 (par. 111).
	6	Set OFF-AC-DC switch to OFF.		Check tubes V2 and V3.

## 20. Tube Testing Techniques

When trouble occurs, check all cabling, connections, and batteries (if dc power is used) before removing any tubes. If tube failure is suspected, use the applicable procedure below.

*a. Use of Tube Tester.* Remove and test one tube at a time. Discard a tube only if its defect is obvious or if the tube tester shows it to be defective. Do not discard a tube that tests at or near its minimum test limit on the tube tester. Put back the original tube, or insert a new one if required, before testing the next one.

*b. Tube Substitution Method.* Replace a suspected tube with a new tube. If the equipment remains inoperative, remove the new tube and put back the original tube. Repeat this procedure with each suspected tube until the defective tube is located.

*c. Replacement of Tubes.*

- (1) Remove the chassis from the case by loosening the six spring-loaded Dzus fas-

- teners at the front; pull the chassis out.
- (2) Unlock the two fasteners (fig. 3) and loosen the two screws on the backplate.
- (3) Separate the two chassis as shown in figure 4. (Tube locations are shown in figure 21.)
- (4) Remove the tube shield by twisting it counterclockwise while pressing down against spring pressure.
- (5) Replace the tube and tube shield.  
*Caution:* Do not rock or rotate a tube when removing it from a socket; pull it straight out with a tube puller.
- (6) Swing the upper chassis back into position and refasten.
- (7) Insert the chassis into the case. Be careful not to pinch any wires between the case and the rear of the front panel. Fasten the six spring-locked Dzus fasteners.

## CHAPTER 4

### THEORY

#### 21. General

The radio set control is used in wire-radio systems to connect radios (transmitters and receivers) with local battery telephone equipment. Two radio set controls can also be used as an automatic relay between two push-to-talk radio sets (C, fig. 2). When the monitor switch is set at the T RADIO & MON position, the radio set control can be left unattended. Facilities exist, however, for the operator to ring the local telephone, ring the remote radio station and wire equipment user, monitor transmissions, and to communicate with both ends of a circuit as described in paragraph 13.

#### 22. Local Telephone Ring Circuit (fig. 10)

The local telephone can be rung by either of two methods. One method (automatic) uses the incoming 1,600-cps ringing signal from the remote location (and through the local receiver) and the other (manual) is accomplished by holding the monitor switch in the R TEL position. Either method energizes local ringing relay K1 to apply operating voltages to 20-cps ringing generator G2 and to connect the generator output to the radio set control LINE terminals.

a. The 1,600-cps ringing signal output of the radio receiver is applied to terminal A of RADIO

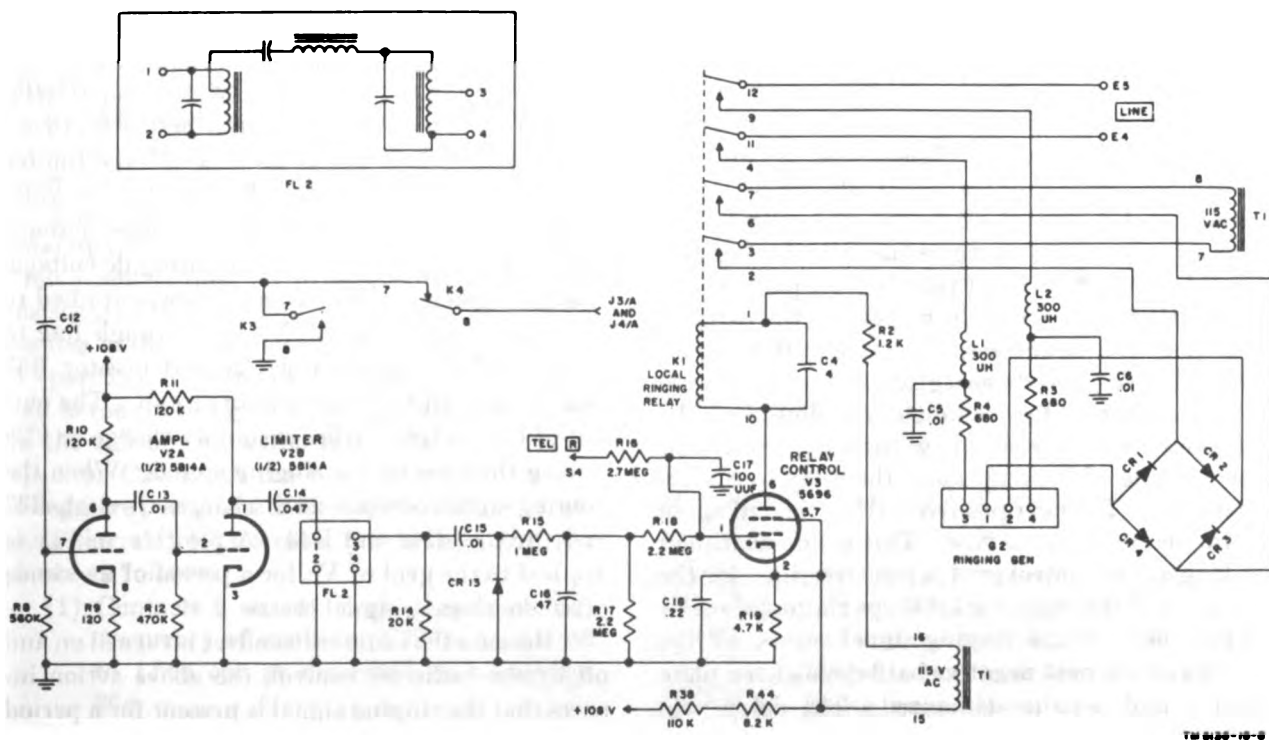


Figure 10. Local telephone ringing circuit.

receptacle J3 or J4 and through capacitor C12 to the grid of amplifier V2A. This circuit is a conventional re-coupled triode amplifier with cathode resistor bias developed across R9. The amplified signal is coupled to the grid of limiter V2B through capacitor C13. Because grid leak bias only is used in this stage and because of low plate voltage, the 1,600-cps signal is limited in amplitude. The plate load of V2B is filter FL2 which is a resonant circuit tuned to the 1,600-cps ringing signal. The 1,600-cps output of the filter is terminated by R14 and coupled by C15 to a rectifier-integrator circuit made up of CR13, R15, and C16. Because rectifier CR13 effectively grounds out the negative portion of the signal, only the positive portion of the signal is applied to the integrating circuit of R15 and C16. The values of R15 and C16 determine the delay from the time the 1,600-cps signal is received until relay K1 operates. This delay is necessary to prevent false operation on speech and noise. The resulting positive dc signal is applied to the control grid of thyratron V3 through isolating resistor R18.

*b.* Cathode resistor R19 of relay control tube V3 is part of a voltage divider (R38, R44, and R19) in the 108-volt power supply line. The fixed voltage at the cathode is 4 volts. The plate operating voltage for V3 is 115 volts ac obtained from terminals 15 and 16 of transformer T1. The 115-volt ac output voltage of T1 is applied between the cathode and plate of V3 through R2 and the coil of relay K1. When the plate is positive and the control grid is zero or positive with respect to the cathode, relay control V3 ionizes and causes plate current to flow and energize the coil of relay K1. On the next half-cycle of the plate supply voltage, the plate is negative with respect to the cathode and the tube de-ionizes. Normally, this would cause K1 to become de-energized; however, because it was charged when plate current flowed on the previous half-cycle, C4 now discharges through the winding of K1 and causes the relay to remain energized. The next positive half-cycle will again cause plate current to flow. This action continues as long as the control grid is positive (i. e., for the duration of the incoming 1,600-cps ringing signal). When the 1,600-cps ringing signal ceases, V3 de-ionizes on the next negative half-cycle of the plate supply and remains de-ionized. The delay provided by R15 and C16 prevents false, intermittent operation of relay K1 on speech or noise.

*c.* When the monitor switch is held in the R TEL position, 24 volts dc is applied to the grid of V3 through resistor R16. Resistor R16 with R18 and R17 form a voltage divider across the 24-volt dc line with the monitor switch in the ring telephone position. Tube V3 conducts continuously as long as the switch is held.

*d.* When local ringing relay K1 is energized, 115 volts ac is applied from terminals 7 and 8 of T1 to bridge rectifier network CR1-CR4 through contacts 2 and 3 and 6 and 7 of K1. The rectifier output is applied to terminals 1 and 2 of ringing generator G2. The 40-volt rms, 20-cps minimum output of the ringing generator is applied through two filter networks and contacts 4 and 11 and 9 and 12 of K1 to the LINE terminals. The filter network consists of R3, C6, and L2 in one line and R4, C5, and L1 in the other.

## 23. Ring Radio Circuits

(fig. 11)

The ring radio circuit is used to contact remote telephone equipment or a radio location via a radio link. The ring circuit to the remote radio station is activated in one of two ways: when the local telephone generates a 20-cps ringing signal or when the monitor switch is held in the R RADIO & MON position.

*a.* The 20-cps ringing signal is applied to the incoming telephone line and through capacitors C27 and C26 to a full-wave bridge rectifier (CR14, CR15, CR16, and CR17). Neon bulb E6 in conjunction with R35 functions as a voltage limiter to prevent the application of more than 80 volts (approximately) to the bridge rectifier circuit. The bridge output, which is a pulsating dc voltage, charges capacitor C28. This voltage is applied to the plate of diode limiter V6 and through R42 to the grid of V8. Capacitor C28 and resistor R37 also serve as an rc time constant circuit. The output of the bridge rectifier sustains a charge on C28 during the time of the ringing signal. When the ringing signal ceases, C28 discharges through R37 and through R42 and R43. A positive voltage is applied to the grid of V8 for a period of 2 seconds after the ringing signal ceases.

*b.* Because the radio transmitter is turned on and off by the radio set control, the above action insures that the ringing signal is present for a period of time after the transmitter filaments have reached operating temperature.

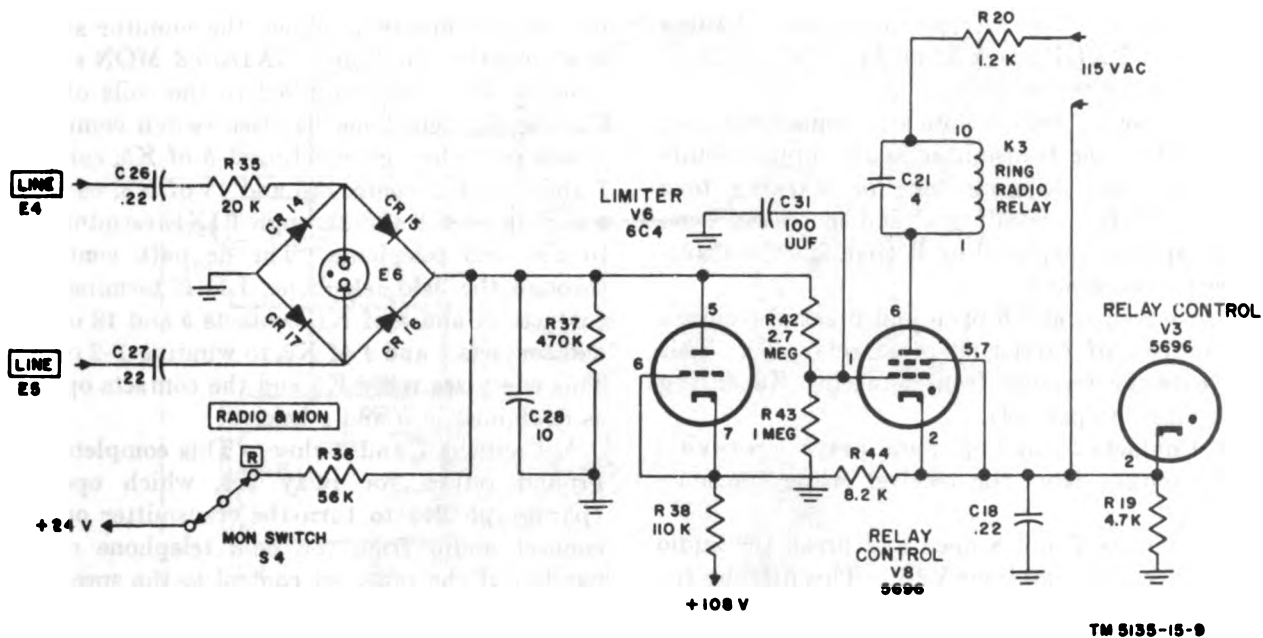


Figure 11. Ring radio circuit.

c. When the monitor switch is held in the R RADIO & MON position, 24 volts dc is applied continuously through R36 to the junction of R37 and C28. Resistors R36 and R37 form a voltage divider network across the 24-volt dc power supply. The voltage at the junction or the dc signal ringing voltage from the rectifier is limited to 12 volts by diode-connected triode V6. The cathode of V6 is held at +12 volts dc by the action of voltage divider R38, R44, and V3 cathode resistor R19. The same voltage divider network holds the cathode of V8 at approximately 4 volts.

d. The voltage at the plate of the limiter (a dc signal up to 12 volts) is applied to the control grid of relay control tube V8 through a voltage divider consisting of R42 and R43. Relay control tube V8 operates in the same manner as relay control tube V3 (par. 22). When the dc ringing signal is applied to the control grid of V8, plate current flows and the coil of ring radio relay K3 is energized. Capacitor C21 keeps the relay energized during the negative portion of the ac supply voltage to V8.

e. When relay K3 operates, the contacts (fig. 16) operate as follows:

- (1) Contacts 2 and 11 close; this causes the frequency of oscillator V7B to be shifted to 1,600 cps as described in paragraph 26a.
- (2) Contacts 9 and 14 close and bring gated amplifier V4 out of cutoff as described in

paragraph 27. This allows the 1,600-cps signal from the oscillator to be applied to mixer transformer T2 and from there (through relay K4, contacts 12 and 9) to the transmitter to modulate the rf carrier.

- (3) Contacts 7 and 8 close and ground the audio input circuit to V2A from the radio receiver (par. 22a); this prevents the operation of the local ringing relay.
- (4) Contacts 6 and 13 and 5 and 12 open, removing all loads from the local telephone line except the 20-cps ringing circuit.
- (5) Contacts 3 and 4 close and complete the ground circuit for transfer relay K4. The 24-volt dc energizing voltage is applied to the K4 coil when the monitor switch is in the T or R RADIO & MON position. The functions of the K4 contacts are given in paragraph 24.

## 24. Transfer Relay K4 Circuits (fig. 16)

Transfer relay K4 can be energized by any one of three procedures: during ring radio operation (par. 23e(5)), during transmission when the radio set control handset push-to-talk switch is pressed, or during transmission by operation of master transfer relay K5 (par. 25a). When relay K4 operates, the contacts operate as follows:

a. Contacts 4 and 11 close and ground the line from F of RADIO jack J3 or J4. This turns on the associated transmitter.

b. Contacts 9 and 12 close and connect winding E of T2 to the transmitter audio input circuits through C23. Ringing tone or warning tone (par. 27d) from winding F and/or speech from the telephone line, winding B (par. 25d), is transferred to winding E.

c. Contacts 5 and 6 open and break the circuit to the coil of carrier-operated relay K2. This prevents the receiver from actuating K2 during transmission (par. 29).

d. Contacts 2 and 3 open and prevent receiving audio output from the receiver while transmitting.

e. Contacts 7 and 8 open and break the audio input circuit to amplifier V2A. This disables the 1,600-cycle amplifier when transmitting.

## 25. Transmit Circuits

(fig. 16)

When the push-to-talk switch of the local telephone is closed, the radio set control turns the transmitter on and effectively connects the telephone line to the speech input of the transmitter. In addition, a 2,000-cps warning tone is mixed with the speech signal to advise the wire line operator that his conversation is being transmitted via radio. During this mode of operation, the various relays are in the position indicated in the following table. The sequence of operation is described in a through d below.

Relay	Energized	De-energized
K2.....		X
K4.....	X	
K5.....	X	
K3.....		X
K1.....		X

a. When the push-to-talk switch in the local telephone handset is closed, a high impedance, low resistance inductance is placed across the telephone line. The circuit involved is shown in figure 16. Because the coil of K5 is split into two sections, and the effective center tap is at alternating current (ac) ground (pin 2 directly to ground, pin 6 through C11C), telephone line balance is maintained. Because the K5 coils have a high impedance, the speech characteristics of the

line are unimpaired. When the monitor switch is set in either the R or T RADIO & MON switch position, 24 volts is applied to the coils of K5. Closing the telephone handset switch completes the dc path through winding 6-5 of K5, contacts 7 and 8 of K2, contacts 6 and 13 of K3, contacts 8 and 12 of K1 and through LINE terminal E5 to the field telephone. The dc path continues through the field telephone, LINE terminal E4, contacts 11 and 5 of K1, contacts 5 and 12 of K3, and contacts 3 and 4 of K2, to winding 1-2 of K5. This energizes relay K5 and the contacts operate as explained in b and c below.

b. Contacts 7 and 8 close. This completes the ground return for relay K4, which operates (paragraph 24) to turn the transmitter on and connect audio from the field telephone or the handset at the radio set control to the speech input circuits of the transmitter.

c. Contacts 3 and 4 close and connect the gate generator V5 output to the control grid of gated amplifier V4 (fig. 13). The pulses from V5 help to provide the warning tones during transmission.

d. Speech signals from the telephone are applied through contacts of unenergized relays K1 and K3 and through contacts of K2 (K2 energized or not, par. 29) to transformer winding B. From winding B, the audio signal is induced into winding E and is then applied to the transmitter audio input circuits when K4 is energized.

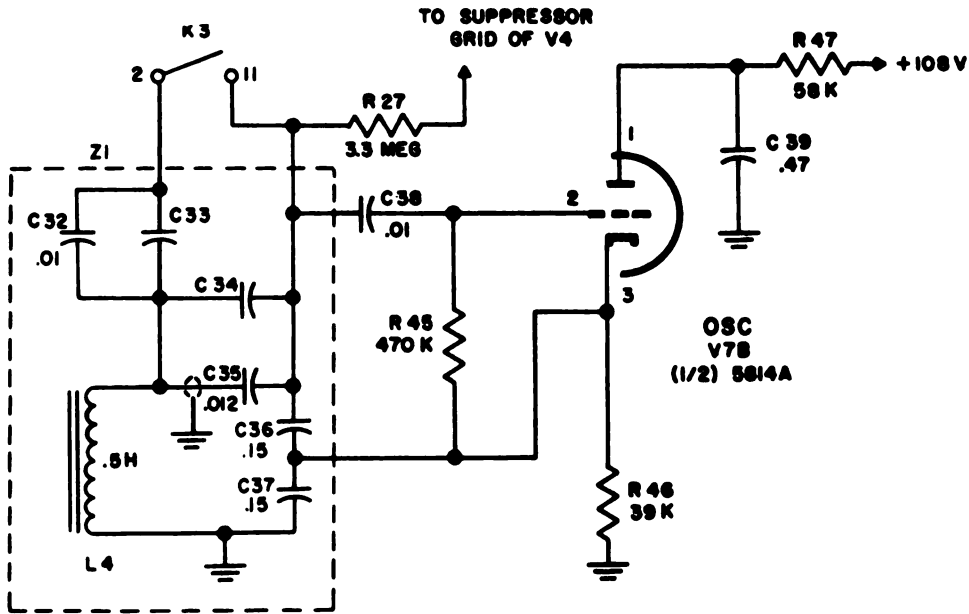
## 26. Warning Tone and Ring Radio Oscillator

(fig. 12)

The oscillator circuit, which normally generates a continuous 2,000-cps tone, performs two functions. When the radio set control is in the transmitting condition (par. 25), this tone is transmitted through gated amplifier V4 (par. 27) in such a manner that short bursts, or *beeps*, of the 2,000-cps tone are obtained. These beeps are in turn applied across the telephone line and serve to advise the telephone equipment user that the conversation is being transmitted via radio. The other function of the oscillator is to provide the 1,600-cps signal which is used to ring via radio.

a. The oscillator employs a standard Clapp circuit. The operating frequency of the oscillator is determined by the series-resonant circuit of L4 in series with paralleled capacitors. The normal frequency determining capacitors are C35 and C34. With only C35 and C34 in the circuit, the oscillator frequency is approximately 2,000 cps. When ring





TM 5135-15-10

Figure 12. Warning tone and ring radio oscillator circuit.

radio relay K3 is energized by a 20-cps ringing signal from the local telephone equipment or by dc voltage from the monitor switch (par. 23), capacitors C32 and C33 are shunted across C35 and C34. With all four capacitors in the circuit, the resonant frequency of the oscillator is 1,600 cps. The output of the oscillator is coupled through isolating resistor R27 to the suppressor grid (pin 7) of gated amplifier V4.

b. The frequency of the oscillator is factory-adjusted by hand-selecting the values of C33 and C34. These capacitors should not be tampered with. If for some reason the frequency must be adjusted, all components shown on figure 12 as located in Z1 should be replaced.

## 27. Gate Generator and Gated Amplifier (figs. 13 and 16)

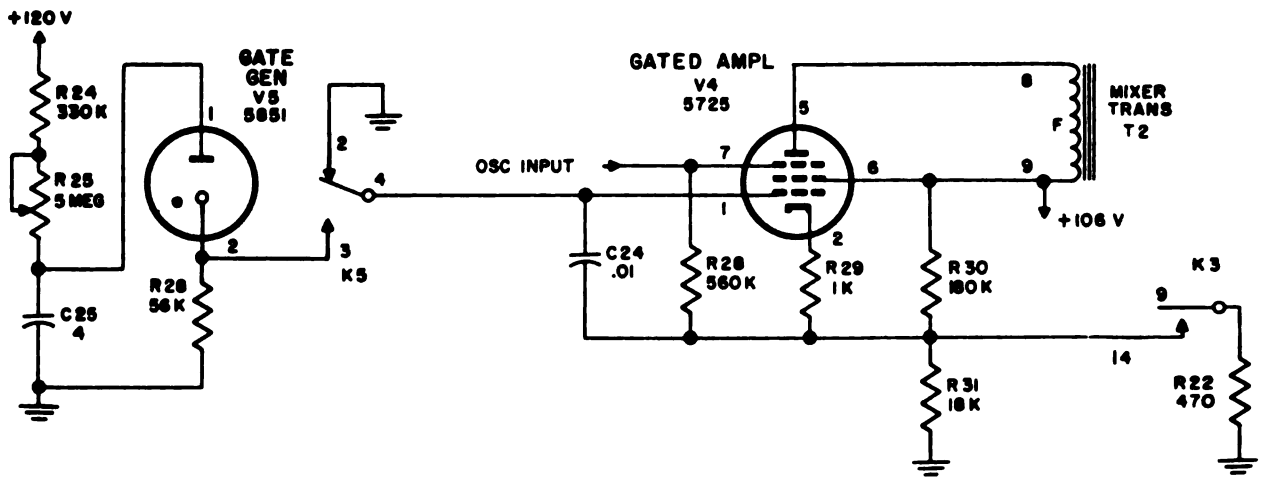
The gate generator applies positive pulses of bias to the grid of the gated amplifier, to allow warning beeps to be heard when the transmitter is on the air. The gated amplifier applies 2,000-cps warning tones or the 1,600-cps ringing tone to mixer transformer T2 during T or R RADIO & MON monitor switch settings respectively. When no tone is needed, the gated amplifier blocks tone from the T2 circuit.

a. Gate generator V5 is a gas tube relaxation oscillator. When 120-volt dc is applied to the V5 circuit, capacitor C25 charges through resistors

R25 and R24. Because C25 in series with R24 and R25 forms a long time-constant circuit, C25 requires 4 to 10 seconds (depending on the setting of R25) to charge to 103 volts. When the 103-volt point is reached, V5 ionizes and C25 discharges through it. Because the resistance of V5 is negligible when conducting, the time of discharge of C25 is short (.2 second). The discharge circuit consists of R26 and C25. Capacitor C25 continues to discharge until the plate voltage of V5 is reduced to the point where de-ionization occurs, thus completing 1 cycle of operation.

b. When V5 conducts (during discharge of C25), a positive pulse, .2 second in duration, is produced across cathode resistor R26. When the radio transmitter is on, this pulse is direct-coupled through terminals 3 and 4 of K5 (K5 is energized during radio transmission) to the control grid, pin 1 of gated amplifier V4. The gated amplifier is normally biased to cutoff by fixed bias applied to the cathode from the junction of voltage divider resistors R30 and R31. When the control grid is made positive by the pulse from V5, V4 conducts and, because the 2,000-cps warning generated by oscillator V7B is continuously applied to the suppressor grid, produces .2-second bursts of the 2,000-cps warning tone in the plate circuit. This is applied to winding F of mixer transformer T2.

c. When the radio transmitter is not on and ring radio relay K3 is energized (par. 23), the gated

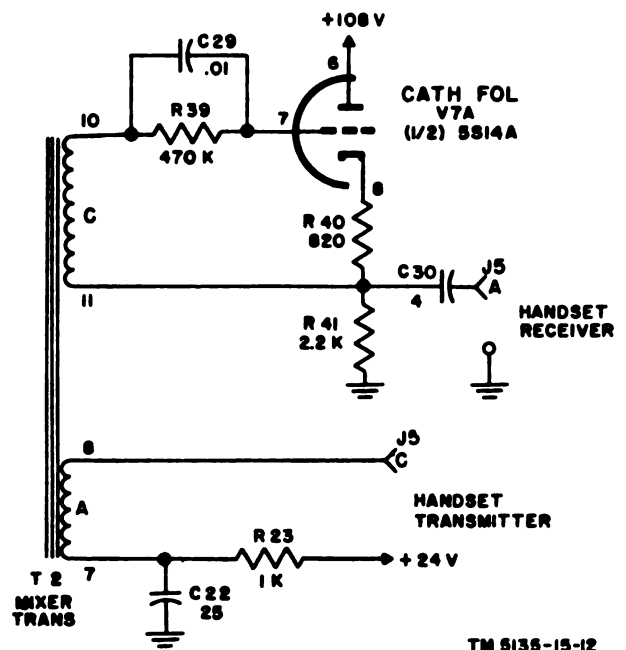


TM 5135-15-11

Figure 13. Gate generator and gated amplifier circuits.

amplifier is also placed in operation. When K3 is energized, resistor R22 (fig. 13) is placed across R31 in the gated amplifier circuit. This reduces the cathode bias to a point where V4 conducts. At the same time, capacitors C32 and C33 connected in the oscillator circuit (fig. 12) produce the 1,600-cps ring radio signal. Relay K5 is not operated and the V4 control grid, pin 1, is grounded during ring radio operation. The 1,600-cps ring radio signal supplied to the suppressor grid, pin 7, of V4 is amplified and applied to mixer transformer T2 in the same manner as the warning tone.

d. The output of V4, whether 2,000-cps warning tone or 1,600-cps ringing tone, is applied to mixer transformer T2, winding F. This signal is coupled to output winding E, terminals 4 and 5, and to winding B. Windings B and E of T2 are shown in figure 16. From terminal 4 of winding E, the signal is passed through contacts 12 and 9 (closed when the monitor switch is in either R or T RADIO & MON position) of transfer relay K4 and C23 to terminal C of the RADIO connectors. The audio signal is fed to the transmitter to modulate the rf carrier. The warning tone signal coupled to winding B is applied to the LINE terminals. The circuit from terminal 1 of winding B is completed through terminals 12 and 5 of K3 and 5 and 11 of K1 to LINE terminal E4. The circuit from terminal 2 of winding B is completed through dc blocking capacitor C19, contacts 7 and 8 of K2, contacts 6 and 13 of K3, and contacts 8 and 12 of K1 to LINE terminal E5.



TM 5135-15-12

Figure 14. Cathode follower V7A.

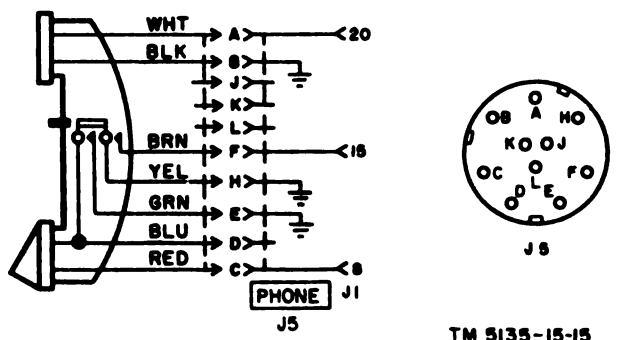


Figure 15. Handset H-33/PT circuit.

## 28. Receive Circuits

(fig. 16)

When an audio signal is fed to the radio set control from the radio receiver, all relays remain de-energized except carrier-operated relay K2 (if connected). Operation of K2 is described in paragraph 29.

*a.* The audio output of the receiver is applied to the radio set control at J3 or J4 pin A and thence through J1 and P1 contact 22 to contacts 3 and 8 of transfer relay K4. The signal at contact 8 is connected through contact 7 to a high impedance circuit at the grid of V2A. This audio signal does not actuate the ringing circuit because of the selective filtering action of FL2 (par. 22*a*).

*b.* The audio signal at contact 3 is fed through contact 2 to the 600-ohm input (windings D and E) of mixer transformer T2. The signal return to the receiver is made through the common ground connection. The audio signal is fed through winding B of T2 to the local telephone via LINE 1 and 2.

*c.* The audio signal at T2 is also transferred to winding C of T2 (fig. 14) and fed to cathode follower V7A. The function of the cathode follower stage is to isolate the handset receiver to decrease loading of the audio lines. The audio signal developed across cathode resistor R41 of the cathode follower is applied to the monitor headset receiver through capacitor C30, P1 and J1 terminal 20, and contact A of PHONE connector J5 (figs. 14 and 15).

## 29. Carrier-Operated Relay K2

(fig. 16)

Carrier-operated relay K2 serves two purposes—to break the circuit to master transfer relay K5 during reception and to control a dc path to allow retransmission as illustrated in C, figure 2.

*a.* Relay K2 is energized whenever the radio receiver gets a signal. For radio sets which supply power when a signal is received, the C. O. POWER switch is set to the EXT. position. When a signal is received, a minimum dc voltage of 16 volts is supplied by the receiver and is applied to the CARR. OP. binding post. From there the circuit is completed through contacts 5 and 6 of K4 and terminal 23 of J1 and P1 to the coil of relay K2. The other side of the K2 coil is connected to the AUX binding post through terminal 11 of P1 and J1 and the C. O. POWER

switch in the EXT. position. The AUX terminal is connected to the receiver to complete the dc path. When the radio receiver contains a carrier-operated relay, pin K of the 10 pin RADIO connector J3, J4 is grounded upon receipt of a signal by the radio receiver. With the C. O. POWER switch set to the INT. position, relay K2 is energized. The energizing voltage is +24v obtained from the C. O. POWER switch S3. The path of the energizing current is as follows: +24v source, through terminal 11 of J1 and P1, the coil of K2, contacts 5 and 6 of K4, terminals 23 of J1 and P1 to pin K of J3 or J4 which connects to ground at the receiver.

*b.* When K2 is not energized (conditions other than receiving) capacitor C19 blocks a dc path to the coil of master transfer relay K5 through winding B of T2. Relay K5 should only be operated by the circuit described in paragraph 25*a*. When relay K2 operates (during reception), contacts 3 and 4 open to prevent operation of K5. Contacts 8 and 6, however, close and thereby place winding B directly across the telephone line. This is essential to allow retransmission. The B winding of T2 fulfills the same function as the high inductance, low dc resistance of the field telephone described in paragraph 25*a*. It completes the K5 coil circuit of the other remote Radio Set Control AN/GSA-7. The local radio set control, actuated by the radio receiver, takes the place of the local telephone (C, fig. 2).

## 30. Monitor at Radio Set Control

Through the use of monitor switch S4 and Handset H-33/PT, an operator (monitor) located at the radio set control can ring and talk to the local telephone (or switchboard) on the wire line or to the remote equipment via radio.

*a.* The monitor can ring the remote equipment via radio by holding spring-return monitor switch, S4, in the R RADIO & MON position (par. 23*c*). This causes a 1,600-cps radio ringing signal to be generated as described in paragraph 23.

*b.* To receive an audio signal via radio with the monitor switch in the T RADIO & MON position at the monitor position, no action by the monitor is necessary. Any audio signal passing through mixer transformer T2 is sampled by winding C and applied to the receiver of the monitor handset through cathode follower V7A.

c. To transmit a voice signal via radio from the monitor position, it is necessary to set monitor switch S4 in the T RADIO & MON position and press the handset switch. When this is done, only relay K4 is energized (par. 24) and turns the transmitter on. Because K3 is not energized during this mode of operation, no ringing tone is generated. When the handset switch is closed, the microphone circuit is also completed (fig. 15). The output of the handset microphone is fed through terminal 8 of J1 and P1 to winding A, terminal 6, of T2. The operating voltage for the microphone is obtained from the 24-volt source through decoupling resistor R23. Capacitor C22 completes the audio signal path to ground. The audio output of the handset is transferred to winding E of T2 and to the transmitter audio input.

d. When the monitor wishes to ring the local telephone (switchboard), switch S4 must be held in the R TEL position for a short period of time. This operates relay K1 and results in the application of a 20-cps ringing signal to the telephone line as described in paragraph 23.

e. When the monitor wishes to talk to the local telephone or switchboard, the monitor switch must be set to the T TEL position and the push-to-talk switch in the handset must be pressed. The audio output of the handset is fed to the telephone line via windings A and B of T2 in a manner similar to that described in *c* above. In the T TEL position, relay K4 is disabled, and the conversation is not transmitted to the radio transmitter via winding E.

### 31. Power Supply

(figs. 17 and 25)

a. The power supply provides dc voltages of 120, 108, and 24 volts and an ac voltage of approximately 115 volts. The above voltages are obtained while operating from primary power sources of 115/230 volts ac  $\pm 10$  per cent, 50 to 400 cps, or from a dc source of 22 to 30 volts. In addition, 25.2 volts ac (filament voltage) is supplied when the equipment is operated on ac.

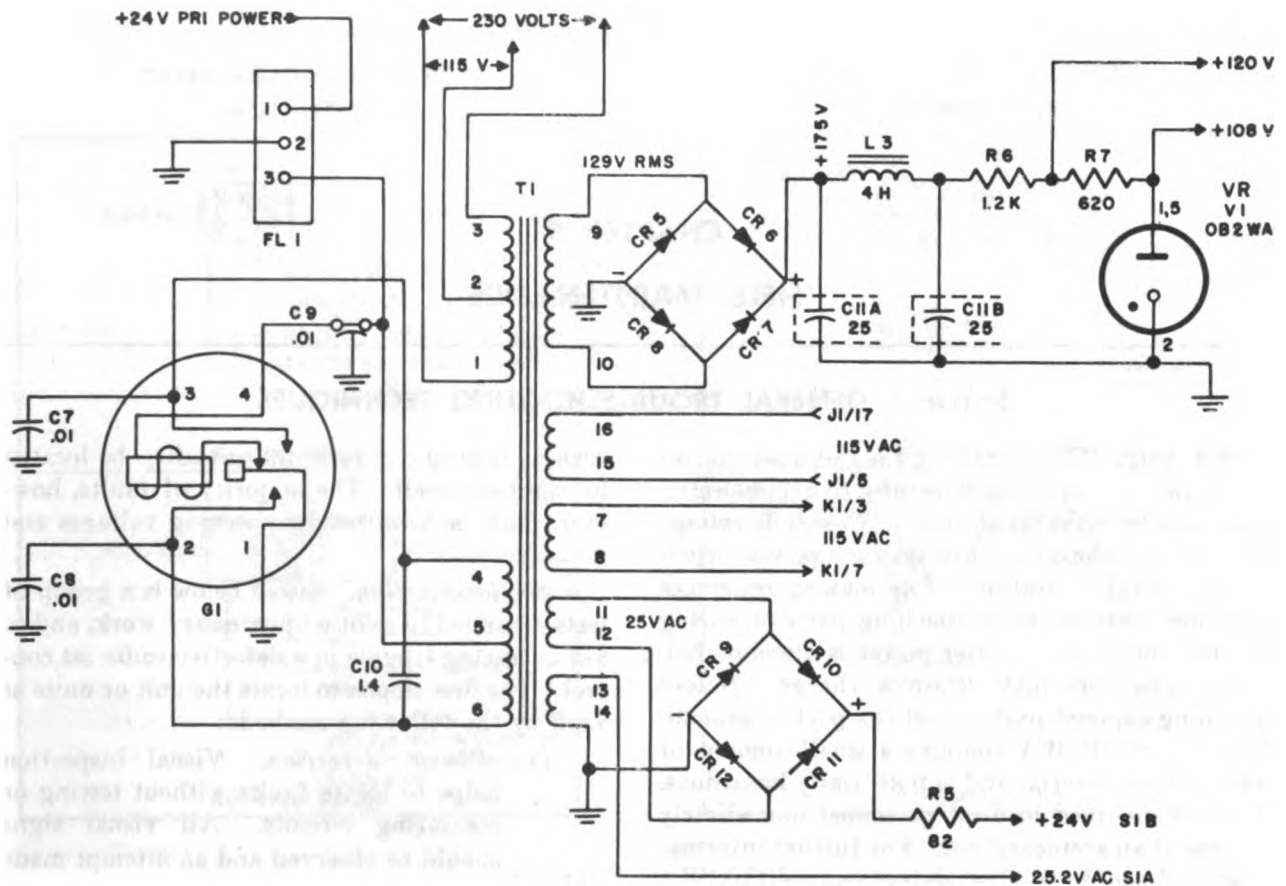
b. Ac voltage is applied to terminals A and C of the POWER CONNECTOR. The line from terminal A is applied through 1-ampere fuse F1 to switch S1A. In the AC position, it is connected to terminal 1 of the primary winding of T1. The line from terminal C connects to S1B and in the AC position, to POWER SELECT

switch S2. In the 115V position, the line is connected to terminal 2; in the 230V position, the line is connected to terminal 3 and the entire primary is in the circuit.

c. When operating from a 24-volt dc source, the power is applied through terminal D of the POWER connector, F2, S1A and terminal 1 of rf hash filter FL1 to the center tap (terminal 5) of the vibrator primary winding. The 24 volts dc is also applied to the winding of vibrator G1. With the reed of G1 in the upper position, terminal 4 of T1 is grounded and this causes current to flow through the T1 winding connected to terminals 5 and 4. At the same time, the vibrator is energized because the coil circuit is also grounded through the reed. The reed is pulled down, grounds the lower contact, and completes the circuit for the T1 winding connected to terminals 5 and 6. The spring action of the reed then returns it to the opposite position, which causes another cycle of operation to start. In this manner, the 24 volt-dc input is effectively changed into an alternating current at T1 and winding 4-6 becomes the transformer primary. Capacitor C10 is a buffer capacitor which prevents sparking at the vibrator contacts. Capacitors C7, C8, and C9 prevent generation of radio interference.

d. The ac voltage developed across terminals 9 and 10 of T1 is applied to full-wave bridge CR5, CR6, CR7, and CR8 for rectification. The negative side of the bridge is grounded and the positive output of the bridge is fed to a pi-type filter made up of C11A, L3, and C11B. Resistor R6 is a series resistor which drops the voltage to 120 volts at the junction of R6 and R7. The 120 volts is applied to the gate generator stage only (fig. 13). Resistor R7 limits the current through voltage regulator V1. The 108-volt output is supplied to the V2, V4, and V7 plate circuits and through voltage divider action to cathode circuits of V3, V6, and V8 (pars. 22b and 23c).

e. Secondary winding, terminals 11 and 12, produces approximately 25 volts ac which is rectified in the full-wave bridge circuit consisting of CR9, CR10, CR11, and CR12. The output of the rectifier is then fed through voltage-dropping resistor R5, and is used for actuating relays and for local handset microphone button voltage. The 24-volt circuit for the microphone is completed through J1-P1 terminal 14, through voltage-dropping resistor R23, winding A of T2, J1-P1



TM 6135-15-13

Figure 17. Power supply circuit.

terminal 8, to C of the PHONE connector. When the handset switch is pressed, the circuit is completed to ground through the carbon button to ground. Capacitor C1 prevents hum in the microphone circuit. As shown in figure 25, resistor R1 is connected across C1 in the OFF position of the DC-AC-OFF switch and discharges the 500 microfarad (uf) capacitor to ground.

f. The winding between terminals 7 and 8 produces 115 volts which operates 20-cps ringing generator G2 during ring telephone operation (par. 22).

g. The winding between terminals 15 and 16 also produces a voltage of 115 volts ac. Isolation

is needed from winding 7-8 because a dc bias voltage is added to the ac voltage used in the operation of thyratrons V8 and V3.

h. The filament voltage winding terminals 13 and 14 of T1 produces 25.2 volts ac which is used as filament voltage only when operating from an ac primary power source. When operating from a 24-volt battery, the battery supplies the filaments through the DC-AC-OFF switch. The filaments are connected in a series-parallel arrangement (fig. 25). Series-connected filaments of V3, V2, and V4 are connected in parallel with the series-connected filaments of V7, V6, and V8.

## CHAPTER 5

### FIELD MAINTENANCE

#### Section I. GENERAL TROUBLESHOOTING TECHNIQUES

**Warning:** When servicing the radio set control while power is applied, be careful to avoid electrical shock from the input ac or +175-volt dc voltage at exposed terminals. Always turn power switch S1 to the OFF position before making resistance measurements or before touching parts or wiring in the control unit. After power is disconnected, some capacitors may retain a charge. Before touching exposed parts, short the part to ground. Tube type OB2WA contains a small amount of radioactive material and is potentially hazardous. Contact qualified medical personnel immediately in case of an accidental cut. For further information and for disposal of defective type OB2WA tubes, refer to TB SIG 225.

#### 32. General Instructions

Troubleshooting at field and depot maintenance level includes all techniques outlined for organizational maintenance and any special or additional techniques required to isolate a defective part. The field and depot maintenance procedures are not complete in themselves but supplement the procedures described in organizational maintenance. The systematic troubleshooting procedure, which begins with the operational checks that can be performed at an organizational level, must be completed by means of sectionalizing, localizing, and isolating techniques.

#### 33. Troubleshooting Procedures

*a. General.* The first step in servicing a defective radio set control is to sectionalize the fault. Sectionalization means tracing the fault to a major circuit responsible for abnormal operation. The second step is to localize the fault. Localization means tracing the fault to a defective part responsible for the abnormal condition. Some faults,

such as burned-out resistors can often be located by sight or smell. The majority of faults, however, must be localized by checking voltages and resistance.

*b. Sectionalization.* Listed below is a group of tests arranged to reduce unnecessary work, and to aid in tracing trouble in a defective radio set control. The first step is to locate the unit or units at fault by the following methods:

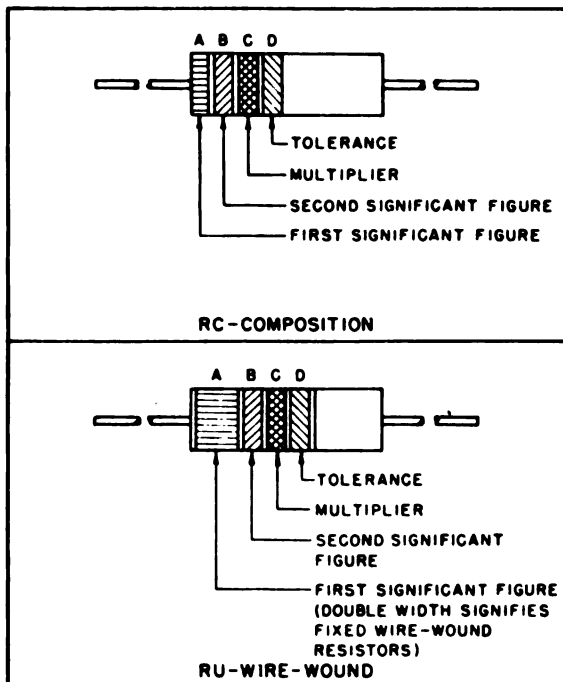
- (1) *Visual inspection.* Visual inspection helps to locate faults without testing or measuring circuits. All visual signs should be observed and an attempt made to sectionalize the fault to a particular circuit.
- (2) *Operational tests.* Operational tests frequently indicate the general location of trouble. In many instances, these tests will help in determining the exact nature of the fault. The equipment performance check list (par. 19) is a good operational test. Additional operational tests are given in paragraph 36.

*c. Localization.* The tests listed below will aid in isolating the trouble. First, localize the trouble to a single stage or circuit, and then isolate the trouble within that circuit by voltage, resistance, and continuity measurements. Use the following methods of trouble localization:

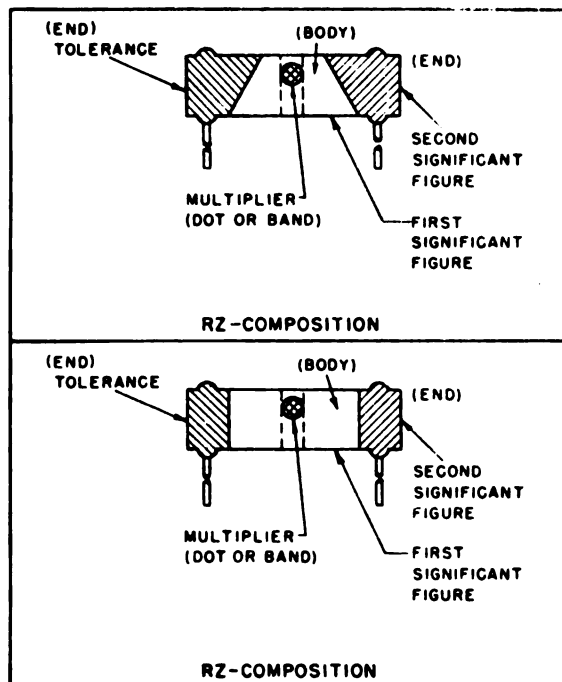
- (1) *Voltage and resistance measurements.* These measurements will help locate the individual component at fault. Use resistor and capacitor color codes (figs. 18 and 19) to find the value of the components. Use the voltage and resistance diagram (fig. 20) to find normal readings, and compare them with readings taken.

## RESISTOR COLOR CODE MARKING (MIL-STD RESISTORS)

### AXIAL-LEAD RESISTORS (INSULATED)



### RADIAL-LEAD RESISTORS (UNINSULATED)



## RESISTOR COLOR CODE

BAND A OR BODY*		BAND B OR END*		BAND C OR DOT OR BAND*		BAND D OR END*	
COLOR	FIRST SIGNIFICANT FIGURE	COLOR	SECOND SIGNIFICANT FIGURE	COLOR	MULTIPLIER	COLOR	RESISTANCE TOLERANCE (PERCENT)
BLACK	0	BLACK	0	BLACK	1	BODY	$\pm 20$
BROWN	1	BROWN	1	BROWN	10	SILVER	$\pm 10$
RED	2	RED	2	RED	100	GOLD	$\pm 5$
ORANGE	3	ORANGE	3	ORANGE	1,000		
YELLOW	4	YELLOW	4	YELLOW	10,000		
GREEN	5	GREEN	5	GREEN	100,000		
BLUE	6	BLUE	6	BLUE	1,000,000		
PURPLE (VIOLET)	7	PURPLE (VIOLET)	7				
GRAY	8	GRAY	8	GOLD	0.1		
WHITE	9	WHITE	9	SILVER	0.01		

\* FOR WIRE-WOUND-TYPE RESISTORS, BAND A SHALL BE DOUBLE-WIDTH WHEN BODY COLOR IS THE SAME AS THE DOT (OR BAND) OR END COLOR, THE COLORS ARE DIFFERENTIATED BY SHADE, GLOSS, OR OTHER MEANS.

#### EXAMPLES (BAND MARKING):

10 OHMS  $\pm 20$  PERCENT: BROWN BAND A, BLACK BAND B, BLACK BAND C; NO BAND D.  
4.7 OHMS  $\pm 5$  PERCENT: YELLOW BAND A, PURPLE BAND B; GOLD BAND C; GOLD BAND D.

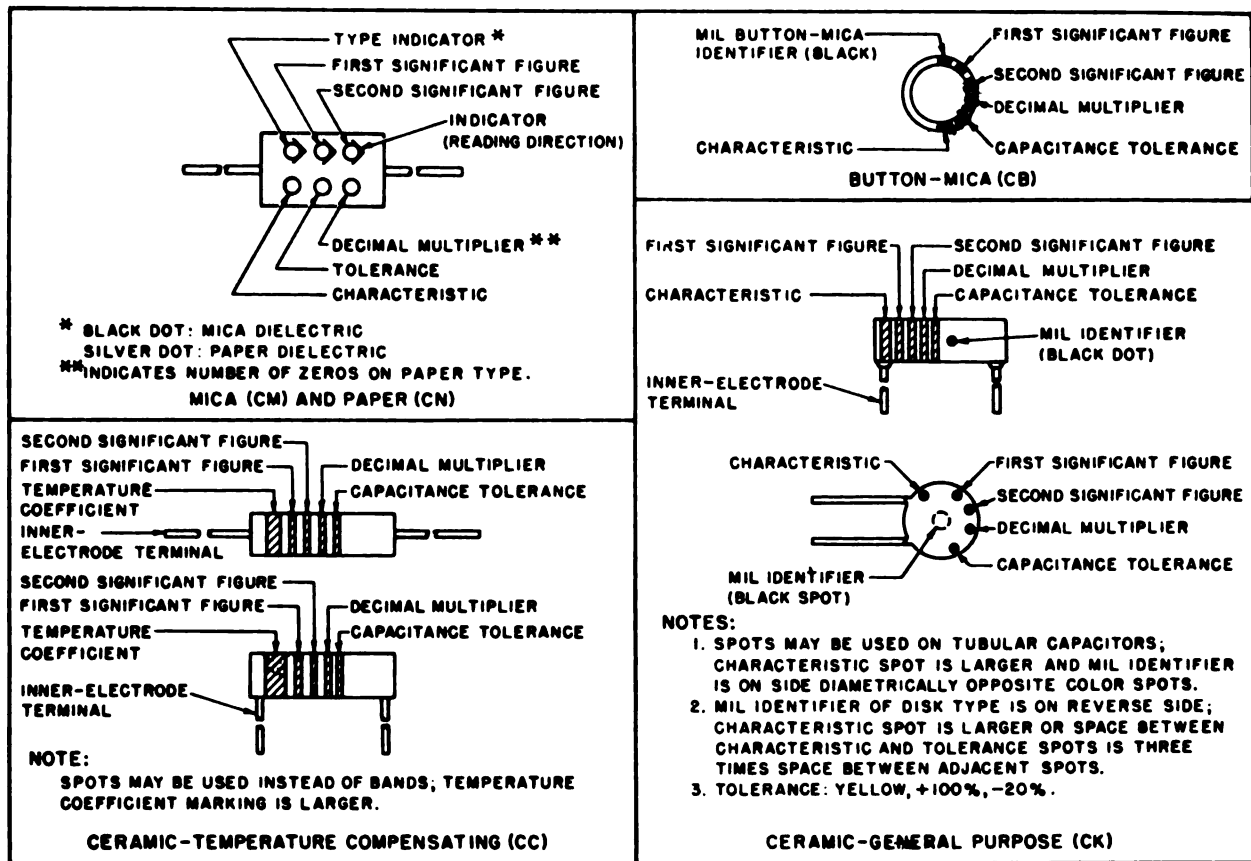
#### EXAMPLES (BODY MARKING):

10 OHMS  $\pm 20$  PERCENT: BROWN BODY, BLACK END; BLACK DOT OR BAND, BODY COLOR ON TOLERANCE END.  
3,000 OHMS  $\pm 10$  PERCENT: ORANGE BODY, BLACK END; RED DOT OR BAND, SILVER END.

STD-R1

Figure 18. MIL-STD resistor color codes.

## CAPACITOR COLOR CODE MARKING (MIL-STD CAPACITORS)



### CAPACITOR COLOR CODE

COLOR	SIG FIG.	MULTIPLIER		CHARACTERISTIC				TOLERANCE 2					TEMPERATURE COEFFICIENT (UUF/UF/°C)
		DECIMAL	NUMBER OF ZEROS	CM	CN	CB	CK	CM	CN	CB	CC		
											OVER 10UUF	10UUF OR LESS	
BLACK	0	1	NONE		A			20	20	20	20	2	ZERO
BROWN	1	10	1	B	E	B	W				1		-30
RED	2	100	2	C	H		X	2		2	2		-80
ORANGE	3	1,000	3	D	J	D			30				-150
YELLOW	4	10,000	4	E	P								-220
GREEN	5		5	F	R						5	0.5	-330
BLUE	6		6		S								-470
PURPLE (VIOLET)	7		7		T	W							-750
GRAY	8		8			X						0.25	+30
WHITE	9		9								10	1	-330(±500) 3
GOLD		0.1						5		5			+100
SILVER		0.01						10	10	10			

1. LETTERS ARE IN TYPE DESIGNATIONS GIVEN IN MIL-C SPECIFICATIONS.  
 2. IN PERCENT, EXCEPT IN UUF FOR CC-TYPE CAPACITORS OF 10 UUF OR LESS.  
 3. INTENDED FOR USE IN CIRCUITS NOT REQUIRING COMPENSATION.

STD-C1

Figure 19. MIL-STD capacitor color codes.



- (2) *Troubleshooting chart.* The trouble symptoms listed in the chart (par. 36d) will aid in localizing trouble to a component part.
- (3) *Intermittent troubles.* In all these tests, the possibility of intermittent troubles should not be overlooked. If present, this type of trouble often may be made to appear by tapping or jarring the equipment. Check the wiring and connections to the associated receiver, transmitter, and local telephone.

### 34. Test Equipment Required

The following chart lists the test equipment required for troubleshooting and final testing (pars. 40 and 41) the radio set control. Associated technical manuals and assigned common names are also listed.

Test equipment	Technical manual	Common name
Electronic Voltmeter ME-30B/U.	TM 11-5132	Vtvm.
Signal Generator SG-15/PCM.	TM 11-2096	Signal generator.
Frequency Meter FR-67/U.	TM 11-2698	Frequency meter.
Electron Tube Test Set TV-2/U.	TM 11-2661	Tube tester.
Audio Oscillator TS-382/U.	TM 11-2684	Audio oscillator.
Telephone Set TA-43/PT.	TM 11-337	Field telephone.
Multimeter ME-77/U.*	-----	Multimeter.
150 ohm, 1 watt resistor.		
2,000 ohm, 1 watt resistor.		
20 uf capacitor.		
Connector U-79/U.		

\*Multimeter TS-297/U may be used until Multimeter ME-77/U becomes available.

## Section II. TROUBLESHOOTING

### 35. Checking Filament and B+ Circuits for Shorts

*a. When to Check.* When any of the following conditions exist, check for short circuits and clear the troubles before applying power.

- (1) When the nature of the trouble symptom is not known.
- (2) When trouble symptoms reported from operational tests indicate possible power supply troubles.

*b. Conditions for Tests.* To prepare for the short-circuit tests—

- (1) Remove the control unit from its case.
- (2) Leave all cords and lines disconnected from the radio set control during all resistance checks.

*c. Measurements.* Make the resistance measurements indicated in the following chart. Resistances can vary between equipments. More than 20 per cent difference with the chart indications should be considered abnormal. If abnormal results are obtained, perform the additional isolating procedures outlined. When the faulty part is found, repair the trouble before applying power to the unit.

Points of measurement	Normal indication	Isolating procedure
Terminal A to terminal C of POWER connector.	With S1 in OFF or DC positions infinite resistance. With S1 in AC position, 17 ohms (S2 at 115V) or 63 ohms (S2 at 230V).	Check wiring; connector J2.  Check T1 primary; check S1 and S2.  If infinite check F1.
Terminal A or C to terminal B of POWER connector.	Infinite resistance regardless of S1 position.	Check POWER connector, wiring, T1 primary as indicated by S1 position.
Terminal D to terminal B of POWER connector.	With S1 in OFF or AC position, infinite resistance. With S1 in DC position, 95 ohms.	Check wiring, connector J2.  Check F2, FL1, S1, and vibrator coil.
Junction of CR6, CR7, and L3 to ground.	35,000 ohms; charge of filter capacitor will occur.	If resistance is low, check capacitors C11A and B. Check rectifiers CR5-CR8. If resistance is high, check L3, R6, R7, seating of J1 and P1, R38, R44, and R19.
Filament terminals of tubes.	Resistances as indicated on figure 20.	Remove tubes as necessary to establish exact location of defect.

### 36. Localizing Troubles

a. *General.* In the troubleshooting chart (*d* below), procedures are outlined for localizing troubles to a stage within the radio set control. Parts locations are indicated in figures 21, 22, and 23. The overall schematic diagram is shown in figure 25. Voltage and resistance measurements at tube sockets are shown in figure 20. Coil resistances are given in paragraph 37. Depending on the nature of the operational symptoms, one or more of the localizing procedures will be necessary. When trouble has been localized to a particular stage, use voltage and resistance measurements to isolate the trouble to a particular part.

b. *Use of Chart.* The troubleshooting chart supplements the equipment performance check

#### d. Troubleshooting Chart.

*Note.* To determine if a relay clicks, touch the fingers lightly to the relay. If the indication is not positive, use a long-bladed, heavy screw driver as a stethoscope.

list (par. 19). If no operational symptoms are known, begin with item 1 of the equipment performance check list and proceed until a symptom of trouble appears.

*Caution:* If operational symptoms are not known or if they indicate the possibility of short circuits within the test set, make the short-circuit check described in paragraph 35 before applying power to the control unit.

c. *Conditions for Tests.* All checks outlined in the chart are to be conducted with the radio set control connected in accordance with installation instructions given in paragraph 11. A field telephone (such as Telephone Set TA-43/PT) may be connected to the LINE terminals instead of the switchboard listed in paragraph 11.

Item No.	Symptom	Probable trouble	Correction
1	With monitor switch held in R RADIO & MON position: a. Radio transmitter does not turn on; no 1,600-cps tone in monitor handset. b. Radio transmitter does not turn on; 1,600-cps tone in monitor handset. c. Radio transmitter turns on; no tone in monitor handset.	a. Relay K3 or K4 defective..... Tube V6 or V8 defective..... Defective monitor switch S4..... b. Relay K4 defective..... Contacts 3 and 4 of K3 defective. RADIO cable to transmitter defective. c. Defective tube V7 or V4..... Defective K3..... Defective handset..... Defective transformer T2 winding F or C.	a. Replace K3 or K4. Replace V6 or V8. Replace switch S4. b. Replace K4. Replace K3.  Replace cable. c. Replace V7 or V4. Replace K3. Replace handset. Replace transformer T2.
2	With monitor switch in T RADIO & MON position: a. Monitor handset button pressed, transmitter does not go on. b. Monitor handset button pressed, transmitter on, no sidetone heard. c. Monitor handset button released and incoming voice signal not heard. d. Monitor handset button released and K2 (if used) does not click.	a. First and third items of 1 b above. Defective monitor handset switch. Defective monitor switch..... b. Defective transformer T2, winding A. Defective tube V7..... Defective handset receiver..... c. Squelch circuit in radio receiver improperly adjusted. Defective RADIO cable or connections to receiver. Defective transformer T2, winding D, E. Defective tube V7..... Defective handset..... d. Relay K2 defective.....	a. First and third items of 1 b above. Replace handset. Replace S4. b. Replace transformer T2.  Replace V7. Replace handset. c. Adjust squelch circuit in radio receiver. Check RADIO cable connections to radio receiver. Replace T2.  Replace V7. Check handset and replace. d. Replace K2.

d. Troubleshooting Chart—Continued

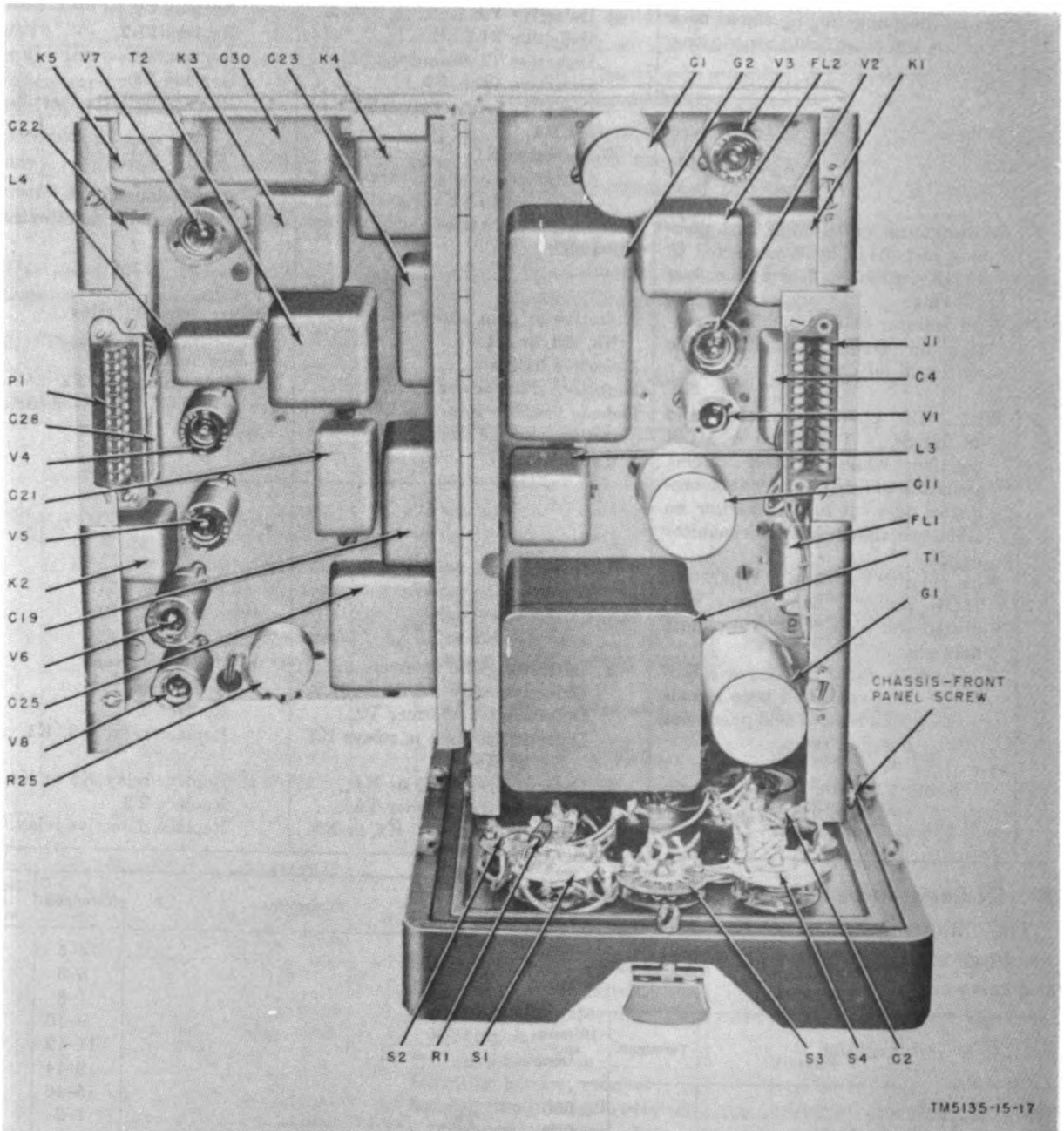
Item No.	Symptom	Probable trouble	Correction
	With monitor switch in T RADIO & MON position—Continued e. Incoming ringing signal does not cause field phone to ring.	e. Defective V2..... Defective FL2..... Defective T1 secondary..... Defective tube V3..... Defective bridge network CR1-CR4. Defective K1..... Defective ringing generator G2. Defective LINE connections...	e. Replace V2. Replace FL2. Replace T1. Replace V3. Replace defective rectifier.  Replace K1. Replace G2. Check connections.
3	With monitor switch in R TEL position and field phone connected to LINE terminals, field phone does not ring.	Last 5 items of 2 e above and monitor switch.	Check and replace monitor switch.
4	With monitor switch in T TEL position no communication possible with field telephone.	Defective or poor contacts in relays K2, K3, or K1. Defective handset..... Defective transformer T2.....	Replace defective relay.  Replace handset. Replace transformer T2.
5	With field phone connected and switch S4 in T RADIO & MON position, while cranking ringing generator of field phone radio transmitter does not turn on and/or no 1,600-cps signal heard in monitor handset.	Defects listed in item 1 above. Defective bridge rectifiers CR14 through CR17.	See 1 above. Replace defective rectifiers.
6	With monitor switch in T RADIO & MON position, field phone connected and radio talking to remote field phone: a. With radio in receive condition voice and beep signals from remote field phone not heard in radio. b. With radio in transmit condition beep signal not heard in radio.	a. Defective radio receiver..... Defective relay K2 (if used).... Defective transformer T2..... Defective contact in relays K3, K1, or K4. b. Defective relay K5 or K4..... Defective transformer T2..... Defective relay K1, K2, or K3..	a. Check receiver. Replace K2. Replace T2. Replace relay K3, K1, or K4.  b. Replace relay K5 or K4. Replace T2. Replace defective relay.

37. Dc Resistances of Transformers and Coils

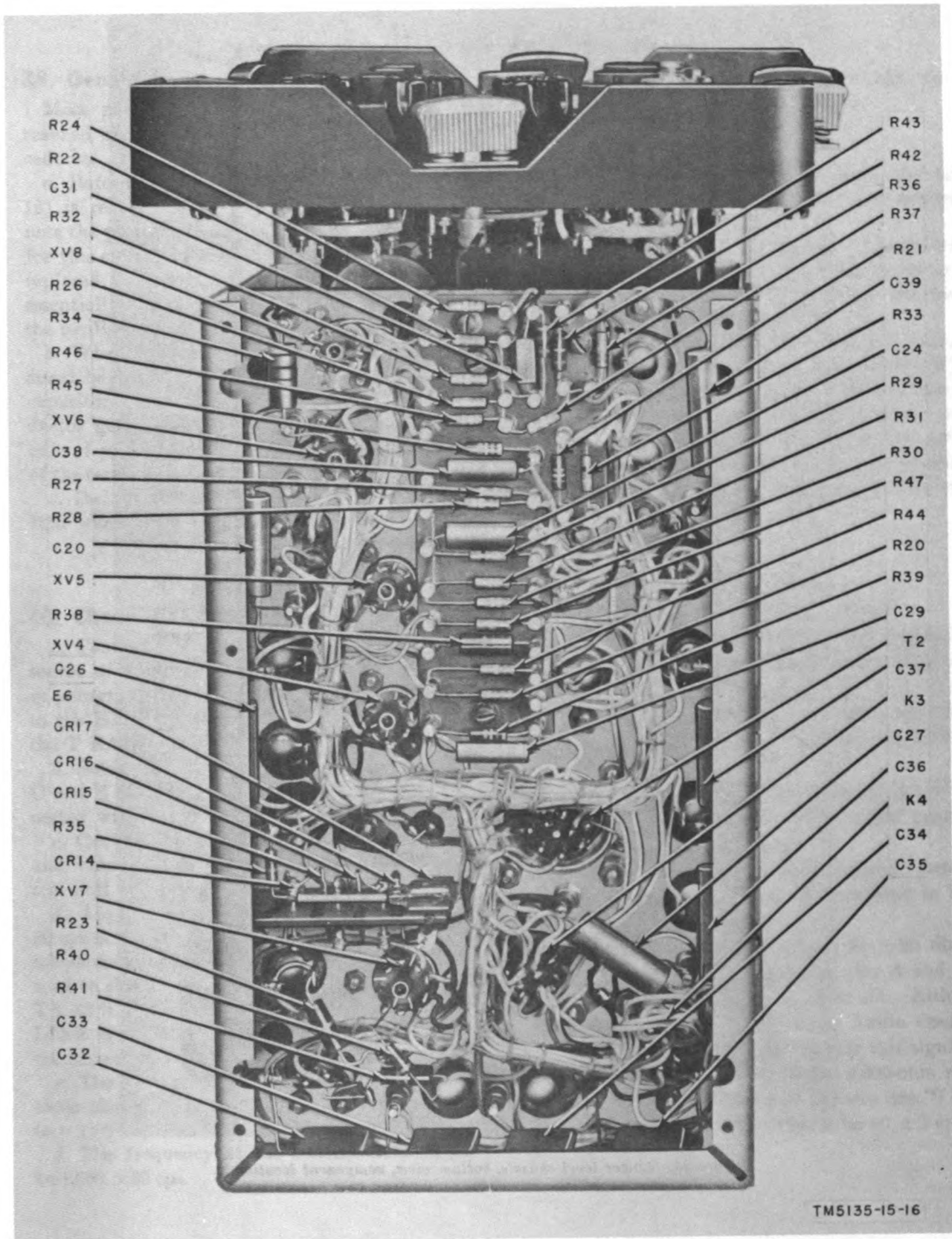
The following table lists the resistance of the windings of the various transformers, inductors, and relay coils.

Component	Terminals	Dc resistance in ohms
K1.....	1-10	5,000
K2.....	1-5	5,000
K3.....	1-10	5,000
K4.....	1-10	1,000
K5.....	1-2	500
	5-6	500
L1, L2.....		2
L3.....	1-2	630
L4.....	1-2	490
T1.....	1-2	17
	2-3	29

Component	Terminals	Dc resistance in ohms
T1.....	4-5	1.5
	5-6	1.5
	7-8	68
	9-10	70
	11-12	14
	13-14	2
T2.....	15-16	70
	1-2	62
	3-4	29
FL1.....	4-5	12
	6-7	3
	8-9	1,650
FL2.....	10-11	1,800
	1-3	75
G1.....	1-2	25
	3-4	25
	1-4	95

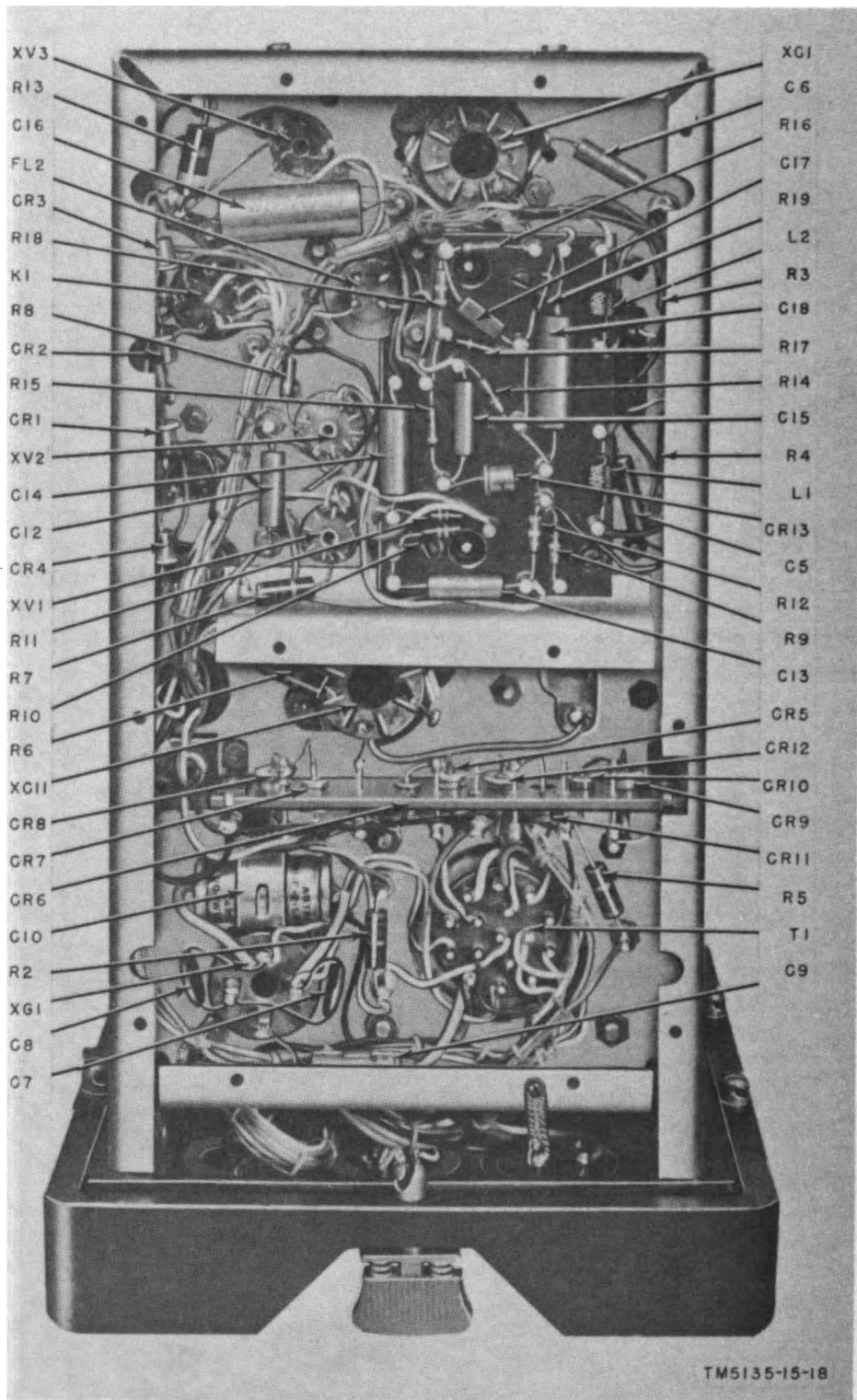


**Figure 21. Control unit, upper level chassis swung open, component location.**



TM5135-15-16

Figure 22. Upper level chassis, top view, component location.



**Figure 23. Lower level chassis, bottom view, component location.**



## Section III. REPAIRS

### 38. General Parts Replacement Techniques

Most parts of the radio set control can be reached easily and replaced without special procedures. The following precautions apply:

a. Before any component listed under Z1 (fig. 12) is removed from the V7B oscillator circuit, note the position of the part and its leads. Parts for this circuit come in matched sets and must be replaced as a group. Wire replacement parts in essentially the same position to avoid changing the oscillator frequency.

b. When feedthrough capacitors are being soldered, be careful to prevent the glass portion of the capacitor from cracking when the center conductor gets hot. Grasp the central lead with a pair of pliers between the glass bead and the eye of the terminal before applying heat.

c. Do not disturb the adjustment of resistor R25 when removing nearby components. This

setting should be changed only when gate generator V5 is being adjusted (par. 117).

### 39. Disassembly

a. *To Remove Outer Case.* Loosen the six Dzus fasteners on the front panel and remove case.

b. *To Separate the Two Chassis.* Loosen the two fasteners accessible through holes in the upper level chassis (fig. 3). Also loosen the two screws fastening the backplate.

c. *Removal of Bottom Plate.* To gain access to components in the lower level chassis (fig. 23), remove the 12 screws that hold the bottom plate.

d. *Removal of Front Panel.* Remove six chassis-to-front panel screws (fig. 21) on the right and left sides of the front panel. In separating the panel from the chassis do not strain the connecting wires and cables.

## Section IV. FINAL TESTING

### 40. Check of 1,600-Cps Output Level

a. Connect the control unit to the available source of power in accordance with instructions in paragraph 11a. Set the C. O. POWER switch to the EXT. position and the monitor switch to the T RADIO & MON position.

b. Solder the 150-ohm resistor across terminals C and E of a U-79/U connector. Mate this connector with either RADIO receptacle J3 or J4.

c. Connect the field telephone, frequency meter and vacuum tube voltmeter (vtvm) to the control unit and resistor as shown in A, figure 24.

d. Apply a signal of 20 volts  $\pm$ 2 volts rms at 20 cps across the LINE terminals. Either a field telephone or Audio Oscillator TS-382/U may be used to supply this voltage. If a Telephone Set TA-43/PT is used, measure the output across the LINE terminals with a vtvm to make sure that the correct voltage is supplied.

e. The voltage output across the 150-ohm resistor should be between .1 and .2 volts rms ( $-6$  to  $-11$  dbm).

f. The frequency at the resistive load should be  $1,600 \pm 20$  cps.

### 41. Check of 20-Cps Output Level

a. Connect the control unit to the available source of power and set switches as described in paragraph 40a.

b. Connect the 20 microfarad (uf) capacitor and 2,000-ohm resistor in series across the LINE terminals.

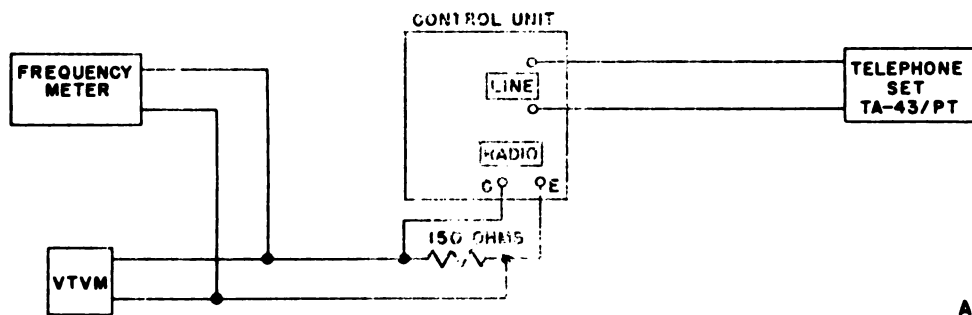
c. Attach a U-79/U connector to either RADIO receptacle J3 or J4 and connect the signal generator to terminals A and B.

d. Connect the vtvm and frequency meter across the 2,000-ohm resistor as illustrated in B, figure 24.

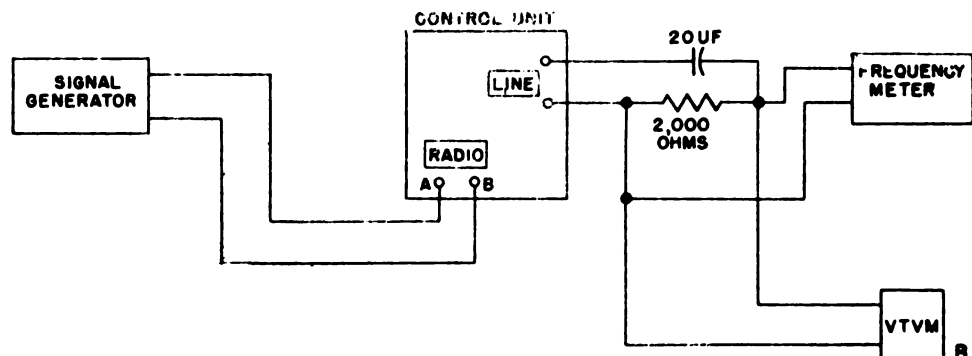
e. Apply a signal of 1,600 cps at  $-20$  dbm (77.5 millivolts (mv), rms) across pins A and B of either RADIO receptacles J3 or J4. Either Signal Generator SG-15/PCM or Audio Oscillator TS-382/U may be used to apply this signal.

f. The output voltage across the 2,000-ohm resistor should be a minimum of 40 volts rms.

g. The output frequency should be  $20 \pm 2$  cps.



A



B

TM5135-15-25

Figure 24. Test equipment connections for final tests.



## CHAPTER 6

### SHIPMENT AND LIMITED STORAGE AND DEMOLITION TO PREVENT ENEMY USE

#### Section I. SHIPMENT AND LIMITED STORAGE

#### 42. Disassembly of Equipment

*a.* Disconnect all cables from the control unit and from the power source and associated receivers and transmitters. Wind the cables and tie them in coils. Place the coiled cables in the canvas bag.

*b.* Remove the control unit from the mounting and then unbolt Mounting MT-791/U from its fixed position. Remount the control unit on the mounting.

#### 43. Repackaging for Shipment or Limited Storage

The exact procedure for repackaging depends on the material available and the conditions under which the equipment is to be shipped or stored. Use the procedures outlined below whenever possible.

##### *a. Material Requirements.*

- (1) The following materials are required for packaging the radio set:

Material	Quantity
Corrugated cardboard .....	10 sq ft.
Filler material .....	3 lb.
Gummed tape .....	5 ft.
Waterproof paper .....	15 sq ft.
Metal strapping .....	15 ft.

- (2) Construct a wooden box the inside dimensions of which are approximately 15 by 15 by 18 inches.

##### *b. Packaging.*

- (1) Cushion the control unit on its mount on all surfaces with pads of filler material. Place the cushioned unit within a wrap of corrugated cardboard. Secure the wrap with gummed tape.
- (2) In similar fashion, wrap the running spares.
- (3) Line the inside of the wooden box with waterproof paper.
- (4) Place the packaged control unit and mount, the canvas bag with cables, and the package of running spares in the wooden box.
- (5) Fill excess space in the box with pads of corrugated cardboard and filler material.
- (6) Use metal strapping around the box if intertheater shipment is intended.

## Section II. DEMOLITION OF MATERIEL TO PREVENT ENEMY USE

### 44. Authority for Demolition

Demolition of the equipment will be accomplished only upon the order of the commander. The destruction procedures outlined in paragraph 45 will be used to prevent further use of the equipment.

### 45. Methods of Destruction

Use any or all of the following methods to destroy the equipment.

*a. Smash.* Smash the controls, tubes, switches, capacitors, and transformers; use sledges, axes,

handaxes, pickaxes, hammers, or crowbars.

*b. Cut.* Cut the signal and power cords; use axes, handaxes, or machetes.

*c. Burn.* Burn cords and technical manuals; use gasoline, kerosene, oil, flame throwers, or incendiary grenades.

*d. Bend.* Bend panel and cabinet.

*e. Explode.* If explosives are necessary, use firearms, grenades, or TNT.

*f. Dispose.* Bury or scatter the destroyed parts in slit trenches, fox holes, or throw them into streams.

## APPENDIX I

### REFERENCES

---

Following is a list of applicable references for the operator, unit repairman, and field and depot maintenance repairman for Radio Set Control AN/GSA-7.

TM 11-284----- Radio Sets AN/GRC-3, -4, -5, -6, -7, and -8.

TM 11-337----- Telephone Sets TA-43/PT and TA-263/PT.

TM 11-612----- Radio Sets AN/PRC-8, -8A, -9, -9A, -10, -10A, and -28, Operation and Organizational Maintenance.

TM 11-4065A---- Radio Sets AN/PRC-8A, -9A, -10A, and -28, Field Maintenance.



**APPENDIX II**  
**MAINTENANCE ALLOCATION CHART**  
**FOR**  
**CONTROL, RADIO SET AN/GSA-7**

---

**Section I. PREFACE**

**1. General**

a. The maintenance allocation portion of the Technical Manual assigns maintenance functions and repair operations to be performed by the lowest appropriate maintenance echelon.

b. The lists in Section II are presented in columns titled as follows:

(1) **PART OR COMPONENT.** Only the nomenclature or standard item name is annotated in this column. Additional descriptive data is included only where clarification is necessary to identify the part. Components and parts comprising a major end item are listed alphabetically. Assemblies and sub-assemblies are in alphabetical sequence with their components listed alphabetically immediately below the assembly listing.

(2) **RELATED OPERATION.** This column indicated the various maintenance functions allocated to the echelon capable of performing the operation. These are defined as follows:

- (a) **Service.** To clean, to preserve, and to replenish fuel and lubricants.
- (b) **Adjust.** To regulate periodically to prevent malfunction.
- (c) **Inspect.** To verify serviceability and to detect incipient electrical or mechanical failure by scrutiny.
- (d) **Test.** To verify serviceability and to detect incipient electrical or mechanical failure by use of special equipment such as gages, meters, etc.
- (e) **Replace.** To substitute serviceable assemblies, sub-assemblies, and parts for unserviceable components.
- (f) **Repair.** To restore to a serviceable condition by replacing unserviceable parts or by any other action required utilizing tools, equipment and skills available, to include welding, grinding, riveting, straightening, adjusting, etc.
- (g) **Align.** To adjust two or more components of an electrical system so that their functions are properly synchronized.
- (h) **Calibrate.** To determine, check, or rectify the graduation of an instrument, weapon, or weapons system, or components of a weapons system.
- (i) **Rebuild.** To restore to a condition comparable to new by disassembling the item to determine the condition of each of its component parts and reassembling it using serviceable, rebuilt, or new assemblies, sub-assemblies, and parts.

(3) **ECHELON ALLOCATED THE MAINTENANCE OPERATION.** The symbol "X" placed in the appropriate column indicates the echelon responsible for performing that particular maintenance operation, but does not necessarily indicate that repair parts will be stocked at that level. Echelons higher than the echelon marked by "X" are authorized to perform the indicated operation.

(4) REPAIR FACILITIES CODE. Code numbers are assigned to each individual tool equipment, test equipment and maintenance equipment referenced under "Inclosure To The Maintenance Allocation Chart". The grouping of codes in the Repair Facilities Code Column of the Maintenance Allocation Chart indicates the tool, test and maintenance equipment required to perform the maintenance operation.

(5) REMARKS. Entries in this column will be utilized when necessary to clarify any of the data cited in the preceding columns.

(6) INCLOSURE TO THE MAINTENANCE ALLOCATION CHART.

(a) FACILITIES REQUIRED FOR MAINTENANCE OPERATIONS. Tools, test and maintenance equipment required to perform the maintenance functions are listed in this column and coded in the Repair Facilities Code column.

(b) ECHELON ALLOCATED THE FACILITY. The symbol "+" placed in the appropriate columns indicates the echelons allocated the facility.

2. Comments or Suggestions

Any comments concerning omissions and discrepancies in this appendix will be prepared on DA Form 2028 and forwarded directly to Commanding Officer, U. S. Army Signal Equipment Support Agency, Fort Monmouth, New Jersey, Attn: SIGFM/ES-ML.

**APPENDIX II  
MAINTENANCE ALLOCATION CHART, PART II, SECTION II**

PART OR COMPONENT	RELATED OPERATION	Echelons Allocated the Maintenance Operation							REPAIR FACILITIES CODE	REFERENCE
		OPERATOR		ORGANIZATIONAL			DEPOT			
		FIRST ECHELON	SECOND ECHELON	FIXED	THIRD ECHELON	FOURTH ECHELON	FIFTH ECHELON			
CONTROL, RADIO SET AM/GSA-7	service adjust inspect test	X			X					Performs continuity test, voltage check to determine condition of circuits, test tubes. Inspect external parts. Performs adjustments, align repaired equipment, trouble shoots by sectionalizing and localizing trouble to component parts. Makes all tests
			X		X			X	9 8 1,2,3,4,5,6,7	
			X							
			X							
CABLES	replace									
	align									
CAPACITORS	rebuild									
	repair									
CONNECTOR, PLUG	replace									
	service									
CONNECTOR, RECEPTACLE	replace									
	replace									
CRYSTAL UNIT, RECTIFYING	replace									
	test									
ELECTRON TUBE	replace									
	replace									
FILTER, BAND-PASS	replace									
	replace									
FUSE, CARTRIDGE	replace									
	replace									

APPENDIX II  
MAINTENANCE ALLOCATION CHART, PART II, SECTION II

PART OR COMPONENT	RELATED OPERATION	ECHELON ALLOCATED THE MAINTENANCE OPERATION							REPAIR FACILITIES CODE	REFERENCE
		OPERATOR		ORGANIZATIONAL			FIELD			
		FIRST ECHELON	SECOND ECHELON	FIXED	THIRD ECHELON	FOURTH ECHELON	FIFTH ECHELON			
AN/CMA-7 (continued)										
GENERATOR, BIASING, STATIC	test				X					
	replace				X					
ENDS	replace									
LAMP, GLOW	replace		X							
POST, BINDING	replace		X							
REACTOR	replace				X					
SOCKET, ELECTRON TUBE	replace				X					
SUPPRESSOR, ELECTRICAL NOISE	replace				X					
SWITCH, ROTARY	replace				X					
TRANSFORMERS	replace				X					
VIBRATOR, NON-SYNCHRONOUS	replace				X					



**APPENDIX II**  
**INCLOSURE TO THE**  
**MAINTENANCE ALLOCATION CHART, PART II, SECTION II**

FACILITIES REQUIRED FOR MAINTENANCE OPERATIONS	Echelons Allocated to the Facility					REPAIR FACILITIES CODE	REFERENCE		
	OPERATOR FIRST ECHELON	ORGANIZATIONAL		THIRD ECHELON	FIELD			FOURTH ECHELON	DEPOT FIFTH ECHELON
		TACTICAL	FIXED						
AN/GSA-7 (continued)									
MULTIMETER ME-77/U			†				1		
SHORT INSTRUMENT MULTIRANGE MX-1471/U			†				2		
TEST SET, ELECTRON TUBE TV-7/U			†				3		
TEST SET, ELECTRON TUBE TV-2/U					†		4		
VOLTMETER, METER ME-30/U					†		5		
SIGNAL GENERATOR SG-15/PCM					†		6		
FREQUENCY METER FR-67/U					†		7		
TOOL EQUIPMENT TE-41			†				8		
TOOL EQUIPMENT TE-113					†		9		

By Order of *Wilber M. Brucker*, Secretary of the Army:

**MAXWELL D. TAYLOR,**  
*General, United States Army,*  
*Chief of Staff.*

**Official:**

**HERBERT M. JONES,**  
*Major General, United States Army,*  
*The Adjutant General.*

**Distribution:**

**Active Army:**

ASA (2)  
 ONGB (1)  
 Technical Stf, DA (1) except CSigO (30)  
 Technical Stf Bd (1)  
 USA Arty Bd (1)  
 USA Armor Bd (1)  
 USA Inf Bd (1)  
 USA Air Def Bd (1)  
 USA Abn & Elct Bd (1)  
 USA Avn Bd (1)  
 USA Armor Bd Test Sec (1)  
 USA Air Def Bd Test Sec (1)  
 USA Arctic Test Bd (1)  
 USCONARC (5)  
 US ARADCOM (2)  
 OS Maj Comd (5)  
 Log Comd (5)  
 MDW (1)  
 Armies (5)  
 Corps (2)  
 USA Corps (Res) (1)

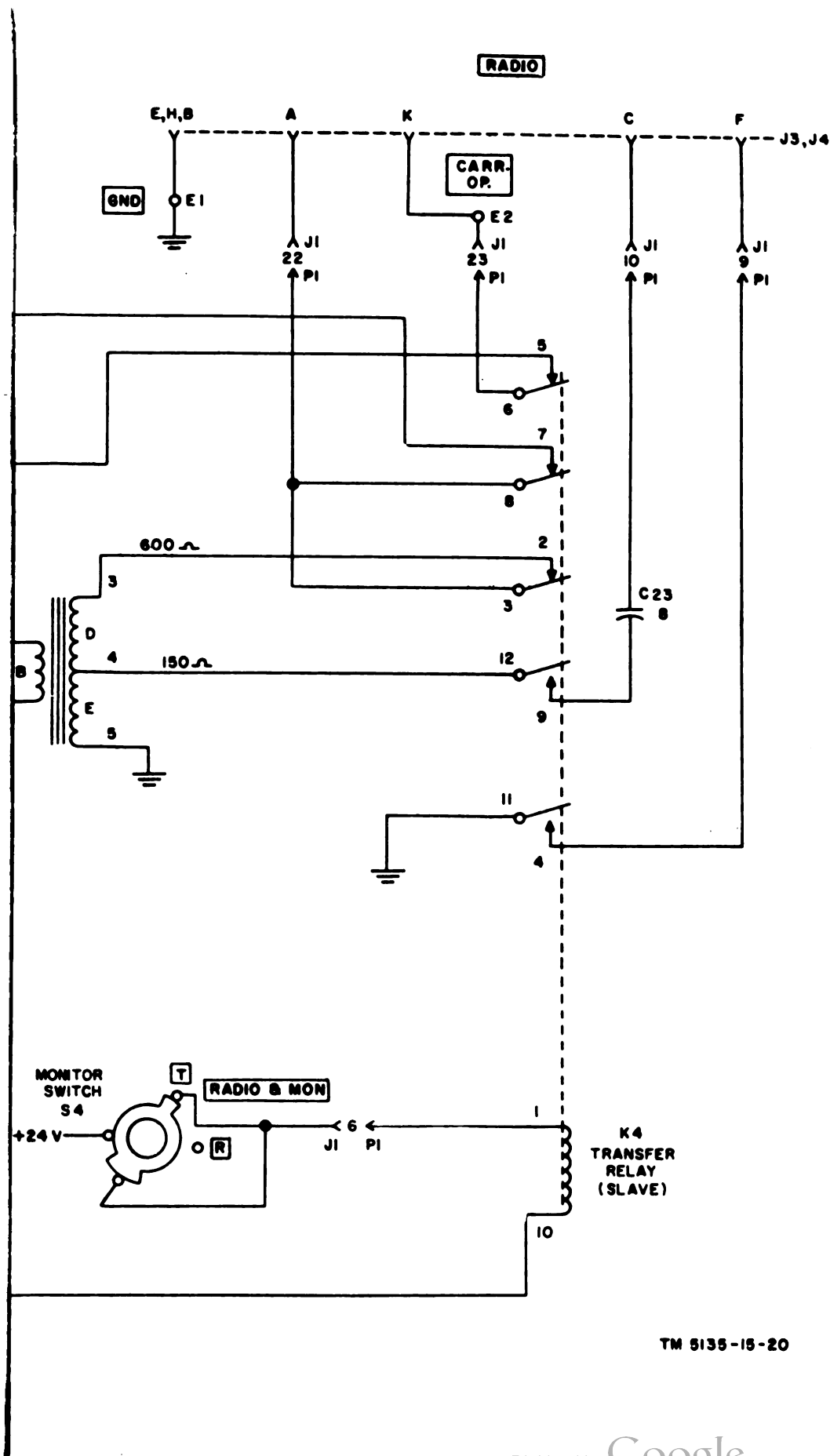
Div (2)  
 USATC (2)  
 Ft & Camps (2)  
 Svc Colleges (5)  
 Br Svc Sch (5) except USASCS (25)  
 Gen Depots (2) except Atlanta Gen Depot (None)  
 Sig Sec, Gen Depots (10)  
 Sig Depots (17)  
 Fld Comd, AFSWP (5)  
 Engr Maint Cen (1)  
 Army Pictorial Cen (2)  
 WRAMC (1)  
 AFIP (1)  
 AMS (1)  
 Port of Emb (OS) (2)  
 Trans Terminal Comd (2)  
 Army Terminals (2)  
 OS Sup Agcy (2)  
 USA Sig Pub Agcy (8)  
 USA Sig Comm Engr Agcy (1)

USA Comm Agcy (2)  
 TASSA (13), Chicago Rgn Ofc (1)  
 USA White Sands Sig Agcy (13)  
 USA Elct PG (1)  
 Sig Fld Maint Shops (3)  
 Sig Lab (5)  
 Mil Dist (1)  
 Sectors, USA Corps (Res) (1)  
 JBUSMC (2)  
 Units organized under following TOE's:  
 11-7  
 11-16  
 11-57  
 11-127  
 11-128  
 11-500 (AA-AB)  
 11-557  
 11-587  
 11-592  
 11-597

**NG:** State AG (6) units—same as Active Army except allowance is one copy to each unit.

**USAR:** None.

For explanation of abbreviations used, see AB 320-50.

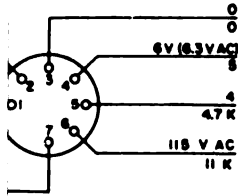


TM 5135-15-20

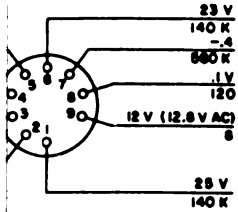


REAR

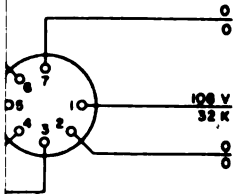
LAY CONTROL  
V3  
8696



L-LIMITER  
V2  
8614A



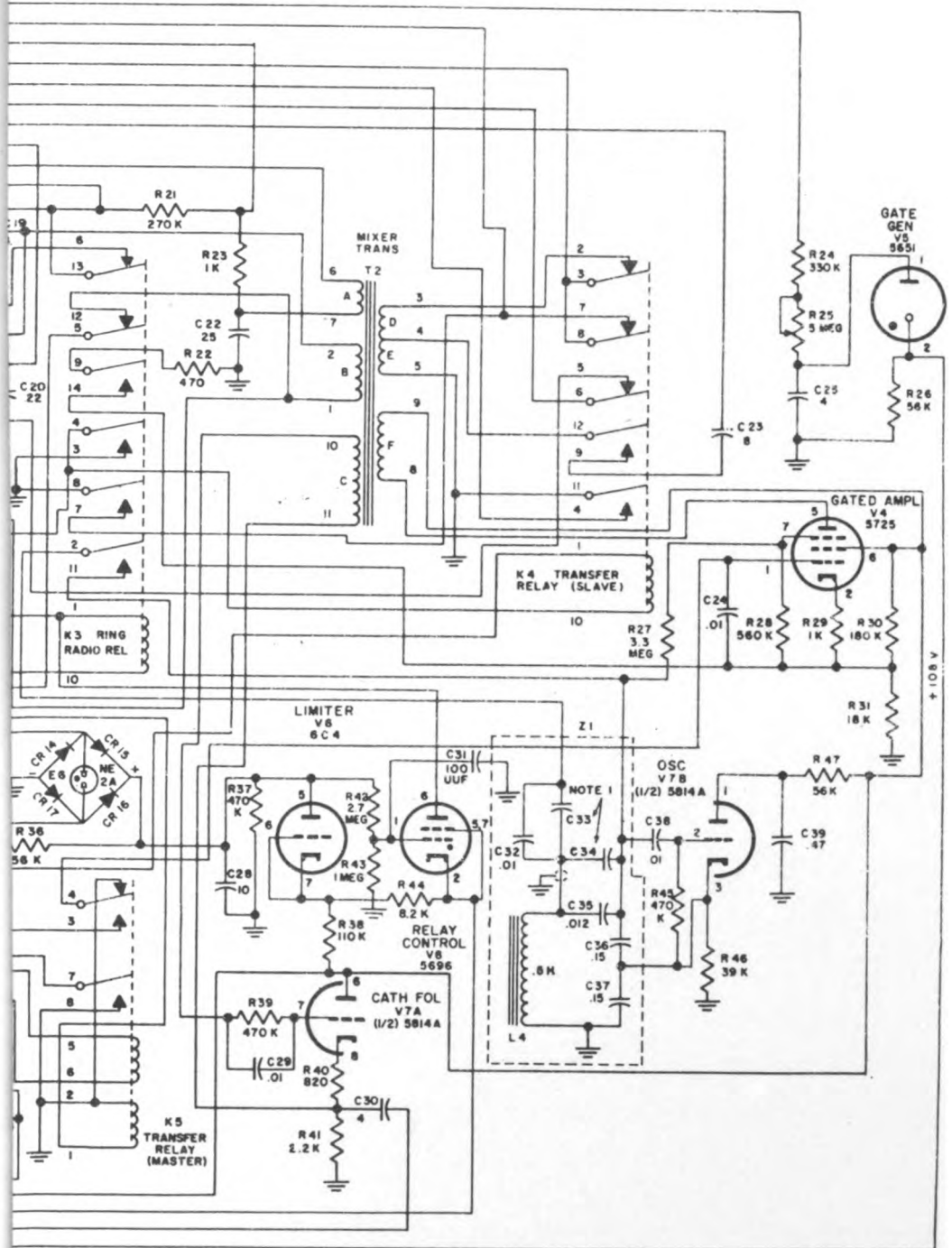
VR  
V1  
082WA



LOWER LEVEL CHASSIS

TM 8138-16-10

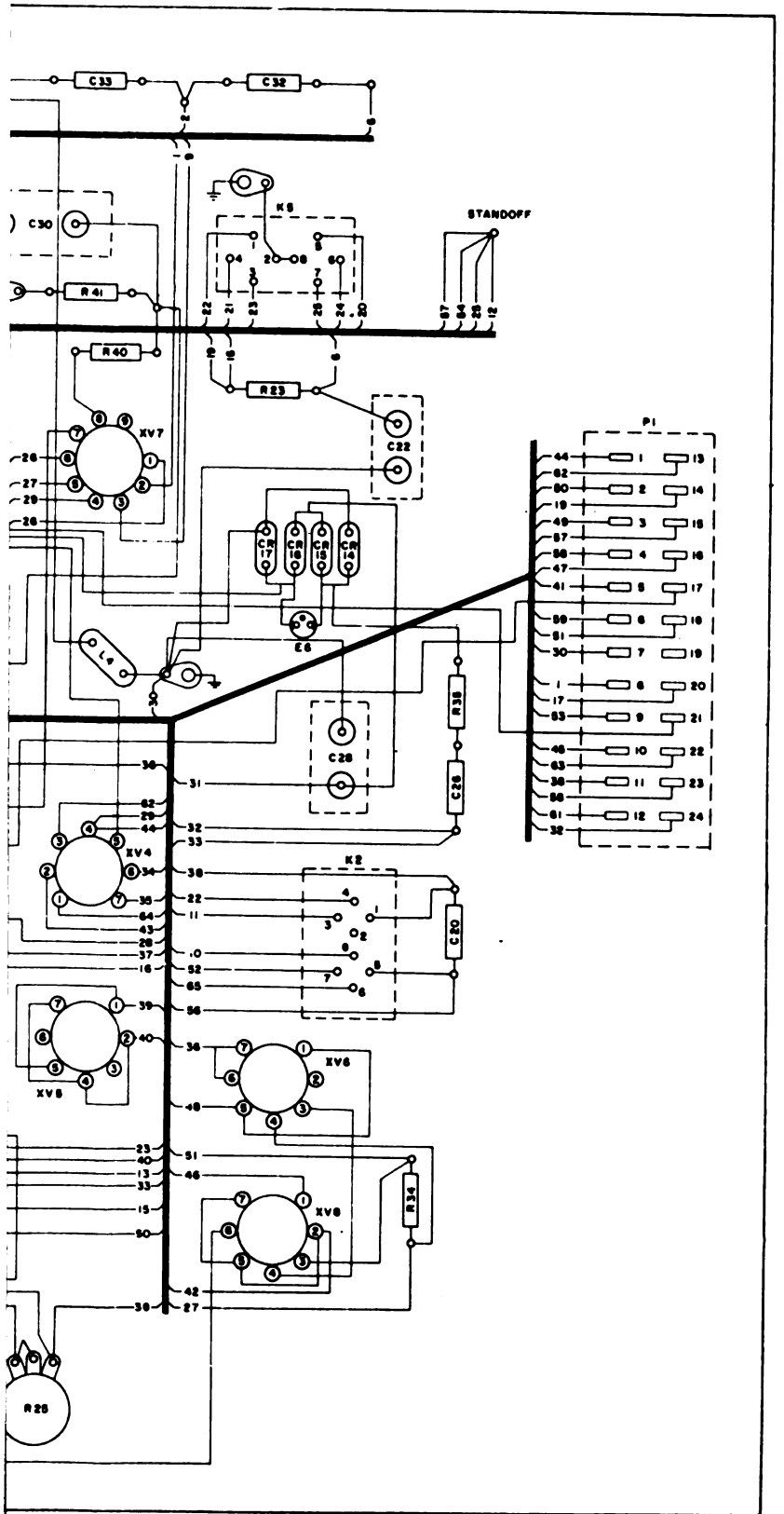




K1, K4







level chassis, wiring diagram.

TM 9135-15-25





