

60 W113
.2
TM
1944

TM 9-894

WAR DEPARTMENT, TECHNICAL MANUAL

U.S. Dept. of Army

11-TON PAYLOAD, 15-TON GROSS, 2-WHEEL (2dt), VAN SEMITRAILER

(OMAHA STANDARD BODY CORP. MODEL F16)

WAR DEPARTMENT

31 MAY 1944

Digitized by Google

Original from
UNIVERSITY OF CALIFORNIA

11-TON PAYLOAD,
15-TON GROSS, 2-WHEEL
(2dt), VAN SEMITRAILER
(OMAHA STANDARD BODY CORP. MODEL F16)



WAR DEPARTMENT

31 MAY 1944

WAR DEPARTMENT
Washington 25, D. C., 31 May 1944

TM 9-894, 11-ton Payload, 15-ton Gross, 2-wheel (2dt), Van Semi-trailer (Omaha Standard Body Corp. Model F16), is published for the information and guidance of all concerned.

[A.G. 300.7 (11 Apr 44)
O.O.M. 461/Rar. Ars. (3-6-44)]

BY ORDER OF THE SECRETARY OF WAR:

G. C. MARSHALL,
Chief of Staff.

OFFICIAL:

J. A. ULIO,
Major General,
The Adjutant General.

DISTRIBUTION: As prescribed in par. 9.a., FM 21-6; X.

(For explanation of symbols, see FM 21-6.)

CONTENTS

U113
.2
TM 9:894
1944

PART ONE—GENERAL

★

SECTION		Paragraphs	Pages
	I. Introduction	1- 2	4- 5
	II. Description and data	3- 4	6- 9

PART TWO—OPERATING INSTRUCTIONS

SECTION	III. Controls and operation	5- 6	10- 16
---------	-----------------------------------	------	--------

PART THREE—ORGANIZATIONAL MAINTENANCE INSTRUCTIONS

SECTION	IV. Lubrication	7- 8	17- 23
	V. First echelon preventive maintenance service	9-13	23- 28
	VI. Second echelon preventive maintenance	14	29- 38
	VII. Trouble shooting	15-23	38- 46
	VIII. Wheels, hubs, bearings, and tires	24-27	47- 55
	IX. Brake system	28-39	55- 78
	X. Spring and radius arm assemblies	40-42	79- 87
	XI. Axle	43-45	88- 91
	XII. Frame and body assembly	46-47	91- 96
	XIII. Electrical system	48-53	96-107
	XIV. Landing gear	54-57	107-112
	XV. Spare wheel and tire carrier	58-60	113-114

PART FOUR—ORDNANCE MAINTENANCE INSTRUCTIONS

SECTION	XVI. Brakes	61-62	115-117
	XVII. Axle	63-64	117-118
	XVIII. Body and frame	65-69	118-124
	XIX. Landing gear	70-74	124-127

APPENDIX

SECTION	XX. Shipment and temporary storage	75-77	128-131
	XXI. References	78-80	132-133
INDEX			134-138

TM 9-894

1-2

**11-TON PAYLOAD, 15-TON GROSS, 2-WHEEL (2dt), VAN
SEMITRAILER (OMAHA STANDARD BODY CORP. MODEL F16)**

PART ONE

GENERAL

Section I

INTRODUCTION

1. SCOPE.

a. These instructions are published for the information and guidance of the personnel to whom this equipment is assigned. This manual* contains information pertaining to the operation and maintenance of the 11-ton Payload, 15-ton Gross, 2-wheel (2dt), Van Semitrailer (Omaha Standard Body Corp. Model F16), as well as descriptions of the major units and their functions in relation to the other components of this equipment.

b. This manual is arranged in four parts.

(1) Part One, General, contains introduction, description, and data.

(2) Part Two, Operating Instructions, contains instructions for the operation of the vehicle.

(3) Part Three, Organizational Maintenance Instructions, contains information needed for the performance of the scheduled lubrication, preventive maintenance services, and instructions for maintenance operations which are the responsibility of the using organizations (first and second echelons).

(4) Part Four, Ordnance Maintenance Instructions, contains information for the guidance of the third and fourth echelon of maintenance.

c. Instructions for shipment and temporary storage, and a list of references which include standard nomenclature lists, technical manuals, and other ordnance publications applicable to the vehicle, are contained in the appendix.

2. RECORDS.

a. Forms and records applicable for use in performing prescribed operations are listed below with brief explanations of each.

(1) **STANDARD FORM NO. 26, DRIVER'S REPORT, ACCIDENT, MOTOR TRANSPORTATION.** One copy of this form will be kept with the vehicle at all times. In case of an accident resulting in injury or property damage, it will be filled out by the driver on the spot or as promptly as practical thereafter.

*To provide operating instructions with the materiel, this technical manual has been published in advance of complete technical review. Any errors or omissions will be corrected by changes or, if extensive, by an early revision.

INTRODUCTION

(2) **WAR DEPARTMENT FORM NO. 48, DRIVER'S TRIP TICKET AND PREVENTIVE MAINTENANCE SERVICE RECORD.** This form, properly executed, will be furnished to the driver when his vehicle is dispatched on nontactical missions. The driver and the official user of the vehicle will complete in detail appropriate parts of this form. These forms need not be issued for vehicles in convoy or on tactical missions. The reverse side of this form contains the driver's daily and weekly preventive maintenance service reminder schedule.

(3) **W.D., A.G.O. FORM NO. 478, MWO AND MAJOR UNIT ASSEMBLY REPLACEMENT RECORD.** This form will be used by all personnel completing a modification or major unit assembly replacement to record clearly the description of work completed, date, vehicle hours, and/or mileage, and MWO number or nomenclature of unit assembly. Personnel performing the operation will initial in the column provided. Minor repairs, parts, and accessory replacements will not be recorded.

(4) **W.D., A.G.O. FORM NO. 6, DUTY ROSTER.** This form, slightly modified, will be used for scheduling and maintaining a record of vehicle maintenance operations. It may be used for lubrication records.

(5) **W.D., A.G.O. FORM NO. 461, PREVENTIVE MAINTENANCE SERVICE AND TECHNICAL INSPECTION WORK SHEET FOR WHEELED AND HALF-TRACK VEHICLES.** This form will be used for all 1,000-mile (monthly) and 6,000-mile (semiannual) maintenance services and all technical inspections performed on wheeled or half-track vehicles.

(6) **W.D., O.O. FORM NO. 7353, SPOT-CHECK INSPECTION REPORT FOR ALL MOTOR VEHICLES.** This form may be used by all commanding officers or their staff representatives in making spot-check inspections on all vehicles.

(7) **W.D., A.G.O. FORM NO. 468, UNSATISFACTORY EQUIPMENT RECORD.** This form will be used for reporting manufacturing, design, or operational defects in materiel with a view to improving and correcting such defects, and for use in recommending modifications of materiel. This form will not be used for reporting failures, isolated materiel defects, or malfunctions of materiel resulting from fair wear and tear or accidental damage, nor for the replacement, repair, or the issue of parts and equipment. It does not replace currently authorized operational or performance records.

(8) **W.D., O.O. FORM NO. 7370, EXCHANGE PART OR UNIT IDENTIFICATION TAG.** This tag, properly executed, may be used when exchanging unserviceable items for like serviceable assemblies, sub-assemblies, parts, vehicles, and tools.

11-TON PAYLOAD, 15-TON GROSS, 2-WHEEL (2d+), VAN SEMITRAILER (OMAHA STANDARD BODY CORP. MODEL F16)

Section II

DESCRIPTION AND DATA

3. DESCRIPTION.

a. **General.** This semitrailer, having a van-type body, is designed to transport cargo (figs. 1 and 2). The semitrailer can be operated from any towing vehicle equipped with a conventional semi-automatic fifth wheel. This vehicle does not incorporate a hand brake, but provides chock blocks for use as a safety measure when the vehicle is uncoupled from the towing vehicle. The serial and model numbers are on a plate which is secured immediately to the rear of the frame drop on the right, or curb, side. A spare wheel and tire carrier is attached beneath the right-hand frame member. A retractable landing gear is attached to the frame at the point of the frame drop, or offset, and is operated by a worm screw and hand crank located on the right side of the frame. The body is constructed of wood and metal, permanently mounted on the frame. The frame is carried on a one-piece forged axle and slip-end, semielliptical, springs. The axle is held in alinement by means of adjustable radius arms equipped with rubber bushings and eccentric adjusting pins.

4. DATA.

a. **Specifications.**

Length, over-all	336 in.
Length, inside van, front center-to-rear	331 in.
Length, inside, straight wall	307 in.
Width, over-all	95½ in.
Width, inside van	88 in.
Height, over-all (loaded)	130¼ in.
Height, over-all (empty)	133½ in.
Height, inside van (roof center-to-floor)	76 in.
Height, inside van (side wall)	74¼ in.
Height at kingpin (empty)	48⅝ in.
Wheel size	20 in.
Rim width	8 in.
Tires:	
Size	10.00x20 in.
Inflation pressure	70 lb
Number of plies	12
Type of tread	Highway
Tread (center-to-center)	67 in.
Weight of vehicle (equipped)	8,000 lb
Maximum gross weight	30,000 lb
Ground clearance under raised landing gear	14½ in.

DESCRIPTION AND DATA

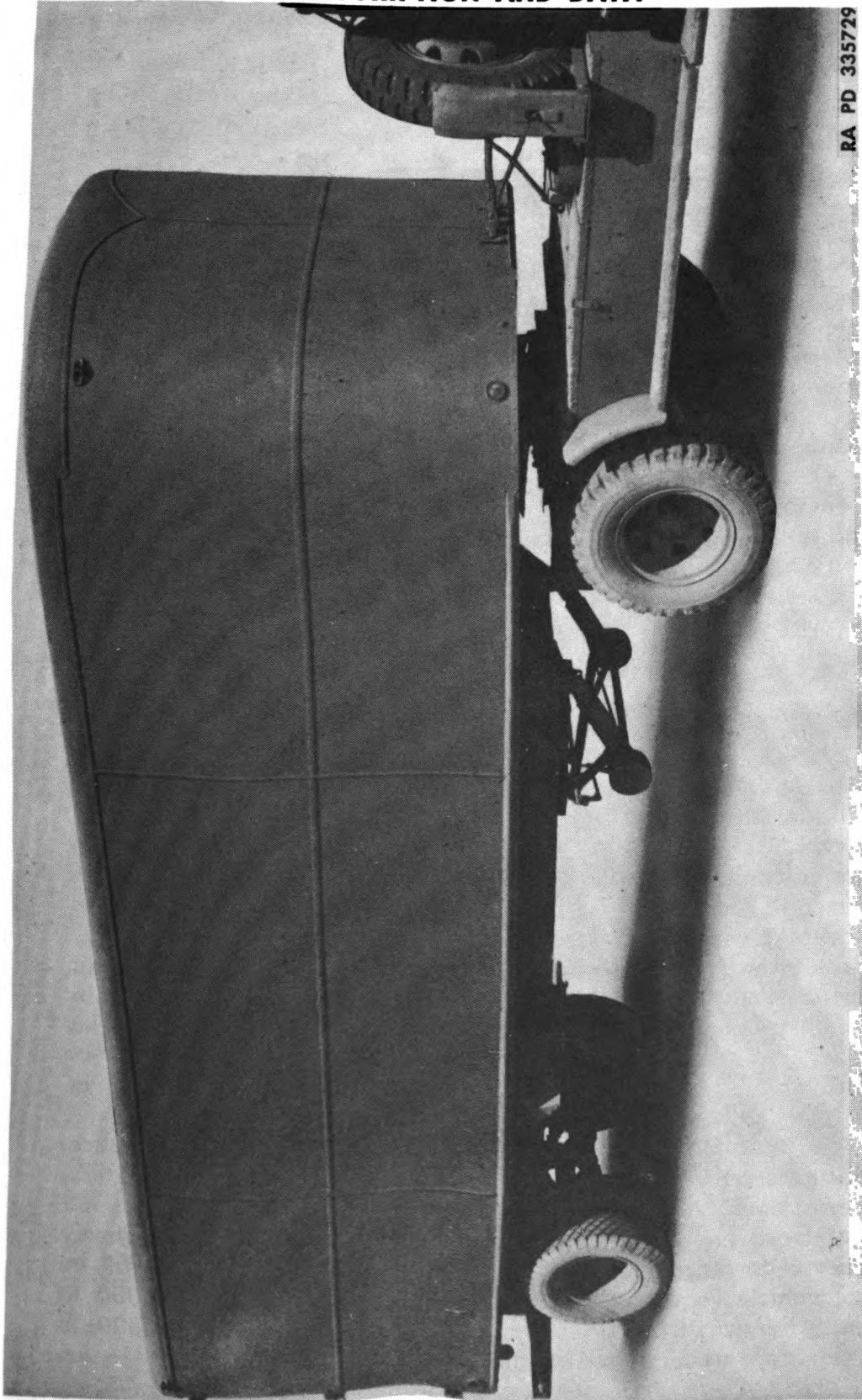

RA PD 335729

Figure 1—11-ton Payload, 15-ton Gross, 2-wheel (2dt), Van Semitrailer—Right Front

TM 9-894

4

11-TON PAYLOAD, 15-TON GROSS, 2-WHEEL (2dt), VAN SEMITRAILER (OMAHA STANDARD BODY CORP. MODEL F16)



RA PD 335730

Figure 2—11-ton Payload, 15-ton Gross, 2-wheel (2dt), Van Semitrailer—Left Rear

DESCRIPTION AND DATA

b. Performance.

Allowable speed	60 mph
Departure angle	45 deg
Towing facilities	Kingpin

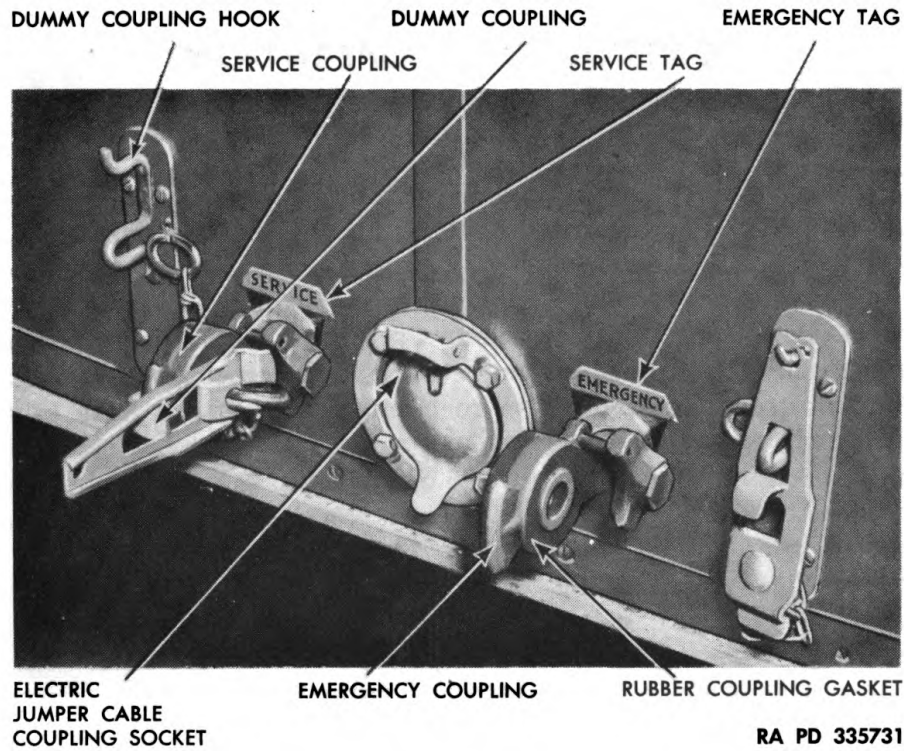

RA PD 335731

Figure 3—Controls—Front

11-TON PAYLOAD, 15-TON GROSS, 2-WHEEL (2d+), VAN SEMITRAILER (OMAHA STANDARD BODY CORP. MODEL F16)**PART TWO****OPERATING INSTRUCTIONS****Section III****CONTROLS AND OPERATION****5. CONTROLS.**

a. Relay Emergency Valve Air Line Connections. There are two air line connections located at the front of the semitrailer (fig. 3). The service air line connection is located on the right or curb side, and the emergency air line connection is located on the left side. Each connection is plainly marked. Care must be taken to connect the emergency hose from the tractor truck to the emergency connector on the semitrailer, and likewise to connect the service hose of the tractor truck with the service connector of the trailer. Air is supplied from the tractor truck through these connections to operate the brake mechanism of the semitrailer. Failure to secure either of these connections renders the brakes inoperative. The air line connectors of the semitrailer, when not connected with the air hose of the tractor, must be covered with the dummy couplings attached by short chains to the front of the semitrailer. The connectors are kept covered with the dummy couplings, when detached from the tractor, to prevent dirt, moisture, or other foreign matter from entering the air lines, and fouling or injuring the mechanism of the relay emergency valve.

b. Trailer Light Socket. This vehicle is equipped with an electrical coupling socket (fig. 3) located at the center of the front cross-member of the frame. It is located midway between the air line connectors. The socket is protected by a hinged cover which is raised when the jumper cable from the tractor truck is attached. The electrical circuit of the semitrailer is energized from the tractor truck when the plug of the jumper cable is inserted in the socket, and the switch in the tractor truck cab is turned to "ON" position.

c. Chock Blocks. Two chock blocks are provided to prevent accidental movement of the semitrailer when uncoupled from the tractor truck. One block (fig. 5) is located on each side of the semitrailer, attached by chains to the frame at points approximately above the axle spindles. When not in use, the blocks are suspended beneath the van body by self-latching snaps located a sufficient distance in front of the wheel line to take the slack from the supporting chains (fig. 7). The chock block chains are of adequate length to permit the

CONTROLS AND OPERATION

blocks to be inserted either in front of the dual tires or behind them, whichever the slope of the ground may require, when the semitrailer is disconnected from the tractor truck.

d. Trailer Blackout and Marker Light Switch. The blackout switch is located at the front of the van body on the right or curb side (fig. 5), 30 inches from the front center line on which the coupling socket is located. The switch is operated by means of a screwdriver or similar tool inserted in a slot in the switch head (fig. 4). This switch has no off, or neutral position. It is either on blackout position or standard light position. The blackout circuit is energized and controlled from the towing tractor truck.

e. Dome Light Switch. The dome light switch is located on the inside of the body, just forward of the upper left door hinge line (fig. 40). One switch controls all dome lights.

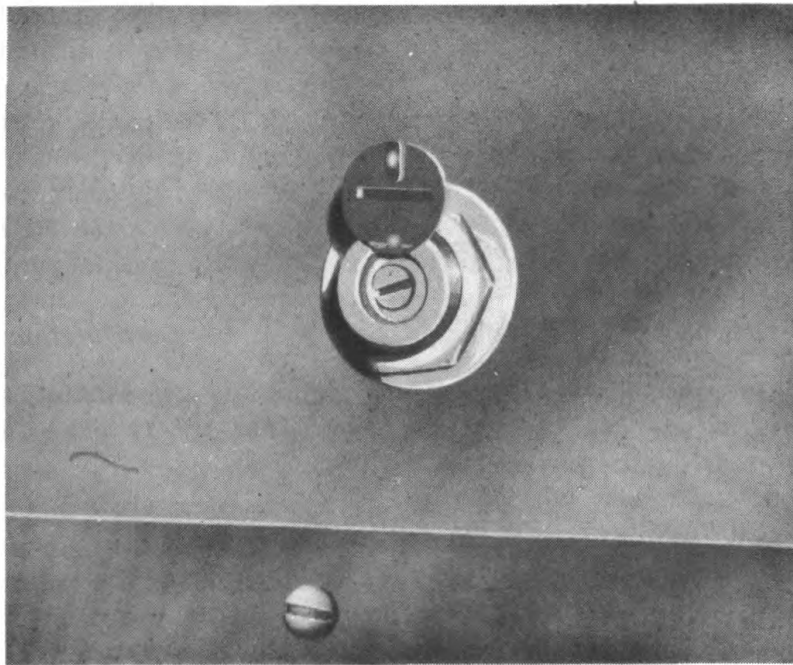

RA PD 335732

Figure 4—Blackout Switch

f. Retractable Landing Gear. The retractable landing gear is lowered by a hand crank which operates a worm screw. Its function is to support the front of the semitrailer when disconnected from the tractor truck (fig. 5). It must be fully lowered before the tractor truck is detached, and must not be operated while supporting the

TM 9-894

5-6

11-TON PAYLOAD, 15-TON GROSS, 2-WHEEL (2dt), VAN SEMITRAILER (OMAHA STANDARD BODY CORP. MODEL F16)

weight of the semitrailer. It can be retracted, extended, or adjusted while the van is supported in locked position upon the fifth wheel of the tractor truck. The operating handle is hinged, and must be swung under the van body and supported upon its suspension hook when not in actual use.

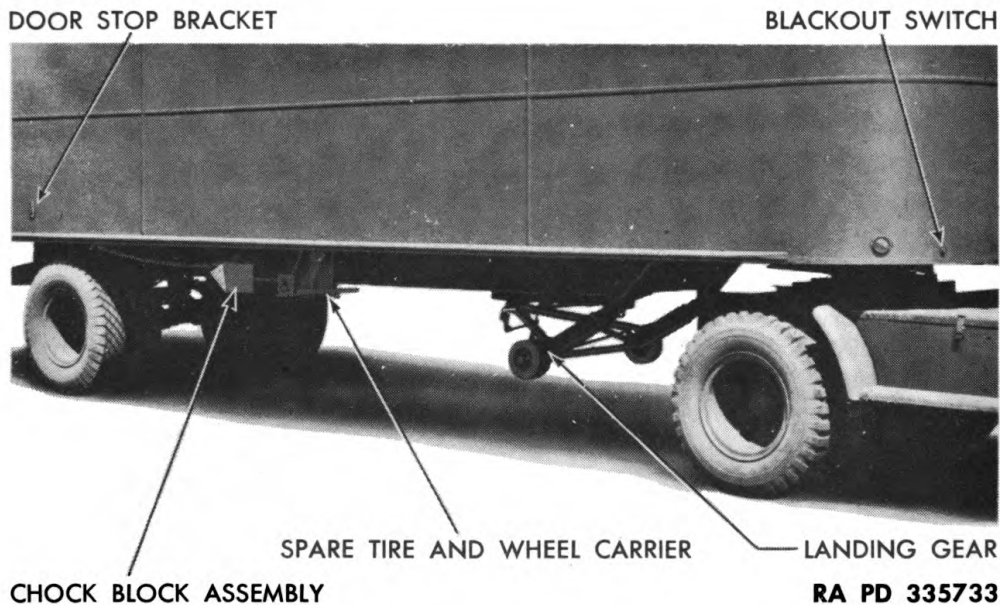

Figure 5—Controls—Right Front

g. Reflectors. Two amber reflex reflectors are located on the lower front of the van body (fig. 1), and four red reflectors are on the lower rear of the body (fig. 2).

h. Supplementary Tractor Controls.

- (1) Air pressure for controlling operation of the semitrailer brakes is turned on by "cut-off" valves located on the tractor truck.
- (2) Electric current is controlled by switch in tractor cab.

6. DRIVING INSTRUCTIONS.

a. Coupling Semitrailer to Tractor Truck (fig. 6).

- (1) Back tractor truck carefully into position in front of the semitrailer so that the fifth wheel is ready to engage the kingpin; then stop the tractor, and check for proper alinement of lower and upper fifth wheel segments for making connection.

CONTROLS AND OPERATION

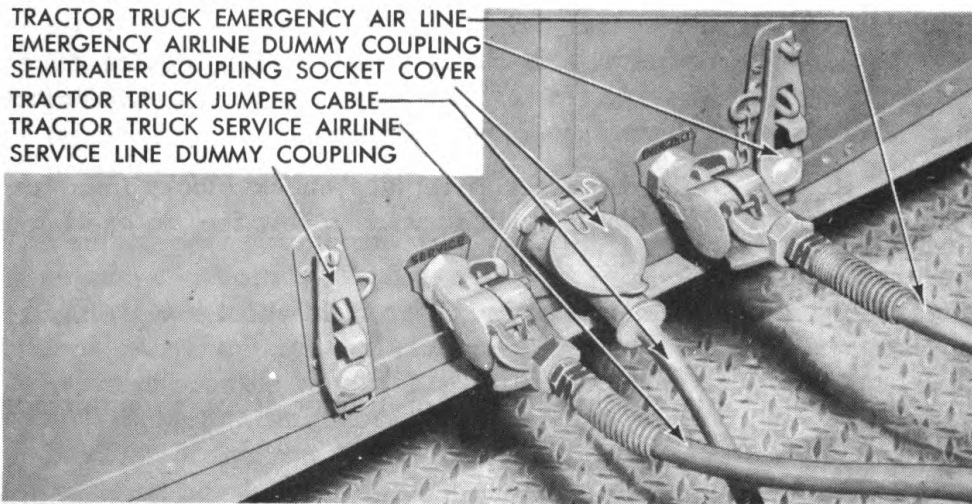

BRAKE LINE COUPLINGS

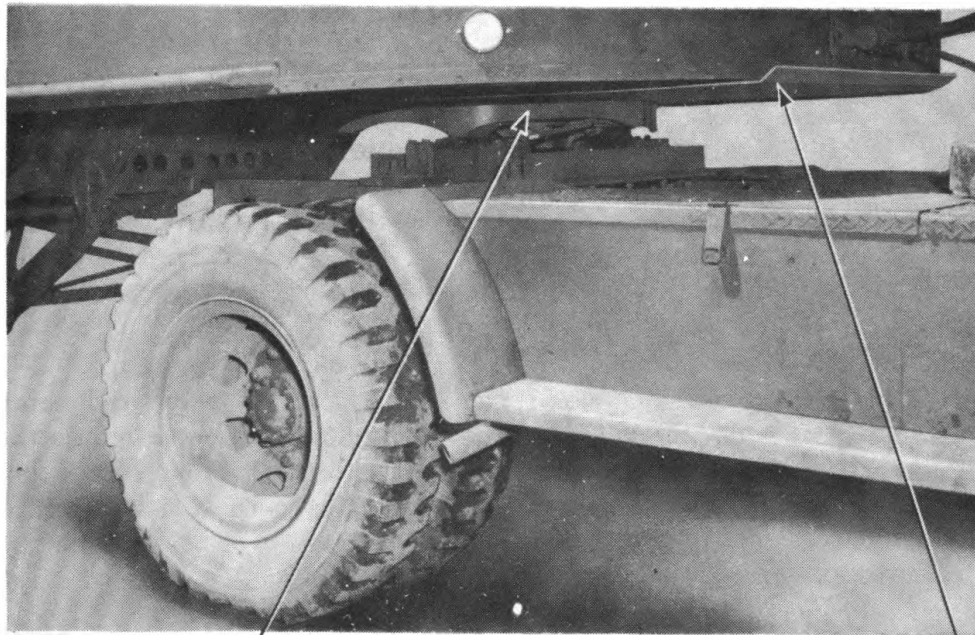

TRACTOR TRUCK FIFTH WHEELS

SEMITRAILER UPPER FIFTH WHEEL PLATE

RA PD 335734

Figure 6—Points for Coupling Semitrailer to Tractor Truck

(2) Place chock blocks behind wheels of trailer, remove dummy couplings from air line connectors, connect air hose attached to tractor truck, open air valves on tractor truck air line, and set brakes of trailer.

(3) Back tractor truck until kingpin is fully engaged in fifth wheel. This will raise the front of the semitrailer so that the landing wheels are free from contact with the ground.

TM 9-894

6

11-TON PAYLOAD, 15-TON GROSS, 2-WHEEL (2d+), VAN SEMITRAILER (OMAHA STANDARD BODY CORP. MODEL F16)

(4) Carefully inspect both jaws of the locking device on the tractor truck fifth wheel to see that they are fully closed. Check locking handle to see that it is in locked position.

(5) Release trailer brakes and replace chock blocks upon supporting snaps. Move tractor truck forward a few feet to exert load tension on kingpin, then stop.

(6) Again examine locking device on fifth wheel to see that it is in place.

(7) Connect light jumper cable of tractor truck to semitrailer by plugging into socket. Test trailer lights.

(8) Raise landing wheels to full road clearance. Hook landing wheel operating crank under body of semitrailer into its suspension hook (figs. 5 and 9).

b. Driving Tractor Truck and Semitrailer.

(1) After all steps in the coupling operation have been completed, the tractor truck and semitrailer combination is ready for driving, and is handled much the same as a conventional truck. When turning corners, however, allow for the fact that the trailer wheels turn "inside" the turning radius of the tractor.

(2) Refer to Before-operation Service (par. 10).

(3) Be very careful when backing a tractor truck and semitrailer. Cut the rear of the right wheel of the tractor out to guide the rear of the semitrailer to the driver's right; cut the rear of the left wheel out to guide the rear of the semitrailer to the driver's left.

c. Braking Tractor Truck and Semitrailer.

(1) Brakes must be applied in coordination with tractor truck brakes. Test the operation of the trailer brakes before normal operating speed is reached. Check air supply on the dash gage. For effective operation of the brakes, the pressure must not be less than 80 pounds.

(2) The semitrailer brakes must not be required to carry the entire braking load. Semitrailer brakes are intended to control only the semitrailer momentum; abuse of this fact will result in undue wear of linings, and will greatly reduce the life of the semitrailer brakes. The best possible stop will be made when the first brake application is as hard as the speed and road condition permit, and graduated off as the speed is reduced, so that at the end of the forward move-

CONTROLS AND OPERATION

ment of the vehicle, little pressure remains in the brake chambers. **CAUTION:** *Do not apply the brakes lightly at first and increase the pressure as the speed diminishes.* Such a stop requires greater distance in which to bring the vehicle under control, and the final high pressure will produce a severe stop. Do not “fan” the brake pedal, as this gives poor brake performance and wastes brake pressure. Fanning does not increase the brake line pressure, but rather decreases pressure in both brake line and reservoir. The air brake is designed so that when the brake pedal is moved to the limit of its stroke, an emergency application results, which will stop the vehicle in the shortest possible time. This full application should be made only in an emergency and never employed in ordinary braking operation. **NOTE:** *Maximum braking efficiency is always reached short of the skidding point.*

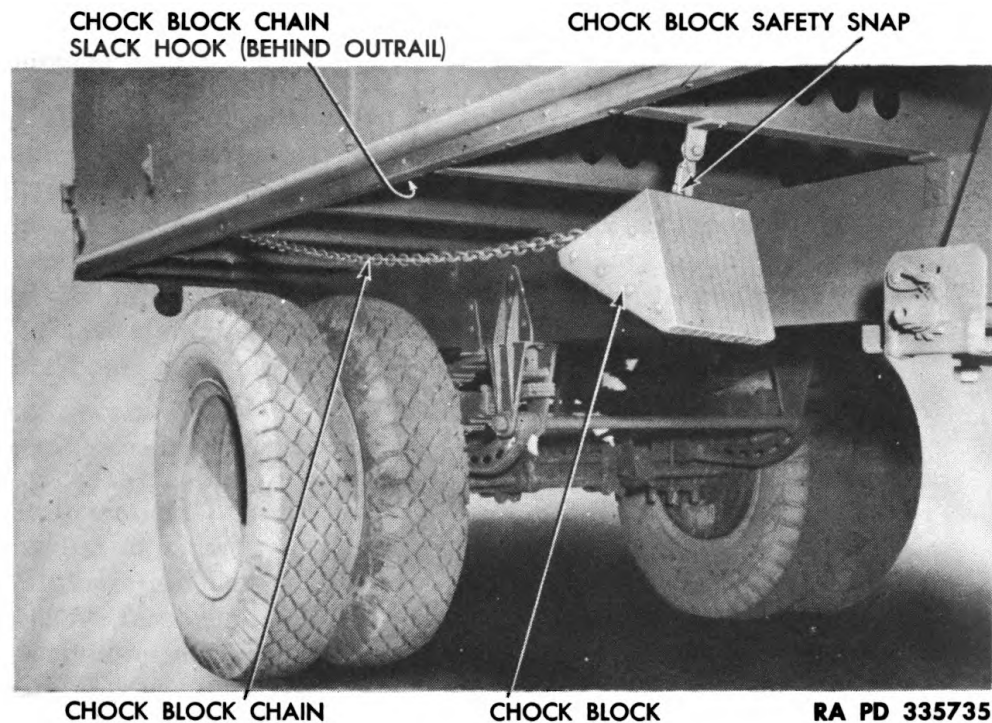

Figure 7—Chock Block Assembly

d. Uncoupling Semitrailer From Tractor Truck.

(1) Apply semitrailer brakes. Unsnap chock blocks, and place them under front of semitrailer wheels. Lower landing gear wheels until legs of landing gear are perpendicular to ground. Pull plug of jumper cable from coupling socket, and hang cable plug on the hook provided on tractor truck for this purpose. Shut the cut-off cocks or

TM 9-894

6

11-TON PAYLOAD, 15-TON GROSS, 2-WHEEL (2d+), VAN SEMITRAILER (OMAHA STANDARD BODY CORP. MODEL F16)

both the emergency and service air lines on the tractor truck. Disconnect air brake hose at couplings on the front of the semitrailer. *CAUTION: Cover the hose couplings with the dummy hose couplings.*

(2) From the right, or curb side of the tractor truck fifth wheel, push the kingpin lock lever across to the left and down into the notch at the bottom of the lever slide at the extreme left side. With the kingpin lock lever in the holding notch in open position, drive the tractor truck forward to disengage the fifth wheel locking mechanism from the kingpin of the semitrailer. As the fifth wheel plate of the tractor truck is pulled from the upper fifth wheel plate of the semitrailer, the semitrailer landing gear wheels come to rest on the ground and support the forward weight of the semitrailer.

PART THREE
ORGANIZATIONAL MAINTENANCE INSTRUCTIONS

Section IV
LUBRICATION

7. GENERAL LUBRICATION INSTRUCTIONS.

- a. Figure 8 prescribes lubrication maintenance for this vehicle.
- b. These lubrication instructions are binding on all echelons of maintenance and there shall be no deviation.
- c. Service intervals specified on figure 8 are for normal operating conditions. Reduce these intervals under extreme conditions such as excessively high or low temperatures, prolonged periods of high speed, continued operation in sand or dust, immersion in water, or exposure to moisture, any one of which may quickly destroy the protective qualities of the lubricant and require servicing in order to prevent malfunctioning or damage to the materiel.
- d. Lubricants are prescribed in the "Key" in accordance with three temperature ranges; above $+32^{\circ}\text{F}$, $+32^{\circ}\text{F}$ to 0°F , and below 0°F . Determine the time to change grades of lubricants by maintaining a close check on operation of the vehicle during the approach to change-over periods. Ordinarily it will be necessary to change grades of lubricants only when air temperatures are consistently in the next higher or lower range, unless malfunctioning occurs sooner due to lubricants being too thin or too heavy.

8. DETAILED LUBRICATION INSTRUCTIONS.

a. **Lubrication Equipment.** Operate lubricating guns carefully and in such a manner as to ensure a proper distribution of the lubricant. If lubrication fitting valves stick and prevent the entrance of the lubricant, remove the fitting, and determine the cause. Replace broken or damaged lubricators. If lubricator cannot be replaced immediately, cover hole with tape as a temporary expedient to prevent the entrance of dirt.

b. **Points of Application.**

(1) Lubrication fittings, grease cups, oilers, and oil holes are readily identifiable on the vehicle (figs. 9, 10, 11, and 12). Wipe clean such lubricators and the surrounding surface before lubricant is applied.

(2) Where relief valves are provided, apply new lubricant until the old lubricant is forced from the vent. Exceptions are specified in notes or on the Lubrication Order.

11-TON PAYLOAD, 15-TON GROSS, 2-WHEEL (2dt), VAN SEMITRAILER (OMAHA STANDARD BODY CORP. MODEL F16)

WAR DEPARTMENT LUBRICATION ORDER
ORDNANCE DEPARTMENT

SEMITRAILER, VAN,
11-TON PAYLOAD, 15-TON GROSS, 2, WHEEL (2DT)

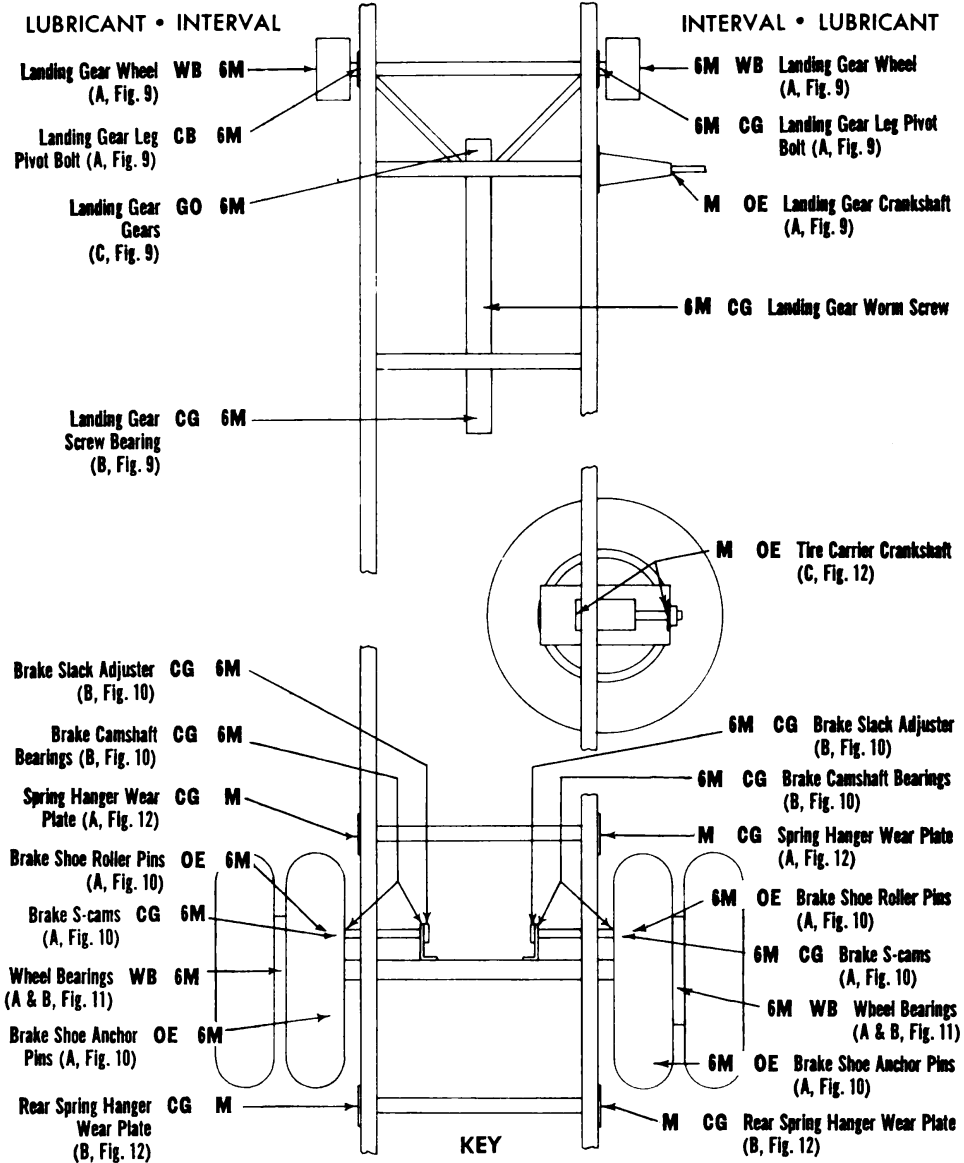

LUBRICANTS	LOWEST ANTICIPATED AIR TEMPERATURE			INTERVALS
	ABOVE +32°F	32° F TO 0°F	BELOW 0°F	
OE—OIL, ENGINE	OE SAE 30	OE SAE 30	PS	M MONTHLY
CG—GREASE GENERAL PURPOSE	CG NO. 1	CG NO. 0	CG NO. 0	
GO—LUBRICANT, GEAR	GO SAE 90	GO SAE 80	GO GRADE 75	
WB—GREASE, GENERAL PURPOSE. NO. 2—ALL TEMPERATURES, PS—OIL, LUBRICANT, PRESERVATIVE. SPECIAL.				6M 6 MONTHS

RA PD 335740

Figure 8—Lubrication Order

LUBRICATION

(3) Always wipe clean metal surfaces on which a film of lubricant must be maintained by manual application, before the film is renewed.

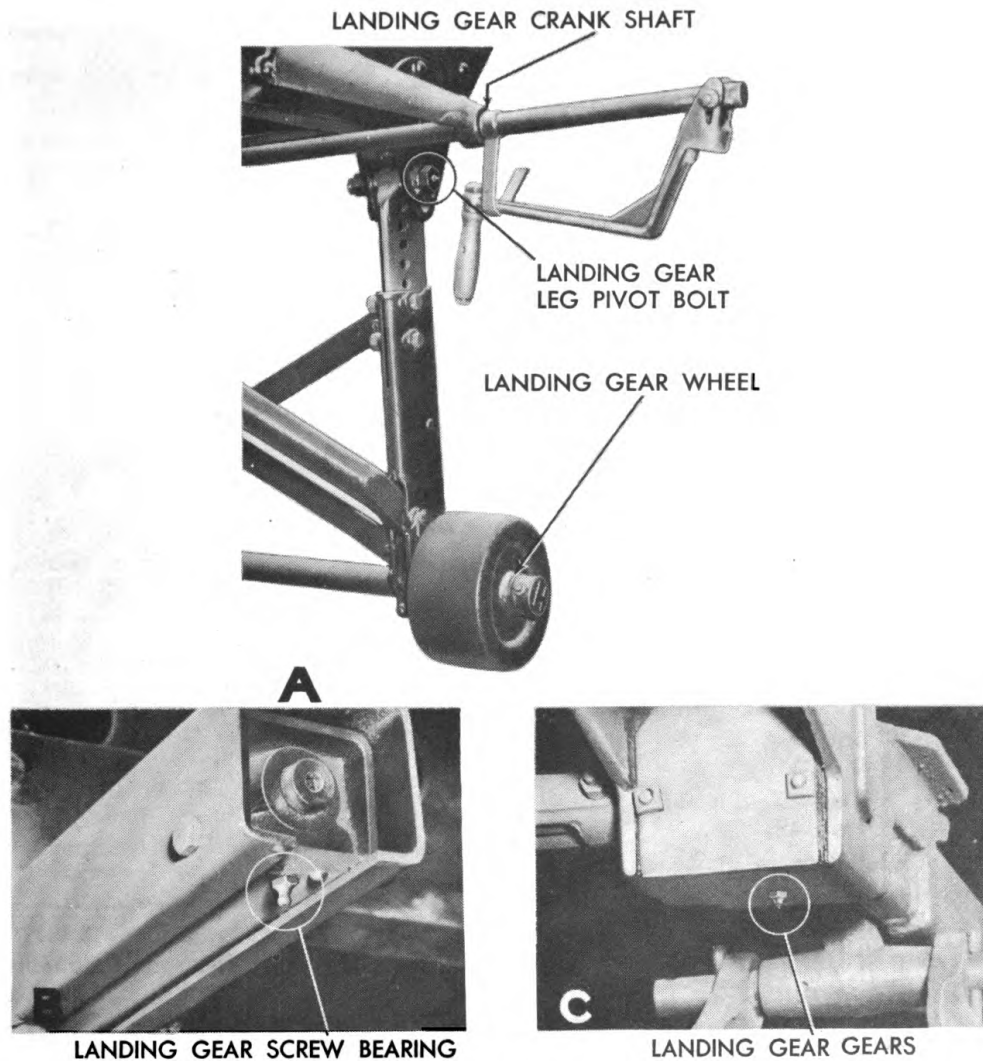

RA PD 335736

Figure 9—Localized Lubrication Points

c. Cleaning. Use SOLVENT, dry-cleaning, or OIL, fuel, Diesel, to clean or wash all parts. Use of gasoline for this purpose is prohibited. After washing, dry all parts thoroughly before applying lubricant.

d. Lubrication Notes on Individual Parts. The following instructions pertain to lubrication and service of individual units and parts (figs. 9, 10, 11, and 12).

11-TON PAYLOAD, 15-TON GROSS, 2-WHEEL (2dt), VAN SEMITRAILER (OMAHA STANDARD BODY CORP. MODEL F16)

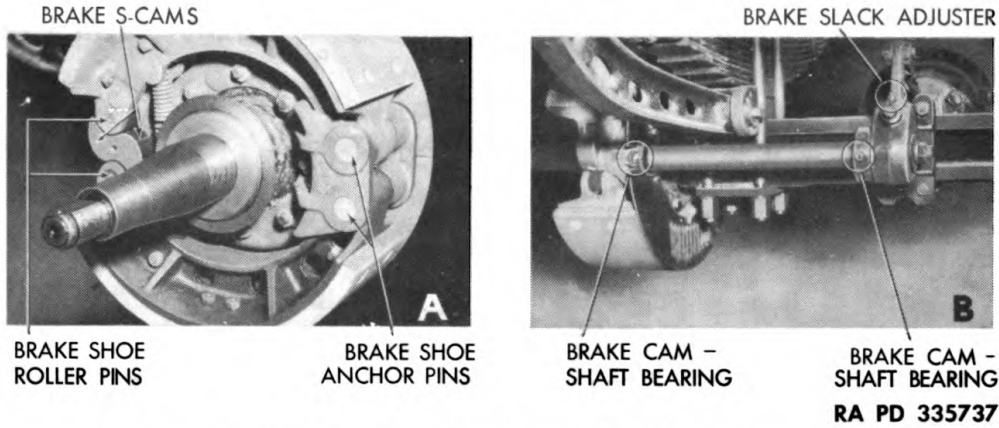

Figure 10—Localized Lubrication Points

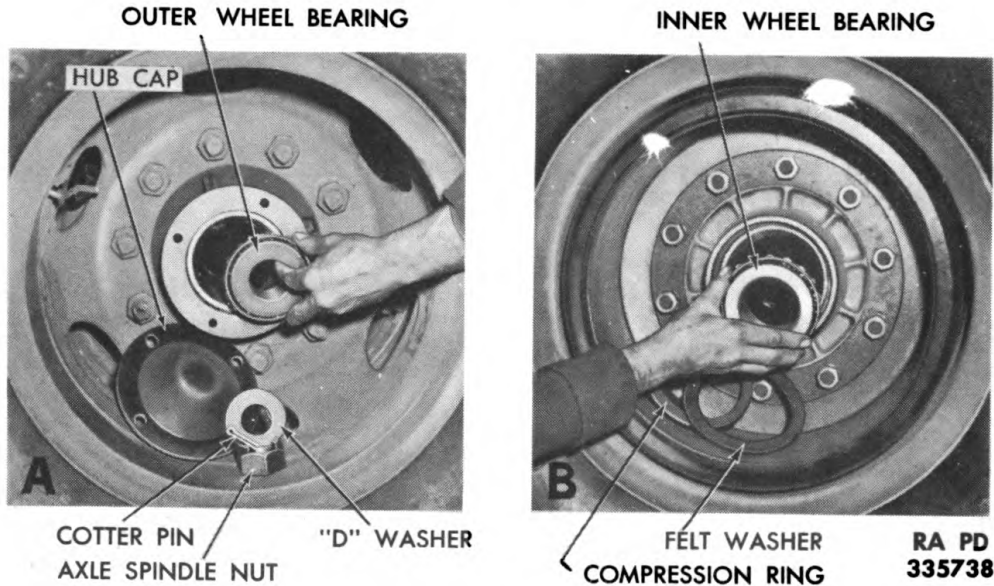
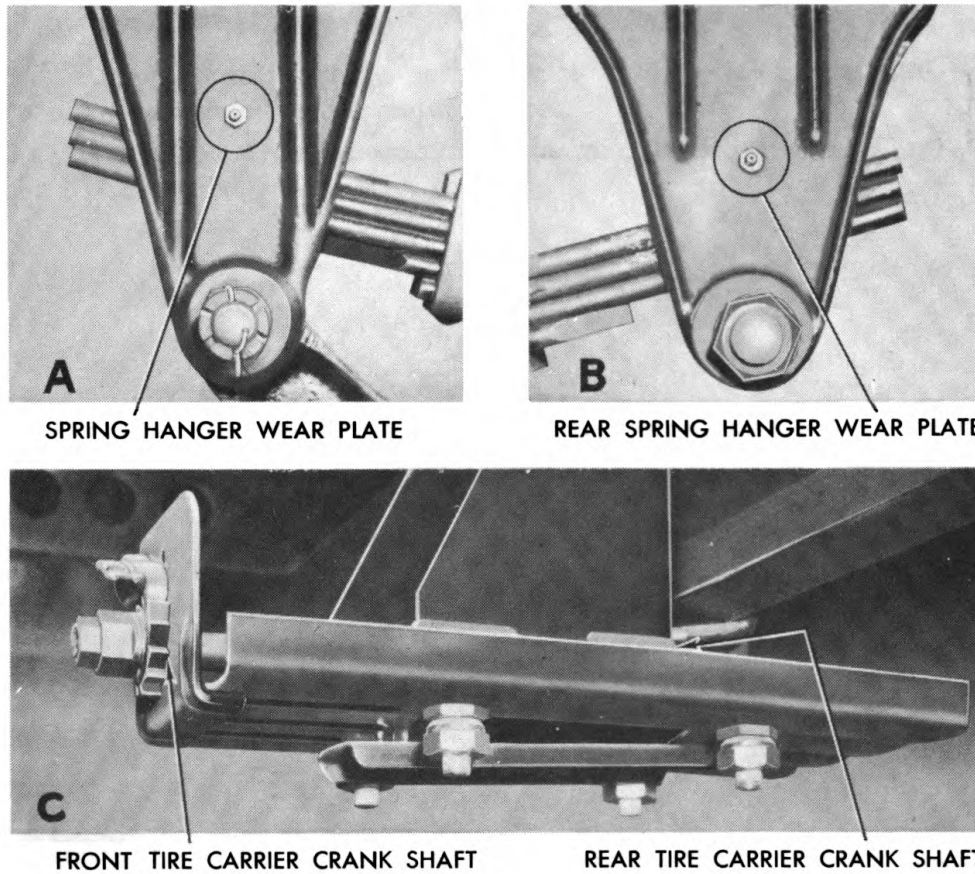

Figure 11—Localized Lubrication Points

(1) **WHEEL BEARINGS.** Remove the wheel, hub, and drum assembly as a unit (par. 25); to clean bearings, and repack with **GREASE**, general purpose, No. 2. To clean and repack wheel bearings properly, they must be removed from the hub (par. 25). Remove bearings from hub and wash with **SOLVENT**, dry-cleaning, until all the old lubricant is removed from both inside and outside the bearing cage. Lay the bearing aside to dry. Wash inside of hub and spindle with **SOLVENT**, dry-cleaning. When bearings are thoroughly dry, coat lightly with **OIL**, engine, seasonal grade, pack races with **GREASE**, general purpose, No. 2, and reassemble in hub (par. 25). To pack a bearing satisfactorily, knead the lubricant by hand

LUBRICATION



RA PD 335739

Figure 12—Localized Lubrication Points

into space between cage and inner race. Coat the inside of hub and axle spindle with a *thin* coating of lubricant to prevent rust. The lubricant packed in bearing races is sufficient to provide lubrication until the next service period. **CAUTION:** *Excessive lubrication may result in leakage into brake drum.*

(2) **LANDING WHEELS.** Remove the nuts, lock washers, and bolts securing the landing wheel hub caps and remove the wheels. **NOTE:** *This operation is easily performed when the semitrailer is attached to a tractor truck and the landing wheels are retracted.* Clean old grease from bearing surfaces of hubs, and clean the landing wheel axle spindles. Lubricate bearing surfaces of hubs and axle spindles with **GREASE**, general purpose, No. 2.

(3) **KINGPIN AND UPPER FIFTH WHEEL PLATE.** Lubricate the kingpin and upper fifth wheel plate (fig. 39) with **GREASE**, general purpose, No. 2. **NOTE:** *Apply lubricant by hand application to points of wear.*

TM 9-894

11-TON PAYLOAD, 15-TON GROSS, 2-WHEEL (2d+), VAN SEMITRAILER (OMAHA STANDARD BODY CORP. MODEL F16)

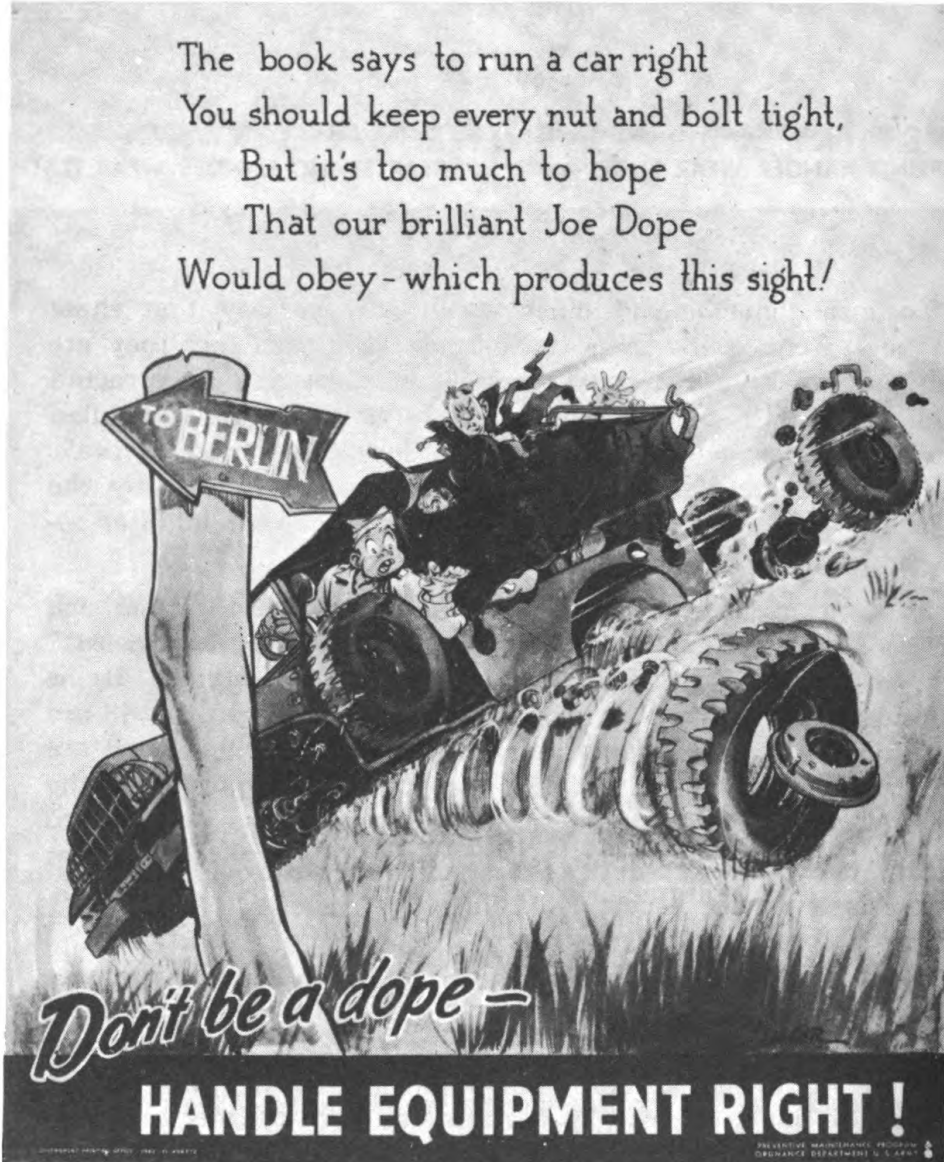

FIRST ECHELON PREVENTIVE MAINTENANCE SERVICE**e. Reports and Records.**

(1) Report unsatisfactory performance of materiel to the Ordnance officer responsible for maintenance.

(2) A record of lubrication may be maintained in the Duty Roster (W.D., A.G.O. Form No. 6).

Section V**FIRST ECHELON PREVENTIVE MAINTENANCE SERVICE****9. PURPOSE.**

a. To insure mechanical efficiency it is necessary that these vehicles be systematically inspected at intervals each day they are operated and weekly, so defects may be discovered and corrected before they result in serious damage or failure. Certain scheduled maintenance services will be performed at these designated intervals. The services set forth in this section are those performed by the driver or crew, before-operation, during-operation, at-halt, after-operation, and weekly.

b. Driver preventive maintenance services are listed on the back of "Driver's Trip Ticket and Preventive Maintenance Service Record," W. D. Form No. 48, to cover vehicles of all types and models. Items peculiar to specific vehicles but not listed on W. D. Form No. 48 are covered in manual proceedings under the items to which they are related. Certain items listed on the form that do not pertain to the vehicles involved are eliminated from the procedure as written into the manual. Every organization must thoroughly school each driver in performing the maintenance procedure set forth in manuals, whether they are listed specifically on W. D. Form 48, or not.

c. The items listed on W. D. Form No. 48 that apply to these vehicles are expanded in this manual to provide specific procedures for accomplishment of the inspections and services. These services are arranged to facilitate inspection and conserve the time of the driver, and are not necessarily in the same numerical order as shown on W. D. Form No. 48. The item numbers, however, are identical with those on that form.

d. The general inspection of each item applies also to any supporting member or connection, and generally includes a check to see whether the item is in good condition, correctly assembled, secure, or excessively worn.



TM 9-894

9-10

11-TON PAYLOAD, 15-TON GROSS, 2-WHEEL (2d+), VAN SEMITRAILER (OMAHA STANDARD BODY CORP. MODEL F16)

(1) The inspection for "good condition" is usually an external visual inspection to determine whether the unit is damaged beyond safe or serviceable limits. The term "good condition" is explained further by the following: Not bent or twisted, not chafed or burned, not broken or cracked, not bare or frayed, not dented or collapsed, not torn or cut.

(2) The inspection of a unit to see that it is "correctly assembled" is usually an external visual inspection to see whether it is in its normal assembled position in the vehicle.

(3) The inspection of a unit to determine if it is "secure" is usually an external visual examination, a wrench, hand-feel, or a pry-bar check for looseness. Such an inspection should include any brackets, lock washers, lock nuts, locking wires, or cotter pins used in assembly.

(4) "Excessively worn" will be understood to mean worn, close to or beyond serviceable limits, and likely to result in a failure if not replaced before the next scheduled inspection.

e. Any defects or unsatisfactory operating characteristics beyond the scope of the first echelon to correct must be reported at the earliest opportunity to the designated individual in authority.

10. BEFORE-OPERATION SERVICE.

a. **Purpose.** This inspection schedule is designed primarily as a check to see that the vehicles have not been damaged, tampered with, or sabotaged since the After-operation Service was performed. Various combat conditions may have rendered the vehicles unsafe for operation, and it is the duty of the driver to determine whether or not the vehicles are in condition to carry out any mission to which they are assigned. This operation will not be entirely omitted, even in extreme tactical situations.

b. **Procedures.** Before-operation Service consists of inspecting items listed below according to the procedure described, and correcting or reporting any deficiencies. Upon completion of the service, results should be reported promptly to the designated individual in authority.

(1) **ITEM 1, TAMPERING AND DAMAGE.** Examine the exterior of vehicle, attachments, and equipment, for injury caused by tampering, sabotage, collision, falling debris, or shell fire since parking.

(2) **ITEM 5, AIR BRAKE TANK AND AIR FILTERS.** Examine air brake reservoir tank, air lines, and connections for looseness or damage. If connected to tractor truck, listen for air leaks, drain water from tank, and close drain cock. Be sure truck to semitrailer air

FIRST ECHELON PREVENTIVE MAINTENANCE SERVICE

couplings are securely connected; or, if not in use, that they are closed and properly supported, and that dummy couplings are attached.

(3) **ITEM 12, LAMPS (LIGHTS) AND REFLECTORS.** Clean all light lenses and warning reflectors, and inspect units for looseness or damage. If semitrailer is connected, and tactical situation permits, open and close semitrailer light switches to see if lamps respond properly.

(4) **ITEM 13, WHEEL AND HUB NUTS.** See that all wheel and hub assembly and mounting nuts are present and secure.

(5) **ITEM 14, TIRES.** Be sure all semitrailer tires are properly inflated to 70 pounds (maximum), cool. Remove foreign objects lodged in treads, carcasses, or between duals; inspect for damage.

(6) **ITEM 15, SPRINGS AND SUSPENSION.** Examine radius arms and springs, spring clips, and U-bolts for looseness or damage. Look for excessive spring sag or shifted leaves.

(7) **ITEM 18, TOWING CONNECTIONS.** Inspect all towing devices for looseness and damage, particularly pintle drawbar, retracting spring, latch, and locking mechanism.

(8) **ITEM 19, BODY AND LOAD.** Inspect all body units and mountings for looseness and damage. See that doors operate freely and latch securely. Check body to frame bolts for security. If loaded, cargo must be properly distributed and secured.

(9) **ITEM 28, DURING-OPERATION CHECK.** The During-operation Services and observation on semitrailer start immediately after the vehicle is put in motion, as follows:

11. DURING-OPERATION SERVICE.

a. Purpose. While the vehicle is in motion, be on the alert for any unusual noise, such as rattles, knocks, squeals, or hums that may indicate trouble. Observe if there is any abnormal sag, side sway, or drag that might indicate broken suspensions, disconnected towing or safety devices, or dragging brakes.

b. Procedures. During-operation Services consist of observing items below according to the procedures following each item, and investigating any indications of serious trouble. Notice minor deficiencies to be corrected or reported at earliest opportunity, usually at next scheduled halt.

(1) **ITEM 27, BRAKES.** Test semitrailer brakes independently of tractor truck brakes, to be sure they are effective and operate without excessive pull to one side, chatter, or squealing.

(2) **ITEM 34, RUNNING GEAR.** Be on the alert for any unusual noise or unsatisfactory operating characteristics of wheels, suspension units, or landing gear. During operation of landing gear, observe any excessive looseness or binding of operating mechanism.

TM 9-894

12-13

11-TON PAYLOAD, 15-TON GROSS, 2-WHEEL (2d+), VAN SEMITRAILER (OMAHA STANDARD BODY CORP. MODEL F16)

12. AT-HALT SERVICE.

a. Importance. At-halt Services may be regarded as minimum maintenance procedures, and should be performed under all tactical conditions, even though more extensive maintenance services must be slighted or omitted altogether.

b. Procedures. At-halt Services consist of investigating any deficiencies noted during operation, inspecting items listed below according to the procedures following the items, and correcting any deficiencies found. Deficiencies not corrected should be reported promptly to the designated individual in authority.

(1) **ITEM 39, TEMPERATURES.** Place hand cautiously on each wheel hub and brake drum to see if it is abnormally hot.

(2) **ITEM 42, SPRINGS AND SUSPENSIONS.** Inspect springs, radius arms, and suspension units for looseness or damage.

(3) **ITEM 44, WHEEL AND HUB NUTS.** See that all wheel and hub assembly and mounting nuts are present and secure.

(4) **ITEM 45, TIRES.** Inspect all tires for under inflation and damage. Remove objects lodged in treads, carcasses, and from between duals.

(5) **ITEM 50, TOWING CONNECTIONS.** Inspect all towing and safety connecting devices for looseness or damage. Be sure all locking devices are secure.

(6) **ITEM 51, BODY AND LOAD.** Inspect all body units and mountings for looseness and damage. See that doors operate freely and latch securely. If loaded, cargo must be properly distributed and secured.

(7) **ITEM 52, GLASS.** Clean all light and reflector glass, and inspect for looseness or damage.

13. AFTER-OPERATION AND WEEKLY SERVICE.

a. Purpose. After-operation Service is particularly important, because at this time the driver inspects his vehicle to detect any deficiencies that may have developed, and corrects those he is permitted to handle. He should report promptly to the designated individual in authority the results of his inspection. If this schedule is performed thoroughly, the vehicle should be ready to roll again on a moment's notice. The Before-operation Service, with a few exceptions, is then necessary only to ascertain whether the vehicle is in the same condition in which it was left upon completion of the After-operation Service. The After-operation Service should never be

FIRST ECHELON PREVENTIVE MAINTENANCE SERVICE

entirely omitted, even in extreme tactical situations, but may be reduced to the bare fundamental services outlined for the At-halt Service, if necessary.

b. Procedures. When performing the After-operation Service, the driver must remember and consider any irregularities noticed during the day in the Before-operation, During-operation, and At-halt Services. The After-operation Service consists of inspecting and servicing the following items. Those items of the After-operation Service that are marked by an asterisk (*) require additional Weekly services, the procedures for which are indicated in subparagraph (b) of each applicable item.

(1) **ITEM 59, LAMPS (LIGHTS) AND REFLECTORS.** Clean all units, and inspect them for looseness and damage. If tactical situation permits, open and close light switches to be sure they operate properly, and see if the lamps respond.

(2) **ITEM 64, ELECTRICAL WIRING.** Examine all accessible wiring and conduits under vehicle for damage, and see that it is properly and securely connected and supported.

(3) **ITEM 68, *TIRES.**

(a) Examine for damage and excessive wear. Remove objects lodged in treads, carcasses, and from between duals. Check for low pressure, proper position of valve stems, and presence of valve caps. Inflate to correct pressure, 70 pounds (maximum), cold.

(b) *Weekly.* Replace badly worn or otherwise unserviceable semitrailer tires. Serviceable tires which show abnormal wear should be rotated to other wheel positions. Apparent mechanical defects causing such wear should be reported for attention by higher echelon.

(4) **ITEM 69, SPRING AND SUSPENSIONS.** Clean out all objects lodged in suspension system or between units and springs, and inspect for excessive spring sag, shifted leaves, loose or damaged clips, shackles, or radius arm brackets. See that radius arm adjusting lock nuts are tight and securely locked.

(5) **ITEM 75, *AIR BRAKE TANK.**

(a) Inspect tank on semitrailer for looseness and damage. See that all connections are tight, and that air lines are properly supported so as not to chafe on other vehicle parts. Drain water from tank and close drain cock.

(b) *Weekly.* Have assistant operate all brake control valves, and listen for air leaks. Tighten tank mountings and all connections where leaks are heard. Clean oil from all semitrailer air line rubber hose. Drain sediment and water from both air line filters.

(6) **ITEM 77, *TOWING CONNECTIONS.**

11-TON PAYLOAD, 15-TON GROSS, 2-WHEEL (2d+), VAN SEMITRAILER (OMAHA STANDARD BODY CORP. MODEL F16)

(a) Examine all tow loops and pintle hook for looseness and damage. Be sure pintle latches properly and locks securely. Inspect fifth wheel plate and kingpin to be sure they are in good condition and well lubricated. If semitrailer is connected to tractor truck be sure fifth wheel is securely connected and locked, and that brake and wiring connections are tight.

(b) *Weekly.* Tighten all towing device mounting and assembly nuts securely. Test fifth wheel connecting and locking mechanism for proper operation. Examine pintle hook spring and draw bar for damage.

(7) **ITEM 78, BODY, FRAME AND ATTACHMENTS.** Examine entire body for damage or loose parts. Be sure doors latch securely and operate properly. Inspect frame for broken welds, loose nuts, or rivets; for damaged rails, crossmembers, or brackets. Be sure all landing gear members, and assembly mounting and lock pins and bolts, are present and secure. Investigate any unsatisfactory landing gear operating characteristics noted during operation.

(8) **ITEM 82, *TIGHTEN.**

(a) Tighten any loose assembly or mounting nuts or screws indicated as necessary during this inspection.

(b) *Weekly.* Tighten wheel mounting and hub nuts, spring clips, and U-bolts, shackles, towing connections, floor skid strips, or bolts, and any other mounting or assembly nuts or screws, that inspection or experience indicate as necessary on a weekly or mileage basis.

(9) **ITEM *LUBRICATE AS NEEDED.**

(a) Lubricate all points where inspection has indicated oilcan or hand greasing is necessary.

(b) *Weekly.* Lubricate all points listed on the vehicle Lubrication Order (par. 8) as requiring weekly attention.

(10) **ITEM 84, *CLEAN VEHICLE.**

(a) Clean excess dirt, grease, and refuse from interior and exterior of vehicle, particularly from around landing gear and brake operating shafts, rods, worm, or gears.

(b) *Weekly.* Wash semitrailer when possible. If not possible, wipe off thoroughly. Inspect paint or camouflage pattern for rust or bright spots which might cause reflections. See that all vehicle markings (unless covered for tactical reasons) are legible. **CAUTION: When vehicles are driven into water for washing, care must be taken to see that water or dirt does not get into wheel bearings, or brakes, or on electrical units or wiring.**

Section VI

SECOND ECHELON PREVENTIVE MAINTENANCE**14. SECOND ECHELON PREVENTIVE MAINTENANCE SERVICES.**

a. Responsibility. Regular scheduled maintenance inspections and services are a preventive maintenance function of the using arms, and are the responsibility of commanders of operating organizations.

(1) **FREQUENCY.** The frequency of the preventive maintenance services outlined herein is considered a minimum requirement for normal operation of vehicles. Under unusual operating conditions such as extreme temperatures, dusty or sandy terrain, it may be necessary to perform certain maintenance services more frequently.

(2) **FIRST ECHELON PARTICIPATION.** The drivers should accompany their vehicles and assist the mechanics while periodic second echelon preventive maintenance services are performed. Ordinarily the driver should present the vehicle for a scheduled preventive maintenance service in a reasonably clean condition; that is, it should be dry and not caked with mud or grease to such an extent that inspection and servicing will be seriously hampered. However, the vehicle should not be washed or wiped thoroughly clean, since certain types of defects, such as cracks, leaks, and loose or shifted parts or assemblies are more evident if the surfaces are slightly soiled or dusty.

(3) **INSTRUCTIONS.** If instructions other than those contained in the general procedures in step (4) or the specific procedures in step (5) which follow, are required for the correct performance of a preventive maintenance service or for correction of a deficiency, other sections of this manual or a designated individual in authority, should be consulted.

(4) **GENERAL PROCEDURES.** These general procedures are basic instructions which are to be followed when performing the services on the items listed in the specific procedures. **NOTE:** *The second echelon personnel must be thoroughly trained in these procedures so that they will apply them automatically.*

(a) When new or overhauled subassemblies are installed to correct deficiencies, care should be taken to see that they are clean, correctly installed, and properly lubricated and adjusted.

(b) When installing new lubricant retainer seals, a coating of the lubricant should be wiped over the sealing surface of the lip of the seal. When the new seal is a leather seal, it should be soaked in SAE 10 engine oil (warm if practicable), for at least 30 minutes. Then the leather lip should be worked carefully by hand before installing the seal. The lip must not be scratched or marred.

11-TON PAYLOAD, 15-TON GROSS, 2-WHEEL (2d†), VAN SEMITRAILER (OMAHA STANDARD BODY CORP. MODEL F16)

(c) The general inspection of each item applies to any supporting member or connection, and usually includes a check to see whether the item is in good condition, correctly assembled, secure, or excessively worn. The mechanics must be thoroughly trained in the following explanations of these terms:

1. The inspection for "good condition" is usually an external visual inspection to determine whether the unit is damaged beyond safe or serviceable limits. The term "good condition" is explained further by the following: Not bent or twisted, not chafed or burned, not broken or cracked, not bare or frayed, not dented or collapsed, not torn or cut.

2. The inspection of a unit to see that it is "correctly assembled" is usually an external visual inspection to see whether it is in its normal assembled position in the vehicle.

3. The inspection of a unit to determine if it is "secure" is usually an external visual examination, a wrench, hand-feel, or a pry-bar check for looseness. Such an inspection should include any brackets, lock washers, lock nuts, locking wires, or cotter pins used in assembly.

4. "Excessively worn" will be understood to mean worn, close to or beyond serviceable limits, and likely to result in a failure if not replaced before the next scheduled inspection.

(d) *Special Services.* These are indicated by repeating the item numbers in the columns which show the interval at which the services are to be performed, and show that the parts or assemblies are to receive certain mandatory services. For example, an item number in one or both columns opposite a **TIGHTEN** procedure means that the actual tightening of the object must be performed. The special services include:

1. *Adjust.* Make all necessary adjustments in accordance with the pertinent section of this manual, special bulletins, or other current directives.

2. *Clean.* Clean units of the vehicle with dry-cleaning solvent to remove excess lubricant, dirt, and other foreign material. After the parts are cleaned, rinse them in clean solvent and dry them thoroughly. Take care to keep the parts clean until reassembled, and be certain to keep dry-cleaning solvent away from rubber or other material which it will damage. Clean the protective grease coating from new parts since this material is not usually a good lubricant.

3. *Special lubrication.* This applies both to lubrication operations that do not appear on the vehicle Lubrication Order and to items that do appear on such Orders but should be performed in connection with the maintenance operations, if parts have to be disassembled for inspection or service.

SECOND ECHELON PREVENTIVE MAINTENANCE

4. *Serve.* This usually consists of performing special operations, such as draining and refilling units with oil, and changing or cleaning the air filters or cartridges.

5. *Tighten.* All tightening operations should be performed with sufficient wrench-torque (force on the wrench handle) to tighten the unit according to good mechanical practice. Use torque-indicating wrench where specified. Do not overtighten, as this may strip threads or cause distortion. Tightening will always be understood to include the correct installation of lock washers, lock nuts, and cotter pins provided to secure the tightening.

(e) When conditions make it difficult to perform the complete preventive maintenance procedures at one time, they can sometimes be handled in sections, planning to complete all operations within the week if possible. All available time at halts and in bivouac areas must be utilized, if necessary, to assure that maintenance operations are complete. When limited by the tactical situation, items with special services in the columns should be given first consideration.

(f) The numbers of the preventive maintenance procedures that follow are identical with those outlined on W.D., A.G.O. Form No. 461, which is the Preventive Maintenance Service Work Sheet for Wheeled and Half-track Vehicles. Certain items on the work sheet that do not apply to this vehicle are not included in the procedures in this manual. In general, this numerical sequence of items on the work sheet is followed in the manual procedures, but in some instances there is deviation for conservation of the mechanic's time and effort.

(5) **SPECIFIC PROCEDURES.** The procedures for performing each item in the 1000-mile (monthly) and 6000-mile (six-month) maintenance procedures, whichever shall occur first, are described in the following chart. Each page of the chart has two columns at its left edge corresponding to the 6000-mile and the 1000-mile maintenance respectively. Very often it will be found that a particular procedure does not apply to both scheduled maintenances. In order to determine which procedure to follow, look down the column corresponding to the maintenance due, and wherever an item number appears, perform the operations indicated opposite the number.

MAINTENANCE	
6000-Mile (6-monthly)	1000-Mile (Monthly)
1	1

ROAD TEST

NOTE: When the tactical situation does not permit a full road test, perform those items which require little or no movement of the vehicle. When a road test is possible, it should be for preferably 4 and not over 6 miles.

Before-operation Inspection. Perform this inspection as outlined in paragraph 10.

11-TON PAYLOAD, 15-TON GROSS, 2-WHEEL (2d+), VAN SEMITRAILER (OMAHA STANDARD BODY CORP. MODEL F16)

MAINTENANCE	
8000-Mile (8-monthly)	1000-Mile (Monthly)
5	5
10	10
12	12
13	13
47	47
	47

Brakes, Service and Emergency (Braking Effect, Side Pull, Noise, Chatter, Air Control). Test semitrailer brakes separately by use of hand control or foot treadle, on truck tractor, truck, and observe if they are effective. Note any erratic action, side pull or noise that might indicate uneven brake shoe pressure, dirty linings or scored drums. Stop semitrailer and disconnect emergency line and observe if brakes automatically hold vehicle.

Unusual Noises (Attachments, Body or Wheels). Be on the alert during road test for any noise that may indicate loose or damaged attachments mounted on semitrailer. Listen particularly for indications of loose wheel mountings. Have assistant listen for any unusual noises in axles, suspension units or connections that would indicate damage or inadequate lubrication.

Air Brake System Leaks. Test semitrailer air brakes for leaks with air pressure at governed maximum. With all brakes applied and engine stopped, there should not be a noticeable drop in pressure within one minute. If any pressure drop occurs during this check, test system for leaks by soapsuds method. Open drain cock on semitrailer air tank and drain condensation.

Temperatures (Brake Drums, Hubs). At completion of run, feel brake drums and hubs for abnormally high temperatures.

MAINTENANCE OPERATIONS

Raise Vehicle and Block

Tires and Rims. See that valve stems are in correct position and undamaged, and that all caps are present and well seated (fingertight). Examine all tires for cuts, bruises, breaks, blisters, and irregular wear. Also inspect spare tire carrier, all rims, lock rings, and flanges for good condition and security.

TIGHTEN. Tighten all wheel inner outer mounting nuts. Replace missing or damaged nuts.

SECOND ECHELON PREVENTIVE MAINTENANCE

MAINTENANCE	
6000-Mile (6-monthly)	1000-Mile (Monthly)
48	
48	
49	

SERVE. With semitrailer tires properly inflated to 70 pounds (cool), check over-all circumferences of tires to be mounted on duals. The difference in over-all circumference must not exceed the 3/4-inch limits as specified. **CAUTION:** *Do not reinstall wheels until wheel-bearing services are complete.*

Brakes. On 6000-mile maintenance, the several wheel bearing and brake items up to and including 52 are group services in which there will be overlap. Perform these services in best order for economy of mechanic's time and effort, and for orderly re-assembly. Remove wheels; inspect and service brakes as follows:

Drums and Supports. Clean dirt and grease from inside of drum and from spider support and dust shield. **CAUTION:** *Keep dry-cleaning solvent away from linings and bearings.* Inspect drums for scored inside surface and cracks, and for secure mounting to hub. Replace damaged wheel studs.

Cams and Shafts. Examine cams and surfaces of brake shoes which contact same for excessive wear. Make sure camshafts operate freely in their bushings, and inspect them for excessive wear. Tighten brake support cap screws and hub to drum nuts securely.

49 Brake Shoes. If vehicle has been operated in deep water, mud, or loose sand, remove right wheel and drum and examine lining for damage. If this lining must be replaced, remove other wheel and service its brakes in a like manner, being sure to clean, lubricate, and adjust all removed wheel bearings as described in paragraph 8.

ADJUST. Adjust trailer shoes by minor method, if necessary (par. 29 b).

With semitrailer wheels and drums removed, inspect linings to see if they are in good condition, tightly secured to brake shoes, in good wearing contact with drums, free of dirt or lubricant, and not excessively worn. Also see if shoes are in good condition, properly secured to anchors, guides, and re-

11-TON PAYLOAD, 15-TON GROSS, 2-WHEEL (2d+), VAN SEMITRAILER (OMAHA STANDARD BODY CORP. MODEL F16)

MAINTENANCE	
6000-Mile (6-monthly)	1000-Mile (Monthly)
50	50
52	52
52	52

tracting springs; and that springs have sufficient tension to return shoes properly to released position. Thickness of lining at most worn point should be enough for at least 1000 miles of service before bolt heads are likely to contact drums.

CLEAN. Clean all dirt and grease from linings with wire brush, cloth, or compressed air.

ADJUST. After subsequent related items to 52 inclusive are completed, adjust shoes by minor method. If new linings have been installed, adjust by major method (par. 29 c). Adjust slack adjusters so diaphragm pushrod travel is at minimum, approximately 3/4 inch. See paragraph 29.

50 **Radius Arms.** Examine for good condition, correct assembly, and security. Be certain that mainspring front bracket is not damaged or loose. Test for worn radius arm bushings. Make sure adjusting nuts are tight and locked.

52 **Rear Wheels.** Examine wheels for cracks, bent flange, or loose assembly. Check for wheel run-out. Without disassembling, spin wheels and test bearings for evidence of looseness and indications of dry and damaged bearings.

52 **SERVE.** When vehicle has been operated in deep water, mud, or similar conditions, remove right rear wheel and check bearing lubricant for contamination. If contaminated, remove bearings from all wheels and service in same manner as 6000-mile procedure.

52 **SERVE.** Disassemble wheel bearings and seals. Clean thoroughly and check for serviceable condition. Replace damaged, loose or worn parts. Before installing, inspect bearings and seals; if worn or damaged, replace. Lubricate bearings and coat the lips of seals with lubricant. Pack the cavities between the seals and adjacent side of inner wheel bearing with lubricant. **CAUTION: Do not pack large cavity in wheel hub between wheel bearings with lubricant.** Reassemble unit, adjust wheel bearing, and tighten lock nut.

SECOND ECHELON PREVENTIVE MAINTENANCE

MAINTENANCE		
6000-Mile (6-monthly)	1000-Mile (Monthly)	
70	70	Air Brake Tank and Filter. Look for loose mounting and connection and check for damage, or indications of leaks.
	70	CLEAN. Remove drain plugs on bottom of brake system air filters and open drain cock in tank to drain sediment. Install drain plugs and close drain cock.
70		SERVE. Renew filter elements in air filters. Use new gaskets.
76	76	Air Brake (Chambers, Rods, Seals, Slack Adjusters). Examine these items to see if they are in good condition, correctly assembled, and secure; that slack adjusters are properly adjusted according to paragraph 35. Examine chambers and air hose connections for indications of leaks. Tighten all assembly and mounting nuts or screws securely.
77	77	Springs (Clips, Leaves, U-Bolts, Hangers, and Shackles). See if all items are in good condition, correctly assembled, and secure. Spring clips and bolts should be in place; spring leaves should not be shifted out of their correct position. This may be an indication of a sheared center bolt. See if deflection of both springs is normal and approximately the same. Test hangers and bolts for excessive wear by means of a pry bar. TIGHTEN. Tighten all spring U-bolts securely and uniformly.
80	80	Frame (Side Rails and Crossmembers). Inspect semitrailer frame, brackets, side rails, and crossmembers to see if they are in good condition, secure, and correctly aligned. If the frame appears to be out of line, report condition.
81	81	Wiring, Conduit, and Grommets. Observe these items underneath semitrailer to see if they are in good condition, properly supported, connected, and secure.
83	83	Brake Lines (Fittings and Hose). Examine all lines and fittings and air brake hose under semitrailer to see if they are in good condition, securely

TM 9-894

14

11-TON PAYLOAD, 15-TON GROSS, 2-WHEEL (2d+), VAN SEMITRAILER (OMAHA STANDARD BODY CORP. MODEL F16)

MAINTENANCE	
6000-Mile (6-monthly)	1000-Mile (Monthly)
83	
85	85
91	91
92	92
100	100
101	101
103	103
124	124
125	125

connected, and supported so that lines or hose will not chafe against other vehicle parts.

Remove semitrailer air brake relay valve, clean thoroughly with brake fluid, and reinstall securely.

Vehicle Lubrication. If due, lubricate in accordance with Lubrication Order, paragraph 8, and current lubrication directives, using only clean lubricant and omitting items that have had special lubrication during this maintenance service. Replace damaged or missing fittings or plugs.

Lamps (Lights). Examine all light units or sockets, to be sure they are in good condition, clean, and secure. If tactical situation permits, test all switches to be sure lamps respond properly.

Safety Reflectors. See if they are all present, in good condition, clean, and secure.

Body (Panels, Rear Doors, and Floor). See that panels are undamaged and secure. Check rear doors for alinement; check door hinges and latches for good condition, secure mounting, and proper operation. Examine floor for damage.

Pintle Hook. Examine pintle to see if it is in good condition and securely mounted to frame. Test pintle and latch to see if they operate properly, are adequately lubricated, and if lock pin is present and securely attached by chain. Pay particular attention to broken spring or worn draw bar.

Paint and Markings. Examine paint of entire trailer. Look for bright and shiny spots, oil and grease, rust scratches, or bare spots. Make sure markings and identifications are legible.

Tow Hitch. Inspect semitrailer fifth wheel plate and kingpin to see if they are in good condition, well lubricated, and not excessively worn. Test latch lever and locking mechanism to be sure they operate properly.

Air Connections. Inspect semitrailer air line connections to truck to be sure they are in good condition, not excessively worn, and will couple securely

SECOND ECHELON PREVENTIVE MAINTENANCE

MAINTENANCE		
8000-Mile (8-monthly)	1000-Mile (Monthly)	
		without leaking. See that safety valve on emergency line operates freely and will latch securely. If semi-trailer is not connected, be sure dummy couplings are present and connected. If rubber seals are hard or cracked, apply a film of brake fluid to rubber surfaces.
127	127	Landing Gear (Shafts, Wheels, Supports, Lock Pins, Gears, Crank). Inspect all the accessible units to see if they are in good condition, correctly assembled, properly lubricated, and not excessively worn. Make an operation test to see that crank, gears, and sliding head function satisfactorily. Spin wheels to see if they are free. Look particularly for damaged or worn assembly pins or bolts.
127		SPECIAL LUBRICATION. Lubricate landing gear according to Lubrication Order, paragraph 8.
		TIGHTEN. Tighten all assembly and mounting nuts or screws securely.
		TOOLS AND EQUIPMENT
131	131	Tools. Check On Vehicle Stowage List, to see that all tools are present; see that they are in good condition, clean, and properly and securely mounted or stowed. When not in use, chock blocks should be mounted on hooks provided, one on each side of semitrailer; jumper air hose and wire tarpaulin should be properly stowed in tool box.
133	133	Decontaminators. Check to see that decontaminators are in good condition, securely mounted, fully charged, and with nozzles free and clean. Inspect refill date on tags. Refill is required every 3 months.
135	135	Publications. Be sure vehicle manuals, Lubrication Orders, Form No. 26, and Form No. 478 are present and properly stowed.
141	141	Modifications (MWO's Completed). Inspect semi-trailer to be sure any modification work orders have been completed, and enter any MWO's or major unit assembly replacements made at time of this service on W.D., A.G.O. Form No. 478.

TM 9-894

14-16

11-TON PAYLOAD, 15-TON GROSS, 2-WHEEL (2dt), VAN SEMITRAILER (OMAHA STANDARD BODY CORP. MODEL F16)

MAINTENANCE	
8000-Mile (6-monthly)	1000-Mile (Monthly)
142	142

Final Road Test. Make a final road test, rechecking items 5, 10, 12, and 13. Confine road test to the minimum distance necessary to make proper observations. *NOTE: Correct or report to designated authority all deficiencies found during final road test.*

Section VII

TROUBLE SHOOTING

15. GENERAL.

a. Arrangement. This section contains trouble shooting information and tests which can be made to help determine the cause of some of the troubles that may develop in semitrailers used under average climatic conditions (above 32° F). Each symptom of trouble given under the individual unit or assembly is followed by a list of possible causes of trouble. The tests necessary to determine which one of the possible causes is responsible for the trouble are explained after each possible cause.

b. Maintenance Instructions. The maintenance instructions apply only if the condition indicated is present after the semitrailer has been carefully checked to definitely locate the source of trouble.

16. BRAKES.

a. Scope. The air brake system on the semitrailer is dependent upon the air brake system of the tractor truck for its air supply and control: It is essential that the air brake system of the tractor truck be in good condition; otherwise, it will be impossible to obtain proper brake performance on the semitrailer.

b. Brake Trouble Shooting. Before attempting to locate the source of any brake trouble, check to see that the semitrailer is properly connected to a tractor truck whose air brake system functions properly.

c. Insufficient Brakes.

(1) **BRAKES NEED ADJUSTING OR LUBRICATING.** Adjust or lubricate brakes (pars. 29 and 8).

TROUBLE SHOOTING

(2) **LOW AIR PRESSURE IN AIR BRAKE SYSTEM (BELOW 80 LB).** Correct cause of low pressure in tractor truck air brake system (par. 32).

(3) **DEFECTIVE RELAY EMERGENCY VALVE.** Repair or replace emergency relay valve (par. 33).

d. Brakes Apply Too Slowly.

(1) **BRAKES NEED ADJUSTING OR LUBRICATING.** Check brakes for lack of lubrication. Check for correct adjustment. Lubricate or adjust as required (pars. 8 and 29).

(2) **LOW AIR PRESSURE IN TRACTOR TRUCK AIR BRAKE SYSTEM.** Correct cause of low pressure in tractor truck air brake system (par. 32).

(3) **BRAKE VALVE PRESSURE FROM TRACTOR TRUCK BELOW NORMAL.** Check brake valve pressure from tractor truck. Adjust brake valve linkage (par. 32), or replace brake valve.

(4) **RESTRICTION IN TUBING OR HOSE LINE.** Repair or replace line (par. 39).

(5) **CLOGGED AIR FILTER.** Clean air filter (par. 36).

(6) **EXCESSIVE LEAKAGE WITH BRAKES APPLIED.** Refer to paragraph 32.

e. Brakes Release Too Slowly.

(1) **BRAKES NEED ADJUSTING OR LUBRICATING.** Adjust or lubricate brakes as required (pars. 29 and 8).

(2) **DEFECTIVE EXHAUST CHECK VALVE IN EXHAUST PORT OF RELAY EMERGENCY VALVE.** Replace (par. 33).

(3) **EXHAUST PORT OF RELAY EMERGENCY VALVE PLUGGED WITH PIPE PLUG.** Remove plug (par. 33).

(4) **RESTRICTED TUBING ON HOSE LINE.** Replace damaged tubing (par. 39).

(5) **CLOGGED AIR FILTER.** Clean air filter (par. 36).

f. Brakes Do Not Apply.

(1) **CUT-OUT COCKS IMPROPERLY CLOSED.** Open cut-out cocks (par. 6).

(2) **BRAKE SYSTEM NOT PROPERLY CONNECTED TO AIR HOSE OF TRACTOR TRUCK.** Connect air lines (par. 38).

(3) **NO AIR PRESSURE IN BRAKE SYSTEM.** Charge brake system to normal operating pressure.



TM 9-894

16

11-TON PAYLOAD, 15-TON GROSS, 2-WHEEL (2d+), VAN SEMITRAILER (OMAHA STANDARD BODY CORP. MODEL F16)

(4) **RESTRICTION OF TUBING IN HOSE LINE.** Repair or replace tubing (par. 39).

(5) **CLOGGED AIR LINE FILTER.** Clean filter (par. 36).

g. Brakes Do Not Release.

(1) **BRAKE SYSTEM IMPROPERLY CONNECTED TO BRAKE SYSTEM OF TRACTOR TRUCK.** Connect lines correctly (par. 38).

(2) **BRAKE VALVE ON TRACTOR TRUCK IN APPLIED POSITION.** Move brake valve of tractor truck to "RELEASE" position.

(3) **BRAKE RIGGING BINDING.** Lubricate or adjust brake rigging (pars. 8 and 29).

(4) **RELAY EMERGENCY VALVE IN EMERGENCY POSITION.** Increase air pressure in tractor truck brake system, or open reservoir drain cock on semitrailer (pars. 32 and 37).

(5) **CUT-OUT COCKS PARTIALLY CLOSED.** Open cut-out cocks on tractor truck.

(6) **RESTRICTION IN TUBING OR HOSE LINE.** Repair or replace damaged tubing (par. 39).

h. Brakes Grab.

(1) **GREASE ON BRAKE LINING.** Reline brakes (pars. 29 and 30).

(2) **BRAKE RIGGING BINDING.** Lubricate brake rigging (par. 8).

(3) **DEFECTIVE BRAKE VALVE ON TRACTOR TRUCK.** Repair or replace defective brake valve. Refer to tractor truck maintenance manual.

(4) **DEFECTIVE RELAY EMERGENCY VALVE.** Replace defective relay emergency valve.

i. Uneven Brakes.

(1) **BRAKES NEED ADJUSTING, LUBRICATING, OR RELINING.** Adjust, lubricate, or reline brakes as required (pars. 29, 8, and 30).

(2) **GREASE ON BRAKE LINING.** Reline brakes (pars. 29 and 30; fig. 22).

(3) **BRAKE SHOE RELEASE SPRING OR BRAKE CHAMBER RELEASE SPRING BROKEN.** Replace broken spring (par. 30).

(4) **BRAKE DRUM OUT-OF-ROUND.** Replace damaged brake drum (fig. 20).

(5) **LEAKING BRAKE CHAMBER DIAPHRAGM.** Replace defective brake chamber diaphragm (par. 34).

TROUBLE SHOOTING

j. Excessive Leakage With Brakes Released.

- (1) **RELAY EMERGENCY VALVE LEAKING.** Replace defective relay emergency valve (par. 33).
- (2) **LEAKING AIR LINES OR CONNECTIONS.** Repair or replace defective air lines or connections (par. 39).

k. Excessive Leakage With Brakes Fully Applied.

- (1) **LEAKING RELAY EMERGENCY VALVE.** Replace defective relay emergency valve (par. 33).
- (2) **LEAKING BRAKE CHAMBER DIAPHRAGM.** Replace damaged diaphragm (par. 34).
- (3) **LEAKING LINES OR CONNECTIONS.** Replace damaged lines or connections (par. 39).

l. Excessive Leakage With Brakes Applied and Relay Emergency Valve in Emergency Position. Replace defective relay emergency valve (par. 33).

m. Air Brake Noisy.

- (1) **RELAY EMERGENCY VALVE GROANS OR CHATTERS WHEN BRAKES ARE APPLIED.** Relay diaphragm guide ring improperly installed. Replace relay emergency valve (par. 33).
- (2) **EXHAUST CHECK VALVE IN RELAY EMERGENCY VALVE WHISTLES WHEN BRAKES ARE APPLIED.** Defective diaphragm in exhaust check valve. Install new diaphragm in exhaust check valve (fig. 27).

n. Excessive Oil and Water Present in Air Brake System.

- (1) **RESERVOIRS NOT DRAINED AT PROPER INTERVALS.** Drain all reservoirs at least once each week, daily if necessary. Clean system if necessary.

17. SUSPENSION.

a. Van Body Leaning or Tipping.

- (1) **UNBALANCED LOAD.** Rearrange load evenly to distribute weight.
- (2) **LOSS OF CAMBER IN SPRING.** If the spring will not return to normal position when not loaded, replace (par. 41).
- (3) **BROKEN SPRING, OR BROKEN LEAVES.** Replace broken spring or broken leaves (par. 41).
- (4) **LOOSE, BROKEN, OR LOST REBOUND CLIPS.** Replace lost or defective clips.

TM 9-894

17-19

11-TON PAYLOAD, 15-TON GROSS, 2-WHEEL (2d†), VAN SEMITRAILER (OMAHA STANDARD BODY CORP. MODEL F16)

(5) **LEAF ENDS SHIFTED SIDEWISE, OR "FANNED OUT."** Caused by broken or lost rebound clips. Replace clips (par. 41).

(6) **LONGITUDINAL SHIFT OF SPRING LEAVES DUE TO BROKEN CENTER BOLT.** Replace broken center bolt (par. 41).

b. Spring Shifted on Axle.

(1) **BROKEN SPRING SEAT.** Replace broken spring seat (par. 41).

(2) **BROKEN U-BOLT.** Replace broken U-bolt (par. 41).

(3) **DAMAGED U-BOLT THREADS.** Replace damaged U-bolt (par. 41).

(4) **DAMAGED U-BOLT NUT THREADS.** Replace damaged nut.

(5) **BROKEN OR DAMAGED PILLOW BLOCK.** Replace pillow block.

18. AXLE.

a. Bent Axle Beam (fig. 37).

(1) **ACCIDENTAL DAMAGE FROM STRIKING OBSTRUCTION, OR OVERLOADING.** Replace axle (par. 45).

b. Broken Spindle.

(1) **ACCIDENTAL IMPACT WITH OBSTRUCTION, OR OVERLOADING.** Replace axle (par. 45).

c. Axle Out of Line (fig. 34).

(1) **BROKEN RADIUS ARM.** Replace broken radius arm (par. 42).

(2) **BROKEN RADIUS ARM ECCENTRIC BOLT.** Replace broken eccentric bolt (par. 42).

(3) **WORN RADIUS ARM RUBBER BUSHING.** Replace worn rubber bushing (par. 42).

(4) **RADIUS ARM OUT OF ADJUSTMENT (fig. 33).** Adjust radius arm eccentric to realine axle (par. 42a).

19. WHEELS, HUBS, AND DRUMS.

a. Noise.

(1) **NOISY BRAKES.** Refer to brake trouble shooting (par. 16).

(2) **BRAKE SHOES DRAG ON DRUMS.** Refer to brake trouble shooting (par. 16).

(3) **BRAKE DRUM OUT-OF-ROUND.** Replace damaged brake drum. (par. 62 and fig. 20).

TROUBLE SHOOTING

(4) **WHEEL NOT PROPERLY ALINED** (fig. 34). Aline wheels (par. 42).

(5) **OBSTRUCTION CAUGHT IN WHEEL, BETWEEN DUALS, OR IN TIRE TREAD.** Remove obstruction.

(6) **DUST SHIELD BENT AGAINST BRAKE DRUM.** Straighten or replace dust shield (par. 29 b).

(7) **WHEEL BEARINGS NOT PROPERLY ADJUSTED.** Adjust wheel bearings (par. 26).

(8) **LOOSE WHEEL STUD NUTS.** Tighten wheel stud nuts.

(9) **BROKEN BRAKE SHOE SPRING.** Replace broken brake shoe spring (par. 30).

b. Undue Wear on Any and All Tires.

(1) **INCORRECT TIRE INFLATION.** Inflate tires to proper pressure.

(2) **OVERLOADING.** Check load weights hauled, and keep within rated gross capacity (par. 4).

(3) **IMPROPER AXLE ALINEMENT WITH KINGPIN.** Adjust radius eccentric to correct axle alinement (par. 45).

(4) **WOBBLY OR LOOSE WHEELS.** Tighten wheel stud nuts and aline wheels (par. 45).

(5) **BENT AXLE SPINDLE.** Replace axle (par. 45).

(6) **INCORRECT AXLE CAMBER** (fig. 36). Replace axle (par. 45).

(7) **BRAKE ACTION TOO SEVERE.** Check and adjust brakes (par. 29).

(8) **DAMAGED WHEEL OR WHEELS.** Replace damaged wheel or wheels (par. 25 a).

c. Undue Tire Wear (Inner or Outer Only).

(1) **DUALS NOT PROPERLY MATCHED.** Match duals.

(2) **BENT AXLE OR SPINDLE** (fig. 37). Replace axle (par. 45).

d. Hot Hub.

(1) **LACK OF WHEEL BEARING LUBRICANT.** Lubricate wheel bearings (par. 8).

(2) **DAMAGED BEARINGS, CONES, OR CUPS.** Replace damaged bearings, cones, or cups (par. 26).

(3) **DAMAGED HUB.** Replace damaged hub (par. 25).

(4) **WHEEL BEARINGS IMPROPERLY ADJUSTED.** Adjust wheel bearings (par. 26).

e. Hot Brake Drum.

(1) **DRAGGING BRAKE SHOES.** Adjust brake shoes (par. 30).

(2) **BROKEN BRAKE BLOCK.** Reline brakes (par. 30).

TM 9-894

19-20

11-TON PAYLOAD, 15-TON GROSS, 2-WHEEL (2dt), VAN SEMITRAILER (OMAHA STANDARD BODY CORP. MODEL F16)

(3) **BROKEN BRAKE SHOE SPRING.** Replace broken brake shoe spring (par. 30).

(4) **IMPROPER WHEEL BEARING ADJUSTMENT.** Adjust wheel bearings (par. 26).

(5) **BENT AXLE SPINDLE.** Replace axle (pars. 44 and 45).

f. Oil or Grease Outside of Wheel or Inside Brake Drum.

(1) **IMPROPER LUBRICANT.** Clean and lubricate according to Lubrication Order (par. 8).

(2) **TOO MUCH GREASE IN HUB DUE TO INCORRECT LUBRICATION.** Clean and lubricate according to paragraph 8.

(3) **LOOSE OR DAMAGED HUB CAP.** Tighten loose hub cap. Replace damaged hub cap.

(4) **TOO MUCH LUBRICANT IN CAMSHAFT NEEDLE BEARINGS (par. 31).** Remove wheel, hub, and drum assembly as a unit and clean brake drum (pars. 25 and 8). If brake lining blocks are greasy, replace brake blocks (par. 30 and fig. 23).

20. FRAME

a. Frame Sprung. A sprung frame is the result of an accident or abusive driving of overloaded semitrailer. Heat sprung frame at point of damage. Employ standard practice to straighten. The use of the tractor truck jack and a heavy hammer are usually sufficient to make this repair.

b. Damaged Bumper.

(1) **BUMPER BENT (fig. 38).** This damage may be repaired by heating at the point of damage, and using the tractor truck jack and a short length of chain to reshape (par. 47).

(2) **SHEARED BUMPER MOUNTING BOLTS.** Replace damaged bumper mounting bolts (par. 47).

(3) **BENT BUMPER MOUNTING PLATES.** Remove bumper mounting plate bolts. Remove bumper diagonal brace bolts, and remove bumper. Straighten bumper mounting plates, and replace bumper (par. 47).

(4) **BENT DIAGONAL BUMPER BRACES.** Remove diagonal bumper brace bolts from both bumper and semitrailer frame. Diagonal brace can now be removed. Heat bumper brace and straighten. Shape brace so that bolt holes in flanges match corresponding holes in bumper and frame of semitrailer (par. 47).

c. Broken or Bent Tire Carrier Assembly. Remove tire carrier from frame by removal of four hook bolts. Repair or replace tire carrier (pars. 59 and 60).

TROUBLE SHOOTING

21. LANDING GEAR.

a. Trailer Leans When Wheels are Down.

- (1) BENT OR BROKEN BACK BRACES (fig. 45). Repair or replace damaged braces (par. 55).
- (2) BROKEN OR DAMAGED LANDING GEAR LEG (fig. 45). Replace damaged parts (par. 56).

b. Landing Gear Cannot Be Lowered to Correct Position.

- (1) BENT OR BROKEN LEGS OR BRACES. Replace broken or damaged parts (par. 56).
- (2) SHEARED OR LOOSE KEYS IN GEARS (fig. 46). Replace broken or worn key (par. 56).
- (3) BROKEN OR DAMAGED LANDING GEAR SCREW (fig. 46). Replace broken or damaged landing gear screw (par. 56).

c. Landing Gear Legs Do Not Move When Operating Crank is Turned.

- (1) LOST OR SHEARED KEYS, PINS, OR BOLTS. Replace lost or damaged part (par. 56).
- (2) BROKEN MITER GEARS (fig. 46). Replace damaged miter gears (par. 57).
- (3) BROKEN BACK BRACES OR PINS DISCONNECTED. Replace back braces or pins as required (par. 56).

d. Operating Crank Moves Landing Gear Partially and Then Jams.

- (1) BENT SCREW OR DAMAGED SCREW HOUSING (fig. 45). Replace damaged part (par. 56).
- (2) GEARS JAMMED OR BROKEN. Replace worn or broken gears (par. 56).
- (3) WORN BUSHINGS (fig. 46). Replace worn bushings (par. 56).

e. Cannot Turn Operating Handle.

- (1) BENT SCREW OR DAMAGED HOUSING. Replace damaged screw or housing (par. 56).
- (2) GEARS JAMMED OR LOCKED. Remove gears. Reassemble correctly if undamaged. Replace if damaged (par. 56).
- (3) DAMAGED CRANK OR SHAFT. Replace damaged part (par. 56).

f. Crank Does Not Turn Freely.

- (1) LACK OF LUBRICATION. Lubricate properly (par. 8).
- (2) BENT SCREW HOUSING OR SHAFT. Replace damaged part (par. 56).

TM 9-894

22-23

11-TON PAYLOAD, 15-TON GROSS, 2-WHEEL (2d†), VAN SEMITRAILER (OMAHA STANDARD BODY CORP. MODEL F16)

22. BODY.

a. Doors Do Not Close Properly (par. 47).

- (1) **HINGE BOLTS LOOSE.** Secure hinge bolts.
- (2) **HINGE BENT OR BROKEN.** Replace hinge.
- (3) **DOOR DAMAGED.** Remove and repair door.

b. Door Lock Does Not Operate (par. 47).

- (1) **KEYWAY JAMMED.** Clean keyway.
- (2) **CENTER LOCK CASE DAMAGED.** Repair or replace damaged case.
- (3) **RODS BENT OR BROKEN.** Replace damaged rods.

c. Damaged Metal Body Paneling. Remove adjacent wood body lining to exposed, bent, or damaged panel. Straighten or repair damaged metal panel. Replace wood body lining (par. 47).

23. ELECTRICAL SYSTEM (fig. 41).

a. No Lights (par. 53).

(1) **DEFECTIVE CONTROL SWITCH ON TRACTOR TRUCK.** Check tractor truck control switch for loose or broken connections. Tighten loose connections. Replace broken connections.

(2) **DAMAGED JUMPER CABLE ON TRACTOR TRUCK.** Check tractor truck jumper cable connections. Check cable plug. Replace damaged units.

(3) **LOOSE WIRING HARNESS CONNECTIONS ON JUNCTION BLOCK.** Tighten loose connections on junction block (par. 49).

(4) **DAMAGED WIRING HARNESS.** Repair damaged wiring harness. Replace if badly damaged (par. 49).

b. Dim Lights (par. 53).

(1) **LOOSE OR DIRTY TERMINALS.** Clean connections and tighten terminals (par. 49).

(2) **LOOSE MARKER LIGHT AND TAILLIGHT GROUND.** Clean and tighten ground connection (par. 49).

c. Lights Out (par. 53).

- (1) **LOOSE OR BROKEN TERMINALS.** Tighten or repair terminals.
- (2) **BROKEN LAMPS.**

d. Switches (pars. 51 and 52).

(1) **BLACKOUT SWITCH DEFECTIVE (fig. 43).** Check for loose terminals, and replace worn or damaged switch (par. 51).

(2) **DOME LIGHT SWITCH (fig. 44).** Check for loose or broken terminals, and replace switch if worn or damaged (par. 52).

Section VIII

WHEELS, HUBS, BEARINGS, AND TIRES

24. DESCRIPTION AND DATA (figs. 13 and 14).

a. Wheels. The wheels are of the pressed-steel, ventilated type, having 20-inch disks and 8-inch rims. Each wheel is fastened to its hub by a separate set of nuts. All the stud nuts on the wheels located on the right-hand side of the semitrailer have right-hand threads. The stud nuts on the left-hand side have left-hand threads. The inner dual wheel is individually held by the inner set of cap nuts. The outer wheel slips over the inner cap nuts, and is independently held by the outer nuts. Each set of dual wheels is held in place on its hub by 10 studs upon which the wheel cap nuts are attached. When removing stud nuts from wheel studs it will be noted that all nuts are marked "R" or "L" to make possible immediate identification of the right-hand or left-hand side to which each belongs.

b. Hubs. The hub supports the dual wheel assembly upon its outer face, and the brake drum is attached to its inner face. The brake drum is attached to the hub by independent threads and nuts on the inner end of the wheel studs. Removal of each inner nut permits removal of its stud from the hub and drum assembly.

c. Bearings. Each wheel and hub assembly is mounted on the axle spindle by two opposed tapered roller bearing assemblies. The bearing cups are pressed into the inner and outer bore of the hub. The bearing cones slide upon, and are supported by, the axle spindle. The hub, with its supporting bearing cups, is adjusted to turn freely upon the tapered bearing cones. The hub is adjusted, and retained in running position upon the bearings, by means of the axle spindle nut which retains the D-washer against the outer bearing (fig. 15).

d. Data.

(1) WHEELS.

Make Budd
 Size 20 in.
 Rim 8 in.

(2) HUBS.

Make Fruehauf

(3) BEARINGS.

Make Timken
 Type Tapered roller
 Inner cup No. 5720
 Outer cup No. 5521

TM 9-894

24-25

11-TON PAYLOAD, 15-TON GROSS, 2-WHEEL (2dt), VAN SEMITRAILER (OMAHA STANDARD BODY CORP. MODEL F16)

Inner cone No. 5752

Outer cone No. 5565

(4) TIRES.

Size 10.00 x 20 in.

Number of plies 12

25. WHEELS AND HUBS.

a. **Wheels.** The wheels of the semitrailer require no service, barring damage due to collision. In the event of wheel damage, replacement is necessary.

b. **Hubs and Drums.** Hub and drum assemblies are removed from the axle spindle by the following procedure:

(1) Using the jack supplied with the tractor truck unit of the semitrailer, jack up the axle assembly until the dual wheels are free from contact with the ground. Block the axle in this position.

(2) Remove outer wheel cap nuts, and remove the outer dual wheel.

(3) Remove the inner cap nuts, and remove the inner wheel.

(4) Remove the four cap screws retaining hub cap, and remove hub cap.

(5) Pull cotter pin from axle spindle, and remove the axle nut by turning in a counterclockwise direction (B, fig. 15).

(6) Remove the D-washer (C, fig. 15) from the axle spindle by inserting the blade of a screwdriver between the washer and the bearing face, and gently tapping with a hammer. Force opposite edges of the D-washer in succession, to prevent wedging.

(7) Jar the hub and drum assembly, and pull outward until the outer bearing is free. Remove the outer bearing. **CAUTION:** *Be sure that the brakes are fully released so that brake shoes do not drag against the drum.*

(8) Remove hub and drum assembly containing the inner bearing from the axle spindle.

c. **Drums.** Remove drum from the hub by removing the nuts on the inside of the drum. Lift drum from the hub and stud assembly. A drum whose braking surface is rough or damaged must be replaced. **CAUTION:** *Do not repair a drum whose braking surface is damaged.*

d. Hubs.

(1) **RUNNING DAMAGE.** Damage seldom occurs to hubs under ordinary driving conditions. Damage will result, however, if bearing cups are carelessly removed from the hub bore. **CAUTION:** *Follow procedure described in paragraph 26 to avoid such damage.* Damage will occur in running if nuts holding wheel studs to the hub and drum assembly become loose, resulting in wear of hub stud holes and seats.

WHEELS, HUBS, BEARINGS, AND TIRES

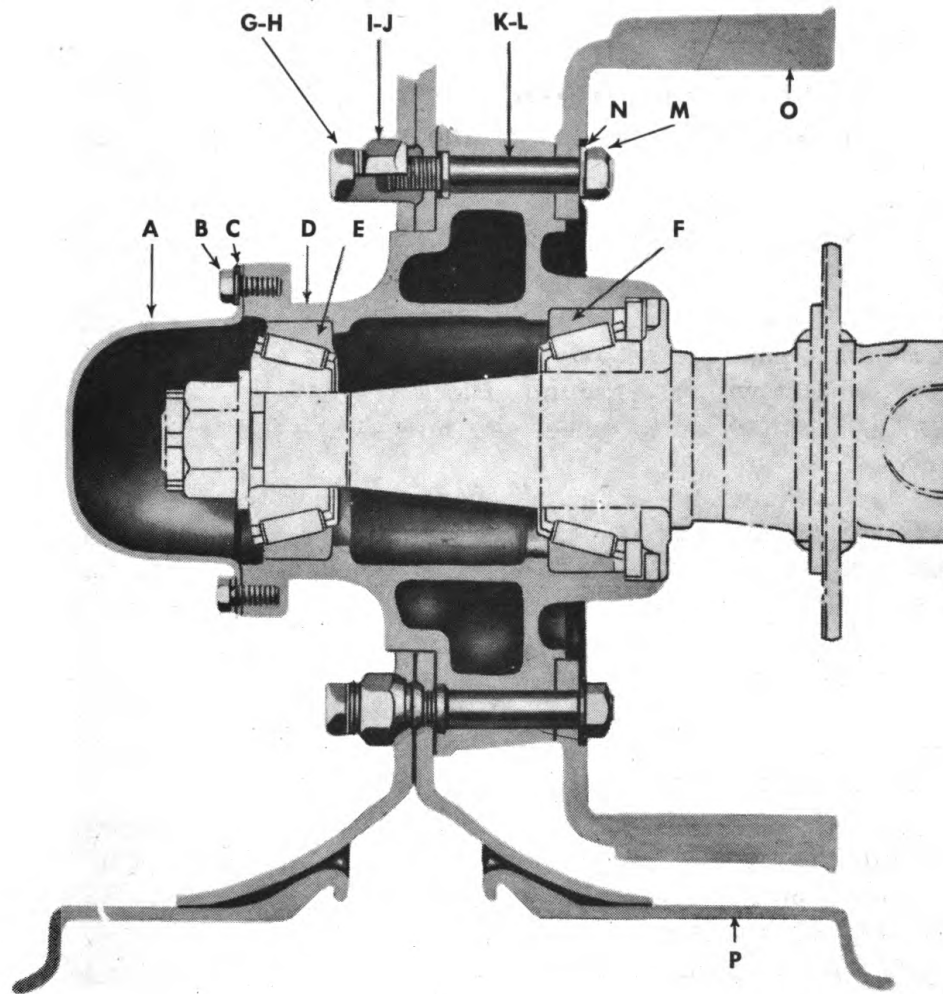

RA PD 335741

- | | |
|--|--|
| <p>A—HUB CAP
 B—HUB CAP BOLT
 C—HUBCAP BOLT LOCK WASHER
 D—HUB
 E—OUTER BEARING CUP
 F—INNER BEARING CUP</p> | <p>G-H—INNER DOUBLE CAP NUT (RIGHT OR LEFT)
 I-J—OUTER DOUBLE CAP NUT (RIGHT OR LEFT)
 K-L—WHEEL STUD (RIGHT OR LEFT)
 M—BRAKE DRUM STUD NUT
 N—BRAKE DRUM STUD NUT LOCK WASHER
 O—BRAKE DRUM
 P—WHEEL</p> |
|--|--|

Figure 13—Wheel, Hub, and Drum Assembly, Sectional View

11-TON PAYLOAD, 15-TON GROSS, 2-WHEEL (2dt), VAN SEMITRAILER (OMAHA STANDARD BODY CORP. MODEL F16)

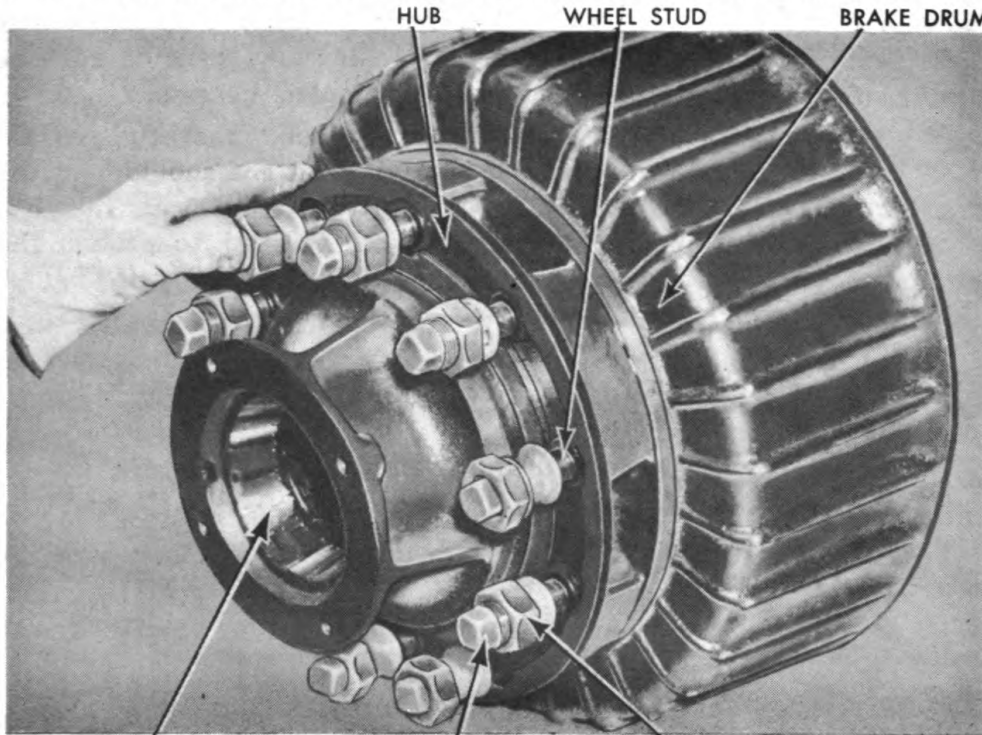

OUTER BEARING CUP

INNER WHEEL CAP NUT

OUTER WHEEL CAP NUT

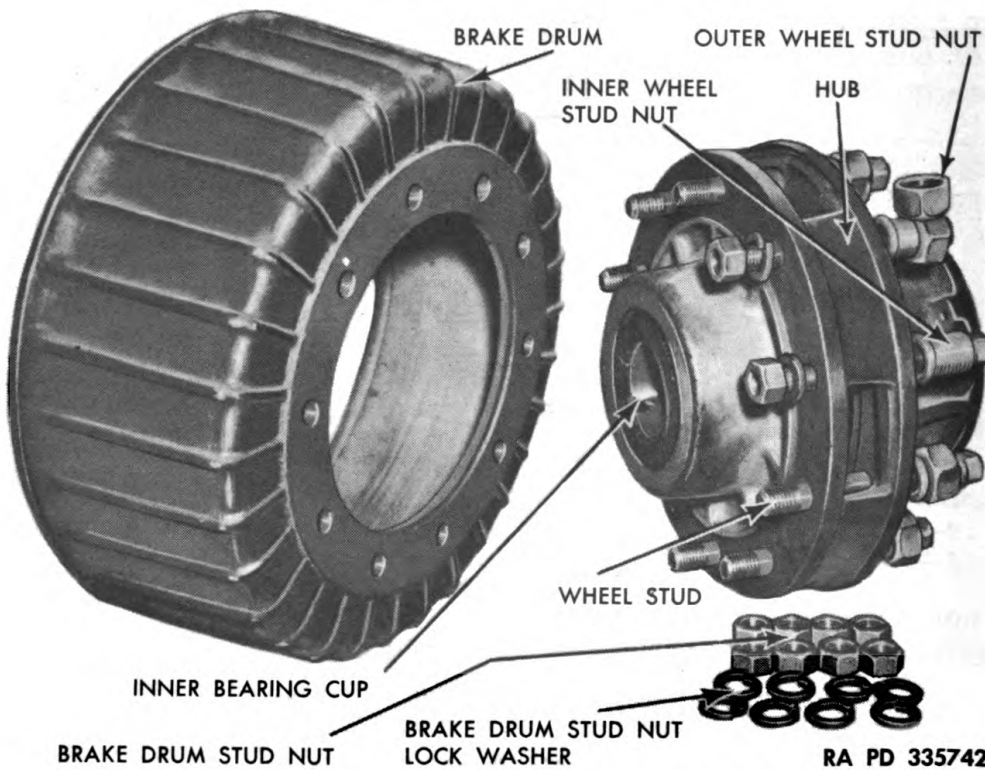

BRAKE DRUM

OUTER WHEEL STUD NUT

INNER WHEEL STUD NUT

HUB

WHEEL STUD

INNER BEARING CUP

BRAKE DRUM STUD NUT

BRAKE DRUM STUD NUT LOCK WASHER

RA PD 335742

Figure 14—Hub and Drum Assembly Partially Disassembled

WHEELS, HUBS, BEARINGS, AND TIRES

(2) **ACCIDENTAL DAMAGE.** The most common hub damage is the result of accident or collision. The hub may become split or sprung. In either case immediate replacement is necessary.

(3) **WHEEL STUDS.** Replace worn or broken wheel studs. Care must be taken, when installing a new stud, to fit the shoulder of the stud into its seat in the hub before it is driven into place. Install a wheel nut on the wheel supporting end of the stud, to protect the outer threads while driving stud into hub. Use a hardwood buffer block between stud and hammer.

26. BEARINGS

a. Remove Cones.

- (1) Remove the hub and drum assembly (par. 25 b).
- (2) Remove outer and inner bearing cones.

b. Remove Cups. Place the hub upon a wood block with the

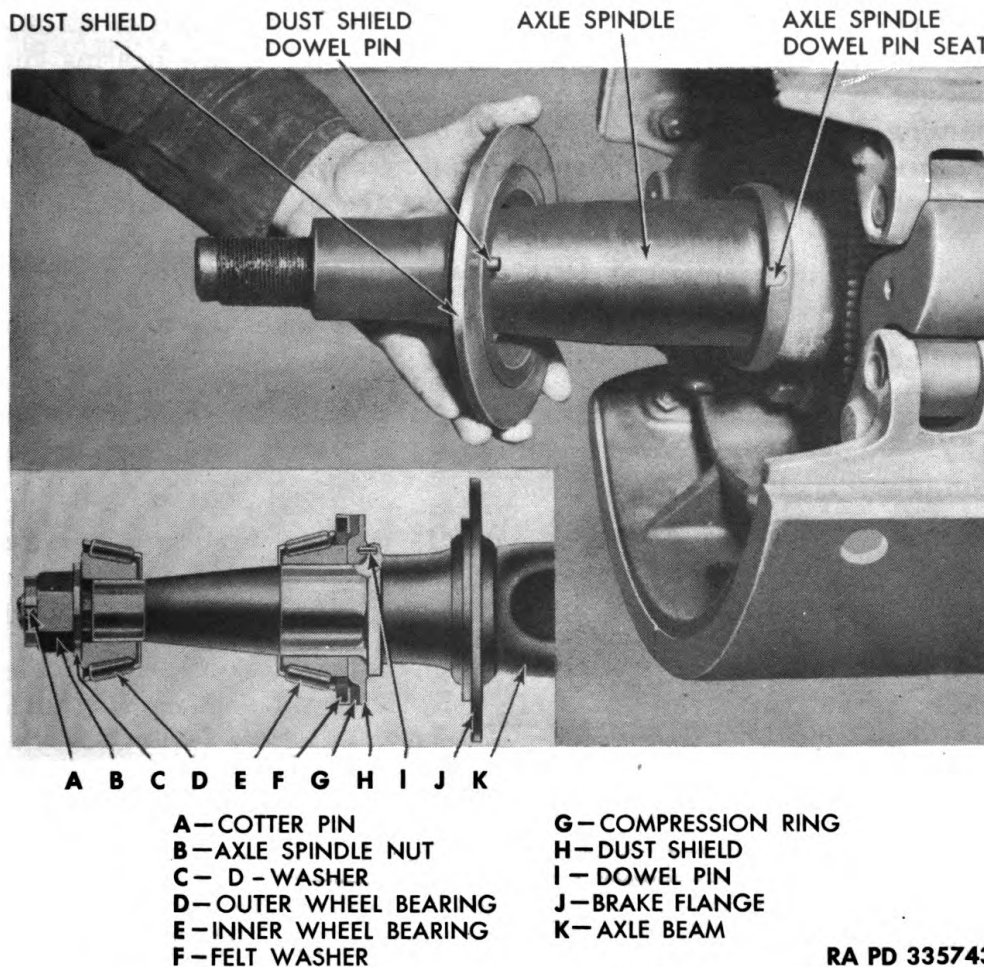

Figure 15—Axle Spindle Partially Disassembled and Sectional View of Spindle Assembly

11-TON PAYLOAD, 15-TON GROSS, 2-WHEEL (2dt), VAN SEMITRAILER (OMAHA STANDARD BODY CORP. MODEL F16)

bearing cup to be removed facing down. Use drift and hammer to drive the damaged cup from the hub bore. Move the end of the drift along the upper face of the cup as it is driven, so that the opposite sides are driven successively. (Be certain to drive the cup outward uniformly to prevent wedging.) It must be driven so that it is uniformly straight with the bore of the hub. Careless use of drift will result in damage to the machined bore of the hub. The same procedure is followed for removing both cups.

c. Replace Cups. Replace cups by facing upward the end of the hub into which the cup is to be inserted. Before replacing cups be sure the hub is clean (par. 8). Place the hub on a wood block, and start the new bearing cup square with the bore of the hub. Face the smaller inside diameter toward the hub. Place a hardwood buffer block upon the cup, and drive into the hub bore until flush with the outer edge. *CAUTION: Use care to drive the bearing cup uniformly into the hub so that it does not become wedged or sprung.* Drive new cup progressively into the hub until the new bearing cup is tight against the flange of the hub bore. *CAUTION: Unless the bearing cups are firmly seated, the hub cannot be kept in adjustment upon the bearings. Complete lubrication of bearings and hub (par. 8) must precede reassembly upon the axle spindle.*

d. Replace Hub and Drum Assemblies (fig. 15).

(1) Replace inner bearing cone in the inner bearing cup of the hub assembly.

(2) Insert the compression ring (G) with its flanged side toward the inside of the hub, and place the felt washer (F) next to the compression ring.

(3) Make sure the dust shield (H) is properly in place on the axle spindle and locked into place by means of the metal dowel pin (I) which fits into a slot on the spindle and a hole in the dust shield.

(4) Using a greased skid plate on the end of the axle spindle, slide the hub and drum assembly onto the spindle. Place the outer wheel bearing (D) in the outer hub bore, and install the D-washer (C).

(5) Turn the axle nut (B) up tight against the D-washer, then slacken off about one-third turn. Before adjusting the hub and bearing assembly upon the axle spindle, replace the dual wheel and tire assembly. Rest one end of a short bar upon the floor beneath the dual tires. Using the bar as a pry against the tires, hold a finger of the free hand upon the outer portion of the bearing cage and the

WHEELS, HUBS, BEARINGS, AND TIRES

edge of the hub to detect excessive play between the bearing and hub. Tighten or loosen the spindle nut as required to complete the adjustment.

- (6) Replace cotter pin (A).
- (7) Replace the hub cap.

27. TIRES.

a. Remove Wheel and Tire Assembly. Using the jack provided with the tractor truck, place under the axle against the lower spring clip plate, and raise the axle until the wheels to be removed are off the ground. Block the dual wheels on the opposite side of the semitrailer, placing the chock block against the dual tires, and on the lower side of any slope in the ground. Place an emergency block on the side of the duals opposite the chock block. Use the tractor truck wheel nut wrench to remove the outer wheel stud nuts, and remove the outer wheel. If the inner wheel and tire assembly is to be removed, remove the inner stud nuts, and lift the inner wheel assembly from the wheel studs.

b. Remove Tire From Wheel. Remove the core from the valve stem of the tube of the tire assembly by unscrewing the core

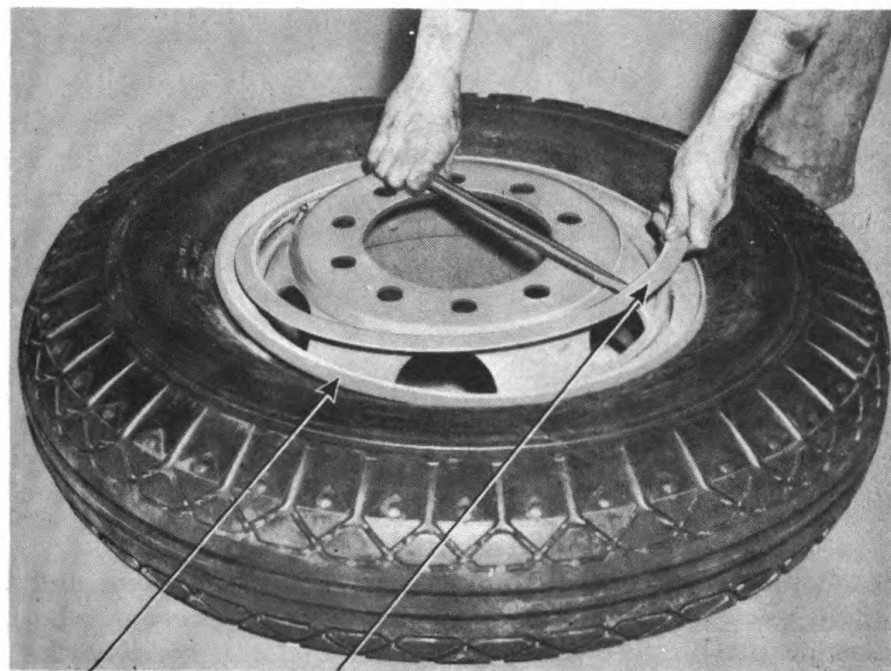

SIDE RING

LOCK RING

RA PD 335744

Figure 16—Removing Tire Lock Ring

11-TON PAYLOAD, 15-TON GROSS, 2-WHEEL (2d+), VAN SEMITRAILER (OMAHA STANDARD BODY CORP. MODEL F16)

with the slotted end of the valve cap. Removal of the valve core permits more rapid deflation of the tube. Place wheel and tire assembly on a level surface with the wheel lock ring up. When the tire is fully inflated, use tire tool to loosen and remove tire lock ring (fig. 16). When the lock ring has been removed, lift the side ring from the wheel rim, and remove tire from the wheel (fig. 17). Replace valve core. Remove tire flap and tube for inspection or repair.

c. Tire Maintenance. Tires must be repaired in accordance with the usual conventional methods. Punctures and tears in the tire, causing exposure of cord or fabric, must be vulcanized. Holes in the inner tube must be repaired by cold patching. **CAUTION:** *Hot patching or vulcanizing inner tubes must not be attempted.*

**RA PD 335745****Figure 17—Removing Tire From Wheel**

d. Replace Tubes and Flaps in Tires. When tubes and flaps are again placed in tires, care must be taken to prevent tube from twisting or pinching between wheel rim and the bead of the tire. Side rings and lock rings must be replaced and the valve stem centered in valve slot of wheel rim before tube is inflated. **CAUTION:** *Be sure that valve stem points outward when tube is replaced in tire.* Check lock ring to see that it is firmly seated in the groove

BRAKE SYSTEM

in the wheel rim. As a safety measure, a length of chain should be wrapped loosely around the tire at two opposite points on the wheel before tire is inflated. This precaution will prevent lock ring from springing up and causing injury, if it has not been securely fastened before tire is inflated. Inflate tire to proper pressure (70 lb) and replace valve cap.

e. **Reassemble Tire and Wheel Units on Hub Assembly.** Replace the inner wheel on the hub, and apply the inner cap nuts. **NOTE:** *Care must be taken to tighten all cap nuts evenly and securely before the outer wheel is mounted.* When installation of the inner wheel has been completed, the outer wheel should be positioned on the cap nuts of the inner wheel and the outer cap nuts replaced. Be sure that the beveled surface on the inner face of each cap nut is evenly seated into the bevel in the wheel stud hole. **NOTE:** *Care in this step of the wheel assembly on the hub is extremely important because the weight of the semitrailer is carried upon the beveled surfaces of the cap nuts. Unless the beveled surfaces of the cap nuts are firmly seated into the corresponding beveled seats in the wheel stud holes, the wheels will become loose and damage to the wheel, studs, or hub will result.*

Section IX

BRAKE SYSTEM

28. DESCRIPTION AND DATA.

a. **General Description.** The brakes of the semitrailer are actuated and controlled by compressed air supplied by the tractor truck through two air hose lines (fig. 18) coupled to the front of the semitrailer. Once the air lines are connected, and the stop cocks on the air lines of the tractor truck are opened, the brakes of the tractor truck and semitrailer are activated and controlled as a single unit. The braking mechanism of the semitrailer is of the internal expanding mechanical type operating on each of the dual wheel brake drums.

b. **Mechanical Operation.** The purpose of the brakes is to stop the semitrailer movement smoothly and evenly. This braking control is accomplished by forcing the brake shoes, lined with heavy blocks of heat resistant high-friction material against surfaces of the brake drums. The brake shoes are in turn actuated by the camshaft assemblies. The camshafts are operated by the air brake system acting directly on the slack adjusters attached to the inner ends of the camshafts. The slack adjuster arms are attached to the push rods of the brake chambers by yokes and clevis pins. The brake chambers are attached, by brackets, to the central section of the axle opposite the cam brackets. Each brake chamber is bolted to the

11-TON PAYLOAD, 15-TON GROSS, 2-WHEEL (2dt), VAN SEMITRAILER (OMAHA STANDARD BODY CORP. MODEL F16)

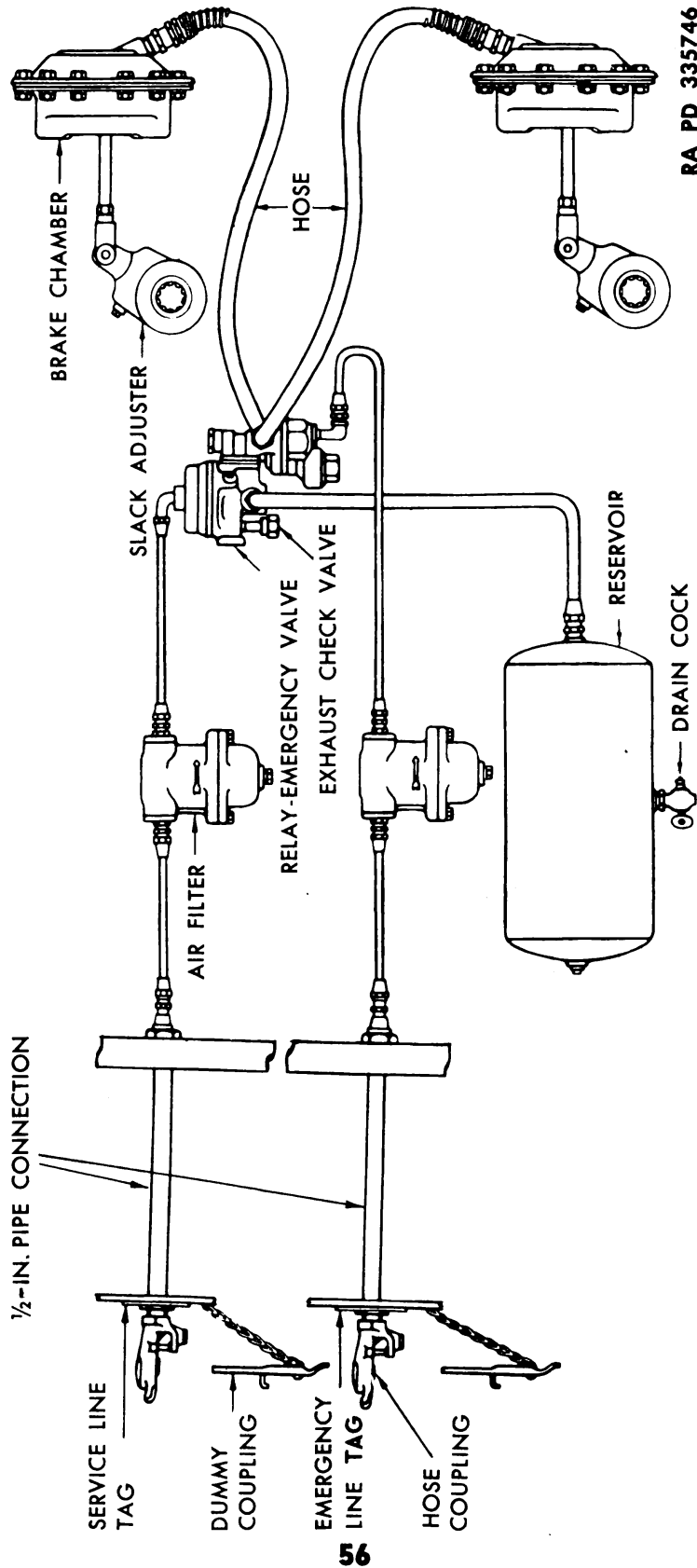

Figure 18—Air Lines Diagram

BRAKE SYSTEM

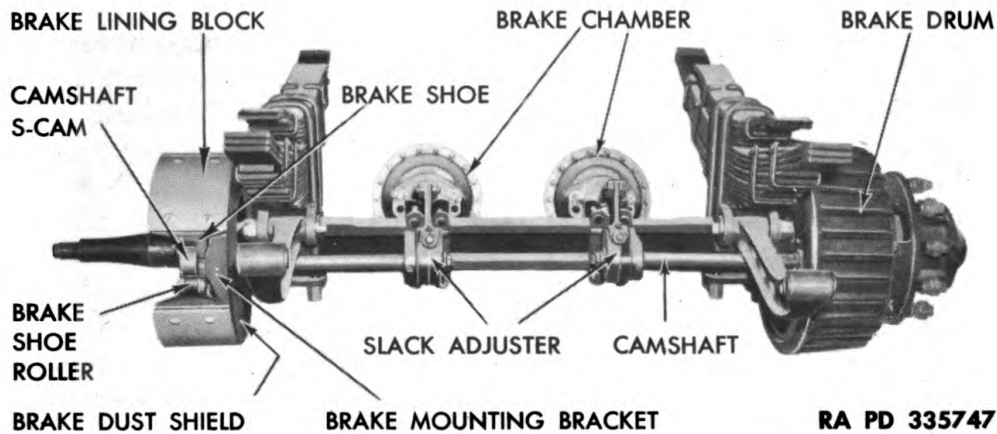

Figure 19—Axle Assembly and Braking Mechanism

opposed cam bracket by four bolts, clamping both brake chamber bracket and cam bracket to the axle (fig. 19). The brake chambers are operated by the air system, acting directly on the slack adjuster arms. The camshafts terminate in S-heads between the brake shoe rollers and communicate the braking force through the brake shoes to the brake drums of the wheel, hub, and drum assemblies. Effective braking action is accomplished only when each unit of the combined braking system is in good mechanical condition and properly adjusted in relation to its dependent units. **NOTE:** *The air brake system of the semitrailer is dependent upon the air brake system of the tractor truck for its air supply and control. The air brake system of the tractor truck must be in good condition; otherwise, it will be impossible to obtain good brake performance on the semitrailer.*

c. Data.

Make	Fruehauf
Brake size	16 in. x 6 in.
Lining block size	9 in. x 6 in.
Lining block thickness	3/4 in.
Blocks per shoe	2

29. BRAKE ADJUSTMENTS.

a. Preparation and Inspection.

(1) **PREPARATION.** Use the tractor truck jack to raise the axle so that when blocked in position both dual wheels remain off the ground. Release the air brakes. Remove the two dust shields which are bolted with six cap screws to the brake adapter plate of each braking unit. This operation exposes the brake linings for inspection (fig. 21).

11-TON PAYLOAD, 15-TON GROSS, 2-WHEEL (2d+), VAN SEMITRAILER (OMAHA STANDARD BODY CORP. MODEL F16)

(2) **INSPECTION.** Check the brake shoe linings for uneven or undue wear. Check for grease on the linings, or on the inner braking surface of the brake drums. Rotate each dual wheel assembly to locate any drag of brake shoe linings against the rotating drums, and to detect any noise in the inner brake shoe assembly. If brake linings are clean and otherwise in good condition, only minor adjustments will be required to service the brakes.

b. Minor Adjustments. The only adjustment required to compensate for normal wear is performed by rotating the slack adjuster lever worm screw clockwise (fig. 29) until the brake shoe linings begin to drag on the brake drums. Then back off with a counterclockwise rotation until the brakes are free. Replace dust shields and remove blocks from under the axle.

c. Major Adjustments.

(1) **REMOVE WHEEL AND HUB ASSEMBLY.** If inspection has revealed dirty brake shoe linings, noise or free play in the brake shoe assembly, or undue wear of the brake lining blocks, remove the

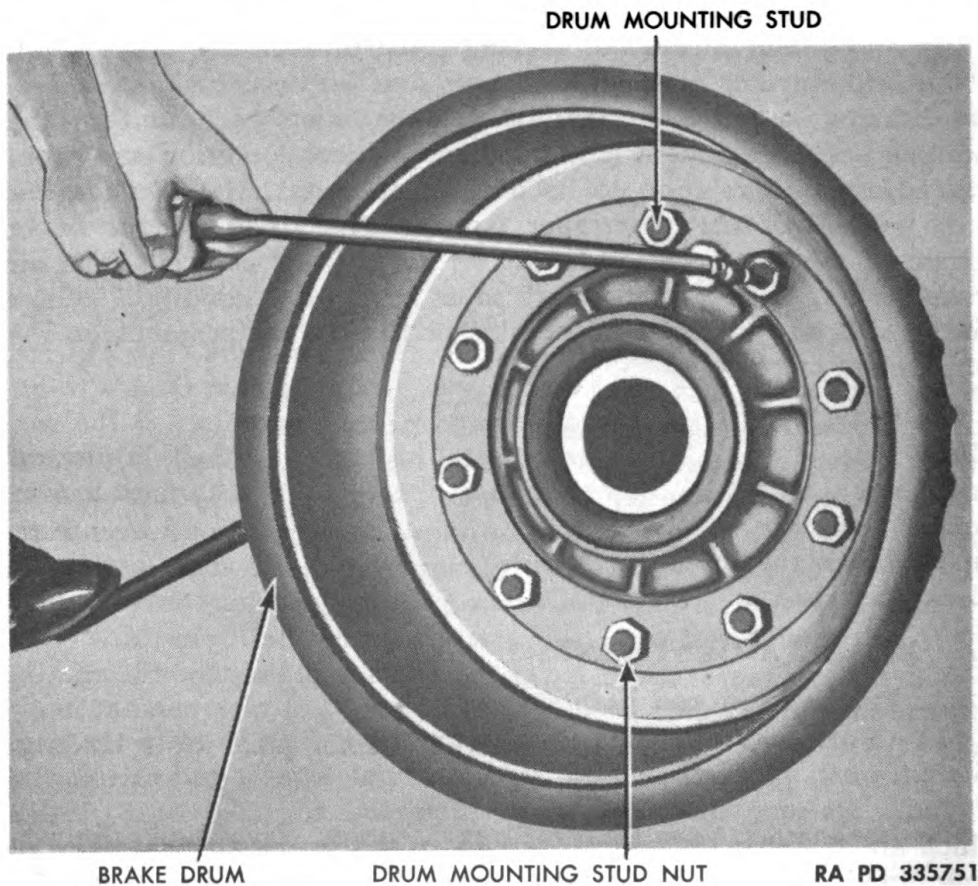
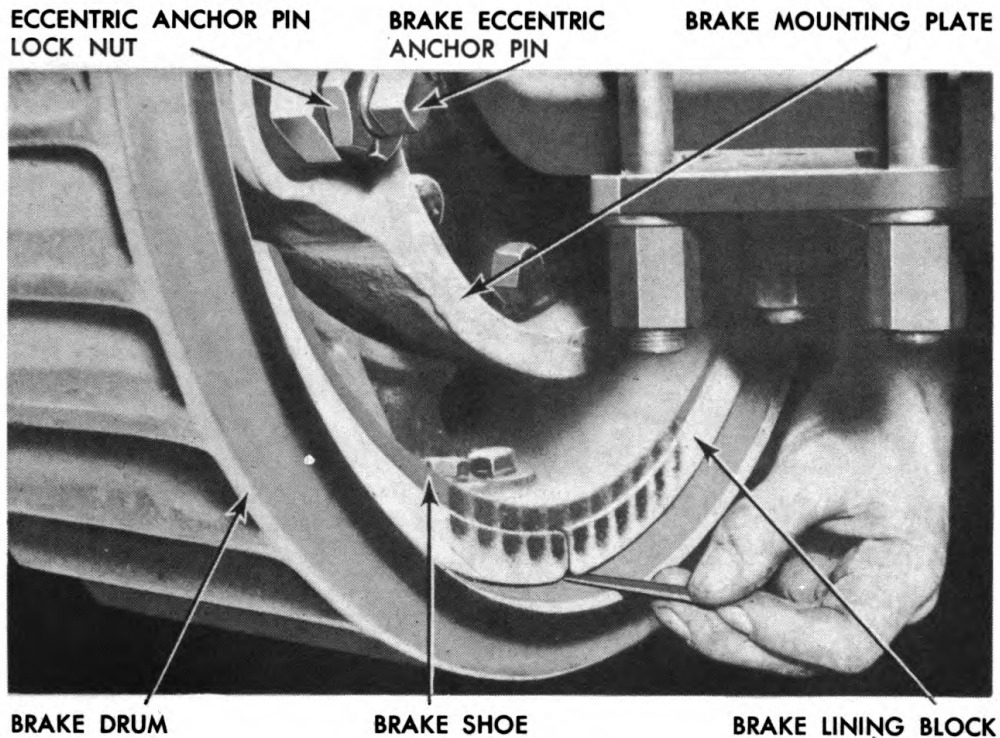

Figure 20—Replacing Brake Drums

BRAKE SYSTEM



RA PD 335748

Figure 21—Inspecting Brake Lining

wheel and hub assembly (par. 25) to make necessary major adjustments or repairs.

(2) **ADJUST BRAKE SHOE.** Installation of new brake shoe linings or new brake drums necessitates readjustment of the brake shoe assembly. Loosen both nuts on both anchor pins (fig. 21) so that the anchor pins can be moved freely. Remove dust shields from adapter plates. Replace the wheel and drum assembly. If the assembly fails to slip into position freely, back off the slack adjusters by counterclockwise rotation of the worm screw (fig. 29) until brake shoes are free from the drum. Centralize the anchor pin eccentrics and tighten the slack adjuster worm screw until the shoes are tight in the brake drum. Turn the brake eccentric anchor pin to right or left as the slack adjuster is tightened, until the brakes are centralized in the drum. Use a feeler gage to set brake-shoe clearance. Set clearance at eccentric end at 0.010 inch. Set clearance at cam end at 0.015 inch. Tighten lock nuts on anchor pins, while holding pins firmly in place.

(3) **READJUST NEW BRAKE SHOE LININGS.** New brake linings must be carefully readjusted after 1 hour, or 25 to 40 miles of operational running in which the brakes have received normal use. Watch

TM 9-894

29

11-TON PAYLOAD, 15-TON GROSS, 2-WHEEL (2d+), VAN SEMITRAILER (OMAHA STANDARD BODY CORP. MODEL F16)

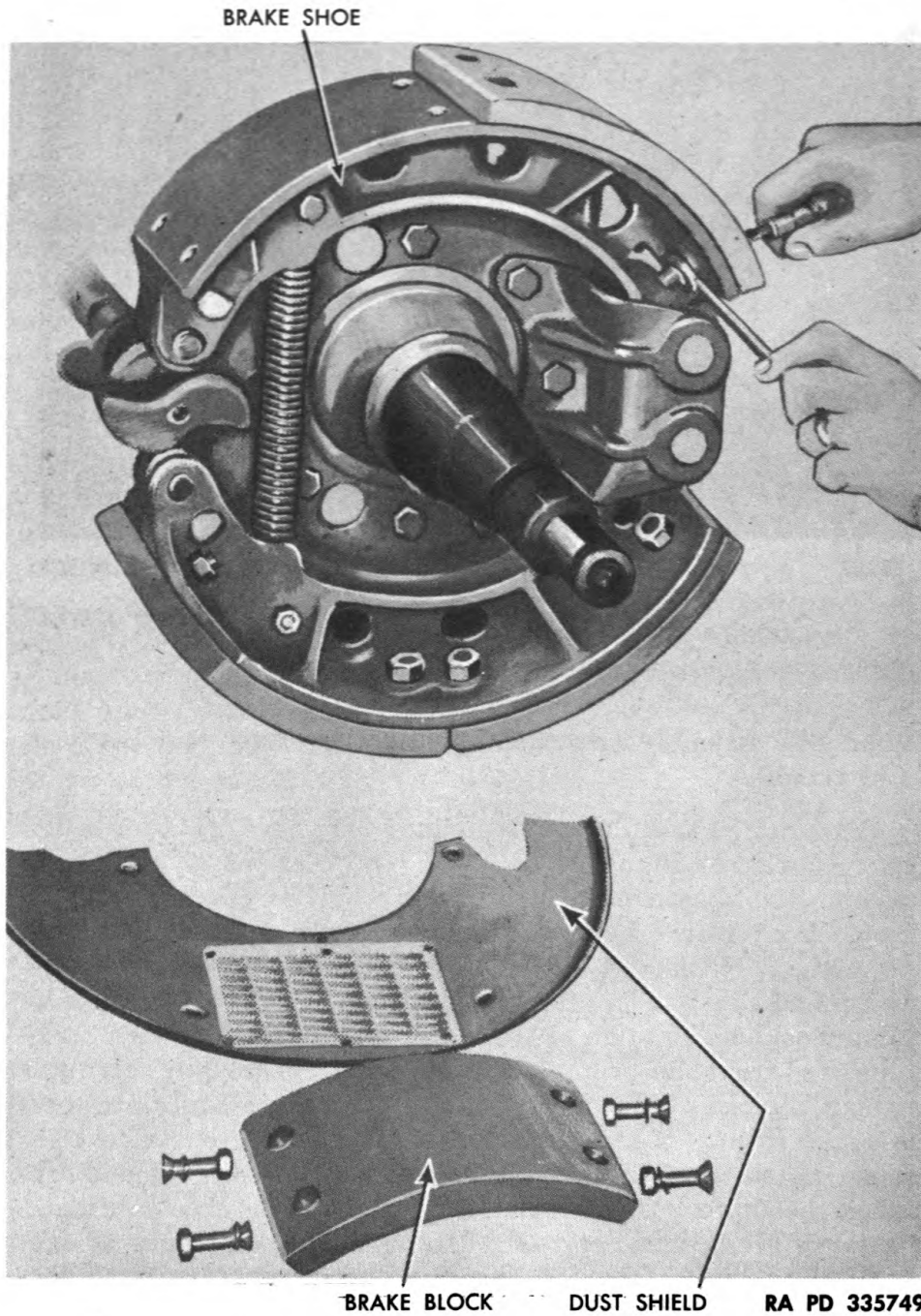

Figure 22—Relining Brakes

BRAKE SYSTEM

the slack adjusters daily during the first 500 to 1,000 miles after brakes have been relined. If the travel of the slack adjusters increases rapidly, they must be adjusted to keep the braking arm at the most effective angle. After proper adjustment, with the brakes applied, the slack adjuster arm and the brake chamber push rod should form an angle slightly less than 90 degrees; and both slack adjusters should set at the same angle.

30. BRAKE SHOE ASSEMBLY.

a. Remove Brake Shoes. Remove wheel, hub, and drum assembly (par. 25). Remove the three bolts holding the anchor pin bracket to the brake mounting plate (fig. 23). Tap the anchor pin bracket free of the anchor pins and pull both shoes free of the assembly. Remove the brake shoe return spring by removing the spring anchor bolt holding the spring to each shoe.

(1) **REPLACE BRAKE LININGS.** When brake blocks need to be replaced, all four blocks of the brake shoe assembly must be replaced. Use a socket wrench and screwdriver to remove the four brass nuts holding each brake block to the shoe (fig. 23). Remove four brass screws holding each section to the shoe. Carefully clean brake shoes, removing all grease and dirt, before installing new blocks.

b. Replace Anchor Pin Bushings. Each brake shoe has two oilite bushings at the anchor pin end. To replace worn bushings, drive out the old bushings. Press or drive new bushings into place. If the bushings are driven, a hardwood block must be used as a buffer between bushing and hammer to prevent burring or distorting the new bushing. A distorted bushing will retard the free movement of brake shoes, both in application and release of the brakes. Bushings come reamed to proper dimensions, and proper care in installation will ensure free movement of the brake shoe upon the anchor pin.

c. Replace Brake Shoe Rollers and Roller Shafts. The brake shoe roller is located on the unanchored end of the brake shoe. The roller is held in position upon a shaft (fig. 19). The shaft is retained in the brake shoe mounting by three heavy prick punch marks on each side. The roller shafts may be driven out and new rollers or shafts replaced without removing the brake shoe assembly. When the new roller and shaft has been replaced, the shaft must be re-anchored with heavy prick punch marks.

d. Replace Brake Shoes. The brake shoe assembly is replaced by reversing the process of removal. Reassemble the brake shoe spring and anchor bolts. Replace the brake shoes in position upon the anchor pin bracket and replace the anchor pins. Position the anchor pin bracket and brake shoe assembly upon the brake mounting plate. Replace the three bolts holding the anchor pin bracket to the brake mounting plate (fig. 23).

TM 9-894

30

11-TON PAYLOAD, 15-TON GROSS, 2-WHEEL (2dt), VAN SEMITRAILER (OMAHA STANDARD BODY CORP. MODEL F16)

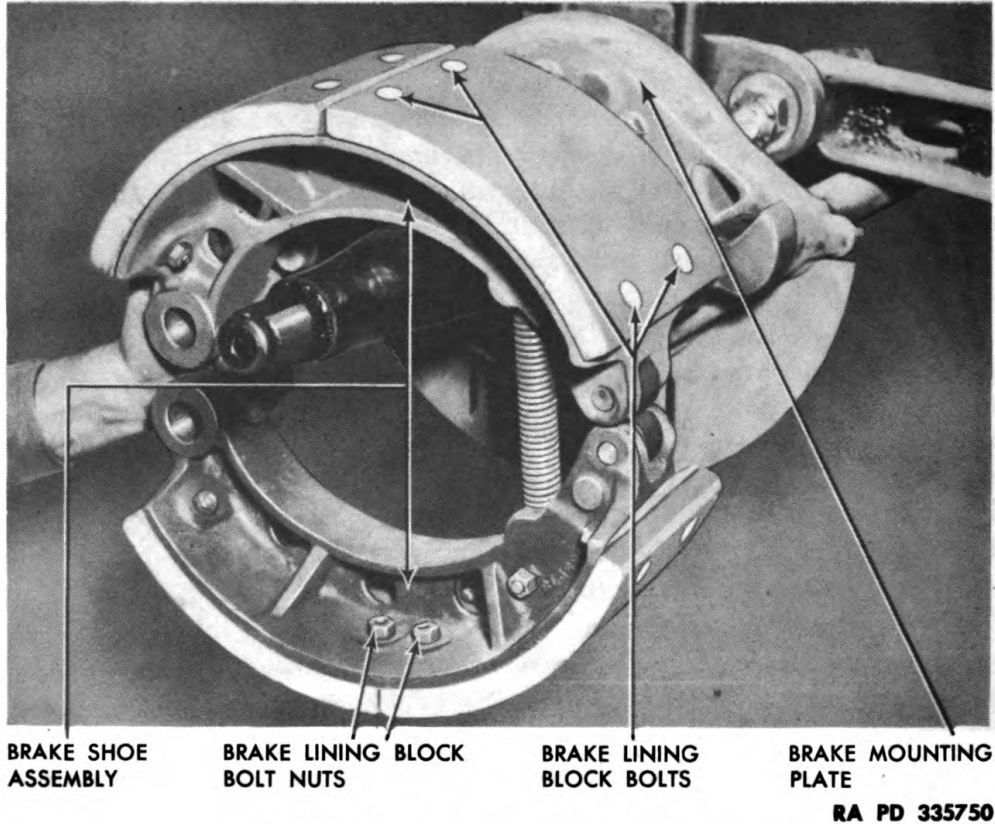
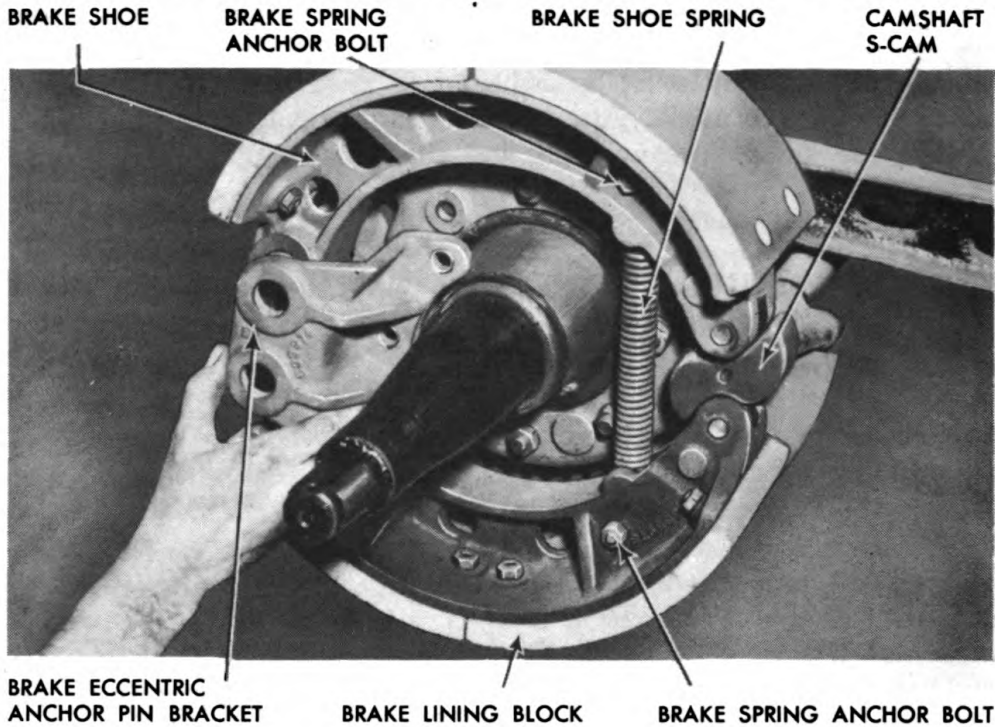

Figure 23—Replacing Brake Shoes

BRAKE SYSTEM

31. BRAKE CAMSHAFT ASSEMBLY.

a. Remove Camshaft.

(1) **PRELIMINARY OPERATIONS.** Jack up axle until dual wheel assembly is free from contact with the ground (par. 27). Remove the wheel and hub assembly (par. 25).

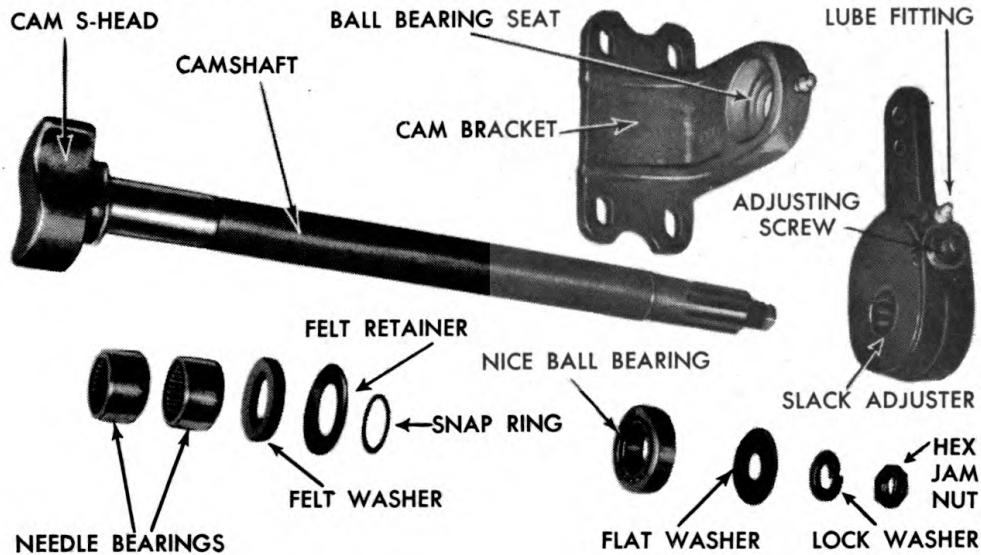

Figure 24—Camshaft Assembly Disassembled

(2) **REMOVE CAMSHAFT.** Remove the nut and lock washer from the slack adjuster end of the camshaft (A, fig. 25). Remove the brake chamber push rod from the slack adjuster arm. Tap slack adjuster off the cam spline, using wood buffer block between the slack adjuster and hammer if the slack adjuster assembly does not slide off freely. A snap ring is located on the cam arm just outside the brake mounting plate (B, fig. 25). Remove snap ring from the seat in camshaft arm, and work toward the splined end of arm. It is not necessary to move the felt retainer and felt washer. These two units will remain against the needle bearing as the camshaft is drawn through the needle bearings in the brake backing plate. The brake shoe rollers will drag upon the camshaft as it is withdrawn, unless the shoes are blocked apart with a block of suitable length. **CAUTION:** Use extreme care in removing the camshaft so that the needle bearings in the brake mounting plate are not damaged. Keep camshaft in line with its normal working position as it is withdrawn.

b. Replace Needle Bearings.

(1) **PRELIMINARY OPERATIONS.** When it is necessary to remove the cam needle bearings, the camshaft must first be removed (subpar. a above).

11-TON PAYLOAD, 15-TON GROSS, 2-WHEEL (2dt), VAN SEMITRAILER (OMAHA STANDARD BODY CORP. MODEL F16)

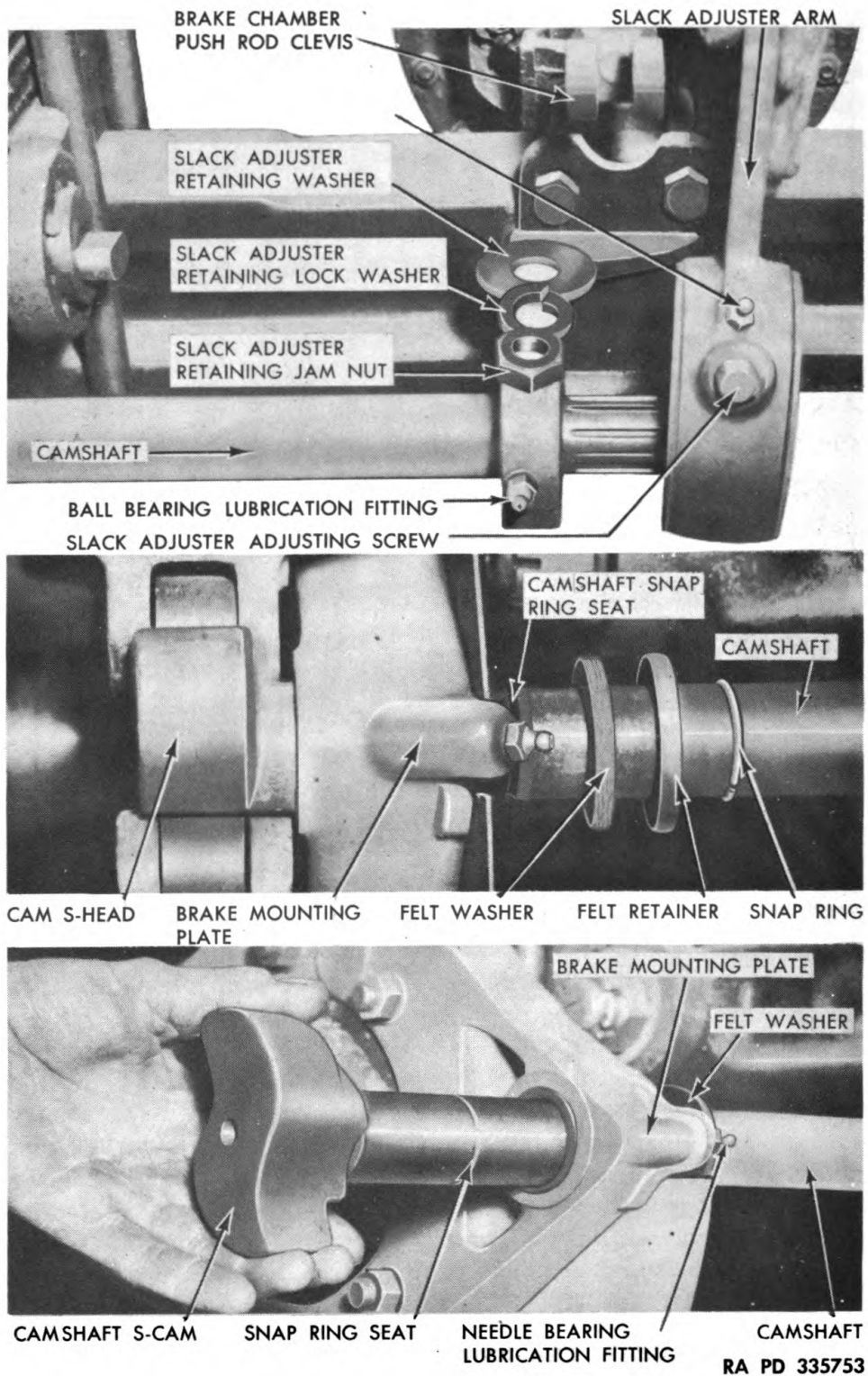

Figure 25—Removing Camshaft

BRAKE SYSTEM

(2) **REMOVE OLD BEARINGS.** The cam needle bearings (fig. 24) will, if properly lubricated, last indefinitely. However, if they are damaged through accident (in removing the camshaft), or other abuse, replace them. There are two bearings in each mounting plate; both may be driven from the bore of the mounting plate in one operation. A hardwood pin of suitable diameter is usually sufficient to permit driving from the mounting plate.

(3) **INSTALL NEEDLE BEARINGS.** Start the new bearings into position in the bore of the brake backing plate. Tap each gently and evenly to start the bearing in straight. When the bearings have been started into place, they should be pressed into operating position. Place pieces of hardwood over the ends of the bearings, and use a clamp to squeeze into position. When fully in position, each bearing must be flush with its outer edge of the brake backing plate.

(4) **REPLACE CAMSHAFT. CAUTION:** *It must be noted that the camshafts are right and left. When replacing them, care must be taken to place the right-hand cam on the right side, and the left-hand cam on the left side. Each cam is stamped on its inner end with a number. The even number is right side, odd number is left side.* The splined end of the camshaft is passed through the needle bearings in the brake mounting plate and pushed to within 3 or 4 inches of the cam bracket containing the ball bearing. Place the felt washer over the splined end of the camshaft, and push over to the brake mounting plate. Slide the felt retainer in place next to the felt washer, and slip the snap ring over the camshaft behind the felt retainer. Push the splined end of the camshaft through the ball bearing in the cam bracket until the S-head of the cam is snug against the brake mounting plate. Seat the felt washer and felt retainer firmly against the brake mounting plate, and slip the snap ring into the retaining groove in the cam arm. Install the slack adjuster (par. 35).

c. Remove Ball Bearing From Cam Bracket. Remove the slack adjuster from the camshaft (subpar. a above). Tap the outer side of the cam bracket beside the bearing bore. This operation will usually cause the bearing to work out of the bracket. If this fails to free the bearing from the bracket, remove the alemite fitting from the bracket. Insert a small screwdriver in the alemite fitting hole, and pry outward against the bearing. Continue tapping the slack adjuster bracket with a small hammer while prying against the bearing with the screwdriver. These combined oper-

TM 9-894

31-32

11-TON PAYLOAD, 15-TON GROSS, 2-WHEEL (2d+), VAN SEMITRAILER (OMAHA STANDARD BODY CORP. MODEL F16)

ations will release the bearing, causing it to slide from the bore of the slack adjuster bracket.

d. Replace Ball Bearing in Cam Bracket. Place the new ball bearing over the splined end of the camshaft. Carefully start the bearing in the bore of the slack adjuster bracket. Once the bearing is started, it may easily be slipped into place. If the alemite fitting was removed to facilitate removal of the old bearing, replace. Replace the slack adjuster. Replace the slack adjuster nut and lock washer. Replace brake chamber push rod on the slack adjuster arm.

32. AIR BRAKE SYSTEM.

a. General Description. The air brake system of the semitrailer consists of a number of individual components connected by air lines which enable the individual units to function together as a single operating mechanism. Fundamentally, the semitrailer air system consists of air devices necessary to direct and control the flow of compressed air, and to transform the energy of compressed air into an effective mechanical force and motion necessary to apply and release the brakes.

b. Serviceability Test.

(1) **PREPARATION.** In order to test the air brake system of the semitrailer for serviceability, connect its air brake system to the air brake system of the tractor truck (par. 6). Charge the combined air brake systems to a pressure of 100 pounds, as registered by the pressure gage on the dash of the tractor truck.

(2) **LEAKAGE TESTS WITH BRAKES RELEASED.** Stop the engine of the tractor truck, and release the brakes. Observe the rate of drop in air pressure as registered by the dash gage on the tractor truck. The normal rate of drop in pressure should not exceed 3 pounds per minute.

(3) **LEAKAGE TESTS WITH BRAKES APPLIED.** With the tractor truck engine stopped and brakes fully applied, observe the rate of drop in air pressure registered on the dash gage of the tractor truck. The rate of drop in pressure should not exceed 4 pounds per minute.

(4) **TRACTOR TRUCK BRAKE LEAKAGE.** In each of the leakage tests indicated, the drop in air pressure was due to the combined loss in the air brake system of both the tractor truck and the semitrailer. Repeat both tests with the cut-out cocks in the air hose lines

BRAKE SYSTEM

connecting the tractor truck to the semitrailer closed. Any loss in air pressure in the latter tests is due to air leaks in the air system of the tractor truck.

(5) **SEMITRAILER BRAKE LEAKAGE.** To determine the air pressure loss in the air brake system of the semitrailer, it is only necessary to subtract the air pressure losses of the tractor truck tests from the corresponding pressure losses of the combined tractor truck and semitrailer losses first observed. This difference in each test indicates the semitrailer air brake system loss in air pressure.

(6) **EXCESSIVE LEAKAGE.** If leakage in either of the above tests is excessive, check all components of the air brake system of the semitrailer for leakage and repair or replace the leaking connection.

c. Operating Tests.

(1) **BRAKING RESPONSE.** With tractor truck and semitrailer properly coupled and moving, apply the brakes and check their effectiveness. Application of the brakes should stop the motion of tractor truck and semitrailer quickly and smoothly. The braking response should be quick and positive both during application and release of the brakes.

(2) **EVEN BRAKING.** With the tractor truck and semitrailer moving, apply brakes fully. Check possible tire marks made by the wheels of the semitrailer to note any indication of unequal braking. If a tendency to unequal braking is noted, as indicated by heavy tire marks from one wheel and not from the other (par. 19), the axle of the semitrailer should be jacked up and blocked with both dual wheels free of the ground. Check each brake shoe lining assembly (fig. 23). Make any adjustments inspection indicates as required (par. 29). Repeat braking tests after any adjustments have been made to be sure the brakes apply and release evenly.

33. EMERGENCY RELAY VALVE (fig. 26).

a. **General.** Any undue loss in pressure in the air brake system of the semitrailer, as indicated by tests, must be located and stopped. Locating of air pressure loss in the air brake system is accomplished by checking the individual units composing the system until all sources of loss in pressure have been corrected.

b. **Function.** The relay emergency valve relays the braking action from the tractor truck to the semitrailer, and provides an automatic brake application on the semitrailer in the event it accidentally breaks away from the tractor truck.

11-TON PAYLOAD, 15-TON GROSS, 2-WHEEL (2d+), VAN SEMITRAILER (OMAHA STANDARD BODY CORP. MODEL F16)

c. Operating Tests.

(1) **BRAKE APPLICATION.** With the air brake system fully charged to normal operating pressure of 80 pounds, apply the brakes and check to be sure all brakes apply properly.

(2) **AIR PRESSURE EXHAUST.** Release brakes and check to be sure air pressure is exhausted promptly from the exhaust port of the relay emergency valve through the exhaust check valve (fig. 27).

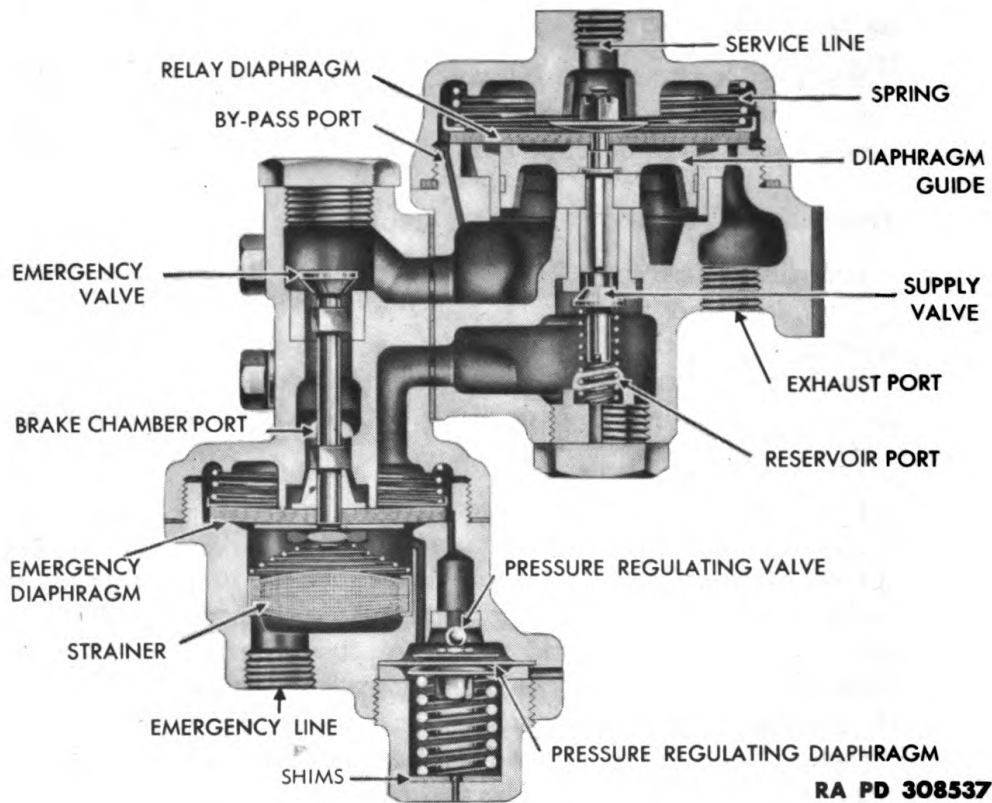

Figure 26—Relay Emergency Valve—Sectional View

(3) **AUTOMATIC EMERGENCY APPLICATION.** With the air brake system fully charged, close the cut-out cock in the emergency air line on the tractor truck, and disconnect the emergency air hose from the semitrailer. Check to be sure the trailer brakes apply automatically. The relay emergency valve is designed to go into its emergency braking position when, for any reason, the air pressure in the emergency air line is cut off, or when the emergency air line pressure drops to a point about 20 pounds below the air pressure in the service brake system of the semitrailer. The instant the emergency line is broken or disconnected, air pressure in the brake system of the semitrailer attempts to flow out through the open emergency line. This causes the emergency diaphragm (fig. 26) to be depressed,

BRAKE SYSTEM

and its outer edge seals off the cavity leading to the emergency line, preventing any loss of pressure past the emergency diaphragm through the open, or broken, emergency line. As the center of the emergency diaphragm is depressed, the emergency valve is closed. Thus, air pressure from the reservoir of the semitrailer flows across the top of the depressed emergency diaphragm into the cavity leading to the brake chamber, and applies the brakes. The closed emergency valve prevents it from escaping through the cavity leading to the exhaust port.

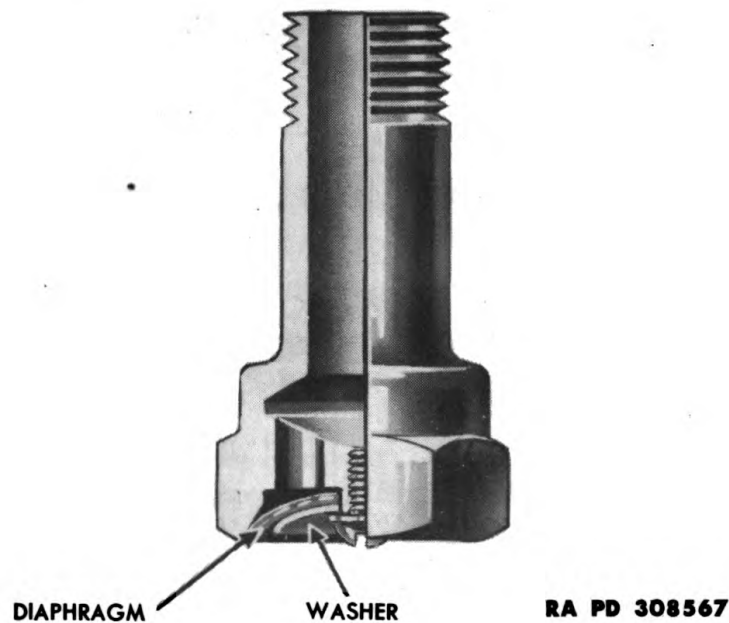

Figure 27—Exhaust Check Valve—Sectional View

d. Leakage Tests.

(1) **EXHAUST PORT.** With the brakes released, coat the exhaust check valve (fig. 27) of the relay emergency valve with soap suds to determine leakage of air past the supply valve, or the upper seal of the emergency diaphragm.

(2) **EMERGENCY DIAPHRAGM.** With brakes fully applied, coat the exhaust port with soap suds to determine leakage past the relay diaphragm.

(3) **EMERGENCY VALVE.** With the relay emergency valve in emergency position, coat the exhaust port of the relay emergency valve with a soap film to determine leakage past the emergency valve.

TM 9-894

33-34

11-TON PAYLOAD, 15-TON GROSS, 2-WHEEL (2dt), VAN SEMITRAILER (OMAHA STANDARD BODY CORP. MODEL F16)

(4) **EMERGENCY HOSE COUPLING.** Test for leakage at the emergency line hose coupling at the front of the trailer to detect leakage past the emergency diaphragm seal.

e. Allowable Leakage. Leakage in any of the above tests should not exceed a 3-inch soap bubble in 3 seconds. Any excessive leakage must be corrected.

f. Causes of Excessive Leakage. Excessive leakage will be caused by dirty or worn diaphragms, valves, or valve seats. Leakage due to dirt must be corrected by cleaning the valve. If the leakage is due to worn parts, replace the valve.

34. BRAKE CHAMBERS (fig. 28).

a. Operating Tests.

(1) Apply the brakes and observe that brake chamber push rods (fig. 28) move out promptly without any evidence of binding.

(2) Release the brakes and observe that brake chamber push rods return to release position promptly without any evidence of binding.

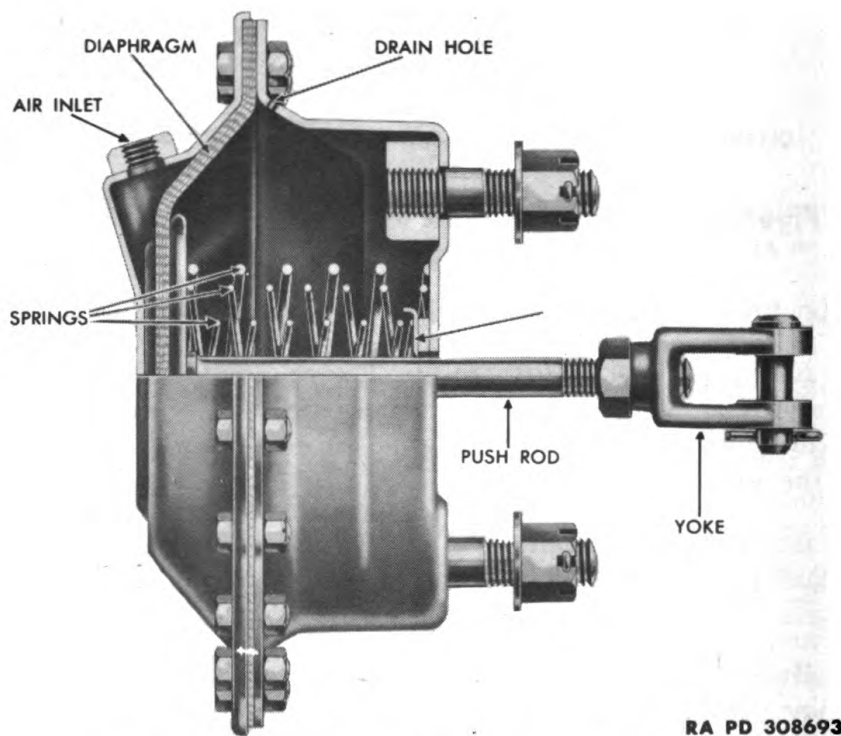

Figure 28—Brake Chamber—Sectional View

BRAKE SYSTEM**b. Leakage Tests.**

(1) **FLANGE LEAKAGE.** With the brakes fully applied, coat the bolting flanges, holding the diaphragm in place, with soap suds to check for leakage. **CAUTION:** *No leakage is permissible.* If leakage is found, tighten flange bolts. It is important that all flange bolts be tightened evenly and only sufficiently to prevent leakage. If extreme pressure is exerted when tightening the flange bolts, the diaphragm will be distorted, and premature failure will result.

(2) **DIAPHRAGM LEAKAGE THROUGH PUSH ROD CLEARANCE HOLE.** With brakes fully applied, check for leakage through the diaphragm by coating the clearance hole around the push rod, and the drain hole in the nonpressure plate, with soap suds. **CAUTION:** *No leakage is permissible.* If leakage is found, replace the diaphragm.

c. Premature Diaphragm Failure of the Brake Chamber Diaphragm. When diaphragms are inspected, brake chamber release springs must also be checked and replaced if weak or broken. When replacing brake chamber springs, it is important to install new springs of the same type as those removed; otherwise, uneven braking will result.

d. Removal and Disassembly. Before removing brake chamber, release air from reservoir by opening drain cock. Disconnect hose from brake chamber. Remove yoke pin cotter pin, and yoke pin from the push rod yoke, releasing the push rod assembly from the slack adjuster arm. Remove nut and washer, releasing brake chamber from the camshaft bracket. Place brake chamber in a vise so that the flange bolt nuts are accessible. Remove the nuts and hex head bolts from the outer flange. This allows the pressure plate and the diaphragm to be removed. Mark the outer rim of the nonpressure plate and the corresponding point on the pressure plate with a center punch, so that proper alignment when the air connection on the pressure plate will be maintained when reassembled.

e. Replace Diaphragm. Place new diaphragm into recess of the pressure plate, taking care that all holes in both sections are in line. Place pressure plate and diaphragm against the push rod, compressing spring until outer flange of nonpressure plate and diaphragm touch. **NOTE:** *Punch marks made on outer rim of both pressure plates must be in alignment.* Install bolts and nuts holding diaphragm between the pressure plate and the nonpressure plate. **CAUTION:** *Tighten the nuts only sufficiently to ensure an airtight seal between the pressure plate and the diaphragm, but not sufficiently to distort the diaphragm.*

11-TON PAYLOAD, 15-TON GROSS, 2-WHEEL (2d+), VAN SEMITRAILER (OMAHA STANDARD BODY CORP. MODEL F16)

35. SLACK ADJUSTERS.

a. **Description.** The slack adjusters are mounted on the splined ends of the brake camshafts. They function as adjustable levers and provide a quick and simple means of adjusting the brakes to compensate for brake lining wear. One slack adjuster assembly is used for the brakes on each wheel assembly. They consist of a worm

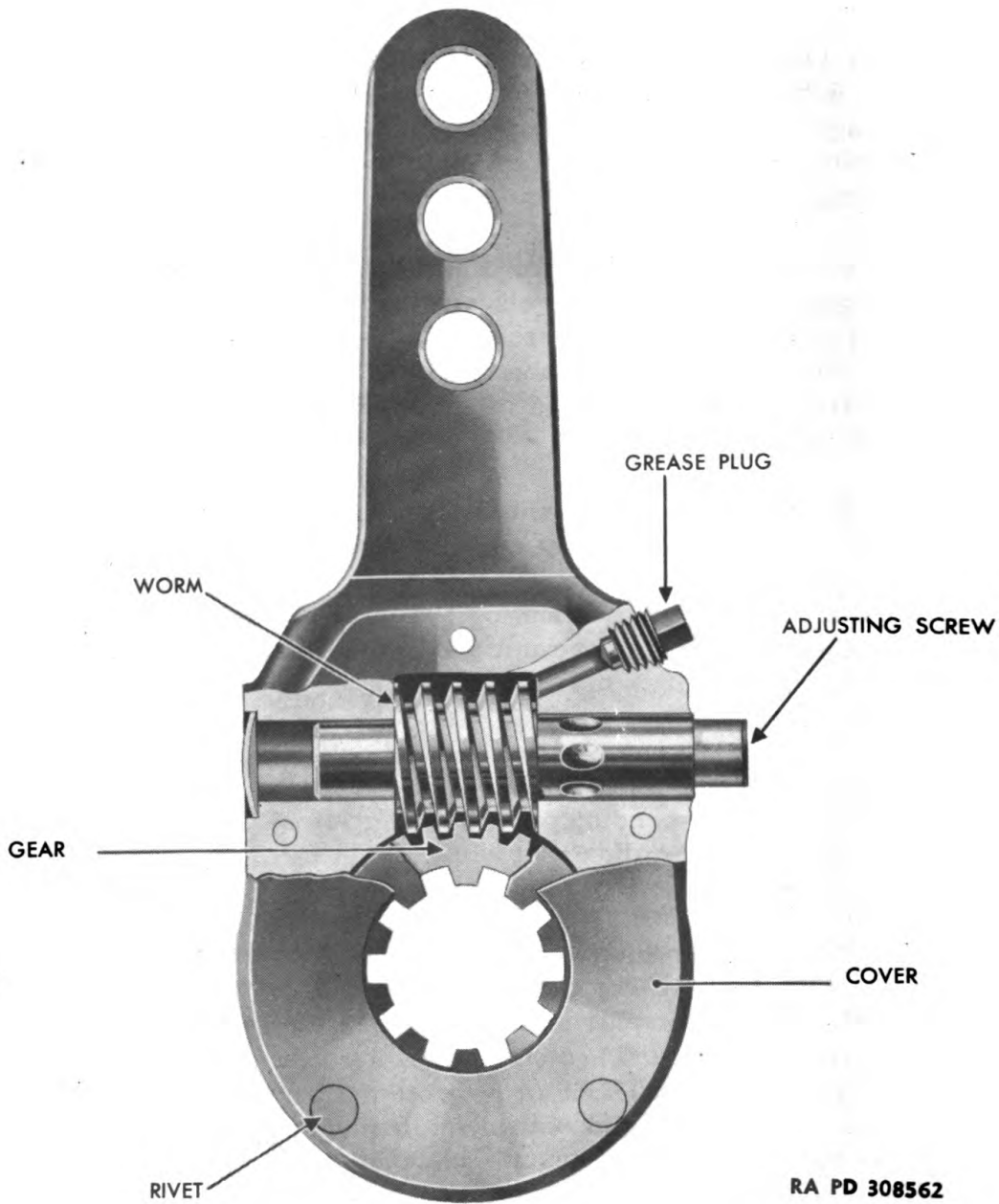

Figure 29—Slack Adjuster—Sectional View

BRAKE SYSTEM

and gear enclosed in a body which serves as a connecting lever between the camshaft and the brake chamber. The slack adjuster arm is attached to the yoke of the brake chamber push rod by means of a clevis pin and cotter pin. Air pressure upon the diaphragm in the brake chamber expands the diaphragm and imparts movement to the brake chamber push rod. This movement is communicated by the slack adjuster to the camshaft.

b. Operating Tests. Adjust brakes (par. 29) and note the amount of brake chamber push rod travel when brakes are applied. Make several brake applications and again check push rod travel. Push rod travel must remain the same as it was after adjustment. If the push rod travel increases, or if it is difficult to keep brakes adjusted in service, the slack adjusters must be replaced.

c. Removal. Disconnect the slack adjuster from the brake chamber push rod yoke by removing the yoke pin cotter pin and the yoke pin. Remove the slack adjuster nut and lock washer at the end of the camshaft, and pull off the slack adjuster.

d. Installation. Slide the slack adjuster on the splined end of the camshaft. Secure with lock washer and nut. Before connecting slack adjuster to the push rod yoke of the brake chamber, check to see that the worm wheel is tight on the camshaft. This can be determined by oscillating the slack adjuster backward and forward in a short motion. Connect slack adjuster to brake chamber yoke with yoke pin, and insert the yoke pin cotter pin. Rotate the slack adjuster worm, and see that it operates easily and smoothly. **NOTE:** *There is a distinct click each one-fourth turn, which is caused by a spring-loaded ball check.*

36. AIR FILTER.

a. Purpose, Description, and Operation.

(1) **PURPOSE.** Air filters (fig. 30) are used in the service line and the emergency line of semitrailers to trap any dirt or foreign matter which might get into these lines through the air hose connectors when the hose lines of the tractor truck are disconnected and the dummy couplings are not in place on the air line couplings of the semitrailer.

(2) **DESCRIPTION.** The sectional case of the air filter encloses a replaceable air strainer of wound-cotton construction. The lower cover of the filter is fitted with a drain plug (fig. 30).

(3) **OPERATION.** The correct direction of the air flow through the filter is indicated by an arrow cast on the body of the filter. Air flowing from the tractor truck to the semitrailer must pass through the filter in the direction indicated by the arrow. Air flow-

11-TON PAYLOAD, 15-TON GROSS, 2-WHEEL (2d+), VAN SEMITRAILER (OMAHA STANDARD BODY CORP. MODEL F16)

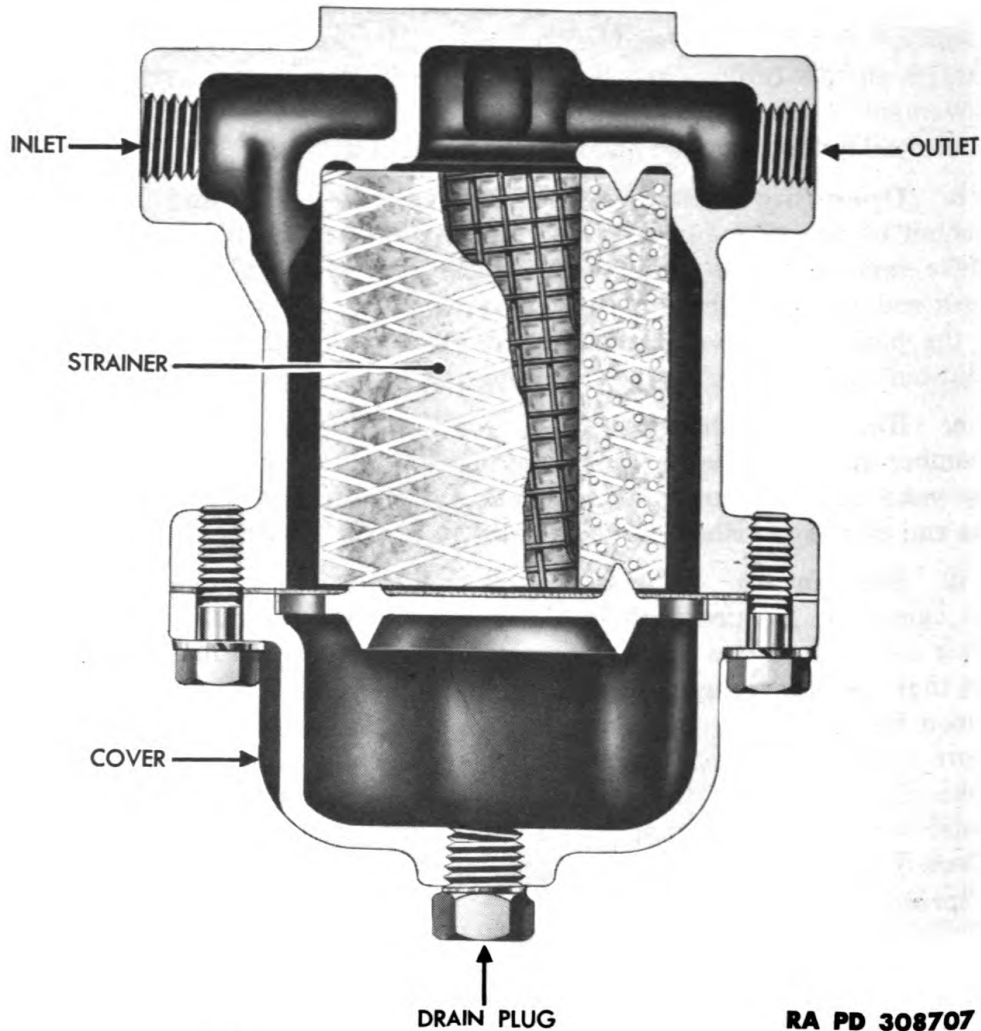

Figure 30—Air Filter—Sectional View

ing through the filter readily passes through the strainer, but any particles of dirt present in the air stream are trapped by the strainer. The accumulation of dirt and moisture trapped by the strainer collects in the bottom of the filter cover, and is eliminated by removing the drain plug.

b. Disassembly.

- (1) Open air reservoir drain cock to release air pressure.
- (2) Remove cap screws and lock washers attaching cover to the body of the filter. Remove the filter cover containing the drain plug.

BRAKE SYSTEM

(3) Remove the gasket from between the body of the filter and the cover, and remove the strainer support. When the strainer support is removed, the strainer may be removed.

c. **Cleaning.** Clean all metal parts with dry-cleaning solvent. If the strainer is dusty, clean by brushing. If any oily or gummy deposit is found, the strainer must be replaced.

d. **Assembly.** Slip strainer in place in the body of the filter. Position gasket and strainer support on the cover, and replace the cover. Replace the cap screws and lock washers attaching the cover to the body of the filter. Close the air reservoir drain cock.

e. **Leakage Test.** When filter has been reassembled, test for air leaks. Charge brake system to normal operating pressure. Coat cover joint of filter with soap suds and apply brakes. No leakage is permissible. If leakage is found past the gasket between the cover and the body of the filter, the cover should be tightened. If leak persists, replace gasket.

37. AIR RESERVOIR AND DRAIN COCK ASSEMBLY.**a. Reservoir.**

(1) **DESCRIPTION.** The reservoir is cylindrical in shape and made of steel with electrically welded seams. Pipe-tapped ferrules are used at the openings and are welded in place. It is the function of the air reservoir to provide storage of compressed air so there is always an ample supply available for immediate use in brake operation. The air supply in the reservoir acts through the relay emergency valve to automatically apply the brakes in the event of accidental uncoupling of the semitrailer from the tractor truck. Another function of the reservoir is to provide a place where the air, heated during compression, may cool. This cooling also allows moisture and oils to condense in the reservoir, where they may be drained off by opening the drain cock.

(2) **LEAKAGE TEST.** With brake system charged, coat the outside of the reservoir with soap suds to check for leakage. No leakage is permissible. If any leakage is found, the reservoir must be replaced.

(3) **INSPECTION.** Open the drain cock to release air pressure. Remove drain cock, and disconnect air lines. Use flashlight to aid in inspecting interior for corrosion or excessive accumulation of dirt. If corrosion is found that might weaken the reservoir, replace the reservoir. If the interior is found to be dirty, clean with hot water or steam.

11-TON PAYLOAD, 15-TON GROSS, 2-WHEEL (2d†), VAN SEMITRAILER (OMAHA STANDARD BODY CORP. MODEL F16)**38. HOSE COUPLINGS (fig. 3).**

a. Location and Use. Two air line hose couplings are located at the front of the semitrailer (fig. 3). They provide a simple and convenient means of connecting and disconnecting air lines between the semitrailer and the tractor truck. The coupling on the right or curb side of the semitrailer is labeled "SERVICE," and connects the service lines of the two vehicles. The coupling on the left is labeled "EMERGENCY," and connects the emergency air lines of the two vehicles. The design of the couplings is such that when the coupling of the tractor truck is properly coupled to the corresponding coupling of the semitrailer, pressure is placed on two rubber gaskets of the couplings, making an airtight seal. This coupling joint can be easily connected or disconnected by hand, yet is secured against accidental uncoupling by a lock pin. Hose couplings on the air lines are interchangeable, so that couplings on a tractor truck can be connected to those of a semitrailer, even though they may be of different types.

b. Dummy Couplings. The dummy couplings used on the semitrailer are fastened to the body by short chains attached to plates located slightly above the outside of the hose couplings. The purpose of the dummy coupling (fig. 3) is to prevent the entrance of dirt, insects, or other foreign matter into the air lines of the braking system when not coupled to the air lines of a tractor truck. The dummy coupling used to protect the service line is drilled with a small hole or vent which prevents air from being trapped in the service line, and keeps the brakes applied as long as air remains in the air reservoir (par. 37).

c. Test Couplings.

(1) With hose couplings connected and brakes applied, coat coupling joints with soap suds. If leakage occurs, replace worn or damaged coupling.

(2) If only the coupling gasket is worn or damaged, replace the gasket. Pry the old gasket from the coupling with a screwdriver. Discard the old gasket and clean the coupling with dry-cleaning solvent. When cleaning hose coupling, give particular attention to the groove into which the flange of the hose coupling gasket fits. This groove must be scraped thoroughly clean, otherwise the new gasket will not go into place properly.

d. Install Gasket. To install a new gasket, partially collapse it with the fingers and insert one side of the gasket flange in the groove of the coupling. Then use a screwdriver to complete pushing the gasket into the groove. **CAUTION:** *Use care to prevent damage to*

BRAKE SYSTEM

the gasket with the blade of the screwdriver. When properly installed, the exposed face of the gasket will lie flat, not bulge or twist at any point.

e. Friction Lock. The friction lock of a coupling consists of a lock pin whose oval point projects beyond the flat connecting surface of the coupling. The pin is maintained in position by a coiled lock spring, held in place in the coupling by a spring plug on the back of the coupling. Remove the spring plug so that the spring and lock pin may be removed for cleaning or replacement.

39. TUBING AND FITTINGS.

a. Pipe Connectors. Both the emergency and service couplings are connected to lengths of ½-inch pipe extending through the front frame member and passing between the upper fifth wheel plate and the floor. Each pipe is 60 inches in length, threaded at both ends, and securely fixed between frame crossmembers by jam nuts. Air line tubing is attached to these pipes by tubing connectors (fig. 18).

b. Tubing Fittings. Standard tubing fittings, consisting of a nipple-type connector body, friction sleeve, and compression nut, are used to connect pipe sections and to attach lengths of tubing to the individual units of the air brake system. *NOTE: Flared-type fittings such as are often used for gasoline lines must not be used in making repairs in the air brake system.*

c. Tubing Unions. A tubing union consists of a nipple-type fitting body, two friction sleeves, and two compression nuts. Such unions are used to connect new tubing repair sections at damaged points in the tubing of the air line. Such a repair is made by cutting out the damaged section and substituting a suitable length of new tubing in place of the damaged section. If repair is made in the tubing line at a point where the old fittings are not removed, two unions are required; and the length of new tubing required to make the repair is determined by laying out the two body sections of the unions, plus the length of new tubing, so that the total length of the tubing and the two seated union body members is equal to the length of the damaged section removed, less the overlap of the union tubing seats upon the old tubing. A tubing repair at the end of a section is similarly made, except that only one union is required. When an air line is repaired by the addition of new sections, all unions must be tested with soap suds with the brakes set. No leakage is permitted.

d. Repair Sections of Air Line Tubing. When replacing tubing lines, or replacing damaged sections, cut the tubing to the required

11-TON PAYLOAD, 15-TON GROSS, 2-WHEEL (2d†), VAN SEMITRAILER (OMAHA STANDARD BODY CORP. MODEL F16)

length. Make sure that the end of the tubing is smooth and square with the line of the side wall of the tubing. Make sure that the ends of the tubing are not crimped or mashed out of shape. Blow out the tubing with an air line to remove all cuttings and fittings. **CAUTION:** *It is very important that the inside of the tubing be absolutely clean.* A fitting is attached to the end of the tubing by first placing a nut on the end of the tubing, tapered end first. Place a sleeve on the end of the tubing, and push the end of the tubing into the recessed seat of the fitting body. Hold the tubing firmly in place, and tighten the nut over the sleeve end on the body of the fitting. Tighten the nut only sufficiently to prevent leakage. Always use a new sleeve when repairing air line tubing. Other fitting members may be used again if in serviceable condition.

e. Hose Assemblies. Lengths of hose and hose fittings are used to connect the relay emergency valve with the brake chambers. These hose assemblies are used to provide a means of making flexible air connections between these points because of the spring suspension of the brake chambers upon the semitrailer axle. The ends of these assemblies are provided with detachable-type hose fittings with spring guards surrounding the adjacent sections of the hose.

f. Replace Hose. Remove connector nut and pull hose out of connector body. Do not attempt to remove used sleeve from the hose. Cut a new piece of hose to the required length, being sure the cut is made at right angles to the wall line of the hose, and that the end of the hose is smooth. Blow out the hose with an air line to remove all cuttings. Place the connector nut and sleeve on the new hose section, being sure the barbs on the inside of the sleeve point toward the end of the hose. Place a new gasket over the end of the guide in the connector body so the side with the removable hose protector will be next to the hose. Remove the protector covering from the gasket. Place the end of the hose in the connector body, making sure the end of the hose and the gasket are firmly in place against the bottom recess in the connector body. Move the sleeve, if necessary, until it is against the edge of the connector body. Tighten the connector nut only sufficiently to ensure an airtight joint. **NOTE:** *When installing the hose assembly, the hose connector at either end may be used as a swivel by loosening the nut on one of the connectors. The hose should then be turned in loose connector to any desired position before the connector is again tightened. This permits the installation of the hose assembly without danger of the hose being kinked or twisted.*

Section X

SPRING AND RADIUS ARM ASSEMBLIES

40. DESCRIPTION AND DATA.

a. General Description.

(1) **SPRING ASSEMBLIES.** Each helper and mainspring assembly is bolted to the axle by two 3/4-inch U-bolts, seated on a pillow block positioned on the helper spring, and passing through holes in a spring clip plate beneath the axle. The U-bolts are supplied with 3/4-inch high nuts and lock washers. A combination spring seat and radius arm eccentric casting is located between the lower leaf of the mainspring and the axle. The spring seats are spaced on the axle by dowels which fit in spaced dowel holes in both the axle and spring seats. Leaves of the mainspring are held in alinement by four spring clips and spring clip bolts. The helper spring leaves are held in alinement by two spring clips clamped around the four upper spring leaves.

(2) **SPRING DATA.**

Material	Silica manganese steel
Rated capacity	8,500 lb each
Mainspring leaves	12
Helper spring leaves	7
Seven main leaves.....	3 in. wide, 7/16 in. thick
Five main leaves.....	3 in. wide, 3/8 in. thick
Helper leaves.....	3 in. wide, 5/16 in. thick
Type	Floating ends
Support points.....	Spring bracket slides

(3) **RADIUS ARM ASSEMBLIES.** The rear end of each radius arm assembly is attached by an eccentric adjusting bolt to the combination spring seat and radius arm casting (fig. 31). Both ends of each radius arm are bushed with rubber bushings whose ends are capped with metal ferrules. The front ends of the radius arms are attached to the lower sections of the front spring hangers by the ends of tie rods which pass through spacer tubes positioned between the front spring hangers. A flat washer, castle nut, and cotter pin are attached to each end of the front tie rod. The eccentric adjusting bolt (fig. 33) is designed to permit alinement of the axle with the kingpin of the upper fifth wheel assembly (par. 42) (fig. 34).

(4) **RADIUS ARM DATA.**

Material	Cast steel
Bushings	Rubber
Adjustment range	3/8 in.
Adjustment type.....	Eccentric bolt assembly

11-TON PAYLOAD, 15-TON GROSS, 2-WHEEL (2dt), VAN SEMITRAILER (OMAHA STANDARD BODY CORP. MODEL F16)

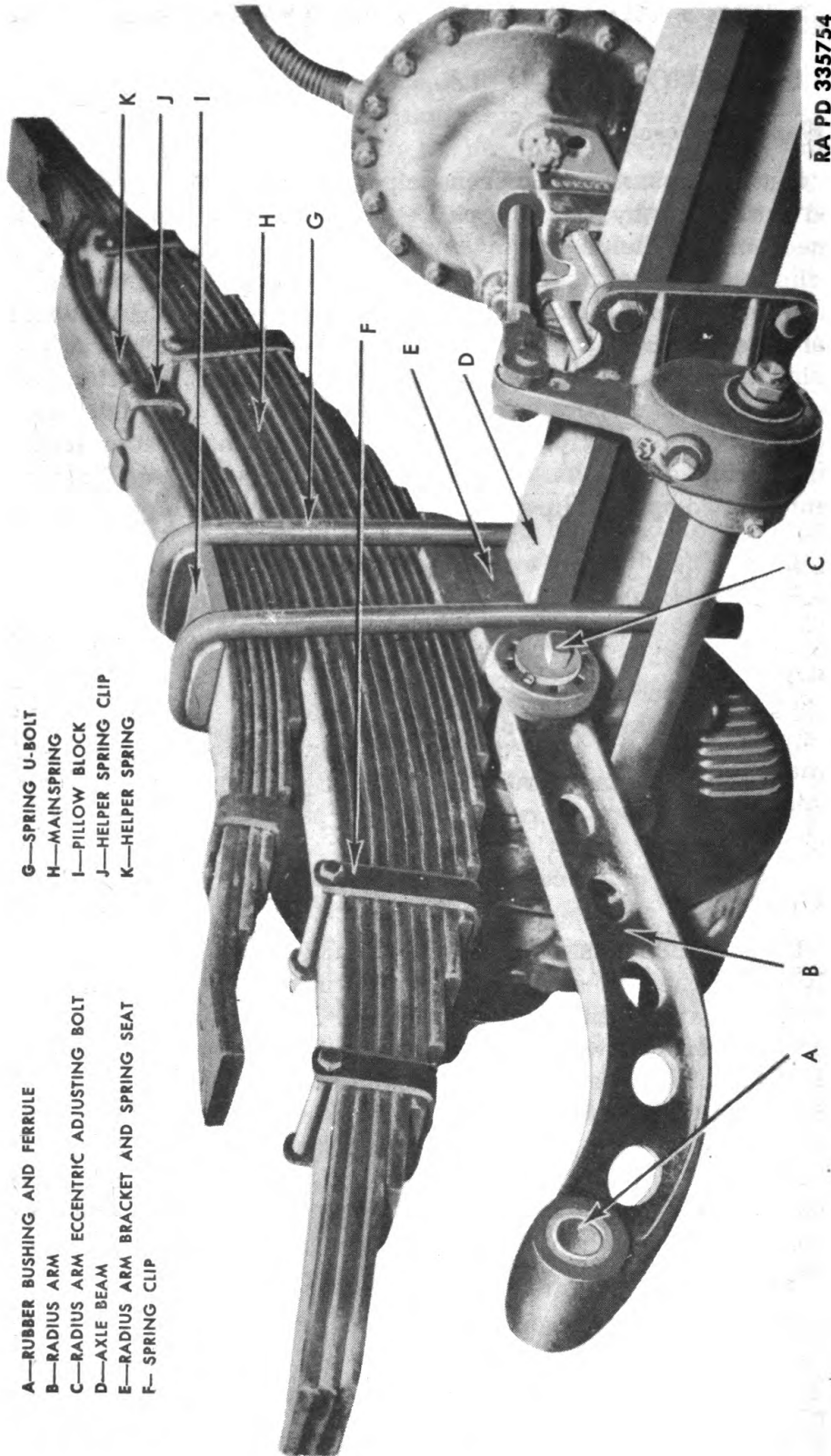

- G—SPRING U-BOLT
- H—MAINSRING
- I—PILLOW BLOCK
- J—HELPER SPRING CLIP
- K—HELPER SPRING

- A—RUBBER BUSHING AND FERRULE
- B—RADIUS ARM
- C—RADIUS ARM ECCENTRIC ADJUSTING BOLT
- D—AXLE BEAM
- E—RADIUS ARM BRACKET AND SPRING SEAT
- F—SPRING CLIP

RA PD 335754

Figure 31—Spring Axle, and Radius Arm Assembly

SPRING AND RADIUS ARM ASSEMBLIES

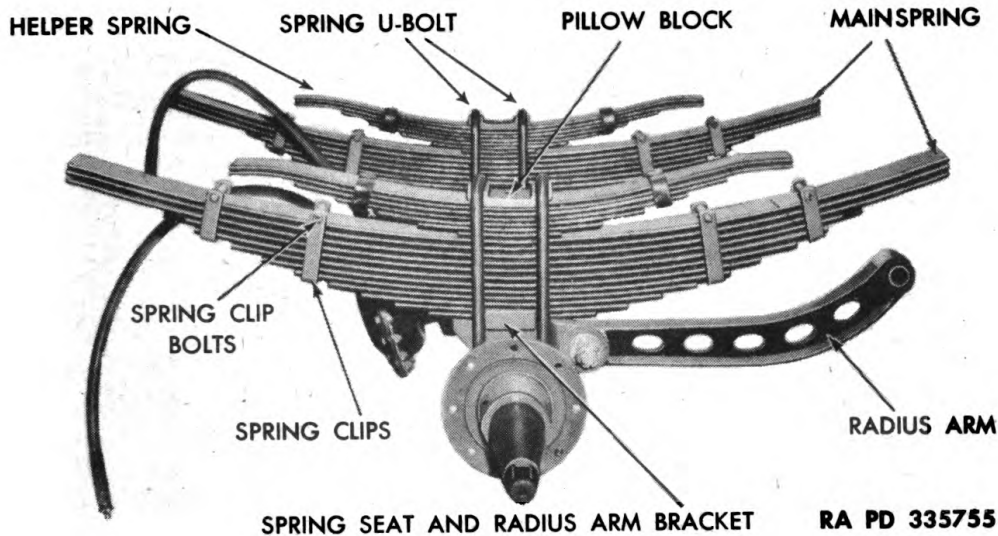

Figure 32—Suspension Assembly

41. SPRING ASSEMBLIES.

a. Mainspring. The mainspring consists of 12 leaves, including 3 main leaves each 52 inches in length. The depth of the mainspring at the center bolt is $4\frac{7}{8}$ inches. The inner pair of spring clips is riveted to the ends of the No. 8 leaf; and the outer clips are riveted to the No. 5 leaf. A single spring center bolt passes through both main and helper spring so that both springs of the assembly are removed from the axle as a single unit.

b. Remove Spring Assembly.

(1) Jack up the frame of the semitrailer until the main leaves rest on the spring bracket tie rod short spacer tubes in the rear, and on the ends of the radius arms in the front brackets. Block the body in this position.

(2) Remove the high nuts and lock washers from the U-bolts securing the spring assembly to the axle, and remove the U-bolts. Remove the pillow block from the helper spring, and pry the head of the spring center bolt from its seat in the spring seat casting.

(3) Slide the spring assembly forward until the main leaves drop below the rear tie rod assembly. Slide the spring assembly backward until the front end of the mainspring is free from the front spring bracket. Slide the spring assembly over the axle and remove.

c. Separate Mainspring and Helper Spring. The mainspring and helper spring are held together by a common center bolt. The nut of the center bolt is located on the top of the helper spring. Remove the nut from the spring center bolt, and lift the helper spring from the center bolt.

TM 9-894

41-42

11-TON PAYLOAD, 15-TON GROSS, 2-WHEEL (2dt), VAN SEMITRAILER (OMAHA STANDARD BODY CORP. MODEL F16)

d. **Replace Mainspring Leaves.** Use a C-clamp to clamp the spring leaves together at a point near the center bolt. **NOTE:** *Do not remove the center bolt.* Remove the bolts from the inner and outer pair of spring clips. Ease off the spring leaf tension against the C-clamp, so that the spring leaves become loose on the center bolt. Lift the leaves from the center bolt, and replace broken leaves.

e. **Reassemble Mainspring.** Position the leaves of the mainspring in proper order on the spring center bolt. Use a C-clamp to compress the leaves at a point near the center until the spring clip bolts can be replaced in the spring clips. Replace the spring clip bolt nuts. Remove C-clamp. Replace helper spring on the spring center bolt, and secure with center bolt nut.

f. **Replace Spring Assembly.** Slide the spring assembly over the axle, and insert the front end in the front spring bracket, sliding the ends along the end of the radius arm as a guide. Slide the spring forward until the rear end of the spring will pass in front of the rear spring bracket tie rod. Lift the spring, and insert the rear end of spring in the rear spring bracket, resting on the bracket tie rod. Position the spring over the axle and upon the spring seat bracket. Place the pillow block in position over the spring center bolt nut on the helper spring. Replace the U-bolts over the spring assembly and beside the axle. Replace the spring clip plate, and install lock washers and U-bolt high nuts. **NOTE:** *Make sure that all units of the assembly are seated in position before tightening the high nuts.*

42. RADIUS ARM ASSEMBLIES.

a. Adjusting Radius Arm Eccentric (fig. 33).

(1) **GENERAL.** The purpose of the radius arm eccentric adjustment is to provide a simple means to realine an axle assembly that is out of alinement with the kingpin of the upper fifth wheel assembly. An axle out of alinement tends to "dog track," or trail to the inside or outside of the path made by the tires of the tractor truck. Such a condition causes the trailer to "whip" while in transit, and makes control of the tractor truck and semitrailer combination difficult. This condition, if not remedied at once, causes uneven and undue tire wear.

(2) ADJUST AXLE ALINEMENT.

(a) Pull the semitrailer on a level surface, lower the landing gear, and disconnect the tractor truck.

(b) Jack up the body of the semitrailer until the springs rest upon the spring bracket spacer rod at the rear and on the ends

SPRING AND RADIUS ARM ASSEMBLIES

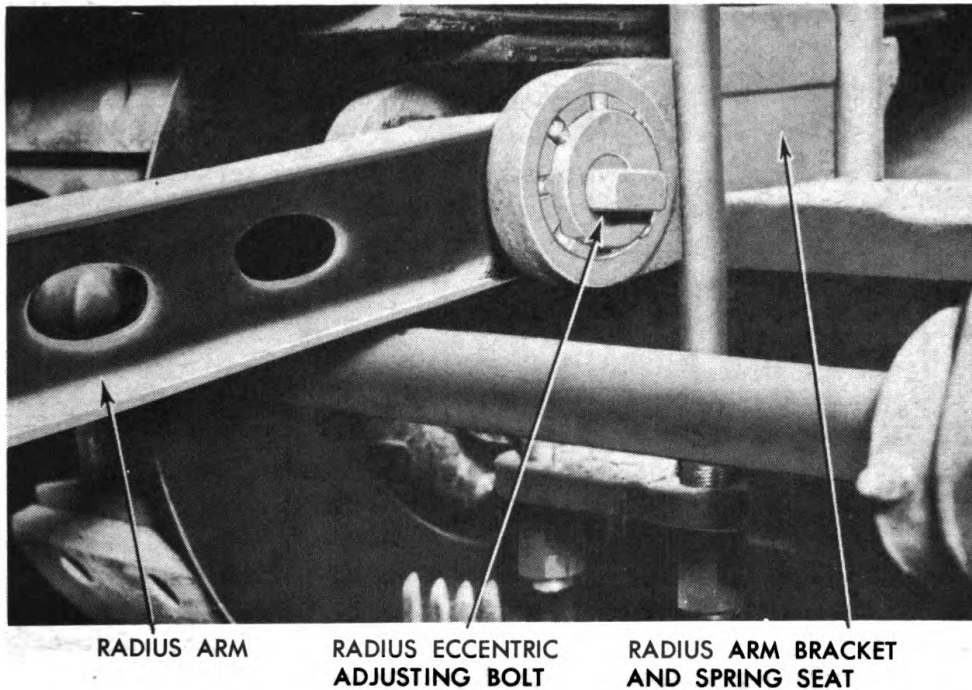

RA PD 335756

Figure 33—Radius Arm and Eccentric Adjustment

of the radius arms at the front of the spring; and the wheels are free from contact with the ground. Block the body securely in this position.

(c) Remove the outer wheels of both dual wheel assemblies (par. 27).

(d) Check the axle alinement by carefully measuring the distance from the center of the kingpin to the center point of the right, or curb side, axle spindle end (fig. 34); and by measuring the distance from the center of the kingpin to the center point of the end of the left-hand axle spindle. **NOTE:** *The length of the curb side check measured must never be greater than the check measure of the left side, but may be as much as one-eighth inch less than the check measure of the left side.* If the difference in the two measurements is greater than one-eighth inch, the axle must be realined.

(e) Begin the adjustment on the side on which the longer measurement was noted. The longer measurement should always be on the left-hand side, unless the axle has been misaligned as the result of an accident. If the total required adjustment is less than $\frac{3}{16}$ inch, the alinement can usually be completed by resetting the eccentric bolt on one side only.

11-TON PAYLOAD, 15-TON GROSS, 2-WHEEL (2dt), VAN SEMITRAILER (OMAHA STANDARD BODY CORP. MODEL F16)

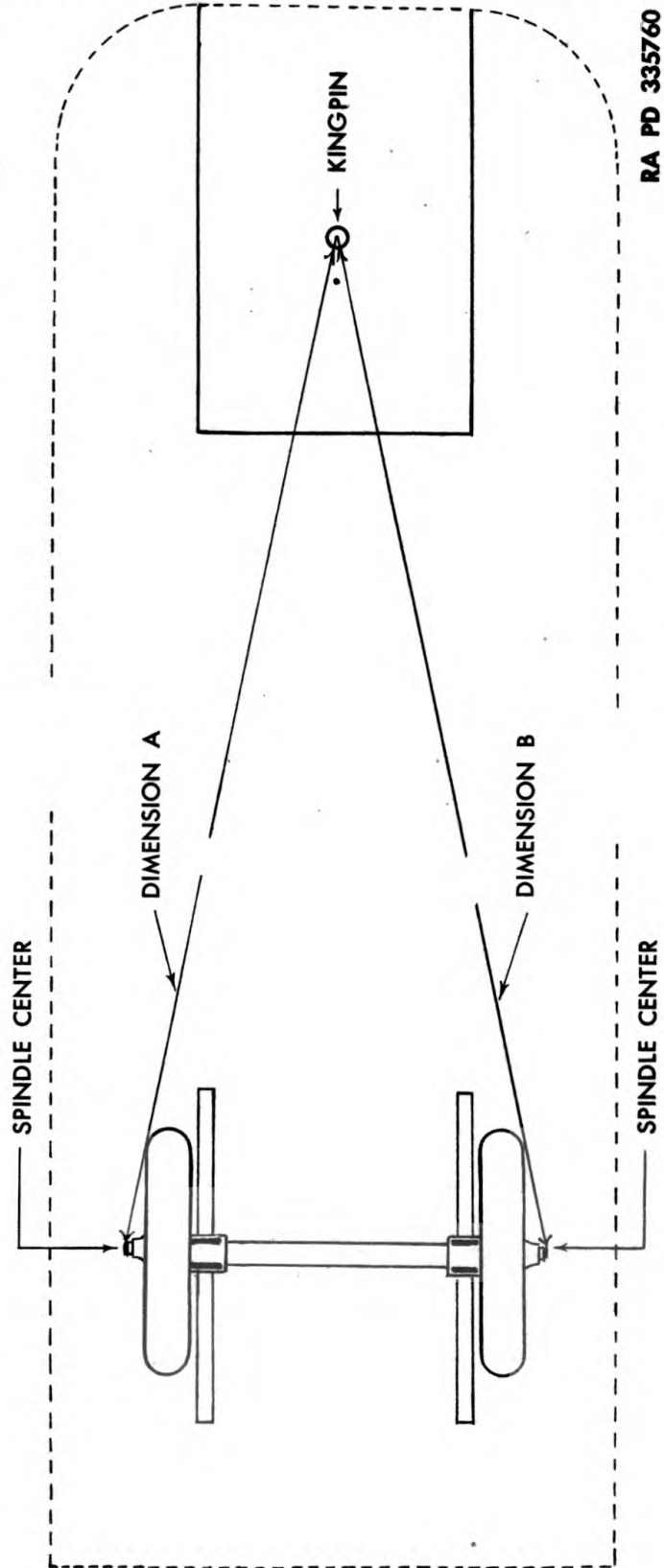

Figure 34—Axle Alinement Diagram

SPRING AND RADIUS ARM ASSEMBLIES

(f) Remove the cotter pin in the outside end of the eccentric bolt, and loosen the castle nut until it is run out on the bolt a distance of $\frac{1}{4}$ inch.

(g) Pry against the nut end of the eccentric bolt assembly until the nut is flush against the spring seat and eccentric casting.

(h) The lock pin on the inside of the eccentric bolt assembly (fig. 33) is now outside the radial seats in the adjusting casting. Fit a wrench to the machined shoulder on the inside of the eccentric bolt assembly, and turn in the direction which rotates the wide face of the eccentric from the axle. This motion will move the end of the axle spindle forward and shorten the "check distance" between the axle spindle center and the center of the kingpin. Stop the eccentric bolt in such a position as to place the eccentric lock pin in line with a set of radial pin seats in the eccentric casting. Again check the axle for alinement by measuring the distance from the center of the kingpin to each of the axle spindle centers. **CAUTION:** *Keep in mind that the left-hand measure may be as much as $\frac{1}{8}$ inch longer than the right, or curb, side check measure; but it must never be less.* If the two measures can be brought within the specified limit, no further adjustment is required. **NOTE:** *The reason that the left-hand measure may be as much as $\frac{1}{8}$ inch more than the right-hand measure, but must never be less, is to compensate for normal road crown and the consequent shifting of center of gravity to the right. The added strain on the rubber bushings of the right-hand radius arm has the effect of slightly elongating the right radius arm assembly, and consequently lengthening the axle spindle to kingpin length on that side.*

(i) Tighten eccentric bolt assembly nut when the adjustment has been completed. Seat the lock pin of the eccentric bolt assembly firmly in the radial seats of the eccentric casting and replace the cotter pin.

(j) If additional adjustment is required, follow the same procedure on the other eccentric assembly; except that, to lengthen the "check measure" length, the eccentric bolt is turned in the direction which rotates the wide face of the eccentric toward the axle. This action moves the axle away from the kingpin, thus increasing the distance between the kingpin center and the center of the end of the axle spindle. Bring the two measurements within the limits indicated in substep (d) above.

(k) Tighten the castle nut on the eccentric bolt assembly as in the first adjustment, and replace the cotter pin in the end of the eccentric bolt.

11-TON PAYLOAD, 15-TON GROSS, 2-WHEEL (2d†), VAN SEMITRAILER (OMAHA STANDARD BODY CORP. MODEL F16)

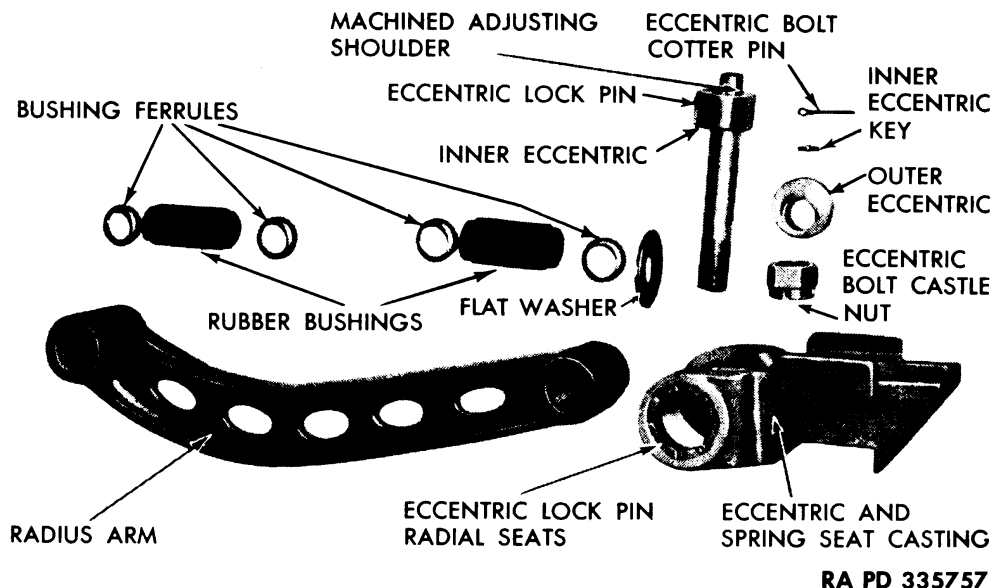

Figure 35—Radius Arm Assembly Partially Disassembled

(1) Remove the blocking from under the semitrailer, and then remove the jacks.

b. Remove Radius Arm Assembly.

(1) Jack up the semitrailer frame on the side from which the radius arm assembly is to be removed. The frame should be raised until the dual wheels (on the side raised) are just off the ground.

(2) Remove the high nuts of the U-bolts from the spring clip plate, and remove the U-bolts.

(3) Remove the front spring bracket tie rod castle nut cotter pin, and remove the tie rod castle nut.

(4) Chain or wire the front end of the spring to the frame so that it does not rest on the end of the radius arm.

(5) Use a drift to drive the tie rod from the front spring hanger bracket, thus freeing the front end of the radius arm of the radius arm assembly.

(6) Pry the spring from its seat in the spring seat and eccentric bracket, and pry the bracket from the axle. This operation frees the entire arm assembly, and it may be removed as a unit.

c. Remove Eccentric Bolt Assembly. With the radius arm assembly removed (subpar. b above), the entire eccentric assembly is accessible. Remove eccentric bolt cotter pin and the eccentric bolt castle nut. Use a drift to drive the eccentric bolt from the eccentric assembly. Remove the keyed eccentric and the keyed

SPRING AND RADIUS ARM ASSEMBLIES

eccentric key from the eccentric bracket, and force the rubber bushing and ferrules from the end bore of the radius arm. This operation completes removal of the eccentric assembly from the radius arm (fig. 33). When the eccentric assembly has been removed, any part is easily accessible for replacement.

d. Install Eccentric Assembly. Insert rubber bushing in straight end of radius arm and position in the eccentric casting. Replace the inside ferrule on the rubber bushing, and replace eccentric bolt with eccentric head and lock pin on inside. Replace outside ferrule on rubber bushing, align keyed eccentric with the eccentric bolt keyway, and insert the key. Replace flat washer, castle nut, and cotter pin on the eccentric bolt. Before seating the pin in the radial grooves of the eccentric casting, center the eccentric so that the wider face is up. This position allows the maximum adjusting range, and both eccentrics should be set in this position when reinstalled. **NOTE:** *Always check axle for alignment following reassembly and installation of radius arm and eccentric assemblies.*

e. Replace Radius Arm Assembly. When the eccentric assembly installation has been completed, the entire radius arm and eccentric assembly is replaced by reversing the process of removal (subpar. **b** above).

(1) Relocate the spring seat and eccentric casting on the axle, and position the spring assembly on the spring seat. Replace pillow block on the helper spring, and install U-bolts in position. Pass ends of U-bolts through holes in spring clip plate under the axle, and replace lock washers and high nuts. **CAUTION:** *Do not tighten the U-bolt high nuts until all units of the spring and radius arm assembly are properly seated in position.* Center the bushing bore of the front end of the radius arm in position in the front springs hanger, and drive the tie rod back in position through the spring hanger. Place a ferrule over one end of the rubber bushing, and slip ferrule and bushing over the tie rod and into the bushing bore of the radius arm. Replace the ferrule on the outside end of the rubber bushing. Replace flat washer, lock washer, and castle nut.

(2) Remove the temporary suspension supporting the front end of the spring from the frame, allowing the spring to drop against the end of the radius arm.

f. Complete Reassembly.

- (1) Replace wheels on the dual wheel assemblies.
- (2) Replace hub caps (par. 26).
- (3) Remove safety blocking from under semitrailer frame.
- (4) Lower and remove jacks.

11-TON PAYLOAD, 15-TON GROSS, 2-WHEEL (2dt), VAN SEMITRAILER (OMAHA STANDARD BODY CORP. MODEL F16)

Section XI

AXLE

43. DESCRIPTION AND DATA.

a. Description. The axle is drop-forged, of modified I-beam cross-section, and single-piece. The forged axle is heat-treated to provide maximum strength with minimum weight. The axle spindles are turned to take No. 5752 Timken tapered roller bearings on the inner bearing seats, and to take No. 5565 Timken tapered roller bearings on the outer seats. The end of the spindle is threaded to take a 1½-inch nut, drilled for ¼-inch cotter pin, and has a milled face to take a D-washer between the spindle nut and outer wheel bearings. Turned flanges are provided inside the spindle sections for supporting the brake mounting plates. Each mounting plate is held to the axle flange by eight bolts. Spring seats are alined on the axle by ½-inch dowels fitted in dowel holes in the upper face of the axle and the lower face of the combination spring seat and eccentric castings. The dowel holes are spaced in the spring seat and eccentric castings to provide a spacing of 38 inches between spring centers. The axle is designed and forged to the proper camber for the rated load capacity of the semitrailer (pars. 45 and 64).

b. Data.

Make	Fruehauf
Type	Modified I-beam section
Capacity	16,000 lb
Tread	64½ in.
Beam width	3 in.
Beam depth	4½ in.

44. REMOVE AXLE.

a. Jack up the semitrailer frame until the springs rest on the short tie rod spacers in the rear spring hanger brackets, and on the ends of the radius arms in the front spring hanger brackets. Block the frame securely in this position, leaving the space behind the axle free so that the axle and wheel assembly can be rolled from beneath the semitrailer when detached. Remove the four U-bolts holding the spring and radius arm assemblies to the axle (par. 41 b). Detach the connector hose from the brake chambers (par. 34). Pry the spring seat and eccentric castings from the dowel spacer pins on the axle. Roll the wheel and axle assembly back to the rear of the semitrailer. Remove the spring bracket spacer dowel pins from the dowel holes in the axle beams. Place the axle and wheel assembly on sup-

AXLE

ports so that the wheels are free from contact with the ground. Remove the wheel assemblies (par. 25). Remove the brake shoes from the axle spindle assembly (par. 30). Remove the camshafts from the axle assembly (par. 31). Remove the brake chambers and camshaft brackets from the axle beam (par. 34). Remove the brake mounting plates from the axle spindle flanges by removing the eight bolts holding each plate.

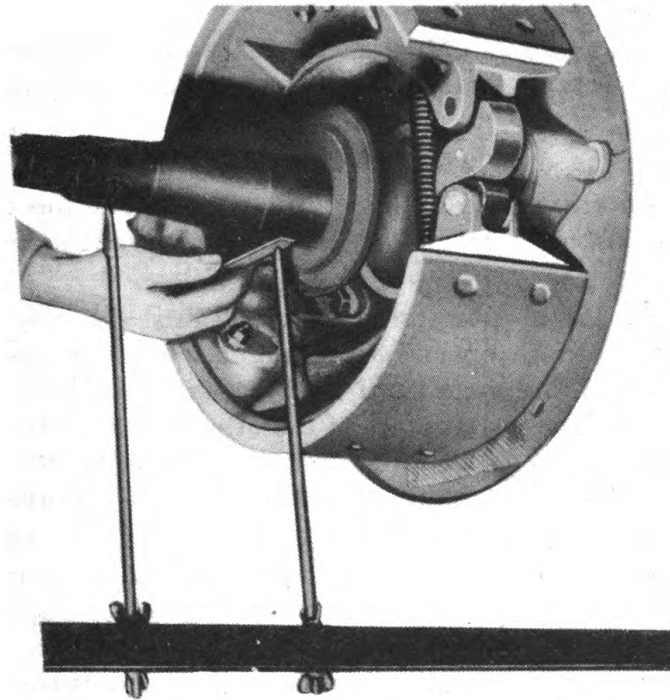

RA PD 335759

Figure 36—Checking Axle for Camber

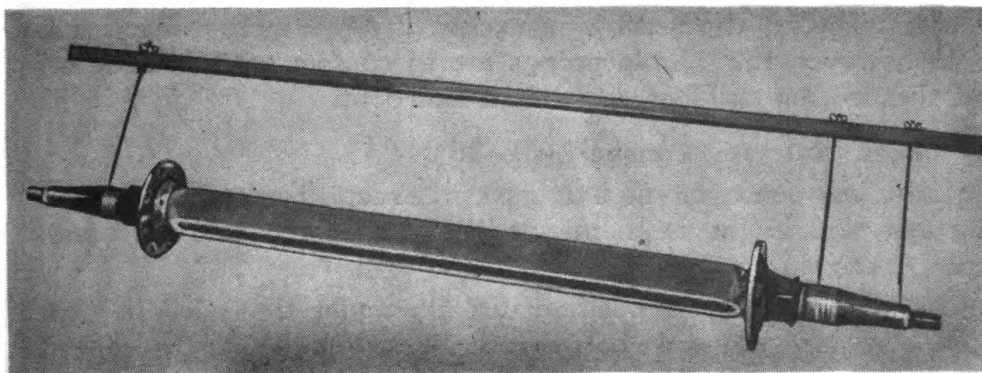

RA PD 335758

Figure 37—Test for Axle Bend

11-TON PAYLOAD, 15-TON GROSS, 2-WHEEL (2d†), VAN SEMITRAILER (OMAHA STANDARD BODY CORP. MODEL F16)**45. INSTALL AXLE.**

a. **General.** Need for axle replacement is not common but may be required because of a broken axle, a bent axle, or by an axle which has lost its camber. A bent axle, or an axle which has lost its camber, will cause undue tire wear; but either condition requires careful checking to determine the defect.

b. **Check Axle for Bend (fig. 37).**

(1) Place jacks under both sides of the semitrailer frame behind the rear spring hangers, and jack up until wheel assemblies are off the ground.

(2) Remove the dual wheel assemblies (par. 25).

(3) Place an adjustable axle gage in position on the front side of the axle. *NOTE: It is not necessary to remove the axle to check for bend or loss of axle camber.*

(4) With the single prong of the gage against the center line of the inner bearing surface on one axle spindle, adjust the two prongs on the other end of the gage until they contact the center lines of the inner and outer bearing surfaces of the other axle spindle (fig. 37). *NOTE: Be careful to have all three prongs of the gage touching their respective bearing surfaces along the center line of the axle spindle.*

(5) Move the gage to the rear side of the axle, and again place the points in position on the bearing faces. If either prong on the double-pronged end of the gage fails to touch when applied along the center line of the bearing surfaces, a bent spindle is indicated. Use a feeler gage to determine the amount of the bend. If the indicated bend is in excess of 0.002 inch, replace the axle (subpar. d below).

(6) If the check of one spindle reveals no bend, reverse the gage with the double prongs at the opposite spindle of the axle, and check both front and rear faces of that spindle without changing the adjustment of the gage. If a clearance occurs at either bearing face, check with feeler gage. If the bend is in excess of 0.002 inch, replace the axle. If, however, the double prongs are in contact with the center line of the bearing surfaces, the axle is not bent.

c. **Check Axle for Camber (fig. 36).**

(1) Set the points of the axle gage in exactly the same position on the axle and in the same manner as in checking axle for bend (subpar. b above).

(2) Place the gage in position directly under the axle. In this position, clearance will exist between the inner prong and the center line of the inner bearing surface. The amount of this clearance must not exceed 0.080 inch, and it must not be less than 0.060 inch. If the camber is not within these limits, replace the axle.

FRAME AND BODY ASSEMBLY

d. Replace Axle.

- (1) Remove the defective axle (par. 44).
- (2) Place the new axle on suitable supports with the ½-inch dowel pin holes up.
- (3) Replace the brake mounting brackets.
- (4) Replace the camshaft brackets and the brake chamber assemblies. *NOTE: Use care to see that the counterbored seats for the ball bearings in the camshaft brackets face inward toward the slack adjusters. In this position, it is possible to replace the ball bearings without removal of the camshaft.*
- (5) Replace the camshafts and the slack adjusters (pars. 31 and 35).
- (6) Replace the brake shoes (par. 30).
- (7) Replace the dual wheel assemblies (par. 25).
- (8) Replace the dowel pins in the dowel holes in the upper surface of the axle beam, and roll the wheel and axle assembly into position, and replace axle under spring seats so that the dowel pins are seated in the dowel holes in the lower face of the spring seats.
- (9) Replace the U-bolts, spring clip plates, lock washers, and U-bolt high nuts.
- (10) Attach hose connectors to brake chambers (par. 34).
- (11) Check brakes for proper adjustment (fig. 21), and adjust if required (par. 29).
- (12) Remove safety blocking from under the semitrailer frame.

Section XII

FRAME AND BODY ASSEMBLY

46. DESCRIPTION AND DATA.

a. Frame.

(1) **GENERAL DESCRIPTION.** The frame is fabricated of structural steel. Each of the two frame side rails consists of a 10-inch channel, 20 feet and 10 inches in length, upon one end of which is an overlapping 6-inch channel increasing each frame member to a total length of 27 feet, 8½ inches. The lower frame line has a 10-inch drop at the channel junction, and the upper front frame line has a 6-inch rise at the junction. The side rails are rigidly joined by crossmembers of structural channel. Bolsters of 6-inch I-beam sections support the body on the 10-inch frame section, and 4-inch-

11-TON PAYLOAD, 15-TON GROSS, 2-WHEEL (2dt), VAN SEMITRAILER (OMAHA STANDARD BODY CORP. MODEL F16)

outriggers are welded to the 6-inch channel section of the front of the frame. The top lines of both bolsters and outriggers lie in the same plane, and support the floor of the semitrailer body. A bumper assembly is bolted to the rear end of the frame and the upper fifth wheel plate, to which the kingpin is attached, and is welded to the lower flange of the front section of the side frame channel. The upper fifth wheel plate extends beyond the front body wall, and serves as a skid against the lower fifth wheel plate of the tractor truck when the semitrailer is attached to the tractor truck. The front outrail is curved to conform to the front body lines, and welded to the outriggers. The body outrails are welded to ends of cross bolsters and serve also as body sills, constituting integral chassis and body construction of unit design. Spring hanger castings are riveted to the lower web and flange of the frame channel. The tire carrier assembly is attached to the right frame member by hook bolts, and the landing wheel hinge bracket is riveted to the front of the 10-inch frame section at the point of the frame drop.

(2) DATA.

Over-all frame length, less bumper	332½ in.
Over-all frame width, less rub rails.....	93 in.
Over-all frame side rail width.....	40⅛ in.
Upper fifth wheel projection from front outrail.....	3½ in.
Bumper extension	4 in.
Bumper drop below main frame line.....	5½ in.

(3) KINGPIN AND UPPER FIFTH WHEEL PLATE. The extension of the kingpin beneath the upper fifth wheel plate is 3⁵/₁₆ inches, and its major diameter is 2.875 inches. The kingpin mounting flange is 8 inches in diameter, and is welded through holes in the flange to the upper face of the upper fifth wheel plate (fig. 39). The flange is also welded to the face of the fifth wheel plate at intervals around the outer edge of the flange.

(4) BUMPER. The semitrailer bumper consists of a 6-inch structural channel attached by bolts and mounting plate brackets to the main frame channels. The bumper is further reinforced by diagonal braces bolted to bumper and frame (fig. 38).

b. Body.

(1) GENERAL DESCRIPTION. The body of the semitrailer is of round-front van type, having metal sides and roof coverings permanently attached to the body frame. The seams of the body wall panels are covered by metal "snap-on" type moulding. The metal roof seams are of weather seal construction. The lower edge of each side of the body is protected by a protruding rub rail which acts

FRAME AND BODY ASSEMBLY

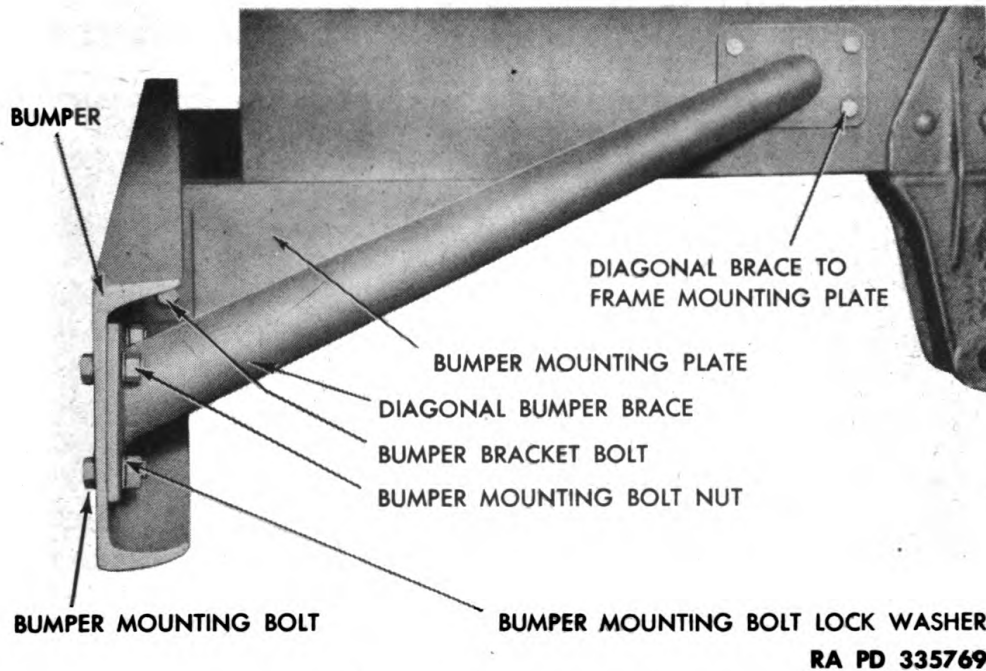

Figure 38—Bumper

as a buffer against accidental impact. The two doors in the rear of the body are each supported by three hinges. The body side walls are lined with $\frac{1}{4}$ -inch fir panel board, screwed to the body frame to provide accessibility in making repairs.

(2) **BODY FRAME.** The superstructure framing of the semitrailer body is of wood construction, reinforced at points of strain by steel braces. The posts of the body frame are riveted to the metal outrail of the chassis, thus joining the body and the chassis frame into an integral unit. The top bows are supported on the upper plate to the body side wall frame, and are attached to the posts by steel braces bolted to each end of the bow and to the opposed body post.

(3) **BODY HARDWARE.**

(a) *Hinges.* The body hinges are of the tight pin-strap-and-bracket type. The body bracket of the hinge is cross-bolted to the rear post of the body frame, and the strap is bolted to the face of the door.

(b) *Door Lock.* The door lock is of heavy-duty, triple-bolt type, actuated by a single handle. The lock handle and escutcheon are equipped with lock rings for padlocking the doors.

(c) *Safety Latches.* The hook assemblies of the safety latches are attached to the doors, and the keepers are screwed to the sides

11-TON PAYLOAD, 15-TON GROSS, 2-WHEEL (2dt), VAN SEMITRAILER (OMAHA STANDARD BODY CORP. MODEL F16)

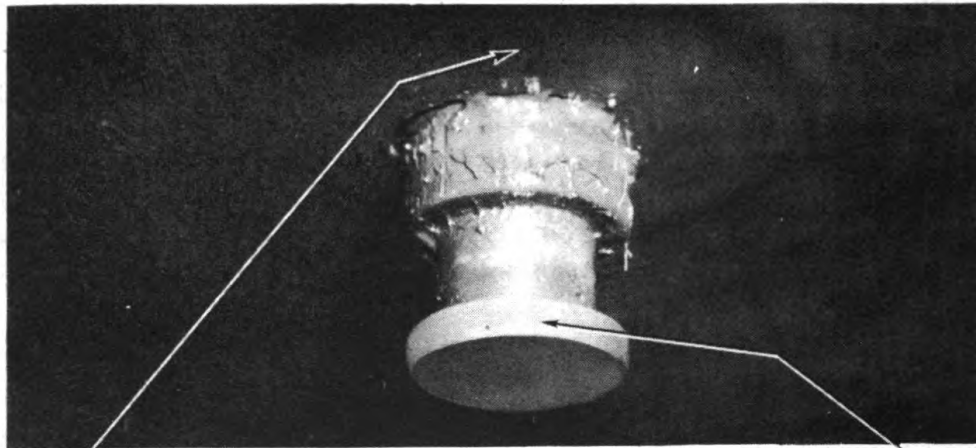

UPPER FIFTH WHEEL PLATE

KINGPIN

RA PD 335761

Figure 39—Kingpin

of the body. These latches are used to hold the doors open when loading or unloading.

(d) *Padlock.* The padlock is military type ID with attaching chain.

(e) *Stay Bolt.* The left-hand door is locked shut by means of a stay bolt attached to inside face of the door at top edge.

(4) **CHOCK BLOCK ASSEMBLIES.** Each of the 2 chock block assemblies consists of a length of 1/4-inch chain with a pear-shaped link at one end to which a triangular-shaped chock block is attached. The block is suspended under the body floor by a safety snap when not in use as an emergency parking brake. The safety snap is bolted to the frame. The free end of the chain is attached to the frame in a position that permits the block to be used either behind or in front of the dual tires. Each chock block is built up of 11 wood sections each 3/4 inch thick, and bolted together.

(5) **FLOOR.** The hardwood floor is 1 1/4 inches thick, and is attached to the chassis bolsters and outriggers by self-tapping metal screws. The rear edge of the floor line at the door opening is protected by a steel angle iron countersunk into the wood.

(6) **DATA.**

Inside body length.....	332 in.
Inside body width.....	88 in.
Over-all body width.....	95 1/2 in.
Inside height at the side wall.....	74 1/4 in.
Inside height at the center.....	76 in.
Width of clear door opening.....	87 in.
Height of clear door opening.....	70 in.

FRAME AND BODY ASSEMBLY**47. FRAME AND BODY MAINTENANCE.**

a. General. Since the chassis frame and van-type body are constructed as an integral unit, they cannot readily be disassembled. The construction of the chassis frame provides sufficient strength to protect it from ordinary accidental damage; but if damage does occur, it can be repaired without difficulty. Accidental damage to the body is usually localized to a relatively small portion of the unit, and repairs of such damage must be governed by the nature and location of the damage.

b. Frame Maintenance.

(1) **INSPECTION.** The entire frame assembly should be carefully inspected at frequent intervals. Look especially for bent, broken, or loose frame members and report such defects to higher authority. Tighten all loose bolts and screws, and check all door hardware to be sure it is in serviceable condition.

(2) **BUMPER.** Because of its purpose and exposed location, the bumper is more liable to damage than any other unit of the frame assembly (fig. 38). Since the bumper, as well as its diagonal braces, can be detached from the frame by removing the bumper mounting bolts, a bent or otherwise damaged bumper may be removed for repair.

(3) **CHOCK BLOCK ASSEMBLIES.** Carefully inspect the attachment of the chock block chain to the frame to see that it is secure. Inspect the safety snap to be sure it is in good condition and that the mounting bolt is tight.

c. Body Maintenance.

(1) **DOOR HARDWARE.** Check the door safety latches, and keep the mounting screws well tightened on both door and body plates. The door lock mechanism is secured with bolts and lock washers which should remain permanently tight. If, however, the lock mechanism requires service, the plywood lining panel of the door can be removed so the lock assembly is accessible for adjustment or repair. Check the bolt on the inside of the left-hand door. Be sure that the bolt seats properly in the keeper.

(2) **RUB RAILS.** Check the condition of the screws holding the rub rails which protect the bottom edges of the body sides. Keep all screws tight, and replace lost or broken screws. In minor accidents, the rub rails are frequently required to absorb the impact of collision. If damage to a rub rail occurs, remove the damaged member, straighten, and replace.

(3) **DENTED OR BENT TOP METAL.** Minor dents in the metal top are repaired by hammering out the dents from the inside of the body. If any of the weather-sealed cross seams of the top are

TM 9-894

47-48

11-TON PAYLOAD, 15-TON GROSS, 2-WHEEL (2d+), VAN SEMITRAILER (OMAHA STANDARD BODY CORP. MODEL F16)

forced open as the result of the accident, hammer the metal of the joints back into shape, caulk the joint, and clinch the seam back in position by hammering the metal joint in place. The outer seam around the top is fastened with bolts or screws and soldered. In the event of damage to this seam, remove the bolts or screws holding the damaged section, hammer the metal back into position, and resolder the seam.

(4) **DENTED METAL SIDE PANEL.** To repair a dented or damaged side panel, locate the point of damage on the inside of the body, and remove the opposed plywood lining panel. Hammer the metal back into place. When the repair has been completed, replace the wood lining panel, and the screws which secure it.

(5) **DAMAGED DOORS.** Minor damage to the doors can be repaired without removing the doors. If, however, removal of the door is required, remove the plywood lining of the door; the nuts holding the door hinge can be removed with an end wrench. Remove the hinge bolts holding the door.

Section XIII

ELECTRICAL SYSTEM

48. DESCRIPTION AND DATA.

a. General Description. The entire electrical system of the semitrailer is energized from the electrical system of the tractor truck and transmitted through the jumper cable of the tractor truck to the electrical coupling socket assembly of the semitrailer. The electrical system of the semitrailer consists of both service and blackout circuits to the taillights, a service marker light circuit to the exterior body lights, and a service dome light circuit controlled by an "ON" and "OFF" switch (fig. 40).

(1) **SERVICE TAILLIGHT AND BLACKOUT TAILLIGHT CIRCUITS** (fig. 40). The service stop and tail, and blackout taillight circuits are carried by a wiring harness extending from the jumper cable coupling socket to the blackout switch (G) and a harness extending from the blackout switch to a four-post junction block (H) on the rear cross sill of the chassis frame. From the junction block a harness extends to the blackout stop and taillight (I) on the right, or curb, side of the semitrailer; and a harness extends from the junction block to the service stop and tail, and blackout taillight (J) at the rear

ELECTRICAL SYSTEM

left side of the semitrailer. The blackout switch is located near the lower front line of the trailer body, about 32 inches to the right of the jumper cable coupling socket. The blackout switch is employed in the circuit to change from service taillight to blackout taillight, or from blackout taillight to service taillight (fig. 41). The main chassis wiring harness of this circuit extends from the blackout switch through a grommet in the right frame side rail, along the service air line above the upper fifth wheel plate, across to the inside of the right side rail of the frame, and along the web of the frame side rail to the four-post junction block on the rear cross sill of the frame. The harness is attached to the service air line by clamp bands, and to the frame by clamps bolted to the web of the frame side rail.

(2) **MARKER LIGHT CIRCUIT.** The marker light circuit is carried with the dome light circuit by a wiring harness extending from the blackout switch along the front outrail of the frame, through a grommet in the right frame side rail to the front center line of the semitrailer body at a point beneath the floor, up the front of the body, and through the notches in the roof bows to a two-post junction block on the rear top bow. The marker lights in the front of the semitrailer body are energized from leads which branch off from the harness at the front bow of the top frame. The marker lights at the rear of the body connect with the two-post junction block on the rear top bow (fig. 40). All marker lights are on when the semitrailer electrical system is on "SERVICE" light of the blackout switch, and off when the blackout switch is on "BLACKOUT."

(3) **DOME LIGHT CIRCUIT.** The dome light circuit is connected to the two-post junction block on the rear top bow of the body by the same wiring harness which carries the marker light circuit (fig. 41). The "ON" and "OFF" switch of the dome light circuit is located near the top of the left lining panel of the body at a point just forward of the left body corner post (par. 5 e). The dome lights are controlled by this switch only when the blackout switch is on "SERVICE." The dome light circuit is not energized when the blackout switch is on "BLACKOUT." *NOTE: Dome lights will light only when the dome light switch is on and the blackout switch is on "SERVICE" (figs. 40 and 41).*

b. Data.

Circuit voltage.....	6-8
Marker and dome light lamps.....	Single contact
Taillight lamp units.....	Sealed
Wiring code.....	Numbered wires
Wire gage.....	14
Marker and dome lights.....	Individual grounds

11-TON PAYLOAD, 15-TON GROSS, 2-WHEEL (2dt), VAN SEMITRAILER (OMAHA STANDARD BODY CORP. MODEL F16)

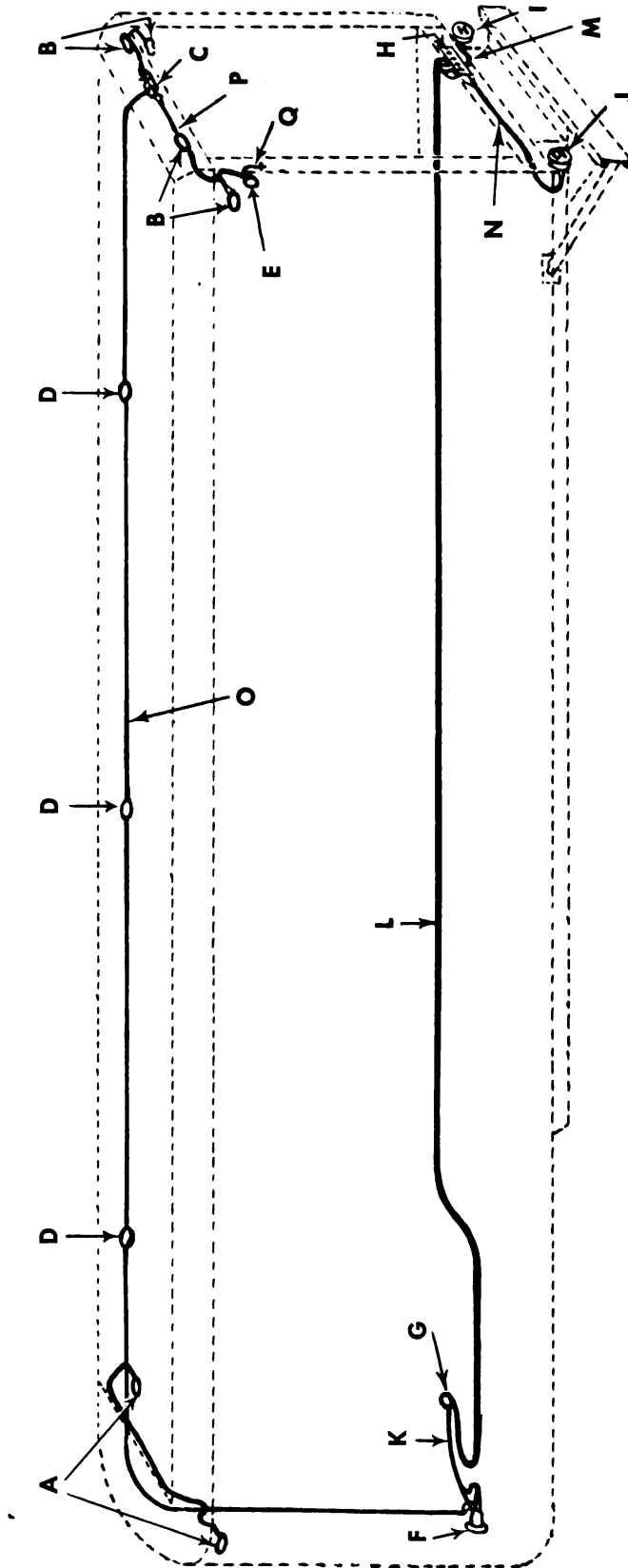

- A—AMBER MARKER LIGHT
- B—RED MARKER LIGHT
- C—TWO-POST JUNCTION BLOCK
- D—DOME LIGHTS
- E—DOME LIGHT SWITCH
- F—COUPLING SOCKET
- G—BLACKOUT SWITCH
- H—FOUR-POST JUNCTION BLOCK
- I—BLACKOUT STOP AND BLACKOUT TAILLIGHT
- J—SERVICE STOP AND TAIL, AND BLACKOUT TAILLIGHT
- K—BLACKOUT SWITCH WIRING HARNESS
- L—CHASSIS WIRING HARNESS
- M—RIGHT REAR WIRING HARNESS
- N—LEFT REAR WIRING HARNESS
- O—MAIN ROOF HARNESS
- P—REAR ROOF HARNESS
- Q—GROUND HARNESS

Figure 40—Wiring Diagram

RA PD 335764

ELECTRICAL SYSTEM

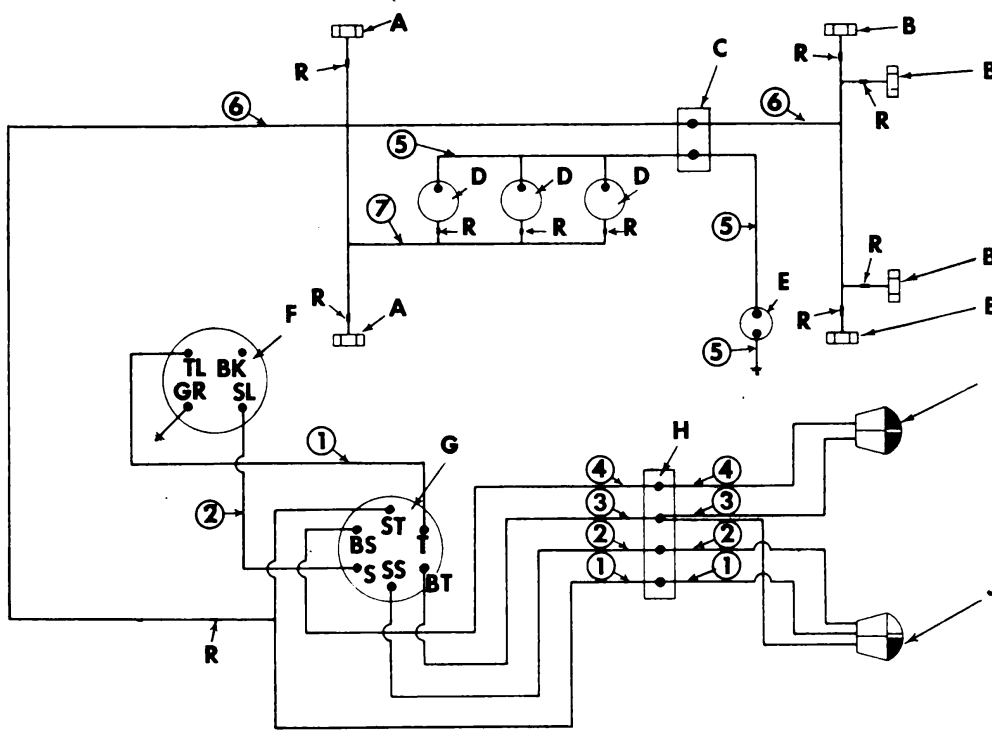

- | | |
|--------------------------|---|
| WIRE NO. 1 SERVICE TAIL | TL, BK, GR, & SL—COUPLING SOCKET TERMINALS. |
| WIRE NO. 2 SERVICE STOP | S & T—BLACKOUT SWITCH WIRING HARNESS |
| WIRE NO. 3 BLACKOUT TAIL | |
| WIRE NO. 4 BLACKOUT STOP | R — WIRE SPLICE |
| WIRE NO. 5 GROUND | |
| WIRE NO. 6 MARKER LIGHTS | |
| WIRE NO. 7 DOME LIGHTS | |

RA PD 335765

Figure 41—Electrical Circuits

49. MAINTENANCE.

a. Wiring Harness Removal.

(1) REPLACE BLACKOUT SWITCH HARNESS.

(a) Remove the bolts holding the jumper cable coupling socket to the body of the semitrailer and pull the socket assembly out until the nut holding the ground terminal and assembly cap is accessible.

(b) Remove the nut and lock washer securing the ground terminal of the harness assembly to the center bolt of the coupling socket terminals.

(c) Remove the ground terminal and the cap covering the coupling socket terminal studs.

(d) Remove the jam nuts and terminal caps from the coupling socket terminal studs to which the blackout switch harness terminals

11-TON PAYLOAD, 15-TON GROSS, 2-WHEEL (2d+), VAN SEMITRAILER (OMAHA STANDARD BODY CORP. MODEL F16)

are attached (fig. 41). These terminal studs are marked "TL" and "SL" on the insulated panel of the coupling socket.

(e) Remove the blackout switch harness terminals from the coupling socket studs.

(f) The blackout switch is secured to the body of the semi-trailer by a nut and internal lock washer on the threaded neck of the switch. The neck, containing the slotted switch control, protrudes through a hole in the body panel. Remove the nut and lock washer from the switch neck, slide the blackout switch back through the hole in the body panel, and lower the switch into a position beneath the outrail of the semitrailer frame where the connecting terminals are accessible.

(g) Remove the nuts, lock washers, and bolt securing the blackout switch cover and gasket to the switch case. Remove the cover and cover gasket.

(h) Loosen the terminal screws holding the blackout switch harness wiring terminals, and pass the terminal connectors out through the hole in the side of the switch case.

(i) The harness can now be pulled through the grommet in the chassis frame member.

(j) A new blackout switch harness is installed by reversing the procedure in removing the old harness. Refer to the wiring circuit detail (fig. 41) as a guide in correctly connecting all terminals of the harness.

(2) REPLACE MAIN CHASSIS HARNESS.

(a) Remove the blackout switch by following the procedure in step (1) above, and disconnect the main chassis harness terminals from the terminals of the blackout switch.

(b) Push the end of the harness through the grommet in the main frame side rail.

(c) The main chassis harness passes from between the upper fifth wheel plate and the semitrailer floor beside the service line of the air line, and is clipped to the air line by banding clips. Access to the space between the upper fifth wheel plate and the floor is gained by removing two short sections of flooring boards at the center front of the floor (par. 65 c). Disconnect the roof harness from the single connecting terminal of the main chassis harness, found about 36 inches from the front end of the main chassis harness. Remove the cable clamps which secure the harness to the service air line extending over the upper fifth wheel plate, and pass the harness out through the hole in the crossmember of the frame at the rear end of the upper fifth wheel plate.

ELECTRICAL SYSTEM

(d) Remove the bolts and cable clips which secure the main chassis harness to the right rail of the frame.

(e) Remove the nuts holding the harness terminals to the studs of the four-post junction block located on the inner face of the rear cross bolster of the frame.

(f) Install a new harness by reversing the procedure followed in removing the old harness. Refer to wiring detail (fig. 41) for guide in connecting terminals of the main chassis harness.

(3) REPLACE RIGHT TAILLIGHT HARNESS.

(a) Disconnect the harness terminals from the four-post junction block. Remove the cable clip bolt and cable clip holding the short taillight harness to the rear cross sill of the frame. Turn the harness connector in the socket of the taillight assembly to release the assembly lock pin, and pull the connector from the light socket.

(b) Install a new right taillight harness by reversing the procedure followed in removing the old harness. Refer to wiring detail (fig. 41) for guide in connecting harness terminals to four-post junction block.

(4) REPLACE LEFT TAILLIGHT HARNESS.

(a) Disconnect harness terminals from the studs of the four-post junction block. Remove the three cable clip bolts and cable clips securing the left taillight harness to the rear cross sill of the frame. Turn the harness connector in each socket of the taillight assembly to release the connector lock pins, and pull the harness connectors from the light sockets.

(b) Install a new harness by reversing the procedure for removal of the old harness. Refer to wiring detail (fig. 41) as a guide in connecting left taillight harness terminals to the four-post junction block.

(5) REPLACE MAIN ROOF HARNESS.

(a) Remove the plywood lining panel from the front center of the semitrailer body by removing the screws which secure the panel to the semitrailer body frame.

(b) Remove the two short sections of flooring boards in the center front of the trailer floor.

(c) Disconnect the terminal of the main roof harness from the connector of the main chassis harness. This connection is located inside the right side rail of the frame at a point near the front of the trailer, and is accessible through the hole in the semitrailer floor made by removing the two short sections of floorboards.

(d) Work the end of the main roof harness up along the inside of the front wall panel of the body, and pull through the curved plate at the top of the wall framing of the trailer.

TM 9-894

49-50

11-TON PAYLOAD, 15-TON GROSS, 2-WHEEL (2d+), VAN SEMITRAILER (OMAHA STANDARD BODY CORP. MODEL F16)

(e) Disconnect the pig tails of the front marker lights and the dome lights from the respective terminals of the main roof harness.

(f) Remove the nuts securing the terminal of the main roof harness to the junction block located on the rear roof bow of the body frame, and remove the terminal from the stud of the junction block.

(g) Beginning at the rear end of the trailer roof, work the harness through the notches in the roof bows until free of the front double bow.

(h) Remove the clip staples securing the harness to the front face of the double roof bow at the front of the trailer.

(i) Install a new main roof harness by reversing the procedure for removing the old harness. Refer to wiring detail (fig. 41) as a guide in connecting harness to terminals when installing new harness.

(6) REPLACE REAR ROOF HARNESS.

(a) Remove rear roof harness terminals from two-post junction block on body rear top bow. Remove cable clip screws and cable clips which secure harness to body top bow. Disconnect harness terminals from pig tails of rear marker lights. Remove screws which secure the dome light toggle switch to upper corner of the rear left body lining panel, remove the switch, and detach the rear roof harness terminal from the toggle switch.

(b) Install a new rear roof harness by reversing the procedure followed in removing the old harness. Refer to wiring detail (fig. 41) as a guide in connecting harness terminals when installing new harness.

(7) REPLACE GROUND HARNESS.

(a) To replace the short ground harness at the dome light toggle switch, remove the screws which secure the switch to the body lining panel, and pull the switch from the body wall. Disconnect the ground harness terminal at the toggle switch. Remove the screw which secures the ground harness terminal to the rear left body post.

(b) Install a new ground harness by reversing the procedure for removal of the old harness.

50. JUMPER CABLE COUPLING SOCKET.

a. Disassemble Jumper Cable Coupling Socket (fig. 42).

(1) REMOVE JUMPER CABLE COUPLING SOCKET. Refer to paragraph 49 a.

(2) DISASSEMBLY PROCEDURE.

(a) Remove nut and lock washer securing wiring harness ground and coupling socket assembly cover cap, and remove the ground harness terminal and the assembly cap.

ELECTRICAL SYSTEM

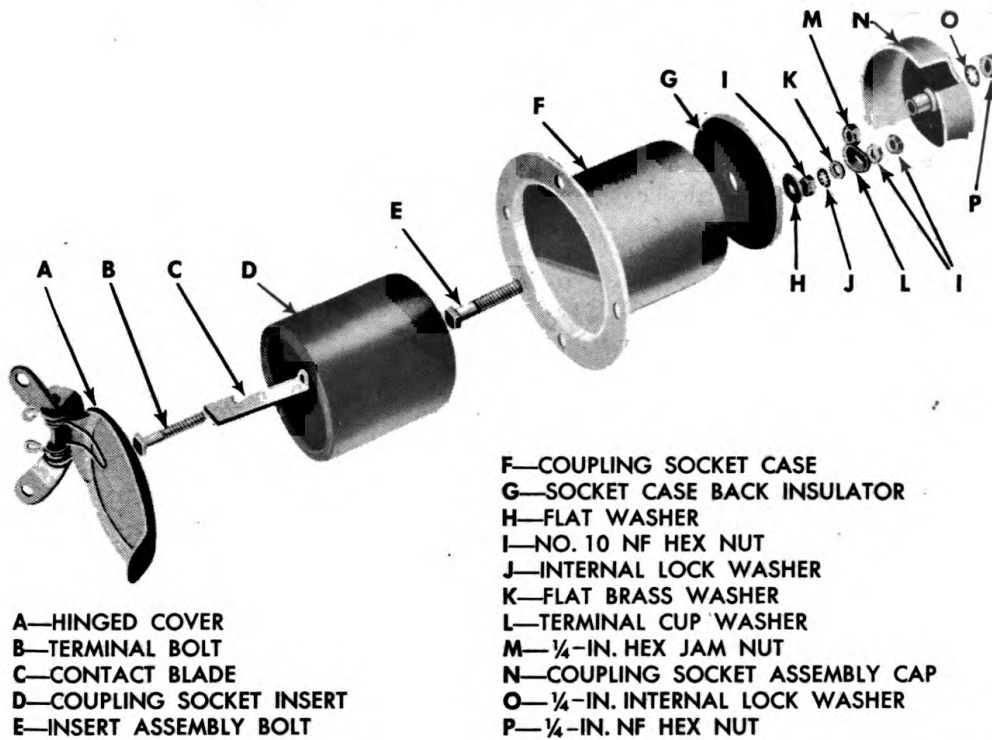

A—HINGED COVER
B—TERMINAL BOLT
C—CONTACT BLADE
D—COUPLING SOCKET INSERT
E—INSERT ASSEMBLY BOLT

F—COUPLING SOCKET CASE
G—SOCKET CASE BACK INSULATOR
H—FLAT WASHER
I—NO. 10 NF HEX NUT
J—INTERNAL LOCK WASHER
K—FLAT BRASS WASHER
L—TERMINAL CUP WASHER
M— $\frac{1}{4}$ -IN. HEX JAM NUT
N—COUPLING SOCKET ASSEMBLY CAP
O— $\frac{1}{4}$ -IN. INTERNAL LOCK WASHER
P— $\frac{1}{4}$ -IN. NF HEX NUT

RA PD 335768

Figure 42—Coupling Socket Partially Disassembled

(b) Remove the double nuts which secure the four terminal stud caps, and remove the terminal caps and harness terminals from the terminal studs of the jumper cable coupling socket.

(c) Remove the retaining nuts at the base of each of the four terminal studs of the coupling socket assembly. Remove the retaining nut at the base of the main assembly center bolt.

(d) Remove the lock washers from terminal studs and assembly center bolt.

(e) Complete the disassembly of the main unit of the coupling socket by pulling out the center assembly bolt and removing the insulating sleeve and contact blades from the case of the coupling socket (fig. 42).

(f) Reassemble the jumper cable coupling socket by reversing the procedure followed in disassembling the coupling socket assembly.

51. BLACKOUT SWITCH.

a. **Remove Blackout Switch.** Refer to paragraph 49 a.

b. **Description.** The blackout switch (fig. 43) consists primarily of a switch case containing a terminal block supporting six terminal connectors and terminal connector screws. Each terminal is identified by key letters (fig. 41) so that harness terminals can be readily

11-TON PAYLOAD, 15-TON GROSS, 2-WHEEL (2d+), VAN SEMITRAILER (OMAHA STANDARD BODY CORP. MODEL F16)

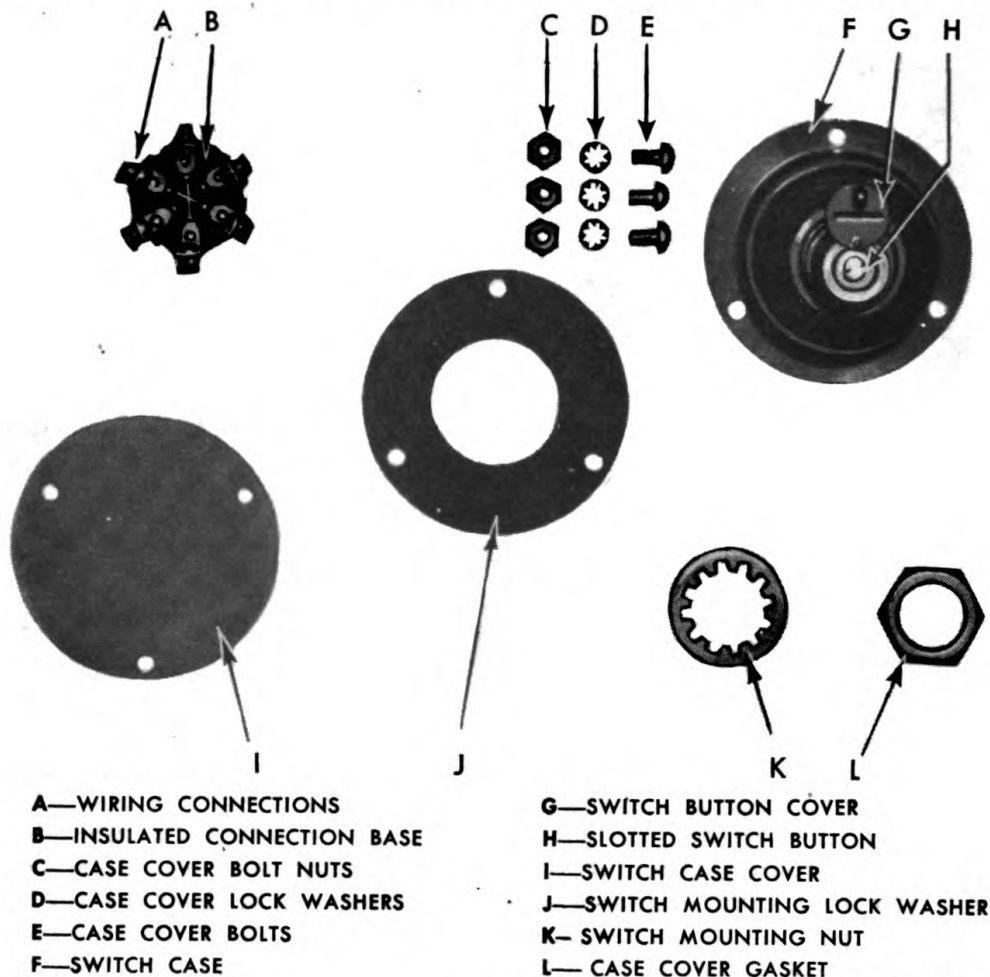

RA PD 335767

Figure 43—Blackout Switch Partially Disassembled

connected to the proper switch terminal. The slotted switch key in the face of the switch case is turned by inserting a coin or screwdriver in the slot. The face and control key of the switch is protected from dirt and exposure to rain and water by a circular cover attached by a swivel pin to the upper rim of the switch face. Complete disassembly of the switch is not practical. A defective switch must be replaced. Except for accidental damage, the blackout switch should require no maintenance care. *NOTE: Care must be exercised in removing or replacing the wiring harness terminals to prevent accidental damage to the delicate mechanism of the switch assembly.*

c. **Location** (par. 5 d). The location of the blackout switch on the lower edge of the left curved body panel of the front of the semitrailer exposes the switch to the danger of accidental damage. Inspect the switch frequently and test it to see that it is in proper operating condition.

ELECTRICAL SYSTEM

52. DOME LIGHT SWITCH.

a. Description and Use. The single-pole dome light toggle switch controls the dome light circuit only when the blackout switch is on "SERVICE." The dome light circuit is off when the blackout switch is at "BLACKOUT." The dome light switch is connected to a single terminal of the rear roof harness and to a terminal of the ground wiring harness (fig. 40). The switch toggle is protected by a metal switch plate attached by two screws to the lining panel of the semitrailer body.

b. Location. The location of the dome light switch (par. 5 e) provides maximum protection from accidental damage. The switch is readily accessible for inspection or removal.

c. Replace Dome Light Switch. Except for minor adjustment, a damaged dome light switch should be replaced. The damaged switch is replaced as a unit.

53. LIGHTS.

a. Replace Taillight.

(1) **REMOVE TAILLIGHT ASSEMBLY.** The taillight assembly is attached to a chassis bracket by two studs in the body case of the taillight unit. Turn the taillight harness connector in the light socket to release the lock pins and pull out the connector. Remove the nuts and lock washers from the studs which secure the light unit to the support bracket, and remove the taillight assembly.

(2) **REMOVE THE SEALED LAMP-UNIT.** Use a screwdriver to remove two screws from the front cover of the taillight, and remove the cover from the body case of the light assembly. Slide the sealed lamp-unit from the case of the light. Lamps of a sealed unit are not replaceable. Replace a damaged unit (fig. 44).

(3) **INSTALL SEALED LAMP-UNIT.** Insert the new sealed lamp-unit in the body of the light case; replace the front cover in position on the case so that the screw holes in the cover are directly over the threaded screw holes in the case. Replace the cover screws.

(4) **INSTALL TAILLIGHT.** Position the fixed studs of the taillight assembly in the holes in the taillight mounting bracket, and replace the lock washers and nuts on the mounting studs of the light assembly.

b. Dome Lights.

(1) **REMOVE DOME LIGHT.** Remove the wood screws holding the dome light in place, and remove the screws holding the light cover

11-TON PAYLOAD, 15-TON GROSS, 2-WHEEL (2d+), VAN SEMITRAILER (OMAHA STANDARD BODY CORP. MODEL F16)

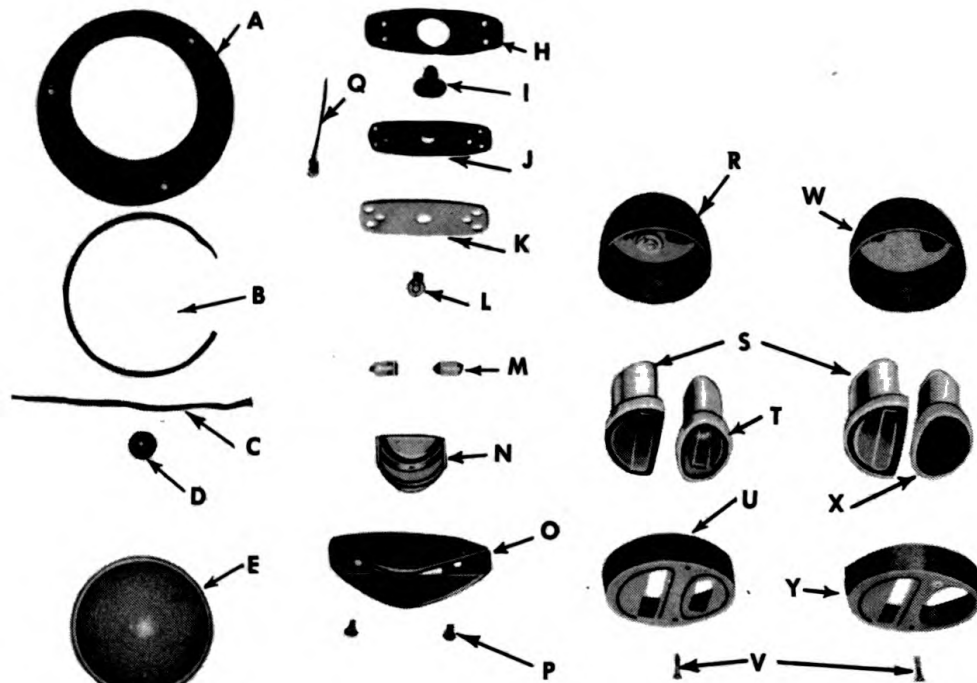

- A—LIGHT HOUSING
- B—LENS SNAP RING
- C—PIG TAIL ASSEMBLY
- D—INSULATING NIPPLE
- E—LENS
- F—LAMP
- G—BACKING PLATE

- H—MOUNTING PAD
- I—NIPPLE
- J—BACKING PLATE
- K—INSIDE GASKET
- L—LAMP
- M—LENS CLIPS
- N—LENS
- O—LIGHT HOUSING
- P—MOUNTING PLATE SCREWS
- Q—PIG TAIL ASSEMBLY
- R—BLACKOUT LIGHT HOUSING
- S—BLACKOUT TAILLIGHT LOWER UNIT
- T—BLACKOUT STOP LIGHT UPPER UNIT
- U—BLACKOUT LIGHT HOUSING DOOR
- V—HOUSING TO DOOR SCREWS
- W—SERVICE AND BLACKOUT LIGHT HOUSING
- X—SERVICE STOP AND TAILLIGHT UPPER UNIT
- Y—SERVICE AND BLACKOUT HOUSING DOOR

RA PD 335766

Figure 44—Dome, Taillight and Marker Light, Disassembled

LANDING GEAR

of the dome light assembly. Remove the face of the dome light from the cover containing the light socket. Remove the defective lamp from the socket and replace with a new lamp.

(2) **REPLACE DOME LIGHT LENS.** Remove the dome light as in step (1) above. Remove the snap ring from the face and lens assembly of the dome light, and remove the defective lens. Replace the defective lens, and replace the snap ring that retains the lens in the face of the dome light (B, fig. 44).

(3) **REPLACE DOME LIGHT.** Replace the dome light cover, and replace the screws holding the cover to the face and lens assembly. Replace the wood screws which secure the dome light to the body top.

c. Marker Lights.

(1) **REPLACE MARKER LAMP.**

(a) Remove the screws securing the marker light to the backing plate, and remove the light body and lens assembly. Remove the lamp from the socket in the light backing plate assembly.

(b) Insert new lamp in light socket, and replace the light body and lens assembly.

(c) Replace screws securing the light body to the backing plate.

(2) **REPLACE MARKER LIGHT ASSEMBLY.**

(a) Remove the two screws securing the body and lens assembly of the marker light, and remove the body and lens assembly.

(b) Remove the four screws securing the light backing plate assembly to the body of the semitrailer. Disconnect the wiring terminal of the marker light assembly from the rear roof wiring harness, and pull the pig tail of the marker light assembly out with the marker light backing plate assembly. Remove the rubber gasket and nipple from the pig tail of backing plate assembly.

(c) To remove the pig tail connector from the backing plate assembly, remove the lamp from the light socket, and push the pig tail assembly out through the socket.

(d) The marker light assembly is replaced by reversing the procedure for its removal.

Section XIV

LANDING GEAR

54. DESCRIPTION AND DATA.

a. **General Description.** The landing gear assembly is attached to the forward end of the 10-inch side sills of the chassis frame at the point of the frame drop, and to the two cross channels of the frame immediately to the rear of the frame drop. The landing gear leg hinge castings are riveted to the side rails of the frame, and the

11-TON PAYLOAD, 15-TON GROSS, 2-WHEEL (2d+), VAN SEMITRAILER (OMAHA STANDARD BODY CORP. MODEL F16)

screw assembly housing is secured to crossmembers of the frame. A hand crankshaft bracket is riveted to the right side rail of the frame at a point opposite the shaft of the landing gear assembly (fig. 45). A coupling joins the crankshaft to the shaft of the gear assembly. The crank is hinged to the crankshaft so that it can be suspended from a supporting hook when not in use. The legs of the landing gear are adjustable to compensate for variation in the height of fifth wheel assemblies on tractor trucks.

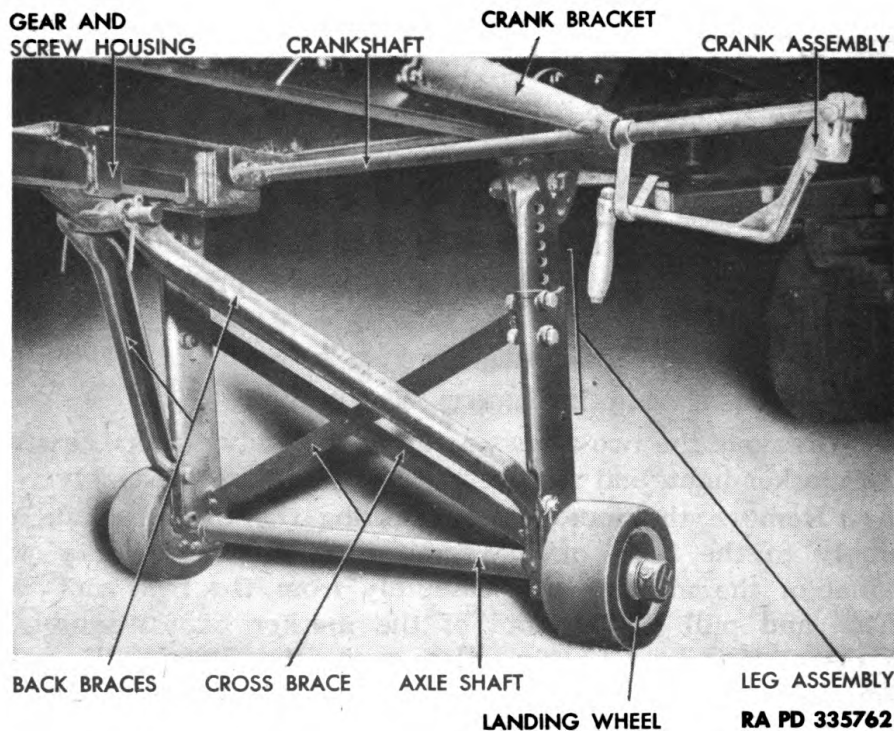

Figure 45—Landing Gear

b. Data.

Type	Retractable
Wheel size	5½ x 10 in.
Normal retracted road clearance	13 in.
Leg adjustment range	13¾ in.
Make	Holland

c. Operation. The landing gear is operated by a crank through miter gears and a horizontal worm screw. The worm screw passes through an operating nut assembly attached to the back braces of the landing gear. The leg and wheel assembly is lowered by turning the operating crank in a clockwise direction, and raised by turning

LANDING GEAR

in a counterclockwise direction. To raise or lower the landing gear, unhook the crank from the crank holder on the crankshaft, seat the hinged crank firmly on the crankshaft, and turn. The trailer must not be moved along the ground with the landing wheels down. When the semitrailer is attached to a tractor truck, the wheels must be fully retracted before the semitrailer is moved.

55. REMOVE LANDING GEAR MECHANISM.

a. **Remove Wheel, Leg, and Back Brace Assembly.** Jack up the front of the semitrailer, and place safety blocks under the upper fifth wheel plate. Remove the nuts, lock washers, and bolts securing the hub caps, and remove the hub caps and wheels. Remove the pin which secures the back braces to the operating nut assembly, and remove the two pins which secure the back braces to the leg assembly. Remove the back braces. Remove the two nuts, lock washers, and bolts which secure the leg assembly to the leg hinge brackets of the frame, and remove the leg assembly. Remove the two nuts, lock washers, and bolts securing each lower leg casting to the axle shaft, and remove the axle shaft. Remove the four nuts, lock washers, and bolts securing the cross braces to the lower leg castings, and release the leg castings from the cross braces.

b. **Remove Miter Gear and Screw Mechanism.** Remove nuts from studs of gear housing cover plate, and lift off the cover plate. Remove the nut, lock washer, and bolt from each end of crankshaft connecting sleeve, and pull out the hand crank and crankshaft assembly. Drive the taper pin from hub of miter gear, releasing gear shaft. Remove the thrust bearing sleeve, gear, and shaft. Remove the jam nut from end of the horizontal screw shaft, and drive out key from the gear hub. Remove the gear, thrust bearing, and sleeve by tapping the gear off the end of the worm screw. Remove nut, lock washer, and bolt at rear of the worm screw housing. Push the worm screw back until the thrust bearing is out of the housing, and remove the bearing from the end of the worm screw. Pull the worm screw and guide bracket from the housing.

56. MAINTENANCE.

a. **Cleaning.** Wash all parts thoroughly in dry-cleaning solvent. **NOTE:** *Be careful to keep all parts in order to facilitate installation (fig. 46).*

b. **Inspection.** Inspect miter gear and worm gear teeth for breaks, chips, or cracks. Replace if defective. Inspect thrust bearing and sleeve for wear. Replace if worn or damaged. Inspect the hand crank assembly. Repair or replace hand crank handle if bent or damaged. Inspect bronze nut and the worm screw for extreme wear or damage. Replace if condition is not serviceable.

11-TON PAYLOAD, 15-TON GROSS, 2-WHEEL (2d+), VAN SEMITRAILER (OMAHA STANDARD BODY CORP. MODEL F16)

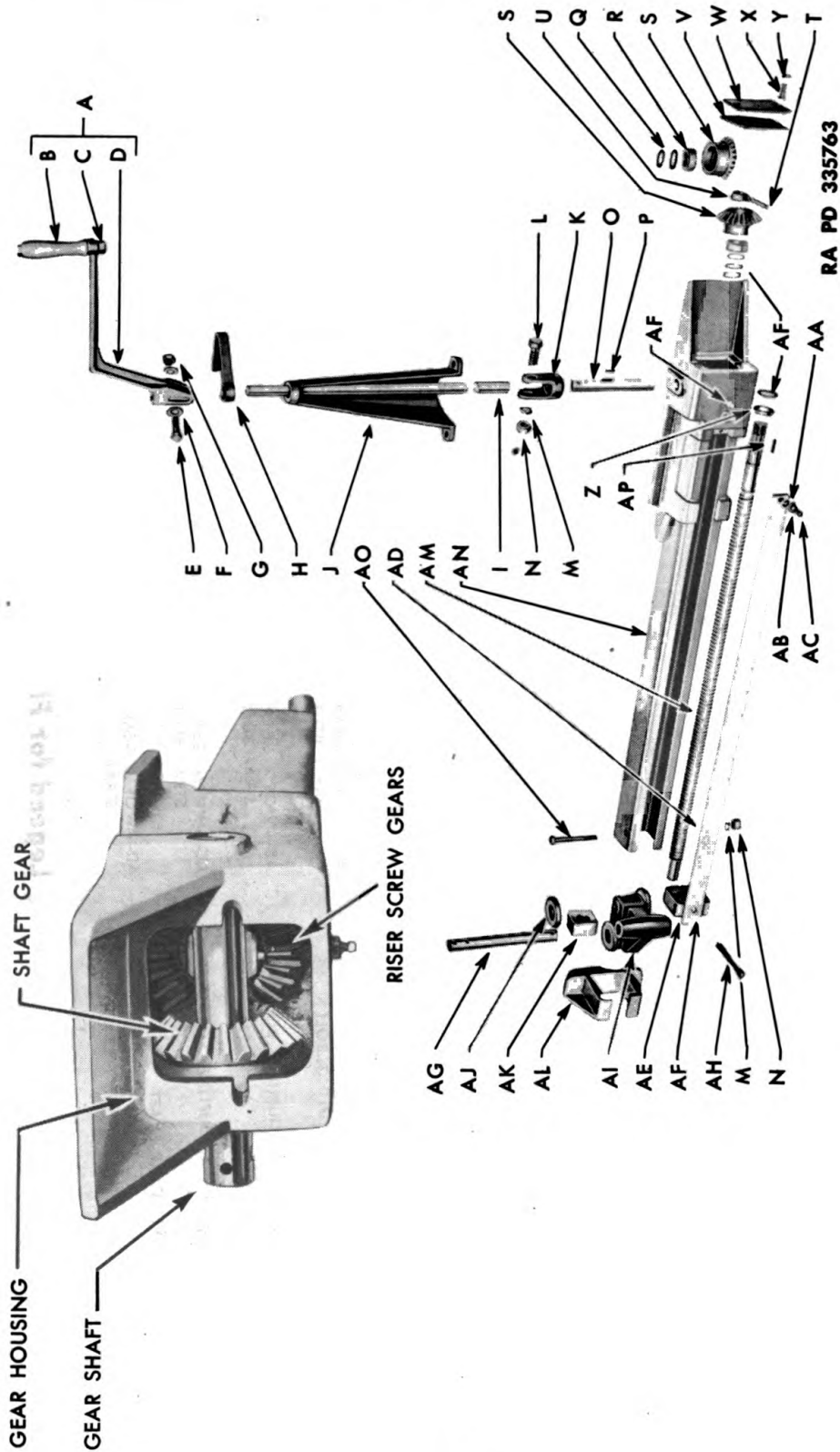

Figure 46—Landing Gear Screw Disassembled

LANDING GEAR

- | | | |
|---|---|--|
| A—CRANK ASSEMBLY | P—BEVEL GEAR WOODRUFF KEY | AE—WORM SCREW REAR THRUST BEARING |
| B—CRANK HANDLE | Q—THRUST WASHER | AF—WORM SCREW REAR THRUST BEARING COVER STRAP BOLT |
| C—CRANK HANDLE BOLT (1/2-IN. X 6 1/2-IN.) | R—BEVEL GEAR THRUST BEARING | AG—GUIDE BRACKET BACK BRACE ANCHOR PIN |
| D—CRANK ARM | S—SHAFT BEVEL GEAR | AH—GUIDE BRACKET BACK BRACE ANCHOR PIN COTTER PIN |
| E—CRANK ASSEMBLY MOUNTING BOLT | T—TAPER PIN | AI—GUIDE BRACKET |
| F—FLAT WASHER | U—TAPER PIN COLLAR | AJ—GUIDE BRACKET WHEEL |
| G—CRANK ASSEMBLY MOUNTING BOLT NUT | V—GEAR BOX COVER PLATE GASKET | AK—GUIDE BRACKET BRONZE WORM SCREW NUT |
| H—CRANK HOLDER | W—GEAR BOX COVER PLATE | AL—WORM SCREW REAR HOUSING BRACKET |
| I—CRANKSHAFT | X—GEAR BOX COVER PLATE BOLT | AM—WORM SCREW |
| J—CRANK BRACKET | Y—GEAR BOX COVER PLATE BOLT SQUARE NUT | AN—WORM SCREW HOUSING |
| K—UNIVERSAL CRANKSHAFT COUPLING | Z—THRUST WASHER | AO—WORM SCREW REAR THRUST BEARING ANCHOR BOLT |
| L—UNIVERSAL COUPLING BOLT | AA—WORM GEAR HOUSING COVER STRAP BOLT LOCK WASHER | AP—WORM SCREW GEAR KEY (1/4-IN. X 7/8-IN.) |
| M—UNIVERSAL COUPLING BOLT LOCK WASHER | AB—WORM GEAR HOUSING COVER STRAP BOLT NUT | |
| N—UNIVERSAL COUPLING BOLT NUT | AC—WORM GEAR HOUSING COVER STRAP BOLT | |
| O—BEVEL GEAR SHAFT | AD—WORM GEAR HOUSING COVER STRAP | |

RA PD 335763B

Legend for Figure 46

TM 9-894

56-57

11-TON PAYLOAD, 15-TON GROSS, 2-WHEEL (2d+), VAN SEMITRAILER (OMAHA STANDARD BODY CORP. MODEL F16)

c. **Gear Housing.** Inspect the worm screw and gear housing. See that the bolts securing the housing to the frame are tight. Inspect the gear box housing bracket. Replace if damaged.

d. **Landing Gear Legs.** Inspect the landing gear legs for damage. Replace if cracked. Inspect the bearings of the upper leg hinge assemblies. Replace the bearings if worn. Inspect the landing gear leg hinge bolts. See that oilholes are free from obstruction. Remove the lubrication fitting and inspect. Replace worn landing gear leg hinge bolts.

e. **Bolts and Nuts.** Check all bolts and nuts of the assembly for wear or damage. Replace worn or damaged bolts or nuts.

57. INSTALLATION.

a. **Miter Gear and Screw Mechanism.** Start the bronze nut and guide bracket assembly on the worm screw. Hold the bracket and turn the worm screw until the bracket is at the front end of the screw. Place the thrust bearing on the rear end of the worm screw, and slide the worm screw and bracket assembly in the worm and miter gear housing. Line the thrust bearing up with the bolt holes in the housing. Secure the rear thrust bearing by installing bolt, lock washer, and nut through the rear end of the housing. Place the sleeve, thrust bearing, and gear on the front end of the worm screw, lining up the keyway on the worm screw shaft and the gear hub. Install the key and replace the jam nut. Install the miter gear shaft, sleeve, and thrust bearing on the miter gear assembly. With the gear teeth in mesh, tap the gear on the end of the shaft, at the same time lining up the taper holes in the gear hub and shaft. Secure by inserting and driving in the taper pin.

b. **Hand Crank Assembly.** Slide the connecting sleeve on the gear shaft and replace the bolt, lock washer, and nut securing it to the shaft. Slide the crankshaft of the hand crank assembly through the crank bracket bearing, and insert the end of the crankshaft in the connecting sleeve on the end of the gear shaft. Line up the bolt holes, insert the bolt, and replace lock washer and nut.

c. **Gear Housing Plate.** Position the gear housing cover plate on the gear housing studs, and install the nuts.

d. **Wheel, Leg, and Back Brace Assembly.** Reassemble the wheel, leg, and back brace assembly and complete the installation by reversing the procedure for removing the assembly (par. 55 a). **NOTE:** *Lubricate the wheels of the landing gear assembly before replacing them on the axle shaft, and lubricate the landing gear at points indicated in Lubrication Order when reassembly has been completed (fig. 8).*

Section XV

SPARE WHEEL AND TIRE CARRIER**58. DESCRIPTION AND MAINTENANCE.**

a. **Description.** The spare wheel and tire carrier assembly is secured by four hook bolts, lock washers, and nuts to the right-hand frame side rail at a point about 52 inches forward from the front spring casting. The wheel and tire assembly is elevated into position on the carrier by a winch-type double cable lift. The ends of the cable are secured by U-bolts, lock washers, and nuts to an anchor plate. The anchor plate of the elevating mechanism is passed through the hub opening of the wheel and retained in position by projecting stops. The elevating mechanism of the carrier is provided to raise the wheel and tire assembly in position on the four retaining studs of the tire carrier. The wheel and tire assembly is retained on the studs of the carrier by means of nuts of the same size and shape as those used to secure the wheel assembly to the hub of the semitrailer. The winch of the elevating mechanism is retained in its elevated position by a ratchet wheel mounted on the outer end of the crankshaft of the winch. The ratchet is locked by a pawl attached to the frame of the carrier assembly, and positioned to engage the teeth of the ratchet. The winch of the tire carrier mechanism is operated by the tire wrench of the tractor truck attached to the semitrailer.

b. Maintenance.

(1) **TIRE CARRIER MOUNTING.** Precaution must be taken to see that the nuts of the hook bolts securing the tire carrier to the frame of the semitrailer are kept tight. These nuts are located on the vertical face of the tire carrier frame.

(2) **WHEEL AND TIRE ASSEMBLY MOUNTING NUTS.** Keep the four wheel and tire assembly mounting nuts tight at all times. The winch assembly is not designed to carry the weight of the mounted wheel and tire assembly.

(3) **ANCHOR PLATE U-BOLTS.** Keep the four nuts securing the anchor plate to cable U-bolts tight.

59. REMOVE WHEEL AND TIRE ASSEMBLY FROM CARRIER.

a. **Procedure.** Remove the four nuts securing the wheel and tire assembly to the carrier frame. Place the tire nut wrench on the operating nut of the winch, and release the tension against the pawl of the ratchet assembly. Disengage the pawl of the ratchet assembly,

TM 9-894

59-60

11-TON PAYLOAD, 15-TON GROSS, 2-WHEEL (2dt), VAN SEMITRAILER (OMAHA STANDARD BODY CORP. MODEL F16)

and lower the wheel and tire assembly to the ground. Disengage the anchor plate of the tire carrier operating mechanism from the wheel hub hole.

60. INSTALL WHEEL AND TIRE ASSEMBLY ON CARRIER.

a. Procedure. Position the spare wheel and tire assembly directly under the operating mechanism of the carrier with the convex side of the wheel facing toward the carrier. Disengage the pawl from the ratchet, and lower the cable anchor plate to the spare wheel and tire assembly. Insert the anchor plate in the hub hole of the wheel. Engage the spacer stops of the anchor plate in the hub hole of the wheel, and position the pawl in the teeth of the ratchet. Place the wheel nut wrench on the operating nut of the winch, and elevate the wheel and tire assembly into position on the four anchor studs of the tire carrier. Secure the nuts on the anchor studs to hold the wheel and tire in position. Disengage the pawl from the ratchet, and drop it back in position after the tension on the operating cable has been released.

PART FOUR

ORDNANCE MAINTENANCE INSTRUCTIONS

Section XVI

BRAKES

61. SCOPE.

a. For general instructions regarding operational inspections, maintenance, and adjustment of the semitrailer brake system, refer to section IX, paragraphs 28 to 39. Trouble shooting information (par. 16) is intended to serve as a general guide in checking the causes of brake failure or faulty operation, and whether such malfunctions are due to failure of the air system or to defective mechanical units of the brake assembly.

b. Bendix-Westinghouse designed brakes are used on this vehicle, and ordnance maintenance instructions for the slack adjusters, air filters, reservoir, relay emergency valve, and the brake chambers will be found in TM 9-1827A. It is the purpose of this section to cover in detail the cleaning, inspection, and repair of the brake shoes and drums.

62. CLEANING, INSPECTION, AND REPAIR OF SHOES AND DRUMS.

a. **Clean Brake Shoes.** Remove the brake shoes (par. 30) and steam-clean all parts, including the linings. Remove all cap screws, nuts, and lock washers securing linings to shoes. Carefully note the condition of all lining blocks to determine whether salvage is advisable. Unless steam-cleaning has removed all traces of impregnated oil, the block must be scrapped. If free from oil and of serviceable thickness and uniformity, the block can be reinstalled. *NOTE: If lining is to be reinstalled on shoe after disassembly, mark each lining and shoe for reassembly. Only salvaged linings of the same thickness can be installed on a brake shoe assembly. Never install a new and a salvaged block on the same shoe. If brake shoe roller fails to rotate easily after cleaning, replace roller or roller shaft as required (par. 30 c). If the oilite brake shoe bushings are worn excessively, press out the defective bushings, and replace.*

b. **Replace Brake Shoe Bushings.** Press one bushing into bushing bore of brake shoe, leaving the end of the bushing flush with the face of the shoe. Press other bushing into bore from the opposite side of the shoe in the same manner. Shoe bushings are supplied reamed to proper diameter. Test anchor pin in bushing bore for size. If reaming is necessary, ream to 1.132 inches subpar. e below).

11-TON PAYLOAD, 15-TON GROSS, 2-WHEEL (2dt), VAN SEMITRAILER (OMAHA STANDARD BODY CORP. MODEL F16)

c. Install Brake Shoe Rollers. Position roller in slotted section of the shoe boss bore and install roller shaft, using a soft hammer. Secure roller shaft in position in shoe by placing four heavy center punch marks in shoe bosses adjacent to shaft at four equally spaced places around end of roller shaft. **CAUTION:** *When making center punch marks, do not strike roller shaft with punch.*

d. Clean Brake Shoe. After brake shoe has been steam-cleaned, remove all rust from surface of shoes.

e. Brake Shoe Fits and Tolerances.

Outside diameter oilite bushing.....	1.3155 in.
Bushing ream diameter (after assembly)	1.132 in.
Bushing length.....	1 in.
Lining thickness.....	0.75 in.
Minimum thickness (replace beyond).....	0.25 in.
Brake shoe bushing bore.....	1.313 in.

f. Inspect Brake Shoe Linings. Place new brake lining screw in hole of salvaged brake lining. If the head of the screw projects beyond the countersunk surface of the lining, discard the lining. **NOTE:** *Do not deepen original countersunk holes in worn linings to bring head of lining screw flush with outer surface of lining.*

g. Brake Drum.

(1) **REMOVE BRAKE DRUM** (fig. 14). Remove the brake drum (par. 25 c), and steam-clean all parts.

(2) **INSPECT BRAKE DRUM.** Check brake drum for out-of-round. Drums must be true within 0.010-inch total indicator reading. Reface out-of-round drum if out-of-round is not excessive and drum is otherwise in serviceable condition. Heat checking, unless severe, does not necessitate drum replacement. Check inside diameter of drum for excessive wear. Remachine if wear is not excessive. Replace drum if salvage is not feasible.

(3) **REPAIR BRAKE DRUM.** It is permissible to remachine drums up to 0.030 inch beyond their original diameter without shimming the lining. If salvage is urgent, the drum may be machined beyond 0.030 inch to "true-up" the drum braking surface; however, shims must then be inserted between brake blocks and brake shoes used in "oversize" drums. Such shims must be of proper thickness to maintain uniform tolerance between brake lining and drum.

(4) **INSTALL BRAKE DRUM.** Position drum over drum pilot of hub and over the projecting studs in the hub assembly. Replace lock washers and drum nuts. **NOTE:** *Tighten opposed nuts succes-*

AXLE

sively to bring the drum into position on the hub evenly to prevent its "cocking" on hub pilot.

h. Brake Drum Fits and Tolerances.

Inside diameter	16.0 in.
Remachine if worn beyond.....	16.030 in.
Drum bore	9.5 in.

Section XVII

AXLE

63. DESCRIPTION AND DATA.

a. Description (par. 43 a). The axle is forged with the proper inherent camber for the rated load capacity of the semitrailer. This rated capacity of 16,000 pounds is exclusive of a safety factor sufficient to support occasional emergency overloads without producing permanent deflection of the axle. **CAUTION:** *Intentional overloading of the semitrailer will not be permitted.* Most cases of permanent axle deflection are due to accident rather than overloading. **NOTE:** *The axle load is carried on two focal points located on the axles at the transverse centers of the springs, and the maximum bending effort is at these points. Permanent axle deflection due to overloading is greatest at these points.*

b. Data (par. 43 b).

Over-all length of axle spindle, outside brake flange face....	14 ¹ / ₈ in.
Maximum spindle diameter.....	2 ⁷ / ₈ in.
Distance between axle brake flange faces.....	49 ⁷ / ₈ in.
Center distance between axle dowel holes.....	36 in.
Over-all axle length.....	78 ¹ / ₈ in.

64. CLEANING, INSPECTION, AND REPAIR.

a. Cleaning.

- (1) **REMOVE AXLE.** Remove the axle assembly from the semitrailer and disassemble (par. 44).
- (2) **CLEAN AXLE.** Steam-clean the axle and all its parts. Scrape or sand all rust scale from the axle beam.

b. Inspect Axle.

(1) AXLE SPINDLE.

(a) Check axle spindle nut threads for excessive wear or damage. Rebuild diameter by welding new metal and remachine new threads. **NOTE:** *Metalizing process may be substituted for welding to build stock to oversize for remachining.*

TM 9-894

64-65

11-TON PAYLOAD, 15-TON GROSS, 2-WHEEL (2d+), VAN SEMITRAILER (OMAHA STANDARD BODY CORP. MODEL F16)

(b) Check bearing seats for wear. Build up worn seats by welding new metal to oversize and remachine bearing seats.

(2) AXLE BEAM (figs. 36 and 37).

(a) Check the axle beam for bend (par. 45 b). If bend in excess of 0.002 inch is indicated by gage, employ cold-press process to straighten axle.

(b) Check axle for camber (par. 45 c). If clearance on the axle gage is in excess of 0.080 inch, or less than 0.060 inch, employ cold-press process to recamber axle within indicated limits.

(3) SPINDLE NUTS. Check axle spindle nuts for worn or stripped threads. If nut threads are badly worn or damaged, discard nut.

Section XVIII

BODY AND FRAME

65. DESCRIPTION AND DATA.

a. **General Description.** The frame and body of the semitrailer are designed and built into an integral unit (par. 46). The drop-type frame of the chassis is fabricated of structural channels and I-beams, riveted and welded to combine the greatest possible strength with a definite elasticity to absorb road shocks, and to minimize the possibility of metal failure as a result of vibration. The elasticity of the body is increased by the use of reinforced wood framing. Metal reinforcing members are used at points of greatest strain in the wood frame assembly. Joints of the metal side paneling of the body are lapped and nailed to the wood upright posts of the body frame, and to the upper and lower body plates. The joints of the side panels are covered with "snap-on" moulding. The base member of the "snap-on" moulding is nailed to the wood frame members of the body. The joints between the dome cap and the front body panels are covered by plastic moulding. The lower body line of the curved front is covered by a flat strap metal moulding, and the lower body lines of the side panels are covered, and protected, by formed metal rub rails attached to the body frame by screws.

b. **Doors.** The doors are framed upon 16-gage metal channels.

BODY AND FRAME

Each frame is welded into a unit, covered by a metal outside panel, and by a wood panel board inside lining attached to the metal frame by type-A, self-threading metal screws. An oak backing rail reinforces the door directly opposite the point of attachment of each of the three hinge straps. The hinge straps are secured to the doors by 3/8-in. x 2 1/4-in. carriage bolts. The door lock mechanism is mounted between the outer metal panel and the plywood lining of the right-hand door. Door bolts project through the upper and lower door frame members, and a center latch engages the left-hand door at a point opposite the lock handle. The outside, or side wall edges, of the doors are equipped with protruding weather seal tongues which seat into sponge rubber inserts set into grooves in the inner faces of the rear corner post assemblies. The top edge of both doors, and the inside edge of the right-hand door, are equipped with right angle weather seal flanges which press against the faces of sponge rubber weather strips set into the top edge of the door opening of the body of the semitrailer, and into a channel along the inside edge of the left-hand door. The inside face of the bottom edge of each door is equipped with a flush-mounted sponge rubber weather strip which seats against the angular metal door stop set into the ends of the body floorboards in line with the inside faces of the doors in fully closed position.

c. **Floor.** The hardwood floor of the semitrailer body is screwed to the metal bolsters of the chassis with self-tapping metal screws, and secured by wood screws to the wood end rail blocks set between the front posts of the wood body frame. Removable front end sections of two center floorboards are provided to give access to the space between the upper fifth wheel plate and the floor. The upper kingpin flange is accessible through the opening provided by removal of this floor section.

d. **Data (par. 46).**

Metal body and door side panels	22 ga
Metal top panels.....	24 ga
Formed door channels.....	16 ga
10-in. side rail sections.....	15.3 lb
6 - in. side rail sections.....	10.5 lb
Length of lap of side rail sections at frame drop.....	20 in.
Steel outrail.....	16 ga
8-in. frame crossmembers.....	11.5 lb
6-in. I-beam bolsters.....	4.4 lb
4-in. channel outriggers.....	5.4 lb
Curved front outrail, half of 12-in. channel.....	10.6 lb
Upper fifth wheel plate.....	5/16 in. x 40 in. x 58 in.
Kingpin center to front of fifth wheel plate.....	38 in.

TM 9-894

66-67

11-TON PAYLOAD, 15-TON GROSS, 2-WHEEL (2dt), VAN SEMITRAILER (OMAHA STANDARD BODY CORP. MODEL F16)

66. BUMPER.

a. General Description (fig. 38). The bumper is of full-body width supported by channel brackets whose upper edges are welded to the lower flange of the frame side rails. The clear space between the bumper and the end of the chassis frame is 2 inches. The bumper is secured to the channel frame brackets by angular mounting brackets bolted to the bumper, and to the channel frame brackets. Tubular diagonal braces are bolted to the frame and to the bumper to provide additional support to the outer ends.

b. Repair.

(1) **REMOVE BUMPER.** Remove the bolts securing the bumper to the angular mounting brackets, and from the anchor plates of the diagonal bumper braces.

(2) **REPAIR BUMPER CHANNEL.** The bumper channel can be straightened by cold-press method or by heating. Inspect flanges for cracks. Weld cracks.

(3) **REPAIR DIAGONAL BUMPER BRACES.** Remove damaged diagonal brace from frame by removing the bolts securing the anchor plate of the brace to the frame. Straighten bent brace by cold-press method or by heating. Inspect diagonal brace for cracks or other defects. Weld cracks or other defective portion of brace. Inspect welded connections of anchor plates to body of the diagonal brace. If weld is cracked or defective, reweld defective section.

(4) **BUMPER BOLTS.** Inspect all bolts and nuts of the bumper assembly, and replace all defective bolts and nuts.

c. Install Bumper. Replace the bolts, lock washers, and nuts securing the diagonal braces to the frame. Tighten the nuts of these bolts finger-tight only until the bumper bar has been attached to the angular bumper brackets of the frame, and to the anchor plates of the diagonal braces. Secure all bolts of the assembly by firmly tightening all nuts.

67. UPPER FIFTH WHEEL.

a. Inspect Kingpin and Fifth Wheel Plate.

(1) **DETACH SEMITRAILER FROM TRACTOR TRUCK.** Lower the landing wheels of the semitrailer, and detach the semitrailer from the tractor truck.

(2) **INSPECT UPPER FIFTH WHEEL PLATE.** Remove the front center plywood lining panel of the body. Remove the screws secur-

BODY AND FRAME

ing the two removable floorboard sections in the front center of the floor. Remove the two short sections of flooring. Carefully inspect the upper face of the fifth wheel plate adjacent to the welds of the kingpin flange. Note condition of the plate for cracks extending under the flange of the kingpin, and examine all welded sections around the edge of the kingpin flange for failure of weld. Follow inspection of the upper face of the upper fifth wheel plate by a careful inspection of the lower face of the plate. Note especially the surface of the plate near each corner, and the surface surrounding the kingpin. **NOTE:** *An accurate inspection of the lower face of the fifth wheel plate can be made only after the plate has been thoroughly steam-cleaned.* If cracks are found in the plate near the kingpin, they should be repaired by welding the upper surface of the plate.

b. Defective Kingpin.

(1) **INSPECT KINGPIN.** Tap the kingpin with a hammer to detect absence of a distinct and clear metallic tone in the sound. If the tone is muffled or dead, partial weld-failure may be the cause. Check all welds of kingpin to the upper face of the upper fifth wheel plate to locate broken or defective welds. Check the kingpin for excessive wear.

(2) **KINGPIN DATA.**

Make	Holland
Diameter of holding head (tolerance plus or minus 0.005 in.)	2.8125 in.
Diameter of neck	2.000 in.
Diameter of upper stem or shoulder	2.975 in.
Diameter of flange	8 in.
Pin projection below upper fifth wheel plate	3 ⁵ / ₁₆ in.

(3) **TOLERANCE.** When the standard 2-inch diameter of the latch neck has worn to 1.9325 inches or less, it is advisable to replace the pin. Wear beyond this tolerance permits excessive play in the locking device of the fifth wheel of the tractor truck, but does not prevent safe and positive locking of the kingpin in the fifth wheel.

(4) **REMOVE KINGPIN.** Remove defective kingpin by severing the welds around the outside of the kingpin flange. The body of the flange is held by seven plug welds to the upper face of the upper fifth wheel plate. Cut out small triangular segments of the flange around each of the seven plug welds. When all the plug welds have been cleanly severed from the flange of the kingpin, the pin may be driven up through the hole in the upper fifth wheel plate and removed.

CAUTION: *Care must be exercised in cutting the kingpin flange segments which surround the plug welds to prevent excess heat from cutting flame from burning into the metal surface of the fifth wheel plate. The surface of the plate can best be protected by directing the*

11-TON PAYLOAD, 15-TON GROSS, 2-WHEEL (2d+), VAN SEMITRAILER (OMAHA STANDARD BODY CORP. MODEL F16)

flame into the metal of the flange from a plane horizontal to the surface of the fifth wheel plate. Carefully grind any metal of the old welds from the upper surface of the upper fifth wheel plate.

(5) **INSTALL KINGPIN.** Position the new kingpin in the hole in the upper fifth wheel plate. If the flange of the pin does not fit smoothly upon the surface of the plate, grind off any excess metal of the plug welds on the surface of the plate that may prevent close contact of the pin flange with the surface of the upper fifth wheel plate. Tack-weld the kingpin in position, and build up the plug welds carefully. Make successive welds in opposed holes in the kingpin flange. When the plug welds have been completed, weld the outer flange of the kingpin to the plate at several points around the outside edge.

c. Replace Body Floor Section. Replace the two floorboard sections removed from the center front of the semitrailer floor. Replace the metal screws in the metal cross bolsters of the chassis frame, and replace the wood screws which secure the forward ends of the floorboards to the wood frame members of the body. Replace the plywood lining panel in the center section of the body front, and secure the panel in place with screws.

68. SPRINGS AND RADIUS ARMS.

a. Remove Springs. Refer to paragraph 41.

b. Inspect Springs. Disassemble the spring assemblies (par. 41 c), and steam-clean all parts. Carefully check each piece for damage or wear. Discard broken or damaged helper spring clips. Check spring center bolts and nuts for stripped threads or other damage. Discard damaged bolts or nuts. Check each spring leaf for cracks radiating from the center bolt holes. Replace damaged spring leaves. Check old spring leaves against corresponding new leaves to determine whether old leaves have lost camber. Camber of an assembled spring, or of a single leaf, is determined by placing a straight-edge across the concave face of the spring with the straightedge resting on the ends of the leaf. The amount of camber is determined by measuring the distance from the surface of the leaf at the center bolt hole to the face of the straightedge which is in contact with the ends of the leaf. If old leaves are recambered, they should be tempered to the camber of corresponding new leaves.

c. Reassemble Springs. Be sure that all rust has been removed from surfaces of spring leaves before beginning to reassemble the springs. Reassemble the leaves in their proper order on the spring

BODY AND FRAME

center bolt. Use no lubricant between the spring leaves. Assemble all the main spring leaves on the spring center bolt, progressing from the shortest to the successively longer leaves. Use care to nest the leaves in the spring clips attached to the ends of the fifth and eighth leaves of the mainspring. The leaves of the helper spring are assembled in like manner upon the center bolt of the mainspring. Use a suitable C-clamp to compress the leaves of the main and helper spring assembly until the mainspring center bolt nut can be applied to the center bolt. Replace the mainspring clip bolts, ferrules, and spring clip bolt nuts. Secure the helper spring clips by reclamping the ends of the clip firmly down upon the face of the main leaf.

d. Data (par. 40 a).

Rated capacity of mainspring	6,600 lb
Rated capacity of helper spring	1,900 lb
Mainspring support centers	46 in.
Working camber of mainspring	4¼ in.
Working camber of helper spring	3⅜ in.
Spring assembly depth at center bolt	7⅛ in.

e. Remove Radius Arm Assembly. Refer to paragraph 42 b.

f. Inspect Radius Arm Assembly.

(1) **DISASSEMBLE AND CLEAN RADIUS ARM ASSEMBLY.** Disassemble the radius arm assembly (fig. 35). Steam-clean all parts of the assembly except the rubber bushings. Discard defective rubber bushings.

(a) Examine the combination spring seat and eccentric bracket casting; replace if cracked, broken, or otherwise defective.

(b) Examine the threads of the eccentric bolt and of the eccentric bolt castle nut for worn or stripped threads. Replace bolts or nuts having worn or damaged threads.

(c) Remove the eccentric bolt lock pin from the fixed eccentric of the bolt assembly and examine for wear or distortion. Replace if worn or distorted.

(d) Replace worn or damaged rubber bushing ferrules.

(e) Replace distorted or otherwise damaged rubber bushings.

(f) Examine radius arm for cracks or other damage. Replace bent, cracked, or broken radius arms.

g. Install Radius Arm Assembly. Refer to paragraph 42.

h. Install Spring Assembly. Refer to paragraph 41 f.

69. FRAME.

a. Inspect Frame. Carefully check all-welded or riveted joints of the frame for evidence of failure or damage. Reweld defective welds, and replace loose or broken rivets. Check all bolt nuts

11-TON PAYLOAD, 15-TON GROSS, 2-WHEEL (2dt), VAN SEMITRAILER (OMAHA STANDARD BODY CORP. MODEL F16)

to see that they are tight. Examine threads on all bolts where loose nuts are found, and check the threads on all loose nuts. Replace bolts and nuts having worn or defective threads. Replace broken or defective lock washers. Check flanges of frame channels, and repair a cracked flange by welding. Check all brackets riveted to the frame. Replace cracked or broken brackets.

b. Bent Frame Members. A short jack, a length of $\frac{3}{8}$ -inch chain, and a welding torch are all the tools usually required for straightening a bent frame member. Set up the jack in a chain cradle supported on each side of the point of the bend with the jack screw pressure applied on the outside, or convex side, of the bend. Screw the jack into position with sufficient pressure to hold, and apply heat to the bent frame section by use of the torch. Gradually tighten the tension on the jack as the temperature of the bent section of the frame increases. If unable to complete the straightening process with a single setting of the jack and chain, reset to bring the pressure of the jack to bear on the point to be bent when heated. Kinks which develop in flanges during the process of straightening may be heated and hammered into line while hot.

Section XIX**LANDING GEAR****70. DESCRIPTION AND DATA.**

a. General Description. It is the purpose of the landing gear to support the weight of the forward section of the semitrailer when detached from a tractor truck. The complete landing gear consists of two separate but dependent assemblies. The supporting assembly consists of the landing gear leg and wheel and axle assembly. The operating mechanism consists of a hand crank, a crankshaft extending to, and connected with, the gear shaft of the worm and gear assembly, and two back braces connecting the lower ends of the landing wheel legs to the guide bracket and operating nut of the worm screw. The leg and wheel assembly is lowered or retracted by the forward or backward movement of the guide bracket and nut actuated by the worm screw of the operating mechanism. The upper ends of the leg assemblies are attached to, and hinge upon, brackets attached to the main side rails of the semitrailer frame. The housing of the operating mechanism is attached to crossmembers of the semitrailer frame midway between the side rails. The hand crank of the operating mecha-

LANDING GEAR

nism is located on the right side of the semitrailer at a point opposite the gear shaft of the operating screw assembly (fig. 45).

b. Data. (par. 54 b).

Maximum length of adjustable legs	34 ¹ / ₁₆ in.
Minimum length of adjustable legs	20 ¹⁵ / ₁₆ in.
Hinge bolt adjustment in leg brackets	1 ¹ / ₂ in.
Maximum adjustment range of leg assembly	15 ¹ / ₈ in.
Proper operating clearance extended wheel assembly with semitrailer attached to tractor truck	2 in.
Guide bracket and operating nut travel on worm screw	26 in.
Over-all length of axle and hub cap assembly	52 ⁷ / ₈ in.

71. WHEELS AND AXLE.

a. Wheels. The landing wheels are malleable castings having an axle bore of 2 inches. The wheel diameter is 10 inches, and the width 5¹/₂ inches. No special maintenance is required other than lubrication in accordance with the Lubrication Order (fig. 8). A broken or damaged wheel must be replaced. Wheel hubs are not subject to appreciable wear, since the total turning action of the wheel upon the axle during a complete extension or retraction of the landing wheel assembly is less than one complete revolution. The hub bore must be kept clean and free from rust. *NOTE: The semitrailer must not be moved while the weight of the vehicle is resting upon the landing wheel assembly.*

b. Axle. The tubular axle shaft is 1⁵/₁₆ inches in diameter. It is secured in position in the landing gear assembly by a split mounting bore and two tension bolts at the lower end of each lower leg casting. The wheel hubs are attached to the axle by bolts, lock washers, and nuts.

(1) **REMOVE LANDING WHEEL AXLE.** Extend the landing gear fully and disconnect the semitrailer from the tractor truck. Block the front end of the trailer securely in position, and retract the landing gear sufficiently to clear the landing wheels from contact with the ground. Remove the nuts, lock washers, and bolts securing the hub caps, and remove the hub caps. Remove the landing wheels from the landing wheel axle shaft. Loosen the nuts of the four tension bolts securing the axle shaft in the split mounting bore of each leg casting. If the tension of the split mounting bore is not released when the tension bolt nuts are loosened, force small wedges between the extension lips of the split mounting bore until the axle shaft can be turned freely in the bore. Pull the axle shaft from the leg assembly.

(2) **INSPECT AXLE.** Steam-clean the axle shaft and examine for bend or other defect. A bent axle can be straightened by the cold press process. A cracked or otherwise defective axle must be replaced.

(3) **INSTALL LANDING WHEEL AXLE.** Install a landing wheel axle shaft by reversing the procedure followed in its removal.

11-TON PAYLOAD, 15-TON GROSS, 2-WHEEL (2dt), VAN SEMITRAILER (OMAHA STANDARD BODY CORP. MODEL F16)**72. LEGS AND BACK BRACE ASSEMBLY.**

a. **Landing Wheel Legs.** Each leg of the landing gear assembly consists of two pieces, an upper and lower leg casting. The upper leg casting can be slid up or down in the lower casting to permit adjustment in the length of the leg assembly. A row of holes located behind the median line of the upper leg casting can be brought into line with two holes in the lower leg casting, and the two leg members secured at the desired length by two bolts through the opposed holes. Each leg is hinged to the leg bracket of the semitrailer frame by a hinge bolt supplied with an alemite fitting for its proper lubrication. The hinge bore of each leg casting is equipped with a sleeve-type bushing. The legs are held in alignment by two cross braces secured by bolts to lugs projecting from the inner face of each lower leg casting. The cross braces are attached to the lower leg castings by four hex-head machine bolts, nuts, and lock washers.

b. **Back Braces.** The back braces connect the leg and landing wheel assembly with the screw operating mechanism. The back braces are hinged to the lower end of the leg castings and to the guide bracket of the worm screw mechanism.

(1) **REPLACE BACK BRACE.** Detach the semitrailer from the tractor truck, and block up the front end with the landing gear fully extended. Retract the landing wheel assembly until the wheels are off the ground. Remove the cotter pin from the hinge pin which secures the back braces to the guide bracket, and remove the hinge pin. Remove the cotter pin and hinge pin which secures each back brace to the hinge socket of a leg assembly. Examine each brace for undue wear in hinge pin holes and for cracks in the brace at the hinge pin hole. If the brace is badly worn in the hinge pin holes or otherwise damaged, replace the brace. The back braces are made of cast steel and cracks can be repaired by welding. A new or repaired back brace is installed by reversing the procedure followed in removing the old brace.

73. CRANK AND SHAFT ASSEMBLY.

a. **General Description.** The crank consists of a crank arm, a crank handle, and a crank handle bolt. The shaft end of the crank arm is fitted with a shaft attachment eye and two bolt slots which slide over the crank arm attachment bolt in the crankshaft. When the crank arm attachment eye is pulled from the end of the crankshaft, the bolt slots in the arm slide out upon the crank attachment bolt and act as a hinge upon the bolt, permitting the crank to be

LANDING GEAR

swung back under the body of the semitrailer and hooked upon a crank holder suspended from the crankshaft. The outer end of the crankshaft passes through a support bearing in the end of the crankshaft bracket, and under the right frame side rail to the shaft coupling secured to the outer end of the gear shaft of the operating mechanism. The shaft coupling is attached to the crankshaft and to the gear shaft by hex-head machine bolts, lock washers, and nuts.

b. Install Crank and Shaft Assembly. A damaged crank and shaft assembly can be removed by removing the nut, lock washer, and bolt securing the crankshaft to the coupling on the gear shaft of the operating mechanism, and removing the old shaft from the support bearing of the crankshaft bracket. To install a new crank and shaft assembly, pass the end of the crankshaft through the support bearing of the crankshaft bracket, place the crank hanger on the crankshaft, and push the end of the crankshaft into the shaft coupling. Turn the crankshaft to aline the hole with the holes in the shaft coupling, install the bolt, lock washer, and nut which secures the crankshaft to the coupling.

c. Inspection and Repair. A bent crankshaft can be removed and straightened by the cold-press process. Inspect all bolts and nuts of the crank and shaft assembly. Replace bolts or nuts having worn or damaged threads. Tighten the bolts which secure the crankshaft bracket to the side rail of the semitrailer frame. Replace a worn or damaged crankshaft bracket. Replace a broken or damaged crank arm and handle assembly.

74. SCREW AND OPERATING ASSEMBLY.

a. Remove Screw and Miter Gear Mechanism. Refer to paragraph 55 b.

b. Clean and Inspect Operating Assembly. Steam-clean all parts of the screw and operating assembly. Inspect each part carefully for wear or other defects. Examine the gear and screw housing for damage resulting from accident. Repair or replace damaged housing. Examine the screw bearings and replace if they show excessive wear. Examine both bevel gears for excessive wear, cracked or broken teeth, or any other defect which would prevent their proper functioning in operation. Replace defective bevel gears. Inspect the operating screw for bend or defective threads. Replace defective operating screw. Inspect the bronze nut of the screw assembly. Replace if worn or otherwise defective. Inspect keys and pins for wear or other defects. Replace defective keys. Examine bolts which secure the gear and screw housing to the chassis frame. Replace bolts or nuts having defective threads.

c. Install Screw and Operating Assembly. Refer to paragraph 57.

TM 9-894

75-76

11-TON PAYLOAD, 15-TON GROSS, 2-WHEEL (2dt), VAN SEMITRAILER (OMAHA STANDARD BODY CORP. MODEL F16)

APPENDIX

Section XX

SHIPMENT AND TEMPORARY STORAGE

75. GENERAL INSTRUCTIONS.

a. Preparation for domestic shipment of the semitrailer is the same, with the exception of minor added precautions as preparation for temporary storage. Preparation for shipment by rail includes instructions for loading the semitrailer, blocking necessary for securing on freight cars, and other information necessary to properly prepare the vehicle for domestic rail shipment. For more detailed information and for preparation for indefinite storage, refer to AR 850-18.

76. PREPARATION FOR TEMPORARY STORAGE.

a. Semitrailers to be prepared for temporary storage are those ready for immediate service but not used for less than 30 days. If vehicles are to be indefinitely stored after shipment by rail, they must be prepared for such storage at their destination.

b. If the vehicles are to be temporarily stored, take the following precautions.

(1) **LUBRICATION.** Lubricate completely (par. 8).

(2) **TIRES.** Clean, inspect, and properly inflate all tires, including spares. Replace with serviceable tires all tires requiring repairing or retreading. Do not store rubber-tired vehicles on floors, cinders, or other surfaces which are soaked with oil or grease. Wash off immediately any oil, grease, gasoline, or kerosene which comes in contact with tires under any circumstances.

(3) **ROAD TEST.** The preparation for limited storage must include a road test after lubrication service to check on the general condition of the vehicle. Correct any defects noted in the vehicle operation before the vehicle is stored, or note on a tag attached to the service line dummy coupling, stating the repairs needed or describing the condition present. A written report of these items must then be made to the officer in charge.

(4) **EXTERIOR OF VEHICLE.** Remove rust appearing on any part of the vehicle exterior with flint paper. Repaint painted surfaces whenever necessary to protect wood or metal. Coat exposed polished

SHIPMENT AND TEMPORARY STORAGE

metal surfaces susceptible to rust, such as chains, with medium grade preservative lubricating oil. Close the doors. Leave rubber floor mats (when provided) in an unrolled position on the floor, not rolled or curled up.

(5) **INSPECTION.** Make a systematic inspection just before shipment or temporary storage to ensure all above steps have been covered, and that the vehicle is ready for operation on call. Make a list of all missing or damaged items, and attach it to the service line dummy coupling. Refer to Before-operation Service (par. 10).

(6) **CHOCKING.** Chock the wheels.

c. **Inspections in Limited Storage.** Inspect vehicles in limited storage weekly for tire failures, evidence of vandalism, tampering, etc.

77. LOADING AND BLOCKING FOR RAIL SHIPMENT.

a. **Preparation.** In addition to the preparation described in paragraph 75 when ordnance vehicles are prepared for domestic shipment, the following preparation and precautions must be taken.

(1) **LOCATION.** The vehicles must be located on the car in such a manner as to prevent the car from carrying an unbalanced load after being positioned with a brake-wheel clearance of at least 6 inches.

(2) **MARKING CARS.** All cars containing ordnance vehicles must be placarded "DO NOT HUMP."

(3) **TYPES OF CARS.** Ordnance vehicles may be shipped on flat cars, end-door box cars, or drop-end gondola cars, whichever type car is the most convenient.

b. **Facilities for Loading.** Whenever possible, load and unload vehicles from open cars by means of the towing vehicle, using permanent end ramps and spanning platforms. Movement from one flat car to another along the length of the train is made possible by cross-over plates or spanning platforms. If no permanent end ramp is available, an improvised ramp can be made from railroad ties. Vehicles may be loaded in gondola cars without drop ends by using a crane.

c. **Securing Vehicles.** In securing or blocking a vehicle, three motions: lengthwise, sidewise, and bouncing, must be prevented. Two methods for blocking vehicle on freight cars (fig. 47) are given below. **NOTE:** *All wheel blocking must be located against the outside wheel of the dual.*

(1) **FIRST METHOD (FRONT OF VEHICLE)** (fig. 47). Position supporting frame to the rear of and against the kingpin so that cross beam is at right angles to the trailer frame, nail one cleat (2-in. x 4-in. x 8-in.) to the top of the cross beam against the outside of the frame on each side, using four 40-penny nails for each cleat. Toe-nail the

11-TON PAYLOAD, 15-TON GROSS, 2-WHEEL (2dt), VAN SEMITRAILER (OMAHA STANDARD BODY CORP. MODEL F16)

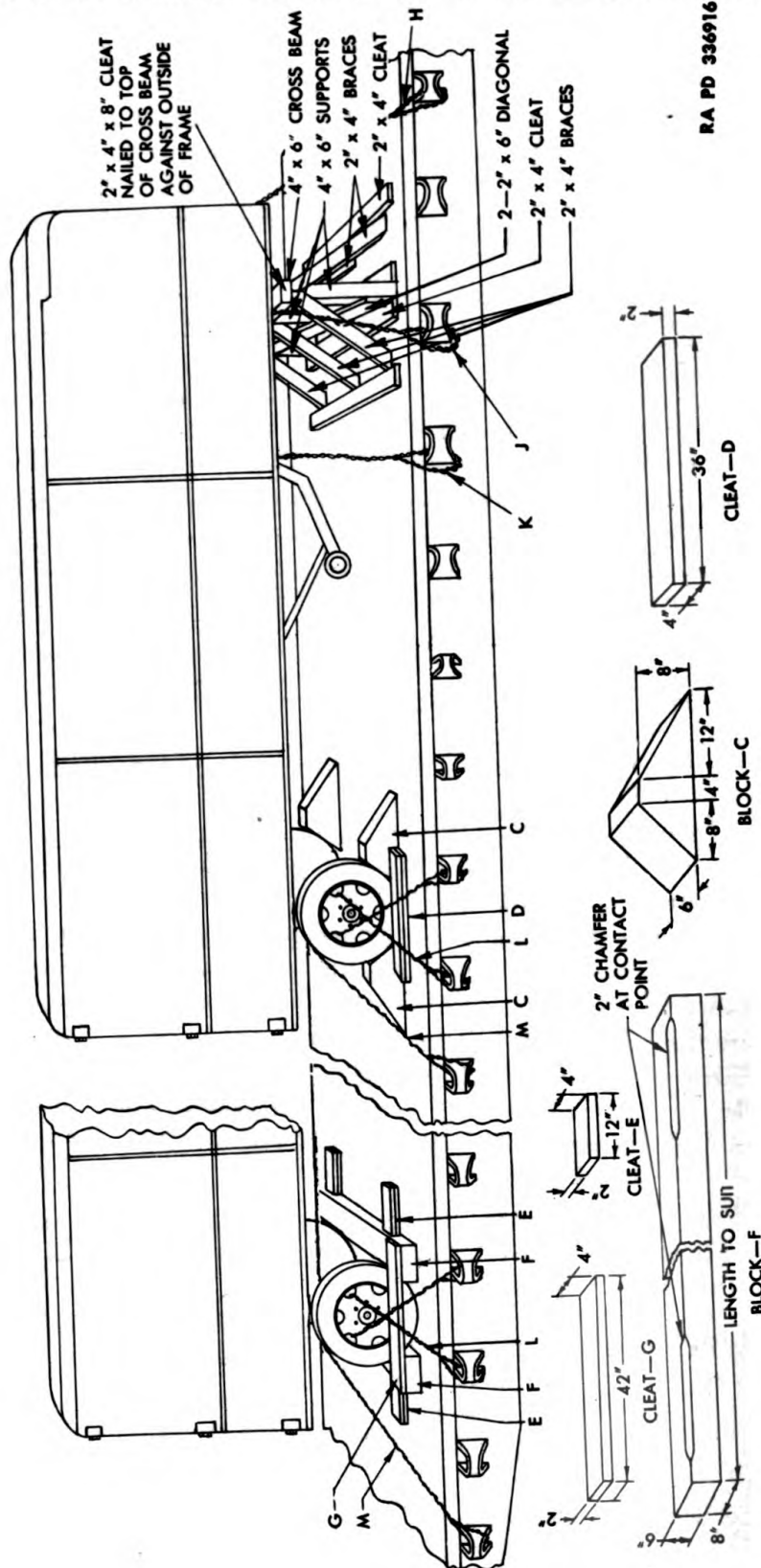

Figure 47—Blocking Requirements for Rail Shipment

SHIPMENT AND TEMPORARY STORAGE

three supports to the car floor, using 40-penny nails. Toe-nail braces and nail all cleats to the car floor with 40-penny nails.

(2) **FIRST METHOD (REAR OF VEHICLE)** (fig. 47). Place one block (C) at the front of each outside wheel and one at the rear of each outside wheel (four blocks (C) required). Nail the heel of the block to the car floor with five 40-penny nails, and nail the portion of the block under the tire to the car floor with two 40-penny nails. Place two cleats (D) to the outside of each wheel (four cleats (D) required). Nail the lower cleat to the car floor with three 40-penny nails, and nail the top cleat to the cleat below with three 40-penny nails.

(3) **STRAPPING VEHICLE** (fig. 47). Secure vehicle in front (H) and at the side (J) by strapping, consisting of four strands, two wrappings, of No. 8 gage, black annealed wire, passed through the upper section of landing gear, and secure at the stake pockets of the railroad car. Secure center of vehicle (K) by strapping, passing wire around chassis frame and attaching at the closest stake pocket. Secure vehicle at axle (L) by passing wire through opposite openings in the wheels, and attaching at the closest stake pocket of the car. Secure vehicle at the rear by passing wire through the spring shackles (M), and attach at stake pockets of the car. *NOTE: Angularity of strapping at the rear should be approximately 45 degrees.*

(4) **SECOND METHOD (FRONT OF VEHICLE)**. The front of the vehicle is blocked the same as in first method (step (1) above).

(5) **SECOND METHOD (REAR OF VEHICLE)** (fig. 47). Place one block (F) across the front and one across the rear of the wheels. Blocks (F) must be at least as long as the over-all width of the vehicle at the car floor. Place cleats (G) against the outside face of the wheels on top of blocks (F). Nail cleats (G) to blocks (F) with 40-penny nails, using two nails at each end of cleat (G). Place cleats (E) against blocks (F), two to the front and two to the rear of each outside wheel. Nail each lower cleat to the car floor with three 40-penny nails, then nail each top cleat to the cleat below with three 40-penny nails.

(6) **STRAPPING VEHICLE**. Strapping is applied in the second method as in step (3) above.

d. Shipping Data.

Length of semitrailer (over-all)	336 in.
Width of semitrailer (over-all)	95½ in.
Height of semitrailer (over-all)	133½ in.
Area of car floor occupied per vehicle	222 sq ft
Volume occupied per vehicle	2,479 cu ft
Shipping weight per vehicle	8,000 lb

TM 9-894

78-79

11-TON PAYLOAD, 15-TON GROSS, 2-WHEEL (2dt), VAN SEMITRAILER (OMAHA STANDARD BODY CORP. MODEL F16)

Section XXI

REFERENCES

78. PUBLICATIONS INDEXES.

The following publications indexes should be consulted frequently for latest changes or revisions of the references given in this section and for new publications relating to materiel covered in this manual:

- a. Introduction to Ordnance Catalog (explaining SNL system) ASF Cat. ORD-1 IOC
- b. Ordnance Publications for Supply Index (index to SNL's) ASF Cat. ORD-2 OPSI
- c. Index to Ordnance Publications (listing FM's, TM's, TC's, and TB's of interest to ordnance personnel, MWO's, OPSR, BSD, S of SR's, OSSC's, and OFSB's, and includes alphabetical listing of Ordnance major items with publications pertaining thereto) OFSB 1-1
- d. List of Publications for Training (listing MR's, MTP's, T/BA's, T/A's, FM's, TM's, and TR's concerning training) FM 21-6
- e. List of Training Films, Film Strips and Film Bulletins (listing TF's, FS's, and FB's by serial number and subject) FM 21-7
- f. Military Training Aids (listing graphic training aids, models, devices, and displays) FM 21-8

79. STANDARD NOMENCLATURE LISTS.

- Cleaning, preserving, and lubrication materials, recoil fluids, special oils, and miscellaneous related items SNL K-1
- Ordnance maintenance sets SNL N-21
- Semitrailer, 11-ton payload, 15-ton gross, 2-wheel (2dt), van (28 ft), 1944 SNL G-677
- Soldering, brazing and welding materials, gases, and related items SNL K-2
- Tool sets—for ordnance service command, automotive shops SNL N-30
- Tool sets—motor transport SNL N-19
- Tools, maintenance, for repair of automotive vehicles SNL G-27

REFERENCES

80. EXPLANATORY PUBLICATIONS.

a. Fundamental Principles.

Automotive electricity	TM 10-580
Automotive lubrication	TM 10-540
Basic maintenance manual	TM 38-250
Chassis, body, and trailer units	TM 10-560
Driver selection and training	TM 21-300
Driver's manual	TM 10-460
Electrical fundamentals	TM 1-455
Military motor vehicles	AR 850-15
Motor vehicle inspections and preventive main- tenance service	TM 9-2810
Precautions in handling gasoline	AR 850-20
Standard military motor vehicles	TM 9-2800

b. Maintenance and Repair.

Cleaning, preserving, lubricating, and welding materials and similar items issued by the Ordnance Department	TM 9-850
Cold weather lubrication and service of combat vehicles and automotive materiel.....	OFSB 6-11
Maintenance and care of pneumatic tires and rubber treads	TM 31-200
Ordnance maintenance: Power brake systems (Bendix-Westinghouse)	TM 9-1827A

c. Protection of Materiel.

Camouflage	FM 5-20
Chemical decontamination materials and equip- ment	TM 3-220
Decontamination of armored force vehicles.....	FM 17-59
Defense against chemical attack	FM 21-40
Explosives and demolitions	FM 5-25

d. Storage and Shipment.

Ordnance storage and shipment chart, group G—Major items	OSSC-G
Registration of motor vehicles	AR 850-10
Rules governing the loading of mechanized and motorized army equipment, also major caliber guns, for the United States Army and Navy, on open top equipment, published by Opera- tions and Maintenance Department of Asso- ciation of American Railroads.	
Storage of motor vehicle equipment	AR 850-18

INDEX

B—(contd.)	Page		Page
Brake shoes—(contd.)		description and data	94
installation of rollers	116	placing blocks behind vehicle	13
removal of assembly	61	Cleaning	
replacement		all parts	19
bushings	115	vehicle	28
shoes	61, 91	Coupling	
road test	33	semitrailer and tractor truck	12
Brake system		test	76
data and adjustments	57	Crank and shaft assembly (landing gear)	
description and operation	55	description	126
Brakes		installation, inspection, and repair	127
apply too slowly or do not apply	39	Crossmembers	35
do not release	40		
during-operation service	25	D	
insufficient	38	Decontaminators, road test	37
leakage		Diaphragm brake chambers (See Brake chambers)	
semitrailer	67	Dome light	
tractor truck	66	description and use (switch)	105
operating tests	67	removal	105
release too slowly	39	replacement (light and lens)	107
removal of camshaft	63	Dome light circuit	97
replacement	65	Driver's report, Standard Form No. 26	4
road test	33	Driver's trip ticket and preventive maintenance service record, W. D. Form No. 48	23
trouble shooting	38	Driving instructions	10
uneven	40	Drums, brake	
Brakes, emergency, road test	32	cleaning, inspection, and repair	115
Brakes, service, road test	32	fits and tolerances	117
Braking, tractor truck and semitrailer	14	hot	43
(See also Air brake and Air brake system)		inspection, repair and installation	116
Bumper		removal	48, 52, 116
description	92, 120	replacement	52
repair and installation	120	road test	33
C		trouble shooting	42
Camber, check axle for	90	Dummy couplings	76
Cams		During-operation service	25
operation	55	E	
road test	33	Eccentric assembly	
Camshaft		installation	87
operation	55	removal (bolt assembly)	86
removal	63		
replacement	65		
road test	33		
Chassis, main, replacement of harness	100		
Chock block assemblies			
controls and operation	10		

11-TON PAYLOAD, 15-TON GROSS, 2-WHEEL (2dt), VAN SEMITRAILER (OMAHA STANDARD BODY CORP. MODEL F16)

E—(contd.)	Page		Page
Echelon, preventive maintenance service		removal (hub and drum assemblies)	48, 52
first	23	replacement (hub and drum assemblies)	52
second	29	running damage	48
Electrical system		tightening of assembly and mounting nuts	25
description and data	96	trouble shooting	42
maintenance	99		
trouble shooting	46	J	
wiring, after-operation and weekly service	27	Jumper cable coupling socket	102
Emergency			
automatic application	68	K	
leakage tests		Kingpin	
diaphragm	69	data	92, 121
hose	70	inspection	120
Emergency relay valve		installation	122
defective	39	lubrication	21
description and functioning	67	tolerance and removal	121
leakage tests	69		
operating tests	68	L	
F		Lamps (lights)	
Fifth wheel plate, upper		after-operation and weekly service	27
data	92	before-operation service	25
inspection	120	road test	36
lubrication	21	Lamp-unit, sealed	105
Floor section, replacement	122	Landing gear	
Frame		data	107, 124, 125
data	92	description	
description	91	crank and shaft assembly	126, 127
inspection	123	gear	107, 124
maintenance	95	legs and back braces	126
road test	35	operating crank, jammed	45
G		operation	108
Gear, retractable landing	11	road test	37
Gear, running (See Running gear)		trouble shooting	45
Glass, at-halt service	26	Landing gear mechanism	
H		installation	110
Hose		maintenance	109
description and replacement (assemblies)	78	removal	109
location and use (couplings)	76	Landing wheels	
Hubs		inspection	37
accidental damage	51	lubrication	21
at-halt service	26	raise to full road clearance	14
description and data	47	Leakage	
		air brake system	32

INDEX

L—(contd.)	Page	P	Page
Leakage—(contd.)		Paint and markings, road test	36
excessive	41	Pintle hook, road test	36
flange and diaphragm	71	Publications	37
tests for	69		
Light jumper cable	14	R	
Light socket (semitrailer)	10	Radius arm assemblies	
Load, maintenance services		adjustment (radius arm eccen-	
at-halt	26	tric)	82
before-operation	25	data and description	79
Lock, friction	77	inspection, disassembly, and in-	
Lock pins	37	stallation	123
Lubrication		removal	86
equipment for	17	replace and reassemble	87
instructions	17	road test	34
kingpin	21	Rail shipment	
landing wheels	21	loading, blocking, and securing	
points of application	17	of vehicles	129
road test (vehicle)	36	methods of securing vehicles	130
special	30	Rear wheels, road test	34
wheel bearings	20	Reflectors	
M		after-operation and weekly ser-	
MWO and major unit assembly		vice	27
replacement record	5	at-halt service	26
Mainspring		before-operation service	25
description and removal	81	location	12
reassembly and replacement		Relay emergency valve, controls	
(assembly and leaves)	82	and operation	10
Maintenance operations	32	Relief valves, lubrication	17
Maintenance, preventive		Reports and records	4, 23
first echelon services	23	Retractable landing gear (See	
second echelon services	29	Gear, retractable landing)	
special lubrication and services	30	Road test	31, 38
Marker lights		Running gear, during-operation	
description of circuit	97	service	25
replacement of lights	107		
N		S	
Needle bearings	65	Safety reflectors, road test	36
O		Screw assembly (landing gear)	127
O.O. forms No. 7353 and No. 7370	5	Shipment and temporary storage	128
Operating assembly (landing gear)	127	Slack adjusters	
Operational inspections	115	adjustment	35
Ordnance maintenance, instruc-		description	72
tions	115	operating tests	73
Organizational maintenance in-		removal and installation	73
structions	17	Spare wheel and tire carrier	113
		Spindle, broken	42

11-TON PAYLOAD, 15-TON GROSS, 2-WHEEL (2dt), VAN SEMITRAILER (OMAHA STANDARD BODY CORP. MODEL F16)

S—(contd.)		Page	Page
Springs			
after-operation and weekly service	27	Trouble shooting	38
at-halt service	26	Tubing (hose)	77
before-operation service	25		
data	123	U	
description (assemblies)	79	U-bolts	
inspection and reassembly	122	damaged threads	42
removal		replacement	91
assemblies	81	tighten	35
springs	122	Uncoupling, trailer from tractor truck	15
road test	35	Unusual noises, road test	32
shifted on axle	42		
Suspensions		V	
at-halt service	26	Valve, emergency relay (See Emergency relay valve)	
before-operation service	25	Vehicle	
trouble shooting	41	after-operation and weekly service	26
T		at-halt service	26
Taillight		before-operation inspection	32
blackout and service circuits	96	service	24
removal of harness	101	coupling to tractor truck	12
replacement and installation	105	description and data	7
Temperatures		during-operation service	25
checking of	26	lubrication road test	36
road test	32		
Tires		W	
after-operation and weekly service	27	Water, present in air brake system	41
at-halt service	26	Wheel and tire assembly	
before-operation service	25	installation on carrier	114
data	7	removal from carrier	113
maintenance	54	Wheels (landing gear)	125
reassemble tire and wheel units on hub assembly	55	Wheels (semitrailer)	
removal (wheel and tire assembly)	53	description and data	47
road test (tires and rims)	32	disassembly (bearings)	34
undue wear	43	lubrication (bearings)	20
Tools and equipment, road test	37	replacement	48
Tow hitch, road test	36	size	7
Towing connections		tightening of nuts	25
after-operation and weekly service	27	trouble shooting	42
at-halt service	26	Wiring	
before-operation service	25	removal of harness	99
Tractor truck	12	replacement of:	
		main chassis harness	100
		main roof harness	101
		road test	35