

MICROWAVE TECHNIQUES

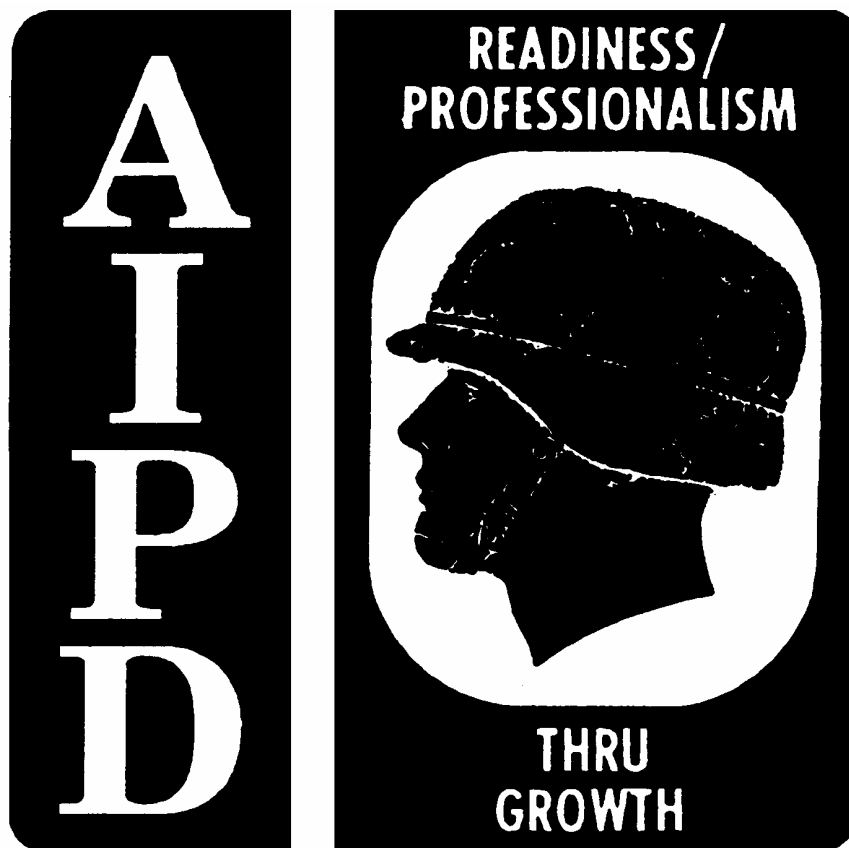

**THE ARMY INSTITUTE FOR PROFESSIONAL DEVELOPMENT
ARMY CORRESPONDENCE COURSE PROGRAM**

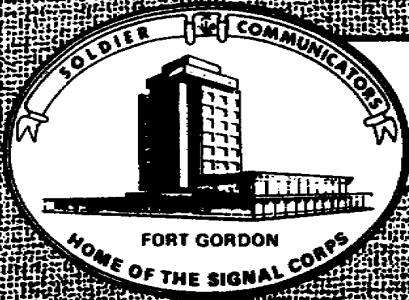

**UNITED STATES ARMY
SIGNAL SCHOOL
FORT GORDON, GEORGIA**

SIGNAL SUBCOURSE 344

MICROWAVE TECHNIQUES

SSO 344 4

This is a Signal School publication.

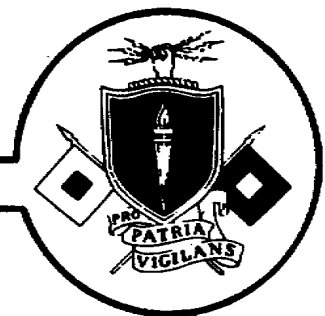

***** IMPORTANT NOTICE *****

THE PASSING SCORE FOR ALL ACCP MATERIAL IS NOW 70%.

PLEASE DISREGARD ALL REFERENCES TO THE 75% REQUIREMENT.

EXTENSION COURSE OF THE US ARMY SIGNAL SCHOOL

SIGNAL SUBCOURSE 344, MICROWAVE TECHNIQUES

INTRODUCTION

From the time that Marconi sent the first message by radio, it was only a matter of time until man's curiosity and ingenuity would develop communications to their present level.

Communication using microwave frequencies has been a fact for many years, and new developments in electronics have made it possible to expand the methods of communication in the microwave region. Today we use voice, teletypewriter, facsimile, and television to communicate at microwave frequencies. We can even send microwave signals to satellites for relay back to earth.

Who can foresee what the future will bring in the way of communication developments?

Perhaps you, who are today's student of electronics, will be tomorrow's innovator, developing a new circuit or tube that will provide a breakthrough in communication.

Those who plan to make a career in electronics must have an understanding of electronic principles, including microwave.

This subcourse has been developed to add to your knowledge some of the techniques used in microwave communication.

This subcourse consists of four lessons and an examination, as follows:

Lesson 1. Microwave Amplifying Devices

Lesson 2. RF System Components

Lesson 3. Microwave Transmitters and Receivers

Lesson 4. Receiver Parameters

Examination

Credit Hours: 13

THE ONLY TIME LIMITATION PLACED ON YOU IS THAT YOU MUST COMPLETE THIS SUBCOURSE WITHIN 1 YEAR FROM THE DATE OF INITIAL ENROLLMENT. SHOULD YOU FAIL THE EXAMINATION, YOU MAY RETAKE IT ANYTIME UP TO 60 DAYS FROM THE DATE OF THE INITIAL EXAMINATION. HOWEVER, IF YOU FAIL THE SECOND EXAMINATION, YOU MUST WAIT 1 YEAR BEFORE YOU ARE ELIGIBLE FOR FURTHER TESTING.

Texts and materials furnished:

Subcourse Booklet

You may keep the texts and materials furnished.

LESSON 1

MICROWAVE AMPLIFYING DEVICES

SCOPE.....	Concepts of velocity modulation. Characteristics and applications of traveling-wave tubes, parametric amplifiers, klystrons, and backward-wave oscillators.
TEXT ASSIGNMENT	Pages 2 thru 57
MATERIALS REQUIRED.....	None
SUGGESTIONS.....	Skim pages 34 thru 42, and 53 thru 57 Read thoroughly pages 43 thru 52,

LESSON OBJECTIVES

When you have completed this lesson, you should:

1. Understand the principles of velocity modulation.
2. Know the characteristics of klystrons, backward-wave oscillators, parametric amplifiers, and traveling-wave tubes.
3. Know the application of the various microwave amplifiers.

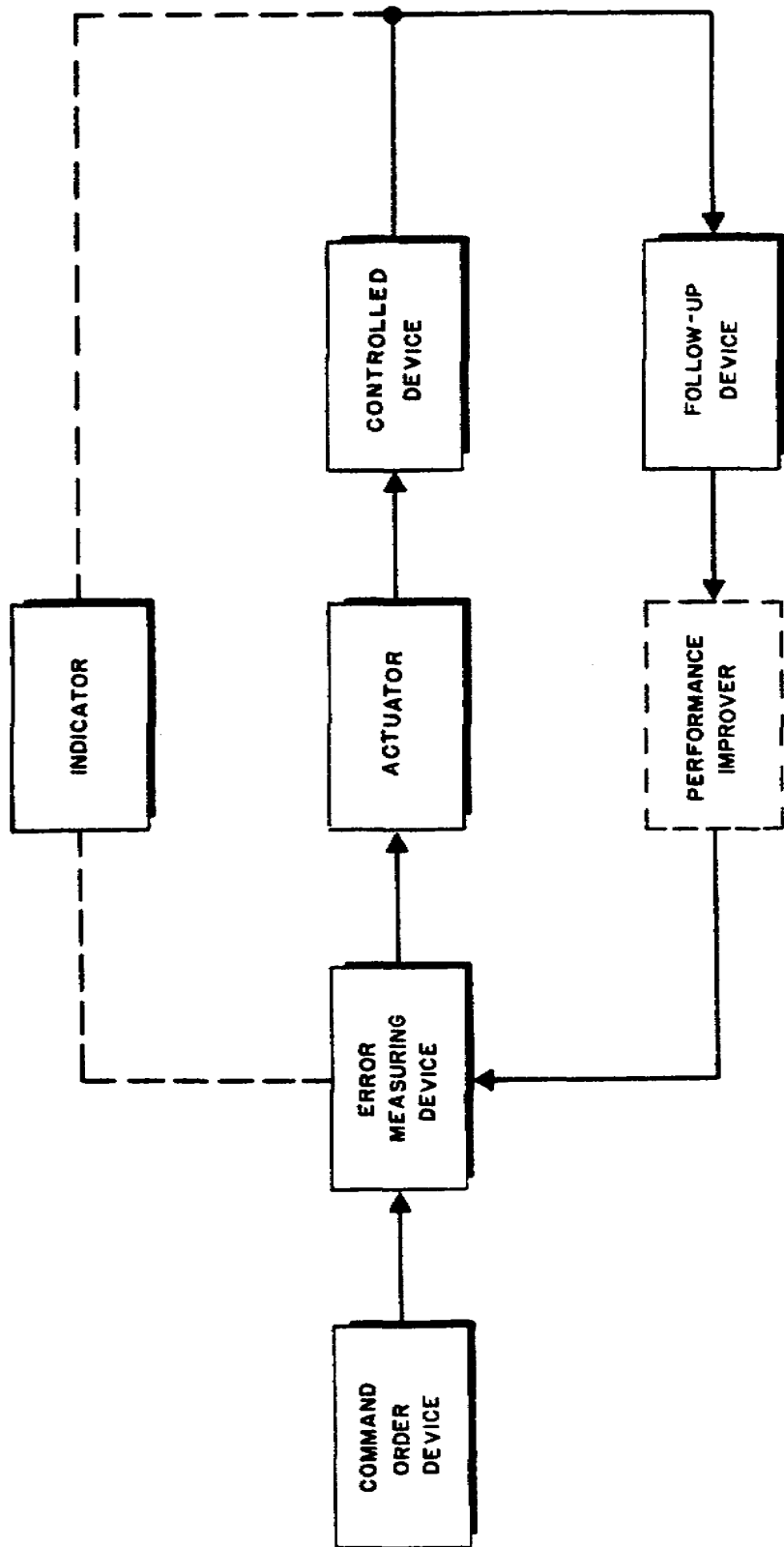

Figure 1. Functional servosystem.

MICROWAVE AMPLIFYING DEVICES

Section I. VELOCITY MODULATION

1-1. MODULATION PRINCIPLES

a. A long transit time is used very effectively in special types of tubes. Tubes that use a long transit time are commonly called velocity-modulated tubes. This is in contrast to the space-charge control of the conventional electron tube.

b. In a conventional electron tube, operating in a conventional circuit, the electron beam is modulated by varying the number of electrons. In a velocity-modulated tube, the electron beam is modulated by varying the velocity of the electrons. The electron velocities are varied by causing some electrons to move slowly and others to move rapidly through the inter-electrode space. When fast-moving electrons overtake a group of slower moving electrons and two groups arrive at a designated point at the same instant, bunching occurs. In a velocity-modulated tube, the electrons arrive at a designated point in bunches.

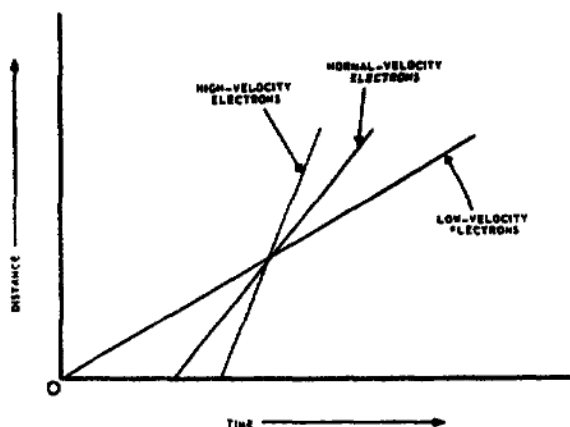

Figure 2. Electron velocities.

b. The bunching of electrons is a necessary function in velocity-modulated tubes. When the electrons are bunched, this group of electrons can then be accelerated or decelerated to the desired velocity. When electrons change velocity, they change energy levels. Electrons that are accelerated take on energy, and electrons that are decelerated give up energy.

1-2. BUNCHING PRINCIPLES

a. Figure 2 shows the distance traveled by the electrons as a function of time. The slower moving or low-velocity electrons require a longer period of time to cover the same distance than the faster moving or high-velocity electrons. The point where the lines for the different velocities intersect is where bunching takes place. Therefore, if the velocity of the electrons is controlled, bunching will take place at a definite distance from the electron source.

Section II. FUNDAMENTAL KLYSTRONS

1-3. PRINCIPLES OF OPERATION

a. A common type of velocity-modulated tube is the klystron. A klystron consists of four parts: a beam source, a velocity-modulating unit called a

buncher, a drift tube through which the velocity-modulated beam travels, and a unit called a catcher.

b. The klystron beam source, shown in figure 3, consists of the heater, cathode, control grid, and accelerating grid. The control grid controls only the number of electrons in the beam. No signal is applied to it to cause the flow of electrons to vary. The accelerating grid speeds up the electrons that are passed by the control grid. The velocity of the electrons passing through the accelerating grid can be changed by varying the accelerator grid voltage.

c. The buncher is the resonant cavity and is usually called the buncher cavity. This is a reentrant type cavity and has grids in the cavity, as shown in figure 4.

d. If microwave energy is coupled into the cavity by the coupling loop, oscillations are set up and an alternating voltage appears between the bunching grids. When the second grid is more positive than the first grid, electrons passing through the buncher grids are speeded up, or accelerated. When the second grid is more negative than the first grid, electrons passing through the buncher grids are slowed down. The electron beam is now velocity modulated as it passes through the buncher grids.

e. The buncher cavity is a reentrant-type cavity in order to reduce the spacing between the buncher grids. The electron velocity is usually high so that the time required for an electron to pass between the buncher grids is only a small fraction of a cycle.

f. The drift tube is an evacuated tube and provides a path for the velocity-modulated electron beam. The drift tube is between the buncher and catcher cavities, as shown in figure 3. The catcher cavity and the buncher cavity are identical in size and shape but their functions are different.

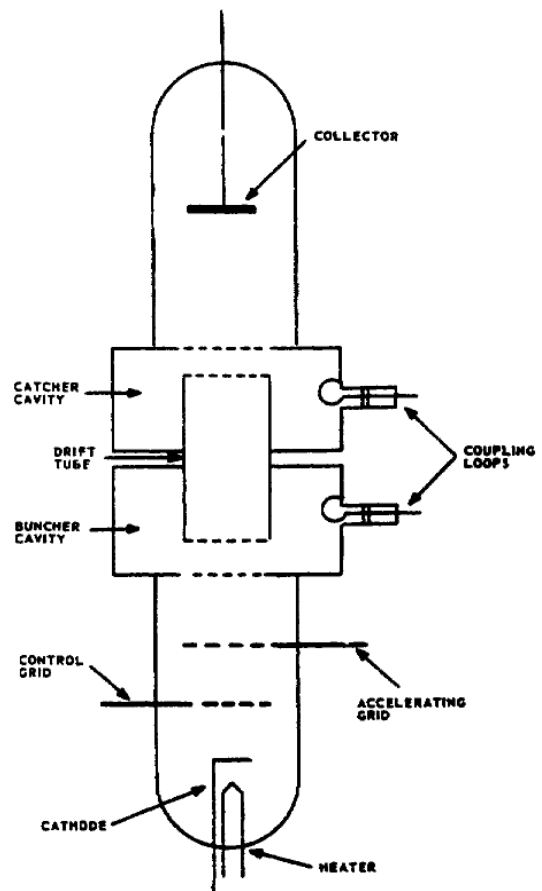

Figure 3. Simple klystron.

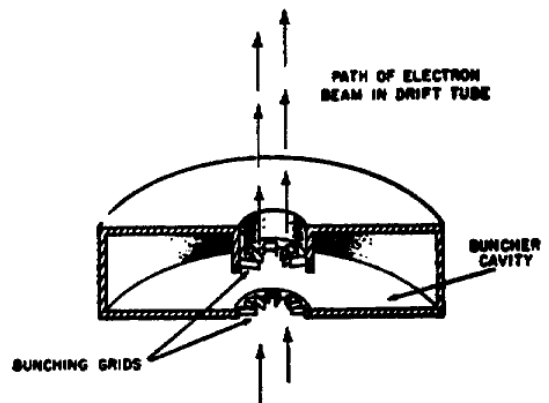

Figure 4. Buncher cavity.

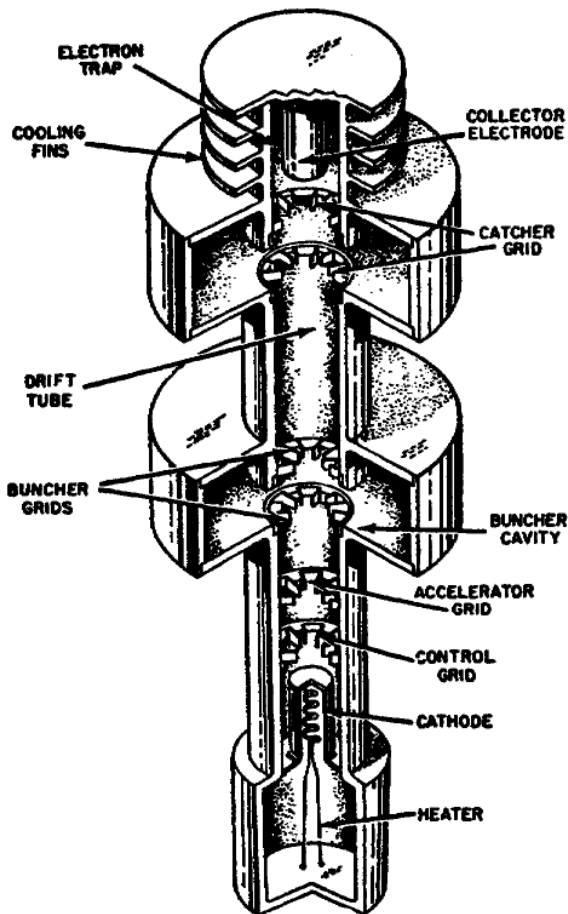

Figure 5. Two-cavity klystron.

g. The collector electrode provides an external path for the electrons to return to the cathode.

1-4. TWO-CAVITY KLYSTRON

a. A two-cavity klystron is shown in figure 5. The elements of this klystron are usually at ground potential, with the exception of the cathode and control grid, which are below ground potential.

b. In normal operation, the electron beam is passed through the buncher grids and is velocity modulated by the buncher cavity. As the beam travels through the drift tube, the electrons are bunched. Bunching is completed before the electrons pass through the first grid of the catcher cavity. The electrons will now pass through the catcher grids in bunches at the input frequency. As the bunches of electrons pass through the catcher grids, they are slowed down, or decelerated, causing the bunches to give up energy to the catcher cavity.

c. The klystron is an amplifier because it takes in low-level energy at the buncher cavity and delivers a higher level output at the catcher cavity. If it is adjusted correctly, the klystron will oscillate when a small amount of energy is taken from the catcher cavity and coupled back to the buncher cavity. These oscillations are the klystron output signal; developed in the catcher cavity.

The cavities in the klystron are usually adjusted by an inductive tuning slug. Energy is coupled into the buncher cavity and out of the catcher cavity by coupling loops. The orientation of the loop determines the amount of coupling.

d. It is necessary to tune both resonant cavities of the klystron before it will operate properly, as well as to insure that electron bunching is completed before the electrons pass through the catcher grids. This is controlled by adjusting the negative cathode voltage. The adjusted voltage difference between the cathode and the accelerator grid is the accelerating voltage, which causes the electrons to travel at the proper velocity so that bunching occurs at the proper place. If bunching occurs too soon or too late, the klystron cannot deliver much power because of collisions between electrons of different velocities.

Section III. REFLEX KLYSTRONS

1-5. DESCRIPTION

Reflex klystrons are used whenever microwave signals at low-power levels are required. Reflex klystrons are used frequently as oscillators in microwave terminals. The main difference between the reflex klystron and the two-cavity klystron is that the reflex klystron uses only one resonant cavity, as shown in figure 6. This resonant cavity is used to velocity-modulate the electron beam and is very similar to the buncher and catcher cavities in the two-cavity klystron. The control grid in the reflex klystron controls the number of electrons, and the first grid in the cavity acts as an accelerator. The second cavity grid modulates the electron beam. The reflector electrode is operated at a voltage more negative than the cathode and is commonly called the repeller plate.

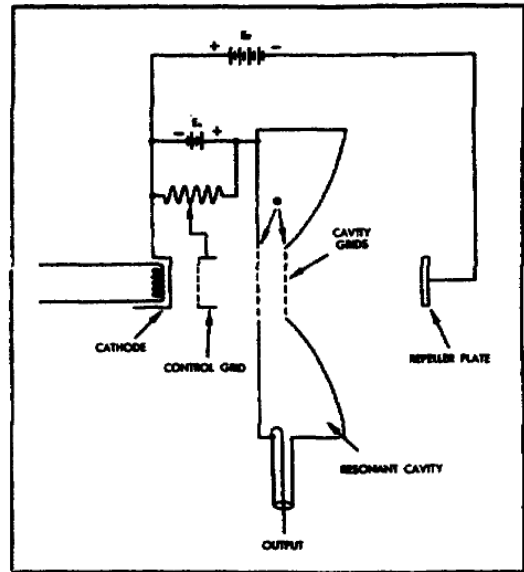

Figure 6. Reflex klystron, schematic.

1-6. OPERATION

a. The operation of a reflex klystron is considerably different from that of the two-cavity klystron. The electrons emitted from the cathode travel toward the cavity grids at a velocity determined by the potential E_a . Most of the electrons pass through the control grid and the cavity grids, and continue on toward the repeller plate. After passing the cavity grids, they come to a region where the electric field opposes their motion because the repeller plate is negative with respect to the cathode. The voltage between the cavity grids and the repeller plate is considerably greater than the plate-to-cathode potential, and the repeller plate is negative with respect to the cavity grids. The negative repeller plate slows down the electrons, causing them to come to a stop, reverse direction, and pass back through the cavity grids. The electrons are then collected by the control grid, the tube shell, or the cathode.

b. With the resonant cavity oscillating at a microwave frequency, a high-frequency voltage (cavity signal) appears between the two cavity grids. The electric field between the grids will reverse twice during each cycle of operation. As the electrons from the cathode approach these grids, the electron stream is uniform. The time that is required for the electrons to pass through the short distance between the cavity grids is small compared with the period of oscillations. Electrons that enter the space between the cavity grids when the cavity signal is zero will not encounter an electrical field and will pass through the cavity grids at normal velocity. The electrons that enter the space between the cavity grids when the cavity signal makes the first grid negative | and the second grid positive will encounter a field which tends to accelerate them. The amount they are

accelerated is determined by the amplitude of the cavity signal. Electrons entering the space between the cavity grids when the cavity signal is reversed are decelerated. Those electrons that are accelerated most will travel farther toward the repeller plate before being turned back, while those that are decelerated most will be turned back before getting close to the repeller plate. By now you probably realize that with the proper magnitude of the cavity signal, E_a , and E_r , the electrons will arrive in bunches.

1-7. FEEDBACK

a. The positions of the electrons in the tube at various times during their transit are shown in figure 7. The zero distance position is midway between the cavity grids. Electrons at time A arrive when the cavity signal is positive. These electrons are now accelerated and will travel farther before being turned back by the repeller plate. Electrons at time B are unaffected because the cavity signal is zero. Electrons at time C are decelerated by the cavity signal and are turned back after traveling a shorter distance. Notice how all of the electrons are returned to the cavity grids at the same time.

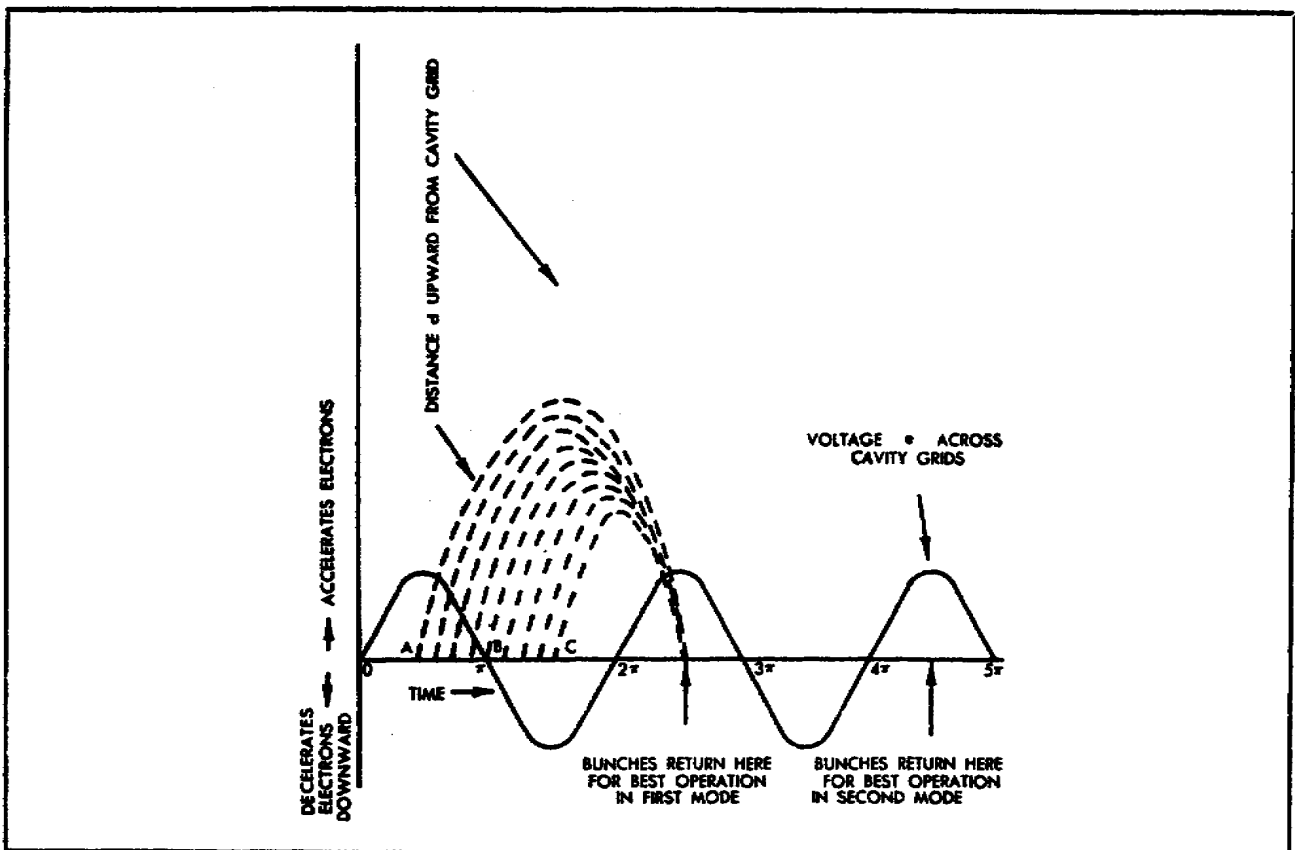

Figure 7. Bunching action.

b. When the electrons are being returned by the repeller plate, the cavity signal again has an effect on them. The electrons are now traveling in the opposite direction and will be decelerated when the cavity signal is positive. The bunches of electrons that arrive back at the cavity grids are

decelerated and give up energy to the cavity. For maximum transfer of energy, the bunches must arrive when the cavity signal is positive.

c. The electrons that are outbound from the cathode take on most of their energy from the dc power supply (E_a). The energy in the cavity (cavity signal) contributes very little to the energy the electrons take on. This is how energy is taken from the dc source and transferred to the cavity so that the klystron can have a useful ac output.

1-8. MODES OF OPERATION

a. Notice that during the first cycle of the cavity signal (voltage across cavity grids) the electrons are accelerated on their way to the repeller plate. During the succeeding cycles of the cavity signal, the electrons are bunched and decelerated. The cycle where the electrons are decelerated determines the mode of operation. When the electrons are decelerated by the first positive signal after the initial acceleration, the paths of electrons are operating in the first mode. When the electrons are decelerated by the second positive signal, the paths of electrons are operating in the second mode. There are three or four modes in which it is possible for the reflex klystron to oscillate.

b. The transit time determines the mode of operation, and the transit time is determined by the electron velocity. The original velocity of the electron depends on E_a . The distance the electron travels before turning back and the velocity with which it returns depend on the difference between E_a and E_r . It is possible to adjust the two voltages E_a and E_r for any of the modes. The voltage E_a is usually fixed in magnitude, since varying it produces greater initial velocity which, in turn, causes a farther excursion and a greater return velocity. Since it is not feasible to make E_a variable, E_r is variable. For operation in the first mode, the round trip must be completed in the shortest time. This is accomplished by making the repeller plate most negative. For greater time in the interelectrode space, the repeller is made less negative.

c. In figure 8, showing power output and frequency of oscillations as functions of the repeller voltage for three modes of operation, notice that the frequency at the point of maximum output is identical for all three modes and is the resonant frequency of the cavity. In addition, note that the power output for the various modes at the resonant frequency is not the same and that it is least in the highest mode.

1-9. REFLEX KLYSTRON TUNING

a. Within these modes it is possible to change the frequency of oscillation by changing the repeller plate voltage. Thus it is possible to tune the oscillator by turning a dial which controls this voltage.

b. If the repeller voltage is greater than that required to bring the electrons back through the grids at the instant of peak positive cavity signal, the electrons return too soon. The current between the grids then leads the voltage, and the reactance is capacitive. This is equivalent to decreasing the capacitance between the grids. With smaller capacitance, the circuit will be resonant at a higher frequency.

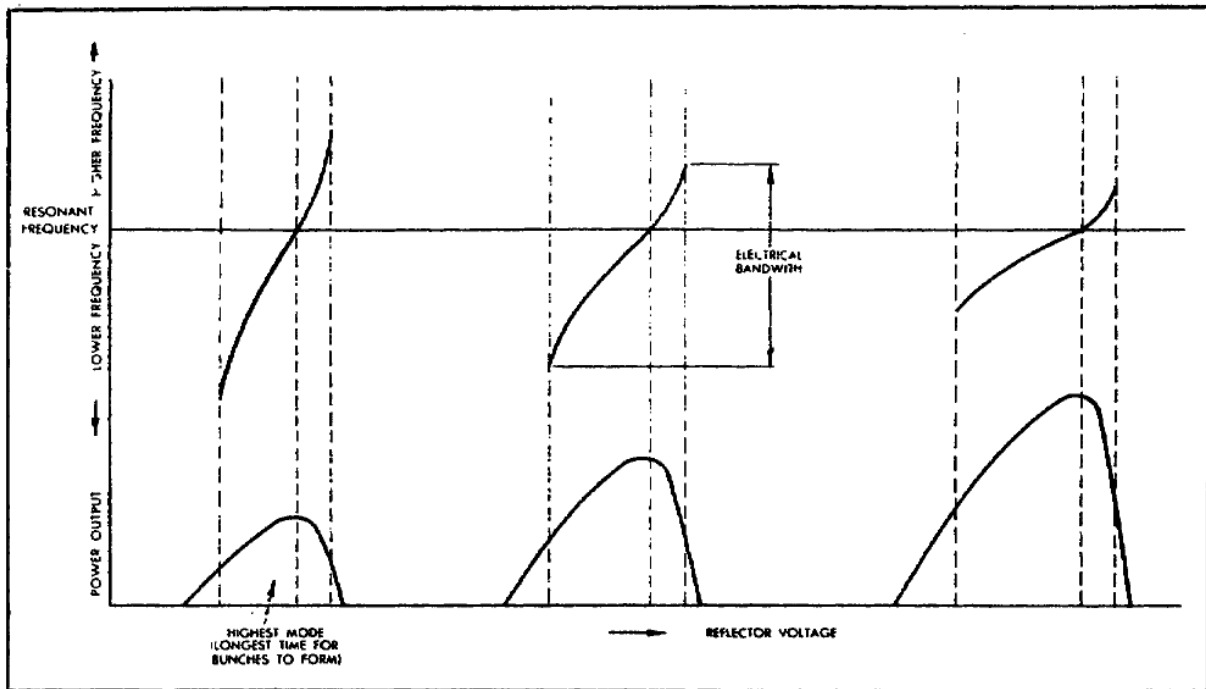

Figure 8. Klystron modes and electrical bandwidth.

c. If the repeller plate voltage is changed to be less negative (in the same mode), the reactance introduced is inductive. The frequency of oscillations will now be lower than the resonant frequency of the cavity.

d. Broader tuning ranges are available in the higher modes, but the power output is decreased considerably. This influences the desired mode of operation because the most powerful mode has the narrowest tuning range.

e. Klystrons are also tuned mechanically over much wider ranges than is possible with electrical tuning. Figure 9 shows a reflex klystron commonly used in microwave equipment. The resonant cavity is small and shaped like a doughnut. The upper shoulder of the metal tube envelope is part of the cavity wall and is made flexible. When pressure is applied to the top of the tube by means of the tuning strut, the upper cavity grid is moved closer to the lower cavity grid and the capacitance between the grids increases. This decreases the resonant frequency of the cavity. The electrical tuning range is greatest near the center of the mechanical tuning range. Mechanical tuning is used as a coarse frequency adjustment, and electrical tuning is used as a fine frequency adjustment. Tuning slugs, tuning paddles, and plungers are also available as mechanical tuning devices for klystrons.

Section IV. MULTICAVITY POWER-AMPLIFIER KLYSTRON

1-10. INTRODUCTION

Electron transit time makes operation of the klystron possible. To take advantage of transit time effects, the klystron must be made relatively large. The larger klystrons, with more than two resonant cavities, develop much higher gain and operate with greater efficiency.

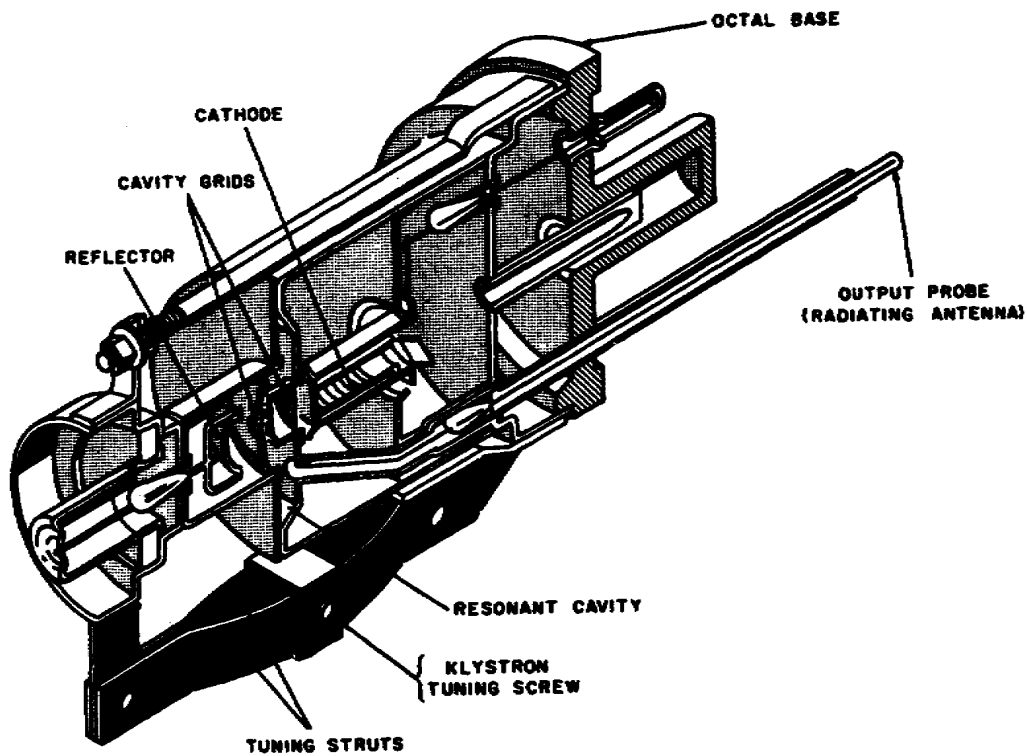

Figure 9. Reflex klystron.

1-11. OPERATION

a. The operation of the multicavity klystron is similar to that of the two-cavity klystron. Notice in figure 10 that the multicavity klystron does not have a control grid. The number of electrons in the stream is controlled by changing the cathode voltage. Also notice the absence of grids in the cavities. The large number of electrons flowing and the high electron velocities would be seriously affected by the grids that are normally used in the two-cavity klystron.

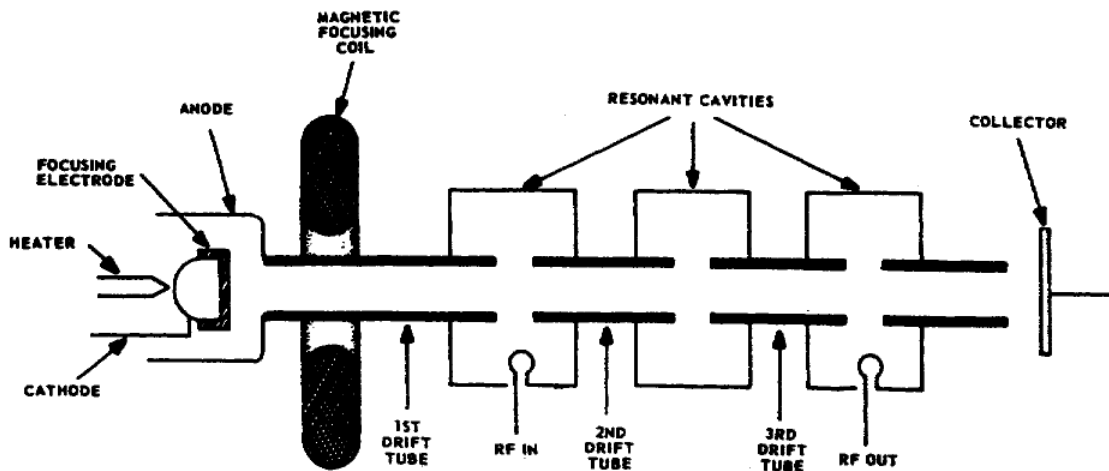

Figure 10. Multicavity power klystron.

b. Figure 11 represents the electron source in a multicavity klystron. The cathode has a concave shape which partly forms the emitted electrons into a beam. The focusing electrode is mounted so that it encircles the outer edge of the cathode and is operated at the cathode potential. The anode is located next to the focusing electrode and directs the electrons to enter the first drift tube. The body assembly of the klystron (anode, drift tubes, and cavities) is operated at ground potential, and the cathode is operated at a high negative potential. A strong electric field exists between the first drift tube and the cathode.

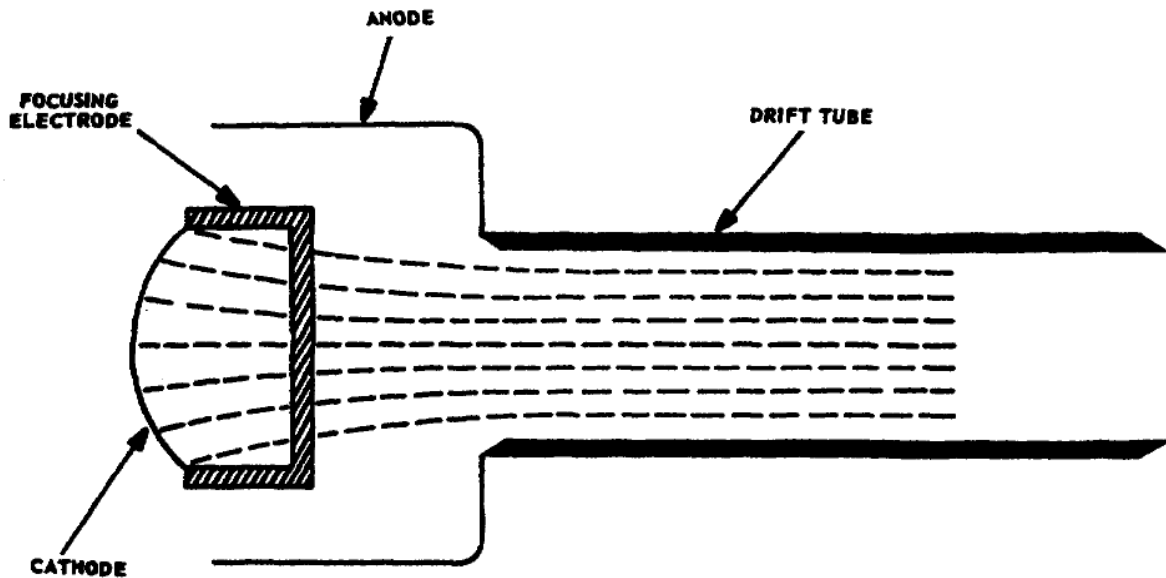

Figure 11. Electrons entering drift tube.

c. The electrons that leave the cathode are formed into a tighter beam by the zero or negative potential of the focusing electrode. The strong electric field between the cathode and the first drift tube causes the electrons to form into a converging beam which focuses inside the first drift tube section. The electric field does not extend into the first drift tube any appreciable distance, so the mutually repellent forces of the electrons tend to spread the beam. As the beam spreads out, the electrons strike the drift tube wall and set up current flow in the wall. This is known as body current. A high body current causes the electron energy to be dissipated as heat and greatly reduces the efficiency of the klystron.

d. To prevent the electron beam from spreading out, a magnetic focusing system is used to confine the electron stream into a narrow beam. The magnetic field is symmetrical around the drift tube axis. The magnetic focusing action shown in A of figure 12 causes the electrons to spiral down the drift tube. The spiral makes a tighter circle as the electrons travel through the magnetic field. Part B of figure 12 shows how the magnetic lines are axial in the drift tube.

e. Electrons released from the cathode are accelerated toward the drift tube and experience only slight effects from the magnetic field. These electrons travel an almost straight-line path to the drift tube entrance. The overall effect of the magnetic field is to force all of the electrons into the drift tube and keep them in a beam that will prohibit them from

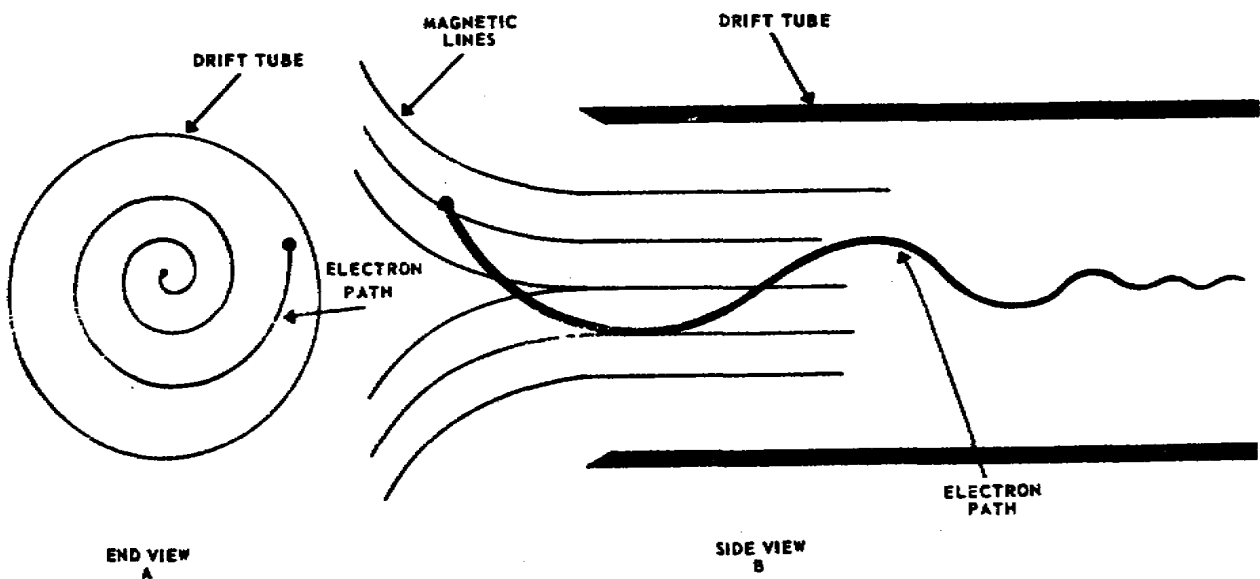

Figure 12. Electron path in drift tube.

striking the sides of the drift tube. Once the electrons enter the drift tube they are no longer under the accelerating effects of the cathode-to-drift-tube potential. The electrons will then coast or drift at a constant velocity until they encounter the electric field across the gaps of the resonant cavities along the length of the drift tube.

f. The axial magnetic field produced by the body coil assembly (fig. 13), extends the length of the drift tube assembly. The electrons in the drift tubes travel parallel with the axial magnetic field. It is impossible to get the degree of focusing required to prevent all the electrons from being directed from the beam and striking the walls of the drift tube. However, by proper adjustment of the magnetic body coils, it is possible to keep stray electrons to a practical minimum.

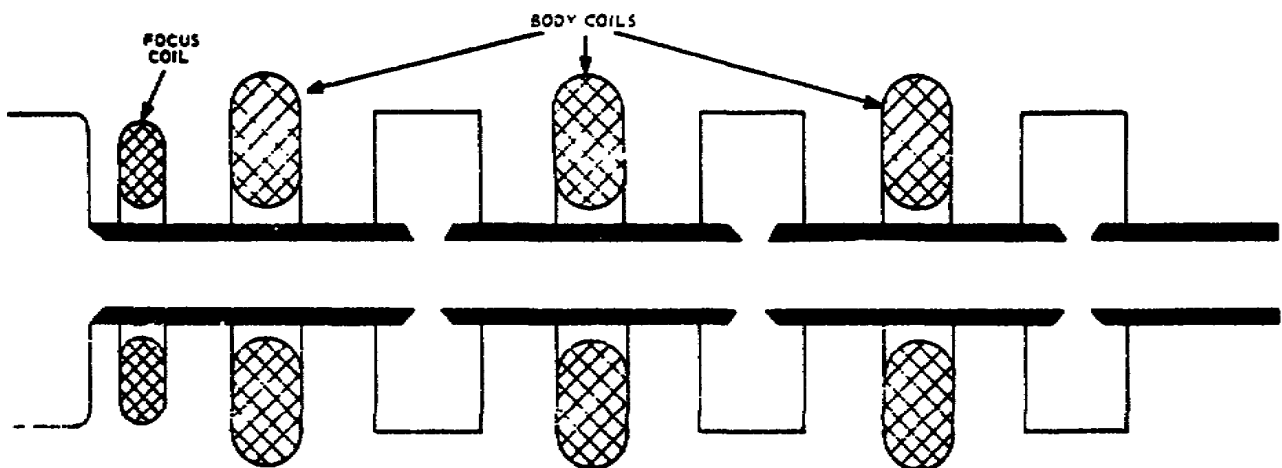

Figure 13. Magnetic coils.

1-12. COMPONENT DIMENSIONS AND PLACEMENT

a. The grids are eliminated in the resonant cavities in the multicavity klystron because of the high electron velocities. The edges of the cavity gaps are flush with the drift tube wall to avoid interrupting electrons in the beam. The cavity gap spacing is determined by the electron transit time between gaps and the amplitude of the RF voltage (cavity signal) across the gap. The ideal condition is zero transit time, but this is not possible. A cavity gap that produces a transit time of one-quarter cycle is usually satisfactory.

b. If the gap spacing is very small to reduce transit time, the cavity impedance is lowered, and this is the same as increasing the capacitance of a tuned parallel resonant circuit. In the high-power multicavity klystron, the reduction of gap spacing will allow the high RF voltage to arc over and the klystron will fail to operate.

c. The diameter of the drift tube determines the degree of coupling between the cavities and the electron beam, and affects the complexity of the arrangement for focusing the electron beam. The smaller diameter provides a higher degree of coupling, but it complicates the focusing. The limiting condition of the drift tube diameter is that the diameter of the tube must be approximately one-half the wavelength of the operating frequency. This is necessary to avoid standing waves along the drift tube. The drift tube diameter should permit satisfactory beam coupling and practical focusing.

1-13. BUNCHING

a. The output of any klystron is developed by velocity modulation which produces bunching. The multicavity klystron uses higher electron velocities than the two-cavity klystron, so more velocity changes by RF voltages are required for bunching. The electrons that leave the cathode are influenced only by the voltage between the cathode and drift tube. As the electrons pass through the input cavity, velocity modulation takes place. As electrons reach the second cavity, enough bunching has occurred to excite the second cavity, causing it to oscillate. The cavity signal across the second cavity causes additional velocity modulation so that bunching will occur at the output cavity.

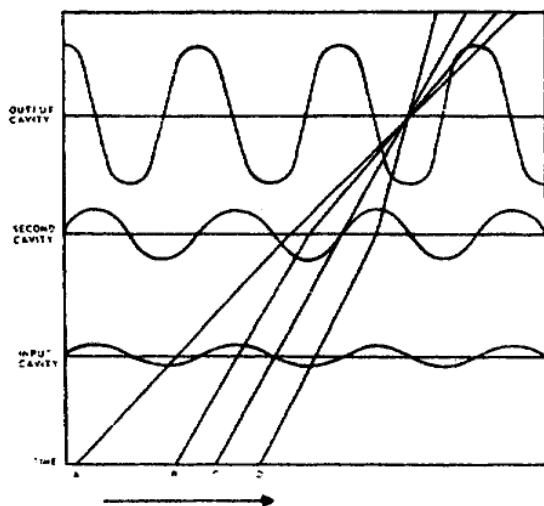

Figure 14. Bunching action in a multicavity klystron.

b. In figure 14, the electrons at time A experience a uniform deceleration from the input and second cavities. The electrons at time B experience acceleration from the input cavity and then are decelerated by the second cavity signal so that they will arrive at the output cavity at the same time as the time A electrons. Electrons at time C have no cavity fields acting on them. Electrons at time D are decelerated by the input cavity signal but are accelerated by the second cavity signal. The result is bunching at the output cavity in one cycle of the input signal.

c. The input cavity signal is a low-amplitude signal from an external circuit. The second cavity signal is the resonant frequency of the cavity energized by the electrons that have partially bunched in the cavity gap. This is a slightly higher amplitude signal than the input cavity signal, and the energy that is delivered to this cavity from the electron stream is negligible. Bunching that occurs in the output cavity delivers a large amount of energy to it. The energy is taken from the output cavity by a coupling loop and is delivered to a matched load.

d. The higher electron velocities in a klystron require more cavities to control bunching. Some klystrons may have six or seven cavities and use very high electron velocities.

1-14. APPLICATIONS

The multicavity klystron is commonly used as a power amplifier but may also be adapted as a frequency multiplier. If it is used as a frequency multiplier, the output cavity is smaller and resonant to a harmonic of the input cavity signal. The efficiency of the klystron used as a frequency multiplier is considerably lower than when it is used as a power amplifier.

Section V. KLYSTRON POWER AMPLIFIER

1-15. PURPOSE

The klystron power amplifier receives its driving power from an exciter. The cavity-type tube is designed to boost the low-power angle-modulated driving signal to a high-power angle-modulated signal. The klystron amplifiers used for this application will contain from three to five cavities, depending on the power output and type of equipment in use. The klystron may or may not have an associated heat exchanger.

1-16. ELECTRON GUN

a. The electron gun shown in figure 15 is the source of the electron beam. The gun has a filament, a cathode, focusing electrodes, and a modulating anode. The beam is a fast-moving stream of electrons emitted from the cathode. The electrons are held grouped together by the focusing electrode, which is operated at cathode potential or negative with respect to the cathode. This charge applied to the focusing electrode causes the electrons to converge on the axis of the tube.

b. The entire beam flows through a hole in the modulating anode to the first section of the drift tube. In this application, the modulating anode is grounded through a 10-kilohm resistor. This feature prevents damage to the tube if arcing occurs within the electron gun section. When arcing occurs, a large current flows to the anode. This current flowing through the 10-kilohm resistor develops a negative bias which cuts off the beam current until arcing stops.

1-17. RF SYSTEM

a. When the beam enters the input cavity, the number of electrons is constant; however, their velocity is changed by the signal to be amplified.

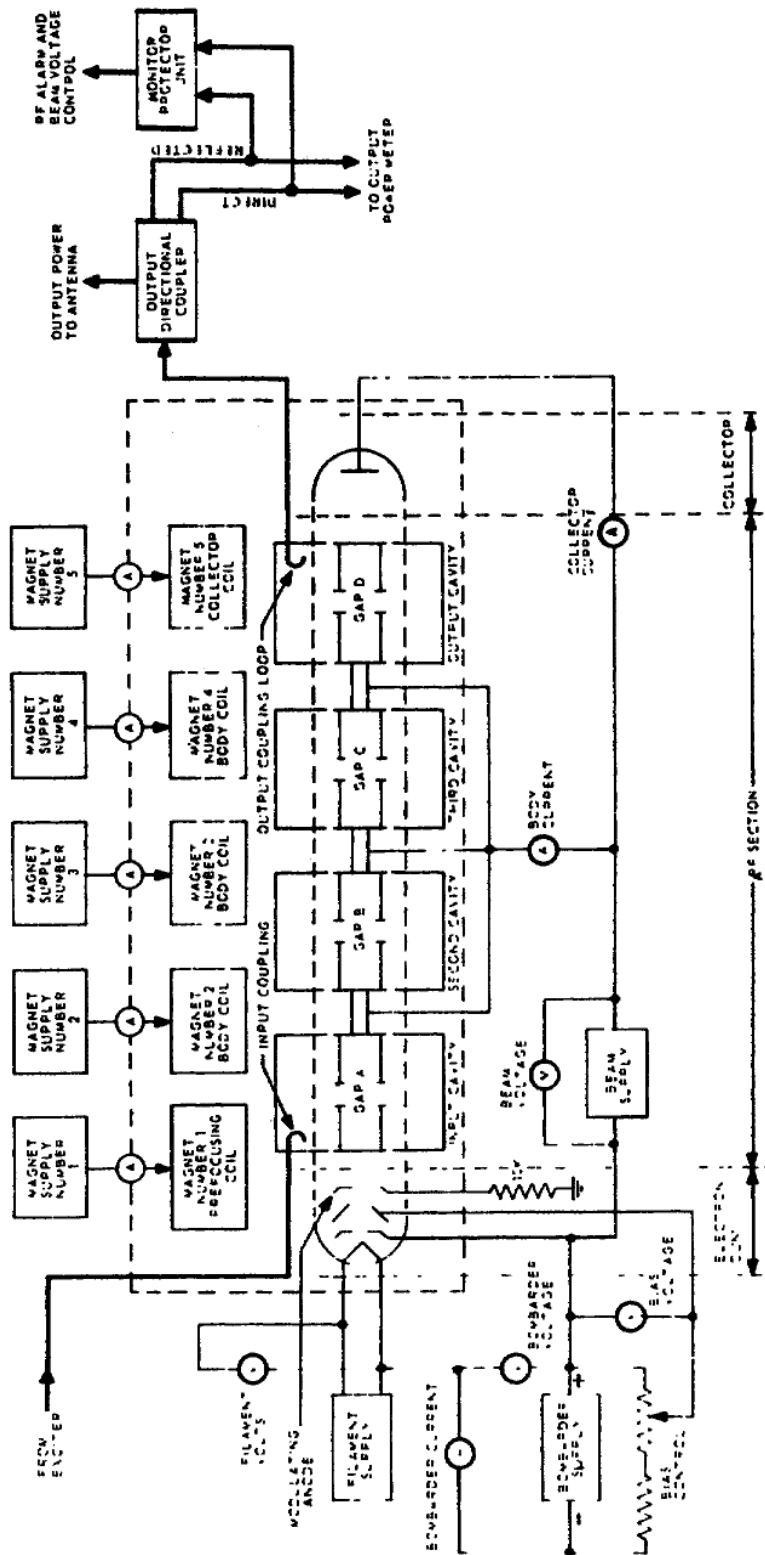

Figure 15. Typical four-cavity power-amplifier klystron.

A large signal has a greater influence on electron velocity than a small signal. If an electron reaches the cavity at gap A when the RF voltage is zero, the speed of the electron is unaffected. However, any electron reaching gap A when the voltage is positive will be accelerated, while those electrons reaching the gap when the voltage is negative will have their speed reduced. Now, if the electrons that were accelerated travel long enough, they will eventually catch up with those that were slowed down shortly before on a previous negative half-cycle. Thus, velocity modulation becomes a density modulation.

b. The RF section is made up of the drift tube and four resonant cavities which surround it at intervals along its length. The drift tube is a round interrupted tube with a length almost 20 times its diameter. There are four interruptions, or gaps, along the length of the drift tube. They are arranged so that the sides of the drift tube protrude into the cavity wall. These opposing high-voltage points are surrounded by ceramic windows. Thus, these drift tube tips become capacitance-loading elements when the cavity is excited. The external demountable tuning boxes (resonant cavities) are assembled around the ceramic sections.

c. As the electrons pass through the remaining cavities, the bunching becomes more pronounced. As the bunches pass through the output cavity, oscillations are set up in the cavity in much the same way that pulses of current excite the plate-tank circuit of a class C amplifier.

d. Since power delivered to the output cavity is greater than power delivered to the input cavity, amplification results. Power output is transferred to the antenna through a directional coupler by the output coupling loop in the output cavity.

1-18. COLLECTOR SECTION

The collector section of the klystron consists of one electrode, the collector. Approximately 30 percent of the beam energy is absorbed by the collector. The collector electrode gathers the unused electrons and passes them out of the klystron into an external circuit leading to the positive terminal of the beam power supply.

1-19. MAGNETIC CONTROL OF ELECTRONS

a. A magnetic field is used to control the electrons in the drift tube. This magnetic field is created by controlling amounts of direct current flowing in electromagnetic coils surrounding the klystron, as shown in figure 16. The number of coils required varies with the tube type.

b. The prefocusing coil is inclosed in a special magnetic shell containing an annular airgap. The flux outside the airgap forms a magnetic lens on the axis of the klystron at the point where the convergent paths of the electrons are focused. The magnetic lens keeps the electrons from striking the drift tube wall before the beam enters the main magnetic field created by the body coils.

c. The magnetic field in the body coils is adjusted to control the diameter and direction of the electron beam as it passes through the klystron, so that as little beam current as possible will strike the drift tube wall

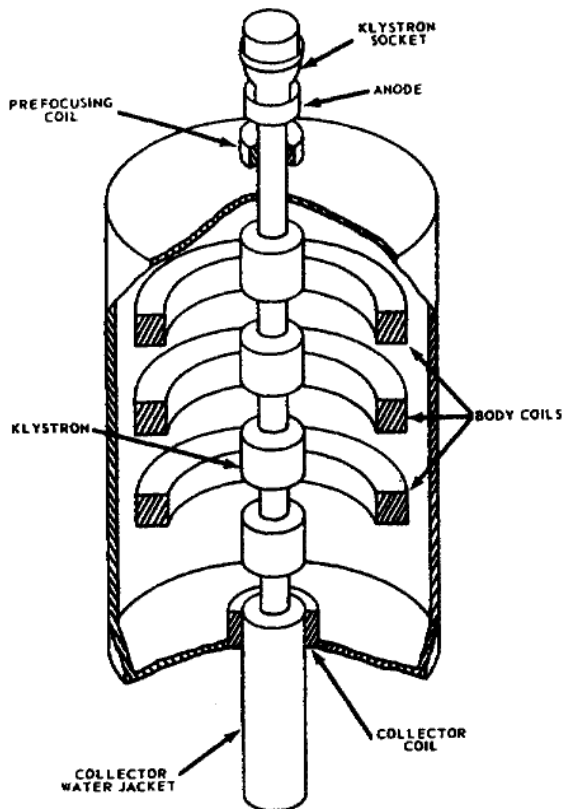

Figure 16. Klystron and magnetic coils.

and be wasted. The electrons that do strike the drift tube wall become body current. Body current is passed through an external circuit, back to the positive terminal of the beam power supply, as shown in figure 15. This current is read on the meter labeled BODY CURRENT. By adjustment of the individual coil currents, body current is kept to a minimum.

d. The collector coil is located in the bottom of the magnetic frame which supports the mounting flange of the klystron. The mounting flange, being of magnetic material, serves to establish the magnetic field needed near the end of the drift tube. The collector coil current is adjusted in the same manner as the body coil current so as to reduce the body current.

1-20. KLYSTRON TUNING

a. Klystrons with as many as six cavities have been developed to permit broadband tuning. The conventional tuning methods are stagger tuning and cavity loading. No rules can be given to account for all the methods and variations in the various broadband tuning systems. Each system is a

separate tuning problem, and the klystron can be correctly tuned only by careful observance of the instructions that accompany it into the field.

b. In general, three-cavity klystrons will provide bandwidths of approximately 0.3 percent of their operating frequency when they are correctly tuned and their driving power is suitably increased. Four-cavity klystrons can provide bandwidths of about 0.6 percent of their operating frequency when they are correctly stagger tuned, and with increased driving power.

c. Cavity loading in combination with stagger tuning will give increased bandwidths up to 2.0 percent of the operating frequency when used with klystrons of five and six cavities. However, loading materially diminishes the gain of the klystron and results in reduced efficiency and power output.

1-21. HEAT EXCHANGER

a. The purpose of the heat exchanger is to cool and circulate the liquid that removes the heat from the klystron. The operation of the heat exchanger shown in figure 17 is similar to the operation of the cooling system of an automobile. Assume that the coolant is of normal room temperature when the unit is started. The coolant will bypass the heat transfer coils because the thermostatic bypass valve will be closed, thus closing off that portion of the line which goes to that area. As the heat from the drift tube heats

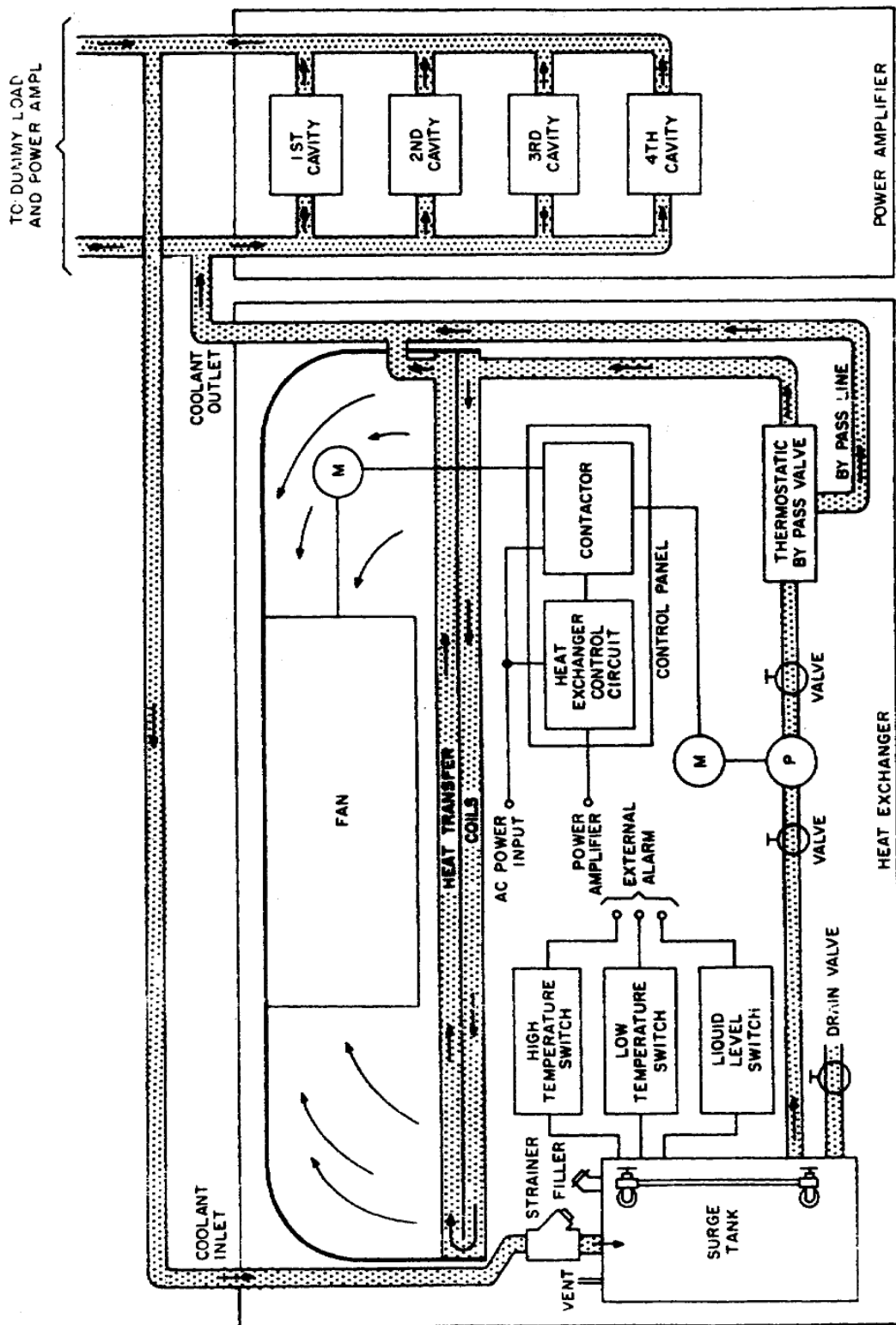

Figure 17. Heat exchanger.

the coolant, the thermostatic bypass opens. The coolant now flows through the heat transfer coils, where it is cooled by circulated air before it is returned to the klystron drift tube.

b. The alarm circuits within the heat exchanger are used to monitor the temperature and level of the coolant.

Section VI. TRAVELING-WAVE TUBES

1-22. INTRODUCTION

a. The traveling-wave tube (TWT) has been with us since 1946. Originally, it required almost perfect operating conditions because it was temperamental in its performance. The temperamental features have been overcome and the unusual operating characteristics of this tube have permitted the development of new electronic equipment.

b. Traveling-wave tubes are made in several sizes to meet almost every power requirement. Because of their high-gain and broadband characteristics, new communication equipment is being developed.

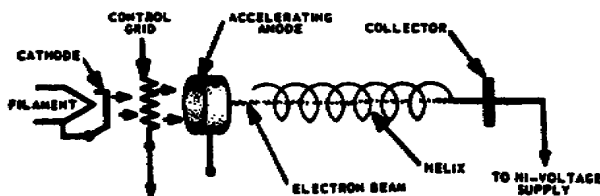

Figure 18. Traveling-wave tube.

1-23. PHYSICAL CONSTRUCTION

a. The TWT (fig. 18) has an electron gun similar to the gun used in the klystron. The cathode has a parabolic shape to give the initial focusing to the electron stream emitted from it. The accelerating anode does very little to focus the electron stream, but it does increase the velocity of the electrons.

The control grid controls the number of electrons in the electron stream.

b. It is the helix (loosely wound coil) that makes this tube different from all other tubes. The electron beam is passed through the center of the helix and is eventually captured by the collector anode. The collector anode is operated at a comparatively high voltage and causes the electrons to be continually accelerated. The helix is operated at the same dc potential as the collector anode.

c. The beam of electrons passing through the helix presents the same problem as the electrons in the drift tube of the klystron; that is, the natural repelling forces of the electrons tend to scatter the beam. To keep the electrons in a tightly focused beam, the whole tube is surrounded with a magnetic focusing coil (fig. 19). The size of the electron beam is controlled directly by the current through the magnetic coil. The higher the coil or solenoid current, the tighter the beam. If the magnetic field of the solenoid were lost for an instant, the electron beam would spread, intersect the helix, and destroy the traveling-wave tube.

d. The physical structure of the tube must have an RF input and output. In figure 19, the RF input and output are transformer-coupled to and from the helix. Notice the attenuator between these couplers. The attenuator is a ferrite isolator that prevents the output signal from returning to the input coupler and causing oscillations.

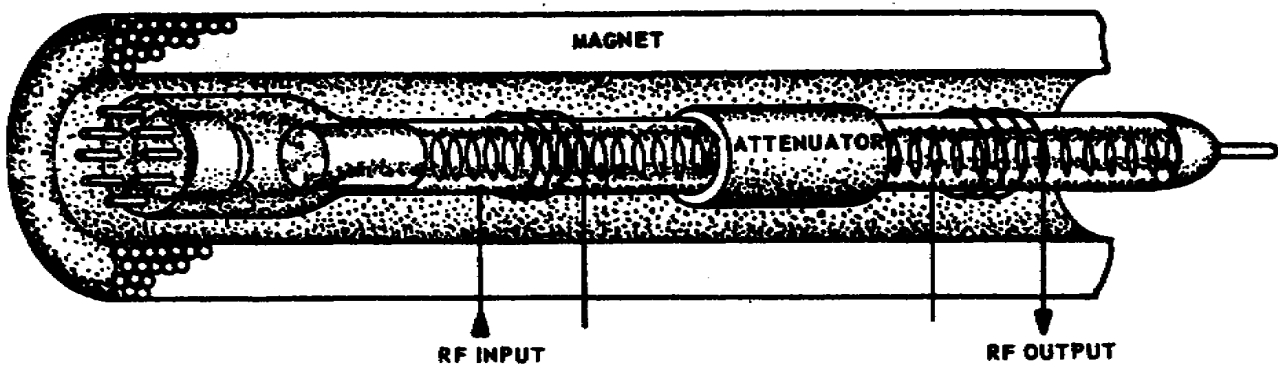

Figure 19. Traveling-wave tube with focusing coil.

1-24. OPERATION

a. The TWT can be compared with a klystron in that both tubes velocity-modulate a high-velocity electron beam. The electron beam takes on energy from the dc power through the acceleration of the electrons. An RF signal along the path of the electron beam causes the electron velocities to change so that some are speeded up and others are slowed down. Changing the individual velocities of the electrons in the beam forces them into groups, or bunches. At the output end of these tubes, the electron bunches are decelerated, causing them to give up their energy to an output circuit.

b. In the klystron the RF signal that interrupts the electron velocities is from a resonant cavity, and in the TWT the RF signal is from the helix. Here the similarity between the TWT and the klystron ends.

c. The TWT differs from the klystron in that the electrons interact with a traveling wave rather than a standing wave. This interaction is distributed along the helix, not localized as in the klystron. There are no high-Q resonant circuits in the TWT, so it can amplify over a broad band of frequencies.

d. A simple concept of a traveling-wave tube is shown in figure 20. An RF signal is applied to a straight-wire transmission line at the input side, and an electron beam is passed along, parallel with the straight-wire line. If the output of the straight-wire line is terminated in its characteristic impedance, the line is nonresonant and will pass a broad band of frequencies. When an RF signal is applied to the straight-wire line, part of the RF signal's electric field is parallel with the direction of travel of the electron beam. This will cause interaction between the RF signal and the electron beam.

e. If the electrons in the beam could be accelerated so as to travel faster than the RF signal (electromagnetic wave) on the straight wire, bunching would occur because of the effect of the RF signal on the electron beam. Some of the bunches that are decelerated give up energy to the RF signal on the straight-wire line and increase the amplitude of the original RF signal. This action is possible over a wide range of frequencies, allowing the TWT to act as a broadband amplifier.

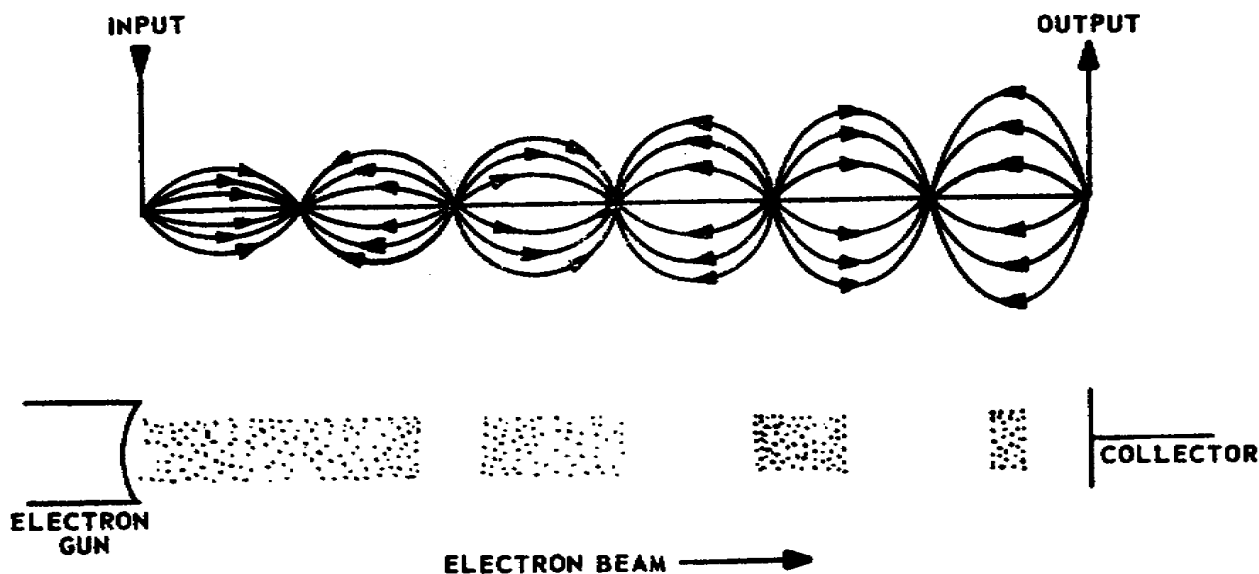

Figure 20. Simple traveling-wave tube.

f. This simplified traveling-wave tube will not work because the RF signal travels at the speed of light and the electron beam cannot be accelerated beyond this velocity. For this reason the TWT is designed with a slow wave structure that will delay the RF signal so that the electron beam can be accelerated to a higher speed than that of the RF signal. The transmission line used to delay the RF signal is a helix (coil of wire). The helix (a nonresonant line) delays the axial velocity of the RF signal so that it is only one-tenth of the axial velocity in the straight-wire line. Now the axial velocity of the electron beam can be controlled so that it is equal to or greater than the axial velocity of the RF signal. The helical-type delay line permits a greater concentration of the RF field parallel with the axis of the helix and causes better velocity modulation of the electron beam.

g. In figure 21, if an electron beam is directed through the center of the helix and an RF signal is applied to the RF input, the traveling-wavetube will amplify the input signal. (Bear in mind that the focusing magnet, not shown here, is a vital part of the TWT.) The RF signal is coupled to the helix through the transformer coupling and causes bunching to occur, as shown by the wave shape in figure 21. Amplification of the RF signal on the helix begins as the field formed by the bunches interacts with the field from the RF signal. Each newly formed electron bunch adds a small amount of energy to the RF signal on the helix. The slightly amplified RF signal then causes a denser electron bunch, which, in turn, adds still more energy to the RF signal. This process is continuous as the RF signal and the bunches progress along the helix. Notice how amplification of the RF signal increases as the electron bunches get more in phase with the negative field of the RF signal. This is when maximum deceleration occurs and the electron beam gives up maximum energy to the helix. This energy then is coupled from the helix to the output coupler of the tube.

h. The attenuator placed near the center of the helix reduces or attenuates the RF signal on the helix so that the signal from the output side cannot

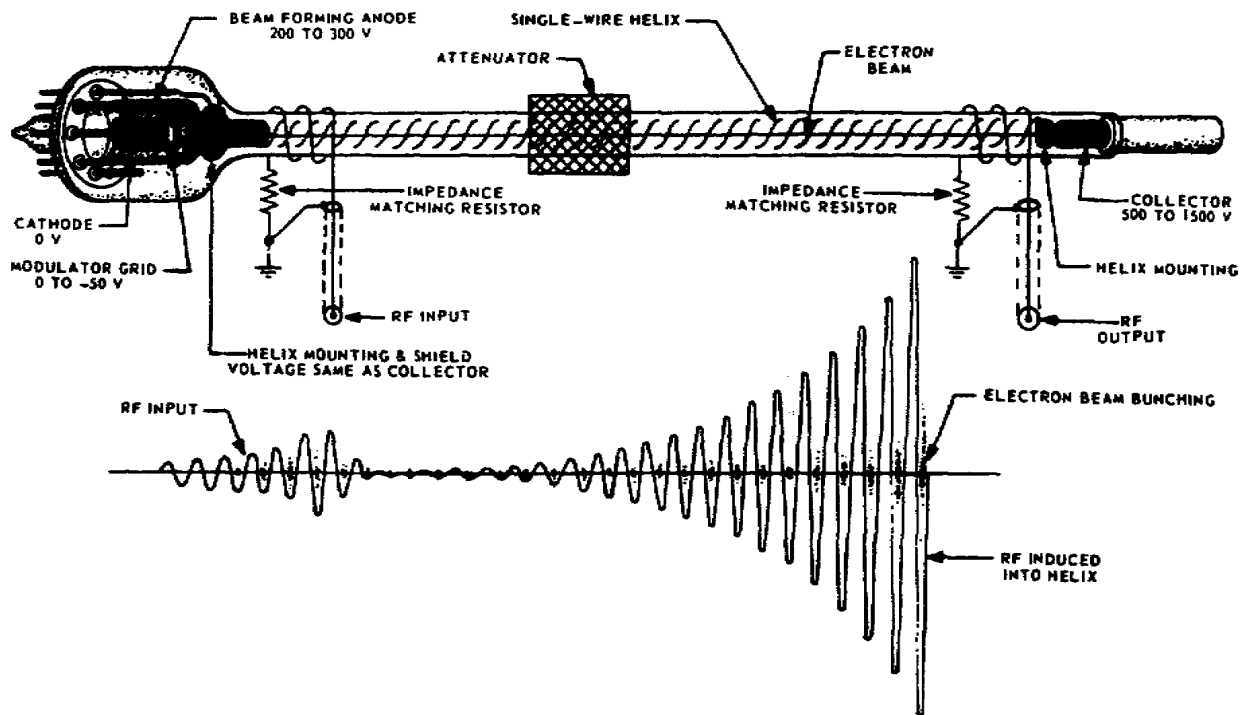

Figure 21. Velocity modulation in a traveling-wave tube.

feed back to the input side and cause oscillations. At the same time, though, the forward-going signal is also attenuated as shown in the wave shapes. This does not have an appreciable effect because the electron bunches are not affected by the attenuator. The electron bunches that emerge from the attenuator induce a new RF signal on the helix, and it is of the same frequency as the input signal. The electron bunches and the newly induced RF signal again start the interaction and amplification.

1-25. COUPLING METHODS

a. Four methods are used to couple energy into and out of a TWT. The type of TWT, desired bandwidth, and power requirements usually are the decisive factors in determining which type of coupling is most efficient. In A of figure 22, the waveguide coupling is fairly simple. The waveguide is terminated in a nonreflecting impedance and the helix is inserted into the waveguide like a quarter-wave stub. The efficiency of this system is good but the waveguide has a much higher Q than the TWT. This means that the broadband characteristics of the TWT are considerably suppressed in that the entire bandwidth of the TWT is not available for amplification.

b. In B of figure 22, the cavity coupling is similar to the waveguide coupling. The helix is inserted in the cavity so that the E field in the cavity will induce RF energy into the helix. The cavity is excited by a coupling probe or a coupling loop on the input side; the same method is used on the output side, but the action is reversed. The helix excites the cavity and the probe or loop removes the energy from the cavity. At higher frequencies, the size of the cavity is small and the amount of output power must be limited to avoid serious arcing. Cavities can be made to resonate over a

broader band of frequencies than the waveguide but they still have a high Q compared with the traveling-wave tube.

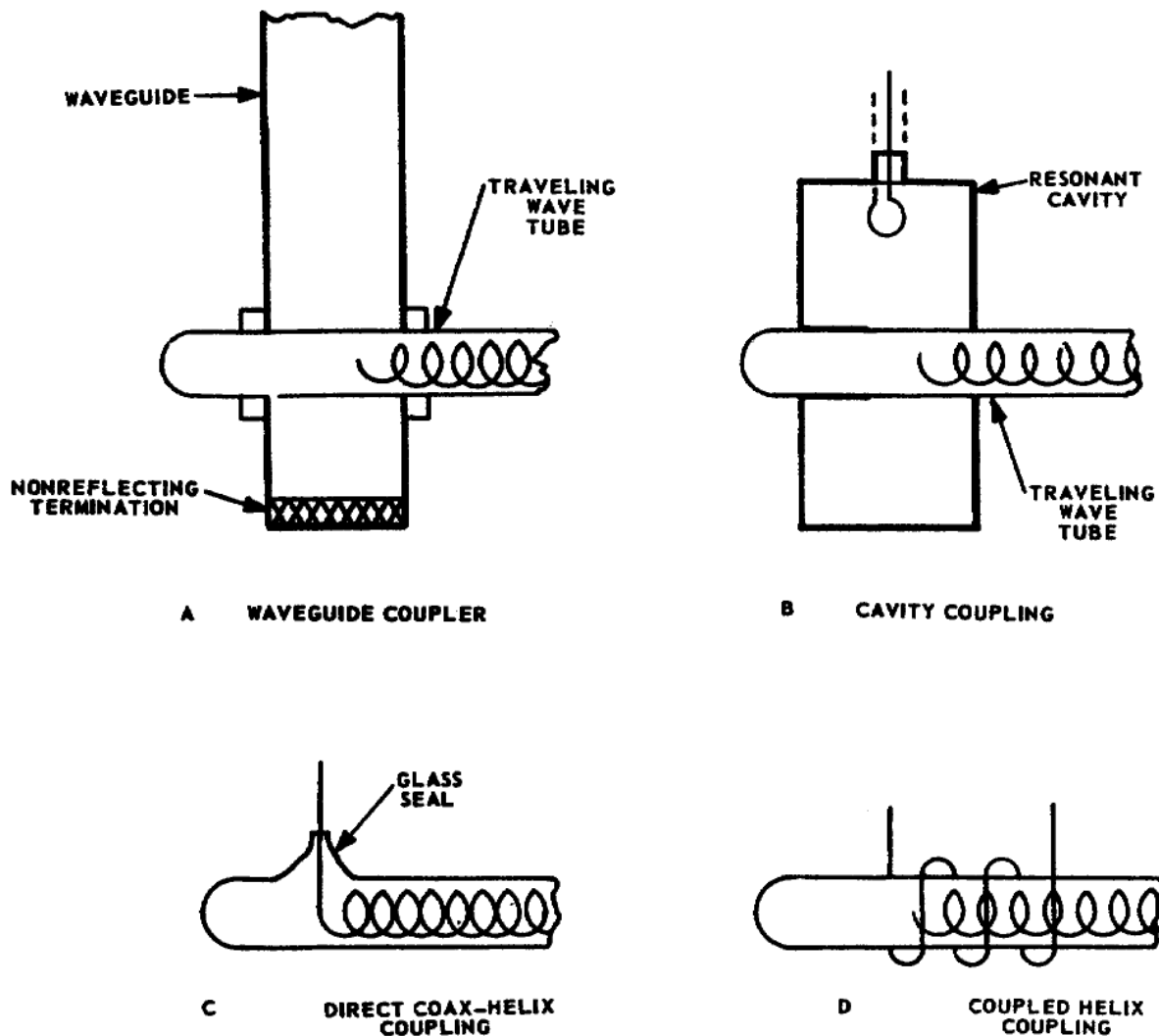

Figure 22. Traveling-wave-tube couplers.

c. The direct coax-helix coupling shown in C of figure 22 is sometimes called direct-pin coupling. It is a very simple method of coupling because the center conductor of a coaxial line is connected directly to the helix of the traveling-wave tube. This type of coupling usually is used in high-power TWT's. The power-handling capability is limited only by the amount of heat generated by the standing waves that are on the pin. The pin goes through a glass seal on the tube, and heating sometimes causes the glass seal to break and damage the tube.

d. The coupled helix in D of figure 22, is a commonly used coupling. The short helix encircles and magnetically couples to the ends of the main helix. This type of coupling has a broader bandwidth than the waveguide and cavity coupling and it also has better standing-wave characteristics than

direct coax-helix coupling. Even though this type of coupling appears to be most desirable, it is limited to handling low power because it is structurally unable to handle high power.

1-26. ADVANTAGES AND DISADVANTAGES

a. The broadband characteristics of the traveling-wave tube have satisfied the demand for a broadband device more than any other tube developed today. This unique advantage of the TWT is almost offset by several disadvantages. The external magnetic focusing coil may require as much as 11 amperes of solenoid current with a voltage drop across the coil of 15 to 85 volts. None of this power can be recovered in the output.

b. This high power required by the solenoid generates a tremendous amount of heat which must be dissipated, because the tube must be kept cool. This usually requires large air conditioning units. Even slight heating can distort the helix and cause nonuniformity in it. A nonuniform helix causes "holes" or areas of no transmission in the output of the TWT. Areas of no transmission relate to the inability of the tube to operate at some frequencies. Holes may exist in a normal TWT because it is almost impossible to manufacture one that is perfect.

c. Because the holes are known to exist, their positions (frequencies) must be accurately determined. To locate these holes, one of the most elaborate tube testers has been developed to evaluate a traveling-wave tube. So much difference exists between each tube that they must be calibrated individually.

d. Despite their many disadvantages, the TWT's are allowing the development of more new electronic equipment. For example, a microwave repeater in a communication link can be made with a single TWT.

Section VII. BACKWARD-WAVE OSCILLATORS

1-27. INTRODUCTION

A backward-wave oscillator is similar to a traveling-wave tube, except for the following differences:

a. Unlike the TWT, the backward-wave oscillator has no attenuator. As a result, the RF signals that travel backward toward the cathode are not suppressed.

b. The helix is terminated with a matching impedance.

c. The output is taken from the end of the helix nearest the electron gun.

d. The insertion of a terminating impedance causes dissipation of the RF signal traveling in a forward direction toward the collector; this does not occur in a traveling-wave tube.

e. The electron beam interacts with an RF signal traveling in the opposite direction on the helix (backward) toward the cathode.

1-28. O-TYPE BACKWARD-WAVE OSCILLATOR

a. In figure 23, as the electrons leave the electron gun and are accelerated toward the collector anode, they generate noise by shot and thermal effects. The noise signal is random in frequency, and almost all frequencies from $0-10^9$ hertz are present. Each of these frequencies tends to develop a wave traveling on the helix. This wave travels back toward the electron gun end of the tube. If the electron beam has a slightly higher velocity than the velocity of the signal on the helix, there will be interaction between the electron beam and the signal on the helix, causing the electron beam to give up energy to the signal on the helix. The signal on the helix will increase in amplitude as it approaches the gun end of the tube. This amplification is due to the signal on the helix taking energy from the electron beam as bunching occurs in the beam.

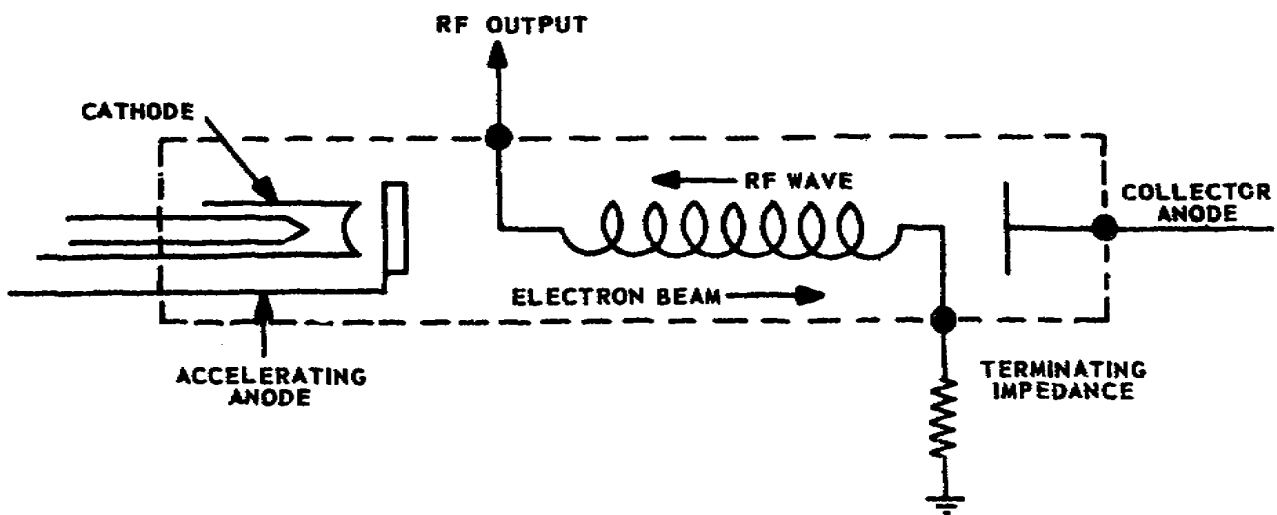

Figure 23. Backward-wave oscillator.

b. The bunched electrons now represent an RF signal being fed to the terminating impedance end of the helix. This starts a new signal traveling toward the cathode end of the helix. The new signal frequency causes bunching in the electron beam. Energy drawn from the beam causes amplification and oscillation at the new frequency. Since the electron beam can assume only one velocity at a time, the beam can give up energy to only one of the backward waves on the helix. The selection of the desired frequency depends on the velocity of the electron beam. This is determined by the difference of potential between the cathode and the accelerating anode. A change in this voltage will change the frequency of oscillation.

1-29. M-CROSSFIELD OSCILLATOR

a. Both the traveling-wave tube and the O-type backward-wave oscillator use a helix to reduce the axial velocity of the RF energy. The crossfield

oscillator, or carcinotron, reduces the axial velocity of the RF energy by means of a delay line. The delay line is developed from a waveguide as shown in figure 24. The movement of energy after the 6-foot section of waveguide has been folded to an overall length of 1 foot as indicated by S, S1 and S2.

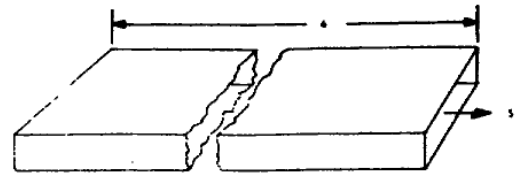

b. The phase velocity in a straight waveguide is comparable to the axial velocity of the RF energy. To have effective velocity modulation of the electron beam in a TWT, the axial velocity of the modulating signal (RF) must be reduced. To reduce the axial velocity of the RF energy in a waveguide, the waveguide is folded as shown in B of figure 24. Now the axial velocity of the RF energy has been reduced six times. Folding a waveguide is difficult and the result can be quite cumbersome. Instead of a folded waveguide, an interdigital delay line is often used to reduce the axial velocity of the RF signal. An interdigital delay line is shown in figure 25.

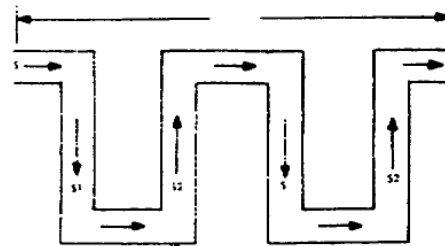

Figure 24. Folded waveguide.

c. The interdigital delay line can be considered as a specially designed waveguide that is open on the sides. The RF energy in the delay line has electromagnetic fields that appear at the open sides. This magnetic field will cause modulation (bunching) in the electron beam as the beam passes parallel to the delay line on its way to the collector.

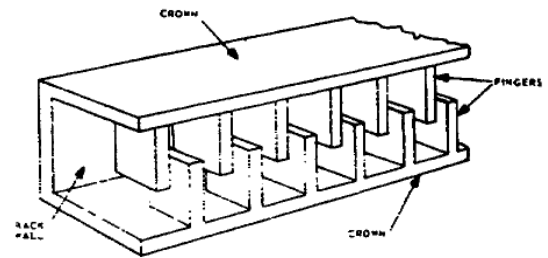

Figure 25. Interdigital delay line.

The phase shifting of the RF energy is shown in B of figure 24 where S1 and S2 have opposing directions in the delay line but have the same axial direction, S. The resultant RF field is similar to the one that is developed on the helix shown in figure 26.

d. The M-type backward-wave oscillator is represented in figure 27. The size of the electron beam is controlled by a beam-forming grid. The grid can control the number of electrons, but its main function is to control the size of the electron beam while the accelerating anode controls the velocity of the electrons. The magnetic field, B (which goes into the page in figure 27), is from a permanent magnet placed across the tube. The electric field, E, exists between the delay line and the sole of the tube. The sole of the M-type tube is a nonemitting electrode and is usually the same length as the

axial length of the delay line so that the electric field, E , is uniform over this length. The electric field and the magnetic field are crossed (at right angles to each other).

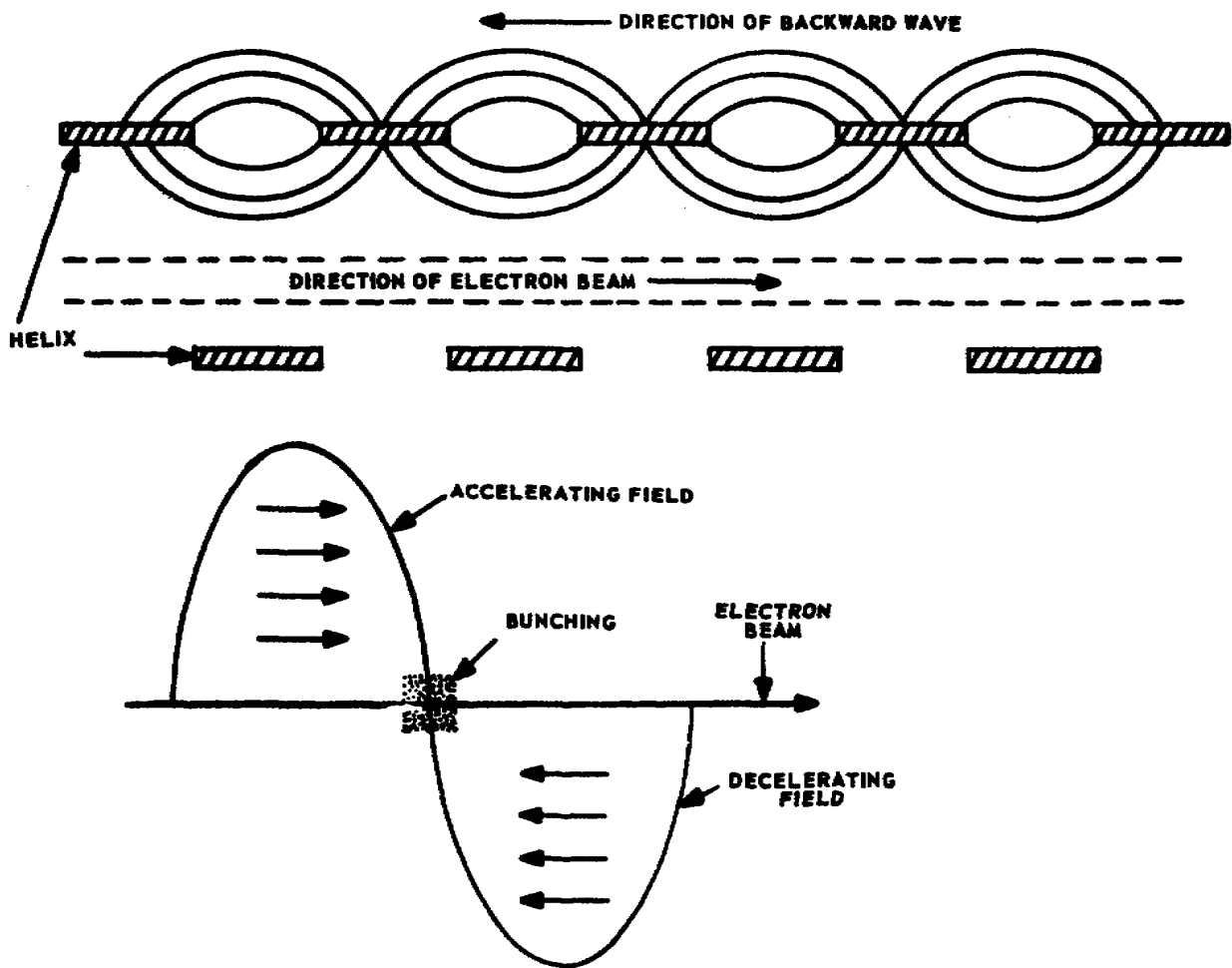

Figure 26. RF fields in a backward-wave oscillator.

e. When the electron beam leaves the electron gun, the magnetic field gives the beam a forward motion (toward the collector). The electric field exists between the delay line and the sole, and causes the electron beam to travel parallel to the delay line and the sole. As the electron beam comes under the influence of the RF fields on the delay line, bunching will start. As the electrons move down the tube, they also tend to move toward the delay line, giving up energy to the RF signal on the delay line. The RF output is taken from the cathode end of the tube because the RF energy in the delay line travels backward from the terminating impedance, opposite to the axial motion of the electron beam. There are many frequencies present on the delay lines but the one that will be amplified because of bunching is determined by either the sole voltage (which determines the strength of the electric field, E) or by the acceleration voltage which controls the velocity of the electrons.

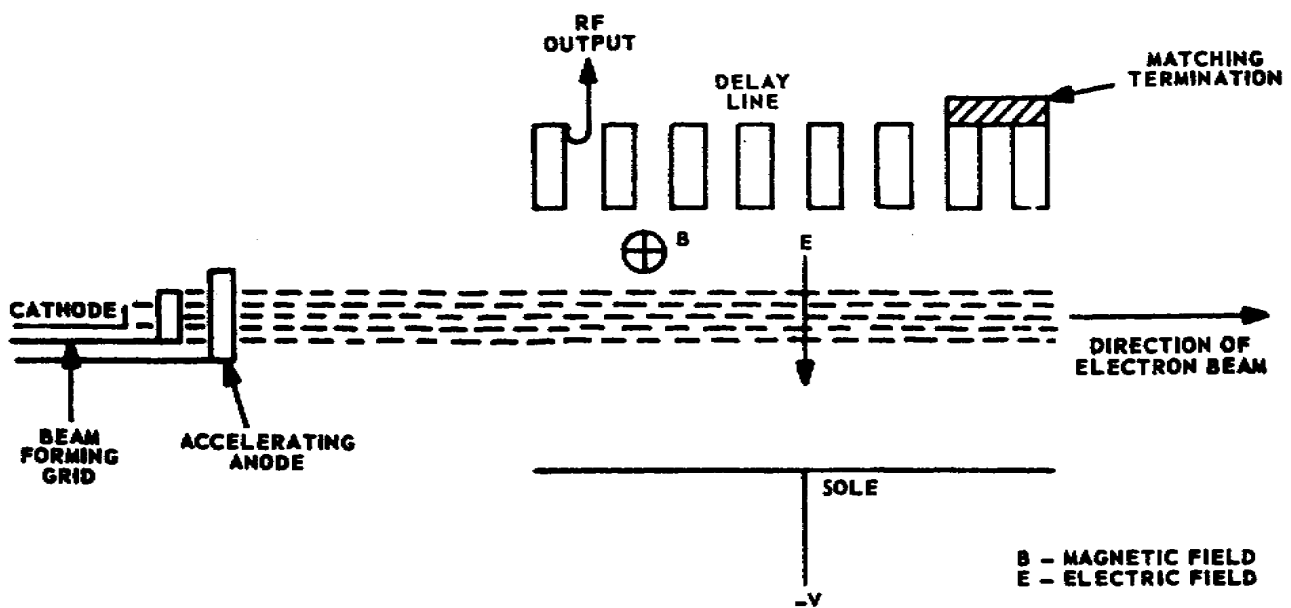

Figure 27. M-type backward-wave oscillator (carcinotron).

f. The M-type backward oscillator is most unusual in that it can be amplitude- or frequency-modulated. To amplitude-modulate this tube the accelerator voltage is modulated, and to frequency-modulate the tube, the sole voltage is modulated. The tube can also be amplitude- and frequency-modulated simultaneously.

Section VIII. PARAMETRIC AMPLIFIERS

1-30. INTRODUCTION

a. The gain of a device can be controlled by the use of a source (pump) frequency to control the device's inductive or capacitive parameter. Devices that produce signal gain through the control of the inductive or capacitive parameter are called parametric amplifiers. Instead of using dc power, as does a conventional-type amplifier, the parametric amplifier uses ac power to build up signal power. This principle is not new. Increased attention has been given to it in recent years as a result of the advanced developments of solid-state diodes.

b. With the long trunks used for communications, there is always considerable attenuation in the transmission path. The parametric amplifier allows us to make up for a weak signal by using an extremely low noise amplifier as the receiver preamplifier. A receiver with a parametric preamplifier may have a noise figure 12 decibels (db) below that of a conventional receiver. This 12-db improvement is equivalent to having increased transmitter power 16 times to achieve the same improvement in carrier signal-to-noise ratio.

1-31. NOISE REDUCTION

a. Parametric amplifiers are considered members of a large family of amplifiers known as reactance amplifiers. A resistor, even at room temperature, has a noise voltage developed across it. Any device that dissipates energy acts like a resistor and has a corresponding noise voltage. An ordinary electron-tube amplifier contains many dissipative components, and the electron tube itself presents an equivalent resistance to the circuit. These dissipative components all contribute noise to the amplifier. The amplification of a parametric amplifier, however, depends on the use of reactive components. A purely reactive component (capacitor or inductor) does not dissipate energy. Consequently, a parametric amplifier does not have the noise-producing, dissipative components of an electron-tube amplifier.

b. Since no component is purely reactive, some noise will be generated in a parametric amplifier. This noise, as in any dissipative element, arises from thermal agitation of the electrons within the element. By cooling a parametric amplifier to a very low temperature, it is possible to substantially reduce the thermal agitation of the electrons and the noise created thereby. Obviously, this technique would be impractical with an electron-tube amplifier, because an electron tube depends on a relatively hot cathode for its operation.

c. It should not be assumed that all parametric amplifiers are cooled. The improvement to be realized is often not worth the problems that arise with cooling a parametric amplifier. Generally liquid nitrogen, which is at 78° Kelvin (K) (-320° F), or liquid helium, which is at 4.2° K (-452° F), is used for cooling. Some of the representative noise figures for parametric amplifiers in the 8-gigahertz range are:

- (1) Uncooled, 3.0 db.
- (2) Mechanical refrigerator with liquid nitrogen cooled, 2.0 db.
- (3) Argon-nitrogen refrigerator cooled, 1.7 db.
- (4) If entire varactor assembly is immersed in liquid nitrogen (varactor diodes, waveguide, etc.), about 1.3 db.

1-32. OPERATION

a. Essentially, a parametric amplifier consists of a variable reactance device, an ac power source which supplies a pump frequency, and a signal source. The pump frequency is generally supplied by a reflex klystron oscillator. When a klystron is used for this purpose it is commonly called a pump klystron. The variable reactance converts the pump frequency into signal power, and thus produces amplification. This can be done by a variable inductance or capacitance. Parametric amplifiers that use a variable inductance are more commonly known as magnetic amplifiers. Our interest, however, is in parametric amplifiers that employ reverse-biased semiconductor diodes, which are variable-capacitance devices. Varactors and tunnel diodes are commonly used in parametric amplifiers.

b. Note in figure 28 that the pump voltage is applied across the diode. The diode is reverse biased so as to behave as a capacitor that changes with voltage. Thus, as the pump voltage varies at a high-frequency rate, so also does the circuit capacitance. The nonlinear variation of the capacitance with voltage causes a mixing (heterodyning) of the signal and the pump frequency. As a result, sum and difference frequencies, called idler frequencies, are produced.

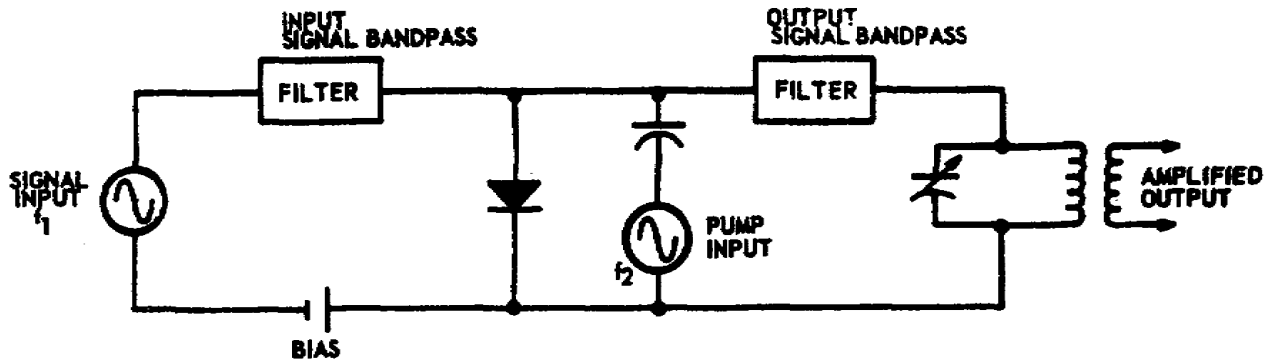

Figure 28. Parametric amplifier.

c. As a special case, we will consider only the idler difference frequency of the pump and signal frequency and stipulate that the pump frequency is twice the signal frequency. This makes the difference idler frequency equal to the signal frequency. Since the idler frequency receives power from the pump frequency and the idler has the same frequency as the signal, signal power is boosted. More specifically, we will assume a signal frequency of 100 megahertz (MHz) and a pump frequency of 200 MHz. When heterodyned, there is produced an idler frequency $200 \text{ MHz} - 100 \text{ MHz} = 100 \text{ MHz}$. This 100-MHz idler frequency can have far greater power than the 100-MHz signal input power because it obtains its power from the pump source. This means that it is possible to obtain an output power at 100 MHz, which is considerably more than the input signal power. Therefore, the signal is amplified.

d. Another viewpoint to explain the pump action is to regard the diode as a negative resistance (in other words, a generator source) to the signal. This viewpoint is justified inasmuch as a mathematical analysis of the heterodyning action shows that the variable-capacitance diode presents a positive resistance to the pump frequency and a negative resistance to the signal frequency. A gain is obtained when a device acts as a negative resistance.

e. The simple amplifier shown in figure 28 illustrates the principle of the parametric amplifier. However, this particular circuit is not practical because it requires that the proper phase and frequency relationship between the signal and pump frequencies be maintained. This relationship holds that the pump frequency must coincide with the positive and negative peaks of the input signal. While this phase and frequency relationship is required for maximum transfer of energy, amplification can still be obtained when the relationship is not maintained. If the pump frequency is not twice the signal frequency, sum and difference frequencies result from the heterodyning of the two frequencies.

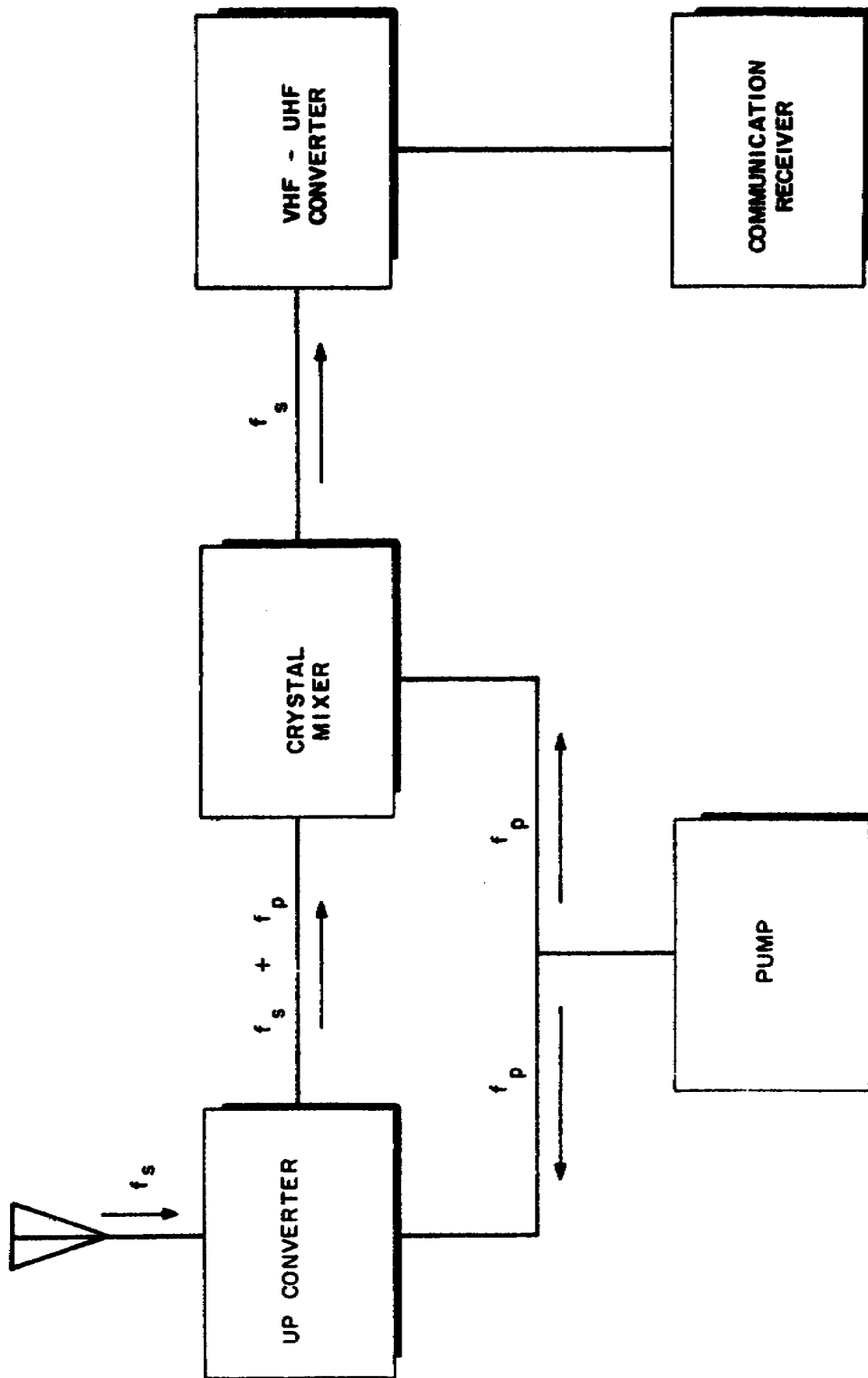

Figure 29. Parametric amplifier used as an up-converter.

f. The sum frequency can be referred to as the upper sideband, and the difference frequency as the lower sideband. Amplification takes place at the signal frequency and at both sideband frequencies. The relationship between the pump and input signal frequencies determines the relative amplifications produced at the resulting frequencies.

g. One frequently used parametric amplifier is the up-converter amplifier. In the up-converter, so named because the output is taken at a higher frequency than the input signal frequency, the pump frequency is many times the signal frequency. Consequently, both the upper and lower sidebands are much higher than the signal frequency, and most of the amplification takes place in the sidebands. Either the upper or lower sideband in the up-converter can be used.

h. Figure 29 is a block diagram of a typical up-converter parametric amplifier using the upper sideband. The signal arriving at the antenna is designated f_s . It is mixed with the pump frequency f_p in the up-converter, and the amplified output frequency is then at a frequency f_s plus f_p . This is then mixed in a conventional crystal mixer with the pump frequency, and the difference frequency, f_s , is selected and passed on to a converter. The converter heterodynes the signal down to a frequency where a conventional communication receiver can process the signal.

SECTION IX. KLYSTRON THEORY

1-33. INTRODUCTORY INFORMATION

a. The reflex klystron tube operates as a low-power RF oscillator in the microwave region (from 1 GHz to 10 GHz). Because of its low power characteristic (1 watt or less), the reflex klystron's application is limited to receivers, test equipment and low power transmitters.

b. The reflex klystron, however, is one of the two basic types of klystrons within a large klystron family. The other basic type is known as the high-power multicavity klystron. Unlike the one-cavity reflex klystron, the multicavity klystron has two or more cavities.

c. Because of its microwave high-power handling capability, the multicavity klystron is used in many microwave electronic systems such as in tropospheric and ionospheric scatter systems and in satellite communications systems. Multicavity klystrons are also used extensively in fixed radar installations and in UHF television.

1-34. TYPICAL MULTICAVIDITY KLYSTRONS

a. Figure 30 shows two typical multicavity klystrons. Their size and shape largely determine their operating frequency and power handling capability. Smaller klystrons operate at higher frequencies and larger klystrons have the higher power handling capability.

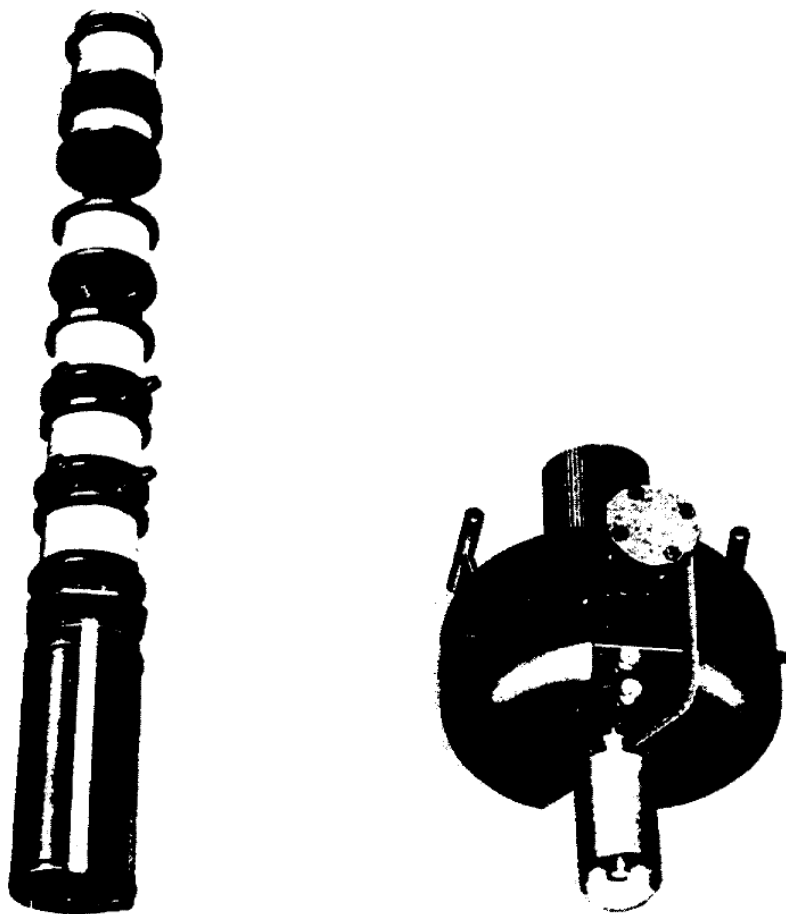

Figure 30. Typical multicavity klystrons.

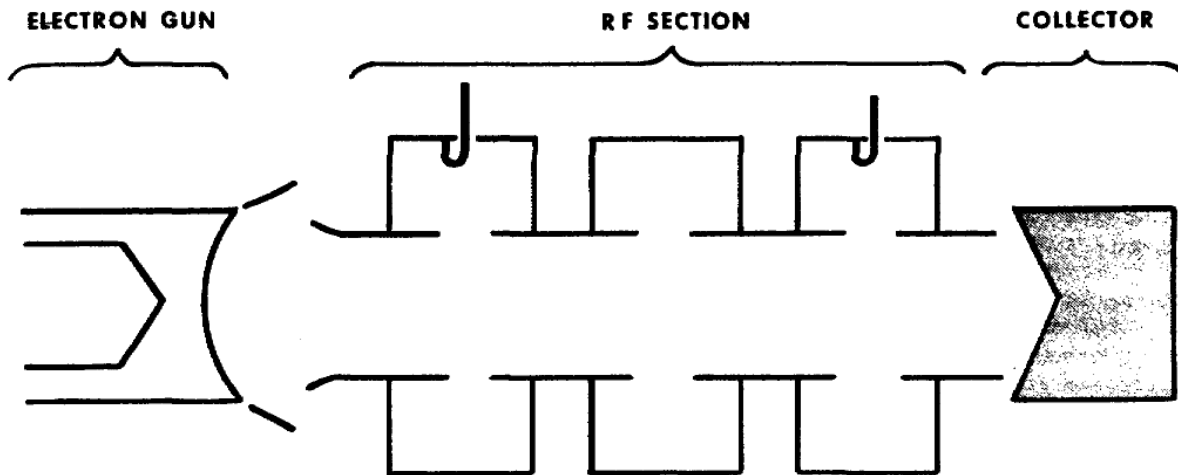

Figure 31. Functional sections of multicavity klystron.

b. Figure 31 shows a typical klystron divided into its three functional sections: the electron gun, the RF section and the collector. We will discuss the function of each section in the following paragraphs.

1-35. FUNCTION OF THE ELECTRON GUN

a. The electron gun (fig 32) is the source of an electron stream. The action of the electron gun causes electron acceleration and focusing because of the way it's constructed. This is what happens.

(1) The heated CATHODE emits electrons. The amount of electron acceleration is due, in part, to the filament (heater) that heats the cathode. The cathode's emitting surface is concave. This causes the electron trajectories and helps to focus the electron stream into a narrow beam.

(2) A cylindrical FOCUS electrode surrounds the cathode. The focus electrode is kept either at cathode potential or at some negative potential with respect to the cathode. This causes a squeezing effect on the electron stream to focus the stream into a narrow beam along the axis.

(3) The cup-shaped MODULATING anode provides a "funnel" through which the electrons flow. The modulating anode potential is positive with respect to the cathode, and therefore causes the electrons to flow away from the cathode toward the anode itself.

b. The combined effects of the curvature of the cathode disc, the focus electrode, and the modulating anode give an overall effect of an electrostatic lens within the electronic gun. The electrostatic lens focuses the electron beam into the first drift tube section.

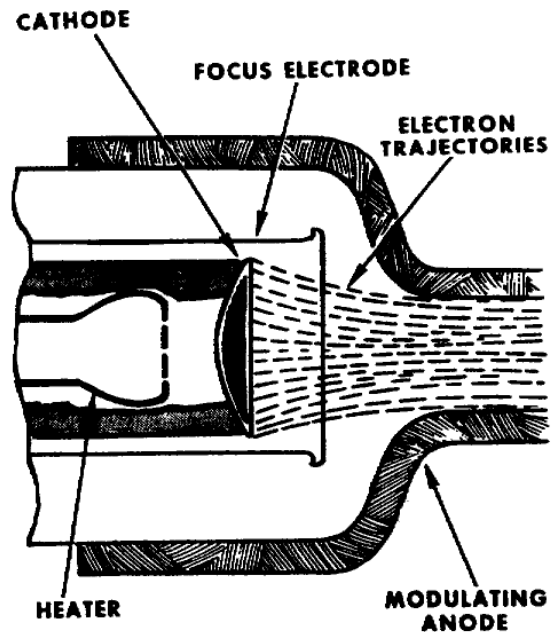

Figure 32. Simplified view of electron gun.

1-36. FUNCTION OF THE RF SECTION

The RF section (fig 33) includes a DRIFT TUBE, and from 2 to 6 RESONANT CAVITIES placed at intervals along the tube. In addition to the drift tube and resonant cavities, the RF section usually includes a magnetic field coil assembly (not shown). The combined action of the RF section's components permits velocity modulation of the electron beam. In turn, the velocity-modulated electrons become density modulated and electron bunches form that cause a large amount of microwave power amplification for the output.

1-37. THE DRIFT TUBE

The drift tube has a number of gaps (fig 33) at intervals along its length. The number of gaps equals the number of resonant cavities. For example, if there are three resonant cavities, there will be three gaps. The resonant cavity surrounds each gap and the ends of the drift tube sections extend inside the cavity. Electrons flowing through the drift tube cannot escape through the gaps into the cavities because each gap is covered by a ceramic window seal. The ceramic window seal also maintains a vacuum inside the drift tube.

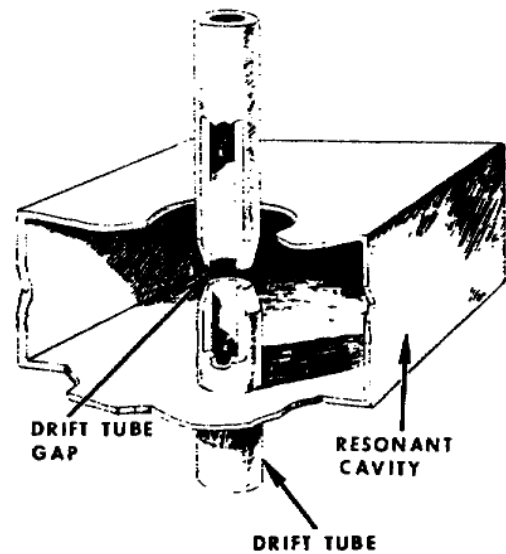

Figure 33. Resonant cavity surrounding drift tube gap.

1-38. THE RESONANT CAVITY

Resonant cavities are hollow chambers with conducting walls. They come in various sizes and shapes (rectangular, circular, etc.) depending on the application. The kind of resonant cavity used in a typical high-power klystron is as shown in figure 34.

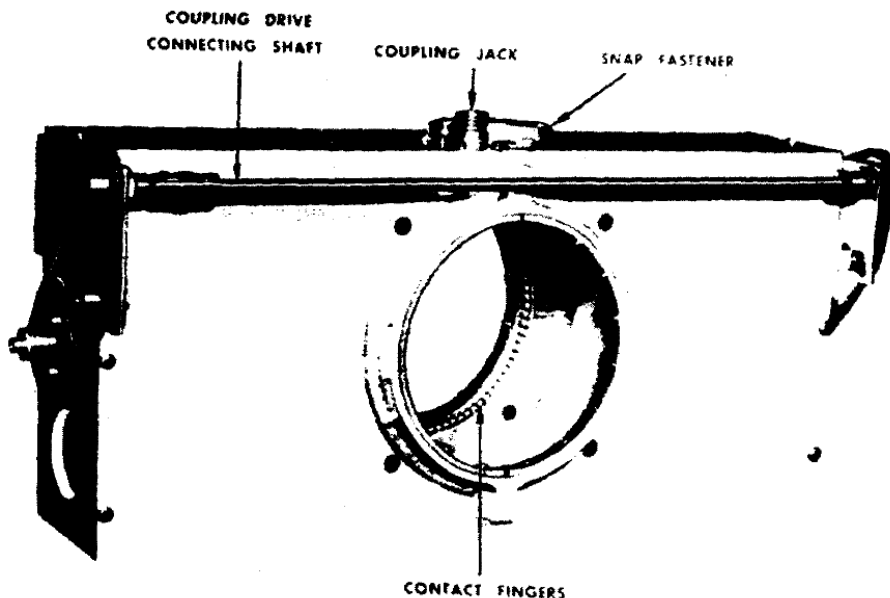

Figure 34. Resonant cavity used in typical high power klystron.

b. The resonant cavity is to the klystron amplifier as the LC tuned circuit is to the conventional electron tube amplifier. In fact, in the microwave frequency region, the resonant cavity replaces the LC tuned circuit as a frequency determining device. The frequency determining device for ultra-high frequencies (UHF) requires extremely small values of capacitance and inductance. This means that the resonant cavity has capacitive and inductive properties.

c. You'll recall that when electrical energy is applied to a capacitor, an electric field builds up between its plates. Likewise, when electrical energy is applied to a resonant cavity, an electric field builds up between its inner walls. A representation of the electric (E) field within a rectangular cavity is shown in A of figure 35. The electric field exists because a potential difference is developed within the cavity between its upper wall and lower wall. By use of appropriate measuring instruments, you can determine the point of greatest potential difference. As in A of figure 35, the point of greatest potential difference between the upper and lower walls is where the electric (E) field intensity is greatest -- at the exact center between the upper and lower walls.

d. When we charge a capacitor, it takes a definite amount of time before the potential difference (electric field) builds up to maximum between the capacitor plates. The time required for the electric field to reach maximum intensity is equal to the time required for the electrons on one plate to move to the other plate. A similar action occurs within the resonant cavity when you apply electrical energy between its inner walls. While the electric (E) field is building up to maximum intensity between two opposite walls, electrons flow between the same walls. For example, let's consider the actions of the electric (E) field and electron flow within the cavity shown in B of figure 35. While the electric (E) field is building up between the upper and lower walls, electrons flow from the lower wall, along the four vertical walls, to the upper wall. Therefore, the upper wall becomes negative with respect to the lower wall, because of the excess of electron accumulation on the upper wall. In reality, the paths of electron flow extend over the entire surface

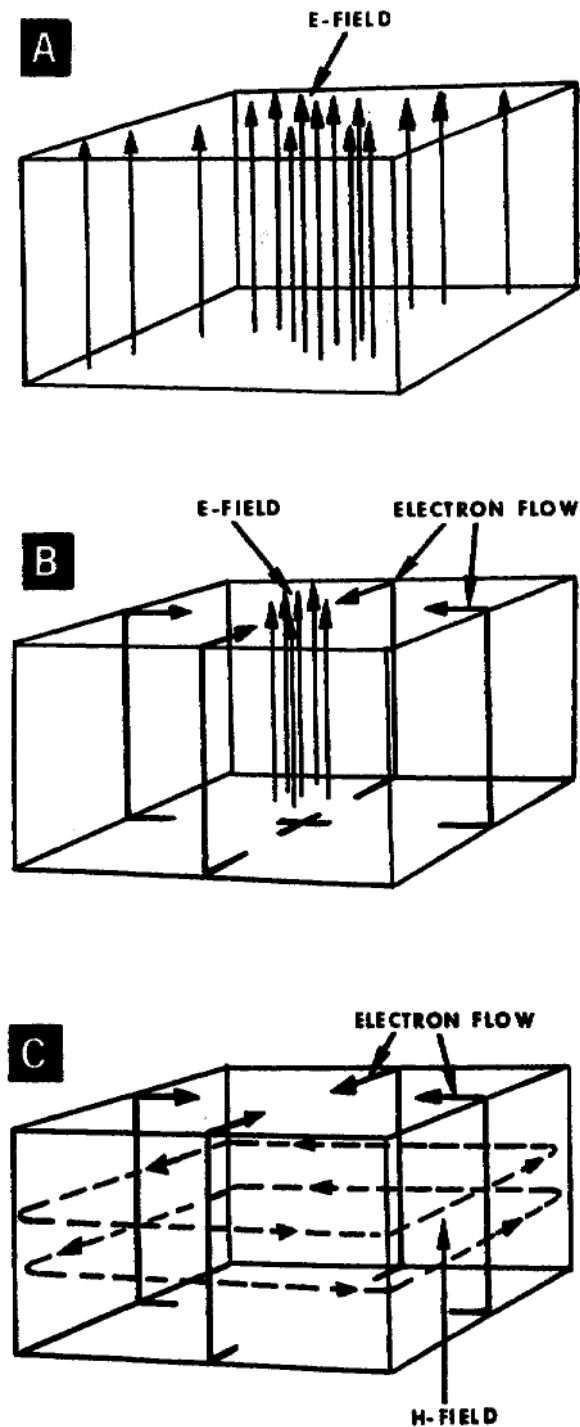

Figure 35. Resonant cavities' E-field (A), E-field and electron flow (B), and electron flow and H-field (C).

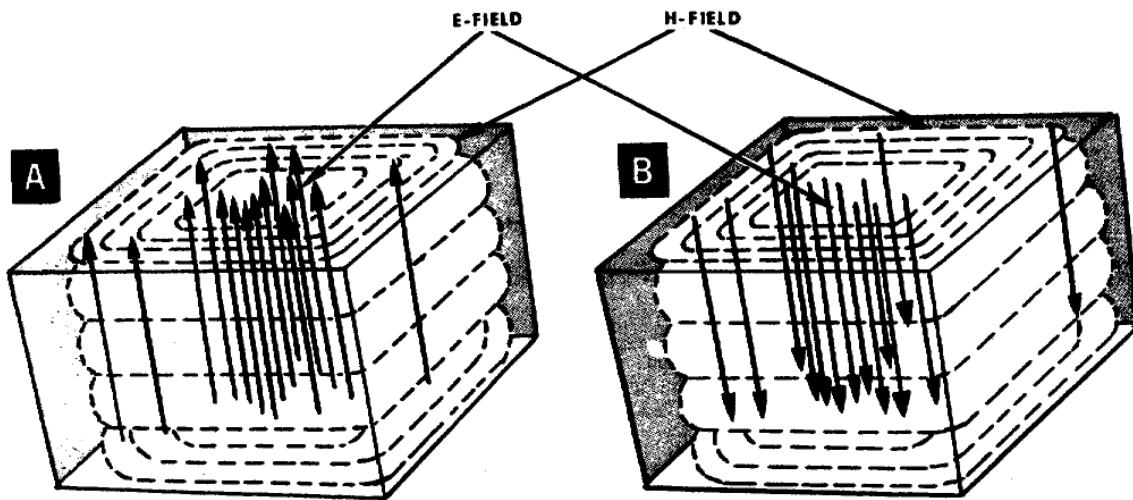

Figure 36. Electric and magnetic field pattern for alternate half-cycles.

of the low resistance conducting wall. The walls are coated with a low resistance material to make them good conductors.

e. Because the cavity's four vertical walls are actually conductors along which electrons flow, a magnetic (H) field exists within the cavity. The electron flow generates the magnetic field. The magnetic (H) field loops are in a direction perpendicular to the direction of electron flow in the vertical walls, as shown in C of figure 35.

f. The electric and magnetic field combination represents the presence of voltage potential difference and current flow within the cavity. The voltage and current buildup and collapse in the resonant cavity just like they do in the ordinary LC circuit. Within the cavity, both the voltage polarity and direction of current flow alternate. The alternating voltage polarity causes an alternating electric (E) field; the alternating current flow causes an alternating magnetic (H) field. For example, the diagram in A of figure 36 represents the alternating electric (E) and magnetic (H) field combination during one-half cycle. The diagram in B of figure 36 represents the E and H field combination during the next half cycle.

g. The electric (E) and magnetic (H) field patterns as shown in figure 36 represent one of many possible operating modes of resonant cavities. The operating mode for any particular resonant cavity largely depends upon two factors: the cavity design

and the operating frequency being used with the cavity. The pattern shown in figure 36, however, represents the most efficient mode. And to simplify our discussion in this text, we will cover only one operating mode -- the one represented in figure 36.

1-39. CAVITY - DRIFT TUBE ASSEMBLY

a. The drift tube sections extend through the center of the larger walls of the resonant cavity as shown in figure 37. This narrows the center spacing between the larger walls is equal to the space or width of the drift tube gap. Thus, the drift tube gap

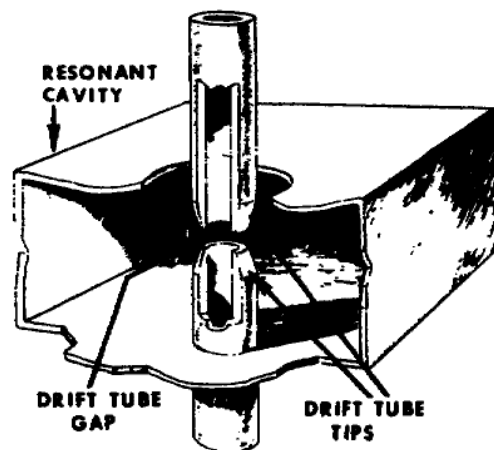

Figure 37. Drift tube sections.

(inside the cavity) is the capacitive element of the resonant cavity. In addition, the center area between the larger walls is where the electric (E) field intensity and voltage potential difference are greatest. The drift tube gap, therefore, is the point of highest potential difference within the resonant cavity.

b. A potential occurs across the drift tube gap when, and only when, the resonant cavity oscillates. Because of the oscillations, electrons flow from one tip of the drift tube to the other. An example of the electron path during one-half cycle is shown in A of figure 38. Remember that the electrons make a sweeping path over the entire surface of the cavity walls. The upper tip of the gap becomes negative with respect to the lower tip because of the accumulation of electrons on the upper tip.

c. For the same half cycle, B of figure 38 represents the electric field extending from the positive tip to the negative tip. The intensity of the electric field is greatest between the drift tube tips.

d. Also for the same half cycle, C of figure 38 represents the magnetic (H) field. The intensity of the magnetic field is greatest near the surface of the walls because of the heavy current flow along them.

e. The electric (E) and magnetic (H) fields for one-half cycle are represented in A of figure 39. On the next half cycle, the direction of current flow reverses and the E and H fields also reverse as shown in B of figure 39. So you can see that the E and H fields periodically change in direction as well as in intensity.

f. Because of the resonant cavity characteristics, the electric and magnetic fields can make these periodic changes or oscillations at the rate of millions of times per second. However, energy must be supplied to the resonant cavity in order to keep the oscillations going. Otherwise, the oscillations will eventually stop because of the small amount of cavity resistance that dissipates energy. The resonant cavity in the high power klystron can use either of two kinds of energy sources (paras 9-11 below) for starting and sustaining oscillations.

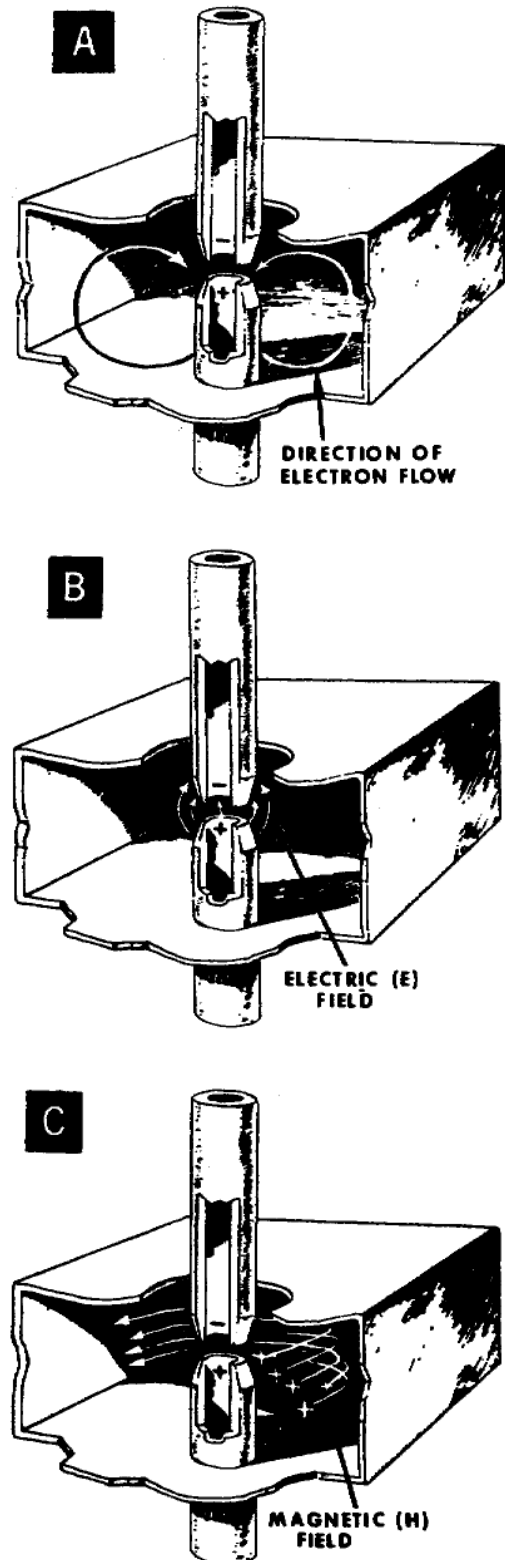

Figure 38. Drift tube protrusion intensifies field pattern.

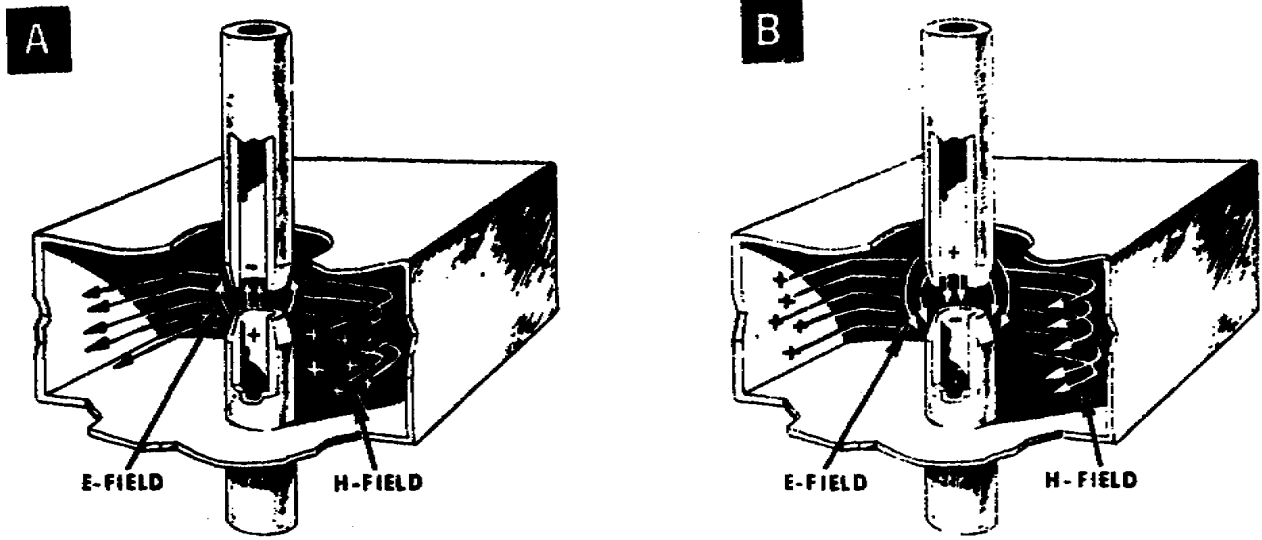

Figure 39. Electric and magnetic field combination for alternate half-cycles in high-power klystron cavity.

1-40. ENERGY SOURCES FOR CAVITY EXCITATION

Cavity excitation means that you provide electrical energy to cause oscillating electric and magnetic fields within the resonant cavity. Both alternating current (ac) and direct current (dc) energy is required. The ac is usually microwave (RF) power because it is already ultrahigh frequency power when fed into the cavity. The dc is commonly called beam energy because it is the energy supplied to the cavity by the electron beam focused through the drift tube.

1-41. CAVITY EXCITATION WITH MICROWAVE POWER

a. There are several ways to excite the cavity with ac (microwave) power. Some examples are by loop coupling, probe coupling, and waveguide or window coupling. In this text, we will use the loop coupling method.

b. You can easily recognize when the cavity is using loop coupling for its input (or output), because the loop connects to a jack on one of the cavities' four narrow walls, as shown in figure 40. The loop is simply the end of the inner conductor of an input line, bent and fastened to the

cavity wall. Because of its shape, the loop acts like the primary circuit of an ordinary transformer.

c. The ordinary transformer transfers energy from its primary to its secondary circuit by magnetic induction. Loop coupling uses the same principle. The energy gets from the loop to the inner wall of the cavity by magnetic induction.

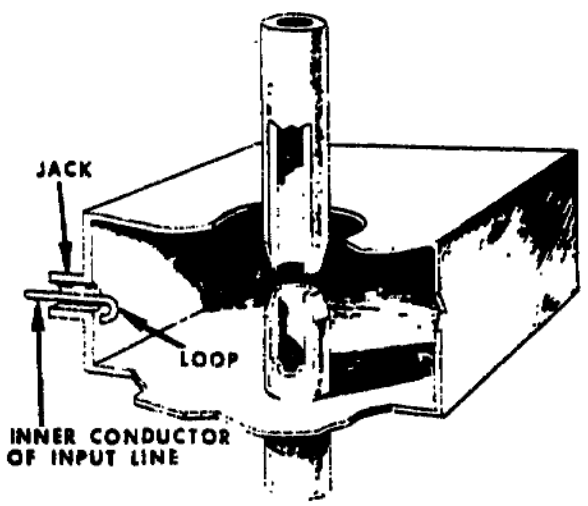

Figure 40. Coupling loop connects to jack on cavity's narrow wall.

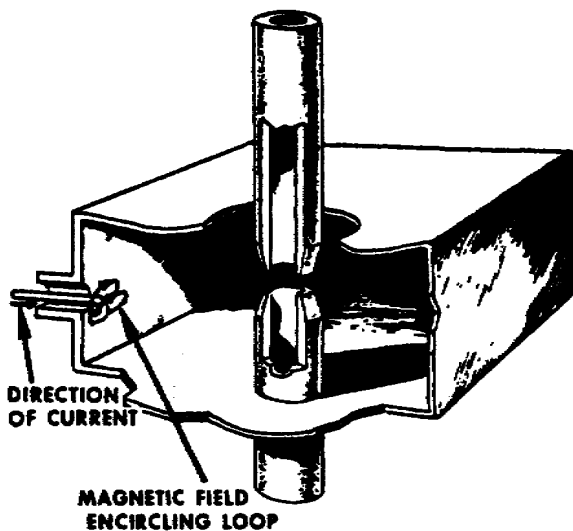

Figure 41. Coupling loop has circling magnetic field because of its current flow.

(1) The microwave (RF) power source causes alternating current flow through the loop.

(2) Current flow in the loop causes a strong magnetic field that encircles the loop as shown in figure 41. This magnetic field expands and contracts.

(3) Because the motion of the magnetic field is against the inner wall of the cavity where the loop is connected, an alternating (RF) current flow is induced on the surface of that wall.

(4) The RF current flow, in turn, causes alternating electric and magnetic fields within the cavity (para 8b).

(5) The amount of RF power applied to the cavity determines the intensity of the resultant electric and magnetic fields. The RF input frequency must also be at or near the resonant frequency of the cavity.

1-42. CAVITY EXCITATION WITH DC (BEAM) ENERGY

a. Excitation of the cavity with dc energy is provided by the high velocity dc electron beam focused through the drift tube. Electrons in the beam cannot escape through the drift tube gaps because of the ceramic windows that seal the gaps. However, the drift tube gap permits dc energy

coupling into the cavity. The energy that the electron beam gives up to the cavity starts and sustains oscillations within the cavity. For example, consider the action of a single electron as it travels past the region of the drift tube gap. First let's consider a property of the traveling electron and also the drift tube through which it travels. The electron traveling through the drift tube is a moving negative charge. The drift tube, because it is a good conductor, contains free electrons that can become moving negative charges, if they are attracted by a positive charge or repelled by a negative charge. Figures 42 through 44 show a series of actions as the traveling electron approaches and passes beyond the drift tube gap, as explained below. The drift tube tips are labeled with letters (L and R) to simplify the explanation.

(1) Figure 42 shows the electron at L approaching the edge of the gap. As it approaches the gap, it repels the free electrons from tip L, through the cavity wall surface, and to tip R. Example paths of the free electrons flow are shown by the arrows along the cavity walls. Electrons flowing in this direction cause tip R to become negative with respect to tip L.

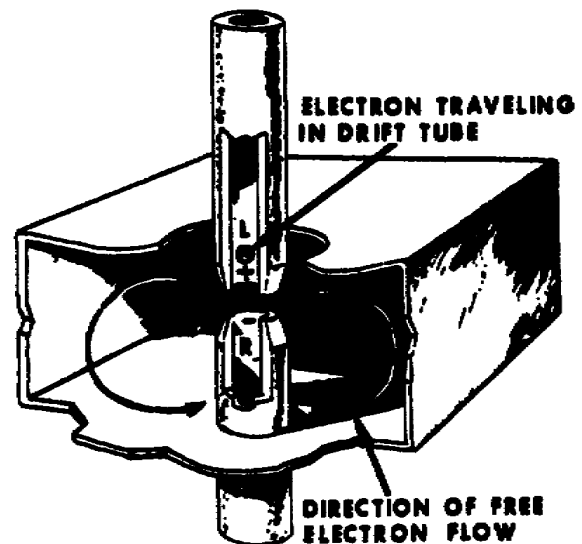

Figure 42. Electron approaches gap.

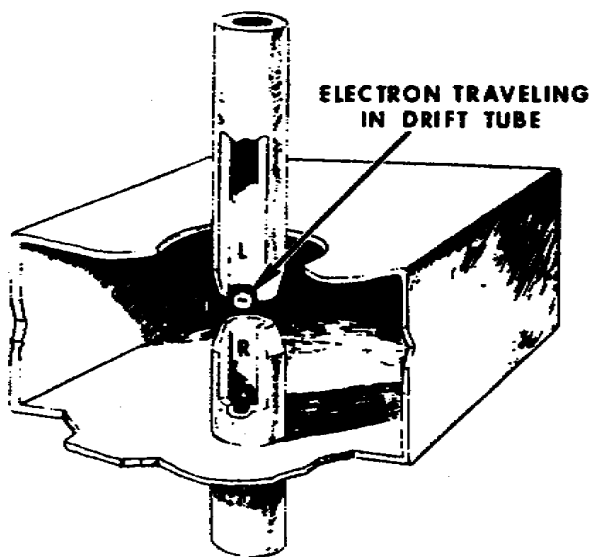

Figure 43. Electron in gap.

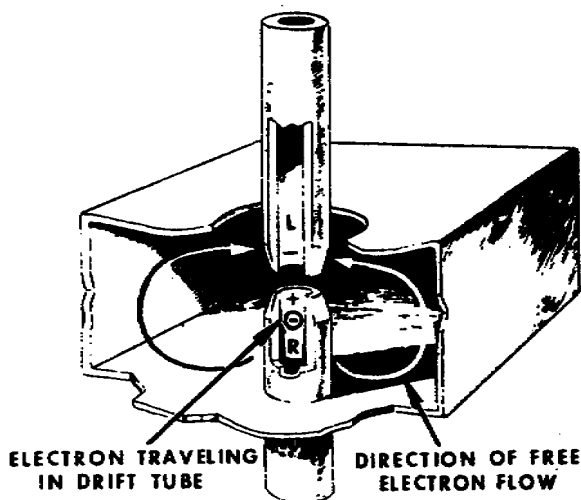

Figure 44. Electron passes through gap.

(2) Figure 43 shows the time instant when the electron is in the gap. At this time, the traveling electron repels the free electrons in both tips equally. Therefore, the net current flow is zero and there is zero potential difference between the tips.

(3) Figure 44 shows the time instant just after the electron has passed beyond the gap on the side of tip R. The electron repels the accumulated free electrons in tip R. You'll recall that tip R received some free electrons from tip L. Because

the traveling electron is at tip R, the free electrons redistribute themselves along the indicated paths toward tip L.

b. In reality, instead of a single electron, a "bunch" of electrons passes the gap at one time. The bunch occurs periodically. Each electron bunch that passes the gap causes a large number of free electrons to move within the cavity, as in (1) through (3) above. The electron movement within the cavity causes a large alternating potential difference between the drift tube tips. The alternating potential difference, in turn, causes oscillating electric and magnetic fields within the cavity. Repeated electron bunches passing the drift tube gap sustain the oscillations in the cavity.

c. The klystron's operation depends upon dc energy, more than it does ac energy, to excite and sustain the cavity oscillations. The dc electron beam supplies some energy to each cavity surrounding the drift tube. Therefore, the beam's net energy levels decreases as it travels from the electron gun to the collector.

1-43. FUNCTION OF THE COLLECTOR

a. The electron beam gives up some of its energy to sustain oscillation in the klystron's RF section. But the balance of its energy is carried through to the collector. The collector operates at ground potential; however, it may be a 100 kv or more positive with respect to the cathode. The collector-to-cathode potential enables the collector to gather the electrons and pass them out of the klystron to an external circuit that leads to a beam power supply.

b. A large amount of kinetic energy still remains with the electrons as they reach the collector. These electrons strike the collector with great impact and cause the collector to become hot. To get rid of accumulated collector heat, air or a liquid coolant, such as water, is used to cool the collector. Some high power klystrons may use both air and liquid coolants. The liquid coolants do not affect the operation of the klystron because the collector operates at ground potential.

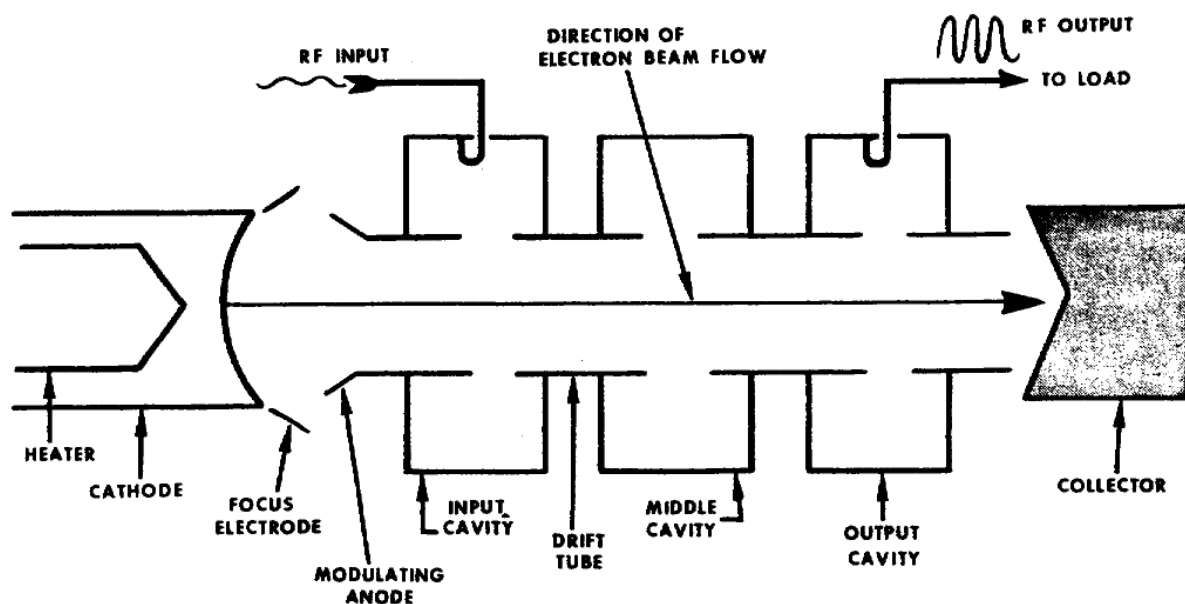

Figure 45. Only the input cavity of klystron has RF input.

Section III MULTICAVIDY KLYSTRON AMPLIFIER

1-44. GENERAL

Figure 45 is a schematic diagram of a three-cavity klystron with its cavities arranged in cascade. The three resonant cavities are: the input cavity; the middle or intermediate cavity; and, the output cavity. A cavity surrounds each of the three gaps along the length of the drift tube, through which the electron beam flows. For the purpose of the following discussion, figure 45 represents the multicavity klystron.

1-45. PURPOSE FOR CASCADE ARRANGEMENT OF CAVITIES

a. Like the cascade arrangement of electron tube amplifiers, the multicavity klystron uses two or more resonant cavities in cascade to obtain an increase in power gain. The cascade arrangement means that the cavities are situated such that there will be a series of interactions between the cavity electric (E) fields and the electron beam.

b. The klystron begins the operation with the input cavity. The input cavity contains an

electric field because of the RF input as shown in figure 45. The RF input power is much less than the dc power of the electron beam. This means that the klystron's operation must begin with an interaction between a very low power electric field and a high power electron beam.

c. During the electric field and electron beam interaction, the beam takes some RF energy from the electric field and the electric field, in turn, takes some dc energy from the beam. Eventually, the middle and output cavities also become sources of electric fields through dc excitation (para 11) and a similar interaction occurs between their electric fields and the beam. Now, the electron beam exchanges energy with electric fields of three cavities. The output cavity, however, delivers large amounts of RF power to the load. This is evidence that the beam expends most of its energy in the output cavity. That is why we arrange the cavities in cascade, so that they can extract most of the energy from the electron beam that flows through the drift tube. The following paragraphs explain how the cavities take power from the electron beam.

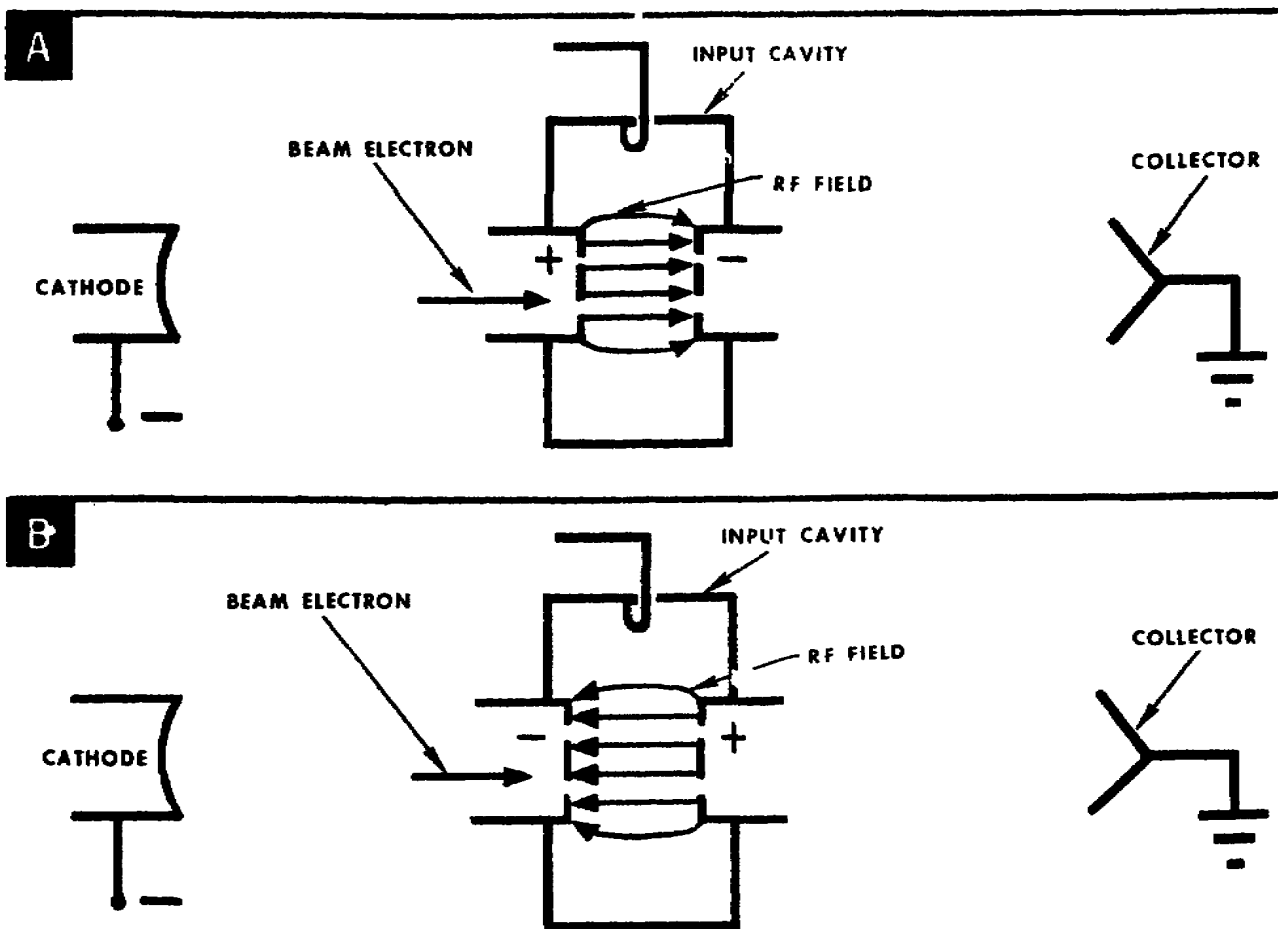

Figure 46. Varying electric field at drift tube gap causes velocity changes in beam electrons.

1-46. ELECTRON VELOCITY MODULATION

a. Because of the interaction between the electron beam and cavity electric fields, some of the beam electrons accelerate and others decelerate. This process is known as velocity modulation. For example, let's consider what happens to the electron beam as it passes the first gap in the drift tube. That's the gap surrounded by the input cavity. The diagrams in figure 46 will help you to understand how a varying electric field causes velocity changes in the beam electrons.

b. In each diagram (A and B of figure 46), the dotted lines represent the grids at the tips of the drift tube. This means that the electron beam passes through a pair of grids whenever it passes a drift tube gap. The grids are made of the same conducting material as the drift tube. For this

reason, the microwave (RF) voltage applied to the input cavity causes a varying electric field (para 10c) between the grids inside the input cavity.

c. Part A of figure 46 shows the half cycle during which the RF field is in the same direction as the beam electrons' movement. However, the RF field exerts a force that causes a velocity decrease in the beam electrons as they travel past the positive grid toward the negative grid.

d. Every other half cycle, the input cavity grids will have the polarity as shown in A of figure 46. On alternate half cycles, the grids reverse polarity as shown in B of figure 46. The RF field, therefore, causes the beam electrons to accelerate. That's because the beam electrons go past the negative grid toward the positive grid.

e. All of the electrons emitted by the cathode have a constant velocity until they reach the RF field across the drift tube gap. The interaction between the electrons and the RF field results in beam electron velocity changes. The beam electron velocity decreases (c, above) because the beam electrons lose energy to the RF field. The beam electron velocity increases (d, above), because the electron beam gains energy from the RF field. The RF input voltage causes the RF field across the first gap in the drift tube. Therefore, the RF input voltage starts velocity modulation. This is true because the first gap in the drift tube is where the beam electrons undergoes the first velocity change, while flowing through the drift tube.

f. The middle and output cavities also cause velocity modulation of the beam electrons. And, like the input cavity, middle and output cavities require excitation. However, instead of excitation by the RF input, the middle and output cavities are excited by the velocity modulated electrons passing through the drift tube (para 11).

g. After they are excited, the middle and output cavities have varying RF fields. The interactions between the beam electrons and RF fields of these cavities are similar to that described for the input cavity (c and d above). Each cavity RF field causes some electrons to accelerate, some to decelerate; while others are unaffected. This means that beam electrons, passing an RF field, will either move faster, slower or remain unchanged. Now let's consider what happens to the electrons that have a change in velocity.

1-47. ELECTRON DENSITY MODULATION

a. First, we'll consider the beam electrons in the drift tube region between the first and second gaps in the drift tube. These are the gaps surrounded by the input and middle cavities. The faster (accelerated) electrons overtake the slower (decelerated) electrons at some time after passing the first gap. When the faster electrons catch up with the slower electrons, electron bunching occurs. These bunched electrons undergo another velocity change while passing the second gap which causes an action similar to that of the first gap.

b. As in the region between the first and second gap, electron bunches occur between the second and third (last) gaps. In this region, the electron bunch has a greater density because the middle cavity RF field is stronger than the input cavity RF field.

c. In reality, the beam electrons bunch and debunch periodically. This process is called electron density modulation. Density modulation is a result of velocity modulation.

d. The diagram in figure 47 shows that the electron density modulation begins after the electrons pass the first gap in the drift tube. Notice that the electron bunch at the output cavity has the greatest density. The output cavity, therefore, absorbs most of the energy from the electron beam because of the successive bunching effect.

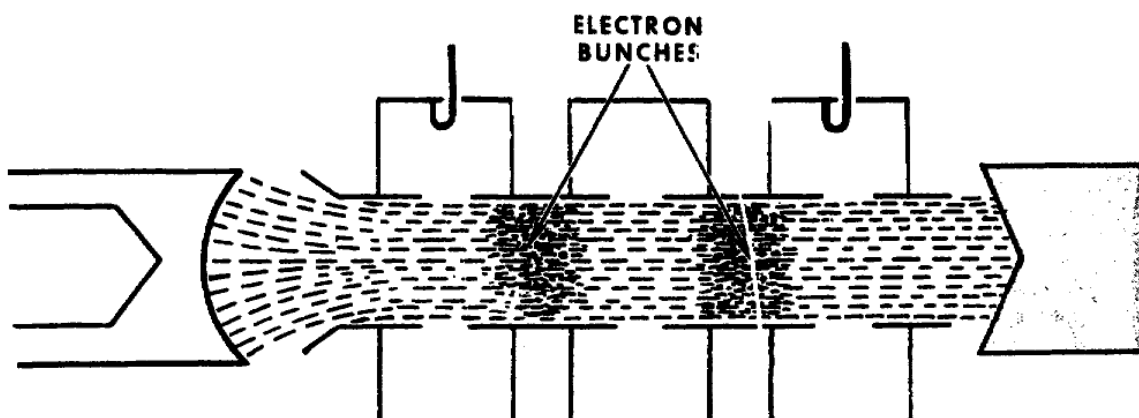

Figure 47. Density modulated electrons form electron bunches.

e. The RF output depends on the amount of energy that the electron beam gives to the output cavity. The energy to the output cavity, in turn, depends on the density of the electrons as they approach the output cavity region. Electron velocity and drift time are two factors that contribute to the beam's density. This means that the drift tube's length has an effect on the density of the beam. Although a longer drift tube allows better bunching, the electron transit time (between cathode and collector) increases as the drift tube becomes longer. Odd as it may seem, this is a desirable feature. You'll recall that long transit time causes ordinary electron tubes to be less efficient at microwave frequencies. However, efficient operation of the multicavity klystron largely depends on long transit time. For example, the electron transit time for a multicavity klystron may exceed the time for several cycles of the klystron's cavity RF voltage as explained below.

1-48. ELECTRON MODULATION CONCEPT

a. The graph in figure 48 is a simplified Applegate diagram. The vertical dimensions of the graph represent the distance that the beam electrons travel through the drift tube. The horizontal dimensions represents the time for the beam electrons to travel the total length of the tube. Three sinusoidal waves represent the three cavities' RF voltages or voltage variation across the three gaps in the tube. Each of the three diagonal lines represents the distance of travel per given time for the beam electrons. Each line, therefore, shows the instantaneous velocity of a group of electrons.

b. Any change in slope (or bend) of a line indicates a change in velocity. For example, an upward bend indicates acceleration; whereas, a downward bend indicates deceleration.

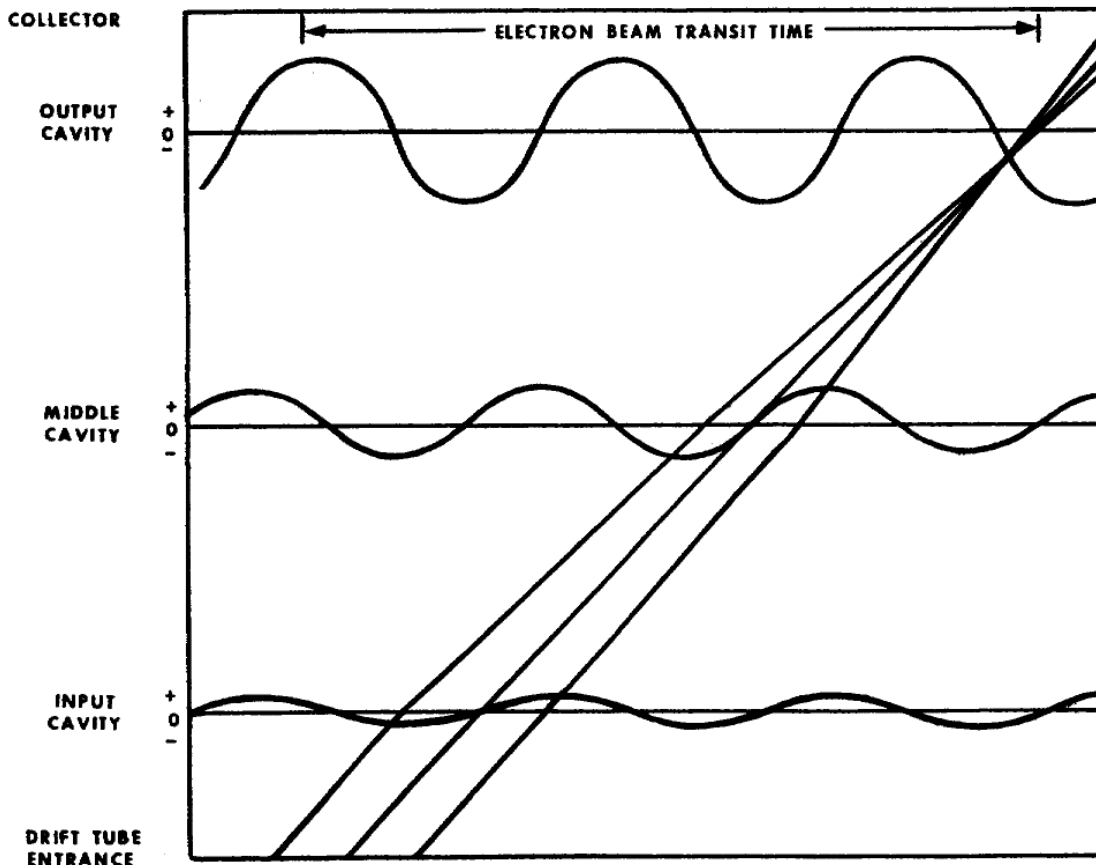

Figure 48. Electron beam transit time exceeds time for three RF cycles.

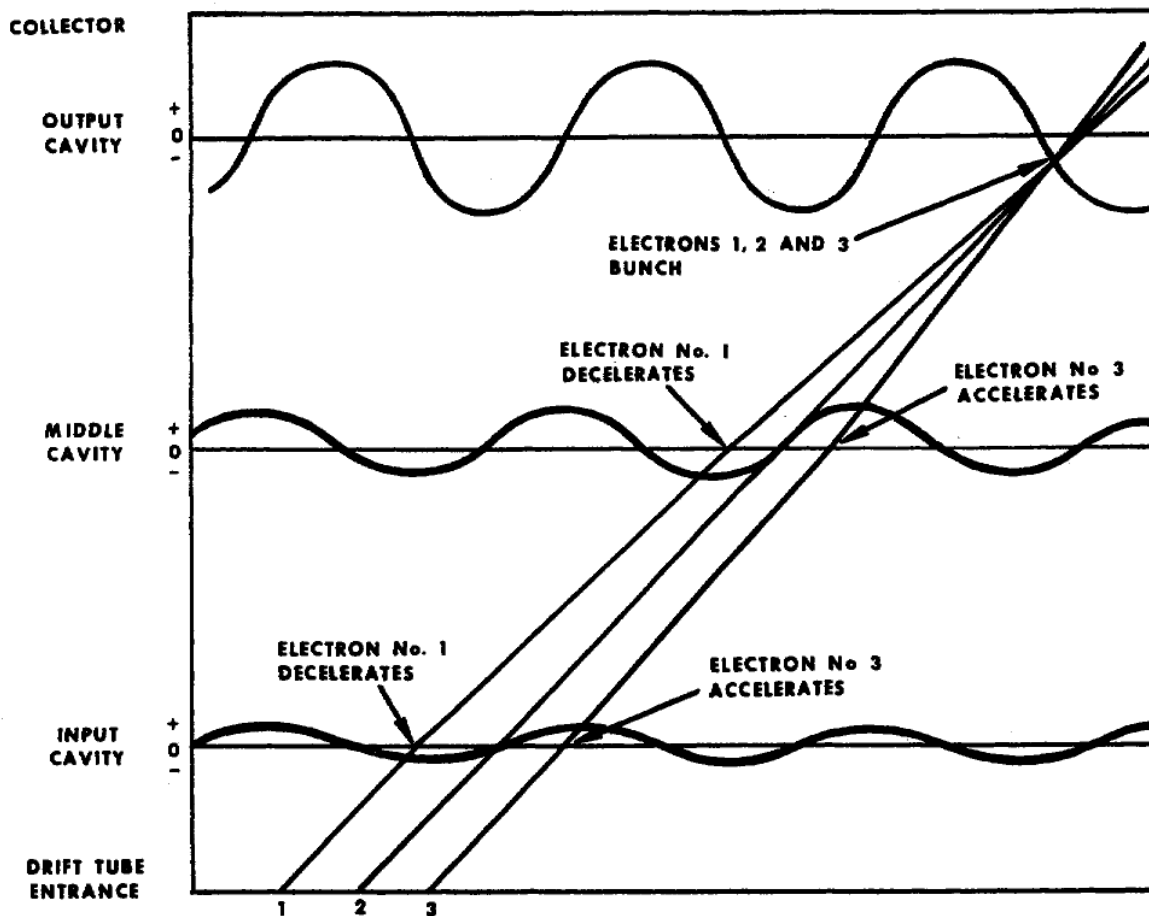

Figure 49. Applegate diagram showing beam electrons velocity and density modulation.

c. Now refer to figure 49 and notice that the diagonal lines are numbered 1, 2, and 3. For the purpose of this explanation let's assume that these lines are electron paths. As shown, all three lines have equal slopes (parallel to each other) until they reach the input cavity waveform. This indicates that all three electrons have equal velocities until they reach the first gap, as follows.

(1) Electron number 1 passes the first gap when the input cavity RF voltage is negative, electron number 1 surrenders a portion of its energy to the input cavity. This causes the velocity of the electron to decrease. This deceleration is indicated by a decrease in the slope of line 1 where it crosses the input cavity waveform. Electron number 1 continues through the middle cavity at a time when the RF voltage is negative. This negative voltage causes electron number 1 to lose additional energy and further deceleration.

(2) A short time after electron number 1, electron number 2 passes the first gap, and then the second gap. However, electron number 2 passes each gap at a time when the cavity RF voltage is zero.

(3) Exactly one-half cycle after electron number 1, electron number 3 passes the first and second gaps. Notice that at this time both cavity RF voltages are positive. Electron number 3, therefore, accelerates at each gap crossing. This acceleration is indicated by the upward bends in line number 3 where it crosses the input and middle cavity waveforms.

d. Although each electron enters the drift tube at a different time, all three electrons reach the output cavity at the same

time. The reason is that the velocity of electron number 1 decreased, the velocity of electron number 2 did not change, and the velocity of electron number 3 increased. Thus, the faster electrons overtake the slower electrons and form a bunch within the region of the output cavity. Because the output cavity RF voltage is negative, the electron bunch surrenders a large amount of energy to the output cavity. This energy is the klystron's RF output.

e. After passing the output cavity gap the partly spent electrons terminate at the collector dissipating their remaining energy.

f. The principle shown in figure 49 can be applied to billions of electrons. Although the three electrons shown in figure 49 bunch only near the output cavity, in reality the electrons may bunch and debunch repeatedly before reaching the output cavity. When the beam electrons bunch and debunch, they are undergoing density modulation. The number of times that they bunch depends on the distance between cavities and the amplitude and frequency of the RF voltage within the cavity.

g. The klystron operates at its highest efficiency when the output cavity RF voltage causes tightly bunched electrons to loose velocity. This

happens only when the electron bunch passes the output gap during the time that the output cavity RF voltage is negative.

h. For the maximum number of beam electrons to pass the output cavity, there must be some means for confining or restraining the electrons along the axis of the drift tube. Thus, the multicavity klystron requires an electron deflection or suppressing element to prevent the beam electrons from colliding with the drift tube wall.

1-49. MAGNETIC DEFLECTION OF THE ELECTRON BEAM

a. As in a cathode ray tube, either electrostatic or magnetic deflection can be used to control the electron beam in the klystron. We will limit our discussion to magnetic deflection because it is the most successful of the two methods.

b. The type of magnetic deflection used is usually electromagnetic deflection. The reason is that it provides a means of adjusting the magnetic field strength by adjusting the current through the coils. Figure 50 shows a cross-sectional view of the three-cavity klystron with its magnetic field coil assembly. The field coil assembly encases the entire length of the cavity-drift tube assembly.

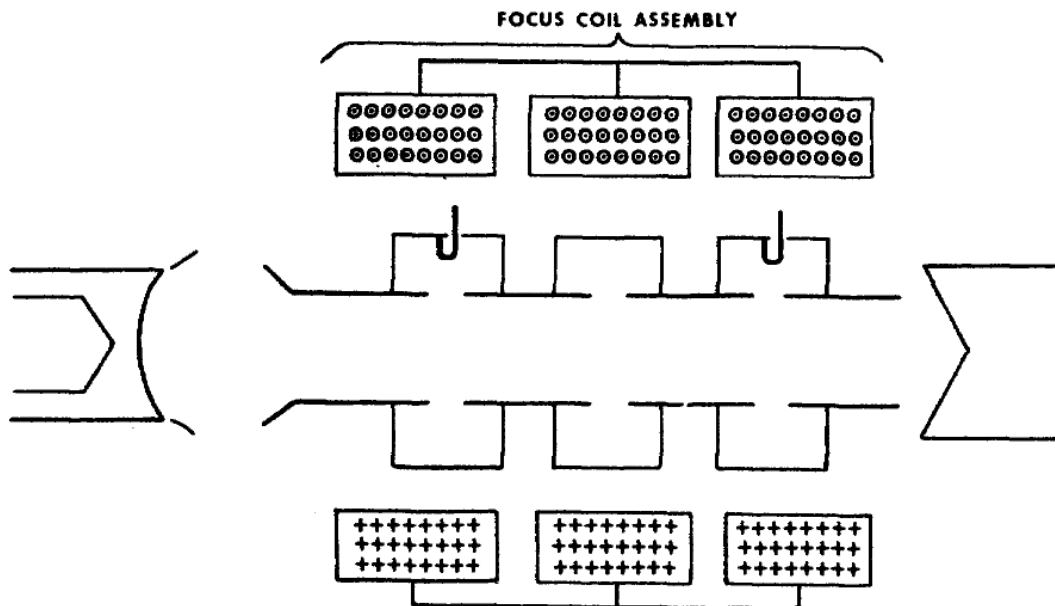

Figure 50. Multicavity klystron's magnetic field coil assembly.

(1) Each coil is wound identically and each has the same amount of current flow. Since the coils have the same direction of current flow, the magnetic field produced by one coil adds to the field produced by the adjacent coil. In this way, the magnetic field is continuous along the drift-tube axis as shown in figure 51.

(2) The magnetic field lines may extend in either direction, that is with or against the direction of beam electrons flow. In the figure, the magnetic lines are opposite to the direction of beam electron flow.

c. High density electrons enter the drift tube and they have to travel the long length of the drift tube. Because of the electrons' density and length of travel, they repeatedly repel each other. This mutual repulsive force causes unwanted effects, beginning right at the drift tube entrance. For example, assume that point A on figure 52 represents the position of one beam electron entering the drift tube. Because the electron is a negative charge, it is repelled by nearby electrons (also negative charges). As shown by the vertical arrow, the repelling force is at right angles with respect to the drift tube axis. The horizontal arrow represents the direction of force caused by the dc electric field lines (shown dotted) existing between cathode and drift-tube entrance.

(1) The dc electric field lines do not extend into the tube for any appreciable distance. However, the beam electrons receive enough energy from the electric field to complete the trip through the tube.

(2) With only the electric field present, the beam electron at position A would tend to follow a field line. Notice that each field line's path is from cathode-to-drift tube entrance. This means that the beam electrons traveling from the cathode would bombard the drift tube entrance. This would cause excessive heat. This action, and the possibility of excessive heat, is prevented by the field coil assembly.

d. In addition to the electric field lines, the magnetic field lines, generated by the field coil assembly, occur as shown in figure 53. The magnetic field lines produce a force that counteract the upward vertical force on the electron (c above). Now the vertical force is downward and causes the electron to move toward the drift tube axis.

e. In reality, the electric and magnetic flux provide primary control over the electron's path. The electric field imparts the energy that gives the electron its motion parallel to the drift tube axis; whereas, the magnetic field imparts the energy that makes the electron move in a cyclotron (or spiral) about the drift tube axis.

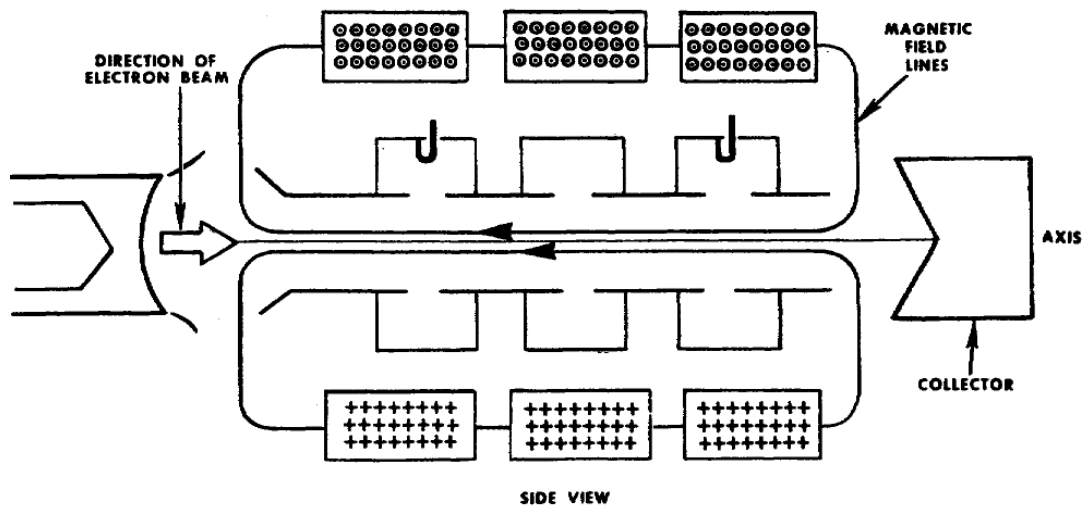

Figure 51. Continuous magnetic field lines along drift tube axis.

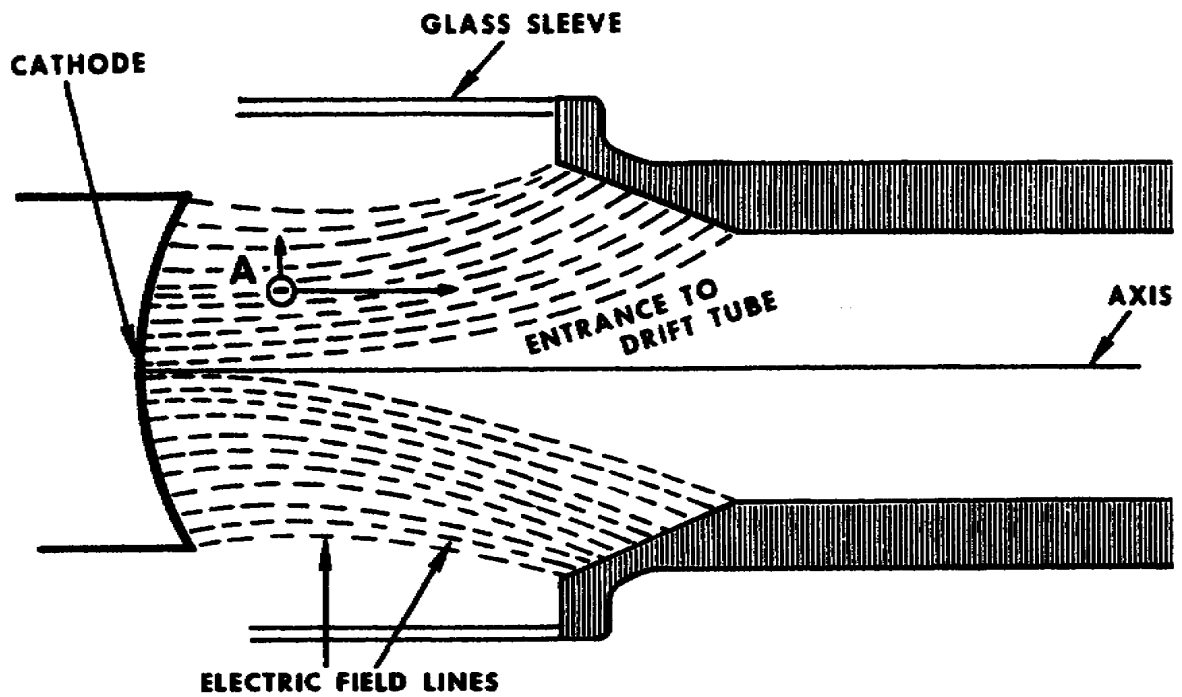

Figure 52. Beam electrons' mutual repulsion forces electrons away from drift tube axis.

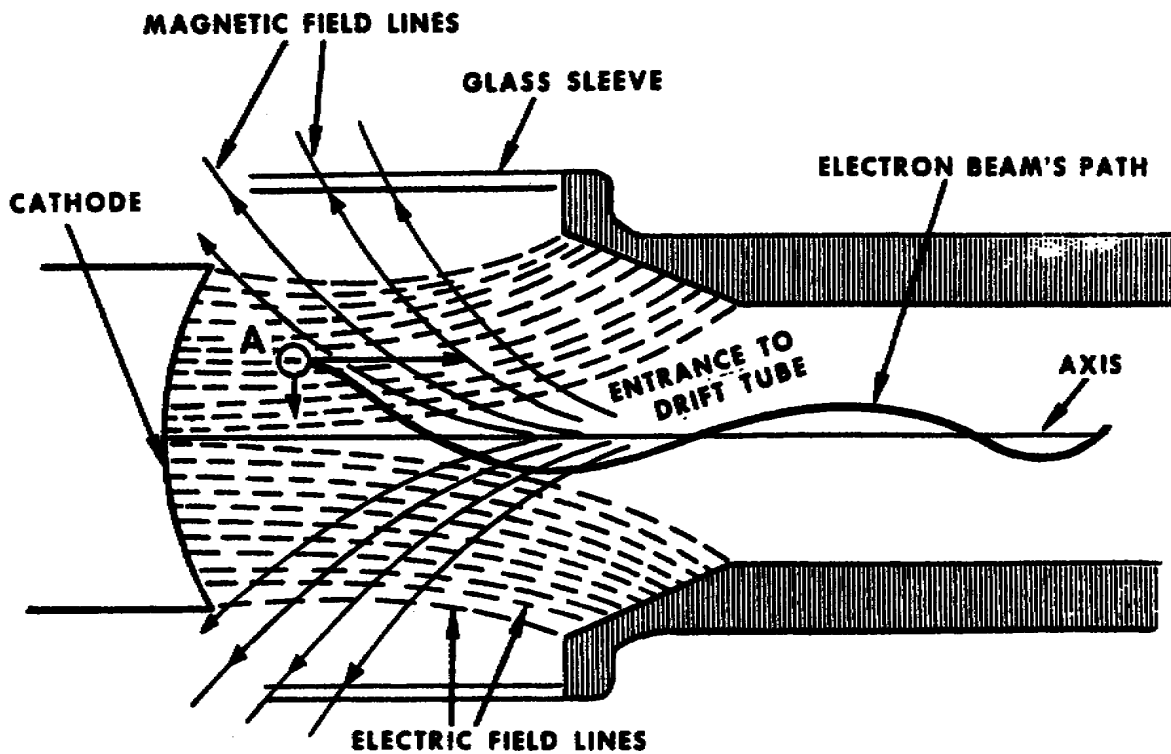

Figure 53. Magnetic lines of field coil assembly counteract effect of beam electrons mutual repulsive force.

1-50. CYCLOTRON EFFECT CAUSED BY MAGNETIC DEFLECTION

a. First, assume that you are at the collector end of the drift tube (fig 54). Assume, also, that you can see the three things represented in the figure: the drift tube wall; the plus (+) sign symbols designating the tail end of stationary magnetic field lines; and, arrows representing an electron moving in four different directions.

b. Because the electron is in motion, it, too, creates magnetic field lines that encircles its path. Interaction between the electron's magnetic field lines and the stationary magnetic field lines causes a strong field and a weak field on opposite sides of the electron's path. The strong field is the result of the electron's magnetic field lines reinforcing the stationary magnetic field lines. The weak field is the result of the electron's magnetic field lines opposing the stationary magnetic field lines. The electron is always deflected in the direction of the weak field.

(1) At position one, the electron moves to the left and away from the drift tube axis. By the left-hand rule, the electron generates magnetic field lines in the direction indicated by the small white dot (.) and plus (+) sign. The plus (+) designates the tail end of the flu line and the dot (.) designates the head end. Therefore, the stronger field is in the plus (+) position of the electrons' path, and the weaker field is at the dot (.) position. The electron moves in the direction of the weaker field toward position two.

(2) At position two, the same thing happens but now the electron moves toward position 3. It keeps moving in the direction shown.

(3) Because of the direction of the stationary magnetic lines, the electron's cycloidal motion is clockwise (from your viewing position). It always returns to the drift tube axis.

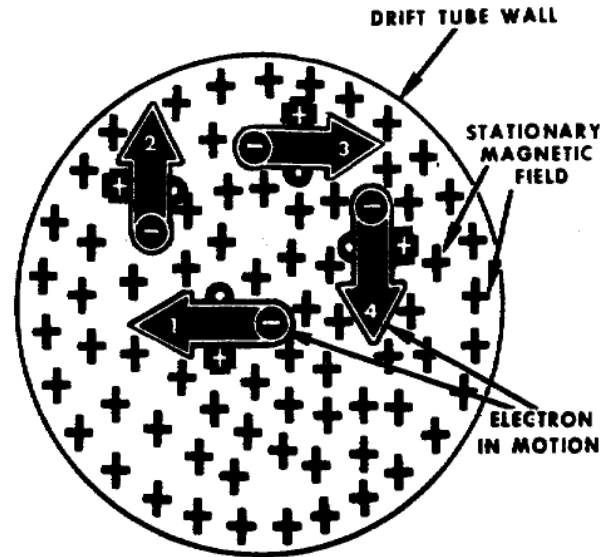

Figure 54. Electron interaction with stationary magnetic field.

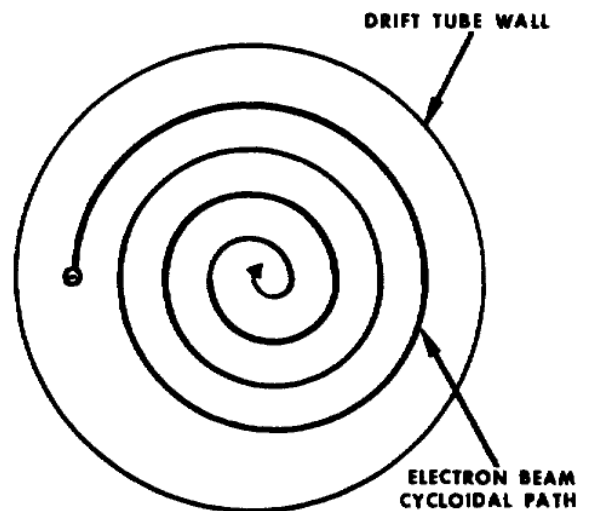

Figure 55. Drift tube's end view of electron beam's cycloidal path.

c. The diagram in figure 55 represents the same end view of the drift tube, and shows the path of the beam electron in a cyclotron. The electron actually spirals around the drift tube axis; and, at the same time, it moves along the axis (length) of the drift tube.

d. In addition to deflecting the beam electrons away from the drift tube wall, the cyclotron effect influences the electron density modulation (or bunching rate). Intervals between bunches become shorter with increase in strength of stationary magnetic field lines. These same magnetic lines determine the direction (clockwise or counterclockwise) of the electrons' cycloidal motion.

1-51. EXTERNAL AND INTERNAL CAVITIES

Two types of resonant cavities are used with klystrons -- internal and external. Internal cavities are within the vacuum envelope of the tube. External cavities are outside the vacuum envelope.

a. One advantage of external cavities is that they are easier to tune and maintain. They can provide a tuning range twice that of internal cavities. External cavities, however, require a sealed ceramic window at each cavity and the windows cause considerable power loss at high frequencies.

b. Internal cavities are totally within the vacuum envelope and windows are required at only

the input and output cavities. For this reason, a klystron with internal cavities has less power loss at higher frequencies.

1-52. NAMES OF THE KLYSTRON CAVITIES

a. Ordinarily, when you have to make adjustments on the klystron, you cannot see the part of the klystron that your adjustment is affecting. For example, when you have to tune each cavity, you don't ordinarily see the cavity itself; you only see a panel control that has a connecting link to the cavity. The panel control is identified by the name of the cavity to which it connects.

b. The klystron may have from two to six cavities, but those most common in the field have either three or four. Some of the klystron's cavities (fig 56) have names that correspond to the functions they perform. The first cavity is usually called the "input cavity," no matter how many cavities may follow it. Similarly, the last cavity is referred to as the "output cavity" because it transfers power to the output transmission line.

c. The cavity next to the output cavity is sometimes called the "penultimate cavity." The word penultimate means "next to the last."

d. The remaining cavities are referred to by their position on the drift tube as "second cavity," "third cavity," and so on.

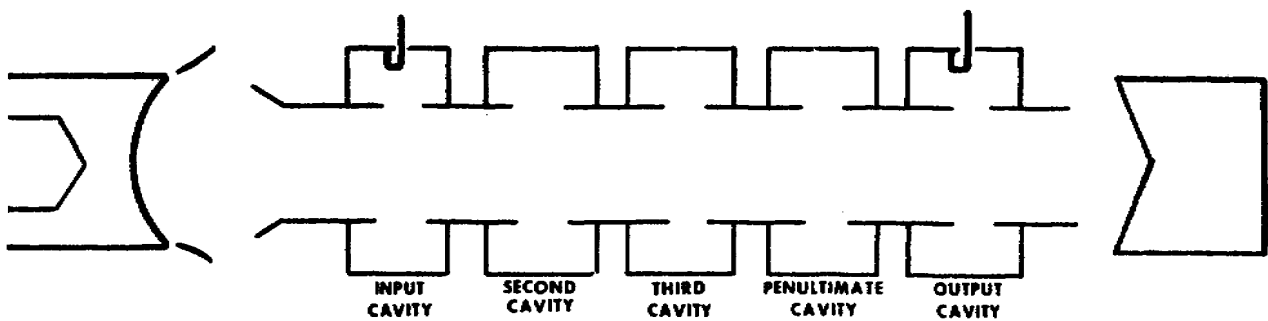

Figure 56. Next-to-the-last cavity is called penultimate cavity.

Section IV TUNING A MULTICAVIDITY KLYSTRON

1-53. TUNING METHODS

a. There are two methods of tuning a multicavity klystron -- synchronous tuning or stagger tuning. The method used depends on whether maximum gain or broad bandwidth is desired. Synchronous tuning provides the highest gain and stagger tuning provides the broadest bandwidth. So when you can use narrow band transmission, synchronous tuning may be used for maximum gain. However, to handle multichannel communications, the stagger tuning method must be used to pass the broad band of frequencies involved.

b. Stagger tuning does not mean that you have to operate with low power. With stagger tuning the klystron is capable of producing the required power output by having its input power increased or by operating at saturation.

1-54. SYNCHRONOUS TUNING PROCEDURE

a. Figure 57 shows a typical four-cavity klystron amplifier front panel control. The front panel controls are the kinds that you'll use when tuning a multicavity klystron.

b. A general procedure for synchronous tuning is as follows.

(1) Adjust all tuning cavities to the highest possible frequency.

(2) Adjust the RF drive power input to the value specified for the klystron.

(3) Tune the input cavity for minimum reflected power. Minimum reflected power indicates that the input cavity is tuned to drive frequency and is absorbing most of the input. Reflected power is sometimes referred to as back power or return power. All three names have the same meaning.

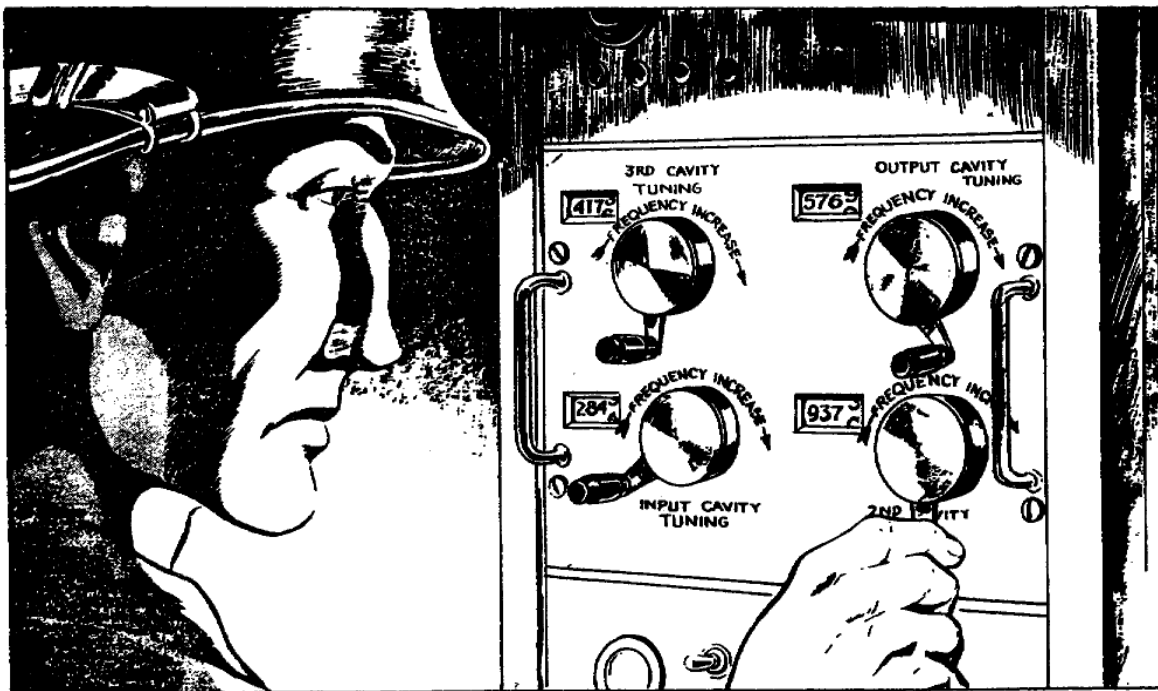

Figure 57. Typical front panel controls for tuning multicavity klystron.

(4) Tune the second cavity and then the output cavity for maximum power output. In the case of a five-cavity klystron, this step would instruct you to tune the second, third, and output cavity (in that exact order) for maximum power output.

(5) This step is the most critical. Slowly tune the last (penultimate) cavity (in this case, the third cavity) toward a lower frequency until the output power reaches maximum and then decreases slightly. Return the tuning to the point of maximum power and then detune to the high frequency side until the output power drops slightly below maximum. **DO NOT OPERATE PENULTIMATE CAVITY AT LOW FREQUENCY SIDE OF MAXIMUM POWER POINT.** Figure 58 shows the correct tuning point for the penultimate cavity.

(6) After the cavities are tuned decrease the drive to a low value, then increase the drive to a point where increased drive no longer results in increased output power. Then reduce the drive slightly to the point where output power just begins to decrease. This is the stable operating point. For stable operation, drive power should be no more than necessary. Excess drive will cause saturation and decrease in power output as well as excess current in the cavities.

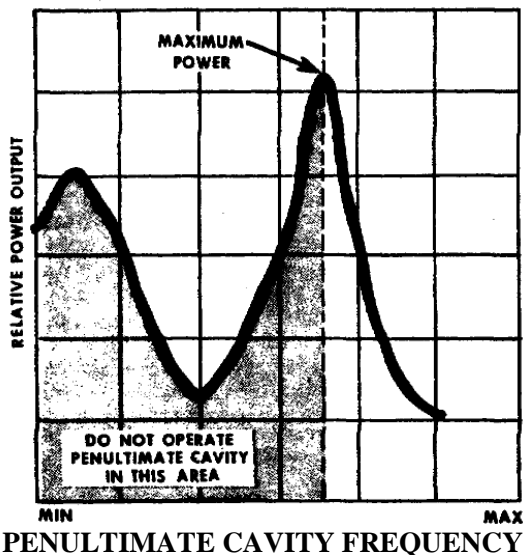

Figure 58. Penultimate cavity tuning.

1-55. STAGGER TUNING METHODS

We will discuss two methods of stagger tuning a klystron. To keep things straight, we will call them METHOD 1 and METHOD 2. Both methods require pretuning the klystron by the synchronous method, then stagger tuning. In METHOD 1, you have to readjust the penultimate cavity and the input RF drive. METHOD 2 requires a rapid-sweep RF driver or exciter.

1-56. METHOD 1, STAGGER TUNING

a. Tune the klystron by the synchronous method (para 22).

b. The first step is to increase the RF input power until the tube is operating at saturation.

c. The second step is to detune the penultimate cavity in the higher-frequency direction. Detuning should be continued until the output power drops approximately 1/4 to 1/10 of maximum. As you detune the penultimate cavity, the output power will decrease, because more input power is needed for saturation.

d. The next step is to increase the RF input power until the tube is, again, operating at saturation. You will find that this "new" saturation power output is higher than the power output which you were able to obtain with the tube synchronously-tuned. You may be able to "squeeze a little more out" of the tube, but probably not much. You can detune the penultimate cavity still further and then increase the drive to see if you get more power output than you had before. The maximum power output is normally quite broad; you will find that you can detune the penultimate cavity considerably around either side of this point without making an appreciable change in the saturation power output. Eventually, the extent to which you can increase the output power will become limited by the available power from the exciter.

1-57. METHOD 2, STAGGER TUNING

Stagger tuning by sweeping the frequency of the RF driver achieves the broadest bandwidth characteristics over the passband. However, the details of broad-band tuning which you may be required to accomplish

are beyond the scope of this text. Detailed procedures are provided in instruction manuals for individual tube type. The steps below are merely an indication of the equipment which is necessary and the general procedures to be followed.

a. The first consideration is the RF driver whose frequency can be electronically swept rapidly, and whose power output is constant as it is swept in frequency. In addition, you'll need a crystal detector, a sweep signal generation and an oscilloscope.

b. The diagram in figure 59 shows the method of connecting the test equipment to the exciter. You will need to sample the exciter's RF output with the crystal detector. Therefore, you apply the detector's output to the Y-axis of the oscilloscope so that you can see the pass band of the tube. The X-axis of the oscilloscope sweep must be synchronized with the RF input sweep voltage. So you have to apply the exciter's RF input sweep voltage (from sweep signal generator) to the horizontal sync input of the oscilloscope.

c. To broad band the tube, it is usually best to detune the penultimate cavity to the high frequency side, and to detune the second cavity to the low frequency side (assuming a four-cavity klystron here). The input and output cavity normally are left tuned to the center of the passband. It may be desirable to adjust the RF input power periodically, as you detune the klystron, to keep operating near saturation. The bandwidth of the tube

is larger when you are operating at saturation than below saturation.

Section V. GENERAL REQUIREMENTS FOR KLYSTRON APPLICATION

1-58. PROTECTIVE DEVICES

a. Systems in which the klystron is used usually provide built-in protective devices for the tube. It is important that you become fully acquainted with them.

b. Some protective devices and their function are listed below. These are installed on equipment to prevent damage to the klystron in the event of equipment malfunction.

(1) Air flow and water flow interlocks to remove all electro potentials in case of cooling failure.

(2) Body current overload relay to remove beam power when maximum body current is exceeded.

(3) Current overload relays to remove the beam power and cathode heating power in the event that excessive current should flow in either of those circuits.

(4) VSWR interlock to remove the beam power of RF drive in the case of malfunction of the transmission line or antenna.

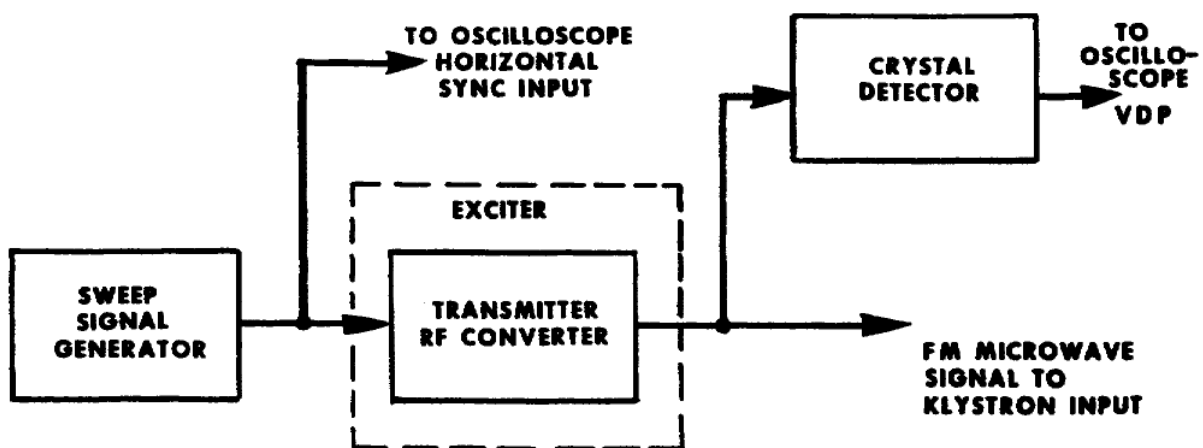

Figure 59. Broad-banding with sweep signal generator.

(5) Magnetic coil current interlock to remove the beam power in the event of magnetic coil power supply failure.

(6) Water temperature and collector temperature interlocks to remove the beam power in case of pooling failure.

1-59. INDICATORS ASSOCIATED WITH THE KLYSTRON

a. The most important indicators that you will use for correct klystron tuning are the relative power output and body current meters. These meters are usually placed at a convenient viewing level near the RF tuning and magnetic coil controls.

b. Your equipment will have additional meters, as required, to monitor filament voltage, filament current, bombarder voltage, bombarder current, focus electrode voltage, beam voltage, beam current, collector current, modulation anode current, forward and backward RF drive power, forward and backward RF output power, total elapsed beam hours and individual magnetic coil current.

1-60. PRECAUTIONS AND DANGERS

a. The high voltages klystron power amplifiers can be instantly deadly even if accidentally and momentarily touched. Always know what you are doing and never allow yourself to become careless.

b. Do not disable safety-interlock systems even to make measurements. You can obtain all required operating information from meters installed in the equipment.

c. Learn the high-voltage parts of the klystron amplifier. The body and cavities of the klystron amplifiers are normally operated at ground potential. The filament end, which is at a high (negative) voltage with respect to the body and ground, is dangerous even though it may be covered with air bonnet. Low-powered klystrons amplifier up to 10 kw frequently have the klystron mounted with the filament end up. Higher-powered klystrons sometimes have

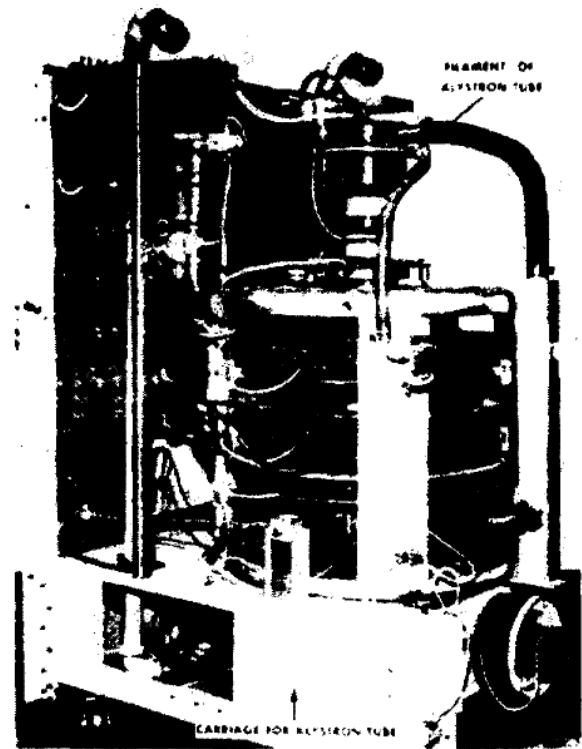

Figure 60. High power klystron in carriage.

the filament end mounted downward or in the carriage (fig 60), but this does not make them safe.

d. Learn the danger spots of the klystron amplifier and power supply. You should never place full confidence in any interlock circuit which is intended to remove the high voltage from these danger areas. Although these devices are usually very reliable, the stakes are too high to gamble your life on their proper operation.

e. The higher voltages used to obtain higher beam velocities will generate some X-rays that leave the klystron via the ceramic and glass sections. Since the cavities and magnetic structure provide some shielding, most of the X-ray radiation occurs near the filament-end of the tube. The X-ray radiation is small, and the normal steel cubicles provides adequate protection when closed. Prolonged operation of the klystron is not recommended with doors of the cubicle or transmitter cabinet open.

1-61. METHODS OF HANDLING THE KLYSTRON

Klystrons must be handled with the same care as other types of tubes of the same weight and size. By doing this you can obtain maximum tube life and satisfactory performance from them. Always read carefully and follow the manufacturer's recommendations for handling. The handling precautions which follow are simple and easily remembered.

a. Because of the shape of the klystron, it is especially susceptible to bending near the center; therefore, when picking up the klystron in the

horizontal position you should provide support at two or more points as shown in figure 61. You should lift larger tubes with a mechanical or motor-driven hoist.

b. Under no circumstances should you lift the tube by the output transmission line coupling or the waveguide coupling. These couplings are not strong enough to support the klystron weight without danger of damaging the ceramic window. Do not lift by coolant pipes or insulated section of the collector. For internal-cavity klystrons, ordinarily, there is a mechanical structure that links the cavities together to form a strong mechanical unit. This is usually the best place to lift the tube.



Figure 61. Support klystron at two or more points when lifting.

LESSON EXERCISES

In each of the following exercises, select the ONE answer that BEST completes the statement or answers the question. Indicate your solution by circling the letter opposite the correct answer in the subcourse booklet.

1. In a klystron tube, electrons will give up energy when they
 - a. are slowed down.
 - b. enter a magnetic field.
 - c. pass through a cavity.
 - d. pass through a focusing anode.

2. The electron beam in a reflex klystron is best described as
 - a. an amplitude-modulated beam.
 - b. a frequency-modulated beam.
 - c. a velocity-modulated beam.
 - d. an unmodulated beam.
3. The purpose of the repeller plate in the reflex klystron is to
 - a. collect the electrons and return them to the cathode.
 - b. accelerate the electrons that are moving toward it.
 - c. reverse the direction of the electron stream.
 - d. couple the output to the adjacent circuit.
4. The mode of operation in a reflex klystron is determined by the
 - a. number of electrons in the stream.
 - b. frequency of the input signal.
 - c. electron transit time.
 - d. size of the cavity.
5. Modes other than the most powerful modes are used in a reflex klystron oscillator to provide
 - a. a broader tuning range.
 - b. a narrower tuning range.
 - c. electrical tuning of the tube.
 - d. mechanical tuning of the tube.
6. Mechanical tuning is sometimes used in reflex klystrons because
 - a. electrical tuning would involve interference between the oscillator and the local oscillator.
 - b. small frequency changes can be made conveniently while the set is in operation.
 - c. the mechanical tuning range is broader than the electrical tuning range.
 - d. the electrical tuning range would involve changes in operating mode.

7. The purpose of the magnetic field in a klystron tube is to
 - a. control the output of the electron gun.
 - b. provide additional velocity for the electrons.
 - c. cause the electrons to spiral into a closer beam.
 - d. cause the electrons to strike the walls of the drift tube.

8. The strength of the electric field in the klystron's drift tube is established by the potential on the

a. focusing electrode.	c. repeller.
b. resonant cavities.	d. cathode.

9. The diameter of the klystron's drift tube affects the focusing of the electron beam. For satisfactory coupling and focusing, the drift tube's diameter should be approximately
 - a. one-half wavelength of the operating frequency at the first cavity, and tapered to one-quarter wavelength at the final cavity.
 - b. one-quarter wavelength of the operating frequency.
 - c. one-half wavelength of the operating frequency.
 - d. the same as the gap across the resonant cavity.

10. The velocity of the electrons entering the first cavity of a klystron power amplifier is controlled by the
 - a. intensity of the magnetic field which controls the electrons in the drift tube.
 - b. potential between the cathode and the focusing anode.
 - c. amplitude of the RF signal to be amplified.
 - d. density of the beam current.

11. One of the effects of cavity loading in a klystron power amplifier is an increase in

a. overall bandwidth.	c. efficiency.
b. power output.	d. gain.

12. The magnetic field which controls the diameter of the electron beam in the drift tube of the power-amplifier klystron is created by the

a. repeller plate potential.	c. collector coil.
b. prefocusing coil.	d. body coils.

13. One difference between a klystron and a traveling-wave tube (TWT) is simply that the klystron
- uses a standing wave to influence the signal, and the TWT uses a traveling wave to influence the signal.
 - acts as a capacitive reactance, and the TWT acts as an inductive reactance.
 - is velocity-modulated, and the TWT is space-charge modulated.
 - is an amplifier, and the TWT is an oscillator.
14. Amplification in a TWT is accomplished through the interaction of the RF signal and the electron stream in the slow-wave structure of the TWT. The weak RF signal to be amplified by the TWT is applied to the electrode that is identified as the
- helix.
 - control grid.
 - resonant cavity.
 - accelerating anode.
15. Direct-pin coupling is generally NOT used as a means of coupling from a TWT because it
- is a complex coupling system.
 - handles only low-power signals.
 - has standing waves that generate heat.
 - reduces the effects of the focusing field.
16. If the temperature of a TWT's helix increases, the helix becomes distorted. Operation of a TWT with a distorted helix can cause the TWT to
- become an oscillator.
 - fail at some frequencies.
 - become a broadband amplifier.
 - conduct in a reverse direction.
17. In a parametric amplifier, amplification is produced by varying a parameter of the diode with a
- refrigerant.
 - traveling wave.
 - magnetic field.
 - pump frequency.

18. In a backward-wave oscillator, amplification occurs when
- bunching occurs in the beam.
 - the signal on the helix reaches the gun end of the tube.
 - the cathode voltage exceeds the voltage on the accelerating anode.
 - the velocity of the signal on the helix is greater than that of the electrons in the beam.
19. In both the traveling-wave tube and the O-type backward-wave oscillator, the axial velocity of the RF signal is reduced by using a helix. In a cross-field oscillator (carcinotron) the same function is performed by the
- sole of the tube.
 - accelerating anode.
 - matching termination.
 - interdigital delay line.
20. The primary reason for using a parametric amplifier as the preamplifier in a microwave receiver is that the parametric amplifier has a
- wide bandpass.
 - low-noise figure.
 - low-power requirement.
 - high-resonant frequency.
21. The parametric amplifiers used in communication receivers are either cooled or refrigerated. The purpose of this temperature reduction is to
- overcome the atmospheric noise.
 - reduce the resistance of the amplifiers.
 - eliminate the pump-frequency requirements.
 - reduce the noise figures of the amplifiers.
22. The varactor diode parameter that is varied to produce signal gain is identified as the junction
- inductance.
 - resistance.
 - conductance.
 - capacitance.
23. If the incoming signal frequency to the parametric amplifier shown in figure 29 is 8 GHz and the pump frequency is 32 GHz, what frequency is applied and utilized by the VHF-UHF converter stage?
- 8 GHz
 - 32 GHz
 - 40 GHz
 - 48 GHz

24. Klystrons with external cavities are easy to tune and maintain. In comparison, those with internal cavities have
- a. no tuning requirement.
 - b. fewer cavities.
 - c. no "penultimate" cavity.
 - d. less power loss at higher frequencies.
25. Where does the action that causes velocity modulation in a multicavity klystron take place?
- a. In the output cavity
 - b. In the drift tube gaps
 - c. Between the cathode and the input cavity
 - d. Between the focus electrode and the modulating anode

CHECK YOUR ANSWERS WITH LESSON 1 SOLUTION SHEET PAGE 64.

LESSON SOLUTIONS

LESSON 1Microwave Amplifying Devices

1. a--para 1-2b
2. c--para 1-5
3. c--para 1-6b
4. c--para 1-8b
5. a--para 1-9d, fig. 8
6. c--para 1-9e
7. c--para 1-11d
8. b--para 1-11e
9. c--para 1-12c
10. c--para 1-17a
11. a--para 1-20c
12. d--para 1-19c
13. a--para 1-24c
14. a--para 1-24g
15. c--para 1-25c
16. b--para 1-26b
17. d--para 1-30a
18. a--para 1-28a
19. d--para 1-29a, b
20. b--para 1-30b
21. d--para 1-31a, b
22. d--para 1-32a
23. a--para 1-32h, fig. 29
24. d--para 1-51b
25. b--para 1-46e, f

LESSON 2

RF SYSTEM COMPONENTS

SCOPE.....	Purpose and characteristics of waveguides, waveguide filters, joints, mode launchers, isolators, circulators, dipole horn feed, polyrod feed, cassegrainian feed, parabolic and hyperbolic reflectors, and surface-wave transmission lines.
TEXT ASSIGNMENT	Pages 65 thru 97
MATERIALS REQUIRED.....	None
SUGGESTIONS.....	None

LESSON OBJECTIVES

When you have completed this lesson, you should:

1. Know the functions of waveguides and waveguide filters, joints, isolators, and circulators.
2. Know the various methods of feeding the signal to the antenna.
3. Be able to identify and explain the characteristics of parabolic and hyperbolic reflectors.

RF SYSTEM COMPONENTS

Section I. WAVEGUIDE PRINCIPLES

2-1. TRANSMISSION OF ENERGY

a. The transmission of energy at the microwave frequencies requires special care to avoid loss of energy. Transmission lines used at these frequencies are considerably different, physically and electrically, from those used for lower frequencies.

b. The reason for the special transmission lines is that the radiation loss in a two-wire conductor increases as the frequency increases. This radiation effect increases to a point where most of the energy will be radiated into space and practically none will reach the output end.

c. A coaxial line may be used for transmission at these frequencies; even though the inner conductor radiates energy, all of this energy is kept within the confines of the outer and inner conductors. The energy cannot escape into space because the outer conductor prevents this. The outer conductor of a coaxial line controls the energy more than the inner conductors. If the inner conductor is not needed, it can be removed. When this is done, the resulting transmission line is called a cylindrical, or circular, waveguide. When a hollow rectangular conductor is used, the transmission line is called a rectangular waveguide.

d. Moving electrical energy consists of magnetic and electric fields, and ordinary current and voltage are incidental phenomena that are results of these fields. When a piece of hollow conductor is used as a transmission line, it is difficult to discuss it in terms of current and voltage, so the electromagnetic wave concept becomes more useful.

2-2. ADVANTAGES

a. Waveguides have several advantages over ordinary conductors for transmitting energy at microwave frequencies. At these frequencies, ordinary conductors radiate most of the energy applied to them. In waveguides, radiation losses are almost zero because all of the energy is confined inside the waveguide.

b. In a coaxial line, leakage in the dielectric used to support the inner and outer conductors causes considerable signal attenuation. The frequency of the transmitted energy determines the amount of dielectric loss. As the frequency increases, the amount of electromagnetic energy absorbed by the dielectric also increases. Dielectric loss of energy is eliminated in a waveguide because there is no center conductor requiring a solid dielectric support.

c. The cross-sectional area of the inner conductor in a coaxial line is considerably smaller than that of the outer conductor. Therefore, skin

effect makes the effective resistance of the inner conductor much higher than that of the outer conductor. The removal of the center conductor in a coaxial line eliminates a major cause of skin-effect loss. The inner surface of a waveguide is large enough to reduce the skin-effect loss considerably.

d. As a result of these advantages, the waveguide is a very efficient transmission line for RF energy above 1,000 MHz.

2-3. DIMENSIONS

a. In any system of transmission, the ability to handle high power is usually limited by the distance between the conducting surfaces and the type of dielectric used. If the diameter of a coaxial line is too small for a given transmitted power, the energy will arc over from the center conductor to the outer or ground conductor.

b. A waveguide of the same diameter will handle much higher power than will the coaxial line because the distance of the arc-over path is twice as long.

c. Despite these advantages, the waveguide has not entirely replaced the coaxial line. The size of the waveguide is determined by the wavelength of the energy to be transmitted. Unlike other transmission lines, waveguides have a limiting frequency below which they cannot transmit energy. This is known as the cutoff frequency. The rectangular waveguide is the most commonly used, and its cutoff frequency varies inversely with the dimensions of the waveguide. This relationship is such that waveguides are practical only at and above the microwave frequency range.

Section II. WAVE PROPAGATION

2-4. WAVEGUIDE CONSTRUCTION

The mechanics of a waveguide can be explained in terms of the two-wire transmission line theory. A shorted quarter-wave stub has a high impedance and can be used as an insulated support. We can construct a two-wire line rigidly supported above and below by a large number of quarter-wave stubs and still use the line successfully. The resemblance between a rectangular waveguide and a two-wire transmission line is shown in figure 62. Part A is a single quarter-wave stub support. In part B, many stubs extending both ways from the two-wire line have been added, and they still do not affect the propagation of the desired frequency. In part C, the stubs have been joined into a rectangular tube that represents a waveguide.

2-5. PROPAGATION RULES

Before we start discussing how energy can be moved through a waveguide, let's look at these rules:

a. Energy propagated in space consists of magnetic and electric lines at right angles to each other and at right angles to the direction of propagation.

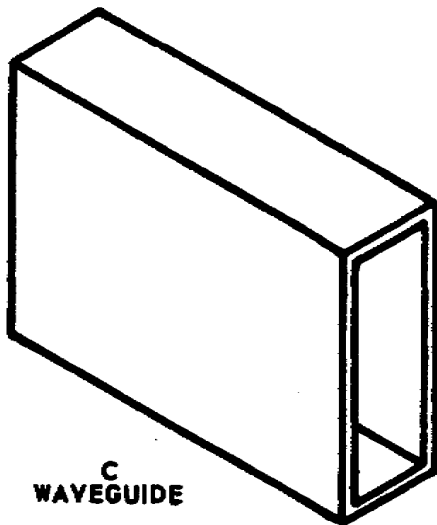
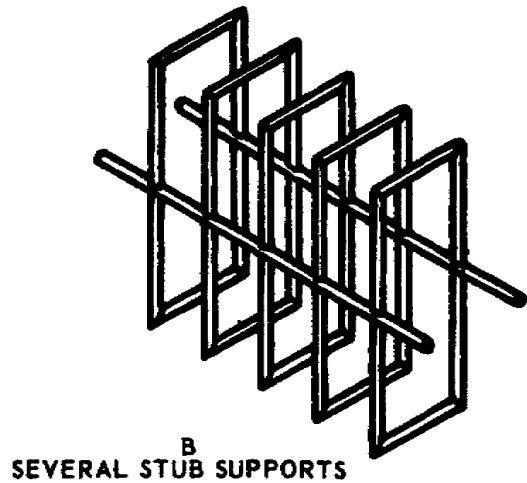
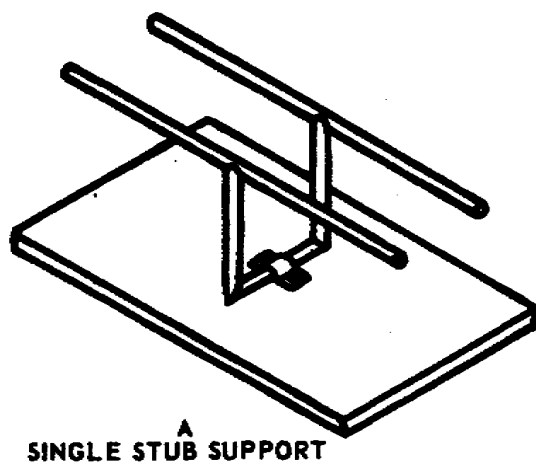

Figure 62. Waveguide developed from quarter-wave stubs.

b. At the surface of a perfect conductor in an electromagnetic field that varies with time, the electric field is perpendicular to the surface of the conductor and the magnetic field is parallel to the surface of the conductor. Any component of the electric field parallel to the surface is shorted out and ceases to exist. Any component of the magnetic field perpendicular to the surface induces a current in the surface that produces an equal and opposite magnetic field. Then the perpendicular component of the magnetic field also ceases to exist.

2-6. PROPAGATION THROUGH WAVEGUIDES

a. The electromagnetic field shown in A of figure 63 represents the energy radiated into space in the form of a vertically polarized wave. A horizontally polarized wave will have the E and H fields rotated 90° . Notice that the E lines (electric) and the H lines (magnetic) are at right angles to each other and that both are at right angles to the direction of propagation.

b. If two parallel conducting planes are placed in the electromagnetic field with the conducting planes perpendicular to the E lines, as shown in 8 of figure 63, the waves comply with the rules presented in paragraph 1-5 and can exist without change in shape between the two parallel conducting planes.

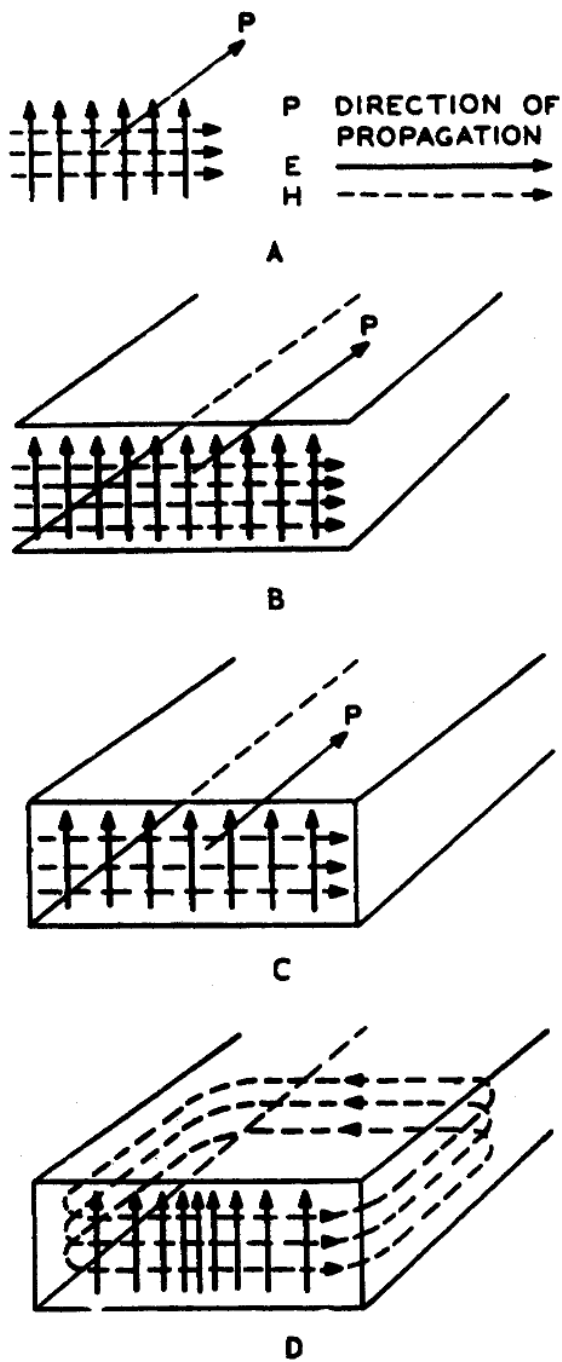

Figure 63. Electromagnetic lines, free and confined.

this, the E lines are maximum at the center of the waveguide with a sinusoidal distribution between the sidewalls and the center of the waveguide. The magnetic field, however, remains parallel with the sidewalls by turning through a right angle near each wall, -as shown in D of figure 63. The H lines form

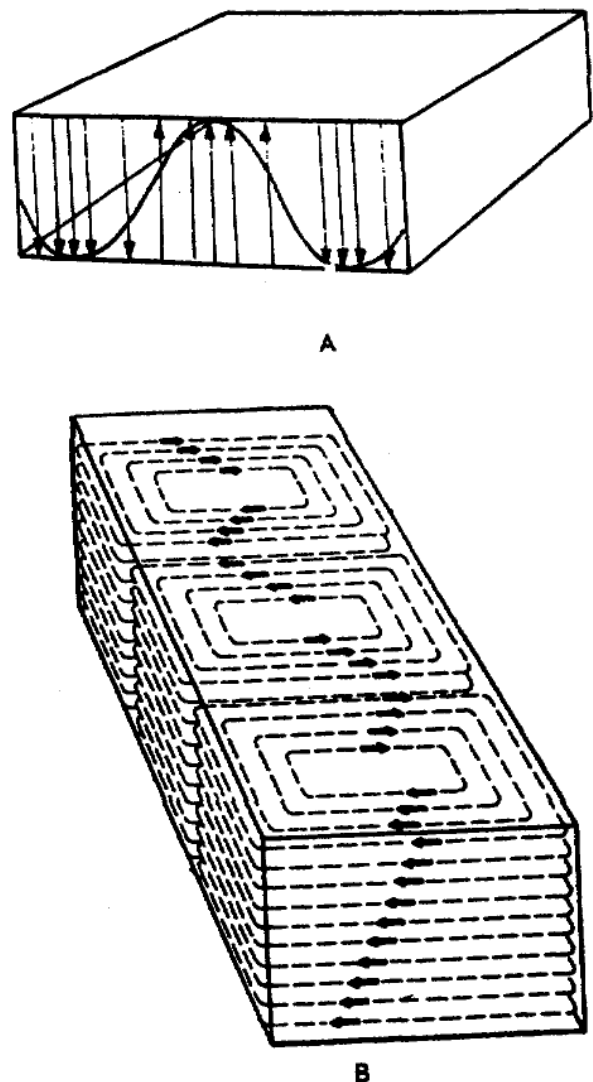

Figure 64. E and H field distribution in a waveguide.

c. If two walls are placed perpendicular to the conducting planes, as shown in C of figure 63, the E lines will be parallel with the sidewalls and perpendicular to the top and bottom walls. And it appears as though the H lines are perpendicular to the sidewalls. The rule in paragraph 1-5b states that E lines parallel to a conductor and H lines perpendicular to a conductor cancel out. Because of

closed loops, since magnetic lines of force cannot otherwise exist. The distribution of both fields is shown in figure 64. The intensity of the magnetic field varies sinusoidally down the center of the waveguide the same as the electric field, but perpendicular to the electric field. Figure 65 may give you a better idea how the E lines are distributed in a waveguide.

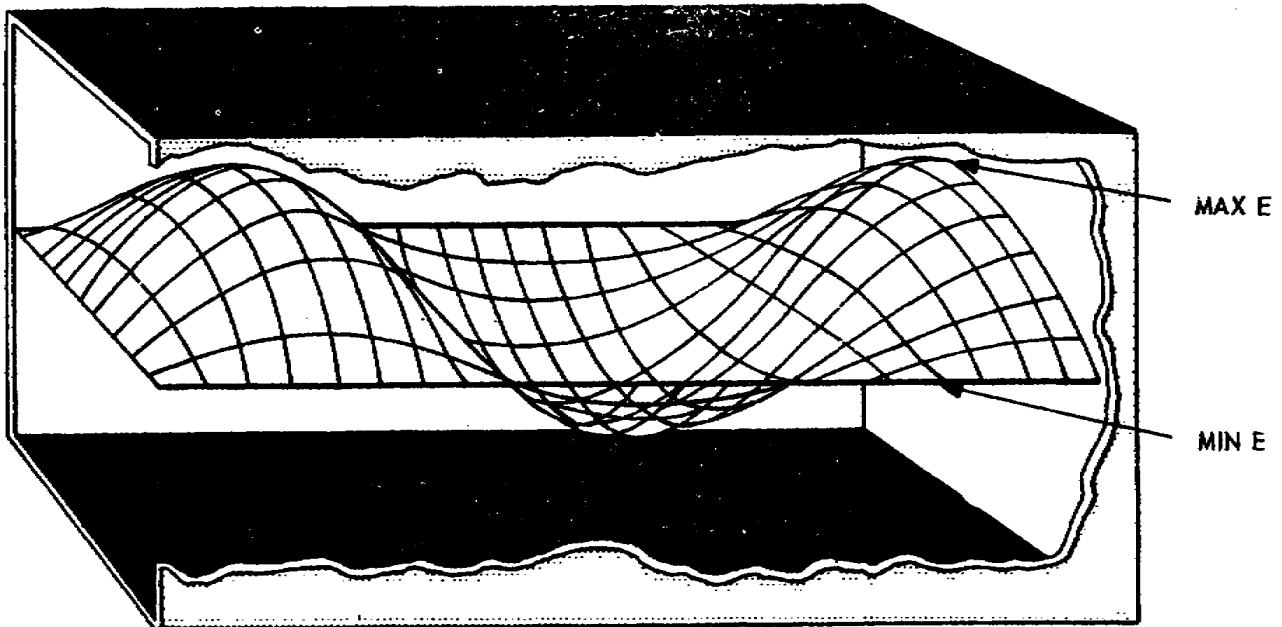

Figure 65. E field distribution in a waveguide.

d. The electromagnetic energy is put into the waveguide by an antenna or a radiator. The antenna radiates in all directions. There are only two angles of radiation at which proper addition and cancellation take place to produce a wave that fulfills the boundary conditions required to sustain energy propagation.

e. Figure 66 shows electromagnetic waves put into a waveguide by an antenna in the form of wavefronts. The wavefronts bounce off the walls and cross at an angle. The antenna is oriented so that these wavefronts strike the sidewalls at the incident angle needed to obtain the desired field pattern in the waveguide.

f. When wavefronts crisscross, the two fronts add at the center of the waveguide and cancel at the sides of the waveguide. The resultant field distribution has a sine wave pattern across the width of the waveguide, but at some angle to the waveguide wall.

g. As the frequency of the energy in the waveguide is decreased, the incident angle decreases. As the angle approaches zero, the direction of propagation is back and forth between the walls of the waveguide instead of down the waveguide. At this point we have reached the cutoff frequency and the energy below this frequency is dissipated by the resistance of the walls of the waveguide.

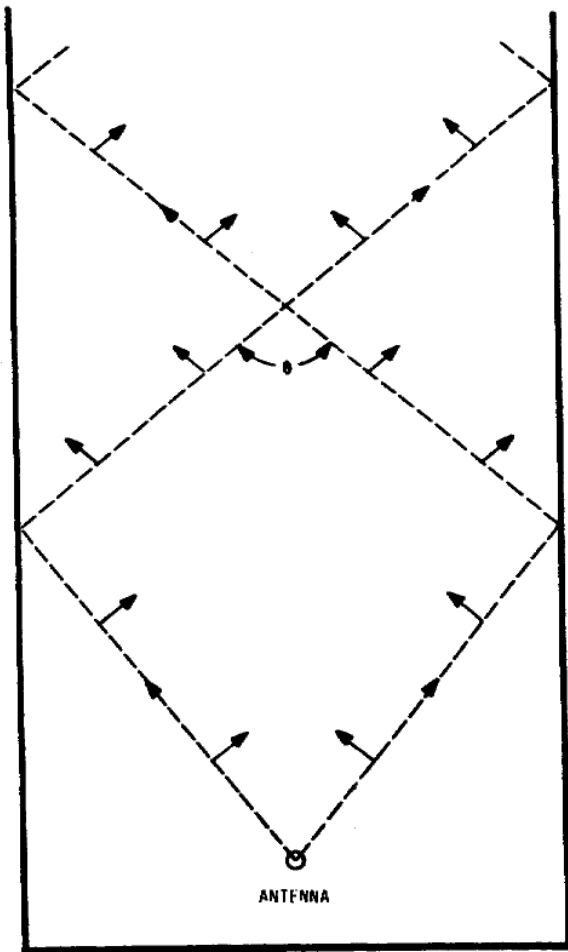

Figure 66. Crisscrossing plane waves in a waveguide.

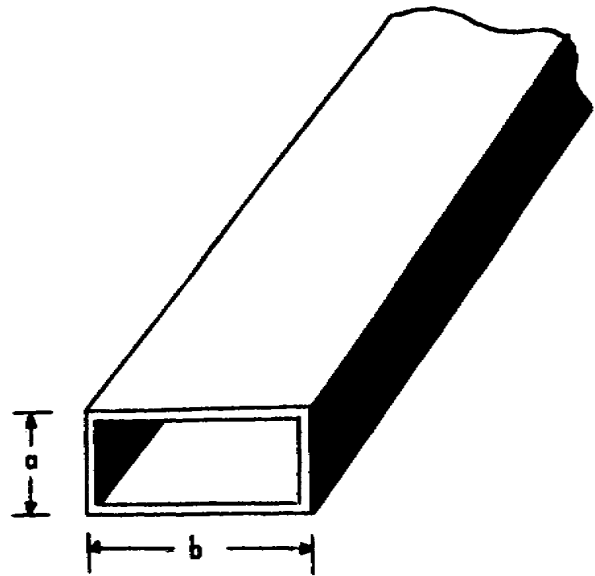

Figure 67. Waveguide dimensions.

2-7. SIZE

The correct size of a waveguide is determined by the frequency (or wavelength) of the energy that will be fed into the waveguide. Figure 67 shows that the narrow walls, or sidewalls, are side a, and the top and bottom walls are side b. If side b is one-half wavelength or less, cutoff will occur. So the cutoff frequency can be determined when $\underline{b} = \lambda/2$.

a. To have energy travel through the waveguide shown in figure 3-6 with minimum loss, side b should be greater than one-half wavelength, but less than 1 wavelength. The lower and upper

limits can be expressed, respectively, as $\lambda/2$ and λ . For the ideal waveguide the arbitrary figure for the width is $b = 0.7\lambda$.

b. Side a of the waveguide is not critical since the field does not vary in this direction. However, the dimension must be considered when determining the amount of power the waveguide must handle. Side a, the smaller dimension, is where arc-over may take place. Also, if side a is greater than one-half wavelength, then a half-cycle of vertical variation is possible and the signal will be attenuated. Therefore, side a should be smaller than $\lambda/2$. The outside dimensions of a rectangular waveguide should be such that the width is twice the height. The ratio of the inside dimensions is somewhat greater than 2 to 1.

2-8. MODES

a. The shape, or pattern, of the electric and magnetic fields in a waveguide is determined by the frequency of the input signal and the size of the waveguide. This pattern will be called the field configuration.

b. The various field configurations are known as modes. The mode is identified by the field that is transverse, or perpendicular to the direction of propagation. The two main classes of modes are the transverse electric (TE) and the transverse magnetic (TM). A system of subscripts is used to further identify the different TE and TM modes that can occur.

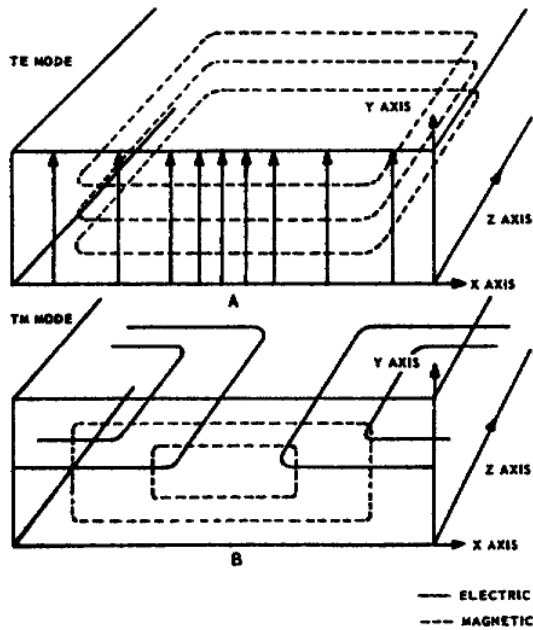

Figure 68. TE and TM modes.

(1) In a TE mode, all components of the electric field lie in a plane that is transverse, or perpendicular to the direction of propagation, as shown in A of figure 68. The field is propagated along the Z axis. The distribution of the electric field is along the X axis or along the width of the waveguide, and it is parallel to the Y axis. The magnetic field is parallel with the X and Z axes. The mode therefore is a TE, or transverse electric, mode.

(2) In the TM mode shown in B of figure 68, the magnetic field is parallel with the X and Y axes and it is also perpendicular to the Z axis or direction of propagation. The electric field is parallel with the X and Z axes.

Section III. WAVEGUIDE DEVICES

2-9. COUPLING METHODS

Energy may be transferred either to or from a waveguide with the same efficiency. The three basic methods of coupling energy into and out of a waveguide are the probe, loop, and window methods.

a. Probe Coupling. A coupling probe is a small metallic conductor inserted in the waveguide, usually parallel with the lines of the electric field. The waveguide shown in figure 69 is to be operated in the TE mode. For this mode, the probe is inserted in the center of the wide side of the waveguide. The electric field extends across the width of the waveguide, but it is maximum at the center.

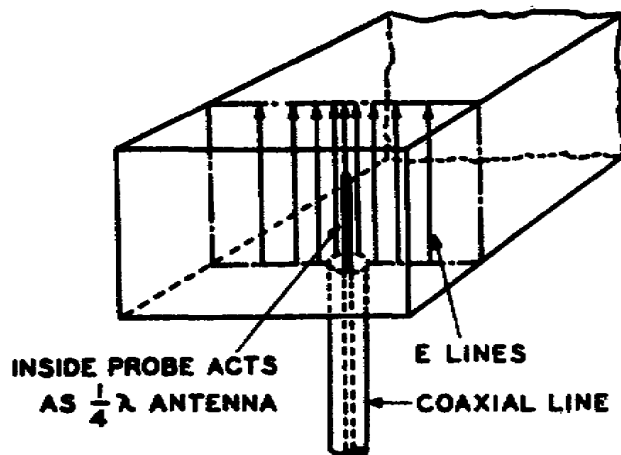

Figure 69. Probe coupling.

- (1) For maximum coupling between the probe and the field, the probe is one-quarter wavelength away from the shorted (closed) end of the waveguide. The probe will work equally well if it is placed at a three-quarter-wavelength distance from the shorted end.
- (2) Usually the probe is fed with a coaxial line, as shown in figure 69. This coaxial line is limited to extremely short lengths to avoid loss of energy. Varying the distance between the probe and the shorted end of the waveguide matches the impedance between the coaxial line and the waveguide. The end of the waveguide is fitted with a movable plunger which moves the shorted end of the waveguide closer to or farther from the probe. Usually the position of the probe and the shorted end of the waveguide is predetermined by the factory and is fixed permanently.
- (3) The degree of excitation, or the amount of energy put into the waveguide, is controlled by varying the depth of the probe into the waveguide. To increase excitation the probe is moved deeper into the waveguide, and to decrease excitation the probe depth is decreased. The desired depth of the probe is usually one-quarter wavelength so that the action of the probe will be similar to that of a quarter-wave antenna. The depth of the probe also assists in matching impedance between the coaxial line and the waveguide.
- (4) When a probe is used to couple energy out of a waveguide, it is placed in a similar position on the opposite end of the waveguide. When the probe at the output end of the waveguide matches the probe at the input end of the waveguide, the energy is coupled out of the waveguide with no change in efficiency.

b. Loop Coupling. To put energy into the waveguide with maximum efficiency, a small loop is placed in the waveguide at a point of maximum magnetic field intensity. You will recall, the probe was inserted at a point of maximum electric field intensity. For comparison, notice that the loop is placed in a waveguide at a point of maximum magnetic field intensity.

- (1) The loop is a one-half wavelength in circumference and is similar to a parallel resonant circuit. The current through the loop

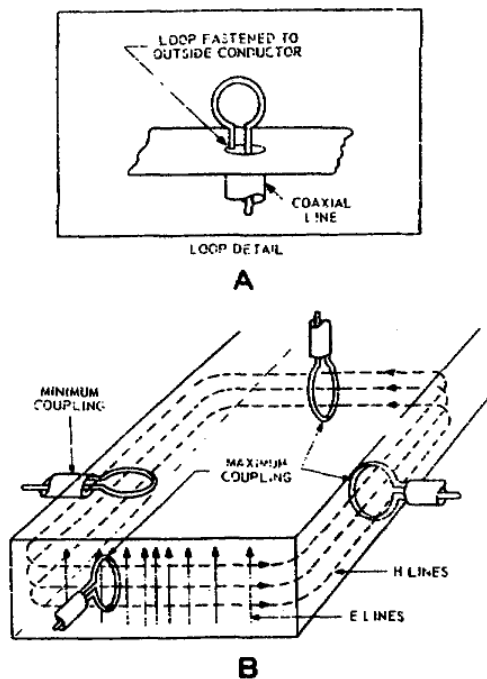

Figure 70. Orientation of the coupling loop.

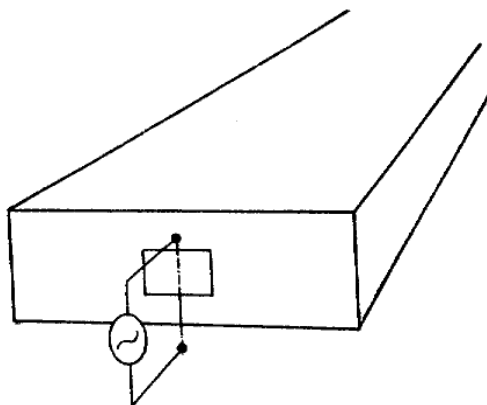

Figure 71. Window coupling.

the wire. The E lines will pass through the window and position themselves in the waveguide. If the frequency of the signal matches the waveguide dimensions, a properly proportioned window will transfer energy to the waveguide with a minimum of reflections. The coupling may be changed by varying the size and the location of the window. This method of coupling is not very efficient. Notice how the E lines radiate in all directions from the wire and only a small part of the energy enters the waveguide.

builds up a magnetic field around the loop. The magnetic field then expands and fits into the waveguide. This pattern moves down the waveguide at the phase velocity. The location of the loop for maximum coupling to the waveguide is at the place where the magnetic field is of greatest strength, as shown in B of figure 70. The construction and mounting of a loop is shown in A of figure 70.

- (2) Loop coupling is the most common method of coupling energy into or out of a waveguide. It offers no loading effect to the waveguide because it is inductive coupling, whereas the probe is capacitive coupling. If less coupling is desired, the loop may be rotated so that it encircles a smaller number of magnetic lines, as shown in B of figure 70 (left side). Usually it is desirable to have maximum coupling. The loop is also a broadband coupling device and will handle high-power signals.

c. Window Coupling. The third method of coupling energy into and out of a waveguide is the iris, aperture, slot, or window coupling. Energy can be put into or taken out of a waveguide through a window, or opening, in the waveguide. This method is sometimes used when very loose coupling is desired. Energy enters the waveguide, as shown in figure 71, through a small window, and the E field will expand into the waveguide. A single wire, as shown in figure 72, has E lines set up parallel with

2-10. IMPEDANCE MATCHING

a. Waveguide Termination. When energy is coupled into or out of a waveguide, there should be an impedance match between the generator, the coupling elements, the waveguide, and the load. In this respect, the waveguide is affected the same as a two-wire line. Unless the waveguide is terminated in its characteristic impedance, standing waves will be created. The characteristic impedance of the rectangular waveguide may be of any value, depending on the dimensions of the waveguide and the frequency of the energy coupled to it.

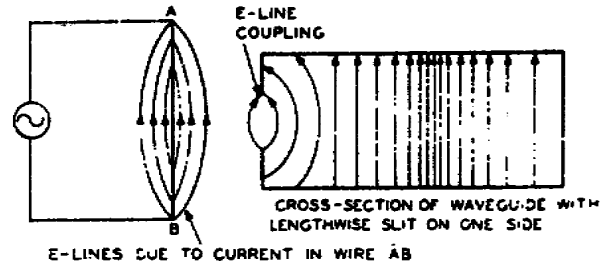

Figure 72. Excitation through the window.

b. Characteristic Impedance. Since a waveguide is a single conductor, it is not easy to define the characteristic impedance. You may, however, think of the characteristic impedance as being approximately equal to the ratio of the strength of the electric field to the strength of the magnetic field for energy traveling in one direction. This ratio is equivalent to the voltage-to-current ratio in a coaxial line that has no standing waves. In the rectangular waveguide, the characteristic impedance may vary from approximately 0 to 465 ohms. The characteristic impedance may also be expressed in terms of the free-space wavelength and the wavelength in the waveguide.

c. Tuning Screws. Impedance matching in a waveguide is done with reflector elements. Any obstruction in a waveguide can act as a reflector element if the obstruction does not consume power and the longitudinal dimension of the element projecting into the waveguide is small compared with the wavelength in the waveguide. The tuning screws (fig. 73) are threaded cylindrical posts that go through the top of the waveguide. A single tuning screw may be used, but the positioning and adjusting of this screw is very critical. Three tuning screws are usually used. These screws are one-quarter wavelength (in the waveguide) apart. When the tuning screw extends less than a free-space quarter wavelength into the waveguide, it introduces capacitance into the waveguide. An inductance is introduced into the waveguide when the tuning screw is more than a free-space quarter wavelength. When using this element, the inductive tuning is usually not used because of the danger of voltage breakdown. If the tuning screws are placed in the waveguide where they are parallel with the electric field, they can be adjusted for a minimum standing-wave ratio.

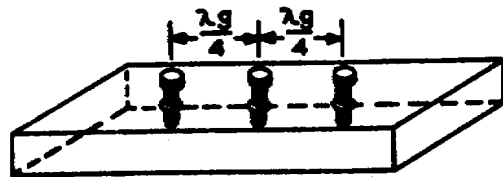

Figure 73. Tuning screws.

d. Reactive Plates (Inductive). Small fins or plates are sometimes used to match impedance in a waveguide. Figure 74 shows a number of reactive plates that will introduce inductance or capacitance in a waveguide. These reactive plates are put into the waveguide so that they are at right angles to the direction of propagation. The position of the plates in A of figure 74 introduces an inductive reactance. The wider the space between the plates, the greater the inductive reactance.

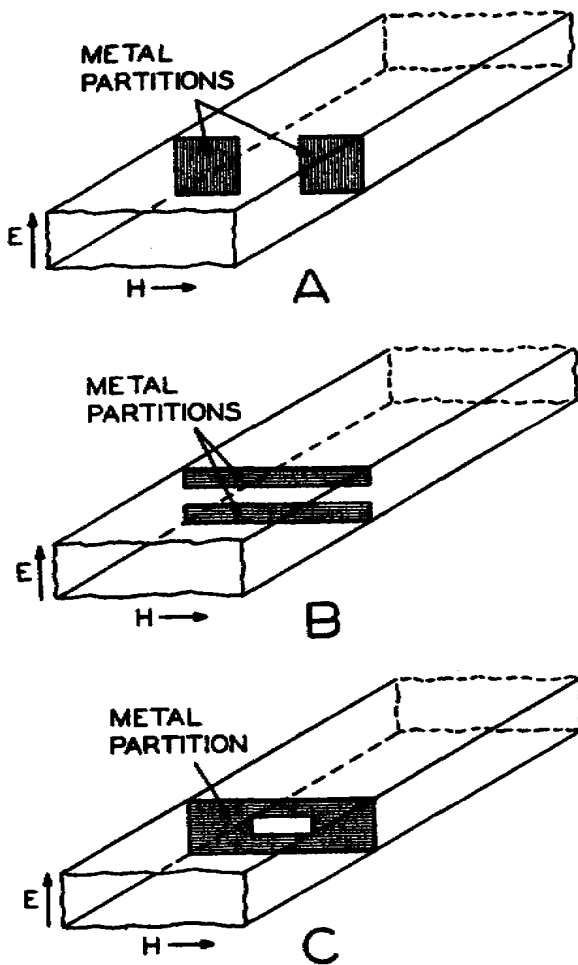

Figure 74. Reactive plates in a waveguide.

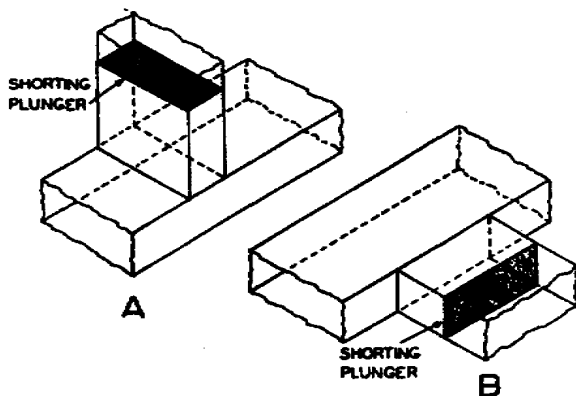

Figure 75. Waveguide stubs.

e. Reactive Plates (Capacitive). When the reactive plates are arranged as shown in B of figure 74 a local E field and higher modes of operation are set up between the edges of the plates. These oscillations cannot be propagated but they do introduce a capacitive reactance into the waveguide. The capacitive reactance increases as the space between the plates is increased.

f. Reactive Plates (Resonant). By combining both types of plates and leaving an opening, as shown in C of figure 74 we have the equivalent of a parallel resonant circuit. If the dimensions of the reactive plates are correct, the inductive reactance will equal the capacitive reactance and the opening will present a pure resistance. At resonance, a parallel resonant circuit offers a high resistance. In this condition the waveguide has in effect a high resistance across it.

g. Waveguide Stubs. Waveguide stubs, as shown in figure 75 are sometimes used as reactive elements. These stubs may act as an open or short circuit to the waveguide in the same manner as stubs used in a two-wire line. Shorted stubs are used to prevent undesired radiation of energy. When placed as shown in A of figure 75 the stub acts as an impedance in series with the line and is called a series stub. In B of figure 75 the stub acts as a shunt impedance across the waveguide and is called a shunt stub.

h. Waveguide Transformer. An impedance transformer is used to change from one value of impedance to another. One type is the tapered-line transformer (fig. 76). The dimensions of the waveguide are varied very gradually by the tapered section. This changes the characteristic impedance of the main waveguide to the value of the load. The tapered section must be longer than two wavelengths of the signal in free space. The impedance transformation is gradual and is effective over a wide band of frequencies.

2-11. BENDS

To have energy move from one end of a waveguide to the other without reflections or standing waves, the size, shape, and dielectric material of the waveguide must be constant throughout its entire length. Any abrupt change in the size or shape of the waveguide will cause reflections; therefore, any change must be very gradual unless special devices are used. When it is necessary to change the shape or direction of a waveguide, then bends, twists, or terminations are used. These are sometimes called waveguide plumbing.

a. Twisted Bends. In some installations it is necessary to change the direction of the waveguide or to rotate the electromagnetic field. When a waveguide is terminated with an antenna, the electromagnetic field may have to be rotated so that the antenna can be properly polarized. This can be done by twisting the waveguide, as shown in figure 77. The twist is gradual and is extended over two wavelengths or more to prevent reflections.

b. Gradual Bends. When the direction of a waveguide is changed, a gradual bend is used, as shown in figure 78. Some bends may be 90° and others may be more or less than 90°. The radius of the bend must be greater than two wavelengths to minimize reflections.

c. Sharp Bends. Some installations may require a sharp bend, as shown in figure 79. These bends are bent twice at 45°, one-quarter wavelength apart. Reflections do occur in these bends, but the combination of the direct reflection at one bend and the inverted reflection at the other will cancel. The fields then appear as though no reflection had occurred.

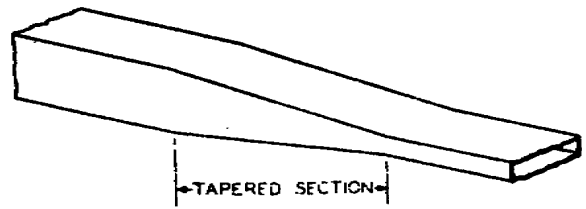

Figure 76. Waveguide transformer.

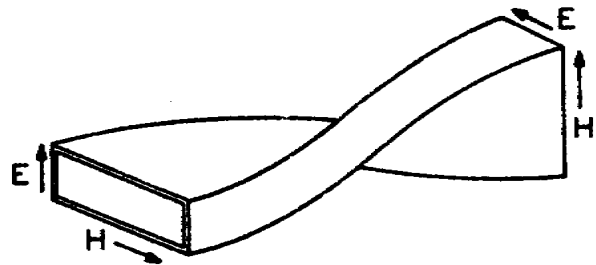

Figure 77. Twisted section of waveguide.

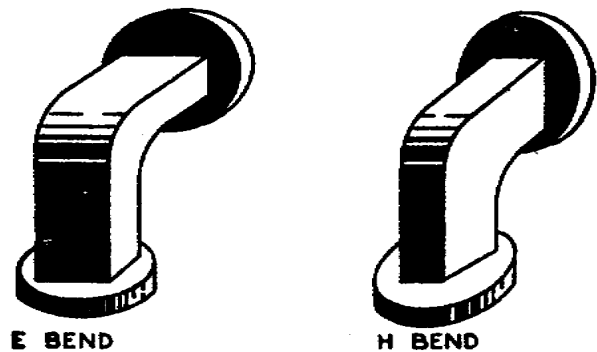

Figure 78. Gradual bends.

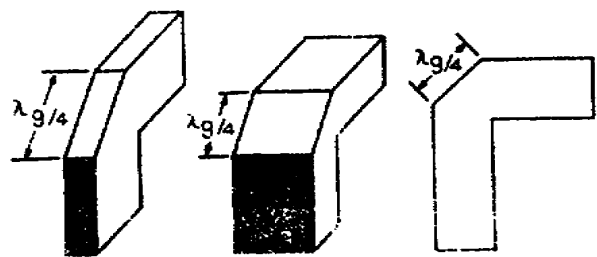

Figure 79. Sharp bends.

d. Construction. All bends can be made in either the narrow or wide dimension of the waveguide without changing the mode of operation. The construction of these bends is very critical. The inside of the waveguide must be smooth and free of dents or ripples. Any distortion of the inside surface will cause undesired reflection. Because of this, the twists and bends are made at the factory and supplied to the installation.

2-12. FLEXIBLE WAVEGUIDE

A section of flexible waveguide is sometimes used to connect two rigid sections of waveguide when there is an alignment or vibration problem. It is also used where the waveguide is subject to flexure at a low rate. Because of its construction, the flexible waveguide may be bent or twisted in any desired direction.

a. Some common types of flexible waveguides and their construction are shown in figure 80 and explained in (1) through (4) below.

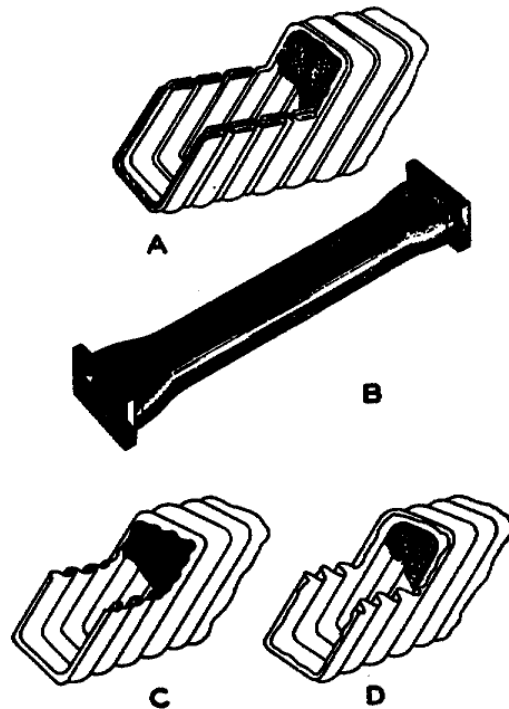

Figure 80. Flexible waveguide.

- (1) The type of waveguide shown in A, figure 80, is constructed of spirally wound strips of brass which are crimped together. When the waveguide is flexed, the strips slide one over the other and contact is maintained.
- (2) Part B of figure 80, shows a similar section covered with rubber and with flanged connectors soldered to the ends. The rubber covering seals the waveguide so that it may be pressurized and serves as a mechanical protection. This is the general appearance of all types of flexible waveguides.
- (3) Part C of figure 80, shows another spirally constructed waveguide. Each strip is crimped tightly to the next stage so that no slippage is possible. The waveguide is flexed by bending the thin walls of the corrugated metal.
- (4) Part D of figure 80 shows a flexible, one-piece waveguide. Here again the thin corrugated metal is bent.

b. Since skin effect keeps the current on the inner surface of the waveguide, the inside surfaces of the flexible section are either chromium plated or silver plated for maximum current conductivity. The higher power losses caused by reflections and standing waves of flexible waveguide make it impractical for general use. In places where the use of flexible waveguide is required, the length is kept as short as possible to keep losses at a minimum.

2-13. JOINTS

It is almost impossible to construct an entire waveguide system in one piece. The waveguide system is made up in sections and the sections are connected by special joints. It would seem reasonable to assume that joining two waveguide sections would only require that the sections be the same size and fit tightly at the joint. Unfortunately, it is not as simple as this because the slightest irregularity in the joint will cause reflections, standing waves, and loss of energy. The two main types of joints are permanent and semipermanent.

a. Permanent Joints. The permanent-type joint has no irregularities and does not disturb the electromagnetic energy in the waveguide. The waveguide sections are machined within a few thousandths of an inch and then welded together. The result is a hermetically sealed and mirror-smooth joint. The permanent joint cannot be used where the installation is in limited space, and the waveguide must be installed in sections. Also, it is sometimes necessary to remove waveguide sections for maintenance and repairs. When this situation occurs, it is more desirable to use the semipermanent joint.

b. Semipermanent Joint. The semipermanent joint most commonly used is the choke joint. A cross-sectional view of the choke joint is shown in figure 81. It is made up of a flat flange and a slotted flange. The slotted flange shown in B of figure 81 has a groove, or slot, that is one-quarter wave deep. This slot is one-quarter wave distance from the center of the wide side of the waveguide. In A of figure 80, notice that the depth of the groove plus the distance from the waveguide add up to a distance of one-half wavelength. The bottom of the groove is shorted so that the half wave now reflects a short where the waveguide walls are joined together. Electrically this creates a short circuit at the junction of the two waveguides. This is just as effective as a permanent joint.

- (1) The two sections can be separated as much as one-tenth of a wavelength without much loss of energy at the joint. This separation allows a gasket to be inserted to seal the waveguide. In some installations the waveguide is pressurized with dry air or

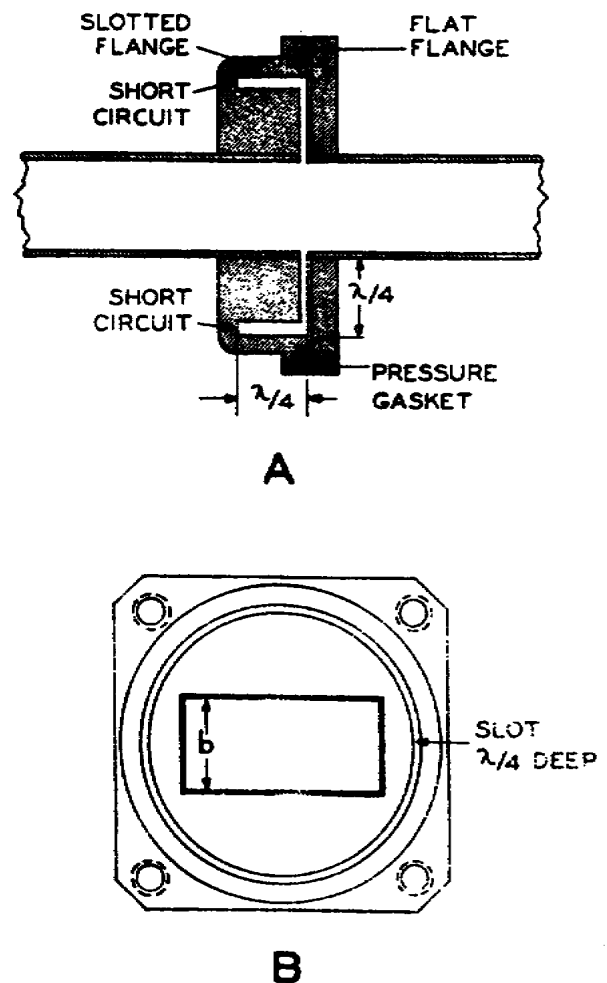

Figure 81. Choke joint.

nitrogen gas. This pressurization allows the waveguide to handle more power with less chance of arc-over and also prevents the collection of moisture or condensation in the waveguide. Cooling systems are used to remove heat from waveguides that handle high power.

- (2) The choke joint operates like an RF choke in a power supply. An RF choke keeps RF energy in the circuit where it belongs, and the choke joint keeps the electromagnetic energy in the waveguide where it belongs. The energy loss in a good choke joint is less than 0.03-db and the loss in a well-machined, unsoldered joint is less than 0.05-db.

2-14. CIRCULAR WAVEGUIDE

For mechanical reasons, a rotating joint must be circular and requires a coaxial line or a section of circular waveguide.

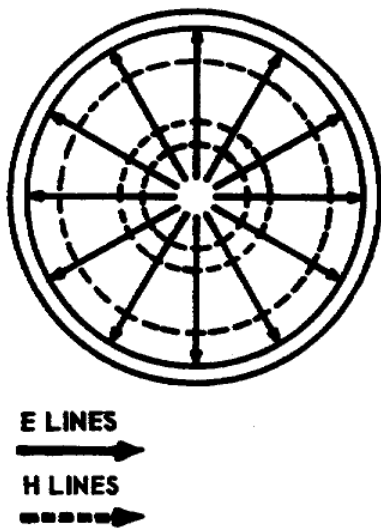

Figure 82. Field configuration in a circular waveguide.

a. Transverse electric (TE) and transverse magnetic (TM) waves are propagated in circular waveguides in almost the same manner as in rectangular waveguides. The field configuration in the circular waveguide closely follows a sine wave pattern (fig. 65).

b. The boundary conditions used in the rectangular waveguide also apply to the circular waveguide. Under these conditions the electric field must be perpendicular to the surface of the conductor, and the magnetic field parallel to the surface of the conductor. When these boundary conditions are fulfilled in the circular waveguide, the electric field exists between the center of the waveguide and the wall, and the magnetic field exists around the inside of the waveguide as shown in figure 82.

c. The dominant mode in the circular waveguide is similar to the dominant mode in the rectangular waveguide. In the TE mode, the electric field is perpendicular to the direction of propagation. In the TM mode, the magnetic field is perpendicular to the direction of propagation. The TE mode in figure 83 shows that the electric lines are circular around the center of the waveguide and perpendicular to the direction of propagation. In the TM mode, the magnetic lines are circular around the center of the waveguide and perpendicular to the direction of propagation.

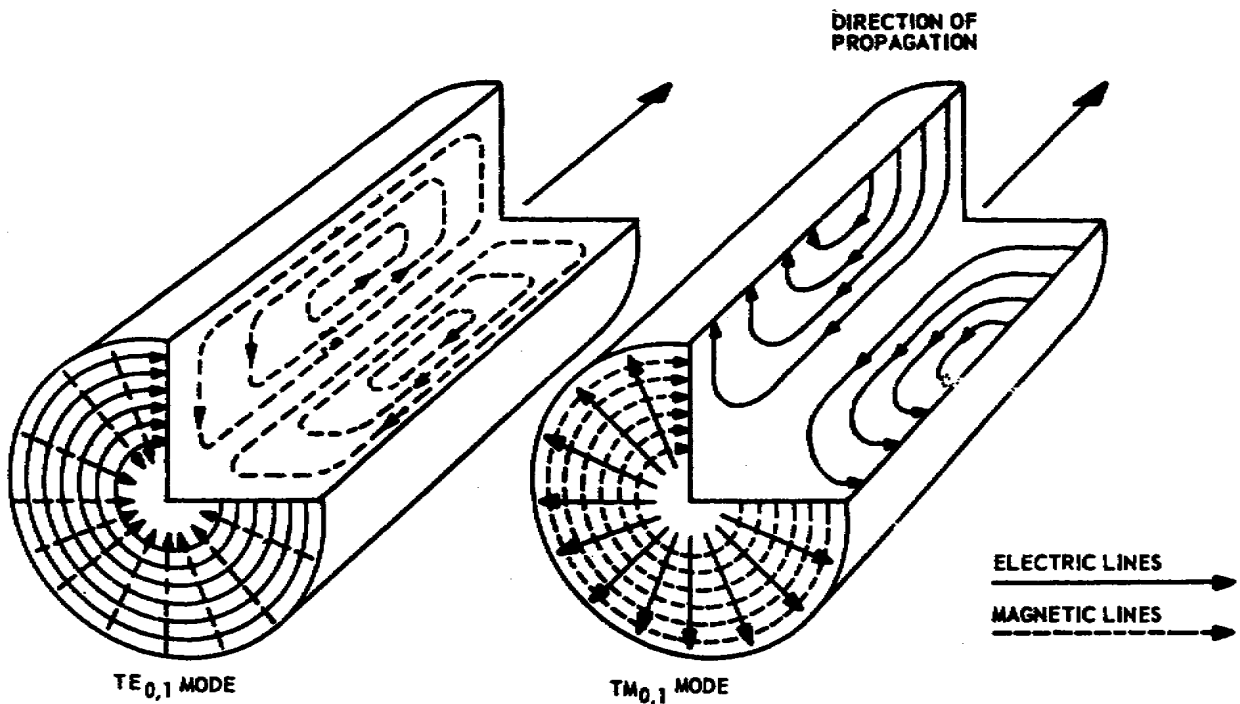

Figure 83. TE and TM modes in circular waveguide.

2-15. ROTARY JOINT

a. Some waveguide systems are terminated with an antenna that must be rotated. These systems use a rotating joint between the waveguide and the antenna system. A simple method for rotating part of a waveguide system is the use of a mode of operation that is symmetrical about the axis. This requirement is met by a circular waveguide. In this method a choke joint is used to separate the sections mechanically and to join them electrically, as shown in figure 84. As explained previously, no actual mechanical connection is needed in a choke joint. The electrical connection is made because of the low impedance that exists between the two sections of waveguide.

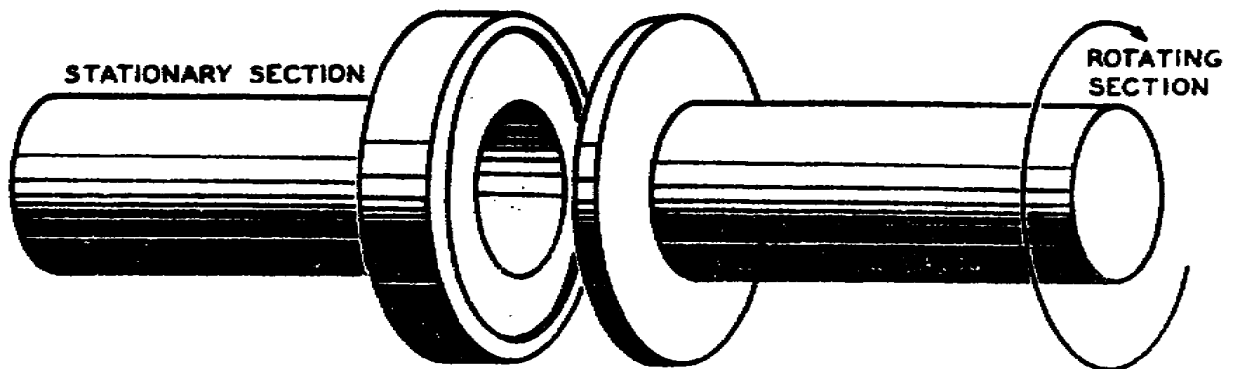

Figure 84. Rotating choke joint.

b. A system using both rectangular and circular waveguides is shown in figure 85. A rectangular waveguide transfers the energy from the

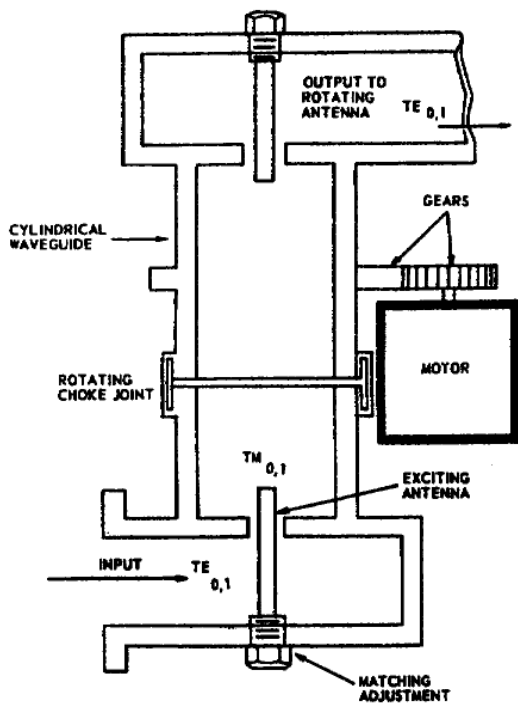

Figure 85. Rectangular waveguide with circular rotary joints.

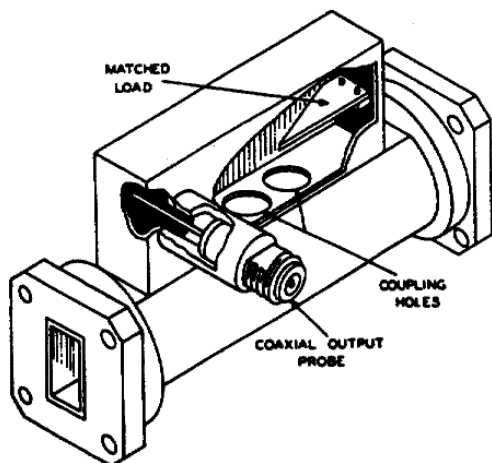

Figure 86. Directional coupler.

two samples arrive at point F in phase and are picked up by the coaxial probe. With regard to the matched load, however, path C-D-F-E is one-half wavelength longer than path C-E, because the two holes are one-quarter wavelength apart. Therefore, the two samples arriving at point E are 180° out of phase with each other. The

installation to a rotating antenna. To do this, the energy must be transferred from a rectangular waveguide to a circular waveguide, and back to a rectangular waveguide that is terminated with an antenna. The energy put into the rectangular waveguide is in one of the TE modes. A probe terminates this section of rectangular waveguide. The probe extends through the rectangular waveguide into the circular waveguide. Energy is put into the circular waveguide by the probe in one of the TM modes. This exchange of energy and modes in the two waveguides is done with very little loss. The energy in the circular waveguide is stable and does not rotate with the waveguide, so there is no change in polarization. The energy from the rotating section of the circular waveguide is transferred through another probe to the rectangular section of the waveguide that feeds the antenna. The energy transmitted to the antenna is now in the original TE mode.

2-16. DIRECTIONAL COUPLER

a. The directional coupler, as the name implies, couples (or samples) energy only from a wave traveling in one particular direction in a waveguide. Figure 86 shows a common type of directional coupler, which consists of a short section of waveguide coupled to the main-line waveguide by means of two small holes. It contains a matched load in one end and a probe in the other end. The degree of coupling between the mainline waveguide and the auxiliary is determined by the size of the two holes.

b. The action of this waveguide is explained through the diagrams in figures 87 and 88. In figure 87 power is shown flowing from left to right, and two small samples are coupled out at points C and D. Since the two paths (C-D-F and C-E-F) to the coaxial probe are the same length, the

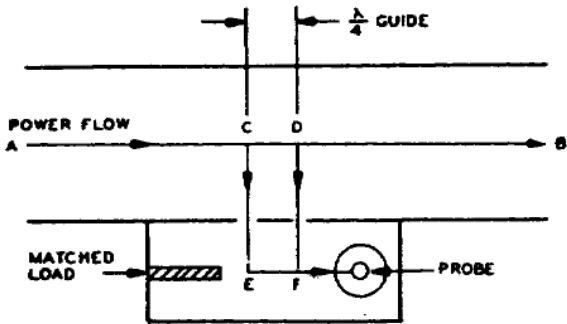

Figure 87. Directional coupler, incident power flow.

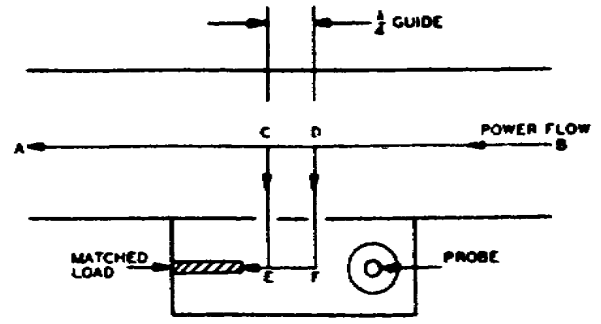

Figure 88. Directional coupler, reflected power flow.

out-of-phase waves cancel each other and no power is delivered to the load. Figure 88 shows the same coupler with power flowing in the reverse direction. Again samples are removed at points C and D. The two paths, D-F-E and D-C-E, are the same length, and the two samples arrive at point E in phase and are absorbed by the load. However, path D-C-E-F is a half wavelength longer than path D-F, and the resulting 180° phase shift causes cancellation at point E. The result is that the coaxial probe receives energy only from a wave traveling from left to right in the main line, and any reflections causing power to flow from right to left have no effect upon the coupled signal. In practice, the attenuation between the coaxial output and the main-line power flowing from left to right is usually adjusted to be over 20 db and is called the nominal attenuation (or simply the attenuation) or the coupling factor.

c. Directional couplers serve as accurate, stable, and relatively broad band coupling devices, which can be inserted into a transmission line so as to sample either incident or reflected power. This sample is then used by test instruments to analyze equipment operation.

2-17. ATTENUATORS

a. Attenuators in present use are classified as dissipative and nondissipative. The nondissipative uses a waveguide which is operated below its cutoff frequency. Attenuation is achieved through mismatch, which reduces the power output by reflecting a portion of the incident power. The amount of mismatch depends upon the length and the size of the waveguide. In the dissipative type, the difference between the output power levels is absorbed within the transmission system.

b. Both fixed and variable attenuators for rectangular waveguides usually employ resistive plates inserted parallel with the electric field. In

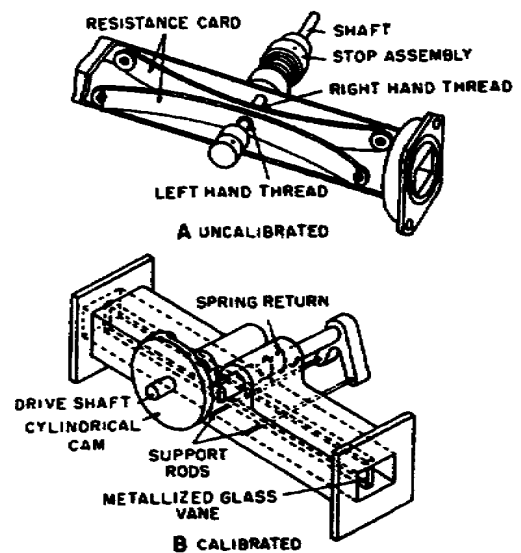

Figure 89. Waveguide attenuators.

precision types, the resistive element is a metalized-glass plate which may be inserted either from one of the narrow sidewalls or through a slot milled in the center of the upper wall. Two variable attenuators using dissipative elements are shown in figure 89.

2-18. CIRCULATORS

a. The circulator allows up to three transmitters and three receivers to use a common antenna. This is done in such a way that no transmitter interferes with either of the others. In a dual-frequency-diversity system, however, only three of the four ports are used, and the remaining port is blocked by a plate, as shown in figure 90.

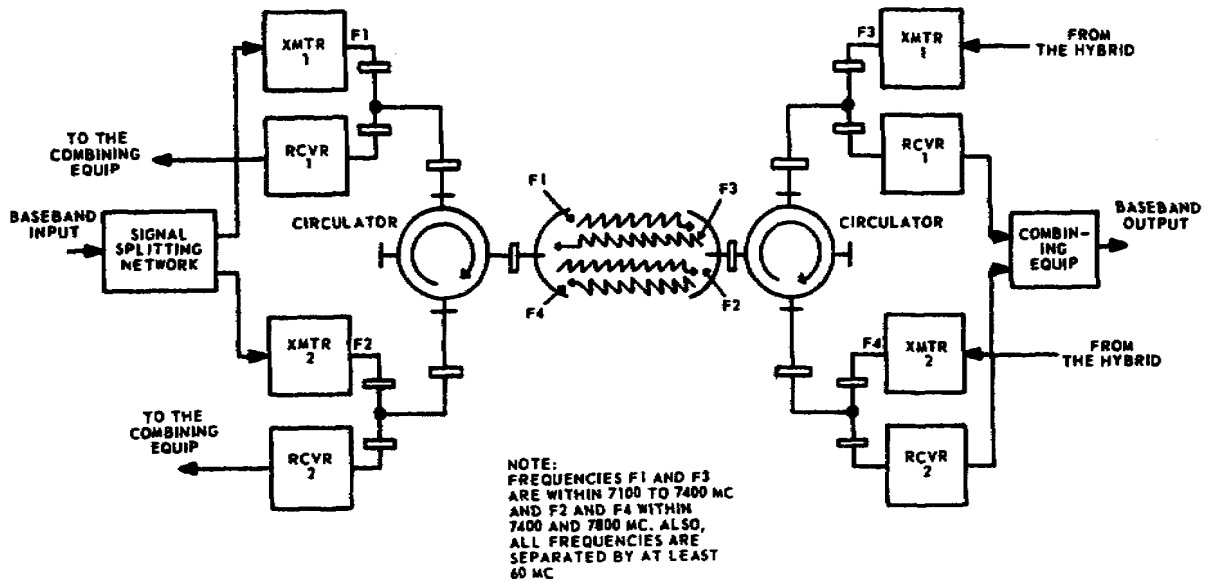

Figure 90. Dual-frequency-diversity microwave system.

b. The transmitter path through the circulator is as follows: microwave energy entering any port passes through the circulator in the direction of the arrow (clockwise) to the next port, where it emerges.

- (1) Assuming connections as shown in figure 91, microwave energy from transmitter A enters the circulator at port 4 and emerges at port 1. The transmitter and receiver bandpass filters associated with transmitter A and receiver B reflect the microwave energy from transmitter A back to the circulator. The transmitter A energy reenters the circulator at port 1. This energy is circulated in a clockwise direction, emerges at port 2, and is delivered to the antenna.
- (2) Microwave energy from transmitter B enters the circulator at port 1, is circulated clockwise, emerges at port 2, and is delivered to the antenna.

- (3) Microwave energy in the circulator is prevented from circulating in a counterclockwise direction by the ferrite material making up the circulator. There are some cases where the energy is passed in a counterclockwise direction, and circulation in a clockwise direction is prevented. This is done to prevent signal interference.

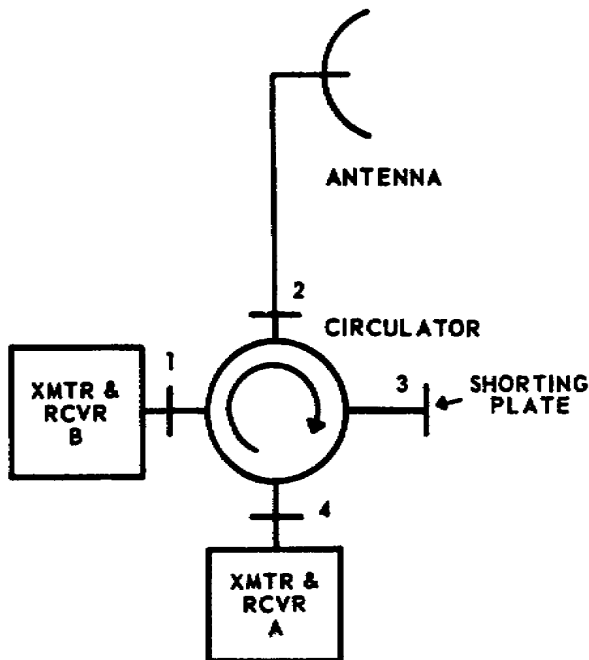

Figure 91. Circulator.

c. As shown in figure 90, the two microwave signals are transmitted to the distant station, received by the antenna system, and applied to a circulator on the waveguide.

d. The receiver path through the circulator is as follows: assuming the circulator is connected as shown in figure 91, the two microwave signals enter the circulator at port 2 and emerge at port 3. The shorting plate reflects both signals, which are circulated on to port 4. The signals emerge at port 4. The bandpass filter associated with receiver A passes the appropriate signal to receiver, but reflects the other signal back to the circulator. This signal reenters the circulator at port 4, is circulated clockwise, and emerges at port 1. The bandpass filter associated with receiver B passes the signal to the receiver.

2-19. MODE LAUNCHERS

a. Mode launchers are used to convert RF energy from one type of mode to another. They are usually needed when a rectangular waveguide is joined to a circular waveguide. When used to join these two sections together, the mode launcher will change the TE rectangular mode to the TE circular mode that is required for propagation in the circular waveguide. Subscripts are used to provide additional mode information. Mode launchers are also used to convert circular operating modes to rectangular operating modes.

b. A functional diagram of a mode launcher is shown in figure 92. Details A and B show the standard E and H field distribution pattern for the TE mode that exists in rectangular waveguide and the TE mode that is required for the circular waveguide. In detail C, the arrows indicate the direction of the E field in the mode launcher. For simplicity, the H field is not shown, since the primary consideration here is the conversion of the E field. As shown in detail C, the input signal is split so that one-half of the power is fed into each of the two branches. The signal in each branch is again split so that one-quarter of the original power is applied to each of the four ports in the circulator. These four signal components are then recombined in the circulator with very little loss, so that nearly 100 percent of the original input power is converted to the required circular TE mode. It should be observed that the E field lines in the rectangular waveguide are aligned in such a direction as to automatically set up the required TE circular mode when the four signal ports are added.

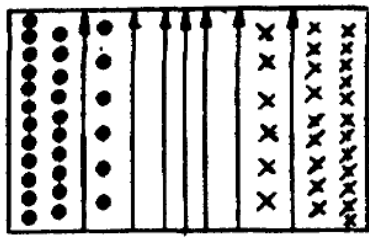

DETAIL-A TE_{10} RECTANGULAR MODE

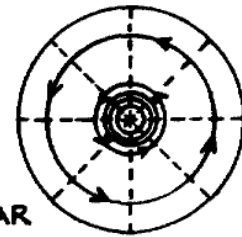

TE_{01} CIRCULAR MODE

DETAIL-B



VIEW X-X
CROSS SECTION OF
MODE LAUNCHER

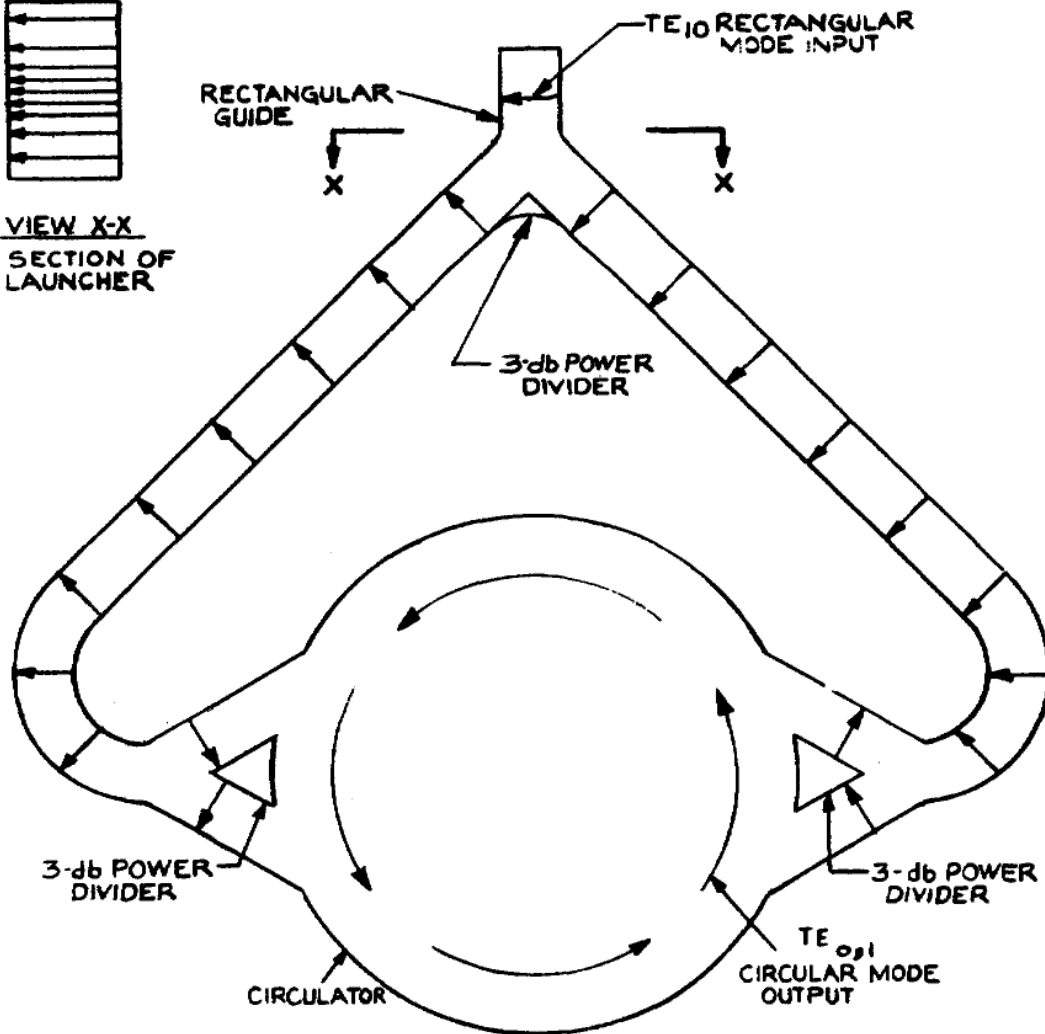

DETAIL-C

NOTE
1-ARROWS DENOTE DIRECTION
OF ELECTRIC FIELD

Figure 92. Mode launcher

2-20. MODE FILTERS

a. Mode filters are inserted in waveguides to insure that only the desired modes are propagated through the waveguides. Theoretically, when a certain type of TE mode is propagated through a circular waveguide, there should be zero current in the walls of the waveguide. This can be seen by observing detail B of figure 92. Notice that maximum current (maximum number of circles) is at the center of the waveguide and diminishes to zero at the waveguide wall. Therefore, with zero current in the waveguide wall there should be zero power loss in the waveguide wall. The function of the mode filter is to absorb any current in the waveguide wall caused by spurious modes. As shown in figure 93, the mode filter comprises a series of polyiron segments inserted in the waveguide wall. These polyiron segments absorb the currents that might be contained in the waveguide wall and then transmit this energy in the form of heat to the surrounding air through the heat-conducting fins.

b. Mode filters are usually placed near the outputs of mode launchers and near flexible sections of waveguide. When placed near the mode launcher as shown in figure 92, the filter removes the energy that was propagated at the TE rectangular mode, which might have passed through the mode launcher from the rectangular waveguide. When used near a section of flexible waveguide, the filter is used to eliminate any spurious modes that may have been set up by the bands and ridges of the flexible waveguide section.

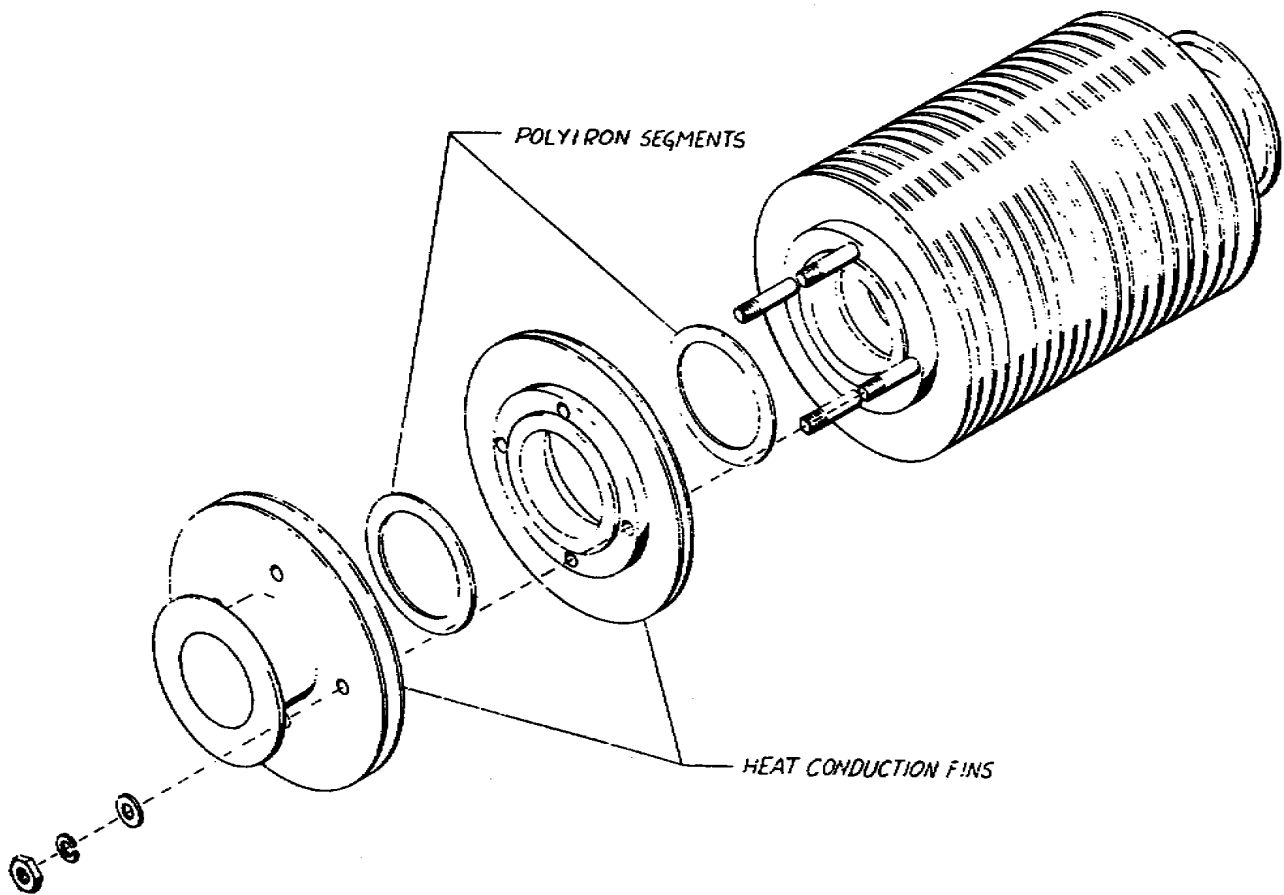

Figure 93. Assembly of mode filter.

2-21. ISOLATORS

Isolators are used to minimize reflections in waveguides. One type of isolator is shown in figure 94. This circulator-isolator is basically a four-port isolator, consisting of a folded magic tee, two 90° nonreciprocal phase shifters, a 3-db short-slot hybrid, and two terminating loads.

a. Detail B of figure 94 illustrates the energy path from the transmitter. The energy enters the magic tee at port 1 and is then split into two equal and in-phase components, A and B. The split signal is fed through the two 90° nonreciprocal ferrite phase shifters, where component A is retarded 90° relative to component B. These two components are recombined in the 3-db short-slot hybrid. Since the two components are of equal amplitude and differ in phase by 90° (component A lagging), they add to give an output at port 2.

b. Detail C illustrates the reflected energy path. Reflected energy enters the isolator at the 3-db short-slot hybrid at port 2 and is divided into two equal amplitude components, A and B. Component B, however, lags A by 90° . These two components propagate through the 90° nonreciprocal ferrite phase shifters, where B is delayed by an additional 90° (relative to A), thereby making a total differential phase shift of 180° . The two components are recombined in the folded magic tee. Since the two components are of equal amplitude and differ in phase by 180° , they add to give an output at port 3. The magic tee prevents the out-of-phase energy from being propagated through port 1. The energy from port 3 is then absorbed in a load. Thus, it can be seen that the circulator-isolator permits the transmitted energy to be propagated with very slight attenuation, but absorbs antenna reflections in a load (where the reflected energy is dissipated as heat).

2-22. POLARIZERS

A polarizer is an iris-loaded section of circular waveguide that is used to change the polarization of the transmitted and received signals in certain microwave applications.

Section IV. ANTENNA FEED SYSTEMS

2-23. GENERAL

An antenna is used either for sending electromagnetic energy into space or for collecting electromagnetic energy from space. Fortunately, separate antennas are not required for communication equipment to transmit and receive electromagnetic energy. Any antenna will receive energy from space with the same efficiency with which it transfers energy into space. Because of this property, known as reciprocity, this discussion will treat antennas from the viewpoint of the transmitting antenna. The same principles apply when the antennas are used for receiving electromagnetic energy.

2-24. WAVEGUIDE RADIATOR

a. When electromagnetic energy is to be radiated into space, the efficiency of the radiator is a major consideration. Suppose the waveguide is left open on one end, as shown in figure 95. The energy propagated to the open end

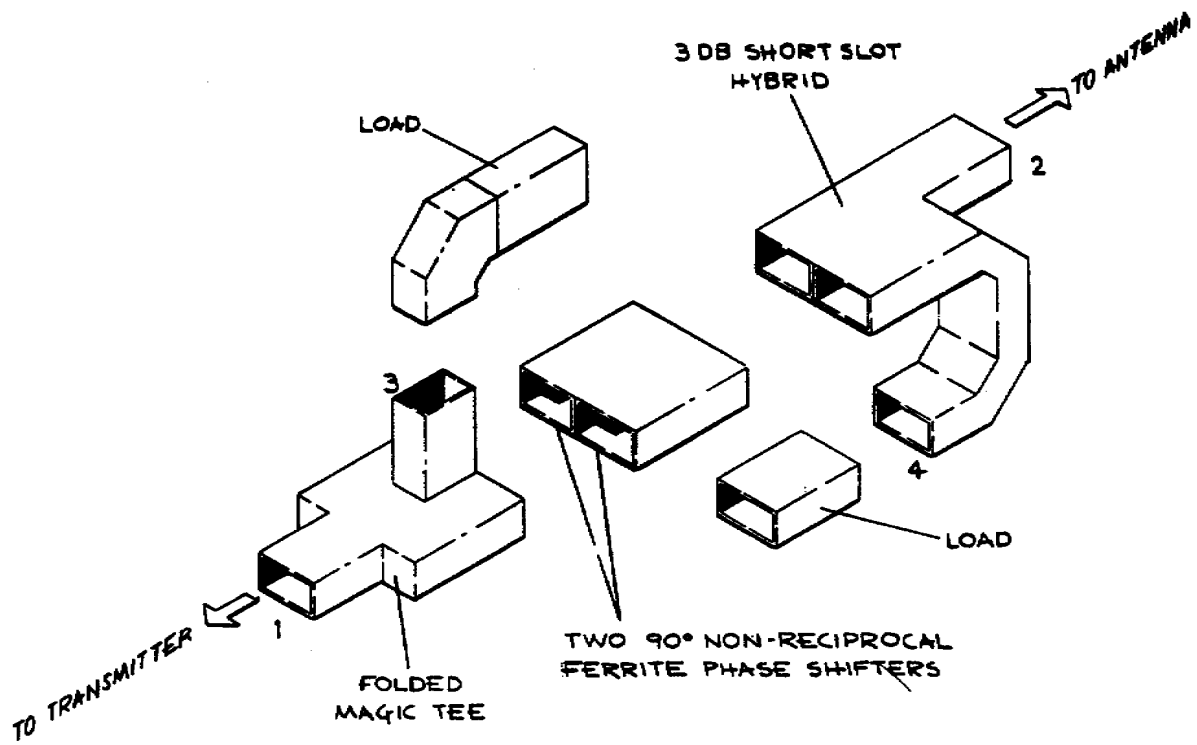

DETAIL A
PHYSICAL BREAKDOWN

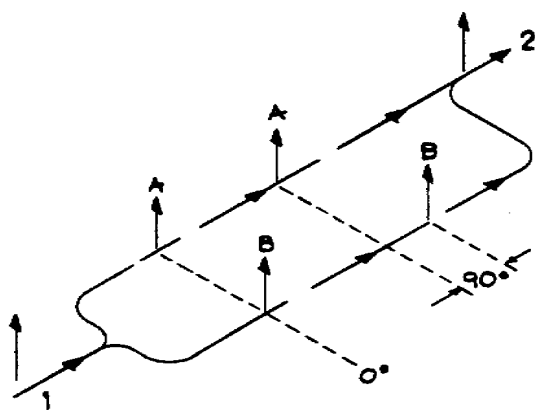

DETAIL B
TRANSMITTED ENERGY PATH

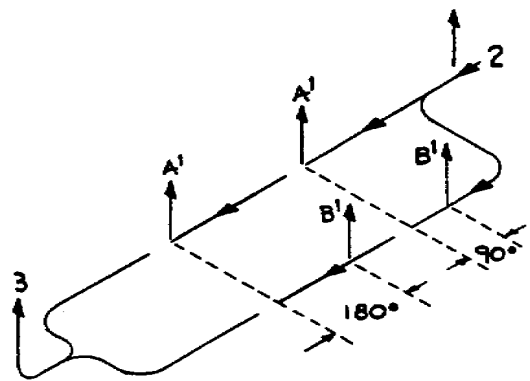

DETAIL C
REFLECTED ENERGY PATH

Figure 94. Isolator.

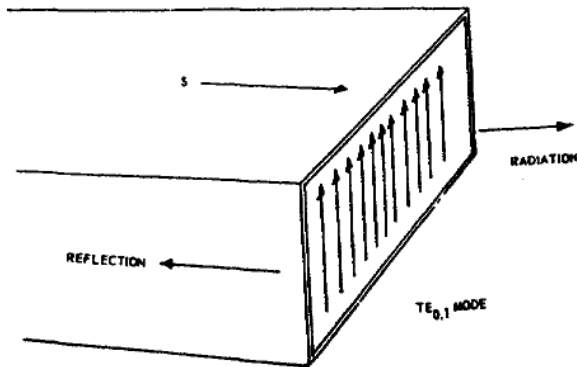

Figure 95. Waveguide radiator.

will encounter an impedance mismatch between the waveguide and space. Part of the energy will be radiated into space, and part will be reflected back into the waveguide because of the impedance mismatch. The reflected energy will cause standing waves in the waveguide.

b. Despite this loss of efficiency, the waveguide radiator is sometimes used to radiate energy into space. The waveguide opening is an aperture, and the size and shape of this aperture determines the polar distribution and gain of the radiator. Because the waveguide radiator is the open end of the waveguide, the aperture dimensions are the waveguide dimensions.

c. Strange as it may seem, the gain of the waveguide radiator is somewhat greater than the gain of a dipole. The polar distribution in the electric plane is similar to the figure-8 pattern of the dipole. The waveguide radiator also has a greater tuning range than the dipole. The tuning range limits are the same as the waveguide limits. As the frequency of the energy in the waveguide is increased to where the waveguide dimension is more than one wavelength, the energy is attenuated. Also, if the frequency is decreased sufficiently, it will reach the cutoff frequency of the waveguide, and propagation ceases.

2-25. DIPOLE TERMINATION

The fact that a waveguide radiator has greater gain than a dipole might lead you to think that it is a simple way to radiate energy into space. Actually it is simple, but there is still the problem of the impedance mismatch between the waveguide and space. An impedance mismatch prevents maximum transfer of energy, so energy is lost in the waveguide because of standing waves.

a. If a waveguide is terminated with a dipole, as shown in figure 96, a good impedance match can be obtained. It is much simpler to excite a dipole from a waveguide than from a coaxial line. To excite a dipole from a waveguide, the dipole is mounted on a web that fits into the open end of the waveguide. The web is mounted in the waveguide so that it is parallel with the wide side of the waveguide, and this places the dipole so that it is parallel to the E lines in the waveguide.

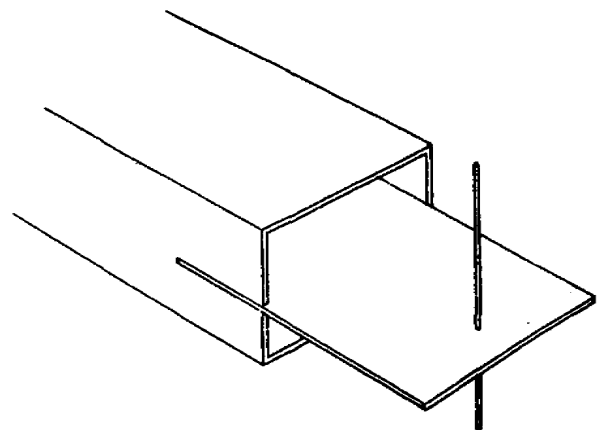

Figure 96. Dipole termination of a waveguide.

b. The impedance of the dipole is determined by the depth to which the web is inserted and the position of the dipole with respect to the opening in the waveguide. Usually, the waveguide has a tapered section on the end and the web is inserted in this section. This provides a very good impedance match between the waveguide and space.

c. To obtain the desired radiation pattern, several dipole elements may be mounted on the web. The most common arrangement though, is a single dipole with a reflecting element. The reflecting element can be either another dipole or some type of reflecting material shaped according to the beam pattern desired.

2-26. TAPERED HORN

a. The gain of a waveguide radiator may be increased by enlarging the aperture. This is done by attaching a flare or horn to the waveguide, as shown in figure 97. The waveguide termination is commonly known as a tapered horn antenna. The tapered horn antenna is designed to transform a transverse wave at the end of the waveguide to a similar transverse wave at the end of the tapered horn without causing attenuation. The throat of the tapered horn (the junction between the tapered horn and the waveguide) serves as a filter device and allows only a single mode to be propagated freely to the aperture. The tapered horn will not support propagation of a particular mode unless the transverse dimensions of the tapered horn are greater than the dimensions of the waveguide.

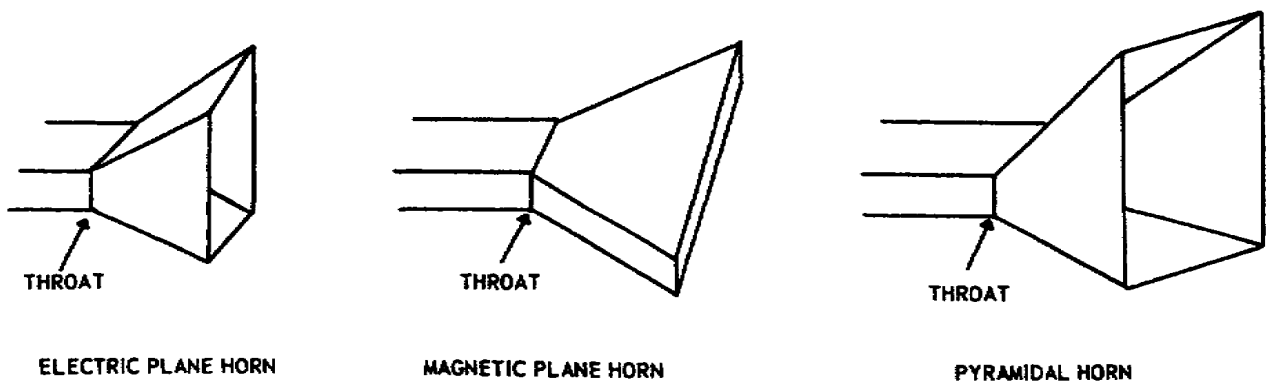

Figure 97. Tapered horn antenna.

b. The dimensions of the open end of the tapered horn are chosen to obtain the desired radiation pattern and to prevent spherical distortion of the propagated wave. The taper of the horn serves to match the impedance of the waveguide to the impedance of space. At one end, the impedance of the tapered section matches that of space; at the other end, it matches the impedance of the waveguide.

2-27. REFLECTOR FEED SYSTEMS

a. Since microwave frequencies have essentially the same behavior as light waves, they can be focused into beams. One of the reflectors used to focus

the energy into a narrow beam is a paraboloid. The focal point and the contour of the reflector determine the size of the reflected beam. The paraboloid reflector is often called a parabolic reflector.

b. The parabolic reflector on a reflector-type antenna system may be fed by a front- or rear-feed system. In a front-feed system the waveguide is curved around the edge of the reflector and then curved again so that the waveguide opening faces the reflector, as shown in A of figure 98. In a rear-feed system, the waveguide passes through the reflector from the back side as shown in B of figure 98.

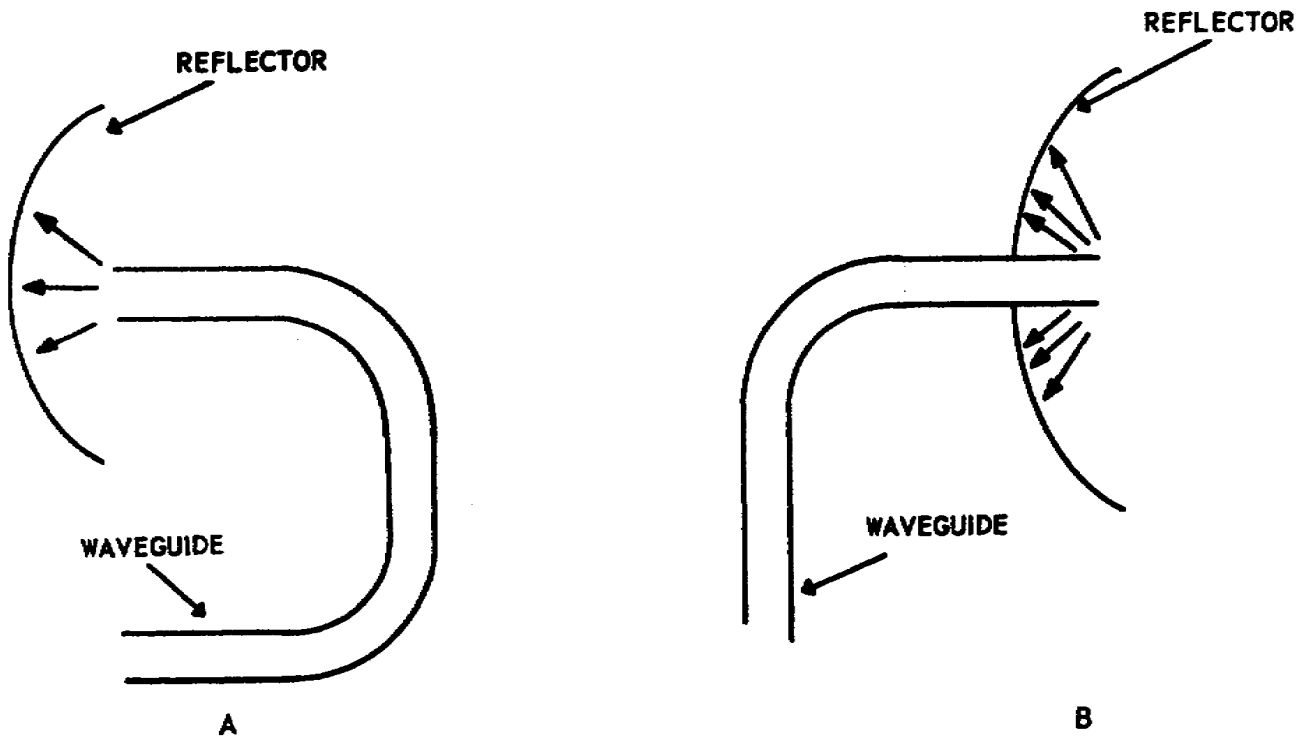

Figure 98. Reflector feed systems.

2-28. CASSEGRAINIAN ANTENNA

A cassegrainian antenna is a rear-fed antenna which uses two reflectors to concentrate the electromagnetic energy into a narrow beam. The antenna system is composed of a feed system, a hyperboloidal reflecting surface (also called a hyperbolic reflector), and a parabolic reflecting surface, as shown in figure 99. The waveguide horn illuminates the hyperbolic subreflector which, in turn, illuminates the main parabolic reflector. Use of the hyperboloid insures a more uniform illumination of the main paraboloid.

2-29. POLYROD ANTENNA

A polyrod antenna is an end-fed directional dielectric antenna that consists of a long, tapered rod energized by a section of waveguide. A dielectric material such as polystyrene is used to construct the rod. The dielectric rod guides the electromagnetic waves in the direction of the rod's axis. The polyrod antenna may be used alone, as shown in figure 100, or it may be used with conventional reflectors.

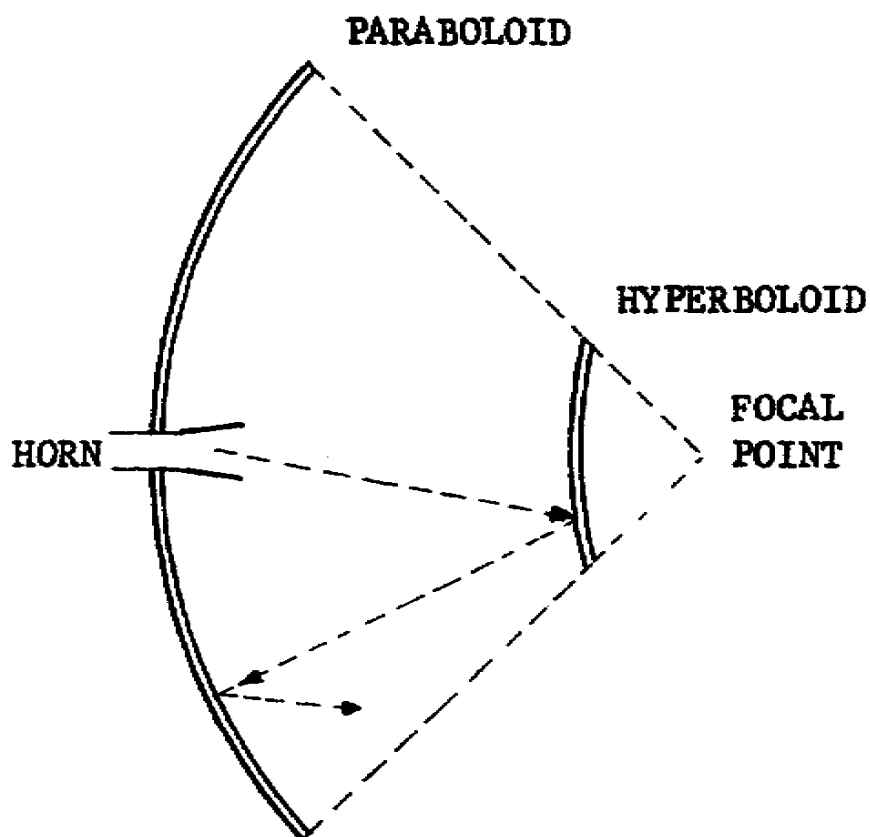

Figure 99. Cassegrainian antenna.

2-30. CASSEGRAINIAN ANTENNA WITH POLYROD FEED

The polyrod feed system can also be used in conjunction with the cassegrainian antenna to obtain a highly efficient low-noise antenna system as shown in figure 101. The polyrod feed guides the electromagnetic energy to the hyperboloid subreflector. The polyrod's dielectric material is tapered toward the waveguide horn so that the dielectric material can provide a uniform illumination of the hyperboloid subreflector. By using the combined polyrod feed and the cassegrainian antenna instead of the conventional cassegrainian feed and antenna system, the overall antenna size can be reduced by approximately 40 percent.

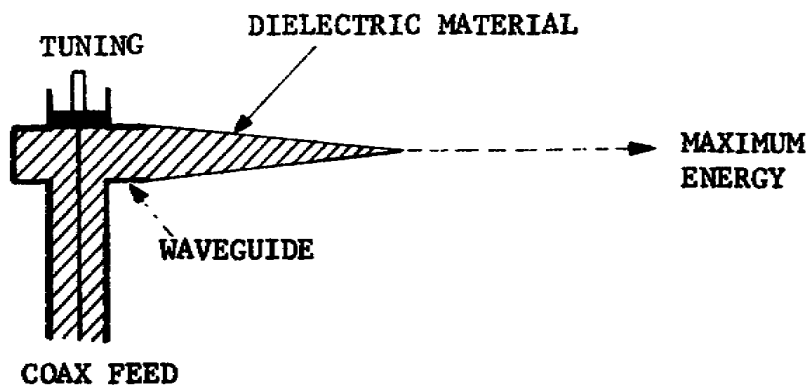

Figure 100. Polyrod antenna.

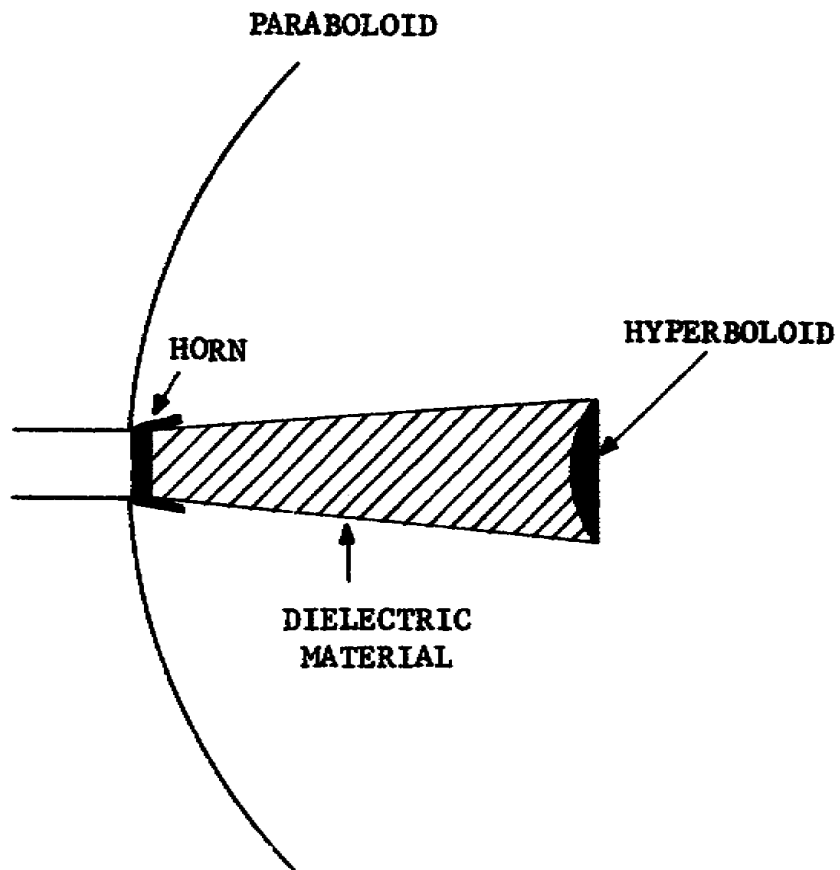

Figure 101. Cassegrainian antenna with polyrod feed.

2-31. SURFACE-WAVE TRANSMISSION LINE

a. General. The surface-wave transmission line (SWTL) is a new type of low-loss transmission line. It uses a single, dielectric-coated conductor as a means of wave conduction. The SWTL solves the problem of reducing the radiation loss so that the line will not act as a long-wire antenna. The nonradiating-wave mode is brought about by the resistivity of the wire. A perfectly conducting wire could not guide a nonradiating wave. The SWTL causes a reduction in the phase velocity of the radio energy field, as compared with the free-space velocity. This reduction in phase velocity is

caused by the limits of the conductivity of the transmission line, and establishes conditions that make possible the propagation of nonradiating waves. If the phase velocity can be reduced enough, for instance, by covering the surface of the wire with a dielectric layer, the nonradiating wave becomes stable and can be excited more easily and with a high degree of efficiency.

b. Wave Development. The functioning of the SWTL is best understood if it is compared with a coaxial line, to which it is closely related. The guided wave is a transverse electric and magnetic wave that propagates with the velocity of light (A, fig. 102). If the space between the inner and outer conductors is filled with a dielectric material, the wave is unchanged, but the velocity of transmission is reduced. If the inner conductor is covered with a dielectric that only partially fills the space, the velocity will be somewhere between that of a solid dielectric and an air-filled line. An important modification of the electric field occurs as shown in B of figure 102. The field lines become curved and some of them no longer reach the outer conductor. If the diameter of the outer conductor is increased while the inner conductor and its dielectric sheath are unchanged, less of the return current reaches the outer conductor. If the outer conductor is large enough, conduction current along the outer conductor becomes practically zero. Thus, the outer conductor becomes unnecessary (C, fig. 102). To form a practical transmission line, this mode must be the only mode on the line which becomes excited. A method of exciting this single mode is to start from a coaxial line section, the inner conductor of which has a dielectric coat, and gradually increase the diameter of the outer conductor until it is so large that it has no appreciable effect on the field. This is illustrated in figure 103. In this manner, a wave on a coaxial line is gradually changed to a guided wave on a SWTL. The gradual expansion of the outer conductor is done by a waterproof, cone-shaped unit called a launcher. The dielectric cover of the wire extends only to the tip of the launcher where the wire enters, and no cover is needed on the line in the taper section.

c. Line Loss. As the outside of the coaxial cable is enlarged while keeping the same center conductor,

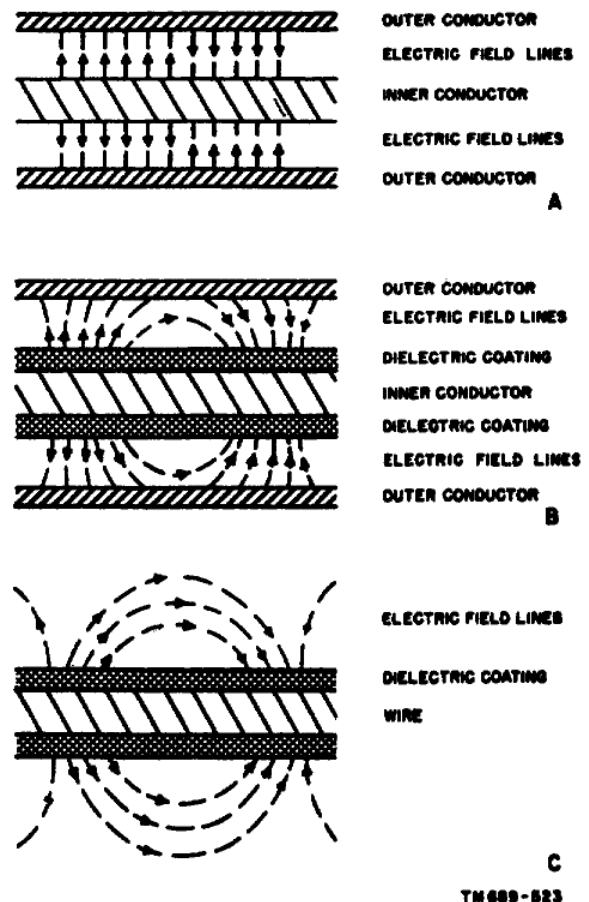

A—Coaxial line
 B—Partial dielectric line
 C—Surface-wave transmission line

Figure 102. Field distribution.

the impedance of the line is raised and the loss is reduced because less current is generated in the higher impedance for a given power transmission. The SWTL has an impedance of 200 to 400 ohms and, therefore, the loss in such a line is a fraction of that of an ordinary coaxial cable with the same size inner conductor. Compared with a two-wire line of the same impedance and the same size wire, the loss is about half, because dissipation occurs in only one wire instead of two wires. The dielectric coat introduces slightly greater loss than would be expected from the open-wire line.

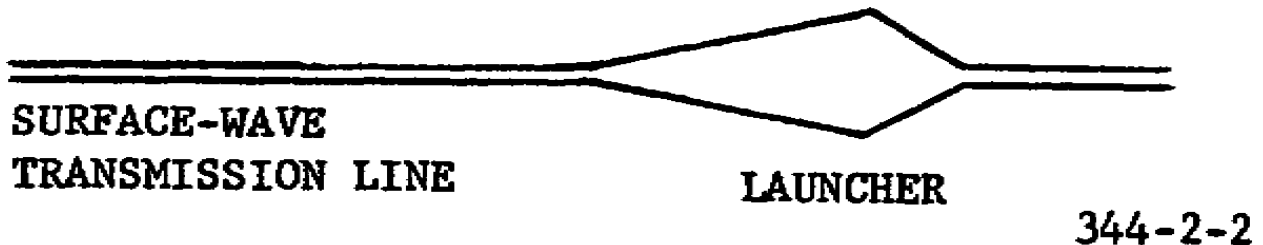

Figure 103. Transmission line with launcher.

d. Radiation Loss. There is a radiation loss inherent with the formation of surface waves. This loss depends on the design of the launchers and their physical size, rather than the length of the line. For long lines, the launching loss is of little importance, and the SWTL is superior to ordinary transmission line.

e. Climatic Effects. Being an open wave-guiding line, the SWTL is subject to weather conditions, but to a lesser degree than open two-wire lines. Rain and dry snow have little effect. Droplets of water on the line, however, act as small radiating dipoles and increase the loss of the line. Such droplets form on lines that are nearly horizontal, but there is no problem in vertical installations. The formation of ice is more serious and must not be permitted. De-icing units are available for use in areas where ice is a possibility.

LESSON EXERCISES

In each of the following exercises, select the ONE answer that BEST completes the statement or answers the question. Indicate your solution by circling the letter opposite the correct answer in the subcourse booklet.

1. Waveguides are capable of handling more power than a coaxial cable because the waveguide
 - a. has an arc-over path twice as long as the coaxial line's path.
 - b. has less resistance than the coaxial line.
 - c. has an inner coating of silver.
 - d. does not use dielectric supports.

2. The energy inside a waveguide can be described as an electromagnetic wave whose
 - a. H lines exist in closed loops.
 - b. E and H lines are parallel to the sidewalls.
 - c. E lines have maximum amplitude at the sidewalls.
 - d. E and H lines are spherical in shape and travel down the center.

3. Assume that RF energy is injected into a waveguide at a power level of 1,000 watts. If the energy strikes the wall at a 0° incident angle, how much of the power is dissipated in the walls of the waveguide?

a. Zero watt	c. 500 watts
b. 250 watts	d. 1,000 watts

4. Assume that the waveguide shown in figure 67 has the dimensions $a = 1.6$ centimeters and $b = 2.0$ centimeters. The wavelength of the lowest frequency that can be propagated through the waveguide is approximately

a. 1.6 centimeters.	c. 3.9 centimeters.
b. 1.9 centimeters.	d. 4.1 centimeters.

5. The amount of power a rectangular waveguide can handle is determined by the
 - a. a dimension (height) of the waveguide.
 - b. b dimension (width) of the waveguide.
 - c. method of terminating the waveguide.
 - d. length of the waveguide.

6. For maximum transfer of energy from one end of a waveguide to the other, the dimensions of the waveguide must be designed so that side
 - a. b is equal to $2a$.
 - b. a is equal to $2b$.
 - c. a and side b are equal to 1 wavelength.
 - d. a and side b are equal to 0.7 wavelength.

7. A waveguide is being operated in a TM mode when the
 - a. field configuration in the waveguide is magnetic.
 - b. electric field does not exist inside the waveguide.

- c. magnetic field is along the length of the waveguide.
 - d. magnetic field is perpendicular to the Z axis of the waveguide.
8. What type of coupling method is most commonly used to couple energy into a waveguide?
- a. Iris
 - b. Loop
 - c. Probe
 - d. Aperture
9. How is the propagated energy in a waveguide affected if the energy encounters a sudden change in the size of the waveguide?
- a. Reflections occur in the waveguide.
 - b. Operation changes from a TE mode to a TM mode.
 - c. All of the energy is dissipated in the form of heat.
 - d. All of the energy traveling in the waveguide is blocked.
10. Assume that a section of waveguide is manufactured with several tuning devices. The one tuning device that can be adjusted to make the waveguide either capacitive or inductive is the
- a. movable plunger.
 - b. reactive plate.
 - c. tuning screw,
 - d. reactive stub.
11. It is sometimes necessary to change the polarization of the energy inside a waveguide. A device that is commonly used for this alteration is a
- a. choke joint.
 - b. tapered horn.
 - c. directional coupler.
 - d. twisted section of waveguide.
12. Flexible sections of waveguide are seldom used in RF feed systems because they
- a. have poor insulation.
 - b. change the polarity of the wave.
 - c. absorb energy in their resistive surfaces.
 - d. cause reflections that result in a loss of power.
13. Care must be taken to protect the inside surface of a waveguide because any

- a. small dent in the waveguide will cause the energy to change from a TE mode to a TM mode.
 - b. irregularity in the waveguide surface will cause reflections.
 - c. ripple in the waveguide will cause skin-effect loss.
 - d. rough surface will cause cutoff to occur too soon.
14. Two waveguide sections that are mechanically connected by a choke joint also possess a good electrical connection. This good electrical connection is realized because the
- a. depth of the choke joint groove is $\lambda/2$.
 - b. depth of the choke joint groove is $\lambda/4$.
 - c. distance from the inside wall of the waveguide to the bottom of the choke joint groove is $\lambda/4$.
 - d. distance from the inside wall of the waveguide to the bottom of the choke joint groove is $\lambda/2$.
15. A waveguide system is pressurized to
- a. keep the waveguide free of dust.
 - b. allow the waveguide to handle more power.
 - c. prevent loss of energy due to leaks in the waveguide.
 - d. prevent the collapse of the waveguide at high altitudes.
16. Circular and rectangular waveguides can be operated in either a TM mode or a TE mode. The field configurations that represent operation in a TM mode are shown in figure 104 in the sketches labeled
- a. A and C.
 - b. A and D.
 - c. B and C.
 - d. B and D.
17. Most microwave RF systems contain an isolator, a mode filter, a mode launcher, and several directional couplers. The purpose of the directional coupler is to
- a. remove a sample of the transmitted or received energy for test purposes.
 - b. insure that only the desired mode is propagated through the waveguide.
 - c. change the RF energy from one mode to another.
 - d. reduce waveguide reflections.

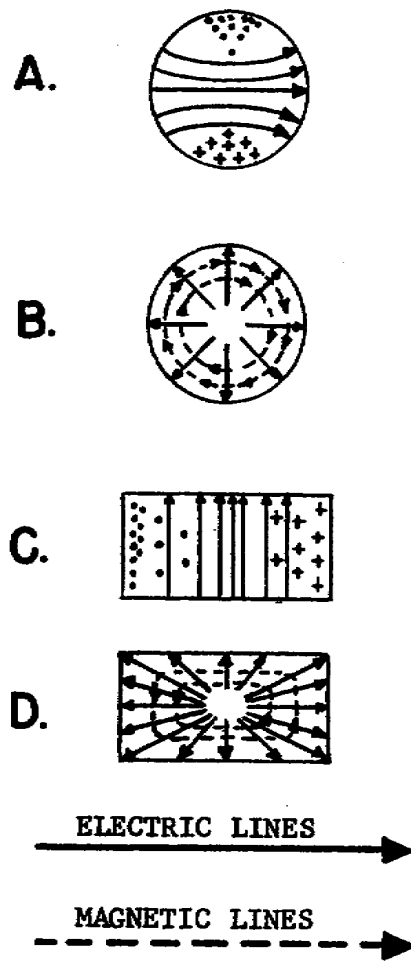

393-1

Figure 104. Waveguide operating modes.

18. When a circulator is used with microwave communication equipment, its purpose is to
 - a. cause circulation of the RF energy in a rectangular waveguide.
 - b. provide air circulation around a multicavity klystron power amplifier.
 - c. permit more than one transmitter and receiver to use a common antenna.
 - d. circulate the liquid coolant around a multicavity klystron power amplifier.

19. Assume that a microwave station's RF system contains isolators, mode filters, directional couplers, and mode launchers. The purpose of the mode launcher is to
 - a. reduce waveguide reflections.
 - b. change the RF energy from one mode to another.

- c. insure that only the desired mode is propagated through the waveguide.
 - d. remove a sample of the transmitted or received energy for test purposes.
20. The use of a single antenna, both to receive and transmit energy, is based on the property known as
- a. reciprocity.
 - b. compatability.
 - c. waveguide radiation.
 - d. two-way propagation.
21. Additional dipole elements may be added to the simple dipole antenna to
- a. provide an impedance match between the waveguide and space.
 - b. form the energy into the desired radiation pattern.
 - c. make antenna reciprocity possible.
 - d. prevent mode changes.
22. In the tapered horn antenna, the throat of the horn serves as an impedance-matching device for the waveguide-to-horn impedance. It also serves as a
- a. filter.
 - b. polarizer.
 - c. mode launcher.
 - d. dielectric guide.
23. Parabolic reflectors are used to control energy in the microwave frequency ranges because
- a. they are nonresonant at microwave frequencies.
 - b. they provide a simple all-purpose antenna system.
 - c. there is no other way to control microwave energy.
 - d. microwave energy can be handled in the same manner as light energy.
24. In a cassegrainian antenna system, the final narrow RF beam is formed by the
- a. paraboloid.
 - b. hyperboloid.
 - c. horn antenna.
 - d. polyrod feed system.

25. In a surface-wave transmission line, the wave on a coaxial line is changed to a guided wave by use of a
- a. rectangular waveguide.
 - b. circular waveguide.
 - c. coaxial line.
 - d. launcher.

CHECK YOUR ANSWERS WITH LESSON 2 SOLUTION SHEET, PAGE 104.

LESSON SOLUTIONS

1. a--para 2-3b
2. a--para 2-6c
3. d--para 2-6g
4. c--para 2-7

Since $b = \lambda/2$ the wavelength λ must be at least $2b$. Since $2b$ is 4.0 centimeters, a frequency with a wavelength of 3.9 centimeters can be propagated through the waveguide.

5. a--para 2-7b
6. a--para 2-7b
7. d--para 2-8b(2)
8. b--para 2-9b(2)
9. a--para 2-11
10. c--para 2-10c
11. d--para 2-11a
12. d--para 2-12b
13. b--para 2-13
14. d--para 2-13b
15. b--para 2-13b(1)
16. d--para 2-8b(2); 2-14c; fig. 68, 83
17. a--para 2-16a, c
18. c--para 2-18a
19. b--para 2-19a
20. a--para 2-23
21. b--para 2-25c
22. a--para 2-26a
23. d--para 2-27a
24. a--para 2-28, fig. 99
25. d--para 2-31

LESSON 3

MICROWAVE TRANSMITTERS AND RECEIVERS

SCOPE.....	Block diagrams of direct - and indirect - angle modulators and transmitters, purpose of preemphasis and deemphasis networks, and frequency multipliers.
TEXT ASSIGNMENT	Pages 105 through 130
MATERIALS REQUIRED.....	None
SUGGESTIONS.....	None

LESSON OBJECTIVES

When you have completed this lesson, you should:

1. Know the direct and indirect methods of modulation.
2. Know the operating characteristics of microwave receivers and transmitters.
3. Be able to use block diagrams to analyze microwave transmitters and receivers.

TRANSMITTING SYSTEM ANALYSIS

Section I. MODULATOR ANALYSIS

3-1. PURPOSE

The primary purpose of the modulator is to convert a baseband input from the terminal equipment to an angle-modulated signal. Angle modulation is a modulation category that includes both frequency modulation and phase modulation. The baseband input usually consists of frequency-division-multiplexed signals from the tt/voice multiplexing equipment.

3-2. MODULATOR STAGES

a. A typical modulator unit will contain various shaping circuits and amplifiers, as well as the actual modulating circuit. A block diagram of a simplified modulator unit is represented in figure 105.

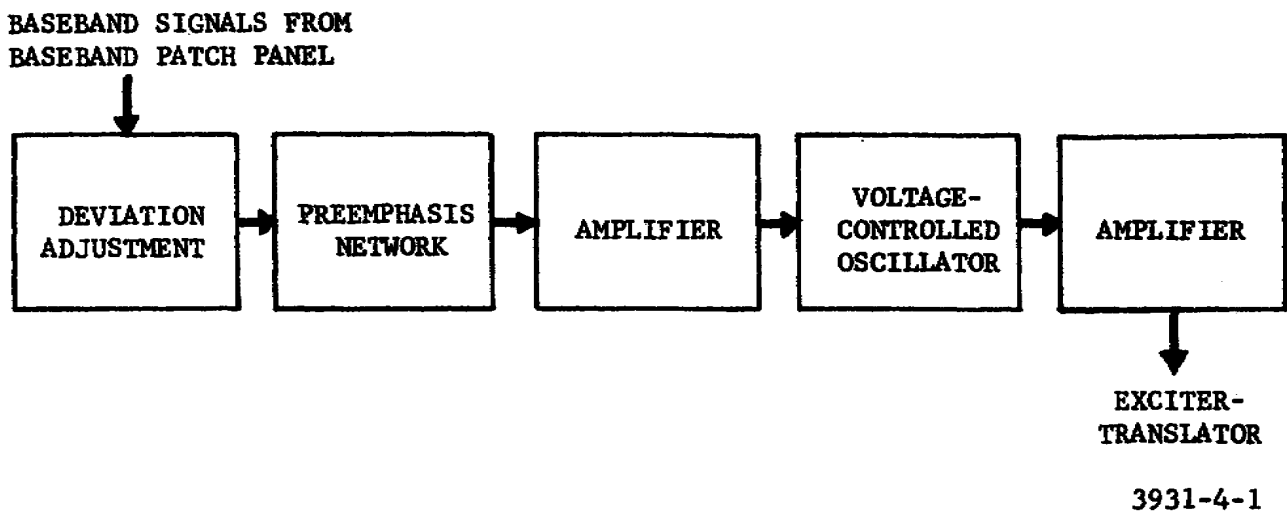

Figure 105. Simplified modulator unit.

b. The normal baseband input is coupled from the baseband patch panel to a series of circuits which prepare the baseband signals for modulation.

- (1) Deviation adjustments are used to establish the desired amplitude of the baseband signals and, since signal amplitudes are converted to frequency deviations during modulation, the adjustments also determine the frequency deviations of the modulated signals.
- (2) A preemphasis network emphasizes the high-frequency components by reducing the amplitude of the low-frequency components of the baseband signal by a greater amount than that of the higher frequencies. This unbalance in the overall signal causes the signal power level in the receiver (after demodulation and filtering) to be increasingly large at the higher frequencies, thus compensating for the

increased noise that occurs at the higher frequencies. The receiver will be equipped with a deemphasis circuit to restore the signal to its original amplitude. This compensation tends to equalize the signal-to-noise ratio across the frequency band. A preemphasis network is also called a high-pass filter circuit.

- (3) The baseband amplifier provides the required amplification for the baseband signals prior to modulation. In some modulators, the amplifier network comprises additional shaping circuits, such as: clippers, limiters, preemphasis networks, deemphasis networks, and filters. These additional shaping circuits are used to reduce the overall noise and to improve the baseband signal.

c. Direct- and indirect-angle-modulation techniques are employed in various types of microwave communication terminals.

- (1) If a direct-angle modulation technique is used, the baseband signals, after preparation, are applied directly to the subcarrier oscillator circuit to produce the desired type of angle modulation. If low values of oscillator frequency and frequency deviation exist, it may be necessary to include a number of multiplier stages to raise them to the desired values.
- (2) If indirect-angle modulation techniques are used, the baseband signals and the output of the subcarrier oscillator are applied to a modulation-amplifier circuit to produce the desired type of angle modulation.

d. After modulation, the signal generally undergoes additional amplification in an RF amplifier stage. The signal is then coupled to the exciter-translator unit in the transmitter.

Section II. INDIRECT-ANGLE-MODULATED TRANSMITTER

3-3. INTRODUCTION

Most transmitters amplify and multiply an angle-modulated signal up to the desired frequency and power level. The block diagram of a simple indirect-angle-modulated transmitter is shown in figure 106

3-4. BASEBAND CIRCUITS

a. The input amplifier is a linear amplifier used to prepare the baseband signal for modulation. The baseband circuits must alter the signals so that they have the correct frequency and amplitude relationship. The amplitude and frequency of the baseband signal must be accurately controlled to properly modulate the subcarrier frequency. The output of the amplifier is coupled to the baseband-shaping circuits.

b. Preemphasis, deemphasis, and limiter circuits are used as baseband-shaping circuits. The limiter circuits remove the portions of the baseband signal that exceed the predetermined limits. The preemphasis and deemphasis circuits operate on the high frequencies in such a manner as to improve the overall signal-to-noise ratio of the baseband signal.

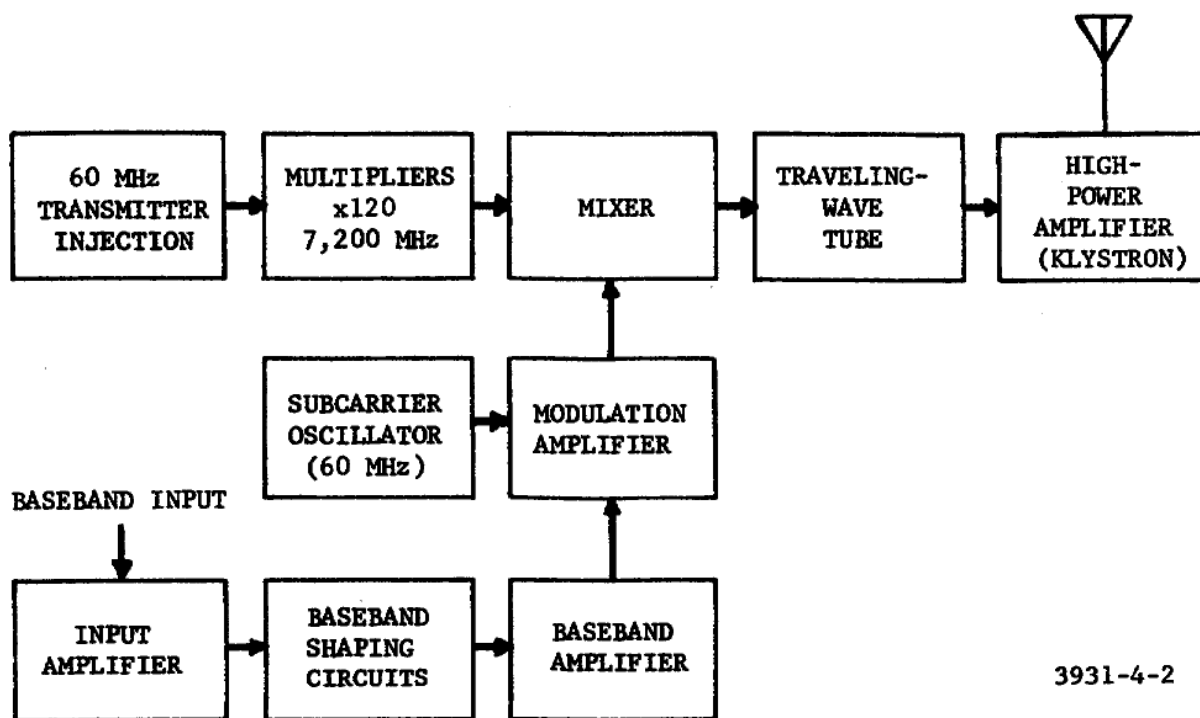

Figure 106. Indirect-angle-modulated transmitter.

c. The baseband amplifier increases the power level of the baseband signal and isolates the shaping circuits from the modulation amplifier.

3-5. MODULATOR

The prepared baseband signal and the unmodulated 60-MHz subcarrier signal are combined in the modulation amplifier to form the modulated-subcarrier signal. The indirect-modulation process in this amplifier involves amplitude-, phase-, and frequency-modulation techniques.

3-6. TRANSMITTER INJECTION STAGES

a. The transmitter injection voltages are usually generated by a separate frequency-generating subsystem. This subsystem usually contains a highly stable frequency standard, amplifiers, and frequency synthesizers. In addition to the injection output used in the transmitter, the subsystem also provides synchronizing voltages for other subsystems within the communication system.

b. The transmitter injection voltage can also be developed by a single highly stable oscillator. For example, the stage illustrated in figure 106 could be a single crystal oscillator stage operating at a frequency of 60 MHz.

3-7. FREQUENCY MULTIPLIERS

The frequency of the transmitter injection voltage is multiplied by a series of multiplying stages to a value of approximately 7,200 MHz, the frequency required for transmission. The individual circuits used to perform this

multiplication generally do not multiply the frequency by more than 6. To perform the multiplication of 120, as shown in figure 106 three stages of multiplication can be used: x6, x4, and x5.

3-8. MIXER

The mixer circuit heterodynes the 60-MHz angle-modulated subcarrier signal from the modulator and the 7,200 MHz injection signal from the multiplier stages to produce a 7,200-MHz modulated carrier to be used as the up-link frequency.

3-9. TRAVELING-WAVE TUBE

The TWT is a special type of electron tube which provides amplification for wideband signals. The operation of the TWT depends upon the technique of velocity-modulating the electron beam inside the tube structure.

3-10. HIGH-POWER AMPLIFIER

a. Another type of velocity-modulated tube, a klystron, is used to provide the final amplification needed to raise the modulated signal to the desired power level for transmission. This circuit usually operates with very high voltages and requires a cooling system to reduce the operating temperature.

b. Several fault detection circuits are used to remove the high voltage or the RF drive from the high-power amplifier when any defect or malfunction occurs.

Section III. DIRECT-ANGLE-MODULATED TRANSMITTER

3-11. INTRODUCTION

All angle-modulated transmitters use either direct or indirect methods for producing the angle modulation. The modulating signal in the direct method has a direct effect on the frequency of the carrier. In the indirect method, the modulating signal uses the frequency variations caused by phase modulation. In either case, the output of the transmitter is an angle-modulated wave, and the receiver cannot distinguish between them. A simplified directly modulated transmitter is shown in figure 107.

3-12. BASEBAND CIRCUITS

a. The baseband input signal is applied to the voltage-controlled oscillator (VCO). The VCO's output frequency of 34 MHz is varied in proportion to the baseband input frequency.

b. The amplifier amplifies the modulated subcarrier and applies the signal to the phase detector stage.

3-13. HARMONIC MIXER

The injection voltage from the multiplier stages is applied to an x4 multiplying circuit within the harmonic mixer stage. The multiplied output

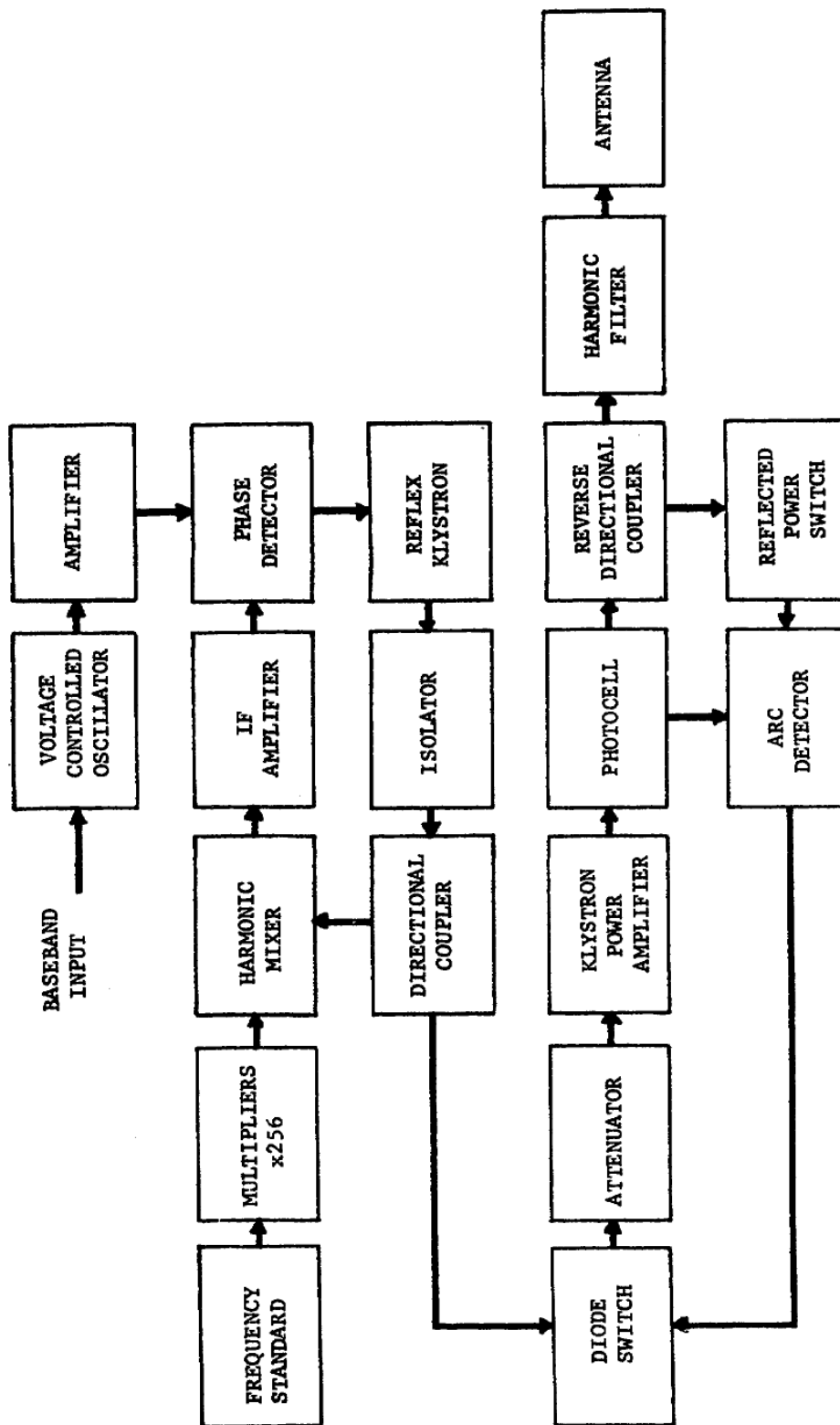

Figure 107. Direct-angle-modulated transmitter.

is mixed with the transmit frequency from the reflex klystron after the transmit frequency has been coupled through an isolator and a directional coupler. The output from the harmonic mixer is a 34-MHz IF that is amplified and coupled to the phase detector.

3-14. PHASE-LOCK LOOP

a. The inputs to the phase detector consist of a modulated subcarrier and a nominal IF of 34 MHz, which is the difference between the transmit frequency and the multiplied frequency standard output. The output of the phase detector, therefore, is proportional to the modulated subcarrier input and the difference in frequency between the outputs of the reflex klystron and the multiplied frequency standard. The output of the phase detector is applied to the repeller plate of the reflex klystron. If the output of the phase detector is positive, the output frequency of the reflex klystron will decrease; a negative output from the phase detector will cause the klystron frequency to increase.

b. When an input from the baseband circuits is applied to the phase detector, the phase detector will produce an output that causes the reflex klystron to deviate from its center frequency. The output of the klystron is fed through an isolator and a directional coupler, and a sample of this signal is applied to the harmonic mixer. The changing input to the mixer causes the 34-MHz IF signal to change, and this variation is applied to the phase detector as the reference input.

c. When a small frequency difference exists between the modulated subcarrier input and the reference signal, the output of the phase detector is a sinusoidal voltage. This sinusoidal voltage will modulate the reflex klystron, thus producing phase lock automatically. The signal from the klystron now only requires amplification before transmission.

d. The phase-lock-loop circuit consists of the phase detector, reflex klystron, isolator, directional coupler, harmonic mixer, and IF amplifier. Its purpose is to reduce the deviation of the klystron's modulated output signal or to compress the signal into a narrower bandwidth.

3-15. POWER AMPLIFIER

a. The input stages for the klystron power amplifier are a diode switch, and a ferrite attenuator that function as an isolator. The diode switch normally allows the input drive to be coupled to the klystron power amplifier. However, an input from the protection circuits will cause the diode switch to remove the input drive from the klystron power amplifier. The ferrite attenuator is a variable attenuator that is used to vary the power level of the input drive.

b. The klystron power amplifier is a velocity-modulated amplifier that is used to raise the power level of the RF input signal to the level required for transmission. Power amplifiers used in transmitters are usually equipped with a heat exchanger or some type of cooling system to remove the excess heat from the amplifier.

c. The harmonic filter absorbs the unwanted harmonic energy from the signal to be transmitted.

3-16. FAULT DETECTION CIRCUITS

a. The fault detection system removes the RF drive from the klystron power amplifier if arcing or if an excessive voltage standing wave ratio exists in the waveguide system.

b. The photocell will sense an arc in the output waveguide and will apply the signal to the arc detector. The output of the arc detector will cause the diode switch to remove the RF drive from the klystron power amplifier.

c. The reverse directional coupler samples the reflected energy in the waveguide. When the voltage standing-wave ratio exceeds a predetermined value, the reflected power switch and the arc detector will cause the RF drive to be removed from the klystron power amplifier.

Section IV. TRANSMITTER ANALYSIS

3-17. TRANSMITTER INJECTION

Voltages used for transmitter injection can be considered as an additional subcarrier's output. The frequencies will be mixed with the modulator's output in the translator portion of the transmitter to form the final angle-modulated output signal.

3-18. FREQUENCY GENERATOR SUBSYSTEM

The frequency generator subsystem provides signals that are used throughout a microwave communication station. All of the frequency outputs of this system are derived from a frequency standard. The frequency standard produces an extremely accurate output signal which is continually monitored and compared with appropriate frequency references. An error in the frequency standard's output can be corrected through adjustments. The output of the frequency standard is coupled to the injection units through a synthesizer driver, frequency synthesizers, and an injection patch panel (fig. 108). These simplified block diagrams represent the techniques used in one particular station, but similar techniques will be used in other types of stations to develop the required injection voltages.

a. The synthesizer driver, using the frequency standard's output signal, develops the fixed frequencies needed to drive the frequency synthesizers. In this particular example, the synthesizer driver receives an input of 5 MHz from the frequency standard, divides it to 1 MHz, and develops 22 different output frequencies which are used as the inputs to the frequency synthesizers.

b. The frequency synthesizers contain circuits which are capable of converting the relatively few (22) fixed input frequencies into outputs that can be varied from 0.01 Hz to 50 MHz in selectable steps as low as 0.01 Hz. Frequency selections are made by the pushbuttons on the front panels of the frequency synthesizer units.

c. The transmitter injection units contain circuits which prepare the input signals for application to the transmitter's translator circuits.

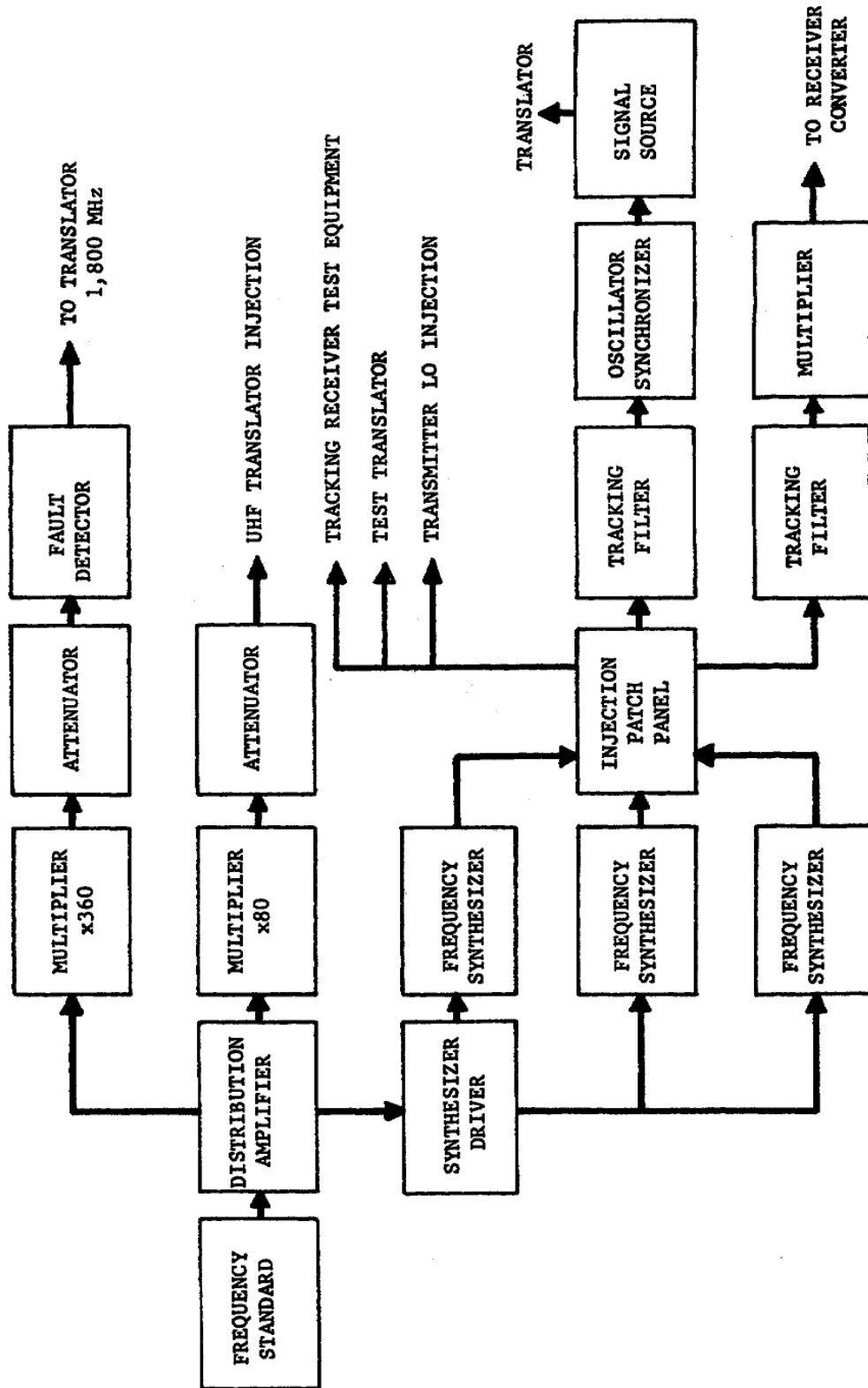

3931-4-4

Figure 108. Frequency generator subsystem.

- (1) Tracking filters are used in some injection units to filter the synthesizer's input signal frequency spectrum to improve the signal-to-noise ratio. The tracking filter is basically a voltage-controlled oscillator that has a phase-lock-loop circuit. The output of the voltage-controlled oscillator is locked to the input frequency through the action of the phase-lock-loop circuit.
- (2) Basically, the oscillator-synchronizer functions in the same manner as the tracking filter. The main difference is that the input signal is compared with a reference signal, but there is no oscillator output signal. Instead of the conventional oscillator output, there is an output error signal which is used to control another signal source (usually a klystron oscillator).
- (3) Multipliers are used in some injection units to raise the frequencies to the values required for efficient operation in the translator unit.

3-19. TRANSLATOR

The translator provides the necessary mixing action required to prepare the modulated signal for transmission. The translator unit is composed of isolators, buffer amplifiers, filters, mixers, and attenuators (fig. 109).

3-20. TRANSLATOR OPERATION

a. Each isolator allows the energy that is propagated in a forward direction to pass through with negligible opposition, but energy that is propagated in a reverse direction is shunted to a dissipating element which effectively absorbs this reverse or backward-wave energy.

b. The overall translating process uses three mixing stages. If a single mixing stage is used with the 70-MHz modulated signal mixing with the final-oscillator-injection voltage, two disadvantages are apparent. The final oscillator-injection voltage would have to approach the final transmitted frequency. This is not too important in itself, but it creates a major problem in that both the upper and lower sideband frequencies are very close to the carrier frequency. Any attempt to reduce the amplitude of the undesired lower sideband without affecting the upper sideband is difficult. The use of multiple mixers provides easier suppression of the undesired sideband and other spurious signals.

- (1) The first translator mixes the 70-MHz modulated signal with the 400-MHz injection frequency to produce the output of 470 MHz. The filter removes the lower sideband from the output signal.
- (2) The 470-MHz output of the first translator is mixed with the 1,800-MHz injection frequency to produce an upper sideband of 2,270 MHz (lower sideband removed by filter). This output signal is then mixed with the final injection frequency of 5.005 gigahertz (GHz) to 6.105 GHz to produce the final modulated signal. This signal is in the range of 7.25 to 8.4 GHz.

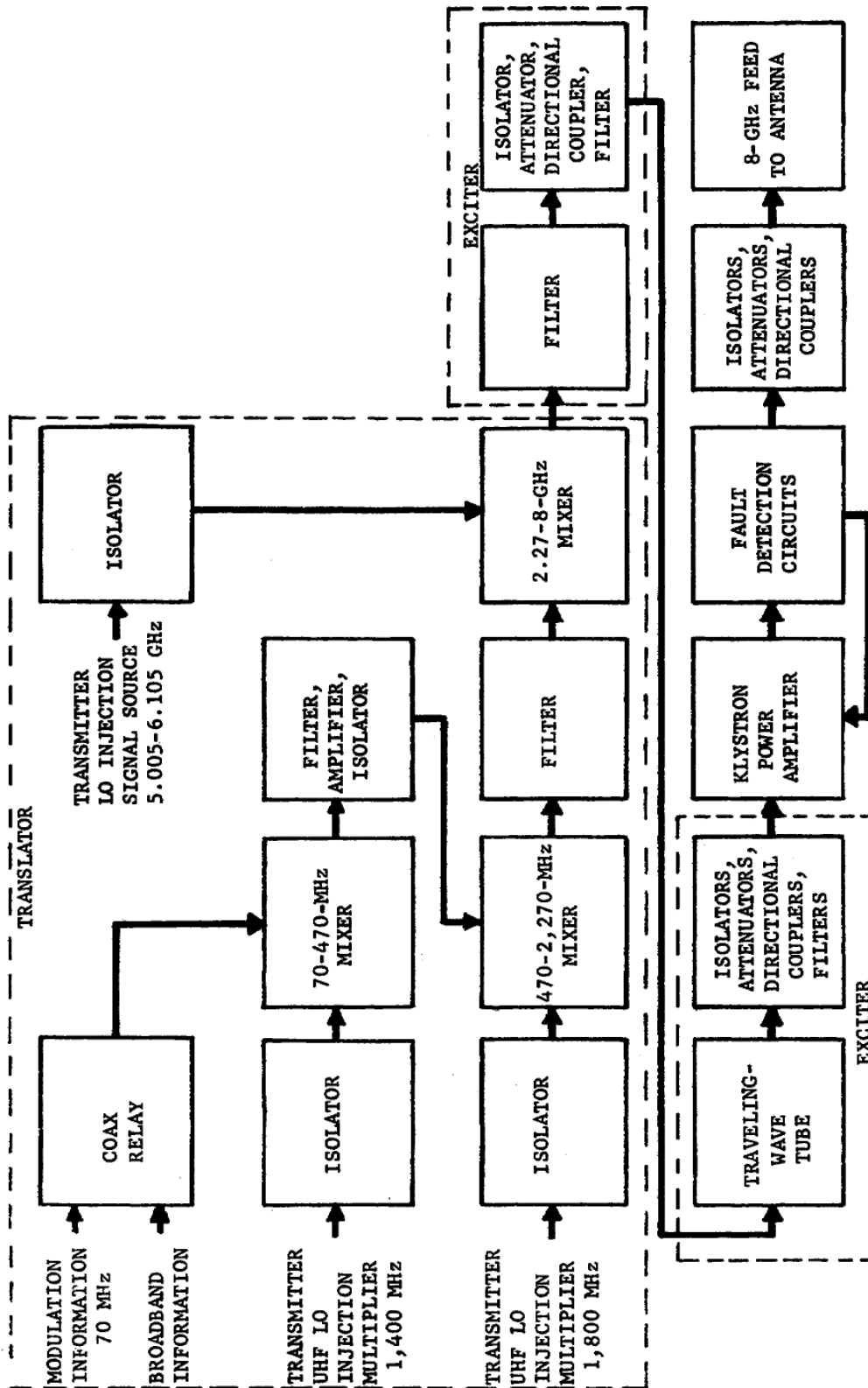

Figure 109. Transmitter subsystem.

3-21. EXCITER

a. The exciter in a microwave transmitting system can be a TWT with its associated filters, attenuators, and couplers. Its purpose is to amplify the modulated signal to a power level that will satisfactorily drive the power amplifier.

b. Variable attenuators are used to provide a means to remotely control the input power levels to the exciter and the final-power amplifier.

3-22. POWER AMPLIFIER

a. The final power amplifier employed in most microwave transmitters is a multicavity-klystron tube. The klystron will amplify the input power by approximately 20,000.

b. Devices that operate continuously at high-power levels generally require a means of cooling to prevent heat damage. This cooling system can be a refrigeration system, a heat-exchanger system, or a simple blower. The study of cooling systems is known as cryogenics.

3-23. FAULT DETECTION

a. Fault detection circuits are used throughout a communication station to protect its components from overloads that may be caused by the failure of other components.

b. Various types of fault detection circuits are used to protect the klystron power amplifier. Some of these circuits are also installed to insure the safety of the operator.

- (1) An extensive interlock chain is provided in each station for maximum safety of personnel and equipment. The klystron beam voltage is removed immediately whenever the high-voltage section of the power-amplifier cabinet is opened. Beam voltage also is removed for a failure due to improper filament current, improper focus current, body current and beam overcurrent, coolant over-temperature, coolant underflow, or coolant overpressure.
- (2) Arc protection is usually achieved by sensing a change in body current and firing a triggered spark gap which crowbars (instantly removes) the beam supply voltage. Protection from excessive reflected power and RF arcing is achieved by removing RF drive from the klystron when the input-waveguide solid-state switch is reverse biased.

RECEIVER CIRCUITS

Section I. RECEIVER CONTROL CIRCUITS

3-24. FREQUENCY-MODULATION FEEDBACK

a. Angle modulation is a technique used to achieve improvement factors greater than 1. This means that at the receiver's input the demodulated or baseband signal-to-noise ratio is better (higher) than the carrier-to-noise ratio. For ordinary demodulation (without feedback) of an angle-modulated signal, the carrier-to-noise ratio at the input must be greater than the moderately high carrier-to-noise thresholds for the improvement ratio to be realized. A communication link must achieve a satisfactory baseband signal-to-noise ratio quality at the lowest possible carrier-to-noise power. The relatively high threshold of carrier-to-noise ratio that an angle-modulated signal must exceed for satisfactory demodulation of the signal with conventional FM detectors is therefore an obvious disadvantage. However, in recent years two demodulation techniques have been developed that can demodulate satisfactorily down to considerably lower threshold levels, and that retain the improvement factor of angle modulation at signal levels above the threshold. One demodulation technique utilizes frequency-modulation feedback (FMFB). The FMFB circuit is also called a threshold extension circuit and a signal enhancer. The second technique employs a phase-lock-loop (PL) detector. The FMFB and phase-lock-loop circuitry differ considerably, but the performance is essentially the same for both circuits.

b. The received signals are at relatively low power levels. Therefore, the amount of noise that accompanies the received signals is of prime importance. This noise may be reduced by narrowing the receiver's bandpass, but this method would also introduce distortion should the deviation of the angle-modulated signal exceed the bandpass of the receiver. A more acceptable method is to degenerate the signal automatically when the deviation exceeds certain limits. In effect the bandpass appears to be narrower to the higher frequency (more troublesome) noise signals. Both frequency and phase modulation have a carrier that deviates (higher and lower, or ahead and behind, in phase) with the complex wave shape of the baseband signal but, practically, it also contains noise. The greater the deviation, the greater the bandwidth occupied by the spectrum of the modulated carrier. A functional diagram of an FMFB circuit is shown in figure 110.

c. Assume for the moment that switch S in figure 110 is in the "open-loop" position and that a large deviation frequency modulated wave with modulation index MI^* is applied to the input terminal of the mixer at point A. At the same time an identical FM wave, but with a slightly reduced deviation (modulation index M_2), is applied to the other terminal of the mixer at point B. The mixer output will be the sum and difference frequencies of the two

*Modulation Index is the ratio between the maximum frequency deviation and the maximum frequency of the modulating signal.

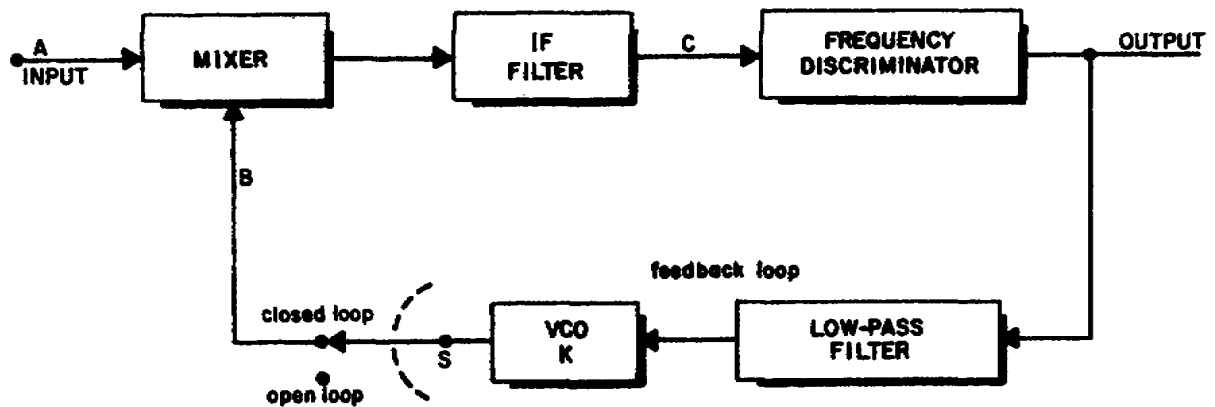

Figure 110. FMFB block diagram.

waves. The difference frequency is selected by an IF filter. This difference frequency at point C will have a modulation index M_3 which will be the difference of the modulation indexes of the two FM waves ($M_3 = M_1 - M_2$). This resulting waveform with reduced deviation may be passed through a filter whose bandwidth is approximately M_3/M_1 times that required of the large deviation wave. The signal is then frequency-detected in a circuit such as a discriminator. The second FM wave (M_2) can actually be derived by feeding the output signal of the frequency discriminator through a low-pass filter to frequency-deviate a voltage-controlled oscillator (VCO). The larger the gain in the feedback loop, the more the input deviation is reduced in the IF.

d. To explain the threshold improvement gained by using FMFB, the threshold mechanism of conventional FM will be detailed. The threshold occurs in a conventional FM receiver when the random-noise peaks exceed the carrier amplitude prior to the frequency detector (discriminator) for a sufficient percentage of time. Each time a noise peak exceeds the carrier amplitude, an impulse in amplitude (a spike) appears at the frequency discriminator output. This noise appears as a random sequence of spikes which are heard as sharp pops in an audio system or seen as spots on a TV screen. For voice, data, or TV channel, operation below threshold is generally unsatisfactory.

e. The FMFB, then, must reduce these noise spikes, and thereby reduce the threshold. This is accomplished by feeding the detected signal and noise back to the VCO. The noise that is fed back will reduce the incoming noise, thereby reducing the threshold of the system; and, at the same time, the improvement factor for high-level signal-to-noise ratios will remain that of the transmitted wave. These are significant improvements in terms of equipment. To demonstrate this action, let us take two examples.

- (1) First, a 100,000-to-1 (50 db) signal-to-noise ratio is desired at the output or baseband signal. By using conventional FM (fig. 6-2), a minimum carrier-to-noise ratio of 560-to-1 (27.5 db) is required; for FMFB, only 70-to-1 (18.5 db) is needed. This means that by using FMFB we are able to reduce the carrier power by 9 db, which is a factor of 8.

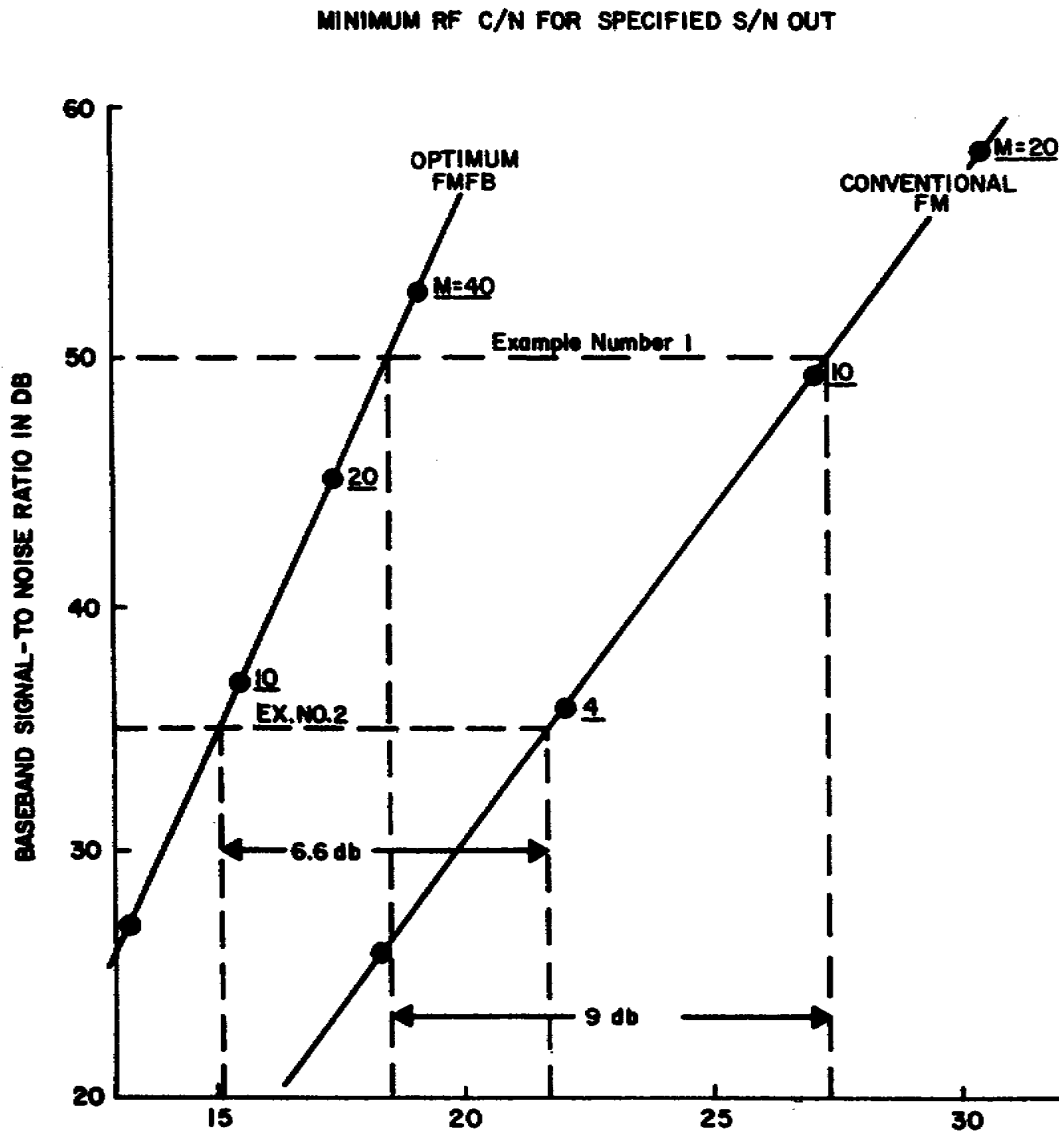

Figure 111. RF carrier-to-noise threshold.

- (2) As a second example, take a more typical baseband signal-to-noise ratio of 3,000-to-1 (35 db). Again referring to figure 111, we see that the carrier power can be reduced by 6.6 db, or a factor of 4.6. Realize that a decrease of 6 db is equivalent to halving the receiving antenna diameter or doubling the slant range.

f. Shown in figure 111 are the modulation indexes needed to design an optimum system. Since bandwidth is directly proportional to the modulation index, the RF bandwidth can be computed. For the two examples just presented, the modulation indexes are between two and three times larger for FMFB; hence, we can expect the RF bandwidth for optimum FMFB to be two to three times larger than conventional FM.

g. Noise operates on an angle-modulated signal in such a way that only some of the noise energy angle-modulates the carrier and only the angle-modulated portion of the noise is reduced by the feedback. For moderately

high input angle-modulation indexes, requiring only a moderate amount of loop-feedback gain, networks can be designed which will ignore the amplitude-modulated portions of the noise. As the modulation index of the input signal is increased, the amplitude portion of the noise modulation causes the threshold to rise to some intermediate value between the 6-db lower angle-modulation limit and the high threshold it would have had without feedback.

h. An example of the action of FMFB can be seen in figure 112. Let A indicate the normal amount of carrier deviation that would occur in the IF signal if FMFB were not used. Noise would cause unwanted carrier deviations as shown. Introduction of FMFB will minimize carrier deviation due to noise as shown in waveform B.

3-25. AUTOMATIC FREQUENCY CONTROL

a. During the receiving-demodulation process, the local-oscillator output is mixed with the incoming carrier signal to produce an intermediate frequency. The difference between the local oscillator and carrier frequencies is the intermediate frequency.

b. If the carrier frequency or the local-oscillator frequency drifts, the average intermediate frequency will change. If the average frequency of the IF signal is permitted to drift, the extremes of the carrier deviation will exceed the limits of the IF amplifier bandpass. As a result, distortion will appear in the demodulated signal. Therefore, it is necessary to produce an IF signal whose average frequency is centered in the IF amplifier bandpass. This will insure that the deviation of the incoming signal will not exceed the limits of the IF amplifier bandpass.

c. To insure the centering of the signal in the IF amplifier bandpass, it is necessary to have a circuit that will sense the average frequency (or phase) changes and produce a voltage that will change the frequency of the local oscillator. The automatic frequency control (AFC) circuit will produce this corrective voltage.

3-26. FREQUENCY-SENSITIVE AFC LOOP

a. The block diagram of an AFC circuit is shown in figure 113. Here the mixer combines the local-oscillator and incoming carrier frequencies and generates a difference (intermediate) frequency. The IF amplifier increases the amplitude of the signal to a level sufficient for demodulation by the discriminator.

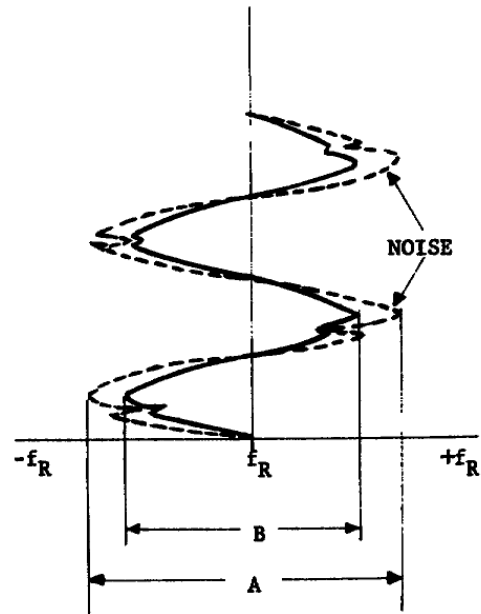

3931-6-3

Figure 112. FMFB effects on carrier deviation.

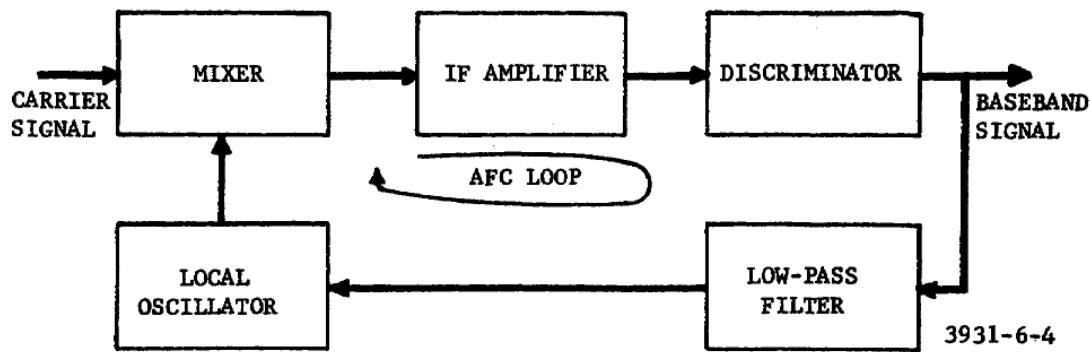

Figure 113. Frequency-sensitive AFC circuit.

b. The discriminator is a frequency-sensitive device that converts the IF changes that are above or below the desired IF into positive or negative dc (baseband) signals. If there are no frequency changes in the IF, there is no output from the discriminator.

c. Since the incoming signal is frequency modulated, the IF varies at the baseband-frequency rate. If these variations are fed back to the local oscillator, the local oscillator's frequency will change and cause the mixer to reduce the deviations in the IF signal. It is generally undesirable to use the baseband to control the local oscillator. Therefore, AFC circuits use a low-pass filter to prevent the baseband frequency from being fed back to the local oscillator. The low-frequency variations representing the drift of the IF average value will be passed by the low-pass filter to the local-oscillator stage.

d. The local oscillator is a voltage-controlled oscillator (VCO) whose output is combined in the mixer to produce the IF. A dc voltage is applied to the local oscillator from the discriminator through the low-pass filter to control the operating frequency.

e. The AFC loop will attempt to maintain the IF at a constant value regardless of whether the IF tends to increase or decrease.

- (1) Assume that the IF increases and that, as a result, the discriminator produces an average output which is positive. (The output polarity depends on the actual circuit configuration and the requirements of the local oscillator.) The positive voltage, when applied through the low-pass filter, causes the local-oscillator frequency to increase. As the frequency of the local oscillator increases, the IF decreases toward the desired value. As the IF decreases, the output voltage from the discriminator will also decrease. When the average IF is at the proper value, the output from the discriminator has an average value of zero.
- (2) As the IF decreases, the output from the discriminator assumes an average voltage which is negative. The average negative voltage causes the local-oscillator frequency to decrease and the IF to increase toward the desired value. As the IF approaches the desired value, the voltage output from the discriminator approaches an average value of zero.

3-27. PHASE-SENSITIVE AFC

a. Except for the phase detector and the reference oscillator, the phase-sensitive AFC loop shown in figure 114 is essentially the same as the frequency-sensitive AFC loop shown in figure 113.

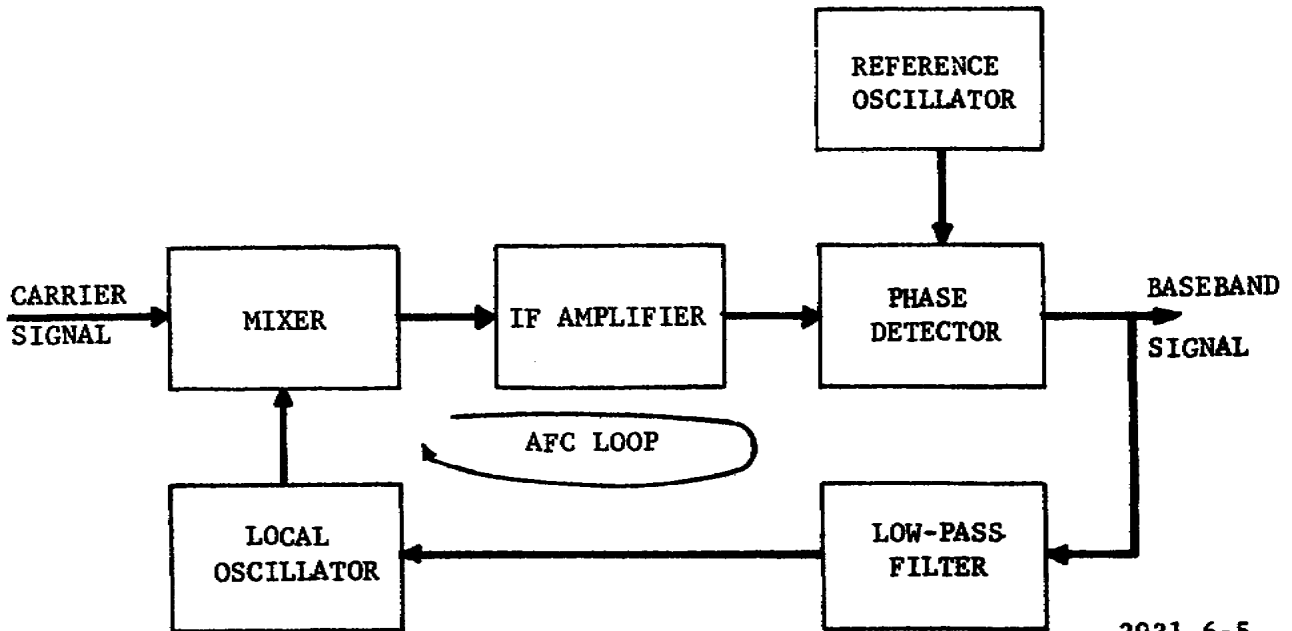

Figure 114. Phase-sensitive AFC loop.

b. The phase detector senses the changes in the phase of the IF with reference to the output signal's phase from the reference oscillator. These phase changes cause an average dc output from the phase detector. The reference oscillator is a highly stable oscillator that operates at the same frequency as the IF.

c. An increase in the IF is sensed as an advance in the phase of the IF. The phase detector will produce an average dc output that is proportional to the amount of the phase change. This output voltage is applied to the local oscillator as in the frequency-sensitive AFC loop. A decrease in the IF is sensed as a lag in phase by the phase detector which will produce an average output of opposite polarity from that generated by an advance in phase. When there is no phase difference, the output is zero. The phase-sensitive AFC circuit is similar to a phase-lock-loop demodulator.

3-28. AUTOMATIC GAIN CONTROL

a. Because of fluctuations in the propagation characteristics of free space and the earth's atmosphere, the power level of the received signals will not be constant. These fluctuations will cause undesired amplitude variations in the demodulated signal.

b. The effects of these variations may be minimized by reducing the gain of the IF amplifiers when the received signal is at a relatively high amplitude,

and increasing the gain when the signal is at a low level. The circuit used to provide this gain control is called an automatic gain control (AGC) circuit.

c. Control of IF amplifier gain may be accomplished either automatically or manually. A combination of both methods is generally used.

Section II. FREQUENCY-MODULATION FEEDBACK RECEIVER

3-29. GENERAL

The simplified FM receiver shown in figure 115 includes circuits used for AGC, AFC, and FMFB. The preamplifier and the first conversion stages are omitted from this figure, but are similar to those in the receiver shown in figure 116.

3-30. BASIC OPERATION

a. Frequency conversion takes place in the mixer stages. Since this receiver uses three conversion (mixer) stages, it is commonly called a triple-conversion receiver. The 60-MHz IF amplifier amplifies the input from the first mixer. The amplified 60-MHz output is mixed with a frequency of 49.2 MHz in the second mixer stage to produce a lower IF of 10.8 MHz. Before applying the 10.8-MHz IF to the third mixer stage, the IF is amplified by the 10.8-MHz IF amplifier stage. The 10.8-MHz IF is mixed with the output of the second VCO to produce an 800-kHz IF.

b. The 800-kHz output of the mixer has a variable bandwidth, which is controlled by mode selector switches on the receiver control panel. The passband of the mixer is varied by the different resistive loads that are placed across the mixer's tank circuit by the noise selector switches.

c. After the desired bandwidth is selected at the third mixer, a conventional stage of amplification amplifies the 800-kHz IF signal and passes it to the limiting stage. The limiter operates on both the positive and negative swings of the IF signal to control the amplitude of the signal applied to the discriminator. The discriminator circuit converts the FM intelligence from the 800-kHz IF signal to usable audio or video signals. The circuits in the video-amplifier stage filter, attenuate, and amplify the signal according to the selected mode and bandwidth.

3-31. AGC LOOP

The 800-kHz IF is also applied to the AGC detector and amplifier. The AGC amplifier provides an amplified dc correction voltage to the 60-MHz IF amplifier. The AGC voltage is capable of varying the 60-MHz IF amplifier's gain over a range of 20 db.

3-32. FMFB LOOP

a. The FMFB loop uses degenerative feedback to effectively compress the FM signal deviation in order to maintain a narrow IF bandpass. A demodulator using FMFB permits an increase in the output signal-to-noise ratio above that

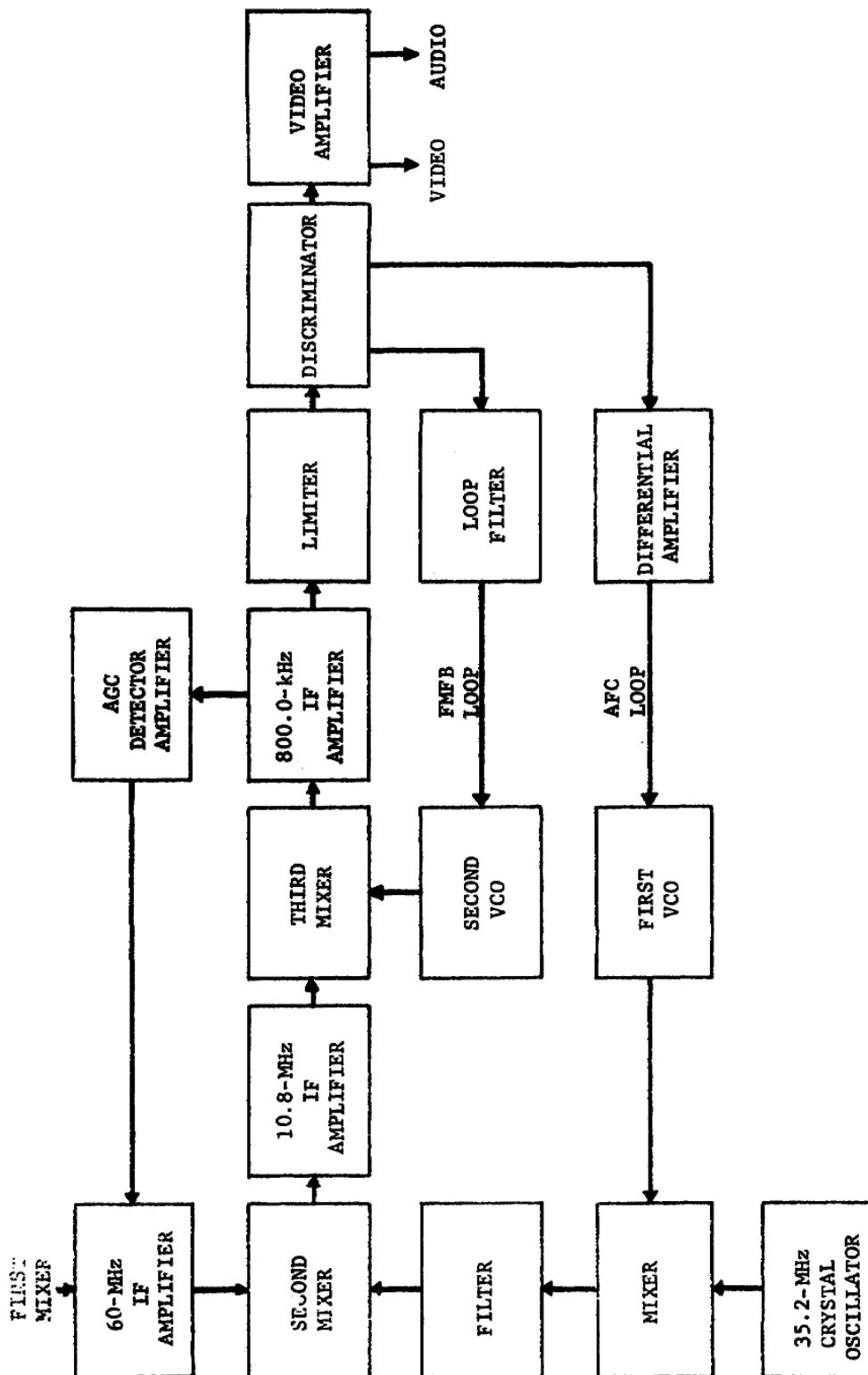

Figure 115. Simplified FMFB receiver block diagram.

of a conventional FM demodulator at low-signal levels. The increase in the signal-to-noise ratio is obtained by processing the signal input to the demodulator so that it will pass through a smaller IF bandwidth than would be required by an unprocessed signal. The reduction in the IF bandwidth allows a smaller amount of noise power to be delivered to the limiter and the discriminator and, therefore, produces a better output signal-to-noise ratio.

b. The process by which the FM signal deviation is reduced consists of varying the injection frequency into the third mixer in the same direction as that of the received FM signal deviation. The resulting mixer-output-frequency deviation is the difference between the input signal deviation and the injection-frequency deviation. This signal with reduced deviation is filtered and amplified in the 800-kHz IF amplifier and then demodulated in the discriminator. The resulting signal, at audio or video frequencies, is then returned to the second VCO and is used to vary the oscillator's frequency with the incoming signal's frequency deviation. This feedback process is necessary for proper reduction of signal deviation which, in turn, is required when using a narrow IF bandwidth.

c. The FMFB loop is closed only during certain demodulation modes. In the other modes of operation of the demodulator, the FMFB loop is open and the second VCO, not receiving a tracking voltage from the FMFB loop filter, acts as a conventional local oscillator. When the FMFB loop is open, the receiver operates as a conventional FM receiver.

3-33. AFC LOOP

a. A portion of the discriminator's output is applied to the differential amplifier stage. When the input to the differential amplifier is 0 volt, the differential amplifier permits the first VCO to operate at its center frequency of 14 MHz. When the input is other than 0 volt, the differential amplifier changes the operating frequency of the first VCO.

b. The 14-MHz output of the first VCO is mixed with the 35.2-MHz crystal oscillator output to provide the 49.2-MHz injection voltage for the second mixer. The AFC circuit controls the 49.2-MHz injection voltage which, in turn, controls the 10.8-MHz IF.

Section III. PHASE-LOCK RECEIVER

3-34. GENERAL

The simplified receiver shown in figure 116 is representative of the receivers designed for use with present near synchronous satellites. This receiver is capable of operating on any one of four preset 2.5-MHz-wide channels in the 50- to 90-MHz frequency range. The operating channel of the receiver is selected by means of the channel select signals from the receiver control circuits. In addition, the receiver can be operated in any one of nine modes of operation selected by means of the mode-select signals from the receiver control circuits. The receiver consists of a preamplifier section, a converter section, an amplifier-converter section, a preselector

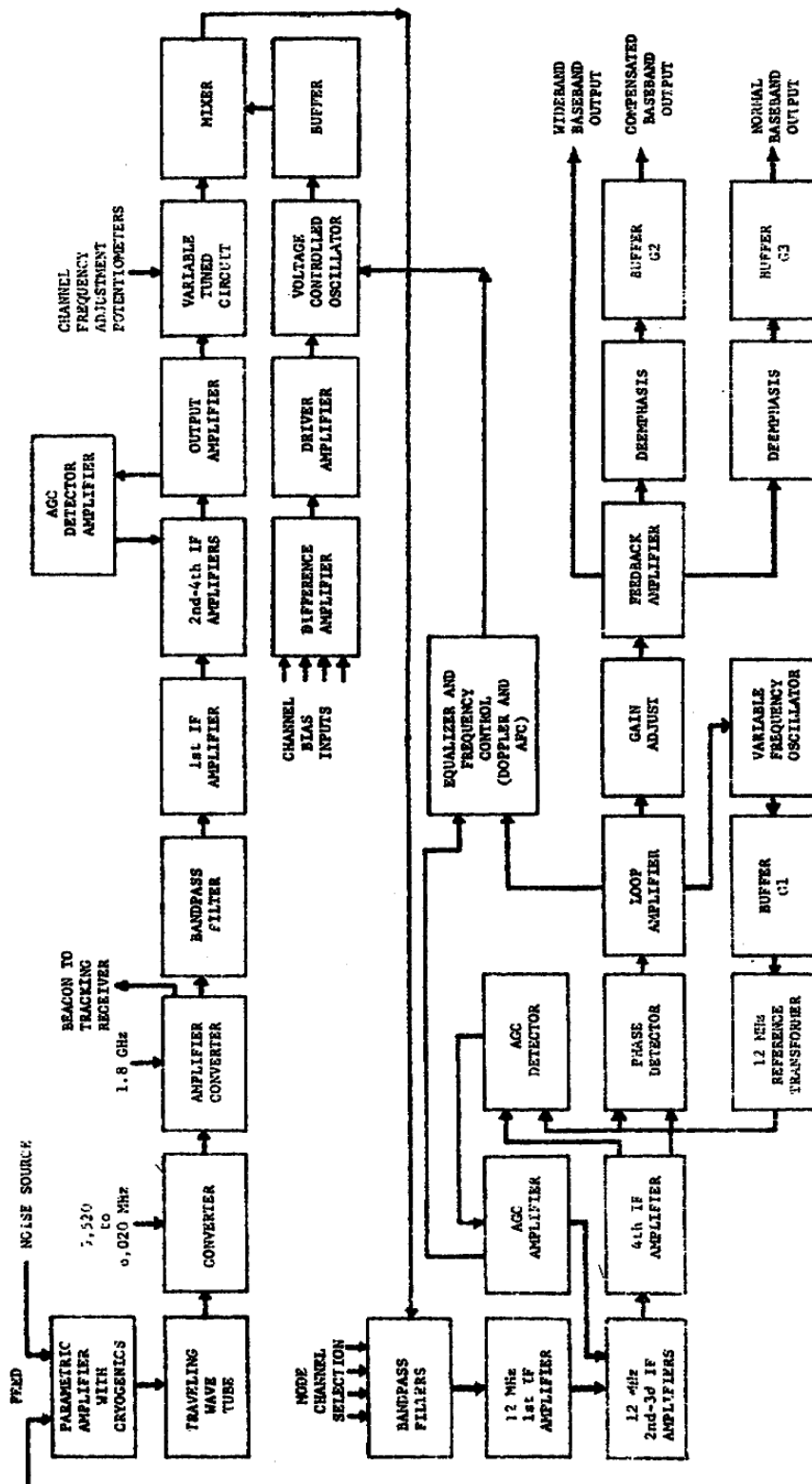

3931-6-7

Figure 116. Simplified phase-lock receiver block diagram.

section, a demodulator section, a baseband amplifier section, and a control section.

3-35. PREAMPLIFIER

The components contained in the receiver's preamplifier are usually located as near the antenna as possible to provide for maximum receiver sensitivity. The input signals are coupled directly from the antenna to the preamplifier. The preamplifier section of the simplified receiver contains a parametric amplifier and a traveling-wave tube.

a. A low noise, cryogenic parametric amplifier is used in the preamplifier to provide sufficient gain and to insure an equivalent noise temperature of less than 200° Kelvin for the receiver when tuned across the receive band of frequencies. Since the parametric amplifier is the first amplifier in the receiver, it determines the noise characteristics for the complete receiver.

b. The power requirements of the parametric amplifier's RF pump are met by an RF module (noise source). The component in the RF module that generates the pump frequency is a klystron.

c. The low-noise wideband traveling-wave tube (TWT) provides additional amplification of the 8-GHz incoming signal.

3-36. CONVERTER

The converter unit provides the first frequency conversion for the receiver. The signals applied to the converter have a bandwidth of approximately 500 MHz. The mixer stage within the converter unit converts the 8-GHz signals from the TWT to 1,730 MHz. The beacon signal channel can be any designated frequency within the range from 1,230 to 2,230 MHz which results in an output bandwidth of 1 GHz. The TWT located in this unit provides the required gain needed to offset the losses incurred in the transmission downline and the rotary joint appearing between the antenna and the receiver.

3-37. AMPLIFIER CONVERTER

The amplifier-converter unit performs two significant functions. The first is that of diplexing between the beacon and communication channels; the second is that of converting the communication channel frequency to an output frequency centered at 70 MHz with a bandwidth of 50 MHz.

a. The beacon channel part of the diplexing function is provided with a tunable preselector which can be tuned within the frequency range of 1,230 to 2,230 MHz, which corresponds to the input operating range of the tracking receiver. The beacon signal is applied to the tracking receiver.

b. The communication channel part of the diplexing capability is mixed with the local-oscillator injection voltage to generate the 70-MHz IF. Feedback of the injection voltage into the beacon channel is minimized by the isolators and the bandpass filters in the unit. The 70-MHz output is amplified by a TWT to the level required by the communication channel. Two 70-MHz outputs are provided by the amplifier-converter unit; one output is used as the input to the noise figure meter, and the second is fed through the receiver patch panel to the bandpass filter.

3-38. PRESELECTOR

The preselector section of the receiver consists of the bandpass filter, the 0-MHz IF amplifiers, and the variable-tuned circuit.

a. The 70-MHz input signal is coupled by means of a coaxial cable from the RF patch panel to the input of the bandpass filter. The bandpass filter passes the signals in the 50- to 90-MHz frequency range with an attenuation of less than 1 db. The filtered signal is then fed to the 70-MHz IF amplifiers.

b. The wideband five-stage amplifier provides a gain of up to 50 db (100,000) in the 50- to 90-MHz range. The second, third, and fourth IF amplifier stages are controlled by an AGC signal which is developed by the AGC detector and amplifier. The AGC signal is capable of maintaining the output level constant to within 2 db with an input variation of as much as 50 db above the threshold level.

c. The amplified 50- to 90-MHz signal is coupled to the variable-tuned circuit. The variable-tuned circuit is a voltage-controlled tuned circuit with a 2.5-MHz bandpass. The center frequency of the tuned circuit is determined by the voltage applied to it from the channel-frequency potentiometers. The voltage applied to it, and thus its frequency, is determined by the setting of the selected potentiometer.

3-39. DEMODULATOR

The demodulator section of the receiver contains an AGC loop, an AFC loop, and a phase-lock loop, and consists of a mixer, a difference amplifier, a driver amplifier, a VCO, a buffer amplifier, bandpass filters, 12-MHz IF amplifiers, a phase-lock demodulator, and an equalizer and frequency control circuit.

a. The AFC loop signal, which controls the frequency of the VCO can be either a sweep signal or a doppler tracking signal. The AGC signal controls the gain of the second and third 12-MHz IF amplifiers, and also turns the AFC sweep signal on and off. The phase-lock signal controls the frequency of the variable frequency oscillator.

b. The selected signal from the preselector section is fed to the mixer, where it is mixed with the output of the VCO to produce a 12-MHz IF signal. The basic frequency of the VCO is set by the voltage from one of four channel-frequency-adjust potentiometers in the preselector section, and one of them is selected at the same time that a channel-frequency potentiometer is selected. The selected VCO-bias-adjust potentiometer is adjusted so that the frequency of the VCO is 12 MHz above the frequency which was tuned with the selected channel-frequency-adjust potentiometer. The voltage from the VCO-bias-adjust potentiometer is coupled to the VCO by way of the difference amplifier and the driver amplifier. The difference and driver amplifiers maintain the linearity of the frequency-to-voltage characteristic of the VCO for all portions of the band.

c. Although the basic frequency of the VCO is determined by the setting of the selected VCO-bias-adjust potentiometer, its exact frequency is controlled by the AFC voltage from the AFC loop. The 12-MHz signal from the mixer is filtered by the selected filter in the bandpass filter network, amplified by the 12-MHz IF amplifiers, and coupled to the AGC detector and phase detector in the phase-lock demodulator. The AGC detector detects the amplitude characteristic of the selected signal, while the phase detector detects the frequency deviation. When the selected signal is not present at the AGC detector, there is no AGC output. The AGC detector output is coupled to the AGC amplifier in the equalizer and frequency control unit, while the output of the phase detector is coupled by way of the loop amplifier to the equalizer and frequency control unit. When there is no signal present at the input of the AGC detector, there is no output from the AGC amplifier. When there is no output from the AGC amplifier, the equalizer and frequency control unit produces an alternating sweep voltage. The sweep voltage is coupled to the VCO and causes the oscillator to sweep up and down in frequency. The sweeping action continues until a 12-MHz IF is produced. This 12-MHz IF signal appears at the input of the AGC detector and permits an AGC voltage to be developed. When the level of the AGC detector output exceeds the AGC amplifier's threshold level, the AGC amplifier produces an output signal that eliminates the alternating sweep voltage. The output of the equalizer and frequency control unit is then controlled by the output of the phase detector. If the input to the phase detector drifts from 12 MHz, the equalizer and frequency control unit produces a signal that causes the VCO to change frequency and return the IF signal to 12 MHz.

d. The bandwidth of the signal fed to the detectors is determined by the bandpass filter unit which contains six different bandwidth filters, individually selectable according to the mode of operation. The bandpass of each filter is centered at 12 MHz.

e. The four-stage 12-MHz wideband amplifier is capable of a gain of 60 db and has an AGC range in excess of 40 db. Therefore, its output level of 0 dbm can be maintained essentially constant with input signal variations from -20 to -60 dbm.

f. The 12-MHz IF signal is shifted 90° in phase and coupled to the AGC detector, and is fed unshifted in phase to the phase detector. Both of these detectors perform their functions by comparing the incoming 12-MHz IF signal with a 12-MHz reference signal developed by the 12-MHz variable frequency oscillator and fed to the detectors by way of the buffer stage and the 12-MHz reference transformer.

g. The phase-lock loop controls the frequency of the 12-MHz variable frequency oscillator for most of its modes of operation. This phase-lock demodulation process permits demodulation of signals with carrier-to-noise ratios below the carrier-to-noise thresholds. For conditions of severe signal loss, the phase-lock loop is disconnected from the variable frequency oscillator and a crystal is used to stabilize the variable frequency oscillator's frequency. When the receiver is operating under these conditions, the AFC loop that controls VCO becomes a narrow-band loop that tracks the carrier component of the incoming signal.

3-40. BASEBAND AMPLIFIER

a. The baseband signal, which is the demodulated output from the phase detector in the demodulator section, is coupled to the baseband amplifier section where it passes through one of seven gain-adjust potentiometers. The gain-adjust potentiometers provide preset gain for the different modes of operation. The baseband-signal is fed through one of these potentiometers which is selected according to the mode of operation, to the baseband amplifiers.

b. The feedback-pair amplifier is a wideband amplifier with a 75-ohm output that is essentially flat from 300 Hz to 500 kHz. This wideband output is not now being used but is available for future use.

c. Buffer amplifier G2 is 4 baseband amplifier that accommodates 12 to 60 voice channels. It has a 75-ohm output with a frequency response of 300 Hz to 252 kHz. Amplitude reduction of the input signal's high-frequency components applied to this amplifier is provided by one of three selectable deemphasis filters. The broadband 75-ohm output is not currently used but is available for future multiple access use.

d. Buffer amplifier G3 is the normal baseband amplifier and has a 600-ohm balanced output with a frequency response of 300 Hz to 20 kHz. This amplifier's input is deemphasized by the deemphasis filter. The output of this amplifier is coupled to the baseband patch panel in the terminal equipment. This output accommodates from one to five voice channels.

3-41. MONITORS AND CONTROL CIRCUITS

a. Meters and indicator lights are used to monitor AGC voltages, AFC-sweep voltages, voltage outputs from power supplies, baseband output levels, and threshold margin levels. Carrier loss and carrier lock-on signals from the equalizer and frequency control unit are coupled to the receiver control circuits. These signals are fed to indicator lamps to indicate whether or not the receiver is locked onto the received signals.

b. The nine mode-select signals from the receiver control circuits are distributed to various modules in the receiver. These mode-select signals are applied through OR gates to the designated receiver circuits.

c. The receiver control circuits, consisting of indicators and selector switches, are located on a remote-control panel. The remote-control panel contains nine electrically interlocked mode selector switches, four electrically interlocked satellite channel selector switches, a carrier loss/lock-on indicator, and a threshold margin meter.

LESSON EXERCISES

In each of the following exercises, select the ONE answer that BEST completes the statement or answers the question. Indicate your solution by circling the letter opposite the correct answer in the subcourse booklet.

1. The principal function performed by the modulator unit in a communication station is conversion of
 - a. baseband signals to modulated signals.
 - b. modulated signals to baseband signals.
 - c. beacon signals to modulated data signals.
 - d. modulated data signals to beacon signals.

2. The purpose of using preemphasis and deemphasis networks in angle-modulated transmitters is to
 - a. attenuate the high-frequency components.
 - b. increase the power output of the transmitter.
 - c. improve the baseband's signal-to-noise ratio.
 - d. distribute the noise more uniformly throughout the audible frequency spectrum.

3. Some angle-modulated transmitters used in communication stations require several multiplier stages. These multiplier stages are needed to
 - a. provide the frequency required to indirectly modulate the subcarrier
 - b. raise the power level of the subcarrier oscillator output signals.
 - c. increase the frequency deviation and the subcarrier oscillator frequencies to the desired values.
 - d. create additional harmonics to synchronize other subsystems in the communications network.
4. The subsystem in a radio communication system that amplifies and multiplies the angle-modulated signal to the desired frequency and power level is called the
 - a. exciter.
 - b. klystron.
 - c. modulator.
 - d. transmitter.
5. The purpose of the multiplier stages in the transmitter shown in figure 106 is to increase the
 - a. baseband frequency.
 - b. modulated subcarrier's frequency.
 - c. deviation of the modulated signal.
 - d. frequency of the injection signal.
6. The signals combined in each of the mixer stages of the transmitter shown in figure 109 are the
 - a. modulated subcarrier signal and the injection signal.
 - b. reflected power signal and the arc detector's signal.
 - c. unmodulated subcarrier signal and the baseband signal.
 - d. arc detector's signal and the modulated carrier signal.
7. What happens when fault detection circuits sense a malfunction in a transmitter's RF system?

- a. The antenna is disengaged from the transmitter.
- b. The baseband signal is removed from the modulator.
- c. The RF drive is removed from the high-power amplifier.
- d. The transmitter injection voltage is removed from the translator-mixer stage.

SITUATION:

One of your duties as a microwave repairman is to train new personnel in the maintenance of microwave equipment. In a stage-by-stage discussion of a direct-angle-modulated transmitter, you use the block diagram shown in figure 107.

Exercises 8 and 9 are based on this situation.

- 8. In a direct-angle-modulated transmitter, a modulated subcarrier signal is developed in the voltage-controlled oscillator stage. The stage that changes the frequency of the modulated subcarrier signal to the frequency required for transmission is the
 - a. diode switch.
 - b. phase detector.
 - c. harmonic mixer.
 - d. reflex klystron.
- 9. To operate correctly, the phase detector in the phase-lock loop must have a reference input. This reference signal is derived by mixing the modulated
 - a. subcarrier signal with the multiplied frequency standard output.
 - b. klystron output with the multiplied frequency standard output.
 - c. subcarrier signal with the modulated klystron output.
 - d. klystron output with the arc detector output.

SITUATION:

To develop an understanding of the subsystems that are used in microwave systems you must also learn the functions of the major stages within each subsystem. Assume that you must learn the functions of the stages in the transmitter shown in figure 107 so that you will be prepared to give an orientation on the transmitter. Your study gives you a list of points to be stressed in your orientation.

Exercises 10 through 12 are based on the above situation.

- 10. Besides locking the reflex klystron, the phase-lock-loop circuit also
 - a. locks the frequency standard.
 - b. locks the high-power klystron amplifier.

- c. compresses the modulated signal into a narrower bandwidth.
 - d. expands the modulated signal into a spread-spectrum signal.
11. The stage that removes the undesired harmonics from the signal to be transmitted is the
- a. attenuator.
 - b. harmonic mixer.
 - c. harmonic filter.
 - d. reverse directional coupler.
12. The function of the reverse-directional coupler and the reflected power switch is to remove
- a. excess power from the RF system.
 - b. the RF drive from the klystron when an arc is detected in the RF system.
 - c. the RF drive from the klystron when the voltage standing-wave ratio exceeds the critical value.
 - d. a portion of the transmitted signal so that a locking signal can be developed to lock the klystron.
13. What is the disadvantage of using only one mixing stage in the translator subsystem?
- a. Bandwidth of the final signal is too wide.
 - b. It is difficult to suppress unwanted signals.
 - c. Power levels of the modulated signals are too low.
 - d. It is difficult to generate the final frequency by only one oscillator.
14. The stages used as the exciter in a ground station transmitter generally contain a traveling-wave tube, attenuators, filters, and directional couplers. The purpose of the exciter is to raise the power level of the
- a. baseband signal prior to modulation.
 - b. injection voltage prior to modulation.
 - c. modulated signal prior to final amplification.
 - d. modulated signal prior to mixing with the injection voltage.
15. The purpose of the heat exchanger unit in the microwave transmitter is to cool the
- a. translator.
 - b. attenuators.
 - c. modulation amplifier.
 - d. high-power amplifier.

16. The purpose of using feedback in the demodulation process is to provide a means of satisfactorily demodulating signals that have
- high threshold levels.
 - high signal-to-noise ratios.
 - low carrier-to-noise ratios.
 - a constant intermediate frequency.
17. The demodulator circuit that causes the receiver's bandpass to appear narrower to signals with high-noise content than to signals with low-noise content is called an
- AFC circuit.
 - AGC circuit.
 - AMFB circuit.
 - FMFB circuit.
18. The purpose of automatic frequency control in a receiver is to insure that
- the average IF is constant.
 - a maximum IF deviation is achieved.
 - a minimum IF deviation is achieved.
 - the IF signal amplitude is constant.
19. When the IF signal in a receiver is in phase with the reference oscillator's signal, what is the output of the phase detector?
- Zero
 - Positive
 - Negative
 - Alternating
20. How many conversion stages are used in the signal path of the FMFB receiver shown in figure 115?
- Three**
 - Four**
 - Five**
 - Six**
- NOTE: Include first conversion stage, which is not shown on the diagram.**

SITUATION:

Assume that the simplified block diagram shown in figure 115 represents a receiver used in a microwave communication system. You must orient yourself with the purposes and uses of each stage in the receiver.

Exercises 21 through 25 are based on the above situation.

21. The first two intermediate frequencies in the FMFB receiver have fixed bandwidths, and the third IF has a variable bandwidth. This variable bandwidth is attained by
- a. varying the frequency of the second VCO.
 - b. applying an AGC voltage to the 60-MHz IF amplifier.
 - c. placing different resistance values across the third mixer's tank circuit.
 - d. permitting the limiter to operate on both positive and negative alternations.
22. The stage that converts the IF signal into a usable baseband frequency output is the
- a. AGC detector-amplifier.
 - b. differential amplifier.
 - c. video amplifier.
 - d. discriminator.
23. Compression of the FM signal's deviation to improve the output signal-to-noise ratio is accomplished by the
- a. regenerative feedback developed in the AFC loop.
 - b. degenerative feedback developed in the AFC loop.
 - c. degenerative feedback developed in the FMFB loop.
 - d. regenerative feedback developed in the FMFB loop.
24. What is gained by reducing the effective bandwidth of the 800-kHz IF signal?
- a. Reduction of noise power applied to the discriminator
 - b. Increase of signal power applied to the discriminator
 - c. Reduction in the carrier-to-noise ratio applied to the limiter
 - d. Increase in the frequency deviation of the FM signal applied to the limiter
25. When the discriminator does NOT provide an output for coupling to the differential amplifier, the differential amplifier causes the second mixer's injection voltage to be at a frequency of
- a. 0.8 MHz.
 - b. 10.8 MHz.
 - c. 35.2 MHz.
 - d. 49.2 MHz.

CHECK YOUR ANSWERS WITH LESSON 3 SOLUTION SHEET PAGE 137

LESSON SOLUTIONS

LESSON 3Microwave Transmitters and Receivers

1. a--para 3-1
2. c--para 3-2b(2)
3. c--para 3-2c(1)
4. d--para 3-3
5. d--para 3-3, 3-7
6. a--para 3-8, 3-20b (2)
7. c--para 3-10b, 3-16a
8. d--para 3-14c
9. b--para 3-14a
10. c--para 3-14d
11. c--para 3-15c
12. c--para 3-16c
13. b--para 3-20b
14. c--para 3-21a
15. d--para 3-22b
16. c--para 3-24a
17. d--para 3-24a, b
18. a--para 3-25b
19. a--para 3-27e
20. a--para 3-30a
21. c--para 3-30b
22. d--para 3-30c
23. c--para 3-32a
24. a--para 3-32a
25. d--para 3-33

LESSON 4

RECEIVER PARAMETERS

SCOPE.....	Definitions and factors controlling baseband and bandwidth; FM improvement factors, system noise, and noise measurement.
TEXT ASSIGNMENT	Pages 139 thru 156
MATERIALS REQUIRED.....	None
SUGGESTIONS.....	None

LESSON OBJECTIVES

When you have completed this lesson, you should:

1. Understand the factors controlling baseband and bandwidth.
2. Know the various sources of noise and their effects on microwave communication.
3. Know the methods used to measure receiver noise.

RECEIVER PARAMETERS

Section I. INTERFERENCE

4-1. GENERAL

External interference consists of all external natural and manmade disturbances which interrupt or interfere with the electrical or electronic properties of operation, maintenance, or testing, and which cause either improper operation or indication, or diminished equipment performance.

4-2. ATMOSPHERIC

a. Atmospheric interference is caused by the many thunderstorms that occur over the surface of the earth. In ordinary communication equipment, this interference appears as noise, a constant background rumble with loud crashes occurring at irregular intervals. The noise may not be heard at all times, but it is always present in receivers and may be a source of an unidentifiable interference problem.

b. Lightning produces electromagnetic waves which are scattered in all directions. These waves are received locally as overriding volume crashes. In addition, the waves can be transmitted to distant antennas because these waves can be reflected and refracted from the ionosphere at such an angle as to be directed to the distant receiving antennas.

4-3. CELESTIAL

a. Cosmic noise is a continuous noise received from other galaxies. This noise is probably caused by magnetic storms resulting from the thermonuclear reactions continuously occurring on the suns of these distant galaxies. This noise is not particularly directional because the transmitting galaxies completely surround our own galaxy.

b. The noises received from within our own galaxy are called galactic noise and are normally directional because they originate from definite traceable sources. Again, this is a type of noise that is comparatively constant.

c. Noise received from the stars within our own galaxy is highly directional and normally possesses a greater amplitude than cosmic interfering signals.

d. The noise received as a result of the thermonuclear reactions occurring on the sun is the greatest source of noise existing outside the sphere of our own planet. During periods of sunspot activity, this highly directional source will vary as the earth rotates, and maximum interference will result when the receiving antenna is directed toward the sun. This solar noise has the greatest effect in the Arctic Zone and the least effect in the Torrid Zone.

4-4. SEASONAL

a. In any given area, the change from spring to summer or from any season to another will result in changes in both atmospheric noises and interference caused by solar radiation.

b. The atmospheric seasonal changes are primarily due to changes in temperature and humidity. As the temperature or humidity gradually increases, the interfering noises will increase in direct proportion.

c. During the night, when the portion of the earth in which you are located is not facing the sun, you will not receive the same amplitude of solar noises. The electron bands in the upper atmosphere will lift and be a greater distance from the earth. Interfering noise from the sun will diminish because the sun is not primarily directed toward the night side of the earth.

4-5. TERRESTRIAL

a. Interference caused by geographical conditions is associated with the metallic or chemical content of the earth surrounding the location of the ground station.

b. In specific areas or points, the earth may have a high metallic content which will effectively introduce a magnetic field. This magnetic field may be coupled into the transmitting or receiving equipment by way of the desired signal, it may couple the desired signal to ground, or it may reduce the power of the signal. This metallic interference normally remains constant.

c. The interfering noise signals that accompany volcanic eruptions are normally effective only in the local region. The noise is caused by particles that have been electrostatically charged by the movement of gas and lava up through the earth's surface, by the heat of the lava, and by the precipitation of dust or smoke particles.

4-6. FADING

a. Signal fading is not a noise-producing type of interference. It is classed as interference only because it makes reception of a desired signal difficult and thus interferes with the efficiency and accuracy of electrical or electronic equipment.

b. Fading, or fluctuation, of a desired signal may be due to disturbances in the medium through which the signal is propagated. The tropospheric, stratospheric, and ionospheric layers above the earth's surface constitute the medium. An incoming signal may lose or gain strength; either condition is called fading. However, it is only when the normal signal strength weakens that reception becomes difficult. The signal strength may drop so low that the signal fades or disappears in the background noise. While the background noise level may remain constant, the desired signal may rise or fall below that level. The frequency of the fading cycle may be slow or rapid and may result in an instantaneous complete loss of the signal.

c. For all practical purposes, the effect of fading is a function of the signal-plus-noise-to-noise ratio $\left(\frac{S + N}{N}\right)$ of the particular equipment involved.

If the background noise level remains constant and the signal diminishes, the reception of a weak signal becomes difficult. The application of automatic gain control is useless, because increasing the gain to amplify the fading signal to the normal level will cause the noise level to be amplified an equal amount, and the result is the same poor signal-plus-noise-to-noise ratio. The peculiar atmospheric conditions that cause fading may last for hours, or only a few minutes. Generally fading is more prevalent during the summer months and during daylight hours.

4-7. INTERNAL AND MANMADE

a. Internal interference is present to some extent in every electrical or electronic receiver. This noise arises from the natural action of electrons in transit within electron tubes and in other circuit components. Even if the receiving equipment is perfectly aligned and all of the internal components are in the best condition, the internal interference will still exist.

- (1) Thermal noise is caused by the thermal agitation of electrons in conductors. Thermally agitated electrons generate minute voltages which add to or subtract from the circuit voltage, and thereby cause electric noise.
- (2) Shot-effect noise is caused by the inconsistency of electrical currents. Electrical current is composed of minute electrical impulses which are the result of electrons changing energy states. This lack of continuity creates noise. Shot-effect and thermal noise are closely related in their causes and effects.
- (3) Spontaneous emission is created by electrons giving up energy when they revert to a lower energy state. This energy induces noise voltages into the conductors.

b. Many kinds and types of equipment produce undesirable radio frequency impulses which are transmitted and travel out through the air exactly as if they were deliberately prepared for broadcast. In addition, some equipments radiate back through the power line to other equipments unless the radiation is stopped by an impedance or absorbed by a reactance.

Section. II. NOISE MEASUREMENTS

4-8. NOISE TEMPERATURE

a. The noise voltage appearing across the terminals of a resistor is proportional to the temperature of the resistor. The noise voltage is due to thermal agitation, that is, electron motion caused by the heating of the electrons in the structure of the resistor. If the resistor is heated to a higher temperature, the noise voltage increases; if the temperature is lowered, the noise voltage decreases. A useful measure of these noise voltages is a quantity that is proportional to voltage squared, or power. The rule that this noise power or voltage increases with temperature can be expressed in a more precise way if the noise is measured as a noise power and the temperature is measured on an absolute scale.

the system doubles the measured power; halving the bandwidth halves the power. This means that the power available from the resistor depends on bandwidth as well as temperature. The previous expression for noise power can be rewritten to include the bandwidth.

$$P_n = K_2TB \text{ when } P_n = \text{noise power,}$$

$$K_2 = \text{a constant (different from } K_1),$$

$$T = \text{absolute temperature, in degrees Kelvin,}$$

$$B = \text{bandwidth in Hz.}$$

c. This indicates that specifying the amount of noise power available from a resistor does not mean too much unless we also know the bandwidth of the measuring system. This is where the noise temperature becomes valuable, inasmuch as it gives a measure of the noise power available from the resistor. The noise temperature does not depend on the bandwidth of the measuring system. Further measurements might be made to determine whether changing the resistance of the resistor while maintaining the same temperature would yield different noise powers. The results of this experiment would give a negative result; therefore, the power does not depend on the value of the resistance.

d. Many other sources of noise behave in much the same manner as the resistor discussed. In the case of the resistor, the thermal noise temperature and noise temperature were the same numerically, since the equivalent is defined on that basis. In the case of other equivalents, this often is not true.

e. If proper units are chosen, the equation for the noise power that can be delivered by a matched source at a noise temperature, T ($P_n = K_2TB$), is:

$$P_n = KTB \text{ when } P_n = \text{power in watts,}$$

$$B = \text{bandwidth of load in Hz,}$$

$$T = \text{temperature of source in degrees Kelvin,}$$

$$K = \text{Boltzman's constant,}$$

$$1.38 \times 10^{-23} \text{ joules/degree Kelvin}$$

$$\text{(or watt sec/degree Kelvin).}$$

f. Since receiver bandwidths vary greatly, it is more convenient to express noise power in terms of noise per unit of bandwidth.

$$\frac{P_n}{B} = KT$$

4-9. NOISE FIGURE

a. Some criterion is needed to rate receivers and receiving systems, indicating whether they are good, poor, etc. The noise figure provides a numerical indicator as far as the noise performance is concerned. The noise figure does not completely specify receiver performance since it says nothing about gain, bandwidth, distortion, etc., all of which must be satisfactory as well.

b. The concept of noise figure has gone through many stages of development, and many slightly different types of noise figure (spot noise figure, average

noise figure) have been developed. This paragraph treats only one type, average noise figure, the noise figure normally used in measuring a receiving system's performance. The noise figure expresses the relative merit of a receiver in comparison with a so-called perfect receiver. The perfect receiver is one that adds no noise to that produced by the antenna resistance and has a noise figure of 0 db. The quantity normally is expressed as a power ratio converted to decibels, and the smaller the noise figure the better the receiver. The noise figure to be considered is a single number characterizing the receiver and, in a sense, is an average noise figure over the passband of the receiving system. Separate noise figures or spot noise figures could be quoted at each frequency within the band, much the same as different gains can be quoted at various frequencies for a simple amplifier. Just as it is common to refer to an amplifier as a 20-db amplifier, meaning that its maximum gain is 20 db (100), so is it also common to quote a single noise figure as an average over the whole passband. It is this average noise figure that will be of greatest interest as a criterion for rating a system's performance. More specifically, it will be the average standard noise figure.

c. The average standard noise figure gives a measure of the amount of noise that an amplifier (or any other component) contributes to its output. The noise power at the output of an amplifier (P_{no}) consists of the power contributed from two separate power sources--noise power developed within the amplifier (P_{n2}), and matched source noise power (P_{n1}) applied to the amplifier's input. Since the input noise power undergoes amplification within the amplifier stage, the input noise power (P_{n1}) is multiplied by the gain (G) of the stage. The noise output can then be written as

$$P_{no} = GP_{n1} + P_{n2}.$$

d. If the amplifier were a perfect amplifier and contributed no noise of its own, the total noise output of the amplifier would be GP_{n1} . However, any practical amplifier contributes some noise.

e. The noise figure of an amplifier is simply the noise output at the load (P_{no}) divided by the matched source noise power (P_{n1}) and the gain (G) of the stage,

$$F = \frac{P_{no}}{GP_{n1}}$$

$$F = \frac{GP_{n1} + P_{n2}}{GP_{n1}}$$

$$F = 1 + \frac{P_{n2}}{GP_{n1}}$$

Explanation of symbols:

F = noise figure,

P_{n2} = amplifier noise power,

G = amplifier gain,

**P_{n1} = matched source noise power
at a temperature of
290° Kelvin.**

f. The noise figure may be quoted as a number or a ratio, or in terms of decibels. For example, a noise figure of 2 and a noise figure of 3 db have the same meaning. Both expressions indicate that the noise from the amplifier and the noise from the matched source are the same. The noise figure in decibels can be determined by formula.

$$F_{db} = 10 \log \left[1 + \frac{Pn2}{GPn1} \right]$$

4-10. EQUIVALENT NOISE TEMPERATURE

a. Sensitivity is one of the most important receiver parameters. It is defined as the minimum input signal required to produce a specified output signal having a specified signal-to-noise ratio.

b. The signal-to-noise ratio of a receiver is determined by the amount of receiver gain and the noise contribution. Generally this ratio is expressed as S/N. We are most concerned with the noise contribution of a receiver, and therefore we use the expression $Pn2/G$.

c. The expression $Pn2/G$ indicates the relative noise contribution and gain of an amplifier. This expression is the equivalent noise temperature of the receiver (T_e).

d. The first step in arriving at T_e is to determine the noise figure. The noise figure of a receiver is obtained by measuring the noise power. Once the noise figure has been obtained, conversion to equivalent noise temperature may be performed.

e. The equivalent noise temperature is obtained by rearranging the noise figure expression.

$$F = 1 + \frac{Pn2}{GPn1}$$

$$Pn1(F - 1) = \frac{Pn2}{G} = T_e \text{ (equivalent noise temperature)}$$

$$290(F - 1) = T_e \text{ (in degrees Kelvin)}$$

4-11. FACTOR METHOD OF DETERMINING NOISE CONTRIBUTION

a. A simplified method of determining the relative noise contribution of a receiver is in current use. This method is known as the Y factor method. This method does not use complex devices or calculations.

b. The Y factor method provides a means of determining the relative noisiness of a receiver on a day-to-day basis. The Y factor of a receiver cannot be compared with the Y factor of another type of receiver without introducing constants and subsequent calculations.

c. The Y factor of a receiver is defined as the receiver's noise power output with a matched source (290°K) input divided by the noise power output without the noise source supplied.



d. The Y factor may be expressed in terms of a number or a ratio, or in decibels. It is usually expressed in terms of decibels. To express the Y factor in decibels, use the formula

$$Y_{\text{db}} = 10 \log \left[\frac{P_{n2} + P_{n1}}{P_{n2}} \right].$$

Section III. NOISE MEASURING TECHNIQUES

4-12. METHODS OF MEASUREMENT

An ideal receiver would be one with no noise other than that generated by thermal agitation. The degree to which a receiver approaches this ideal is indicated by the noise figure. There are several methods that can be used to obtain the measurements necessary to determine the noise figure.

4-13. NOISE GENERATOR METHOD

a. A noise generator is designed to produce a random noise signal that covers a frequency range in excess of the receiver bandwidth. The dc input reading of the generator can be converted to obtain the true noise power. The noise generator method of determining the noise figure has the advantage over other methods because no knowledge of either the gain or the response characteristics of the amplifier is necessary, since the amount of noise from the noise generator is amplified and governed by the effective bandwidth. The noise generator method of measurement consists of comparing the noise actually present in the receiver with the calibrated output of the noise generator. The measurements are taken with an ac voltmeter, a db meter, or a milliwatt meter.

b. For an accurate measurement, the noise generator output impedance is adjusted to the same impedance as the normal signal source for the equipment under test. This is the impedance at the transmission line termination from an antenna or antenna multicoupler. The shortest possible leads should be used between the noise generator and the receiver.

c. The indicator (an ac voltmeter, db meter, or milliwatt meter) may be connected across either the detector load or the receiver output. If an ac voltmeter is used as an indicator, the noise generator should be adjusted for an output voltage 1.4 times the no-input voltage indication; if a db meter is used, the noise generator should be adjusted for a 3-db increase over the no-input meter indication; if a milliwatt meter is used, the noise generator should be adjusted for twice the no-input reading. The noise figure is then indicated on the output level control of the noise generator.

4-14. SIGNAL GENERATOR METHOD

a. Sine wave signal generators are usually available in maintenance shops more often than noise generators. However, the signal generator method is not as practical or accurate as the noise generator method for field measurements. When using the signal generator method, you must take into account the bandwidth and response curve of the receiver. Generally the bandwidth

used is the frequency range between the half-power points of the response curve. For an accurate measurement, the sine wave generator output impedance should be the same impedance as the normal signal source for the receiver.

b. When using the sine wave generator, the measuring procedure is similar to that for the noise generator method. First, with no signal output from the signal generator, measure the noise power output of the receiver. Then turn the signal generator on, set the output signal at the center frequency of the response curve for the receiver, and adjust the output signal level until the test meter indicates twice the power of the no-signal level. With the reading from the meter¹ the noise figure can now be calculated.

4-15. ENSI METHOD

a. The equivalent-noise-sideband-input (ensi) method of noise level measurement determines the equivalent input voltage of all random noise that appears in the output of the receiver being tested. This test is sometimes used in preference to other methods of measuring noise level because, over a limited frequency range, it is not appreciably affected by changes in the input signal.

b. The receiver volume control should be set to avoid overloading the audio amplifiers, and the tone control should be set for maximum high-frequency response. The signal generator is set at the center frequency of the receiver response curve, and adjusted for an unmodulated carrier signal output. A voltmeter is connected in a manner similar to that used for the noise generator method, and used to measure the output power. The signal and noise output power can be measured together. The signal output power can then be calculated by subtracting the noise output power from the combined power output. With this figure, the noise level can be calculated.

Section IV. PARAMETER CONTROL

4-16. IMPROVEMENT FACTOR

a. For the receiver to deliver to the baseband output a recovered baseband wave of the best possible quality (highest signal-to-noise ratio), the receiver's amplifier and demodulator stages must be designed not only for the type of modulation, but also for the exact parameters of the chosen type of modulation. The primary function of the receiver is to amplify and frequency-translate. If the type of modulation is amplitude modulation (AM), the receiver must have a sufficiently accurate automatic gain control (AGC) to avoid overload, nonlinearity, and limiting. Any nonlinear amplifying of an AM wave will distort the demodulated baseband wave. On the other hand, angle-modulated receivers usually limit the amplitude intentionally to provide better immunity against noise. Amplitude limiting has no effect on the frequency or phase deviations in an angle-modulated wave.

b. The receiver's bandwidth must be wide enough to pass the modulated spectrum bandwidth to avoid distortion in the demodulated baseband signal. This means that for single sideband, the receiver's bandwidth need be only as

wide as the baseband. For receivers using angle modulation, the receiver's bandwidth can be many times the width of the baseband, depending on the chosen magnitude of the modulation index. The receiver's bandwidth should not be wider than the minimum needed to pass the modulated wave. By using a minimum bandwidth, the receiver's noise power is minimized. The bandwidth of the receiver has a greater influence than any other receiver parameter on the receiver output signal-to-noise ratio. The noise content of any demodulated output signal is related directly to the bandwidth of the input signal.

c. The efficiency of any demodulator is measured by its ability to produce the highest quality output signal-to-noise ratio with the least possible input carrier-to-noise ratio. The improvement factor (F_m) has been developed as an indication of the efficiency of any demodulator.

d. The improvement factor (F_m) is defined as the baseband signal-to-noise ratio (S/N) output divided by the carrier-to-noise (C/N) input.

$$F_m = \frac{S/N \text{ (output)}}{C/N \text{ (input)}}.$$

It has been pointed out that achieving the desired S/N output quality with the highest possible improvement factor is extremely desirable. The maximum possible improvement factor for amplitude modulation is 1. This is realized with single sideband (SSB). The largest improvement factor for double sideband is one-half. For angle modulation the improvement factor can be much larger than 1, as shown in figure 117. For comparison, the broken line shows the S/N output to be exactly equal to the C/N input for SSB. The frequency-modulation improvement factor (in db) is the S/N difference between the frequency-modulation line and the SSB line. It is seen from figure 117 that the larger the modulation index, the greater the improvement factor for frequency modulation. However, frequency modulation has a carrier-to-noise threshold which must be exceeded for the full modulation improvement factor to be in effect. For example, again from figure 117, a modulation index (M) of 2 has an improvement factor of 6 (8 db) but the C/N ratio must exceed an 18-db threshold. When M is 10, the improvement factor is 150 (22 db) and the threshold is 28 db. For carrier-to-noise ratios greater than the threshold, the improvement factor is

$$F_m = \frac{3M^2}{2}.$$

As the carrier-to-noise level decreases below threshold, in addition to the rapid degradation of the improvement factor, the audible-noise character in the baseband output changes from a fine-grain "hiss" to an erratic sputter of "pops." In practice, the threshold demarcation is gradual rather than sharply discontinuous, as shown in figure 117.

4-17. BASEBAND AND BANDWIDTH CONTROLS

a. The transmitter in a typical microwave station is used to convert the baseband input from the terminal equipment into an angle-modulated signal whose carrier frequency is in the range of 50 to 90 MHz. The receiver is used to convert the angle-modulated signal back to the baseband signal prior to applying the signal to the terminal equipment.

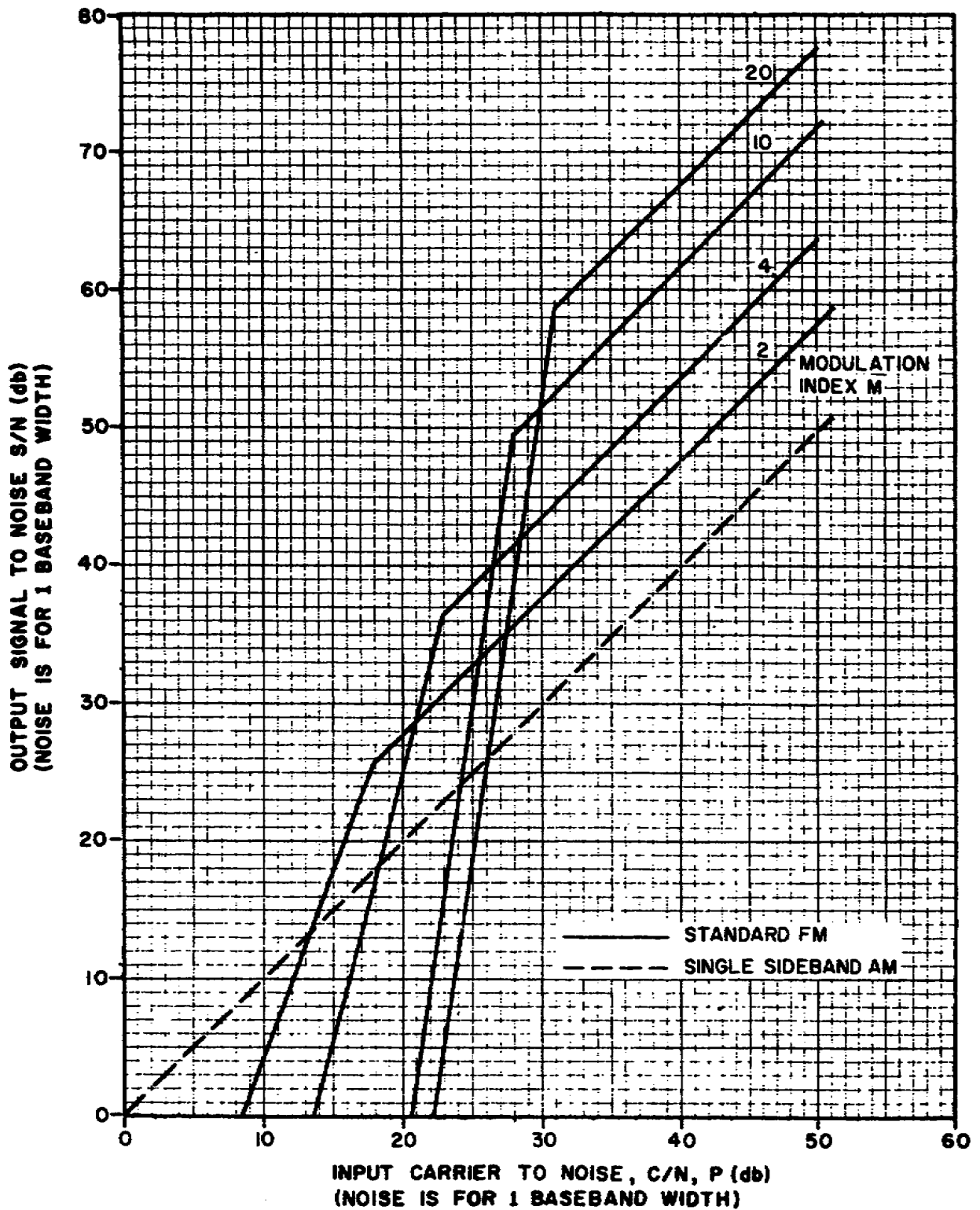

Figure 117. S/N versus C/N for frequency modulation.

b. Both the transmitter and the receiver have the same number of operating modes. The selected mode determines the number of voice-frequency channels that can be used, the maximum baseband frequency range that can be satisfactorily processed, and the type of modulation that will be employed. An example of a nine-mode system is shown in table II.

c. Mode selection in the receiver involves the selection of appropriate filters, deemphasis circuits, output circuits, and feedback circuits. The selected filters and circuits control the bandwidth of the receiver, which, in turn, controls the number of channels that can be passed on to the terminal equipment.

d. Additional controls throughout the voice-frequency circuits are used to control the range of the baseband frequencies. Compressor assemblies contain compressors and expandors, compressors for voice-frequency signals being transmitted, and expandors for signals being received. These circuits compress the dynamic range of the voice-frequency signals at the sending end, and expand the signals to their original condition at the receiving end.

TABLE II
OPERATING MODES

Mode	No. of 4-kHz channels	Typical user input	Maximum baseband frequency (kHz)	Type of modulation	Full-load frequency deviation (after modulation) (kHz)
1	1	1 tt	4	phase	3.3
2	1	2 tt	4	phase	3.3
3	1	4 tt	4	phase	3.3
4	2	1 tt 1 voice	8	frequency	69
5	3	2 tt 2 voice	12	frequency	65
6	5	4 tt 4 voice	20	frequency	132
7	12	12 voice	60	frequency	222
8	24	24 voice	108	frequency	394
9	60	60 voice	252	frequency	600

SECTION V. DECIBELS

4-18. INTRODUCTION

a. In operating certain types of equipment you'll be measuring power losses and gains. A unit called the decibel (db) simplifies your task because instead of having to calculate losses and gains that range anywhere from .000001 watt up to .004 watt, you use meters that express power losses and gains in terms of minus db's and plus db's. With this method there are no complex decimal calculations to perform.

b. Before you can use the decibel, you have to know something about it. That's the aim of this section -- to tell you what the decibel is -- how the decibel is derived -- and, most important, how you'll use the decibel in your daily work.

4-19. WHAT IS THE DECIBEL?

a. The decibel (db) is a transmission measuring unit used to express power loss and gain. When used to express lose, a minus sign is placed before db like this: -10 db. When used to express gain, a plus sign is placed before db like this: +10 db.

b. The db does not express exact amounts like the inch, the pound, or the gallon. The db does not tell you how much power you have. Instead, the db tells you the ratio of power in a circuit.

c. In other words, the db compares the output power of a circuit to the input power. If there is less output power than input power, then you have a db loss. If there is more output power than input power, then you have a db gain.

4-20. HOW YOU COMPUTE DB LOSS AND DB GAIN

Db losses and gains are computed using the following formula:

$$\text{No. of db} = 10 \times \log \frac{P1 \text{ (larger power)}}{P2 \text{ (smaller power)}}$$

Note: This formula is used both for db loss and db gain. The rule to follow is to always let P1 equal the larger amount of power. You'll know you have a loss (-db) when the input power is greater than the output power. Similarly, you'll know you have a gain (+db) when the output power is greater than the input power.

4-21. SOLVING THE FORMULA FOR DB LOSS

A transmission line is shown in figure 118. The input power to the line is 1 milliwatt (mw) and the output power is .5 mw. It is easy to see that this line causes a power loss of 50 percent. But what is the db loss? You can use the formula to find out

$$\text{No. of db} = 10 \times \log \frac{P1 \text{ (larger power)}}{P2 \text{ (smaller power)}}$$

$$\text{db} = 10 \times \log \frac{1}{.5}$$

Dividing 1 by .5 you get 2 as the result. This gives:

$$\text{db} = 10 \times \log 2$$

Now look at Table III to find the log of 2. The log is .3010 so you have:

$$\text{db} = 10 \times .3010$$

Since you're dealing with a power loss, you use a minus sign to express the final answer:

$$-3.01 \text{ db or approximately } -3 \text{ db}$$

TABLE III

LOGARITHMS

LOG 1 = 0.0000	LOG 8 = 0.9031
LOG 2 = 0.3010	LOG 9 = 0.9542
LOG 3 = 0.4771	LOG 10 = 1.0000
LOG 4 = 0.6021	LOG 20 = 1.3010
LOG 5 = 0.6990	LOG 30 = 1.4771
LOG 6 = 0.7782	LOG 40 = 1.6021
LOG 7 = 0.8451	

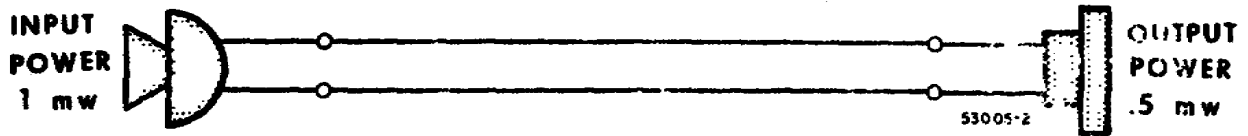

Figure 118. Transmission line with 50 percent power loss.

4-22. SOLVING THE FORMULA FOR DB GAIN

a. Figure 119 shows a repeater that amplifies the input power to twice its original value. You see that the input power to the repeater is 1 mw and the output power is 2 mw. You can find out how much db gain this repeater provides by using the formula:

$$\text{No. of db} = 10 \times \log \frac{P_2 \text{ (larger power)}}{P_1 \text{ (smaller power)}}$$

$$\text{db} = 10 \times \log \frac{2}{1}$$

$$\text{db} = 10 \times \log 2$$

You know the log of 2 is .3010. Therefore you have:

$$\text{db} = 10 \times .3010$$

This time you have a gain so you use a plus sign to express the final result:

$$+3.01 \text{ db or approximately } +3 \text{ db.}$$

b. In the first example you had a power loss of 50 percent and this gave a loss of 3 db. Then, in the second example, you had a gain of twice as much power and this gave you a gain of 3 db. This brings out two important facts that you should remember:

- (1) A LOSS OF 3 DB ALWAYS REPRESENTS A 50-PERCENT POWER LOSS. It doesn't matter how much power is involved. When you lose half the power you always have a loss of 3 db.
- (2) A GAIN OF 3 DB ALWAYS REPRESENTS A GAIN OF TWICE AS MUCH POWER. Again the amount of power involved doesn't matter. Whenever you gain twice as much power, you have a gain of 3 db.

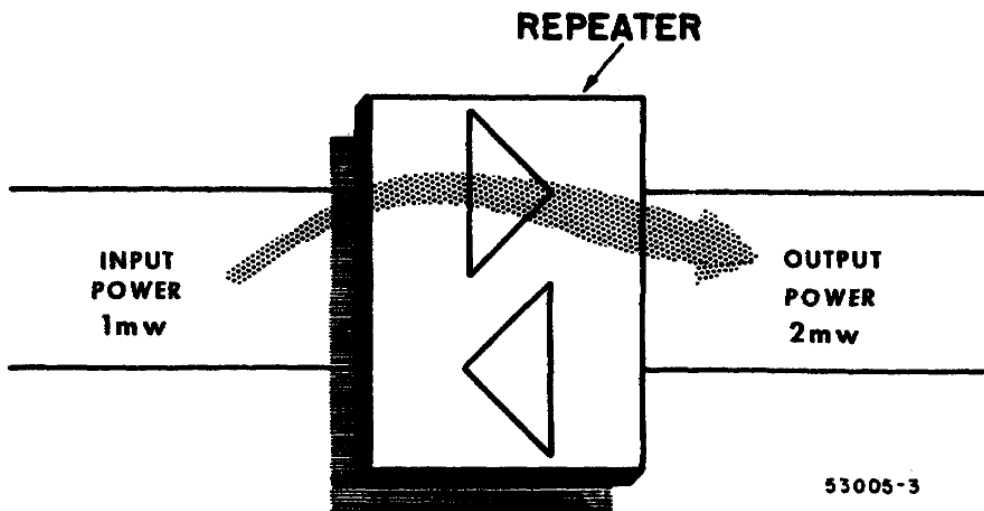

Figure 119. Repeater providing power gain.

c. Seeing how formulas for db loss and gain are solved has given you an idea of how db's express the power ratio in a circuit. There is no need to go into any further computations. Instead the formula have been worked out for several common db losses and gains. The results of these computations are given in Table IV.

TABLE

WHEN YOU HAVE THIS DB LOSS OR GAIN	LARGER POWER DIVIDED BY SMALLER POWER IS
1 db	1.25
2 db	1.6
3 db	2.0
4 db	2.5
5 db	3.2
6 db	4.0
7 db	5.0
8 db	6.4
9 db	8.0
10 db	10.0
20 db	100.0
30 db	1,000.0
40 db	10,000.0

4-23. USING TABLE IV

You can find out how much power is lost or gained if you know the number of db's lost or gained. Or you can find out the number of db's lost or gained when you know the amount of power lost or gained. To show you how to use Table IV, here are a few examples.

a. Example 1. Suppose you have a circuit like that shown in figure 120 input power is .001 watt and the output power is .000001 watt. The input power is greater than the output power so you have a power loss. To find the power loss, you divide .001 by .000001 which equals 1,000. In Table IV this corresponds to 30 db. So your answer is: -30 db.

b. Example 2. Suppose you know the db gain is 40 db. The ratio of the output power to the input power is found by referring to Table IV where 40 db corresponds to a ratio of 10,000. If you know the input power is .001 watt, -you can find the output power by multiplication: .001 watt x 10,000 = 10 watts.

4-24. THE DBM REPRESENTS A REFERENCE LEVEL

a. Before explaining the dbm, let's first find out what is meant by a reference level. The simplest way to explain it is to use an everyday example.

b. Suppose you had \$100 in a savings account at the beginning of a year. This \$100 could act as a reference level. You could actually plot your savings account for the whole year on a graph as shown in figure 121. You'd put \$100 in the center of the vertical axis. And then place plus signs above \$100 and minus signs below \$100. Then as the year went on, if you deposited \$10 in February, you'd plot +\$10 (above \$100). Then, if in March you had to withdraw \$40 you'd plot this to show that you had -\$30 (below \$100). And as the year progressed you'd plot the other months as shown.



Figure 120. Circuit showing power loss.

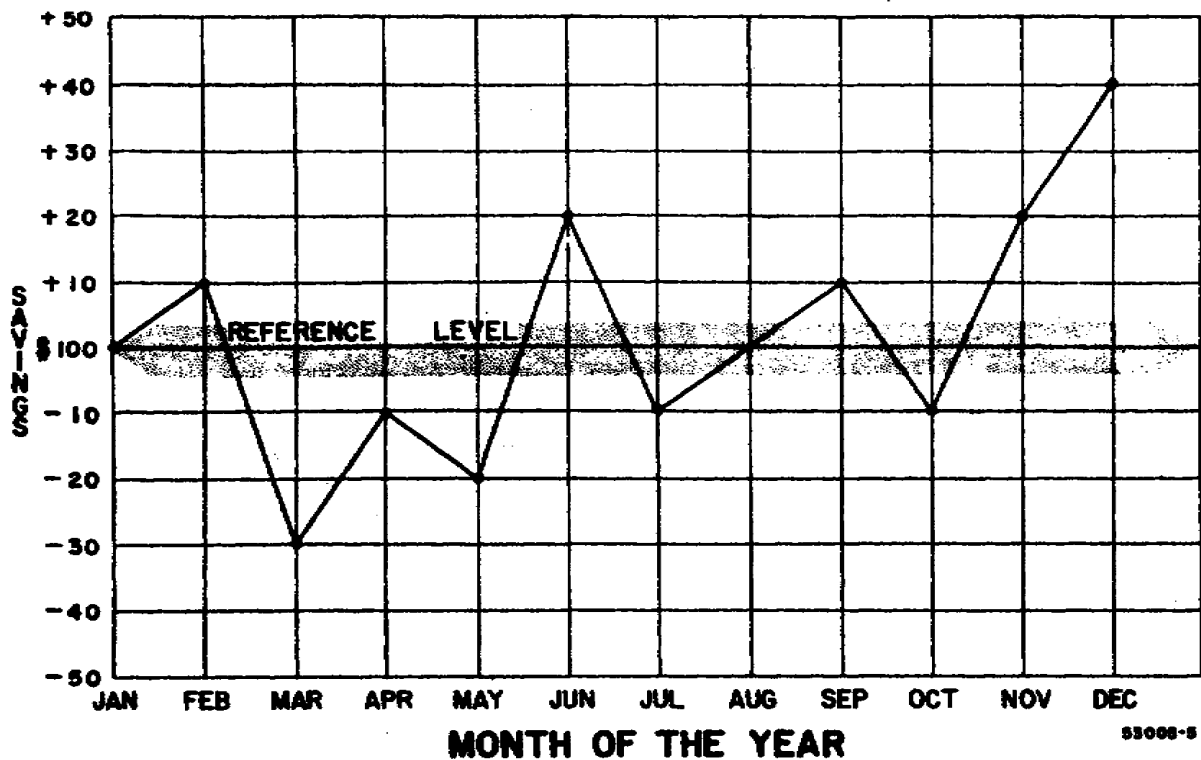

Figure 121. The use of a reference level.

c. Using this method, at the end of a year you'd be able to tell exactly what your net savings were for that year. All you'd need to do is check the last month. In the graph you can see that the last month shows a level of +\$40 (above \$100). This means that, although your account has changed many times during the year above and below \$100, you still come out with a NET GAIN of \$40 (above \$100). The actual amount of money that this represents is \$140. Now just as we use an amount of money here for a reference level, in telephone work we use an amount of power as a reference level.

4-25. THE REFERENCE LEVEL FOR DBM IS 1 MILLIWATT OF POWER

a. The reference level used in telephone work is .001 watt (1 mw) of power. This level was chosen because it represents the average amount of power generated by the voice in a telephone transmitter. And by using 1 mw you can compare all db losses and gains in a circuit to this reference level.

b. For convenience, 1 mw is designated as

being equal to 0 db. Then, to make sure no one forgets that 1 mw is the reference level, a small letter m is tacked on after 0 db like this: 0 dbm. The letter m, of course, stands for 1 mw. Summing up, then: The standard reference level used in telephone work is 1 mw which is expressed as 0 dbm. Remember, whenever you see 0 dbm it means 1 milliwatt of power.

4-26. HOW YOU USE THIS REFERENCE LEVEL

a. The easiest way to find out is to look at what happens in an average telephone system like that shown in figure 122.

b. In the figure you see a telephone system with a graph (energy level diagram) below it. The graph shows what's happening to the voice power as it travels along the system. You can see that the INPUT LEVEL is 0 dbm (meaning 1 mw). The first section of line extending from the line input to the repeater gives a loss of 30 db. This brings the power level at the repeater input down to -30 dbm (30 db below the reference level of 0 dbm).

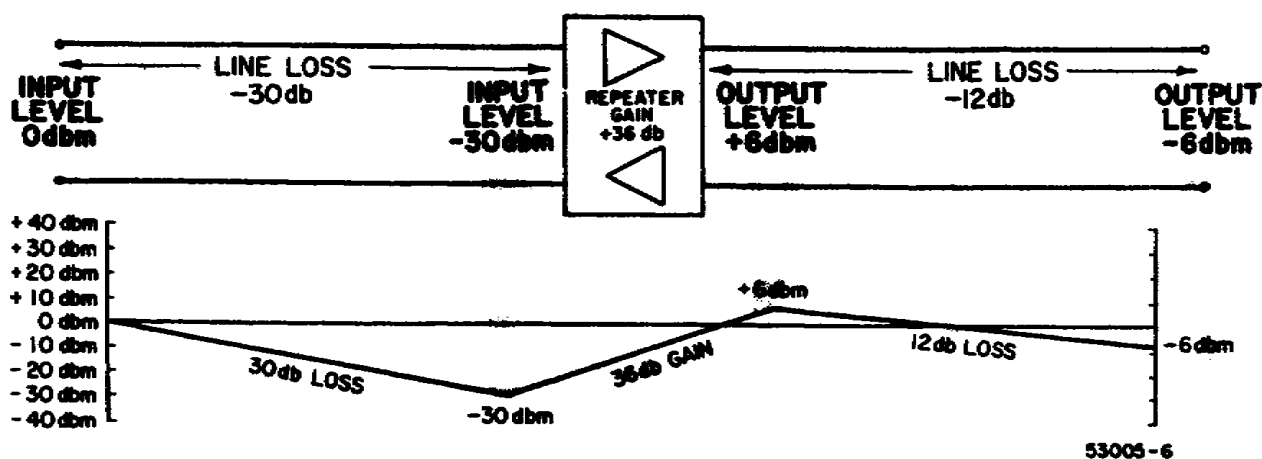

Figure 122. How dbm is used in a telephone system.

c. Then the power represented by -30 dbm (actually .001 mw) enters the repeater and becomes amplified. The repeater provides a gain of 36 db. This brings the power at the output of the repeater up to a new level of +6 dbm (which represents 4 mw).

d. Next, as the power moves toward the end of the line, it suffers another loss of 12 db. This gives a final OUTPUT LEVEL of -6 dbm (actual power is .25 mw).

4-27. DBM CONCLUSIONS

a. You can see that db losses and gains are added algebraically. That is, a +36 db and a -30 db gives a +6 db. And a +6 db and a -12 db gives a -6 db.

b. Notice that db and dbm are not used in the same way. The db is used to express the amount of loss or gain. Then, after the loss or gain has taken place, dbm is used to express the new power level arrived at because of the loss or gain.

c. By using 0 dbm as the reference level you can easily tell the net loss in the circuit. Even though the power level changed several times along the circuit the received power is at a level of -6 dbm. The letter m after db tells us that this is 6 db below the input level of 0 dbm. So we can say that, regardless of how much loss or gain has taken place, the circuit NET LOSS is only 6 db. If this seems a

little hard to understand, think back to the money example. Remember how at the end of the year you had saved \$40 above the reference level of \$100. You called this +\$40 a NET GAIN for the whole year.

4-28. THE STANDARD FREQUENCY FOR DBM

a. You know now that 0 dbm represents 1 mw of power. And this 1 mw, in turn, represents the voice power. Now, since voice power is made up of ac voltage and current you must also be concerned with frequency. This means that when you state that the input level to a circuit is 0 dbm you must also specify the frequency.

b. The standard frequency used for testing in telephone work is 1,000 Hertz (1 kHz). When you make db loss and gain measurements you'll use a device that feeds a frequency of 1 kHz at a level a 1 0 dbm to the line input. Then, at various points along the line, another device will be used to measure the db loss or gain. This device will not only tell how much loss or gain there is but it will also indicate the level in dbm.

c. These devices are used as shown in figure 123. The one that supplies the power is called an oscillator. And the one that measures the power is called a decibel meter.

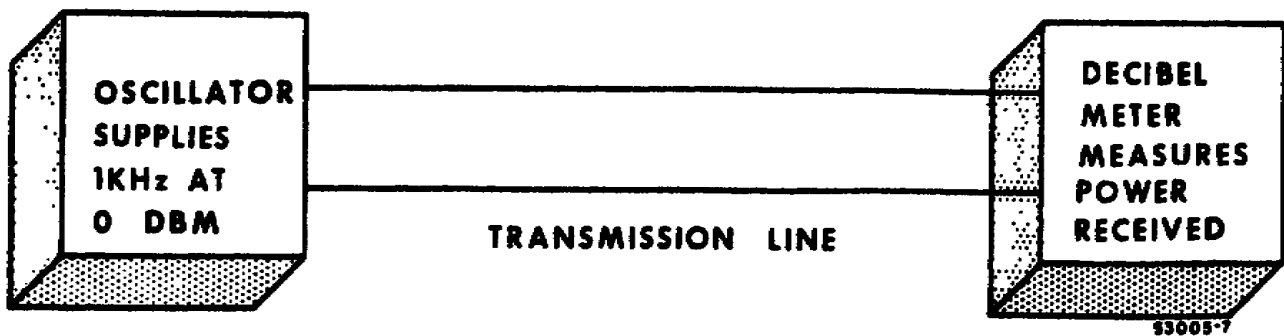

Figure 123. Use of oscillator and transmission measuring set.

4-29. SUMMARY

Here are the most important points covered in this information sheet:

a. The db is a transmission measuring unit used to express power loss and gain in a telephone system.

b. A minus sign placed before db (-3 db) indicates a power loss.

c. A plus sign placed before db (+3 db) indicates a power gain.

d. Db losses and gains in a circuit are added algebraically.

e. The db by itself indicates an amount of power loss or gain but it does not tell exactly how much power is involved.

f. A reference level of 1 mw of power is used with the db so that the db can express a definite amount of power.

g. To accomplish this, 1 mw is designated as being equal to 0 dbm.

h. This 0 dbm is then used as a reference level and all losses and gains are compared to 0 dbm. This means that a level of -3 db is 3 db below the reference level. And, since a 3 db loss represents a 50 percent power loss, a level of -3 db is equal to .5 mw. Similarly, a level of +3 db is equal to 2 mw since a gain of 3 db doubles the power.

i. The frequency used with the reference level of dbm is 1,000 Hertz (1 kHz).

j. This, then, is the standard frequency and testing power used in telephone work: 1 kHz at 0 dbm.

k. In transmission measurement 1 kHz at 0 dbm is supplied by an oscillator. And a decibel meter is used to measure the amount of db loss or gain at many points along the circuit.

LESSON EXERCISES

In each of the following exercises, select the ONE answer that BEST completes the statement or answers the question. Indicate your solution by circling the letter opposite the correct answer in the subcourse booklet.

1. Any external disturbances that interrupt or interfere with the normal operation of a receiver are classified as external noise. Among the types of noise that are classified as external are
 - a. galactic, cosmic, and thermal.
 - b. solar, cosmic, and terrestrial.
 - c. spontaneous emission, and cosmic.
 - d. thermal and spontaneous emission.

2. If the intensities of the various noises are recorded at a strategic microwave terminal for a period of 1 year, there will be seasonal variations in noise intensities. The most significant intensity changes will be in the solar noise and the
- thermal noise.
 - manmade noise.
 - terrestrial noise.
 - atmospheric noise.
3. Fluctuations in the strength of the incoming signal make reception of the desired signal difficult. These fluctuations can be caused by
- solar radiation.
 - atmospheric noises.
 - disturbances in the propagating medium.
 - electrons giving up energy as they revert to a power energy state.
4. Reception of weak signals becomes difficult when propagation conditions cause fading of the incoming signal. The effect of fading is a function of the ratio
- $\frac{C}{N}$
 - $\frac{S}{N}$
 - $\frac{C+N}{N}$
 - $\frac{S+N}{N}$
5. All electronic receivers have some degree of internal interference. One of the causes of internal interference is the
- inconsistencies of the magnetic field strength surrounding the equipment.
 - small voltages generated by electrons moving within the components of the receiver.
 - dust or smoke particles which reduce the amount of energy that can be picked up by the antenna.
 - bombardment of the antenna by particles created by the thermonuclear reactions on the sun.
6. The noise power developed across a resistive device establishes a noise threshold level. Incoming signals must exceed this noise threshold, or the resistive device cannot produce a useful output. The noise power developed across the resistive device is caused by
- variations in the system's bandwidth.
 - amount of opposition offered by the device.

- c. thermal agitation of the electrons in the resistive device.
 - d. inconsistencies in the composition of the resistive device.
7. When comparing noise temperature measurements, it is necessary to use a standard noise temperature reference. The standard noise temperature reference in Fahrenheit is
- a. 17°.
 - b. 62.6°.
 - c. 273.7°.
 - d. 290°.
8. If the noise temperature of a resistor is measured on a centigrade scale, the temperature value must be converted to the Kelvin scale before it can be used in the noise power formula. If a 35° centigrade measurement is converted to the Kelvin scale, the temperature becomes
- a. 95° Kelvin.
 - b. 275° Kelvin.
 - c. 290° Kelvin.
 - d. 308° Kelvin.
9. The noise power that is available across a resistor is determined by the
- a. frequency of the signal and the resistance of the resistor.
 - b. temperature of the resistor and the frequency of the signal.
 - c. bandwidth of the measuring system and the temperature of the resistor.
 - d. resistance of the resistor and the bandwidth of the measuring system.
10. Which of the following is the best receiver noise figure?
- a. 3 db
 - b. 5 db
 - c. 7 db
 - d. 10 db
11. If the noise output of a certain device is equal to the noise applied to the device, what is the device's noise figure?
- a. 1
 - b. 2
 - c. 3
 - d. 4
12. When the noise contribution of a receiver is determined by the Y factor method, the Y factor is expressed in
- a. volts.
 - b. decibels.
 - c. milliamperes.
 - d. degrees Kelvin.

13. The noise generator method of obtaining the noise figure has the advantage over other methods because
- the ac input reading of the generator can be converted to give the true noise figure.
 - it is not necessary to know the gain or response characteristics of the receiver.
 - noise generators are usually available when other generators are not.
 - no equipment is necessary with this method.
14. Each microwave terminal contains an assembly that compresses the dynamic range of the voice-frequency signals to be transmitted and expands the received voice-frequency signals to their original condition. This assembly is known as a
- compandor assembly.
 - deemphasis assembly.
 - compressor assembly.
 - mode selector assembly.
15. The performance computation that provides an indication of a receiver's relative noisiness on a day-to-day basis is called the
- Y factor.
 - noise power.
 - improvement factor.
 - threshold temperature.
16. Which receiver parameter has the greatest effect on the output S/N?
- Gain
 - Impedance
 - Bandwidth
 - Frequency
17. To what receiver function is the improvement factor F_m related?
- AGC
 - Gain
 - Selectivity
 - Demodulation
18. The maximum improvement factor obtainable from an AM receiver that is using automatic gain control is
- 0.5.
 - 1.0.
 - 6.0.
 - 150.
19. If a frequency-modulated signal has a modulation index of 4, the value of the improvement factor F_m is approximately
- 8 db.
 - 13 db.
 - 22 db.
 - 150 db.

20. The purpose of the receiver in a microwave station is to
- a. convert the modulated input signal back to a baseband signal.
 - b. convert the baseband input signal into a modulated signal.
 - c. compress the dynamic range of the voice-frequency signals.
 - d. expand the dynamic range of the voice-frequency signals.

CHECK YOUR ANSWERS WITH LESSON 4 SOLUTION SHEET PAGES 162 and 163.

HOLD ALL TEXTS AND MATERIALS FOR USE WITH EXAMINATION.

LESSON SOLUTION

LESSON 4Receiver Parameters

1. b--para 4-3a, d; 4-5
2. d--para 4-4a
3. c--para 4-6b
4. d--para 4-6c
5. b--para 4-7a(1)
6. c--para 4-8a
7. b--para 4-8a(3)
8. d--para 4-8a(4); table I

$$\begin{aligned} \text{Degrees Kelvin} &= C + 273 \\ &= 35 + 273 \\ &= 308 \end{aligned}$$

9. c--para 4-8b
10. a--para 4-9b
11. a--para 4-9e

$$F = \frac{Pno}{GPn1}$$

$$F = \frac{1}{1}$$

$$F = 1$$

12. b--para 4-11d
13. b--para 4-13a
14. a--para 4-17d
15. a--para 4-11b

16. c--para 4-16b
17. d--para 4-16c
18. b--para 4-16d
19. b--para 4-16d, fig. 117

The improvement factor is the signal-to-noise difference between the FM line of modulation index (M) and the SSB line. After the C/N ration exceeds the C/N threshold, the S/N difference between the two lines remains at 13 db.

20. a--para 4-17a