

68 1113
12
TM
1941

RESTRICTED

TM 11-231

U.S. Dept. of Army

WAR DEPARTMENT

TECHNICAL MANUAL

RADIO SETS SCR-178 AND SCR-179

December 15, 1941

66113

*TM 11-231

RESTRICTED

TM 11:231

1941

TECHNICAL MANUAL }
No. 11-231 }

WAR DEPARTMENT,
WASHINGTON, December 15, 1941.

RADIO SETS SCR-178 AND SCR-179

Prepared under direction of the
Chief Signal Officer

SECTION I. General.	Paragraph
Purpose	1
Description	2
Characteristics	3
Transportation	4
 II. Employment.	
Location	5
Initial procedure	6
Installing batteries and tubes	7
Antenna	8
Counterpoise assembly	9
Generator	10
Preparation for use	11
Operation	12
Removal from service	13
 III. Detailed functioning of parts.	
Radio transmitter BC-187 or BC-187-A	14
Radio modulator BC-188 or BC-188-A	15
Radio receiver BC-186	16
Generator GN-37	17
 IV. Servicing, repair, and storage.	
Servicing	18
Generator GN-37	19
Repairs	20
Tests	21
Alinement	22
Storage	23
Troubles	24
 V. Supplemental data and parts list.	
Operating voltages and currents of vacuum tubes	25
Circuit elements, transmitter	26
Circuit elements, modulator	27
Circuit elements, radio receiver BC-186	28
Parts list for radio sets SCR-178 and SCR-179	29

*This manual supersedes TR 1210-21, April 5, 1937, including ~~1~~, January 3, 1939.

SECTION I

GENERAL

Purpose.....	Paragraph 1
Description.....	2
Characteristics.....	3
Transportation.....	4

1. **Purpose.**—The radio sets SCR-178 and SCR-179 are intended for point-to-point and ground-to-plane communication between 75-mm and pack artillery units and aircraft for observation purposes.

2. **Description.**—*a. Radio set SCR-178 (fig. 1).*—The radio set SCR-178 is a portable, low power, high frequency transmitter and receiver. It has a sectional mast antenna of steel tubing approximately 28 feet in height when erected. Power for the transmitter is furnished by a hand generator and that for the receiver by dry batteries.

b. Radio set SCR-179.—The radio set SCR-179 is identical with SCR-178 set except that its carrying chests CH-28 and CH-29 are adapted for transportation on pack animals. It is intended for issue to pack artillery units.

3. **Characteristics.**—*a. Range.*—Continuous wave, tone, or voice (otherwise designated as type A1, A2, or A3 transmission, respectively) may be employed over the following distances:

	Range in miles		
	C. W.	Tone	Voice
Point-to-point.....	25	20	10
Ground-to-plane.....	100	75	30

b. Frequency.—Either set may be operated at any frequency throughout its range of 2400 to 3700 kilocycles. The practical frequency separation depends upon several variable factors, such as distance between transmitting and receiving stations, characteristics of the set with which communication is desired, characteristics of the receiver with which the transmitter is likely to interfere, type of transmission employed (continuous wave, tone, or voice), and propagation characteristics of the terrain. In general, a frequency separation equivalent to approximately 1 percent of the frequency employed is practicable, provided that the station with which the set is to com-

municate is also capable of operating at this separation or less without interference. In view of the above, it may be considered that 27 channels with 50 kilocycles separation are available for communication.

4. Transportation.—All of the components of radio set SCR-178 (or SCR-179) are packed for transportation in three containers (fig. 5) as follows:

*a. Chest CH-38 (or CH-28).*¹—An operating chest used for carrying (but does not include) the transmitter, modulator, receiver, battery box units, the headset, and key (fig. 2). Weight packed, 87 pounds.

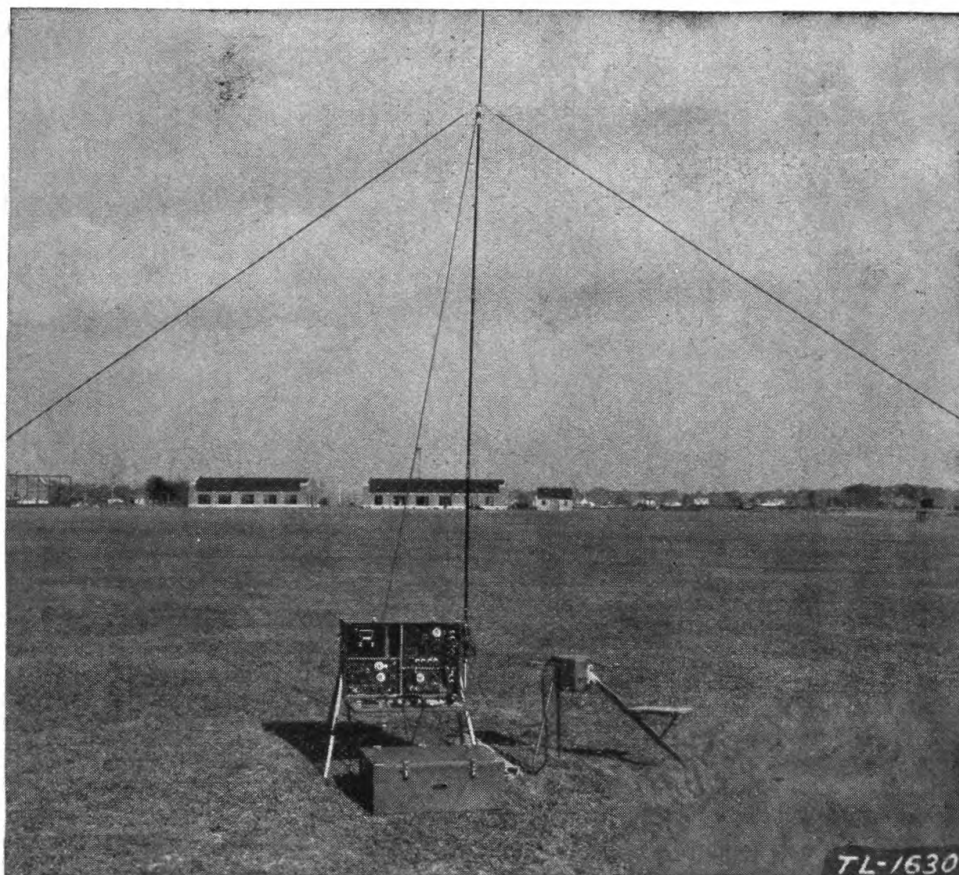

FIGURE 1.—Radio set SCR-178 set up for operation.

*b. Chest CH-39 (or CH-29).*²—An equipment chest used for carrying (but does not include) the hand generator, antenna guy assembly and reel, counterpoise assembly and reel, microphones, tool equipment, spare tubes, batteries, and headset (fig. 3). Weight packed, 103 pounds.

¹ Chest CH-28 is a component of radio set SCR-179.

² Chest CH-29 is a component of radio set SCR-179.

c. Roll BG-58.—A canvas roll used for carrying (but does not include) the mast sections, generator cranks, generator legs, operating chest legs, and stakes (fig. 4). Weight packed, 13 pounds.

d. Pack transportation.—The chests CH-28 and CH-29 are furnished with radio set SCR-179 for transportation on pack animals. They differ from chests CH-38 and CH-39 merely by having necessary fittings added for pack saddle mounting. Figure 6 shows the

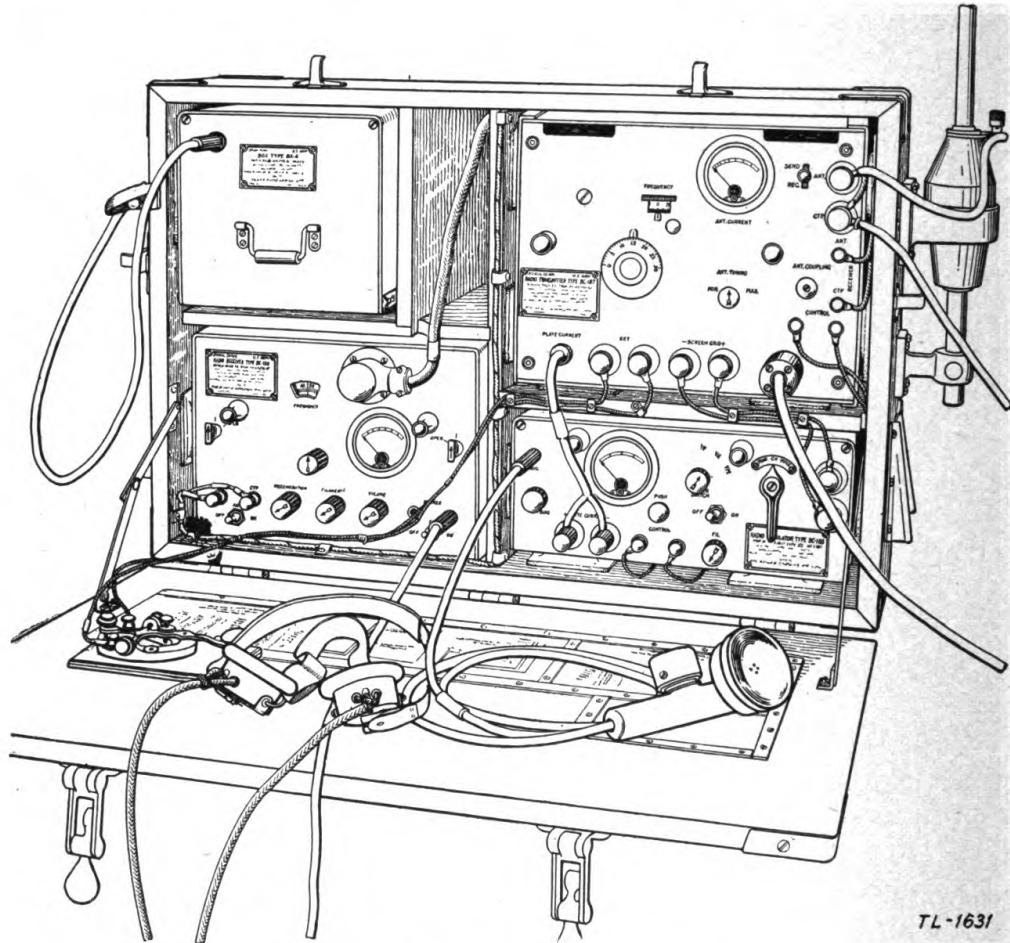

FIGURE 2.—Chest CH-38 open for operation.

top load consisting of the roll BG-58. Figures 7, 8, and 9 are three-quarter front, three-quarter rear, and rear views, respectively, of the complete pack loads. It should be noted that chest CH-28, the operating chest, is carried on the left side of the pack saddle and that chest CH-29, the equipment chest, is carried on the right side.

e. Weight.—The total weight of radio set SCR-178 or SCR-179 when packed for transportation is approximately 225 pounds, with a net volume of 14 cubic feet.

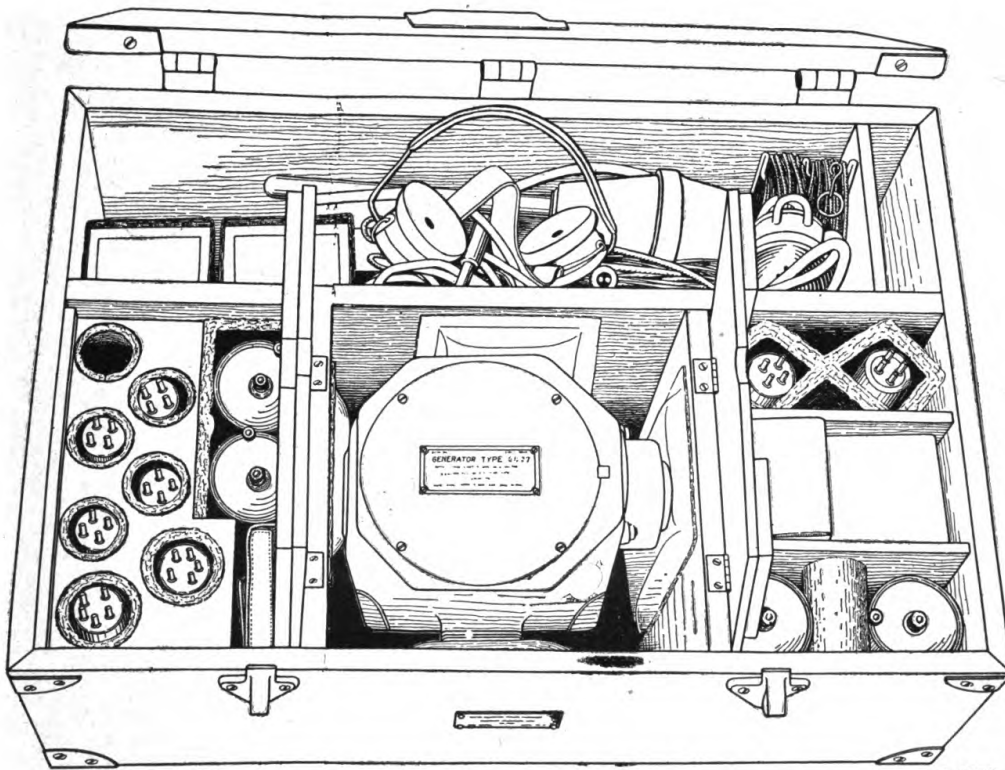

FIGURE 3.—Chest CH-39, packed.

TL-1632

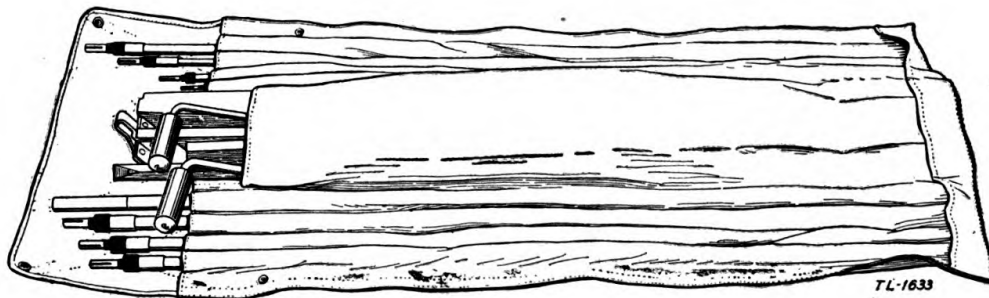
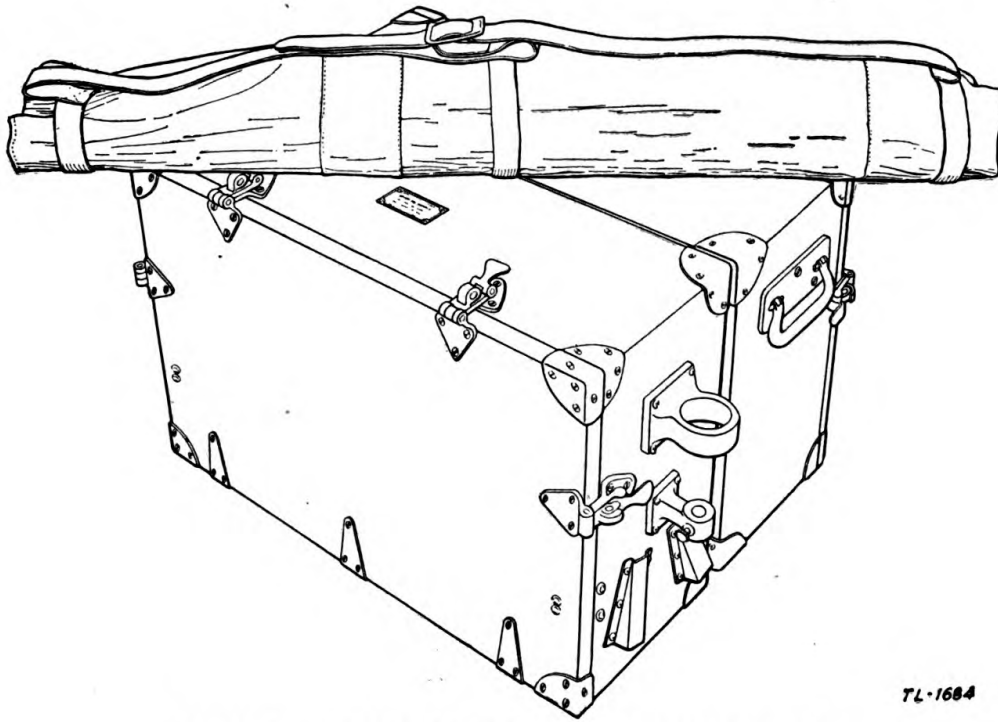

FIGURE 4.—Roll BG-58, packed.

TL-1633



TL-1684

FIGURE 5.—Radio Set SCR-178, packed for transportation.

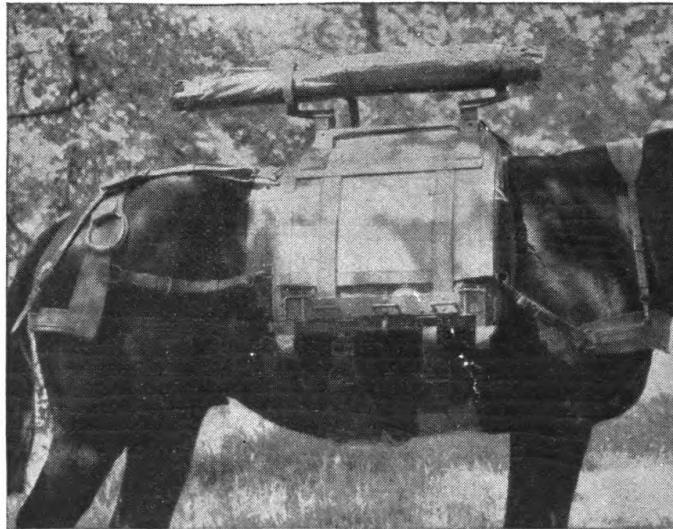

FIGURE 6.—Pack view, top load only.

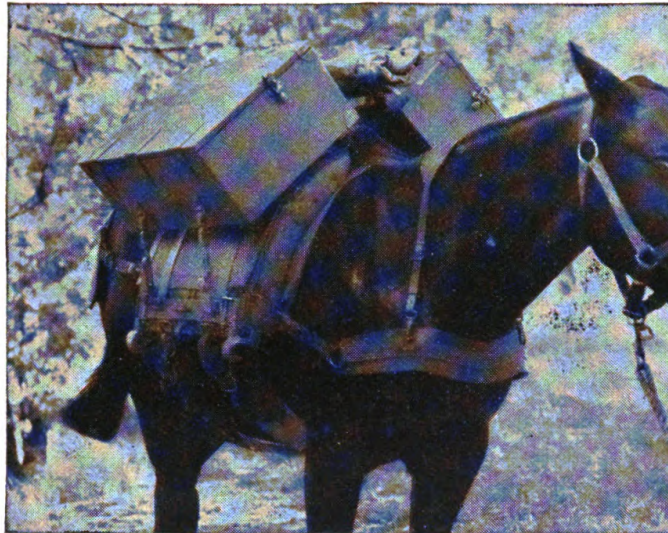

FIGURE 7.—Pack view, three-quarter front.



FIGURE 8.—Pack view, three-quarter rear.



FIGURE 9.—Pack view, rear.

SECTION II

EMPLOYMENT

	Paragraph
Location.....	5
Initial procedure.....	6
Installing batteries and tubes.....	7
Antenna.....	8
Counterpoise assembly.....	9
Generator.....	10
Preparation for use.....	11
Operation.....	12
Removal from service.....	13

5. Location.—A level ground area with no obstructions of any kind is ideally suited for installation. If it is necessary to set up the equipment in wooded areas, a space should be selected large enough to permit swinging the mast antenna in any direction with its base close to the operating chest. Operation in woods or heavy brush tends to reduce the operating range. This effect is especially noticeable in the spring when the sap is running.

6. Initial procedure.—Open the canvas roll. Remove the four wooden legs with tapered ends. Turn the operating chest on its side and insert the legs in the metal brackets. Set the chest up securely on its legs. Unlatch the chest and lower the cover until the metal

brackets on the side are extended. Place the equipment chest in position to serve as a seat for the operator, with the hinged side toward the operating chest, and unlatch it.

7. Installing batteries and tubes.—Remove the units from the operating chest and install batteries and tubes indicated below. The type number of the tube required is plainly marked on each socket. Battery voltage and polarity are indicated at each binding post.

a. Transmitter (fig. 12).—Loosen the four knurled headscrews at the corners of the panel and remove the panel and chassis assembly from the case. Install one tube VT-25 and one tube VT-55 in the proper sockets and replace the panel.

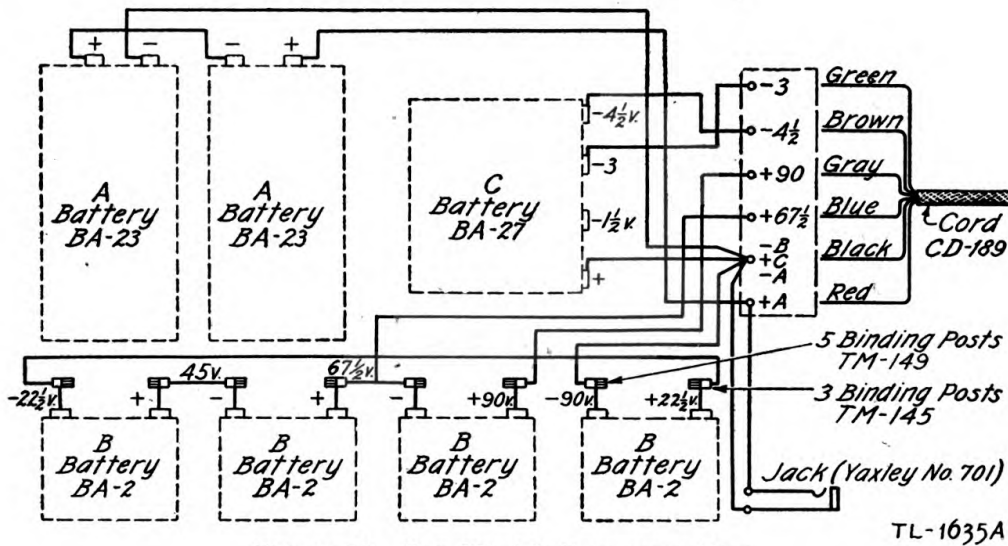

FIGURE 10.—Box BX-4 battery connections.

b. Modulator (fig. 13).—Unfasten the snap slides, two on either side of the cover, and remove the modulator from the chassis. Install two tubes VT-27 in the proper sockets, two batteries BA-23 and one battery BA-27 in the proper battery compartments, and replace.

c. Receiver (fig. 14).—Turn the two latches on either side of the panel to the OPEN position and remove the panel and chassis from the case. Install two tubes VT-27 and two tubes VT-54 in the proper sockets, and replace.

NOTE.—To remove the plug of the receiver power supply cord from the socket on the front panel of the receiver, it is necessary to press the spring catch on the lower left-hand part of the plug, and at the same time pull the plug.

d. Battery box.—(1) Unfasten the four snap slides, two on either side of the cover, and remove battery box from the chassis. Install four batteries BA-2, two batteries BA-23, and one battery BA-27 in the proper battery compartments, and replace. The power supply

cord should be clamped to the rear of the case and properly connected to the binding posts. Labeled and permanently installed leads should connect the battery terminals to the binding posts. (See fig. 10.)

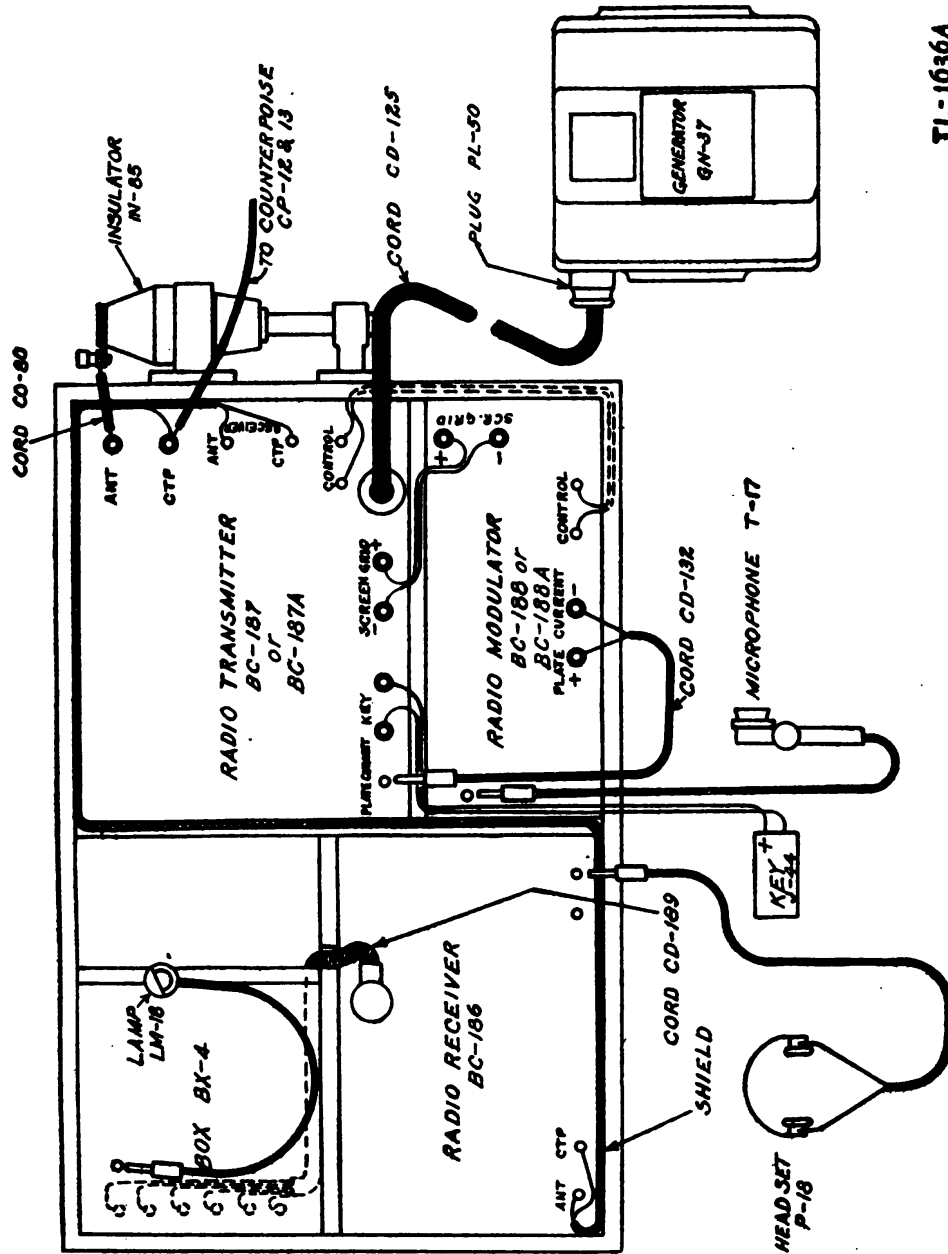

FIGURE 11.—Chest CH-38 cording diagram.

(2) Replace the units and connect all leads secured in the chest to binding posts according to the diagram on the inside of the cover (fig. 11). Draw the cord from the battery box through the adjoining compartment and connect it to the receptacle on the panel of the receiver. Slip the key into the brackets on the inside of the cover.

8. Antenna.—*a. Mast sections.*—Remove the mast sections from the canvas roll. There are eight sections, numbered at the lower end MS-49 to MS-56, inclusive. The bottom section is fitted with a shank which fits into the mast base insulator on the operating chest. The top section terminates in a blunt point. Ends which are connected in assembling have enameled marks of the same color. Assemble consecutively, matching colors, starting with the heaviest section.

b. Guy assembly.—Guy GY-11 consists of two guy lines, each permanently attached by a hook to a mast clamping ring. Guy GY-12 consists of a single guy line with a hook attached. Each guy line consists of a 20-foot length of heavy fishline with a strain insulator at the mast end and a small S-hook at the outer end. Unwind the guys from the reel RL-28, and slip the mast clamping ring around the lower end of the fourth mast section from the bottom. Close the clamping ring by inserting the hook on the mast end of the guy GY-12. (See that all hooks extend in the direction of the heavier sections.) Slip the mast base insulator over the bottom of the assembled mast. The antenna is now ready for erection. With the mast lying on the ground, place the guy lines parallel to it from the point of connection at the clamping ring to the bottom of the mast. Raise the mast in one continuous movement until it is vertical, and slip it into the holder on the right side of the operating chest. Secure the bottom of the insulator by means of the thumb-screw on the holder. Guy the mast by staking the lines at points as nearly equidistant as feasible. Guard against excessive bending of the mast in raising and guying operations. Connect the terminal on the mast base insulator to the antenna binding post on the transmitter by means of the short rubber cord provided for the purpose.

9. Counterpoise assembly.—Counterpoise CP-12 consists of a metal junction strip with two 25-foot wires attached to one end, and two 25-foot wires and a 4-foot lead-in attached to the other end. Counterpoise CP-13 is similar to counterpoise CP-12, except that it does not include a lead-in. Unwind the two counterpoises from the reel RL-29, and connect their junction strips crosswise by means of the wing nut on the CP-12. Lay the 25-foot wires on the ground radially so as to form approximately the same angle between adjacent rays. Connect the lead-in wire of counterpoise CP-12 to the counterpoise terminal of the transmitter.

10. Generator.—Remove the generator from the chest and set it on the ground. Remove the two metal legs and the leg with the wooden seat from the canvas roll and secure them to the generator.

Set up the generator on its legs and see that the seat is fairly level. Remove the cranks from the roll and insert them into the sockets on either side of the generator. Connect the generator to the transmitter by means of the rubber-covered cord with a four-point plug at each end. The index mark on each plug must coincide with the index mark of the socket on both generator and transmitter.

11. Preparation for use.—Examine the installation generally. See that the location of the several items of equipment is suitable. Determine that the mast antenna is securely guyed in a vertical position and entirely clear of obstructions. (In wet weather it is particularly important to guard against the mast end contacting trees or other grounded obstructions.) Check the power supply of the receiver and modulator by snapping on the filament switches and turning up the rheostats. Check the power supply of the transmitter by cranking the generator. (See sec. III.) See that all wire and cord connections are tight. Adjust the key to suit. The lamp should be used only when light is required, and may be clamped to the edge of the chest and plugged into the jack of the battery box. See that all controls operate easily. In wet weather insure that all panel surfaces, particularly the areas around the binding posts, are dry by wiping thoroughly with a soft cloth.

12. Operation.—**Caution:** *Radio transmitter BC-187 or BC-187-A operates at high voltages which are dangerous to life. Do not attempt to make internal adjustments while cranking the generator. The generator GN-37 should not be operated with cord CD-125 attached to it unless the other end of the cord is attached to the radio set. A dangerous high potential of 500 volts exists across the exposed contact pins of the plug.*

a. Transmitting (figs. 12 and 13).—(1) *Continuous wave.*—(a) Move the SEND-REC. switch on the transmitter to the SEND position. This will connect the antenna to the transmitter, short circuit the receiver input, and close the modulator circuit. Turn the selector switch on the modulator to the C.W. position. Turn the METER SWITCH (see fig. 13) to I_p and insert the plug of the modulator cord into the PLATE CURRENT jack of the transmitter.

(b) The dial labeled FREQUENCY (see fig. 12) revolves on a vertical shaft and turns the oscillator capacitor by means of worm gearing. The dial on the vertical shaft is graduated into 100 divisions and the dial on the horizontal shaft into 30 divisions. The first dial makes a complete revolution through 100 divisions in order to rotate the second dial through one division. The frequency scale may therefore be read directly in numerals from 0 to 3,000. By referring

to the transmitter calibration chart mounted on the cover of the operating chest, this indication may be translated into transmitter frequency. Turn the FREQUENCY dial to the position indicated on

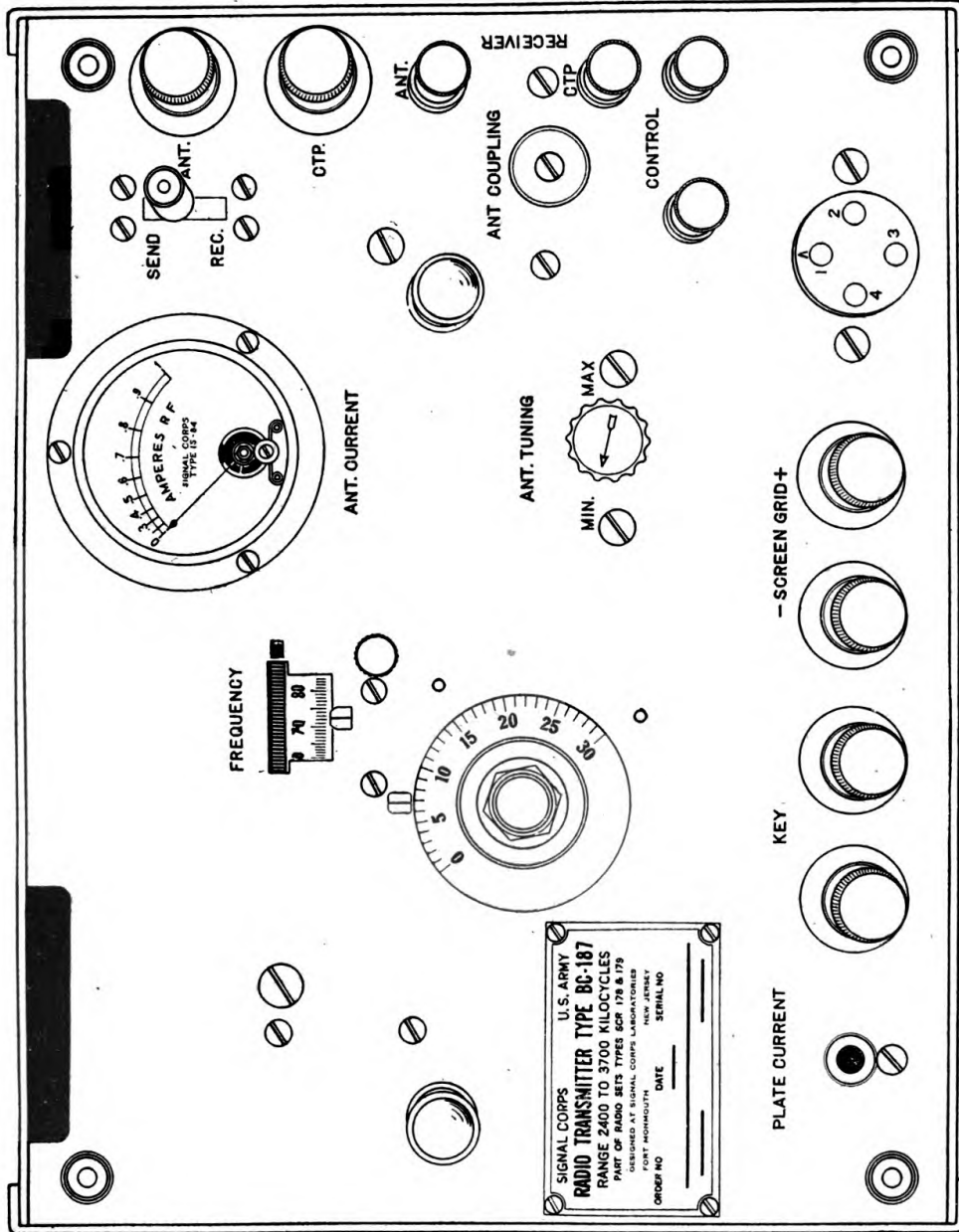
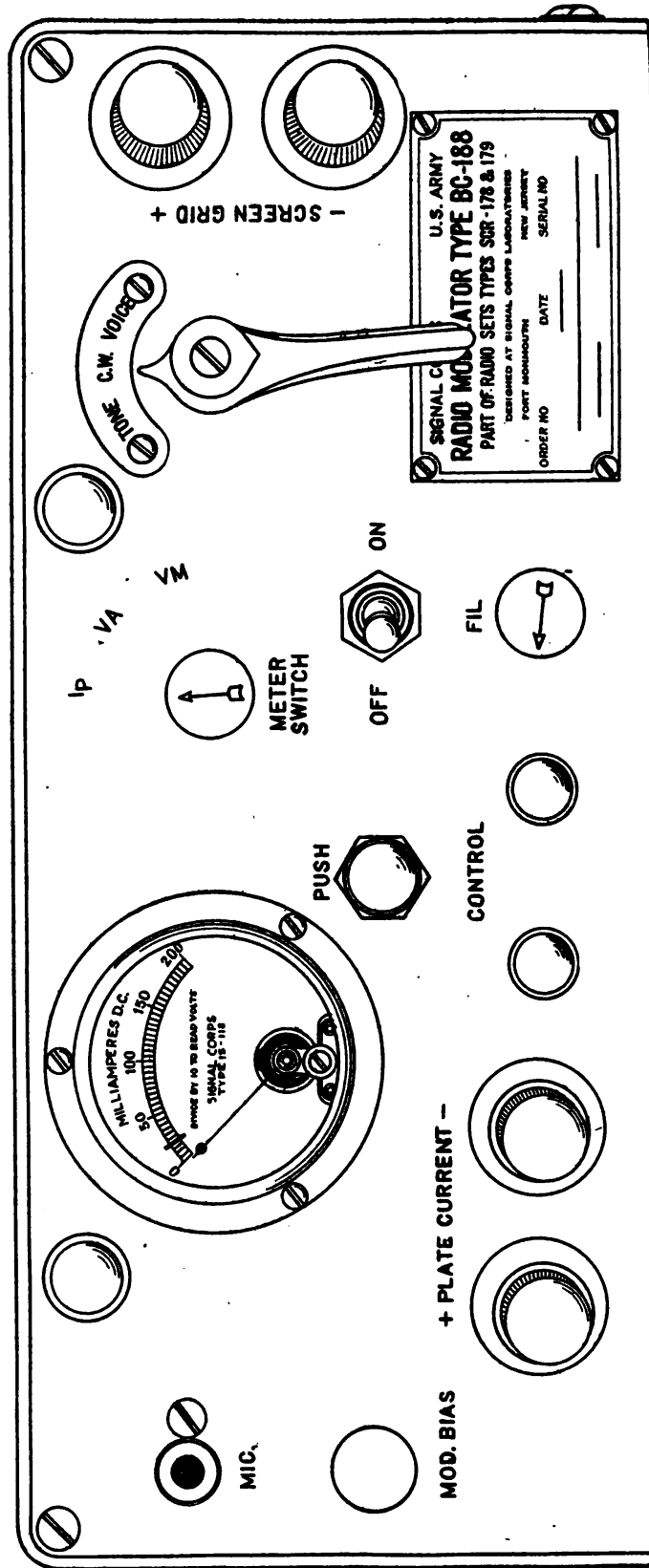

FIGURE 12.—Radio transmitter BC-187.

the chart for the transmission frequency desired, and lock the setting by turning clockwise the small thumbscrew below and to the right of the dial.



7L-1625A

FIGURE 18.—Radio modulator BC-188.

(c) Turn the generator crank at about 60 revolutions per minute. The transmitter antenna circuit should next be tuned to secure maximum power output.

NOTE.—Always tune the transmitter antenna circuit with the selector switch on the modulator turned to the C. W. position. Any other procedure will result in reduced power output, and will also cause distortion on voice operation.

(d) The antenna circuit is tuned by adjusting the ANT. COUPLING and ANT. TUNING controls (see fig. 12) with the key depressed. The ANT. COUPLING knob, which slides the secondary coil in or out of the primary coil, should be pulled halfway out. Then vary the ANT. TUNING knob, which controls the antenna tuning capacitor, until the antenna current as indicated by the meter on the transmitter attains a maximum value. Reset the ANT. COUPLING and ANT. TUNING controls until the proper setting for each is determined by maximum antenna current. The key must be depressed while tuning, but should not be held down steadily. The operation of tuning is somewhat critical and must be done carefully if satisfactory output and transmission range are to be obtained. The meter on the transmitter should indicate between 0.5 and 1.0 ampere when the key is depressed, and the meter on the modulator between 70 and 90 milliamperes. Check the above outlined procedure.

(e) After the transmitter is operating properly, the plug of the plate current cord CD-132 may be withdrawn as the plate current reading of the meter on the modulator is not essential to transmission. The transmitter must be tuned each time the frequency is changed.

(2) *Tone.*—Do not attempt to transmit with the METER SWITCH on the modulator set at VA or VM while the plug of the plate current cord is in the jack of the transmitter, since under these conditions the transmitting circuit is open at the METER SWITCH. Before transmitting, the switch should be turned to I_p or the plug removed from the jack. Tune in the same manner as for continuous wave transmission and then turn the selector switch on the modulator to the TONE position. Snap on the modulator filament toggle switch. Turn the METER SWITCH to VA, press the PUSH button, and at the same time adjust the filament voltage of the modulator tubes to 2 volts (shown by red line on meter) by turning the knob of the filament rheostat marked FIL. Turn the meter switch to VM, press the PUSH button, and read the meter. This indicates the buzzer supply voltage which should be at least 4½ volts. The meter in the modulator reads 20 volts full scale when the METER SWITCH is in either the VA or the VM position. Return the METER SWITCH to I_p before transmitting.

(3) *Voice*.—Tune in the same manner as for continuous wave transmission and then turn the selector switch on the modulator to the VOICE position. Snap on the modulator filament toggle switch, and adjust filament voltage to 2 volts as in tone operation. Turn the METER SWITCH to VM, press the PUSH button, and read the meter. This indicates the microphone voltage (the same battery as used for the buzzer in tone operation) which should be at least $4\frac{1}{2}$ volts. Return the METER SWITCH to I_p . Slide the button on the transmitting key to the VOICE position. Plug the microphone into the jack on the modulator. By turning the MOD. BIAS knob on the modulator, reduce the ANT. CURRENT, as indicated by the meter on the transmitter, somewhat below its value on C. W. transmission. An antenna current of one-half its value on C. W. is recommended, although in some cases it is not possible to reduce the ANT. CURRENT reading to this value by means of the MOD. BIAS knob. VOICE operation with ANT. CURRENT readings above half the normal value on C. W. will reduce the modulation capability of the modulator somewhat. (See par. 14c.) The proper setting of the control may be determined by trial. Speak slowly, distinctly, and directly into the microphone. Hold the microphone about 1 inch away from the lips and press the button when speaking. When finished transmitting, snap all filament switches to the OFF position and move the SEND-REC. switch to the horizontal position.

b. *Receiving* (fig. 14).—(1) Move the SEND-REC. switch on the transmitter to the REC. position. Snap the ANT. (antenna) and FIL. (filament) toggle switches of the receiver to the ON position. Plug in the headset. Two jacks are provided to enable two headsets to be used simultaneously if desired. Adjust the filament voltage to 2 volts (shown by red line on meter) by turning the knob of the filament rheostat marked FILAMENTS. Check the plate voltage by pushing the pin in the bottom of the meter. The meter should read approximately 90 volts on the upper scale. There is only one tuning control knob; it is located to the left of the meter. The dial labeled FREQUENCY is graduated into 100 divisions. Adjust the tuning control to the frequency of the desired signals by referring to the calibration chart on the inside of the cover. To receive continuous wave signals, adjust the regeneration control by turning the knob marked REGENERATION until the beat note is suitable. To secure maximum sensitivity on tone or voice signals, increase the regeneration by turning the control clockwise to a point just below the point at which the receiver breaks into oscillation (indicated by a sudden increase of

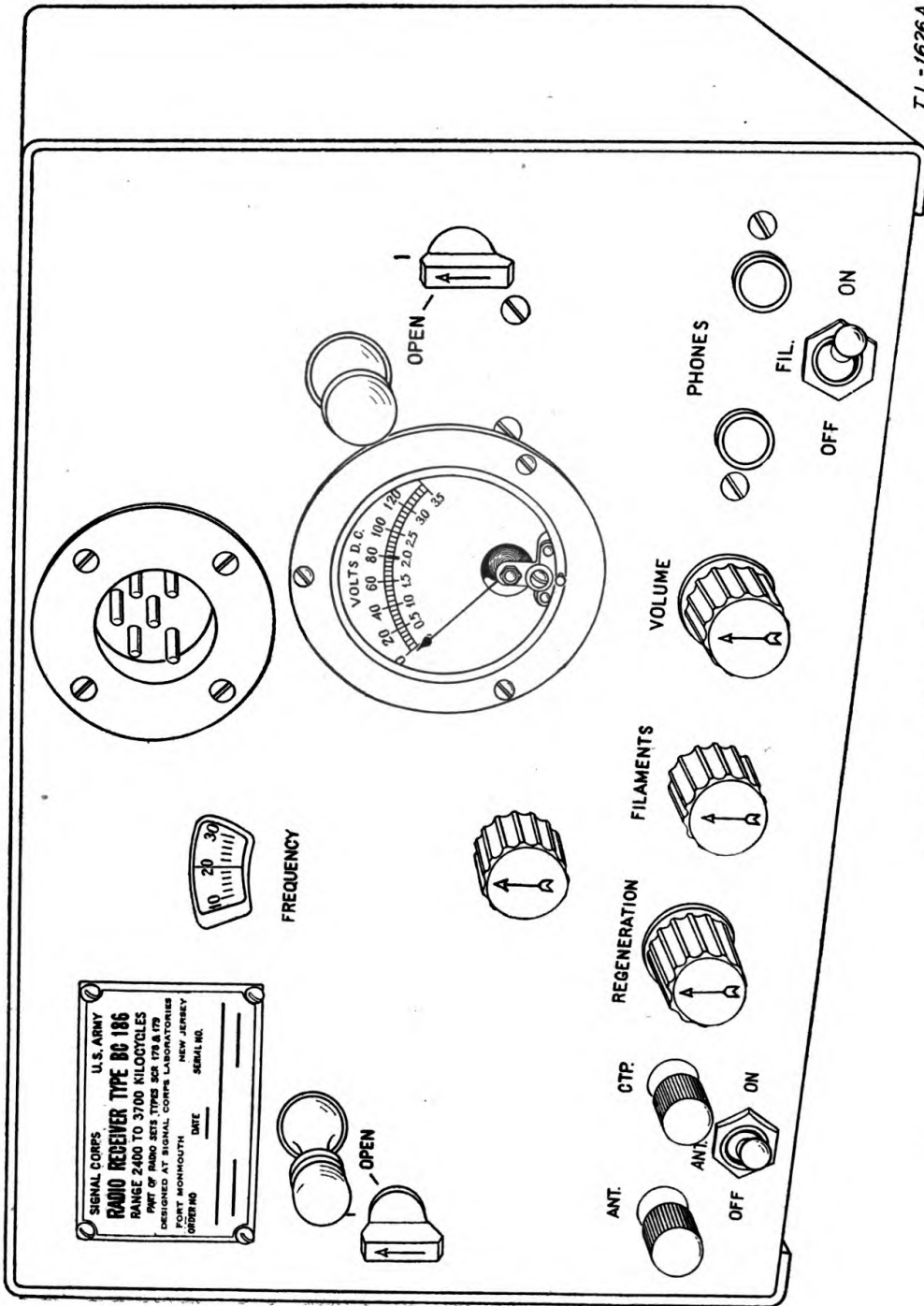

TL-1626A

FIGURE 14.—Radio receiver BC-186.

rushing sound). Adjust the **VOLUME** control for suitable signal intensity.

(2) The calibration chart is to be used as an accurate guide only and not as absolute data. Keep in mind that weather conditions, inaccurate tuning of the transmitter, and that mechanical and electrical aging of all equipment tend to produce slight differences in the tuning point of the receiver. Signals should therefore be sought over a narrow range and not at a point.

(3) When finished receiving, snap the antenna and filament switches to the **OFF** position. If receiving and transmitting intermittently, the filament switch may be left on. Placing the antenna switch in the **OFF** position while transmitting prevents receiver blocking and permits monitoring the transmitted signals.

13. Removal from service.—*a.* In removing the equipment from service, reverse the order given for installation. Disconnect the counterpoise lead and the junction strips, and wind up the wires on the reel. (Put counterpoise **CP-13** on last as this facilitates installation and assembly.) Disconnect the generator, remove the cranks, turn it over and remove the legs. Return cranks and legs to center pocket of the canvas roll and the cord to the equipment chest. Pull up the guy stakes, disconnect the antenna from the set, raise the mast out of the holder, and lower it slowly in one continuous movement to the ground. Remove the locking hook on the single guy line and then slip the collar of the guy assembly from the mast. Wind it up and put it in the equipment chest. Unscrew the sections of the mast and return to the small pockets in the canvas roll. Place microphone and lamp in the equipment chest. Remove the key from the cover, the battery cord and the headset from the receiver, and place these items in the compartment to the right of the battery box.

b. The modulator cord may be left connected but the plug should be slipped under the **KEY** wires of the transmitter. The equipment and operating chests appear as shown in figures 2 and 3. The components in the canvas roll are shown in figure 4. The chests should be latched, and the roll closed, taking care to have all items in their proper places. The units should now appear as shown in figure 5.

c. Under normal operating conditions the batteries and tubes are retained in their respective places in the operating units. Only the spares are carried in the equipment chest. However, if the units are to remain out of service for a period of several weeks or longer, the batteries should be removed, as the corrosion and swelling which inevitably result may damage the operating units.

SECTION III

DETAILED FUNCTIONING OF PARTS

	Paragraph
Radio transmitter BC-187 or BC-187-A.....	14
Radio modulator BC-188 or BC-188-A.....	15
Radio receiver BC-186.....	16
Generator GN-37.....	17

NOTE.—The following detailed analyses are given with reference to the schematic diagrams and circuit element drawings shown in figures 15 to 30, inclusive. Descriptions of parts represented by code figures are given in paragraphs 26, 27, and 28.

14. Radio transmitter BC-187 (figs. 15, 16, and 17) or BC-187-A (figs. 17, 18, and 19).—These units are interchangeable, and differ only in minor respects (see par. 26).

a. The transmitter consists of a master oscillator with a power amplifier stage. Tone or voice modulation is obtainable by the use of an external modulator unit. The master oscillator is of the Hartley type with series feed. The output of the tube VT-25 is transferred to the power amplifier (VT-55) screen grid tube through the capacitor C_6 . The amplifier output is in turn transferred to the antenna system through an output transformer consisting of coils L_2 and L_3 . The master oscillator circuit consists of a coil L_1 and three parallel capacitors C_4 , C_7 , and C_{12} . C_4 is fixed and determines the frequency band. It also provides a favorable C/L ratio in the tank circuit for frequency stability. C_7 is variable and is used for tuning the set, while C_{12} is a small variable capacitor used for trimming in order to correct the frequency obtained so as to correspond with the calibration of the set. C_1 is the blocking capacitor in the oscillator grid circuit. R_4 reduces the plate voltage of the oscillator and also aids in stabilizing the frequency. The power amplifier plate is series fed through a high impedance coil L_2 whose natural period lies in the middle of the frequency band of the set. R_3 and C_{13} are, respectively, the resistor and audio-frequency capacitor in the screen grid circuit from the modulator.

b. The load applied to the power amplifier plate is varied by varying the coupling between coils L_2 and L_3 . The antenna circuit is tuned by means of coil L_4 and a variable capacitor C_8 , resonance being indicated by a radio-frequency ammeter. Referring to the transmitter as a whole, C_2 , C_3 , C_5 , C_9 , C_{10} , and C_{11} are all bypass capacitors. R_5 and R_6 are keying resistors. J_1 is the jack for the plate current cord plug and is used for measuring the total plate current. SO_1 is the power supply socket.

c. Continuous wave, tone, or voice may be transmitted. On continuous wave the transmitter functions without the modulator, the

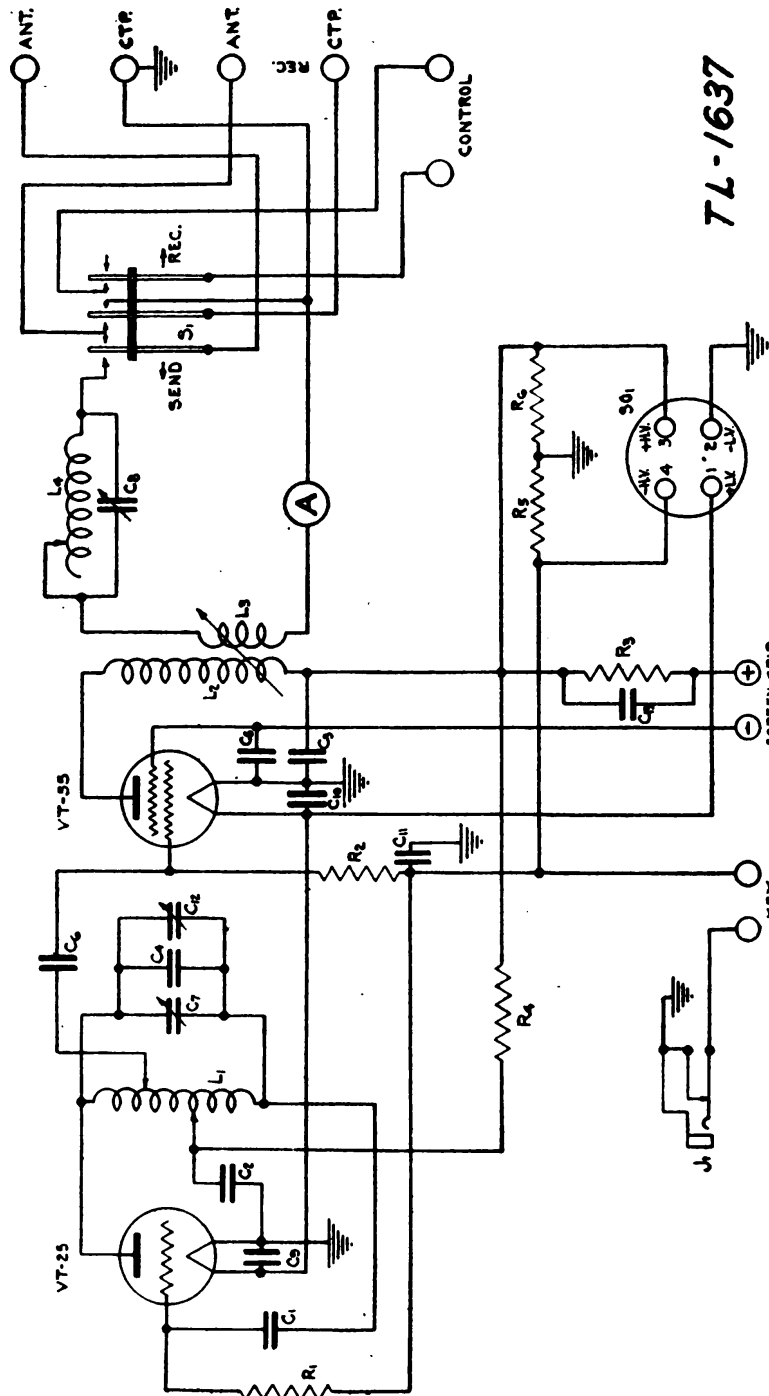

FIGURE 15.—Radio transmitter BC-187, circuit diagram. (Circuit elements.)

selector switch in the modulator unit serving to short circuit the screen-grid terminals of the transmitter. On either tone or voice

the modulator is connected to the circuit by means of the screen-grid leads, which serve to connect the modulator tubes in series with the screen-grid circuit of the amplifier tube. Modulation is effected by varying the plate to filament resistance of the modulator tubes at the desired tone or voice frequencies. This variation of resistance in the screen-grid circuit results in a similar variation in screen-grid potential, which in turn varies the power amplifier plate current and radio-frequency output. When operating on voice in the manner de-

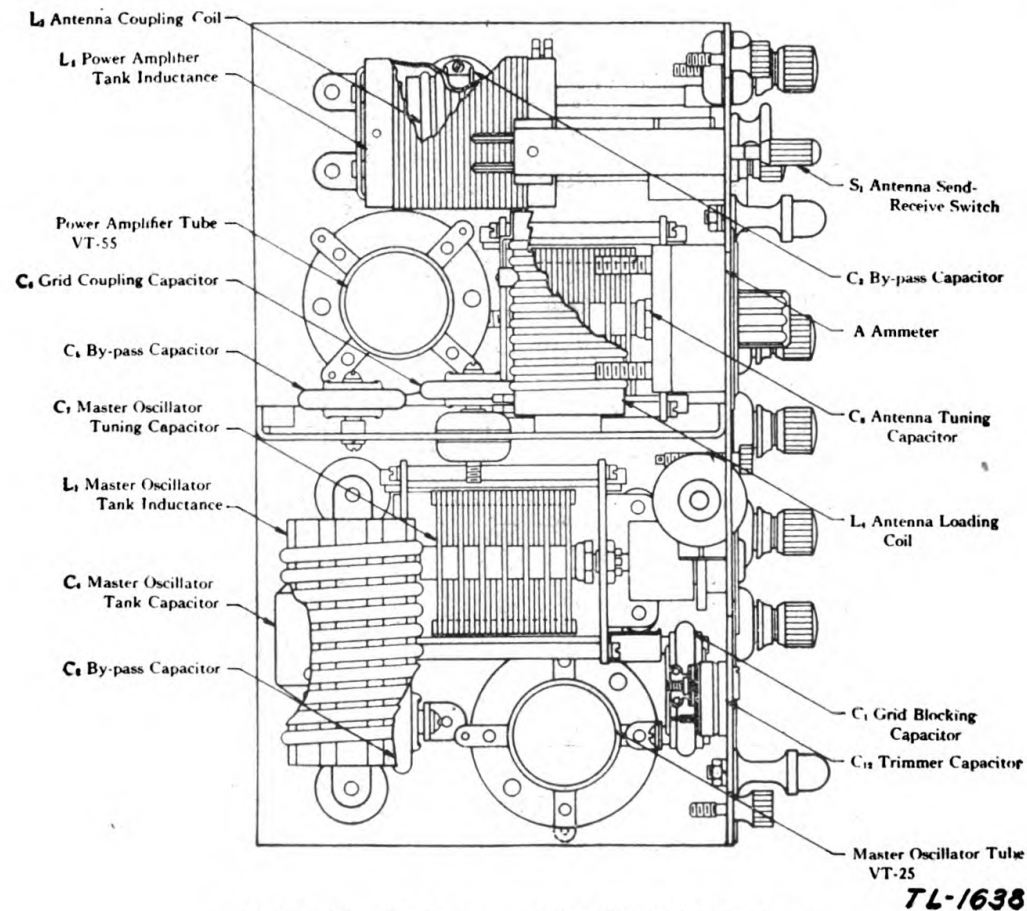

FIGURE 16.—Radio transmitter BC-187, top view.

scribed, the set is capable of modulating the carrier output approximately 90 percent with approximately 0.1 volt input from the microphone.

d. Keying is effected by means of short-circuiting the keying resistor R_5 . With the key in the open position the grids of both the oscillator and power amplifier tubes are biased sufficiently negative with respect to their filaments (due to the voltage drop across R_5) to cut off the flow of plate current, and thus effectively prevent radiation.

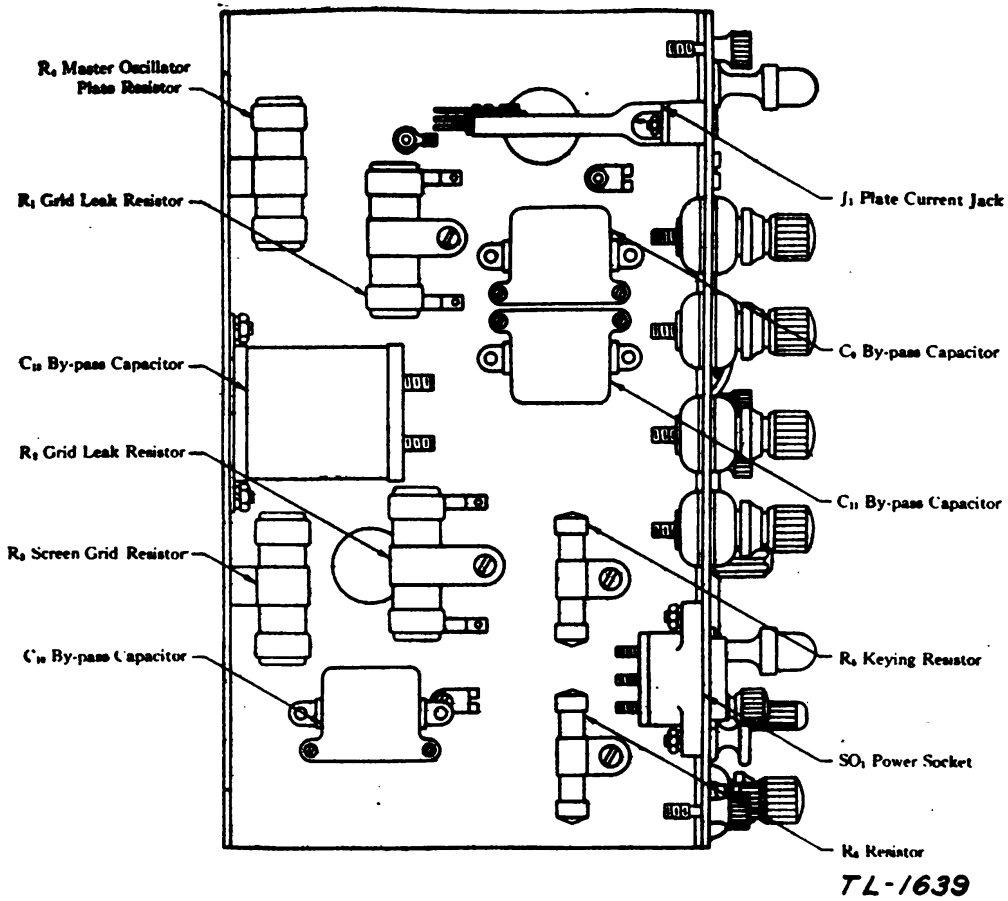

FIGURE 17.—Radio transmitters BC-187 and BC-187-A, bottom view.

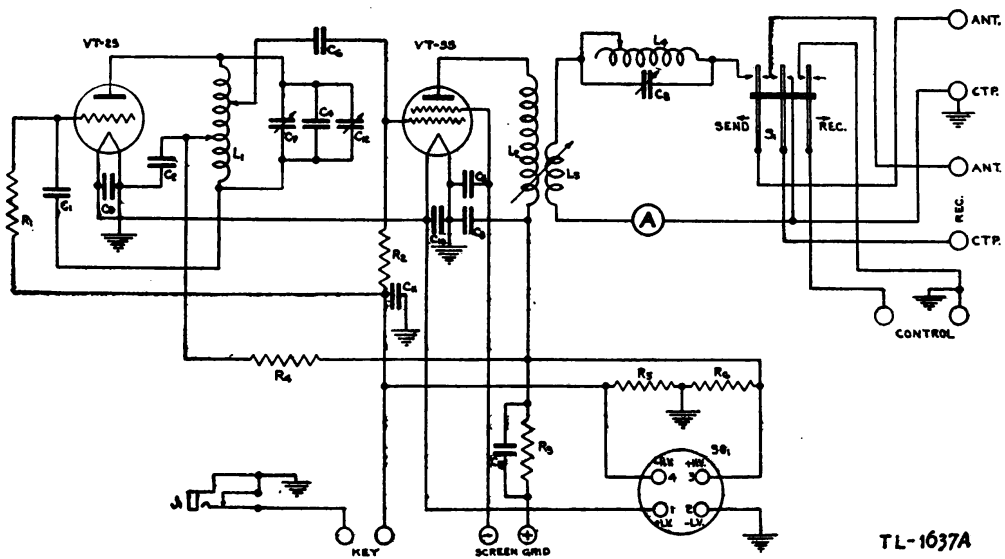

FIGURE 18.—Radio transmitter BC-187-A, circuit diagram.

15. Radio modulator BC-188 (figs. 20 and 21) or BC-188-A (figs. 21 and 22).—These units are interchangeable, and differ only in minor respects. (See par. 27.) The modulator consists of two audio-frequency amplifier tubes in parallel, a microphone transformer, an interrupter for tone operation, and a microphone (external) for voice operation. The modulator is connected in the power amplifier screen supply lead and acts as a variable resistance, changing the

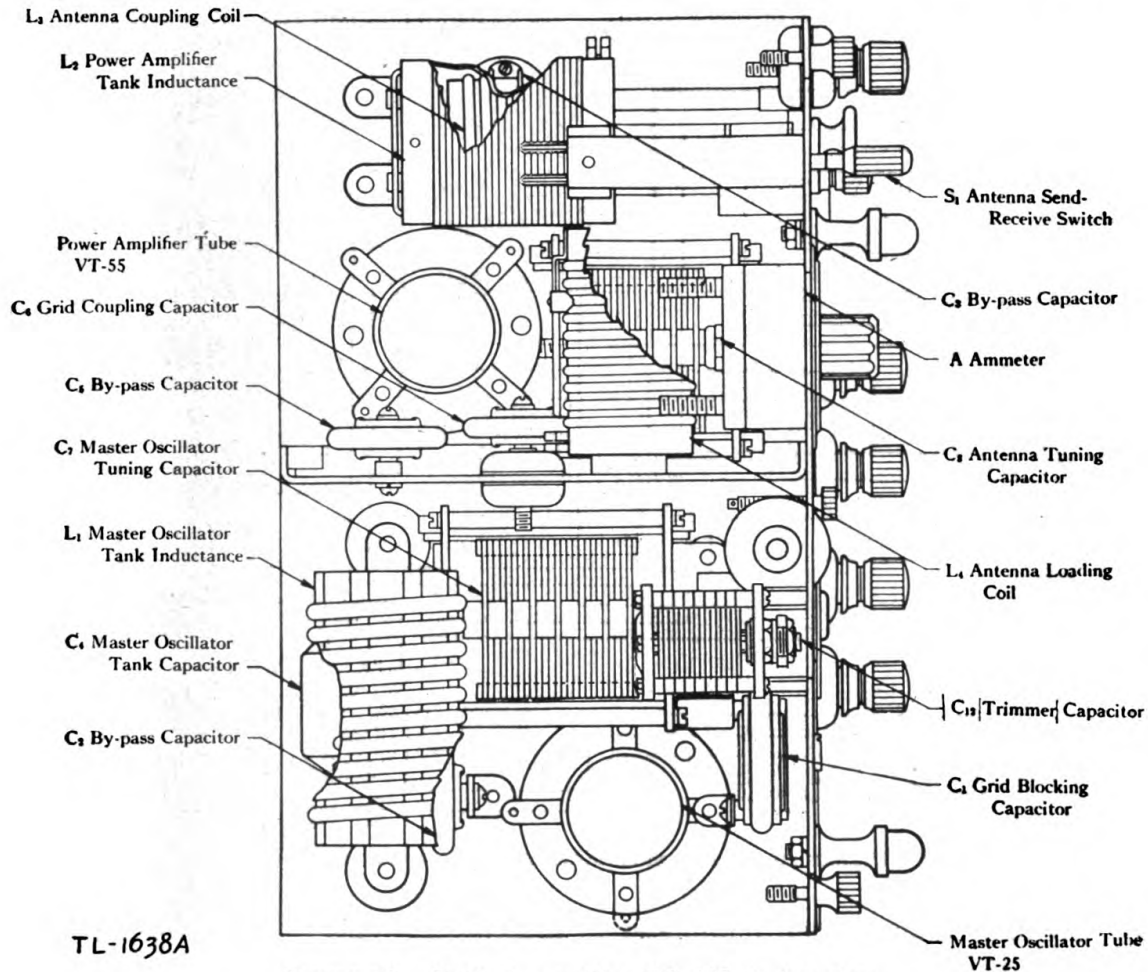

FIGURE 19.—Radio transmitter BC-187-A, top view.

screen potential of the power amplifier in accordance with the audio frequency supplied the modulator tubes on either tone or voice operation.

a. *Tone* (fig. 23).—The 4.5-volt battery supplies the power for the interrupter (BZ-5 in BC-188 and BZ-7-() in BC-188-A) and primary circuit of the microphone transformer T_1 . The output of the microphone transformer T_1 is impressed across the load impedance R_2 and on the grids of the vacuum tubes. The plates of the tubes are con-

nected to the transmitter screen-grid circuit. Grid bias is controlled by rectified grid current through R_1 which causes it to act as an automatic biasing resistor and to reduce the continuous wave carrier output of the transmitter to the proper value for modulation. C_2 is an audio-frequency bypass capacitor. Filament power supply is controlled by switch S_4 and rheostat R_4 . S_2 (fig. 20) is the meter switch. It indicates filament voltage on VA and microphone or interrupter voltage on VM. S_3 (fig. 20) is the push button which closes the circuit through the meter switch for either indication. R_3 (fig. 20) is the resistance which

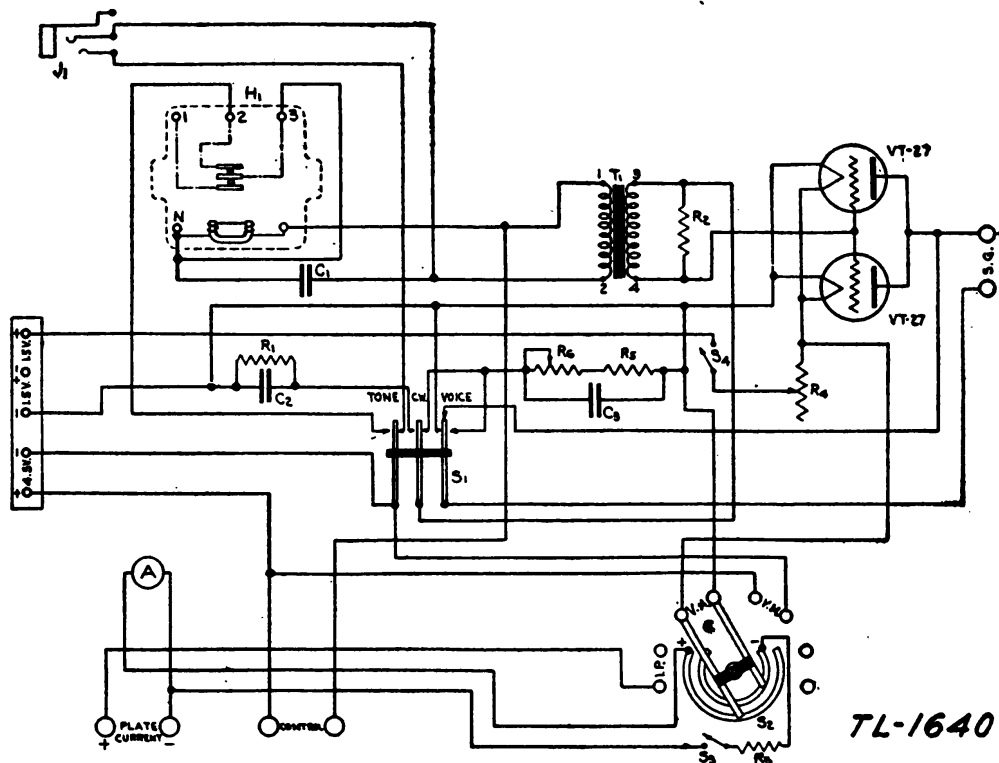

FIGURE 20.—Radio modulator BC-188, circuit diagram.

accommodates the milliammeter to indicate voltage. On I_p the meter indicates transmitter plate current. (The plate current cord must be in place for this reading.) Capacitor C_1 prevents direct current from flowing in the transformer input circuit.

b. Voice (fig. 25).—Operation on voice is similar to that on tone. The microphone (external) (fig. 26) is in the primary circuit of the transformer in place of the interrupter. Grid bias is controlled by plate current through resistor R_5 and potentiometer R_6 (in the modulator portion of the diagram, fig. 25). The setting of this potentiometer affects the screen-grid potential of the amplifier tube in the transmitter and, in turn, the power output. It is used to reduce the

unmodulated continuous wave carrier to about one-half that used on continuous wave transmission. C_3 is an audio-frequency bypass capacitor.

16. Radio receiver BC-186 (figs. 27, 28, and 29).—*a.* The receiver consists of one stage of radio-frequency amplification, a detector, and two stages of audio-frequency amplification. The antenna counter-poise circuit is inductively coupled to the radio-frequency amplifier by transformer T_1 . The radio-frequency amplifier is coupled to the

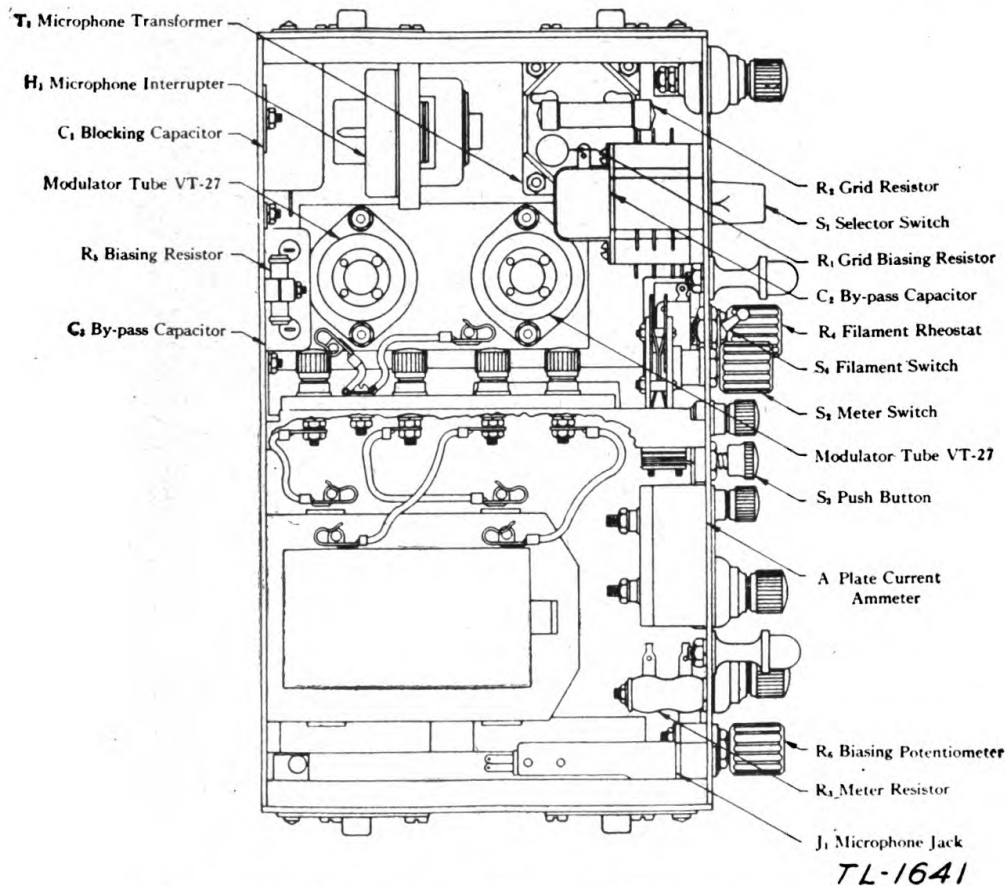
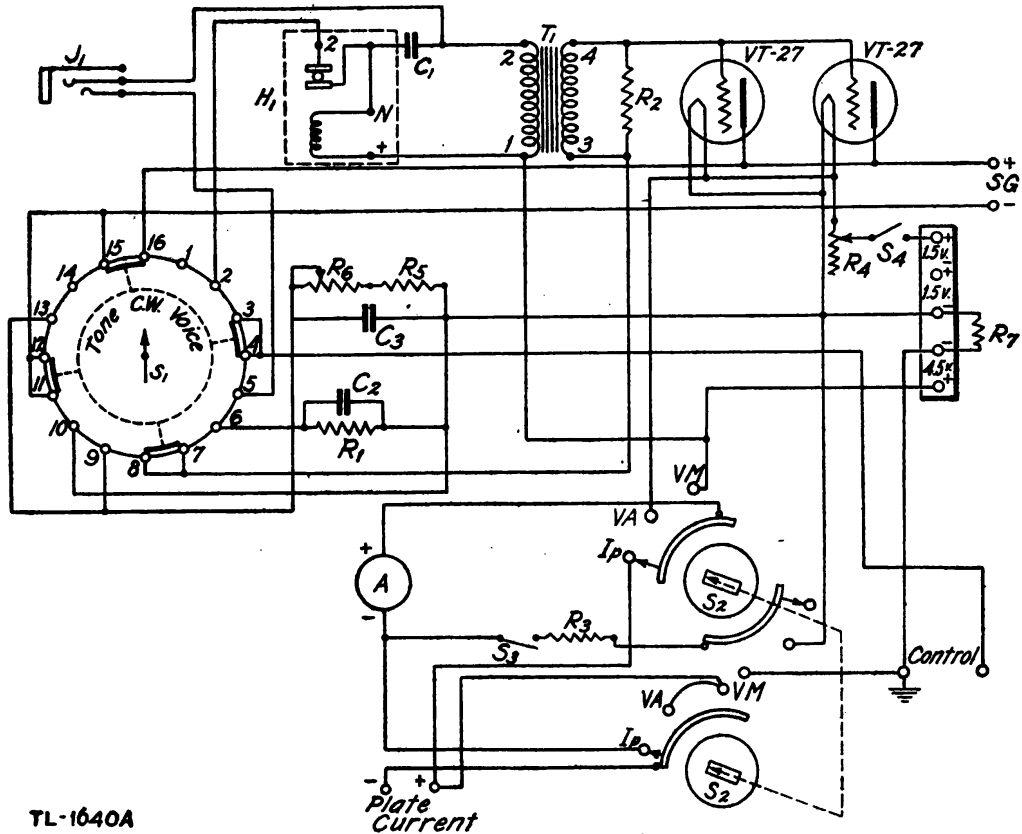

FIGURE 21.—Radio modulators BC-188 and BC-188-A, top view.

detector by transformer T_2 . The detector is coupled to the first audio-frequency stage by resistors R_8 , R_9 , and capacitor C_5 . Transformer T_3 and potentiometer R_3 couple the first and second audio-frequency stages. The output of the second audio-frequency stage is transferred by transformer T_4 and the jacks to the headsets.

b. Power is supplied by three sets of batteries located in the box BX-4, and connected by means of the cord to the receiver. All battery circuits are closed by switch S_1 . Filament voltage for all tubes is controlled by rheostat R_1 . The third winding in T_2 serves



TL-1640A

FIGURE 22.—Radio modulator BC-188-A, circuit diagram.

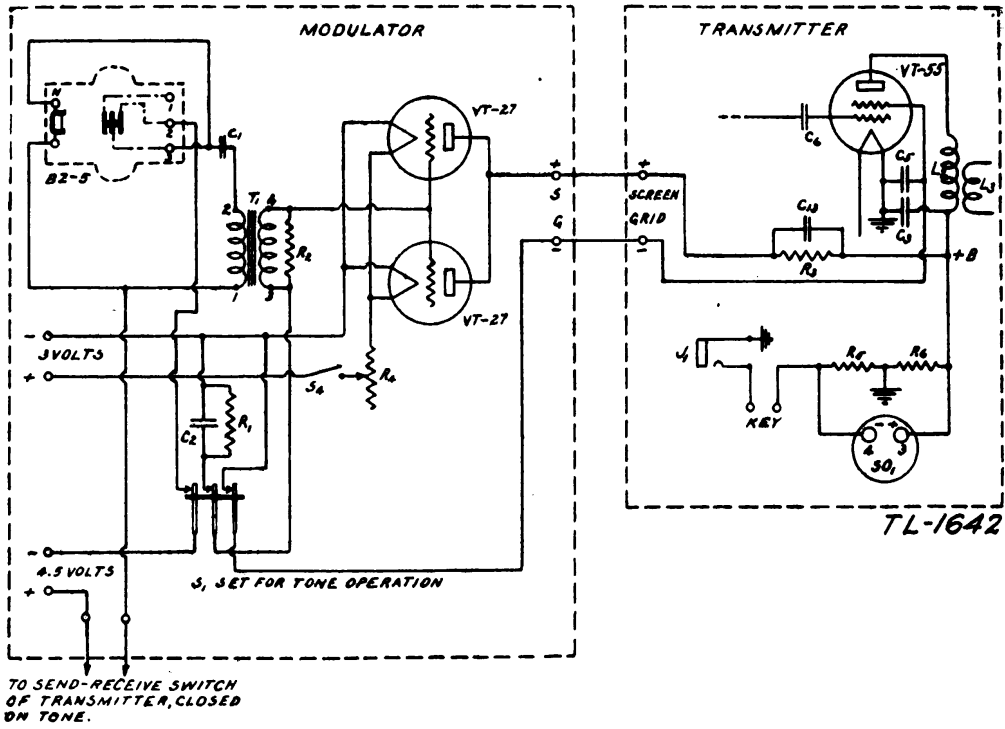
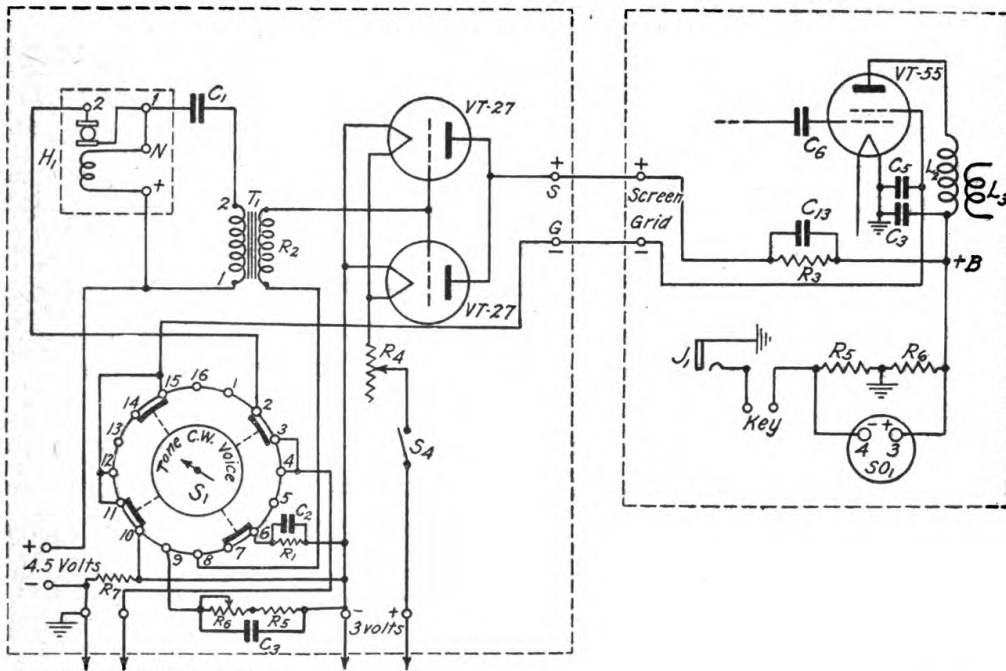

FIGURE 23.—Radio sets SCR-178 and SCR-179 (using BC-187 and BC-188), functional diagram, tone operation.



To send-receive switch or transmitter, closed on tone.

TL-1642A

FIGURE 24.—Radio sets SCR-178 and SCR-179 (using BC-187-A and BC-188-A), functional diagram, tone operation.

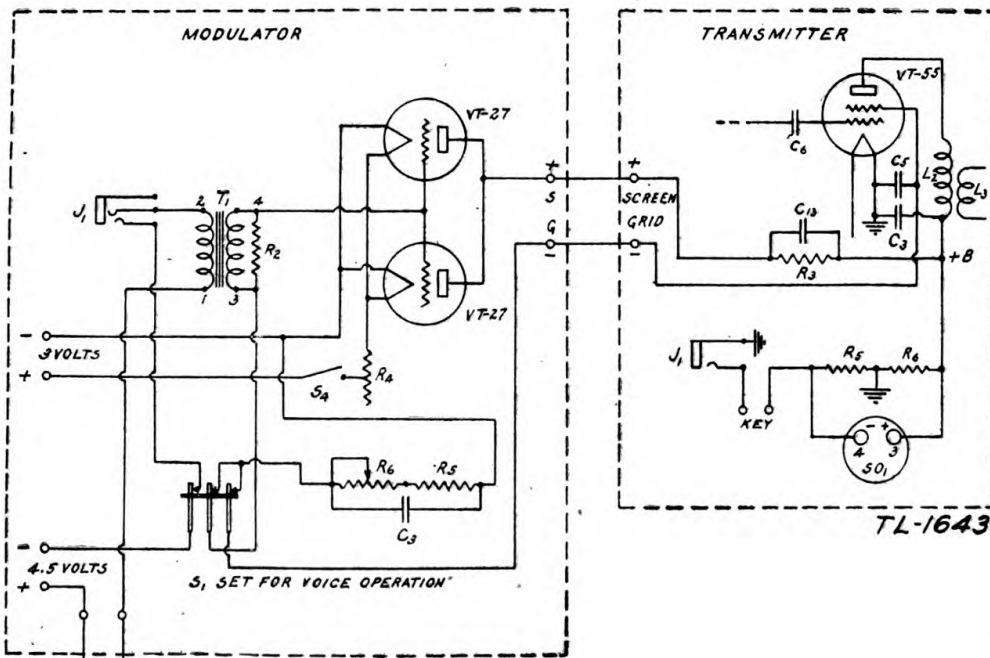

TO SEND-RECEIVE SWITCH OF TRANSMITTER, CLOSED ON VOICE.

TL-1643

FIGURE 25.—Radio sets SCR-178 and SCR-179 (using BC-187 and BC-188), functional diagram, voice operation.

to transfer a part of the detector output to its input, thus providing regeneration. R_4 , R_5 , R_6 , R_7 form a potentiometer resistance network acting to reduce and to regulate the voltage on the screen grid of the detector. This voltage variation serves to control the regeneration.

c. The input circuits of the radio-frequency and detector stages are tuned jointly by the two-section capacitor C_1 . Potentiometer R_3 acts as an audio-frequency load impedance of the first audio-frequency stage and to permit variation of the voltage impressed on the grid of the second audio-frequency stage. This voltage variation serves to control the volume.

d. Switch S_2 , when closed, short-circuits the primary of the transformer T_1 and thus prevents blocking the receiver by radiation from the adjacent transmitter. C_2 and C_3 are trimming capacitors in the

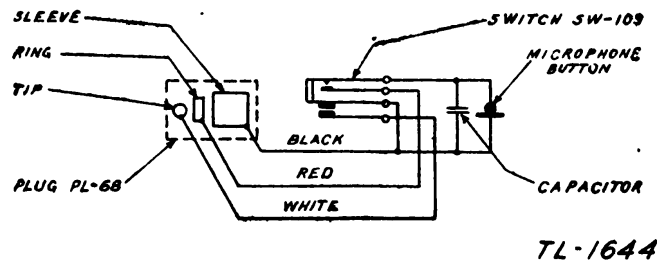

FIGURE 26.—Microphone T-17, circuit diagram.

input circuits of the radio-frequency amplifier and detector stages. C_4 is a grid coupling capacitor, and R_2 is a grid leak. C_6 , C_7 , C_9 , and C_{10} are bypass capacitors. C_8 is a three-section bypass capacitor.

e. The normal output impedance of this receiver is 8,000 ohms. If speakers or headsets with an impedance of 400 ohms are to be used, the connection to tap number 5 on transformer T_4 should be changed to tap number 4. This change requires the use of a soldering iron.

17. Generator GN-37 (fig. 30).—The generator is shunt wound, and the armature has two windings to provide both filament and plate power for transmitting. The voltage, both for filaments and plates, is automatically controlled by the regulator in the generator. The field exciting current is supplied from the low voltage windings through the voltage regulator, which functions as follows: When the voltage output is low, current is furnished the field on the following path: positive brush (+) to screw A, then to screw C through the field to the negative brush (-), which is grounded. Current can also flow from A to terminal 2 on the regulator resistance through 23 ohms, through the regulator relay windings to B, to ground. As the

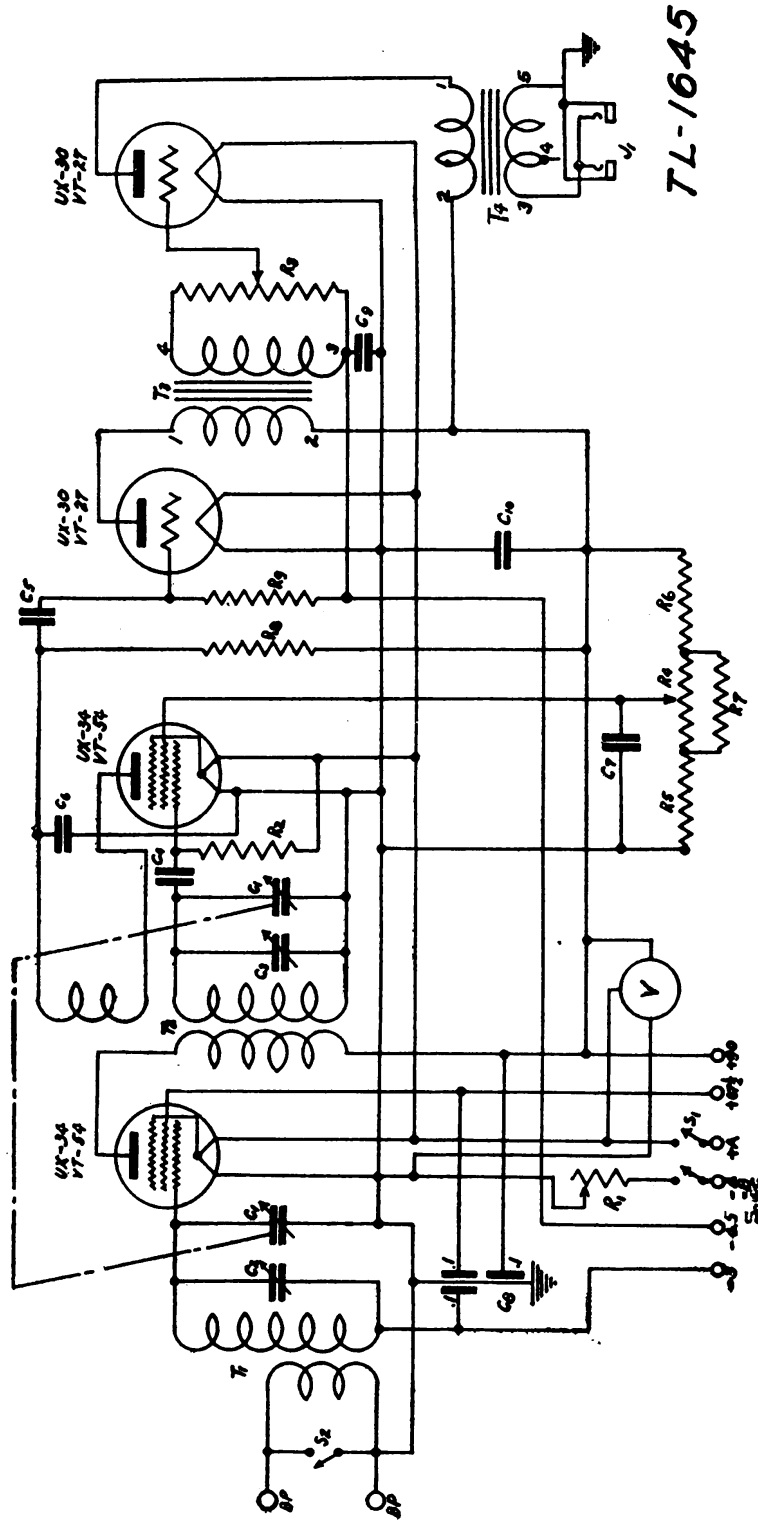

FIGURE 27.—Radio receiver BC-186, circuit diagram.

voltage increases due to the excitation of the field, the amount of current flowing through the regulator relay windings actuates the relay and causes the armature to move toward B. In the intermediate position, current for the field must flow from the positive brush (+) to A, to terminal 2 on the resistance through 20 ohms to C, to the field, thence to ground. However, the field current is being limited due to the 20-ohm resistor in series; therefore the voltage generated is increasing at a lower rate. When the armature reaches

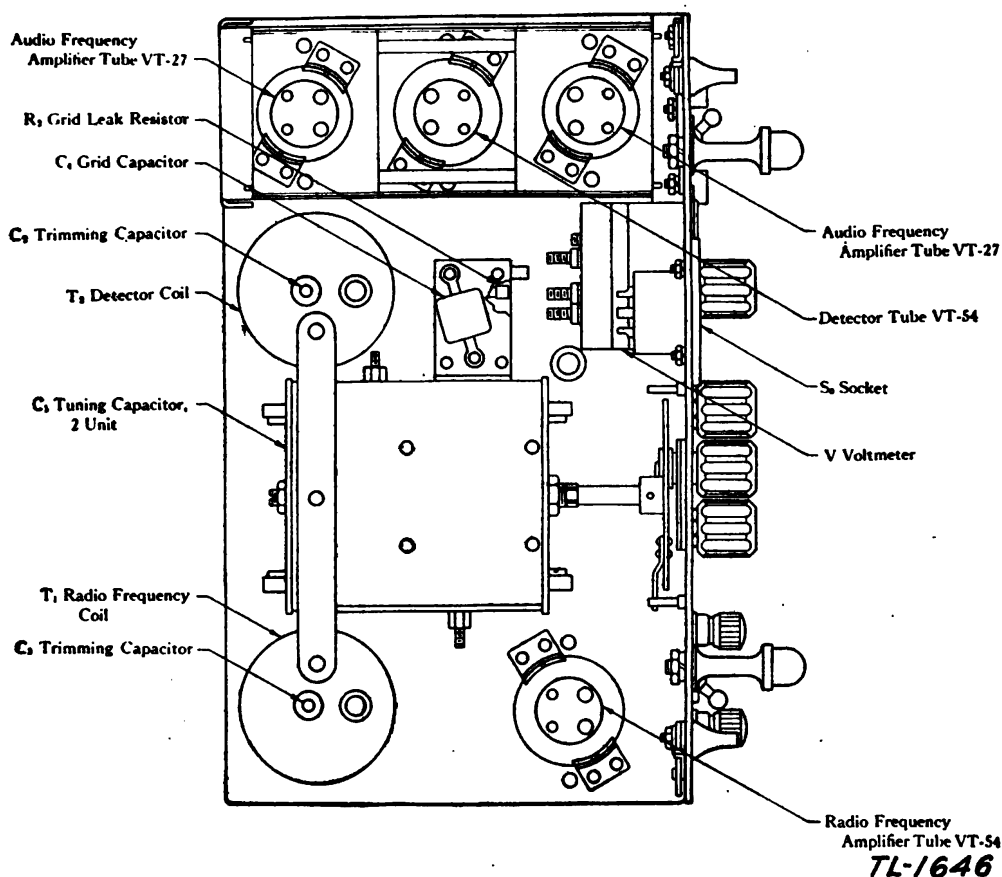

FIGURE 28.—Radio receiver BC-186, top view.

screw B and makes contact thereto, the field is short-circuited by being grounded at both ends; therefore the excitation is decreased, and consequently the generated voltage is decreased. Sufficient current is not available to actuate the regulator relay, hence the armature springs back against screw A. The cycle then is repeated, and the operation of the relay regulates the generated voltages steadily enough for the use intended. The rating of the generator is 8 volts, 3.25 amperes, and 500 volts, 0.1 ampere. The crankshaft is geared to

the high inertia armature so as to increase the speed of the armature in the ratio of 35 to 1.

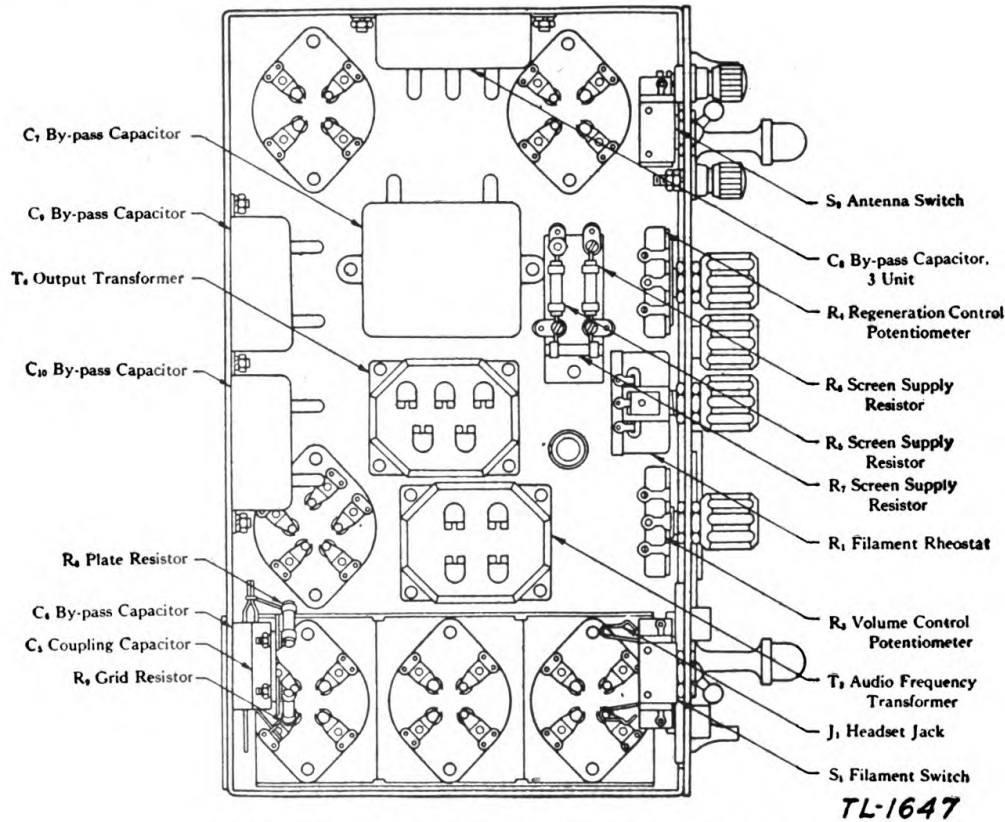

FIGURE 29.—Radio receiver BC-186, bottom view.

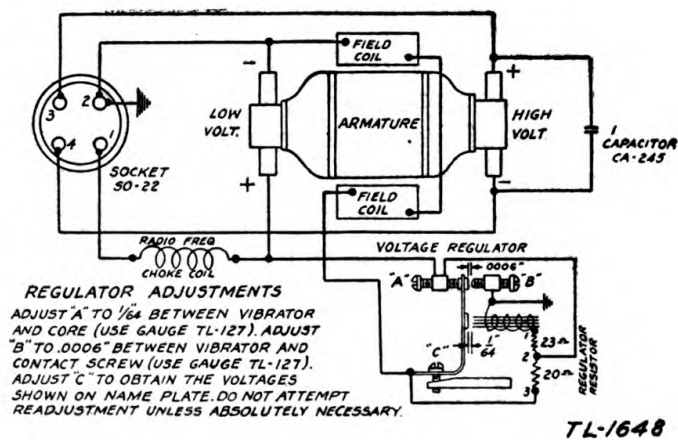

FIGURE 30.—Generator GN-37, circuit diagram.

SECTION IV

SERVICING, REPAIR, AND STORAGE

	Paragraph
Servicing.....	18
Generator GN-37.....	19
Repairs.....	20
Tests.....	21
Alinement.....	22
Storage.....	23
Troubles.....	24

18. Servicing.—The component units of the set should be inspected and cleaned periodically to determine that they are mechanically and electrically in good operating condition. Tubes should be tested with a test set or by interchanging with tubes known to be satisfactory. Use batteries the voltage of which is at least 80 percent of the rated voltage as indicated by a reliable voltmeter. Batteries indicating lower voltages decrease the operating efficiency considerably and are likely to be noisy. Check all connections regularly as loose and broken leads are the source of most operating troubles. For location of circuit elements see figures 16, 17, 19, 21, 28, and 29.

19. Generator GN-37.—The generator is so constructed as to require a minimum of care. At regular intervals the bearings and gears should be examined and thoroughly cleaned with gasoline. A small quantity of petrolatum should be applied to both bearings and gears.

Caution: Do not pack the bearings. This type of bearing requires very little lubrication, the principal purpose of the petrolatum being to protect the bearing against rust and corrosion. All bearings and the gears on one side of the generator case are accessible by removing the gear case secured with five machine screws. The bearings on the opposite side of the generator case are accessible by removing the two small plates each secured with two machine screws.

a. The leg support links on the generator GN-37 are fastened to mounting plates by means of aluminum rivets. Experience in the field has disclosed the fact that these aluminum rivets pull out as a result of the strain incident to use. The following item may be used to overcome this difficulty:

Signal Corps General Catalog Stock No. 3H2337/37:

Plate assemblies, leg mounting; plates, items 1 to 8, and rivets, dwg. SC-D-1737C, assembled and painted. (Replacement for unsatisfactory parts of generator GN-37 on orders Nos. 9484-NY-34 and 10311-NY-35.)

b. When generator GN-37 becomes unserviceable because of the unserviceability of a leg support assembly, requisitions should be submitted for the replacement assembly as described above.

c. The gage TL-127 is provided with the generator in order to measure the regulator clearances for proper adjustment. Such adjustment should be made only when absolutely necessary and then only by qualified depot repair personnel in the following manner (fig. 30): Loosen both small locking screws which lock screws A and B. Back off screw B so that the $\frac{1}{64}$ -inch end of the gage may be inserted between the core and the vibrator. Screw up on screw A until the vibrator to core clearance is adjusted to $\frac{1}{64}$ inch. Leave screw A in place and insert the 0.0006-inch end of the gage between the armature contact and screw B; then screw up B for an easy slip fit. Lock screws A and B with their respective locking screws and then proceed to adjust the voltages by screw C so as to obtain 8 to 8.25 volts and 485 to 515 volts while furnishing power to the set. Turning screw C clockwise raises the generated voltages.

20. Repairs.—Repairs other than those of a very minor nature should not be attempted except at authorized Signal Corps repair shops. If minor repairs are to be made, remove all sources of voltage and all vacuum tubes. Use tools that are in good working order and serviceable. Use a nonacid flux in soldering. Remove the meter first if any hammering is to be done. Meter jewels fracture easily.

21. Tests.—Test all circuits for continuity. See that capacitors are not short-circuited or leaky. Measure resistors for short circuits if suspected. Check all switch circuits to see that contacts are in good working order. Check the calibration of the meters by comparison with a meter of reliable accuracy. Ordinarily, inaccuracies greater than 5 percent indicate that the meter should be shipped to the depot for repair or replacement.

22. Alinement.—The radio-frequency circuits of the receiver may be "lined up" when necessary by utilizing any radio-frequency signal as the input to the receiver. The regeneration control is set at its optimum point (according to receiver signal), and the trimmer capacitor C_3 , which is mounted inside the radio-frequency coil shield, adjusted by turning the screw at the top of coil T_1 (C-135) to give maximum signal output at minimum capacitance (highest frequency) setting of the capacitors. As adjustment of the detector trimmer capacitor C_2 at the top of coil T_2 (C-134) will react on the calibration, it should not be adjusted unless a signal the frequency of which is accurately known is available for calibration. Adjust-

ments should be made with the input to the receiver connected to its normal antenna through the shielded cables provided in chest CH-38.

Caution: Incorrect alinement results in poor receiver performance. The alinement operation should not be undertaken without the use of proper equipment and only by competently trained personnel. A screw driver of bakelite or other nonmetallic material must be used. The use of a metallic tool will result in incorrect alinement at the higher frequencies and is also likely to cause a short circuit of the high voltage supply.

23. Storage.—If the equipment is to be stored for a period of several months, a location that is dry and cool is preferable. Remove all batteries. Keep the accumulation of dirt down to a minimum. The ends of the mast sections may be covered freely with grease or vaseline and wrapped with a heavy grade of wax paper. Do not put anything on the units of the equipment itself but wrap them with a heavy grade of manila paper and seal.

24. Troubles.—If the set does not operate or function satisfactorily, remove all sources of voltage and check each cause as listed below. Follow each possibility until that cause is definitely eliminated, then check the next. Always examine the simple causes of failure first. Apparatus is sometimes damaged by internal alterations when the service failure was really due to a defective cord, plug, power supply, or tube. Radio set SCR-178 is a complex piece of apparatus. Successful operation depends upon accurate adjustment. Changes are to be made only when absolutely necessary and only after all outside causes of trouble have been eliminated definitely.

a. Transmitter.

<i>Trouble</i>	<i>Cause</i>
(1) No filament voltage.	(1) (a) Open power lead. (b) No generator output. 1. Open field. 2. Brushes loose. 3. Voltage regulator out of adjustment. (c) Damaged bypass capacitor. (d) Poor plug contact.
(2) No plate voltage.	(2) (a) No generator output. 1. Open field. 2. Brushes loose. 3. Voltage regulator out of adjustment.

<i>Trouble</i>	<i>Cause</i>
	(b) Poor plug contact.
	(c) Open cable.
	(d) Damaged bypass capacitor.
(3) No radio-frequency output with all voltages properly indicated.	(3) (a) Poor tubes.
	(b) Insulation failure on radio-frequency coils, leads, or switches.
	(c) Damaged bypass capacitors.
	(d) Damaged meter.
	(e) Defective key circuit.
	(f) Poor contact through plate current cord.
(4) No voice modulation or tone telegraph.	(4) (a) Damaged microphone or open microphone cord.
	(b) No contact or open microphone cord.
	(c) Open microphone transformer.
	(d) Poor modulator tubes.
	(e) Open, short, or ground in audio circuit.
	(f) Damaged buzzer.
	(g) Improper input voltages.
	(h) Poor switch contacts.
	(i) Corrosion on microphone plug.

b. Receiver.—(1) *Noisy reception.*—Probably the most common cause of poor radio reception in all installations of high sensitivity receivers is electrical noise of both local and atmospheric origin. Operators should learn by experience to identify those noises which indicate faults in the apparatus or installation. Such identification by ear will greatly facilitate the correction of the fault. The following tabulation may be used as a guide:

(a) Disturbances which do not originate in electrical equipment but which are produced by the natural elements cannot be eliminated, but may in some instances be reduced with any given installation. The signal level must be sufficiently above the static level for operation.

(b) Disturbances which are traceable to electrical equipment may be reduced or eliminated entirely by correcting the conditions causing them.

(c) If the static level is too high to do any testing of the receiver with antenna and counterpoise connected, they may be disconnected and the terminals connected to each other through a 100-microfarad capacitor. This will eliminate the greater part of the outside interference and permit analysis of the receiver by itself.

(d) Regular crackles and hums may be due to electrical machinery of any description, to thermostatic devices and flashers, to vacuum tubes, to leaky or defective capacitors, and to defective wiring in the radio receiver or in the power supply.

(e) Irregular crackles or hums may generally be traced to power lines which are grounded or broken down, or to leaky capacitors in the radio receiver or in the power supply. In the case of seasonal electrical storms, such noises may be due to an electrical discharge across lightning arresters. Noises caused by loose connections can be located by moving the suspected member, thus aggravating the condition and definitely indicating the defect.

(f) Whistles and squeals, either regular or irregular, are generally due to the heterodyning of the carrier waves of two or more stations which are operating on nearly the same frequency, or to a radio receiver which is being carelessly operated at the oscillating or regenerating point. These can also be traced to oscillation of the receiver in which the interference is noted.

(g) Clicks, either regular or irregular, may usually be traced to telephone dialing systems or to the operation of switches in or near the region of the radio receiver, and also to the keying of radio transmitters in the vicinity.

(h) No signals or intermittent poor reception may be caused by accidental contact of the connection from the antenna to the set with a grounded fixture or contact between connections in the set; mechanical defects in capacitors, coils, or resistors causing open or short circuits; or defective tubes.

(2) *Poor location.*—If a set has been newly installed, the vicinity should be analyzed for shielding in the form of metal construction located either within or outside of buildings. Tall stacks, masts, bridges, and even ground obstructions such as elevations and hills may act to cut off or reduce the radiation from the transmitting antenna. The latter effect is particularly apparent in communication using the higher frequencies.

c. Generator.—Generator noise may be identified by substituting another power source, preferably battery power, which is known to be noiseless. Noise may be caused by several factors. See that all connections are tight. Determine that the commutator is bright and smooth and the insulation intact. It should run with full load at rated speed without sparking. The commutator should be cleaned with a fine grade (No. 000 or finer) of sandpaper by holding the sandpaper against the copper segments while the machine is turning over, taking care to clean the entire surface until it is smooth. A cloth saturated with carbon tetrachloride should be used to wipe off any oil or grease. Under no circumstances should emery or oil be used. If the regulator is suspected, it may be disconnected and the open field coil lead connected to the choke terminal which is connected to the positive brush of the low voltage side. If the choke coil or capacitor is suspected, it should be disconnected and tested.

SECTION V

SUPPLEMENTAL DATA AND PARTS LIST

	Paragraph
Operating voltages and currents of vacuum tubes.....	25
Circuit elements, transmitter.....	26
Circuit elements, modulator.....	27
Circuit elements, radio receiver BC-186.....	28
Parts list for radio sets SCR-178 and SCR-179.....	29

25. Operating voltages and currents of vacuum tubes.—*a.* Radio transmitter BC-187 utilizes the two tubes listed below:

Type	Use	Voltage		
		Fila- ment	Plate	Screen grid
1 VT-25 (RMA '10).....	Master oscillator.....	7.5	450	-----
1 VT-55 (RMA '65).....	Power amplifier.....	7.5	500	125

b. Radio modulator BC-188 utilizes two VT-27 (RMA '30) tubes in parallel.

c. Radio receiver BC-186 utilizes the four tubes listed below:

Type	Use	Voltage			
		Fila- ment	Plate	Bias	Screen grid
1 VT-54 (RMA '34)-----	R-f stage-----	2	90	-3.0	67
1 VT-54 (RMA '34)-----	Detector-----	2	90	-----	-----
1 VT-27 (RMA '30)-----	First audio stage-----	2	90	-4.5	-----
1 VT-27 (RMA '30)-----	Second audio stage--	2	90	-4.5	-----

The total filament current drain is 0.25 ampere; the total plate current drain is 7 milliamperes.

26. Circuit elements, transmitter (figs. 15 to 19, incl., 23, 24, and 25).

Code	Name	BC-187	BC-187-A	Description
A	Ammeter-----	IS-84	IS-84	Antenna.
C ₁	Capacitor-----	CA-206	CA-206	Grid blocking, 0.0001 μ f.
C ₂	do-----	CA-208	CA-208	Bypass, 0.01 μ f.
C ₃	do-----	CA-208	CA-208	Bypass, 0.01 μ f.
C ₄	do-----	CA-227	CA-227	Master oscillator, tank, 175 μ f max.
C ₅	do-----	CA-176	CA-176	Bypass, 0.005 μ f.
C ₆	do-----	CA-207	CA-334	Grid coupling, 0.00025 μ f.
C ₇	do-----	CA-228	CA-260	Master oscillator, tuning; 385 and 395 μ f max., respectively.
C ₈	do-----	CA-229	CA-229	Antenna tuning, 285 μ f max.
C ₉	do-----	CA-183	CA-183	Bypass, 0.01 μ f.
C ₁₀	do-----	CA-183	CA-183	Bypass, 0.01 μ f.
C ₁₁	do-----	CA-183	CA-183	Bypass, 0.01 μ f.
C ₁₂	do-----	CA-230	CA-363	Trimmer; 10-70 and 6-75 μ f, respectively.
C ₁₃	do-----	CA-245	CA-245	Bypass, 1 μ f.
L ₁	Coil-----	-----	-----	Master oscillator, tank inductance.
L ₂	do-----	-----	-----	Power amplifier, tank inductance.
L ₃	do-----	-----	-----	Antenna coupling.
L ₄	do-----	-----	-----	Antenna loading.
R ₁	Resistor-----	RS-137	RS-137	Grid leak, 25,000 ohms.
R ₂	do-----	RS-137	RS-137	Grid leak, 25,000 ohms.
R ₃	do-----	RS-137	RS-137	Screen grid, 25,000 ohms.
R ₄	do-----	RS-138	RS-138	Master oscillator plate, 3,000 ohms.
R ₅	do-----	RS-136	RS-234	Keying; 25,000 and 15,000 ohms respectively.

Code	Name	BC-187	BC-187-A	Description
R ₆	Resistor	RS-88	RS-88	250,000 ohms.
S ₁	Switch	SW-112	SW-112	Antenna, send-receive.
SO ₁	Socket	SO-22	SO-22	Power.
J ₁	Jack	JK-24	JK-24	Plate current.

27. Circuit elements, modulator (figs. 20 to 25, incl.).

Code	Name	BC-188	BC-188-A	Description
A	Ammeter	IS-118	IS-118	Plate current.
C ₁	Capacitor	CA-209	CA-209	1.9 μ f.
C ₂	do	CA-177-A	CA-177-A	.5 μ f.
C ₃	do	CA-177-A	CA-177-A	.5 μ f.
H ₁	Interrupter	BZ-5	BZ-7-()	Audio tone.
J ₁	Jack	JK-23	JK-23	Microphone.
R ₁	Resistor	RS-88	RS-88	250,000 ohms.
R ₂	do	RS-88	RS-88	250,000 ohms.
R ₃	do	RS-145	RS-145	90 ohms.
R ₄	Rheostat	RS-106	RS-106	10 ohms.
R ₅	Resistor	RS-146	RS-235	4,000 and 3,000 ohms, respectively.
R ₆	Potentiometer	RS-147	RS-229	3,000 and 5,000 ohms, respectively.
R ₇	Resistor	-----	RS-230	25,000 ohms.
S ₁	Switch	SW-117	SW-117	Tone-c.w.-voice.
S ₂	do	SW-114	SW-140	Meter.
S ₃	do	SW-115	SW-115	Push-button, meter.
S ₄	do	SW-105	SW-105	Filament.
T ₁	Transformer	C-107	C-107	Microphone.

28. Circuit elements, radio receiver BC-186 (figs. 27, 28, and 29).

Code	Name	Description
C ₁	Capacitor CA-233	Tuning, 2-unit, 138 μ μ f max. each unit.
C ₂	Capacitor CA-151 ¹	Trimming, 80 μ μ f max.
C ₃	Capacitor CA-150 ¹	Trimming, 35 μ μ f max.
C ₄	Capacitor CA-218	Grid, 150 μ μ f.
C ₅	Capacitor CA-197	Coupling, 0.01 μ f.
C ₆	Capacitor CA-175 ²	Bypass, 0.002 μ f.

¹ This is capacitor CA-253, trimming, 75 μ μ f max. on sets procured on order No. 16081-NY-38.

² This is capacitor CA-153, bypass, 250 μ μ f on sets procured on order No. 16081-NY-38.

Code	Name	Description
C ₇	Capacitor CA-234	Bypass, 1 μf .
C ₈	Capacitor CA-184	Bypass, 3-unit, 0.1 μf each.
C ₉	Capacitor CA-243	Bypass, 0.5 μf .
C ₁₀	Capacitor CA-243	Bypass, 0.5 μf .
T ₁	Coil C-135	First radio frequency.
T ₂	Coil C-134	Detector.
T ₃	Transformer C-65	Audio frequency.
T ₄	Transformer C-124	Output.
S ₁	Switch SW-116	Filament.
S ₂	Switch SW-105	Antenna.
SO	Socket SO-34	
R ₁	Rheostat RS-106	
R ₂	Resistor RS-142	Grid leak, 2 megohms.
R ₃	Potentiometer RS-144	Volume control, 500,000 ohms.
R ₄	Potentiometer RS-107	Regeneration control, 100,000 ohms.
R ₅	Resistor RS-129	10,000 ohms.
R ₆	Resistor RS-148	200,000 ohms.
R ₇	Resistor RS-149	40,000 ohms.
R ₈	Resistor RS-150	100,000 ohms.
R ₉	Resistor RS-134	1 megohm.
J ₁	Jack JK-30	Head set.
BP	Binding post TM-152	
V	Voltmeter IS-117	

29. Parts list for radio sets SCR-178 and SCR-179.

178	179	Article	Weight of each in pounds
1	1	Axe TL-135	4.0
8	8	Battery BA-2; 4 in use, 4 spare	1.2
8	8	Battery BA-23; 4 in use, 4 spare	2.5
4	4	Battery BA-27; 2 in use, 2 spare	1.0
1	1	Box BX-4 (8 $\frac{1}{8}$ w \times 6 $\frac{1}{8}$ h \times 7 $\frac{1}{8}$ d)	1.8
---	1	Chest CH-28	39.0
---	1	Chest CH-29	40.7
1	---	Chest CH-38	36.5
1	---	Chest CH-39	39.2
1	1	Cord CD-125	1.0
1	1	Cord CD-132	0.1
1	1	Counterpoise CP-12	1.5
1	1	Counterpoise CP-13	1.5
2	2	Crank GC-7	0.8
1	1	Generator GN-37	28.8
1	1	Guy GY-11	0.1
1	1	Guy GY-12	0.1

178	179	Article	Weight of each in pounds
2	2	Headset P-18.....	1.0
1	1	Insulator IN-85.....	1.0
1	1	Key J-44.....	0.4
6	6	Lamps LM-23, 1 in use, 5 spare.....	0.1
1	1	Lamp fixture M-142.....	0.2
1	1	Leg LG-2-A.....	2.8
2	2	Leg LG-3.....	0.8
5	5	Leg LG-8-A, 4 in use, 1 spare.....	0.3
1	1	Mast section MS-49.....	0.1
1	1	Mast section MS-50.....	0.3
1	1	Mast section MS-51.....	0.5
1	1	Mast section MS-52.....	0.6
1	1	Mast section MS-53.....	0.7
1	1	Mast section MS-54.....	0.9
1	1	Mast section MS-55.....	1.1
1	1	Mast section MS-56.....	1.3
2	2	Microphone T-17, 1 in use, 1 spare.....	0.7
1	1	Radio modulator BC-188 or BC-188-A (11 ¹⁵ / ₁₆ w × 4 ¹ / ₁₆ h × 7 ⁵ / ₈ d).....	6.1
1	1	Radio receiver BC-186 (10 ¹³ / ₁₆ w × 7 ¹ / ₈ h × 7 ³ / ₄ d).....	9.2
1	1	Radio transmitter BC-187 or BC-187-A (11 ¹⁵ / ₁₆ w × 8 ⁷ / ₈ h × 7 ¹ / ₁₆ d).....	12.2
1	1	Reel RL-28.....	0.3
1	1	Reel RL-29.....	1.0
1	1	Roll BG-58.....	2.0
4	4	Stake GP-27, 3 in use, 1 spare.....	0.2
4	4	Strap ST-26.....	1.0
1	1	Tool equipment TE-5.....	1.3
2	2	Tube VT-25, 1 in use, 1 spare.....	0.2
8	8	Tube VT-27, 4 in use, 4 spare.....	0.1
4	4	Tube VT-54, 2 in use, 2 spare.....	0.1
2	2	Tube VT-55, 1 in use, 1 spare.....	0.3

[A.G. 062.11 (6-26-41).]

BY ORDER OF THE SECRETARY OF WAR:

G. C. MARSHALL,
Chief of Staff.

OFFICIAL:

E. S. ADAMS,
Major General,
The Adjutant General.

DISTRIBUTION:

D (2); Bn and H 6 (5); IC 11 (10).
(For explanation of symbols see FM 21-6.)