

OPERATING INSTRUCTIONS

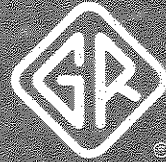

TYPE 1105-B
FREQUENCY MEASURING
EQUIPMENT

1105-B

G E N E R A L R A D I O C O M P A N Y

OPERATING INSTRUCTIONS

TYPE 1105-B
FREQUENCY MEASURING
EQUIPMENT

1105-0100-G
February, 1962

GENERAL RADIO COMPANY
WEST CONCORD, MASSACHUSETTS, USA

SPECIFICATIONS

- ACCURACY:** The accuracy of measurement that can be realized is ± 0.1 cycle in the difference between unknown and standard frequencies. Resolution varies with the frequency being measured, ranging from 2 parts in 10^5 at low frequencies to 1 part in 10^8 at high frequencies.
- POWER SUPPLY:** 105 to 125 (or 210 to 250) volts, 50 - 60 cycles. Power input receptacle will accept either 2-wire (Type CAP-35) or 3-wire (Type CAP-15) power cord. Two-wire cord is supplied. Power consumption is 200 watts.
- ACCESSORIES SUPPLIED:** Spare fuses, blank panels, connecting cables, including power cords.
- MOUNTING:** The complete assembly, except for the Type 1107-A Interpolation Oscillator, mounts in a standard 19-inch Type 480-MA Cabinet Rack. This rack includes service outlets for each instrument. The interpolation oscillator mounts in the frequency standard rack, as shown in Figure 1.
- DIMENSIONS:** Height 76-1/8 in., width 22 in., depth 20-1/2 in. (195 by 55 by 50 mm), over-all. Total rack space is 40 rack units, or 70 in. (180 mm).
- WEIGHT:** 375 lb (170 kg), including rack.

U. S. Patent No. 2,548,457

TABLE OF CONTENTS

| | |
|---|----|
| INTRODUCTION | 1 |
| PART I DESCRIPTION OF COMPONENT INSTRUMENTS | 1 |
| TYPE 1108 COUPLING PANEL. | 1 |
| TYPE 1106 FREQUENCY TRANSFER UNITS | 1 |
| TYPE 1107 INTERPOLATION OSCILLATOR | 1 |
| TYPE 1109 COMPARISON OSCILLOSCOPE. | 2 |
| PART II ASSEMBLY OF INSTRUMENTS | 2 |
| PART III CONNECTIONS | 2 |
| POWER SUPPLY | 2 |
| RADIO-FREQUENCY CONNECTIONS | 4 |
| AUDIO-FREQUENCY CONNECTIONS | 4 |
| PART IV METHODS OF MAKING FREQUENCY MEASUREMENTS. | 5 |
| AUDIO FREQUENCIES 0 TO 5 KC. | 5 |
| FREQUENCIES FROM 5 TO 100 KC | 5 |
| FREQUENCIES FROM 100 KC TO 10 MC OR MORE. | 6 |
| FREQUENCIES 10 MC TO 100 MC. | 6 |
| FREQUENCIES ABOVE 100 MC | 6 |
| PART V TYPE 1108 COUPLING PANEL | 6 |
| FREQUENCY MEASUREMENT. | 6 |
| WIRING DIAGRAM FOR TYPE 1108-B COUPLING PANEL | 8 |
| MICRODIAL | 9 |
| PART VI MAKING FREQUENCY MEASUREMENTS - STEPS REQUIRED | 9 |
| PART VII MAKING FREQUENCY MEASUREMENTS: PROCEDURE | 10 |
| PART VIII TYPE 1109 COMPARISON OSCILLOSCOPE | 15 |
| WIRING DIAGRAM FOR TYPE 1109-B COMPARISON OSCILLOSCOPE | 17 |
| APPLICATIONS. | 20 |
| TYPE 1106 FREQUENCY TRANSFER UNITS. | 21 |
| SECTION 1 DESCRIPTION. | 21 |
| SECTION 2 INSTALLATION | 21 |
| SECTION 3 OPERATION | 23 |
| TYPE 1107 INTERPOLATION OSCILLATOR. | 25 |
| SECTION 1 DESCRIPTION. | 25 |
| SECTION 2 INSTALLATION | 27 |
| SECTION 3 OPERATION | 27 |
| SECTION 4 MAINTENANCE | 28 |
| WIRING DIAGRAM FOR TYPE 1107-A INTERPOLATION OSCILLATOR | |
| WIRING DIAGRAM FOR TYPE 1106-A FREQUENCY TRANSFER UNIT | |
| WIRING DIAGRAM FOR TYPE 1106-B FREQUENCY TRANSFER UNIT | |
| WIRING DIAGRAM FOR TYPE 1106-C FREQUENCY TRANSFER UNIT | |

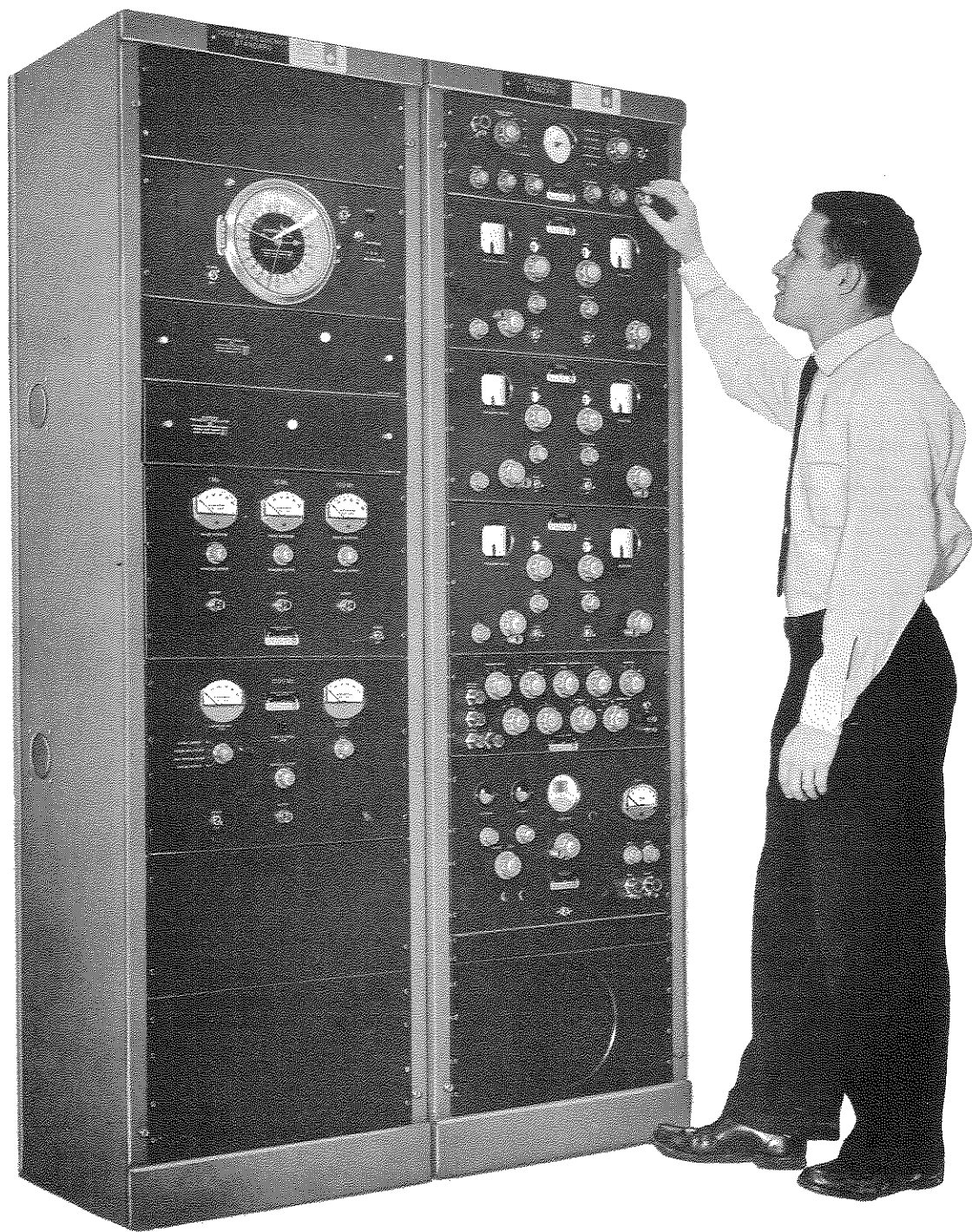

Figure 1. Type 1105-B Frequency Measuring Equipment (right) with Type 1120-AH Primary Frequency Standard.

Left, top to bottom: Type 1103-B Synchronometer, Type 1114-A Frequency Divider, , Type 1113-A Standard-Frequency Oscillator, Type 1112-A Standard-Frequency Multiplier, Type 1112-B 1000-Mc Standard-Frequency Multiplier.

Right, top to bottom: Type 1109-B Comparison Oscilloscope, Type 1106-A Frequency Transfer Unit, Type 1106-B Frequency Transfer Unit, Type 1106-C Frequency Transfer Unit, Type 1108-B Coupling Panel, Type 1107-A Interpolation Oscillator.

TYPE 1105-B FREQUENCY MEASURING EQUIPMENT

INTRODUCTION

A General Radio Type 1120-A Primary Frequency Standard supplies a multitude of accurately known standard-frequency reference points distributed at convenient intervals over the audio- and radio-frequency spectrum. The equipment for measuring a frequency lying somewhere between these standard reference points is termed the interpolating or measuring equipment.

The complete assembly of frequency standard and measuring equipment provides means for measuring frequencies throughout the range from very low audio frequencies to 100 Mc or more with an accuracy of one cycle or better up to 10 Mc or more, and one part in a million or better from 10 Mc to 100 Mc or more. The equipment can also be used to produce any frequency desired in the range above 100 kc up to 100 Mc or more with corresponding accuracies. Audio frequencies can be produced in the range up to 5000 cycles per second.

The Type 1105-B Frequency Measuring Equipment consists of the following instruments:

Type 1109 Comparison Oscilloscope
Type 1106 Frequency Transfer Units (Three)
Type 1107 Interpolation Oscillator
Type 1108 Coupling Panel

This book supplies detailed instructions for setting up and making frequency measurements with the above equipment. Every effort has been made to make the equipment meet every measuring problem within its scope and to make the instructions as clear as possible. If questions should arise, the Engineering Department of the General Radio Company will be glad to give any possible assistance.

PART I

DESCRIPTION OF COMPONENT INSTRUMENTS

A brief general description of the individual instruments of the Type 1105 Frequency Measuring Equipment is given in the following paragraphs. Detailed instructions for the Type 1106 Frequency Transfer Units are given on page 21, for the Type 1107 Interpolation Oscillator on page 25, and for the Type 1109 Comparison Oscilloscope on page 15.

TYPE 1108 COUPLING PANEL

This unit is the centralized control panel to which the frequency standard and measuring instruments are connected for all necessary interconnections required in making measurements. These operations are carried out by use of the switches and volume controls provided on the coupling panel. This unit contains 10-kc and 100-kc harmonic generators, which produce harmonics up to 100 Mc.

TYPE 1106 FREQUENCY TRANSFER UNITS

There are three of these units, each consisting of a heterodyne frequency meter and a heterodyne detector, covering frequency ranges of 100 - 2000 kc, 1 - 10 Mc, and 10 - 100 Mc respectively. Both the frequency meter and detector have range switches and direct-reading frequency dials.

The frequency meter is used for accurate identification of harmonic frequencies of the frequency standard; as a substitute source when the frequency being

measured is subjected to static interference, fading or intermittent operation such as keying; as a means of determining the sign of beat frequency differences; as a means of avoiding very low beat frequencies; and as a source of a desired accurately known frequency.

The harmonic outputs of the heterodyne frequency meters are available at concentric shielded jacks on the panel of the Type 1108 Coupling Panel, for use in external equipment.

The heterodyne detector is utilized to pick up and identify the frequency to be measured; to obtain the beat-frequency difference between a frequency being measured and a harmonic of the standard; and as a means of accurately matching two frequencies by the "three-oscillator" method.

TYPE 1107 INTERPOLATION OSCILLATOR

This instrument is used particularly for evaluating the frequency difference between a frequency being measured and a harmonic of the frequency standard. It is a beat-frequency oscillator, having a linear, easily read, scale of 5000 divisions. It covers a frequency range of 0 - 5000 cycles per second. Provision is made, through reversing the direction of frequency variation with dial reading and through the use of a second scale, to obtain results so that no subtraction is required in measuring frequencies.

GENERAL RADIO COMPANY

Provision is made for rapidly checking and correcting the oscillator calibration in terms of the frequency standard so that interpolation can be carried out with the best possible precision.

The output voltmeter can be used as a beat indicator for matching the oscillator frequency with another frequency in cases where the cathode ray oscilloscope is not used.

TYPE 1109 COMPARISON OSCILLOSCOPE

The cathode ray oscilloscope provides a versatile, rapid, and accurate means of comparing frequencies. Through the use of multiple patterns a very large number of known frequencies are obtainable from a given standard frequency. The instrument also safeguards against errors in matching frequencies, since the pattern immediately indicates whether or not the frequency ratio is one-to-one. (It has been found that many persons so lack a sense of pitch that they will "match" frequencies in

ratios of 2:1 or 1:2 by aural methods thinking they have a ratio of 1:1.)

Easily interpreted patterns are obtained through the use of a circular sweep; this gives a symmetrical pattern without overlapping of the "forward" and "return" traces. The frequency being checked causes the spot to be deflected radially, through the use of a special radial deflection electrode. When two frequencies are nearly matched, the pattern slowly rotates; the direction of rotation indicates immediately which is the higher of the two frequencies - the sign of the frequency difference.

The comparison oscilloscope is particularly useful as an audio-frequency standardizing and calibrating device, and is generally so employed in making frequency measurements. Provision is made to use the oscilloscope with a variable frequency circular sweep, which permits the oscilloscope to be used as a frequency measuring device for frequencies up to a few hundred kilocycles.

PART II

ASSEMBLY OF INSTRUMENTS

It is recommended that the equipment be assembled as shown in Figure 1. The measuring equipment may be placed on the other side of the standard, if desired. The position shown is somewhat more convenient. Openings in the cabinets, with removable cover plates, are pro-

vided for the connections which pass between the two racks. Remove the cover plates of the openings required for the desired assembly before placing the cabinet racks together.

PART III

CONNECTIONS

All of the interconnecting cables for the units of the Primary Frequency Standard are supplied with the standard. For connections between the frequency standard and measuring equipment, and between the various units of the measuring equipment, shielded concentric cables are supplied. These are of sufficient length to

serve for either arrangement of the equipment described in Part II.

The following list tabulates the connections to be made. All references to right or left, etc. are as seen from the rear of the assembly. Refer to Figure 2.

POWER SUPPLY

- P-1 Using the short power cords, supplied with the 480-MA Racks, plug a cord into the Type 1109 Comparison Oscillator receptacle, make a round turn, and plug into adjacent receptacle of service strip on left hand side of cabinet. (The service strip is not delineated in Figure 2.)
- P-2 Repeat (P-1) for Type 1106-A Frequency Transfer Unit.
- P-3 Repeat (P-1) for Type 1106-B Frequency Transfer Unit.
- P-4 Repeat (P-1) for Type 1106-C Frequency Transfer Unit.
- P-5 Repeat (P-1) for Type 1108-B Coupling Panel.

- P-6 Repeat (P-1) for Type 1103-B Synchronometer.
- P-7 Repeat (P-1) for Type 1113-A Standard-Frequency Oscillator.
- P-8 Repeat (P-1) for Type 1107-A Interpolation Oscillator.
- P-9 Repeat (P-1) for Type 1112-A Standard-Frequency Multiplier.
- P-10 Repeat (P-1) for Type 1112-B Standard-Frequency Multiplier.
- P-11 Plug cord from Type 1114-A Standard-Frequency Divider into service strip.

TYPE 1105-B FREQUENCY MEASURING EQUIPMENT

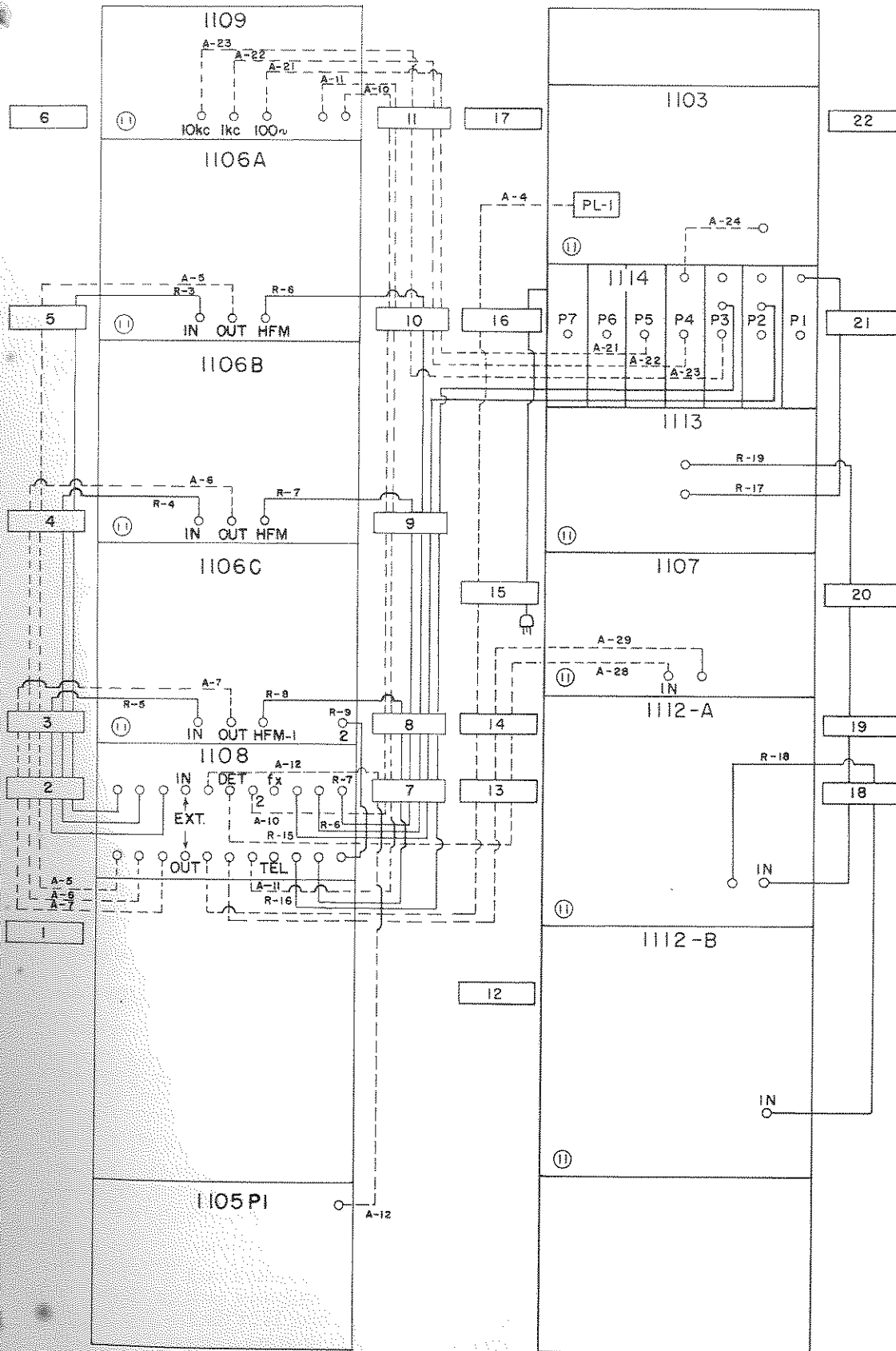

Figure 2. A rear view outline sketch of the complete Type 1120-A Frequency Standard and Type 1105-B Frequency Measuring Equipment showing the location and arrangement of the interconnecting cables.

GENERAL RADIO COMPANY

RADIO-FREQUENCY CONNECTIONS

All connections are made with patch cords of RG-58-U radio-frequency cable.

| Length (In in.) | Run | Length (In in.) | Run |
|--------------------|--|--------------------|---|
| 47 | R-3 | | rings 8, 7, to HFM-H-1 (High Frequency) jack on 1108 Coupling Panel. |
| | From DET INPUT jack on 1106-A Frequency Transfer Unit, through rings 5, 4, 3, 2, to DET INPUT-L (Low Frequency) jack on 1108 Coupling Panel. | 12 | R-9 |
| 36 | R-4 | | From HFM OUT-2 jack on 1106-C Frequency Transfer Unit (right hand jack), to HFM-H-2 (High Frequency-2) jack on 1108 Coupling Panel. |
| | From DET INPUT jack on 1106-B Frequency Transfer Unit, through rings 4, 3, 2, to DET INPUT-M (Medium Frequency) jack on 1108 Coupling Panel. | 65 | R-15 |
| 28 | R-5 | | From 100-kc OUT ^u jack on Type 1114-P2 Frequency Divider through upper rack opening, rings 9, 8, and 7, to STD 100 kc jack on 1108 Coupling Panel. |
| | From DET INPUT jack on 1106-C Frequency Transfer Unit, through rings 3, 2, to DET INPUT-H (High Frequency) jack on 1108 Coupling Panel. | 65 | R-16 |
| 47 | R-6 | | From right-hand 10-kc OUT ^u jack on 1114-P3, through upper rack opening, rings 9, 8, and 7, to STD 10 kc jack on 1108 Coupling Panel. |
| | From HFM OUT jack on 1106-A Frequency Transfer Unit, through rings 10, 9, 8, 7, to HFM-L (Low Frequency) jack on 1108 Coupling Panel. | 28 | R-17 |
| 36 | R-7 | | From Type 1113-A 5Mc OUT jack, through ring 21, to Type 1114-P1 5Mc IN jack. |
| | From HFM OUT jack on 1106-B Frequency Transfer Unit, through rings 9, 8, 7, to HFM-M (Medium Frequency) jack on 1108 Coupling Panel. | 28 | R-18 |
| 28 | R-8 | | From Type 1112-A 100Mc OUT jack, through ring 18, to Type 1112-B 100Mc IN jack. |
| | From HFM OUT-1 jack on 1106-C Frequency Transfer Unit (center group of jacks), through | 28 | R-19 |
| | | | From Type 1112-A STD IN jack, through rings 18, 19, and 20, to Type 1113-A 5Mc OUT to 1112-A jack. |

AUDIO-FREQUENCY CONNECTIONS

| Length (In in.) | Run | Length (In in.) | Run |
|--------------------|---|--------------------|---|
| 74 | A-4 | | 9, 8, 7, to DET OUT-2 jack on 1108 Coupling Panel. |
| | From PL-1 on Type 1103 Synchronometer through rings 16, 15, 14, 13, through the lower rack opening, to MICRODIAL jack on 1108 Coupling Panel. | 55 | A-11 |
| 47 | A-5 | | From INTERP OUT jack of the 1109 Comparison Oscilloscope, through rings 11, 10, 9, 8, 7, to INTERP OUT-2 jack on 1108 Coupling Panel. |
| | From the DET OUT jack of the 1106-A Frequency Transfer Unit, through rings 5, 4, 3, 2, to DET OUTPUT-L (Low Frequency) jack on 1108 Coupling Panel. | 36 | A-12 |
| 36 | A-6 | | From SPKR jack on 1108 Coupling Panel, through ring 7 to jack on the 1105-P1 Loudspeaker Panel. |
| | From the DET OUT jack of the 1106-B Frequency Transfer Unit, through rings 4, 3, 2, to DET OUTPUT-M (Medium Frequency) jack on 1108 Coupling Panel. | 55 | A-21 |
| 28 | A-7 | | From the 100-cycle output jack on the 1114-P5 Frequency Divider, through upper rack opening, through rings 10, 11, to 100-cycle input jack on Type 1109 Comparison Oscilloscope.* |
| | From the DET OUT jack of the 1106-C Frequency Transfer Unit, through rings 3, 2, to DET OUTPUT-H (High Frequency) jack on 1108 Coupling Panel. | | |
| 55 | A-10 | | |
| | From the DET OUT jack of the 1109 Comparison Oscilloscope, through rings 11, 10, | | |

*When the frequency standard rack is at the left of the measuring equipment rack the cable can be led through ring 14 in the frequency standard cabinet to improve appearance.

TYPE 1105-B FREQUENCY MEASURING EQUIPMENT

- 55 A-22 Repeat A-21 for 1 kc from 1114-P4.
- 55 A-23 Repeat A-21 for 10 kc from 1114-P3.
- 12 A-24 From Type 1103-B 1 kc jack to Type 1113-P4 1 kc OUT (upper).
- 47 A-28 From the INPUT jack of the 1107 Interpolation Oscillator, through rings 14 and 13, then through the lower rack opening, to DET OUT-1 jack on 1108 Coupling Panel.
- 47 A-29 From the OUTPUT jack of the 1107 Interpolation Oscillator, through rings 14 and 13, then through the lower rack opening to INTERP OUT-1 jack on 1108 Coupling Panel.

NOTE: Completion of the above connections leaves certain terminals unused on the 1108 Coupling Panel. These are: DET INPUT EXT and DET OUTPUT EXT, which are for connection of an external receiver, if desired; the fx2 connection, which is for connection, at the rear of the assembly, of the source whose frequency is to be measured (the fx1 connection of the front panel of the 1108 Coupling Panel is separate from the fx2 jack); and the TEL connection for the connection, at the rear of the assembly, of a pair of telephones. (This is sometimes a convenience when adjusting the frequency standard against standard frequency transmissions.)

PART IV METHODS OF MAKING FREQUENCY MEASUREMENTS

The method used in measuring a particular frequency depends primarily upon the range in which the unknown frequency falls. The most convenient outline is based on the frequency ranges involved, as follows:

I AUDIO FREQUENCIES 0 TO 5 KC

Audio frequencies in the range 0 to 5kc are quickly measured by matching with the Type 1107 Interpolation Oscillator, using the DIRECT scale. The oscillator frequency can be brought to equality with the frequency being measured by means of the output meter of the oscillator (used as a beat indicator) or by means of the 1109 Comparison Oscilloscope. The oscillator can be checked or standardized, at a number of points on its scale, against the frequency standard, using the 1109 Comparison Oscilloscope as an indicator. In such cases, the zero adjustment of the oscillator is used to correct the oscillator calibration at a point very near to the final reading.

For very low frequencies, the 1109 Comparison Oscilloscope is most useful since it permits the 1107 Interpolation Oscillator to be set accurately to a mul-

tipole of the frequency being measured. The type of pattern obtained on the oscilloscope gives definitely the multiple used.

II FREQUENCIES FROM 5 TO 100 KC

In this range two methods are readily available. The first utilizes the 1109 Comparison Oscilloscope with a variable frequency circular sweep produced by the 1107 Interpolation Oscillator. The frequency to be measured is connected to the radial deflection amplifier of the oscilloscope. Starting with the 1107 Interpolation Oscillator at 5 kc on the DIRECT scale, the oscillator frequency is gradually reduced until a "single line" pattern is obtained. The number of scallops around the pattern gives the number of times the oscillator frequency is contained in the unknown frequency, or the number of times the oscillator frequency must be multiplied to obtain the unknown frequency. Further details are given in Part VIII.

The oscillator calibration can be standardized against the frequency standard and readings of the oscillator frequency can be made within ± 0.1 cycle.

GENERAL RADIO COMPANY

giving results within a cycle or two for frequencies up to 100 kc.

The second method is to utilize harmonics of the frequency being measured, so that a usable signal can be obtained at a frequency over 100 kc, the lower limit of the Type 1106-A Frequency Transfer Unit, and proceeding as outlined in the following section. If the source has no harmonics, they can be generated by passing the source output through a rectifier or distorting amplifier.

For harmonics which fall in the range just above 100 kc, the frequencies can be measured within ± 0.1 cycle, or ± 1 in 1,000,000, which is better than in the preceding method.

III FREQUENCIES FROM 100 KC TO 10 MC

Frequencies throughout this range are measured in terms of 10-kc harmonics from the frequency standard. Frequencies below this range may be brought up into the range by harmonic multiplication (see preceding section). Measurements can be made with an accuracy of ± 0.1 cycle.

Any frequency in this range will lie between two adjacent 10-kc harmonics of the frequency standard and will not be over 5000 cycles away from one of them. The difference in frequency between the unknown and nearest standard frequency is obtained by beating in the DETECTOR of the Type 1106 Frequency Transfer Units. This difference in the frequency is then measured by matching with the Type 1107 Interpolation Oscillator.

If the unknown frequency lies very near the standard frequency, either above or below it, special procedures simplify obtaining the frequency difference and determining whether the unknown is above or below the standard frequency. These are given in Part VII, Procedure.

IV FREQUENCIES 10 MC TO 100 MC

For frequencies above 10 Mc or so, it is more difficult to utilize 10-kc standard harmonic frequencies for measurements. Difficulties are encountered mainly in identifying such high order harmonics. An alternative is, in effect, to divide the frequency by a known number to bring the resultant back into range covered by the previous section.

One method of doing this is to utilize a highly stable, accurately calibrated oscillator as a divider. A harmonic of this oscillator (heterodyne frequency meter) is accurately matched to the frequency being measured. The fundamental frequency (or, in some cases, another harmonic frequency) of the heterodyne frequency meter is then measured by beating against the standard frequency harmonic. The unknown frequency is then this measured value multiplied by the number of the harmonic of the heterodyne frequency meter used to match the unknown.

As stated in this general way, the procedure is straight-forward enough, but is likely to be time consuming, particularly as to determining which harmonic of the heterodyne frequency meter is being used. Through the use of calibrated harmonic scales for the heterodyne frequency meter, and through the use of coordinated ranges for heterodyne frequency meters and heterodyne detectors, harmonic division becomes almost automatic. Full details are given in Part VII, Procedure. After identification of the 10-kc harmonic in use, proceed as in III above.

V FREQUENCIES ABOVE 100 MC

If sensitive receiving equipment is available for frequencies above 100 Mc, harmonics of 100-kc and 10-kc may be used for direct measurement above 100 Mc. Use of a transfer oscillator will permit extension to higher frequencies.

PART V TYPE 1108 COUPLING PANEL

A photograph of the Type 1108 Coupling Panel appears in Figure 3. A block diagram of the functions performed by the coupling panel is given in Figure 4 and a wiring diagram in Figure 5.

The Type 1108-B Coupling Panel contains two harmonic-generating units, which are driven by the frequency standard. Each harmonic generator contains a blocking-oscillator trigger circuit and an avalanche-transistor pulse generator. The negative-going input trigger pulses to the blocking-oscillator are fed through an R-C differentiating network, which produces sharp trigger pulses. These units are normally driven by the square-wave output of the 10-kc and 100-kc stages of the Type 1114-A Frequency Divider. They may also be driven by the 10-kc and 100-kc output signals from the Type 1102-A Multivibrator, but with this equipment it is necessary to insert a 50-ohm, 6-db pad in the 10-kc

input circuit and a 50-ohm, 3-db pad in the 100-kc circuit.

The harmonics generated by these units are strong enough up to 100 Mc to permit direct measurement of frequency against both 10-kc and 100-kc harmonic series. If sensitive receiving equipment is used with the DETECTOR switch at EXT, the harmonics are usable beyond 100 Mc. The rise time of the current pulse in the avalanche pulse generator is about 2 nanoseconds. The output impedance of these generators depends on the setting of the output level (10-kc or 100-kc) control, and is about 100 ohms. The output circuit of the 100-kc harmonic generator is arranged to reduce high-frequency output level (near 100 Mc). For higher level 100-kc harmonics above 100 Mc, it may be desired to short out L3 in the 100-kc harmonic generator.

TYPE 1105-B FREQUENCY MEASURING EQUIPMENT

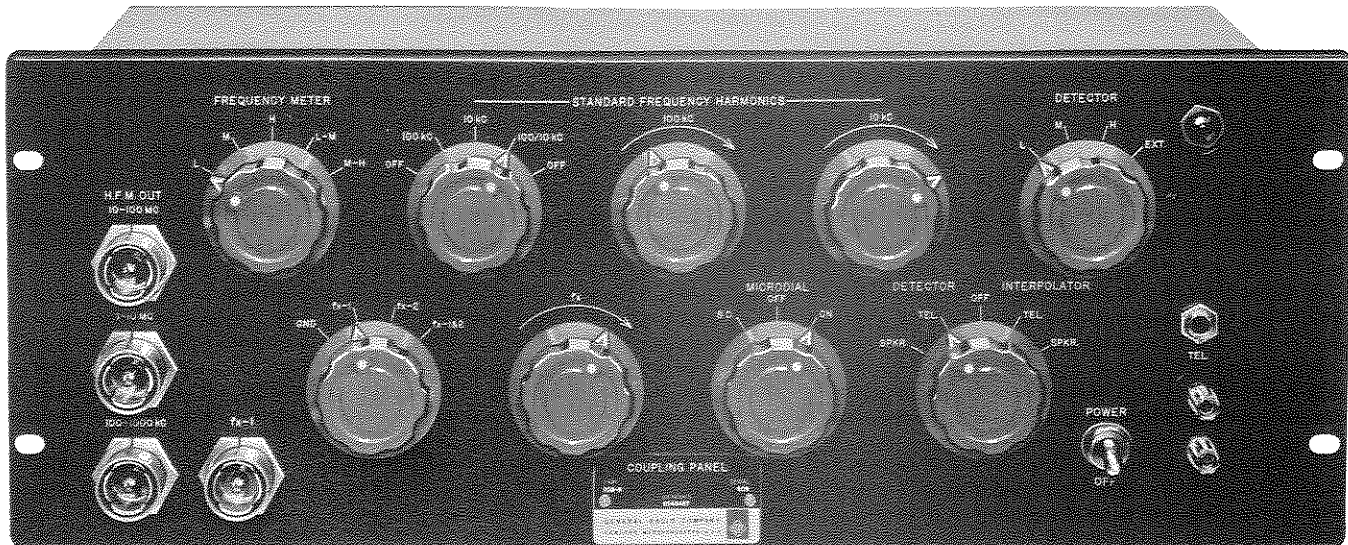

Figure 3. Panel View of the Type 1108-B Coupling Panel Showing All Controls.

FREQUENCY MEASUREMENT

The operation of the assembly is readily traced on the block diagram, Figure 4. The frequency to be measured, f_x , is introduced at either the front or rear f_x jack, through the f_x switch (for removing the signal without disconnecting the external connections) and f_x volume control to the input side of the DETECTOR selector switch.

The appropriate detector unit is selected by operation of the DETECTOR selector switch. Telephones or loudspeaker are connected to the selected detector by operation of the TEL-SPEAKER switch. The frequency to be measured is then picked up by tuning the selected detector unit.

In the direct method, if the beat difference between f_x and a standard harmonic is to be obtained, the standard harmonic is then introduced by operating the SELECTOR switch for 100 kc, 10 kc, or both together, (which is sometimes helpful at the high frequencies), and volume controls. The beat difference is automatically passed to the Type 1107 Interpolation Oscillator. In matching by use of the Type 1107 Interpolation Oscillator alone, transfer the telephones or speaker to the interpolation oscillator output, by throwing the TEL-SPEAKER switch to the INTERPOLATOR side. Simultaneous aural and visual indication of matching can then be had. The use of the Type 1109 Oscilloscope is given in detail later.

In the transfer-oscillator method, if the fundamental, or a harmonic, frequency of a heterodyne frequency

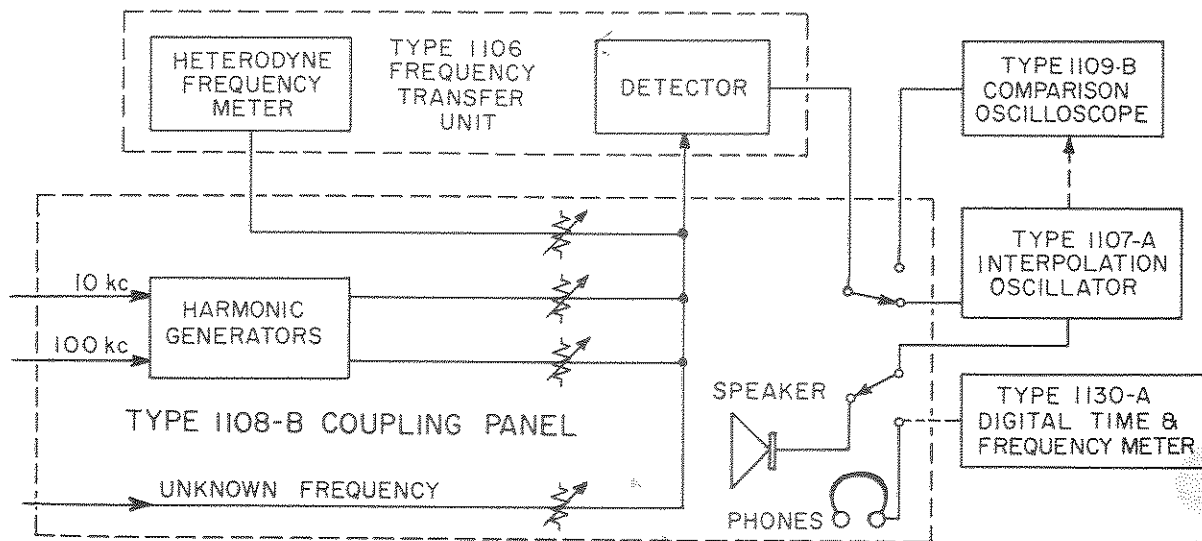

Figure 4. Block Diagram of the Type 1108-B Coupling Panel and associated equipment.

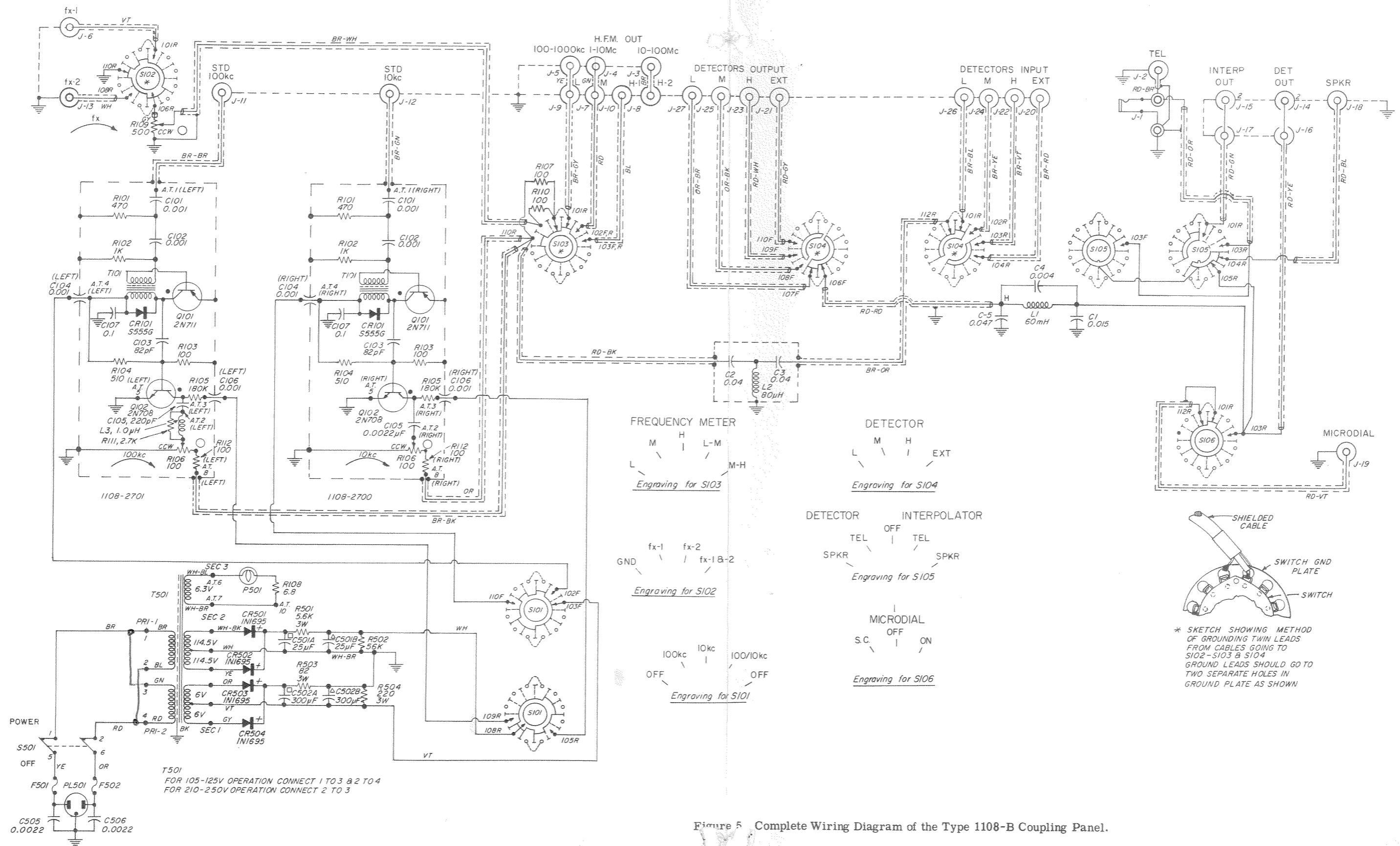

Figure 5 Complete Wiring Diagram of the Type 1108-B Coupling Panel.

RESISTORS

| | | | | |
|------|------|------|------|----------|
| R101 | 470 | ±5% | 1/2w | REC-20BF |
| R102 | 1k | ±5% | 1/2w | REC-20BF |
| R103 | 100 | ±5% | 1/2w | REC-20BF |
| R104 | 510 | ±5% | 1/2w | REC-20BF |
| R105 | 180k | ±5% | 1/2w | REC-20BF |
| R106 | 100 | ±5% | 1/2w | POSC-12 |
| R107 | 100 | ±5% | 1/2w | REC-20BF |
| R108 | 6.8 | ±5% | 1/2w | REW-3C |
| R109 | 500 | ±10% | 1/2w | POSC-12 |
| R110 | 100 | ±5% | 1/2w | REC-20BF |
| R111 | 2.7k | ±5% | 1/2w | REC-20BF |
| R112 | 100 | ±5% | 1/2w | REC-20BF |
| R501 | 5.6k | ±5% | 3w | REPO-45 |
| R502 | 56k | ±5% | 1/2w | REC-20BF |
| R503 | 82 | ±5% | 3w | REPO-45 |
| R504 | 220 | ±5% | 3w | REPO-45 |

CAPACITORS

| | | | | |
|-------|--------------|-----------|---------|----------|
| C1 | 0.015µf | ±10% | 600dcwv | COM-50B |
| C2 | 0.04µf | ±10% | 600dcwv | COM-50B |
| C3 | 0.04µf | ±10% | 600dcwv | COM-50B |
| C4 | 0.004µf | ±10% | 600dcwv | COM-50B |
| C5 | 0.047µf | ±20% | 500dcwv | COC-64 |
| C101 | 0.001µf | ±20% | 500dcwv | COC-60 |
| C102 | 0.001µf | ±20% | 500dcwv | COC-60 |
| C103 | 82pf | ±20% | 500dcwv | COC-60 |
| C104 | 0.001µf | +100, -0% | 500dcwv | COC-3 |
| C105 | (for 10kc): | | | |
| | 2200pf | ±20% | 500dcwv | COC-61 |
| | (for 100kc): | | | |
| | 220pf | ±20% | 500dcwv | COC-60 |
| C106 | 0.001µf | +100, -0% | 500dcwv | COC-3 |
| C107 | 0.1µf | +80, -20% | 50dcwv | COC-63-3 |
| C501A | 25µf | | 200dcwv | COE-51 |
| C501B | 25µf | | 200dcwv | COE-51 |
| C502A | 300µf | | 15dcwv | COE-36 |
| C502B | 300µf | | 15dcwv | COE-36 |
| C505 | 2200pf | ±20% | 500dcwv | COC-61 |
| C506 | 2200pf | ±20% | 500dcwv | COC-61 |

MISCELLANEOUS

| | | |
|-------|--------------------|--------------------|
| CR101 | Crystal Diode | S555G |
| CR501 | | |
| thru | Crystal Diode | 1N1695 |
| CR504 | | |
| F501 | (for 115v): | |
| | Fuse, 0.1 amp | FUF-1 |
| | (for 230v): | |
| | Fuse, 0.05 amp | FUF-1 |
| F502 | (for 115v): | |
| | Fuse, 0.1 amp | FUF-1 |
| | (for 230v): | |
| | Fuse, 0.05 amp | FUF-1 |
| L1 | Inductor | 379-R |
| L2 | Choke, 80µh | ZCHA-39 |
| L3 | Choke, 1.0µh ± 10% | CHM-1 |
| P501 | Pilot Lamp | 2LAP-6 |
| PL501 | Plug | CDPP-10 |
| Q101 | Transistor | 2N711 |
| Q102 | Transistor | 2N708 |
| S101 | Switch | SWRW-2720 |
| S102 | Switch | SWRW-2730 |
| S103 | Switch | SWRW-2840 |
| S104 | Switch | SWRW-2850 |
| S105 | Switch | SWRW-42 |
| S106 | Switch | SWRW-39 |
| S501 | Switch | SWT-333 |
| T101 | Transformer | 1108-2000 3.7 0 |
| T501 | Transformer | 0345-4000# 3 0.4 0 |

TYPE 1105-B FREQUENCY MEASURING EQUIPMENT

meter is to be matched to the unknown f_x , the proper heterodyne frequency meter is selected by operating the FREQUENCY METER selector switch. Matching is then obtained by adjusting the frequency meter. This can be done by zero beat, detector not oscillating, or, more precisely, by the "three-oscillator" method with the detector oscillating. The f_x is then removed by operating the f_x switch.

The harmonic used above, or the fundamental, of the heterodyne frequency meter is then measured against the standard by injecting the standard frequency through operation of the STANDARD FREQUENCY selector switch and volume control. If the fundamental is to be measured, the detector must then be tuned to the fundamental fre-

quency. In some cases this requires selecting the detector of next lower frequency range.

MICRODIAL

To compare the synchronometer reading with time signals, of the type transmitted by the U.S. Naval Observatory, the time signal can be picked up through the f_x switch and volume control on the selected detector unit. The MICRODIAL switch is then operated, placing the microdial contactor across the detector output. The microdial is then adjusted toward earlier time (lower numbers on the three-digit counter) until just the nose of the time signals is audible in the telephones or speaker. The time difference, as a positive fraction of a second, is then indicated on the microdial counter.

PART VI

MAKING FREQUENCY MEASUREMENTS - STEPS REQUIRED

In making frequency measurements certain successive steps are required. These are given below and are considered in detail in the section following. In many cases this full procedure can be simplified. Certain general statements have been made in Part V bearing on these steps.

STEP 1: Picking up and identifying the signal, the frequency of which is to be measured, for transfer to and comparison with the frequency standard.

This step may be very simple in the case of a local oscillator or transmitter; it may be rather complicated and time consuming in the case of a remote high frequency transmitter. In many cases, particularly in measuring remote transmitters subject to noise, fading, or keying, it is desirable to utilize a heterodyne frequency meter as a substitute source, which, once adjusted to match the frequency to be measured, permits the balance of the measurement to be completed free from disturbances.

STEP 2: Transferring the frequency for comparison with the standard.

This transfer may be made at the original signal frequency, or for various reasons, may be at a multiple or submultiple of the signal frequency. In this equipment the use of direct-reading dials and coordinated ranges frequently permits the use of factors of 10:1, or 1:10, so that multiplication or division by the harmonic number is reduced to shifting the decimal point.

STEP 3: Obtaining the audio beat-frequency difference between the transferred frequency and the nearest standard frequency (which is generally a 10-kc standard harmonic).

STEP 4: Determining the sign of the beat-frequency difference obtained in Step 3. This is equivalent to determining whether the unknown is above or below the standard harmonic.

STEP 5: Determining the value of the beat-frequency difference obtained in Step 3. If Step 4 indicates that the unknown is above the standard harmonic frequency, the DIRECT scale of the interpolation oscillator is used and the value of the beat-frequency difference (0-5000 cycles) is added to the value of the standard frequency to obtain the final result. If Step 4 indicates that the unknown frequency is below the standard harmonic frequency, the REVERSE scale of the interpolation oscillator is used and the "value" of the beat frequency difference (5000 - 10,000 cycles) is added to the next lower standard harmonic frequency.

STEP 6: Determination of the value of the standard harmonic frequency used in the measurement. This is done either by use of the detector, or heterodyne frequency meter scales.

In cases where the frequency transferred to the standard for measurement is NOT the original signal frequency, either of the two following steps may be necessary.

STEP 7: Identification of the harmonic of the heterodyne frequency meter which was used in the measurement. Through the use of direct-reading frequency dials, coordinated ranges and a general range chart, the harmonic used is generally chosen in advance. This step is, in general, necessary only in the measurement of very high frequencies.

STEP 8: Identification of the harmonic of the unknown frequency which was used in the measurement. If not already known from other considerations it can generally be determined directly from the scale of the heterodyne detector. This step, is in general, necessary only in the measurement of very low radio frequencies.

In many cases some of these steps may be eliminated, or may be taken simultaneously with other steps thereby simplifying the procedure. This is particularly true in routine measurements of frequencies where the measurement conditions are known in advance.

GENERAL RADIO COMPANY

PART VII

MAKING FREQUENCY MEASUREMENTS: PROCEDURE

A brief summary of the operation involved in carrying out the successive steps of a frequency measurement will be given, followed by some suggestions on operation which may prove helpful.

To simplify the details of procedure, the Type 1109 Comparison Oscilloscope is considered separately. (See Part VIII.) In becoming familiar with the operations given here all that is necessary is to bear in mind that the comparison oscilloscope will give better results in checking calibrations, calibrating equipment, or measuring frequencies than can usually be obtained by simple aural or beat indicator comparisons. After becoming acquainted with the handling of the measuring equipment one turns naturally to the oscilloscope as the comparison device in nearly all measurements.

Refer to the schematic diagram, Figure 4.

STEP 1: Picking up the signal, the frequency of which is to be measured.

Connect the source to the fx jack on the front, or at the rear of the 1108 Coupling Panel. The concentric line may be connected to a coupling point in a local oscillator, to a pick-up coil coupled to the oscillator or may be coupled through a small capacitance to the oscillator to be measured. If the line is connected to an antenna, a coupling transformer or network may or may not be essential, depending on the frequency and the local conditions. The cable impedance is approximately 50 ohms.

Throw the fx switch on the Type 1108 Coupling Panel to fx-1 if the input is applied through the panel (fx-1) jack, to fx-2 if the rear (fx-2) connector is used. Advance the fx volume control. Throw the DETECTOR selector switch to the appropriate Frequency Transfer Unit (L = low frequency, 100 kc - 2000 kc. M = medium frequency, 1 Mc - 10 Mc. H = high frequency, 10 Mc - 100 Mc. EXT = External Unit. Input and output connections must be made at jacks on rear of the Type 1108 Coupling Panel.) Throw TEL-SPEAKER switch to TEL or SPEAKER on the DETECTOR side.

Turn on the selected frequency transfer unit by throwing the POWER switch on its panel to ON. Select the frequency range to be used by turning the DETECTOR RANGE switch. Adjust the fx volume control, the DETECTOR tuning and regeneration to obtain the required signal at its fundamental frequency.

SUGGESTIONS:

1. Effective operation of a regenerative detector requires a certain amount of practice. The beginning of oscillation usually occurs with the regeneration control advanced about one-quarter to one-half from the minimum position. For any given frequency setting, the

most sensitive condition for receiving continuous wave signals is just after oscillations have started. The most sensitive condition for modulated signals is just below the point where oscillations start. Careful adjustment of the regeneration control is therefore important.

2. Do not overload the detector with strong signals. The sensitivity is best at fairly low signal strength. In getting beats between two signals, adjust them individually to about the same level.

3. If difficulty is experienced in picking up a signal, whose frequency is only approximately known, introduce a standard harmonic signal by throwing the STANDARD FREQUENCY selector switch to 100 kc or 10 kc and advancing the corresponding volume control. Adjustment of the detector can then be made to obtain a sensitive oscillating condition on any one of the standard frequency signals. Throwing the STANDARD FREQUENCY selector to OFF then permits search for the desired signal, with a "pre-adjusted" heterodyne detector.

STEP 2: Transferring the signal for comparison with the standard.

If the frequency to be measured lies between 100 kc and about 20 Mc, the operations above are all that are necessary for transferring the frequency for comparison with the standard.

SUGGESTIONS:

1. If the frequency to be measured is below 100 kc, introduce a harmonic of this frequency, at either fx jack on the Type 1108 Coupling Panel, such that the harmonic measured will lie above 100 kc (the lower frequency limit of the Type 1106-A Frequency Transfer Unit).

The fundamental frequency can be measured using the Type 1107 Interpolation Oscillator and the Type 1109 Comparison Oscilloscope as explained in Part VIII.

2. If the frequency is higher than 10 to 20 Mc, it is not easy to obtain the beat-frequency difference directly against the standard, because the harmonics of the 10-kc standard are so close together (successive harmonics being 0.1% apart at 10 Mc) that considerable care is necessary in identifying the one used in the measurement.

3. When a high frequency is to be measured, in a range where satisfactory beats are difficult to obtain, the frequency meters of the Type 1106 Transfer Units can be used. Since the approximate value of the frequency being measured is known immediately from the calibration of the detector unit, it is possible to set the heterodyne frequency meter (either the one in the Type 1106 Frequency Transfer Unit used for picking up the signal, or in the Type 1106 Frequency Transfer Unit of next lower frequency range) to a known fraction of the

TYPE 1105-B FREQUENCY MEASURING EQUIPMENT

frequency being measured. The fundamental frequency of the heterodyne frequency meter is then measured against the standard, the result being multiplied by the number of the harmonic to obtain the value of the unknown frequency. It is for operations such as this that the frequency-meter selector switch on the Type 1108 Coupling Panel has the positions L-M and M-H.

STEP 3: Obtaining the audio beat difference between the transferred frequency and the standard.

The signal frequency to be measured having been picked up and identified in the detector unit of the Type 1106 Frequency Transfer Unit, usually with the detector in the oscillating condition, the next step is to introduce the standard frequency harmonics into the detector.

Throw the standard-frequency harmonics selector switch to the 10-kc position and advance the corresponding volume control. Next reduce the amount of regeneration in the detector, by retarding the regeneration control slightly, until oscillation just stops. A single clear tone should then be heard in the telephones or speaker. The adjustments of the fx and 10-kc volume controls may be varied and the standard selector switch may be tried on the 100/10-kc position (if a high frequency is being measured) with adjustment of both the 100- and 10-kc volume controls, to obtain the best beat-frequency signal.

SUGGESTIONS:

1. When the detector is being operated in the non-oscillating condition, and signal levels are large enough, critical regeneration is not needed. The radio-frequency signal levels can be adjusted to higher values, giving greater beat-frequency output. However, do not adjust for more than a comfortable telephone signal, as high level output is not needed.

2. When weak signals are obtained, regeneration must be advanced to the point where oscillation almost begins. In this case careful adjustment of detector tuning and regeneration is necessary to obtain the best beat-frequency output.

STEP 4: Determining the sign of the beat-frequency difference obtained in Step 3.

In many cases the sign of the beat-frequency difference is known in advance; that is, it is known whether the frequency being measured is above or below the standard frequency harmonic being used in the measurement.

If it is not known, then in cases where the beat-frequency difference is not too small, the location of the unknown frequency relative to the standard harmonic frequency can be determined from the heterodyne detector tuning adjustment. Using the detector in the oscillating condition, set for zero beat against the frequency being measured. Throw the ix switch to GND and throw the standard frequency harmonic selector switch to 10 kc. A beat note will then be heard in the telephones. Carefully advance the detector tuning control

(turning control knob clockwise). If the beat tone rises, the unknown frequency is higher than the standard frequency, and the sign of the beat frequency difference is taken as plus. If the beat tone falls, the unknown frequency is lower than the standard frequency, and the sign of the beat frequency difference is taken as minus.

It will be observed that this determination can easily be handled as part of Step 3 when one is familiar with the handling of the equipment.

SUGGESTION:

1. It is possible to determine the sign of the beat-frequency difference when the difference is very small by use of the heterodyne frequency meter. In this case the unknown and standard frequencies are very nearly equal. Throw the heterodyne frequency meter plate switch to ON. Set the heterodyne frequency meter to nearly the same frequency as the detector, and adjust output control to obtain a good beat. Set the frequency meter to a lower frequency than the other two, by an amount giving a few hundred cycles beat tone. Then measure the beat frequencies (see later steps) of (1) the unknown and heterodyne frequency meter (fx - fh), and then (2) the standard and heterodyne frequency meter (fs - fh). If the first beat frequency exceeds the second, the unknown is above the standard frequency; if it is less than the second, the unknown is below the standard frequency. The difference of the two beat frequencies is the amount by which the unknown differs from the standard frequency.

STEP 5: Determining value of beat-frequency difference obtained in Step 3.

The beat-frequency difference is automatically applied to the input terminals of the interpolation oscillator. For listening to the match between the interpolation oscillator and the beat frequency, throw the TEL-SPEAKER switch to the INTERPOLATOR side. Adjust the INPUT (beat-frequency) and OUTPUT (oscillator) volume controls of the interpolation oscillator to obtain about equal deflections of the OUTPUT meter at about one-half scale.

If the sign of the beat-frequency difference is plus, throw the scale selector switch to DIRECT. Adjust the frequency of the interpolation oscillator to match the beat frequency. As the match is approached, the output meter needle will swing from nearly zero to nearly full scale. Adjust the frequency of the interpolation oscillator until the meter needle stands still, or moves only very slowly. Slow oscillation of the meter needle is accompanied by a slow waxing and waning of the intensity of the tone heard in the telephones connected to the output of the interpolation oscillator. The DIRECT scale reading of the interpolation oscillator then gives the value of the beat frequency in cycles per second. (This reading is subject to a small correction which can be made zero by checking the interpolation oscillator against the frequency standard. This checking is described in detail in Part VIII.) This value of beat-frequency difference

is added to the value of the standard frequency to obtain the final value of the frequency being measured. If the sign of the beat-frequency difference is minus, throw the scale selector switch to REVERSE. Proceed as in the preceding paragraph to match the beat frequency. The REVERSE scale reading of the interpolation oscillator then gives the value of frequency difference to be added to the next lower standard-frequency harmonic to obtain the final value of the frequency being measured. The same remarks apply here to checking the interpolation oscillator calibration.

When the sign of the beat-frequency difference is plus, it simply means that the unknown frequency is higher than the standard frequency. When the beat frequency is matched with the interpolation oscillator, we start, in effect, at zero frequency difference at the standard frequency and progress to higher frequencies on the DIRECT scale until a frequency equal to the beat frequency is reached. The sum of the beat frequency and standard frequency then gives the unknown frequency.

When the sign of the beat frequency is negative, the unknown frequency is below the standard frequency. Again starting with zero frequency difference at the standard frequency, we progress to high interpolation oscillator frequencies on the DIRECT scale, applying a negative sign, until a frequency equal to the beat frequency is reached. The difference of the standard frequency and the beat frequency then gives the unknown frequency.

If, now, we provide a means of switching the fixed frequency oscillator to a value just 5000 cycles different, the sense of frequency change with dial reading of the interpolation oscillator is reversed. (That is, in terms of the original 0 - 5000 division scale, the frequency is 5000 cycles when the dial is at zero and is 0 cycles when dial is at 5000.) It will then be seen that a dial reading 5000 to 10,000 divisions can be used, with the next lower 10-kc standard frequency harmonic as a reference, to give the final result by addition (instead of subtraction, as described in the last paragraph).

For illustration, assume a frequency of 1398.125 kc is being measured. If the DIRECT scale is used, a beat frequency of 1875 cycles is matched and a negative sign is employed. The unknown frequency is then

$$1400.000 - 1.875 = 1398.125 \text{ kc.}$$

When the REVERSE scale is used, a frequency of 1875 cycles is obtained, and is matched to the beat frequency, at a scale reading of 8,125 divisions. If this is added to the frequency of the next lower standard harmonic frequency, 1390.000 kc, the result is 1398.125 kc, the value of the unknown frequency.

In operation, the matching is carried out without knowing the actual value of the beat frequency or of the oscillator frequency, as given in the example above.

Provision is made for carrying out both the matching operation and checking of the interpolation oscillator by use of the comparison oscilloscope. Details

of operation are given in Part VIII.

The Type 1107-A Interpolation Oscillator can be used independently as a linearly calibrated audio-frequency oscillator covering 0 to 5000 cycles per second. The calibration can be checked by plugging in any suitable standard-frequency voltage (such as are available from tuning-fork, or other, audio-frequency standards) at the INPUT terminals. The INPUT control permits setting the level of this voltage at the mixer stage. The OUTPUT control controls the audio-frequency output of the instrument and, in effect, controls the oscillator output at the mixer. In this way the two voltages at the mixer can be brought to about the same level to obtain the most pronounced beats as indicated by the swing of the output meter, or by the waxing and waning of intensity of the tone heard in telephones connected to the output. If the frequency of an audio-frequency voltage is to be determined, it is connected to the INPUT terminals in the same manner as the standard-frequency voltage mentioned above.

STEP 6: Determination of the value of the standard frequency used in the measurement.

Over a large part of the frequency range this operation may be combined with STEPS 2 and 4.

Proceeding as in STEP 4, after determining the sign of the beat frequency, bring the detector to zero beat with the standard harmonic. In many cases it is then possible to determine the value of the standard frequency harmonic from the receiver calibration. If the receiver calibration is not sufficiently accurate, or is not calibrated at sufficiently close intervals, use can be made of the heterodyne frequency meter. Throw the frequency meter plate switch to ON. Turn to the same range as the one in use on the detector, and set for zero beat. The standard frequency harmonic can then be determined from the frequency meter calibration.

SUGGESTION:

1. At very high frequencies, where the change in frequency in going from one standard frequency harmonic to the next is very small, a counting method may have to be employed. Note the detector reading for the standard frequency used in the measurement, as described in the preceding paragraph. Throw the standard harmonic selector switch on the coupling panel to 100 kc. Change the detector tuning to obtain zero beat with the nearest multiple of 100 kc. Then throw the standard frequency selector switch to 10 kc. Return the detector slowly from this point to the original setting, counting the number of 10-kc harmonics passed over. The value of the standard frequency is then known at once as the value of the 100-kc harmonic frequency (which can be determined without ambiguity from the detector calibration) plus or minus the number of 10-kc intervals passed over.

STEP 7: Identification of the harmonic of the heterodyne frequency meter used in a measurement of a high radio frequency.

TYPE 1105-B FREQUENCY MEASURING EQUIPMENT

When a heterodyne frequency meter is used as a means of reducing a high frequency to a value more adaptable to measurement against the standard, it is so adjusted as to bring one of its harmonics into zero beat with the frequency being measured. After measurement of the fundamental frequency of the heterodyne frequency meter, the value obtained must be multiplied by the number of the frequency meter harmonic to obtain the value of the unknown frequency.

Since the detector is tuned to the unknown frequency (STEP 1) its approximate value is evident at once from the detector calibration. By setting the frequency meter to the same frequency range as the detector, and to the same frequency, a selected harmonic has been brought into zero beat with the unknown frequency. The number of this harmonic can always be determined at once from the Range Chart, Figure 6, since one, and only one, calibrated harmonic range will agree with the range in use of the detector. This operation will result in harmonic numbers which will be 1, 2, 4, or 5.

NOTE: Since all harmonics, through at least the 10th, are present in the output of the heterodyne frequency meter, there will be settings at other frequencies which will produce beats in the detector which is tuned to the unknown frequency. These are to be disregarded. If the same range and the same frequency indication on the dial of the frequency meter as those used on the detector are employed, as described in the last paragraph, no ambiguity will result.

SUGGESTIONS:

1. A multiplier of 10 can be used, if desired, in measuring frequencies from 10 to 100 Mc. Referring to Figure 6, and using the Type 1106-C Frequency Transfer Unit, a harmonic of the frequency meter is set to zero beat with the frequency being measured, as described above. Inspection of Figure 6 shows not only which harmonic is used, but which of the first three (fundamental) ranges of the frequency meter is the one producing the harmonic. Turn the frequency meter range switch to this fundamental range. Because of switching error, the harmonic may not be in zero beat with the unknown frequency. Reset to zero beat if necessary. Then do not touch the heterodyne frequency meter controls. Bring the detector to the same range as the fundamental heterodyne frequency meter range; set approximate zero beat.

Turn on the frequency meter of the next lower range frequency transfer unit; turn the FREQUENCY METER selector switch to M-H. Set this frequency meter to 1/10th the frequency indicated on the high frequency unit, which will occur on the corresponding one of the first three ranges. A beat will then be heard in the detector of the Type 1106-C Frequency Transfer Unit. Off-set the DETECTOR tuning to obtain a beat of a few hundred cycles; carefully set the Type 1106-B Frequency Meter to obtain a very slow waxing and waning of the

beat tone. Next measure the frequency of the Type 1106-B Heterodyne Frequency Meter against the standard, using the same harmonic number as was used originally in setting to zero beat against the unknown frequency. Inspection of Figure 6 shows that this harmonic frequency is always the unknown frequency divided by 10. In obtaining the final result, therefore, multiplying by the number of the harmonic is done simply by moving the decimal point one place.

2. When using an external transfer oscillator (such as a Type 1211-B Unit Oscillator) to make measurements of frequencies above 100 Mc and up to a few hundred Mc, first set the Type 1211-B to zero beat with the frequency to be measured. Determine the number of the harmonic, n , used in this zero beat adjustment. Next couple the output of the Type 1106-B heterodyne frequency meter to the Type 1211-B; set the 1106-B to 1/10th the dial reading of the Type 1211-B. Listening for the beat note in the external receiver (or detector), set the 1106-B for zero beat. Measure the 1106-B fundamental frequency against the standard. The measured frequency is then $1/10n$ times the unknown frequency.

STEP 8: Identification of the harmonic of the unknown frequency used in the measurement of a low radio frequency.

When a harmonic of the unknown frequency is measured, as in measuring a frequency below 100 kc, it is necessary to know which harmonic is used.

If the approximate value of the frequency being measured is known, then the harmonic number is given by the indicated detector frequency divided by the approximate value of the frequency being measured. The result must of course be a whole number. The result will lie close to a whole number indicating the whole number which is to be taken.

If the approximate value of the frequency being measured is not known, then tune the detector to two successive harmonics noting the detector frequency reading for each. The difference of these two frequencies gives an approximate value for the frequency being measured, which can then be used as in the preceding paragraph.

SUGGESTION:

1. Except where the highest possible precision is required, it is generally much quicker and more satisfactory to measure frequencies below 100 kc through the use of the 1109 Comparison Oscilloscope with a variable frequency circular sweep obtained from the 1107 Interpolation Oscillator. This procedure is detailed in Part VIII.

Although they are not presented on the dials, the 10th harmonic ranges of the 1106-B and 1106-C Units are perfectly usable with heterodyne frequency meters, or other instruments having dials reading directly in

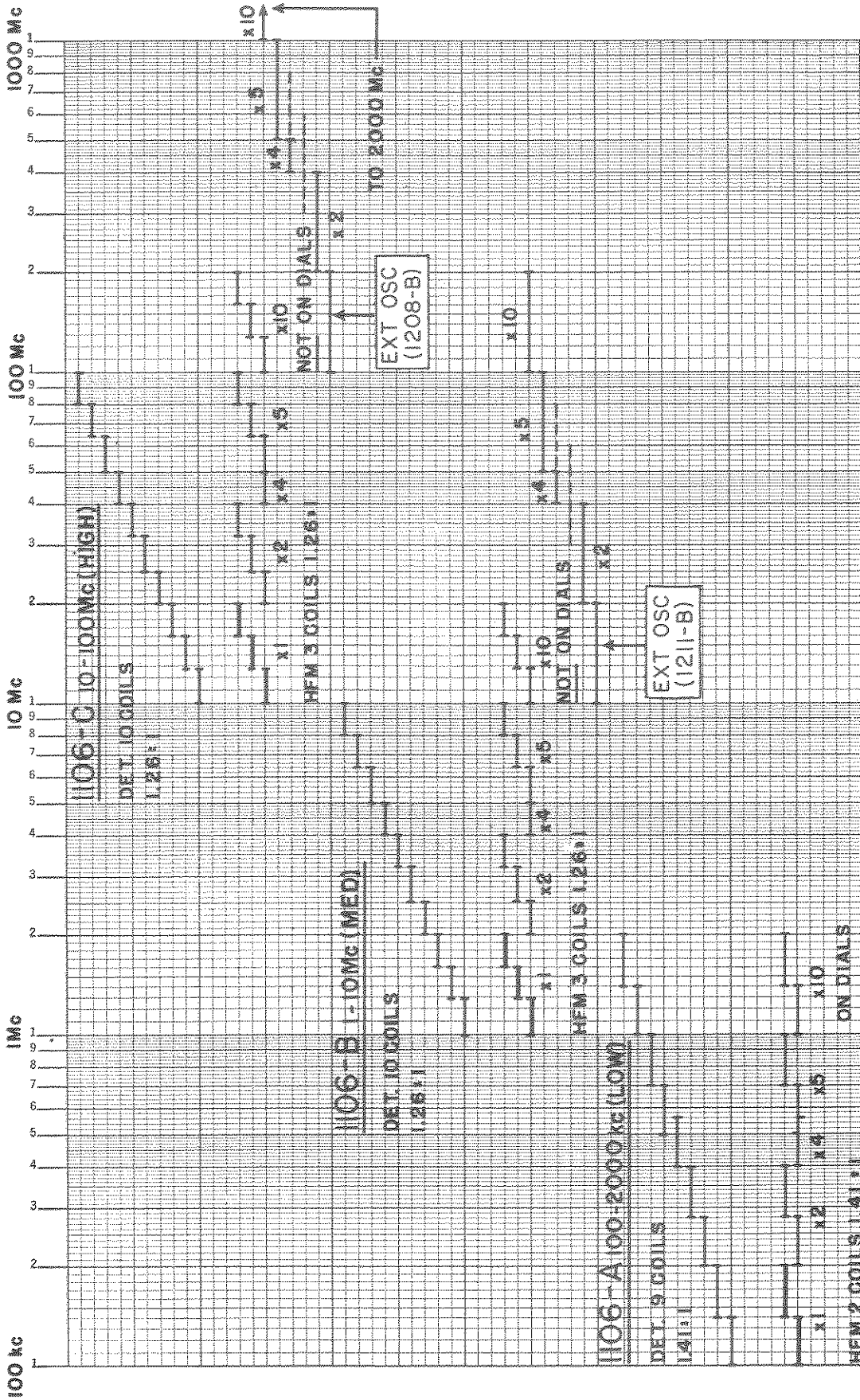

Figure 6. Range Chart
 This chart presents, on a logarithmic frequency scale, the limits of each range of the heterodyne detectors and heterodyne frequency meters of the Type 1106 Frequency Transfer Units. The 1106-A (Low) Unit covers 100 - 2000 kc; the 1106-B (Medium) Unit covers 1 - 10 Mc; the 1106-C (High) Unit covers 10 - 100 Mc.

Successive fundamental frequency ranges are presented at successively higher levels giving a stair-type figure. Harmonic ranges are presented horizontally to the right of the fundamental range which produces them and are marked with the number of the harmonic. These harmonic ranges, except where noted, are given calibrations on the dials of the heterodyne frequency meters.

TYPE 1105-B FREQUENCY MEASURING EQUIPMENT

fundamental frequency. By setting the 1106-B or 1106-C heterodyne frequency meters to 1/10th the frequency shown on the external heterodyne frequency meter dials, the 10th harmonic of the 1106-B or 1106-C frequency

meters can be brought to zero beat with the fundamental frequency of the external heterodyne frequency meter without ambiguity.

PART VIII

TYPE 1109 COMPARISON OSCILLOSCOPE

This cathode ray oscilloscope unit is designed particularly for use as a frequency comparison device. The three-inch cathode-ray tube includes horizontal and vertical deflection plates, by means of which a circular sweep can be produced, and a radial deflection electrode, by means of which the voltage to be studied produces deflections radially inward and outward from the circular-sweep base. This type of display is particularly useful for frequency comparisons since the patterns are not distorted at the sides as in older systems.

The panel of the Type 1109 Comparison Oscilloscope is shown in the photograph of Figure 7. A schematic diagram is given in Figure 8 and a wiring diagram in Figure 9. At the left side is the x jack for introducing a frequency from an external source. Adjacent is the switch for selecting the frequency of the circular sweep; the five positions give LINE, 100 cycles, 1 kc, 10 kc and INTERPolation OSCillator. The LINE position gives the frequency of the power line supplying the unit; the INTERPolation OSCillator position gives a variable frequency circular sweep, the frequency being adjustable at the interpolation oscillator. The CRO tube face is in the center, with the SELECTOR switch to the right. The SELECTOR switch permits selection of the pairs of sources which are to be compared. These are x vs INTERPolator CIRCular SWEEP; x vs STANdard CIRCular SWEEP; DETector output vs STANdard CIRCular SWEEP;

INTERPolator vs STANdard CIRCular SWEEP; and DETector output vs INTERPolator (Lissajous pattern). At the right is the power supply switch. Along the lower edge of the panel are the following controls: DIAMETER and SHAPING controls for circular sweep; HORIZONTAL and VERTICAL CENTERING controls and FOCUS and BRILLIANCE controls for cathode ray tube.

Concentric jacks at the rear provide for connecting the unit to the 100-cycle, 1-kc, and 10-kc outputs of the frequency standard and to the outputs of the three 1106 Frequency Transfer Units and the 1107 Interpolation Oscillator. (These last are obtained at the rear of the 1108 Coupling Unit.)

Following is a brief description of the types of pattern obtained in the various cases:

With the SELECTOR on the DETector vs INTERPolation OSCillator position, a 1:1 Lissajous pattern is obtained when the interpolation oscillator is adjusted to match the beat-frequency output of the Type 1106 Frequency Transfer Units. The pattern appears as a circle or ellipse gradually closing to a straight line and then opening up again at a rate which is equal to the difference in frequency of the two frequencies being matched. (See Figure 10.) If a perfect match is obtained, the pattern does not change with time.

GENERAL RADIO COMPANY

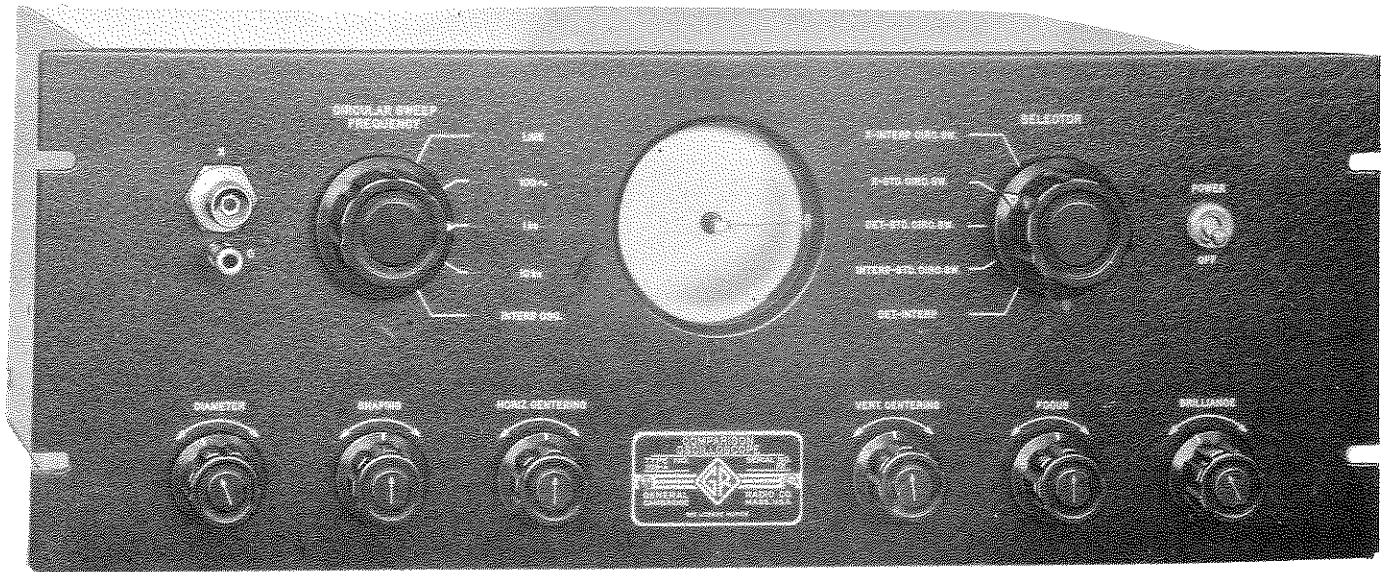

Figure 7. Panel View of the Type 1109-B Comparison Oscilloscope Showing All Controls.

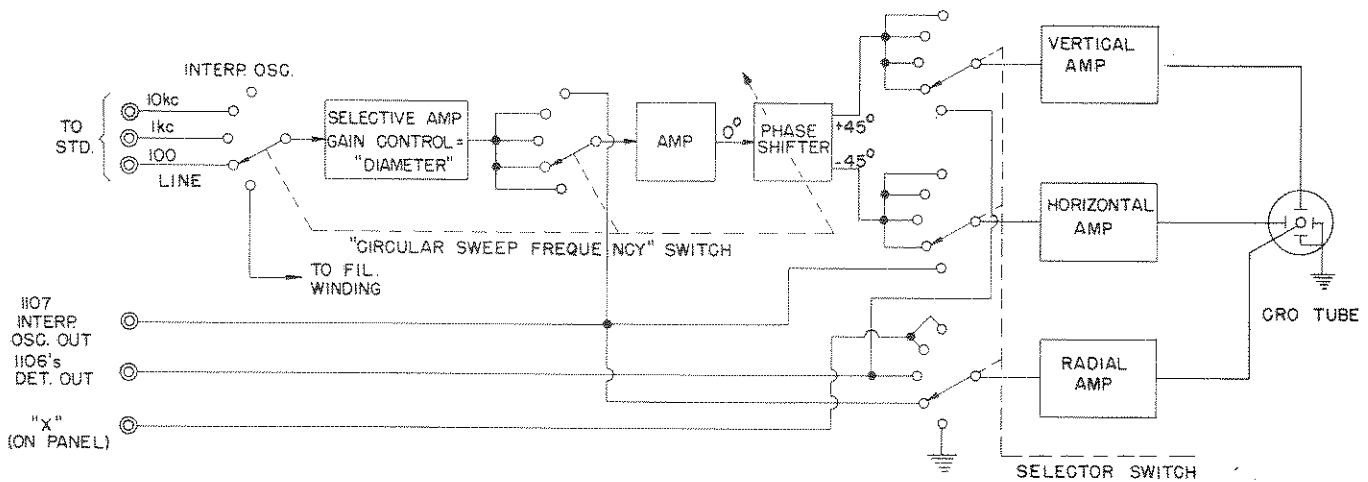

Figure 8. Functional Block Diagram of the Type 1109-B Comparison Oscilloscope.

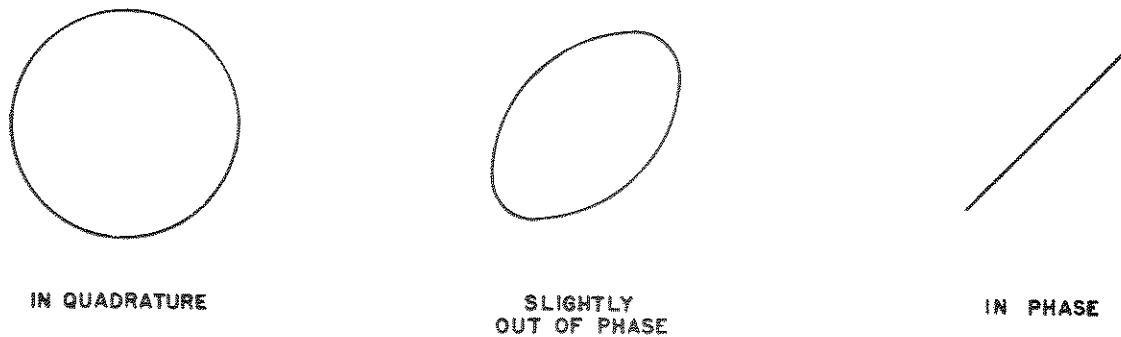

Figure 10. Lissajous Figures for a 1:1 Frequency Ratio.

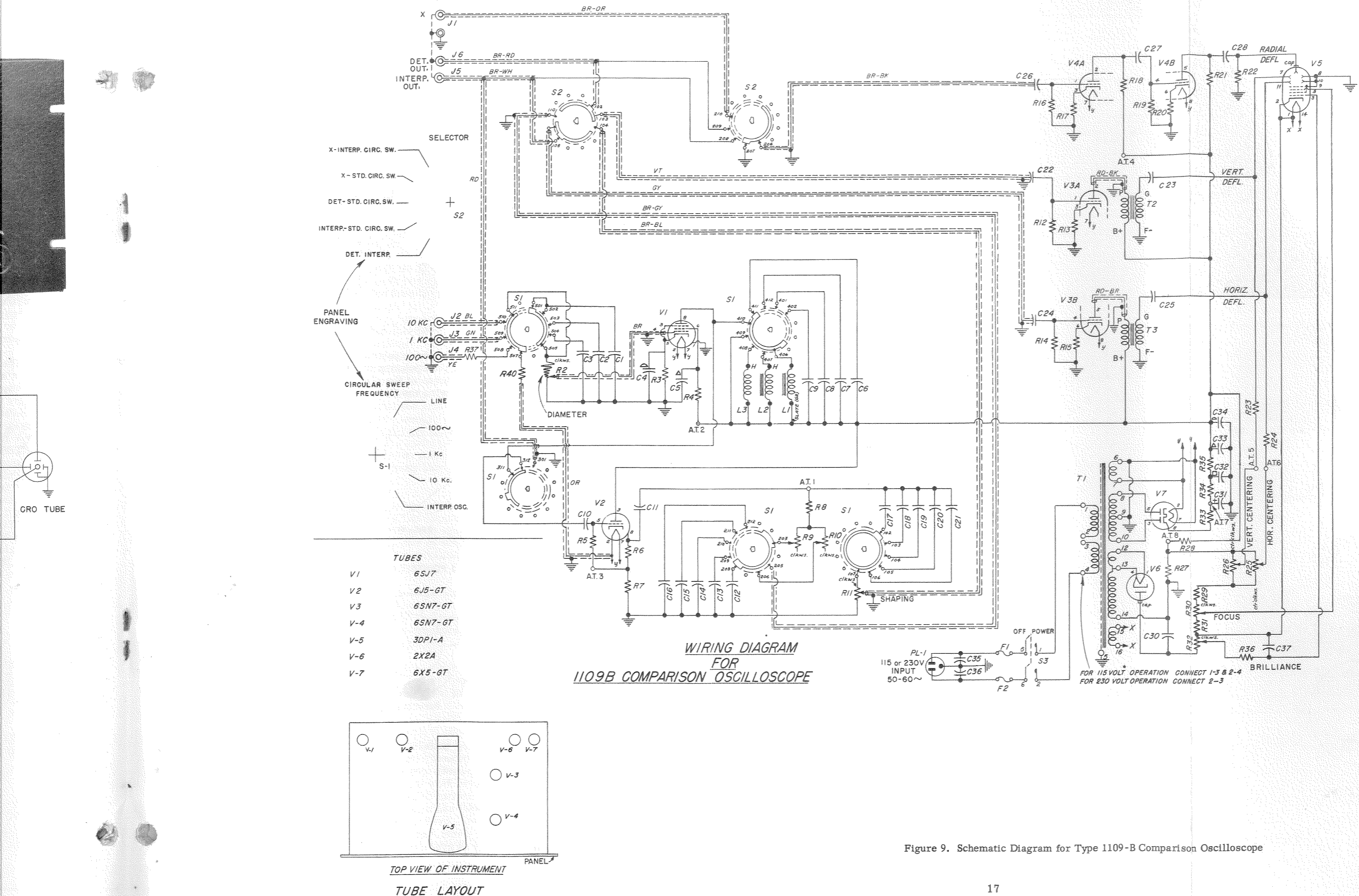

Figure 9. Schematic Diagram for Type 1109-B Comparison Oscilloscope

If a low beat frequency is to be matched, it is sometimes helpful to use the detector in an oscillating condition. The output of the Type 1106 Frequency Transfer Unit then consists of an audio-frequency tone, waxing and waning at a rate equal to the low beat frequency. If the beat frequency is several cycles per second, or more, the waxing and waning is rapid and is better described as a flutter. This flutter can be matched with the interpolation oscillator set at the flutter frequency or at a multiple thereof. The pattern for a 1:1 match is indicated in Figure 11a, in various phases of rotation. If the matching frequency is a multiple of the flutter,

the pattern at the ends of the figure is the Lissajous pattern for the multiple used. Figure 11b shows the pattern, when the interpolation oscillator is set at twice the flutter frequency, in various phases of rotation.

With the SELECTOR switch set on the other positions, circular sweep patterns are obtained. With the radial deflection voltage reduced to zero, a circle should be obtained. This can be changed in size by the DIAMETER control and in shape by the SHAPING control. The circle can be centered by the use of the HORIZONTAL and VERTICAL CENTERING controls.

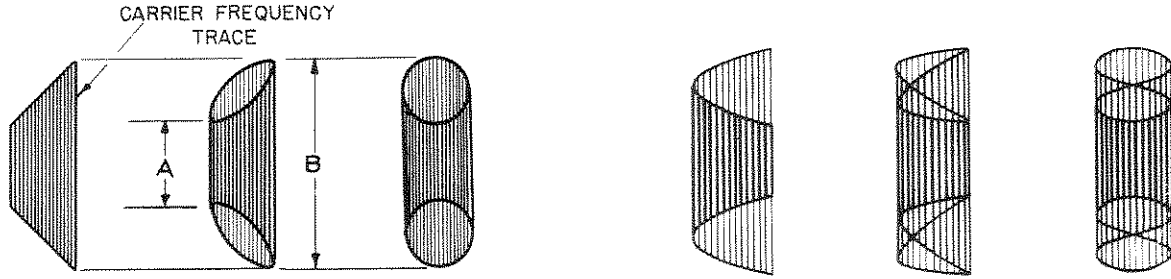

Figure 11. Modulated, or flutter, wave patterns. (a) The three patterns at the left show, for different phases of rotation, a 1:1 match where the interpolation oscillator frequency is the same as the flutter frequency. (b) The three patterns at the right show, for different phases, a match where the oscillator frequency is twice the flutter frequency.

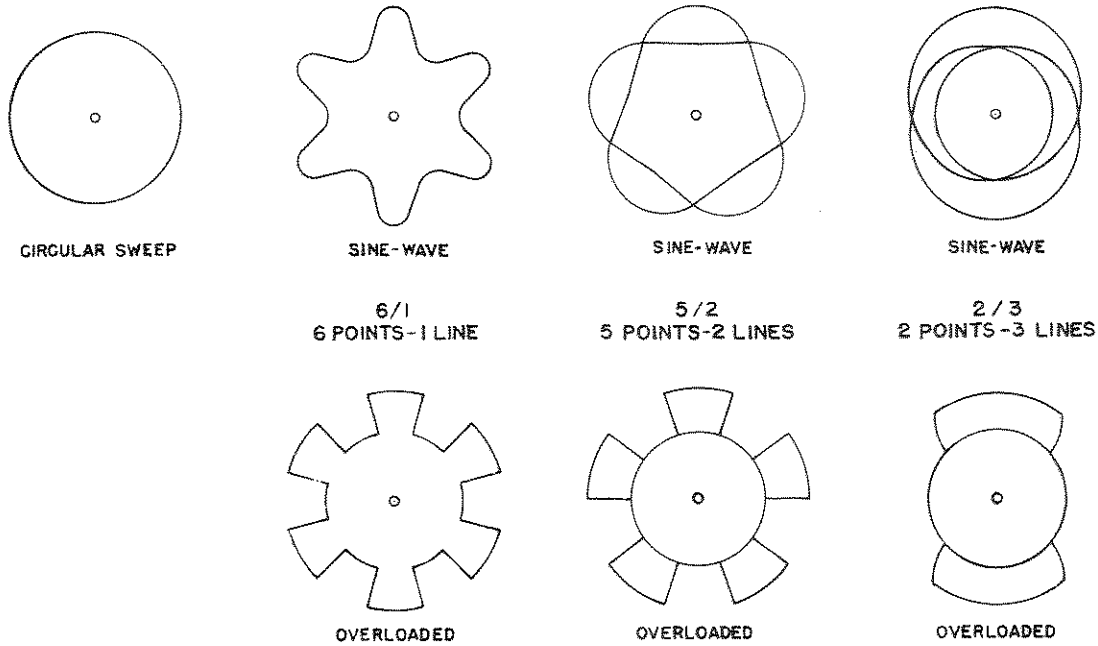

Figure 12.

Circular sweep pattern with radial deflection frequency equal to six times circular sweep frequency. SINGLE-LINE pattern. Note that with single-line patterns the inner and outer circles are not complete when the radial amplifier is overloaded.

Circular sweep pattern with radial deflection frequency equal to 5/2 times circular sweep frequency. TWO-LINE pattern. Note that with multiple-line patterns either the inner, or both inner and outer circles are complete, overlapping the teeth of the wheel, when the radial amplifier is overloaded.

Circular sweep pattern with radial deflection frequency equal to 2/3 times circular sweep frequency. THREE-LINE pattern. The effect of nearly concentric circles is characteristic when the radial deflection frequency is below the circular sweep frequency.

TYPE 1105-B FREQUENCY MEASURING EQUIPMENT

When the radial deflection voltage is applied and is not large enough to overload the amplifier and when the frequency of the applied voltage is an exact multiple of the sweep frequency, the pattern appears as in Figure 12 for a ratio of 6:1. If the pattern rotates slowly clockwise, the radial deflection frequency is slightly higher than the circular sweep frequency; if counter clockwise, the radial deflection frequency is slightly lower than the circular sweep frequency.

This is a "single line" pattern. Similar patterns are obtained for every multiple of the circular sweep frequency, one more scallop appearing each time the ratio is increased by one. That is, a ratio of 10:1 gives 10 scallops; 11:1, eleven scallops, etc.

The circular sweep voltage available from the standard frequencies is much more than is required to produce a circle of the diameter of the screen. It is very convenient to make use of this feature in cases where very high multiples of the standard frequency are to be used. Using a circular sweep of about one-half the screen diameter, the pattern shows the scallops crowded very close together. By increasing the circular sweep voltage to obtain a circle of several screen diameters and then using the VERTICAL CENTERING control to bring the top or bottom portion of the large circle onto the screen, the pattern will be opened out so that the scallops are easily distinguished. In this manner, multiples of the standard frequency to a hundred or more are easily used. This method of operation is particularly useful in "filling in" a series of closely spaced calibration points, where widely separated key points have already been spotted by the use of the regular patterns.

If the radial deflection amplifier is overloaded, the scallops become sharp-sided and flat-topped, appearing somewhat as gear teeth. It is much easier to count the number of teeth than the number of scallops, particularly on multiple patterns. The advantages of overloading are considered further below.

If the radial deflection frequency is an odd multiple of one-half the circular sweep frequency, a "two-line" pattern is obtained as illustrated in Figure 12, for a ratio of 5:2. A similar pattern with two more loops in the chain is obtained for a ratio of 7:2, etc.

This leads to interpreting the patterns on the basis of the "number of lines" (not overloaded) and the "number of points", or teeth (overloaded). The number of lines is obtainable by not overloading the amplifier; count outward, radially, the number of lines composing the pattern. The number of lines indicates at once the number of intervals into which the interval between one multiple of the standard frequency and the next has been divided. This is summarized in Figure 13 for patterns up to "five-line". The use of five-line patterns, for example, is equivalent to having a standard frequency at one-fifth the value of the actual circular sweep frequency. In other words, five-line patterns provide a standard frequency within ± 10 cycles of any audio frequency when using a 100-cycle circular sweep frequency. Another way of stating this

is to say that the system shown in Figure 13 indicates known frequencies which can be inserted in each standard frequency interval between one multiple of the standard circular sweep frequency and the next. For a 100-cycle circular sweep this means that in each 100-cycle interval between two successive multiples, points at 20, 25, 33.3, 40, 50, 60, 66.7, 75, and 80 cycles can be readily filled in, using not more than "five-line" patterns. For a 1-kc circular sweep, multiply all these points by 10; for a 10-kc circular sweep, multiply all these points by 100.

In many applications, as in measuring frequencies, the oscillator calibration is fairly well known and it is desired simply to correct small errors. The advantage of the circular sweep method in such cases is that the frequency ratio does not have to be obtained by counting, (it is given at once by the oscillator calibration) and the multiple-line patterns provide a very large number of known calibrating frequencies at closely spaced intervals throughout the range of the oscillator. The oscillator scale can therefore be made to read correctly at any one of these points and the interpolation error for small ranges about these points is negligible.

An important feature of these multiple-line patterns is that the sequence represented in Figure 12 repeats in every interval between one multiple of the standard circular sweep frequency and the next. That is, exactly the same sequence is obtained in going from 500 to 600 cycles, and from 600 to 700 cycles, etc., when using a 100-cycle circular sweep frequency. If the standard frequency is multiplied by 10, the same patterns are again obtained at intervals 10 times as large, and so on.

On an undistorted multiple-line pattern, considerable difficulty is encountered in counting the number of scallops. If the radial deflection voltage is increased until the amplifier is overloaded, the pattern will have radial, or nearly radial lines, which divide the figure into the same number of parts as the number of scallops. The difference is made evident in Figure 12.

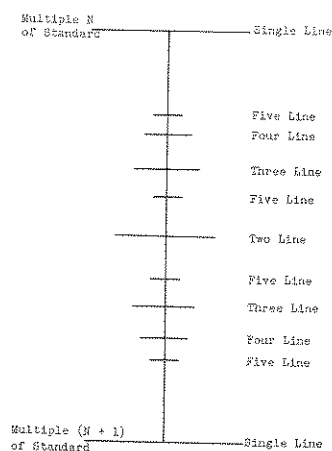

Figure 13. Division of a Standard-Frequency Interval by Multiple-Line Oscilloscope Patterns.

The following simple rule then emerges for determining the frequency ratios. The number of points divided by the number of lines is the frequency ratio. This rule holds no matter whether the radial deflection frequency is above or below the circular sweep frequency.

When the radial deflection frequency is below the standard circular sweep frequency, the pattern consists of nearly concentric circles when no overloading occurs and the frequency ratio is the ratio of small whole numbers. When overloading occurs, points similar to those previously described are obtained. This type of pattern is shown in Figure 12.

APPLICATIONS

In making frequency measurements, the various SELECTOR switch positions are used as follows:

1. DET. vs INTERP. For matching the beat-frequency output of the Type 1106 Frequency Transfer Units. Set the interpolation oscillator so that the 1:1 Lissajous figure stands still. Read the value of the beat frequency from the interpolation oscillator scales.

Suggestion: If the beat-frequency voltage is not great enough to produce a large pattern on the cathode ray tube, swing the pattern to one side of center by use of the centering control.

Suggestion: For the measurement of very low beat frequencies, the detector of the Type 1106 Frequency Transfer Units may be used in the oscillating condition. Adjust the levels of the standard and unknown frequencies to about the same value. The output of the detector then consists of an audio-frequency tone, waxing and waning in intensity at a rate equal to the difference of the standard and unknown frequencies. If this difference is several cycles per second, or more, the waxing and waning is better described as a flutter. This flutter can be matched with the interpolation oscillator set at the flutter frequency or a multiple thereof.

Suggestion: Keep INPUT control of the Type 1107 Interpolation Oscillator at zero, when matching frequency from the output of one of the Type 1106 Frequency Transfer Units. This is because the output of the Type 1106 Frequency Transfer Unit is connected to the INPUT of the Type 1107 Interpolation Oscillator at all times, for matching by using the output meter as a beat indicator.

2. INTERP. vs STD. CIRC. SW. This position permits rapid checking of the calibration of the Type 1107 Interpolation Oscillator.

Suggestion: Keep INPUT control of the Type 1107 Interpolation Oscillator at zero, to prevent any output signal from the Type 1106 Frequency Transfer Unit from appearing on the pattern.

Suggestion: In making frequency measurements, make the approximate match in (1) above, then check the oscillator calibration and set for zero error at the check point nearest the approximate setting. Return to (1) and take the final reading. This operation can be done so quickly that it is well worthwhile in obtaining the most precise results.

3. DET. vs STD. CIRC. SW. This position is for the purpose of accurately setting the frequency of a radio-frequency source to values which are not multiples of the standard harmonic frequency.

Suggestion: A particular application of this position is in producing crystals for frequency monitors, where the crystal frequency must be off-set from the channel frequency by a specified amount such as 0.5 or 1.0 kc. Using a 1-kc standard circular sweep frequency, the above differences give simple patterns.

4. X vs STD. CIRC. SW. This position is for calibrating an external audio- or low-radio-frequency oscillator, or for standardizing such an oscillator at any one of the many known frequencies obtainable by the circular sweep patterns.

Suggestion: In calibrating an oscillator, which has no calibration at all, start with the highest circular sweep frequency appropriate to the oscillator range and identify principal points on the oscillator scale. Having established such known key points, the calibration can be continued using the same or a lower circular sweep frequency. For example, an oscillator covering a range of 48 to 68kc would give simple key patterns against a 10-kc circular sweep at 50, 55, 60, and 65 kc (one- and two-line patterns). Using a 1-kc sweep, points can be filled in at every 0.5 and 1.0 kc using only one- or two-line patterns.

Suggestion: Where a complete Type 1105 Frequency Measuring Equipment is being used, the oscillator to be calibrated can be connected to the INPUT terminals of the Type 1107 Interpolation Oscillator. Turn the interpolation OUTPUT control to zero. Throw the SELECTOR switch on the Type 1109 Comparison Oscilloscope to INTERP. vs STD. CIRC. SW. The INPUT control of the interpolation oscillator then serves as a volume control for the oscillator being calibrated. This method of operation does not permit as high a frequency range to be covered as that obtained by direct connection at the x jack on the Type 1109 Comparison Oscilloscope (see 5, below).

5. X vs INTERP. CIRC. SW. This position is primarily for measuring a frequency, introduced at the x jack, by means of the interpolation oscillator using the comparison oscilloscope as the comparison device. It is effective over the range from 5 kc to 100 kc or more.

Suggestion: Turn the interpolation oscillator to the DIRECT scale and set for 5000 cycles. Introduce the frequency to be measured. Gradually reduce the frequency of the interpolation oscillator until a one-line pattern is obtained. The number of points on this pattern gives the ratio of the unknown to the interpolation oscillator frequency. Multiply the oscillator frequency by the number of points to get the value of the unknown frequency.

In the measurement of fairly high frequencies the number of points becomes very large, for example, measuring 100 kc gives a pattern with 20 points. If it is desired to avoid counting the number of points, proceed as directed above and obtain the first one-line pattern. Note the oscillator frequency reading, calling it f_1 . Then continue to reduce the oscillator frequency until the next one-line pattern is obtained. Note the oscillator frequency reading, calling it f_2 . Then $n_1 f_1 = n_2 f_2 = f_x$. But $n_2 = (n_1 + 1)$, so $(n_1 + 1)/n_1 = f_1/f_2$ and n_1 is easily

TYPE 1105-B FREQUENCY MEASURING EQUIPMENT

determined. Also $n_1 = (n_2 - 1)$, so $n_2/(n_2 - 1) = f_1/f_2$, giving n_2 and making it unnecessary to return to f_1 to complete the measurement.

Having found n_2 , obtain the final value of f_2 by

checking the interpolation oscillator against the standard at the nearest known frequency and resetting for zero error. Then take final setting of f_2 against the unknown frequency. Multiply this value of f_2 by n_2 to obtain the value of f_x .

TYPE 1106 FREQUENCY TRANSFER UNITS

SECTION 1 DESCRIPTION

PURPOSE

The Type 1106 Frequency Transfer Units are designed for use in frequency measurements, either as calibrated instruments or in conjunction with harmonic frequency standards.

The units are used to pick-up and identify the frequency to be measured; to obtain the beat-frequency difference between a harmonic of a frequency standard and the frequency under measurement; to supply a substitute signal for measurement where the original signal is subject to fading, interference, or keying; to serve as a source of frequency of a desired value; to provide means for avoiding measurements involving very small beat-frequency differences between standard and unknown frequencies; and to provide means for accurately matching two radio frequencies.

PRINCIPLES OF OPERATION

There are three frequency transfer units, differing principally in the frequency ranges covered. These are

| TYPE | RANGE |
|--------|---------------|
| 1106-A | 100 - 2000 Kc |
| 1106-B | 1 - 10 Mc |
| 1106-C | 10 - 100 Mc |

Each Type 1106 Frequency Transfer Unit consists of a heterodyne frequency meter and a regenerative detector with a two-stage audio-frequency amplifier. Both the frequency meter and the detector are provided with range switching and direct-reading frequency calibrated dials. The ranges of the frequency meter and detector are the same, at corresponding positions of the range switch. This feature is of considerable importance for easy operation. The frequency controls of both instruments give increasing frequency with right-handed rotation of the control knob.

While the detector has an actual fundamental range for each range switch position, the frequency meters have either two or three fundamental ranges (for the first two or three ranges) with the balance covered by selected harmonics. The fundamental ranges, the harmonic ranges, the frequency coverage of every range and the number of the harmonic used for coverage of a harmonic range are all indicated on the accompanying range chart. Further, the chart indicates which one of the fundamental ranges is involved in the coverage of each of the harmonic ranges. The harmonic ranges are all calibrated on the frequency dial, and in the normal use of the instrument, there is no noticeable difference in operation on either fundamental or harmonic ranges.

The use of harmonic frequency ranges in the frequency meter permits the use of fewer coils. The coils that are needed can, therefore, be made of much greater volume with a resulting higher Q, giving much improved performance.

The output circuit of the heterodyne frequency meter includes a buffer amplifier, a rectifier for harmonic generation, and a control for adjusting the level. The output connection is a concentric plug at the rear.

The radio-frequency input circuit to the detector is at a concentric plug at the rear. The input circuit is designed to work from an impedance level of about 50 ohms. The audio-frequency output is obtained at a concentric plug at the rear, and is at approximately 500-ohm impedance level. All of these connections are intended for use with the Type 1108 Coupling Unit.

The detector is supplied with a regeneration control so that the detector can be operated in either the oscillating or non-oscillating condition.

SECTION 2 INSTALLATION

(1) Install vacuum tubes, if not shipped in place, in accordance with the tube tags.

(2) Connect power supply by means of cord and plug

supplied. Be certain that power corresponds in voltage and frequency with values given on plate at receptacle.

(3) For change from 105 - 125 volts to 210 - 250 volts,

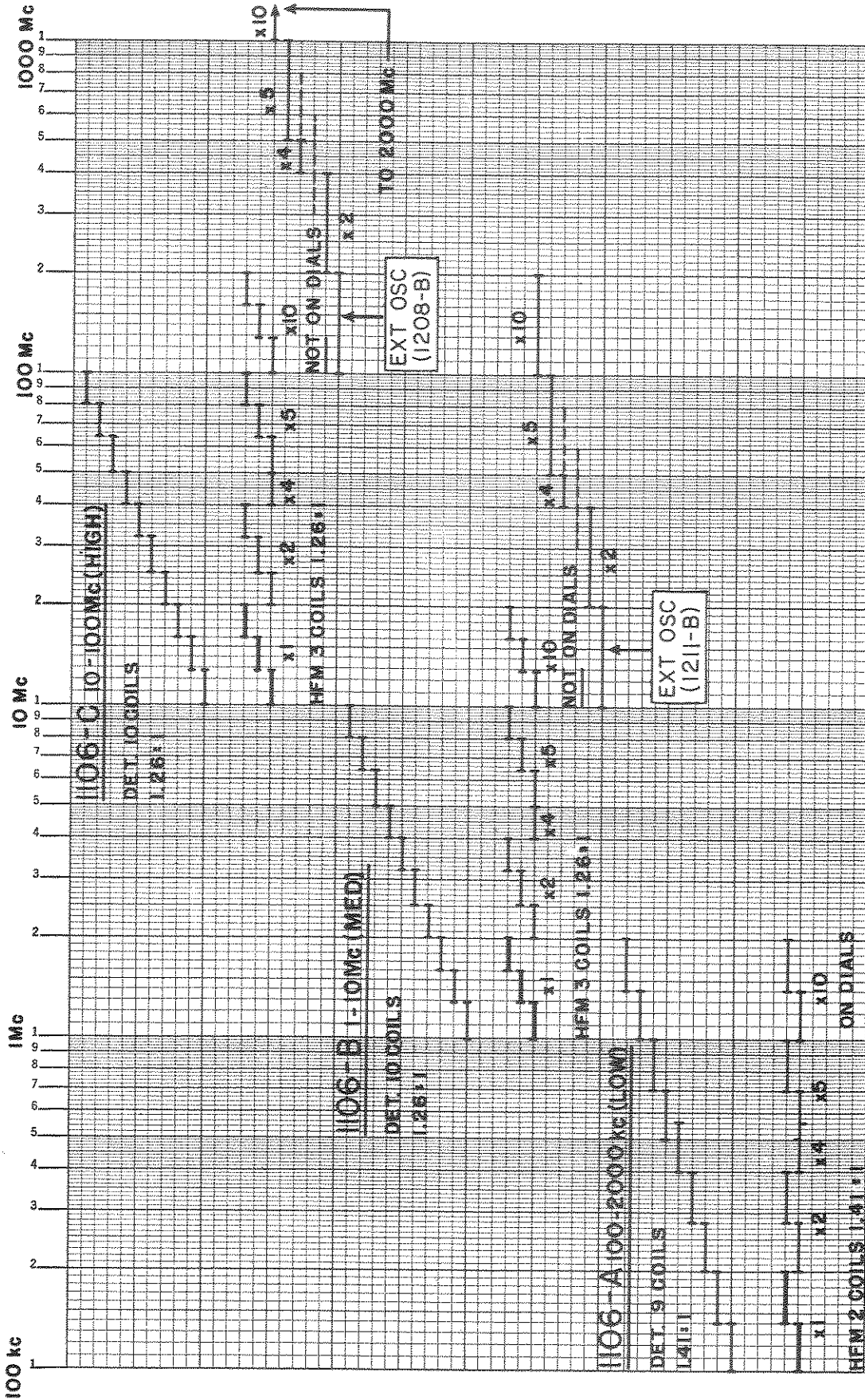

Range Chart

This chart presents, on a logarithmic frequency scale, the limits of each range of the heterodyne detectors and heterodyne frequency meters of the Type 1106 Frequency Transfer Units. The 1106-A (Low) Unit covers 100 - 2000 kc; the 1106-B (Medium) Unit covers 1 - 10 Mc; the 1106-C (High) Unit covers 10 - 100 Mc.

Successive fundamental frequency ranges are presented at successively higher levels giving a stair-type figure. Harmonic ranges are presented horizontally to the right of the fundamental range which produces them and are marked with the number of the harmonic. These harmonic ranges, except where noted, are given calibrations on the dials of the heterodyne frequency meters.

or vice-versa, connect primary windings of transformer as shown in wiring diagram and change fuses as indicated in parts list.

(4) Input and output connections are made by concentric plugs at the rear.

(5) Throwing the POWER switch to ON supplies power to the whole instrument. The PLATE switch permits removing the plate voltage of the heterodyne frequency meter, so that its signal may be removed, during a measurement, without changing the dial setting.

SECTION 3 OPERATION

DETECTOR

The effective operation of a regenerative detector requires a certain amount of practice. The beginning of oscillations usually occurs with the regeneration control advanced about one-quarter to one-half from the minimum position. For any given frequency setting, the most sensitive condition for receiving continuous wave signals is just after oscillations have started. The most sensitive condition for modulated signals is just below where oscillations start. Careful adjustment of the regeneration control is therefore important. If the regeneration control is advanced too far, a squeal may be heard in the output, due to blocking of the detector.

Do not overload the detector tube with strong signals. The sensitivity is best at fairly low signal strength. When receiving continuous wave signals, too strong a signal applied may lock the detector into synchronization over an appreciable range on the frequency dial.

If difficulty is encountered in picking up a signal whose frequency is only approximately known, introduce a standard-harmonic signal such as multiples of 10 kc or 100 kc. Adjustment of the detector can then be made to the most sensitive oscillating condition. Removing the standard-harmonic signal then permits search over a small range with "preadjusted" detector.

The frequency calibration of the detector is somewhat affected by the setting of the regeneration control. It is most accurate when regeneration is adjusted where oscillations just start, that is, when adjusted for normal operation in the most sensitive condition.

HETERODYNE FREQUENCY METER

In measuring a frequency, or in identifying a harmonic of a frequency standard, the output of the frequency meter is combined with the unknown or standard frequency and both are applied to the input of the detector. Means are provided in the Type 1108 Coupling Panel for carrying out all the necessary switching, as well as regulation of the voltage levels of the standard frequency harmonics and unknown frequency. When the Type 1106 Frequency Transfer Unit is used independently, means must be provided externally for combining the voltages and for regulation of the amplitude of the frequency being measured.

Having picked up and identified the frequency to

be measured in the oscillating detector, set the heterodyne frequency meter to the same range and dial setting. Then search in the vicinity of this dial setting until a beat note is heard. Adjust the frequency meter output so that beats of about equal intensity are obtained in the detector for the unknown and heterodyne frequency meter signals.

The heterodyne frequency meter can then be set accurately in agreement with the unknown frequency by the "three oscillator method". Detune the detector so that beat tones of a kilocycle or so are obtained with the frequencies of the unknown and the heterodyne frequency meter. This beat tone will wax and wane in intensity at a rate equal to the difference of the frequencies of the unknown and the heterodyne frequency meter. By careful adjustment of the frequency meter, the rate of waxing and waning can be reduced to a very small value, in which case the frequency meter is closely matched to the unknown frequency. The value of the unknown frequency is then read from the frequency meter dial.

Since the waxing and waning effect can be produced by matching any pair of the three frequencies, it is well to be certain that the correct pair has been matched, that is, the unknown and frequency meter frequencies. When the waxing and waning has been adjusted to a low value, change the detector tuning slightly. The pitch only of the beat tone heard should change but not the rate of waxing and waning. If either of the other two pairs of frequencies have been matched in error, the rate of waxing and waning will change tremendously when the detector tuning is altered.

In using harmonics of the heterodyne frequency meter, it is evident, from the accompanying range chart, that when the detector is employed, the correlated ranges automatically insure the use of the correct harmonic. The same is true with an external calibrated receiver, if the heterodyne frequency meter is set so that the dial reading corresponds to the frequency of the receiver. With an external receiver it is easy to extend the range of the heterodyne frequency meter to include the use of the 10th harmonic (which is not on the calibrated dials of the 1106-B and 1106-C frequency meters). When the receiver is tuned to frequencies in the range from 10 to 20 Mc, or 100 to 200 Mc, the heterodyne frequency meter of the corresponding unit is set by using one of the fundamental frequency ranges (the first three range switch positions) and adjusting the frequency

GENERAL RADIO COMPANY

meter for 1/10th of the receiver frequency.

At times, when the output of the heterodyne frequency meter is taken to external equipment, situations arise where the harmonic of the frequency meter is not identified by the method of use. In such cases considerable confusion can result if the range settings corresponding to the harmonic ranges, shown in the range chart, are used.

If the unknown frequency is above the fundamental range of the frequency meter, first establish which harmonic is being used, by utilizing the fundamental scales only. With the heterodyne frequency meter set at the highest fundamental frequency, gradually reduce the frequency until a beat is obtained against the unknown frequency. Note the frequency meter reading for zero beat. Then continue to reduce the frequency of the frequency meter until the next beat is obtained against the unknown frequency. Note the frequency meter reading for zero beat. Then, if f_1 is the first reading and f_2 the second, we have:

$$nf_1 = (n + 1)f_2 = f_x$$

$$\text{and } n = \frac{f_2}{f_1 - f_2}$$

The harmonic number n should be an integer; if the calculated result does not give an integral value, it is evident what the nearest integral value is, and this value should be used.

If this integer corresponds to one of the harmonic numbers appearing on the range chart, the range switch of the frequency meter can be set for the corresponding range, giving a direct-reading scale. If the integer is not one appearing on the range chart, it is a simple matter to choose another value of n , by taking successively lower settings on the fundamental frequency meter scales.

If the unknown frequency is below the fundamental frequency range of the heterodyne frequency meter, any beat which is obtained is due to a harmonic of the unknown frequency beating with the fundamental (or a harmonic) frequency of the frequency meter. The harmonic can be identified most easily by use of the detector. Starting with the lowest frequency, gradually raise the detector frequency until a beat is obtained. Note the frequency reading for zero beat. Raise the detector frequency until the next beat is obtained and note the frequency reading for zero beat. Then if f_1 is the first and f_2 is the second frequency reading, we have:

$$nf_x = f_1$$

$$(n + 1)f_x = f_2$$

$$f_2 - f_1 = f_x$$

The difference of the two frequency readings gives an approximate value for f_x , which, when substituted in either of the first two equations permits identification of n , since n must be an integer.

TYPE 1105-B FREQUENCY MEASURING EQUIPMENT

TYPE 1107-A INTERPOLATION OSCILLATOR

SECTION 1 DESCRIPTION

PURPOSE

The Type 1107-A Interpolation Oscillator is designed particularly for use in conjunction with standard-frequency equipment to measure the audio-frequency difference between the unknown frequency and a harmonic of 10 kc from the standard. This difference ranges from 0 to 5000 cycles, for all such measurements.

ADVANTAGES

The Type 1107-A Interpolation Oscillator is of the beat-frequency type, with a direct-reading linear scale; each division of the scale corresponds to an increment of one cycle. A special feature is the use of "direct" and "reverse" scales, permitting frequency measurements to be made by addition only. This feature is described in detail below.

Provision is made for readily introducing a standard frequency for checking the calibration of the interpolation oscillator, utilizing the output voltmeter as a beat indicating meter. In a similar manner, an audio frequency, the value of which is to be determined, can be introduced. Separate volume controls are provided for adjustment of the levels of the interpolation oscillator output and the input signal from either the frequency standard or the source under measurement.

Separate incremental-frequency dials, covering a range of plus or minus 10 cycles, are provided for both "direct" and "reverse" scales. These are also used as zero adjustments.

PRINCIPLES OF OPERATION

The audio frequency output (0 - 5000 cycles) is derived from the difference in frequency of two radio frequency oscillators operating at 42 or 47 kc and 42 to 47 kc. The fixed frequency of 42 or 47 kc is selected by the "direct" and "reverse" switch positions respectively. In the "direct" position, as the dial is moved over the 0 - 5000 divisions scale, the output frequency varies from 0 upward to 5000 cycles. In the "reverse" position, as the dial is moved over the 0 - 5000 division scale, the output frequency varies from 5000 cycles downward to zero. The "reverse" scale is separate from the "direct" scale and is marked to be read from 5000 to 10000 cycles. The scale in use is marked by an illuminated index, the illumination changing from one index to the other, when the "direct-reverse" switch is operated.

The accompanying figures indicate the manner of use for measuring frequencies in conjunction with a 10-kc harmonic standard frequency.

In Figure A, the unknown frequency is less than 5000 cycles above the 10-kc standard frequency harmonic f_1 . Using the "direct" scale, the difference in frequency $f_x - f_1 = f_b$ is matched by using the interpolation oscillator. The value of f_x is then given by $f_x = f_1 + f_b$.

In Figure B, the unknown frequency is more than 5000 cycles above the 10-kc standard frequency harmonic f_1 . Using the "direct" scale, the difference in frequency $f_2 - f_x = f_b$ is matched by using the interpolation oscillator. The value of f_x is then given by $f_x = f_2 - f_b$. It will be noted that the "direct" scale corresponds to the usual interpolation oscillator having but one scale. It will also be noted that, in effect, the scale divisions are laid off to the left of f_2 , that is, in a negative direction, corresponding to the subtraction of f_b from f_2 .

In Figure C, the use of the "reverse" scale is indicated. On throwing the switch to the "reverse" position, the fixed oscillator frequency is shifted by 5000 cycles. The output frequency then varies from 5000 cycles at zero divisions on the original scale to zero at 5000 divisions on the original scale. In other words, the sense of the frequency change with dial reading has been reversed. Using the original vernier dial, a new main scale is provided which is marked to read 5000 divisions (at zero of the original scale) to 10,000 divisions (at 5000 divisions of the original scale). For the same value of $f_2 - f_x = f_b$ as in Figure B, the actual interpolation oscillator output frequency must, of course, be the same as before to obtain a match. Referred to the initial 10-kc standard frequency harmonic, f_1 , we can write for $f_x = f_2 - f_b$, $f_x = f_1 + (f_2 - f_1 - f_b)$. The difference $f_2 - f_1$ is of course equal to 10 kc, the base standard frequency. The quantity in parenthesis is then equal to 10 kc minus the beat frequency f_b . This quantity is evidently the same as f_b' , read in a positive sense from f_1 , the initial 10-kc standard frequency harmonic, and $f_x = f_1 + f_b'$, where f_b' is read from the scale provided for the "reverse" switch position.

In Figure D, the frequency and dial divisions of the interpolation oscillator are shown, for use of the "direct" and "reverse" scales, as required for covering a complete interval from one 10-kc standard frequency harmonic, f_1 , to the next higher, f_2 . Figure D, in effect, combines Figures A and C.

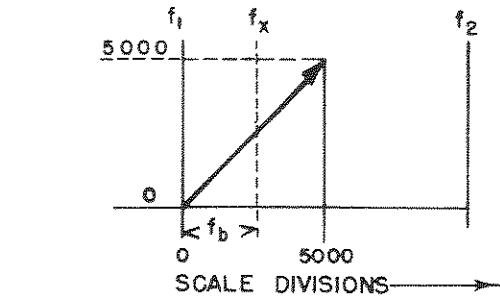

"DIRECT" SCALE

$$f_x = f_1 + f_b$$

(A)

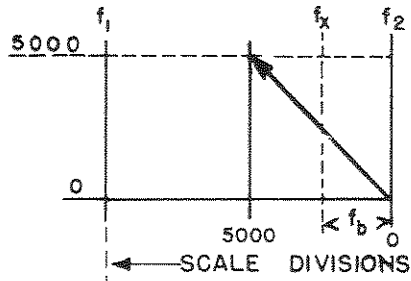

"DIRECT" SCALE

$$f_x = f_2 - f_b$$

(B)

FREQUENCY IN CYCLES

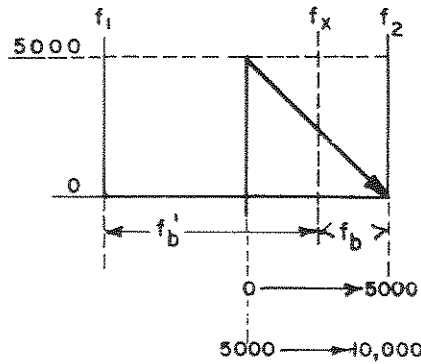

"REVERSE" SCALE

$$f_x = f_1 + (f_2 - f_1 - f_b)$$

$$= f_1 + f'_b$$

(C)

ORIGINAL SCALE DIVISIONS, WHICH

ARE MARKED TO BE READ AS 5000-10,000 CYCLES, ON THE "REVERSE" SCALE.

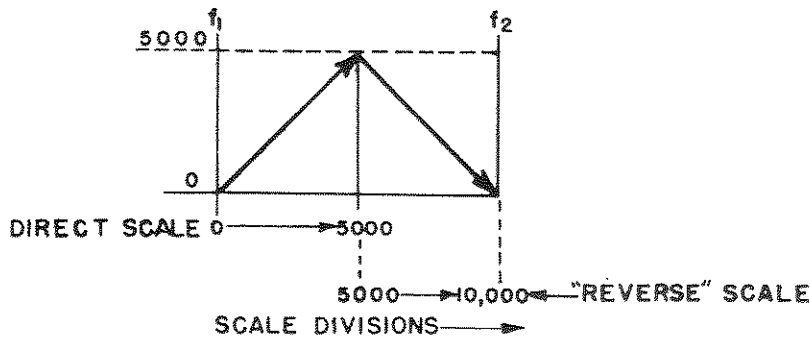

(D)

TYPE 1107-A INTERPOLATION OSCILLATOR

SECTION 2 INSTALLATION

- (1) Install vacuum tubes, if not shipped in place, in accordance with the tube tags.
- (2) Connect the line plug to the power line. Be sure that voltage and frequency correspond to values given on nameplate beside power socket.
- (3) For change from 105 - 125 volts to 210 - 250 volts or vice-versa, connect primary windings of transformer as shown in wiring diagram and change fuses as indicated in parts list.
- (4) When the power switch is thrown to ON, a bright disc of light should appear at the index of the scale, on the lower scale for the DIRECT-REVERSE switch in the DIRECT position, and on the upper scale for the switch in the REVERSE position. The disc of light thus serves as a "pilot" as well as indicating the scale in use.
- (5) Separate input and output terminals are supplied both on the panel and at the rear. The output voltage of the oscillator is available at the output terminals; the output level is controlled by adjustment of the OUTPUT volume control. The INPUT terminals are provided for introduction of the audio frequency to be matched on the oscillator. The level is controlled by adjustment of the INPUT control.
- (6) The panel terminals for input and output are arranged for use with either Type 274 Plugs or concentric connectors; the rear terminals are arranged for use with concentric connectors only, which are supplied on the patch cords for connecting Type 1105 Measuring Equipment.

SECTION 3 OPERATION

CALIBRATION

The instrument is adjusted at the factory so that the scale is direct-reading within ± 2 cycles.

STANDARDIZATION

As the instrument is normally used as an interpolation oscillator, in conjunction with a frequency standard, provision has been made in the Type 1105 Frequency Measuring Equipment for the rapid and convenient checking of the oscillator calibration against 100- or 1000-cycle standard frequency, using a cathode ray oscilloscope. This method provides a tremendous number of known frequencies, so that the oscillator can be checked at points within 10 cycles of any frequency in the range from 0 to 5000 cycles. In use it is more convenient to bring the scale error to zero, by adjustment of the " Δf " dial, as a "zero set", than it is to determine the value of the error.

ALTERNATIVE METHOD

When the interpolation oscillator is not being used with a frequency standard, a few volts derived from the a-c power line can be used as a standardizing source.

USE

Beat Indication: In matching an unknown frequency with the interpolation oscillator, it is generally most convenient to use telephones or loudspeaker while watching the beats on the output meter. If the source being measured provides ample signal, adjust the INPUT volume control (with the OUTPUT control at minimum) until a deflection of roughly one-half scale is obtained

on the meter. Then advance the OUTPUT control to obtain the maximum swing on the meter, when the oscillator frequency has been adjusted nearly to the frequency being measured. Under these conditions, the meter needle will swing from nearly zero to nearly full scale. Accurate matching is then obtained when the oscillator frequency is adjusted to stop the motion of the needle at mid-swing.

Weak Signals: If the source being measured provides only a weak signal, advance the INPUT control to maximum. Advance the OUTPUT control only far enough to cause the meter needle to swing near to zero on the scale. This adjustment gives the greatest possible swing, which, however, may be over only the first few divisions of the meter scale.

If the oscillator has been set to one-half or twice the frequency being measured, although a small swing of the meter needle may be observed, it is not possible to obtain the pronounced swings, down to zero, as described above.

Beat Matching with the CRO: In matching a very low frequency, it is difficult to tell by ear whether or not the oscillator is equal to the frequency being measured. Frequently, it is found that the oscillator has been set to one-half or twice the low frequency. With the precautions previously outlined it is usually possible to get a match by use of the output voltmeter. It is much more reliable and generally much quicker to use a cathode ray oscilloscope, since the form of the pattern leaves no doubt as to the frequency ratio. A further advantage is that the oscillator can be set to a known multiple of the frequency being measured and a more accurate result is obtained.

GENERAL RADIO COMPANY

Small Changes in Frequency: The "Δf" dials are provided with scales covering +10 cycles, in 0.5 cycle divisions. In measuring small changes in frequency, set the Δf dial at zero and adjust the main frequency control to the reference frequency. The small changes in frequency are then matched by use of the Δf dial, the + portion indicating an increase and the - portion a

decrease in frequency from the reference value.

Audio Source: To use the interpolation oscillator as an audio-frequency source, use the DIRECT scale. Turn the INPUT control to minimum. The output voltage is controlled by adjustment of the OUTPUT control. The meter indicates the voltage applied to the load connected to the "output" terminals.

SECTION 4 MAINTENANCE

If it is found that, over a period of time, the settings of the Δf dials have drifted from zero when the main scale is set to correct reading against a standard frequency, realignment is readily made as follows: Set the main dial to the correct reading for the frequency of the standard. Adjust the Δf dial for zero beat. Adjust the trimmer capacitor corresponding with the Δf dial in use (under snap covers just below the DIRECT-REVERSE switch) until zero beat is again obtained at zero on the Δf dial.

If it is found that the number of divisions on the main scale, to cover the range from 1 to 5 kc is greater

(or less) than the correct number, it indicates that the variable capacitance is too small (too large) relative to the fixed capacitance, in the variable oscillator circuit. The initial capacitance of the circuit should therefore be reduced (increased) slightly. This is done by removing the snap cover, to the right of the main frequency control, and adjusting the trimmer capacitance.

Having made a change in the setting of the trimmer, reset the oscillator to 1 kc, readjusting the Δf capacitor as necessary; then check the scale reading obtained at 5 kc. Repeat the trimmer adjustment as necessary to obtain correct alignment.

| RESISTORS | | | | CONDENSERS | | | | TYPE |
|-----------|------|--------|------|------------|-------|----|-----------|-----------------|
| R1 | 1 | Megohm | ±10% | C1 | 0.001 | μf | ±10% | COM-45B |
| R2 | 22 | K Ohms | ±10% | C2 | 0.04 | μf | ±10% | 505-462 |
| R3 | 50 | K Ohms | ±10% | C3 | 0.04 | μf | ±10% | 505-462 |
| R4 | 1 | Megohm | ±10% | C4 | 890 | μf | | 1107-25 |
| R5 | 5 | K Ohms | ±10% | C5 | 0.05 | μf | ±10% | COM-50B |
| R6 | 56 | K Ohms | ±10% | C6 | 1 | μf | ±10% | COL-45 |
| R7 | 560 | K Ohms | ±10% | C7 | | | | |
| R8 | 5 | K Ohms | ±10% | C8 | 140 | μf | | COA-5 |
| R9 | 22 | K Ohms | ±10% | C9 | | | | 368-414-2 |
| R10 | 560 | Ohms | ±10% | C10 | 140 | μf | | COA-5 |
| R11 | 2700 | Ohms | ±10% | C11 | 325 | μf | | COA-5-2 |
| R12 | 1 | Megohm | ±10% | C12 | | | | 368-414 |
| R13 | 1 | Megohm | ±10% | C13 | | | | COM-45B |
| R14 | 22 | K Ohms | ±10% | C14 | 500 | μf | ±10% | COL-3 |
| R15 | 50 | K Ohms | ±10% | C15 | 0.25 | μf | ±10% | COM-45B |
| R16 | 1500 | Ohms | ±10% | C16 | 500 | μf | ±10% | COM-45B |
| R17 | 47 | K Ohms | ±10% | C17 | 0.001 | μf | ±10% | COM-45B |
| R18 | 100 | K Ohms | ±10% | C18 | 0.04 | μf | ±10% | 505-462 |
| R19 | 12 | K Ohms | ±10% | C19 | 0.04 | μf | ±10% | 505-462 |
| R20 | 33 | K Ohms | ±10% | C20 | | | | 622-401 |
| R21 | 47 | K Ohms | ±10% | *C21 | 140 | μf | | COA-5 |
| R22 | 30 | K Ohms | ±10% | *C22 | 25 | μf | | COA-1 |
| R23 | 56 | K Ohms | ±10% | C23 | 0.05 | μf | ±10% | COM-50B |
| R24 | 560 | Ohms | ±10% | C24 | 1 | μf | ±10% | COM-45 |
| R25 | 22 | K Ohms | ±10% | C25 | 100 | μf | ±10% | COM-45B |
| R26 | 22 | K Ohms | ±10% | C26 | 0.002 | μf | ±10% | COM-45B |
| R27 | 1 | Megohm | ±10% | C27 | 100 | μf | | COA-4 |
| R28 | 560 | Ohms | ±10% | C28 | 0.002 | μf | ±10% | COM-45B |
| R29 | 22 | K Ohms | ±10% | C29 | 20 | μf | 450 volts | Part of COEB-25 |
| R30 | 22 | K Ohms | ±10% | C30 | 0.05 | μf | ±10% | COM-50B |
| R31 | 1 | Megohm | ±10% | C31 | 20 | μf | 450 volts | Part of COEB-25 |
| R32 | 560 | Ohms | ±10% | C32 | 0.05 | μf | ±10% | COM-50B |
| R33 | 3300 | Ohms | ±10% | C33 | 20 | μf | 450 volts | Part of COEB-25 |
| R34 | 50 | K Ohms | ±10% | C34 | 0.05 | μf | ±10% | COM-50B |
| R35 | 1 | Megohm | ±10% | C35 | 16 | μf | 150 volts | COE-4 |
| R36 | 560 | Ohms | ±10% | C36 | 0.05 | μf | ±10% | COM-50B |
| R37 | 3300 | Ohms | ±10% | C37 | 0.05 | μf | ±10% | COM-50B |
| R38 | 22 | K Ohms | ±10% | C38 | 16 | μf | 150 volts | COE-4 |
| R39 | 270 | Ohms | ±10% | C39 | 20 | μf | 450 volts | Part of COEB-25 |
| R40 | 270 | Ohms | ±10% | C40 | 0.01 | μf | ±10% | COL-71 |
| R41 | 270 | Ohms | ±10% | C41 | 0.01 | μf | ±10% | COL-71 |
| R42 | 3.6 | Ohms | ±10% | C42 | 100 | μf | 500 volts | COE-10 |
| R43 | 560 | Ohms | ±10% | C43 | 100 | μf | 500 volts | COE-10 |
| R44 | 560 | Ohms | ±10% | C44 | 100 | μf | 500 volts | COE-10 |

INDUCTORS

| | | | |
|----|------|----|-------------------|
| L1 | 11.4 | mh | 1107-26 |
| L2 | 80 | mh | 379-R |
| L3 | 11.4 | mh | 1107-26 |
| L4 | 80 | mh | 379-R |
| L5 | 250 | mh | 119-A (9 OR COIL) |

* Part of 622-401

MISCELLANEOUS

| | | |
|-----|-----------------------------|------------------------|
| T1 | Transformer | 485-439-2 |
| S1 | Switch DPST | SWT-333, NP |
| S2 | Switch SWRW | 46 |
| F1 | Fuse 8/10 amp Slow Blow 3AG | (G.R. FUF-1) 115 volts |
| F2 | Fuse 8/10 amp Slow Blow 3AG | (G.R. FUF-1) 115 volts |
| F1 | Fuse 3/10 amp Slow Blow 3AG | (G.R. FUF-1) 230 volts |
| F2 | Fuse 3/10 amp Slow Blow 3AG | (G.R. FUF-1) 230 volts |
| PL1 | Plug | ZCDPP-10 |
| J-1 | Jack | 874-406 |
| J-2 | Jack | 874-406 |
| J-3 | Jack | 874-P |
| J-4 | Jack | 874-P |
| P1 | 6.3 volt Pilot Light | 2LAP-939 |
| P2 | 6.3 volt Pilot Light | 2LAP-939 |
| M1 | | MEDS-103 |

TUBES

| | |
|-----|-----------|
| V-1 | = 6AC7 |
| V-2 | = 6J5-GT |
| V-3 | = 6J5-GT |
| V-4 | = 6AC7 |
| V-5 | = 6SN7-GT |
| V-6 | = 6SN7-GT |
| V-7 | = 6J5-GT |
| V-8 | = 6X5-GT |
| V-9 | = OD3 |

GENERAL RADIO COMPANY

TYPE 1106-A FREQUENCY TRANSFER UNIT

| RESISTORS | | | TYPE | CONDENSERS | | | |
|-----------|------------|------|---------------------------|------------|-----------------|--------------|------------|
| R-1 = | 39 K Ohms | ±10% | REC-30BF | C-1 = | 0.0002 μ f | ±10% | COM-45B |
| R-2 = | 10 K Ohms | ±10% | REC-30BF | C-2 = | 0.025 μ f | ±10% | COM-50B |
| R-3 = | 33 K Ohms | ±10% | REC-30BF | C-3 = | 0.025 μ f | ±10% | COM-50B |
| R-4 = | 1 Megohm | ±10% | REC-20BF | C-4 = | 0.01 μ f | ±2% | COM-45E |
| R-5 = | 1 Megohm | ±10% | REC-20BF | C-5 = | 0.01 μ f | ±2% | COM-45E |
| R-6 = | 750 Ohms | ±5% | REW-4C | C-6 = | 325 μ mf | | GR 1106-29 |
| R-7 = | 0.1 Megohm | ±10% | REC-30BF | C-7 = | 500 μ mf | | 779-403 |
| R-8 = | 10 K Ohms | ±10% | REC-30BF | C-8 = | 25 μ mf | ±10% | COM-20B |
| R-9 = | 200 Ohms | ±10% | POSC-10 | | | | |
| R-10 = | 220 Ohms | ±10% | REC-20BF | C-10 = | 1 μ f | ±10% | COL-5 |
| R-11 = | | | | C-11 = | 1 μ f | ±10% | COL-5 |
| R-12 = | | | | C-12 = | 0.01 μ f | ±10% | COM-45B |
| R-13 = | | | | C-13 = | 0.01 μ f | ±10% | COM-45B |
| R-14 = | | | | C-14 = | | | |
| R-15 = | | | | C-15 = | | | |
| R-16 = | 240 Ohms | ±5% | REW-6C | C-16 = | | | |
| R-17 = | 240 Ohms | ±5% | REW-6C | C-17 = | | | |
| R-18 = | 240 Ohms | ±5% | REW-6C | C-18 = | 15 μ mf | | 368-A |
| R-19 = | 5 K Ohms | ±2% | REPO-1037 | C-19 = | | | |
| R-20 = | | | | C-20 = | 0.01 μ f | ±10% | COL-71 |
| R-21 = | 10 Ohms | ±10% | REPO-1028 | C-21 = | 0.01 μ f | ±10% | COL-71 |
| R-22 = | 10 Ohms | ±10% | REPO-1028 | C-22 = | 100 μ f | 450 D.C.W.V. | COE-10 |
| R-23 = | | | | C-23 = | 100 μ f | 450 D.C.W.V. | COE-10 |
| R-24 = | 10 K Ohms | ±10% | REC-30BF | C-24 = | 100 μ f | 450 D.C.W.V. | COE-10 |
| R-25 = | 1 Megohm | ±10% | REC-20BF | C-25 = | | | |
| R-26 = | 0.1 Megohm | ±10% | REC-30BF | C-26 = | | | |
| R-27 = | 10 K Ohms | | POSC-9 | C-27 = | 0.001 μ f | ±10% | COM-30B |
| R-28 = | 47 K Ohms | ±10% | REC-30BF | C-28 = | 0.001 μ f | ±10% | COM-30B |
| R-29 = | 47 K Ohms | ±10% | REC-30BF | C-29 = | 0.005 μ f | ±2% | COM-45E |
| R-30 = | 10 K Ohms | ±10% | REC-30BF | C-30 = | 500 μ mf | | 779-401 |
| R-31 = | 1 Megohm | ±10% | REC-20BF | C-31 = | 320 μ mf | | GR 1106-29 |
| R-32 = | 470 Ohms | ±10% | REW-4C | C-32 = | 0.00025 μ f | ±10% | COM-10B |
| R-33 = | 47 K Ohms | ±10% | REC-30BF | C-33 = | 100 μ mf | ±10% | COM-20B |
| R-34 = | 1 Megohm | ±10% | REC-20BF | C-34 = | 0.01 μ f | +20% ±10% | GR COM-16 |
| R-35 = | 470 Ohms | ±10% | REW-4C | C-35 = | 1 μ f | ±10% | COM-16 |
| R-36 = | 47 K Ohms | ±10% | REC-30BF | C-36 = | 20 μ f | 450 D.C.W.V. | COE-5 |
| R-37 = | 0.1 Megohm | ±10% | REC-20BF | C-37 = | 0.05 μ f | ±10% | COM-50B |
| R-38 = | 270 Ohms | ±10% | REC-20BF | C-38 = | 200 μ f | 10 D.C.W.V. | COM-6 |
| R-39 = | 10 K Ohms | ±10% | REC-30BF | C-39 = | 0.05 μ f | ±10% | COM-50B |
| R-40 = | 60 Ohms | ±10% | REC-20BF, 120 Ohms, in // | C-40 = | 200 μ f | 10 D.C.W.V. | COM-6 |
| R-41 = | 47 Ohms | ±10% | REC-20BF | C-41 = | 0.05 μ f | ±10% | COM-50B |
| | | | | C-42 = | 16 μ f | 150 D.C.W.V. | COE-4 |

| INDUCTORS | | MISCELLANEOUS | |
|-------------|----------------|---------------|-------------------------|
| L-1 = | 1106-26-1 | S-1 = | Switch 1106-28 |
| L-2 = | 1106-26-2 | S-2 = | Switch DPST SWT-333, NP |
| L-3 = | 60 mh 379-R | S-3 = | Switch DPST SWT-333, NP |
| L-4 = | 2.5 mh CHA-597 | S-4 = | Switch 1106-27 |
| L-5 = | | | |
| L-6 = | | | |
| L-7 = | | J-1 = | Jack 374-406 |
| L-8A & B = | 1106-25-1 | J-2 = | Jack 374-P |
| L-9A & B = | 1106-25-2 | J-3 = | Jack 374-P |
| L-10A & B = | 1106-25-3 | | |
| L-11A & B = | 1106-25-4 | P-1 = | Pilot Light 2LAP-939 |
| L-12A & B = | 1106-25-5 | P-2 = | Pilot Light 2LAP-939 |
| L-13A & B = | 1106-25-6 | | |
| L-14A & B = | 1106-25-7 | PL-1 = | Plug ZCDPP-10 |
| L-15A & B = | 1106-25-8 | | |
| L-16A & B = | 1106-25-9 | T-1 = | Transformer 485-439-2 |

FUSES

| | | | |
|----------------------|----------|---------------|----------|
| For 115 v. operation | | | |
| F-1 = | 0.5 amp. | Slow Blow 3AG | GR FUF-1 |
| F-2 = | 0.5 amp. | Slow Blow 3AG | GR FUF-1 |
| For 230 v. operation | | | |
| F-1 = | 0.3 amp. | Slow Blow 3AG | GR FUF-1 |
| F-2 = | 0.3 amp. | Slow Blow 3AG | GR FUF-1 |

GENERAL RADIO COMPANY

TYPE 1106-B FREQUENCY TRANSFER UNIT

| RESISTORS | | | TYPE | CONDENSERS | | TYPE |
|-----------|------------|------|------------------------|------------|---------------------|----------------------------|
| R-1 = | 33 K Ohms | ±10% | REC-30BF | C-1 = | 0.0002 μ f | ±10% COM-45B |
| R-2 = | 3300 Ohms | ±10% | REC-30BF | C-2 = | 0.025 μ f | ±10% COM-50B |
| R-3 = | 3300 Ohms | ±10% | REC-30BF | C-3 = | 0.025 μ f | ±10% COM-50B |
| R-4 = | 33 K Ohms | ±10% | REC-30BF | C-4 = | 0.001 μ f | ±2% COM-45E |
| R-5 = | 1 Megohm | ±10% | REC-20BF | C-5 = | 0.001 μ f | ±2% COM-45E |
| R-6 = | 1 Megohm | ±10% | REC-20BF | C-7 = | 50 μ f | GR 779-408 |
| R-7 = | 750 Ohms | ±5% | REW-4C | C-7A = | 50 μ f | GR COA-2 (Part of 779-408) |
| R-8 = | 100 K Ohms | ±10% | REC-30BF | C-8 = | 0.00001 μ f | ±10% COM-20B |
| R-9 = | 200 Ohms | | POSC-10 | C-9 = | 0.00002 μ f | ±10% COM-20B |
| R-10 = | 220 Ohms | ±10% | REC-20BF | C-10 = | 1 μ f | COL-5 |
| R-11 = | 10 K Ohms | ±10% | REC-30BF | C-11 = | 1 μ f | COL-5 |
| R-12 = | | | | C-12 = | 0.0001 μ f | ±10% COM-45B |
| R-13 = | | | | C-13 = | 0.01 μ f | ±10% COM-45B |
| R-14 = | | | | C-14 = | | |
| R-15 = | | | | C-15 = | | |
| R-16 = | 240 Ohms | ±5% | REW-6C | C-16 = | | |
| R-17 = | 240 Ohms | ±5% | REW-6C | C-17 = | | |
| R-18 = | 240 Ohms | ±5% | REW-6C | C-18 = | 7.5 μ f APPROX. | 368-404 |
| R-19 = | 5 K Ohms | | REPO-1037 | C-19 = | | |
| R-20 = | | | | C-20 = | 0.01 μ f | ±10% COL-7I |
| R-21 = | 10 Ohms | ±10% | REPO-1028 | C-21 = | 0.01 μ f | ±10% COL-7I |
| R-22 = | 10 Ohms | ±10% | REPO-1028 | C-22 = | 100 μ f | 450 D.C.W.V. COE-10 |
| R-23 = | | | | C-23 = | 100 μ f | 450 D.C.W.V. COE-10 |
| R-24 = | | | | C-24 = | 100 μ f | 450 D.C.W.V. COE-10 |
| R-25 = | 820 k ohms | ±10% | REC-20BF | C-25 = | | |
| R-26 = | 100 K Ohms | ±10% | REC-30BF | C-26 = | | |
| R-27 = | 10 K Ohms | | POSC-9 | C-27 = | | |
| R-28 = | 47 K Ohms | ±10% | REC-30BF | C-28 = | 0.0005 μ f | ±10% COM-30B |
| R-29 = | 47 K Ohms | ±10% | REC-30BF | C-29 = | | |
| R-30 = | 10 K Ohms | ±10% | REC-30BF | C-30 = | 50 μ f | 779-402 |
| R-31 = | 1 Megohm | ±10% | REC-20BF | C-30A = | 25 μ f | GR COA-1 (Part of 779-402) |
| R-32 = | 470 Ohms | ±10% | REW-4C | C-32 = | 0.00025 μ f | ±10% COM-10B |
| R-33 = | 47 K Ohms | ±10% | REC-30BF | C-33 = | 5 μ f | ±30% COM-10B |
| R-34 = | 1 Megohm | ±10% | REC-20BF | C-34 = | 0.005 μ f | +20% -10% GR COM-15 |
| R-35 = | 470 Ohms | ±10% | REW-4C | C-35 = | 1 μ f | ±10% COW-16 |
| R-36 = | 47 K Ohms | ±10% | REC-30BF | C-36 = | 20 μ f | 450 D.C.W.V. COE-5 |
| R-37 = | 100 K Ohms | ±10% | REC-20BF | C-37 = | 0.05 μ f | ±10% COM-50B |
| R-38 = | 270 Ohms | ±10% | REC-20BF | C-38 = | 200 μ f | 10 D.C.W.V. COE-8 |
| R-39 = | 10 K Ohms | ±10% | REC-30BF | C-39 = | 0.05 μ f | ±10% COM-50B |
| R-40 = | 50 Ohms | ±10% | REC-20BF, 2 1000 in // | C-40 = | 200 μ f | 10 D.C.W.V. COE-6 |
| R-41 = | 47 Ohms | ±10% | REC-20BF | C-41 = | 0.05 μ f | ±10% COM-50B |
| | | | | C-42 = | 16 μ f | 150 D.C.W.V. COE-4 |

INDUCTORS

| | |
|-------------|----------------|
| L-1 = | 1106-214-1 |
| L-2 = | 1106-212-2 |
| L-3 = | 1106-212-3 |
| L-4 = | 8 mh 379-T |
| L-5 = | 2.5 mh CHA-597 |
| L-6 = | |
| L-7 = | |
| L-8A & B = | 1106-25-10 |
| L-9A & B = | 1106-25-11 |
| L-10A & B = | 1106-25-12 |
| L-11A & B = | 1106-25-13 |
| L-12A & B = | 1106-211-1 |
| L-13A & B = | 1106-211-2 |
| L-14A & B = | 1106-211-3 |
| L-15A & B = | 1106-211-4 |
| L-16A & B = | 1106-211-5 |
| L-17A & B = | 1106-211-6 |

MISCELLANEOUS

| | | |
|--------|-------------|------------|
| S-1 = | Switch | 1106-214 |
| S-2 = | Switch DPST | SWT-333,NP |
| S-3 = | Switch DPST | SWT-333,NP |
| S-4 = | Switch | 1106-213 |
| J-1 = | Jack | 874-406 |
| J-2 = | Jack | 874-P |
| J-3 = | Jack | 874-P |
| P-1 = | Pilot Light | 2LAP-330 |
| P-2 = | Pilot Light | 2LAP-939 |
| PL-1 = | Plug | ZCDPP-10 |
| T-1 = | Transformer | 485-1-39-2 |

FUSES

| | | |
|---------------------|------------------------|----------|
| For 115 v operation | | |
| F-1 = | 0.5 amp. Slow Blow 3AG | GR FUF-1 |
| F-2 = | 0.5 amp. Slow Blow 3AG | GR FUF-1 |
| For 230 v operation | | |
| F-1 = | 0.3 amp Slow Blow 3AG | GR FUF-1 |
| F-2 = | 0.3 amp Slow Blow 3AG | GR FUF-1 |

WIRING DIAGRAM FOR 1106-B FREQUENCY TRANSFER UNIT (1.00-10.00 Mc)

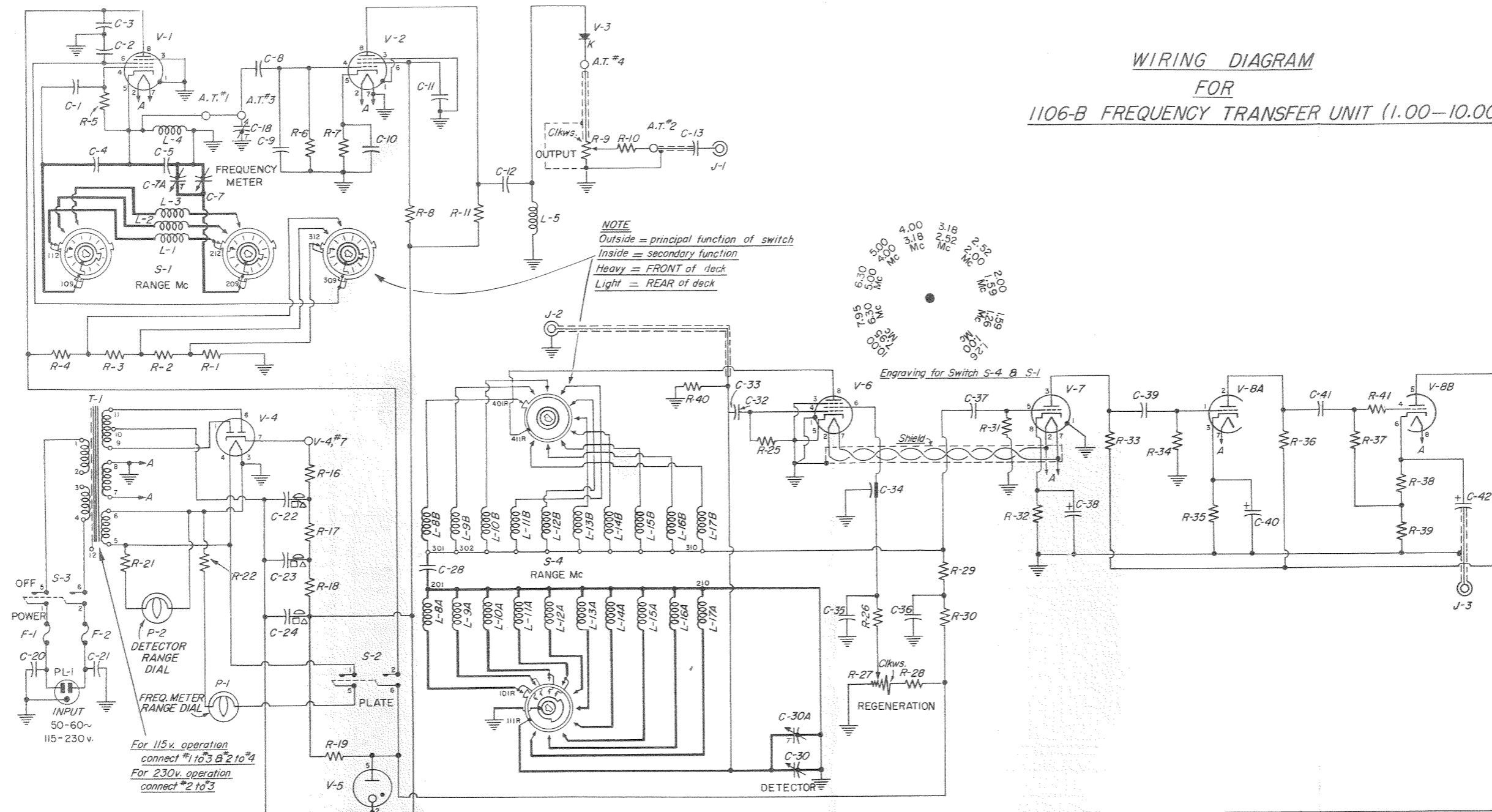

For 115v. operation connect #1 to 3 & 2 to 4
For 230v. operation connect #2 to 3

TUBES

| | |
|-----|---------|
| V-1 | 6SJ7 |
| V-2 | 6SJ7 |
| V-3 | 1N51 |
| V-4 | 6X4 |
| V-5 | OD3 |
| V-6 | 6SJ7 |
| V-7 | 6J5-GT |
| V-8 | 6SN7-GT |

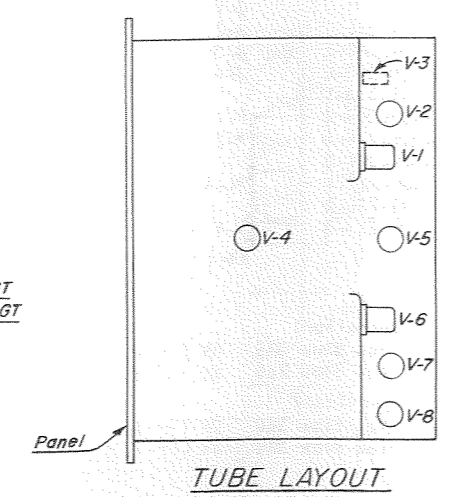

| RANGE | FREQ. Mc | ACTIVE COIL |
|------------|----------|-------------|
| 1.00-1.26 | | L-1 |
| 1.26-1.59 | | L-2 |
| 1.59-2.00 | | L-3 |
| 2.00-2.52 | | L-1 |
| 2.52-3.18 | | L-2 |
| 3.18-4.00 | | L-3 |
| 4.00-5.00 | | L-1 |
| 5.00-6.30 | | L-1 |
| 6.30-7.95 | | L-2 |
| 7.95-10.00 | | L-3 |

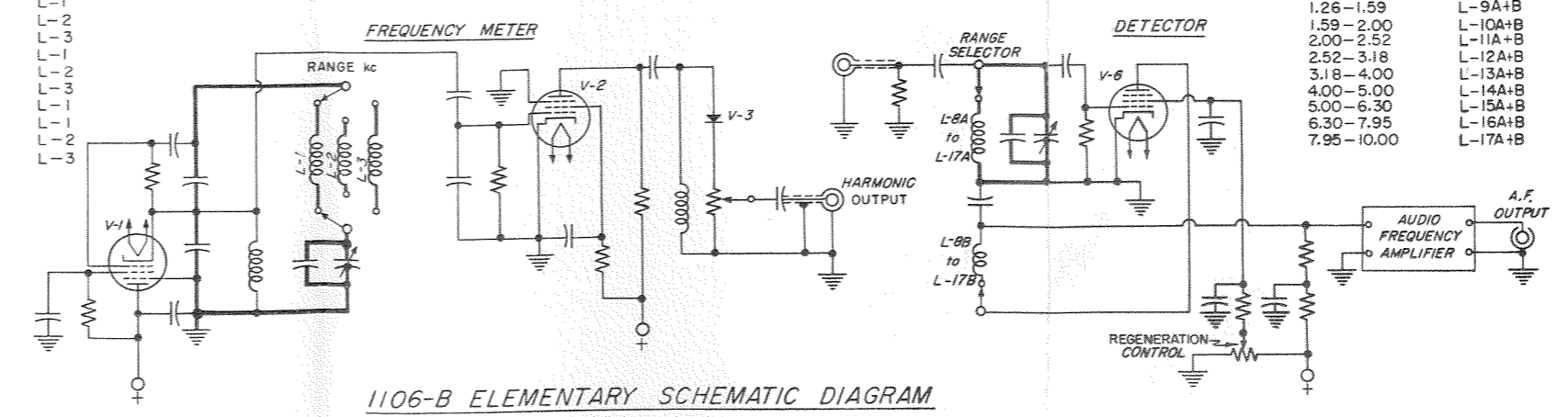

1106-B ELEMENTARY SCHEMATIC DIAGRAM

of 779-405)

WIRING DIAGRAM FOR 1106-C FREQUENCY TRANSFER UNIT (10.0 - 100.0 Mc)

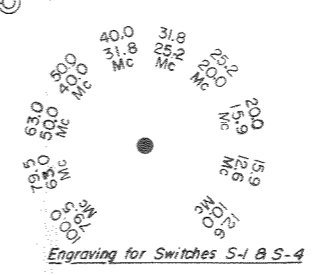
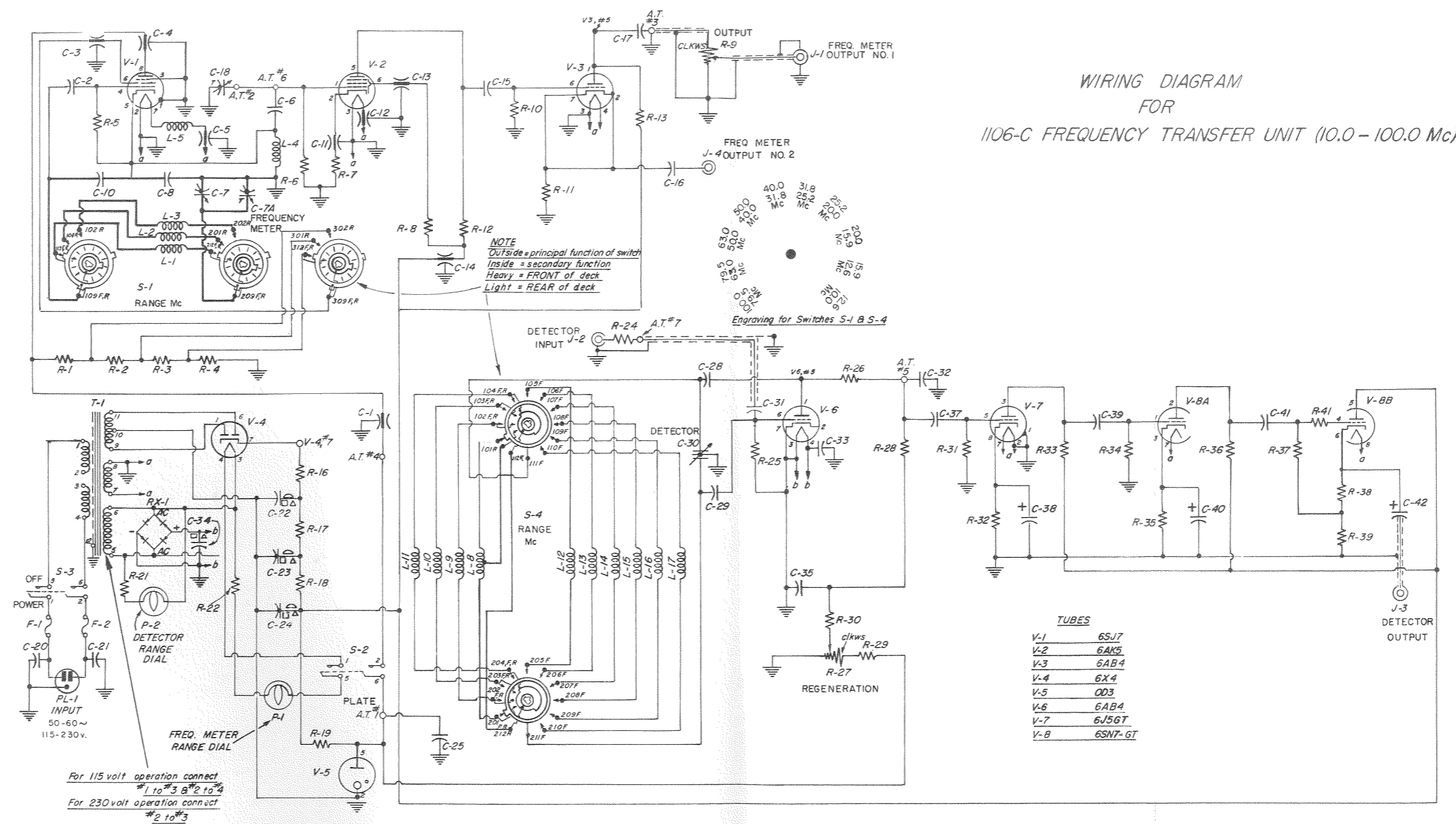

TUBES

| | |
|-----|---------|
| V-1 | 6SJ7 |
| V-2 | 6AK5 |
| V-3 | 6AB4 |
| V-4 | 6X4 |
| V-5 | 003 |
| V-6 | 6AB4 |
| V-7 | 6J5GT |
| V-8 | 6SN7-GT |

For 115 volt operation connect #1 to #3, #8 to #2 to #4
 For 230 volt operation connect #2 to #3

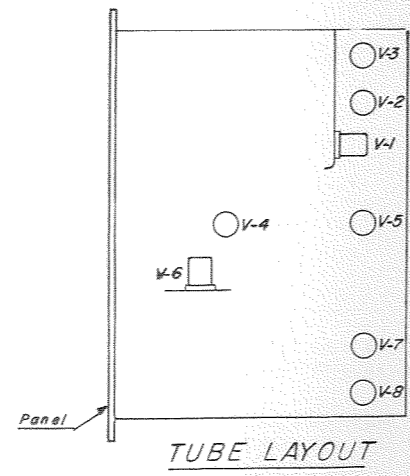

| RANGE | FREQ. Mc | ACTIVE COIL |
|--------------|----------|-------------|
| 10.0 - 12.6 | | L-1 |
| 12.6 - 15.9 | | L-2 |
| 15.9 - 20.0 | | L-3 |
| 20.0 - 25.2 | | L-1 |
| 25.2 - 31.8 | | L-2 |
| 31.8 - 40.0 | | L-3 |
| 40.0 - 50.0 | | L-1 |
| 50.0 - 63.0 | | L-1 |
| 63.0 - 79.5 | | L-2 |
| 79.5 - 100.0 | | L-3 |

| RANGE | FREQ. Mc | ACTIVE COIL |
|--------------|----------|-------------|
| 10.0 - 12.6 | | L-8 |
| 12.6 - 15.9 | | L-9 |
| 15.9 - 20.0 | | L-10 |
| 20.0 - 25.2 | | L-11 |
| 25.2 - 31.8 | | L-12 |
| 31.8 - 40.0 | | L-13 |
| 40.0 - 50.0 | | L-14 |
| 50.0 - 63.0 | | L-15 |
| 63.0 - 79.5 | | L-16 |
| 79.5 - 100.0 | | L-17 |

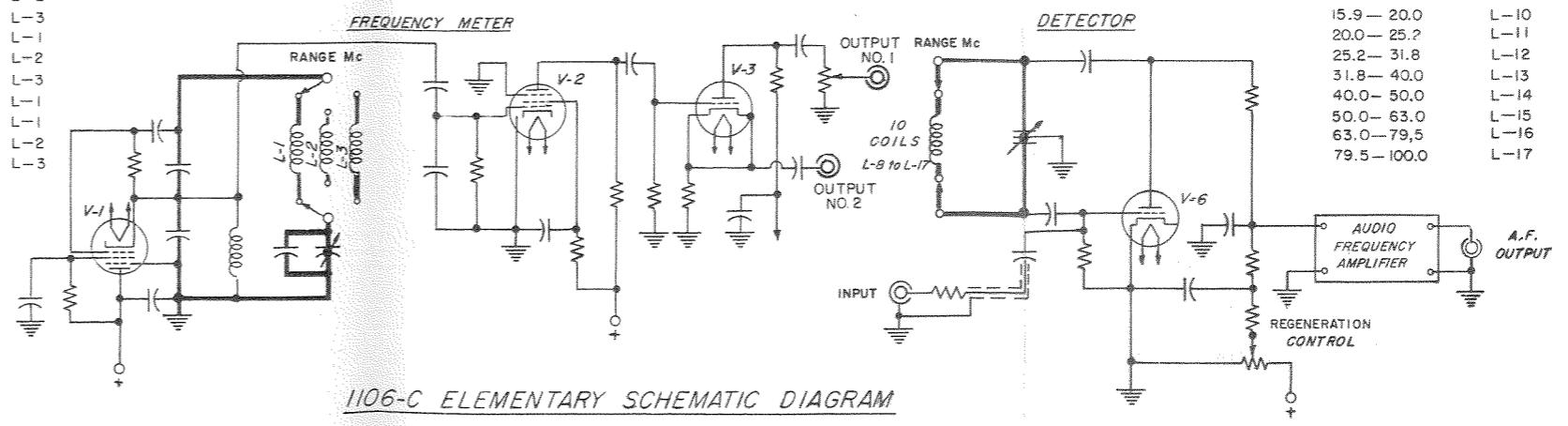

1106-C ELEMENTARY SCHEMATIC DIAGRAM

GENERAL RADIO COMPANY

WEST CONCORD, MASSACHUSETTS

EMerson 9-4400

Mission 6-7400

DISTRICT OFFICES

NEW YORK

Broad Ave. at Linden, Ridgefield, N. J.
Telephone N.Y. WOrth 4-2722
N.J. WHitney 3-3140

SYRACUSE

Pickard Bldg.
East Molloy Rd., Syracuse 11, N. Y.
Telephone GLenview 4-9323

PHILADELPHIA

1150 York Rd., Abington, Penna.
Telephone TURner 7-8486
Phila., HAncock 4-7419

WASHINGTON

8055 13th St., Silver Spring, Md.
Telephone JUNiper 5-1088

FLORIDA

113 East Colonial Drive, Orlando, Fla.
Telephone GArden 5-4671

CHICAGO

6605 West North Ave., Oak Park, Ill.
Telephone Village 8-9400

LOS ANGELES

1000 N. Seward St., Los Angeles 38, Calif.
Telephone HOLlywood 9-6201

SAN FRANCISCO

1186 Los Altos Ave., Los Altos, Calif.
Telephone WHitecliff 8-8233

CANADA

99 Floral Pkwy., Toronto 15, Ont.
Telephone CHerry 6-2171

REPAIR SERVICES

EAST COAST

General Radio Company
Service Department
22 Baker Ave., W. Concord, Mass.
Telephone EMerson 9-4400

NEW YORK

General Radio Company
Service Department
Broad Ave. at Linden, Ridgefield, N. J.
Telephone N.Y. WOrth 4-2722
N.J. WHitney 3-3140

MIDWEST

General Radio Company
Service Department
6605 West North Ave., Oak Park, Ill.
Telephone Village 8-9400

WEST COAST

General Radio Company
Service Department
1000 N. Seward St.
Los Angeles 38, Calif.
Telephone HOLlywood 9-6201

CANADA

General Radio Company
Service Department
99 Floral Pkwy., Toronto 15, Ont.
Telephone CHerry 6-2171

General Radio Company (Overseas), Zurich, Switzerland
Representatives in Principal Overseas Countries