

# TM 11-333

WAR DEPARTMENT TECHNICAL MANUAL

---

## TELEPHONES

EE-8, EE-8-A

AND EE-8-B

**WARNING:** The material forming the subject matter of this manual is the property of the United States Government and it is printed and distributed solely for the use of the military, naval, and civilian personnel of the War and Navy Departments, and may not be published or reproduced in whole or in part in any manner or form except upon specific approval by authorized military public relations agencies.

---

WAR DEPARTMENT • MARCH 1945

**TECHNICAL MANUAL**  
**TELEPHONES**  
**EE-8, EE-8-A, AND EE-8-B**

CHANGES }  
 No. 1 }

DEPARTMENT OF THE ARMY  
 WASHINGTON 25, D. C., 9 June 1950

TM 11-333, 23 March 1945, is changed as follows:

**21.1 (added.) Operation of Telephone in Arctic Winter Temperatures**

*a.* EFFECT OF WINTER CONDITIONS IN ARCTIC ON EQUIPMENT. In the Arctic it often is essential to operate Telephone EE-8-(\*) in temperatures as low as  $-60^{\circ}$  F. Under conditions of extremely low temperature combined with the effects of ice, snow, rain, fog, frost, or moisture caused by temperature changes condensed on the equipment, the efficiency of the telephone can be affected severely. Batteries BA-30 lose considerable electrical capacity in low temperatures because of decreased chemical activity, and in very low temperatures they become unusable. In addition, the generator shaft and gears may freeze, and moisture condenses and freezes on the transmitter diaphragm.

*b.* OPERATION IN ARCTIC WINTER TEMPERATURES. To insure the satisfactory performance of Telephone EE-8-(\*) in temperatures as low as  $-60^{\circ}$  F. when operation of this equipment is essential, proceed as follows:

- (1) Use two low-temperature Batteries BA-2030/U instead of batteries BA-30. If batteries BA-30 must be used at low temperatures, however, carry a pair of replacement batteries in an inner pocket of the clothing so that a set warmed by body heat will be available when the pair in use fails.
- (2) Protect the handset transmitter and receiver with Microphone Cover CW-111/U (Signal Corps stock No. 2B250-111) to prevent the accumulation of frost on the transmitter diaphragm and to prevent frostbite when the operator's ear comes in contact with the cold receiver cap.
- (3) Remove the lubricant from Generator GN-38-(\*) and re-lubricate according to instructions in paragraph 68*d*.

## 25.1 (added.) Preventive Maintenance Techniques in the Arctic

*a.* ARCTIC WINTER CONDITIONS. Because of extremely low temperatures, often as low as  $-60^{\circ}$  F., adverse weather conditions, and the bulky protective clothing worn by operating personnel, preventive maintenance techniques that can be performed by using organizations in the open or in unheated shelters are limited to those operations which must be performed to keep a system functioning and which can be performed when the operator's hands are protected by gloves. Wherever possible, except for changing batteries and for performing the operations for items 1, 5, 8, and 9 in the checklist (par. 36), perform preventive maintenance operations in a heated shelter.

*b.* OTHER ARCTIC CONDITIONS. During other seasons of the year, temperature and weather conditions in the Arctic range from very low temperatures with ice and snow to mild weather such as is found in temperate climates. Therefore, preventive maintenance operations by using personnel will vary from those given in *a* above to normal temperate zone operations during the season of the year when the weather is not severe.

## 26. Case, Exterior

\* \* \* \* \*

*c.* CLEAN (C). With a clean \* \* \* hand generator crank. Under normal weather conditions and in a heated shelter under Arctic winter conditions, use saddle soap and neat's-foot oil for cleaning and preserving the leather case and strap.

## 33. Handset TS-9-(\* )

*a.* INSPECT (I). Carefully inspect the handset for dirt, dust, chipped or cracked places, and moisture condensation on the microphone. Do not disassemble \* \* \* the exterior only.

*b.* CLEAN (C). Wipe all dirt, dust, foreign matter, and moisture off the handset, using a clean dry cloth.

## 34. Cord CC-333

\* \* \* \* \*

*b.* CLEAN (C). Wipe off all \* \* \* clean dry cloth. If it becomes necessary to remove oil or grease, use Solvent, dry-cleaning (SD) (Federal spec P-S-661a, QM supply No. 51-5-4385). Under Arctic winter conditions, perform this operation in a heated shelter.

## 36. Check List

a. For case and \* \* \* and monthly items.

*Note.* The time intervals for performing the preventive maintenance outlined in the preceding paragraphs and the check list may be varied at any time by the local commander. However, for best \* \* \* the check list.

b. The general techniques \* \* \* for satisfactory performance.

Item	Operation	Description	When performed					Echelon
			Daily	Weekly	Monthly	Every 6 months	Yearly	
*	*	* * *	*		*		*	
2	IC	Case, interior (par. 27) <sup>1</sup> -----			*			1
3	ITC	Jack assembly and lever switch (par. 28) <sup>1</sup> -----			*			2
4	ITC	Generator (par. 29) <sup>1</sup> -----			*			2
5	IC	Battery compartment (par. 30)-----	*					1
6	ITC	Induction and holding coils (par. 31) <sup>1</sup> -----			*			2
7	IC	Chassis (par. 32) <sup>1</sup> -----			*			2
*	*	* * *	*		*		*	

F            I            T            C            A            L  
 Feel----- Inspect----- Tighten----- Clean----- Adjust----- Lubricate

<sup>1</sup>(Added.) In Arctic winter temperatures, perform preventive maintenance operations in a heated shelter.

## 39. Generator GN-38-(\*)

The only parts \* \* \* of Generator GN-38-(\*). Instructions for lubricating the generator are contained in paragraphs 68c and d.

## Section V. WEATHERPROOFING

### 40. General (superseded.)

Signal Corps equipment, when operated under severe climatic conditions such as prevail in tropical, arctic, and desert regions, requires special treatment and maintenance. Fungus growth, insects, dust, corrosion, salt spray, excessive moisture, and extreme temperatures are harmful to most materials.

### 41. (Superseded.) Tropical Maintenance

A special moistureproofing and fungiproofing treatment has been devised which, if properly applied, provides a reasonable degree of protection. This treatment is explained fully in TB SIG 13 and TB SIG 72.



## 42. Moistureproofing and Fungiproofing Telephone EE-8-(\*)

\* \* \* \* \*

### 42.1 (Added.) Winter Maintenance

a. GENERAL. Special precautions necessary to make equipment perform satisfactorily and to prevent total operational failure in extremely low temperatures are explained fully in TB SIG 66 and TB SIG 219.

b. TELEPHONE EE-8-(\*). Telephone EE-8-(\* will give satisfactory performance in temperatures as low as  $-60^{\circ}$  F. provided additional maintenance is performed and precautions are taken to prevent equipment failure. When the telephone is used under conditions such as prevail in the Arctic during the winter, the following problems may be encountered:

- (1) The shock-resistant characteristics of material change at very low temperatures, and steel shrinks and becomes brittle. Handle the equipment with reasonable care.
- (2) Leather becomes stiff and should be given all possible protection to prevent damage from freezing. When using a telephone with a leather case, keep the leather as dry as possible. Apply a light coat of neat's-foot oil to the rough side of the leather once a week to improve its resistance to moisture.
- (3) Canvas will freeze and lose its pliability. Handle telephones with a canvas case carefully to avoid cracking the canvas.
- (4) Dry-cell batteries may become completely nonoperative at extremely low temperatures. Use low-temperature batteries or keep extra batteries warm in an inner pocket of the clothing so that they will be operative when the ones in use fail (par. 21.1b).
- (5) Extreme cold will cause cords and wiring to become brittle. Handle handset cords and wiring carefully.
- (6) Frost which forms from the breath in the holes of the handset transmitter affects transmission. Place a protective cover (par. 21.1b) over the transmitter before placing the equipment in operation, and have a spare transmitter unit available in case the one in use fails to function properly.
- (7) Water in the receiver will freeze and impede the action of the diaphragm, and a receiver exposed to very low temperatures may freeze the operator's ear if he uses the receiver in contact with his ear. Place a protective cover (par. 21.1b) over the handset receiver before using the equipment. If the receiver becomes wet, unscrew the bakelite cap, remove the ice, and wipe the receiver unit dry with a dry cloth.

- (8) The shafts and gears of the hand generator will be difficult to turn if these parts are not lubricated properly for cold weather operation. Lubricate for Arctic winter operation according to instructions in paragraph 68d.

#### **42.2 (added.) Desert Maintenance**

a. **GENERAL.** Special precautions necessary to prevent equipment failure in areas subject to extremely high temperatures, low humidity, and excessive sand and dust are explained fully in TB SIG 75.

b. **TELEPHONE EE-8-(\*).** Special dustproofing treatment is not necessary for Telephone EE-8-(\*). Take all possible precautions to keep dust, dirt, and sand from getting on lubricated parts. Daily inspection and cleaning of the equipment is recommended. Instead of merely adding new lubricants to the generator, clean and relubricate the equipment whenever practicable.

#### **42.3 (added.) Lubrication Under Extreme Temperature Conditions**

The effects of extreme cold and heat on materials and lubricants are explained in TB SIG 69. Observe all precautions and pay strict attention to all lubrication instructions when operating equipment under conditions of extreme cold or heat.

In figure 32, change designation PS to read PL; change the lubricant key to read PL—OIL, LUBRICATING, PRESERVATIVE, SPECIAL—JAN—L—644; GL—GREASE, LUBRICATING, INSTRUMENT—USA 2-134.

#### **68. Generator GN-38-(\*)**

Failure of the \* \* \* replace the generator.

\* \* \* \* \*

c. **LUBRICATION UNDER NORMAL CONDITIONS.** Normally, it will \* \* \* should be lubricated. Under normal or temperate zone temperature conditions, use oil (PL) (Ordnance supply No. 14-0-2833) and grease (GL) (Ordnance supply No. 14-G-611) as directed in figure 32. Before lubricating parts with oil (PL), wipe dust from exposed surfaces. Lubricate sparingly to \* \* \* on electrical contacts. Use only solvent (SD) for cleaning the generator.

d. (Added.) **LUBRICATION FOR OPERATION IN ARCTIC WINTER TEMPERATURES.** To insure satisfactory performance of Generator GN-38-(\* ) at temperatures as low as -60° F., proceed as follows:

- (1) Remove the lubricant from the generator gears and bearings, using solvent (SD) and a small, stiff bristle brush.

- (2) Relubricate sparingly—the points indicated in figure 32— with Oil, lubricating, aircraft instrument (Army-Navy spec AN-0-11, Quartermaster supply No. 14-0-1341). Be especially careful not to overlubricate, and be sure that the lubricant does not touch electrical contact parts. If electrical contact parts have been touched with oil, make sure that no oil remains on any contact surfaces. During other seasons of the year when weather in the Arctic becomes milder, relubricate according to directions in *c* above.

## APPENDIX II

### REFERENCES AND ABBREVIATIONS

#### 9. Other Technical Publications

SR 110-1-1	Index of Army Motion Picture and Film Strips.
SR 310-20 series	Indexes of Army Publications.
FM 21-8	Military Training Aids.
*            *	*            *            *            *
TB SIG 75	Desert Maintenance of Ground Signal Equipment.
TB SIG 219	Operation of Signal Equipment at Low Temperatures.
TB 11-430-1	Maintenance of Batteries in Nontemperate Areas.
*            *	*            *            *            *

[AG 300.7 (9 May 50)]

BY ORDER OF THE SECRETARY OF THE ARMY:

OFFICIAL:

EDWARD F. WITSELL  
Major General, USA  
The Adjutant General

J. LAWTON COLLINS

*Chief of Staff, United States Army*

**DISTRIBUTION:**

Tech Sv (2) except 11 (50); Arm & Sv Bd (1); AFF Bd (ea Sv Test Sec) (1); AFF (5); OS Maj Comd (5); Base Comd (3); MDW (5); A (20); CHQ (2); FC (2); Sch (2) except 11 (10); Gen Dep (2); Dep 11 (5); Tng Div (2); PE (10), OSD (2); Lab 11 (2); 4th & 5th Ech Maint Shops 11 (2); Two (2) copies to each of the following T/O & E's: 2-26; 3-26; 3-27; 3-267; 4-157; 4-260-1; 5-16N; 5-17N; 5-36; 5-37; 5-72; 5-76; 5-122; 5-136; 5-166T; 5-192; 5-216N; 5-217N; 5-218N; 5-250-1; 5-297; 5-324; 5-327; 5-367-OS; 5-526T; 5-627; 6-10-1N; 6-12; 6-20-1; 6-26-OS; 6-26N; 6-26; 6-27N; 6-29N; 6-50-1; 6-56-OS; 6-56; 6-57; 6-67; 6-76; 6-77; 6-86; 6-87; 6-127; 6-160-1N; 6-166N; 6-167N; 6-169N; 6-176; 6-177; 6-186; 6-187; 6-196N; 6-197N; 6-200-1T; 6-216T; 6-217T; 6-218T; 6-226T; 6-227T; 6-327; 6-336N; 6-337N; 6-339N; 6-357; 6-367; 6-397; 6-437; 6-457; 6-467; 6-497T; 7-12N; 7-13N; 7-36T; 7-46S; 7-47S; 7-52T; 7-56T; 7-96; 8-7N; 8-16N; 8-17N; 8-18N; 8-27; 8-56; 8-580; 8-591T; 8-667; 9-7; 9-8N; 9-17; 9-37; 9-66N; 9-76; 9-127; 9-316; 10-17N; 10-46N; 10-47N; 10-48N; 10-67; 10-157; 10-197; 10-536; 11-7S; 11-7N; 11-16; 11-47; 11-57N; 11-87S; 11-97; 11-107; 11-127; 11-500 EF, EO, ET, GM, GS, GT, IA, IB, IF, IJ, IK, IP, IQ, IR, IS, IU, IV, IW, SG, SH, SI, SJ, SM, SN; 11-537S; 11-537T; 11-557T; 11-587; 11-592; 11-597; 11-657S; 11-667S; 11-687S; 11-697S; 17-17; 17-20; 17-26N; 17-27; 17-27N; 17-36N; 17-37N; 17-37N-22; 17-46N; 17-52; 17-53; 17-56; 17-58; 19-27N; 19-37; 19-56; 19-57; 20-7N; 30-17T; 30-30T; 30-600; 41-500; 44-7; 44-8; 44-10-1; 44-12; 44-16; 44-17; 44-26; 44-27; 44-76N; 44-116; 44-117; 44-126; 44-127; 44-136; 44-138; 44-200-1; 44-276T; 44-277T; 44-278T; 55-17; 55-19; 55-37; 55-117; 55-118; 55-227; SPECIAL DISTRIBUTION.

For explanation of distribution formula, see SR 310-90-1.

WAR DEPARTMENT TECHNICAL MANUAL  
TM 11-333

*This manual supersedes TM 11-333, 6 March 1942, including C 1, 2 April 1943, and C 2, 19 September 1944; TM 11-349, 14 August 1943; TB 11-333-1, 22 March 1944; TB 11-333-2, 25 April 1944; TB 11-333-3, December 1944.*

---

TELEPHONES  
EE-8, EE-8-A  
AND EE-8-B



WAR DEPARTMENT • MARCH 1945

---

United States Government Printing Office  
Washington: 1945

WAR DEPARTMENT.

Washington 25, D. C., 23 March, 1945

TM 11-333, Telephones EE-8, EE-8-A, and EE-8-B, is published for the information and guidance of all concerned.

[AG 300.7 (24 Aug 44)]

BY ORDER OF THE SECRETARY OF WAR:

G. C. MARSHALL  
*Chief of Staff*

OFFICIAL:

J. A. ULIO  
*Major General*  
*The Adjutant General*

DISTRIBUTION:

AAF (5); AGF (5); ASF (2); T of Opn (5); Dept (5); Def Comd (2); Base Comd (5); AAF Comd (2); Arm & Sv Bd (2); S Div ASF (1); Tech Sv (2); SvC (5); Area ASvC (2); WDGS Lib (5); PC&S (2); PE (2); Dep 11 (2); Gen Oversea SOS Dep (Sig Sec) (2); GH (2); M Conc C (2); Air Base Hosp (2); Gen Sv Sch (5); Sp Sv Sch (10); USMA (10); ROTC (5); Lab 11 (2); Sig AS (2); Rep Shop 11 (2); A (5); D (2); B 2, 4, 6, (5); Rn 2, 4, 5, 7 (5); Bn 2, 3, 4, 5, 6, 7, 9 (5), 11 (10); C 2, 3, 4, 5, 6, 7, 9 (5), 11 (10); AF (2); W (5); G (5); S (5); F (5).

Refer to FM 21-6 for explanation of distribution formula.

# CONTENTS

<b>CHAPTER 1. GENERAL.</b>		<i>Paragraph Page</i>	
<i>Section I.</i>	Description of Telephones EE-8, FE-8-A, and EE-8-B.		
	General .....	1	1
	Description .....	2	1
	Shipping weights and dimensions of packed telephones .....	3	7
	Differences in models of Telephone EE-8-(*) .....	4	8
<i>II.</i>	Application of Telephone EE-8-(*) .		
	Point-to-point circuits .....	5	9
	Local battery switchboard systems .....	6	10
	Common battery switchboard systems .....	7	11
<i>III.</i>	Installation and assembly.		
	Uncrating, unpacking and checking .....	8	11
	Siting .....	9	13
	Battery installation .....	10	15
	Preliminary tests .....	11	16
	Connection of incoming lines .....	12	16
	Repacking for transport .....	13	17
<i>IV.</i>	Initial adjustments.		
	Adjustments for operation .....	14	18
	Precautions .....	15	19
<b>CHAPTER 2. OPERATING INSTRUCTIONS.</b>			
<i>Section I.</i>	Procedure for operation.		
	Local battery operation .....	16	21
	Common battery operation .....	17	21
	Special precautions .....	18	21
	Closing station .....	19	23
<i>II.</i>	Operation under unusual conditions.		
	Damping and silencing ringer .....	20	23
	Use of telephone with a gas mask .....	21	25
<i>III.</i>	Equipment performance check list.		
	Purpose and use .....	22	26
	Check list .....	23	27
<b>CHAPTER 3. PREVENTIVE MAINTENANCE.</b>			
<i>Section I.</i>	Preventive maintenance techniques.		
	Meaning of preventive maintenance .....	24	28
	Description of preventive maintenance techniques .....	25	28
	Case, exterior .....	26	29
	Case, interior .....	27	30
	Jack assembly and lever switch .....	28	30
	Generator .....	29	30
	Battery compartment .....	30	30
	Induction and holding coils .....	31	31
	Chassis .....	32	31
	Handset TS-9-(*) .....	33	31
	Cord CC-333 .....	34	31
<i>II.</i>	Itemized preventive maintenance.		
	Common materials needed .....	35	31
	Check list .....	36	32

<i>III.</i>	Special instructions.		
	Cleaning and burnishing lever switch contacts.....	37	33
	Equipment dusting .....	38	33
<i>IV.</i>	Lubrication.		
	Generator GN-38-(*).....	39	33
<i>V.</i>	Moistureproofing and fungiproofing.		
	General .....	40	33
	Treatment .....	41	34
	Step-by-Step instructions for treating Telephone EE-8-(*) .....	42	34
 <b>CHAPTER 4. AUXILIARY EQUIPMENT (not used).</b>			
 <b>CHAPTER 5. REPAIR INSTRUCTIONS.</b>			
<i>Section</i>	<i>I.</i>	Theory of Telephone EE-8-(*).	
		Circuit elements .....	43 38
		Theory of operation.....	44 39
	<i>II.</i>	Test equipment.	
		Voltohmmeters .....	45 41
	<i>III.</i>	Trouble shooting.	
		General .....	46 42
		Procedures .....	47 42
		Trouble-shooting chart .....	48 47
	<i>IV.</i>	Test and analysis data.	
		Voltage and resistance chart.....	49 48
		Characteristics of circuit elements.....	50 49
	<i>V.</i>	Removal and replacement of parts.	
		General .....	51 49
		Body .....	52 50
		Crank GC-9 .....	53 51
		Capacitor CA-355 .....	54 51
		Generator GN-38-(*).....	55 52
		Lever and screw switch assembly.....	56 53
		Ringer MC-131 .....	57 54
		Jack assembly .....	58 54
		Induction coil (Coil C-105).....	59 54
		Holding coil (Coil C-158).....	60 55
		L1 and L2 binding posts.....	61 55
		BAT- binding post.....	62 56
		Battery contacts .....	63 56
		Battery contact springs.....	64 57
		Handset TS-9-(*) and component parts.....	65 57
		Leather straps .....	66 58
	<i>VI.</i>	Detailed repairs.	
		General .....	67 58
		Generator GN-38-(*) .....	68 59
		Ringer MC-131 .....	69 60
		Handset switch .....	70 62
		Painting and refinishing.....	71 62
		Unsatisfactory equipment report.....	72 62
 <b>APPENDIX I. MAINTENANCE PARTS LIST FOR TELEPHONE EE-8-(*)</b>			
			— 64
 <b>II. REFERENCES AND ABBREVIATIONS.....</b>			
			— 65



## DESTRUCTION NOTICE

---

**WHY** — To prevent the enemy from using or salvaging this equipment for his benefit.

**WHEN** — When ordered by your commander.

- HOW** —
1. Smash — Use sledges, axes, hand axes, pickaxes, hammers, crowbars, heavy tools.
  2. Cut — Use axes, handaxes, machetes.
  3. Burn — Use gasoline, kerosene, oil, flame throwers, incendiary grenades.
  4. Explosives—Use firearms, grenades, TNT.
  5. Disposal — Bury in slit trenches, fox holes, other holes. Throw in streams. Scatter.

### USE ANYTHING IMMEDIATELY AVAILABLE FOR DESTRUCTION OF THIS EQUIPMENT

- WHAT** —
1. Smash — Holding coil, induction coil, ringer coils, capacitors, generator armature, generator gears, all switches, transmitter, receiver, and handset handle.
  2. Cut — all chassis wiring, handset cord, and handset wiring.
  3. Burn — All remaining equipment, smashed parts, technical manuals, circuit labels, and traffic diagrams.
  4. Bury or scatter — All of the above pieces after destroying their usefulness.

### DESTROY EVERYTHING

BLANK

*This manual supersedes TM 11-333, 6 March 1942, including C 1, 2 April 1943, and C 2, 19 September 1944; TM 11-349, 14 August 1943; TB 11-333-1, 22 March 1944; TB 11-333-2, 25 April 1944; TB 11-333-3, December 1944.*

## CHAPTER I

### GENERAL

---

#### Section I. DESCRIPTION OF TELEPHONES EE-8, ES-8-A, AND EE-8-B

##### 1. General

a. CHARACTERISTICS. Telephone EE-8-(\*) is a portable field telephone designed for use on either local or common battery telephone systems. It is compact, rugged, and portable, and in performance equals the best present day commercial telephones. It contains all the elements necessary for a combination local battery and common battery telephone, and the circuit elements are arranged for antisidetone transmission. The talking and signaling range of the telephone varies with the type of line wire use, the condition of the wire, whether the wire is dry or wet, and whether the wire is on the ground or in the air. The telephone will operate satisfactorily over the distances usually found in corps and subordinate wire systems, provided the lines are well constructed. When Telephone EE-8-(\*) is used as a local battery telephone, talking range of 11 to 17 miles may be expected on Wire W-110-B, depending on weather conditions and the type of construction of the wire line. These distances may be increased by the proper use of loading coils. Capabilities of the telephone when applied to different systems are discussed in paragraphs 5, 6, and 7.

b. NOMENCLATURE. Telephones EE-8, EE-8-A, and EE-8-B are referred to in this Technical Manual as Telephone EE-8-(\*). Such nomenclature refers to any one or all of the above three models. Similarly, Generator GN-38-(\*) refers to Generators GN-38, GN-38-A, and GN-38-B, and Handset TS-9-(\*) refers to Handsets TS-9-A, -C, -E, -F, -G, -H, -J, -K, -L, -N, -O, -Q, -R, -T, -U, -V, -W, -AA, -AC, -AE, -AF, -AJ, and -AL.

##### 2. Description

a. GENERAL. Telephones EE-8-A and EE-8-B are each contained in a case  $9\frac{1}{8}$  by  $7\frac{1}{4}$  by  $3\frac{1}{2}$  inches and weigh about  $9\frac{3}{4}$  pounds, including batteries. Telephone EE-8 is contained in a case  $9\frac{3}{8}$  by  $7\frac{1}{4}$  by  $3\frac{1}{2}$



Figure 1. Telephone EE-8-A, in use.

inches. A rectangular portion of the leather has been cut out of the cover of Telephone EE-8 and replaced by a more flexible material. This permits the handset to depress the lever switch when it is hung on the outside of the case. Otherwise, Telephone EE-8 is externally similar to Telephones EE-8-A and EE-8-B.

*b. CASE.* The case containing Telephone EE-8-(\*) is made of leather or canvas and has an adjustable carrying strap. (See figs. 2 and 3.) The cover is hinged at the back, overlaps the sides and front, and fastens in front with a snap fastener. The space within the case not occupied by the body is used for storing the handset.

*c. BODY.* All elements of Telephones EE-8 and EE-8-A are mounted on an aluminum alloy chassis. The elements of Telephone EE-8-B are mounted on a sheet steel chassis. This assembly of the chassis and the elements mounted on it is called the body. (See fig. 4.) The battery compartment is on the upper left side of the body. The chassis is fastened to the case by seven machine screws.

(1) *Terminal block.* The terminal block (fig. 5) forms the top of the body. On it are mounted the following:

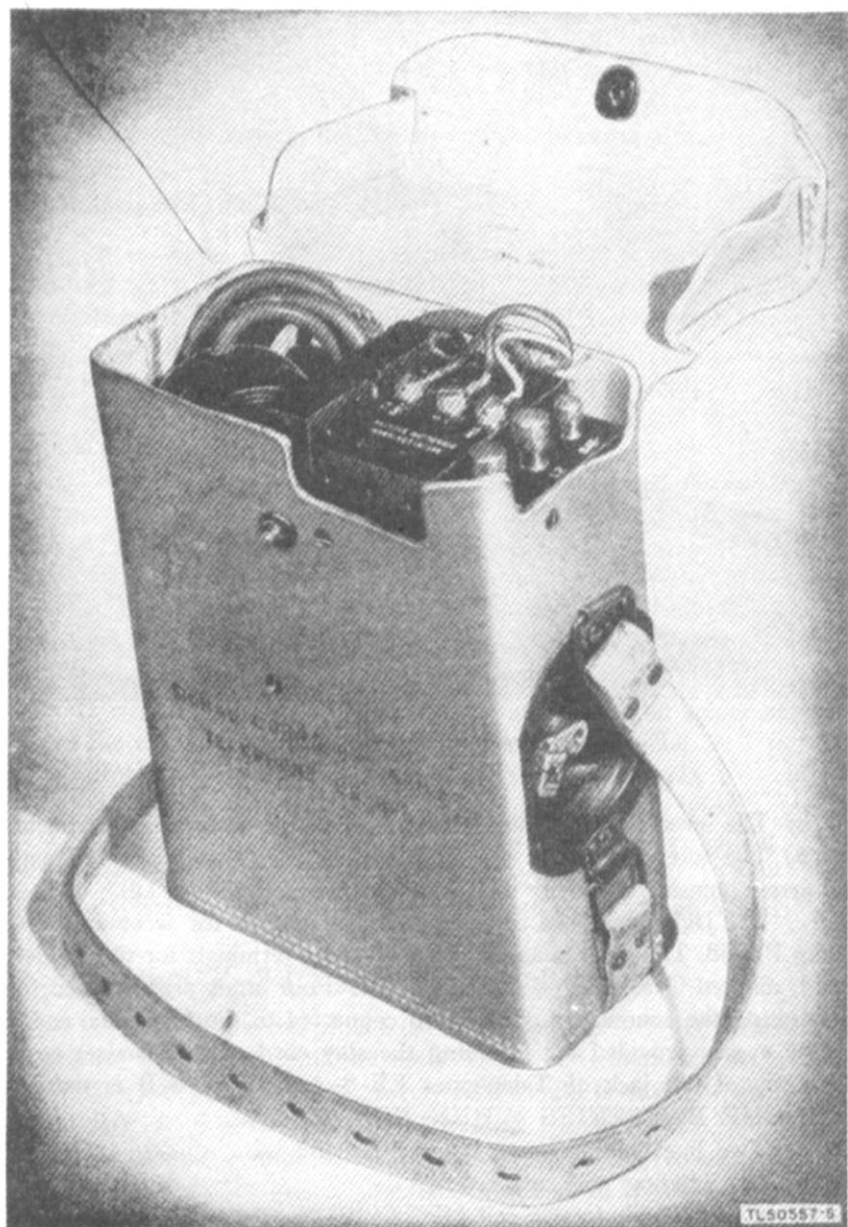

Figure 2. Telephone EE-8-B with leather case.

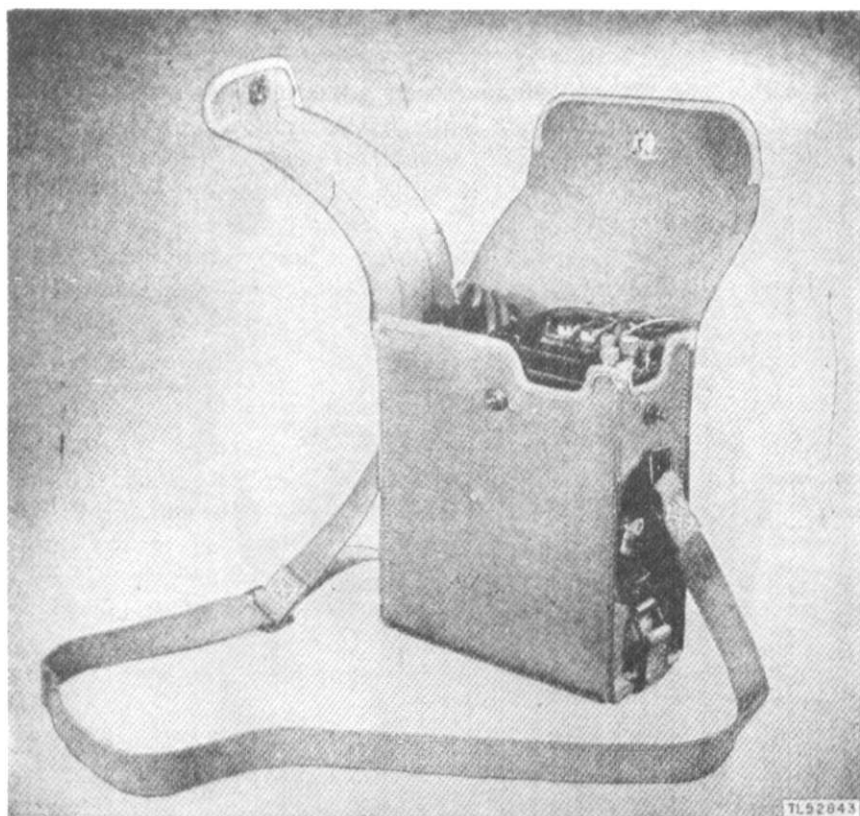

Figure 3. Telephone EE-8-A with canvas case.

(a) The lever switch on the left edge above the battery compartment.  
 (b) The screw switch to the right to the lever switch, marked with an arrow pointing clockwise to CB and counterclockwise to LB.

(c) The jack, which is a three-contact jack suitable for accommodating Plug PL-58. This jack is assembled with three terminals for the handset cord, marked T & BAT +, C, and REC. Four studs are provided for separating the conductors of the cord connected to the terminals, and a screw eye is provided for fastening the stay cord of the handset cord. The top of the jack of Telephones EE-8-A and EE-8-B is marked REMOVE BATTERIES WHEN NOT IN USE.

(d) Two line binding posts, marked L1 and L2.

(e) One binding post, marked BAT-.

(2) *Coils.* The induction coil (Coil C-105) and the holding coil (Coil C-158) are mounted directly under the terminal block (figs. 6, 7, and 8).

(3) *Generator GN-38(\*).* Generator GN-38, which is used in Telephones EE-8 and EE-8-A (figs. 6 and 7), or Generator GN-38-A or GN-38-B, which is used in Telephone EE-8-B (fig. 8), is mounted

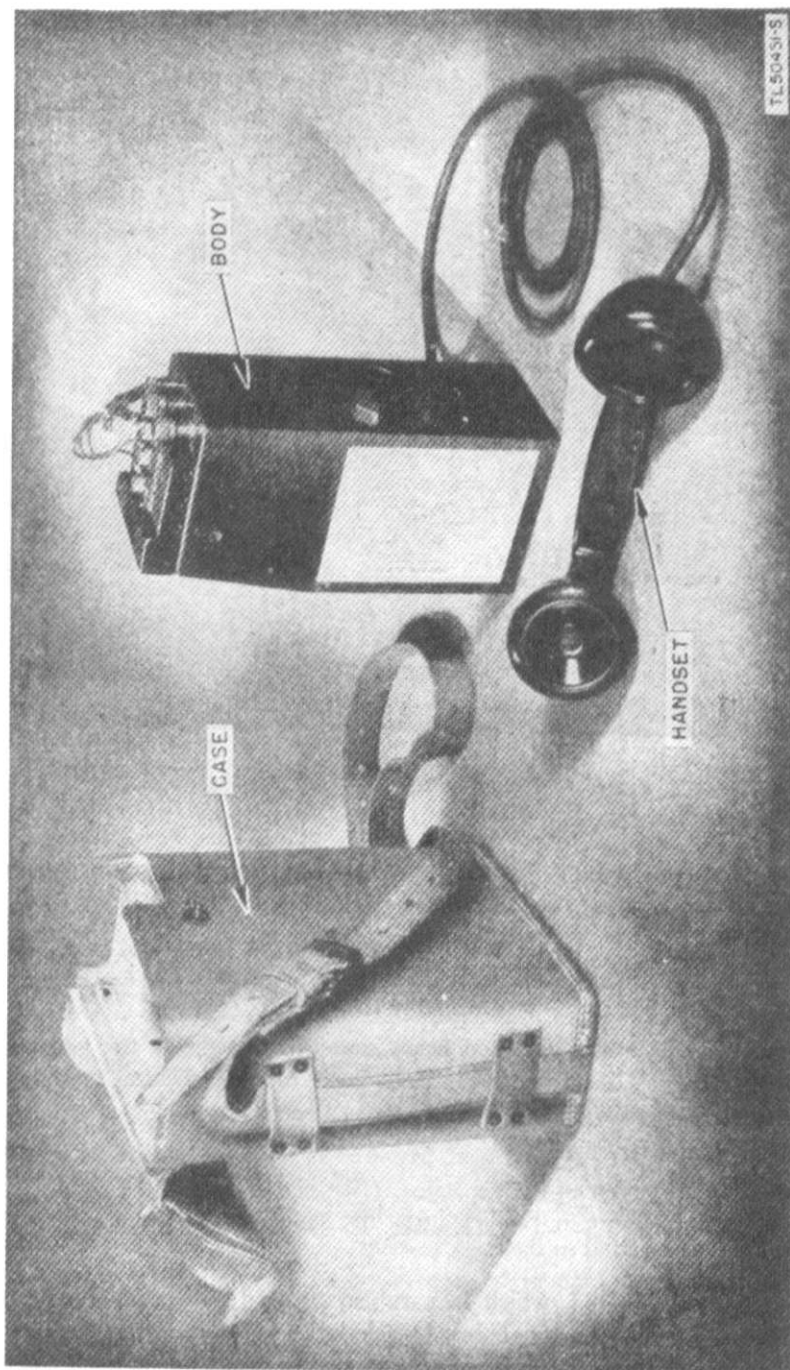

Figure 4. Telephone EE-8-A, body removed from case.

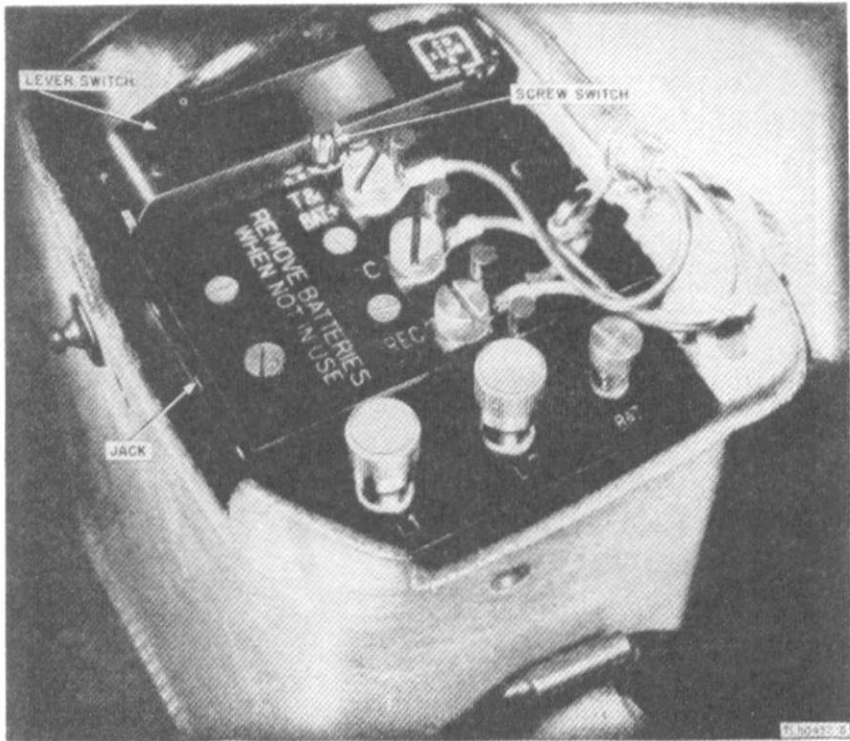

Figure 5. Telephone EE-8-A—top view, case open.

under the coils. Crank GC-9 is used with but not a part of Generator GN-38-(\*).

(4) *Capacitors.* Capacitor CA-355 is mounted below and to the right of the generator in Telephones EE-8-A and EE-8-B. (See figs. 7 and 8). Telephone EE-8 uses Capacitors CA-209, CA-177-A, and CA-259. Capacitor CA-209 is mounted below and to the right of the generator, and Capacitors CA-177-A and CA-259 are mounted behind the holding coil with Capacitor CA-177-A on top. (See fig. 6).

(5) *Ringer MC-131.* Ringer MC-131 is mounted on the floor of the body and to the left of the capacitor. (See figs. 6, 7, and 8.)

d. *HANDSET TS-9-(\*).* Handset TS-9-(\*) includes the following (figs. 4 and 9):

(1) Cord CC-333, which is a rubber-covered cord containing three rubber-covered conductors colored black, red, and white. These conductors at one end of the cord are connected to the terminals on the jack marked T & BAT +, C, and REC, respectively. The conductors at the other end of the cord are connected to terminals marked BK (or B), R, and W of the handset respectively. Stay cords are fastened at both ends.



(2) The handle, which contains suitable terminals, connections between the parts of the handset, and the handset switch in the transmitter circuit.

(3) A receiver element or unit in one end of the handle and a transmitter element or unit in the other end.

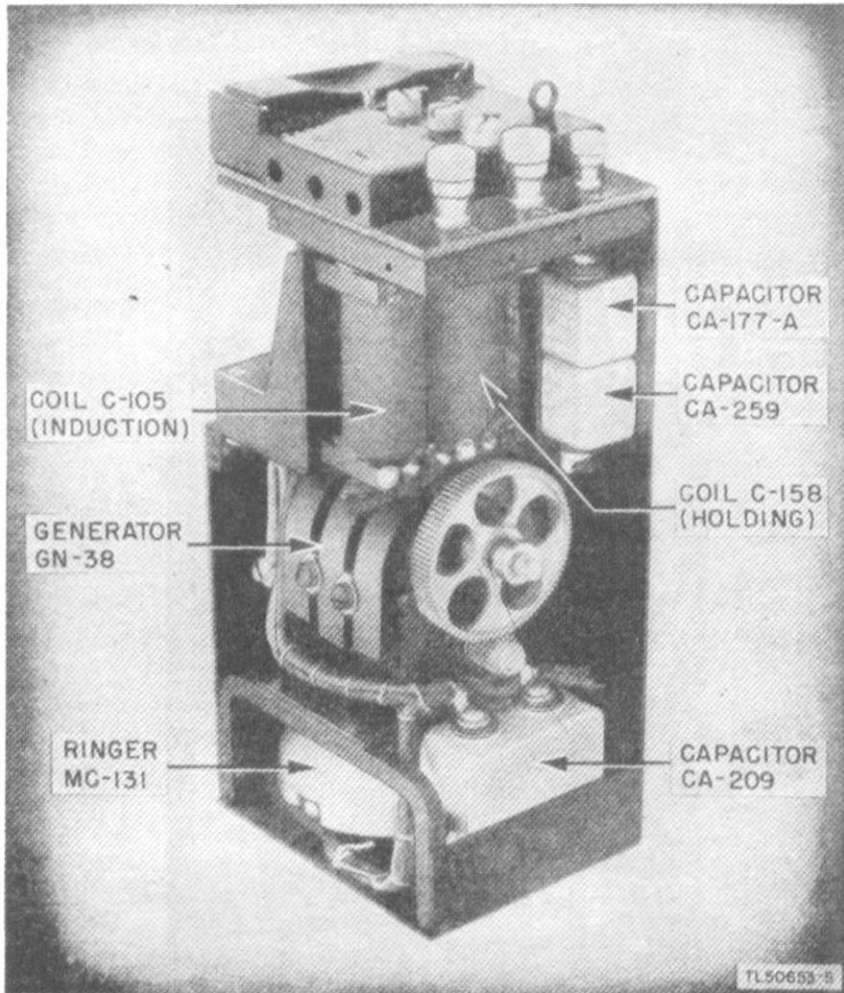

Figure 6. Telephone EE-8 body with the front wall, crank, and side wall removed.

### 3. Shipping Weights and Dimensions of Packed Telephones

a. Each Telephone EE-8-(\*) is packed in a corrugated fiberboard box 14¾ inches high, 11½ inches wide, and 5¾ inches deep. The fiberboard box containing one telephone weighs approximately 16½ pounds.

b. Three Telephones EE-8-(\*), each in a fiberboard box, are packed in a wooden box  $20\frac{3}{4}$  inches long,  $15\frac{7}{8}$  inches wide, and  $12\frac{5}{8}$  inches high. This wooden box containing three telephones weighs approximately 60 to 65 pounds.

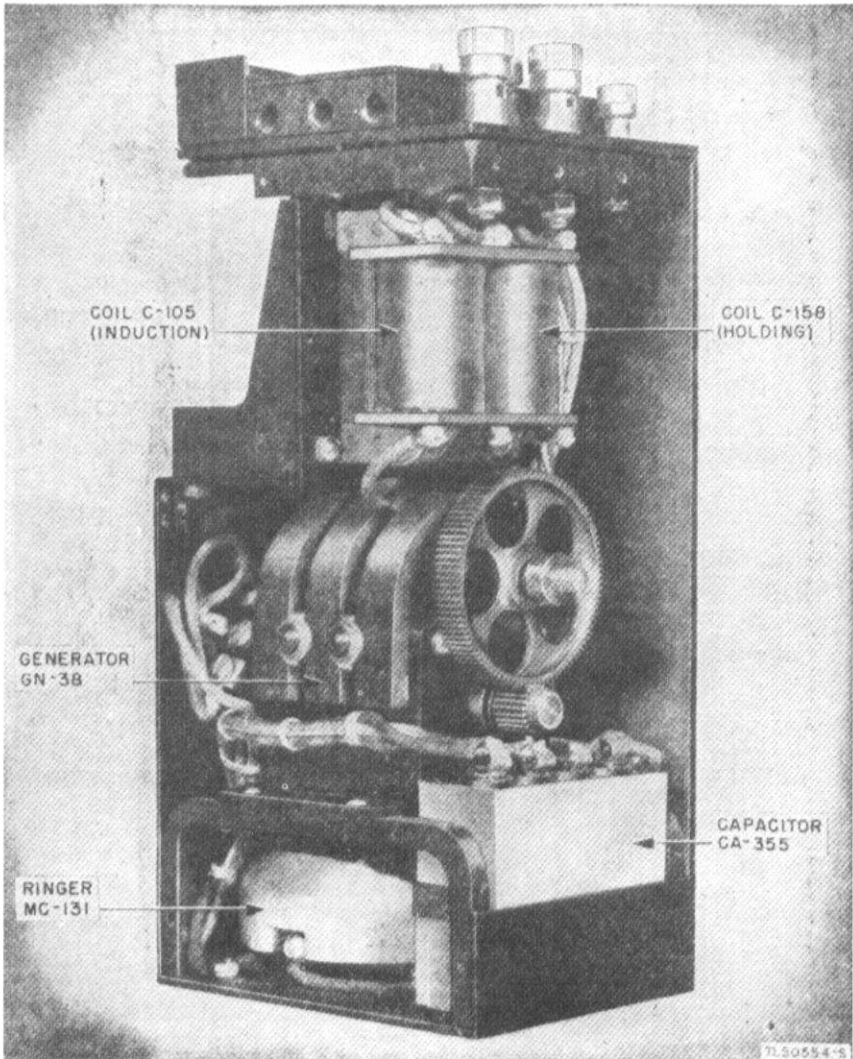

Figure 7. Telephone EE-8-A body with the front wall, crank, and side wall removed.

#### 4. Differences in Models of Telephone EE-8-(\* )

The differences in models of Telephone EE-8-(\* ) are described in paragraph 2. Operation is the same for all models of Telephone EE-8-(\* ).

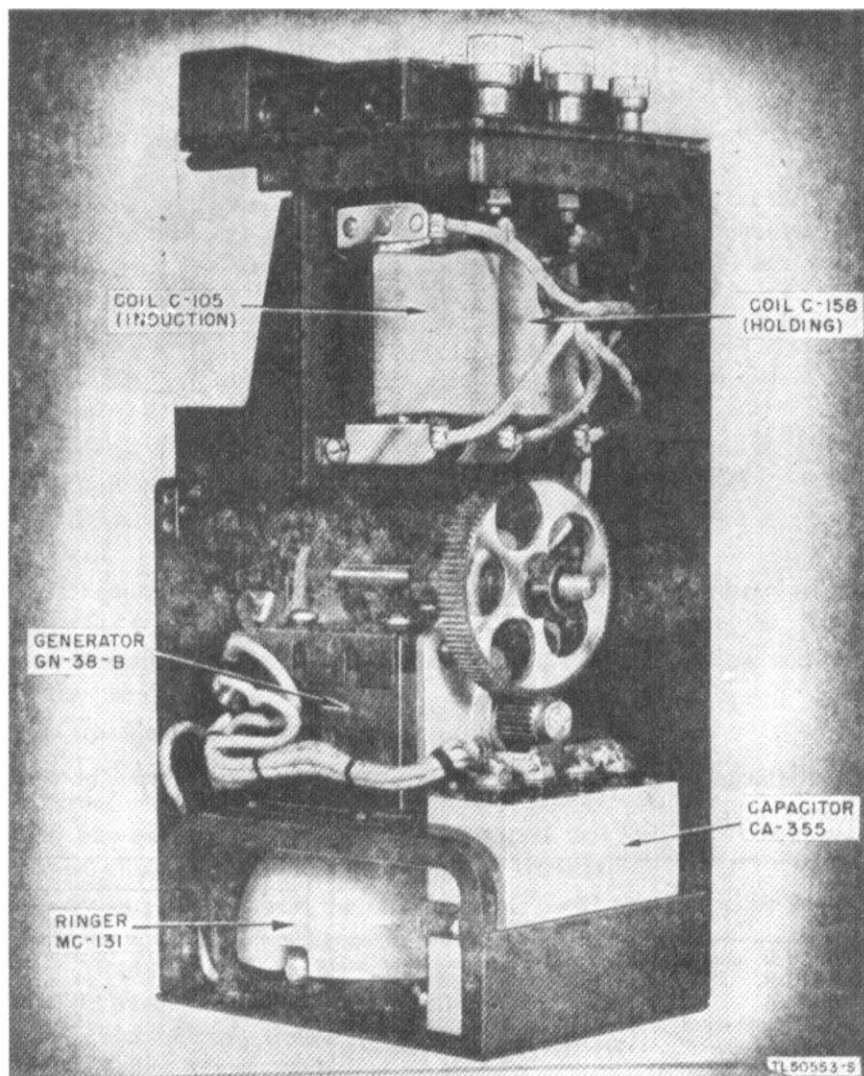

Figure 8. Telephone EE-8-B body with the front wall, crank, and side wall removed.

## Section II. APPLICATION OF TELEPHONE EE-8-(\*)

### 5. Point-to-Point Circuits

a. In point-to-point circuits, local battery operation is used, and the telephones at each end of the circuit are connected together without intervening switchboards. The hand generator is used for signaling.

b. The allowable distance between two Telephones EE-8-(\*) depends primarily upon the type of wire line used. The following table shows

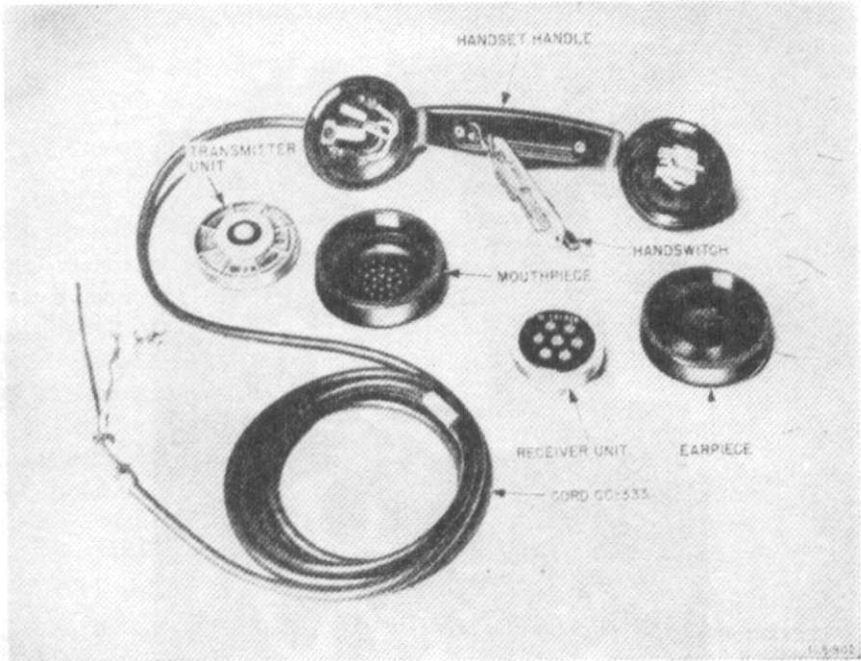

Figure 9. Handset TS-9-F, disassembled.

approximate ranges which may be expected from various types of wire lines.

Type of wire lines	Miles <sup>1</sup>	
	Point-to-point circuit	Switchboard systems <sup>2</sup>
W-110-B, nonloaded.....	11	2
W-110-B, 5,280-88 <sup>2</sup> .....	19	4
W-130-A .....	4.5	0.9
W-143, nonloaded.....	25	5
W-143, 3,300-88 <sup>2</sup> .....	100	20
<i>Open wire</i>		
080 copper-steel, 40%.....	120	24
104 copper-steel, 40%.....	165	33
128 copper-steel, 40%.....	230	46
080 copper .....	230	46
104 copper .....	360	72

<sup>1</sup>Nonrepeated, based on wet weather attenuation.

<sup>2</sup>Indicates loading. First figure is coil spacing in feet; second figure is coil loading in millihenries.

<sup>3</sup>Recommended maximum local loop involving trunk circuits.

## 6. Local Battery Switchboard Systems

a. In local battery switchboard systems, local battery operation is used, and all telephones are connected to switchboards so that circuits may be

set up when necessary between any telephones in the system. The hand generator is used for signaling.

*b.* Several local battery switchboards may be connected together by trunks to permit connection from any telephone of one switchboard to any of the telephones connected to the other switchboards. In order to insure satisfactory transmission on such built-up connections it is necessary to limit the lengths of the individual loops connected to the switchboards. The telephone can be used on various types of lines at distances from the switchboard up to one-fifth the distances allowable for point-to-point circuits. These distances are shown in the right-hand column of the table in paragraph 5. When no trunks to other switchboards are involved, the allowable distances may be increased to approximately one-half that allowable for point-to-point circuits.

*c.* The use of repeating coils on lines of a local battery system reduces the ringing range up to 50 percent and decreases transmission approximately 0.7 db for each coil.

## 7. Common Battery Switchboard Systems

*a.* In common battery systems, Telephone EE-8-(\*) uses common battery signaling and local battery transmission. To provide local battery transmission it is necessary to use batteries with the telephone and to operate the handset switch when talking. The lever switch of the telephone is used to signal the switchboard operator. Repeating coils cannot be used on a common battery system since the coil would short-circuit the line and cause a permanent signal on the switchboard.

*b.* The allowable distance from the telephone to a common battery switchboard depends to a great extent upon the type of switchboard as well as upon the type of wire line used. Allowable distances will be found in the technical manuals on the switchboard equipment. In the absence of other information, if the lengths shown in the right-hand column of the table in paragraph 5 are not exceeded, satisfactory results will usually be obtained. A 48-volt common battery system in good condition may be signaled over distances considerably greater than maximum distances for a 24-volt common battery system.

## Section III. INSTALLATION AND ASSEMBLY

### 8. Uncrating, Unpacking, and Checking

Telephones EE-8-(\*) are packed in a nailed wooden box as shown in figure 10. Each wooden box contains three telephones which are individually packed in fiberboard inner packing boxes. Figure 11 shows the method of packing a telephone in its inner packing box and the sizes and shapes of the fiberboard cells and pads. The cells and pads are

shown projected away from their respective places in the fiberboard box. Each interior packing box contains four dustproof packages of silica gel crystals which are provided to absorb any moisture that may be present. To unpack the telephones from the wooden box and from the inner fiberboard boxes, follow the procedure outlined below.

- a. Place the wooden box in a convenient place for opening.
- b. Cut and remove the steel straps.

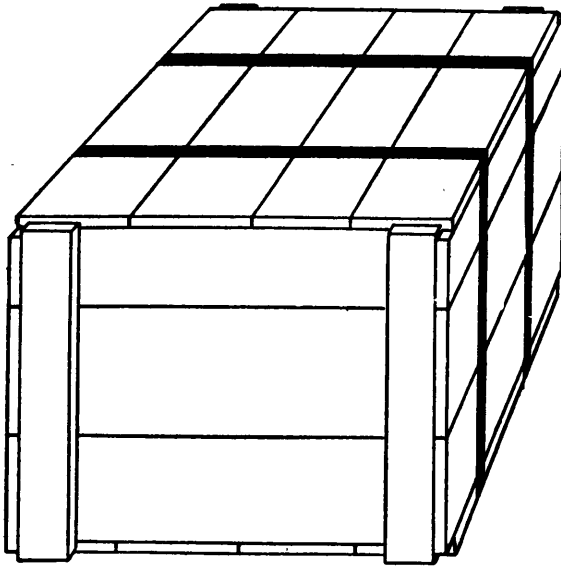

TL53726

Figure 10. Wooden box used for packing Telephones EE-8-(\*).

- c. Remove the nails with a nail puller and take off the top of the wooden box. Do not pry off the top of the box as this may cause damage to the equipment.

- d. Remove the individually packaged telephones from the wooden box and set them in a convenient place for opening the inner packing boxes.

- e. Open the top of each fiberboard inner packing box and remove the fiberboard pad and the cell containing four dustproof bags of silica gel located on the top of the telephone cases.

- f. Withdraw the telephone from the inner packing box.

*Caution:* When removing waterproofing and other protective coatings, care should be taken not to remove moistureproofing and fungiproofing coatings.

- g. Open the top of the telephone case and withdraw the handset.

- h. Remove the greaseproof paper from the microphone and receiver ends of the handset.

- i. Remove the liner bag from the handset compartment of the telephone case.

j. Remove the pieces of cotton tape that bind the carrying strap to the strap rings on the sides of the case. Unfold the straps.

k. Carefully inspect the equipment for possible damage during shipment.

l. Check the equipment against the master packing slip.

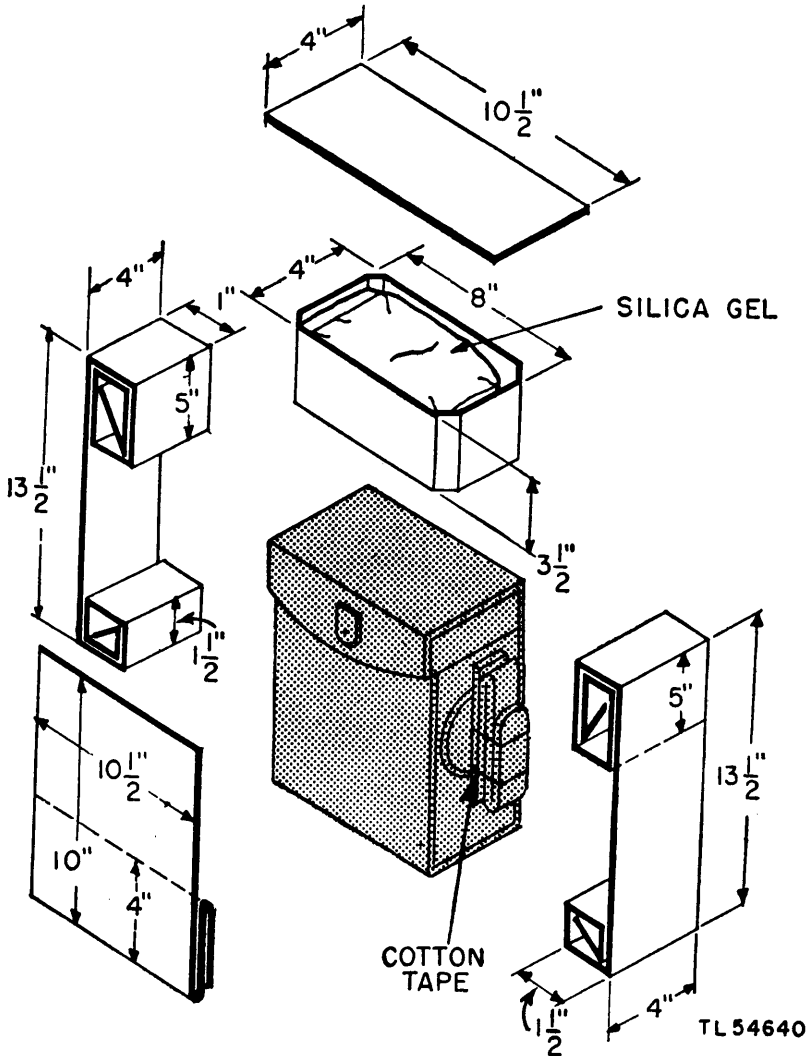

Figure 11. Packing and cushioning of Telephone EE-8-(\*) inside fiberboard box.

## 9. Siting

Locate Telephone EE-8-(\*) where it will not be subject to adverse weather conditions. Place the telephone in an upright position in a manner providing convenient access to the handset and crank. If the tele-

phone is suspended from a tree trunk or tent pole, tie the telephone securely to prevent swinging. (See fig. 12.) The telephone should be mounted in such a way that the line can be brought to it with the least amount of trouble. A wooden rack or seat is desirable for holding the telephone in position if it is to be installed semipermanently on a table or other flat surface. In this case place the strap so as not to interfere with operation of the telephone.



*Figure 12. Telephone EE-8-A suspended from tree trunk,*



## 10. Battery Installation

- a. Open the case and take out the handset.
- b. Place two Batteries BA-30 in the battery compartment. (See fig. 13.) Make certain that the bottoms of the batteries rest on the coiled springs and that the tops of the batteries rest against the contacts at the top of the compartment. These batteries are connected in series by the interior wiring of the telephone.

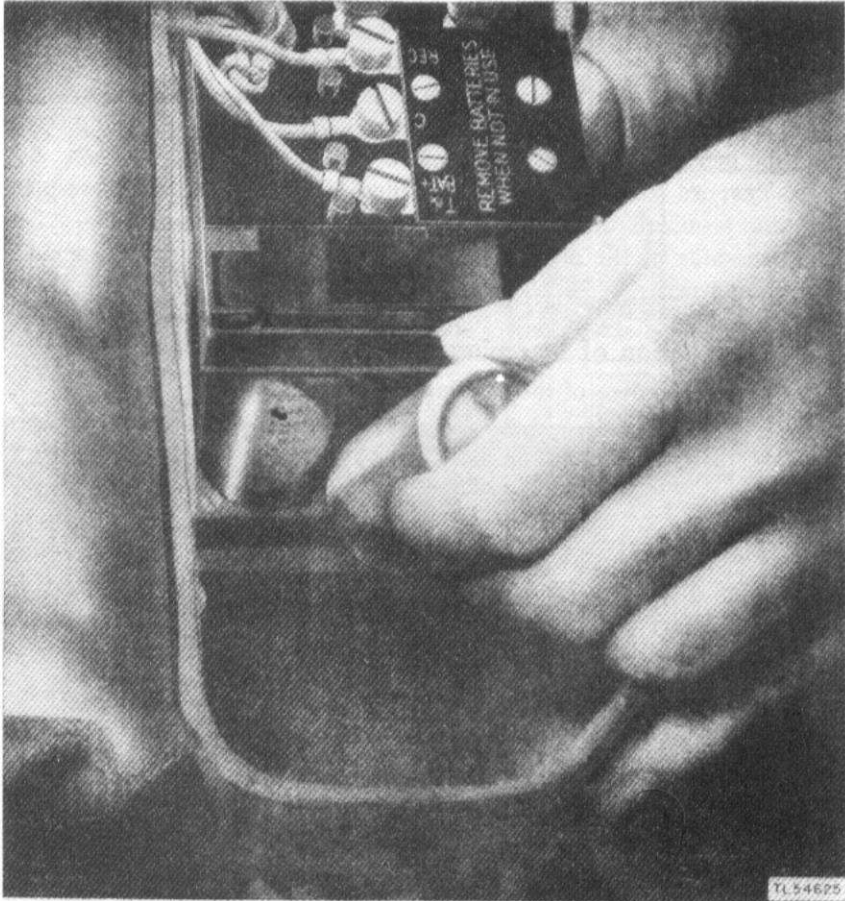

Figure 13. Installation of batteries.

- c. If Batteries BA-30 are not available, any 3-volt d-c source of power may be used by connecting the positive lead to the terminal on the jack marked T & BAT+ and the negative lead to the terminal marked BAT-. Always remove any batteries installed in the telephone before connecting an external source of power and be sure that the voltage of the external source does not exceed 3 volts.

## II. Preliminary Tests

*a.* TESTING TRANSMITTER AND RECEIVER. Hold the receiver to the ear and blow steadily into the transmitter while alternately operating and releasing the handset switch. The sound (sidetone) should be heard strongly in the receiver when the switch is in the operated position, but should not be heard when the switch is in the unoperated position.

*b.* TESTING GENERATOR. While holding the receiver to the ear, rapidly turn the generator clockwise for several turns. The generator should turn easily and the impulses should be heard in the receiver. The ringer should not operate. Short circuit line terminals L1 and L2 with a screw driver or short piece of field wire, hold the receiver to the ear, and again turn the generator. The generator should now turn hard as though a drag had been placed on it, the impulses should be heard in the receiver, and the bell should not ring. Remove the short circuit.

*c.* TESTING RINGER. Connect terminals L1 and L2 to the corresponding line terminals of another telephone known to be serviceable. Turn the generator of the other telephone. The bell of the telephone under test should ring.

## 12. Connection of Incoming Lines

*a.* Open the cover of the telephone case.

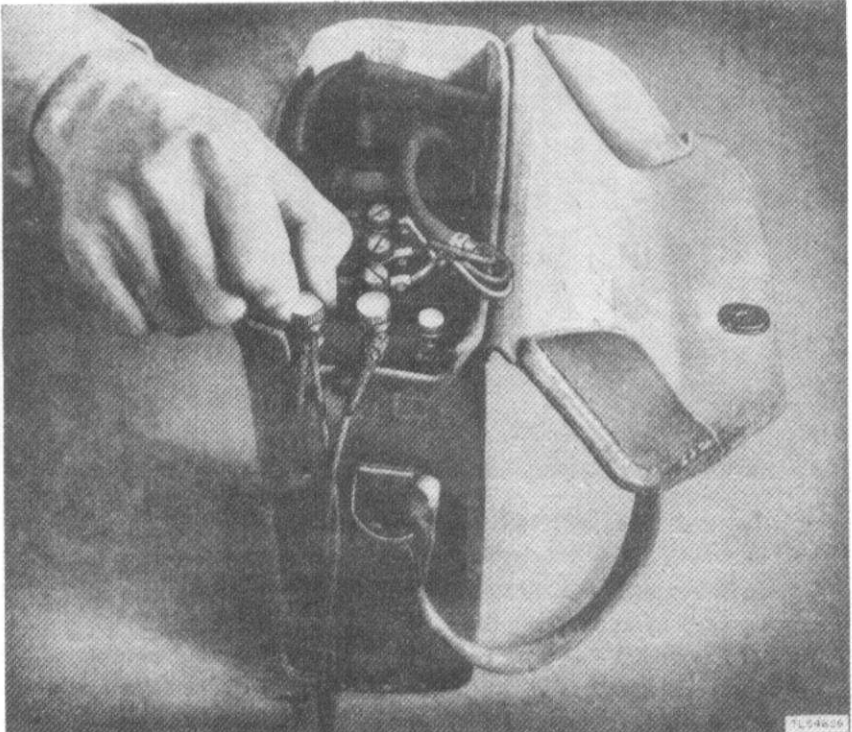

Figure 14. Connecting line wires to Telephone EE-8-A.

b. Starting approximately 4 inches from the ends of the wires to which the telephone is to be connected, strip off about 2 inches of insulation. Scrape and clean the bared metal of the wires.

c. If the telephone is being connected to a metallic circuit, connect one wire of the line to the terminal marked L1 on the terminal block of the telephone. Connect the other line wire to the terminal marked L2. (See fig. 14.)

d. If the telephone is being connected to a ground-return circuit, connect the line wire to either line terminal L1 or L2. Connect the other line terminal to a good ground.

### 13. Repacking for Transport

Chest BC-5 may be used for transporting Telephones EE-8-(\*) in the field. The chest is designed to hold 12 telephones as shown in figure 15.



Figure 15. Chest BC-5 containing 12 telephones for transport

## Section IV. INITIAL ADJUSTMENTS

### 14. Adjustments for Operation

a. **LOCAL BATTERY.** With a screw driver turn the screw switch counterclockwise as indicated by the arrow pointing to LB until the screw comes to a stop. (See fig. 16.)

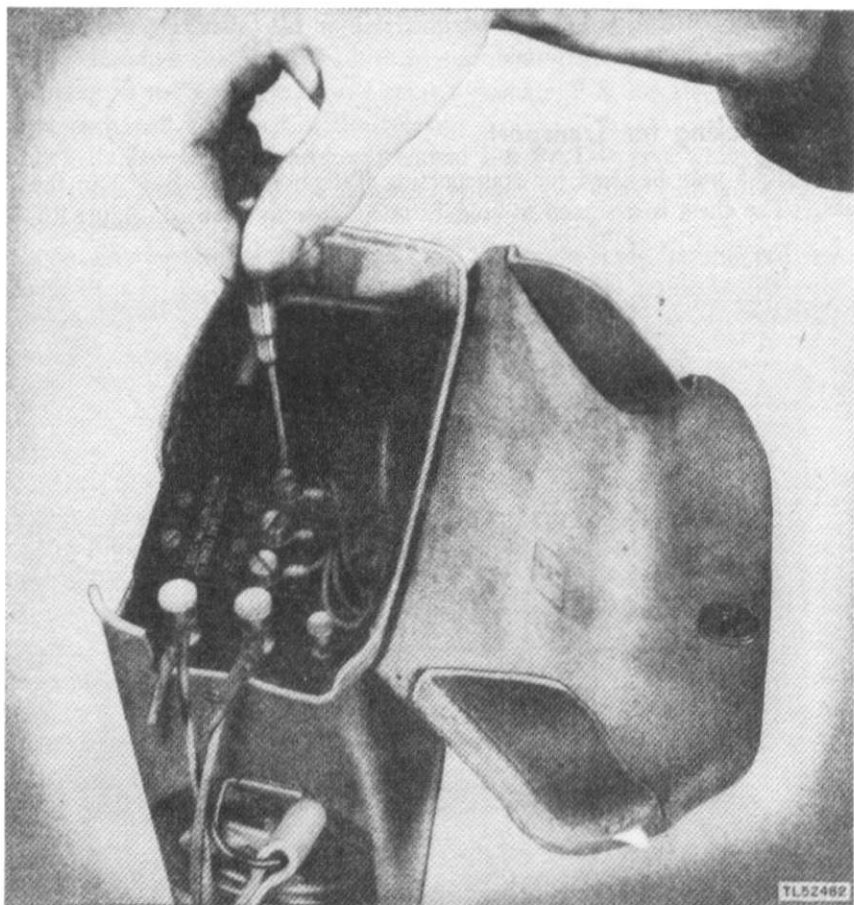

Figure 16. Adjustment of screw switch.

*Caution:* Do not attempt to force the screw switch past its final position. Use of force may damage the equipment.

b. **COMMON BATTERY.** With a screw driver turn the screw switch clockwise as indicated by the arrow pointing to CB as far as it will go. When the telephone is used on common battery systems, hang the handset on the lever switch. (See figs. 17 and 18.)

## 15. Precautions

Make sure that the screw switch is in the proper position for the type of circuit on which the telephone is to be used. Improper placement of the screw switch when the telephone is used on common battery systems will cause a permanent signal to appear on the switchboard. Improper position of the screw switch when the telephone is used on local battery systems will prevent operation of the ringer by an incoming ringing signal unless the handset is kept hanging on the lever switch when the telephone is idle.



*Figure 17. Telephone EE-8-B, position of handset on lever switch with case open.*

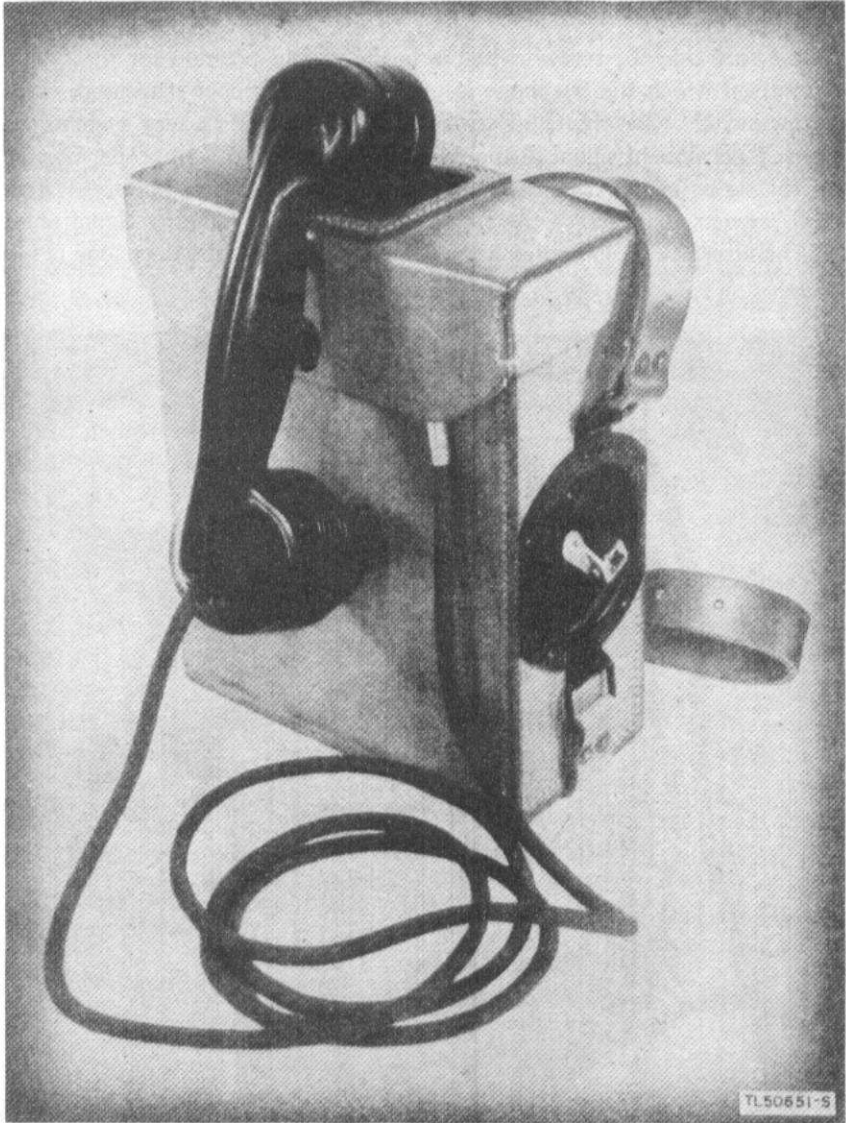

*Figure 18. Telephone EE-8, handset holding down lever switch through flexible cover insert.*

## CHAPTER 2

# OPERATING INSTRUCTIONS

*Note.* For instructions on destroying the equipment to prevent enemy use, see destruction notice at the front of this manual.

---

### Section I. PROCEDURE FOR OPERATION

#### 16. Local Battery Operation

*a.* SIGNALING. Turn the generator rapidly in a clockwise direction for several turns.

*b.* TRANSMITTING AND RECEIVING. Hold the handset with the transmitter close to the lips and the receiver to the ear. While talking, hold the handset switch operated with the thumb and talk directly into the transmitter. Release the handset switch while listening to conserve the batteries.

*c.* RINGING OFF. When conversation is completed on a call established through a switchboard, ring off by two or three sharp turns of the generator crank. This will operate a supervisory light or drop on the switchboard to notify the switchboard operator that the connection is no longer wanted or that a new connection is desired. After ringing off, if a new connection is not desired, replace the handset in the case.

#### 17. Common Battery Operation

*a.* SIGNALING. To signal the switchboard operator on a common battery system, remove the handset from its position on the lever switch.

*b.* TRANSMITTING AND RECEIVING. These operations are the same for both local and common battery operation. (See par. 16b.)

*c.* TO RECALL OPERATOR. *Slowly* depress and release the lever switch several times.

*d.* TO INDICATE COMPLETION OF CALL. Replace the handset in position on the lever switch so that the lever switch is depressed.

#### 18. Special Precautions

*a.* BATTERY DETERIORATION. Avoid battery deterioration which will cause leakage of highly corrosive chemicals in the telephone. This deterioration begins in a short time (48 hours) if the handset switch is left in its operated position, and also if the telephone is stored for a long period with batteries installed even though this switch is not in the



operated position. The pressure of the spiral spring tends to break down the battery physically. This pressure, if left on very long, will break the sealing compound and allow the electrolyte to leak out, causing corrosion. Consequently, when a telephone is removed from a circuit, or turned in for test, repair, replacement, storage, shipment, or other purpose, always inspect it, and if it is not to be installed *immediately* on another circuit, remove the batteries.

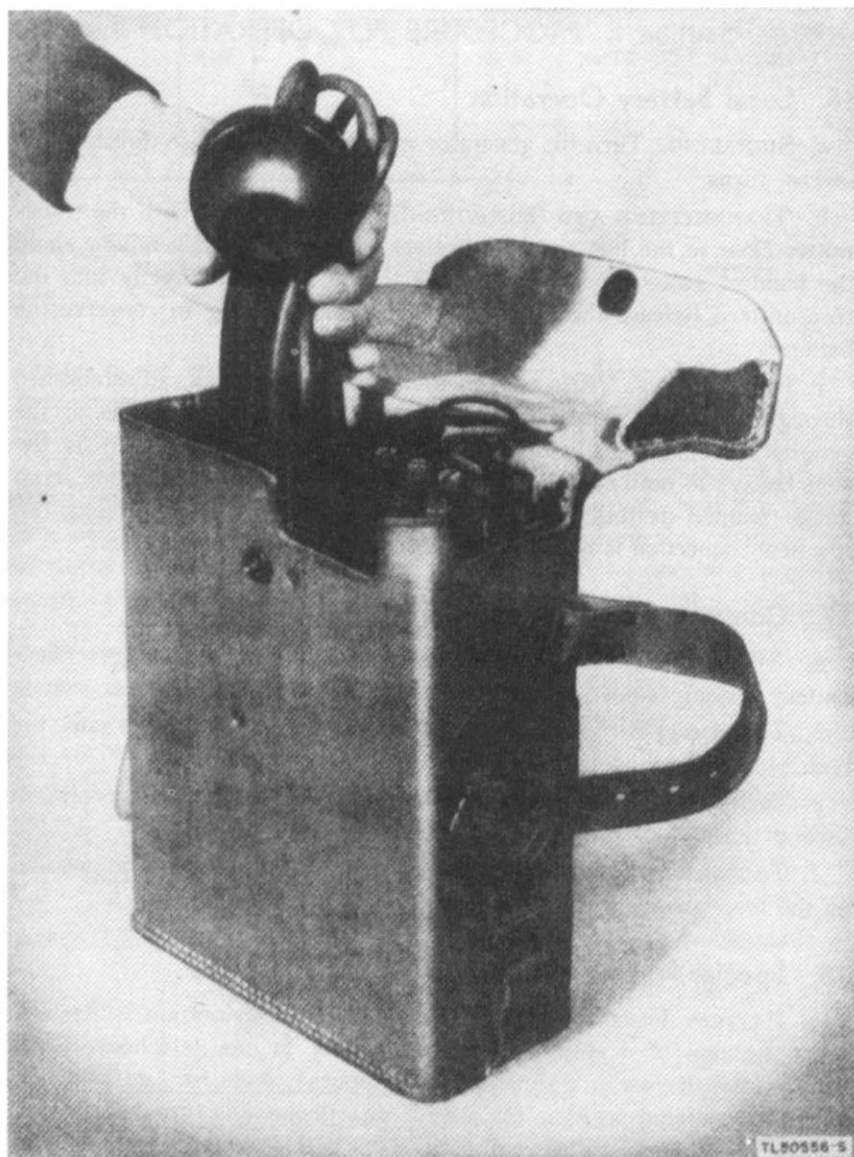

Figure 19. Replacing handset in compartment of telephone case



*b.* **PROTECTION.** Protect the telephone from the weather as far as practicable when installed, and place it in a cool, dry spot when stored.

*c.* **CLEANLINESS.** Do not permit dirt to accumulate on any part of the telephone. This applies particularly to terminals, binding posts, and contacts.

*d.* **CONNECTIONS.** Keep all wire connections and screws tight.

## 19. Closing Station

Remove the connections from line terminals L1 and L2. Remove the batteries unless the telephone is to be installed on another circuit *immediately*. Fold the cord loosely into folds about as long as the handset, place the folds alongside the handset, and insert the handset, receiver end first, into its compartment in the case. (See fig. 19.) *Do not wrap the cord around the handset* because this may operate the handset switch and, if the batteries have not been removed from the telephone, may exhaust the batteries and cause serious damage to the telephone.

## Section II. OPERATION UNDER UNUSUAL CONDITIONS

### 20. Damping and Silencing Ringer

*a.* **GENERAL.** The use of Telephone EE-8-(\*) in positions close to the enemy might disclose the location of the operator if the audible signal of the ringer were not partially or wholly silenced. Methods of damping or completely silencing the ringer are given in *b* and *c* below. The method used will depend upon the tactical situation or requirements of the operator.

*b.* **DAMPING.** (1) *Removal of gong* (fig. 20). With the gong removed, the incoming ringing signal will be a dull vibrating sound. To remove the gong:

(*a*) Open the top flap of the case.

(*b*) Remove the seven screws from the outer side of the case.

(*c*) Remove the handset and the telephone chassis from the case.

(*d*) Remove the four *corner* screws from the bottom plate of the chassis, and pull out the plate sufficiently to provide access to the screws on top of the gong. *Do not disconnect the wiring.*

(*e*) Remove the two screws from the top of the gong and take out the gong.

(*f*) Replace the bottom plate and the case. (2) *Taping ringer armature.* Further damping of the ringer can be accomplished by taping the points where the ringer armature strikes the pole pieces of the ringer. Follow the above steps for removal of the gong, but before re-

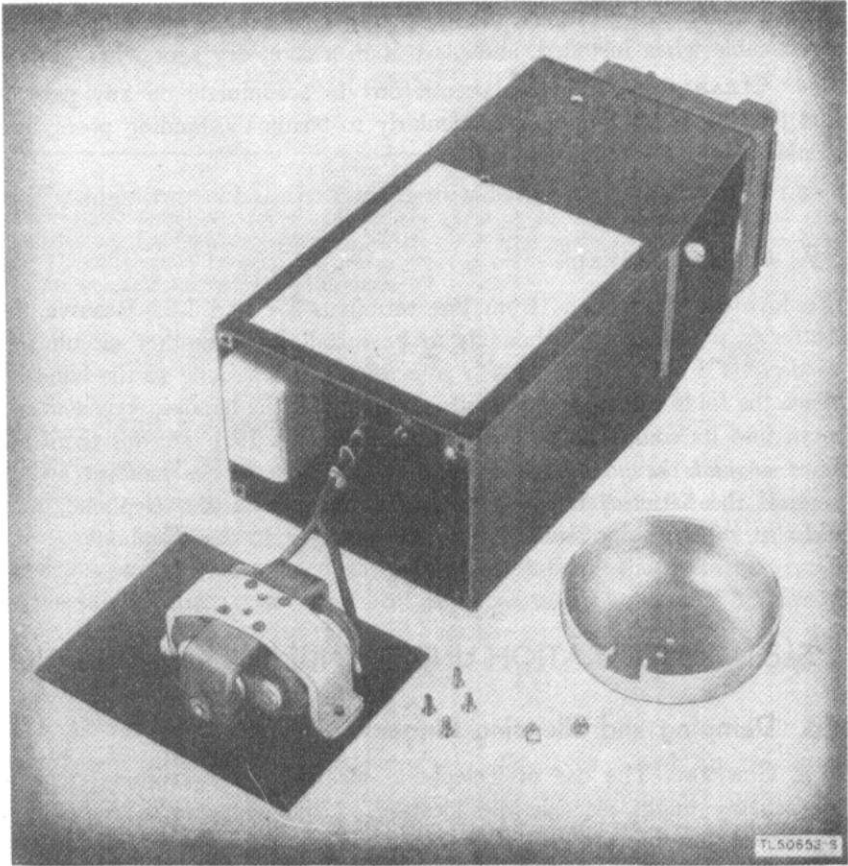

Figure 20. Telephone EE-8, gong removed from ringer assembly.

placing the bottom plate insert two strips of friction tape (approx.  $\frac{1}{2}$  inch square) on the contact point of each ringer coil. The tape restricts the travel distance of the armature and further reduces the sound output of the ringer on an incoming signal.

*c. COMPLETE SILENCING. (1) Disconnecting ringer circuit.* When a completely silenced ringer is required, permanently disconnect the ringer circuit from the line by the following method:

- (a) Remove the seven screws from the outer side of the case.
- (b) Remove the handset and the telephone chassis from the case.
- (c) Remove the five screws from the front plate and take off the plate.
- (d) Loosen the top screw on the generator spring pack and remove the black lead.
- (e) Wrap the spade type terminal of the black lead thoroughly with insulating tape and push the lead into a convenient place in the chassis.
- (f) Replace the front plate and the case. (2) *Pushing in generator*

*handle*. In case the telephone has not been previously damped or silenced and an emergency requires immediate silencing of an incoming call, push in the hand generator handle. This disconnects the ringer from the line. *The generator handle must be held in to keep the ringer disconnected from the line.*

d. **VISUAL SIGNAL.** When it is desired to substitute a visual signal for the ringer, Adapter Plug U-4/GT, if available, may be used. Disconnect the ringer as described in c above and connect Adapter Plug U-4/GT across line terminals L1 and L2. For a description of Adapter Plug U-4/GT, see TB SIG 147.

e. **IDENTIFICATION OF MODIFIED TELEPHONES.** Tag each telephone with a description of any modifications which have been made. The tag readily identifies the telephone for future use and prevents another user from thinking the telephone is defective.

## 21. Use of Telephone with Gas Mask

a. **GENERAL.** Equipment has been provided to aid in maintaining telephone communication when a gas mask is worn. Microphone T-45, the lip microphone, or Microphone T-30, the throat microphone, used when Microphone T-45 is not available, will afford satisfactory communication under any gas mask when suitably connected to Telephones EE-8, or EE-8-A, or EE-8-B as described in TB SIG 50. However, some users of the telephone may not have Microphone T-45 or Microphone



Figure 21. Talking position for Handset TS-9-(\*), used with gas mask.



*Figure 22. Listening position for Handset TS-9-(\*), used with gas mask.*

T-30 available. In the event of gas warfare, communications may be seriously handicapped unless the ordinary telephone handset is properly used with a gas mask.

*b. USE OF HANDSET.* Position of the handset is of primary importance, for if the handset is held in the normal position, a gas mask will greatly hamper communication. The following procedure should be followed:

(1) While speaking, hold the transmitter directly over, and in close contact with, the outlet valve guard of the service mask or the speech diaphragm of the diaphragm type mask. (See fig. 21.)

(2) To listen, change position of the handset so the receiver is over the ear. (See fig. 22.)

(3) The change of position takes time, and it is therefore necessary for the user to signify in some definite manner when he has finished speaking. The word "over" or some other simple code may be used to indicate this.

### **Section III. EQUIPMENT PERFORMANCE CHECK LIST**

#### **22. Purpose and Use**

*a. GENERAL.* The equipment performance check list (par. 23) will help the operator to determine whether Telephone EE-8-(\* ) is functioning properly. The check list gives the item to be checked, the conditions under which the item is to be checked, the normal indications, and the corrective measures that the operator can take.

*b. ACTION.* Information given in the action or condition column represents an action that must be taken in order to check the normal indications given in the normal indications column.

c. **NORMAL INDICATIONS.** The normal indications listed include visible and audible signs that the operator will perceive when he checks the items listed. If the indications are not normal, the operator should apply the recommended corrective measures.

d. **CORRECTIVE MEASURES.** The corrective measures listed are those that the operator can make without turning the equipment in for repairs. References to paragraph 48 in the table indicate that the trouble cannot be corrected during operation and that trouble shooting by an experienced repairman is required. If the set is completely inoperative or if the recommended corrective measures do not yield results, trouble shooting is necessary. However, if the tactical situation requires that communication be maintained and if the set is not completely inoperative, the operator must maintain the set in operation as long as it is possible to do so.

### 23. Check List

	Item No.	Item	Action or condition	Normal indications	Corrective measures
Preparatory	1.	Binding posts L1 and L2	Incoming lines connected.		
	2.	Battery BA-30	Two batteries installed in compartment of body.		
	3.	Screw switch.	Turn to CB (common battery) or LB (local battery) depending upon type of system used.		
Start	4.	Signaling circuit (local battery).	Turn hand generator.	Called station or switchboard operator answers.	Refer to paragraph 48.
	5.	Signaling circuit (common battery).	Lift handset from lever switch.	Switchboard operator answers.	Refer to paragraph 48. Check lever switch.
Equipment performance	6.	Handset Switch.	Operated when talking. Unoperated when listening.		
	7.	Ringer circuit.	Distant operator or station rings in to telephone.	Bell rings.	Refer to paragraph 48.
	8.	Transmitting circuit.	Handset switch operated.	Transmission possible to distant station.	Check batteries. Refer to paragraph 48.
	9.	Receiving circuit.	Handset switch unoperated.	Reception possible from distant station.	Refer to paragraph 48.

## CHAPTER 3

### PREVENTIVE MAINTENANCE

---

#### Section I. PREVENTIVE MAINTENANCE TECHNIQUES

##### 24. Meaning of Preventive Maintenance

Preventive maintenance is a systematic series of operations performed at regular intervals on equipment to eliminate major break-downs and unwanted interruptions in service, and to keep the equipment operating at top efficiency. To understand what is meant by preventive maintenance, it is necessary to distinguish between preventive maintenance, trouble shooting, and repair. The primary function of preventive maintenance is the prevention of break-downs and, therefore, the need for repair. On the other hand, the primary function of trouble shooting and repair is the location and correction of existing defects. The importance of preventive maintenance cannot be overemphasized. The entire system of wire communication depends upon each set being *in operation* when it is needed and also upon its *operating efficiency*.

*Note:* The operations in sections I and II, are considered first and second echelon (organization operators and repairmen) maintenance. Some operations in sections IV and V are considered higher echelon maintenance.

##### 25. Description of Preventive Maintenance Techniques

*a. GENERAL.* Most of the parts used in Telephone EE-8-(\*) require routine preventive maintenance. Those requiring maintenance differ in the amount and kind required. Because hit-or-miss maintenance techniques cannot be applied, definite and specific instructions are needed. This section of the manual contains these specific instructions and serves as a guide for personnel assigned to perform the six basic maintenance operations: Feel, Inspect, Tighten, Clean, Adjust, and Lubricate. Throughout this manual the following lettering system will be used for the six operations:

- F — Feel
- I — Inspect
- T — Tighten
- C — Clean
- A — Adjust
- L — Lubricate

The first two operations establish the need for the other four. The selection of operations is based on the general knowledge of field needs.

For example, dust encountered on dirt roads during cross-country travel filters into the equipment no matter how much care is taken to prevent it. Rapid changes in weather (such as heavy rain followed by blistering heat), excessive dampness, snow and ice tend to cause corrosion of exposed surfaces and parts. Without frequent inspections and the performance of necessary tightening, cleaning, and lubricating operations, equipment becomes undependable and subject to break-down.

*b. FEEL.* The feel operation is used most often to check for overheating.

*c. INSPECT.* Inspection is the most important operation in the preventive maintenance program. A careless observer will overlook the evidences of minor trouble. Although these minor defects may not interfere with the performance of the equipment, valuable time and effort can be saved if they are corrected before they lead to major break-downs. Make every effort to become thoroughly familiar with the indications of normal functioning, in order to be able to recognize the signs of defective equipment. Inspection consists of carefully observing all parts of the equipment, noticing their color, placement, state of cleanliness, etc. Inspect for the following conditions:

(1) Overheating, as indicated by discoloration, blistering, or bulging of the parts or surface of the container; leakage of insulating compounds; and oxidation of metal contact surfaces.

(2) Placement, by observing that all leads and cabling are in their original positions.

(3) Cleanliness, by carefully examining all recesses in the units for accumulation of dust, especially between connecting terminals. Parts, connections, and joints should be free of dust, corrosion, and other foreign matter. In tropical and high humidity locations, look for fungus growth and mildew.

(4) Tightness, by testing any connection or mounting which appears to be loose.

*d. TIGHTEN, CLEAN, AND ADJUST.* These operations are self-explanatory. Specific procedures for performing them are given in paragraphs 26 through 34 whenever necessary.

*Caution:* Screws, bolts, and nuts should not be tightened carelessly. Fittings tightened beyond the pressure for which they are designed will be damaged or broken. Whenever a loose connection is tightened, moistureproof and fungiproof it again by applying the varnish with a small brush. See section V for details of moistureproofing and fungiproofing.

*e. LUBRICATE.* Lubrication means the addition of oil or grease to form a film between two surfaces that slide against each other, in order to prevent mechanical wear from friction.

## 26. Case, Exterior

*a. INSPECT (I).* Carefully examine the leather case and strap for cut or torn places, dirt, oil, grease, and mildew. Inspect the metal parts of

the case for damaged places, dirt, dust, rust, corrosion, and loose, damaged, or missing screws.

*b.* **TIGHTEN (T).** With a suitable screw driver, tighten all screws snugly.

*c.* **CLEAN (C).** With a clean dry cloth, wipe all dirt and dust off the case. Pay particular attention to the small crevices around the hand generator crank. Use saddle soap and neat's-foot oil for cleaning and preserving the leather case and strap.

## **27. Case, Interior**

*Note.* In order to perform the preventive maintenance operations contained in the following paragraphs, it will be necessary to remove the telephone from its case.

*a.* **INSPECT (I).** Inspect the interior of the case for damaged places, dirt, dust, oil, grease, and mildew.

*b.* **CLEAN (C.)** With a clean dry cloth, wipe all dirt, dust, and foreign matter from the inside of the case.

## **28. Jack Assembly and Lever Switch**

*a.* **INSPECT (I).** Carefully inspect the jack assembly and lever switch for dirt, dust, rust, and corrosion. Inspect the jack assembly for loose, damaged, or missing terminals, and for loose, damaged, or missing mounting screws. Carefully inspect the contacts of the lever switch for dirt, corrosion, and pitted places.

*b.* **TIGHTEN (T).** Tighten all of the jack assembly and lever-switch screws securely, using a suitable screw driver.

*c.* **CLEAN (C).** Carefully wipe all dirt, dust, and foreign matter from the jack assembly, using a clean dry cloth. With a soft bristle brush, remove all dirt, dust, and foreign matter under the lever switch. Carefully burnish and flush the lever switch contacts as outlined in paragraph 37.

## **29. Generator**

*a.* **INSPECT (I).** Inspect the generator for dirt, dust, rust, corrosion, and foreign matter, and for damaged, loose, or missing mounting screws and terminal screws. Do not remove the cover from the generator (Generator GN-38-B).

*b.* **TIGHTEN (T).** Tighten all terminal screws and mounting screws securely.

*c.* **CLEAN (C).** Carefully remove all dirt, dust, and foreign matter on the generator, using a soft bristle brush. Be careful not to disconnect any wires when performing this operation.

## **30. Battery Compartment**

*a.* **INSPECT (I).** Carefully inspect the battery compartment for dirt, dust, corrosion, and loose or missing battery contact springs.



*b.* **CLEAN (C).** With a soft bristle brush, remove all dirt, dust, and foreign matter from the battery compartment. Carefully clean the battery contact springs with crocus cloth to insure good electrical connections.

### **31. Induction and Holding Coils**

*a.* **INSPECT (I).** Carefully inspect the induction and holding coils for damaged places, worn or frayed insulation, dirt, dust, and loose or missing mounting screws.

*b.* **TIGHTEN (T).** Tighten all mounting screws securely.

*c.* **CLEAN (C).** Remove all dirt and dust, using a soft bristle brush. Be careful not to disconnect any wires while performing this operation.

### **32. Chassis**

*a.* **INSPECT (I).** Carefully inspect the chassis of the telephone for damaged places, dirt, dust, and corrosion. Pay particular attention to the small crevices and obscure places.

*b.* **CLEAN (C).** With a soft bristle brush, carefully remove all dirt, dust, and foreign matter from the chassis. Be careful not to disconnect any wiring. Brush all dirt and dust away from the component parts that are mounted on the chassis.

### **33. Handset TS-9-(\*)**

*a.* **INSPECT (I).** Carefully inspect the handset for dirt, dust, and chipped or cracked places. Do not disassemble the handset. Inspect the exterior only.

*b.* **CLEAN (C).** Wipe all dirt, dust, and foreign matter off the handset, using a clean dry cloth.

### **34. Cord CC-333**

*a.* **INSPECT (I).** Inspect the cord for dirt, dust, oil, grease, and damaged or broken insulation. Examine the cord, where it enters the handset, for worn places and tightness of connection.

*b.* **CLEAN (C).** Wipe off all dust and dirt, using a clean dry cloth. If it becomes necessary to remove oil or grease, use dry-cleaning solvent.

## **Section II. ITEMIZED PREVENTIVE MAINTENANCE**

### **35. Common Materials Needed**

*Note:* The tools and materials listed below must be at hand before starting the preventive maintenance procedures.

The following is a list of the tools and materials needed for performing preventive maintenance operations on Telephone EE-8-(\*).

Long-nose pliers

Diagonal pliers

3½ inch cabinet screwdriver  
 Solvent, dry-cleaning, Federal Spec. No. P-S-661a  
 Saddle soap  
 Neat's-foot oil  
 Contact burnisher  
 Bristle brushes  
 Cleaning cloths  
 Crocus cloth

*Note.* Leaded gasoline will not be used as a cleaning fluid for any purpose. Solvent, dry-cleaning, Federal Spec. No. P-S-661a, is available as a cleaning fluid through established supply channels. Oil, Fuel, Diesel, U. S. Army Spec. 2-102B, may be used for cleaning purposes when dry-cleaning solvent is not at hand. Since unleaded gasoline is available only in limited quantities, and only in certain localities, it should be used for cleaning purposes only when no other agent is available. Carbon tetrachloride, or fire-extinguishing liquid (carbon tetrachloride base), will be used, if necessary, *only on contact parts of electronic equipment.*

### 36. Check List

a. For ease and efficiency of performance, it is suggested that preventive maintenance on Telephone EE-8-(\*) be broken down into daily, weekly, and monthly items.

*Note.* The time intervals for performing the preventive maintenance outlined in the preceding paragraphs and the check list may be varied at any time by the local commander. However, for best performance of the equipment, it is recommended that the operations be performed at least as frequently as called for in the check list.

b. The general techniques involved and the application of FITCAL operations in performing preventive maintenance on individual parts are discussed in section I. These general instructions are not repeated in this section. Personnel performing preventive maintenance should refer to section I when more detailed information is required on the items listed in the following schedule. After preventive maintenance has been performed on a given day, the equipment should be put into operation and checked for satisfactory performance.

Item	Operation	Description	When performed					Echelon
			Daily	Weekly	Monthly	Every 6 months	Yearly	
1.	ITC	Case, exterior (par. 26).	*					1
2.	IC	Case, interior (par. 27).						1
3.	ITC	Jack assembly and lever switch (par. 28).			*			2
4.	ITC	Generator (par. 29).			*			2
5.	IC	Battery compartment (par. 30).			*			1
6.	ITC	Induction and holding coils (par. 31)			*			2
7.	IC	Chassis (par. 32).		*				2
8.	IC	Handset TS-9-(*) (par. 33).	*					1
9.	IC	Cord CC-333 (par. 34).	*					1
	F Feel	I Inspect	T Tighten	C Clean	A Adjust	L Lubricate		

### Section III. SPECIAL INSTRUCTIONS

#### 37. Cleaning and Burnishing Lever Switch Contacts

*a. GENERAL.* Under extreme dust conditions, dust filters into the lever switch contacts of Telephone EE-8-(\*). To correct this condition, it is necessary to clean and burnish the lever switch contacts.

*b. CLEANING AND BURNISHING.* (1) Flush spring contacts with dry-cleaning solvent applied with a pencil brush, taking care to keep cleaning fluid away from insulators. Wipe dry with a clean cloth.

(2) After cleaning, burnish spring contacts with a fine grained contact burnisher. *Do not use a file.* Two strokes of the burnisher between the contacts with the lever switch in its operated position should be sufficient.

(3) Clean the burnisher before using and during use with dry-cleaning solvent, wiping dry with a clean cloth. Do not touch or rub the blade with fingers.

#### 38. Equipment Dusting

*a.* Fashion a cleaning stick from  $\frac{1}{8}$ -inch wood,  $1\frac{1}{2}$  inches wide and 11 inches long. When cleaning flat surfaces, place a cloth over the cleaning stick holding the loose ends of the cloth in the hand to prevent loose dust and lint from being shaken from the cloth while cleaning is being done.

*b.* Shift the cloth on the cleaning stick from time to time so as to present a new surface to the area being cleaned. When one side of the cloth is no longer serviceable, reverse it and proceed in a similar manner. In this way, the entire area of the cloth may be utilized. Continue to shift the cloth with respect to the cleaning stick until there is some indication that its absorption qualities are such that it will no longer pick up and hold dust and lint.

### Section IV. LUBRICATION

#### 39. Generator GN-38-(\*)

The only parts of Telephone EE-8-(\*), which require lubrication are the moving parts of Generator GN-38-(\*). Instructions for lubricating the generator are contained in paragraph 68c.

### Section V. MOISTUREPROOFING AND FUNGIPROOFING

#### 40. General

The operation of Signal Corps equipment in tropical areas where temperature and relative humidity are extremely high requires special attention. The following items represent problems which may be encountered in operation:

- a. Resistors, capacitors, coils, etc., fail.
- b. Electrolytic action takes place in resistors, coils, etc., causing eventual breakdown.
- c. Hook-up wire and cable insulation break down. Fungus growth accelerates deterioration.
- d. Moisture forms electrical leakage paths on terminal boards and insulating strips, causing flash-overs and crosstalk.
- e. Moisture provides leakage paths between battery terminals.

#### **41. Treatment**

A moistureproofing and fungiproofing treatment has been devised which, if properly applied, provides a reasonable degree of protection against fungus growth, insects, corrosion, salt spray, and moisture. The treatment involves the use of a moisture- and fungi-resistant varnish applied with a spray gun or brush. Refer to TB SIG 13, Moistureproofing and Fungiproofing Signal Corps Equipment, for a detailed description of the varnish-spray method of moistureproofing and fungiproofing and the supplies and equipment required in this treatment.

*Caution:* Varnish spray may have poisonous effects if inhaled. To avoid inhaling spray, use respirator if available; otherwise, fasten cheesecloth or other cloth material over the nose and mouth.

#### **42. Step-by-Step Instructions for Treating Telephone EE-8-(\* )**

- a. PREPARATION. Make all repairs and adjustments necessary for proper operation of the equipment.
- b. DISASSEMBLY. (1) Remove the seven screws from the outside of the case.
  - (2) Remove the handset and chassis from the case.
  - (3) Remove the handset leads from the three terminals on top of the chassis.
  - (4) Untie the stay cord, and remove the handset and cord.
  - (5) Remove the batteries.
  - (6) Remove the five screws from the front plate and take off the plate.
  - (7) Remove the generator handle.
  - (8) Remove the three screws from the generator side of the chassis and take off the plate.
  - (9) Remove the rubber and steel washers from the generator gear.
  - (10) Remove the four screws from the bakelite cover plate and remove the cover plate from the top of the chassis.
  - (11) Remove the two screws under the lever switch.
  - (12) Remove the screw eye from the top panel.
  - (13) Lift the lever switch, jack assembly, and terminal block. DO NOT UNSOLDER THE LEADS.
  - (14) Remove the seven screws from the bottom plate of the chassis and take off the plate.
  - (15) Remove the two screws from the ringer and remove the gong from the assembly.

- (16) Remove the ringer coils and clapper assembly.
- (17) Remove the three generator leads.
- (18) Remove the four screws from the bottom of the generator assembly.
- (19) Remove the generator.
- (20) Remove the bakelite instrument plate.
- (21) Remove Capacitor CA-355 (for Telephones EE-8-A and EE-8-B only). Remove Capacitors CA-209, CA-259, and CA-177 (for Telephone EE-8 only). DO NOT UNSOLDER THE LEADS.
- (22) Remove the screws holding Coils C-105 and C-158 to the chassis and remove the coils. DO NOT UNSOLDER THE LEADS.
- (23) Remove the two screws from the generator spring pack, and take off the spring pack.
- (24) Remove the four screws from the top of the generator.
- (25) Remove the two lower screws from each side plate of the generator.
- (26) Remove the bottom field plate and the magnets. (*Generator GN-38 only*).
- (27) Remove the two screws from the handset lever switch, and lift out the handset switch assembly. DO NOT UNSOLDER THE LEADS.
- (28) Remove the receiver cap, and take out the receiver unit.
- (29) Remove the transmitter cap, and take out the transmitter unit.
- (30) Tighten all loosened screws where electrical contact is made.
- (31) Clean all dirt, dust, rust, fungus, oil, grease, etc., from the equipment.

*c. MASKING.* Cover the following parts with masking tape. (1) The electrical contact points on the receiver (fig. 23 (1) and (2)) and on the transmitter (fig. 23 (3) and (4)).

- (2) The two points where the clapper strikes the gong (fig. 23 (5) and (6)).
- (3) The core contacts on the ringer coils (fig. 23 (7) and (8)).
- (4) The battery contacts (fig. 23 (9), (10), (11), and (12)).
- (5) The jack holes (fig. 23 (13), (14), and (15)).
- (6) The spring contacts of the lever switch and handset switch (fig. 23 (16), (17), (18), and (19)).
- (7) The opening below the screw switch (fig. 23 (20)).
- (8) The contact points on the generator spring pack (fig. 23 (21) and (22)).
- (9) The spade terminals of the three leads to the generator (fig. 23 (23), (24), and (25)).

*d. DRYING.* Place all equipment, except the case and the batteries, in an oven. Dry for 2 to 3 hours at 160° F. DO NOT APPLY HEAT TO THE BATTERIES.

*e. VARNISHING.* Apply three coats of moisture- and fungi-resistant varnish (Lacquer, Fungus-resistant, Spec. No. 71-2202 (stock No.

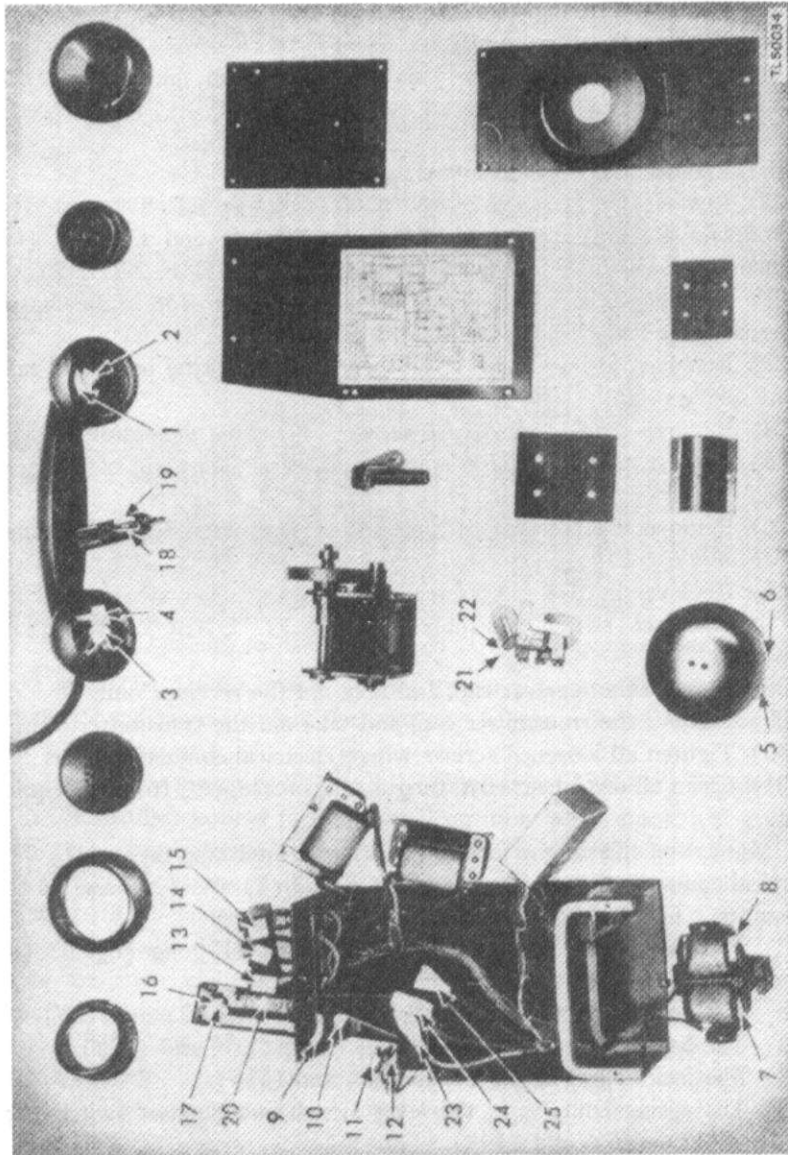

Figure 23. Telephone EE-8-A, disassembled and masked (case and generator magnets not shown).

6G1005.3), or equal). DO NOT SPRAY THE GENERATOR. VARNISH WITH A BRUSH.

f. REASSEMBLY. Remove all masking tape. Clean all contacts with varnish remover and burnish the contacts. Reassemble the telephone and test for proper operation.

g. MARKING. Mark MFP and date of treatment on the terminal block.

Example: MFP—8 June 1944.

CHAPTER 4

AUXILIARY EQUIPMENT

---

(Not used)

## CHAPTER 5

### REPAIR INSTRUCTIONS

*Note.* Failure or unsatisfactory performance of equipment used by Army Ground Forces and Army Service Forces will be reported on WD, AGO Form 468 (Unsatisfactory Equipment Report); by Army Air Forces, on Army Air Forces Form 54 (Unsatisfactory report). If neither form is available, prepare the data according to the sample form reproduced in figure 34.

#### Section I. THEORY OF TELEPHONE EE-8-(\*)

##### 43. Circuit Elements

a. **HANDSET TS-9-(\*)**. Handset TS-9-(\*) contains a high output nonpositional transmitter and a high fidelity receiver. The transmitter element is of the granular carbon type. The diaphragm, carbon inclosure, and frame are constructed in unit form making the element readily replaceable. The receiver element is a permanent-magnet, diaphragm type. It gives high fidelity response over the audible frequency range, and is effectively compensated for stable performance over a wide temperature range.

b. **GENERATOR (FIG. 24)**. Generator GN-38 has three small cobalt steel permanent magnets arranged in two pole faces about an armature. Generator GN-38-A has a rotating magnet with stationary coils. Generator GN-38-B has two stationary magnets and two pole pieces arranged alternately about an armature. The generator switch consists of spring contacts which in normal position connect the ringer across the line, but which upon rotation of the crank disconnect the ringer and place the output of the generator across the line. The crank handle folds into the metal-faced recess on the right side of the case.

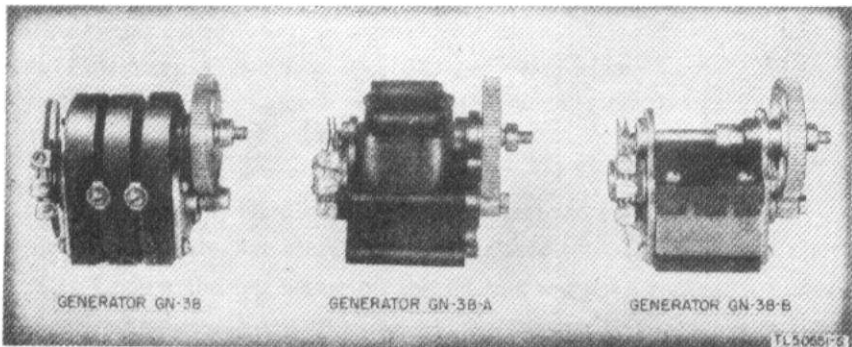

Figure 24. Generators GN-38, GN-38-A, and GN-38-B



*c.* RINGER. Ringer MC-131 is of the single-gong type. The ringer coils, armature, and clapper are mounted internally to the gong (figs. 6, 7, 8, and 20). When energized by ringing current, the armature operates the clapper about a pivot to strike alternately two internal projections of the gong rim. The acoustical output is high for a relatively low electrical input.

*d.* HOLDING COIL. The holding coil (Coil C-158) is bridged across the line circuit when the screw switch is in the CB position and the lever switch is released. With the lever switch depressed, the coil is disconnected. If the screw switch is in the LB position, the coil is permanently disconnected, independent of the lever switch position. The purpose of this coil is to provide a low resistance d-c path through the telephone for operating the line relay and holding the supervisory relay energized on a common battery switchboard. The holding coil has high impedance to voice-frequency currents to minimize transmission losses.

*e.* INDUCTION COIL. The induction coil (Coil C-105) is an autotransformer with one continuous winding tapped at terminals 2 and 3 so as to form the 1-2 section, the 2-3 section, and the 3-4 section. (See figs. 25 and 26.)

*f.* LEVER SWITCH. The lever switch has two contacts which are operated by a hinged lever and plunger. The switch is held depressed by the weight of the handset which is hung on it, and is automatically raised by a spring when the handset is removed. The contacts are open when the lever switch is depressed and closed when the switch is released. The lever switch is used only on common battery circuits.

*g.* CAPACITORS. In Telephone EE-8, three physically separate capacitors, of 1.9-mf, 0.5-mf, and 0.3-mf capacitance are used. (See figs. 25 and 27.) In Telephones EE-8-A and EE-8-B, Capacitor CA-355 comprises a 2.0-mf, a 0.5-mf, and a 0.3-mf capacitance element, all assembled into one container and internally connected to the terminals numbered 1, 2, 3, and 4. (See figs. 26, 28, and 29.)

## 44. Theory of Operation

The schematic diagram of Telephone EE-8 is shown in figure 25 and the schematic diagram of Telephones EE-8-A and EE-8-B is shown in figure 26.

*a.* TRANSMITTING CIRCUIT. (1) The transmitter, receiver, induction coil, and the 0.3-mf capacitor are connected in an antisidetone circuit in which the impedance of these elements and the characteristic impedance of the average line (Wire W-110-B) are so balanced as to reduce the sidetone in the receiver to the proper level. This results in an effective gain since the effect of noise in the vicinity of the transmitter of the receiving telephone is reduced. The user also unconsciously speaks more loudly into the transmitter when he does not hear his own voice

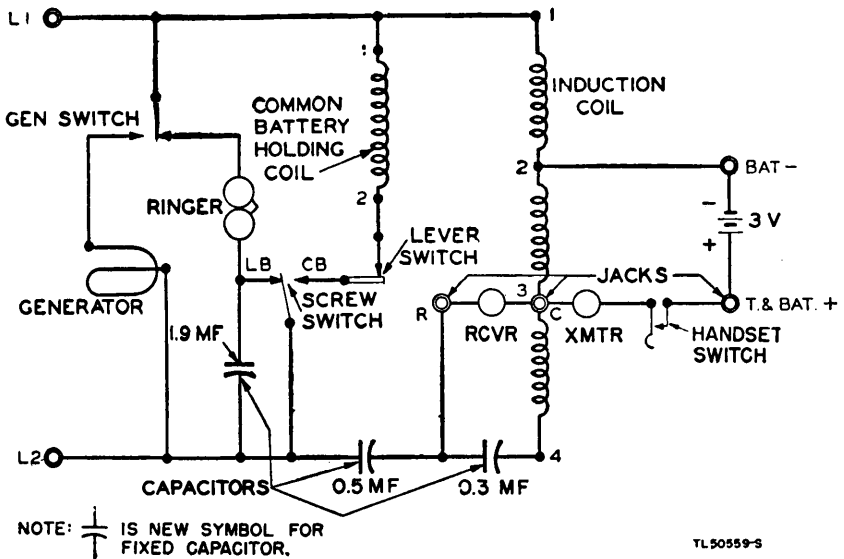

Figure 25. Telephone EE-8—schematic diagram.

loudly in the receiver. This results in effective transmitting gain. On lines shorter than the average, the sidetone is more pronounced and the antisidetone effect is lessened.

(2) Operating the handset switch closes the circuit consisting of the switch, battery, transmitter, and 2-3 section of the induction coil. Since this circuit has a relatively low impedance, large current changes are produced by the transmitter when it is activated by speaking into the transmitter. These current changes induce relatively high voltages in

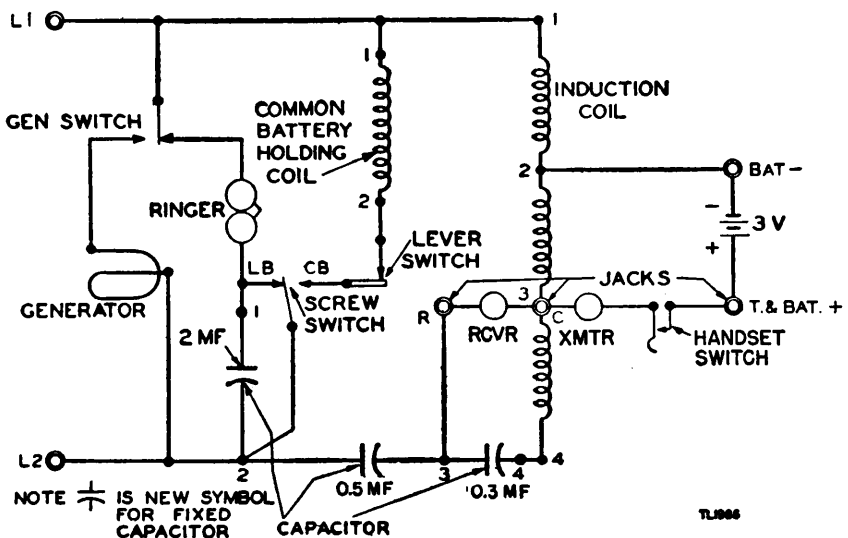

Figure 26. Telephones EE-8-A and EE-8-B—schematic diagram.

the entire 1-4 winding of the induction coil and across terminals L1 and L2 to which the line is connected.

(3) The antisidetone operation of the circuit results from the electrical balance between the impedance of the 3-4 section of the induction coil in series with the 0.3-mf capacitor, and the impedance of the line circuit consisting of 4 miles or more of Wire W-110-B connected to terminals L1 and L2. On shorter lines the antisidetone is less pronounced, although still effective.

*b. RECEIVING CIRCUIT.* (1) The induction coil, 0.3-mf capacitor, and receiver are so designed that the greater portion of the incoming line current will flow through the receiver over the voice-frequency range. This results in a maximum sound output.

(2) The 0.5-mf capacitor is placed in series with the receiver to prevent the flow of direct current through the receiver, either from the batteries in the telephone or from the central office battery, when the telephone is connected to a common battery system. This capacitor also limits 16-cycle ringing current through the receiving circuit and permits the permanent connection of the listening circuit across the line.

(3) The transmission loss through the ringer, or the ringer and the capacitor in series, and the holding coil is negligible because of the high impedance to voice-frequency currents of these elements.

*c. SIGNALING CIRCUIT.* The 1.9-mf capacitor in Telephone EE-8, or the 2.0-mf capacitor in Telephones EE-8-A and EE-8-B, is in series with the ringer when the screw switch is in the CB position. This capacitor prevents direct current from biasing the ringer and also prevents the ringer from interfering with d-c signaling or supervision when the telephone is connected to a common battery system. The capacitor is short-circuited when the screw switch is turned to the LB position.

## Section II. TEST EQUIPMENT

### 45. Voltohmmeters

A voltohmmeter is the only type of test equipment normally required for field maintenance of Telephone EE-8-(\*). Two voltohmmeters which will be available in the field are Voltohmmeter I-166 and Test Set TS-26 / TSM.

*Caution:* Before using a voltohmmeter for making resistance measurements in Telephone EE-8-(\*), always remove the batteries from the telephone to prevent damage to the voltohmmeter.

*a. VOLTOHMMETER I-166.* This test set is contained in Test Equipment IE-29. Voltohmmeter I-166 can be used for making continuity, voltage, and resistance measurements. For operation and use of Voltohmmeter I-166, see TM 11-2613.

*b. TEST SET TS-26 / TSM.* This test set can be used for making

continuity, voltage, and resistance measurements. For operation and use of Test Set TS-26 / TSM, see TM 11-2017.

### Section III. TROUBLE SHOOTING

#### 46. General

No matter how well equipment is designed and manufactured, faults occur in service. When such faults occur the repairman must locate and correct them as rapidly as possible. This section contains general information to aid personnel engaged in the important duty of trouble shooting.

*a. TROUBLE-SHOOTING DATA.* Take advantage of the material supplied in this manual to help in the rapid location of faults. Consult the following trouble-shooting data when necessary:

- (1) Trouble-shooting chart (par. 48).
- (2) Wiring diagrams of Telephone EE-8-(\*) (figs. 27, 28, and 29).
- (3) Complete schematic diagrams (figs. 25 and 26).
- (4) Voltage and resistance chart (par. 49).
- (5) Illustrations of components which aid in locating or identifying parts (figs. 5, 6, 7, and 8).

*b. TROUBLE-SHOOTING STEPS.* First, analyze the trouble report to determine the probable causes of the trouble. When analyzing the trouble report, use the schematic diagram to localize the fault to a particular component. Make a complete visual inspection of the wiring and connections to the associated equipment. If no wires or connections are broken, the trouble must be located by making continuity, voltage, and resistance measurements. By following the circuit with a systematic process of elimination, the fault can usually be located in the least amount of time. Start at a point where the circuit is known, from the analysis, to be good and proceed step-by-step eliminating parts of the circuit until the fault is located.

#### 47. Procedures

*a. GENERAL.* To aid the repairman in locating or localizing faults, the indications of trouble and tests for localizing the fault are described in the following subparagraphs. The trouble-shooting chart (par. 48), if properly used, simplifies trouble shooting. Before starting these tests be sure the screw switch is turned in the direction of the arrow pointing to LB as far as it will go. Also, see that the batteries are installed.

*b. SIDETONE TEST.* Hold the receiver of the telephone to the ear and blow steadily into the transmitter while alternately operating and releasing the handset switch.

*c. GENERATOR TEST.* While holding the receiver to the ear, rapidly turn the generator clockwise for several turns.

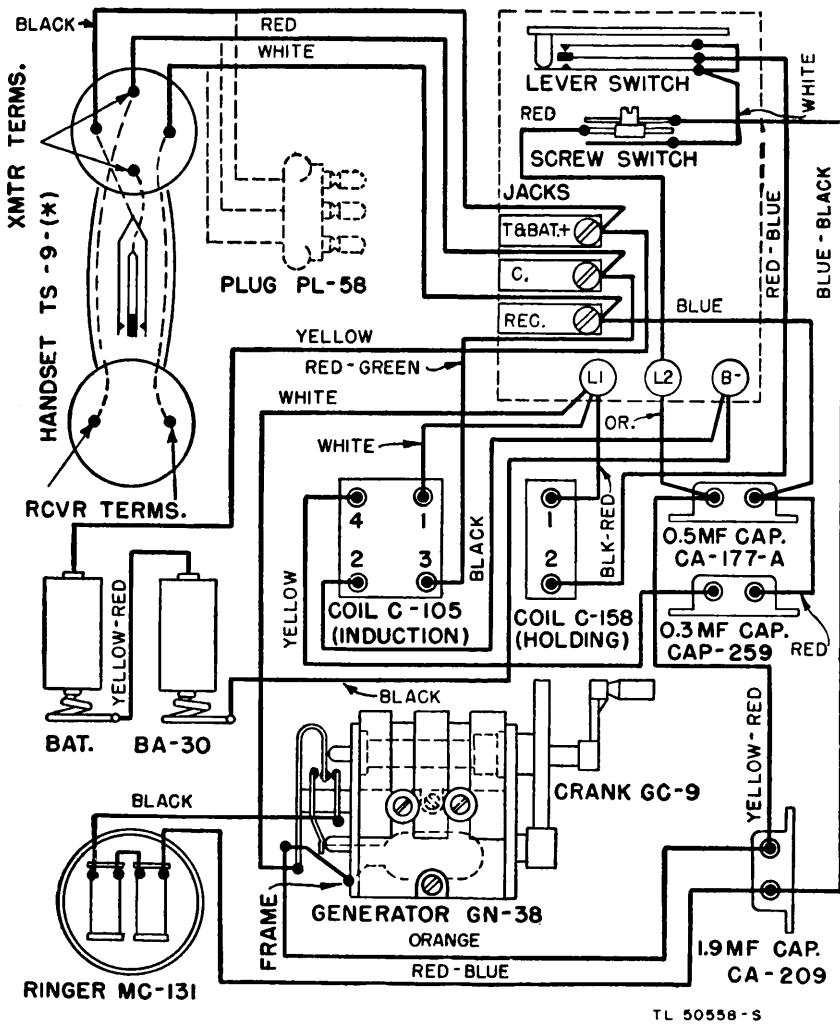

Figure 27. Telephone EE-8—wiring diagram.

d. INDICATIONS OF TROUBLE. After making the test in b and c above, one of the four following combinations will be obtained:

(1) No sidetone, or slight sidetone, and generator current heard in the receiver.

(2) Full sidetone but no generator current heard in the receiver.

(3) Neither sidetone nor generator current heard in the receiver.

(4) Both sidetone and generator current heard in the receiver. Although this condition usually indicates a good telephone, certain parts may be defective as explained in subparagraph h below.

e. NO SIDETONE, OR SLIGHT SIDETONE, AND GENERATOR CURRENT HEARD IN RECEIVER. Under this condition, the trouble will usually be

dead batteries, open transmitter, short-circuited transmitter, short-circuited induction coil, open 3-4 winding of induction coil, or reversed black and white leads from the handset.

(1) *Dead batteries.* Replace with new batteries.

(2) *Open transmitter.* If the transmitter or either the red or black lead in the handset cord is open, the results as indicated in the three tests described below will be obtained.

(a) While listening in the receiver, short circuit terminals T & BAT+ and C. A *loud* click will be heard in the receiver.

(b) Remove the black lead from terminal T & BAT+, and, while listening in the receiver, short-circuit terminals T & BAT+ and C. A *loud* click will be heard in the receiver.

(c) Replace the black lead on terminal T & BAT+, and, while listening in the receiver, operate the handset switch. *No* click will be heard in the receiver.

(3) *Short-circuited transmitter.* If the transmitter or the red and black leads in the handset cord are short-circuited, the results as indicated in (2) (a) and (b) above will be obtained. However, the test described in (2) (c) above will produce a *loud* click in the receiver.

(4) *Short-circuited induction coil.* If the induction coil is short-circuited, the results as indicated in the following two tests will be obtained.

(a) While listening in the receiver, short-circuit terminals T & BAT+ and C. A *faint* click will be heard in the receiver.

(b) Short-circuit line terminals L1 and L2 and then make the sidetone test described in b above. With the line terminals short-circuited, a *slight* increase in sidetone will be noted.

(5) *Open 3-4 winding of induction coil.* If the 3-4 winding of the induction coil, or the 0.3-mf capacitor is open, the result indicated in (4) (a) above will be obtained. However, the test described in (4) (b) above will produce *full* sidetone in the receiver.

(6) *Reversed black and white leads from handset.* If the black and white leads from the handset are reversed, the results as indicated in the following two tests will be obtained.

(a) While listening in the receiver, short-circuit terminals T & BAT+ and C. A *loud* click will be heard in the receiver.

(b) Remove the black lead from terminal T & BAT+, and while listening in the receiver, short-circuit terminals T & BAT+ and C. A *faint* click or *no* click will be heard in the receiver.

f. FULL SIDETONE BUT NO GENERATOR CURRENT HEARD IN RECEIVER. Under this condition, the trouble will usually be an open generator, short-circuited generator, or open 1-2 winding of the induction coil.

(1) OPEN GENERATOR. If the generator coil or the leads to the generator contacts are open, the results indicated for the following two tests will be obtained.

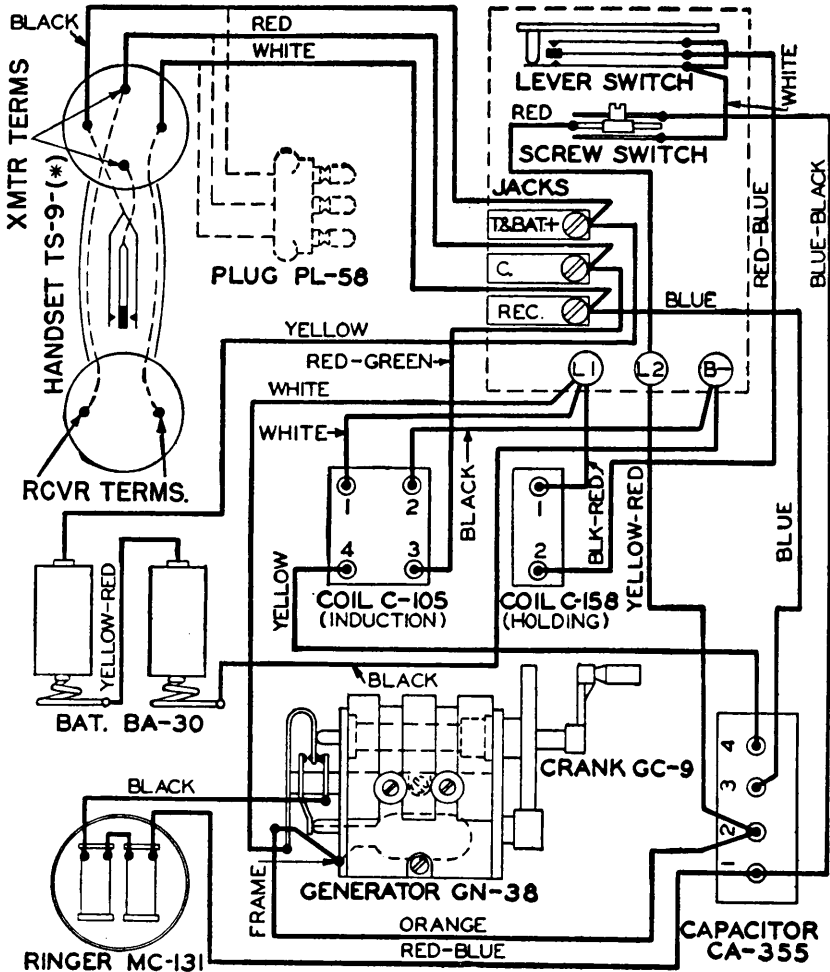

TL50560-S

Figure 28. Telephone EE-8-A—wiring diagram.

- (a) With all conditions normal, the generator will turn *easily*.
- (b) With line terminals L1 and L2 short-circuited, the generator will turn *easily*.
- (2) *Short-circuited generator.* If the generator is short-circuited, the results indicated for the following two tests will be obtained.
- (a) With all conditions normal, the generator will turn *hard* as if a drag had been placed on it.
- (b) With line terminals L1 and L2 short-circuited, *little* or *no* change will be noted in the drag on the generator.
- (3) *Open 1-2 winding of induction coil.* Short-circuit line terminal L1 and terminal BAT—, and while listening in the receiver, turn the

generator. If the 1-2 winding of the induction coil is open, the generator current will be heard.

*g. NEITHER SIDETONE NOR GENERATOR CURRENT HEARD IN RECEIVER.* Under this condition the trouble will usually be an open receiver, a short-circuited receiver, or an open 2-3 winding of the induction coil.

(1) *Open receiver.* If the receiver or either the white or red lead in the handset cord is open, the results as indicated by the two tests described below will be obtained.

(a) While holding two fingers of one hand on terminals C and R, turn the generator. The generator current *will be* felt.

(b) While listening in the receiver, operate the handset switch and turn the generator. The generator current *will not* be heard.

(2) *Short-circuited receiver.* If the receiver or the red and white leads in the handset cord are short-circuited, the results as indicated in the three tests described below will be obtained.

(a) While holding two fingers of one hand on terminals C and R, turn the generator. The generator current *will not* be felt.

(b) While listening in the receiver, operate the handset switch and turn the generator. The generator current *will not* be heard.

(c) Remove the white lead from terminal R. While holding two fingers of one hand on terminals C and R, turn the generator. The generator current *will be* felt.

(3) *Open 2-3 winding of induction coil.* If the 2-3 winding of the induction coil is open, the results as indicated in the two tests described below will be obtained.

(a) While holding two fingers of one hand on terminals C and R, turn the generator. The generator current *will not* be felt.

(b) While listening in the receiver, operate the handset switch and turn the generator. The generator current *will be* heard.

*h. BOTH SIDETONE AND GENERATOR CURRENT HEARD IN RECEIVER.* This condition ordinarily indicates a good telephone. However, the handset switch could be short-circuited, the ringer could be open or short-circuited, or the holding coil could be open.

(1) *Short-circuited handset switch.* If the handset switch is short-circuited, sidetone will be heard when making the sidetone test (b above) with the handset switch *unoperated*.

(2) *Open ringer.* Connect terminals L1 and L2 of the telephone under test to the corresponding terminals of another telephone known to be serviceable. If the generator of the good telephone turns easily and the ringer of the telephone under test *does not* operate, the ringer is open.

(3) *Short-circuited ringer.* Repeat the test described in (2) above. If the generator of the good telephone turns hard as if a drag had been placed on it and if the ringer of the telephone under test *does not* operate, the ringer is short-circuited.

(4) *Open holding coil.* Turn the screw switch in the direction indi-



cated by the arrow pointing to CB until the screw comes to a stop. While turning the generator, release the lever switch and note any difference in drag on the generator. If no difference in drag is noted, either the holding coil or the lever switch is open.

## 48. Trouble-Shooting Chart

Symptoms	Probable Trouble	Corrections
1. No transmission; normal reception.	Batteries dead.	Replace batteries.
	Faulty or packed transmitter unit.	Replace transmitter unit.
	Dirty or open contacts of handset switch.	Clean or adjust contacts. Replace handset switch.
	Spring contacts to transmitter unit dirty or not making.	Clean or adjust contacts.
2. No reception; normal transmission.	Open conductor (black) in handset cord.	Replace handset cord.
	Faulty receiver unit.	Replace receiver unit.
3. No transmission and no reception.	Spring contacts to receiver unit dirty or not making.	Clean or adjust contacts.
	Open conductor (white) in handset cord.	Replace handset cord.
	Open handset cord.	Replace handset cord.
4. Bell does not ring on incoming signal.	Open or shorted induction coil.	Replace induction coil.
	Shorted holding coil when screw switch is on CB.	Replace holding coil.
	Open 0.5-mf or 0.3-mf capacitor.	Replace capacitor.
	Open or shorted ringer.	Replace ringer.
5. Cannot ring out.	Break contact on generator dirty or not making.	Clean or adjust contact.
	Open 1.9-mf capacitor (Telephone EE-8) or 2.0-mf capacitor (Telephones EF-8-A or EE-8-B) when screw switch is on CB.	Replace capacitor.
	Open or shorted generator coil.	Replace generator.
6. Cannot signal operator on common battery line.	Make contact on generator dirty or not making.	Clean or adjust contact.
	Open or dirty contacts on lever switch.	Clean or adjust contacts.
	Open contact of screw switch.	Replace screw switch.
	Open holding coil.	Replace holding coil.
7. Poor transmission; normal reception.	Parkerized lockwashers on battery contact terminals.	Replace lockwashers with nickel-plated lockwashers, Sig C stock No. 6L73006.

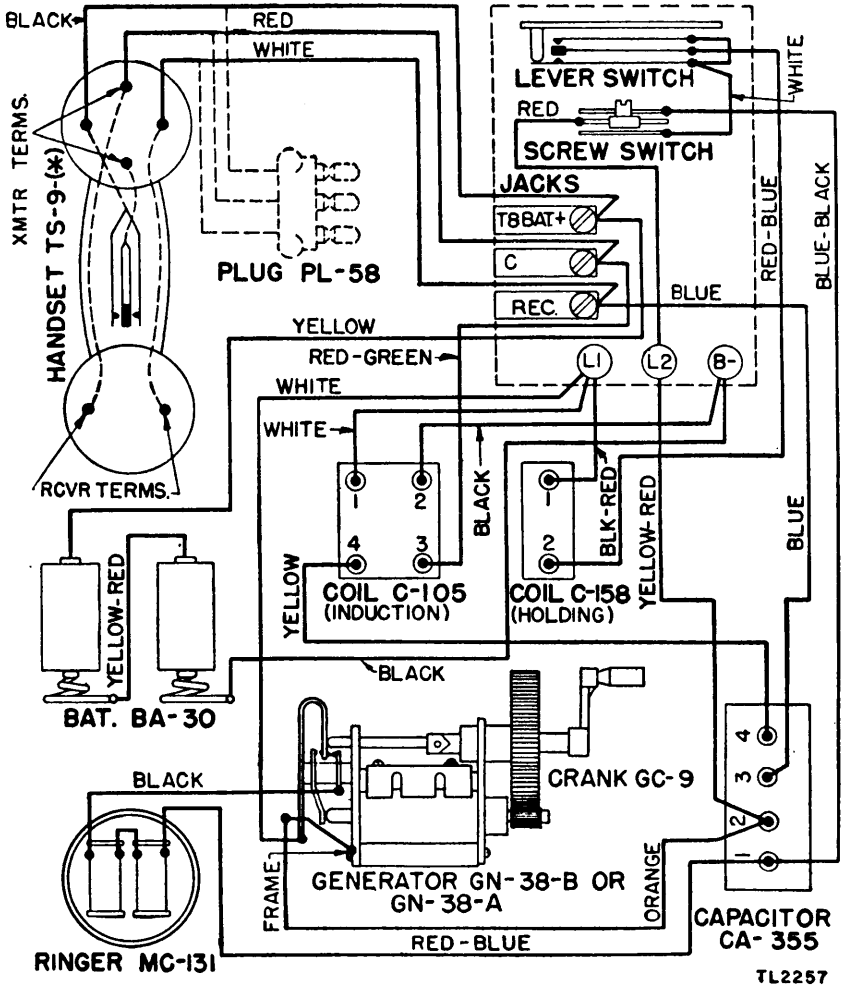

Figure 29. Telephone EE-8-B—wiring diagram.

### Section IV. TEST AND ANALYSIS DATA

#### 49. Voltage and Resistance Chart

Between (points of measurement)	Voltage (volts)	Resistance (ohms)
L1 and L2 (screw switch on LB).		1,300
L1 and L2 (screw switch on CB).		100
1 and 2 of holding coil (Coil C-158).		100
C and R on terminal block.		55
C and T & BAT + on terminal block (handset switch operated).	3	250
1 and 2 of induction coil (Coil C-105).		Approx 8 to 22
2 and 3 of induction coil (Coil C-105).		Approx 3
3 and 4 of induction coil (Coil C-105).		Approx 370

## 50. Characteristics of Circuit Elements

### a. TRANSMITTER.

- (1) Average direct current through transmitter in use .....0.1 ampere
- (2) Power output (over voice frequency range).....3 milliwatts

### b. RECEIVER.

- (1) D-c resistance (approx.) .....55 ohms
- (2) Average motional impedance (600 to 1,000 cycles) .....256 ohms

### c. GENERATOR.

- (1) D-c resistance of armature (approx.).....400 ohms
- (2) Output frequency at 1,000 rpm.....16 cycles
- (3) Open circuit voltage (approx.).....100 volts
- (4) Output current at 1,000 rpm:
  - (a) 200 ohm load.....90 milliamperes
  - (b) 1,000 ohm load.....50 milliamperes
  - (c) 10,000 ohm load.....9.5 milliamperes

### d. RINGER.

- (1) D-c resistance, two coils in series (approx.)....1,300 ohms
- (2) Inductance .....3.0 henries
- (3) Impedance at 1,000 cycles.....18,750 ohms.

### e. HOLDING COIL.

- (1) D-c resistance (approx.).....100 ohms
- (2) Inductance .....1 henry
- (3) Impedance at 1,000 cycles.....6,300 ohms
- (4) Transmission loss when bridged across circuit...less than 0.4 db

### f. INDUCTION COIL.

Section of winding	D-c resistance (ohms)	Inductance (millihenries)
1-2	8 to 22 (approx.)	120 $\pm$ 10 percent
2-3	3 approx	5 $\pm$ 10 percent
3-4	370 (approx.)	80 $\pm$ 10 percent
2-3 to 1-4		42 $\pm$ 10 percent

## Section V. REMOVAL AND REPLACEMENT OF PARTS

### 51. General

When trouble has been localized to a specific unit, it is necessary to gain access to the defective part to inspect, adjust, or replace it. Parts are either directly accessible or are reached by removing other parts and screws, as necessary. Consult the wiring diagram when replacing parts to be certain that the wiring color code is followed accurately. The following paragraphs give information on the removal and replacement of only those units which require special means and involve certain precautions.

*Note.* Those parts of replaced units which can be salvaged should be retained by the repairman for his own use. If the repairman has no use for them, they

should be disposed of through the established channels for salvage. It will be particularly advantageous to retain parts of replaced generators and handsets as these units vary in design when produced by different manufacturers. Possession of such parts may enable the repairman to make emergency repairs which would be impossible otherwise.



Figure 30. Principal parts used in Telephone EE-8-(\*).

## 52. Body

a. To remove the body from the case, remove the seven screws in the outside of the case and lift out the body assembly.

b. To replace the body, insert it in the case and tighten the seven mounting screws securely.

### 53. Crank GC-9

- a. To remove the generator crank, pull on the handle of the crank, and at the same time, turn counterclockwise (to the left) off the shaft.
- b. To replace the crank, carefully pull out the rubber disk on the shaft behind the side wall. Be careful that the lockwasher on the shaft behind the disk does not fall down inside the case. Force the hub on the arm of the crank through the hole in the disk. Screw the crank clockwise (to the right) on the shaft. Push the disk through the hole in the side wall.

### 54. Capacitor CA-355

When removing and replacing Capacitor CA-355, follow the procedure outlined below :

- a. Remove the body from the case as outlined in paragraph 52a.
  - b. Remove the generator crank as outlined in paragraph 53a.
  - c. Remove the side wall by taking out the three screws in the edges of the wall.
  - d. Remove the front wall by taking out the five screws in the edges of the wall.
  - e. Remove the bottom plate by taking out the four screws in the corners of the plate.
  - f. Unsolder the leads on the four terminals of the capacitor.
  - g. Loosen the outside screw in the capacitor strap and slip the capacitor from under the strap.
  - h. Slip the new capacitor under the strap so that terminal 1 (stamped on the capacitor) is to the left. Tighten the strap.
  - i. Replace the wires in the terminal lugs, connecting the wires in accordance with the following color code :
    - Red-blue and blue-black to terminal 1
    - Orange and yellow-red to terminal 2
    - Blue to terminal 3
    - Yellow to terminal 4
  - j. Resolder the wires and press down the lugs.
  - k. Mount the bottom plate in place, insert the four mounting screws in the corners, and tighten securely. Be sure the capacitor rests on the bottom plate.
  - l. Mount the front wall in place, insert the five mounting screws in the edges of the wall, and tighten the screws securely.
- Note.* If the front wall does not fit easily, loosen the two screws in the front edge of the bottom plate, secure the front wall in place, and tighten the bottom plate. Mount the side wall in place, insert the four mounting screws in the edges of the wall, and tighten the screws securely.
- m. Replace the crank as outlined in paragraph 53b.
  - n. Replace the body in the case as outlined in paragraph 52b.

## 55. Generator GN-38-(\* )

To change the hand generator, follow the procedure outlined below :

*Note.* Either Generator GN-38-A or Generator GN-38-B may be used to repair Telephones EE-8, EE-8-A, or EE-8-B. It is not advisable to replace the generator in a Telephone EE-8-B with a Generator GN-38 which has been removed from an old field telephone. The output of Generator GN-38 is lowered when placed in the steel chassis of a Telephone EE-8-B.

- a. Remove the body from the case as outlined in paragraph 52a.
- b. Remove the crank as outlined in paragraph 53a.
- c. Remove the side wall, front wall, and bottom plate as outlined in paragraph 54c, d, and e.
- d. Loosen the three terminal screws on the back of the generator and remove the wires from the terminals.
- e. Remove the four mounting screws under the base plate on which the generator is mounted. Do not remove the base plate.
- f. Loosen the screw in the capacitor mounting strap and slide the capacitor down to allow clearance for the removal of the generator.
- g. Pull the generator out over the capacitor.
- h. Slide the new generator in place.

*Note.* Be sure the insulating plate is in place between the generator base and the chassis.

i. Line up the holes in the generator base, the insulating plate, and the chassis.

j. Assemble the washers and bushing on the mounting screw as shown in figure 31. Be careful to get each piece in its proper order on the screw.

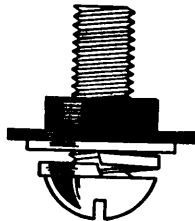

TL 54636

Figure 31. Generator screw assembly.

k. Screw this assembly through the mounting plate into the generator. Be sure the insulating bushing on the mounting screw fits into the hole in the mounting plate.

l. Replace the bottom plate as outlined in paragraph 54k.

m. Reconnect the three wires to the generator terminals in accordance with the following color code :

- Black wire to top terminal
- Orange wire to center terminal
- White wire to bottom terminal

- n.* Tighten the terminal screws securely. Be careful that the spade lugs do not touch the generator frame.
- o.* Replace the lockwasher on the generator shaft.
- p.* Replace the side and front walls as outlined in paragraph 54l.
- q.* Replace the crank as outlined in paragraph 53b.
- r.* Replace the body as outlined in paragraph 52b.

## 56. Lever and Screw Switch Assembly

To remove and replace the lever and screw switch assembly, proceed as outlined below :

- a.* Remove the body from the case as outlined in paragraph 52a.
  - b.* Remove the stay cord, the eye screw, and the large screw opposite the eye screw on the jack assembly.
  - c.* Remove the two screws in the top of the battery compartment next to the battery contacts.
  - d.* Unsolder the three leads on the screw switch and the two leads on the lever switch.
  - e.* Remove the lever switch and screw switch.
  - f.* Place the new lever switch and screw switch in position in the body assembly.
  - g.* Insert the white wire up through the two lugs on the right of the lever switch and solder it to each lug. Be careful that solder does not run down to the lever switch.
  - h.* Insert the red-blue wire through the other lever switch terminal and solder.
  - i.* Bend the terminal lugs down slightly on the right of the screw switch.
  - j.* Insert the blue-black wire through the upper right terminal of the screw switch, from top down. Turn the end of the wire over and solder. Push the terminals up.
  - k.* Insert the white wire up through the lower right terminal on the screw switch. Turn the end of the wire over and solder.
  - l.* Insert the red wire through the lug on the left side of the screw switch. Turn the end of the wire over and solder.
  - m.* Fasten the switches to the chassis with the two screws in the top of the battery compartment.
- Note.* Check to be sure the lower right terminal on the screw switch does not touch the upper terminal or nut on the terminal board. Equalize the clearance by forcing a screw driver between the contacts. Be sure the left terminal does not touch the nut on the terminal board.
- n.* Lay the red and yellow wires on the terminal board so that they run around and to the front of the screw switch. This allows for clearance of the wires under the pack assembly block.
  - o.* Replace the jack assembly block, the eye screw, the stay cord, and the large screw opposite the eye screw.
  - p.* Replace the body in the case as outlined in paragraph 52b.

## 57. Ringer MC-131

To remove and replace Ringer MC-131, follow the procedure outlined below:

- a. Remove the body from the case as outlined in paragraph 52a.
- b. Remove the bottom plate as outlined in paragraph 54e.
- c. Remove the two screws holding the ringer to the bottom plate.
- d. Unsolder the two wires on the coils and remove the ringer.
- e. Solder the two wires on the new ringer so that the black wire is on the left coil terminal lug and the red-blue wire is on the right coil terminal lug (ringer positioned with clapper facing front).
- f. Mount and secure the ringer in position on the bottom plate. Push the wires against the bottom plate. If the wires touch the ringer, the sound will be deadened.
- g. Replace the bottom plate on the chassis as outlined in paragraph 54k.
- h. Replace the body in the case as outlined in paragraph 52b.

## 58. Jack Assembly

To remove and replace the jack assembly, follow the procedure outlined below:

- a. Remove the stay cord, the eye screw, and the large screw opposite the eye screw.
- b. Unsolder the three wires on the bottom of the jack assembly and remove the jack assembly.
- c. Solder the wires to the new jack assembly in accordance with the following color code:
  - Yellow wire to T & BAT+
  - Red-green wire to C
  - Blue wire to REC
- d. Mount the new jack assembly in position and replace the two screws and the stay cord.

## 59. Induction Coil (Coil C-105)

To remove and replace the induction coil, follow the procedure outlined below:

- a. Remove the body from the case as outlined in paragraph 52a.
- b. Remove the crank as outlined in paragraph 53a.
- c. Remove the side and front walls as outlined in paragraph 54c and d.
- d. Unsolder the wires from the four terminals on the induction coil.
- e. Remove the two screws that hold the induction coil in place. Be careful not to lose the washers.
- f. Install the new coil by placing the top screw through the washer and the hole in the coil. Hold in place with a screw driver. Guide into place and tighten the screw. Replace the bottom screw and washer.



*g.* Twist the wires around the terminals and solder, following the color code given below :

White wire to terminal 1

Black wire to terminal 2

Red-green wire to terminal 3

Yellow wire to terminal 4

*h.* Replace the side and front walls as outlined in paragraph 54i.

*i.* Replace the crank as outlined in paragraph 53b.

*j.* Replace the body in the case as outlined in paragraph 52b.

## 60. Holding Coil (Coil C-158)

To remove and replace the holding coil, follow the procedure outlined below :

*a.* Remove the body from the case as outlined in paragraph 52a.

*b.* Remove the crank as outlined in paragraph 53a.

*c.* Remove the side and front walls as outlined in paragraph 54c and d.

*d.* Remove the two screws from the induction coil and move it aside.

*e.* Unsolder the two wires on the holding coil.

*f.* Unscrew the two mounting screws and remove the holding coil.

*g.* Install the new holding coil by placing the top screw through the washer and the hole in the coil. Hold in place with a screw driver. Guide into place and tighten the screw. Replace the bottom screw and washer.

*h.* Twist the wires around the terminals and solder. Follow the color code given below :

Black-red wire to terminal 1

Red-blue wire to terminal 2

*i.* Replace the induction coil as outlined in paragraph 59f.

*j.* Replace the side and front walls as outlined in paragraph 54i.

*k.* Replace the crank as outlined in paragraph 53b.

*l.* Replace the body in the case as outlined in paragraph 52b.

## 61. L1 and L2 Binding Posts

To remove and replace a line binding post, follow the procedure outlined below :

*a.* Remove the body from the case as outlined in paragraph 52a.

*b.* Remove the crank as outlined in paragraph 53a.

*c.* Remove the side and front walls as outlined in paragraph 54c and d.

*d.* Unscrew the jack assembly as outlined in paragraph 58a. *Do not unsolder the wires.*

*e.* Unscrew the lever switch assembly as outlined in paragraph 56b and c. *Do not unsolder the wires.*

*f.* Lift up the terminal board. Remove the nuts, terminals, lockwasher, washer, and spacer from the binding post to be replaced. When taking

off the nuts, hold the head of the binding post with pliers or a pin inserted through the head of the binding post.

g. Insert the new binding post through the hole in the terminal board. Replace the spacer, washer, lockwasher, nut, terminal lugs on the ends of the wires, and the nut. If both binding posts are to be replaced, connect the wires in accordance with the following color code:

Black-red wire and two white wires to post L1

Yellow-red (or orange) wire and red wire to post L2

h. Replace the lever switch and jack assembly as outlined in paragraph 56m, n, and o.

i. Replace the side and front walls as outlined in paragraph 54l.

j. Replace the crank as outlined in paragraph 53b.

k. Replace the body as outlined in paragraph 52b.

## 62. Bat — Binding Post

To remove and replace the BAT— binding post, follow the procedure outlined below:

a. Remove the body from the case as outlined in paragraph 52a.

b. Remove the crank as outlined in paragraph 53a.

c. Remove the side and front walls as outlined in paragraph 54c and d.

d. Unscrew the jack assembly as outlined in paragraph 58a. *Do not unsolder the wires.*

e. Unscrew the lever switch as outlined in paragraph 56b and c. *Do not unsolder the wires.*

f. Lift up the terminal board and remove the nuts, terminals, lockwasher, washer, and spacer from the binding post. When taking off the nuts, hold the head of the binding post with pliers or a pin inserted through the hole in the head of the binding post.

g. Insert the new binding post through the hole in the terminal board. Replace the spacer, washer, lockwasher, nut, terminal lugs on the ends of the wires, and the nut.

h. Replace the lever switch and jack assembly as outlined in paragraph 56m, n, and o.

i. Replace the side and front walls as outlined in paragraph 54l.

j. Replace the crank as outlined in paragraph 53b.

k. Replace the body in the case as outlined in paragraph 52b.

## 63. Battery Contacts

To remove and replace a battery contact, follow the procedure outlined below:

a. Remove the body from the case as outlined in paragraph 52a.

b. Unscrew the jack assembly as outlined in paragraph 58a. *Do not unsolder the wires.*

c. Unscrew the lever switch as outlined in paragraph 56b and c. *Do not unsolder the wires.*

- d. Remove the nut on the contact by holding the insulator tightly with pliers and unscrewing the nut.
- e. Insert the new contact through the insulator and insert through the hole in the terminal board. Replace the terminal lug, lockwasher, and the nut; tighten securely.
- f. Replace the lever switch and jack assembly as outlined in paragraph 56m, n, and o.
- g. Replace the body in the case as outlined in paragraph 52b.

#### 64. Battery Contact Springs

To remove and replace a battery contact spring, follow the procedure outlined below:

- a. Remove the body from the case as outlined in paragraph 52a.
- b. Remove the crank as outlined in paragraph 53a.
- c. Remove the side and front walls as outlined in paragraph 54c and d.
- d. Loosen the induction coil as outlined in paragraph 59e. *Do not unsolder the wires.*
- e. Loosen the holding coil as outlined in paragraph 60f. *Do not unsolder the wires.*
- f. Unsolder the wire from the end of the spring and remove the spring by pulling the offset out of the battery block.
- g. Place the bottom of the new spring in the seat in the battery block. With pliers, force the offset into the hole in the top of the battery block. Be careful not to bend the spring.
- h. Twist the wire around the end of the spring and solder securely. Keep the wire as close to the end of the spring as possible.
- i. Replace the holding coil as outlined in paragraph 60g.
- j. Replace the induction coil as outlined in paragraph 59f.
- k. Replace the side and front walls as outlined in paragraph 54l.
- l. Replace the crank as outlined in paragraph 53b.
- m. Replace the body in the case as outlined in paragraph 52b.

#### 65. Handset TS-9-(\*) and Component Parts

a. **GENERAL.** The component parts of Handset TS-9-(\*) are easily accessible and, therefore, no difficulty should be encountered in removing and replacing these parts. However, care should be taken when replacements are made to be sure the replacement part is correct. This is particularly applicable when salvaged parts are used for replacements. The handset switch assemblies are interchangeable on all Handsets TS-9-(\*). Also, if the letter replacing the parenthesis in Handset TS-9-(\*) is the same on two handsets, then all corresponding parts on the two handsets are interchangeable.

b. **CORD CC-333.** To remove and replace Cord CC-333 in the handset, follow the procedure outlined below:

(1) Remove the transmitter cover by unscrewing counterclockwise (to the left).

(2) Remove the transmitter unit from the housing and loosen the screws on the rubber-covered red, white, and black wires. Remove the terminal lugs of these wires from under the screws.

(3) Remove the screw through the stay cord or clamp hook and pull Cord CC-333 out of the handset.

(4) Push the new cord, terminals first, through the hole in the handset, fasten the stay cord, and connect the three wires under the terminal screws.

*Note.* The arrangement of the screws within the transmitter housing differs for various models of Handset TS-9-(\*). The only sure guide to follow is to connect the new cord in exactly the same manner as the old cord was connected.

(5) Place the transmitter unit in the cap, and screw the cap in place on the handset. Be sure the spring contacts are not pushed down so that they do not make contact on the back of the transmitter unit.

c. HANDSET TS-9-(\*). To remove and replace the entire handset, follow the procedure outlined below :

(1) Loosen the three handset terminal screws on the jack assembly block and remove the terminal lugs from under the screw heads. Untie the loop of the stay cord on the eye screw, and remove the handset from the case.

(2) Place the stay cord of the new handset through the eye screw, loop around, and pass through the eye screw again. Pull the stay cord tight and tie to the connecting cord.

(3) Insert the handset terminal lugs under the terminal screw heads and tighten securely. Do not use pliers to tighten the terminals. Connect the three wires in accordance with the following color code :

Black wire to T & BAT+

Red wire to C

White wire to REC

## 66. Leather Straps

To remove and replace a leather strap, cut the old strap between the rivets and the end of the loop near the D-ring or the square ring. Insert the new strap through the ring and loop it around the ring. Push the rivets through the holes provided, with the heads of the rivets on the inside or short end of the strap. Put burrs on the rivets and head over the ends of the rivets with a hammer.

## Section VI. DETAILED REPAIRS

### 67. General

Units which do not possess trained repairmen or proper repair facilities should exchange a defective telephone for a serviceable one. Repair

should not be attempted beyond the tightening of loose connections, and the repair of broken connections.

### 68. Generator GN-38-(\*)

Failure of the generator to deliver output to the line may be caused by an open or short-circuited armature coil, or the generator contact springs may be dirty or out of adjustment. If the armature coil is open or short-circuited, replace the generator.

a. CLEANING GENERATOR CONTACTS. (1) Remove the telephone body from the case (par. 52a) and take off the front wall of the telephone (par. 54d).

(2) Clean the contacts by applying dry-cleaning solvent with a pencil brush to the contact points.

(3) Burnish the contacts with a fine-grained contact burnisher. *Do not use a file.*

b. ADJUSTING GENERATOR CONTACT SPRINGS. (1) Remove the generator from the chassis (par. 55).

(2) With the crankshaft in the normal position, the center (float) contact spring should make contact with the short inner contact spring, and should clear the end of the crankshaft by approximately 1/32 inch.

(3) The separation between the outer contact spring and the float spring should be 1/32 inch when the crankshaft is in the normal position.

(4) When the crankshaft is moved to its fully operated position, the float spring should make contact with the outer contact spring with a follow of 1/32 inch.

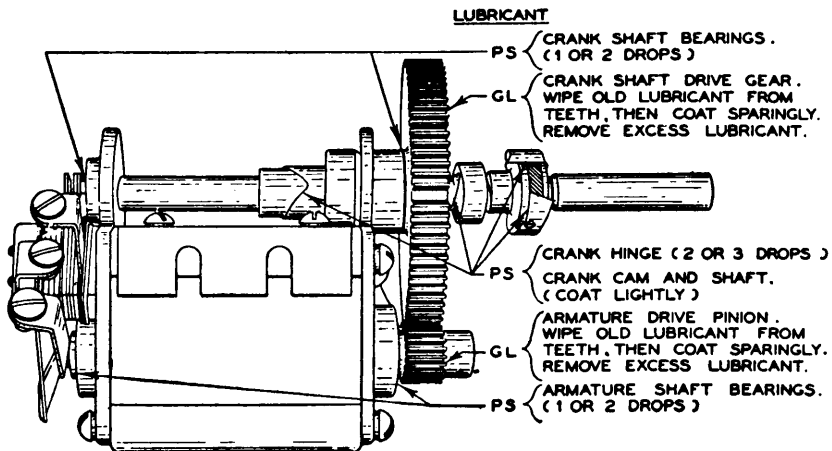

- KEY -

LUBRICANT	
PS - OIL, LUBRICATING, PRESERVATIVE, SPECIAL.	U.S. ARMY 2-120
GL - GREASE, LUBRICATING, SPECIAL.	SPEC. NO. AXS-637

TL90785A

Figure 32. Lubricants and lubrication points for Generator GN-38-(\*)

(5) Adjust the springs with a spring bender or duck bill pliers by applying pressure to the spring at the point where it leaves the spring assembly.

c. LUBRICATION. Normally, it will not be necessary to lubricate Generator GN-38-(\*). However, when the generator has been disassembled in a repair shop for other repairs, the moving parts of Generator GN-38-(\* ) should be lubricated. Use either oil (lubricating, preservative, special), or grease (lubricating, special) as directed in figure 32. The lubricants recommended can be used at all temperatures. Before lubricating parts with oil (lubricating, preservative, special), wipe dust from exposed surfaces. Lubricate sparingly to prevent lubricant from entering the generator case or getting on electrical contacts. Use only dry-cleaning solvent for cleaning the generator.

### 69. Ringer MC-131

A number of Telephones EE-8-(\* ) were equipped with Ringers MC-131 having both clapper and gong made of steel. When this condition exists, a leakage path is formed for the magnetic flux of the ringer magnet, causing the ringer to stick. Also, the ringer may fail to operate because of dirt which has filtered into the bottom of the telephone or because of the gong or armature being out of adjustment.

a. ELIMINATION OF MAGNETIC LEAKAGE. (1) If clapper and gong are both made of steel, either may be replaced with one made of brass from stock or a discarded set.

(2) When neither a brass clapper or a brass gong is available, the travel of the armature may be adjusted so that there will be clearance of 0.020 to 0.025 inch between clapper and the nearest gong projection when the armature is against the pole piece, as indicated on figure 33.

b. CLEANING. (1) Keep the ringer free from dirt, grease, corrosion, and extraneous matter, particularly between the core ends, armature stop pins, and pivots of the armature assembly. If ringer is mounted in telephone, remove mounting screws so that ringer will be accessible for cleaning. Brush off ringer with a suitable brush and blow out with compressed air.

(2) With reasonable care in keeping the leather or canvas cover of Telephone EE-8-(\* ) closed, there should not be an excessive amount of dirt filtering into the bottom of this equipment. The cause of the ringer sticking is more likely to be the high humidity to which the equipment is being subjected, and will require more preventive maintenance than if it were used in relatively dry climate. *Do not use lubricants.* The application of lubricants to the pivot bearings will aggravate the condition, as particles of dust or other extraneous material will have a tendency to adhere to the bearings.

c. ADJUSTMENT OF GONG. (1) Remove the ringer from the telephone (par. 57a, b, c, and d). *Do not disconnect wiring.*

(2) With a screw driver, loosen the two gong mounting screws located

on top of the gong. Move the gong slightly clockwise or counterclockwise until the desired sound of the bell is obtained. Tighten the gong mounting screws.

d. ADJUSTMENT OF ARMATURE. The armature assembly should move without bind in its pivots. End and side play should not exceed 0.005 inch. If adjustment of end or side play is necessary, loosen upper pivot

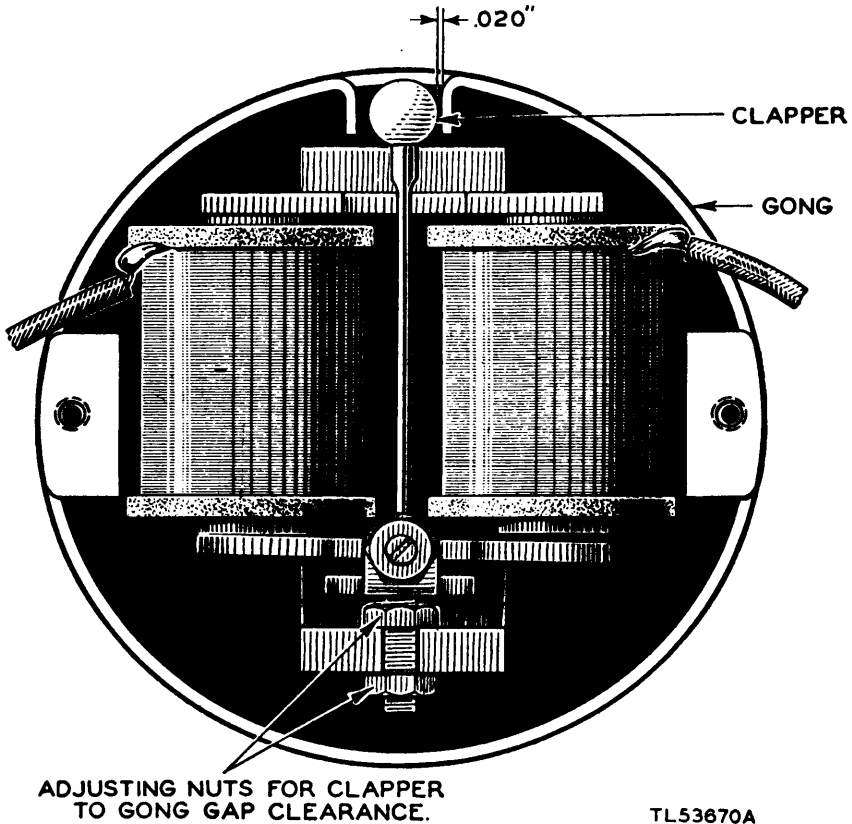

Figure 33. Ringer MC-131

nut and screw. Adjust pivot, retighten nut, and check for bind. Adjust armature travel as follows (fig. 33):

(1) Increase armature travel by loosening the hexagonal nut, located between the armature pivot bracket and the magnet support assembly, using a  $\frac{5}{16}$ -inch, hexagonal, open-end, flat wrench. Tighten the hexagonal nut, which is located outside the magnet support assembly. Be sure the nuts are tight when the desired armature travel is obtained.

(2) Decrease the armature travel by loosening the hexagonal nut, located outside the magnet support assembly, using a  $\frac{5}{16}$ -inch, hexagonal, open-end, flat wrench. Tighten the hexagonal nut, which is located between the armature pivot bracket and the magnet support assembly. Be sure the nuts are tight when the desired armature travel is obtained.

## 70. Handset Switch

Trouble in the handset switch will usually be caused by dirty contacts or by contact springs being out of adjustment.

*a. CLEANING HANDSET SWITCH CONTACTS.* (1) Remove the switch from the handset by removing the two mounting screws and pulling the switch out of the recess in the handset handle. *Do not disconnect the wiring.*

(2) Clean the contacts by applying dry-cleaning solvent to the contact points with a pencil brush.

(3) Burnish the contacts with a fine-grained contact burnishing tool. *Do not use a file or abrasive cloth or paper.*

*b. ADJUSTING HANDSET SWITCH CONTACTS.* (1) Remove the switch from the handset handle (a(1) above).

(2) Contact separation should be at least  $\frac{1}{32}$  inch when the switch is in the normal position.

(3) When the switch is operated to the maximum position, the inner contact springs should make contact with the outer contact springs with a follow of approximately 1/64 inch.

(4) Adjust the springs as required, using a spring bender or duck bill pliers. Apply pressure at a point on the spring where it leaves the spring pile-up.

## 71. Painting and Refinishing

When any painted portion of the body or chassis has been scarred or damaged, rust and corrosion can be prevented by touching up the bared surfaces in the following manner:

*a.* Using No. 00 or No. 000 sandpaper, clean the surface down to the bare metal. Obtain a bright smooth finish. In severe cases it may be necessary to use dry-cleaning solvent to soften the rust, and sandpaper to complete the preparation for painting.

*Caution:* The use of steel wool, although permitting rapid removal of rust, is not recommended. Minute particles of steel wool frequently sift into the equipment and cause harmful shorting or grounding of circuits.

*b.* After cleaning the surface thoroughly as outlined above, apply the paint with a small brush, making sure the entire bared surface is covered. Paint used will be authorized consistent with existing regulations.

## 72. Unsatisfactory Equipment Report

*a.* When trouble in equipment used by Army Ground Forces or Army Service Forces occurs more often than repair personnel feel is normal, War Department Unsatisfactory Equipment Report, WD AGO Form 468 (fig. 34), should be filled out and forwarded through channels to The Chief Signal Officer, Washington 25, D. C.



b. When trouble in equipment used by Army Air Forces occurs more often than repair personnel feel is normal, Army Air Forces Form 54 should be filled out and forwarded through channels.

c. If either form is not available, Form 468 (fig. 34) may be reproduced, filled out, and forwarded through channels. When Army Air Forces Form 54 is required but not available, reproduce Form 468 and forward it through channels in accordance with directions on Form 468.

WAR DEPARTMENT UNSATISFACTORY EQUIPMENT REPORT			
FOR (Technical service) FROM <i>Signal Corps</i>		DATE <i>20 Jan 45</i>	
TO (Organization) <i>508 Sig Repair Co.</i>		MATERIEL (Station) <i>San Francisco</i>	
TO (Technical service) <i>Signal Officer</i>		APD 215 (Station) <i>Ninth Army</i>	
NOMENCLATURE COMPLETE MAJOR ITEM <i>Telephone EE-8-B</i>			
MODEL <i>B</i>		TYPE <i>Field, portable</i>	
U. S. A. REG. NO. <i>Order No. 22894-Phila-43</i>		MANUFACTURER <i>Stromberg-Carlson Tel. Mfg. Co.</i>	
EQUIPMENT WITH WHICH USED (IF APPLICABLE) <i>489</i>		DATE RECEIVED <i>19 Sep 44</i>	
NOMENCLATURE OF DEFECTIVE COMPONENT			
PART NO. <i>Sig C stock No. 3E333</i>		TYPE <i>Cord C.C.-333</i>	
DATE OF INITIAL TROUBLE <i>20 Nov 44</i>		LENGTH OF SERVICE TOTAL PERIOD OF OPERATION BEFORE FAILURE (FILL IN WHERE APPLICABLE)	
TOTAL YEARS MONTHS DAYS <i>1 24</i>		YEARS MONTHS DAYS HOURS MINUTES <i>28</i>	
DESCRIPTION OF TROUBLE AND PROBABLE CAUSE GIVE TYPE OF FAILURE: MECHANICAL, ELECTRICAL, WORKMANSHIP, MATERIAL, DESIGN <i>Cord breaks near connections to telephone.</i>			
UNUSUAL SERVICE CONDITIONS GIVE BRIEF DESCRIPTION <i>Operation in tropics</i>			
TRAINING OF SKILL OF USING PERSONNEL (CHECK ONE) POOR FAIR GOOD <input checked="" type="checkbox"/>			
DESCRIPTION OF ANY REMEDIAL ACTION TAKEN <i>Staycord retied by means of two clove hitches around end of cord. Clamp to be added to telephone to hold end of cord near terminals</i>			
OFFICE STATION DATE		SIGNATURE ORIGINATING OFFICER <i>John J. Jones</i>	
TO CHIEF (Technical service) NAME <i>Signal Officer, Washington 25, DC</i>		NAME <i>JOHN J. JONES</i>	
STATION RANK		RANK AND TITLE <i>Capt., Sig. C</i>	
		ORGANIZATION <i>508 Sig Repair Co.</i>	
INSTRUCTIONS			
1. It is imperative that the Chief of Technical Service concerned be advised at the earliest practical moment of any constructional, design, or operational defect in material. This form is designed to facilitate such reports and to provide a uniform method of submitting the required data.		5. It will not be practicable or desirable in all cases to fill all blank spaces of the report. However, the report should be as complete as possible in order to expedite necessary corrective action. Additional pertinent information not provided for in the blank spaces should be submitted as inclosures to the form. Photographs, sketches or other illustrative material are highly desirable.	
2. This form will be used for reporting manufacturing, design or operational defects in material with a view to improving and correcting such defects, and for use in recommending modifications of material.		6. When cases arise where it is necessary to communicate with a chief of service in order to ensure safety to personnel, more expeditious means of communication are authorized. This form should be used to confirm reports made by more expeditious means.	
3. This form will not be used for reporting failures, isolated material defects or malfunctions of material resulting from fair wear and tear or accidental damage nor for the replacement, repair, or the issue of parts and equipment. It does not replace currently authorized operational or performance records.		7. This form will be made out by using or service organizations and forwarded to duplicate through command channels to the chief of technical service. The office of the chief of technical service receiving the report will forward an information copy to the Commanding General, Army Ground Forces or Army Air Forces, whichever is applicable, and to the Commanding General, Army Service Forces.	
4. Reports of malfunctions and accidents involving equipment will continue to be submitted as directed in the manner described in AR 750-10 (Change No. 3).		8. Necessity for using this form will be determined by the using or service troops.	
W. D. A. G. O. Form No. 468 1 December 1943		16-27741-1 U. S. GOVERNMENT PRINTING OFFICE TL52269-5	

Figure 34. War Department Unsatisfactory Equipment Report with sample entries.

## APPENDIX I

### MAINTENANCE PARTS LIST FOR TELEPHONE EE-8-(\*)

---

For maintenance parts information, see appropriate section of Army Service Forces Signal Supply Catalog SIG 8 EE-8, Higher Echelon Spare Parts.

## APPENDIX II.

### REFERENCES AND ABBREVIATIONS

---

#### 1. Army Regulations

AR 380-5, Restricted Documents.

#### 2. Parts List

SIG 1, Introduction to ASF Signal Supply Catalog.

SIG 2, Complete Index to ASF Signal Supply Catalog.

SIG 3, List of Items for Troop Issue.

SIG 4-1, Allowances of Expendable Supplies.

SIG 4-2, Allowances of Expendable Supplies for Schools, Training Centers, and Boards.

SIG 5, Stock List of All Items.

SIG 6, Sets and P&I Control List.

SIG 7 (series), Organizational Spare Parts.

SIG 8 (series), Higher Echelon Spare Parts.

SIG 10, Fixed Plant.

SB 11-6, Dry Battery Supply Data.

#### 3. Technical Manuals on Auxiliary Equipment and Test Equipment

TM 11-2017, Test Set TS-26/TSM.

TM 11-2057, Test Set TS-27/TSM.

TM 11-361, Test Sets EE-65 and EE-65-A through -G.

TM 11-2613, Voltohmmeter I-166.

#### 4. Painting, Preserving, and Lubrication

TB SIG 123, Preventive Maintenance Practices for Ground Signal Equipment.

#### 5. Shipping Instruction

U.S. Army Spec. No. 100-14A, Army-Navy General Specification for Packaging and Packing for Oversea shipment.

#### 6. Decontamination

TM 3-220, Decontamination.

#### 7. Demolition

FM 5-25, Explosives and Demolitions.

#### 8. Camouflage

FM 5-20, Camouflage, Basic Principles.

#### 9. Other Technical Publications

FM 21-6, List of Publications for Training.

- FM 21-7, List of Training Films, Film Strips, and Film Bulletins.  
 FM 21-8, Military Training Aids.  
 FM 21-40, Defense Against Chemical Attack.  
 FM 24-5, Signal Communication.  
 FM 24-20, Field Wire Systems.  
 TB SIG 13, Moistureproofing and Fungiproofing Signal Corps Equipment.  
 TB SIG 25, Preventive Maintenance of Power Cords.  
 TB SIG 29, Impedance Unbalance Tests for Coils C-161 and C-288.  
 TB SIG 66, Winter Maintenance of Signal Equipment.  
 TB SIG 69, Lubrication of Ground Signal Equipment.  
 TB SIG 72, Tropical Maintenance of Ground Signal Equipment.  
 TB SIG 75, Desert Maintenance of Ground Signal Equipment.  
 TB 11-430-1, Maintenance of Batteries in Nontemperate Areas.  
 TM 11-430, Batteries for Signal Communication Except Those Pertaining to Aircraft.  
 TM 1-455, Electrical Fundamentals.  
 TM 11-457, Local Battery Telephone Equipment.  
 TM 11-462, Reference Data.  
 TM 11-473, Central Office Maintenance.  
 TM 11-498, Fundamentals of Telephony and Manual Telegraphy.  
 TM 38-250, Basic Maintenance Manual.

## 10. Forms

- WD, AGO Form 468, Unsatisfactory Equipment Report.  
 AAF Form 54, Unsatisfactory Report.

## 11. Abbreviations

AAF	Army Air Forces
AGO	Adjutant General's Office
ASF	Army Service Forces
db	decibel (s)
d-c	direct current
fig.	figure
gen.	generator
mf	microfarad
No.	number
par.	paragraph
revr.	receiver
rpm	revolutions per minute
spec.	specification
subpar.	subparagraph
term.	terminal
v.	volt(s)
WD	War Department
xmtr.	transmitter