

80223

1 copies 3-22-72
number 408 72

**INSTRUCTION BOOK
FOR
RADIO SET SCR-245-GX
RADIO SET SCR-245-JX
RADIO SET SCR-245-MX
RADIO SET SCR-245-NX
RADIO SET SCR-245-PX**

Manufactured by
THE RAULAND CORP.
Chicago, Ill. U.S.A.



RESTRICTED

**PUBLISHED BY AUTHORITY
OF
THE CHIEF SIGNAL OFFICER
ORDER NUMBER 321-CHI-41**

CONTENTS

SECTION I—GENERAL DESCRIPTION

Paragraph	Page
1—Purpose.....	1
2—Power.....	1
3—Modes of Transmission and Reception.....	1
4—Distance Ranges.....	1
5—Frequency Ranges.....	2
6—Channels.....	2
7—Transport.....	3
8—Weights and Volumes.....	3
9—Major Components.....	3
10—Radio Transmitter BC-223-AX.....	5
11—Transmitter Tuning Units TU-17-A, TU-18-A and TU-25-A.....	6
12—Radio Receiver BC-312-().....	6
13—Vibrator Unit PE-125-AX.....	6
14—Mast Sections MS-49 to MS-53, Inclusive, and Mast Base MP-37.....	7
15—Boxes BX-19, BX-20, BX-21 and Case CS-56.....	7
16—Covers BG-67, BG-75, BG-77, BG-86 and Roll BG-56-A.....	7
17—Vehicular Accessories.....	7
18—Dynamotor Unit PE-135-AX.....	7

SECTION II—EMPLOYMENT

19—Limitations.....	8
20—Installation.....	8
21—Check and Adjustments Prior to Operation.....	10
22—Operating in General.....	11
23—Operation of the Transmitter.....	12
24—Receiving.....	15
25—Care and Adjustments.....	15
26—Storage.....	15

SECTION III—SERVICING AND REPAIR

27—Servicing.....	15
28—Inspection.....	15
29—Lubrication.....	24
30—Special Adjustments to Radio Transmitter BC-223-AX.....	24
31—Normal Current and Voltage Readings.....	26
32—Procedure in Case of Set Failure.....	27
33—Locating Trouble.....	27
34—Repairs.....	27

SECTION IV—SUPPLEMENTARY DATA AND LIST OF REPLACEABLE PARTS

35—Radio Set Components, Weights and Dimensions.....	34
36—Replaceable Parts.....	36

ILLUSTRATIONS

Figure	Page
1—Transmitter BC-223-AX, Front View.....	VIII
2—Radio Set SCR-245-GX, Cording Diagram.....	2
3—Radio Set SCR-245-JX, Cording Diagram.....	3
4—Radio Set SCR-245-MX, Cording Diagram.....	4
5—Radio Set SCR-245-NX, Cording Diagram.....	5
6—Radio Set SCR-245-PX, Cording Diagram.....	6
7—Radio Transmitter BC-223-AX, Transmitter Tuning Units TU-17-A, TU-18-A, and TU-25-A: Schematic Diagram.....	17
8—(Part 1) Radio Sets SCR-245-GX, JX and PX: Schematic Diagram ..	18
8—(Part 2) Radio Sets SCR-245-GX, JX and PX: Schematic Diagram ..	19
9—(Part 1) Radio Sets SCR-245-MX and NX: Schematic Diagram.....	20
9—(Part 2) Radio Sets SCR-245-MX and NX: Schematic Diagram.....	21
10—Vibrator Unit PE-125-AX, Schematic Diagram.....	22
11—Dynamotor Unit PE-135-AX, Schematic Diagram.....	23
12—Transmitter BC-223-AX, Left End View.....	29
13—Transmitter BC-223-AX, Rear View.....	30
14—Tuning Unit TU-18-A, Front View.....	31
15—Tuning Unit TU-18-A, Rear View.....	32
16—Tuning Unit TU-18-A, Front View (Panel Removed).....	33

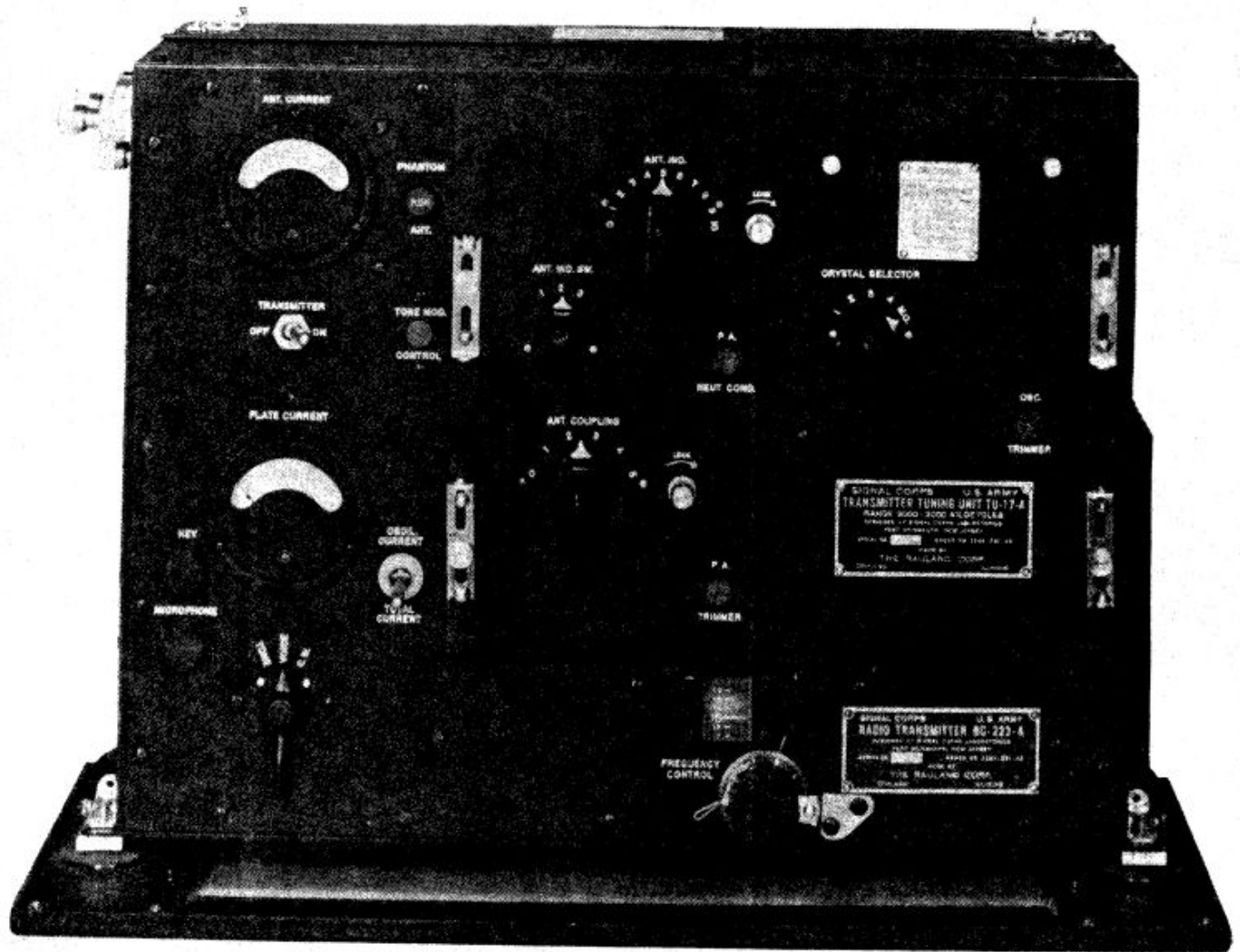

Figure 1—Transmitter BC-223-AX, Front View

RESTRICTED

INSTRUCTION BOOK FOR RADIO SET SCR-245-GX RADIO SET SCR-245-JX RADIO SET SCR-245-MX RADIO SET SCR-245-NX RADIO SET SCR-245-PX

SECTION 1

GENERAL DESCRIPTION

1. Purpose.—Radio Sets SCR-245-GX, SCR-245-JX, SCR-245-MX, SCR-245-NX, and SCR-245-PX are designed primarily for installation in vehicles for the purpose of obtaining intervehicular communication whether the vehicles are stationary or moving. These radio sets have been assigned different type numbers because of minor differences in component parts necessary to effect suitable installations in the particular vehicles, as follows:

- SCR-245-GX—Scout Car M3A1
- SCR-245-JX—Truck, ½-ton 4x4 Command (Radio)
- SCR-245-MX—Medium Tank M3
- SCR-245-NX—Light Tank M3
- SCR-245-PX—Car, Half Track M2

2. Power.—

a. Input.—The primary source of power required to operate the transmitters and receivers of these sets is the 12 or 24 volt vehicular storage battery (not a radio set component). For normal storage battery current consumption of the receivers and transmitters under various modes of operation, see paragraph 31.

b. Output.—The transmitters have a nominal output rating of 10 watts.

3. Modes of Transmission and Reception.—

a. Radio Sets SCR-245-GX, JX, MX, NX, and PX transmit and receive the following:

- (1) Continuous-wave telegraph, abbreviated as "cw".
- (2) Tone-modulated, continuous-wave telegraph, abbreviated as "tone."
- (3) Voice-modulated, continuous-wave telephone, abbreviated as "voice."

b. All modes of transmission given in paragraph 3a may be master-oscillator or crystal controlled.

4. Distance Ranges.—The distance between stations over which communication may be established with these radio sets may vary considerably due to frequency, mode of operation, and as a result of terrestrial, atmospheric, and electrical conditions. In general, approximate reliable communication ranges of these sets in miles are as follows:

	Cw	Tone	Voice
Stationary.....	45	35	20
Moving.....	15	15	15

For operation from a moving vehicle voice appears to be most satisfactory. For operation from a stationary vehicle an increased range will be found by using a wire antenna external to the vehicle. The range may be still farther extended by increasing the height of the antenna wire.

5. Frequency Ranges.—

a. Receivers of these sets have a frequency range of 1,500 to 18,000 kilocycles (kc).

b. The transmitters have a frequency range of 2,000 to 5,250 kc. When employing Transmitter Tuning Unit TU-17-A, the frequency range is 2,000 to 3,000 kc. When employing Transmitter Tuning Unit TU-18-A, the frequency range is 3,000 to 4,500 kc.

c. Transmitter Tuning Unit TU-25-A has a frequency range of 3,500 to 5,250 kc. This unit is available only as authorized for any using organization.

6. Channels.—The number of radio channels available under average conditions together with frequency separations for a frequency range 2,000 to 4,500 kc. are as follows:

Control..... Mode of Operation....	Master Oscillator			Crystal		
	Cw	Tone	Voice	Cw	Tone	Voice
Frequency separation in kilocycles.....	20	40	40	10	20	20
Number of channels.....	125	62	62	250	125	125

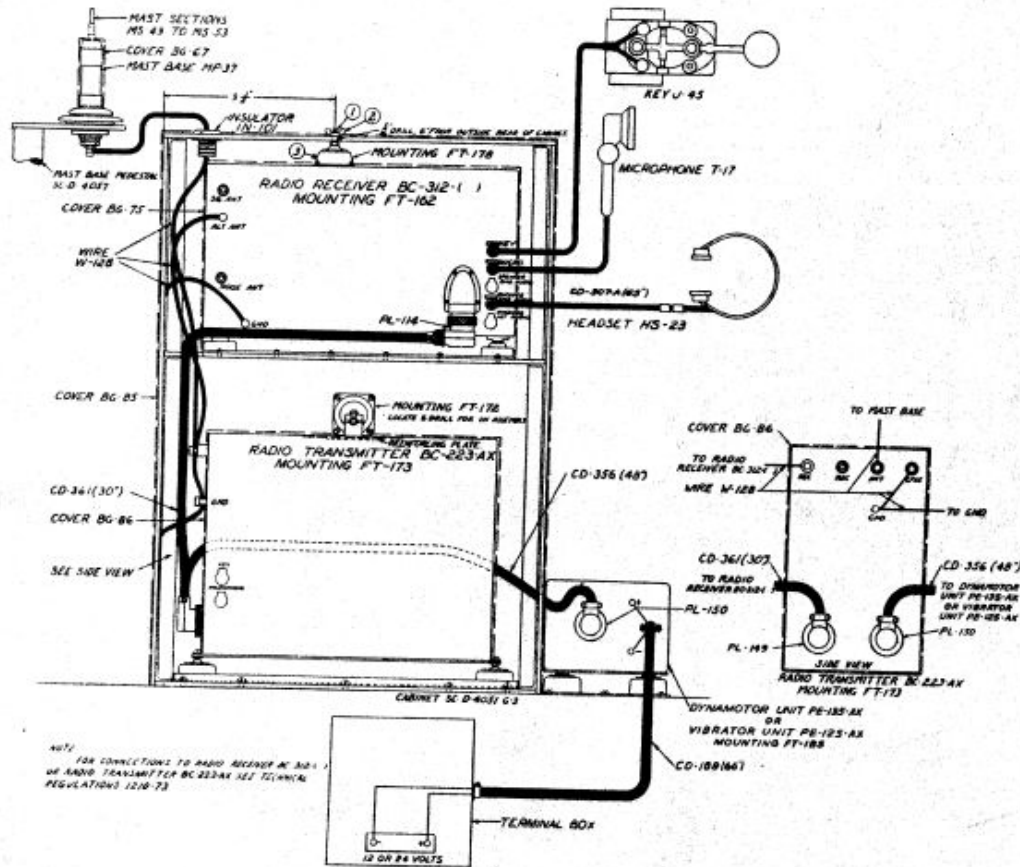

Figure 2—Radio Set SCR-245-GX—Cording Diagram

Note.—The frequency separations indicated above are approximate and are affected by terrestrial, atmospheric, and electrical conditions, as well as the distance between stations. They are generally reliable for distances between stations of 3 miles or more. At closer distances, greater frequency separation of channels is required.

7. Transport.—

a. Each vehicle named in paragraph 1, except for Truck, ½-ton 4x4 Command (Radio), is prepared by the Ordnance Department with all the necessary mounting holes and many of the brackets required for radio installation. The ignition system is shielded, a 12 or 24 volt, 180 ampere hour storage battery is installed, and a generator is employed in the vehicle to maintain the charge of the battery.

b. All components of the radio sets are designed for vehicular use. Where necessary, suitable shock mountings are provided to prevent damage from excessive shock or vibration.

8. Weights and Volumes.—

a. The approximate weights and volumes for the assembled radio sets are as follows:

	Weight Pounds	Volume Cubic Feet
SCR-245-GX.....	190	4
SCR-245-JX.....	300	10.5
SCR-245-MX.....	182	4
SCR-245-NX.....	183	4
SCR-245-PX.....	181	4

b. Dimensions and weights of components are given in paragraph 35.

9. Major Components.—

a. The radio sets include the following major components:

- (1) Radio Transmitter BC-223-AX
- (2) Transmitter Tuning Units TU-17-A, TU-18-A, and TU-25-A
- (3) Radio Receiver BC-312-()

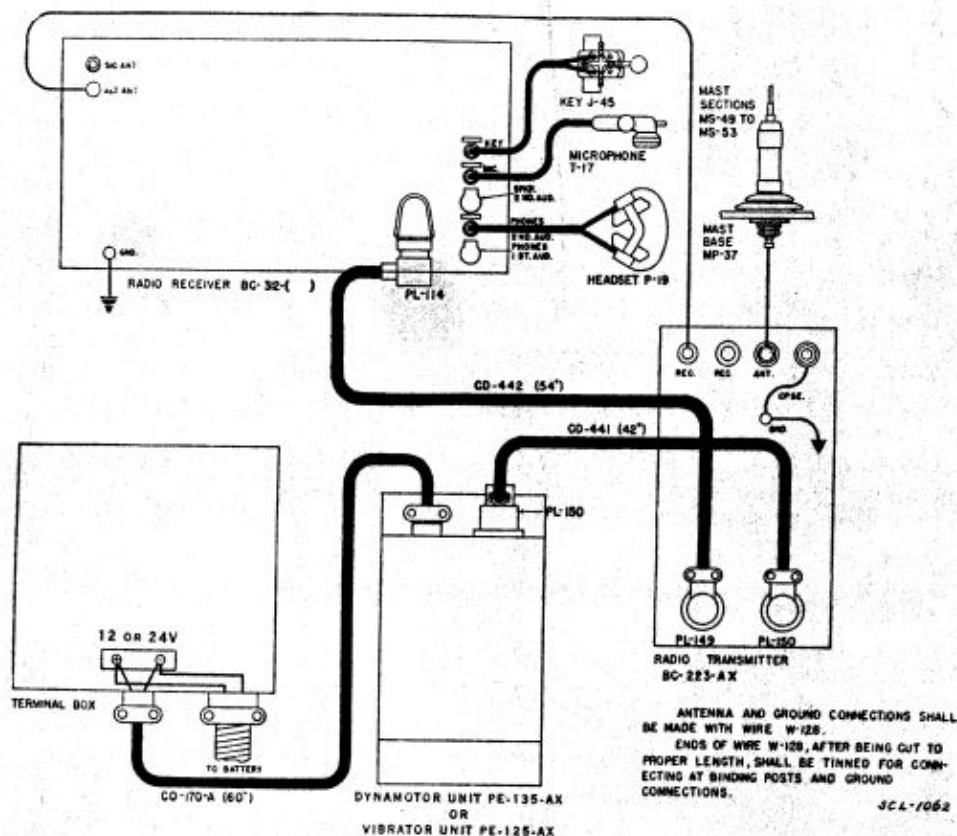

Figure 3—Radio Set SCR-245-JX—Cording Diagram

- (4) Dynamotor Unit PE-135-AX for use on 12 or 24 volts, or Vibrator Unit PE-125-AX for use on 12 or 24 volts.
- (5) Mast Sections MS-49 to MS-53, inclusive and Mast Base MP-37
- (6) Boxes BX-19, BX-20, BX-21* and Case CS-56

- (7) Covers BG-67, BG-75, BG-77*, BG-86*, and Roll BG-56-A.

*Components not included in Radio Set SCR-245-JX.

b. Major components, except Radio Receiver BC-312-(), are covered separately in paragraphs 10 to 16, inclusive. Radio Receiver BC-312-() is covered by a separate instruction book.

NOTE: Headset HS-30-() and associated Cord CO-605, if available should replace all other types indicated on the following diagrams, or in the text.

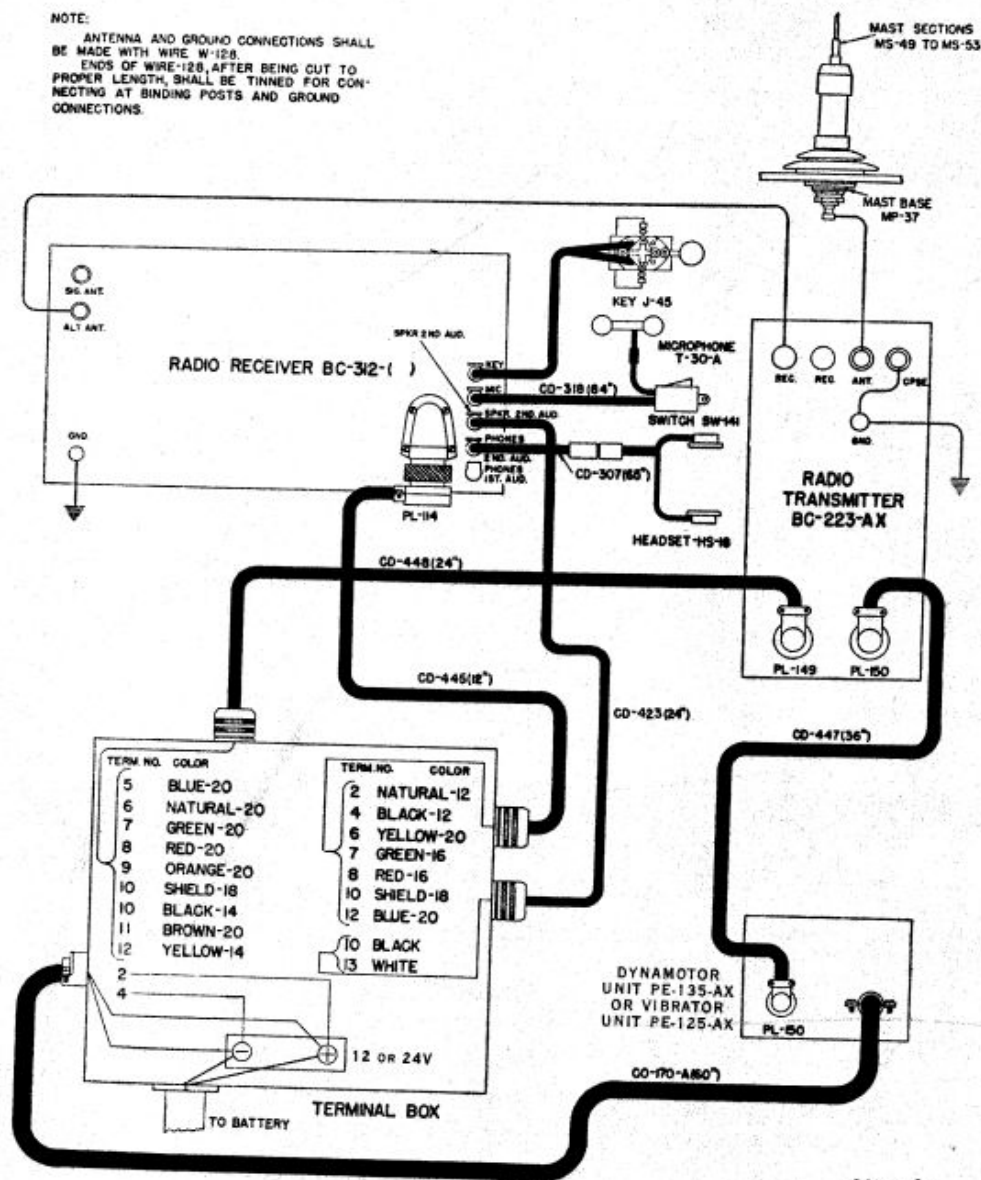

Figure 4—Radio Set SCR-245-MX—Cording Diagram

10. Radio Transmitter BC-223-AX.—

The transmitter elements are housed in a metal cabinet composed of a front panel, top, sides, back, and bottom supported by a metal frame. See Figures 1, 12, 13. The transmitter includes a calibration chart, pilot Lamp LM-33, and shock Mounting FT-173. Any one of the three transmitter tuning units may be plugged into a compartment in the right front part of the transmitter so that the tuning unit front panel becomes a part of the transmitter front panel. Extensions at the corners of the bottom plate of the transmitter cabinet have snap slide catches for securing the cabinet to the four rubber shock elements of Mounting FT-173. Releasing

the two rear snap-slide catches of this mounting permits the cabinet to be tilted forward on hinges provided on the front shock elements. Releasing two snap slide catches on the top of the cabinet permits removal of the top shield and provides access to the transmitter tube compartment. Removal of the lower back plate permits access to other circuit elements of the transmitter. A metal pocket on the right-side panel is provided for carrying the calibration chart. Output terminals and power sockets are located on the left side. Ventilation is provided by louvres in the sides, back, and tube compartment shield. Rubber shock Mounting FT-172 is fastened to the vehicle and top of the cabinet to provide additional support for the transmitter.

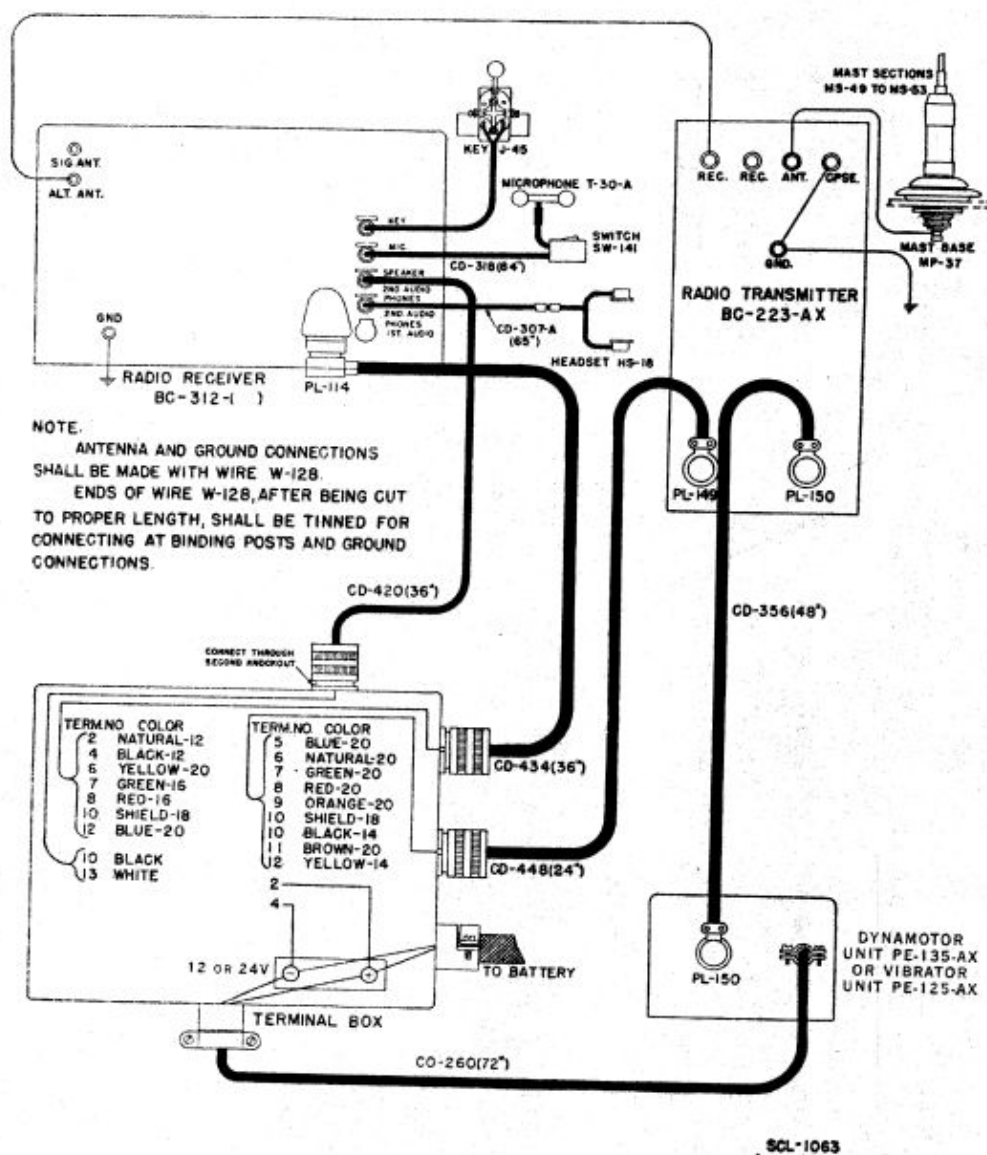

Figure 5—Radio Set SCR-245-NX—Cording Diagram

11. Transmitter Tuning Units TU-17-A, TU-18-A, and TU-25-A.—Transmitter Tuning Units TU-17-A, TU-18-A, and TU-25-A (See Figures 14, 15 and 16) are of the plug-in type and serially numbered the same as the transmitter. Refer to paragraph 5 for the frequency ranges of these units. Each tuning unit contains all of the required radio frequency determining elements and controls with the exception of the main tuning capacitor. Space is also provided in each tuning unit for four crystals mounted in Crystal Holder FT-171-B. The transmitter tuning units plug into a compartment on the right front panel of the transmitter and form a part of the front panel when in place.

Caution.—Transmitters and tuning units should never be issued separately. The serial numbers of transmitter and tuning units must be identical.

12. Radio Receiver BC-312-().—See separate instruction books for this receiver.

13. Vibrator Unit PE-125-AX.—This unit consists of two individual vibrators mounted on a metal box base. Associated circuit components such as transformers, chokes, etc., are included. Four snap-slides recessed inside the bottom plate secure the unit to Mounting FT-185. A socket and a hole in the left side panel of the box base provide for terminal connections to the unit. Releasing two

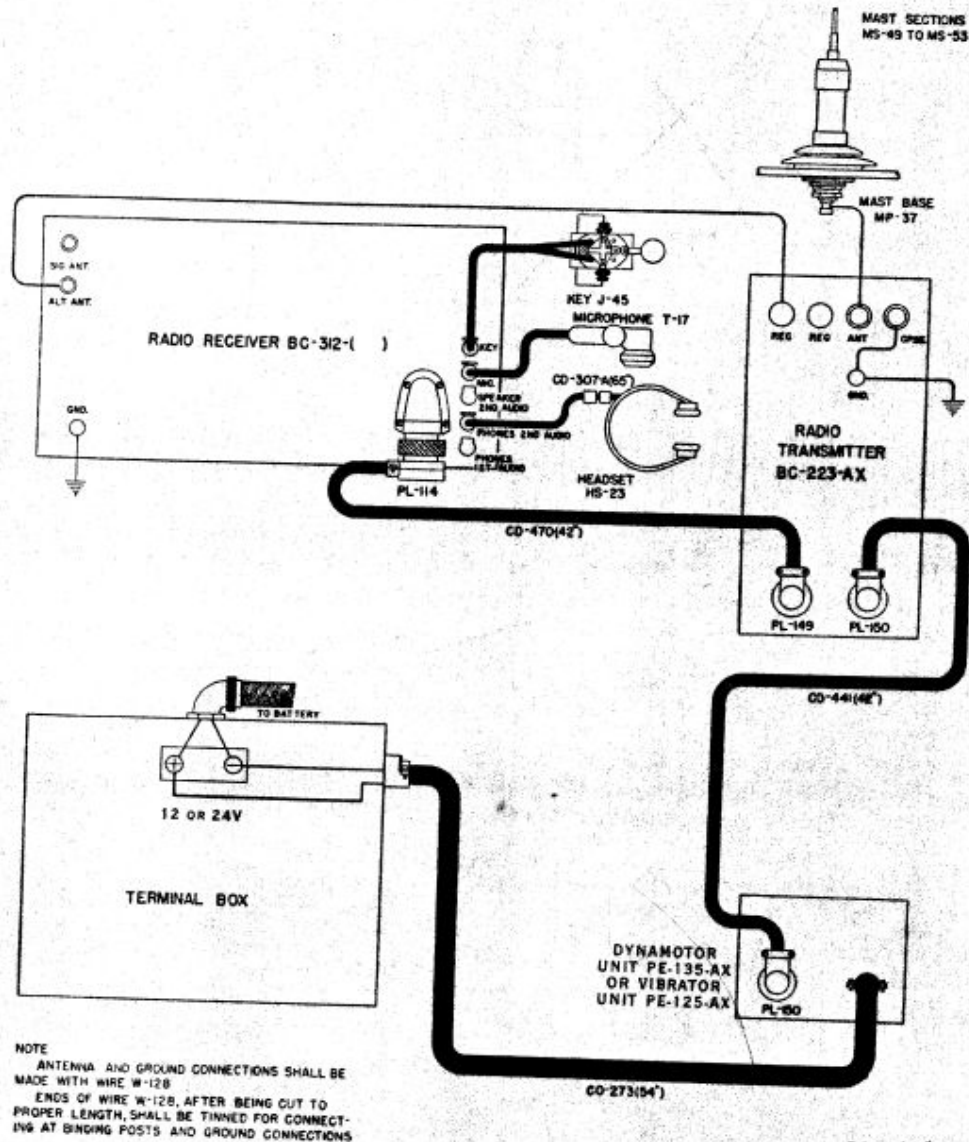

Figure 6—Radio Set SCR-245-PX—Cording Diagram

snap slide catches on the front panel permits removal of the cover and access to circuit elements within the box base. Fuses FU-30, 30 ampere, 250 volt; *F-0010 10 ampere, 250 volts; *F-0013, 5 ampere, 250 volts; *F-0011 $\frac{1}{2}$ ampere, 250 volts, and Mounting FT-185 are included as part of this vibrator unit. The main fuse FU-30 is in the circuit for both vibrators, for filament supply, and for receiver supply. Individual vibrator Fuses *F-0010 10 ampere, 250 volts are provided for 12 volt operation, and individual *F-0013 5 ampere, 250 volts for 24 volt operation. The proper fuse, depending on battery voltage, must be selected and inserted at the time the unit is installed. Individual high voltage Fuses *F-0011 $\frac{1}{2}$ ampere, 250 volts are provided in each vibrator circuit.

*Denotes Rauland Corp. part numbers.

Caution.—Dynamotor Unit PE-55 is replaced by Dynamotor Unit PE-135-AX or Vibrator Unit PE-125-AX in all 12 and 24 volt models. See paragraphs 13 and 18 in this section for description. **BE SURE VIBRATOR UNIT PE-125-AX OR DYNAMOTOR UNIT PE-135-AX IS CONNECTED FOR CORRECT VOLTAGE.**

14. Mast Section MS-49 to MS-53 inclusive, and Mast Base MP-37.—The five mast sections are made of high tensile-strength flexible steel. Mast Section MS-49 forms the top of the antenna when all sections are used and the others follow in sequence of their type numbers. Mast Section MS-53 screws into Mast Base MP-37 which is rigidly secured to the vehicle. A large helical spring in the mast base provides additional flexibility to the antenna. The upper end of the Mast Section MS-49 terminates in a blunt point. The lower end of each mast section is fitted with a serrated shank and screw for engaging the threaded upper ends of the next mast sections. Ends which are joined in assembling have enamel marks of the same color. The body of each section is enameled black and bears the type number at the lower end. The overall length of the assembled antenna is $15\frac{3}{4}$ feet.

15. Boxes BX-19, BX-20, BX-21 and Case CS-56.—Case CS-56 is a metal container with a hinged top which may be secured in the closed position by two snap-slide catches. This case may be rigidly fastened in the vehicle and houses Transmitter Tuning Unit TU-17-A, TU-18-A, or TU-25-A when not in use. Four lugs inside the case are engaged by the snap-slide catches on the panel of the transmitter tuning unit to secure the latter inside the case. A separate case is required for each spare

tuning unit. Boxes BX-19 and BX-20 carry spare tubes, fuses, and pilot lamps for the receiver and spare tubes for the transmitter respectively. Box BX-21 carries spare parts; the microphone, key and headsets when not in use. These boxes may be rigidly fastened inside the vehicle. The metal covers of Boxes BX-19 and BX-20 are secured to metal bases by spring clips. The cover of Box BX-21 is secured by a hinged hasp. A spare parts box is furnished with each Vibrator Unit PE-125-AX. It contains 2 Vibrators VB-5, 2 Tubes VT-249, 3 Fuses FU-30, 3 Fuses *F-0013 5 ampere, 250 volts, 3 Fuses *F-0010 10 ampere 250 volts, and 4 Fuses *F-0011 $\frac{1}{2}$ ampere, 250 volts.

*Denotes Rauland Corp. part numbers.

16. Covers BG-67, BG-75, BG-77, BG-86 and Roll BG-56-A.—Cover BG-67 is made of black canvas duck and is placed over Mast Base MP-37 when the antenna is not in use. It is secured to the mast base by a leather strap fastened at the bottom of the cover. Covers BG-75, BG-86, and BG-77 are made of hard-texture, water-repellant canvas duck and protect the receiver, transmitter, and dynamotor unit, respectively. Slide fasteners on the fronts of Covers BG-75 and BG-86 may be opened to provide access to the front panels of the receiver and transmitter. The flaps, released by opening the slide fasteners may be held back by snap fasteners on the tops of the covers. Openings on the sides of the latter three covers permit the entry of connecting cords to the components within. Roll BG-56-A is made of black canvas duck and holds two sets of five mast sections each in separate compartments. The opening on one end and along the side is closed by a suitable fastener.

17. Vehicular Accessories.—A car terminal box is installed by the Ordnance Department in each vehicle, except the truck, named in paragraph 1. In it are mounted a terminal block for storage battery connections and brackets for the installation of Terminal Block TM-183.

18. Dynamotor Unit PE-135-AX.—This unit consists of Dynamotor DM-49-AX rigidly mounted on a metal box. Extensions of the bottom panel of the box base have four snap-slide catches for securing the unit to the four rubber shock mount elements of Mounting FT-185. A socket and a hole in the left-side panel of the box base provide for terminal connections to the unit. Releasing two snap-slide catches on the front panel permits removal of the cover and access to circuit elements within the box

base. Fuses FU-30, FU-26, FU-47 and Mounting FT-185 are included as parts of this dynamotor unit. At the lower edge of the panel are located the links for changing from 12 to 24 volt operation. A circuit diagram is shown in Figure 11. Drawings of the links in both 12 and 24 volt positions are shown in Figure 11. Individual fuses are provided for low and high voltage circuits in the dynamotor unit. Upon installation of the dynamotor, the proper fuse

should be installed and the spare fuses packed for future use. The correct fuses to use are as follows:

24 volt—FU-47—20 ampere—250 volts
 12 volt—FU-30—30 ampere—250 volts

The proper value of fuse should also be inserted in the spare fuse holder. Dynamotor Unit PE-135-AX and Vibrator Unit PE-125-AX are completely interchangeable.

SECTION II EMPLOYMENT

19. Limitations.—These sets have the usual limitations possessed by any radio set of the same power, mobility, and frequency range. The distance ranges (par. 4) and the channels (par. 6) must be considered approximations which are affected by many factors, the majority of which are not controlled by the use of the set. Some of the factors which are controllable are listed below and require the attention of the user if the sets are to operate most effectively.

a.—Distance Range.

(1) All other things being equal, maximum range is maintained by:

(a) Frequent inspection of the set and correction of all defects. For inspection procedure, see paragraph 28.

(b) Using *cw* in preference to *tone*, and either *cw* or *tone* in preference to voice, except while in motion. It will be noted that distances indicated for the moving vehicle are not comparable to those for stationary operation. The difference is due to fading during mobile operation which interferes with communications on both *cw* and *tone*, since there is no automatic volume control used on the receiver for either *cw* or *tone*.

(c) Accurate tuning and transmission.

(d) Avoiding all obstructions either natural or man-made, particularly intervening eminences, such as tall metal structures, power, telephone, and telegraph lines. The type and contour of the ground affect the range, and a more favorable location may increase it.

(e) The use of a higher and longer antenna than that normally used with the vehicle. A wire antenna longer than the standard mast antenna properly installed between the mast base and a tree or other elevated object will serve this purpose.

(2) In some situations where only short ranges are required, the range may be decreased and interference reduced by the removal of one or two mast sections, provided the reduced antenna can be properly tuned to the prescribed frequency. In Radio Transmitter BC-223-AX, use of the phantom antenna may allow communication over a few hundred feet without interference to other services. It is also pointed out that this provides a communication of greater secrecy.

b. Channels.—(1) All other things being equal, the maximum number of channels available is maintained by:

(a) The action indicated in *a* (1) (a), (b), and (c) above, particularly that in (b).

(b) Assignment of frequencies as far apart as possible to nets which must be located close to each other on the ground.

(c) The use of crystal control in the transmitter.

20. Installation.—

a. Care.—Particular care must be observed when unpacking or handling the equipment because when not protected by cabinets or shock mountings it may be easily damaged. Inspect equipment visually for damage when removing it

from the shipping box. If necessary, clean with brush or blower before installation.

b. Instructions.—Detailed information relative to the installation of these sets is found in installation instructions for the particular type of vehicle concerned. These instructions are issued to using organizations, and because of their volume and possible changes, will not be repeated here. Figures 2, 3, 4, 5 and 6 show the external wiring and cording diagrams of the radio sets when installed.

c. Minor Replacements.—Replacements of such parts as pilot lamps, tubes, and crystals, are made as indicated in (1) and (2) below. All controls, knobs, switches, jacks, etc. identified by markings will hereafter be designated by such markings; that is, a three-position switch on the front panel of the transmitter has the marking CW TONE VOICE above the three possible positions of the switch pointer. This switch will hereafter be designated the CW TONE VOICE switch.

(1) *Radio Transmitter BC-223-AX.*—This transmitter is constructed with a special switch located on the tube shelf directly in line with the tubes. This switch is designed to allow either 12 or 24 volt operation when used with the proper dynamotor or power supply. Either Dynamotor Unit PE-135-AX or Vibrator Unit PE-125-AX may be used with Radio Transmitter BC-223-AX for either 12 or 24 volt operation. Be sure to check the position of the switch. A protecting cover is mounted over the switch and fastened with screws to prevent unauthorized moving of the switch. To change switch remove the two screws holding the protecting cover. Throw switch in direction indicated by markings on tube shelf. Only two markings are shown, 24V and 12V. Throw switch to 24V for 24 volt battery operation and to 12V for 12 volt battery operation. Be very careful never to have this switch in the wrong position for the voltage supply used.

(a) The transmitter should be shipped from the factory complete with a pilot light in the socket, however, if necessary, place a

pilot Lamp LM-33 in the socket on the bracket assembly located above the main capacitor dial on the front panel. This is accomplished by first removing the transmitter tuning unit. Then the bracket assembly is released by unscrewing a screw in the front panel about 1½ inches above the index marking for the vernier knob marked FREQUENCY CONTROL.

(b) Remove the tube compartment cover and insert corresponding vacuum tubes in sockets marked with respective vacuum tube Signal Corps numbers. Remove the cover of the 12-24 volt change over switch located on the tube shelf next to the oscillator tube (VT-62). Throw change over switch to side marked 12V for 12 volt operation or 24V for 24 volt operation. Replace switch cover; fastening with both screws, and both lockwashers. If the Dynamotor Unit PE-135-AX is used, be sure to set links for proper voltage. If the Vibrator Unit PE-125-AX is used, remove the plug in the rear and adjust 12-24 volt switch for correct voltage.

(c) Insert Crystal Holders FT-171-B in the crystal compartment of the transmitter tuning unit being used, making sure that the marking TOP on the front end of the crystal holder is uppermost. The compartment cover may be removed by unscrewing two thumbscrews. Mark the position of the crystals in the proper place on the chart attached to the compartment cover. The transmitter will operate satisfactorily on master oscillator and crystals are not necessary.

(2) *Radio Receiver BC-312-()*.—See separate instruction book for this item. The Radio Receiver BC-312-HX is to be used only when a 24 volt battery is used. Other models of the Radio Receiver BC-312-() are to be used on twelve volt batteries only, that is, Radio Receiver BC-312-A through Radio Receiver BC-312-G. **Warning.**—**Destruction of the receiver will result if the 12 volt receivers are connected to a 24 volt battery.** In Radio Receiver BC-312-HX, connection to a 12 volt battery will not result in damage to the receiver, however, the receiver will not operate. Check voltage supply carefully to avoid:

- a. Damage to receiver or
- b. Improper operation.

21. Check and Adjustments Prior to Operation.—

Caution.—Operation of this equipment involves the use of high voltages which are dangerous to life. *Operating personnel will observe safety regulations at all times. Do not change fuses or make adjustments inside equipment with the high-voltage supply on.*

a. *Check.*—Make a detailed inspection of the equipment and installation as prescribed in paragraph 20 and correct where necessary.

b. *Adjustments Prior to Operation.*—On Vibrator Unit PE-125-AX and Dynamotor Unit PE-135-AX, the filament resistors were adjusted approximately before leaving the factory. Due to different tubes being used, a recheck of filament voltage should be made prior to operation. After making a detailed inspection, check and adjust the filament voltages for the transmitter as follows:

- (1) On the transmitter panel, turn the TRANSMITTER OFF-ON switch to OFF.
- (2) Remove the front panel on the box base of Dynamotor Unit PE-135-AX. Check position of links on terminal panel to be sure that they correspond to the correct voltage. Figure 11 shows correct position of links for 12 or 24 volt operation. Do not connect battery until the link mechanisms are in the proper position.
- (3) Remove H.V. ACTIVE fuse within by unscrewing corresponding fuse cap.
- (4) Connect a voltmeter taken from test set I-56-A (or any other voltmeter capable of indicating 8.2 volt d-c) between ground and the slider of the FIL VOLT ADJUST resistor on the front panel of the dynamotor unit. The positive lead of the voltmeter is to be connected to the resistor. The negative lead of the voltmeter should be grounded.
- (5) Turn the TONE VOICE CW switch to TONE.
- (6) Turn the TRANSMITTER OFF-ON switch to ON.
- (7) For 12 volt operation adjust only the FILAMENT VOLTS ADJUST resistor located on the terminal panel. For 24 volt operation adjust only

the large resistor in the wire screen cage. Adjust filament voltage to 8.2 volts for both 12 and 24 volt operation. Be sure all adjustable clamps are tightened thoroughly but not sufficiently to damage resistor or clamps.

- (8) Turn the TRANSMITTER OFF-ON switch to OFF.
- (9) Replace the HIGH VOLTAGE ACTIVE fuse, the front panel on the box base of the dynamotor unit.
- (10) **THE FOLLOWING INSTRUCTIONS APPLY ONLY TO THE VIBRATOR UNIT PE-125-AX.** On the Transmitter Panel turn the TRANSMITTER OFF-ON switch to the OFF position.
- (11) See that 12-24 volt switch reached through screw cap on back of base is set for proper voltage. **CAUTION: CHECK CAREFULLY.**
- (12) Remove the front panel on the box base of Vibrator Unit PE-125-AX.
- (13) Remove the two lower cartridge fuses marked VIBRATOR FUSE.
- (14) Connect a voltmeter taken from Test Set I-56-A or any other voltmeter capable of indicating 8.2 volts d-c between ground and the sliding tap of the top resistor under the protecting screen.
- (15) Turn the TONE VOICE CW switch to TONE.
- (16) Turn the TRANSMITTER OFF-ON switch to ON.
- (17) Filament voltage should be 8.1-8.25 volts. If it is necessary to make an adjustment to obtain this voltage, adjust the upper resistor only when on 24 volt operation. Adjust the RS-211 resistor (the adjustable resistor in the middle section) when on 12 volts. Make all measurements at 12 volts or 24 volts battery.
- (18) Turn the TRANSMITTER OFF-ON switch to OFF.
- (19) Replace the fuses removed from the front panel of the Vibrator Unit PE-125-AX.

22. Operation in General.—

a. Interference.—

(1) Interference with reception may result from atmospheric electrical disturbances (static), or by the operation of electrical equipment in the vicinity of the radio set. These effects may be minimized by cw operation.

(2) Power lines may constitute a source of interference, particularly at the higher frequencies. This type of interference cannot be overcome without sacrificing signal strength. Avoid operation in the vicinity of power lines.

(3) A form of interference called track static, may be generated by track-laying vehicles. This type of interference must be cured at the source.

(4) A form of interference due to improper joining of metal parts of the vehicle may be prevented by care in grounding the radio equipment and carefully bonding (connecting) all metal parts of the vehicle.

(5) After some experience, the above forms of interference and any others may be identified by characteristic noises.

b. Net Operation.—If net operation is prescribed, each set in the net must be accurately tuned to the same frequency. If master-oscillator operation is used in the transmitter, frequency adjustment is best accomplished with the aid of a frequency meter. *Tune all sets within the same net under substantially the same conditions.* The position and length of the antenna, the temperature, and battery terminal voltages must be fairly uniform. Avoid tuning in the immediate vicinity of buildings and metal structures. If operation in motion is required tune sets with the engines of the vehicle running. Lock all transmitter controls after the net tuning operation, particularly the main tuning control. A toggle type lock is provided for the main tuning control. Where nets of more than three stations are set up, use of crystal control in the transmitter is desirable. Quartz crystals in Crystal Holder FT-171-B which are not part of Radio Set SCR-245-GX through PX, must be requisitioned separately, through the usual channels.

c. Methods of Operation.—

(1) Always operate the transmitter with the antenna tuned. This is particularly important when employing the master oscillator in net operation to maintain the correct frequency. Tone transmission, being broad, is well adapted to net operation but produces more interference to nearby radio sets than does cw transmission. Voice transmission produces more interference than does tone transmission.

(1) *Controls.*—Observe care in handling controls. Most of the controls are equipped with stops to limit their movement. Forcing a control beyond its normal stop will seriously damage the equipment. This caution applies particularly in the receiver to controls marked *VERNIER*, and *VOL.* In the transmitter, do not force the *ANT IND* and the *ANT COUPLING* controls after they have been locked in position. When tightening the lock do not apply more force than necessary to hold the controls from turning.

(2) *Serial Numbers*—The serial numbers and order numbers of transmitter tuning units must be identical with the serial number and order number of the transmitter with which they are used except Transmitter Tuning Unit TU-25-A which may be supplied independently. In this case, a blank calibration card is furnished. The main effects of inter-mixing tuning units are changes in calibration and changes in tracking. Do not interchange transmitter tuning units with those of other transmitters. The calibration cards for the transmitter tuning units which are not supplied as a part of a transmitter order have a space for indicating which transmitters they will be calibrated with. During calibration it is wise to note the number of transmitter and order number applying to each tuning unit so that mixing will be avoided.

(3) *Vacuum Tubes.*—A marked decrease in the life of the transmitter vacuum tubes results from over or under voltage applied to the filaments. Check the filament voltage frequently and adjust if necessary as prescribed in paragraph 21b.

(4) *Relay Contacts.*—When transmitting on voice the microphone button controls the starting and stopping of transmitting Dynamotor Unit PE-135-AX or Vibrator Unit PE-125-AX. When using the dynamotor, after depressing the button, do not release it until the dynamotor has obtained normal operating speed. If it is released before then the starting relay must break the heavy starting current causing rapid pitting of the relay contacts. This caution does not apply to the Vibrator Unit PE-125-AX.

(5) *Band Change.*—In changing the frequency band of the receiver it is possible to stop the BAND CHANGE switch between two bands. Turn this switch until it definitely engages the desired band.

(6) *Receiver Power Cord.*—Avoid undue pulling or stressing of this cord. Disconnect the cord from the receiver before the receiver panel and chassis assembly is removed from the cabinet. At no time apply power to the receiver while the panel and chassis assembly is being handled.

(7) *SEND REC Switch.*—When not being used during actual transmission periods, place the SEND REC switch in the REC position. If left in the SEND position, there will be a small current drain placed on the battery.

23. Operation of the Transmitter.—

a. Transmitting Controls.—Transmission is accomplished or controlled by the following:

- (1) (a) Dynamotor Unit PE-135-AX or
(b) Vibrator Unit PE-125-AX.
- (2) On Receiver BC-312-():
 - (a) KEY and MICRO jacks and a key and microphone for CW and TONE, or VOICE, respectively, connected thereto.
 - (b) SEND-RECEIVE Switch.
- (3) On Radio Transmitter BC-223-AX or connected to it:
 - (a) An antenna described in paragraph 14 connected to the ANT terminal on the upper left-side panel.
 - (b) A thermocouple 0 to 3 amperes radio-frequency ammeter marked ANTENNA CURRENT located in the upper left-hand corner of the panel. This meter indicates the output current of the transmitter.

(c) A TRANSMITTER OFF-ON toggle switch below the ANT CURRENT meter.

(d) A 0 to 300 milliamperes, direct-current ammeter marked PLATE CURRENT below the TRANSMITTER OFF-ON switch. This meter indicates the plate current of the oscillator tube or total plate current of the transmitter tubes as controlled by the switch described in (e) below.

(e) An OSCIL CURRENT-TOTAL CURRENT toggle switch located at the lower right of the PLATE CURRENT meter.

(f) KEY and MICROPHONE jacks and a key and microphone connected thereto. These jacks are located to the lower left of the PLATE CURRENT meter.

(g) A three-position switch with a pointer for indicating TONE VOICE CW positions, respectively. This switch is located below the PLATE CURRENT meter.

(h) A knob marked FREQUENCY CONTROL located at the lower right center of the panel which rotates a dial within the window above the knob. The knob is marked with 100 equal divisions on its periphery for interpolating the divisions on the dial. A lock is provided for locking this control in place.

(4) On Transmitter Tuning Units TU-17-A, TU-18-A and TU-25-A:

(a) An antenna inductance control marked ANT IND located in the upper left-hand corner of the tuning unit. Numbers on the panel are used for indicating the position of the pointer of this control. A lock is provided for locking this control in place.

(b) An antenna inductance switch marked ANT IND SW located to the lower left of the ANT IND control.

(c) An antenna coupling control marked ANT COUPLING located below the ANT IND SW switch. Numbers on the panel are used for indicating the position of the pointer of this control. A LOCK is provided for locking this control in place.

(d) Crystals which are inserted in any of four numbered positions within a compartment in the upper right-hand corner of the tuning unit.

(e) A five-position switch marked CRYSTAL SELECTOR located below the crystal compartment cover. Markings 1 2 3 4 MO above switch pointer positions indicate the crystal selected or master oscillator operation in the case of MO.

(f) Four controls on the transmitter and tuning unit panels which are accessible by use of a screw driver upon removal of screw caps. They are marked OSC TRIMMER, PA NEUT COND, PA TRIMMER, and TONE MOD CONTROL, respectively. These controls are not normally adjusted during operation of the transmitter but may be adjusted if necessary as prescribed in paragraph 30.

(5) A *phantom antenna unit* is incorporated in the radio transmitter. The phantom antenna is connected permanently in the circuit and may be placed in operation by pressing firmly upon the switch marked PUSH PHANTOM ANTENNA located just to the right of the ANTENNA CURRENT meter. After tuning the transmitter up on the phantom antenna it may be placed in normal transmit operation by merely retuning the ANT IND control.

b. Transmitting Procedure.—The transmitter may be operated for cw, tone or voice transmission with crystal or master oscillator control. *In all cases adjust the transmitter initially for cw transmission.* The procedure employing the master oscillator is prescribed in (1) below. The procedure employing crystal control is prescribed in (2) below.

(1) *For Cw Master Oscillator Operation.*

- (a) Read paragraphs 21 and 22.
- (b) Turn TRANSMITTER OFF-ON switch to OFF.
- (c) Plug into the transmitter the transmitter tuning unit which covers the assigned frequency.
- (d) Determine the dial setting for the assigned frequency from the calibration chart located in the right-side metal pocket. If the prescribed frequency is between any two tabulated frequencies, interpolate the correct dial setting.
- (e) Turn the FREQUENCY CONTROL knob and dial to the setting determined in (d) above.
- (f) Place the ANT COUPLING control near position 1 or 2.

(g) Throw the TONE VOICE CW switch to CW.

(h) Turn the CRYSTAL SELECTOR switch to MO.

(i) Insert the plug for the key in the KEY jack. If the key plug is inserted in the KEY jack of the receiver, move the SEND REC switch in the receiver panel to the SEND position. Be sure that the dummy antenna switch is pressed firmly during use. For use in a vehicle, the post marked CPSE and the post marked GND are connected together and both are connected to the frame of the vehicle.

(j) Turn the TRANSMITTER OFF-ON switch to ON. The dynamotor or power unit will start and the oscillator and power amplifier tube filaments will light.

(k) Depress key and observe total plate current, which should be about 60 ma with antenna coupling control set at 0.

(l) Increase antenna coupling control and tune the antenna to resonance by moving the ANT IND control until a maximum indication is obtained in the ANT CURRENT meter. If the antenna does not tune to resonance, move the ANT IND SW switch to another position and retune with the ANT IND control.

(m) Increase the ANT COUPLING control and readjust the ANT IND control until a total plate current of 120 milliamperes is obtained when the antenna current is a maximum.

(n) Lock the ANT IND and ANT COUPLING controls and the main tuning control in place with the LOCKS provided therefor.

(2) *For Cw Crystal-Controlled Operation.*

- (a) Read paragraphs 21 and 22.
- (b) Turn the TRANSMITTER OFF-ON switch to the OFF position.
- (c) Plug into the transmitter the transmitter tuning unit which covers the assigned frequency.
- (d) Place the CRYSTAL SELECTOR switch on the position selecting the Crystal of the assigned frequency.
- (e) Determine the dial setting for the assigned frequency from the calibration chart located in the right-side metal pocket. If the desired frequency is between any two tabulated frequencies, interpolate the correct dial setting.

(f) Turn the FREQUENCY CONTROL knob and dial to the setting determined in (e) above.

(g) Place the ANT COUPLING control near position 1 or 2.

(h) Place the TONE VOICE CW switch on CW.

(i) Insert the plug for the key in the KEY jack. If the key plug is inserted in the KEY jack of the receiver, move the SEND REC switch in the receiver panel to the SEND position. Be sure that the dummy antenna switch is pressed firmly during use. For use in a vehicle, the post marked CPSE and the post marked GND are connected together and both are connected to the frame of the vehicle.

(j) Turn the TRANSMITTER OFF-ON switch to ON. This will light the tubes and start the dynamotor or vibrator unit.

(k) Move the OSCIL CURRENT-TOTAL CURRENT switch to the OSCIL CURRENT position and hold it there by means of some support or by having someone hold it in place while the operations described below are performed.

(l) Depress the key.

(m) Watch the PLATE CURRENT meter closely during this operation. Turn the FREQUENCY CONTROL knob on both sides of its initial setting until a sharp dip in the oscillator plate current is noted in the PLATE CURRENT meter. At the point of minimum reading (bottom of dip) the oscillator is tuned to the crystal frequency. In tuning into this dip it will be observed that the dip is more abrupt on one side than on the other. Tune slightly toward the sides of the less abrupt dip. If the crystal stops oscillating (indicated by a sudden increase in total plate current), tune further toward the side of the less abrupt dip.

(n) Depress the key several times and note if the plate-current indication returns to the same value each time. If it does not, retune as indicated in (m) above, but further toward the side of the less abrupt dip. Depress the key for the next operation.

(o) Tune the antenna to resonance and adjust the antenna coupling as directed in (1) (e) (m), and (n) above.

(3) *For Tone Operation.*—Having completed the procedure directed in (1) or (2) above:

(a) Move the TRANSMITTER OFF-ON switch to OFF.

(b) Turn the TONE VOICE CW switch to TONE.

(c) Move the TRANSMITTER OFF-ON switch to ON. The tubes will light and the dynamotor or vibrator power unit will start.

(d) Depress the key. At resonance, the plate current with key depressed as indicated in the PLATE CURRENT meter should not exceed 260 milliamperes.

(4) *For Voice Operation.*—Having completed the procedure directed in (1) or (2) above:

(a) Move the TRANSMITTER OFF-ON switch to the OFF position.

(b) Place the TONE VOICE CW switch on the VOICE position.

(c) Insert the plug for the microphone in the MIC jack.

(d) Move the TRANSMITTER OFF-ON switch to the ON position.

(e) Depress the microphone button. The dynamotor will start and all filaments in the transmitting tubes will light. *Do not release the button until the dynamotor has attained normal operating speed. If a Vibrator Unit PE-125-AX is used this precaution is unnecessary.*

(f) Check the antenna tuning.

(g) With a sustained normal voice spoken into the microphone, the ANT CURRENT meter and the PLATE CURRENT meter should show increases, the result of modulation. The maximum total plate current with the sustained normal voice should not exceed 260 milliamperes.

(h) Under operation from a 12-14 volt or 24-28 volt battery talking extremely loud in the microphone should produce a slight upward movement of the antenna current meter. Downward movement of the antenna current meter or remaining stationary under modulation indicates (a) antenna coupling is too tight for satisfactory operation; (b) defective tubes exist in the transmitter; (c) grounded antenna; (d) some other defect.

Caution:—Do not be misled into using too close antenna coupling. Although it may seem a waste of energy the transmitter operates most satisfactorily considering overall life and communication ability with a total plate current, on voice, unmodulated of 155 to 160 milliamperes.

(i) The transmitter may thereafter be controlled "push to talk" by depressing the microphone button to transmit and releasing it to receive. Before talking into the microphone wait about three seconds to allow the tubes to warm up.

24. Receiving.—See separate instruction book for the operation of the receiver.

25. Care and Adjustments.—

a. Inspections.—To insure uninterrupted service, visually inspect the various components of each installation before and after each day's operation. Make a thorough inspection of each installation after every 50 hours of operation. For inspection instructions, see paragraph 28.

b. At all times when the transmitter, receiver, or dynamotor unit are not in actual operation, place Covers BG-86, BG-75, and BG-77 respectively, over these components. Close all slide fasteners. Securely fasten boxes and cases containing the transmitter tuning unit not in use, spare tubes, and other accessories at all times. Remove headsets, keys, and microphones when not in use and put in a safe place. The antenna may or may not be disassembled depending on its prospective use. If it is disassembled, insert mast sections in compartments of Roll BG-56-A and place the latter in a safe place. Screw a bolt provided for

the purpose in the top of the mast base and strap Cover BG-67 over the whole. To avoid injury due to shock or vibration of the vehicle when in motion, secure or pad all items of these sets which are not otherwise protected.

c. Lubrication.—Components of these sets will be lubricated according to instructions outlined in paragraph 29.

d. Special Adjustments.—See paragraph 30.

e. In Inclement Weather.—Where there is a likelihood of exposure of the set components, cover these components as in (b) above. These sets may be operated with covers on. Slide fasteners on the covers of the receiver and transmitter are opened and the front flaps held up and back by snap fasteners, during operation.

26. Storage.—

a. If these sets are to remain out of service but within the vehicles for more than a few days, proceed as directed in paragraph 25b. Disassemble the antenna and cover the ends of the mast sections with petroleum jelly before placing in Roll BG-56-A.

b. If set components are to be removed from the vehicle and stored elsewhere, handle them carefully, cover or wrap securely against dust, place in a dry, protected location, and safeguard against accidental injury. Inspect frequently for dust, rust, or injury, and clean and repair if necessary.

SECTION III

SERVICING AND REPAIR

27. Servicing.—

Caution.—Care must be observed in servicing this radio equipment. Using personnel will make only such repairs as are indicated in paragraph 34. Servicing should be attempted only by competent personnel supplied with adequate equipment.

28. Inspection.—

a. Daily Inspection.—The various components of Radio Sets SCR-245-GX, SCR-245-JX, SCR-245-MX, SCR-245-NX, and SCR-245-PX should be given a thorough inspection before and after each days operation to insure that the set

is ready for use at any time. This inspection includes examination of all cordage for proper fastening and for damage. All accessible components are examined for dirt and cleaned if necessary. At the end of a long period of storage, this inspection also includes a check to see that the dynamotor armature revolves freely, and that relay contacts are clean.

b. 50-Hour Inspection.—A thorough inspection of the complete installation should be made after every 50 hours of operation. This materially aids in securing uninterrupted performance in the field. The procedure for this inspection is as follows:

(1) Check to see that the storage battery is at the proper specific gravity and that the charging generator and regulator are adjusted so as to keep the battery fully charged.

(2) Clean accumulated dust and dirt from all units, using air hose or bellows where necessary.

(3) Make sure that all wiring is in place, that all mounting brackets and supports are rigidly fastened, and that all nuts and machine screws are supplied with lock washers and are tight.

(4) Determine that the cords are not damaged and that all ground connections are secure.

(5) Inspect plugs for proper fit and sockets for compressed pin springs. Pin springs which have taken a permanent set can usually be restored by a light hammer blow at the end of the pin.

(6) Make certain that all cartridge fuses are held tightly in their clips. A loosely held fuse should be removed and the clips bent by hand until they grip the fuse tightly. Clean clips and fuse ends. Clean all contact surfaces.

(7) Inspect the high voltage fuses after removal from mounting. Carefully clean all contact surfaces and replace the fuses.

(8) Inspect the antenna system for broken or frayed leads or loose mast sections. Wipe the insulator clean. To prevent loosening and loss of mast sections, joints should be covered with rubber tape. Make sure that antenna leads have not

been bent close to metalwork, where high antenna voltages might cause sparkovers.

(9) Inspect key and microphone for defective cords and damaged plugs.

(10) Inspect dynamotor brushes for length. Inspect the face of each brush. It should show that at least 70 percent of the face of the brush is making contact with the commutator. The brush face should show no deep scratches or rough spots.

(11) Inspect all dynamotor commutators for cleanliness and for excessive wear.

(12) Rotate the dynamotor armature by hand and make certain that it turns freely and is not rubbing against the field poles or leads. When the brushes have been removed, the armature should spin freely on its bearings.

(13) Upon completion of an inspection, all plugs and sockets should be completely reengaged and screwed down tightly. All tubes should be inserted all the way into their corresponding sockets and grid-cap connections, if any, firmly made. Chassis should be effectively locked in their boxes by means of the locking catches on the front panels.

c. Receiver Vacuum Tubes.—The vacuum tubes used in Radio Receiver BC-312-() normally have an effective life of two to three years. However, to insure best performance of the receiver, they should be checked frequently with an accurate tube checker, particularly just prior to extended field maneuvers. Tubes which are found serviceable should be replaced in same socket from which removed. Where no tube checker is available, a receiver that is known to be good may be used. Set the receiver for telephone operation on one of the higher frequency bands. Turn the volume control wide open and with the phone plug inserted in the second audio jack a loud rushing sound should be noticeable. Usually, upon touching the antenna post of the receiver this rushing sound will increase in strength. Substituting questionable tubes for tubes known to be good in the receiver should not change the strength of the back ground noise if the substituted tube is satisfactory. A poor tube will result in less back ground noise. This is only a rough test and is to be used where no tube checker is available.

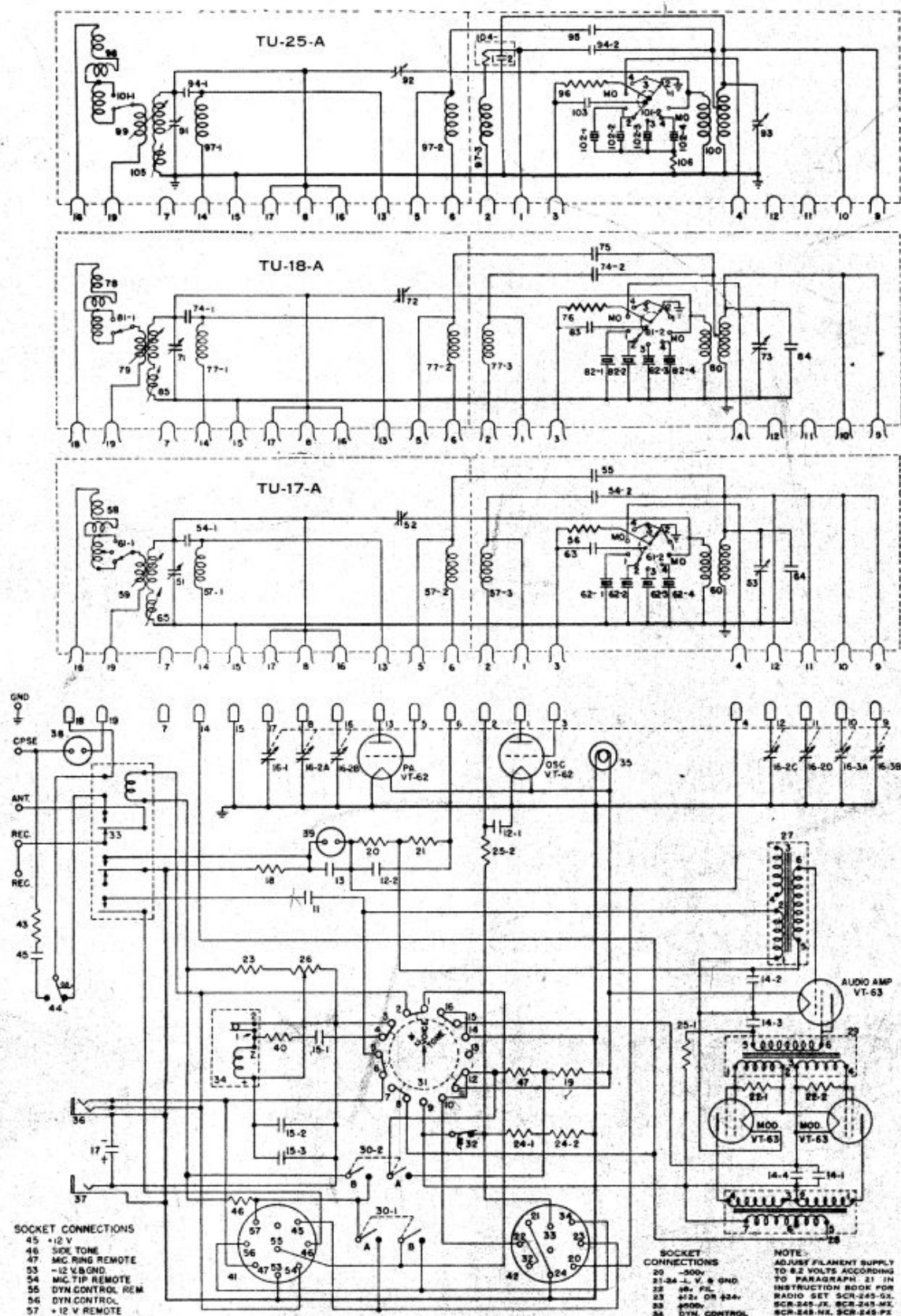

Figure 7—Radio Transmitter BC-223-AX, Transmitter Tuning Units TU-17-A, TU-18-A, and TU-25-A: Schematic Diagram.

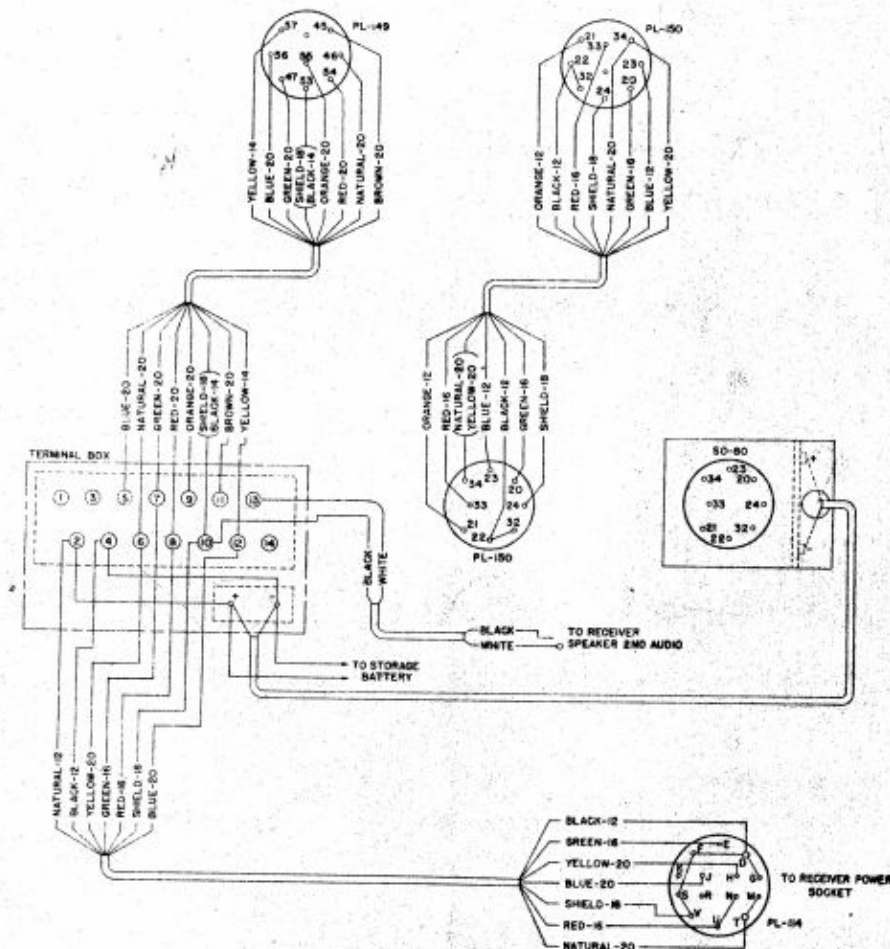
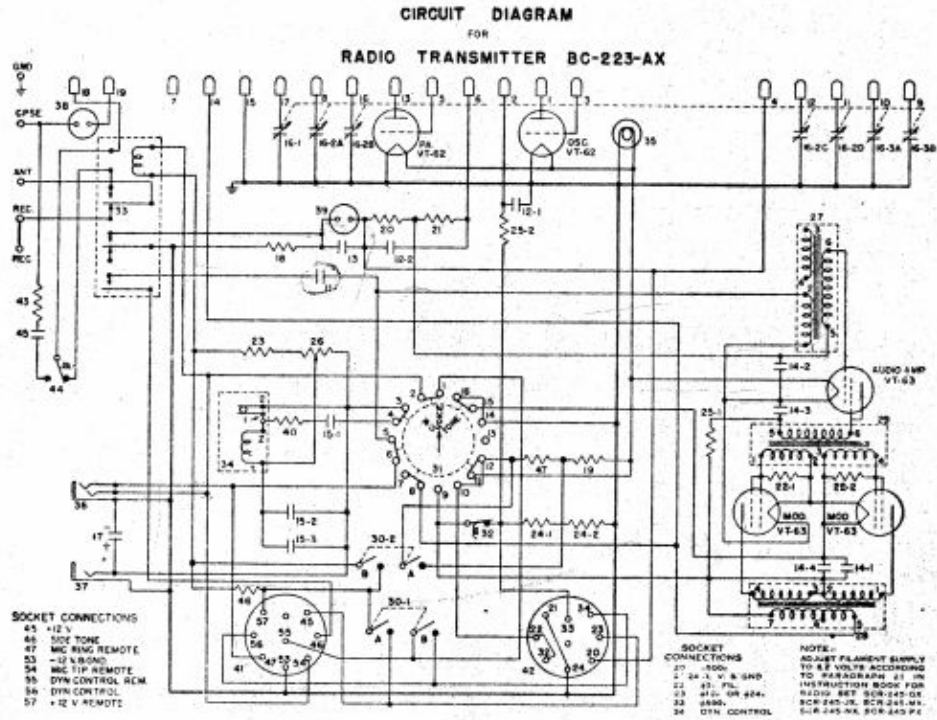

Figure 9—Part 1—Radio Sets SCR-245-MX and NX, Schematic Diagram

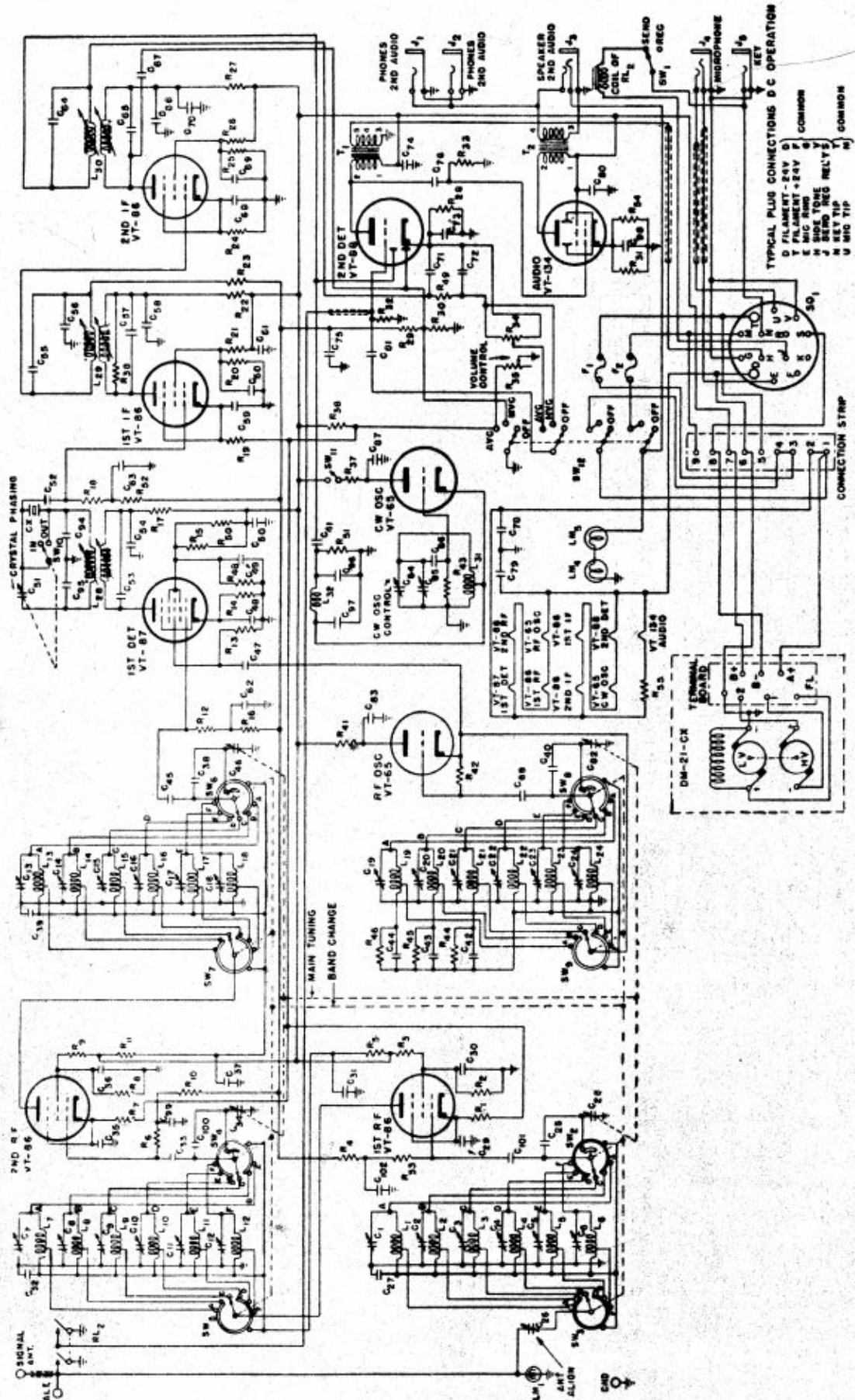
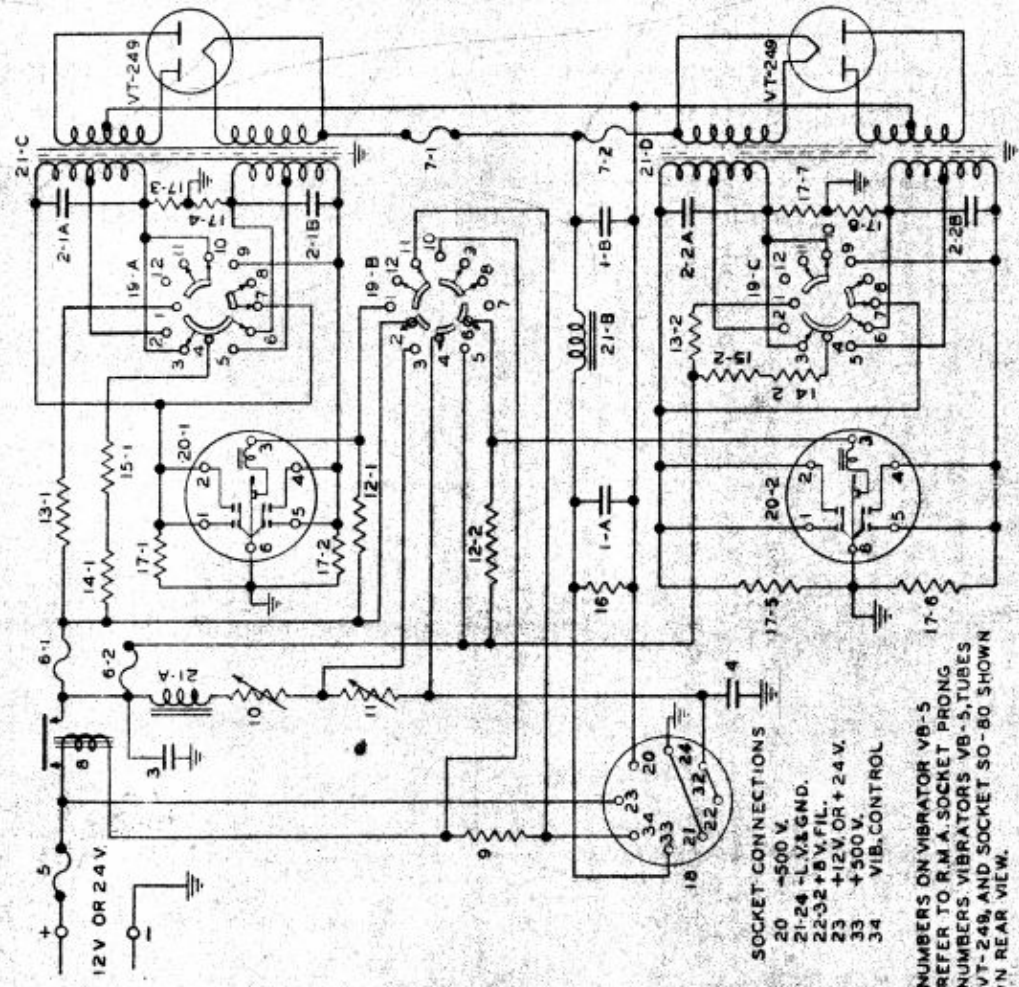

Figure 9—Part 2 Radio Sets SCR-245-MX and NX, Schematic Diagram

CIRCUIT DIAGRAM
FOR
VIBRATOR UNIT PE-125-AX



SOCKET CONNECTIONS
 20 -500 V.
 21-24 -L.V.&GND.
 22-32 +B.V.FIL.
 23 +12V. OR +24 V.
 33 +500 V.
 34 VIB. CONTROL

NUMBERS ON VIBRATOR VB-5 REFER TO R.M.A. SOCKET PRONG NUMBERS. VIBRATORS VB-5, TUBES VT-249, AND SOCKET SO-80 SHOWN IN REAR VIEW.

APPARATUS LEGEND

PART NO.	TYPE NO.	DESCRIPTION	QUAN.
1	* CO-605-B	CAPACITOR DUAL 4 MFD. 1000 V.	1
2	* CO-405-B	CAPACITOR DUAL 2 MFD. 100 V.	2
3	* CP-504-D	CAPACITOR 1/2 MFD. 100 V. (NON INDUCTIVE)	1
4	* CE-1207	CAPACITOR 1200 MFD. 25 V. (ELECTROLYTIC)	1
5	* F-0009	FUSE (CART.) 30 AMP. FUSETRON,	1
6	* F-0013	FUSE (CART.) 5 AMP. ON 24 V.	2
7	* F-0010	FUSE (CART.) 10 AMP. ON 12 V.	2
8	BK-17-A	RELAY	1
9	RS-271	RESISTOR 35 OHMS 10 W.	1
10	RS-211	RESISTOR 2 OHMS 20 W. ADJ.	1
11	RS-275	RESISTOR 2.75 OHMS 100 W. ADJ.	1
12	* RW-1500-Z	RESISTOR 45 OHMS 5 W.	2
13	* RW-3010-Y	RESISTOR 0.2 OHMS 20 W.	2
14	RS-202	RESISTOR 0.75 OHMS 20 W.	2
15	* RW-3010-X	RESISTOR 0.4 OHMS 20 W.	2
16	* RW-9253	RESISTOR 25,000 OHMS 100 W.	1
17	* RC-3501	RESISTOR 500 OHMS 1 W.	8
18	SO-80	SOCKET	1
19	* X-0057	SWITCH VOLTAGE CHANGE	1
20	VB-5	VIBRATOR	2
21	* VU-0001	CHOKE & POWER TRANSFORMER ASSEMBLY	1

* DENOTES RAULAND CORP. PART NUMBERS ALL OTHERS ARE SIGNAL CORPS.

SWITCH SHOWN IN 24 V POSITION
 TURN ROTOR CLOCKWISE 30° FOR 12 V POSITION

SWITCH DECKS
 19-A NEAREST CHASSIS
 19-B MIDDLE
 19-C FURTHEST FROM CHASSIS

Figure 10—Vibrator Unit PE-125-AX, Schematic Diagram

SCL-1203

CIRCUIT DIAGRAM FOR DYNAMOTOR UNIT PE-135-AX

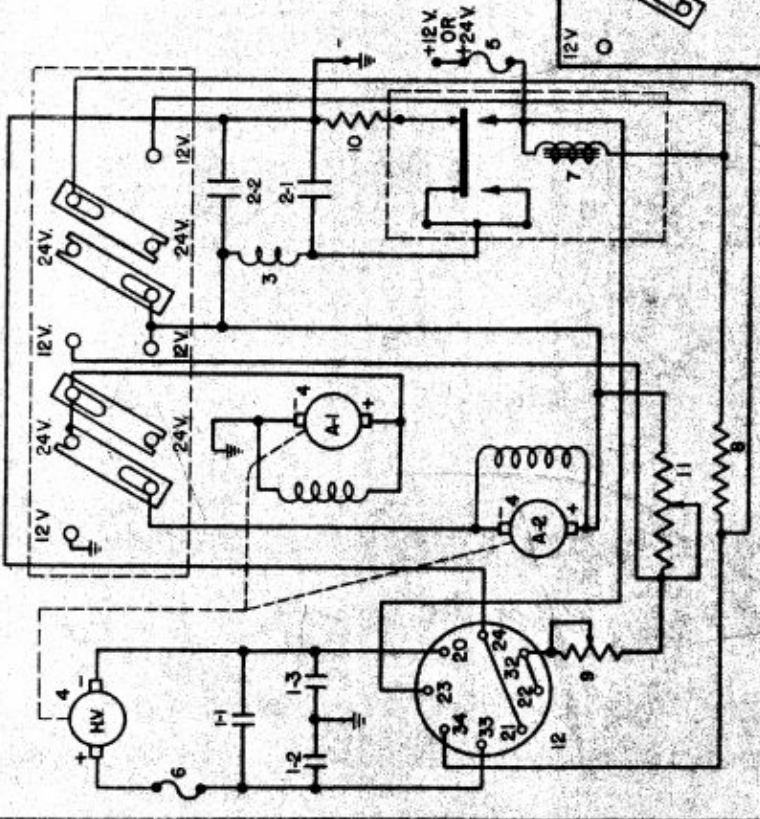

APPARATUS LEGEND

PART TYPE	DESCRIPTION	QUAN
1 CA-333	CAPACITOR 1MF.	3
2 CA-328	CAPACITOR 2MF	2
3 C-291	CHOKE	1
4 DM-49-AX	DYNAMOTOR	
5 FU-47	FUSE (CART.)	20AMP ON 24 V. 30AMP ON 12 V.
FU-30	FUSE (CART.)	
6 FU-26	FUSE (CART.)	1 AMP.
7 BK-17-A	RELAY	
8 RS-271	RESISTOR	35 OHMS 10W.
9 RS-211	RESISTOR	2 OHMS 20W. ADJ.
10 RS-202	RESISTOR	0.75 OHMS 20W.
11 RS-275	RESISTOR	2.75 OHMS 100W ADJ.
12 SO-80	SOCKET	

POSITION OF CONNECTOR LINKS

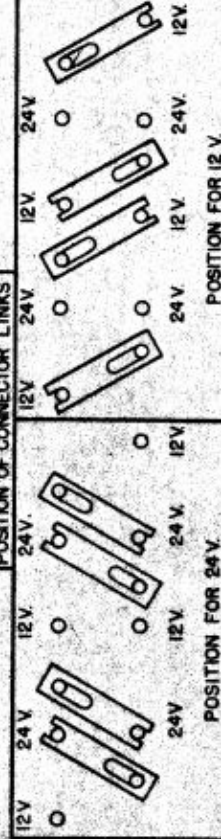

SC-D-7995-A

Figure 11—Dynamotor Unit PE-135-AX Schematic Diagram

29. Lubrication.—Lubrication should be accomplished in accordance with the chart below. *Do not use excessive amounts of oil or grease and do not allow electrical connections to become greasy.* Excess lubricant in dynamotors will tend to work out of bearing housings and onto commutators where it will cause trouble. It also may cause the bearings to overheat. Make sure that lubricants and oilholes are clean and free from sand, grit, or dirt. These abrasives are the chief causes of bearing wear and the necessity for bearing replacement.

30. Special Adjustments to Radio Transmitter BC-223-AX.—

a. Auxiliary Equipment.—The following auxiliary apparatus should be used to properly adjust Radio Transmitter BC-223-AX. This auxiliary apparatus is not issued as a component of these sets but must be obtained elsewhere.

(1) One Frequency Meter Set SCR-211-().

(2) One radio-frequency milliammeter (100 or 200 milliamperes full scale).

(3) One alternating current voltmeter (one or two volts full scale, 1000 ohms per volt).

b. Neutralization.—Radio Transmitter BC-223-AX is adjusted for neutralization by the manufacturer and normally will not require adjustment in the field. When necessary, neutralization may be checked and adjusted as follows:

(1) Set the FREQUENCY CONTROL to 3,000 kc for Transmitter Tuning Unit TU-17-A or to 4,500 kc for Transmitter Tuning Unit TU-18-A or to 5,250 kc for Transmitter Tuning Unit TU-25-A.

(2) Turn TONE VOICE CW switch to CW.

LUBRICATION CHART

<i>Apparatus</i>	<i>Points of Lubrication</i>	<i>Lubricant to Be Employed</i>	<i>Quantity of Lubricant</i>	<i>Service Periods</i>	<i>Special Instructions</i>
Dynamotor Unit PE-135-AX	Ball bearings	High temperature ball-bearing grease 295 grade Air Corps spec. 36-50. Also No. 1572 N.Y & N.J. Lubricant Co. or Calol grease made by New Departure Mfg. Company	As required by special instructions	1,000 hrs. or at six month intervals.	Remove the bearing end cover cap and insert sufficient grease to coat the ball-bearing container. At least every 2 years remove the armature from the dynamotor thoroughly clean the bearings and bearing housings with carbon tetrachloride, and repack each ball bearing with approved ball-bearing grease. The quantity of grease should be sufficient to cover thoroughly the ball bearing assembly surfaces. Excess grease should be removed.
Radio Transmitter BC-223-AX; Transmitter Tuning Units TU-17-A, TU-18-A and TU-25-A	Switch shafts	SAE 20 mineral oil	Very thin film	Whenever apparatus is removed from service and thoroughly cleaned.	
	Switch contacts;	White petroleum jelly	Very thin film	Whenever apparatus is removed from service and thoroughly cleaned.	

(3) Turn OFF-ON switch to ON and tune the antenna circuit for maximum radio-frequency output as described in paragraph 23b, using the regular vehicular antenna or the dummy antenna.

(4) Turn OFF-ON switch to OFF and insert the radio-frequency milliammeter in series with the antenna.

(5) *Caution.*—Prior to turning the transmitter ON, the plate current switch *must* be moved up to the OSCIL CURRENT position and held there during the entire time that the 100-milliamper or 200-milliamper radio frequency ammeter is in the antenna circuit, the transmitter is ON, and the key closed. If the plate current switch is released and allowed to resume its position of TOTAL PLATE CURRENT while the key is closed, the external radio-frequency ammeter will be burned out. It is advisable to tie the OSCIL CURRENT-PLATE CURRENT switch in the OSCIL CURRENT position to prevent accidental burn-out of this meter.

(6) With the key up, again turn the OFF ON switch to ON.

(7) Hold the OSCIL CURRENT-PLATE CURRENT switch in the OSCIL CURRENT position and press the key. If the external radio-frequency ammeter indicates less than 20 milliamperes antenna current, the power amplifier is neutralized satisfactorily. If it reads more than 20 milliamperes, the panel screw cap PA NEUT COND should be removed and with an insulated shank screw driver this control adjusted to give a minimum current in the external radio-frequency ammeter. Return the antenna variometer through resonance to make sure that this meter is indicating correctly. After making neutralization adjustments, the calibration and tracking should be checked.

(8) If a 100 to 200 milliamper radio-frequency ammeter is not available, the transmitter antenna ammeter may be used, provided a fixed capacitor of 100 uuf is placed across the ANT and GND binding posts and the antenna circuit adjusted to give three amperes current; the procedure is then the same as outlined above except that PA NEUT COND is varied to give minimum current in the transmitter antenna ammeter.

Caution.—Do not exceed three amperes or the ammeter may be damaged.

c. Calibration Reset.—The calibration of the transmitter should be checked periodically, employing Frequency Meter Set SCR-211-() for the purpose. If the check indicates that the transmitter varies more than 3 kilocycles from the frequency indicated on the FREQUENCY CONTROL dial, the oscillator frequency should be adjusted as follows:

(1) Warm up the transmitter for at least 30 minutes, with the dummy antenna load tuned for rated output, prior to adjusting.

(2) Set the frequency meter set to 3,000 kc when the Transmitter Tuning Unit TU-17-A is used, 4,500 kc when the Transmitter Tuning Unit TU-18-A is used or 5,250 kc when the Transmitter Tuning Unit TU-25-A is used. Place the FREQUENCY CONTROL so that the dial indicates the above frequencies for the corresponding tuning unit.

(3) Adjust the OSC TRIMMER until the transmitter zero beats with the frequency meter.

d. Tracking.—Since the oscillator and power amplifier are tuned by the FREQUENCY CONTROL knob it is essential for satisfactory operation that for any setting of the FREQUENCY CONTROL the power amplifier remain in tune. This is termed power amplifier tracking. The tracking of the power amplifier is checked by placing the transmitter in operation on CW with the antenna disconnected. Close the key and observe the PLATE CURRENT meter as the FREQUENCY CONTROL knob is rotated through the calibrated range. The power amplifier is tracking satisfactorily if the plate current does not vary more than 10 milliamperes. If the plate current variation is greater than 10 milliamperes, the FREQUENCY CONTROL should be set to 3,000 kc, 4,500 kc or 5,250 kc for Transmitter Tuning Units TU-17-A, TU-18-A or TU-25-A, respectively, and the PA TRIMMER adjusted to give a minimum plate current. Recheck the tracking as above. The plate current during these tests will normally be between 60 and 70 milliamperes.

e. Tone.—To check the setting of the tone modulation potentiometer, remove the receiver cable plug from Socket SO-79 on the left side of the transmitter and connect a Weston Output Meter 571 (supplied with Test Set I-56-A) or equal a-c voltmeter (one or two volts full scale, 1,000 ohms per volt) between terminals 46 and 53. With the TONE VOICE CW switch set to CW and the TRANSMITTER OFF ON switch moved to the ON position,

the key is depressed; the voltmeter should read approximately .6 volt. With the TONE VOICE CW switch set to TONE, the TRANSMITTER OFF ON switch moved to the ON position and the key depressed, the voltmeter should read approximately .55 volt. If these values are not obtained, the panel screw cap marked TONE MOD CONTROL should be removed and a screw driver used to adjust this control to give the above values. Rotating in clockwise direction increases the tone output.

31. Normal Current and Voltage Readings.—The following normal current and voltage readings are furnished for the information and guidance of servicing personnel. (The values are approximate and will vary slightly with different sets and different measuring equipments.)

a. Current Readings.

(1) The following tables give the current consumptions of the receiver and transmitter when measured at the vehicular storage battery. The voltages listed are measured at the battery. Where the voltage supplied is 14.2 volts the vehicular storage battery generator is operating (vehicular motor running). Similarly for 24 volt operation where the voltage supplied is 28.4 volts, the vehicular storage battery generator is operating.

(a) Radio Receiver BC-312-()

Battery Volts	Current (amperes)
12.....	4.2
14.2.....	4.6
24.....	2.5
28.4.....	2.6

(b) Radio Transmitter BC-223-AX.

Mode of Operation	Current (amperes)			
	12v.	14.2v.	24v.	28.4v.
CW Key Up.....	7.5	8.6	5.05	5.55
CW Key Down....	13.6	15.9	8.05	9.05
Tone Key Up.....	9.7	11.0	6.95	7.5
Tone Key Down....	19.5	23.3	10.85	13.7
Voice Unmodulated	17.2	20.0	10.7	12.1

These readings are approximate as tube differences will change readings 20%.

(2) The following table gives current readings of Radio Transmitter BC-223-AX taken from the PLATE CURRENT meter for CW, and voice operation (no modulation). The high voltage supply to the transmitter is read between terminal 2 (positive) of Transformer C-223 and terminal 53 (negative) of Socket SO-79 and is varied to give a range of readings.

b. Voltage Readings.—The following tables give voltage measured at points indicated in the tables for the transmitter.

High voltage supply (volts)	(Current (milliamperes))				
	Cw (key depressed)			Voice	
	Oscillator	Amplifier	Total Plate	Oscillator	Total Plate
400.....	35	60	95	35	128
450.....	40	70	110	40	145
500.....	48	72	120	48	165
550.....	50	85	135	50	185

High voltage supply (volts)	Voltages (volts)				
	Oscillator 2 (+) and 15 (-) of tuning unit terminal strip	Power amplifier 14 (+) and 15 (-) of tuning unit terminal strip	A-F amplifier 6 (+) of transformer 29 (C-22A) and GND	1st Modulator 4 (+) of transformer 28 (C-223) and GND	2nd Modulator 1 (+) of transformer 28 (C-223) and GND
400.....	275	385	255	400	400
450.....	305	435	285	450	450
500.....	340	480	320	500	500
550.....	375	530	340	550	550

(1) *Radio Transmitter BC-223-AX.*—These readings are made on voice operation (no modulation). Terminal connections of transmitter tuning units are accessible from within the transmitter upon removal of the back plate. The high voltage supply is read between terminal 2 (positive) of Transformer C-223 and Terminal 53 (negative) of Socket SO-79 and is varied to give a range of readings.

32. Procedure in Case of Set Failure.—

Caution.—Do not change fuses or make repairs with the high voltage on. With this radio equipment, which receives severe field service, failure to operate is usually due to worn, broken, or disconnected cords, plugs, or sockets, run-down storage battery, worn dynamotor brushes, or defective tubes. These items should be checked first. If failure of both transmitter and receiver occurs simultaneously, the trouble is usually in the primary power source or leads connected thereto. If only one component fails to operate, determine first if it is receiving proper supply voltages. This usually determines whether the trouble is inside or outside of the component. Check fuses in the equipment at an early stage in "trouble shooting." Do not continue to burn out fuses before looking elsewhere to determine the basic source of trouble.

33. Locating Trouble.—The following causes of set trouble may be present in the event that the component fails to function properly.

a. Radio Receiver BC-312-().—See separate instruction book.

b. Radio Transmitter BC-223-AX.

(1) *Symptom.*—No filament voltage.

Cause.—

- Poor battery.
- Open power lead.
- Short-circuited power lead.
- Defective TONE VOICE CW switch.
- Burned-out fuse.
- Damaged bypass capacitor.
- Starting relay not functioning properly.
- Loose connections inside transmitter or dynamotor unit.

(2) *Symptom.*—No plate voltage.

Cause.—

- Poor battery.
- Open or shorted cord.
- Poor plug contact.
- Burned-out fuse.
- Defective power unit.
- Loose connection inside transmitter.

Shorted bypass capacitor.

Open resistor.

Damaged choke coil.

(3) *Symptom.*—No rf output.

Cause.—

- No external grounds.
- Damaged master oscillator or power amplifier tubes.
- Damaged antenna ammeter.
- Inoperative keying relay.
- Defective TONE VOICE CW switch.
- Damaged choke coil.
- Damaged coupling capacitor.
- No plate voltage.
- Excessive bias voltage (open grid resistor).
- No ant. connection.

(4) *Symptom.*—No modulation.

Cause.—

- Damaged audio amplifier or modulator tubes.
- Improper or excessive bias.
- Poor microphone.
- Damaged transformers.
- Inoperative Interrupter BZ-7-().

34. Repairs.—Repairs other than the following will not be attempted by using personnel unless specifically authorized under the provisions of Appendix C, Signal Corps General Catalog:

a. Cords.—Cords may become defective because of an open circuit in one or more conductors, a short circuit between two or more conductors, or between any conductor and ground. These defects most frequently occur at the point of attachment of the cord to its corresponding plug. These points should be examined and where possible necessary repairs made. In the event that the damage occurs any great distance from either end of the cord, it is normally impossible to make a serviceable permanent repair of the cord. A new cord should be obtained and installed. However, in an emergency the defective portion of the cord may be cut out and jumpers used to restore the necessary circuits until a new cord can be obtained. If cords have been badly damaged they should be replaced as soon as practicable.

b. Headsets.—The failure of a headset to operate properly is usually due to a defective cord or plug which may be repairable. However, if the damage is within the phones, a new headset should be secured and the defective unit shipped to the proper agency for repair.

c. *Dynamotor DM-49-AX.*—Normally if this dynamotor has become defective, it should be removed and replaced. Replacements are obtained through the usual channels. The replacement of brushes, turning down of commutators, freeing of bearings, and all repairing of shopstive receiver dynamotors is done at Signal Corps repair shops or Signal Corps radio sections at air depots. In event the dynamotor cannot be replaced or where an emergency requires the same, local repairs are allowable. Where local repairs are made, careful sanding-in of new brushes to fit the commutator, proper spring adjustment, and a running-in period are necessary to insure quiet receiver operation. If results following local replacement of brushes are unsatisfactory, the dynamotor should be returned to a depot for overhaul when it can best be spared. Commutators not unduly worn may be cleaned with a fine grade of sandpaper and wiping off thoroughly with carbon tetrachloride. If the bearings are not damaged but merely need freeing, a drop of light oil may be added to each. If the trouble is due to an open or short-circuited winding, grooved commutators or some other serious defect, the dynamotor should be replaced.

d. *Dynamotor Unit PE-135-AX.*—The probable causes of trouble in this unit are loose or defective brushes, locked or damaged bearings, dirty or undercut commutator, open or short-circuited windings. These should all be checked and treated in the same manner as described for Dynamotor DM-49-AX. Brush springs are furnished for local replacement in this unit.

e. *Vibrator Unit PE-125-AX.*—The probable causes of trouble in the PE-125-AX vibrator unit are:

1. Defective Tubes VT-249.
2. Defective Vibrators VB-5.
3. Blown Fuses FU-30, 10A vibrator fuses, or $\frac{1}{2}$ Amp. high voltage fuses
4. Dirty relay contacts.

If wiping of relay contacts, replacing of fuses, tubes and vibrators does not restore proper operation, repairing should be done at Signal Corps repair shops or Signal Corps radio sections at air depots.

f. *Additional Suggestions for Emergency Repairs.*—Several combinations of transmitters and receivers may be used which are not listed in this instruction book. The Radio Transmitter BC-223-AX with the change-over switch in the 12 volt position may be used with a standard Dynamotor

Unit PE-55 and any 12 volt Receiver BC-312-() on 12 volts only. Up to the time of the issuance of this book, the only 24 volt receiver of the BC-312-() series was the Radio Receiver BC-312-HX. In an emergency, communication may be obtained using a 12 volt receiver, a 12 volt dynamotor such as Dynamotor Unit PE-55 and Radio Transmitter BC-223-AX with its 12-24 volt switch in the 12 volt position, operating all of this equipment from one half of a 24 volt vehicular storage battery. This is only an expedient and should not be used for any length of time. The main disadvantage is that the half of the vehicular battery so used will be discharged rapidly when the radio equipment is operated from it. The Vibrator Unit PE-125-AX, adjusted for 12 volt operation may be used with the standard Transmitter BC-223A for 12 volt operation. In an extreme emergency if only *voice* or *icw* (not *cw*) communication is desired, standard Radio Transmitter BC-223-A may be used with either Vibrator Unit PE-125-AX or Dynamotor Unit PE-135-AX from a 24 volt source. At no time is the Radio Receiver BC-312-() to be used on 24 volts except Radio Receiver BC-312-HX. With the change-over switch adjusted for 12 volts, Radio Transmitter BC-223-AX is identical to Radio Transmitter 223-A.

g. In addition to the circuit diagrams and cording diagrams shown, Figs. 1, and 12 through 16 show details of Radio Transmitter BC-223-AX and its tuning units.

Fig. 1 is a front view of Radio Transmitter BC-223-AX mounted on a Shock mounting FT-173. Controls and tuning units are described in paragraphs 10 and 11.

Fig. 12 is a left end view of Radio Transmitter BC-223-AX showing connecting sockets.

Fig. 13 is a back view of Radio Transmitter BC-223-AX showing tubes, 12-24 volt change-over switch and other major components.

Fig. 14 is a front view of Tuning Unit TU-18-A. See paragraph 23.

Fig. 15 is a back view of Tuning Unit TU-18-A showing connecting jacks which fit plugs in Radio Transmitter BC-223-AX.

Fig. 16 is a front view of Tuning Unit TU-18-A with panel removed showing important components. Tuning Units TU-17-A, TU-18-A, and TU-25-A are similar except for the number of turns on the coils. Numbers stamped with ink on the component parts refer to circuit diagram apparatus legend numbers. These numbers are stamped on every unit.

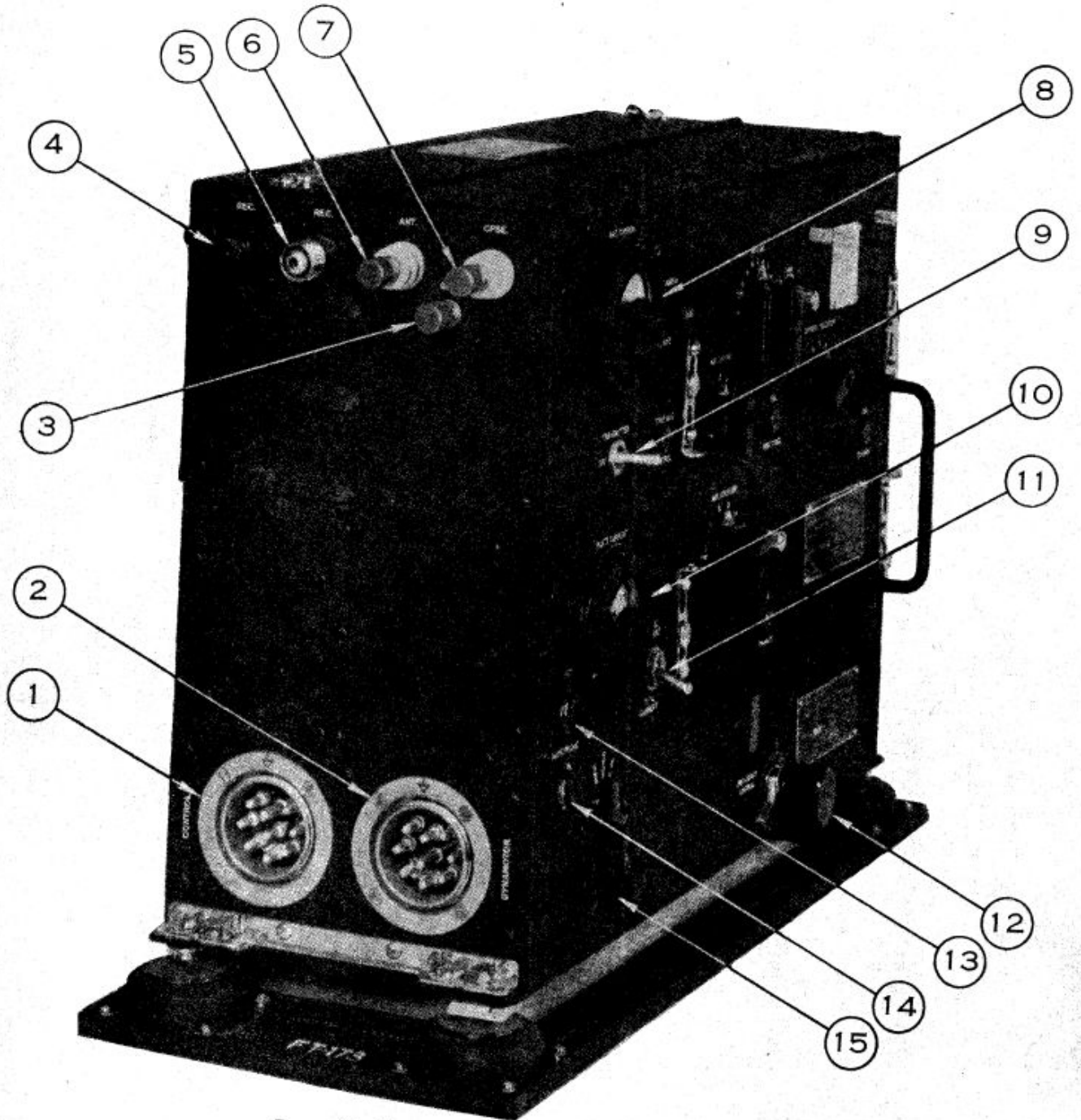

Figure 12—Transmitter BC-223-AX, Left End View

- 1—Socket—Control Socket, SO-79
- 2—Socket—Dynamotor Socket, SO-80
- 3—Binding Post—ground
- 4—Binding Post—receiver (unshielded)
- 5—Binding Post—Receiver (shielded)
- 6—Binding Post—Ant.
- 7—Binding Post—Counterpoise
- 8—Meter—IS-128—0.3 amperes r-f Ant. Current

- 9—Switch SW-116 On-Off
- 10—Meter IS-129—0.300 ma. Plate Current
- 11—Switch SW-133-PA & OSC Current Meter Switch
- 12—Tuning Knob
- 13—Jack for Key JK-34-A
- 14—Jack for Microphone JK-33-A
- 15—Switch SW-132 TONE-VOICE-CW

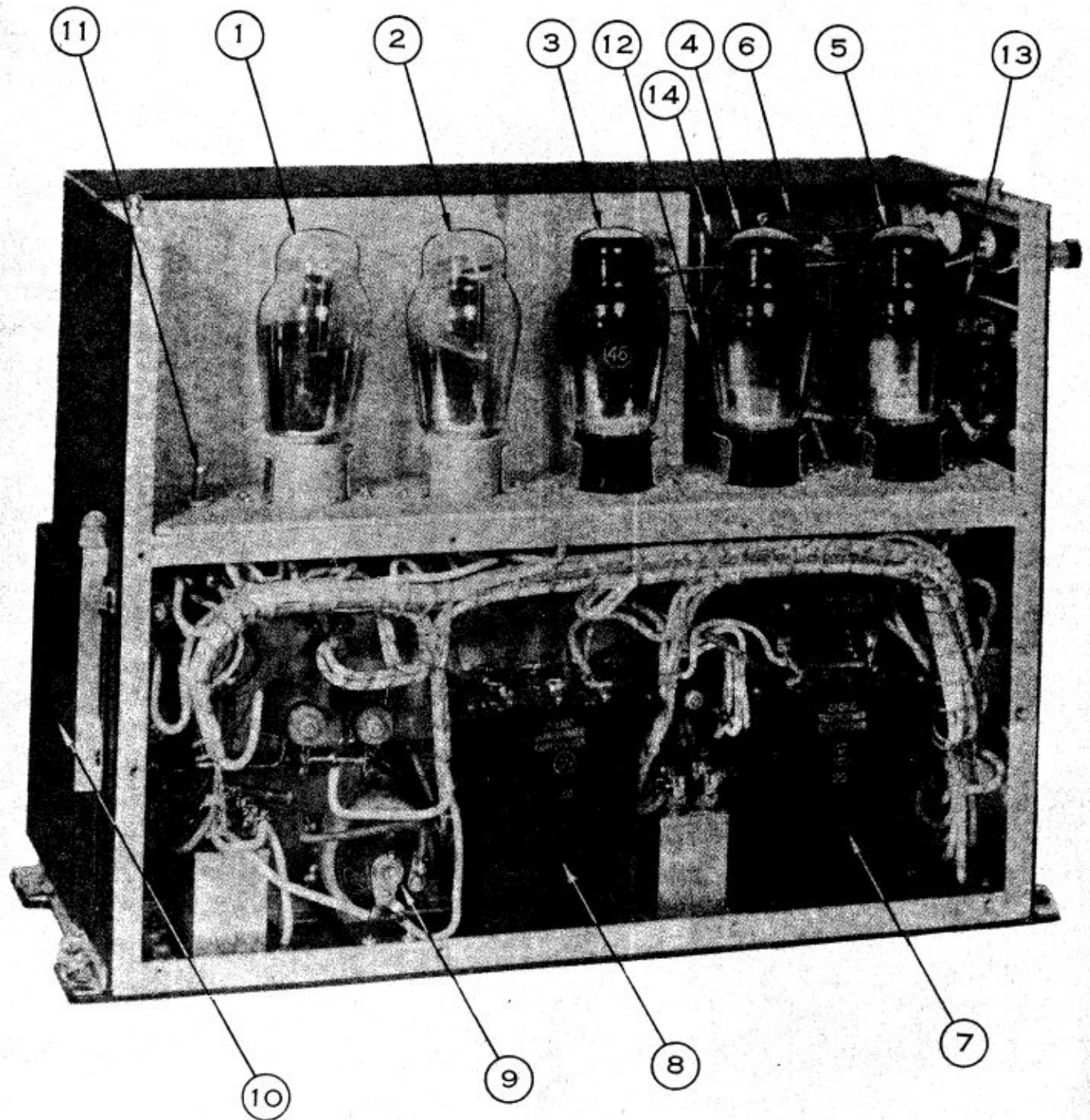

Figure 13—Transmitter BC-223-AX, Rear View

- | | |
|---|------------------------------------|
| 1—VT-62 Oscillator | 8—Transformer C-223 Class B Output |
| 2—VT-62 r-f Power Amplifier | 9—Interrupter BZ-7-D |
| 3—VT-63 Class B Modulator tube | 10—Calibration Chart Holder |
| 4—VT-63 Class B Modulator tube | 11—Switch—12-24 Volt |
| 5—VT-63 Speech Amplifier | 12—Capacitor—Dummy Ant. |
| 6—Meter—IS-128 Ant. Current 0-3 Amperes r-f | 13—Antenna Relay BK-16 |
| 7—Transformer C224 Class B Input | 14—Switch—Phantom Ant. |

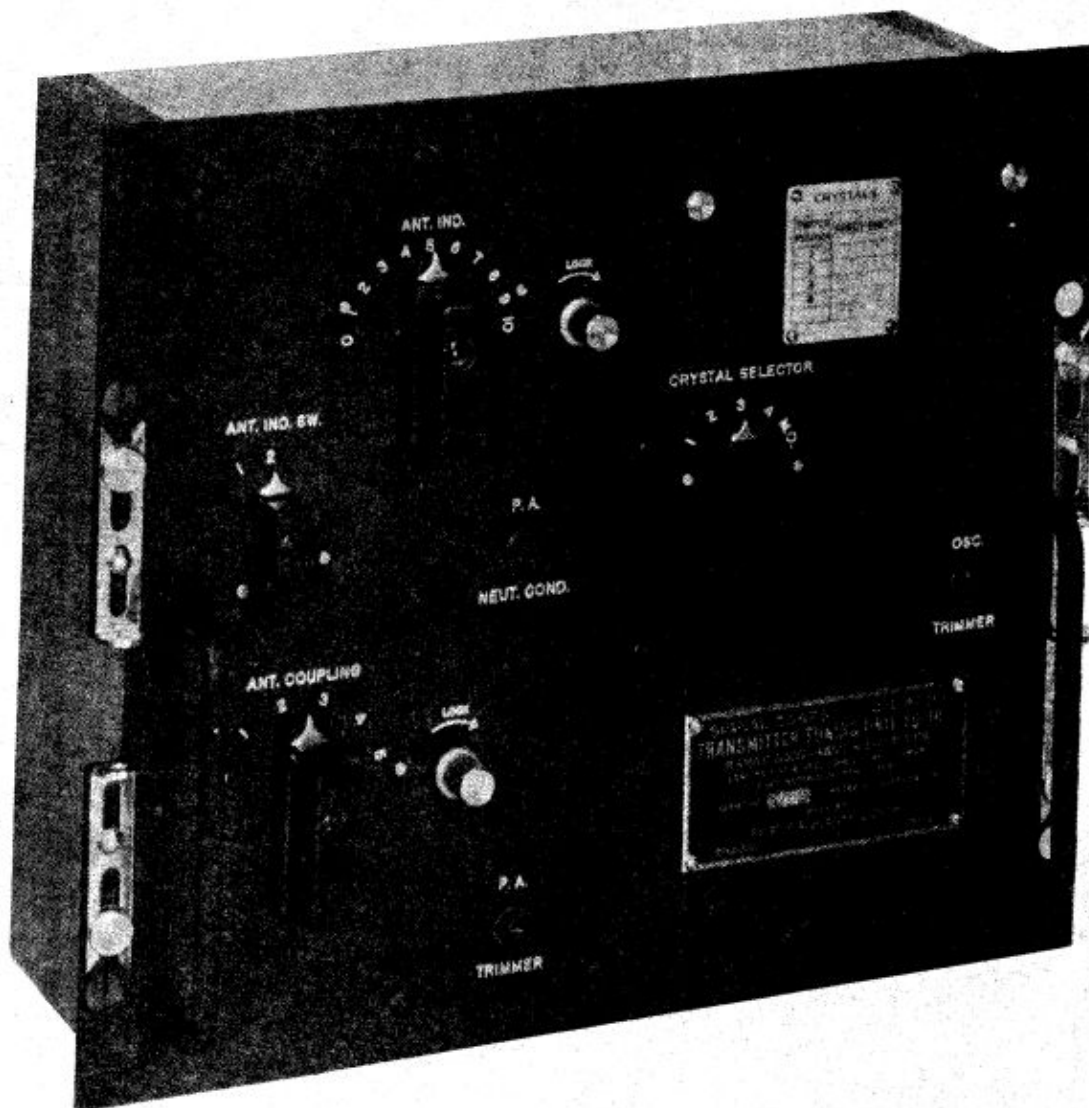

Figure 14—Tuning Unit TU-18-A, Front View

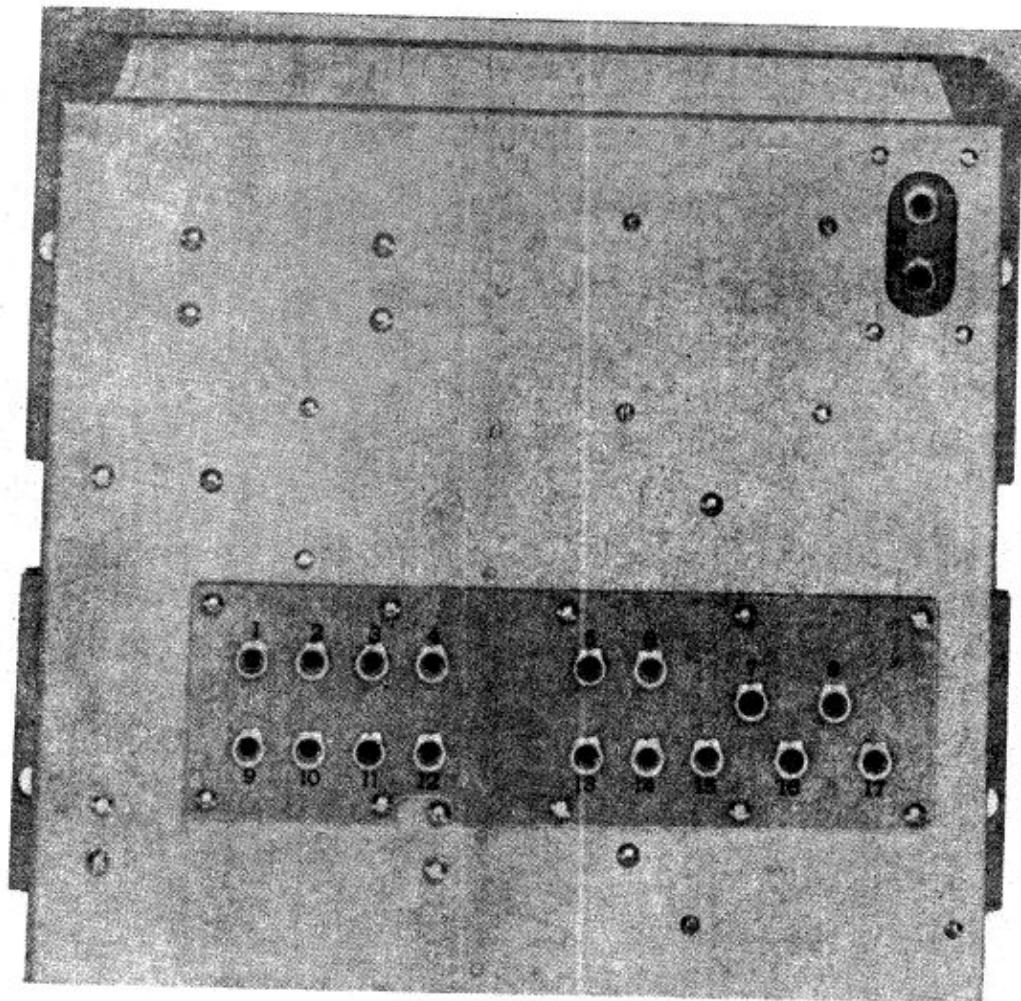

Figure 15—Tuning Unit TU-18-A, Rear View

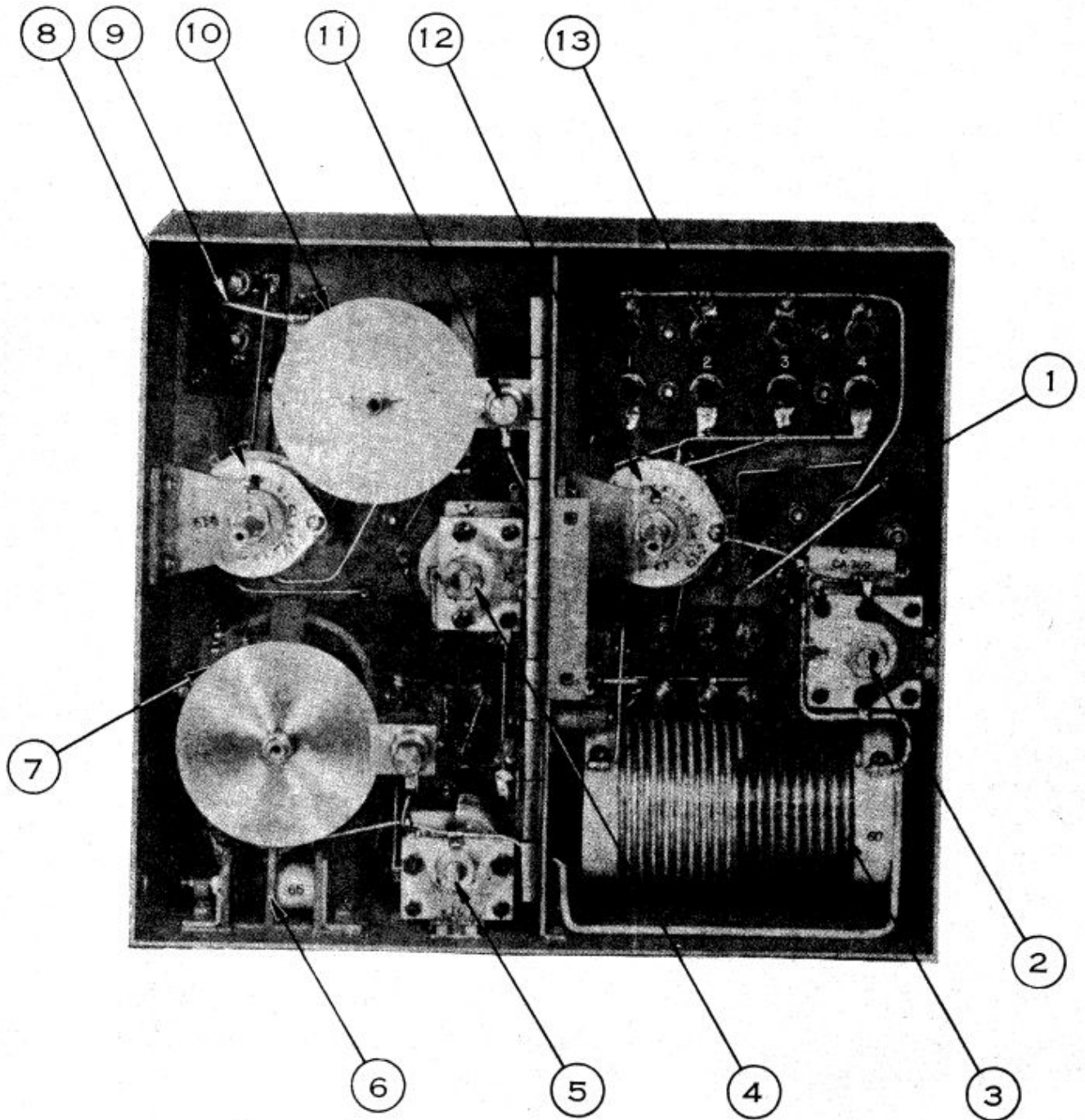

Figure 16—Tuning Unit TU-18-A, Front View (Panel Removed)

- 1—r-f Choke
- 2—Capacitor—Osc. Trimming
- 3—Inductance—OCS
- 4—Capacitor—Neutralizing
- 5—Capacitor—P.A. trimming
- 6—Compensating Coil
- 7—Ant. coupling Coil

- 8—Switch—Ant. Inductance
- 9—Ant.—Cpse. Terminal Strip
- 10—Variometer—Ant. Tuning
- 11—Dial Lock
- 12—Switch—Crystal Selector
- 13—Mounting Board for Crystals

SECTION IV

35. Supplementary Data and List of Replaceable Parts.
Radio Set Components, Weights and Dimensions.—

Dimensions and weights, where unappreciably are omitted.

Radio Set	SCR-245-GX	Radio Set	SCR-245-JX	Radio Set	SCR-245-MX	Radio Set	SCR-245-NX	Radio Set	SCR-245-PX	Article	Dimensions (Inches)			Unit Weight (Pounds)
											Height	Width	Depth	
2	2	2	2	2	2	2	2	2	2	Book, Instruction, for Radio Receivers BC-312-C and BC-342-C.....	11	8½	¼	
2	2	2	2	2	2	2	2	2	2	Book, Instruction, for Radio Sets SCR-245-GX, SCR-245-JX, SCR-245-MX, SCR-245-NX, SCR-245-PX.....				
1	1	1	1	1	1	1	1	1	1	Box BX-19.....	1¾	12¼	4¼	2.5
1	1	1	1	1	1	1	1	1	1	Box BX-20.....	2¾	11¾	6	3.0
1		1	1	1	1	1	1	1	1	Box BX-21.....	13½	10	11¼	2.5
2	2	2	2	2	2	2	2	2	2	Brush, H. V. [for Dynamotor DM-21-()]; spare.....				
2	2	2	2	2	2	2	2	2	2	Brush, L. V. [for Dynamotor DM-21-()]; spare.....				
2	2	2	2	2	2	2	2	2	2	Brush, H. V. [for Dynamotor DM-49-AX()]; spare.....				
4	4	4	4	4	4	4	4	4	4	Brush, L. V. [for Dynamotor DM-49-AX()]; spare.....				
	1									Cabinet CH-60.....	27¾	53⅝	11⅝	118.0
1	1	1	1	1	1	1	1	1	1	Case CS-56.....	10⅞	11⅝	5¼	14.0
2		2	2	2	2	2	2	2	2	Cord CD-307-A..... length 65				
		2	2							Cord CD-318..... " 60				
1		1								Cord CD-356..... " 48				
1										Cord CD-361..... " 30				
		1								Cord CD-420..... " 36				
		1								Cord CD-434..... " 36				
	1		1							Cord CD-441..... " 42				
	1									Cord CD-442..... " 54				
		1								Cord CD-445..... " 12				
		1								Cord CD-446..... " 12				
		1								Cord CD-447..... " 36				
	1	1								Cord CD-448..... " 24				
			1							Cord CD-470..... " 42				
		1								Cord CO-166-A..... " 36				
1										Cord CO-170-A..... " 60				
1										Cord CO-189..... " 66				
		1								Cord CO-260..... " 72				
			1							Cord CO-273..... " 54				
1	1	1	1	1	1	1	1	1	1	Cover BG-67.....	12	3	3	0.50
1		1	1	1	1	1	1	1	1	Cover BG-75.....	10¼	18½	8½	1.25
1		1	1	1	1	1	1	1	1	Cover BG-77.....	11⅞	11⅞	9	0.50
1										Cover BG-85.....	31⅞	23	10⅝	
1		1	1	1	1	1	1	1	1	Cover BG-86.....	15	21	10	2.00
	Note 2									Crystal Holder FT-171-B, with crystal.....	3	1½	1	0.25
1	1	1	1	1	1	1	1	1	1	Dynamotor Unit PE-135-AX, includes:	12	13⅞	7⅝	33.00
										1 Dynamotor DM-49-AX()				
										4 Fuse FU-30; 1 in use, 3 spare (30 amp.) for 12 volt				
										4 Fuse FU-47; 1 in use, 3 spare (20 amp.) for 24 volt				
										8 Fuse FU-26; 1 in use, 7 spare (1 amp.).....				
										1 Mounting FT-185.....				
4	4	4	4	4	4	4	4	4	4	Fuse FU-21-A; spare.....				

Radio Set	SCR-245-GX	Radio Set	SCR-245-JX	Radio Set	SCR-245-MX	Radio Set	SCR-245-NX	Radio Set	SCR-245-PX	Article	Dimensions (Inches)			Unit Weight (Pounds)
											Height	Width	Depth	
		2	2							Headset HS-18.....				.60
2				2						Headset HS-23.....				.80
		2								Headset P-19.....				1.12
2	2	2	2	2	2					Instructions, for Radio Installation.....				
3										Insulator IN-86.....				
		1	2							Insulator IN-89.....				
		1	5		2					Insulator IN-98.....				.25
		2		3	2					Insulator IN-101.....				.25
					2					Insulator IN-104.....				.25
				2						Insulator IN-111.....				
1	1	1	1	1	1					Key J-45.....				1.0
2	2	2	2	2	2					Lamp LM-27; spare.....				
2	2	2	2	2	2					Lamp LM-33; spare.....				
1	1	1	1	1	1					Mast Base MP-37.....				
		1								Mast Base Bracket MP-41.....	10	8	4	6.0
2	2	2	2	2	2					Mast Section MS-49; 1 in use, 1 spare.....	37			0.16
2	2	2	2	2	2					Mast Section MS-50; 1 in use, 1 spare.....	38			0.38
2	2	2	2	2	2					Mast Section MS-51; 1 in use, 1 spare.....	38			0.48
2	2	2	2	2	2					Mast Section MS-52; 1 in use, 1 spare.....	38			0.66
2	2	2	2	2	2					Mast Section MS-53; 1 in use, 1 spare.....	38			0.81
2	2			2						Microphone T-17.....	6¼	2¾	2½	0.88
		2	2							Microphone T-30-A.....				.20
1	1	1	1	1	1					Mounting FT-172.....	2½	2½	1	0.25
1	1	1	1	1	1					Mounting FT-178.....	2½	2½	12	0.25
1	1	1	1	1	1					Radio Receiver BC-312-C, includes: 1 Dynamotor DM-21-B (or DM-21-A)..... 3 Fuse FU-21-A; 2 in use, 1 spare (10 amp.)..... 2 Lamp LM-27..... 1 Mounting F-162.....	10¾	18	8¾	42.00
1	1	1	1	1	1					Radio Transmitter BC-223-AX (Note 1)..... Includes: 1 Calibration Chart (Note 1)..... 1 Lamp LM-33..... 1 Mounting FT-173.....	14½	20¾	8¾	26.5
1	1	1	1	1	1					Roll BG-56-A.....	42½	3	1½	2.0
1	1	1	1	1	1					Screws, Nuts and Lockwashers.....				
set	set	set	set	set	set					Springs, brush holder [for Dynamotor DM-19-()]; spare.....				
1	1	1	1	1	1					Terminal Block TM-183.....	1¾	5½	1	0.5
1	1	1	1	1	1					Transmitter Tuning Unit TU-17-B (Note 1).....	8¾	10	3½	8.8
1	1	1	1	1	1					Transmitter Tuning Unit TU-18-B (Note 1).....	8¾	10	3½	8.8
										Transmitter Tuning Unit TU-25-A (Note 4).....	8¾	10	3½	8.8
4	4	4	4	4	4					Tube VT-62; 2 in use, 2 spare.....	8¾	10	3½	8.8
6	6	6	6	6	6					Tube VT-63; 3 in use, 3 spare.....				
4	4	4	4	4	4					Tube VT-65; 2 in use, 2 spare.....				
2	2	2	2	2	2					Tube VT-66; 1 in use, 1 spare.....				
8	8	8	8	8	8					Tube VT-86; 4 in use, 4 spare.....				
2	2	2	2	2	2					Tube VT-87; 1 in use, 1 spare.....				
2	2	2	2	2	2					Tube VT-88; 1 in use, 1 spare.....				
20	20	20	20	20	20					Wire W-128.....				
ft.	ft.	ft.	ft.	ft.	ft.									

Pars. 35-36

Note 1.—The serial number and order number of each calibration chart and transmitter tuning unit must agree with that of the radio transmitter with which used.

Note 2.—The quantity of Crystal Holder FT-171-B and the frequency of the crystals therein will be as authorized for each using organization. Crystal Holder FT-171 or FT-171-A may be substituted for FT-171-B.

Note 3.—Radio Receivers BC-312-A, BC-312-D, BC-312-E, or BC-312-F may be substituted for BC-312-C. However, in the case of the BC-312-A, substitution of one Adapter FT-197 must also be supplied.

Note 4.—Transmitter Tuning Unit TU-25-A will be issued only as authorized for any using organization.

Note 5.—Headset HS-23 may be substituted for P-19 in which case one Cord CD-307-A (65") must also be supplied.

36 Replaceable Parts

a. Radio Receiver BC-312-() See Separate instruction book covering this item.

b. Radio Transmitter BC-223-AX.

Ref. No.	Stock No.	Name of Part	Description	Function	Drawing No			
11	3D243	Capacitor CA-243	Paper 0.5 μ f	Side tone coupling	SC-D-512			
12-1	3D183	Capacitor CA-183	Mica; 0.01 μ f—1,250 v.	Plate bypass	RL-D-6222			
12-2	3D183	Capacitor CA-183	Mica; 0.01 μ f—1,250 v.	Grid bypass	RL-D-6222			
13	3D211	Capacitor CA-211	Mica; 0.002 μ f—250 v.	Meter bypass	SC-D-1993			
14-1	3D321	Capacitor CA-321	Pyranol 0.5 μ f—1,000 v.	Plate bypass	SC-D-512			
14-2	3D321	Capacitor CA-321	Pyranol 0.5 μ f—1,000 v.	Grid bypass	SC-D-512			
14-3	3D321	Capacitor CA-321	Pyranol 0.5 μ f—1,000 v.	Plate bypass	SC-D-512			
14-4	3D321	Capacitor CA-321	Pyranol 0.5 μ f—1,000 v.	Plate bypass	SC-D-512			
15-1	3D322	Capacitor CA-322	1 μ f—500 v.	Audio coupling	SC-D-512			
15-2	3D322	Capacitor CA-322	1 μ f—500 v.	Audio bypass	SC-D-512			
15-3	3D322	Capacitor CA-322	1 μ f—500 v.	Audio bypass	SC-D-512			
16-1	3D325*	Capacitor CA-325	Ganged { 80 μ f	Power amplifier tuning	SC-D-1461			
16-2A						100 μ f	Power amplifier tuning	SC-D-1461
16-2B	or	Capacitor CA-325-A	Ganged { 100 μ f	Power amplifier tuning	SC-D-1461			
16-2C	3D325A					100 μ f	Master oscillator tuning	SC-D-1461
16-2D	or					100 μ f	Master oscillator tuning	SC-D-1461
16-3A	3D325B					200 μ f	Master oscillator tuning	SC-D-1461
16-3B	or	Capacitor CA-325-B	Ganged { 200 μ f	Master oscillator tuning	SC-D-1461			
	3D325C					200 μ f	Master oscillator tuning	SC-D-1461
17	3D337	Capacitor CA-337	Electrolytic; 16 μ f—200 v.	Surge quenching	SC-D-1291			
18	3Z4537	Resistor RS-137	Vitreous; 25,000 ohms	Keying	RL-D-6223			
19	3Z4602	Resistor RS-202	Vitreous; 0.75 ohms	Filament	RL-D-6223			
20	3Z4604	Resistor RS-204	Vitreous; 3,500 ohms	Power amplifier and audio amplifier bias	RL-D-6223			
21	3Z4605	Resistor RS-205	Vitreous; 11,500 ohms	Power amplifier bias	RL-D-6223			
22-1	3Z4606	Resistor RS-206	Vitreous; 1,000 ohms	Modulator grid load	RL-D-6223			
22-2	3Z4606	Resistor RS-206	Vitreous; 1,000 ohms	Modulator grid load	RL-D-6223			
23	3Z4612	Resistor RS-212	100 ohms, 1 w.	Interrupter	SC-D-970			
24-1	3Z4608	Resistor RS-208	100,000 ohms, 1 w.	Bleeder	SC-D-970			
24-2	3Z4608	Resistor RS-208	100,000 ohms, 1 w.	Bleeder	SC-D-970			
25-1	3Z4470	Resistor RS-70	5,000 ohms	Audio amplifier plate	RL-D-6223			
25-2	3Z4470	Resistor RS-70	5,000 ohms	Master oscillator plate	RL-D-6223			
26	2Z7287	Potentiometer RS-152	100 ohms	Tone output control	SC-D-1982			
27	2Z9759	Transformer C-159	Audio freq.; 12.5:1 pri. to sec. 50:1 pri. to tertiary.	Audio input	SC-D-1373			
28	2Z9823	Transformer C-223	Audio freq.; 2:1 sec. to each pri.	Modulating transformer	SC-D-1420			
29	2Z9824	Transformer C-224	Audio freq.; 3:1 sec. to each pri.	Audio interstage	SC-D-1419			
30-1-A, B	3Z8116	Switch SW-116	2 pole, single throw	On-Off	SC-A-1042			
30-2-A, B	3Z8116	Switch SW-116	2-pole, single throw	On-Off	SC-A-1042			
31	3Z8132	Switch SW-132	Rotary 16 contacts	Signal	SC-D-1854			
32	3Z8133	Switch SW-133	Toggle normally closed	Osc. current-total current	SC-A-1042			
33	2Z7616	Relay BK-16	Double coil	Keying	SC-A-877			

Ref. No.	Stock No.	Name of Part	Description	Function	Drawing No.
34	4Z5007D	Interrupter BZ-7-()	Single button	Tone source	SC-D-2587
35	2Z5933	Lamp LM-33	Mazda No. 16	Dial light	
36	2Z5533A	Jack JK-33-A		Microphone	SC-D-1585
37	2Z5534A	Jack JK-34-A		Key	SC-D-1585
38	3F328	Ammeter IS-128	Flush mounting; 0.3 amps. r-f	Output current	SC-D-1549
39	3F329	Ammeter IS-129	Flush mounting; 0-300 mils. d-c	Plate current	SC-D-1549
40	3Z4607	Resistor RS-207	750, 1 w.	Interrupter	SC-D-970
41	2Z8779	Socket SO-79	8-contact; fits PL-149 or PL-159	Control connections	SC-D-1506
42	2Z8780	Socket SO-80	8-contact; fits PL-150 or PL-160	Power connections	SCD-1506
43	_____	Resistor RS-261	Vitreous	Phantom Ant.	_____
44	_____	Switch SW-189	Single pole double throw	Phantom Ant.	_____
45	_____	Capacitor CA-421	107 μmf	Phantom Ant.	_____
46	_____	Resistor 35 ohm 10 w.	Vitreous	Relay Dropping	_____
47	_____	Resistor 2 ohm 20 w.	Vitreous	Filament	_____

c. Transmitter Tuning Unit TU-17-A.

51	3D377	Capacitor CA-377	Variable air; 55 μmf	Trimmer, power amplifier	SC-D-2811
52	3D330	Capacitor CA-330	Variable air; 50 μmf	Neutralizing capacitor	SC-D-2811
53	3D332	Capacitor CA-332	Variable air; 200 μmf	Trimmer, osc.	SC-D-2811
54-1	3D183	Capacitor CA-183	Mica; 0.01 μf —1,250 v.	R-f coupling power amplifier	RL-D-6222
54-2	3D183	Capacitor CA-183	Mica; 0.01 μf —1,250 v.	R-f coupling osc.	RL-D-6222
55	3D174	Capacitor CA-174	Mica; 0.002 μf	R-f coupling stage	RL-D-6222
56	3Z4537	Resistor RS-137	Vitreous; 25,000 ohms	Bias oscillator	RL-D-6222
57-1	2C8017/10	Coil Assembly, choke, r-f		R-f choke power amplifier plate	SC-D-2802
57-2	2C8017/10	Coil Assembly, choke r-f		R-f choke power amplifier grid	SC-D-2802
57-3	2C8017/10	Coil Assembly, choke, r-f		R-f choke osc. plate	SC-D-2802
58	2C8017/33	Variometer Assembly		Antenna tuning	SC-D-2804
59	2C8017/11	Coil Assembly, coupling		Output coupling	SC-D-2807
60	2C8017/12	Coil Assembly, oscillator		Oscillator inductance	SC-D-2803
61-1	3Z8137	Switch SW-137	Rotary	Inductance change	SC-D-2812
61-2	3Z8137	Switch SW-137	Rotary	Crystal selector	SC-D-2812
62-1	2Z3531B	Crystal Holder FT-171-B	Crystal and crystal holder	Frequency control	SC-D-5213
62-2	2Z3531B	Crystal Holder FT-171-B	Crystal and crystal holder	Frequency control	SC-D-5213
62-3	2Z3531B	Crystal Holder FT-171-B	Crystal and crystal holder	Frequency control	SC-D-5213
62-4	2Z3531B	Crystal Holder FT-171-B	Crystal and crystal holder	Frequency control	SC-D-5213
63	3D365	Capacitor CA-365	Mica, fixed; 100 μmf	R-f coupling, MO grid	RL-D-6222
64	3D401	Capacitor CA-401	Ceramic, fixed; 40 μmf	Compensating	SC-D-4147
65	2C8017B/C1	Compensating Coil		Tracking adjustment	SC-D-4987

d. Transmitter Tuning Unit TU-18-A.

71	3D377	Capacitor CA-377	Variable air; 55 μmf	Trimmer, power amplifier	SC-D-2811
72	3D330	Capacitor CA-330	Variable air; 50 μmf	Neutralizing capacitor	SC-D-2811
73	3D376	Capacitor CA-376	Variable air; 100 μmf	Trimmer, osc.	SC-D-2811
74-1	3D183	Capacitor CA-183	Mica; 0.01 μf —1,250 v.	R-f coupling power amplifier	RL-D-6222
74-2	3D183	Capacitor CA-183	Mica; 0.01 μf —1,250 v.	R-f coupling osc.	RL-D-6222
75	3D174	Capacitor CA-174	Mica; 0.002 μf	R-f coupling stage	RL-D-6222
76	3Z4537	Resistor RS-137	Vitreous; 25,000 ohms	Bias oscillator	RL-D-6223
77-1	2C8018/10	Coil Assembly, choke r-f		R-f choke power amplifier plate	SC-D-2802
77-2	2C8018/10	Coil Assembly, choke, r-f		R-f choke power amplifier grid	SC-D-2802
77-3	2C8018/10	Coil Assembly, choke, r-f		R-f choke osc. plate	SC-D-2802
78	2C8018/33	Variometer Assembly		Antenna tuning	SC-D-2804
79	2C8018/11	Coil Assembly, coupling		Output coupling	SC-D-2807
80	2C8018/12	Coil Assembly, oscillator		Oscillator inductance	SC-D-2803
81-1	3Z8137	Switch SW-137	Rotary	Inductance change	SC-D-2812
81-2	3Z8137	Switch SW-137	Rotary	Crystal selector	SC-D-2812
82-1	2Z3531B	Crystal Holder FT-171-B	Crystal and crystal holder	Frequency control	SC-D-5213
82-2	2Z3531B	Crystal Holder FT-171-B	Crystal and crystal holder	Frequency control	SC-D-5213
82-3	2Z3531B	Crystal Holder FT-171-B	Crystal and crystal holder	Frequency control	SC-D-5213
82-4	2Z3531B	Crystal Holder FT-171-B	Crystal and crystal holder	Frequency control	SC-D-5213

Ref. No.	Stock No.	Name of Part	Description	Function	Drawing No.
83	3D365	Capacitor CA-365	Mica, fixed; 100 $\mu\mu\text{f}$	R-f coupling, MO grid	RL-D-6222
84	3D402	Capacitor CA-402	Ceramic, fixed, 15 $\mu\mu\text{f}$	Compensating	SC-D-4147
85	2C8017B/C1	Compensating Coil		Tracking adjustment	SC-D-4987

e. Transmitter Tuning Unit TU-25-A.

91	3D377	Capacitor CA-377	Variable air; 55 $\mu\mu\text{f}$	Trimmer, power amplifier	SC-D-2811
92	3D330	Capacitor CA-330	Variable air; 50 $\mu\mu\text{f}$	Neutralizing capacitor	SC-D-2811
93	3D376	Capacitor CA-376	Variable air; 100 $\mu\mu\text{f}$	Trimmer, osc.	SC-D-2811
94-1	3D183	Capacitor CA-183	Mica; 0.01 μf —1,250 v.	R-f coupling, power amplifier	RL-D-6222
94-2	3D183	Capacitor CA-183	Mica; 0.01 μf —1,250 v.	R-f coupling osc.	RL-D-6222
95	3D174	Capacitor CA-174	Mica; 0.002 μf	R-f coupling stage	RL-D-6222
96	3Z4537	Resistor RS-137	Vitreous; 25,000 ohms	Bias oscillator	RL-D-6222
97-1	2C8018/10	Coil Assembly, choke, r-f		R-f choke power amplifier plate	SC-D-2803
97-2	2C8018/10	Coil Assembly, choke, r-f		R-f choke power amplifier grid	SC-D-2802
97-3	2C8018/10	Coil Assembly, choke r-f		R-f choke osc. plate	SC-D-2802
98	2C8018/33	Variometer Assembly		Antenna tuning	SC-D-2804
99	2C8018/11	Coil Assembly, coupling		Output coupling	SC-D-2807
100	2C8018/12	Coil Assembly, oscillator		Oscillator inductance	SC-D-2803
101-1	3Z8137	Switch SW-137	Rotary	Inductance change	SC-D-2812
101-2	3Z8137	Switch SW-137	Rotary	Crystal selector	SC-D-2812
102-1	2Z3531B	Crystal Holder FT-171-B	Crystal and crystal holder	Frequency control	SC-D-5213
102-2	2Z3531B	Crystal Holder FT-171-B	Crystal and crystal holder	Frequency control	SC-D-5213
102-3	2Z3531B	Crystal Holder FT-171-B	Crystal and crystal holder	Frequency control	SC-D-5213
102-4	2Z3531B	Crystal Holder FT-171-B	Crystal and crystal holder	Frequency control	SC-D-5213
103	3D365	Capacitor CA-365	Mica, fixed; 100 $\mu\mu\text{f}$	R-f coupling, MO grid	RL-D-6222
104	3D391	Capacitor CA-391	Ceramic, fixed; 20 $\mu\mu\text{f}$	Compensating	
105	2C8017B/C1	Compensating Coil		Tracking adjustment	SC-D-4987

f. Dynamotor Unit PE-135-AX.

1-1	3D333	Capacitor CA-333	Paper; 1 μf —1,000 v.	Filter high voltage	SC-D-512
1-2	3D333	Capacitor CA-333	Paper; 1 μf —1,000 v.	Filter high voltage	SC-D-512
1-3	3D333	Capacitor CA-333	Paper; 1 μf —1,000 v.	Filter high voltage	SC-D-512
2-1	3D328	Capacitor 328	Paper; 2 μf —600 v.	Filter low voltage	SC-D-512
2-2	3D328	Capacitor 328	Paper; 2 μf —600 v.	Filter low voltage	SC-D-512
3		Coil, filter		Filter low voltage	
4		Dynamotor DM-49-AX	500 v.	High voltage source	
5	3Z1930	Fuse FU-30	250 v.—30 amp. on 12 v.	Low voltage protective	SC-D-2784
5		Fuse FU-47	250 v.—20 amp. on 24 v.	Low voltage protective	
6	3Z1926	Fuse FU-26	250 v.—1 amp.	High voltage protective	SC-D-2784
7	2Z7167A	Relay BK-17-A	14 v.—0.3 amp.	Fil. and dyn. control	SC-A-2727
8		Resistor RS-271	35 ohms—10 w.	Relay	
9	3Z4611	Resistor RS-211	2½"x½"—2.0 ohms	Fil. voltage adjusting	RL-D-6223
10	3Z4602	Resistor RS-202	Vitreous, 0.75 ohms	Braking	RL-D-6223
11		Resistor RS-275	2.75 ohms 100 w. adj.	Filament dropping	
12	2Z8780	Socket SO-80	8 prong	Output connection	SC-D-1506

g. Vibrator Unit PE-125-AX.

1		*Capacitor CO-805-B	4-4 μfd , 1000 v.	Filter	
2-1		*Capacitor CO-405-B	2-2 μfd , 200 v.	Buffer	
2-2		*Capacitor CO-405-B	2-2 μfd , 200 v.	Buffer	
3		*Capacitor CP-504-D	.5 μfd , 100 v.	Hash filter	
4		*Capacitor CE-1207	1200 μfd , 25 v.	Filament filter	
5	3Z1930	Fuse FU-30	250 v.—30 amp.	Main fuse	SC-D-2784
6-1		*Fuse F-0010	250 v.—10 amp.	Vibrator fuse	} on 12 v. only
6-2		*Fuse F-0010	250 v.—10 amp.	Vibrator fuse	
6-1		*Fuse F-0013	250 v.—5 amp.	Vibrator fuse	} on 24 volts only
6-2		*Fuse F-0013	250 v.—5 amp.	Vibrator fuse	
7-1		*Fuse F-0011	250 v.—½ amp.	High voltage	
7-2		*Fuse F-0011	250 v.—½ amp.	High voltage	
8	2Z7167A	Relay BK-17-A	14 v.—0.3 amp.	Fil. & Power	SC-A-2727

*Rauland Corp. Part Numbers

<i>Ref. No.</i>	<i>Stock No.</i>	<i>Name of Part</i>	<i>Description</i>	<i>Function</i>	<i>Drawing No.</i>
9		Resistor RS-271	Vitreous; 35 ohm, 10 w.	Series Relay	RL-D-6223
10	3Z4611	Resistor RS-211	Vitreous; 2 ohm, 20 w.	Filament	RL-D-6223
11		Resistor RS-275	Vitreous; 2.75 ohm, 100 w.	Filament	RL-D-6223
12-1		*Resistor RW-1500-Z	Vitreous; 45 ohm, 5 w.	Vibrator coil	
12-2		*Resistor RW-1500-Z	Vitreous; 45 ohm, 5 w.	Vibrator coil	
13-1		*Resistor RW-3010Y	Vitreous; 0.2 ohm, 20 w.	Surge protective	
13-2		*Resistor RW-3010Y	Vitreous; 0.2 ohm, 20 w.	Surge protective	
14-1		Resistor RS-202	Vitreous; .75 ohm, 20 w.	Surge protective	RL-D-6223
14-2		Resistor RS-202	Vitreous; .75 ohm, 20 w.	Surge protective	RL-D-6223
15-1		*Resistor RW-3010X	Vitreous; 0.4 ohm, 20 w.	Surge protective	
15-2		*Resistor RW-3010X	Vitreous; 0.4 ohm, 20 w.	Surge protective	
16		*Resistor RW-9253	Vitreous; 25,000 ohm, 20 w.	Bleeder	
17-1		*Resistor RO-3501	Carbon 500 ohm, 1 w.	Vibrator	
17-2		*Resistor RO-3501	Carbon 500 ohm, 1 w.	Vibrator	
17-3		*Resistor RO-3501	Carbon 500 ohm, 1 w.	Vibrator	
17-4		*Resistor RO-3501	Carbon 500 ohm, 1 w.	Vibrator	
17-5		*Resistor RO-3501	Carbon 500 ohm, 1 w.	Vibrator	
17-6		*Resistor RO-3501	Carbon 500 ohm, 1 w.	Vibrator	
17-7		*Resistor RO-3501	Carbon 500 ohm, 1 w.	Vibrator	
17-8		*Resistor RO-3501	Carbon 500 ohm, 1 w.	Vibrator	
18		Socket SO-80	8 prong	Output connection	SC-D-1506
19		Switch X-0057	12 v.—24 v.	Voltage change (see separate print)	
20-1		Vibrator VB-5	12 volt	Inverter	SC-A-2727
20-2		Vibrator VB-5	12 volt	Inverter	SC-A-2727
21		Choke & Transformer assembly VU-.0001	12-24 volt	Power and filter	SC-D-1506
		Tube VT-249	Rectifier	Plate supply	
		Tube VT-249	Rectifier	Plate supply	

*Rauland Corp. Part Numbers.