

TM 5-6115-440-20

DEPARTMENT OF THE ARMY TECHNICAL MANUAL

TECHNICAL MANUAL

ORGANIZATIONAL MAINTENANCE MANUAL

GENERATOR SET: 7.5 KW, 28 V DC,

G.E.D., AIR COOLED, 2 WHEEL MTD,

PNEUMATIC TIRES

(JOHN R. HOLLINGSWORTH MODEL JHGV7.5A)

FSN 6115-074-6396

HEADQUARTERS, DEPARTMENT OF THE ARMY

FEBRUARY 1971

WARNING

Take particular heed to specific cautions and warnings throughout this manual.

HIGH VOLTAGE

is used in the operation of this equipment

DEATH

or severe burns may result if personnel fail to observe safety precautions. Do not operate this generator set until the ground terminal stud has been connected to a suitable ground.

Disconnect the battery ground cable before removing and installing components on engine or in electrical control panel system.

Before making load connections be sure the generator sets are not operating and load control switch is in the OFF position

On gasoline engine driven generator set utilizing magnetos, set magneto switch to OFF or STOP position

Do not attempt to change load connects when generator is running.

Before servicing any part of a generator set, make sure unit is completely de-energized.

DANGEROUS GASES

are generated as a result of operating of this equipment

DEATH

or severe injury may result if personnel fail to observe safety precautions Utilize extreme caution, do not smoke, or use open flame in vicinity when servicing batteries.

Batteries generate explosive gas during charging.

Always maintain metal to metal contact when filling the fuel tank.

Do not smoke or use open flame in vicinity when filling the fuel tank.

Do not attempt to fill fuel tank when generator is running.

Do not operate generator sets in inclosed areas unless exhaust gases are properly vented to the outside. Exhaust discharge contains noxious and deadly fumes.

Use extreme care, should a selenium rectifier malfunction, to avoid inhalation of poisonous fumes.

If generator set is shut-down by the operation of a safety device, do not attempt to operate unit until the cause has been determined and eliminated.

CHANGE }
NO. 3 }

HEADQUARTERS
DEPARTMENT OF THE ARMY
WASHINGTON, D. C., 8 March 1984

ORGANIZATIONAL MAINTENANCE MANUAL

GENERATOR SET: 7.5 KW, 28 V DC,
G. E. D., AIR COOLED, 2 WHEEL MTD,
PNEUMATIC TIRES
(JOHN R. HOLLINGSWORTH MODEL JHGV7.5A)

NSN 6115-00-074-6396

TM 5-6115-440-20, 2 February 1971 is changed as follows:

Page 2-3, Table 2-1, the following is added as Item 1. Change remaining Item numbers accordingly.

Item number	Interval						B - Before Operation D - During Operation	A - After Operation W - Weekly	M - Monthly Q - Quarterly	Item to be Inspected	Procedure	Reference
	Operator			Org.								
	B	D	A	W	M	Q						
1				X					Generator Set	Start generator set. Check that output voltage is 28 volts and that all instruments operate properly.		

By Order of the Secretary of the Army:

E. C. MEYER
General, United States Army
Chief of Staff

Official:

ROBERT M. JOYCE
Major General, United States Army
The Adjutant General

DISTRIBUTION:

To be distributed in accordance with DA Form 12-25D, Organizational maintenance requirements for Generator Sets, Engine Driven, 7.5 KW, DC.

CHANGE }
 NO. 2 }

HEADQUARTERS
 DEPARTMENT OF THE ARMY
 WASHINGTON, D.C., 31 July 1981

ORGANIZATIONAL MAINTENANCE MANUAL

GENERATOR SET: 7.5 KW, 28 V DC,
 G. E. D., AIR COOLED, 2 WHEEL MTD,
 PNEUMATIC TIRES
 (JOHN R. HOLLINGSWORTH MODEL JHGV7.5A)
 NSN 6115-00-074-6396

TM 5-6115-440-20, 2 February 1971, is changed as follows:

Page 2-3, Table 2-1. The intervals for checks for Item numbers 1, 2 and 3 are changed from "Org. Monthly" column to "Operator Daily Before" column.

Page 2-3, Table 2-1. The intervals for checks for Item numbers 4, 5, 10 and 12 are changed from "Org. Quarterly" column to "Operator Daily Before" column.

By Order of the Secretary of the Army:

E. C. MEYER
General, United States Army
Chief of Staff

Official:

ROBERT M. JOYCE
Brigadier General, United States Army
The Adjutant General

DISTRIBUTION:

To be distributed in accordance with DA Form 12-25D, Organizational Maintenance requirements, Generator Sets, Engine Driven, 7.5 KW D.C.

URGENT

TM 5-6115-440-20

C1

CHANGE

No. 1

DEPARTMENT OF THE ARMY
US ARMY DARGCOM MATERIEL READINESS SUPPORT AGENCY
WASHINGTON, KY 40390

HEADQUARTERS
DEPARTMENT OF THE ARMY
WASHINGTON, D. C., 24 July 1979

ORGANIZATIONAL MAINTENANCE MANUAL

**GENERATOR SET: 7.5 KW, 28 V DC,
G. E. D., AIR COOLED, 2 WHEEL MTD,
PNEUMATIC TIRES
(JOHN R. HOLLINGSWORTH MODEL JHGV7.5A)**

NSN 6115-00-074-6396

TM 5-6115-440-20, 2 February 1971 is changed as follows:

Title is changed as shown above.

Page 2-3. Table 2-1, item 12, "Procedures" is changed to read:

Check power cable connections on the back of the control box for security prior to operating the Generator Set. Tighten any loose connections. If protective compound has deteriorated and terminals are exposed, remove remaining compound and apply a new coating using RTV3145 adhesive/sealant FSCM 71984, NSN 8040-00-144-9774.

Page 2-8. Paragraph 2-21, the following WARNING is added:

WARNING

Extreme caution should be used when working around the terminal board and load studs while generator set is operating. Tools or other metal objects dropped between the control box and fuel tank, while generator set is in operation, may cause serious injury to personnel due to electrical short between the load studs and the fuel tank.

By Order of the Secretary of the Army:

Official:

J. C. PENNINGTON
Major General, United States Army
The Adjutant General

E. C. MEYER
General, United States Army
Chief of Staff

DISTRIBUTION:

To be distributed in accordance with DA Form 12-25D, Organizational maintenance requirements for Generator Sets, Engine Driven, 7.5 KW, DC.

URGENT

TECHNICAL MANUAL }
 NO. 5-6115-440-20 }

HEADQUARTERS
 DEPARTMENT OF THE ARMY
 WASHINGTON, D. C., 2 February 1971

ORGANIZATIONAL MAINTENANCE MANUAL
GENERATOR SET: 7.5 KW, 28 V DC,
G.E.D., AIR COOLED, 2 WHEEL MTD,
PNEUMATIC TIRES
(JOHN R. HOLLINGSWORTH MODEL JHGV7.5A)
FSN 6115-074-6396

		Paragraph	Page
CHAPTER	1. INTRODUCTION		
Section	I. General	1-1—1-5	1-1
	II. Description and data	1-6. 1-7	1-1
CHAPTER	2. ORGANIZATIONAL MAINTENANCE INSTRUCTIONS		
Section	I. Service upon receipt of equipment	2-1, 2-2	2-1
	II. Movement to a new worksite	2-3	2-1
	III. Repair parts, special tools and equipment	2-4—2-6	2-2
	IV. Preventive maintenance checks and services	2-7—2-9	2-2
	V. Troubleshooting		2-4
	VI. Radio interference suppression	2-10—2-13	2-4
	VII. Maintenance of generator set	2-14—2-16	2-5
	VIII. Control box components	2-17—2-22	2-6
	IX. Fuel system	2-23—2-29	2-8
	X. Lubricating system	2-30—2-32	2-12
	XI. Electrical system	2-33—2-37	2-15
	XII. Exhaust system	2-38—2-40	2-21
	XIII. Drive belts, engine and starter-generator, sheave and lifting bar	2-41—2-44	2-24
	XIV. Engine assembly	2-45—2-48	2-26
	XV. Wheel assembly, kick stand and tow bar assembly	2-49—2-52	2-29

***This technical manual supersedes the organizational portion of TM 5-6115-440-15, 17 June 1968, including all changes.**

LIST OF ILLUSTRATIONS

<i>Number</i>	<i>Title</i>	<i>Page</i>
1-1	Generator set, front view	1-3
1-2	Generator set, rearview	1-4
1-3	Generator set, winterized, left front view	1-5
1-4	Practical wiring diagram	1-6
2-1	Location and replacement of radio suppression components	2-5
2-2	Instruments, switches and instruction plates, removal and installation	2-7
2-3	Voltage regulator, removal and installation	2-8
2-4	Air cleaner, removal and installation	2-8
2-5	Fuel strainer and fuel pump, removal and installation	2-9
2-6	Carburetor, removal and installation	2-10
2-7	Fuel selector valve and bracket, removal and installation	2-11
2-8	Fuel tank, removal and installation	2-12
2-9	Oil filter service	2-13
2-10	Oil filter and bracket, removal and installation	2-14
2-11	Oil drain assembly, removal and installation	2-15
2-12	Magneto spark check	2-17
2-13	Magneto breaker point adjustment	2-18
2-14	Magneto, removal and installation	2-19
2-15	Alignment of magneto gear to magneto	2-20
2-16	Timing of magneto	2-20
2-17	Muffler and weather cap, removal and installation	2-22
2-18	Intake and exhaust manifold, removal and installation	2-23
2-19	Drive belt adjustment, removal and installation	2-25
2-20	Lifting bar, removal and installation	2-26
2-21	Governor lever adjustment chart	2-27
2-22	Air shroud and air deflector exploded view	2-28
2-23	Wheel assembly, tow bar and kick stand, removal and installation	2-30

CHAPTER 1

INTRODUCTION

Section I. GENERAL

1-1. Scope

a. These instructions are published for use by personnel to whom the John R. Hollingsworth Co. Model JHGV7.5A generator is issued. Chapters 1 and 2 provide information on preventive maintenance checks and services, troubleshooting, and organizational maintenance of equipment, accessories, components and attachments. Also included are descriptions of main units and their functions in relationship to other components.

b. Numbers in parentheses following nomenclature callouts on illustrations indicate quantity; numbers preceding nomenclature callouts indicate preferred sequence.

1-2. Forms and Records

Maintenance forms, records and reports which are to be used by maintenance personnel at all maintenance levels are listed and prescribed by TM 38-750.

1-3. Reporting of Errors

Report of errors, omissions, and recommendations for improving this publication by the individual user is encouraged. Reports should be submitted on DA Form 2028 (Recommended Changes to Publications) and forwarded direct to Commanding General, U.S. Army Mobility Equipment Command, ATTN: AMSME-MPP, 4300 Goodfellow Boulevard, St. Louis, Mo. 63120.

1-4. Administrative Storage

Refer to TM 740-90-1 (Administrative Storage of Equipment), for information and instructions pertaining to organizational administrative storage.

1-5. Destruction of Army Material to Prevent Enemy Use

Refer to TM 740-90-1 (Administrative Storage of Equipment), for information and instructions pertaining to organizational administrative storage.

Section II. DESCRIPTION AND DATA

1-6. Description

A general description of the generator set is contained in TM 5-6115-440-10. A more detailed description of specific components and assemblies are contained in the applicable sections of this manual. Detailed descriptions of the components of the generator set are provided in the applicable maintenance paragraphs of this manual.

1-7. Identification and Tabulated Data

a. *Identification.* The generator set has two (2) major identification plates. The information contained on the plates is listed below.

(1) *Generator set plate.*

U.S. Army Generator Set	Gasoline engine
Stock Number	FSN 6115-074-6396
Manufacturer	John R. Hollingsworth Co.
Model	JHGV7.5A
Volts	28 DC
Amps	268
KW	7.5
RPM	2800
Contract No	DAAK01-67-C-D402, DAAK01-69-C-6628
Length	40 in.
Width	40 in.
Height	40 in.

Weight	810 lbs.
Eng. Mfr.	WISCONSIN MOTORS
Model	MVH4D

(2) *Starter generator plate.*

Aircraft DC Generator:

Weight	51.5 lbs.
Volts	30
Amps	300
Rotation	Clockwise
Speed RPM	4500/6500
Model	30010-004

Lear Siegler, Inc.

Power Equipment Division
Cleveland, Ohio

b. *Tabulated Data.*

(1) *Generator set.*

Manufacturer	John R. Hollingsworth Co.
Model	JHGV7.5A
Type	Gasoline engine

(2) *Engine.*

Manufacturer	Wisconsin Motors
Type	Air-cooled
Model	MVH4D
Specification	305962 (MIL-E-11275-D)
Number of Cylinders	4
Cycle	4
RPM	2725
Bore	3¼ in. (inches)

Stroke 3¼ in.
Piston Displacement . . . 107.7 cu. in. (cubic inches)
Compression Ratio . . . 5.5:1

(3) Starter generator.

Manufacturer Lear Siegler, Inc.
Model 30010-004
Rated Speed 4500/6500 rpm
Continuous Operating Speed . . 6500 rpm
Minimum speed for Regulation 5000 rpm
Maximum Speed for Regulation 10,000 rpm
Output Voltage 30 volts DC
Rated Current 300 amp
Regulated Field Current . . 8 amp max.

(4) Voltage regulator.

Manufacturer General Electric Co.
Model E-1597-2
Type Carbon pile

(5) Carburetor.

Manufacturer Zenith
Model 68-7
Type Single venturi

(6) Magneto.

Manufacturer Fairbanks-Morse
Model FM-XZE4B7-4

(7) Fuel strainer.

Manufacturer Tillotson
Model OW-418-T

(8) Fuel pump.

Manufacturer Wisconsin Motors

Model LP-38-C
Type Cold-weather operation

(9) Air cleaner.

Manufacturer Donaldson
Model KAXOO-0354
Specification MS35875-3

(10) Oil filter.

Manufacturer Fram
Model F21-P
Specification F-F351, Type 1, Class 2

(11) Sparkplug.

Manufacturer Champion
Model XMD-21

(12) Nut and bolt torque data.

Spark Plug 25-30 ft-lb
Cylinder head screws 22-24 ft-lb
Gear cover cap screws 14-18 ft-lb
Oil pan mounting screws 6-9 ft-lb
Cylinder block mounting nuts 40-50 ft-lb
Connecting rod nuts 22-24 ft-lb
Main bearing plate cap screws 25-30 ft-lb
Carburetor manifold mounting
nuts23 ft-lb max

(13) Adjustment data.

Spark plug gap 0.030 in.
Magneto breaker point gap 0.015 in.
Spark advance 23 degrees
Valve tappets (engine cold):
Inlet 0.008 in.
Exhaust 0.016 in.

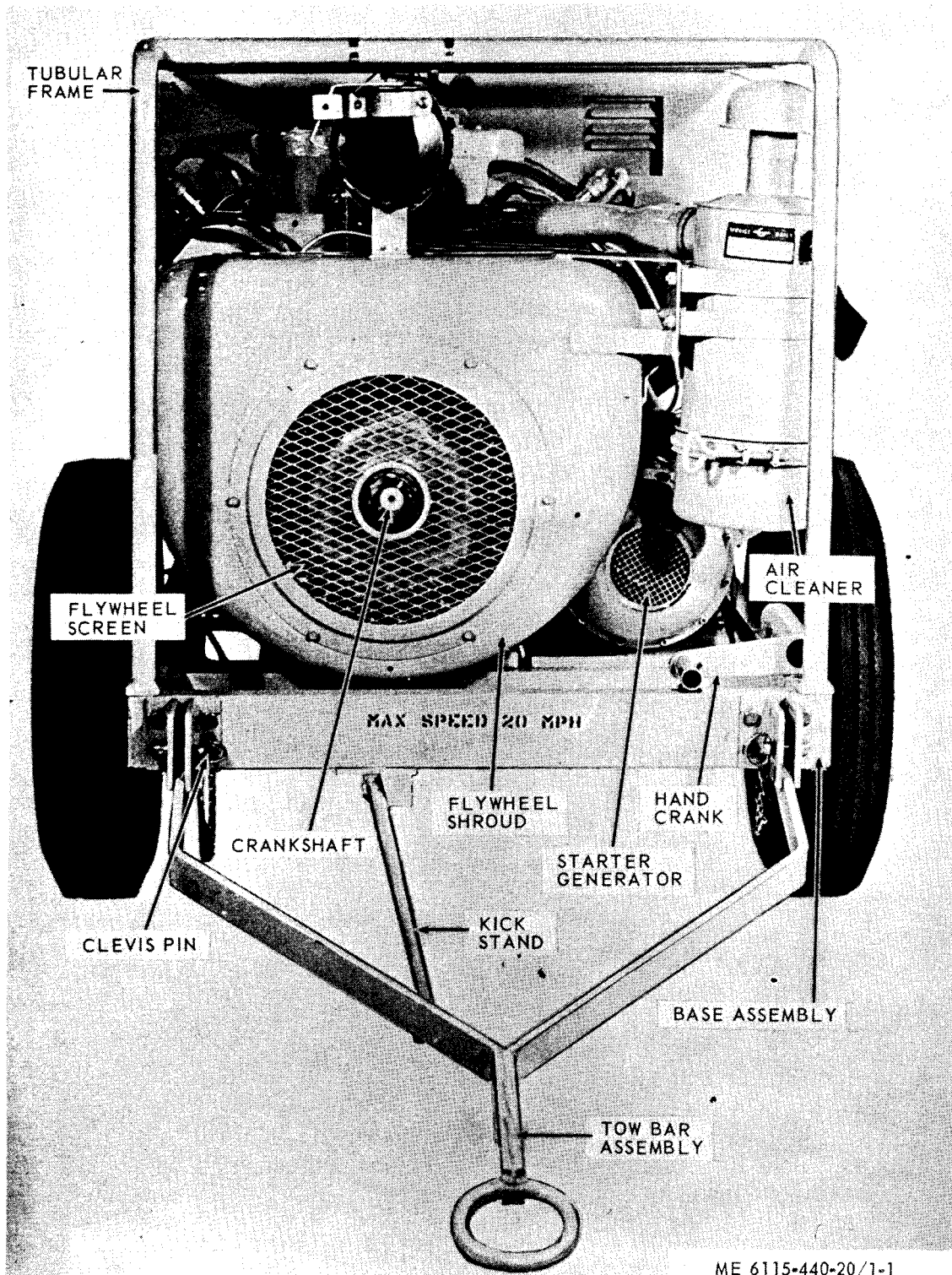
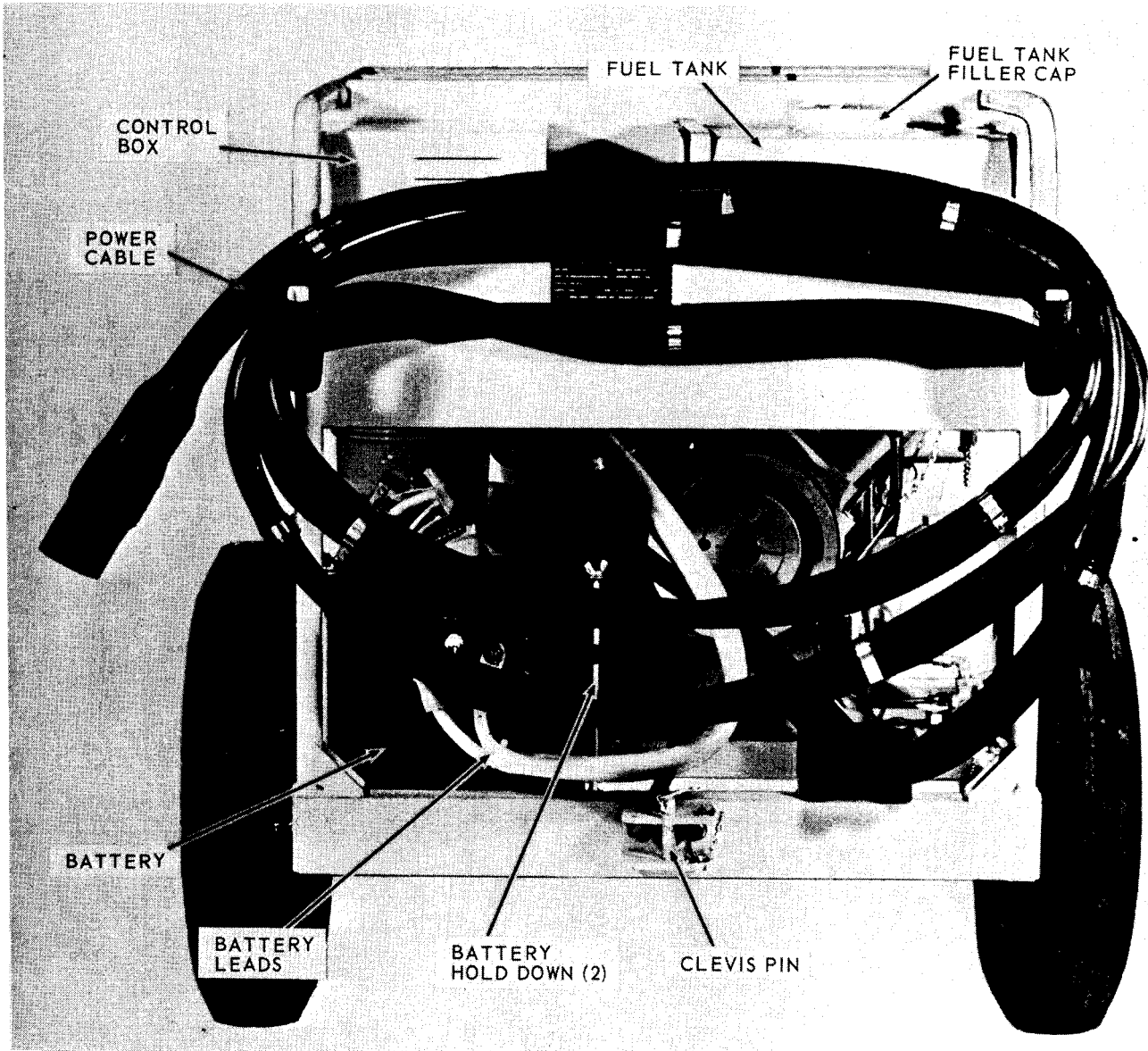

Figure 1-1. Generator set, front view.



ME 6115-440-20/1-2

Figure 1-2. Generator set, rear view.

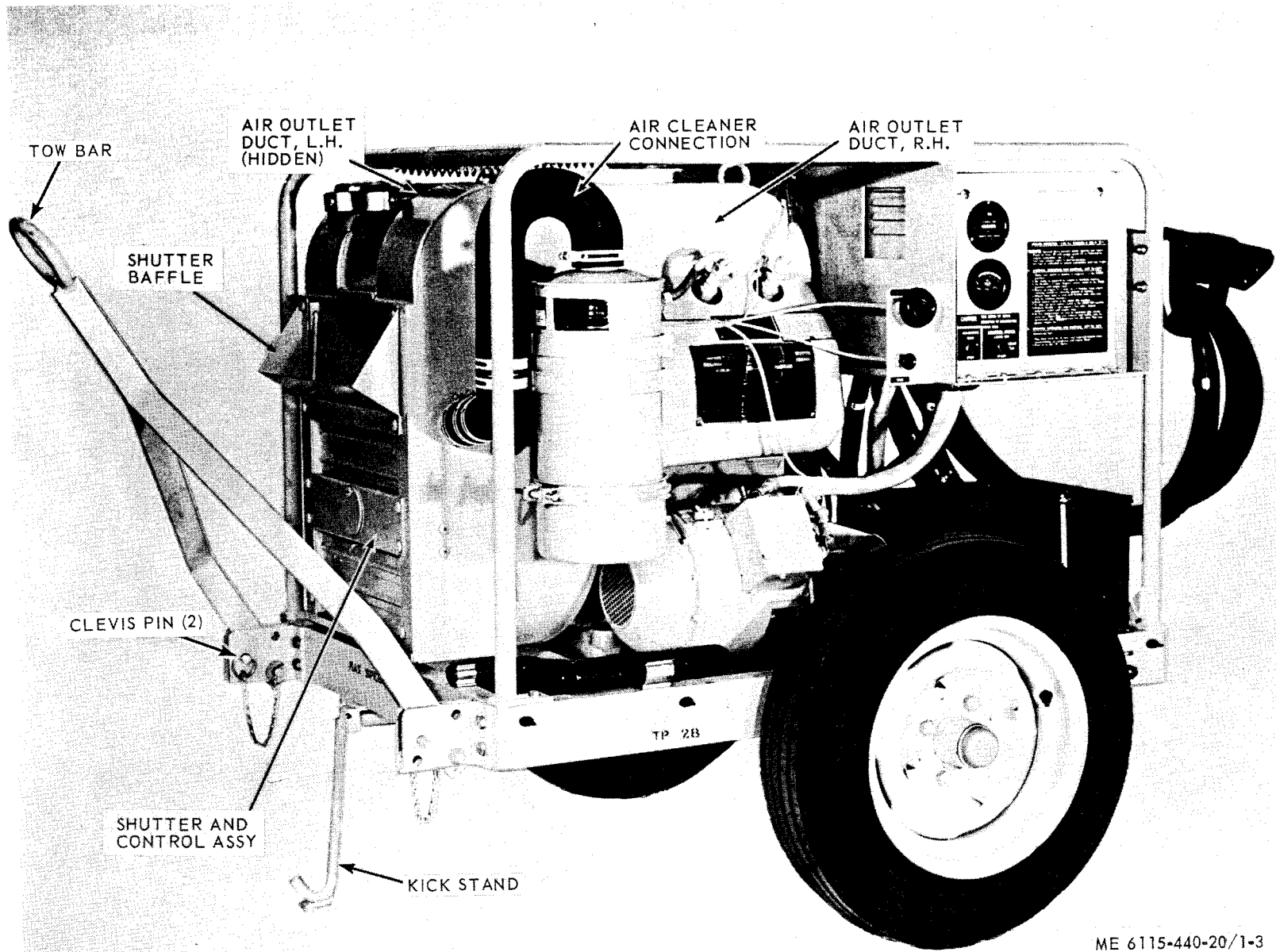
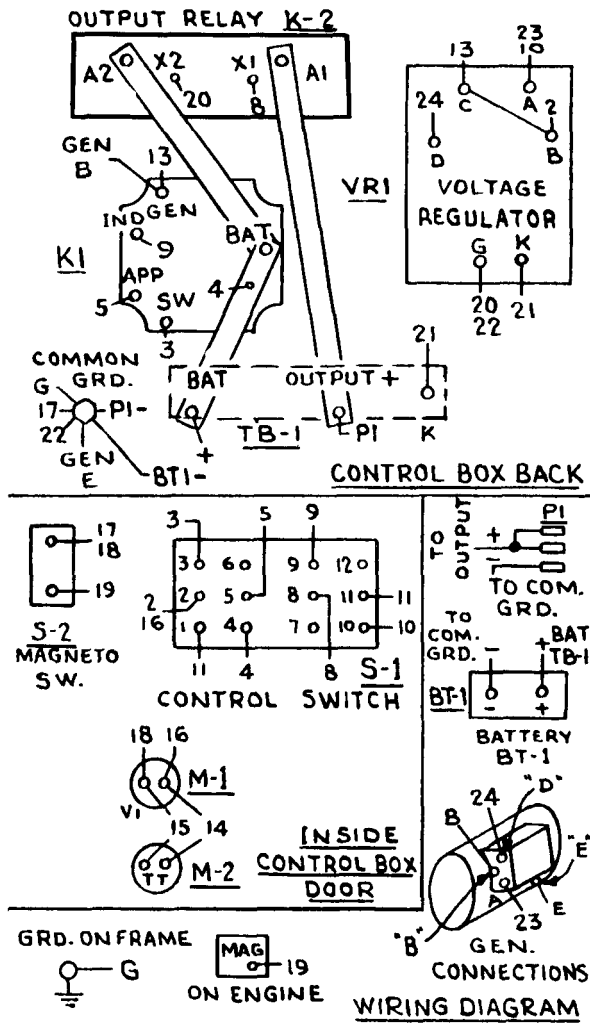

Figure 1-3. Generator set, winterized, left front view.



ME 6115-440-20/1-4

Figure 1-4. Practical wiring diagram.

CHAPTER 2

ORGANIZATIONAL MAINTENANCE INSTRUCTIONS

Section I. SERVICE UPON RECEIPT OF MATERIAL

2-1. Inspecting and Servicing Equipment

- a. Remove the canvas cover from generator set
- b. Prepare the generator set for inspection and operation as outlined on DA Form 2258 (Depreservation Guide for Vehicles and Equipment), attached on or near the operational controls.
- c. Inspect the generator set for damage and missing parts and accessories.
- d. Insert starting hand crank over the crankshaft and turn the engine over (one or two revolutions) to check for free rotation of the engine. Listen for any unusual noises which may be caused by damaged engine components.
- e. Install and fill battery with battery acid to $\frac{3}{8}$ inch above plates.

2-2. Installation

a. *Location.* The generator set is designed to be operated in its normal condition; that is, supported by the wheel and tire assemblies and the kick stand (in downward position). Provide shelter during inclement weather. Position the generator set to allow adequate air circulation and make sure that the exhaust fumes are directed away from the operator (in windy weather, position the front or muffler end of the equipment in a downwind direction).

b. *Grounding.* The generator set must be grounded prior to operation. The ground can be in order of preference, an under-ground metallic water piping system, a driven metal rod or a buried metal plate. A ground rod must have a minimum diameter of $\frac{5}{8}$ inch if solid or $\frac{3}{4}$ inch if pipe, and must be driven to a minimum depth of 8 feet. A ground plate must have a minimum area of 9 square feet and be buried at a minimum depth of 4 feet. The ground

lead must be a No. 6 AWG (American Wire Gage) copper wire and be bolted or clamped to the rod, plate, or piping system. Connect the other end of the ground cable to the generator ground terminal stud.

WARNING

Do not operate the generator set in an enclosed area unless exhaust gases are piped to the outside. Inhalation of exhaust fumes will result in serious illness or death.

c. *Indoor Installation.* If the generator set is to be operated indoors, use 2-inches ID (inside diameter) flexible exhaust tubing to vent the exhaust fumes out of the building. Keep the tubing as short and straight as possible. Make sure all exhaust connections are tight and that the room is well ventilated. Provide adequate air ventilation around the generator set to prevent overheating. Observe the additional requirements of a above.

d. *Using Auxiliary Fuel Tank.*

NOTE

The generator set is provided with a three-position fuel tank selector valve. When the valve handle is positioned down (OFF), no fuel is supplied to the system. When the valve handle is positioned to the right (SET TANK), the integral fuel tank is connected. When the valve handle is positioned up (AUXILIARY), an auxiliary fuel tank can be connected for longer duration operation.

- (1) Using a $\frac{5}{8}$ inch wrench, loosen and remove the cap fitting on the left side of the valve. Replace cap when use of the auxiliary fuel tank is completed.
- (2) Connect the auxiliary fuel line to the $\frac{1}{2}$ -20 threaded male connection on the valve fitting.
- (3) Set fuel tank selector valve handle to AUXILIARY.

Section II. MOVEMENT TO NEW WORKSITE

2-3. Dismantling for Movement and Reinstallation After Movement

a. *Dismantle.*

(1) If the generator set is to be towed by truck for short distances, it is permissible to move the equipment while fuel remains in the tank. Disconnect the auxiliary fuel line (if used), position

the fuel tank selector valve handle down, and make sure the fuel tank cap is securely tightened.

(2) If the generator set is to be transported by rail, or for long distances, drain the fuel tank before shipment. Proceed as follows in draining the fuel tank:

(a) Remove the cap and chain assembly on bottom of fuel tank.

(b) Attach a hose to the 37½° fitting on bottom of fuel tank and drain tank.

b. *Reinstallation.* Refer to paragraph 2-2 for reinstallation procedures.

Section III. REPAIR PARTS, SPECIAL TOOLS AND EQUIPMENT

2-4. Tools and Equipment

Tools, equipment, and repair parts issued with or authorized for the generator set are listed in the basic issue items list, TM 5-6115-440-10.

2-5. Special Tools and Equipment

No special tools or equipment are required by

organizational maintenance personnel for maintenance of the generator set.

2-6. Maintenance Repair Parts

Repair parts and equipment are listed and illustrated in the repair parts and special tools list covering organizational maintenance for this equipment in TM 5-6115-440-24P.

Section IV. PREVENTIVE MAINTENANCE CHECKS AND SERVICES

2-7. General

To insure that the generator set is ready for operation at all times, it must be inspected systematically so that defects may be discovered and corrected before they result in serious damage or failure. The necessary preventive maintenance services to be performed are listed and described in paragraphs 2-8 and 2-9. Item numbers indicate the sequence of minimum inspection requirements. Defects discovered during operation of the unit shall be noted for future correction, to be made as soon as operation has ceased. Stop operation immediately if a deficiency is noticed which would damage the equipment if operation were continued. All deficiencies and shortcomings will be recorded together with the corrective action taken on DA Form 2404 (Equipment Inspection and Maintenance Worksheet) at the earliest possible opportunity.

2-8. Daily Preventive Maintenance Checks and Services

This paragraph contains an illustrated tabulated

listing of preventive maintenance checks and services which must be performed by the operator or organizational maintenance personnel. The item numbers are listed consecutively and indicate the sequence of minimum requirements. Refer to Table 2-1 for the daily preventive maintenance checks and services.

2-9. Quarterly Preventive Maintenance Checks and Services

a. This paragraph contains an illustrated tabulated listing of preventive maintenance checks and services which must be performed by organizational maintenance personnel at quarterly intervals. A quarterly interval is equal to 3 calendar months, or 250 hours of operation, whichever occurs first.

b. The item numbers are listed consecutively and indicate the sequence of minimum requirements. Refer to table 2-1 for the quarterly preventive maintenance checks and services.

Table 2-1. Preventive Maintenance Checks and Services

Item number	Interval						Item to be Inspected	Procedure	Reference			
	Operator			Org.						B — Before Operation	A — After Operation	M — Monthly
	B	D	A	W	M	Q				D — During Operation	W — Weekly	Q — Quarterly
1					X		Lubricate in accordance with current Lubrication Order. Battery	Tighten loose cables and mountings. Remove corrosion. Fill to $\frac{3}{8}$ in. above plates. In freezing weather, run engine a minimum of one hour after adding water.	para 2-35			
2					X		Fuel Tank	Add fuel as required. Check for leaks.	para 2-29			
3					X		Fuel Lines	Inspect for leaks and loose connections.	para 2-23			
4						X	Drive Belts	Check for worn and frayed belts. Check that belts deflect approximately $\frac{1}{2}$ in. midway between pulleys.	para 2-42			
5						X	Crankcase Oil	Check oil level. Drain and refill (100 hours).				
6						X	Oil Filter	Replace oil filter cartridge (100 hours).	para 2-31			
7					X		Fuel Strainer	Clean screen and bowl (50 hours).	para 2-25			
8						X	Spark Plugs	Clean and regap (50 hours). Replace (100 hours).	para 2-34			
9					X		Air Cleaner	Service air cleaner.	para 2-24			
10						X	Tires	Check for proper air pressure (28 pounds) in tires.				
11						X	Starter Generator Brushes	Inspect starter generator brushes. Replace if brush wear line is not visible (total length less than $9/16$ in.).	para 2-37			
12						X	Electrical Connections	Check all electrical connections for loose connections, worn and frayed insulation, damaged terminals, or poor contact. Brush corrosion from battery terminals with a stiff nonwire brush.	para 2-33			
13					X		Control Box Assembly	Inspect for worn or frayed wiring and insecure mounting. Inspect interior of panel for loose or damaged components and faulty electrical connections.	para 2-20			

Section V. TROUBLESHOOTING

Table 2-2. Troubleshooting

Malfunction	Probable Cause	Corrective Action
1. Engine Fails to Start or Starts with Difficulty.	<ul style="list-style-type: none"> a. Excessive carbon, dirt, or moisture on spark plug. b. Spark plug gap incorrect. c. Magneto defective. d. Fuel pump defective. e. Starter-generator defective. f. Breaker points defective or improperly gapped. g. Carburetor dirty or improperly adjusted. 	<ul style="list-style-type: none"> a. Clean or replace spark plug (para 2-34). b. Regap spark plug (para 2-34). c. Perform magneto spark check and replace if necessary (para 2-36). d. Replace fuel pump (para 2-26). e. Repair or replace starter-generator (para 2-27). f. Regap breaker points or replace magneto (para 2-36). g. Adjust or replace carburetor (para 2-27).
2. Engine Overheats and Lacks Power.	<ul style="list-style-type: none"> a. Carburetor improperly adjusted. b. Engine speed incorrect. c. Generator set overloaded. d. Spark plug fouled. 	<ul style="list-style-type: none"> a. Adjust carburetor (para 2-27). b. Adjust governor (para 2-46). c. Check load and reduce if necessary. d. Clean and regap or replace spark plug (para 2-34).
3. Engine Misfires.	<ul style="list-style-type: none"> a. Carburetor improperly adjusted. b. Spark plug fouled or incorrectly gapped. c. Magneto defective. 	<ul style="list-style-type: none"> a. Adjust carburetor (para 2-27). b. Clean and regap spark plug (para 2-34). c. Replace magneto (para 2-36).
4. Excessive Smoke From Muffler.	<ul style="list-style-type: none"> a. Carburetor set too rich. b. Oil or water in fuel tank. 	<ul style="list-style-type: none"> a. Adjust carburetor (para 2-27). b. Drain fuel tank and fill with correct fuel, TM 5-6115-440-10.
5. Generator Voltage Too Low.	<ul style="list-style-type: none"> a. Starter-generator has insufficient residual magnetism in field circuit. b. Voltage regulator defective. c. Generator drive belt improperly adjusted. 	<ul style="list-style-type: none"> a. Flash starter-generator field circuit. b. Replace voltage regulator (para 2-22). c. Adjust drive belt (para 2-42).

Section VI. RADIO INTERFERENCE SUPPRESSION

2-10. General Methods Used to Attain Proper Suppression

Essentially, suppression is attained by providing a low resistance path to ground stray currents. Methods used include shielding the ignition and high-frequency wires, grounding the frame with bonding straps, and using capacitors and resistors.

2-11. Interference Suppression Components

The suppression components used on the generator set consist of the shielded ignition cables, suppressor-type spark plugs, and radio shielded magneto. Refer to figure 2-1 for location and replacement of suppression components.

2-12. Replacement of Suppression Components

- a. *Spark Plugs.* Remove and replace spark plugs as described in paragraph 2-34.
- b. *Shielded Ignition Cables.*

NOTE

Do not pull on cable or twist braided shielding. Gently work cable from side to side and free the

rubber seal. Do not use sharp metal tools to install rubber seals.

- (1) Disconnect shielded ignition cables from spark plugs (para a).
- (2) Unscrew cable connecting nuts from end caps of magneto.
- (3) Remove four screws and external tooth lock washers securing clips to engine.
- (4) Tag each shielded ignition cable with the proper cylinder number to facilitate assembly. The cable lengths differ.

NOTE

When connecting shielded ignition cables, make sure the cylinder numbers and the end cap numbers correspond.

c. *Magneto.*

- (1) Refer to paragraph 2-36 and remove the magneto.
- (2) Refer to paragraph 2-36 and install the magneto.

2-13. Testing of Radio Interference Suppression Components

Test the capacitors for leaks and shorts on a capacitor tester; replace defective capacitors. If test

equipment is not available and interference is indicated, isolate cause by the trial-and-error method of replacing each capacitor in turn until the cause of interference is located and eliminated.

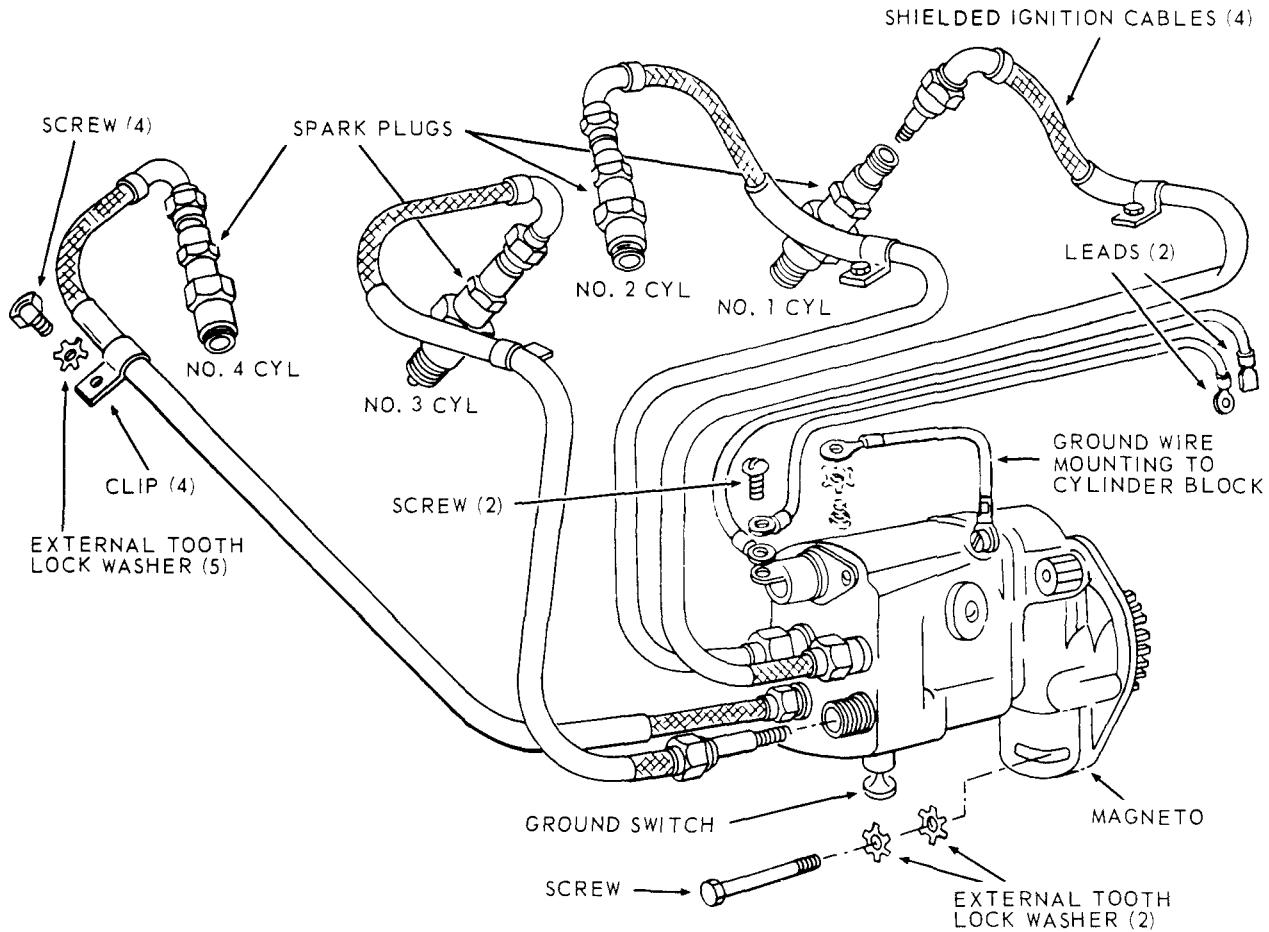

ME 6115-440-20/2-1

Figure 2-1. Location and replacement of radio suppression components.

Section VII. MAINTENANCE OF GENERATOR SET

2-14. General Cleaning and Inspection.

- Clean all metal parts in an approved cleaning solvent (e.g., Fed P-D-680).
- Clean all surfaces and install new gaskets.
- Inspect all parts before installing or reinstallation for cracks, wear, rust, corrosion, deterioration or any type damage.
- Inspect all hardware for damaged threads.
- Inspect all lines, hoses, and fittings for damage. Replace a defective line, hose, or fitting.

2-15. Canvas Cover

- Inspection.*
 - Inspect the generator set canvas cover for rips and tears.

- Inspect for damage or missing hardware.
- Repair.*
 - If canvas cover is torn, repair by sewing.
 - Replace missing hardware.
 - Replace canvas cover if damaged or deteriorated beyond repair.

2-16. Muffler Cover

- Removal.* Remove the four screws, nuts and clamps and remove the muffler cover (fig. 2-18).
- Installation.* Install the muffler cover clamp, screws and nuts (fig. 2-18).

Section VIII. CONTROL BOX COMPONENTS

2-17. Voltmeter and Total Time Meter

a. Removal. Refer to figure 2-2 and remove the voltmeter and total time meter.

b. Installation. Refer to figure 2-2 and install the voltmeter and total time meter.

c. Test. Test the voltmeter and total time meter for proper operation.

2-18. Switches

a. Removal. Refer to figure 2-2 and remove magneto switch and control switch.

b. Installation. Refer to figure 2-2 and install the magneto switch and control switch.

c. Test. Test the magneto switch and the control switch for proper operation.

2-19. Instruction Plates

a. Removal. Refer to figure 2-2 and remove the instruction plates.

b. Installation. Refer to figure 2-2 and install the instruction plates.

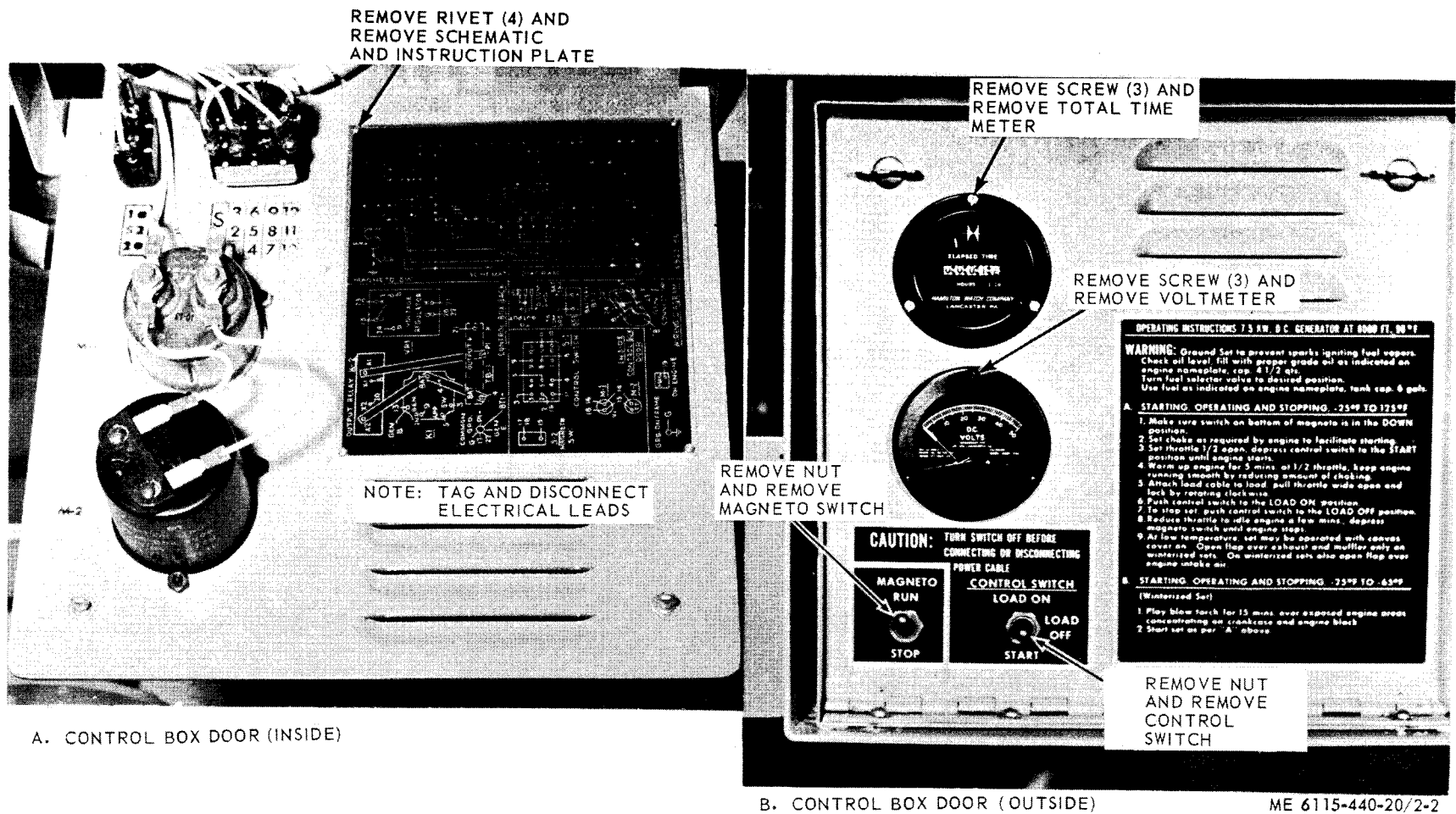

Figure 2-2. Instruments, switches and instruction plates, removal and installation.

2-20. Control Box Wiring Harness

a. *Inspection.* Inspect all wiring insulation for cracks and frayed places.

b. *Testing.* To test the lead for continuity, disconnect each end of a lead from the component to which it is attached. Touch the probes of a test light to each end of the lead. If lamp does not light, lead is defective.

2-21. Terminal Board and Load Stud Power Cable

Inspect the terminal board and load studs for cracks, breaks, looseness and corrosion.

2-22. Voltage Regulator

a. *Removal.* Refer to figure 2-3 and remove the voltage regulator.

b. *Installation.* Refer to figure 2-3 and install the voltage regulator.

c. *Adjustment.* Turn the voltage regulator rheostat adjusting knob (fig. 2-3) with a screwdriver until the output voltage indicated on the voltmeter is correct (normal reading is 28 volts).

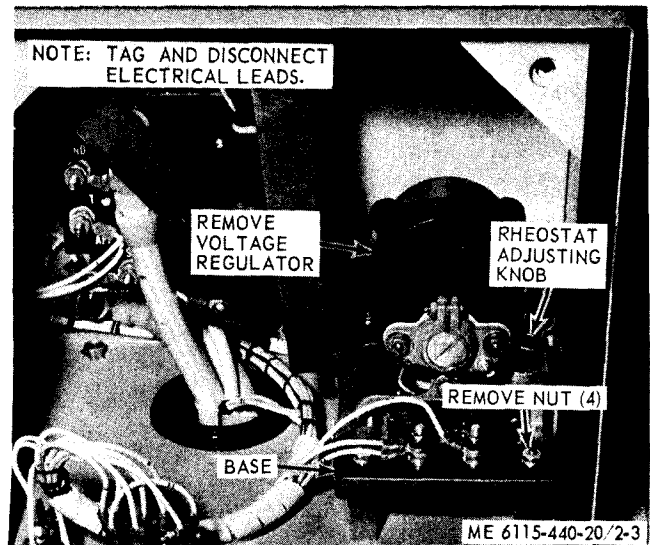

Figure 2-3. Voltage regulator, removal and installation.

Section IX. FUEL SYSTEM

2-23. General

The fuel system consists of the air cleaner, fuel strainer, fuel pump, carburetor, fuel selector valve and fuel tank. The air cleaner is secured to a mounting plate on the front left end of the engine flywheel shroud. The fuel pump is connected to an adapter and primer which is used to help pump the fuel when an engine has been out of operation for a long time. The fuel is filtered by a fuel strainer before it enters the fuel pump. The carburetor is located directly under the exhaust manifold. The carburetor is of the updraft single venturi design.

2-24. Air Cleaner

a. *Removal.* Refer to figure 2-4 and remove the air cleaner.

b. *Installation.* Refer to figure 2-4 and install the air cleaner.

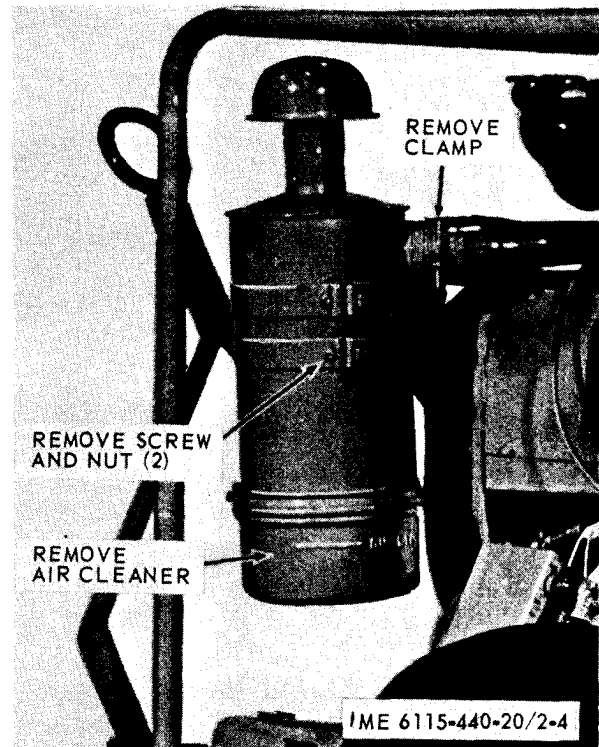

Figure 2-4. Air cleaner, removal and installation.

2-25. Fuel Strainer

a. Removal.

(1) Place fuel selector valve handle in OFF position.

(2) Refer to figure 2-5 and remove the fuel strainer.

b. Installation. Refer to figure 2-5 and install the fuel strainer.

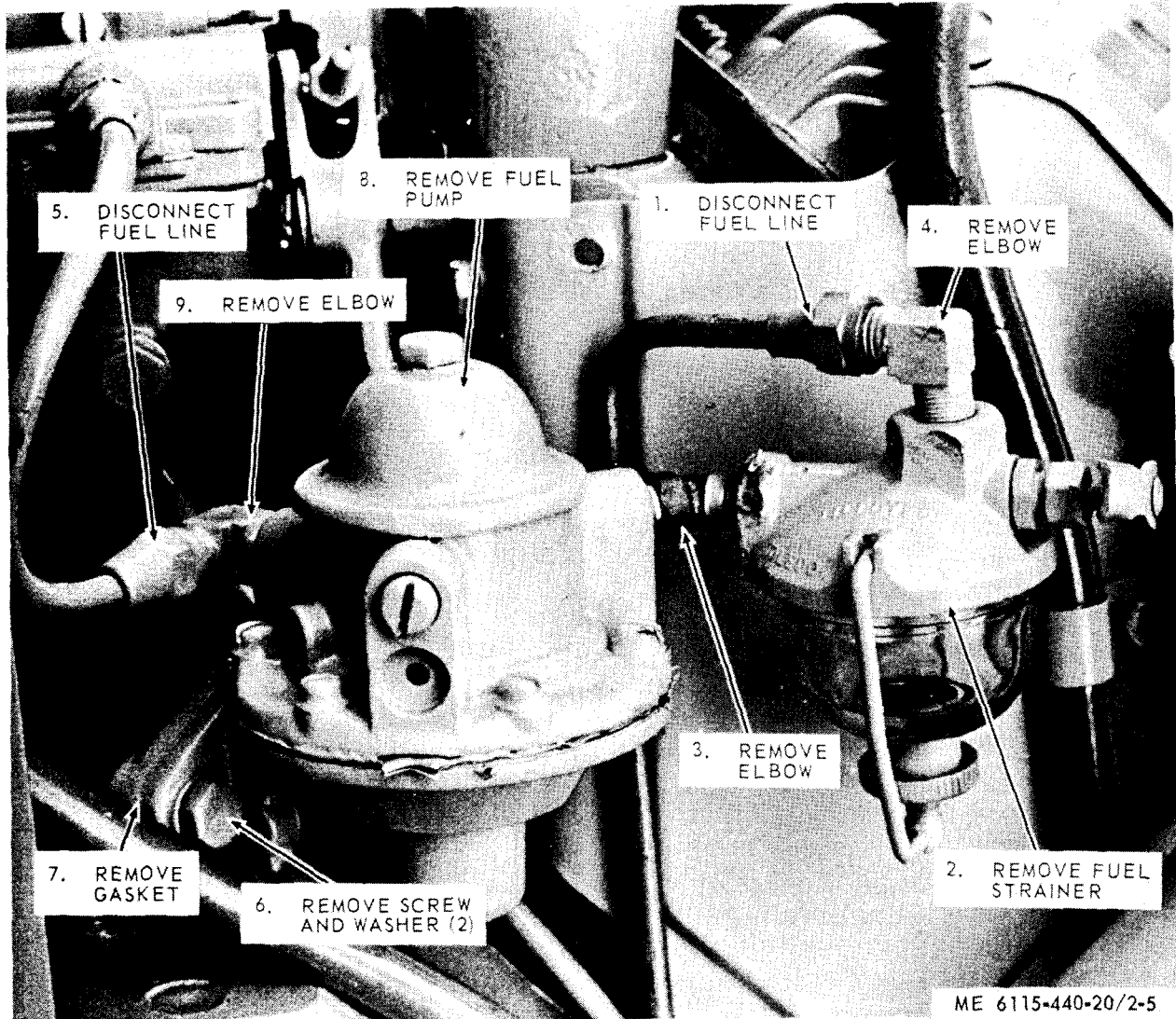

Figure 2-5. Fuel strainer and fuel pump, removal and installation.

2-26. Fuel Pump

a. Removal.

(1) Place fuel selector valve handle in OFF position.

(2) Refer to figure 2-5 and remove the fuel pump.

b. Installation. Refer to figure 2-5 and install the fuel pump.

c. Test. Test the fuel pump for proper operation.

2-27. Carburetor

a. Adjustment. If engine idles roughly, set the idle adjusting needle for best low speed smooth operation. Turning the idle adjusting needle (fig. 2-

6) inward (clockwise) increases the fuel suction and results in a richer mixture. Turning the idle adjusting needle outward (counter-clockwise) increases the quantity of air and results in a leaner mixture.

b. Removal. Refer to figure 2-6 and remove the carburetor.

c. Inspection.

(1) Inspect the carburetor for damage or leaks.

(2) Inspect the choke control assembly for damage or broken cable. Replace a defective choke cable.

d. Installation. Refer to figure 2-6 and install the carburetor.

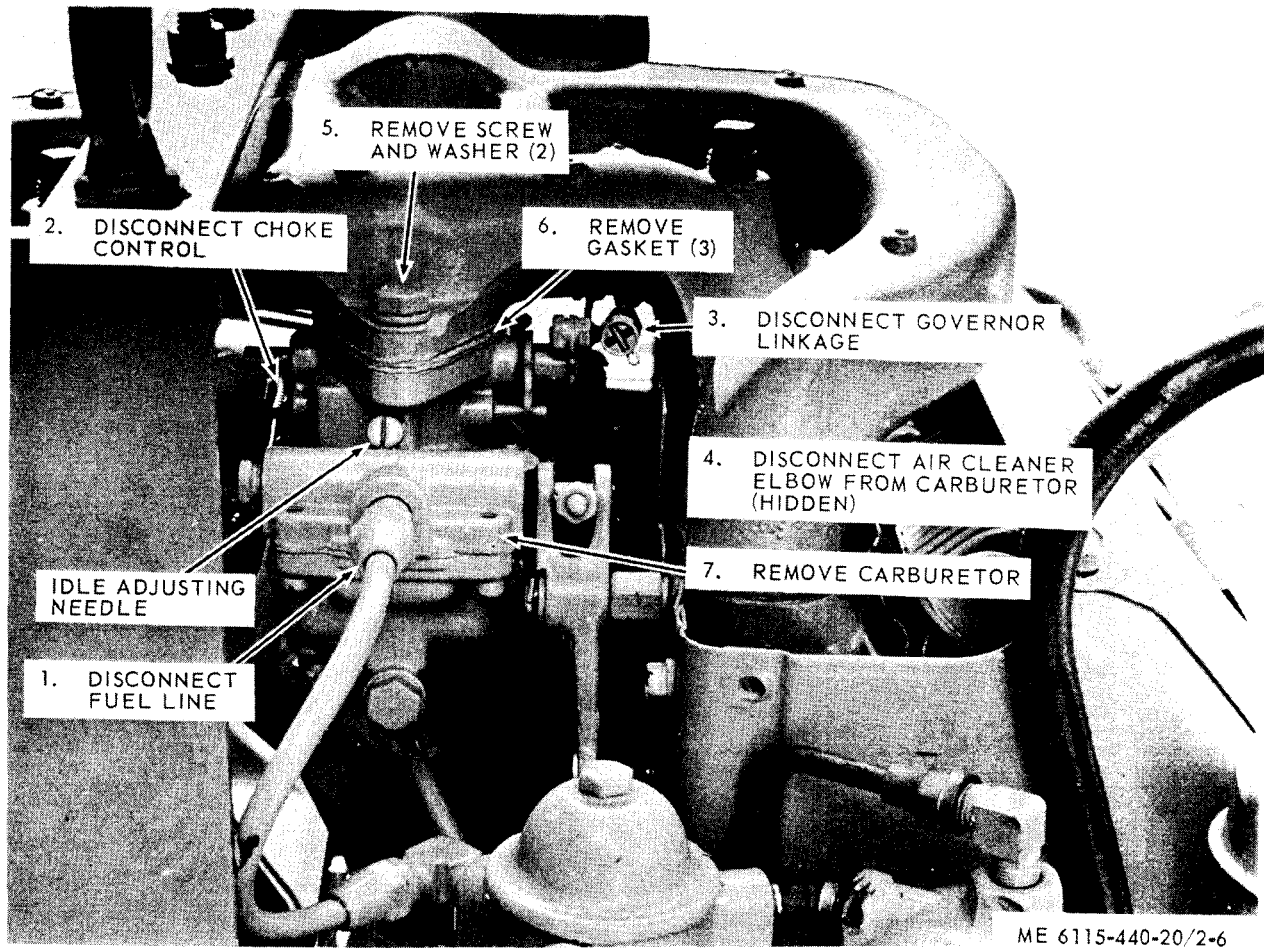

Figure 2-6. Carburetor, removal and installation.

2-28. Fuel Selector Valve and Bracket

a. Removal.

- (1) Drain fuel tank (TM 5-6115-440-10).
- (2) Refer to figure 2-7 and remove the fuel selector valve and bracket.

b. Installation.

- (1) Refer to figure 2-7 and install the fuel selector valve and bracket.
- (2) Fill fuel tank (TM 5-6115-440-10).

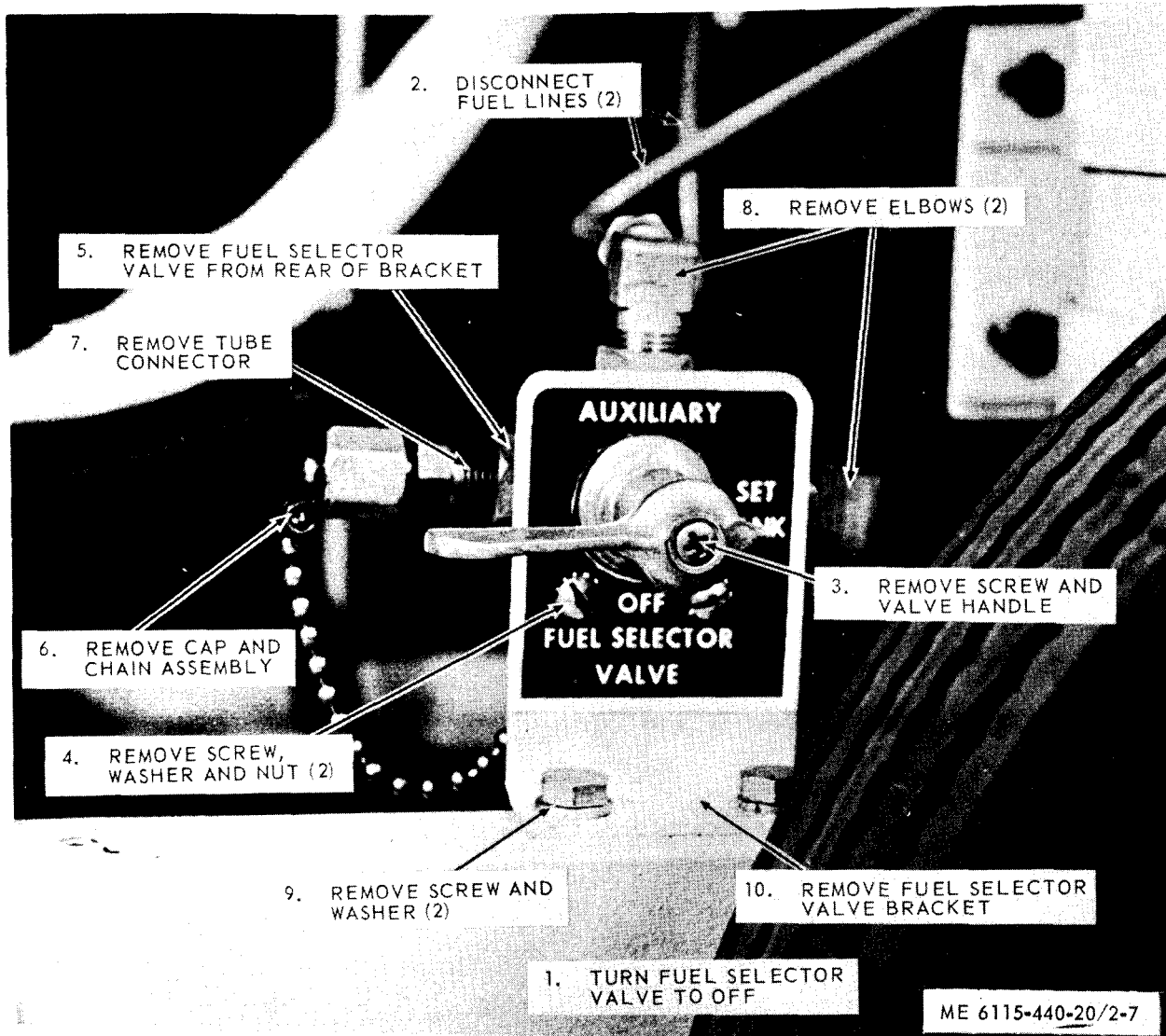

Figure 2-7. Fuel selector valve and bracket, removal and installation.

2-29. Fuel Tank

a. *Removal.* Refer to figure 2-8 and remove the fuel tank.

b. *Installation.* Refer to figure 2-8 and install the fuel tank.

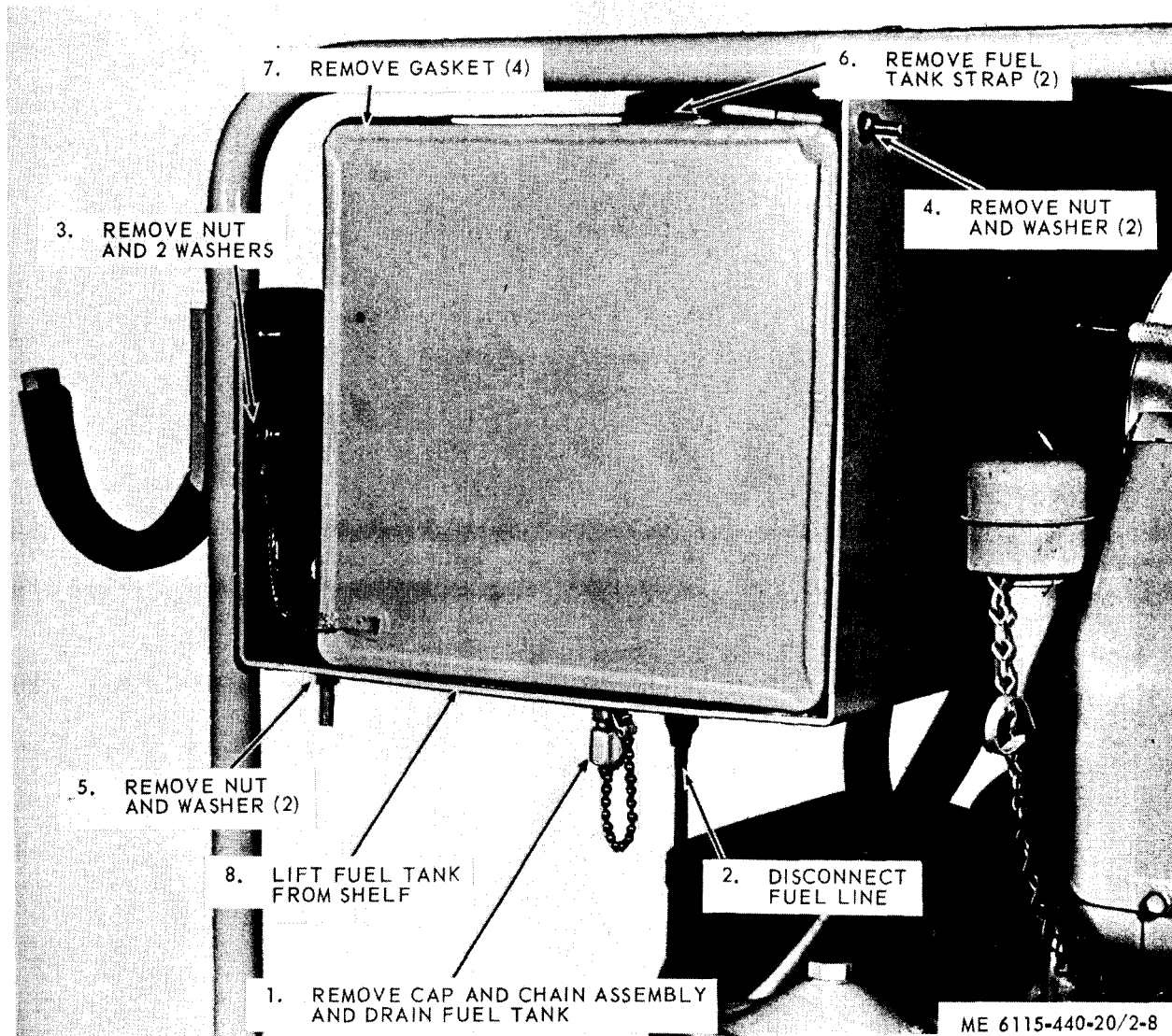

Figure 2-8. Fuel tank, removal and installation.

Section X. LUBRICATING SYSTEM

2-30. General

The oil filter filters the impurities from the oil at the rate of one quart every five minutes. A special restrictive fitting is provided in the connection to the oil filter which restricts the amount of oil going through the filter. The oil drain assembly is located on the crankcase on the right side of the generator set.

2-31. Oil Filter and Bracket

a. Service. Refer to figure 2-9 and service the engine oil filter.

b. Removal.

- (1) Remove the engine belt sheave (para 2-42).
- (2) Refer to figure 2-10 and remove oil filter and bracket.

c. Installation.

- (1) Refer to figure 2-10 and install the oil filter and bracket.
- (2) Install engine belt sheave (para 2-42).

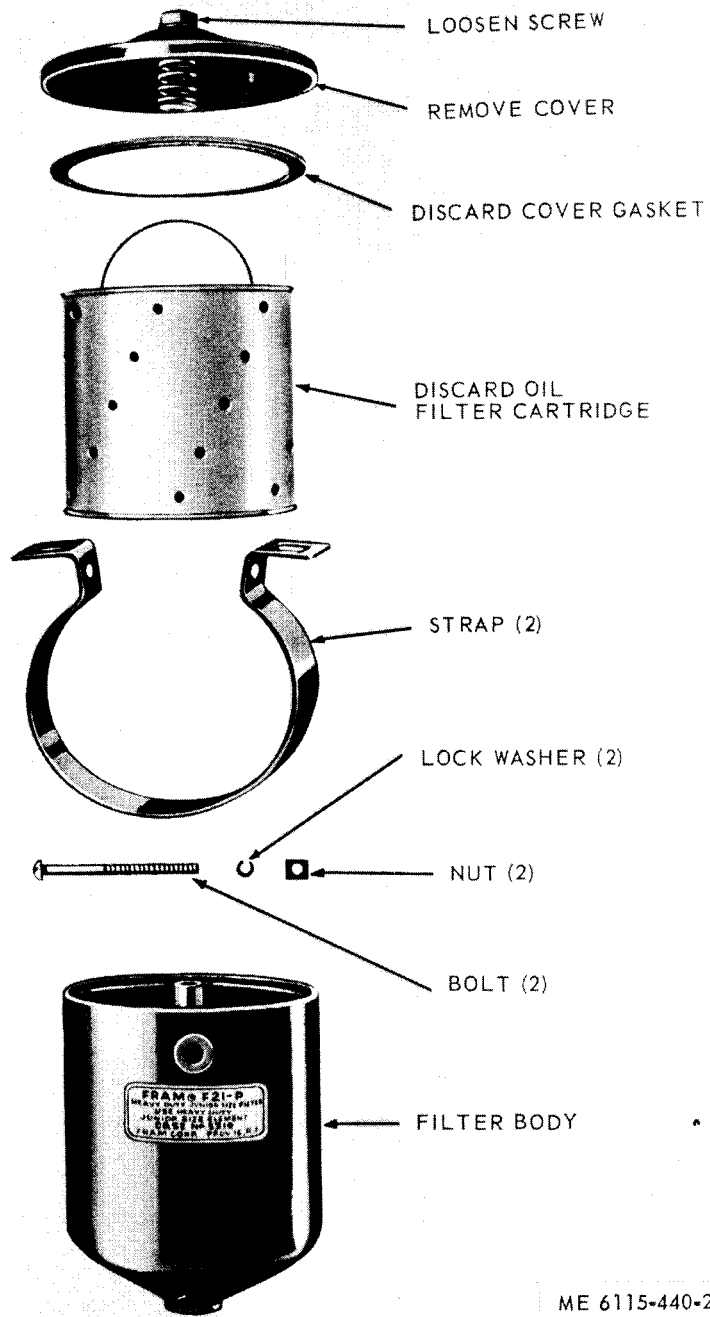

NOTE:
 SERVICE AFTER EACH 100
 HOURS OF OPERATION. CLEAN
 COVER AND FILTER BODY WITH
 APPROVED CLEANING SOLVENT
 AND CLEAN CLOTH.

ME 6115-440-20/2-9

Figure 2-9. Oil filter service.

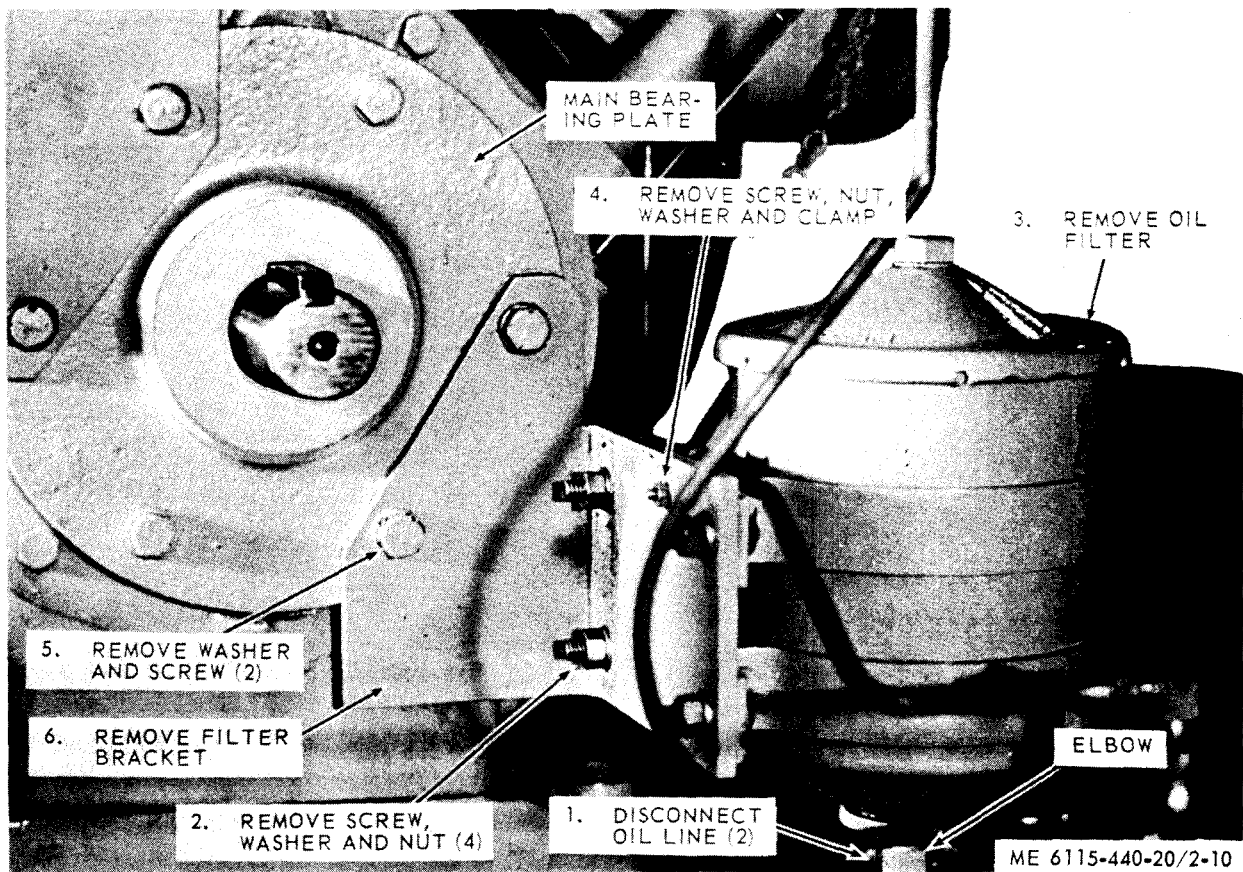

Figure 2-10. Oil filter and bracket, removal and installation.

2-32. Oil Drain Assembly

a. Removal.

- (1) Open oil drain valve and drain oil into a suitable container.
- (2) Refer to figure 2-11 and remove oil drain assembly.

b. Installation.

- (1) Refer to figure 2-11 and install the oil drain assembly.
- (2) Service the engine oil assembly in accordance with current lubrication order.

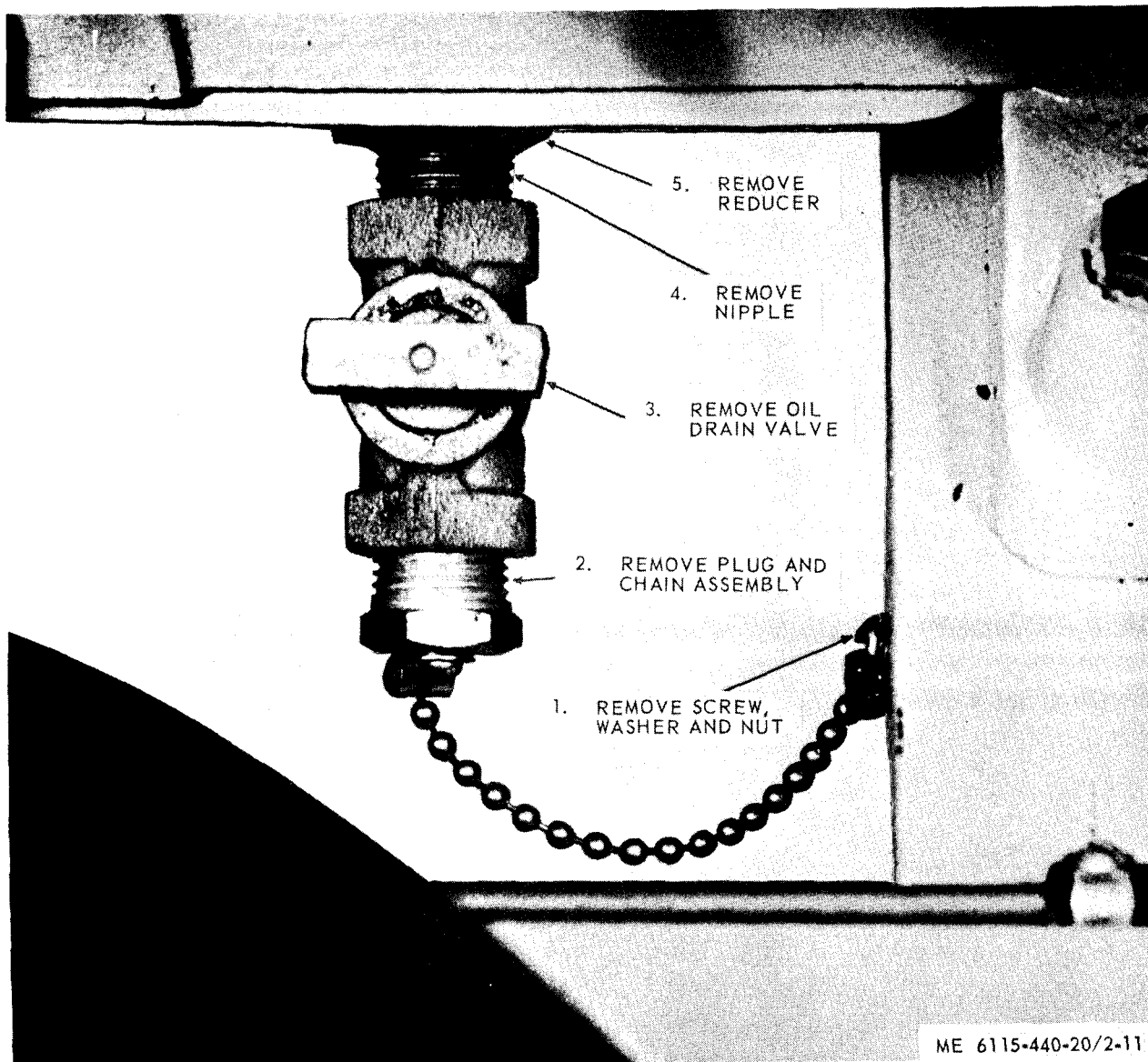

Figure 2-11. Oil drain assembly, removal and installation.

Section XI. ELECTRICAL SYSTEM

2-33. General

The engine electrical system consists of the magneto, spark plugs and ignition leads. The magneto is a radio shielded assembly that contains the breaker points, capacitor and timing gears for determining the spark advance.

2-34. Spark Plug

a. Removal.

(1) To remove spark plug use an open wrench to loosen the shielded ignition cable connecting nuts (fig. 2-1). Unscrew the nuts and separate each cable from the spark plug.

(2) Using a deep socket wrench, remove the spark plug.

b. Clean and Adjust.

(1) Inspect the spark plug for cracks and excessive gap.

(2) Clean the spark plug by wire-brushing and by digging out carbon around the insulator with a sharp instrument.

(3) Using a 0.030 inch spark plug gage, set the spark plug gap.

c. Installation.

(1) Install spark plug and tighten to a torque of 25 to 30 foot-pounds.

(2) Insert the shielded ignition cable ends into the spark plugs and tighten the connector nuts. Replace a defective spark plug cable (fig. 2-1).

2-35. Battery and Battery Cables

a. Removal.

- (1) Remove the battery cover (TM 5-6115-440-10).
- (2) Disconnect battery cables.
- (3) Lift battery out of frame.

b. Inspection.

- (1) Inspect battery for cracks, corrosion and correct electrolyte level (TM 5-6115-440-10).
- (2) Inspect battery cables for deterioration, breaks and corrosion. Replace a defective cable or battery.

c. Installation.

- (1) Position battery in frame.
- (2) Connect battery cables.
- (3) Install battery holddown and cover (TM 5-6115-440-10).

2-36. Magneto

a. *Magneto Spark Check and Inspection.* If magneto is suspected to providing weak or no ignition sparks (engine misfiring or hard starting), perform the following check before attempting any magneto adjustment or repair.

- (1) Unscrew shielded ignition cable from the cylinder No. 1 spark plug.
- (2) Insert the starting hand crank over the crankshaft (fig. 2-12).
- (3) Holding the terminal end of the shielded ignition cable 1/8 inch from the air shroud (or other electrical ground), turn the engine over slowly for at least two revolutions with the starting hand crank.
- (4) Observe the terminal end of the shielded ignition cable for spark discharges which should occur during each cycle.
- (5) Reconnect the shielded ignition cable to the spark plug and repeat the check with shielded ignition cables from cylinders No. 2, 3, and 4, in turn.

NOTE

Reconnect each ignition cable to the proper spark plug before removing the next ignition cable.

- (6) If weak sparks, or no sparks are observed, check breaker point gap adjustment.
 - (7) If strong sparks are observed from all shielded ignition cables, the magneto and cables can be eliminated as sources of trouble. Inspect spark plugs, electrical connections, and other leads for damage.
- b. *Breaker Point Adjustment.* If the ignition spark is weak when checked, breaker points may require adjustment.

- (1) Remove four end cover screws from the magneto and lift away the end cover with the shielded ignition cables attached.
- (2) Inspect the breaker points. If there is

evidence of pitting, resurface the points with a small tungsten file.

- (3) If points are badly pitted or worn, replace them.
- (4) Check breaker point gap by inserting the starting hand crank and rotating the engine until the breaker point gap is fully open. Measure the gap with a feeler gage (fig. 2-13). The gap should be 0.015 inch.
- (5) If the breaker point gap is not correct loosen two locking screws on the contact plate (fig 2-13).
- (6) Insert a small screwdriver into the contact plate adjusting slot and open or close the gap by moving the contact plate as required.
- (7) When the gap is correct, tighten the locking screws and recheck the gap.
- (8) Install magneto end cover and gasket carefully to assure proper seal, and secure with four screws and lock washers.

NOTE

The two longer screws are to be installed in the outer pair of mounting holes.

- (9) Replace a defective magneto.

c. *Removal.* Refer to figure 2-14 and remove magneto.

d. *Installation and Timing.* Refer to figure 2-14 and install magneto as follows:

- (1) Attach magneto gear to magneto as shown in figure 2-15.
- (2) Remove flywheel screen.
- (3) Using the starting hand crank, crank engine until the reference vane on the flywheel is aligned with centerline mark on shroud (fig. 2-16).
- (4) Position magneto with magneto gear indexed as shown in figure 2-16.
- (5) Secure magneto to gear cover with a screw, washer, and a nut for the lower bracket mounting hole; and with a nut, stud and washer on the upper mounting hole (fig. 2-14).
- (6) Connect the ground wire and magneto leads (fig. 2-13).
- (7) Connect the shielded ignition cables to the corresponding cylinder numbered end caps.
- (8) Using chalk or paint, mark the edge of the flywheel reference vane.
- (9) Connect a timing light to the No. 1 terminal of the magneto (fig. 2-16).
- (10) Using starting hand crank, slowly turn crankshaft. Timing light must flash when marked vane is aligned with centerline of No. 1 and No. 3 cylinders (fig. 2-16).
- (11) Start engine. Timing light must flash when flywheel reference vane is 23 degrees before centerline of No. 1 and No. 3 cylinders.

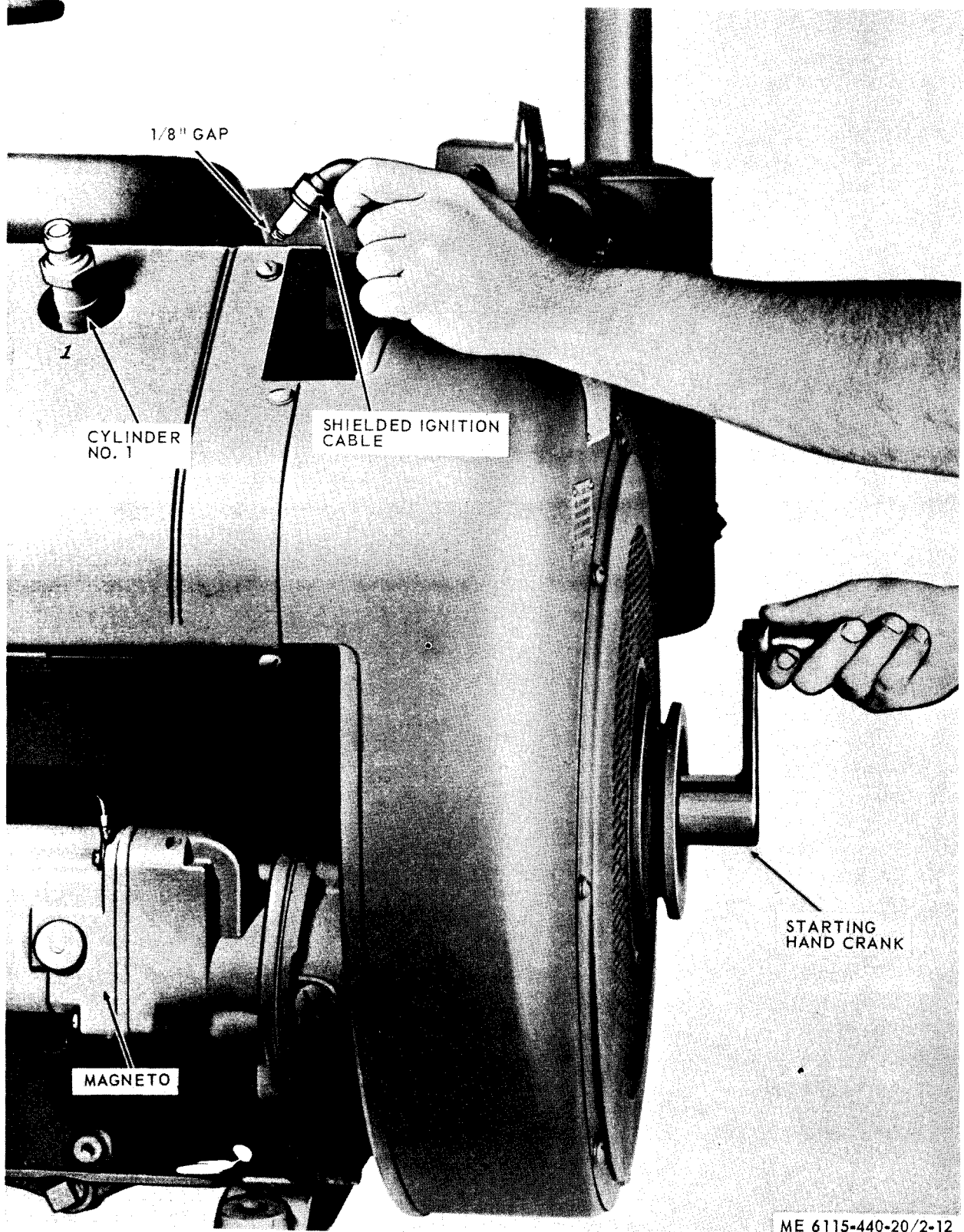
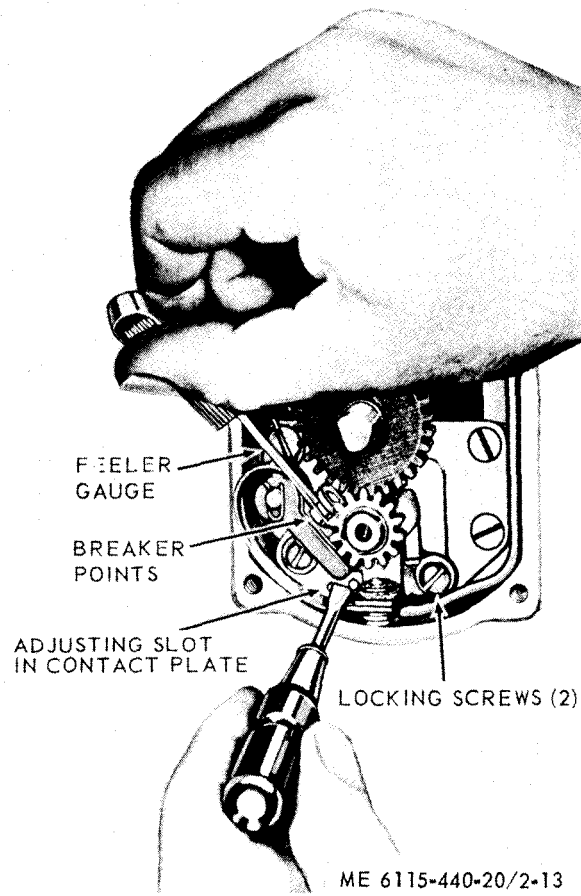

Figure 2-12. Magneto spark check.



ME 6115-440-20/2-13

Figure 2-13. Magneto breaker point adjustment.

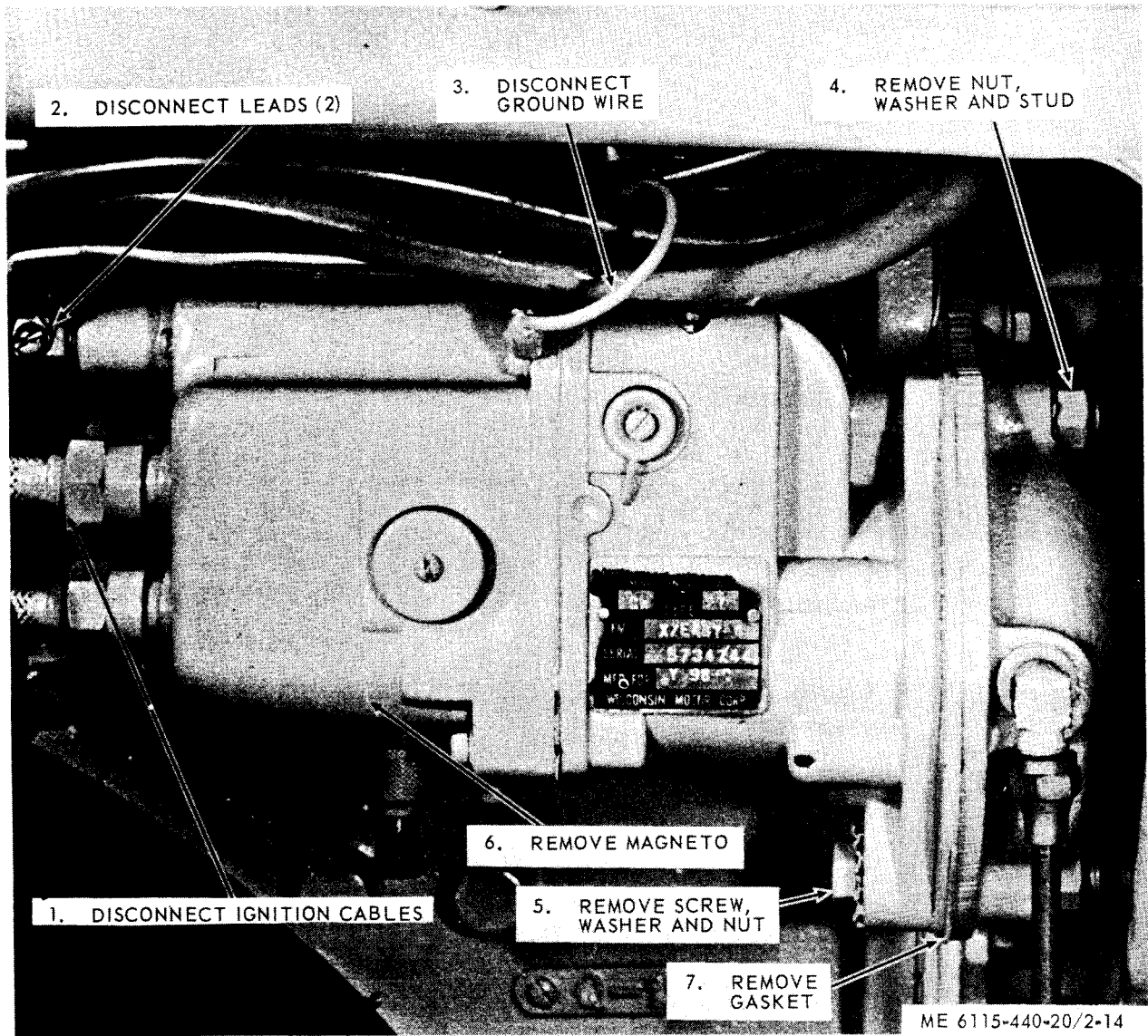
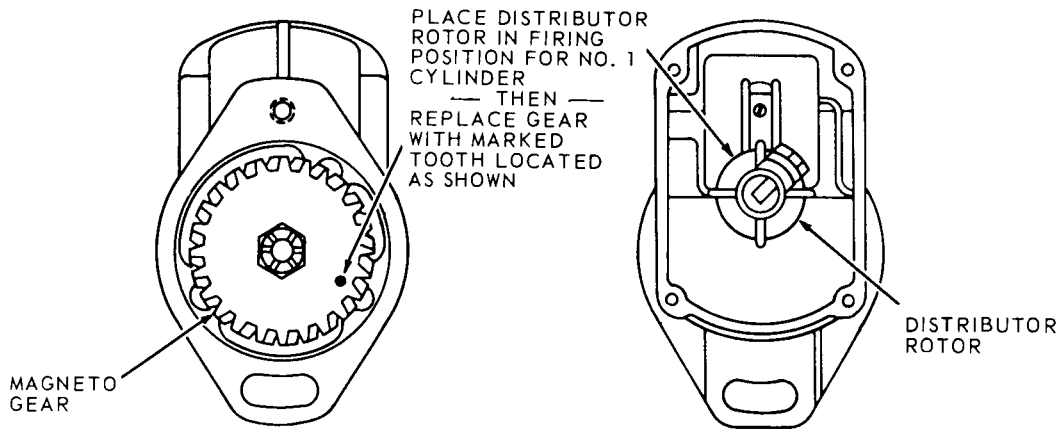
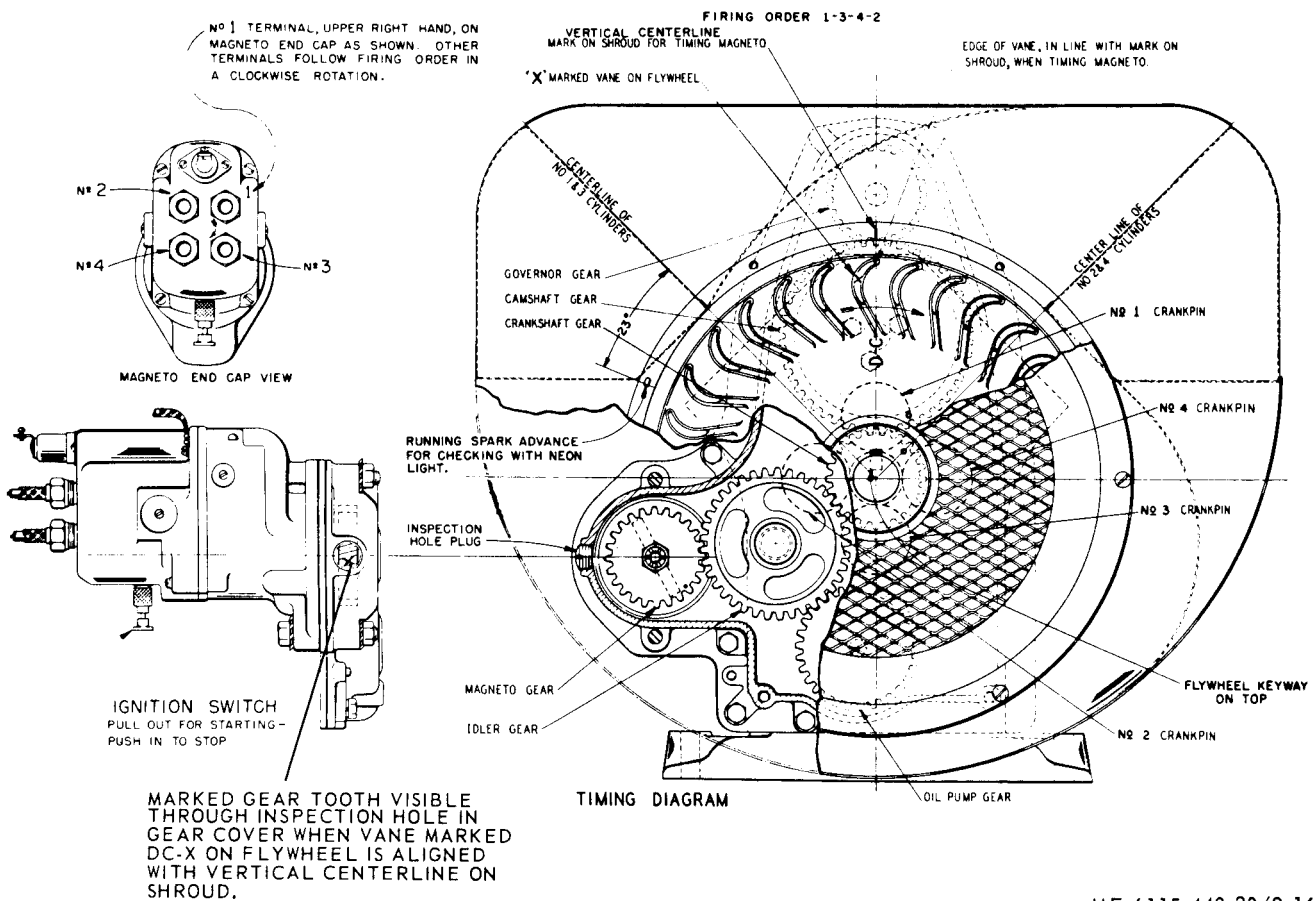

Figure 2-14. Magneto, removal and installation



ME 6115-440-20/2-15

Figure 2-15. Alignment of magneto gear to magneto.



ME 6115-440-20/2-16

Figure 2-16. Timing of magneto.

2-37. Starter-Generator

a. General. The starter-generator serves the dual purpose of starting the engine and of providing the output voltage by being driven by the engine during normal operation. The starter-generator is mounted alongside the engine and is coupled to the engine by a sheave and belt arrangement.

b. Brush Replacement.

(1) Remove the brush cover band assembly from the starter generator.

(2) Remove the screws and lift out the six brushes. Replace old brushes with new brushes.

(3) Reinstall the brush cover band assembly on the starter-generator.

c. Flashing the Starter-Generator Fields. If the starter-generator voltage does not build up properly due to loss of residual magnetism in the shunt field circuit, flash the field as follows:

(1) Connect the positive terminal of a 12-volt battery through an SPST (single-pole, single-throw) knife switch to terminal A on the starter generator.

CAUTION

Always use a knife switch when flashing the field. Opening the circuit at the starter generator or battery terminals can result in severe damage to the terminals or explosion of the battery.

(2) Connect the negative terminal of the battery to terminal E on the starter generator.

(3) Apply battery current to the shunt field for 5 seconds by closing the knife switch.

(4) Repeat the operation several times to be sure that the field is properly flashed.

d. Brush Treatment.

(1) *General.* New brushes must be properly seated on the commutator before making the generator performance test. If the brushes have been replaced they should be sanded and run-in to properly seat them on the commutator before applying a load to the generator. Failure to properly seat the brushes will result in excessive sparking, thus causing premature burning and pitting on the commutator.

(2) Preliminary Brush Seating.

(a) Using a stiff wire hook raise each brush spring and lift the brush away from the commutator far enough to permit a strip of 5/0 sandpaper to slip under the brush. The sandpaper strip must be slightly wider than the combined width of the two brushes and located with sand side out. Cut the sandpaper so that, when tight against the commutator, the two ends of the strip will lack approximately 1/32 inch of meeting. Secure the ends of the sandpaper with a small piece of adhesive tape.

(b) Lower all brushes in place carefully against the sandpaper making certain the brush springs are properly positioned on the brushes.

(c) Rotate the armature slowly by hand in the normal direction of rotation (clockwise when viewed from air inlet end) until the brush contour matches the cylindrical surface of the commutator. A brush should be raised and inspected occasionally so that the progress of the seating operation can be observed and the removal of unnecessary material avoided.

(d) Raise the brushes, remove the sandpaper strip and carefully release the brushes against the commutator.

Section XII. EXHAUST SYSTEM

2-38. General

The exhaust system of the generator set consists of the exhaust manifold and muffler. The muffler is provided with a weather cap to keep moisture out of the system.

2-39. Muffler and Weather Cap

a. Removal. Refer to figure 2-17 and remove the muffler and weather cap.

b. Installation. Refer to figure 2-17 and install the muffler and weather cap.

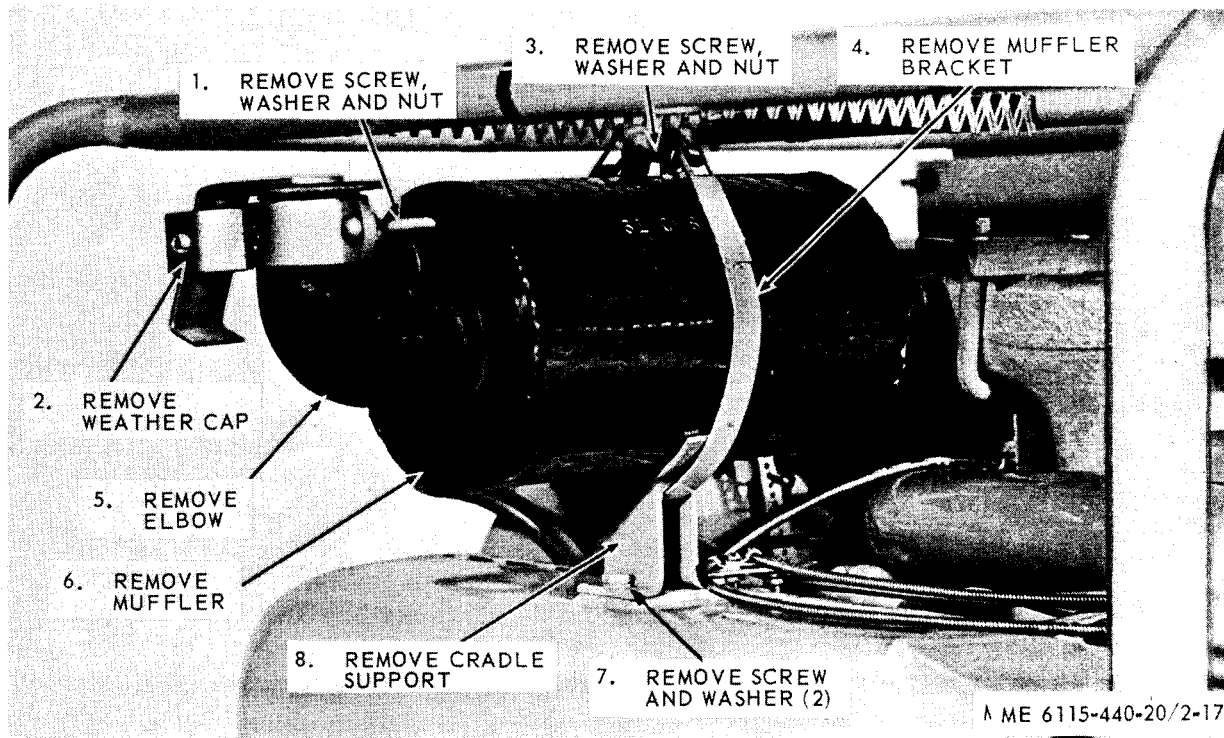

Figure 2-17. Muffler and weather cap, removal and installation.

2-40. Intake and Exhaust Manifold

a. Removal.

- (1) Remove muffler (para 2-39).
- (2) Remove lifting bar (para 2-44).
- (3) Refer to figure 2-18 and remove the intake and exhaust manifold.

b. Installation.

- (1) Refer to figure 2-18 and install the intake and exhaust manifold.
- (2) Install the lifting bar (para 2-44).
- (3) Install the muffler (para 2-39).

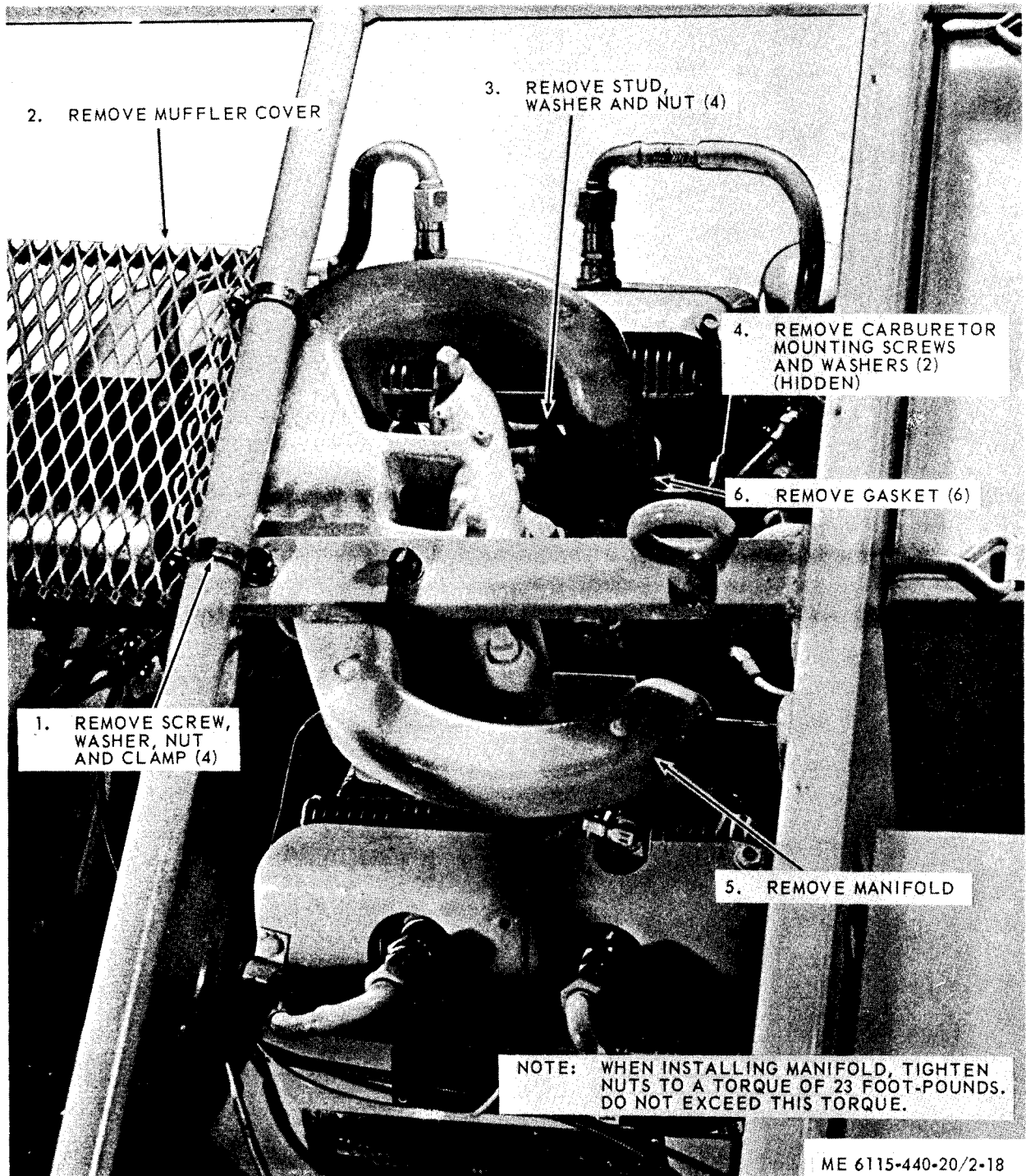

Figure 2-18. Intake and exhaust manifold, removal and installation.

Section XIII. DRIVE BELTS, ENGINE AND STARTER-GENERATOR SHEAVE AND LIFTING BAR

2-41. General

The three drive belts used to turn the starter generator during operation, and to turn the engine over during starting, ride on three-groove sheaves mounted on the engine crankshaft and the starter generator drive shaft.

2-42. Drive Belts

a. Tension Check and Adjustment.

(1) To check the drive belts for proper tension, press the thumb down on each belt midway between the two sheaves. If the tension is correct, each belt will deflect approximately $\frac{1}{2}$ inch (fig. 2-19).

NOTE

If the tension on one or two of the belts is incorrect, the adjustment procedure will not correct the trouble and one or more of the belts will require replacement.

(2) To adjust drive belt tension, loosen four nuts in the slotted generator adapter plate (fig. 2-19). Using a steel bar as a prying device, shift the starter generator position until drive belt tension is correct. Holding the steel bar in position to prevent movement, tighten the four nuts.

(3) Recheck drive belt tension after adjustment.

b. *Removal.* If one or more of the drive belts are worn, frayed, or cracked, replace the drive belt.

Loosen the starter generator mounting nuts and slide the starter generator toward the engine until the belts are loose enough for removal.

c. *Installation.*

(1) With the four nuts (fig. 2-19) loose, and the starter generator moved as close to the engine as possible, bring the loose ends of each drive belt over the loose sheave and insert into the proper grooves.

(2) Check and adjust the drive belt tension (see above).

2-43. Engine and Starter Generator Sheaves

a. *Removal.* Proceed as follows when removing either the engine or starter generator sheave:

(1) Loosen drive belts from sheave to be removed (para 2-42).

(2) Remove two set screws (fig. 2-19) from bushing.

(3) Insert one set screw into third hole which did not originally contain a set screw and tighten. This will loosen bushing.

(4) Drive chisel into slot in bushing and lift out bushing.

(5) Remove sheave and square key from crankshaft or generator adapter shaft.

b. *Installation.* Installation procedure for the engine or starter sheave is the reverse of the removal procedure.

Figure 2-19. Drive belt adjustment, removal and installation.

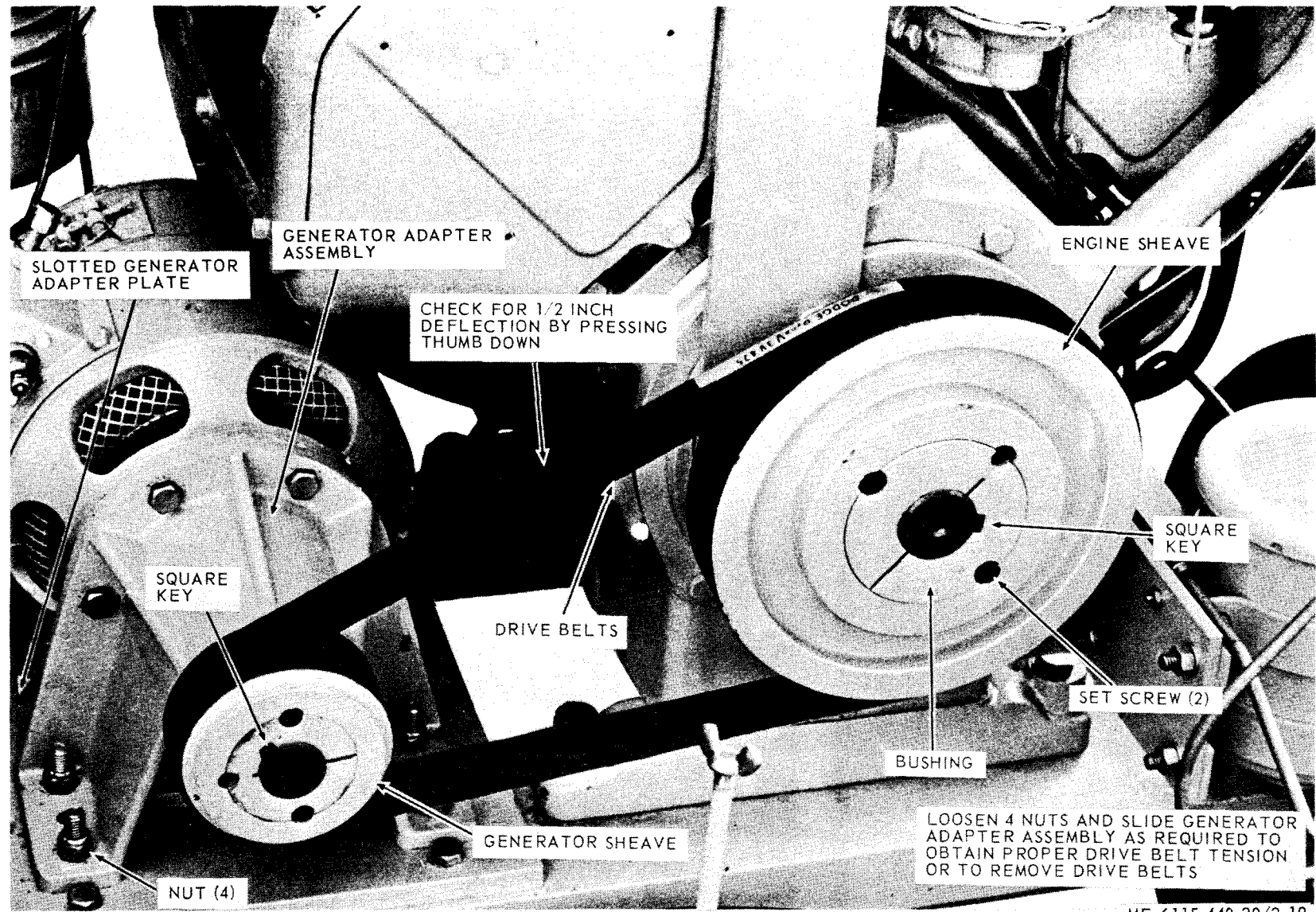

ME 6115-440-20/2-19

2-44. Lifting Bar

a. Removal.

(1) Remove two nuts (1, fig. 2-20), washers (2), and U-bolt (3) from lifting bar (5) on top of engine.

(2) Remove engine sheave (para 2-43).

(3) Remove two screws (4) which secure the lifting bar (5) to the main bearing plate on the engine.

(4) Remove lifting bar.

(5) Remove nut (6), washer (7), and lifting eye (8).

(8).

b. *Installation.* Installation procedure for the lifting bar is the reverse of the removal procedure.

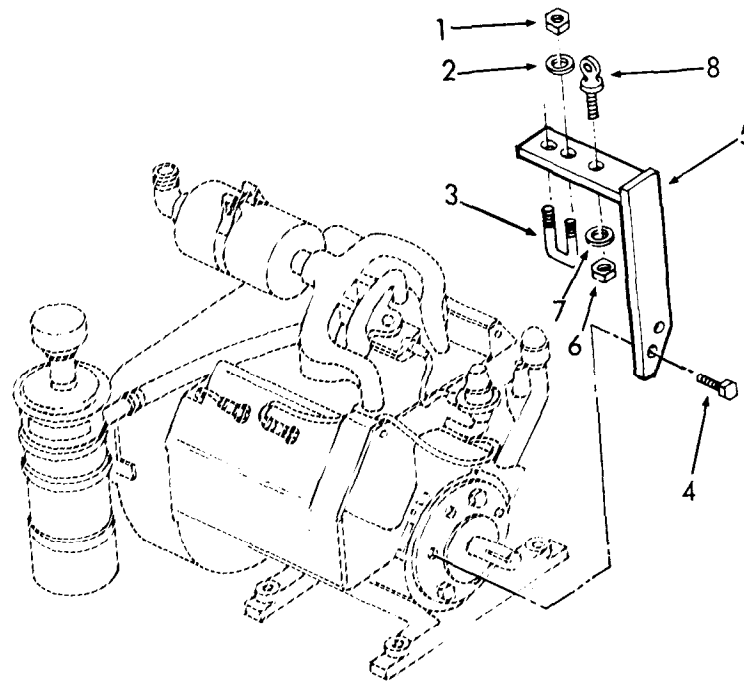

ME 6115-440-20/2-20

1 Nut
2 Washer
3 U-bolt
4 Screw

5 Lifting bar
6 Nut
7 Washer
8 Lifting eye

Figure 2-20. Lifting bar, removal and installation.

Section XIV. ENGINE ASSEMBLY

2-45. General

The generator set engine is a four-cylinder, four-cycle engine. A governor of the centrifugal flyball type controls the engine speed by varying the throttle opening to suit the load imposed upon the engine.

2-46. Governor and Governor Control Adjustment

a. The control rod between the governor and carburetor must be adjusted to the proper length, otherwise governor action will be faulty. With the engine at rest the governor spring will hold the flyweights in, and the control rod must be of such length as to hold the carburetor throttle wide open at that point. The accuracy of this adjustment can be

tested by disconnecting the control rod ball joint from the governor lever, and then pushing the rod assembly toward the carburetor as far as it will go. This will open the throttle wide. The governor lever should then be moved as far as possible in the same direction. Holding both parts in the above position, the ball joint should be screwed on to the control rod until the right angle stud on the ball joint fitting will align with the hole in the lever, then, screw fitting in two more turns. Insert ball joint stud into the hole in the governor lever, assemble and tighten locknuts. With the governor lever pushed toward the carburetor as far as it will go, there should be about a 1/16 inch clearance between the throttle lever

and the stop pin on the carburetor. The clearance will cause the lever to bounce back from the stop pin, rather than jam against the pin, when a load is suddenly applied to an idling engine. This will eliminate excessive wear on the threads of the control rod and ball joints.

b. The governor lever is furnished with 12 holes for attaching the governor spring as shown in figure 2-21. It is very important that the spring is hooked into the proper hole to suit the speed at which the engine is operated. The governor lever chart (fig. 2-21) shows the full load and no load speeds of the engine and the hole corresponding thereto. The full load speed will be from 150 to 125 revolutions less than the no load speed. As an example; if the engine is to be operated at 2000 revolutions per minute under load, the spring should be hooked into the 8th hole in the governor lever and the spring tension adjusted by means of the adjusting screw connected to the spring, to run 2150 revolutions per minute, without load. The speed at full load will then be approximately 2000 revolutions per minute. A tachometer or revolution counter should be used against the crankshaft while making this adjustment.

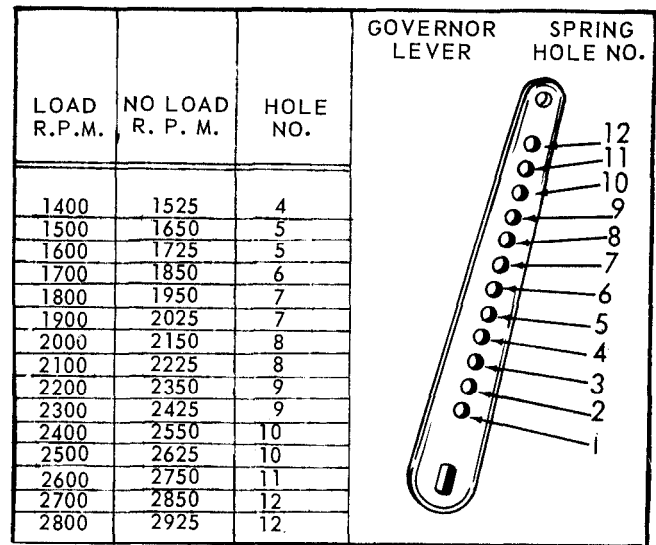

ME 6115-440-20/2-21

Figure 2-21. Governor lever adjustment chart.

2-47. Engine Air Shroud and Air Deflector

a. *General.* The engine air shrouds and air deflectors are installed around the cylinder block

assemblies and cylinder beads to guide and direct the air that provides the cooling of the engine.

b. Removal. Refer to figure 2-22 and remove the engine air shroud and air deflectors.

c. Inspection. Inspect the shroud and deflectors

for cracks, breaks, dents. Replace a defective engine shroud.

d. Installation. Refer to figure 2-22 and install the engine air shroud and air deflector.

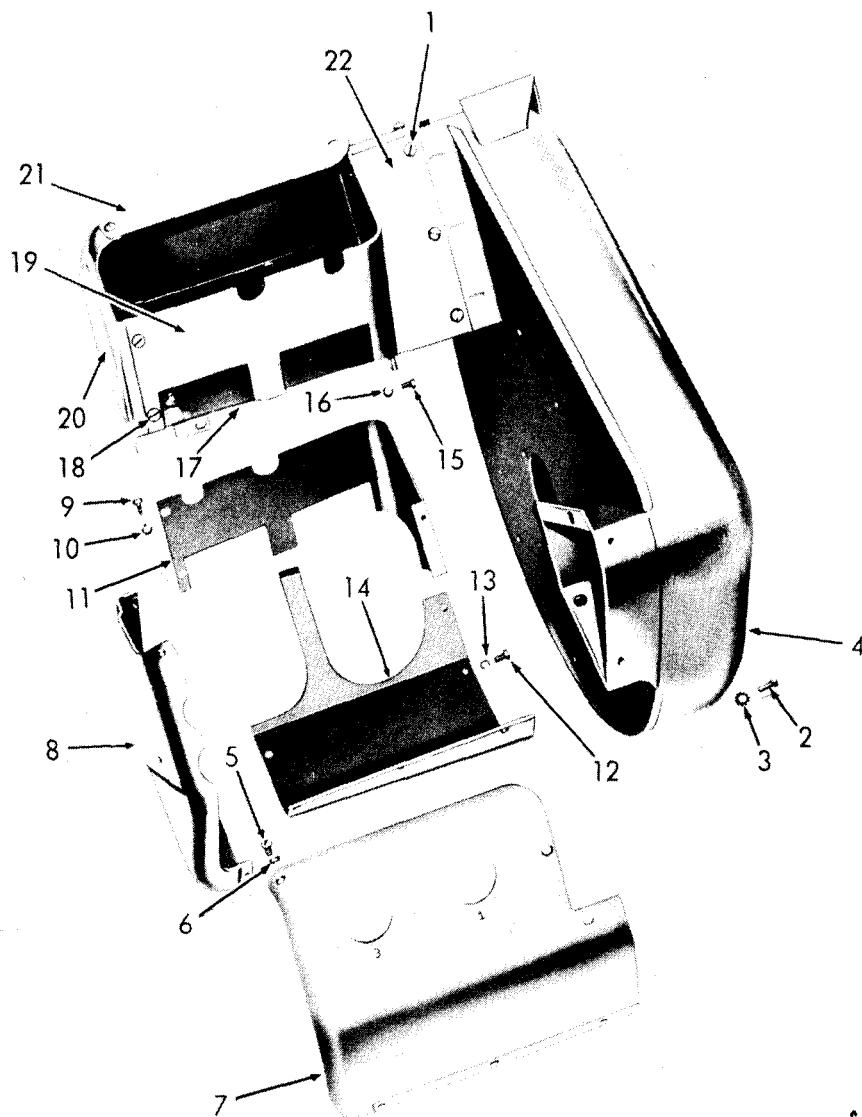

ME 6115-440-20/2-22

- 1 Screw, round head
- 2 Screw, hex head
- 3 Washer, lock
- 4 Shroud, flywheel
- 5 Screw, round head
- 6 Washer, lock
- 7 Shroud, cylinder head
- 8 Cover, rear shroud
- 9 Screw, hex head
- 10 Washer, lock
- 11 Deflector, cylinder heat

- 12 Screw, round head
- 13 Washer, lock
- 14 Shroud, lower cylinder
- 15 Screw, round head
- 16 Washer, lock
- 17 Shroud, lower cylinder
- 18 Screw, round head
- 19 Deflector cylinder heat
- 20 Cover, rear shroud
- 21 Shroud, cylinder head
- 22 Cover, shroud

Figure 2-22. Air shroud and air deflector exploded view.

2-48. Valve Lifter Adjustment

- a. Remove the valve lifter cover.
- b. Using a feeler gage, measure the clearance between the valve lifter adjusting screw and rotor cap. In event clearance is not 0.016 inch for the exhaust valves and 0.008 inch for the inlet valves when the engine is cold, proceed as follows:

- (1) Hold the valve lifter in place by securing it with a wrench on the flats.

- (2) Use a wrench and thread the valve lifter adjusting screw in or out of the valve lifter to obtain the correct dimensional clearances.

- (3) Measure the adjusted clearance with a feeler gage. Then turn the engine over several times with the starter and remeasure the valve clearance. Readjust if necessary.

- c. Replace the valve lifter cover.

Section XV. WHEEL ASSEMBLY, KICK STAND AND TOW BAR ASSEMBLY

2-49. General

The generator set is mounted on two wheels, secured to the axle by the wheel hub, wheel bearings and a slotted hex nut. The pneumatic tire is mounted to the wheel. The tow bar assembly is mounted to the front of the generator set and is used for towing the unit short distances. The clevis pin is used for stowing the tow bar in the raised position. The kick stand is used during operation to keep generator set in a level position.

2-50. Wheel Assembly

a. Removal.

- (1) Install a suitable lifting device.
- (2) Remove the grease cap (3, fig. 2-23).
- (3) Remove cotter pin (4) and remove hex nut (5) securing wheel assembly to axle.

NOTE

When removing wheel assembly from axle be careful not to drop outer bearing (6).

- (4) Remove the wheel (2) and wheel hub (7), as an assembly, from the axle.

b. Cleaning and Inspection.

- (1) Clean the bearings (6 and 8) in an approved cleaning solvent (Fed P-D-680).

- (2) Inspect the bearing and bearing cones for pitting and wear.

- (3) Inspect the tire (10) and wheel (2) for damage. Refer to TM 9-1870-1 for care and maintenance of pneumatic tires.

- (4) Inspect the hub assembly (7) for cracks or damage.

- (5) Replace a defective part.

c. Installation.

NOTE

Before reassembly, repack the wheel bearings with lubricant in accordance with current lubrication order.

- (1) Install lubricated wheel bearing (8) into hub assembly (7) and install grease seal (9).

- (2) Install hub and wheel assembly onto the axle assembly.

- (3) Install front wheel bearing (6) and secure wheel assembly to axle with slotted hex nut (5).

- (4) Install new cotter pin (4) and install the wheel grease cap (3).

NOTE

The wheel may be removed without removing hub assembly by removing the four hex bolts (1, fig. 2-23) securing wheel and tire to hub assembly.

2-51. Tow Bar Assembly

a. *Removal.* Remove cotter pin (12, fig. 2-23), and remove the tow bar washer (13) and pin (14), and remove tow bar (15) from frame assembly.

b. *Inspection.* Inspect the tow bar assembly (15) for cracks and breaks.

c. Installation.

- (1) Align tow bar assembly (15) holes with clevis bar holes on frame assembly.

- (2) Install tow bar pins (14), washers (13) and install cotter pin (12).

2-52. Kick Stand

a. Removal.

- (1) Remove bolt (16, fig. 2-23) and remove kick stand base plate assembly (17).

- (2) Remove nut (18), spring (19) and remove kick stand (20) from base plate assembly.

b. Inspection.

- (1) Inspect the kick stand (20) for bends or breaks.

- (2) Inspect spring (19) for cracks.

c. *Installation.* Reassemble and install in the reverse procedure of removal.

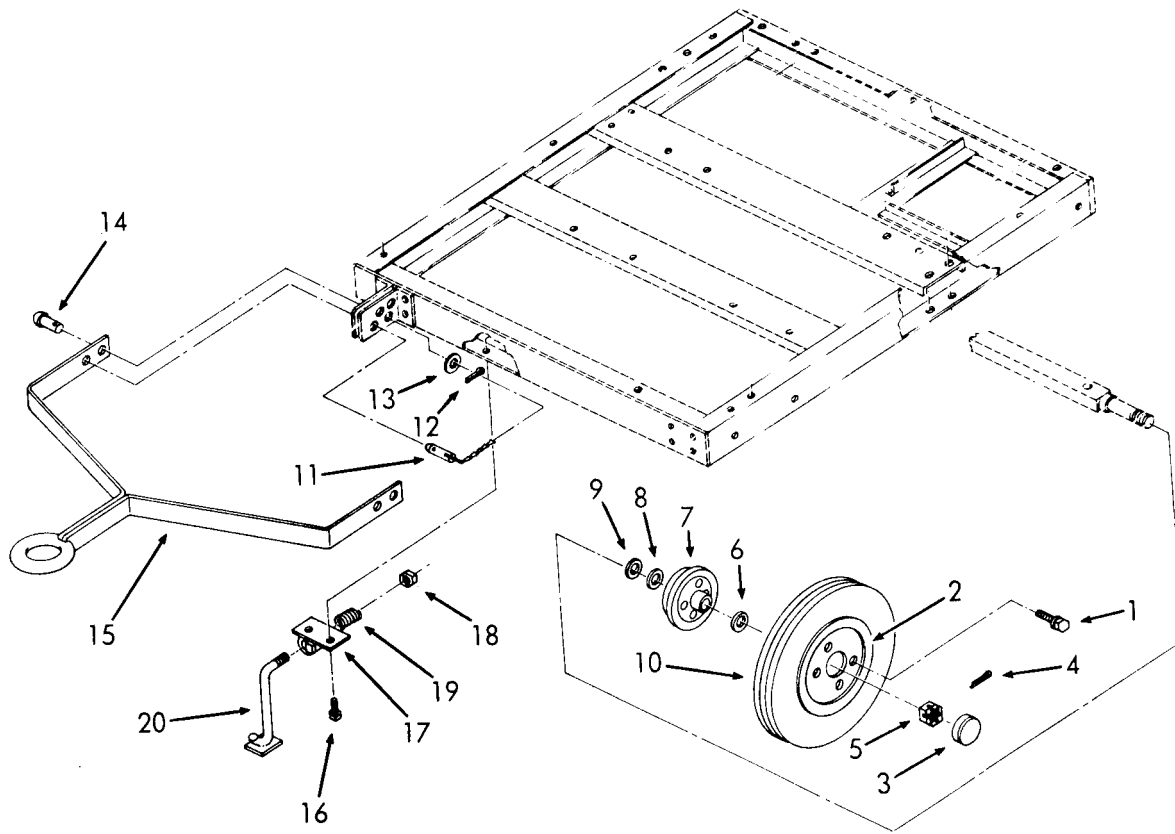

ME 6115-440-20/2-23

- | | |
|-----------------|------------------------|
| 1 Bolt | 11 Clevis pin |
| 2 Wheel | 12 Cotter pin |
| 3 Grease cap | 13 Washer |
| 4 Cotter pin | 14 Pin |
| 5 Hex nut | 15 Tow bar assembly |
| 6 Outer bearing | 16 Bolt |
| 7 Wheel hub | 17 Base plate assembly |
| 8 Inner bearing | 18 Nut |
| 9 Grease seal | 19 Spring |
| 10 Tire | 20 Kick stand |

Figure 2-23. Wheel assembly, tow bar and kick stand, removal and installation.

APPENDIX A

REFERENCES

A-1. Fire Protection

TB 5-4200-200-10

Hand Portable Fire Extinguishers for Army Users

A-2. Lubrication

C910OIL

LO 5-6115-440-12

Fuel, Lubricants, Oils and Waxes

Lubrication Order

A-3. Painting

TM 9-213

Painting Instructions for Field Use

A-4. Radio Suppression

TM 11-483

Radio Interference Suppression

A-5. Maintenance

TM 9-1870-1

TM 38-750

TM 5-6115-440-10

TM 5-6115-440-24P

Care and Maintenance of Pneumatic Tires

The Army Maintenance Management System

Operator's Maintenance Manual

Organizational, Direct and General Support

Maintenance Repair Parts and Special Tools List

A-6. Administrative Storage

TM 740-90-1

Administrative Storage of Equipment

A-7. Destruction of Equipment

TM 750-244-3

Procedures for Destruction of Equipment to
Prevent Enemy Use

APPENDIX B

MAINTENANCE ALLOCATION CHART

B-1. General

a. This section provides a general explanation of all maintenance and repair functions authorized at various maintenance levels.

b. Section II designates overall responsibility for the performance of maintenance functions on the identified end item or component. The implementation of the maintenance functions upon the end item or component will be consistent with the assigned maintenance functions.

c. Section III — Not applicable.

d. Section IV contains supplemental instructions, explanatory notes and /or illustrations required for a particular maintenance function.

B-2. Explanation of Columns in Section II

a. *Group Number, Column (1)*. The assembly group is a numerical group assigned to each assembly in a top down breakdown sequence. The applicable assembly groups are listed on the MAC in disassembly sequence beginning with the first assembly removed in a top down disassembly sequence.

b. *Assembly Group, Column (2)*. This column contains a brief description of the components of each assembly group.

c. *Maintenance Functions, Column (3)*. This column lists the various maintenance functions (A through K). The lowest maintenance category authorized to perform these functions are indicated by a symbol in the appropriate column. The symbol designations for the various maintenance categories are as follows:

- C — Operator or crew
- O — Organizational maintenance
- F — Direct support maintenance
- H — General support maintenance
- D — Depot maintenance

The maintenance functions are defined as follows:

- A — **INSPECT**: To determine serviceability of an item by comparing its physical, mechanical, and electrical characteristics with established standards.
- B — **TEST**: To verify serviceability and to detect electrical or mechanical failure by use of test equipment.
- C — **SERVICE** : To clean, to preserve, to charge, and to add fuel, lubricants, cooling agents, and air. If it is desired that elements, such as painting and lubricating, be defined separately, they may be so listed.
- D — **ADJUST**: To rectify to the extent necessary to bring into proper operating range.

E — **ALIGN** : To adjust specified variable elements of an item to bring to optimum performance.

F — **CALIBRATE**: To determine the corrections to be made in the readings of instruments or test equipment used in precise measurement. Consists of the comparison of two instruments, one of which is a certified standard of known accuracy, to detect and adjust any discrepancy in the accuracy of the instrument being compared with the certified standard.

G — **INSTALL**: To set up for use in an operational environment such as an emplacement, site, or vehicle.

H — **REPLACE** : To replace unserviceable items with serviceable like items.

I — **REPAIR**: Those maintenance operations necessary to restore an item to serviceable condition through correction of material damage or a specific failure. Repair may be accomplished at each category of maintenance.

J — **OVERHAUL**: Normally, the highest degree of maintenance performed by the Army in order to minimize time work in process is consistent with quality and economy of operation. It consists of that maintenance necessary to restore an item to completely serviceable condition as prescribed by maintenance standards in technical publications for each item of equipment. Overhaul normally does not return an item to like new, zero mileage, or zero hour condition.

K — **REBUILD**: The highest degree of materiel maintenance. It consists of restoring equipment as nearly as possible to new condition in accordance with original manufacturing standards. Rebuild is performed only when required by operational considerations or other paramount factors and then only at the depot maintenance category. Rebuild reduces to zero the hours or miles the equipment, or component thereof, has been in use.

d. *Tools and Equipment, Column (4)*. This column is provided for referencing by code the special tools and test equipment (Sec. III) required to perform the maintenance functions (Sec. H).

e. *Remarks, Column (5)*. This column is provided for referencing by code the remarks (Sec. IV) pertinent to the maintenance functions.

B-3. Explanation of Columns in Section IV

a. *Reference Code*. This column consists of two letters separated by a dash, both of which are references to section II. The first letter references column (5) and the second letter references a maintenance function, column (3), A through K.

b. *Remarks*. This column lists information pertinent to the maintenance function being performed, as indicated on the MAC, section II.

Section II. MAINTENANCE ALLOCATION CHART

(1) Group No.	(2) Functional group	(3) Maintenance functions											(4) Tools and equipment	(5) Remarks				
		A	B	C	D	E	F	G	H	I	J	K						
		Inspect	Test	Service	Adjust	Align	Calibrate	Install	Replace	Repair	Overhaul	Rebuild						
01	Canvas Cover and Tubular Frame																	
	Canvas cover	C	C	O	O	A-1
	Tubular frame	C	F	F	F	
	Muffler cover	O	O	
02	Control Box Door																	
	Voltmeter	O	O	
	Meter, time totalizing	O	O	
	Switches	O	O	
	Instruction plates	C	O	
03	Control Box																	
	Cable, power	O	O	
	Control box	F	F	
	Harness, wiring	C	O	F	F	
	Relay, reverse current	F	F	
	Output relay	F	F	
	Terminal board assembly	O	F	
	Load stud assembly	O	F	
04	Voltage Regulator																	
	Regulator assembly	F	..	O	O	F	
05	Fuel Tank																	
	Tank assembly, fuel	C	..	C	O	F	
	Selector valve, fuel	C	O	
	Line assembly, fuel	C	O	
06	Governor Control																	
	Governor control assembly	O	F	
07	Battery																	
	Battery, storage	C	C	C	O	O	
	Battery cables	C	C	C	O	O	
08	Oil Filter																	
	Lines, oil	C	O	

Section II. MAINTENANCE ALLOCATION CHART

(1) Group No.	(2) Functional group	(3) Maintenance functions										(4) Tools and equipment	(5) Remarks		
		A	B	C	D	E	F	G	H	I	J			K	
		Inspect	Test	Service	Adjust	Align	Calibrate	Install	Replace	Repair	Overhaul			Rebuild	
17	Crankshaft Piston and Connecting Rod														
	Crankshaft assembly	H							H						
	Bearing sets	H							H						
	Flywheel, engine	H							H						
	Rod assembly	H							H						
	Piston assembly	H							H						
18	Governor Assembly				O				F						
19	Camshaft and Fuel Pump														
	Camshaft	H							H						
	Fuel pump assembly		O						O						
20	Idler Gear and Oil Filler														
	Idler gear	H							H						
	Oil filler assembly	O							O						
21	Cylinder Block:														
	Block assembly cylinder								H	H					
	Guide valves	F							F						
	Seat, valve spring	F							F						
	Spring, valves		F						F						
	Valves	F							F						
	Tappet, valve lifting				O				F						
22	Oil Pump:														
	Oil pump assembly								F	F					
	Oil pan assembly	F							F						
23	Base, Tow Bar, Wheel and Axle Assemblies:														
	Base assy.								F	F					
	Wheel assy.			C					O	O					

Section IV. REMARKS

Reference code	Remarks	Reference code	Remarks
A-I	Welding	D-I	Test includes engine operation and compression
B-I	Repair dents and cracks by welding or silver solder	E-C	Install starter-generator brushes
C-I	Install kit		

ALPHABETICAL INDEX

<i>Subject</i>	<i>Paragraph, Figure, Table, Number</i>	<i>Subject</i>	<i>Paragraph, Figure, Table, Number</i>
A			
Adjustment, governor and governor control	2-46 2-26	Intake manifold	2-40 2-22
Adjustment, valve lifter	2-48 2-29	Interference suppression components	2-11 2-4
Administrative storage	1-4 1-1	K	
Air cleaner	2-24 2-8	Kick stand	2-52 2-29
Air deflector, engine	2-47 2-27	L	
Air shroud, engine	2-47 2-27	Lifting bar	2-44 2-26
B			
Bar, lifting	2-44 2-26	Load stud	2-21 2-8
Battery	2-35 2-16	Lubricating system	2-30 2-12
Battery cable	2-35 2-16	M	
Belts, drive	2-42 2-24	Magneto	2-36 2-16
Bracket, oil filter	2-31 2-12	Maintenance repair parts	2-6 2-2
C			
Cable, battery	2-35 2-16	Manifold, intake and exhaust	2-40 2-22
Canvas cover	2-15 2-5	Muffler	2-38 2-21
Cap, weather (muffler)	2-39 2-21	Muffler, cover cap	2-38 2-21
Carburetor	2-27 2-9	O	
Cleaning, general	2-14 2-5	Oil drain assembly	2-32 2-14
Control box wiring harness	2-20 2-8	Oil filter	2-31 2-12
Control, governor	2-46 2-26	P	
D			
Daily preventive maintenance		Plugs, spark	2-34 2-15
checks and services	2-8 2-2	Q	
Description	1-6 1-1	Quarterly preventive maintenance checks	
Destruction of army material to		and services	2-9 2-2
prevent enemy use	1-5 1-1	R	
Dismantling for movement	2-3 2-1	Reinstallation after movement	2-3 2-1
E			
Electrical system	2-33 2-15	Replacement of suppression components	2-12 2-4
Engine air shroud and air deflector	2-47 2-27	Reporting of errors	1-3 1-1
Engine assembly	2-45 2-26	S	
Engine sheave	2-43 2-24	Scope	1-1 1-1
Exhaust manifold	2-40 2-22	Sheaves, engine and starter	2-43 2-24
Exhaust system	2-38 2-21	Spark plug	2-34 2-15
F			
Forms and records	1-2 1-1	Special tools and equipment	2-5 2-2
Fuel pump	2-26 2-9	Stand, kick	2-52 2-29
Fuel selector valve and bracket	2-28 2-10	Starter-generator	2-37 2-21
Fuel strainer	2-25 2-9	Strainer, fuel	2-25 2-9
Fuel system	2-23 2-8	Switches	2-18 2-6
Fuel tank	2-29 2-11	T	
G			
General cleaning and inspection	2-14 2-5	Tabulated data	1-7 1-1
General methods used to attain proper		Terminal board	2-21 2-8
suppression	2-10 2-4	Testing of radio interference suppression	
Generator sheave	2-43 2-24	components	2-13 2-5
Generator, starter	2-37 2-21	Tools and equipment	2-4 2-2
Governor	2-46 2-26	Total time meter	2-17 2-6
I			
Identification	1-7 1-1	Tow bar assembly	2-51 2-29
Inspecting and servicing of equipment	2-1 2-1	V	
Inspection, general	2-14 2-5	Valve, fuel selector	2-28 2-10
Installation	2-2 2-1	Valve lifter	2-48 2-29
Instruction plates	2-19 2-6	Voltage regulator	2-22 2-8
J			
K			
L			
M			
N			
O			
P			
Q			
R			
S			
T			
U			
V			
W			
Wheel assembly	2-50 2-29	Wiring harness, control box	2-20 2-8
Wiring harness, control box	2-20 2-8		1-1

By Order of the Secretary of the Army:

W.C. WESTMORELAND,
General, United States Army,
Chief of Staff.

Official:

KENNETH G. WICKHAM,
Major General, United States Army,
The Adjutant General.

Distribution:

To be distributed in accordance with DA Form 12-25, (qty rqr block no. 718) Section IV, Organizational maintenance requirements for Generator Sets, Engine Driven, 7.5 KW, DC.

TM 5-6115-440-20 GENERATOR SET: 7.5 KW, 28 V DC, G.E.D., AIR COOLED, -1971