

DEPARTMENT OF THE ARMY TECHNICAL MANUAL

DEPARTMENT OF THE AIR FORCE TECHNICAL ORDER

TM 11-468
TO 31W-1-102

**SUBSTATION
MAINTENANCE**

This copy is a reprint which includes current pages from Changes 1 through 3.

DEPARTMENTS OF THE ARMY AND THE AIR FORCE

DECEMBER 1954

Changes in force: C 2 and C 3

CHANGE }
No. 3 }

HEADQUARTERS
DEPARTMENT OF THE ARMY
WASHINGTON, D.C. 11 December 1975

SUBSTATION MAINTENANCE

TM 11-468, 28 December 1954, TO 31W-1-102 is changed as follows:

Page 3, paragraph. 1.1 Delete paragraph 1.1 and substitute:

1.1. Indexes of Publications

a. DA Pam 310-4. Refer to the latest issue of DA Pam 310-4 to determine whether there are new editions, changes, or additional publications pertaining to the equipment.

b. DA Pam 310-7. Refer to DA Pam 310-7 to determine whether there are modification work orders (MWO's) pertaining to the equipment.

Paragraph 2. Delete paragraph and substitute:

2. Maintenance Forms and Records

Maintenance forms, records, and reports which are to be used by maintenance personnel at all maintenance levels are listed in and prescribed by TM 38-750. Paragraph 2.1 is added as follows.

2.1. Reporting of Errors

The reporting of errors, omissions, and recommendations for improving this publication by the individual user is encouraged. Reports should be submitted on DA Form 2028 (Recommended Changes to Publications) and forwarded direct to Commander, US Army Electronics Command, ATTN: AMSELMA-C, Fort Monmouth, NY 07703.

Page 106, appendix III. Delete appendix III.

By Order of the Secretary of the Army:

CREIGHTON W. ABRAMS
General, United States Army
Chief of Staff

Official:

VERNE L.. BOWERS
Major General, United States Army
The Adjutant General

Distribution:

Active Army:

USASA (2)
 CNGB (1)
 ACSC-E (2)
 Dir of Trans (1)
 COE (1)
 TSG (1)
 USAARENBD (1)
 USAMB (10)
 AMC (1)
 TRADOC (2)
 ARADCOM (2)
 ARADCOM Rgn (2)
 OS Maj Comd (4)
 LOGCOMDS (8)
 MICOM (2)
 TECOM (2)
 USACC-CONUS (2)
 USACC-EUR (2)
 USACC-PAC (2)
 USACC-SO (2)
 USACC SIG GP-T (2)
 USACC (4)
 MDW (1)
 Armies (2)
 Corps (2)
 HISA (ECOM) (21)
 Svc Colleges (1)
 USASESS (6)
 USAADS (2)
 USAFAS (2)
 USAARMS (2)
 USAIS (2)
 USAES (2)
 USAINTS (3)
 WRAMC (1)
 USACDCEC (10)
 ATS (1)

NG: None

USAR: None

Instl (2) except
 Fort Gordon (10)
 Fort Huachuca (10)
 Fort Carson (5)
 Ft Richardson (ECOM Ofc) (2)
 WSMR (1)
 Army Dep (2) except
 LBAD (14)
 SAAD (30)
 TOAD (14)
 ATAD (10)
 USA Dep (2)
 Sig Sec USA Dep (2)
 Sig Dep (2)
 Sig FLDMS (1)
 USAERDAA (1)
 USAERDAW (1)
 MAAG (1)
 USARMIS (1)
 Units org under fol TOE:
 (1 copy each)
 11-16
 11-32
 11-85
 11-86
 11-95
 11-96
 11-97
 11-98
 11-117
 11-158
 11-302
 11-337
 11-500 (AA-AC)
 29-134
 29-136

For explanation of abbreviations used, see AR 310-60.

Change In force: C 2

SUBSTATION MAINTENANCE

CHANGE }
No. 2 }

HEADQUARTERS
DEPARTMENT OF THE ARMY
WASHINGTON, D.C., 21 September 1964

TM 11-468, 28 December 1954, is changed as follows:

Page 3. Add paragraph 1.1 after paragraph 1.

1.1. Index of Publications

Refer to the latest issue of DA Pam 310-4 to determine whether there are new editions, changes, or additional publications pertaining to the equipment. DA Pam 310-4 is an index. Of current technical manuals, technical bulletins, supply manuals (types 4, 6, 7, 8, and 9), supply bulletins, lubrication orders, and modification work orders that are available through publications supply channels. The index lists the individual parts (-10, -20, -35, etc.) and the latest changes to and revisions of each equipment publications.

Paragraph 2 (as changed by C 1, 5 Dec 1960). Delete and substitute:

2. Forms and Records

a. Reports of Maintenance and Unsatisfactory Equipment. Use equipment forms and records in accordance with instructions in TM1 38-750.

b. Report of Damaged or Improper Shipment. Fill out and forward DD Form 6 (Report of Damaged or Improper Shipment) as prescribed in AR 700-58 (Army), NAVSANDA Publication 378 (Navy), and AFR 71-4 (Air Force).

c. Reporting of Equipment Manual Improvements. The direct reporting, by the individual user, of errors, omissions, and recommendations for improving this manual is authorized and encouraged. DA Form 2828 (Recommended Changes to DA Publications) will be used for reporting these improvements. This form will be completed in triplicate using pencil, pen, or typewriter. The original and one copy will be forwarded direct to Commanding General, U.S. Army Electronics Command, ATTN: AMSEIMR-MP-P, Fort Monmouth, N.J. 07703. One information copy will be furnished to the individual's immediate supervisor (officer, noncommissioned officer, supervisor, etc.).

Page 106. Change Appendixes I and II (as added by C 1, 5 Dec 60) to Appendixes II and III. Add Appendix I:

APPENDIX I

REFERENCES

DA Pam 310-4-Military Publications, Index of Technical Manuals, Technical Bulletins, Supply Manuals (types 4, 6,

7, 8 and 9) Supply Bulletins, Lubrication Orders, and Modification Work Orders.

*. this change supersedes C 1, 5 December 1960

APPENDIX II

MAINTENANCE ALLOCATION

Section I. INTRODUCTION

1. General

a. This section assigns maintenance functions to be performed on components, assemblies, and subassemblies by the lowest appropriate maintenance category.

b. Columns in the maintenance allocation chart are as follows:

(1) Part or component. This column shows only the nomenclature or standard item name. Additional descriptive data are included only where clarification is necessary to identify the component. Components, assemblies, and subassemblies are listed in top-down order. That is, the assemblies which are part of a component are listed immediately below that component, and the subassemblies which are part of an assembly are listed immediately below that assembly. Each generation breakdown (components, assemblies, or subassemblies) is listed in disassembly order or alphabetical order.

(2) Maintenance function. This column indicates the various maintenance functions allocated to the categories.

(a) Service. To clean, to preserve, and to replenish lubricants.

(b) Adjust. To regulate periodically to prevent malfunction.

(c) Inspect. To verify serviceability and to detect incipient electrical or mechanical failure by scrutiny. td)

Test. To verify serviceability and to detect incipient electrical or mechanical failure by use of special equipment such as gages, meters, etc.

(e) Replace. To substitute serviceable components, assemblies, or subassemblies, for serviceable components, or subassemblies.

(f) Repair. To restore an item to serviceable condition through correction of a specific failure or unserviceable condition. This function includes but is not limited to welding, grinding, riveting, straightening, and replacement of parts other than the trial and error replacement of running spare type items such as fuses, lamps, or electron tubes.

(g) Align. To adjust two or more components of an electrical system so that their functions are properly synchronized.

(h) Calibrate. To determine, check, or rectify the graduation of an instrument, weapon, or weapons system, or components of a weapons system.

(i) Overhaul. To restore an item to completely serviceable condition as prescribed by serviceability standards. This is accomplished through employment of the technique of Inspect and Repair Only as Necessary (IROAN). Maximum utilization of diagnostic and test equipment is combined with minimum disassembly of the item during the overhaul process.

(j) Rebuild. To restore an item to a standard as near as possible to original or new condition in appearance, performance, and life expectancy. This is accomplished

through the maintenance technique of complete disassembly of the item, inspection of all parts of components, repair or replacement of worn or unserviceable elements using original manufacturing tolerances and/or specifications and subsequent reassembly of the item.

- (3) *1st, 2d, 3d, 4th, 5th echelons (operator, organization, direct support, general support, and depot).* The symbol X indicates the categories responsible for performing that particular maintenance operation, but does not necessarily indicate that repair parts will be stocked at that level. Categories higher than those marked by X are authorized to perform the indicated operation.
- (4) Tools required. This column indicates codes assigned to each individual tool equipment, test equipment, and maintenance equipment referenced. The grouping of codes in this column of the maintenance allocation chart indicates the tool, test, and maintenance equipment required to perform the maintenance function.

- (5) *Remarks.* Entries in this column will be utilized when necessary to clarify any of the data cited in the preceding columns.

c. Columns in the allocation of tools for maintenance functions are as follows:

- (1) Tools required for maintenance functions. This column lists tools, test, and maintenance equipment required to perform the maintenance functions.
- (2) 1st, 2d, 3d, 4th, 5th echelons (operator, organization, direct support, general support, and depot). The dagger (†) symbol indicates the categories normally allocated the facility.
- (3) Tool code. This column lists the tool code assigned.

2. Maintenance by Using Organizations

When this equipment is used by signal services organizations organic to theater head- quarters or communication zones to provide theater communications, those maintenance functions allocated up to an including general support are authorized to the organization operating this equipment.

Section II. MAINTENANCE ALLOCATION CHART

PART OR COMPONENT	MAINTENANCE FUNCTION	O/C	O	DS	GS	D	TOOLS REQUIRED	REMARKS
TELEPHONE SET TA-236/FT	service	X	X					Exterior Interior
	adjust		X				4	
	inspect	X					1	continuity
	test				X	X	1	All testing
	repair			X			4	All repairs except replacement of contact assembly, foot mtg, handle handset, insulator plate, network, ringer telephone, rivet, shell, terminal board.
overhaul				X	X	3,5 1,2,3,5		

Section III. ALLOCCATION OF TOOLS FOR MAINTENANCE FUNCTIONS

TOOLS REQUIRED FOR MAINTENANCE FUNCTIONS	O/C	O	DS	GS	D	TOOLS CODE	REMARKS
TA-236/FT (continued)							
Multimeter TS-352/U t			t	t	t	1	
Test Set AN/PTM-6				t	t	2	
Tool Equipment TE-49			t	t	t	3	*When available use TS-716/U
Tool Equipment TE-23		t				4	
Tool Equipment TE-111			t	t	t	5	

APPENDIX III

BASIC ISSUE ITEM LIST

Section I. INTRODUCTION

1. General

This appendix lists items supplied for initial operation and for running spares. End items of equipment are issued on the basis of allowances prescribed in equipment authorization tables and other documents that are a basis for requisitioning.

2. Columns

Columns are as follows:

- a. *Source, Maintenance, and Recoverability Code.* Not used.
- b. *Federal Stock Number.* This column lists the 11-digit Federal stock number.
- c. *Designation by Model.* Not used.

d. *Description.* Nomenclature or the standard item name and brief identifying data for each item are listed in this column. When requisitioning, enter the nomenclature and description.

e. *Unit of Issue.* The unit of issue is each unless otherwise indicated and is the supply term by which the individual item is counted for procurement, storage, requisitioning, allowances, and issue purposes.

f. *Expendability.* *Nonexpendable* items are indicated by NX. Expendable items are not annotated.

g. *Quantity Authorized.* Under "Items Comprising an Operable Equipment", the column lists the quantity of items supplied for the initial operation of the equipment.

h. *Illustrations.* Not used.

SECTION II. FUNCTIONAL PARTS LIST

SOURCE MAINT. AND RECOVER- BILITY	FEDERAL STOCK NUMBER	DESIGNATION BY MODEL	DESCRIPTION	UNIT ISSUE	BILITY	QTY OF UNIT	ILLUSTRATION	
							EXPEN- FIG. NO.	DIRECT ITEM NO.
			ITEMS COMPRISING AN OPERABLE EQUIPMENT					
			TELEPHONE SET TA-236/FT					
	5806-503-2774		TELEPHONE SET TA-236 /FT	ea.	NX			
	Ord thru AGC		TECHNICAL MANUAL TM 11-46R	ea	X	2		
			RUNNING SPARES AND ACCESSORY ITEM					
			TELEPHONE SET TA-236/FT					
NO PARTS AUTHORIZED FOR STOCKAGE AT FIRST ECHELON								

By Order of the Secretary of the Army:

HAROLD K. JOHNSON,
General, United States Army,
Chief of Staff

Official:

J. C. LAMBERT,
Major General, United States Army,
The Adjutant General.

Distribution:

Active Army:

- CNGB (1)
- CofT (1)
- CofEngrs (1)
- TSG (1)
- CofSptS (1)
- C/COMMEL (7)
- USASA (2)
- USCONARC (5)
- USAMC (5)
- ARADCOM (2)
- ARADCOM Rgn (2)
- OS Maj Comd (3)
- OS Base Comd (2)
- LOGCOMD (2)
- USAMICOM (4)
- USAECOM (32)
- USA Avn Mat Comd (1)
- USASCC (4)
- *USASMCOM (2)
- USA Rsch Spt Gp (5)
- USADCCEA, Ft Monmouth (1)
- MDW (1)
- Armies (2)
- Corps (2)
- USA Corps (3)
- Chicago Proc Dist (1)
- Instl (2) except
 Ft Monmouth (63)
- USAINTC (5)
- 1st Fld Sta, USASA (5)
- USARSOUTHCOM Sig Agey (1)
- USAARMBD (2)
- USAARTYBD (2)
- USATC AD (2)
- USATC Armor (2)
- USATC Engr (2)
- USATC Inf (2)
- USASTC (S)
- USA Pie Cen (2)
- WRAMC (1)
- AMS (1)

- USACDC Agencies (1)
- Blue Grass Army Dep (8)
- 11th Air Assault Div (3)
- US Army Tml (1) except Oakland (5)
- POE (1)
- Sig Fld Maint Shops (3)
- USAERDL (2)
- USA Cold Rgns R&E Lab (2)
- Svc Colleges (2)
- Br Svc Sch (2) except USASCS (41J1)
- Army Dep (2) except Tobyhanna,
 Lexington (12) Sacramento (28)
 Ft Worth (8) Letterkenny, Navajo,
 Savanna (5) Charleston, Sharpe (3)
- GENDEP (OS) (2)
- Sig Sec, GENDEP (OS) (6)
- Sig Dep (OS) (12)
- USA Elct R&D Agcy:
 Yuma PG (2)
 WSMR (13)
 Ft Gordon (5)
 Ft Huachuca (10)
- USASESCS (40)
- USATCA (1)
- USATCG (1)
- USATCP (1)
- Units org under fol TOE (2 ea UNOINDC):
 11-16
 11-32
 11-57
 11-85
 11-86
 11-95
 11-96
 11-117
 11-155
 11-157
 11-337
 11-500 AA-AE (4)
 11-557
 11-587
 11-592
 11-697

NG: None

USAR: None.

For explanation of abbreviations used, see AR 320-50.

This manual contains copyrighted material

TECHNICAL MANUAL }
 No. 11-468 }
 TECHNICAL ORDER }
 No. 31W-1-102 }

DEPARTMENTS OF THE ARMY AND
 THE AIR FORCE,
 WASHINGTON 25, D. C., 28 December 1954

SUBSTATION MAINTENANCE

	Paragraph	Page
CHAPTER 1. INTRODUCTION		
Section I. General	1,2	3
II. Description and data.....	3--15	3--39
CHAPTER 2. THEORY OF OPERATION		
Section I. General	16, 17	40
II. Telephone TPA.....	18-21	40--41
III. Telephone Set TA-236/FT, component operation	22--26	42--16
IV. Telephone Set TA-236/FT, circuit operation.....	27--38	46--52
CHAPTER 3. MAINTENANCE		
Section I. Tools and test equipment	39, 40	53--54
II. Preventive maintenance services	41, 42	54--58
III. Lubrication	43-45	58--60
IV. Troubleshooting	46-61	60--78
CHAPTER 4. REPAIR PROCEDURES		
Section I. Adjustments and tests	62--66	79--83
II. Contact maintenance.....	67--71	84, 85
III. Repair and replacement of parts	2--77	85--88
IV. Final testing	78--80	91, 92
CHAPTER 5. SHIPMENT AND LIMITED STORAGE AND DEMOLITION TO PREVENT ENEMY USE.....	81-83	93
Index.....		107

***This manual supersedes TM 11-48, 3 January 1 1952, including C 1, 22 December 1962.**



Figure 1. Telephone set TA-236/FT.

CHAPTER 1

INTRODUCTION

Section I. GENERAL

1. Scope

This manual contains information on the theory of operation, maintenance, and repair of telephone substation equipment.

2. Forms

The following forms will be used for reporting unsatisfactory conditions of Army equipment and in performing preventive maintenance:

a. DD Form 6, Report of Damaged or Improper Shipment, will be filled out and forwarded as prescribed in SR 745-45-5 (Army); Navy Shipping Guide, Article 1850-4, (Navy), and AFR 71-4 (Air Force).

b. DA Form 468, Unsatisfactory Equipment Report, will be filled out and forwarded to the Office of the Chief Signal Officer, as prescribed in SR 700-45-5.

c. DD Form 535, Unsatisfactory Report, will be filled out and forwarded as prescribed in SR 700-45-5 and TO 00-35D-54.

d. DA Form 11-240, Operator First Echelon Maintenance Checklist for Signal Corps Equipment (Telephone Set), will be prepared in accordance with instructions on the back of the form (par. 42).

e. DA Form 11-241, Second and Third Echelon Maintenance Checklist for Signal Corps Equipment (Telephone Set), will be prepared in accordance with instructions on the back of the form (par. 42).

f. Use other forms and records as authorized.

Section II. DESCRIPTION AND DATA

Note. Basic nomenclature followed by the symbol (*) is used to indicate all models of an item of equipment covered in this publication. For example, Dial TA- 45 (*)/GT represents TA-45/GT and TA-45B/GT.

3. TP-6 Desk-Type Telephone Sets

a. Telephone TP- (figs. 2 through 15). Telephone TP-6 represents seven models of desk-type telephone sets. These are cradle-type telephone sets that can be converted from manual to dial operation by installing a dial. They can be used with party-ringing or a metallic ringing circuit and include an antisidetone circuit.

Although these equipments may be interchanged with one another in an existing telephone system, the parts with a few exceptions, are not interchangeable among the various models. Note that several of these equipments that are classified as Telephone TP-6 have individual official nomenclature. It has been common practice in the past to refer to these telephone sets as TP-6 types; this practice is retained in this manual. The table below indicates the abbreviated form of the commercial name, official nomenclature (if any), and the figure references for each of the seven types.

Commercial name	Abbreviated form	Official nomenclature	Fig. ref.
Western Electric Co. No. 302AW-3	WEC Co No. 302AW-3	2 and 3.
Automatic Electric Company No. 40.....	Auto Elec No. 40	Telephone TA-101/FTC_	4 and 5.
Kellogg Switchboard & Supply Co. No. 925BAX.	Kellogg No. 925BAX	Telephone TA-102/FTC_	6 and 7.
Stromberg-Carlson Co. No. 1222BW	St Carl No. 1222BW	Telephone TA-113/FTC_	8 and 9.
North Electric Mfg. Co. No. 3H6SL*	North Elec Mfg No. 3H6SL.....		10 and 11.
North Electric Mfg Co. No. H-600SL*	North Elece Mfg No. H-.....		10 and 11.
600SL.			
Stromberg-Carlson Co. No. 1242WA.....	St Carl No. 1242WA		12 and 13.

*Although these telephone sets have different commercial names, there are only minor mechanical differences between them. The parts, circuits, and color-codes are identical for both equipments.

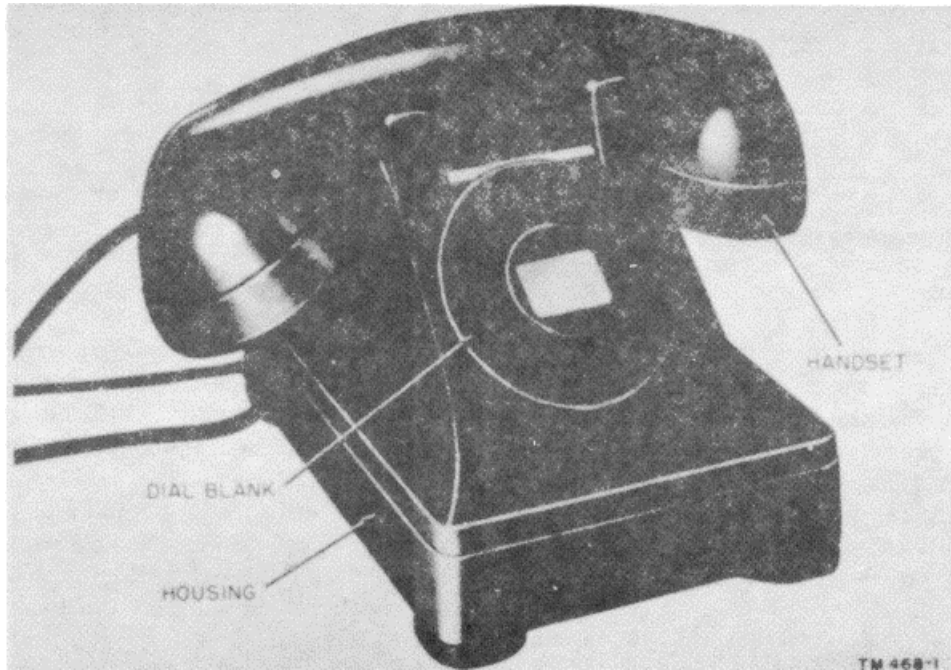

Figure 2. Telephone TP-6, arranged for manual operation

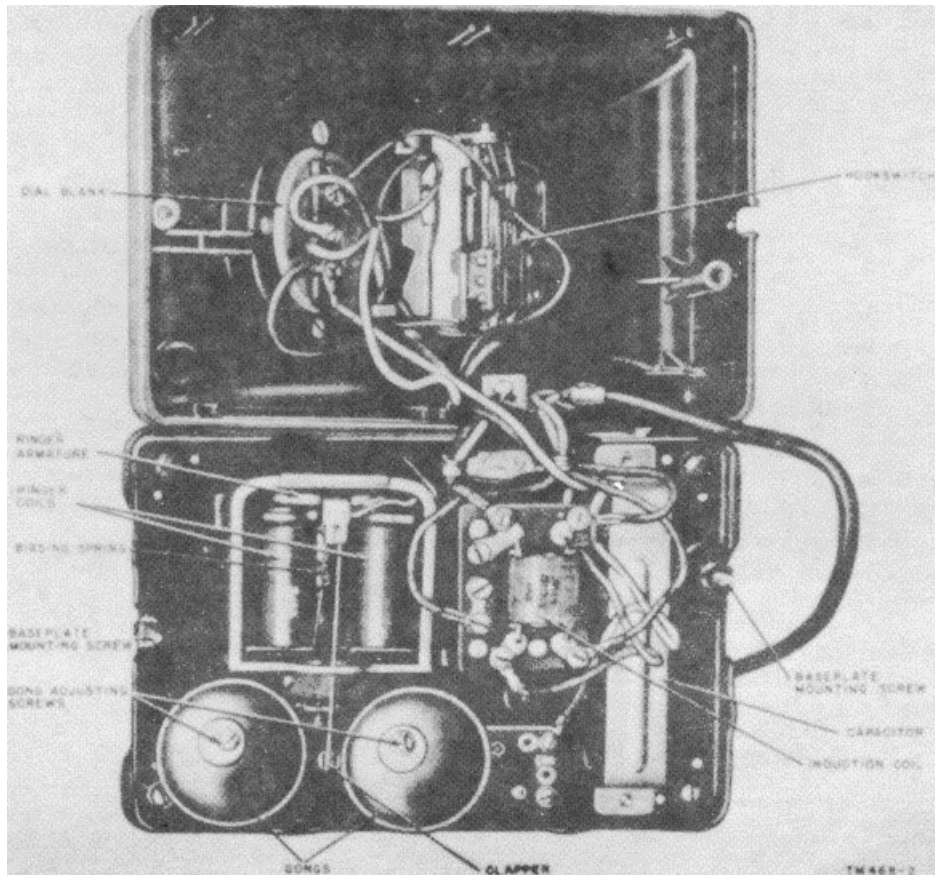

Figure 3. Telephone TP-6, with base plate open

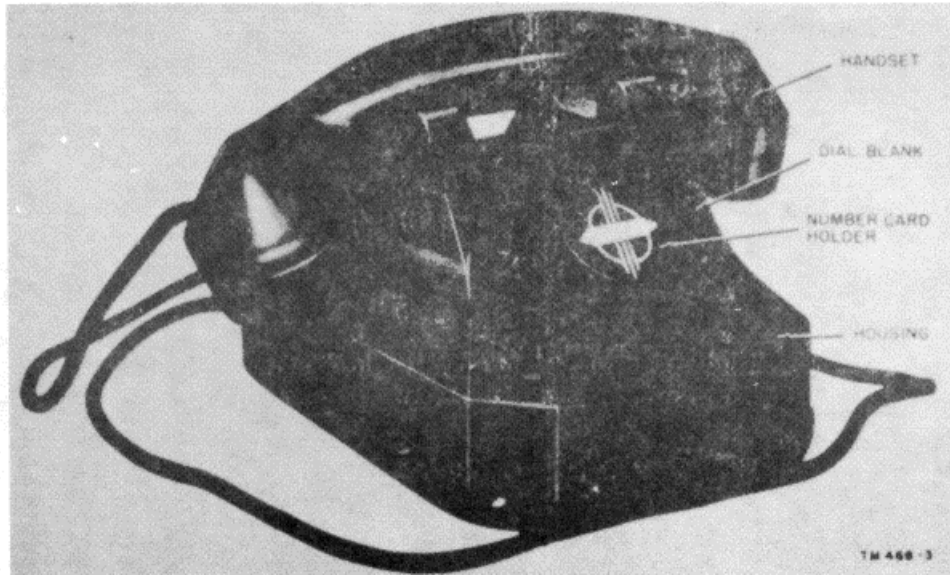

Figure 4. Telephone TA-101/FTC (Auto Elec No. 40), arranged for manual operation

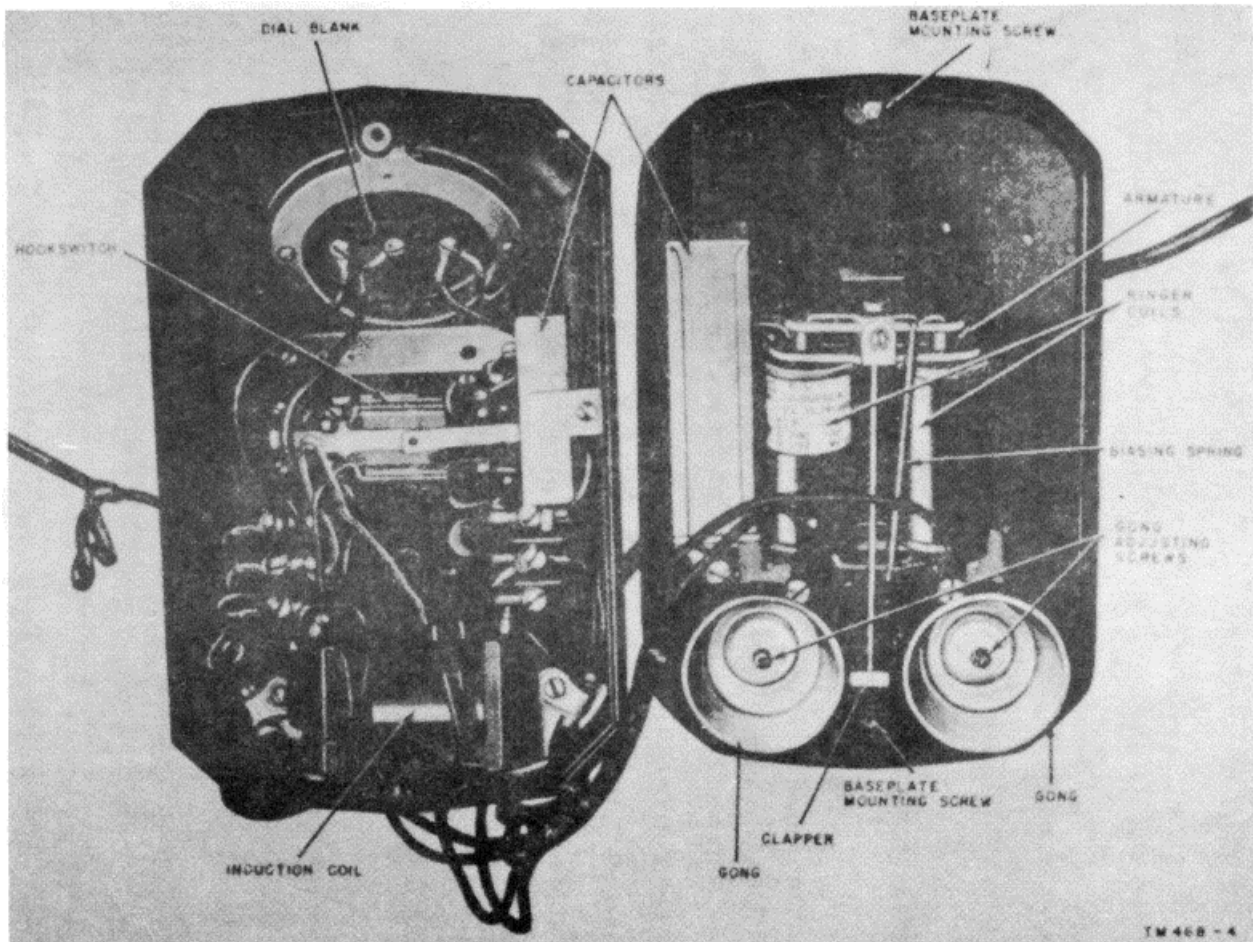

Figure 5. Telephone TA-101/FTC (Auto Elec No. 40), with base plate open

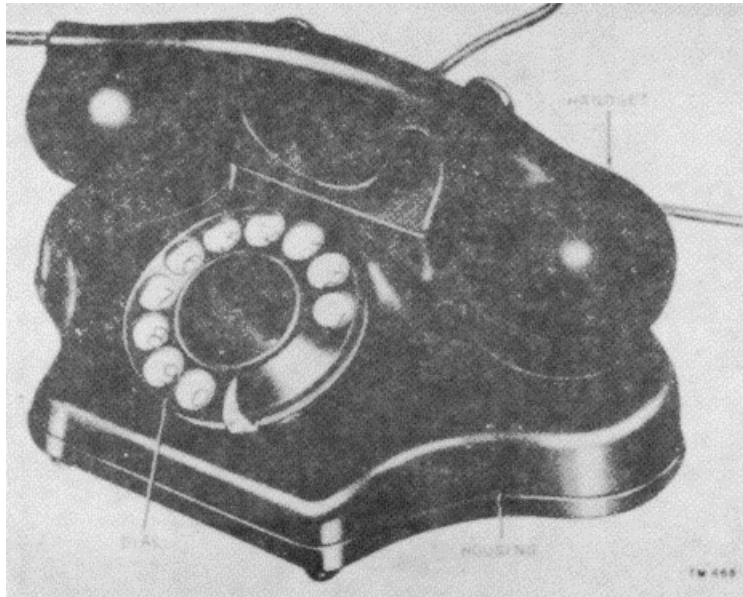

Figure 6. Telephone TA-102/FTC (Kellogg No. 925BAX), arranged for dial operation.

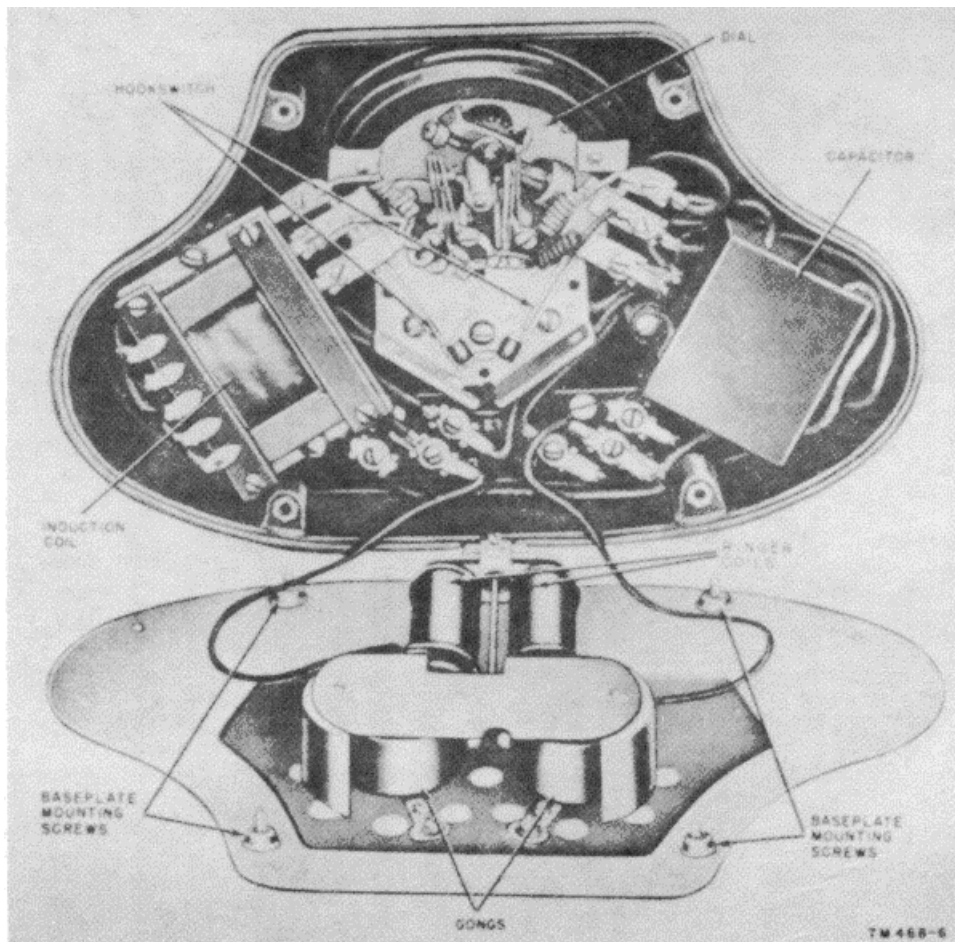

Figure 7. Telephone TA-102/FTC (Kellogg No. 925BAX), showing location of parts

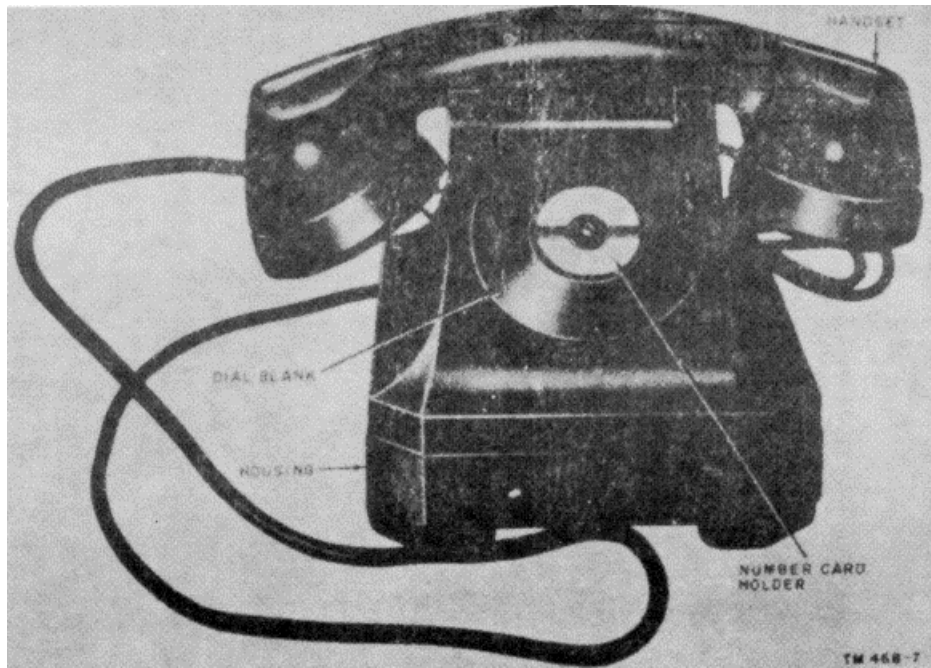

Figure 8. Telephone TA-113/FTC (St. Carl No. 1222BW), arranged for manual operation

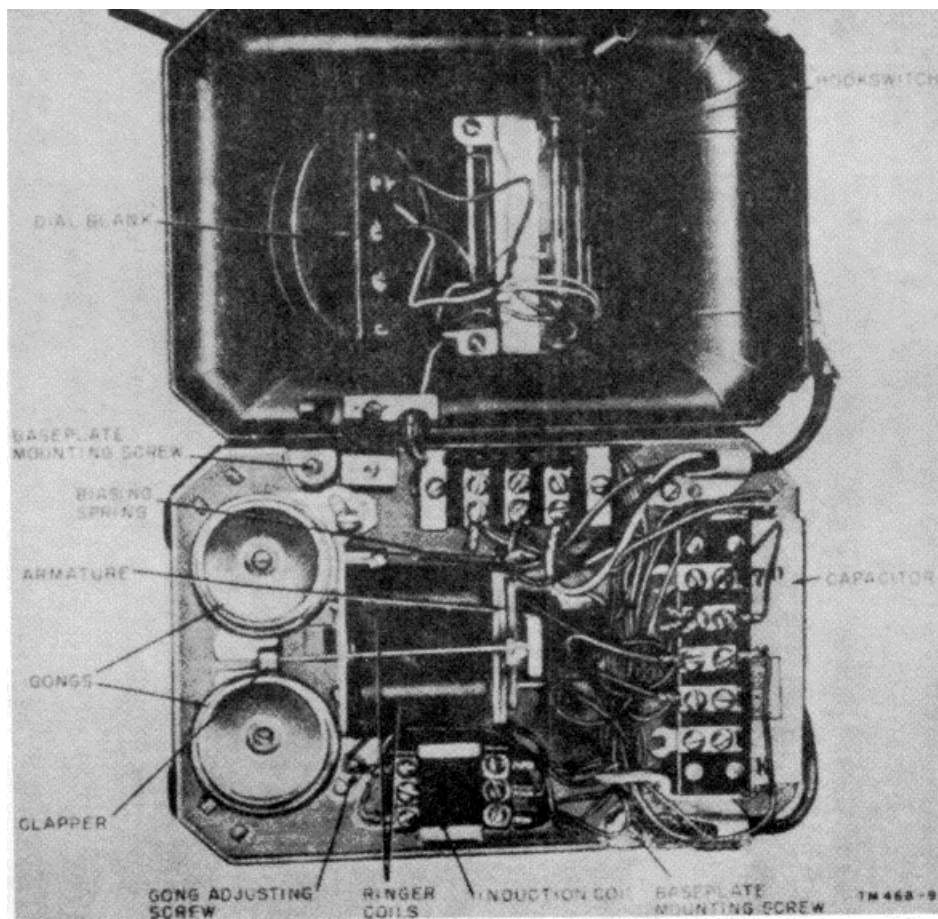

Figure 9. Telephone TA-113/FTC (St. Carl NO. 1222BW), with base plate open



Figure 10. Telephone TP-6 (North Elec Mfg No. H-600SL), arranged for dial operation

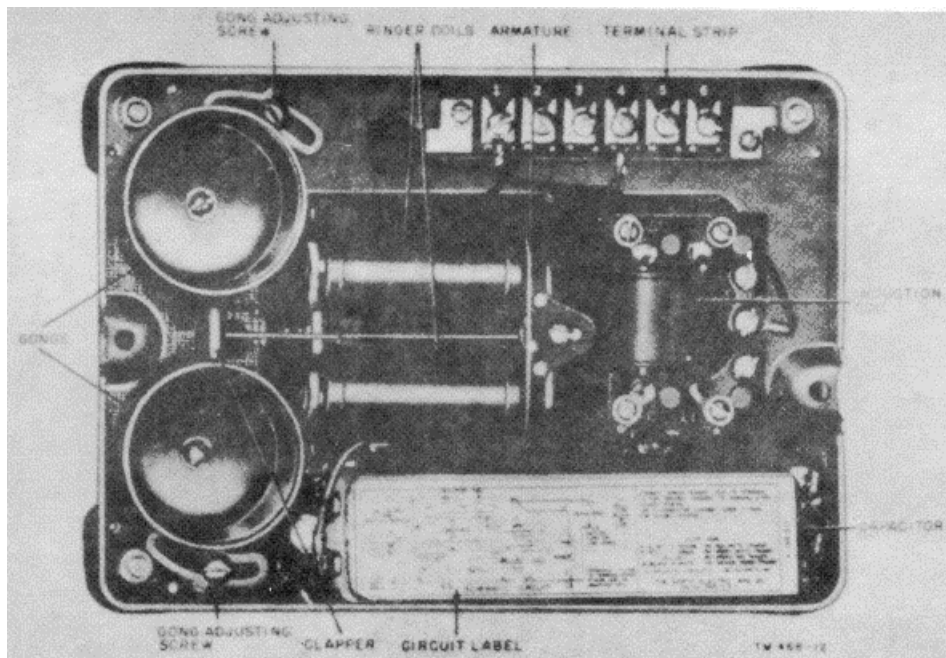

Figure 11. Telephone TP-6 (North Elec Mfg No. H-600SL and No. 3H6SL), with base plate open, showing locations of parts

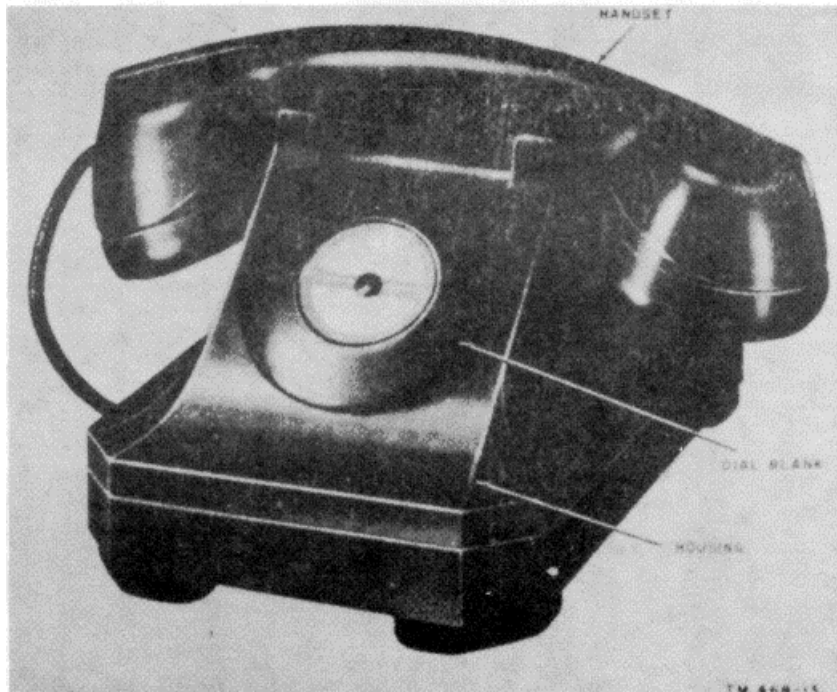

Figure 12. Telephone TP-6 (St. Carl No. 1242WA), arranged for manual operation.

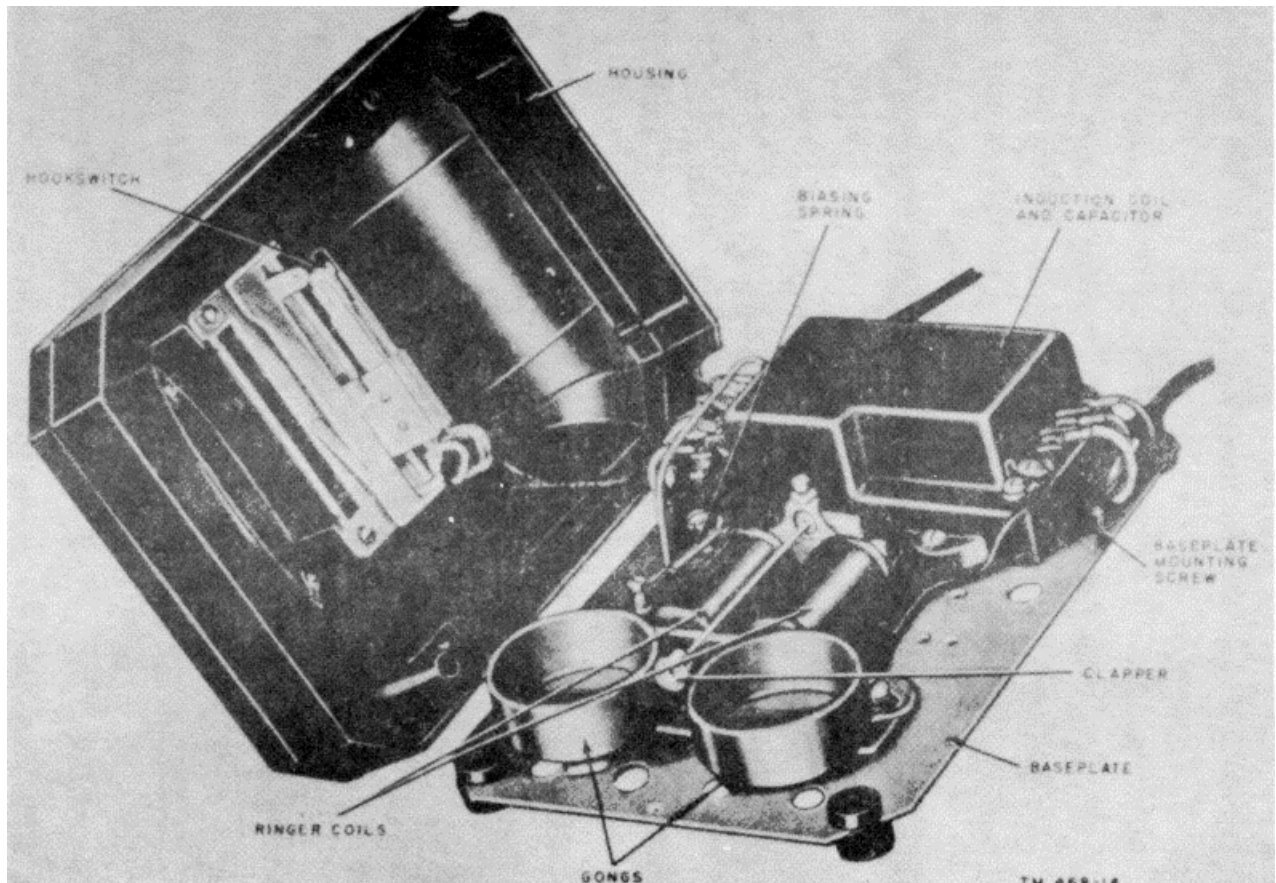

Figure 13. Telephone TP-6 (St. Carl No. 1242WA), showing location of parts

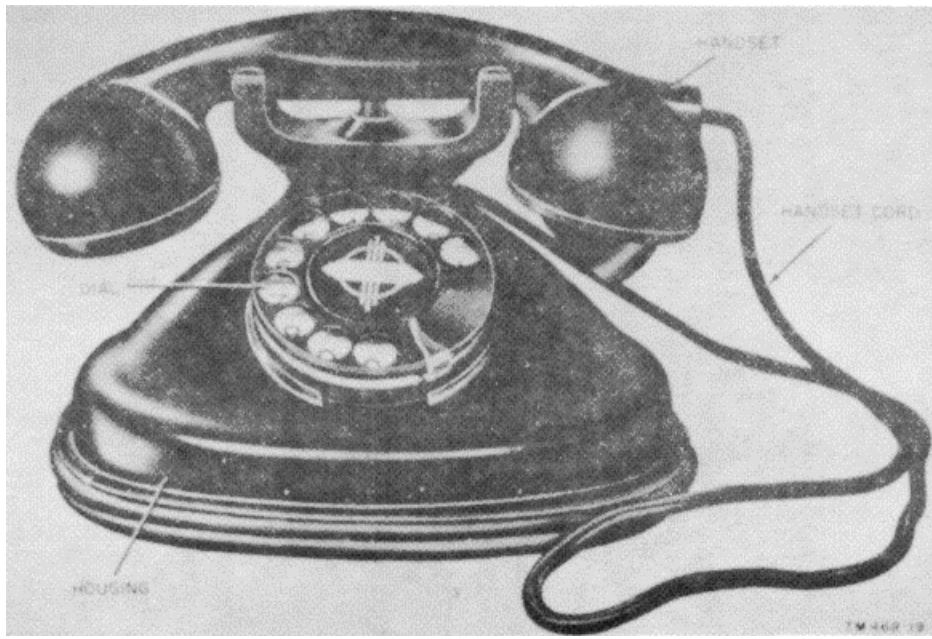

Figure 14. St. Carl No. 1212ABZ, telephone set.

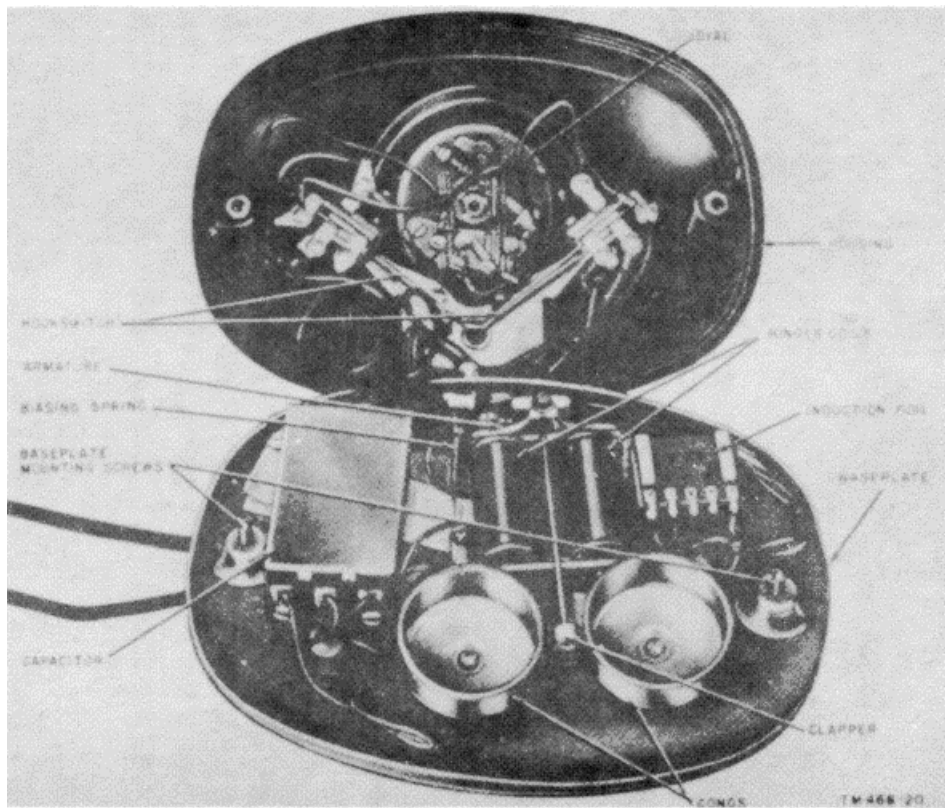

Figure 15. St. Carl No. 1212ABZ, showing location of parts.

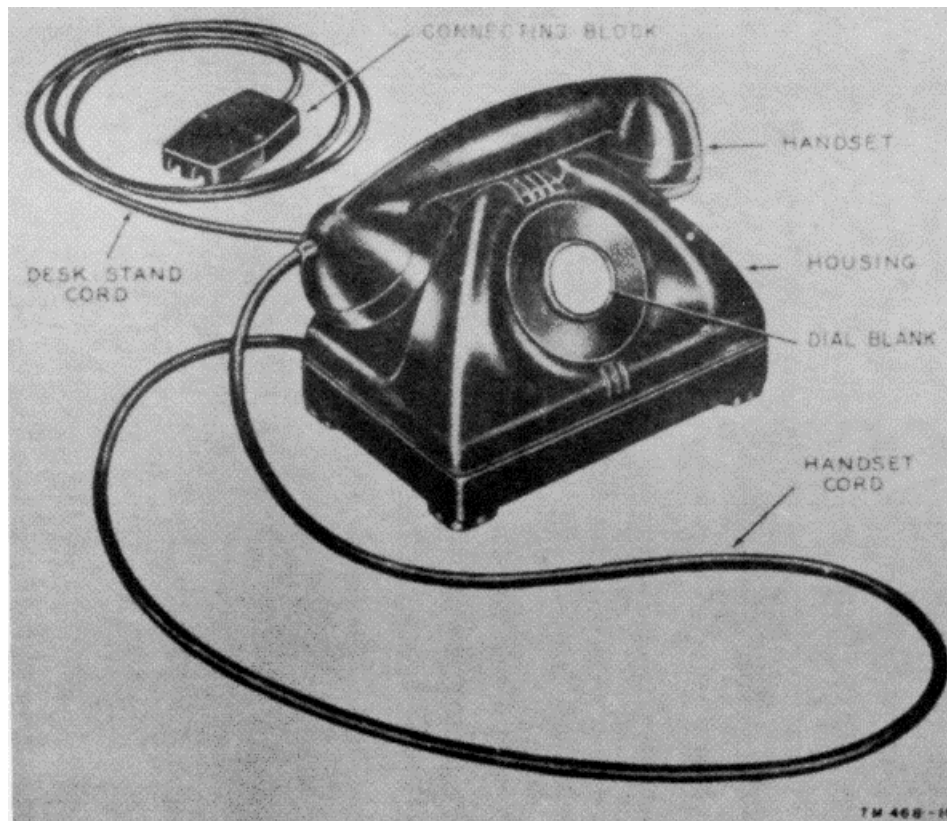

Figure 16. Telephone TP-6-A, arranged for manual operation.

b. Telephone TP-6-A (figs. 16 and 17). Telephone TP-6-A is similar in operation and internal construction to the TP-6 type telephone sets.

In addition, it is moistureproofed and fungiproofed to permit its operation in tropical areas. However, the TP-6-A is not a moistureproofed and fungiproofed model of any of the telephone sets that comprise the TP-6. It is a completely different equipment, and its parts are not interchangeable with those of any of the TP-6 type equipments, except WECO No. 302AW-3. Figure 16 shows the front view of the TP-6-A; figure 17 shows the location of parts with the base plate opened.

c. Telephone TA-107/FTC (figs. 18 and 19).

Telephone TA-107/FTC is similar in operation and construction to the TP-4-type telephone sets, but its parts are not interchangeable with those of any of the TP--type telephone sets. Figure 18 shows the front view of the TA-107/FTC; figure 19 shows the location of parts with the base plate, open.

d. St Carl No. 1212ABZ Telephone (figs. 14 and 15). This telephone is similar in operation and construction to the TP-type telephone sets, but, and for manual operation its parts are not interchangeable with used out, of doors as a military police, guard, or

those of the TP- type telephone sets. As the absence of official nomenclature indicates, this telephone set is of relative unimportance. There are, however, sufficient quantities of this equipment still in use to require adequate maintenance information. Figure 14 shows the front view of the St Carl No. 1212ABZ telephone; figure 15 shows the location of parts with the base plate opened.

e. Telephone Set TA-36/FT. This telephone is mechanically and electrically different from the TP-6 type telephone and is described in detail in paragraphs 9 and 10.

4. Wall-Type Telephone Set, Telephone TA-105/FTC (figs. 20 and 21)

Telephone TA-105/FTC is a wall-type telephone which can be converted from manual to dial operation by the installation of a dial. It uses a metallic ringing circuit and an antisidetone circuit. The TA-105/FTC is inclosed in a ventilated cast-iron housing and is equipped with a waterproof locking door. The TA-105/FTC is

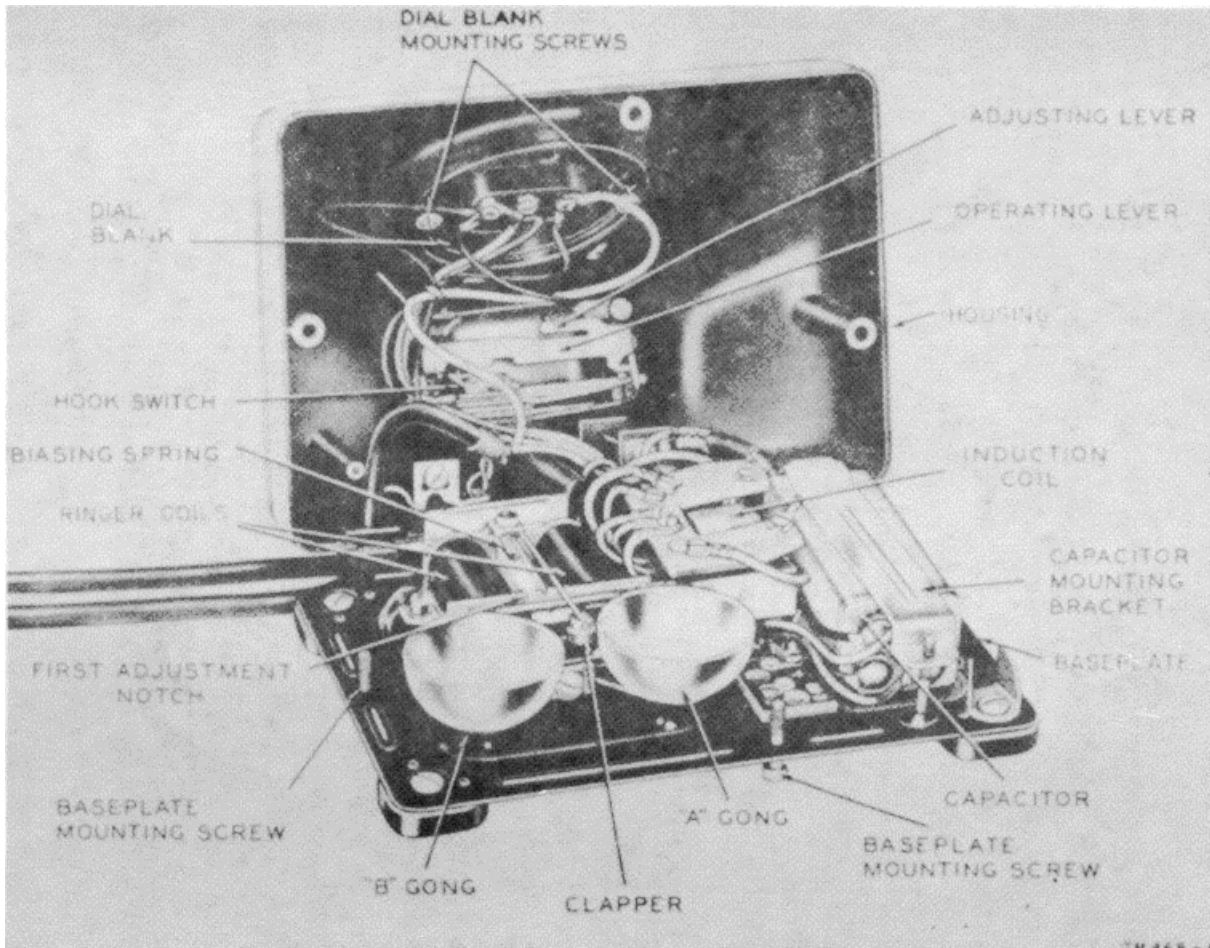

Figure 17. Telephone TP-6-A, with base plate open showing location of parts.

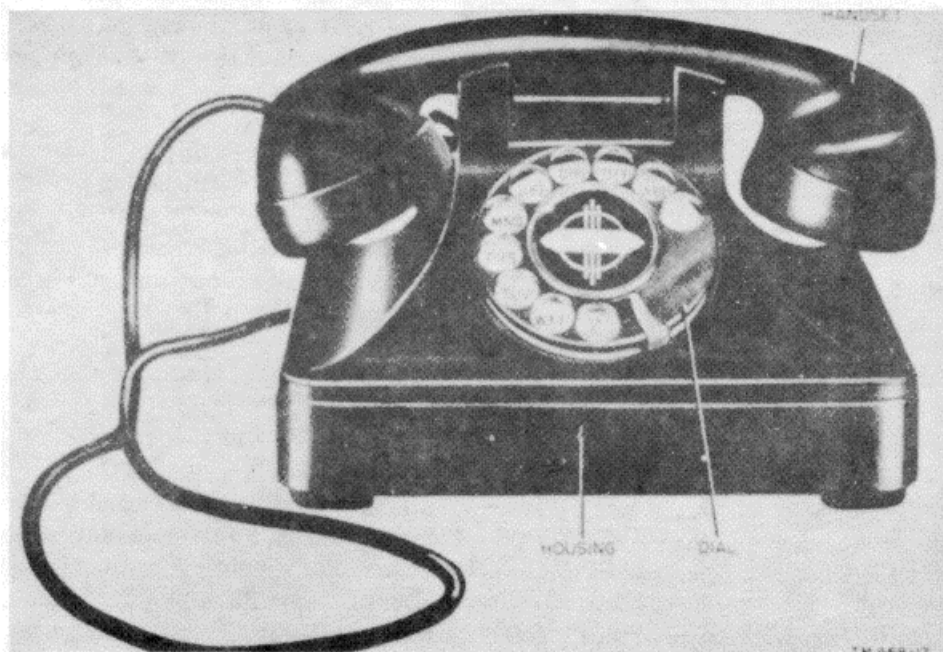

Figure 18. Telephone Set TA-107/FTC, arranged for dial operation

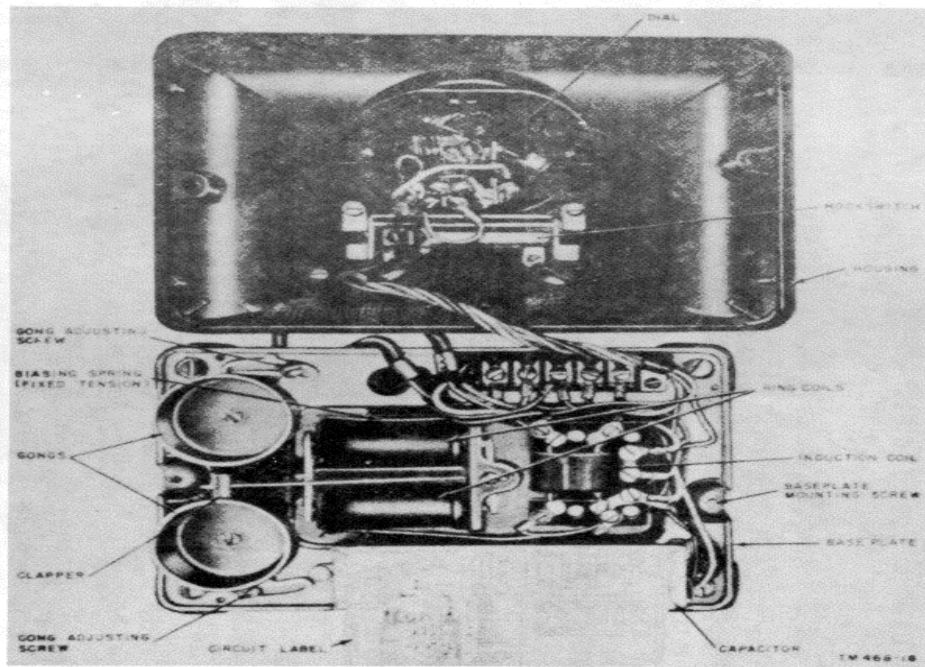

Figure 19. Telephone Set TA-107/FTC, with base plate open.

fire-alarm call box. Figure 20 shows the front view of the TA-105/FTC; figure 21 shows the location of parts with the panel removed.

5. Combination Wall- and Desk-Type Telephone Set, Telephone TA-166/U (figs. 22 and 23)

Telephone TA-166/U consists of Telephone TP-6-A with the base plate and cradle modified to permit the telephone set to be used as a walltype or a desk-type telephone. The telephone set may be used in either manner with no additional modification of the equipment. In addition, provision is made for automatically depressing the hookswitch plungers when the base plate is opened and the dial mounting plate is raised. This permits signaling of the telephone undergoing repair;

it is not necessary to disconnect the leads at the connecting block. Figure 22 shows the front view of Telephone TA-166/U; figure 23 shows the location of parts with the base plate open.

6. Telephone Box EE-91 (figs. 24 and 25)

Telephone Box EE-91 is a wall-mounted telephone box designed for common-battery operation. No handset is supplied with the equipment; however, Handset TS-12-F (par. 7) usually is used with this equipment. The EE-91 is inclosed in a metal box and may be used either indoors or outdoors. Figure 24 shows the front view of Telephone Box EE-91; figure 25 shows the components of the EE-91.

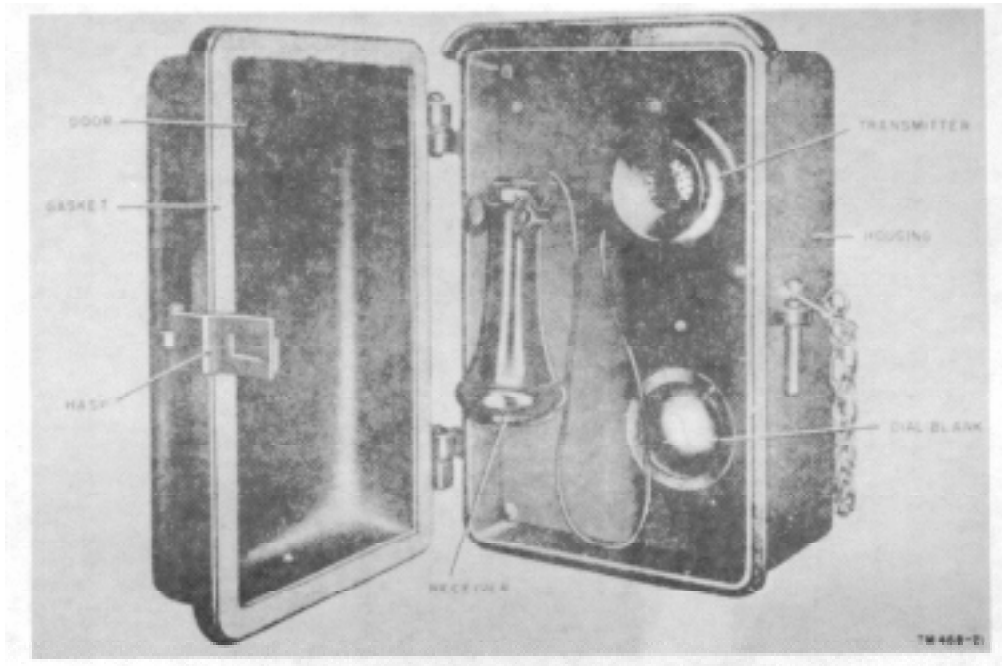

Figure 20. Telephone TA-105/FTC, guard and fire telephone.

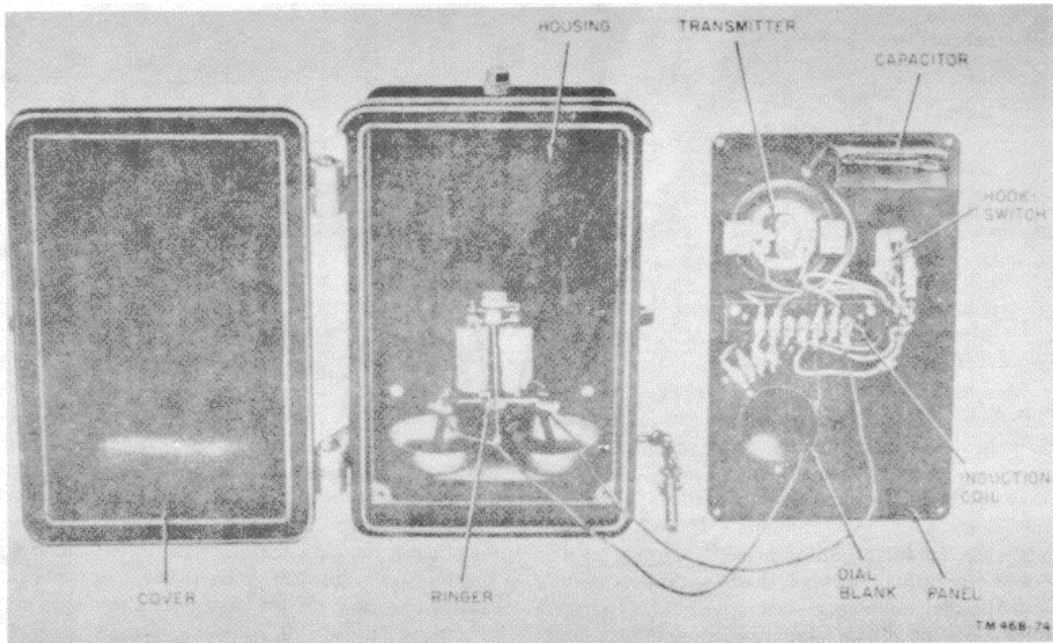

Figure 21. Telephone TA-105/FTC, with panel removed, showing location of parts.

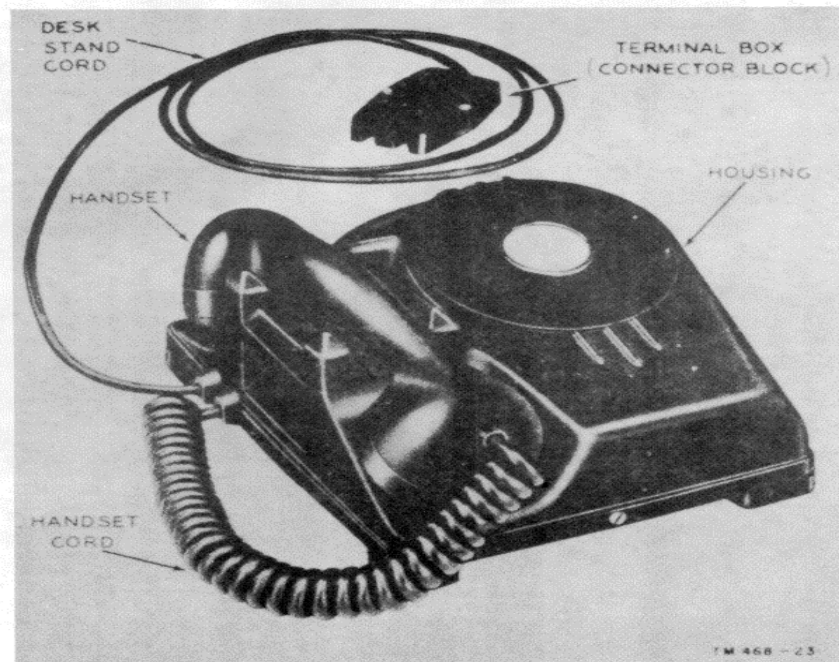

Figure 22. Telephone TA-166/U, arranged for manual operation.

7. Handsets

a. (figs. 26 and 27). Handset TS-12-F is a telephone handset that consists of a receiver element, a transmitter element, a butterfly switch, Cord CC-333, and Hanger FT-155-A. These parts are inclosed in, or attached to, a black phenolic handle. The TS-12-F is used as the receiving and transmitting equipment of Telephone Box EE-91. Figure 26 shows Handset TS-12-F with all parts in place; figure 27 is an exploded view of the TS-12-F.

b. (fig. 28). The handset for the TP-6 or TP-A is similar to Handset TS-12-F, except that it has no butterfly switch or Hanger FT155-A. Figure 28 is an exploded view, showing the parts of the handset.

8. Dial TA-45(*)/GT (figs. 29 through 32)

Dial TA45(*)/GT represents TA45/GT and TA45B/GT. Dial TA-45(*)/GT is the only standard dial approved by the Signal Corps on substation equipment except the dial used with the TA-236/FT. It consists essentially of a shaft which carries a movable dial wheel, a spring-driven restoring gear, a governor driving gear to regulate dial-speed pulsing, and a device which opens and closes two sets of contacts called the impulse contact assembly and the off-normal contact assembly. In the TA-45/GT, this device consists of a pulse cam and a shunt cam; in the TA45B/GT, this device consists of an impulse wheel and a shunt cam. Mounting holes are drilled in the dial assem-

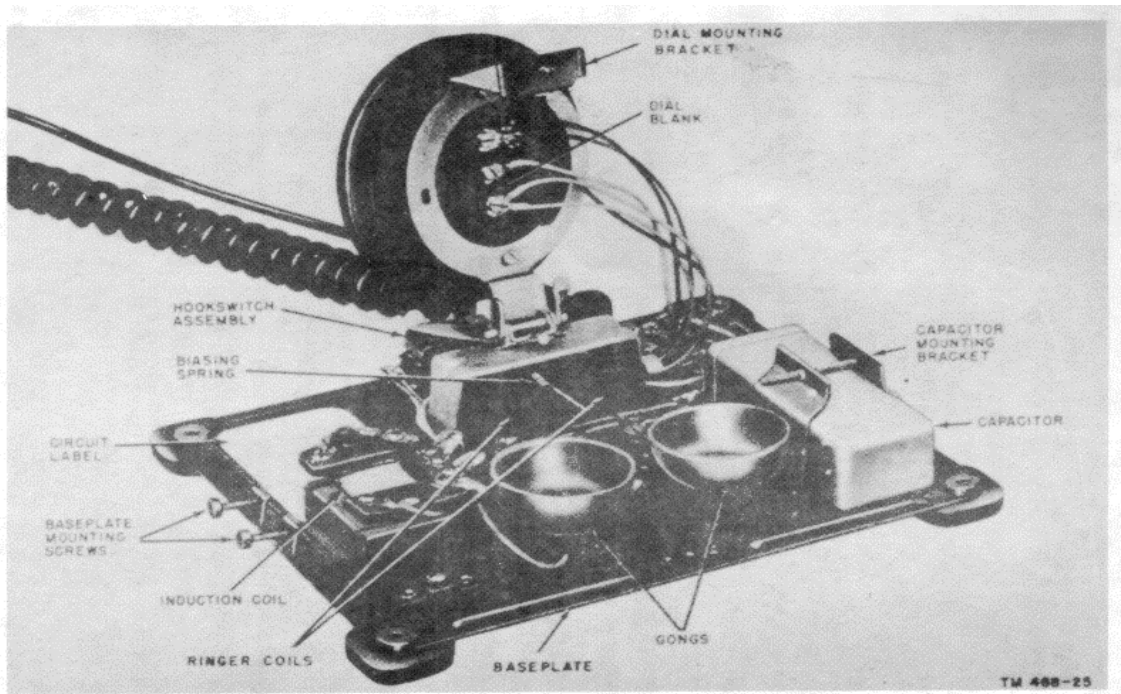

Figure 23. Telephone TA-1661U, with base plate open, showing location of parts.

bly to permit the mounting of the dial in any telephone that is equipped to accept a dial. *No dial adapter is required for any of the telephone sets described in this manual except North Elec. Mfg telephone sets.* Figure 29 shows the front view of the TA-45(*)/GT. Figure 30 shows the rear view of the TA-45(*)/GT manufactured by the Automatic Electric Company; figure 31 shows the rear view of the TA-45/GT manufactured by the Telephonic Corporation; figure 32 shows the rear view of the TA-45B/GT.

9. Telephone Set TA-236/FT, General (fig. 33)

Telephone Set TA-236/FT is a desk-type, antisidetone set that provides service in a common battery system that uses nonpolarized ringing current. In general outline, the TA-236/FT com

pares with Telephone TP-6 and similar-type telephone sets; however, *none of the Telephone Set TA-236/FT parts are interchangeable with those of other types of telephones.* The set can be equipped to provide either dial or manual service. Wiring facilities are provided to adapt the set to the particular service required. In addition to the dial or dial blank, the set houses a ringer, capacitors, an induction coil, a hookswitch, a balancing network, a three-conductor deskstand cord for connecting the set to the line, and a four-conductor handset cord for connecting the handset to the set. A notched wheel in the base of the mounting assembly is used to adjust ringer loudness to any one of four loudness levels. The line is terminated at a connecting block near the set. The base of the set is about 1 inch longer than that of the TP-6. A complete description of individual components is given in paragraph 10.

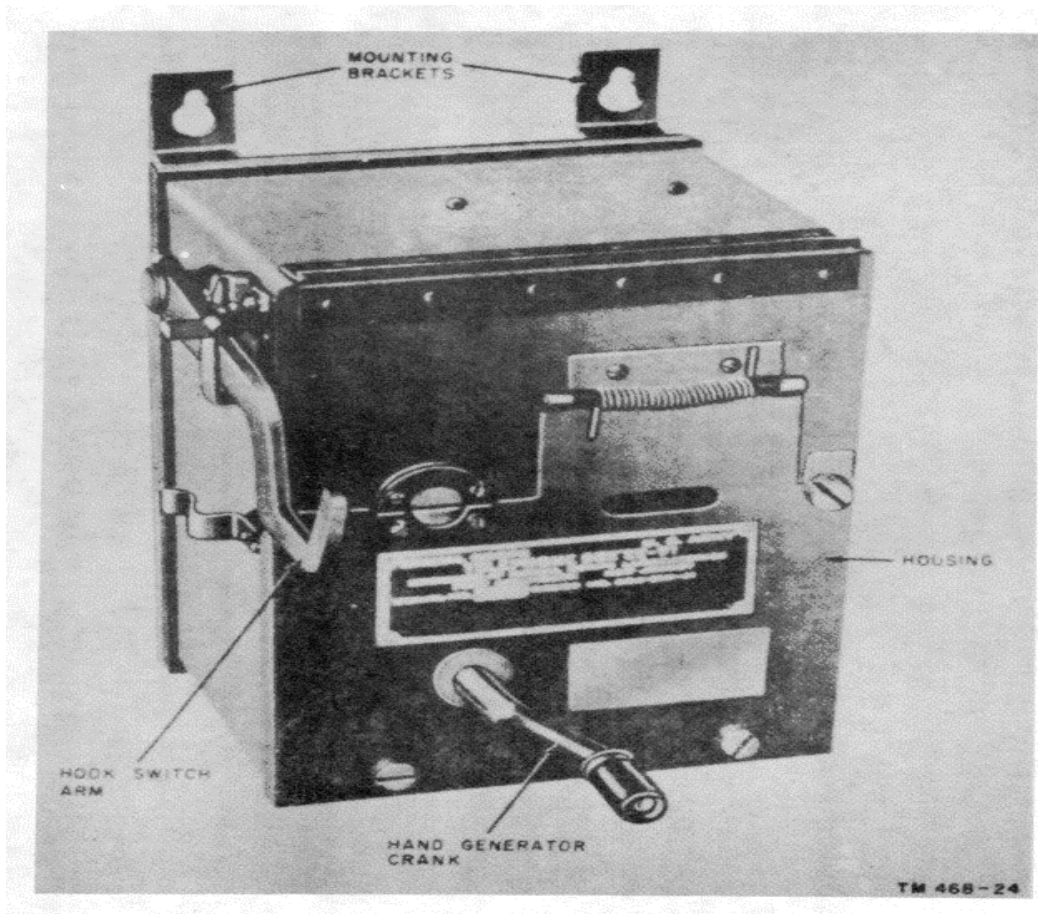

Figure 24. Telephone Box EE-91, common-battery telephone.

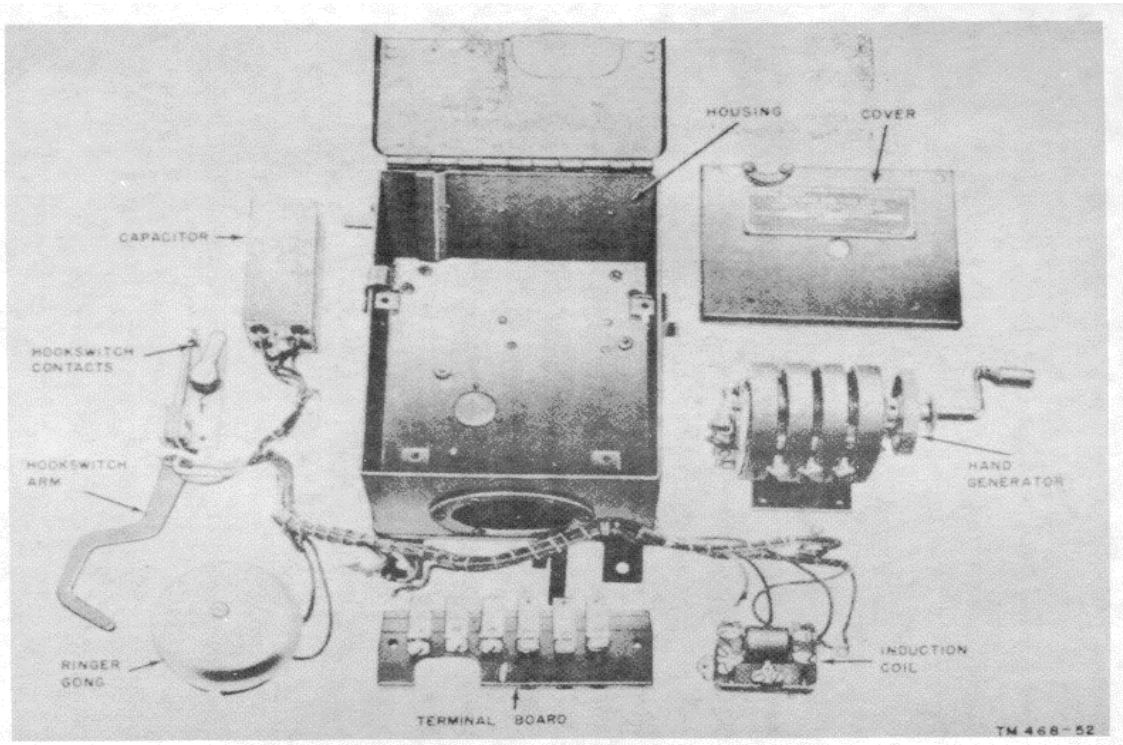

Figure 25. Component of Telephone Box EE-91.

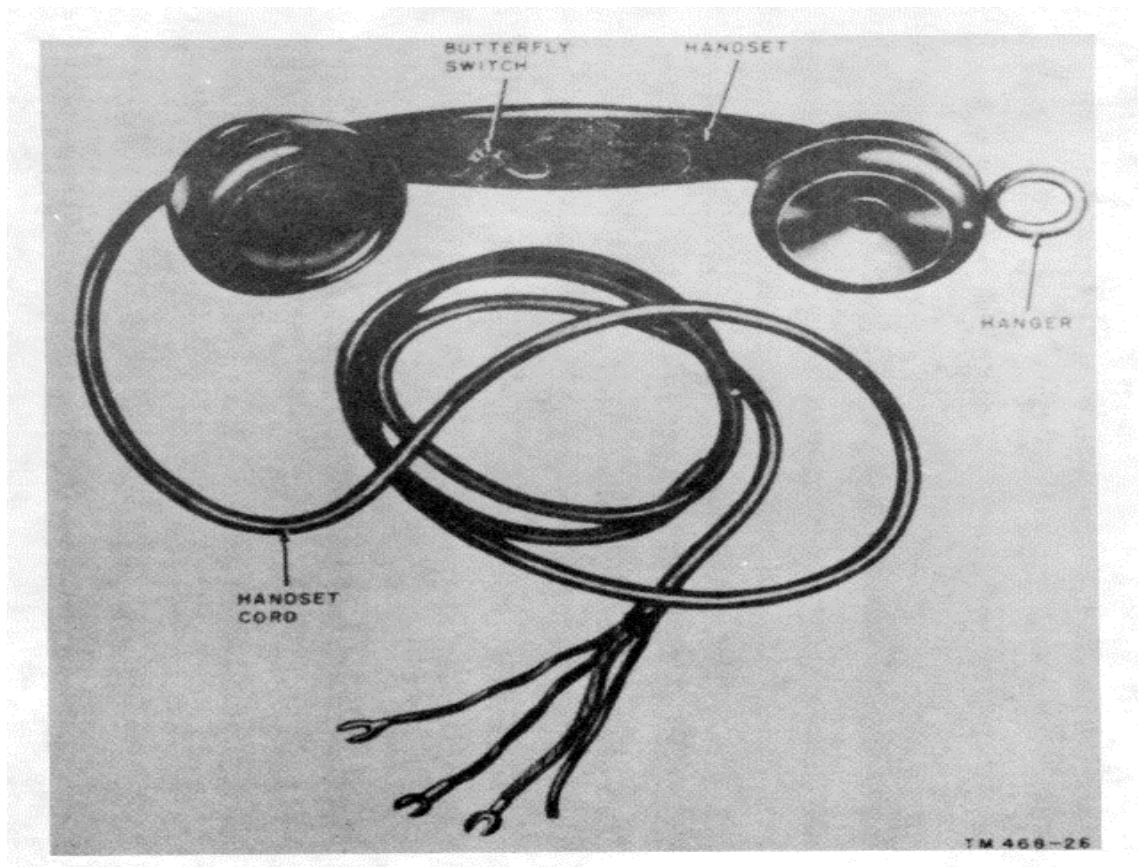

Figure 26. Handset TS-12-F.

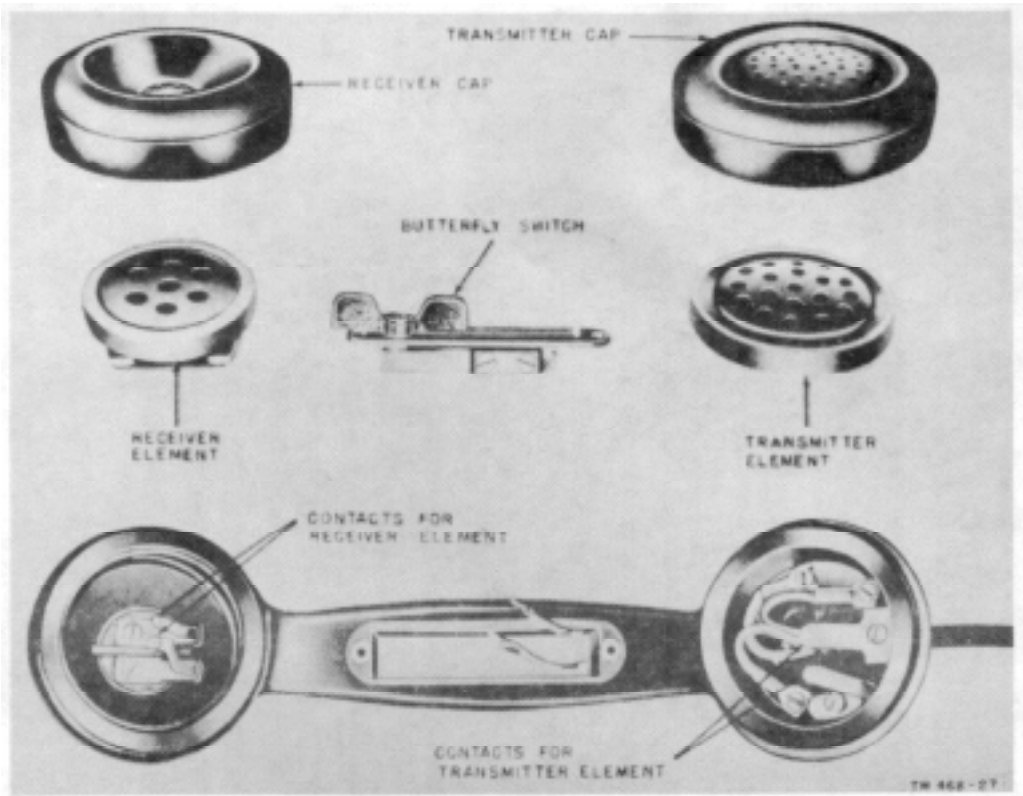

Figure 27. Handed TS-12-F, exploded view.

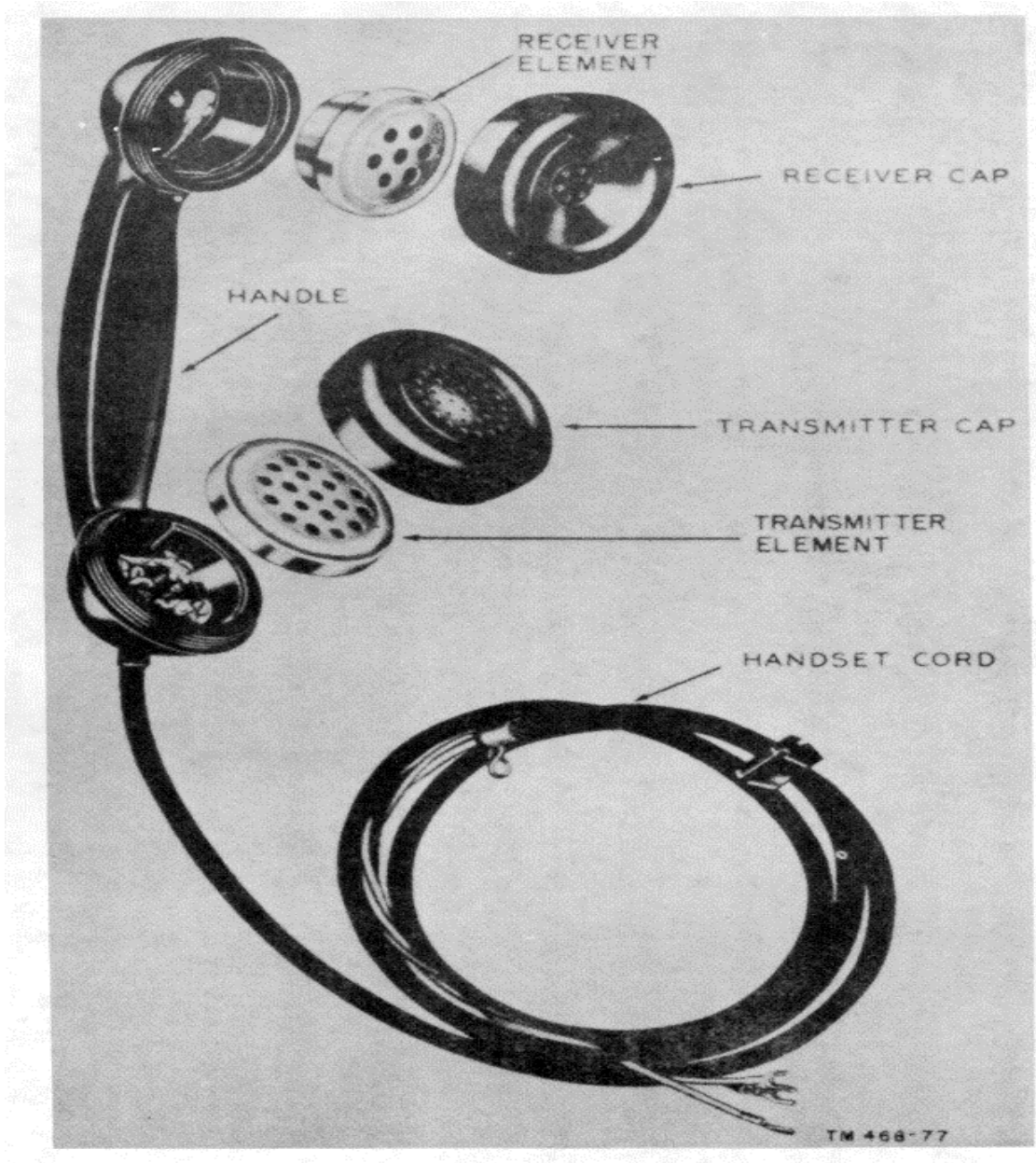

Figure 28. TP-6 or TP-6-A handset, exploded view.

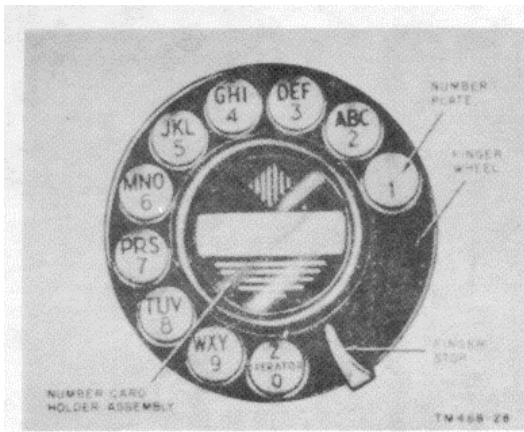

Figure 29. Dial TA-45(*)/GT (Auto Elec), front view.

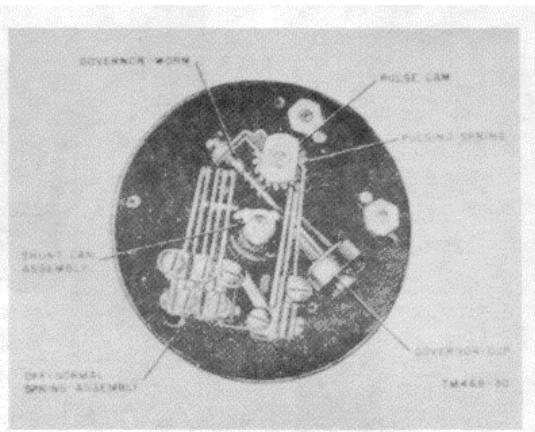

Figure 31. Dial TA-45/IGT (Telephonic), rear view, showing location of parts.

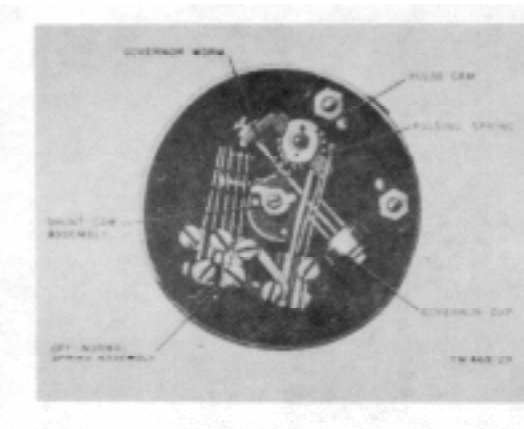

Figure 30. Dial TA-45(*)/GT (Auto Elec), rear view.

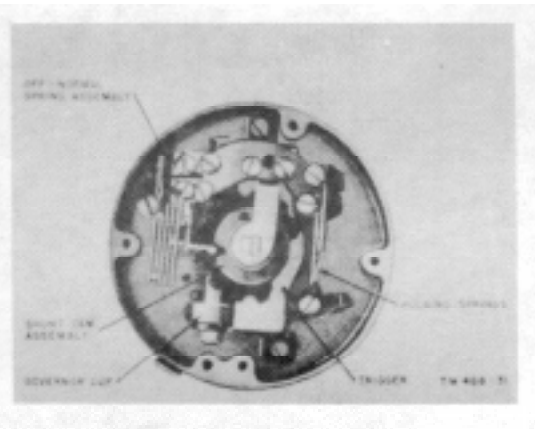

Figure 32. Dial TA-45B/GT, rear view, showing location of parts

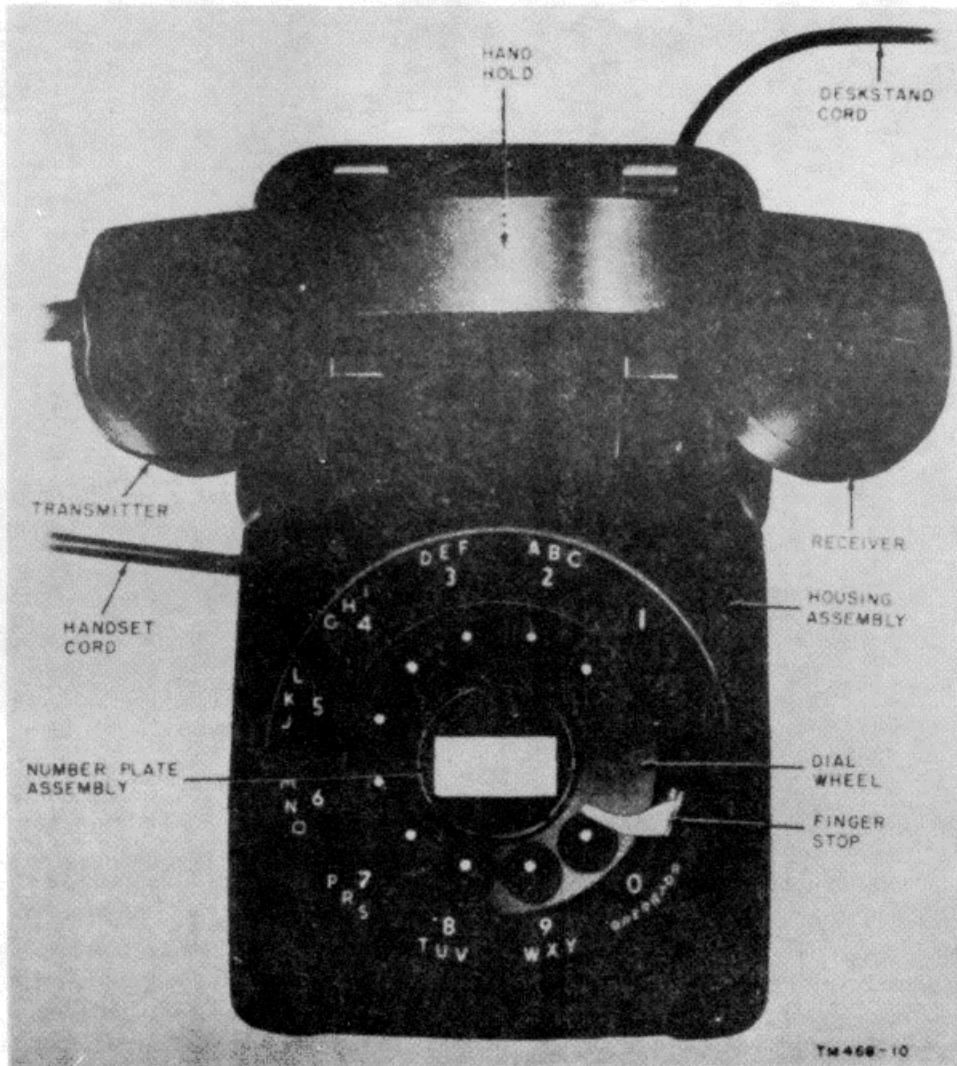

Figure 33. Telephone Set TA-236IFT, arranged for dial operation.

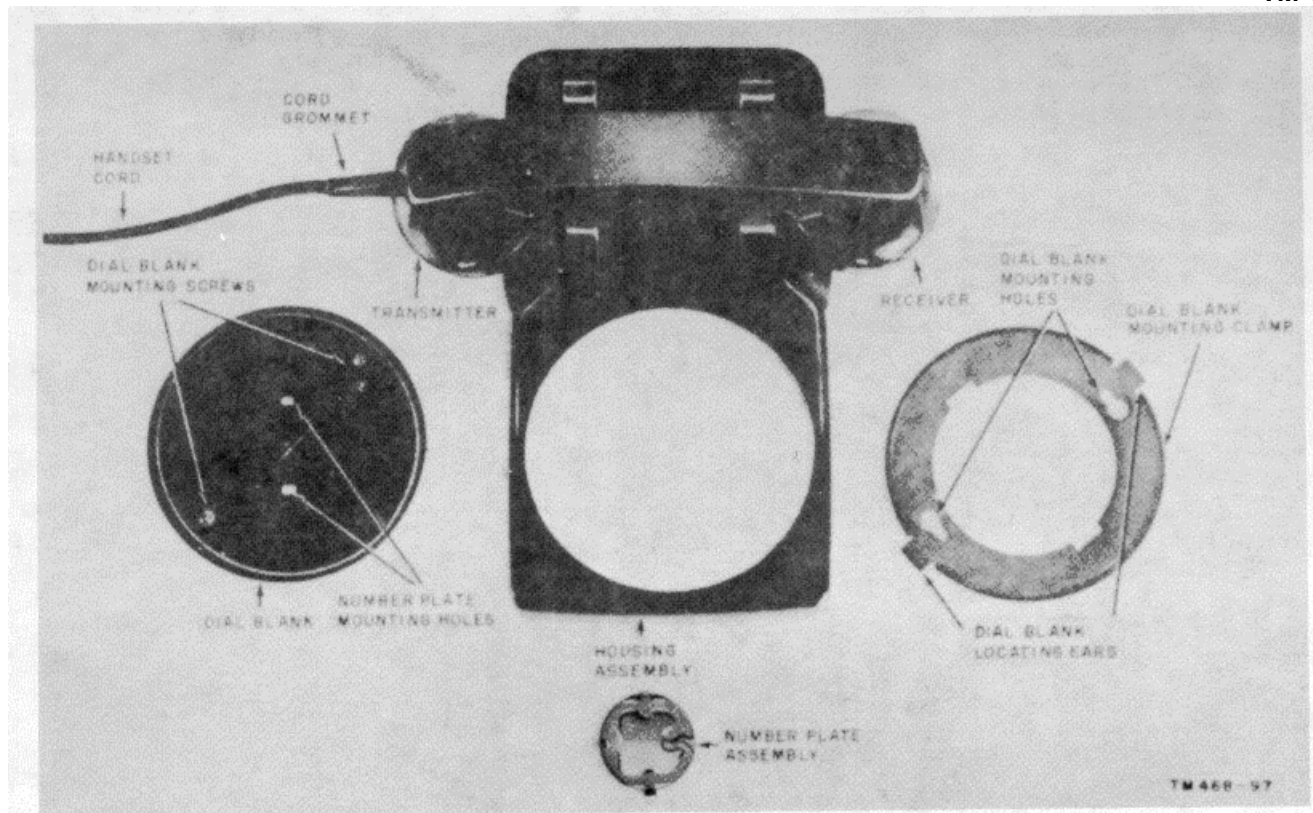

Figure 34. Telephone Set TA-236/FT, housing assembly

10. Component Description for Telephone Set TA-236/FT

a. Housing Assembly (fig. 34). The housing assembly is made of a permanent black finish thermoplastic material; is fragile and must be handled carefully.

b. Base Plate Assembly (fig. 35). The steel base plate assembly is used for mounting the network assembly, dial, ringer, and switch assembly. A dial mounting, equipped with three slots for the accommodation of the dial mounting screws, is attached permanently to the base plate with three rivets. In a similar manner, the network and switch assemblies are attached to the plate. A friction pad is riveted to each corner of the base plate. Two screws, captive in the base plate, fasten the housing assembly to the base. In the upturned edge of the base plate are two small rectangular slots; the slot in the end section is

used for anchoring the deskstand cord, and that in the side for anchoring the handset cord.

c. Handset (fig. 36). The handset is smaller and 25 percent lighter in weight than those of the TP-6 type. The separation between the transmitter and the receiver is one-half inch less, which brings the transmitter closer to the speaker's mouth when the receiver is placed at the ear. The handset handle is of cored construction; the cord is a lightweight, flexible, neoprene jacketed type that is held in place and reinforced by a tapered molded grommet at the handset end. The transmitter and the receiver caps and elements are removable and replaceable.

d. Transmitter (fig. 37). The transmitter is smaller, has an improved frequency response, better stability characteristics, and greater efficiency than the transmitter used with the TP-6 or TP-A.

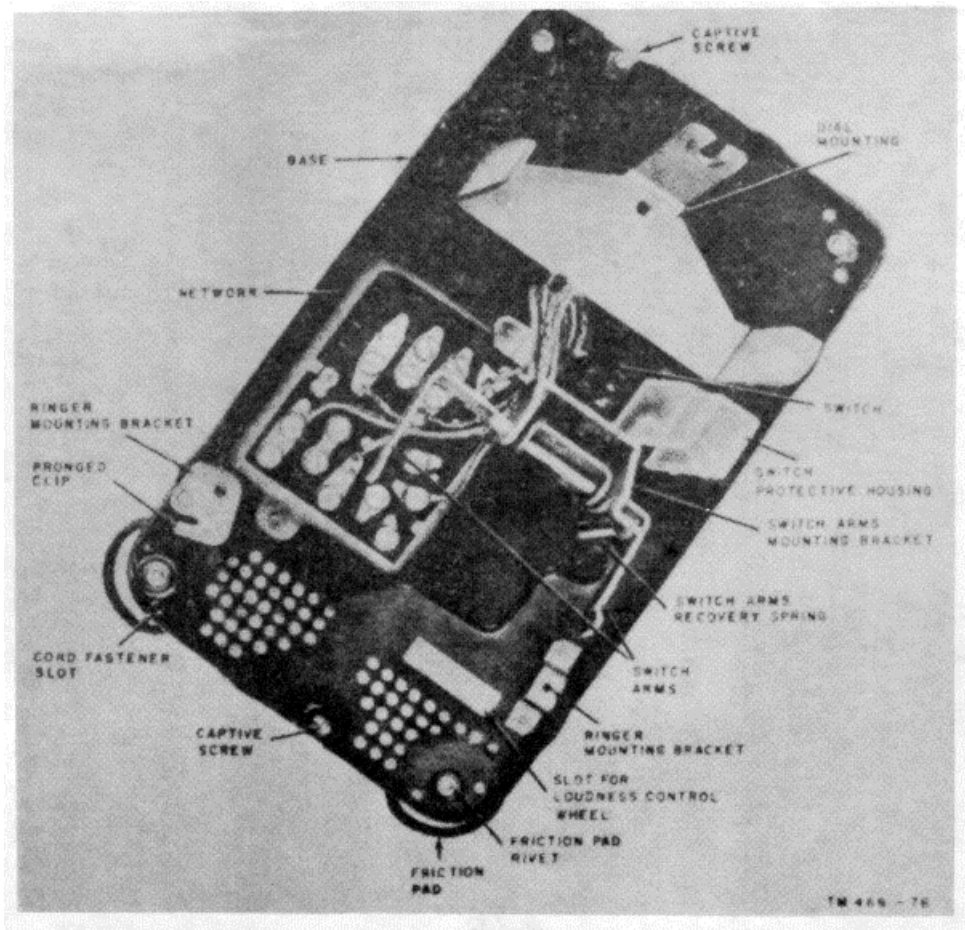

Figure 35. Telephone Set TA-236/FT, base plate assembly

c. Receiver (fig. 38). The receiver has a domed diaphragm of low mass and high effective area driven at the circumference by a ring-shaped magnet. This receiver is more efficient and has a greater frequency range than those of the TP-6 type telephones. Because of its higher efficiency and power capacity, a varistor is assembled as an integral part of the receiver.

f. Ringer (figs. 39 and 40).

- (1) The ringer components include a ringer frame, two ringer coils wound on a single spool, a ringer coil core consisting of a cluster of 16 silicon steel laminations, two permanently mounted resonator shells, two brass gongs, a biasing spring, an armature stop rod, and a ringer loudness-control arrangement.
- (2) All parts of the ringer are attached to the ringer frame (fig. 39). The loudness-control feature is accessible to the user

through the medium of a knurled section (control wheel) of the control mechanism. The knurled section projects through a rectangular slot in the base plate. An arrow and the word LOUD are stencilled on the base plate adjacent to the control wheel; the arrow barb indicates the direction of control rotation (fig. 58). The ringer provides a louder signal, when adjusted for maximum loudness, than any of the earlier types. Signal loudness can be selected at any one of four levels. By the application of a simple mechanical modification, a user controlled ringer cutoff can be provided.

- (3) Except for the ringer coil, coil core, and the brass gongs, no part of the ringer is replaceable at any maintenance level; however, the entire ringer can be replaced. The procedures to follow in

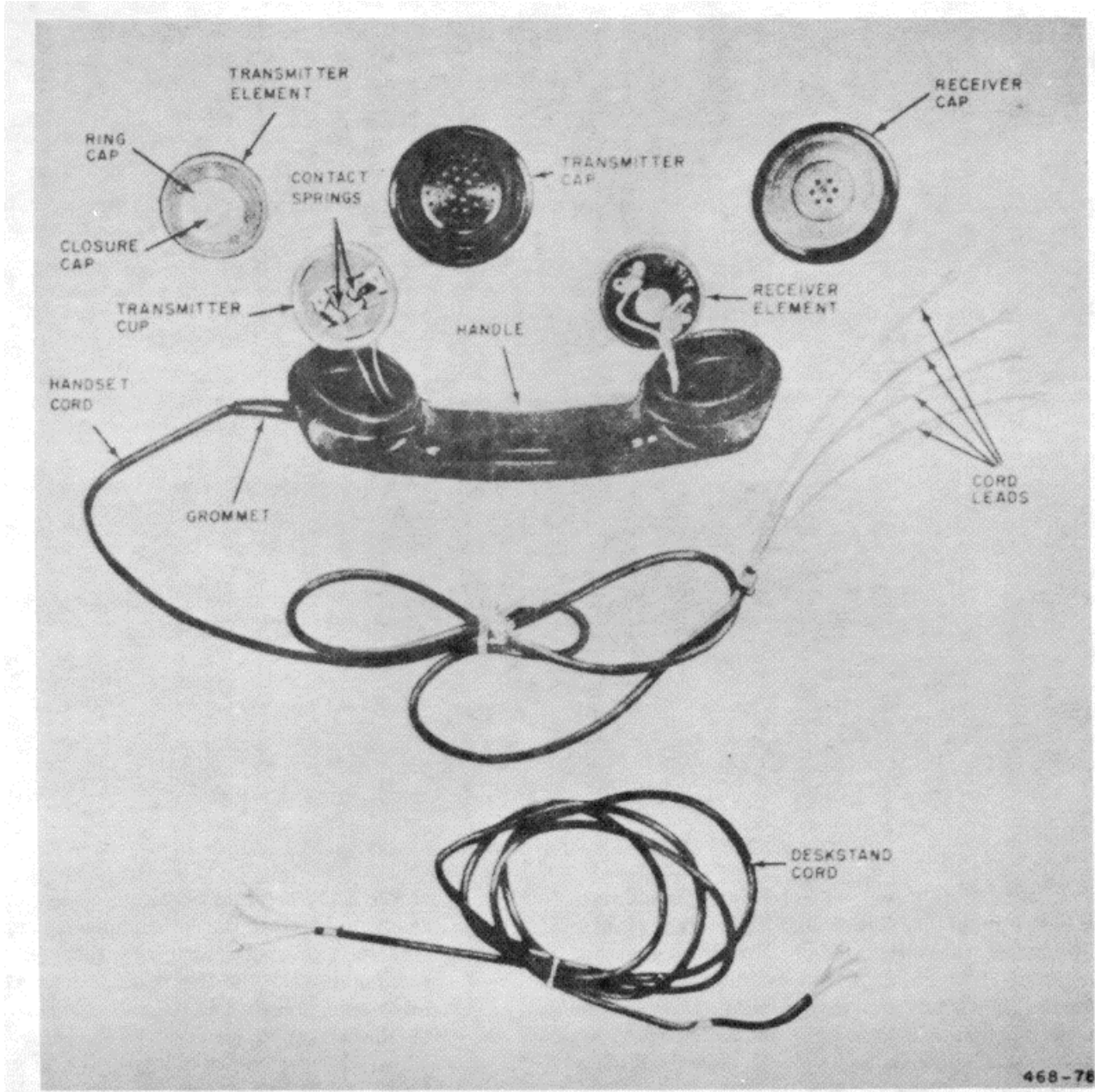

Figure 36. Handset for Telephone Set TA-236/FT, partially disassembled.

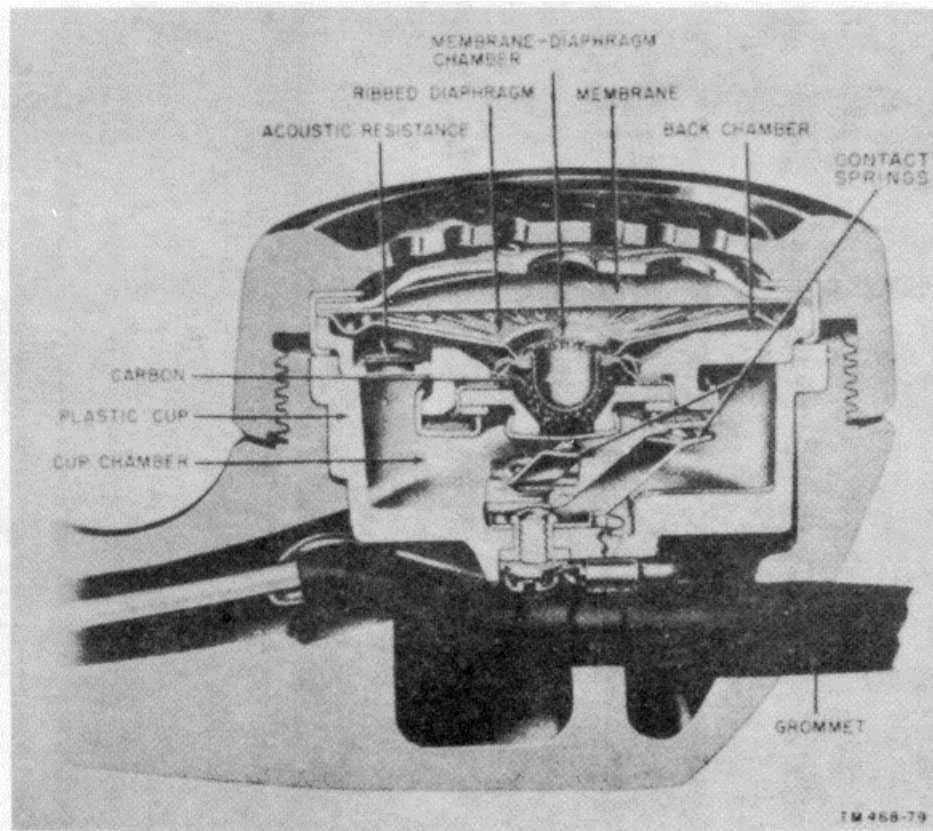

Figure 37. Transmitter unit for Telephone Set TA-236/FT, sectional view.

completing a ringer replacement are discussed in paragraph 77d.

- (4) Biasing spring tension is determined by which of two notches the spring rests in the biasing spring bracket. One notch provides high tension, the other low tension.
- (5) On a fully assembled ringer, one gong is movable and the other is fixed. The fundamental frequency of vibration of the two gongs differs so that the combination of fundamentals, overtones, and resonator effects produces a signal that is pleasing to the ear. The resonators cause an approximate gain of 15 decibels in the fundamental frequencies of the gongs. The large low frequency gain effectively increases the attracting qualities of the signal; also, it is helpful to people whose hearing is impaired in the higher frequency range.

- (6) The ringer impedances are designed, with respect to ringer and to voice frequencies, so that up to five ringing bridges may be connected to the line.
- (7) Up to the point of ringer burnout, the ringer will not suffer demagnetization in services from line surges due to lightning or accidental contact with power lines. The magnetic paths of the electromagnet are proportioned so that saturation occurs long before the field strength becomes great enough to appreciably affect the permanent magnet. A magnetic shunt is placed across the core. In addition to its normal function in the magnetic circuit, it serves also to increase the coil impedance, and, in joining the two pole pieces, adds mechanical strength to the structure.

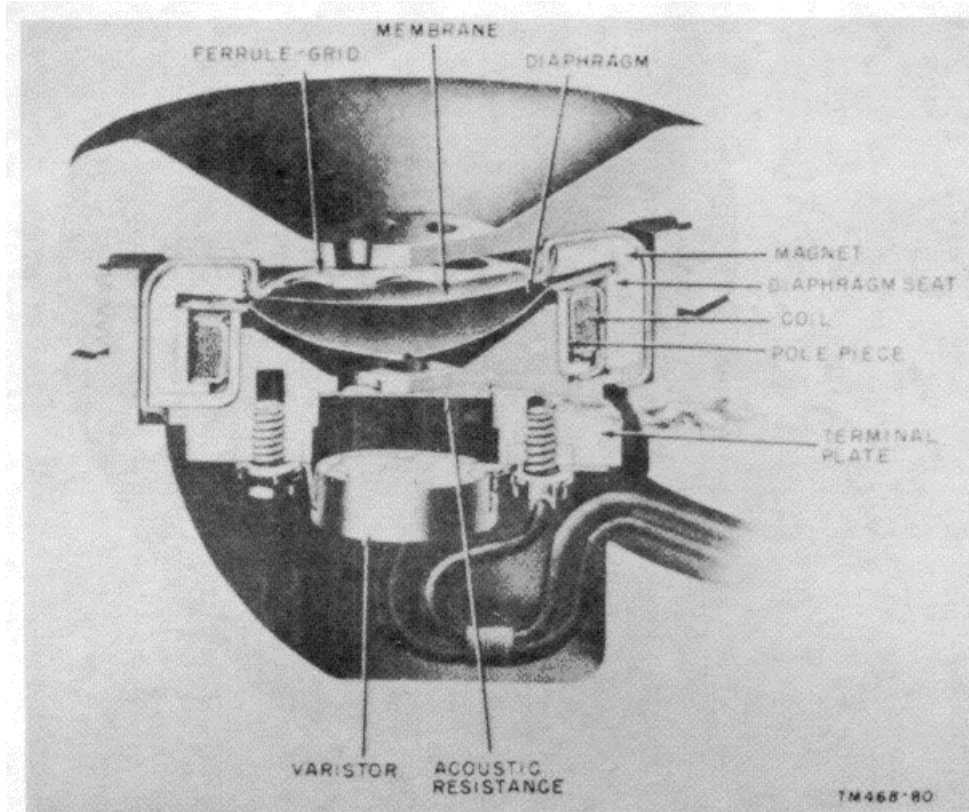

Figure 38. Receiver unit for Telephone Set TA-236/FT, sectional view.

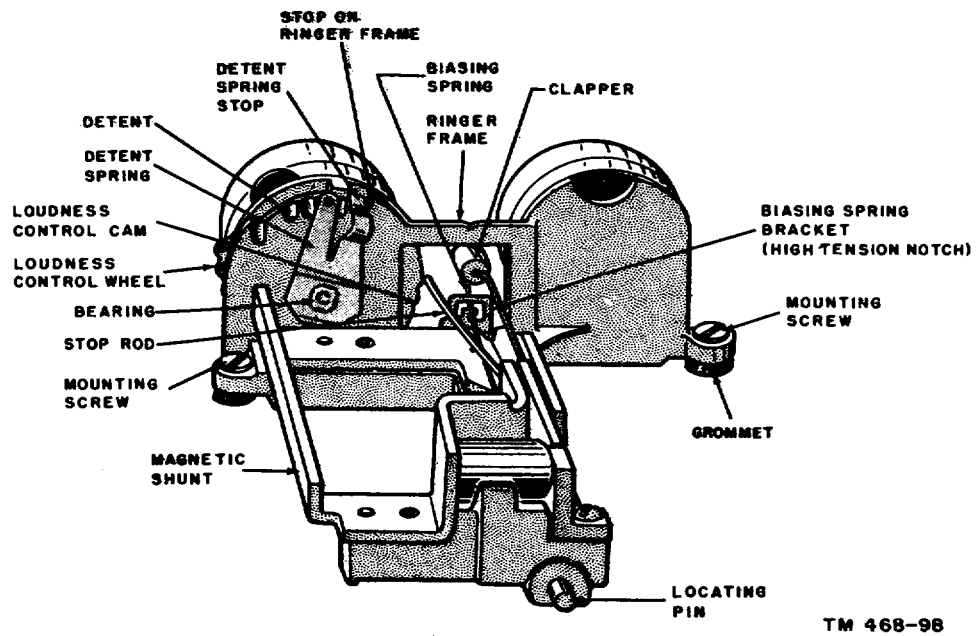

Figure 39. Ringer frame and permanently attached elements.

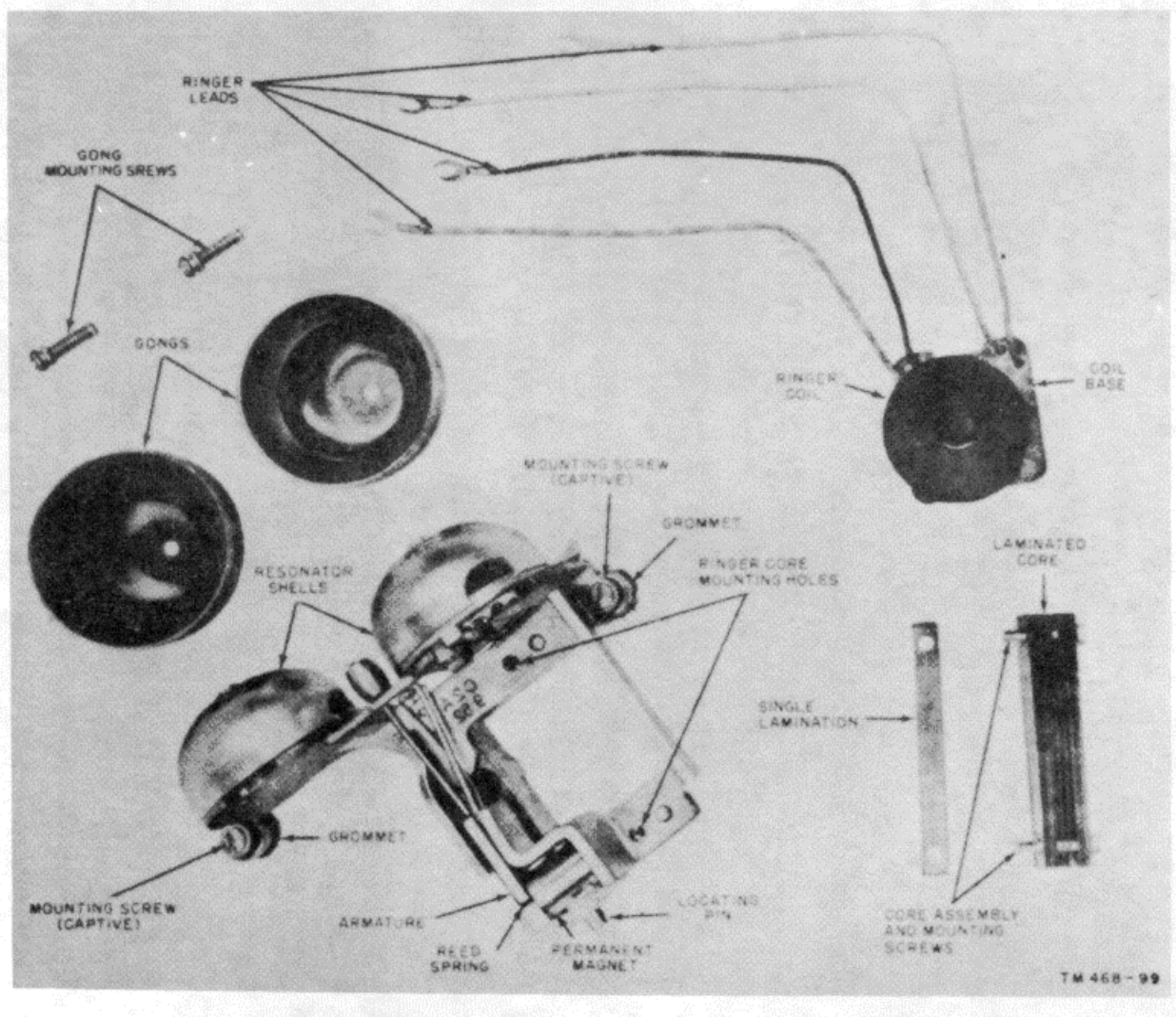

Figure 40. Ringer for Telephone Set TA-236/FT, exploded view.

g. Dial (fig. 41).

- (1) The user manipulates the dial in a manner similar to that of Telephone TP-. One noticeable difference in the dial is the location of the characters on the dial number plate. They are outside the finger wheel (fig. 41). This location makes them legible over a wider angle of vision and less susceptible to erasure as a result of dial use.
- (2) The number plate designations are white on a black background; a white marker spot appears under each finger-wheel opening to facilitate dialing.
- (3) The dial contact springs are molded in a block of insulating material (fig. 41); leads, equipped with spade tips, are

- brought out from the spring terminals and connected to screw terminals at the network terminal board (fig. 35). Only two pairs of contact springs are provided: one pair for pulsing, and the other for short-circuiting the receiver winding when the dial is in the off-normal position.
- (4) The dial mechanism is protected by a plastic cover which leaves only the spring terminals exposed. The dial is equipped to accommodate the standard number-card holder assembly. The improved dial mechanism makes it possible to send effective pulses over greater distances than could be done with dials of earlier design.

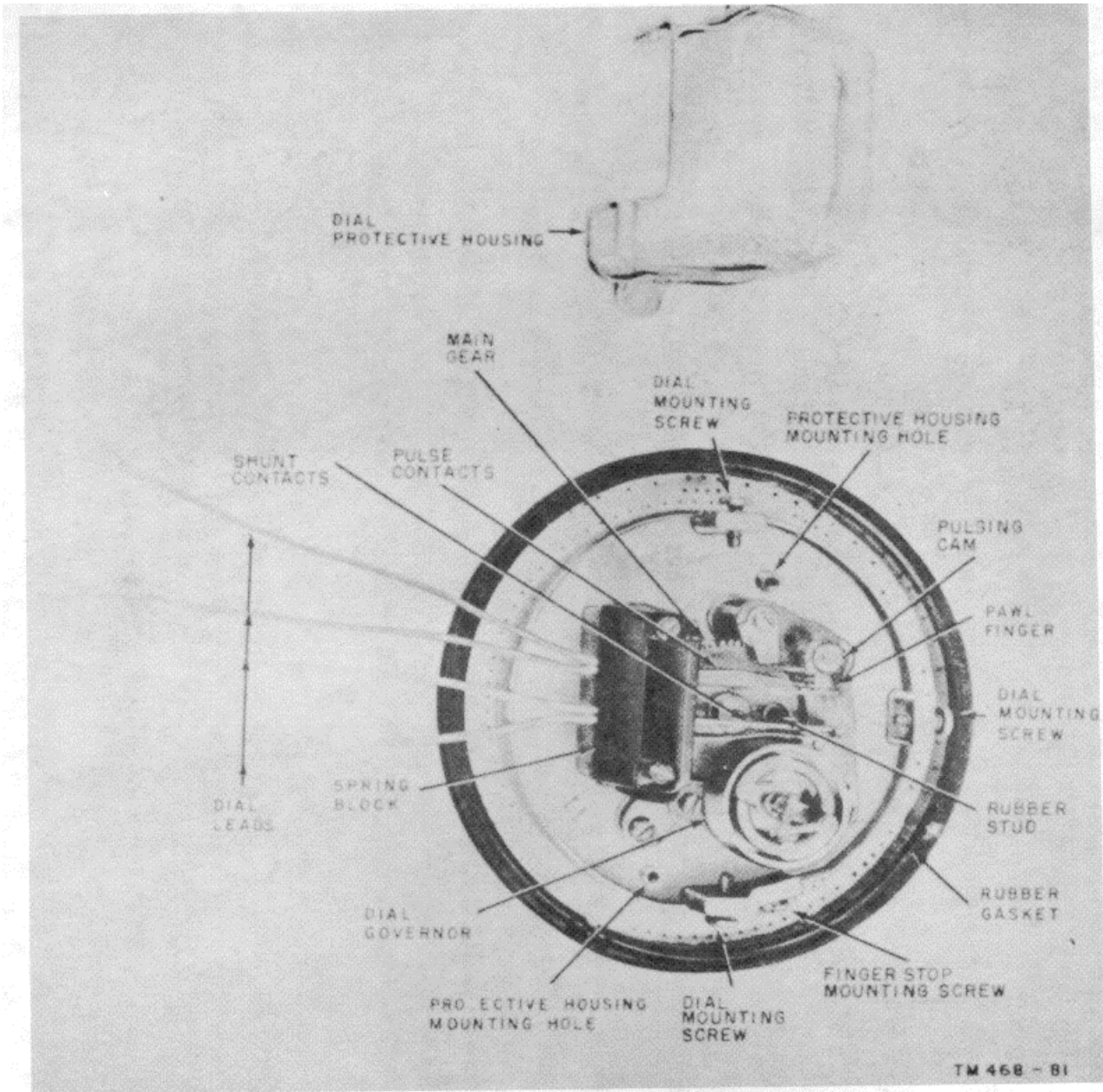

Figure 41. Dial for Telephone Set TA-236/FT, showing mechanism and housing.

h. Network (fig. 35).

- (1) The network assembly includes an induction coil, four capacitors, a dial radio interference filter, and an impedance balancing network. The assembly is housed in a metal can. Any remaining space in the can is filled with a moisture-proofing compound.
- (2) The circuit components, within the network, are wired to a molded plastic terminal board mounted in the top of the network can. Each terminal designation is molded on the terminal board surface adjacent to the associated terminal. Molded projections on the terminal board hold the set wires in place during soldering operations. Molded stop studs and terminals mounted at different surface levels prevent accidental contacts between cord tips and adjacent terminals. Other molded studs prevent cord tips from backing out from under the terminal screws when screws are being tightened.
- (3) Network components are not accessible for inspection or maintenance purposes. A defective network element requires replacement of the complete network assembly. The can acts as a shield to prevent cross talk when the talking circuit and the ringing circuit are connected to different lines. The can is riveted permanently to the base plate. The capacitors used in the network are newly-developed, metalized paper capacitors less than one-half the size of the conventional foil-paper capacitor of like capacity. These capacitors are *self-healing* in case of dielectric failure caused by high voltage surges.

i. Switch (fig. 35).

- (1) The switch, with its protective plastic

housing removed, is shown in figure 35. The switch twin-contact springs are adjusted permanently by the manufacturer. A notched detail, controlled by the hookswitch lever assembly, controls the movements of springs B, D, and G (fig. 67). A second notched detail limits the travel distance of springs A, C, E, and F. Seven wire leads connect the switch contact springs to associated terminals at the network terminal board. Two of these leads are equipped with spade tips; the remaining five leads are soldered.

- (2) Two machine screws attach the switch assembly to the switch bracket. Three rivets attach the switch bracket to the base plate. A removable, plastic housing is used to protect the switch assembly from foreign matter.
- (3) A twin-armed switch control lever is pivoted to the switch bracket, and a restoring spring is suspended between the bracket and the control lever.

11. Telephone Set TA-21 2/U (figs. 42 and 43)

Telephone Set TA-212/U is a common-battery, wall-type telephone set that is used in an area exposed to combustible gas. The TA-212/U can be converted from manual operation to dial operation by adding a dial. It is equipped with a standard handset. The circuit components, excluding the handset, are inclosed in a cast aluminum housing strong enough to withstand an explosion inside the set. This prevents the flames from igniting fumes or gas in the area outside the set. All connections to the set are sealed and the line wires are placed in conduit which is attached to the set by means of threaded openings and sealed.

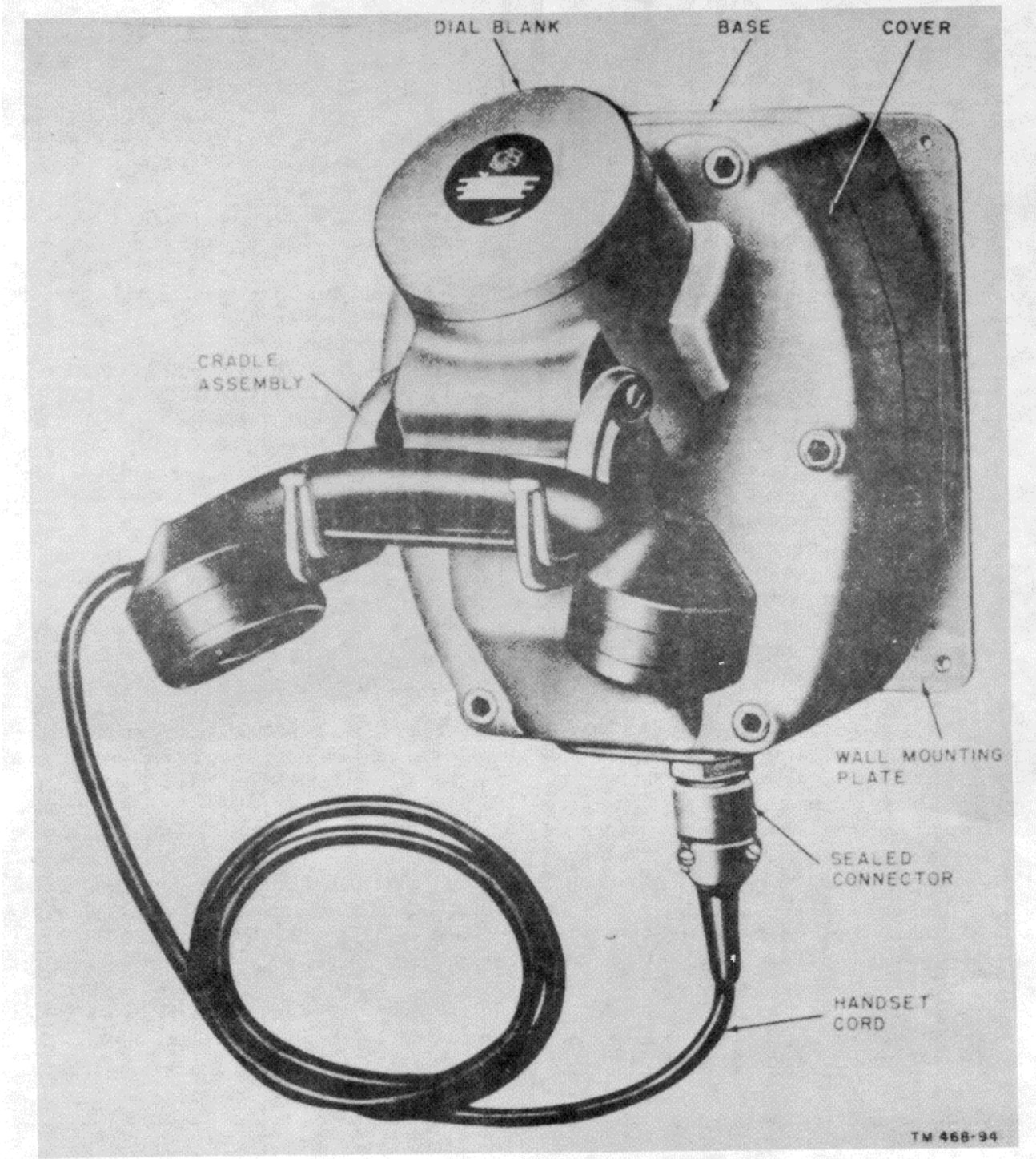

Figure 42. Telephone Set TA-212/ U, explosionproof wall-type telephone for common-battery use.

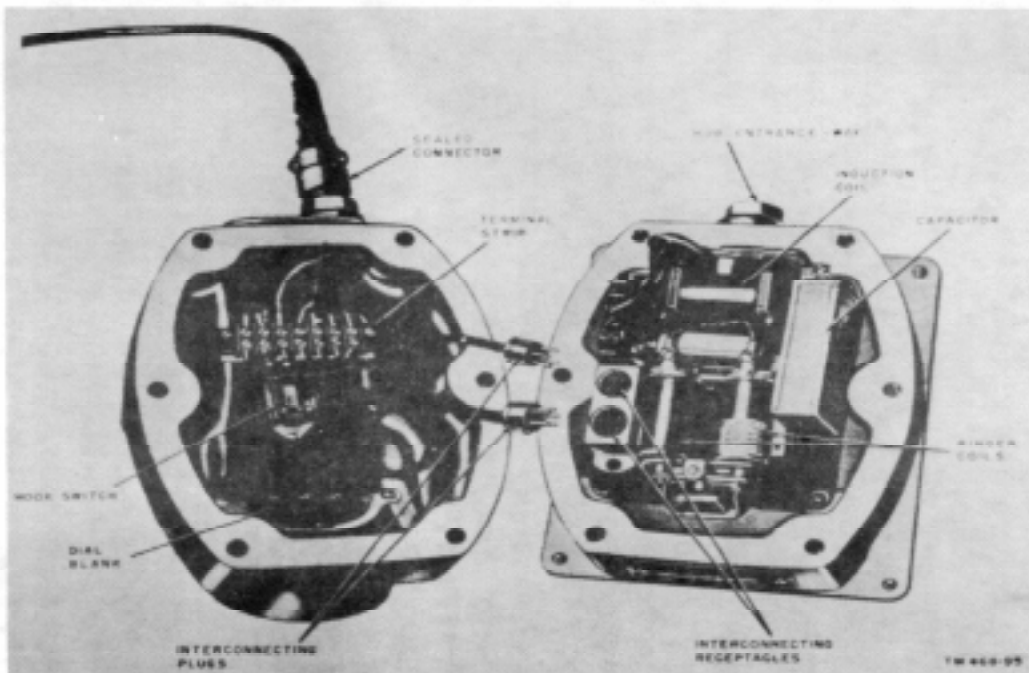

Figure 43. Telephone Set TA-212/U, with cover open, showing location of parts.

12. Telephone Set TA-213/U
(fig. 44)

Telephone Set TA-213/U is similar to the TA212/U (par. 11) except that it is used with a local battery system. The TA-213/U is equipped with Battery Box CY-1149 to provide an explosion proof compartment for the transmission battery. A hand-ringing generator is also contained in the explosion proof housing to provide signaling current.

13. Bell Box, WECO. No. 684A (Antisidetone)
(figs. 45 and 46)

This set contains an induction coil, a ringer, and capacitors. It is not a complete telephone set; auxiliary equipment consisting of a transmitter, a receiver, and a hookswitch is necessary to make up a complete telephone set. The bell box is wired in a manner identical with the TP-6 type (WECO. No. 302AW-3) telephone. Although other bell boxes are in use throughout the Signal Corps,

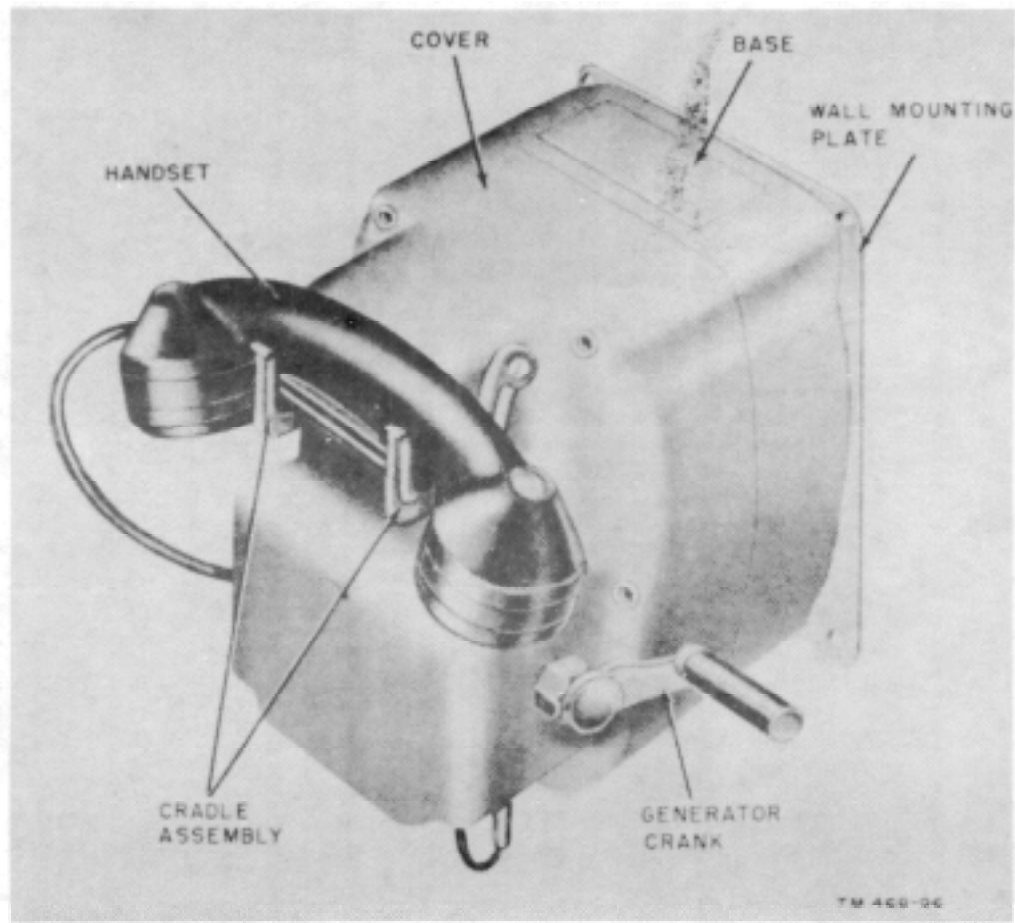

Figure 44. Telephone Set TA-213/U, less Battery Box CY-1149.

specific maintenance instructions will be given only for WECO. No. 684A bell box. Most of the other bell boxes may be maintained in a similar manner.

14. Connecting Blocks

(figs. 47 through 49)

Connecting blocks are used to interconnect the telephone set with the outside wiring. All the telephone sets discussed in this manual are equipped with connecting blocks supplied by the manufacturer. Since there is relatively little difference between individual connecting blocks, only the WECO. types will be discussed. These are the most prevalent types and are most likely to be encountered by the maintenance man. The WECO. 42-type connecting block is equipped with four screw terminals and a metal cover which is held in place by a retaining screw. It may be used to terminate two-, three-, and four-conductor cords, and cords having winged-type cord stays.



Figure 45. Bell box, WECO. No. 684A

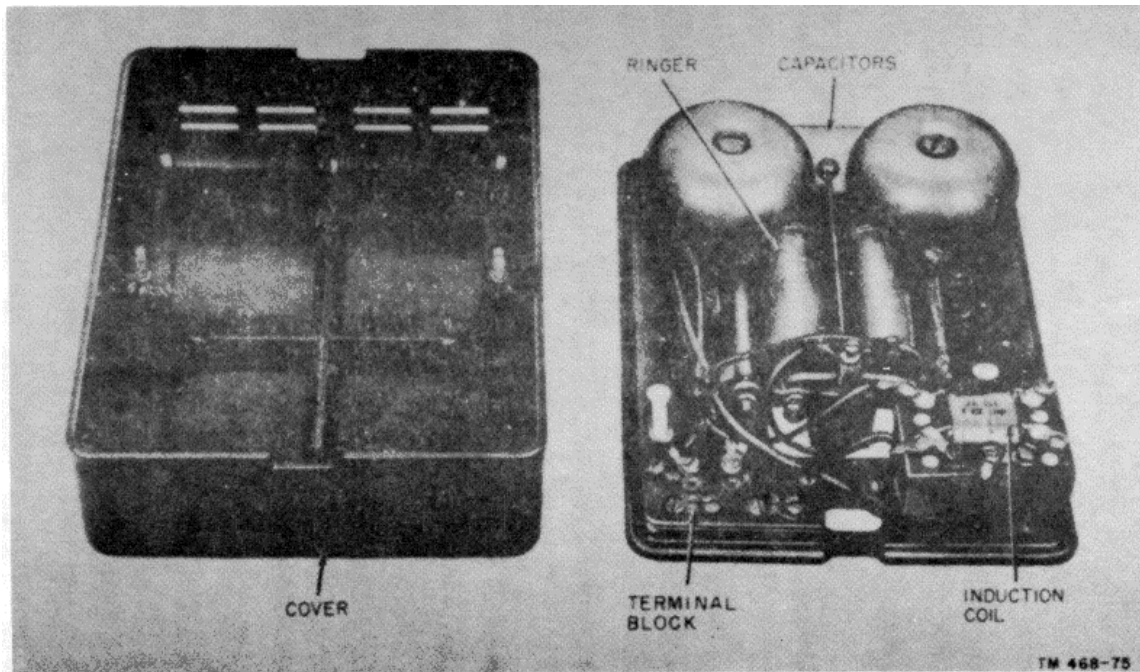

Figure 46. Bell box, WECO. No. 684A, showing location of parts.

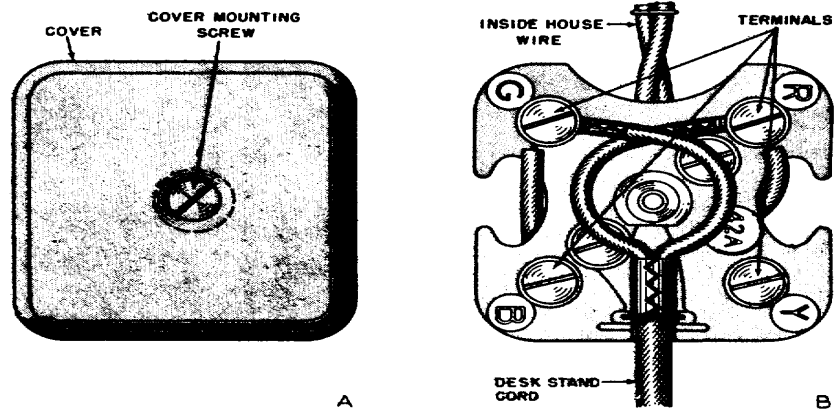

Figure 47. WECO 42-type connecting block.

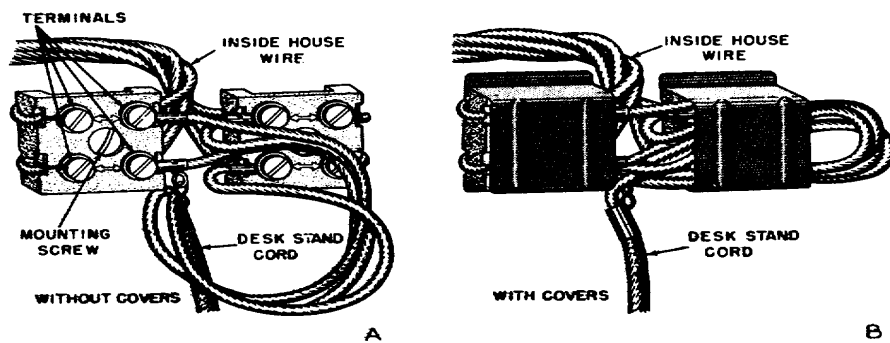
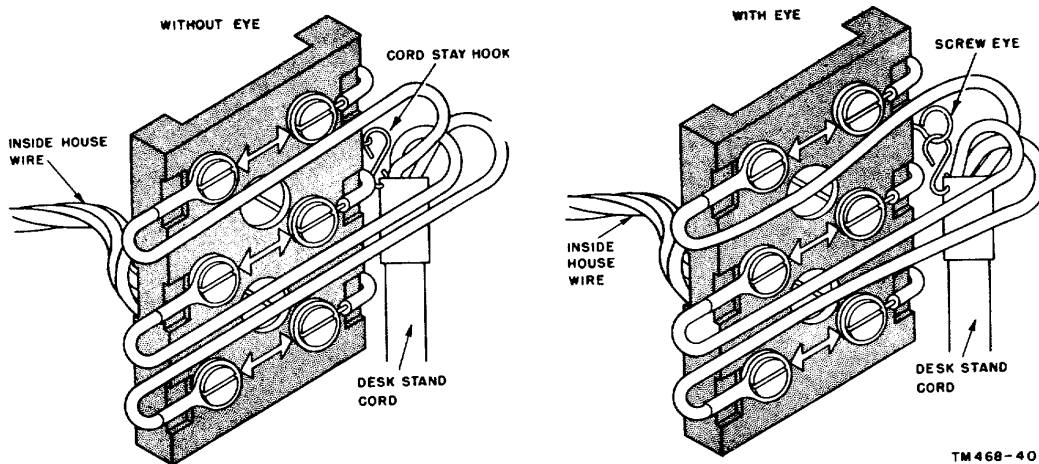

Figure 48. WECO 11-type connecting block.



TM 468-40

Figure 49. WECO 12-type connecting block.

15. Protectors

(figs. 50 through 53)

Protectors discussed in this manual are used to protect telephone sets from the effects of lightning and other high-voltage surges that may accidentally become present on telephone lines. All the protectors described in this manual are equipped with carbon block space cutouts and throw-away fuses.

a. There are two general types of protectors, the indoor and outdoor type. Protectors AR (Reliable Electric Co. No. 1000) and AR-6-A (WEC Co. No. 1093A and Cookeco No. 0-9) are designed for outdoor use. For indoor use the cover of the WEC Co. 1093A protector is removed and the protector is then called the WEC Co. No. 98A protector. The WEC Co. No. 98A is the only standard protector designed for indoor use.

b. The protector blocks for Protector AR-6 (Reliable Electric Co. No. 1000) and the WEC Co. No. 98A protector consist of a solid carbon block and a porcelain block with a carbon insert. The carbon insert is connected electrically to one side of the line and the carbon block is connected to ground. When installed on the protector, the carbon block and the insert are spaced .003 inch apart, forming an air gap.

c. Protector AREA (Cook Electric Co. No. 0-9) is equipped with two solid carbon blocks separated by a mica insert .003-inch thick, which forms an air gap. One of the blocks is connected to ground and the other is connected to one side of the line.

d. Both types of open space cutouts (b and c above) provide protection for the station against high voltage, such as lightning and power lines. When the voltage becomes too high on either side or both sides of the line, it will arc across the air gap to ground. If the voltage is considerable or if the arc continues for a period of time, the carbon blocks will fuse together causing a permanent ground on either side or both sides of the line.

Caution: Never change the air gap dimensions of the protector blocks, because a change in the air gap will change the operating limits of the protector block.

e. Protector fuses are used to protect the telephone apparatus from a sustained abnormal current flow which may be established through the operation of the carbon blocks. These fuses are designed to operate on a current flow of 7 amperes or more.

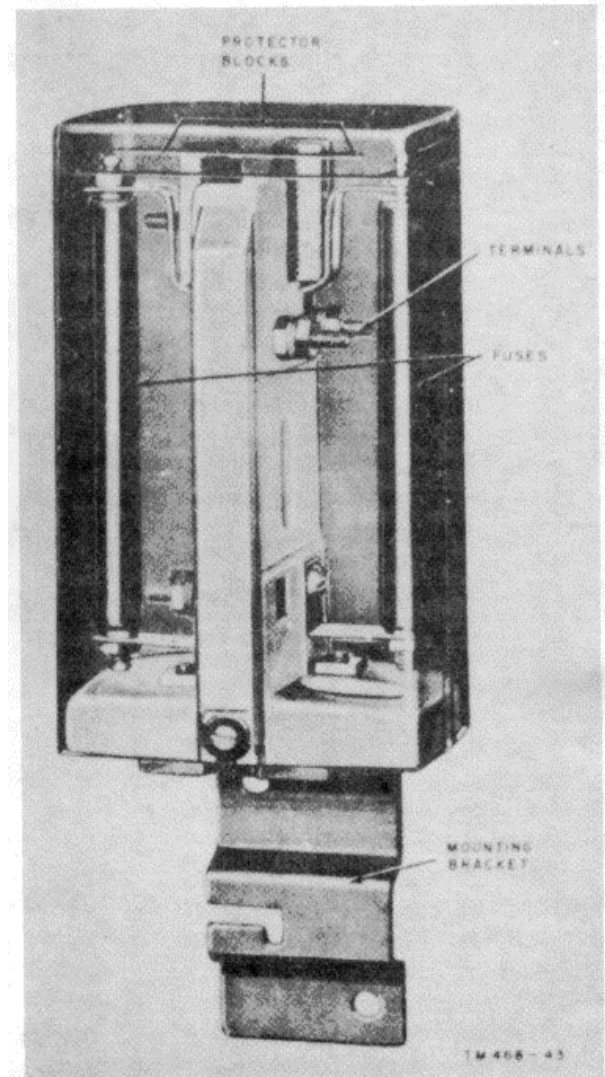

Figure 50. Protector AR-8 (Reliable Electric Co. No. 1000).

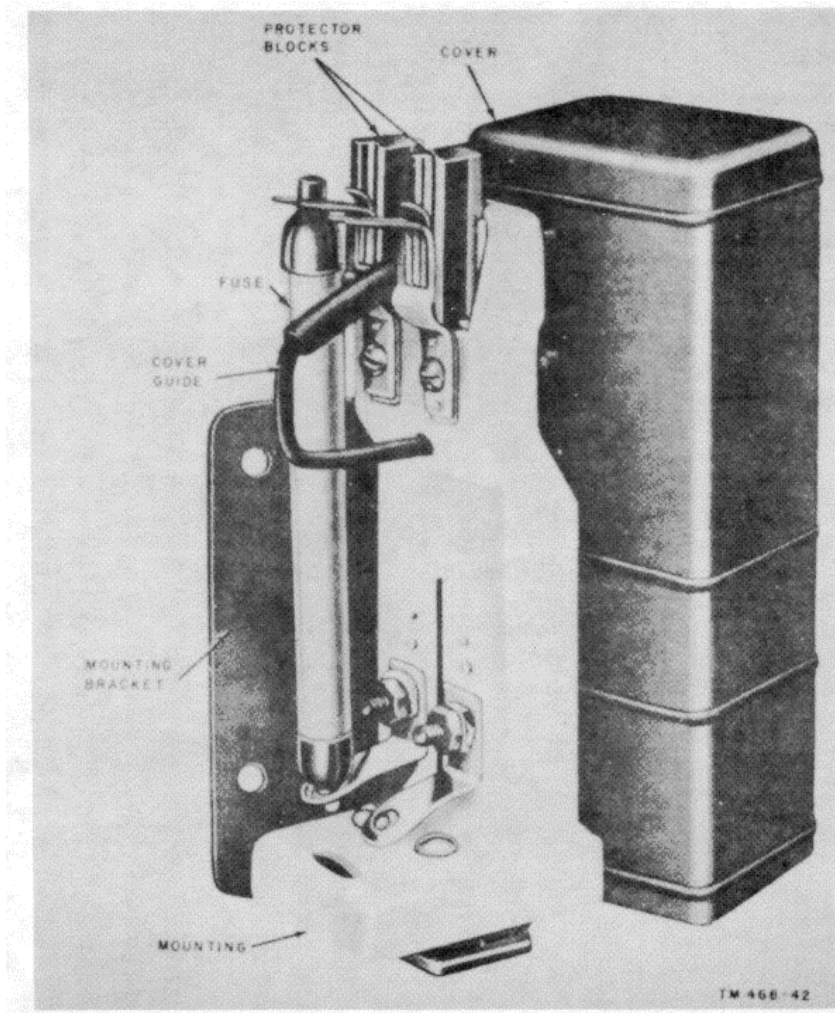

Figure 51. Protector AR-6A (Cookeco. No. 0-9).

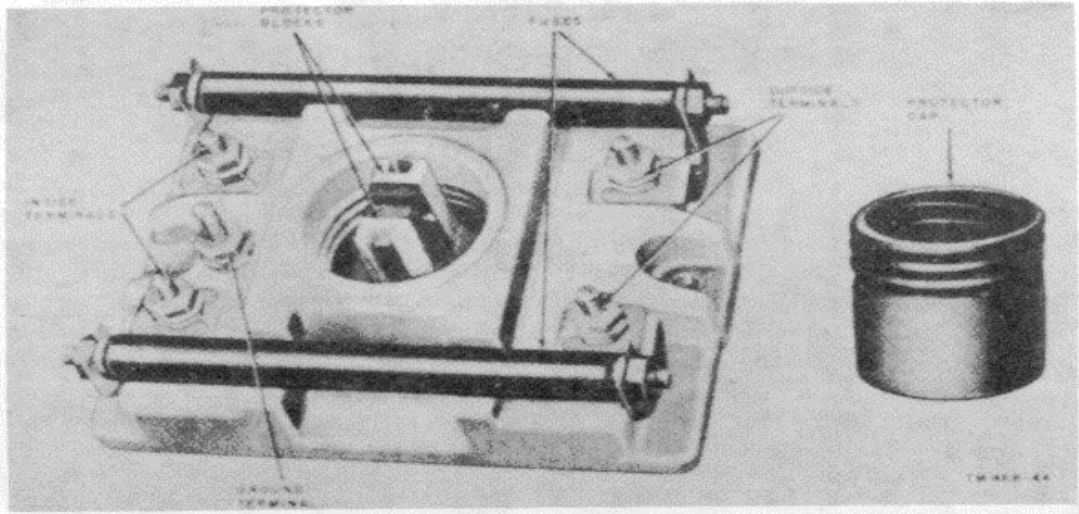

Figure 52. WECo. No. 98A protector, for inside installation.

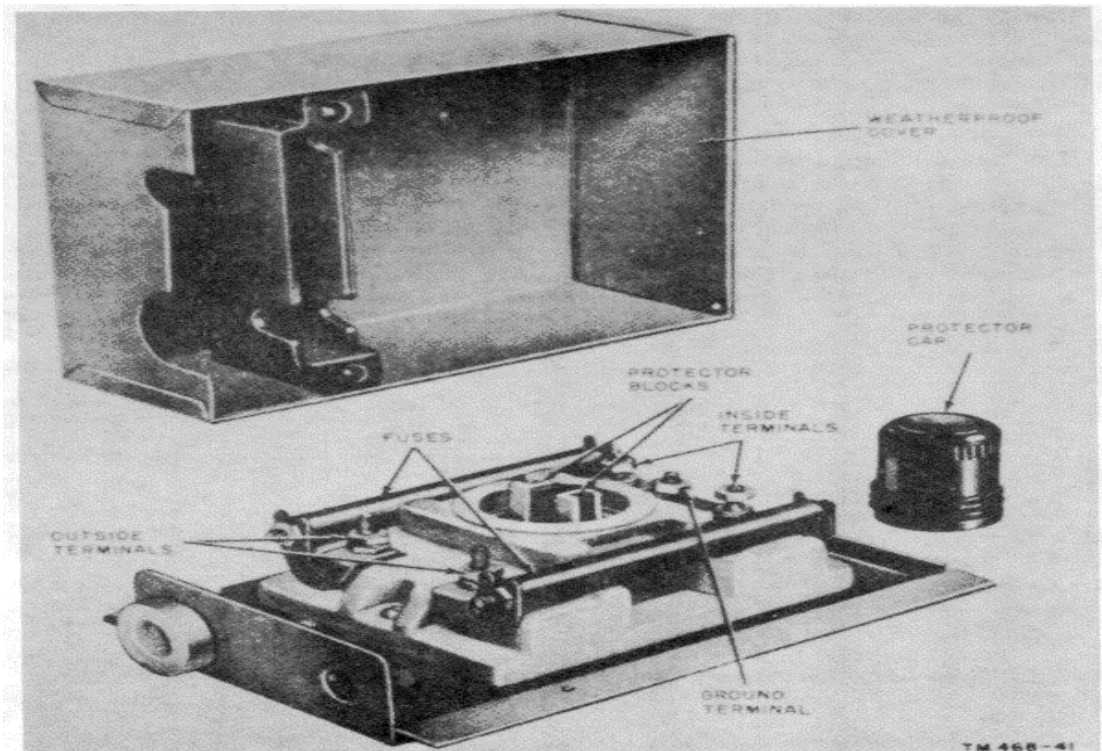

Figure 53. Protector AREA (WECo. No. 1093A), for outside installation.

CHAPTER 2
THEORY OF OPERATION

Section I. GENERAL

16. TP- Type Telephones

The TP-6 type telephones are similar in circuit operation to the TP-6-A, TA-166/U, TA-212/U, and the TA-105/FT. The circuit analysis of the TP-6-A as covered in this chapter is typical and applicable with slight modification to all the TP-6 type telephones. The circuits and circuit components are fundamentally the same; the chief difference is in the mechanical construction of the parts and the color coding of the wiring. The components of these telephones are interconnected to provide an antisidetone telephone as described in TM 11478. The theory of the TP-6-A is discussed in detail in section II of this chapter.

17. Telephone Set TA-236/FT

The TA-236/FT is similar in appearance to the TP-6 and the TP-6-A, but the circuits are electrically different, and the circuit components are mechanically different. The circuit components of TA-236/FT are a ringer, transmitter, receiver, and a network assembly. The network assembly contains the induction coil, four capacitors, three resistors, and two varistors, which are required for the transmission circuit. The circuits of the TA-236/FT are the ringer, transmitter, receiver, and antisidetone. The theory of operation of this telephone is discussed in detail in sections III and IV of this chapter.

Section II. TELEPHONE TP-6-A

18. General

(fig. 54)

A simplified schematic diagram of a loop circuit showing two telephones TP-6-A with the switchboard apparatus omitted from the diagram for simplicity is illustrated in figure 54. To simplify the circuit explanation, the circuit will be treated as if it were divided into three separate sections-the transmitting and receiving circuits,

the ringing circuit, and the antisidetone circuit.

19. Transmitting and Receiving Circuits

a. The basic parts of a transmitter are a diaphragm, a small carbon disk attached to the back of the diaphragm, and a small cup of carbon granules mounted behind the diaphragm. The diaphragm vibrates at the same rate as the sound waves directed against it. As the diaphragm

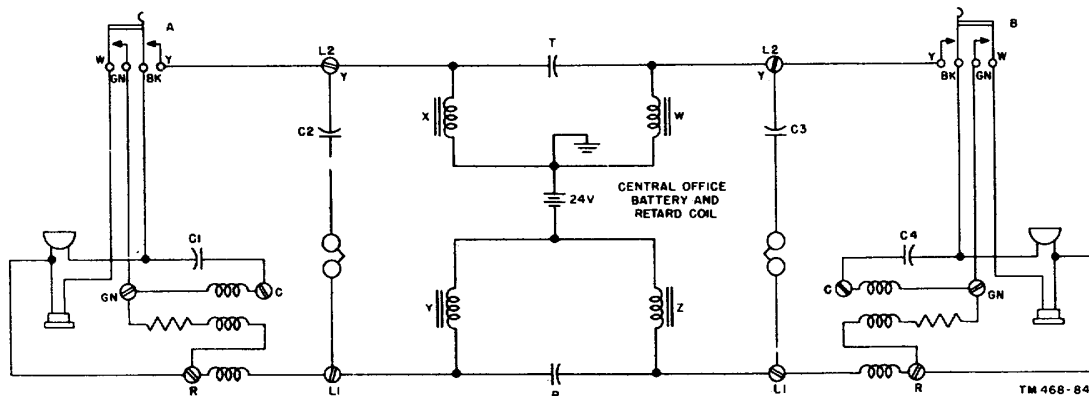

Figure 54. Loop circuit with two Telephones TP-6-A, schematic diagram.

vibrates, the carbon disk varies the compactness of the carbon granules in the cup which changes the transmitter resistance. The transmitter is in series with the line. Therefore, the direct current (dc) in the primary circuit and on the line will change to a fluctuating dc (voice current).

b. Battery is supplied to station A through the X and Y windings of the retardation coil and to station B through the W and Z windings. The transmission path between station A and station B is as follows: From the transmitter of station A, through the BK and Y contacts of the hookswitch, L2 terminal, to capacitor T; from capacitor T to the L2 terminal of station B, through the Y and BK contacts of the hookswitch, through the transmitter, to terminal R on the induction coil; from terminal R on the induction coil through the primary winding of the induction coil, L1 of station B to capacitor R; from capacitor R to L1 of station A, through the primary winding of the induction coil, terminal R, and back to the transmitter at station A. The high impedance of the ringer coils prevents shunting the voice currents through the ringer circuit.

c. The receiver includes a combined permanent magnet and electromagnet, and a diaphragm. As the voice currents flow through the windings of the electromagnet, a magnetic field, which alternately aids and opposes the field of the permanent magnet, is established. The varying strength of the magnetic field causes the receiver diaphragm to vibrate at the same rate as the diaphragm in the distant transmitter. This reproduces the sound picked up by the distant transmitter.

d. The voice currents originating at station A operate the receiver at station B over the following circuit: voice currents flowing through the primary winding of the induction coil at station B will induce a voltage in the secondary winding of the induction coil. The induced voltage will cause voice currents to flow to capacitor C4; from capacitor C4 through the transmitter, receiver, W and GN contacts on the hookswitch, terminal GN on the induction coil, and back to the secondary winding of the induction coil. The effect of the

balancing winding on the incoming voice currents is negligible. The transmission for both telephones is the same and these instructions apply equally to station A and station B.

20. Ringing Circuit

The ringing circuit provides for signaling a telephone from a dial central office or from a manual switchboard. In both cases, 20 cycles per second (cps) alternating current (ac) is applied to terminals L1 and L2 of the called telephone. The ringer is in series with a capacitor and is permanently connected across terminals L1 and L2 to provide a path for ringing current. Ringing current is blocked from the transmission circuit by the open hookswitch contacts. The capacitor prevents a permanent signal at the telephone central office by opening the ringing circuit to dc. The high impedance of the ringer coils to voice-frequency currents prevents voice currents from being shunted through the ringing circuit. Either side of the ringer may be grounded for party-line service.

21. Antisidetone Circuit

Sidetone is the name given to the sound picked up by the transmitter and reproduced in the receiver of the same telephone. When a telephone is used in a noisy location, sidetone may be so loud that it is impossible to hear the incoming conversation. This effect must be reduced or eliminated. To reduce or eliminate sidetone without affecting the receiving circuit, a balancing (tertiary) winding with a noninductive resistance has been added to the induction coil. Voice currents produced by the transmitter induce a voltage in the secondary winding and the balancing winding. If the circuit could be perfectly balanced the induced voltages would cancel, completely eliminating sidetone. However, a perfect balance cannot be obtained under field conditions, so the sidetone is reduced instead of being completely eliminated. The balancing winding is wound so that it has little or no effect on the incoming voice currents. For a more detailed explanation of antisidetone circuit theory, refer to TM 11-678

Section III. TELEPHONE SET TA-236/FT, COMPONENT OPERATION

22. Transmitter

(fig. 37)

a. In general appearance and in some parts of its structural design, the transmitter resembles those that are at present in use with Telephone TP-6 and similar types of telephones. There have been several design changes in addition to a special treatment of the transmitter carbon grains that, in combination, provide a decided transmission improvement over transmitters of different design.

b. When in use, the transmitter is brought closer to the speaker's mouth. This desirable condition results from the newly designed handset handle.

c. The transmitter leads in the handset cord terminate at two terminals on a plastic cup located in the transmitter element cavity at the handset handle. The plastic cup mounts two transmitter contact springs and acts as a partial receptacle for the transmitter element. It also serves as a controlled acoustic (sound wave) cavity for the transmitter and as an acoustic shield between the transmitter and the receiver. Such a shield is necessary; otherwise, the transmitter and the receiver would be coupled acoustically.

23. Receiver

(fig. 38)

a. The receiver differs radically in design from that of other types of receivers. The simple diaphragm of the TP-6 type receiver is replaced by a ring armature, a dome-shaped diaphragm of phenolic impregnated fabric cemented to a circular magnetic ring. The outer edge of the ring rests on a circular seat of nonmagnetic material. The inner edge is close to a circular pole piece which conducts the magnetic flux from a ring-shaped permanent magnet. This design lowers the mechanical impedance of the diaphragm and improves the radiation efficiency. As a result, when the receiver is held away from the ear, the intelligibility of speech is much better than that of other receivers.

b. An acoustical network couples the back chamber of the diaphragm through four holes covered with acoustic resistance fabric to the handset cavity. The chamber above the diaphragm exhausts through the holes in the receiver cap. The frequency response is virtually flat from 400 to 3,500 cps.

c. A varistor protects the user from high acoustic levels caused by transient electrical disturbances

in the telephone circuit. This varistor also protects the receiver magnet from demagnetization hazards of such disturbances.

24. Dial

(fig. 41)

a. The dial pulsing mechanism (fig. 55) shows the operating features of the dial. The pulsing contacts are actuated by a single-lobed cam, mounted on a shaft, and geared to a finger wheel in a ratio of 12 to 1. When the dial is in its at rest position, the cam is oriented so that the contacts, which are a part of the transmitter circuit, are held closed firmly. When the dial is wound up, a spring-controlled friction drive carries the pawl around to rest against a stop (position 1, fig. 55).

b. During the first camshaft revolution, the cam lifts and lowers both springs A and B once for each rotation of the cam. However, because spring A is tensioned against spring B, the contacts remain closed and no pulses are formed during this revolution. At the end of the windup, the springs are resting on the cam high dwell (broken lines, fig. 55). To increase the reliability of the pulsing contacts operations, springs A and B carry dual contacts and spring A is split into two forks.

c. When the dial is released, it is returned to its normal position by the tensioned motor spring at a speed controlled by the governor (fig. 56). As the dial runs down, the cam first lowers and then lifts the springs during its first revolution. During this interval, no pulse occurs because the contacts in motion remain tensioned, one against the other. Also, during this revolution, the pawl finger travels clockwise to position 2 where it supports spring A and prevents it from following spring B during the break portion of the cam cycle in the course of the second cam revolution. Thereafter, as spring B continues to follow the cam, the contacts are opened and closed once per cam revolution to produce pulses. Rundown stops with the springs resting on the cam high dwell and the contacts closed.

d. The time interval between successive sequences of pulses, corresponding to the digits of the dialed telephone number, is termed Interdigital time. This time interval must be long enough to enable line selecting relays to respond properly to separate sequences. Interdigital time is composed of hunt (the time required by the user to locate the next digit to be dialed), windup, and the con

trolled increment added during the first no pulse rotation of the camshaft during rundown. Hunt and windup time may be of short duration when low value digits are dialed; therefore, the controlled increment is provided to insure that line relays do not confuse, for example, a pair of ones with a single two.

e. The dial is equipped with a pair of off-normal contacts (shunt contacts, fig. 41) that are held open by a rubber stud on the main gear when the dial is in its normal position. When the stud is moved away, during the act of dialing, these contacts close. This short-circuits the receiver winding and, by bypassing the receiver impedance, increases the dialing range; also, it prevents the high-voltage transients, caused by breaking the inductive line circuit, from reaching the receiver.

f. On completion of dialing each digit, there is a minimum interval of .015 second before the contacts open to restore the receiver; this is enough time to permit the decay of objectionable transients.

g. Average dial speed required that pulsing be not less than 9 and not more than 10.5 pulses per second. Dials having defective pulsing mechanism should be replaced.

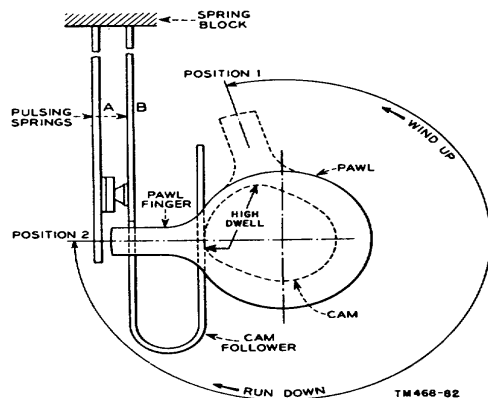

Figure 55. Dial pulsing mechanism.

25. Network

a. Varistor CR2 is bridged across the set in series with resistor R3 (fig. 60). Variation in the resistance (600 to 4,000 ohms) of this bridge with

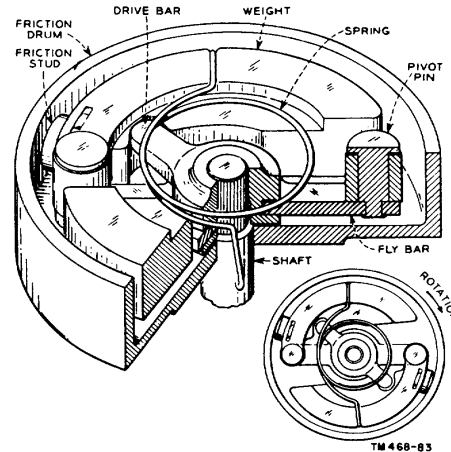

Figure 56. Dial speed governor.

loop current introduces a shunt loss between the impedance (approximately 800 ohms) of the set and the impedance (600 to 1,000 ohms) of the loop or trunk and provides the bulk equalization feature. This varistor has little effect on the transmitter current on short loops.

b. Varistor CR1 (fig. 66) is bridged across the receiver, winding S2 of the induction coil, and capacitor C2. It serves two functions. It maintains the sidetone balance, and it provides a de shunt path for the transmitter element.

c. Varistor CR3 (fig. 63) bypasses any high amplitude currents and thus acts as a click reducer; it is not a part of the transmission equalizer. On long loops, the resistance of varistors CR1 and CR2 is very high, and neither varistor has any reaction on the performance of the circuit. Under such conditions, the resistor and the capacitor elements shown in the balancing network provide adequate balance for the line facility. As the loop is shortened, varistor CR2 tends to reduce the line impedance as seen from the set and makes this impedance more nearly resistive. Correspondingly, the resistance of CR1 also decreases and reduces the impedance of the balancing network circuit and makes it more resistive.

d. With this type of equalizer, both line and network impedance's are correspondingly changed, and the degree of sidetone balance is maintained directly without any change in the instrument efficiencies.

e. The second function of varistor CR1 is that of providing a dc shunt path for the transmitter element. On long loops, this varistor has a very high resistance and has no important reaction on the transmitter current. As the loops are shortened, the resistance of the varistor drops. On very short loops its resistance substantially approaches that of the transmitter branch; therefore, it provides a small transmission adjustment in the form of battery supply loss plus the protection feature of limiting the current in the transmitter element.

f. Resistor R3, in conjunction with capacitor C3 (fig. 66), acts as a filter to reduce radio interference caused by dialing. This combination acts also in the equalizing circuit.

g. The primary winding of the induction coil is split with one part (P1) connected into the ring side of the line, and the other part (P2) into the tip side of the line. This improves circuit impedance balance.

26. Ringer

(figs. 39 and 40)

a. A general description of the ringer used in the TA-236/PT is outlined in paragraph 10f. Figures 39 and 40 show that it differs in design and construction from ringers normally in use. The only two degrees of ringer bias tension avail

able are high and low. Normally, the ringer is arranged for high tension bias. However, when three or more stations with ringers are bridged across a line, or where the loop is very long, the sensitivity is increased when the biasing spring is positioned in the low tension notch at the biasing ' spring bracket.

b. When the ringer loudness control mechanism is set for maximum loudness, the ringer operates similar to that of any other standard nonpolarized telephone set ringer, but with a greater signal volume. Under this condition, the stop rod is free to operate through its maximum travel distance, and the maximum impact force of the clapper is applied to the gongs. As the ringer loudness control wheel is changed from the position of maximum loudness into the next lower loudness level, the detent spring leaves the maximum loudness detent in the ringer frame and moves into the adjacent detent. The loudness control cam is rotated automatically as the control wheel is rotated. Its sawtooth edge becomes positioned so that the stop-rod travel distance is reduced, and the movable gong is brought closer to the clapper.

c. This reduction of the stop-rod travel distance reduces the impact force of the clapper to the gongs. Thus the signal loudness is reduced.

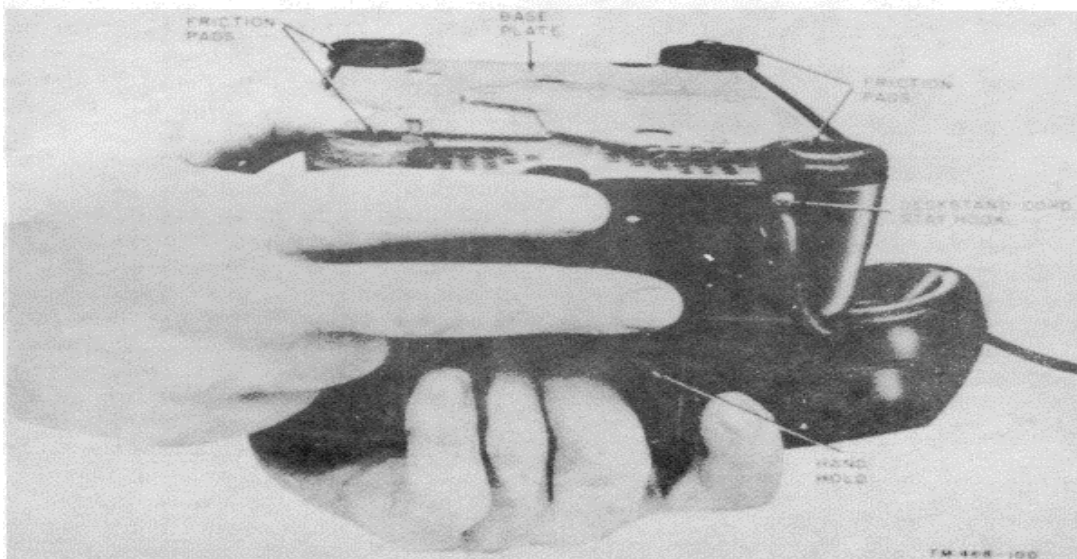

Figure 57. Inverting the set to adjust ringer loudness control.

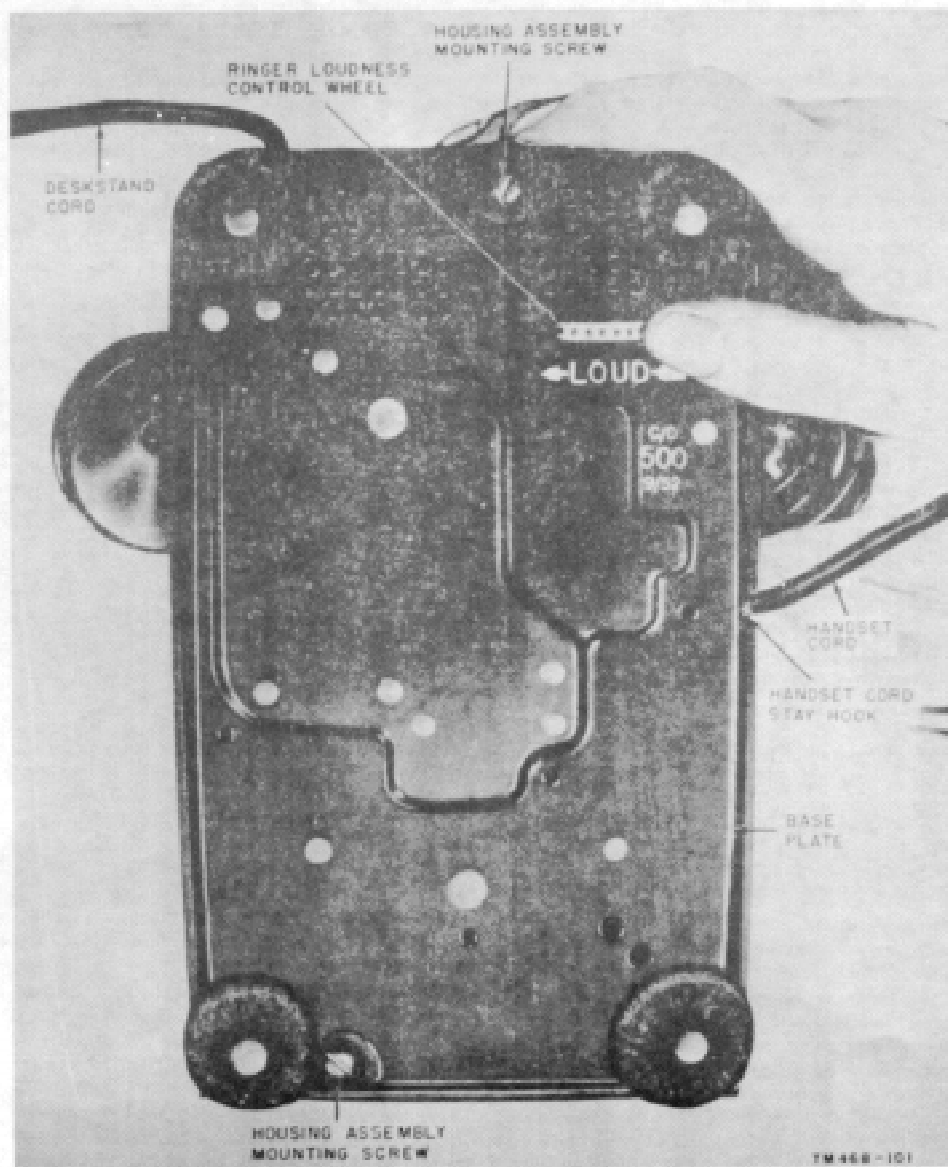

Figure 58. Adjusting the ringer loudness control.

d. Each change in position of the control wheel from maximum through two intermediate levels to minimum loudness causes a repetition of the changes outlined in b and c above. As the control wheel position changes, a new surface in the sawtooth edge of the cam is brought adjacent to the stop rod; each of these surface areas further reduces the stop-rod travel distance, and the movable gong is moved nearer to the clapper.

e. Figure 57 shows how to prepare the set for loudness control adjustment while holding the handset in its cradle. Figure 58 shows the position of the set in the hands of the user at the time the adjustment is being applied.

f. Ringer cutoff can be provided when this feature is required. Cutoff may be permanent or it may be user-controlled. Permanent cutoff prevents the ringer from operating at any time. User-controlled cutoff may be applied and removed at will by the user. The circuit and mechanical adjustments required in establishing these service features are explained further in paragraph 65b.

g. Figure 39 shows the biasing spring in the high tension biasing notch at the biasing spring bracket. Low tension is obtained when the spring is moved to the adjacent notch.

Section IV. TELEPHONE SET TA-236/FT, CIRCUIT OPERATION

27. General

a. The individual circuits of the TA-236/FT are discussed in paragraphs 28 through 38. Unless otherwise noted, all terminals referred to in this section are at the network terminal board. The designations of the elements within the network, shown in the drawings, have been assigned arbitrarily for reference identification.

b. In paragraphs 29 through 37, the circuit description of each individual circuit of the Telephone Set TA-236/FT is outlined together with the continuity tracing of the wiring diagram of each circuit. The circuit description of the simplified schematic for each circuit may be used for circuit tracing and study. The continuity tracing of each circuit may be used for troubleshooting and wiring each individual circuit in the telephone.

28. Ringer Circuit
(fig. 59)

Ring current from the ringing power source passes over the ring side of the line to the connecting block and through the YEL deskstand cord lead to terminal G. The current then passes through the BLK ringer lead and the 1,000-ohm ringer coil winding and the GY ringer lead to terminal K. Ringing current leaves terminal K and flows through capacitor C4 to terminal A, through the GY-RED ringer lead, the 2,650-ohm ringer coil winding and the RED ringer lead to terminal L2, through the RED deskstand cord lead to the connecting block, and the tip side of the line to the ringing power source.

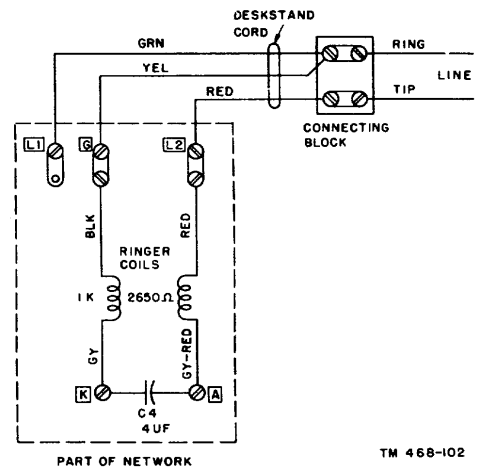

Figure 59. Ringer circuit, wiring.

29. Transmitter Circuit, Description
(fig. 60)

Dc from the central office battery passes over the ring side of the line to the connecting block. It then flows through the GRN deskstand cord lead to terminal L1, through operated hookswitch contacts D-E to terminal RR, through winding P1 of the induction coil to terminal R, through the transmitter to terminal B, through resistor R1 and winding P2 of the induction coil to terminal C, through operated switch contacts C-B to terminal L2, through the RED deskstand cord

lead to the connecting block, and the tip side of the line to the central office battery. Figure 67 shows a parallel path consisting of resistor R3 and varistor CR2 connected between terminals RR and C. Another path, from terminal R through varistor CR1 and winding S2, is in parallel with the transmitter and resistor R1 part of the original circuit. These parallel circuits act in the equalizing functions of the set and are

wired permanently within the network assembly.

30. Continuity Tracing of Transmitter Circuit (Manual) (fig. 61)

Dc from the central office battery passes over the ring side of the line to the connecting block, through the GRN deskstand cord lead to terminal L1. The dc then flows through the GY-GRN lead, operated switch contacts D-E and GY-WH lead to terminal RR, through winding P1 of the induction coil to terminal R. It leaves terminal R through the RED handset cord lead and flows through the transmitter and the BLK handset cord lead to terminal B, through resistor R1 and winding P2 to terminal C. The current then passes through the GY-BRN lead, operated switch contacts C-B and GY-YEL lead to terminal L2, through the RED deskstand cord lead to the connecting block, and the tip side of the line to the central office battery.

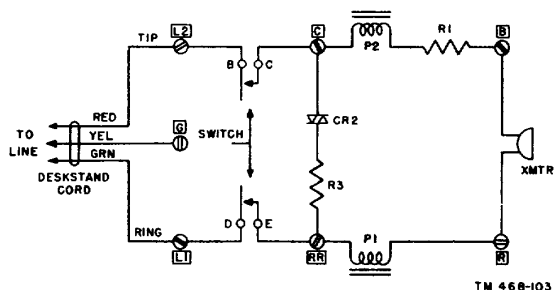

Figure 60. Transmitter circuit, manual, schematic.

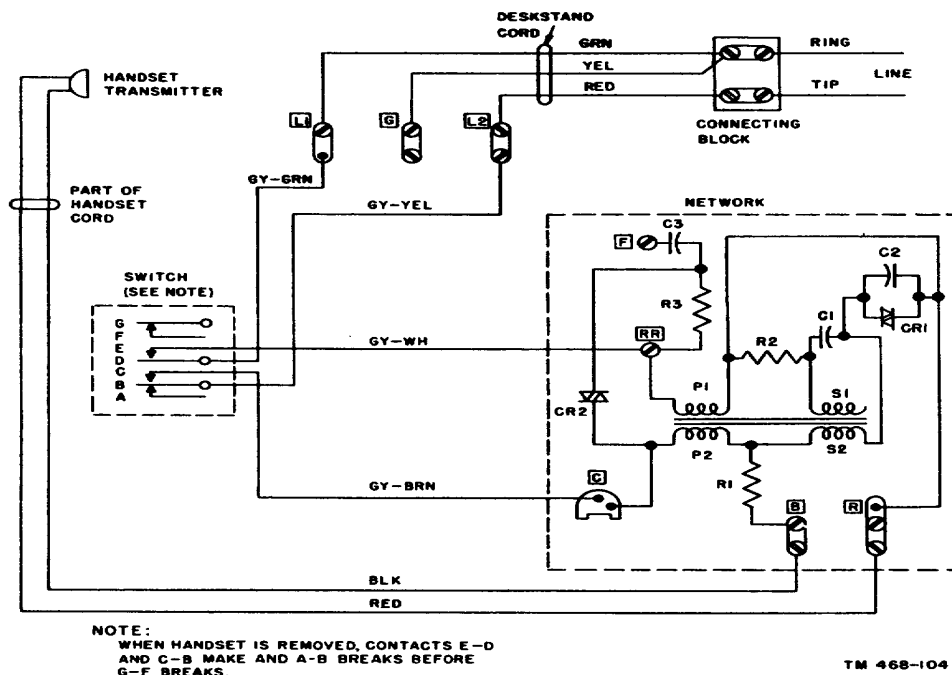

Figure 61. Transmitter circuit, manual, wiring.

**31. Continuity Tracing of Transmitter Circuit
(Dial)**
(fig. 62)

Dc from the central office battery passes over the ring side of the line to the connecting block, through the GRN deskstand cord lead to terminal L1, through the GY-GRN lead, operated switch contacts D-E and GY-WH lead to terminal F, through the BLU dial lead, normally made dial pulse contacts and GRN dial lead to terminal RR. The current then flows through induction coil winding P1 to terminal R, through the RED handset cord lead, transmitter, and BLK handset cord lead to terminal B, through resistor R1 and winding P2 to terminal C, through the GY-BRN lead, operated switch contacts C-B and GY-YEL lead to terminal L2, through the RED deskstand cord lead to the connecting block, and the tip side of the line to the central office battery.

32. Receiver Circuit Description (Manual)
(fig. 63)

When the set is in operation, an alternating voltage is induced into winding S1 from P1 and P2 and is present at the terminals of induction coil winding S1. This voltage transmits an ac that flows from winding S1, to terminal GN, through the receiver winding to terminal R. From this point in the circuit there are four paths through which this current can return to its source at winding S1. They are as follows: from terminal R through the series connected capacitors C2 and C1 to S1; from terminal R through resistor R2 to S1; from terminal R through varistor CR1 and capacitor C1, in series, to S1; from terminal R through the series connected RED handset cord lead, transmitter, BLK handset cord lead, to terminal B, through resistor R1, winding S2 and capacitor C1, to S1. The antisidetone circuit and theory of operation is discussed in paragraph 38.

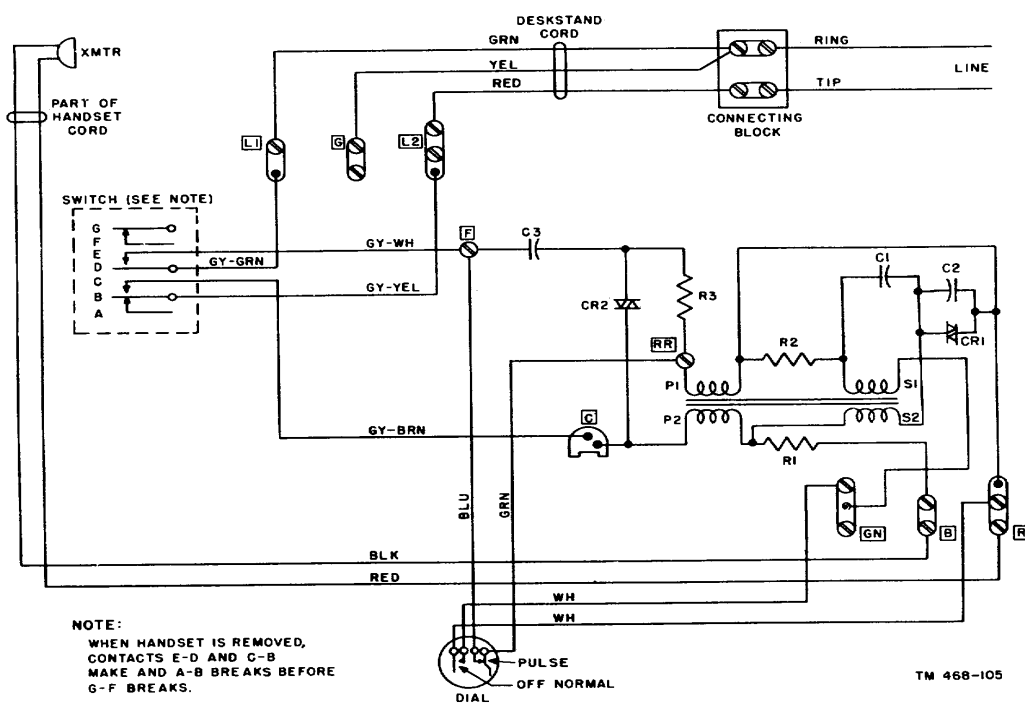

Figure 62. Transmitter circuit, dial, wiring.

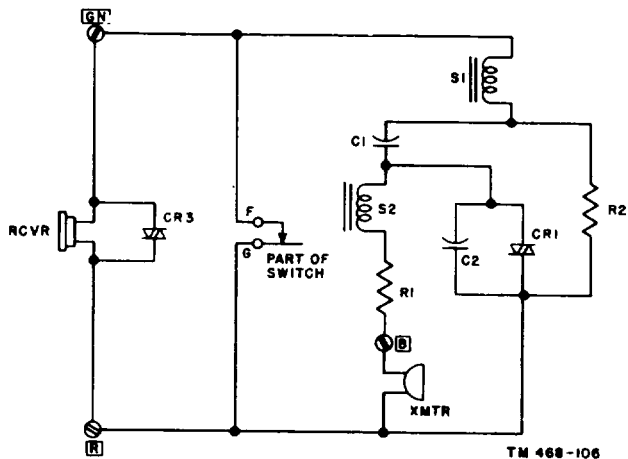

Figure 63. Receiver circuit, manual, schematic.

33. Receiver Circuit Description (Dial)
(fig. 64)

Figure 64 illustrates the only difference between the manual schematic and the dial schematic circuits, namely, the addition of the off-normal contacts of the dial shown connected across terminals R and GN. The off-normal contacts of the dial provide a shunt path across the receiver which prevents clicks in the calling party's ear during the dialing period.

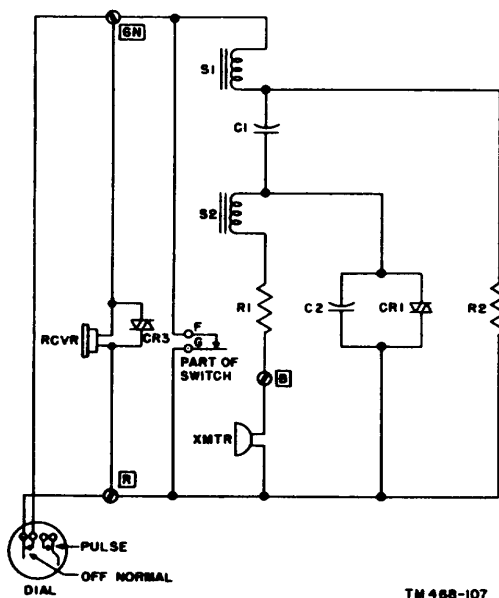

Figure 64. Receiver circuit, dial, schematic.

34. Continuity Tracing of Receiver Circuit (Manual)
(fig. 65)

Voice currents are induced into winding S1 from windings P1 and P2. The ac from winding S1 flows through set wiring to terminal GN, through the WH lead of the handset cord, receiver winding, WH lead to terminal R, and through the four parallel-connected paths (par. 32) to S1.

35. Continuity Tracing of Receiver Circuit (Dial)
(fig. 67)

Ac from winding S1 passes through the set wiring to terminal GN, through the WH handset cord lead, the receiver winding and the WH handset cord lead to terminal R, through the set wiring and the four parallel-connected paths (par. 32) to S1. The two WH leads connecting the off normal contacts of the dial with terminals R and GN complete the short circuit that is connected across the receiver winding when the dial is in operation. The GY-RED and the GY-BLK leads

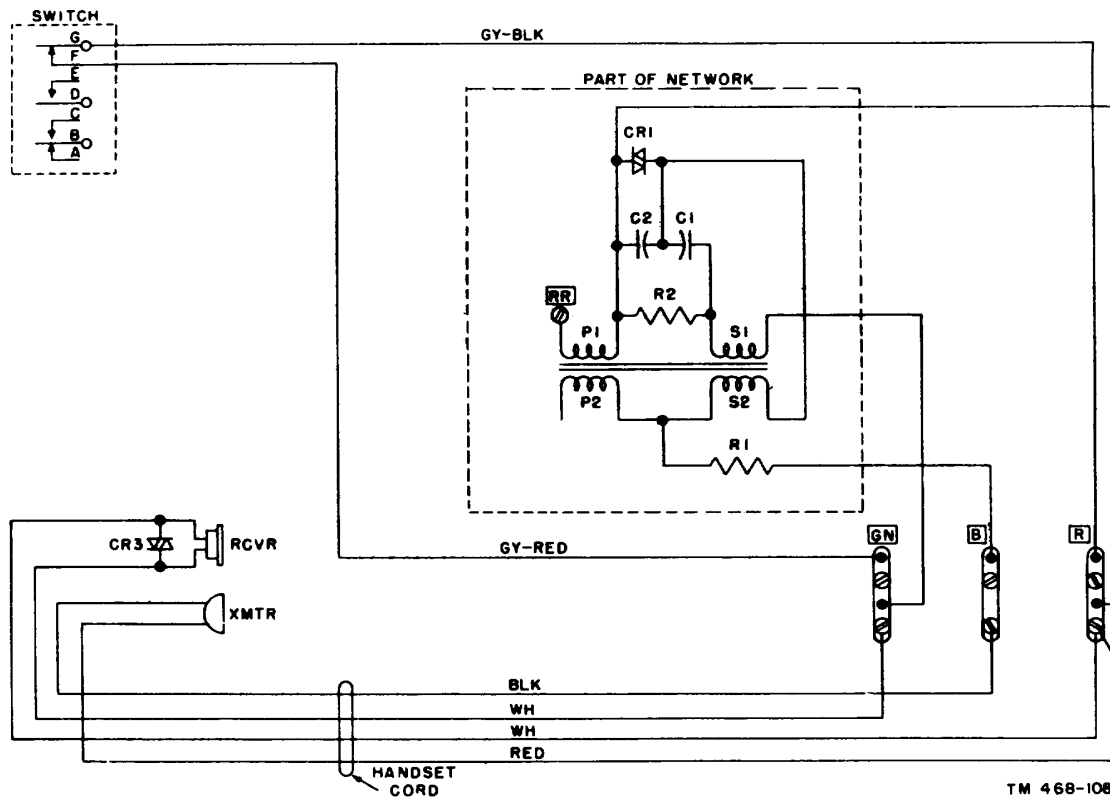

Figure 65. Receiver circuit, manual, wiring.

connecting switch contacts F and G with terminals GN and R, respectively, complete the short circuit that is connected across the receiver winding when the hookswitch is agitated (jiggled) to recall the operator to the line. This circuit prevents annoying clicks at the receiver during recall periods.

36. Dialing Circuit Description
(fig. 66)

Dialing current from the central office battery passes over the ring side of the line to the connecting block, through the GRN deskstand cord lead to terminal LJ1, through the operated switch contacts D-E to terminal F, through the normally made dial pulsing contacts to terminal RR. From terminal RR the current passes over three parallel-connected paths to terminal C, through operated switch contacts C-B to terminal 1,2, through the RED deskstand cord lead to the connecting block, and the tip side of the line to the central office battery. The three parallel paths, referred to above, are as follows:

from terminal RR through series-connected resistor R3 and varistor CR2 to terminal C; from terminal RR through series-connected winding P1 varistor CR1, windings S2 and P2 to terminal C; the series-connected transmitter and resistor R1 are connected in parallel with varistor CR1 and winding S2.

37. Continuity Tracing of Dialing Circuit
(fig. 67)

Dialing current, from the central office battery passes over the ring side of the line to the connecting block, through the GRN deskstand cord lead to terminal L1, through the GY-GRN switch lead, operated switch contacts D-E and GY-WH lead to terminal F, through the BLU dial lead, normally made dial pulse contacts, and GRN dial lead to terminal RR. From terminal RR the current passes over three parallel-connected paths to terminal C (par. 36), through the GY-BRN lead, operated switch contacts C-B, and GY-YEL

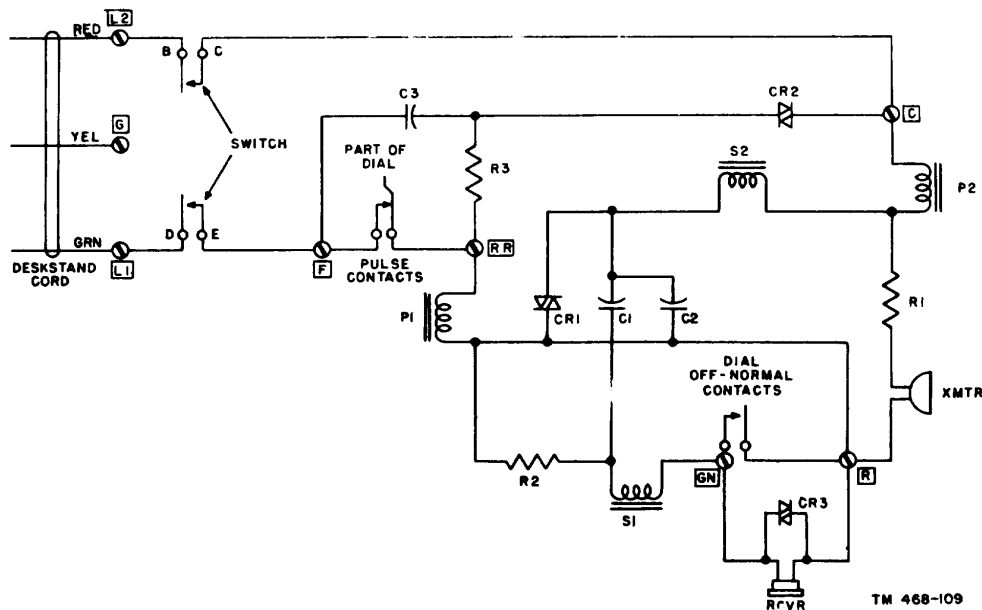

Figure 66. Dialing circuit, schematic.

lead to terminal L2, through the RED deskstand cord lead to the connecting block, and the tip side of the line to the central office battery.

38. Antisidetone

a. Figures 61 and 62 show the transmitter circuit. Figures 65 and 67 show the receiver circuit.

The drawings show the balancing network associated with both circuits.

b. The speech currents received from the line, in passing through windings P1, P2, and S2, induce additive voltages in winding S1, which is connected to the receiver winding.

c. These additive voltages tend to cause currents to flow in resistor R2. However, these currents, in passing through winding S2, induce a voltage that is 180° out of phase and approximately equal in amplitude to the voltages induced by windings P1 and P2. The resultant voltage across resistor R2, therefore, is very small. Maximum useful receiving currents thus are obtained without appreciable power loss in the network resistance.

d. When the local transmitter is in operation, a voltage drop is developed across its terminals. This voltage acts on windings P1 and P2. It also acts across winding S2 which, in this instance, is parallel-connected with windings P1 and P2. The currents resulting from these voltages cause voltages to be induced in winding S1. The voltages induced in S1, as a result of the currents flowing in P1 and P2, are substantially equal and opposite to the voltage induced as a result of the currents flowing in S2. Also, part of the currents flowing out of S2 pass through resistor R2. These currents develop a voltage drop across resistor R2, which is phased to oppose the resultant voltage at winding S1.

e. The overall effect of this balance is that the currents in the receiver winding, as a result of the voltage developed across the transmitter, are small. This results in higher transmitting levels, because there is little power loss in the receiver circuit.

j. Sidetone balance will not be equal under all transmission conditions, because loop impedances vary greatly in magnitude and phase for different plant conditions.

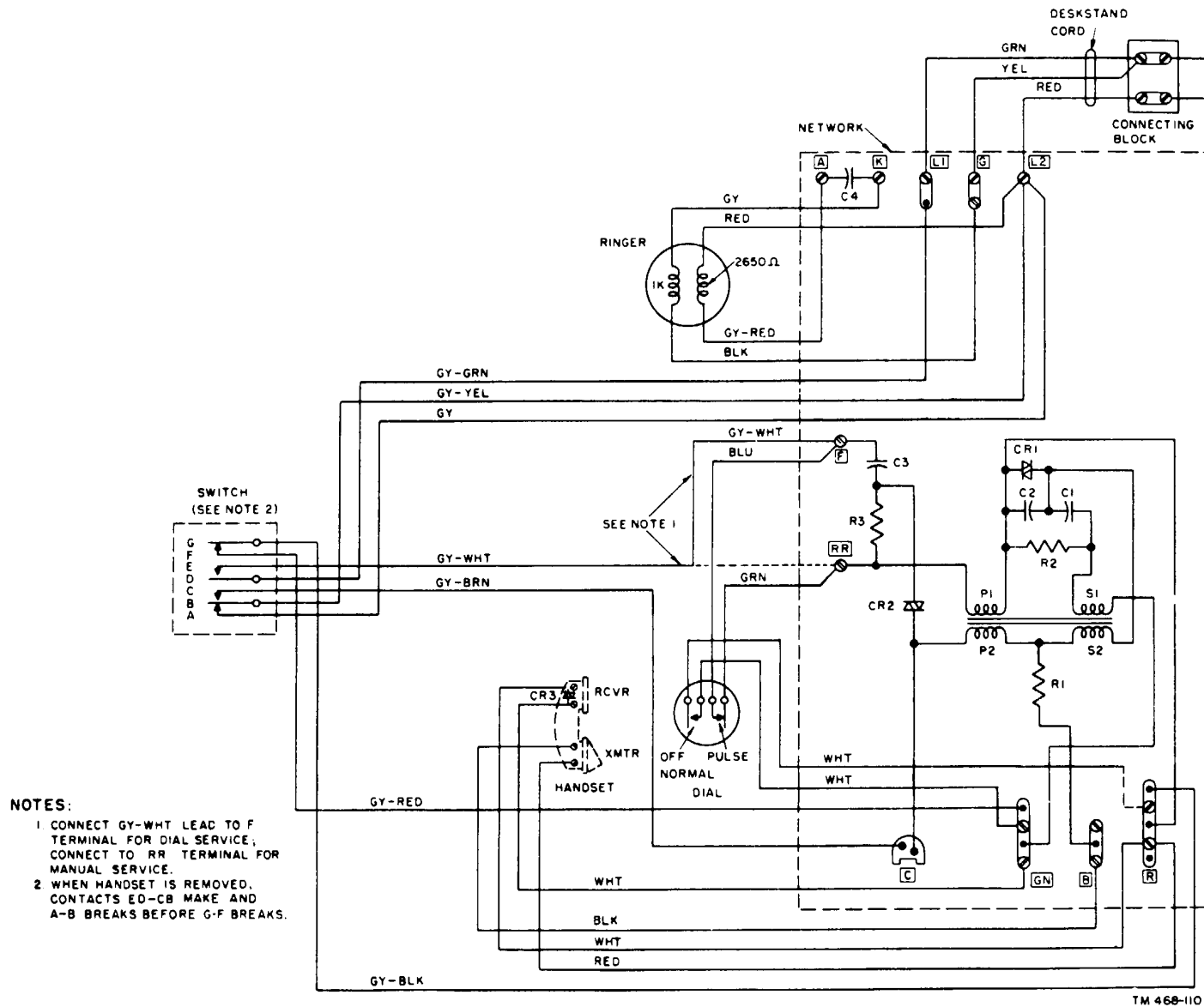

TM 468-110

Figure 67. Telephone TA-236/PT, dial, wiring.

CHAPTER 3
MAINTENANCE

Section I. TOOLS AND TEST EQUIPMENT

39. Tool Equipments

The tool equipments listed in a through c below are authorized for repair of substation equipment. The lists are for information only and are not to be used as a basis for requisitioning.

a. Tool Equipment TE-3S.

Quantity	Item	Signal Corps stock No.
1	Knife TL-29-----	6Q60229
1	Pliers TL-13-A: side-cutting ----	6R4513
1	Pouch CS-34-----	6R6534

b. Tool Equipment TE-49.

Quantity	Item	Signal Corps stock No.
1	Bag, tool-----	6Q17930
1	Bag, tool: canvas -----	6Q17980
1	Brush TL-72: camel's-hair, flat -6Z1372	
1	Brush, painting: camel's-hair; flat	6Z1402
1	Burnisher: contact -----	6R41065C
1	Chest CH-77 -----	6Q19095
6	Clip, test-----	6H4N65
7	Connector, plug -----	6R41160A
1	Cord: test, 3' -----	3E3849
1	Flashlight TL- 122 -----	6Z4002
1	Gage: thickness; 9 leaves, .0015" to .012".	6Q45709
(¹)	Gloves LC-10: size 91/2 -----	6Z4810-91/2
1	Hammer: ball-peen-----	6Q49708
1	Knife TL-29-----	6Q60229
6	Lug, terminal: spade-type -----	6R41164
1	Mirror: dental-----	6Z7072
1	Oiler: 1 oz, 4%" spout -----	6Z7301-1
1	Pliers TL-13: side-cutting -----	6R4513
1	Pliers TL-103: diagonal-cutting -6R4603	
1	Pliers TL-107: side-cutting -----	6R4607
1	Pliers TL-126: long chain-nosed	6R4626
1	Rule: boxwood; 2'; 4 folds-----	6R9502
1	Rule: steel, graduated in 32ds and 64ths inch.	6R9906
1	Screw driver-----	6R40909.
1	Screw driver TL-21: 5/32" tip ---	6R15310
1 ¹	Pair.	

b. Tool Equipment TE-49-Continued

Quantity	Item	Signal Corps stock No.
1	Screw driver TL-44: 1/4" tip-----	6R16510
1	Screw driver: jewelers-----	6R19040. 4
1	Screw driver: 3/4" long; 90° offset	6R40896
1	Shears TL-354/U -----	6H38005/1
1	Soldering Iron TL-117 -----	6R24617
1	Telephone EE-8-----	4B5008
1	Test Pick TL-340/GT -----	6R41211A
1	Test Set TS-190/U -----	3F4316.1
1	Tool, alignments spring-hook pull	4T75765
1	Whistle: 1,000/19 cps -----	6R38049/WI
1	Wrench -----	6R40872
1	Wrench: double open-end-----	6R40929B
1	Wrench: single open-end-----	6R41009
1	Wrench: triple open-end -----	6R40863
1	Wrench Set TL-483/U -----	6R55502
1	Wrench TL-111-----	6R55006

Quantity-	Unit of measure	Item	Signal Corps stock No.
1	Sheet--	Abrasive: crocus cloth*+	6Z2000
1	Sheet--	Abrasive sheet: sand-paper #0000*.	6Z7500-0000
1	Sheet--	Cloth: emery; #0*	6Z2000-0
2	Yard--	Cloth, textile: lint-free*	6Z1989
1	Each--	Orange stick	6Z7360
1	Roll--	Tape TL-83: friction; 3/4" wide.*	6N8583
1	Roll--	Tape TL-192: rubber; 3/4" wide.*	6N8692

c. Tool Equipment TE-73.

Quantity	Item	Signal Corps stock No.
1	Case: tool; leather-----	6Q17930
1	Pliers, diagonal-cutting: with strip-ping notches and skinning hole.	6R4790-5.5
1	Pliers: long-nosed; 61/2" long--	6R4748-6.5
1	Pliers: short-nosed; 6" long ----	6R4774-6.5
1	Screw driver: 3" blade-----	6R15424
1	Spudger; fiber; 51/2" long -----	6R25351

*Expendable supply.

40. Test Set TS-1 90/U
(fig. 68)

Test Set TS-190/UT is furnished as a part of Tool Equipment TE-49 (par. 39b). It consists of a 1,000-ohm impedance telephone receiver with a switch-controlled external resistance of 50,000 ohms. The test set is equipped with a three conductor test cord. Two of these conductors are connected to a test pick and a switch in the test-pick handle for controlling the external resistance. The other conductor is terminated in a spring-socket chuck to which suitable test clips may be attached. The external resistance of 50,000 ohms is normally in series with the receiver element, but may be short circuited by depressing the switch in the test-pick handle. The external resistance protects the operator's

ears against excessive clicks when testing for potentials in circuits. The receiver and the external resistor may be bridged across circuits which contain relays, without causing the relays to operate. Test Set TS-190/U is used in troubleshooting and maintenance of telephone equipment. Faults, such as opens, grounds, shorts, and crosses, may be located with this test set. When a circuit is completed through the test set, a click will be heard in the receiver.

Note. A lineman telephone handset (Test Set TS-365/ GT, SigC stock No. 4B1158) may be used with Test Set TS-19/U when necessary.

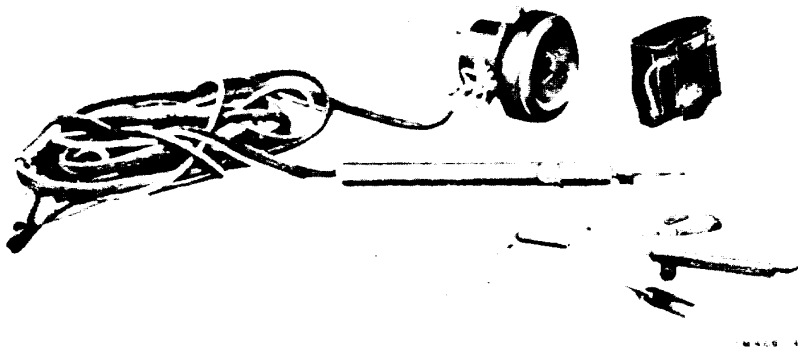

Figure 68. Test set TS-190/U.

Section II. PREVENTIVE MAINTENANCE SERVICES

41. General

a. Definition of Preventive Maintenance. Preventive maintenance is work performed on equipment (usually when the equipment is not in use) to keep it in good working condition so that breakdowns and needless interruptions in service will be kept to a minimum. Preventive maintenance differs from troubleshooting and repair because its objective is to prevent certain troubles from occurring. See AR 750-5.

b. Use of Preventive Maintenance Forms.

- (1) The decision as to which items on DA Forms 11-240 and 11-241 are applicable to a specific telephone is a

tactical decision to be made in case of first echelon maintenance by the communications officer/chief or his designated representative, and in the case of second or third echelon maintenance, by the individual making the inspection. Instructions for the use of each form appear on the reverse side of the form.

- (2) Circled items in figures 69 and 70 are partially or totally applicable to the telephones described in this manual. References in the ITEM column refer to paragraphs in the text that contain additional maintenance information.

42. Preventive Maintenance Techniques*(figs. 69 and 70)*

- a. Drop or Block Wire.
- (1) Inspect the drop of block wires leading from the pole. When wiring is deteriorated or damaged, replace, rerun, or repair it, depending on the degree of deterioration (TM 11-474).
 - (2) See that the wiring is placed properly and supported securely. Wires may not have adequate clearance from trees, electric light and power wires, cables, buildings, or other poles. Damage to the insulation will result from inadequate clearance. Where cases of inadequate clearances are discovered, reroute the wires, place guards, or report the condition to the wire chief.
- b. Protectors.
- (1) See that the protector is situated so that there is little possibility of damage from moisture or mechanical injury to the cover. Only when necessary, reposition the protector, or report the condition to the wire chief.
 - (2) Examine the protector mountings. Replace those that are broken or defective. See that the asbestos mat (where required) is not missing, and has been placed properly.
 - (3) Inspect the fuses. Replace those that are broken or of improper type. Tighten all of the fuses, and see that they are placed so that the slots face the porcelain base.
 - (4) Remove the carbon blocks. Replace those that are broken or pitted badly; clean those that are dirty. When cleaning the carbon blocks, be careful not to increase the open-space cutout between adjacent carbons. Replace the blocks so that they are held securely in the mountings. Replace protector caps that are missing. Screw the cap on tightly.
 - (5) Examine all wire connections; tighten any wire that is found loose. Check the ground connection. A protector with a poor or a high-resistance ground may be entirely ineffective as a protective device.
- c. Inside Wiring.
- (1) Inspect the condition of all accessible inside wiring. If the wiring is not fastened properly or securely, rerun or refasten it as required. If the insulation is defective or damaged, repair the wiring, or report the condition to the wire chief. Check for adequate clearance from electric wires, water pipes, etc. Rerun the wire, if necessary. If adequate clearance cannot be maintained, protect the wire with porcelain tubing or rubber tape.
- (2) Locate the wiring so that there is little possibility of damage from moisture or mechanical injury.
- (3) Inspect the connecting block. See that it is mounted properly, that the connections are tight, and that the cover has not been bent so far that it will come in contact with the terminals.
- (4) Inspect the ground connection for proper grounding. Where insufficient separation from electric light or power lines exists, repair or provide a new ground connection. Check the ground connection to see that it is not subject to mechanical injury. Attach a tag at the ground connection marked: TELEPHONE GROUND CONNECTION. DO NOT REMOVE. This will help prevent unauthorized removal of the ground clamp.
- d. Telephone Set.
- (1) Transmitter.
 - (a) Check the mouthpiece for cracks and breaks.
 - (b) See that the rim screws are not missing.
 - (c) See that the transmitter element is mounted or fastened securely.
 - (d) See that no dirt or moisture has settled in the transmitter.
 - (e) Check all connections.
 - (f) Be sure that the contact springs are secured properly.
 - (2) Receiver.
 - (a) Check the handset or receiver shell for cracks.
 - (b) Inspect the receiver diaphragm for dents, rust, etc.
 - (c) See that the receiver element is free of dirt and moisture.
 - (d) Tap the handset behind the receiver element. A rattling sound indicates a loose diaphragm.
 - (3) Capacitors.
 - (a) See that the leads are soldered properly.
 - (b) See that the terminals are not loose.

OPERATOR FIRST ECHELON MAINTENANCE CHECK LIST FOR SIGNAL CORPS EQUIPMENT TELEPHONE SET										
<i>INSTRUCTIONS: See other side</i>										
EQUIPMENT NOMENCLATURE TELEPHONE SET					EQUIPMENT SERIAL NO.					
LEGEND FOR MARKING CONDITIONS: ✓ Satisfactory; I Adjustment, repair or replacement required; ⊗ Defect corrected. NOTE: Strike out items not applicable.										
DAILY										
NO.	ITEM	CONDITION								
		S	M	T	W	T	F	S		
1	INSPECT CORDS FOR KINKS, FRAYING, CUTS, BREAKS. (Outdoor use).									
2	INSPECT EXTERIOR CONNECTIONS FOR SNUG FIT AND GOOD CONTACT. (Outdoor use).									
3	CLEAN CORDS, CASES, HANDSET, AND BATTERY COMPARTMENT OF MOISTURE, DIRT, GRIME, BATTERY ACID, MILDEW, CORROSION. (Outdoor use).									
4	INSPECT FOR SECURE MOUNTING STRAPS. (Outdoor use).									
5	INSPECT BATTERY COMPARTMENT FOR CORROSION, GOOD BATTERIES, BROKEN OR MISSING SPRINGS, BATTERY ACID. (Local battery use).									
6	OPERATE THE TELEPHONE AND CHECK FOR PROPER RINGING AND TALKING. PAR. 47d									
7	INSPECT VACUUM TUBES FOR LIGHTED FILAMENTS AND SECURE MOUNTING. (Amplifier type).									
WEEKLY										
NO.	ITEM	COND- TION	NO.	ITEM	COND- TION					
8	INSPECT CORDS FOR KINKS, FRAYING, CUTS, BREAKS. (Indoor use). PAR. 42d(9)		14	INSPECT HANDSET FOR CHIPS, CRACKS, LOOSE CAPS OR CAPSULES, DIRT, GREASE, MOISTURE.						
9	INSPECT EXTERIOR CONNECTIONS FOR SNUG FIT AND GOOD CONTACT. (Indoor use). PAR. 42c		15	INSPECT SNAP FASTENER ON CASE. (Outdoor use).						
10	CLEAN CORDS, BATTERY COMPARTMENT, EXTERIOR OF CASE, HOUSING, DIAL, HANDSET. (Indoor use). PAR. 42e		16	INSPECT LEATHER AND CANVAS ITEMS FOR MILDEW, TEARS, AND FRAYING.						
11	INSPECT EXTERIOR FOR CHIPS, CRACKS, CORROSION, RUST, MOISTURE, MILDEW, DIRT, GREASE, BROKEN OR MISSING GENERATOR HANDLE. PAR. 42d (1), (2), (4), (6) THRU (8)		17	INSPECT TELEPHONE SET FOR COMPLETENESS - CORDS, DIALS, HANDSET, BATTERIES, GENERATORS, TUBES, CARRYING CASES, ACCESSORIES, TECHNICAL MANUALS, RUNNING SPARE PARTS. PAR. 42d						
12	TIGHTEN LOOSE ASSEMBLY AND MOUNTING HARDWARE. PAR. 42d (11)		18	INSPECT FOR PROPER INSTALLATION IN COOL, DRY PLACE. PAR. 42 a, b AND c						
13	INSPECT MARKINGS FOR LEGIBILITY, CORROSION. PAR. 42d(8)									
19	IF DEFICIENCIES NOTED ARE NOT CORRECTED DURING INSPECTION, INDICATE ACTION TAKEN FOR CORRECTION.									

DA FORM 11-240

REPLACES DA AGO FORM 419, 1 DEC 50, WHICH IS OBSOLETE.

TM 468-120

Figure 69. DA Form 11-240.

SECOND AND THIRD ECHELON MAINTENANCE CHECK LIST FOR SIGNAL CORPS EQUIPMENT TELEPHONE SET			
<i>INSTRUCTIONS: See other side</i>			
EQUIPMENT NOMENCLATURE TELEPHONE SET		EQUIPMENT SERIAL NO.	
LEGEND FOR MARKING CONDITIONS: ✓ Satisfactory; X Adjustment, repair or replacement required; ⊕ Defect corrected. NOTE: Strike out items not applicable.			
NO.	ITEM	NO.	ITEM
1	INSPECT CORDS FOR KINKS, PRAYING, CUTS, BREAKS. (Outdoor use).	17	INSPECT TELEPHONE SET FOR COMPLETENESS - CORDS, DIALS, HANDSET, BATTERIES, GENERATORS, TUBES, CARRYING CASES, ACCESSORIES, TECHNICAL MANUALS, RUNNING SPARE PARTS. PAR. 42d
2	INSPECT EXTERIOR CONNECTIONS FOR SNUG FIT AND GOOD CONTACT. (Outdoor use).	18	INSPECT FOR PROPER INSTALLATION IN COOL, DRY PLACE. PAR. 42g, b AND c
3	CLEAN CORDS, CASES, HANDSET, AND BATTERY COMPARTMENT OF MOISTURE, DIRT, GRIME, BATTERY ACID, WILKEN, CORROSION. (Outdoor use).	19	INSPECT CORDS AND LINE TERMINALS FOR PRAYING, BREAKS, CUTS, PROPER CONNECTIONS FOR CD OR LA OPERATION. PAR. 42g THRU d
4	INSPECT FOR SECURE MOUNTING STRAPS. (Outdoor use).	20	CLEAN INTERIORS OF TELEPHONE HOUSINGS, CHASSIS, CARRYING CASES, BATTERY COMPARTMENTS OF ALL CORROSION, MOISTURE, WILKEN, RUST, EXCESS SOLDER, DIRT, GRIME, GREASE. PAR. 42g
5	INSPECT BATTERY COMPARTMENT FOR CORROSION, GOOD BATTERIES, BROKEN OR MISSING SPRINGS, BATTERY ACID. (Local battery use).	21	INSPECT INTERIOR WIRING AND CONNECTIONS FOR GOOD CONTACT, BREAKS, CUTS, PRAYING. PAR. 42c
6	OPERATE THE TELEPHONE AND CHECK FOR PROPER RINGING AND TALKING. PAR. 47d	22	INSPECT GENERATOR FOR WORN OR CHIPPED GEARS, LOOSE SCREWS, BURN RUBBER, BROKEN CONTACT SPRINGS. (Local battery use).
7	INSPECT VACUUM TUBES FOR LIGHTED FILAMENTS AND SECURE MOUNTING. (Amplifier type).	23	BURNISH GENERATOR CONTACTS AND ADJUST SPRINGS. (Local battery use).
8	INSPECT CORDS FOR KINKS, PRAYING, CUTS, BREAKS. (Indoor use). PAR. 42d (B)	24	TIGHTEN ALL LOOSE ASSEMBLY AND MOUNTING SCREWS. PAR. 42d (ii)
9	INSPECT EXTERIOR CONNECTIONS FOR SNUG FIT AND GOOD CONTACT. (Indoor use). PAR. 42c	25	INSPECT HOON SWITCHES, CANDLE SWITCHES, HANDSET BUTTERFLY SWITCH AND CONTROL SWITCHES FOR POSITIVE ACTION AND GOOD CONTACT. PAR. 42d (B)
10	CLEAN CORDS, BATTERY COMPARTMENT, EXTERIOR OF CASE, HOUSING, DIAL, HANDSET. (Indoor use). PAR. 42g	26	INSPECT VACUUM TUBES FOR SECURE MOUNTING, VISIBLE DAMAGE, AND LIGHTED FILAMENT. (Amplifier type).
11	INSPECT EXTERIOR FOR CHIPS, CRACKS, CORROSION, RUST, MOISTURE, WILKEN, DIRT, GREASE, BROKEN OR MISSING GENERATOR HANDLE. PAR. 42d (1), (2), (4), (6) THRU (8)	27	INSPECT PLUGS AND JACKS FOR SNUG FIT AND GOOD CONTACT.
12	TIGHTEN LOOSE ASSEMBLY AND MOUNTING HARDWARE. PAR. 42d (ii)	28	CLEAN PLUGS AND JACKS OF RUST, MOISTURE, DIRT, GRIME, AND GREASE.
13	INSPECT MARKINGS FOR LEGIBILITY, CORROSION. PAR. 42d (B)	29	INSPECT RELAYS FOR POSITIVE ACTION AND GOOD CONTACT.
14	INSPECT HANDSET FOR CHIPS, CRACKS, LOOSE CAPS OR CAPSULES, DIRT, GREASE, MOISTURE.	30	CLEAN SWITCHES AND RELAYS OF DIRT, DUST AND MOISTURE.
15	INSPECT SNAP FASTENER ON CASE. (Outdoor use).	31	CLEAN AND TIGHTEN ALL TERMINAL CONNECTIONS. PAR. 42d (ii) AND g
16	INSPECT LEATHER AND CANVAS ITEMS FOR WILKEN, TEARS, AND PRAYING.	32	LUBRICATE THE EQUIPMENT USING THE LATEST DEPARTMENT OF THE ARMY LUBRICATION ORDER.
		33	INSPECT THE TELEPHONE SET FOR PROPER MOISTURE AND FUNGUS PROOFING.
34	IF DEFICIENCIES NOTED ARE NOT CORRECTED DURING INSPECTION, INDICATE ACTION TAKEN FOR CORRECTION.		

DA FORM 11-241

REPLACES DA AGO FORM 419, 1 DEC 50, WHICH IS OBSOLETE

16-44880-1

TM 468-121

Figure 70. DA Form 11-241.

- (c) Check the cover for cracks or holes.
- (4) Ringer.
 - (a) See that the ringer is mounted properly and securely.
 - (b) See that the gongs are not loose.
 - (c) Inspect the coils for nicks, dents, and improper connections.
 - (d) Inspect the biasing spring to see that it is not broken or lacking in tension.
- (5) Induction coil.
 - (a) See that the coil is mounted securely.
 - (b) Inspect the windings for nicks, dents, and breaks.
- (6) Hookswitch.
 - (a) Check the springs for bends, rust, pitting, etc.
 - (b) Check for free lever action.
 - (c) See that the contacts make and break properly.
- (7) Case.
 - (a) Inspect for cracks or broken pieces.
 - (b) Check the bottom of the deskstand for the condition of the rubber or felt pads.
 - (c) See that all parts are clean.
- (8) Dial.
 - (a) See that the dial is mounted securely.
 - (b) Inspect for bent finger wheel or finger stop.
- (c) See that the dial is not operating sluggishly or quickly.
- (d) See that the number card is legible.
- (9) Cords.
 - (a) Straighten the cords that are twisted.
 - (b) See that the stay cords or hooks are secured.
 - (c) Inspect for bad tips and frayed or worn places.
- (10) Wire forms.
 - (a) Check for correct color-code and connections.
 - (b) Check for frayed or broken wires.
 - (c) Check the solder connections.
 - (d) Check the form lacing.
 - (e) Check the wire lengths to insure that the smallest length possible is used.
- (11) Screws and nuts. Check all parts for missing, stripped, or worn screws and nuts.
 - e. Cleaning. Use a clean, dry, lint-free cloth, or a dry brush for cleaning. If necessary, except for electrical contacts, moisten the cloth or brush with Solvent, Dry Cleaning (SD); then wipe the parts dry with a cloth.

Section III. LUBRICATION

43. General

The equipment described in this manual does not require extensive and frequent lubrication. With the exception of the dial, all parts are lubricated by the manufacturer, and no further lubrication is required. Lubricate the dial only when necessary; for example, when the dial has been taken apart for adjustment, or when the dial has been used for some period of time in an atmosphere conducive to corrosion. There is no definite schedule of dial lubrication; this depends on maintenance procedures at a particular installation.

44. Lubricant

The following table lists the lubricants required for servicing Dial TA-45(*)/GT. *Do not use any other lubricants.* The use of other than the recommended lubricants may result in faulty operation and eventual breakdown of the dial.

Product symbol	Standard nomenclature	Specification and QMC stock No.
OCW	Oil, Clock and Watch--	U. S. Army spec No. 2-47B; QMC No. 140-680.
OAI	Oil, Lubricating, Aircraft Instrument (Low Volatility).	AN-O-11: QMC No. 14-0-1341.

45. Lubrication Instructions

(fig. 71)

a. Definitions.

- (1) A drop of oil is released from the end of a bare tinned copper No. 22 B & S wire, after the wire has been dipped one-half inch into the oil and quickly withdrawn.
- (2) A dip of oil is retained in the bristles of a No. 6 camel's-hair brush (Brush TL72)

after the brush has been dipped three-eighths inch into the oil, and then drawn across the edge of the container to remove the surplus oil. There should not be enough oil remaining in the bristles to form a drop at the end of the brush.

b. Dial TA-45/GT. Remove the screws that hold the dial in the dial mounting, and remove and tag the leads to the dial. Prepare the dial for lubrication by removing the dial escutcheon assembly and the finger-plate mounting screw (par. 76). Remove the finger plate.

(1) Lubricate the dial (fig. 71) by applying oil (OCW), in the amount specified, to the following parts:

(a) Distribute 1 dip of oil to the wormwheel shaft bearings (1, fig. 71), and brush a small amount of oil over the surface of the worm-wheel shaft, from the worm wheel to the finger stop bearing, for rust protection.

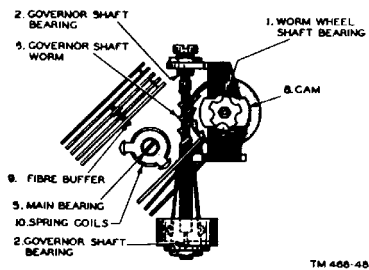
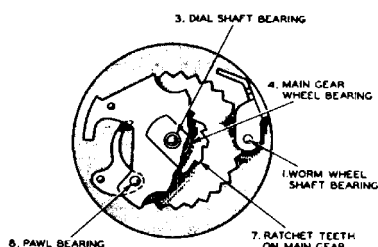

Figure 71. Lubrication points for Dial TA-45/GT.

(b) Distribute 1 dip of oil on the governor shaft bearings (2, fig. 71)

(c) Place 1 drop of oil in the finger-plate mounting screw hole to lubricate the dial shaft bearings (3, fig. 71).

(d) Apply 1 dip of oil to the main gear wheel bearing (4, fig. 71).

(e) Cover the exposed portion of the main bearing (5, fig. 71) on the governor side of the mounting plate with 1 dip of oil for rust protection. (The spring should be removed.) (f) Apply 1 dip of oil to the governor shaft worm (6, fig. 71). Brush a small quantity of oil on the shaft under the governor wings, for rust protection.

(2) Lubricate the following parts of the dial by applying instrument oil in the amount specified:

(a) Brush 1 dip of oil evenly over the ratchet teeth (7, fig. 71). Brush 1 dip of oil evenly over the gear teeth.

(b) Distribute 1 dip of oil on the edge of the cam and threaded portion of the camshaft and on the pawl bearing (8, fig. 71).

(c) Distribute 1 dip of oil on the fiber buffers of the shunt and pulse springs (9, fig. 71). Allow the oil to remain for a short time, and remove the surplus oil.

Caution: Do not apply oil to the rubber buffers.

(d) Distribute 1 drop of oil between the spring coils (10, fig. 71) for rust protection.

(3) Remove any excess lubricant from the surfaces when the lubrication is completed.

c. Dial TA-45B/GT. Prepare the dial for lubrication as described in b above.

(1) Lubricate the dial by applying oil (OCW), in the amount specified, to the following parts:

(a) Distribute 1 drop of oil on the governor shaft bearings.

(b) Lubricate each governor weight with X drop of oil; rotate the finger wheel to distribute the lubricant.

(c) Hold the dial vertically; distribute 1 drop of oil on the governor shaft worm.

(d) Distribute 1 drop of oil over the periphery and boss of the impulse cam.

(e) Apply 1 drop of oil to the lower washer and 1 drop of oil to the upper washer of the trigger assembly.

(2) Rotate the trigger from its normal position and apply instrument oil to the trigger surfaces.

Section IV. TROUBLESHOOTING

46. Types of Troubles

Most of the troubles that occur in substation equipment result from a failure or malfunction in any of the four functions of the telephone set.

- a. Signaling of the operator or seizing of automatic switching equipment.
- b. Signaling of the telephone user.
- c. Transmitting of the message.
- d. Receiving of the message.

47. Troubleshooting Considerations

a. Before beginning any troubleshooting procedure, investigate the effect of the following items on the cause of the trouble:

- (1) The type of service involved (dial or manual).
- (2) The type of apparatus involved.
- (3) The effect of the trouble on the telephone user's service.
- (4) The weather conditions at the time the trouble was reported. Rain, sleet, snow, or ice may cause shorts or grounds, which, in turn, may cause a permanent signal.
- (5) The maintenance history of the equipment involved. If frequent maintenance has been performed on the equipment, replace it, rather than continue needless repairs or adjustments.

b. Before the repairman is sent to work on any equipment, certain procedures should be completed by the wire chief at the test desk.

- (1) A TMT (transmission test) to test the condition of the transmitter or receiver. This is done only when the telephone is not completely out of order.
- (2) Tests to locate the source of trouble as being definitely outside of the central office.

c. Frequently several factors may cause an interruption or impairment of service. A logical step-by-step procedure must be followed to localize and eliminate the sources of trouble. Paragraphs 49 through 61 describe the procedures to be followed in localizing the most common troubles. To eliminate all sources of trouble, follow the troubleshooting procedures to completion, even if the source of trouble has been discovered in one of the intermediate steps.

This may result in the discovery of incipient troubles, which may later develop into serious troubles, necessitating another service call.

d. When arriving at the location of the substation that has been reported as defective, proceed as follows:

- (1) Determine the exact nature of the trouble. Most troubles will be reported by personnel unfamiliar with the operation of telephone circuits. The trouble may have been exaggerated or underestimated. In some instances, the trouble may result from unfamiliarity with the proper procedure for using a telephone set. If this is the case, instruct the telephone user in the proper procedures; however, a test must be made to determine the general operating condition of the equipment. Test for proper ringing and transmission by calling the operator or test desk (par. 80).
- (2) Check the equipment for obvious faults. Examine the equipment and all wiring for mechanical damage. Determine if the telephone set has been dropped or damaged. Check the wiring for breaks, torn or damaged insulation, and proper connection to terminals.
- (3) Test at the cross-connecting box or aerial cable terminal first. The first procedure to be followed when determining the cause of any trouble is to test at the cross-connecting box or aerial cable terminal. The proper terminals will have been identified by the wire chief. The procedures to be followed in testing for shorts, opens, grounds, or crosses are outlined in paragraphs 57 through 61. Test at the proper terminals to determine if the source of the trouble does not lie on the central office side of the equipment. If the trouble does lie on the central office side, report this to the wire chief. However, the subset must be checked to determine if it is in good working order.

- A simple test to determine the condition of the subset may be made as follows:
- (a) Request the wire chief to furnish the numbers of a spare pair of terminals. This may be accomplished by calling the wire chief from a nearby telephone or by connecting Test Set TS-365/GT across the terminals of a good pair and dialing the number associated with the test desk.
 - (b) Connect the test handset across the spare terminals to determine if they are in good working order.
 - (c) Connect the telephone set to be tested to the new terminals. Call the test desk and instruct the test desk man to run a TMT. If no test desk is available, call the wire chief at the test board or test turret. Determine whether transmission and reception are acceptable. Instruct the test man to ring on the line. If any of the above tests indicates that there is a trouble in the equipment, follow the procedure for clearing the particular trouble.
- (4) Test the inside wiring before testing the substation equipment. If the indicated trouble lies on the substation side of the equipment, always check the inside wiring first. Remove the cover from the connecting block and disconnect the leads from the telephone set. Connect the test handset across the terminals of the connecting block to determine if the in

side wiring is in good working order. In most instances, it will be more advisable to replace defective inside wiring than to try to determine the exact location of the trouble.

e. The troubleshooting procedures outlined in paragraphs 50 through 55 apply specifically to the schematic and wiring diagrams for Telephone TP-6-A. When testing other TP-6 type telephones, refer to the wiring and schematic diagrams for that particular equipment (figs. 90 through 103). Troubleshooting procedures for Telephone Set TA-236/FT are given in paragraph 61.

48. Troubleshooting Charts

Note. The abbreviations appearing in the Symptom column of the troubleshooting charts are the standard abbreviations used on trouble tickets (DA Form 11-23 Telephone Trouble Report). These designations are explained in the first chart and are used without explanation in the second chart.

a. Telephone TP-6-A. The troubleshooting chart below lists the common troubles that may occur in the TP-6-A and other TP-6-type telephone sets. Paragraphs 49 through 60 describe the methods to be used in locating sources of troubles. Wherever internal wiring of the telephone set is found to be defective, replace it with the properly colored wiring. Replace all defective parts; do not attempt to repair them. After clearing a reported trouble, call the test desk or test board, and test the general telephone operation. If extensive replacement of parts is required, replace the telephone set with a new or reconditioned one.

Symptom	Probable Trouble	Correction
Cannot raise operator (CRO)----- No dial tone (NDT)-----	Open black handset lead----- Open transmitter----- Dirty hookswitch contact----- Open yellow instrument lead----- Open primary of induction coil----- Open line from cross-connecting box--- to connecting block.	Replace handset cord. Replace transmitter. Clean or burnish contacts. Repair or replace lead. Replace induction coil. Repair open conductor.
Permanent signal (PERM)-----	Crossed yellow and black instrument--- leads. Crossed yellow and green instrument--- leads. Crossed yellow and red instrument----- leads. Crossed hookswitch leads----- Crossed capacitor leads----- Shorted ringing capacitor----- Short in deskstand cord----- Ring ground-----	Repair or replace leads. Repair or replace leads. Repair or replace leads. Repair insulation. Repair insulation. Replace capacitor. Replace deskstand cord. Repair insulation of ring conductor.

Symptom	Probable Trouble	Correction
Permanent signal (PERM)-----	Both sides grounded ----- conductor.	Repair insulation of both tip and ring
	Tip-ring cross ----- replace lead.	Refer to TM 11-757. Repair or
	Ring-tip cross ----- replace lead.	Refer to TM 11-757. Repair or
Bell does not ring (BDR) -----	Open ringer or ringer leads ----- in the coils.	Replace ringer if there is an opening
	Open ringing capacitor or capacitor ----- leads.	Replace capacitor.
	Shorted ringer coils -----	Replace ringer.
Transmitter dead, or cannot be heard-- CBH).	Mechanical defects in ringer -----	Replace ringer.
	Crossed red and black leads in handset cord.	Repair or replace leads.
Receiver dead, or cannot hear (CH)----	Shorted or packed transmitter -----	Replace transmitter unit.
	Crossed red and white leads in handset cord.	Replace handset cord.
	Crossed black and white leads in hand- set cord.	Replace handset cord.
	Open green instrument lead-----	Replace lead.
	Open white lead in handset cord-----	Replace handset cord.
	Dirty dial spring contacts -----	Clean dial springs or replace dial.
	Dirty receiver spring contacts -----	Clean contacts.
	Receiver contacts not contacting ----- receiver.	Bend contacts.
Cannot be heard well (CBHW) -----	Shorted receiver unit -----	Replace receiver unit
	Open or shorted talking capacitor-----	Replace capacitor.
	Open black instrument lead -----	Replace or repair lead.
Cannot hear well (CHW) -----	Open red instrument lead -----	Replace or repair lead.
	Open red lead in handset cord -----	Replace handset cord.
	Open secondary winding of induction coil.	Replace induction coil.
	Open tertiary winding of induction coil---	Replace induction coil.
	Crossed red and white leads of hand- set cord.	Replace handset cord.
	Crossed red and green instrument leads	Repair or replace leads.
	Crossed green and black instrument --- leads.	Repair or replace leads.
	Crossed red and black instrument----- leads.	Repair or replace leads.
	Shorted primary winding of induction --- coil.	Replace induction coil.
	Shorted tertiary winding of induction ---- coil.	Replace induction coil.
	Shorted secondary winding of induction coil.	Replace induction coil.
Clicks in ear while dialing -----	Open red instrument lead-----	Repair or replace leads.
Noisy line-----	Open red lead in handset cord -----	Replace handset cord.
	Tip ground-----	Repair insulation of tip conductor.
	Defective handset cord-----	Replace cord.
Cross talk -----	Tip-tip cross-----	Refer to TM 11-757.
	Ring-ring cross-----	Refer to TM 11-757.

- b. Telephone Set TA-236/PT. The troubleshooting chart below lists the troubles that may occur in Telephone Set TA-236/PT.
- c. All terminals terminal board, unless otherwise stated. Obtain tests,

- d. reports, and records from the wire chief. Paragraphs 56 through 61 describe methods for locating sources of trouble

Symptom	Probable Trouble	Correction
<p>1. NDT; CRO (manual)-----</p>	<p>Open cable lead----- Open line wire----- Open inside wire----- Open protector fuse----- Open RED deskstand cord lead----- Open GY-GRN set lead----- Faulty D-E switch contacts----- Open GY-WH set lead----- Open BLU dial lead (dial sets----- only). Faulty dial pulse contacts (dial----- sets only). Open GRN dial lead (dial sets----- only). Open network between terminals----- RR and R. Open RED handset cord lead----- Open or loose connection at the----- transmitter cup terminals. Faulty contact between cup----- contacts and transmitter element. Open transmitter element----- Open BLK handset lead----- Open network between terminals B and C. Open GY-BRN set lead----- Faulty C-B switch contacts----- Open GY-YEL set lead----- Open GRN deskstand lead----- Open line, tip side-----</p>	<p>Refer to wire chief for testing. Locate and repair. Locate and repair or replace. Replace defective fuse. Substitute YEL deskstand cord lead and transfer the BLK ringer lead from terminal G to terminal L1. Repair if practicable; otherwise, replace the set. Clean (par. 71); if this fails to clear the trouble, replace the set. Repair if practicable; otherwise replace the set. Repair or replace the lead with one of similar color code, otherwise replace the dial. Clean (par. 71); if this fails to clear the trouble, re- place the dial. Repair or replace the lead or replace dial. Replace the set. Replace the cord. Tighten faulty contact. Clean contacts, element ring cap, and closure cap (fig. 36) with solvent (SD). Do not burnish these contacts. If trouble continues, adjust the contacts. Replace the element. Replace the handset cord. Replace the set. Repair the lead or replace the set. Clean (par. 71); if this fails to clear the trouble, replace the set. Repair the lead or replace the set. Substitute the YEL for the GRN lead and transfer the BLK ringer lead from terminal G to L1. Be sure to transfer the YEL lead from the ring side to the tip side of the line at the connecting block. Locate and repair the line.</p> <p style="text-align: center;">Note. In manual operation the GY-WHT set lead from the switch is connected to terminal RR instead of terminal F as in dial operation (fig. 67). Except for the steps noted above in this subparagraph (dial sets only), the same procedure is applied in locating this fault.</p>
<p>2. PERM (permanent signal at the central office).</p>	<p>Shorted ring and tip in the line----- Crossed RED and GRN deskstand cord leads. Crossed YEL and GCRN desk- stand cord leads. Switch contact D crossed with contact B. Short-circuited capacitor C4 (fig. 59). Grounded line, ring side-----</p>	<p>Locate and clear (par. 59). Substitute the YEL for the GRN deskstand cord lead and transfer the BLK ringer lead from terminal G to L1 Disconnect the YEL lead from terminal G and from the ring side of the line at the connecting block; transfer the BLK ringer lead from terminal G to L1. Replace the set. Replace the set. Locate and clear (par. 59).</p>

Symptom	Probable Trouble	Correction
3. BDR-----	Open ringer coil----- Open ringer lead-----	Replace the ringer coil. Repair or replace the lead; otherwise, replace the ringer coil.
4. CBH-----	Open YEL deskstand lead----- Wrong bias tension----- Ringer cutoff feature operated----- Improper ringer connections----- Mechanical failure of ringer----- component. Loose connection----- RED and BLK handset cord leads crossed. Transmitter element carbon grains packed. User confusing the transmitter and receiver ends of the handset. User positioning the transmitter too far away from the mouth. Other faulty user practices. Central office equipment failure	Transfer the BLK ringer lead from terminal G to L1. Correct the fault. Instruct all using personnel. Correct the fault. Replace the ringer. Check the line and the transmitter circuit for continuity. Replace the handset cord. Replace transmitter element. Instruct the user. Explain the necessity for proper use, and demonstrate proper positioning. When tests indicate that no plant fault exists, observe for faulty use and explain to the user. Arrange to have the line tested. Make corrections according to tester report.
5. CH (fig. 67)-----	Network assembly failure----- Switch assembly failure----- Network failure----- Loose connection between WH handset cord lead and terminal GN. Open WH lead connecting terminal G with receiver element terminal. Loose connection at receiver element terminal. Faulty receiver element----- Open WH lead connecting receiver element with terminal R. Dial off-normal contacts crossed (dial operation only). Switch contacts G-F fail to open when the handset is removed from the cradle.	Replace the set. Replace the set. Replace the set. Tighten connection. Replace handset cord. Tighten connection. Replace receiver element. Replace handset cord. Replace the dial. Replace the set.
6. CHW-----	Faulty use----- Faulty network----- Loose connection----- High resistance short circuit at switch contact assembly. Faulty receiver element----- Faulty use-----	Instruct the user. Replace the set. Check receiver circuit connections for tightness. Replace the set. Replace the element. Instruct the user.

Symptom	Probable Trouble	Correction
6. CHW -----	Receiver cap perforations clogged with foreign matter.	Remove foreign substance with a spudger or other suitable tool. If available, dry compressed air may be used. Be sure the line pressure does not exceed 60 psi, and be careful to prevent damage by blast concentration.
7. CBHW -----	Faulty network ----- Loose connection----- Faulty switch contact D-E or C-B. Transmitter element carbon grains packed. Transmitter cap perforations clogged with foreign matter.	Replace the set. Check transmitter circuit connections for tightness. Clean contacts. If trouble continues, replace the set. Replace the transmitter element. Remove foreign substances with a spudger or other suitable tool. If available, dry compressed air may be used. Be sure the line pressure does not exceed 60 psi, and be careful to prevent damage by blast concentration. Note .In general, Telephone Set TA-23PT (because of its high resistance) should not be used as an extension station or operator telephone at cord-type switchboards, or other types of switchboards not equipped with line relays.
8. Clicks at receiver during dialing (figs.64 and 67). 9. Excessive clicks at receiver when flashing the operator. 10. Excessive line noise-----	Dial off-normal contacts fail to close while dial is in use. Switch contacts F-G dirty or out of adjustment. Protector blocks dirty or operated	Replace the dial. Clean contacts F-G. If clicks continue, replace set
11.Excessive sidetone-----	Line induction----- Loose connections----- Faulty central office facilities ----- Faulty network-----	Remove protector blocks and check noise condition; clean or if necessary, replace the blocks.(See Caution, par.15d.) When noise originates in the line or cable, obtain the cooperation of the wire chief. Check and correct faulty connections. Refer to the wire chief. Replace the set.

49. Telephone TP- Continuity Testing
(fig. 90)

The continuity of the entire telephone set circuit may be checked by the tests listed in a through d below. With the exception of the tests described in d below, it is not necessary to remove the handset or receiver from the hookswitch. *Do not disconnect the telephone from the connecting block to check continuity.*

a. Connect one test clip of the test receiver (TS-190/U or equivalent) to terminal L2Y; tap terminal C with the other test clip. A clicking sound in the test receiver indicates that the circuit, through the primary, secondary, and tertiary, or balancing, windings of the induction coil is not open.

b. With the test clip still connected to terminal L2Y, tap terminal BK in the base with the other test clip. A clicking sound indicates that the circuit, through the

black deskstand lead, the black handset lead, the transmitter, the transmitter contacts, the red handset lead, the red deskstand lead, and the primary of the induction coil is not open.

c. With the test clip still connected to terminal L2Y, tap terminal W with the other test clip. A clicking noise in the test receiver indicates that the circuit, through the white handset lead, the receiver, the red handset lead, the red deskstand lead, and through the primary winding of the induction coil is not open.

d. Remove the handset from the hookswitch. Open the red deskstand lead at terminal R. Connect one test clip to terminal L1 tap terminal GN with the other test clip. A clicking sound in the test receiver indicates that the circuit, through the receiver contacts, the white handset lead, the receiver, the transmitter, the black handset lead, the hookswitch contacts, and through the yellow desk stand lead to terminal L2Y is not open.

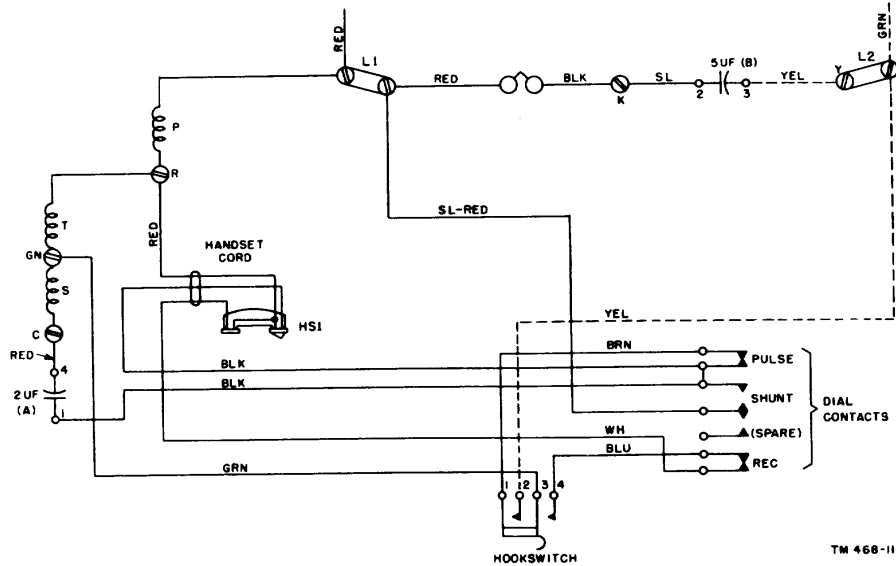

Figure 72. Telephone TP-6-A, with dial, schematic diagram.

50. Telephone TP-A Continuity Testing

(figs. 72, 73, and 74)

A wiring diagram of Telephone TP-6-A (Contelco) is shown in figure 73. The circuits are substantially the same as those of Telephone TP-6. The wiring in figure 73 is shown partly by solid lines and partly by dotted lines to help understand the circuit continuity tests. From any point on any solid line a path can be traced to the ring side of the line at terminal L1. Thus, to test any of these paths for continuity only, connect one of the test leads from the test set to the tip side of the line at terminal L1. The test in a through g below assumes that the line circuit to terminals L1 and L2Y is good. If a click is not heard at the circuit farthest from terminal L1, test at suitable test points, backward through the circuit under test, to terminal L1. When a click is heard, an open lies between that point and the last point tested. Unless noted otherwise, leave the receiver on the hookswitch throughout the following tests.

a. To test the secondary, tertiary (balancing), and primary windings of the induction coil, 66 w, with dial, schematic diagram. connect one test set lead to terminal L2Y. Touch the free test lead to terminal No. 4 of capacitor A.

A click indicates continuity between the test point and terminal L1.

Note. To avoid repetition, one test set lead will remain on terminal L2Y throughout the tests for continuity between test points and terminal L1.

b. To test the brown deskstand lead, the pulsing contacts of the dial, the black handset cord lead, the transmitter element, the red handset cord lead, and the primary winding of the induction coil to terminal L1, touch the free test lead to hookswitch contact No. 1. A click indicates continuity in the part of the circuit under test.

Note. The numbered hookswitch terminals (fig. 73) provide reference points. They do not appear in the telephone set.

c. To test the black deskstand lead running from terminal No. 1 at capacitor A, touch the free lead to terminal No. 1. A click indicates that the black lead is good.

d. To test the blue deskstand lead, the receiver contacts of the dial, the white handset cord lead, the receiver element, and the handset strap, touch the free test set lead to hookswitch contact

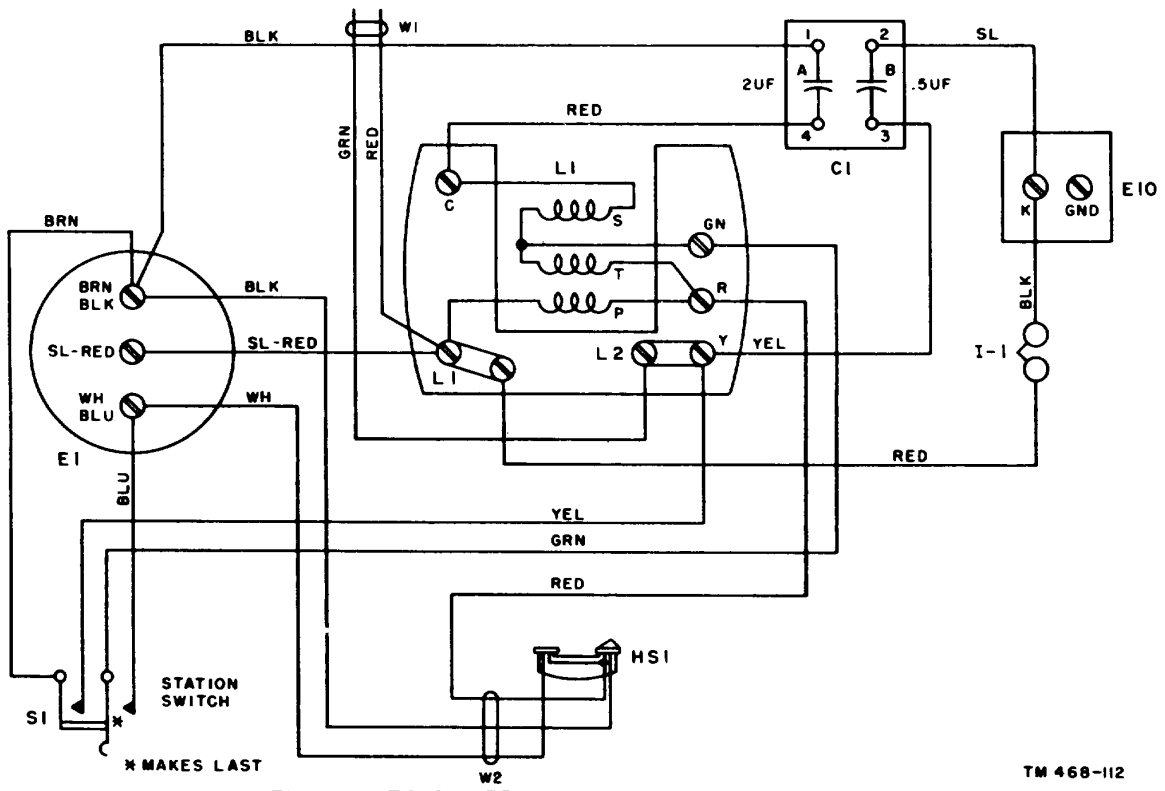

TM 468-112

Figure 73. Telephone TP-6-A, manual operation, wiring diagram.

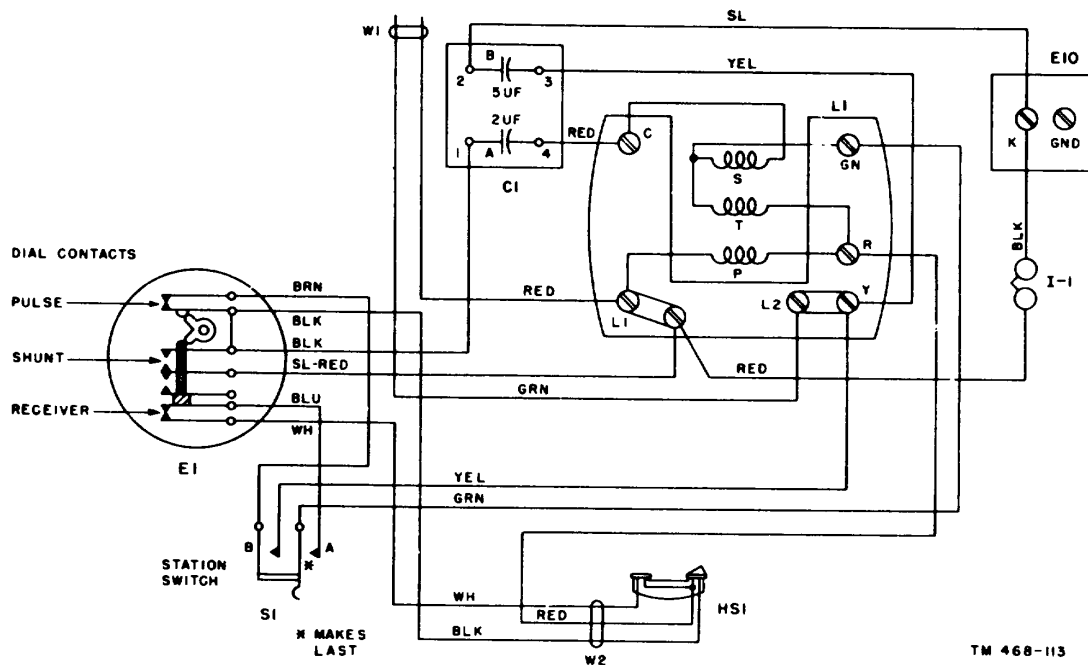

TM 468-113

Figure 74. Telephone TP-6-A, with dial, wiring diagram.

No. 4. A click indicates continuity of the circuit part under test.

e. To test the green deskstand lead, touch the free test set lead to contact No. 3 of the hookswitch. A click indicates that the green lead is good.

f. To test the slate-red deskstand lead, touch the free test set lead to the shunt contact of the dial. A click indicates that the slate-red lead is good.

g. To test the ringer coils and leads, touch the free test set lead to terminal No. 2 of capacitor B. A click indicates continuity of the circuit part under test. This test concludes the continuity tests on all leads connected electrically to terminal L1.

h. To test the yellow lead between hookswitch contact No. 2 and terminal L2Y, connect one test set lead to terminal L1, and touch the free test set lead to hookswitch contact No. 2. A click indicates that the lead under test is good.

i. To test the yellow lead running between terminal No. 3 at capacitor B and terminal L2Y, connect one test set lead to terminal L1 and touch the free test set lead to terminal No. 3 of capacitor B. A click indicates that the lead under test is good.

51. Location of Telephone Set Opens (TP-6-A)

If no clicks are heard at any point in the above tests, test back to either L2Y or L1; this depends on the test. For example, if during the test (par. 49b), no clicking sound is heard, the circuit must be tested, point by point, to locate the open. With the test clip still connected to terminal L2Y, tap terminal BK of the hookswitch. If no clicking noise is heard, tap, in turn, terminals BK of the handset, terminal R of the handset, terminal R of the base, terminal R of the induction coil, and terminal L1 of the induction coil. Whenever a clicking noise is heard, the open lies between the terminal at which the noise was heard and the preceding terminal tested.

52. Testing Ringer Circuit (TP-A)

Connect one test clip to terminal L2Y and tap terminal K with the other test clip. A clicking sound indicates that the circuit is not open.

53. Testing Capacitors (TP-A)

(figs. 78 and 79)

a. Ringing Capacitor. To test the ringing capacitor, open the slate lead of the capacitor at terminal K. Connect one test set lead to the disconnected end of the slate lead. Tap terminal L2Y and L1 alternately, and in the order given. If the capacitor is good, a click will be heard when terminal L2Y is touched, because the capacitor is discharging through the test set. Another click will be heard when terminal L1 is touched, because the capacitor is recharging. If a click is heard at terminal L1, but not terminal L2Y, the capacitor is short-circuited. No click is heard at terminal L2Y when the capacitor is short-circuited because a short circuited capacitor will not retain a charge.

b. Talking Capacitor. Disconnect the red lead from terminal C at the induction coil. Connect one test set lead to the disconnected end of the red lead and, with the free test set lead, touch terminal No. 1 of the capacitor and terminal L2Y alternately. If the capacitor is good, a click will be heard as each terminal is touched. If a click is heard, when terminal L2Y is touched, but no click is heard when terminal No. 1 is touched, the capacitor is short-circuited.

54. Telephone Set Short-Circuit Test

(figs. 75 through 79)

Generally, a unit of telephone station apparatus is tested for a short circuit by causing a current to flow in the unit, and then connecting a test set in parallel with the unit. Thus, a parallel circuit between the unit under test and the test set is established. If the unit is short-circuited, the test set connected in parallel with the unit also will be short-circuited (fig. 75). Since the receiver must be off the hookswitch during tests for short circuits, try to prevent tying up central office of PBX equipment unnecessarily. At manual PBX stations, request the operator to leave a cord in the line jack. At stations connected to central offices, call the test desk or wire chief, and request that the line be left up on the test cord during the test period. At stations connected to step-by-step central offices, where no test desk or wire chief is available, dial the digit 3 before proceeding with the tests. The tests in a through

h below assume that the line circuit on the test was found to be good. Take the receiver off the hookswitch and proceed as follows:

- a. Primary Coil (fig. 76). Connect the test

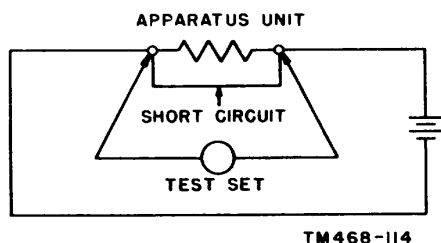

TM 468-114

Figure 76. Telephone TP-6-A, short-circuit test, schematic diagram.

set (A) to terminals L1 and R. If no click is heard in the test receiver, the primary coil is short-circuited.

b. Transmitter (fig. 76). Connect one lead of test set (B) to terminal R of the induction coil, and connect the other test set lead to the pulsing contact of the dial to which the black handset cord is connected. If no click is heard, the transmitter is short-circuited.

c. Tertiary Coil (fig. 77). Disconnect the red handset lead from terminal R, and connect the leads of test set (C) to terminals R and GN. If no click is heard, the tertiary coil is short-circuited.

d. Receiver (fig. 77). With the red handset lead disconnected from terminal R (c above), connect one lead of test set (D) to the dial terminal to which the

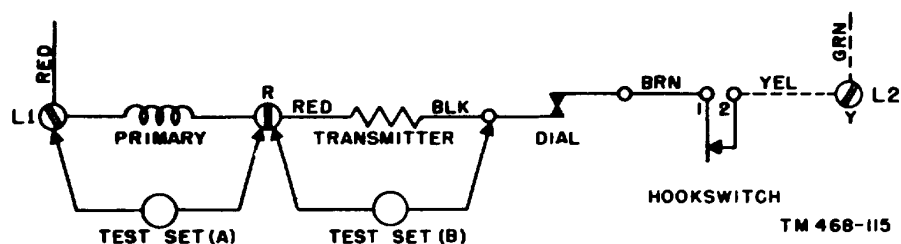

TM 468-115

Figure 76. Telephone TP-A, tea for short-circuited primary winding and transmitter, wiring diagram.

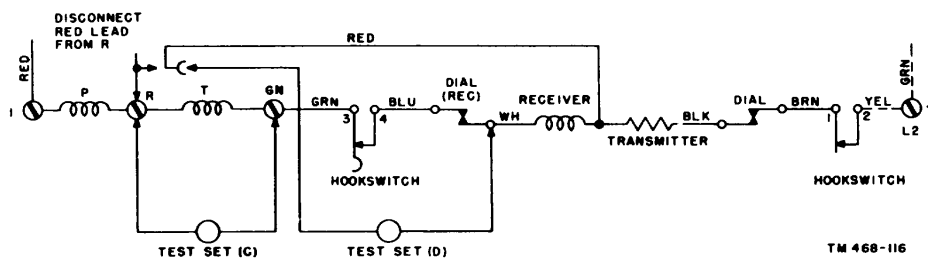

TM 468-116

Figure 77. Telephone TP-A, tests for short-circuited tertiary winding and primary winding, wiring diagram.

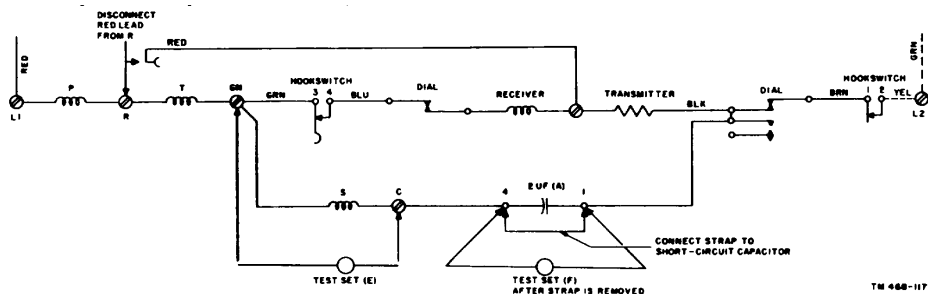

TM 468-117

Figure 78. Telephone TP-6A, tests for short-circuited secondary winding and capacitor A.

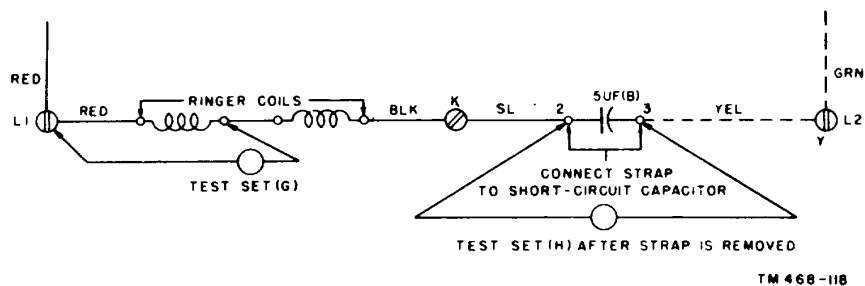

Figure 79. Telephone TP-6-A, tests for short-circuited ringer coil and capacitor B.

white handset cord is connected and connect the other test set lead to the disconnected end of the red handset lead. If no click is heard, the receiver winding is short-circuited.

e. Secondary Coil (fig. 78). With the red handset lead disconnected from terminal R (c above), connect a short-circuiting strap across terminals No. 4 and 1 of capacitor A. Connect one lead of test set (E) lead to terminal C and touch the other lead to terminal GN. If no click is heard, the secondary coil is short-circuited.

f. Capacitor A (fig. 78). Remove the short-circuiting strap from capacitor A (e above) and connect the leads of test set (F) across terminals No. 4 and No. 1 of capacitor A. If no click is heard, capacitor A is short-circuited.

Note Replace the receiver on the hookswitch and reconnect the red handset cord lead to terminal R of the induction coil.

g. Ringer Coils (fig. 79)

- (1) Connect a short-circuiting strap across terminals No. 2 and No. 3 of capacitor B. Connect one lead of test set (G) to the strap that normally connects the two ringer coils and, with the other test lead, touch terminal L1. If no click is heard, the ringer coil is short-circuited.
- (2) If a click is heard, remove the test set lead from terminal L1 and, with the same test set lead, touch terminal K. If no click is heard at this point, the coil under test is short-circuited.

h. Capacitor B (fig. 79). Remove the strap from terminals No. 2 and No. 3 of capacitor B. Connect the leads of test set (H) across terminals No. 2 and No. 3 of capacitor B. If no click is heard, capacitor B is short-circuited.

55. Locating Crosses in Telephone Set Leads, Telephone TP-A (fig. 80)

To locate crosses between any two leads in a telephone set, first consider the nature of the service failure present. From this information a clue may be obtained, which will help to locate the fault. If the telephone user cannot hear, the fault may be in the receiver circuit. If the user cannot be heard, usually the fault will be in the transmitter circuit. When the dial tone cannot be heard or the operator does not answer, the fault is probably in the transmitter circuit. Make the tests in a through e below with the receiver on the hookswitch. In f through h below, test with the hookswitch plunger depressed.

a. Crossed Green and Yellow Deskstand Leads. This fault will cause a permanent signal to appear at the central office or PBX.

- (1) Disconnect the green lead at terminal GN of the induction coil.
- (2) Connect one test set lead to terminal GN. Touch the other test set lead to the disconnected end of the green lead.
- (3) If a click is heard, the leads under test are crossed.

b. Crossed Brown and Yellow Deskstand Leads. This fault will cause a permanent signal to appear at the central office or the PBX.

- (1) Disconnect the brown lead at the dial terminal.
- (2) Connect one test lead to terminal L1 of the induction coil. Touch the other test set lead to the disconnected end of the brown lead.
- (3) If a click is heard, the leads under test are crossed.

c. Crossed Blue and Green Deskstand Leads. This fault will cause annoying clicks at the receiver when the hookswitch is operated.

- (1) Disconnect the blue lead at the dial terminal.
- (2) Connect one test set lead to terminal L2Y of the induction coil. Touch the other test set lead to the disconnected end of the blue lead.
- (3) If a click is heard, the leads under test are crossed.

d. Crossed Blue and Yellow Deskstand Leads. This fault will cause a permanent signal to appear at the central office or the PBX.

- (1) Disconnect the blue lead at the dial terminal.
- (2) Connect one test set lead to the dial terminal. Touch the other test set lead to the disconnected end of the blue lead.
- (3) If a click is heard, the leads under test are crossed.

e. Crossed Blue and Brown Deskstand Leads. This fault will short-circuit the receiver.

- (1) Disconnect the brown lead at the dial terminal.
- (2) Connect one test lead to terminal L2Y of the induction coil. Touch the other test set lead to the disconnected end of the brown lead.
- (3) If a click is heard, the leads under test are crossed.

f. Crossed Red and White Handset Leads. This fault will place a short circuit on both the receiver element and the tertiary winding of the induction coil.

- (1) Remove the receiver element and the transmitter element.
- (2) Connect one test set lead to terminal L2Y of the induction coil. Touch the other test set lead to terminal WH in the handset.
- (3) If a click is heard, the leads under test are crossed.

g. Crossed Red and Black Handset Leads. This fault will short-circuit the transmitter.

- (1) Remove the transmitter element and the receiver element.

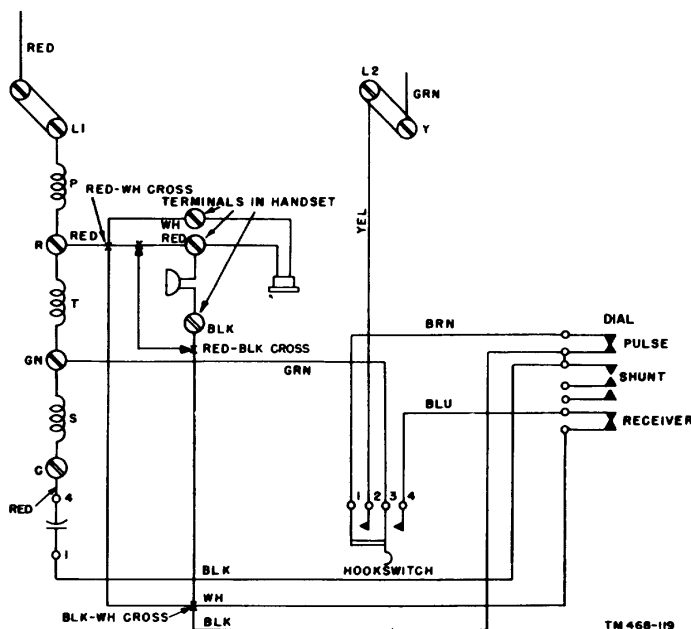

Figure 80. Telephone TP-A, schematic diagram showing crossed leads.

- (2) Disconnect the black lead at the dial terminal.
- (3) Connect one test set lead to terminal L2Y of the induction coil. Touch the other test set lead to terminal BLK in the handset.
- (4) If a click is heard, the leads under test are crossed.

h. Crossed White and Black Handset Leads.

This fault will short-circuit the receiver.

- (1) Remove the receiver cap and the receiver element.
- (2) Disconnect the white lead at the dial terminal.
- (3) Connect one test set lead to terminal 1,2Y of the induction coil. Touch the other test set lead to terminal WH in the handset.
- (4) If a click is heard, the leads under test are crossed.

56. Line Fault Location

Many subset troubles will be caused by faults in the line cord and in the wiring leading to the cross-connecting box. There are four types of faults commonly encountered: opens, shorts, grounds, and crosses. The testing procedures are described in paragraphs 57 through 60 below.

57. Line Opens

a. Causes. Opens are commonly caused by the following:

- (1) Cable wiring broken by excessive bending or twisting when the cable is placed.
- (2) Bullets piercing a cable or wire.
- (3) Kinks and nicks in the wire causing the conductors to break.
- (4) Poor splices pulling out-under tension.
- (5) Inside wiring nails driven too far into the insulation and breaking the conductors.
- (6) Loose or dirty connections and lugs.
- (7) Blown, broken, or badly warped fuses.
- (8) Defects in the manufacture of the wire.
- (9) Excessive strain on the wire at the terminals causing conductors to become loose.
- (10) Sharp or heavy objects striking a wire and causing a break.

b. Testing for and Locating Line Opens (fig. 81).

- (1) Connect one lead of the test receiver to the tip or ring conductor of the line at the cross-connecting box. Tap the other conductor with the test pick. A click will be heard every time the connection is made and every time it

is broken if the line is good at that point. The absence of a click indicates an open in the line toward the central office. If the line tests good toward the central office, the open is toward the substation.

- (2) The method used in locating an open is determined by the nature of the line construction toward the substation. If open wire is used, a quick inspection of the entire line between the cross-connecting box and the substation may reveal a broken lead. If no broken lead is found, test at the end of the line. If the open is located back toward the cross-connecting box, go back over the line and test at reasonably spaced intervals until the open is located between two test points. Continue to test at intervals until the fault is located between two adjacent poles. If the leads are both in the air, the fault is probably a poorly made splice. If the pole line carries another working common battery circuit, connect one lead of the test set to one side of this circuit, and connect the spare lead to one side of the line under test. If a click or dial tone is heard, that lead is good. If no click or dial tone is heard, move the test set lead to the other side of the working line and repeat the test. If a click or dial tone is heard, the side of the circuit under test is good. Secure the faulty lead toward the substation, and cut it toward the cross-connecting box far enough away from the pole tie to permit a sleeve splice later. Examine the lead, locate the open, and make the necessary repairs.

- (3) If the open is in an insulated paired wire proceed as in (2) above to the point where the fault is located between two adjacent poles. Because there is no advantage in determining whether the open is in the ring side or the tip side of the line, cut the wire toward the cross-connecting box, and test at intervals along the line back toward the cross-connecting box until the fault is located. Repair the open to restore service, and then inspect the line; the conditions that caused the interruption in service should be remedied.

- (4) If the open is located in a cable pair, consult the cable records for authority, and transfer the circuit to a good spare pair.

c. Testing for and Locating Open Ground

- (1) To determine whether the ground wire of the substation protector is open, connect the test receiver across the line at the protector.
- (2) If a click is heard, the line is good at this point. With the test pick connected to the ring conductor, tap the ground binding post with the other test clip. A click, heard each time the connection is made and broken, indicates a good ground lead; lack of a click indicates an open ground lead.
- (3) A visual inspection of the ground wire and connections will usually reveal the source of the trouble.

d. Locating Opens in Drop and Inside Wires.

- (1) Opens in drop. The term drop wire refers to a covered twisted pair or parallel twin wires that run between the premises on which the substation is located, and the cable terminal, or to an open wire lead nearest the premises and on a public highway. An open in a drop wire can rarely be located by visual inspection. If possible, loosen the drop wire at the building and drop it to ground level. Because the drop wire is still connected to the line or cable pair, test along the wire until the fault is located. If this cannot be done, remove the drop wire from the building and take it to the foot of the pole. Another method is to remove the drop wire from the pole or cable terminal and draw it to the building. Connect

the ends of the drop wire to another working circuit on the premises, if one is available, and locate the fault by testing. To locate an open use the procedure described in (2) and (3) below.

- (2) Opens in bridle wire runs. The term bridle wire run refers to a wire run that is located on fences or buildings and is supported by rings placed at intervals along the fence or building, which is located between a cable terminal and the substation location. Bridle wire, because of its lack of tensile strength, is not designed for spans of more than a few feet. When testing for an open, start at the cable terminal and test at intervals until the open is located.
- (3) Opens in inside wire runs. The term inside wire run refers to the Fires that run between the station protector (if one is used) or connecting terminal at which the outside and inside wires meet and the substation. Start at the protector or terminal and test at intervals until the open is located.

58. Line Shorts

a. Causes. Shorts commonly are caused by the following:

- (1) A drop or bridle wire swinging or rubbing against an object repeatedly, thus damaging or removing the insulation so that the bared conductors or the pair come into electrical contact. If the contact is permanent, the condition is referred to as a short. If the contact makes and breaks intermittently, it is referred to as a swinging short.

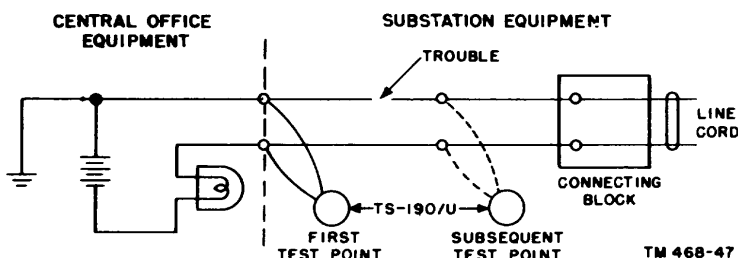

Figure 81. Method of testing for a line open.

- (2) A break in the insulation of a drop wire at the drop (clamp, with the clamp serving as the connection between the two conductors.
 - (3) Water settling on an old deteriorated drop wire and acting as a conductor.
 - (4) Dirty faceplates on terminal cans that serve as a conductor between two lugs.
 - (5) Wiring at any point of termination extending too far and contacting another lug.
 - (6) Inside wiring nails driven so that the metal nail penetrates the insulation of two leads in such a way that it makes contact with both.
 - (7) A pair of open wire leads having excessive slack between supports; these leads may swing into contact during wind storms and produce a swinging short. A pair of open wire leads may wrap around each other during a violent wind storm or as the result of a heavy impact against a line support and remain in this position.
- b. Testing for and Locating Shorts (fig. 82).
- (1) Testing for line shorts requires a knowledge of the physical position of the line under test with respect to other working lines. If the line under test is a single pair of open wire leads or a single drop, bridle or inside wire pair, testing is simplified. For any one of these conditions, open either lead of the pair at fault toward the central office or PBX, and connect the test set between the end of the lead just removed and the terminal from which the lead was removed. If the open is made on the tip side of the line, line battery will flow from the ring side of the line out across the short circuit, back on the tip side of the line, through the test receiver, and back to the source. A click will be heard in the test receiver. If no short existed, there would be no path from the ring side of the line to the tip side and no current would flow in the test set. However, if the pair under test is one of many working pairs in a cable, more care must be taken to diagnose properly the true nature of the fault.
 - (2) To test for a short-circuited pair in a cable containing other working circuits, set up the conditions for test

as outlined 74 in (1) above with the open on the tip side of the line. If a click is heard, either the pair may be shorted, or the tip side of the line under test may be crossed with the ring side of another working pair. Determine which fault exists by disconnecting the ring side of the line under test from the line toward the central office and test again. If a click is heard, the fault is a cross. If no click is heard, the pair under test is short-circuited.

- (3) Close the tip side of the line and open the ring side. Connect the test set between the open lead and the terminal from which the lead was removed. A click will indicate either that the pair under test is short-circuited, or the ring side of the line under test is crossed with the tip side of another working pair. To determine which of the two conditions exist, disconnect the tip side of the pair under test, and test again. If a click is heard, the fault is a cross. If no click is heard, the fault is a short circuit.

Note. A faulty pair should be tested for grounds before it is tested for short circuits because a ground on either side of the line may cause an improper diagnosis of the fault.

c. Clearing Shorts From Line. The exact location of a short in the open, drop, bridle, or inside wiring may be found by visual examination. If this is impossible to perform, or if the wiring is damaged or deteriorated, replace the wiring and rerun or reroute the wiring, or reinforce the insulation, as required.

59. Line Grounds

Most line grounds occur at the substation protector. This is caused by pitting of the carbon blocks when high voltages arc across the .003-inch gap, causing the blocks to make contact with each other. Dust particles settling between the carbon blocks will cause them to make contact with each other.

a. Causes of Line Grounds. Line grounds are caused by the following:

- (1) Bare conductors of a worn drop wire which make contact with any grounded metallic object will often result in an intermittent ground.
- (2) Wet or worn inside wiring which makes contact with a grounded metallic object.

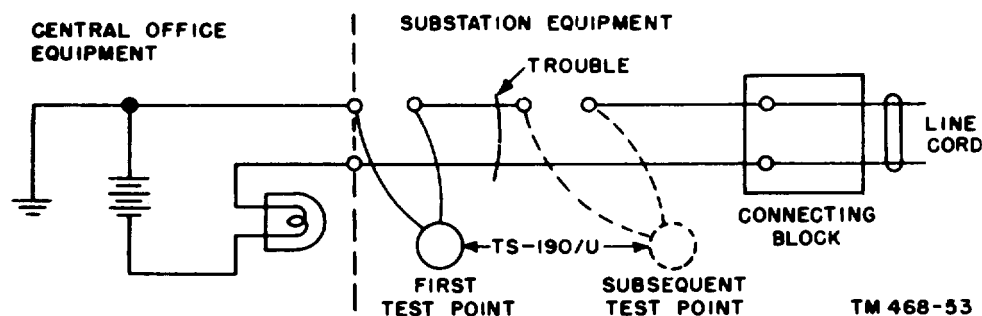

Figure 82. Testing for a line short.

- (3) A broken braid at the terminal can which makes contact with the terminal, cable stub, etc.

b. Testing for and Locating Ring Ground.

- (1) The term ring ground refers to an undesired electrical connection between the ring side of a working line and ground. The first step in locating this fault is to determine the portion of the circuit in which the fault lies (in the distributing cable, drop, protector, inside wire, or telephone set). When practicable, the tests should begin at the cross-connecting box.

Note. Assume that the fault is at the telephone set, that the first test is being made at the crossconnecting box, and that a protector is used in the circuit.

- (a) Disconnect both leads from the feeder cable.
 - (b) Connect one lead of the test set to the ring side of the line toward the central office.
 - (c) Touch the other test set lead alternately and repeatedly to both of the open leads. A relatively loud click will be heard each time the grounded lead is touched.
 - (d) Reconnect the leads as they were originally found.
- (2) Repeat the procedure given in (1)(a) through (d) above at the following points:
- (a) Where the leads connect with the distributing cable or line.
 - (b) Where the leads connect with the protector.
 - (c) Where the inside wire connects with the protector.
 - (d) Where the inside wire connects with the telephone set terminals.

- (3) Continue fault locating by a process of elimination. Observe if the telephone is mounted on a grounded surface. Note whether there is excessive dampness in the vicinity of the telephone or whether some other unusual condition prevails. If either of these conditions has caused the fault, remove the cause or remove the telephone to a suitable location. Determine the exact location of the fault by opening up the leads that are connected electrically with terminal I11 in the telephone set and, with one test set lead connected to the ring conductor of the inside wire, touch each telephone set lead as it is opened. A click will be heard in the faulty lead.

c. Testing for and Locating Tip Ground (fig. 84).

The term tip ground refers to an undesired electrical connection between the tip side of a working line and ground. To test for and locate a tip ground, follow the same procedure as for a ring ground (b above).

d. Testing for and Locating Grounds on Tip and Ring.

- (1) A tip and ring ground has the same characteristics as a short circuit, since the ring side of the line is connected electrically to the tip side through the ground. Disconnect the faulty pair from the feeder cable. Connect one test set lead to the ring side of the line toward the central office and touch the other test set lead alternately to the faulty leads. A click will be heard as each lead is touched. If the pair were short-circuited only, these clicks would not be heard.
- (2) As a rule, where both sides of a line are grounded, the faults are adjacent. Be

cause this is not always the case, test to determine the portion of the circuit in which each fault exists. When the general location has been established, locate each fault individually.

- (a) When an open wire lead is grounded, locate the fault by inspection, if possible. If the fault cannot be located by inspection, open the line at one or more points and test to locate the ground definitely.
- (b) When a drop wire is grounded, locate the fault by observation, if possible. If the fault cannot be located by observation, open the drop wire lead at one or more points and test to localize the fault. When the fault has been located, remove the cause of the fault and make necessary repairs. If the cause of the fault cannot be removed, relocate the line adjacent to that point. When the damage to the drop wire is great, replace the damaged part with new wire.
- (c) When a protector is grounded, determine whether cleaning the carbon

blocks or replacing them is the better maintenance job. If the blocks are to be cleaned, be careful not to increase the air gap between the blocks.

- (d) An inside wire can become grounded in many ways. Insufficient insulation when the wire is crossing a grounded object, excessive moisture, interference as a result of repairs or changes to the premises, or improper installation at the telephone set or protector are some causes of a grounded inside wire. When the trouble has been located, determine whether the wire should be repaired or replaced.

e. Clearing grounds.

- (1) The exact location of a ground on the drop, block, open, inside, or bridle wiring may be determined by visual examination. Where visual examination is impracticable or difficult, rerun the line and reinforce the insulation at points of contact with possible ground leads.
- (2) A ground in the substation protector may be cleared by cleaning or by replacing the carbon blocks.

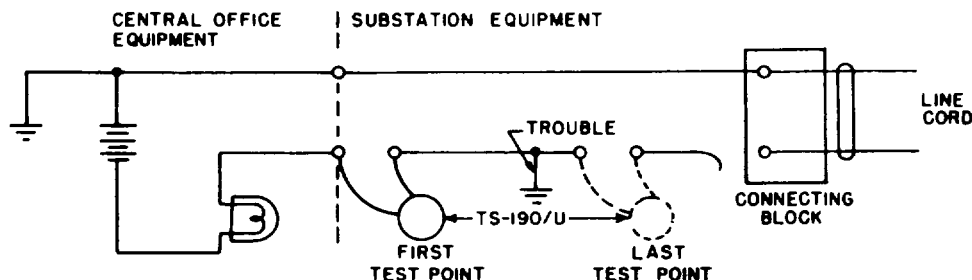

TM 468-54

Figure 83. Method of testing for and locating a RING ground on a line.

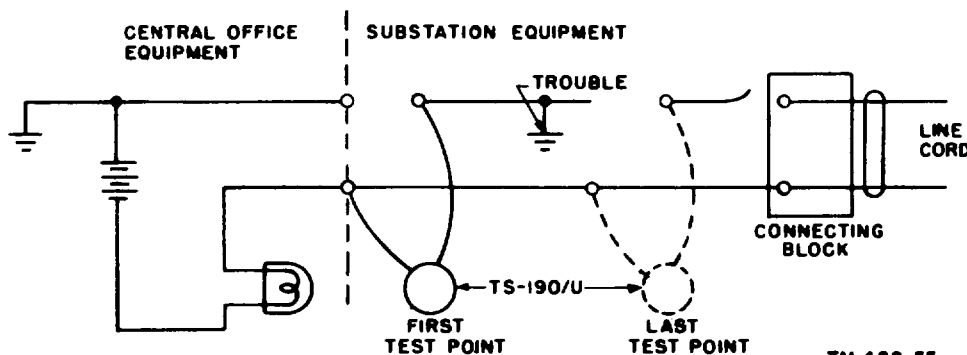

TM 468-55

60. Line Crosses

The procedures for the removal of crosses from drop, block, inside, and bridle wiring are similar to those for the removal of crosses from telephone cables. Refer to TM 11-757 for the procedures to be followed.

61. Telephone Set TA-236/FT, Continuity Test

The continuity test for each of the circuits in the TA-236/FT is covered in a through d below. It will be necessary to remove the housing assembly for all of the continuity tests and to operate the hookswitch manually. The contact designations on the circuit-diagrams are used for reference purposes only and do not appear on the contacts.

a. Ringer Circuit (fig. 59). Connect one lead of the test receiver to terminal L2; with the other lead, test at the following points: terminal K, the end of the GY ringer lead at the ringer coil, the end of the BLK lead at the coil terminal, terminal G, and the ring side of the line at the connecting block. Transfer the test receiver lead from terminal L2 to terminal G and test at terminal A, the GY-RED lead at the coil terminal, terminal L2, and the tip side of the line at the connecting block.

b. Transmitter Circuit, Manual (fig. 61).

- (1) Remove the protective plastic housing from the switch assembly by grasping the sides of the housing with the finger and thumb and then applying a gentle pressure. This disengages two small projections from slots in the switch mounting. Draw the bottom end of the housing away from the mounting.
- (2) Block switch contacts B-C to prevent them from closing when the switch is in the operated position.
- (3) Connect one lead of the test receiver to terminal L2, and with the other lead, test at switch contact C, terminal C, and then terminal B.
- (4) Remove the transmitter cap, the transmitter cup, and the transmitter element from the handset handle.
- (5) Reseat the element in the cup and hold it in this position by hand; then continue to test at the BLK lead terminal and RED lead terminal at the cup.
- (6) Reassemble the transmitter in the handset handle.

- (7) Continue the tests at terminal R, terminal RR, the switch contacts E and D, terminal LI, and the ring side of the line at the connecting block.
- (8) Transfer the test receiver lead from terminal L2 to L1 and test at switch contact B, terminal L2, and the tip side of the line at the connecting block. Remove the block from contacts B-C.
- (9) Viewed from the dial mounting end of the base plate, switch contact A is the contact nearest the observer. Switch contact A, with its associated GY lead, serves no useful purpose in individual line service.

c. Transmitter Circuit, Dial (fig. 62).

- (1) These tests differ from those outlined in b above in that a test at terminal F is necessary immediately before the test at the RR terminal.
- (2) If a click is heard on the test at terminal F and not at RR, remove the screws that fasten the dial protective housing and those that fasten the dial spring block to the dial. Remove the housing and lift the spring away from the dial just enough to allow tests at the spring contacts. Test at the dial contact terminal on which the BLU lead is connected and then at the contact terminal on which the GRN lead is connected.
- (3) Reassemble the dial components with the tip of the pawl finger in the position as shown in figure 41 and with the protective housing slot properly fitted to the dial spring block.

Note. Figure 62 shows that while circuit continuity may be apparent during the test at terminal C, necessary continuity does not exist. This condition can result from current flowing in the circuit from terminal RR, through resistor R3, and varistor CR2 to terminal C, while the more useful part of the circuit from the terminal RR, through the induction coil winding PI, to terminal R, over the RED handset cord lead, the transmitter element, the BLK handset cord lead, to terminal B, resistor RI, and winding P2 to terminal C. may be open at some point in that section of the circuit. Network construction has no means available by which either one of these parallel-connected paths can be isolated from the other to allow for individual testing; therefore, when the other circuit components meet circuit requirements and transmission fails, replace the complete set.

d. Receiver Circuit, Manual and Dial (fig. 67).

- (1) Block switch contacts B-C to prevent them from closing when the switch is in the operated position.
- (2) Remove the transmitter cap and the transmitter element from the plastic cup.
- (3) Remove the receiver cap and the receiver unit from the handset. Do not disconnect the WH leads at the receiver unit terminals.
- (4) Disconnect the WH handset cord lead at the terminal R.
- (5) Connect one lead of the test receiver to

terminal L2; with the other lead, test at the end of the WH wire which is disconnected from terminal R, at both terminals at the receiver unit, at terminal GN, and at terminal RR.

- (6) When continuity is lost through failure of any component in the handset cord or the receiver unit, replace the cord or the unit as required.
- (7) When a click is heard at terminal GN and not at terminal RR, replace the complete set.
- (8) Remove the block from contacts B-C.

**CHAPTER 4
REPAIR PROCEDURES**

Section I. ADJUSTMENTS AND TESTS

62. General

Only three mechanical parts in the telephone set require adjustment: the hookswitch, the ringer, and the dial. Periodic adjustment of these parts is not required; adjust them only when the reported trouble indicates that they are not functioning properly.

63. Dial Adjustments

The dial must be checked for proper speed and pulse ratio when the reported trouble indicates that wrong numbers are being dialed frequently from one telephone set. The speed of the dial is checked from the test desk (a below).

a. Testing Dial From Test Desk. In most dial central offices, a test desk is available to the repairman. To test the dial, call the test desk man, and request that the test desk be prepared for a dial speed check. After the test man indicates that the test desk is prepared, dial the number 0 or 10 several times. The test man will indicate if the dial is functioning properly. If it is not, replace it with a new or reconditioned dial.

b. Dial TA-45()/GT.* The procedures for adjusting the TA-45(*)/GT are explained in TM 11-2103.

c. Dial of Telephone Set TA-2S6/FT.

- (1) Fasteners. Dial mounting screws should be adequate and secure.
- (2) Speed. The average speed of the dial should be a minimum 9.0 and a maximum 10.5 pulses per second. Replace or return for correction a dial which does not meet this requirement after five tries. For this test, the apparatus in which the dial is mounted should be in its normal operating position.
- (3) Rundown response (fig. 55). During the rundown movement of the dial, and with the pawl finger in a position at rest against pulsing spring A, spring A moves away

from the tip of the pawl finger each time the high dwell (high segment) of the pulsing cam comes into contact with spring B.

- (4) *Shunt contacts* (fig. 41). The shunt contacts should be open when the dial is in its unoperated position and remain open until the finger wheel has been moved off normal at least one-sixteenth inch at the outer edge of the finger wheel. They should be closed when digit 1 is dialed, and remain closed until after the last pulse is completed, during the return operation of the dial.
- (5) Contact clearance. The clearance (gap) between the shunt contacts should be a minimum .015 inch.
- (6) Insulation. Wiring and current-carrying parts should not be crossed electrically with noncurrent-carrying parts of the dial. Test with a minimum 20volt de.
- (7) Dial return. The dial should return from the fully wound position to its normal position without stopping when the finger wheel is retarded at a uniform rate of about one-third its normal speed.

64. Ringer Adjustments (TP-6 Types)

The ringer is adjusted only when reducing or increasing the ringing signal and when reducing or eliminating bell tapping. The increasing or decreasing of the ringing signal should be done with the telephone user present, so that the volume of the signal may be checked. Using personnel need not be present when adjustments are performed to eliminate bell tapping.

a. Reducing Loudness of Ringing Signals. A ringing signal of reduced loudness is desirable in quiet locations such as small offices and hospital rooms. Where ringer construction permits, the

ringing volume may be reduced by decreasing the armature air gap enough to make the ringing volume satisfactory, but in no case should the air gap be reduced below .004 inch. Whether or not the adjustment can be made depends on the type of ringer. A biased ringer with an unequal armature air gap) adjustment is equipped with an armature stop screw. On this type of ringer, diminish the signal volume by reducing the armature travel on the stop screw side. On a ringer equipped with an adjusting screw, which usually is located in a threaded hole through the ringer side posts yoke, adjust the armature air gap by loosening the stop screw locknut and turning down the stop screw. Adjust a WECO. B-type ringer for reduced volume by bending the stroke-limiting arm toward the yoke (with a pair of long-nosed pliers) until the signal volume is satisfactory, or until the armature air gap, on the side opposite the stroke-limiting arm, measures .004 inch. In all cases, the final adjustment of the armature air gap should not be less than .004 inch. Immediately following the adjustment, readjust the ringer gongs to operate properly under the new clapper ball travel limitations. If the signal is still too loud, one of the following arrangements should be made:

- (1) Loosen the gong adjusting screws and spread the gongs apart so that the clapper does not strike them when ringing current is applied.
- (2) Replace the gongs with special-purpose low-ringing gongs.
- (3) To be sure that ringing signals will be heard under all normal conditions, the user should stand at the point farthest away from the telephone that the signal is expected to be heard. Final volume adjustments should be made only under this condition.

b. Increasing Loudness of Ringer Signals.

Maximum ringing volume should be provided at noisy locations, where there is a large area to be covered by each ringer, and at locations where no one is normally nearby to answer calls. To increase the loudness of the ringing signal, use the following procedure:

- (1) Measure the clearance between the gong and the clapper. Adjust these parts by loosening the gong adjusting screws, so that the clearance between them measures between .015 and .020 inch. Tighten the gong adjusting screws.

- (2) A telephone set ringer that is equipped with an adjustable armature may be adjusted for increased signaling volume. Measure the armature air gap. Adjust it by increasing the armature travel on the biasing spring side to .060 inch and on the other side to .024 inch. After adjusting the air gap, readjust the gongs and check the ringer for tapping.

Note. Signaling volume cannot be increased in Telephones TP-6, TP-6-A, and TA-166/U where the armature travel cannot be changed.

- (3) Replace the base plate on the subset and test the ringer for audibility.
- (4) If the loudness of the ringer has not been increased sufficiently, install washers, as spacers, to produce a gap between the base plate and the base of the subset.
 - (a) Remove the base plate.
 - (b) Place two brass flat washers (Sig C stock No. 6L50008-3, or equal), $\frac{3}{16}$ -inch inside diameter, $\frac{3}{8}$ -inch outside diameter, and $\frac{1}{32}$ -inch thick, on each of the base plate mounting screws, between the base plate and the base of the subset.

Caution: Do not install these washers if the subset is used in a locality where insects may enter through the aperture that is produced.
 - (c) Replace the base plate.
 - (d) If the ringing signal is still unsatisfactory, report the condition to the wire chief.

c. Elimination of Bell Tapping. When two or more telephones share the same line, dialing at one phone may result in bell tapping at all of the telephones every time the pulsing springs open and close. This also may occur in manual operation when the hookswitch is being agitated (jiggled), as in recalling the operator. This is called *bell tapping*. Eliminate bell tapping by proceeding as follows:

- (1) Interchange the line cord connections. If this does not stop or lessen bell tapping, restore the line cord leads to their original terminals.
- (2) Remove the base plate.
 - (a) If the telephone set is equipped with a biasing spring, the tension of which is adjusted by moving the biasing spring into notches, move the biasing spring to the next available right-hand notch.

If bell tapping continues when the biasing spring is in the extreme righthand notch, change the ringer.

- (b) If the telephone set is equipped with a biasing spring, the tension of which is adjusted by turning a screw, turn the screw one-sixteenth of a turn in the direction to increase tension. Test for tapping in dial areas by dialing zero, and in manual areas by agitating the hookswitch rapidly. Repeat the adjustment until tapping stops; then increase the tension one-half turn. Test the ringer for normal operation. If this is satisfactory, reduce the tension one-fourth turn. If ringing is not satisfactory, replace the ringer.

Note. If it is necessary to turn the biasing spring as far as the stud before the additional one-half turn is given, the spring is defective and should be replaced.

65. Tests and Adjustments for Telephone Set TA-236/FT

a. Ringer Tests.

- (1) *Maximum loudness test.* Place the biasing spring in the notch specified for the existing condition, and set the loudness control for maximum loudness. Then obtain a ring from the central office or the testing center. A loud ring should be heard.

Note. When three or more ringers are connected across the line, place the biasing spring in the low tension notch. When not more than two ringers are connected, place it in the high tension notch.

- (2) *Loudness control test.* Move the loudness control wheel through the four loudness levels while the ringing current is applied to the line, and observe that each level causes a change in the signal loudness.
- (3) *Bell tapping test.* With the dial tone on the line, dial the number of the station under test. The ringer should not tap. If it does, follow the procedure outlined in b(5) below. When bias tension is changed from low to high to eliminate tapping, recheck for satisfactory ringing signal.
- (4) *Controlled cutoff test.* With the ringing current connected to the line, operate the

loudness control wheel in the cutoff position. The ringer should be silenced.

b. Ringer Adjustments.

- (1) *Cleaning and inspecting.* Clean the ringer; visually inspect the air gap between both faces of the pole pieces and the armature and between the permanent magnet and the armature for magnetized particles. Broken parts should be replaced. Check to see that the coil core and the gongs are mounted securely, that the lockwashers are present under the heads of the gong mounting screws, and that the ringer is mounted securely in the three rubber grommets. Two of these grommets are integral parts of the ringer; the other one is located in the switch mounting bracket.
- (2) *Biasing spring and detent spring tension.* With the base of the set in normal position, the tension of the biasing spring in the low tension notch should be sufficient to restore the armature to the nonoperate side of the air gap. The detent spring should have a positive detent action at each position of the loudness control wheel. The loudness control requires a torque of 700±400 inch-grams to cause movement from one position to any other position. The stop tab on the detent spring (fig. 39) should prevent the loudness control wheel from being moved to the ringer cutoff position and must not interfere with normal loudness settings. If adjustment of the stop tab is necessary, bend it to clear the frame by approximately one thirty-second inch and to stop positively against the stop provided on the frame, adjacent to the low loudness position. The movable gong is designated A, and the fixed gong is designated B. Gongs should not be dented or visibly distorted from a round shape, nor should they be filed, cut, slotted, or altered so as to distort their ringing tone. The biasing spring bracket (fig. 39) should be free from any distortion that would prevent the biasing spring from readily being positioned in either notch.
- (3) *Detent spring adjustment to provide controlled ringer cutoff.*
 - (a) Apply the jaws of a long-nosed pliers to the detent spring stop (fig. 39) at

the point designated area B (fig. 85).

- (b) Bend the spring until it no longer engages the stop on the ringer frame when the loudness control wheel is rotated through the minimum loudness level.
- (c) When properly adjusted, the cam section of the movable gong mounting will engage the stop rod and prevent armature and clapper movement, when the control wheel is moved through the minimum loudness level.
- (d) Restrict the bend to the curved section of the spring designated area A (fig. 58) Do not bend in the area C.
- (e) When bending the detent spring stop, do not change the position or the tension of the adjacent detent spring Figure 85. Disabling the stop tab to provide controlled ringer cutoff.

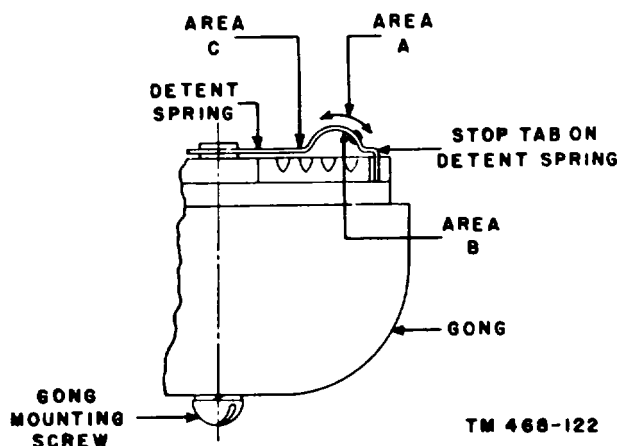

Figure 85. Disabling

- (4) Permanent ringer cutoff. Transfer the YEL deskstand lead from the ring side to the tip side of the line at the connecting block.
- (5) Eliminating bell tapping. To eliminate bell tapping, move the biasing spring from the low to the high tension notch at the biasing spring bracket. Test the telephone (a(3) above). If the bell tapping has not been eliminated, replace the ringer Do not bend or otherwise distort the biasing spring.

c. *Special Tests and Adjustments.* When the required apparatus and facilities are available, the following tests and adjustments can be applied:

- (1) With the base of the set in its normal position, the biasing spring in the low tension notch, the loudness control wheel

in the maximum loudness position, and the ringer connected in series with the capacitor in the set ringer circuit and a 25,000-ohm noninductive resistor, the clapper ball should not tap either gong when 90-volt, 20-cps ringing current is applied to the circuit. Disregard fluttering or vibration of the clapper.

- (2) Under similar circuit conditions ((1) above). but with a 15,000-ohm noninductive resistor substituted for the 25,000-ohm noninductive resistor, the ringer operates with the clapper striking one or both gongs. Irregularities and interruptions in striking both gongs are not objectionable, and loudness of the signal is not a requirement.
- (3) When a minimum 4,000-ohm noninductive resistor is substituted for a 15,000ohm noninductive resistor ((2) above), a steady ring should be produced on at least one gong when the loudness control wheel is in the minimum loudness position, and on both gongs when it is in the next higher loudness position. Both requirements apply when the biasing spring is in the high or in the low tension positions at the biasing bracket. The loudness should increase noticeably as the loudness control wheel is moved through the intermediate loudness levels, between minimum and maximum.
- (4) With the armature in the nonoperate position, and the control wheel in the minimum loudness level, the stop rod should have a .023-inch maximum clearance from the cam surface and should align within the diameter of the stop rod, with the index mark on the back of the cam. The index mark is visible only when the loudness control is in the minimum and next louder levels. Adjust the stop rod, as necessary, to meet these requirements. By keeping to this clearance as closely as practical, the requirements, in connection with the 4,000-ohm noninductive resistor ((3) above), will be easier to obtain.
- (5) With the base of the set in its normal position, the stop rod held in contact with the cam without distorting the stop rod, and the clapper ball hanging freely on the clapper rod, there should

- be visible clearance between the clapper ball and movable gong A, with the loudness control wheel in each loudness level. Adjust the clapper rod to meet this requirement.
- (6) With the base of the set in its normal position, the armature in the nonoperate position, and the clapper ball hanging freely on the clapper rod, the clearance between the clapper ball and the fixed gong should be a minimum .011) inch. If adjustment is necessary to meet this requirement, loosen the fixed gong mounting screw that repositions gong B, and retighten the screw.
- (7) The parts listed below, which are adjacent to one another in the ringer, should not touch or rub. This may prevent the free operation of the ringer in each loudness level.
- (a) Stop rod and biasing spring bracket.
 (b) Stop rod and movable gong A.
 (c) Clapper rod and pole piece.
 (d) Clapper rod and bridge on ringer frame.

66. Hookswitch Adjustments

Note. The hookswitch assembly of Telephone TA166/U and TA-236/FT is a sealed unit. Do not perform any adjustment of this assembly. If troubleshooting procedures indicate that the hookswitch assembly is dirty or out of adjustment, replace the entire unit.

a. Contact Alinement. Contacts should line up so that the full width of the contacting surface of each falls wholly within the width of the other mating contact. If the contacts are not in proper alinement, remove the hookswitch assembly from the mounting and loosen the spring pile-up mounting screws. Shift the springs until the contacts cross one another at right angles and are as near the middle of the contacts as possible. Tighten the screws securely and replace the switch assembly.

b. Operating Spring Tension. Adjust the tension in the springs so that the springs will meet the following requirements:

- (1) The operating springs will return the lever to the full limit of its travel when the plunger or plungers are released slowly from their operated to their unoperated positions. If necessary, increase the tension in the springs by bending them carefully.

- (2) Slowly lower the handset on the cradle. The plungers should move downward until the handset rests on one or both of the supporting surfaces on the mounting. Check this for both positions of the handset. Gage by sight and touch and, if necessary, decrease the tension in the springs.

c. Contact Sequence of Operation. This adjustment applies only if the hookswitch is equipped with two sets of contacts, one set of which makes before the other set. The contacts of the open set should have a clearance of .006 inch after the other contact set has made. Gage by eye; .006 inch is approximately half the thickness of the spring.

d. Contact Follow. This adjustment applies only if the hookswitch is equipped with two sets of contacts, one set of which makes before the other set. The contacts associated with the contact set which makes first should have a follow of approximately one thirty-second inch. Check as follows:

- (1) Release the plungers.
 (2) Insert the .050-inc'i leaf (or .020- and .030-inch leaves combined) of the feeler gage between the lever stud and the make spring of the contact set which makes first. With this separation, the contacts should remain closed. If necessary, carefully bend the spring (g below).

e. Contact Separation. This adjustment applies only if the hookswitch is equipped with two sets of contacts, one set of which makes before the other set. There should be an air gap of .028 inch between the contacts associated with the contact set which makes last, when the hookswitch plungers are depressed to the level of the handset supporting surfaces. Check with the feeler gage, and bend the spring carefully, if necessary (g below).

f. Spring Clearance. There should be a minimum clearance of one thirty-second inch between the operating spring which makes first and the split spring that is associated with the operating spring which makes last, when the lever is against its stop in the extreme downward position. Gage by eye, and bend the spring carefully, if necessary (g below).

g. Spring Adjusting. No adjustments other than those absolutely necessary to meet the foregoing requirements should be made on the contact springs. To adjust the springs, use a spring

adjuster (SigC stock No. 6R41266A), and proceed as follows:

- (1) Use the small end of the spring adjuster, and be sure that the full depth of the slot in the tool engages the springs.
- (2) To adjust split springs, apply the spring adjuster tool close to the spring pile-up and bend the springs slightly.
- (3) To aline fingers on the split springs, adjust the top fingers only.
- (4) To increase the tension in the operating springs, apply the spring adjuster tool at a point close to the contacts, between the contacts and the free end of the springs, and bow the springs in the required direction.

- (5) To decrease the tension in the operating springs, apply the spring adjuster tool at successive points along the springs, and slightly flex them at these points in the required direction.
- (6) Be careful not to kink the springs. If springs are kinked, the entire hookswitch assembly must be replaced.
- (7) After making an adjustment on the contact springs, recheck all spring requirements which might be affected by the adjustment.
- (8) If the springs cannot be adjusted properly, replace the entire hookswitch assembly.

Section II. CONTACT MAINTENANCE

67. General

Pitted or built-up contacts, on the hookswitch, dial, and key equipment contacts, are not necessarily an indication that the contact is no longer useful. Do not replace the apparatus because of contact erosion, unless one of the contacts of the mating pair has reached such a state that contact is made on the base metal to which the contact is welded. In the case of twin contacts, one of each mating pair should be worn through to the base metal before replacement is required. When necessary, contacts which are not worn through to the base metal should be reconditioned. *This reconditioning should be performed only in a field maintenance shop. In no instance are dials with eroded contacts to be reconditioned. Replace the dial and send the defective dial to afield repair shop.*

68. Build-Ups and Pits

Build-ups and pits on contacts result from the action of electrical current striking an arc as the contacts make and break.

a. Pitted Contacts. Progressive stages of contact pitting are illustrated in figure 86. The types of contacts shown are the bar and disk type contacts. The contacts on the left side of the illustration are new and would require no maintenance. The center contacts are pitted, but could be reconditioned. Illustrated on the right side of figure 86 are contacts that are pitted so badly that contact would be made with the base metal; these contacts should be replaced.

b. Build-Ups on Contacts. Contact build-ups are usually composed of the residue of the mating

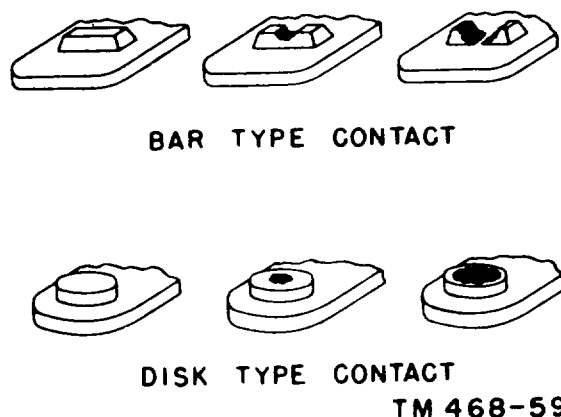

Figure 86. Progressive stages of contact pitting (bar and disk-type contacts).

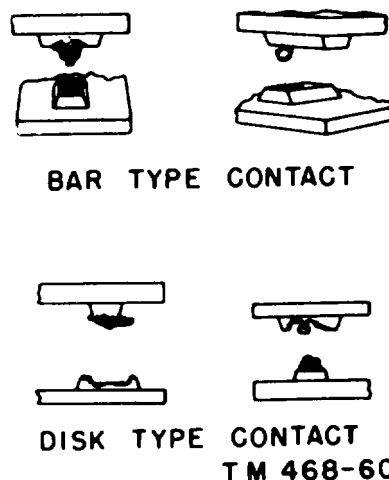

Figure 87. Build-ups and pits on contacts (bar and disk-type contracts)

contact which has pitted. Some examples of contact build-ups and pitting are illustrated in figure 87. These build-ups often can be reduced by cleaning and burnishing the contacts (pars. 69 through 71).

69. Cleaning Switch Contacts

a. To clean contacts, flush the contacts with carbon tetrachloride applied with a clean toothpick. Dip the flat end of the toothpick into the carbon tetrachloride to a depth of about one-half inch, and deposit the liquid on the contacts without rubbing. Hold the contacts slightly separated during this process.

Caution: Repeated contact of carbon tetrachloride with the skin or prolonged breathing of the fumes is dangerous. Be sure adequate ventilation is provided.

b. Dip the flat end of another toothpick into the carbon tetrachloride and deposit it on the contact, also without rubbing, to flush away the dirt that was loosened on the first application. Keep the carbon tetrachloride away from the insulators.

c. When the contacts are thoroughly dry, burnish them so that no deposit or residue from the solution or other foreign material remains on them.

70. Burnishing Switch Contacts (fig. 88)

a. Burnish contacts with the steel blade of the contact burnisher. Clean the contact burnisher before using by wiping the blade with a clean, dry cloth. During the burnishing process, wipe the blade frequently with a cloth moistened with carbon tetrachloride.

b. When burnishing normally open contacts,

press the contacts together by hand to give a slight pressure on the blade of the burnisher. When contacts normally are closed, the tension of the springs usually will furnish sufficient pressure against the burnisher. On springs which have a heavy tension, lift one of the springs away to insert the blade of the burnisher, if necessary.

c. Rub the burnisher against the contacts two or three times only. Two or three forward and withdrawal motions of the burnisher blade are sufficient to clean the contacts and reduce wear of the contact metal to a minimum. Be careful to exert a moderate, even pressure between the contacts being burnished and the burnishing tool. (Sig C stock No. 6R41065 C). Do not use abrasives other than the burnisher blade.

71. Burnishing Pitted Switch Contacts

Pitted contacts do not always indicate that the contact must be replaced. Frequently, contacts can be reconditioned by cleaning and burnishing. Burnish pitted contacts in the same manner as nonpitted contacts. However, additional strokes of the burnisher blade may be required. When contacts are pitted badly, use the ball-type burnisher furnished with the burnishing tool.

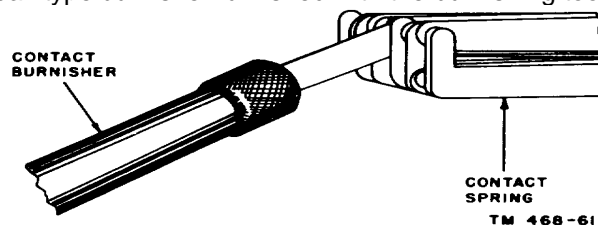

Figure 88. Cleansing contacts with contact burnisher.

Section III. REPAIR AND REPLACEMENT OF PARTS

72. General

Whenever defective parts are discovered in troubleshooting procedures, they must be replaced by new or reconditioned parts. Do not repair any of the electrical components; such repairs that are possible on mechanical components and wiring are described in this section. The instructions in this section apply generally to all of the telephone sets and the bell box described in this manual.

73. Special Precautions

a. Before removing any part of the telephone set, obtain the replacement part.

b. Carefully note the color of the leads going to each terminal of the defective part.

c. If the part to be replaced is the ringer assembly or the capacitor, carefully note where each lead from the equipment terminates.

d. Check the color of the leads against the applicable wiring diagram to be certain that incorrectly colored leads have not been used.

e. Before disconnecting leads from the defective part, tag each lead with the designation of the terminal to which it is attached. If the part to be replaced is the ringer or capacitor, tag the leads of the new part with the proper terminal designation.

f. If the standard wire form is not available, lace all new wiring after installation; keep as close to the original form as possible.

g. Use the properly sized screwdriver to loosen screw terminals. Do not force the screwdriver blade into a screw slot too small to accept it. Loosen the screw just enough to permit the spade lug to be removed.

h. Be careful to save all screws which mount the part to be replaced. Many of these screws are of odd sizes and are not easily replaced.

i. If any of the parts or wiring to be replaced is connected to solder terminals, follow the procedures outlined in TM 11-471, Shop Work.

j. When replacing parts, do not force the mounting screws with the screwdriver. If the screw does not appear to be traveling evenly into the mounting hole, remove the screw and examine it for traces of stripping. Replace the screw or base plate, as required, if the screw or mounting holes are stripped too badly. Be sure that any flakes of metal from the screw or screwdriver do not fall into the telephone.

74. Repair of Wiring

a. Inside wiring should be repaired only after the fault location procedures (pars. 55 through 60) have been followed. Do not repair internal wiring of telephone sets or key equipments. If defective internal wiring is discovered, replace it with wiring of the exact same length and color coding. If the color coding of the new wiring does not agree with the color coding of the defective wiring, make a notation to that effect, and place it under the capacitor mounting bracket, above the circuit label. TM 11 474 describes the procedures to be followed in the repairing and splicing of inside wiring.

b. The causes for damage or deterioration of wiring should be investigated and, if possible, removed. If this is not done, the damage or deterioration will occur again with time wasted on unnecessary service calls.

75. Replacement Procedures (TP-6 Type Telephones)

Before replacing any parts, disconnect the telephone at the connecting block. Select a clean, well-lighted working area. Loosen the base plate mounting screws and open the base plate.

a. Replacement of Ringer.

- (1) TP 6 type telephones except WECO. 302AW-3. Loosen and remove the ringer

mounting screws on the underside (outside) of the base plate. Loosen the screw terminals that are associated with the ringer leads. Remove the ringer carefully. Place the new ringer in the same position as the old one. Line up the ringer mounting holes with the base plate mounting holes. Lift up the base plate from the working surface. Drive in each of the mounting screws fingertight. Turn over the base plate and tighten the screws with the screwdriver. Connect the leads to the proper terminals.

- (2) Telephone TA-105/FTC. Loosen and remove the ringer mounting screws. Loosen the screw terminals that are associated with the ringer leads, and disconnect the leads. Remove the ringer carefully. Place the new ringer in the same position as the old one. Line up the ringer mounting holes with the holes on the base plate. Tighten the ringer mounting screws with the screwdriver. Connect the ringer leads to the proper terminal.
- (3) *Telephones TP-6-A and TA-166/U and WECO. 320AW-3 telephone.* Loosen the ringer mounting screw located near the clapper. The other steps in this paragraph are the same as for Telephone TA- 105/FTC.

b. Replacement of Induction Coil. The mounting of the induction coil varies among the telephones described in this manual. The WECO. 302AW-3 telephone has a more or less typical arrangement for the mounting of the induction coil. The procedure described in (1) through (4) below is for the removal and replacement of the induction coil of the WECO. 302AW-3. Modify this procedure for other telephones.

- (1) Loosen and remove the induction coil retaining screw which is located on the side of the induction coil nearest the hookswitch. Lift up this side of the induction coil and slide it from under the clamp on the other side.
- (2) Loosen the screw terminals and remove the induction coil leads (par. 73e).
- (3) Remove the induction coil.
- (4) Replace the induction coil in a manner exactly opposite to that followed for removing the coil.

c. Replacement of Capacitor. The capacitor may be retained in any one of three ways-by a clamp

which fits over it, by a screw which must be removed from the outside of the base plate, or by screws which may be removed only after the base plate is opened. Determine the manner in which the capacitor to be replaced is mounted.

- (1) Loosen and remove the retaining screws and clamp, if any. Loosen the screw terminals that are associated with the capacitor leads. Be sure that the leads of the new capacitor are tagged properly. Remove the capacitor leads and remove the capacitor.
- (2) Mount the new capacitor in the manner required by the telephone. Connect the capacitor leads to the proper terminals. Tighten the screw terminals.

d. Replacement of Hookswitch. Examine the telephone carefully to locate the hookswitch mounting-screws. These mounting screws are usually located near the screw terminals that are associated with the hookswitch. Be sure, before proceeding further, that the screws decided on are the hookswitch mounting screws. Tag all leads that terminate at the hookswitch with the proper terminal. Loosen all screw terminals and disconnect the leads. Slide the hookswitch slowly in the same direction as the hookswitch plunger. After the hookswitch plungers are free of their channels, remove the hookswitch. Carefully slide the new hookswitch into the proper position. Drive the mounting screws carefully with the screwdriver. Connect the hookswitch leads to the proper terminals. Tighten the screw terminals.

e. Replacement of Dial. Loosen the screw terminals associated with the dial. Tag and disconnect all of the dial leads. Loosen and remove the dial retaining screws. With one hand on the face of the dial, slowly push the dial from the rear with the other hand until it is free of the telephone set. Place the new dial in position from the outside of the telephone. Line up the dial mounting holes with the corresponding holes in the cover. Drive the mounting screws carefully with the screwdriver. Connect the dial leads to the proper terminals.

Note The replacement procedures described in a through c above are the only procedures which require the telephone base plate to be removed. Perform all other replacement procedures with the telephone assembled.

f. Replacement of Transmitter or Receiver. Unscrew the transmitter or receiver cap located on the

handset. (When replacing the transmitter or receiver of Telephone TA-105/FTC, remove the transmitter assembly from the telephone; when replacing the receiver, unscrew the receiver cap.) Remove the defective part; insert the new part and screw on the cap.

g. Replacement of Handset. Unscrew the transmitter cap and remove the transmitter. Loosen the three screw terminals that are associated with the transmitter contacts. Disconnect all of the leads, and remove the stay cord after loosening or removing the stay-hook retaining screw. Gently pull the handset cord away from the handset. Gently push the handset cord through the entrance on the new handset until the three leads are into the handset a sufficient distance so that they can be connected to the proper terminals. Fasten the stay cord, and connect the leads to the proper terminals. Replace the transmitter and screw on the cap.

76. Removal and Replacement of Dial Escutcheon Assembly

Note. These instructions apply only to Dial TA-45/GT. No special instructions are necessary to remove and replace the dial escutcheon assembly of dial TA-45B/GT.

a. Insert the escutcheon tool (Sig C stock No. 4D26917) under the escutcheon ring at the digit 5 finger hole (A, fig. 89). Press the tool down against the locking lever under the card. Move the tool counterclockwise to the digit 6 finger hole (B, fig. 89). This unlocks the card assembly. With the tip of the tool, lift the escutcheon ring at the digit 6 finger hole and remove the card assembly (B, fig. 89).

b. The escutcheon ring, transparent cover, number card, and number-card clamping plate comprise the card assembly. Release the components by turning the assembly face down and slightly rotating the notched clamping plate in a counterclockwise direction. Note the relative position of the parts as they are removed. They must be assembled in the reverse order of their removal.

c. In reassembling the components of the card assembly, place the transparent cover in the escutcheon ring first so that it will protect the dial card. Next place the dial card in the ring; place the dial card clamping plate over the number card last. Turn the clamping plate in a clockwise direction to engage its tongue which locks the assembly.

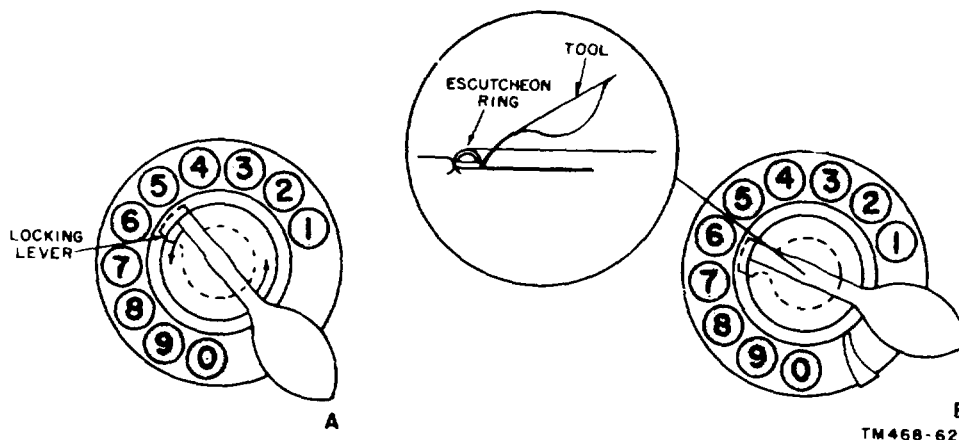

Figure 89. Removing escutcheon ring and dial card from dial.

77. Replacement Procedures for Telephone Set TA-2361FT

a. Housing Assembly.

- (1) Remove the handset from its cradle.
- (2) Back out the two captive screws at both ends of the outer surface of the base plate until the housing assembly is released from the base plate.
- (3) Remove the housing assembly from the base plate. The housing assembly is brittle and should be handled carefully.
- (4) Install the new assembly by reversing the procedures given in (2) and (3) above.
- (5) Replace the handset in its cradle.

b. Handset Cord.

- (1) Remove the transmitter cap.
- (2) Pluck out the transmitter element and the plastic cup.
- (3) Disconnect the BLK and RED cord leads from the cup terminals.
- (4) Remove the receiver cap.
- (5) Remove the receiver element.
- (6) Disconnect the two WH cord leads from the receiver element terminals.
- (7) Attach a short length of string to one of the WH leads (drag line).
- (8) With long-nosed pliers, release the cord grommet from the groove in the anchor post at the transmitter element cavity (fig. 37).
- (9) Withdraw the cord from the handle. Leave the string in the handle cavity.
- (10) Disconnect the cord leads from the terminals at the network terminal board.
- (11) Pass the new cord leads through the opening at the transmitter end of the

handle until the approaching end of the grommet just enters the handle.

- (12) Attach the drag string to the tipped ends of the two WH leads, and draw them through the handle cavity toward the receiver end of the handle until the leads can be connected to the receiver unit.
- (13) Connect the two WH leads securely to the receiver unit terminals, and place the unit into its cavity.
- (14) Place the receiver cap and secure it hand-tight. Do not use any tool to tighten either cap on a handset handle.
- (15) With long-nosed pliers, draw the grommet into the transmitter cavity until the grommet groove can be pressed into the anchor post groove. Press the grommet into the anchor post groove.
- (16) Connect the RED and BLK leads securely to the cup terminals.
- (17) Insert the cup into the transmitter cavity with the boss on the cup fitted into the groove in the cavity wall.
- (18) Place the transmitter element in the cup, replace the cap, and secure it hand-tight.
- (19) Connect the cord leads at the network terminal board.

c. Deskstand Cord.

- (1) Disconnect the cord leads at the network terminal board.
- (2) Disengage the stayband hook from the base slot.
- (3) Install the new cord by reversing the procedures given in (1) and (2) above.

d. Ringer.

- (1) Note the network terminals to which the four ringer leads are connected.

- (2) Remove the ringer leads from the network terminals.
- (3) Back out the two captive mounting screws that attach the ringer frame to the frame mounting brackets until they clear the brackets.
- (4) Raise up the gong end of the ringer frame slightly and draw the ringer away from the switch bracket until the locating pin becomes free from the switch bracket grommet.
- (5) Replace the ringer by reversing the procedure given in (2) through (4) above.

e. Ringer Coil.

- (1) Note the network terminals to which the four ringer leads are connected and the position of the coil on the ringer core.
- (2) Remove the ringer leads from the network terminals.
- (3) Remove the two mounting screws that attach the laminated ringer core to the ringer frame.
- (4) Withdraw the core laminations from the coil spool.
- (5) Lift the coil from the frame.
- (6) Place the new coil in the frame in the exact position held by the removed coil.
- (7) Slide the core laminations through the center of the coil spool and arrange them so that the holes in the laminations are aligned and are in line with the ringer frame mounting holes.
- (8) Place the two core mounting screws and fasten them securely.
- (9) Connect the four ringer leads, according to color code, to the network terminals from which the replaced leads have been removed.

f. Ringer Mounting Bracket.

- (1) Remove the ringer from the set (d above).
- (2) Note that there are two mounting brackets and that they differ in design.
- (3) Remove the two rivets that attach the bracket to the base plate.
- (4) Place the new bracket in position, according to type; with two suitable rivets, attach the bracket to the base plate.
- (5) Replace and fasten the ringer.

g. Gongs.

- (1) A gong is mounted over an associated resonator and attached to a gong mounting post with a screw and washer.

- (2) There are two gongs. The movable gong, with the designation A stamped on its outer surface adjacent to its mounting hole, is mounted on the movable part of the ringer assembly directly above the ringer coil. The other gong (fixed) has the designation B. The gongs are not interchangeable.

h. Dial (fig. 41).

- (1) Note the network terminals to which the four dial leads are connected.
- (2) Remove the dial leads from the network terminals.
- (3) Back out the two diametrically opposite mounting screws about 2 turns and the remaining screw about 3 turns from the dial mounting bracket.
- (4) Raise the dial upward from the short bracket post, and withdraw the dial from the bracket.
- (5) Place the new dial in the mounting bracket, fasten it securely, and connect the dial leads to the same network terminals from which the replaced leads were removed.

i. Dial Protective Housing.

- (1) Remove the dial from the dial mounting bracket.
- (2) Withdraw the two housing mounting screws from the dial mounting plate.
- (3) Raise the housing straight away from the mounting plate.
- (4) Position the new housing, with the curved corner of the housing fitted closely to the curved corner of the dial spring block, the remainder of the open edge of the housing fitted to the block groove, and the mounting holes aligned with the dial plate mounting holes.
- (5) Replace the housing mounting screws and fasten them securely.
- (6) Replace the dial in its mounting bracket and fasten it securely.

j. Dial Spring Block.

- (1) Note the network terminals to which the four dial leads are connected.
- (2) Remove the dial leads from the network terminals.
- (3) Remove the dial from its mounting (h(3) and (4) above).
- (4) Remove the dial protective housing (i(2) and (3) above).

- (5) Note carefully the relative positions of the pawl finger with springs A and B (fig. 55).
- (6) Back out the two spring block fasteners until the block is detached from the dial mounting.
- (7) Rotate the finger wheel enough to cause the pawl finger to move to a position against the pawl-finger stop.
- (8) Lift the spring block upward from the dial mounting and in a slightly forward direction to prevent snagging the hook on spring B on the pawl finger stop.
- (9) Place the new spring block assembly with each of its components in its proper position, and fasten it securely to the dial mounting.
- (10) Spin the dial five times through its full travel distance and observe that its operation meets all requirements.
- (11) Replace the protective housing over the dial mechanism, replace the dial on its mounting, and fasten both securely. Check for the presence of the gasket tubing around the outer edge of the dial.
- (12) Connect the dial leads to the same network terminals from which the replaced leads were removed.

k. Dial Finger Stop.

- (1) Remove the dial from its mounting bracket.
- (2) Back out the finger stop fastening screw enough to release the stop.
- (3) Lift the finger stop away from the front face of the dial.
- (4) Place the new finger stop and fasten it securely.
- (5) Replace the dial on its mounting bracket and fasten it securely.

l. Dial Finger Wheel.

- (1) Remove the dial from its mounting bracket.
- (2) Remove the station number card holder assembly from the dial wheel.
- (3) Remove the dial finger stop (k(2) and (3) above).
- (4) With a suitable ⁷/₈-inch wrench, remove the finger wheel retaining nut from the dial shaft.

Caution: Hold down on the finger wheel while removing or loosening the finger-wheel nut to prevent the hub retainer from leaving the shaft; otherwise the hub assembly and motor spring may

jump out of their proper operating position, which would require a replacement of the dial.

- (5) Note that the cupped surface of the finger-wheel washer is placed against the finger wheel; then remove the washer.
- (6) Note the position of the 1 and 0 dial openings with respect to the rectangular, finger stop in the dial number plate. Then remove the finger wheel.
- (7) Place the new finger wheel on the shaft and reassemble the dial components by reversing the procedure for disassembly.

m. Dial Number Plate.

- (1) Remove the dial from its mounting bracket (h(3) and (4) above).
- (2) Remove the finger stop (k(2) and (3) above).
- (3) Remove the station number card assembly from the finger wheel.
- (4) Remove the finger wheel (1(4) through (6) above).
- (5) Remove the three mounting screws from the dial number plate.
- (6) Carefully note the position of the dial number plate on the dial mounting.
- (7) Lift the number plate away from the dial mounting.
Place the new number plate on the dial mounting in the same position as that previously occupied by the replaced plate.
- (9) Place and secure the number plate mounting screws.
- (10) Reassemble the dial components by reversing the disassembly procedure.

n. Dial Mounting Bracket.

- (1) Remove the dial from its mounting bracket.
- (2) Remove the three fastening rivets that attach the bracket to the base plate.
- (3) Place and rivet the new bracket to the base plate.
- (4) Replace and fasten the dial on the bracket.

o. Switch Protective Housing.

- (1) With the finger and thumb, press inward on the sides of the housing.
- (2) Withdraw the bottom end of the housing away from the switch assembly.
- (3) Remove the housing.
- (4) When replacing the housing, insert the vertical surface of the angular tang component of the housing into the slot in the

switch assembly bracket, adjacent to the top end of the switch assembly.

- (5) With the finger and thumb, press inward on the sides of the housing, and guide the housing into place in the switch assembly bracket.

p. Switch Assembly.

- (1) Remove the dial from its mounting.
- (2) Note the network terminals to which the seven switch leads are connected.
- (3) Disconnect or unsolder, as required, these leads at the network terminal board.
- (4) Remove the three fastening rivets that attach the assembly to the base plate.
- (5) Position the new switch assembly, and rivet it fast to the base plate.
- (6) Connect or solder the switch leads to the same terminals as were occupied by the removed leads.
- (7) Replace the switch protective housing (o(4) and (5) above).

q. Network Assembly.

- (1) Remove the dial from its mounting bracket.
- (2) Disconnect or unsolder, at the network terminal board, all wires and leads that terminate at the board.
- (3) Remove the three rivets that attach the network assembly to the base plate.
- (4) Remove the assembly.
- (5) Place the new assembly, and rivet it fast to the base plate.
- (6) Reconnect all wires and leads, previously removed or unsoldered, at the terminal board (fig. 67).
- (7) Replace the dial on its mounting bracket and fasten it securely.

r. Replacement of Station Dial with Dial Blank (fig. 34).

- (1) Remove the dial as outlined in h(2) through (4) above.

- (2) Transfer the GY-WH switch lead from terminal F to terminal RR at the network terminal board.

- (3) Place the dial blank in the space in the housing assembly previously occupied by the dial.

- (4) Invert the housing and adjust the blank until the barb of the arrow points toward the front of the housing. The arrow and the word FRONT are molded on the inside surface of the blank.

- (5) Place the dial-blank mounting clamp inside the housing, with its flanged surface toward the dial blank and with the circular section of each mounting hole directly over the heads of the mounting screws.

- (6) Pass the mounting clamp down and over the screw heads and adjust the clamp until its two locating ears fit into the two slots in the bead that circles the edge of the dial opening in the housing assembly.

- (7) While holding the assembly in the secured position, rotate the dial blank until the screw shanks prevent any further rotation of the blank.

- (8) Tighten the two screws securely.

- (9) Place the station number card assembly on the dial blank.

s. Friction Pad.

- (1) Release the pad from the base plate by removing the single rivet that attaches the pad to the plate.

- (2) Place the new pad in position with its two bosses aligned with the two small holes in the base plate.

- (3) With a suitable rivet, secure the pad to the plate.

Note. Observe that the dimensions of the rivet used to attach the friction pad (.166 inch in diameter by Ci-inch long) do not match the rivet used to attach the other rivet-attached set components, which are .136 inch in diameter by W)-inch long.

Section IV. FINAL TESTING

78. General

After completing all troubleshooting and repairs and adjustments, the telephone set should be final-tested to determine that it is in good working order. Final testing is divided into two parts-visual examination and performance testing.

79. Visual Examination

a. Wiring.

- (1) Examine all connections for tightness.
- (2) Examine all splices for adequate strength and proper insulation.

- (3) Check all new internal wiring for excessive length as compared to old wiring.
- (4) Check all new inside wiring to be certain that there are no points where wearing of insulation or straining of wiring will occur.

b. Internal Components.

- (1) Check all new parts for tightness of mounting.
- (2) Check all leads for proper termination.
- (3) Make certain that no small pieces of insulation, wiring, or solder have fallen between the ringer armature and the coils.

80. Performance Testing

There is only one test for proper performance of the telephone set. The telephone must be tested under actual operating conditions.

a. Remove the handset from the cradle. Note if the dial tone is received or the operator answers.

b. Dial or call the number of the test desk or test board.

c. Note if transmission and reception are satisfactory.

d. Instruct the test man to ring on the line and replace the handset on the cradle.

e. Note if the ringing signal is of satisfactory audibility.

CHAPTER 5

SHIPMENT AND LIMITED STORAGE AND DEMOLITION TO PREVENT ENEMY USE

81. Removing from Service

- a. Remove the line fuses from the substation protector.
- b. Remove the cover from the connector block.
- c. Disconnect the inside house wire from the connector block and unscrew the block from its mounting.
- d. Replace the cover on the connector block. Leave the deskstand cord fastened inside the connector block to prevent loss.
- e. With the handset in the cradle, wrap the handset and deskstand cord neatly around the base of the telephone and the handset.

82. Repacking

Note. The circumstances involved in shipment and storage vary. The following instructions are recommended as a guide for preparing a common battery telephone for transportation and storage. Whenever possible, use the original packaging materials.

- a. Cushion the telephone on all surfaces with some type of cushioning material such as cell material, pads fabricated of corrugated fiberboard, or excelsior. This will absorb the shock of impact normally encountered in handling and during transit.
- b. If possible, place a dehydrating agent, such as silica gel, inside the cushioning material.
- c. Place the cushioned equipment in a close-fitting corrugated fiberboard box. Seal the entire closure with gummed paper tape. Blunt the corners of the box.
- d. Place the boxed equipment in a water

vaporproofed barrier. Extract the air and heat-seal the barrier.

- e. Place the barrier-wrapped box in a second close-fitting corrugated fiberboard box. Seal the box with water-resistant tape or adhesive.

83. Methods of Destruction

The demolition procedures outlined below will be used to prevent the enemy from using or salvaging the equipment. Demolition of the equipment will be accomplished only upon order of the commander.

a. *Smash.* Smash the handset shell and the transmitter and receiver units. Smash the housing assembly, capacitors, induction coil, dial, hookswitch, connector block, hand generator (EE-91), and the ringer; use sledges, axes, handaxes, pickaxes, hammers, crowbars, or other heavy tools.

b. *Cut.* Cut handset cord, deskstand cord, internal wiring, and spring terminals in the transmitter and receiver mounting; use axes, handaxes, diagonal pliers, side-cutting pliers, or machetes.

c. *Burn.* Burn the plastic housing assembly, wiring, ringer coils, induction coil, handset cord, deskstand cord, and handset shell; use gasoline, kerosene, oil, flame throwers, or incendiary grenades.

d. *Explosives.* If explosives are necessary, use firearms, grenades, or TNT.

e. *Disposal.* Bury or scatter the destroyed parts in slit trenches, foxholes, or other holes in the ground, or throw them into streams.

f. *Destroy.* Destroy everything.

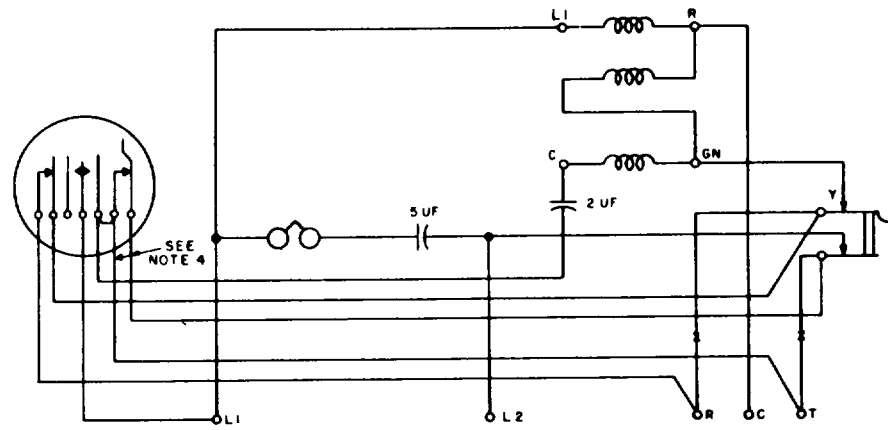

NOTES

1. JUMPERS MARKED X NOT CONNECTED WHEN DIAL IS USED.
2. HOOKSWITCH SHOWN WITH HANDSET REMOVED FROM CRADLE.
3. Y CONTACTS OF HOOKSWITCH MAKE LAST.
4. STRAP LEADS WHEN DIAL IS NOT USED.

A

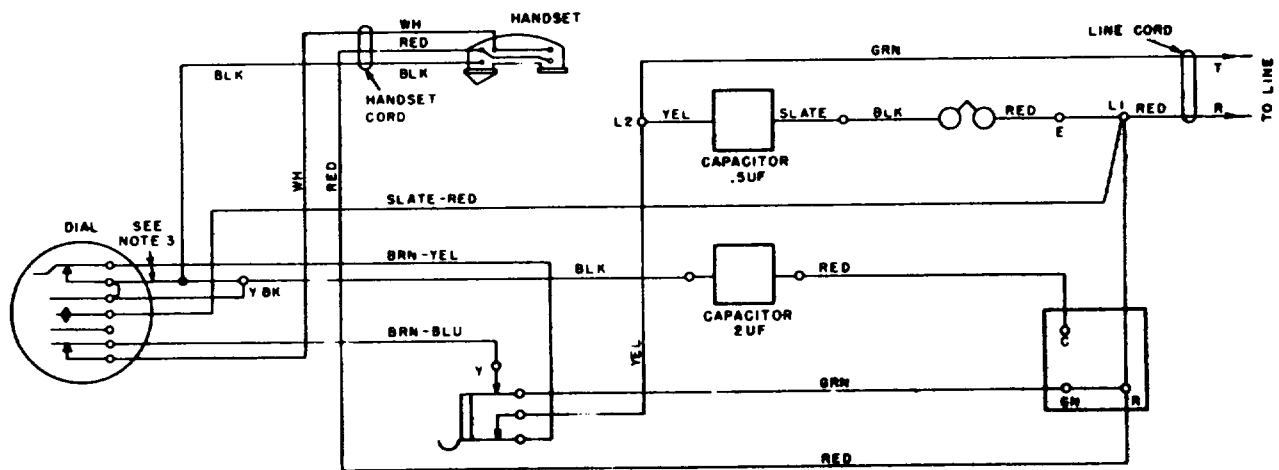

NOTES:

1. HOOKSWITCH SHOWN WITH HANDSET REMOVED FROM CRADLE
2. Y CONTACTS OF HOOKSWITCH MAKE LAST.
3. STRAP LEADS WHEN DIAL IS NOT USED

B

TM 468-63

Figure 90. Telephone TP-6 (WECo. 302AW-3), schematic (A) and wiring (B) diagram.

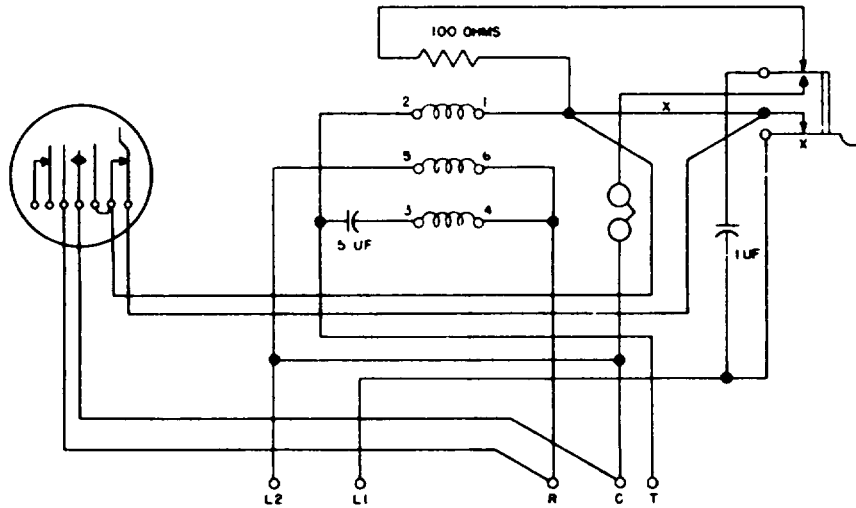

- NOTES
- 1 JUMPERS MARKED X NOT CONNECTED WHEN DIAL IS USED.
 - 2 HOOK SWITCH SHOWN WITH HANDSET REMOVED FROM CRADLE.
 - 3 X CONTACTS BREAK FIRST AND MAKE LAST.

A

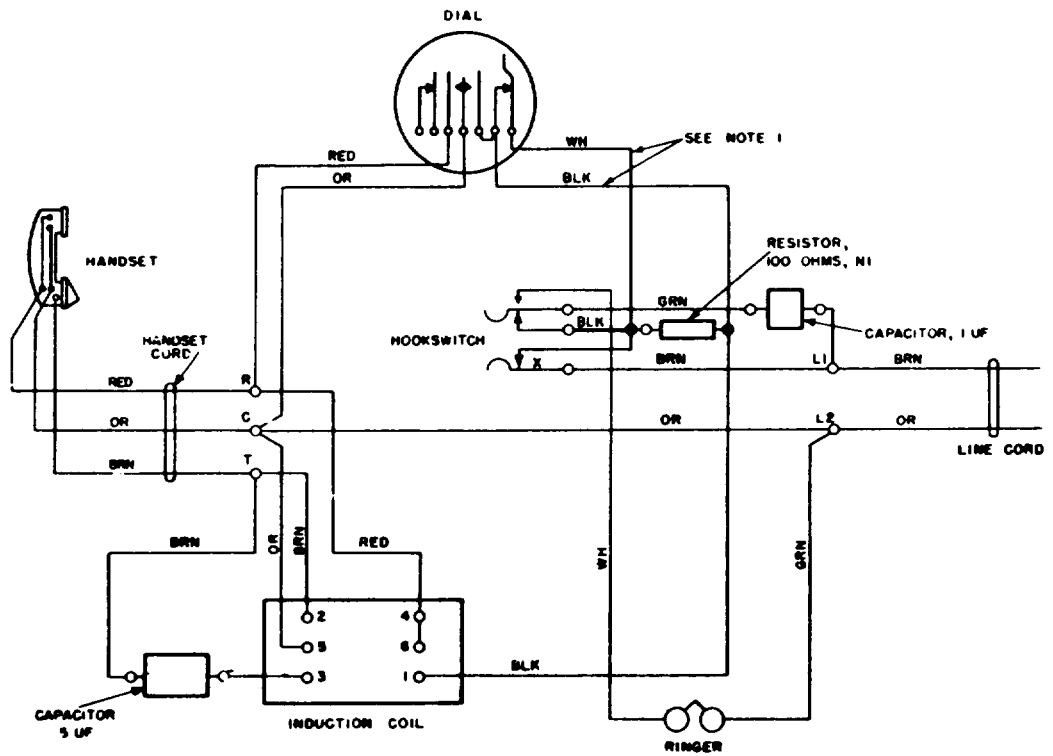

- NOTES:
1. STRAP LEADS WHEN DIAL IS NOT USED.
 2. X CONTACTS BREAK FIRST AND MAKE LAST

8
TM 468-64

Figure 91. Telephone TA-101/FTC (Auto Elec 40), schematic (A) and wiring (B) diagrams.

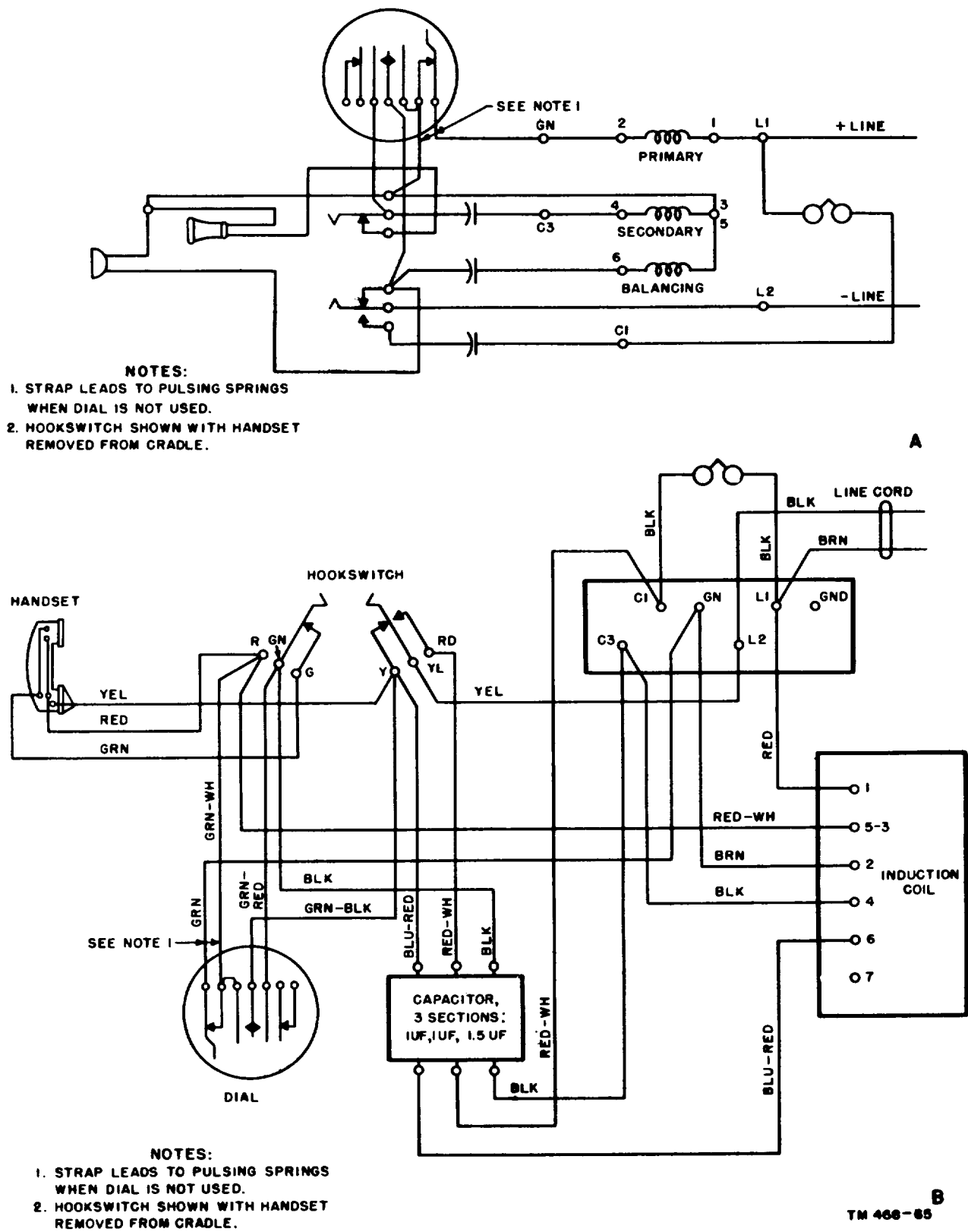
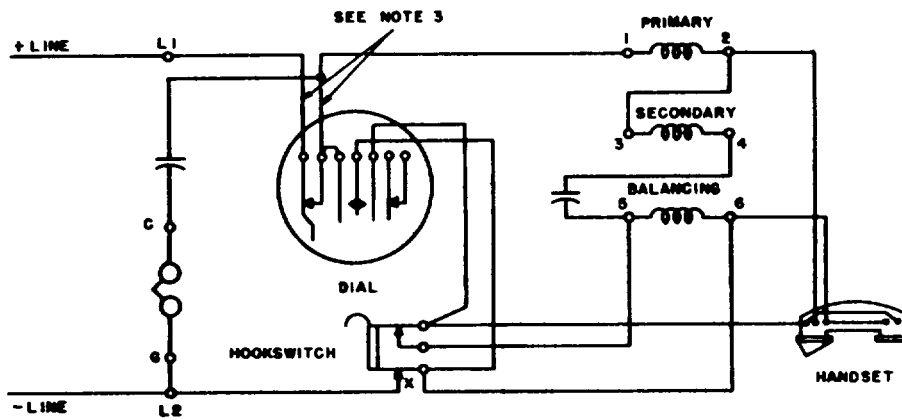
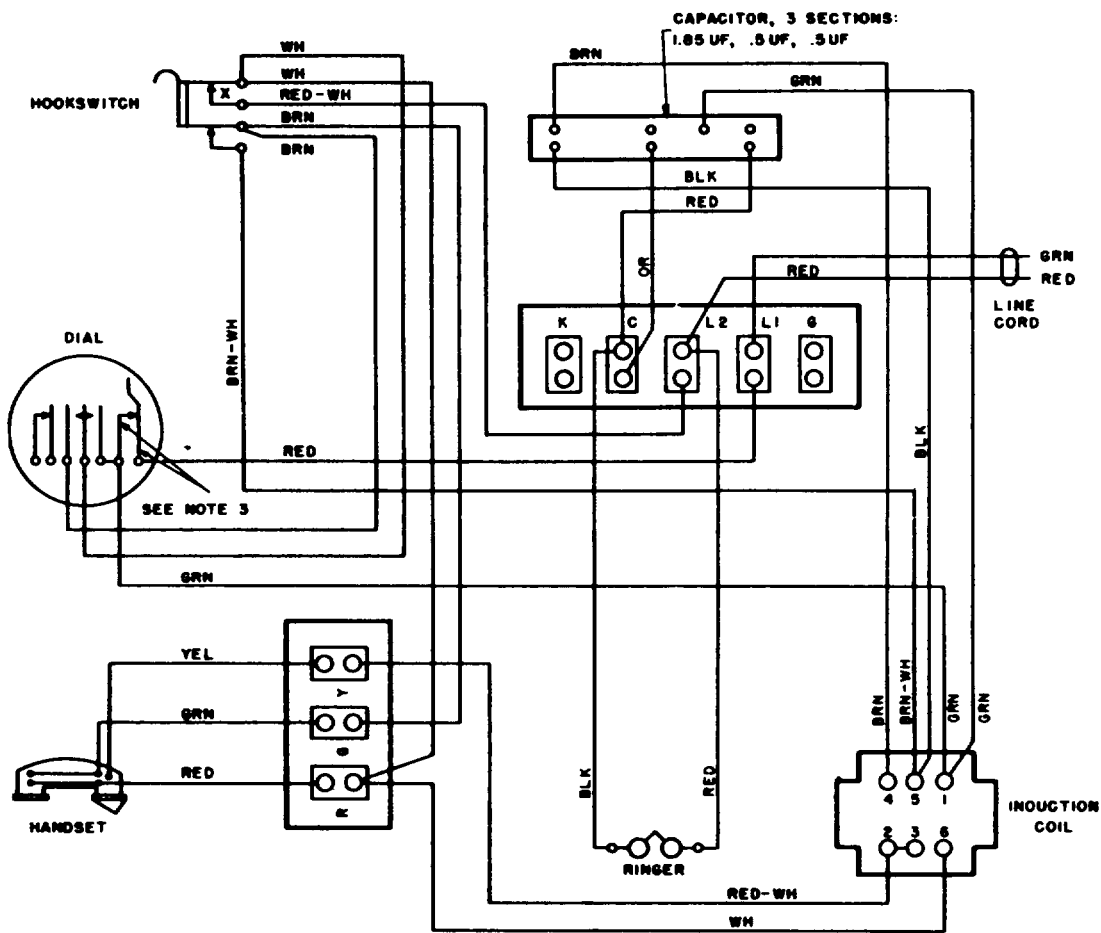

Figure 92. Telephone TA-LOS/FTC (Kellogg 9 BAX). schematic (A) and wiring (B) diagrams.



- NOTES:**
1. HOOKSWITCH SHOWN WITH HANDSET REMOVED FROM CRADLE
 2. X CONTACTS OF HOOKSWITCH MAKE FIRST.
 3. STRAP THESE LEADS WHEN DIAL IS NOT USED.

A



- NOTES:**
1. HOOKSWITCH SHOWN WITH HANDSET REMOVED FROM CRADLE.
 2. X CONTACTS OF HOOKSWITCH MAKE FIRST.
 3. STRAP THESE LEADS WHEN DIAL IS NOT USED.

B

TM 468-66

Figure 98. Telephone TA-113/FTC (St Carl 1222 BW), schematic (A) and wiring (B) diagrams.

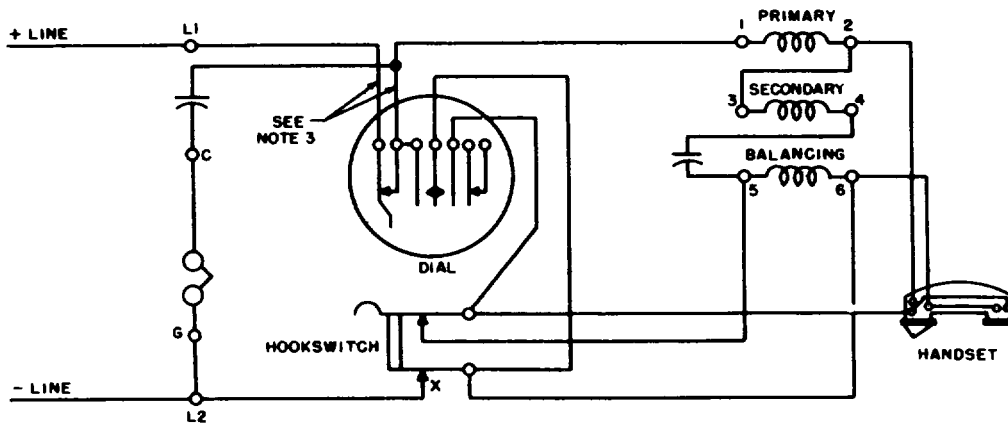

- NOTES:**
1. HOOKSWITCH SHOWN WITH HANDSET REMOVED FROM CRADLE.
 2. X CONTACTS OF HOOKSWITCH MAKE FIRST.
 3. STRAP THESE LEADS WHEN DIAL IS NOT USED.

A

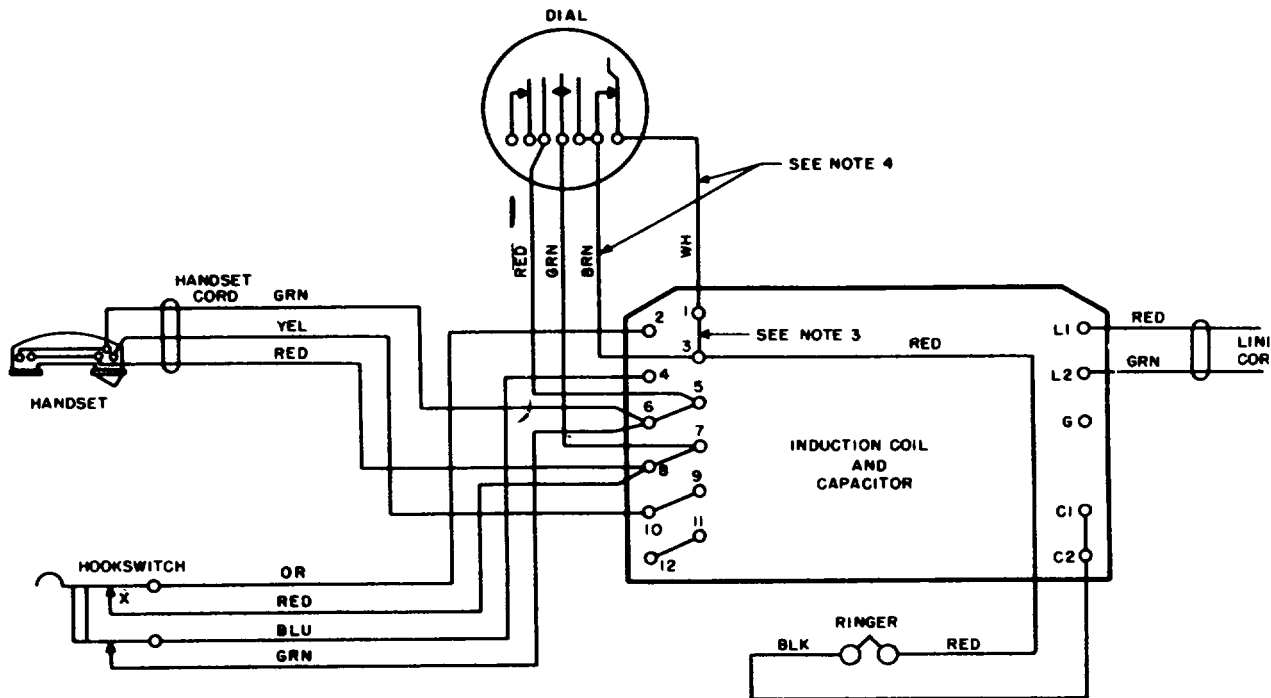

- NOTES:**
1. HOOKSWITCH SHOWN WITH HANDSET REMOVED FROM CRADLE.
 2. X CONTACTS OF HOOKSWITCH MAKE FIRST.
 3. REMOVE STRAP WHEN DIAL IS USED.
 4. STRAP THESE LEADS WHEN DIAL IS NOT USED.

B
TM 468-67

Figure 94. Telephone TP-6 (St Carl 1242 WA), schematic (A) and wiring (B) diagrams.

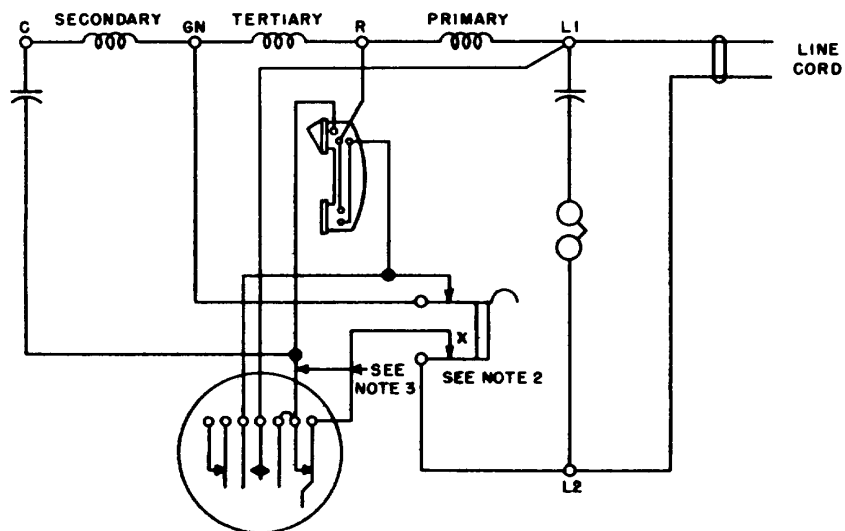

- NOTES:**
1. HOOKSWITCH CONTACTS SHOWN WITH HANDSET REMOVED FROM CRADLE.
 2. X CONTACTS MAKE FIRST AND BREAK LAST.
 3. STRAP THESE LEADS WHEN DIAL IS NOT USED.

A

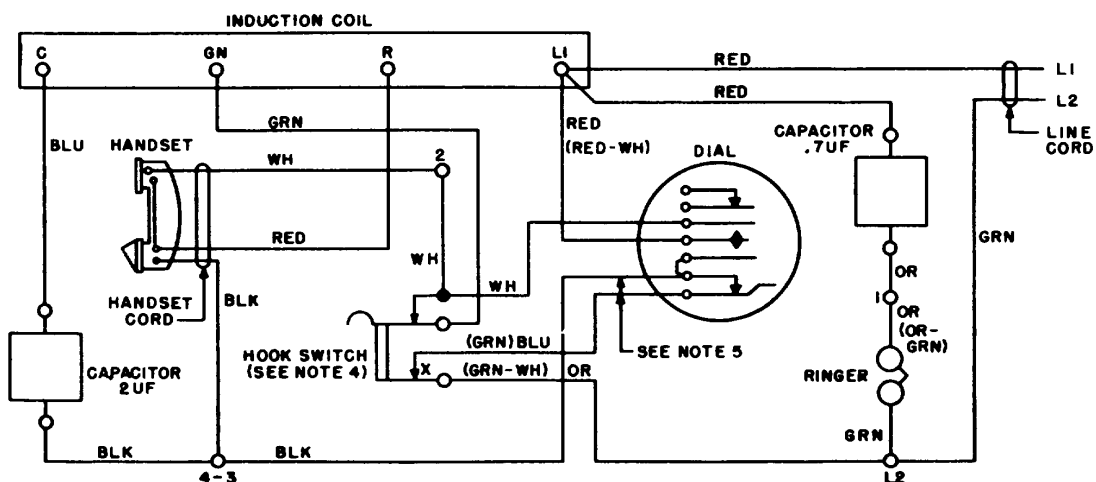

- NOTES:**
1. HOOKSWITCH CONTACTS SHOWN WITH HANDSET REMOVED FROM CRADLE.
 2. TERMINALS 1 THROUGH 5 ARE ON TERMINAL BOARD; OTHER TERMINALS ARE ON INDUCTION COIL.
 3. COLORS SHOWN IN BRACKETS ARE USED ON EARLIER MODELS.
 4. X CONTACTS MAKE FIRST AND BREAK LAST.
 5. STRAP THESE LEADS WHEN DIAL IS NOT USED.

B

TM 468-66

Figure 96. Telephone TP-6 (North Elec. MFG 3H4SL and H-600SL), schematic (A) and wiring (B) diagrams.

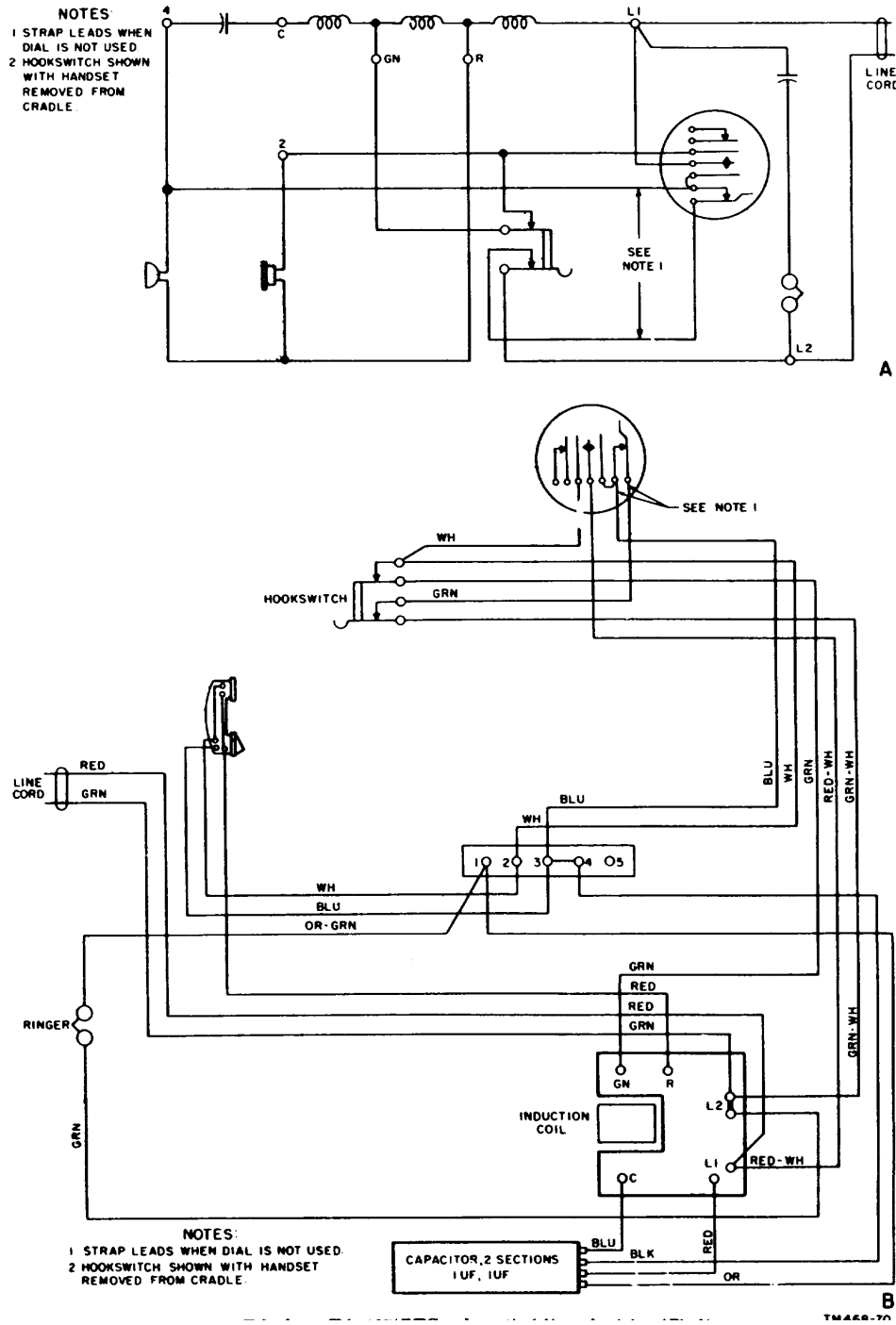
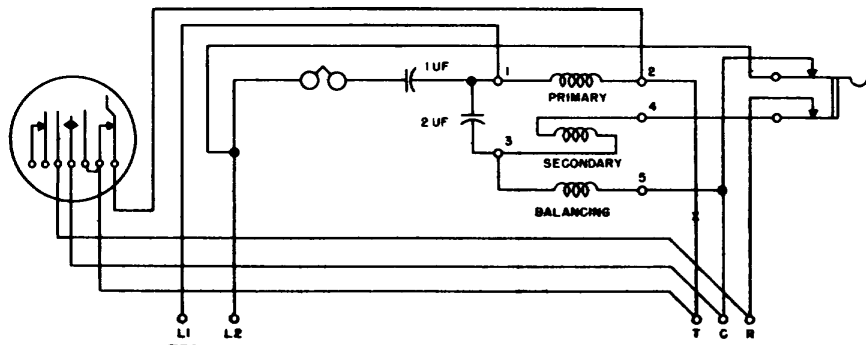
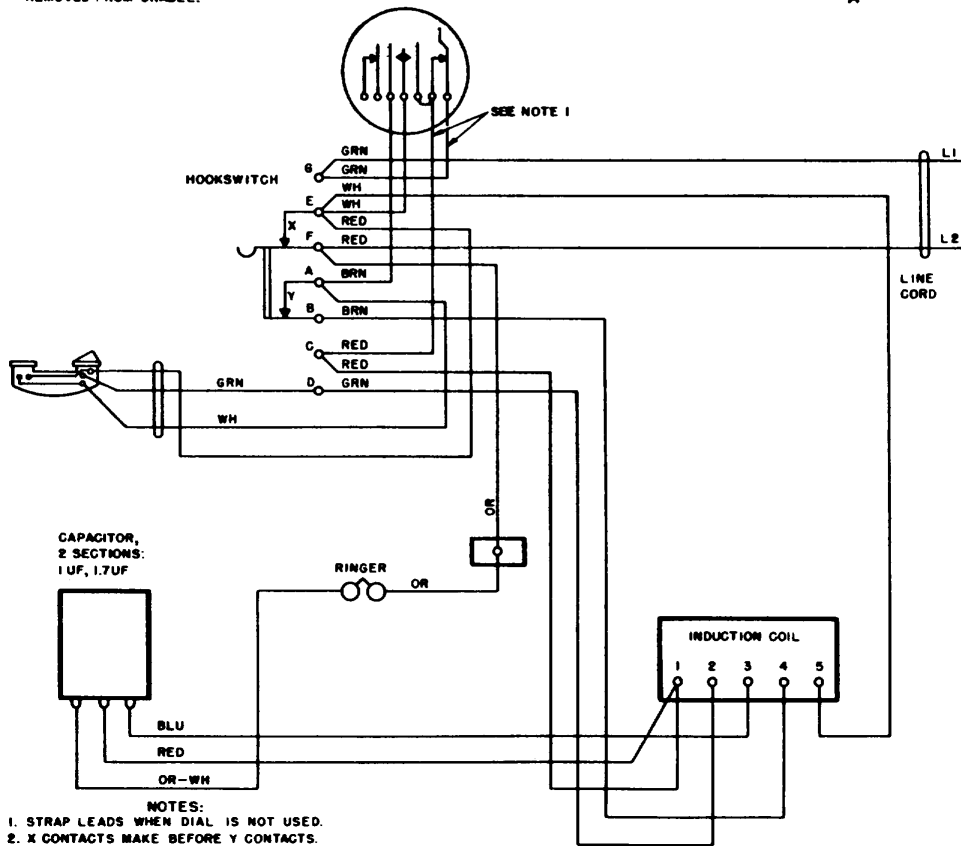

Figure 96. Telephone TA-107/FTC, schematic (A) and wiring (B) diagrams.



- NOTES:
1. JUMPER MARKED X NOT CONNECTED WHEN DIAL IS IN USE.
 2. HOOKSWITCH SHOWN WITH HANDSET REMOVED FROM GRADLE.

A



- NOTES:
1. STRAP LEADS WHEN DIAL IS NOT USED.
 2. X CONTACTS MAKE BEFORE Y CONTACTS.
 3. HOOKSWITCH SHOWN WITH HANDSET REMOVED FROM GRADLE.

B

TM 468-71

Figure 97. St. Carl 1212 ABZ telephone, schematic (A) and wiring (B) diagrams.

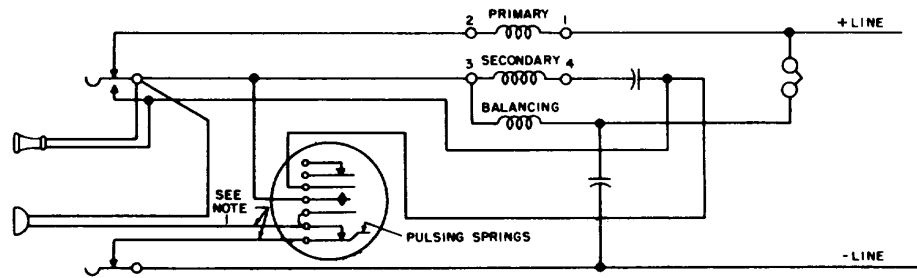

- NOTES:
 1. STRAP LEADS WHEN DIAL IS NOT USED
 2. HOOKSWITCH SHOWN WITH HANDSET REMOVED FROM CRADLE

A

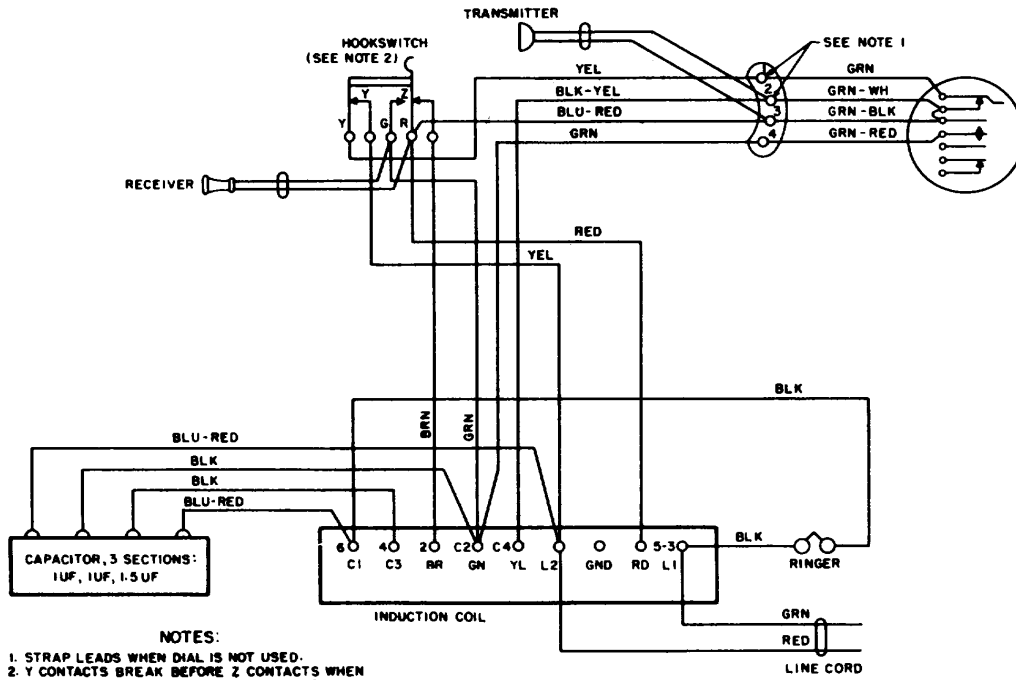

- NOTES:
 1. STRAP LEADS WHEN DIAL IS NOT USED.
 2. Y CONTACTS BREAK BEFORE Z CONTACTS WHEN THE RECEIVER IS PLACED ON HOOKSWITCH.
 3. HOOKSWITCH SHOWN WITH HANDSET REMOVED FROM CRADLE.

B
 TM 468-72

Figure 98. Telephone TA-105/FTC, schematic (A) and wiring (B) diagrams.

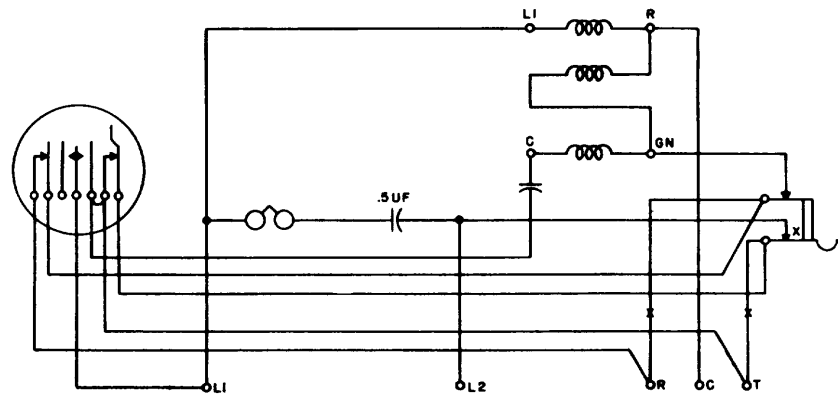

- NOTES:**
1. JUMPERS MARKED X NOT CONNECTED WHEN DIAL IS USED.
 2. HOOKSWITCH SHOWN WITH HANDSET REMOVED FROM CRADLE.
 3. X CONTACTS OF HOOKSWITCH MAKE FIRST.

A

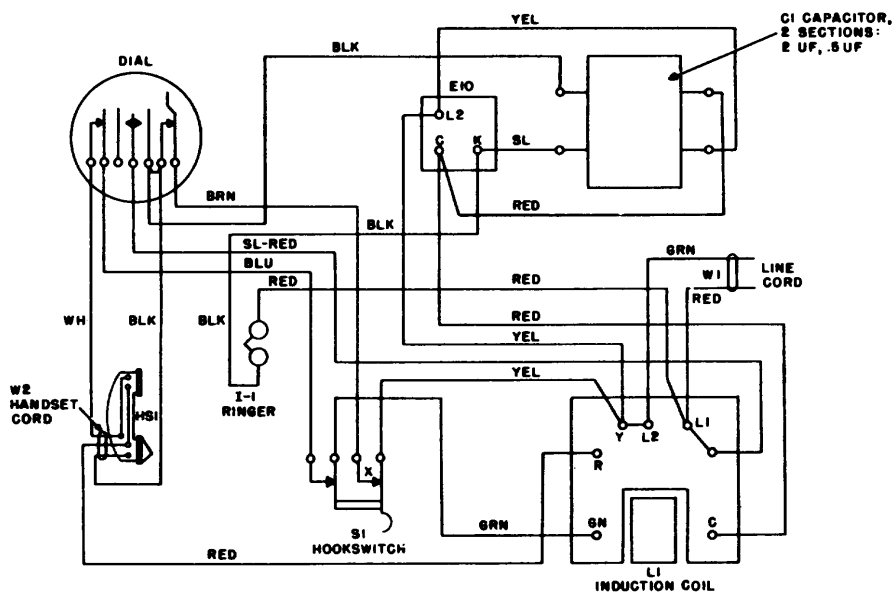

1. X CONTACTS OF HOOKSWITCH MAKE FIRST.
2. WHEN DIAL IS NOT USED, TIE BLK, BLK AND BRN LEADS TOGETHER AND TIE WH AND BLU LEADS TOGETHER.
3. HOOKSWITCH SHOWN WITH HANDSET REMOVED FROM CRADLE.

B

TM 468-73

Figure 99. Telephone TA-166/U (dial operation), schematic (A) and wiring (B) diagrams.

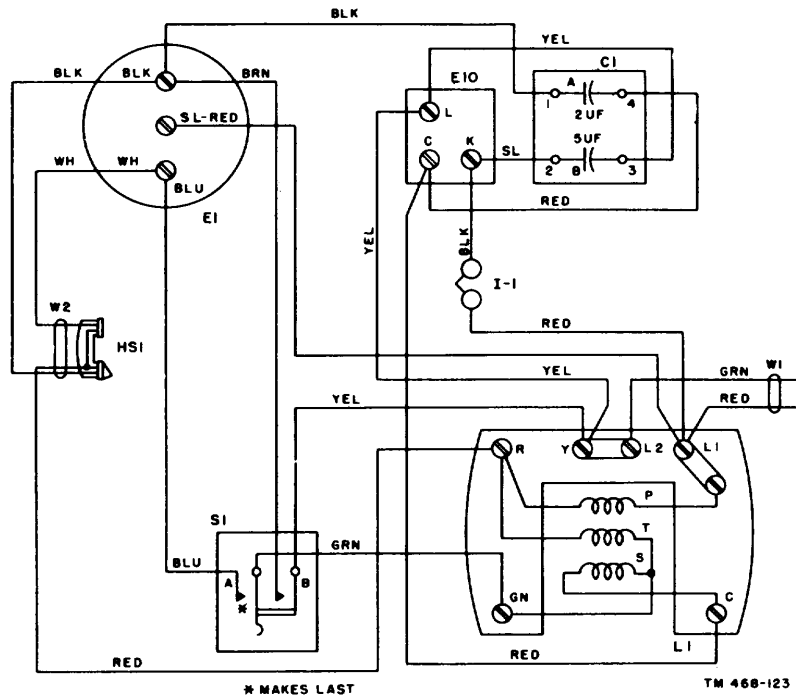

Figure 100. Telephone TA-168/U (manual operation), wiring diagram.

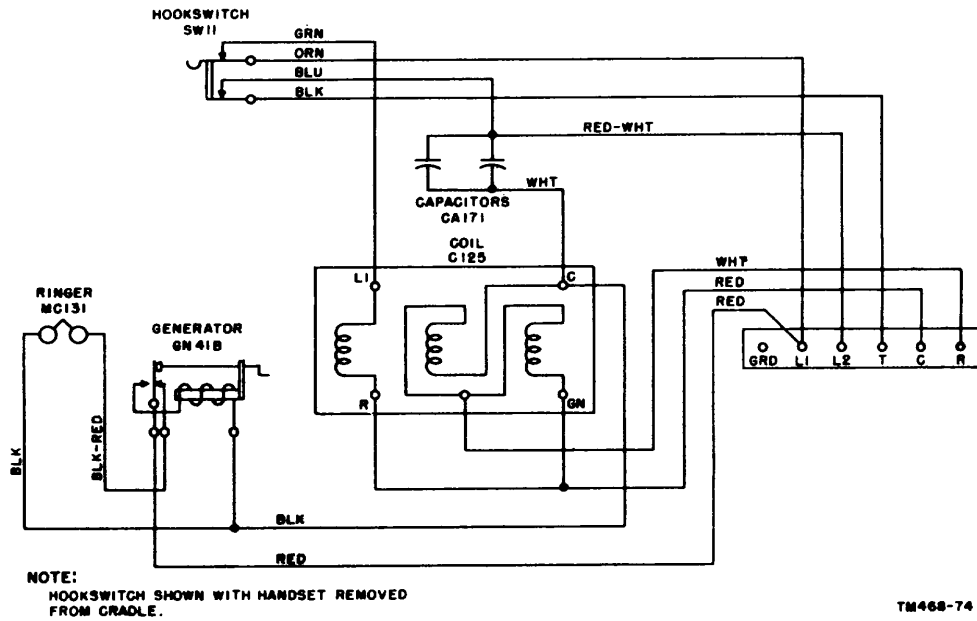

Figure 101. Wiring diagram for Telephone Box EE-91.

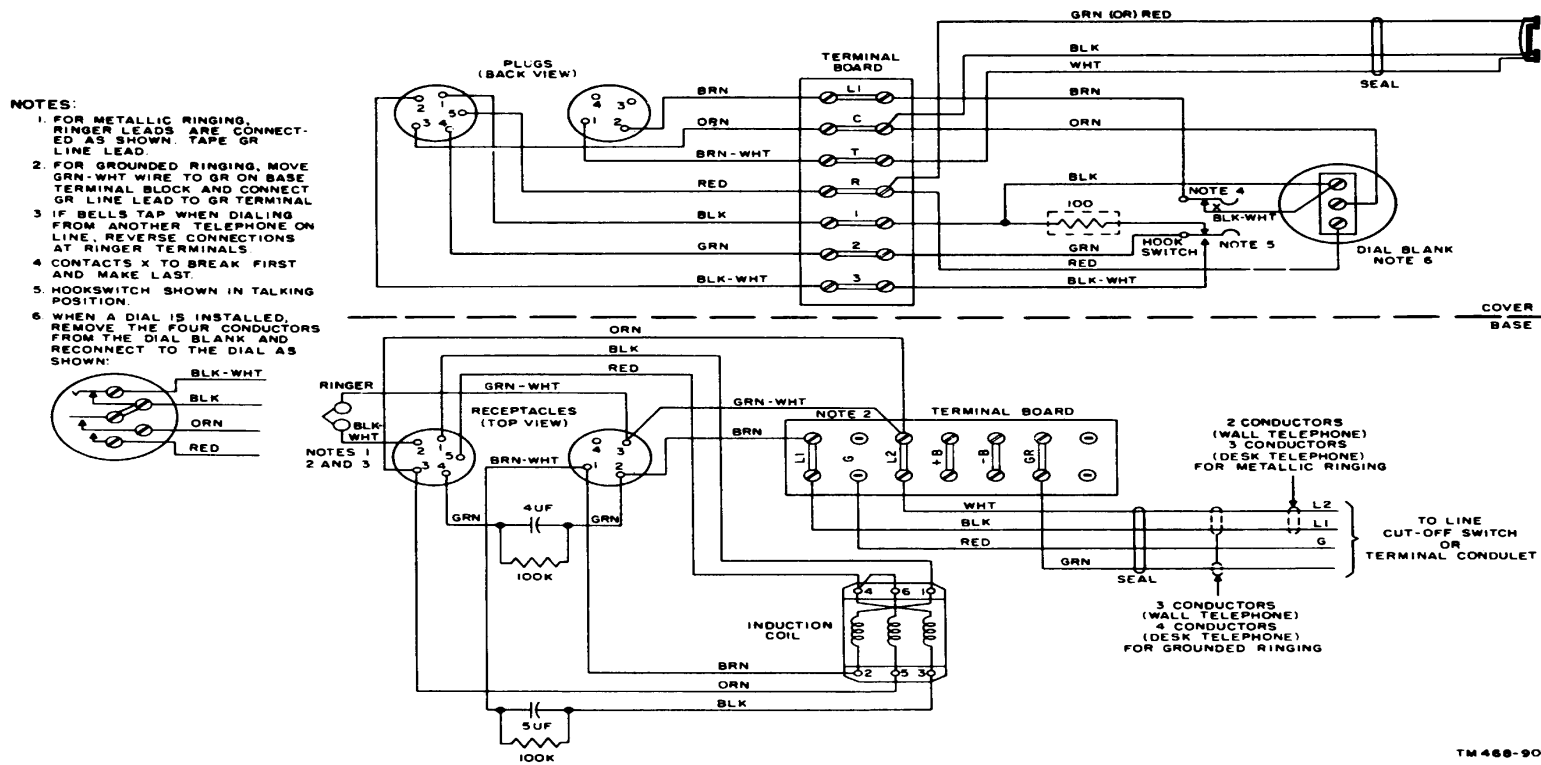

Figure 102. Telephone TA-212/U, wiring diagram.

NOTES:

1. FOR METALLIC RINGING, RINGER LEADS ARE CONNECTED AS SHOWN.
2. FOR GROUNDED RINGING, MOVE GRN-WHT WIRE TO GR ON BASE TERMINAL BLOCK.
3. FOR COMMON-BATTERY TALKING, REMOVE BATTERY FROM BATTERY BOX, FOLD BACK LUGS ON BATTERY LEADS AND INSULATE. REMOVE BRN AND GRN-WHT LEADS FROM GENERATOR, FOLD BACK LUGS AND INSULATE. CONNECT JUMPER BETWEEN TERMINALS B+ AND L2 ON BASE TERMINAL BLOCK.
4. CONTACTS X TO BREAK FIRST AND MAKE LAST.
5. SPRINGS SHOWN IN TALKING POSITION.

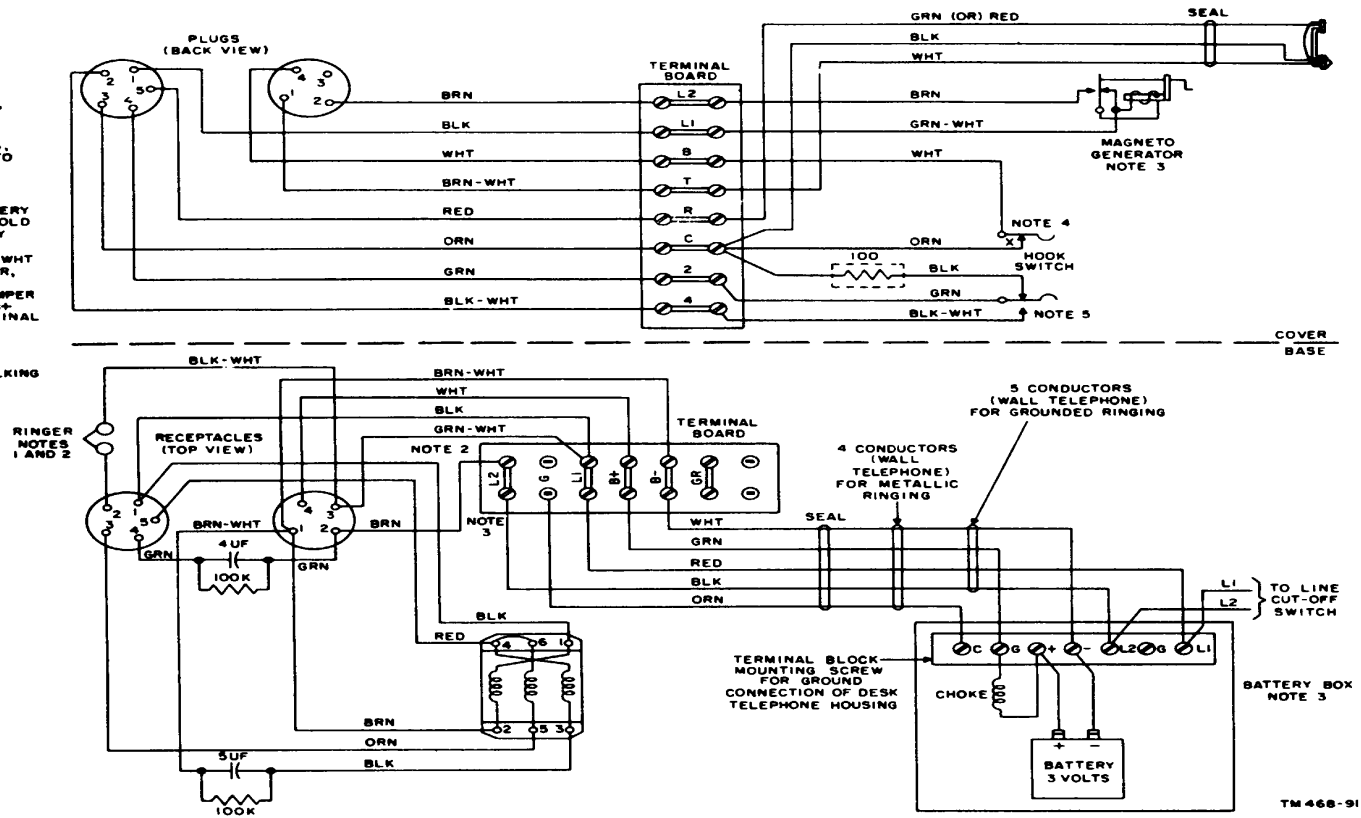

Figure 103. Telephone TA-213/U, wiring diagram.

INDEX

Adjustments:	<i>Para- graph</i>	<i>Page</i>	Description-Continued	<i>Para- graph</i>	<i>Page</i>
Dial, TA-236/FT.....	63c	79	Receiver, TA-236/FT.....	10e	25
Dial, TA-45(*)/GT.....	63b	79	Ringer, TA-236/FT.....	10f	25
Hookswitch.....	66	83	Set components, TA-236/FT.....	10	24
Ringer, TA-236/FT.....	65	81	St. Carl 1212ABZ telephone.....	3d	11
Ringer, TP-6.....	64	79	Switch assembly, TA-236/FT.....	10i	31
Antisidetone circuit:			Telephone:		
TA-236/FT.....	- 38	51	TA-107/FTC.....	3c	11
TP-6-A.....	21	41	TA-166/U.....	5	13
Base plate assembly,			TA-212/U.....	11	31
scription.....	10b	24	TA-213/.....	12	33
Bell box, description.....	13	33	TP-6-A.....	3b	11
Blocks:			Telephone Box EE-91.....	6	13
Connecting.....	14	35	Telephone Set TA-105/FTC.....	4	11
Protector.....	15c	37	Telephone Set TA-236/FT.....	9	16
Bridle wire, opens.....	57d	73	Transmitter, TA-236/FT.....	10d	24
Build-ups and pits, contacts.....	68	84	Desk-type telephones.....	3	3
Build-ups on contacts.....	68b	84	Destruction, methods.....	83	93
Burnishing, contact.....	70	85	Dial:		
Capacitors, testing, TP-6-A.....	53	68	TA-45(*)/GT, description.....	8	15
Chart, Troubleshooting:			TA-45/GT, lubrication.....	45b	59
TA-236/FT.....	48b	63	TA-45B/GT, lubrication.....	45c	59
TP-6-A.....	48a	61	TA-236/FT, description.....	10g	29
Circuit:			TA-236/FT, theory.....	24	42
Antisidetone, TP-6A.....	21	41	Testing.....	63a	79
Ringing, TP-6-A.....	20	41	Dial adjusting:		
Transmitter and receiver, TP-6-A.....	19	40	Dial, TA-45(*)/GT.....	63b	79
Cleaning.....	42e	58	Dial, TA-236/FT.....	63c	79
Cleaning switch contacts.....	69	85	Dial escutcheon, replacement.....	76	87
Clearing shorts.....	58c	74	Dialing circuit, TA-236/FT:		
Components, TA-236/FT.....	10	24	Schematic.....	36	50
Connecting blocks.....	14	35	Wiring.....	37	50
Contacts:			Dropwire:		
Build-ups.....	68b	84	Opens.....	57d	73
Burnishing.....	70	85	Preventive maintenance.....	42a	55
Maintenance.....	67	84	Equalizer, theory.....	25d	43
Pitted.....	68a	84	Equipment, Tool:		
Switch, cleaning.....	69	85	TE-33.....	39a	53
Continuity test:			TE-49.....	39b	53
TA-236/FT.....	61	77	TE-73.....	39c	53
Telephone, general.....	49	65	Examination, visual.....	79	91
TP-6-A.....	50	66	Fault location.....	46-61	60-77
Crosses			Faults, line, location.....	56	72
Line.....	60	77	Forms.....	2	3
Telephone set.....	55	70	Fuses, protector.....	15e	37
Description:			Ground lead, opens.....	57c	73
Baseplate assembly, TA-236/FT.....	10b	24	Handsets:		
Bell box.....	13	33	Description.....	8	15
Dial, TA-236/FT.....	10g	29	TA-236/FT.....	10c	24
Dial, TA-45(*)/GT.....	8	15	TP-6.....	8b	15
Handset:			TS-12-F.....	8a	15
TA-236/FT.....	10c	24	Hookswitch adjustments.....	66	83
TP-6 type.....	7b	15	Inside wire, opens.....	57d	73
TS-12-F.....	7a	15	Inside wiring, preventive maintenance's.....	42c	55
Network, TA-236/FT.....	10h	31	Instructions, lubricating.....	45	58

Line:	Para- graph	Page	Ringer circuit:	Para- graph	Page
Crosses	60	77	TA-236/FT, theory	28	46
Faults	56	72	TP-6-A, testing	52	68
Opens	57	72	TP-6-A, theory	20	41
Opens, locating	576	72	Ringer, TA-236/FT:		
Shorts	58	73	Description	10f	25
Locating crosses, TP-6A	55	70	Theory	26	46
Locating line faults	56	72	Service, removing from	81	93
Locating line faults	56	72	Set components, TA-236/FT	10	24
Lubricants	44	58	Short-circuits, telephone sets, test	54	68
Lubricating instructions	45	58	Shorts, line	58	73
Lubricating instructions	45	58	Substation protectors	15	37
Lubrication:			Switch contacts, cleaning	69	85
Lubrication:			Switch, TA-236/FT, description	10i	31
Dial, TA-45/GT	45b	59	Telephone Box E-91, description	6	13
Dial, TA-45B/GT	45c	59	Telephone, description:		
General	43	58	St. Carl, 121.2 ABZ	3d	11
Maintenance:			TA-107/FTC	3	11
Contact	67	84	TA-166/U	5	13
Preventive, definition	41	54	TA-166/U	5	13
Preventive, definition	41	54	TP-6	3a	3
Preventive techniques	42	55	Theory	16	40
Methods of destruction	83	93	Telephone set:		
Network assembly, TA-236/FT:			-Continuity test	49	65
Description	10h	31	Desk-type, description	3	3
Theory	25	43	Opens	51	68
Opens:			Preventive maintenance	42d	55
Line	57	72	Short-circuit tests	54	68
Telephone sets	51	68	Telephone Set TA-236/FT:		
Performance testing	80	92	Antisidetone circuit	38	51
Pits, build-ups and	68	84	Continuity test	61	77
Pitted contacts	68a	84	Description	9	16
Pitted contacts, burnishing	71	85	Dial, theory of	24	42
Preventive maintenance, definition	41	54	Dialing circuit, schematic	36	50
Preventive maintenance techniques:			Dialing circuit, wiring	37	50
Drop wire	42a	55	Network assembly, theory	25	43
Inside wire	42c	55	Receiver circuit:		
Protectors	426	55	Dial schematic	33	49
Telephone set	42d	55	Dial wiring	35	49
Protectors:			Manual schematic	32	48
AR-6 and AR-6-A	15b	37	Manual wiring	34	49
Blocks	15c	37	Theory	23	42
Fuses	15e	37	Replacement procedures	77	88
Preventive maintenance	426	55	Ringer adjustment	65	81
Receiver circuit, TA-236/FT:			Ringer circuit, theory	28	46
Dial, schematic	33	49	Ringer, theory	26	46
Dial, wiring	35	49	Transmitter circuit:		
Manual, schematic	32	48	Dial, wiring, theory	31	48
Manual, wiring	34	49	Manual, schematic, theory	29	46
Receiver, TA-236/FT, description	10e	25	Manual, wiring, theory	30	47
Receiver, TA-236/FT, theory	23	42	Transmitter, theory	22	42
Removing from service	81	93	Telephone Set TA-212/U, description	11	31
Repacking	82	93	Telephone Set TA-213/U, description	12	33
Repair:			Telephone TP-6-A:		
General	72	85	Continuity testing	50	66
Special precautions	73	85	Cross	55	70
Wiring	74	86	Description	36	11
Replacement:			Opens	51	68
Dial escutcheon	76	87	Replacement procedures	75	86
Procedures for TA-236/FT	77	88	Ringer circuit. Testing	52	68
Procedures for TP-6 type	75	86	Short-circuit tests	54	68
Ringer adjustments:			Testing capacitors	53	68
TA-236/FT	65	81	Theory	18-21	40,41
TP-6	64	79			

	<i>Para</i>	Page		<i>Para</i>	Page
Testing:	graph		Trouble:	graph	
Capacitor., TP-6-A.....	53	68	Considerations.....	47	60
Continuity, TA-236/FT.....	61	77	Shooting.....	46-61	60-77
Dial.....	63a	79	Types.....	46	60
Performance.....	80	92	Troubleshooting:		
Test Set TS-190/U.....	40	54	Chart, TA-236/FT.....	48b	63
Tool equipment:.....			Chart, TP-6-A.....	48a	61
TE-33.....	39a	53	Procedures.....	47	60
TE-49.....	39b	53	Varistor, TA-236/FT:		
TE-73.....	39c	53	Theory:		
Transmitter circuit, TA-236/FT:.....			CR-1.....	25b	43
Dial, wiring, theory.....	31	48	CR-2.....	25a	43
Manual, schematic, theory.....	29	46	CR-3.....	25c	43
Manual, wiring, theory.....	30	47	Visual examination.....	79	91
Transmitter, receiver circuit, TP-6-A.....	19	40	Wall- and desk-type telephones.....	5	13
Transmitter, TA-236/FT:.....			Wall-type telephone, TA-105/FTC, de-		
Description.....	10d	24	scription.....	4	11
Theory.....	22	42	Wiring, repair.....	74	86

[AG 413.4 (15 Nov 54)]

BY ORDER OF THE SECRETARIES OF THE ARMY AND THE AIR FORCE:

OFFICIAL:

JOHN A. KLEIN,
Major General, United States Army,
The Adjutant General.

M. B. RIDGWAY,
General, United States Army,
Chief Of Staff.

OFFICIAL:

E. E. TORO,
Colonel, United States Air Force,
Air Adjutant General.

N. F. TWINING,
Chief of Staff, United States Air Force.

DISTRIBUTION:

Active Army:

Tee Svc, DA (1)	SigC Sch (25)	Units organized under following
Tee Svc Bd (1)	Gen. Depots (2)	TOE's-Continued
AFF (5)	SigC Sec, Gen. Depots (10)	11-127, Big Rep Co (2)
AFF Bd (incl. ea Test Sec) (1)	SigC Depots (20)	11-128A, Sig Depot Co (2)
Army AA Comd (2)	POE (2)	11-500A (AA through AE),
OS Maj. Comd (5)	OS Sup Agencies (2)	Sig Svc Org (2)
OS Base Comd (5)	SigC Fld Maint Shops (3)	11-587A, Sig Base Maint Co
Log Comd (5)	SigC Lab (5)	(2)
MDW (1)	Mil Dist (1)	11-592A, Hq&Hq Co, Sig Base
Armies (5)	Units organized under following	Depot (2)
Corps (2)	TOE's:	11-597A, Big Base Depot Co
Tng Div (2)	11-18, Wire-Rad Relay Opr Co	(2)
Ft & Cp (2)	(2)	
Gen & Br Svc Sch (5)	11-97, Wire Opr Co, Sig Bn (2)	

NG: Same as Active Army except allowance is one copy for each unit.

USAR: None.

Unless otherwise noted, distribution applies to Con US and over. For explanation of abbreviations used see 8R 320-50-1.

* U.S. GOVERNMENT PRINTING OFFICE : 1993 O - 342-421 (61879)

This fine document...

Was brought to you by me:



[Liberated Manuals -- free army and government manuals](#)

Why do I do it? I am tired of sleazy CD-ROM sellers, who take publicly available information, slap “watermarks” and other junk on it, and sell it. Those masters of search engine manipulation make sure that their sites that sell free information, come up first in search engines. They did not create it... They did not even scan it... Why should they get your money? Why are not letting you give those free manuals to your friends?

I am setting this document FREE. This document was made by the US Government and is NOT protected by Copyright. Feel free to share, republish, sell and so on.

I am not asking you for donations, fees or handouts. If you can, please provide a link to liberatedmanuals.com, so that free manuals come up first in search engines:

<A HREF=<http://www.liberatedmanuals.com/>>Free Military and Government Manuals

- Sincerely
Igor Chudov
<http://igor.chudov.com/>
- [Chicago Machinery Movers](#)