

# TM 11-1223

DEPARTMENT OF THE ARMY TECHNICAL MANUAL

---

## COMPUTER TEST SET TS-909/PPM

This copy is a reprint which includes current pages from Changes 1,3,4,5 and 6.

---

HEADQUARTERS Ž DEPARTMENT OF THE ARMY

JUNE 1957

WARNING

**DANGEROUS VOLTAGES EXIST IN THIS EQUIPMENT**

**Be careful when working on the  
220-volt power supply circuits, or  
on the 115-volt ac line connections**

**DON'T TAKE CHANCES!**

**CHANGE** }  
**No. 6** }

**HEADQUARTERS**  
**DEPARTMENT OF THE ARMY**  
**WASHINGTON, DC, 10 October 1975**

COMPUTER TEST SET TS-909/PPM  
INCLUDING REPAIR PARTS AND SPECIAL TOOL LISTS

TM 11-1223, 24 June 1957, is changed as follows  
*Page 3, paragraph 2.* Delete paragraph 2 and  
Substitute:

2. Forms and Records

*a. Reports of Maintenance and Unsatisfactory Equipment.* Maintenance forms, records, and reports which are to be used by maintenance personnel at all maintenance levels are listed in and prescribed by TM 38-750.

*b. Reports of Packaging and Handling Deficiencies.* Fill out and forward DD Form 6 (Packaging Improvement Report) as prescribed in AR 700-58/NAVSUPINST 4030.29/AFR 71-13/MCO P4030.29A, and DSAR 4145.8

*c. Discrepancy in Shipment Report (DISREP) (SF 361).* Fill out and forward Discrepancy in Shipment Report (DISREP) (SF 361) as pre-

scribed in AR 55-38/NAVSUPINST 4610.33A/AFR 75-18/MCO P4610.19B, and DSAR 4500.15.

Paragraph 2. Subparagraph *c* is superseded as follows

**2.2. Reporting Of Equipment Publication Improvements**

The reporting of errors, omissions, and recommendations for improving this publication by the individual user is encouraged. Reports should be submitted on DA Form 2028 (Recommended Changes to Publications and Blank Forms) and forwarded direct to Commander, US Army Electronics Command, ATTN: AMSEL-MA-Q, Fort Monmouth, NJ 07703.

*Page 4, paragraph 5a.* Delete paragraph 5a and substitute:

5. Items Comprising an Operable Equipment

nsn	Qty	Nomenclature	Fig No.
6625-00-510-1839		Test Set, Computer TS-909/PPM Consisting of:	
	1	Cable Assembly, Power Electrical CX-3382/U	2
6625-00-668-7193	1	Cable Assembly, Radio frequency CG-784B/U	2
6625-00-965-1478	1	Lead Test CX-10144/U	2
6625-00-395-9313	1	Test Lead Set CX-1331/U	2

Subparagraph *b.* Redesignate subparagraph *b* as "5.1 Running Spares."  
*Page 12, paragraph 18.1, sequence No. 1.* Delete "App. III" from the Procedure and References columns,

Paragraph 18.4, Sequence No. 3. Delete "App.

III" from the References column.

*Page 30, appendix II.* Delete appendix II in its entirety.

Appendix IV (page 11, C 4). Insert "Section II" over chart.

By Order of the Secretary of the Army:

**FRED C. WEYAND**  
*General, United States Army*  
*Chief of Staff*

Official:

**PAUL T. SMITH**  
*Major General, United States Army*  
*The Adjutant General*

Distribution:

*Active Army:*

USASA (2)	WRAMC (1)
Dir of Trans (1)	USARMIS (1)
COE (1)	USAERDAA (1)
TSG (1)	USAERDAW (1)
USAARENBD (1)	Sig FLDMS (1)
AMC (1)	Units org under fol TOE: 1 ea.
MICOM (2)	6-100
TECOM (2)	6-115
TRADOC (2)	6-116
ARADCOM (2)	6-155
ARADCOM Rgn (2)	6-156
OS Maj Comd (4)	6-185
LOGCOMD (3)	6-215
USACC (4)	6-216
MDW (1)	6-300
Armies (2)	6-365
Corps (2)	6-366
HISA (Ft Monmouth) (43)	7
Ft Gillem (10)	7-100
Ft Gordon (10)	11-117
Ft Huachuca (10)	11-500(AA-AC)
Ft Carson (5)	17
Ft Richardson (ECOM Ofc) (2)	29-1
WSMR (1)	29-11
Svc Colleges (1)	2915
USASESS (5)	29-16
USAFAS (5)	29-21
USAINTC (3)	29-25
USAADS (2)	29-26
USAARMS (2)	29-35
USAIS (2)	29-36
USAES (2)	29-41
AD (1) except	29-85
SAAD (30)	29-86
LBAD (14)	29-87
TOAD (14)	29-134
SHAD (3)	28-136
USA Dep (2)	29-427
Sig Sec USA Dep (2)	37
Sig Dep (2)	57
ATS (1)	57-100
MAAG (1)	

*ARNG & USAR: None.*

For explanation of abbreviations used, see AR 310-50.

stock should meet the standards given in these tests. form a part of the test requirements.

b. *Technical Publications.* Refer to appendix I for the technical publications applicable to this equipment.

c. *Modification Work Orders.* Perform all modification work orders applicable to this equipment before making the tests specified. DA Pam 310-7 lists all available MWO'S.

### 43. Test Facilities Required

The following items, or suitable equivalents, are required for depot testing this equipment.

<i>Test equipment</i>	<i>Technical manual</i>
Audio Oscillator TS-421/U	TM 11-6625-355-12
Multimeter AN/USM-189 (part of AN/USM-187).	
Power Supply PP-3135/U	TM 11-6130-231-14
Resistance Bridge ZM-4A/U	TM 11-2019
Ratio Transformer, Gertsch Model PT-5 (FSN 5950-779-2880).	
Connector, Plug, MIL Type AN 3106A-207S (FSN 5935-149-0160) (P4601).	

### 44. General Test Requirements

a. The equipment shall be allowed a warmup period of at least 15 minutes, and the tests shall be performed in the sequence given in paragraph 45.

b. The TS-421/U frequency controls shall be maintained for 2v400-Hz output and the IMPEDANCE switch shall be set at 5000.

### 45. Test Procedures

a. *Dekapot (Decade Precision Potentiometer) Resistance Test.*

(1) Set the BRIDGE ADJ control (outer, intermediate, and inner dials) to zero.

(2) The residual resistance measured between terminals 1 and 2 of BRIDGE ADJ potentiometer

(2) Set the TS-909/PPM MAIN POWER switch to ON. Adjust the TS-421/U 400-Hz balanced output to 115 vac as indicated on the AN/USM-189.

(3) Adjust the PP-3135/U output to 220 vdc as indicated on the front panel meter.

(4) At the TS-909/PPM front panel, short the TEST PROBE, + REF VOLT and, - REF VOLT jack leads to the GROUND jack lead.

(5) Vary balance adjustment R4608 at the rear of the TS-909/PPM chassis throughout its range. Accordingly, the NULL METER needle shall deflect to right and left of zero at least 25 percent of full scale. Adjust R4608 so that the NULL METER reads zero. Remove all power.

c. *Linearity Test.*

(1) Connect equipment as shown in figure 2. Adjust the TS-421/U 400-Hz output to 58 vac as indicated on the AN/USM-189.

(2) Set the ratio transformer to 0.001, and adjust the inner dial of the BRIDGE ADJ control on the TS-909/PPM for balance (zero reading) on the NULL METER. The inner dial shall indicate 1 (or 10 depending upon procurement model being tested)  $\pm 1$  minor division.

(3) Step the ratio transformer to 0.002, and adjust for a null. The inner dial on the BRIDGE ADJ control shall indicate 2 (or 20 depending upon procurement model being tested)  $\pm 1$  minor division. Repeat tests at each major division of the inner dial while stepping the ratio transformer as previously indicated. The dial indication shall be within  $\pm 1$  minor division of the major division for each test.

(4) Set the inner dial to the first minor division off zero, and the intermediate dial to 1. Set the ratio transformer to 0.0101. The NULL METER shall indicate zero for a setting within zero and the second minor division of the inner dial on the BRIDGE ADJ control.

(5) Change the ratio transformer to 0.0201 (maintain the least significant digit throughout tests) and the intermediate dial on the BRIDGE ADJ control to 2. Zero meter reading shall be obtained for a setting within the first two divisions of the inner dial. Repeat tests through position 9 on the intermediate dial while stepping the ratio transformer. A null shall be obtained for each position of the intermediate dial and the first two

outer dial to 1. Maintain the inner dial at the first minor division. Set the ratio transformer to 0.1001. The NULL METER shall indicate zero for a setting within zero and the second minor division of the inner dial. Repeat through position 9 on the outer dial of the BRIDGE ADJ control, being certain to step or change only the most significant value on the ratio transformer. A null shall be

obtained for each position of the outer dial and the first two minor divisions of the inner dial.

*d. Sensitivity Test.*

(1) From a condition of balance for a ratio setting of 0.005, change the ratio setting on the ratio transformer by 0.0001 (set ratio transformer to 0.0051). This shall result in at least a half-scale needle deflection on the NULL METER.

(2) Change the setting of the ratio transformer to 0.0049. The needle on the NULL METER shall deflect at least half scale in the opposite direction (from zero).

*e. Resolution Test.*

(1) From a condition of balance for a ratio setting of 0.005, change the ratio setting on the ratio transformer (use the continuous X.0000001 dial) to give a noticeable needle deflection on the NULL METER.

(2) The ratio change for the NULL METER needle deflection shall be not more than 0.0000040.

*f. Phase Sensitivity Test.*

(1) Disconnect the TEST PROBE lead from terminal O of the ratio transformer. Set the ratio to 0.2. Connect the TEST PROBE lead to the ratio transformer output terminal C together with the - REF VOLT lead. Disconnect the + REF lead from the TS-421/U, and connect the + REF lead to terminal O of the ratio transformer.

(2) Set BRIDGE ADJ control on the TS-909/PPM for half-scale needle deflection on the NULL METER.

(3) Interchange the lead connections at terminals C and O of the ratio transformer. The NULL METER needle shall deflect the same amount in the opposite direction; that is, a change of not more than one division on the inner dial shall be necessary to obtain equal deflection in each direction relative to zero.

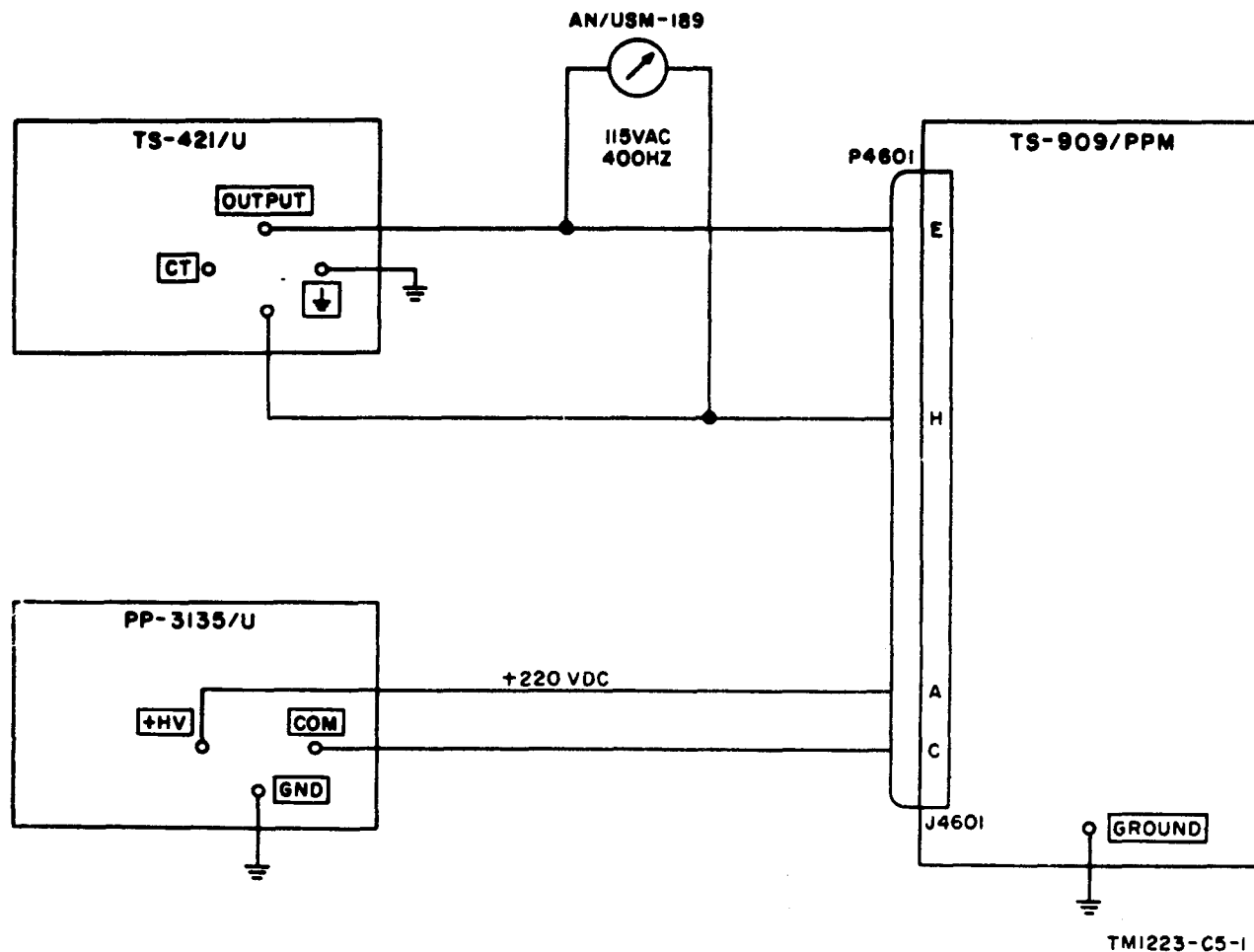

Figure 19. Test setup for balance test.

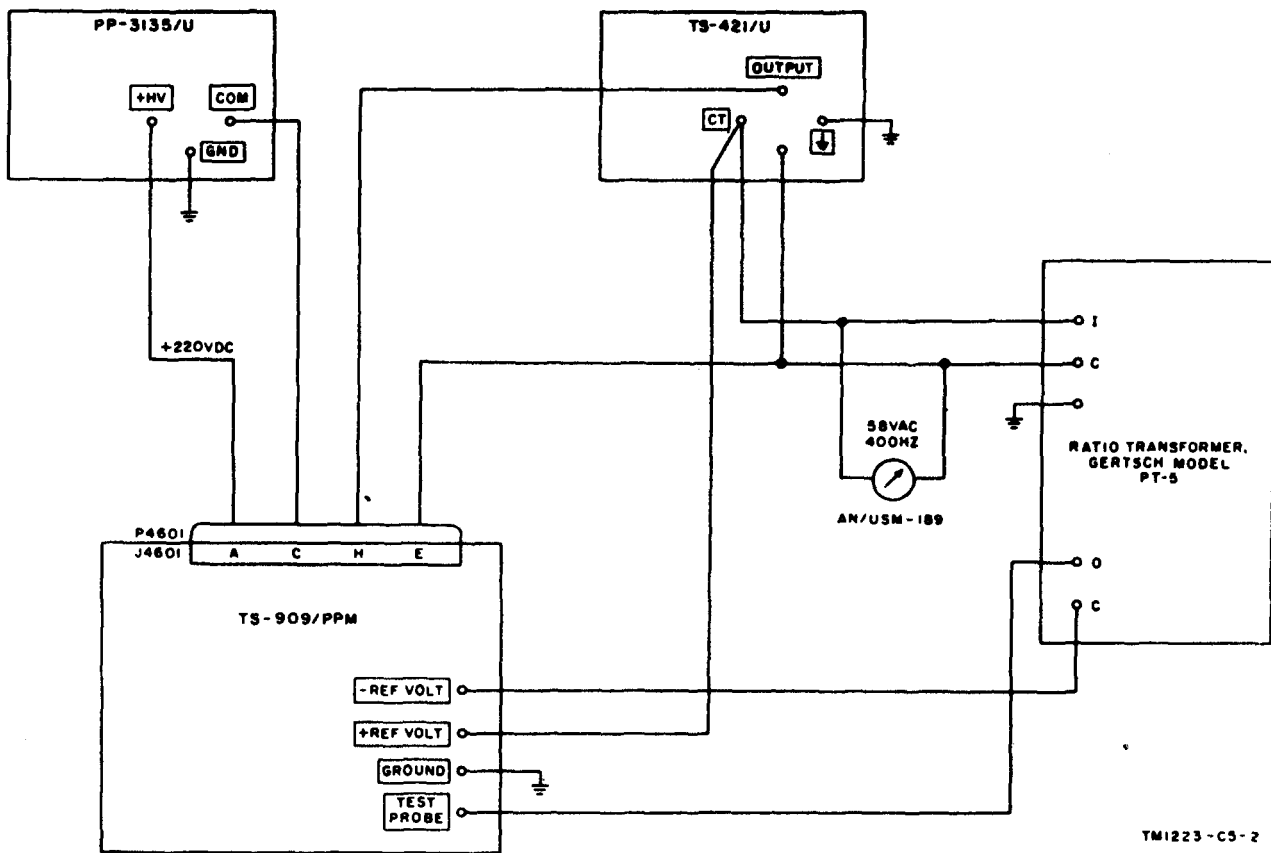

Figure 20. Test setup for linearity, sensitivity, and resolution tests.

Appendix I. Delete appendix I and substitute:

## APPENDIX I REFERENCES

DA Pam 310-4	Index of Technical Manuals, Technical Bulletins, Supply Manuals (types 7, 8 and 9), Supply Bulletins, and Lubrication Orders
DA Pam 310-7	U.S. Army Equipment Index of Modification Work Orders
SB 11-573	Painting and Preservation Supplies Available for Field Use for Electronics Command Equipment
SB 38-100	Preservation, Packaging, Packing, and Marking Materials, Supplies and Equipment used by the Army
SM 11-4-5180-R08	Toolkit, Radar and Radio Repairman TK-87/U
SM 11-4-5180-R12	Toolkit, Radar and Radio Repairman TK-88/U
TB 746-10	Field Instructions for Painting and Preserving Electronics Command Equipment
TM 11-1242	Crystal Rectifier Test Sets TS-268/U, TS-268A/U, TS-268B/U, TS-268C/U, TS-268D/U, and TS-268E/U
TM 11-2019	Test Sets I-49, I-49-A, and I-49-B and Resistance Bridges ZM-4A/U and ZM-4B/U



**TM 11-6130-231-14** Operator, Organizational and Field Maintenance Manual Power Supply PP-3135/U  
**TM 11-6625-200-15** Operator's, Organizational, DS, GS, and Depot Maintenance Manual, Multi-meters ME-26A/U, ME-26B/U, ME-26C/U, and ME-26D/U  
**TM 11-6625-274-12** Operator's and Organizational Maintenance Manual: Test Sets Electron Tube TV-7/U, TV-7A/U, TV-7B/U, and RV-7D/U  
**TM 11-6625-316-12** Operator and Organizational Maintenance Manual, Test Sets, Electron Tube TV-2/U, TV-2A/U, TV-2B/U, and TV-2C/U  
**TM 11-6625-320-12** Operator and Organizational Maintenance Manual, Voltmeter, Meter ME-30A/U and Voltmeters, Electronic ME-30B/U, ME-30C/U, and ME-30E/U  
**TM 11-6625-355-12** Organizational Maintenance Manual, Audio Oscillators TS-421/U and TS-421A/U  
**TM 38-750** The Army Maintenance Management Systems (TAMMS)  
**TM 740-90-1** Administrative Storage of Equipment

By Order of the Secretary of the Army:

**BRUCE PALMER, JR.**  
*General, U. S. Army*  
*Acting Chief of Staff*

Official:

**VERNE L. BOWERS**  
*Major General, United States Army,*  
*The Adjutant General*

Distribution:

*Active Army:*

USASA (2)	Instl (2) except	USARMIS (1)	17
CNGB (1)	Ft Carson (15)	USAERDAW (5)	17-100
ACSC-E (2)	Ft Gordon (10)	USAERDAA (2)	29-1
Dir of Trans (1)	Ft Huachuca (10)	USACRREL (2)	29-11
COE (1)	WSMR (3)	Sig FLDMS (2)	29-15
TSG (1)	Svc Colleges (2)	Units org under fol TOE:—1 ea.	29-16
CoFSptS (1)	USASESS (10)	6-100	29-21
USAARENBD (2)	USAFAS (10)	6-115	29-25
USAMB (10)	USAINTS (3)	6-116	29-26
AMC (1)	USAADS (2)	6-155	29-35
USASTRATCOM (4)	USAARMS (2)	6-156	29-36
MI'COM (4)	USAIS (2)	6-185	29-41
TECOM (2)	USAES (2)	6-186	29-85
USAESC (70)	Army Dep (2) except	6-200	29-86
USACDC (2)	SAAD (30)	6-215	29-87
USACDC Agy (1)	LBAD (14)	6-216	29-134
USACDCEC (10)	TOAD (14)	6-300	29-136
CONARC (5)	ATAD (10)	6-315	29-138
ARADCOM (2)	LEAD (7)	6-316	29-127
ARADCOM Rgn (2)	NAAD (5)	6-365	29-500(AA-AD)
OS Maj Comd (4)	SVAD (5)	6-366	37
USARYIS (5)	Gen Dep (2)	6-386	37-100
LOGCOMD (5)	Sig Sec: Gen Dep (5)	7	47
MDW (1)	Sig Dep (10)	7-100	57
Armies (2)	ATS (1)	11-117	57-100
Corps (2)	MAAG (1)	11-158	77-100
1st Cav Div (3)	WRAMC (1)	11-500(AA-AC)	

*ARNG & USAR: None.*

For explanation of abbreviations used, see AR 310-50.



CHANGE }  
No. 4 }

HEADQUARTERS  
DEPARTMENT OF THE ARMY  
WASHINGTON, D. C., 10 January 1966

**COMPUTER TEST SET TS-909/PPM  
INCLUDING REPAIR PARTS AND SPECIAL TOOL LISTS**

TM 11-1223, 24 June 1957, is changed as follows:

The title of the manual is changed as shown above.

*Note.* The parenthetical reference to previous changes (example: Page 1 of C 3) indicates that pertinent material was published in that change.

*Page 3, paragraph 2* (page 1 of C 3). Delete subparagraph *c* and substitute:

*c. Reporting of Equipment Manual Improvements.* The direct reporting of errors, omissions, and recommendations for improving this manual by the individual user is authorized and encouraged.

DA Form 2028 (Recommended Changes to DA Publications) will be used for reporting these improvements. This form will be completed using pencil, pen, or typewriter and forwarded direct to Commanding General, U.S. Army Electronics Command, ATTN: AMSEL-MR-(NMP)-MA, Fort Monmouth, N.J. 07703.

*Page 30, appendix I* (page 3 of C 3). Delete appendix I and substitute:

\* This change supersedes C 2, 28 March 1961; and TM 11-6625-357-20P, 16 March 1961; and TM 11-6625-357-35P, 28 March 1961.

## **APPENDIX I**

### **REFERENCES**

---

<b>DA Pam 310-4</b>	<b>Index of Technical Manuals, Technical Bulletins, Supply Manuals (Types 7, 8, and 9), Supply Bulletins, Lubrication Orders, and Modification Work Orders</b>
<b>SB 11-573</b>	<b>Painting and Preservation Supplies Available for Field Use for Electronics Command Equipment</b>
<b>TB SIG 364</b>	<b>Field Instructions for Painting and Preserving Electronics Command Equipment</b>
<b>TM 9-213</b>	<b>Painting Instructions for Field Use</b>
<b>TM 38-750</b>	<b>Army Equipment Record Procedures</b>

Appendixes II and III (page 3 of C 3). Delete appendixes II and III and substitute the following:

tables and other documents that are a basis for requisitioning.

## 2. Columns

Columns are as follows:

a. *Federal Stock Number.* This column lists the 11-digit Federal stock number.

b. *Designation by Model.* Not used.

c. *Description.* Nomenclature or the standard item name and brief identifying data for each item are listed in this column. When requisitioning, enter the nomenclature and description.

d. *Unit of Issue.* The unit of issue is each unless

ing an Operable Equipment," the column lists the quantity of items supplied for the initial operation of the equipment. Under "Running Spare Items" the quantities listed are those issued initially with the equipment as spare parts. The quantities are authorized to be kept on hand by the operator for maintenance of the equipment.

g. *Illustration.* The "Item No." column lists the reference designations that appear on the part in the equipment. These same designations are also used on any illustrations of the equipment. The numbers in the "Figure No." column refer to the illustrations where the part is shown.

## Section II. ORGANIZATIONAL FUNCTIONAL PARTS LIST

FEDERAL STOCK NUMBER	DESIGNATION BY MODEL	DESCRIPTION	UNIT OF ISSUE	EXP	QTY IN UNIT	MAINT ORG ALLOW.	ILLUSTRATION	
							FIGURE NO.	ITEM NO.
		TS-909/PPM						
6625-510-1839		TEST SET, COMPUTER TS-909/PPM: 115 v, 400 cyc, single ph; ac; 220 vdc; a null-indicating device used for aligning and adjusting 400 cyc analog computers of radar sets		NX				
5935-223-0572		ADAPTER, CONNECTOR: MIL type MS3057-12A			2	*		H4401 H4402
5940-260-0461		CLIP, SPRING TENSION: 1-1/8 in. lg x 5/8 in. w; Mueller #10-HS Sig dwg SM-B-199797			1	*		H4603
5960-193-5145		ELECTRON TUBE: MIL type 5/51.			1	*	5	V4601
5920-519-9722		FUSE, CARTRIDGE: MIL type F02A250V1/100A			1	*	4,15	F4401
5920-356-2193		FUSE, CARTRIDGE: MIL type F02GR500A			1	*	4,15	F4602
5920-509-5071		INDICATOR, BLOWN FUSE: Busaman #6323-1/2-W; Sig dwg SM-B-189680			2	*	4,15	I4601 I4602
6240-155-8706		LAMP, INCANDESCENT: 6-8 v; 0.15 amp; G.E. #47; MIL type MS15571-2, type TB-14			1	*	4,15	I4603
6210-500-0169		LENS, INDICATOR LIGHT: Clear; Dialco #82-137			2	*	4,15	XI4601-1 XI4602-1
6210-299-3004		LENS, INDICATOR LIGHT: Red; Dialco #82-111			1	*	4,15	XI4603-1
5935-283-3831		PLUG, TIP: Red; 1-15/16 in. lg o/a; H.H. Smith #200-A-red; Sig dwg SM-B-125420			1	*	2	E4622
6625-840-4476		PROD, TEST: Blk; 4-1/2 in. lg o/a; H. H. Smith #302-black			1	*	2	E4623
6625-892-4555		PROD, TEST: Red; 4-1/2 in. lg o/a; H. H. Smith #302 red			1	*	2	E4624
5340-897-9949		SCREW, CAPTIVE: 1.25 in. lg; 10-32 thd; f/front panel; G. E. #4042033; Sig dwg SM-B-199764			6	*	4	
5960-669-6884		SEMICONDUCTOR DEVICE, DIODE: MIL type 1N277			4	*	15	CR4601 thru CR4604
5960-264-3004		SHIELD, ELECTRON TUBE: JAN type TS103U02			1	*	5	

# APPENDIX III

## MAINTENANCE ALLOCATION

---

### Section I. INTRODUCTION

#### 1. General

a. This appendix assigns maintenance functions to be performed on components, assemblies, and subassemblies by the lowest appropriate maintenance category.

b. Columns in the maintenance allocation chart are as follows:

- (1) *Part or component.* This column shows only the nomenclature or standard item name. Additional descriptive data are included only where clarification is necessary to identify the component. Components, assemblies, and subassemblies are listed in top-down order. That is, the assemblies which are part of a component are listed immediately below that component, and subassemblies which are part of an assembly are listed immediately below that assembly. Each generation breakdown (components, assemblies, or subassemblies) is listed in disassembly order or alphabetical order.
- (2) *Maintenance function.* This column indicates the various maintenance functions allocated to the categories.
  - (a) *Service.* To clean, to preserve, and to replenish lubricants.
  - (b) *Adjust.* To regulate periodically to prevent malfunction.
  - (c) *Inspect.* To verify serviceability and detect incipient electrical or mechanical failure by scrutiny.
  - (d) *Test.* To verify serviceability and to detect incipient electrical or mechanical failure by use of special equipment such as gages, meters, etc.
  - (e) *Replace.* To substitute serviceable components, assemblies, or subassemblies,

for unserviceable components, assemblies, or subassemblies.

- (f) *Repair.* To restore an item to serviceable condition through correction of a specific failure or unserviceable condition. This function includes but is not limited to welding, grinding, riveting, strengthening, and replacement of parts other than the trial and error replacement of running spare type items such as fuses, lamps, or electron tubes.
- (g) *Align.* To adjust two or more components of an electrical system so that their functions are properly synchronized.
- (h) *Calibrate.* To determine, check, or rectify the graduation of an instrument, weapon, or weapons system, or components of a weapons system.
- (i) *Overhaul.* To restore an item to *completely serviceable* condition as prescribed by serviceability standards. This is accomplished through employment of the technique of "Inspect and Repair Only as Necessary" (IROAN). Maximum utilization of diagnostic and test equipment is combined with minimum disassembly of the item during the overhaul process.
- (j) *Rebuild.* To restore an item to a standard as near as possible to original or new condition in appearance, performance, and life expectancy. This is accomplished through the maintenance technique of complete disassembly of the item, inspection of all parts or components, repair or replacement of worn or unserviceable elements using original manufacturing tolerances and/or speci-

fications, and subsequent reassembly of the item.

- (3) *Operator, organization, direct support, general support, and depot.* The symbol X indicates the categories responsible for performing that particular maintenance operation, but does not necessarily indicate that repair parts will be stocked at that level. Categories higher than those marked by X are authorized to perform the indicated operation.
- (4) *Tools required.* This column indicates codes assigned to each individual tool equipment, test equipment, and maintenance equipment referenced. The grouping of codes in this column of the maintenance allocation chart indicates the tool, test, and maintenance equipment required to perform the maintenance function.
- (5) *Remarks.* Entries in this column will be utilized when necessary to clarify any of the data cited in the preceding columns.

c. Columns in the allocation of tools for maintenance functions are as follows:

- (1) *Tools required for maintenance functions.* This column lists tools, test, and maintenance equipment required to perform the maintenance functions.
- (2) *Operator, organization, direct support, general support, and depot.* The dagger (†) indicates the categories normally allocated the facility.
- (3) *Tool code.* This column lists the tool code assigned.

## **2. Maintenance by Using Organizations**

When this equipment is used by Signal services organizations organic to theater headquarters or communication zones to provide theater communications, those maintenance functions allocated up to and including general support are authorized to the organization operating this equipment.



## SECTION II. MAINTENANCE ALLOCATION CHART

PART OR COMPONENT	MAINTENANCE FUNCTION	ECHOLON					TOOLS REQUIRED	REMARKS
		O/C	O	DS	GS	D		
COMPUTER TEST SET TS-909/PPM	service				X		1,2,4,7 5,6 5,6	Preventive maintenance Visual Depot facilities In accordance with calibration procedures Depot facilities Shop facilities
	inspect				X			
	test				X	X		
	replace				X			
	repair				X			
	calibrate					X		
	rebuild					X		
	overhaul				X			
BOARD ASSEMBLY	repair				X			
PANEL ASSEMBLY	repair				X			
LIGHT ASSEMBLY	repair				X			
FUSE ASSEMBLY	repair				X			
CABLE ASSEMBLY	repair				X			
LAMP ASSEMBLY	repair				X			

7-010 001-7

SECTION III. ALLOCATION OF TOOLS FOR MAINTENANCE FUNCTIONS

TOOLS REQUIRED FOR MAINTENANCE FUNCTIONS	ECHELON					TOOL CODE	TYPE SERVICE CLASS	REMARKS
	O/C	O	DS	GS	D			
CRYSTAL RECTIFIER TEST SET TS-268E/U				†	†	1	Army A	
ELECTRONIC MULTIMETER ME-26/U				†	†	2	Army A	
TEST SET, ELECTRON TUBE TV-2/U					†	3	Army A	
TEST SET, ELECTRON TUBE TV-7/U				†		4	Army A	
TOOL KIT, RADAR AND RADIO REPAIRMAN TK-87/U				†	†	5	Army A	
TOOL KIT, SUPPLEMENTAL, RADAR AND RADIO REPAIRMAN TK-88/U				†	†	6	Army A	
VOLTMETER ME-30( )/U				†	†	7	Army A	

Add appendix IV after appendix III.

## APPENDIX IV

### ORGANIZATIONAL, DS, GS, AND DEPOT REPAIR PARTS AND SPECIAL TOOL LISTS

---

#### Section I. INTRODUCTION

##### 1. General

a. This appendix includes an organizational, direct and general support, and depot maintenance special tool lists.

- (1) The organizational maintenance repair parts and special tools list shows the repair parts authorized for organizational maintenance and is a basis for requisitioning by organizations which are authorized the major item of equipment. End items of equipments are issued on the basis of allowances prescribed in equipment authorization tables and other documents that are a basis for requisitioning.
- (2) Direct and general support and depot maintenance repair parts and special tools list shows the quantities of repair parts authorized for direct and general support maintenance and is a basis for requisitioning authorized parts. It is also a guide for depot maintenance in establishing initial levels of spare parts.

b. Columns are as follows:

- (1) *Source, maintenance, and recoverability code.* Source, maintenance, and recoverability codes indicate the commodity command responsible for supply, the maintenance category at which an item is stocked, categories at which an item is installed or repaired, and whether an item is repairable or salvageable. The source code column is divided into four parts.

(a) *Column A.* This column indicates the materiel code and designates the area of responsibility for supply. AR 310-1 defines the basic numbers used to identify the materiel code. If the part is Signal

materiel responsibility, the column is left blank.

- (b) *Column B.* This column indicates the point within the maintenance system where the part is available. "P" indicates that the repair part is a high mortality part; procured by commodity commands stocked in and supplied from the Army depot system, and authorized for use at indicated maintenance categories. "P1" indicates that the repair part is a low mortality part; procured by commodity commands stocked only in and supplied from Army depot systems and authorized for installation at indicated maintenance categories.
- (c) *Column C.* This column indicates the lowest maintenance category authorized to install the part.  
"O"—Organizational maintenance (operator and organizational).  
"H"—General support maintenance.
- (d) *Column D.* The symbols in this column indicate whether the item is repairable or salvageable, as follows:  
"R"—indicates that the part or assembly is economically repairable and is supplied, when available, on an exchange basis.
- (2) *Federal stock number.* This column lists the 11-digit Federal stock number.
- (3) *Designation by model.* Not used.
- (4) *Description.* Nomenclature or the standard item name and brief identifying data for each item are listed in this column. When requisitioning, enter the nomenclature and description.
- (5) *Unit of issue.* The unit of issue is each

unless otherwise indicated and is the supply term by which the individual item is counted for procurement, storage, requisitioning, allowances, and issue purposes.

- (6) *Expendability.* Nonexpendable items are indicated by NX. Expendable items are not annotated.
- (7) *Quantity incorporated in unit.* This column lists the quantity of each part found in a given assembly, component, or equipment.
- (8) *Organizational.* An asterisk indicates that an item is not authorized for stockage but if required may be requisitioned for immediate use only.
- (9) *Direct support.* No parts authorized for stockage at direct support level.
- (10) *General support.* The numbers in this column indicate quantities of repair parts authorized for initial stockage for use in general support maintenance. The quantities are based on 100 equipments to be maintained for a 15-day period.
- (11) *Depot.* The numbers in this column indicate quantities of repair parts authorized for depot maintenance and for initial stockage for maintenance, and for supply support to lower categories. The entries are based on the quantity required for rebuild of 100 equipments.
- (12) *Illustration.* The "Item No." column lists the reference designations that appear on the part in the equipment. These same designations are also used on any illustrations of the equipment. The numbers in the "Figure No." column refer to the illustrations where the part is shown.

## 2. Parts for Maintenance

When this equipment is used by Signal service organizations organic to theater headquarters or

communication zones to provide theater communications, those repair parts authorized up to and including general support are authorized for stockage by the organization operating this equipment.

## 3. Electron Tubes

The consumption rates given for tubes are conservative theoretical estimates and are provided for use only when more complete information, such as data based on operating experience, is not available. These figures are based on levels and requirements for equipment actually in use, not on authorizations or equipment stored in depots.

## 4. Requisitioning Information

a. The allowance factors are based on 100 equipments. In order to determine the number of parts authorized for initial stockage for the specific number of equipments supported, the following formula will be used and carried out to two decimal places.

$$\frac{\text{Specific number of equipments supported} \times \text{allowance factor}}{100} =$$

number of parts authorized for initial stockage.

b. Fractional values obtained from above computation will be rounded to whole numbers as follows:

- (1) When the total number of parts authorized is less than 0.5, the quantity authorized will be zero.
- (2) When the total number of parts authorized is between 0.5 and 1.0, the quantity authorized will be one.
- (3) For all values above one, fractional values below 0.5 will revert to the next lower whole number and fractional value 0.5 and above will advance to the next higher whole number.

c. The quantities determined in accordance with the above computation represent the initial stockage for a 15-day period.

FEDERAL STOCK NUMBER	DESIGNATION BY MODEL	DESCRIPTION	UNIT OF ISSUE	EXP	QTY AUTH	ILLUSTRATION	
						FIGURE NO.	ITEM NO.
6625-510-1839		TEST SET, COMPUTER TS-909/PPM: 115 v, 400 cyc, single ph; ac; 220 vdc a null-indicating device used for aligning and adjusting 400 cyc analog computers of radar sets					
		ITEMS COMPRISING AN OPERABLE EQUIPMENT					
ORD THRU AGC		TECHNICAL MANUAL TM11-1223			2		
6625-502-6084		CABLE ASSEMBLY, POWER ELECTRICAL CX-3382/U			1	2	W4601
6625-668-7193		CABLE ASSEMBLY, RADIOFREQUENCY CG-784B/U			1	2	W4602
6625-965-1478		LEAD TEST CX-10144/U			1	2	W4605
6625-395-9313		TEST LEAD SET CX-1331/U			1	2	W4603 W4604
		RUNNING SPARE ITEMS					
5960-193-5145		ELECTRON TUBE: MIL type 5751			1	5	V4601
5920-519-9722		FUSE, CARTRIDGE: MIL type FO2A250V1/100A			5	4,15	P4601
5920-356-2193		FUSE, CARTRIDGE: MIL type FO2OR500A			5	4,15	P4602
5920-509-5071		INDICATOR, BLOWN FUSE: Bussman p/n 6323-1/2-W Sig dwg SM-B-1896fo			3	4,15	I4601 I4602
6240-155-8706		LAMP, INCANDESCENT: G.E. p/n 47			3	4,15	I4603
5960-669-6884		SEMICONDUCTOR DEVICE, DIODE: MIL type 1N277			2	15	CR4601 thru CR4604

## SECTION III. DIRECT AND GENERAL SUPPORT AND DEPOT FUNCTIONAL PARTS LIST

SOURCE CODE	FEDERAL STOCK NUMBER	DESIGNATION BY MODEL	DESCRIPTION	UNIT OF ISSUE	EXP	QTY IN UNIT	DIRECT SUPPORT	GENERAL SUPPORT	DEPOT	ILLUSTRATION	
										FIGURE NO.	ITEM NO.
P O R	6625-510-1839		TEST SET, COMPUTER TS-909/PPM: 115 v, 400 cyc, single ph; ac; 220 vdc; a null-indicating device used for aligning and adjusting 400 cyc analog computers of radar sets		NX						
PI O	5935-223-0572		ADAPTER, CONNECTOR: MIL type MS-3057-12A			2		0.6	4.0		H4601, H4602
PI H	5340-897-9950		BUMPER: steel; 1.02 in dia X 0.26 in thk; 0.204 in dia mtg hole; for bottom of case; G.E. #4042014; Sig dwg SM-B-199777			4		0.6	4.0	4	
PI H	6145-229-9862		CABLE, POWER, ELECTRICAL: 1-No. 18 AWG stranded cond; blk rubber jacket; Sig dwg SM-B-199795-1	ft		11		7.7	55.0	2	W4603, W4605
PI H	6145-537-3509		CABLE, POWER, ELECTRICAL: 1-No. 18 AWG stranded cond; red rubber jacket; Sig dwg SM-B-199795-2	ft		6		4.2	30.0	2	W4604
PI H	6145-125-9322		CABLE, POWER, ELECTRICAL: 6-No. 16 AWG stranded cond; Sig dwg SM-C-199807-1	ft		6		4.2	30.0	2	W4601
PI H	6145-661-0191		CABLE, RADIOFREQUENCY: MIL type RG-59B/U	ft		6		4.2	30.0	2	W4602
P H	5910-170-4196		CAPACITOR, FIXED, PAPER DIELECTRIC: MIL type CP25A1EG103K			1		0.4	2.0	16	C4603
P H	5910-192-9784		CAPACITOR, FIXED, PAPER DIELECTRIC: MIL type CP25A1EF104K			2		0.6	4.0	16	C4601, C4602
PI H	5340-574-6618		CATCH, FLUSH, STEEL: 2-9/32 in lg X 1-5/32 in w X 3/8 in thk; 2 mtg holes 0.143 in dia. Corbin #15384			6		0.8	6.0	1	
PI O	5940-260-0461		CLIP, SPRING TENSION: 1-1/8 in lg X 5/8 in w; Mueller #60-HS; Sig dwg SM-B-199797			1		0.3	1.0		H4603
PI H	5935-686-0439		CONNECTOR, PLUG, ELECTRICAL: MIL type UG-260C/U			1		0.4	2.0	2	P4602
PI H	5935-405-0375		CONNECTOR, PLUG, ELECTRICAL: MIL type MS3106A-20-7P			1		0.4	2.0	2	P898

SOURCE CODE	FEDERAL STOCK NUMBER	DESIGNATION BY MODEL	DESCRIPTION	UNIT OF ISSUE	EXP	QTY IN UNIT	DIRECT SUPPORT	GENERAL SUPPORT	DEPOT	ILLUSTRATION	
										FIGURE NO.	ITEM NO.
			TS-909/PPM (continued)								
Pl H	5935-259-0065		CONNECTOR, PLUG, ELECTRICAL: type MS3106A-20-78			1		0.4	2.0	2	P4601
Pl H	5935-201-3511		CONNECTOR, RECEPTACLE, ELECT L: MIL type UG-290A/U			1		0.4	2.0	15	J4602
Pl H	5935-280-1874		CONNECTOR, RECEPTACLE, ELECT L: MIL type MS3102A-20-7P			1		0.4	2.0	15	J4601
P O	5960-193-5145		ELECTRON TUBE: MIL type 5751			1		3.3	100.0	5	V4601
P O	5920-519-5722		FUSE, CARTRIDGE: MIL type F02 10V1/100A			1		7.0	100.0	4,15	F4601
P O	5920-356-2193		FUSE, CARTRIDGE: MIL type F02 100A			1		7.0	100.0	4,15	F4602
Pl H	5920-026-9928		FUSEHOLDER: Bussman #HKL; Sig SM-B-199808			2		0.4	2.0	15	XF4601, XF4602
Pl H	6625-859-2594		GASKET: neoprene; 1-1/2 in lg 1-1/4 in dia; aperture; for G.E. #4042023; Sig Dwg SM-1			1		0.4	2.0		
Pl H	6625-896-3004		GASKET: neoprene; 7.57 in lg 0.12 in thk; one 0.31 in mt center; G.E. #4042019; Sig			1		0.4	2.0		
Pl H	6625-896-3005		GASKET: neoprene; 11.32 in lg 0.12 in thk; two 0.31 in d spaced 8.00 in C to C; G.E. dwg SM-B-199776			1		0.4	2.0		
Pl H	5920-853-4834		HOLDER, FUSE AND LAMP ASSEMB #HKL-XWZ-150K; Sig dwg SM-1			1		0.3	1.0	15.1	
Pl O	5920-509-5071		INDICATOR, BLOWN FUSE: Bussman Sig dwg SM-B-189680			2		0.4	2.0	4,15	I4601, I4602
Pl H	5935-283-3826		JACK, TIP: std phone tip; 1/1 MIL type MS16108-3			2		0.4	2.0	15	J4603, J4605
Pl H	5935-501-5487		JACK, TIP: phone type connect mtg; E.F. Johnson #105-602			1		0.3	1.0	15	J4604

SOURCE CODE				FEDERAL STOCK NUMBER	DESIGNATION BY MODEL	DESCRIPTION	UNIT OF ISSUE	EXP	QTY IN UNIT	DIRECT SUPPORT	GENERAL SUPPORT	DEPOT	ILLUSTRATION	
A	B	C	D										FIGURE NO.	ITEM NO.
						TS-909/PPM (continued)								
P	O			6240-155-8706		LAMP, INCANDESCENT: 6-8 v; 0.15 amp; G.E. #47 MIL type MS15571-2, type TB-14			1		1.2	10.0	4,15	I4603
PL	O			6210-500-0169		LENS, INDICATOR LIGHT: clear; Dialco #82-137			2		0.4	2.0	4	XI4601-1, XI4602-1
PL	O			6210-299-3004		LENS, INDICATOR LIGHT: red; Dialco #82-111			1		0.3	1.0	4	XI4603-1
PL	H			6210-295-2924		LIGHT, INDICATOR: w/o lens; Dialco #022210-1			3		0.5	3.0	15	XI4601, XI4602, XI4603
PL	H			6629-188-3116		METER, ARBITRARY SCALE: 5 scale graduation; full scale current 100 ua; Marion Elec Co #RS2 at 5 scale graduations			1		0.3	1.0	4	M4601
PL	H			5935-201-8583		PLUG, TIP: blk; 15/16 in lg o/a; Insuline #876B			2		0.4	2.0	2	E4625 E4626
PL	H			5935-510-7560		PLUG, TIP: red; 1-1/4 in lg o/a; Insuline #876R			1		0.3	1.0	2	E4627
PL	O			5935-283-3831		PLUG, TIP: red; 1-15/16 in lg o/a; H.H. Smith #200-A-red; Sig dwg SM-B-125420			1		0.3	1.0	2	E4622
PL	O			6625-840-4476		PROD, TEST: blk; 4-1/2 in lg o/a; H.H. Smith #302-BLACK			1		0.3	1.0	2	E4623
PL	O			6625-892-4555		PROD, TEST: red; 4-1/2 in lg o/a; H.H. Smith #302-RED			1		0.3	1.0	2	E4624
P	H			6625-669-1214		RESISTOR, DECADE: 0 to 10,000 ohms range; 0.5% accuracy; Electro Measurements #CA-451-2; Sig dwg SM-C-199760			1		0.4	2.0	17	R4611
P	H			5905-192-3971		RESISTOR, FIXED, COMPOSITION: MIL type RC20GF331J			1		0.4	2.0	16	R4606
P	H			5905-190-8881		RESISTOR, FIXED, COMPOSITION: MIL type RC20GF182J			1		0.4	2.0	16	R4603
P	H			5905-257-0926		RESISTOR, FIXED, COMPOSITION: MIL type RC42GF332J			2		0.6	4.0	16	R4607, R4609
P	H			5905-279-3504		RESISTOR, FIXED, COMPOSITION: MIL type RC20GF472J			2		0.6	4.0	16	R4610, R4613



SOURCE CODE				FEDERAL STOCK NUMBER	DESIGNATION BY MODEL	DESCRIPTION	UNIT OF ISSUE	EXP	QTY IN UNIT	DIRECT SUPPORT	GENERAL SUPPORT	DEPOT	ILLUSTRATION	
A	B	C	D	FIGURE NO.	ITEM NO.									
						TS-909/PPM (continued)								
P	H			5905-171-1998		RESISTOR, FIXED, COMPOSITION: MIL type RC20GF333J			1		0.4	2.0	16	R4612
P	H			5905-192-3981		RESISTOR, FIXED, COMPOSITION: MIL type RC20GF124J			1		0.4	2.0	16	R4604
P	H			5905-279-2522		RESISTOR, FIXED, COMPOSITION: MIL type RC20GF154J			1		0.4	2.0	15	R4602
P	H			5905-279-2519		RESISTOR, FIXED, COMPOSITION: MIL type RC20GF334J			1		0.4	2.0	15	R4601
P	H			5905-279-2515		RESISTOR, FIXED, COMPOSITION: MIL type RC20GF474J			1		0.4	2.0	16	R4605
P	H			5905-158-5450		RESISTOR, VARIABLE: MIL type RA20A25D352AF			1		0.5	3.0	16	R4608
P	O			5340-897-9949		SCREW, CAPTIVE: 1.25 in lg; 10-32 thk; for front panel; G.E. #4042033; Sig dwg SM-B-199764			6		0.8	6.0	4	
P	O			5960-669-6884		SEMICONDUCTOR DEVICE, DIODE: MIL type IN277			4		1.0	8.0	15	CR4601 thru CR4604
P	O			5960-264-3004		SHIELD, ELECTRON TUBE: JAN type TS103U02			1		0.3	1.0	5	
P	H			5935-160-1365		SOCKET, ELECTRON TUBE: JAN type TS103P01			1		0.4	2.0	16	XV4601
P	H			5930-276-9282		SWITCH, TOGGLE: 4 pole st; Cutler-Hammer #7661K6; Sig dwg SM-B-199768			1		0.6	4.0	15	S4601
F	H			5950-648-5721		TRANSFORMER, AUDIO FREQUENCY: G.E. #98G491 Sig dwg SM-C-199752			1		0.5	3.0	5	T4601
P	H			5950-521-1248		TRANSFORMER, AUDIO FREQUENCY: G.E. #98G492 Sig dwg SM-C-199751			2		0.8	6.0	5	T4602, T4603
P	H			5950-323-6119		TRANSFORMER, POWER, STEP-DOWN: G.E. #98G493 Sig dwg SM-B-199753			1		0.5	3.0	5	T4604

USASA (2)	A Dep (2) except	6-315
CNGB (1)	SAAD (30)	6-316
CC-E (7)	TOAD (14)	6-345
Dir of Trans (1)	FTWOAD (10)	6-346
CofEngrs (1)	LEAD (7)	6-365
TSG (1)	SHAD (3)	6-366
CofSptS (1)	NAAD (5)	6-385
USACDCEA (1)	SVAD (5)	6-386
USACDCCBRA (1)	CHAD (3)	7
USACDCCEA (1)	ATAD (10)	7-100
USACDCOA (1)	LBAD (14)	11-56
USACDCQMA (1)	USASTC (2)	11-57
USACDCTA (1)	USATC AD (2)	11-97
USACDCADA (1)	USATC Armor (2)	11-98
USACDCARMA (1)	USATC Engr (2)	11-117
USACDCAVNA (1)	USATC Inf (2)	11-127
USACDCARTYA (1)	WRAMC (2)	11-155
USACDCSWA (1)	Army Pic Cen (2)	11-157
USACDCCEA:	Instl (2) except	11-158
Ft Monmouth (1)	Ft Monmouth (70)	11-500 (AA-AC)
USACDCEC (10)	Ft Hancock (4)	11-587
USAMC (5)	Ft Gordon (10)	11-592
USCONARC (5)	Ft Huachuca (10)	11-597
ARADCOM (5)	Ft Carson (25)	17
ARADCOM Rgn (2)	Ft Knox (12)	17-100
OS Maj Comd (4)	WSMR (5)	29-1
LOGCOMD (2)	Sig Fld Maint Shops (2)	29-11
USAMICOM (4)	AMS (1)	29-15
USASMC (2)	USAERDAA (2)	29-16
USASCC (4)	USAERDAW (13)	29-21
MDW (1)	Units org under fol TOE:	29-25
Armies (2)	(2 copies each)	29-26
Corps (2)	1-27	29-35
USAC (3)	6-100	29-36
11th Air Aslt Div (3)	6-101	29-41
Svc Colleges (2)	6-155	29-85
Br Svc Sch (2) except	6-156	29-86
USASCS (50)	6-185	29-87
USAAMS (50)	6-186	37
USAOGMS (10)	6-200	37-100
USAADS (10)	6-215	47
GENDEP (2)	6-216	57
	6-285	57-100

NG: State AG (3); units—same as active Army except allowance is one copy.

USAR: None.

For explanation of abbreviations used, see AR 320-50.

TECHNICAL MANUAL  
COMPUTER TEST SET TS-909/PPM

TM 11-1223 }  
CHANGE NO. 3 }

HEADQUARTERS,  
DEPARTMENT OF THE ARMY  
WASHINGTON, D.C., 23 September 1963

TM 11-1223, 24 June 1957, is changed as follows:

*Note.* The parenthetical reference to a previous change (example: "page 1 of C 2") indicates that pertinent material was published in that change.

*Page 3.* Make the following changes:

After paragraph 1, add paragraph 1.1:

### 1.1. Index of Publications

Refer to the latest issue of DA Pam 310-4 to determine whether there are new editions, changes, or additional publications pertaining to the equipment. DA Pam 310-4 is an index of current technical manuals, technical bulletins, supply bulletins, lubrication orders, and modification work orders available through publications supply channels. The index lists the individual parts (-10, -20, -35P, etc.) and the latest changes to and revisions of each equipment publication.

Delete paragraph 2 (page 1 of C 2) and substitute:

## 2. Forms and Records

*a. Reports of Maintenance and Unsatisfactory Equipment.* Use equipment forms and records in accordance with instructions in TM 38-750.

*Page 12.* Make the following changes:

Delete the chapter heading and substitute: MAINTENANCE INSTRUCTIONS.

Delete section I and substitute:

## Section I. OPERATOR'S AND ORGANIZATIONAL MAINTENANCE

### 16. Scope of Maintenance

The maintenance duties assigned to the operator and organizational repairman of the test set are listed below together with a reference to the paragraphs covering the specific maintenance functions.

*a.* Daily preventive maintenance checks and services (par. 18.1).

*b.* Weekly preventive maintenance checks and services (par. 18.2).

*b. Report of Damaged or Improper Shipment* Fill out and forward DD Form 6 (Report of Damaged or Improper Shipment) as prescribed in AR 700-58 (Army), NAVSANDA Publication 378 (Navy), and AFR 71-4 (Air Force).

*c. Reporting of Equipment Manual Improvements.* The direct reporting by the individual user of errors, omissions, and recommendations for improving this manual is authorized and encouraged. DA Form 2028 (Recommended changes to DA technical manual parts lists or supply manual 7, 8 or 9) will be used for reporting these improvements. This form will be completed in triplicate using pencil, pen, or typewriter. The original and one copy will be forwarded direct to Commanding Officer, U.S. Army Electronics Materiel Support Agency, ATTN: SELMS-MP, Fort Monmouth N. J. 07703. One information copy will be furnished to the individual's immediate supervisor (officer, noncommissioned officer, supervisor etc.).

*c.* Monthly preventive maintenance checks and services (par. 18.3).

*d.* Quarterly preventive maintenance checks and services (par. 18.4).

*e.* Cleaning (par. 18.5).

*f.* Touchup painting (par. 18.6).

*g.* Troubleshooting (par. 21).

### 17. Preventive Maintenance

Preventive maintenance is the systematic care, servicing, and inspection of equipment to prevent

and to assure that the equipment is serviceable.

a. *Systematic Care.* The procedures given in paragraphs 18.1 through 18.6 cover routine systematic care and cleaning essential to proper upkeep and operation of the equipment.

b. *Preventive Maintenance Checks and Services.* The preventive maintenance checks and services charts (pars. 18.1-18.4) outline functions to be performed at specific intervals. These checks and services are to maintain army electronic equipment in a combat serviceable condition; that is, in good general (physical) condition and in good operating condition. To assist operators in maintaining combat serviceability, the chart indicates what to check, how to check, and what the normal conditions are. The *References* column lists the illustrations, paragraphs, or manuals that contain detailed repair or replacement procedures. If the

corrective actions listed, higher echelon maintenance or repair is required. Records and reports of these checks and services must be made in accordance with the requirements set forth in TM 38-750.

## 18. Preventive Maintenance Checks and Services Periods

Preventive maintenance checks and services of the test set are required daily, weekly, monthly, and quarterly.

a. Paragraph 18.1 specifies the checks and services that must be accomplished daily (or at least once each week if the equipment is maintained in standby condition).

b. Paragraphs 18.2, 18.3, and 18.4 specify *additional* checks and services that must be performed on a weekly, monthly, and quarterly basis, respectively.

### 18.1. Daily Preventive Maintenance Checks and Services Chart

Sequence No.	Item	Procedure	References
1	Completeness.....	See that the equipment is complete (app. III).....	App. III.
2	Exterior surfaces.....	Clean the exterior surfaces, including the panel and meter glasses (par. 18.5). Check all meter glasses and indicator lenses for cracks.	Par. 18.5.
3	Connectors.....	Check the tightness of all connectors.	
4	Controls and indicators.....	While making the operating checks (item 5), observe that the mechanical action of each knob, dial, and switch is smooth and free of external or internal binding, and that there is no excessive looseness. Also, check the meter for sticking or bent pointer.	
5	Operation.....	Operate the equipment according to paragraph 22.	Par. 22.

### 18.2. Weekly Preventive Maintenance Checks and Services Chart

Sequence No.	Item	Procedure	References
1	Cables.....	Inspect cords, cables, and wires for chafed, cracked, or frayed insulation. Replace connectors that are broken, arced, stripped, or worn excessively (fig. 2).	Fig. 2.
2	Handles and latches.....	Inspect handles, latches, and hinges for looseness. Replace or tighten as necessary (fig. 4).	Fig. 4.
3	Metal surfaces.....	Inspect exposed metal surfaces for rust and corrosion. Clean and touchup paint as required (par. 18.6).	Par. 18.6.

### 18.3. Monthly Preventive Maintenance Checks and Services Chart

Sequence No.	Item	Procedure	References
1	Pluckout items.....	Inspect seating of pluckout items. Make certain that tube clamps grip tube bases tightly (figs. 4 and 5).	Figs. 4 and 5.
2	Jacks.....	Inspect jacks for snug fit and good contact (fig. 4)...	Fig. 4.
3	Transformer terminals.....	Inspect the terminals on the power transformer. There should be no evidence of dirt or corrosion.	
4	Resistors and capacitors.....	Inspect the resistors and capacitors for cracks, blistering, or other detrimental defects.	
5	Insulators.....	Inspect gaskets, bushings, and sleeves for cracks, chipping, and excessive wear.	
6	Interior.....	Clean interior of chassis and cabinet.	

### 18.4. Quarterly Preventive Maintenance, Maintenance Checks and Services Chart

Sequence No.	Item	Procedure	References
1	Publications.....	See that all publications are complete, serviceable, and current.	DA Pam 310-4.
2	Modifications.....	Check DA Pam 310-4 to determine if new applicable MWO's have been published. All URGENT MWO's must be applied immediately. All NORMAL MWO's must be scheduled.	TM 38-750 and DA Pam 310-4.
3	Spare parts.....	Check all spare parts (operator and organizational) for general condition and method of storage. There should be no evidence of overstock, and all shortages must be on valid requisitions.	App. III and TM 11-6625-357-20P.

### 18.5. Cleaning

Inspect the exterior of the equipment. The exterior surfaces should be clean, and free of dust, dirt, grease, and fungus.

a. Remove dust and loose dirt with a clean soft cloth.

**Warning:** Cleaning compound is flammable and its fumes are toxic. Provide adequate ventilation. **Do not use near a flame.**

b. Remove grease, fungus, and ground-in dirt from the cases; use a cloth dampened (not wet) with cleaning compound (Federal stock No. 7930-395-9542). After cleaning, wipe dry with a cloth.

c. Remove dust or dirt from plugs and jacks with a brush.

**Caution:** Do not press on the meter face (glass) when cleaning; the meter may become damaged.

d. Clean the front panels, meters, and control knobs; use a soft clean cloth. If necessary, dampen the cloth with water; mild soap may be used for more effective cleaning.

### 18.6. Touchup Painting Instructions

Remove rust and corrosion from metal surfaces by lightly sanding them with fine sandpaper. Brush two thin coats of paint on the bare metal to protect it from further corrosion. Refer to the applicable cleaning and refinishing practices specified in TM 9-213.

*Pages 13 and 14.* Delete figures 7 and 8.

*Page 30 (page 2 of C 2).* Make the following changes:

Renumber the existing appendixes "I" and "II" to: II and III.

Add appendix I before appendix II.

## **APPENDIX I**

### **REFERENCES**

- |              |  |                    |  |
|--------------|--|--------------------|--|
| DA Pam 310-4 | Index of Technical Manuals, Technical Bulletins, Supply Bulletins, Lubrication Orders, and Modification Work Orders. | TM 11-6625-357-20P | Organizational Maintenance Repair Parts and Special Tools List: Test Set, Computer TS-909/PPM. |
| TM 9-213     | Painting Instructions for Field Use.   | TM 38-750          | The Army Equipment Record System and Procedures.   |

By Order of the Secretary of the Army:

EARLE G. WHEELER,  
General, United States Army,  
Chief of Staff.

Official:

J. C. LAMBERT,  
Major General, United States Army,  
The Adjutant General.

Distribution:

Active Army:

DASA (6)  
USASA (2)  
CNGB (1)  
CofEngrs (1)  
TSG (1)  
CSigO (7)  
CofT (1)  
OCofSptS (1)  
USA CD Agcy (1)  
USCONARC (5)  
USAMC (5)  
ARADCOM (2)  
ARADCOM Rgn (2)  
OS Maj Comd (3)  
OS Base Comd (2)  
LOGCOMD (2)  
USAECOM (5)  
USAMICOM (4)  
USASCC (4)  
MDW (1)  
Armies (2)  
Corps (2)  
Div (2)  
USATC AD (2)  
USATC Engr (2)  
USATC Inf (2)  
USATC Armor (2)  
USASTC (5)  
Instl (2) except  
    Ft Monmouth (65)  
Svc Colleges (2)  
Br Svc Sch (2)  
GENDEP (OS) (2)  
Sig Sec, GENDEP (5)  
Sig Dep (OS) (12)  
Army Dep (2) except  
    Ft Worth (8)  
    Lexington (12)  
    Sacramento (28)  
    Tobyhanna (12)  
USA Trans Tml Comd (1)  
Army Tml (1)  
POE (1)  
USAOSA (1)  
AMS (1)  
WRAMC (1)

AFIP (1)  
Army Pic Cen (2)  
USA Elct RD Actv, White Sands (13)  
USA Elct RD Actv, Ft Huachuca (2)  
USA Mbl Spt Cen (1)  
USA Elct Mat Agcy (12)  
Chicago Proc Dist (1)  
USARCARIB Sig Agcy (1)  
Sig Fld Maint Shops (3)  
USA Corps (3)

Units org under fol TOE:

1-27 (2)  
6-100 (2)  
6-101 (2)  
6-155 (2)  
6-156 (2)  
6-185 (2)  
6-186 (2)  
6-200 (2)  
6-215 (2)  
6-216 (2)  
6-285 (2)  
6-286 (2)  
6-300 (2)  
6-315 (2)  
6-316 (2)  
6-345 (2)  
6-346 (2)  
6-385 (2)  
6-386 (2)  
11-7 (2)  
11-16 (2)  
11-55 (2)  
11-56 (2)  
11-98 (2)  
11-117 (2)  
11-155 (2)  
11-157 (2)  
11-500 (AA-AC) (2)  
11-587 (2)  
11-592 (2)  
11-597 (2)  
17-100 (2)  
37-100 (2)  
57-100 (2)

NG: State AG (3); units—same as active Army except allowance is one copy to each unit.

USAR: None.

For explanation of abbreviations used, see AR 320-50.





TECHNICAL MANUAL  
COMPUTER TEST SET TS-909/PPM

TM 11-1223 }  
CHANGES No. 1 }

HEADQUARTERS,  
DEPARTMENT OF THE ARMY  
WASHINGTON 25, D.C., 9 December 1960

TM 11-1223, 24 June 1957, is changed as indicated so that the manual also applies to the following equipment:

Nomenclature	Order No.	Serial No.
Test Set, Computer TS-909/PPM.	4438-PP-60	1 through 179

Page 3, paragraph 1.  
Make the following changes:

Subparagraph *a*, line 3. After "fig. 1," add:  
and 1.1.

Add subparagraph *a.1* after subparagraph *a*.

*a.1*. In this manual, the word test set is used to include Computer Test Set TS-909/PPM equipments, Order No. 16-PP-56, and Test Set, Computer TS-909/PPM equipments which were issued under Order No. 4438-PP-60. The equipment differences are listed in paragraph 6.1. Where two figures are referenced, use the applicable one.

Page 4. Make the following changes:

Paragraph 5*b*, chart. Add superscript "a" to item "Lamp, glow, (NE-51)."

Add the following footnote beneath the chart:

\*Lamp, glow, FHL-17G will be used on Test Set, Computer TS-909/PPM (Order No. 4438-PP-60).

Add paragraph 6.1 after paragraph 6.

### 6.1. Equipment Differences

Computer Test Set TS-909/PPM (Order No. 16-PP-56) and Test Set, Computer TS-909/PPM (Order No. 4438-PP-60) are similar in purpose, operation, and appearance. The differences are as follows:

Item	Equipments included in Order No. 16-PP-56	Equipments included in Order No. 4438-PP-60
Blown-fuse indicator lamps. R4611	Located above fuse-holders	Incorporated in fuse caps.
Inner BRIDGE ADJ dial.	Part name is Dekapot (par. 30). Numbers on dial range from 0 to 9 in steps of one (par.11).	Part name is precision potentiometer (par. 30.1). Numbers on dial range from 0 to 90 in steps of ten (par. 11.1).
Intermediate BRIDGE ADJ dial. Spares locations.	Handle is attached.	No handle attached.
Allen wrench.	Supplied with test set.	Tube is on rear of chassis (fig. 5.1). Two indicator lamps are in sockets above fuse location (fig. 4.1). Other spares are mounted inside front cover (fig. 1.1). Not supplied with test set.
Front panel markings.	Packaged separately. On individual nameplates.	Etched on panel.

Page 8. Make the following changes:

Paragraph 9, line 2. After "fig. 4," add:  
and 4.1.

Paragraph 10. Under heading, after "fig. 4," add: and 4.1.

Paragraph 11, right hand column. Delete

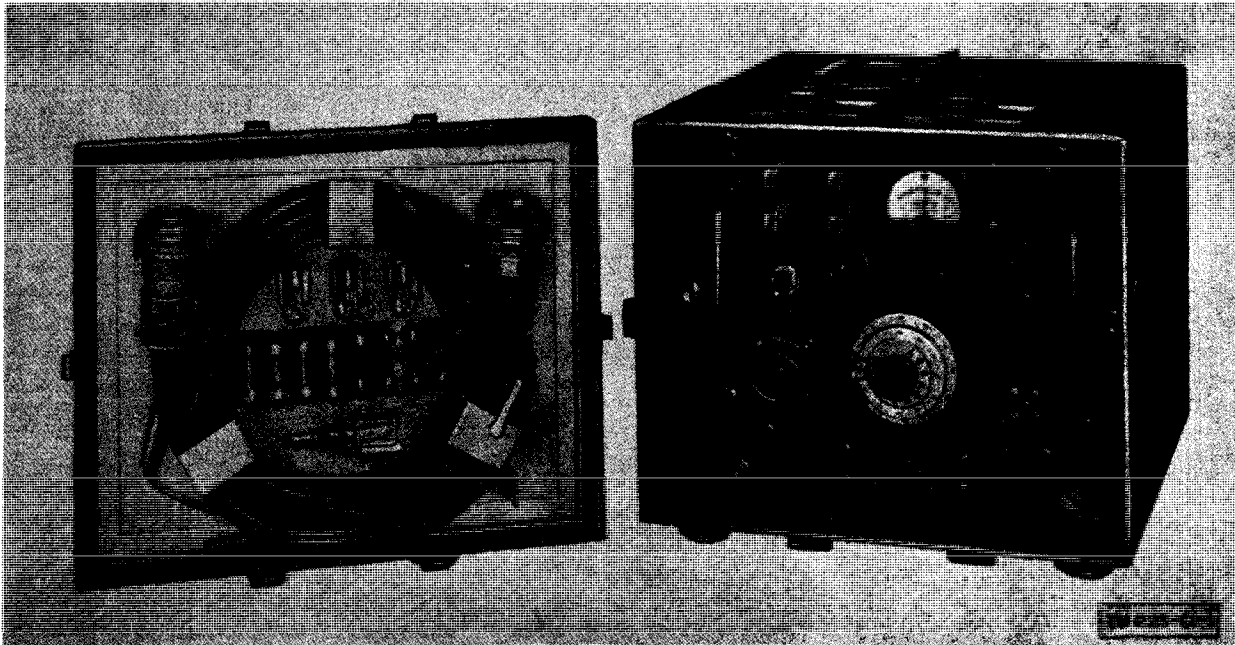

Figure 1.1. (Added) Test Set, Computer TS-909/PPM (Order No. 4438-PP-60).

“ohms” and substitute “units” in the following places:

- Line 1.
- Line 4.
- Line 6.
- Line 9.

Add paragraph 11.1 after paragraph 11.

### 11.1. Bridge ADJ Dial (Order No. 4438-PP-60)

The inner scale of the BRIDGE ADJ dial is controlled by the center knob. It is continuously adjustable from 0 to 100 units. A setting of 30 represents 30 units. The middle dial is turned by first grasping it at its outer edges. It controls a 10-position switch. The settings are in steps of hundreds of units. The outer dial is also turned by first grasping it at its outer edges. It also controls a 10-position switch. The settings are in steps of thousands of units. With the outer dial set at 3, the middle dial set at 4, and the inner dial set half-way between 30 and 40, the reading is 3,435 units.

Paragraph 13e, line 2. After “fig. 5,” add: and 5.1.

Page 10, figure 5. Below callout “DEKAPOT,” add: R4611.

Page 11, paragraph 15c, bottom line. After “figure 1,” add: and 1.1.

Page 12, paragraph 16. After first sentence, add: The Allen wrench is not supplied with the test set on Order No. 4438-PP-60.

Page 15, paragraph 22, chart. In “Normal indication” column, delete the information for item No. 2 and substitute: Blown-fuse indicator lamps remain out.

Page 20, paragraph 26, chart. Make the following changes: “Technical manual” column. Change “TM 11-5083” to: TM 11-6625-274-12. Add the following:

Test equipment	Technical manual
Crystal Rectifier Test Set TS-268/U . . . . .	TM11-1242

Page 21, paragraph 27, chart. Delete the last symptom and the corresponding probable trouble and correction and substitute the following:

Symptom	Probable trouble	Correction
Meter deflects during operation as null meter but BRIDGE ADJ control cannot cause NULL METER to zero.	Unmatched crystals CR 4601, CR 4602, CR-4603, and CR-4604. R4611 (Dekapot) defective.	Match the crystals.  Replace R4611 (par. 30).

Page 25. Make the following changes:

Paragraph 29a, line 3. Change "5, 15, and 16" to: 5, 5.1, 15, 15.1, and 16.

Paragraph 30, heading. After "Dekapot," add: (R4611).

Figure 15. Under the callout "DEKAPOT" add: (R4611).

Page 27. Make the following changes:

Add paragraph 30.1 after paragraph 30.

### 30.1. Disassembly and Reassembly of Precision Potentiometer (R4611)

(fig. 17.1)

**Caution:** The precision potentiometer resistance is contained in a hermetically sealed casing. Do not attempt to open the casing.

#### a. Disassembly.

(1) Turn all dials to their zero position and

leave the shafts in that position until the dials are replaced after remounting. The zero position is located on an unmounted potentiometer by turning the outer dial counterclockwise to a stop position. The intermediate and inner dials do not have stops and can be rotated continuously through zero.

- (2) Use an Allen wrench to loosen the two setscrews that hold the inner dial to the potentiometer shaft and remove the inner dial.
- (3) Loosen the two screws that hold the hairline indicator (fig. 4.1) and remove the hairline indicator.
- (4) Use the Allen wrench to loosen the two setscrews that hold the intermediate dial to the potentiometer shaft. Remove the dial together with the two rubber seal

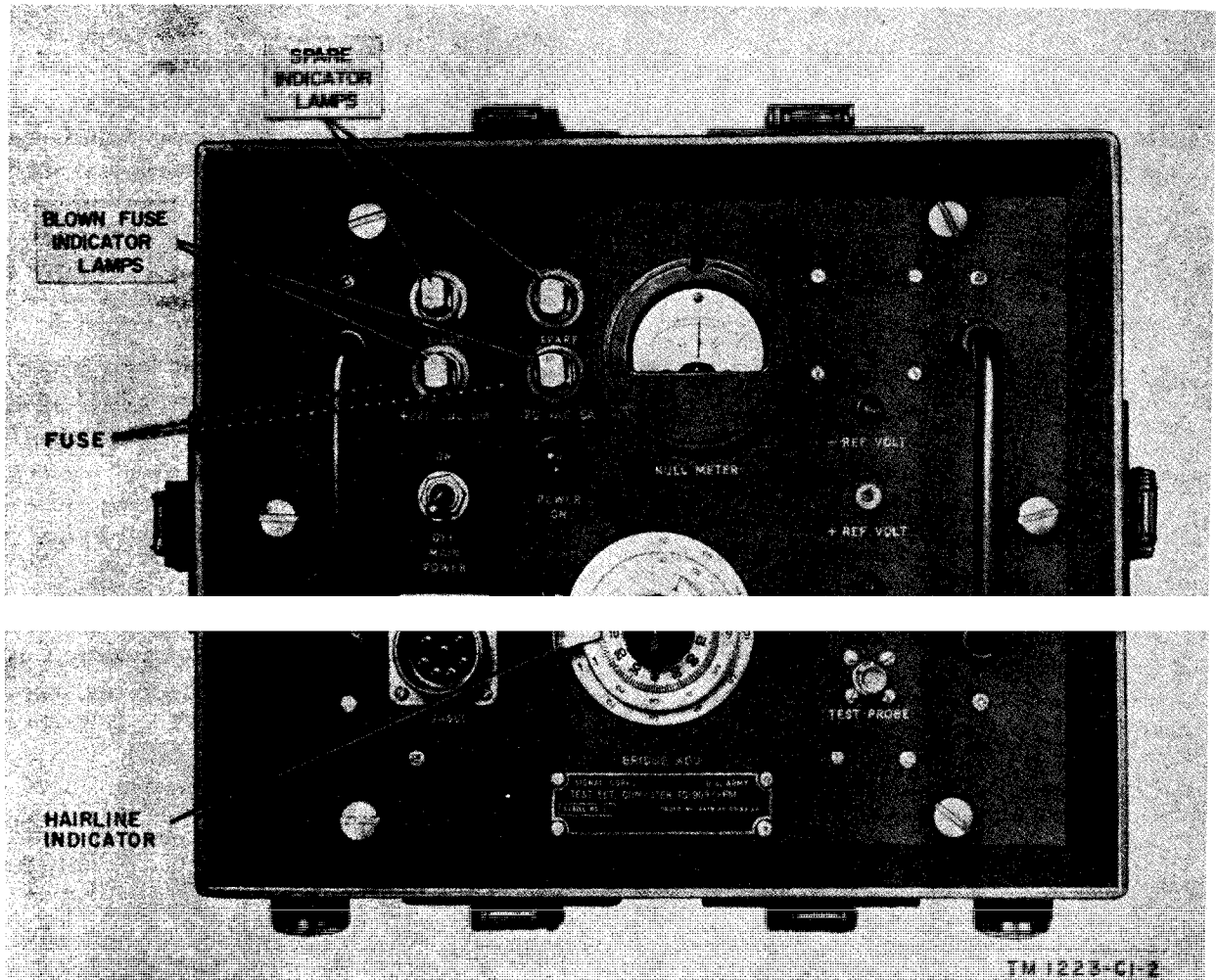

Figure 4.1. (Added) Test Set, Computer TS-909/PPM (Order No. 4438-PP-60), front panel.

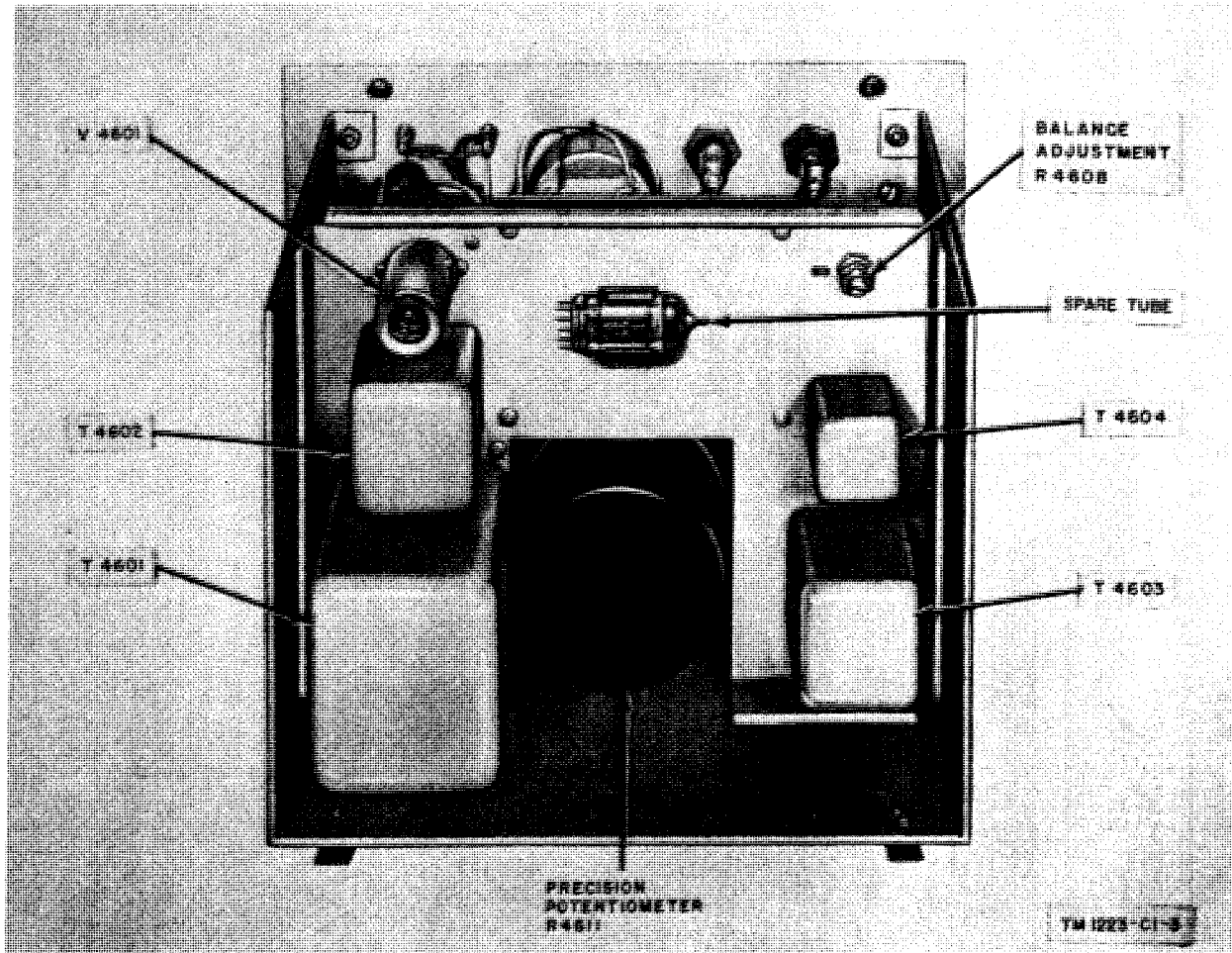

Figure 5.1. (Added) Rear view of test set chassis (Order No. 4438-PP-60).

rings. The seal rings are located on the shaft, one on each side of the dial.

- (5) Use the Allen wrench to loosen the two setscrews that hold the outer dial to the potentiometer shaft. Remove the outer dial together with the split steel bushing. The dial is fitted over the steel bushing.
- (6) Unscrew the hexagonal nut and remove the nut and washer.
- (7) Identify and unsolder the three wires attached to the terminals of the potentiometer.
- (8) Remove the potentiometer clamping bracket (fig. 15.1) by loosening the two Phillips-head screws that hold it, and withdraw the precision potentiometer from the panel.

*b. Reassembly.* To reassemble and reset the dial calibration of the potentiometer, proceed as follows:

- (1) Mount the potentiometer in the panel

hole (fig. 15.1), orienting the casing so that the three terminals are on top for easy access.

- (2) Secure the potentiometer to the panel; use the hexagonal nut and washer.
- (3) Place the potentiometer clamping bracket and secure it with the two Phillips-head screws.
- (4) Identify the three wires and resolder to the proper terminals.
- (5) Place the split steel bushing and the outer dial on the potentiometer shaft. Position the zero in the center of the location of the hairline indicator. Tighten the two setscrews.
- (6) Place the rubber seal ring on the shaft and then the intermediate dial. Position the zero in the center of the location of the hairline indicator. Tighten the two setscrews.
- (7) Place the hairline indicator in position

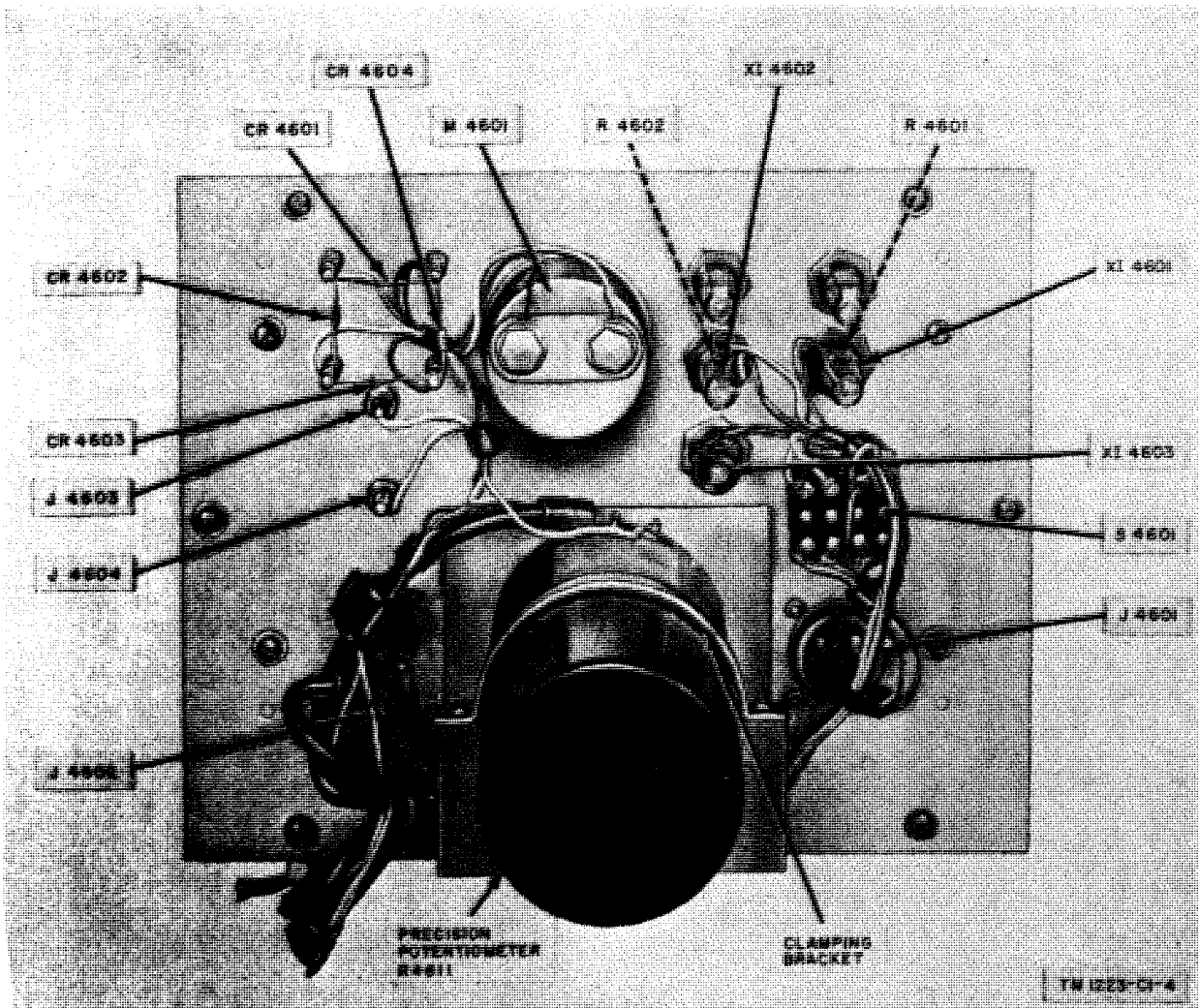

Figure 15.1. Rear view of front panel (Order No. 4438-PP-60).

- and fasten and tighten with proper screws.
- (8) Place the other seal ring and the inner dial on the shaft. Position the dial zero at the indicating hairline. Tighten the inner dial setscrews lightly.
  - (9) Set the inner potentiometer dial accurately as follows:
    - (a) Connect an ohmmeter between terminals 1 and 2 of the potentiometer.
    - (b) Rotate the inner dial counterclockwise until the resistance reading falls to a minimum (less than 0.1 ohm).
    - (c) Slowly rotate the dial clockwise until the resistance reading begins to increase.
    - (d) Loosen the inner dial setscrews and set the dial zero flush with the indicating hairline.
    - (e) Tighten the setscrews.
  - (10) Check the calibration at the upper end of the potentiometer range by rotating the outer and middle dials to nine settings and the inner dial to full scale. Connect the ohmmeter to terminals 2 and 3 of the potentiometer and rotate the inner dial until the resistance reading begins to increase. Loosen and reset the inner dial, if necessary, to obtain an accurate setting at full scale.
  - (11) Check to see that the dials have been correctly set by checking for minimum resistance between terminals 1 and 2 of the potentiometer with all dials set at zero, and for minimum resistance between terminals 2 and 3 of the potentiometer with all dials set at full scale.

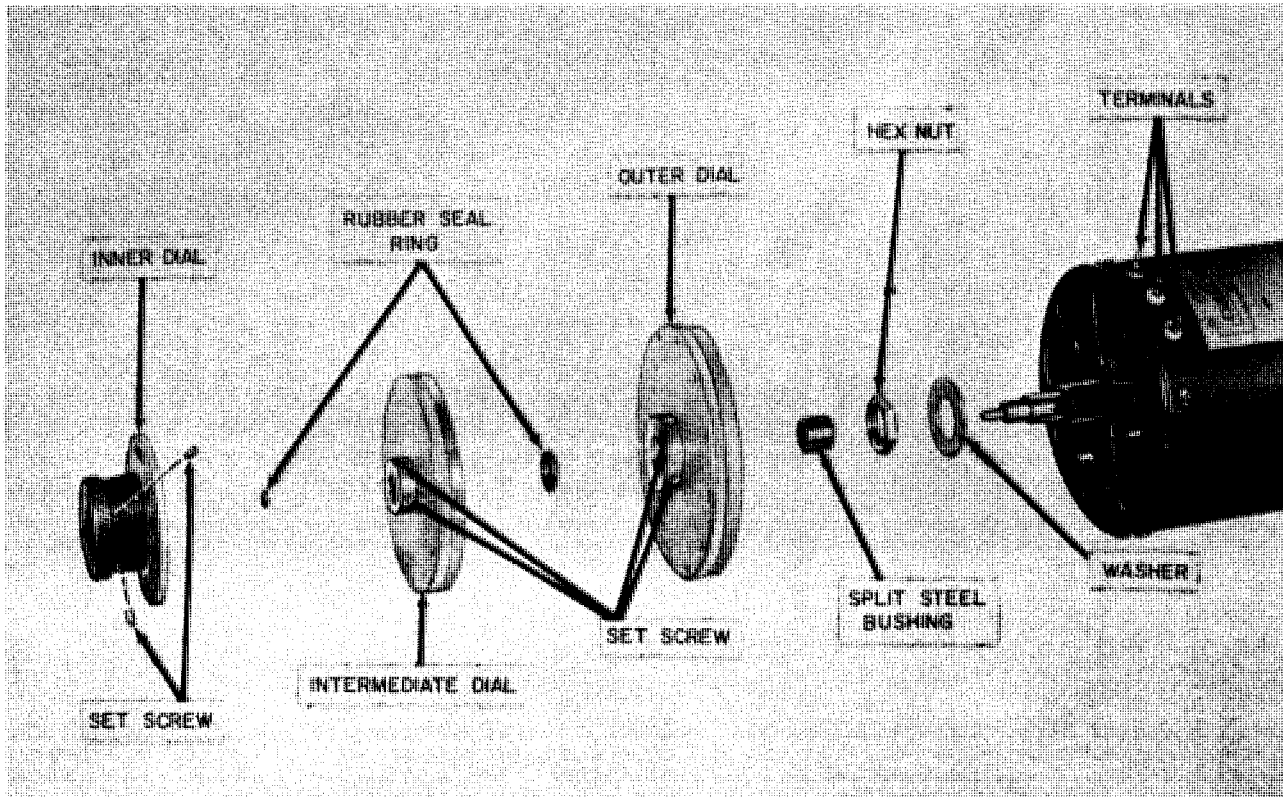

Figure 17.1. (Added) Exploded view of precision potentiometer (Order No. 4438-PP-80).

By Order of *Wilber M. Brucker*, Secretary of the Army:

**G. H. DECKER,**  
*General, United States Army,*  
*Chief of Staff.*

Official:

**R. V. LEE,**  
*Major General, United States Army,*  
*The Adjutant General.*

Distribution:

*Active Army:*

To be distributed in accordance with DA Form 12-7 requirements for TM 11-Series (Unclass) plus the following:

DASA (5)	Units organized under following	11-56 (2)
USASA (2)	TOE's:	11-57 (2)
CNGB (1)	1-27 (2)	11-98 (2)
Tech Stf, DA (1) except CSigO (36)	6-100 (2)	11-117 (2)
US ARADCOM (2)	6-101 (2)	11-155 (2)
US ARADCOM Rgn (2)	6-316 (2)	11-500 (AA-AE) (4)
MDW (1)	7 (2)	11-557 (2)
Seventh USA (2)	11-7 (2)	11-587 (2)
EUSA (2)	11-16 (2)	11-592 (2)
USASCS (85)	11-55 (2)	11-597 (2)

NG: State AG (3); units—same as Active Army except allowance is one copy to each unit.

USAR: None.

For explanation of abbreviations used see AR 320-50.





COMPUTER TEST SET TS-909/PPM

	Paragraph	Page
CHAPTER 1. INTRODUCTION		
Section I. General		
Scope . . . . .	1	3
Forms and records . . . . .	2	3
II Description and data		
Purpose and use . . . . .	3	3
Technical characteristic . . . . .	4	3
Components of Computer Test Set TS-909/PPM . . . . .	5	4
Description . . . . .	6	4
CHAPTER 2. INSTALLATION AND OPERATING INSTRUCTIONS		
Section I. Service upon receipt of equipment		
Unpacking . . . . .	7	6
Checking unpacked equipment . . . . .	8	6
II. Connections and operation		
Controls and instruments . . . . .	9	8
Connections . . . . .	10	8
BRIDGE ADJ dial . . . . .	11	8
Starting procedure . . . . .	12	8
Balance adjustment . . . . .	13	8
Operating procedures . . . . .	14	9
Stopping procedure . . . . .	15	11
CHAPTER 3. ORGANIZATIONAL MAINTENANCE		
Section I. Preventive maintenance services		
Tools and materials . . . . .	16	12
General preventive maintenance techniques . . . . .	17	12
Use of preventive maintenance forms . . . . .	18	12
II. Troubleshooting at organizational maintenance level		
General . . . . .	19	15
Visual inspection . . . . .	20	15
Troubleshooting by using equipment performance check list . . . . .	21	15
Equipment performance check list . . . . .	22	15
CHAPTER 4. THEORY		
Theory of operation . . . . .	23	17
Circuit analysis . . . . .	24	17
CHAPTER 5. FIELD MAINTENANCE		
Section I. Troubleshooting at field maintenance level		
Troubleshooting procedures . . . . .	25	20
Test equipment required for troubleshooting . . . . .	26	20
Troubleshooting chart . . . . .	27	20
Dc resistances of transformers . . . . .	28	21
II. Repairs		
Replacement of parts . . . . .	29	25
Disassembly and reassembly of dekapot . . . . .	30	25
III. Final testing		
Purpose of final testing . . . . .	31	27
Test equipment required for final testing . . . . .	32	27

	Paragraph	Page
Section III	Final testing-continued	
	Resistance check of dekapot .....	33 27
	Phase sensitivity check .....	34 28
	Sensitivity check .....	35 28
<b>SHIPMENT AND LIMITED STORAGE AND DEMOLITION TO PREVENT ENEMY USE</b>		
Shipment and limited storage		
	Disassembly .....	36 29
	Material requirements .....	37 29
	Field repackaging .....	38 29
II. Demolition of material to prevent enemy use		
	Authority for demolition .....	39 29
	Methods of destruction .....	40 30

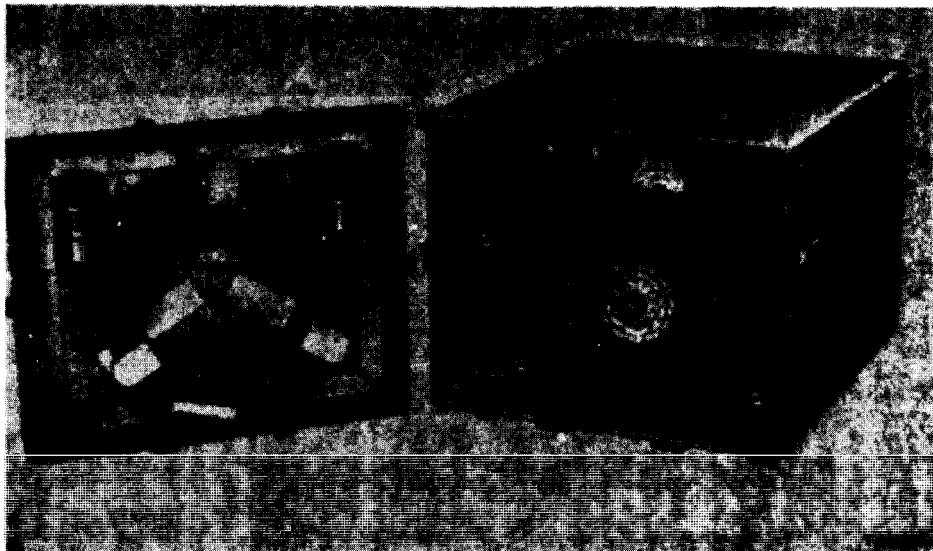

*Figure 1. Computer Test Set TS-909/PPM.*

# CHAPTER 1

## INTRODUCTION

### Section I. GENERAL

#### 1. Scope

a. This manual covers the installation, operation, maintenance, and repair of Computer Test Set TS-909/PPM (fig. 1).

b. Forward comments on this publication directly to Commanding Officer, U. S. Army Signal Publications Agency, Fort Monmouth, N. J.

#### 2. Forms and Records

##### a. *Unsatisfactory Equipment Reports.*

- (1) Fill out and forward DA Form 468 (Unsatisfactory Equipment Report) to Commanding General, U. S. Army Signal Equipment Support Agency, Fort Monmouth, N.J., as prescribed in AR 700-38.
- (2) Fill out and forward AFTO Form 29 (Unsatisfactory Report) to Commander, Air Materiel Command, Wright-Patterson Air Force Base, Dayton,

Ohio, as prescribed in AF TO 00-35D-54.

b. *Damaged or Improper Shipment.* Fill out and forward DD Form 6, (Report of Damaged or Improper Shipment) as prescribed in AR 700-58 (Army), and AFR 71-4 (Air Force).

##### c. *Preventive Maintenance Forms.*

- (1) Prepare DA Form 11-238 (Operator First Echelon Maintenance Check List for Signal Corps Equipment-Radio Communication, Direction Finding, Carrier, Radar) (fig. 7) in accordance with instructions on the back of the form.
- (2) Prepare DA Form 11-239 (Second and Third Echelon Maintenance Check List for Signal Corps Equipment-Radio Communication, Direction Finding, Carrier, Radar) (fig. 8) in accordance with instructions on the back of the form.

### Section II. DESCRIPTION AND DATA

#### 3. Purpose and Use

Computer Test Set TS-909/PPM is a null-indicating device used for alining and adjusting 400-cycle analog computers of radar sets. The computer is alined and adjusted by comparing the computer analog voltages to standard reference voltages applied through the test set. For specific alinement procedures for a particular computer, consult the applicable technical manual for that computer.

#### 4. Technical Characteristics

Reference-voltage  
range . . . . . 200 volts maximum.

#### Input impedance:

Across reference  
terminals . . . . . 0-10,000 ohms.

At signal input  
terminals . . . . . More than 1 megohm.

Sensitivity . . . . . Better than 5 mv at  
input.

#### Power requirements:

Dc . . . . . 10 ma at 200 volts  
(±10 percent).

Ac . . . . . 110-125 volts, 400 cps,  
single phase.

Number of tubes . . . . . 1.

Weight . . . . . 27.5 pounds.

5. Components of Computer Test Set  
TS-909/PPM

a. *Components.* The components of the test set are listed in the following table:

Quantity	Component	Length (in.)	Width (in.)	Height (in.)	Volume (cu ft)	Unit weight (lb)
1	Panel-chassis assembly in case .....	10 3/4	12 9/16	13 3/4	1	27.5
2	Technical Manual TM 11-1223 .....	10 1/4	1/4	7 3/4		.2
1	Cable W4601 .....	60				2.0
1	Cable W4602 .....	60				.2
1	Cable W4603 .....	60				.2
1	Cable W4604 .....	60				.2
1	Cable W4605 .....	60				.2
1 set	Running spares (b below) .....					1.0
<b>Total</b> .....						<b>31.7</b>

b. *Running Spares.* The following is a list of running spares for the test set. These items are stored in a separate package.

Quantity	Item
15	Crystal unit, rectifying 1N63
1	Electron tube type 5751
5	Fuse, cartridge, .5 ampere
5	Fuse, cartridge, .01 ampere
3	Lamp, glow (NE-51)
3	Lamp, panel (Mazda No. 47)

6. Description

a. *Panel-Chassis Assembly.* This test set consists of a panel-chassis assembly contained in a steel case. The case is equipped with a carrying handle and four protective feet. The

cover contains all the cords and cables supplied with the equipment. All controls and test jacks of the test set are mounted on the front panel.

b. *Cables* (fig. 2). Five cables are supplied with the test set. Two of the cables (W4603 and W4604) are single rubber-covered test leads commonly used with multimeters. A third lead (W4605) is identical but has an alligator clip on one end. Cable W4602 is made of AN type RG-59A/U coaxial cable and is terminated at the test set end with connector UG-260/U. At the other end is a conventional test prod. Cable Assembly Power Electrical CX-3382/U (W4601) has six conductors and is terminated with AN-3106A-20-7 male and female connectors. All cables are 5 feet long.

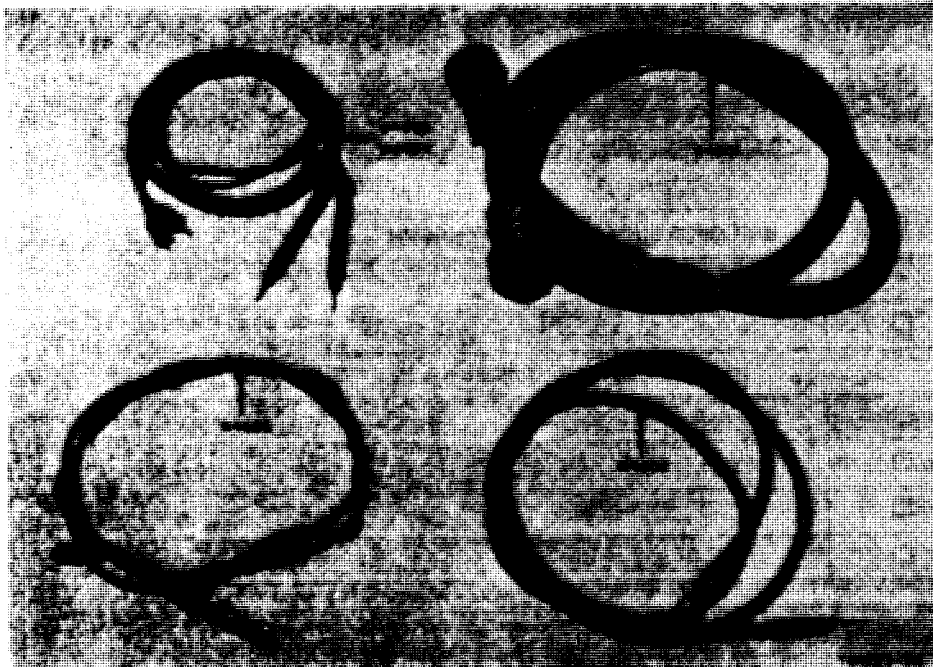

*Figure 2. Cables W4601 through W4605.*

CHAPTER 2  
INSTALLATION AND OPERATING INSTRUCTIONS

---

Section I. SERVICE UPON RECEIPT OF EQUIPMENT

7. Unpacking

*a. Packaging Data.* When packaged for export shipment, the test set is placed in a moisture-vaporproof container and is packed in a wooden case. For domestic shipment, the wooden case may be omitted. The test set packed for export shipment is shown in figure 3. The case is 16½ inches by 19½ inches by 23¾ inches. The volume of the case is 4.4 cubic feet and the total weight is approximately 55 pounds.

*b. Removing Contents* (fig. 3). To unpack the equipment follow procedure in (1) through (4) below.

- (1) Cut and fold back the metal straps.
- (2) Remove the nails from the top and one side of the case with a nail puller. Do not attempt to pry off the sides and top.

(3) Open the moistureproof barrier and remove the outer corrugated carton.

(4) Open the outer and inner corrugated cartons and remove the contents.

8. Checking Unpacked Equipment

*a.* Inspect the test set for damage incurred during shipment. If the equipment is incomplete or has been damaged during shipment, refer to paragraph 2b.

*b.* If the equipment has been used or reconditioned, check to see whether it has been changed by a modification work order (MWO). If modified, the MWO number will appear on the front panel near the nomenclature plate. Indicate the MWO number on the main schematic diagram (fig. 10).

*c.* Loosen the fuse holder caps and check to see that the fuses have the proper amperage rating as listed on the front panel.

**Caution:** To avoid damage to the test set, do not use any fuse other than that specified.

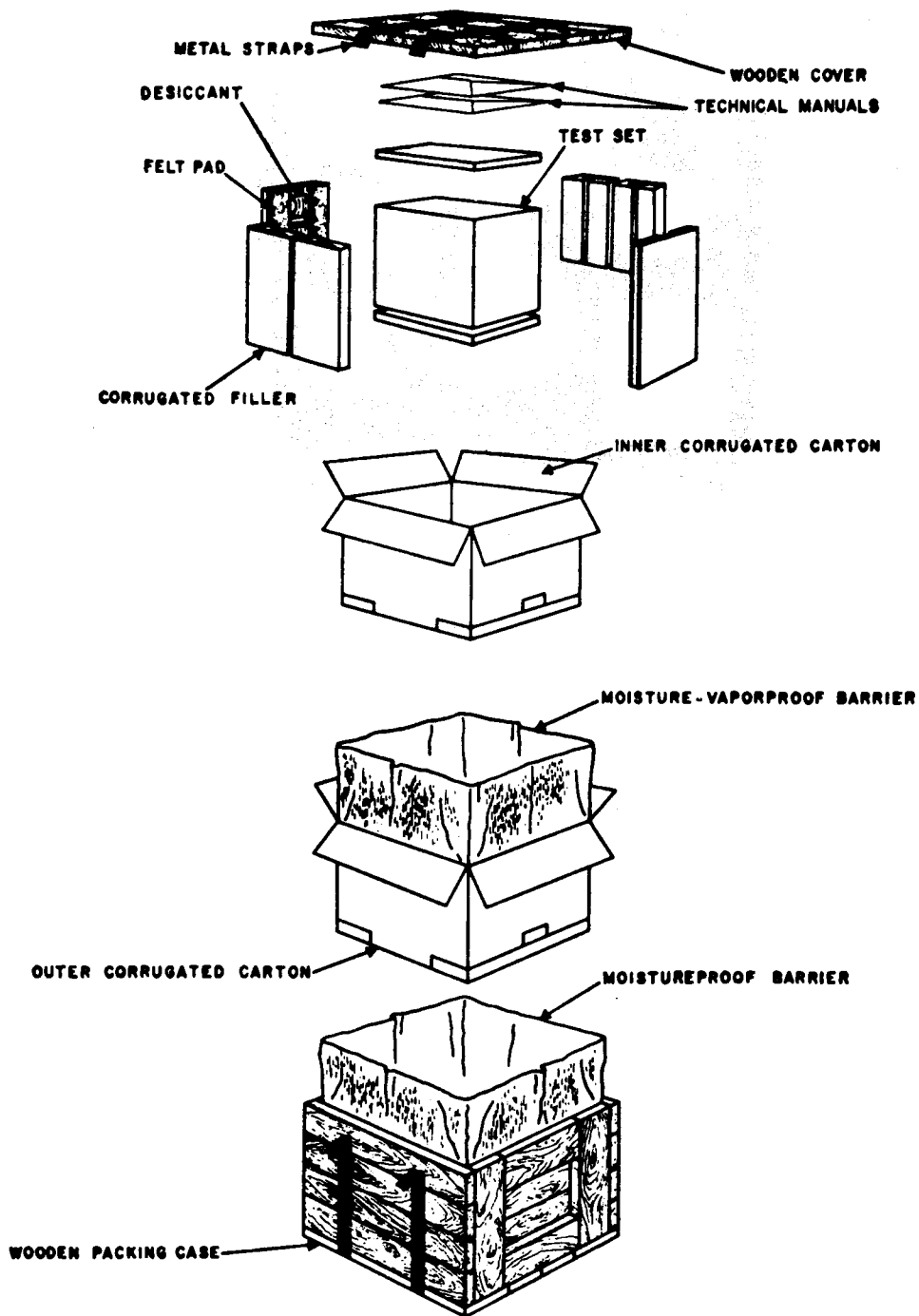

TM1223-3

Figure 3. Packaging diagram.

9. Controls and Instruments

The following chart lists the controls and instruments of the test set (fig. 4) and their functions:

Control or instrument	Function
MAIN POWER switch	In ON position, turns computer test set on.
BRIDGE ADJ dial	Adjusts test set potentiometer to obtain zero reading on NULL METER.
POWER ON lamp	When lit, indicates that power is applied to the test set.
Blown fuse indicator lamps	With power applied to test set, lamp lights when corresponding fuse is open.
NULL METER	Indicates voltage across bridge

10. Connections (fig. 4)

Place the test set on a firm support within 18 inches of the analog computer under test. The test set may be placed on top of the computer dust cover during alinement and adjustment. Position the test set so that its controls and the controls of the equipment being tested are both within easy reach.

**Warning:** Do not allow the test leads or cables to drape across high voltage or radio frequency (rf) circuits. Severe burns or shock and damage to equipment may result.

a. Connect the six-wire cable (W4601) to J4601 on the test set, and to the proper jack on the computer under test. (See technical manual for the individual radar set and analog computer. )

b. Connect the coaxial cable to the TEST PROBE jack on the test set panel.

c. Connect the black (W4603) cable to the -REF VOLT jack on the test set panel.

d. Connect the red (W4604) cable to the +REF VOLT jack on the test set panel.

e. Connect the black (W4605) cable (with clip) to the GROUND jack on the test set panel.

11. BRIDGE ADJ Dial

The inner scale of the BRIDGE ADJ dial is controlled by the center knob and is continuously adjustable from 0 to 100. The dial scale is marked in units of 10. A setting of 3 repre-

sents 30 ohms. The middle dial, operated by a handle fixed to it (fig. 4), controls a 10-position step switch. Each marking represents 100 ohms. With the outer dial set at zero, the middle dial set at 4, and the inner dial half-way between 5 and 6, the reading is 455 ohms. The outer dial is turned by grasping it at its outer edge and also controls a 10-position step switch. Each marking represents 1,000 ohms.

12. Starting Procedure

a. Apply power to the radar set.

b. After a 30-second warm-up period, throw the MAIN POWER switch on the test set to the ON position. The POWER ON pilot lamp of the test set should glow.

c. Connect the coaxial lead test probe (on W4602) and the two reference-voltage probes of the test set to the computer chassis.

d. Check to see that the NULL METER of the test set reads zero. If it does not, set the balance adjustment as described in paragraph 13.

13. Balance Adjustment

Changes in the resistances of the crystal diodes or other circuit components can cause the NULL METER to fail to read zero on initial check (par. 12c and d). Balance adjustment R4608 is used to reset the NULL METER to zero. This adjustment is made as follows :

a. Remove the panel-chassis assembly from the case by loosening the six captive screws in the front panel and pulling the panel-chassis forward.

b. Connect the cables to the front panel jacks as described in paragraph 10.

c. Set the MAIN POWER switch to the ON position.

d. Short the TEST PROBE and the + REF VOLT and -REF VOLT leads to the GROUND lead.

e. Observe the null indicator as balance adjustment R4608 (fig. 5) is rotated fully clockwise and then fully counterclockwise. The needle should deflect to right and left of zero at least 25 percent of full scale in each direction.



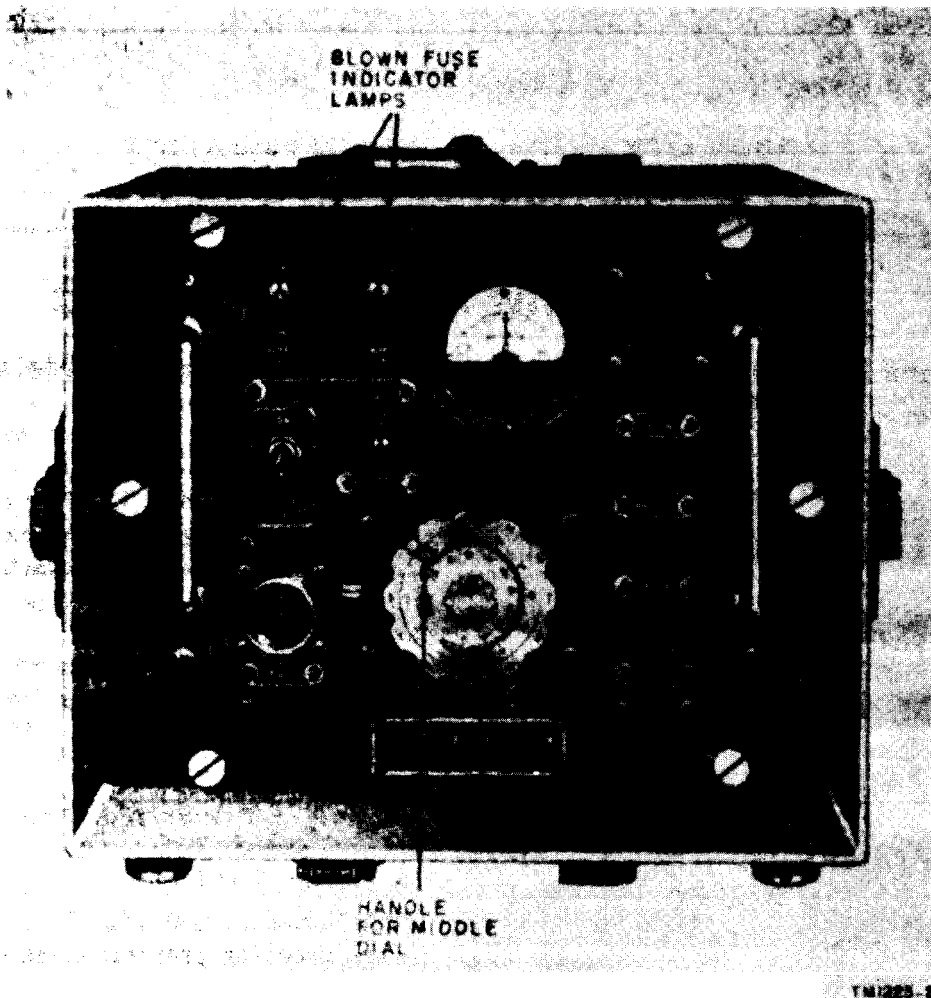

Figure 4. Computer Test Set TS-909/PPM, front panel.

f. Adjust R4608 so that the NULL METER reads zero.

#### 14. Operating Procedures

##### a. Operation as Null Meter.

- (1) Set all dials of the BRIDGE ADJ to zero.
- (2) Connect the GROUND lead to a good ground point on the chassis of the computer under test; connect the TEST PROBE to the test point for the analog voltage to be checked; the red test lead to the plus reference voltage test point in the computer chassis; and the black test lead to the return for the plus reference voltage.

- (3) Set BRIDGE ADJ to obtain a null reading on the meter and check the BRIDGE ADJ dial setting to see that it is within the prescribed limits listed in the computer manual.

##### b. Operation as Computer Alinement Tester.

*Note.* In using the test set to aline a computer system, refer to figure 6, which shows the diagram of a typical 400-cycle analog computer for which the test set was designed. For the specific alinement procedure for a particular computer, consult the applicable technical manual for that computer.

The alinement procedure consists of adjusting potentiometers R1, R2, R3, and setting potentiometer drive linkage between R1 and D, so that the voltage picked off R1 for any given differential input is of the proper predetermined analog value.

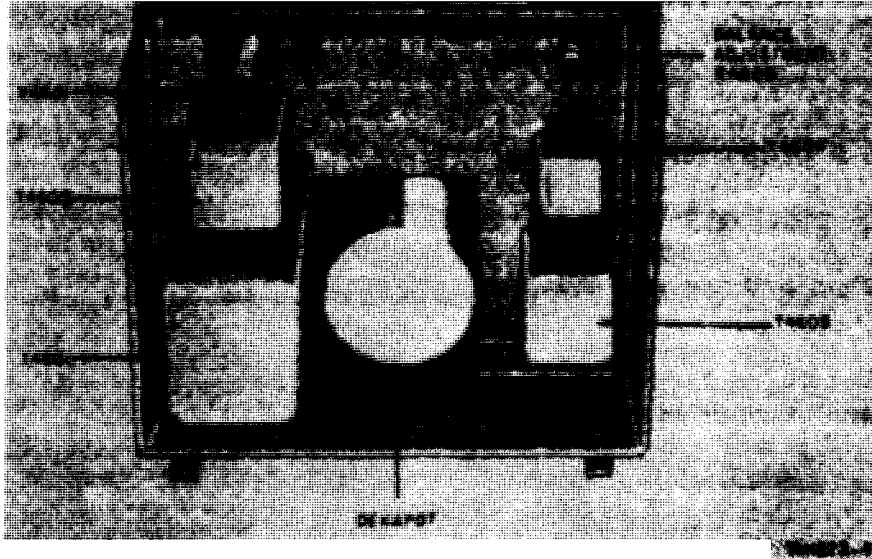
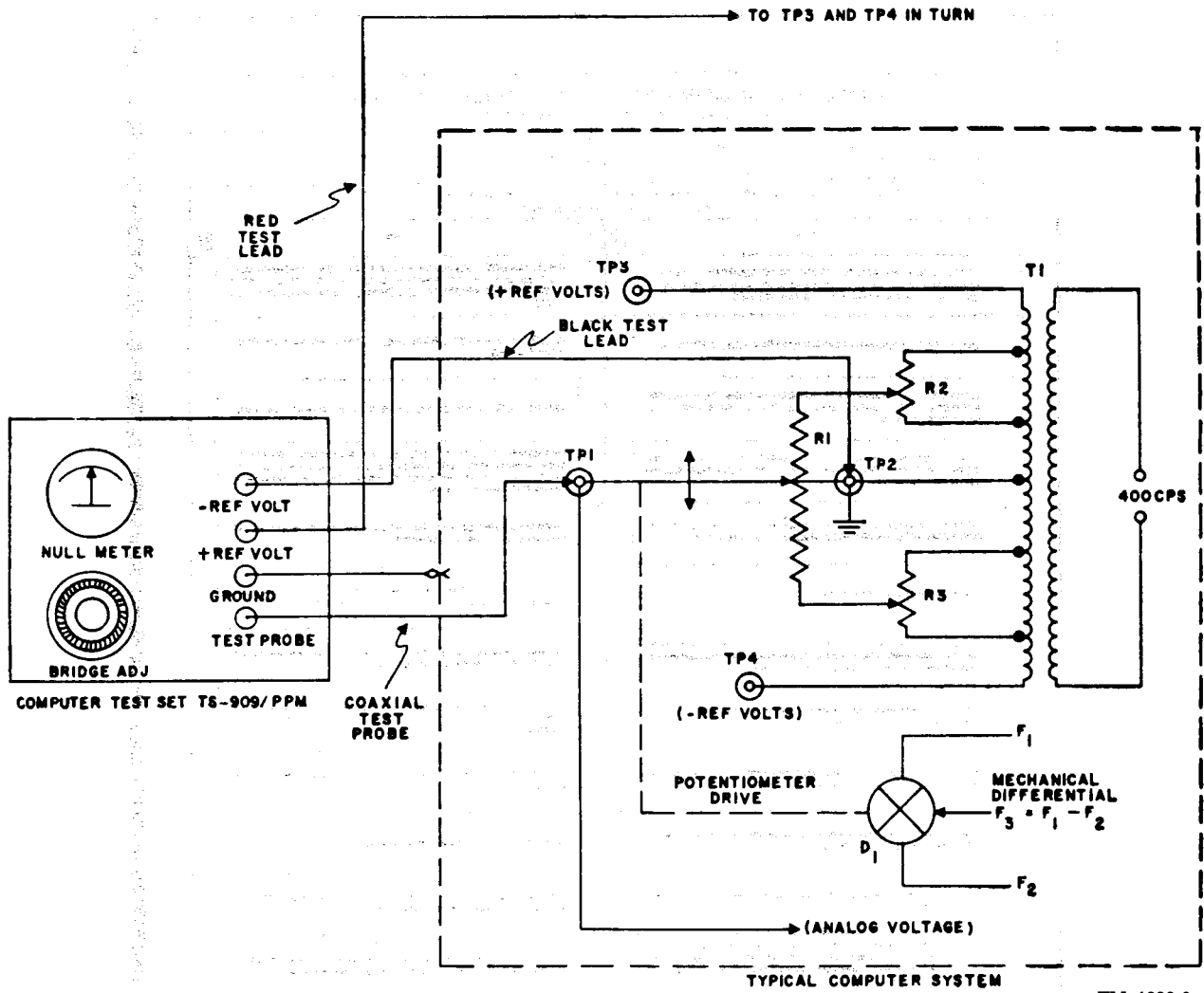

Figure 5. Rear view of test set chassis.

- (1) *Alinement of driven-shaft potentiometer R1 (fig. 6).*
  - (a) Connect the red test lead from the +REF VOLT jack of the test set to the plus reference voltage test point (TP3) of the computer.
  - (b) Connect the black test lead from the -REF VOLT jack of the test set to test point TP2 (return for the reference voltage).
  - (c) Connect the coaxial test probe to test point TP1 (the analog voltage being checked).
  - (d) Set the functions ( $F_1$  and  $F_2$ ) which control the shaft position of R1 to settings which should result in zero voltage at the center tap of R1. (The arm of R1 is mechanically linked to  $F_1$  and  $F_2$  and cannot be rotated except by changing the settings of these functions.)
  - (e) If the NULL METER does not read zero, rotate the *body* of potentiometer R1 until a null is obtained.
- (2) *Alinement of balancing potentiometer R2 (fig. 6).*
  - (a) Consult the computer alinement chart (in computer technical manual) for differential settings of  $F_1$  and  $F_2$  which correspond to a given setting of the test set BRIDGE ADJ dial. Set  $F_1$  and  $F_2$  according to the chart, and set the BRIDGE ADJ dial at the corresponding setting.
  - (b) With the test leads still connected as in (1) above, check to see that the NULL METER reads zero. If it does not, adjust R2 of the computer system to obtain a zero reading.
- (3) *Alinement of opposite balancing potentiometer R3 (fig. 6).*
  - (a) Move the red test lead of the test set from plus reference-voltage test point TP3 of the computer system to minus reference-voltage test point TP4.



TM 1223-6

Figure 6. Test diagram for typical computer system alignment.

(b) Consult the computer alinement chart (in computer technical manual for arbitrary settings of  $F_2$  and  $F_1$  which correspond to a given setting of the test set BRIDGE ADJ dial. Set  $F_2$  and  $F_1$  according to the chart, and set the BRIDGE ADJ dial at the corresponding setting.

(c) If the NULL METER does not read zero, adjust R3 of the computer system to obtain a zero reading.

15. Stopping Procedure

- a. Throw the MAIN POWER switch to OFF.
- b. Disconnect the test probe and test leads and disconnect power cable W4601 from J4601.
- c. Replace the cables in the test set cover as shown in figure 1.

# CHAPTER 3

## ORGANIZATIONAL MAINTENANCE

---

### Section I. PREVENTIVE MAINTENANCE SERVICES

#### 16. Tools and Materials

An Allen wrench (fig. 5) to fit the dekapot (BRIDGE ADJ) dial set screws are furnished with the test set. Tools and materials used, but not supplied with the test set are listed in a and b below.

*a. Tools.*

- 1 Tool Equipment TE-41
- 1 Tube Puller TL-201

*b. Materials.*

- Orange stick
- Cloth, lint-free\*
- Cleaning compound (Federal stock No. 7930-395-9542)
- Sandpaper, flint No. 000\*

*c. Test Equipment.*

- Multimeter TS-352A/U

---

\* Part of Tool Equipment TE-41.

#### 17. General Preventive Maintenance Forms

*a.* Use No. 000 sandpaper to remove corrosion.

*b.* Use a clean, dry, lint-free cloth or a dry brush for cleaning. If necessary, wipe any parts, including electrical contacts, with a cloth moistened with Cleaning Compound; wipe the parts dry with a cloth.

**Caution:** Cleaning Compound is flammable; do not use near a flame. Prolonged breathing of the fumes is dangerous. Make sure that adequate ventilation is provided.

#### 18. Use of Preventive Maintenance Forms (figs. 7 and 8)

DA Forms 11-238 (fig. 7) and 11-239 (fig. 8) are used for preventive maintenance. Instructions for use of the form appear on the reverse side of the form. Items not applicable to the test set are lined out in the figure.

**OPERATOR FIRST ECHELON MAINTENANCE CHECK LIST FOR SIGNAL CORPS EQUIPMENT**  
**RADIO COMMUNICATION, DIRECTION FINDING, CARRIER, RADAR**

INSTRUCTIONS: See other side

EQUIPMENT NOMENCLATURE

*COMPUTER TEST SET TS-909/CPM*

EQUIPMENT SERIAL NO.

LEGEND FOR MARKING CONDITIONS: ✓ Satisfactory; X Adjustment, repair or replacement required; ① Defect corrected.  
 NOTE: Strike out items not applicable.

**DAILY**

NO	ITEM	CONDITION						
		S	M	T	W	T	F	S
1	COMPLETENESS AND GENERAL CONDITION OF EQUIPMENT ( <del>receiver, transmitter, carrying cases, wire and cable, microphone, tubes, spare parts, technical manuals and accessories</del> ).							
2	<del>LOCATION AND INSTALLATION SUITABLE FOR NORMAL OPERATION.</del>							
3	CLEAN DIRT AND MOISTURE FROM <del>ANTENNA, MICROPHONE, HEADSETS, CHECKERS, KEYS, JACKS, PLUGS, TELEPHONES, CARRYING BAGS, COMPONENT PANELS.</del>							
4	INSPECT SEATING OF READILY ACCESSIBLE "PLUCK-OUT" ITEMS: <del>TUBES, LAMPS, CRACKERS, FUSES, CONNECTORS, VIBRATORS, PLUG-IN COILS AND RESISTORS.</del>							
5	INSPECT CONTROLS FOR BINDING, SCRAPING, EXCESSIVE LOOSENESS, <del>BORN OR CHIPPED GEARS, MISALIGNMENT, POSITIVE ACTION.</del>							
6	CHECK FOR NORMAL OPERATION.							

**WEEKLY**

NO.	ITEM	COND- TION	NO	ITEM	COND- TION
7	<del>CLEAN AND TIGHTEN EXTERIOR OF COMPONENTS AND CASES, <del>HOOK MOUNTS, SHOCK MOUNTS, ANTENNA MOUNTS, SIGNAL TRANSMISSION LINES, WAVE GUIDES, AND CABLE CONNECTIONS.</del></del>		13	<del>INSPECT STORAGE DIFFERENTIALS FOR DIRT, LOOSE TERMINALS, ELECTROLYTE LEVEL AND SPECIFIC GRAVITY, AND DAMAGED CASES.</del>	
8	INSPECT CASES, <del>MOUNTINGS, ANTENNAS, TOWERS, AND EXPOSED METAL SURFACES, FOR RUST, CORROSION, AND MOISTURE.</del>		14	CLEAN <del>AIR FILTERS, BRASS NAME PLATES, DIAL AND METER WINDOWS, JEWEL ASSEMBLIES.</del>	
9	INSPECT CORD, CABLE, WIRE, <del>AND SHOCK MOUNTS FOR CUTS, BREAKS, FRAYING, DETERIORATION, KINKS, AND STRAIN.</del>		15	INSPECT METERS FOR DAMAGED GLASS AND CASES.	
10	<del>INSPECT ANTENNA FOR ECCENTRICITIES, CORROSION, LOOSE FIT, DAMAGED INSULATORS AND REFLECTORS.</del>		16	<del>INSPECT SHELTERS AND COVERS FOR ADEQUACY OF WEATHER-PROOFING.</del>	
11	<del>INSPECT CANVAS ITEMS, LEATHER, AND CABLING FOR MILDOW, TEARS, AND FRAYING.</del>		17	CHECK ANTENNA GUY WIRES FOR LOOSENESS AND PROPER TENSION.	
12	INSPECT FOR LOOSENESS OF ACCESSIBLE ITEMS: SWITCHES, <del>KNOBBS, JACKS, CONNECTORS, ELECTROMECHANICAL TRANSFORMERS, POWER STAYS, RELAYS, SELECTIVE MOTORS, DIODES, CAPACITORS, GENERATORS, AND PILOT LIGHT ASSEMBLIES.</del>		18	<del>SHOCK TERMINAL BOX COVERS FOR CRACKS, LEAKS, DAMAGED GASKETS, DIAL AND CAGE.</del>	

19 IF DEFICIENCIES NOTED ARE NOT CORRECTED DURING INSPECTION, INDICATE ACTION TAKEN FOR CORRECTION.

DA FORM 11-238  
 1 MAY 51

REPLACES DA AGO FORM 419, 1 DEC 50, WHICH IS OBSOLETE.

TM 1223-7

Figure 7. DA Form 11-238.

SECOND AND THIRD ECHELON MAINTENANCE CHECK LIST FOR SIGNAL CORPS EQUIPMENT RADIO COMMUNICATION, DIRECTION FINDING, CARRIER, RADAR			
INSTRUCTIONS - See other side			
EQUIPMENT NOMENCLATURE <i>COMPUTER TEST SET TS-909/PPM</i>		EQUIPMENT SERIAL NO.	
LEGEND FOR MARKING CONDITIONS: ✓ Satisfactory; X Adjustment, repair, or replacement required; ⊕ Defect corrected NOTE: Strike out items not applicable			
NO.	ITEM	NO.	ITEM
1	COMPLETENESS AND GENERAL CONDITION OF EQUIPMENT (receiver, transmitter, carrying case, disc and cable, microphone, tubes, spare parts, technical manuals, and accessories).	19	INSPECT TUBES - INSPECT FOR LOOSE CONNECTIONS, CRACKS, CORROSION, BURNED CONTACTS, CORROSION, RESIDUE, CLEAN SURF AND SURF SURFACES, CHECK CONDITION OF RECEIVER FIVE TUBES.
2	SECTION AND INSTRUCTION BOOKS FOR NORMAL OPERATION.	20	INSPECT FUSE SUPPORTS FOR LOOSE PARTS, SURF, MISALIGNMENT, AND CORROSION.
3	CLEAN DIRT AND MOISTURE FROM APPRONS, MICROPHONE, HEADPHONE, MICROPHONE, JACKS, PLUGS, TELEPHONE, GARRING, BAGS, COMPONENT PARTS.	21	INSPECT FUSE CAPACITORS FOR LEAKS, CRACKS, AND DISCOLORATION.
4	INSPECT SEATING OF READILY ACCESSIBLE "PLUCK-OUT" ITEMS TUBES, LAMP SOCKETS, FUSES, CONNECTORS, WELDINGS, PLUG-IN SOLETS, AND RESISTORS.	22	INSPECT RELAYS AND CONTACTS FOR CORROSION, CRACKS, AND DISCOLORATION, CHECK CONTACTS FOR PROPER CONTACTING, CHECK FOR PROPER TIGHTNESS OF PLUNGERS AND WIND PARTS.
5	INSPECT CONTROLS FOR BINDING, SCRAPPING, EXCESSIVE LOOSENESS, WORN OR BIPPED SURF, MISALIGNMENT, POSITIVE ACTION.	23	INSPECT TUBES CAPACITORS FOR SURF, MISALIGNMENT OF PLATES, AND LOOSE MOUNTING.
6	CHECK FOR NORMAL OPERATION.	24	INSPECT RESISTORS, BURNING AND DISCOLORATION FOR CRACKS, CHIPPING, BLISTERING, DISCOLORATION, AND DISCOLORATION.
7	CLEAN AND TIGHTEN EXTERIOR OF COMPONENTS AND CASES. RACK MOUNTS, SHIELD MOUNTS, ANTENNA MOUNTS, COAXIAL TRANSMISSION LINES, WAVE GUIDES, AND CABLE CONNECTIONS.	25	INSPECT TERMINALS OF LINE FUSES CAPACITORS AND RESISTORS FOR CORROSION, SURF, AND LOOSE CONTACTS.
8	INSPECT CASE MOUNTINGS - INSPECTING POWER AND EXPOSED METAL SURFACES, FOR RUST, CORROSION, AND MOISTURE.	26	CLEAN AND POLISH FINISHED, TERMINAL BLOCKS, SLIDERS, RELAY BASES AND INTERIORS OF CHASSIS AND CABINETS NOT READY ASSEMBLY.
9	INSPECT CORD, CABLE WIRE AND SHIELD MOUNTS FOR CUTS, BREAKS, FRAYING, DETERIORATION, KINKS, AND STRAIN.	27	INSPECT TERMINAL BLOCKS FOR LOOSE CONNECTIONS, CRACKS, AND DISCOLORATION.
10	INSPECT SURFACES FOR CORROSION, CRACKS, DISCOLORATION, AND DISCOLORATION.	28	CHECK SETTINGS OF ADJUSTABLE RELAYS.
11	INSPECT SHIELDING, LEATHER, AND CARBON FOR CRACKS, PLAYS, AND FOLDING.	29	CONVERT EQUIPMENT TO ACCORDANCE WITH APPROVED DEPARTMENT OF THE ARMY REGULATION ORDER.
12	INSPECT FOR LOOSENESS OF ACCESSIBLE ITEMS SWITCHES, KNOBS, JACKS, CONNECTORS, TRANSFORMERS, POWER SUPPLY REGULATORS, RELAYS, CAPACITORS, RESISTORS, AND PILOT LIGHT ASSEMBLIES.	30	INSPECT GENERATORS, RELAYS, CONTACTS, AND CONTACTS, CHECK FOR PROPER CONTACTING, AND CONTACTS OF CONTACTS.
13	INSPECT STORAGE BATTERIES FOR SURF, LOOSE TERMINALS, CRACKS, WIND LEVELS, AND SPEAKING CRACKS, AND DISCOLORATION.	31	CLEAN AND TIGHTEN CONNECTIONS AND MOUNTINGS FOR TRANSFORMERS, SHIMMS, POTENTIOMETERS, AND RESISTORS.
14	CLEAN AIR FILTERS, GAUGE NAMEPLATES, DIALS AND METER WINDOWS, JEWEL ASSEMBLIES.	32	INSPECT TRANSFORMERS, SHIMMS POTENTIOMETERS, AND RESISTORS FOR OVERHEATING AND DISCOLORATION.
15	INSPECT METERS FOR DAMAGED GLASS AND CASES.	33	INSPECT SHIMMS OR SHIMMS - REMOVE SURF.
16	INSPECT FILTERS AND COVERS FOR ADEQUACY OF WEATHER PROOFING.	34	INSPECT SHIMMS RAY TUBES FOR SURF, CRACKS, SPOTS.
17	CHECK ANTENNA CUM WIRE FOR LOOSENESS AND PROPER TENSION.	35	INSPECT SHIMMS FOR SHIMMS AND SHIMMS.
18	CHECK TERMINAL BOX COVERS FOR CRACKS, LEAKS, DAMAGED SHIMMS, SURF, AND CRACKS.	36	INSPECT FOR LEAKING WATERPROOF GASKETS, WORN OR DISCOLORATION.
		37	INSPECT AND TIGHTEN.
38	IF DEFICIENCIES NOTED ARE NOT CORRECTED DURING INSPECTION, INDICATE ACTION TAKEN FOR CORRECTION.		

DA FORM 11-239  
MAY 51

Replace DA AGU Form 48, 1 Dec 48, which it obsolete.

16-4885-9

TM 1223-8

Figure 8. DA Form 11-239.

## Section II. TROUBLESHOOTING AT ORGANIZATIONAL MAINTENANCE LEVEL

### 19 General

a. The troubleshooting and repair work that can be performed at the organizational maintenance level (operators and repairmen) are limited by the tools, test equipment, and replaceable parts issued. Accordingly, troubleshooting is based upon the performance of the equipment and the use of the senses in determining such troubles as burned-out fuses, broken cords, defective tube, cracked insulators, etc.

b. Paragraphs 20 through 22 help to determine which component is at fault and in localizing the fault in the circuit to the defective stage or item, such as a tube or fuse.

### 20. Visual Inspection

a. Failure of the test set to operate properly may be caused by one or more of the following:

- (1) Worn, broken, or disconnected cords or plugs.
- (2) Burned-out fuses (indicated on front panel when power is on).
- (3) Broken or disconnected wires.
- (4) Defective tube (tube not lit or broken).

b. When failure is encountered and the cause is not immediately apparent, check as many of these items as possible before starting a systematic troubleshooting procedure. If possible, obtain information from the operator of the

equipment regarding performance at the time trouble occurred.

### 21. Troubleshooting by Using Equipment Performance Checklist

The equipment performance checklist will assist the unit repairman in locating the trouble in the test set systematically. All corrective measures which he can perform are given in the corrective measures column. Start at the beginning of the check list and follow each step in order. In some cases, the abnormal indication permits immediate localization of trouble to a particular part and the corrective measure indicates the specific part to be repaired or replaced. In other cases, however, the abnormal indications only sectionalize the trouble to a particular group of parts. In these latter cases, the corrective measures call for additional testing procedures to localize the trouble. When the procedure referred to is beyond the scope of organizational maintenance personnel, troubleshooting at a higher echelon is required. Note on the repair tag how the equipment performed and what corrective measures were taken.

### 22. Equipment Performance Checklist

Before starting the equipment performance checklist, apply power to the radar set and allow the test set to warm up for at least 30 seconds.

	Item No.	Item	Action or condition	Normal indication	Corrective measure
START	1	MAIN POWER switch	Turn to ON	POWER ON pilot lamp lights.	Check pilot lamp. Check power cable W4601.
	2	Fuses F4601 and F4602		Pilot lamps above fuse receptacles remain out.	Check fuses. If fuse blows when replaced, higher echelon repair is required.
	3	NULL METER	Red test lead, black test lead, and TEST PROBE shorted to GROUND test lead.	NULL METER reads zero.	Adjust R4608 (par. 13) to obtain a null reading. Higher echelon repair may be required.
	4	NULL METER	Make connections to computer for operation as a null meter (par. 14a(2)). Proper reference voltages applied through test leads.	Meter should deflect to right or left.	Check test connections. Check V4601 (fig. 5) by substitution. If meter fails to deflect, higher echelon repair is required.

	Item No.	Item	Action or condition	Normal indication	Corrective measure
EQUIPMENT PERFORMANCE	5	BRIDGE ADJ control	Turn to obtain null reading on meter.	NULL METER reads zero.	Check resistance of dekapot, Higher echelon repair is required.
	6	Test computer	Follow operating procedures in paragraph 14b	Null obtained on NULL METER when computer is properly adjusted.	Dekapot linearity may be impaired. Higher echelon repair is required.
STOP	7	MAIN POWER switch	Turn to OFF.	POWER ON pilot light will go out.	



## CHAPTER 4

### THEORY

---

#### 23. Theory of Operation

Figure 9 is a functional block diagram of the test set. Analog voltage  $E_A$  and reference voltage  $E_R$  are obtained from the computer under test. In the computer system shown in figure 6, the pick-off arm of highly linear potentiometer R1 is linked to the output of mechanical differential  $D_1$ . As shown, the voltage picked off R1 should electrically represent the difference in the two mechanical inputs to the differential ( $F_1 - F_2$ ). The amplitude of the pickoff voltage corresponds to the angular difference in shaft positions  $F_1$  and  $F_2$ , and the phase of the voltage determines whether the difference is positive or negative.

a. *Input Transformer T4601.* This transformer receives analog voltage  $E_A$  at one end of its primary, and reference voltage  $E_R$  through BRIDGE ADJ R4611 at the other end. When these voltages are equal, a null occurs. Any difference between  $E_A$  and  $E_R$ , however, causes a voltage to be induced into the secondary of T4601. This difference voltage,  $E_D$ , is then amplified and applied through the bridge circuit to the NULL METER, causing the meter needle to deflect.

b. *BRIDGE ADJ Potentiometer R4611.* According to a prescribed setting of its dial, this decade potentiometer picks off an accurate percentage of the reference voltage from the system under test and compares it to analog voltage  $E_A$  as described in a above.

c. *Difference Voltage Amplifier V4601.* This two-stage amplifier receives difference voltage  $E_D$  from the secondary of T4601, amplifies it, and applies it through transformer T4602 to the bridge circuit.

d. *Bridge.* The bridge is made up of a phase-sensitive network consisting of the four crystals, CR4601, CR4602, CR4603, and CR4604. The primary of bridge voltage trans-

former T4603 is supplied 115 volts alternating current (ac), 400 cycles, from the computer under test. Bridge voltage  $E_R$  is applied to the bridge to set a standard for phase determination.

#### 24. Circuit Analysis (fig. 10)

a. *Amplifier V4601.* The difference voltage,  $E_D$ , from the secondary of transformer T4601 is applied to control grid (pin 2) of the first stage. The amplified output of the first stage is coupled through capacitor C4601 to the input grid of the second stage. Resistor R4604 is the plate load resistor for the first stage. Resistors R4603 and R4606 are the cathode bias resistors for the first and second stages, respectively. Resistor R4605 is the grid-leak resistor for the second stage, and capacitor C4603 is a noise bypass capacitor. The amplified output of the second stage appears across the primary of T4602. Plate voltage for the two stages is obtained through J4601 from the computer and is applied through .01-ampere fuse F4601. If the fuse should burn out, the plate circuit is completed through R4601 and I 4601 and the neon blown fuse indicator lamp lights.

b. *Bridge.* The bridge standard voltage,  $E_R$ , is applied to the bridge through the resistive network consisting of R4607, balance adjustment R4608, and R4609. Resistor R4608 is adjustable to compensate for resistance variation in the crystal diodes or in other circuit components.

- (1) With no error signal into the bridge ( $E_A = E_R$ ), alternating current due to bridge standard voltage  $E_R$  flows through NULL METER M4601. The meter, however, has a direct current (dc) movement and reads the ac aver-

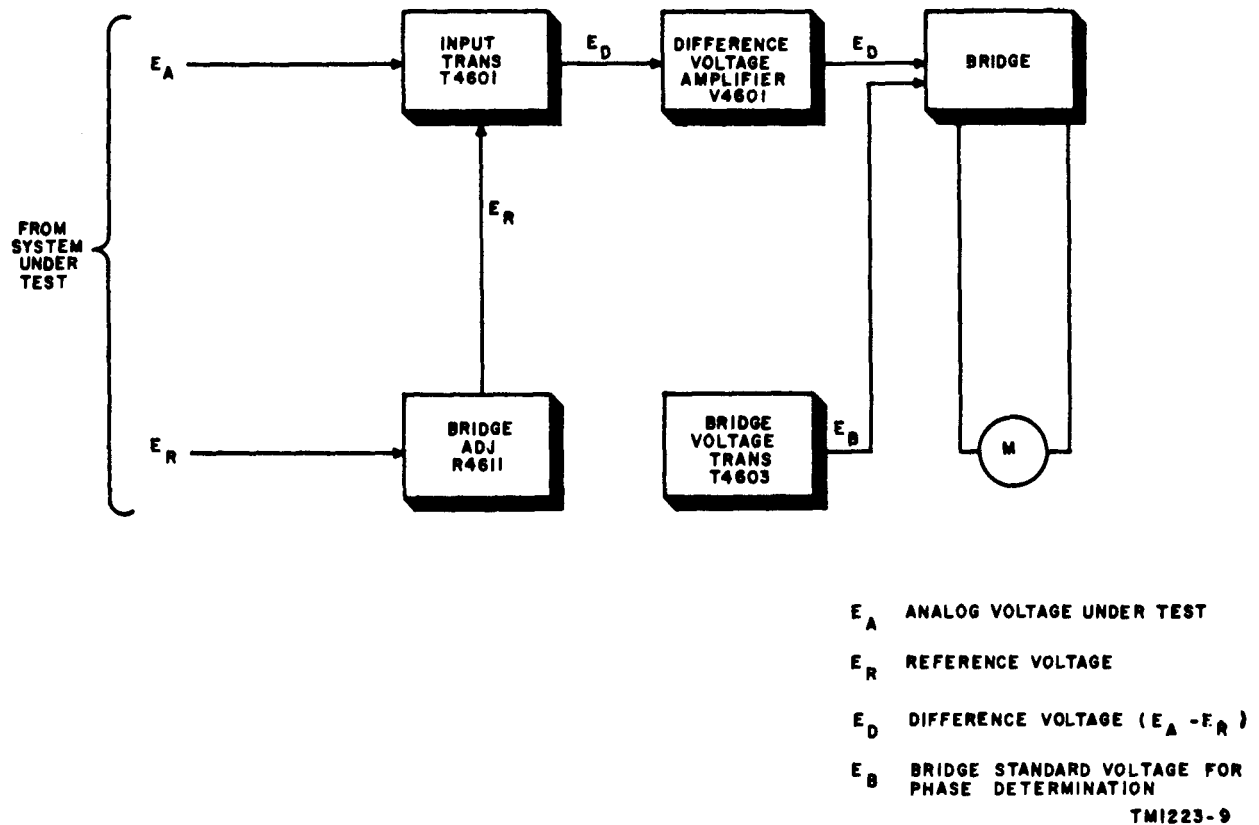
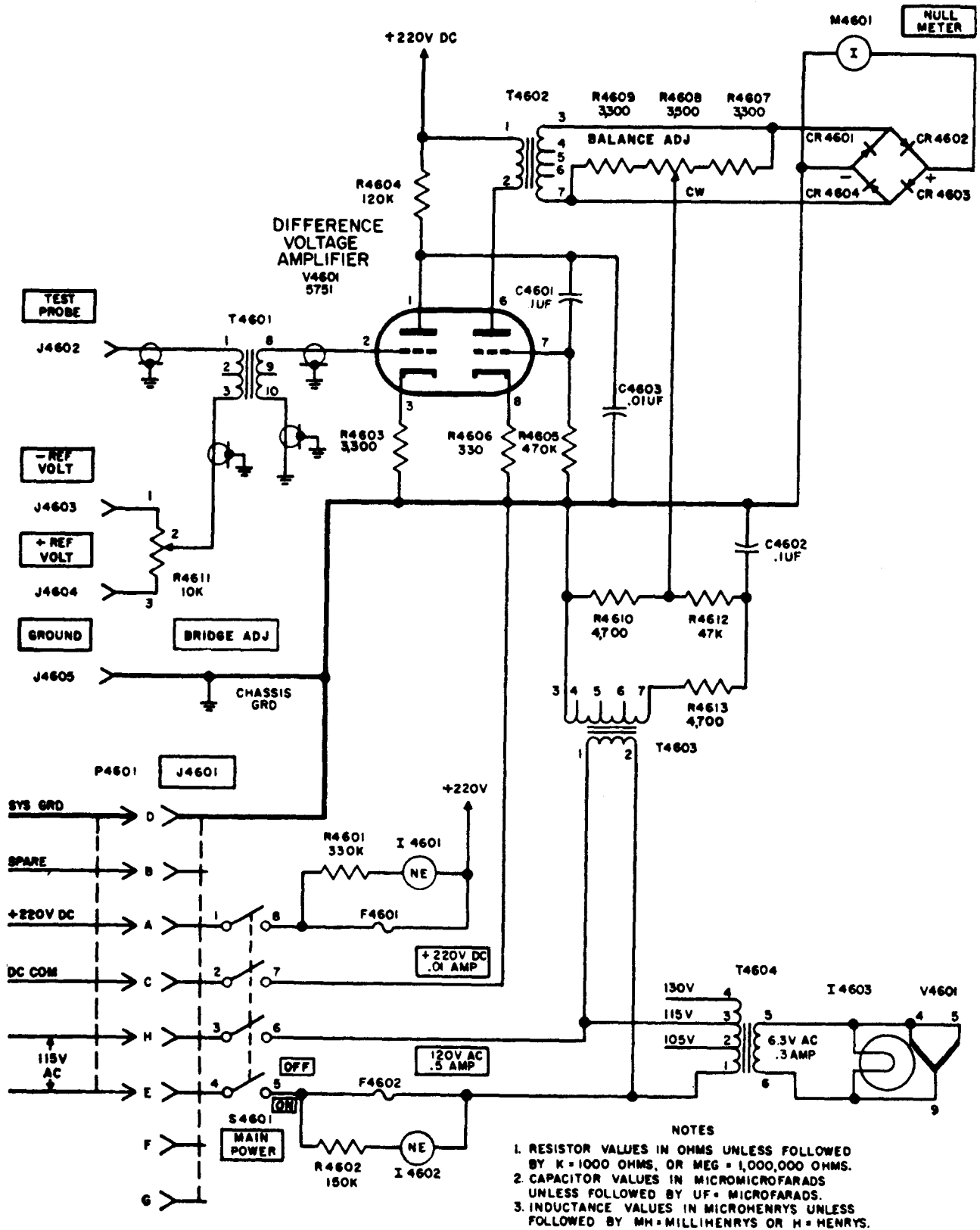

Figure 9. Computer Test Set TS-909/PPM, functional block diagram.

- age, or zero. This zero reading is checked during the starting procedure (par. 12).
- (2) Any difference voltage,  $E_D$ , appearing at the plate of V4601 is inductively coupled into the bridge circuit through T4602, where it combines

with bridge voltage  $E_B$  to increase the meter current during one-half the cycle and to decrease it during the other half cycle. The phase of the difference voltage,  $E_D$ , determines the direction in which the zero center NULL METER deflects.



TM 1223-21

Figure 10. Computer Test Set TS-909/PPM, schematic diagram.

## CHAPTER 5

### FIELD MAINTENANCE

*Note.* This chapter contains field maintenance instructions. The amount of repair that can be performed by units having field maintenance responsibility

is limited only by the tools and test equipment available and by the skill of the repairman.

#### Section I. TROUBLESHOOTING AT FIELD MAINTENANCE LEVEL

**Warning:** Certain points located throughout the chassis of the test set operate at voltages of 200 volts. Do not touch these points while power is applied to the test set. Be very careful when handling or testing any part of the test set while it is connected to the power source.

#### 25. Troubleshooting Procedures

Troubleshooting at field maintenance level includes all the techniques outlined for organizational maintenance and any special or additional techniques required to isolate a defective part. Because of the simplicity of the circuit and the few parts in the test set, servicing a defective set consists only of tracing the fault to the defective component. The tests listed below will aid in isolating the trouble.

*a. Troubleshooting Chart* (par. 27). The trouble symptoms listed in the chart will aid in localizing trouble to a specific component or group of components.

*b. Voltage and Resistance Checks.* These measurements help locate the individual component at fault. Use resistor and capacitor color codes (fig. 11 and 12) to find the value of the components. Use voltage and resistance diagrams (fig. 13 and 14 and par. 28) to find

normal readings and compare them with readings obtained in trouble shooting.

*c. Operational Test.* The equipment performance check list (par. 22) indicates the general location of trouble and in some instances the exact nature of the fault.

*d. Intermittent Troubles.* The possibility of intermittent troubles should not be overlooked. If present, this type of trouble often may be made to appear by tapping or jarring the equipment.

#### 26. Test Equipment Required for Troubleshooting

The test equipment required for troubleshooting the test set is listed below. Technical manuals associated with the equipment also are listed.

Test e	Technical manual
Electronic multimeter TS-505/U	TM 11-5511
Electron Tube Test Set TV-7/ U	TM 11-5083

#### 27. Troubleshooting Chart

The following chart is supplied as an aid in locating trouble in the test set. It lists the

Symptom	Probable trouble	Correction
Main power cable connected to source of power. MAIN POWER switch turned ON. POWER ON lamp does not light. Fuse lamp I 4601 or I 4602 lights.	Defective lamp, power cable, or T4604.	Replace defective component.
	Blown fuse F4601 or F4602 . . . . .	Replace blown fuse with spare fuse. If new fuse F4602 blows, check

Symptom	Probable trouble	Correction
Coaxial TEST PROBE, -REF VOLT and +REF VOLT leads shorted to ground. Failure to obtain a zero reading on NULL METER.	Defective potentiometer R4608. Defective crystal CR4601, CR4602, CR4603, or CR4604. Open R4609 or R4607.	windings of transformers T4603 and T4604 for short circuits. If new fuse R4601 blows, check T4602, R4604, and C4603. Replace defective component.
Meter fails to deflect when proper reference voltages are applied during operation as a null meter (par. 14a(2)).	Tube V4601 defective . . . . . Defective dekapot, T4601, components of V4601 stage.	Replace tube. Replace defective component.
Meter deflects during operation as null meter but BRIDGE ADJ control cannot cause NULL METER to zero.	Defective meter . . . . . Dekapot defective . . . . .	Replace meter. Replace dekapot (par. 30).

symptoms which the repairman observes, either visually or aurally, while making a few simple tests. The procedures described in the equipment performance checklist (par. 22) should be followed.

28. Dc Resistances of Transformers

The dc resistances of the transformers in the test set are listed below:

Transformer	Terminals	Ohms
T4601	1-3	1,100
	8-10	87
T4602	1-2	13,500
	3-7	63
T4603	1-2	13,500
	3-7	63
T4604	1-3	20
	5-6	1

## RESISTOR COLOR CODE MARKING (MIL-STD RESISTORS)

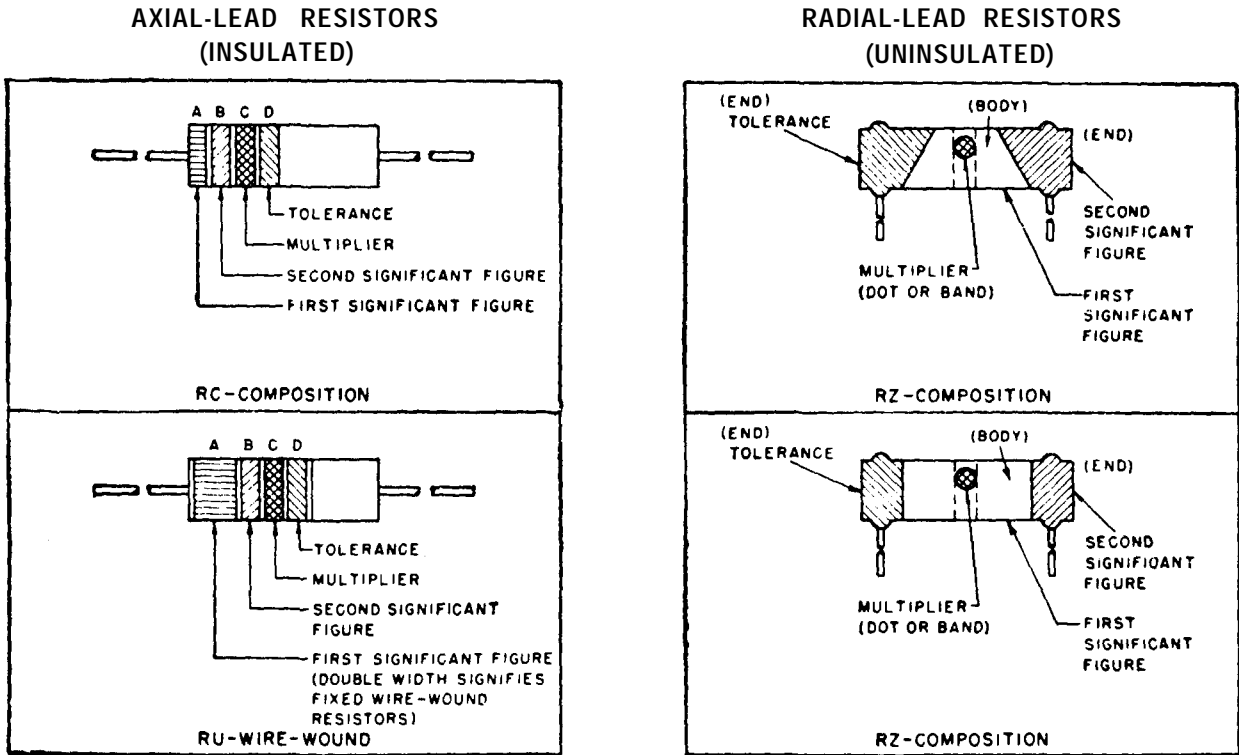

### RESISTOR COLOR CODE

BAND A OR BODY*		BAND B OR END*		BAND C OR DOT OR BAND*		BAND D OR END*	
COLOR	FIRST SIGNIFICANT FIGURE	COLOR	SECOND SIGNIFICANT FIGURE	COLOR	MULTIPLIER	COLOR	RESISTANCE TOLERANCE (PERCENT)
BLACK	0	BLACK	0	BLACK	1	BODY	$\pm 20$
BROWN	1	BROWN	1	BROWN	10	SILVER	$\pm 10$
RED	2	RED	2	RED	100	GOLD	$\pm 5$
ORANGE	3	ORANGE	3	ORANGE	1,000		
YELLOW	4	YELLOW	4	YELLOW	10,000		
GREEN	5	GREEN	5	GREEN	100,000		
BLUE	6	BLUE	6	BLUE	1,000,000		
PURPLE (VIOLET)	7	PURPLE (VIOLET)	7				
GRAY	8	GRAY	8	GOLD	0.1		
WHITE	9	WHITE	9	SILVER	0.01		

\* FOR WIRE-WOUND-TYPE RESISTORS, BAND A SHALL BE DOUBLE-WIDTH. WHEN BODY COLOR IS THE SAME AS THE DOT (OR BAND) OR END COLOR, THE COLORS ARE DIFFERENTIATED BY SHADE, GLOSS, OR OTHER MEANS.

**EXAMPLES (BAND MARKING):**

10 OHMS  $\pm 20$  PERCENT: BROWN BAND A, BLACK BAND B, BLACK BAND C; NO BAND D.  
 4.7 OHMS  $\pm 5$  PERCENT: YELLOW BAND A, PURPLE BAND B; GOLD BAND C; GOLD BAND D.

**EXAMPLES (BODY MARKING):**

10 OHMS  $\pm 20$  PERCENT: BROWN BODY, BLACK END, BLACK DOT OR BAND, BODY COLOR ON TOLERANCE END.  
 3,000 OHMS  $\pm 10$  PERCENT: ORANGE BODY, BLACK END, RED DOT OR BAND, SILVER END.

STD-R1

*Figure 11. MIL-STD resistor color codes.*

## CAPACITOR COLOR CODE MARKING (MIL-STD CAPACITORS)

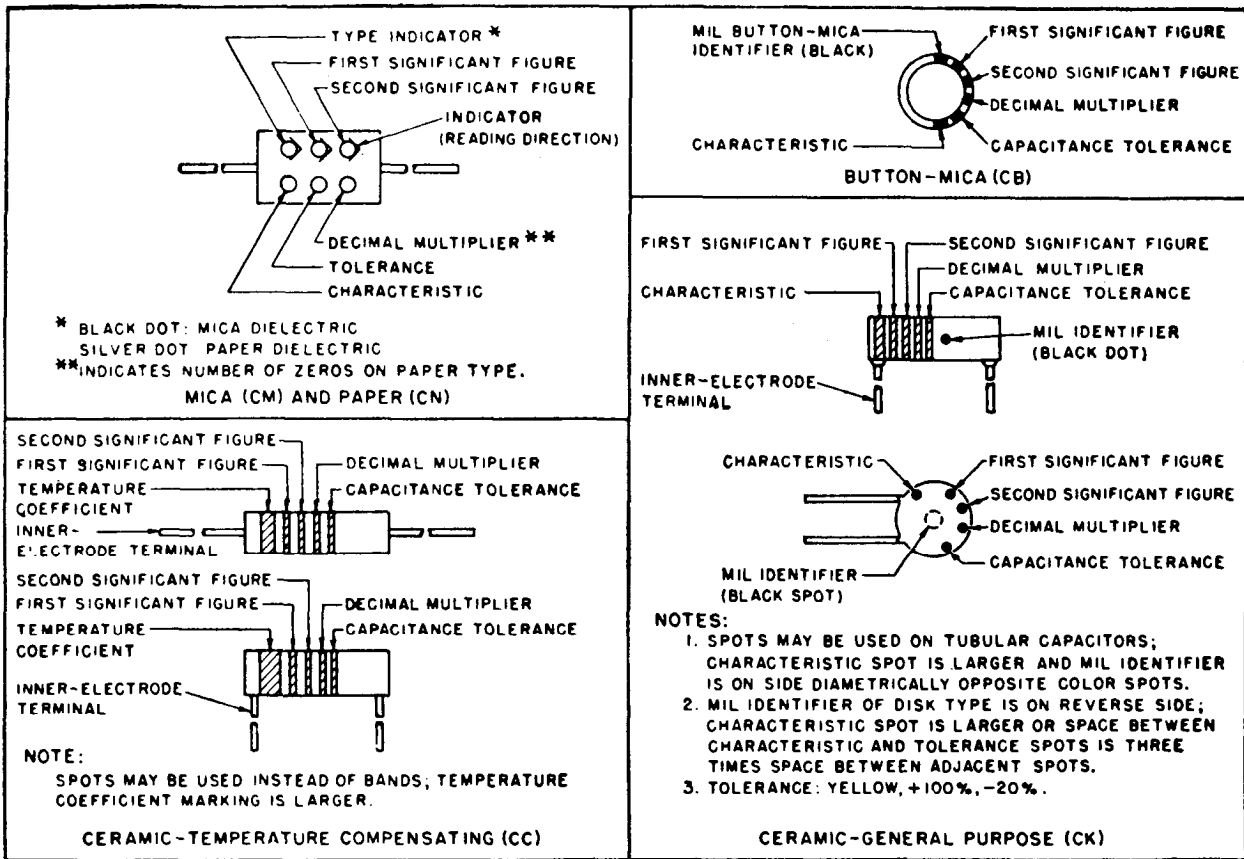

### CAPACITOR COLOR CODE

COLOR	SIG FIG.	MULTIPLIER		CHARACTERISTIC <sup>1</sup>				TOLERANCE <sup>2</sup>					TEMPERATURE COEFFICIENT (UUF/UF/°C)
		DECIMAL	NUMBER OF ZEROS	CM	CN	CB	CK	CM	CN	CB	CC		
											OVER 10UUF	10UUF OR LESS	
BLACK	0	1	NONE		A			20	20	20	20	2	ZERO
BROWN	1	10	1	B	E	B	W					1	-30
RED	2	100	2	C	H		X	2		2	2		-80
ORANGE	3	1,000	3	D	J	D			30				-150
YELLOW	4	10,000	4	E	P								-220
GREEN	5		5	F	R						5	0.5	-330
BLUE	6		6		S								-470
PURPLE (VIOLET)	7		7		T	W							-750
GRAY	8		8			X						0.25	+30
WHITE	9		9								10	1	-330(±500) <sup>3</sup>
GOLD		0.1						5		5			+100
SILVER		0.01						10	10	10			

1. LETTERS ARE IN TYPE DESIGNATIONS GIVEN IN MIL-C SPECIFICATIONS.  
 2. IN PERCENT, EXCEPT IN UUF FOR CC-TYPE CAPACITORS OF 10 UUF OR LESS.  
 3. INTENDED FOR USE IN CIRCUITS NOT REQUIRING COMPENSATION.

STD-C1

Figure 12. MIL-STD capacitor color codes.

DIFFERENCE VOLTAGE

AMPLIFIER  
V4601  
5751/12AX7

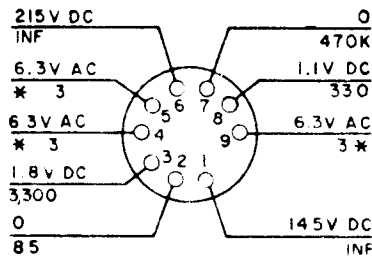

NOTES

1. V & R MEASUREMENTS TAKEN WITH A 20,000 OHMS-PER-VOLT METER.
2. NULL METER ZEROED.
3. INF DENOTES INFINITY.
4. READING TAKEN FROM SOCKET TO GROUND EXCEPT FILAMENTS. PINS 4 AND 5 ARE CONNECTED. MEASURE TO PIN 9.
5. RESISTANCE READINGS TAKEN WITH **MAIN POWER** SWITCH **OFF**
6. \* TUBE REMOVED. READINGS TAKEN FROM 4 AND 5 TO 9

TM1223-15

Figure 13. V4601 voltage and resistance diagram.

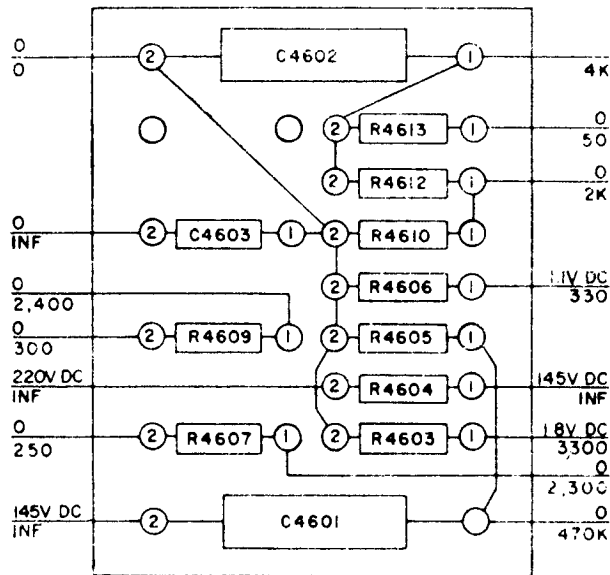

NOTES

1. ALL MEASUREMENTS MADE TO GROUND.
2. VOLTAGES ABOVE THE LINE, RESISTANCES BELOW THE LINE
3. RESISTANCES MEASURED WITH **MAIN POWER** SWITCH **OFF**

TM1223-14

Figure 14. Terminal board voltage and resistance diagram.





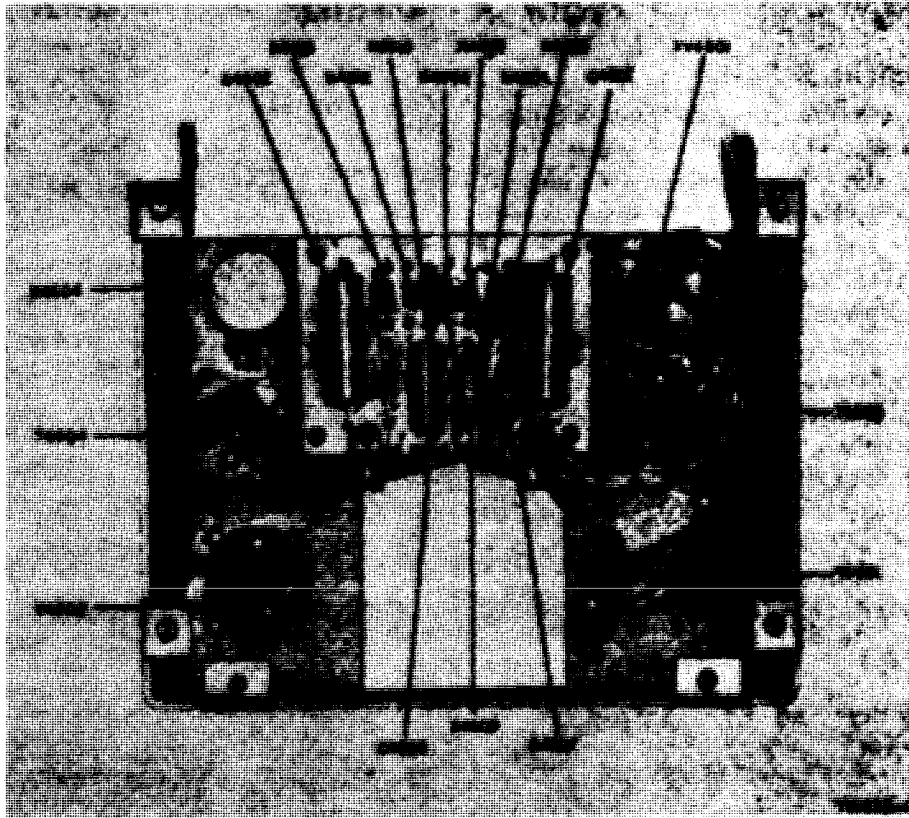

Figure 16. Front view of chassis assembly.

- (4) Return the intermediate dial to zero setting, loosen the second setscrew of the intermediate dial through the access hole, and remove the intermediate dial.
  - (5) Loosen the two setscrews in the boss underneath the outer dial and remove the outer dial.
  - (6) Unscrew the hexagonal nut on the dekapot shaft and remove the nut and lockwasher.
  - (7) Identify and unsolder the three wires attached to the terminals of the dekapot.
  - (8) Remove the dekapot bracket by loosening the two Phillips-head screws and withdraw the dekapot from the panel.
- b. Reassembly.* To reassemble and reset the dial calibration of the dekapot, follow the procedure outlined in (1) through (10) below,
- (1) Mount the dekapot in the panel hole, orienting the can so that the three terminals are facing upward for easy access, and secure it to the panel with the lockwasher and hexagonal nut.
  - (2) Replace the dekapot bracket and secure it to the mounting with the two hexagonal nuts and washers.
  - (3) Identify the three wires and resolder to the terminals.
  - (4) Replace the outer dial, positioning the zero on a horizontal index marker line to the left of the shaft, and tighten the two setscrews.
  - (5) Replace the intermediate dial, positioning its zero in line with the zero of the outer dial, and tighten one setscrew through the access hole in the periphery of the outer dial.
  - (6) Rotate the intermediate dial to position 9 and tighten the other setscrew. Return the intermediate dial to zero.
  - (7) Replace the inner dial and tighten its setscrews very lightly.

- (8) Set the inner potentiometer dial accurately by connecting an ohmmeter between terminals 1 and 2 of the dekapot. Rotate the inner dial counterclockwise until the resistance reading just begins to increase. Loosen the set-screws and reset the dial slightly if necessary to obtain an accurate setting at full scale.
- (9) Check for calibration at the upper end of the dekapot range by rotating outer and middle dials to 9 and the inner dial to full scale. Connect the ohmmeter between terminals 2 and 3 of the dekapot and rotate the inner dial until the resistance reading just begins to increase. Loosen the set-screws and reset the dial slightly if necessary to obtain an accurate setting at full scale.
- (10) Check to see that the dials have been correctly set by checking for minimum resistance between terminals 1 and 2 of the dekapot with all dials set at zero, and for minimum resistance between terminals 2 and 3 of the dekapot with all dials set at full scale.

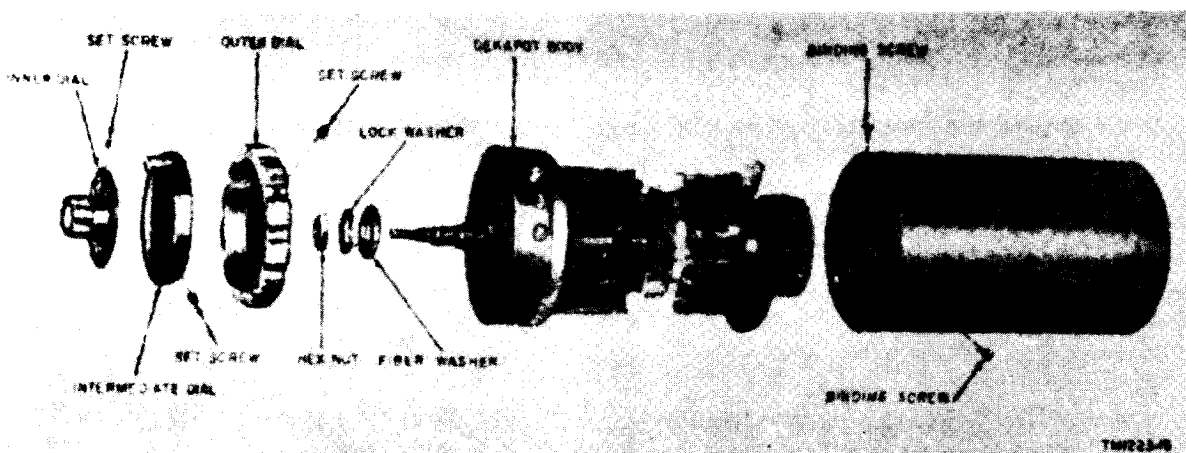

Figure 17. Exploded view of dekapot.

### Section III. FINAL TESTING

#### 31. Purpose of Final Testing

The tests in this section are designed to measure the performance capability of a repaired test set. Equipment that meets the requirements of these tests will furnish satisfactory operation, equivalent to that of new equipment.

#### 32. Test Equipment Required for Final Testing

The following items of test equipment are required for final testing of the test set:

Electronic Multimeter TS-505/U.

6.3-volt filament transformer.

Double-pole, double-throw switch.

#### 33. Resistance Check of Dekapot

With the test set panel and chassis removed from the cabinet, make the following resistance checks:

a. Set the BRIDGE ADJ dial to zero.

b. Use Electronic Multimeter TS-505/U set to the lowest resistance range to measure the resistance between terminals 1 and 2 of the BRIDGE ADJ potentiometer. The resistance should not exceed .2 ohm and should increase

quickly as the inner dial of the BRIDGE ADJ is turned beyond zero.

### 34. Phase Sensitivity Check

With the test set connected as shown in the test setup diagram (fig. 18), make the following phase sensitivity check:

- a. Set the BRIDGE ADJ dial to zero.
- b. Turn the MAIN POWER switch to ON.
- c. Advance the dial setting on the BRIDGE ADJ control until the NULL METER deflects about one-half scale.
- d. Throw the phase reversing switch shown in the test setup diagram to the opposite position. The NULL METER should deflect the same amount in the opposite direction.

### 35. Sensitivity Check

Using the same test setup as described in paragraph 34, make the following check:

- a. Set the BRIDGE ADJ dial to zero.
- b. If necessary, zero the NULL METER as described in the balance adjust procedures of paragraph 13.
- c. Advance the BRIDGE ADJ inner dial to 1 (first engraved line on inner dial). This setting corresponds to an unbalance of approximately .6 millivolts and should cause a noticeable deflection on the NULL METER.
- d. Advance the inner dial of the BRIDGE ADJ to 10 (numeral 1 on inner dial). This setting should cause at least one-half scale deflection on the NULL METER.
- e. Recheck the phase sensitivity as described in paragraph 34.

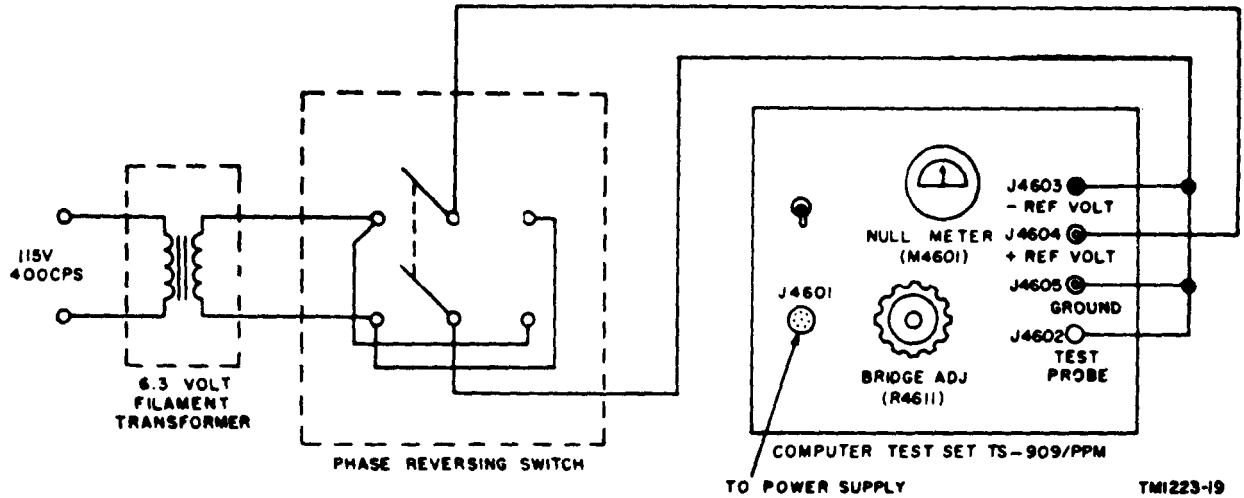

Figure 18. Test setup for phase sensitivity check.

## CHAPTER 6

### SHIPMENT AND LIMITED STORAGE AND DEMOLITION TO PREVENT ENEMY USE

#### Section I. SHIPMENT AND LIMITED STORAGE

##### 36. Disassembly

Disassembly procedures are outlined in *a* through *d* below.

*a.* Remove all leads connected to the jacks on the front panel of the test set.

*b.* Stow the leads in the front cover of the test set as shown in figure 1.

*c.* Check the equipment against the table of components (par. 5).

*d.* Fasten the cover to the carrying case by means of the six snap latches.

##### 37. Material Requirements

*a.* The following materials are required for packaging the test set:

Material	Quantity
Corrugated, single-face, flexible paper	84 sq ft
Moistureproof, barrier material.....	84 sq ft
Excelsior, medium 2" thickness	
all-around.....	10 lb
Water-resistant, gummed Kraft tape	22 ft
Pressure-sensitive tape.....	22 ft
Flat metal straps.....	26 ft
Wooden packing case.....	1

*b.* The wooden packing case is 16½ inches by 19½ inches by 23¾ inches; 4.4 cubic feet in volume; and 12 board feet are used. The weight when packed is approximately 55 pounds.

##### 38. Field Repackaging

Whenever possible, use the procedures given in *a* through *d* below to repackage the equipment. The information concerning the original packaging (par. 7a and fig. 3) may also be helpful.

*a. Test Set.* Secure all covers and fastenings; cushion the control panel with flexible single-face corrugated paper. Cushion the test set on all surfaces with pads fabricated of flexible single-face corrugated paper. Place the cushioned unit within a wrap of flexible single-face corrugated paper. Secure the wrap with gummed Kraft tape.

*b. Tube.* Wrap the spare tube with cellulose wadding and flexible single-face corrugated paper. Secure the wrap with gummed Kraft tape.

*c. Spare Parts.* Wrap electrical spare part items individually as required, with cellulose wadding and flexible single-face corrugated paper. Secure the wrap with gummed Kraft tape.

*Note.* Consolidate the tube, spare parts, and accessories, packaged as described in *b* and *c* above, within a wrap of flexible single-face corrugated paper. Secure the wrap with a gummed Kraft tape.

*d. Packing and Strapping.* Pack the test set package and the spare parts package into the nailed wooden packing case. Fill voids in the box with pads of flexible corrugated paper. Use metal strapping around the case when intended for intertheater shipment.

#### Section II. DEMOLITION OF MATERIAL TO PREVENT ENEMY USE

##### 39. Authority for Demolition

Demolition of the equipment will be accomplished only upon order of the commander.

The destruction procedures outlined in paragraph 40 will be used to prevent further use or salvaging of this equipment.

40. Methods of Destruction

a. *Smash.* Smash the case, controls, tube, switch, capacitors, transformers, dekapot, and meter; use sledges, hammers, crowbars, or other heavy tools,

b. *Cut.* Cut the power and other cords; use axes, handaxes, or machetes.

c. *Burn.* Burn cords and technical manuals; use gasoline, kerosene, oil, flame throwers, or incendiary grenades.

d. *Bend.* Bend panel and case.

e. *Explode.* If explosives are necessary, use firearms, grenades, or TNT.

f. *Dispose.* Bury or scatter the destroyed parts in slit trenches, foxholes, or throw them into streams.

By Order of Wilber M.Brucker, Secretary of the Army:

MAXWELL D. TAYLOR,  
General, United States Army,  
Chief of Staff.

Official:

HERBERT M. JONES,  
Major General, United States Army,  
The Adjutant General.

Distribution:

Active Army:

- ASA
- CNGB
- Technical Svc, DA
- Technical Svc Bd
- USCONARC
- USA Arty Bd
- USA Armor Bd
- USA Inf Bd
- USA Air Def Bd
- USA Abn & Elct Bd
- USA Avn Bd
- USA Arctic Test Bd
- USA Armor Bd Test Sec
- USA Air Def Bd Test Sec
- USARADCOM
- OS Maj Cored
- OS Base Cored
- Log Cored
- SW Cored
- MDW
- Armies
- Corps
- Div
- USATC
- Ft & Camps
- Svc Colleges
- Br Svc Sch
- Gen Depots
- SigC Sec, Gen Depots

- SigC Depots
- POE (OS)
- Trans Terminal Comd
- Army Terminals
- OS Sup Agencies
- SigC Fld Maint Shops
- SigC Lab
- Mil Dist
- Army Sig Comm Engr Agency
- Army Sig Pub Agency
- Army Comm Agency
- Army Sig Pictorial Cen
- Engr Maint Cen
- WRAMC
- JBUSMC
- AMS
- AFIP
- YUMA Test Sta
- Units org under fol TOE:
  - 11-16, Hq & Hq Co, Sig Bn, Corps or Abn Corps
  - 11-57, Armd Sig Co
  - 11-127, Sig Rep Co
  - 11-128, Sig Depot Co
  - 11-500, Sig Svc Org
  - 11-557, Abn Sig Co
  - 11-587, Sig Base Maint Co
  - 11-592, Hq & Hq Co, Sig Base Depot
  - 11-597, Sig Base Depot Co

NG: State AG; units-same as Active Army.

USAR: None.

For explanation of abbreviations used, see AR 320-50.







This fine document...

Was brought to you by me:



## [Liberated Manuals -- free army and government manuals](#)

Why do I do it? I am tired of sleazy CD-ROM sellers, who take publicly available information, slap “watermarks” and other junk on it, and sell it. Those masters of search engine manipulation make sure that their sites that sell free information, come up first in search engines. They did not create it... They did not even scan it... Why should they get your money? Why are not letting you give those free manuals to your friends?

I am setting this document FREE. This document was made by the US Government and is NOT protected by Copyright. Feel free to share, republish, sell and so on.

I am not asking you for donations, fees or handouts. If you can, please provide a link to [liberatedmanuals.com](http://liberatedmanuals.com), so that free manuals come up first in search engines:

<A HREF=<http://www.liberatedmanuals.com/>>Free Military and Government Manuals</A>

- Sincerely  
Igor Chudov  
<http://igor.chudov.com/>
- [Chicago Machinery Movers](#)