

U113  
2  
TM 9-1710  
1942

ORDNANCE MAINTENANCE

POWER TRAIN (AXLES, TRANSMISSION, AND PROPELLER SHAFT)

FOR

HALF-TRACK VEHICLES

	Paragraphs
SECTION I. General.....	1
II. Service maintenance.....	2-4
III. Technical inspection.....	5-7
IV. Lubrication.....	8-10
V. Front axle.....	11-17
VI. Rear axle (jackshaft).....	18-24
VII. Propeller shafts.....	25-31
VIII. Transmission-transfer case.....	32-38
IX. Consolidated service data (fits and clearances).....	39-42
X. Preparation of units for extreme temperatures or unusual conditions.....	43-46
APPENDIX. List of references.....	184
INDEX.....	185

SECTION I

GENERAL

	Paragraph
Scope.....	1

1. **Scope.**—*a.* This manual is published for the information and guidance of ordnance maintenance personnel, and is the first of three maintenance manuals for half-track vehicles. It contains detailed instructions for inspection, disassembly, assembly, maintenance, and repair of the power train (axles, transmission, and propeller shafts) for half-track vehicles, supplementary to those in the Field and Technical Manuals prepared for the using arm. Additional descriptive matter and illustrations are included to aid in providing a complete working knowledge of the matériel.

*b. Vehicle generally.*—Information is included concerning the service maintenance, technical inspection, and lubrication of the entire vehicle.

*c. Power train specifically.*—Information is also included concerning the detailed description, operation, inspection and trouble diag-

nosis, disassembly, maintenance and repair, assembly, and test of major components of the axles, propeller shafts, and transmission, supplementing TM 9-710, prepared for the using arms.

*d. Chassis and body.*—For maintenance information concerning the chassis and body components, refer to TM 9-1712.

*e. Power plant.*—For maintenance information concerning the engine and its accessories, refer to TM 9-1711.

SECTION II

SERVICE MAINTENANCE

	Paragraph
Objective-----	2
Scope -----	3
Allocation of repair jobs-----	4

**2. Objective.**—There is a distinct difference between the missions of organizational maintenance and of service maintenance. Organizational maintenance by the using arms has for its prime objective the routine preventive maintenance, care, and adjustment of vehicles so they will be in good operating condition at all times with a minimum loss of time for repairs. Service maintenance by light and heavy maintenance organizations of the Ordnance Department has, for its prime objectives, supply, technical inspection and corrective action, and repairs beyond the capacity of the using arms. These are accomplished either by unit replacement, overhauling, rebuilding, reclaiming, manufacturing, or any other methods considered most suitable.

**3. Scope.**—The scope of maintenance and repairs by maintenance personnel is determined by the amount of time available, weather conditions, concealment, shelter, proximity to hostile fire, equipment, tools, and parts available, besides skill of the personnel. Since all of these factors are variable, no exact system or procedure can be prescribed or followed.

**4. Allocation of repair jobs.**—The operations herein augment those which may be performed by personnel of the using arms.

*a. Front and rear (jackshaft) axles.*—(1) *Alinement.*—Check and adjust for camber and caster.

(2) *Axle assembly.*—Replace, repair, or rebuild.

(3) *Axle housing.*—Repair, weld, machine, and aline.

(4) *Gear and pinions.*—Adjust.

(5) *Steering knuckles.*—Replace or rebush.

(6) *Wheel turning stop.*—Adjust.

*b. Body.*—See TM 9-1712.

- c. *Bogie suspension and track.*—See TM 9-1712.
- d. *Brakes.*—See TM 9-1712.
- e. *Cooling system.*—See TM 9-1711 and 9-1712.
- f. *Electric generating and starting system.*—See TM 9-1711.
- g. *Electric ignition system.*—See TM 9-1711.
- h. *Electric lighting system and accessories.*—See TM 9-1712.
- i. *Engine.*—See TM 9-1711.
- j. *Frame.*—See TM 9-1712.
- k. *Fuel system.*—See TM 9-1711 and 9-1712.
- l. *Instruments.*—See TM 9-1712.
- m. *Propeller shafts.*—Repair or rebuild.
- n. *Shock absorbers and springs.*—See TM 9-1712.
- o. *Steering gear.*—See TM 9-1712.
- p. *Transmission.*—(1) *Shift levers.*—Repair.  
 (2) *Transfer case components.*—Replace, repair, or rebuild.  
 (3) *Transmission components.*—Replace, repair, or rebuild.
- q. *Wheels.*—See TM 9-1712.

SECTION III

TECHNICAL INSPECTION

Description.....	Paragraph
Inspection form.....	5
Practical application.....	6
	7

**5. Description.**—Technical inspections are a follow-up and check on organizational maintenance inspections and other maintenance functions. They determine whether the vehicle should be continued in service or withdrawn from operation for overhaul. These inspections are covered in AR 850-15.

**6. Inspection form** (fig. 1).—W. D., Q. M. C. Form No. 260 (Technical Inspection Report of Motor Vehicles) is the standard and official form for recording the inspection of all motor vehicles, including combat vehicles of the Ordnance Department. The extent to which use is made of this form or modification of it depends entirely on the technical ability of available personnel, the time factor, and the test and shop equipment available.

**7. Practical application.**—a. *External inspection of body and frame components.*—(1) *Toe-in.*—Check (refer to front axle).

(2) *Caster and camber.*—Check (refer to front axle).

(3) *Other body and frame components.*—Refer to TM 9-1712.

b. *External inspection of chassis components.*—(1) *Front axle.*—Inspect for straightness. Shake wheels to check for “wobble.” Inspect

WAR DEPARTMENT  
GMO Form No. 200  
App. Oct. 14, 1920

TECHNICAL INSPECTION REPORT OF MOTOR VEHICLES

This form indicates the scope of complete technical inspection of all motor vehicles for all echelons. It does not prescribe a required routine of procedure. Items will be checked to the extent of ability of personnel and adequacy of equipment available.

Date \_\_\_\_\_

Vehicle nomenclature \_\_\_\_\_

U. S. A. Registration No. \_\_\_\_\_ Mileage \_\_\_\_\_

Organization \_\_\_\_\_ Station \_\_\_\_\_

Supply arm or service maintaining vehicle \_\_\_\_\_

(Check V, is satisfactory, X adjustment made, XX repair or replacement needed)

<p><b>EXTERNAL INSPECTION</b></p> <p>1. Bumpers _____</p> <p>2. Boards, running _____</p> <p>3. Body _____</p> <p>4. Bows _____</p> <p>5. Camber** _____</p> <p>6. Carrier, tire _____</p> <p>7. Caster** _____</p> <p>8. Curtains _____</p> <p>9. Doors _____</p> <p>10. Fenders _____</p> <p>11. Gets, tail _____</p> <p>12. Glass _____</p> <p>13. Guards, headlight _____</p> <p>14. Guard, radiator _____</p> <p>15. Hood _____</p> <p>16. Hooks, tow _____</p> <p>17. Lights _____</p> <p>18. Paint _____</p> <p>19. Pintles _____</p> <p>20. Radiator _____</p> <p>21. Tires _____</p> <p>22. Top _____</p> <p>23. Toe-in _____</p> <p>24. _____</p> <p>25. _____</p> <p><b>HOOD UP (ENGINE STOPPED)</b></p> <p>26. Antifreeze _____</p> <p>27. Assembly, breaker pt. _____</p> <p>28. Baffles, inter-cyl.* _____</p> <p>29. Battery _____</p> <p>30. Belt, fan _____</p> <p>31. Cleaner, air _____</p> <p>32. Compressor, air _____</p> <p>33. Engine, oil _____</p> <p>34. Fan, cooling _____</p> <p>35. Filter, fuel _____</p> <p>36. Filter, oil (external) _____</p> <p>37. Filter, oil (in eng.)* _____</p> <p>38. Fluid, brake _____</p> <p>39. Governor, seal _____</p> <p>40. Housing, steering gear _____</p> <p>41. Pump, water _____</p> <p>42. Shroud, engine* _____</p> <p>43. Spark plugs _____</p> <p>44. Strainer, fuel pump _____</p> <p>45. Strainer, scavenge oil* _____</p> <p>46. System, fire exting.* _____</p> <p>47. _____</p> <p>48. _____</p>	<p><b>HOIST VEHICLE (if practicable)</b> (Except full track and rear end of half-track vehicles)</p> <p>49. Axle, front _____</p> <p>50. Axle, frt. drive, lubr'n _____</p> <p>51. Axle, rear _____</p> <p>52. Axle, rear, lubr'n _____</p> <p>53. Body, bolts _____</p> <p>54. Engine, side pans _____</p> <p>55. Frame, distortion _____</p> <p>56. Frame, rivets _____</p> <p>57. Joints, universal _____</p> <p>58. Lines, brake (hydr.-air) _____</p> <p>59. Linkage, brake (mech.) _____</p> <p>60. Linkage, steering _____</p> <p>61. Shafts, propeller _____</p> <p>62. Spring, front assembly _____</p> <p>63. Spring, rear assembly _____</p> <p>64. Shock absorbers, fill _____</p> <p>65. Tank, air _____</p> <p>66. Trf. case-sub-trans _____</p> <p>67. Trf. case-sub-tr, lubr'n _____</p> <p>68. Transmission _____</p> <p>69. Transmission, lubr'n _____</p> <p>70. Wheels, front, adjustment and trueness _____</p> <p>71. Wheels, front, lubr'n _____</p> <p>72. Wheels, rear _____</p> <p>73. _____</p> <p>74. _____</p> <p>75. _____</p> <p><b>INTERNAL INSP. (START ENGINE)</b></p> <p>76. Ammeter _____</p> <p>77. Accelerator _____</p> <p>78. Choke _____</p> <p>79. Cut-out _____</p> <p>80. Extinguisher, fire _____</p> <p>81. Filter, trans. oil* _____</p> <p>82. Gage, air _____</p> <p>83. Gage, fuel _____</p> <p>84. Gage, oil _____</p> <p>85. Generator _____</p> <p>86. Horn _____</p> <p>87. Indicator, heat _____</p> <p>88. Insulation, hull* _____</p> <p>89. Lights _____</p> <p>90. Pad, protecting* _____</p> <p>91. Protector, peep hole* _____</p> <p>92. Pump, priming* _____</p> <p>93. Seats, troop _____</p>	<p>94. Starting motor _____</p> <p>95. Switch, battery* _____</p> <p>96. Switch, ignition _____</p> <p>97. Switch, mech. starter* _____</p> <p>98. Switch, sol. starter* _____</p> <p>99. Switch, starter _____</p> <p>100. Tachometer* _____</p> <p>101. Tools _____</p> <p>102. Throttle _____</p> <p>103. Upholstery _____</p> <p>104. Wiper, windshield _____</p> <p>105. Viscometer _____</p> <p>106. Voltmeter* _____</p> <p>107. _____</p> <p>108. _____</p> <p><b>HOOD UP (ENGINE RUNNING)</b></p> <p>109. Engine noise _____</p> <p>110. Engine, smoothness _____</p> <p>111. Engine mounting _____</p> <p>112. Gaskets (all) _____</p> <p>113. Leaks, fuel _____</p> <p>114. Leaks, oil _____</p> <p>115. Leaks, water _____</p> <p>116. Valves, noise _____</p> <p>117. Wiring, ignition _____</p> <p>118. Wiring, other _____</p> <p>119. _____</p> <p>120. _____</p> <p>121. _____</p> <p><b>ROAD TEST VEHICLE</b></p> <p>122. Body, noise _____</p> <p>123. Brakes, hand _____</p> <p>124. Brakes, service _____</p> <p>125. Brakes, steering* _____</p> <p>126. Clutch _____</p> <p>127. Drive units, noise _____</p> <p>128. Engine, noise _____</p> <p>129. Engine, smoothness _____</p> <p>130. Engine, power _____</p> <p>131. Gear shift _____</p> <p>132. Governor _____</p> <p>133. Shock absorbers _____</p> <p>134. Speedometer _____</p> <p>135. Steering mechanism _____</p> <p>136. _____</p> <p>137. _____</p> <p>138. _____</p> <p>139. _____</p> <p>140. _____</p>
--	---	--

\* Ordnance vehicles.

\*\* Normally 2d and 4th echelons.

FIGURE 1.—Technical inspection report.

cross tube. Check for oil leaks and cracked housing. Test all nuts with wrench. Inspect brush guards and universal joint dust shields. Check presence of necessary plugs and lubrication fittings and evidence of proper lubrication. Inspect breather.

(2) *Transmission*.—Inspect for leaks and cracked case. Test all bolts with wrench. Check presence of necessary plugs and lubrication fittings and evidence of proper lubrication. Inspect breather.

(3) *Propeller shafts*.—Inspect for distortion and fractures. Examine flanges. Test all nuts with wrench. Tighten dust caps. Check lubrication and relief valves.

(4) *Rear axle*.—Check for oil leaks and cracked housings. Test all nuts with wrench. Check presence of necessary plugs and lubrication fittings and evidence of proper lubrication. Inspect breather.

(5) *Other chassis components*.—Refer to TM 9-1712.

*c. Road test*.—(1) *Clutch*.—Check for smoothness of operation. Test for effectiveness by setting drive shaft brake or using the service brakes, putting the vehicle in low gear, and releasing the clutch pedal gradually; if the clutch is efficient, the engine should stall.

(2) *Gear box*.—Listen to transmission and transfer case gears for a high-pitched whine or squeal which indicates internal misalignment. In shifting gears, it is usual for the two lower speeds to be much noisier in operation than high gear; unusual noises in the transmission during operation in the high gears should be investigated immediately to avoid severe damage.

(3) *Gear shift*.—Check to see that the gear shift levers are fastened firmly in their retaining sockets and that the gear shift forks on the lower end of the levers move properly through all gear changes selected.

(4) *Steering mechanism*.—Note if steering wheel has a tendency to jerk; such action indicates a looseness in the steering mechanism connection from the front axle to the wheel, or an error in steering geometry. Note any tendency on the part of the vehicle to wander or drive to the right or left, indicating improper adjustment of steering mechanism or brakes, or an error in steering gear geometry. If a thump or knocking is felt in the steering wheel, a part is probably loose in the steering gear worm.

*d. Inspection of other components*.—See TM 9-1711 and 9-1712.

## SECTION IV

## LUBRICATION

	Paragraph
General.....	8
Schedules.....	9
Methods.....	10

**8. General.**—Lubrication is an essential part of preventive maintenance, determining to a great extent the serviceability of parts and assemblies. Lubrication or the lack of it influences repairs and operations materially, and is one of the most important factors affecting dependable service and useful vehicle life. Refer to Ordnance Field Service Bulletin 6-1 for a description of the ordnance lubrication program and see Lubrication of Ordnance Matériel.

**9. Schedules** (fig. 2① and ②).—*a. Records.*—A complete record of lubrication will be kept for every vehicle. Responsible personnel will execute a check sheet at regular intervals to indicate the actual mileage and date at which each component receives such attention as prescribed.

*b. Supplies.*—Lubricants and application equipment should conform to recommendations of the Ordnance Department. Refer to OFSB 6-4 for the product guide. During field service, it may not be possible to supply a complete assortment of lubricants called for by the schedule to meet the recommendations and it will be necessary to make the best use of those available, subject to inspection by the motor officer concerned in consultation with responsible ordnance personnel.

**10. Methods.**—*a. Application.*—Refer to OFSB 6-2 for general lubricating instructions.

*b. Low-temperature lubrication.*—Refer to section III, OFSB 6-G-3, for information which supplements the lubrication guides in connection with chassis, crankcase, and gear lubricants utilized in temperatures below minus 10° F.

*c. Rubber parts.*—Friction and vibration tend to develop squeaks, groans, and improper fit of rubber parts in chassis, instrument panel accessories, and engine mounts. Lubricants such as mineral oil, castor oil, engine oil, or other greases must not be used because they tend to swell or rot the rubber. A suitable lubricating material can be made by mixing colloidal graphite with ethylene glycol or glycerin. Add enough water to prevent rapid drying before the solution has penetrated. The solution can be applied with an ordinary spray, but a needle spray will be needed to force the

POWER TRAIN

TABLE OF CAPACITIES AND RECOMMENDATIONS

	Capacity	Above 90°	Lowest Expected Atmospheric Temperature			
			+32°	+10°	-10°	-30° Below -30°
Crankcase	12 qt.	SAE 30	SAE 30	SAE 30	SAE 10	For operation in these temperature ranges, refer to OFSB 6-G-3.
Trans. and Transfer Case	7½ qt.					
Differential (Front)	3½ qt.	140	140	90	80	
Differential (Rear)	6 qt.					

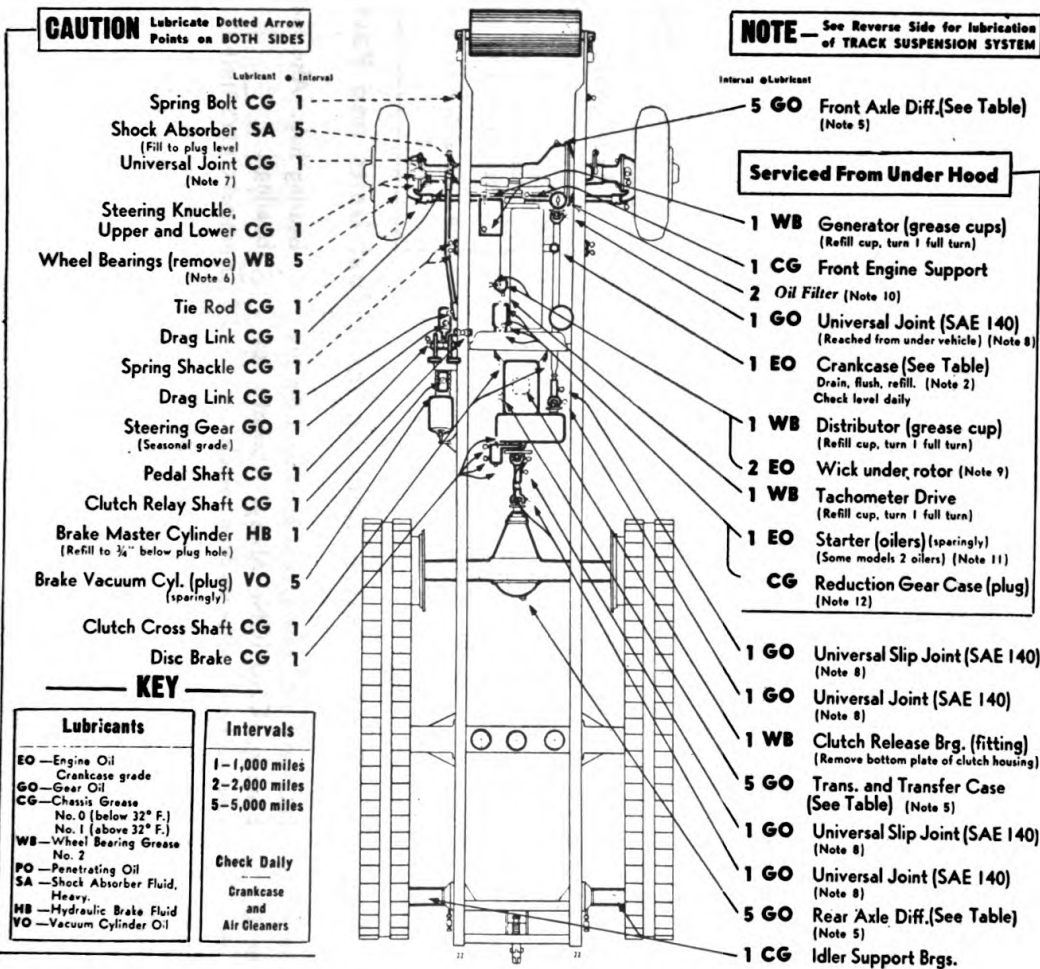

NOTES Additional Lubrication and Service Instructions on Individual Units and Parts

- AIR CLEANERS**—(Engine) Check level and refill oil cup to bead level daily with EO. Drain, clean and refill every 100 to 1,000 miles, depending on operating conditions. Every 2,000 miles, also remove air cleaner and wash all parts. (Brake Vacuum Cylinder) Every 3 months remove brake vacuum cylinder air cleaner, located under hood, clean hair and oil with EO.
- CRANKCASE**—Drain only when engine is hot. Flush with 8 qt. SAE 10, idle engine 5 minutes and drain. Refill to FULL mark on gage. CAUTION: Be sure pressure gage indicates oil is circulating. See Table.
- INTERVALS** indicated are for normal service. For extreme conditions of speed, heat, water, mud, snow, rough roads, dust, etc., change crankcase oil and lubricate more frequently.
- FITTINGS**—Clean before applying lubricant. Lubricate until new grease extrudes from the bearing. CAUTION: Always lubricate chassis points after washing vehicle.
- GEAR CASES**—Check level every 1,000 miles, add lubricant if necessary. Drain, flush and refill at end of first 1,000 miles; thereafter as indicated on guide. Check with vehicle on level ground.
- FRONT WHEEL BEARINGS**—Remove wheel, clean and repack bearings, also remove, clean and lubricate spindle bushing with WB.
- UNIVERSAL JOINTS** (Front wheels)—Remove level plug, fill through rear plug hole until lubricant is level with opposite hole. Every 5,000 miles remove, clean, inspect and reassemble universal joints. Remove plug in spindle, insert fitting and inspect 1 lb. CG. Replace plug. Refill universal joint housing.
- UNIVERSAL JOINTS AND SLIP JOINTS**—Apply lubricant to joint until it overflows at relief valve and to slip joint until lubricant extrudes from vent at universal joint end of spline.
- DISTRIBUTOR**—Wipe distributor breaker cam lightly with CG and lubricate breaker arm pivot with EO sparingly every 2,000 miles.
- OIL FILTER**—Renew filter element every 2,000 miles or oftener if necessary. After renewing element, refill crankcase to FULL mark on gage.
- STARTER**—Remove starter every 5,000 miles, clean, and lubricate Bendix drive sparingly with PO. Lubricate Bendix drive shaft outer bearing through oiler with EO.
- STARTER REDUCTION GEAR CASE**—Every 6 months remove plug in top of housing and refill with CG.
- OIL CAN POINTS**—Lubricate throttle ends, clevises, hinges, latches, vacuum cylinder valve and power lever linkage, bumper roller slides and bushings and pintle with EO every 1,000 miles.
- POINTS REQUIRING NO LUBRICATION**—Springs, Shock Absorber Links, Bumper Roller Brgs., Water Pump and Fan.
- POINTS TO BE LUBRICATED BY ORDNANCE MAINTENANCE PERSONNEL AT TIME OF GENERAL OVERHAUL**—Clutch Pilot Bearings, Speedometer Cable (See OFSB 6-G-102).

CHEK-CHART No. 23

RA PD 3502 C

①

FIGURE 2.—Lubrication chart.

**HALF TRACK SUSPENSION SYSTEM**

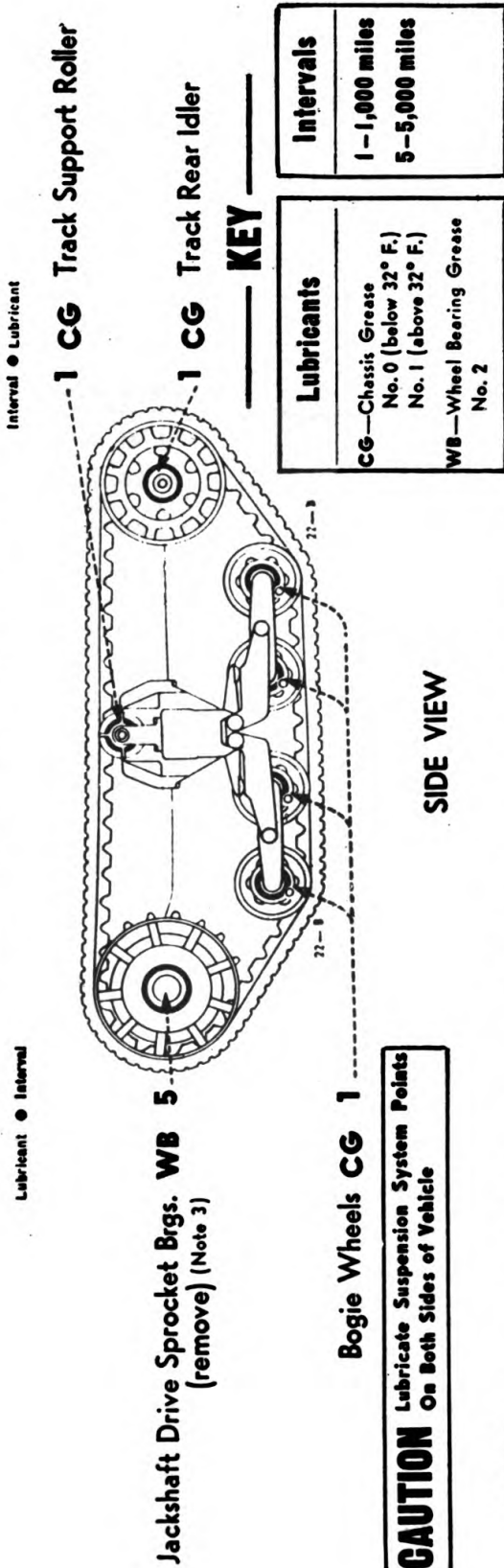

**CAUTION** Lubricate Suspension System Points On Both Sides of Vehicle

**NOTES Additional Lubrication and Service Instructions on Individual Units and Parts NOTES**

1. INTERVALS indicated are for normal service. For extreme conditions of speed, heat, water, mud, snow, rough roads, dust, etc., lubricate more frequently.
2. FITTINGS—Clean before applying lubricant.
3. JACKSHAFT DRIVE SPROCKET BEARINGS —Remove tracks, drive sprocket flanges and bearing hub. Also remove, clean and repack bearings.
4. POINTS REQUIRING NO LUBRICATION—Coil Springs, Bogie Wheel Suspension Linkage and Slides.

CHEK-CHART No. 23

RA PD 3502D

FIGURE 2.—Lubrication chart—Continued.



lubricant between parts having close clearance. Rubber parts which are used to keep other parts from slipping or rotating should not be lubricated.

SECTION V

FRONT AXLE

	Paragraph
Description.....	11
Trouble shooting.....	12
Removal of assembly.....	13
Disassembly of components.....	14
Maintenance and adjustments.....	15
Reassembly of components.....	16
Installation of assembly.....	17

**11. Description** (figs. 3 and 4).—The front axle is of the spiral, bevel-gear, single-reduction, full floating type, with a straddle-mounted pinion gear and a conventional type differential. The front wheels are driven by axle shafts through “Rzeppa” type universal joints inclosed within steering knuckles at the outer ends of the housing.

*a. Construction* (figs. 5 and 6).—(1) The front axle consists of steel tubes, pressed and riveted into the split gear housing at the inner ends and butt-welded to the sockets (or universal joint housings) at the outer ends. Hardened and ground king pins are press-fitted and welded into opposite sides of the sockets, and upon these are mounted the steering knuckle bushings. These pivot bushings support the split-flanged socket housing and can be adjusted by spacers under the upper bushing retaining caps. The upper cap and the drag link steering arm are integral on the left-hand side, and the lower caps and bush guard pins are also integral. The socket housing carries a steering stop which limits the steering angle to 28° and also a steering arm for tie rod attachment. The outer end of the socket housing has a wheel spindle bolted to it, and this fully incloses the constant velocity universal drive shaft assemblies. Synthetic rubber boots encircle the universal joint housings to prevent leakage of lubricant. Damage to these boots is avoided by the presence of the brush guard pins. A full floating hub is mounted upon the spindle by means of tapered roller bearings so that the entire wheel and assembly carries the load independent of the driving shaft.

(2) The hub is attached by studs to the drive flange, which in turn engages with the universal drive shaft by means of a spline. Removal of this drive flange permits adjustment of the inner and outer

Generated on 2016-07-06 12:38 GMT / http://hdl.handle.net/2027/uc1.b3243960  
Public Domain, Google-digitized / http://www.hathitrust.org/access\_use#pd-google

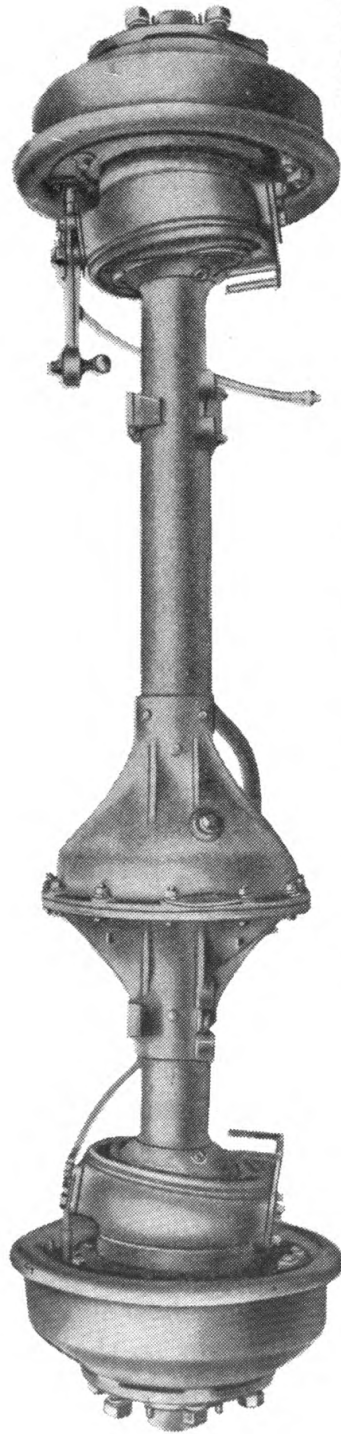

RA PD 6380

FIGURE 3.—Front axle assembly, front view.

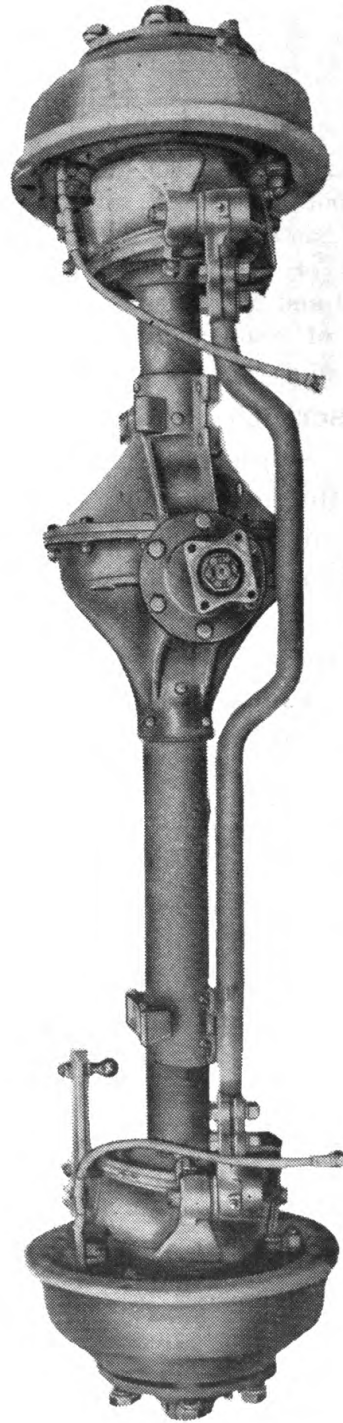

RA PD 6382

FIGURE 4.—Front axle assembly, rear view.

POWER TRAIN

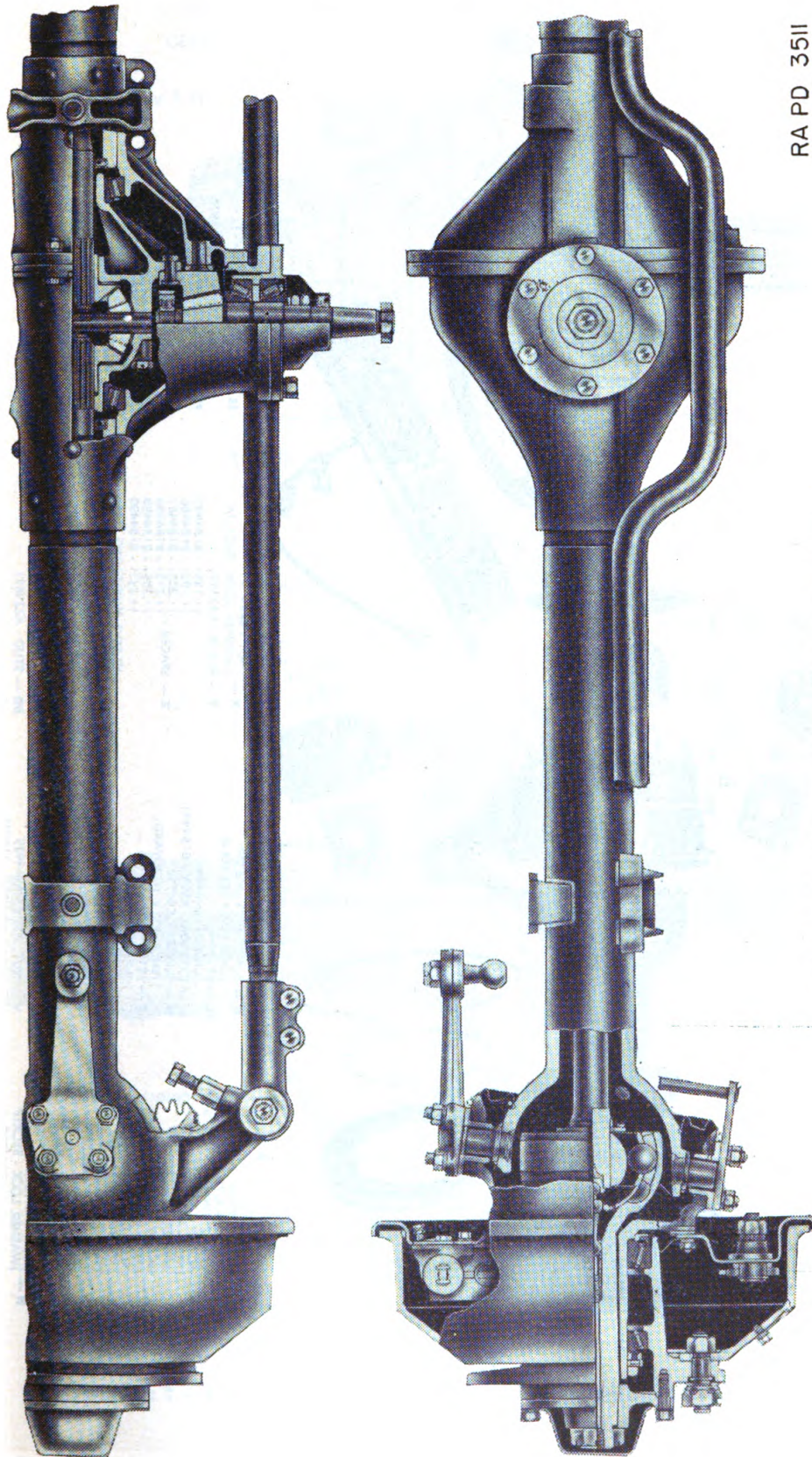

RA PD 35II

FIGURE 5.—Front axle assembly, sectionalized.

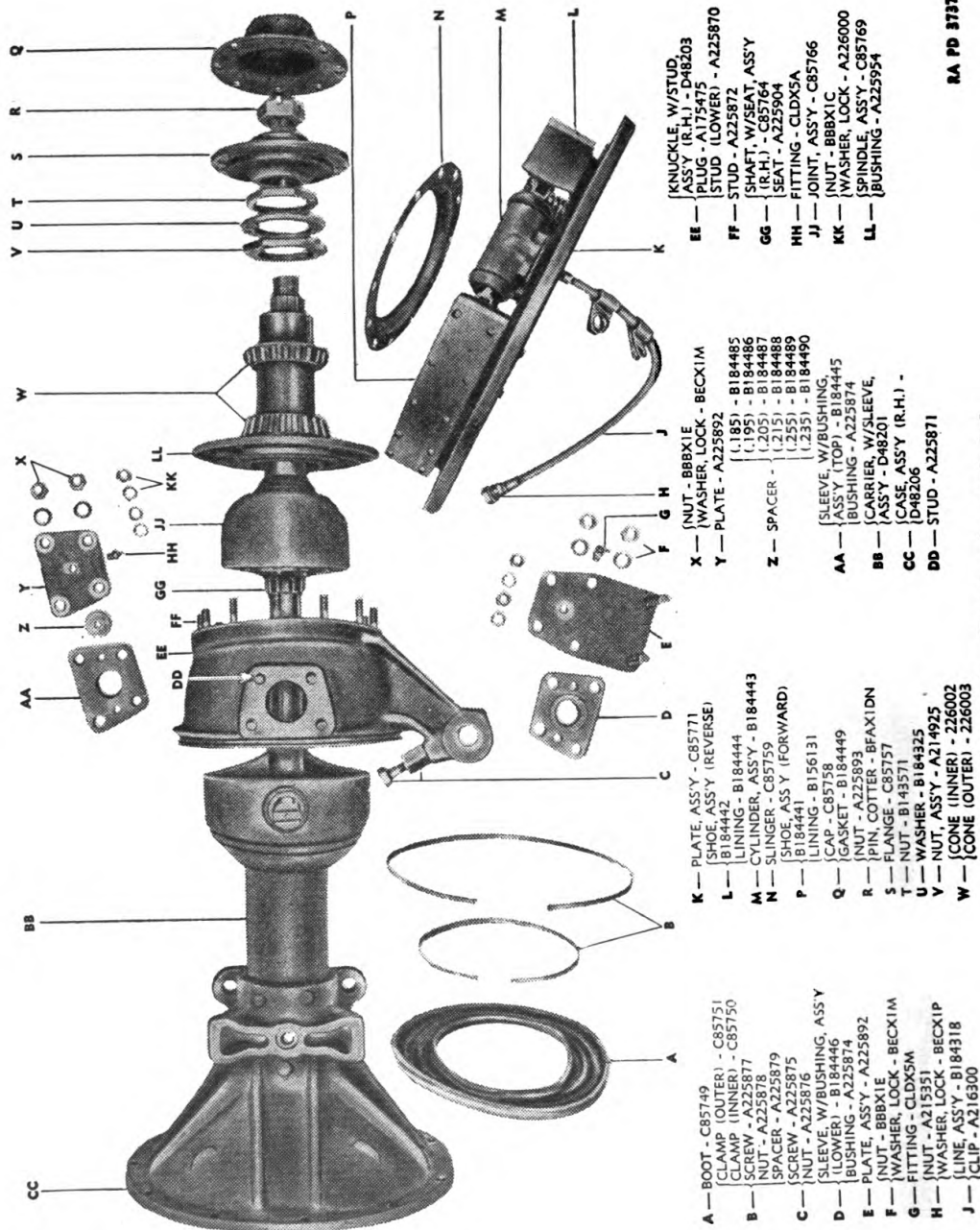
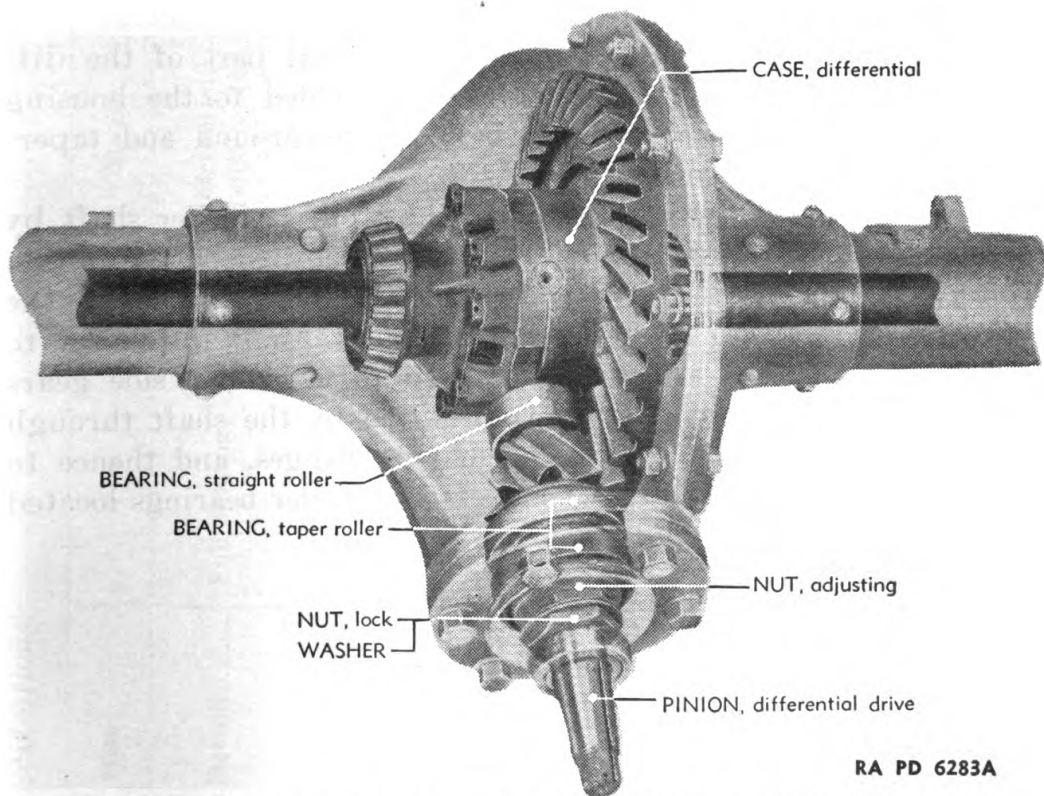
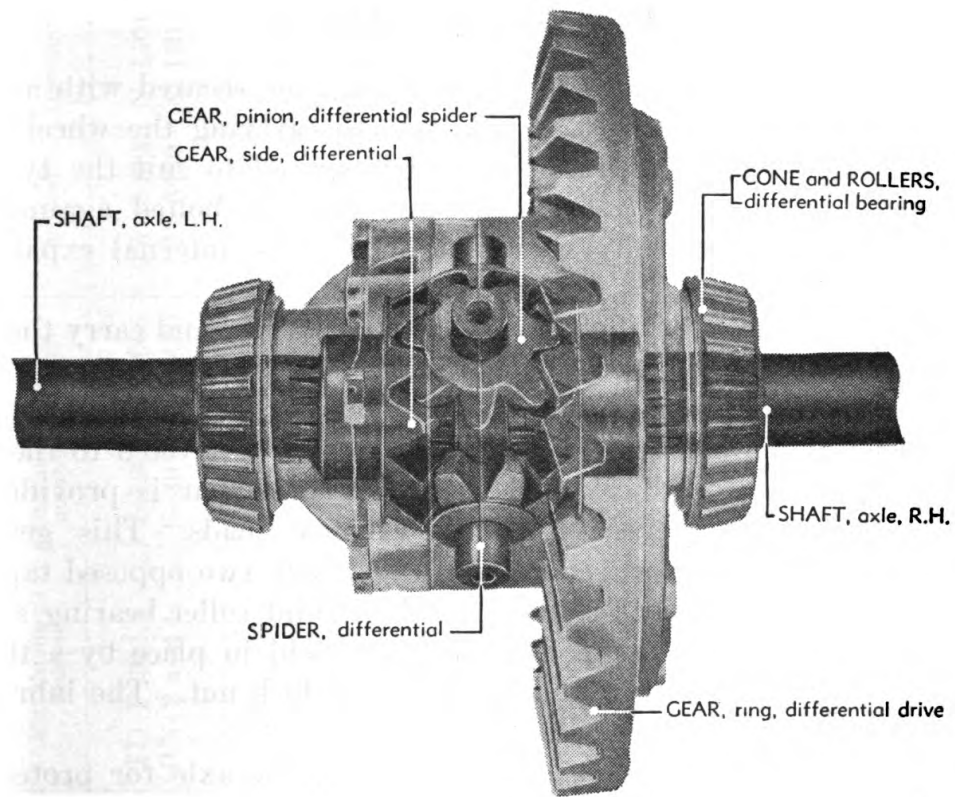

Figure 6.—Front axle, exploded.

RA PD 3737



RA PD 6283A

FIGURE 7.—Front axle differential and drive pinion, phantom view.

wheel bearings by means of two adjusting nuts secured with a locking ring. The hub flange, in addition to carrying the wheel disk, mounts an iron brake drum with studs spaced to suit the type of wheel to be used. The brake backing plate is bolted against the knuckle flange and fully incloses the two shoe internal expanding hydraulic brake.

(3) The inner ends of the axle shaft are splined and carry the differential side gears (fig. 7). The differential is a conventional type and is inclosed in a carrier mounted in the housing on opposed tapered roller bearings. The spiral bevel gear is riveted to the carrier. A backing-up block for the spiral bevel gear is provided to prevent excessive deflection under extreme loads. This gear is driven by a pinion gear, straddle-mounted with two opposed tapered roller bearings at the rear, and a straight solid roller bearing at the front. The roller bearings and shaft are held in place by a thrust washer, adjusting nut, locking washer, and lock nut. The lubricant is sealed at the pinion rear-bearing cover.

(4) A tubular tie rod is mounted behind the axle for protection and is attached to each wheel end by a threaded and clamped tie-rod yoke (figs. 4 and 5). The tie-rod yoke pin fits into the socket housing and is fixed against rotation in the yoke.

(5) The right-hand spring seat is an integral part of the differential housing and the left-hand seat is welded to the housing sleeve or tube. The steering arm ball stud is ground and taper-fitted to the steering arm.

*b. Operation.*—Power is taken from the front propeller shaft by the drive pinion through a flange, and is transmitted by the pinion to the spiral bevel gear. This causes the differential case and the spider pinion gears to rotate as a unit and transmit the power to the pinion side gears, and the axle shafts to which the side gears are splined. The torque is then transmitted by the shaft through the Rzeppa universal joints, to the driving flanges, and thence to the hub and drum assemblies, which rotate on roller bearings located on the steering knuckle spindles.

*c. Specifications.*

Make	Type	Model	Manufacturer's number	Ordinance number	White	Autocar	Diamond T
Timken-Detroit.....	Full floating.....	{ Standard differential..... Hi-traction differential..... }	TD-F-35..... HX-2 and 1.....	E-2801 E-3831	371665 388420	9WA6430 9W6430	N-1501 N-1501A

Housing----- Split type.

Drive----- Through springs.

Differential:

Drive----- Spiral bevel.

Gear ratio----- 6.8 to 1.

Bearing----- Timken tapered roller.

Number:

Cone----- 3982.

Cup----- 3920.

Pinion shaft:

Ratio----- See differential.

Bearings:

Inner----- Hyatt straight roller.

Number----- U-1304-TDM.

Outer----- Timken tapered roller.

Number:

Cone----- 53176.

Cup----- 53375.

Track----- 64½ inches with 5⅛-inch offset wheel.

Spring centers----- 34⅛ inches.

Spring pad width----- 2¼ inches.

Hub equipment----- 6-stud.

Budd----- 8¾-inch BC.

Brakes—

Hydraulic, 16 inches x 2¼ inches, 1⅜-inch diameter cylinder.

Universal joint----- Rzeppa, 1¾ inches.

Wheel bearings:

Inner----- Timken tapered roller.

Number:

Cone----- 33281.

Cup----- 33472.

Outer----- Timken tapered roller.

Number:

Cone----- 395-A.

Cup----- 394-A.

Steering knuckle----- Bushings.



**12. Trouble shooting.**

<i>Symptom and probable cause</i>	<i>Probable remedy</i>
<i>a. Lubricant leaks.</i>	
(1) Leak at housing end seal.	(1) Replace seal.
(2) Leak at differential.	(2) Replace differential or differential cover gasket.
<i>b. Hand steering.</i>	
(1) Lack of lubrication.	(1) Lubricate tie-rod yoke, steering gear and steering drag link.
(2) Tight steering gear.	(2) Readjust (see TM 9-1712).
(3) Improper toe-in.	(3) Adjust tie-rod yoke.
(4) Excessive caster.	(4) See paragraph 15i(2).
(5) Front axle shifted.	(5) Relocate and tighten spring clip nuts.
(6) Bent frame.	(6) Straighten or replace.
(7) Tires improperly inflated.	(7) Inflate to 70 pounds.
(8) Worn Rzeppa joint.	(8) Replace.
<i>c. Wandering.</i>	
(1) Tight steering.	(1) Adjust steering gear.
(2) Tires unevenly inflated.	(2) Inflate to 70 pounds.
(3) Brake dragging.	(3) Adjust.
(4) Spring center bolt sheared and axle shifted.	(4) Replace center bolt and relocate in spring seat.
(5) Loose front wheel bearings.	(5) Adjust bearings.
(6) Excessive or insufficient caster.	(6) See paragraph 15j(2).
(7) Bent axle parts.	(7) Replace.
<i>d. Shimmy.</i>	
(1) Insufficient toe-in.	(1) Adjust at tie-rod yoke.
(2) Steering gear loose.	(2) Tighten.
(3) Improper load distribution.	(3) Equalize the load.
(4) Tie rod loose.	(4) Tighten or replace worn parts.
(5) Knuckle bushings worn or loose.	(5) Readjust or replace.
(6) Excessive or insufficient caster.	(6) See paragraph 15j(2).
(7) Front axle shifted.	(7) Relocate and tighten the spring clip nuts.
(8) Unbalanced wheels.	(8) Balance.

<i>Symptom and probable cause</i>	<i>Probable remedy</i>
<i>e. Axle noisy when coasting.</i>	
(1) Excessive lash between ring gear and pinion.	(1) Readjust ring gear and pinion (par. 15 <i>h</i> ).
(2) End play in pinion shaft.	(2) Readjust or replace pinion tapered roller bearing.
(3) Ring gear and pinion adjustment too tight.	(3) Readjust ring gear and pinion (par. 15 <i>h</i> ).
(4) Worn or damaged pinion or differential bearings.	(4) Replace bearing or bearings.
(5) Loose or worn bearings, wheel bearings.	(5) Adjust or replace bearings.
<i>f. Backlash.</i>	
(1) Worn differential and side gear spacers.	(1) Replace spacers.
(2) Worn universal joints.	(2) Replace joints.
(3) Loose axle shaft flange.	(3) Retighten.
(4) Excessive clearance at axle shaft splines.	(4) Replace worn parts.

**13. Removal of assembly.**—Tools: wheel stud nut wrench, jack, two jack-stands, 5/8-inch box wrench, 9/16-inch open end wrench, drag link end plug wrench, 5/16-inch socket wrench, 7/16-inch open end wrench, 3/4-inch open end wrench.

*a.* Prepare car for work—wheel stud nut wrench. Place vehicle on level spot and apply hand brake or block rear tracks. Loosen but do not remove the six wheel stud nuts on each front wheel.

*b.* Raise front end of car—jack, two jack-stands. Jack up front end. Place a suitable jack-stand on each side of frame just behind front spring rear hanger bracket. Lower front end until weight rests on jack-stands and wheels are about 4 inches from ground. This will allow axle to be rolled from chassis without any underneath interference.

*c.* Disconnect front drive shaft at pinion—5/8-inch box wrench, 9/16-inch open end wrench. Remove four 7/16-inch bolts (A214369), nuts (BBBX1D), and lock washers (BECX1L) from the companion flange at the differential pinion shaft (fig. 8.).

*d.* Disconnect drag link—drag link adjuster. Loosen plug at end of drag link and disengage link from steering arm stud (A167504).

*e.* Disconnect shock absorber links and spring clips—15/16-inch socket wrench. Remove eight 5/8-inch spring clip U-bolt nuts (A160357) and pull out the four U-bolts (B184103 front; A175412

rear). This will disconnect the axle at the springs and the shock absorber links at the axle (fig. 9).

f. Disconnect brake hose at frame— $\frac{15}{16}$ -inch socket wrench,  $\frac{7}{16}$ -inch open end wrench,  $\frac{3}{4}$ -inch open end wrench. Remove protecting-armor side plates (B185136 R. H., B185135 L. H.) attached to frame at each side of engine, by removing holding bolts (BAOX1CB). Disconnect hydraulic brake hoses at frame.

g. Remove axle from car. By juggling slightly, roll out entire axle and wheel assembly from under car (fig. 10).

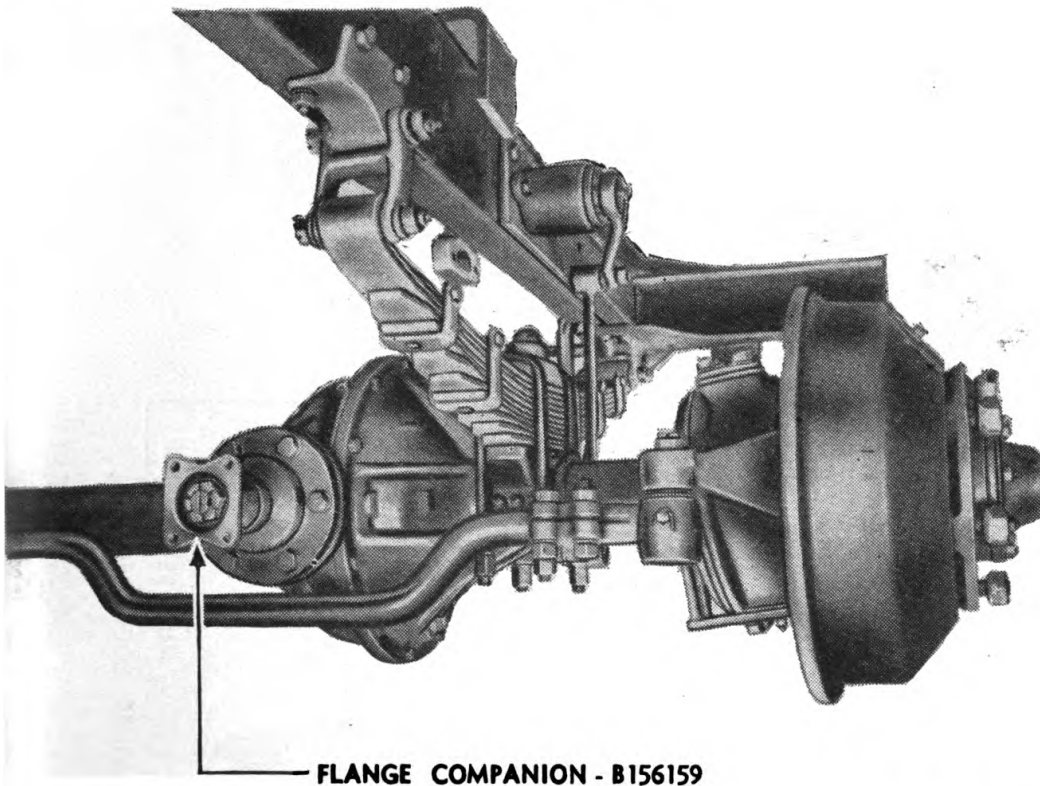

RA PD 3863A

FIGURE 8.—Front axle drive pinion companion flange, installed.

h. Remove wheel and tire assemblies. Block up axle assembly (E3801, E3831) until the tires are just off the ground and remove wheel and tire assemblies (fig. 11). This may be made easier by slipping a greased board under the wheel and sliding it off onto board.

**14. Disassembly of components.**—*a. Hub and drum assemblies.*—Tools: wheel stud nut wrench, jack, two jack-stands,  $\frac{5}{8}$ -inch socket wrench, 2-inch open end wrench, pliers, wheel bearing nut wrench, wheel puller, hammer, brass drift (or bearing puller).

(1) Lift front end of car—wheel stud nut wrench, jack, two jack-stands. Lift front end of car following steps in paragraph 13*a* and *b*.

(2) Remove wheel and tire assemblies. Remove wheel stud nuts and pull off wheel assembly. This may be made easier by slipping a greased board under wheels and sliding them off onto board.

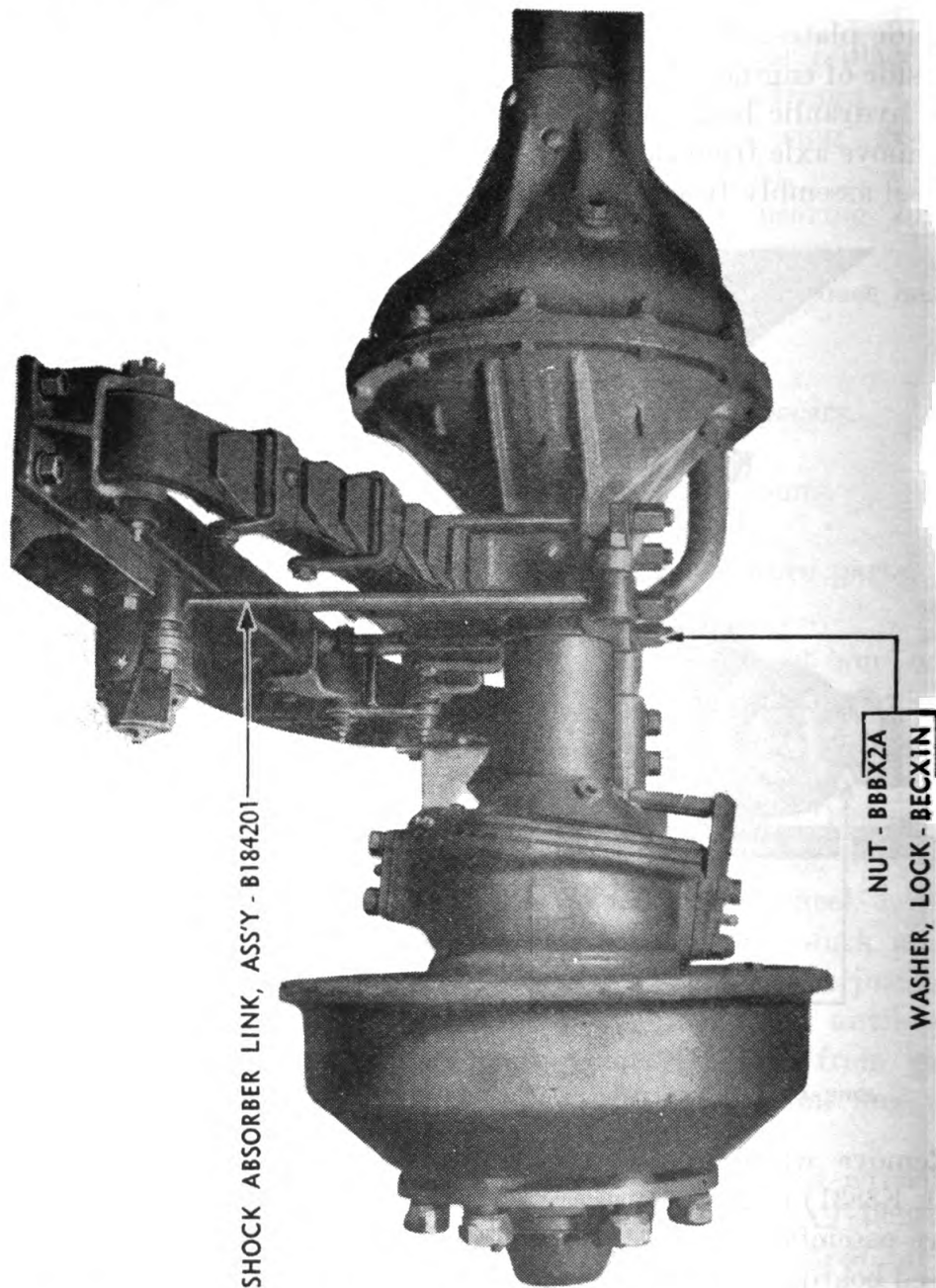

RA PD 3864

FIGURE 9.—Front spring assembly, installed.

(3) Remove hub and drive flange— $\frac{5}{8}$ -inch socket wrench. Remove hub cap stud nuts (BBBX1D) and pull off hub cap (C85758) and drive shaft flange (C85757). Use puller screws in threaded holes to start flange.

(4) Remove axle nut—2-inch open end wrench, pliers. Pull out cotter pin (BFAX1DN) from axle shaft and remove nut (A225893).

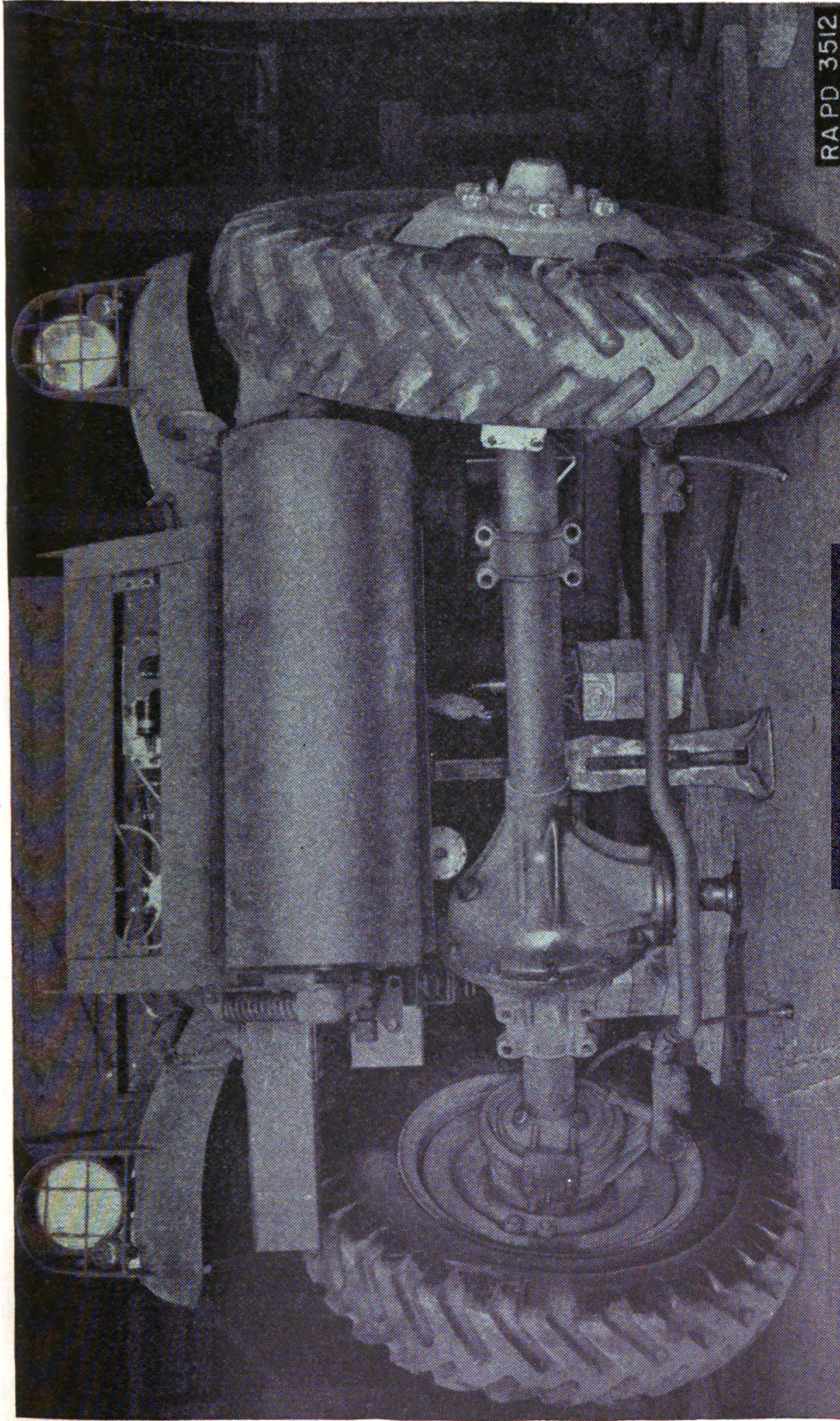

FIGURE 10.—Front axle removal.

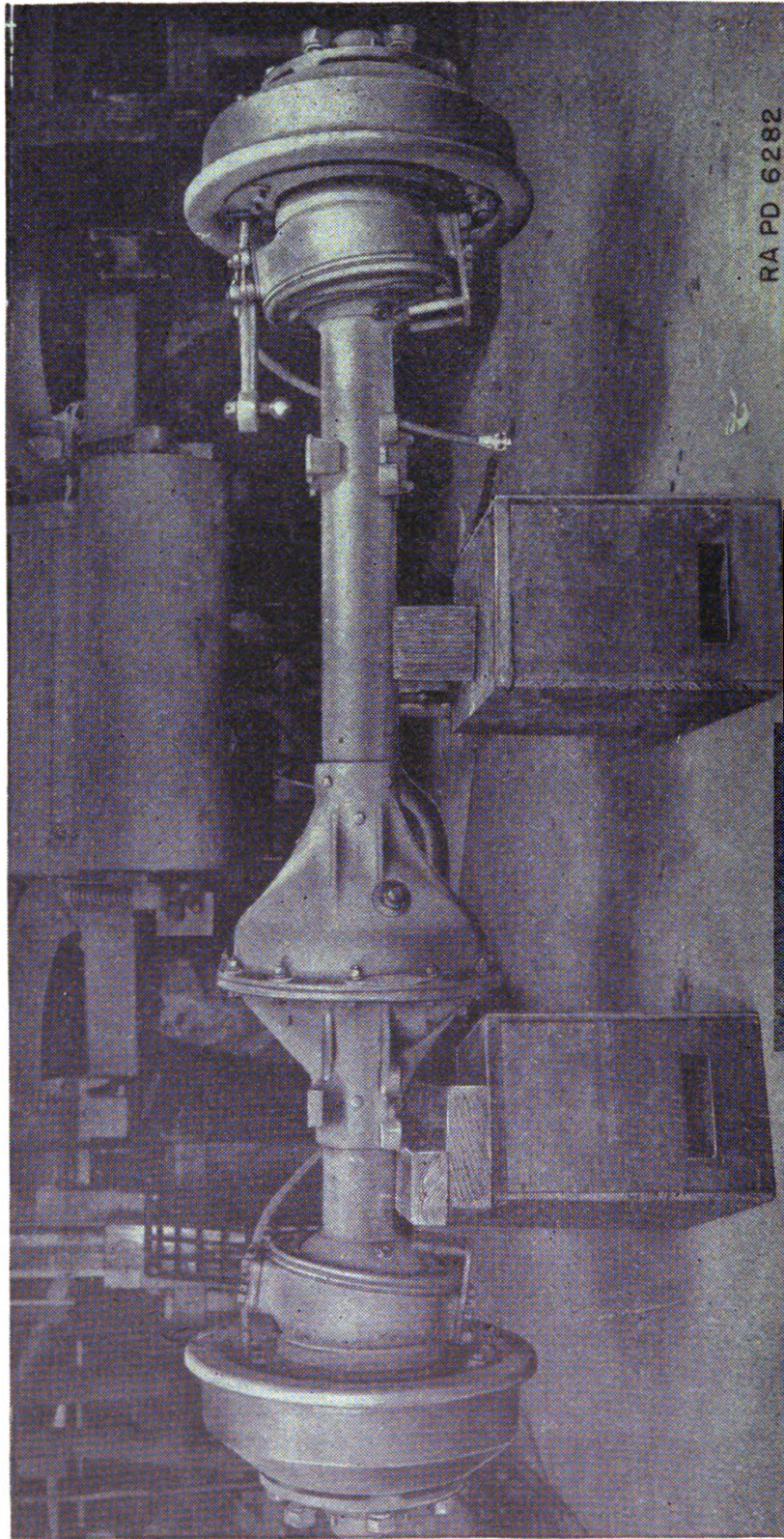
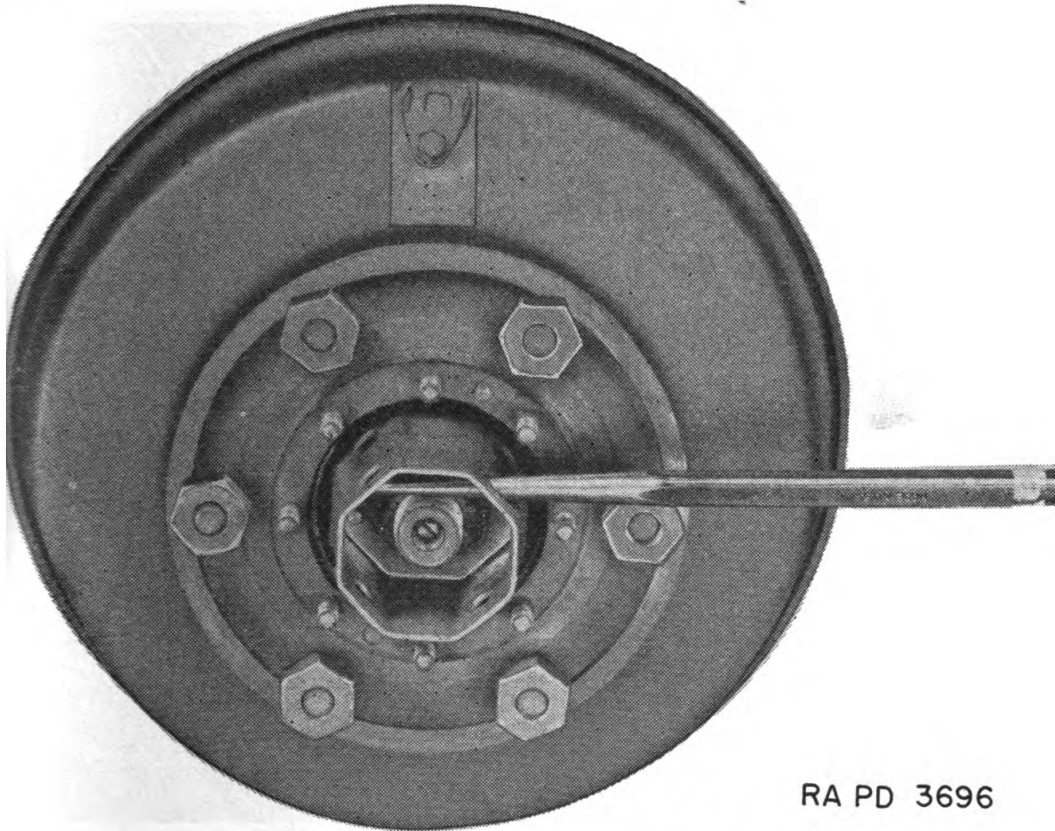

FIGURE 11.—Front axle blocked for disassembly.

(5) Remove wheel bearing nuts—wheel bearing nut wrench. Using both sides of wrench, take off bearing locking nut (B143571), washer (B184325), and adjusting nut (A214925, figs. 12 and 13).

(6) Pull off drum assembly—wheel puller. Remove wheel hub, brake drum (C85767), outer wheel bearing cone and rollers (A226003), and inner and outer bearing cups (A226005, A226006) as an assembly. Use wheel puller if necessary.



RA PD 3696

FIGURE 12.—Front axle wheel bearing nut removal.

(7) Remove wheel bearing cups—hammer, brass drift (or puller). Knock bearing cups out of drum with a hammer and brass drift (figs. 14 and 15), or remove cups with a puller.

*b. Axle shaft and universal joint.*—Same tools as used in *a* above, plus the following:  $\frac{15}{16}$ -inch socket wrench,  $\frac{7}{16}$ -inch open end wrench,  $\frac{3}{4}$ -inch open end wrench,  $\frac{3}{4}$ -inch socket wrench,  $\frac{9}{16}$ -inch socket wrench.

(1) Remove hub and drum assembly and follow steps *a*(1) through (6) above.

(2) Disconnect brake hose— $\frac{15}{16}$ -inch socket wrench,  $\frac{7}{16}$ -inch open end wrench,  $\frac{3}{4}$ -inch open end wrench. Remove engine protecting side armor plate and disconnect hydraulic brake hose at frame.

(3) Release brake hose clips— $\frac{3}{4}$ -inch socket wrench. Remove upper steering knuckle bearing plate nuts (BBBX1E) holding brake hose clips (A216300), and free hoses.

(4) Remove steering knuckle and brake backing plate— $\frac{9}{16}$ -inch socket wrench. Take off twelve  $\frac{3}{8}$ -inch knuckle outer flange stud nuts (BBBX1C) and lock washers (A226000). Pull off hub oil slinger (C85759), brake assembly (D48211 L. H., D42212 R. H.,

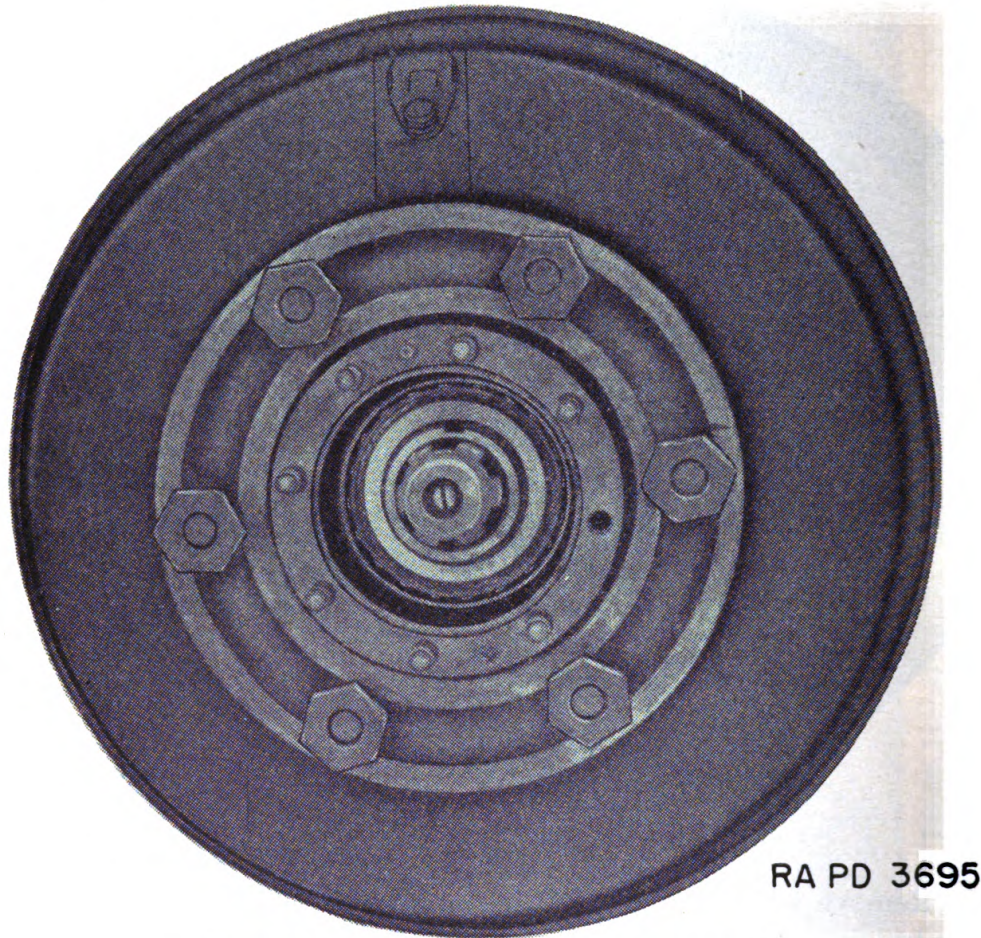

FIGURE 13.—Front axle wheel bearings, installed.

fig. 16), steering spindle (C85769), and inner wheel bearing cone and rollers assembly (A226002). Loosen knuckle spindle from knuckle flange by tapping on side of spindle with a brass hammer and using wedge blocks between spindle flange and knuckle flange.

(5) Remove axle assembly. Pull the front axle drive shaft (C85764 R. H., C85765 L. H.) and universal joint assembly (C85766) from axle housing (figs. 17 and 18).



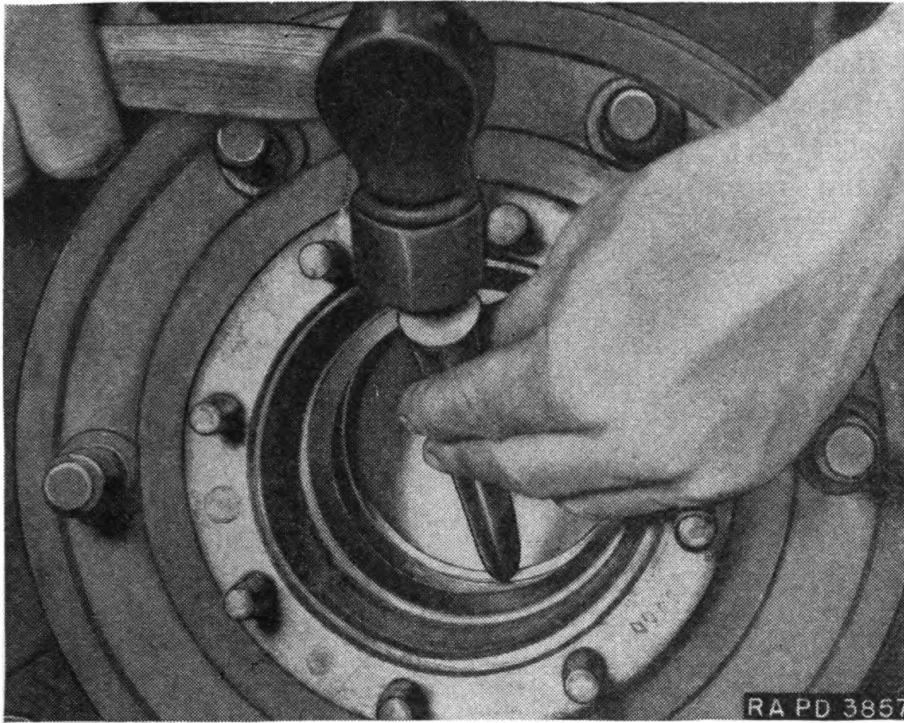

FIGURE 14.—Front axle wheel bearing inner cup removal.

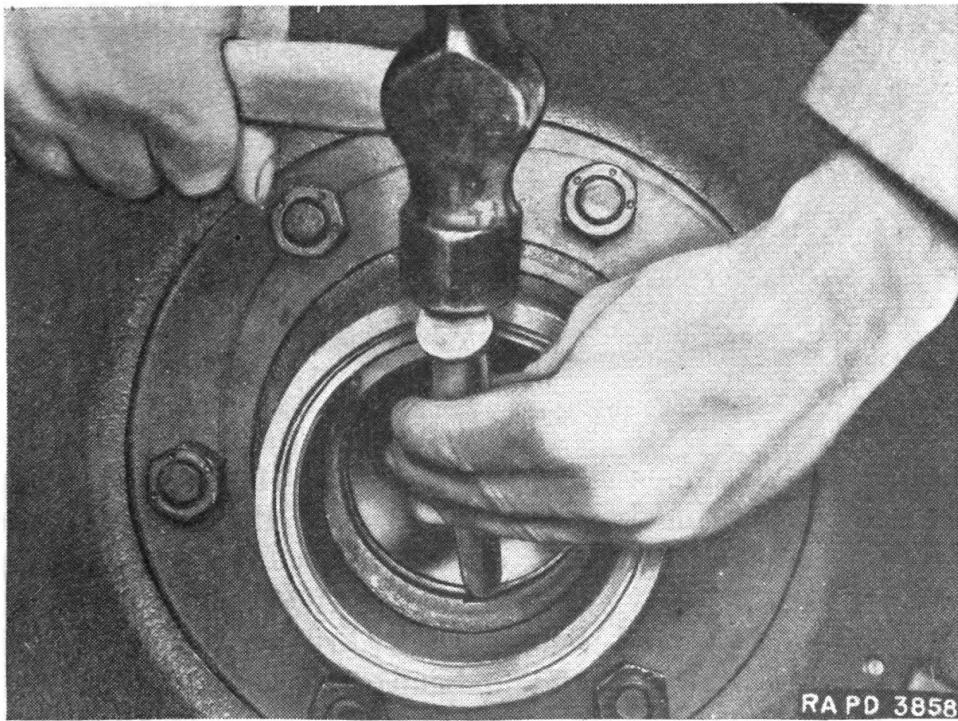

FIGURE 15.—Front axle wheel bearing outer cup removal.

c. *Knuckle pin bushings.*—Tools:  $\frac{3}{4}$ -inch socket wrench; screw driver.

(1) Remove bushing caps and spacers— $\frac{3}{4}$ -inch socket wrench. Take off upper and lower bushing plate stud nuts (BBBX1E) and lock washers (BECX1M), and remove plates (A225892 upper, A225890 lower) and spacers (B184485 to B184490) located under upper cap.

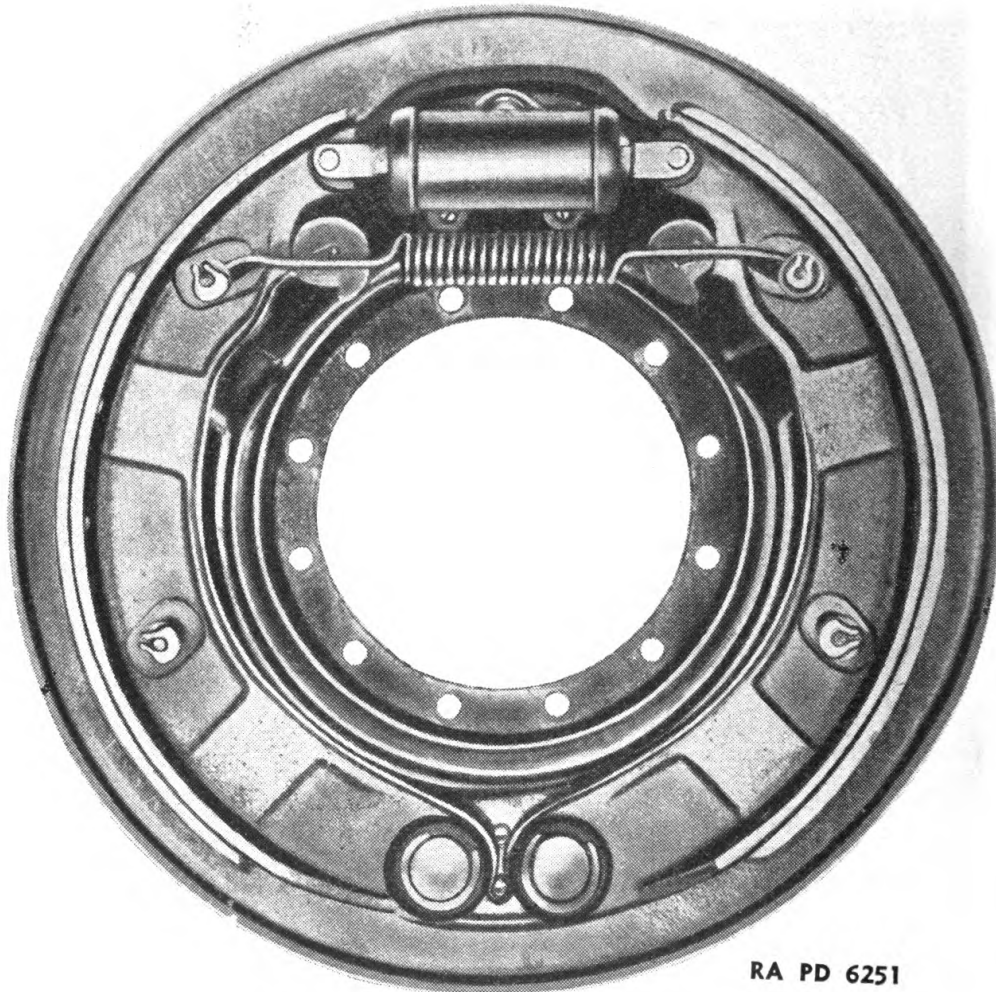

FIGURE 16.—Front wheel brake assembly.

(2) Remove bushings—pull bushings (B184485 upper, B184486 lower) out of steering knuckle outer flange. Bushings and plates should be marked so that they can be reassembled in their proper location.

(3) Remove boot and flange—screw driver. Remove steering knuckle outer flange (D48203) and universal joint housing. Then loosen screws (A225877) on inner and outer boot clamps (C85750 inner, C85751 outer) and remove boots (C85749).

*d. Rzeppa universal joint* (fig. 19).—Same tools as used in *b* above plus a screw driver.

(1) Remove joint assembly—tools as in *b* above. Remove axle shaft and joint assembly as explained in *b* above.

(2) Pull drive shaft—screw driver. Remove drive shaft retainer screws (A167715) and pull shaft out of inner race (A225950, fig. 20b

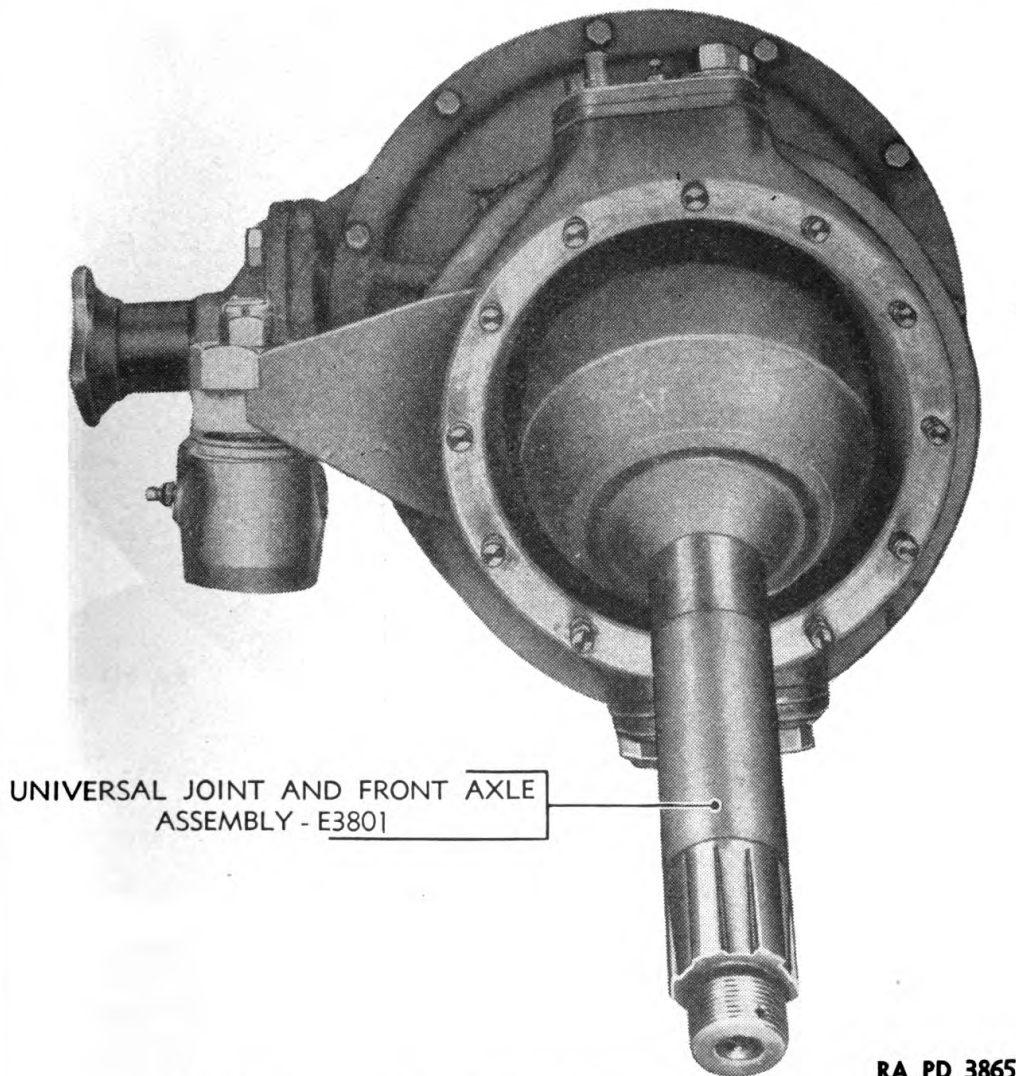

RA PD 3865

FIGURE 17.—Front axle Rzeppa universal joint removal.

and *c*). Remove pilot spring (A225949) and plunger (A225948) assembly (fig. 20d).

(3) Remove balls. Tilt inner race to double angle of cage (A225943) until one ball (A225945) can be removed (fig. 20e). Roll inner race and cage into corresponding position for removal of adjacent ball, and proceed until all six balls are removed.

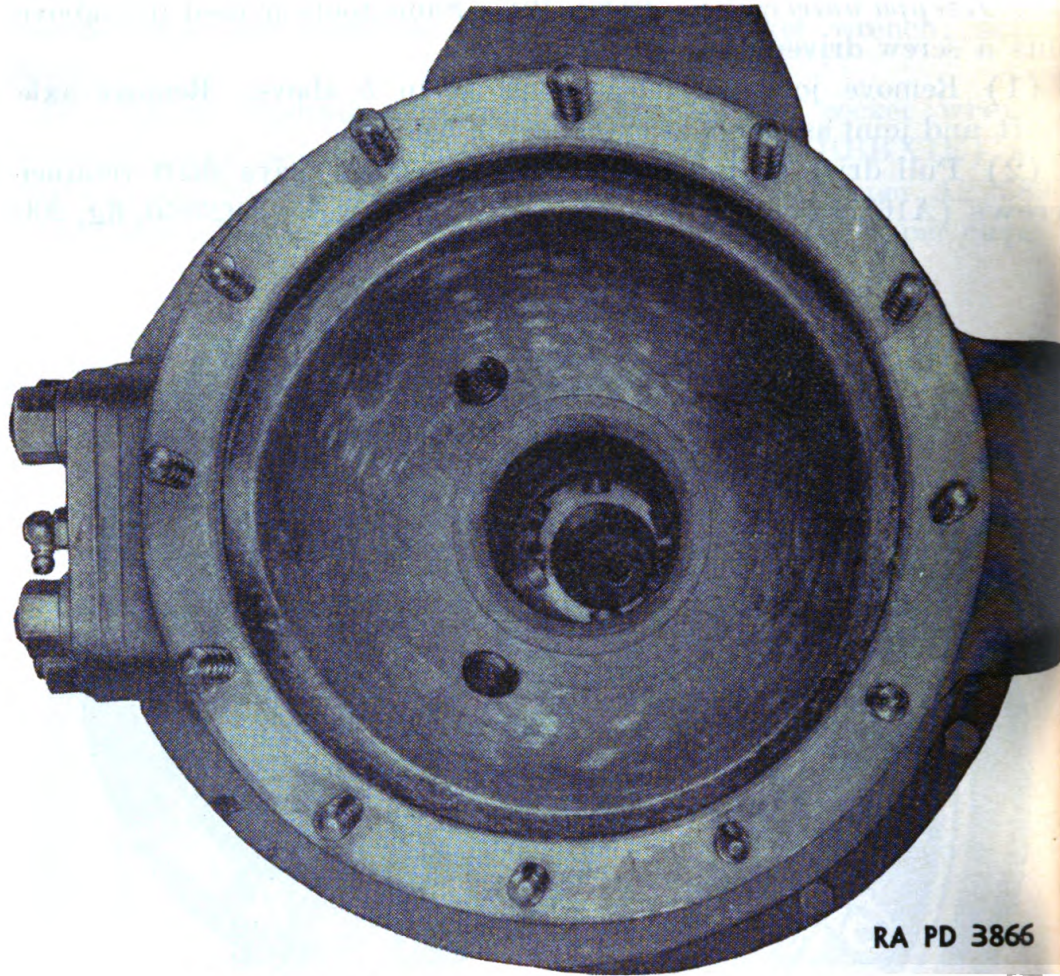

RA PD 3866

FIGURE 18.—Front axle Rzeppa universal joint housing.

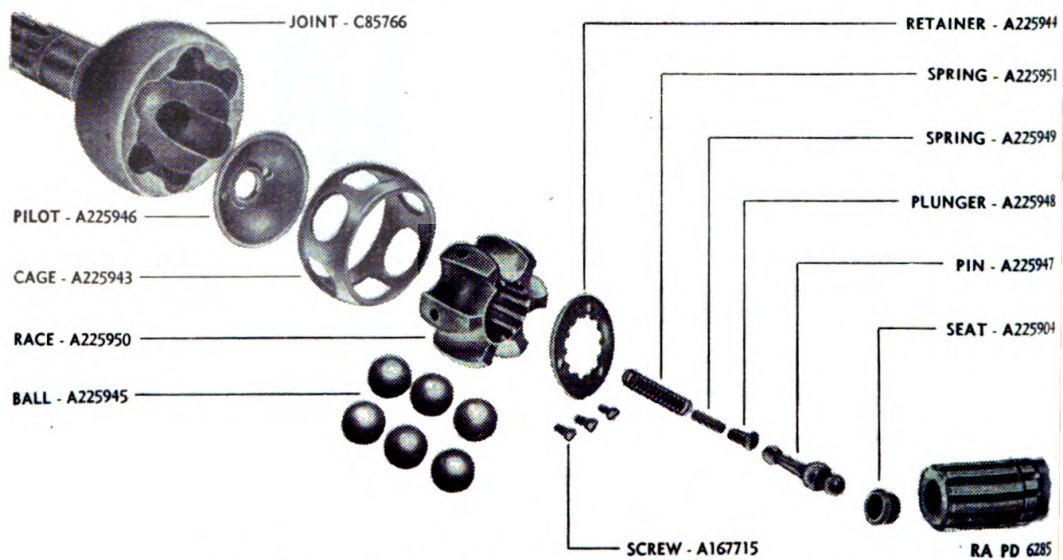
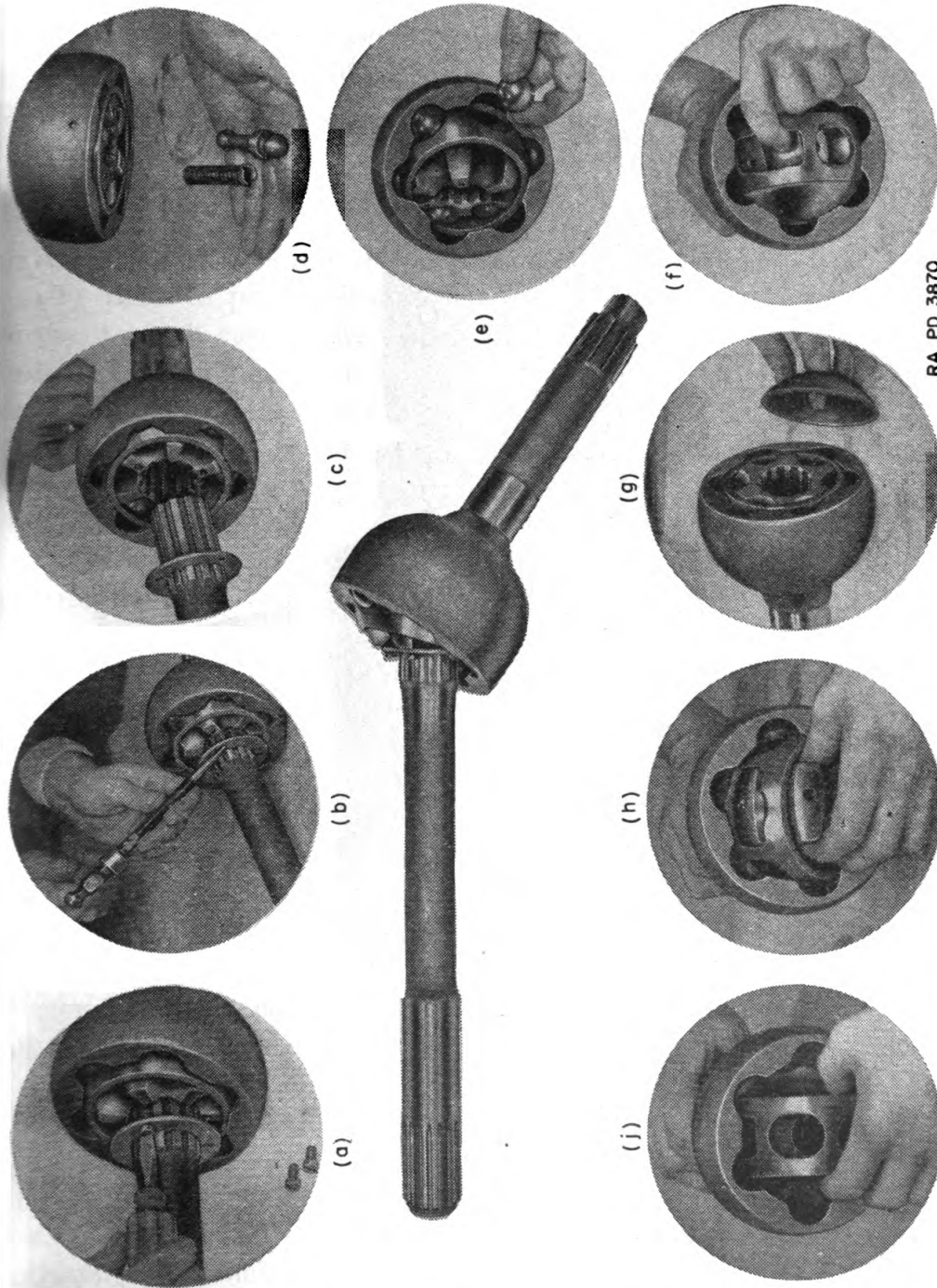

FIGURE 19.—Front axle Rzeppa universal joint, exploded.

POWER TRAIN

(4) Remove pilot. Roll cage 180° (fig. 20f) and remove pilot (A225946, fig. 20g).



RA PD 3870  
 Figure 20.—Front axle Rzeppa universal joint, disassembly and assembly.

(5) Remove inner race. Turn inner race within cage until one tooth projects through rectangular openings of cage (fig. 20h). Roll inner race out of cage.

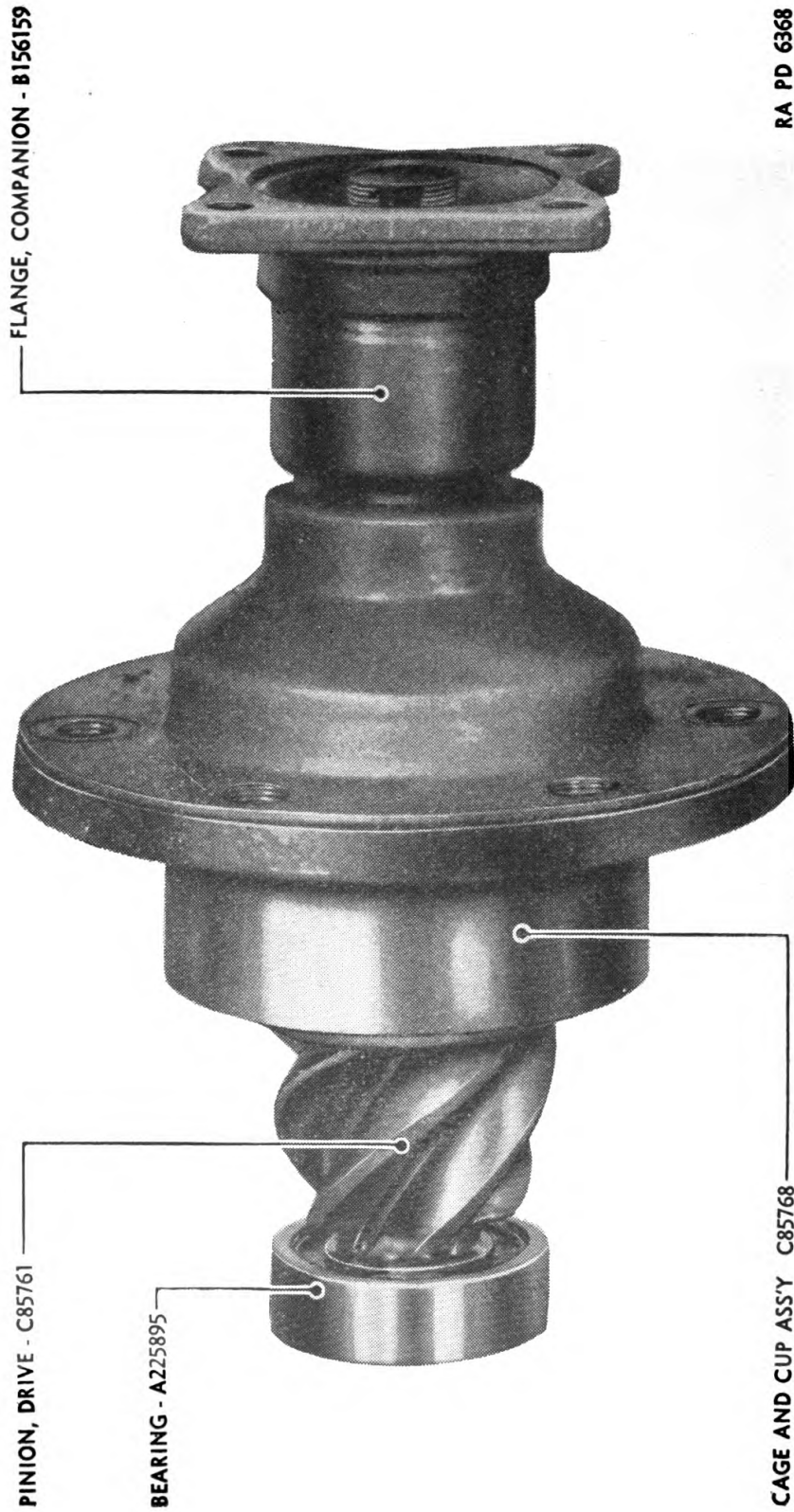

FIGURE 21.—Front axle drive pinion assembly.

RA PD 6368

CAGE AND CUP ASS'Y C85768

(6) Remove cage. Position cage at right angles with outer race so that rectangular cage openings mesh with opposite teeth of outer race (fig. 20j). Withdraw cage.

*e. Drive pinion* (fig. 38).—Tools:  $\frac{5}{8}$ -inch box wrench,  $\frac{9}{16}$ -inch open end wrench,  $\frac{3}{16}$ -inch socket wrench,  $1\frac{1}{2}$ -inch socket wrench, pliers, press,  $1\frac{1}{4}$ -inch open end wrench, wood blocks, brass drift, hammer, press collar.

(1) Disconnect propeller shaft— $\frac{5}{8}$ -inch box wrench,  $\frac{9}{16}$ -inch open end wrench. Remove four  $\frac{7}{16}$ -inch bolts (A214369), nuts (BBBX1D), and lock washers (BECX1L), and disconnect front propeller shaft at drive pinion companion flange.

(2) Remove pinion shaft assembly— $\frac{3}{4}$ -inch socket wrench. Remove  $\frac{9}{16}$ -inch cap screws (A145900) and lock washers (BECX1N) holding pinion outer seal cover (C85763) and bearing cage to housing, and pull out pinion shaft assembly (fig. 21).

(3) Remove shaft nut—pliers or cotter pin puller,  $1\frac{1}{2}$ -inch socket wrench. Pull out pinion shaft cotter pin (BFAX1DL) and unscrew nut (A214932).

(4) Remove companion flange—press. Press off front axle companion flange (B156159, fig. 21) and key (A167690), and remove outer bearing cage cork (A174608).

(5) Remove bearing nuts and washers— $1\frac{1}{4}$ -inch open end wrench. Take off drive pinion outer bearing nut lock (A225902), lock ring (A159568), adjusting nut (A225901), and adjusting nut washer (A225903).

(6) Remove bearing cage—press, wood blocks. Press off outer bearing cage assembly (C85768) and taper bearing cone and rollers assembly (A226004) from shaft (fig. 23).

(7) Remove roller bearing cups—brass drift, hammer. Tap bearing cups (A226007) from cage as shown in figure 24.

(8) Remove inner bearing cone—press. Press inner bearing cone off shaft (fig. 25). (This may also be done with a bearing puller.)

(9) Remove straight roller bearing—press. Press straight roller bearing (A225895) off shaft (fig. 26).

(10) Remove oil seal—press, collar. Press oil seal (A145910) out of retainer from inner side.

*f. Differential.*—Same tools as listed in paragraph 13, plus the following:  $\frac{9}{16}$ -inch open end wrench;  $1\frac{1}{16}$ -inch open end wrench;  $\frac{5}{8}$ -inch socket wrench;  $\frac{5}{8}$ -inch open end wrench, drift, hammer, bearing puller, seal remover.

(1) Remove axle assembly. Axle is removed from car by following steps in *e*(1) through (10) above.

(2) Drain lubricant— $\frac{9}{16}$ -inch open end wrench. Remove magnetic drain plug (A225998) from housing and drain lubricant.

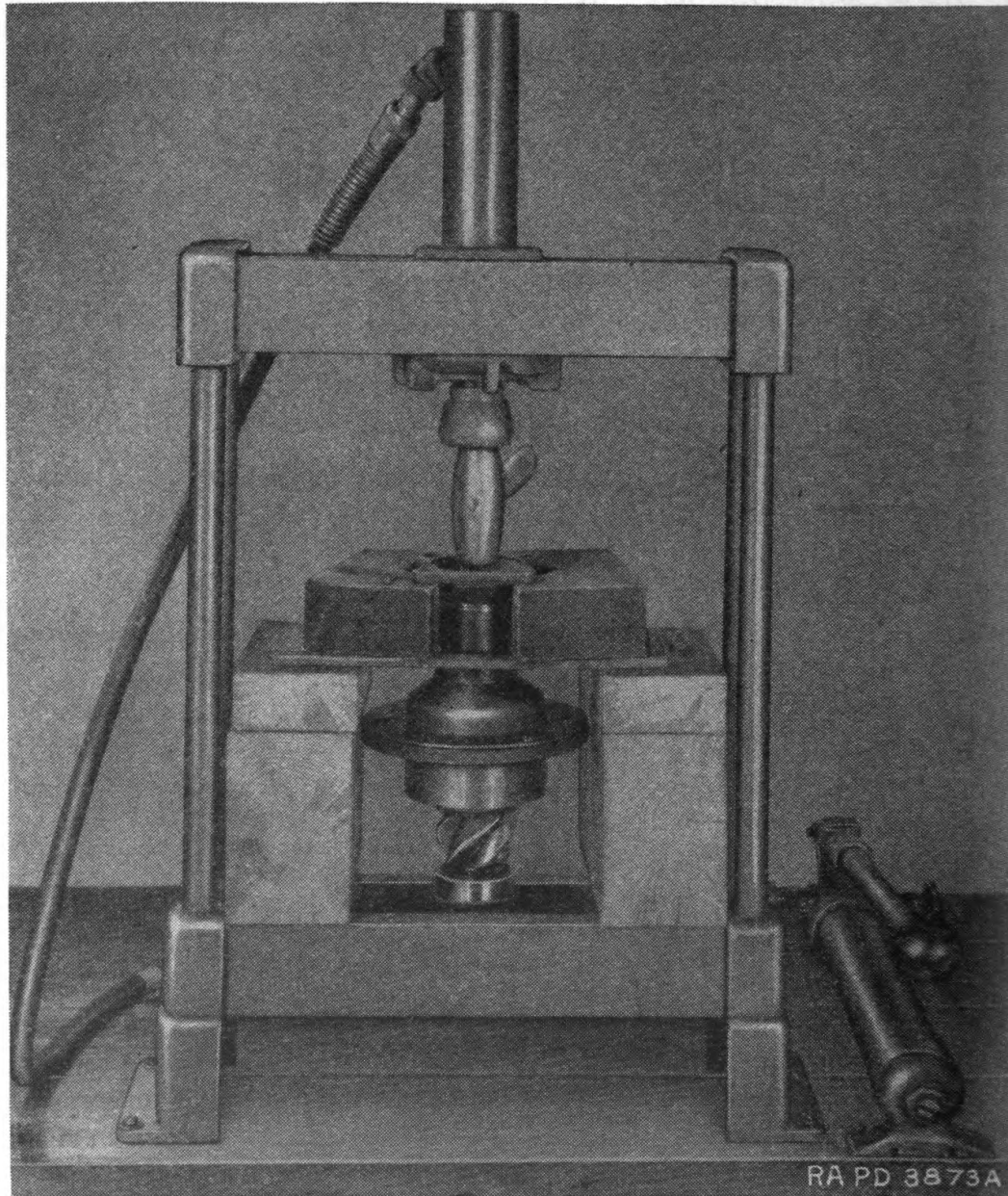

FIGURE 22.—Pressing off front axle drive pinion companion flange.

(3) Disconnect steering cross tube— $1\frac{1}{16}$ -inch socket wrench. Pull end-stud nut cotter pins (BFAX1DK) and remove nuts (A225887). Tap on side to loosen tapered studs (B184448) and pull off cross tube (D48205) from axle.



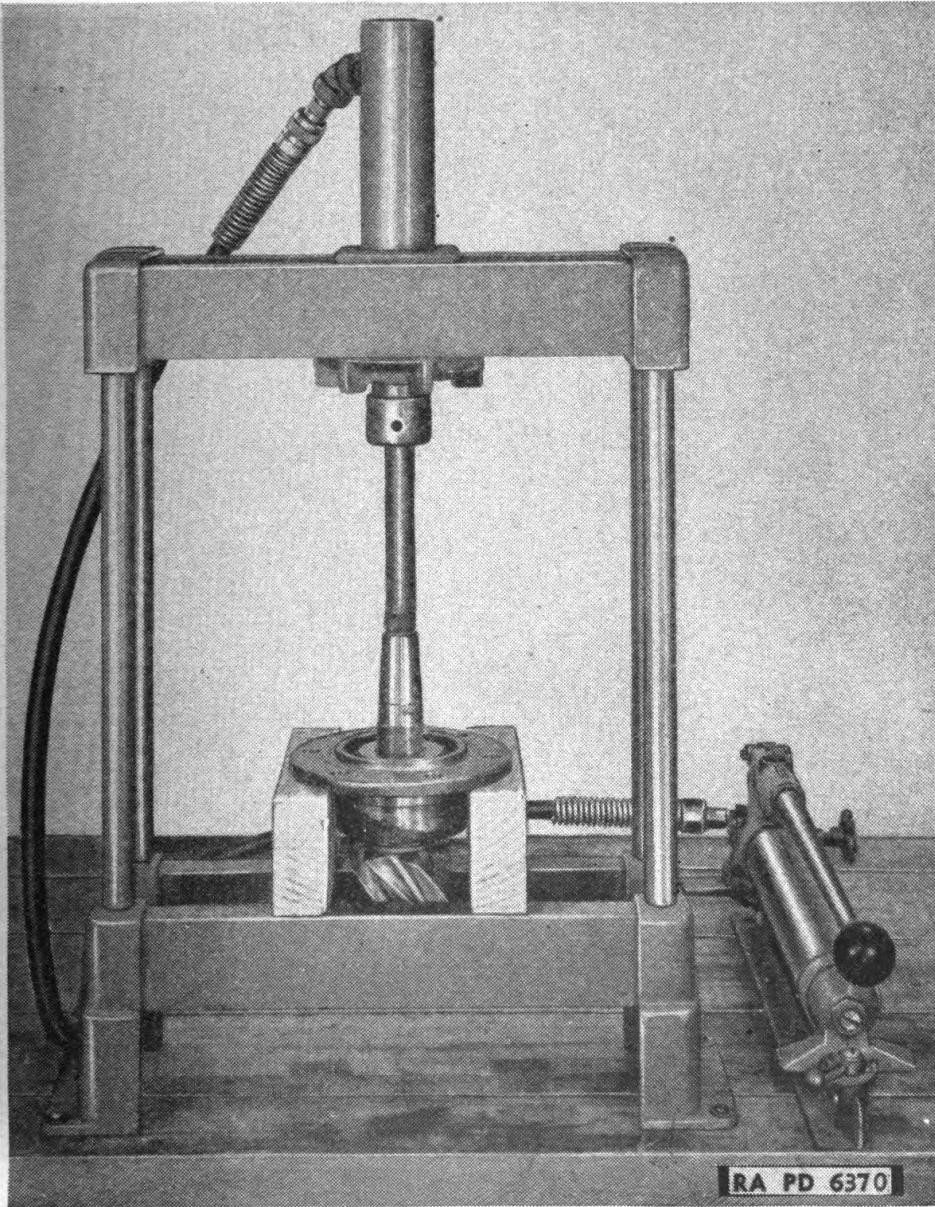

FIGURE 23.—Pressing off front axle drive pinion bearing cage.

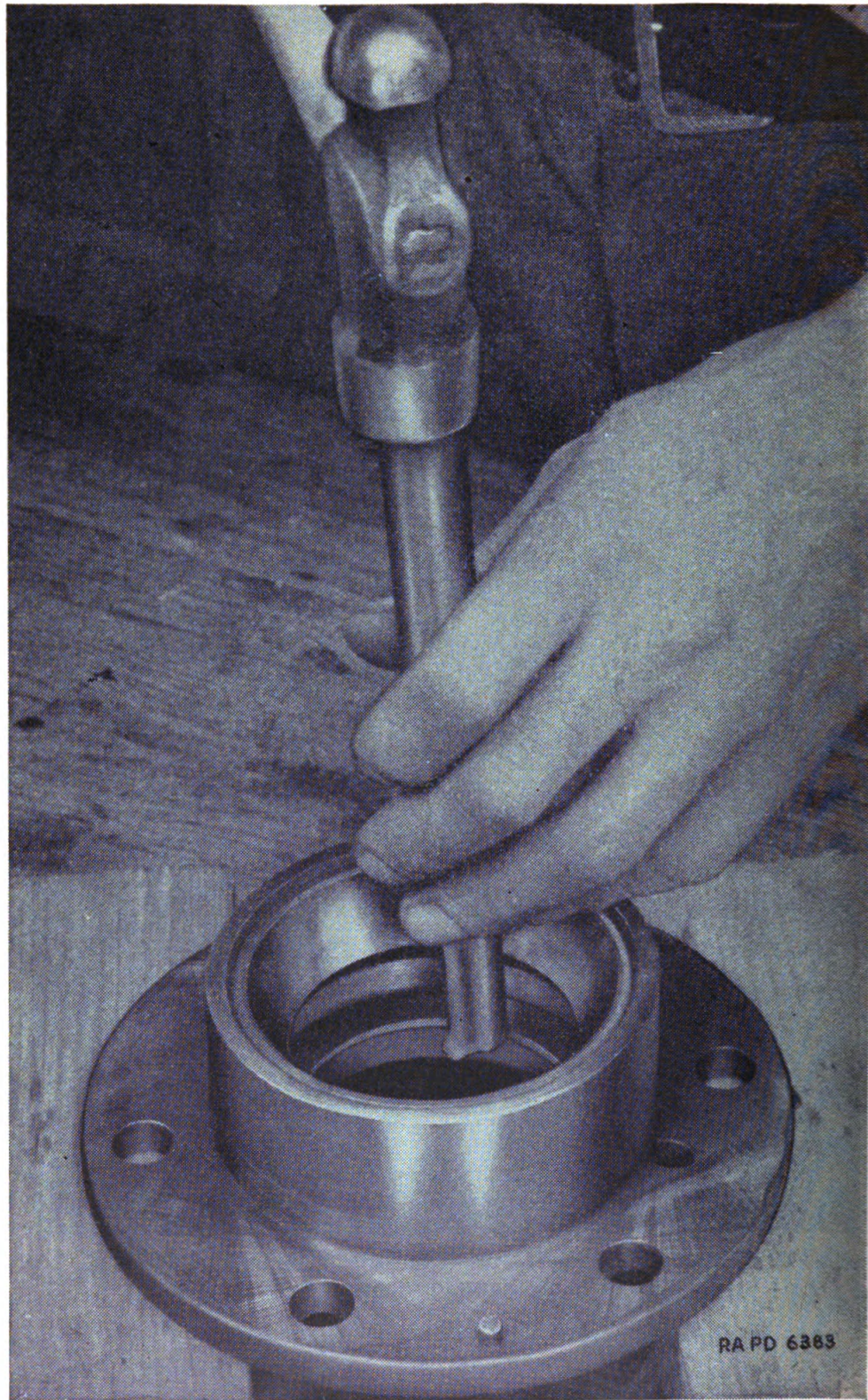

FIGURE 24.—Front axle drive pinion bearing cup removal.

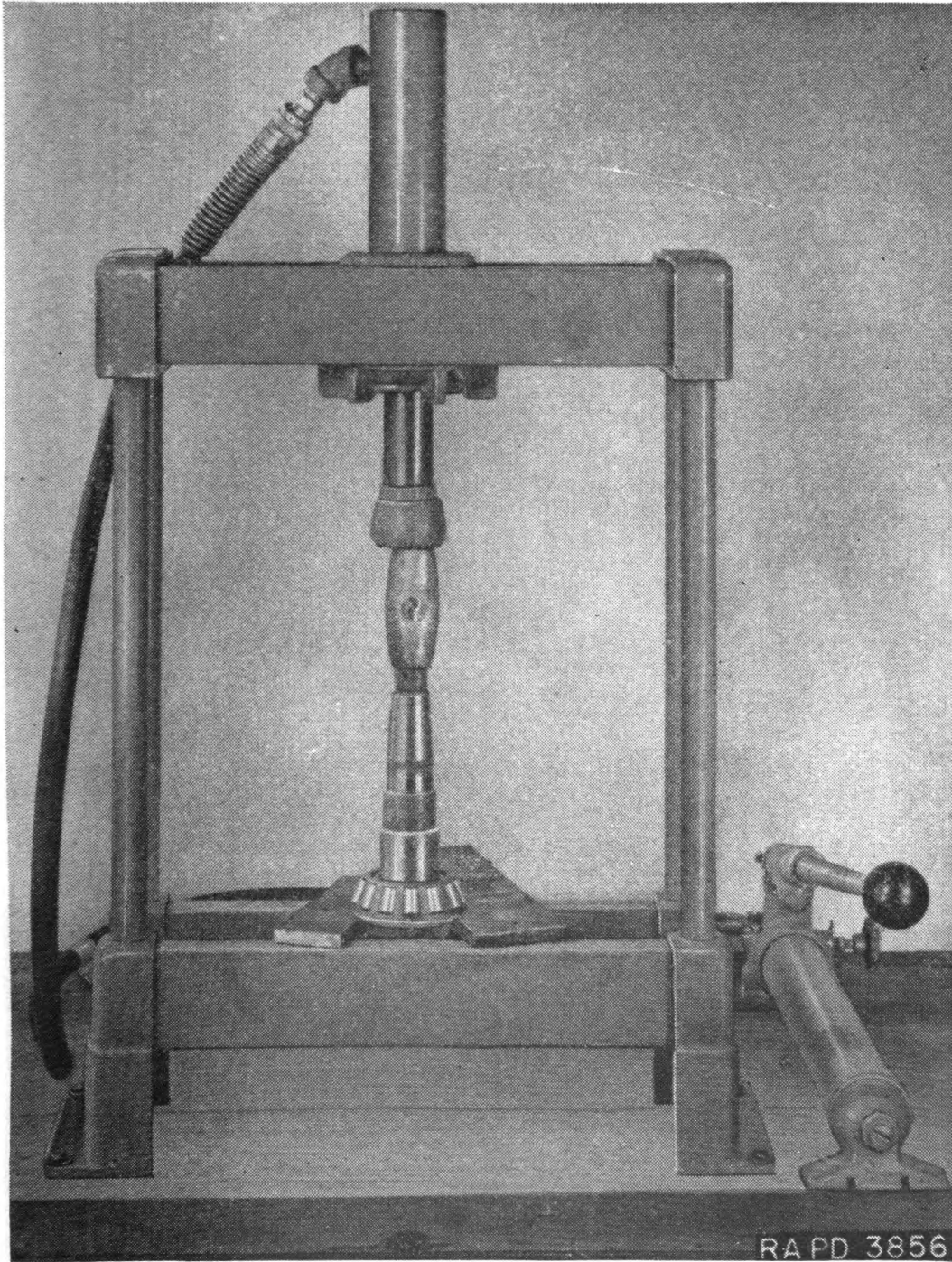

FIGURE 25.—Pressing off front axle drive pinion inner bearing cone.

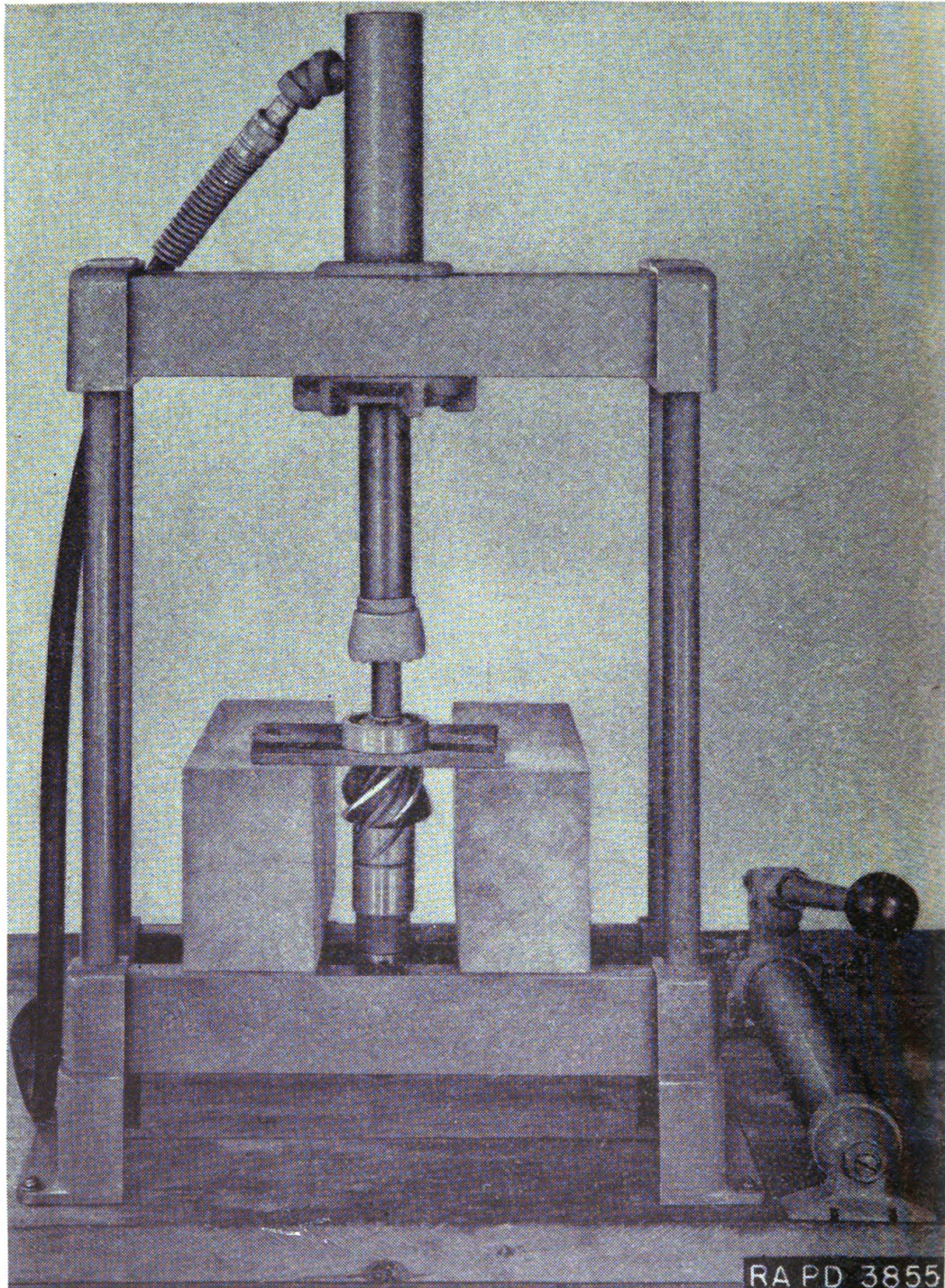

FIGURE 26.—Pressing off front axle drive pinion straight roller bearing.

POWER TRAIN

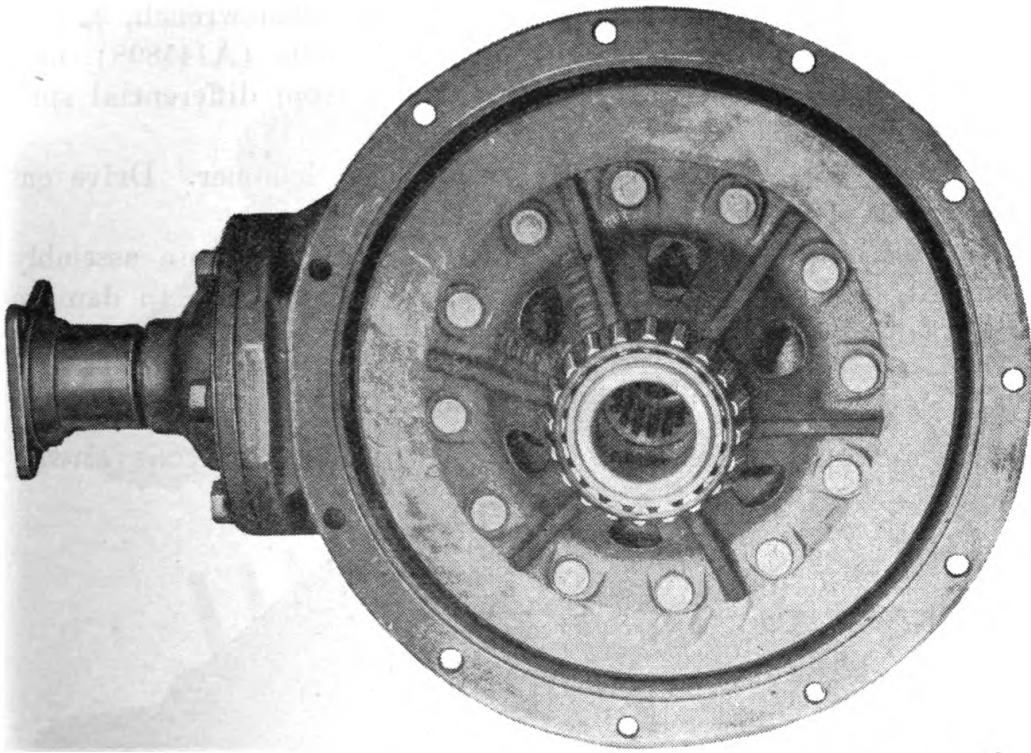

FIGURE 27.—Front axle differential assembly, installed.

RAPD 3859

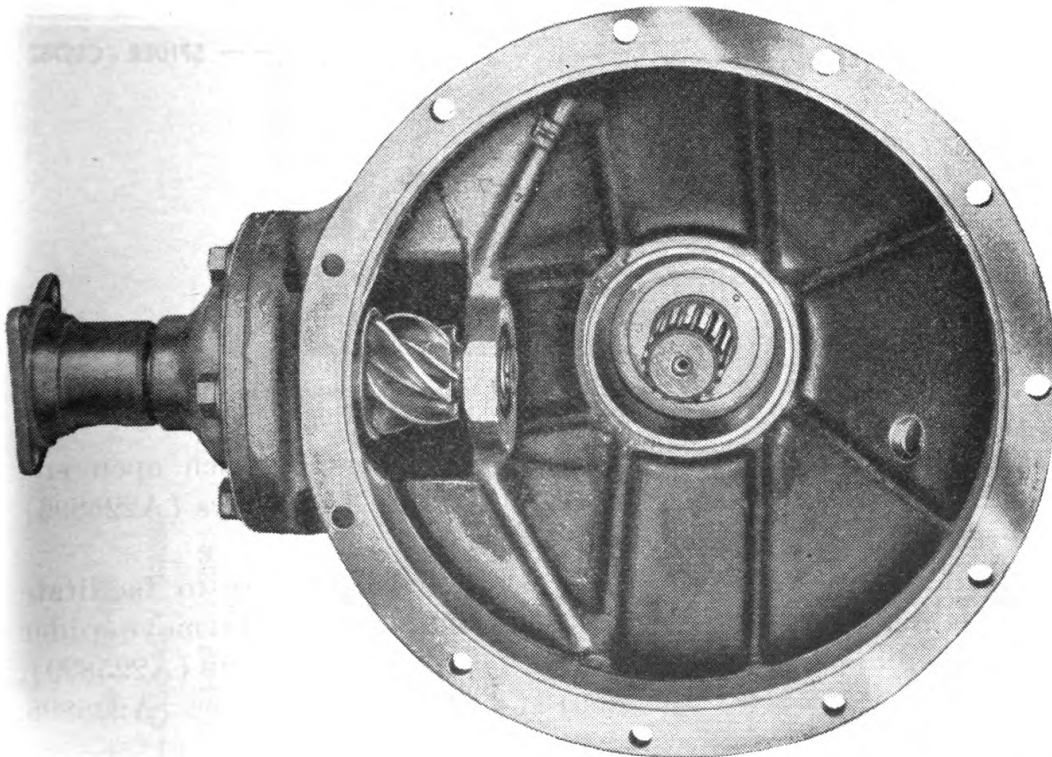

FIGURE 28.—Front axle drive pinion, installed.

RAPD 3860

(4) Separate differential housing— $\frac{5}{8}$ -inch socket wrench,  $\frac{5}{8}$ -inch open end wrench. Remove eleven  $\frac{7}{16}$ -inch bolts (A145898), nuts (BBBX1D), and lock washers (BECX1L) from differential split housing and remove right-hand half (fig. 27).

(5) Remove bevel gear thrust block—drift, hammer. Drive out thrust block (B184450) and pin (A159553).

(6) Pull out case assembly. Remove differential case assembly from left half of housing. Care should be taken not to damage splines (fig. 28).

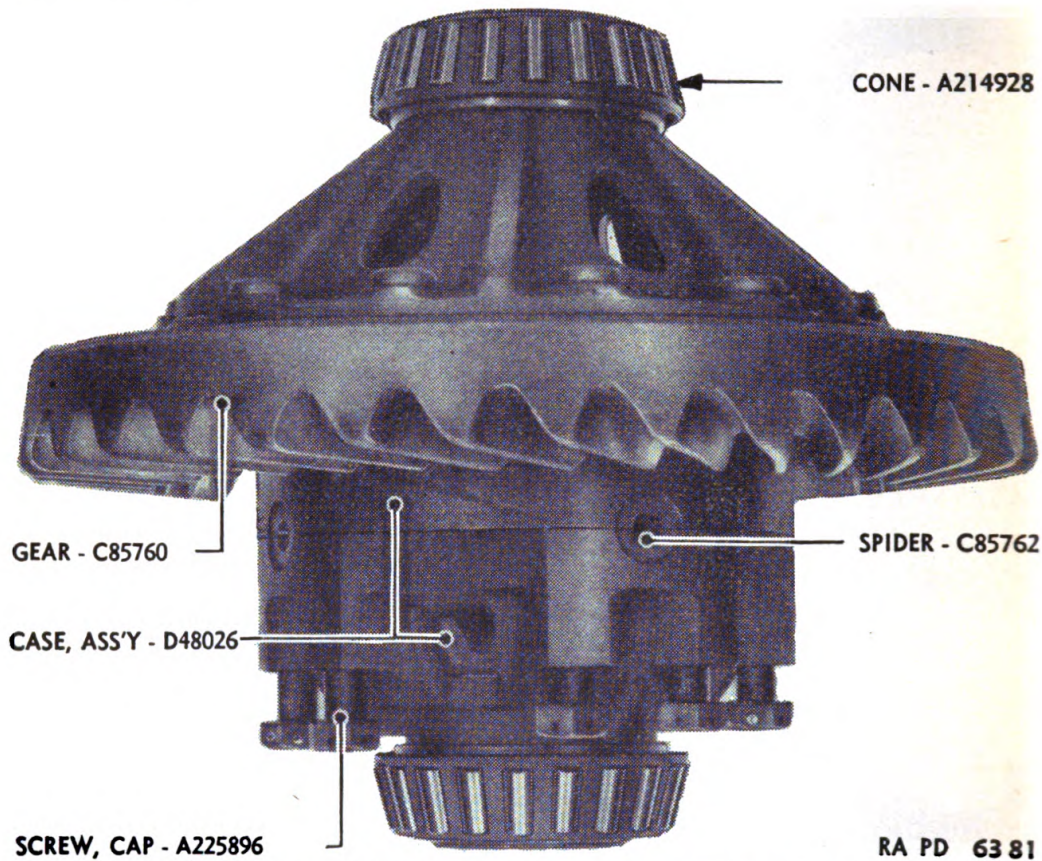

FIGURE 29.—Front axle differential case cap screw removal.

(7) Take out case bolts—wire cutting pliers,  $\frac{9}{16}$ -inch open end wrench. Cut locking wire (A225897) holding case screws (A225896) and remove eight  $\frac{1}{2}$ -inch cap screws (fig. 29).

(8) Remove differential gears. Mark halves of case to facilitate their realinement during assembly. Split case open and remove spider (C85762), pinion gears (B184464, B184481), thrust washers (A225899), and side gears (B184451, B184480) and their thrust washers (A225898, fig. 30).

POWER TRAIN

TM 9-1710  
14

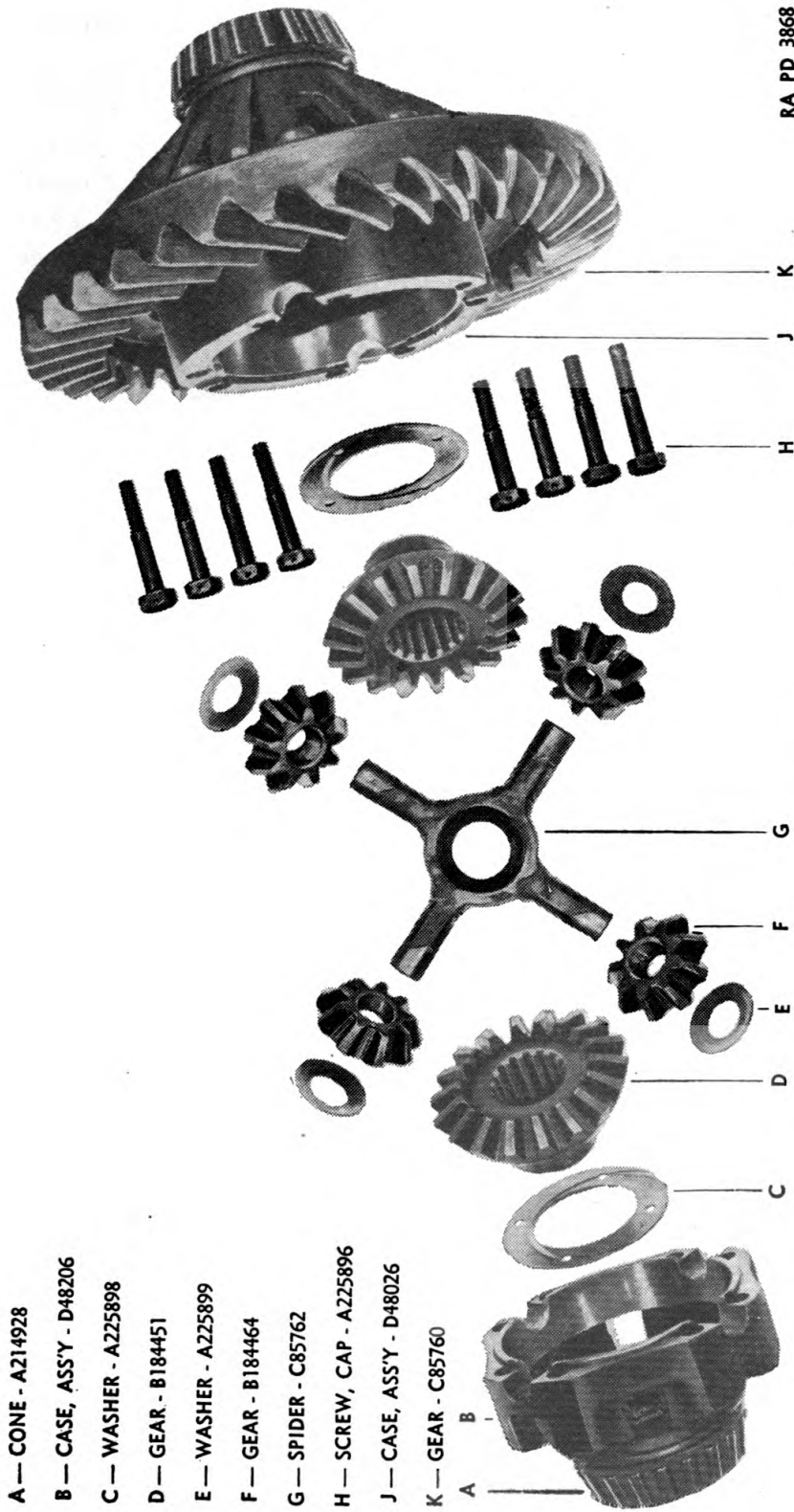
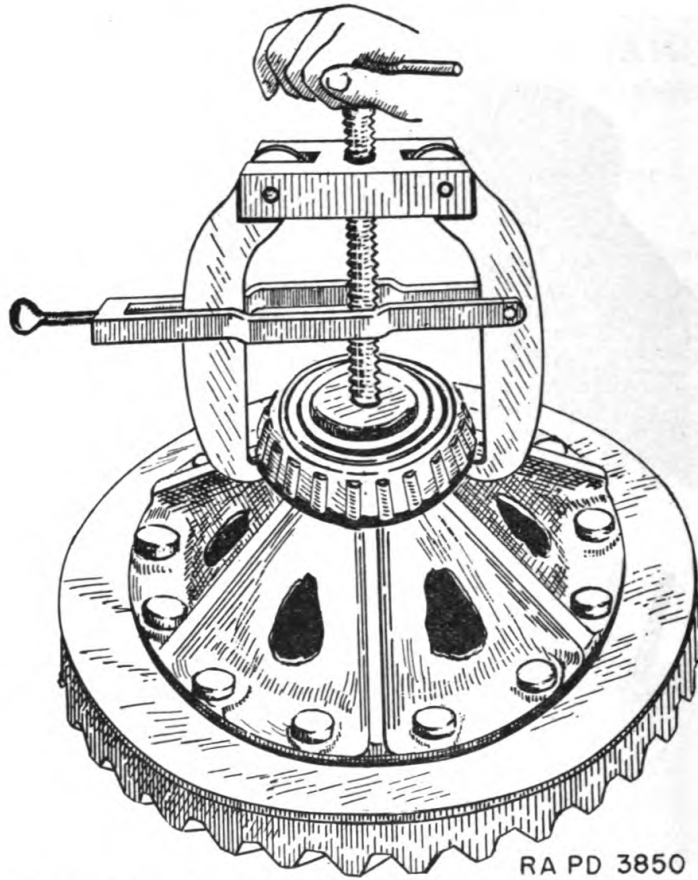

FIGURE 30.—Front axle differential assembly, exploded.

RA PD 3868



RA PD 3850

FIGURE 31.—Front axle differential bearing cone removal.

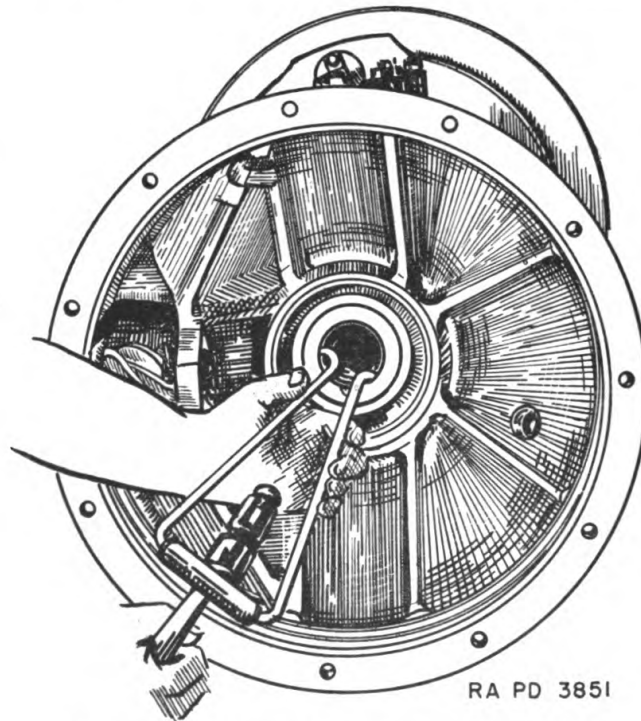

RA PD 3851

FIGURE 32.—Front axle tube oil seal removal.



(9) Remove case bearings—bearing puller. Using a bearing puller as shown in figure 31, pull off taper roller bearing cones (A214928).

(10) Remove oil seals—seal remover. Pull oil seals (A225894) from axle housing at differential end (fig. 32).

*g. Steering cross tube* (fig. 33).—Tools:  $1\frac{1}{16}$ -inch socket wrench, screw driver,  $\frac{15}{16}$ -inch socket wrench,  $\frac{7}{8}$ -inch open end wrench.

(1) Disconnect cross tube— $1\frac{1}{16}$ -inch socket wrench. See operation *f*(3) above.

(2) Remove dust shields. Remove retainer spring (A225889), dust cover (A225884), rubber (A225885), and retainer (A225886) from tapered stud assembly.

(3) Remove end plug—screw driver. Pry out end lock (A225883) and remove end plug (A225882) and spring (B184447) from bottom side of stud housing.

(4) Remove remainder of stud assembly. Pull out ball cup, stud, retainer (A225881), pin (A226061), and stud seat (A225888) from housing.

(5) Take off cross tube ends— $\frac{15}{16}$ -inch socket wrench,  $\frac{7}{8}$ -inch open end wrench. Remove four  $\frac{5}{8}$ -inch end clamp bolts (A225880), nuts (BBX2B), and lock washers (BECX1P), and unscrew ends (C85755 R. H., C85754 L. H.).

**15. Maintenance and adjustments.—*a. Cleaning bearings.***

(1) Put differential side bearings, pinion bearings, and wheel bearings into cleaning fluid and allow them to remain long enough to loosen old grease and lubricant.

(2) After a thorough soaking, bearings should be alternately slushed up and down, and spun slowly below the surface of the liquid to remove as much old grease as possible.

(3) Then remove bearing and strike larger open side of bearing flat against wooden block to jar loose heavier and harder particles of lubricant.

(4) Repeat immersion and striking operations until bearings are cleaned.

(5) Blow out bearings, directing air pressure across bearings to remove last traces of old lubricant; avoid spinning bearings by air blast.

(6) Inspect rollers and races carefully for chipping, cracks, or worn spots to determine fitness of bearings for future use.

(7) If bearings are damaged, replace with new ones; otherwise, repack with the proper grease or lubricant, and wrap in clean paper until ready to reassemble.

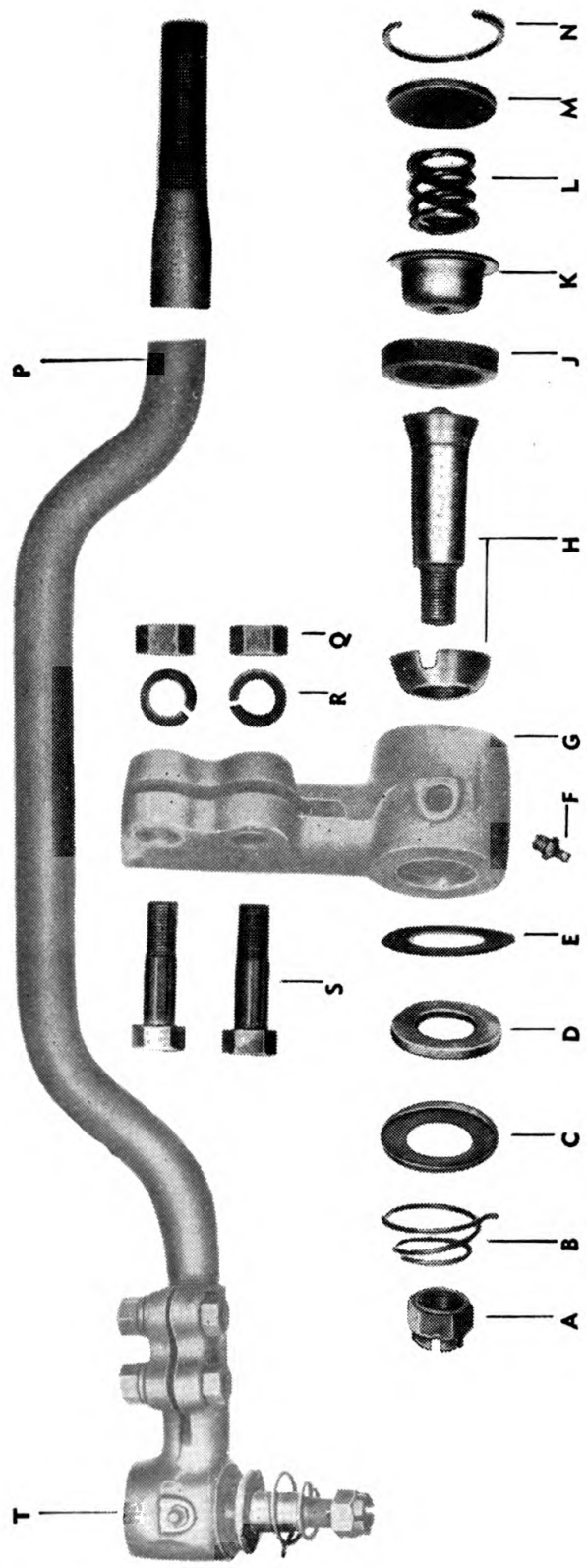

- A** — NUT - A225887
- B** — SPRING - A225889
- C** — COVER - A225884
- D** — RUBBER - A225885
- E** — RETAINER - A225886
- F** — FITTING - CLDX5M
- G** — END - C85754
- H** — STUD, ASS'Y - B184448
- J** — RETAINER - A225881
- K** — SEAT - A225888
- L** — SPRING - B184447
- M** — PLUG - A225882
- N** — WIRE, LOCK - A225883
- P** — TUBE - D48205
- Q** — NUT - BBBX2B
- R** — WASHER, LOCK - BECXIP
- S** — BOLT - A225880
- T** — END, ASS'Y - C85752

**RA PD 6293**

FIGURE 33.—Front axle steering tie rod (cross tube), exploded.

*b. Hub and drum assemblies.*—(1) Check for loose or bent wheel studs and replace with new ones.

(2) Check for loose wheel bearing cups.

(3) Inspect brake drums for scoring.

*c. Axle shaft and universal joint.*—(1) Remove axle shafts as explained above and clean and inspect carefully.

(2) If there is any indication of twisting at either end, the shaft should be replaced.

(3) If the splines are badly worn or damaged, the shaft should be replaced.

*d. Knuckle pin bushing.*—(1) *Inspection.*—Remove the bushings as explained above and inspect carefully. If bushing bore has become oversize or if the bushing is worn on the outside, it should be replaced. See table of fits for proper size.

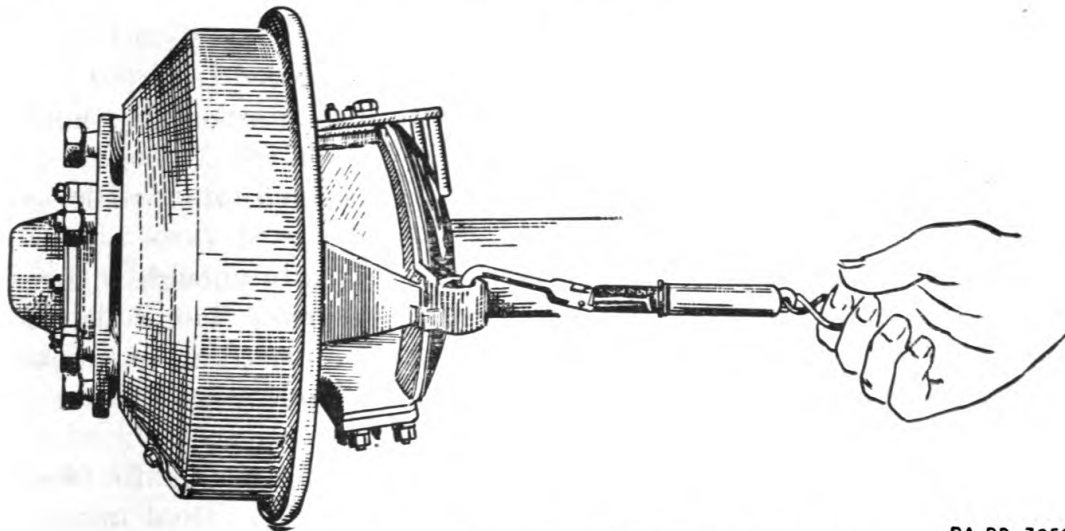

FIGURE 34.—Checking front axle steering knuckle drag.

RA PD 3852

(2) *Adjustments.*—(a) Jack up the front axle and remove the four  $\frac{3}{4}$ -inch nuts and lock washers holding the upper bushing caps. The caps can then be removed and the adjustment accomplished by means of the spacers located under these caps.

(b) Replace the spacers with slightly thicker ones (.010 inch), and replace the bushing caps. When this has been done, there should be a small amount of drag in rotating the steering knuckle (approximately 35 inch-pounds plus or minus 5 inch-pounds after start of rotation) but it should not bind (fig. 34).

*e. Universal joint.*—This should be disassembled as explained in paragraph 14*d*, cleaned, and inspected. If any parts are badly worn or damaged, the joint should be replaced. Lubricate all parts lightly before reassembly.

*f. Drive pinion.*—Disassemble by following steps (1) through (10), paragraph 14e, and clean all parts with a solvent.

(1) Inspect the pinion gear for worn or chipped teeth. If the gear is badly damaged it should be replaced and the bevel gear must also be replaced, because the pinion gear and bevel gear come in matched and lapped sets. These sets of gears should not be separated. This will eliminate confusion with other sets of gears, which may be of different tooth design.

(2) Check fit of bearings in carrier. These should be a close-push fit by hand. If the bearings are badly worn or damaged, they should be replaced. Make sure that bearing cups fit tightly in cage.

(3) Inspect oil seal in outer seal retainer and if it is worn or damaged it should be removed as explained in paragraph 14e(10) and replaced with a new one.

*g. Differential.*—Wash all parts thoroughly in a solvent so they can be inspected and checked.

(1) Check all gears for chipped, cracked, or scored teeth.

(a) The gear teeth should run deep within each other and should make contact on 80 percent of the surface.

(b) If any pinion gears are worn or damaged, the whole set should be replaced. Check fit of gears on spider.

(c) If the bevel gear is worn or damaged badly enough to need replacing, it is good practice to replace the carrier flange also, or at least take a light cut from flange face before installing new bevel gear. If the flange is machined, it should be held to a run-out of .002 inch.

(2) Inspect the thrust surfaces in the housing halves for wear or score marks.

(a) If the side bearing cups are scored or worn, they should be removed and replaced. Make sure cups fit tightly in housing seats.

(b) If the bevel gear thrust block shows any signs of wear, it must be replaced and readjusted at assembly.

(c) Check fit of side gear hubs in differential halves and if they are loose, they should be replaced as a set.

(3) Worn side gear and differential pinion thrust washers should be replaced; see *k* below for correct adjustment and wear allowances.

(4) The differential side bearings should be carefully inspected for worn, checked, scored, or broken rollers. They should then be oiled and rotated by hand, to check for roughness. If they are worn or damaged, they should be replaced.

*h. Drive gear and pinion adjustments.*—Check bearing between pinion and bevel gear. It is necessary that the drive gear be ad-

justed to give proper contact between teeth of gear and teeth of pinion. Proper adjustment distributes the load over a considerable area of the teeth, keeps gearing pressure low, and minimizes its wear. If contact is not correct load will be concentrated on small tooth areas and breakage, chipping, or undue wear will result. A dynamometer or some other device is necessary to turn the axle drive pinion and put a load on the differential drive gear. Paint a few gear teeth with a light coat of mixture of powdered red lead and any light machine oil to allow the bearing surface to be observed. Run the unit a few minutes with a load and observe the tooth bearing on the drive gear teeth.

(1) Condition A (fig. 35) shows a bearing on the bevel gear which is considered satisfactory. The area of contact starts close to the toe (inside end) and extends well out toward the heel (outside end) on the drive side of the tooth.

(2) Condition B (fig. 35) shows a high narrow contact on the gear tooth which is not desirable. If gears are operated with an adjustment of this kind, galling, noise, and a rolling over of the top edges of the teeth will result. To obtain a correct contact, move the pinion toward the gear and correct the backlash by moving the gear away from the pinion.

(3) Condition C (fig. 35) shows a low narrow contact on the gear tooth. If gears are operated with an adjustment of this kind, galling, noise, and grooving of the teeth will result. To obtain a correct contact, move the pinion away from the gear and correct the backlash by moving the gear toward the pinion.

(4) Condition D (fig. 35) shows a short contact on the toe of the gear tooth. If gears are operated with this adjustment the teeth will chip at the edges and there will be excessive wear due to the small contact area. To obtain a correct contact, move the gear away from the pinion and correct the backlash by moving the pinion toward the gear.

(5) Condition E (fig. 35) shows a short contact on the heel of the gear tooth. If gears are operated with this adjustment, chipping, excessive wear, and noise will result. To obtain a correct contact, move the gear toward the pinion and correct the backlash by moving the pinion away from the gear.

*i. Steering tie rod.*—(1) After disassembly, all parts should be washed thoroughly in a grease solvent. Inspect the stud ball and socket joint for scratches, pits, or wearing. Replace any worn or damaged parts.

(2) Replace any soft or weakened springs.

*j. Wheel alinement* (fig. 36).—(1) *Camber*.—This is the amount that the wheels incline at the top from a vertical position. Positive camber is outward inclination of wheels at top; zero camber means no inclination and wheels are held in a vertical plane; and negative or reverse camber is an inward inclination of the wheels at the top.

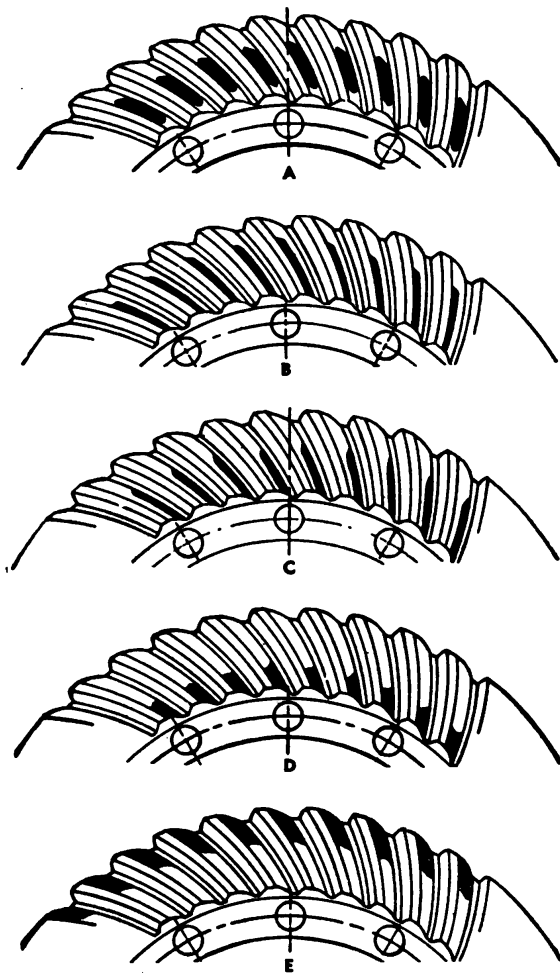

RA PD 4881

FIGURE 35.—Gear tooth bearing surface contact adjustment.

(a) The purpose of camber is to make for easier steering by bringing the tire to road contact point directly under the kingpin. Camber is also used to offset deflection and wear of front parts, preventing wheels from going into reverse camber after long service. See paragraph 12 for results of incorrect camber.

(b) The correct wheel camber for these vehicles is  $\frac{3}{4}^{\circ}$  positive per wheel and is originally set in the axle and cannot be altered

through any adjustments. If upon inspection of the camber angle, with an accurate gage, it is found to be greater than 1° positive or

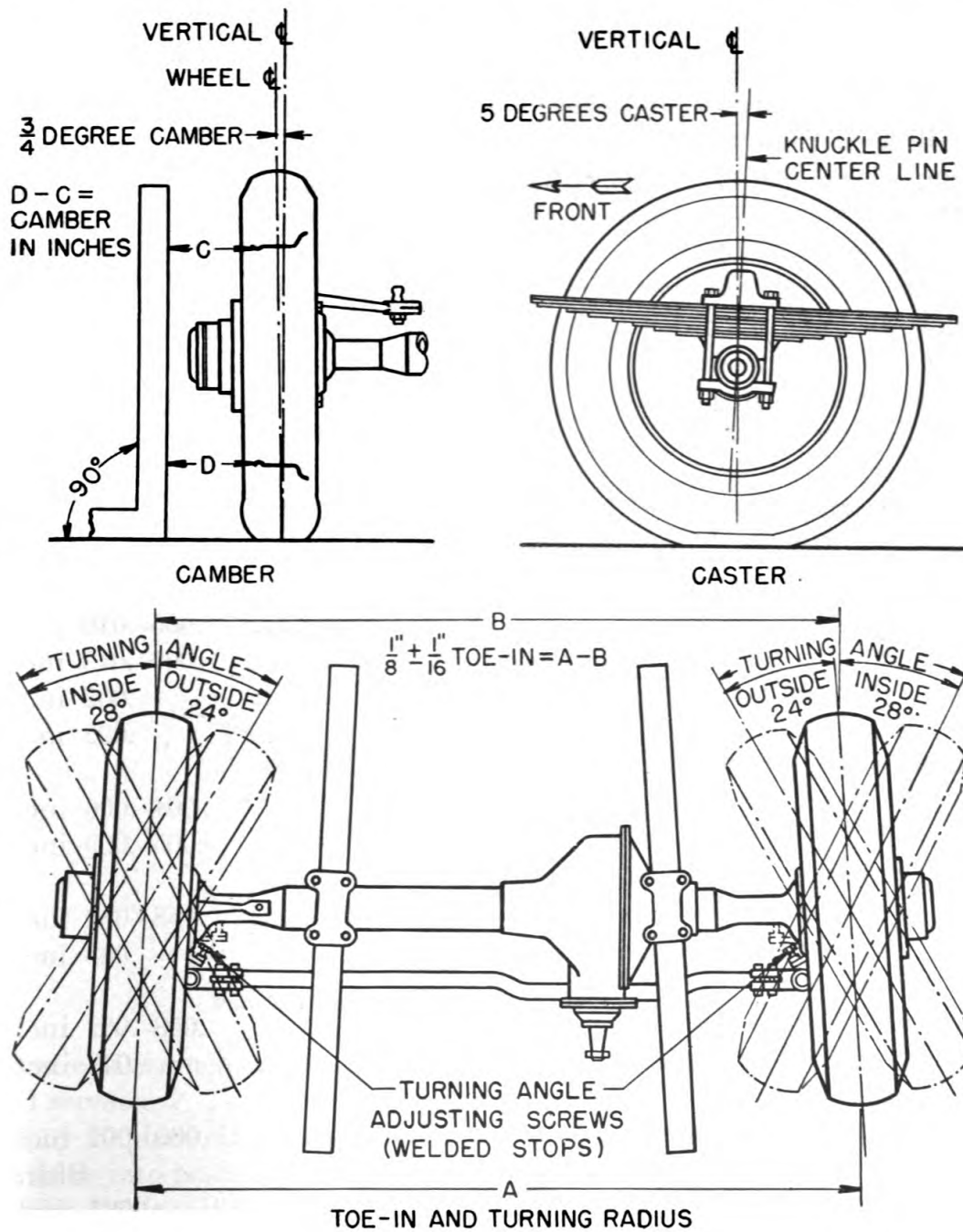

FIGURE 36.—Wheel alignment chart.

RA PD 3515

less than 0° reverse, it is an indication that some part has been bent or excessively worn and should be replaced.

(2) *Caster*.—This is the amount in degrees that steering knuckle pins are tilted toward rear or front of vehicles. Positive caster is inclination of top of knuckle pin toward rear of vehicle; zero caster is vertical position of pins; and negative or reverse caster is an inclination of top of pins toward front of vehicle.

(a) The purpose of caster is to provide steering stability which will keep front wheels in a straight-ahead position to assist in bringing wheels out of a turn on curve. It also controls vibrations and thereby reduces tendency to shimmy. See paragraph 12 for results of incorrect caster.

(b) The correct caster for these vehicles is 5° positive and the only method of correcting any deviations from this angle is by the use of a wedge-shaped plate between the axle spring seat and the lower vehicle spring leaf, or by replacing the faulty parts.

*k. Service data.*

**Differential:**

**Bearing adjustment:**

Adjustable for cup looseness only.

Shims between cup and housing bore.

Shim thickness ----- .005-.010 inch

Gear to pinion backlash ----- .005-.010 inch

Gear run-out, not over ----- .002 inch

Case run-out, not over ----- .002 inch

**Clearance between—**

Pinion and spider ----- .004-.006 inch

Side gear and case ----- .005-.009 inch

**Side gear thrust washers:**

New limits ----- .058-.062 inch

Worn limits ----- .048 inch

**Pinion gear thrust washers:**

New limits ----- .058-.062 inch

Worn limits ----- .048 inch

**Pinion shaft:**

Bearing adjustment ----- .000-.002 inch

Pinion cage adjustment ----- Shim

Shim thickness ----- .0035 inch

**Drive gear thrust block:**

Clearance, block to gear ----- .015-.023 inch

**Block thickness:**

New limits ----- .210-.214 inch

Worn limits ----- .187 inch



Pinion shaft—Continued.

Housing inspection:

Axle shaft run-out, not over ----- .003 inch

Steering knuckle:

Bushing ream ----- 1.121-1.123 inch

Knuckle ream ----- 1.901-1.903 inch

Up- and down-clearance controlled by bearing pin spacers.

Spacers ----- .185-.245 inch

**16. Reassembly of components.—a. Differential.**—Tools: oil seal driving tool, hammer, bearing driving tool, feeler gages,  $\frac{1}{16}$ -inch

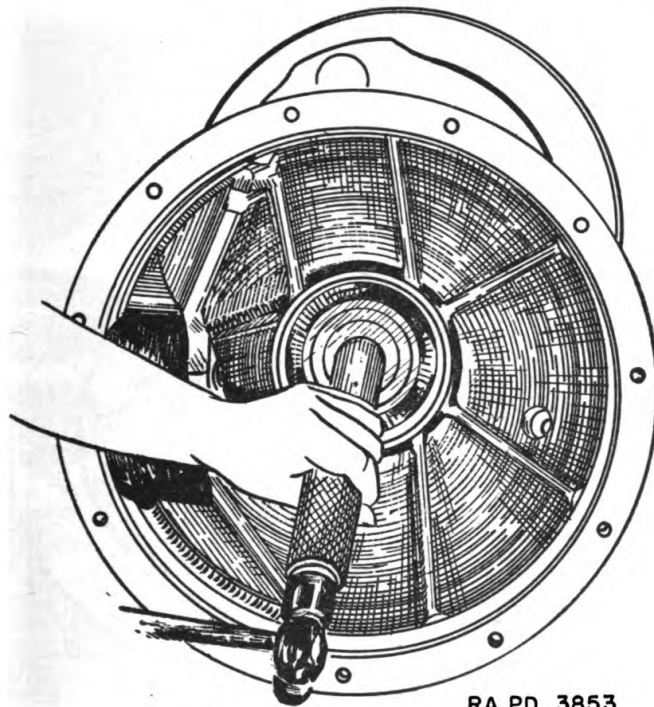

RA PD 3853

FIGURE 37.—Front axle tube oil seal replacement.

open end wrench, pliers, drift,  $\frac{5}{8}$ -inch socket wrench,  $\frac{5}{8}$ -inch open end wrench.

(1) Replace oil seals—hammer, seal driving tool. Drive axle tube oil seals into position at differential end (fig. 37).

(2) Replace differential side bearings—hammer, driving tool. Dip bearing in gear oil. Turn rollers to be sure they are thoroughly lubricated. Drive bearings into position (fig. 38).

(3) Install differential gears—feeler gages,  $\frac{1}{16}$ -inch open end wrench. Replace spider gears and thrust washers into case halves and also side gears and their thrust washers. Bolt halves together tightly and check thrust washer clearances at case (see par. 15*k* for

clearance). Disassemble again, dip gears in gear oil, and reassemble (fig. 30).

(4) Replace locking wire—pliers. Draw soft annealed wire through carrier case bolt heads and tie ends.

(5) Install case assembly in housing. Slip case onto axle shaft splines in left-hand housing half.

(6) Replace bevel gear thrust block—drift, hammer. Drive block and pin into housing. Make sure top of pin is below thrust surface of block.

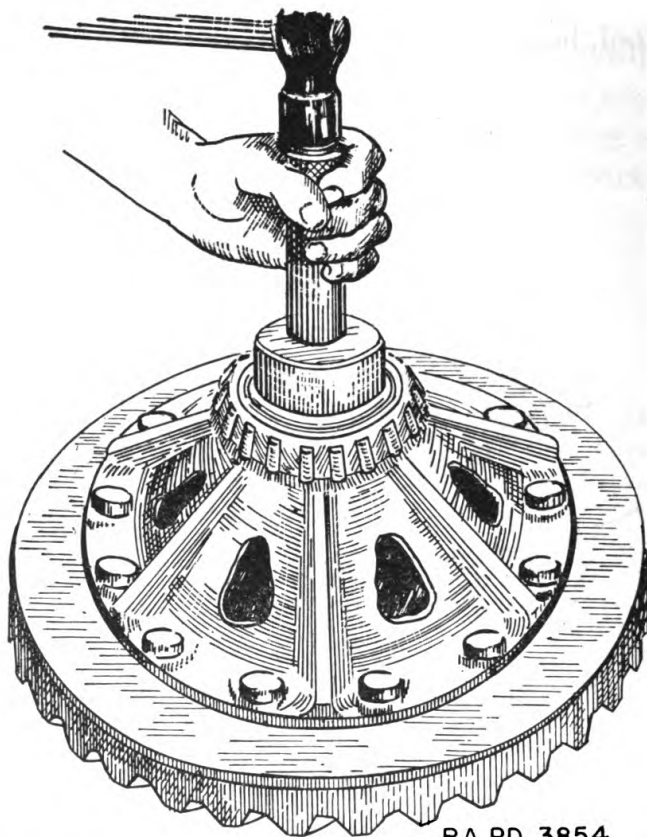

RA PD 3854

FIGURE 38.—Front axle differential bearing cone replacement.

(7) Bolt housing halves— $\frac{5}{8}$ -inch socket wrench,  $\frac{5}{8}$ -inch open end wrench. Use a new gasket between housing halves. Bring halves together, insert bolts, and tighten nuts in rotation.

(8) Refill housing with lubricant. Replace magnetic drain plug, remove filler plug, and fill with  $3\frac{1}{2}$  quarts of proper lubricant. Replace filler plug.

*b. Drive pinion* (fig. 39).—Tools: press, wood blocks, pipe collar, steel plate, screw driver,  $1\frac{1}{4}$ -inch open end wrench,  $1\frac{1}{2}$ -inch socket wrench, pliers,  $\frac{13}{16}$ -inch socket wrench,  $\frac{9}{16}$ -inch open end wrench,  $\frac{5}{8}$ -inch box wrench.

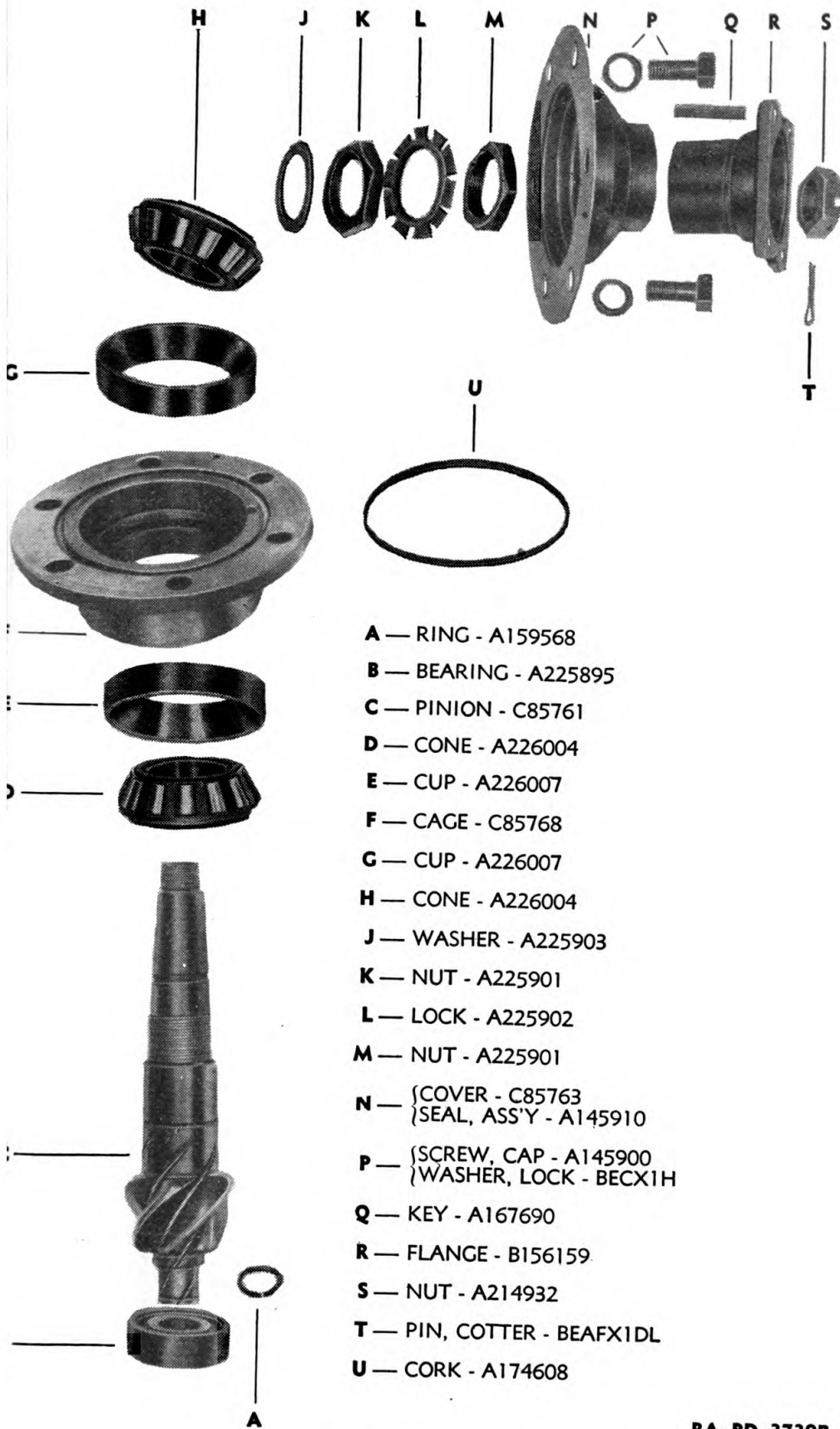

FIGURE 39.—Front axle drive pinion, exploded.

RA PD 3739B

(1) Insert oil seal—press, wood block. Press seal into retainer, making sure cup is straight.

(2) Replace inner bearing cone—press, pipe collar, steel plate. Dip bearing in lubricant and press onto shaft (fig. 40).

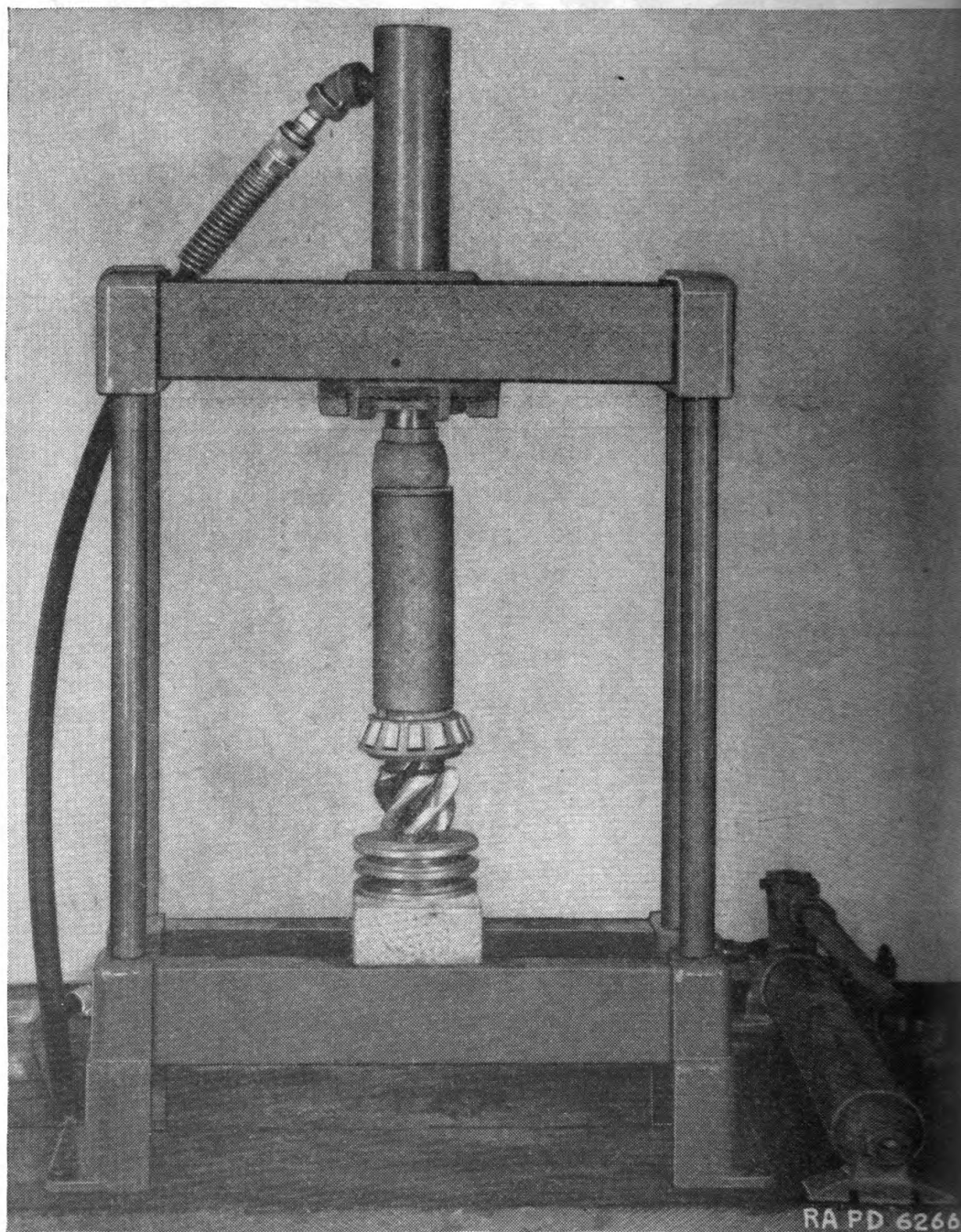

FIGURE 40.—Front axle drive pinion inner bearing cone replacement.

(3) Replace straight roller bearing—press, screw driver. Press bearing onto shaft and lock in position with locking ring.

(4) Reassemble bearing cage—press, wood block. Press inner and outer bearing cups into cage and set cage on shaft (fig. 41).

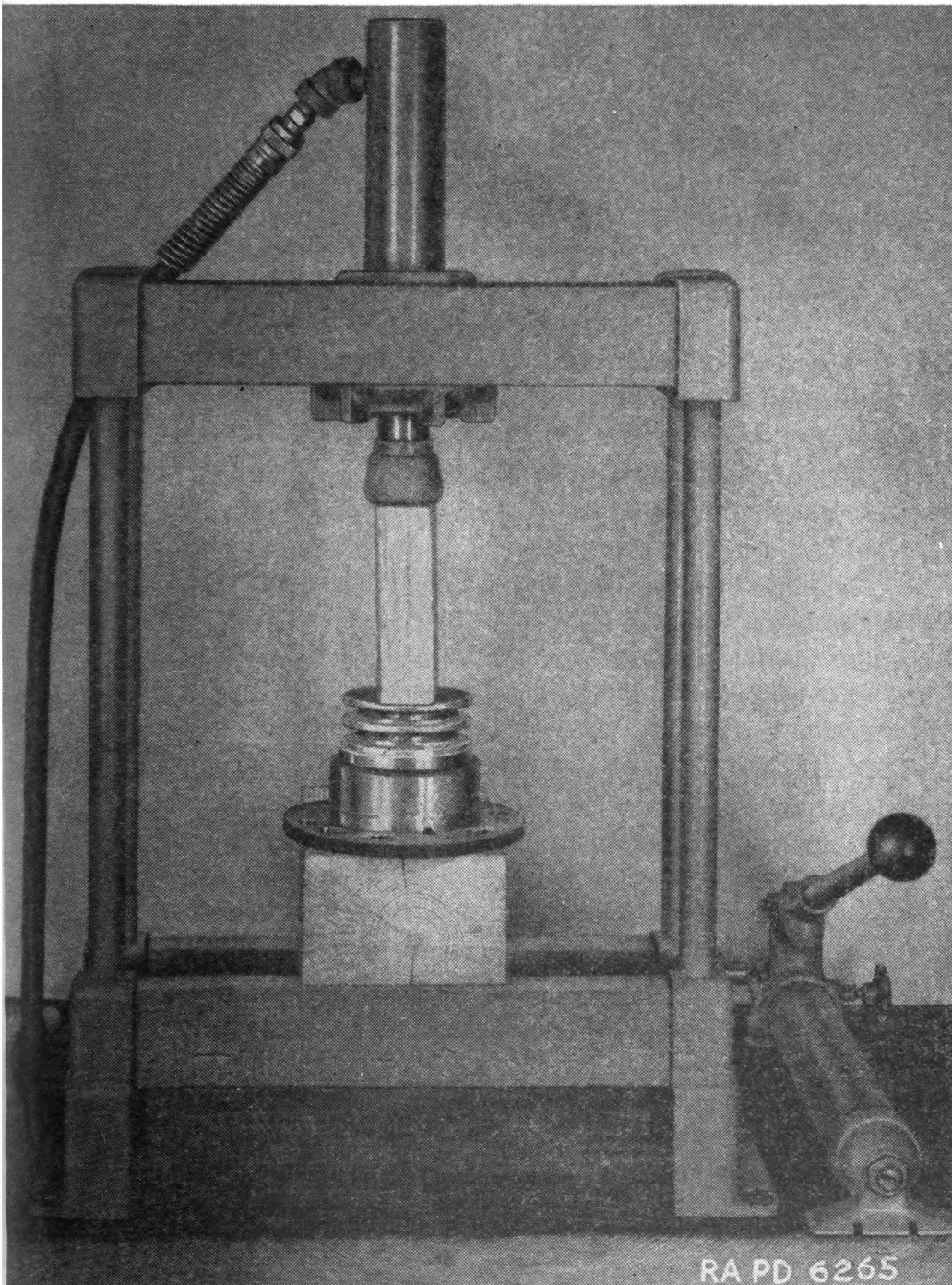

FIGURE 41.—Front axle drive pinion bearing cup replacement.

(5) Replace outer bearing cone—press, pipe collar. Dip bearings in lubricant, spinning rollers to lubricate thoroughly. Press onto shaft.

(6) Replace bearing lock nuts— $1\frac{1}{4}$ -inch open end wrench. Install spacer and adjusting nut up tight to be sure all bearing surfaces seat, and then back off until cage can be turned but will not spin on shaft. Install new lock washer and draw up lock nut securely, checking adjustment to be sure it has not changed during locking operation. Back off adjusting nut slightly, if necessary.

(7) Replace companion flange—press,  $1\frac{1}{2}$ -inch socket wrench. Install cork washer and outer seal retainer in position and press companion flange onto shaft. Lock flange to shaft with nut and cotter pin.

(8) Install pinion shaft assembly— $1\frac{3}{16}$ -inch socket wrench,  $\frac{9}{16}$ -inch open end wrench  $\frac{5}{8}$ -inch box wrench. Replace shaft assembly into differential housing and bolt in place with six cap screws.

*c. Knuckle pin bushings.*—Tools: screw driver,  $\frac{3}{4}$ -inch socket wrench.

(1) Replace steering knuckle outer flange and boot—screw driver. Clamp inner end of boot to axle housing. Set knuckle outer flange over knuckle pins.

(2) Replace bushings—screw driver,  $\frac{3}{4}$ -inch socket wrench. Set the bushings on pins, and replace top and bottom caps, lock washers, and nuts, making sure that spacers are located under top caps. Clamp outer end of boot to knuckle outer flange and adjust bushings as explained in paragraph 15*d*(2).

*d. Rzeppa universal joint.*—Tools: punch, hammer, screw driver.

(1) Install cage into outer race. Insert cage into outer race by positioning rectangular openings of cage so as to clear opposite teeth of outer race (fig. 20*f*). Push cage into place and turn into position, making sure it turns freely.

(2) Install inner race into cage. Put inner race into cage by inserting one inner race tooth into rectangular opening of cage and roll inner race in place (fig. 20*h*). Try for free fit.

(3) Install pilot. Insert pilot, face down (fig. 20*g*). Tapped holes of inner race should be on opposite side of pilot. Roll all internal parts until pilot is at bottom of outer race (fig. 20*f*). Tapped holes are to face outward.

(4) Replace balls. Tilt inner race and cage so that one ball can be inserted through cage opening into groove (fig. 20*e*). Inner race should be tilted at twice the cage angle. Then roll all parts to corresponding position for next ball, and so on, until all balls are assembled.

(5) Install spring and plunger. Fill stem bore with lubricant and insert spring and plunger assembly into bore, plunger on top (fig. 20*d*).

(6) Replace splined shaft—punch, hammer. Press pilot seat into shaft recess up to shoulder. Push retainer up to shoulder on splines (fig. 20c). Insert splined shaft partially into inner race. Turn retainer to locking position on splines (fig. 20b). Complete installing shaft by pushing with a steady motion to insure proper engagement of pilot pin into pilot seat. If pilot pin head does not readily engage the seat in the shaft, level cage with outer race and rock shaft slightly. Do not apply excessive force.

(7) Insert retainer screws—screw driver. Install retainer screws tightly and lock with wire (fig. 20a). Test for free movement through entire operating range ( $37\frac{1}{2}^\circ$  maximum).

*e. Axle shaft and universal joint assembly.*—Tools:  $\frac{9}{16}$ -inch socket wrench, hammer, brass drift.

(1) Replace axle shaft assembly. Insert splined end of shaft into axle until splines engage with those of differential side gear (fig. 17).

(2) Replace brake backing plate and steering knuckle spindle— $\frac{9}{16}$ -inch socket wrench, brass drift, hammer. Drive wheel inner bearing cone onto steering knuckle spindle. In the order given, slip brake backing plate, hub oil slinger, and steering knuckle spindle over axle shaft onto knuckle outer flange studs. Replace lock washers and nuts and tighten down uniformly in rotation.

*f. Hub and drum assemblies.*—Tools: brass drift, hammer, wheel bearing nut wrench, 2-inch open end wrench,  $\frac{5}{8}$ -inch socket wrench.

(1) Replace wheel bearing cups—brass drift, hammer. Knock inner and outer wheel bearing cups into drum hub.

(2) Install drum assembly. Slip drum assembly over steering knuckle spindle so that inner bearing cup fits over cone, and then slide outer bearing cone onto spindle until it sets into its cup. Dip bearings in lubricant before replacing (fig. 13).

(3) Replace bearing adjusting and lock nuts—wheel bearing nut wrench. Draw wheel bearing adjusting nut up against bearing and adjust. Replace locking ring and lock nut (fig. 14).

(4) Replace axle nut—2-inch open end wrench. Slide drive flange onto axle shaft and wheel studs. Replace axle nut and draw up tightly. Insert cotter pin in axle through nut castellations.

(5) Replace hub cap— $\frac{5}{8}$ -inch socket wrench. Slide hub cap onto wheel studs, replace lock washers and stud nuts, and tighten nuts uniformly.

*g. Steering cross tube (tie rod)* (fig. 33).—Tools:  $\frac{15}{16}$ -inch socket wrench,  $\frac{7}{8}$ -inch open end wrench, screw driver, pliers,  $1\frac{1}{16}$ -inch socket wrench.

(1) Replace ends— $\frac{15}{16}$ -inch socket wrench,  $\frac{7}{8}$ -inch open end wrench. Thread left- and right-hand ends onto cross tube. Replace clamp bolts, nuts, and lock washers, and draw up snug until vehicle is tested for "toe-in," after which they should be tightened down.

(2) Replace end stud assembly—screw driver, pliers. Insert stud seat, pin, retainer, stud, spring, and plug into bottom of tube ends, and lock these in position with locking ring.

(3) Install dust shields and top spring. Insert washer, dust seals, and outer spring over stud.

(4) Attach tie-rod assembly to axle—pliers,  $\frac{11}{16}$ -inch socket wrench. Install the tie-rod assembly on the axle and lock in position with nut and cotter pin.

**17. Installation of assembly.**—Tools: wheel stud nut wrench, jack,  $\frac{15}{16}$ -inch socket wrench,  $\frac{7}{16}$ -inch open end wrench,  $\frac{3}{4}$ -inch open end wrench,  $\frac{9}{16}$ -inch box wrench, drag link plug wrench,  $\frac{5}{8}$ -inch box wrench,  $\frac{9}{16}$ -inch open end wrench, wheel alinement gage,  $\frac{7}{8}$ -inch open end wrench.

*a.* Replace wheel and tire assemblies—wheel stud nut wrench. Assemble wheels and tires to brake drum and turn up stud nuts firmly and evenly.

*b.* Position axle to chassis—jack. Place axle under chassis in its approximate running position. Raise axle and make sure spring center bolt heads enter holes in axle spring seats (fig. 42).

*c.* Install U-bolts— $\frac{15}{16}$ -inch socket wrench. Place spring clip U-bolts in position and turn up nuts on rear bolts.

*d.* Connect shock absorber— $\frac{15}{16}$ -inch socket wrench. Slip shock absorber link plates onto front U-bolts and draw up all U-bolt nuts evenly (fig. 9).

*e.* Replace brake hoses— $\frac{15}{16}$ -inch socket wrench,  $\frac{7}{16}$ -inch open end wrench,  $\frac{3}{4}$ -inch open end wrench. Attach hose end connection to frame by replacing holding nut. Then connect front-brake pipe assembly to hose fitting by means of flared tube nut at end of pipe.

*f.* Replace engine protecting plates— $\frac{9}{16}$ -inch box wrench. Bolt the engine protecting armor side plates to the frame.

*g.* Connect drag link—drag link adjuster. Place drag link onto steering arm stud and turn up.

*h.* Connect propeller shaft— $\frac{5}{8}$ -inch box wrench,  $\frac{9}{16}$ -inch open end wrench. Replace four  $\frac{7}{16}$ -inch bolts and nuts holding propeller shaft to drive pinion shaft flange. Tighten nuts alternately to eliminate possibility of distortion or uneven alinement.



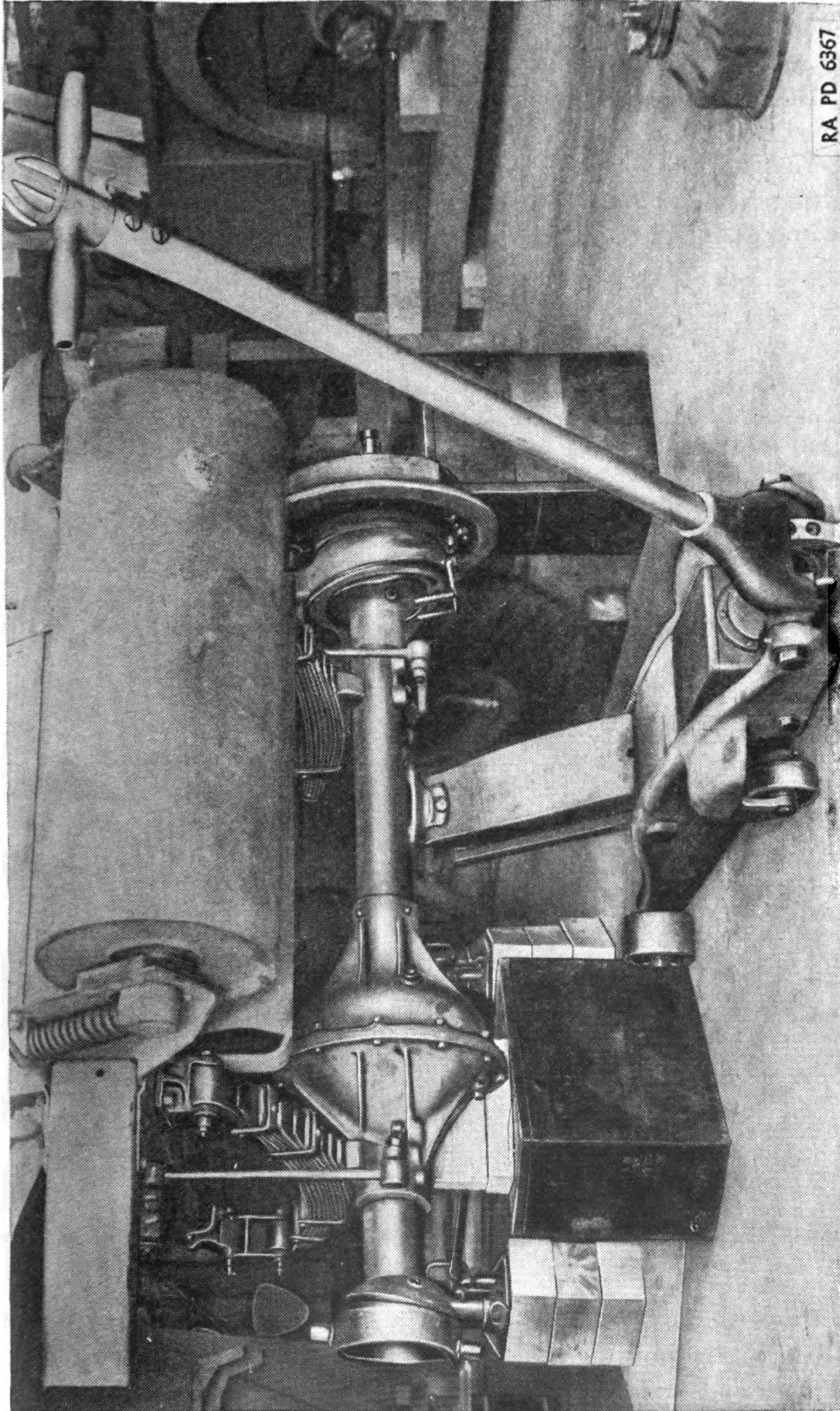

FIGURE 42.—Front axle installation.

*i.* Check wheel alinement—wheel alinement gage,  $\frac{5}{16}$ -inch socket wrench,  $\frac{7}{8}$ -inch open end wrench. Check front end for wheel alinement as described in paragraph 15*j*. Correct any misalignment.

*j.* Bleed brakes. All wheel brake cylinders should be bled as explained in TM 9-710.

*k.* Lubricate differential— $\frac{9}{16}$ -inch socket or open end wrench. Refill differential housing with lubricant. Refer to lubrication chart for type and quantity required.

SECTION VI

REAR AXLE (JACKSHAFT)

	Paragraph
Description.....	18
Trouble shooting.....	19
Removal of assembly.....	20
Disassembly of components.....	21
Maintenance and adjustments.....	22
Reassembly of components.....	23
Installation of assembly.....	24

**18. Description** (fig. 43).—The rear axle (jackshaft) is of the spiral, bevel gear, single reduction, full floating type.

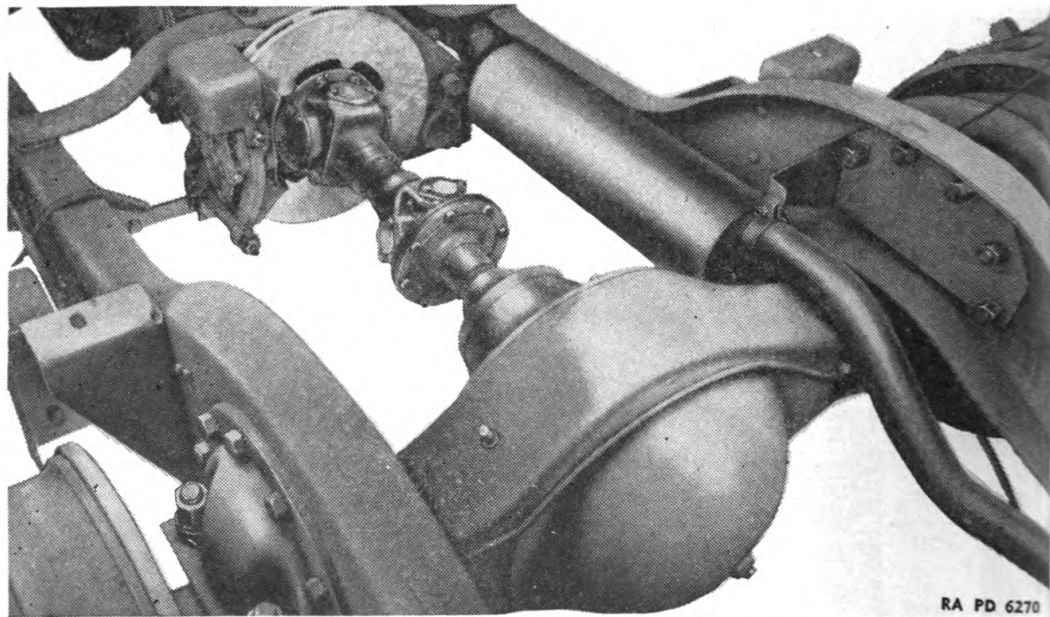

FIGURE 43.—Rear axle (jackshaft) assembly, installed.

*a. Construction* (fig. 44).—(1) The rear axle (jackshaft) consists of a banjo type housing which has a pressed steel center with forged steel outer ends welded to the housing. The differential and bevel gear assembly, together with the pinion assembly, are mounted in the carrier

POWER TRAIN

TM 9-1710

18

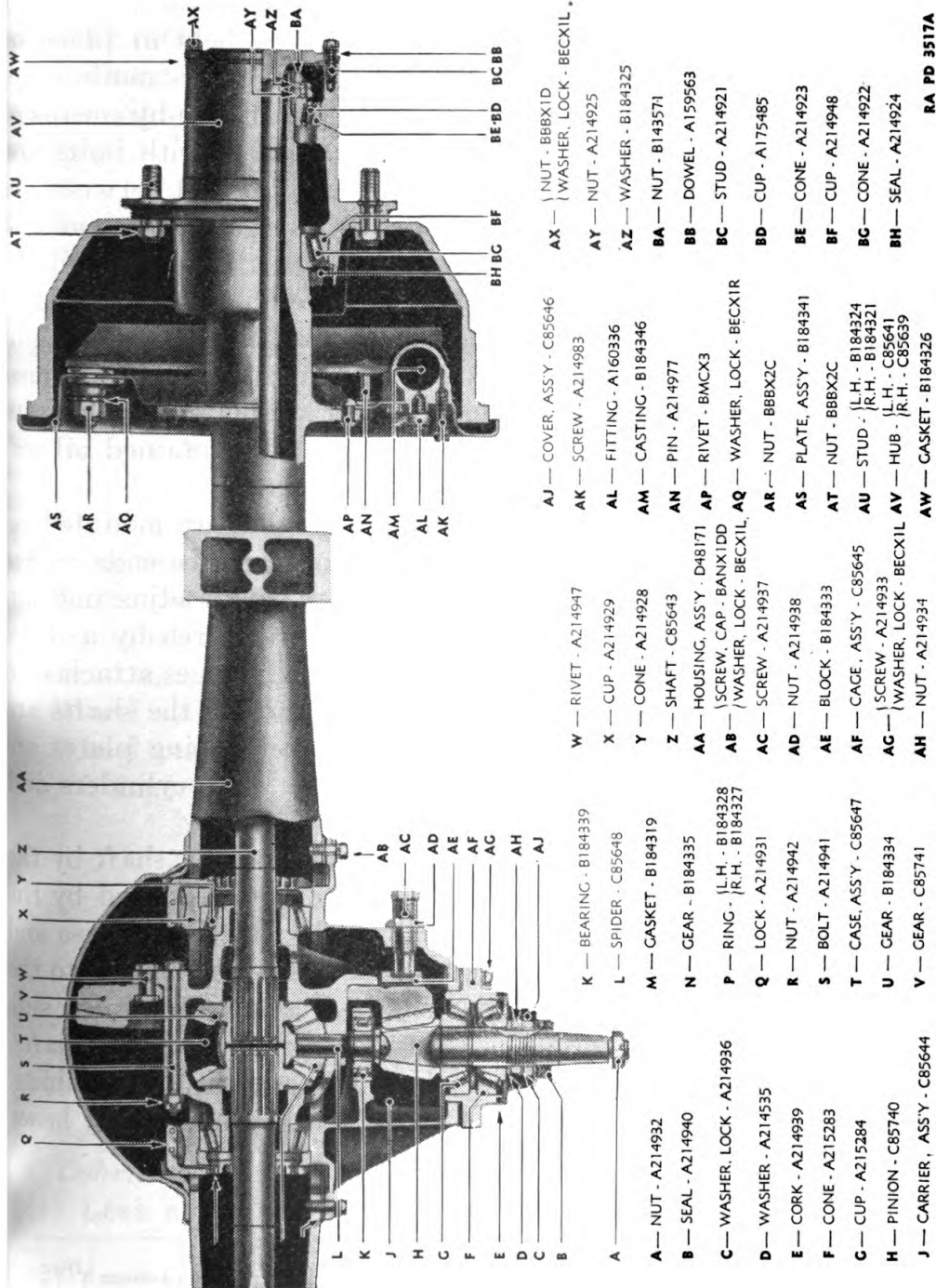

FIGURE 44.—Rear axle (jackshaft) assembly, sectionalized.

- A — NUT - A214932
- B — SEAL - A214940
- C — WASHER, LOCK - A214936
- D — WASHER - A214535
- E — CORK - A214939
- F — CONE - A215283
- G — CUP - A215284
- H — PINION - C85740
- J — CARRIER, ASSY - C85644
- K — BEARING - B184339
- L — SPIDER - C85648
- M — GASKET - B184319
- N — GEAR - B184335
- P — RING - [L.H. - B184328 / R.H. - B184327]
- Q — LOCK - A214931
- R — NUT - A214942
- S — BOLT - A214941
- T — CASE, ASSY - C85647
- U — GEAR - B184334
- V — GEAR - C85741
- W — RIVET - A214947
- X — CUP - A214929
- Y — CONE - A214928
- Z — SHAFT - C85643
- AA — HOUSING, ASSY - D48171
- AB — SCREW, CAP - BANK1DD
- AC — WASHER, LOCK - BECXIL
- AD — NUT - A214938
- AE — BLOCK - B184333
- AF — CAGE, ASSY - C85645
- AG — SCREW - A214933
- AH — NUT - A214934
- AJ — COVER, ASSY - C85646
- AK — SCREW - A214983
- AL — FITTING - A160336
- AM — CASTING - B184346
- AN — PIN - A214977
- AA — HOUSING, ASSY - D48171
- AP — RIVET - BMCX3
- AB — SCREW, CAP - BANK1DD
- AQ — WASHER, LOCK - BECXIL
- AC — SCREW - A214937
- AD — NUT - A214938
- AE — PLATE, ASSY - B184341
- AT — NUT - BBBX2C
- AF — CAGE, ASSY - C85645
- AG — SCREW - A214933
- AH — NUT - A214934
- AJ — COVER, ASSY - C85646
- AK — SCREW - A214983
- AL — FITTING - A160336
- AM — CASTING - B184346
- AN — PIN - A214977
- AP — RIVET - BMCX3
- AB — SCREW, CAP - BANK1DD
- AQ — WASHER, LOCK - BECXIL
- AC — SCREW - A214937
- AD — NUT - BBBX2C
- AS — PLATE, ASSY - B184341
- AT — NUT - BBBX2C
- AU — STUD - [L.H. - B184324 / R.H. - B184321]
- AV — HUB - [L.H. - C85641 / R.H. - C85639]
- AW — GASKET - B184326
- AX — NUT - BBBX1D
- AY — WASHER, LOCK - BECXIL
- AZ — NUT - A214925
- BA — WASHER - B184325
- BB — NUT - B143571
- BB — DOWEL - A159563
- BC — STUD - A214921
- BD — CUP - A175485
- BE — CONE - A214923
- BF — CUP - A214948
- BG — CONE - A214922
- BH — SEAL - A214924
- RA PD 3517A

casting and assembled in the housing as a unit. The axle assembly is bolted to the car frame with U-bolts (clips) and nuts.

(2) The differential and ring gear are mounted in the carrier casting legs on opposed tapered roller bearings which are held in place by adjusting rings and bearing caps. The differential case is made up of two halves with the ring gear mounted to the case flange by means of special steel rivets. The case halves are held together with bolts and nuts and locked by means of a lock wire through the bolt between the nut castellations. A backing-up block for the ring gear is provided to prevent excessive deflection under extreme loads.

(3) The bevel pinion gear and shaft is straddle-mounted on two opposed tapered roller bearings in front of the gear and a straight solid roller bearing at the rear. The roller bearings are held in adjustment by a thrust washer, adjusting nut, lock washer, and lock nut. The lubricant is sealed at the pinion shaft by a self-contained oil seal mounted within the pinion forward bearing cover.

(4) The drive sprocket hub and drum assemblies are mounted on two opposed tapered roller bearings on the housing tube ends. (See fig. 45.) The bearings may be adjusted by means of an adjusting nut, locking ring, and locking nut. The sprockets are driven by a drive shaft. The outer ends of the shafts have integral flanges attached to the sprockets and drums by studs. The inner ends of the shafts are splined to the differential side gears. The brake backing plates are riveted to the axle shaft housings and carry the brake cylinders and brake shoe assemblies.

*b. Operation.*—Power is taken from the rear propeller shaft by the drive pinion through the companion flange and is transmitted by the pinion to the spiral bevel gear. This causes the differential case and spider pinion gears to rotate as a unit and transmit the motion to the pinion side gears and thence the axle shafts to which the pinion side gears are splined. The torque is then transmitted by axle shafts, through the driving flanges at the ends to hub and drum assemblies. The sprockets are bolted to the hub and drum assemblies and hence rotate with them.

*c. Specifications.*

Make	Type	Model	Manufacturer's number	Ordnance number	White	Autocar	Diamond T
Timken-Detroit	Full floating.	56410-G-7	TD-56410-H-X-67	E-3800	371674	4W670	N-2501

Housing..... Banjo type  
 Differential:  
     Drive..... Spiral bevel  
     Gear ratio..... 4.44 to 1  
     Bearings..... Timken tapered roller  
         Number:  
             Cone..... 3984  
             Cup..... 3920  
 Pinion shaft:-  
     Ratio..... See differential  
     Bearings:  
         Inner..... Hyatt straight roller  
             Number..... U-1306-TAM  
         Outer..... Timken tapered roller  
             Number:  
                 Cone..... 53162  
                 Cup..... 53387  
 Attaching centers..... 38<sup>3</sup>/<sub>8</sub> inches  
     Width of pads..... 3<sup>3</sup>/<sub>16</sub> inches  
 Hub equipment..... 6 stud, Budd single cap nuts  
 Brakes..... Hydraulic, 16 inches x 3<sup>1</sup>/<sub>2</sub> inches  
     Wheel cylinder..... 1<sup>3</sup>/<sub>4</sub>-inch diameter  
     Wheel bearings:  
         Inner..... Timken tapered roller  
             Number:  
                 Cone..... 580  
                 Cup..... 572  
         Outer..... Timken tapered roller  
             Number:  
                 Cone..... 479  
                 Cup..... 472A

**19. Trouble shooting.**

*Symptoms and probable cause*

*Probable remedy*

*a. Lubricant leaks.*

(1) Leak at housing outer end seal.

(1) Replace seal.

(2) Leak at differential.

(2) Replace differential or differential cover gasket.

*b. Axle noises.*

(1) Continuous hum.

(1) Readjust wheel bearings or pinion bearings.

<i>Symptoms and probable cause</i>	<i>Probable remedy</i>
(2) Coasting hum.	(2) Inspect wheel bearings and pinion bearings. Inspect pinion to bevel gear adjustment; pinion may require moving away from bevel gear.
(3) Pulling hum.	(3) Inspect pinion to bevel gear adjustment; pinion may require moving toward bevel gear. Check bevel gear thrust block for excessive wear.

*c. Backlash.*

(1) Loose axle shaft flange.	(1) Retighten.
(2) Excessive clearance at axle shaft splines.	(2) Replace worn parts.
(3) Excessive pinion and bevel gear clearance.	(3) Move pinion in to remove excessive backlash.

**20. Removal of assembly.**—Tools: two jacks (or hoist), bogie arm holding clips (or chain), two 4-foot and two 6-foot lengths of 2- by 4-inch lumber, pinch bar, 2-inch open end wrench, 3/4-inch socket wrench, 17/16-inch socket wrench, hammer, wheel stud nut wrench, 9/16-inch open end wrench, 9/16-inch socket wrench, wood block, 1 1/4-inch socket wrench.

*a.* Lift rear end of car—two jacks or hoist. Place jacks under frame back of bogie suspension and jack up rear end. (This can also be done with a stationary or mobile hoist.)

*b.* Remove tracks. Drop idlers and pull tracks from sprocket. See paragraph 58*b*, TM 9-710, or section V, TM 9-1712.

*c.* Remove drive sprocket assemblies—wheel stud nut wrench. Remove drum stud nuts (B184322 R. H., B184323 L. H.) and pull off sprocket assemblies. Left-hand drum studs are threaded for left-hand threaded nuts (fig. 45).

*d.* Disconnect brake lines—9/16-inch, open end wrench. Break hydraulic hoses at wheel cylinders and remove cap screw (BCAX1C) and lock washer (BECX1K) holding brake line tee (A167679) from differential housing, and cap screw (BCAX1CA) and lock washer (BECX1K) holding brake line clip (A214906) to axle housing (fig. 46).

*e.* Disconnect rear propeller shaft—9/16-inch, open end wrench, 9/16-inch, socket wrench. Remove eight 3/8-inch bolts (A214349) and nuts (BBFX1C), and cotter pins (BFAX1CF) holding universal joint flange yoke to jackshaft companion flange (B184101).

f. Block up axle assembly—hydraulic jack or wooden blocks. Place jack under the axle so that it can be lowered, or use wood blocks.  
 g. Remove assembly—1¼-inch socket wrench. Remove four 7/8-inch U-bolt nuts (A214344) and bolts (B185101) holding axle to frame (fig. 43), and lower assembly (E3800).

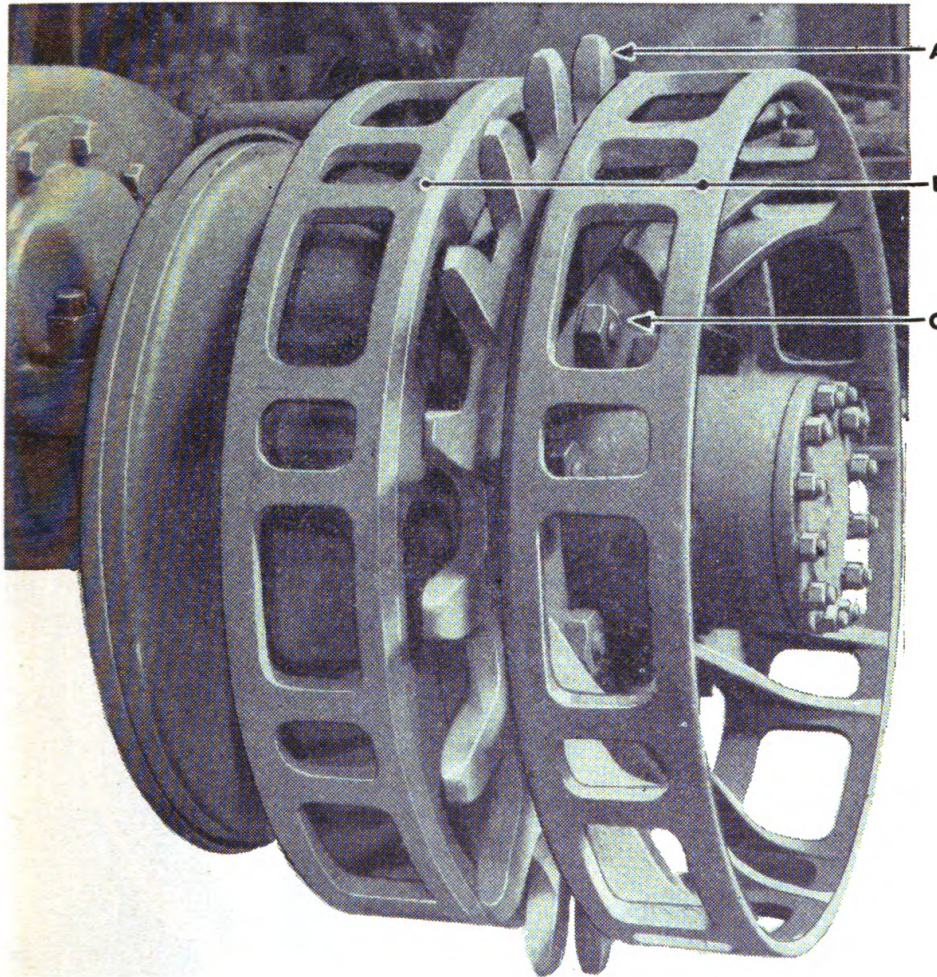

A — SPROCKET - D48406

B — { FLANGE - D48405  
 { SCREW - A215345  
 { NUT - A215352

C — { NUT (R.H.) - B184322  
 { NUT (L.H.) - B184323

RA PD 6269A

FIGURE 45.—Rear axle drive sprocket, installed.

**21. Disassembly of components.—a. Sprockets.**—Tools: two jacks (or hoist), bogie arm holding clips (or chain), two 4-foot and two 6-foot lengths of 2 x 4 inch lumber, pinch bar, 2-inch open end

wrench, 3/4-inch socket wrench, 17/16-inch socket wrench, hammer, wheel stud nut wrench, 3/4-inch box wrench.

(1) Remove sprocket and flange assemblies. Follow steps in paragraph 20a through c.

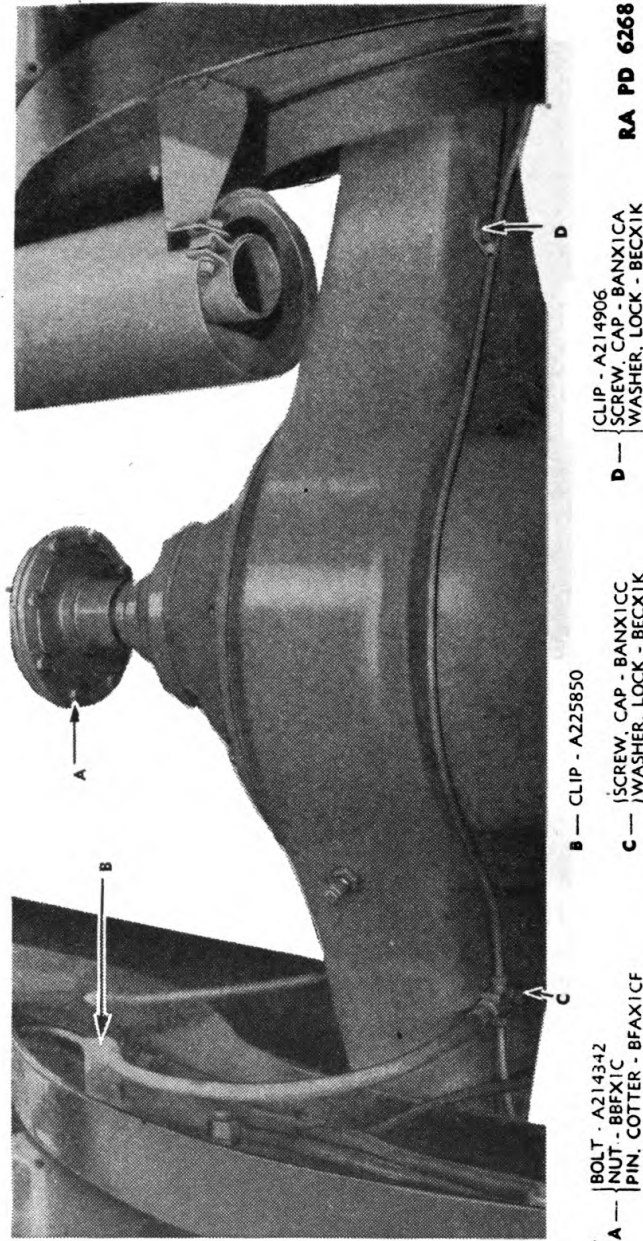

FIGURE 46.—Rear wheel brake lines, installed.

(2) Separate sprocket and flanges—3/4-inch socket wrench, 3/4-inch box wrench. Remove nine 1/2-inch cap screws (A215345) and nuts (A215352) holding flanges (D48405) to sprockets (D48406) and disassemble sprockets (fig. 45).



*b. Hub and drum assemblies.*—Same tools as in the preceding paragraph plus the following:  $\frac{5}{8}$ -inch socket wrench, hammer, pry bar, brass drift, wheel bearing nut wrench, wheel puller.

(1) Remove sprocket assemblies. Follow steps in *a* through *c*, paragraph 20.

(2) Remove drive shaft and flange assemblies— $\frac{5}{8}$ -inch socket wrench, hammer, pry bar. Take off twelve  $\frac{7}{16}$ -inch drive flange nuts (BBBX1D) and lock washers (BECX1L). Use puller screws in flange, tap flange in center with hammer to loosen, and pull out shaft (C85643) with aid of pry bar (fig. 47).

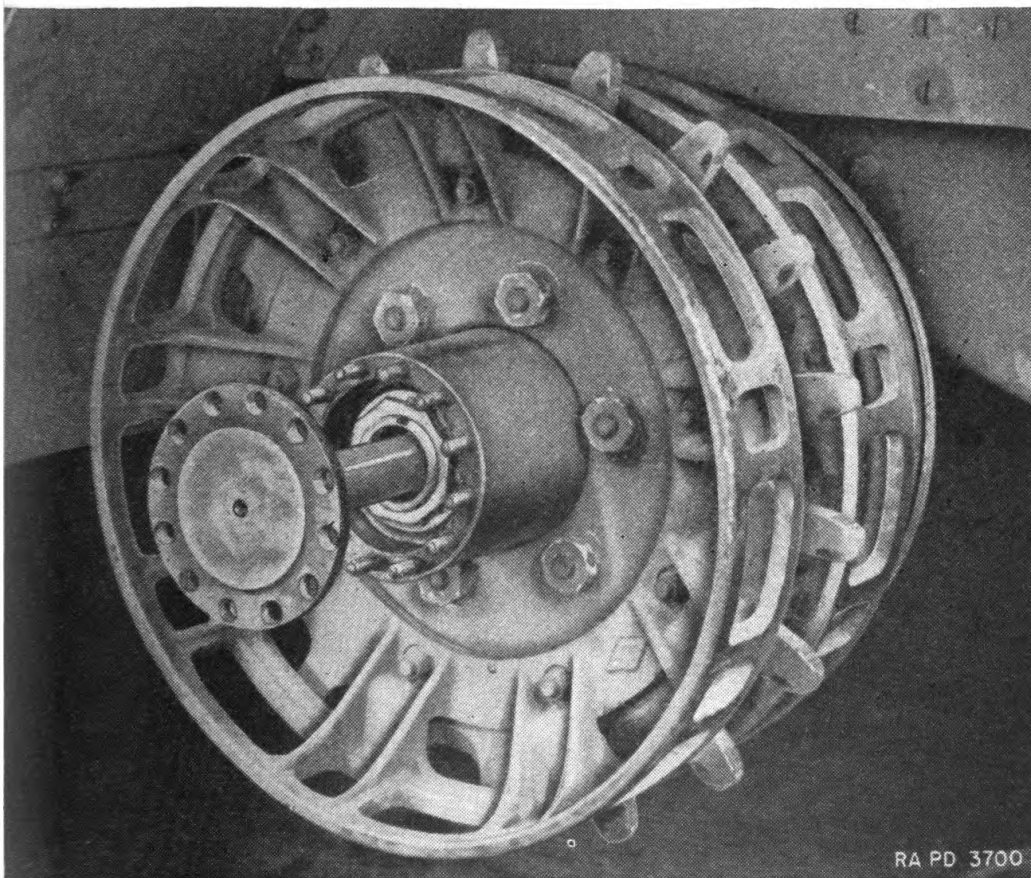

FIGURE 47.—Rear axle drive shaft removal.

(3) Remove bearing nuts—nut wrench, wheel bearing. Using both sides of wrench, remove lock nuts (B143571), thrust washer (B184325), and adjusting nut (A214925, fig. 48).

(4) Remove assemblies—wheel puller (if necessary). Pull off hub and drum assemblies (C85637 L. H., C85638 R. H.), carrying with them the inner and outer bearing assemblies and oil seals.

(5) Remove bearings and seals from hubs—brass drift, hammer. Knock out the outer bearing cups (A175485) and cones and rollers (A214923), the inner bearing seals (A214924), and the inner bearing cups (A214948) and cones and rollers (A214922). (Bearing pullers may be used if available.)

*c. Drive pinion and differential assembly.*—Tools:  $\frac{9}{16}$ -inch open end wrench,  $\frac{9}{16}$ -inch socket wrench,  $\frac{7}{16}$ -inch socket wrench,  $\frac{5}{8}$ -inch socket wrench, center punch, hammer, lifting fixture, sling.

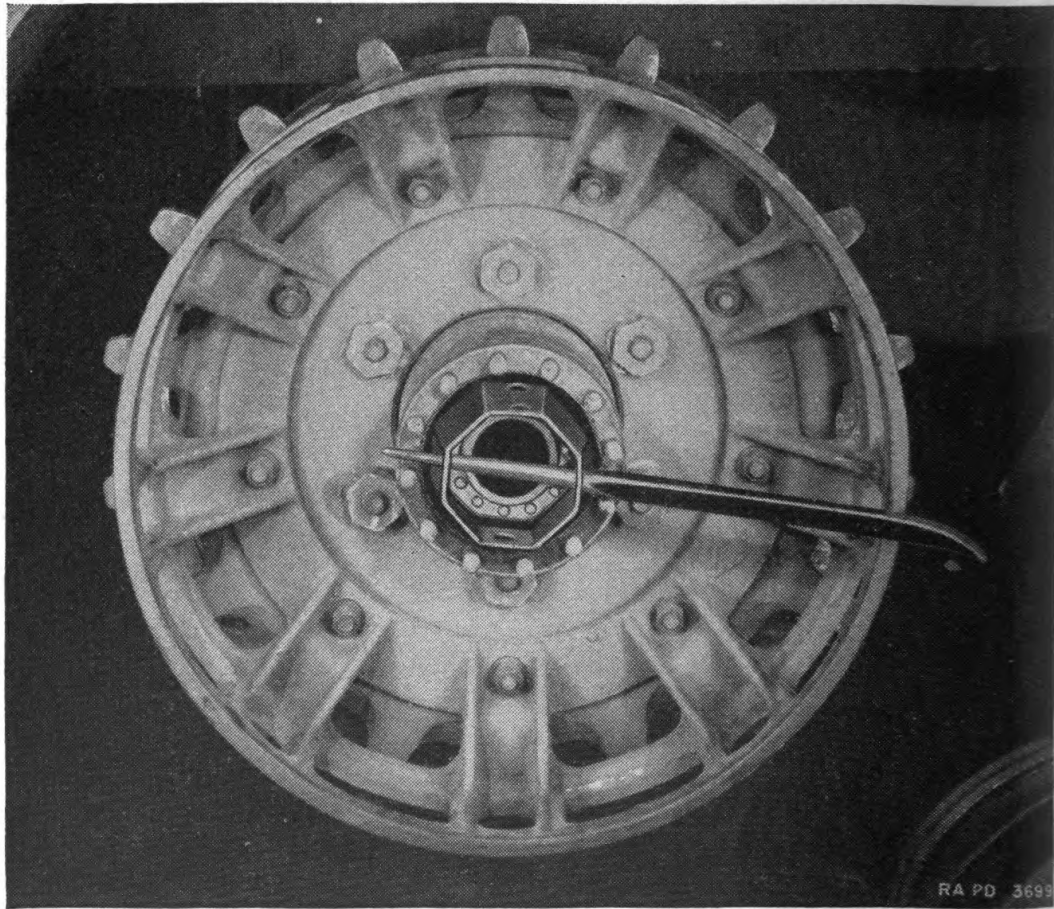

FIGURE 48.—Rear axle drive sprocket bearing nut removal.

(1) Disconnect rear propeller shaft— $\frac{9}{16}$ -inch open end wrench,  $\frac{9}{16}$ -inch socket wrench. Remove eight  $\frac{3}{8}$ -inch bolts, nuts, and cotter pins holding universal joint flange to jackshaft companion flange (fig. 46).

(2) Drain lubricant— $\frac{9}{16}$ -inch open end wrench. Remove magnetic drain pipe plug (A214913) from housing and drain lubricant.

(3) Remove floor plate— $\frac{7}{16}$ -inch socket wrench. Take out screw (BCNX2CF) and nut (BBAX1A) securing floor plates (B185254) over differential housing and remove plates.

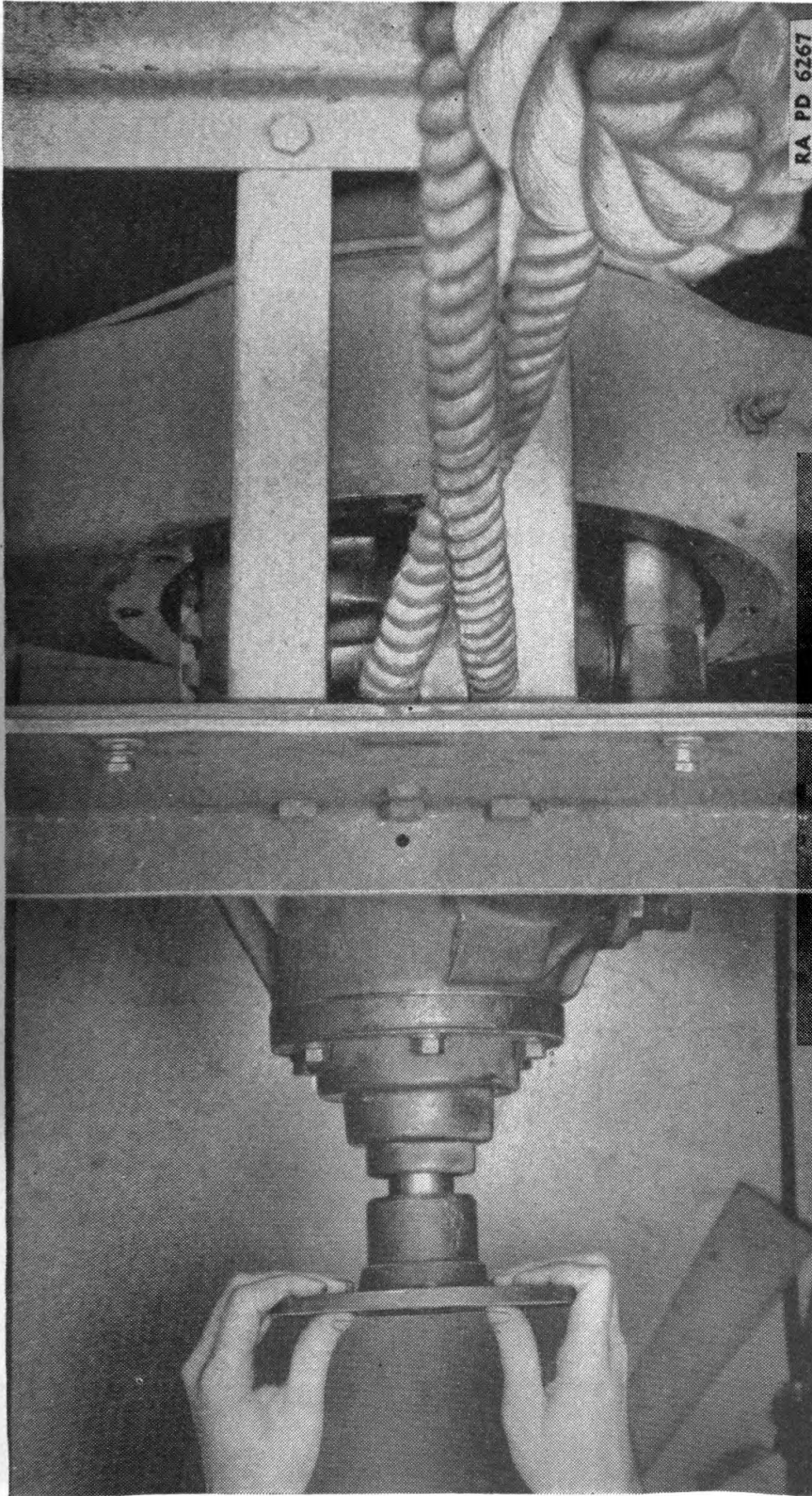

FIGURE 49.—Rear axle differential assembly removal.

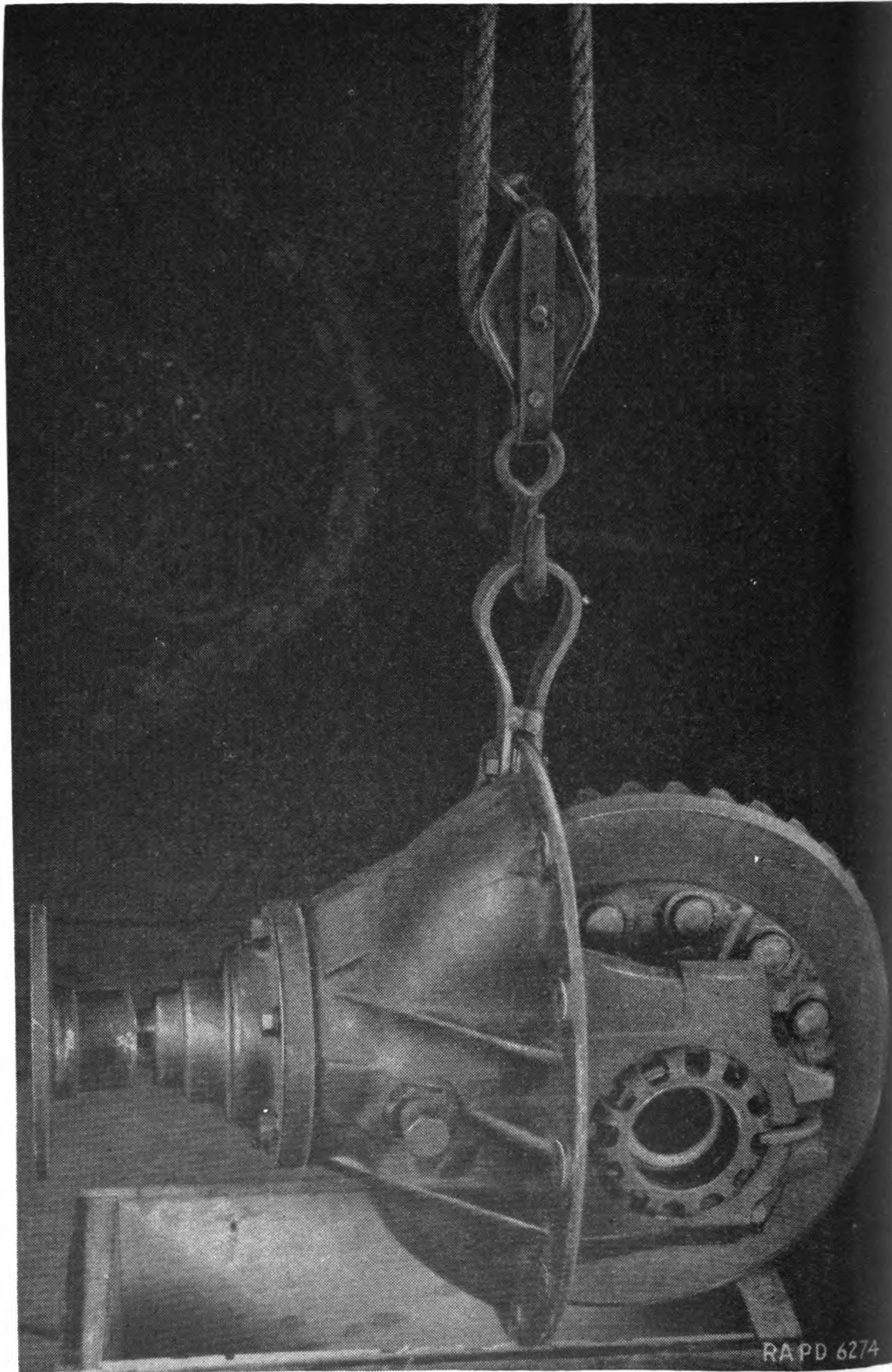
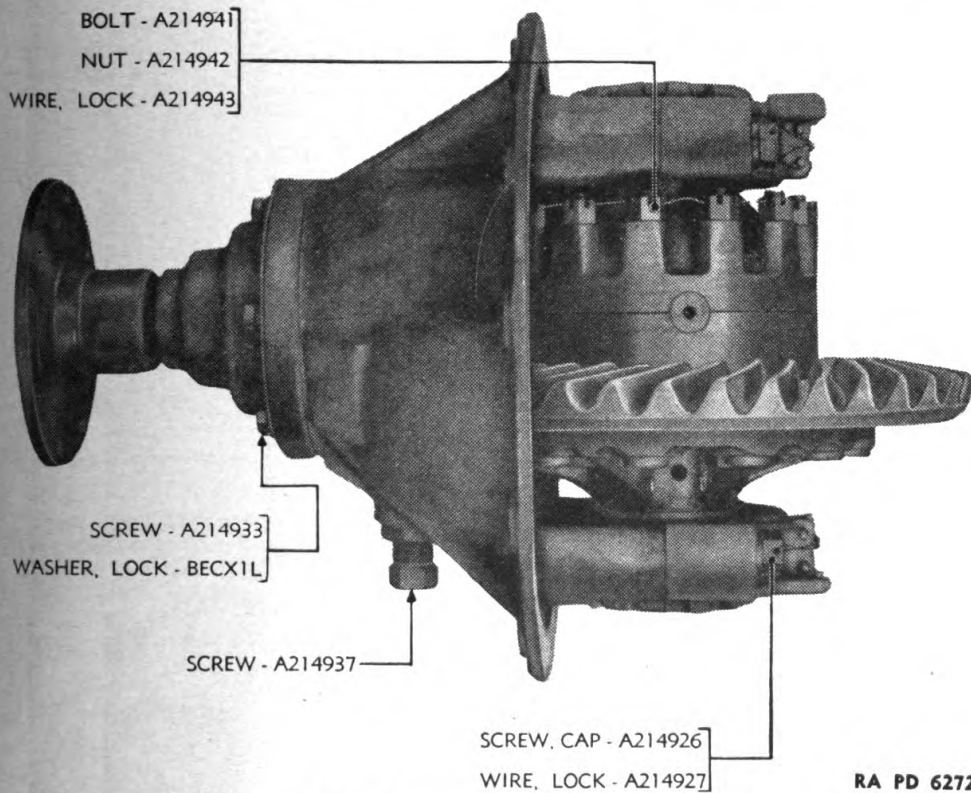

FIGURE 50.—Differential assembly removal using special fixture.

(4) Break differential housing— $\frac{5}{8}$ -inch socket wrench, center punch, hammer. Remove twelve  $\frac{7}{16}$ -inch bolts (BANX1DD) around differential housing. Mark halves so they can be replaced correctly.

(5) Pull out assembly—lifting fixture, sling. Pull the assembly part way out, attach lifting fixture to one cap screw hole, and hook onto sling. Remove unit and lower to floor (figs. 49 and 50).

d. Drive pinion assembly.—Same tools as listed in paragraph 14e, plus one  $\frac{3}{4}$ -inch socket wrench. The drive pinion can be re-



RA PD 6272

FIGURE 51.—Rear axle drive pinion, installed.

moved from carrier without disassembling carrier from axle. However, since it is usually necessary to remove differential at same time, the drive pinion is usually removed as a unit with the carrier.

(1) Remove drive pinion assembly— $\frac{5}{8}$ -inch socket wrench. Remove six  $\frac{7}{16}$ -inch cap screws (A214933) and lock washers holding pinion outer seal retainer and bearing cage to housing and pull out assembly (fig. 51).

(2) Disassemble drive pinion. Follow steps in paragraph 14e (2) through (10) (figs. 52, 53, and 54).

*e. Differential.*—Tools: wire cutting pliers, 1-inch socket wrench, 1 $\frac{3}{8}$ -inch open end wrench,  $\frac{7}{8}$ -inch socket wrench,  $\frac{3}{4}$ -inch socket wrench, hammer, bearing puller.

(1) Remove carrier assembly. Follow steps in *c*(1) through (5) above.

(2) Remove adjusting ring locks—cutting pliers. Cut locking wires (A214927) running through bearing cap bolts (A214926). Remove adjusting ring lock cotter pins (BFA2AK) and remove locks (A214931) (figs. 55 and 56).

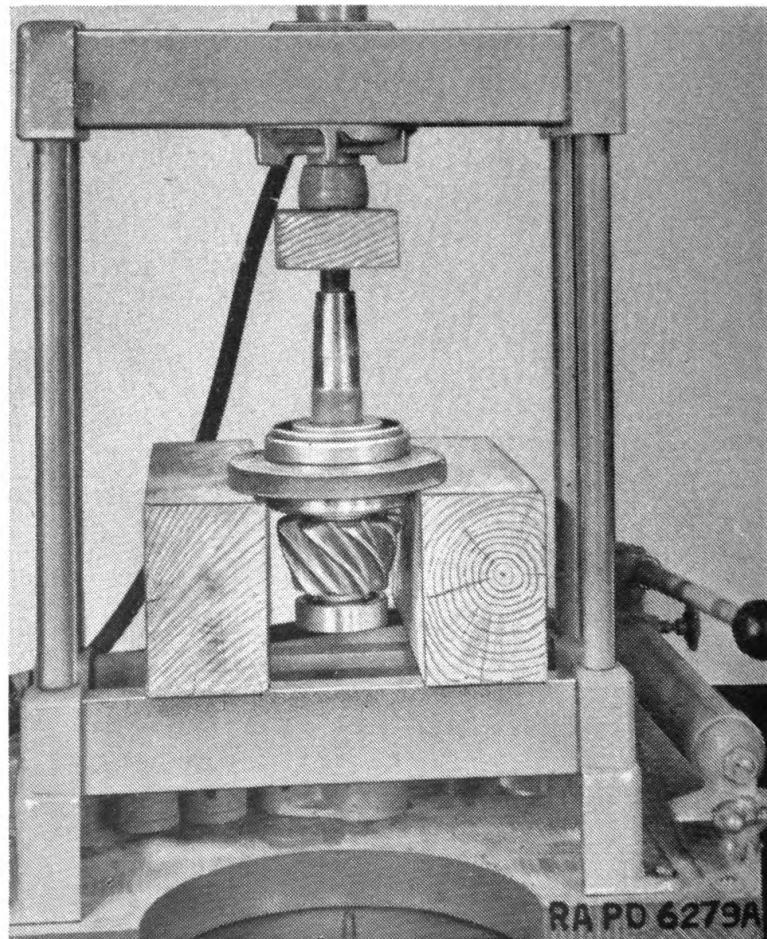

FIGURE 52.—Pressing off rear axle drive pinion bearing cage.

(3) Remove bevel gear thrust block—1-inch socket wrench, 1 $\frac{3}{8}$ -inch open end wrench. Loosen thrust block adjusting screw jam nut (A214938) and screw (A214937) and take out block (B184333).

(4) Remove adjusting rings— $\frac{7}{8}$ -inch socket wrench. Remove the four  $\frac{9}{16}$ -inch bearing cap screws and take off the bearing caps (B184327) and lock rings (B184328) (fig. 57).

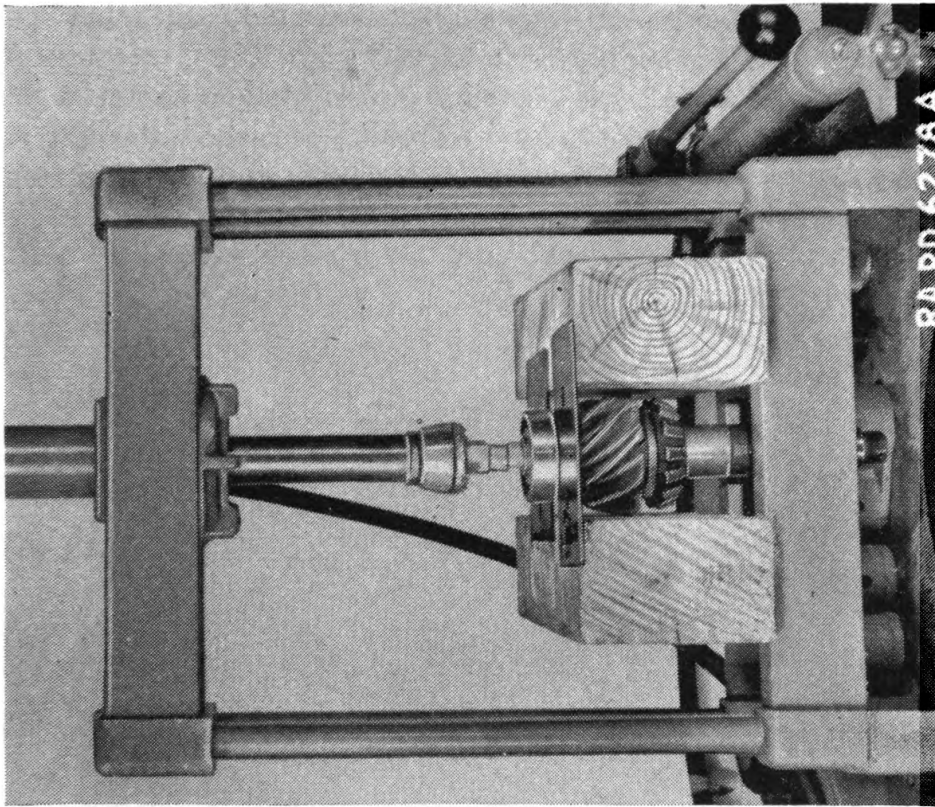

FIGURE 54.—Pressing off rear axle drive pinion straight roller bearing.

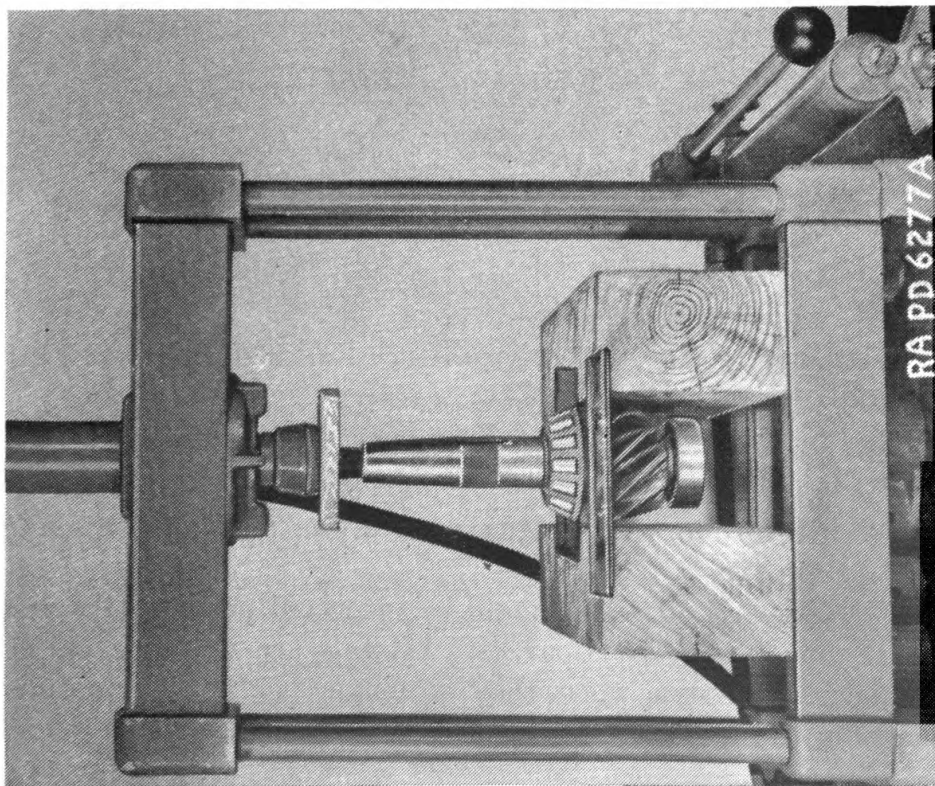
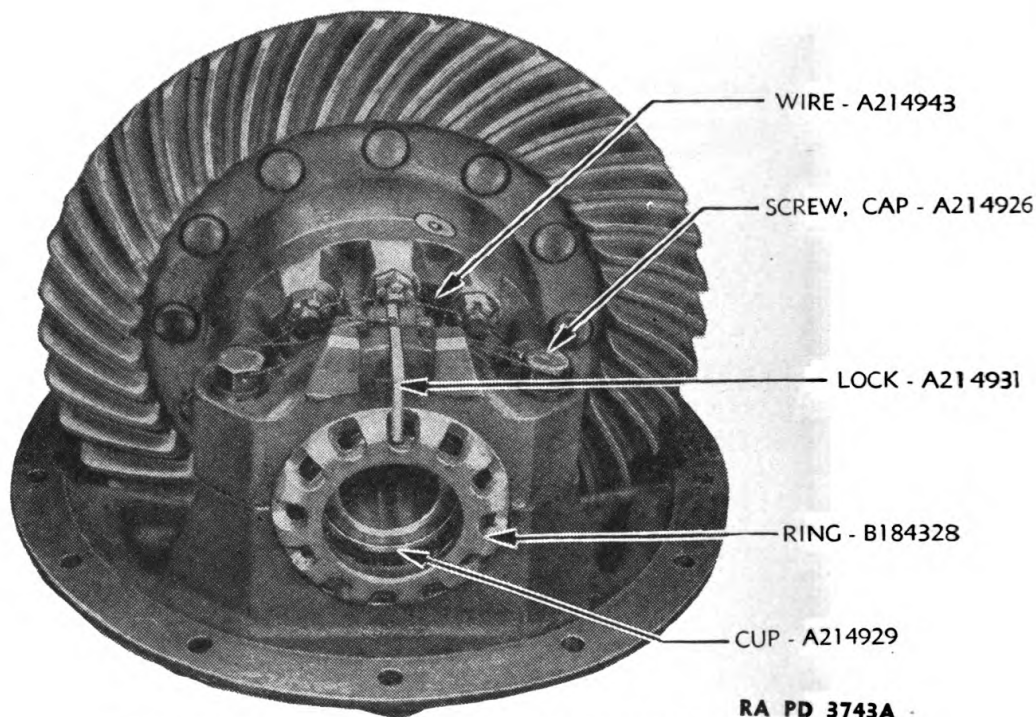

FIGURE 53.—Pressing off rear axle drive pinion bearing cone.

(5) Remove differential assembly. Take off bearing cups (A214929) and lift assembly from carrier (fig. 57).

(6) Split differential case—cutting pliers,  $\frac{3}{4}$ -inch socket wrench, hammer. Cut the locking wire (A214943) threaded through case bolts and remove twelve  $\frac{1}{2}$ -inch bolts (A214941) and nuts (A214942). Tap the side of case to loosen and pull away one half (fig. 58).



RA PD 3743A

FIGURE 55.—Rear axle differential and ring gear dismounted, side view.

(7) Disassemble case—bearing puller. Follow steps in paragraph 14f(8) and (9) (fig. 59).

NOTE.—Whenever procedure steps refer to front axle section, rear axle (jackshaft) piece marks must be substituted for those given.

**22. Maintenance and adjustments.**—*a. Cleaning bearings.*—See paragraph 15a.

*b. Oil seals.*—All oil seals should be inspected periodically and replaced if undue wear is apparent. If seals are allowed to operate after they have become worn, they no longer perform their function of retaining the lubricant in its proper location and many times al-



low the entrance of dirt, grit, and other foreign matter which becomes mixed with the lubricant, causing premature wear and other difficulties.

*c. Sprockets.*—(1) Check for damaged or worn teeth.

(a) If teeth are damaged, they should be repaired or the entire sprocket replaced.

(b) If teeth are worn on one side, the sprockets should be reversed.

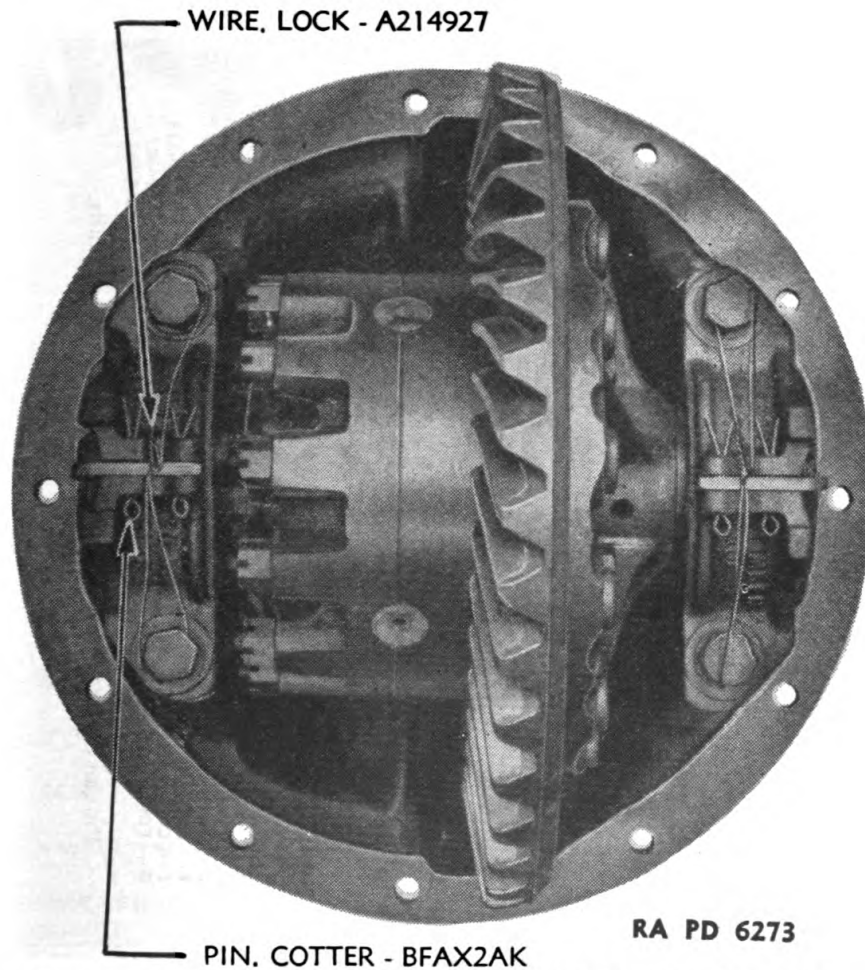

FIGURE 56.—Rear axle differential and ring gear dismounted, top view.

(2) Check bolt holes for wear or tearing. If this is apparent, they should be repaired.

*d. Hub and drum assemblies.*—See paragraph 15*b*.

*e. Axle shafts.*—Remove axle shafts as explained in paragraph 20 and clean and inspect carefully.

(1) If there is any indication of twisting at the splined end or along length of shaft, it should be replaced.

(2) If splines are badly worn or damaged, the shaft should be replaced.

f. *Drive pinion assembly.*—(1) See paragraph 15f.

(2) *Bearing adjustment* (fig. 43).—(a) Disconnect propeller shaft at drive pinion companion flange and remove flange.

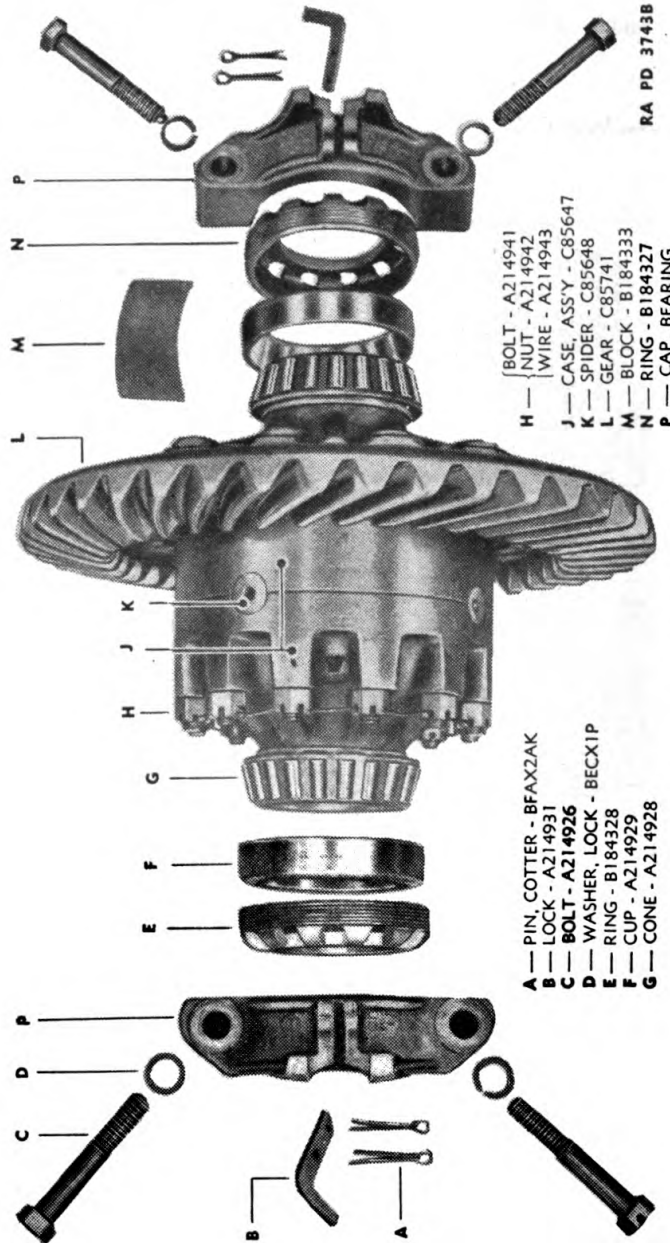

FIGURE 57.—Rear axle differential and ring gear details.

(b) Remove drive pinion outer seal retainer cap screws and pull off retainer, exposing locking and adjusting nuts.

(c) Straighten lock washer between adjusting and locking nuts and back off locking nut.

POWER TRAIN

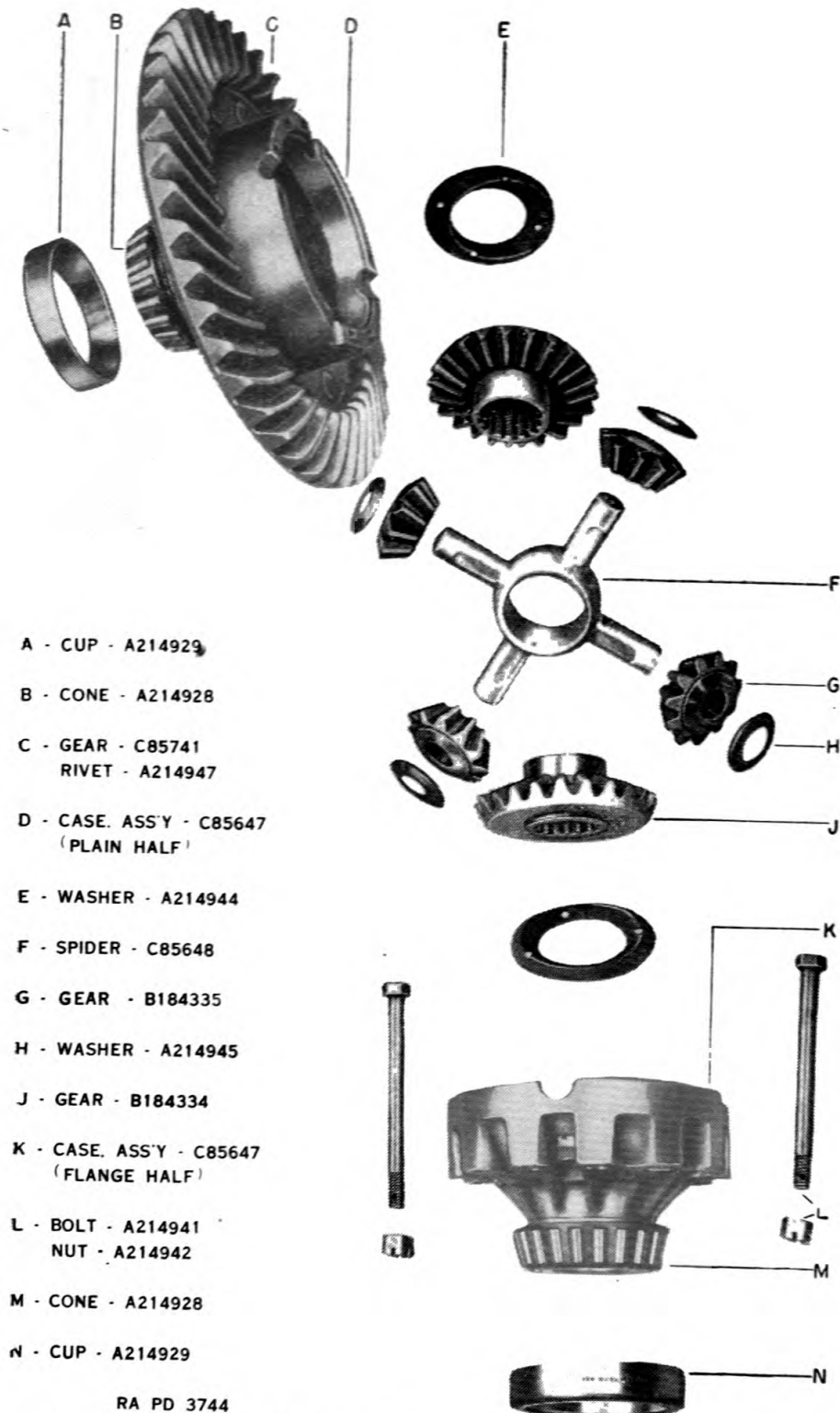

FIGURE 58.—Rear axle differential case assembly, partially exploded.

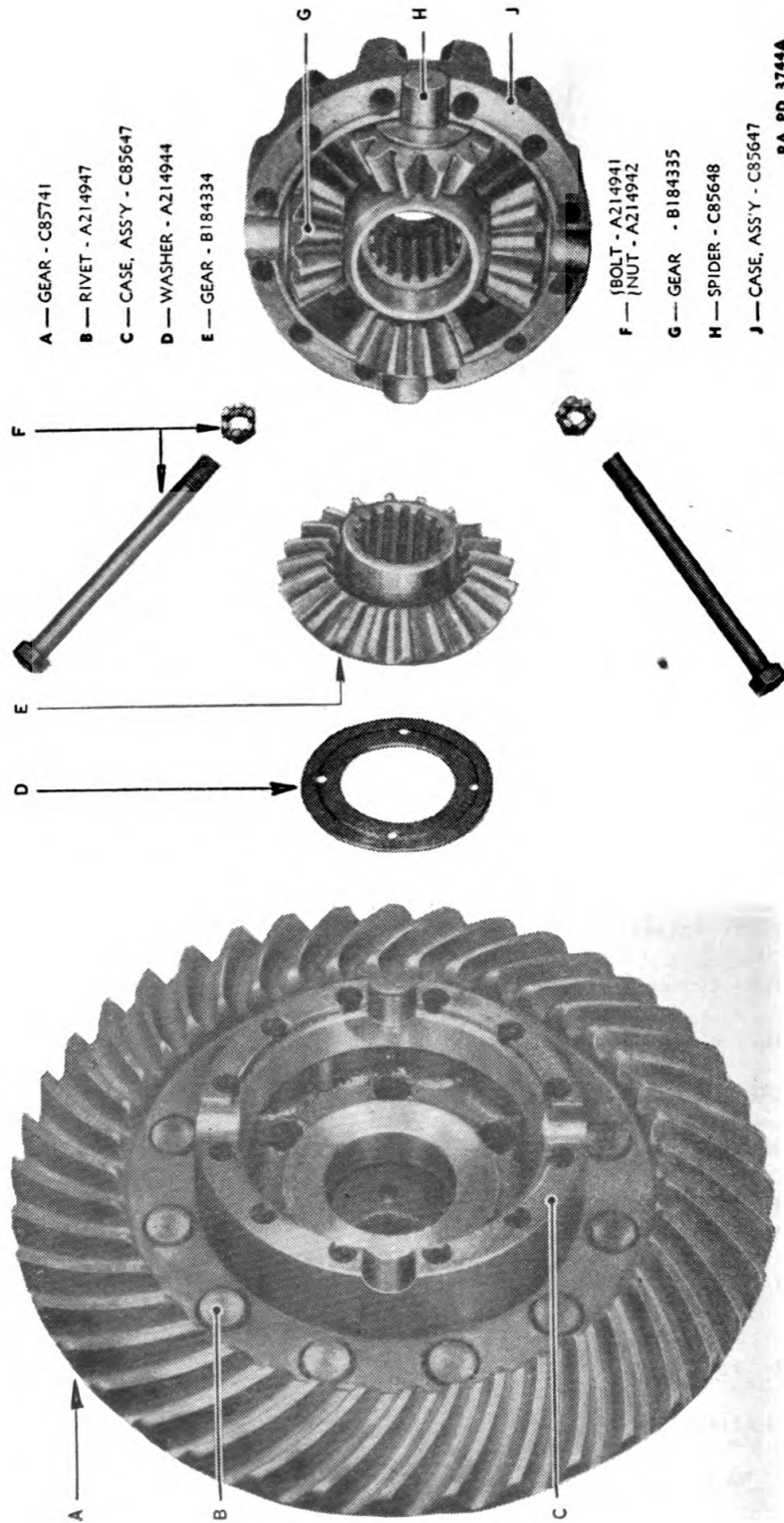

FIGURE 59.—Rear axle differential assembly, exploded.

(d) Tighten or loosen adjusting nut until proper amount of end play and looseness of bearings is obtained. The proper adjustment is .000-.002 inch tight.

(e) Reassemble, making certain that cork gasket and bearing inner thrust washer are in position.

g. *Differential.*—(1) Maintenance should be accomplished in a manner similar to that used on front axle differential (see par. 15a).

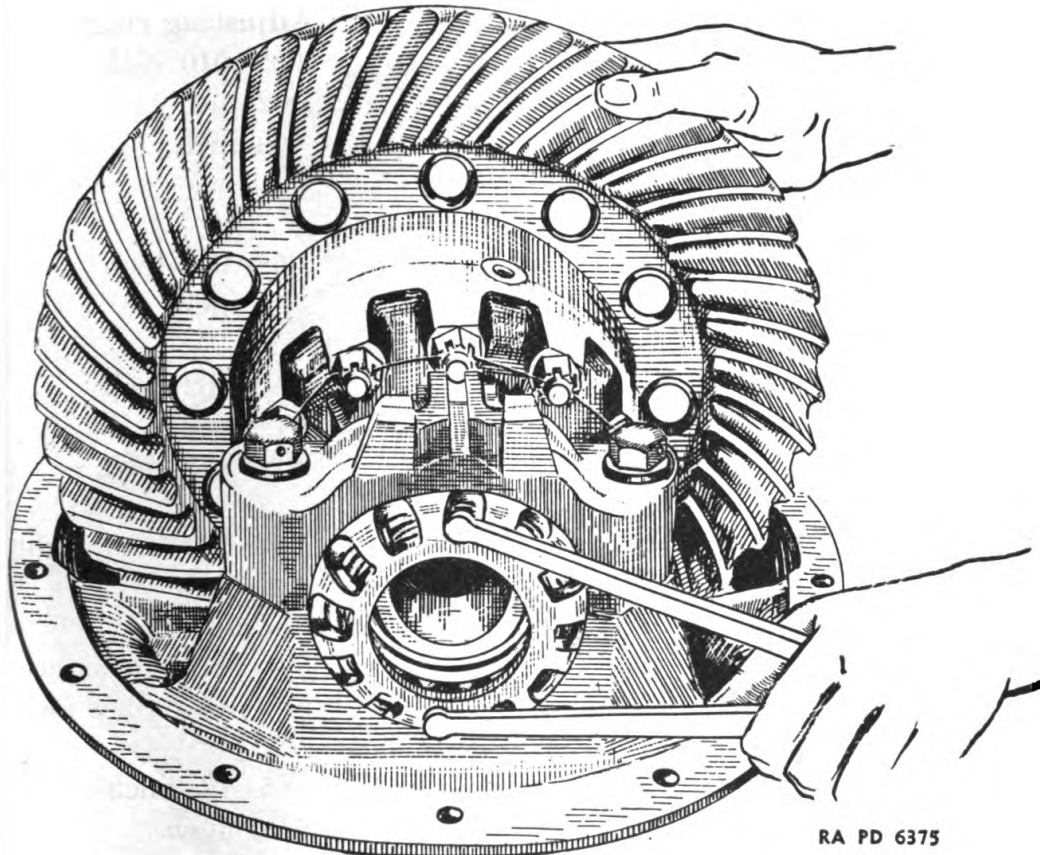

FIGURE 60.—Adjusting rear axle differential ring gear and pinion backlash.

(2) Bearing adjustment (for ring gear and pinion backlash) (fig. 60).

(a) After differential has been assembled to carrier, install bearing caps and tighten down cap screws until lock washers just flatten out.

(b) Screw adjusting rings into carrier, making sure they turn freely and tighten them snugly to straighten up bearing outer races.

(c) Back off right-hand adjusting ring and tighten left-hand ring until all lash between ring gear and pinion is removed.

(d) Back off left-hand ring approximately two notches to locking position and tighten right-hand ring to solid position.

(e) Back off right-hand ring free of bearing, then tighten up right-hand nut until all play in bearing is removed and then one or two notches more to a locking position.

(f) Check ring gear and pinion backlash (.005-.010 inch) and if it is more than this, loosen right-hand ring one notch and tighten left-hand ring one notch; if it is less, reverse the procedure.

*h. Service data.*

Differential:

Bearing adjustment .....	Adjusting rings
Gear to pinion backlash.....	.005-.010 inch
Gear run-out, not over.....	.002 inch
Case run-out, not over.....	.002 inch

Clearance between—

Side gear thrust washer:

New limits.....	.058-.062 inch
Worn limits.....	.048 inch

Pinion gear thrust washer:

New limits.....	.058-.062 inch
Worn limits.....	.048 inch

Thrust block to bevel gear.....	.012-.015 inch
---------------------------------	----------------

Pinion shaft:

Bearing adjustment.....	.000-.002 inch tight
-------------------------	----------------------

Pinion cage:

Adjustment .....	Shims
Shim thickness.....	.003 inch, .005 inch .015 inch, .032 inch

Bearing thrust washer:

New limits.....	.105-.125 inch
Worn limits.....	.0781 inch

Axle shaft run-out, not over.....	.005 inch
-----------------------------------	-----------

**23. Reassembly of components.—a. Differential.—Tools:** hammer, bearing driving tool, feeler gages,  $\frac{9}{16}$ -inch open end wrench, pliers,  $\frac{7}{8}$ -inch socket wrench, spanner wrench (or screw driver), 1-inch socket wrench,  $1\frac{3}{8}$ -inch open end wrench.

(1) Reassemble differential case. Follow steps in paragraph 16a (2) through (4).

(2) Replace differential assembly in carrier— $\frac{7}{8}$ -inch socket wrench. Place bearing cups onto cones and place assembly in carrier. Replace bearing caps, cap screws, and lock washers and tighten down cap screws until lock washers flatten out.

(3) Replace adjusting rings and adjust differential bearings—spanner wrench (or screw driver). Follow steps in paragraph 22a(2)(b) through (f).

(4) Replace bevel gear thrust block—1-inch socket wrench, 1 $\frac{3}{8}$ -inch open end wrench. Set thrust block onto adjusting screw and turn screw in until proper adjustment of block and bevel gear is obtained (see table of clearances). Lock in place with jam nut.

(5) Replace adjusting ring locks—pliers. Set locks into position in bearing blocks and lock rings and replace cotter pins.

(6) Replace bearing cap locking wire—pliers. Tighten down cap screws in bearing cap and pull soft annealed wire through holes in

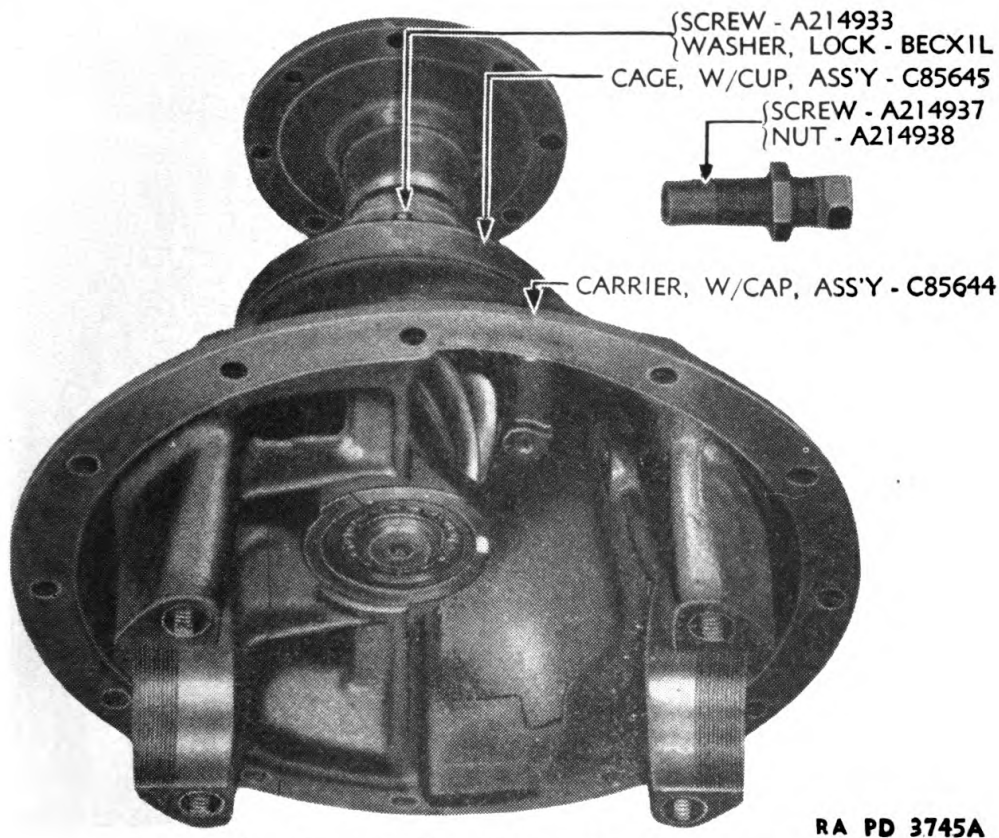

RA PD 3745A

FIGURE 61.—Rear axle drive pinion and bearing cage, exploded.

cap screw heads and over bearing caps. Twist ends of wire together and cut off any extra length.

*b. Drive pinion assembly* (fig. 61).—Tools: press, wood blocks, pipe collar, screw driver, 1 $\frac{1}{4}$ -inch open end wrench, 1 $\frac{1}{2}$ -inch socket wrench, pliers,  $\frac{5}{8}$ -inch socket wrench.

(1) Reassemble drive pinion. Follow steps in paragraph 16*b* (1) through (7) (figs. 62, 63, 64, and 65). Before replacing companion flange, check bearing adjustment as explained in paragraph 15*f*.

(2) Install drive pinion assembly— $\frac{5}{8}$ -inch socket wrench. Replace shaft assembly into differential housing and bolt in place with six  $\frac{7}{16}$ -inch cap screws and lock washers (figs. 66 and 67).

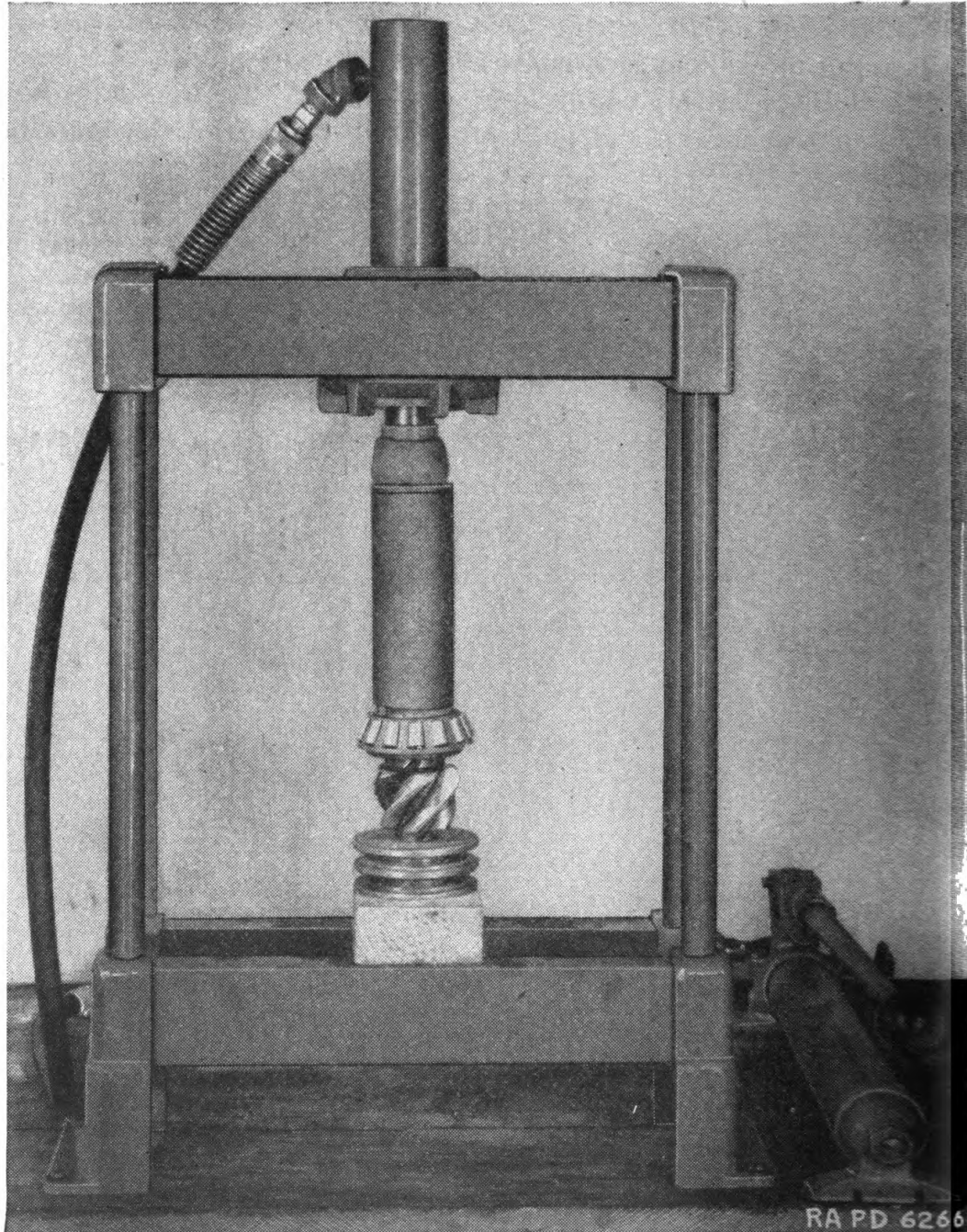

FIGURE 62.—Pressing on rear axle drive pinion inner bearing cone.

*c. Drive pinion and differential carrier assembly—Tools lifting fixture, sling,  $\frac{5}{8}$ -inch socket wrench,  $\frac{7}{16}$ -inch socket wrench,  $\frac{9}{16}$ -inch open end wrench,  $\frac{9}{16}$ -inch socket wrench.*



- (1) Replace carrier in housing—lifting fixture, sling,  $\frac{5}{8}$ -inch socket wrench. Attach lifting fixture to top cap screw hole of carrier and lift into position. Push carrier part way into housing, remove fixture, and replace cap screw, pulling carrier up tight to housing. Use a new gasket around housing bolt holes.
- (2) Replace floor plates— $\frac{7}{16}$ -inch socket wrench. Bolt floor plates into position above differential housing.

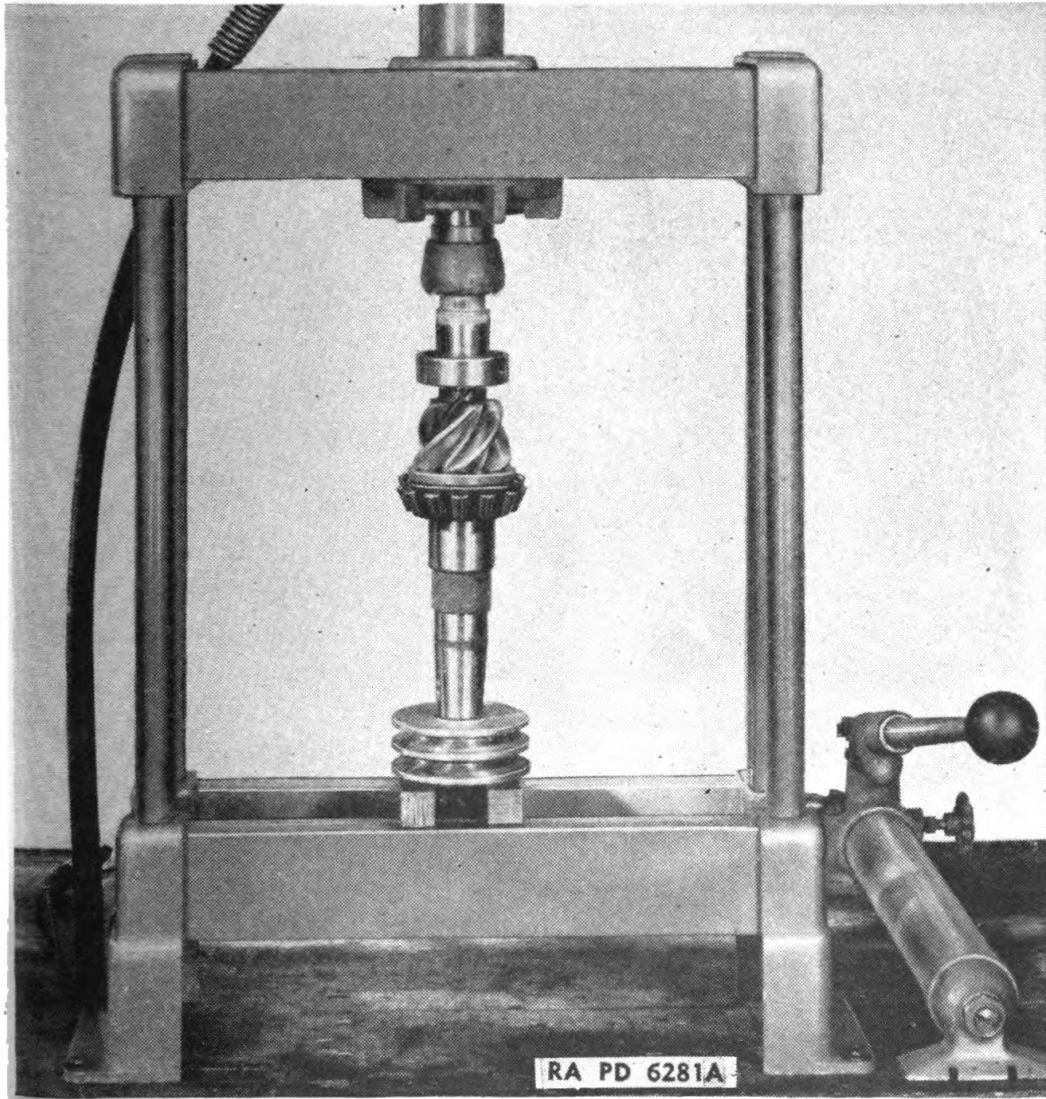

FIGURE 63.—Pressing on rear axle drive pinion straight roller bearing.

- (3) Refill with lubricant— $\frac{9}{16}$ -inch open end wrench. Replace magnetic drain plug, remove filler plug, fill with lubricant, and replace filler plug. See lubrication chart (fig. 2①) for correct type and amount of lubricant.

(4) Reconnect to rear propeller shaft— $\frac{9}{16}$ -inch open end wrench,  $\frac{9}{16}$ -inch socket wrench. Replace the eight  $\frac{3}{8}$ -inch bolts, nuts, and

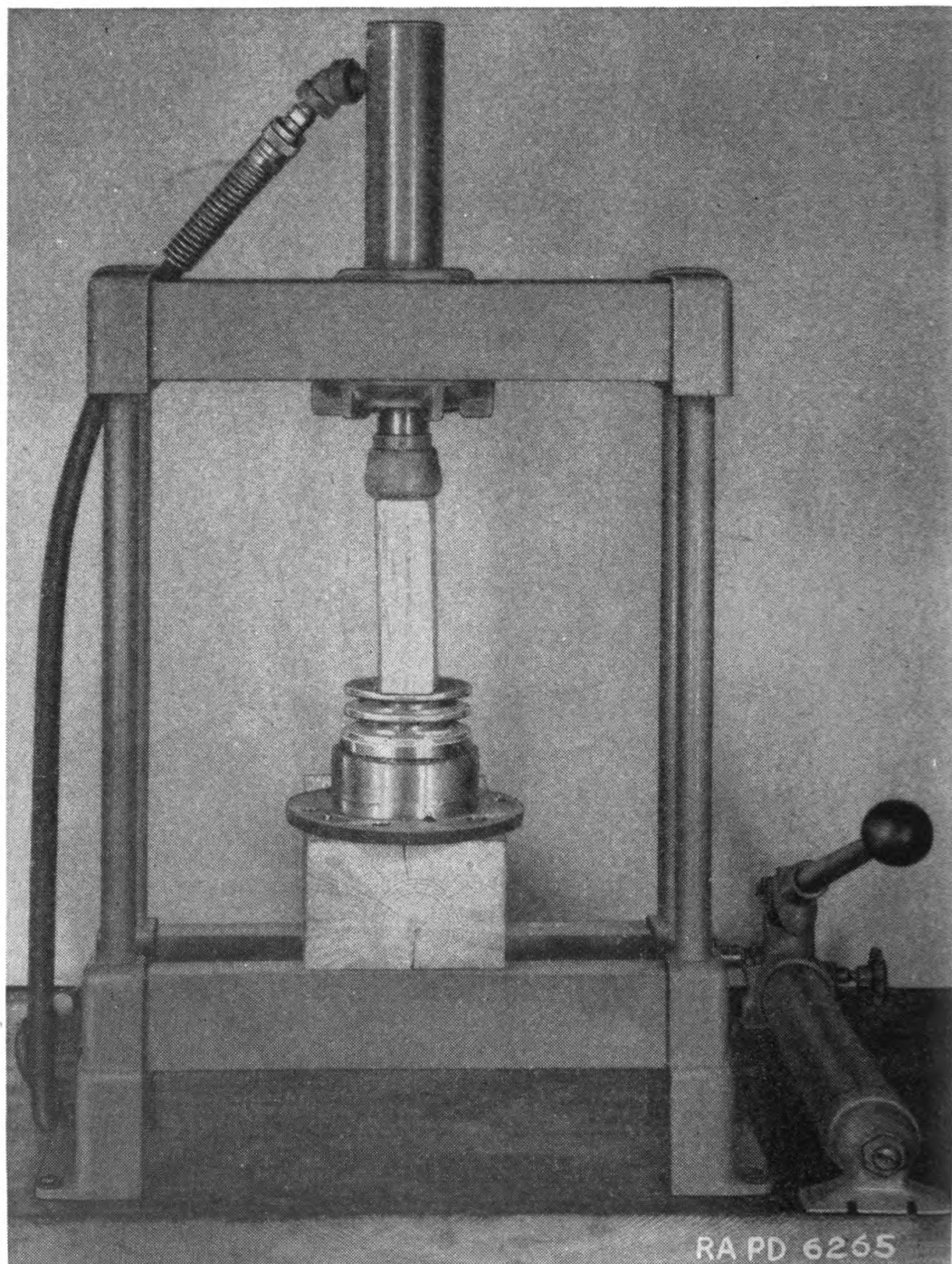

FIGURE 64.—Pressing rear axle drive pinion bearing cup in cage.

lock washers attaching the jackshaft pinion companion flange to the rear propeller shaft universal joint flange.

*d. Hub and drum assemblies.*—Tools: bearing driving tool, seal driving tool, hammer, wheel bearing nut wrench,  $\frac{5}{8}$ -inch socket wrench.

(1) Assemble bearings and seals to hubs—bearing and seal driving tool, hammer. Drive inner and outer bearing assemblies into hubs and then drive inner bearing seals into position in hubs.

(2) Replace assemblies on car—wheel bearing nut wrench. Force assemblies onto axle housing and replace bearing adjusting nut, thrust washers, and locking nuts.

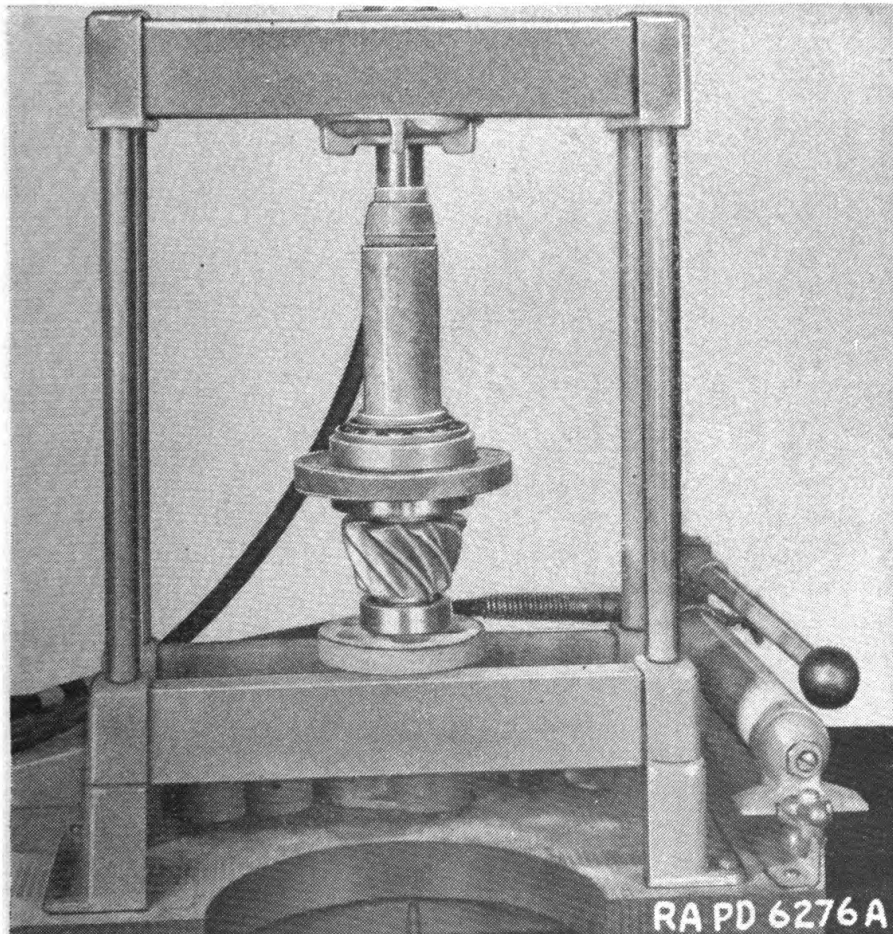

FIGURE 65.—Pressing on rear axle drive pinion outer bearing cone.

(3) Adjust bearings. See paragraph 15.

(4) Install drive shaft and flange assemblies— $\frac{5}{8}$ -inch socket wrench. Insert shafts into housing until splines engage with those of differential side bearings. Fasten in position with flange stud nuts and lock washers.

*e. Sprockets.*—Tools:  $\frac{3}{4}$ -inch socket wrench,  $\frac{3}{4}$ -inch box wrench, wheel stud nut wrench, bogie arm holding clips (or chain), two 4-foot

and two 6-foot lengths of 2 x 4 inch lumber, pinch bar, 2-inch open end wrench,  $1\frac{7}{16}$ -inch socket wrench.

(1) Assemble flanges to sprockets— $\frac{3}{4}$ -inch socket wrench,  $\frac{3}{4}$ -inch box wrench. Bolt outer and inner flanges to sprockets with nine  $\frac{1}{2}$ -inch bolts and nuts.

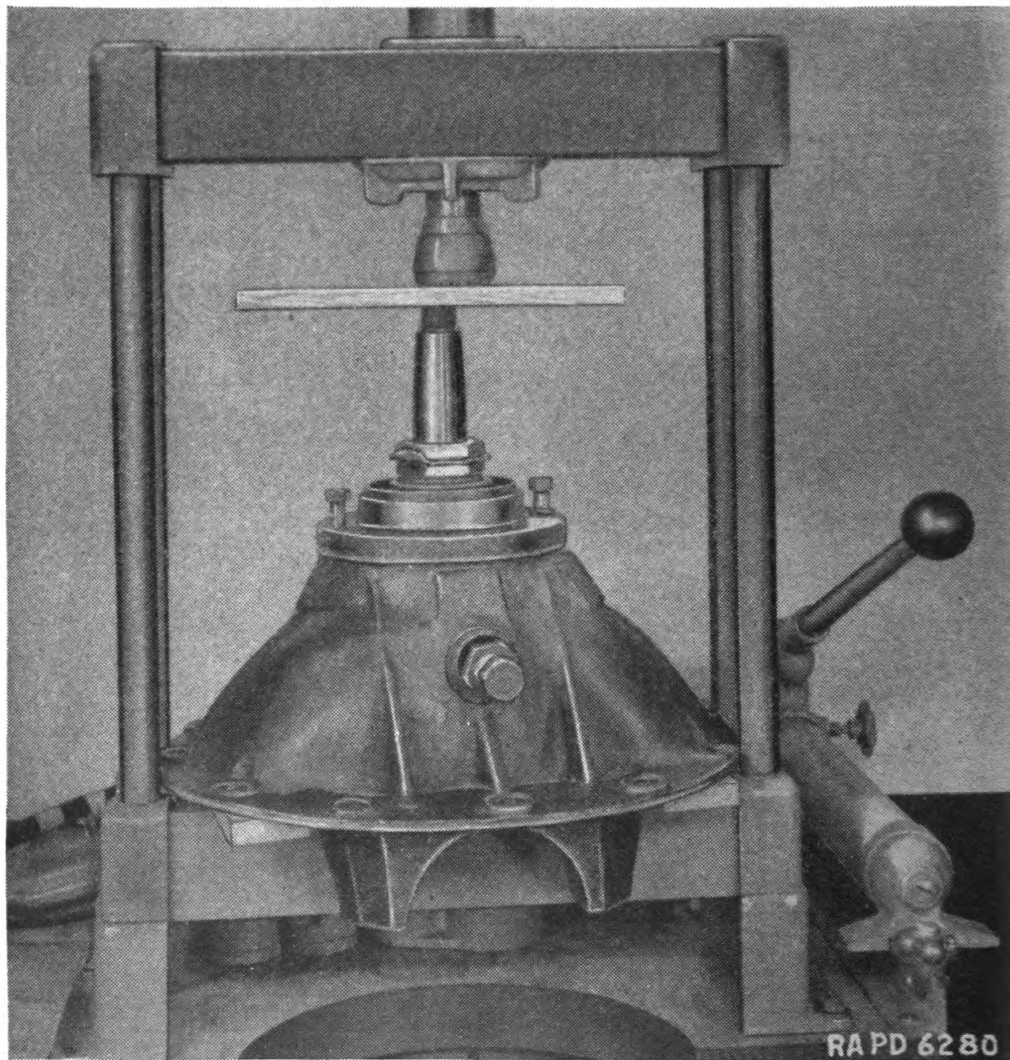

FIGURE 66.—Pressing rear axle drive pinion assembly in carrier.

(2) Attach sprocket assemblies to drums—wheel stud nut wrench. Place sprocket assemblies on drum studs and tighten down stud nuts. Left-hand drum studs have left-hand threads.

(3) Replace tracks. Set tracks on sprockets and adjust idlers for proper track tension. (See TM 9-710 or 9-1712.)

(4) Remove jacks from under car. Lower jacks until rear of car rests on ground and pull out jacks.

POWER TRAIN

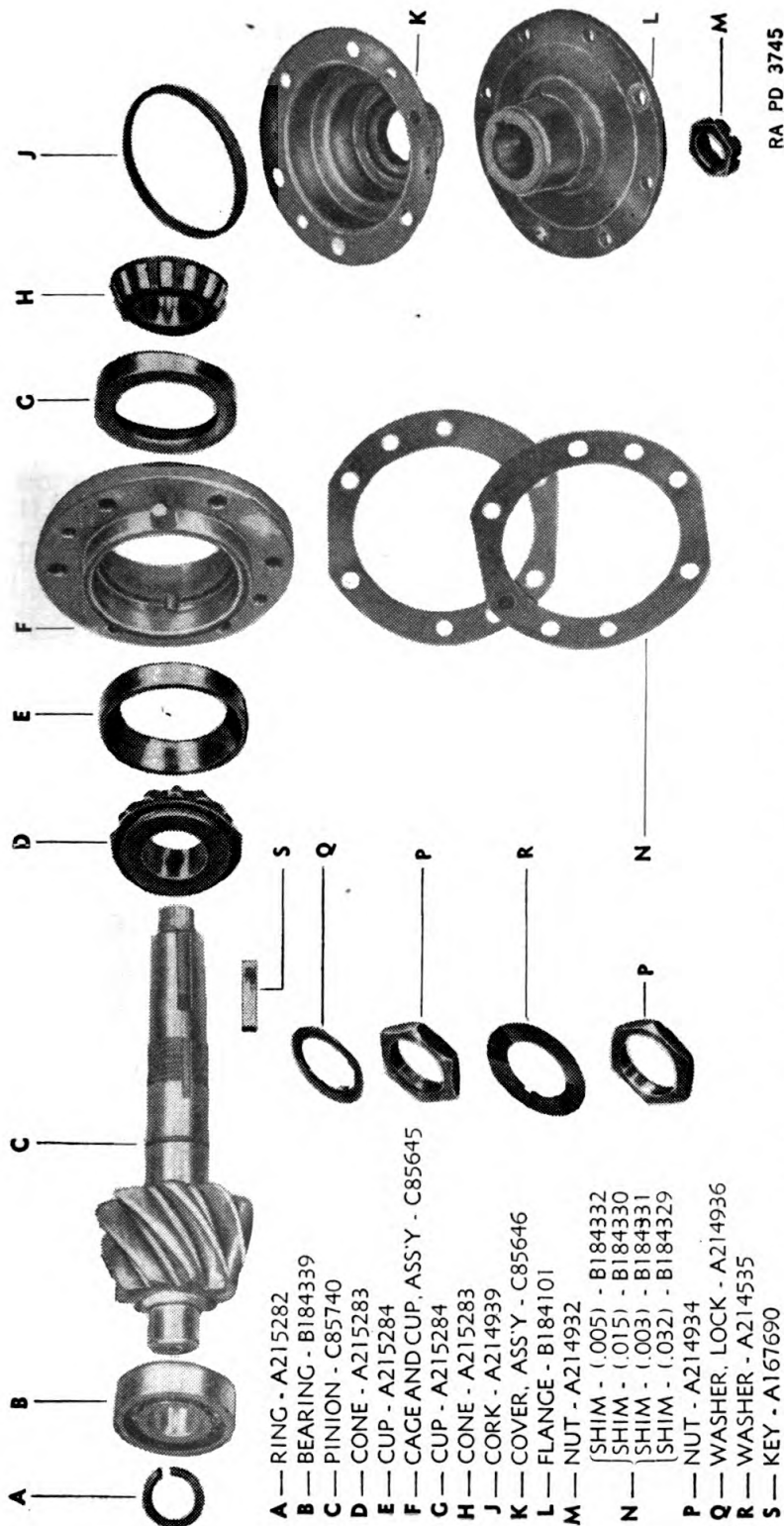

- A — RING - A215282
- B — BEARING - B184339
- C — PINION - C85740
- D — CONE - A215283
- E — CUP - A215284
- F — CAGE AND CUP, ASS'Y - C85645
- G — CUP - A215284
- H — CONE - A215283
- I — CORK - A214939
- J — COVER, ASS'Y - C85646
- K — FLANGE - B184101
- L — NUT - A214932
- M — SHIM - (.005) - B184332  
 SHIM - (.015) - B184330  
 SHIM - (.003) - B184331  
 SHIM - (.032) - B184329
- N — NUT - A214934
- O — WASHER, LOCK - A214936
- P — WASHER - A214535
- S — KEY - A167690

FIGURE 67.—Rear axle differential drive pinion and housing assembly, dismounted.

**24. Installation of assembly.**—Tools: hydraulic jack, 1¼-inch socket wrench, ⅞-inch open end wrench, ⅞-inch socket wrench, wheel stud nut wrench, 1⅞-inch socket wrench, bogie arm holding clips (or chain), two 4-foot and two 6-foot lengths of 2 x 4 inch lumber, pinch bar, 2-inch open end wrench.

*a.* Locate axle to car—hydraulic jack. Place axle assembly on hydraulic jack and raise it to its approximate position under car.

*b.* Attach axle to car—1¼-inch socket wrench. Install U-bolts on axle housing and through holes in frame. Replace nuts and tighten down.

*c.* Connect rear propeller—⅞-inch open end wrench, ⅞-inch socket wrench. Replace eight ⅜-inch bolts, nuts, and lock washers holding propeller shaft universal joint flange to jackshaft pinion companion flange.

*d.* Connect brake lines—⅞-inch open end wrench. Attach hydraulic brake hoses at wheel cylinder fittings. Replace cap screws and lock washers holding brake line clip and tee to axle housing. Bleed brake lines. (See TM 9-710 or 9-1712.)

*e.* Replace drive sprocket assemblies—wheel stud nut wrench. Place drive sprocket assemblies on drum studs. Replace stud nuts and tighten them down.

*f.* Replace track. Set tracks on sprockets and adjust idlers for proper track tension.

*g.* Lower rear end of car. Lower jacks under car until car rests on ground and remove jacks.

SECTION VII

PROPELLER SHAFTS

	Paragraph
Description.....	25
Trouble shooting.....	26
Removal of assembly.....	27
Disassembly of components.....	28
Maintenance and adjustments.....	29
Reassembly of components.....	30
Installation of assembly.....	31

**25. Description** (figs. 68 and 69).—The propeller shafts are of the two joint, needle bearing type.

*a. Construction.*—Each shaft assembly is made up of a slip or sleeve universal joint, a stationary or permanent universal joint, and a connecting tube, assembled to a yoke at one end and a splined shaft at the other. Each universal joint consists of a journal (or cross) assembly mounted into two yokes by means of four needle bearings.

The journal is provided with a relief valve which indicates when sufficient lubricant has been inserted by allowing any excess to escape. The needle bearings in the front axle propeller shaft joints are kept in place by means of lock rings. On the short coupled joint to the



FIGURE 68.—Front axle propeller shaft assembly.

RA PD 6238

rear axle, the bearings are kept in position by bearing caps, lock straps, and two cap screws and lock washers. A flange yoke is provided on each of the universal joints for attaching the respective shafts to the companion flanges of the transfer case and the front and rear axle drive pinions. The splined slip joint at one end of

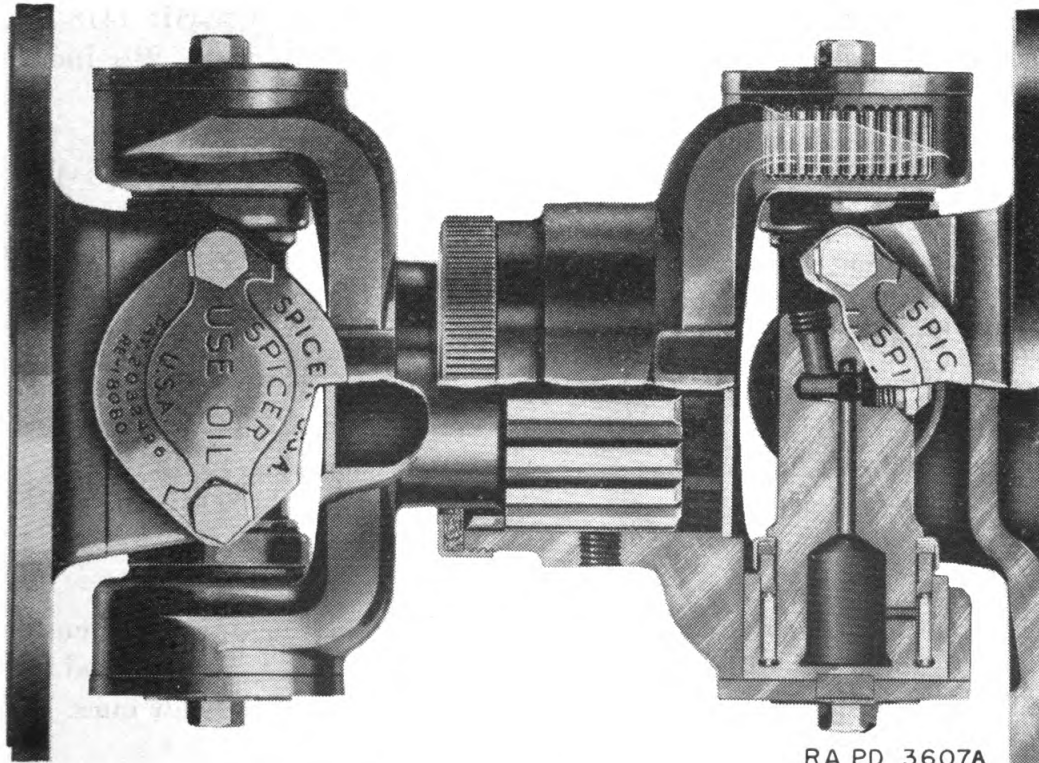

FIGURE 69.—Rear axle propeller shaft, sectionalized.

each shaft allows for a variation in distance between the units to which the shafts are connected. The male and female members of the slip joint are marked by arrows at the time of manufacture so that the splines can be reassembled in original position with the yokes

of the universal joints in correct plane to prevent excessive shaft vibrations.

*b. Specifications.*

Unit	Type	Ordnance number	White	Autocar	Diamond T
Propeller shaft (front axle).	Needle bearing.	C85600	376191	30ZC5410C	N-19129
Propeller shaft (rear axle, short coupled).	Needle bearing.	C85506	371688	30ZLE4133	N-18129

Quantity used ----- 2

Universal joints ----- 4

Transfer case to front axle propeller shaft :

Series ----- 1410

Number ----- SP-8805-SF

Slip joint number ----- SP-1411-6X

Permanent joint number ----- SP-1418-8X

Tube diameter ----- 2½ inches

Transfer case to rear axle propeller shaft (short coupled) :

Series ----- 1600

Number ----- SP-8794-SF

Slip joint number ----- SP-8850-SF

Permanent joint number ----- SP-8851-SF

**26. Trouble shooting.**

*Symptom and probable cause*

*Probable remedy*

*a. Noise.*

(1) Lack of lubrication.

(1) Lubricate joints

(2) Worn journal.

(2) Replace journal.

(3) Worn bearings.

(3) Replace bearings.

*b. Run-out.*

(1) Improper assembly.

(1) Dismount and reassemble with arrows of slip joint alined.

(2) Worn bearings and journals.

(2) Replace with new ones.

nals.

*c. Oil leak.*

(1) Worn washers.

(1) Replace with new washers.

(2) Worn journal and bearings.

(2) Replace with new ones.

(3) Worn oil seals.

(3) Replace with new seals.

**27. Removal of assembly (fig. 70).—a. Front axle propeller shaft.**—Tools: 5/8-inch open end wrench, 5/8-inch socket wrench. Re-



move four  $\frac{7}{16}$ -inch bolts (A214369), nuts (BBBX1D), and lock washers (BECX1L) which secure each universal joint to companion flanges, and lower shaft assembly.

b. *Rear axle (jackshaft) propeller shaft.*—Tools:  $\frac{9}{16}$ -inch open end wrench,  $\frac{9}{16}$ -inch socket wrench, pliers.

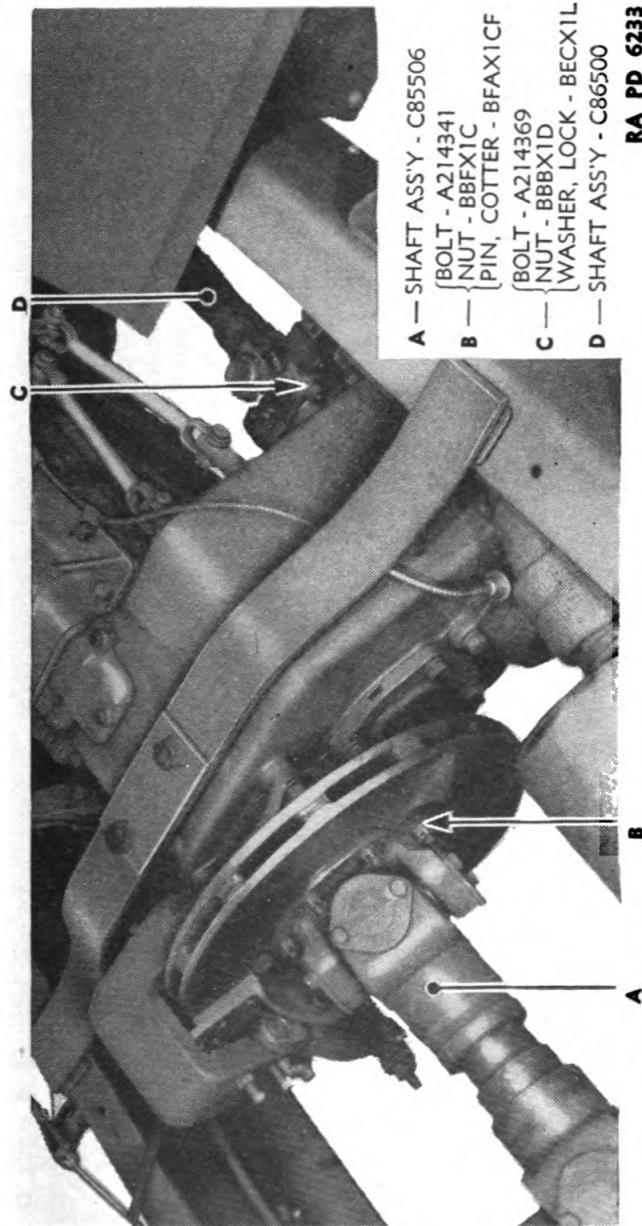

FIGURE 70.—Propeller shafts, installed.

(1) Disconnect flange yoke at drive pinion companion flange— $\frac{9}{16}$ -inch open end wrench,  $\frac{9}{16}$ -inch socket wrench, pliers. Remove eight bolts (A214342), nuts (BBFX1C) and cotter pins (BFAX1CF) which secure flange yoke (C85582) to companion flange (B184101).

(2) Shift transmission gears into neutral. Set gear shift lever

in neutral position to facilitate rotation of the drive shaft parking brake disk and to make companion flange bolts more accessible.

(3) Remove shaft assembly— $\frac{1}{16}$ -inch open end wrench,  $\frac{1}{16}$ -inch socket wrench, pliers. Remove eight bolts (A214341), nuts

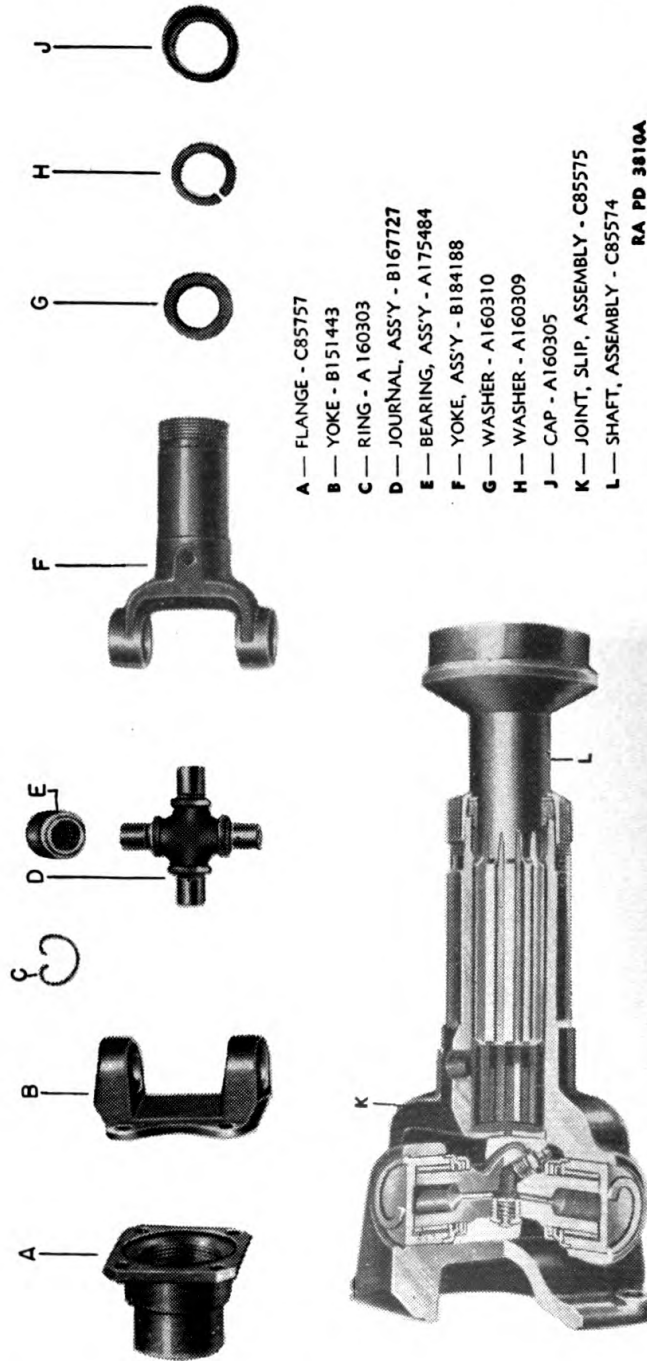

FIGURE 71.—Front axle propeller shaft, exploded.

(BBFX1E), and cotter pins (BFAX1CF) that hold universal joint flange to transfer case companion flange through brake disk lower shaft as unit.

(4) Secure brake— $\frac{9}{16}$ -inch open end wrench,  $\frac{9}{16}$ -inch socket wrench. Re-insert two flange bolts to secure brake disk and prevent damage from falling.

**28. Disassembly of components.**—*a. Front axle propeller shaft* (fig. 71).—Tools: thin nose pliers, brass drift, hammer, screw driver.

(1) Remove universal joint needle bearing snap rings—thin nose pliers. Pinch ends of rings (A160303) and pull out. If ring does

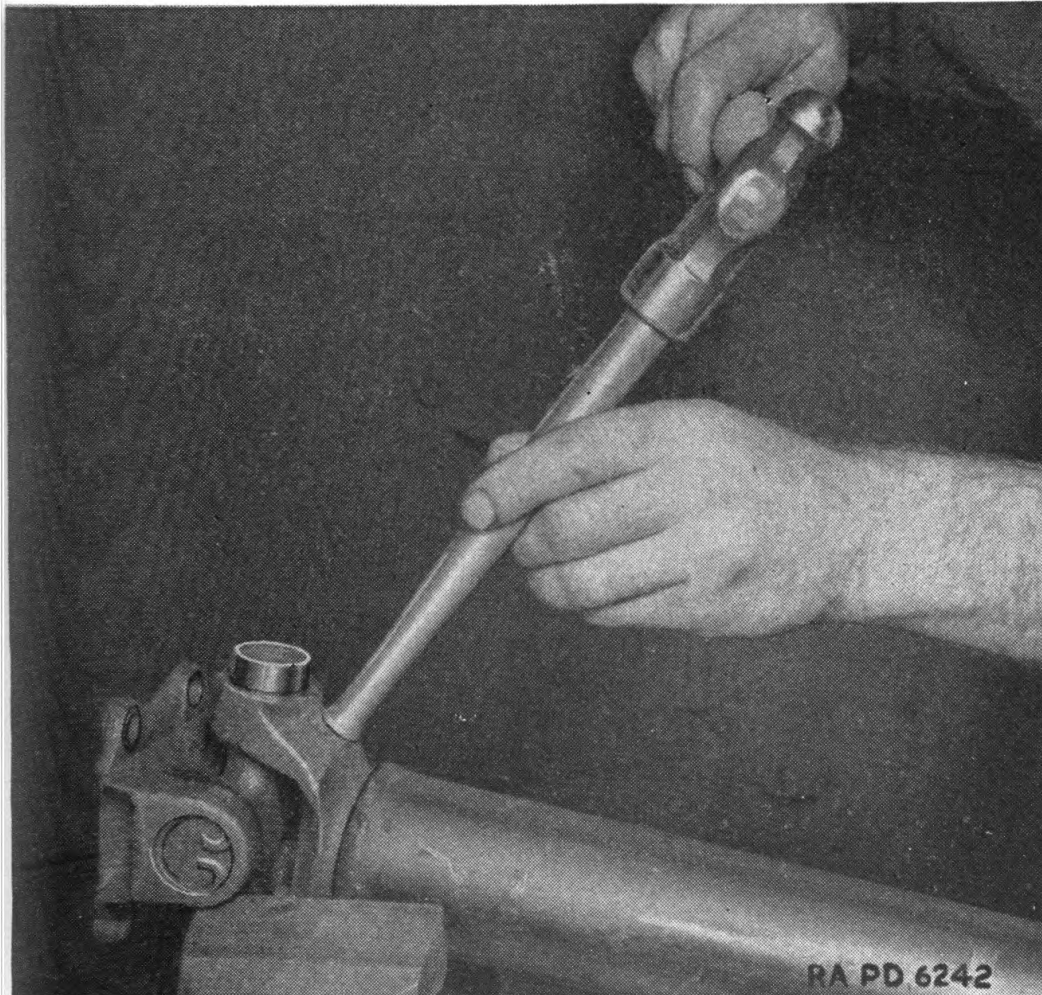

FIGURE 72.—Propeller shaft universal joint needle bearing removal.

not readily snap out of groove, lightly tap top of bearing to relieve pressure against ring.

(2) Remove needle bearing—brass drift, hammer (or press). Drive end of one bearing (A175484) with brass drift until bearing on opposite side of journal drops out of yoke. If bearing does not readily drop out, drive with drift against yoke (fig. 72). This should loosen bearing sufficiently to allow it to be driven out by striking on opposite bearing. Turn joint over and drive first bear-

ing out of yoke by driving on exposed end of journal. Repeat these operations for remaining two bearings.

(3) Remove journal. Lift out journal (B167727) by tilting top of yoke to one side (fig. 73).

(4) Disassemble opposite universal joint. Follow steps (1) through (3) above.

(5) Remove slip joint. Unscrew dust cap (A160305) and pull slip joint (C85575) from shaft splines.

(6) Remove dust cap—screw driver. Lift cork washer (A160310) and split steel washer (A160309) out of cap, and slip cap over shaft splines (fig. 74).

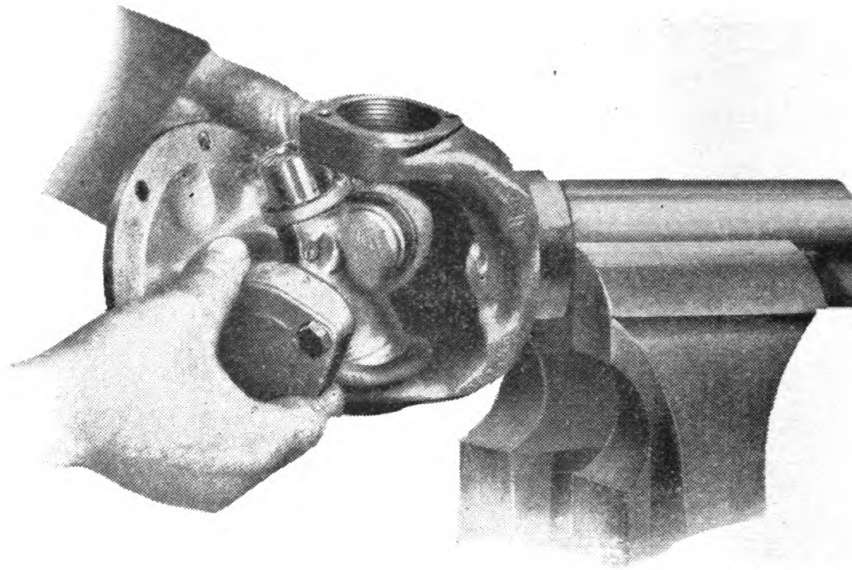

RA PD 6243A

FIGURE 73.—Propeller shaft universal joint journal removal.

*b. Rear axle (jackshaft) propeller shaft (fig. 74).*—Tools: 1/2-inch socket wrench, brass drift, hammer, screw driver.

(1) Remove bearing caps—screw driver, 1/2-inch socket wrench. Bend down locking tabs on lock plate (A214479) with a screw driver. Remove two cap screws (A214483) holding each bearing cap (A214478) and lock plate, and remove plates and caps.

(2) Disassemble remainder of shaft. Follow steps (2) through (6) in *a* above.

NOTE.—Substitute rear shaft piece marks for those given.

**29. Maintenance and adjustments.**—*a. General.*—(1) After disassembly, clean all parts thoroughly and inspect for wear or breakage. The journal and needle bearing assemblies are usually the only parts subject to wear.

POWER TRAIN

(2) Check washers and gaskets and replace with new ones if any wear is noticeable.

(3) Check shaft tube assembly for cracks, twisting, or run-out, and if any is apparent, replace with a new tube. See *b* below for allowable tube run-out.

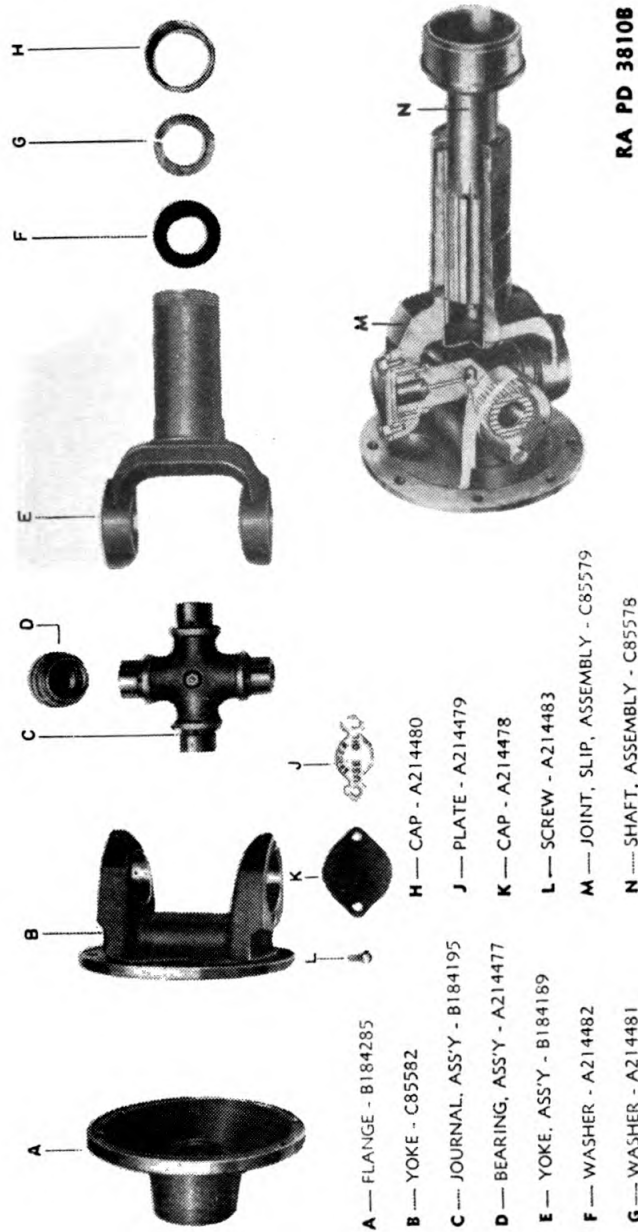

FIGURE 74.—Rear axle propeller shaft, exploded.

(4) Check slip joint splines for wear; see *b* below for allowable clearance. If the splines are worn beyond the limits, replace with new ones.

(5) No adjustments are made on the propeller shafts but care should be taken in reassembly not to injure the bearings and to align the arrow marks on the male and female portions of the slip joints.

*b. Service data.*

Allowable run-out:

Shaft tube, not over..... .020 inch  
 Neck of slip spline, not over..... .005 inch  
 Clearance between shaft splines and yoke splines.... .001-.006 inch

**30. Reassembly of components.**—*a. Front axle propeller shaft.*—(1) Lubricate universal joints—Alemite gun. Repack joints with lubricant (SAE 140) (fig. 2①). Be sure that reservoir in each journal is filled. With bearing rollers in race, fill race about  $\frac{1}{3}$  full.

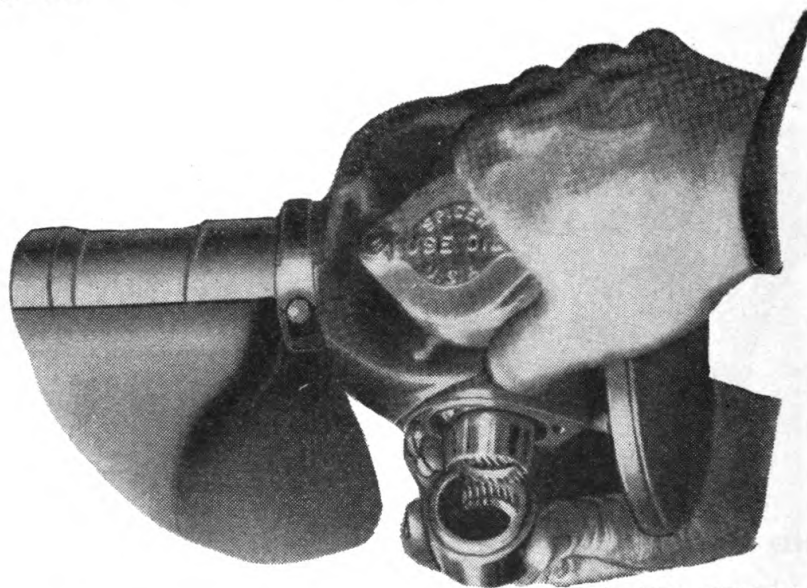

**RA PD 6372A**

FIGURE 75.—Propeller shaft universal joint needle bearing replacement.

(2) Replace journal. Set journal into yokes.

(3) Replace journal needle bearings. Hold bearings in a vertical position to prevent needles from dropping out of race and push bearings onto journal ends (fig. 75).

(4) Replace snap rings—long nose pliers. Install snap rings in yokes to hold bearings in place.

(5) Test assembly—hammer. Flex joint and if it appears to bind, tap yokes lightly with hammer; this will relieve any pressure of bearings on ends of journal. Follow same procedure for opposite joint.

*b. Rear axle (jackshaft) propeller shaft.*—(1) Replace journal bearings—Alemite gun. Follow steps in *a*(1) through (3) above.

(2) Replace bearing caps and lock plates—screw driver, 1/2-inch socket wrench. Set bearing caps and lock straps on yokes and bolt in position with cap screws. Using a screw driver, lock cap screws in place by turning up one tab at each end of lock straps. Do not use original lock straps; replace with new ones.

(3) Test assembly—hammer. See step a(5) above.

**31. Installation of assembly.—a. Front axle propeller shaft.—**Bolt shaft in place—5/8-inch open end wrench, 5/8-inch socket wrench. Locate assembly and replace bolts, nuts, and lock washers which secure it to companion flanges.

*b. Rear axle propeller shaft.—*Bolt shaft in place—9/16-inch open end wrench, 9/16-inch socket wrench, pliers. Remove bolts holding drive shaft brake disk in place. Locate propeller shaft and replace bolts, nuts, and cotter pins which secure it to companion flanges.

SECTION VIII

TRANSMISSION-TRANSFER CASE

Description .....	Paragraph
Description .....	32
Trouble shooting .....	33
Removal of assembly .....	34
Disassembly of components .....	35
Maintenance and adjustments .....	36
Reassembly of components .....	37
Installation of assembly .....	38

**32. Description** (figs. 76 and 77).—The transmission-transfer case is a special combination type with the transmission and transfer case assemblies combined to form one unit. The constant mesh, helical gear type transmission has four forward speeds and one reverse speed, while the transfer case has direct drive and underdrive features, and a declutching device for engaging and disengaging front axle drive.

*a. Construction* (figs. 76, 77, 78, and 79).—The transmission and transfer cases are two distinct units that are readily separable and can be treated individually.

(1) The transmission has a bellhousing mounted on the front end in which is installed the clutch release or throw-out mechanism. The bellhousing forms half of the clutch housing, the flywheel housing on the engine forming the other half. Handholes are provided on the top and bottom of the bellhousing for access to the clutch and clutch release mechanism. A cover is provided over the power take-off hole on the left-front side of the transmission. When the transmission is used with a winch installation this cover is removed to allow the winch gear to mesh with the power take-off gear on the transmission counter-

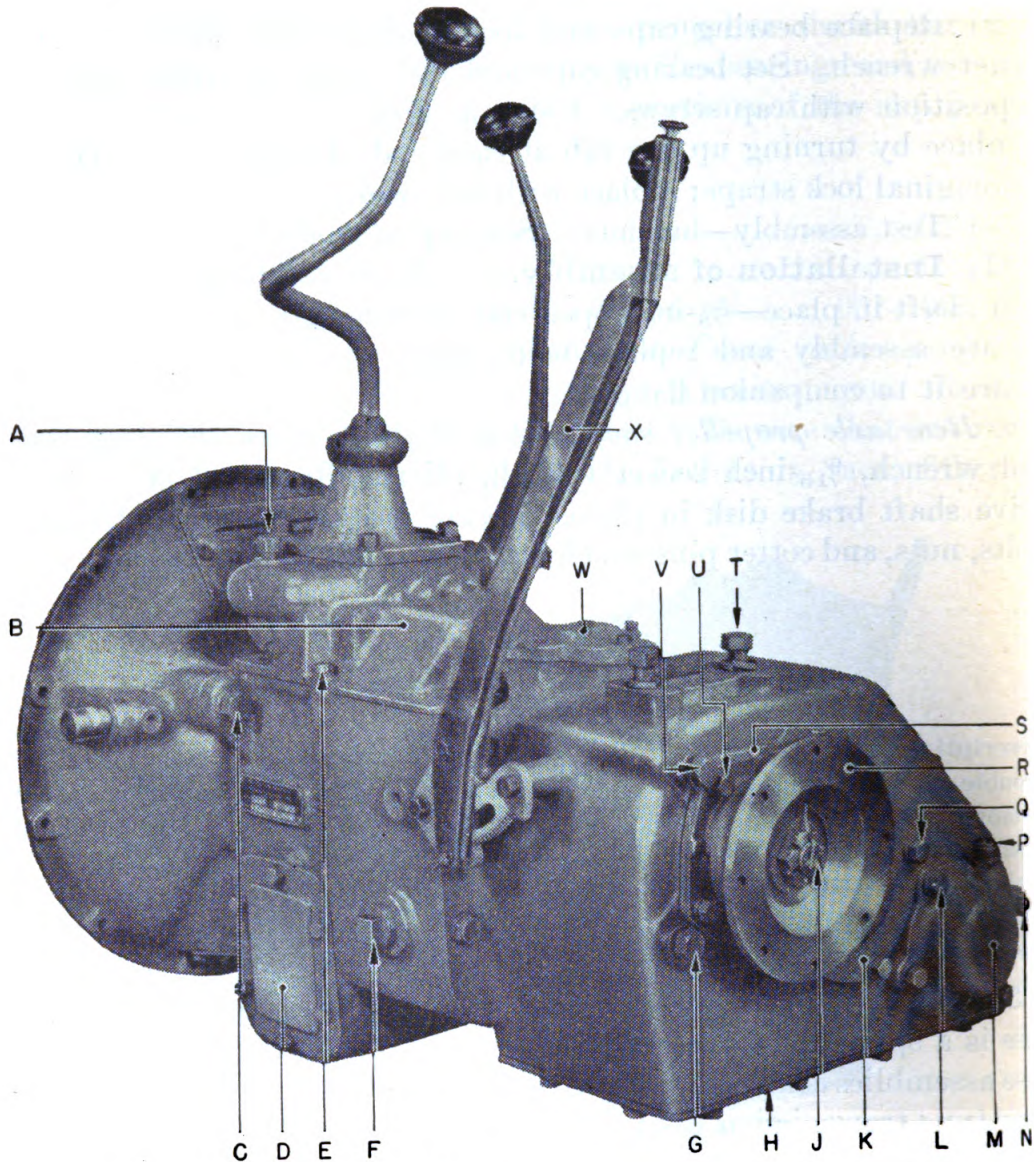

- |   |  |   |
|---|--|---|
| <p><b>A</b> - { HEAD, BREATHER-A214793<br/>STEM-A214794<br/>CORK-A214795<br/>PIN, COTTER-BFAX1CG</p> <p><b>B</b> - { HOUSING, SHIFTER-E3819<br/>GASKET-C85624</p> <p><b>C</b> - { SCREW-A214810<br/>WASHER, LOCK-BECX1P</p> <p><b>D</b> - { COVER-B184269<br/>GASKET-A214787<br/>SCREW, CAP-BCAX1CA<br/>WASHER, LOCK-BECX1K</p> <p><b>E</b> - { SCREW, CAP-BCAX1CC<br/>WASHER, LOCK-BECX1K</p> <p><b>F</b> - PLUG-A214959</p> <p><b>G</b> - { SCREW-A214865<br/>WASHER, LOCK-BECX1N</p> | <p><b>H</b> - { COVER-D48162<br/>GASKET-C85626<br/>SCREW, CAP-BCAX1CC<br/>WASHER, LOCK-BECX1K<br/>PLUG-A214780</p> <p><b>J</b> - { NUT-A214932<br/>WASHER-A214861<br/>PIN, COTTER-BFAX1DM</p> <p><b>K</b> - { CAP-B184243<br/>SHIM-(.003)-B184288<br/>(.010)-B184289<br/>(.031)-B184290<br/>CUP-A214964</p> <p><b>L</b> - { SCREW, CAP-A214862<br/>WASHER, LOCK-BECX1L</p> <p><b>M</b> - { CAP-C85611<br/>SHIM-(.003)-B184291<br/>(.010)-B184292<br/>(.031)-B184293<br/>CUP-A214964</p> <p><b>N</b> - { BOLT-BANX1DE<br/>WASHER, LOCK-BECX1L</p> | <p><b>P</b> - SLEEVE-A167650</p> <p><b>Q</b> - { BOLT-BANX1DE<br/>WASHER, LOCK-BECX1L</p> <p><b>R</b> - { FLANGE-B184285<br/>GUARD-A214848</p> <p><b>S</b> - { CAP-B184246<br/>SEAL, OIL-A214840<br/>GASKET-B184254</p> <p><b>T</b> - { SCREW-A214810<br/>WASHER, LOCK-BECX1P</p> <p><b>U</b> - { SCREW-BCAX1DE<br/>WASHER, LOCK-BECX1L</p> <p><b>V</b> - { SCREW-A214864<br/>WASHER, LOCK-BECX1N</p> <p><b>W</b> - { COVER-B184294<br/>GASKET-B184295<br/>SCREW, CAP-BCAX1CA<br/>WASHER, LOCK-BECX1G</p> <p><b>X</b> - LEVER, ASS'Y-D48163</p> |
|---|--|---|

RA PD 3615A

FIGURE 76.—Transmission assembly, left side.

Generated on 2016-07-07 11:36 GMT / http://hdl.handle.net/2027/uc1.b3243960 Public Domain, Google-digitized / http://www.hathitrust.org/access\_use#pd-google



POWER TRAIN

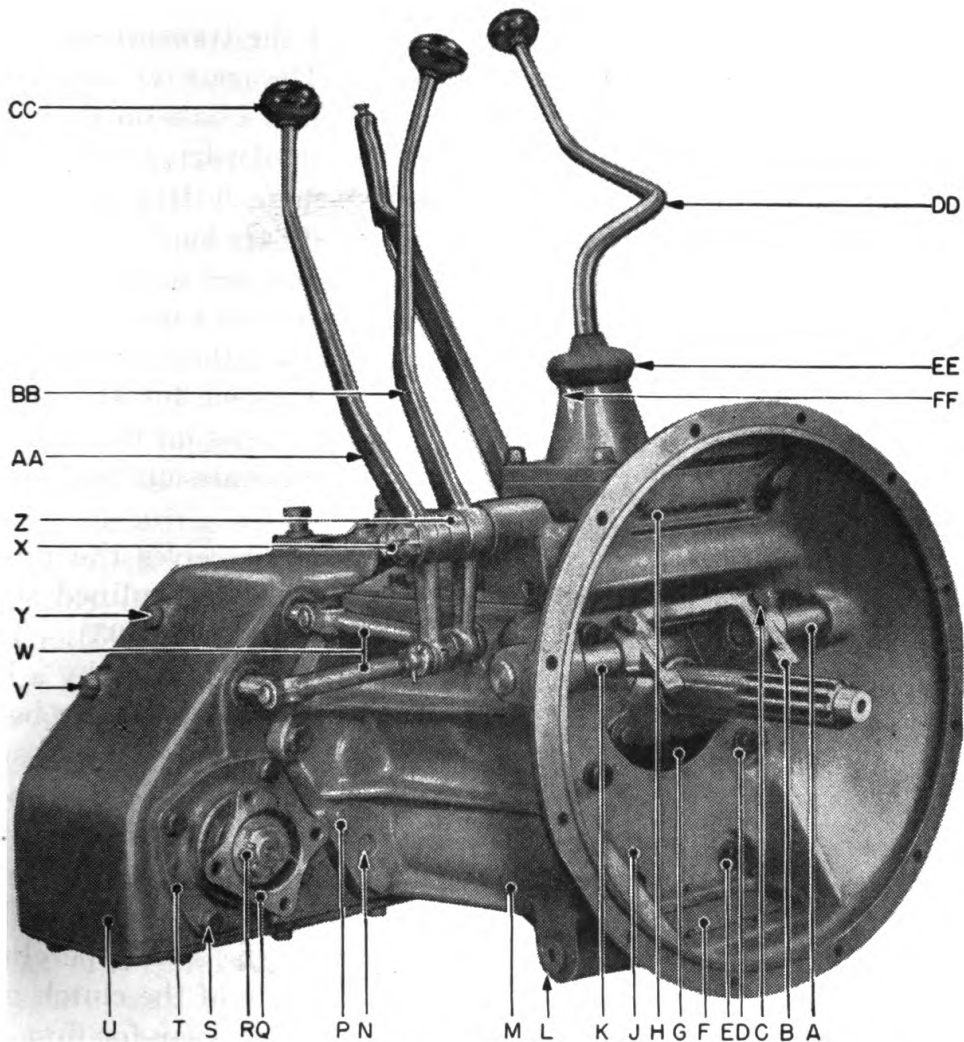

- |   |   |  |
|---|---|--|
| <p><b>A</b> — SHAFT - B184282<br/>KEY - A226033<br/>KEY - BGAX12A</p> <p><b>B</b> — YOKE - B184283</p> <p><b>C</b> — SCREW - A214807<br/>WASHER, LOCK<br/>- BECX1LL</p> <p><b>D</b> — SCREW, CAP - BACX1EE<br/>WASHER, LOCK<br/>- BECX1M</p> <p><b>E</b> — SCREW, CAP - A214866<br/>WASHER, LOCK<br/>- BECX1M</p> <p><b>F</b> — COVER - B184263<br/>GASKET - B184264<br/>SCREW - A214857<br/>WASHER, LOCK<br/>- BECX1H</p> <p><b>G</b> — CAP - B184253<br/>GASKET - B184268<br/>SCREW - A214870<br/>WASHER - A214819<br/>WIRE, LOCKING<br/>- BFWX1B</p> <p><b>H</b> — COVER - B184262<br/>SCREW - A214857<br/>WASHER, LOCK<br/>- BECX1H</p> | <p><b>J</b> — BELL HOUSING - E3820<br/>GASKET - C85625</p> <p><b>K</b> — SHAFT - B184280</p> <p><b>L</b> — PLUG - A214780</p> <p><b>M</b> — CASE - E3818</p> <p><b>N</b> — PIN - A214804<br/>RING - A214805</p> <p><b>P</b> — SCREW - A214858<br/>WASHER, LOCK<br/>- BECX1M</p> <p><b>Q</b> — FLANGE - B184286<br/>GUARD - A214849</p> <p><b>R</b> — NUT - A214932<br/>WASHER - A214861<br/>PIN, COTTER<br/>- BFAX1DM</p> <p><b>S</b> — SCREW, CAP - BCAX1DD<br/>WASHER, LOCK<br/>- BECX1L</p> <p><b>T</b> — CAP - B184244<br/>SEAL, OIL - A214841<br/>GASKET - B184245<br/>CUP - A214964</p> | <p><b>U</b> — CASE - E3821<br/>GASKET - C85627</p> <p><b>V</b> — SCREW - A214967<br/>SPRING - A214835<br/>BALL - A214786</p> <p><b>W</b> — LINK - B184276<br/>PIN - BFFX1F<br/>PIN, COTTER - BFAXICE</p> <p><b>X</b> — SCREW - A214967<br/>SPRING - A214835<br/>BALL - A214786</p> <p><b>Y</b> — SHAFT - B184277<br/>NUT - A214802<br/>WASHER - A214867<br/>PIN, COTTER<br/>- BFAX1DK</p> <p><b>Z</b> — SPACER - A214801</p> <p><b>AA</b> — LEVER - D48159</p> <p><b>BB</b> — LEVER - D48160</p> <p><b>CC</b> — HANDLE - B184279</p> <p><b>DD</b> — LEVER - D48161</p> <p><b>EE</b> — GROMMET - A214806</p> <p><b>FF</b> — PIN - A214803</p> |
|---|---|--|

RA PD 3616A

FIGURE 77.—Transmission assembly, right side.

shaft. The transmission main shift lever is mounted in the shifter housing cover which is set on the top-center of the transmission. A rubber grommet is provided as a dust cover. The transfer case shift levers are mounted on a shaft which is pressed into a boss on the right side of the shifter housing. The direct- and underdrive-shift lever is mounted on the inside and the front drive-shaft shift lever on the outside, with spacer in between. The two levers are kept in place by a slotted nut and cotter pin. The levers are connected to the transfer case shift rods by two double yoke-end links which are mounted with rod end pins and cotter pins at both ends. A breather, mounted on the top-left side of the shifter housing, is provided for the transmission. Two locating dowel pins, seven cap screws on the outside, and two cap screws on the inside, connect the transmission case to the transfer case.

(2) The transmission main drive gear, which receives the power delivered by the engine through the clutch, has a long splined shaft which engages with the splined hub in the clutch (fig. 93). This helical main drive gear is supported in the transmission case by a ball bearing, which is held in place by a snap ring and a cap, the cap being used as a pilot for the bellhousing. The main drive gear has spur type internal clutch teeth for engaging the third and fourth speed clutch gear. The transmission mainshaft is supported in the front by a straight roller bearing set into the recess, or pocket, of the main drive gear, and in the rear by a ball bearing and its retainer. The front end of the mainshaft is splined to receive the spur type clutch gear for third and fourth speeds, with the flat side of the clutch gear toward the front. At the center is an integral spur gear for first and second speeds with a spur type internal tooth clutch collar mounted on it. The spline and thread on the rear end of the shaft are for mounting the transfer case mainshaft drive gear and lock nut. The helical second speed gear is mounted to the front of, and directly against, the integral spur gear, with the external clutch teeth toward the rear. A two-piece thrust washer, with an internal hexagonal shape, and its retaining ring hold the second speed gear in place. A hexagonal groove is cut in the mainshaft to receive the two-piece thrust washer. Against this thrust washer is mounted the helical third speed gear with the internal spur type clutch teeth toward the front. An internally splined thrust washer and a lock ring hold the third speed gear in position. The first speed gear, with its external clutch teeth toward the front, is mounted to the rear of the integral spur gear and is held in place by a thrust washer. The transfer case mainshaft drive gear is mounted on the rear spline of the transmission

mainshaft with the external clutch teeth toward the rear. A special type lock washer and a grooved lock nut hold the gear in place; the lock washer is peened down into the nut in several places. The drive gear, although mounted on the transmission mainshaft and treated as part of the transmission for disassembly purposes, is essentially a part of the transfer case mechanism. The mainshaft first, second, and third speed gears are all provided with oil grooves for self-lubrication as they all ride free on the shaft, but the transfer case mainshaft drive gear is provided with an oil groove to furnish lubrication only for the transfer case mainshaft front bearing. The first, second, third, and fourth speed gears mesh with mating gears on the countershaft.

(3) The transmission countershaft is supported in front by a straight roller bearing and in the rear by a ball bearing (fig. 104). The rear bearing is kept in place by a retaining washer and two cap screws which are locked together with a wire. The countershaft has integrally cut on it a helical gear, which acts as the second speed gear, and a spline which receives the reverse speed spur type clutch gear. To the front of the integral second speed gear, and mounted with Woodruff keys, are the third speed gear, power take-off gear, and fourth speed gear, in the order named. The third and fourth speed gears are helical, while the power take-off gear is of the spur type. The extended hubs on the three gears all project toward the rear. The gears are kept in place by a lock ring. A thrust washer is mounted between the fourth speed gear and the front bearing. The reverse speed clutch gear is mounted on the splined portion of the shaft with the groove for the lower reverse speed shift fork toward the rear. The first speed gear is mounted to the rear of the clutch gear with the external clutch teeth toward the front, and is provided with an oil hole between two of its teeth to provide for self-lubrication. A thrust washer is mounted between the first speed gear and the rear bearing.

(4) The transmission reverse idler gear is mounted on its shaft on the lower left side of the transmission case with two perforated brass thrust washers mounted at either end of the gear (fig. 104). The helical gear portion of the reverse idler gear is toward the rear of the case and is constantly in mesh with the mainshaft first speed gear. The spur gear portion of the reverse idler gear meshes with the countershaft reverse speed clutch gear when the transmission is shifted into reverse speed. The shaft is provided with an oil groove for lubrication of the idler gear bushings and is installed so that the oil groove is in the vertical position.

(5) The transmission shifter mechanism is made up of three shift rods and their component forks, brackets, and interlock balls and springs (figs. 87 and 88). In descending order of length, they are the first and second speed shift rod, the third and fourth speed shift rod, and the reverse speed shift rod. Mounted and locked with set screws onto the first and second speed shift rod are a bracket and a shift fork, with a shoe set in the bracket to receive one end of the relay lever. The bracket is mounted with the shoe arm toward the rear and the fork is placed with the set screw hole toward the front. The bracket is slotted to receive the end of the transmission shift lever. The third and fourth speed shift rod has a fork locked onto it with the fork set screw hole toward the front. A sleeve is provided on this rod to prevent overshifting in third speed. The reverse shift rod has the upper reverse shift fork locked onto it and has a shift bracket at the front. The reverse shift bracket rides free on the rod except when the transmission is shifted into reverse speed, at which time the plunger in the shift bracket presses a ball into a slot into the rod, thereby locking the bracket on the rod. The bracket has a shoe mounted on it, similar to the one on the first and second speed shift bracket, to receive the second end of the relay lever. The rounded bottom end of the upper reverse shift fork fits into a hole in the lower reverse shift fork. The lower fork is mounted on a shaft and the yoke end of the fork engages with the countershaft reverse speed clutch gear. The relay lever is mounted in the housing by a shoulder screw, slotted nut and cotter pin. In the boss, in the center of the housing, directly above the shift rods, are placed three poppet balls and springs. Eight interlock balls, four in the center and four in the rear end of the housing, are provided between the rods to lock in place any of the rods that should not move when the transmission is shifted into any desired speed. Installed on the rear ends of the first and second speed, and third and fourth speed shift rods is an interlock plate whose mounting holes have beveled edges. Three expansion plugs are used to close the shift rod holes at the front end of the housing.

(6) The transfer case is attached to the transmission with the long flat face down, and the inclined face to the right. This sets the shafts in an inclined position relative to each other. The transfer case mainshaft is the uppermost, and is in line with the transmission mainshaft; the intermediate shaft is next, and the front drive shaft is the lowest of the three. A circular flange is mounted on the rear end of the mainshaft to which is attached the rear axle propeller shaft. On the front end of the front drive shaft is mounted a square

flange for attaching the front axle propeller shaft. Both flanges are mounted on splines and are locked in place with washers, slotted nuts, and cotter pins.

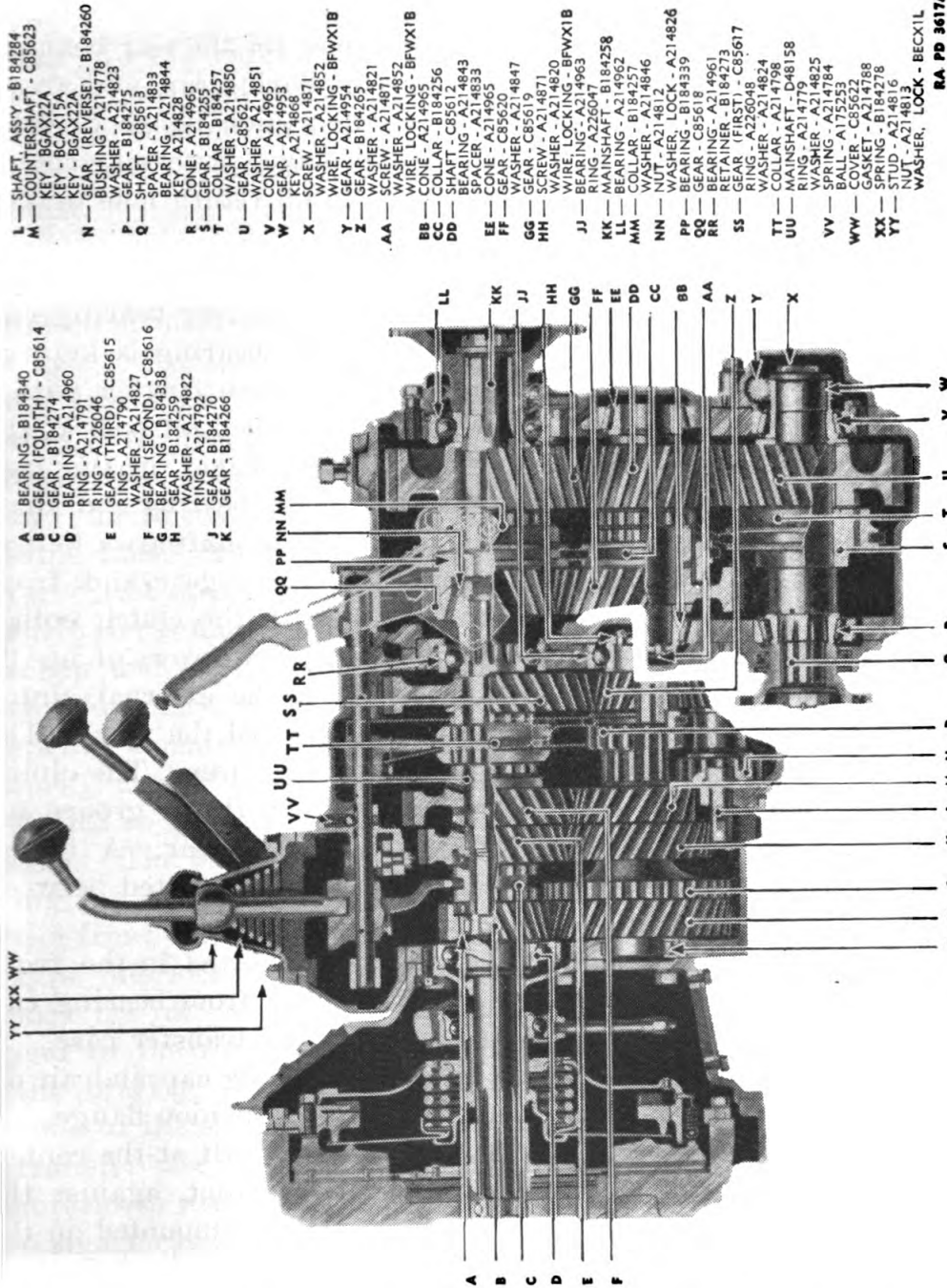

- A — BEARING - B184340
- B — GEAR (FOURTH) - C85614
- C — GEAR - B184274
- D — BEARING - A214960
- E — RING - A214791
- F — RING - THIRD - C85615
- G — RING - A214790
- H — WASHER - A214827
- I — GEAR (SECOND) - C85616
- J — BEARING - B184338
- K — GEAR - B184273
- L — RING - A214792
- M — GEAR - B184270
- N — GEAR - B184266

- L — SHAFT ASSY - B184284
- M — COUNTERSHAFT - C85623
- N — KEY - BGAX22A
- O — KEY - BCAX15A
- P — KEY - BGAX22A
- Q — GEAR (REVERSE) - B184260
- R — BUSHING - A214778
- S — WASHER - A214823
- T — SHAFT - C85613
- U — SPACER - A214833
- V — BEARING - A214844
- W — KEY - A214828
- X — CONE - A214965
- Y — GEAR - B184257
- Z — WASHER - A214850
- AA — WASHER - A214851
- BB — GEAR - A214965
- CC — CONE - A214954
- DD — WIRE LOCKING - BFWX1B
- EE — SCREW - A214871
- FF — WASHER - A214871
- GG — WIRE LOCKING - BFWX1B
- HH — GEAR - B184265
- II — WASHER - A214821
- JJ — WASHER - A214871
- KK — WIRE LOCKING - BFWX1B
- LL — CONE - A214965
- MM — COLLAR - B184256
- NN — SHAFT - C85612
- OO — SPACER - A214843
- PP — BEARING - A214833
- QQ — CONE - A214965
- RR — GEAR - C85620
- SS — WASHER - A214847
- TT — GEAR - C85619
- UU — SCREW - A214871
- VV — WIRE LOCKING - BFWX1B
- WW — WIRE LOCKING - BFWX1B
- XX — BEARING - A214963
- YY — MAINSHAFT - B184258
- ZZ — COLLAR - B184257
- AAA — WASHER - A214846
- BBB — NUT - A214812
- CCC — WASHER LOCK - A214826
- DDD — BEARING - B184339
- EEE — GEAR - C85618
- FFF — BEARING - A214961
- GGG — RETAINER - B184273
- HHH — GEAR - A214968
- III — WASHER - C85617
- JJJ — WASHER - A214824
- KKK — COLLAR - A214798
- LLL — MAINSHAFT - D48158
- MMM — RING - A214779
- NNN — WASHER - A214825
- OOO — BALL - A175284
- PPP — BALL - A175283
- QQQ — COVER - C85622
- RRR — GASKET - A214788
- SSS — SPRING - B184278
- TTT — STUD - A214816
- UUU — NUT - A214813
- VVV — WASHER, LOCK - BECX1L
- RA PD 3617A.

Figure 78.—Transmission assembly, sectionalized.

(7) The transfer case mainshaft is supported in front by a straight roller bearing which is set in the recess of the transfer case mainshaft drive gear, and in the rear by a ball bearing (fig. 121). The mainshaft underdrive gear is mounted on the splined portion of the

Generated on 2016-07-07 11:46 GMT / http://hdl.handle.net/2027/uc1.b3243960 Public Domain, Google-digitized / http://www.hathitrust.org/access\_use#pd-google

shaft against the small tangs on the front end, with the external clutch teeth on the extended hub of the gear toward the front. A clutch collar is installed on the underdrive gear clutch teeth with the groove for the direct- and underdrive-shift fork toward the front. A thrust washer is mounted between the underdrive gear and the rear bearing, and a cap is mounted as a retainer for the rear bearing. A spring type oil seal is installed in the rear bearing cap, and an oil seal guard is mounted on the mainshaft companion flange directly behind the rear bearing cap. The cap is provided with oil grooves so that the bottom oil return groove meets an oil return hole drilled in the rear end of the transfer case.

(8) The transfer case intermediate shaft is supported in the front and rear by taper roller bearings (fig. 117). The rear bearing cup is installed in the rear bearing cap. The front bearing is kept in place by a retainer washer and two cap screws locked together with a wire, the rear bearing by the cap which has a drilled oil hole at the top for lubricating the bearing. Shims are provided on the rear bearing cap for adjustment of the end play of the bearing and shaft after assembly. Integrally cut on the intermediate shaft are a helical gear, which meshes with the mainshaft underdrive gear and front drive shaft gear, and spur teeth to engage with the clutch collar. The intermediate shaft drive gear is mounted on two rows of needle bearings against the integral spur teeth with the external clutch teeth on the extended hub of the drive gear toward the rear. The two rows of needle bearings are separated by a spacer. The clutch collar is mounted on the drive gear clutch teeth with the groove for the direct- and underdrive-shift fork toward the rear. A thrust washer, with its beveled edge toward the front, is mounted between the drive gear and the front bearing.

(9) The transfer case front drive shaft is supported in the front and rear by taper roller bearings (fig. 111). The front bearing cup is installed in a cap, the rear bearing cup in the transfer case. A spring type oil seal is installed in the front bearing cap and an oil seal guard is mounted on the front drive shaft companion flange. A spur type clutch gear is keyed to the front drive shaft at the center, with the extended hub on the gear toward the front, against the adjacent shoulder on the shaft. The clutch collar is mounted on the clutch gear, with the groove for the front drive shaft shift fork toward the front. The front drive shaft gear is mounted on two rows of needle bearings to the rear of the clutch gear, with a thrust washer between. The two rows of needle bearings are separated by a spacer. The external spur type clutch teeth on the extended hub of the gear

are toward the front. The rear bearing is kept in place by a cap which is provided with an oil return hole at the bottom. Shims are provided for adjustment of end play of the shaft and taper roller bearings. The speedometer drive gear is key-mounted on the rear end of the front drive shaft, and is kept in place by a retainer washer and two cap screws locked together with wire. The speedometer driven gear is installed in the front drive shaft rear bearing cap with a bushing and sleeve. The speedometer driven gear is provided with a slot in which is inserted the speedometer flexible drive shaft.

(10) The transfer case shifter mechanism is composed of the direct- and underdrive-shift rod, the front drive shaft shift rod, and the component forks, brackets, interlocks, poppet balls, and spring (figs. 125 and 126). A double yoke type shift fork is mounted on the direct- and underdrive-shift rod and locked with a set screw and wire, with the set screw hole in the fork toward the front of the case. The yokes engage with the grooves on both the mainshaft and intermediate shaft clutch collars, operating them both at the same time. An oil seal is provided in the case at the front end of the direct- and underdrive-shift rod bore. On the front drive shaft shift rod is mounted a bracket and a fork which is locked with a set screw and wire. The bracket guide pin and the set screw hole in the fork face the rear of the case. The bracket guide pin has a spring mounted on it and engages with a hole drilled in the shift fork. A spring type oil seal and a pin-mounted bushing are installed in the case at the front end of the front drive shaft shift rod bore. The bushing has three drilled holes in it, one for the mounting pin and two for the rod type interlocks. Installed in a slot in the front drive shaft shift rod, underneath the bracket, are a rocker type interlock and an interlock ball. One end of the rocker-interlock fits into the rear interlock hole in the bushing, and the other end of the rocker-interlock fits into a groove cut in the inside of the bracket. Two poppet balls and springs, set against the rear ends of the shift rods, are installed from the outer right side of the transfer case and kept in place by screw type plugs. Two rod type interlocks are installed through two holes in the top-front of the transfer case, so that the shorter front drive shaft shift rod interlock is installed in the rear hole, through the three inside bosses of the transfer case, and through the front drive shaft shift rod bushing hole, with the rounded end up and the flat end against the rocker type interlock. The longer first speed shift rod interlock is installed in the front hole with the flat end up, and the rounded end in a

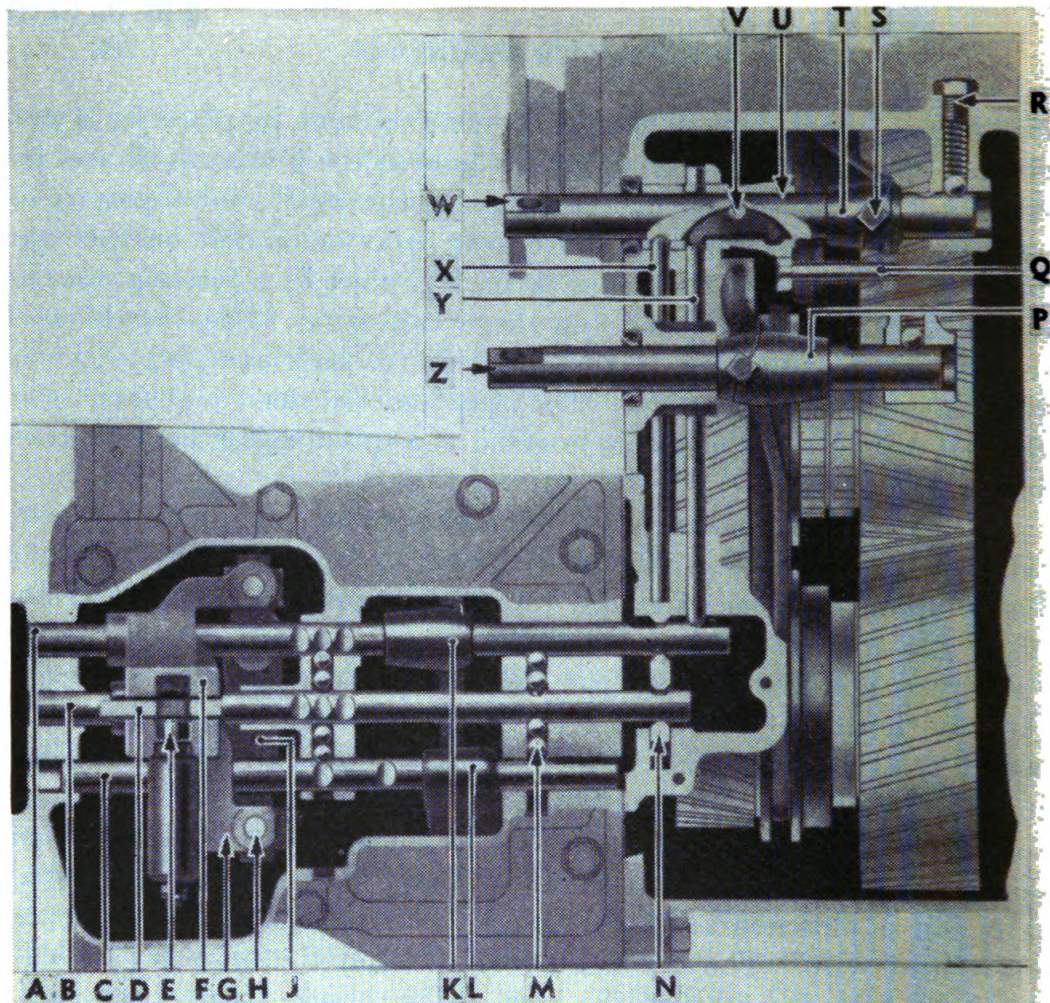

- |                                |                                     |
|--------------------------------|-------------------------------------|
| <b>A</b> — ROD - B184249       | <b>N</b> — PLATE - A214789          |
| <b>B</b> — ROD - B184250       | <b>P</b> — FORK - C85608            |
| <b>C</b> — ROD - B184267       | <b>Q</b> — SPRING - A214834         |
| <b>D</b> — FORK - B184251      | <b>R</b> — { SCREW - A214967        |
| <b>E</b> — { PLUNGER - A214796 | { SPRING - A214835                  |
| { SPRING - A214783             | { BALL - A214786                    |
| { NUT - A214815                | <b>S</b> — { SCREW - A214774        |
| { PIN, COTTER - BFAX1BE        | { WIRE, LOCKING - BFW1B             |
| <b>F</b> — BRACKET - B184272   | <b>T</b> — FORK - C85607            |
| <b>G</b> — BRACKET - B184271   | <b>U</b> — BRACKET, ASS'Y - A214835 |
| <b>H</b> — SHOE - A214809      | <b>V</b> — INTERLOCK - A214831      |
| <b>J</b> — LEVER - B184261     | <b>W</b> — ROD - B184247            |
| <b>K</b> — { FORK - B184252    | <b>X</b> — INTERLOCK - A214830      |
| { SCREW - A214776              | <b>Y</b> — INTERLOCK - A214829      |
| <b>L</b> — { FORK - C85609     | <b>Z</b> — { ROD - A214836          |
| { SCREW - A214776              | { BALL - B184248                    |
| <b>M</b> — BALL - A175253      |                                     |

RA PD 6231

FIGURE 79.—Transmission shifter mechanism, sectionalized.



recess cut in the front drive shaft shift rod. When the transmission and transfer case are assembled, the right side of the interlock plate, which is mounted on the rear end of the transmission shift rods, is against the flat upper end of the first speed shift rod interlock. The flattened end of the first speed shift rod rests against the rounded upper end of the front drive shaft shift rod interlock.

*b. Operation* (figs. 78, 79, 81, and 82).—Power is received by the transmission from the engine, through the clutch, and then through the transmission main drive gear, whose splined shaft engages with the clutch splined hub. Power then flows through the transmission,

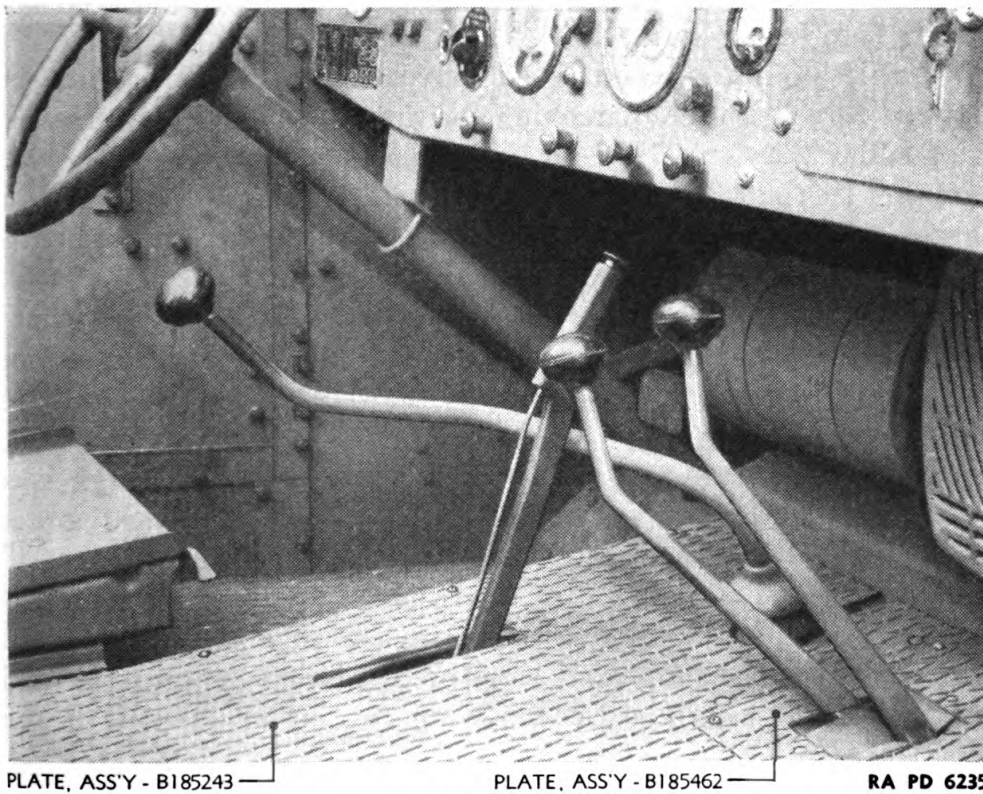

FIGURE 80.—Transmission shift levers and floor plates, installed.

and by means of the transfer case mainshaft drive gear, to the transfer case, and finally to the rear axle propeller shaft and to the front axle propeller shaft (if desired).

(1) All the gears in the transmission rotate at all times during periods of vehicle operation. The first, second, and third speed gears, however, rotate freely on the transmission mainshaft and must be locked to the shaft by means of a clutch gear or collar in order to provide a path of power flow through the unit. The various transmission speeds and gear ratios are selected by locking any one of these three gears, or locking the main drive gear, to the mainshaft.

With none of the gears locked to the mainshaft, the transmission is in the neutral position.

(2) Moving the transmission shift lever to the first speed position moves the lower end of the shift lever to the right, where it engages in the slot provided in the first and second speed shift rod bracket. When the shift lever is moved backward, moving the shift fork on the rod, the first, second, and reverse speed clutch collar is moved to the rear, engaging it with the clutch teeth on the first speed gear. This locks the first speed gear to the mainshaft, and the path of power flow is from the main drive gear, to the countershaft, and then to the mainshaft first speed gear, which drives the mainshaft to which it is locked (fig. 81A).

(3) Shifting into second speed moves the first and second speed shift rod forward, thereby moving the first, second, and reverse speed clutch collar forward. This locks the second speed gear to the mainshaft and the path of power flow is from the main drive gear to the countershaft, to the mainshaft second speed gear, and then out through the mainshaft (fig. 81B).

(4) The shifting sequence into third speed is similar to that of first and second speeds, except that in this case the third and fourth speed shift rod and clutch gear are moved toward the rear (fig. 81C).

(5) When the transmission is shifted into fourth, or high speed, the third and fourth speed clutch gear is moved forward and engages with the internal clutch teeth in the main drive gear. The path of power flow is now directly from the main drive gear to the mainshaft, without passing through the countershaft. The countershaft continues to rotate and so provides lubrication to the mainshaft gears and bearings by splashing the oil upward as it turns (fig. 81D).

(6) When the transmission is shifted into reverse speed, the lower end of the shift lever depresses the lock plunger and lock spring in the reverse speed shift rod bracket. This forces the ball in the bracket into a recess cut in the reverse speed shift rod and locks the bracket to the rod. If the bracket were locked at all times, the reverse speed shift rod would be moved also when shifting into first and second speeds, since the shift brackets are connected by a relay lever. Shifting into reverse speed moves the reverse speed shift rod forward, together with the upper reverse shift fork which is locked to the rod. The lower reverse shift fork, moved by the upper fork, slides forward on its shaft and pushes the countershaft reverse speed clutch gear forward, engaging it with the spur gear

POWER TRAIN

portion of the reverse idler gear. By means of the relay lever, which pivots about its mounting screw, the first and second speed shift rod bracket and shift rod are moved toward the rear, thereby shifting into first speed. Thus, the shift into reverse speed automati-

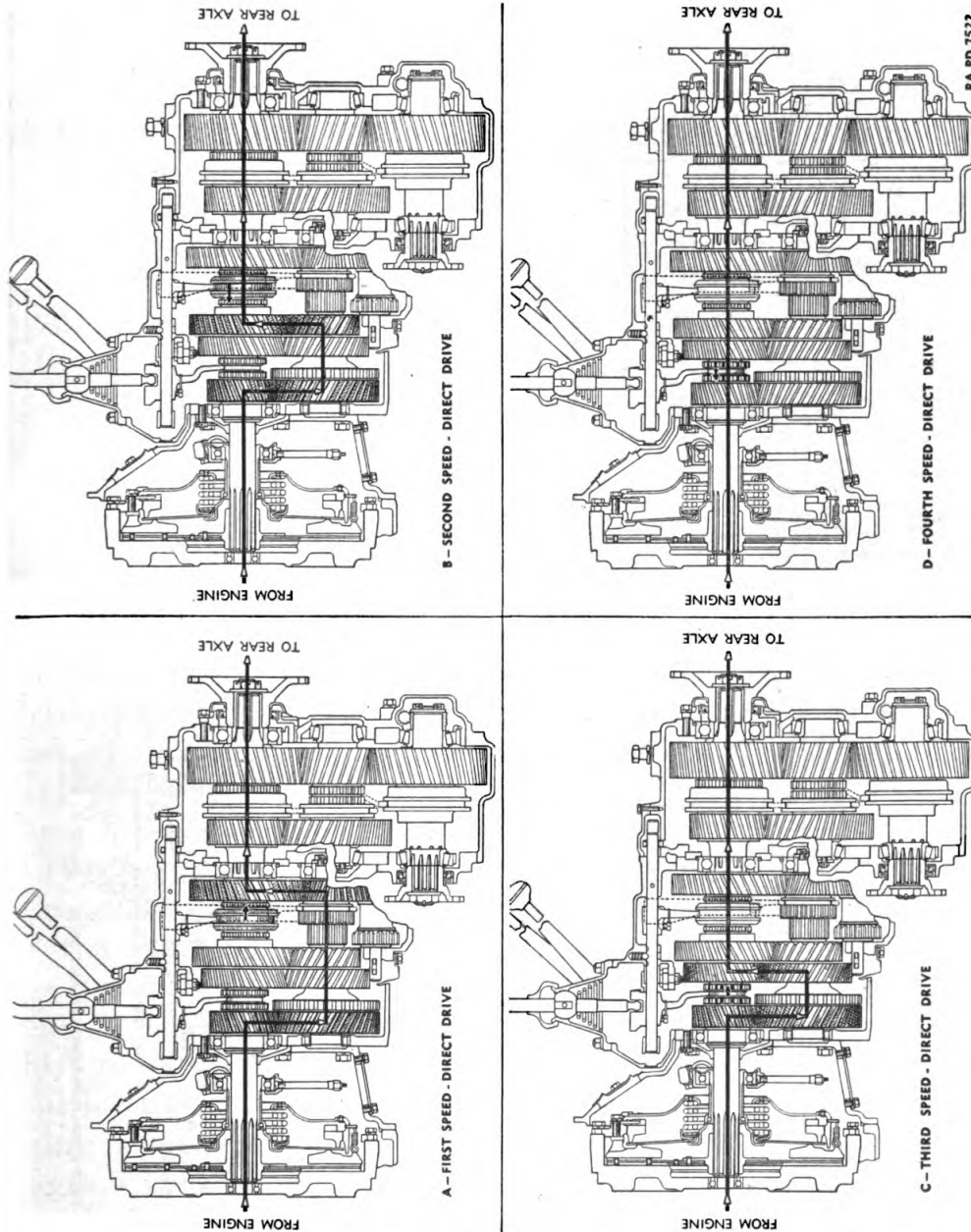

FIGURE 81.—Transmission-transfer case power flow.

cally shifts the transmission into first speed as well. The flow of power is therefore from the main drive gear, to the countershaft, to the countershaft reverse speed clutch gear, to the spur gear portion of the reverse idler gear, to the helical gear portion of the reverse idler gear, to the mainshaft first speed gear (in constant mesh with

helical portion of reverse idler gear), to the mainshaft, and then to the transfer case (fig. 82E).

(7) The poppet balls above the shift rods fit into recesses cut in the rods and prevent the rods from moving except when they are

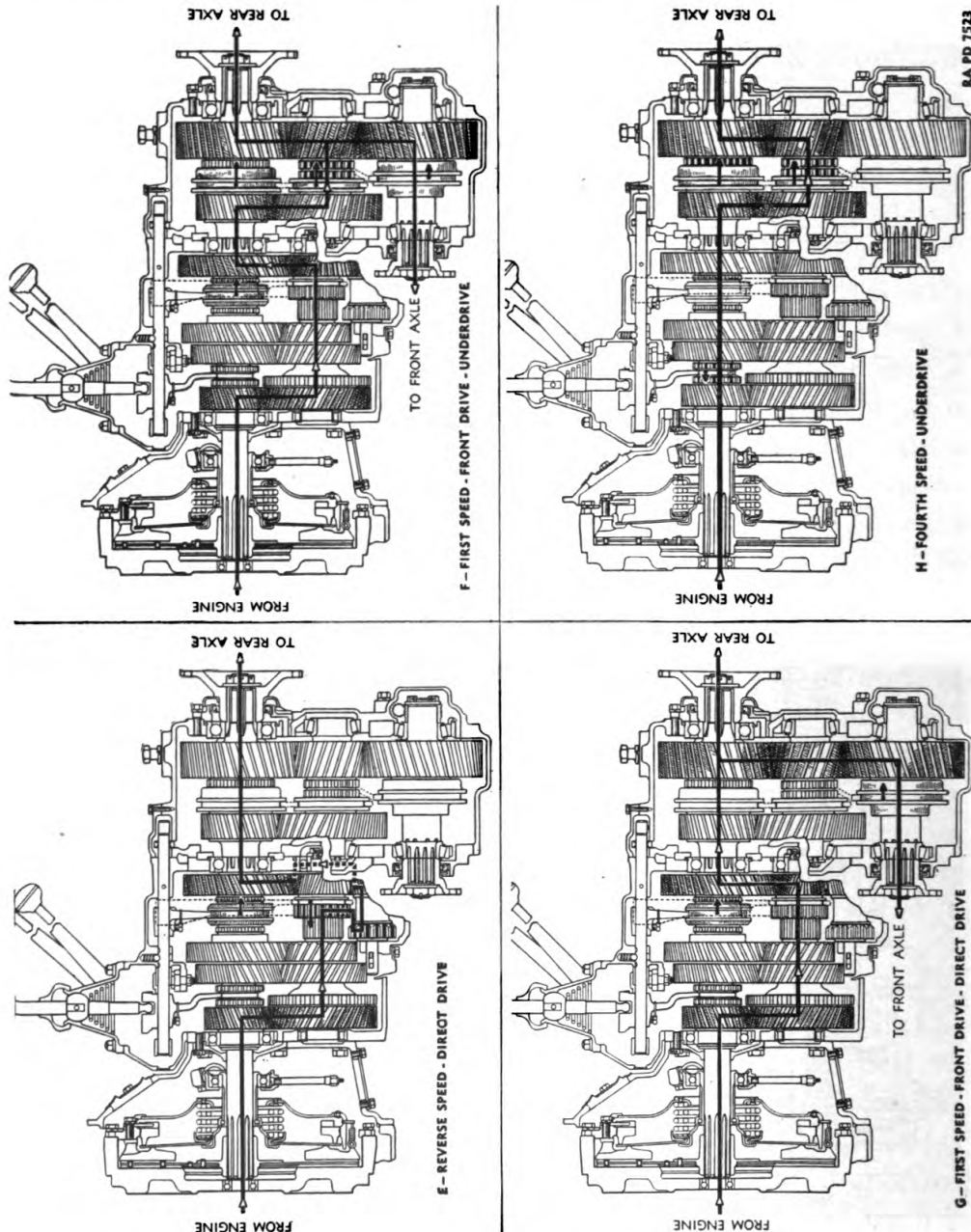

FIGURE 82.---Transmission-transfer case power flow.

manually shifted by the operator. When shifting, the poppet springs are depressed and the balls slip from one recess to another as required. The eight interlock balls between the shift rods lock either one, or two, of the three shift rods in their neutral position

when the third of the shift rods is being moved to engage the desired speed gears (fig. 79). When the first and second speed shift rod is moved, the two right-forward interlock balls are forced out of the recess in the first and second speed shift rod into the recess in the third and fourth speed shift rod, thereby locking the latter in position. The two right-rear interlock balls are forced out of the recess in the shift rod in the same manner and likewise lock the third and fourth speed shift rod. The interlock pin in the third and fourth speed shift rod is forced against the two left-rear interlock balls which lock the reverse speed shift rod. Moving the third and fourth speed shift rod forces all eight balls out of the recesses in this rod and all eight act to lock the other two shift rods. Moving the reverse speed shift rod forces the two left-forward interlock balls against the third and fourth speed shift rod and they lock it. The left-rear balls are forced out of the recess in the reverse speed shift rod but drop onto the flattened end of the rod and therefore do not act to lock either of the other two shift rods. If the end of the reverse shift rod were not flattened, the interlock balls, by means of the interlock pin, would lock the first and second speed shift rod; and the automatic shift into first speed required when shifting into reverse would be prevented.

(8) As in the transmission, all the transfer case gears rotate at all times during vehicle operation. The intermediate shaft underdrive gear and the front drive shaft gear are needle bearing mounted and rotate freely on their respective shafts. It is therefore necessary to lock them to their shafts whenever it is desired to include them in the path of power flow through the transfer case.

(9) The shift into either direct drive (high) or underdrive (low) through the transfer case is accomplished by means of the left one of the two shift levers mounted on the shaft on the right side of the transmission shifter housing. Moving the shift lever to the rear, to shift into direct drive, moves the direct- and underdrive-shift rod and double yoke fork forward. This moves the mainshaft and intermediate shaft clutch collars forward (the double yoke fork being mounted on both collars). The mainshaft clutch collar engages with the clutch teeth on the transfer case mainshaft drive gear and locks the mainshaft drive gear to the mainshaft. The flow of power through the transfer case is directly to the mainshaft and out to the rear axle propeller shaft. Moving the shift lever forward to shift into underdrive moves the clutch collars to the rear, disengaging the mainshaft clutch collar from the drive gear, and locking the intermediate shaft underdrive gear to the intermediate shaft

by means of its clutch collar. The path of power flow is therefore from the main drive gear, to the intermediate shaft underdrive gear, to the intermediate shaft, to the mainshaft underdrive gear, and then to the mainshaft.

(10) The shift into or out of front drive is performed by moving the right-hand lever, and thereby moving the front drive shaft clutch collar into or out of engagement with the front drive shaft gear. Moving the shift lever forward moves the shift rod and yoke, as well as the clutch collar, to the rear and engages the clutch collar with the clutch teeth on the gear. This locks the gear to the shaft and the front drive is engaged. The flow of power is from the integral gear on the intermediate shaft (which always has power available since it is either giving to, or receiving power from, the mainshaft underdrive gear), to the front drive shaft gear, and then to the shaft. Moving the shift lever to the rear disengages the clutch collar from the front drive shaft gear and thereby disengages the front drive (fig. 82F, G, and H).

(11) A system of interlocks is provided in the transfer case and transmission (fig. 79). These interlocks are so arranged that *front drive must be used* in first and reverse speeds with the transfer case in underdrive; *front drive may be used* in first and reverse speeds with the transfer case in direct drive; and *front drive cannot be used* with second, third, and fourth speeds. The projecting lug on the right side of the direct and underdrive double yoke shift fork meets a similar lug on the front drive shift rod bracket (to which the bracket guide pin is attached), when the direct- and underdrive-shift rod and fork are moved toward the rear to shift the transfer case into the underdrive position. With the transmission shifted into neutral or any speed other than first or reverse, the front drive shaft shift rod bracket is free to slide on its shift rod, and it is pushed toward the rear by the underdrive shift fork when the transfer case is shifted into underdrive. With the front drive disengaged (front drive shift rod in forward position), and the transmission shifted into either first or reverse speed, the first speed shift rod interlock is forced down against the front end of the rocker-interlock on the front drive shaft shift rod. The rocker-interlock pivots on the interlock ball and the rear end of the rocker-interlock is forced into a slot in the front drive shaft shift rod bracket, thereby locking the bracket to the shift rod and preventing its sliding along the rod. Thus, with front drive out and the transmission in first or reverse speed, the transfer case cannot be shifted into underdrive because the lug on the fork would strike the lug on the front drive shaft shift rod bracket and would be

prevented from moving further toward underdrive engagement, since the bracket cannot slip along the rod when in its locked position. Therefore, in order to shift into underdrive, with the transmission in first or reverse, the front drive must first be engaged in order to allow the underdrive shift rod to be moved toward the rear; and conversely, front drive *must* be engaged if the transfer case is in underdrive in order to be able to shift the transmission into first or reverse speeds. The reason for the latter is the following: If the transfer case were in underdrive and the front drive out, the front drive shaft shift rod bracket would be moved over far enough toward the rear by the direct and underdrive shift fork to prevent the rear end of the rocker-interlock from slipping into the slot in the bracket, preventing its pivoting, preventing the first speed shift rod interlock from moving down, and thereby preventing the first speed shift rod from moving toward the rear for first and reverse speed engagement. If the transfer case were in direct drive, the transmission could be shifted into first speed regardless of whether the front drive is in or out. The front drive shaft shift rod bracket would be in position to receive the rear end of the rocker-interlock, enabling the first speed shift rod to be moved to the rear. Therefore, front drive *may* be used in first and reverse with the transfer case in direct drive. The first speed shift rod interlock is not affected by shifting the transmission into second, third, or fourth speeds. Therefore, the transfer case can be shifted into underdrive with the transmission in these speeds without engaging the front drive.

(12) When the front drive shaft shift rod is moved toward the rear and front drive engaged, the shift rod interlock, whose lower rounded end sets into a recess into the shift rod, is forced out of the recess, being pushed upward. The upper flat end of the interlock pushes the interlock plate to the left. This interlock plate, which is installed on the ends of the transmission shift rods, has two holes cut into it with the hole edges beveled. The first and second and third and fourth speed shift rods can slide through the interlock plate when it is in its normal position (front drive disengaged). When the front drive is engaged and the plate is forced to the left by the interlock, the beveled edges of the holes in the plate limit the movement of the transmission shift rods. The third and fourth speed shift rod is completely prevented from moving because the slot cut in the rod exactly fits onto the interlock plate, thereby preventing use of these speeds with front drive. The first and second speed shift rod can move only toward the rear for first and reverse speed engagement, because the slot in the rod that fits over the interlock plate is cut to allow only this

movement. Thus, only first and reverse speeds can be used with front drive. Second, third, and fourth speeds *cannot* be used with front drive.

*c. Specifications.*

Make	Manufacturer's number	Ordnance number	White	Autocar	Diamond T
Spicer.....	SP-3641	E-3806	376162	3W71600	N1521

Type.....Combination transmission-transfer case  
 Mounting.....Unit power plant

GEAR RATIOS

Transmission	Direct drive	Underdrive
First speed.....	4. 92:1	12. 20:1
Second speed.....	2. 60:1	6. 44:1
Third speed.....	1. 74:1	4. 31:1
Fourth speed.....	1. 00:1	2. 48:1
Reverse speed.....	4. 37:1	10. 83:1

(1) *Transmission.*

Type.....Constant mesh.  
 Speeds.....Four forward, one reverse.

Bearings:	Number	Type
Main drive gear.....	A214960, MRC-211MFG, ND-47211.....	Ball
Mainshaft front pilot..	B184340, Hyatt-4-1206-TM	Roller
Mainshaft rear.....	A214961, MRC-308MG, ND-41308.....	Ball
Countershaft front....	B184338, Bower-S-1207, Hyatt-1207-TS.....	Roller
Countershaft rear....	A214963, MRC-307MFG, ND-47307.....	Ball
Reverse idler gear.....	A214778, SP-22-24-18.....	Bushings

(2) *Transfer case.*

Type.....Direct and underdrive, front axle declutching

Gear ratio:

Direct or high.....	1.00:1
Underdrive or low.....	2.48:1



Bearings:	<i>Number</i>	<i>Type</i>
Mainshaft front pocket	B184339, Hyatt-4-1306TM	Roller
Mainshaft rear	A214962, MRC-309MG, ND-41309	Ball
Intermediate shaft and front drive shaft, front and rear	A214965, TIM-25577	Taper roller Cone and rollers
	A214964, TIM-25520	Cup
Intermediate shaft underdrive gear	A214843, SP-22-4821	Needle
Front drive shaft gear	A214844, SP-98-776	Needle

**33. Trouble shooting.**

<i>Symptoms and probable cause</i>	<i>Probable remedy</i>
<i>a. Noise.</i>	
(1) Stripped gears.	(1) Replace gears.
(2) Worn bearings.	(2) Replace bearings or needles.
(3) Worn gear teeth.	(3) Replace gears.
(4) Worn clutch teeth.	(4) Replace clutch gear or collar.
(5) Worn shaft splines.	(5) Replace shaft.
(6) Insufficient lubrication.	(6) Fill to proper level.
(7) Improper lubrication.	(7) Drain and replace with proper lubricant. (See fig. 2①.)
(8) Installation out of line.	(8) Adjust so that transmission is in line with engine, and transfer case is in line with transmission.

**NOTE.**—Noises which seem to come from the transmission may actually originate in some other part of the chassis; therefore, before any mechanical work is performed on the transmission, a thorough check should be made. Check in particular the universal joints of the propeller shafts, which may have worn bearings or journals that may cause noise. The propeller shafts may also be out of alinement or out of balance.

*b. Lubricant leaks.*

(1) Worn oil seals in transfer case bearing caps.	(1) Replace seals.
(2) Worn gaskets.	(2) Replace gaskets.

*c. Transmission slipping out of gear.*

- |                                   |                                       |
|-----------------------------------|---------------------------------------|
| (1) Weakened poppet springs.      | (1) Replace springs.                  |
| (2) Gears only partially engaged. | (2) Fully engage gears when shifting. |
| (3) Worn gears.                   | (3) Replace gears.                    |
| (4) Worn bearings.                | (4) Replace bearings or needles.      |

*d. Difficulty in shifting.*

- |   |                               |
|---|-------------------------------|
| (1) Sticking or dragging engine clutch.             | (1) Repair or replace clutch. |
| (2) Burred transmission shifting clutch gear teeth. | (2) Replace gears or collars. |
| (3) Worn bearings.                                  | (3) Replace bearings.         |

*e. End play in shafts.*

- |  |  |
|--|--|
| (1) Worn bearings.                             | (1) Replace bearings.                      |
| (2) Tapered roller bearings out of adjustment. | (2) Adjust by replacing or removing shims. |
| (3) Worn thrust washers.                       | (3) Replace washers.                       |

**34. Removal of assembly** (figs. 83 and 84).—Tools:  $\frac{5}{8}$ -inch open end wrench,  $\frac{5}{8}$ -inch socket wrench,  $\frac{9}{16}$ -inch open end wrench,  $\frac{9}{16}$ -inch socket wrench, pliers,  $\frac{7}{8}$ -inch open end wrench, large pail, screw driver, jack, brass drift, hammer,  $\frac{3}{4}$ -inch socket wrench, 1-inch rope,  $\frac{7}{8}$ -inch socket wrench, chain block and hook,  $\frac{5}{16}$ -inch open end wrench, 1-inch socket wrench.

*a.* Drain transmission and transfer case— $\frac{7}{8}$ -inch open end wrench. large pail. Remove two drain plugs from bottom of transmission and transfer case and drain lubricating oil into pail.

*b.* Remove tunnel floor plates over transmission—screw driver. Remove 11 screws (A215607) holding tunnel plate (B185243), and three screws (BCOX1.1AF) holding transfer case shift lever floor plate (B185462), and remove plates (fig. 80).

*c.* Disconnect speedometer cable—pliers,  $\frac{9}{16}$ -inch socket wrench,  $\frac{9}{16}$ -inch open end wrench. Remove round coupling nut holding speedometer drive shaft (A214905) to transfer case front drive shaft rear bearing cap (fig. 83). Remove two cap screws (BCAX1CC) which secure speedometer cable clips (A214906) to transmission, and remove clips.

*d.* Disconnect propeller shafts and remove drive-shaft parking brake disk. Proceed as outlined in steps in paragraph 27*a* and *b*.

*e.* Disconnect front-drive shift and underdrive-shift lever links—pliers, brass drift, hammer. Remove two cotter pins (BFA X1CE) from shifting link rod end pins (BFFX1F) (at the transfer case

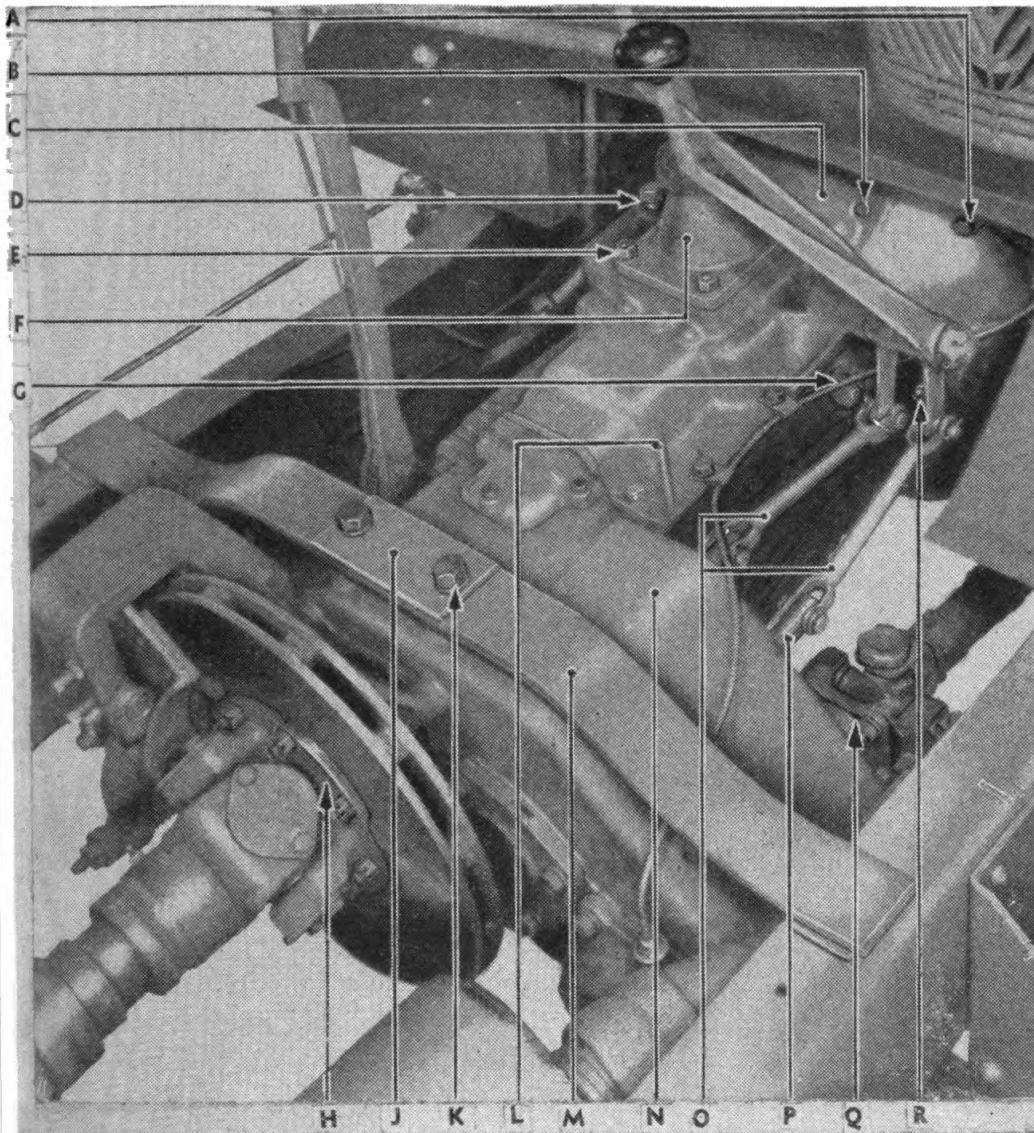

- |  |  |
|--|--|
| A — BOLT - BANX1CD<br>WASHER, LOCK - BECX1K  | J — PLATE - B184133  |
| B — SCREW - A214857<br>WASHER, LOCK - BECX1H   | K — SCREW - A214810<br>WASHER, LOCK - BECX1P               |
| C — COVER - B184262  | L — HOUSING - E3819  |
| D — HEAD, BREATHER - A214793<br>STEM - A214794<br>CORK - A214795<br>PIN, COTTER - BFX1CG | M — SPRING - C85535  |
| E — STUD - A214816<br>NUT - A214813<br>WASHER, LOCK - BECX1L                             | N — CASE - E3821   |
| F — COVER - C85622<br>GASKET - A214788   | O — LINK - B184276<br>PIN - BFFX1F<br>PIN, COTTER - BFX1CE |
| G — SHAFT, ASS'Y - A214905   | P — ROD - B184247  |
| H — FLANGE - B184285<br>GUARD - A214848  | Q — FLANGE - B184286<br>GUARD - A214849                    |
|  | R — FITTING - CLDX5M                                       |

RA PD 3614A

FIGURE 83.—Transmission assembly, installed.

shift rod end) and remove rod end pins (fig. 77). This will allow shifting levers to lie flat to facilitate removal of assembly.

*f.* Remove hand brake lever assembly—pliers, brass drift, hammer,  $\frac{1}{16}$ -inch socket wrench. Remove cotter pin (BFA1DF) and rod end pin (BFFX1F) securing brake pull rod (A214650) to brake lever. Remove two cap screws (BCBX1CC) and lock washers (BECX1K) holding hand brake lever quadrant (B184296) to transfer case (fig. 76). Remove hand brake lever assembly (D48163).

*g.* Remove frame tie cross-member below transmission— $\frac{3}{4}$ -inch socket wrench. Remove four nuts (BBBX1E), cap screws (BCBX1ED), and lock washers (BECX1M) holding cross-member (C86007) to frame, and lower to floor.

*h.* Remove transmission shifter housing cover and shift lever— $\frac{1}{16}$ -inch socket wrench. Remove four nuts (A214813) and lock washers (BECX1L) from studs (A214816) in shifter housing, and remove cover (C85622) and gasket (A214788, fig. 78).

*i.* Mount sling around transmission—1-inch rope, chain block and hook. Put rope around and under transmission, making certain that assembly will be balanced in sling during removal in order to prevent injury to splined shaft (fig. 84).

*j.* Disconnect clutch release shaft lever from clutch linkage—pliers, brass drift, hammer. Remove cotter pin (BFA1DF) and rod end pin (BFFX1F) holding release shaft lever (C85514) to relay shaft lever (B167740).

*k.* Disconnect transmission support spring and spring pressure plate— $\frac{7}{8}$ -inch socket wrench. Remove two cap screws (A214810) and lock washers (BECX1P) holding support spring (C85535) and pressure plate (B184133) to transmission (fig. 83).

*l.* Lower rear end of engine—jack,  $\frac{5}{16}$ -inch open end wrench, 1-inch socket wrench, pliers. Jack up engine beneath the flywheel housing. Remove two cotter pins (BFA1DH) from slotted nuts (BBFX1E) on engine rear support bolts (A214333). Remove nuts and bolts and remove washer (A214890), insulator (B184435), insulator retainer (A214308), insulator seal (A214309), and plain washer (BEBX1CP) from both engine rear supports. Slowly lower rear end of engine onto frame brackets, lowering transmission at same time. (Rear end of engine is lowered in order to lower transmission a sufficient amount, before removing mounting screws, to allow it to be withdrawn far enough toward the rear to release spline shaft from the clutch. If engine and transmission were not lowered, the transmission housing would not clear the exhaust muffler when the transmission is withdrawn.)

POWER TRAIN

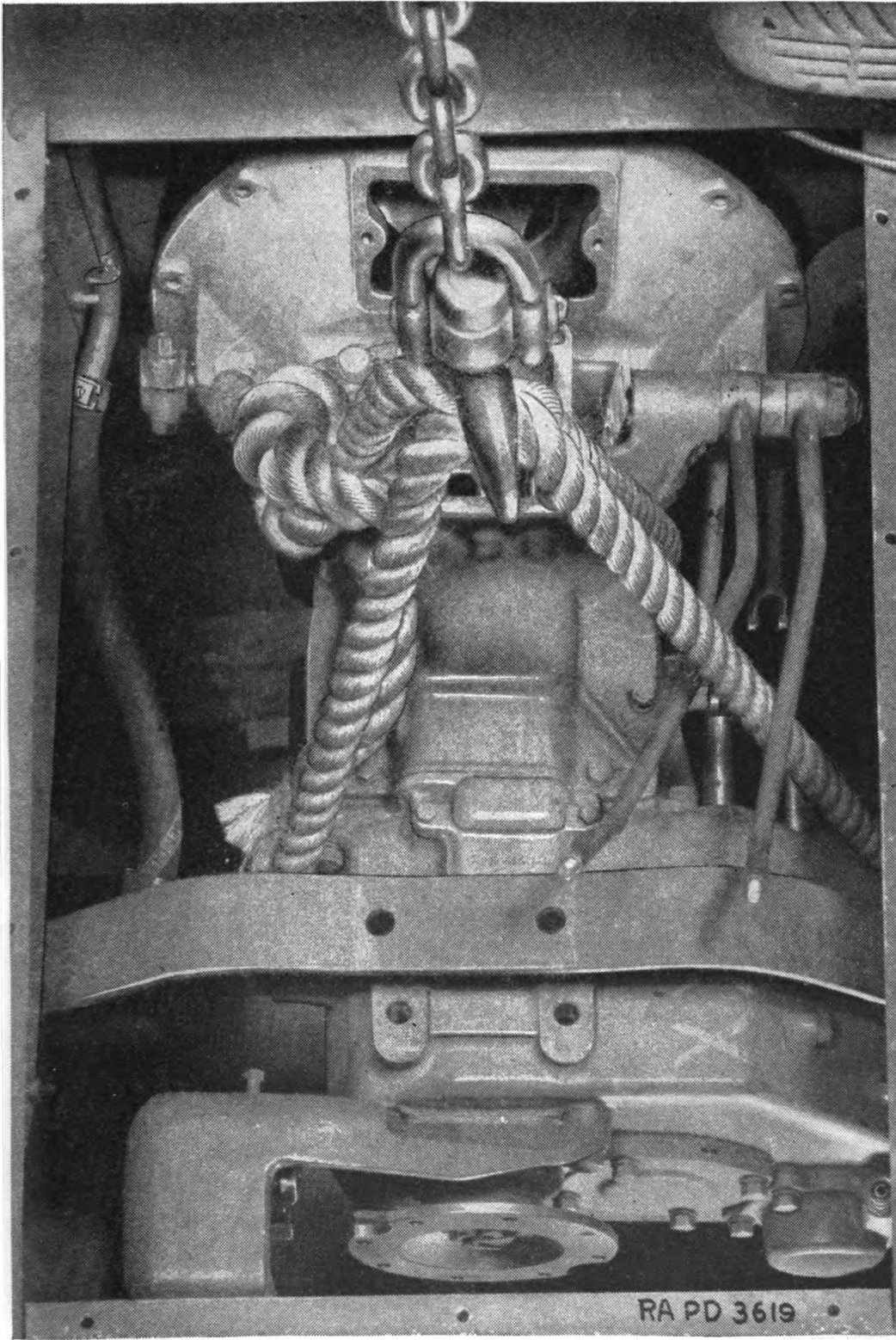

FIGURE 84.—Transmission assembly removal.

*m.* Disconnect transmission bellhousing from engine flywheel housing— $\frac{9}{16}$ -inch socket wrench. Remove 12 cap screws (BCAX1CD) and lock washers (BECX1K) holding bellhousing to flywheel housing.

*n.* Remove transmission. Using sling as a support, slowly push transmission toward rear, rocking it slightly as it is withdrawn, until spline shaft is free from clutch. Be sure to keep transmission in line while removing in order to prevent injury to spline. Lower assembly to floor.

**35. Disassembly of components.**—*a. Shifter housing cover assembly.*—Tools:  $\frac{9}{16}$ -inch socket wrench, pliers.

(1) Remove shifter housing cover from transmission. Proceed as outlined in step in paragraph 34*h*.

(2) Remove transmission shift lever support spring from cover—pliers. Gripping wire at bottom end, twist to release spring (B184278) from holding lug in cover (C85622), and remove spring (fig. 86).

(3) Remove transmission main shift lever—pliers. Remove shift lever (D48161) by sliding through cover, and then remove two steady pins (A214803) from cover. Slide rubber grommet (A214806) off lever (fig. 86).

*b. Shifter housing assembly.*—Tools:  $1\frac{3}{8}$ -inch open end wrench, pliers, punch, hammer,  $\frac{9}{16}$ -inch socket wrench,  $\frac{9}{16}$ -inch open end wrench, cutting pliers,  $\frac{3}{8}$ -inch square socket wrench,  $\frac{5}{8}$ -inch box wrench, long screw driver (or rod).

(1) Remove underdrive-shift and front-drive shift levers— $1\frac{3}{8}$ -inch open end wrench, pliers, punch. Remove cotter pin (BFAX1DK), lever retaining nut (A214802), and washers (A214867), and remove underdrive-shift lever (D48160) and front-drive shift lever (D48159) from shift-lever shaft (B184277) (fig. 77). Screw off shift lever handles (B184279).

(2) Remove shift lever double yoke links—pliers, hammer. Remove cotter pins (BFAX1CE), drive out rod end pins (BFAX1F), and remove shifting links (B184276) from the shift levers (fig. 77).

(3) Remove transmission breather—pliers. Remove cotter pin (BFAX1CG), breather head (A214793), breather cork (A214795), and stem (A214794) (fig. 76).

**NOTE.**—Steps (1) to (3) need not be performed unless it is necessary to replace or repair units removed.

(4) Remove shifter housing from transmission— $\frac{9}{16}$ -inch socket wrench,  $\frac{9}{16}$ -inch open end wrench. Remove seven cap screws (BCAX1CC) and lock washers (BECX1K) holding shifter housing (E3819) to transmission (fig. 76). Remove housing, interlock plate

(A214789), first and second and third and fourth speed shift rods ring gasket (B184287), and shifter housing gasket (C85624) (figs. 85, 86, and 87).

(5) Remove locking wires—cutting pliers. Cut locking wires on shift fork and bracket set screws (fig. 87).

(6) Remove first and second speed shift rod— $\frac{3}{8}$ -inch square socket wrench. Remove set screws (A214776) that hold first and second speed

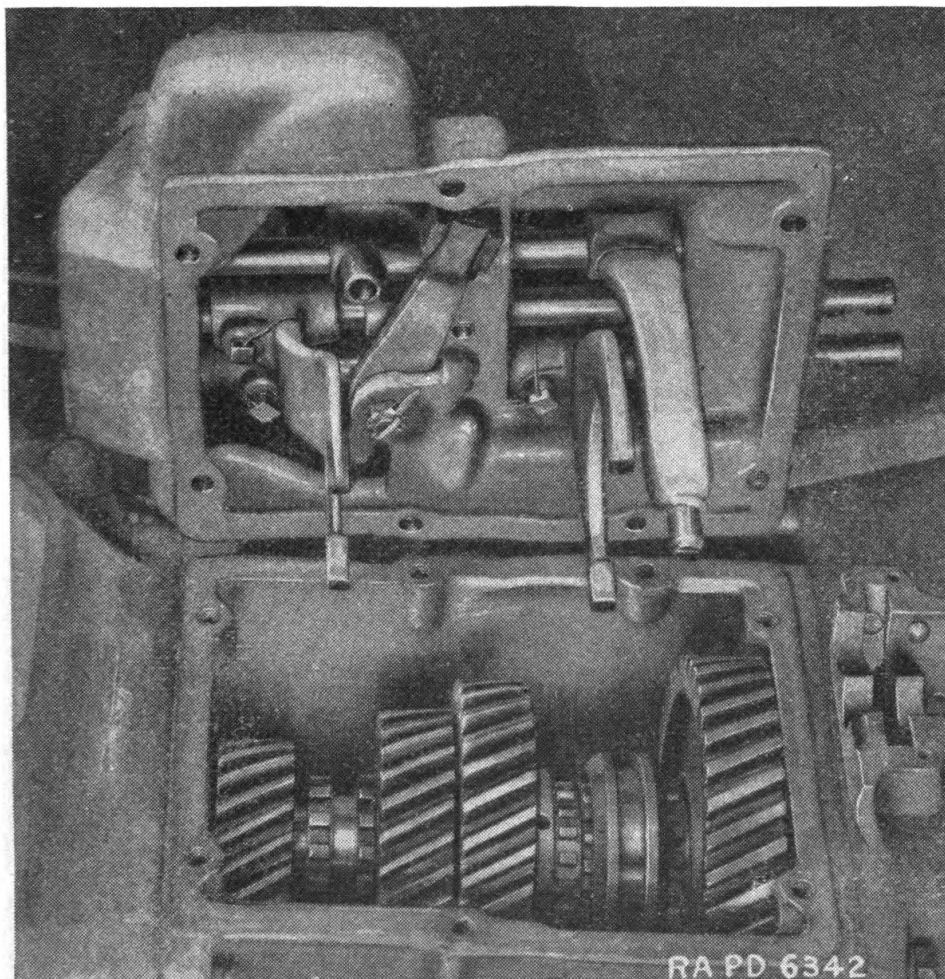

FIGURE 85.—Transmission shifter mechanism removal.

shift fork (B184252) and shift rod bracket (B184272) to shift rod (fig. 88). Pull shift rod (B184249) through rear end of housing and remove fork, bracket, and bracket and relay shoe (A214809) (fig. 89). Tip housing and remove one poppet ball (A175253), one poppet spring (A214784), and four interlock balls (A175253) (fig. 88).

(7) Remove third and fourth speed shift rod— $\frac{3}{8}$ -inch square socket wrench. Remove set screw holding third and fourth speed shift fork (B184251) to shift rod (fig. 88). Pull out shift rod (B184250) and

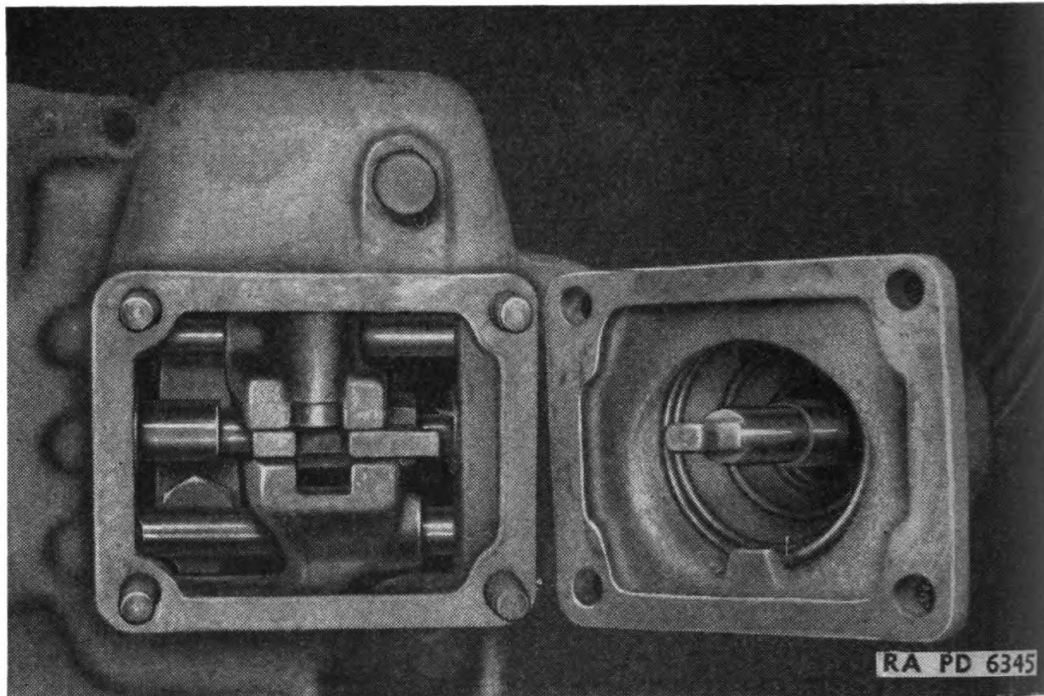

FIGURE 86.—Transmission shifter mechanism, top view.

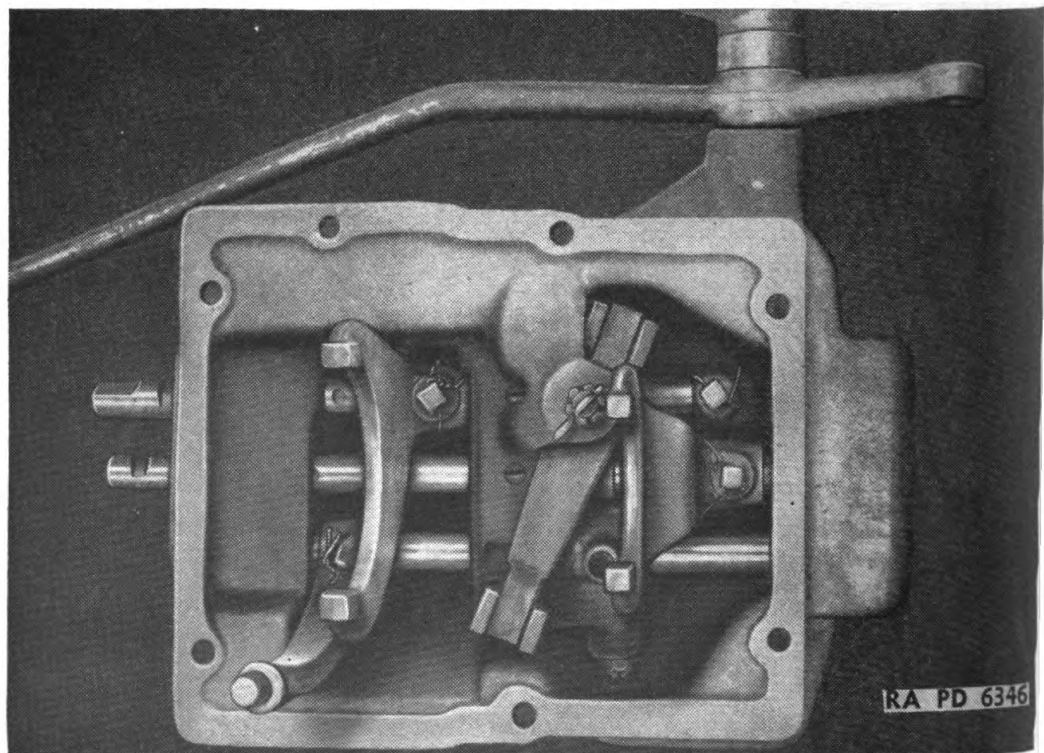

FIGURE 87.—Transmission shifter mechanism, bottom view.



POWER TRAIN

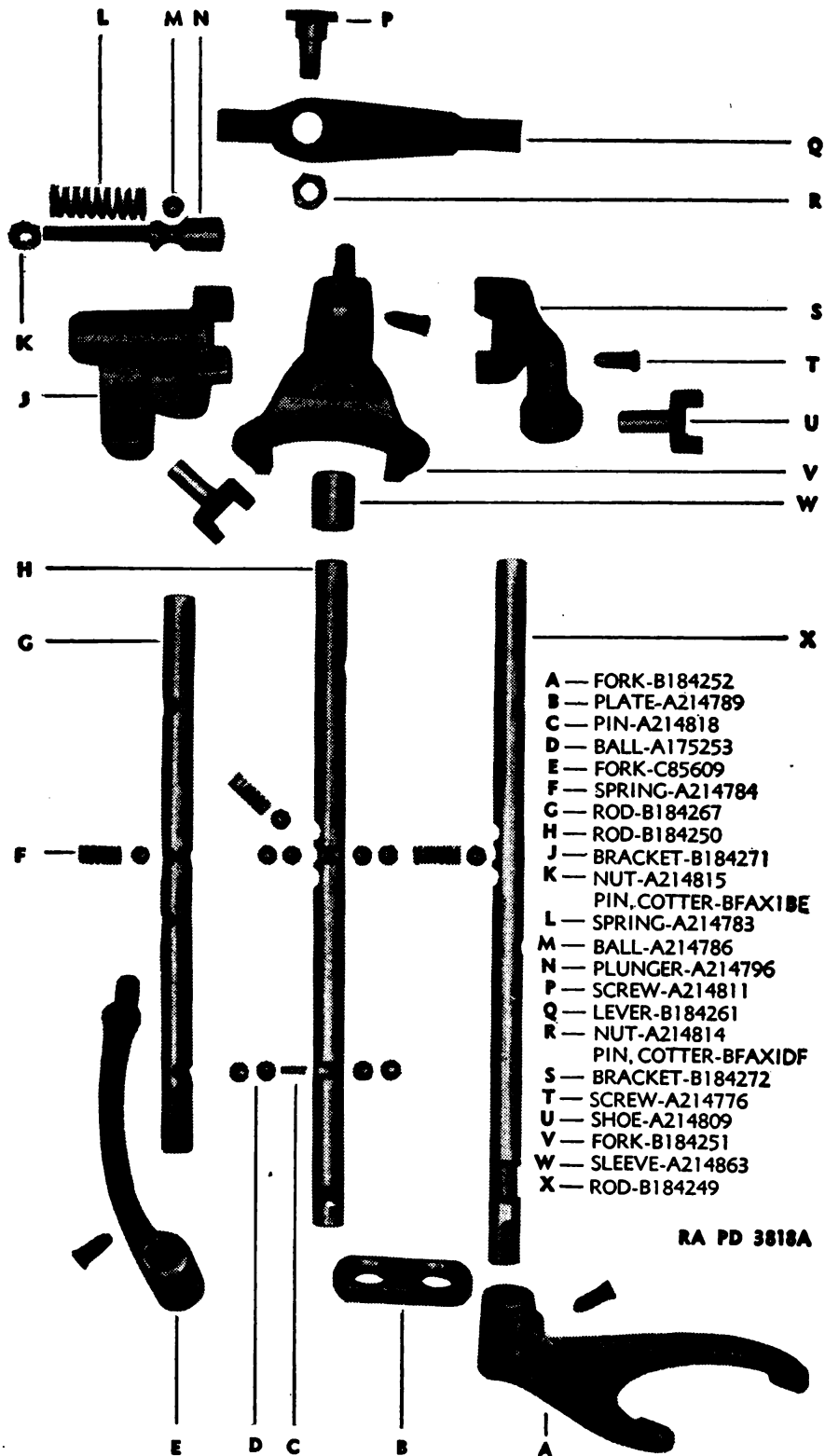

FIGURE 88.—Transmission shifter mechanism, exploded.

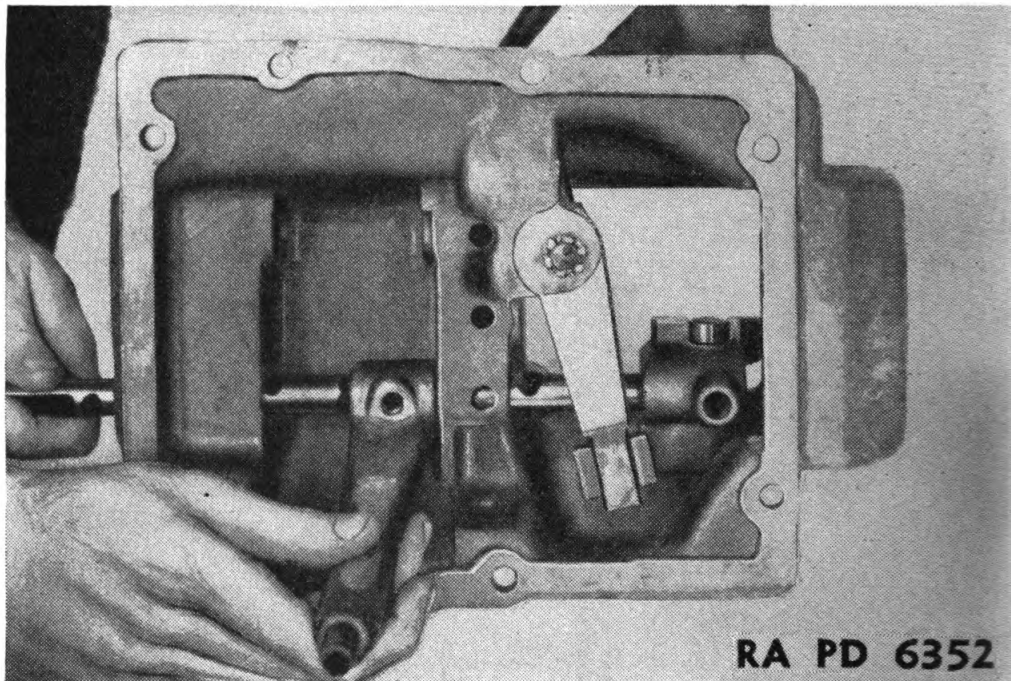

FIGURE 89.—Transmission first and second speed shift rod removal.

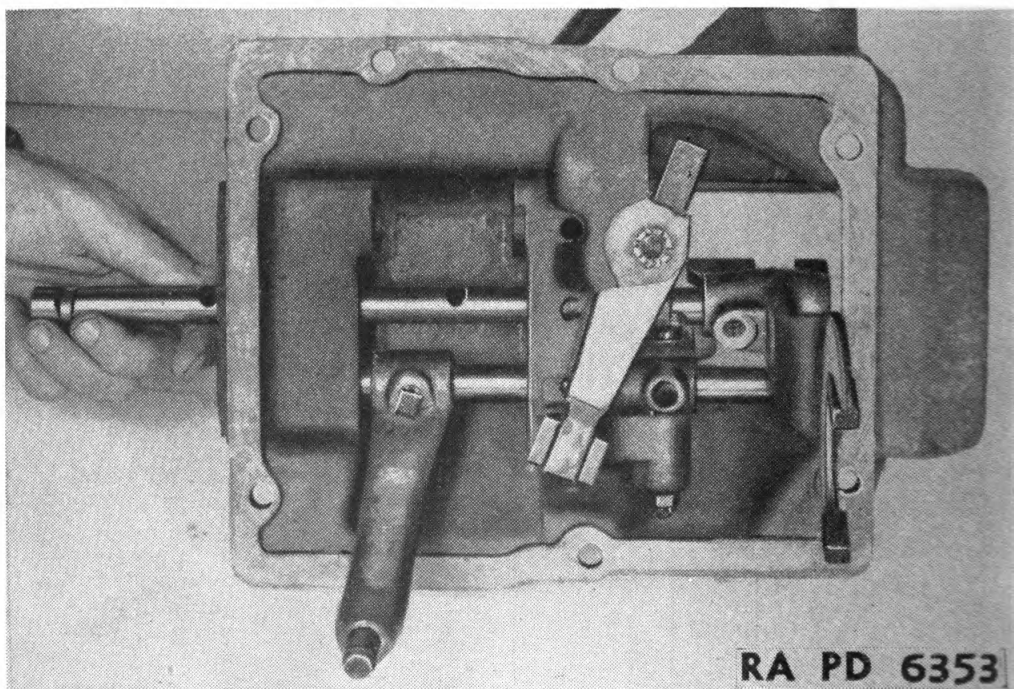

FIGURE 90.—Transmission third and fourth speed shift rod removal.

remove interlock pin (A214818), sleeve (A214863), and fork (fig. 90). Tip housing and remove one poppet ball, one poppet spring, and four interlock balls.

(8) Remove reverse shift rod— $\frac{3}{8}$ -inch square socket wrench. Remove set screw holding upper reverse shift fork (C85609) to shift rod (fig. 88). Pull out shift rod (B184267) and remove reverse shifting bracket (B184271), bracket and relay lever shoe, and reverse bracket lock ball (A1214786) (figs. 88 and 91).

(9) Disassemble reverse shifting bracket—pliers. Remove cotter pin (BFAX1BE) from bracket lock plunger nut (A214815) and

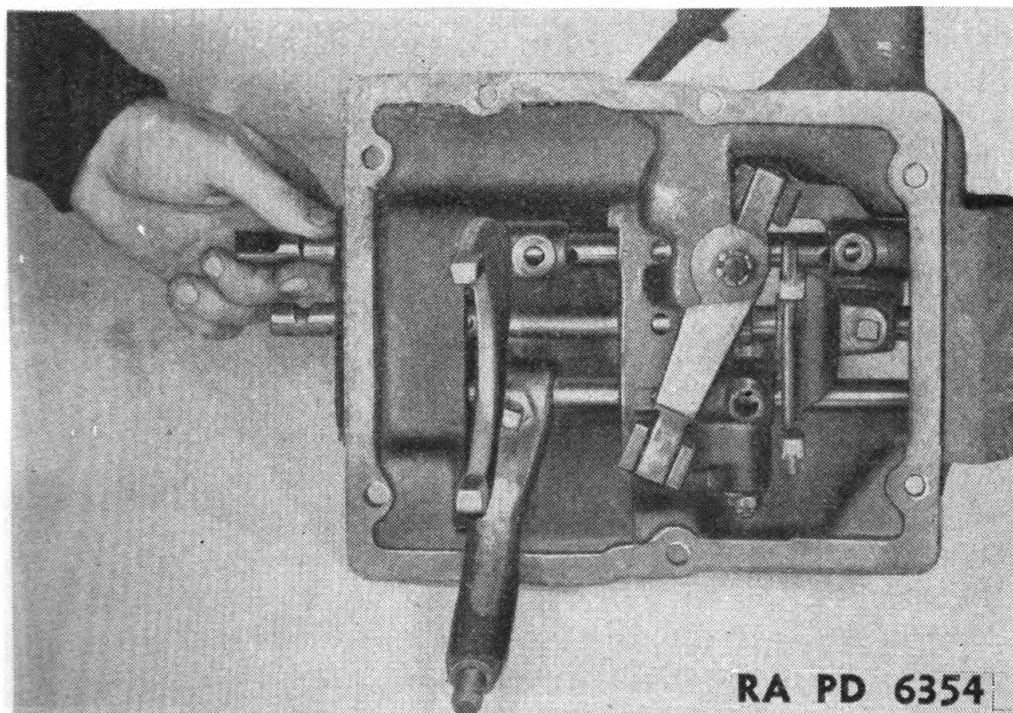

FIGURE 91.—Transmission reverse shift rod removal.

remove nut. Remove reverse bracket lock spring (A214783) and plunger (A214796) (fig. 88).

(10) Remove first and reverse speed relay lever— $\frac{5}{8}$ -inch box wrench,  $\frac{7}{8}$ -inch open end wrench, pliers. Remove cotter pin (BFAX1DF), nut (A214814), and screw (A214811), and remove relay lever (B184261) (fig. 91).

(11) Remove shift rod hole plugs—long screw driver or long rod. Drive plugs (A214782) out of housing by striking on inner faces (fig. 79).

*c. Transmission case*—Tools:  $\frac{1}{2}$ -inch socket wrench,  $\frac{11}{16}$ -inch socket wrench, screw driver,  $\frac{9}{16}$ -inch box wrench, brass drift, hammer,  $\frac{9}{16}$ -inch socket wrench,  $\frac{9}{16}$ -inch open end wrench,  $\frac{3}{8}$ -inch square wrench,

$\frac{7}{8}$ -inch open end wrench,  $\frac{3}{4}$ -inch socket wrench,  $\frac{7}{8}$ -inch socket wrench, cutting pliers,  $\frac{3}{4}$ -inch box wrench, pinch bar, pliers, bearing puller, punch, special wrench (fig. 98) or  $1\frac{3}{4}$ -inch I. D. tubular wrench, gear puller, screw type slide hammer puller.

(1) Remove bellhousing hand hole covers— $\frac{1}{2}$ -inch socket wrench. Remove two cap screws (A214857) and lock washers (BECX1H) and remove top hand hole cover (B184262) (fig. 79). Remove six cap screws (A214857) and lock washers (BECX1H) and remove bottom hand hole cover (B184263) and gasket (B184264) (fig. 79).

(2) Remove clutch release mechanism— $1\frac{1}{16}$ -inch socket wrench, screw driver,  $\frac{9}{16}$ -inch box wrench, brass drift, hammer,  $\frac{9}{16}$ -inch socket wrench,  $\frac{9}{16}$ -inch open end wrench. Loosen lock nut (SP-65J) in bellhousing directly over short clutch release shaft and remove headless set screw (SP-155D) that prevents the shaft from slipping out. Remove lock nut. Remove two clutch release yoke-to-shaft cap screws (A214807) and lock washers (BECX1L) (fig. 77). Remove long clutch release key (A226033). Pull out long shaft (B184282), short shaft (B184280), and yoke (B184283). The shafts may be tight and may have to be driven out. Remove bolt (BAOX1DH), lock washer (BECX1L), and nut (BBBX1D) holding clutch release shaft lever to long clutch release shaft, and remove lever (C85514), and Woodruff key (BCAX12A).

(3) Remove power take-off cover and drain and filler plugs— $\frac{3}{8}$ -inch socket wrench,  $\frac{3}{8}$ -inch square wrench (or  $\frac{3}{8}$ -inch drive ratchet handle),  $\frac{7}{8}$ -inch open end wrench. Remove six cap screws (BCAX1CA) and lock washers (BECX1K) holding power take-off cover (B184269) to case and remove cover and gasket (A214787, fig. 76). Remove oil filler pipe plug (A214959) and magnetic oil drain plug (A214780) (figs. 76 and 77).

NOTE.—Steps (1), (2), and (3) above need not be performed unless it is necessary to repair or replace any of the components removed.

(4) Remove transmission bellhousing— $\frac{3}{4}$ -inch socket wrench,  $\frac{7}{8}$ -inch socket wrench. Remove two short cap screws (A214866), four long cap screws (BCAX1EE), and six lock washers (BECX1M) from inside of bellhousing (fig. 77). Remove two cap screws (A214810) and lock washers (BECX1P) holding bellhousing to case from the outside and remove bellhousing (E3820) and gasket (C85625).

(5) Separate the transmission from the transfer case— $\frac{3}{4}$ -inch socket wrench,  $\frac{9}{16}$ -inch socket wrench, cutting pliers,  $\frac{3}{4}$ -inch box wrench, pinch bar. Remove seven cap screws (A214858) and lock washers (BECX1M) holding transmission case (E3818) to transfer

case (E3821) on outside of cases (fig. 76). Remove 12 cap screws (BCAX1CC) and lock washers (BECX1K) holding transfer case bottom cover (D48162) to case, and remove cover (fig. 76). Cut locking wire and remove two cap screws (A214860) holding cases together on inside. The cases still will be difficult to separate because of rear mainshaft front roller bearing (fig. 78). The cases must be pried apart hard enough to remove bearing from transfer case mainshaft, or to free it at its outer race, which is set in a recess in transfer case mainshaft drive gear. Dowel pins (A214804) are essentially used as alining pins and are usually not tight enough to

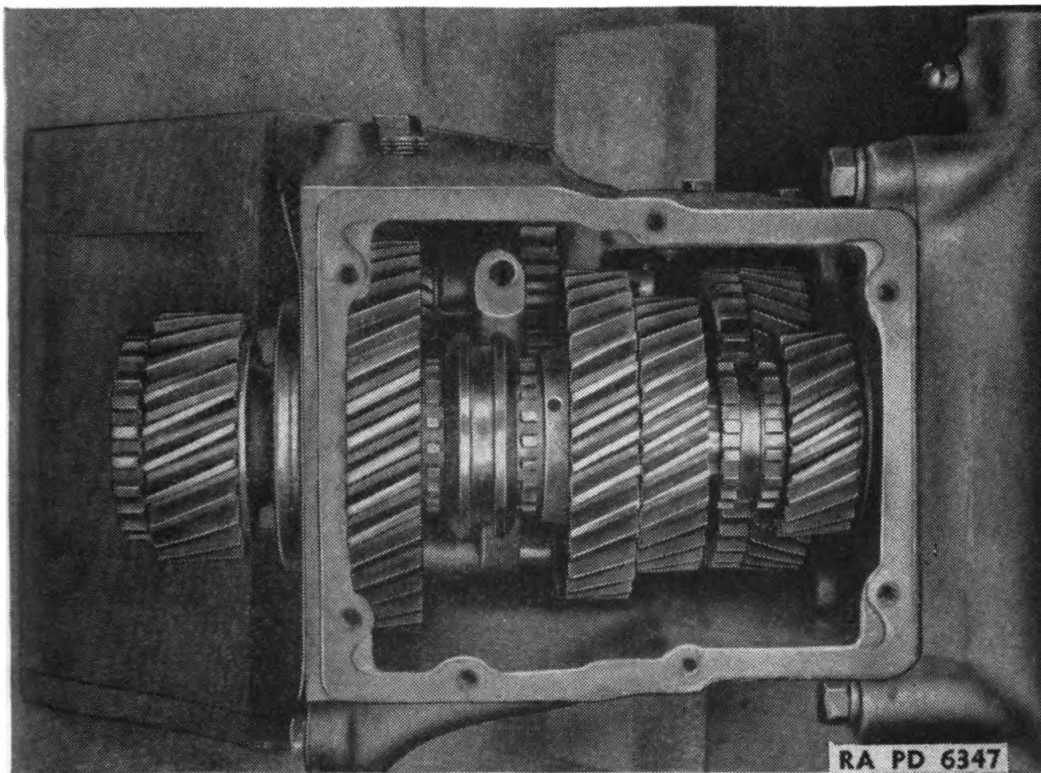

FIGURE 92.—Transmission gears installed.

hamper splitting cases. Remove transmission to transfer case gasket (C85627) (fig. 92).

(6) Remove mainshaft front bearing cap—cutting pliers,  $\frac{9}{16}$ -inch socket wrench. Cut locking wire and remove three cap screws (A214870) and washers (A214819) holding mainshaft front bearing cap to case, and remove cap (B184253) and gasket (B184268) (fig. 93).

(7) Remove transmission main drive gear—screw driver, pliers. Remove main drive gear (C85614) by hand (figs. 93, 94, and 95). Remove main drive gear snap ring (A214791) and ball bearing

(A214960) from shaft portion of gear. Bearing snap ring (A226046) can also be removed.

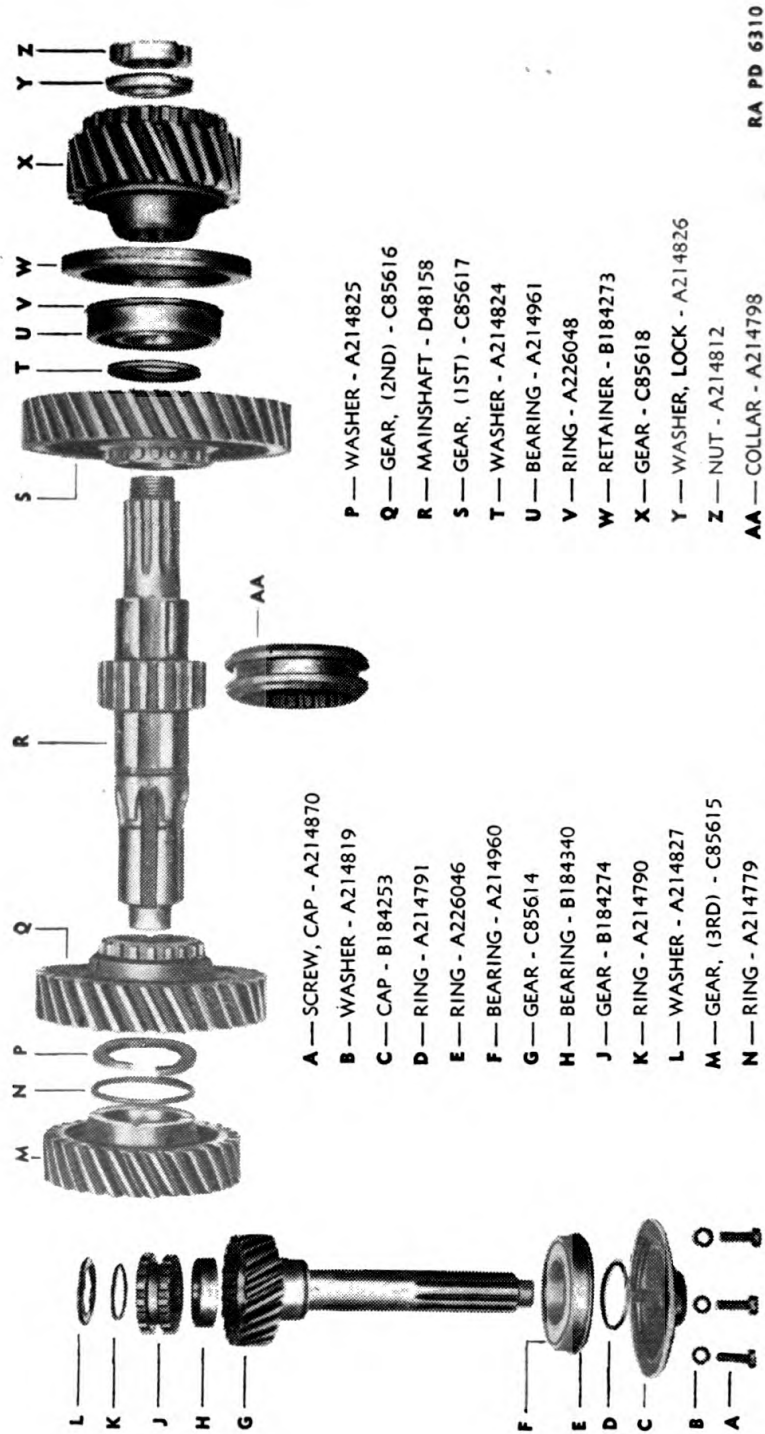

- A — SCREW, CAP - A214870
- B — WASHER - A214819
- C — CAP - B184253
- D — RING - A214791
- E — RING - A226046
- F — BEARING - A214960
- G — GEAR - C85614
- H — BEARING - B184340
- J — GEAR - B184274
- K — RING - A214790
- L — WASHER - A214827
- M — GEAR, (3RD) - C85615
- N — RING - A214779

- P — WASHER - A214825
- Q — GEAR, (2ND) - C85616
- R — MAINSHAFT - D48158
- S — GEAR, (1ST) - C85617
- T — WASHER - A214824
- U — BEARING - A214961
- V — RING - A226048
- W — RETAINER - B184273
- X — GEAR - C85618
- Y — WASHER, LOCK - A214826
- Z — NUT - A214812
- AA — COLLAR - A214798

RA PD 6310

FIGURE 93.—Transmission mainshaft and main drive gear, exploded.

(8) Remove transmission mainshaft pilot bearing and clutch collar—bearing puller. Remove pilot bearing (B184340) from mainshaft with a puller or by striking it with third and fourth speed

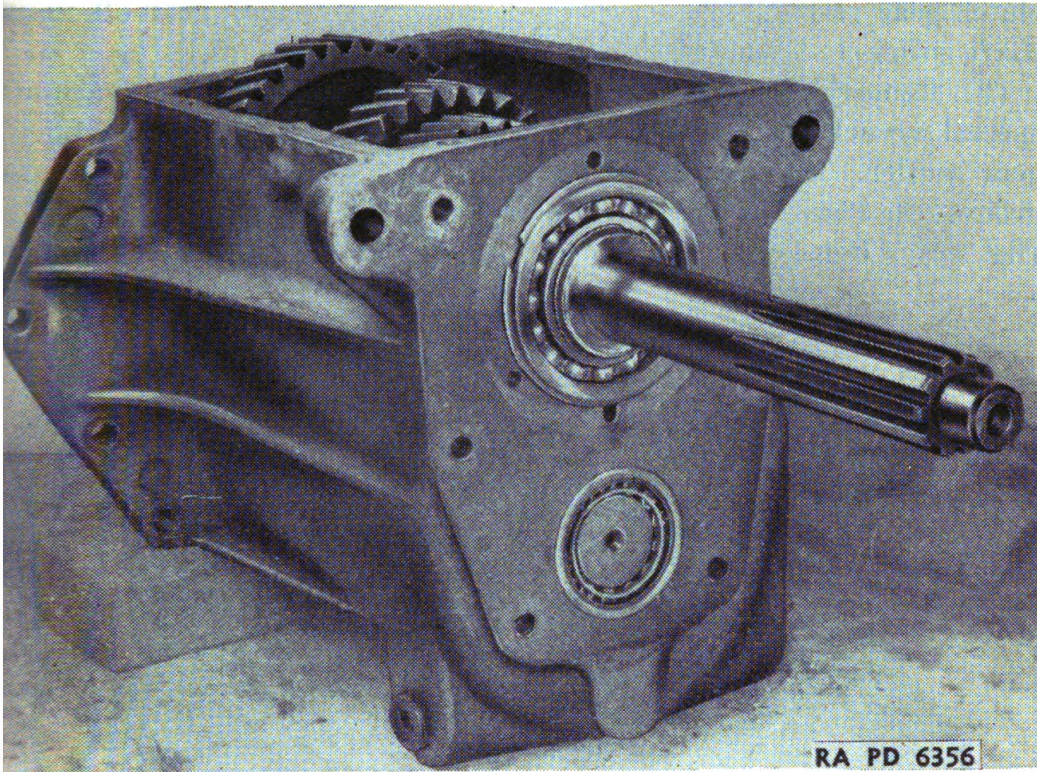

FIGURE 94.—Transmission main drive gear, installed.

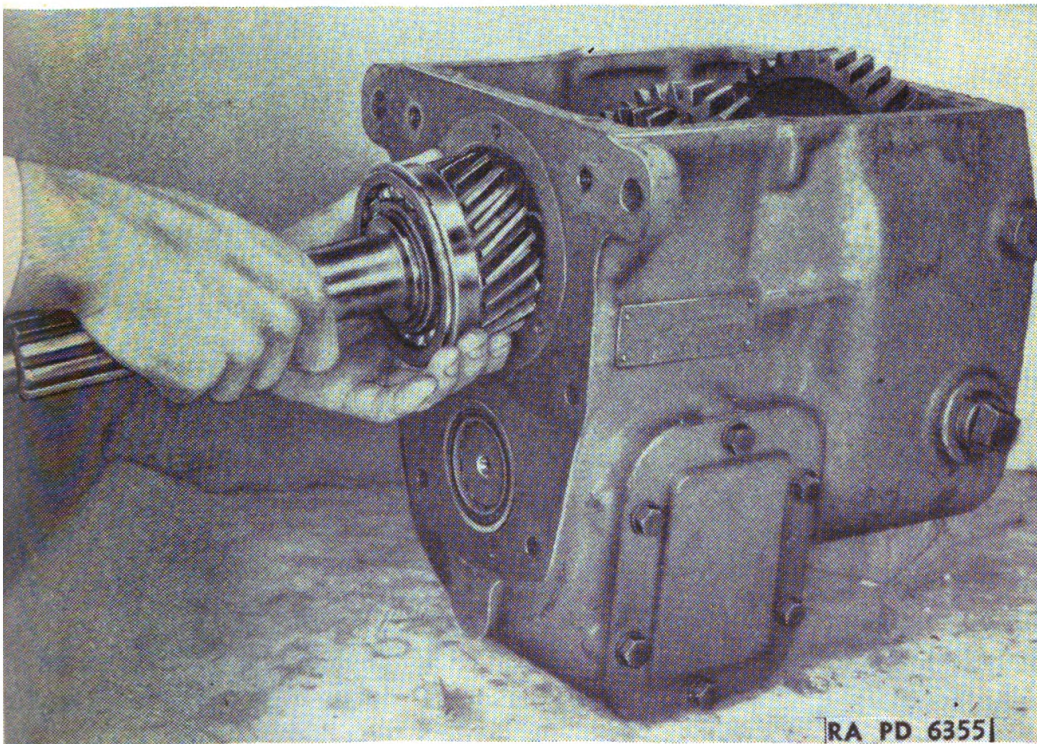

FIGURE 95.—Transmission main drive gear removal.

clutch gear (B184274) (figs. 93 and 96). Slide clutch gear off mainshaft spline and remove (figs. 93 and 97).

(9) Remove transfer case mainshaft drive gear—punch, hammer, special wrench (or 1 $\frac{3}{4}$ -inch I. D. tubular wrench or spanner wrench), gear puller. Straighten lock washer (A214826) peened into the grooves in transfer case mainshaft drive gear lock nut (A214812) (fig. 93). Remove lock nut with special wrench (fig. 98). Remove

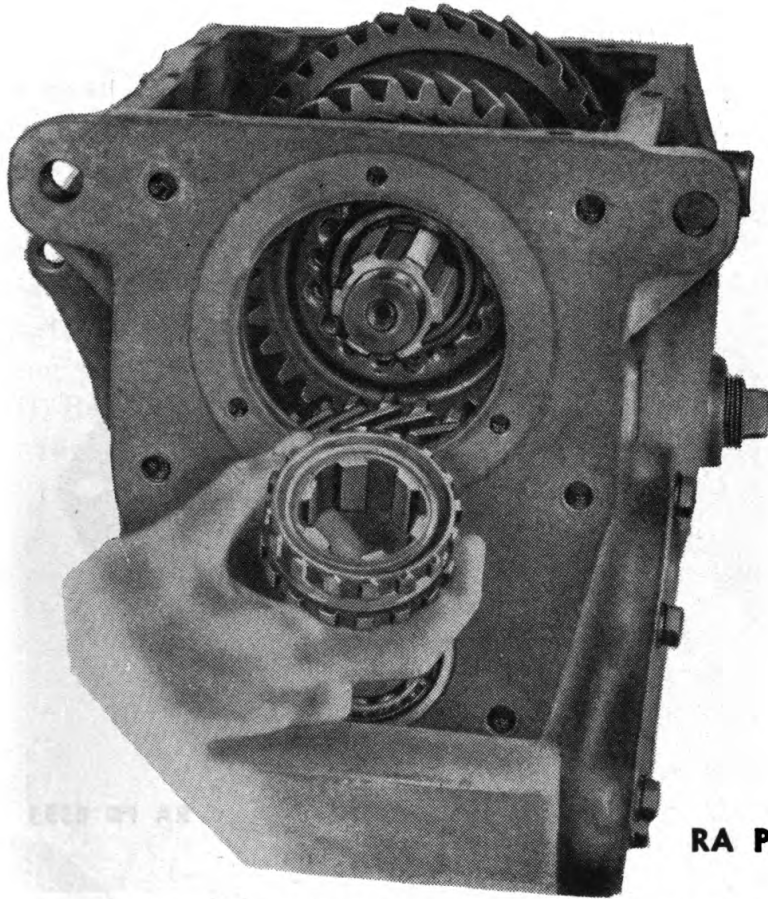

FIGURE 96.—Transmission mainshaft pilot bearing removal.

drive gear (C85618) and lock washer by hand (fig. 99). If it sticks use gear puller.

(10) Remove transmission mainshaft rear bearing—pinch bar, bearing puller, brass drift, hammer, screw driver, pliers. Remove mainshaft rear bearing retainer (B184273) by striking lightly to loosen and then prying it off (fig. 93). Press or drive on rear end of mainshaft until it has been moved about  $\frac{1}{2}$ -inch toward the front. Push shaft toward the rear. This will practically push mainshaft rear bearing (A214961) out of case. Pull or pry to complete removal of the bearing (figs. 93 and 100). Bearing snap ring (A226048) can be removed from the bearing. Slide mainshaft first





**RA PD 6335**

**FIGURE 97.**—Transmission third and fourth speed clutch gear removal.

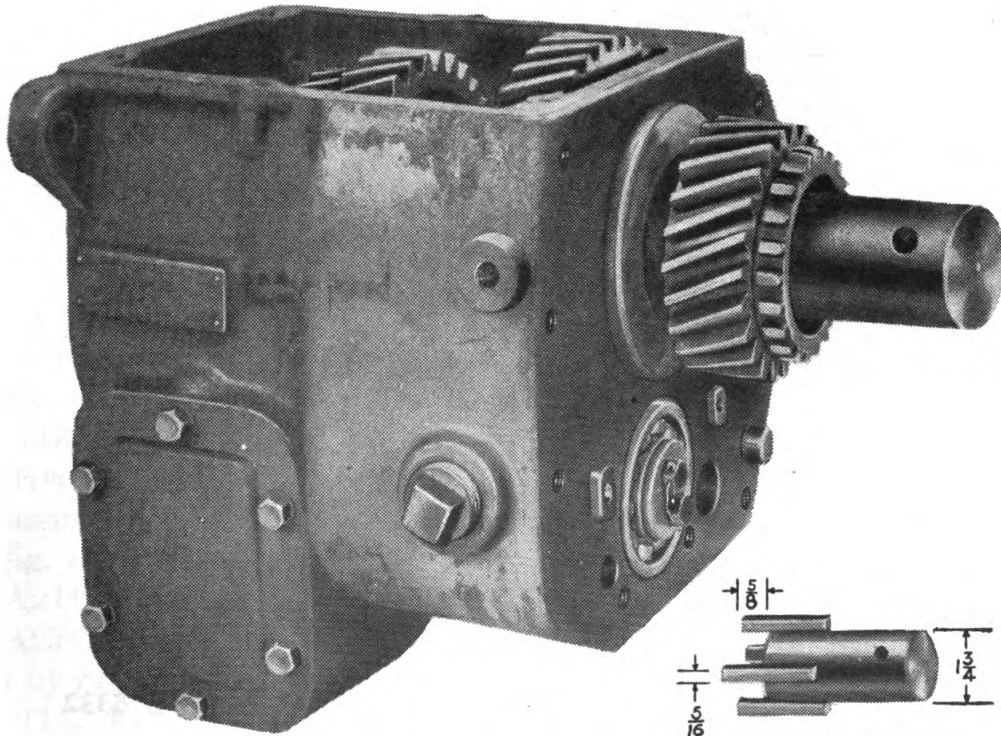

**RA PD 6334**

**FIGURE 98.**—Transmission drive gear lock nut removal.

Generated on 2016-07-07 11:59 GMT / http://hdl.handle.net/2027/uc1.b3243960  
 Public Domain, Google-digitized / http://www.hathitrust.org/access\_use#pd-google

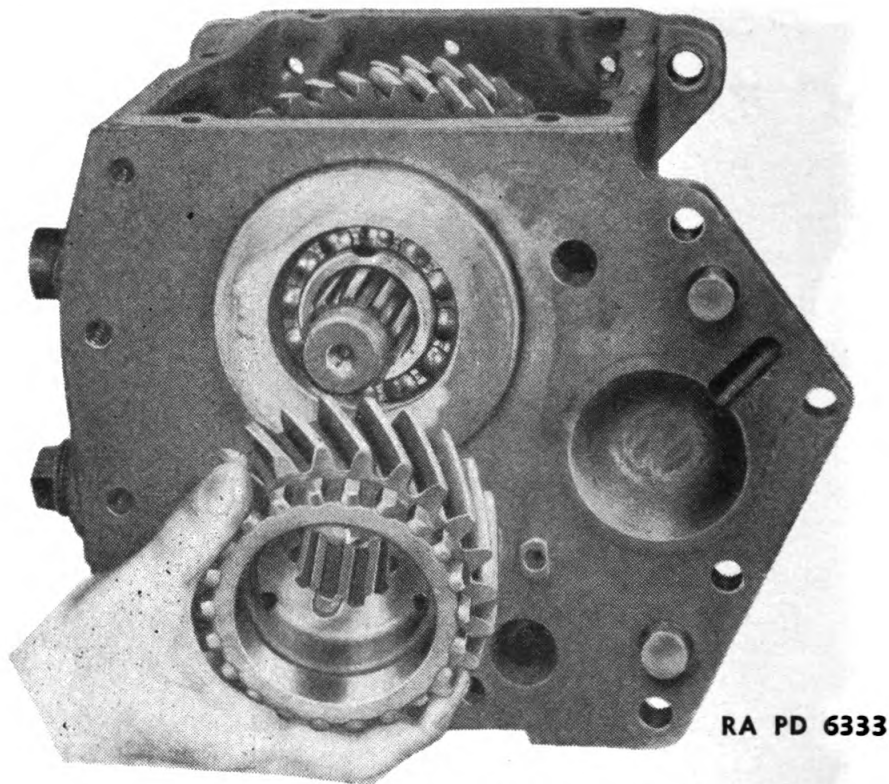

RA PD 6333

FIGURE 99.—Transmission drive gear removal.

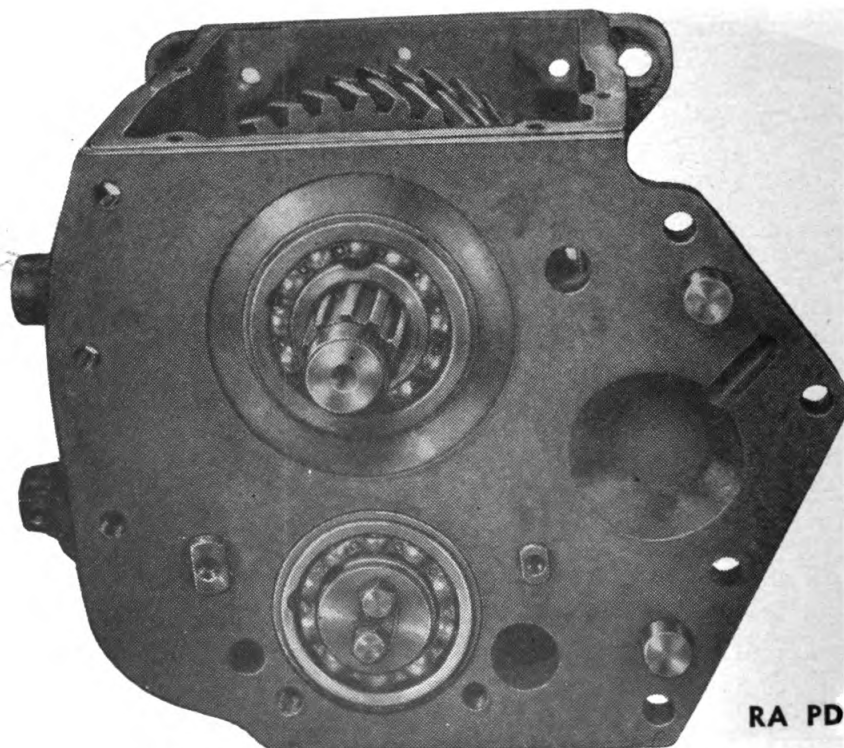

RA PD 6332

FIGURE 100.—Transmission rear bearings, installed.

speed gear thrust washer (A214824) off shaft through the rear bearing bore of case.

(11) Remove lower reverse shift fork guide rod—pinch bar,  $\frac{5}{16}$ -24NF cap screw and washer (or screw type slide hammer puller). Insert cap screw and washer into external threaded end of lower reverse shift fork guide rod (A214797) (fig. 101). Remove with a pinch bar. Rod can also be removed by using screw type slide hammer puller.

(12) Remove transmission mainshaft. Press upper end of the lower reverse shift fork down in order to allow mainshaft (D48158)

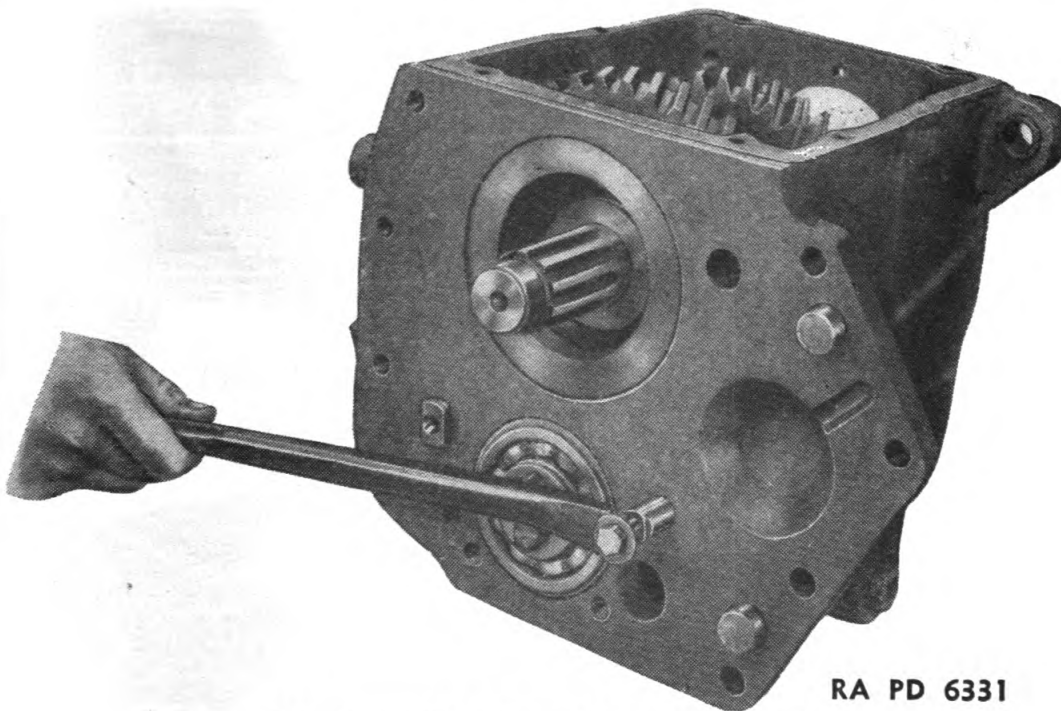

RA PD 6331

FIGURE 101.—Transmission lower shift fork guide rod removal.

and gears to be removed by tilting and lifting from case. Remove mainshaft (fig. 102). Lift out lower reverse shift fork (C85610) (fig. 104).

(13) Remove reverse idler gear—brass drift, hammer, pliers. Drive on inner end of reverse idler gear shaft (B184284) as far as possible, and then remove by pulling on front outer end with pliers (fig. 103). Remove reverse idler gear (B184260) and thrust washers (A214823) from case (fig. 104). Reverse idler gear bushings (A214778) can be removed from gear by driving with brass drift or by pressing them out.

(14) Remove countershaft rear bearing retainer washer—cutting pliers,  $\frac{9}{16}$ -inch socket wrench. Cut locking wire and remove two

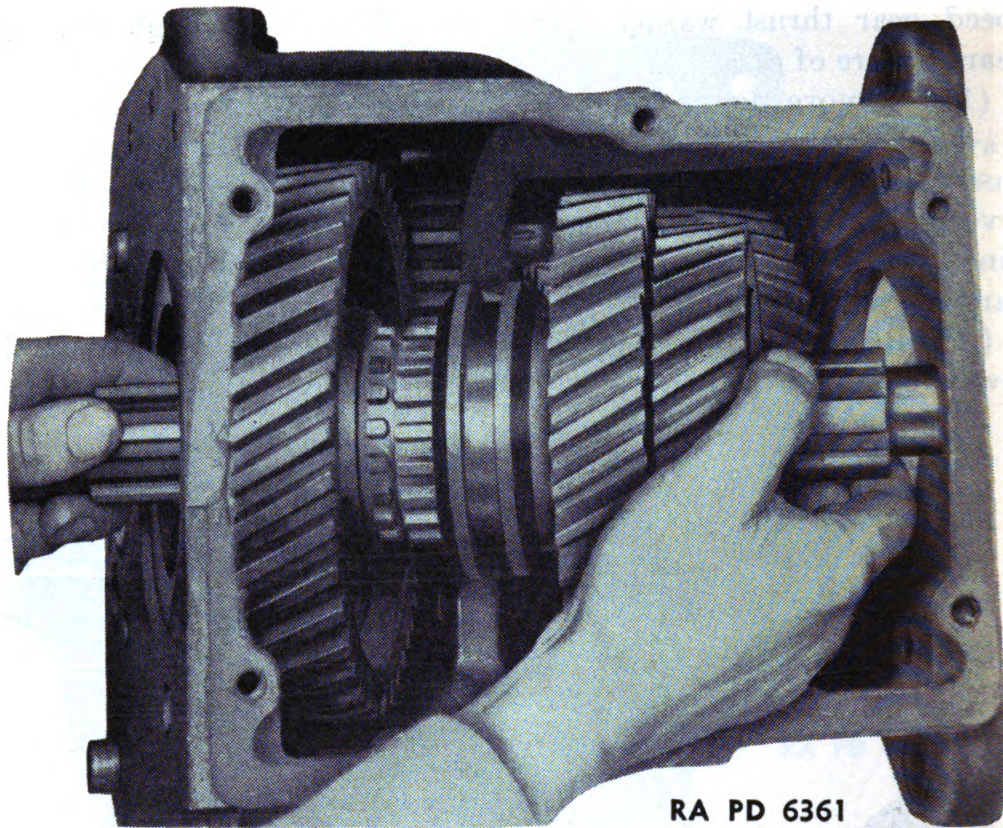

FIGURE 102.—Transmission mainshaft removal.

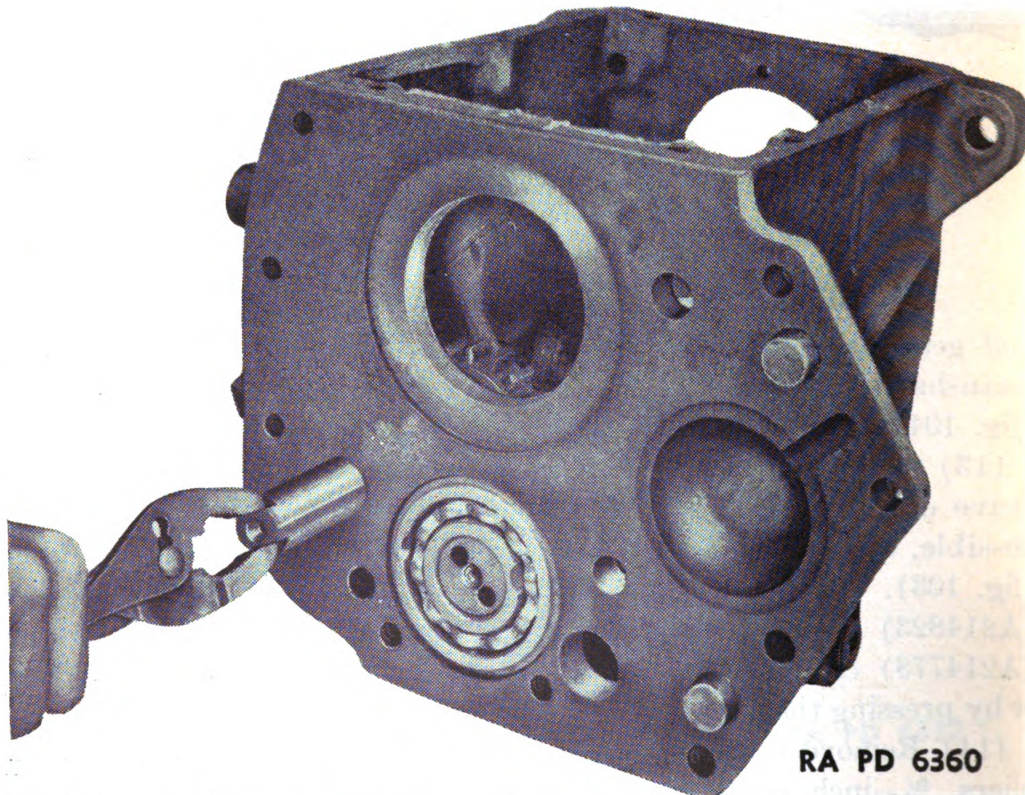

FIGURE 103.—Transmission reverse idler gear shaft removal.

POWER TRAIN

cap screws (A214871) from countershaft rear bearing retaining washer (A214820) and remove washer (fig. 104).

(15) Remove countershaft rear bearing—slide hammer puller, screw driver, pliers. Tilt countershaft so that front end slips out

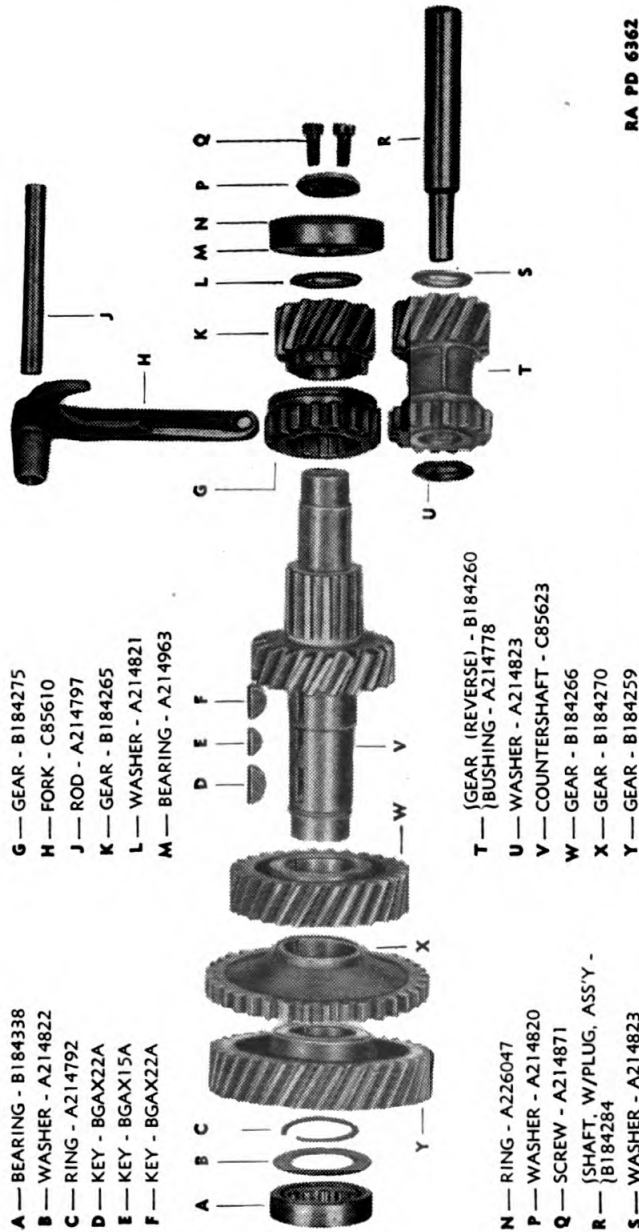
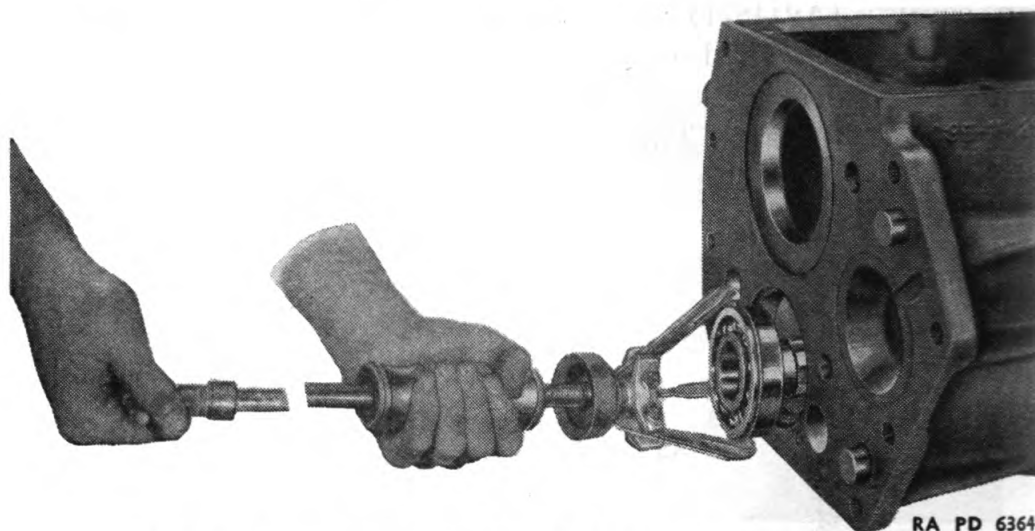

FIGURE 104. Transmission countershaft and reverse idler gear, exploded.

RA PD 6362

of front bearing. This will push rear ball bearing (A214963) out of housing. Use puller to remove bearing from the shaft (fig. 105). Bearing snap ring (A226047) can be removed from bearing.

(16) Remove countershaft. Remove countershaft rear bearing thrust washer (A214821) and first speed gear (B184265) by sliding



RA PD 6364

FIGURE 105.—Transmission countershaft rear bearing removal.

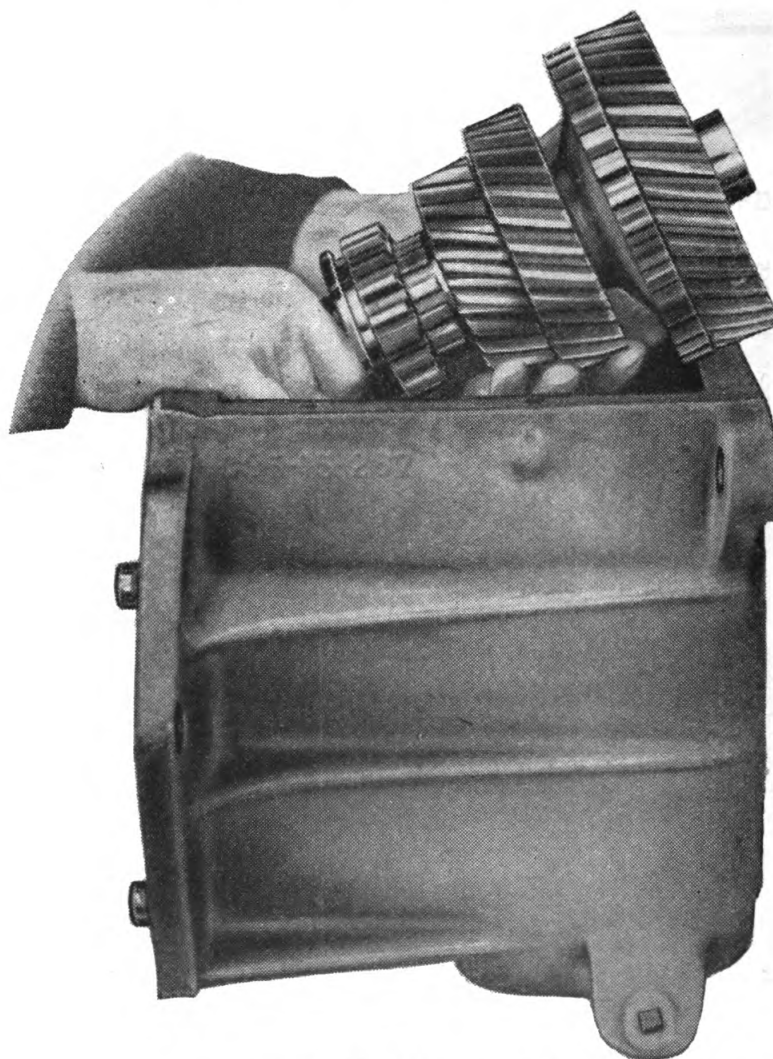

RA PD 6363

FIGURE 106.—Transmission countershaft removal.

off shaft through rear bearing bore of case (fig. 104). Tilt countershaft (C85623) and remove with gears from case (fig. 106).

(17) Remove countershaft front bearing—brass drift, hammer. Drive front bearing (B184338) out of case.

*d. Transmission mainshaft.*—Tools:  $\frac{3}{4}$ -inch socket wrench,  $\frac{7}{8}$ -inch socket wrench,  $\frac{9}{16}$ -inch socket wrench, cutting pliers,  $\frac{3}{4}$ -inch box wrench, pinch bar, two screw drivers, pliers, bearing puller, punch,

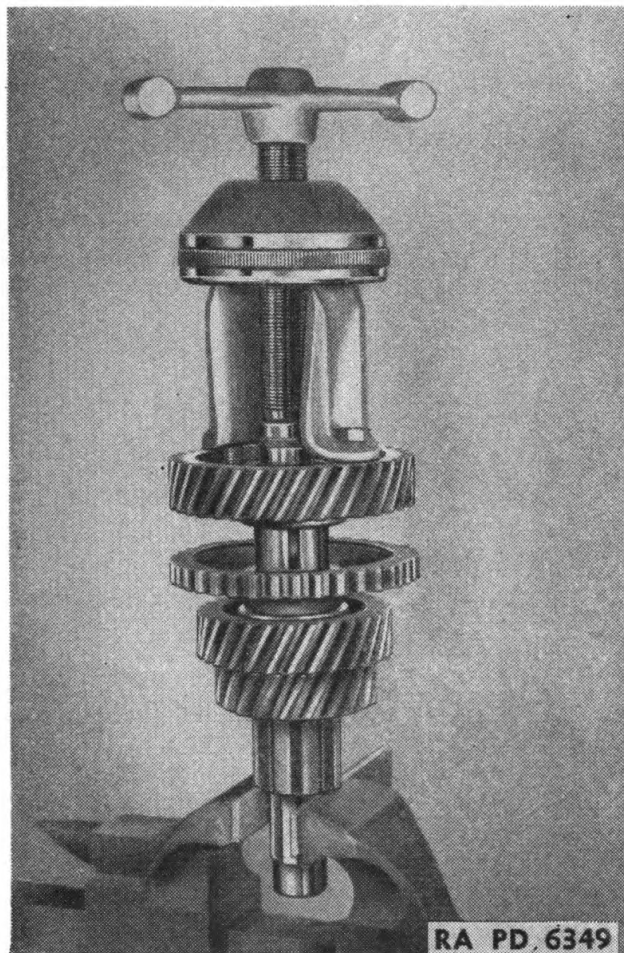

FIGURE 107.—Pulling transmission countershaft drive gear.

hammer, special wrench (fig. 98) or  $1\frac{3}{4}$ -inch I. D. tubular wrench, gear puller, brass drift.

(1) Remove mainshaft from case. Proceed as outlined in steps in *c*(4) through (10) above.

(2) Disassemble mainshaft (figs. 78 and 93)—two screw drivers. Slide first speed gear (C85617) and first and reverse clutch collar (A214798) off shaft (fig. 93). Remove snap ring (A214790), third speed gear thrust washer (A214827), and slide third speed gear (C85615) off shaft. Remove second and third speed gears retaining

ring (A214779) and split thrust washers (A214825). Second speed gear (C85616) can now be removed.

*e. Transmission countershaft.*—Same tools used in *d* above, plus the following: bolt type universal puller, two  $\frac{1}{2}$ -20NF bolts, press, arbor.

(1) Remove countershaft from case. Proceed as outlined in steps in *c*(4) through (13) above.

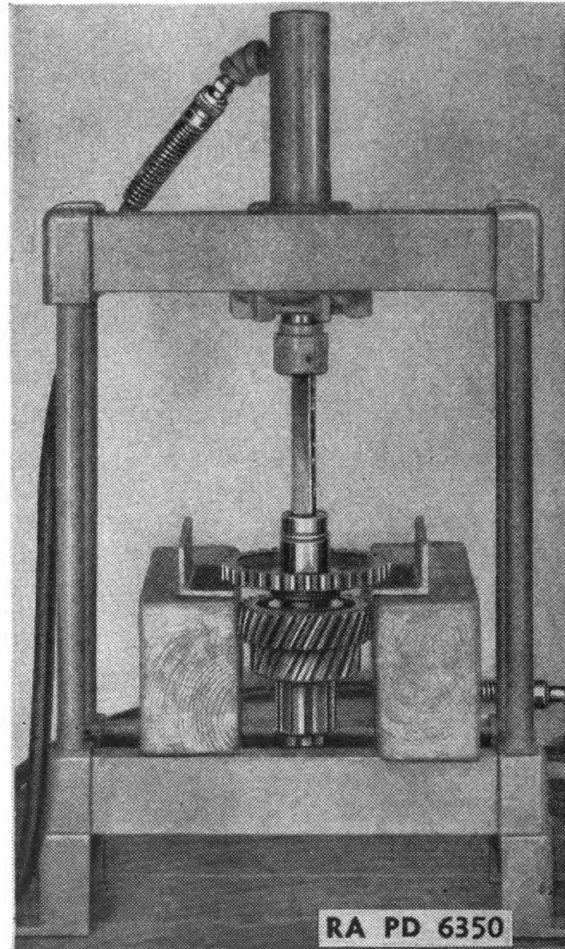

FIGURE 108.—Pressing off countershaft power take-off gear.

(2) Disassemble countershaft—bolt type universal puller, two  $\frac{1}{2}$ -20NF bolts, hammer, press, screw driver, pliers. Slide front bearing washer (A214822) off shaft (fig. 104). Remove countershaft drive gear snap ring (A214792). Set countershaft in vise with drive gear up. Mount universal puller on drive gear (B184259) using two bolts, and remove gear (fig. 107). If puller does not completely remove gear from shaft, pull gear off far enough to enable it to be set up in a press to complete removal. Remove Woodruff keys



(BGAX22A). Press off power take-off gear (B184270) and third speed gear (B184266), and remove Woodruff keys (BGAX15A) (figs. 108 and 109).

*f. Transfer case*—Tools:  $\frac{3}{4}$ -inch socket wrench,  $\frac{9}{16}$ -inch socket wrench, cutting pliers,  $\frac{3}{4}$ -inch box wrench, pinch bar,  $\frac{7}{16}$ -inch socket wrench,  $1\frac{1}{2}$ -inch socket wrench, puller,  $\frac{5}{8}$ -inch socket wrench, pliers, brass drift, hammer,  $\frac{7}{8}$ -inch open end wrench, screw drivers,  $\frac{7}{16}$ -inch square socket wrench, press.

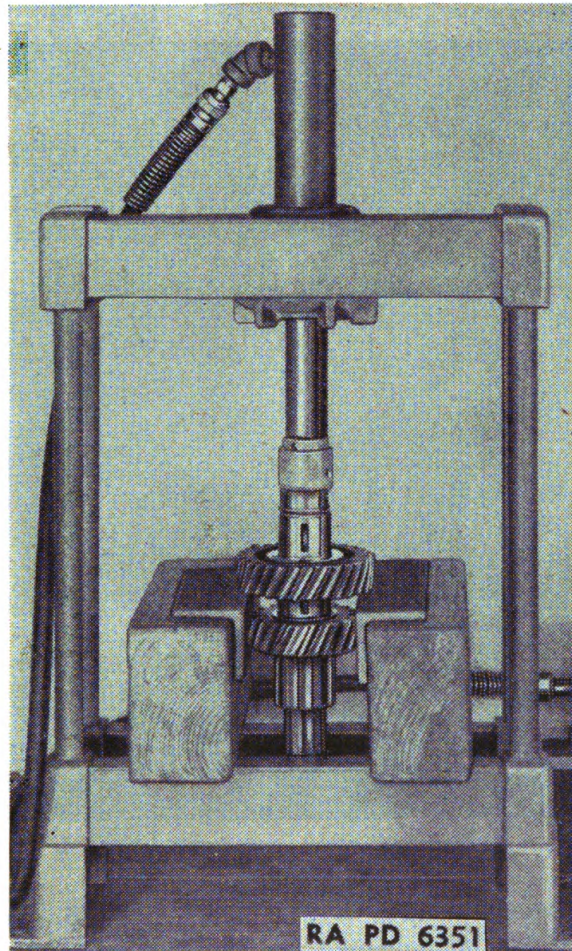

FIGURE 109.—Pressing off countershaft third speed gear.

(1) Separate transfer case from transmission. Proceed as outlined in step *c*(5) above.

(2) Remove shift rod cover and interlocks— $\frac{7}{16}$ -inch socket wrench. Remove three cap screws (BCAX1CA) and lock washers (BECX1G) holding transmission shift rod cover (B184294) to transfer case and remove cover and gasket (B184295) (fig. 76). Lift short first speed shift rod interlock (A214829) and long front drive shift rod interlock (A214830) out of holes in top of case (fig. 125).

(3) Remove front axle drive companion flange—pliers, 1½-inch socket wrench, puller. Remove cotter pin (BFX1DM) and slotted nut (A214932) holding companion flange (B184286) to front drive shaft, and pull flange off shaft (figs. 111 and 112).

(4) Remove front-drive shaft rear bearing cap—5⁄8-inch socket wrench. Remove two long cap screws (A214862) and two short bolts (BANX1DE) holding front-drive shaft rear bearing cap (C85611) to case and remove cap with speedometer gear (A214954) and shims (B184291) (fig. 111).

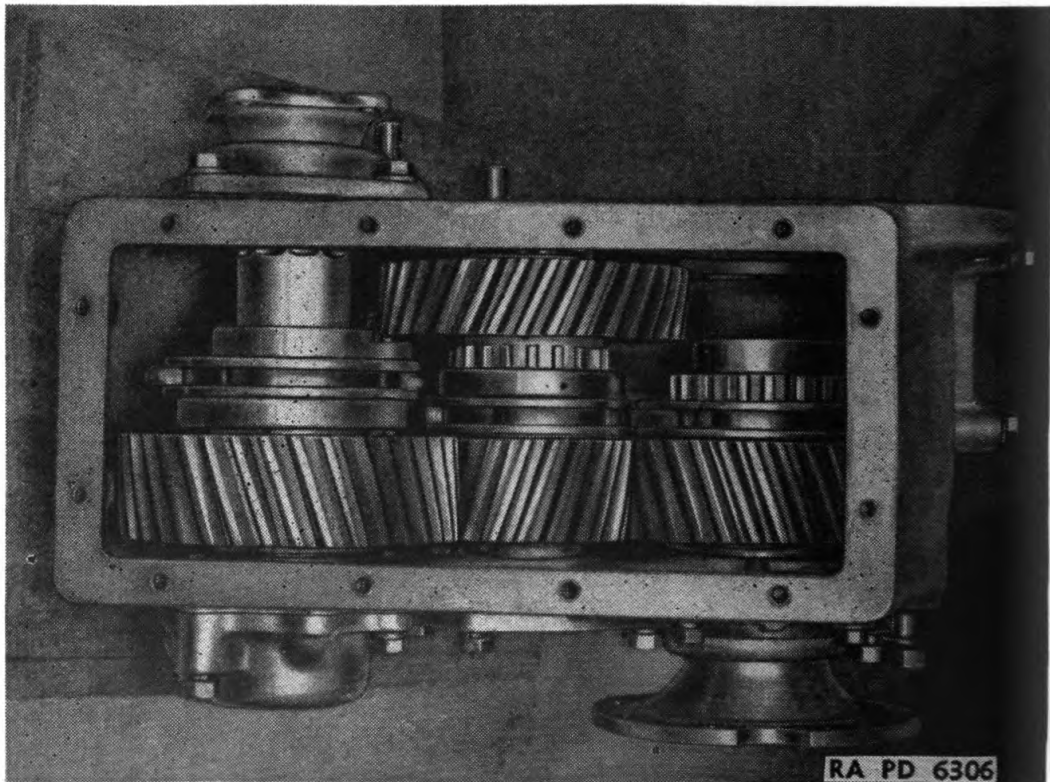

FIGURE 110.—Transfer case gears, installed.

(5) Remove speedometer drive gear—pliers, 9⁄16-inch socket wrench, puller. Remove locking wire and two cap screws (A214871) holding front-drive shaft gear retainer washer (A214852) to rear end of shaft, and remove washer (fig. 111). Pull speedometer drive gear (A214953) off shaft and remove Woodruff key (A214868) (fig. 113).

(6) Remove transfer case front-drive shaft—5⁄8-inch socket wrench, brass drift, hammer. Remove four cap screws (BCAX1DD) and lock washers (BECX1L) from front-drive shaft front bearing cap (B184244) (fig. 111). Drive or press on rear end of front-drive shaft until front bearing cap is loosened from case (fig. 114). Remove

POWER TRAIN

TM 9-1710  
 35

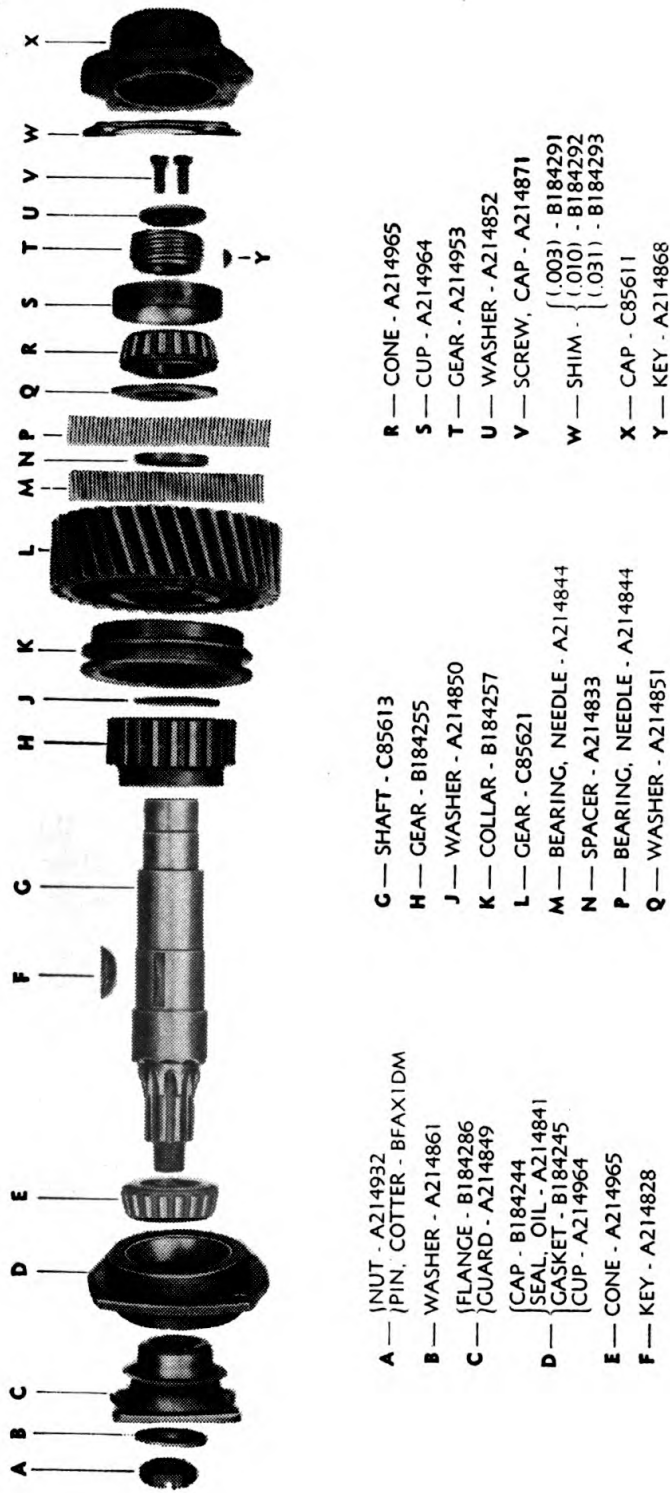

RA PD 6359

FIGURE 111.—Transfer case front-drive shaft, exploded.

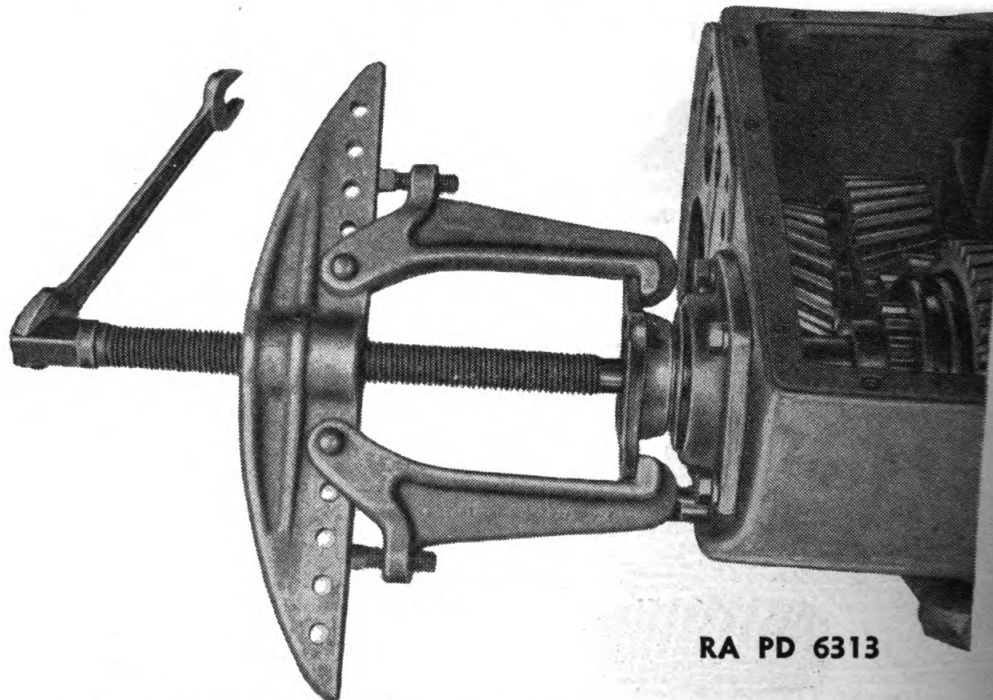

RA PD 6313

FIGURE 112.—Transfer case front-drive shaft companion flange removal.

cap and gasket (B184245). Continue driving until shaft is free from front-drive shaft gear (C85621). The 106 needle bearings (A214844), needle bearing spacer (A214833), front-drive shaft gear thrust washer (A214851), and clutch gear washer (A214850) will drop to the bottom of case. Remove before proceeding with any further disassembly after removing front-drive shaft. Remove front-drive shaft

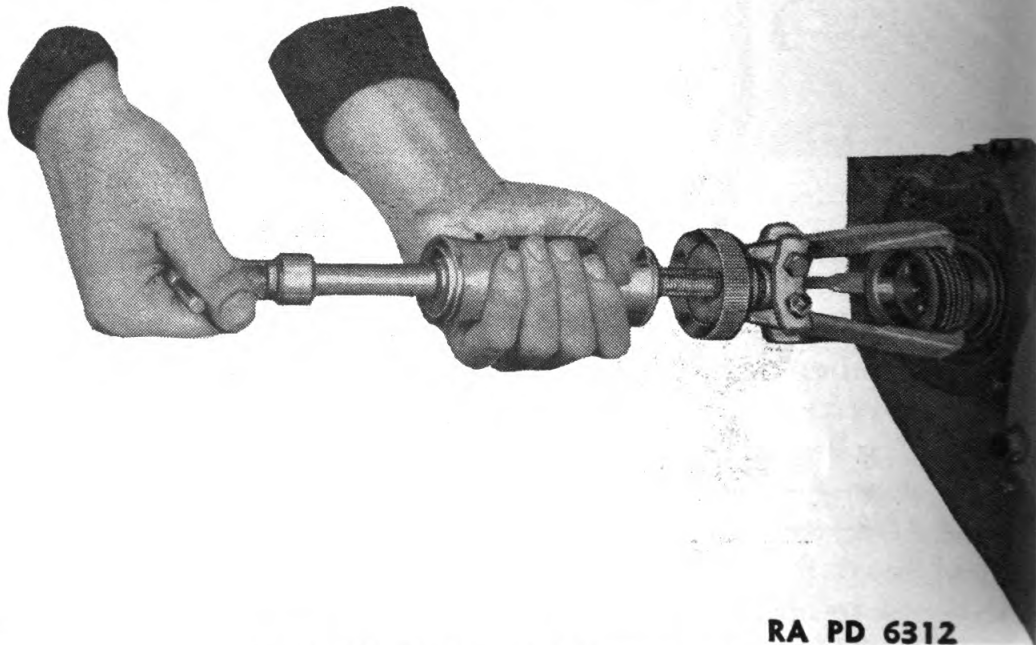

RA PD 6312

FIGURE 113.—Speedometer drive gear removal.

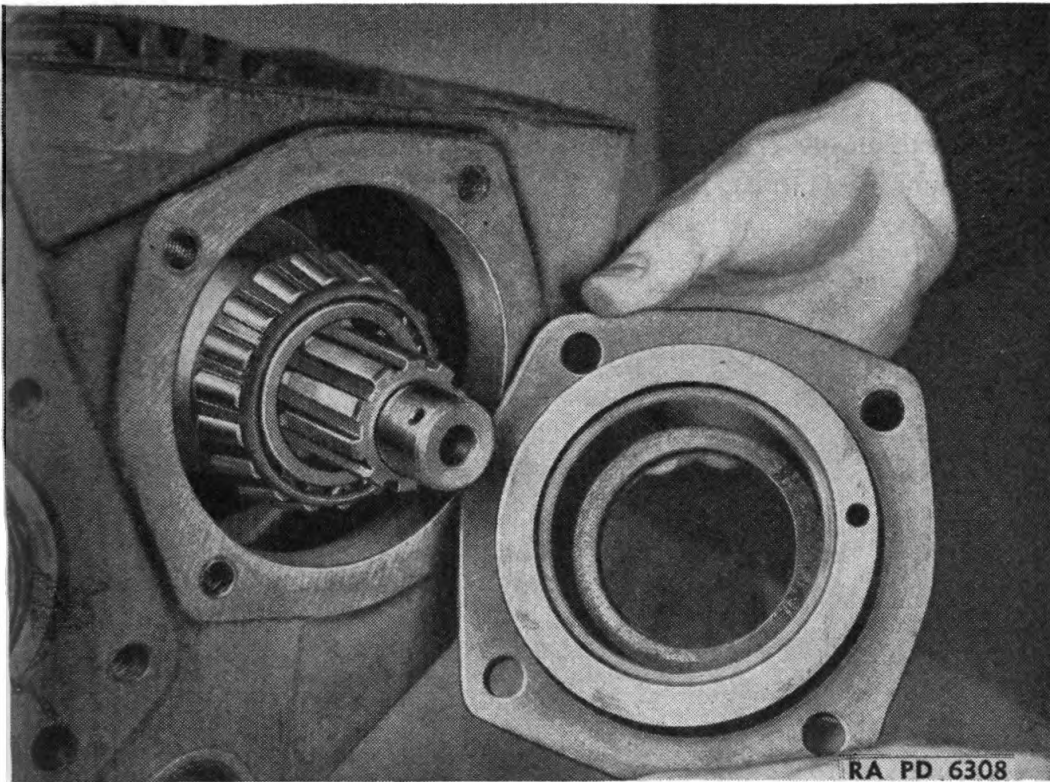

FIGURE 114.—Transfer case front-drive shaft front bearing cap removal.

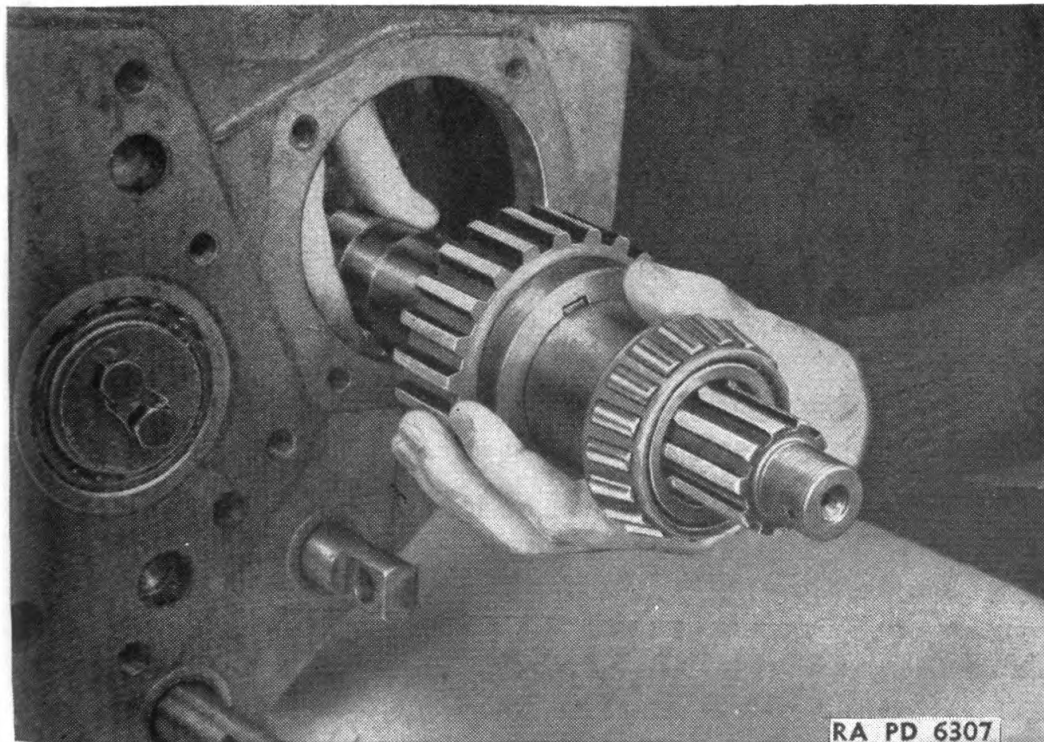

FIGURE 115.—Transfer case front-drive shaft removal.

(C85613) (fig. 115). Lift front-drive shaft gear (C85621) and clutch collar (B184257) off shifting yoke and out of case (fig. 116). Lift rear bearing cone and rollers (A214965) out of bearing cup.

(7) Disassemble front-drive shaft rear bearing cap— $\frac{7}{8}$ -inch open end wrench, brass drift, hammer. Remove sleeve (A167650) by turning on hexagonal portion and remove speedometer driven gear



FIGURE 116.—Transfer case front-drive shaft gear removal.

(A214954). Drive out driven gear bushing (A167516) if replacement is necessary.

(8) Remove bearing cups and oil seal—brass drift, hammer. Drive or press front-drive shaft front bearing cup (A214964) out of cap, and remove oil seal (A214841) (fig. 111). Drive rear bearing cup (A214964) out of case.

(9) Remove intermediate shaft rear bearing cap— $\frac{5}{8}$ -inch socket wrench, pinch bar. Remove four bolts (BANX1DE) and lock wash-

ers (BECX1L) holding intermediate shaft rear bearing cap (B184243) to case, and pry off cap and shims (B184288, B184289, and B184290, fig. 117).

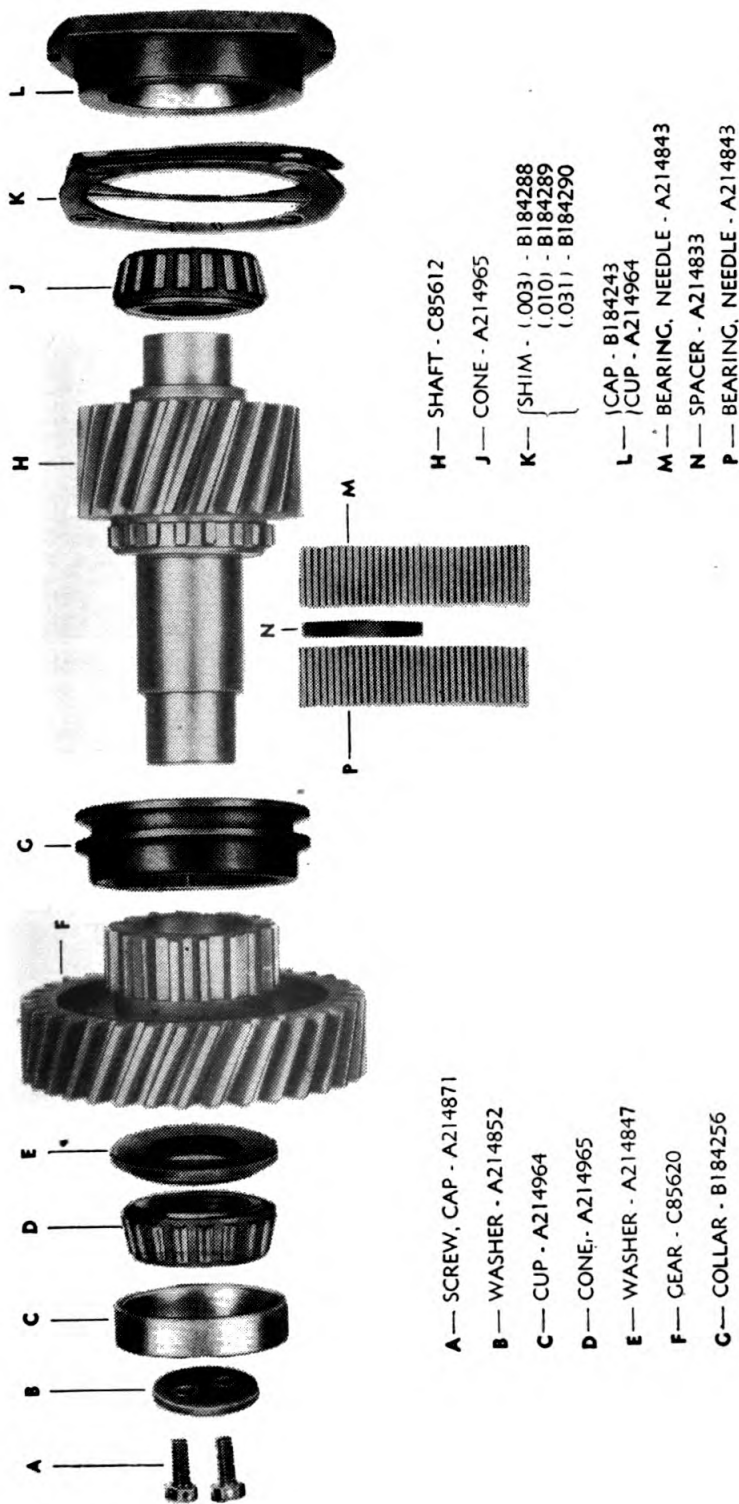

RA PD 6311

FIGURE 117.—Transfer case intermediate shaft, exploded.

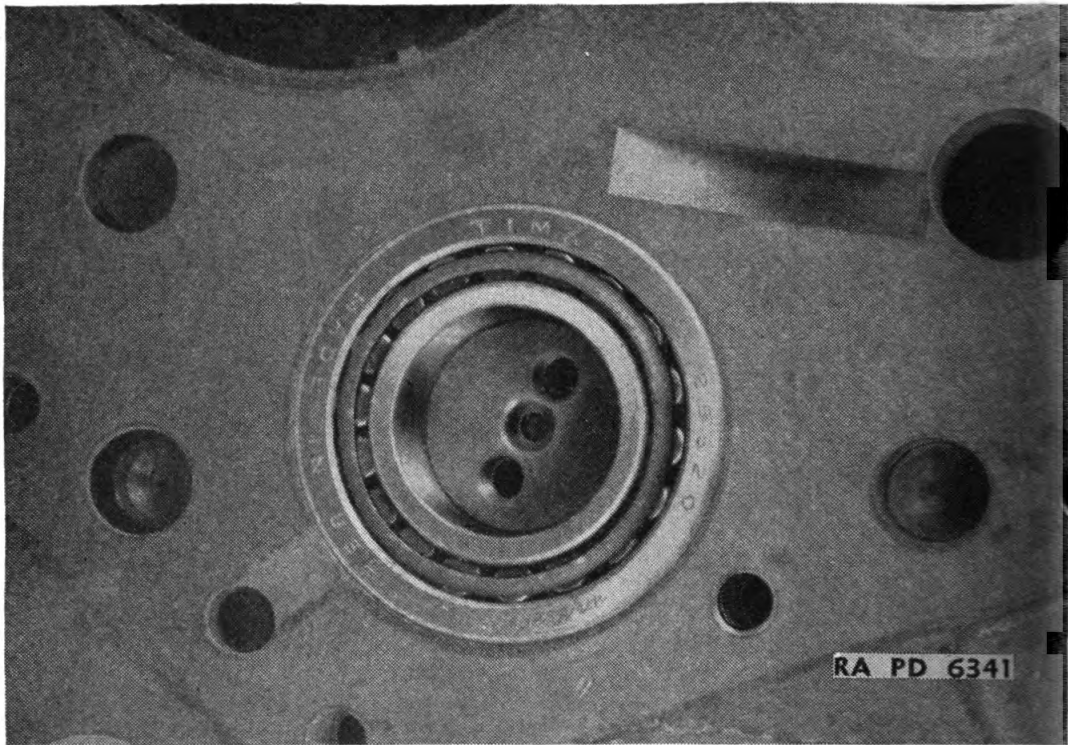

FIGURE 118.—Transfer case intermediate shaft in front bearing.

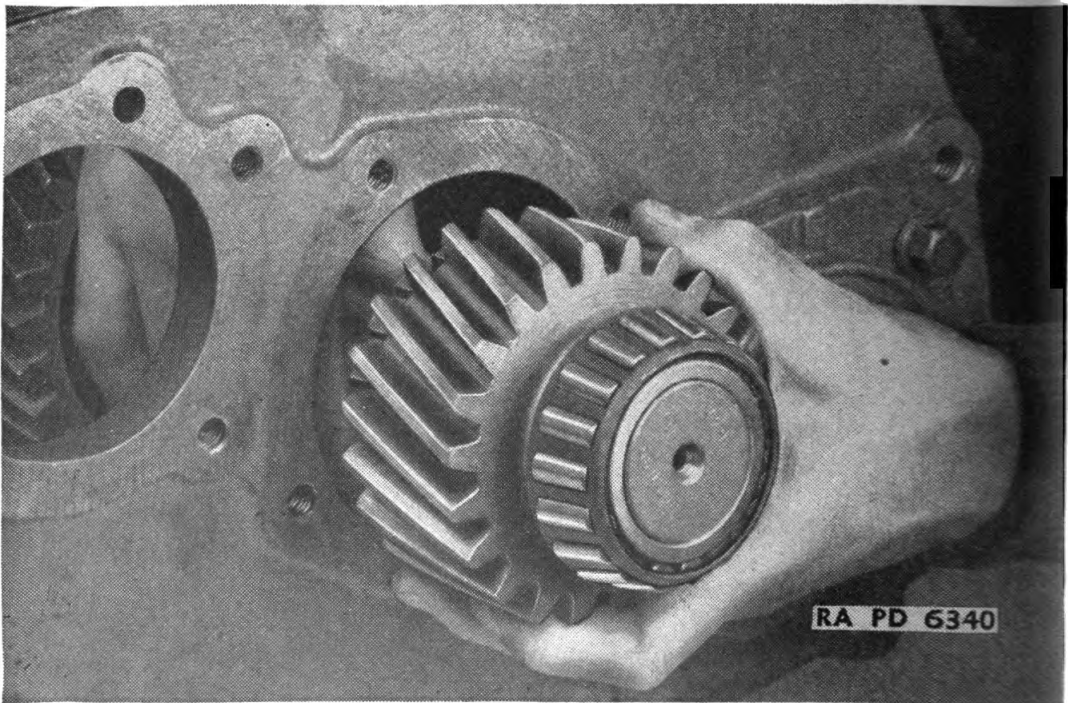

FIGURE 119.—Transfer case intermediate shaft removal.



(10) Remove intermediate shaft front bearing cone retainer washer—cutting pliers,  $\frac{9}{16}$ -inch socket wrench. Remove locking wire and two cap screws (A214871) from front end of intermediate shaft and remove bearing cone retainer washer (A214852) (fig. 117).

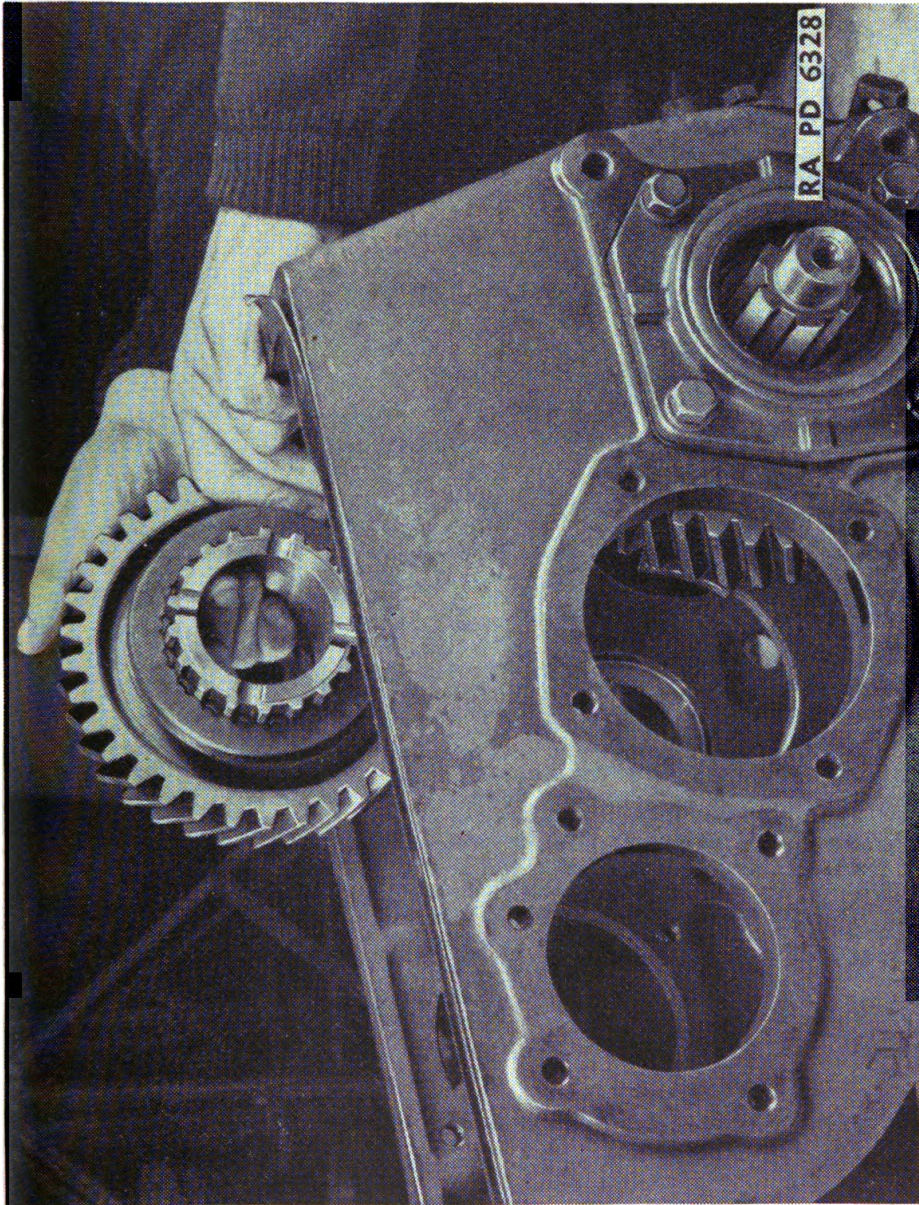

FIGURE 120.—Transfer case intermediate underdrive gear removal.

(11) Remove intermediate shaft—brass drift, hammer. Set wooden block against rear side of underdrive gear between case and gear. Press or drive on front end of intermediate shaft. Block will prevent gear from moving and shaft can be driven through gear. Drive shaft far enough to free it from front bearing cone and rollers (A214965), and from underdrive gear (fig. 118). Bearing cone can

be removed after shaft is driven through. The 106 needle bearings (A214843) and bearing spacer (A214833) will fall to bottom of case. Remove from case after removal of shaft. Remove intermediate shaft (C85612) (fig. 119). Lift underdrive gear (C85620) and clutch collar (B184256) out of case (fig. 120).

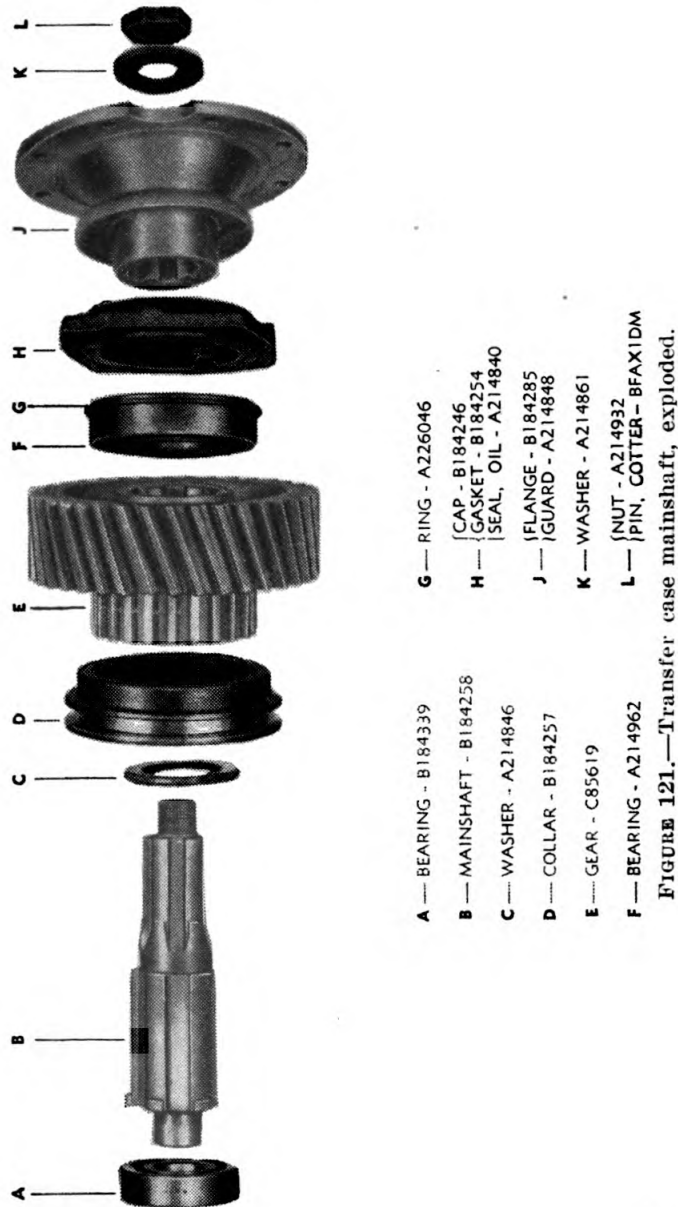

FIGURE 121.—Transfer case mainshaft, exploded.

(12) Remove intermediate shaft bearing cups—brass drift, hammer. Drive cups (A214964) out of front end of case and out of rear bearing cap (fig. 117).

(13) Remove mainshaft companion flange—cutting pliers, 1½-inch socket wrench, puller. Remove cotter pin (BFA1DM), slotted nut

(A214932), and washer (A214861), holding companion flange (B184285) to shaft and pull flange off shaft (figs. 121 and 122).

(14) Remove transfer case mainshaft rear bearing cap— $\frac{5}{8}$ -inch socket wrench, brass drift, hammer. Remove four cap screws (BCAX1DE) and lock washers (BECX1L) holding rear bearing cap to case and remove cap (B184246) and gasket (B184254) (fig. 121). Drive oil seal (A214840) from cap if necessary to replace seal.

(15) Remove transfer case mainshaft—brass drift, hammer. Drive or press on rear end of shaft until it is free from underdrive gear. Remove mainshaft (B184258) (fig. 123). Rear bearing thrust

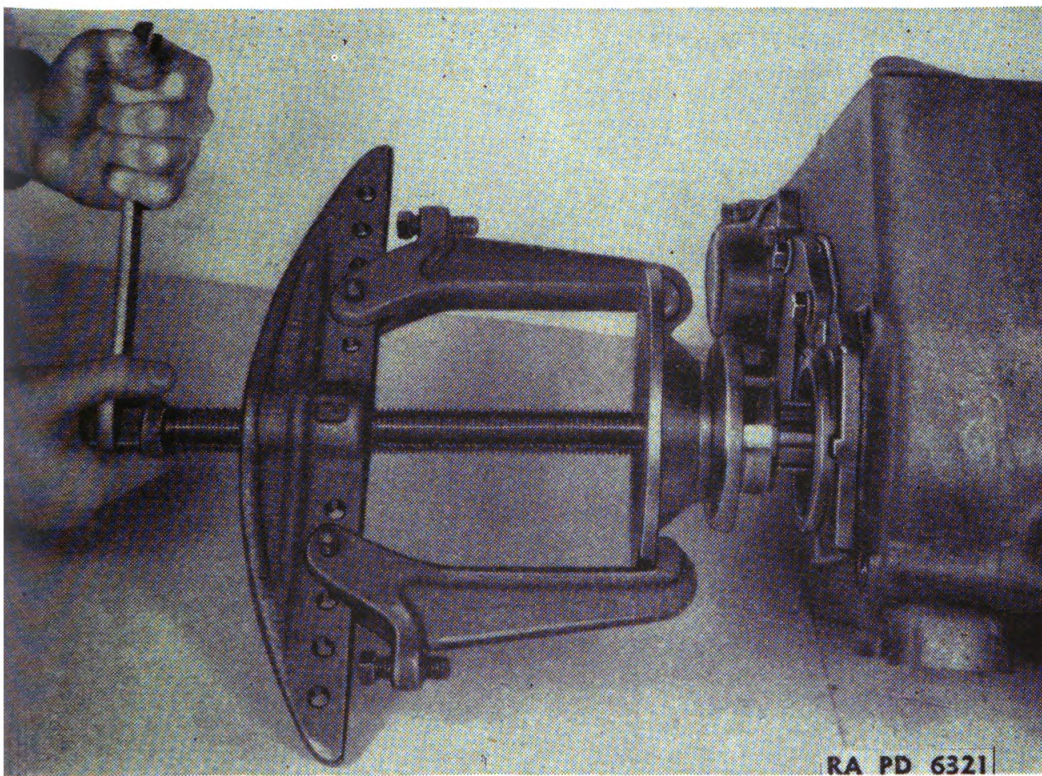

FIGURE 122.—Transfer case mainshaft companion flange removal.

washer (A214846) will fall to bottom and can be lifted from case. Lift out mainshaft underdrive gear (C85619) and clutch collar (B184257) (fig. 124).

(16) Remove mainshaft rear bearing—brass drift, hammer, screw driver. Drive mainshaft rear ball bearing (A214962) out of case, driving from the inside (fig. 121). Remove snap ring (A226046) from bearing.

(17) Remove shift rod poppet balls— $\frac{3}{4}$ -inch socket wrench. Remove two screw type plugs (A214967) from outer right side of trans-

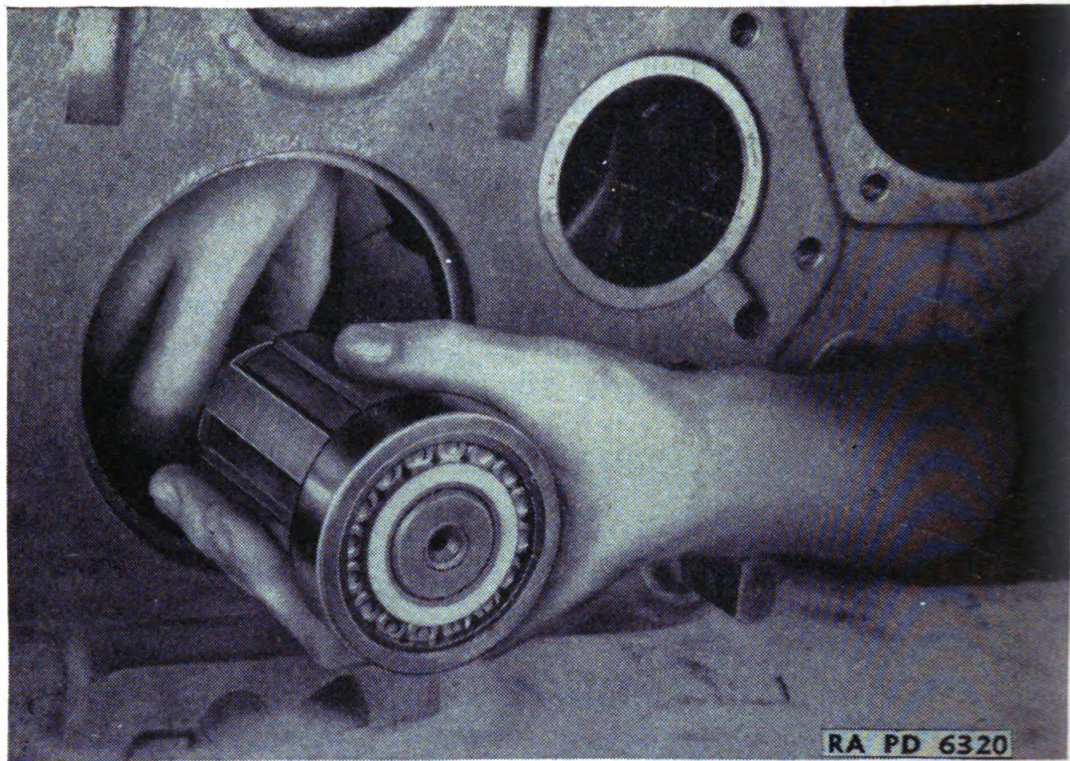

FIGURE 123.—Transfer case mainshaft removal.

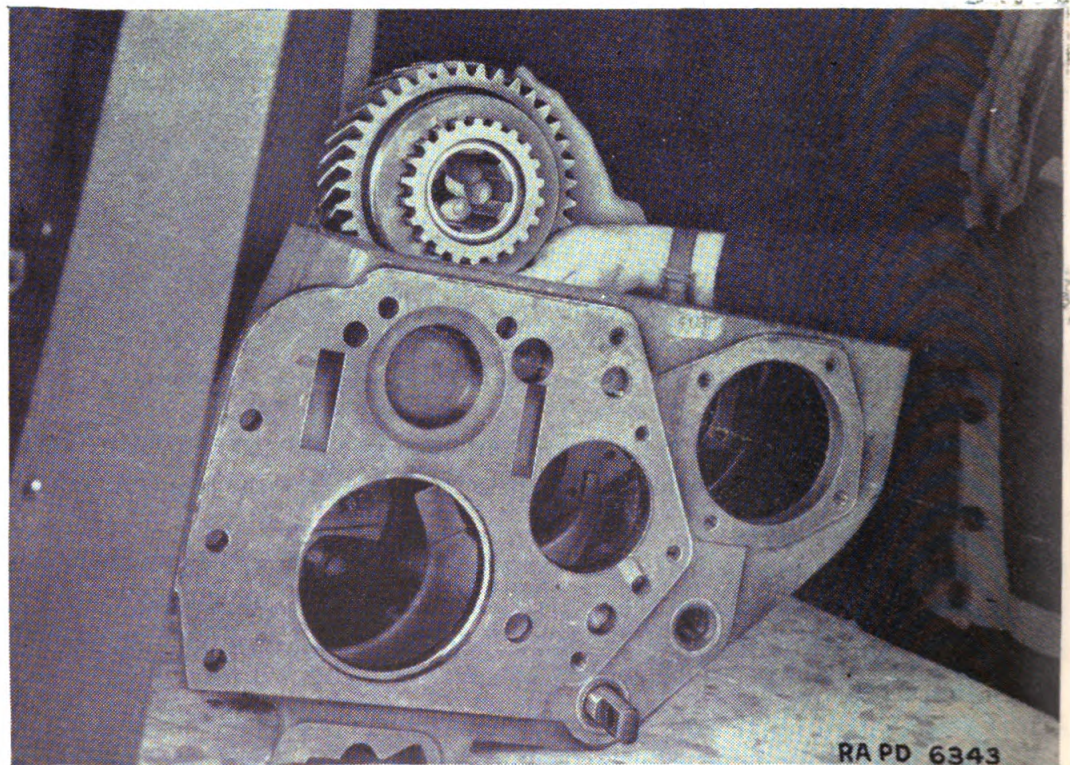

FIGURE 124.—Transfer case mainshaft underdrive gear removal.

POWER TRAIN

fer case, and remove shift rod poppet springs (A214835) and poppet balls (A214786) (figs. 77 and 125).

(18) Remove front-drive shaft shift rod—cutting pliers,  $\frac{7}{16}$ -inch square socket wrench, brass drift, hammer (or press). Remove locking wire and set screw (A214774) holding front-drive shaft shift fork (C85607) to shift rod (B184247) (figs. 125 and 126). Remove front-drive shaft shift rod rocker interlock (A214831) by pushing fork toward rear of case and pressing down on one end of interlock and lifting out of slot in shaft. Pull shaft out and lift the following out of case: shift fork, shift rod bracket (A214837),

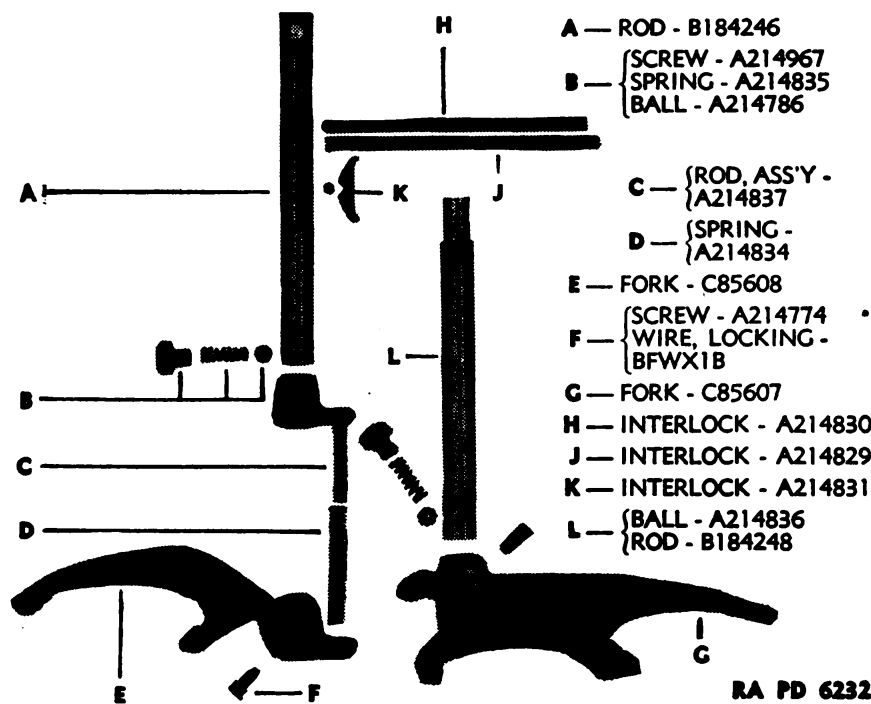

FIGURE 125.—Transfer case shifting mechanism, exploded.

spring (A214834), and interlock ball (A214836). Drive or press front-drive shaft shift rod bushing (A214823) and oil seal (A214842) out of case if necessary to replace bushing or seal.

(19) Remove direct- and underdrive-shift rod—cutting pliers,  $\frac{7}{16}$ -inch square socket wrench. Cut locking wire and remove set screw (A214774) holding direct- and underdrive-shift fork (C85608) to shift rod (B184248) (figs. 125 and 126). Pull shaft out of case and lift fork out.

(20) Remove shift rod oil seal—brass drift, hammer. Drive direct- and underdrive-shift rod oil seal (A214842) out of case, if necessary to replace.

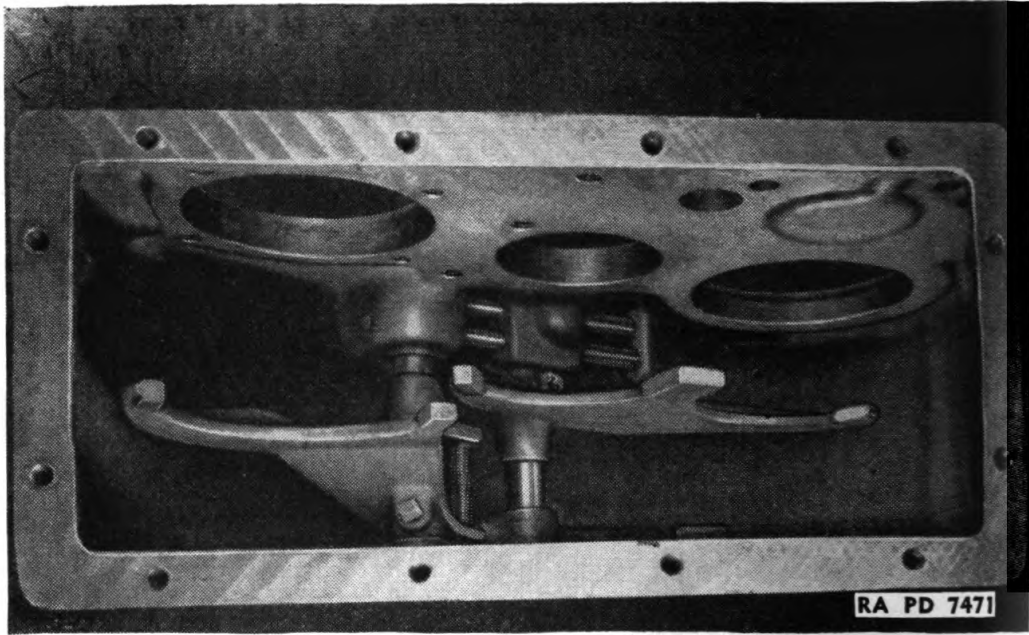

FIGURE 126.—Transfer case shifting mechanism, installed.

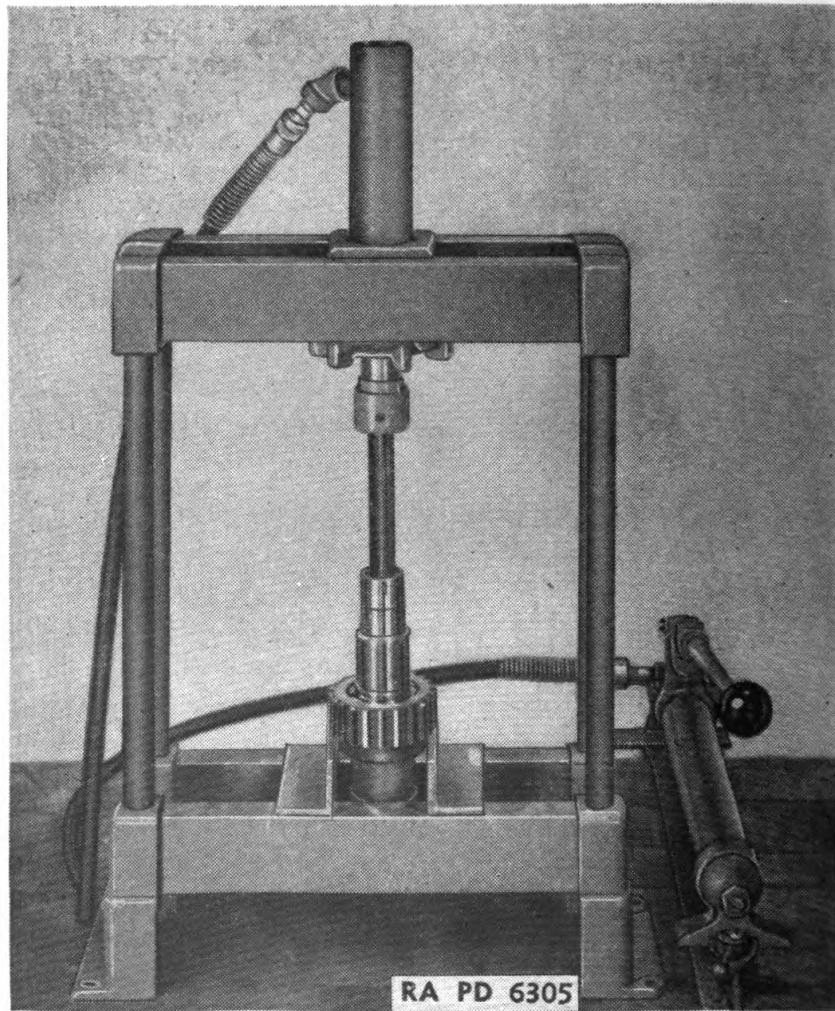

FIGURE 127.—Pressing clutch gear off front-drive shaft.

## POWER TRAIN

*g. Transfer case front drive shaft.*—Tools:  $\frac{3}{4}$ -inch socket wrench,  $\frac{9}{16}$ -inch socket wrench, cutting pliers,  $\frac{3}{4}$ -inch box wrench, pinch bar,  $\frac{7}{16}$ -inch socket wrench, pliers,  $1\frac{1}{2}$ -inch socket wrench, puller,  $\frac{5}{8}$ -inch socket wrench, brass drift, hammer, press, arbor.

(1) Remove front-drive shaft from case. Proceed as outlined in steps in *f*(1) through (6) above.

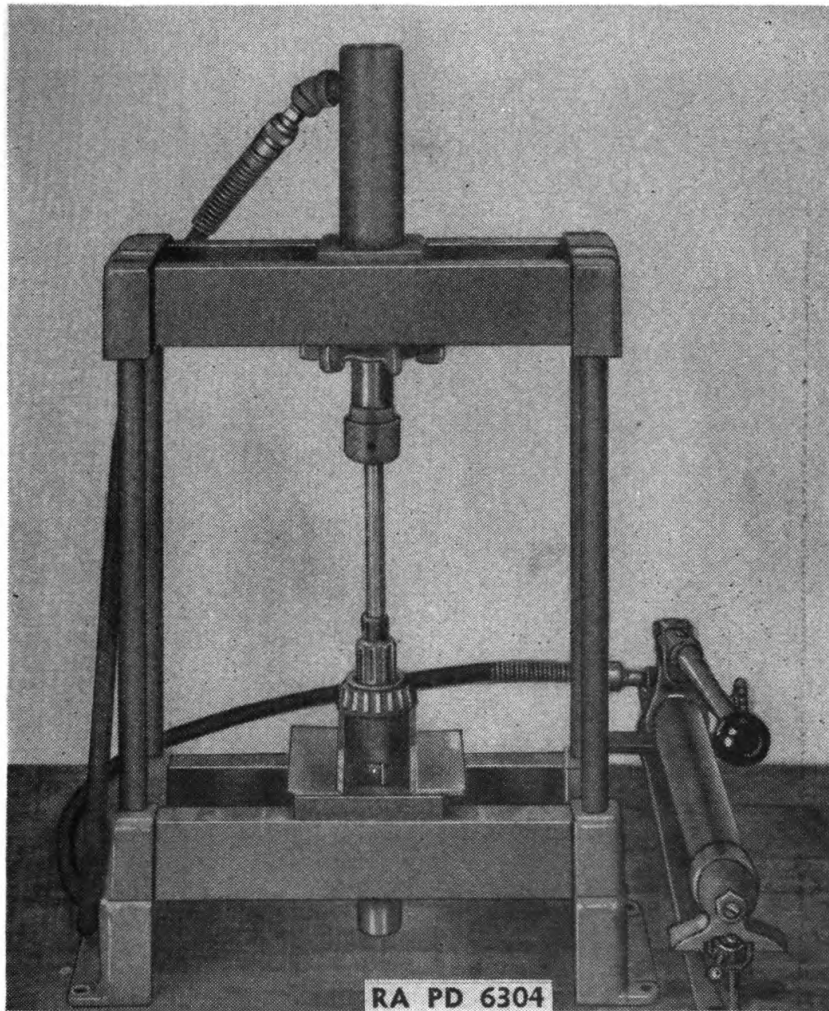

FIGURE 128.—Pressing front bearing off front-drive shaft.

(2) Remove clutch gear—press, brass drift, hammer. Set up in press and remove clutch gear (B184255) and Woodruff key (A214828) (fig. 127).

(3) Remove front-drive shaft front bearing cone—press. Set up in press and remove front bearing cone and rollers (A214965) (fig. 128).

*h. Transfer case intermediate shaft.*—Tools same as listed in *g* above plus  $\frac{7}{8}$ -inch open end wrench.

(1) Remove intermediate shaft from case. Proceed as outlined in steps in *f*(1) through (11) above.

(2) Remove intermediate shaft rear bearing cone—press. Set up in press and remove bearing cone and rollers (A214965) (fig. 129).

*i. Transfer case mainshaft.*—Tools same as listed in *g* plus the  $\frac{7}{8}$ -inch open end wrench.

(1) Remove mainshaft from case. Proceed as outlined in steps in *f*(1) through (15) above.

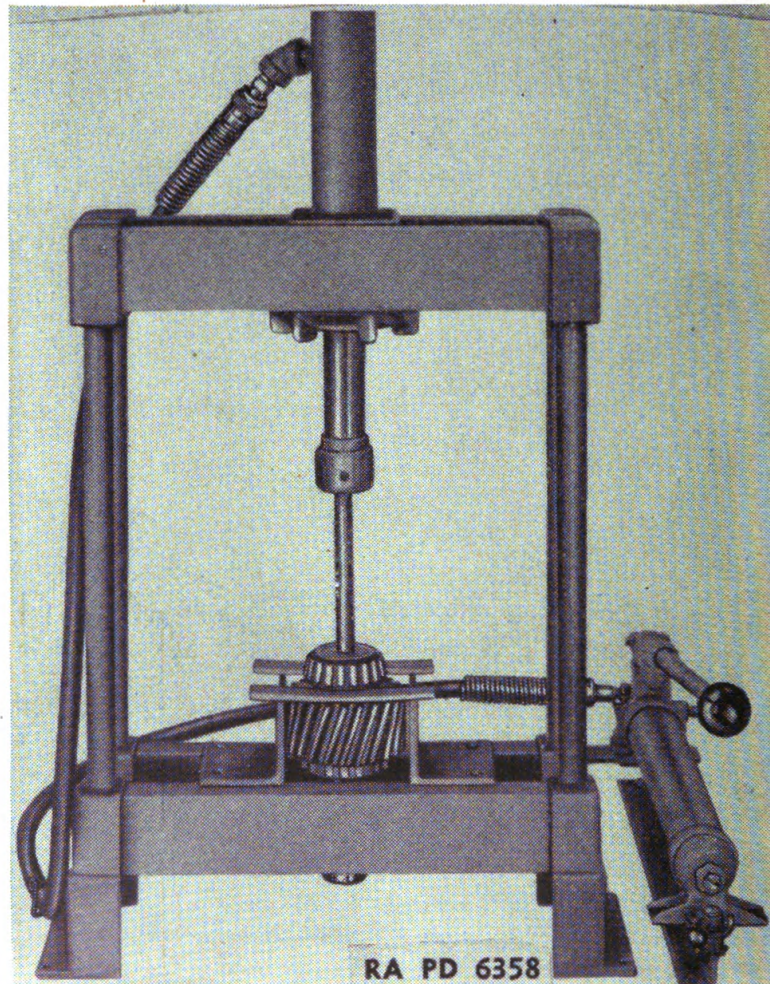

FIGURE 129.—Pressing rear bearing off intermediate shaft.

(2) Remove mainshaft front pilot bearing—press. Set up in press and remove bearing (B184339) (fig. 130).

**36. Maintenance and adjustments.**—Before inspection of parts, clean each component thoroughly in cleaning fluid and remove all traces of old lubricant.



*a. Cleaning bearings.*—(1) Place all shaft roller and ball bearings into cleaning fluid and allow them to remain long enough to loosen old grease and lubricant.

(2) After soaking thoroughly, bearings should be alternately slushed up and down and spun slowly below the surface of the liquid to remove as much of the old grease as possible.

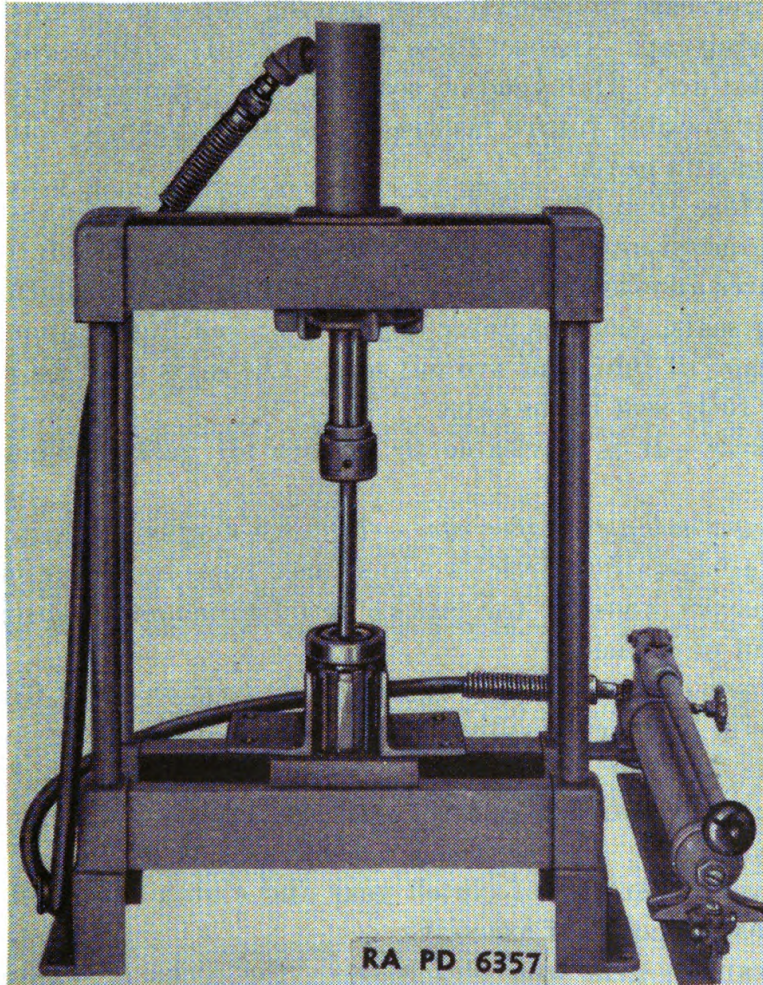

FIGURE 130.—Pressing front bearing off mainshaft.

(3) Remove the bearings from solvent and strike the side of the bearings against a wooden block to jar loose heavier and harder particles of lubricant.

(4) Repeat immersions and striking operations until bearings are cleaned.

(5) Blow out bearings, being careful to direct air pressure across bearings to remove last traces of old lubricant without spinning the bearing.

(6) Inspect rollers, balls, and races carefully for chipping, cracks, or worn spots to determine fitness of bearings for future use.

(7) Replace bearings with new ones if they are damaged. Lubricate before assembling with light oil to prevent scoring during initial periods of operation after reassembly, before the transmission oil has been able to penetrate.

*b. Oil seals.*—(1) Spring-loaded leather type oil seals are used in the transfer case mainshaft rear bearing cap and front-drive shaft front bearing cap. Inspect these seals carefully at disassembly for evidence of failure. Damaged oil seals should be replaced with new ones to prevent possible future failure of the seals that may cause damage to bearings and gears.

(2) Before installing the oil seals soak them in neat's-foot oil or warm engine oil until the leather portion of the seal is soft and pliable. This assures an efficient leakproof seal and assists installation. When installing seals, coat the outer edge with a sealing compound to prevent leakage of lubricant around seal. Oil seals must be replaced so that they fully seat in the caps.

*c. Gaskets.*—It is advisable to replace all gaskets when reassembling.

*d. Transmission-transfer case.*—Remove magnetic drain plugs and clean off all metallic particles which may have been attracted by the plug. Inspect housing for cracks or misalignment, especially after an accident or collision.

*e. Transmission mainshaft and main drive gear.*—(1) Check condition of main drive gear spline for evidences of chipping, twisting, or wear. Replace the gear if worn excessively. (See par. 32c.)

(2) Inspect mainshaft splines and clutch teeth, and replace if worn or chipped.

(3) Check clearance of clutch gear and clutch collar on shaft and replace gear or collar if excessive.

(4) Examine gear and clutch teeth for nicks or excessive wear. Remove small nicks with a slipstone. Replace badly worn gears.

(5) Check thickness of thrust washers and replace when necessary.

(6) Check clearances between gears and shaft. If excessive, rebush gears or replace.

(7) Clean and inspect bearings and replace worn or scored bearings.

*f. Transmission countershaft.*—(1) Inspect gear teeth for wear or nicks. Replace if necessary.

(2) Inspect spline on shaft for wear or chipping. Replace shaft if spline is worn.

(3) Check clearance of first speed gear on shaft. Replace or rebush gear if excessive.

(4) Check thickness of thrust washers. Replace if worn.

(5) Clean and inspect bearings.

*g. Transmission reverse idler gear.*—(1) Inspect gear teeth for wear. Replace if worn.

(2) Check clearance of bushings on shaft. Replace if worn.

(3) Inspect shaft for wear. Replace if necessary.

(4) Check thickness of thrust washers. Replace if worn.

*h. Transfer case front-drive shaft.*—(1) Inspect shaft for wear, especially at points of contact with needle bearings. Replace if worn.

(2) Inspect gear teeth for wear and nicks. Replace if chipped or worn excessively.

(3) Inspect needle bearings for wear, scratches, or nicks. Replace if worn.

(4) Check thickness of thrust washers. Replace if worn.

(5) Check clearance of clutch collar on clutch gear and of front-drive shaft gear on shaft. Replace shaft or collar if clearance is excessive.

(6) Clean and inspect bearings.

(7) Shims are provided on the rear bearing cap to adjust end play of the tapered roller bearings. Remove or replace a sufficient number of shims to allow the shaft to rotate freely with a minimum amount of end play.

*i. Transfer case intermediate shaft.*—(1) Inspect shaft for wear especially at points of contact with needle bearings. Replace if worn.

(2) Inspect gear teeth for wear and nicks. Replace gear if worn excessively.

(3) Inspect needle bearings for wear, scratches, or nicks. Replace if worn.

(4) Check thickness of thrust washer. Replace if worn.

(5) Check clearance of clutch collar on gear and gear on shaft. Replace collar or shaft if clearance is excessive. Rebush where possible.

(6) Shims are provided on the rear bearing cap for adjustment of tapered roller bearing and shaft end play.

*j. Transfer case mainshaft.*—(1) Inspect shaft for wear or twisting. Replace if excessive.

(2) Inspect clutch collar and clutch teeth on gear. Replace if worn.

(3) Inspect gear teeth for wear. Replace gear if excessive.

(4) Clean and inspect bearings.

*k. Service data—(1) Transmission.*

*(a) Mainshaft and gears.*

Clearance between—

Mainshaft and clutch gear.....	.002-.006 inch
Mainshaft and first, second, and third speed gears.....	.003-.005 inch
Shift forks and clutch gear and collar.....	.026-.050 inch

Backlash:

Clutch gear and collar.....	.004-.008 inch
First and second speed gears.....	.006-.010 inch
Third speed gear.....	.004-.007 inch
Main drive gear.....	.004-.007 inch
Mainshaft out of true, not over.....	.002 inch
Main drive gear out of true, not over.....	.002 inch
Third speed gear thrust washer thickness....	.144-.149 inch
Second and third speed gear thrust washer thickness.....	.174-.179 inch
First speed gear thrust washer thickness....	.152-.158 inch

*(b) Countershaft.*

Clearance between shift fork and clutch gear.... .026-.050 inch

Backlash:

Countershaft reverse speed clutch gear.....	.004-.008 inch
Countershaft out of true, not over.....	.002 inch
Rear bearing thrust washer thickness.....	.119-.123 inch

*(c) Reverse idler.*

Clearance between reverse idler gear bushing and  
shaft..... .003-.008 inch

Backlash:

Reverse idler gear:	
Spur gear portion.....	.008-.012 inch
Helical gear portion.....	.006-.010 inch
Reverse idler gear thrust washer thickness....	.085-.090 inch

*(d) Shifter mechanism.*

Poppet springs—first and second and third and  
fourth speed shift rods:

Free length.....	$\frac{7}{8}$ inch
Pressure at $\frac{45}{64}$ -inch length.....	18 pounds

Poppet spring—reverse shift rod:

Free length.....	$1\frac{3}{16}$ inch
Pressure at $\frac{23}{32}$ -inch length.....	30 pounds

Reverse shift bracket lock spring:

Free length.....	17/8 inches
Pressure at 13/8-inch length.....	38 pounds
Poppet and interlock balls.....	3/8-inch diameter

(2) *Transfer case.*

(a) *Mainshaft and gears.*

Clearance between shifter fork on clutch collar... .058-.075 inch

Backlash:

Underdrive gear.....	.006-.010 inch
Direct- and underdrive-clutch collar.....	.004-.008 inch
Mainshaft out of true, not over.....	.002 inch
Underdrive gear thrust washer thickness.....	.172-.178 inch

(b) *Intermediate shaft.*

Backlash:

Intermediate shaft gears.....	.006-.010 inch
Clutch collar.....	.004-.008 inch
Underdrive gear inner diameter.....	2.2505-2.2515 inches
Shaft diameter at needle bearings.....	1.9985-1.9995 inches

Needle bearings:

Quantity.....	106
Diameter.....	1.2450-.12500 inches
Length.....	1.125 inches

Bearing and shaft end play adjustment..... Shims

Location of shims..... Rear bearing cap

Shim thickness:

B184288.....	.003 inch
B184289.....	.010 inch
B184290.....	.031 inch

Adjustment..... No perceptible end play

Shaft out of line, not over..... .002 inch

(c) *Front drive shaft.*

Backlash:

Front-drive shaft gear.....	.006-.010 inch
Clutch collar.....	.004-.008 inch
Front-drive shaft gear inner diameter.....	2.2505-2.2515 inches
Shaft diameter at needle bearings.....	1.9990-2.0000 inches

Needle bearings:

Quantity.....	106
Diameter.....	.12450-.12500 inch
Length.....	.925 inch

Bearing and shaft end play adjustment..... Shims

Location of shims.....	Rear bearing cap
Shim thickness:	
B184291.....	.003 inch
B184292.....	.010 inch
B184293.....	.031 inch
Adjustment.....	No perceptible end play
Thrust washer thickness.....	.185-.190 inch
<i>(d) Shifter mechanism.</i>	
Clearance, front-drive shaft shift rod bushing....	.001-.005 inch
Poppet springs:	
Free length.....	1 $\frac{7}{32}$ inches
Pressure at 1-inch length.....	38 pounds
Interlock bracket guide pin spring:	
Free length.....	3 inches
Pressure at 1 $\frac{3}{4}$ -inch length.....	3 pounds
Poppet balls.....	$\frac{7}{16}$ -inch diameter
Rocker-interlock ball.....	$\frac{5}{16}$ -inch diameter

**37. Reassembly of components.**—*a. Transfer case front drive shaft.*—Replace front-drive shaft clutch gear—brass drift, hammer, press. Replace Woodruff key and set shaft and gear in press and reassemble (fig. 131).

*b. Transfer case.*—Tools: oil seal driving tool,  $\frac{7}{16}$ -inch square socket wrench, pliers,  $\frac{3}{4}$ -inch socket wrench, brass drift, hammer, screw driver,  $\frac{5}{8}$ -inch socket wrench,  $\frac{9}{16}$ -inch socket wrench,  $\frac{7}{8}$ -inch open end wrench,  $\frac{1}{2}$ -inch socket wrench.

(1) Replace front-drive shaft shift fork and rod—oil seal replacer tool, hammer. Replace shift rod bushing, bushing pin, and new oil seal in hole in front side of case (fig. 78). Bushing holes must line up with holes drilled in case inner boss for two rod type interlocks on one side and with pin hole on other side. Place front-drive shaft shift rod interlock bracket into case with guide pin projecting toward rear. Tap front-drive shaft shift rod through its hole from front of case, pushing rod through interlock bracket. Set front-drive shift fork into position with set screw hole toward rear of case and push rod through fork (figs. 79, 125, and 126). Rotate rod so that interlock slot will be facing upward, and drop interlock ball into slot in shaft. Place shift rod rocker-interlock over ball and work rod until ball and interlock drop into place. Turn rod slightly to left and press down on interlock to permit it to slide in under interlock bracket. Pull back slightly on rod and replace interlock bracket guide pin spring. Depress spring, turn rod slightly to right, and insert guide pin into hole in the shift fork (fig. 126). Replace set screw and lock wire in fork after lining up fork

set screw hole with hole in rod. Locking wire should pass through small hole drilled for it in fork.

(2) Replace direct- and underdrive-shift rod oil seal—hammer, oil seal replacer. Drive new oil seal in place in front of case (fig. 79).

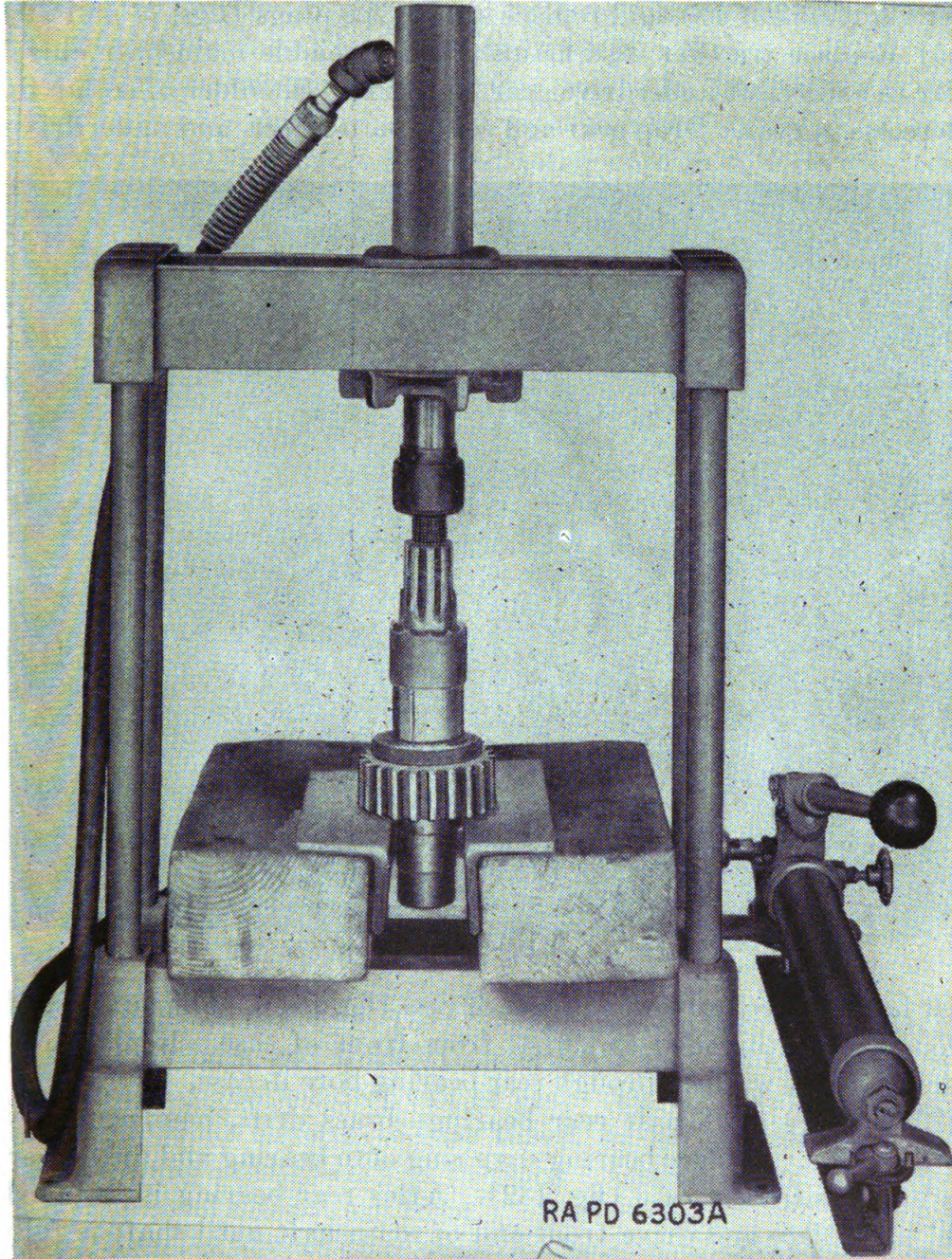

FIGURE 131.—Pressing clutch gear on front drive shaft.

(3) Replace direct- and underdrive-shift fork and rod— $\frac{7}{16}$ -inch square socket wrench, pliers, hammer. Place shift fork in case with set screw hole toward front. Tap shift rod through its hole in front of

case, and through shift fork (fig. 126). Line up set screw holes in fork and shift rod. Replace set screw and locking wire, passing wire through hole provided for it in shift fork.

(4) Replace transfer case shift rod poppet balls and springs— $\frac{3}{4}$ -inch socket wrench. Drop two poppet balls and springs into holes in outer right side of case and replace screw type plugs (figs. 77 and 79).

(5) Replace transfer case mainshaft. Assemble mainshaft clutch collar in mainshaft underdrive gear (fig. 121). Shoulder of collar fits into recess in gear. Drop gear and collar onto direct- and underdrive-

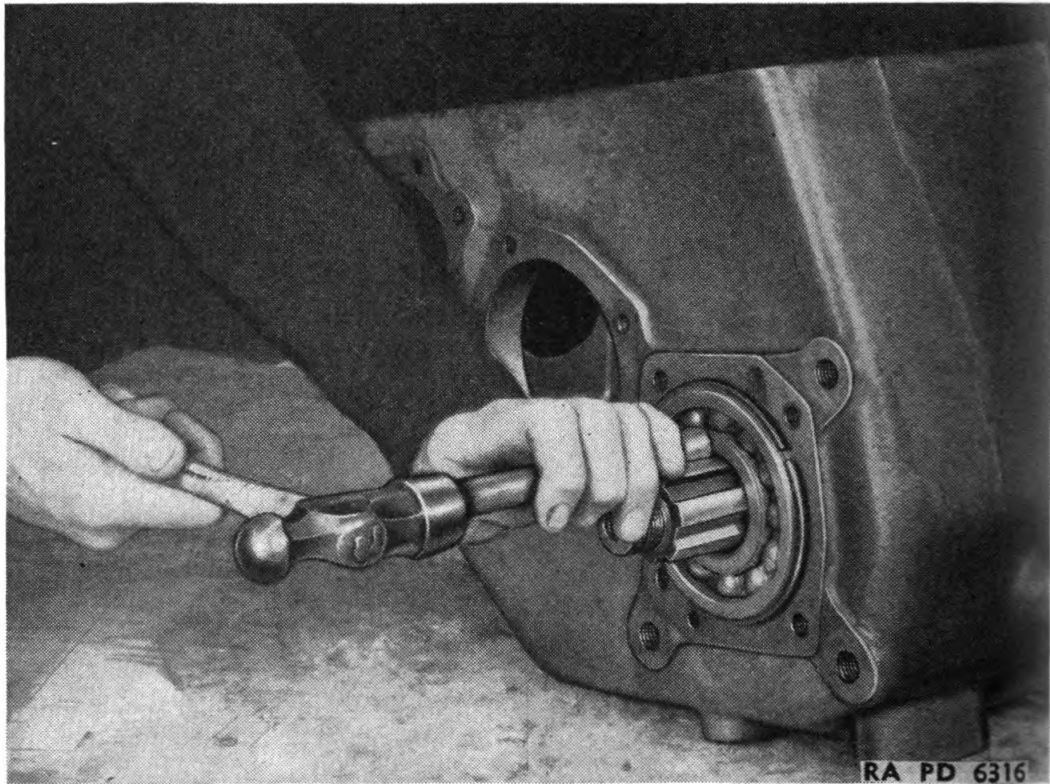

FIGURE 132.—Transfer case mainshaft rear bearing replacement.

shift fork with collar toward front of case (fig. 134). Slide mainshaft through gear, threaded end first, from front of case. Replace rear bearing thrust washer through rear bearing bore in case.

(6) Replace mainshaft rear bearing—brass drift, hammer, screw driver, pliers. Replace bearing snap ring onto bearing and drive bearing into position in case (fig. 132). After rear bearing is installed, hold it in place and drive front end of mainshaft until shaft is fully engaged in underdrive gear. Replace front pocket bearing on front end of mainshaft.



(7) Replace mainshaft rear bearing cap—oil seal replacer, hammer,  $\frac{5}{8}$ -inch socket wrench. Replace oil seal in cap and replace rear bearing cap, gasket, and four cap screws and lock washers.

(8) Replace intermediate shaft underdrive gear needle bearings. Grease bore of the intermediate shaft underdrive gear with a heavy and stiff grease and assemble 106 long needle bearings in two rows with needle bearing spacer between rows (fig. 133).

(9) Replace intermediate shaft. Assemble intermediate shaft clutch collar in underdrive gear with shoulder of collar in recess in gear (fig. 117). Drop gear and collar onto shift fork with collar

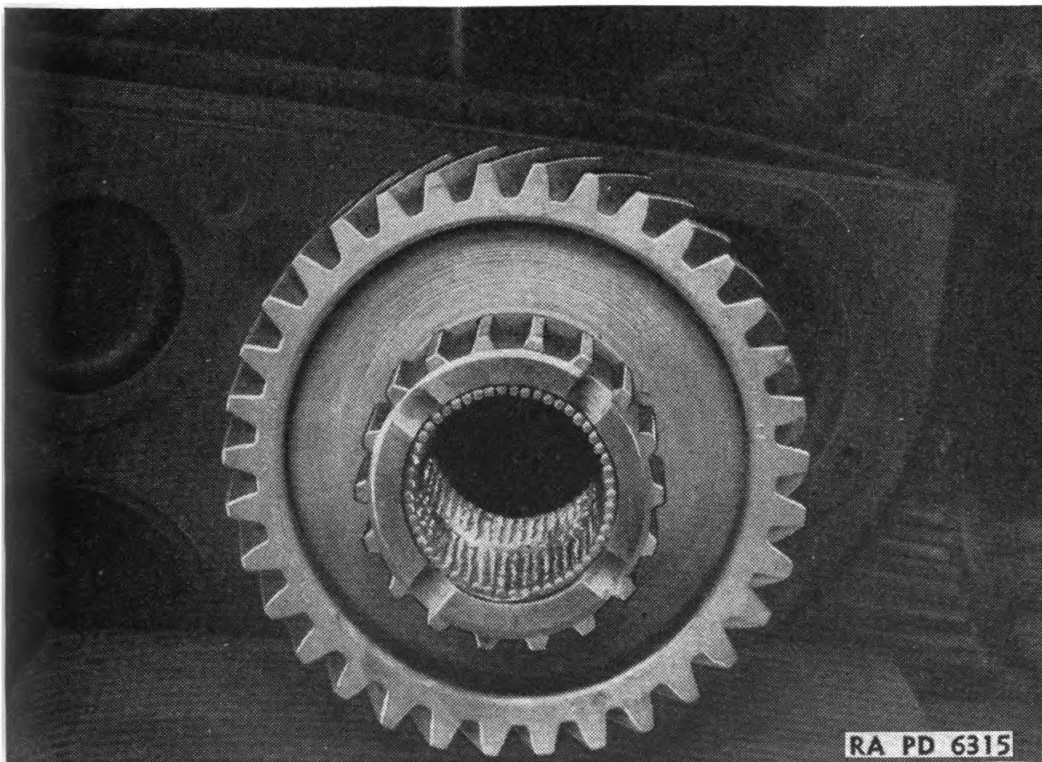

FIGURE 133.—Needle bearings installed in intermediate shaft underdrive gear.

toward rear of case (fig. 134). Slide intermediate shaft through rear bearing bore and through underdrive gear, being careful that needle bearings do not drop out of gear. Do not rotate shaft while inserting. Hold underdrive-gear thrust washer against gear as an aid in keeping needle bearings in place. Assemble thrust washer on shaft with bevel side toward front.

(10) Replace intermediate shaft bearing cones—brass drift, hammer,  $\frac{9}{16}$ -inch socket wrench, pliers. Tap bearing cones into place on both ends of intermediate shaft. Replace front bearing retainer washer, two screws, and lock wire (fig. 117).

(11) Replace intermediate shaft rear bearing cap—brass drift, hammer,  $\frac{5}{8}$ -inch socket wrench. Replace bearing cup in rear bearing cap and assemble bearing cap and shims to case with four cap screws and lock washers.

(12) Replace intermediate shaft front bearing cup—brass drift, hammer. Set cup in place and tap until almost flush with case.

(13) Replace front-drive shaft gear needle bearings. Grease bore of gear with heavy grease and install 106 short needle bearings in two rows with spacer between (fig. 135).

(14) Replace front-drive shaft. Assemble front-drive shaft collar with front-drive shaft gear. Shoulder of collar sets into recess in

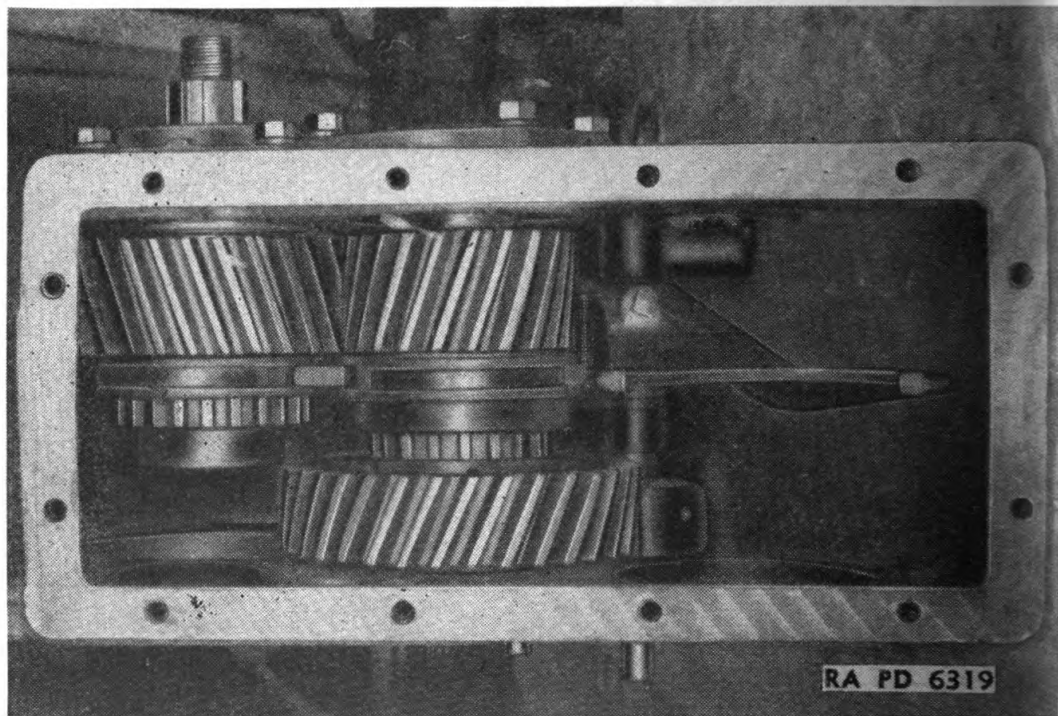

FIGURE 134.—Transfer case mainshaft and intermediate shaft, installed.

gear (fig. 111). Place gear and collar in case on shift fork with collar toward front of case. Place thrust washer in recess of clutch gear mounted on shaft. Slide front-drive shaft through front bearing bore of case and through front-drive shaft gear, being careful not to push needle bearings out of gear (fig. 136). Replace gear thrust washer on shaft from rear of case.

(15) Replace front-drive shaft front and rear bearings—brass drift, hammer. Replace front and rear bearing cones and cups by driving in place (figs. 137, 138, and 139).

(16) Replace front-drive shaft front bearing cap—oil seal replacer, hammer,  $\frac{5}{8}$ -inch socket wrench. Replace new oil seal in

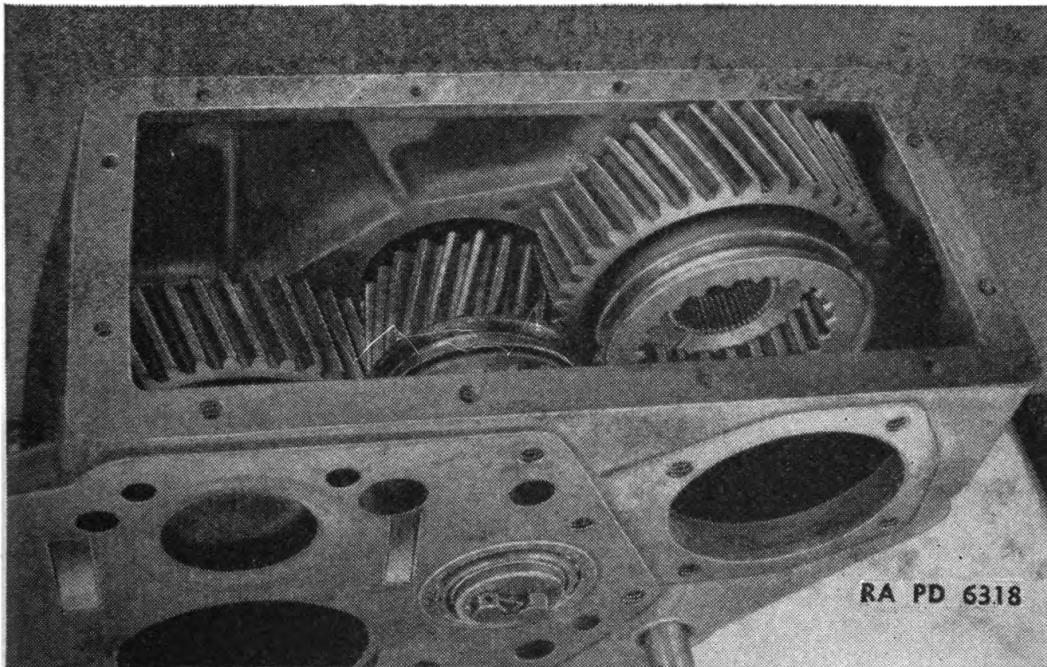

FIGURE 135.—Transfer case front-drive shaft gear replacement.

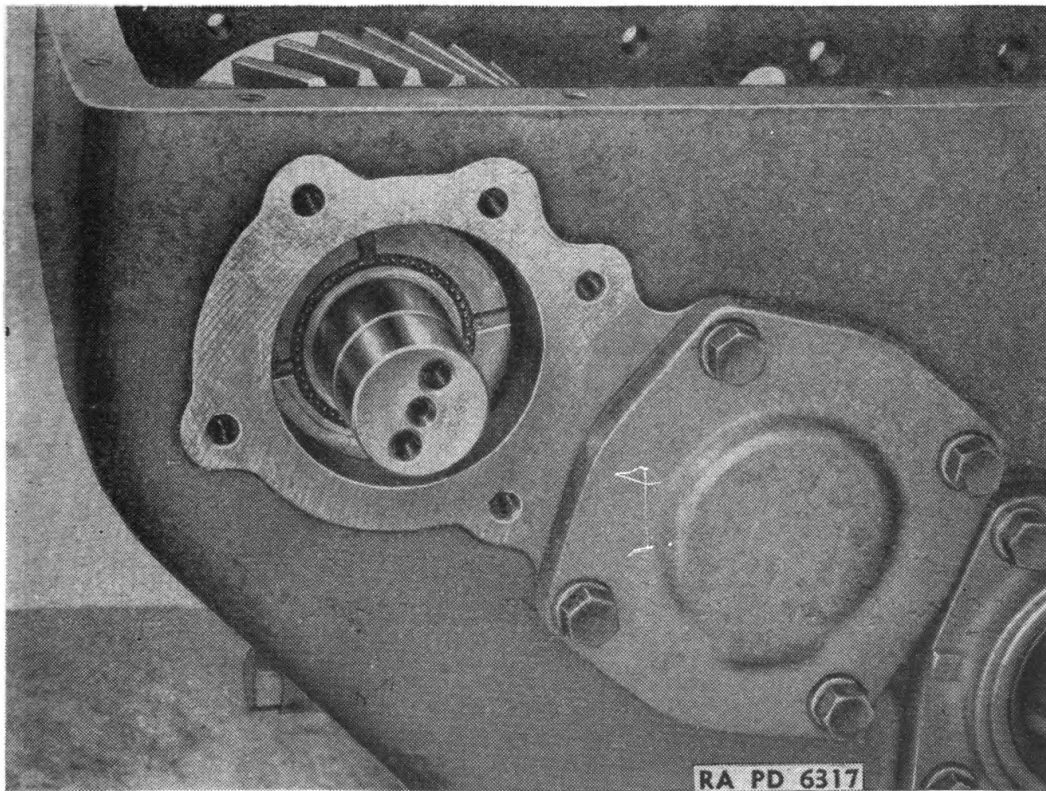

FIGURE 136.—Transfer case front-drive shaft, installed.

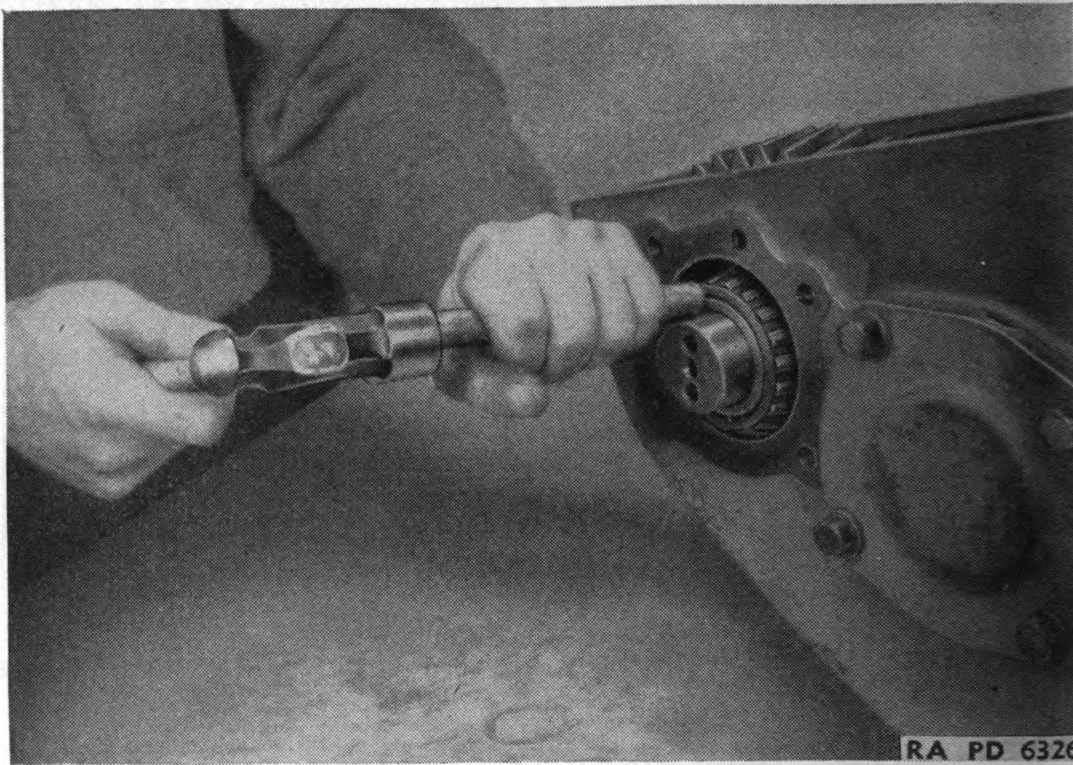

FIGURE 137.—Transfer case front-drive shaft rear bearing cone replacement.

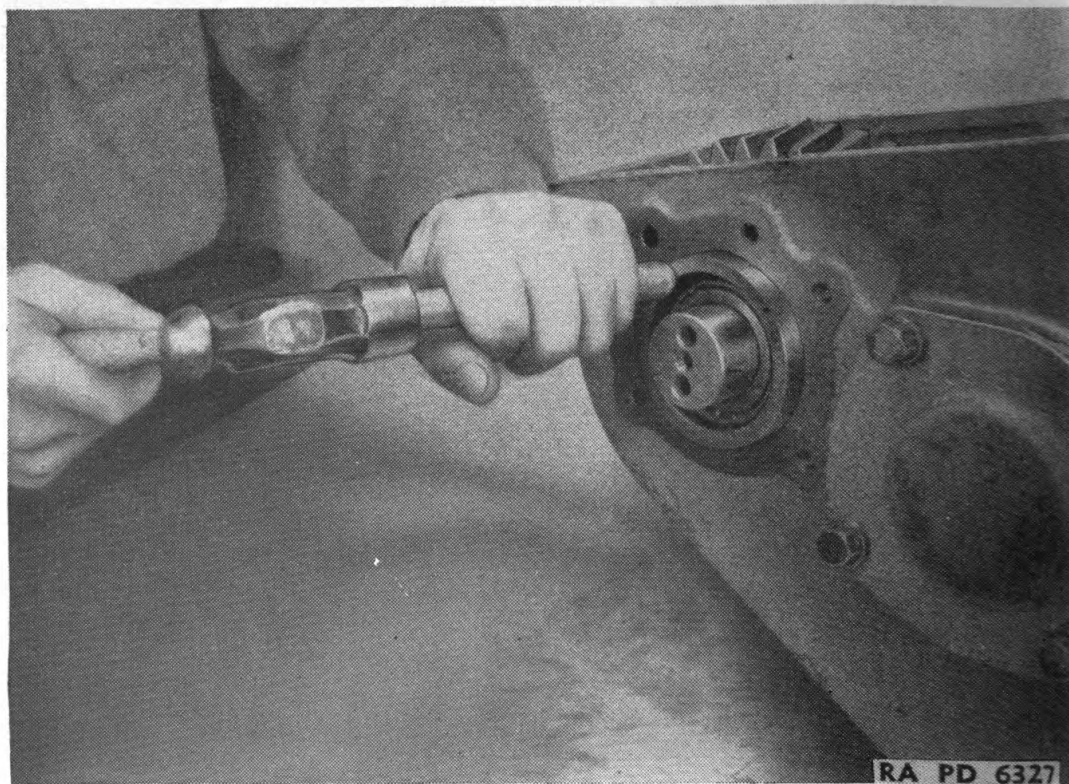

FIGURE 138.—Transfer case front-drive shaft rear bearing cup replacement.

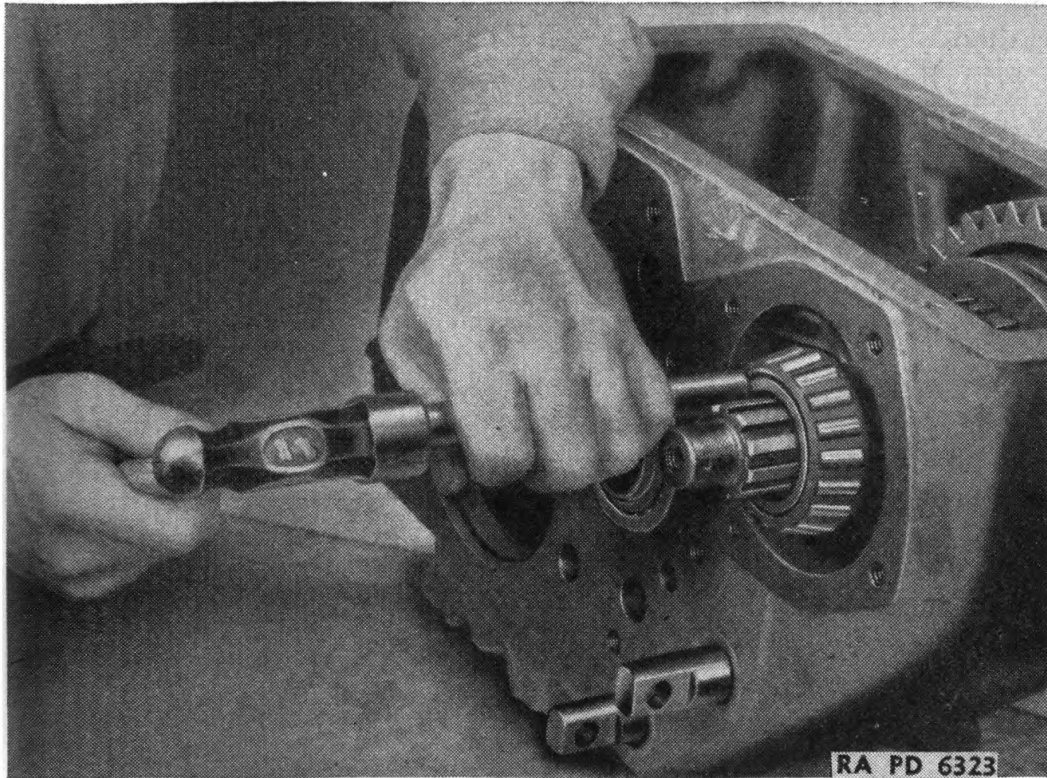

FIGURE 139.—Transfer case front-drive shaft front bearing cone replacement.

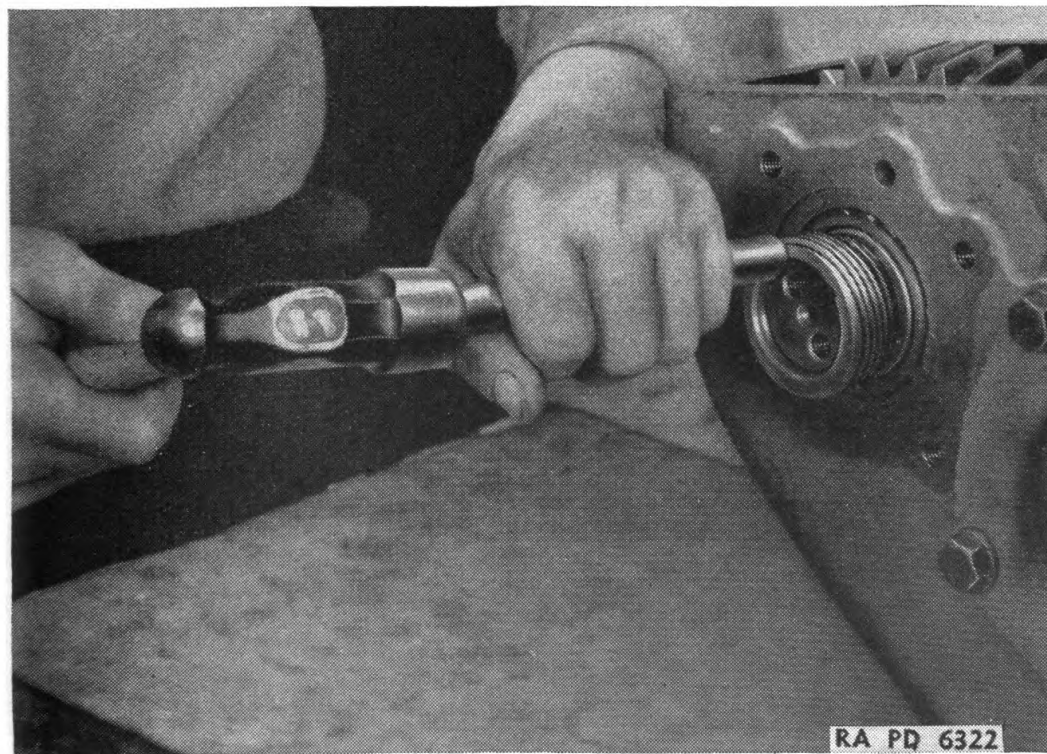

FIGURE 140.—Speedometer drive gear replacement.

cap and replace cap and gasket with four cap screws and lock washers.

(17) Replace speedometer drive gear—brass drift, hammer,  $\frac{9}{16}$ -inch socket wrench, pliers. Replace Woodruff key and drive speedometer drive gear on rear end of front-drive shaft (fig. 140). Replace retaining washer, two cap screws, and locking wire.

(18) Assemble front-drive shaft rear bearing cap—brass drift, hammer,  $\frac{7}{8}$ -inch open end wrench. Replace bushing in cap and replace speedometer driven gear and sleeve.

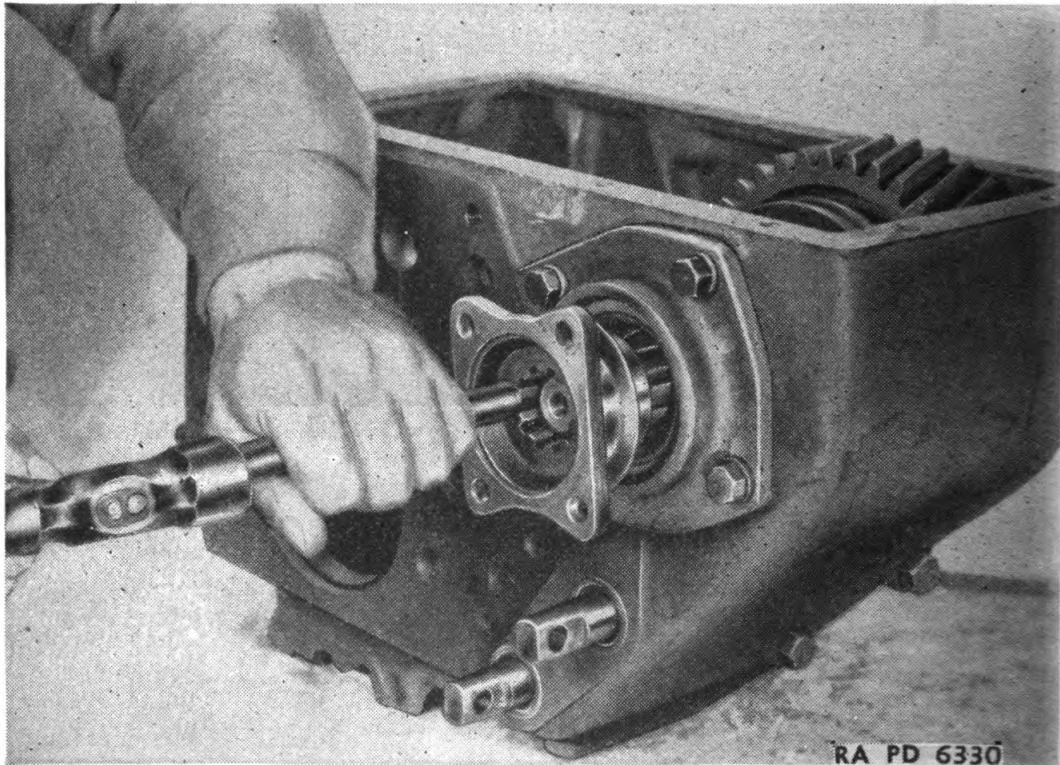

FIGURE 141.—Transfer case front-drive shaft companion flange replacement.

(19) Replace front-drive shaft rear bearing cap— $\frac{5}{8}$ -inch socket wrench. Replace cap and shims with two long and two short cap screws and four lock washers.

(20) Replace front-drive shaft companion flange—brass drift, hammer, pliers,  $\frac{1}{2}$ -inch socket wrench. Drive flange on front end of shaft and replace washer, nut, and cotter pin (fig. 141).

(21) Replace mainshaft companion flange—brass drift, hammer, pliers,  $\frac{1}{2}$ -inch socket wrench. Drive flange on rear end of shaft and replace washer, nut, and cotter pin (fig. 142).

*c. Shifter housing* (figs. 79, 85, 86, and 143).—Tools:  $\frac{5}{8}$ -inch box wrench,  $\frac{7}{8}$ -inch open end wrench, pliers, small diameter brass drift,

$\frac{3}{8}$ -inch square socket wrench, peen hammer,  $1\frac{3}{8}$ -inch open end wrench, brass drift, hammer.

(1) Replace reverse and first relay lever— $\frac{5}{8}$ -inch box wrench,  $\frac{7}{8}$ -inch open end wrench, pliers. Set lever in place and replace shoulder screw, nut, and cotter pin (fig. 143A).

(2) Replace poppet springs. Drop three poppet springs into place in housing by dropping through holes in center (fig. 143B).

(3) Replace first and second speed shift rod—thin brass drift,  $\frac{3}{8}$ -inch square socket wrench. Place first and second speed shift fork

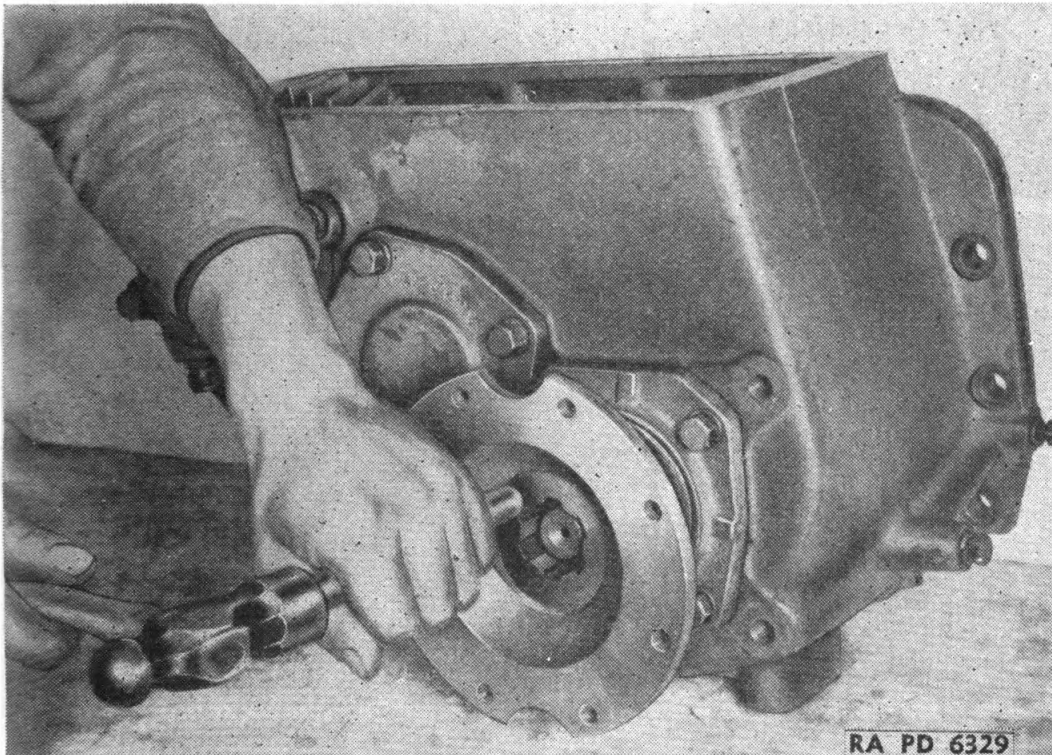

FIGURE 142.—Transfer case mainshaft companion flange replacement.

in position with set screw hole toward front. Slide shift rod through hole in rear end of housing and through fork (fig. 143C). Drop poppet ball into hole in which poppet spring had been placed. Depress ball and spring to allow rod to be pushed through and slide rod through boss. Set first and second speed shift rod bracket with relay lever shoe in place and push shift rod through (fig. 143D). Replace set screws and wire in fork and bracket.

(4) Replace interlock balls. Insert four interlock balls in the housing between the first and second, and third and fourth speed shift rods, two at rear and two at center of rods (fig. 79). Tilt housing slightly to help drop balls in place.



POPPET BALL REPLACEMENT

(C)

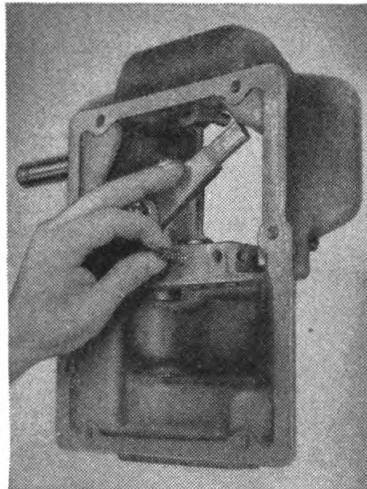

POPPET SPRING REPLACEMENT

(B)

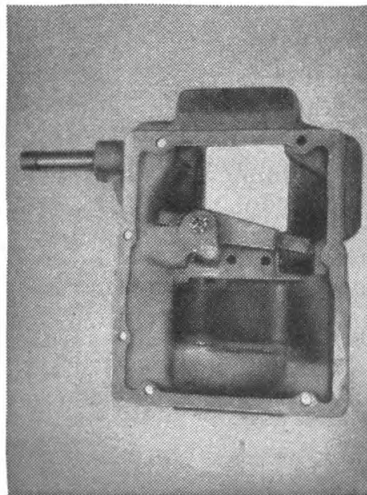

RELAY LEVER INSTALLED

(A)

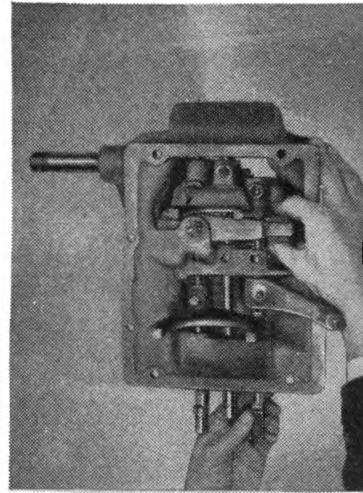

REVERSE SHIFT ROD REPLACEMENT

(F)

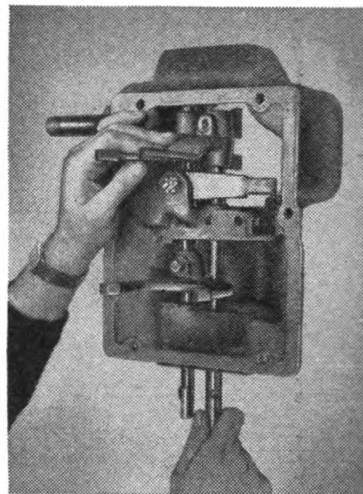

THIRD AND FOURTH SHIFT ROD REPLACEMENT

(E)

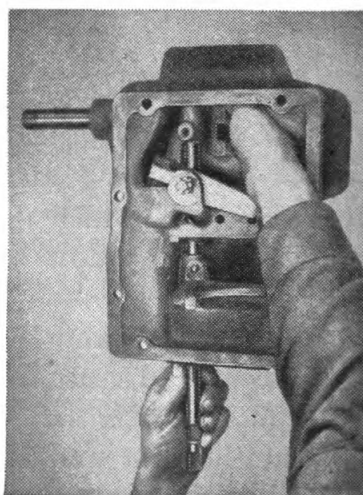

FIRST AND SECOND SHIFT ROD REPLACEMENT

(D)

RA PD 6314

FIGURE 143.—Transmission shifter mechanism reassembly.



(5) Replace third and fourth speed shift rod— $\frac{3}{8}$ -inch square socket wrench, pliers. Slide shift rod into housing from rear end. Insert poppet ball in center of housing. Slide rod through center boss. Replace interlock pin in hole in shaft. Set sleeve and third and fourth speed shift rod in position with set screw hole toward front and push rod through (fig. 143E). Replace set screw and lock wire in fork.

(6) Replace interlock balls. Insert four interlock balls in housing between third and fourth and reverse speed shift rods, two at center and two at rear end of housing (fig. 79).

(7) Assemble reverse shifting bracket—pliers. Replace reverse bracket lock plunger and spring and replace nut and cotter pin (fig. 95). Adjust plunger location with the castellated nut so that plunger groove is in line with bracket ball hole.

(8) Replace reverse shift rod— $\frac{3}{8}$ -inch square socket wrench, pliers, brass drift, peen hammer. Set upper reverse shift fork in place and slide reverse shift rod through rear end of housing and through fork. Insert poppet ball and depress ball while sliding rod through boss. Place reverse shift bracket assembly in position with relay lever shoe and reverse plunger ball in place; push rod through (fig. 143F). Check to see that bracket slides easily on rod. Replace set screw and locking wire in fork. Replace three expansion plugs in front end of housing.

(9) Replace transfer case shift levers— $1\frac{3}{8}$ -inch open end wrench, pliers. Replace underdrive shift lever, lever spacer, and front-drive shift lever on shift lever shaft. Replace washer, lever retainer nut, and cotter pin (fig. 77).

(10) Replace transfer case shifting links—brass drift, hammer, pliers. Replace links on ends of shift levers and replace rod end pins and cotter pins.

(11) Replace breather—pliers. Replace breather stem, cork, and head, and insert cotter pin in head (fig. 76).

*d. Shifter housing cover.*—Tools: pliers.

(1) Replace transmission main shift lever. Replace two steady pins in cover and slide lever with grommet on into the cover with the flats on the pivot ball against the pins. Slip grommet over cover.

(2) Replace support spring—pliers. Place spring in cover with the smaller end set against the pivot ball. Slip the outer spring end under lug in cover.

*e. Transmission countershaft.*—Tools: brass drift, hammer, pliers, screw driver, press.

(1) Replace third speed gear—brass drift, hammer, press. Replace Woodruff key. Set up in press and press gear on shaft (fig. 144).

(2) Replace power take-off gear—brass drift, hammer, press. Replace Woodruff key. Set up in press and press gear on shaft (fig. 145).

(3) Replace drive gear—brass drift, hammer, press. Replace Woodruff key. Set up in press and press gear on shaft (fig. 146).

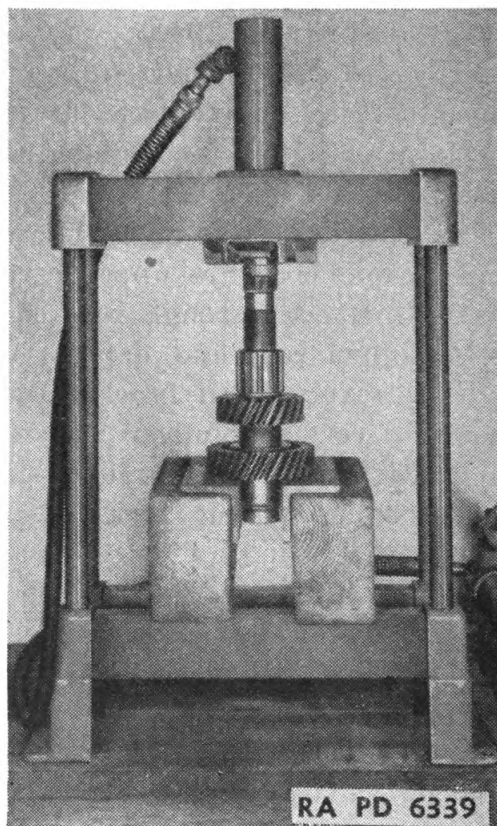

FIGURE 144.—Pressing on transmission countershaft third speed gear.

(4) Replace drive gear snap ring—screw driver, pliers. Slip ring over front end of shaft and insert into groove.

*f. Transmission mainshaft.*—Tools: brass drift, hammer, pliers, screw driver.

(1) Replace second speed gear—vise. Place mainshaft in vise with threaded end down. Slide second speed gear into position with clutch teeth down (fig. 93).

(2) Replace second and third speed gear thrust washer—brass drift, hammer. Insert two halves of washer into groove in shaft. Corners in washer should fit exactly with corners of groove. Drive retaining ring around two halves of washer.

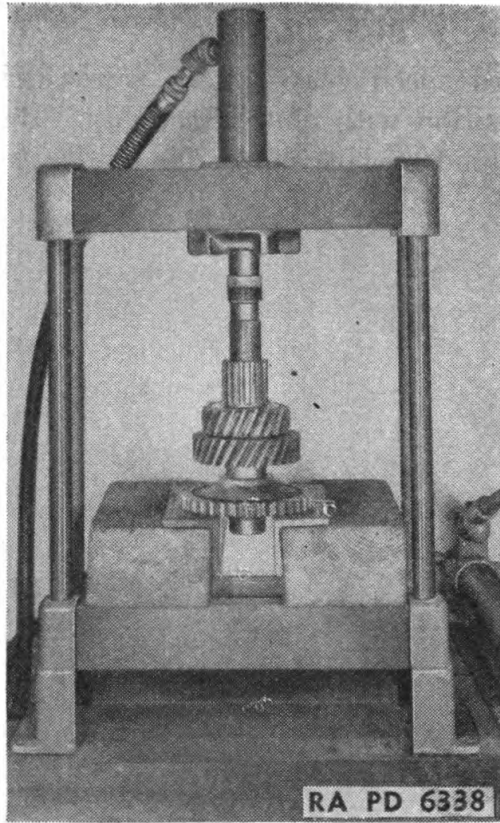

FIGURE 145.—Pressing on transmission countershaft power take-off gear.

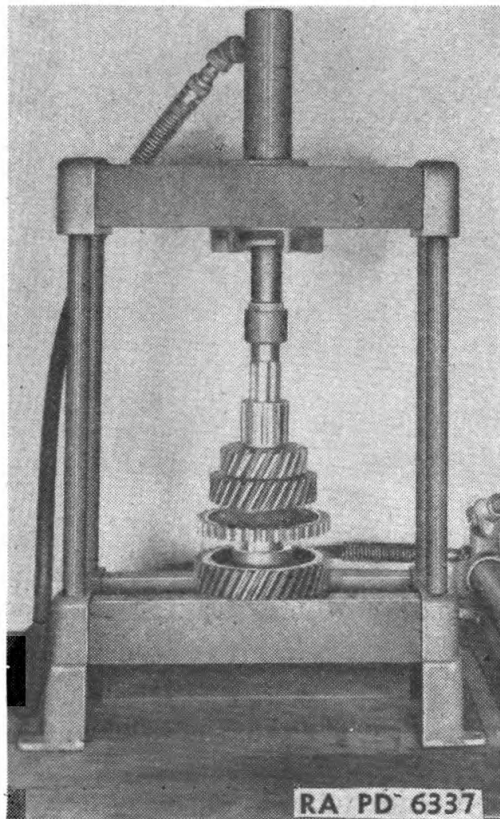

FIGURE 146. Pressing on transmission countershaft drive gear.

(3) Replace third speed gear—pliers, screw driver. Slide third speed gear into position with clutch teeth up. Replace third speed gear thrust washer and replace snap ring.

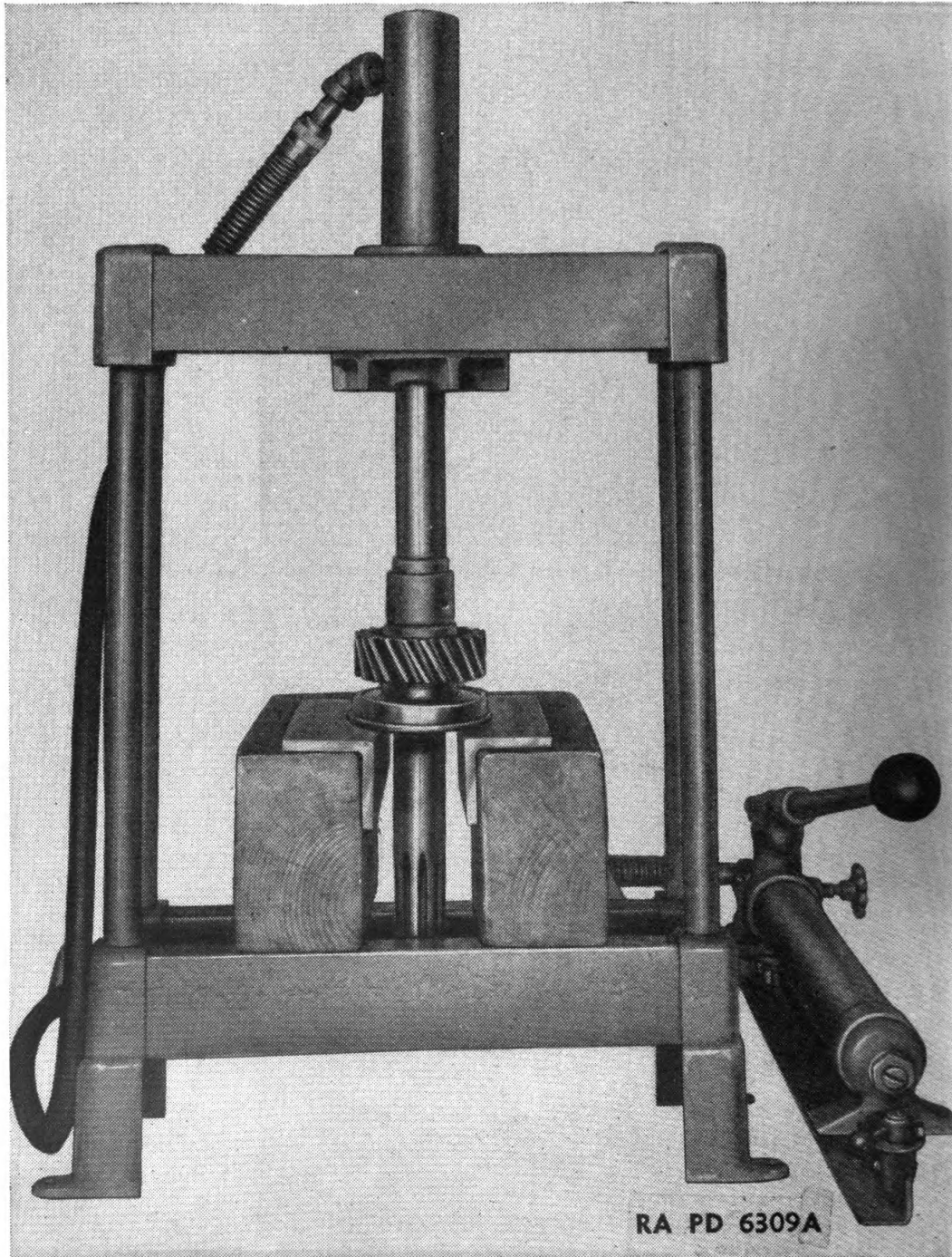

FIGURE 147.—Pressing bearing on transmission main drive gear.

(4) Replace third and fourth speed clutch gear. Slide clutch gear on shaft with flat surface upward.

(5) Replace first and reverse speed clutch collar. Turn shaft over and slide clutch collar onto shaft.

(6) Replace first speed gear. Slide first speed gear onto shaft with clutch teeth down (toward front end of shaft) and replace first speed gear thrust washer.

*g. Transmission main drive gear.*—Tools: press, screw driver, pliers, brass drift, hammer,  $\frac{9}{16}$ -inch socket wrench, special wrench, punch,  $\frac{1}{2}$ -inch socket wrench,  $\frac{9}{16}$ -inch box wrench,  $\frac{9}{16}$ -inch open end wrench. Replace main drive gear ball bearing—press, screw driver,

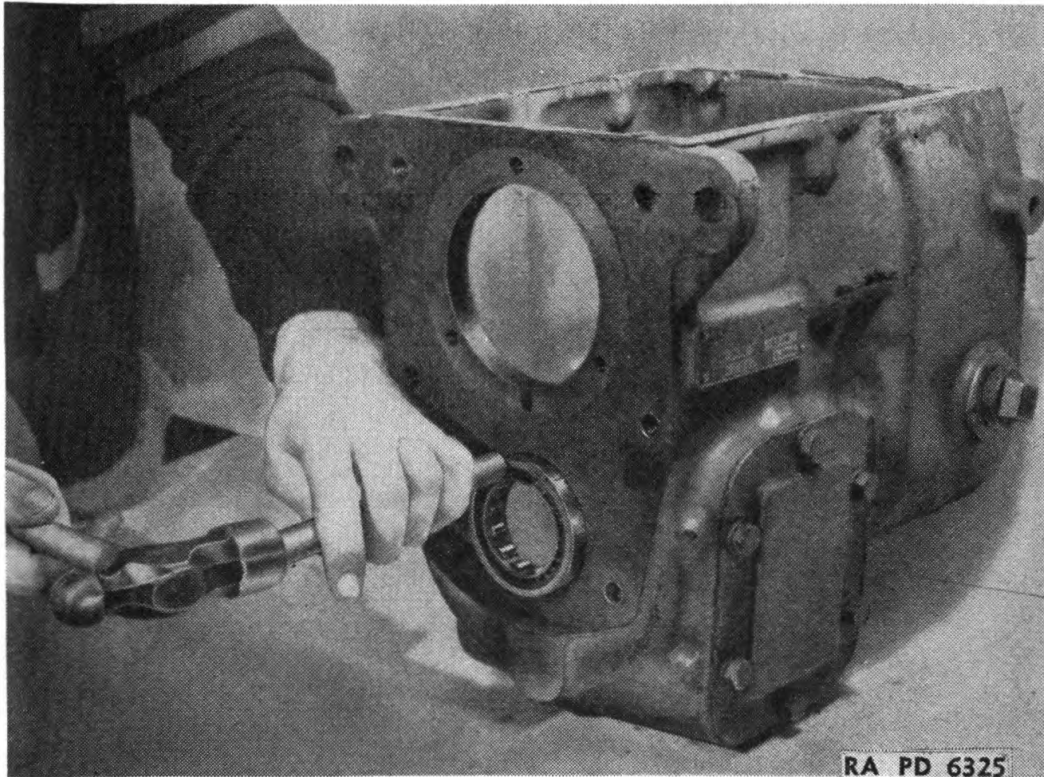

FIGURE 148.—Transmission countershaft front bearing replacement.

pliers. Set up in press and press bearing on drive gear shaft (fig. 147). Replace snap ring on bearing and snap ring in groove on shaft.

*h. Transmission case.*—Tools: brass drift, hammer, punch,  $\frac{1}{2}$ -inch socket wrench,  $\frac{9}{16}$ -inch open end wrench, pliers,  $\frac{9}{16}$ -inch socket wrench, special wrench (fig. 98),  $\frac{9}{16}$ -inch box wrench.

(1) Replace countershaft front bearing—brass drift, hammer. Drive bearing into case (fig. 148).

(2) Replace countershaft. Slide reverse clutch gear on rear end of shaft and front bearing washer on front end (fig. 104). Tilt rear

end of countershaft assembly down and replace countershaft. Slip front end of shaft into front bearing.

(3) Replace first speed gear. Slide gear onto shaft through rear bearing bore in case. Replace first speed gear thrust washer.

(4) Replace countershaft rear bearing—brass drift, hammer. Drive or press bearing into case (fig. 149). Replace rear bearing retainer washer, two screws and locking wire.

(5) Replace lower reverse shift fork. Place fork in slot of countershaft reverse clutch gear (fig. 92).

(6) Replace reverse idler gear—brass drift, hammer. Set reverse idler gear in position with brass thrust washers on both ends (fig.

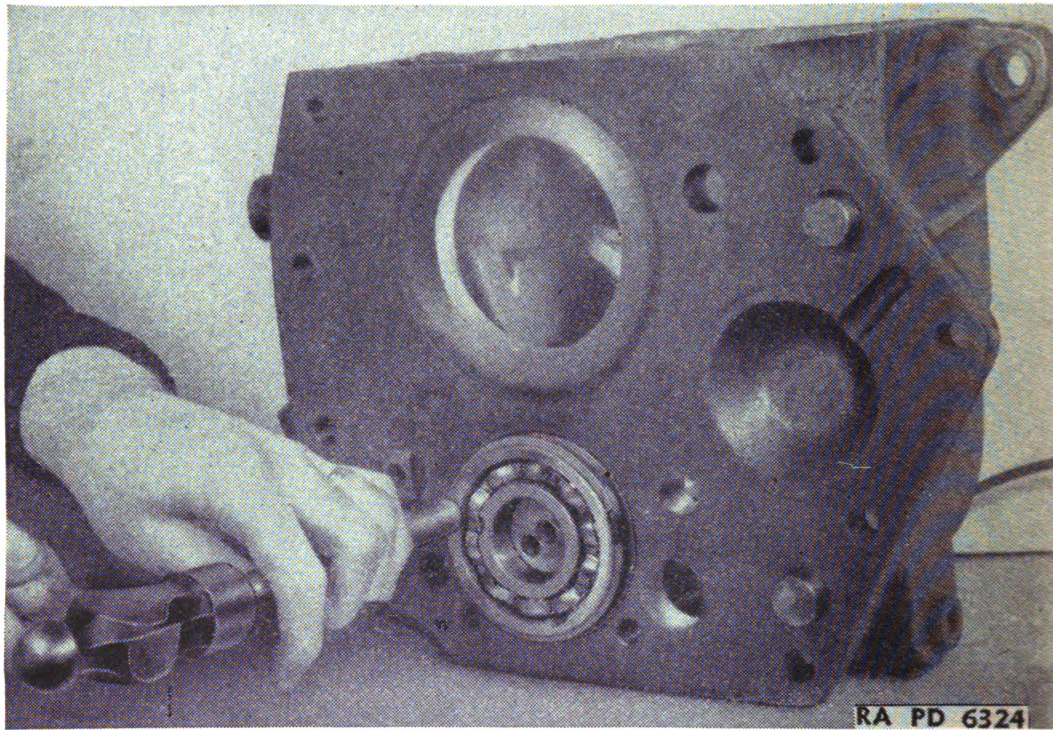

FIGURE 149.—Transmission countershaft rear bearing replacement.

92). Insert idler shaft through hole in rear of case. Keep oil slot facing upward. Tap shaft into position. Front brass washer must seat on larger diameter of shaft in order to allow shaft to be completely inserted. Washer should be held in position while shaft is being driven into place.

(7) Replace mainshaft. Tilt rear end of mainshaft assembly, depress reverse fork, and install, lining up with mating gears on countershaft.

(8) Replace reverse shift fork guide rod—brass drift, hammer. Insert rod through hole in rear of case and tap into position. Keep slotted portion of rod in vertical position.

(9) Replace third and fourth speed clutch gear. Slide clutch gear on shaft through main drive gear bearing bore in front end of case (fig. 93).

(10) Replace mainshaft front pilot bearing—brass drift, hammer. Tap onto front end of shaft.

(11) Replace main drive gear—brass drift, hammer. Push main drive gear into position by hand and then drive bearing into case.

(12) Replace mainshaft front bearing cap—pliers,  $\frac{9}{16}$ -inch socket wrench. Replace new gasket, bearing cap, and three cap screws, lock washers and locking wire. Keep oil return in cap on the bottom.

(13) Replace mainshaft rear bearing—brass drift, hammer. Replace first gear thrust washer on rear end of shaft and replace rear bearing. Replace mainshaft rear bearing retainer.

(14) Replace transfer case mainshaft drive gear—special wrench (fig. 98), hammer, punch. Slide gear on rear end of transmission mainshaft and replace lock washer and lock nut. Peen lock washer in at least two slots in locknut.

(15) Replace bellhousing and covers— $\frac{1}{2}$ -inch socket wrench,  $\frac{9}{16}$ -inch socket wrench. Replace new gasket, bellhousing, two short cap screws, four long cap screws, and six lock washers on inside, and two cap screws and lock washers on outside (fig. 77). Replace top hand hole cover and two cap screws and lock washers. Replace bottom hand hole cover, new gasket, and six cap screws and lock washers. Replace power take-off cover, gasket, and six cap screws and lock washers (fig. 78).

(16) Replace clutch release mechanism—brass drift, hammer,  $\frac{9}{16}$ -inch box wrench. Replace clutch release shaft lever and Woodruff key on shaft with one bolt, nut, and lock washer. Replace short and long shafts into holes in bellhousing (fig. 77). Set yoke in place and push shafts in yoke. Replace round key in long shaft and replace two cap screws and lock washers holding shafts to yoke. Replace headless set screw and lock nut in bellhousing over the short shaft.

(17) Assemble transmission to transfer case— $\frac{3}{4}$ -inch socket wrench,  $\frac{3}{4}$ -inch box wrench, pliers. Replace new gasket and place transmission on end. Place transfer case on transmission and replace seven cap screws and lock washers on outside, and two cap screws, lock washers, and locking wire on inside.

(18) Replace transfer case bottom cover— $\frac{9}{16}$ -inch socket wrench. Replace new gasket, cover, and 12 cap screws and lock washers (fig. 76).

(19) Assemble shifter housing to transmission— $\frac{9}{16}$ -inch socket wrench,  $\frac{9}{16}$ -open end wrench. Before replacing shifter housing on transmission, replace interlock plate and gasket on rear end of first and second and third and fourth speed shift rods. Replace long and short interlocks. Long rod goes in rear slot with flat end outward. Replace shifter housing and seven cap screws and lock washers (fig. 76). Make sure that upper reverse shift fork lines up with lower reverse fork in case. This can be accomplished by feeling with a finger through oil filler hole in left side of case.

**38. Installation of assembly.**—Tools: 1-inch rope chain block and hook, pinch bar,  $\frac{9}{16}$ -inch socket wrench, jack,  $\frac{5}{16}$ -inch open end wrench, 1-inch socket wrench, pliers, hammer,  $\frac{3}{4}$ -inch socket wrench,  $\frac{5}{8}$ -inch socket wrench,  $\frac{5}{8}$ -inch open end wrench,  $\frac{9}{16}$ -inch open end wrench, screw driver,  $\frac{7}{8}$ -inch open end wrench,  $\frac{7}{8}$ -inch socket wrench.

*a.* Install transmission—1-inch rope chain block and hook, pinch bar. Slide transmission under vehicle in approximately correct position and put rope under and around assembly. Raise transmission into position and push assembly forward, engaging the spline in clutch hub. Do not force spline into hub. Apply slight pressure against rear end of assembly while using pinch bar to rotate clutch if spline does not immediately engage. Be sure to keep transmission in line in order to prevent injury to spline.

*b.* Connect transmission bellhousing to flywheel housing— $\frac{9}{16}$ -inch socket wrench. Replace 12 cap screws and lock washers that connect bellhousing to engine.

*c.* Raise rear end of engine—jack,  $\frac{5}{16}$ -inch open end wrench, 1-inch socket wrench, pliers. Jack up engine beneath flywheel housing. Raise rear end of engine, at same time raising transmission by means of chain block and rope. Replace engine rear mounting washers, insulators, retainers, and seals. Also replace engine rear support bolts, slotted nuts, and cotter pins.

*d.* Connect transmission support spring and spring pressure plate— $\frac{7}{8}$ -inch socket wrench. Replace two cap screws and lock washers that hold spring and plate to top-rear end of transfer case (fig. 83).

*e.* Connect clutch release shaft lever to clutch linkage—pliers, hammer. Replace rod end pin and cotter pin that hold lever to clutch linkage.

*f.* Replace transmission shifter cover and shift lever— $\frac{9}{16}$ -inch socket wrench. Place cover and gasket on studs in transmission shifter housing and replace four nuts and lock washers.



*g.* Replace frame cross-member below transmission— $\frac{3}{4}$ -inch socket wrench. Replace four cap screws, nuts, and lock washers that hold cross-member to frame.

*h.* Replace hand brake lever—pliers, hammer,  $\frac{9}{16}$ -inch socket wrench. Place hand brake lever into position and replace two cap screws and lock washers holding quadrant to transfer case. Replace rod end pin that holds brake pull rod to brake lever.

*i.* Connect front-drive shift and underdrive-shift lever links—pliers, hammer. Replace two rod end pins and cotter pins that hold links to shift rods.

*j.* Connect propeller shafts, and replace drive shaft brake disk. Proceed as outlined in steps in paragraph 31*a* and *b*.

*k.* Connect speedometer cable—pliers,  $\frac{9}{16}$ -inch socket wrench,  $\frac{9}{16}$ -inch open end wrench. Replace two speedometer cable clips onto two of the shifter housing mounting cap screws with cable passing through the clips. Put drive end of the cable into speedometer driven gear in transfer case front-drive shaft rear bearing cap, and replace round nut and sleeve.

*l.* Replace floor plates—screw driver. Place floor plates in position and replace 11 machine screws for tunnel plate and three machine screws in transfer case shifter lever floor plate.

*m.* Replace lubricant— $\frac{7}{8}$ -inch open end wrench. Open filler plug and pour in lubricating oil. (See fig. 2①.)

SECTION IX

CONSOLIDATED SERVICE DATA (FITS AND CLEARANCES)

	Paragraph
Front axle.....	39
Rear axle.....	40
Propeller shafts.....	41
Transmission-transfer case.....	42

**39. Front axle.**

Differential:

Bearing adjustment:

Adjustable for cup looseness only.

Shims between cup and housing bore.

Shim thickness..... .005-.010 inch.

Gear to pinion backlash..... .005-.010 inch.

Gear run-out, not over..... .002 inch.

Case run-out, not over..... .002 inch.

Clearance between—	
Pinion and spider-----	.004-.006 inch.
Side gear and case-----	.005-.009 inch.
Side gear thrust washers:	
New limits-----	.058-.062 inch.
Worn limits-----	.048 inch.
Pinion gear thrust washers:	
New limits-----	.058-.062 inch.
Worn limits-----	.048 inch.
Pinion shaft:	
Bearing adjustment-----	.000-.002 inch.
Pinion gage adjustment-----	Shim.
Shim thickness-----	.0035 inch.
Drive gear thrust block clearance, block to gear-----	.015-.023 inch.
Block thickness:	
New limits-----	.210-.214 inch.
Worn limits-----	.187 inch.
Housing inspection, axle shaft run-out, not over-----	.003 inch.
Steering knuckle:	
Bushing ream-----	1.121-1.123 inches.
Knuckle ream-----	1.901-1.903 inches.
Up and down clearance controlled by bearing pin spacers.	
Spacers-----	.185-.245 inch.
<b>40. Rear axle.</b>	
Differential:	
Bearing adjustment-----	Adjusting rings.
Gear to pinion backlash-----	.005-.010 inch.
Gear run-out, not over-----	.002 inch.
Case run-out, not over-----	.002 inch.
Clearance between—	
Side gear thrust washer:	
New limits-----	.058-.062 inch.
Worn limits-----	.048 inch.
Pinion gear thrust washer:	
New limits-----	.058-.062 inch.
Worn limits-----	.048 inch.
Thrust block to bevel gear-----	.012-.015 inch.

## Pinion shaft:

Bearing adjustment..... .000-.002 inch  
tight.

Pinion gage adjustment..... Shims.

Shim thickness..... .003 inch, .005  
inch, .015 inch,  
.032 inch.

## Bearing thrust washer:

New limits..... .105-.125 inch.

Worn limits..... .0781 inch.

Axle shaft run-out, not over..... .005 inch.

**41. Propeller shafts.**

## Allowable run-out:

Shaft tube, not over..... .020 inch.

Neck of slip spline, not over..... .005 inch.

Clearance between shaft splines and yoke  
splines..... .001-.006 inch.

**42. Transmission-transfer case.—a. Trans-  
mission.**(1) *Mainshaft and gears.*

## Clearance between—

Mainshaft and clutch gear..... .002-.006 inch.

Mainshaft and first, second, and third speed  
gears..... .003-.005 inch.

Shift forks and clutch gear and collar..... .026-.050 inch.

## Backlash:

Clutch gear and collar..... .004-.008 inch.

First and second speed gears..... .006-.010 inch.

Third speed gear..... .004-.007 inch.

Main drive gear..... .004-.007 inch.

Mainshaft out of true, not over..... .002 inch.

Main drive gear out of true, not over..... .002 inch.

Third speed gear thrust washer thickness.... .144-.149 inch.

Second and third speed gear thrust washer  
thickness..... .174-.179 inch.

First speed gear thrust washer thickness.... .152-.158 inch.

(2) *Countershaft.*

Clearance between shift fork and clutch gear.... .026-.050 inch.

## Backlash:

Countershaft reverse speed clutch gear..... .004-.008 inch.

Countershaft out of true, not over..... .002 inch.

Rear bearing thrust washer thickness..... .119-.123 inch.

(3) *Reverse idler.*

Clearance between reverse idler gear bushing and shaft ----- .003-.008 inch.

Backlash :

Reverse idler gear :

Spur gear portion ----- .008-.012 inch.

Helical gear portion ----- .006-.010 inch.

Reverse idler gear thrust washer thickness -- .085-.090 inch.

(4) *Shifter mechanism.*

Poppet springs, first and second and third and fourth speed shift rods :

Free length -----  $\frac{7}{8}$  inch.

Pressure at  $\frac{45}{64}$ -inch length ----- 18 pounds.

Poppet spring, reverse shift rod :

Free length -----  $\frac{13}{16}$  inch.

Pressure at  $\frac{23}{32}$ -inch length ----- 30 pounds.

Reverse shift bracket lock spring :

Free length -----  $1\frac{7}{8}$  inches.

Pressure at  $1\frac{3}{8}$ -inch length ----- 38 pounds.

Poppet and interlock balls -----  $\frac{3}{8}$ -inch diameter.

Reverse shift bracket lock ball -----  $\frac{7}{16}$ -inch diameter.

b. *Transfer case.*

(1) *Mainshaft and gears.*

Clearance between shifter fork on clutch collar --- .058-.075 inch.

Backlash :

Underdrive gear ----- .006-.010 inch.

Direct and underdrive clutch collar ----- .004-.008 inch.

Mainshaft out of true, not over ----- .002 inch.

Underdrive gear thrust washer thickness --- .172-.178 inch.

(2) *Intermediate shaft.*

Backlash :

Intermediate shaft gears ----- .006-.010 inch.

Clutch collar ----- .004-.008 inch.

Underdrive gear inner diameter ----- 2.2505-2.2515 inches.

Shaft diameter at needle bearings ----- 1.9990-1.9995 inches.

Needle bearings :

Quantity ----- 106.

Diameter ----- .12450-.12500 inch.

Length ----- 1.125 inches.

POWER TRAIN

Bearing and shaft end play adjustment-----	Shims.
Location of shims-----	Rear bearing cap.
Shim thickness:	
B184288-----	.003 inch.
B184289-----	.010 inch.
B184290-----	.031 inch.
Adjustment-----	No perceptible end play.
Shaft out of line, not over-----	.002 inch.
(3) <i>Front-drive shaft.</i>	
Backlash:	
Front-drive shaft gear-----	.006-.010 inch.
Clutch collar-----	.004-.008 inch.
Front-drive shaft gear inner diameter-----	2.2505-2.2515 inches.
Shaft diameter at needle bearings-----	1.9995-2.0000 inches.
Needle bearings:	
Quantity-----	106.
Diameter-----	.12450-.12500 inch.
Length-----	.925 inch.
Bearing and shaft end play adjustment-----	Shims.
Location of shims-----	Rear bearing cap.
Shim thickness:	
B184291-----	.003 inch.
B184292-----	.010 inch.
B184293-----	.031 inch.
Adjustment-----	No perceptible end play.
Thrust washer thickness-----	.187-.190 inch.
(4) <i>Shifter mechanism.</i>	
Clearance, front-drive shaft shift rod bushing---	.001-.005 inch.
Poppet springs:	
Free length-----	1 $\frac{7}{32}$ inches.
Pressure at 1-inch length-----	38 pounds.
Interlock bracket guide pin spring:	
Free length-----	3 inches.
Pressure at 1 $\frac{3}{4}$ -inch length-----	3 pounds.
Poppet balls-----	$\frac{7}{16}$ -inch diameter.
Rocker interlock ball-----	$\frac{5}{16}$ -inch diameter.

SECTION X

PREPARATION OF UNITS FOR EXTREME TEMPERATURES OR UNUSUAL CONDITIONS

	Paragraph
Care in extreme temperatures.....	43
Care after fording streams or in flood conditions.....	44
Care after traversing deep muddy terrain.....	45
Care in sandy terrain and deserts.....	46

**43. Care in extreme temperatures.**—Temperatures ranging between  $-10^{\circ}$  F. and  $-30^{\circ}$  F. are designated as low, and temperatures below  $-30^{\circ}$  F. as extreme. OFSB 6-G-102 covers lubrication for temperatures above  $-10^{\circ}$  F. and these same lubricants can be used if the temperature drops to  $-20^{\circ}$  F. for only short periods (overnight). In temperatures below  $-30^{\circ}$  F. any remaining heavy greases installed when the temperatures were above freezing must be replaced with lighter greases. Otherwise the heavy greases will solidify and bind moving parts.

*a. Axles.*—(1) In extreme temperatures it may be necessary to replace sealed ball and roller bearings with bearings which have been packed with special low temperature lubricants. (See OFSB 6-A, Product Guide, for low temperature lubricants.)

(2) For temperatures below  $-15^{\circ}$  F., dilute the differential lubricant prescribed for use at  $-10^{\circ}$  F. with 10 percent kerosene or gasoline or 15 percent Diesel fuel. If circumstances prevent diluting lubricants, heat differential cases with a blow torch preparatory to starting. Play torch lightly over the entire gear case, being careful not to concentrate heat on one spot. Continue to heat until the lubricant temperature is well above its pour point.

*b. Transmission-transfer case.*—Treat lubricant in gear cases in same manner prescribed for the axle differential in *a*(2) above.

**44. Care after fording streams or in flood conditions.**—After fording shallow streams it is not usually necessary to take any preventive maintenance steps. However, *if the units have been submerged for several hours or more due to fording deep streams or being in a flooded area it is necessary to remove all foreign matter which may have been accumulated. This is done by thoroughly dismantling units, washing each part in cleaning fluid, and then spreading a thin film of oil over the parts.* In instances when emergency requirements make an immediate, complete cleansing impossible, some damage may partially be prevented and the vehicle kept in service by the following procedure:

*a. Axles.*—(1) Drain all driving axles completely and refill with  $\frac{1}{2}$  gallon of flushing oil. With the vehicle wheel and tracks free of ground, drive the axles at a speed of 15 mph for 30 minutes to flush the axle driving mechanism completely. Again drain completely and refill the axles with the correct SAE grade of lubricant. See lubrication chart, figure 2① and ②.

(2) Remove all wheel bearings, completely clean and repack with recommended lubricant, and reassemble. Always replace grease retainers at wheel hubs, as old gritty ones, if reinstalled, may damage or cut away the seal and cause leakage.

*b. Transmission.*—Drain the transmission and transfer case completely. Then refill, using half gasoline and half regular transmission lubricant. Next, with the driving units raised off the ground, drive the wheels and sprockets through the transmission gears for 10 minutes so that the gasoline can cut all dirt from gears and bearings. Drain completely and then refill with correct SAE grade of lubricant.

*c. Propeller shafts.*—The universal joints should be disassembled, washed thoroughly in cleaning fluid, and coated with a light film of lubricant. Then reassemble joints and completely lubricate in the usual manner.

*d. General.*—Clean engine air cleaner of all accumulated water or other foreign matter.

**NOTE:**—At the first opportunity completely disassemble units and clean thoroughly.

**45. Care after traversing deep muddy terrain.**—No data on this subject is available at the present time. Data to be furnished by field service, maintenance division.

**46. Care in sandy terrain and deserts.**—No data available at present time. To be furnished by field service, maintenance division.

APPENDIX

LIST OF REFERENCES

1. Standard Nomenclature Lists.

Cleaning, preserving, and lubricating materials---	SNL K-1
Soldering, brazing, and welding materials-----	SNL K-2
Car, half-track, M2; carrier, personnel, half-track, M3; 81-mm mortar, half-track, M4-----	SNL G-102
Current Standard Nomenclature Lists are as tabu- lated here. An up-to-date list of SNL's is main- tained as the "Ordnance Publications for Supply Index" -----	OPSI

2. Explanatory publications.

Cleaning, preserving, lubricating, and welding materials-----	TM 9-850
Automotive lubrication-----	TM 10-540
Automotive power transmission units-----	TM 10-585
Ordnance maintenance—body and chassis for car, half-track, M2; carrier personnel, half-track, M3; carrier, 81-mm mortar, half-track, M4-----	TM 9-1712
Car, half-track, M2; carrier, personnel, half-track, M3; carrier, 81-mm mortar, half-track, M4-----	TM 9-710
Detailed lubrication instructions for ordnance maté- riel-----	OFSB-6 series
Echelon system of maintenance-----	TM 10-525
Fire prevention, safety precautions, accidents-----	TM 10-360
Hand, measuring, and power tools-----	TM 10-590
Motor transport inspections-----	TM 10-545
Maintenance and repair-----	TM 10-520
Military motor transportation-----	TM 10-505
Military motor vehicles-----	AR 850-15
Motor transport circular 1-10-----	QMC
Motor transport technical service bulletins-----	QMC
Motor transport-----	FM 25-10
81-mm mortar M1-----	FM 23-90
Storage of motor vehicle equipment-----	AR 850-18
The "Army Motors" monthly (QMC Motor Trans- port School)-----	QMC
The motor vehicle-----	TM 10-510
Ordnance maintenance—White 160AX engine for half-track vehicles-----	TM 9-1711



# INDEX

---

	Paragraph	Page
Alinement, wheel, front axle.....	15	41
Axle. (See Front axle; Rear axle.)		
Axle shaft and universal joint, front axle:		
Disassembly.....	14	19
Maintenance.....	15	41
Reassembly.....	16	49
Axle shaft, rear axle:		
Removal.....	21	63
Maintenance.....	22	72
Bearing cap, propeller shaft:		
Removal.....	28	91
Replacement.....	30	94
Bearing cap, transmission-transfer case:		
Removal.....	35	118
Replacement.....	37	158
Bearing, needle. (See Needle bearing.)		
Bearings, cleaning.....	15, 36	41, 152
Bearings, transmission-transfer case:		
Removal.....	35	118
Replacement.....	37	158
Bearings, wheel:		
Front axle, removal from.....	14	19
Front axle, replacement in.....	16	49
Rear axle, removal from.....	21	63
Rear axle, replacement in.....	23	78
Bellhousing, transmission:		
Removal.....	35	118
Replacement.....	37	158
Block, thrust, rear axle differential drive gear:		
Removal.....	21	63
Replacement.....	23	78
Boot, front axle steering knuckle.....	14	19
Bracket, transmission reverse shifting:		
Disassembly.....	35	118
Reassembly.....	37	158
Bushing, knuckle pin. (See Knuckle pin bushing.)		
Cable, speedometer, (See Speedometer cable.)		
Cap bearing. (See Bearing cap.)		
Care after fording streams or in flood conditions.....	44	182
Care after traversing deep muddy terrain.....	45	183
Care in extreme temperatures.....	43	182

INDEX

	Paragraph	Page
Care in sandy terrain and deserts.....	46	183
Carrier, differential, rear axle:		
Removal.....	21	63
Replacement.....	23	78
Case, differential, rear axle:		
Reassembly.....	23	78
Splitting.....	21	63
Case, transmission-transfer:		
Disassembly.....	35	118
Maintenance.....	36	152
Reassembly.....	37	158
Clutch housing. (See Bellhousing.)		
Clutch release mechanism:		
Removal.....	35	118
Replacement.....	37	158
Consolidated service data (fits and clearances).....	39-42	177
Construction:		
Front axle.....	11	9
Propeller shafts.....	25	86
Rear axle.....	18	58
Transmission-transfer case.....	32	95
Countershaft, transmission:		
Disassembly.....	35	118
Maintenance.....	36	152
Reassembly.....	37	158
Cover, transmission hand hole.....	35	118
Cover, transmission power take-off.....	35	118
Cross. (See Journal.)		
Data, service. (See Consolidated service data.)		
Description:		
Front axle.....	11	9
Propeller shafts.....	25	86
Rear axle.....	18	58
Transmission-transfer case.....	32	95
Differential, front axle:		
Disassembly.....	14	19
Maintenance.....	15	41
Reassembly.....	16	49
Differential, rear axle:		
Disassembly.....	21	63
Maintenance.....	22	72
Reassembly.....	23	78
Disassembly of components:		
Front axle.....	14	19
Propeller shafts.....	28	91
Rear axle.....	21	63
Transmission-transfer case.....	35	118
Drive flange, front axle.....	14	19
Drive gear and pinion, axle, adjustment.....	15	41

INDEX

	Paragraph	Page
Drive gear, speedometer:		
Removal.....	35	118
Replacement.....	37	158
Drive gear, transfer case mainshaft:		
Removal.....	35	118
Replacement.....	37	158
Drive pinion:		
Disassembly.....	14	19
Maintenance.....	15	41
Reassembly.....	16	49
Drive pinion and differential carrier, rear axle:		
Disassembly.....	21	63
Reassembly.....	23	78
Drum, brake. (See Hub and drum.)		
Flange, drive. (See Drive flange.)		
Front axle:		
Care after fording streams.....	44	182
Care in extreme temperatures.....	43	182
Consolidated service data.....	39	177
Description.....	11	9
Disassembly of components.....	14	19
Installation of assembly.....	17	56
Maintenance and adjustments.....	15	41
Reassembly of components.....	16	49
Removal of assembly.....	13	18
Trouble shooting.....	12	17
Front drive shaft, transfer case:		
Disassembly.....	35	118
Maintenance.....	36	152
Reassembly.....	37	158
Gaskets, maintenance.....	36	152
Gear, drive. (See Drive gear.)		
Gear main drive. (See Main drive gear.)		
Gear, reverse idler. (See Idler gear.)		
Guide rod, transmission lower reverse shift fork:		
Removal.....	35	118
Replacement.....	37	158
Hand brake lever. (See Lever, hand brake.)		
Hand hole cover. (See Cover.)		
Housing, shifter. (See Shifter housing.)		
Hub and drum assemblies, front axle:		
Disassembly.....	14	19
Maintenance.....	15	41
Reassembly.....	16	49
Hub and drum assemblies, rear axle:		
Disassembly.....	21	63
Maintenance.....	22	72
Reassembly.....	23	78

INDEX

	Paragraph	Page
<b>Installation of assembly:</b>		
Front axle.....	17	56
Propeller shafts.....	31	95
Rear axle.....	24	86
Transmission transfer case.....	38	176
<b>Intermediate shaft, transfer case:</b>		
Disassembly.....	35	118
Maintenance.....	36	152
Replacement.....	37	158
<b>Jackshaft. (See Rear axle.)</b>		
<b>Joint, universal. (See Universal joint.)</b>		
<b>Journal, propeller shaft:</b>		
Removal.....	28	91
Replacement.....	30	94
<b>Knuckle pin bushing, front axle:</b>		
Disassembly.....	14	19
Maintenance.....	15	41
Reassembly.....	16	49
<b>Lever, hand brake:</b>		
Removal.....	34	114
Replacement.....	38	176
<b>Lever, relay. (See Relay lever.)</b>		
<b>Lever, shift. (See Shift lever.)</b>		
<b>Link, transfer case shift lever:</b>		
Removal.....	34, 35	114, 158
Replacement.....	37	118
<b>Lubrication.....</b>	8-10	6
<b>Main drive gear, transmission:</b>		
Reassembly.....	37	158
Removal.....	35	118
<b>Mainshaft, transmission:</b>		
Disassembly.....	35	118
Maintenance.....	36	152
Reassembly.....	37	158
<b>Maintenance and adjustments:</b>		
Front axle.....	15	41
Propeller shafts.....	29	92
Rear axle.....	22	72
Transmission-transfer case.....	36	152
<b>Needle bearing, propeller shaft:</b>		
Removal.....	28	91
Replacement.....	30	94
<b>Needle bearings, transfer case.....</b>	37	158
<b>Oil seals, maintenance.....</b>	22, 36	72, 152

INDEX

	Paragraph	Page
<b>Operation:</b>		
Front axle.....	11	9
Rear axle.....	18	58
Transmission-transfer case.....	32	95
Pilot bearing. (See Bearing, pilot.)		
Pinion, drive. (See Drive pinion.)		
Preparation of units for extreme temperatures or unusual conditions:		
Care after fording streams or in flood conditions.....	44	182
Care after traversing deep muddy terrain.....	45	183
Care in extreme temperatures.....	43	182
Care in sandy terrain and deserts.....	46	183
Propeller shafts:		
Care after fording streams.....	44	182
Consolidated service data.....	41	179
Description.....	25	86
Disassembly of components.....	28	91
Installation of assembly.....	31	95
Maintenance and adjustments.....	29	92
Reassembly of components.....	30	94
Removal of assembly.....	27	88
Trouble shooting.....	26	88
Rear axle (jackshaft):		
Care after fording streams.....	44	182
Care in extreme temperatures.....	43	182
Consolidated service data.....	40	178
Description.....	18	58
Disassembly of components.....	21	63
Installation of assembly.....	24	86
Maintenance and adjustments.....	22	72
Reassembly of components.....	23	78
Removal of assembly.....	20	62
Trouble shooting.....	19	61
Reassembly of components:		
Front axle.....	16	49
Propeller shafts.....	30	94
Rear axle.....	23	78
Transmission-transfer case.....	37	158
References.....	app.	184
Relay lever, shifter housing:		
Removal.....	35	118
Replacement.....	37	158
Removal of assembly:		
Front axle.....	13	18
Propeller shafts.....	27	88
Rear axle.....	20	62
Transmission-transfer case.....	34	114

	Paragraph	Page
Reverse idler gear, transmission:		
Maintenance.....	36	152
Removal.....	35	118
Replacement.....	37	158
Rod, guide. (See Guide rod.)		
Rod, shift. (See Shift rod.)		
Scope of manual.....	1	1
Seal, oil. (See Oil seal.)		
Service maintenance.....	2-4	2
Shaft. (See Intermediate shaft; Countershaft; Mainshaft; Front drive shaft.)		
Shaft, propeller. (See Propeller shaft.)		
Shift lever, transfer case:		
Removal.....	35	118
Replacement.....	37	158
Shift lever, transmission:		
Removal.....	34	114
Replacement.....	37	158
Shift rods:		
Removal.....	35	118
Replacement.....	37	158
Shifter housing cover, transmission:		
Disassembly.....	35	118
Reassembly.....	37	158
Removal.....	34	114
Replacement.....	38	176
Shifter housing, transmission:		
Disassembly.....	35	118
Reassembly.....	37	158
Specifications:		
Front axle.....	11	9
Propeller shafts.....	25	86
Rear axle.....	18	58
Transmission-transfer case.....	32	95
Speedometer cable:		
Removal.....	34	114
Replacement.....	38	176
Spring, transmission support. (See Support spring.)		
Sprockets, rear axle:		
Disassembly.....	21	63
Maintenance.....	22	72
Reassembly.....	23	78
Removal.....	20	62
Steering cross tube, front axle:		
Disassembly.....	14	19
Maintenance.....	15	41
Reassembly.....	16	49
Support spring, transmission:		
Removal.....	34	114
Replacement.....	38	176

INDEX

	Paragraph	Page
Technical inspection.....	5-7	3
Throw-out, clutch. (See Clutch release.)		
Thrust block. (See Block, thrust.)		
Tie rod, front axle. (See Steering cross tube.)		
Transmission-transfer case:		
Care after fording streams.....	44	182
Care in extreme temperatures.....	43	182
Consolidated service data.....	42	179
Description.....	32	95
Disassembly of components.....	35	128
Installations of assembly.....	38	176
Reassembly of components.....	37	158
Removal of assembly.....	34	114
Trouble shooting.....	33	113
Trouble shooting:		
Front axle.....	12	17
Propeller shafts.....	26	88
Rear axle.....	19	61
Transmission-transfer case.....	33	113
Universal joint, front axle:		
Disassembly.....	14	19
Maintenance.....	15	41
Reassembly.....	16	49
Wheel alinement, front axle.....	15	41
Wheel bearing. (See Bearing, wheel.)		
[A. G. 062.11 (3-23-42).]		

BY ORDER OF THE SECRETARY OF WAR:

G. C. MARSHALL,  
*Chief of Staff.*

OFFICIAL:

J. A. ULIO,  
*Major General,*  
*The Adjutant General.*

DISTRIBUTION:

D 2, 7, 17 (2); R 17 (5); B 2, 6 (3); IB 4 (3); IBn 9 (2);  
IC 9 (4).

(For explanation of symbols see FM 21-6.)

