

*1/4 bd U113  
TM  
1944*

# TM 9-820

WAR DEPARTMENT TECHNICAL MANUAL

*U.S. Dept. of Army*

## TRACTOR TRUCK (FEDERAL)

4- TO 5-TON, 4x4

WAR DEPARTMENT • 15 MARCH 1944

*WAR DEPARTMENT TECHNICAL MANUAL*  
*TM 9-820*

---

**TRACTOR TRUCK**  
**(FEDERAL)**  
**4- TO 5-TON, 4x4**



*WAR DEPARTMENT* . *15 MARCH 1944*

---

*United States Government Printing Office*  
*Washington : 1947*

**WAR DEPARTMENT**

**WASHINGTON 25, D. C., 15 March 1944**

**TM 9-820, Tractor Truck (Federal), 4- to 5-ton, 4 x 4, is published  
for the information and guidance of all concerned.**

[AG 300.7 (18 Nov 43)]

[OOM 461/Rar Ars (3-17-44)]

**BY ORDER OF THE SECRETARY OF WAR:**

**G. C. MARSHALL,**  
*Chief of Staff.*

**OFFICIAL:**

**J. A. ULIO,**  
*Major General,*  
*The Adjutant General.*

**DISTRIBUTION: X.**

(For explanation of symbols, see FM 21-6.)

U113  
.2  
TM 9:50  
1944.

# CONTENTS



## PART ONE — VEHICLE OPERATING INSTRUCTIONS

	Paragraphs	Pages
SECTION I. Introduction .....	1	5
II. Description and tabulated data	2- 3	5- 8
III. Driving controls and operation	4- 6	8- 15
IV. Operation under unusual conditions .....	7- 10	16- 23
V. First echelon preventive maintenance services .....	11- 15	23- 35
VI. Lubrication .....	16- 17	35- 43
VII. Tools and equipment stowage on the vehicle .....	18	44- 45

## PART TWO — VEHICLE MAINTENANCE INSTRUCTIONS

SECTION VIII. Vehicle modification records ..	19	46
IX. New vehicle run-in test .....	20- 21	46- 51
X. Second echelon preventive maintenance .....	22	51- 78
XI. Organization tools and equipment .....	23	79
XII. Trouble shooting .....	24- 45	79- 98
XIII. Engine data, maintenance, and adjustment in vehicle ....	46- 55	99-113
XIV. Engine removal and installation .....	56- 57	113-124
XV. Clutch .....	58- 60	125-129
XVI. Fuel system .....	61- 66	129-138

\*This Technical Manual, together with TM 9-1816 and TM 9-1832A, supersedes TM 10-1107, dated 10 July 1941, TM 10-1407, dated December 1942, and TM 10-1459, dated 2 February 1942. In addition, this manual supersedes all pertinent information from TB 800-21, dated 30 November 1943 and TB ORD 20, dated 24 January 1944.

M574610

# CONTENTS—Cont'd

## PART TWO—VEHICLE MAINTENANCE INSTRUCTIONS— Cont'd

	Paragraphs	Pages
SECTION XVII. Intake and exhaust systems . . .	67– 71	139–143
XVIII. Cooling system . . . . .	72– 78	143–154
XIX. Ignition system . . . . .	79– 85	154–162
XX. Starting and generating systems . . . . .	86– 92	162–173
XXI. Transmission . . . . .	93– 95	173–176
XXII. Transfer case . . . . .	96–100	176–179
XXIII. Propeller shafts and universal joints . . . . .	101–104	180–183
XXIV. Front axle . . . . .	105–108	183–186
XXV. Rear axle . . . . .	109–111	186–188
XXVI. Service brake system . . . . .	112–128	188–212
XXVII. Propeller shaft brake system . . . . .	129–133	212–215
XXVIII. Wheels, hubs, wheel bearings, and tires . . . . .	134–136	215–220
XXIX. Springs and shock absorbers . . . . .	137–139	220–223
XXX. Steering gear . . . . .	140–144	223–226
XXXI. Body and frame . . . . .	145–153	226–233
XXXII. Battery and lighting system . . . . .	154–169	233–249
XXXIII. Instruments . . . . .	170–177	250–256
XXXIV. Fifth wheel . . . . .	178–180	256–257
XXXV. Radio noise suppression system . . . . .	181–185	257–261
XXXVI. Shipment and temporary storage . . . . .	186–188	261–265
REFERENCES . . . . .		266–267
INDEX . . . . .		268–283

**PART ONE**  
**VEHICLE OPERATING INSTRUCTIONS**

**Section I**

**INTRODUCTION**

**I. SCOPE.\***

a. This Technical Manual is published for the information and guidance of the using arms personnel charged with the operation, maintenance, and minor repair of this materiel.

b. In addition to a description of Federal, 4- to 5-ton, 4 x 4 tractor truck, this manual contains technical information required for the identification, use, and care of the materiel. The manual is divided into two parts: Part One, section I through section VII, gives operating instructions; Part Two, section VIII through section XXXV, gives vehicle maintenance instructions to using arm personnel charged with the responsibility of doing maintenance work within their jurisdiction.

c. In all cases where the nature of the repair, modifications, or adjustment is beyond the scope or facilities of the unit, the responsible ordnance service should be informed so that trained personnel with suitable tools and equipment may be provided, or proper instructions issued.

---

**Section II**

**DESCRIPTION AND TABULATED DATA**

**2. DESCRIPTION (figs. 1 and 2).**

a. **General.** The Federal, 4- to 5-ton, 4 x 4 tractor truck is a cab-over-engine, open-cab type vehicle. It is powered by a Hercules, Model RXC engine. A four-wheel drive system of power transmission permits use of the front wheel drive when necessary, through a centrally located transfer case. The truck has dual rear wheels and provisions for carrying two spare tires at rear of cab. The front of the truck mounts a heavy solid-bar bumper surmounted with a relatively straight vertical protective radiator brush guard. Midway between the front and rear wheels and outside the frame on the left side is the rectangular, 60-gallon fuel tank (fig. 2). The battery box and the tool box (fig. 1) are located in a similar position on the right side.

---

\*To provide operating instructions with the materiel, this Technical Manual has been published in advance of complete technical review. Any errors or omissions will be corrected by changes, or, if extensive, by an early revision.

4- TO 5-TON 4x4 TRACTOR TRUCK (FEDERAL)

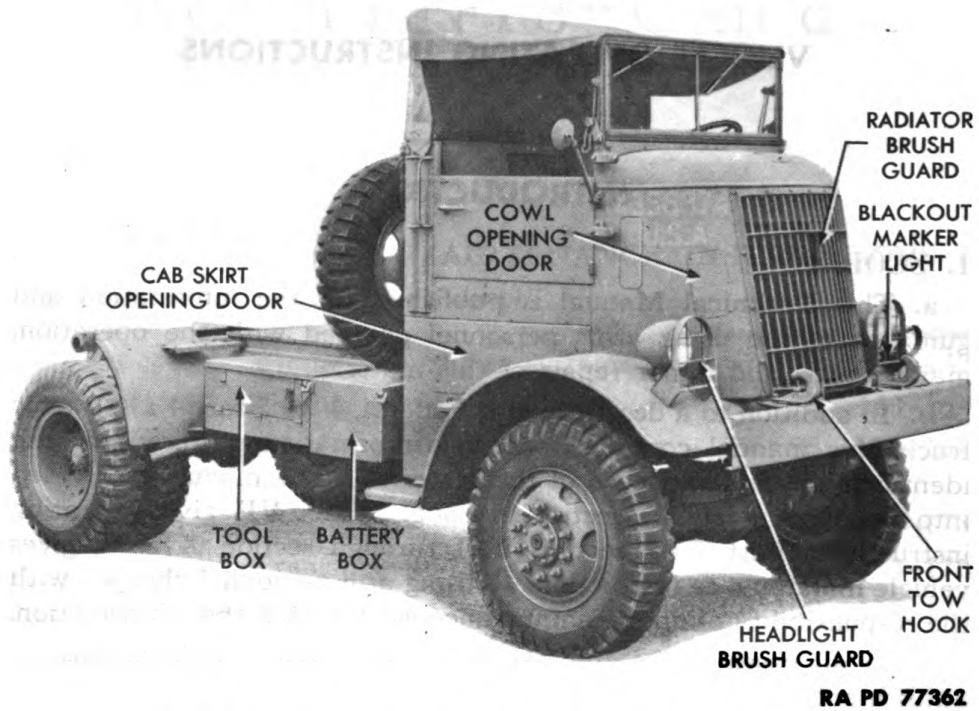


Figure 1 – Tractor Truck – Right Front View

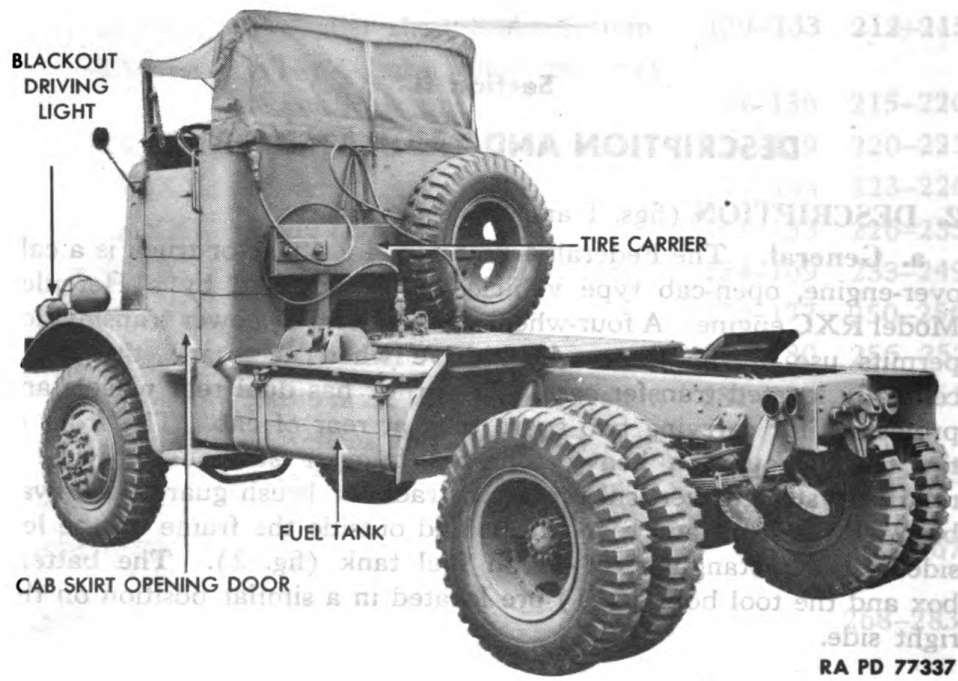


Figure 2 – Tractor Truck – Left Rear View

**DESCRIPTION AND TABULATED DATA**

b. This truck comes equipped with two types of cabs. Some have open-type cabs and some have closed cabs.

**3. DATA.**

**a. Vehicle Specifications.**

Tractor truck manufacturer	Federal Motor Co
Tractor truck, model number	94X43C
Weight of vehicle:	
Empty	11,950 lb
Loaded	20,220 lb
Length, over-all (uncrated)	202 <sup>5</sup> / <sub>8</sub> in.
Width, over-all (uncrated)	95 <sup>1</sup> / <sub>2</sub> in.
Height, over-all (top up)	109 in.
Wheel base	134 <sup>3</sup> / <sub>8</sub> in.
Tire:	
Size	9:00 x 20—10 ply
Type	Mud and snow
Tread (center-to-center):	
Front	73 <sup>3</sup> / <sub>4</sub> in.
Rear, inside	59 <sup>3</sup> / <sub>4</sub> in.
Rear, outside	34 <sup>1</sup> / <sub>2</sub> in.
Weight distribution:	
Front axle	6,831 lb
Rear axle	13,389 lb
Ground clearance:	
Front	11 <sup>1</sup> / <sub>2</sub> in.
Rear	12 in.
Pintle height	38 in.
Maximum speed	40 mph

**b. Performance.**

Speeds allowable without front wheels driving:	
1st gear	4 mph
2nd gear	8 mph
3rd gear	17 mph
4th gear	31 mph
5th gear	40 mph
Speeds allowable with front wheels driving:	
1st gear	4 mph
2nd gear	8 mph
3rd gear	10 mph
4th gear	10 mph
5th gear	10 mph
Minimum turning radius	27 ft



**TM 9-820**

**3-4**

**4- TO 5-TON 4x4 TRACTOR TRUCK (FEDERAL)**

Towing facilities:

Front .....	Two hooks
Rear .....	1 pintle hook
Maximum draw-bar pull (in 4th gear) .....	450 lb
Maximum allowable engine speed .....	2,400 rpm
Miles per gallon .....	3 to 5
Cruising range .....	180 miles

**c. Capacities.**

Transmission .....	10 qt
Transfer Case .....	2 qt
Front axle .....	6 qt
Rear axle .....	6 qt
Fuel tank (70 or higher octane gasoline) .....	62½ gal
Cooling system .....	40 qt
Crankcase .....	10 qt
Oil bath air cleaner .....	3 pt
Steering gear .....	1½ pt

---

**Section III**

**DRIVING CONTROLS AND OPERATION**

**4. INSTRUMENTS AND CONTROLS.**

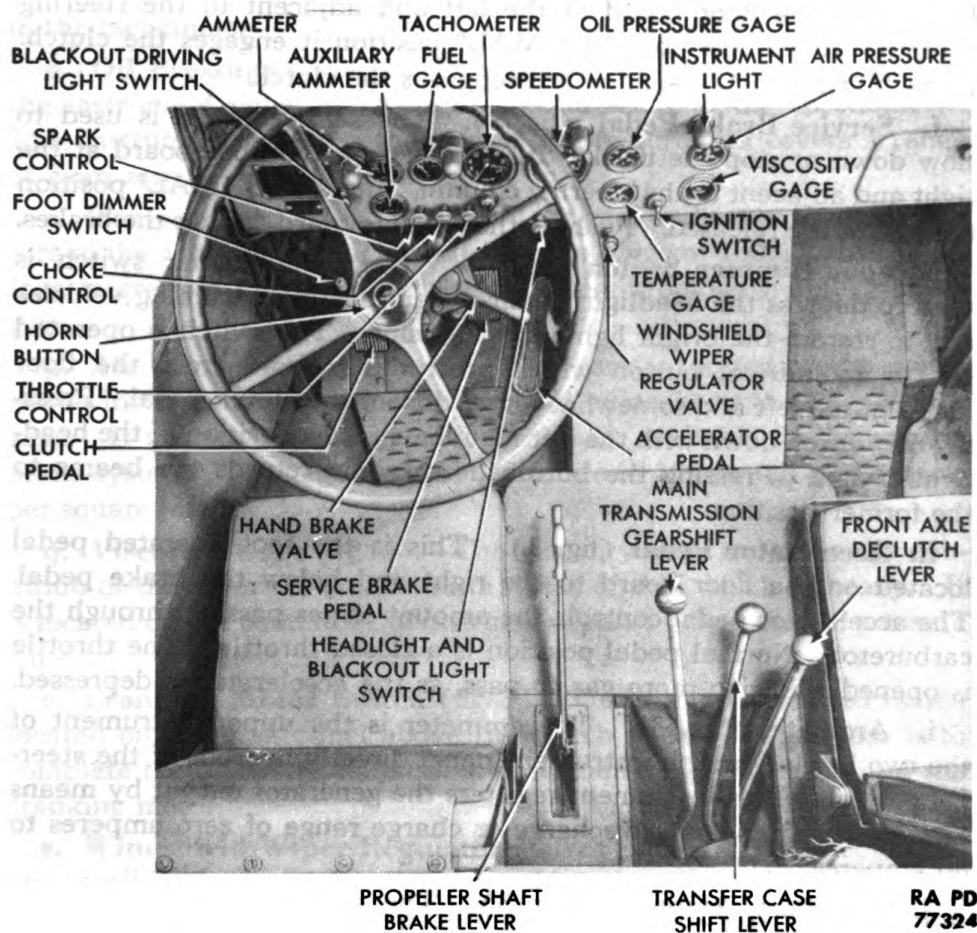
**a. Propeller Shaft Brake Lever** (fig. 3). The propeller shaft brake lever is the first lever which comes through the floor board to the right hand of the driver's seat. It is primarily a parking brake but can be used in an emergency as a stopping brake.

**b. Main Transmission Gearshift Lever** (fig. 3). This lever comes through the large floor board opening at the right of the driver's seat and is the first lever to the right of the propeller shaft brake lever. It is used to shift all gears in the main transmission. It has five forward positions and one reverse position.

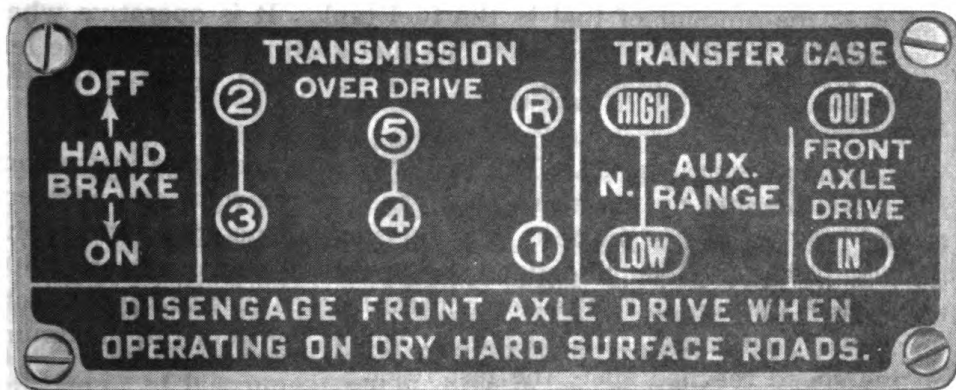
**c. Transfer Case Shift Lever** (fig. 3). The transfer case shift lever also comes through the large floor board opening and is located to the right and adjacent to the main transmission gearshift lever. This lever has a high, a low, and a neutral position and controls the transfer case gears.

**d. Front Axle Declutch Lever** (fig. 3). The front axle declutch lever is the third lever which comes through the large floor board opening and is to the right and adjacent to the transfer case shift lever. This lever controls the front axle drive. There is an "IN" and "OUT" position.

**DRIVING CONTROLS AND OPERATION**



**Figure 3 – Operator's Controls**



RA PD 77305

**Figure 4 – Gearshift Instruction Plate**

**4- TO 5-TON 4x4 TRACTOR TRUCK (FEDERAL)**

e. **Clutch Pedal** (fig. 3). The clutch pedal is the foot pedal located on the floor board at the left and adjacent to the steering column. In its "UP" or "NORMAL" position it engages the clutch. In its "FORWARD" position it disengages the clutch.

f. **Service Brake Pedal** (fig. 3). The service brake is used to slow down or stop the truck. It is located on the floor board at the right and adjacent to the steering column. In its "NORMAL" position the brakes are released. Pushing the pedal forward applies the brakes.

g. **Foot Dimmer Switch** (fig. 3). The foot dimmer switch is used to depress the headlight beams when meeting oncoming vehicles and to restore the bright lights after passing. The switch is operated by the cylindrical button which protrudes upward from the floor board at the left and somewhat forward from the clutch pedal. Pressing the button down with the left foot changes the position of the headlight beams. Pressing the button down again returns the beams to the former position.

h. **Accelerator Pedal** (fig. 3). This is the foot operated pedal located on the floor board to the right and below the brake pedal. The accelerator pedal controls the amount of gas passing through the carburetor. Normal pedal position is a closed throttle. The throttle is opened, allowing more gas to pass, as the accelerator is depressed.

i. **Ammeter** (fig. 3). The ammeter is the upper instrument of the two located on the instrument panel directly in front of the steering column. This instrument registers the generator output by means of a hand. It covers a discharge or charge range of zero amperes to 50 amperes.

j. **Auxiliary Ammeter** (fig. 3). The auxiliary ammeter is the instrument on the instrument panel located directly below the ammeter. Its purpose is to indicate charge or discharge operation of auxiliary storage battery.

k. **Fuel Gage** (fig. 3). The fuel gage is an instrument which indicates the amount of fuel in the fuel tank. It is operative when the ignition switch is turned on. The fuel gage is located at the left center of the instrument panel at the right and adjacent to the ammeter.

l. **Tachometer** (fig. 3). The tachometer is the large instrument located left center on the instrument panel, at the right and adjacent to the fuel gage. Its purpose is to register engine speed in revolutions per minute. The indicating hand covers a range of zero to 2,500 revolutions per minute. The key control located just below the tachometer is used to reset the red hand which registers the maximum engine speed reached since the last reset.

m. **Speedometer** (fig. 3). This instrument indicates road speed in miles per hour and records both trip and total mileage. It is located

## DRIVING CONTROLS AND OPERATION

on the left center of the instrument panel at the right and adjacent to the tachometer.

**n. Oil Pressure Gage (fig. 3).** The oil pressure gage is located on the instrument panel at the right and adjacent to the speedometer. This instrument indicates the engine oil pressure and covers a range of from zero to 80 pound per square inch.

**o. Temperature Gage (fig. 3).** This gage indicates the temperature of the water in the engine. It covers a range of 100° F. to 220° F. It is located on the instrument panel directly below the oil pressure gage.

**p. Air Pressure Gage (fig. 3).** This gage is located on the center of the instrument panel at the right and adjacent to the oil pressure gage. It shows the amount of air pressure available in the service brake system. The gage registers from zero to 150-pound air pressure per square inch.

**q. Viscosity Gage (fig. 3).** The viscosity gage indicates the condition of the oil in the crankcase in terms of thin, ideal, or heavy. It is located on the center of the instrument panel below the air pressure gage.

**r. Cranking Motor Switch (fig. 5).** This is a foot operated switch located on the dash panel above the clutch pedal. Its purpose is to complete the electrical contact between the storage batteries and the cranking motor.

**s. Windshield Wiper Regulator Valves (fig. 3).** These consist of two small knobs located on a small subpanel connected to the instrument panel below the temperature gage. The left knob controls the wiper in front of the driver's seat and the right knob controls the wiper to the right. Turning the knob counterclockwise opens the valve starting the wiper and also controls its speed. Turning knob clockwise closes the valve and stops the wiper.

**t. Headlight and Blackout Light Switch (fig. 3).** This is a push-pull type switch with four positions. All lights are out in the first position when the knob is pushed all the way in. Pulling the knob out to the second position lights only the blackout lights. A spring plunger lock holds switch in this position. Releasing plunger and pulling switch out to the "THIRD" position lights headlights, service tail and stop lights. In this position instrument panel lights can be lighted by their separate switch. Pulling switch all the way out to the "FOURTH" position lights the service stop light when the brakes are applied; all other lights are out. The switch knob is located at the left center of instrument panel directly below the speedometer.

**u. Choke Control (fig. 3).** The choke control knob is located on the lower left of the instrument panel below and to the right of the

**4- TO 5-TON 4x4 TRACTOR TRUCK (FEDERAL)**

auxiliary ammeter. Pulling the knob out reduces the amount of air admitted to the carburetor, thereby making a richer gas mixture. The richness of the mixture is controlled by the distance the knob is pulled from the panel.

v. **Ignition Switch** (fig. 3). The ignition is located in lower center of instrument panel between the temperature and viscosity gage. It is a lever-type switch and controls the engine electrical supply and must be in the left or "ON" position to start engine. The lever should be kept in the right or "OFF" position except when starting engine, operating engine, or checking gage readings.

w. **Throttle Control** (fig. 3). The throttle control knob is located on the lower left of the instrument panel below the speedometer. This control operates by push-pull. Pulling increases the amount of gas and thereby increases the engine speed. Pushing reduces gas and engine speed.

x. **Spark Control** (fig. 3). This is a push-pull type control knob located on the instrument panel below the fuel gage. Pulling out the knob retards the spark and pushing advances the spark. It is used in starting and as a spark adjustment for low grade fuel.

y. **Instrument Lighting Switch** (fig. 95). This is a push-pull type switch and is used to control the instrument panel lights. It can be operated only when the headlight and blackout light switch is in "SECOND" or service position. The instrument lighting switch is located on the instrument panel to the right of the headlight and blackout light switch.

z. **Blackout Driving Light Switch** (fig. 3). This is a push-pull knob type switch and is located at the extreme left of the instrument panel.

aa. **Hand Brake Valve** (fig. 3). This is a hand lever operated valve located on the steering column directly below the steering wheel. This valve independently controls the trailer brake.

bb. **Horn Button**. The horn button is the rounded disk in the top center of the steering column. Depressing the button makes the electrical contact which operates the horn. Releasing or removing the hand pressure breaks the contact.

**5. USE OF INSTRUMENTS AND CONTROLS IN OPERATION OF VEHICLE.**

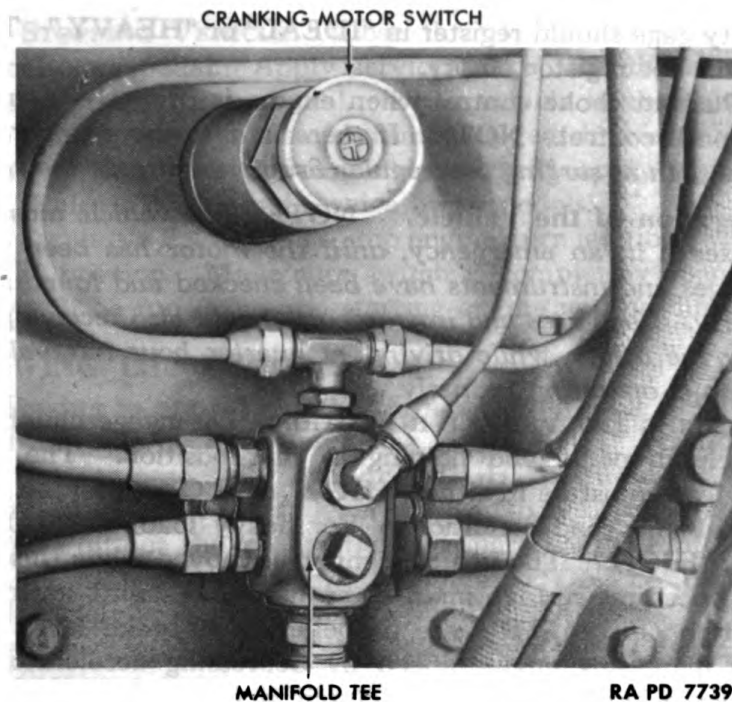
a. **Before-operation Service**. Perform the services in paragraph 12 before attempting to start the engine.

b. **Starting the Engine**.

(1) Apply propeller shaft brake to hold vehicle stationary.

(2) Place main transmission gearshift lever in neutral position (fig. 4).

### DRIVING CONTROLS AND OPERATION



**Figure 5 – Cranking Motor Switch and Oil Manifold Tee Installed**

(3) Pull choke control completely out to provide a rich starting mixture, if the engine is cold. If engine is warm, use only part choke or none at all.

(4) Pull out throttle control about  $\frac{1}{2}$  inch. Less throttle is needed for a warm engine.

(5) Pull out spark control  $\frac{3}{4}$  inch.

(6) Turn ignition switch to "ON" position.

(7) Depress clutch pedal and hold down until engine starts.

(8) Depress cranking motor switch with left foot, until engine starts, then release immediately.

(9) After the engine has started, push in throttle control when engine runs evenly. Read the gages and instruments. The oil pressure gage must register 40 pounds or above. If it registers less, stop the engine immediately and investigate. The air pressure gage must register 60 pounds or above. A buzzing sound, indicating insufficient air pressure for brake operation, will be heard until operating pressure above 60 pounds is reached. The vehicle must not be moved until the buzzing stops. If the buzzer sounds while the vehicle is being operated, stop vehicle immediately and determine cause of loss of air pressure. The ammeter must read "CHARGE." The tachometer should read about 750 revolutions per minute. The water temperature gage should show a gradual rise to 140 to 160 degrees. The

## DRIVING CONTROLS AND OPERATION

(4) **STOPPING VEHICLE.** Close throttle by removing foot from the accelerator pedal. Apply service brake carefully as needed by depressing service brake pedal. When vehicle is about to stop, disengage clutch and move main transmission gearshift lever into neutral position. When truck is completely stopped, apply propeller shaft brake. Release clutch and service brake pedals.

(5) **STOPPING ENGINE.** To stop engine, turn ignition switch (fig. 3) to "OFF" position. Make sure switch is completely open, otherwise battery will be run down and starting engine will be difficult.

### 6. TOWING THE VEHICLE.

a. **Towing to Start Vehicle.** Attach towing cable to towing hooks. Place front axle declutch lever (fig. 3) in "OUT" position (fig. 4). Move transfer case shift lever to "HIGH" position (fig. 4). Shift main transmission gearshift lever to the No. 5 or overdrive position (fig. 4). Pull out choke, throttle, and spark controls into same position as for starting. Turn ignition switch to "ON" position. Release propeller shaft brake lever and depress clutch pedal. When a reasonable speed is reached, slowly release clutch. As soon as engine starts, disengage clutch and adjust controls, as necessary, to provide a smooth running engine. If it is necessary to stop the vehicle before the engine starts and air cannot be made available from the towing truck, use propeller shaft brake. Exercise extreme caution in applying this brake.

b. **Towing Disabled Vehicle.** Check tires for proper inflation to make towing easier (par. 136 b). Attach towing cable to towing hooks. Be sure towing cable is long enough to make harsh usage of brakes unnecessary. Connect air supply, if any, on towing vehicle to trailer connections behind front bumper. This will enable operator of disabled vehicle to use service brakes. Move the front axle declutch lever to the "OUT" position (fig. 4). Place main transmission gearshift lever in the "NEUTRAL" position (fig. 4). Push propeller shaft brake lever all the way down into the "OFF" position. If air supply is not connected, the propeller shaft brake provides the only possible means for stopping. Because this brake is extremely severe, utmost care must be observed in using it. If necessary to hoist front end of truck, attach lifting tackle to bumper. Use care in wrapping chain around bumper to avoid crushing air tubing. Use necessary blocking between tow truck and bumper to prevent vehicle from running into tow truck. If necessary to hoist rear of truck, wrap chain around the entire frame immediately in front of rear spring rear bracket. Be sure to get chain between spring and frame, so that frame will carry the load. Attach necessary blocking between tow truck and rear frame rail to prevent damage through collision. Straighten front wheels and clamp on the steering wheel to prevent turning.

## 4- TO 5-TON 4x4 TRACTOR TRUCK (FEDERAL)

## Section IV

## OPERATION UNDER UNUSUAL CONDITIONS

## 7. COLD WEATHER OPERATION.

a. **Purpose.** Operation of automotive equipment at subzero temperatures presents problems that demand special precautions and extra careful servicing from both operation and maintenance personnel, if poor performance and total functional failure are to be avoided.

b. **Gasoline.** Winter grade of gasoline is designed to reduce cold weather starting difficulties; therefore the winter grade fuel should be used in cold weather operation.

c. **Storage and Handling of Gasoline.** Due to condensation of moisture from the air, water will accumulate in tanks, drums, and containers. At low temperatures, this water will form ice crystals that will clog fuel lines and carburetor jets unless the following precautions are taken:

(1) Strain the fuel through filter paper, or any other type of strainer that will prevent the passage of water. **CAUTION:** *Gasoline flowing over a surface generates static electricity that will result in a spark, unless means are provided to ground the electricity. Always provide a metallic contact between the container and the tank, to assure an effective ground.*

(2) Keep tank full, if possible. The more fuel there is in the tank, the smaller the volume of air will be from which moisture can be condensed.

(3) Add ½ pint of denatured alcohol, grade 3, to the fuel tank each time it is filled. This will reduce the hazard of ice formation in the fuel.

(4) Be sure that all containers are thoroughly clean and free from rust before storing fuel in them.

(5) If possible, after filling or moving a container, allow the fuel to settle before filling fuel tank from it.

(6) Keep all openings of containers tight to prevent snow, ice, dirt, and other foreign matter from entering.

(7) Wipe all snow or ice from dispensing equipment and from around fuel tank filler cap before removing cap to refuel vehicle.

d. **Lubrication.**

(1) **TRANSMISSION AND DIFFERENTIAL.**

(a) Universal gear lubricant, SAE 80, where specified on figures 5 and 6 or War Department Lubrication Guide, is suitable for temperatures as low as -20°F. If consistent temperature below 0°F. is anticipated, drain the gear cases while warm and refill with grade 75 uni-



**OPERATION UNDER UNUSUAL CONDITIONS**

versal gear lubricant, which is suitable for operation at all temperatures below 0°F. If grade 75 universal gear lubricant is not available, SAE 80 universal gear lubricant diluted with the fuel used by the engine, in the proportion of one part fuel to six parts universal gear lubricant, may be used. Dilute make-up oil in the same proportion before it is added to gear cases.

(b) After engine has been warmed up, engage clutch and maintain engine speed at fast idle for 5 minutes, or until gears can be engaged. Put transmission in low (first) gear, and drive vehicle for 100 yards, being careful not to stall the engine. This will heat gear lubricants to the point where normal operation can be expected.

(2) **CHASSIS POINTS.** Lubricate chassis points with general purpose grease, No. 0.

(3) **STEERING GEAR HOUSING.** Drain housing, if possible, or use suction gun to remove as much lubricant as possible. Refill with universal gear lubricant, Grade 75, or, if not available, SAE 80 universal gear lubricant diluted with fuel used in the engine, in the proportion of one part fuel to six parts SAE 80 universal gear lubricant. Dilute make-up oil in the same proportion before it is added to the housing.

(4) **OILCAN POINTS.** For oilcan points where engine oil is prescribed for above 0°F., use light lubricating, preservative oil.

(5) **PRECAUTIONS.**

(a) Keep crankcase oil fluid by one of the following methods, listed in order or preference:

1. Keep vehicle in a heated enclosure when not in use.

2. After stopping engine, drain crankcase oil while still hot. Place warning tag in a conspicuous place in the cab to indicate crankcase is empty. Store oil in a warm place if possible; otherwise, heat oil before reinstalling.

3. Cover entire cab and engine section with tarpaulin. Place fire pots under tarpaulin about 3 hours before engine is to be started. A Primus, Van Prag, or other type blowtorch, and ordinary kerosene lanterns may be used. **CAUTION:** *Be careful in applying flame directly to oil pan.*

4. Do not move the vehicle from a warm place into subzero temperature, unless necessary.

5. Park vehicle without setting propeller shaft brake to avoid brake freezing. Block wheels to prevent rolling of vehicle, and keep a blowtorch handy to thaw frozen propeller shaft or service brakes.

6. Inspect vehicle frequently for broken screws, bolts or other metal parts, and for loosened nuts.

7. Dilute crankcase oil with gasoline, or with Diesel fuel in an emergency. Turn engine over several times to mix oil and diluent. After four or more hours of operation, redilute oil if vehicle is to be left standing unprotected for 3 or more hours. Use diluent for both original dilution and redilution as follows:

**4- TO 5-TON 4x4 TRACTOR TRUCK (FEDERAL)**

Temperature	Diluent	Quantity
0° F. to -20° F.	Gasoline	½ qt to each 4½ qt of engine oil
0° F. to -20° F.	Diesel fuel	½ qt to each 3½ qt of engine oil
Below -20° F.	Gasoline	1 qt to each 5 qt of engine oil
Below -20° F.	Diesel fuel	1 qt to each 4 qt of engine oil

NOTE: Presence of diluent increases engine oil consumption. Check oil level frequently.

**e. Protection of Cooling Systems.**

(1) **USE ANTIFREEZE COMPOUND.** Protect the system with antifreeze compound (ethylene-glycol type) for operation below +32° F. The following instructions apply to use of new antifreeze compound.

(2) **CLEAN COOLING SYSTEM.** Before adding antifreeze compound, clean the cooling system, and completely free it from rust. If the cooling system has been cleaned recently, it may be necessary only to drain, refill with clean water, and again drain. Otherwise clean the system with cleaning compound.

(3) **REPAIR LEAKS.** Inspect all hose and replace if deteriorated. Inspect all hose clamps, plugs, and pet cocks, and tighten if necessary. Repair all radiator leaks before adding antifreeze compound. Correct all leakage of exhaust gas or air into the cooling system.

(4) **ADD ANTIFREEZE COMPOUND.** When the cooling system is clean and tight, fill the system with water to about one-third capacity. Then add antifreeze compound, using the proportion of antifreeze compound to the cooling system capacity indicated below. Protect the system to at least 10° F. below the lowest temperature expected to be experienced during the winter season.

**ANTIFREEZE COMPOUND CHART**  
(for 40-quart capacity cooling system)

Temperature	Antifreeze Compound (ethylene-glycol type)
+30° F.	5 qt
+20° F.	7½ qt
+10° F.	10 qt
0° F.	12½ qt
-10° F.	15 qt
-20° F.	17½ qt
-30° F.	20 qt
-40° F.	22½ qt
-50° F.	22½ qt
-60° F.	25 qt
-70° F.	25 qt

**OPERATION UNDER UNUSUAL CONDITIONS**

(5) **WARM THE ENGINE.** After adding antifreeze compound, fill with water to slightly below the filler neck; then start and warm the engine to normal operating temperature.

(6) **TEST STRENGTH OF SOLUTION.** Stop the engine and check the solution with a hydrometer, adding antifreeze compound if required.

(7) **INSPECT WEEKLY.** In service, inspect the coolant weekly for strength and color. If rusty, drain and clean cooling system thoroughly, and add new solution of the required strength.

(8) **PRECAUTIONS.**

(a) Antifreeze compound is the only antifreeze material authorized for ordnance materiel.

(b) It is essential that antifreeze solutions be kept clean. Use only containers and water that are free from dirt, rust, and oil.

(c) Use an accurate hydrometer. To test a hydrometer, use one part antifreeze compound to two parts water. This solution will produce a hydrometer reading of 0°F.

(d) Do not spill antifreeze compound on painted surfaces.

**f. Electrical Systems.**

(1) **GENERATOR AND CRANKING MOTOR.** Check the brushes, commutators, and bearings. See that the commutators are clean. The large surges of current which occur when starting a cold engine require good contact between brushes and commutators.

(2) **WIRING.** Check, clean, and tighten all connections, especially the battery terminals. Be sure that no short circuits are present.

(3) **COIL.** Check coil for proper functioning by noting quality of spark.

(4) **DISTRIBUTOR.** Clean thoroughly, and clean or replace points. Check the points frequently. In cold weather, slightly pitted points may prevent engine from starting.

(5) **SPARK PLUGS.** Clean and adjust spark plugs or replace, if necessary. If it is difficult to make the engine fire, reduce the gap to 0.005 inch less than that recommended for normal operation (par. 83 c (2)). This will make ignition more effective at reduced voltages likely to prevail.

(6) **TIMING.** Check the timing carefully. Be sure that the spark is not unduly advanced nor retarded.

(7) **BATTERY.**

(a) The efficiency of batteries decreases sharply with decreasing temperatures, and becomes practically nil at -40°F. Do not try to start the engine with the battery when it has been chilled to temperatures below -30°F., until battery has been heated, unless a warm slave battery is available. See that the battery is always fully charged, with the hydrometer reading between 1.275 and 1.300. A fully charged battery will not freeze at temperatures likely to be

**4- TO 5-TON 4x4 TRACTOR TRUCK (FEDERAL)**

encountered even in Arctic climates, but a fully discharged battery will freeze and rupture at  $+5^{\circ}\text{F}$ .

(b) Do not add water to a battery when it has been exposed to subzero temperatures unless the battery is to be charged immediately. If water is added and the battery not put on charge, the layer of water will stay at the top and freeze before it has a chance to mix with the acid.

(8) **LIGHTS.** Inspect the lights carefully. Check for short circuits and presence of moisture around sockets.

(9) **ICE.** Before every start, see that the spark plugs, wiring, or other electrical equipment are free from ice.

**g. Starting and Operating Engine.**

(1) **INSPECT CRANKING MOTOR MECHANISM.** Be sure that no heavy grease or dirt has been left on the cranking motor throw-out mechanism. Heavy grease or dirt is liable to keep the gears from being meshed, or cause them to remain in mesh after the engine starts running. The latter will ruin the cranking motor and necessitate repairs.

(2) **USE OF CHOKE.** A full choke is necessary to secure the rich air-fuel mixture required for cold weather starting. Check the butterfly valve to see that it closes all the way and otherwise functions properly.

(3) **CARBURETOR AND FUEL PUMP.** The carburetor, which will give no appreciable trouble at normal temperatures, is liable not to operate satisfactorily at low temperatures. Be sure the fuel pump has no leaky valves or diaphragm, as this will prevent the fuel pump from delivering the amount of fuel required to start the engine at low temperatures when running speeds are reduced to between 30 and 60 revolutions per minute.

(4) **AIR CLEANERS.** At temperatures below  $0^{\circ}\text{F}$ ., do not use oil in air cleaners. The oil will congeal and prevent the easy flow of air. Wash screens in dry-cleaning solvent, dry, and replace. Ice and frost formations on the air cleaner screens can cause an abnormally high intake vacuum in the carburetor air horn hose, resulting in collapse.

(5) **FUEL SYSTEM.** Remove and clean sediment bowl, strainers, etc., daily. Also drain fuel tank sump daily to remove water and dirt.

**h. Chassis.**

(1) **BRAKE BANDS.** Brake bands, particularly on new vehicles, have a tendency to bind when they are very cold. Always have a blowtorch handy to warm up these parts, if they bind prior to moving, or attempting to move, the vehicle. Parking the vehicle with the brake released will eliminate most of the binding. Precaution must be taken, under these circumstances, to block the wheels or otherwise prevent movement of the vehicle.

## OPERATION UNDER UNUSUAL CONDITIONS

(2) **EFFECT OF LOW TEMPERATURES ON METALS.** Inspect the vehicle frequently. Shock resistance of metals, or resistance against breaking, is greatly reduced at extremely low temperatures. Operation of vehicles on hard, frozen ground causes strain and jolting which will result in screws breaking, or nuts jarring loose.

(3) **SPEEDOMETER CABLE.** Disconnect the oil-lubricated speedometer cable at the drive end when operating the vehicle at temperatures of  $-30^{\circ}\text{F.}$  and below. The cable will often fail to work properly at these temperatures, and sometimes will break, due to the excessive drag caused by the high viscosity of the oil with which it is lubricated.

### 8. HOT WEATHER OPERATION.

a. **General.** Operation of these vehicles in high temperatures requires regular maintenance of cooling units, lubrication-filtering devices, and air cleaners. In extremely high temperatures, water-saving devices such as surge or overflow tanks should be employed. Avoid the continuous use of low gear ratios whenever possible. Make frequent inspections and servicing of air cleaners, fuel filter, and oil filter if side panels are removed during operation in dusty areas. Watch the temperature and oil gages constantly. Check and replenish oil and water frequently. **CAUTION:** *Inspect vehicle frequently for broken screws, bolts, or other metal parts, and for loosened nuts.*

#### b. Cooling System Maintenance.

(1) **COOLING LIQUID.** Formation of scale and rust in cooling system occurs more often during operation in extremely high temperatures; therefore rust preventives should always be added to the cooling liquids. Use only clean water. Avoid the use of water that contains alkali or other substances which may cause scale and rust formations.

(2) **COOLING SYSTEM.** Thoroughly clean and flush the cooling system at frequent intervals when operating in extremely high temperatures.

(3) **FAN BELT AND WATER PUMP.** Inspect fan belt at regular intervals and adjust if necessary (par. 78). Water pump must be kept in good operating condition.

(4) **THERMOSTAT.** Check operation of thermostat (par. 76). Thermostat must open at calibrated temperature to prevent overheating of cooling liquid.

(5) **HOSE CONNECTIONS.** Check hose connections frequently for leaks.

#### c. Hot, Dry Climates.

(1) Keep cooling system full of recommended coolant and maintain proper level of correct grade of lubricating oil in lubricating system. Check engine temperature frequently, and if temperature rises to  $212^{\circ}\text{F.}$ , stop engine and inspect cooling system. Flush

**4- TO 5-TON 4x4 TRACTOR TRUCK (FEDERAL)**

cooling system if necessary; look for sand in radiator fins; blow out with compressed air, if available.

(2) Under desert conditions, check oil filter, carburetor, air cleaner, and air compressor air filter every few hours, and service as necessary.

(3) Under sandy conditions, use lubricants sparingly and clean all sand from fittings before lubricating.

(4) Avoid touching machined surfaces when making repairs.

(5) Do not park vehicle in sun for long periods, because this shortens life of tires. If possible, place vehicle under cover to protect it from sand and dust. Cover inactive vehicles with tarpaulin if no suitable building is available.

**d. Hot, Damp Climates.**

(1) Keep cooling system clean and filled with clean fresh (not salt) water. Use soft water when possible. Note engine temperature as registered by temperature gage frequently. Stop vehicle immediately if temperature of engine reaches 212°F.

(2) Protect exterior surfaces from atmosphere by renewing paint on all painted surfaces, and keeping a film of light engine oil on unfinished exterior metal surfaces.

(3) Flush metal surfaces which have been exposed to salt water with fresh water, and apply a film of light engine oil to unfinished metal parts.

(4) Make frequent inspections of stored vehicles. Remove corrosion from exterior surfaces with flint paper 2/0 (from machined surfaces with crocus cloth), and apply a protective coating of paint, oil, or rust preventive compound.

**e. Battery.**

(1) **WATER LEVEL.** In torrid zones, cell water level should be checked daily and replenished if necessary with pure distilled water. If this is not available, any water fit to drink may be used. However, continuous use of water with high mineral content will eventually cause damage to battery and should be avoided.

(2) **SPECIFIC GRAVITY.** Batteries operating in torrid climates should have a weaker electrolyte than for temperate climates. Instead of 1.300 gravity, the electrolyte should be adjusted to around 1.210 to 1.230 for a fully charged battery. This will prolong the life of the negative plates and separators. Under this condition battery should be recharged at about 1.160. Where freezing conditions do not prevail, there is no danger with gravities from 1.230 to 1.075.

(3) **SELF-DISCHARGE.** A battery will "self-discharge" at a greater rate at high temperatures if standing for long periods. This must be taken into consideration when operating in torrid zones. If necessary to park for several days, remove battery and store in a cool place.

**FIRST ECHELON PREVENTIVE MAINTENANCE SERVICES****9. OPERATION IN MUD, SNOW, ICE, SAND, AND FLOOD.**

a. **Mud.** Install tire chains on both rear wheels, and select low enough gear ratio to move vehicle steadily without putting undue driving strain on engine and axles.

b. **Snow and Ice.** Skidding is the general hazard encountered in these conditions. Install chains, and select the proper gear ratio to move the vehicle steadily, without imposing undue strain on engine and axle. When skidding occurs, turn the front wheels, in the same direction that the rear end is skidding. Decelerate the engine, and apply brakes very gradually until vehicle is under control. Proceed with caution. Remove chains as soon as their use is no longer necessary.

c. **Sand.** The main objective when driving in sand is to avoid the possibility of spinning the driving wheels. If possible, lay an improvised track with planks or brush in order to prevent the wheels coming in contact with the loose footing. Do not let the motor labor. Reverse and go forward several times if necessary, until a solid roadbed is reached.

d. **Flood.** Know the fording depth of this vehicle, and do not exceed its known limits. Reduce the vehicle speed to 4 miles per hour and proceed with caution. Exercise care to avoid water damage to electrical and driving systems. Lubricated parts which have been affected by mud and water must be serviced at earliest opportunity.

e. **Precautions.** Do not allow mud, snow, or ice to cake on wheels, slack adjusters, steering knuckles, and steering arms, or to gather on the air system safety valve, oil filter, or air filter openings. Inspect and clean mud, snow, or ice off radiator core, fan, and fan belts. Keep mud, snow, ice, and moisture off all electrical connections.

**10. DECONTAMINATION.**

a. **Poisonous Gas.** Removing and destroying dangerous chemical agents encountered when operating in affected areas is known as decontamination and is covered by instructions contained in FM 17-59.

---

**Section V****FIRST ECHELON PREVENTIVE MAINTENANCE SERVICES****11. PURPOSE.**

a. To insure mechanical efficiency it is necessary that the vehicle be systematically inspected at intervals each day it is operated and weekly, so defects may be discovered and corrected before they

**4- TO 5-TON 4x4 TRACTOR TRUCK (FEDERAL)**

result in serious damage or failure. Certain scheduled maintenance services will be performed at these designated intervals. The services set forth in this section are those performed by driver or crew Before-operation, During-operation, At-halt, After-operation and weekly.

b. Driver preventive maintenance services are listed on the back of "Driver's Trip Ticket and Preventive Maintenance Service Record" W.D. Form No. 48 to cover vehicles of all types and models. Items peculiar to specific vehicles, but not listed on W.D. Form No. 48, are covered in manual procedures under the items to which they are related. Certain items listed on the form that do not pertain to the vehicle involved are eliminated from the procedures as written into the manual. Every organization must thoroughly school each driver in performing the maintenance procedures set forth in manuals whether they are listed specifically on W.D. Form 48 or not.

c. The items listed on W.D. Form No. 48 that apply to this vehicle are expanded in this manual to provide specific procedures for accomplishment of the inspections and services. These services are arranged to facilitate inspection and conserve the time of the driver and are not necessarily in the same numerical order as shown on W.D. Form No. 48. The item numbers, however, are identical with those shown on that form.

d. The general inspection of each item applies also to any supporting member or connection, and generally includes a check to see whether the item is in good condition, correctly assembled, secure, or excessively worn.

(1) The inspection for "good condition" is usually an external visual inspection to determine whether the unit is damaged beyond safe or serviceable limits. The term "good condition" is explained further by the following: Not bent or twisted, not chafed or burned, not broken or cracked, not bare or frayed, not dented or collapsed, not torn or cut.

(2) The inspection of a unit to see that it is "correctly assembled" is usually an external visual inspection to see if it is in its normal assembled position in the vehicle.

(3) The inspection of a unit to determine if it is "secure" is usually an external visual examination, a wrench, hand-feel, or a pry-bar check for looseness. Such an inspection should include any brackets, lock washers, lock nuts, locking wires, or cotter pins used in assembly.

(4) "Excessively worn" will be understood to mean worn close to, or beyond, serviceable limits, and likely to result in a failure if not replaced before the next scheduled inspection.

e. Any defects or unsatisfactory operating characteristics beyond the scope of first echelon to correct must be reported at the earliest opportunity to the designated individual in authority.



**FIRST ECHELON PREVENTIVE MAINTENANCE SERVICES****12. BEFORE-OPERATION SERVICE.**

a. This inspection schedule is designed primarily as a check to see that the vehicle has not been damaged, tampered with, or sabotaged since the After-operation Service was performed. Various combat conditions may have rendered the vehicle unsafe for operation and it is the duty of the driver to determine whether or not the vehicle is in condition to carry out any mission to which it is assigned. This operation will not be entirely omitted, even in extreme tactical situations.

b. **Procedures.** Before-operation Service consists of inspecting items listed below according to the procedure described, and correcting or reporting any deficiencies. Upon completion of the service, results should be reported promptly to the designated individual in authority.

(1) **ITEM 1, TAMPERING AND DAMAGE.** Look for any injury to vehicle, its accessories or equipment, caused by tampering or sabotage, collision, falling debris, or shell fire since parking. Look in engine compartment for evidence of above conditions, and for loosened or damaged engine accessories or drive belts, loose fuel, oil or coolant lines, or disconnected control linkage.

(2) **ITEM 2, FIRE EXTINGUISHER.** See that it is securely mounted and not damaged, and look for evidence of opened operating valve or leakage.

(3) **ITEM 3, FUEL, ENGINE OIL, AND COOLANT SUPPLY.** Check amount of fuel in tank. Check crankcase oil level on dip stick. Check coolant level. If necessary add fuel to complete mission or to operate vehicle to next scheduled fueling point. Add engine oil and coolant as needed to bring to correct level. *NOTE: Any appreciable drop in levels since After-operation Service should be investigated, and cause corrected or reported. During freezing weather when antifreeze solution is in use, if any appreciable addition of water is needed, antifreeze value should be tested by second echelon and added if necessary. Be sure spare fuel, oil, and water cans are full and securely mounted.*

(4) **ITEM 4, ACCESSORIES AND DRIVES.** Examine units, such as carburetor, generator, cranking motor, air compressor, fan, and air cleaners for looseness, damage or leaks. Be sure drive belts are in good condition and that adjustment is satisfactory. Belts should have  $\frac{1}{2}$ - to  $\frac{3}{4}$ -inch finger pressure deflection.

(5) **ITEM 5, AIR-BRAKE TANKS.** Check the air-brake reservoir tanks to see that they are secure and undamaged; and that all air line connections are tight. Also be sure that water (condensation) has been drained from the tanks and that pet cocks are closed.

(6) **ITEM 6, LEAKS, GENERAL.** Inspect ground and under vehicle and within engine compartment for indications of fuel, engine oil,

4- TO 5-TON 4x4 TRACTOR TRUCK (FEDERAL)

coolant, and gear oil leaks. Pay particular attention to fuel tanks and lines, crankcase and oil filters, radiator, water pump, water lines, and connections, and all gear cases. Trace any leaks found to their source, and correct or report them.

(7) **ITEM 7, ENGINE WARM-UP.** Start engine and note any tendency toward hard starting. Observe action of cranking motor particularly if it has adequate cranking speed, and engages and disengages without unusual noise when in operation. Set hand throttle to idle engine at about 750 revolutions per minute, and during warm-up proceed with following Before-operation Services. **NOTE:** *If oil pressure is not evident in 30 seconds, stop engine and investigate.*

(8) **ITEM 8, CHOKE.** As engine is being started, check operation of choke. As engine warms up, reset choke as required for engine to run smoothly and to prevent overchoking and oil dilution.

(9) **ITEM 9, INSTRUMENTS.**

(a) *Oil Gage.* Pressure at normal engine operating speed should be about 26 pounds.

(b) *Ammeters.* Regular ammeter should show positive (+) charge with engine at fast idle, and at slower speeds with lights on may show on negative (-) side. "B" ammeter indicates that second battery or "B" battery is charging or discharging. High charge readings may be indicated until generator restores to batteries current used in starting engine.

(c) *Engine Temperature Gage.* Reading should increase gradually during warm-up period to normal operating range 140° F. to 160° F. Maximum safe temperature 200° F. **NOTE:** *Do not move vehicle until temperature reaches minimum operating range, 135° F.*

(d) *Viscometer.* After engine has reached operating temperature reading should be in "ideal" range.

(e) *Tachometer.* White pointer should indicate actual engine revolutions per minute at any given time engine is running. Red hand indicates and remains at highest engine revolutions per minute reached which should not exceed 2,300 revolutions per minute.

(f) *Air Pressure Gage.* Gage should register 60 pounds before vehicle is moved. Low pressure indicator "buzzer" should sound at pressure below 60 pounds and cut-out above 60 pounds. Maximum governed pressure is 105 pounds.

(g) *Fuel Gage.* Inspect to see that gage registers the approximate amount of fuel in tank. Ordinarily tank will be filled after operation and gage should register "full."

(10) **ITEM 10, HORN AND WINDSHIELD WIPERS.** If tactical situation permits, test horn for proper operation and tone. Test wipers to see that they operate, and observe whether the blades contact glass evenly and arms travel through full stroke. Inspect for damage.

(11) **ITEM 11, GLASS AND REAR-VISION MIRROR.** Clean all glass

**FIRST ECHELON PREVENTIVE MAINTENANCE SERVICES**

and inspect for damage. Aim rear vision mirror properly and see that it is secure.

(12) **ITEM 12, LAMPS (LIGHTS) AND REFLECTORS.** See that all lights and warning reflectors are clean. Examine them for looseness or damage. If tactical situation permits, open and close switches and observe if lights respond properly. Include stop and blackout lights.

(13) **ITEM 13, WHEEL AND FLANGE NUTS.** See that all wheel mounting, and axle flange nuts are present and secure.

(14) **ITEM 14, TIRES.** Pressure 65 pounds (maximum) cool. Inspect tires for damage, and remove any imbedded objects from treads, carcass, or between duals.

(15) **ITEM 15, SPRINGS AND SUSPENSIONS.** Inspect springs and shock absorbers to see that they are secure and not damaged, and that all assembly and mounting nuts and screws are tight. Examine shocks for leaks.

(16) **ITEM 16, STEERING LINKAGE.** Inspect gear case and all rods and points for looseness, damage, or excessive lubricant leaks.

(17) **ITEM 17, FENDERS AND BUMPERS.** Inspect for looseness or damage.

(18) **ITEM 18, TOWING CONNECTIONS.** Inspect for looseness or damage. Examine pintle to be sure it operates freely and locks securely.

(19) **ITEM 19, BODY AND TARPAULIN.** Inspect cab and top tarpaulin for damage. See that doors and latches operate properly, and that floor plates and engine cover are secure.

(20) **ITEM 20, DECONTAMINATOR.** Be sure it is present, fully charged and secure.

(21) **ITEM 21, TOOLS AND EQUIPMENT.** Be sure all items are present, serviceable, and properly mounted or stowed.

(22) **ITEM 22, ENGINE OPERATION.** Before vehicle is put in motion, be sure engine has reached operating temperature and idles smoothly. Accelerate and decelerate and listen for any unusual vibration or noise. Note any unsatisfactory operating characteristics or excessive exhaust smoke.

(23) **ITEM 23, DRIVER'S PERMIT AND FORM 26.** Driver must have his operator's permit on his person. Check to see that Accident Form No. 26, operator's manual, and lubrication guide are present in vehicle, legible, and properly stowed.

(24) **ITEM 25, DURING-OPERATION CHECK.** The During-operation Services and observations start immediately after the vehicle is put in motion as follows.

**13. DURING-OPERATION SERVICE.**

a. While vehicle is in motion, listen for any sounds such as rattles, knocks, squeals, or hums that may indicate trouble. Look for indications of trouble in cooling system and smoke from any part

**4- TO 5-TON 4x4 TRACTOR TRUCK (FEDERAL)**

of the vehicle. Be on the alert to detect any odor of overheated components or units such as generator, brakes or clutch, fuel vapor from a leak in fuel system, exhaust gas or other signs of trouble. Any time the brakes are used, gears shifted, or vehicle turned consider this a test and notice any unsatisfactory or unusual performance. Watch the instruments constantly. Notice promptly any unusual instrument indication that may signify possible trouble in system to which the instrument applies.

**b. Procedures.** During-operation Services consist of observing items listed below according to the procedures following each item, and investigating any indications of serious trouble. Notice minor deficiencies to be corrected or reported at earliest opportunity, usually next scheduled halt.

(1) **ITEM 27, FOOT AND HAND BRAKES.** Foot brakes should stop vehicle smoothly and effectively with normal pedal pressure, and return to "OFF" position immediately foot pressure is released. If towed vehicle is connected, test hand operated air application valve separately and note if brake action on trailer is satisfactory. Hand brake should hold vehicle on a reasonable incline, leaving  $\frac{1}{2}$  ratchet travel in reserve, and should lock securely in applied position.

(2) **ITEM 28, CLUTCH.** Clutch should not grab, chatter, or squeal during engagement, or slip when fully engaged under load. Pedal should have  $1\frac{1}{2}$ -inch free travel before meeting resistance.

(3) **ITEM 29, TRANSMISSION.** Gears should shift smoothly and quietly, and not creep out of mesh during operation.

(4) **ITEM 30, TRANSFER.** Transfer unit range gears and declutching mechanism should shift easily and quietly and not creep out of mesh during operation.

(5) **ITEM 31, ENGINE AND CONTROLS.** The driver must be on the alert for deficiencies in engine performance such as lack of usual power, misfiring or stalling, unusual noise or vibration, indications of overheating or excessive exhaust smoke. Observe if engine responds to all controls and if controls appear to be in proper adjustment, and not excessively loose or binding.

(6) **ITEM 32, INSTRUMENTS.** Observe readings of all instruments frequently during operation to be sure units to which they apply are functioning satisfactorily.

(a) *Oil Pressure Gage.* Reading should show normal operating pressure, about 40 pounds.

(b) *Ammeters.* During operation with all lamps and accessories turned off the main ammeter should indicate a positive (+) charge at operating speed or with fully charged batteries and regulator unit cut in may register zero. "B" ammeter should also show positive (+) or zero charge. Investigate or report excessive negative (-) readings.

(c) *Engine Temperature Gage.* Reading should increase gradually during warm-up to normal operating temperature, 160° F.

## FIRST ECHELON PREVENTIVE MAINTENANCE SERVICES

**CAUTION:** *Do not move vehicle until engine temperature has reached 135° F. Maximum safe temperature 200° F.*

(d) *Viscometer.* During operation viscometer pointer should remain in "ideal" range. Thin range reading may indicate oil dilution. Heavy range reading may indicate oil contamination such as presence of dirt or sludge. Abnormal readings should be investigated or reported.

(e) *Air Pressure Gage.* Maximum reading should be 105 pounds, minimum 60 pounds.

(f) *Tachometer.* White pointer should register actual engine revolutions per minute and red pointer should not exceed maximum governed speed, 2,300 revolutions per minute.

(g) *Speedometer.* Pointer should indicate actual vehicle speed and odometer should register total accumulating mileage.

(h) *Fuel Gage.* Fuel gage should continue to register approximate amount of fuel in tank.

(7) **ITEM 33, STEERING GEAR.** Note any indication of looseness or binding, pull to one side, wandering, shimmy, wheel tramp, or unusual noise.

(8) **ITEM 34, RUNNING GEAR.** Be on alert for any unusual operating characteristics or noise from wheels, axles, or suspension units that might indicate looseness or damage, or underinflated tires.

(9) **ITEM 35, BODY.** Note any noise or abnormal condition that might indicate shifting, loose top tarpaulin or curtains, loose or damaged doors, hardware, floor or inspection plates or mounted body attachments.

### 14. AT-HALT SERVICE.

a. At-halt Services may be regarded as minimum maintenance procedures and should be performed under all tactical conditions even though more extensive maintenance services must be slighted or omitted altogether.

b. **Procedures.** At-halt Services consist of investigating any deficiencies noted during operation, inspecting items listed below according to the procedures following the items, and correcting any deficiencies found. Deficiencies not corrected should be reported promptly to the designated individual in authority.

(1) **ITEM 38, FUEL, OIL AND WATER SUPPLY.** Check the fuel supply to see that it is adequate to operate the vehicle to the next refueling point. When refueling, use safety precautions for grounding static electricity, and allow space for expansion in filler neck. Filler-cap vents must be open, pressure cap valves must be free and caps must be replaced securely. Check the crankcase oil level and, if necessary, add oil to proper level. Remove radiator filler cap being careful of steam, especially if a pressure cap is used and check coolant to see that it is at proper level, and replenish as necessary. Do not

**4- TO 5-TON 4x4 TRACTOR TRUCK (FEDERAL)**

fill to overflowing but leave sufficient space for expansion. If engine is hot, fill slowly while engine is running at a fast idle.

(2) **ITEM 39, TEMPERATURES: HUBS, BRAKE DRUMS, TRANSFER, TRANSMISSION, AND AXLES.** Place hand cautiously on each brake drum and wheel hub to see if it is abnormally hot. Inspect transfer case, transmission, and axle housings for overheating and note any excessive lubricant leaks.

(3) **ITEM 40, AXLE AND TRANSFER VENTS.** Wipe clean and inspect vents for damage or clogging. Vents must be kept open.

(4) **ITEM 41, PROPELLER SHAFTS.** Inspect all drive shafts and U-joints for looseness, damage, and excessive lubricant leaks. Remove any foreign matter wound around shafts or joints.

(5) **ITEM 42, SPRINGS AND SUSPENSIONS.** Inspect for broken or shifted spring leaves, damaged or loose U-bolts, eyebolts, shackles, rebound clips or shock absorber bodies and linkage, or excessive shock fluid leaks.

(6) **ITEM 43, STEERING LINKAGE.** Examine all steering control mechanism, arms, and linkage frictional joints for looseness or damage. Investigate any unusual condition noted during operation.

(7) **ITEM 44, WHEEL AND FLANGE NUTS.** See that all wheel mounting and axle flange nuts are present and secure.

(8) **ITEM 45, TIRES.** Inspect all tires for under inflation or damage. Remove embedded objects in treads or carcasses and from between duals. See that spare is inflated and secure in carrier.

(9) **ITEM 46, LEAKS — GENERAL.** Look under vehicle and within engine compartment for indication of fuel, oil or coolant leaks. Trace any found to their source and correct or report them.

(10) **ITEM 47, ACCESSORIES AND BELTS.** Examine all accessible units for looseness or damage. Be sure generator, fan, and compressor drive belt tension is satisfactory. If radio noise contributable to operation of this engine was observed, examine all radio noise suppression devices for looseness and damage, particularly resistor-suppressors on spark plugs and distributor. See paragraphs 181-185 for locations.

(11) **ITEM 48, AIR CLEANERS.** If operating under extremely dusty or sandy conditions, inspect air cleaner and breather cap to see that they are in condition to deliver clean air properly. Service as necessary.

(12) **ITEM 49, FENDERS AND BUMPER.** Inspect front bumper and fenders and rear splash guards for looseness or damage.

(13) **ITEM 50, TOWING CONNECTIONS.** Inspect all connections for looseness or damage. Be sure locking devices are secure, and that trailer brake air hose is supported so as not to chafe on other vehicle parts.

(14) **ITEM 51, BODY AND TARPAULIN.** Inspect for damage, or indications of looseness or shifting of cab.

### FIRST ECHELON PREVENTIVE MAINTENANCE SERVICES

(15) ITEM 52, GLASS. Clean all windshield, mirror, light, and warning reflector glass and inspect for damage.

#### 15. AFTER-OPERATION AND WEEKLY SERVICE.

a. After-operation Servicing is particularly important because at this time the driver inspects his vehicle to detect any deficiencies that may have developed and corrects those he is permitted to handle. He should report promptly, to the designated individual in authority the results of his inspection. If this schedule is performed thoroughly, the vehicle should be ready to roll again on a moment's notice. The Before-operation Service, with a few exceptions, is then necessary only to ascertain if the vehicle is in the same condition in which it was left upon completion of the After-operation Service. The After-operation Service should never be entirely omitted even in extreme tactical situations, but may be reduced to the bare fundamental services outlined for the At-halt Service if necessary.

b. **Procedures.** When performing the After-operation Service the driver must remember and consider any irregularities noticed during the day in the Before-operation, During-operation, and At-halt Services. The After-operation Service consists of inspecting and servicing the following items. Those items of the After-operation Services that are marked by an asterisk (\*) require additional weekly services, the procedures for which are indicated in subparagraph (b) of each applicable item.

(1) ITEM 55, ENGINE OPERATION. Test engine for satisfactory performance and smooth idle. Accelerate and decelerate engine and note any tendency to miss or backfire. Listen for any unusual noise or vibration that may indicate worn or inadequately lubricated parts, loose mountings, incorrect fuel mixture, or faulty ignition. Note any unusual exhaust smoke. Investigate and correct or report any deficiencies noted during operation.

(2) ITEM 56, INSTRUMENTS. Check all pertinent instruments to be sure all are operating properly and continue to register or indicate correct performance of the units to which they apply. Stop engine, allowing it to cool off for four or five minutes if it is at or beyond normal temperature.

(3) ITEM 54, FUEL, OIL AND WATER SUPPLY. Fill fuel tanks: (See if fuel gage indicates full.) Check crankcase oil and add as necessary to bring to correct level. Check coolant level and add as necessary to bring to correct level. NOTE: *Do not overfill fuel tanks or radiator. Allow room for expansion. In freezing weather if any appreciable amount of coolant is necessary have antifreeze value checked and add sufficient to protect cooling system against freezing. Do not add coolant while engine is too hot. Fill all spare fuel, oil and water cans if supply has been used.*

(4) ITEM 57, HORN AND WINDSHIELD WIPERS. Inspect to see if

**4- TO 5-TON 4x4 TRACTOR TRUCK (FEDERAL)**

these items are secure and not damaged. If tactical conditions permit, test horn for proper operation and tone.

(5) **ITEM 58, GLASS AND REAR VISION MIRROR.** Clean and inspect for damage and see that mountings are secure.

(6) **ITEM 59, LAMPS (LIGHTS) AND REFLECTORS.** Inspect for looseness or damage. If tactical situation permits, test all lights and switches for proper operation. Clean lenses.

(7) **ITEM 60, FIRE EXTINGUISHER.** Inspect for looseness or damage and full charge. If extinguisher has been in use or valves opened, report for refill or exchange.

(8) **ITEM 61, DECONTAMINATOR.** Inspect for looseness or damage and full charge. If used, report for refill or exchange.

(9) **ITEM 62, \*BATTERIES.**

(a) Inspect batteries to see that they are clean, secure, and not leaking or damaged. See that cell caps are fingertight.

(b) *Weekly.* Clean dirt from top of batteries. If terminal connections or posts are corroded, clean them thoroughly and apply fresh, thin coating of grease. Tighten terminal bolts if loose. Remove vent caps and check level of electrolyte. Add water if required, taking precautions so that battery will not be damaged during freezing temperatures. Battery should be secure, not bulging or cracked or leaking electrolyte; battery carrier should be secure, clean, free of rust, and well painted. If mountings are loose, tighten them cautiously so as not to damage the battery case. Report any defects.

(10) **ITEM 63, ACCESSORIES AND BELTS.** Inspect units such as carburetor, generator, cranking motor, fan, water pump, compressor, distributor, regulator unit and oil filters, for looseness, damage or leaks. Check condition and adjustment of drive belts. Should have  $\frac{1}{2}$  to  $\frac{3}{4}$  inch finger pressure deflection. Investigate and correct or report any deficiencies of accessory units or drives noted during operation.

(11) **ITEM 64, ELECTRICAL WIRING.** Inspect all ignition wiring for looseness or damage, wipe off excessive grease or moisture. Also make an inspection of all accessible low-voltage wiring and connections for looseness or damage and be sure all wiring is supported, so as not to chafe against other vehicle parts. Examine all radio noise suppression devices, paragraphs 181-185, for loose mountings or connections and tighten as necessary.

(12) **ITEM 65, \*AIR CLEANER AND BREATHER CAPS.**

(a) Inspect for looseness or damage. Examine oil in reservoirs for correct level and excessive dirt. When operating in sandy or dusty conditions, clean and service air cleaner and breather cap as often as necessary.

(b) *Weekly.* Remove air cleaner and breather reservoirs and elements, wash in dry-cleaning solvent, refill reservoirs with clean oil



**FIRST ECHELON PREVENTIVE MAINTENANCE SERVICES**

and reinstall securely. Be sure all gaskets seal properly and that joints and connections are secure.

(13) **ITEM 66, \*FUEL FILTER.**

(a) Inspect for looseness, damage and fuel leaks.

(b) *Weekly.* Remove sediment bowl drain plug and drain off all accumulated dirt and water. If draining of fuel pump sediment bowl shows excessive dirt or water, remove and clean element in dry-cleaning solvent.

(14) **ITEM 67, ENGINE CONTROLS.** Examine all engine operating control linkage for looseness, damage, excessive wear, and adequate lubrication.

(15) **ITEM 68, \*TIRES.**

(a) Examine all tires including spares for damage and excessive wear. Remove all embedded foreign matter, such as nails, glass, or stones, from treads and carcasses and from between duals. Check for low pressures and proper position of valve stem and presence of valve caps. Inflate to correct pressure as needed—65 pounds (maximum) cool.

(b) *Weekly.* Replace badly worn or otherwise unserviceable tires. Serviceable tires which show abnormal wear should be relocated to other wheels to even wear. Apparent mechanical deficiencies causing such wear should be reported for attention by higher echelon.

(16) **ITEM 69, SPRINGS AND SUSPENSIONS.** Inspect for looseness or damage, abnormal spring sag, shifted spring leaves, and shock absorber leakage. Investigate any noise or unusual condition noted during operation.

(17) **ITEM 70, STEERING LINKAGE.** Inspect for looseness or damage. Examine steering gear case and frictional joints for excessive lubricant leakage, or lack of lubrication. Investigate any unusual operating conditions noted during operation.

(18) **ITEM 71, PROPELLER SHAFTS.** Inspect all drive shafts and U-joints for looseness or damage and excessive oil leaks. Remove any foreign material wound around shafts or joints.

(19) **ITEM 72, \*AXLE AND TRANSFER VENTS.**

(a) See that all axle housing and transfer case vents are present, in good condition and clean. Inspect for indications of lubricant leakage from vents.

(b) *Weekly.* Remove vents and clean out passages. Reinstall securely.

(20) **ITEM 73, LEAKS—GENERAL.** Look in engine compartment and under vehicle for indications of fuel, engine oil, coolant, or gear oil leaks.

(21) **ITEM 74, GEAR OIL LEVELS.** Check gear oil levels in differentials, transfer case, transmission and steering gear housing, and report if low. Correct levels are from lower edge of filler hole to ½ inch below when cool.

**4- TO 5-TON 4x4 TRACTOR TRUCK (FEDERAL)**

(22) **ITEM 75, \*AIR BRAKE TANKS.**

(a) Inspect tanks and lines for looseness or damage. Open reservoir drain cocks and drain off all accumulated condensate.

(b) *Weekly.* Tighten tank mountings and line connections. Clean air line rubber hose of all grease or oil.

(23) **ITEM 76, FENDERS AND BUMPERS.** Inspect front fenders and bumper and rear splash guards for looseness or damage.

(24) **ITEM 77, \*TOWING CONNECTIONS.**

(a) Inspect towing hooks, truck tractor fifth wheel (if used) or pintle hook and safety chains for looseness, excessive wear or damage.

(b) *Weekly.* Lower trailer landing gear, if connected, and unhitch trailer. Clean contacting surfaces of fifth wheel plate, and kingpin latch mechanism. Inspect them for wear and damage, and apply a fresh coating of clean grease. Rehitch the trailer, noticing whether the hand lever works easily and whether the latching mechanism closes completely and latches securely.

(25) **ITEM 78, BODY AND TARPULIN.** Inspect cab carefully for damage or loose parts. Examine top tarpaulin and side curtains for worn spots or other damage, and see that they are secure.

(26) **ITEM 82, \*TIGHTENING.**

(a) Tighten any mounting or external assembly nuts or screws where inspection of vehicle has indicated the necessity.

(b) *Weekly.* Tighten wheel mounting and axle flange nuts and cap screws; spring U-bolts, eyebolts, shackles and rebound clips; U-joint companion flanges; engine mountings, transfer case mountings; steering arms, towing connections, or any other mounting or assembly nuts or screws that inspection or experience indicates are necessary on a weekly or mileage basis.

(27) **ITEM 83, \*LUBRICATE AS NEEDED.**

(a) Lubricate all items such as shackles, hinges, latches, control linkage frictional joints, or any point where inspection has indicated oilcan or hand greasing is needed.

(b) *Weekly.* Lubricate all points of the vehicle indicated on the lubrication guide as needing lubrication on a weekly or a mileage basis.

(28) **ITEM 84, \*CLEAN ENGINE AND VEHICLE.**

(a) Clean dirt and grease or oil drippings from inside cab, and from engine compartment and exterior of engine. Wipe off excess dirt and grease from entire vehicle.

(b) *Weekly.* Wash vehicle when possible. If not possible, wipe off thoroughly. Inspect paint or camouflage pattern for rust or for bright spots which might cause light reflections. See that vehicle markings are legible unless covered for tactical reasons. **CAUTION:** *If vehicle is driven into water for washing, care must be taken to see that water or dirt does not get into wheel bearings, gear cases or brakes, or on electrical units or wiring.*

## LUBRICATION

(29) ITEM 85, \*TOOLS AND EQUIPMENT.

(a) Check vehicle stowage and tool lists (par. 18), to see that all items are present. Inspect items to see that they are in good condition and properly mounted or stowed.

(b) *Weekly.* Clean all tools and equipment of rust or dirt, and apply preservative where necessary when possible. See that tools with cutting edge are sharp and properly protected and that all items are securely mounted or stowed. *NOTE: When services are completed, be sure all inspection plates are replaced securely.*

---

### Section VI

## LUBRICATION

### 16. LUBRICATION GUIDE.

a. War Department Lubrication Guide (fig. 6) prescribes lubrication maintenance for 4- to 5-ton tractor truck (Federal). Localized lubrication points are illustrated in figures 7, 8, 9, and 10.

b. A lubrication guide is placed on or is issued with each vehicle and is to be carried with it at all times. In the event the vehicle is received without a guide, the using arms shall immediately requisition a replacement from the Commanding Officer, Fort Wayne Ordnance Depot, Detroit, 32, Mich.

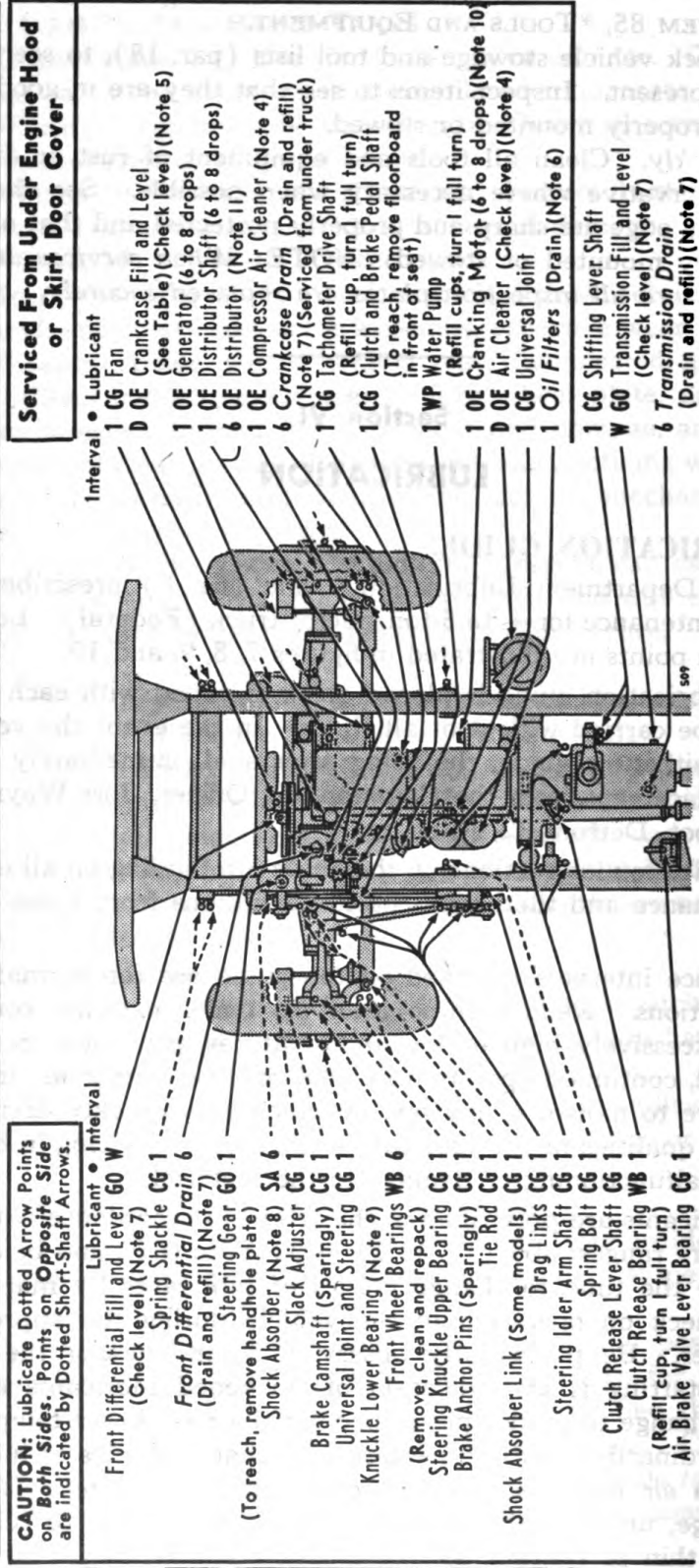
c. Lubrication instructions on the guide are binding on all echelons of maintenance and there shall be no deviations from these instructions.

d. Service intervals specified on the guide are for normal operation conditions. Reduce these intervals under extreme conditions such as excessively high or low temperatures, prolonged periods of high speed, continued operation in sand or dust, immersion in water, or exposure to moisture, any one of which may quickly destroy the protective qualities of the lubricant and require servicing in order to prevent malfunctioning or damage to the materiel.

e. Lubricants are prescribed in the "Key" in accordance with three temperature ranges; above  $+32^{\circ}\text{F.}$ ,  $+32^{\circ}\text{F.}$  to  $0^{\circ}\text{F.}$ , and below  $0^{\circ}\text{F.}$ . Determine the time to change grades of lubricants by maintaining a close check on operation of the vehicle during the approach to change-over. Be particularly observant when starting the engine. Sluggish starting is an indication of thickened lubricants and the signal to change to grades prescribed for the next lower temperature range. Ordinarily it will be necessary to change grades of lubricants *only when air temperatures are consistently in the next higher or lower range*, unless malfunctioning occurs sooner due to lubricants being too thin or too heavy.

4- TO 5-TON 4x4 TRACTOR TRUCK (FEDERAL)

MANUFACTURER'S SERIAL NUMBER located at front of frame on left side.



- CAUTION:** Lubricate Dotted Arrow Points on Both Sides. Points on Opposite Side are indicated by Dotted Short-Shaft Arrows.
- |   |                      |   |                      |
|---|----------------------|---|----------------------|
| Front Differential Fill and Level (Check level)(Note 7) | Lubricant • Interval | Front Differential Fill and Level (Check level)(Note 7) | Lubricant • Interval |
| Spring Shackle  | G0 W                 | Spring Shackle  | C6 1                 |
| Front Differential Drain (Drain and refill)(Note 7)     | 6                    | Front Differential Drain (Drain and refill)(Note 7)     | C6 6                 |
| Steering Gear   | G0 1                 | Steering Gear   | G0 1                 |
| (To reach, remove handhole plate)                       |                      | (To reach, remove handhole plate)                       |                      |
| Shock Absorber (Note 8)                                 | SA 6                 | Shock Absorber (Note 8)                                 | SA 6                 |
| Slack Adjuster  | C6 1                 | Slack Adjuster  | C6 1                 |
| Brake Camshaft (Sparingly)                              | C6 1                 | Brake Camshaft (Sparingly)                              | C6 1                 |
| Universal Joint and Steering                            | C6 1                 | Universal Joint and Steering                            | C6 1                 |
| Knuckle Lower Bearing (Note 9)                          |                      | Knuckle Lower Bearing (Note 9)                          |                      |
| Front Wheel Bearings (Remove, clean and repack)         | WB 6                 | Front Wheel Bearings (Remove, clean and repack)         | WB 6                 |
| Steering Knuckle Upper Bearing                          | C6 1                 | Steering Knuckle Upper Bearing                          | C6 1                 |
| Brake Anchor Pins (Sparingly)                           | C6 1                 | Brake Anchor Pins (Sparingly)                           | C6 1                 |
| Tie Rod   | C6 1                 | Tie Rod   | C6 1                 |
| Shock Absorber Link (Some models)                       | C6 1                 | Shock Absorber Link (Some models)                       | C6 1                 |
| Drag Links  | C6 1                 | Drag Links  | C6 1                 |
| Steering Idler Arm Shaft                                | C6 1                 | Steering Idler Arm Shaft                                | C6 1                 |
| Spring Bolt   | C6 1                 | Spring Bolt   | C6 1                 |
| Clutch Release Lever Shaft                              | C6 1                 | Clutch Release Lever Shaft                              | C6 1                 |
| Clutch Release Bearing (Refill cup, turn 1 full turn)   | WB 1                 | Clutch Release Bearing (Refill cup, turn 1 full turn)   | WB 1                 |
| Air Brake Valve Lever Bearing                           | C6 1                 | Air Brake Valve Lever Bearing                           | C6 1                 |

- |  |  |
|--|--|
| Interval • Lubricant   | Interval • Lubricant   |
| 1 C6 Fan   | 1 C6 Fan   |
| D OE Crankcase Fill and Level (See Table)(Check level)(Note 5)                   | D OE Crankcase Fill and Level (See Table)(Check level)(Note 5)                   |
| 1 OE Generator (6 to 8 drops)  | 1 OE Generator (6 to 8 drops)  |
| 1 OE Distributor Shaft (6 to 8 drops)  | 1 OE Distributor Shaft (6 to 8 drops)  |
| 6 OE Distributor (Note 11)   | 6 OE Distributor (Note 11)   |
| 1 OE Compressor Air Cleaner (Note 4)   | 1 OE Compressor Air Cleaner (Note 4)   |
| 6 Crankcase Drain (Drain and refill)(Note 7)(Serviced from under truck)          | 6 Crankcase Drain (Drain and refill)(Note 7)(Serviced from under truck)          |
| 1 C6 Tachometer Drive Shaft (Refill cup, turn 1 full turn)                       | 1 C6 Tachometer Drive Shaft (Refill cup, turn 1 full turn)                       |
| 1 C6 Clutch and Brake Pedal Shaft (To reach, remove floorboard in front of seat) | 1 C6 Clutch and Brake Pedal Shaft (To reach, remove floorboard in front of seat) |
| 1 WP Water Pump (Refill cups, turn 1 full turn)                                  | 1 WP Water Pump (Refill cups, turn 1 full turn)                                  |
| 1 OE Cranking Motor (6 to 8 drops)(Note 10)                                      | 1 OE Cranking Motor (6 to 8 drops)(Note 10)                                      |
| D OE Air Cleaner (Check level)(Note 4)   | D OE Air Cleaner (Check level)(Note 4)   |
| 1 C6 Universal Joint   | 1 C6 Universal Joint   |
| 1 Oil Filfers (Drain)(Note 6)  | 1 Oil Filfers (Drain)(Note 6)  |
| 1 C6 Shifting Lever Shaft  | 1 C6 Shifting Lever Shaft  |
| W G0 Transmission Fill and Level (Check level)(Note 7)                           | W G0 Transmission Fill and Level (Check level)(Note 7)                           |
| 6 Transmission Drain (Drain and refill)(Note 7)                                  | 6 Transmission Drain (Drain and refill)(Note 7)                                  |

RA PD 328238

Generated on 2013-06-23 07:30 GMT / http://hdl.handle.net/2027/uc1.b3243770  
Public Domain, Google-digitized / http://www.hathitrust.org/access\_use#pd-google



4- TO 5-TON 4x4 TRACTOR TRUCK (FEDERAL)

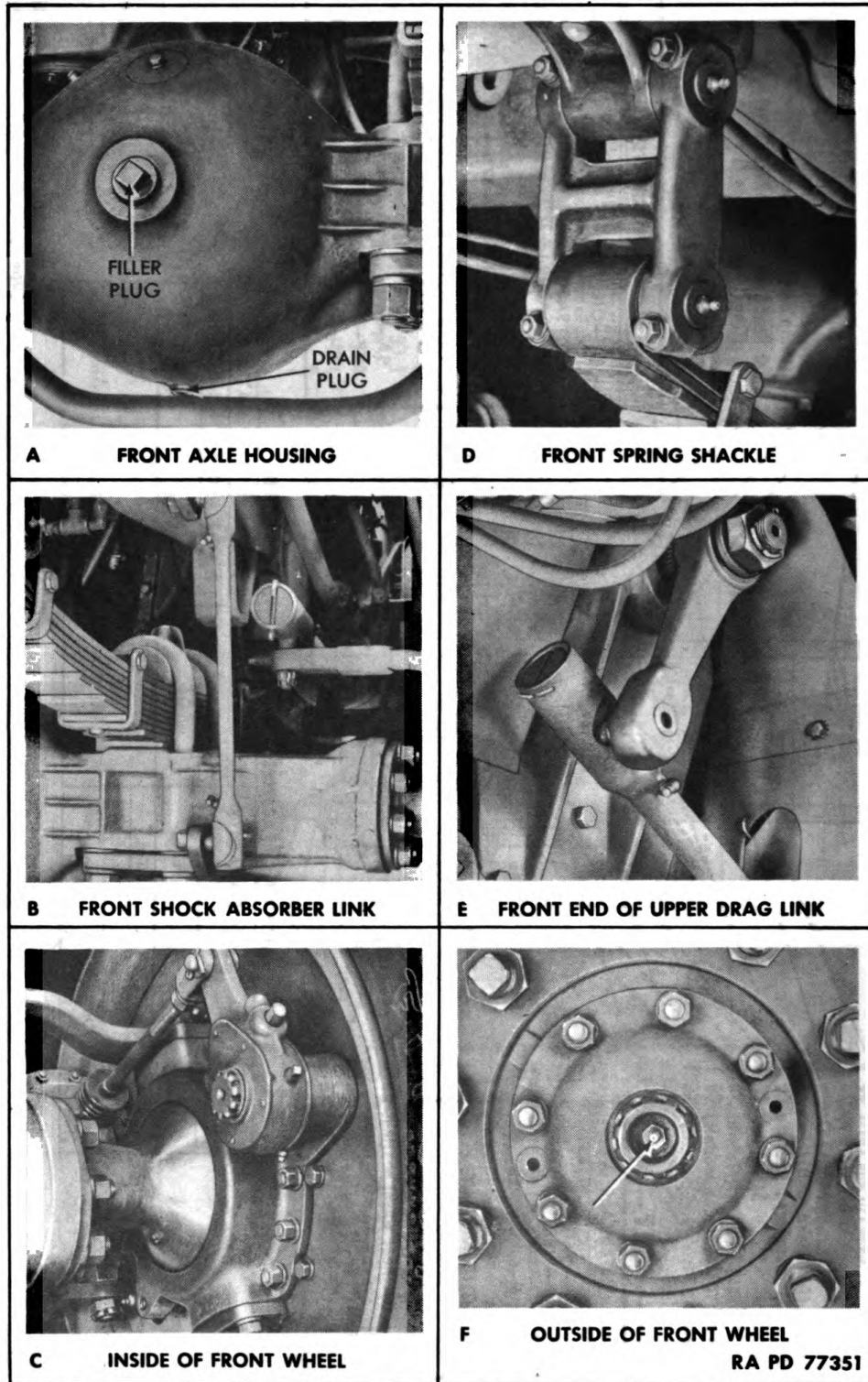
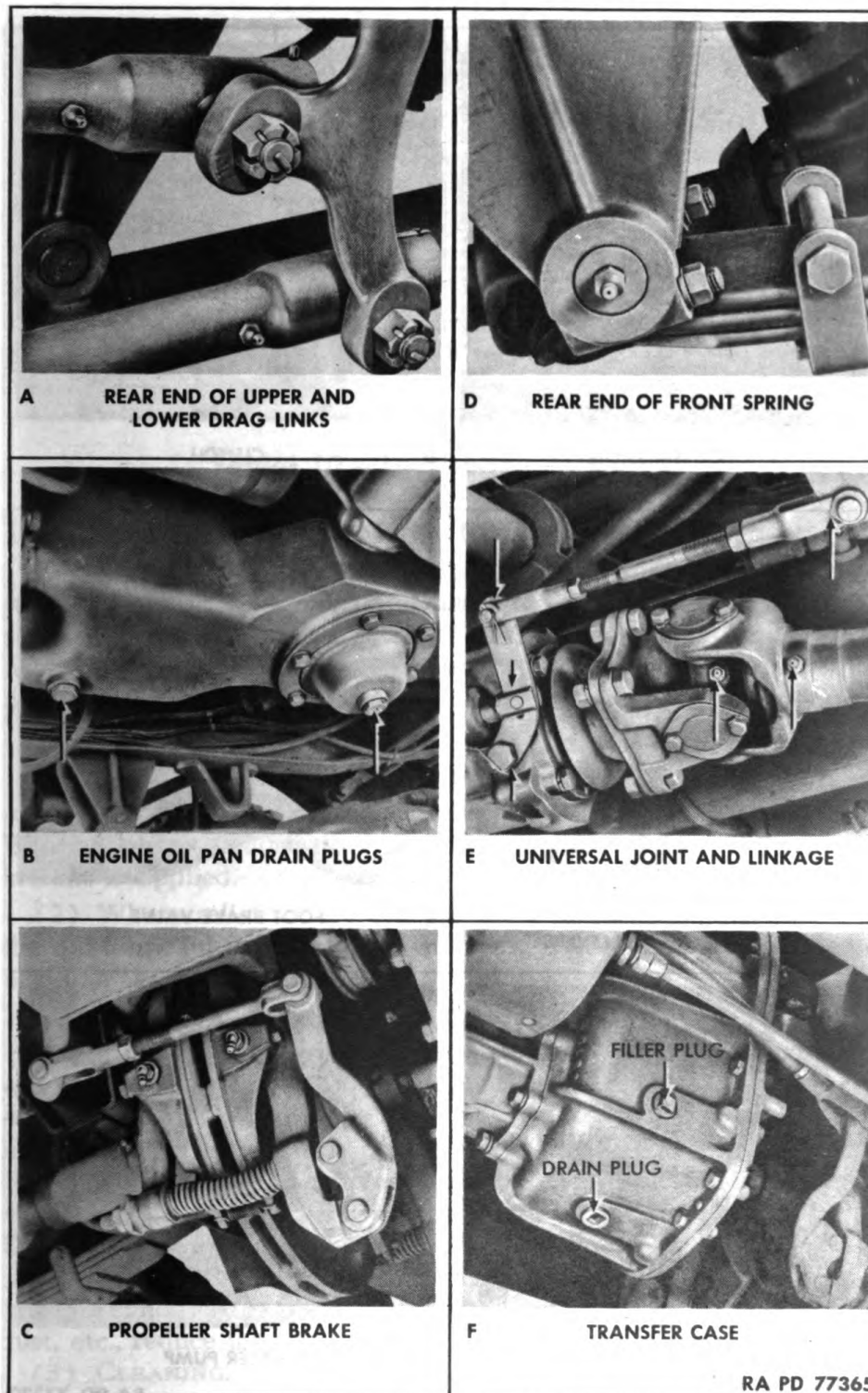


Figure 7 - Lubrication Points - A

**LUBRICATION**



**Figure 8 – Lubrication Points – B**

4- TO 5-TON 4x4 TRACTOR TRUCK (FEDERAL)

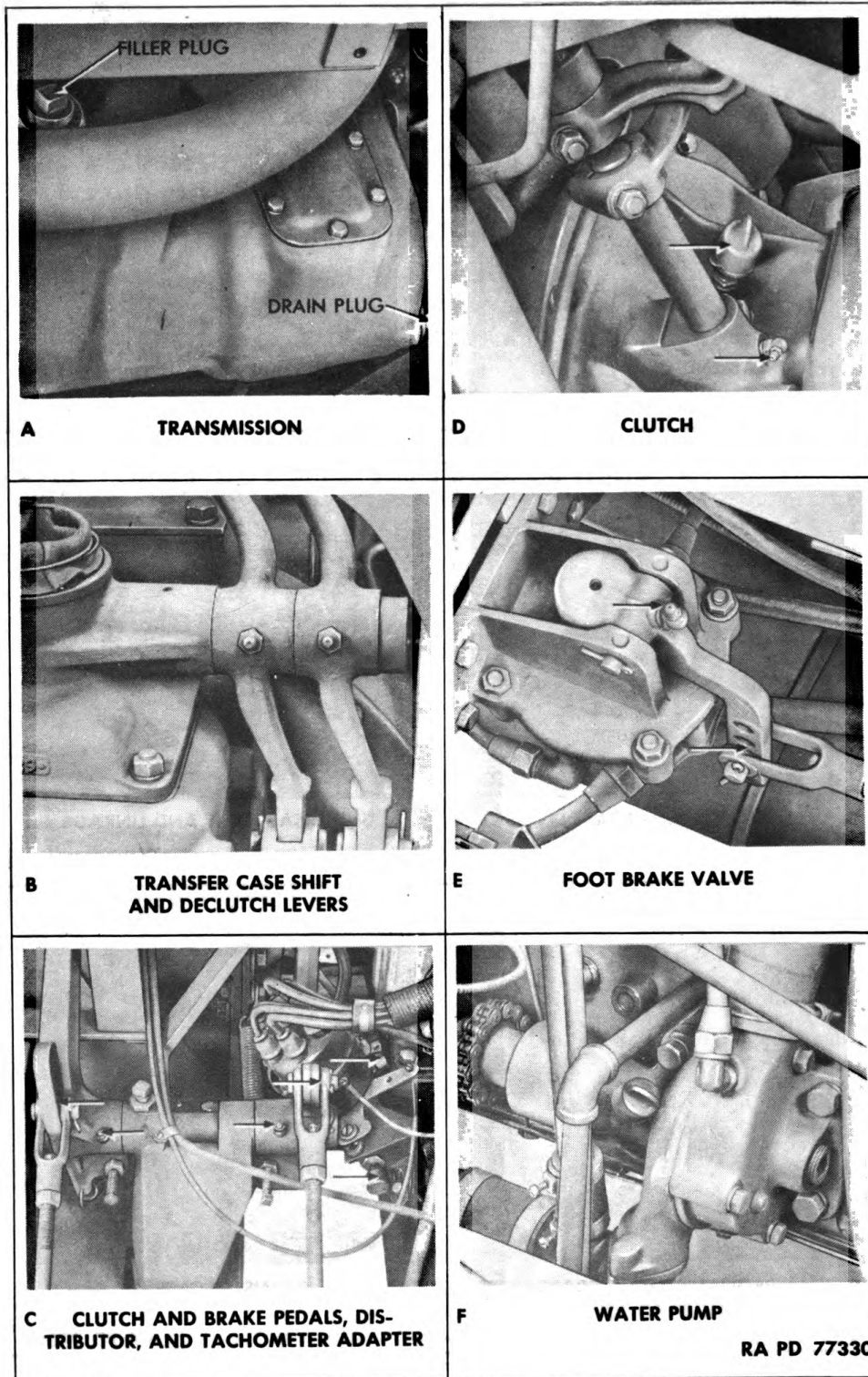
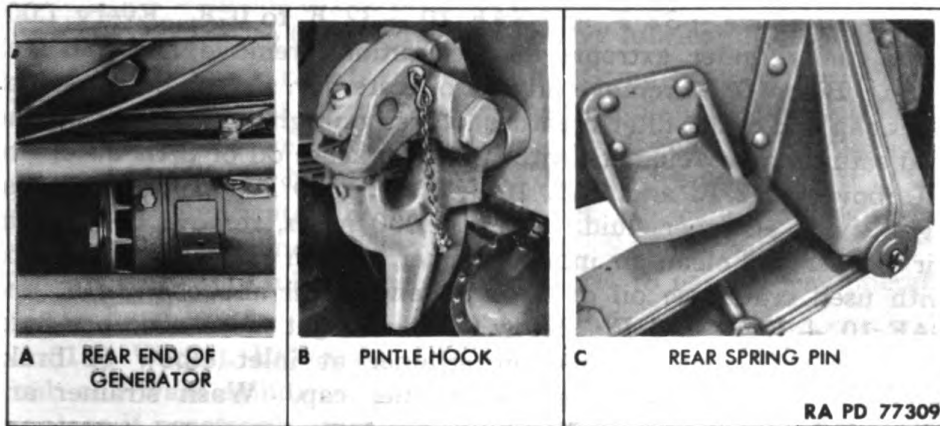


Figure 9 - Lubrication Points - C



## LUBRICATION



**Figure 10 – Lubrication Points – D**

## 17. DETAILED LUBRICATION INSTRUCTIONS.

**a. Lubrication Equipment.** Each piece of materiel is supplied with lubrication equipment adequate to maintain the materiel. Be sure to clean this equipment both before and after use. Operate lubricating guns carefully and in such manner as to insure a proper distribution of the lubricant.

### **b. Points of Application.**

(1) Red circles surrounding lubrication fittings, grease cups, oilers and oilholes make them readily identifiable on the vehicle. Wipe clean such lubricators and the surrounding surface before lubricant is applied.

(2) Where relief valves are provided, apply new lubricant until the old lubricant is forced from the vent. Exceptions are specified in notes on the Lubrication Guide.

**c. Lubrication Notes on Individual Units and Parts.** The following instructions supplement those notes on the Lubrication Guide which pertain to lubrication and service of individual units and parts. All note references in the guide itself are to the subparagraph below having the corresponding number.

(1) **FITTINGS.** Clean before applying lubricant. Lubricate until new lubricant is forced from the bearing, unless otherwise specified. **CAUTION:** *Lubricate chassis points after washing truck and trailer.*

(2) **INTERVALS.** Intervals indicated are for normal service. For extreme conditions of speed, heat, water, sand, mud, snow, rough roads, dust, etc., reduce interval by  $\frac{1}{3}$  or  $\frac{1}{2}$ , or more if conditions warrant.

(3) **CLEANING.** Dry-cleaning solvent or Diesel fuel oil will be used to clean or wash all parts. Use of gasoline for this purpose is prohibited. All parts will be thoroughly dry before relubrication.

(4) **AIR CLEANERS.** Daily check level and refill oil reservoir of

**4- TO 5-TON 4x4 TRACTOR TRUCK (FEDERAL)**

engine air cleaner to bead level with used crankcase oil or SAE 30 engine oil above  $+32^{\circ}\text{F.}$  and SAE 10  $+32^{\circ}\text{F.}$  to  $0^{\circ}\text{F.}$  Every 1,000 miles, daily under extreme dust conditions, remove and wash all parts. Below  $0^{\circ}\text{F.}$ , remove oil and operate dry. Wash crankcase oil filler cap and outlet filter breather located on right rear side of engine, and saturate filter element with used crankcase oil or SAE 30 engine oil above  $+32^{\circ}\text{F.}$  and SAE 10  $+32^{\circ}\text{F.}$  to  $0^{\circ}\text{F.}$  Below  $0^{\circ}\text{F.}$ , use light shock absorber fluid. Every 1,000 miles, remove compressor air cleaner and clean air intake strainer. Wash curled hair and reoil with used crankcase oil or SAE 30 engine oil above  $+32^{\circ}\text{F.}$  and SAE 10  $+32^{\circ}\text{F.}$  to  $0^{\circ}\text{F.}$  Below  $0^{\circ}\text{F.}$ , use light shock absorber fluid. Every 6,000 miles, remove air strainer at inlet elbow of brake governor by first removing the strainer cap. Wash strainer and reinstall.

(5) **CRANKCASE.** Drain only when engine is hot (B, fig. 8). Refill to "FULL" mark on gage. Gage reached through inspection cover under driver's seat. Run engine a few minutes and recheck oil level. **CAUTION:** *Be sure pressure gage indicates oil is circulating.*

(6) **OIL FILTERS.** Every 1,000 miles, remove drain plug in filter base (reached by removing cab skirt panel on left side) to drain sediment. Every 6,000 miles or more often if filter becomes clogged, renew filter element. After renewing element refill crankcase to "FULL" mark on gage. Run engine a few minutes, check crankcase level, and add engine oil to "FULL" mark on gage (SAE 30 above  $+32^{\circ}\text{F.}$ , SAE 10  $+32^{\circ}\text{F.}$  to  $0^{\circ}\text{F.}$ ; below  $0^{\circ}\text{F.}$ , refer to OFSB 6-11).

(7) **GEAR CASES** (F, fig. 8; A, fig. 7; A, fig. 9). Weekly, check level with truck on level ground and, if necessary, add lubricant to within  $\frac{1}{2}$  inch of plug level when cold or to plug level when hot. Drain and refill at intervals indicated on guide. Drain only after operation. Keep all gear case vents clean (*double reduction front axle and transfer case*). Before refilling, pour  $\frac{1}{2}$  quart of universal gear lubricant through fill plug openings in differential drive pinion cage and transfer case declutching unit housing.

(8) **SHOCK ABSORBERS.** Refill Houde absorbers with heavy shock absorber fluid. Refill Delco absorbers with light shock absorber fluid.

(9) **UNIVERSAL JOINT (FRONT WHEELS)** (C, fig. 7). With truck on level ground, remove inspection plug in lower side of universal joint housing and fill through fitting in wheel hub to level of plug hole.

(10) **CRANKING MOTOR.** Every 6,000 miles, remove starter, clean and lubricate Bendix drive with 6 to 8 drops of special preservative lubricating oil.

(11) **DISTRIBUTOR** (C, fig. 9). Every 6,000 miles, wipe distributor breaker cam lightly with No. 1 general purpose grease above  $+32^{\circ}\text{F.}$  and No. 0 below  $+32^{\circ}\text{F.}$  and lubricate breaker arm pivot and wick

## LUBRICATION

under rotor with one to two drops of SAE 30 engine oil above +32°F.; SAE 10 +32°F. to 0°F.; light preservative lubricating oil below 0°F.

(12) **TURNTABLE (FIFTH WHEEL).** Some types of early models have two additional fittings. Keep the turntable, coupler pin locking jaws and guides well lubricated with No. 1 general purpose grease above +32°F. and No. 0 below +32°F. If covered with grit or sand, clean and relubricate. Every 1,000 miles, lubricate the kingpin lock with SAE 30 engine oil above +32°F.; SAE 10 +32°F. to 0°F.; light preservative lubricating oil below 0°F. to permit easy operation of the hand lever.

(13) **WHEEL BEARINGS.** Remove bearing cone assemblies from hub and wash spindle and inside of hub. Inspect bearing races and replace if necessary. Wet the spindle and inside of hub and hub cap with No. 2 general purpose grease to a maximum thickness of  $\frac{1}{16}$  inch only to retard rust. Wash bearing cones and grease seals. Inspect and replace if necessary. Lubricate bearings with No. 2 general purpose grease with a packer or by hand, kneading lubricant into all spaces in the bearing. Use extreme care to protect bearings from dirt and immediately reassemble and replace wheel. The lubricant in the bearings is sufficient to provide lubrication until the next service period. Do not fill hub or hub cap. Any excess might result in leakage into the brake drum.

(14) **OILCAN POINTS (C and E, fig. 8; C, fig. 7; C and D, fig. 9; A and B, fig. 10).** Every 1,000 miles, lubricate throttle and spark control rod ends, clevises, hinges, latches, pintle hook, foot brake and clutch control linkage, emergency brake control lever spring and ratchet, air compressor rocker arm shaft with SAE 30 engine oil above +32°F.; SAE 10 +32°F. to 0°F.; light preservative lubricating oil below 0°F.

(15) **RUBBER BUSHINGS.** Every 1,000 miles, apply hydraulic brake fluid to shock absorber links (some models). **CAUTION: Do not use oil.**

(16) **POINTS REQUIRING NO-LUBRICATION SERVICE.** Chassis springs, rear spring wearing plates, air compressor.

(17) **POINTS TO BE SERVICED AND/OR LUBRICATED BY ORDNANCE MAINTENANCE PERSONNEL.**

(a) *Brake Governor Upper Valve Stem.* Every 12,000 miles, the cover on the brake governor should be removed and the upper valve stem lubricated with a few drops of special preservative lubricating oil.

(b) *Steering Gear Tube Upper Bearing.* When the steering gear is disassembled, the steering gear tube upper bearing will be cleaned and repacked with ball and roller bearing grease.

4- TO 5-TON 4x4 TRACTOR TRUCK (FEDERAL)

Section VII

TOOLS AND EQUIPMENT STOWAGE ON THE VEHICLE

18. VEHICLE TOOLS, EQUIPMENT, AND SPARE PARTS.

a. All tools are stowed in a tool box (fig. 11) attached to the frame on the right-hand side of the truck just ahead of rear wheels. A 1-quart carbon tetrachloride-plunger type fire extinguisher is stored on a bracket between the two seats. The lists below are for information only and are not a basis for requisition. Tools equipment and spare parts furnished are as follows:

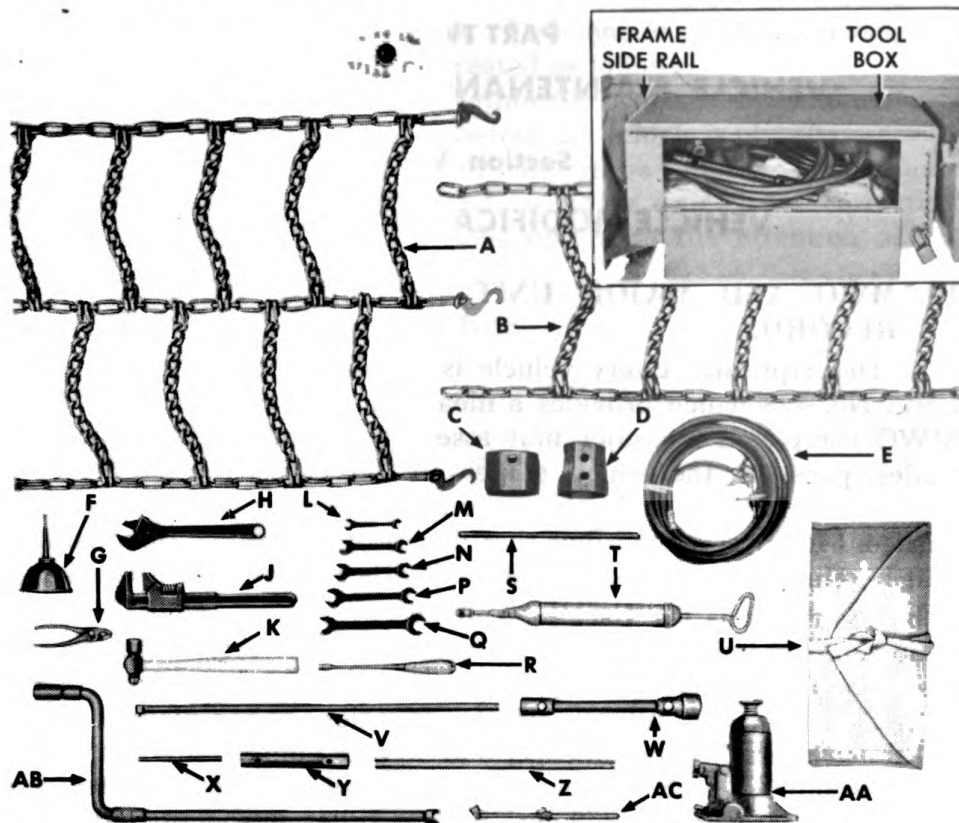
b. Vehicle Tools.

Name	Federal Stock Number
Hammer, machinists, ballpeen, 16-oz	41-H-523
Handle, wheel bearing nut wrench	
Handle, wheel stud nut wrench	41-H-1517-50
Jack, hydraulic, 8-ton, w/handle	41-J-73-5
Pliers, combination, slip joint, 6-in.	41-P-1650
Screwdriver, common, 6-in.	41-S-1076
Wrench, adjustable, single end, 12-in.	41-W-488
Wrench, engineers, open-end, $\frac{3}{8}$ - x $\frac{7}{16}$ -in.	41-W-991
Wrench, engineers, open-end, $\frac{9}{16}$ - x $1\frac{1}{16}$ -in.	41-W-1005-5
Wrench, engineers, open-end, $\frac{1}{2}$ - x $1\frac{9}{32}$ -in.	41-W-1003
Wrench, engineers, open-end, $\frac{5}{8}$ - x $2\frac{5}{32}$ -in.	41-W-1008-10
Wrench, engineers, open-end, $\frac{3}{4}$ - x $\frac{7}{8}$ -in.	41-W-1012-5
Wrench, screw, adjustable, auto. type, 15-in.	41-W-450
Wrench, socket, front wheel bearing nut	41-W-1493-25
Wrench, socket, rear wheel bearing nut	41-W-1991-10
Wrench, socket, wheel stud nut	41-W-3838-30
Wrench, spark plug, w/handle	41-W-3335-30

c. Equipment and Spare Parts.

Bag, tool	41-B-15
Bracket, for fire extinguisher	38-B-385
Crank, engine starting	
Extinguisher, fire, 1 qt capacity	58-E-202
Gage, tire pressure	8-G-615
Gun, lubricating	41-G-1344-35
Gun, lubricating, hydraulic, chassis	41-G-1344-40
Hose, tire inflation (25 ft long)	
Kit, spare parts	
Nozzle, air chuck	
Oiler	13-O-1530
Pump, tire, hand, single cylinder (except air brake trucks)	8-P-5000
Tire chains, front 9.00 x 20 single (1 pair)	
Tire chains, rear, 9.00 x 20 dual (1 pair)	

**TOOLS AND EQUIPMENT STOWAGE ON THE VEHICLE**



- A—DUAL 9.00 x 20 TIRE CHAIN
- B—SINGLE 9.00 x 20 FRONT TIRE CHAIN
- C—REAR WHEEL BEARING NUT WRENCH
- D—FRONT WHEEL BEARING NUT WRENCH
- E—TIRE INFLATION HOSE
- F—OILER
- G—WIRE-CUTTING, SLIP JOINT COMBINATION PLIERS
- H—CRESCENT WRENCH—8-IN.
- J—AUTOMOBILE-TYPE ADJUSTABLE WRENCH
- K—16-OUNCE MACHINIST BALL PEEN HAMMER
- L—OPEN-END, DOUBLE-HEAD, 15-DEGREE ENGINEER'S WRENCH,  $\frac{3}{8}$ —7/16-IN.
- M—OPEN-END, DOUBLE-HEAD, 15-DEGREE ENGINEER'S WRENCH,  $\frac{1}{2}$ —19/32-IN.
- N—OPEN-END, DOUBLE-HEAD, 15-DEGREE ENGINEER'S WRENCH,  $\frac{9}{16}$ —11/16-IN.
- P—OPEN-END, DOUBLE-HEAD, 15-DEGREE ENGINEER'S WRENCH,  $\frac{5}{8}$ —25/32-IN.
- Q—OPEN-END, DOUBLE-HEAD, 15-DEGREE ENGINEER'S WRENCH,  $\frac{3}{4}$ — $\frac{7}{8}$ -IN.
- R—HEAVY-DUTY SCREWDRIVER WITH INTEGRAL HANDLE
- S—WHEEL BEARING WRENCH HANDLE
- T—HYDRAULIC CHASSIS LUBRICATING GUN
- U—CLOTH TOOL CASE
- V—WHEEL NUT SOCKET WRENCH HANDLE
- W—WHEEL NUT SOCKET WRENCH
- X—SPARK PLUG WRENCH HANDLE
- Y—SPARK PLUG WRENCH
- Z—HYDRAULIC JACK HANDLE
- AA—8-TON HYDRAULIC JACK
- AB—ENGINE STARTING CRANK
- AC—TIRE PRESSURE GAGE

RA PD  
77369

**Figure 11 — Tool Box and Tools**

4- TO 5-TON 4x4 TRACTOR TRUCK (FEDERAL)

PART TWO  
VEHICLE MAINTENANCE INSTRUCTIONS

Section VIII

VEHICLE MODIFICATION RECORDS

19. MWO AND MAJOR UNIT ASSEMBLY REPLACEMENT RECORD.

a. **Description.** Every vehicle is supplied with a copy of AGO Form No. 478 which provides a means of keeping a record of each MWO completed or major unit assembly replaced. This form includes spaces for the vehicle name and U.S.A. Registration Number, instructions for use, and information pertinent to the work accomplished. It is very important that the form be used as directed and that it remain with vehicle until vehicle is removed from service.

b. **Instructions for Use.** Personnel performing modifications or major unit assembly replacements must record clearly on the form a description of the work completed and must initial the form in the columns provided. When each modification is completed, record the date, hours and/or mileage, and MWO number. When major unit assemblies, such as engines, transmissions, transfer cases, are replaced, record the date, hours and/or mileage and nomenclature of the unit assembly. Minor repairs and minor parts and accessory replacements need not be recorded.

c. **Early Modifications.** Upon receipt by a third or fourth echelon repair facility of a vehicle for modification or repair, maintenance personnel will record the MWO numbers of modifications applied prior to the date of AGO Form No. 478.

---

Section IX

NEW VEHICLE RUN-IN TEST

20. INTRODUCTION.

a. **Purpose.** When a new or reconditioned vehicle is received at the using organization, it is necessary for second echelon personnel to determine whether or not the vehicle will operate satisfactorily when placed in service. For this purpose, inspect all accessories, sub-assemblies, assemblies, tools, and equipment to see that they are in place and correctly adjusted. In addition, they will perform a run-in test of at least 50 miles as directed in AR 850-15, paragraph 25, table III, according to procedures in paragraph 21 below.

## NEW VEHICLE RUN-IN TEST

**b. Correction of Deficiencies.** Deficiencies disclosed during the course of the run-in test will be treated as follows:

- (1) Correct any deficiencies within the scope of the maintenance echelon of the using organization before the vehicle is placed in service.
- (2) Refer deficiencies beyond the scope of the maintenance echelon of the using organization to a higher echelon for correction.
- (3) Bring deficiencies of serious nature to the attention of the supplying organization.

## 21. RUN-IN TEST PROCEDURES.

### a. Preliminary Service.

(1) **FIRE EXTINGUISHER.** See that portable extinguisher is present, in good condition. Test for proper operation, and mount it securely.

(2) **FUEL, OIL, AND WATER.** Fill fuel tank. Check crankcase oil and coolant supply and add as necessary to bring to correct levels. Allow room for expansion in fuel tank and radiator. During freezing weather, test value of antifreeze and add as necessary to protect cooling system against freezing. **CAUTION:** *If there is a tag attached to filler cap or steering wheel concerning engine oil in crankcase, follow instructions on tag before driving the vehicle.*

(3) **FUEL FILTERS.** Inspect fuel filter for leaks, damage, and secure mountings and connections. Remove drain plug and drain, if any appreciable amount of water or dirt is present, remove elements and clean cases and elements in dry-cleaning solvent. Replace elements using new gaskets.

(4) **BATTERIES.** Make hydrometer and voltage test of batteries and add clean water if needed to level electrolyte to  $\frac{3}{8}$  inch above top of plates.

(5) **AIR-BRAKE TANKS.** Drain air-brake reservoir tanks. Close valves securely.

(6) **AIR CLEANER AND BREATHER CAP.** Examine carburetor, air compressor, air cleaners, and crankcase ventilator breather cap to see if they are in good condition and secure. Remove element from these units and wash thoroughly in dry-cleaning solvent. Apply a film of oil to breather elements, and fill air cleaner reservoir to bead level with fresh oil. Reinstall securely, making sure all gaskets are in good condition and ducts and air horn connections are tight.

(7) **ACCESSORIES AND BELTS.** See that accessories such as carburetor, generator, regulator, cranking motor, distributor, water pump, fan, oil filter, and air compressor are securely mounted. Check the fan, generator and air compressor belts for good condition and adjustment. Belts must have  $\frac{1}{2}$ - to  $\frac{3}{4}$ -inch finger pressure deflection.

(8) **ELECTRICAL WIRING.** Examine all accessible wiring and conduits to see if they are in good condition and securely connected.

(9) **TIRES.** See that all tires, including spare, are properly inflated to 65 pounds cool; that stems are in correct position, all valve caps

**4- TO 5-TON 4x4 TRACTOR TRUCK (FEDERAL)**

present and fingertight. Remove objects lodged in treads and carcasses, and between duals and inspect for damage.

(10) **WHEEL AND FLANGE NUTS.** See that all wheel mounting and axle flange nuts are present and secure.

(11) **FENDERS AND BUMPER.** Examine fenders and bumper for looseness and damage.

(12) **TOWING CONNECTIONS.** Inspect towing hooks, truck tractor fifth wheel and pintle hook for looseness or damage.

(13) **BODY (CAB).** See that all cab and body mountings are secure. Inspect attachments, hardware, glass, doors and windows, to see that they are in good condition, secure and operate properly. See that fifth wheel is properly assembled, in good condition and securely mounted. Be sure trailer connecting mechanism operates properly and latches securely. See that trailer brake lines and connections are in good condition and securely connected or supported. Test all hinges, locks, windshield and window lift mechanism, to see that they function satisfactorily.

(14) **LUBRICATE.** Perform a complete lubrication of the vehicle, covering all intervals, according to the instructions on the lubrication guide, paragraph 17, except gear cases, wheel bearings, and other units lubricated in items (1) to (14). Check all gear case oil levels, and add as necessary to bring to correct level; change only if condition of oil indicates the necessity, or if gear oil is not of proper grade for existing atmospheric temperature. *NOTE: Perform items (15) through (18) during lubrication.*

(15) **SPRINGS AND SUSPENSIONS.** Inspect springs for sag, broken or shifted leaves and loose clips. Check shock absorbers for secure mounting and linkage.

(16) **STEERING LINKAGE.** See that all steering arms, rods, and connections are in good condition and secure; and that gear case is securely mounted and not leaking excessively.

(17) **PROPELLER SHAFTS AND UNIVERSAL JOINTS.** Inspect all propeller shafts and universal joints to see if they are in good condition, correctly assembled, alined, secure, and not leaking excessively.

(18) **AXLE AND TRANSFER VENTS.** See that axle housing and transfer case vents are present, in good condition, and not clogged.

(19) **CHOKE.** Examine choke to be sure it opens and closes fully in response to operation of choke button.

(20) **ENGINE WARM-UP.** Start engine, noting if cranking motor action is satisfactory, and any tendency toward hard starting. Set hand throttle to run engine at fast idle during warm-up. During warm-up, reset choke button so engine will run smoothly, and to prevent overchoking and oil dilution.

(21) **INSTRUMENTS.**

(a) *Oil Gage.* Immediately after engine starts, observe if oil pressure is satisfactory. (Normal operating pressure, hot, is about



**NEW VEHICLE RUN-IN TEST**

40 pounds at 1,600 revolutions per minute.) Stop engine if pressure is not indicated in 30 seconds.

(b) *Ammeters.* Main ammeter should show slight positive charge for a short period after starting engine, until generator restores to battery, current used in starting. "B" ammeter should show charge to indicate "B" battery is receiving current from generator.

(c) *Temperature Gage.* Engine temperature should rise gradually during warm-up to normal operating range, 140 F. to 160 F.

(d) *Fuel Gage.* Fuel gage should register "FULL" if tank has been filled.

(e) *Viscometer.* With engine oil at normal operating temperature, indicator should remain in ideal range. If pointer remains in heavy range inspect oil for dirt or sludge. If pointer goes to thin range it may indicate oil dilution.

(f) *Tachometer.* White pointer should indicate actual engine revolutions per minute at any given time. Red pointer indicates and remains at highest revolutions per minute attained and should not exceed recommended governed engine speed, 2,300 revolutions per minute.

(g) *Air Pressure Gage.* During warm-up period operate engine at fast idle long enough to observe whether or not air-brake pressure builds up a normal rate to specified maximum (105 pounds) and whether governor then cuts off air from compressor. With the engine at normal idling speed, bleed air pressure from system by repeated brake applications and observe if compressor cuts in at 85 pounds. Low pressure indicator (buzzer) should sound at pressures below 60 pounds.

(h) *Speedometer and Odometer.* When vehicle is in motion, speedometer should indicate vehicle speed, and odometer should register accumulating mileage.

(22) **ENGINE CONTROLS.** Observe if engine responds properly to controls and if controls operate without excessive looseness or binding.

(23) **HORN AND WINDSHIELD WIPERS.** See that these items are in good condition and secure. If tactical situation permits, test horn for proper operation and tone. See if wiper arms will operate through their full range and that blade contacts glass evenly and firmly.

(24) **GLASS AND REAR VIEW MIRRORS.** Clean all body glass and mirrors and inspect for looseness and damage. Adjust rear view mirrors for correct vision.

(25) **LAMPS (LIGHTS) AND REFLECTORS.** Clean lenses and inspect all units for looseness and damage. If tactical situation permits, open and close all light switches to see if lamps respond properly.

(26) **LEAKS, GENERAL.** Look under vehicle, and within engine compartment, for indications of fuel, oil, and coolant leaks. Trace any found to source and correct or report them.

(27) **TOOLS AND EQUIPMENT.** Check tools and on vehicle stow-

**4- TO 5-TON 4x4 TRACTOR TRUCK (FEDERAL)**

age lists, paragraph 18, to be sure all items are present, and see that they are serviceable and properly mounted or stowed.

**b. Run-in Test.** Perform the following procedures (1) to (11) inclusive during the road test of the vehicle. On vehicles which have been driven 50 miles or more in the course of delivery from the supplying to the using organization, reduce the length of the road test to the least mileage necessary to make observations listed below. **CAUTION:** *Continuous operation of the vehicle at speed approaching the maximums indicated on the caution plate should be avoided during the test.*

(1) **DASH INSTRUMENTS AND GAGES.** Do not move vehicle until engine temperature reaches 135°F. Maximum safe operating temperature 200°F. Observe readings of oil gage, ammeters, temperature gage, air pressure gage, tachometer, viscometer, and fuel gage to be sure they are indicating the proper function of the units to which they apply. Also see that speedometer registers the vehicle speed and that odometer registers accumulating mileage.

(2) **BRAKES: FOOT AND HAND.** Test service brakes to see if they stop vehicle effectively without side pull, chatter, or squealing. Parking brakes should hold vehicle on a reasonable incline with  $\frac{1}{3}$  ratchet travel in reserve. Apply hand application valve to see if it functions without binding.

(3) **CLUTCH.** Observe if clutch operates smoothly without grab, chatter or squeal on engagement, or slippage when fully engaged, under load. See that pedal has 1½ inch free travel before meeting resistance. **CAUTION:** *Do not ride clutch pedal at any time, and do not engage and disengage new clutch severely or unnecessarily until driven and driving disks have become properly worn in. Never allow pedal free play to become less than ¾ inch. Adjust only according to instructions in paragraph 59.*

(4) **TRANSMISSION AND TRANSFER.** Gearshift mechanism should operate easily and smoothly, and gears should operate without unusual noise and not slip out of mesh. Test front axle declutching for proper operation.

(5) **STEERING.** Observe steering action for binding or looseness, and note any excessive pull to one side, wander, shimmy, or wheel tramp. See that column bracket and wheel are secure. Pay particular attention to Pitman arm to see that it is secure.

(6) **ENGINE.** Be on the alert for any abnormal engine operating characteristics or unusual noise, such as lack of pulling power or acceleration; backfiring, misfiring, stalling, overheating, or excessive exhaust smoke. Observe if engine responds properly to all controls. Do not run engine above governed speed of 2,300 revolutions per minute.

(7) **UNUSUAL NOISE.** Be on the alert throughout road test for any unusual noise from body and attachments, running gear, suspensions

## SECOND ECHELON PREVENTIVE MAINTENANCE

or wheels, that might indicate looseness, damage, wear, inadequate lubrication or underinflated tires.

(8) **HALT VEHICLE AT 10-MILE INTERVALS FOR SERVICES (9) TO (11) BELOW.**

(9) **AIR-BRAKE SYSTEM LEAKS.** With the air pressure at governed maximum and the brakes applied, stop engine. There should not be a noticeable drop in pressure within 1 minute.

(10) **TEMPERATURES.** Cautiously hand-feel each brake drum and wheel hub for abnormal temperatures. Examine transmission, transfer case, and differential housings for indications of overheating and excessive lubricant leaks at seals, gaskets, or vents. *NOTE: Transfer case temperatures are normally higher than other gear cases.*

(11) **LEAKS.** With engine running, and fuel, engine oil, and cooling systems under pressure, look within engine compartment and under vehicle for indications of leaks.

### c. Vehicle Publications and Reports.

(1) **PUBLICATIONS.** See that vehicle Technical Manuals, Lubrication Guide, Standard Form No. 26 (Drivers Report-accident, Motor Transportation) W.D., AGO Form No. 478 (MWO and Major Unit Assembly Replacement Record), are in the vehicle, legible, and properly stowed. *NOTE: U.S.A. registration number and vehicle nomenclature must be filled in on Form No. 478, for new vehicles.*

(2) **REPORTS.** Upon completion of the run-in test, correct or report any deficiencies noted. Report general conditions of the vehicle to designated individual in authority.

---

## SECTION X

## SECOND ECHELON PREVENTIVE MAINTENANCE

### 22. SECOND ECHELON PREVENTIVE MAINTENANCE SERVICES.

a. Regular scheduled maintenance inspections and services are a preventive maintenance function of the using arms, and are the responsibility of commanders of operating organizations.

(1) **FREQUENCY.** The frequency of the preventive maintenance services outlined herein is considered a minimum requirement for normal operation of vehicles. Under unusual operating conditions, such as extreme temperatures, dusty or sandy terrain, it may be necessary to perform certain maintenance services more frequently.

(2) **FIRST ECHELON PARTICIPATION.** The drivers should accompany their vehicles and assist the mechanics while periodic second echelon preventive maintenance services are performed. Ordinarily the driver should present the vehicle for a scheduled preventive

**4- TO 5-TON 4x4 TRACTOR TRUCK (FEDERAL)**

maintenance service in a reasonably clean condition; that is, it should be dry and not caked with mud or grease to such an extent that inspection and servicing will be seriously hampered. However, the vehicle should not be washed or wiped thoroughly clean, since certain types of defects, such as cracks, leaks, and loose or shifted parts or assemblies are more evident if the surfaces are slightly soiled or dusty.

(3) If instructions other than those contained in the general procedures in step (4) or the specific procedures in step (5) which follow, are required for the correct performance of a preventive maintenance service, or for correction of a deficiency, other sections of this manual pertaining to the item involved, or a designated individual in authority, should be consulted.

(4) **GENERAL PROCEDURES.** These general procedures are basic instructions which are to be followed when performing the services on the items listed in the specific procedures. **NOTE:** *The second echelon personnel must be thoroughly trained in these procedures so that they will apply them automatically.*

(a) When new or overhauled subassemblies are installed to correct deficiencies, care should be taken to see that they are clean, correctly installed, properly lubricated, and adjusted.

(b) When installing new lubricant retainer seals, a coating of the lubricant should be wiped over the sealing surface of the lip of the seal. When the new seal is a leather seal, it should be soaked in SAE 10, engine oil (warm if practicable) for at least 30 minutes. Then the leather lip should be worked carefully by hand before installing the seal. The lip must not be scratched or marred.

(c) The general inspection of each item applies also to any supporting member or connection, and usually includes a check to see whether or not the item is in good condition, correctly assembled, secure, or excessively worn. The mechanic must be thoroughly trained in the following explanations of these terms:

1. The inspection for "good condition" is usually an external visual inspection to determine if the unit is damaged beyond safe or serviceable limits. The term good condition is explained further by the following terms: not bent or twisted, not chafed or burned, not broken or cracked, not bare or frayed, not dented or collapsed, not torn or cut.

2. The inspection of a unit to see that it is "correctly assembled" is usually an external visual inspection to see whether or not it is in its normal assembled position in the vehicle.

3. The inspection of a unit to determine if it is "secure" is usually an external visual examination, a wrench, hand-feel or a pry-bar check for looseness. Such an inspection should include any brackets, lock washers, lock nuts, locking wires, or cotter pins used in assembly.

4. "Excessively worn" will be understood to mean worn close to, or beyond, serviceable limits, and likely to result in a failure if not replaced before the next scheduled inspection.

## SECOND ECHELON PREVENTIVE MAINTENANCE

(d) *Special Services.* These are indicated by repeating the item numbers in the columns which show the interval at which the services are to be performed, and show that the parts, or assemblies, are to receive certain mandatory services. For example, an item number in one or both columns opposite a **TIGHTEN** procedure, means that the actual tightening of the object must be performed. The special services include:

1. *Adjust.* Make all necessary adjustments in accordance with the pertinent section of this manual, special bulletins, or other current directives.

2. *Clean.* Clean units of the vehicle with dry-cleaning solvent to remove excess lubricant, dirt, and other foreign material. After the parts are cleaned, rinse them in clean fluid and dry them thoroughly. Take care to keep the parts clean until reassembled, and be certain to keep cleaning fluid away from rubber or other material that it would damage. Clean the protective grease coating from new parts since this material is usually not a good lubricant.

3. *Special lubrication.* This applies either to lubrication operations that do not appear on the vehicle lubrication chart, or to items that do appear on such charts, but should be performed in connection with the maintenance operations, if parts have been disassembled for inspection or service.

4. *Serve.* This usually consists of performing special operations, such as replenishing battery water, draining and refilling units with oil, and changing or cleaning the oil filter or cartridge.

5. *Tighten.* All tightening operations should be performed with sufficient wrench torque (force on the wrench handle) to tighten the unit according to good mechanical practice. Use torque-indicating wrench where specified. Do not overtighten, as this may strip threads or cause distortion. Tightening will always be understood to include the correct installation of lock washers, lock nuts, and cotter pins provided to secure the tightening.

(e) When conditions make it difficult to perform the complete preventive maintenance procedures at one time, they can sometimes be handled in sections, planning to complete all operations within the week if possible. All available time at halts, and in bivouac areas, must be utilized if necessary to assure that maintenance operations are completed. When limited by the tactical situation, items with Special Services in the columns, should be given first consideration.

(f) The numbers of the preventive maintenance procedures that follow are identical with those outlined on W.D. AGO Form No. 461, which is the Preventive Maintenance Service Work Sheet for Wheeled and Half-track Vehicles. Certain items on the work sheet, that do not apply to this vehicle, are not included in the procedures in this manual. In general, the numerical sequence of items on the work sheet is followed in the manual procedures, but in some instances

**4- TO 5-TON 4x4 TRACTOR TRUCK (FEDERAL)**

there is deviation for conservation of the mechanic's time and effort.

(5) **SPECIFIC PROCEDURES.** The procedures for performing each item in the 1,000-mile (monthly) and 6,000-mile (6-month) maintenance procedures are described in the following chart. Each page of the chart has two columns at its left edge corresponding to the 6,000-mile and the 1,000-mile maintenance respectively. Very often it will be found that a particular procedure does not apply to both scheduled maintenance. In order to determine which procedure to follow, look down the column corresponding to the maintenance due, and wherever an item number appears perform the operations indicated opposite the number.

6,000 Mile Maint (six- month)	1,000 Mile Maint (mon- thly)
1	1
2	2
3	3

**ROAD TEST**

*NOTE: When the tactical situation does not permit a full road test, perform those items which require little, or no, movement of the vehicle. When a road test is possible, it should be for preferably 5 miles and not over 10 miles.*

**1** *Before-operation Service.* Perform the before-operation service as described in paragraph 12.

**2** *Air Pressure (Build-up, Governor Cut-off, Low-pressure Indicator).* During warm-up period operate engine at fast idle long enough to observe if air-brake pressure builds up at normal rate to specified maximum (105 lb) and that governor then cuts off air from compressor. With engine at normal idling speed, bleed air pressure from system by repeated brake application and observe if compressor cuts in at about 85 pounds. Low-pressure indicator (buzzer) should sound at pressures below 60 pounds. Any abnormal drop in air pressure except from brake application should be investigated by making elimination soapsuds tests as described in paragraph 124.

**3** *Dash Instruments and Gages.*  
*Oil Pressure Gage.* Oil pressure should be 40 pounds minimum at 1,600 revolutions per minute, 10 to 15 pounds at normal idling speed. **CAUTION: Stop engine if oil pressure is too low for safe engine operation at any speed.**

*Ammeters.* Main ammeter should show a positive (+) charge for short period after starting engine, until generator restores to batteries current used in starting.

**SECOND ECHELON PREVENTIVE MAINTENANCE**

6,000 Mile Maint (six- month)	1,000 Mile Maint (mon- thly)	
		<p>Time will depend on condition of charge of batteries and electrical load carried. With batteries fully charged and regulator unit cut in, ammeter may show zero or only slight charge. "B" ammeter should show charge to indicate "B" battery is receiving current from generator. Stop engine and investigate discharge (-) readings with engine running and lights and accessories turned off.</p> <p><i>Viscometer.</i> With engine oil at normal operating temperature, indicator should remain in "ideal" range. If pointer remains in "heavy" range inspect oil for dirt or sludge. If pointer goes to "thin" range it may indicate oil dilution.</p> <p><i>Engine Temperature Gage.</i> Reading should increase gradually during warm-up to normal operating temperature 153°F. to 183°F. <b>CAUTION: Do not move vehicle until engine temperature has reached 135°F. Maximum safe temperature 200°F.</b></p> <p><i>Tachometer.</i> White pointer should indicate actual engine revolutions per minute at any given time. Red pointer indicates and remains at highest revolution per minute attained and should not exceed recommended governed engine speed, 2,300 revolutions per minute.</p> <p><i>Speedometer.</i> While vehicle is in motion, speedometer should register actual vehicle miles per hour, and odometer should record total accumulated mileage.</p> <p><i>Fuel Gage.</i> Should register approximate amount of fuel in tank at all times.</p> <p><i>Air Pressure Gage.</i> Refer to item 2 for specifications and tests.</p>
4	4	<p><i>Horns, Mirrors, and Windshield Wipers.</i> If tactical situation permits, test horns for proper operation and tone. Examine rear vision mirror and wipers to see if they are in good condition, and secure. Test operation of wiper motors and see that wiper blades contact glass evenly and operate through their full range without indications of loose wiper motor mountings. Adjust rear vision mirror for correct vision.</p>
5	5	<p><i>Brakes (Service and Parking, Braking Effect, Feel, Side Pull, Noise, Chatter, Pedal Travel, Hand Control).</i> Operate brakes at various speeds during road test.</p>

4- TO 5-TON 4x4 TRACTOR TRUCK (FEDERAL)

6,000 Mile Maint (six- month)	1,000 Mile Maint (mon- thly)	
		<p><i>Service Brakes.</i> Apply foot pedal sufficiently to stop vehicle in minimum distance and observe their effectiveness, any pull to one side, unusual noise, or chatter. Pedal should depress with little effort, and should return to "OFF" position when released. Apply hand application valve to see if it functions without binding.</p> <p><i>Parking Brake.</i> Stop vehicle on reasonable incline; apply parking brake and observe if it holds vehicle effectively; that lever has at least <math>\frac{1}{3}</math> travel in reserve, and that ratchet and pawl latch the applied brake securely.</p>
6	6	<p><i>Clutch (Free Travel, Drag, Noise, Chatter, Grab, Slip).</i> Pedal free travel should be <math>1\frac{1}{2}</math> inches before meeting resistance. Test clutch for drag when shifting into low gear. Note any unusual noise when pedal is depressed which may indicate defective or dry release bearing. With transmission in gear, note any tendency to chatter or grab when clutch is engaged or slippage when fully engaged under load.</p> <p>NOTE: Never allow pedal free play to become less than <math>\frac{3}{4}</math> inch.</p>
7	7	<p><i>Transmission and Transfer (Lever Action, Declutching, Vibration, Noise).</i> Levers should move into each gear range position easily and quietly. Test declutching lever to see that front axle engages properly. Note any vibration that may indicate loose mountings or noise that may indicate damaged, excessively worn or inadequately lubricated parts.</p>
8	8	<p><i>Steering (Free Play, Bind, Wander, Shimmy, Side Pull, Column, and Wheel).</i> With vehicle in motion move steering wheel fully in both directions and observe whether there is any indication of looseness or binding. Note any tendency to wander, shimmy, or pull to one side. See that steering column and wheel are in good condition and secure.</p>
9	9	<p><i>Engine (Idle, Acceleration, Power, Noise and Governed Speed).</i> Observe engine operating characteristics as follows:</p> <p><i>Idle.</i> Engine should idle smoothly without stalling.</p> <p><i>Unusual Noises.</i> Listen for knocks and rattles as the</p>



**SECOND ECHELON PREVENTIVE MAINTENANCE**

6,000 Mile Maint (six- month)	1,000 Mile Maint (mon- thly)	
		<p>engine is accelerated and decelerated, and while it is under both light and heavy loads.</p> <p><i>Acceleration and Power.</i> Operate the engine at various speeds in all gear ratios, noting if the vehicle has normal pulling power and acceleration. Note any tendency to stall while shifting. A slight ping during fast acceleration is normal. Continued or heavy ping may indicate early timing, or heavy accumulation of carbon.</p> <p><i>Governed Speed.</i> With the vehicle in a low gear, slowly depress the accelerator to the toeboard and by observing the speedometer reading, see if the vehicle reaches, but does not exceed, the governed speed specified on the caution plate. Observe tachometer reading and note if the engine speed exceeds the specified 2,300 revolutions per minute.</p>
10	10	<p><i>Unusual Noises (Attachments, Cab, Wheels).</i> Be on alert during road test for any noise that may indicate loose or damaged attachments mounted on vehicle, loose cab mountings, floor plates, doors, windshield or hardware. Listen particularly for indications of loose wheel mountings.</p>
12	12	<p><i>Air-brake System Leaks.</i> With the air pressure at the governed maximum and the brakes applied, stop the engine. There should not be a noticeable drop in pressure within one minute. If any pressure drop occurs during this check, test the air-brake system for leaks by the soapsuds method.</p>
13	13	<p><i>Temperatures (Brake Drums, Hubs, Axles, Transmission, Transfer).</i> Place hand cautiously on all brake drums and wheel hubs to see if they are abnormally hot. Inspect axle housings, transmission and transfer case for indications of overheating.</p>
14	14	<p><i>Leaks (Engine Oil, Water, Fuel).</i> Look in engine compartment, and under vehicle for indications of engine oil, coolant or fuel leaks. Trace any found to their source and correct or report them.</p>
		<p><b>MAINTENANCE OPERATIONS</b></p> <p>Raise Vehicle — Block Safely</p>
16	16	<p><i>Gear Oil Level and Leaks (Axles, Transmission, and Transfer).</i> Remove filler plugs in front and rear axles,</p>

4- TO 5-TON 4x4 TRACTOR TRUCK (FEDERAL)

6,000 Mile Maint (six- month)	1,000 Mile Maint (mon- thly)	
		transmission, and transfer case and check lubricant levels. Proper level is from lower edge of filler hole when hot, to 1/2 inch below when cold. Allow sufficient time for foaming to subside before checking levels. Note condition of lubricant. If an oil change is due in any of these units or condition of lubricant indicates an oil change is necessary, drain and refill units with fresh specified oil. Note any indications of excessive lubricant leaks at oil seals or gaskets.
17	17	<p><i>Unusual Noises (Engine, Belts, Accessories, Transmission, Transfer, Shafts and Joints, Axles and Wheel Bearings).</i> With engine running observe as follows:</p> <p><i>Engine, Belts and Accessories.</i> Accelerate and decelerate the engine momentarily and listen for any unusual noise in these units that might indicate damaged, loose, or excessively worn engine parts, drive belts or accessories. Also be sure to locate and correct or report any unusual engine noise heard during the road test.</p> <p><i>Transmission, Transfer, Propeller Shafts and Joints, Axles, and Wheel Bearings.</i> With the transmission in an intermediate gear, and front driving axle engaged, operate these units at a constant, moderate speed by use of the hand throttle, and listen for any unusual noise that might indicate damaged, loose or excessively worn unit parts. Also observe all propeller shafts and wheels for vibrations and run-out, and for vibration in the other units which may indicate looseness or unbalance. Slow running wheels may indicate tight brakes or wheel bearings. Also be sure to locate, correct, or report any noise noted during road test.</p>
18	18	<p><i>Cylinder Heads and Gaskets.</i> Look for cracks or indications of oil, coolant, or compression leaks around studs, cap screws and gaskets. <b>CAUTION: Cylinder heads should not be tightened unless there is definite evidence of leaks. If tightening is necessary, use torque-indicating wrench, and tighten head nuts in the proper sequence and to 52 1/2 foot-pounds tension. Be sure bond straps are secure.</b></p>
	19	<p><i>Valve Mechanism (Clearance, Cover Gaskets).</i> Adjust valve stem clearance only if noisy. Intake valve clearance must be 0.006 inch, hot; exhaust valve clearance, 0.010 inch, hot.</p>

SECOND ECHELON PREVENTIVE MAINTENANCE

6,000 Mile Maint (six- month)	1,000 Mile Maint (mon- thly)	
19		<i>Adjust.</i> Set valve stem clearance to above specifications. See if valve stems, springs, seats and locks, are in good condition, correctly assembled and secure. Inspect valve covers to be sure they are in good condition. Reinstall them securely using new gaskets if necessary.
22	22	<i>Battery (Cables, Hold-down, Carrier, Record Gravity and Voltage).</i> Inspect battery case for cracks and leaks. Clean top of battery. Inspect cables, terminals, bolts, posts, straps and hold-downs for good condition. Test specific gravity and voltage and record on W.D. AGO Form No. 461. Specific gravity readings below 1.225 indicate battery should be recharged or replaced. Electrolyte level should be above top of plates and may extend ½ inch above plates.
22		Perform high-rate discharge test according to instructions for "condition" test which accompany test instrument and record voltage on W.D. AGO Form No. 461. Cell variation should not be more than 30 percent. <b>NOTE:</b> <i>Specific gravity must be above 1.225 to make this test.</i>
22	22	Bring electrolyte to proper level by adding distilled or clean water. Clean entire battery and carrier. Repaint carrier if corroded. Clean battery cable terminals, terminal bolts and nuts, and battery posts and grease lightly. Inspect bolts for serviceability. Tighten terminals and hold-downs carefully to avoid damage to battery. Tighten battery to cover bond straps.
	20	<i>Spark Plugs (Gaps, Deposits).</i> Without removal wipe off plugs and examine insulators for damage or indications of compression leaks.
20		Remove all plugs and examine to see if they are in good condition. Pay particular attention to broken insulators, excessive carbon or oxide deposits, and to electrodes burned thin. Clean plugs thoroughly. If plug cleaner is not available, install new or reconditioned plugs. ( <b>NOTE:</b> <i>Do not install plugs until item 21 has been performed.</i> ) Set plug gaps to 0.025 inch by bending only grounded electrodes.
21		<i>Compression Test.</i> Test compression with all spark plugs removed. Compression pressure at cranking speed is normally 90 to 95 pounds. There should be

4- TO 5-TON 4x4 TRACTOR TRUCK (FEDERAL)

6,000 Mile Maint (six- month)	1,000 Mile Maint (mon- thly)	
23	23	<p>not more than 10-pound variation between cylinders. Record compression pressures on space provided on back of work sheet, Form No. 461.</p> <p><i>Crankcase (Leaks, Oil Level).</i> With engine idling examine crankcase, valve covers, timing-gear cover, and clutch housing for oil leaks. Stop engine and after oil has drained into crankcase, check to see if it is up to proper level. If an oil change is due, or condition of oil indicates the necessity, drain crankcase and refill to correct level with fresh specified oil. <b>NOTE: Do not again start engine until item 23 has been performed.</b></p>
24	24	<p><i>Oil Filters and Lines.</i> Inspect filters and external engine oil lines to see if they are in good condition, secure, and not leaking. Remove filter body drain plugs and drain off contents. Remove filter cartridge and check condition. If cartridge change is due, or condition indicates the necessity, replace with new cartridge being sure gaskets are in place and tighten covers and drain plugs securely.</p>
25	25	<p><i>Radiator (Core, Shell, Mountings, Hose, Cap and Gasket, Antifreeze Record, Overflow Pipe).</i> Inspect all applicable items to see if they are in good condition, secure, and not leaking. Be sure overflow pipe is not kinked or clogged. Examine condition of coolant to see whether it is so contaminated that cooling system should be cleaned. If cleaning is necessary, proceed only according to current directives covering proper procedure and recommended cleaner, neutralizer, and inhibitor materials. Clean all insects, dirt or grease deposits from core air passages and inspect for bent cooling fins. <b>CAUTION: Use only a suitably shaped piece of wood or blunt instrument to straighten fins.</b> If antifreeze is in use, test its protective value and record in space provided on back of work sheet Form No. 461.</p>
25		<p><i>Tighten.</i> Carefully tighten all loose radiator mountings, water connections and hose clamps and bond straps.</p>
26	26	<p><i>Water Pump and Fan.</i> Inspect pump to see if it is in good condition, secure and not leaking. Examine shaft for end play or bearing looseness. Inspect fan to see if it is in good condition and that blades and hub are secure. Loosen drive belts and examine fan for hub or</p>

SECOND ECHELON PREVENTIVE MAINTENANCE

6,000 Mile Maint (six- month)	1,000 Mile Maint (mon- thly)	
		bearing wear. Leave drive belts loose until adjustment is made (item 29).
		<i>Tighten.</i> Carefully tighten water pump and fan assembly and mounting nuts.
27	27	<i>Generator, Starter, and Switch.</i> Inspect generator, cranking motor and cranking motor switch to see if they are in good condition, securely mounted, and if wiring connections are clean and secure. See that generator radio noise capacitor is secure and not damaged.
27		Remove generator and cranking motor inspection covers and examine commutators and brushes to see if they are in good condition and clean; if brushes are free in brush holders and have sufficient spring tension to hold them in proper contact with commutators; and if brush connection wires are secure and not chafing.
27		<i>Clean.</i> Blow out commutator end of generator and cranking motor with compressed air. If commutators are dirty, clean only with 2/0 flintpaper (do not use emery) placed over end of suitable sized piece of wood and again blow out with air.
27		<i>Tighten.</i> Carefully tighten cranking motor mounting bolts securely.
28	28	<i>Air Compressor (Unloader Valve, Governor, Lines).</i> Examine the air compressor to see that it is in good condition, properly alined with its drive pulleys, and secure. Check unloader valve for satisfactory valve clearance. See if the governor appears to be in good condition and secure; if all the compressor water, oil, and air lines within engine compartment are in good condition and secure, and that oil and water lines do not leak.
		<i>Clean.</i> Clean governor hair air strainer in dry-cleaning solvent; dry, and apply a thin film of engine oil to strainer and reinstall.
28		<i>Special Lubrication.</i> Apply a few drops of engine oil on the unloader valve fulcrum pin.
		Apply a few drops of kerosene or dry-cleaning solvent on upper valve stem of governor.
		Adjust unloader valve clearance 0.010 inch to 0.015 inch.

4- TO 5-TON 4x4 TRACTOR TRUCK (FEDERAL)

6,000 Mile Maint (six- month)	1,000 Mile Maint (mon- thly)	
29	29	<p><b>Drive Belts and Pulleys.</b> Examine all drive belts for evidence of fraying condition, excessive wear, and deterioration. Inspect all drive pulleys and hubs to see if they are in good condition and securely mounted.</p> <p><b>Adjust.</b> Set adjustment so drive belts have 1/2- to 3/4-inch finger-pressure deflection.</p>
30	30	<p><b>Tachometer Drive and Adapter.</b> See if they are in good condition, correctly assembled, and secure. Inspect the flexible drive shaft for kinks, and connection for indications of oil leaks.</p>
31	31	<p><b>Distributor (Cap, Rotor, Points, Shaft, Advance Units).</b> Observe if distributor body and external attachment are in good condition and secure. Examine other parts as follows:</p> <p><b>Cap, Rotor, and Points.</b> Clean dirt from cap and remove. Inspect cap, rotor and breaker plate to see if they are in good condition, secure and serviceably clean. Pay particular attention to cracks in cap and rotor, corrosion of terminals and connections, and to burned rotor bar or contact points. See that points are well alined and adjusted to 0.020 inch when wide open.</p> <p>If inside of distributor is dirty, remove assembly, clean in solvent, dry thoroughly with compressed air and lubricate its friction parts very lightly. When cleaning remove wick and lubrication cup, clean them, reoil and replace after cleaning distributor. If breaker points are pitted, burned or worn to an unserviceable degree, replace. Also replace condenser if points are burned as this may be the cause. When cleaning points use fine file or 2/0 flintpaper (never use emery) and blow out filings with compressed air.</p> <p><b>Shaft.</b> Test shaft by hand feel for excessive wear in shaft or bushings.</p> <p><b>Centrifugal Advance.</b> Install rotor on shaft and test distributor governor by finger force for normal range of movement permitted by mechanism. Note if it will return to original position when released without hang up or binding.</p>
31	31	<p><b>Special Lubrication.</b> Lubricate cam surfaces, breaker arm pin, and wick according to lubrication guide instructions.</p>

**SECOND ECHELON PREVENTIVE MAINTENANCE**

6,000 Mile Maint (six- month)	1,000 Mile Maint (mon- thly)	
31		<i>Adjust.</i> Set breaker point gaps to 0.020 inch.
32	32	<i>Coil and Wiring.</i> Inspect coil, ignition wiring including shielding or conduits to see if they are in good condition, clean, securely connected and properly supported. Be sure radio noise resistor-suppressors on spark plug and coil to distributor wires and coil filter unit are in good condition and properly connected. Inspect all low voltage wiring in engine compartment in a like manner.
33	33	<i>Manifolds and Gaskets.</i> Inspect for looseness, damage or exhaust leaks at gaskets. Examine for evidence of cracks or sand holes usually indicated by carbon streaks.
33		<i>Tighten.</i> Carefully tighten all manifold assembly and mounting nuts securely.
34	34	<i>Air Cleaner.</i> Inspect carburetor air cleaner to see if it is in good condition, securely mounted and connected and not leaking. Remove reservoir and element, clean in dry-cleaning solvent; dry, fill reservoir to proper level with clean engine oil and reassemble. Be sure gaskets are in place, and that bond straps, and all joints and air horn connections tight.
35	35	<i>Breather Cap.</i> Inspect crankcase breather cap to see if it is in good condition, secure and not leaking. Remove oil reservoir and element, wash clean in dry-cleaning solvent, refill reservoir with fresh engine oil and reassemble securely.
36	36	<i>Carburetor (Choke, Throttle, Linkage and Governor).</i> See if they are in good condition, correctly assembled, and securely installed; that carburetor does not leak; that control linkage, including choke and throttle shaft, is not excessively worn; if choke valve opens fully when the control is in its released position; if throttle valve opens fully when the accelerator is fully depressed; and if the governor is secure and properly sealed.
37	37	<i>Fuel Filter and Lines.</i> Examine filter to see if it is in good condition, securely mounted and connected and not leaking.  <i>Clean.</i> Close fuel shut-off and remove filter sediment bowl and element. Wash clean in dry-cleaning solvent and reassemble securely being sure gaskets are in place.

4- TO 5-TON 4x4 TRACTOR TRUCK (FEDERAL)

6,000 Mile Maint (six- month)	1,000 Mile Maint (mon- thly)	
		(CAUTION: <i>If element cannot be cleaned by washing replace unit. Do not scrape element to clean</i> ). Turn on fuel supply and recheck for leaks.
38	38	<b>Fuel Pump (Pressure).</b> Inspect pump to see if it is in good condition, securely mounted and not leaking. Remove sediment bowl and screen and wash in dry-cleaning solvent. Be sure gasket is in place and serviceable when bowl is reinstalled.
38		Attach a test gage to pressure side of fuel pump and after starting engine as in item 39 see that pressure is satisfactory. Should be 2 pounds minimum, 3¾ pounds maximum at idle speed.
39	39	<b>Starter (Action, Noise, Speed).</b> Start the engine observing if general action of cranking motor is satisfactory, particularly that it engages and operates properly without excessive noise and has adequate cranking speed; and if the engine starts readily. Also, as soon as engine starts, note whether oil pressure gage and ammeter indications are satisfactory.
40	40	<b>Leaks (Engine Oil, Fuel, and Water).</b> With engine running recheck all points of oil, fuel and cooling systems for leaks. Trace any found to source and correct or report them.
41	41	<b>Ignition Timing (Advance).</b> With engine running and a neon timing light connected, observe if ignition timing is correct. Also note whether automatic controls advance the timing as engine is accelerated gradually.
41		<b>Adjust.</b> Ignition timing to specifications in paragraph 81 b.
42	42	<b>Engine Idle and Vacuum Test.</b> Inspect as follows: <b>Adjust.</b> Connect a vacuum gage to intake manifold, adjust engine to its normal idle speed by means of throttle stop screw, and then adjust the idle-mixture adjusting needle until vacuum gage indicates a steady maximum reading. If these latter adjustments are made simultaneously, time will be saved.
42	42	<b>Vacuum Test.</b> With the engine running at normal idling speed, vacuum gage should read about 18 to 21 inches and pointer should be steady. A badly fluctuating needle between 10 and 15 inches may indicate a defec-



**SECOND ECHELON PREVENTIVE MAINTENANCE**

6,000 Mile Maint (six- month)	1,000 Mile Maint (mon- thly)	
		<p>tive cylinder head gasket or valve. An extremely low reading may indicate a leak in intake manifold or gasket. Accelerate and decelerate engine quickly. If vacuum gage indicator fails to drop to approximately 2 inches as throttle is opened, and then fails to recoil to at least 24 inches as throttle is closed, it may be an indication of diluted oil, poor piston ring sealing, or abnormal restriction in carburetor, air cleaner, or exhaust. <b>NOTE:</b> <i>Above readings apply to sea level. There will be approximately a 1-inch drop for each 1,000 feet of altitude.</i></p>
43	43	<p><b>Regulator Unit (Connections, Voltage, Current, and Cut-out).</b> Inspect regulator unit and radio suppression filters, to see if they are in good condition, securely mounted and connected and clean.</p>
43		<p><b>Test.</b> Connect a low-voltage-circuit tester and observe if voltage regulator, current regulator, and cut-out, control generator out-put properly. Follow instructions in vehicle manual, or those which accompany test instrument. Replace if test shows faulty operation. <b>CAUTION:</b> <i>This test should be made only after regulator unit has reached normal operating temperature.</i></p>
44	44	<p><b>Power Tire Inflation (Connection, Line).</b> Inspect tire inflation connection at reserve tank to see that it is in good condition and clean. Be sure cap is present and connected by safety chain. Note whether valve turns easily and is not excessively worn. Examine air hose for deterioration and check for damage or clogging. Connect hose and test system for proper function when performing item No. 47.</p>
47	47	<p><b>Tires and Rims (Valve Stems and Caps, Condition, Direction, Matching Spare Carrier).</b> Inspect as follows:</p> <p><b>Valve Stems and Caps.</b> Observe if all valve stems are in good condition and in correct position, and if all valve caps are present and installed securely. Do not tighten with pliers.</p> <p><b>Condition.</b> Examine all tires for cuts, bruises, breaks, and blisters. Remove embedded glass, nails, and stones. Look for irregular tread wear, watching for any sign of flat spots, cupping, feather edges, and one-sided wear. Remove tires worn thin at center of tread (or other un-</p>

4- TO 5-TON 4x4 TRACTOR TRUCK (FEDERAL)

6,000 Mile Maint (six- month)	1,000 Mile Maint (mon- thly)	
		<p>serviceable tires) and exchange for new or retreaded tires. Any mechanical deficiencies causing such conditions should be determined and corrected or reported. Wheel positions of tires with irregular wear should be changed to even up wear. Front tires, worn irregularly, should be moved to rear-wheel positions.</p> <p><i>Direction.</i> Directional tires and nondirectional tires should not be installed on same vehicle. Directional tires on rear wheels should be mounted so that the "V" of chevron will point down when viewed from the front. Directional tires on all front wheels will ordinarily be mounted so that "V" of chevrons will point up when viewed from front of vehicle.</p> <p><i>Matching.</i> With tires properly inflated, inspect them to see if they are matched according to over-all circumference and type of tread.</p> <p><i>Spare-tire Carriers.</i> See whether spare-tire carriers are in good condition and secure.</p> <p><i>Rims.</i> All rims and their lock rings or flanges should be in good condition and secure.</p>
	47	<p><i>Tighten.</i> Tighten all wheel rim flange or lug nuts securely.</p>
	47	<p><i>Serve.</i> With tires properly inflated to 65 pounds (cool) check over-all circumference of all tires including spares. Select tires to be mounted on duals or on driving axles, so they will not have differences in over-all circumference exceeding the 3/4-inch limits specified in current directives and bulletins. Mount all dual tires with the larger tire outside. The valve stem on inner wheels should point out and the valve stem on outer wheel should point in, and should be opposite each other. Spares must be matched properly and mounted for use on one of the road wheels at intervals not exceeding 90 days. A convenient time to do this is during these maintenance services. After performing the tire-matching service, do not reinstall wheels until wheel-bearing services are completed.</p>
	48	<p><i>Rear Brakes (Drums, Supports, Cams, and Shafts).</i> Inspect and service as follows: Remove rear wheels. NOTE: On 6,000-mile maintenance several wheel bear-</p>

**SECOND ECHELON PREVENTIVE MAINTENANCE**

6,000 Mile Maint (six- month)	1,000 Mile Maint (mon- thly)
	<p>49</p>

*ing and brake items up to 52 are group services and overlap. Perform in best order for economy of time and orderly reassembly.*

*Drums and Supports.* Clean dirt and grease from drums and supports (dust shields) keeping dry-cleaning solvent away from linings. Examine drums and supports to see if they are in good condition, securely mounted, and if drums are excessively worn or scored.

*Cams and Shafts.* See if cams and shafts, where they contact, are excessively worn; if camshafts operate free in collar and if shafts and collars are worn.

*Tighten.* Tighten brake support cap screws and hub to drum nuts securely.

*Rear Brake Shoes (Linings, Anchors, Springs).* Examine linings through inspection holes to see if they are so worn, rivet heads may contact drums within next 1,000 miles of operation. If vehicle has been operated in deep water, mud or loose sand, remove right rear wheel and examine lining for damage. If this lining must be replaced, remove all wheels, check their brakes and service as necessary, being sure to clean, lubricate and adjust all removed wheel bearings as described in item 52, below, for 6,000-mile service.

*Adjust.* Adjust shoes by minor method if necessary.

Remove rear wheels and inspect linings to see if they are in good condition, tightly secured to brake shoes, in good wearing contact with drums, free of dirt or lubricant and not excessively worn. Also see if shoes are in good condition, properly secured to anchors, guides and retracting springs and that springs have sufficient tension to return shoes properly to released position. Thickness of lining at most worn points should be enough for at least 1,000 miles of service before rivet heads are likely to contact drums.

*Clean.* Clean all dirt and grease from linings with wire brush, cloth, or compressed air.

*Adjust.* After subsequent related items to 60 inclusive are completed, adjust shoes by minor method. If new linings have been installed, adjust by major method described in paragraph 127 b. Adjust slack adjusters

4- TO 5-TON 4x4 TRACTOR TRUCK (FEDERAL)

6,000 Mile Maint (six- month)	1,000 Mile Maint (mon- thly)	
		so diaphragm push-rod travel is at minimum as described in paragraph 127 b.
52	52	<i>Rear Wheels (Bearings, Seals, Drive Flanges and Nuts).</i> Inspect and service as follows:
	52	<i>Wheels.</i> Inspect wheels to see if they are in good condition and secure.
		<i>Bearings and Seals.</i> Check for looseness of wheel bearing adjustment. Revolve wheels and listen for evidence of dry or damaged bearings. Inspect around flanges and brake supports for lubricant leaks.
		<i>Drive Flanges and Nuts.</i> Note if they are in good condition and if nuts are tightened securely.
52		<i>Clean.</i> Disassemble rear wheel bearings and oil seals. Clean thoroughly in dry-cleaning solvent and examine bearing cups and cones to see if they are in good condition, if machined surfaces they contact are in good condition, and if there is any excessive wear.
52		<i>Special Lubrication.</i> When all of the related items are to the point where wheel bearings are to be re-installed lubricate bearings according to lubrication guide, paragraph 17 c (13). Coat the cups or outer races and the lips of the oil seals with lubricants and install new lubricant retainer seals if necessary. <b>CAUTION:</b> <i>Do not pack the large cavity in wheel hubs between wheel bearings with lubricant. To do so will cause leakage past the seals.</i>
52		<i>Adjust.</i> After lubricating wheel bearings, reassemble hub and drum assemblies into place and adjust wheel bearings correctly according to paragraph 135 b. After bearings have been adjusted and adjustment securely locked, bearings should be neither loose nor so tight they bind.
	53	<i>Front Brakes (Drums, Supports, Cams and Shafts, Hose, Air Chambers, Push Rods and Seals, Slack Adjusters).</i> Inspect brake hose, chambers, push rods and seals, and slack adjusters to see if they are in good condition, correctly assembled, and secure.
53		Remove front wheels and inspect and service as follows:

SECOND ECHELON PREVENTIVE MAINTENANCE

6,000 Mile Maint (six- month)	1,000 Mile Maint (mon- thly)	
		<i>Drums and Supports.</i> Clean and inspect in same manner as in item 48.
		<i>Cams and Shafts.</i> Inspect in same manner as in item 48.
	54	<i>Front Brake Shoes (Linings, Anchors, Springs).</i> Inspect in same manner as in item 49.
54		<i>Adjust.</i> Adjust by minor method if necessary.  Remove front wheels and inspect shoes, linings, anchors and springs in same manner as in item 49 at 6,000-mile service.
		<i>Clean.</i> Clean in same manner as in item 49.
54	54	<i>Adjust.</i> Adjust in same manner as in item 49 after subsequent related items to 60 inclusive are completed.
55	55	<i>Steering Knuckles (Joints, Bearings, Seals).</i> Inspect to see if knuckle housings are in good condition. Look particularly for cracks around steering arms. See if outside knuckle felt seals and seal flanges are in good condition and secure. Remove lubrication plug and examine sample of lubricant to see if it appears to be contaminated.
55		<i>Clean.</i> Remove constant velocity U-joint assembly. Wash thoroughly in dry-cleaning solvent without disassembly of U-joint. Inspect parts to see if they are in good condition and not excessively worn. Pay particular attention to U-joint washers, balls and races, axle splines, flanges and pivot bearings or bushings.
55		<i>Special Lubrication.</i> Pack new lubricant wall into constant velocity U-joint until it fills all space between balls, cages, and races. Reassemble steering knuckle taking care to replace any unserviceable lubricant retainer seals, boots or gaskets.
55		<i>Adjust.</i> Use every precaution to reinstall shims and spacers in the original position from which they were removed at disassembly to insure correct pivot bearing and axle end play adjustment.
56	56	<i>Front Springs (Clips, Leaves, U-Bolts, Hangers, and Shackles).</i> See if they are in good condition, correctly assembled, and secure. Spring clips and bolts should be in place; spring leaves should not be shifted out of their

4- TO 5-TON 4x4 TRACTOR TRUCK (FEDERAL)

6,000 Mile Maint (six- month)	1,000 Mile Maint (mon- thly)	
		<p>correct position. This may be an indication of a sheared center bolt. Note if deflection of both springs is normal and approximately the same. Test hangers and bolts for excessive wear by means of a pry bar.</p> <p><i>Tighten.</i> Tighten all spring U-bolts securely and uniformly.</p>
57	57	<p><i>Steering (Arms, Tie Rods, Drag-link, Seals, and Boots, Pitman Arm, Gear, Column and Wheel).</i> See if these items are in good condition, correctly and securely assembled and mounted, if steering gear case is leaking lubricant and if lubricant is at proper level. Pay particular attention to Pitman arm to see if it is securely mounted and not bent out of its normal shape. Also observe if steering system is in good adjustment. See that bond strap from column to bracket is secure.</p>
57		<p><i>Tighten.</i> Tighten Pitman-arm-shaft nut securely. Also tighten steering-gear-case assembly and mounting nuts or screws, taking care not to disturb adjusting screws and lock nuts. <b>CAUTION: Loosen steering column bracket when tightening steering case mounting nuts, so as not to distort column.</b></p>
58	58	<p><i>Front Shock Absorbers and Links.</i> See if bodies are in good condition, secure to frame and not leaking, if links are secure and not damaged and if rubber bushings are hard or cracked, apply brake fluid to exposed surfaces.</p>
58		<p><i>Serve.</i> Fill shock absorber bodies with specified fluid. Work arm several times and add more fluid. Repeat operation until all air is expelled and reservoir is full. Then disconnect link and observe if action is normal. When arm is moved by hand there should be resistance both ways.</p>
60	60	<p><i>Front Wheels (Bearings, Seals, Flanges, Axle End Play and Nuts).</i> Inspect front wheels, bearings, seals, drive flanges and nuts in same manner as in item 52 for similar rear wheel items.</p>
60		<p><i>Clean.</i> Disassemble, clean, and inspect the front-wheel bearings and oil seals in the same manner as described in item 52, taking care to check the U-joint end play as the drive flanges are removed so that the end play adjustment may be made conveniently, when reassembling.</p>

**SECOND ECHELON PREVENTIVE MAINTENANCE**

6,000 Mile Maint (six- month)	1,000 Mile Maint (mon- thly)	
60		<i>Special Lubrication.</i> Apply in same manner as described in item 52.
60		<i>Adjust.</i> Adjust wheel bearings in same manner as described in item 52, and adjust brake shoes as described in item 49.
61	61	<i>Front Axle (Pinion End Play, Seal, Vent and Alignment).</i> If front axle appears to be out of line, measure distance from front spring eyebolt to center of axle spring pad on each side. Distance should be equal. Inspect axle housing to see if it is in good condition and not leaking. Examine pinion shaft for excessive end play and seal for leaks. <i>Clean.</i> Clean axle housing vent thoroughly.
62	62	<i>Front Propeller Shaft (Joints, Alinement, Seals, and Flanges).</i> See if these items are in good condition, correctly and securely assembled and mounted; if the U-joints are properly alined with each other and are not excessively worn; that the slip joint is free, not excessively worn, and well lubricated; and that the seals on the U-joints and slip joint do not leak.
62		<i>Tighten.</i> Tighten all U-joint assembly and companion flange bolts securely.
63	63	<i>Engine (Mountings, Ground Strap, Side Panel).</i> These items should be in good condition and securely mounted and connected. Be sure to examine both front and rear engine mountings; and to see, on rubber mountings, that rubber is not separating from its metal backing. If mounting bolts are loose, tighten them properly, taking care not to overtighten. Remove oil or grease from rubber mountings. Apply a film of brake fluid if rubber is hard or cracking. See that bond straps at engine supports are secure.
64	64	<i>Hand Brake (Ratchet and Pawl, Linkage, Disk and Lining).</i> Examine to see if ratchet, pawl and linkage are in good condition, secure, and not excessively worn, that disk is not scored or oily, and that lining is not oil soaked or worn too thin.
64		<i>Adjust.</i> Set clearance between brake disk and lining to $\frac{1}{16}$ inch when brake lever is released.

4- TO 5-TON 4x4 TRACTOR TRUCK (FEDERAL)

6,000 Mile Maint (six- month)	1,000 Mile Maint (mon- thly)	
65	65	<i>Clutch Pedal (Free Travel, Linkage, and Return Spring).</i> Check pedal free travel. Should be 1½ inches before meeting resistance. Examine to see if pedal is securely mounted to shaft, if clutch operating linkage is in good condition, secure and not excessively worn at friction joints. See if return spring has proper tension to bring pedal to correct released position.
65		<i>Adjust.</i> Adjust plate so clutch pedal free travel is to 1½ inches. <b>CAUTION: No pedal adjustment should be made. For correct procedure see paragraph 59.</b>
66	66	<i>Brake Pedal (Linkage and Return Spring).</i> Pedal should operate easily. Inspect all linkage to see if it is in good condition, securely connected, and not excessively worn at friction joints. Be sure return spring has tension to bring pedal to correct released position.
69	69	<i>Air Brake Application Valve.</i> See if application valve and linkage are in good condition, correctly assembled and secure; and that valve closes fully when brake pedal is released.
70	70	<i>Air Brake Reservoirs.</i> Observe whether they are in good condition and secure. Open the drain cocks and drain off condensate.
71	71	<i>Transmission (Mountings, Seals, Linkage).</i> Note if transmission case is in good condition, securely mounted and inspect for lubricant leaks at seals and gaskets. Examine control linkage and shift mechanism for damage or excessive wear.
72	72	<i>Transfer (Mountings, Linkage, Seals, Vent).</i> See if case is in good condition, securely mounted, that transmission and declutching control linkage and shift mechanism is securely connected and not damaged and if vent is open. Look for evidence of lubrication leaks at seals and gaskets. Clean vent passage if clogged. See that bond strap from transfer case to frame is secure.
72		<i>Tighten.</i> Draw up all external assembly and mounting nuts securely.
73	73	<i>Rear Propeller Shaft.</i> Inspect in same manner as in item 62.



SECOND ECHELON PREVENTIVE MAINTENANCE

6,000 Mile Maint (six- month)	1,000 Mile Maint (mon- thly)	
		<i>Tighten.</i> Draw up all U-joint and companion flange bolts securely.
75	75	<i>Rear Axle (Pinion End Play, Seals, Vent, and Aline-ment).</i> Inspect in the same manner as in item 61 for front axle.
		<i>Clean.</i> Clean axle housing vent thoroughly.
76	76	<i>Rear Air Brakes (Chambers, Rods, Seals, and Slack Adjusters).</i> See if all items are in good condition, securely connected and mounted. Examine rods for excessive wear and seals for lubricant leaks.
77	77	<i>Rear Springs (Clips, Leaves, U-Bolts).</i> Inspect and tighten in same manner as in item 56.
78	78	<i>Rear Shock Absorbers and Links.</i> Inspect in same manner as in item 58.
78		<i>Serve.</i> Service and make operating check in same manner as in item 58.
79	79	<i>Cab Mountings.</i> Note if they are all in good condition and secure. On cab mountings using coil springs, be sure springs are in good condition and properly compressed. These springs should be neither loose, nor compressed until solid.
		<i>Tighten.</i> Tighten cab mounting bolts securely, taking care to loosen the steering-column clamp before tightening. When tightening spring-loaded mounting bolts, do not compress springs fully. After completing this service, be sure to tighten steering-column clamp.
80	80	<i>Frame (Side and Cross Members).</i> Inspect frame, brackets, side rails, and cross members to see if they are in good condition, secure, and correctly aligned. If the frame appears to be out of line, report condition. See that oil bond straps connected to frame are in good condition and secure.
81	81	<i>Wiring, Conduit, and Grommets.</i> Observe these items underneath the vehicle, to see if they are in good condition, properly supported, connected, and secure.
82	82	<i>Fuel Tank, Fittings, and Lines.</i> Inspect fuel tank to see if it is in good condition and securely mounted. Examine cap for defective gasket or plugged vent. Remove strainer and clean thoroughly. See that filler neck is in

4- TO 5-TON 4x4 TRACTOR TRUCK (FEDERAL)

6,000 Mile Maint (six- month)	1,000 Mile Maint (mon- thly)
82	
83	83
84	84
85	85

good condition and that cap fits securely. Be sure bond strap from tank to bracket is secure.

Remove fuel tank drain plug and drain off accumulated water and dirt in bottom of tank. Drain only until fuel runs clear. Use necessary precautions against fire.

**83 83 Brake Lines (Fittings and Hose).** Examine all lines and fittings and air brake hose under vehicle to see if they are in good condition, securely connected, and supported so lines or hose will not chafe against other vehicle parts.

**84 84 Exhaust Pipes and Muffler.** Examine exhaust pipe to see if it is securely attached to exhaust manifold, that gasket or packing does not show visible evidence of leakage, and that the other end is clamped securely to muffler. Inspect muffler to see if it is in good condition and securely mounted. Check tail pipe to see if it is securely clamped to muffler, properly supported, and unobstructed at its outer end. See that drain holes in muffler are at lowest point and not clogged.

**85 85 Vehicle Lubrication.** Lubricate all points of vehicle in accordance with instructions in vehicle, lubrication guide (pars. 16 and 17) and current lubrication bulletins or directives, and the following instructions: Use only clean lubricant. Keep all lubricant containers and dispensers covered except when withdrawing lubricant.

Lubrication of items on the "Preventive Maintenance Service and Technical Inspection Work Sheet" that are marked with an "L" (special lubrication symbol) should be omitted on this "Vehicle Lubrication" service *with the exception of the external lubrication cup of the distributor*. This will avoid duplication and, in some cases, overlubrication.

On all unsealed bushings or joints, lubricant should be applied until it appears at openings. On units such as universal joints, which are provided with lubricant-retainer seals, use an appropriate hand-operated grease gun and do not force lubricant beyond seals. Open any clogged lubrication passages until lubricant is properly delivered.

When draining oil from engine, transmission, transfer case, or axle housings, always drain immediately after it has been warmed and agitated to a good draining con-

**SECOND ECHELON PREVENTIVE MAINTENANCE**

6,000 Mile Maint (six- month)	1,000 Mile Maint (mon- thly)
86	86
88	88
89	89

dition by operation of engine or vehicle. Refill units to correct level with specified oil as soon as draining is completed, so there will be little hazard that they may be operated without lubricant.

**CAUTION:** *Do not fill to overflowing. Reinstall all drain and filler plugs securely. Take care that any required gaskets are in good condition and in place on the reinstalled plugs.*

Do not apply more than the specified amount of lubricant to generator, cranking motor, distributor, or water pump.

Wipe off excess lubricant that may drip onto brakes, rubber parts, or detract from vehicle's appearance.

**LOWER VEHICLE TO GROUND**

**86 86** *Toe-in and Turning Stops.* With front wheels on ground and in straight ahead position use a toe-in gage to determine if adjustment is as specified. Should be  $\frac{1}{8}$  to  $\frac{3}{16}$  inch. Turn wheels fully in both directions and see if turn is limited by stops. In this position note if tires clear all parts of vehicle. If there is any indication turning angle exceeds specified limits (inside wheel  $28^\circ$ , outside wheel  $24^\circ$ ) such as loose wheel stops, scuffing of tires against vehicle, or abnormal front-drive U-joint wear, report for check of turning angle by higher echelon.

**88 88** *Fifth Wheel (Bed Plate and Bolts).* Observe fifth-wheel rocker plate and bed plate to see if they are in good condition, securely assembled and mounted. Examine kingpin lock to see that it operates properly, locks securely and that kingpin latch is not excessively worn.

*Tighten.* Securely tighten all assembly and mounting bolts.

*Special Lubrication:* Clean fifth-wheel plate and lubricate with chassis lubricant. Lubricate all fifth wheel assembly grease fittings. Also hand-pack lubricant into latching mechanism. **CAUTION:** *When a trailer is not attached, cover the fifth wheel to prevent accumulation of dirt.*

**89 89** *Tractor to Trailer Brake Hose and Connections.* Examine brake hose to see if they are in good condition, properly supported, and if connecting fittings are in good condition and not excessively worn.

4- TO 5-TON 4x4 TRACTOR TRUCK (FEDERAL)

6,000 Mile Maint (six- month)	1,000 Mile Maint (mon- thly)	
91	91	<i>Lamps (Lights) (Head, Tail, Body, Stop, and Blackout).</i> Operate all switches and note if lamps respond. Include stop and blackout lamps. See if foot switch controls head lamp beams properly and if beams are aimed so as not to blind oncoming traffic. Examine all lights to see if they are in good condition and securely mounted and whether lenses are dirty or reflectors discolored.
91		<i>Adjust Lamp Unit Beams.</i>
92	92	<i>Safety Reflectors.</i> See if they are all present, in good condition, clean, and secure.
93	93	<i>Front Bumper Tow Hooks, Brush Guards and Grille.</i> See if they are in good condition, secure, and that radiator grille is not obstructed.
94	94	<i>Hood and Fasteners.</i> Inspect engine hood (cover) in cab to see if it is in good condition and that fasteners operate properly and hold hood securely.
95	95	<i>Front Fenders and Running Boards.</i> Examine fenders, running boards and steps to cab to see if they are in good condition and securely mounted.
96	96	<i>Cab (Doors, Hardware, Windshield and Glass, Top and Frame, Side Curtains, Seats, Gun Racks, Grab Rails, Floor Boards, Ventilators, Platforms).</i> Inspect these items to see if they are in good condition and secure; that the hardware and ventilators operate properly and are adequately lubricated; and if the doors engage their bumpers and strikers and latch properly in the closed position. See that the doors are properly aligned with their openings. Be sure wood platforms over gas tank and rear of cab are securely bolted and not damaged.
98	98	<i>Circuit Breakers.</i> Observe if they are in good condition, clean, dry, and securely connected and mounted.
99	99	<i>Rear Splash Guards.</i> See that they are in good condition and securely mounted.
101	101	<i>Pintle Hook.</i> Examine pintle to see if it is in good condition and securely mounted to frame. Test pintle and latch to see if they operate properly, are adequately lubricated, and if lock pin is present and securely attached to chain. Pay particular attention for broken spring has been drawbar.

**SECOND ECHELON PREVENTIVE MAINTENANCE**

6,000 Mile Maint (six- month)	1,000 Mile Maint (mon- thly)	
103	103	<i>Paint and Marking.</i> Examine paint of entire vehicle to see if it is in good condition, paying particular attention to any bright spots in finish that might cause glare or reflection. Inspect vehicle markings and identification for legibility. Include identification plates and their mountings if furnished.
104	104	<i>Radio Bonding (Suppressors, Filters, Condensers and Shielding).</i> See that all radio noise suppression devices not covered in the foregoing specific procedures are in good condition and securely mounted or connected. Be sure all additional noise suppression bond straps and toothed lock washers listed in (pars. 181 and 185) are inspected for looseness and damage and see that contact surfaces are clean. <i>NOTE: If objectionable radio noise from vehicle has been reported, make tests in accordance with (pars. 181 and 185). If cleaning and tightening of mountings and connections, and replacement of defective noise suppression units, does not eliminate the trouble, the radio operator involved will report the condition to the designated individual in authority.</i>
<b>TOOLS AND EQUIPMENT</b>		
131	131	<i>Tools (Vehicle and Pioneer).</i> Inspect standard vehicle and pioneer tools to see if they are all present (see vehicle stowage list) in good condition, clean, and properly stowed or securely mounted, and if tool box is in good condition and securely mounted and locked. Also examine tools which have cutting edges to see that they are sharp. Any tools mounted on outside of vehicle which have bright or polished surfaces, should be painted or otherwise treated to prevent rust, glare, or reflection.
132	132	<i>Fire Extinguisher.</i> See if it is in good condition, securely mounted, and fully charged. The charge may be determined on gas-type extinguishers by weighing with a scale, and on liquid-type by shaking. Also be sure nozzles are free from corrosion.
133	133	<i>Decontaminator.</i> See if it is in good condition, securely mounted and fully charged. Make the latter check by

4- TO 5-TON 4x4 TRACTOR TRUCK (FEDERAL)

6,000 Mile Maint (six- month)	1,000 Mile Maint (mon- thly)	
		removing filler plug. <b>NOTE:</b> <i>This solution must be replaced every three months as it deteriorates.</i>
134	134	<b>First Aid Kit (if specified).</b> See if it is in good condition, and that all of its items are present and properly packed. Report any deficiencies immediately.
135	135	<b>Publications and Form No. 26.</b> See that the vehicle manuals and lubrication guide, Form No. 26 (accident report) and W.D., AGO Form No. 478 (MWO and Major Unit Assembly Replacement Record), are present, legible and properly stowed.
136	136	<b>Traction Devices (Chains).</b> Examine tire chains to be sure they are in good condition, clean (if not in use) not excessively worn, protected against rust, and properly mounted or stowed.
137	137	<b>Tow (Chains, Cables, Rope, Snatch Blocks).</b> See if the provided towing devices are in good condition, clean, and properly stowed. Tow chains or cables should be properly protected against rust when not in use. If snatch blocks are furnished, check to see that they operate freely.
139	139	<b>Fuel and Water Cans and Brackets.</b> Observe if they are in good condition, secure, if the caps fit tightly and are secured to the cans with a chain, and if cans are leaking.
141	141	<b>Modifications (MWO Completed).</b> Inspect vehicle to determine if all Field Service Modification Work Orders have been completed, and enter all modifications or major unit assembly replacements made at time of this service on Form No. 478.
142	142	<b>Final Road Test.</b> Make a final road test rechecking items 2 to 15 inclusive, and also be sure to recheck the transmission, transfer case, and all driving axles to see that the lubricant is at the correct level and not leaking. Confine this road test to the minimum distance necessary to make satisfactory observations. <b>NOTE:</b> <i>Correct or report all deficiencies found during final road test.</i> <b>CAUTION:</b> <i>Be sure all inspection plates on cab, cowl, floor, plates, and battery covers are replaced and securely fastened.</i>

## Section XI

### ORGANIZATION TOOLS AND EQUIPMENT

#### 23. TOOL SETS.

a. **Standard Tool Sets.** The tool sets available to individuals (specialists) and organizations, dependent upon the allocation in the table of equipment, are listed in SNL N-19. The components of these tool sets are also listed and illustrated.

b. **Special Tool Set.** The special tools available for organizational maintenance establishments are listed in the Organizational Spare Parts and Equipment List of SNL G-510.

---

## Section XII

### TROUBLE SHOOTING

#### 24. GENERAL.

a. This section contains trouble shooting information and tests which can be made to help determine the causes of some of the troubles that may develop in trucks used under average climatic conditions (above 32°F.). Each symptom of trouble given under the individual unit or system is followed by a list of possible causes of the trouble. The tests necessary to determine which one of the possible causes is responsible for the trouble are explained after each possible cause.

#### 25. ENGINE.

a. **Engine Will Not Turn.**

(1) **HYDROSTATIC LOCK OR SEIZURE.** Remove spark plugs (par. 83 b) and attempt to turn engine with hand crank to check for excess fuel or oil in cylinders. If engine turns, the lock will be relieved. If engine does not turn, test for jammed cranking motor throw-out mechanism (step (2) below).

(2) **CRANKING MOTOR THROW-OUT MECHANISM JAMMED.** Remove cranking motor (par 89 b). Clean grease and dirt from throw-out mechanism. Inspect mechanism for broken parts. Replace broken parts and install cranking motor (par. 89 c). If engine still will not turn, seizure due to internal damage is indicated. Notify higher authority.

(3) **INCORRECT OIL VISCOSITY.** Drain crankcase and refill with proper grade oil (par. 17).

**4- TO 5-TON 4x4 TRACTOR TRUCK (FEDERAL)****b. Engine Turns but Will Not Start.**

(1) **INOPERATIVE FUEL SYSTEM.** Remove fuel line from carburetor. With ignition switch off, turn engine over with the cranking motor. If free flow of fuel is not evident, fuel is not reaching carburetor (par 27 a). If fuel flows freely, trouble in the carburetor is indicated. Replace faulty carburetor (par. 62 c).

(2) **INOPERATIVE IGNITION SYSTEM.** Remove a cable from a spark plug. Turn on ignition switch. Hold spark plug cable terminal  $\frac{1}{4}$  inch from engine casting and crank engine. If spark does not jump the  $\frac{1}{4}$ -inch gap, the ignition is inadequate (par. 30 a).

(3) **SLOW CRANKING SPEED** (par. 31 e).

**c. Engine Does Not Develop Full Power.**

(1) **IMPROPER IGNITION** (par. 30 a).

(2) **ENGINE OVERHEATED** (par. 29 a).

(3) **IMPROPER VALVE ADJUSTMENT.** Check clearance and adjust if necessary (par. 50 e).

(4) **USE OF IMPROPER TYPE OF FUEL** (par. 61).

(5) **PREIGNITION.** If proper octane fuel is being used and the ignition system is functioning satisfactorily, spark plug of improper heat range may be the cause of the trouble (par. 83 a and c). Otherwise internal engine troubles would be indicated. Notify higher authority.

(6) **AIR LEAKS AT CARBURETOR OR MANIFOLD FLANGES.** With engine running at 800 revolutions per minute, apply a small amount of oil at carburetor and manifold flange gaskets. If oil is sucked in, there is evidence of a leak. Tighten flange bolt nuts and test again. If leak persists, replace gaskets.

(7) **LOW ENGINE COMPRESSION OR IMPROPER VALVE TIMING.** If the engine does not develop full power with fuel reaching combustion chambers, adequate ignition and the proper grade and quantity of oil in crankcase, low compression or improper valve timing would be indicated. Notify higher authority.

(8) **INCORRECT GOVERNOR SETTING.** Disconnect governor linkage at the carburetor and check for spring linkage or stuck throttle. If throttle and linkage operate freely, start and accelerate the engine with the governor disconnected. If a speed of 2,400 revolutions per minute is reached, the governor is faulty. Refer to higher authority for repairs.

**d. Engine Misfires.**

(1) **FAULTY IGNITION SYSTEM** (par. 30 a).

(2) **LOW ENGINE COMPRESSION** (step (7) above).

(3) **INCORRECT CARBURETOR ADJUSTMENT.** Adjust carburetor (par. 62 b).

(4) **CLOGGED FUEL TANK CAP VENT.** Open vents or replace cap.

(5) **RESTRICTED FUEL FLOW** (par. 66 h).



## TROUBLE SHOOTING

(6) **WATER IN FUEL.** Remove drain plug from bottom of carburetor and inspect for water. If water is present, drain all fuel from system and refill with pure gasoline.

### e. Excessive Oil Consumption.

(1) **OIL VISCOSITY TOO LOW.** Drain crankcase and refill with proper oil (par. 17).

(2) **EXTERNAL OIL LEAKS.** Inspect for oil leaks at oil connections and at gaskets. Tighten loose connections. If leakage is detected at oil pan gasket or at main bearing flanges, notify higher authority.

(3) **PISTON RINGS WORN OR DAMAGED.** If high oil consumption continues with proper oil in crankcase and with no external leaks, faulty piston rings are indicated. Blue smoke in the exhaust also indicates worn or damaged piston ring. Notify higher authority.

### f. Engine Will Not Stop.

(1) **DEFECTIVE IGNITION SWITCH.** Replace switch (par. 84 b).

(2) **ENGINE OVERHEATED** (par. 29 a).

## 26. CLUTCH.

### a. Clutch Slips.

(1) **CLUTCH OUT OF ADJUSTMENT.** Adjust clutch (par. 59).

(2) **CLUTCH PEDAL OR LINKAGE BENT OR BINDING.** Disconnect linkage and inspect for bent or binding part. Replace defective parts (par. 60 a).

(3) **CLUTCH WORN OR BROKEN INTERNALLY.** If linkage is in satisfactory condition and slippage cannot be removed through adjustment, internal wear or breakage is indicated. Notify higher authority.

### b. Clutch Grabs.

(1) **LOOSE MOUNTING.** Tighten external mounting nuts.

(2) **INTERNAL DIFFICULTY.** If tightening external mounting nuts fails to remove trouble, internal difficulty is indicated. Notify higher authority.

### c. Clutch Rattles.

(1) **LOOSE OR WORN CONTROL LINKAGE.** Inspect clutch linkage. Replace worn parts. Tighten loose parts.

(2) **INTERNAL DIFFICULTY.** If rattle persists with linkage in satisfactory condition, internal difficulty is indicated. Notify higher authority.

### d. Clutch Will Not Release.

(1) **CLUTCH LINKAGE OUT OF ADJUSTMENT.** Bent or binding. Adjust clutch linkage to eliminate looseness (par. 60 b). Replace defective parts of linkage (par. 60 a).

(2) **CLUTCH OUT OF ADJUSTMENT.** Adjust clutch (par. 59).

(3) **INTERNAL DIFFICULTY.** If clutch cannot be adjusted to re-

**4- TO 5-TON 4x4 TRACTOR TRUCK (FEDERAL)**

lease and linkage is in satisfactory condition and adjustment, internal difficulty is indicated. Notify higher authority.

**e. Clutch Makes a Scrubbing Noise.**

- (1) **CLUTCH SLEEVE SCORED OR RIDGED.** Notify higher authority.

**27. FUEL SYSTEM.**

**a. Fuel Does Not Reach Carburetor.**

- (1) **LACK OF FUEL.** Check gage on instrument panel and replenish fuel.

- (2) **CLOGGED FUEL TANK VENT.** Remove obstruction from vent or replace cap.

- (3) **INOPERATIVE FUEL PUMP: CLOGGED FUEL FILTER OR LINES.** Remove drain plug from fuel filter and check passage from tank by blowing through line. If obstruction is indicated, remove and clean fuel line. Service fuel filter. If passage to fuel pump is unobstructed, reconnect fuel line. Disconnect fuel line to carburetor from fuel pump. Turn engine over by means of cranking motor. If fuel does not flow from pump, a defective pump is indicated. Otherwise, the fuel line from pump to carburetor is obstructed. Repair or replace defective parts (par. 63 c).

**b. Fuel Does Not Reach Cylinders.**

- (1) **CARBURETOR STRAINER CLOGGED.** Clean strainer or replace carburetor (par. 62 c).

- (2) **THROTTLE NOT OPENING.** Adjust throttle (par. 62 b (2)).

- (3) **CARBURETOR JETS CLOGGED.** Replace carburetor (par. 62 c).

**28. INTAKE AND EXHAUST SYSTEMS.**

**a. Air Passage to Carburetor Restricted.**

- (1) **AIR CLEANER DIRTY.** Service air cleaner (par. 68 b).

- (2) **AIR PIPE CRUSHED.** Visually inspect air pipe. Replace if damaged (par. 68 c).

**b. Dirt Laden Air Entering Carburetor.**

- (1) **AIR CLEANER DIRTY.** Service air cleaner (par. 68 b).

- (2) **NO OIL IN AIR CLEANER.** Service air cleaner (par. 68 b).

- (3) **AIR PIPE DISCONNECTED OR LOOSELY CONNECTED.** Connect air pipe tightly (par. 68 d).

**c. Exhaust Makes Excessive Noise and/or System Emits Unpleasant Gas.**

- (1) **MANIFOLD GASKETS LEAKING.** Visually inspect gaskets with engine running. If gaskets are leaking, tighten manifold attaching nuts. If leak persists, notify higher authority.

- (2) **LEAK AT EXHAUST PIPE FLANGE.** Visually inspect connection with engine running. If gasket leaks, tighten nuts. If leak persists, replace gasket (par. 69 b).

- (3) **EXHAUST PIPE BROKEN OR BENT AND PULLED FROM MUFFLER.**

## TROUBLE SHOOTING

Visually inspect pipe with engine running. Replace pipe if broken or bent (par. 69 b).

(4) **TAIL PIPE PULLED FROM MUFFLER, LOST OR BROKEN.** Visually inspect tail pipe. Connect if disconnected. Replace if lost or broken (par. 71 b).

(5) **MUFFLER DEFECTIVE.** If other parts of system are in satisfactory condition and excessive noise persists, a defective muffler is indicated. Replace muffler (par. 70 b).

### 29. COOLING SYSTEM.

#### a. Engine Overheats.

(1) **INSUFFICIENT COOLANT.** Check quantity of coolant and fill cooling system (par. 72 a).

(2) **FAN BELT LOOSE OR BROKEN.** Inspect fan belt. Replace if broken (par. 78 c). Adjust tension if loose (par. 78 b).

(3) **THERMOSTAT STICKING SHUT.** Remove (par. 76 c) and test thermostat by dropping it in water heated to 180°F. If it fails to open, replace it.

(4) **COOLING SYSTEM CLOGGED.** Fill system to capacity. Start and accelerate engine. Water flowing from the radiator overflow indicates a clogged radiator. Flush system.

(5) **WATER PUMP INOPERATIVE.** Disconnect upper hose connection (par. 73 b). Fill both engine and radiator as full as possible with hose disconnected. Start engine. If water fails to flow from upper hose connection for a brief period, an inoperative water pump is indicated. Replace water pump (par. 74 b).

(6) **CAUSED BY CONDITION EXTERNAL TO COOLING SYSTEM.** Some conditions external to cooling system which can cause engine overheating are, incorrect ignition timing, dragging brakes, insufficient lubrication, and incorrect valve timing. If the cause for overheating cannot be isolated within the cooling system, check each of these.

#### b. Engine Slow To Warm Up.

(1) **THERMOSTAT DEFECTIVE.** Remove thermostat (par. 76 c). Replace it if it is open at room temperature.

(2) **TEMPERATURE GAGE DEFECTIVE.** If this condition should exist, the gage might indicate a cold engine while the engine would really be warm. If this condition is suspected, remove the instrument and install one known to be accurate.

#### c. System Leaks Coolant.

(1) **DEFECTIVE HOSE CONNECTION.** Inspect hose connection. Tighten leaking connections. If leak persists, replace hose (par. 75 b).

(2) **WATER PUMP PACKING WORN.** This condition is indicated by leakage from water pump. Refer to higher authority.

(3) **RADIATOR CORE LEAKING.** Visually inspect core. Replace radiator if leak is detected (par. 73 b). Refer radiator to higher authority for repair.

**4- TO 5-TON 4x4 TRACTOR TRUCK (FEDERAL)**

**30. IGNITION SYSTEM.**

**a. Improper Ignition.**

(1) **SPARK PLUGS FAULTY.** Uneven operation at idle speed, misfiring at high speed, or loss of power may be due to faulty spark plugs. Remove and inspect spark plugs (par. 83 b and c). Replace faulty plugs.

(2) **DISTRIBUTOR POINTS FAULTY.** Hard starting or complete failure to start on the part of the engine may be due to faulty distributor points. Remove distributor cap and inspect points. Measure gap. Crank engine and observe opening and closing of points. Adjust points if out of adjustment (par. 82 b). Replace points if pitted, burned, or broken (par. 82 b). Replace distributor if mechanical action of opening and closing mechanism is out of order (par. 82 c). Refer old distributor to higher authority for repair or rebuilding.

(3) **IGNITION COIL OR CONDENSER FAULTY.** Weak or no spark, with fully charged battery and serviceable spark plugs and distributor points installed, may indicate a faulty ignition coil or condenser. Remove suspected coil and/or condenser and replace it with a part known to function properly (par. 80 b and/or 81 b).

(4) **IGNITION FILTER FAULTY.** If check of other components of system fails to locate trouble, a faulty filter in ignition system is indicated. Test filter (par. 182 b) and replace (par. 182 c) if faulty.

**31. STARTING AND GENERATING SYSTEMS.**

**a. Low Generator Output.**

(1) **BATTERY FULLY CHARGED.** This is a natural condition due to the action of the voltage regulator. No repair is necessary.

(2) **DIRT ON COMMUTATOR.** Remove inspection cover from generator. If dirt can be seen on commutator bars, start engine and hold a piece of 2/0 flintpaper against bars. Blow dust from generator with a blast of dry compressed air.

(3) **BRUSHES WORN.** Inspect brushes (par. 87 b). Replace if they are so worn that they no longer fit snugly in their holders (par. 87 b).

(4) **THIRD BRUSH INCORRECTLY SET.** Adjust generator output (par. 87 b). If this procedure rectifies the trouble, no further correction is necessary.

(5) **VOLTAGE REGULATOR OUT OF ADJUSTMENT.** If none of the causes enumerated above is at fault, improper adjustment of the voltage regulator is indicated. Replace voltage regulator (par. 88 b).

(6) **CAUSES EXTERNAL TO GENERATOR.** Low generator output could be caused by high resistance in either the battery or wiring between the generator and the batteries, or by a faulty field filter, supply filter, or generator capacitor. Check all wiring connections to be sure they are clean and tight. Check filters (par. 182 b) and replace capacitor with one known to function correctly (par. 183 b).

**TROUBLE SHOOTING**

Test individual wires with a test lamp. If trouble persists, replace the batteries (par. 155 c).

**b. Unsteady or No-generator Output.**

- (1) DIRT ON COMMUTATOR (step (2) above).
- (2) BRUSHES WORN (step (3) above).
- (3) SHORTED, OPEN, OR GROUNDED WIRING: LOOSE, OPEN, OR DIRTY CONNECTION. Inspect all wiring. Use test lamp to test individual wires. Clean and tighten all connections. Replace or repair broken or poorly insulated wires.
- (4) VOLTAGE REGULATOR INOPERATIVE. Replace voltage regulator (par. 88 b).
- (5) FAULTY RADIO NOISE SUPPRESSION UNIT. Short out supply and field filters one at a time. Disconnect generator capacitor. Replace unit which proves defective (filter, par. 182 c; capacitor, par. 184 c).

**c. High Generator Output.**

- (1) LOW BATTERY. Test battery with a hydrometer. If specific gravity is below 1.275, high generator output is normal. No repair is necessary.
- (2) HIGH RESISTANCE WIRING. Inspect wiring. Use test lamp on individual wires. Clean and tighten all connections. Replace wires found to be defective.
- (3) OVERHEATED BATTERY. Feel of battery case. If battery feels hot, allow it to cool. Add water before using battery again (par. 155 b).
- (4) VOLTAGE REGULATOR INOPERATIVE. Replace voltage regulator (par. 88 b).
- (5) SHORTED OR GROUNDED GENERATOR FIELD CIRCUIT. If none of the above are the cause of the difficulty a shorted or grounded field circuit is indicated. Replace generator (par. 87 c) and refer old generator to higher authority for repair.

**d. Noisy Generator.**

- (1) MOUNTING BOLTS LOOSE. Attempt to tighten mounting bolts. If trouble disappears upon tightening, no further correction is necessary.
- (2) LACK OF LUBRICATION. Lubricate generator (par. 17). If noise disappears, no further correction is necessary.
- (3) WORN COMMUTATOR OR BEARINGS. If noise persists after tightening and lubricating, replace generator (par. 87 c).

**e. Cranking Motor Inoperative.**

- (1) DISCHARGED BATTERY. Check battery (par. 155 b).
- (2) BROKEN BATTERY CABLE OR TERMINAL. Inspect cables from batteries to ground, and from batteries to cranking motor. Replace broken cables (par. 92 c).
- (3) INOPERATIVE SWITCH. Short circuit terminals of switch with

## **TM 9-820**

**31-33**

### **4- TO 5-TON 4x4 TRACTOR TRUCK (FEDERAL)**

a heavy metal tool pressed firmly across terminals. If cranking motor operates, an inoperative switch is indicated. Replace switch (par. 91 b).

(4) **INTERNAL DEFECT IN CRANKING MOTOR.** Disconnect cable from cranking motor. Press on cranking motor switch. Touch end of cable to frame of vehicle for an instant. Presence of sparks indicates inoperative cranking motor has internal defect. Replace cranking motor (par. 89 b).

### **32. TRANSMISSION.**

#### **a. Transmission Noisy.**

(1) **INCORRECT OR INSUFFICIENT LUBRICANT.** Check lubricant and lubricate if necessary (par. 17).

(2) **TRANSMISSION CASE LOOSE ON CLUTCH HOUSING.** Tighten housing. If noise disappears, further corrective measures are unnecessary.

(3) **CLUTCH HOUSING LOOSE ON ENGINE.** Tighten housing. If noise disappears, condition is corrected.

(4) **INTERNAL DEFECT.** If noise persists after above measures have been taken, report trouble to higher authority.

#### **b. Gears Slip Out of Mesh.**

(1) **INTERNAL DEFECT.** Report condition to higher authority.

#### **c. Lubricant Leaks From Case.**

(1) **LOOSE CASE BOLTS.** Tighten case. If trouble disappears, further correction is unnecessary.

(2) **INTERNAL DEFECT.** Report condition to higher authority.

### **33. TRANSFER CASE.**

#### **a. Transfer Case Noisy.**

(1) **LOOSE MOUNTING.** Tighten mounting. If trouble ceases, further correction is unnecessary.

(2) **INCORRECT OR INSUFFICIENT LUBRICANT.** Check lubricant and lubricate if necessary (par. 17).

(3) **CONNECTING PROPELLER SHAFT LOOSE.** Tighten propeller shaft. If noise stops, no further correction is needed.

(4) **INTERNAL DEFECT.** If noise persists after the above checks, report the condition to higher authority.

**b. Transfer Case Slips Out of Gear.** If linkage is broken or out of adjustment, inspect linkage. Replace broken parts. Adjust linkage (par. 98).

#### **c. Transfer Case Leaks Lubricant.**

(1) **LOOSE HOUSING.** Tighten housing bolts. If trouble stops, no further correction is needed.

(2) **INTERNAL DEFECT.** Report condition to higher authority.

## TROUBLE SHOOTING

### 34. PROPELLER SHAFTS AND UNIVERSAL JOINTS.

#### a. Propeller Shaft Rattles When Vehicle is Coasting.

(1) **WORN SPLINES OR BEARING CUPS.** Replace propeller shaft and attached universal joints (pars. 102 a, 103 a, and 104 a). Refer old shaft to higher authority for repair.

#### b. Propeller Shaft Vibrates.

(1) **LOOSE BOLTS AT UNIVERSAL JOINT COMPANION FLANGES.** Tighten loose bolts.

(2) **PROPELLER SHAFT OUT OF BALANCE OR MISALINED.** Replace propeller shaft and attached universal joints (pars. 102 a, 103 a, and 104 a). Refer old assembly to higher authority for repair.

#### c. Backlash in Propeller Shaft.

(1) **WORN BEARING IN UNIVERSAL JOINT.** Replace assembly (pars. 102 a, 103 a, and 104 a). Refer old part to higher authority for repair.

(2) **LOOSE BOLTS AT UNIVERSAL JOINT COMPANION FLANGES.** Tighten loose bolts.

### 35. FRONT AXLE.

#### a. Continuous Humming Noise.

(1) **LACK OF LUBRICATION.** Lubricate properly (par. 17).

(2) **WHEEL BEARINGS TOO TIGHT.** Adjust wheel bearing (par. 135 b).

(3) **BEVEL OR SPUR PINION BEARINGS TOO TIGHT.** Notify higher authority.

#### b. Humming Noise Noticeable Only When Coasting.

(1) **WHEEL BEARINGS WORN.** Replace wheel bearings (par. 135 c).

(2) **INTERNAL PARTS WORN OR OUT OF ADJUSTMENT.** Notify higher authority.

#### c. Humming Noise Noticeable Only When Pulling.

(1) **INCORRECT BACKLASH ADJUSTMENT BETWEEN BEVEL GEAR AND PINION.** Notify higher authority.

#### d. Backlash Noticeable in Front Wheels When Stopping and/or Starting.

(1) **PROPELLER SHAFT LOOSE.** Tighten propeller shaft.

(2) **INTERNAL PART WORN OR MALADJUSTED.** Notify higher authority.

#### e. Lubricant Leaks From Housing.

(1) **LOOSE HOUSING BOLTS.** Tighten loose housing bolts.

(2) **DEFECTIVE GASKET, OIL SEAL, OR GREASE RETAINER.** Notify higher authority.

**4- TO 5-TON 4x4 TRACTOR TRUCK (FEDERAL)**

**36. REAR AXLE.**

**a. Continuous Humming Noise.**

(1) **LACK OF OR IMPROPER LUBRICATION.** Lubricate properly (par. 17).

(2) **BEARINGS TOO TIGHT.** Notify higher authority.

**b. Humming Noise Noticeable Only When Coasting.**

(1) **WORN BEARINGS OR INCORRECT BEVEL GEAR AND PINION ADJUSTMENT.** Notify higher authority.

**c. Humming Noise Noticeable Only When Pulling.**

(1) **INCORRECT BEVEL GEAR AND PINION ADJUSTMENT.** Notify higher authority.

**d. Backlash Noticeable When Stopping and/or Starting.**

(1) **LOOSE PROPELLER SHAFT.** Tighten propeller shaft (pars. 102 b, 103 b, and 104 b).

(2) **CLUTCH OUT OF ADJUSTMENT OR WORN.** Adjust clutch. If trouble persists, notify higher authority.

(3) **INTERNAL MALADJUSTMENT OR WEAR.** Notify higher authority.

**e. Lubricant Leaks From Housing.**

(1) **LOOSE HOUSING BOLTS.** Tighten loose bolts.

(2) **WORN OR DAMAGED GASKET, OIL SEAL, OR GREASE RETAINER.** Notify higher authority.

**37. SERVICE BRAKE SYSTEM.**

**a. Brake Pedal Goes to Floor Board.**

(1) **NORMAL WEAR OF BRAKE LINING.** Adjust brakes (par. 127 b). If worn so that adjustment fails to eliminate trouble, notify higher authority.

(2) **LOW AIR PRESSURE.** Observe pressure as indicated on gage. If less than 105 pounds, start engine and build up pressure. Should pressure fail to build up, check system for leaks or inoperative units.

(3) **WATER TRAPPED IN AIR SYSTEM.** Drain reservoir tank (par. 115 b).

**b. Brakes Drag.**

(1) **BRAKE CONTROL ROD ADJUSTED TOO SHORT.** Remove clevis pin and loosen lock nut. Turn yoke counterclockwise to lengthen rod. Tighten lock nut and connect rod.

(2) **BRAKE CONTROL ROD RETURN SPRING WEAKENED OR BROKEN.** Remove spring from control rod and brake application valve bracket. Replace with serviceable spring.

(3) **WATER TRAPPED IN SYSTEM.** Drain reservoir tank (par. 115 b).

**c. One Brake Drags.**

(1) **GREASE IN BRAKE LINING.** Replace brake shoes (par. 128 c).



**TROUBLE SHOOTING**

Return old shoes to third echelon for relining. Check condition of grease retainers. Replace if defective.

(2) **BRAKE SHOES OUT OF ADJUSTMENT.** Adjust brakes (par. 127 h).

(3) **LINING LOOSENED FROM SHOE.** Replace brake shoes (par. 128 c).

(4) **BRAKE SHOE SPRING WEAKENED OR BROKEN.** Replace brake shoe spring (par. 128 c).

(5) **CLOGGED AIR TUBE OR HOSE.** Clean or replace obstructed part.

(6) **BRAKE ANCHOR PIN TIGHT.** Replace brake anchor pin (par. 128 c).

(7) **WHEEL BEARINGS OUT OF ADJUSTMENT.** Adjust wheel bearings (par. 135 h).

**d. Truck Pulls to Right or Left When Brakes Are Applied and/or Brakes Are Uneven.**

(1) **BRAKE ON FRONT WHEEL DRAGGING** (subpar. c above).

(2) **BRAKES NEED ADJUSTING OR LUBRICATING.** Adjust (par. 127 h) and/or lubricate (par. 17) brakes.

(3) **BRAKES NEED RELINING.** Report to higher authority.

(4) **GREASE ON BRAKE LINING.** Report to higher authority.

(5) **BRAKE SHOE RELEASE SPRING OR BRAKE DIAPHRAGM CHAMBER RELEASE SPRING BROKEN.** Replace broken spring.

(6) **BRAKE DRUM OUT-OF-ROUND.** Replace drum (par. 135 d).

(7) **LEAKING BRAKE CHAMBER DIAPHRAGM.** Replace diaphragm (par. 123 b).

**e. Brakes Take Hold Slowly.**

(1) **BRAKES OUT OF ADJUSTMENT.** Adjust brakes (par. 127 h).

(2) **BRAKE LINING WORN.** Replace brake shoes (par. 128 c).

(3) **BRAKE DRUMS WORN.** Replace drums (par. 135 d). Return used parts to higher authority for repair.

(4) **RESTRICTION IN AIR LINE.** Remove obstruction from air line or hose, or replace offending part.

(5) **BRAKE MECHANISM NEEDS LUBRICATION.** Lubricate vehicle (par. 17).

(6) **LOW AIR PRESSURE IN BRAKE SYSTEM** (subpar. k below).

(7) **BRAKE VALVE DELIVERY LOW.** Check brake valve delivery pressure. Adjust brake valve linkage or replace brake valve (par. 117 h).

(8) **EXCESSIVE LEAKAGE WITH BRAKES APPLIED** (subpar. o below).

(9) **RESTRICTION IN TUBING LINES.** Disconnect both ends of suspected line. Apply air pressure to blow out obstruction. Replace line if impossible to remove obstruction.

(10) **RESTRICTION IN HOSE LINE.** Disconnect both ends of suspected line. Apply air pressure to blow out obstruction. Replace line if impossible to remove obstruction.

**4- TO 5-TON 4x4 TRACTOR TRUCK (FEDERAL)**

**f. Brakes Release Slowly.**

(1) **BRAKE CONTROL ROD NOT RETURNING PROPERLY.** Check adjustment of control rod. Adjust if necessary (par. 117 c). Check condition of brake control rod return spring. Replace spring if weak or broken.

(2) **RESTRICTION IN AIR TUBE OR HOSE.** Remove obstruction (par. 125 c) or replace faulty tube or hose (par. 125 b).

(3) **DEFECTIVE AIR VALVE.** Replace defective valve (par. 117 b).

(4) **BRAKE CAMSHAFT BINDING.** Lubricate brake cam with engine oil. Do not get oil on lining.

(5) **BRAKES NEED ADJUSTING OR LUBRICATING.** Adjust (par. 127 b) and/or lubricate (par. 17) brakes.

(6) **EXHAUST PORT OF BRAKE VALVE, QUICK RELEASE VALVE, OR RELAY VALVE OBSTRUCTED.** Remove obstruction.

(7) **DEFECTIVE BRAKE VALVE, QUICK RELEASE VALVE, OR RELAY VALVE.** Replace defective valve (pars. 117 b, 119 b, and 120 b respectively).

**g. Insufficient Brakes.**

(1) **BRAKES NEED ADJUSTING, LUBRICATING, OR RELINING.** Adjust brakes (par. 127 b), lubricate (par. 17) brakes, or report to higher authority.

(2) **LOW AIR PRESSURE** (subpar. h below).

(3) **BRAKE VALVE DELIVERY PRESSURE LOW.** Check brake valve delivery pressure. Adjust valve linkage or replace valve (par. 117 b).

**h. Brakes Do Not Apply.**

(1) **NO AIR PRESSURE.** Start engine and build up air pressure.

(2) **RESTRICTED OR BROKEN TUBING OR HOSE.** Disconnect both ends of restricted line and apply air pressure. Replace line, if impossible to remove obstruction or if line is broken.

(3) **DEFECTIVE BRAKE VALVE.** Replace valve (par. 117 b).

**i. Brakes Do Not Release.**

(1) **BRAKE RIGGING BINDING.** Straighten or replace bent parts. Replace worn or broken parts. Lubricate rigging (par. 17).

(2) **BRAKE VALVE NOT RETURNING TO FULL RELEASED POSITION.** Adjust retracting spring tension. Check control rod and pedal to see if either is binding. Free and lubricate binding parts.

(3) **BRAKE VALVE IN APPLIED POSITION.** Move valve to released position.

(4) **BRAKE VALVE DEFECTIVE.** Replace valve (par. 117 b).

(5) **RESTRICTION IN TUBING OR HOSE.** Disconnect both ends of suspected line and blow out with compressed air. Replace line if impossible to remove obstruction.

(6) **AIR TRAPPED IN FRONT SERVICE LINE BEYOND DOUBLE CHECK VALVE.** This is caused by obstruction, or absence, of venthole

### TROUBLE SHOOTING

in dummy coupling. Clear venthole in dummy coupling or replace dummy coupling with one having venthole.

**j. Brakes Grab.**

- (1) GREASE ON LINING. Report to higher authority.
- (2) BRAKE DRUM OUT-OF-ROUND. Replace drum (par. 135 d).
- (3) DEFECTIVE BRAKE VALVE. Replace valve (par. 117 b).
- (4) BRAKE RIGGING BINDING. Straighten or replace bent parts. Replace broken and worn parts. Lubricate rigging (par. 17).

**k. Air Pressure Will Not Rise to Normal (80 to 105 pounds).**

- (1) DEFECTIVE AIR GAGE REGISTERING INCORRECTLY. Replace gage (par. 176 b).
- (2) EXCESSIVE LEAKAGE. Start engine and build up as much pressure as possible. Check all connections and units for leaks, with brakes applied and not applied. Use soapy water to detect leaks which cannot be felt or heard. Tighten loose connections and replace defective parts.
- (3) RESERVOIR TANK DRAIN COCK OPEN. Close drain cock on bottom of each tank.
- (4) GOVERNOR OUT OF ADJUSTMENT. Adjust governor (par. 114 b).
- (5) NO CLEARANCE AT COMPRESSOR UNLOADING VALVES. Adjust clearance to 0.010 inch minimum, 0.015 inch maximum (par. 113 b).
- (6) FAN BELTS SLIPPING ON COMPRESSOR PULLEY. Adjust fan belt tension (par. 78 b).

- (7) DEFECTIVE COMPRESSOR. Replace compressor (par. 113 c).

**l. Air Pressure Rises Too Slowly to Normal (80 to 105 pounds).**

- (1) EXCESSIVE LEAKAGE. Check for leakage and service or replace defective units.
- (2) CLOGGED COMPRESSOR AIR FILTER. Service air filter (par. 113 b).
- (3) NO CLEARANCE AT COMPRESSOR UNLOADING VALVES. Adjust clearance to 0.010 inch minimum, 0.015 inch maximum (par. 113 b).
- (4) ENGINE SPEED TOO LOW. Increase engine speed.
- (5) COMPRESSOR DISCHARGE VALVES LEAKING. Replace compressor (par. 113 c).
- (6) EXCESSIVE CARBON IN COMPRESSOR CYLINDER HEAD OR DISCHARGE LINE. Replace compressor, or discharge line (pars. 113 b and 125 c).

**m. Air Pressure Rises Above Normal (80 to 105 pounds).**

- (1) DEFECTIVE AIR GAGE REGISTERING INCORRECTLY. Replace gage (par. 176 b).
- (2) DEFECTIVE GOVERNOR. Replace governor (par. 114 c).
- (3) GOVERNOR OUT OF ADJUSTMENT. Adjust governor (par. 114 b).
- (4) RESTRICTION IN GOVERNOR TO COMPRESSOR TUBE. Discon-

**4- TO 5-TON 4x4 TRACTOR TRUCK (FEDERAL)**

nect both ends of tube and apply compressed air. If impossible to remove obstruction, replace tube.

(5) **TOO MUCH CLEARANCE AT COMPRESSOR UNLOADING VALVES.** Adjust clearance to 0.010 inch minimum, 0.015 inch maximum (par. 113 b).

(6) **UNLOADING VALVE CAVITIES OR UNLOADING PASSAGE BLOCKED WITH CARBON.** Replace compressor (par. 113 c).

(7) **UNLOADING VALVES STUCK CLOSED.** Replace compressor (par. 113 c).

**n. Air Pressure Drops Quickly With Engine Stopped and Brakes Released.**

(1) **LEAKING BRAKE VALVE.** Replace valve (par. 117 b).

(2) **LEAKING RELAY VALVE.** Replace valve (par. 117 b).

(3) **LEAKING TUBING OR HOSE.** Service or replace line (par. 125 b).

(4) **COMPRESSOR DISCHARGE VALVES LEAKING.** Replace compressor (par. 113 c).

(5) **GOVERNOR LEAKING.** Service or replace governor (par. 114 c).

(6) **EXCESSIVE LEAKAGE ELSEWHERE IN SYSTEM** (subpar. k (2) above).

**o. Air Pressure Drops Quickly With Engine Stopped and Brakes Fully Applied.**

(1) **LEAKING BRAKE CHAMBER DIAPHRAGMS.** Replace diaphragm chambers (par. 123 b).

(2) **LEAK IN BRAKE VALVE, RELAY VALVE, TUBING OR HOSE.** Service or replace leaking part.

(3) **DRAIN COCK OR CUT-OUT COCK LEFT OPEN.** Close cock.

**p. Compressor Knocks.**

(1) **LOOSE DRIVE PULLEY.** Tighten pulley.

(2) **BACKLASH IN DRIVE GEARS OR DRIVE COUPLING.** Report to higher authority or replace compressor (par. 113 c).

(3) **WORN BEARINGS.** Replace compressor (par. 113 c).

(4) **EXCESSIVE CARBON IN COMPRESSOR CYLINDER HEAD.** Replace compressor (par. 113 c).

**q. Brake Valve "Groans" When Brakes Are Applied.**

(1) **DEFECTIVE BRAKE VALVE.** Replace valve (par. 117 b).

**r. Relay Valve "Groans" or "Chatters" When Brakes Are Applied.**

(1) **DEFECTIVE RELAY VALVE.** Replace valve (par. 117 b).

**s. Quick Release Valve "Blats" When Brakes Are Released.**

(1) **DEFECTIVE QUICK RELEASE VALVE.** Replace valve (par. 117 b).

## TROUBLE SHOOTING

### t. Safety Valve Blows Off.

- (1) SAFETY VALVE OUT OF ADJUSTMENT. Replace safety valve (par. 116 b).
- (2) AIR PRESSURE ABOVE NORMAL (subpar. m above).

## 38. PROPELLER SHAFT BRAKE SYSTEM.

### a. Brake Does Not Hold.

- (1) BRAKE OUT OF ADJUSTMENT. Adjust brake (par. 130 b).
- (2) BRAKE LINING WORN. Try adjusting brakes (par. 130 b). If trouble persists, replace shoes (par. 128 c).
- (3) BRAKE SHOE LINING GLAZED OR GREASED. Replace brake shoes (par. 130 c).
- (4) BRAKE DRUM WORN AND/OR GLAZED. Report trouble to higher authority.

## 39. WHEELS, HUBS, WHEEL BEARINGS, AND TIRES (par. 41).

### a. Pounding or Squeaking Noise in Wheel.

- (1) WHEEL HUB STUD CAP NUTS LOOSE. Tighten cap nuts securely (par. 134 c).
- (2) TIRE MOUNTED OUT OF BALANCE. Disassemble tire and assemble correctly (par. 136 c).

### b. Wheel Drags and Wheel Bearing Heats.

- (1) WHEEL BEARING ADJUSTED TOO TIGHT. Adjust wheel bearing (par. 135 b).

### c. Tires Overheat.

- (1) TIRES UNDERINFLATED. Inflate tires properly (par. 136 b).

### d. Excessive or Uneven Tire Wear.

- (1) TIRES INFLATED INCORRECTLY. Inflate tires properly (par. 136 b).
- (2) TOE-IN OUT OF ADJUSTMENT. Adjust toe-in (par. 106 b).
- (3) TIRES MOUNTED OUT OF BALANCE. Remove tires and install correctly (par. 136 c).

## 40. SPRINGS AND SHOCK ABSORBERS.

### a. Vehicle Bottoms or Skews.

- (1) BROKEN FRONT OR REAR SPRING. Replace broken spring (pars. 137 b and 138 b).
- (2) INOPERATIVE SHOCK ABSORBER. Replace inoperative shock absorbers (par. 139 d).

### b. Truck Exceptionally Hard Riding.

- (1) SPRINGS LACK LUBRICATION. Lubricate vehicle (par. 17).
- (2) SHACKLE PINS FROZEN IN SHACKLE. Replace shackle pins (par. 137 b).

### c. Exaggerated Spring Action.

- (1) SHOCK ABSORBER INOPERATIVE. Replace shock absorber (par. 139 c).

**4- TO 5-TON 4x4 TRACTOR TRUCK (FEDERAL)**

(2) **WORN SHACKLE PINS AND BUSHINGS.** Replace shackle pins, springs, and shackles (pars. 137 b and 138 b).

(3) **BROKEN SPRING REBOUND CLIPS.** Replace spring (pars. 137 b and 138 b).

**d. Springs Noisy.**

(1) **SHACKLE PINS AND BUSHINGS WORN.** Replace shackles, springs, and pins (pars. 137 b and 138 b).

(2) **SPRING REBOUND CLIPS LOOSE OR BROKEN.** Tighten loose clips. If clips are broken, replace spring.

(3) **BROKEN SPRING OR SHACKLE.** Replace broken part (pars. 137 b and 138 b).

**41. STEERING GEAR.**

**a. Front Wheels Shimmy.**

(1) **WHEEL AND TIRE OUT OF BALANCE.** Inspect tire. If incorrectly mounted (with valve and balancing mark on tire not alined), dismount tire and assemble correctly (par. 136 c). If this does not remedy the trouble, refer the wheel and tire to higher authority for balancing.

(2) **DRAG LINK LOOSE.** Shake drag link. Tighten and adjust if loose (par. 143).

(3) **STEERING GEAR OUT OF ADJUSTMENT.** Adjust steering gear (par. 141).

(4) **STEERING GEAR WORN.** Refer to higher authority for repair.

(5) **FRONT WHEEL BENT.** Jack up front of truck. Spin wheels and look for wobble. Replace bent wheel (par. 134 b).

(6) **LOOSE FRONT WHEEL BEARINGS.** Jack up truck. Check bearings for play. Adjust loose bearing (par. 135 b).

(7) **FRONT TIRE, WHEEL AND/OR HUB OUT OF BALANCE.** Jack up front of truck. Spin wheels repeatedly and notice if they always stop and rock at same point. If out of balance, check mounting of tire. Dismount and mount correctly if valve and balancing mark on tire are not alined (par. 183 c). If trouble persists, refer entire assembly to higher authority for balancing.

(8) **IMPROPER CASTER OR CAMBER.** Notify higher authority.

(9) **BENT FRAME.** Notify higher authority.

**b. Front Wheel Wander.**

(1) **DRAG LINK LOOSE.** Shake drag link. Tighten and adjust if loose (par. 143).

(2) **WORN STEERING GEAR.** Refer to higher authority for repair.

(3) **FRAME OF VEHICLE BENT.** Notify higher authority.

**c. Vehicle Steers Hard.**

(1) **STEERING GEAR AND/OR FRONT AXLE LACK PROPER LUBRICATION.** Lubricate vehicle correctly (par. 17).

(2) **TIRES UNDERINFLATED.** Inflate tires correctly (par. 136 b).

## TROUBLE SHOOTING

(3) **FRONT SPRING CLIPS LOOSE OR BROKEN.** Inspect front spring clips. Tighten if loose. If clips are broken, replace spring (pars. 137 b and 138 b).

(4) **WORN STEERING GEAR.** Refer to higher authority for repair.

(5) **FRAME OF VEHICLE BENT.** Notify higher authority.

**d. Road Shocks Felt at Steering Wheel.**

(1) **DRAG LINK ADJUSTED TOO TIGHT.** Adjust drag link (par. 141).

(2) **WORN STEERING GEAR.** Refer to higher authority for repair.

**e. Truck Pulls to Right or Left.**

(1) **TIRES INFLATED UNEVENLY.** Inflate tires properly (par. 136 b).

**f. Vehicle Hard to Straighten Out After Turn to Right or Left.**

(1) **IMPROPER TIRE INFLATION.** Inflate tires properly (par. 136 b).

## 42. BODY AND FRAME.

**a. Windshield Wiper Inoperative.**

(1) **LEAK IN TUBING FROM MANIFOLD TO WIPER.** Start engine and inspect tubing. Place a liquid on doubtful spots. If it bubbles, a leak is indicated. Replace punctured or defective tubing.

(2) **KINKED HOSE OR TUBING.** Visually inspect tubing and hose. Straighten out kinks. Replace hose or tubing if it cracks or breaks.

(3) **DIRT ON EXTERIOR OF WIPER CASE BLOCKING AIR INTAKE.** Blow dirt from outside wiper motor case with compressed air.

(4) **INTERNAL DIRT OR WEAR.** Replace wiper (par. 146 c).

**b. Vehicle Steers Hard, Shimmies, Wanders, or Wheels Do Not Track.**

(1) **FRAME BENT.** Notify higher authority.

## 43. BATTERY AND LIGHTING SYSTEM.

**a. Battery Cells All Test Over 1.250 Specific Gravity.**

(1) **BATTERY NORMAL.** No corrective measures necessary in summer. For cold weather operation, give batteries booster charge if cells are under 1.275.

**b. Battery Cells All Test Under 1.250 Specific Gravity.**

(1) **BATTERY WILL NOT HOLD A CHARGE.** Replace battery (par. 155 c).

(2) **DEMAND FROM BATTERIES EXCEEDS INPUT FROM GENERATOR.** Recharge batteries. Check electrical system for short circuits, loose connections, and low generator output. Increase charging rate (par. 87 b).

**c. Frequent Additions of Water Necessary.**

(1) **EXCESSIVE GENERATOR CHARGING RATE.** Adjust generator charging rate (par. 87 b).

(2) **BROKEN BATTERY CASE.** Replace battery. Refer used battery to higher authority to repair.

**4- TO 5-TON 4x4 TRACTOR TRUCK (FEDERAL)**

**d. Bulge in Battery Case.**

(1) **EXCESSIVE TEMPERATURE DUE TO OVERCHARGING.** Adjust generator output (par. 87 b).

**e. Corrosion on Battery Terminals.**

(1) **EXCESSIVE CHARGING RATE CAUSING ACID TO SPRAY ON TERMINALS.** Remove terminals from posts. Clean posts and terminals thoroughly. Replace cable if terminal is weakened by corrosion. Connect terminals and apply a film of No. 2 general purpose grease or vaseline to exposed metal. Adjust generator output (par. 87 b).

(2) **LEAD COATING ON TERMINALS DESTROYED** (subpar. (1) above).

**f. Broken Terminal Post on Battery.**

(1) **LOOSE BATTERY INSTALLATION.** Replace battery (par. 155 c).

(2) **BATTERY CABLE TOO SHORT.** Replace battery and cable (pars. 155 c and 92 c).

**g. All Lamps Fail To Light.**

(1) **CIRCUIT BREAKS OPEN.** Close circuit breaker. If it snaps open again, look for short circuit.

(2) **BATTERIES DEAD.** Check for cause. Eliminate short circuits. Recharge or replace batteries.

(3) **OPEN CIRCUIT IN CABLE OR WIRES.** Visually inspect wiring. If visual inspection reveals no open circuit, locate with test lamp. Connect disconnected wires or cables. Replace broken wires or cables.

**h. One Lamp Fails To Light.**

(1) **BURNED OUT BULB.** Replace bulb.

(2) **BULB LOOSE IN SOCKET.** Install bulb properly.

(3) **OPEN CIRCUIT IN CIRCUIT TO LAMP** (subpar. g (3) above).

(4) **LIGHT NOT GROUNDED.** Remove light. Clean points of contact on light and vehicle until shiny. Install light.

**44. INSTRUMENTS.**

**a. Ammeter Inoperative.**

(1) **WIRE DISCONNECTED OR BROKEN.** Connect disconnected wire. Splice or replace broken wire.

(2) **INTERNAL DEFECT.** Check with one known to be right. Replace if found defective (par. 170 b).

**b. Fuel Gage. Apparently inoperative.**

(1) **NO FUEL IN TANK.** Fill fuel tank.

(2) **OPEN CIRCUIT IN WIRING.** Visually inspect wires to see if any are broken or disconnected. Use a test lamp if open circuit cannot be located visually. Connect disconnected wires and replace broken wires.

(3) **FUEL GAGE TANK UNIT INOPERATIVE.** Replace tank unit (par. 171 b).

(4) **GAGE INOPERATIVE.** Replace gage (par. 171 d).



**TROUBLE SHOOTING****c. Tachometer Pointer Noisy and/or Fluctuates and Jumps.**

(1) **FLEXIBLE SHAFT KINKED.** Examine cable. Remove kinks. Replace cable if permanently distorted (par. 172 b).

(2) **FLEXIBLE SHAFT WORN AND BINDING.** Replace cable (par. 172 b).

(3) **TACHOMETER HEAD WORN.** Replace tachometer head (par. 172 b).

**d. Tachometer Inoperative.**

(1) **FLEXIBLE SHAFT BROKEN.** Examine shaft and replace if broken (par. 172 b).

(2) **DRIVE UNIT INOPERATIVE.** Replace drive unit.

(3) **HEAD INOPERATIVE.** Replace tachometer head (par. 172 b).

**e. Speedometer Fluctuates and Jumps and/or Is Noisy.**

(1) **CABLE KINKED.** Examine cable and eliminate kinks. Replace cable if permanently bent (par. 173 d).

(2) **CABLE WORN AND BINDING.** Replace cable (par. 173 d).

(3) **SPEEDOMETER WORN.** Replace speedometer (par. 173 b).

**f. Speedometer Inoperative.**

(1) **CABLE DISCONNECTED.** Connect cable (par. 173 a).

(2) **CABLE BROKEN.** Replace cable (par. 173 d).

(3) **DRIVE UNIT INOPERATIVE.** Replace drive unit.

(4) **INSTRUMENT INOPERATIVE.** Replace speedometer (par. 173 b).

**g. Oil Gage Apparently Inoperative.**

(1) **OIL PUMP INOPERATIVE OR ENGINE WITHOUT OIL PRESSURE FOR OTHER REASON.** Stop engine. Inspect oil lines to see if any are broken. Look for signs of oil leakage. Replace broken lines. If lines are apparently in satisfactory condition, an inoperative oil pump is indicated. Notify higher authority.

(2) **LINE TO GAGE PLUGGED.** Remove line and remove obstruction or replace line (par. 174 b).

(3) **GAGE DEFECTIVE.** Replace gage (par. 174 b).

**h. Temperature Gage Inoperative.**

(1) **TUBE BROKEN OR DISCONNECTED.** Trace tube from gage to left side of read cylinder head. Replace if broken. Connect if disconnected (par. 175 c).

(2) **GAGE DEFECTIVE.** Replace gage (par. 175 b).

**i. Air Pressure Gage Apparently Inoperative.**

(1) **NO AIR PRESSURE.** Start engine but do not drive truck. Buzzing of low-pressure buzzer indicates no or low air pressure. Let engine run until pressure builds up. If pressure fails to build up or if system fails to hold pressure, check tubing, hosing, fittings, and units in system for pressure of leaks. Tighten or replace leaking parts.

**4- TO 5-TON 4x4 TRACTOR TRUCK (FEDERAL)**

(2) **OBSTRUCTION IN LINE TO GAGE.** Disconnect line from gage and run engine. If air fails to come from line, an obstruction is indicated. Disconnect tubing from fitting on engine side of air compressor. Disassemble two pieces of tubing from connecting hose. Remove obstruction or replace plugged tubing or hose.

(3) **DEFECTIVE GAGE.** If air is emitted from tubing (subpar. (2) above), a defective gage is indicated. Replace gage (par. 176 b).

**j. Viscosity Gage Apparently Inoperative.**

(1) **NO OIL IN CRANKCASE.** Check engine oil and add oil if necessary (par. 17).

(2) **VISCOSITY GAGE OIL LINE OBSTRUCTED.** Disconnect line at gage and at viscosity gage instrument, near rear of left side of oil pan. Attempt to blow through line. If plugged, remove obstruction or replace line.

(3) **VISCOSITY GAGE INSTRUMENT DEFECTIVE.** If line was unobstructed but empty a defective viscosity instrument is indicated. Remove instrument from near rear of left side of oil pan and replace with a serviceable unit.

(4) **VISCOSITY GAGE DEFECTIVE.** If tubing and instrument are in satisfactory condition, as determined in the two preceding steps, a defective gage is indicated. Replace gage (par. 177 b).

**45. RADIO NOISE SUPPRESSION.**

**a. Radio Interference Noticeable With Engine Running and Vehicle Standing.**

(1) **IGNITION CIRCUIT NOISY.** Accelerate engine and turn off ignition switch. If crackling noise stops instant switch brakes circuit, a faulty ignition filter or resistor suppressors are indicated. Test filter (par. 182 b). Replace resistor suppressors (par. 184 c). Clean and tighten all connections in circuit.

(2) **REGULATOR NOISY.** If irregular clicking continues a moment after switch is shut off, a faulty field filter is indicated. Test filter (par. 182 b) and replace (par. 182 c) if defective. Clean and tighten all connections. Replace regulator if noise persists.

(3) **GENERATOR NOISY.** If whining noise varies with engine speed and continues a moment after switch is turned off, a noisy generator is indicated. Replace capacitor (par. 183 b). If trouble persists, test field filter (par. 182 b). Replace filter if defective (par. 182 c). clean and tighten all connections. Replace generator if noise persists.

**b. Radio Interference Noticeable With Vehicle in Motion but Not Noticeable With Vehicle Standing, Engine Running.** This is due to faulty bond straps or bending bolts. Check all bond straps (par. 185 b) and bonding bolts for clean and tight connections. Tighten body and frame nuts. Replace all missing bond straps, bolts, washers, and nuts.

Section XIII

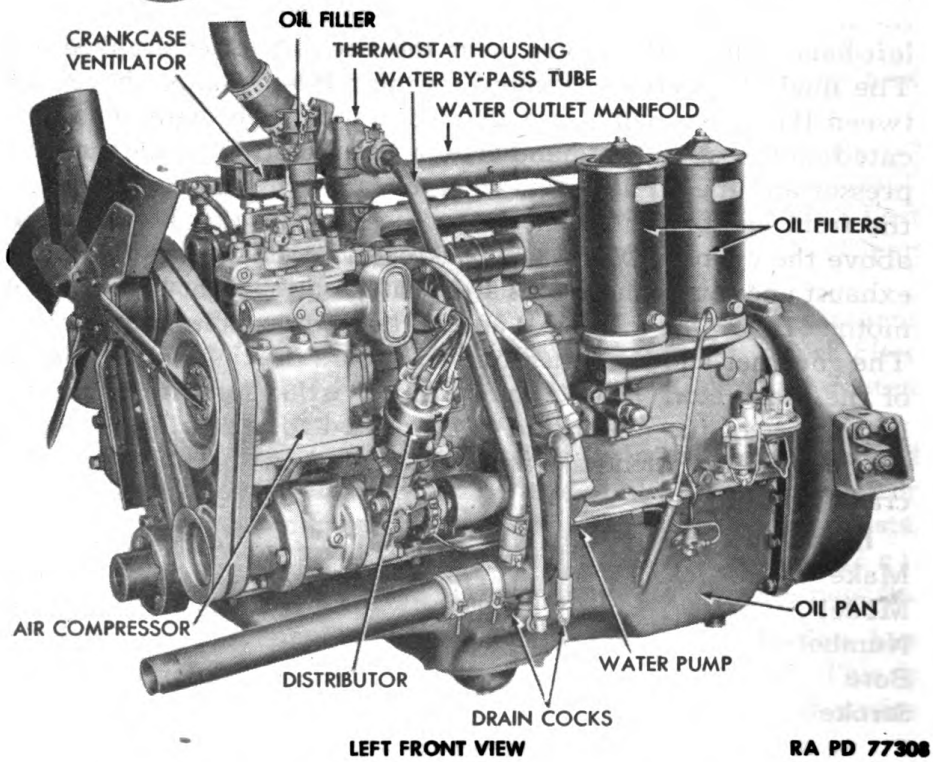
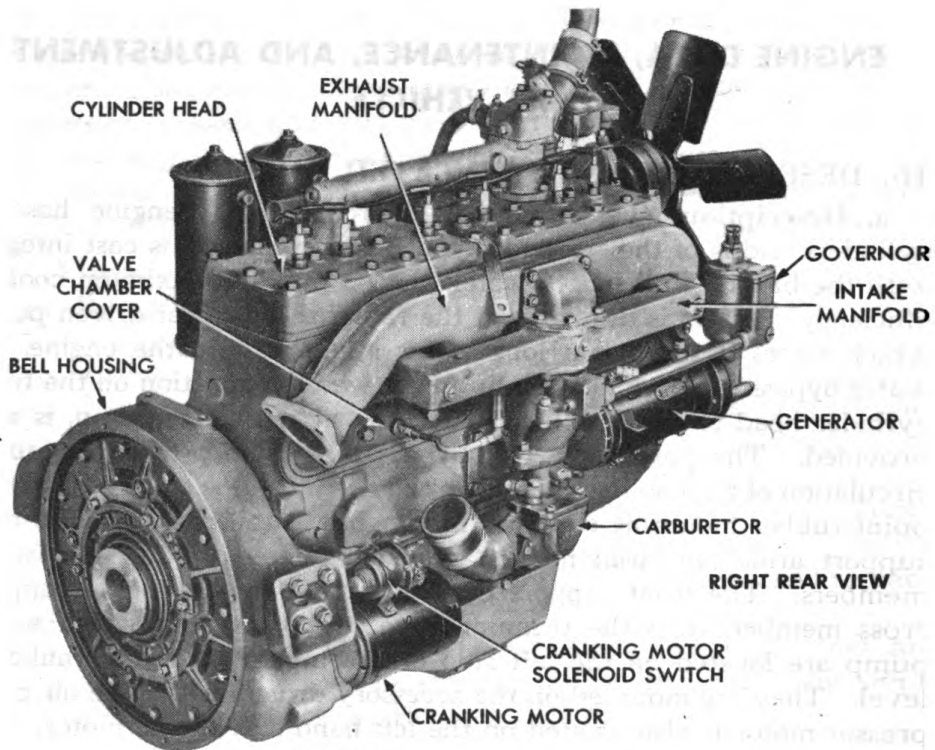
**ENGINE DATA, MAINTENANCE, AND ADJUSTMENT  
IN VEHICLE**

**46. DESCRIPTION AND TABULATED DATA.**

a. **Description** (fig. 12). The Hercules **RXC** engine has six cylinders and is of the "L"-head type. The crankcase is cast integral with the block. Full length water jackets provide maximum cooling efficiency. Water is drawn from the radiator by a gear-driven pump which forces it through a long water manifold into the engine. A water bypass tube, which leads from the water connection on the front cylinder head to the coupling connection at the water pump, is also provided. The purpose of this bypass tube is to provide adequate circulation of the cooling fluid when the thermostat is closed. A three-point rubber mounting supports the engine in the chassis. The rear support arms are cushioned on brackets riveted to the side frame members. The front support bracket, bolted to the engine support cross member, is of the trunnion type. The distributor and water pump are located on the left side of the motor at lower crankcase level. They are mounted on the accessory drive shaft. The air compressor motor is also located on the left-hand side of the motor, near the front and above the distributor. The fuel pump is located on the left-hand side of the motor, near the back at lower crankcase level. The dual oil filters are located on the left-hand side, above and between the water pump and the fuel pump. The ignition coil is located on the upper left-hand side of the motor, between the air compressor and the oil filters. The crankcase ventilator is located above the front end of the front cylinder head. The thermostat is located above the cylinder block and back of the crankcase ventilator. The exhaust and intake manifolds are located on the right-hand side of the motor. Below the manifolds and in the lower center is the carburetor. The governor and the generator are also on the right-hand side, ahead of the carburetor. The cranking motor is located on the right-hand lower part of the motor and is connected to the bell housing. The cranking motor solenoid switch is mounted on the upper part of the cranking motor.

**b. Data.**

Make .....	Hercules
Model .....	RXC
Number of cylinders .....	6
Bore .....	4 <sup>5</sup> / <sub>8</sub> in.
Stroke .....	5 <sup>1</sup> / <sub>4</sub> in.
Firing order .....	1-5-3-6-2-4
Displacement .....	529 cu in.
Rated net horsepower at 2,300 rpm .....	131



**Figure 12 – Engine Removed From Vehicle**

**ENGINE DATA, MAINTENANCE, AND ADJUSTMENT IN VEHICLE**

Maximum permissible engine speed:

Short periods	2,400 rpm
Sustained	1,900 rpm

Oil capacity (to refill engine) . . . . . 10 qt  
Cooling system capacity . . . . . 50 qt  
Octane rating of fuel necessary for maximum efficiency . . . . . 72 to 87  
Serial number location . . . . . Left-hand side of cylinder block. Also stamped in cylinder block at upper right-hand corner in front.

**47. TUNE-UP.**

**a. General.** Engine tune-up consists of a systematic series of adjustments to ensure efficient engine operation. Tune up engine after installation and every 1,000 miles or every month, whichever comes first. To avoid hit-and-miss tuning, make adjustments in the order given below:

- (1) **ADJUST VALVE TAPPETS** (par. 51).
- (2) **TEST ENGINE COMPRESSION.** Remove spark plugs (par. 83 b). Insert a compression gage into a spark plug hole. Crank engine and observe gage reading. Repeat test on each cylinder. If compression is below 85 pounds in any cylinder, or if it varies as much as 10 or 15 pounds between cylinders, notify higher authority. It is not possible to tune an engine having faulty compression.
- (3) **CLEAN AND ADJUST SPARK PLUGS.** Clean plugs in a sandblast spark plug cleaner. Measure gap between electrodes. Bend outside electrode to secure 0.025-inch gap. Test plugs in a spark plug testing machine. Replace plug if spark fails to flow freely across gap while under 105-pound air pressure. Install spark plugs (par. 83 d).
- (4) **CLEAN AND TIGHTEN CABLES.** Clean terminals and tighten connections of battery cables and ignition wires.
- (5) **ADJUST DISTRIBUTOR POINTS.** Check condition of distributor points and adjust if necessary (par. 82 b).
- (6) **ADJUST CARBURETOR** (par. 62 b).

**48. CYLINDER HEAD AND GASKET REMOVAL.**

**a. Drain Cooling System.** Open drain cock at rear of radiator outlet pipe and drain cock on left side of cylinder block.

**b. Remove Engine Covers** (figs. 21 and 22). The front cover is secured by two spring catches. Disengage the catches and lift cover from cab floor boards. Remove nine screws and toothed lock washers which hold cover over rear end of engine, and lift off cover. Remove eight bolts, nuts, plain washers, and lock washers which secure rear engine cover riser, and lift riser from cab. Remove two screws which hold transmission cover plate. Tip seat cushions back, and work plate over shifting levers and propeller shaft brake lever.

4- TO 5-TON 4x4 TRACTOR TRUCK (FEDERAL)

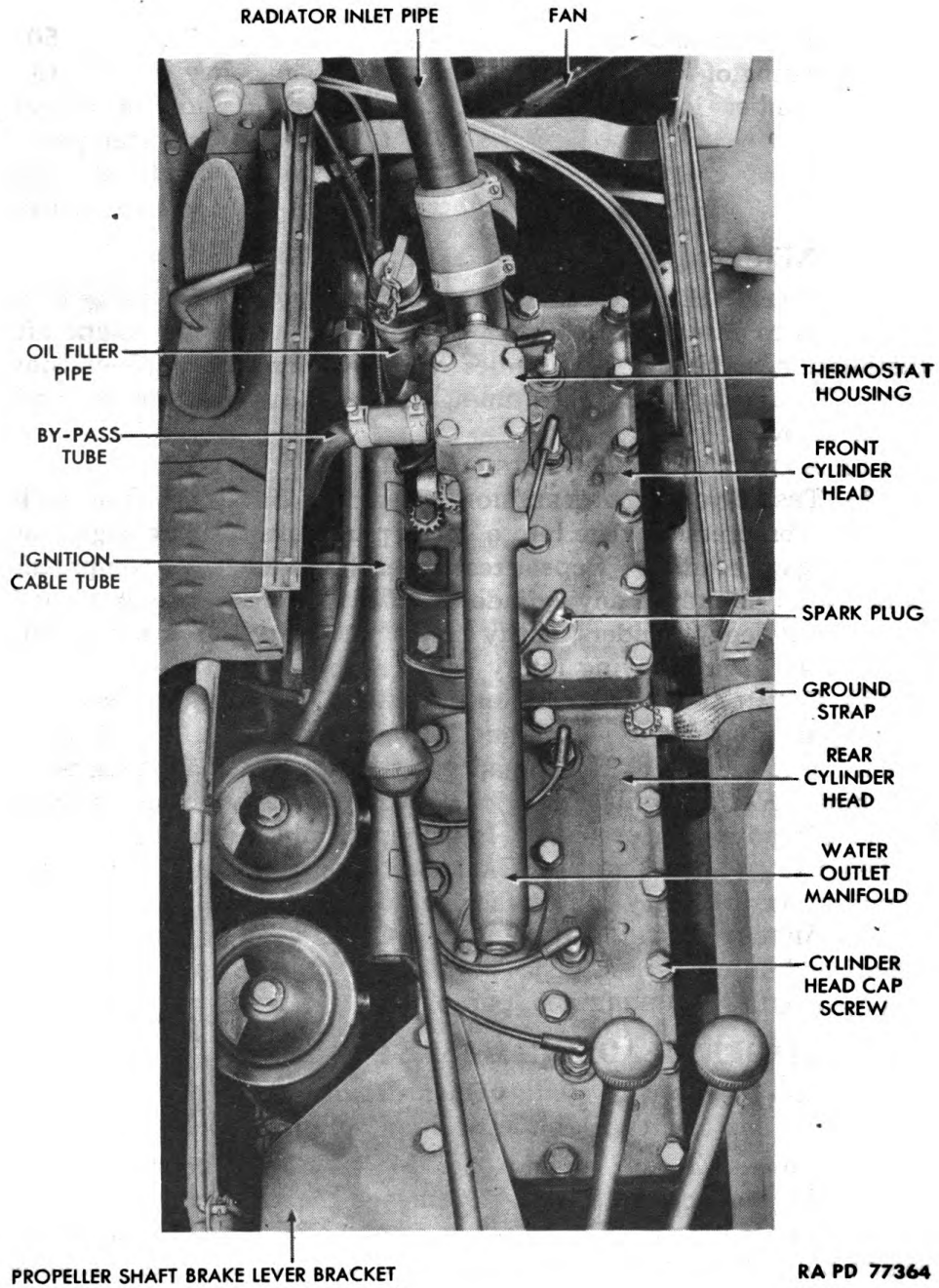


Figure 13 — Installed Engine — Top View

### ENGINE DATA, MAINTENANCE, AND ADJUSTMENT IN VEHICLE

c. **Remove Transverse Cab Support.** Remove four cap screws, nuts, and lock washers which secure transverse cab support to cab frame, and lift support from frame.

d. **Remove Oil Filler Pipe** (fig. 13). Remove the cylinder head cap screw which secures oil filler pipe bracket to cylinder head. Lift straight up on filler pipe to pull it from cylinder block. Twist pipe to clear hose connection, and lift it from engine.

e. **Disconnect Water Hoses** (fig. 13). Loosen hose clamps on radiator inlet pipe hose and upper bypass hose. Work radiator hose up onto radiator inlet tube. Pull bypass hose from outlet elbow at thermostat housing.

f. **Remove Water Outlet Manifold** (fig. 13). Remove four cap screws and lock washers which attach water outlet manifold to the two cylinder heads, and lift manifold and gaskets from cylinder heads.

g. **Disconnect Propeller Shaft Brake Lever Bracket** (fig. 13). Remove the two cylinder head cap screws which anchor brake lever bracket to cylinder head. Remove two cap screws and lock washers which secure bracket to top of bell housing, and tip bracket back out of way.

h. **Remove Ignition Cable Tube** (fig. 13). Remove the two cylinder head cap screws which attach ignition cable tube to cylinder head. Disconnect the six ignition wires from spark plugs. Tip tube and wires out of way, toward left side of truck.

i. **Remove Spark Plugs** (fig. 13) (par. 83 b).

j. **Disconnect Fan Bracket From Cylinder Head** (fig. 13). Remove the cylinder head cap screw which attaches iron strap from fan bracket adjusting screw to cylinder head. Push iron strap to one side.

k. **Remove Cylinder Heads** (fig. 13). Remove remaining cylinder head cap screws. Lift both cylinder heads and cylinder head gaskets from engine.

### 49. CARBON REMOVAL.

a. **Remove Cylinder Heads** (par. 48 k).

b. **Remove Carbon.** Remove carbon, from top of cylinder block, using a scraper and wire brush, being careful to get all carbon from around valve seats. Do not allow carbon to enter water jacket openings. Remove carbon from under side of cylinder heads in the same manner.

c. **Install Cylinder Heads** (par. 50).

### 50. CYLINDER HEAD AND GASKET INSTALLATION.

a. **Place Gaskets and Heads in Position.** Soak cylinder head gaskets in water for about 15 minutes. Place gaskets in position on top of cylinder blocks. Place front and rear cylinder heads in position on gaskets.

4- TO 5-TON 4x4 TRACTOR TRUCK (FEDERAL)

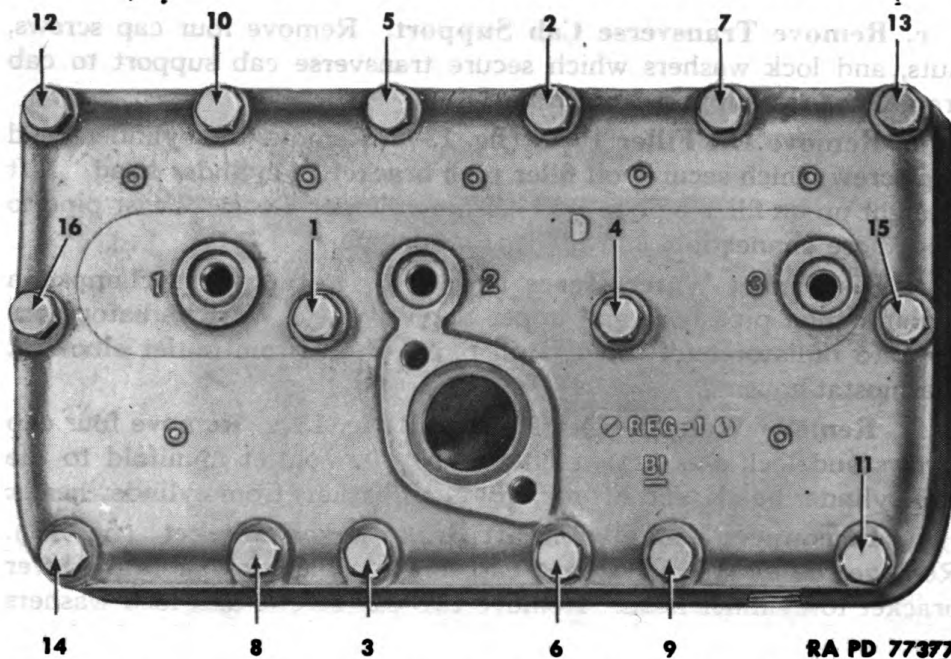


Figure 14 – Sequence for Tightening Cylinder Head Cap Screws

b. **Connect Fan Bracket** (fig. 13). Pull iron strap from fan bracket adjusting screw into position on front cylinder head left front cap screw hole. Install cylinder head cap screw fingertight.

c. **Install Ignition Cable Tube** (fig. 13). Place ignition cable tube in position along left side of cylinder heads. Aline cable tube front bracket with cap screw hole third from rear of front cylinder head. Place radio bonding strap over screw hole under bracket. Aline rear bracket with screw hole third from front of rear cylinder head. Install two cylinder head cap screws, fingertight, through the brackets.

d. **Install Propeller Shaft Brake Lever Bracket** (fig. 13). Tip propeller shaft brake lever bracket forward into position on rear cylinder head and bell housing. Install two left rear cylinder head cap screws, fingertight, through bracket. Install and tighten securely the two lock washers and cap screws which attach bracket to bell housing.

e. **Install Oil Filler Pipe** (fig. 13). Insert lower end of oil filler pipe into its opening in cylinder block. Aline bracket with cylinder head cap screw hole second from front on left side of front cylinder head, and install cap screw fingertight.

f. **Install Cylinder Head Cap Screws** (fig. 13). Install remaining cylinder head cap screws fingertight. Be sure to put radio bonding strap on cap screw at right front corner of rear head. Beginning at center and working toward ends of cylinder head, tighten cylinder



## ENGINE DATA, MAINTENANCE, AND ADJUSTMENT IN VEHICLE

head cap screws on each cylinder head (fig. 14). Proper tension is 52½ foot-pounds.

**g. Install Water Outlet Manifold** (fig. 13). Place water outlet manifold gaskets in position on top of cylinder heads. Place manifold in position on gaskets. Install the four lock washers and cap screws which hold manifold to cylinder heads, and tighten cap screws evenly and securely.

**h. Connect Water Hoses** (fig. 13). Work radiator inlet pipe hose down onto outlet elbow at thermostat housing, and tighten both clamps. Work bypass hose onto its flange on thermostat housing, and tighten both hose clamps.

**i. Install Transverse Cab Support.** Place transverse cab support in position on cab frame; the support crosses the top of the engine between the two cylinder heads. Install the four cap screws, lock washers, and nuts, which secure the support to the frame, and tighten nuts.

**j. Install Spark Plugs** (par. 83 d).

**k. Install Engine Covers** (fig. 22). Work transmission cover plate into position over gearshift levers and parking brake lever. Work leather lever boots down to base of levers. Install two toothed lock washers and screws which secure rear of plate to seat risers. Place rear engine cover riser in position between seat risers and front engine cover riser, and secure with eight bolts, flat washers, lock washers, and nuts. Place rear engine cover in position on its riser, and secure to riser with nine lock washers and screws. Place front engine cover in position on its riser, and hook the two spring catches which hold cover in place.

**l. Fill Cooling System.** Close drain cock at rear of radiator outlet pipe and drain cock on left side of engine cylinder block. Fill the cooling system with 50 quarts of clean, fresh water. Use soft water if available.

## 51. VALVE TAPPET ADJUSTMENT.

**a. Remove Cab Skirt Opening Door** (fig. 1). Remove 10 screws and toothed lock washers which secure right-hand cab skirt opening door to cab, and lift door from cab.

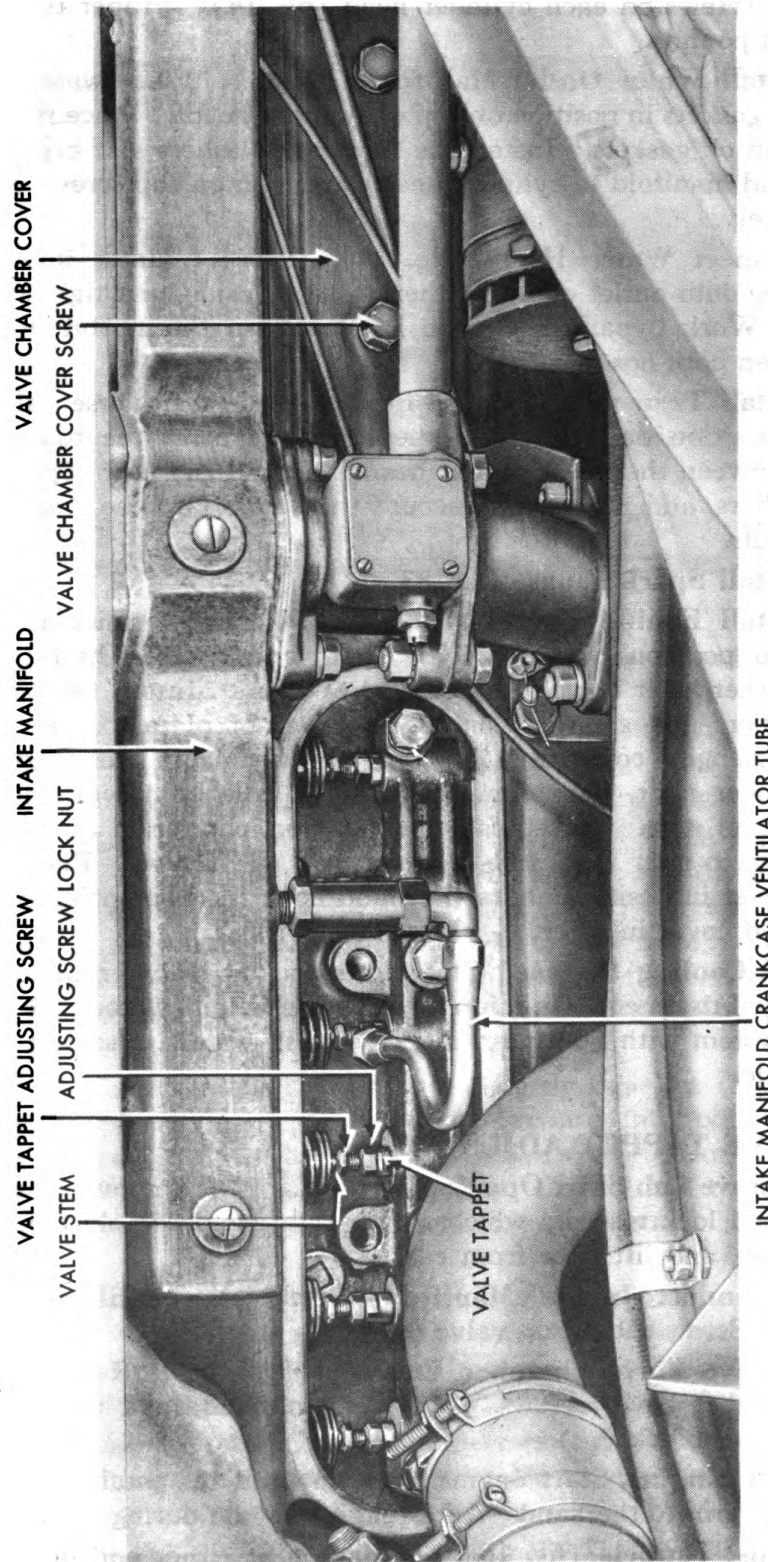
**b. Disconnect Intake Manifold Crankcase Ventilator Tube** (fig. 15). Screw tube from valve on intake manifold.

**c. Remove Valve Chamber Covers** (fig. 15). Remove four valve chamber cover screws. Lift the two covers and two gaskets from cylinder block.

**d. Start Engine.** Start engine and run until the intake manifold is at least warm to the hand. Allow engine to idle during adjustment.

**e. Adjust Tappets** (fig. 15). Beginning at either end of engine,

4- TO 5-TON 4x4 TRACTOR TRUCK (FEDERAL)



RA PD 77363

Figure 15 — Valve Chamber — Cover Removed

## ENGINE DATA, MAINTENANCE, AND ADJUSTMENT IN VEHICLE

the valves are exhaust, intake, intake, exhaust, exhaust, intake, intake, exhaust, exhaust, intake, intake, and exhaust, respectively. Beginning with valve at extreme front of engine, loosen adjusting screw lock nut. Insert a 0.010-inch feeler gage between lower end of valve stem and valve tappet adjusting screw. Turn valve tappet adjusting screw into or out of valve tappet until just a light drag can be felt on feeler gage as it is pulled from between the valve stem and valve tappet adjusting screw. Hold valve tappet adjusting screw to keep it from turning, and tighten adjusting screw lock nut. Repeat procedure to adjust each of the other valve tappets, and stop engine. Proper clearance for exhaust valves is 0.010 inch and for the intake valves 0.006 inch.

f. **Replace Valve Chamber Covers** (fig. 15). Place valve chamber cover gaskets in position on cylinder block. Place valve chamber covers in position on gaskets, and install each cover with two plain washers and screws.

g. **Connect Intake Manifold Crankcase Ventilator Tube** (fig. 15). Connect tube to valve on intake manifold, and tighten fitting nut.

h. **Install Cab Skirt Opening Door** (fig. 1). Place door in position over opening on side of cab, and secure with 10 toothed lock washers and screws.

## 52. INTAKE AND EXHAUST MANIFOLDS AND GASKETS.

### a. Removal.

(1) **REMOVE ENGINE COVERS** (fig. 3). Disengage the two spring catches which hold front engine cover in place. Lift cover from cab. Remove screws which attach rear engine cover, and lift cover from cab.

(2) **REMOVE CAB SKIRT OPENING DOOR** (fig. 1). Remove the 10 screws and toothed lock washers which secure right-hand door to opening, and lift door from cab.

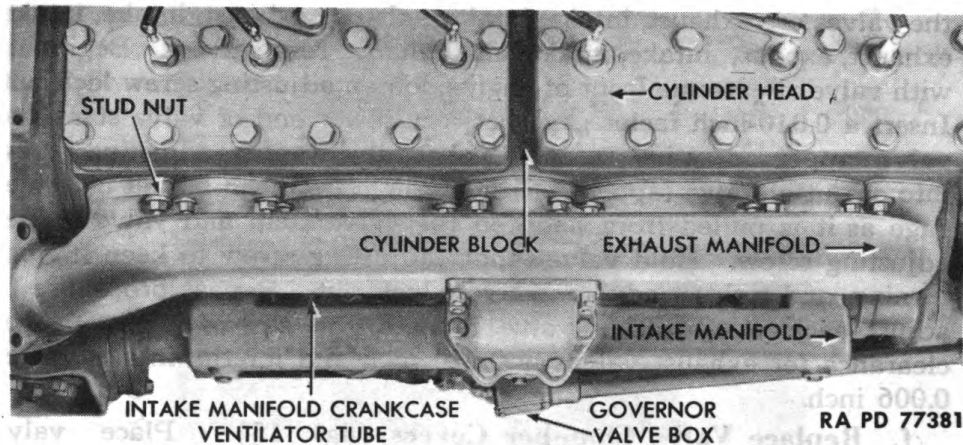
(3) **DISCONNECT CARBURETOR CONTROLS**. Disconnect throttle and choke control wires from carburetor, and pull both cables up through opening in manifold. Disconnect carburetor control rod from carburetor throttle lever.

(4) **DETACH GOVERNOR VALVE BOX** (fig. 16). Remove two cap screws which secure valve box to intake manifold. Pull valve box, gasket, and attached carburetor free of intake manifold.

(5) **DISCONNECT INTAKE MANIFOLD CRANKCASE VENTILATOR TUBE** (fig. 16). Detach ventilator tube from ventilator valve on bottom of intake manifold.

(6) **DISCONNECT EXHAUST PIPE** (fig. 42). Remove the three flange bolts and nuts which secure exhaust manifold to exhaust pipe and slide flange down.

(7) **REMOVE MANIFOLDS AND GASKETS** (fig. 16). Remove 14 stud nuts and plain washers which secure intake and exhaust mani-

**4- TO 5-TON 4x4 TRACTOR TRUCK (FEDERAL)****Figure 16 – Engine Manifolds Installed**

folds to cylinder block, and remove manifolds through cab skirt opening. Remove 7 gaskets from manifolds or from engine block.

**b. Installation.**

(1) **ATTACH GASKETS AND MANIFOLDS TO CYLINDER BLOCK AND CONNECT EXHAUST PIPE** (fig. 16). Use 7 new gaskets. Slide end of exhaust manifold through engine inspection plate opening over exhaust pipe, and fit manifolds in position on engine block. Secure manifolds to block with 14 stud nuts and plain washers. Connect exhaust pipe to manifold (par. 69 c).

(2) **CONNECT INTAKE MANIFOLD CRANKCASE VENTILATOR TUBE** (fig. 16). Attach ventilator tube to ventilator valve at bottom of intake manifold.

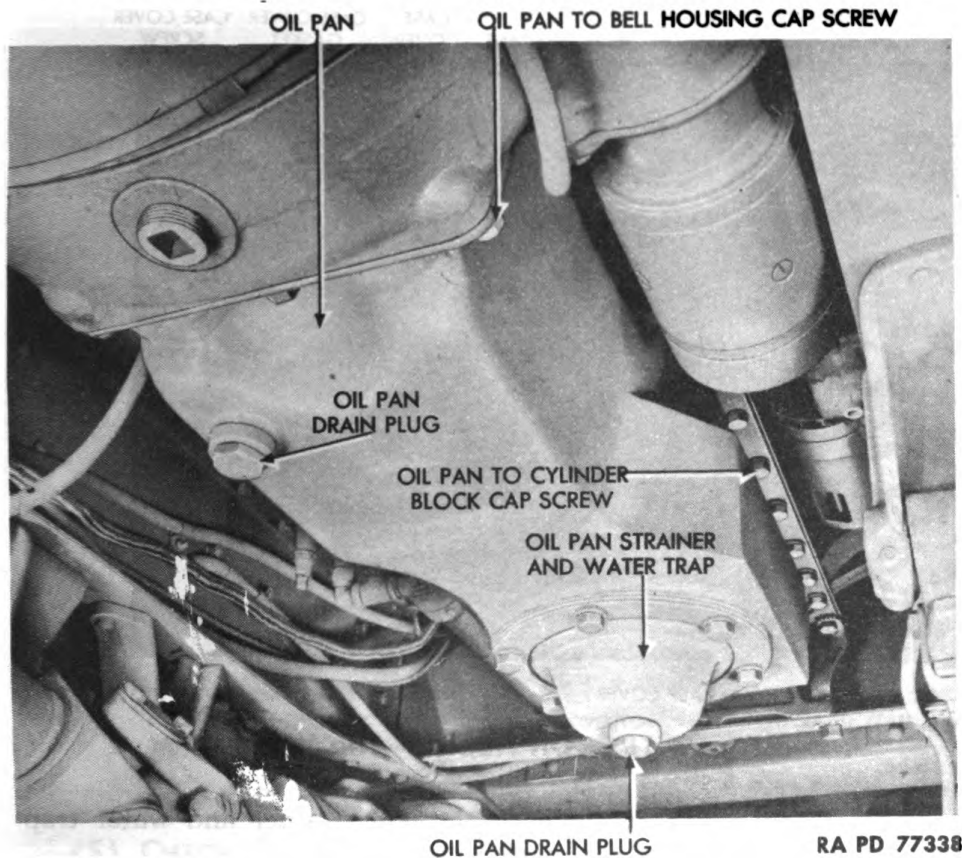
(3) **ATTACH GOVERNOR VALVE BOX** (fig. 16). Place a new valve box gasket, valve box, and attached carburetor in position on studs on intake manifold and secure with two cap screws.

(4) **CONNECT CARBURETOR CONTROLS** (fig. 16). Connect carburetor control rod to carburetor throttle lever. Pull both throttle and choke control cables down through opening between No. 1 cylinder intake and exhaust flanges and attach wires to carburetor.

(5) **TEST INSTALLATION.** Start engine. Inspect manifolds to see if any gas is escaping. If engine runs satisfactorily and if no gas escapes, proper manifold installation is indicated.

(6) **INSTALL CAB SKIRT OPENING DOOR** (fig. 1). Place right-hand cab skirt opening door in position on cab and secure with the 10 screws and toothed lock washers.

(7) **INSTALL ENGINE COVERS** (fig. 21). Place front engine cover in position over engine and engage the two spring catches. Place rear engine cover plate in position and install toothed lock washers and screws which attach it to its riser.

**ENGINE DATA, MAINTENANCE, AND ADJUSTMENT IN VEHICLE****Figure 17 – Installed Engine – Bottom View****53. OIL PAN.****a. Removal.**

(1) **REMOVE BAYONET GAGE.** Remove left-hand cab skirt opening door (fig. 2) and pull bayonet gage from its boss in oil pan.

(2) **DRAIN ENGINE OIL** (fig. 16). Remove drain plug and gasket from oil pan strainer and water trap. Remove drain plug and gasket from rear of oil pan. Drain oil into a clean container.

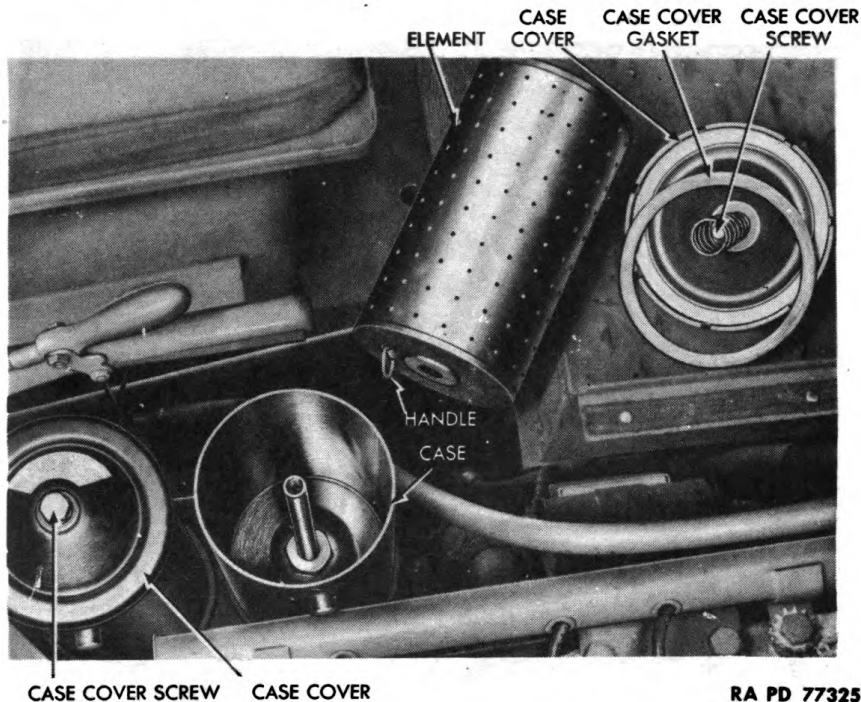
(3) **REMOVE OIL PAN AND GASKETS** (fig. 17). Unscrew oil overflow pipe from oil pan fitting. Remove 7 cap screws and lock washers which secure oil pan to bell housing. Remove 26 cap screws and lock washers which secure pan to cylinder block, and lower pan to floor. Remove the 2 side gaskets and front cork seal. **NOTE: Do not damage or attempt to remove cork seal from bell housing.**

**b. Cleaning.**

(1) **REMOVE STRAINER AND WATER TRAP** (fig. 17). Remove six cap screws and lock washers. Lift strainer and water trap and its gasket from oil pan.

(2) **WIPE SLUDGE FROM INSIDE OIL PAN.** Turn crankshaft so

## 4- TO 5-TON 4x4 TRACTOR TRUCK (FEDERAL)



**Figure 18 – Oil Filters – Top View**

throw arms are horizontal. Reach through strainer and water trap hole and clear interior of pan with a clean cloth.

(3) **CLEAN STRAINER AND WATER TRAP** (fig. 17). Wash the assembly in dry-cleaning solvent. Dry it with a clean cloth.

(4) **INSTALL STRAINER AND WATER TRAP** (fig. 17). Examine gasket carefully, and replace it if torn or crushed. Place serviceable gasket and strainer and water trap assembly in position in oil pan, and secure with six lock washers and cap screws,

**c. Installation.**

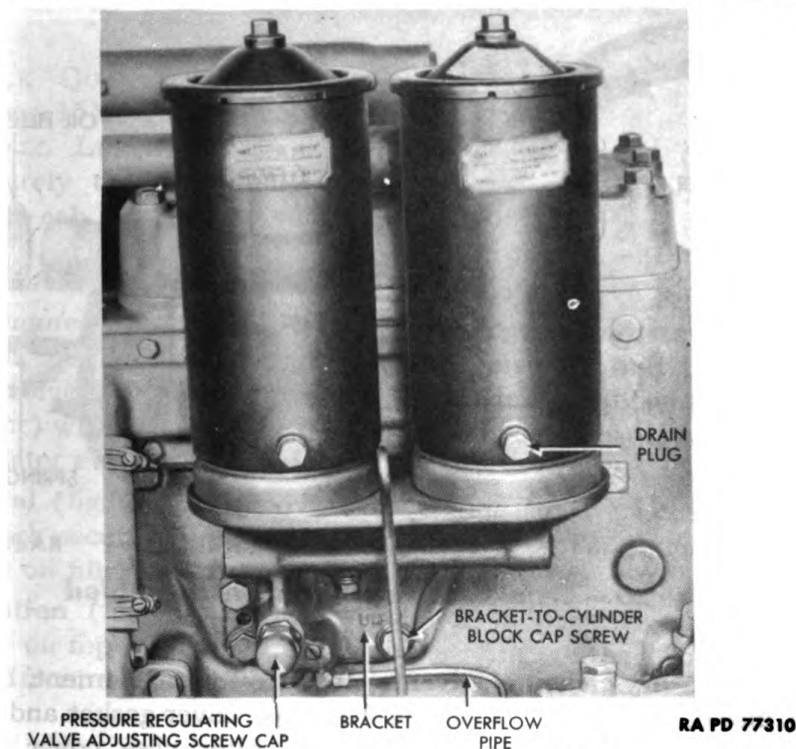
(1) **INSTALL GASKETS.** Coat gaskets with a film of general purpose grease. Place side gaskets and front cork seal in position on oil pan. Put a light coat of the same grease on surface which gaskets will contact on cylinder block.

(2) **INSTALL OIL PAN** (fig. 17). Place oil pan in position, install two oil-pan-to-cylinder-block cap screws and lock washers, and tighten cap screws fingertight. Secure oil pan-to-bell housing with 7 cap screws and lock washers and install remaining 24 oil-pan-to-cylinder-block cap screws and lock washers. Tighten all cap screws.

(3) **CONNECT OIL OVERFLOW PIPE.** Connect overflow pipe to fitting on left side of oil pan, and tighten it securely.

(4) **INSTALL BAYONET OIL GAGE AND CAB SKIRT DOOR.** Insert gage into its boss on left side of oil pan. Place cab skirt door in position and secure with 10 screws and toothed lock washers.

**ENGINE DATA, MAINTENANCE, AND ADJUSTMENT IN VEHICLE**



**Figure 19 – Oil Filter Installed**

(5) **CHECK INSTALLATION.** Refill crankcase with correct grade of oil (par. 16). Start engine and inspect oil pan for leaks. Absence of leakage indicates satisfactory installation.

**54. OIL FILTER.**

**a. Maintenance.**

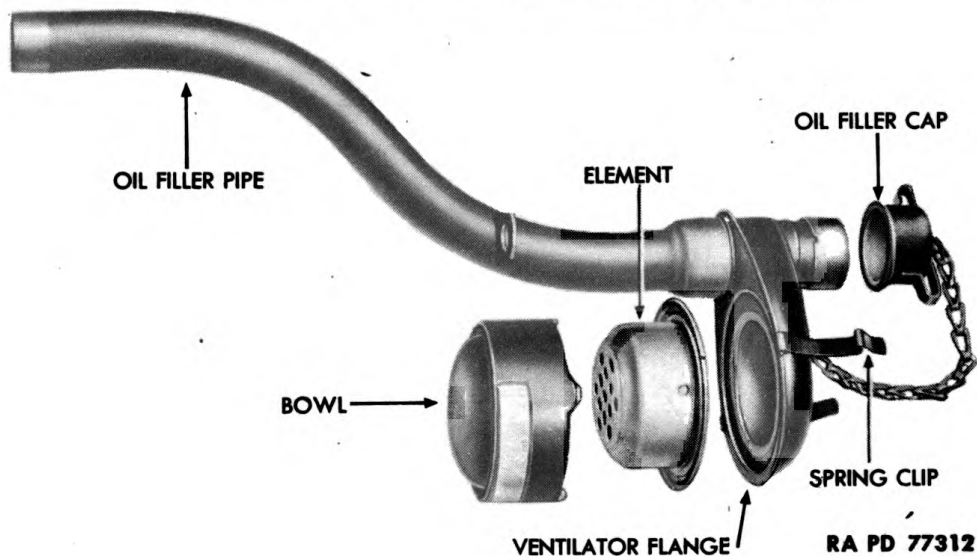
(1) **GENERAL** (fig. 19). Refer to paragraph 17.

(2) **ADJUST OIL PRESSURE** (fig. 19). Remove the oil filter pressure relief valve adjusting screw cap (acorn nut) from filter bracket. Loosen oil filter pressure relief valve adjusting screw lock nut. Turn oil filter pressure relief valve adjusting screw clockwise to increase pressure; counterclockwise to decrease pressure. Oil pressure should be 26 pounds minimum at 1,600 revolutions per minute. After desired pressure is attained, hold adjusting screw to keep it from turning and tighten lock nut. Replace cap. **NOTE:** *Low oil pressure may be caused by bearing wear, too low viscosity oil, worn out oil, etc. Therefore, do not adjust pressure until cause of drop has been ascertained and corrected.*

(3) **REMOVE OIL FILTER ELEMENT** (fig. 18). Remove rear engine cover. Completely unscrew oil filter case cover screw and gasket. Lift cover and gasket from case. Grasp handle on top of oil filter element and pull element from case.

(4) **INSTALL NEW OIL FILTER ELEMENT** (fig. 18). Clean oil

## 4- TO 5-TON 4x4 TRACTOR TRUCK (FEDERAL)



**Figure 20 – Crankcase Ventilator Disassembled**

filter case with dry-cleaning solvent. Insert oil filter element, handle end up, into oil filter case. Place oil filter case cover gasket and cover in position on top of case. Tighten oil filter case cover screw. Remove left-hand engine inspection plate. Check quantity of oil in crankcase and add if low (par. 17). Install rear engine cover and left-hand engine inspection plate.

**b. Removal.**

(1) **REMOVE LEFT-HAND CAB SKIRT OPENING DOOR** (fig. 2). Remove 10 screws and toothed lock washers which secure it to cab, and lift door from opening.

(2) **DISCONNECT OIL OVERFLOW PIPE** (fig. 19). Disconnect overflow pipe from crankcase at oil filter bracket.

(3) **REMOVE OIL FILTER ASSEMBLY FROM CYLINDER BLOCK** (fig. 19). Remove four screws and lock washers, and lift off filters and bracket assembly and gasket.

**c. Installation.**

(1) **ASSEMBLE GASKET TO BRACKET** (fig. 19). Spread a thin film of No. 2 general purpose grease on both sides of the oil filter bracket gasket. Place gasket in position on oil filter bracket.

(2) **ATTACH BRACKET WITH ATTACHED OIL FILTER ASSEMBLY TO CYLINDER BLOCK** (fig. 19). Carefully aline dowels on bracket with dowel holes in cylinder block. Install the bracket to cylinder block with four cap screw lock washers and cap screws.

(3) **CONNECT OIL OVERFLOW PIPE TO FITTING ON BRACKET** (fig. 19). This line runs from bracket to fitting on left side of oil pan.

(4) **TEST INSTALLATION.** Start engine and inspect oil filter for leaks. Absence of leaks indicates satisfactory installation. Stop



## ENGINE REMOVAL AND INSTALLATION

engine.

(5) **CHECK QUANTITY OF CRANKCASE ENGINE OIL.** Add if necessary (par. 16).

(6) **INSTALL LEFT-HAND CAB SKIRT OPENING DOOR** (fig. 2). Tighten securely the 10 toothed lock washers and screws which secure door to cab.

### 55. CRANKCASE VENTILATOR.

a. **Maintenance** (fig. 20). Remove crankcase ventilator, from upper end of oil filler pipe, weekly. Clean element and bowl in dry-cleaning solvent and dry with compressed air. Fill bowl to bead (about  $\frac{1}{8}$  pint) with clean engine oil. Under extreme dust conditions, service ventilator every four hours.

b. **Removal** (fig. 20). Remove front engine cover. Loosen the two clips which secure crankcase ventilator bowl to flange on upper end of engine oil filler pipe. Lift ventilator from pipe.

c. **Installation** (fig. 20). Place ventilator in position on under side of flange on top of engine oil filler pipe. Engage the two spring clips. Install front engine cover.

---

## Section XIV

## ENGINE REMOVAL AND INSTALLATION

### 56. REMOVAL.

a. **Position Vehicle.** Place vehicle under suitable engine lifting equipment. Arrange to have tools, lift hooks, wood blocking, and supports available for use when needed. Block wheels to prevent vehicle from moving.

b. **Drain Radiator and Cylinder Block.** Open drain cocks (fig. 11) at base of water pump inlet connection and at end of extension pipe from cylinder block.

c. **Drain Engine Lubricant.** Place a suitable container under engine oil pan. Remove drain plug from rear bottom of pan (fig. 17). Remove drain plug from sump at center of pan (fig. 17). Drain lubricant from crankcase. Replace plugs.

d. **Disconnect Batteries** (fig. 23). Remove battery box cover by loosening the two wing nuts on end plate to cover latches (fig. 1). Disengage latches and remove cover. Loosen bolts which clamp battery cables to battery terminals. Disengage cables from batteries.

e. **Remove Front Engine Cover.** Disengage the two latch catches (figs. 21 and 22) which hold cover in place. Remove cover.

4- TO 5-TON 4x4 TRACTOR TRUCK (FEDERAL)

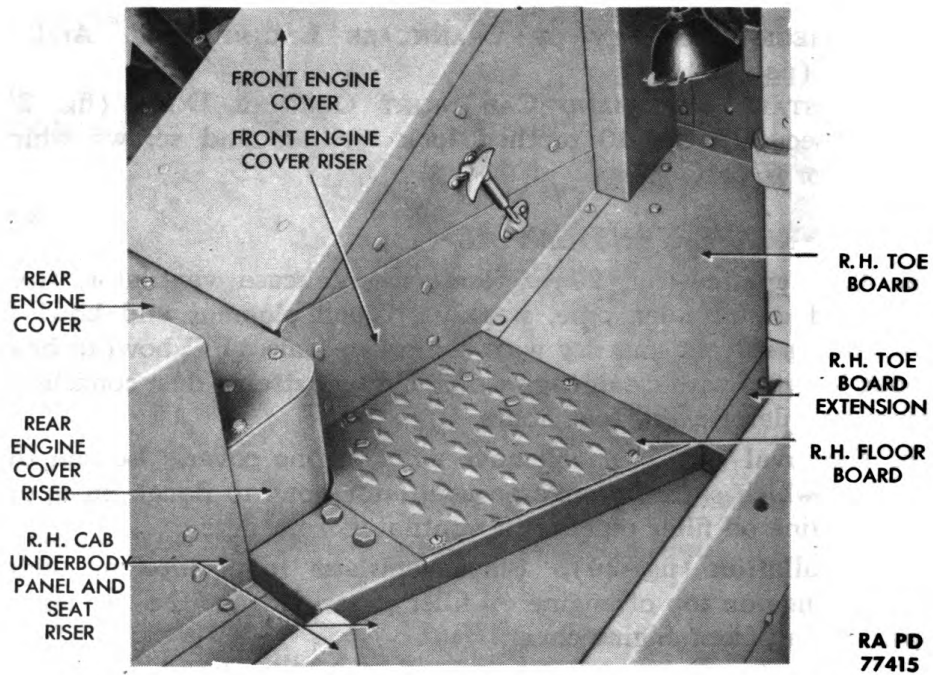


Figure 21 - Floor Boards and Engine Covers - Right Side

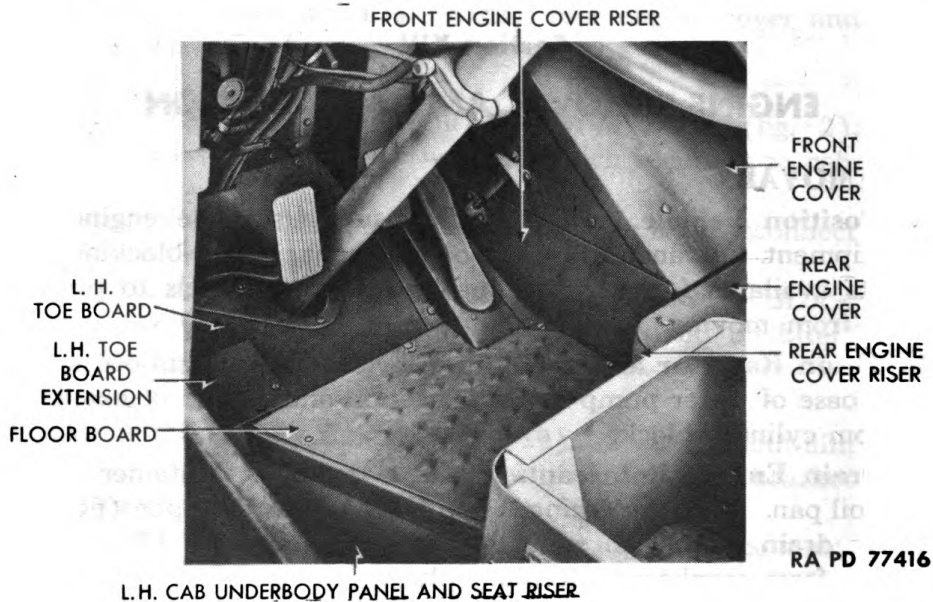
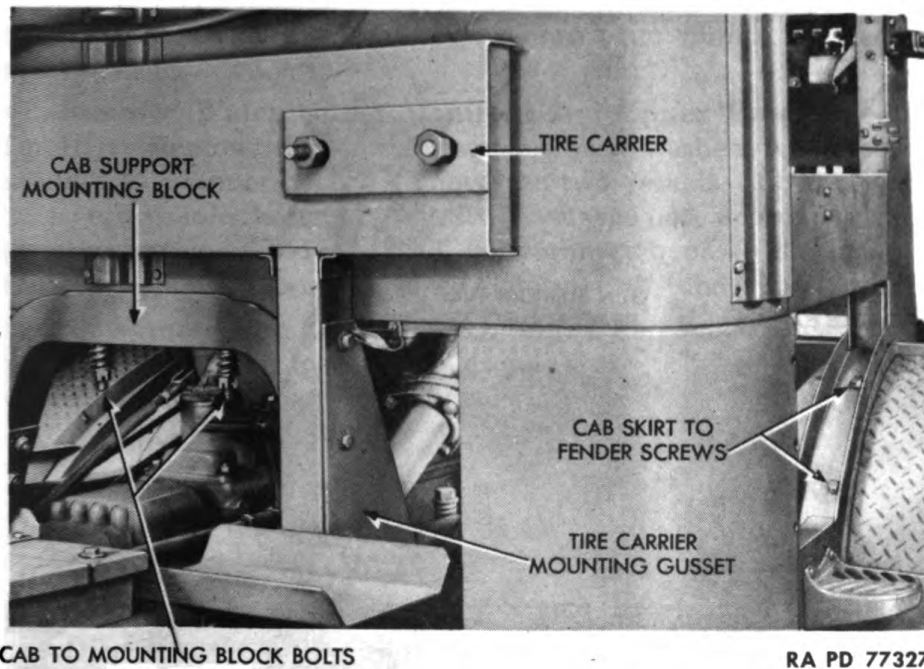


Figure 22 - Floor Boards and Engine Covers - Left Side

f. Remove Toeboards (figs. 21 and 22). Disengage left-hand and right-hand toeboards by removing the 14 screws and toothed lock washers which hold them to floor boards, engine cover risers, and toeboard extensions. Remove the toeboards.

## ENGINE REMOVAL AND INSTALLATION



**Figure 23 – Cab Mounting Points**

- g. Remove Cab Top** (par. 148 c).
- h. Remove Tire Carrier** (fig. 23). Detach tire carrier by removing the six bolts and nuts which secure it to tire carrier mounting gussets. Remove assembly from vehicle.
- i. Disconnect Cab From Vehicle** (fig. 23). Disengage cab from cowl by removing the six screws and shakeproof washers which secure it. Remove the four screws and toothed lock washers securing cab skirt to fenders. Disengage cab from cab support mounting block by removing the two cotter pins, bolts nuts, bolts, mounting springs, and the four mounting spring retainers which secure it to block.
- j. Remove Cab From Vehicle** (fig. 24). Attach a rope or other suitable lifting tackle to cab as follows: Anchor tackle to grab handle at left side of cab. Pass rope through skirt opening to rear center. Push rope through gun support tube bracket U-bolts at top of cab. Return rope through U-bolts leaving a small loop at top. Pass rope from center through skirt opening on right side and attach to grab handle. Loop now formed at top of cab is a suitable fulcrum point for lifting cab. Raise cab slowly and guide carefully from vehicle.
- k. Disengage Radiator Lower Hose Assembly.** Disengage water pump inlet elbow by removing the two screws (fig. 45) and lock

4- TO 5-TON 4x4 TRACTOR TRUCK (FEDERAL)



RA PD 77306

Figure 24 — Hoisting Cab From Vehicle

**ENGINE REMOVAL AND INSTALLATION**

washers which secure it to pump. Free from pump and remove gasket.

**l. Remove Water Outlet Manifold and Upper Hose Assembly** (fig. 12). Remove the four screws and lock washers which secure manifold to cylinder head. Remove the two gaskets. Loosen clamp which secures inlet hose to radiator. Disengage hose and remove hose assembly and manifold as a unit. Disconnect bypass tube at upper hose connection by loosening hose clamp. Pull tube from hose.

**m. Disconnect Air Cleaner** (fig. 41). Remove the carburetor to air cleaner tube by loosening the screw securing tube to carburetor. Loosen top hose clamp. Remove tube from vehicle.

**n. Remove Exhaust Pipe** (par. 69 b).

**o. Remove Oil Filler** (par. 55 b).

**p. Remove Fuel Pump** (par. 63 c).

**q. Disconnect Accelerator Rod.** Disengage rod at carburetor by removing the nut which secures rod ball joint to throttle lever (fig. 35).

**r. Disconnect Choke and Throttle Controls** (fig. 35). Disengage choke and throttle at carburetor by loosening clamp nuts which secure controls to carburetor. Pull controls free.

**s. Disconnect Tachometer Cable.** Disengage cable at tachometer drive beneath the distributor (fig. 51). Pull cable free.

**t. Disconnect Temperature Gage Cable and Tube.** Disengage tube from rear left side or rear cylinder head by removing fitting which secures it. Pull tube free.

**u. Disconnect Oil Pressure Gage Tube.** Trace tube from instrument panel (fig. 114) and loosen tube nut which joins tubes together at front of engine. Disengage tubes.

**v. Disconnect Viscosity Gage Tube.** Trace tube from instrument panel (fig. 114) and loosen tube nut which joins tubes together at the front of the engine. Disengage tubes.

**w. Disconnect Generator to Regulator and Ground Wires.** Remove the nut and lock washer which secure each of the three wires to generator (fig. 55). Note position of wires so that correct installation may be made.

**x. Disconnect Cranking Motor Switch, Battery, and Ground Cables** (fig. 106). Remove the nut and lock washer which secure the battery cable (large) to the cranking motor. Remove the nut and lock washer to disengage switch cable (red). Remove the nut and lock washer to disengage ground cable (black). Pull cables free from motor.

**y. Disconnect Fuel Filter to Fuel Pump Fuel Line** (fig. 36). Remove the tube nut which secures fuel line to fuel pump at pump.

4- TO 5-TON 4x4 TRACTOR TRUCK (FEDERAL)

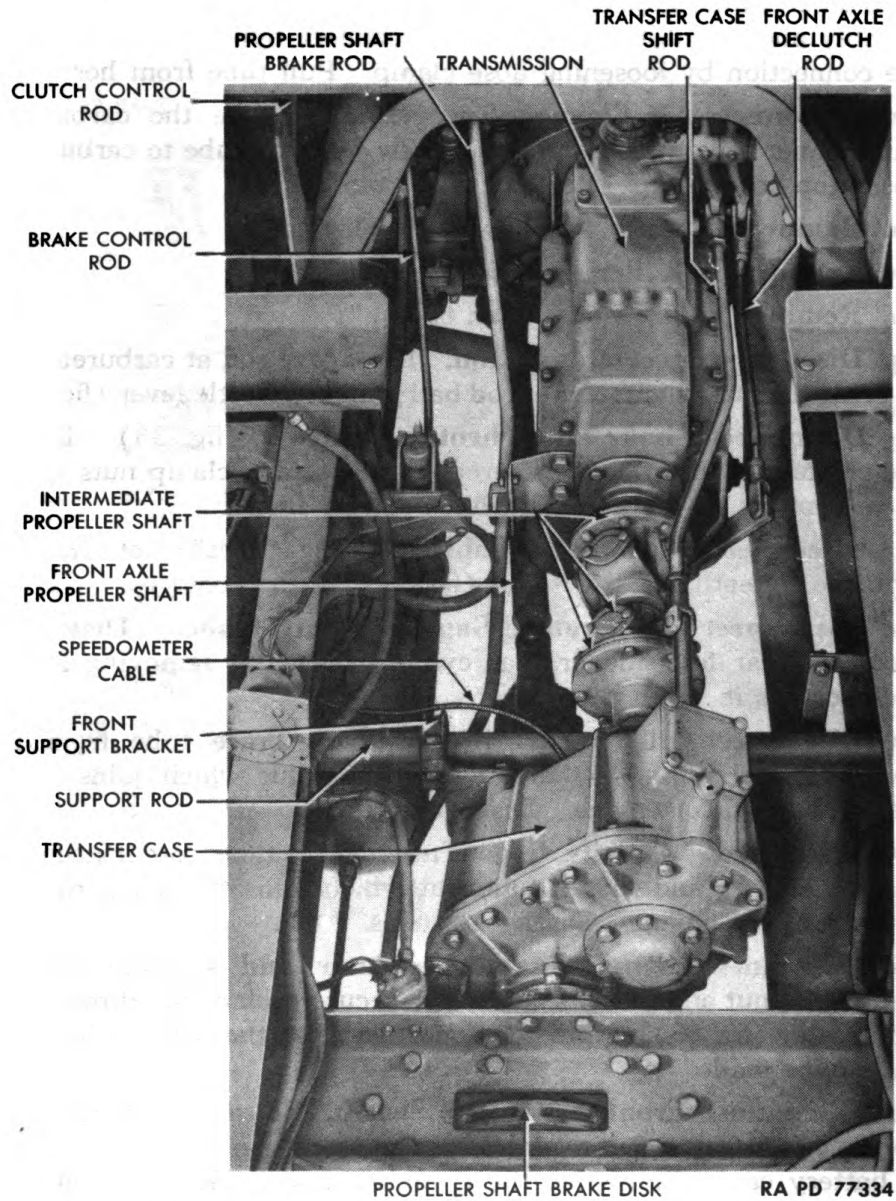
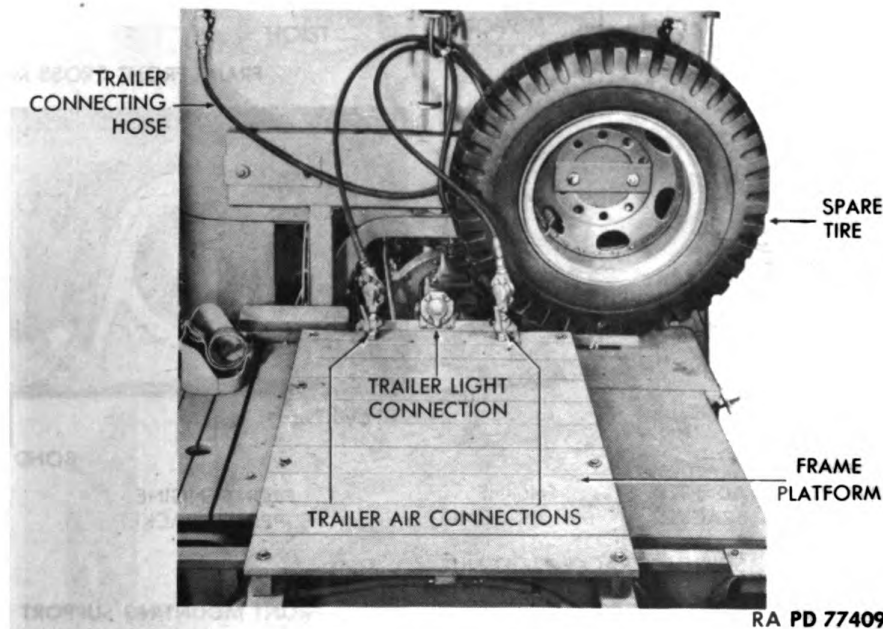


Figure 25 — Control Rods Installed

## ENGINE REMOVAL AND INSTALLATION



**Figure 26 – Trailer Connections and Frame Platform**

**z. Disconnect Air Compressor Lines (fig. 70).** Loosen tube nut which secures compressor to governor tube outlet elbow to compressor. Pull tube free. Disengage compressor to tank tube at compressor main discharge fitting by loosening tube nut. Pull tube free.

**aa. Disconnect Transfer Case Shift Rod (fig. 25).** Remove cotter pin and clevis pin at both ends. Remove rod.

**bb. Disconnect Front Axle Declutch Rod (fig. 25).** Remove cotter key and clevis pin at bell crank. Drop rod down.

**cc. Disconnect Clutch and Brake Rods (fig. 25).** Remove cotter pins and clevis pins at both ends of propeller shaft brake rod, brake control rod, and clutch control rod. Remove rods.

**dd. Remove Intermediate Propeller Shaft (fig. 25).** Remove the 16 bolts, nuts and lock washers which secure shaft to transmission and transfer case. Remove shaft.

**ee. Disconnect Trailer Connections and Remove Frame Platform (fig. 26).** Remove the two clamp nuts securing trailer air connections to frame platform. Remove the two screws, lock washers, and nuts securing trailer light connection to frame platform. Remove the seven hexagon cap screws, flat washers, lock washers, and nuts which secure platform to frame. Remove platform.

**ff. Remove Transmission.** Use hoist and rope sling to hold transmission while it is being disengaged. Remove the 12 screws and

4- TO 5-TON 4x4 TRACTOR TRUCK (FEDERAL)

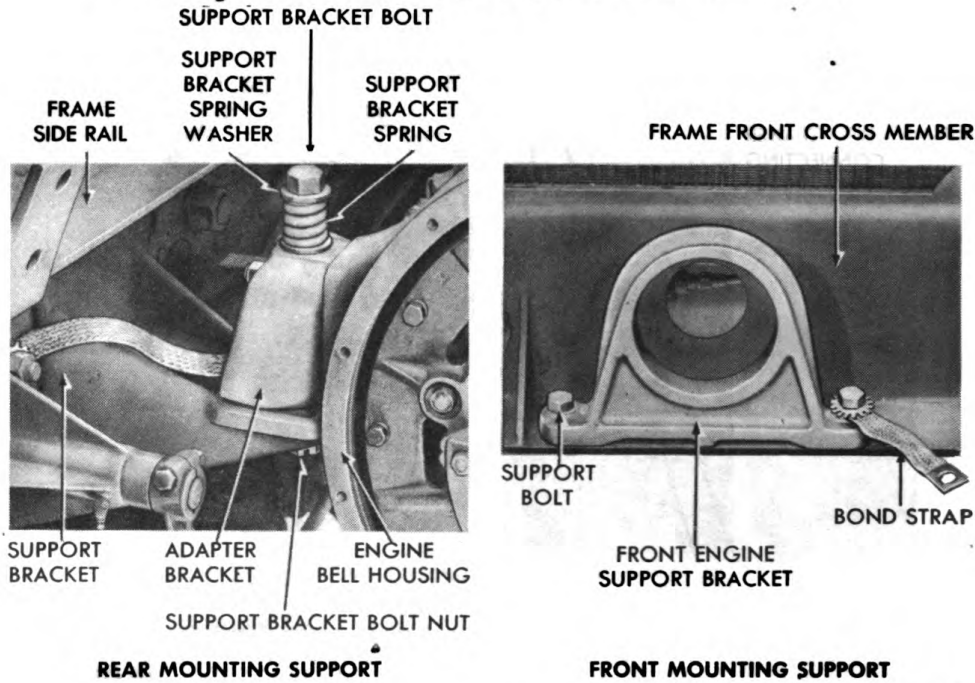


Figure 27 - Engine Mounting Supports

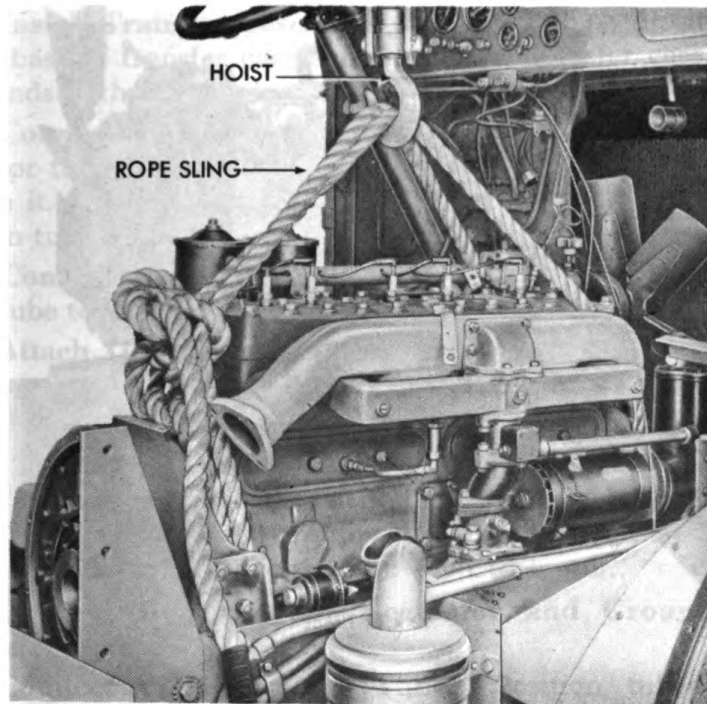
RA PD 77394

lock washers which secure transmission to bell housing (fig. 12). Remove transmission by pulling straight back until main drive gear clears clutch, then lowering to floor. **NOTE: Do not let transmission drag on clutch as this will damage clutch beyond repair. (Engine may be removed with transmission attached, or transmission may be removed separately. Procedure is optional.)**

**gg. Attach Rope Sling to Engine** (fig. 28). Use a chain, rope, or other suitable lifting tackle. Loop center of rope under crankshaft starting jaw housing to which front engine support bracket is attached. Using right-hand end of rope proceed as follows: Pull rope up front of engine; across upper right-hand corner of front cylinder head; across engine to left side of bell housing; down left side, under, and up right side to top center of housing. Using left-hand end of rope proceed as follows: Pull rope up front of engine; between air compressor assembly and fan bracket; across engine outside exhaust manifold to right side of bell housing; down right side, under, and up left side to top center of housing. Tie ropes together with a square knot or other suitable knot. Loop ends around ropes on either side which run from top of engine under bell housing. Pull ropes together and secure with a square knot or other suitable knot. Place lifting hook under both ropes at center between front and rear cylinder heads. **NOTE: Check hook-up thoroughly to make certain that rope will not slip, that damage will not be done to assemblies attached to engine, and that rope is tied securely.**



## ENGINE REMOVAL AND INSTALLATION



**Figure 28 – Hoisting Engine From Vehicle**

**hh. Disconnect Engine Support Bolts (fig. 27).** Remove the two bolts, lock proof washers, toothed lock washers, and nuts which secure front of engine to frame cross member. Remove the two cotter pins, bolts, springs, lock washers, and nuts which secure rear of engine to frame.

**ii. Remove Engine From Vehicle (fig. 28).** Lift engine slowly off supports. Gradually move chassis forward until fan assembly is clear of cowl center supports and instrument panel. Continue raising engine and remove from vehicle. Remove engine support cushions.

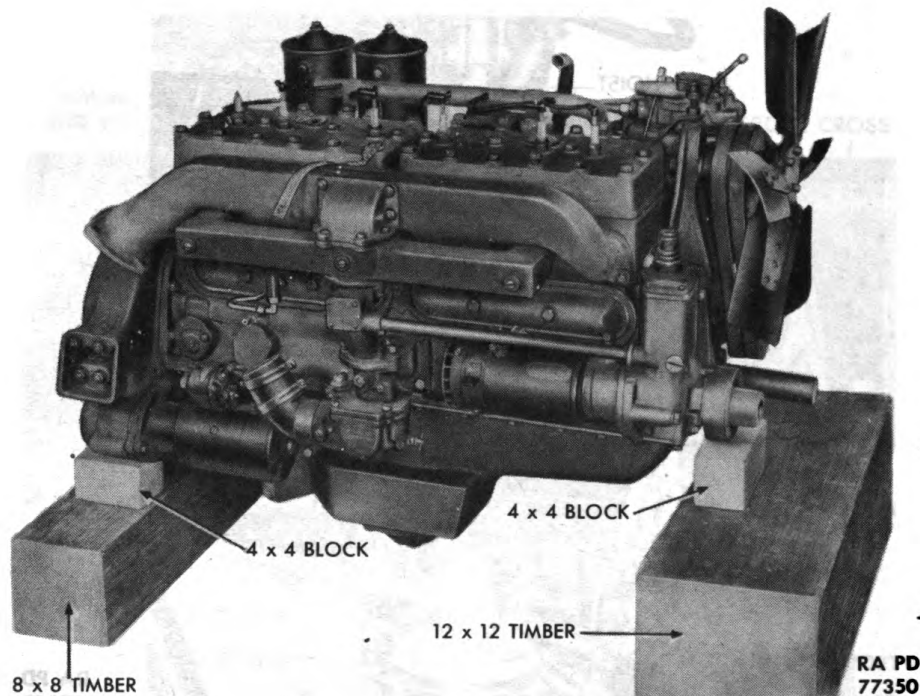
**jj. Support Removed Engine.** Lower engine into a regular engine stand. If stand is not available, support engine with wood blocks as illustrated (fig. 29).

### 57. INSTALLATION.

**a. Attach Rope Sling to Engine (par. 56 gg).**

**b. Position Engine on Vehicle (fig. 27).** Use new springs and cushions in position on rear engine supports. Lower engine slowly, keeping fan assembly in line between cowl center supports. When fan assembly is below instrument panel level, move chassis back gradually until engine supports and frame supports are in line. Lower engine supports.

## 4- TO 5-TON 4x4 TRACTOR TRUCK (FEDERAL)



**Figure 29 – Method of Blocking Removed Engine**

c. **Install Engine Support Bolts** (fig. 27). Attach rear engine supports to frame with the two bolts, lock washers, nuts, and cotter pins. Attach front engine supports to frame cross member with the two bolts, toothed lock washers, lock proof washers and nuts. Attach bond strap grounding engine to frame cross member (fig. 13).

d. **Install Transmission** (par. 95). *NOTE: This step not applicable if engine and transmission are being installed as a unit.*

e. **Install Intermediate Propeller Shaft** (fig. 25). Position shaft between transmission and transfer case. Secure with the eight bolts, nuts, and lock washers. *NOTE: If transmission was removed separately, it must be installed before shaft is installed. Proceed as follows: Position transmission on bell housing. Secure with the 12 cap screws and lock washers.*

f. **Install Brake and Clutch Rods** (fig. 25). Position propeller shaft brake rod between base of brake lever and propeller shaft brake disk. Secure at both ends with the clevis pin and cotter pin. Position brake control rod between pedal and foot control valve. Install clevis pin and cotter pin at each end. Position clutch control rod between pedal and throw-out shaft lever. Install clevis pin and cotter pin at each end.

g. **Connect Front Axle Declutch Rod** (fig. 25). Attach front end of rod to bell crank by securing with the clevis pin and cotter pin.

**ENGINE REMOVAL AND INSTALLATION**

**h. Install Transfer Case Shift Rod** (fig. 25). Position rod between base of transfer case shift lever and transfer case. Secure at both ends with the clevis pin and cotter pin.

**i. Connect Air Compressor Lines** (fig. 70). Fit compressor to governor tube outlet elbow to compressor. Tighten tube nut which secures it. Attach compressor main discharge fitting to compressor. Tighten tube nut which secures it.

**j. Connect Fuel Filter to Fuel Pump Fuel Line** (fig. 36). Position tube to pump. Install the tube nut which secures tube to pump.

**k. Attach Oil Filler** (par. 55 c).

**l. Attach Fuel Pump** (par. 63 d).

**m. Attach Switch, Battery, and Ground Cables to Cranking Motor** (fig. 106). Position cables on motor; battery (large) on large lower left-hand terminal post; switch (red) to upper left-hand terminal post; and ground (black) to upper right-hand terminal post. Install nut and lock washer which secure each to motor.

**n. Connect Generator to Regulator and Ground Wires to Generator** (par. 87 d).

**o. Connect Viscosity Gage Tube.** Position tubes (fig. 114) together at front of cylinder block. Secure by tightening tube nut.

**p. Connect Oil Pressure Gage Tube.** Position tubes (fig. 114) together at front of cylinder block. Secure by tightening tube nut.

**q. Connect Temperature Gage Cable and Tube.** Attach tube to rear left side of cylinder head by installing fitting which secures it.

**r. Connect Tachometer Cable** (fig. 51). Attach cable to distributor by installing drive adapter on end of cable to distributor shaft.

**s. Connect Accelerator Rod, Choke and Throttle Controls to Carburetor** (par. 62 d (4)).

**t. Install Exhaust Pipe** (par. 69 c).

**u. Install Air Cleaner Tube** (fig. 41). Position air cleaner tube between carburetor and top of air cleaner assembly. Tighten the one screw securing tube to carburetor. Tighten upper hose connection.

**v. Attach Radiator Lower Hose Assembly** (fig. 45). Use new gasket. Position water pump inlet elbow to base of water pump. Secure with the two screws and lock washers.

**w. Attach Water Outlet Manifold and Upper Hose Assembly** (fig. 11). Use two new gaskets. Position manifold and hose assembly on cylinder head. Secure manifold by installing four screws and lock washers. Position upper hose to radiator. Secure by tightening clamp. Connect bypass tube to upper hose connection and secure by tightening clamp.

**4- TO 5-TON 4x4 TRACTOR TRUCK (FEDERAL)**

x. **Install Cab on Vehicle** (fig. 24). Attach a rope, cable, chain or other suitable lifting tackle to cab (par. 56 f). Lower cab into position on vehicle.

y. **Connect Cab to Vehicle** (fig. 23). Attach cab to cab support mounting block by installing two bolts, mounting springs, bolt nuts, cotter pins, and four mounting spring retainers which secure it. Install four screws and toothed lock washers which secure cab skirt to fenders. Install six screws and toothed lock washers which secure cab to cowl. *NOTE: Attach bond straps grounding cab to mounting block, fenders, and cowl.*

z. **Install Tire Carrier** (fig. 23). Position support on tire carrier mounting gussets. Install six bolts and nuts which secure it. *NOTE: Attach bond strap which grounds cab to tire support.*

aa. **Install Cab Top Assembly** (par. 148 d).

bb. **Install Toeboards** (figs. 21 and 22). Position toeboards between floor boards and toeboard extensions. Install 14 screws and toothed lock washers which secure them.

cc. **Connect Batteries** (fig. 106). Position battery cable clamps on battery terminals. Secure them by tightening clamp bolts. Place cover on battery box. Position the two end plate to cover latches and tighten the two wing nuts.

dd. **Install Frame Platform and Trailer Connections** (fig. 26). Position platform on frame and secure with six bolts, flat washers, lock washers, and nuts. Engage two air lines and two trailer connections by tightening two clamp nuts which secure them. Position trailer light connection on frame platform and secure with two screws, lock washers, and nuts.

ee. **Replace Engine Lubricant.** Check two drain plugs in pan for tightness. Remove cover from oil filler pipe under front engine cover. Fill crankcase with lubricant (par. 17). Replace filler pipe cover.

ff. **Install Front Engine Cover** (figs. 21 and 22). Position cover over engine. Secure with two latches.

gg. **Replace Cooling System Fluid.** Close two drain cocks at base of water pump inlet connection and at end of extension pipe from cylinder block. Fill cooling system. Remove tools, blocking, and supports.

Section XV

CLUTCH

58. DESCRIPTION AND TABULATED DATA.

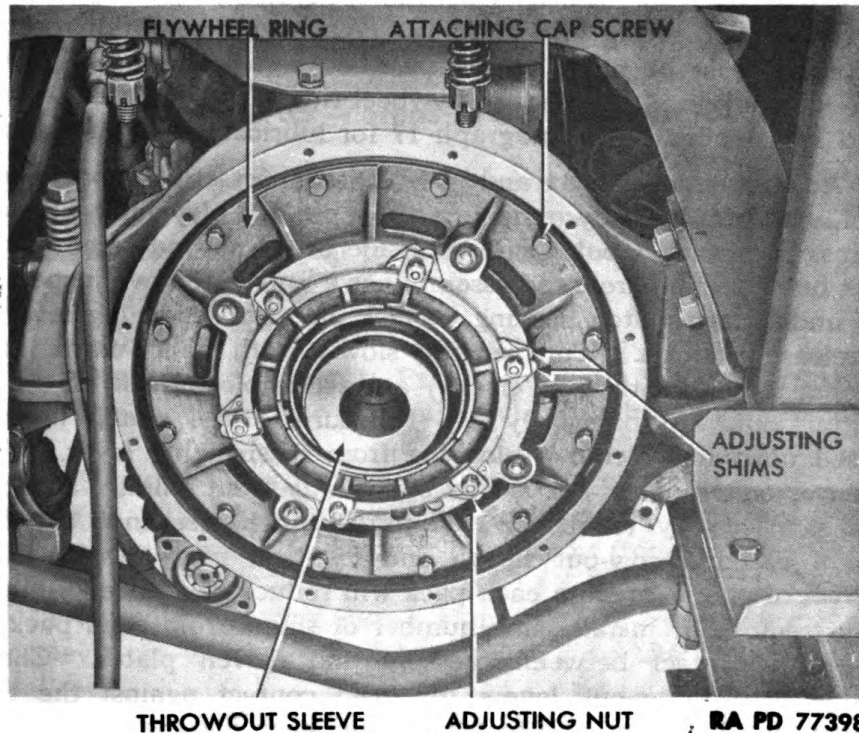
a. **Description** (figs. 30 and 60). The clutch is a two plate, single dry-disk type. The inside face of the flywheel forms the one drive plate, and pressure plate forms the other. The dry disk, which is the driven plate, is located and held by spring action between the two driving plates. The driven plate in turn drives the transmission through the splined end of the transmission drive gear. Depressing the clutch pedal relieves the pressure of the driving plates, allowing the driven disk to revolve or stop independently of the driving plates. The flow of engine power is thereby interrupted.

b. **Tabulated Data.**

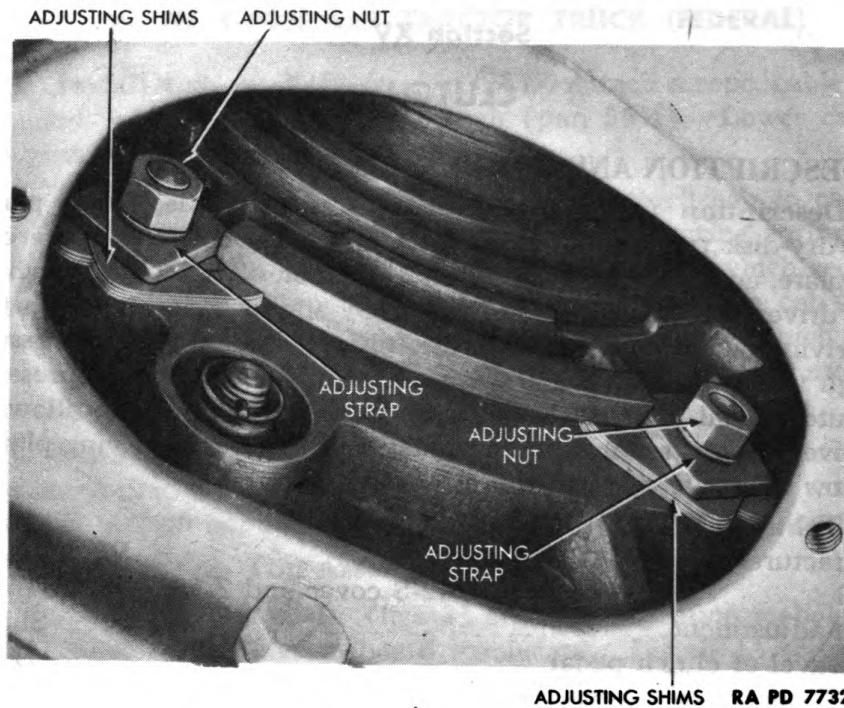
Manufacturer .....	W. C. Lipe
Model .....	Z-42-S cover and Z-15-2 driven plate
Clutch adjustment .....	Shims
Free travel of clutch pedal .....	1 in.

59. MAINTENANCE AND ADJUSTMENT.

a. **Maintenance.** When operating vehicle, note amount of free pedal movement before the clutch disengages. Safe range of clear-



**Figure 30 – Clutch Installed – Transmission Removed**

**4- TO 5-TON 4x4 TRACTOR TRUCK (FEDERAL)**

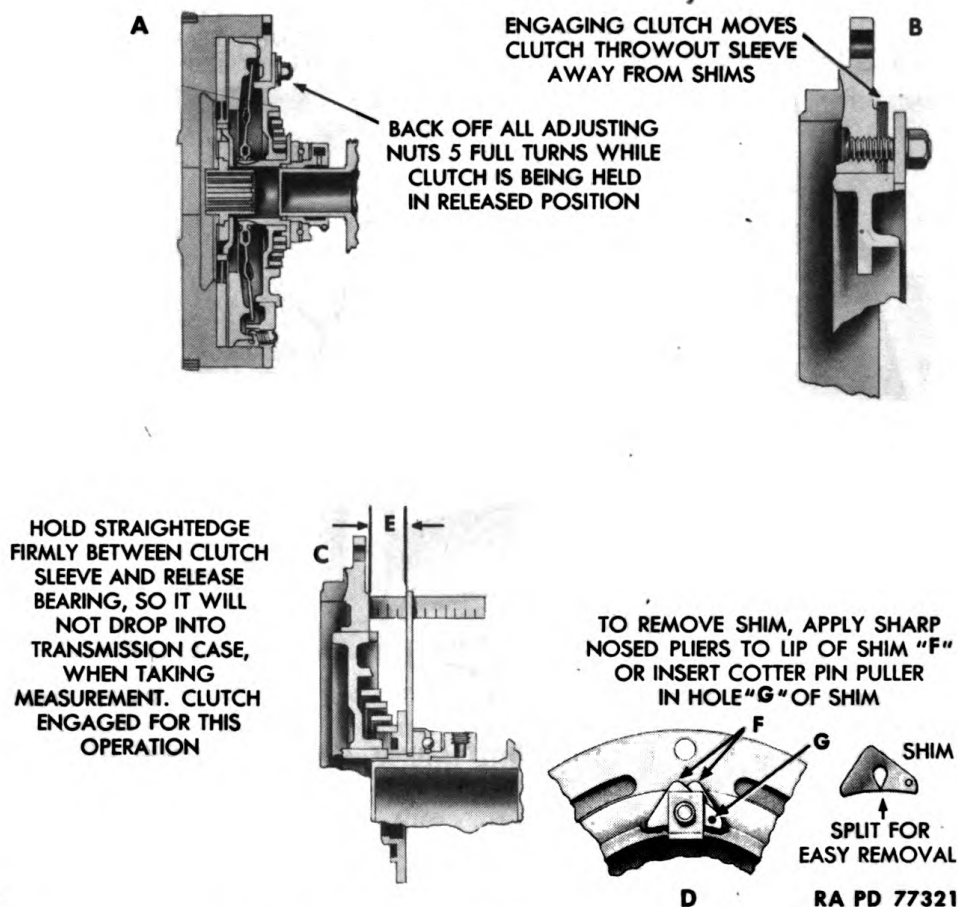
ADJUSTING SHIMS RA PD 77326

**Figure 31 – Clutch Adjustment**

ance is from  $1\frac{1}{2}$  to  $\frac{3}{4}$  inches. Operation of clutch with less clearance may cause overheating and slipping. When this condition occurs, adjustment must be made in distance between rear face of clutch throw-out sleeve and rear face of flywheel ring. This should measure  $1\frac{1}{8}$  to  $1\frac{3}{16}$  inches. See paragraph 17 for lubrication instructions.

**b. Adjustment** (figs. 31 and 32). Disconnect clutch control rod and clutch pedal lever by removing cotter pin and clevis pin. Loosen six cross rod bracket bolts on either side of frame and remove step plates, brackets, and cross rod assembly as a unit. Remove inspection plate underneath clutch housing. Block clutch disengaging lever in full release position. Turn engine slowly with hand crank until adjusting straps (with shim packs) are accessible. Back off all six adjusting nuts approximately five full turns while clutch is in a released position. Remove blocking from disengaging lever. This will move clutch throw-out sleeve back away from shims. Remove shims as necessary to obtain  $1\frac{1}{8}$ - to  $1\frac{3}{16}$ -inch clearance between faces of clutch throw-out sleeve and flywheel ring (E, fig. 32). Removal of one shim from each pack will reduce clearance  $\frac{7}{64}$  inch. Always remove or install same number of shims from each pack to ensure full contact between pressure and driven plates. Check trunnion fork throw-out levers for even contact against the two trunnion lugs, by inserting a feeler between each lug and lever at the

**CLUTCH**



**Figure 32 – Steps in Adjusting Clutch**

same time. Levers must engage lugs evenly at both sides; otherwise block will not slide freely on sleeve and poor clutch engagement will result. Levers can be bent to provide even engagement.

**60. CLUTCH LINKAGE.**

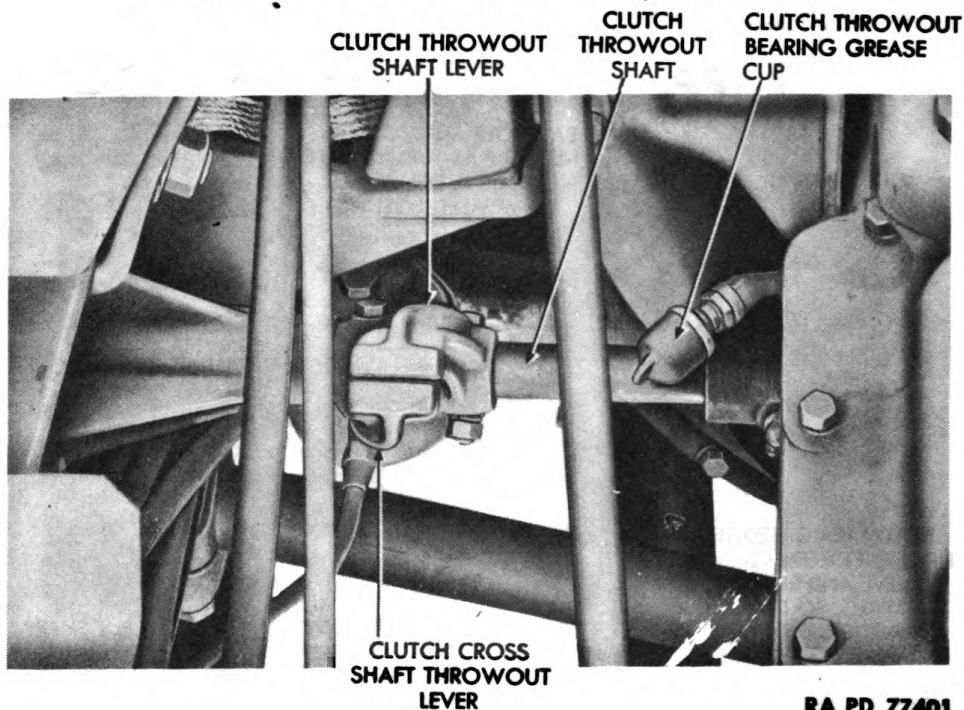
**a. Removal.**

(1) **DISCONNECT CLUTCH PEDAL ROD AND CLUTCH PEDAL** (fig. 82). Remove the cotter pin and clevis pin which link pedal rod to pedal.

(2) **REMOVE CLUTCH PEDAL FROM CLUTCH AND BRAKE PEDAL SHAFT** (fig. 82). Remove taper pin, lock ring, and flat washer which hold pedal on shaft. Slide shaft over away from clutch side. Pull pedal off.

(3) **REMOVE CLUTCH PEDAL ROD** (fig. 82). Remove cotter pin and clevis pin which secure pedal rod to cross shaft lever. Remove pedal rod.

(4) **DISCONNECT CLUTCH CROSS SHAFT LEVER FROM CLUTCH CROSS SHAFT** (fig. 82). Remove nut, lock washer, and clamp bolt

**4- TO 5-TON 4x4 TRACTOR TRUCK (FEDERAL)**

RA PD 77401

**Figure 33 – Clutch Cross Shaft Lever and Throw-out Shaft**

which secure shaft lever to shaft. Slide lever from shaft and tap Woodruff key from shaft.

(5) **DISCONNECT CLUTCH CROSS SHAFT THROW-OUT LEVER FROM CLUTCH CROSS SHAFT** (fig. 33). Remove nut, lock washer, and clamp bolt which secure lever to shaft. Remove lever and tap Woodruff key from shaft.

(6) **REMOVE CLUTCH CROSS SHAFT** (fig. 82). Pull shaft from bracket.

**b. Installation.**

(1) **INSTALL CLUTCH CROSS SHAFT** (fig. 82). Slide shaft through cross shaft bracket to proper position.

(2) **INSTALL CLUTCH CROSS SHAFT THROW-OUT LEVER** (fig. 33). Tap Woodruff key on shaft. Position lever on shaft. Secure with nut, lock washer, and clamp bolt.

(3) **INSTALL CLUTCH CROSS SHAFT LEVER** (fig. 82). Tap Woodruff key on shaft. Slide lever on shaft. Secure with nut, lock washer, and clamp bolt.

(4) **INSTALL CLUTCH PEDAL ROD** (fig. 82). Position pedal rod to cross shaft lever. Secure with the clevis pin and cotter pin.

(5) **INSTALL CLUTCH PEDAL** (fig. 82). Position pedal on clutch and brake pedal shaft. Slide shaft as far as possible to clutch pedal side. Secure in this position with the flat washer, lock ring, and taper pin.



**FUEL SYSTEM**

(6) CONNECT CLUTCH PEDAL ROD TO CLUTCH PEDAL (fig. 82). Position pedal rod to pedal. Insert the clevis pin and cotter pin which secure them.

(7) ADJUST CLUTCH (par. 59).

**Section XVI**

**FUEL SYSTEM**

**61. DESCRIPTION AND DATA (fig. 34).**

**a. Description.**

(1) **FUEL USED.** This fuel system requires gasoline having a minimum octane rating of 70.

(2) **FUEL SYSTEM.** Components of the fuel system are carburetor, fuel pump, gasoline filter, fuel tank, three fuel lines, and governor. Fuel lines conduct the gasoline from the fuel tank to the gasoline filter, thence to the fuel pump. The fuel pump forces fuel to the carburetor where it is mixed with air that has been cleaned by the air cleaner. The mixture is then drawn into the combustion chamber of the engine by vacuum caused by the down stroke of the pistons.

(3) **GOVERNOR.** The governor is a device which controls the maximum engine speed. It does so by controlling a butterfly valve located between the carburetor and the intake manifold. This limits the fuel mixture passing to the engine when the controlled engine speed is reached. The governor requires no maintenance; do not tamper with it. In case of governor failure, notify higher authority.

**b. Data.**

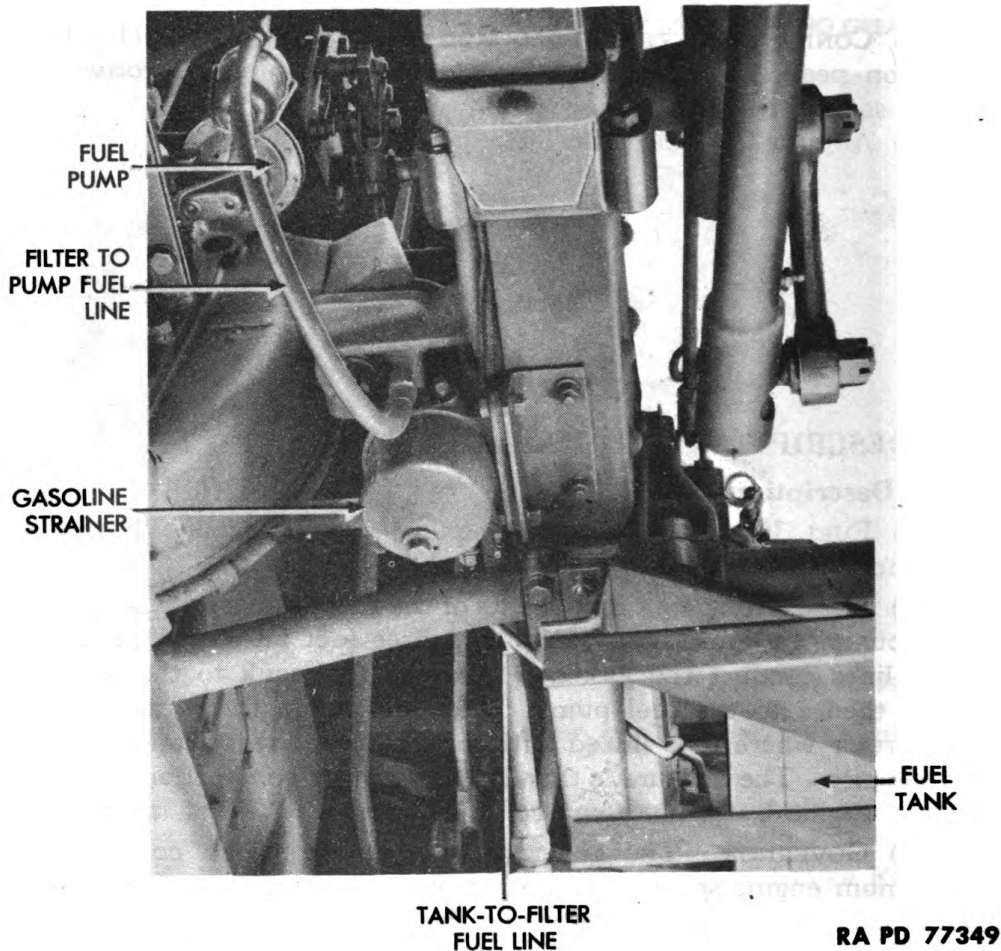
**Fuel pump**

Make .....	AC Spark Plug Co
Model .....	D
Manufacturer's symbol .....	1534471
Location .....	Left side of engine near bell housing
Driven by .....	Camshaft
Maximum capacity .....	1 pt per min
Sediment bowl .....	Yes
Hand priming lever .....	Yes

**Carburetor**

Make .....	Zenith
Model .....	457-2
Type .....	Updraft

4- TO 5-TON 4x4 TRACTOR TRUCK (FEDERAL)



**Figure 34 – Fuel System Components Installed**

**Gasoline Filter**

Make ..... AC Spark Plug Co  
 Model ..... T2  
 Location ..... Right side of engine

**Fuel tank**

Capacity ..... 60 gal  
 Location ..... Left-hand frame side rail

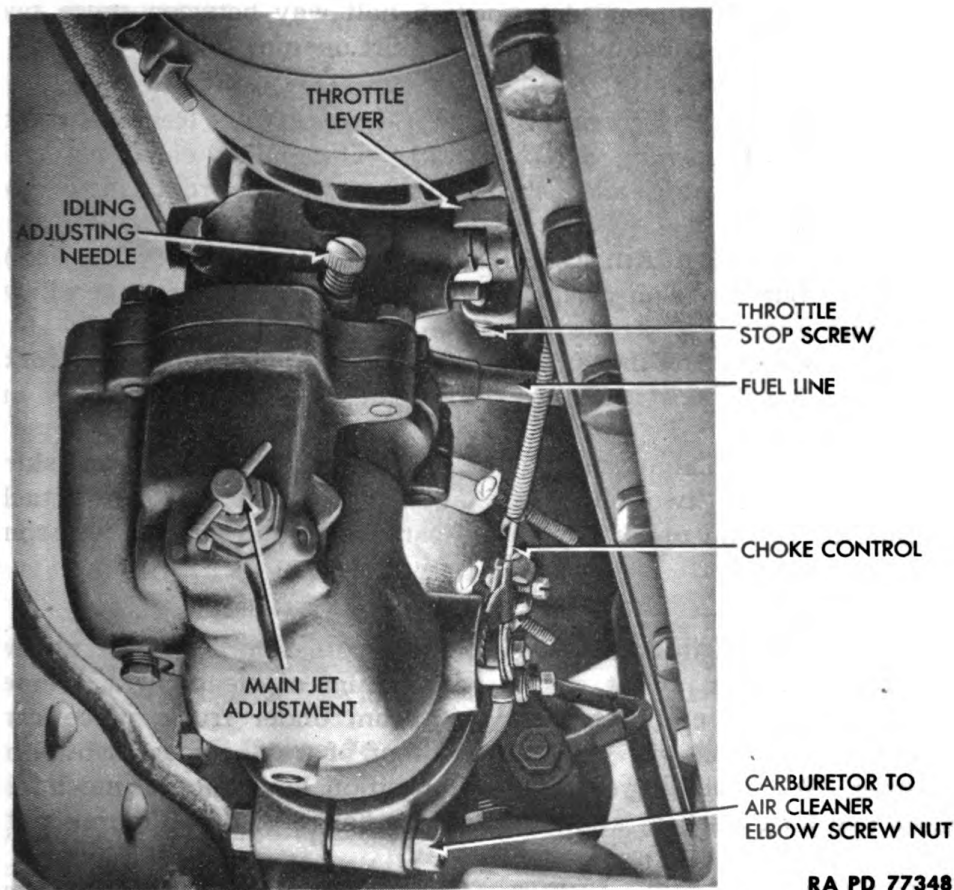
**62. CARBURETOR (fig. 35).**

**a. Description.** The carburetor is the updraft type and is located on the right-hand side of the engine between the engine and frame. It is reached through the right-hand cab skirt opening door. The carburetor is a plain-tube type with adjustable main jet, accelerating pump, and economizing device.

**b. Adjustment.**

(1) **ADJUST THROTTLE STOP SCREW (fig. 35).** Start engine and allow it to run during adjustment. Remove right-hand cab skirt

**FUEL SYSTEM**



RA PD 77348

**Figure 35 – Carburetor Installed**

opening door (fig. 1); Wait until intake manifold is at least warm to the hand. Close throttle. Adjust throttle stop screw on carburetor until engine idles at 350 revolutions per minute. Stop engine and install cab skirt opening door.

(2) **ADJUST IDLING MIXTURE** (fig. 35). Adjust throttle stop screw (step (1) above). Leave cab skirt opening door off and engine running. Turn idling adjusting needle near top of carburetor in until engine slows down. Back needle out until engine attains maximum speed for throttle setting. Set throttle stop screw so engine idles at 350 revolutions per minute. Stop engine and install cab skirt opening door.

(3) **ADJUST INTERMEDIATE AND HIGH-SPEED MIXTURE** (fig. 35). Start engine and set throttle so tachometer registers 550 revolutions per minute. Remove right-hand cab skirt opening door. Wait until intake manifold is warm to the hand. Turn main jet adjustment on under side of carburetor in (clockwise) until engine slows down. Then open adjustment (turn counterclockwise) until engine slows

**4- TO 5-TON 4x4 TRACTOR TRUCK (FEDERAL)**

down. Turn adjustment to a position half way between these two extremes. Stop engine and install cab skirt opening door.

**c. Removal.**

(1) **DISCONNECT CONTROLS FROM CARBURETOR.** Remove right-hand cab skirt opening door (fig. 1). Disconnect choke control, throttle control cable, and accelerator control rod from carburetor (fig. 35).

(2) **DISCONNECT AIR CLEANER FROM CARBURETOR** (fig. 35). Loosen carburetor-to-air-cleaner elbow screw nut and disengage elbow from carburetor.

(3) **DISCONNECT FUEL LINE FROM CARBURETOR** (fig. 35). Working through cab skirt opening, disconnect fuel line from union on carburetor.

(4) **REMOVE CARBURETOR** (fig. 35). Working through cab skirt opening, remove two stud nuts and lock washers which attach carburetor. From under truck, pull carburetor and gasket free from carburetor adapter.

**d. Installation.**

(1) **ATTACH CARBURETOR TO CARBURETOR ADAPTER.** Use a new carburetor gasket. Coat gasket with a film of clean, light grease. Place gasket on carburetor flange. From under truck, place carburetor in position with air intake to rear of truck under carburetor adapter. While holding carburetor in position, have another mechanic start two lock washers and stud nuts on flange studs. Tighten nuts securely.

(2) **CONNECT FUEL LINE TO CARBURETOR** (fig. 35). Tighten inlet connection securely onto nipple on carburetor.

(3) **CONNECT AIR CLEANER TO CARBURETOR** (fig. 35). From under truck, work air cleaner elbow onto air inlet flange on carburetor. Tighten air cleaner elbow screw nut securely.

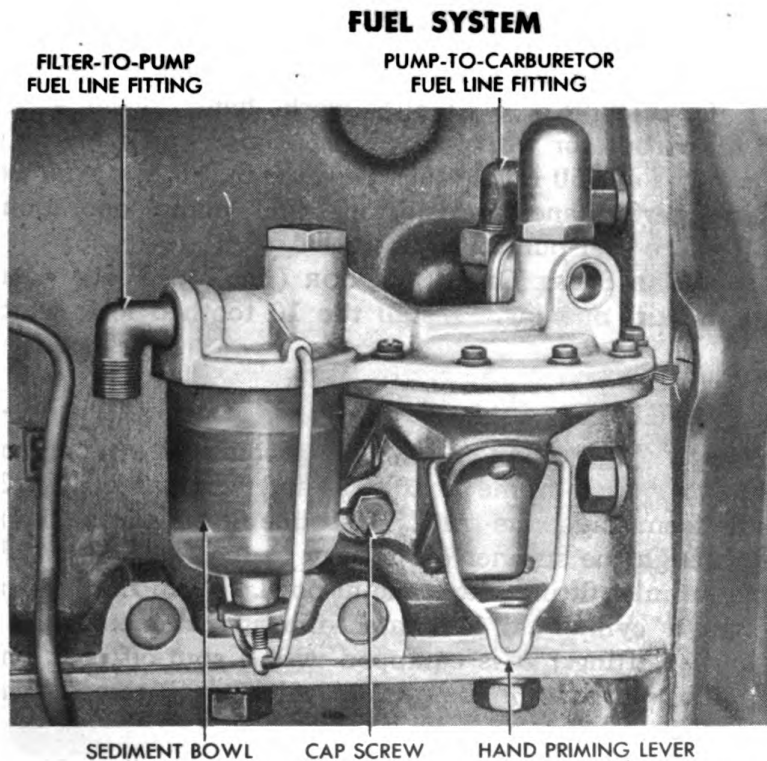
(4) **CONNECT CONTROLS** (fig. 35). Connect choke control to air shutter lever. Be sure air shutter is open when choke button on dash is in. Connect throttle control cable to throttle lever. Be sure throttle is closed when throttle button on dash is in. Connect accelerator control rod to carburetor throttle lever.

(5) **TEST INSTALLATION.** Start engine. Satisfactory engine performance indicates proper carburetor installation. If out of adjustment, see step b (1) of this paragraph.

(6) **REPLACE CAB SKIRT OPENING DOOR** (fig. 1). Place door in position and install the 10 toothed lock washers and screws.

**63. FUEL PUMP.**

**a. Description** (fig. 36). The fuel pump is mounted on the left side of the engine, approximately level with the top of the chassis frame. It is reached through the cab skirt opening (fig. 34). The



RA PD  
77376

**Figure 36 – Fuel Pump Installed**

pump is of the diaphragm-type and is equipped with a sediment bowl and a hand priming lever (fig. 36). In operation the rocker arm is actuated by a cam on the engine camshaft.

**b. Maintenance** (fig. 36). Remove and empty sediment bowl. Wipe bowl out with a clean cloth. Check bowl seat nut and gasket to see if looseness or leakage is present.

**c. Removal.**

(1) **REMOVE CAB SKIRT OPENING DOOR** (fig. 2). Remove the 10 screws and toothed lock washers which secure left-hand cab skirt opening door to cab. Lift door from cab.

(2) **DISCONNECT FUEL LINES** (fig. 36). Screw filter to pump fuel line (fig. 34) and pump to carburetor fuel line from their respective fittings on fuel pump.

(3) **REMOVE PUMP FROM CYLINDER BLOCK** (fig. 36). Remove the two cap screws and lock washers. Lift pump and gasket from cylinder block.

**d. Installation.**

(1) **ATTACH PUMP TO CYLINDER BLOCK** (fig. 36). Place fuel pump gasket and pump in position on cylinder block. Install two lock washers and cap screws.

(2) **CONNECT FUEL LINES** (fig. 36). Connect filter to pump fuel line to fitting on sediment bowl end of fuel pump. Connect pump-

**4- TO 5-TON 4x4 TRACTOR TRUCK (FEDERAL)**

to-carburetor fuel line to fitting on air dome plug end of fuel pump.

(3) **TEST OPERATION.** Manually work hand priming lever (fig. 36) to fill carburetor with fuel. Start engine and allow to run at least 15 minutes at 550 revolutions per minute. If test run shows normal engine performance, satisfactory fuel pump operation is indicated. Replace fuel pump if inoperative.

(4) **INSTALL CAB SKIRT OPENING DOOR** (fig. 2). Place door in position on cab skirt opening. Install the 10 toothed lock washers and screws.

**64. GASOLINE FILTER.**

**a. Description** (figs. 37 and 38). The gasoline filter is mounted on the inside of chassis frame near left-hand step plate (fig. 34). It is accessible from under the truck. Gasoline flowing from the fuel tank passes through the strainer on its way to the fuel pump. Fuel flows through an inlet fitting into a metal bowl. From the bowl it is forced through a cylindrical laminated filtering element and out through an outlet fitting. It is equipped with a shut-off cock on its inlet fitting. The purpose of the gasoline filter is to remove water or impurities from the fuel.

**b. Maintenance** (figs. 37 and 38). Service gasoline filter as follows: Turn off shut-off cock on inlet fitting. Remove cover bolt from top center of filter. Lower the bowl, gasket, and element from top cover. Clean all parts in dry-cleaning solvent. Dry with compressed air. Inspect element and gasket carefully. Replace damaged parts. Place element spring in position over stem at bottom and inside of bowl. Place element in position on top of element spring. Place gasket in position on top of bowl. Hold bowl in position against top cover and install cover bolt. Loosen one of the two pipe plugs on top cover and run engine until fuel runs out loose pipe plug. Tighten pipe plug.

**c. Removal.**

(1) **DISCONNECT FUEL LINES** (fig. 38). Disconnect tank to filter fuel line from filter. Disconnect filter to pump fuel line from filter.

(2) **REMOVE FILTER FROM BRACKET** (fig. 38). Remove both cap bolt nuts, lock washers, and bolts which secure filter to bracket. Lift filter from bracket.

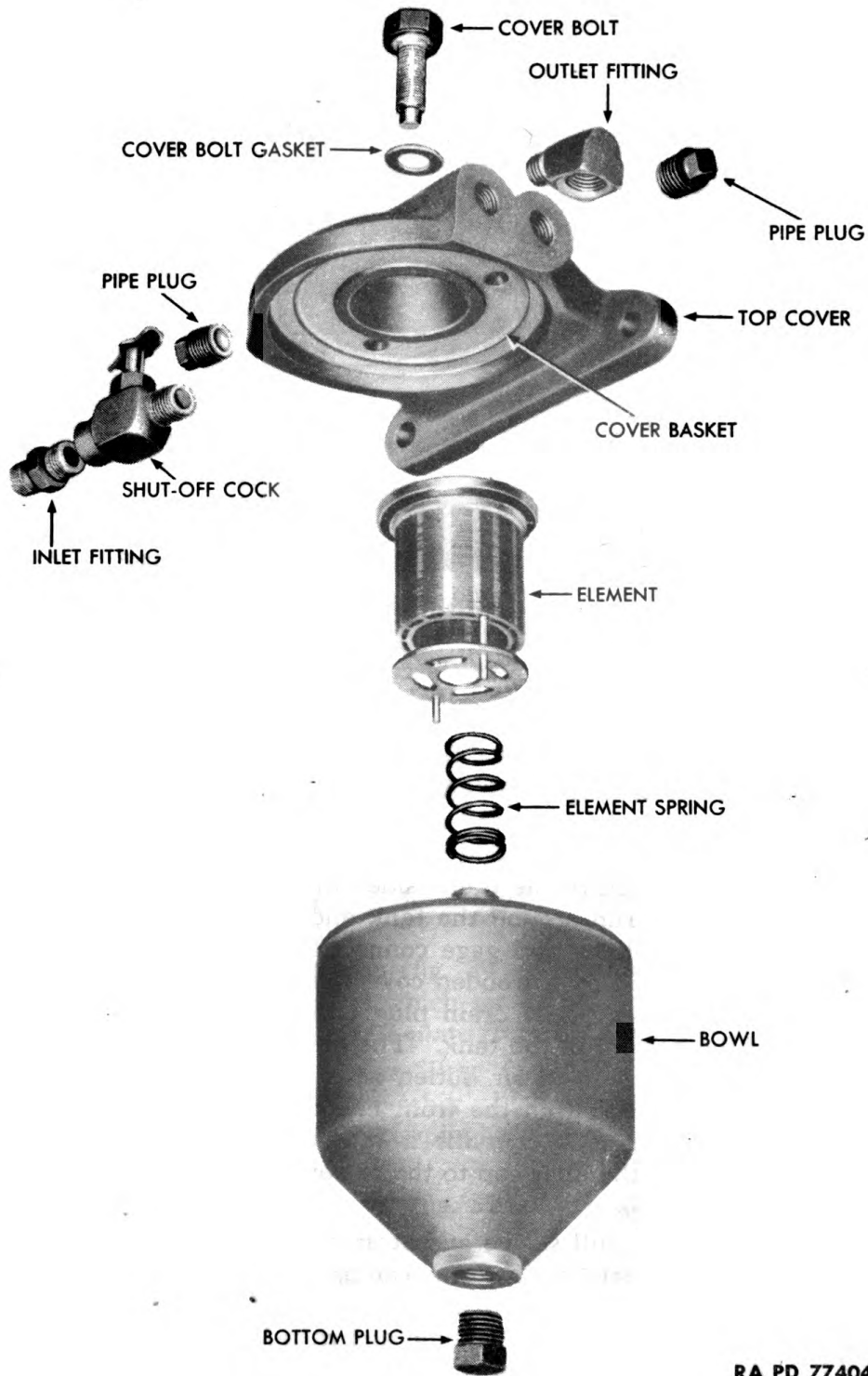
**d. Installation.**

(1) **ATTACH FILTER TO BRACKET** (fig. 38). Place filter in position on its bracket. Install two cap bolts, lock washers, and nuts.

(2) **CONNECT FUEL LINES** (fig. 38). Connect tank to filter fuel line to fitting on rear of filter. Connect filter to pump fuel line to fitting on front side of filter.

(3) **FILL FILTER WITH FUEL** (fig. 38). Loosen one of the two

FUEL SYSTEM



RA PD 77404

**Figure 37 – Gasoline Filter Disassembled**

4- TO 5-TON 4x4 TRACTOR TRUCK (FEDERAL)

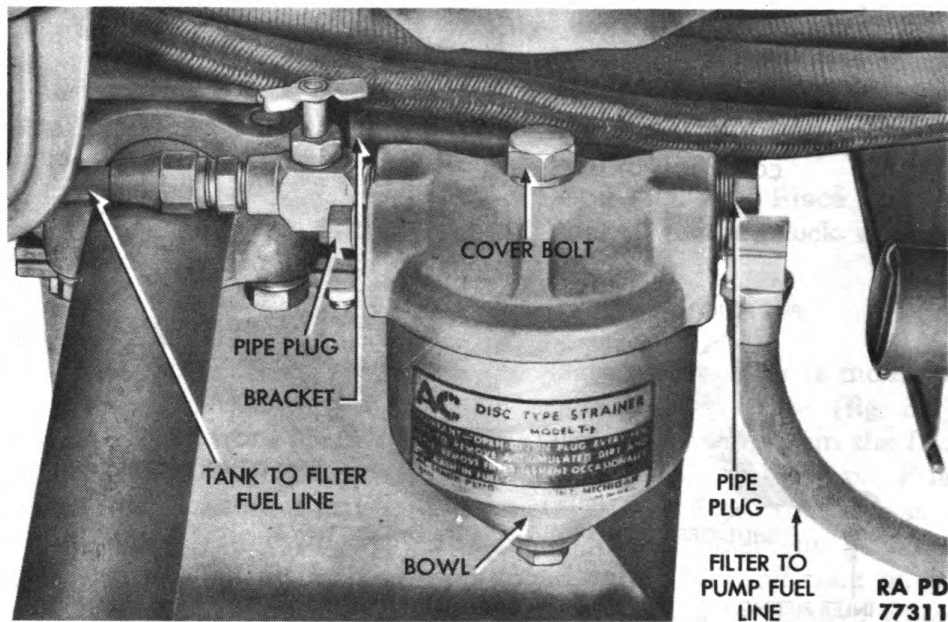


Figure 38 – Gasoline Filter Installed

pipe plugs on top cover and start engine. When fuel flows from loose pipe plug, stop engine and tighten pipe plug.

**65. FUEL TANK.**

**a. Description** (fig. 39). A rectangular 60-gallon fuel tank is attached to the outside of the chassis frame ahead of the left rear wheel. The tank is of welded sheet metal construction. Two cast iron brackets, bolted to the frame side rail, extend out over the tank. Two steel straps run around the tank and secure it to the brackets. The fuel outlet elbow and gage connection are on top of the tank. They are protected by a wooden cover plate bolted to the fuel tank brackets. A conventional drain plug is located in the approximate center of the bottom of the tank. The filler neck, which is equipped with an internal built-in air outlet, is an integral part of the tank. It extends obliquely from the front end of the tank near its upper left corner. The neck contains a removable sleeve and strainer. A chain attaches the filler cap to the removable sleeve.

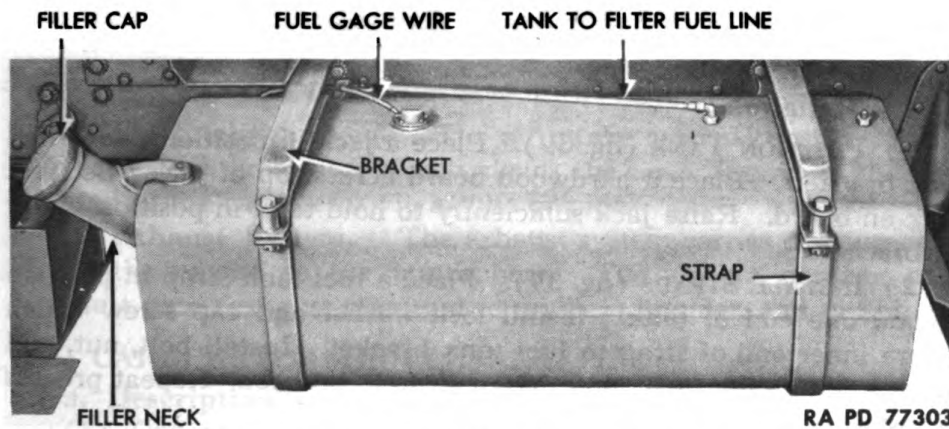
**b. Maintenance.**

(1) Twist and pull sleeve and strainer from filler neck (fig. 39). Clean sleeve and strainer in dry-cleaning solvent and dry with compressed air. Install the unit in filler neck. Check tightness of all mounting and strap bolts. Tighten any nuts found to be loose.

(2) At all times, and especially during cold weather, keep tank as nearly full as possible to reduce condensation. Whenever excessive water is in evidence in gasoline filter or in sediment bowl of fuel



**FUEL SYSTEM**



**Figure 39 – Fuel Tank With Cover Plate Removed**

pump, remove drain plug from fuel tank. Catch gasoline in clean containers. Strain through a chamois skin or other filter which will remove water. Install drain plug and refill tank.

(3) Remove foreign matter (gravel, stones, scale, rust, etc.) from fuel tank whenever its presence becomes known. Clogged tank-to-filter fuel line, rapid fouling of gasoline filter, plugging of drain or noise in fuel tank are indications of presence of foreign matter. Remove tank (step c). Twist and pull sleeve and strainer from filler neck. Empty foreign matter from filler neck. Rinse tank with dry-cleaning solvent. Inspect tank carefully for leaks or other damage done by foreign matter. Replace tank if damaged. Install tank (step d).

**c. Removal.**

(1) **DRAIN TANK.** Remove drain plug. Catch gasoline in clean containers. Install drain plug.

(2) **REMOVE COVER PLATE** (fig. 39). Remove six cap screws, lock washers, and flat washers which secure wooden fuel tank cover plate to fuel tank brackets. Lift plate from brackets.

(3) **DISCONNECT FUEL GAGE WIRE** (fig. 39). Turn off ignition switch. Remove nut and lock washer which secure gage wire to tank unit terminal. Lift wire from terminal and insulate tip of wire with tape or cloth.

(4) **DISCONNECT FUEL LINE** (fig. 39). Disconnect tank to filter fuel line from tank fitting.

(5) **REMOVE TANK STRAPS AND TANK** (fig. 39). Support the tank with a hardwood block placed across the top of a jack. Remove two cotter pins, nuts and bolts which hold outer ends of tank straps to brackets. Remove the two cap screws and lock washers which hold inner ends of straps to brackets. Lift straps from vehicle. Carefully lower tank to ground. Do not rest tank on its top or

**TM 9-820**  
**65-66**

**4- TO 5-TON 4x4 TRACTOR TRUCK (FEDERAL)**

bottom, as damage to fuel and gage fittings or drain plug boss may result.

**d. Installation.**

(1) **POSITION TANK** (fig. 39). Place a jack in position under fuel tank brackets. Place a hardwood board across top of jack. Set fuel tank on board. Raise jack sufficiently to hold tank in position under its brackets.

(2) **INSTALL STRAPS** (fig. 39). Place a fuel tank strap in position around one end of tank. Install lock washer and cap screw which secure inner end of strap to fuel tank bracket. Install bolt, nut, and cotter key which attach outer end of strap to bracket. Repeat process to install other strap.

(3) **CONNECT FUEL LINE** (fig. 39). Connect tank to filter fuel line to tank fitting.

(4) **CONNECT FUEL GAGE WIRE** (fig. 39). Place wire tip in position on tank unit terminal and install lock washer and nut.

(5) **INSTALL COVER PLATE** (fig. 39). Place fuel tank cover plate in position on fuel tank brackets. Install six flat washers, lock washers, and cap screws which secure plate to brackets.

(6) **FILL TANK**. Ascertain that drain plug is installed and tight. Fill tank with fuel.

**66. FUEL LINES.**

**a. Description.** Three fuel lines are used. The tank to filter fuel line and the pump to carburetor fuel line are made of steel. They have ferruled ends. The filter-to-pump fuel line is a flexible line. Brass sleeve coupling nuts are used throughout.

**b. Maintenance.**

(1) **CLEANING.** If fuel line becomes plugged, disconnect both ends of line. Apply compressed air at one end to blow obstruction from line. Do not apply compressed air to any line if other end is connected.

(2) **CUTTING AND BENDING TUBING AND INSTALLING FITTINGS.** If a complete tubing assembly is not available for replacement purposes, cut new tubing to same length as original. Bend tubing on a jig to shape of original part (steel tubing cannot be bent without a jig). Place a sleeve coupling nut and a ferrule over each end and install tubing (step d below) (fig. 80).

**c. Removal** (fig. 80). Completely unscrew sleeve coupling nut on each end of tubing. Remove clips if any. Work tubing from vehicle.

**d. Installation** (fig. 80). Place tubing in position occupied by original installation. Connect sleeve coupling nut at each end of tubing. Install clips, if any.

Section XVII

INTAKE AND EXHAUST SYSTEMS

67. DESCRIPTION.

a. **Air Intake System.** The air intake system consists of an oil air-bath type air cleaner which cleans the air. The air is then conducted to the carburetor via a tube or pipe.

b. **Exhaust System.** The exhaust system carries the burned gas from the engine to the atmosphere. The system consists of an exhaust pipe (exhaust manifold to muffler), muffler, and tail pipe.

68. CARBURETOR AIR CLEANER.

a. **Description and Tabulated Data.**

(1) **DESCRIPTION** (fig. 40). The air cleaner is mounted outside the frame right-hand side rail, and is accessible through the right-hand cab skirt opening. It is an oil-bath type connected to the carburetor by means of an air tube, two hose connections, and two elbows. The function of the air cleaner is to remove dust and other foreign matter from air drawn into the engine through the carburetor. This is accomplished by forcing the air to pass through an element of fine metal shavings which is kept constantly moist by oil vapors. As oil condenses on the element, it flows back into the oil bath and carries with it dirt removed from the air.

(2) **TABULATED DATA.**

Manufacturer	United Specialties Co
Model	T1 75
Oil capacity	3 pt

b. **Maintenance** (fig. 40). Loosen the two wing nuts which secure oil reservoir to body. Remove and empty reservoir. Wipe reservoir with a clean cloth. Fill reservoir to "OIL LEVEL" mark with same oil as used in engine and install reservoir on air cleaner body. Tighten wing nuts fingertight only. Every third time air cleaner oil is changed, wash body and element in dry-cleaning solvent.

c. **Removal.**

(1) **DISCONNECT AIR TUBE** (fig. 41). Loosen hose clamp and push hose from elbow.

(2) **REMOVE CLEANER FROM BRACKET** (fig. 41). Remove four cap bolt nuts, lock washers, and bolts which attach air cleaner straps to air cleaner bracket. Lift cleaner from bracket.

d. **Installation.**

(1) **ATTACH AIR CLEANER TO BRACKET** (fig. 41). Place air cleaner in position on its bracket. Install four cap bolts, lock washers, and nuts which attach air cleaner straps to bracket. Be sure to place end of bonding strap under lower right nut and washer.

(2) **CONNECT AIR TUBE** (fig. 41). Push hose connection over elbow and tighten hose clamp.

TM 9-820  
68

4- TO 5-TON 4x4 TRACTOR TRUCK (FEDERAL)

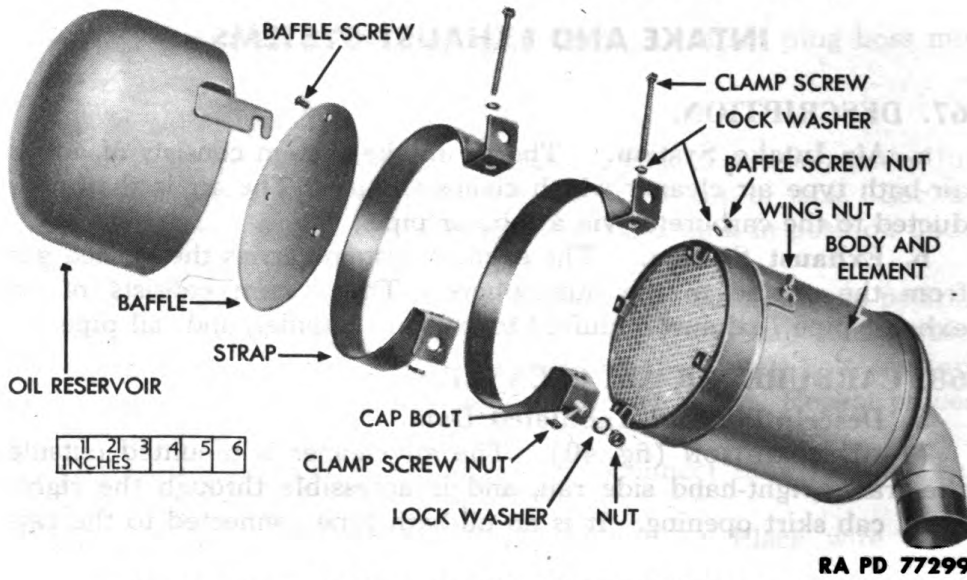


Figure 40 – Carburetor Air Cleaner Disassembled

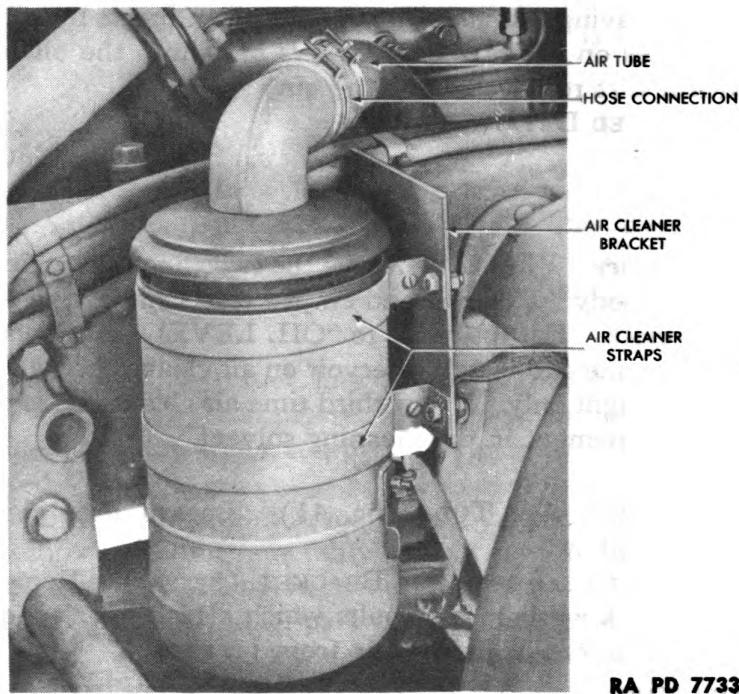
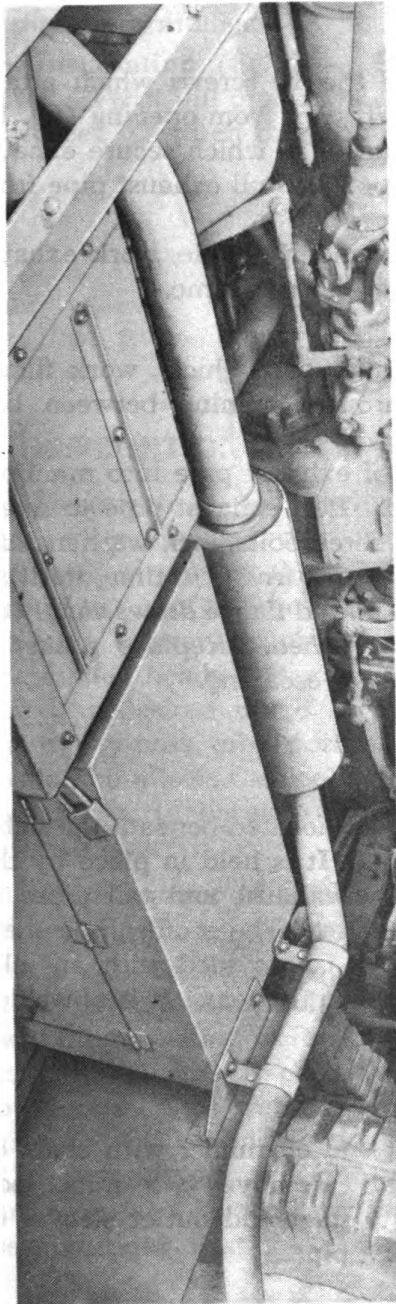
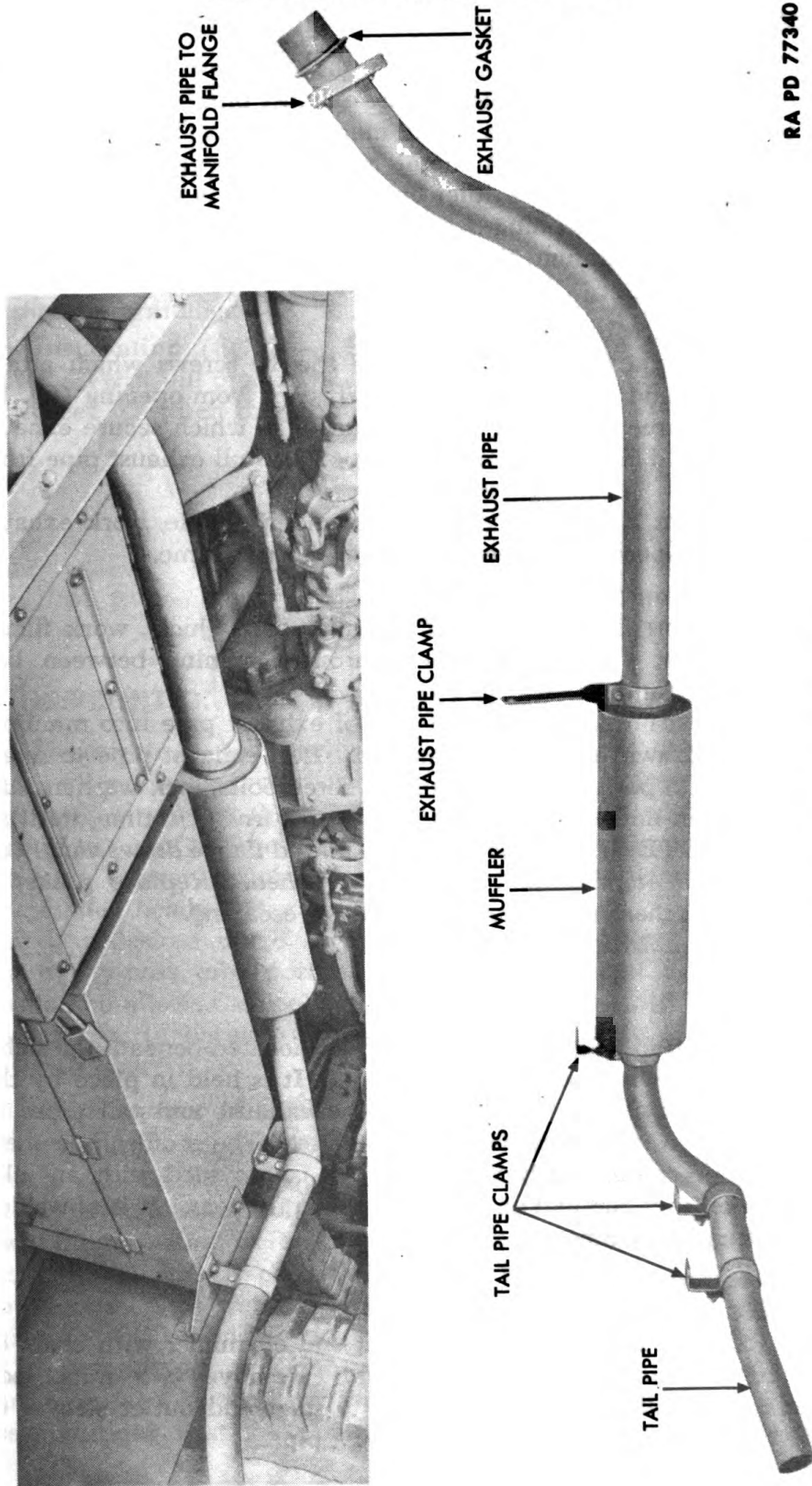


Figure 41 – Air Cleaner Installed

**INTAKE AND EXHAUST SYSTEMS**



**Figure 42 — Exhaust System**

**4- TO 5-TON 4x4 TRACTOR TRUCK (FEDERAL)**

**69. EXHAUST PIPE.**

**a. Description** (fig. 42). Exhaust gases are conducted from the exhaust manifold to the muffler by the exhaust pipe. This pipe is an iron tube fitted with a flange on its manifold end. The flange bolts directly to the manifold. A metal and asbestos gasket is used to ensure a gas-tight fit. The other end of the pipe is plain and enters into a split tube extending from the muffler. This split tube is tightened securely around the muffler by means of a clamp.

**b. Removal** (fig. 42).

(1) **REMOVE MUFFLER** (par. 69 b).

(2) **DISCONNECT FLANGE.** Remove the 10 screws which attach door to right-hand cab skirt opening. Lift door from opening (fig. 1). Remove the three nuts, lock washers and bolts which secure exhaust pipe to manifold flange to manifold (fig. 42). Pull exhaust pipe from manifold.

(3) **REMOVE EXHAUST PIPE.** From under vehicle, work exhaust pipe through opening between bell housing and frame.

**c. Installation** (fig. 42).

(1) **POSITION EXHAUST PIPE.** From under vehicle, work flange end of exhaust pipe into position through opening between bell housing and frame.

(2) **CONNECT FLANGE.** Insert end of exhaust pipe into manifold so gasket is drawn up against manifold. Pull exhaust pipe to manifold flange into position and install the three bolts, lock washers, and nuts. Tighten nuts alternately, a couple of turns at a time, until all are tight. *NOTE: If exhaust pipe to manifold flange draws snugly up against flange on manifold, gasket is crushed. Replace gasket if crushed, since there is danger of deadly gas escaping.*

(3) **INSTALL MUFFLER** (par. 70 c).

**70. MUFFLER.**

**a. Description** (fig. 42). The muffler is located beneath the right-hand frame side rail behind the tool box. It is held in place by the muffler support clamps which clamp the exhaust and tail pipes to it. Its function is to decrease exhaust noise. The muffler is a sheet iron cylinder containing baffle plates. It is provided with an inlet sleeve on its front end and an outlet sleeve on the rear. It is of welded construction and cannot be disassembled.

**b. Removal** (fig. 42).

(1) **REMOVE TAIL PIPE** (par. 71 b).

(2) **REMOVE MUFFLER.** Mark inlet end of muffler with chalk or paint to facilitate correct installation. Remove two nuts, lock washers, and bolts which lock clamps to inlet and outlet sleeves of muffler. Pull muffler from end of exhaust pipe.

## COOLING SYSTEM

c. **Installation** (fig. 42). Slide inlet sleeve of muffler onto back end of exhaust pipe and install bolt, lock washers, and nut on clamp. Install tail pipe (par. 71 c).

### 71. TAIL PIPE.

a. **Description** (fig. 42). The tail pipe is an L-shaped iron tube. It conducts exhaust gases from the muffler to a point directly in front of the right rear wheel.

b. **Removal** (fig. 42). Loosen the three tail pipe clamps. Pull tail pipe from muffler.

c. **Installation** (fig. 42). Engage tail pipe with outlet sleeve of muffler. Twist tail pipe so its discharge end projects in front of right rear wheel. Tighten three tail pipe clamps.

---

## Section XVIII

## COOLING SYSTEM

### 72. DESCRIPTION AND MAINTENANCE.

a. **Description.** The cooling system is composed of three major units: radiator, water pump, and fan. Cool water is drawn from base of radiator, circulated through the engine where it absorbs heat, and returned to top of radiator for re-cooling. A thermostat, located in the inlet tube (upper), controls flow of water to keep temperature in the cylinder heads. It also keeps the cylinder block temperature within the desired range and provides for quick engine warm up. A metal by-pass tube positioned behind thermostat and ahead of water pump allows the cooling solution to circulate within the engine until sufficiently warm to open thermostat. Capacity of cooling system is 40 quarts.

#### b. Maintenance of Cooling System.

(1) **FILLING COOLING SYSTEM.** Never fill radiator when engine is hot, as cylinder head or block may be cracked by cooling too rapidly. Allow a hot engine to cool half an hour, then run it at idle speed while slowly filling radiator. Remove cover from radiator cap opening and then remove radiator cap. Fill cooling system. Start engine and allow to run until water temperature gage reads 180°F. Shut off engine and fill cooling system again.

(2) **INSPECTION OF COOLING SYSTEM UNITS.** Inspect all hose connections and hose connection clamps. Clamps must be tight and hose connections must not leak. Inspect drain cocks on radiator, water

**TM 9-820**  
**72-73**

**4- TO 5-TON 4x4 TRACTOR TRUCK (FEDERAL)**

pump, and cylinder block for leakage. Examine all gaskets at water connections for leaks and tighten all bolts and nuts at these water connections.

(3) **REVERSE FLUSHING.**

(a) *Radiator.* Remove upper and lower radiator hoses, and replace radiator cap. Attach a length of hose to the radiator top connection, then attach a length of hose to the radiator lower connections and insert reverse flushing gun in this hose. Connect the water hose of the gun to a water tap and the air hose to a compressed air line. Turn on the water and when the radiator is full, turn on the air in short blasts. Allow radiator to fill with water between blasts of air. Continue this flushing until water from top hose runs clear.

(b) *Cylinder.* Remove hose from water pump inlet and attach a length of hose to the inlet, then remove hose from water pump outlet and attach a length of hose to the outlet, then insert gun in this hose. Repeat procedure (step (a) above).

(4) **ANTIFREEZE.** Ethylene glycol is the only antifreeze compound prescribed for use in Ordnance vehicles. Pour solution into radiator until radiator appears to be full. Start engine and run until water temperature gage registers 185 degrees. Pour remainder of solution into radiator.

(5) **ANTIFREEZE CHART.**

Ethylene Glycol (Quart)	Water (Quart)	Protects to Zero F.	Gravity
0	40	32	1.000
4	36	26	1.016
8	32	16	1.031
12	28	3	1.045
16	24	11	1.058
20	20	31	1.070

(6) **DRAINING OF COOLING SYSTEM.** Open cylinder block drain cock and two water pump drain cocks. Cylinder block drain cock is on left side of cylinder block. Water pump drain cocks are at bottom of water pump. Drain ethylene glycol solution into containers so that it can be used again. **CAUTION:** *If radiator is not immediately filled, attach a warning card to steering wheel reading "NO WATER".*

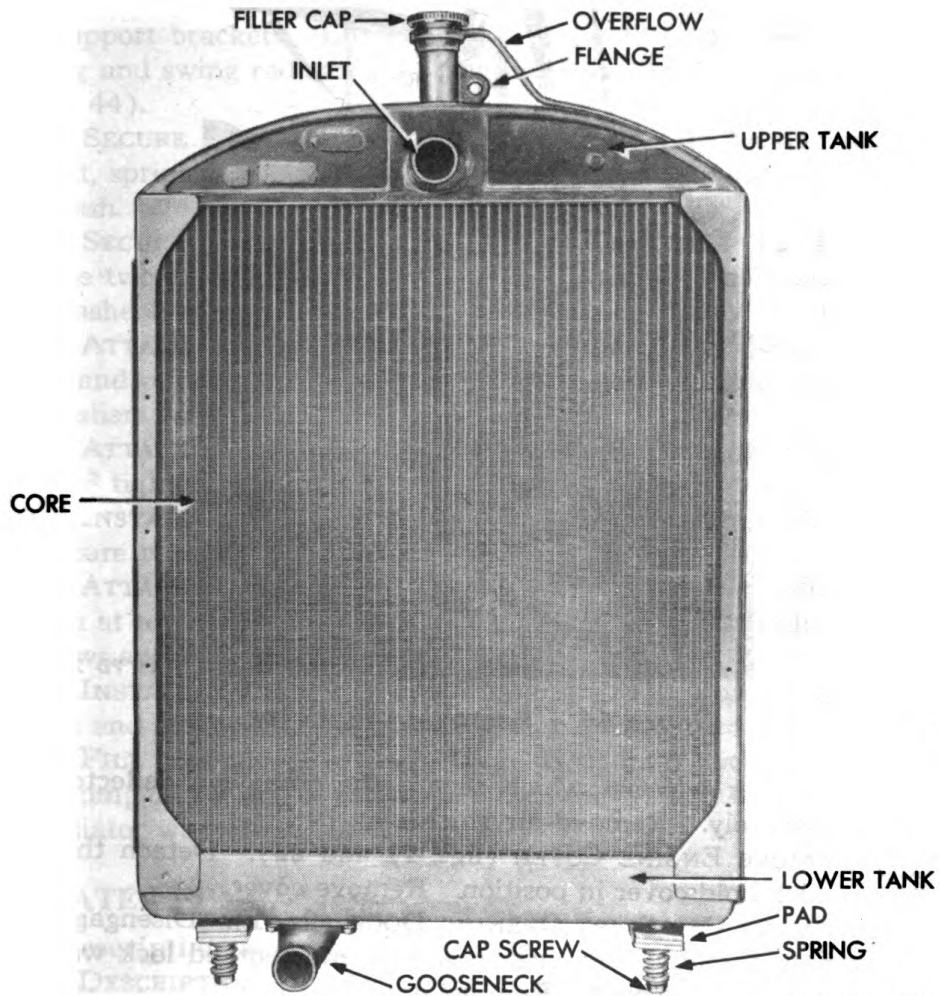
**73. RADIATOR.**

**a. Description and Tabulated Data.**

(1) **DESCRIPTION** (fig. 43). The radiator consists of a core and two tanks made as a unit. The core is the tube-and-fin-type. Three radiator air deflectors located at top and on either side of radiator help to direct air through the core. The radiator filler cap, attached at top of upper tank, provides means for filling radiator.



**COOLING SYSTEM**



RA PD 77331

**Figure 43 – Radiator Assembly**

**(2) TABULATED DATA.**

Manufacturer ..... Long  
 Type ..... Tube and fin  
 Model ..... RAA

**b. Removal.**

(1) **DRAIN RADIATOR AND CYLINDER BLOCK (fig. 11).** Remove both cab skirt opening doors. Open two drain cocks at base of water pump inlet connection and at end of extension pipe from cylinder block.

(2) **REMOVE RADIATOR BRUSH GUARD (fig. 1).** Remove 16 hex bolts, nuts, and toothed lock washers which secure guard to cowling. Remove brush guard.

(3) **REMOVE RADIATOR AIR DEFLECTORS.** Remove 14 screws and

4- TO 5-TON 4x4 TRACTOR TRUCK (FEDERAL)



RA PD 77383

**Figure 44 – Removing Radiator**

16 toothed lock washers which secure the three air deflectors to radiator assembly. Remove air shields.

(4) REMOVE ENGINE COVER (figs. 21 and 22). Detach the two catches which hold cover in position. Remove cover.

(5) REMOVE CAB SKIRT OPENING DOOR (fig. 1). Disengage cab skirt opening door by removing 10 screws and toothed lock washers which secure it to cab skirt. Remove door.

(6) DISCONNECT RADIATOR INLET PIPE (fig. 43). Loosen upper hose clamp and disengage hose from pipe.

(7) REMOVE LOWER GOOSENECK OUTLET (fig. 43). Remove four hex cap screws and washers which secure it to bottom of radiator. Remove gasket.

(8) DISCONNECT RADIATOR BASE FROM FRAME BRACKETS (fig. 43). Remove two hex cap screws, springs, nuts, and four toothed lock washers which secure base to brackets. Remove the two pads.

(9) DISCONNECT RADIATOR FROM COWL DASH. Remove one hex tie rod, nut, spring, and two washers and bushings which secure it to cowl dash.

(10) LIFT RADIATOR FROM VEHICLE (fig. 44). Attach rope or other suitable lifting material to hole in flange (fig. 43), on radiator filler neck. Lift neck of radiator up through filler cap door opening. Tilt base of radiator forward and remove from cowl.

**c. Installation.**

(1) POSITION RADIATOR IN VEHICLE. Place new pads on radiator

## COOLING SYSTEM

base support brackets. Lift neck of radiator through filler cap door opening and swing radiator into position over support brackets (figs. 43 and 44).

(2) **SECURE RADIATOR TO COWL DASH.** Install the one hex tie rod, nut, spring, and two flat washers and bushings which hold it to cowl dash.

(3) **SECURE RADIATOR BASE TO FRAME BRACKETS** (fig. 43). Install the two hex cap screws, springs, and nuts, and the four toothed lock washers which secure base to brackets.

(4) **ATTACH LOWER GOOSENECK OUTLET** (fig. 43). Position new gasket and outlet at bottom of radiator. Insert the four cap screws and washers which secure it to radiator.

(5) **ATTACH RADIATOR INLET PIPE** (fig. 43). Fit upper hose over pipe and tighten hose clamp.

(6) **INSTALL ENGINE COVER** (fig. 21). Position cover over engine and secure with the two latches.

(7) **ATTACH RADIATOR AIR DEFLECTORS.** Place air deflectors in position at top and on each side of radiator. Secure to radiator with 14 screws and 16 toothed lock washers.

(8) **INSTALL RADIATOR BRUSH GUARD** (fig. 1). Position guard on cowling and secure with 16 hex bolts, nuts, and toothed lock washers.

(9) **FILL COOLING SYSTEM.** Close two drain cocks at base of water pump and at end of extension pipe from cylinder block (fig. 11). Fill radiator with clean, soft water.

## 74. WATER PUMP.

### a. Description and Tabulated Data.

(1) **DESCRIPTION** (fig. 45). Water pump, attached to left-hand side of cylinder block, is driven from an accessory shaft by means of a sprocket and chain coupling. Packing is internal. Conventional packing nuts are not used.

### (2) TABULATED DATA.

Manufacturer .....	Hercules
Type .....	Pack
Location .....	Left-hand side of engine

### b. Removal.

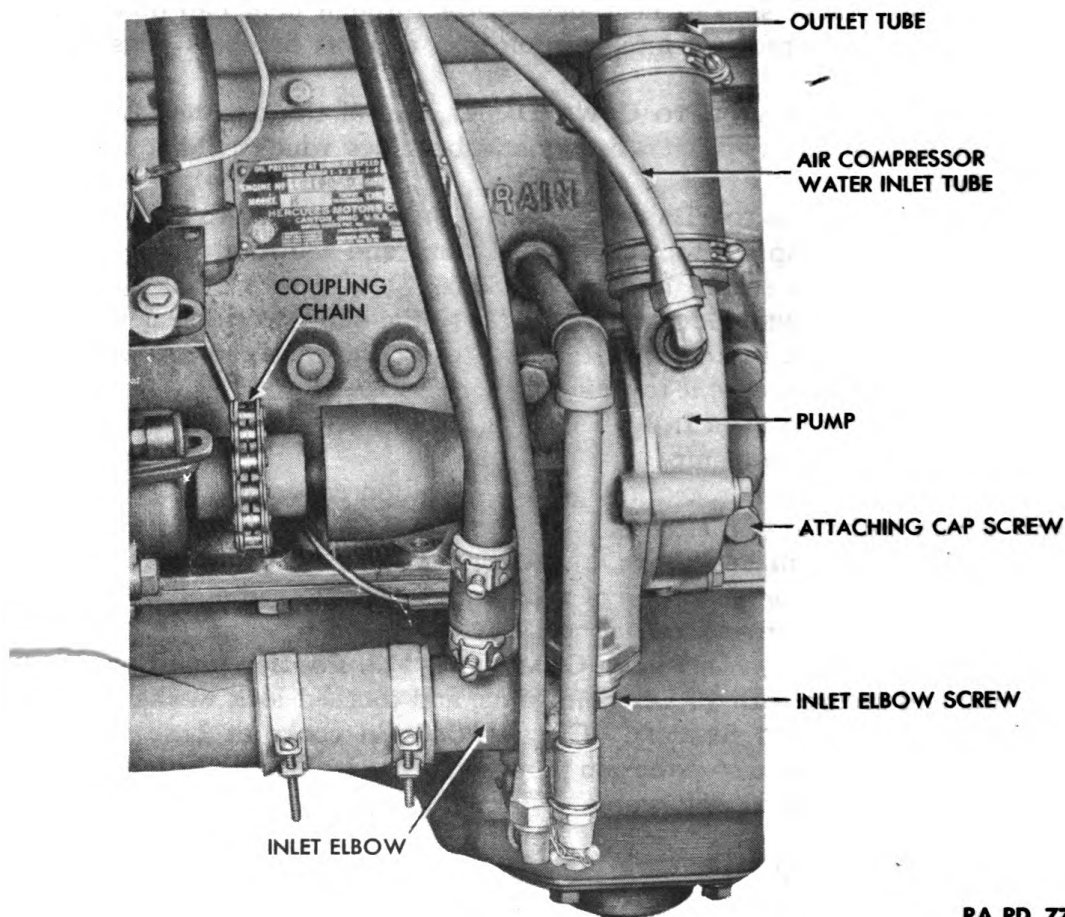
(1) **DISENGAGE PUMP OUTLET TUBE** (fig. 45). Loosen hose clamp which secures hose to pump. Disengage hose from pump.

(2) **DISCONNECT PUMP INLET ELBOW** (fig. 45). Remove two screws and washers which secure elbow to pump. Remove elbow gasket.

(3) **DISCONNECT AIR COMPRESSOR WATER INLET TUBE** (fig. 45). Screw tube nut from fitting on pump.

(4) **REMOVE PUMP COUPLING CHAIN** (fig. 45). Drive connecting

4- TO 5-TON 4x4 TRACTOR TRUCK (FEDERAL)



RA PD 77352

**Figure 45 – Water Pump Installed**

link lock on front of chain from connecting link. Remove link cover and pry link from chain. Remove chain.

(5) **DISENGAGE PUMP FROM CYLINDER BLOCK (fig. 45).** Remove four attaching cap screws and lock washers which secure pump to block. Remove pump. Remove gasket.

**c. Installation.**

(1) **ATTACH PUMP TO CYLINDER BLOCK (fig. 45).** Use new gasket. Position pump on block using dowel guide. Secure with four attaching cap screws and lock washers.

(2) **INSTALL PUMP COUPLING CHAIN (fig. 45).** Fit chain over pump coupling sprocket. Insert connecting link. Replace cover and secure with lock.

(3) **CONNECT PUMP INLET ELBOW (fig. 45).** Use new gasket. Fit elbow to base of pump. Secure with the two screws and washers.

(4) **CONNECT PUMP OUTLET TUBE (fig. 45).** Fit hose over tube and tighten hose clamp.

**COOLING SYSTEM**

(5) **CONNECT AIR COMPRESSOR WATER INLET TUBE** (fig. 45). Screw tube nut onto fitting on pump. Tighten nut securely.

**75. HOSE CONNECTIONS.**

**a. Description and Tabulated Data.**

(1) **DESCRIPTION** (fig. 12). Connections consist chiefly of two lengths of pipe connected to engine and radiator with short lengths of rubber hose. Metal clamps secure hose to pipes. Another pipe of lesser diameter bypasses water from cylinder head to pump. Additional parts consist of inlet and outlet elbows and short pipes.

(2) **TABULATED DATA.**

	<b>Material</b>	<b>Number Required</b>	<b>Diameter</b>	<b>Length</b>
Hose	Rubber	4	2 in.	3½ in.
	Rubber	1	2 in.	5¼ in.
	Rubber	2	1 in.	2½ in.
Clamps	Steel	14		
Pipes	Steel	1	1¾ in.	13 in.
	Steel	1	1¾ in.	17 in.
(By-pass)	Steel	1	1 in.	
(Cylinder block drain)	Steel	2	1 in.	
(Air compressor)	Copper	1	½ in.	21 in.
	Copper	1	½ in.	27 in.
Elbows (Thermostat)	Cast iron	1	1½ in.	
	Cast iron	1	1½ in.	
(Water pump)	Cast iron	1	1½ in.	
(Drain pipe)	Cast iron	1	¾ in.	
(Air compressor)	Copper	2	½ in.	

**b. Removal** (fig. 12). Connections secured by clamps are severed as follows: Loosen clamp screws. Slide clamp away from hose end. Pull hose free. Connections secured by screws and washers are disengaged by removing screws and washers.

**c. Installation** (fig. 12). Hose connections secured by clamps are made as follows: Fit hose over pipe. Slide clamp to position at end of hose. Tighten clamp. Connections secured with screws and washers are made as follows: Use new washers. Fit together parts to be joined. Install screws and washers.

**76. THERMOSTAT.**

**a. Description and Tabulated Data.**

(1) **DESCRIPTION** (fig. 46). An automatic valve-type thermostat is located on the cylinder head at the front of water outlet manifold. It is constructed to control the circulation in accordance with the temperature of the cooling system. It shortens the engine warm-up

4- TO 5-TON 4x4 TRACTOR TRUCK (FEDERAL)

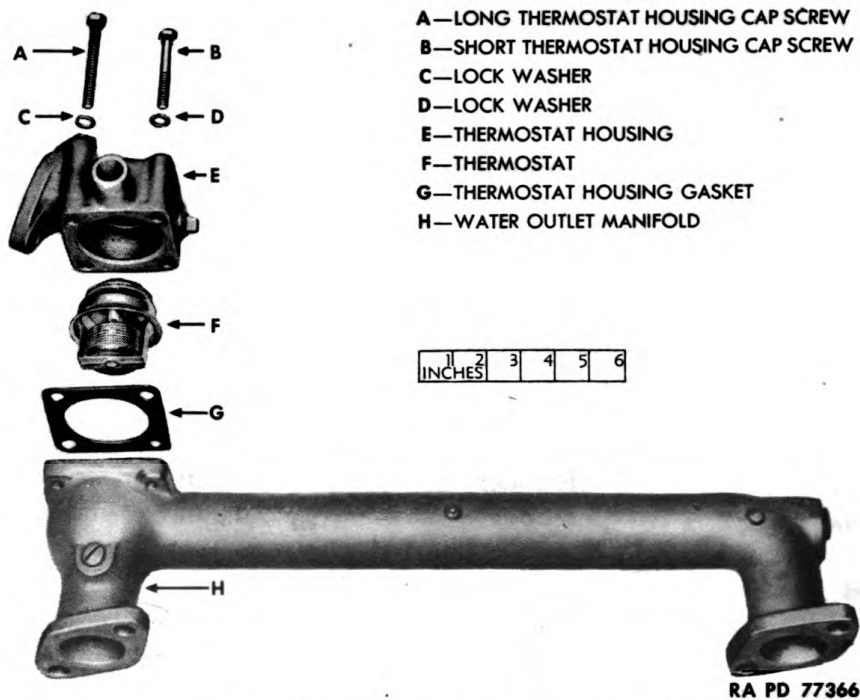


Figure 46 — Thermostat and Housing Disassembled

period by keeping the cooling fluid in the engine until an efficient operating temperature has been reached.

(2) TABULATED DATA.

Manufacturer .....	Hercules
Model .....	11770BS
Opening temperature .....	183°F.
Closing temperature .....	157°F.

b. **Maintenance.** Place thermostat suspected of malfunctioning in pan of water. Apply heat to pan. Thermostat should open at approximately 157°F. and be fully opened at 183°F. If not within 5 degrees of these temperatures, replace thermostat.

c. **Removal.**

(1) **DISCONNECT BYPASS TUBE** (fig. 46). Loosen clamp securing hose to thermostat housing. Slide clamp back and pull hose free.

(2) **DISCONNECT OUTLET ELBOW** (fig. 46). Remove two hex cap screws and lock washers securing elbow to thermostat housing. Disengage elbow. Remove gasket.

(3) **DISCONNECT THERMOSTAT HOUSING FROM OUTLET MANIFOLD** (fig. 46). Remove four hex cap screws and lock washers securing thermostat housing to manifold. Remove thermostat housing, gasket, and thermostat.

## COOLING SYSTEM

### d. Installation.

(1) **CONNECT THERMOSTAT HOUSING TO WATER OUTLET MANIFOLD** (fig. 46). Use new gasket. Position thermostat in manifold. Place housing in position on thermostat. Secure housing with four screws and lock washers.

(2) **CONNECT OUTLET ELBOW** (fig. 46). Use new gasket. Fit elbow to thermostat housing. Secure with two screws and lock washers.

(3) **CONNECT BYPASS TUBE** (fig. 46). Fit top hose of tube to thermostat housing. Position clamp at end of hose. Tighten clamp.

## 77. FAN.

### a. Description and Tabulated Data.

(1) **DESCRIPTION** (fig. 47). Fan is a roller-bearing type. It is attached to front of engine by means of a bracket. Its purpose is to cool the engine by drawing air through radiator core and to keep air circulating through engine compartment. The fan is belt driven by two V-belts from a pulley on the engine accessory drive shaft.

### (2) TABULATED DATA.

Manufacturer	Schwitzer Cummins
Model	A-111545
Number blades	Six

### b. Removal.

(1) **REMOVE FRONT MOTOR COVER AND RIGHT FRONT MOTOR COVER RISER.** Release motor cover latch on each side of front motor cover, and lift cover from cab. Remove three screws which secure right motor cover riser to toe and floor boards, and two bolts that secure riser to rear motor cover riser. Slide right riser to left, and lift riser from cab.

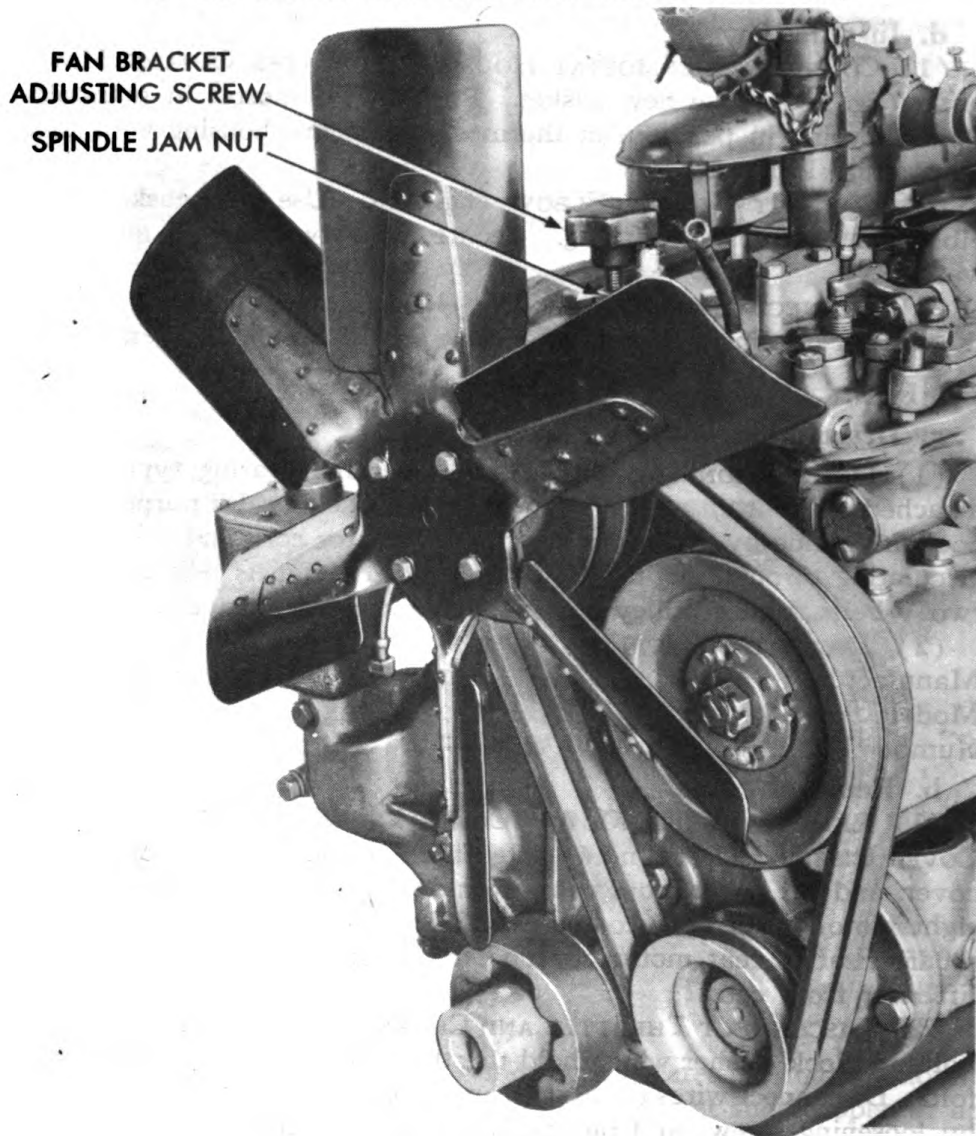
(2) **DISCONNECT THROTTLE AND CHOKE CONTROLS.** Remove nut, bolt, and lock washer which hold throttle control clip to intake manifold. Disconnect wires of throttle and choke controls from carburetor by loosening screws and pulling wires out of clamps. Pull controls free of accelerator and cross shaft assembly, and lay them aside.

(3) **REMOVE ACCELERATOR CROSS SHAFT AND SUPPORT BRACKET ASSEMBLY.** Disconnect accelerator rod and accelerator pedal link from accelerator shaft levers by removing cotter and clevis pins from the connecting yokes. Remove bolts that secure bracket to toeboards. Lay cross shaft and support bracket assembly to one side.

(4) **REMOVE RIGHT FLOOR AND TOEBOARDS.** Remove three screws and toothed washers that secure right front floor board, and lift it out. Remove three remaining screws securing right toeboard assembly, and lift it out.

(5) **REMOVE FAN BLADE ASSEMBLY.** Remove four cap screws that secure fan blade assembly to fan hub. Lift out fan blades and gasket.

**4- TO 5-TON 4x4 TRACTOR TRUCK (FEDERAL)**



RA PD 77323

**Figure 47 – Fan and Belts Installed**

(6) **REMOVE FAN HUB AND BRACKET.** Unscrew left front cylinder head cap screw to release fan bracket brace. Loosen fan spindle jam nut. Loosen fan bracket adjusting screw nut. Turn fan bracket adjusting screw to lower fan hub and loosen belts. Lift fan belts from hub. Take out three hex cap screws and one slotted countersunk screw securing fan bracket to engine and lift out fan hub and bracket.

**c. Installation.**

(1) **INSTALL FAN HUB AND BRACKET.** Install fan hub and bracket by fastening bracket to engine with three hex screws and one slotted



**COOLING SYSTEM**

countersunk screw. Fasten fan bracket base to cylinder head with left front cylinder head cap screw. Install fan belts.

(2) **INSTALL FAN BLADE ASSEMBLY.** Install fan blade assembly using a new blade gasket, and secure to hub with four hex screws. Turn fan bracket adjusting screw to tighten fan belts until they have 1/2-inch play. Tighten adjusting screw nut. Tighten fan spindle jam nut.

(3) **INSTALL RIGHT TOEBOARD ASSEMBLY.** Install right toeboard assembly, securing top of board to cowl with two screws, and then securing upper left corner of board to floor brace with one screw.

(4) **INSTALL ACCELERATOR CROSS SHAFT AND SUPPORT BRACKET ASSEMBLY.** Install accelerator cross shaft and support bracket assembly, securing it to right and left toeboards using one nut and bolt on each board. Connect accelerator rod and accelerator pedal links to their respective cross shaft levers by inserting clevis pins through yokes and securing with cotter pins.

(5) **CONNECT THROTTLE AND CHOKE CONTROLS.** Pass throttle and choke controls between accelerator cross shaft and cross shaft support bracket from front to rear. Connect throttle control to throttle shaft lever by inserting control wire into clamp and tightening clamp screw. Connect choke control to air shutter lever in same manner. Secure clip on throttle control to intake manifold with bolt, nut, and lock washer.

(6) **INSTALL RIGHT MOTOR COVER RISER AND FRONT MOTOR COVER.** Install right motor cover riser, securing it to rear motor cover riser with two bolts and to right toeboard with two screws. Position front motor cover and fasten with motor cover latch on each side.

(7) **INSTALL RIGHT FLOOR BOARD.** Install right floor board securing it with three screws and toothed washers at the front and right side and with one cap screw to the right motor cover riser.

**78. FAN BELTS.**

**a. Description and Tabulated Data.**

(1) **DESCRIPTION** (fig. 47). The two fan belts are of rubber, fabric, and cord construction. They are V-type and drive the fan and air compressor.

(2) **TABULATED DATA.**

Manufacturer .....	Gates
Length, OD .....	49 in.
Deflection permissible .....	1/2 to 3/4 in.
Adjustment .....	Raise fan in bracket

**b. Adjustment** (fig. 47). Loosen fan bracket adjusting screw nut. Loosen fan spindle jam nut. Turn fan bracket adjusting screw clockwise to tighten, counterclockwise to loosen. Deflection permissible is 1/2 to 3/4 inch midway between pulleys. After adjustment is made, tighten bracket adjusting screw nut and spindle jam nut.

**TM 9-820**  
**78-79**

**4- TO 5-TON 4x4 TRACTOR TRUCK (FEDERAL)**

c. **Removal** (fig. 47). Loosen bracket adjusting screw nut and spindle jam nut. Move spindle down by turning adjusting screw. Remove belts.

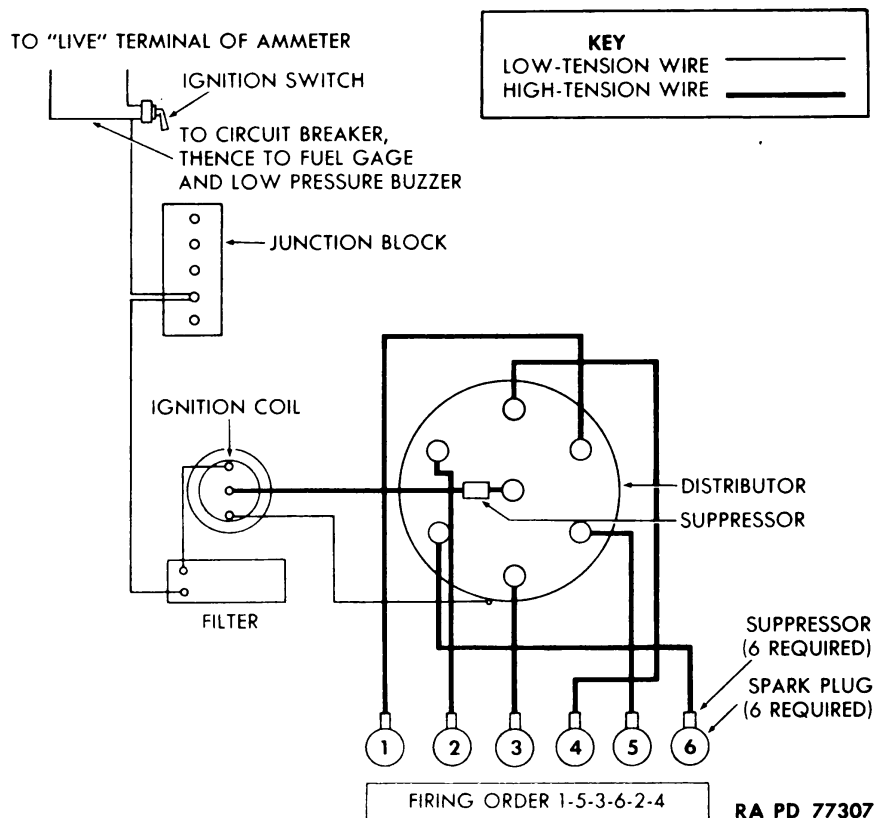
d. **Installation** (fig. 47). Place belts around pulleys. Turn adjusting screw to proper belt tightness (subpar. b, above). Tighten adjusting screw nut and spindle jam nut.

**Section XIX**

**IGNITION SYSTEM**

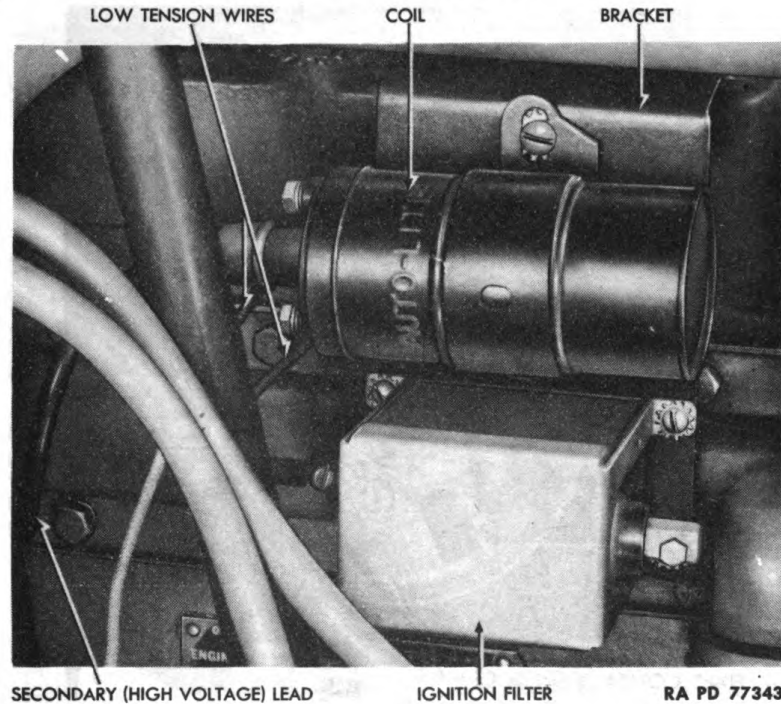
**79. DESCRIPTION.**

a. This truck uses the storage-battery type 6-volt ignition system. Components of the system are the ignition coil, condenser, distributor, spark plugs, ignition switch, and high- and low-tension wiring (fig. 48).



**Figure 48 – Wiring Diagram of Ignition System**

### IGNITION SYSTEM



**Figure 49 – Ignition Coil Installed**

b. Each unit of the ignition system is described in the paragraph of this section which deals with the particular unit.

#### 80. IGNITION COIL.

##### a. Description and Tabulated Data.

(1) **DESCRIPTION** (fig. 49). The ignition coil is mounted on a bracket which is attached to the left side of the engine near the rear of the front cylinder head. It may be reached through the left-hand cab skirt opening. Its function is to "step up" voltage for ignition.

##### (2) **TABULATED DATA.**

Manufacturer.....Auto Lite  
Model.....6 volt, 1G-4070-H

##### b. **Removal.**

(1) **REMOVE CAB SKIRT OPENING DOOR.** (fig. 2). Remove the 10 screws and toothed lock washers which secure door to left-hand cab skirt opening. Lift door from opening.

(2) **DISCONNECT WIRING** (fig. 49). Pull high-tension wire from tower on end of coil. Remove both nuts and lock washers from low-tension terminals on end of coil. Lift one wire from each terminal. Tag wires to aid in correct assembly.

(3) **REMOVE COIL FROM BRACKET** (fig. 49). Remove the two screws and lock washers which attach coil to bracket. Lift coil from bracket.

4- TO 5-TON 4x4 TRACTOR-TRUCK (FEDERAL)

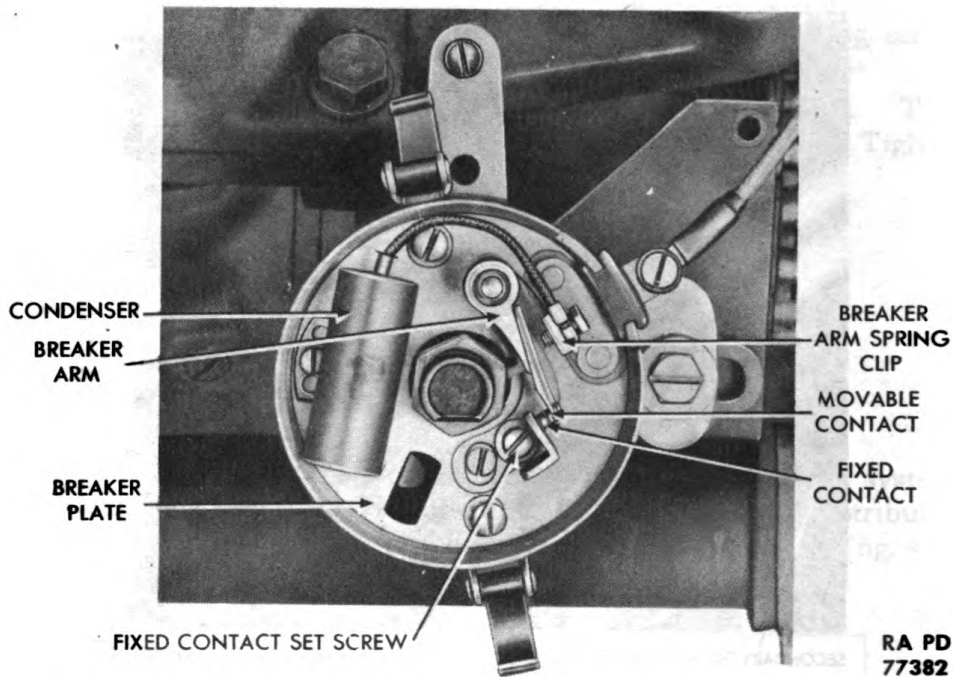


Figure 50 - Distributor - Cap and Rotor Removed

c. Installation.

(1) ATTACH COIL TO BRACKET (fig. 49). Place coil in position on its bracket and install two lock washers and screws.

(2) CONNECT WIRING (fig. 49). Place low-tension wire from distributor onto coil low-tension terminal marked "+". Place wire from filter (square metal box immediately below coil) on coil low-tension terminal marked "-". Install both lock washers and nuts on coil low-tension terminals. Plug high-tension wire from center tower of distributor into tower on coil.

(3) INSTALL CAB SKIRT OPENING DOOR (fig. 2). Place door in position on opening and install 10 toothed lock washers and screws.

81. CONDENSER.

a. Description and Tabulated Data.

(1) DESCRIPTION (fig. 50). A conventional automotive-type distributor condenser is used. Its function is to intensify the spark. It is located on the distributor breaker plate. It can be reached through the left-hand cab skirt opening.

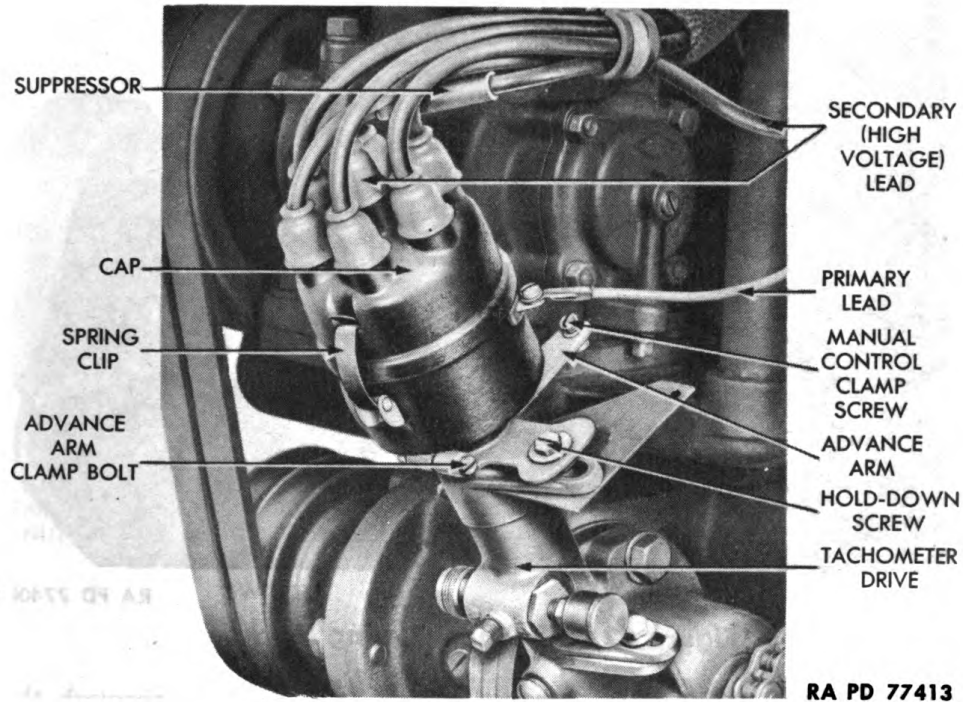
(2) TABULATED DATA.

Manufacturer .....	Auto Lite
Model .....	1GW3139

b. Removal.

(1) REMOVE CAB SKIRT OPENING DOOR (fig. 2). Remove the 10

**IGNITION SYSTEM**



**Figure 51 – Distributor Installed**

screws and toothed lock washers which hold left-hand cab skirt opening door to cab. Lift door from opening.

(2) **REMOVE DISTRIBUTOR CAP AND ROTOR** (fig. 51). Unsnap both spring clips and lift cap from body. Lift rotor.

(3) **REMOVE CONDENSER FROM BREAKER PLATE** (fig. 50). Remove screw and lock washer which attach condenser pigtail to breaker arm spring clip. Remove screw and lock washer which attach condenser to breaker plate. Lift condenser from distributor.

**c. Installation.**

(1) **INSTALL CONDENSER IN DISTRIBUTOR** (fig. 50). Place condenser in position on distributor breaker plate. Install lock washer and screw which attach condenser to breaker plate. Connect condenser pigtail to breaker arm spring clip with lock washer and screw provided for the purpose. Replace rotor. Place distributor cap in position on body and engage both spring clips.

(2) **TEST OPERATION.** Start engine. Proper functioning of engine indicates correct condenser installation.

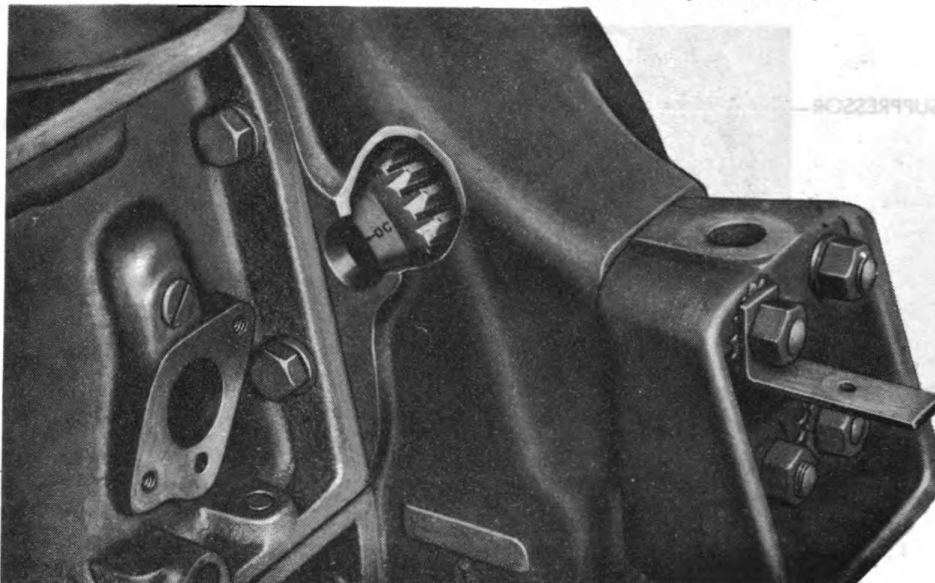
(3) **INSTALL CAB SKIRT OPENING DOOR** (fig. 2). Place door in position on opening and install the 10 toothed lock washers and screws.

**82. DISTRIBUTOR.**

**a. Description and Tabulated Data.**

(1) **DESCRIPTION** (fig. 51). The distributor is located on the

4- TO 5-TON 4x4 TRACTOR TRUCK (FEDERAL)



RA PD 77400

**Figure 52 – Flywheel Timing Marks**

left side of the engine toward the front. It is reached through the left-hand cab skirt opening. It is gear driven from the accessory shaft. Its function is to distribute high-tension voltage to the various spark plugs at the proper instant. Its major components are base, drive shaft and governor, cam, breaker plate, cap and rotor.

(2) TABULATED DATA.

Manufacturer .....	Auto Lite
Model .....	1GC-4701
Rotation (viewed from top) .....	Clockwise
Type .....	Semiautomatic
Timing provisions .....	Adjustable base, 360-degree range
Point gap .....	0.020 in.

**b. Maintenance and Adjustment.**

(1) SET IGNITION TIMING (fig. 51). Remove all spark plugs (par. 83 b) to relieve compression. Rotate engine with hand crank until No. 1 piston is on compression stroke, and "DC" mark on flywheel (fig. 52) is centered in peephole on left front side of bell housing behind fuel pump. This places number one cylinder in firing position. Loosen clamp bolt on advance arm. Loosen manual control clamp screw. Unsnap both spring clips and lift distributor cap and rotor. Rotate distributor clockwise, viewed from top, to end of slot in advance arm. Continue to rotate until points just start to open. Tighten clamp bolt on advance arm. Rotate distributor counterclockwise 1½ divisions on advance arm marker. Tighten manual control clamp screw. Place cap in position on distributor

IGNITION SYSTEM

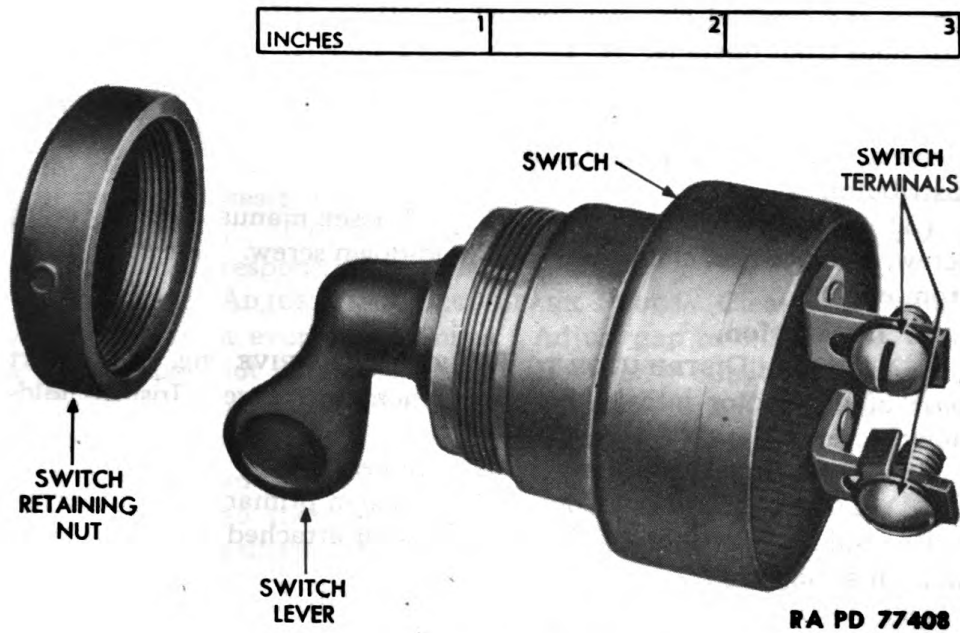


Figure 53 — Ignition Switch

and engage both spring clips. Install spark plugs (par. 83 d). This will set ignition to fire 6 degrees before top center.

(2) **ADJUST BREAKER POINT GAP** (fig. 50). Loosen both spring clips and lift cap from distributor. Lift rotor from distributor. Rotate engine with hand crank until points are opened to widest gap. Measure gap. It should be 0.020 inch. If within 0.002 inch of correct setting, no adjustment is necessary. Otherwise, loosen fixed contact set screw and moved fixed contact until gap measures 0.020 inch. Tighten set screw. Check breaker arm spring tension and adjust if necessary (step (3) below). Push rotor into place on shaft. Place cap in position on body and engage spring clips.

(3) **REPLACE BREAKER POINTS** (fig. 50). If breaker points are a grayish color and only slightly pitted, they need not be replaced. Replace rough or pitted contacts as instructed below. If it is necessary to use the old breaker points, hone them with a stone to a smooth, flat surface. Do not file. Unsnap spring clips and lift cap from distributor. Lift rotor. Remove breaker arm and condenser wire screw. Lift breaker arm from pivot. Remove fixed contact set screw and lift out contact plate. Place new contact plate in position and install fixed contact set screw fingertight. Place breaker arm in position on pivot. Install breaker arm and condenser wire screw. Adjust breaker point gap (step (2) above). Place rotor in position on shaft. Place cap in position on body and engage both spring clips.

**c. Removal.**

(1) **REMOVE CAB SKIRT OPENING DOOR** (fig. 2). Remove the 10

**4- TO 5-TON 4x4 TRACTOR TRUCK (FEDERAL)**

screws and toothed lock washers which attach left-hand door to cab. Lift door from opening.

(2) **DISCONNECT WIRES** (fig. 51). Unsnap spring clips and remove distributor cap. Leave high-tension wires attached to cap. Disconnect low-tension primary lead wire from terminal on side of distributor.

(3) **DETACH DISTRIBUTOR** (fig. 51). Loosen manual control clamp screw, advance arm clamp bolt, and hold-down screw. Lift distributor from engine.

**d. Installation.**

(1) **ATTACH DISTRIBUTOR TO TACHOMETER DRIVE** (fig. 51). Insert base of distributor into its boss in tachometer drive. Install hold-down screw.

(2) **TIME IGNITION.** Step b (1) above.

(3) **CONNECT WIRES.** Connect low-tension primary lead to terminal on side of distributor. Place cap (with attached wires) in position on spring clips.

(4) **TEST OPERATION.** Start engine. Satisfactory performance indicates correct distributor installation and timing.

(5) **INSTALL CAB SKIRT OPENING DOOR** (fig. 2). Place door in position over opening and install the 10 toothed lock washers and screws.

**83. SPARK PLUGS.**

**a. Description and Tabulated Data.**

(1) **DESCRIPTION** (fig. 13). Each cylinder is equipped with one conventional, one-piece spark plug. Spark plugs are provided to furnish an easily replaceable insulated pair of electrodes for the spark to arc across to fire the cylinders. All spark plugs project from the top of the cylinder heads and are easily reached through the right-hand cab skirt opening.

(2) **TABULATED DATA.**

Manufacturer .....	AC
Type .....	45S
Size .....	14 mm
Number per cylinder .....	1
Number per engine .....	6
Gap setting .....	0.025 in.

**b. Removal** (fig. 13). Remove 10 screws and toothed lock washers which attach right-hand cab skirt opening door to cab. Lift door from opening. Pull spark plug wires straight up to remove them from plugs. Screw spark plugs from cylinder heads. Lift gaskets from cylinder heads or spark plugs.

**c. Maintenance and Adjustment.**

(1) **INSPECT SPARK PLUGS.** Examine spark plugs upon removal. Note condition of electrodes; replace plug if electrodes are burned.



### IGNITION SYSTEM

Examine porcelain; replace plug if porcelain is cracked or broken. Note color of porcelain tip adjacent to electrode. A light brown color indicates plug is operating normally. A dead white color indicates need of a colder-type spark plug. A glossy black deposit indicates piston is "pumping" oil. A dull black deposit indicates carburetor out of adjustment, poor ignition, or low compression. If spark plug coloration indicates presence of malfunction, correct the trouble or notify higher authority. This will depend on whether job is a second or higher echelon responsibility (par. 20).

(2) CLEAN, ADJUST, AND TEST SPARK PLUGS. Clean spark plugs with a sandblast every 3,000 miles. Adjust gap to 0.025 inch. Use a round-type (not flat) feeler gage. Bend only outside electrode to make adjustment. Test cleaned and adjusted spark plugs under 105-pound air pressure. If spark fails to flow freely, replace plug.

d. Installation (fig. 13). Place a gasket on each spark plug. Screw plugs into their openings on top of cylinder heads. Push spark plug wires down onto spark plug terminals. Start engine; satisfactory performance indicates correct installation. Place cab skirt opening door over opening and install ten toothed lock washers and screws.

#### 84. IGNITION SWITCH.

##### a. Description and Tabulated Data.

(1) DESCRIPTION (fig. 53). A lever-type ignition switch is located near the lower center of the instrument panel. No lock or key is provided. The "live" wire is connected to the ammeter battery post, and the lead wire to the filter below the ignition coil. Another wire from the lead terminal diverts current to operate the fuel gage.

##### (2) TABULATED DATA.

Manufacturer ..... Douglass  
Type ..... Lever

b. Removal (fig. 53). Disconnect all three wires from the two terminals on rear of switch. Screw switch retaining nut from face of instrument panel. Pull switch from reverse side of panel.

c. Installation (fig. 53). Insert switch, lever first, through its opening in instrument panel from reverse side of panel. Turn switch so lever points down, and install switch retaining nut. Connect leads from circuit breaker and from terminal block to top terminal on switch. Connect "live" lead from ammeter battery post to lower terminal on switch. Start engine. Satisfactory engine performance indicates proper switch installation.

#### 85. WIRING.

##### a. Description and Tabulated Data.

(1) DESCRIPTION (fig. 48). High-tension wires are used to conduct high-voltage current from ignition coil to distributor and from

**4- TO 5-TON 4x4 TRACTOR TRUCK (FEDERAL)**

distributor to spark plugs. The low-tension part of the ignition system ties into the wiring harness. The spark plug wires are collected together above the distributor by a clip padded with a rubber grommet through which they all pass. The group of wires then enters a piece of loom which leads into a cable tube attached to the top of the engine by cylinder head screws. Holes along the tube provide an exit for each wire adjacent to the spark plug to which it is attached.

(2) TABULATED DATA.

High-tension Wire	Approximate Length of Wire in Inches	Federal Part Number
Spark plug wire No. 1	25	5A8153
Spark plug wire No. 2	31	5A8155
Spark plug wire No. 3	33	5A8152
Spark plug wire No. 4	38	5A8176
Spark plug wire No. 5	41	5A8180
Spark plug wire No. 6	41	5A8177
Coil to distributor wire	15	5A7544

b. **Maintenance.** Wipe all dirt from high-tension ignition wires weekly, and more often under adverse conditions. Observe condition of insulation. Replace wires having worn or cracked insulation. Inspect tips. If corroded, clean with sandpaper.

c. **Remove Spark Plug Wire.** Remove both right- and left-hand cab skirt opening doors. Pull wire from tower on distributor cap and securely attach a piece of strong cord to end of wire. Pull other end of wire from spark plug. Pull wire from cable tube. Detach cord from wire and leave string threaded through cable tube.

d. **Install Spark Plug Wire.** Attach distributor end of wire securely to string projecting from cable tube on spark plug end. Pull on string to draw wire into position through cable tube. Push tips of wire onto spark plug and into tower in distributor cap. Install doors over right- and left-hand cab skirt openings with 10 toothed lock washers and screws.

---

**Section XX**

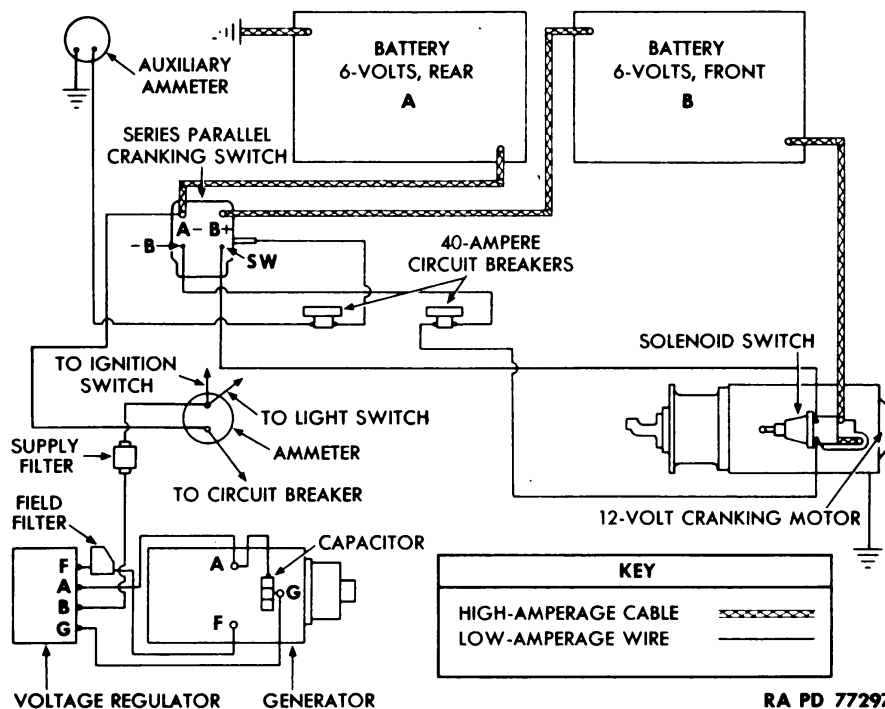
**STARTING AND GENERATING SYSTEMS**

**86. DESCRIPTION AND DATA.**

a. **Description** (fig. 54).

(1) **STARTING SYSTEM.** The starting system consists of a 12-volt cranking motor and a switch-operated solenoid, and operates from two 6-volt batteries. A series parallel cranking switch (fig. 5) connects both batteries into series to operate the cranking motor. The remainder of the electrical system operates on 6 volts with the two

**STARTING AND GENERATING SYSTEMS**



**Figure 54 – Wiring Diagram of Starting and Generating Systems**

batteries connected in parallel by means of the switch action.

(2) **GENERATING SYSTEM.** The generating system consists of a six-volt generator and a separate voltage and current regulator. Action of the series parallel cranking switch keeps the batteries hooked in parallel (6-volt) while charging, and hooked in series (12-volt) during cranking motor operation. Except for the presence of two batteries, the circuit is conventional.

**b. Data.**

<b>Generator</b>	
Make .....	Electric Auto Lite
Model .....	GEW-4802
<b>Voltage regulator</b>	
Make .....	Electric Auto Lite
Model .....	VRV-4201A
Type .....	3-unit
<b>Cranking motor</b>	
Make .....	Electric Auto Lite
Model .....	ML-4209
Type .....	12-volt
Drive .....	Bendix
<b>Solenoid switch</b>	
Make .....	Delco-Remy
Model .....	XA-569
Type .....	12-volt

4- TO 5-TON 4x4 TRACTOR TRUCK (FEDERAL)

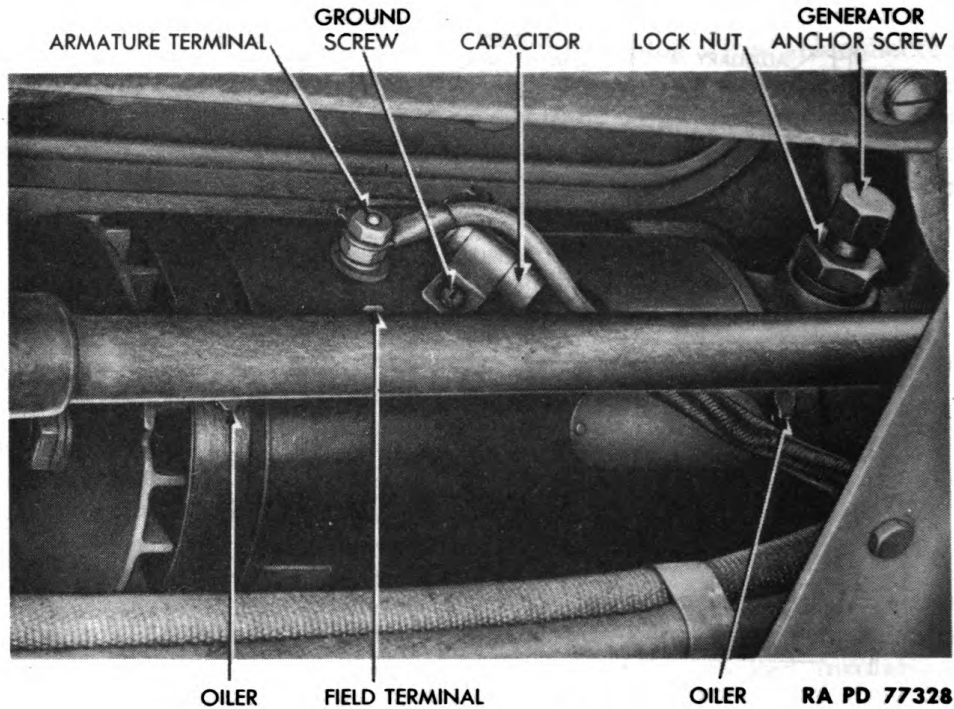


Figure 55 - Generator Installed

Cranking motor switch

Make ..... Electric Auto Lite  
 Model ..... XA-570  
 Type ..... Series parallel

Cables	Federal Part Number
Battery to solenoid .....	16A3942
Battery to "A" negative on series parallel switch .....	16A3939
Battery to "B" positive on series parallel switch .....	16A3936
Ground strap .....	16A7316

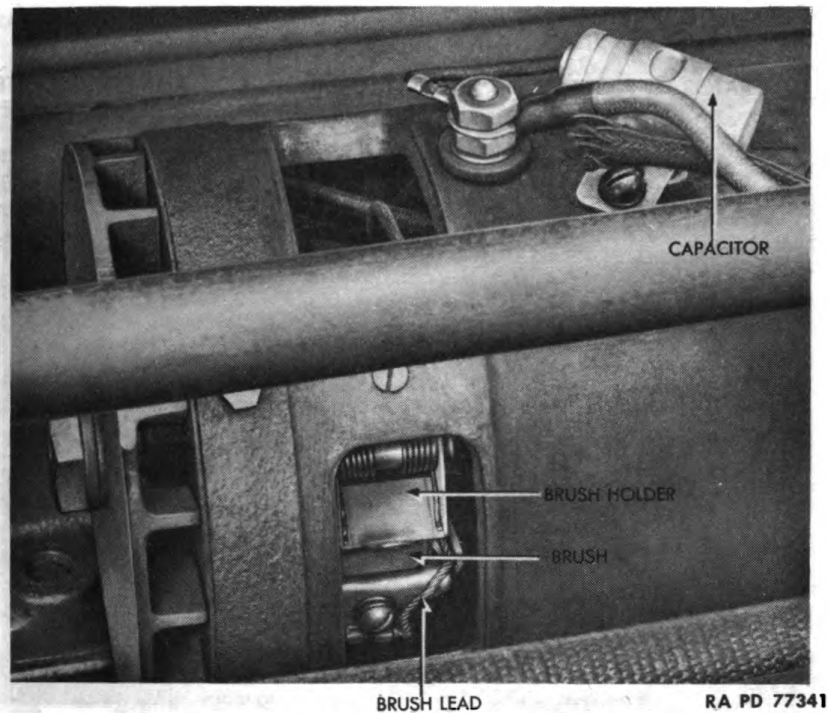
87. GENERATOR.

a. **Description** (fig. 55). A heavy-duty, two-brush type, 6-volt generator is used. It is located at the right front of the engine between the engine and the frame side rail. It can be reached through the right-hand cab skirt opening and from under the truck. It is gear driven from the engine gear case. Removal of the head band provides easy access to the commutator and two brushes. The armature shaft rides on two ball bearings which are lubricated through two built-in oilers. The function of the generator is to furnish electrical energy to keep the batteries charged, and to operate the vehicle's electrical system.

b. **Maintenance.**

(1) **INSPECT GENERATOR** (fig. 56). Remove generator head band. Note condition of commutator. If dirty or discolored, clean com-

**STARTING AND GENERATING SYSTEMS**



**Figure 56 – Generator Brush Cover Removed**

mutator (step (2) below). If commutator is rough, out-of-round, or has high mica, notify higher authority. Inspect brushes. If worn to one-half original length, replace brushes (step (3) below). Check brush lead connections to be sure they are clean and tight. Secure head band.

(2) **CLEAN COMMUTATOR.** Remove head band. Hold a piece of 2/0 flintpaper against commutator and crank engine. Blow dust from commutator with a dry air blast. Replace head band.

(3) **REPLACE BRUSHES** (fig. 56). Remove head band. Remove screw and lock washer which secure brush lead to brush holder. Lift up on brush holder lever and pull brush from holder. Raise lever and insert new brush into position in holder. Connect brush lead to holder with lock washer and screw provided for the purpose. Repeat the procedure to install other brushes. Install head band.

**c. Removal.**

(1) **REMOVE CAB SKIRT OPENING DOOR** (fig. 1). Remove the 10 screws and toothed lock washers which secure right-hand door to cab skirt opening. Lift door from cab.

(2) **DISCONNECT WIRES** (fig. 55). Disconnect the three wires from top of generator. Tag wires to facilitate installation.

(3) **DETACH GENERATOR** (fig. 55). Loosen lock nut and generator anchor screw. Work generator back carefully until generator and governor gears are out of mesh.

4- TO 5-TON 4x4 TRACTOR TRUCK (FEDERAL)

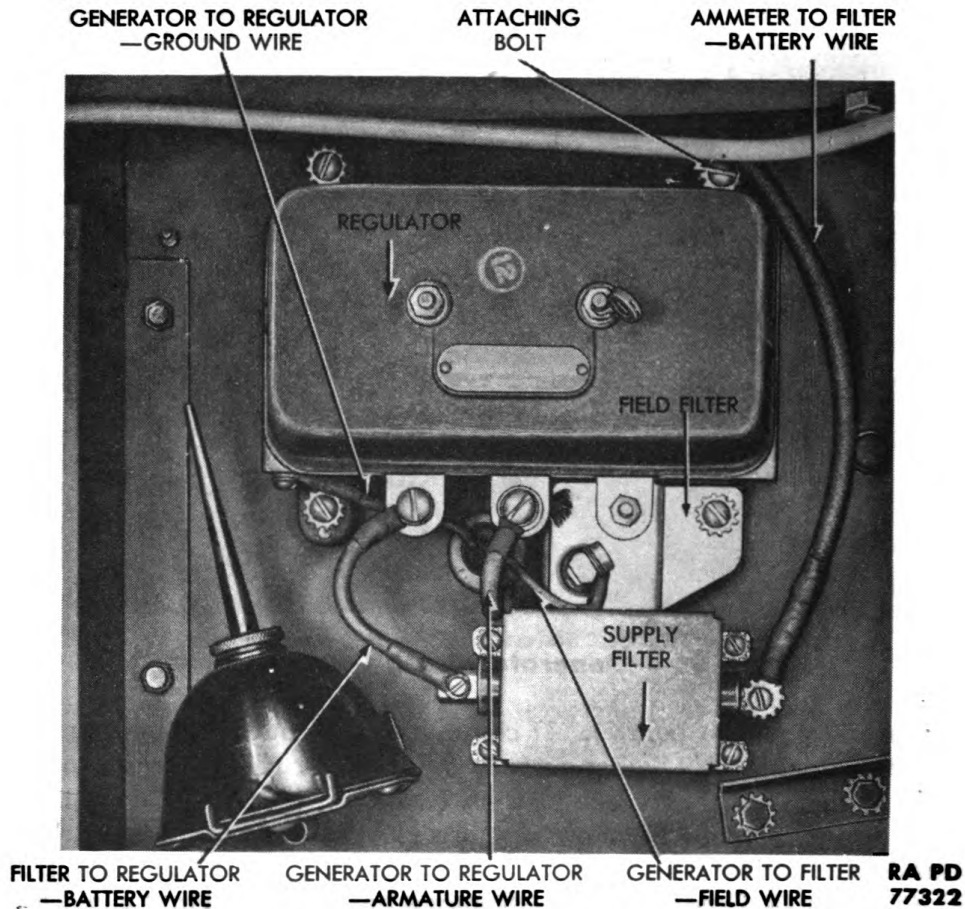


Figure 57 - Generator Regulator Installed

**d. Installation.**

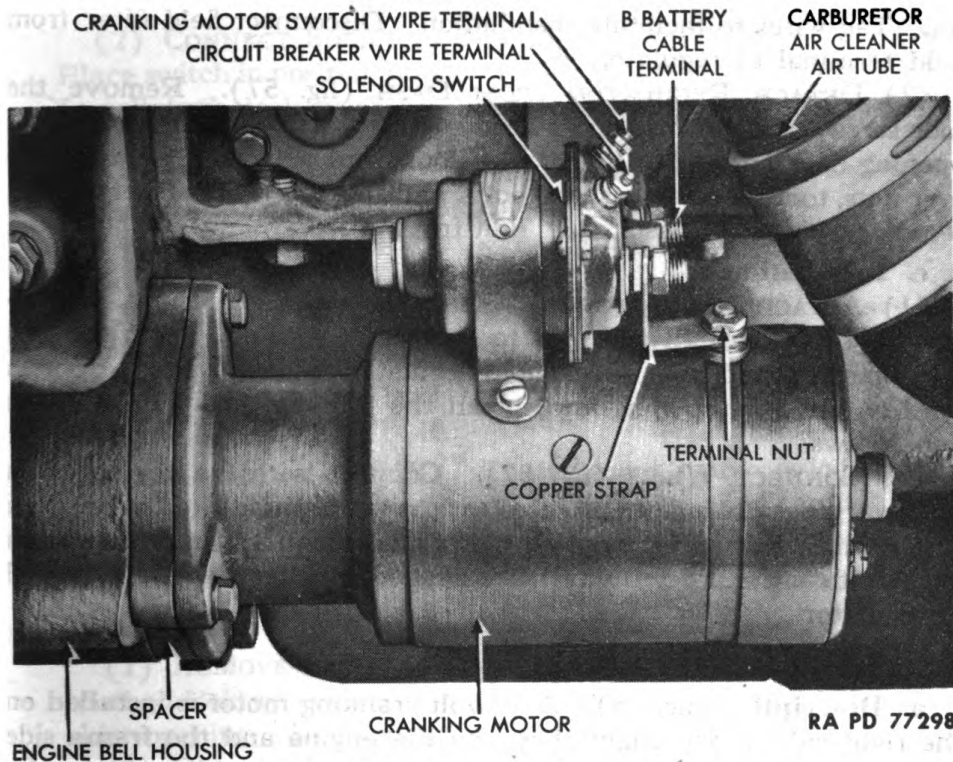
(1) **CHECK GOVERNOR GEAR.** Observe governor gear to be certain it is properly mounted, and that drilled head cap screws are wire locked.

(2) **ATTACH GENERATOR TO ENGINE** (fig. 55). Insert generator into engine opening and carefully work gear into mesh with camshaft and governor gears. Tighten anchor screw and lock nut.

(3) **CONNECT WIRES** (fig. 55). Three wires project from harness at generator. Connect as follows: black to ground screw, yellow to field (small) terminal, and red to armature (large) terminal. If a capacitor (or condenser) is used, mount it on ground screw and connect its lead to armature terminal.

(4) **POLARIZE GENERATOR** (figs. 55 and 57). Momentarily connect a jumper wire between armature terminals on generator and voltage regulator. This permits a momentary surge of current to

### STARTING AND GENERATING SYSTEMS



**Figure 58 – Cranking Motor and Solenoid**

flow to the generator which correctly polarizes it with respect to the battery. Remove jumper wire.

(5) **TEST OPERATION** (fig. 3). Start engine and observe ammeters. Eight amperes at 600 revolutions per minute indicates correct installation.

(6) **INSTALL CAB SKIRT OPENING DOOR** (fig. 1). Place door over opening and install the 10 toothed lock washers and screws.

### 88. VOLTAGE REGULATOR.

**a. Description** (fig. 57). The current and voltage regulator is mounted in the driver's compartment on the dash under the glove compartment. It is composed of three units: circuit breaker, current limiting regulator, and voltage regulator. The circuit breaker operates the same as a cut-out relay. It prevents the battery from discharging through the generator when the engine is not running. The current limiting regulator controls the amount of current delivered by the generator to the batteries. It prevents overcharging. The voltage regulator controls voltage built up by the electrical system. It thus prevents damage to lamps, circuit breakers, and other units of the electrical system.

**b. Removal** (fig. 57).

(1) **DISCONNECT WIRES.** Disconnect all three wires from regula-

**TM 9-820**  
**88-89**

**4- TO 5-TON 4x4 TRACTOR TRUCK (FEDERAL)**

tor. Tag wires to facilitate installation. Disconnect field filter from field terminal of regulator.

(2) **DETACH REGULATOR FROM DASH** (fig. 57). Remove the four screws and toothed lock washers which attach right-hand cowl opening door (fig. 1) to cowl. Lift door from opening. Remove the four nuts, toothed lock washers, bolts, and toothed lock washers which secure regulator to dash. Lift unit from dash.

**c. Installation.**

(1) **ATTACH REGULATOR TO DASH** (fig. 57). Place unit in position on dash. Install the four toothed lock washers, bolts, toothed lock washers, and nuts which hold regulator to dash. Place door in position on cowl opening and install the four toothed lock washers and screws.

(2) **CONNECT WIRES** (fig. 57). Connect wires to regulator as follows: black wire from harness to ground terminal, red wire from supply filter below regulator to battery terminal, and red wire from harness to armature terminal. Connect field filter to field terminal of regulator.

**89. CRANKING MOTOR.**

**a. Description** (fig. 58). A 12-volt cranking motor is installed on the right side of the engine between the engine and the frame side rail. It can be reached through the right-hand cab skirt opening by first removing the carburetor air cleaner air tube. It can also be reached from under the truck. Engagement with the gear on engine flywheel while cranking is accomplished by means of a Bendix drive.

**b. Removal.**

(1) **REMOVE CAB SKIRT OPENING DOOR** (fig. 1). Remove the 10 screws and toothed lock washers which secure right-hand cab skirt opening door to cab. Lift door from opening.

(2) **REMOVE CARBURETOR AIR CLEANER AIR TUBE** (par. 68 c).

(3) **DISCONNECT SOLENOID SWITCH FROM CRANKING MOTOR** (fig. 58). Remove cranking motor terminal nut and lock washer. Remove the two screws and lock washers which attach switch to motor. Lift switch from motor.

(4) **DETACH CRANKING MOTOR FROM ENGINE** (fig. 58). Remove the three cap screws and lock washers which attach cranking motor to engine bell housing. Two are accessible through cab skirt opening and one from under truck. Lift cranking motor and spacer from engine from under truck.

**c. Installation.**

(1) **ATTACH CRANKING MOTOR TO ENGINE** (fig. 58). From under truck, place spacer and cranking motor in position on engine bell housing. Install the three lock washers and cap screws which secure motor to engine. One can be installed from under truck and two through cab skirt opening.



## STARTING AND GENERATING SYSTEMS

(2) **CONNECT SOLENOID SWITCH TO CRANKING MOTOR** (fig. 58). Place switch in position on motor with copper strap on motor terminal. Install both lock washers and screws which hold switch to motor. Install cranking motor terminal, lock washer, and nut.

(3) **TEST OPERATION**. Push cranking switch. If engine cranks, satisfactory installation is indicated.

(4) **CONNECT CARBURETOR AIR CLEANER AIR TUBE** (fig. 58) (par. 68 d).

(5) **INSTALL CAB SKIRT OPENING DOOR** (fig. 1). Place door in position on opening and install the 10 toothed lock washers and screws.

### 90. SOLENOID SWITCH.

**a. Description** (fig. 58). The solenoid switch is located directly on top of the cranking motor, and may be reached through the right-hand cab skirt opening. This switch provides for a direct battery-to-cranking-motor circuit when starting.

#### **b. Removal.**

(1) **REMOVE CAB SKIRT OPENING DOOR** (fig. 1). Remove the 10 toothed lock washers and screws which secure door to right-hand cab skirt opening. Lift door from opening.

(2) **REMOVE CARBURETOR AIR CLEANER AIR TUBE** (fig. 58) (par. 68 c).

(3) **DISCONNECT WIRING FROM SWITCH** (fig. 58). From switch top right-hand terminal, disconnect black lead from harness. From switch top left-hand terminal, disconnect red lead from harness and short red lead which goes to switch front left terminal. From switch left front terminal, disconnect battery cable and short red lead which goes to switch left-hand terminal. From switch front right terminal, disconnect flat copper strap which goes to cranking motor terminal.

(4) **DETACH SWITCH FROM CRANKING MOTOR** (fig. 58). Remove the two screws and lock washers which secure switch to cranking motor. Lift switch from motor.

#### **c. Installation.**

(1) **ATTACH SWITCH TO CRANKING MOTOR** (fig. 58). Place switch in position on motor and install the two lock washers and screws.

(2) **CONNECT WIRING TO SWITCH** (fig. 58). On switch front right-hand terminal, install flat copper strap from cranking motor terminal, lock washer, and nut. On switch front left-hand terminal install short red lead which goes to switch left-hand terminal, battery cable, lock washer, and nut. On switch left-hand top terminal (adjacent to engine), install short red lead from switch front terminal, red lead from harness, lock washer, and nut. On switch right-hand top terminal (adjacent to frame side rail), install black lead from harness, lock washer, and nut.

4- TO 5-TON 4x4 TRACTOR TRUCK (FEDERAL)

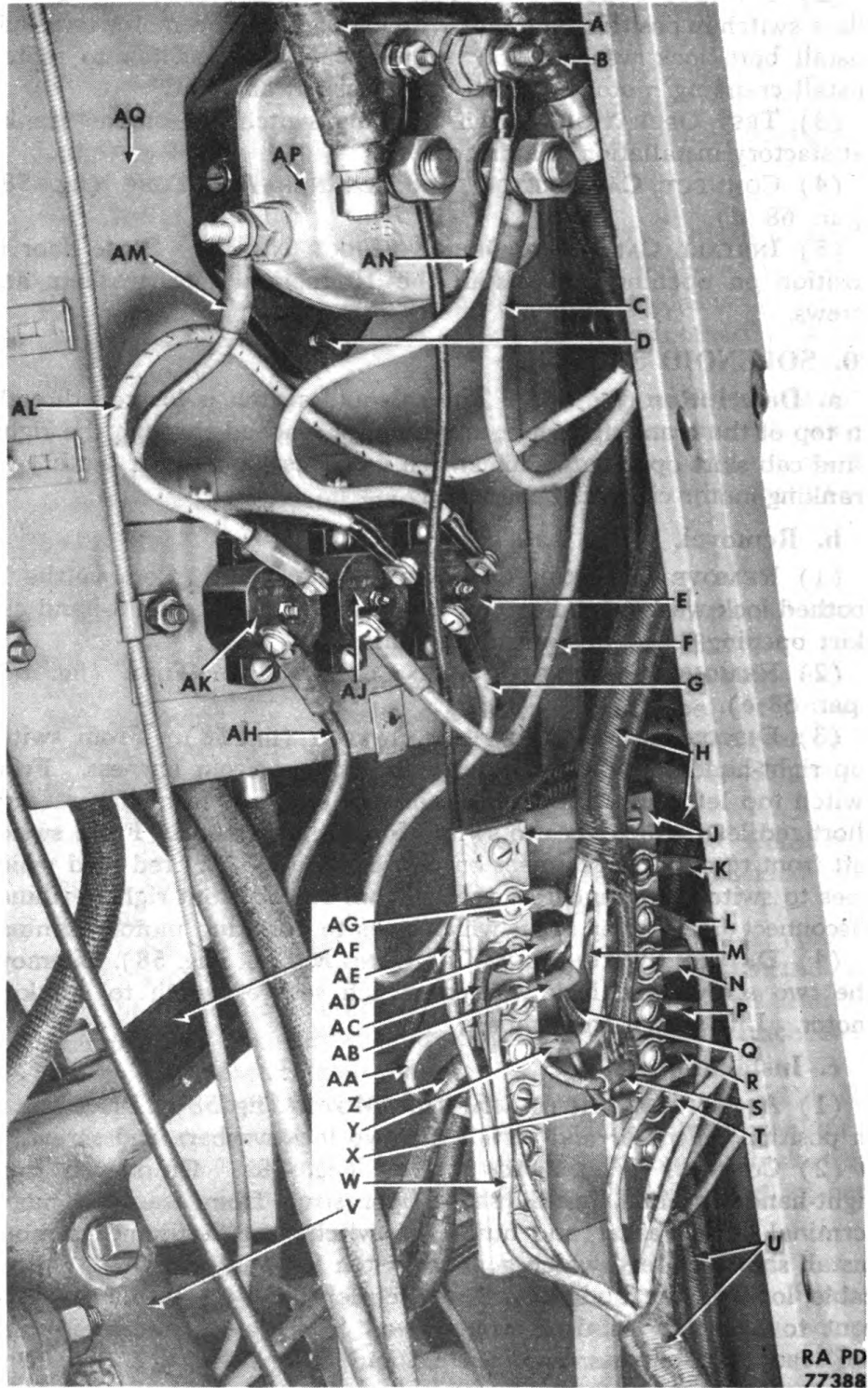


Figure 59 — Electrical Units on Reverse Side of Left-hand Dash

**STARTING AND GENERATING SYSTEMS**

**A**—"B+" BATTERY CABLE  
**B**—"A-" BATTERY CABLE  
**C**—SWITCH TO AMMETER WIRE  
**D**—DASH TO SWITCH CAP SCREW  
**E**—SOLENOID SWITCH CIRCUIT BREAKER  
**F**—AUXILIARY AMMETER TO BREAKER WIRE  
**G**—SOLENOID SWITCH TO BREAKER WIRE  
**H**—WIRING HARNESS  
**J**—JUNCTION BLOCK  
**K**—JUNCTION BLOCK TO BLACKOUT TAILLIGHT WIRE  
**L**—JUNCTION BLOCK TO TRAILER CONNECTION "TL" WIRE  
**M**—LIGHTING SWITCH "HT" TO JUNCTION BLOCK WIRE  
**N**—JUNCTION BLOCK TO FOOT DIMMER SWITCH WIRE  
**P**—JUNCTION BLOCK TO STOP LIGHT SWITCH WIRE  
**Q**—LIGHTING SWITCH "A" TO JUNCTION BLOCK WIRE  
**R**—JUNCTION BLOCK TO BLACKOUT STOP LIGHT WIRE  
**S**—LIGHTING SWITCH "BS" TO JUNCTION BLOCK WIRE  
**T**—JUNCTION BLOCK TO BLACKOUT DRIVING LIGHT WIRE  
**U**—WIRING HARNESS  
**V**—STEERING GEAR  
**W**—JUNCTION BLOCK TO BLACKOUT TAILLIGHTS WIRE  
**X**—BLACKOUT DRIVING LIGHT SWITCH TO JUNCTION BLOCK WIRE  
**Y**—IGNITION SWITCH TO JUNCTION BLOCK WIRE  
**Z**—JUNCTION BLOCK TO FILTER WIRE  
**AA**—JUNCTION BLOCK TO BLACKOUT MARKER LIGHTS WIRE  
**AB**—LIGHTING SWITCH "BHT" TO JUNCTION BLOCK WIRE  
**AC**—JUNCTION BLOCK TO FUEL GAGE TANK UNIT WIRE  
**AD**—FUEL GAGE TO JUNCTION BLOCK WIRE  
**AE**—JUNCTION BLOCK TO STOP LIGHT SWITCH WIRE  
**AF**—CLUTCH PEDAL  
**AG**—LIGHTING SWITCH "SS" TO JUNCTION BLOCK WIRE  
**AH**—AMMETER TO HORN BREAKER WIRE  
**AJ**—AUXILIARY AMMETER CIRCUIT BREAKER  
**AK**—HORN CIRCUIT BREAKER  
**AL**—HORN RELAY TO BREAKER WIRE  
**AM**—SWITCH TO AUXILIARY AMMETER BREAKER WIRE  
**AN**—SWITCH TO SOLENOID BREAKER WIRE  
**AP**—CRANKING MOTOR SWITCH  
**AQ**—DASH

RA PD 77388A

**Legend for Figure 59 – Electrical Units  
on Reverse Side of Left-hand Dash**

**4- TO 5-TON 4x4 TRACTOR TRUCK (FEDERAL)**

(3) **TEST OPERATION.** Depress cranking motor switch. Normal operation of cranking motor indicates correct switch installation.

(4) **INSTALL CARBURETOR AIR CLEANER AIR TUBE** (fig. 58) (par. 68 d).

(5) **INSTALL CAB SKIRT OPENING DOOR** (fig. 1). Place door in position on opening and install the 10 toothed lock washers and screws.

**91. CRANKING MOTOR SWITCH.**

**a. Description** (figs. 5 and 59). The cranking motor switch is located on the dash above the clutch pedal. The main body of the switch is on the reverse side of the dash, but the push button extends through the dash into the driver's compartment. Access to the main body is through the left-hand cowl opening door. The switch is operated with the left foot. Pressing the button operates the magnetic switch, which, in turn, operates the cranking motor. When depressed, the switch connects the batteries in series for 12-volt cranking motor operation. When released, the switch connects the batteries in parallel for 6-volt generator operation.

**b. Removal.**

(1) **REMOVE COWL OPENING DOOR** (fig. 1). Remove the four screws and toothed lock washers which attach door to left-hand cowl opening. Lift door from opening.

(2) **DISCONNECT WIRES FROM SWITCH** (fig. 59). Disconnect all five wires from switch. Tag wires to facilitate installation.

(3) **DETACH SWITCH FROM DASH** (fig. 59). From driver's compartment, remove the two cap screws which hold switch to dash. Lift switch from dash through cowl opening.

**c. Installation.**

(1) **ATTACH SWITCH TO DASH** (fig. 59). Insert switch through cowl opening into position on dash. Hold switch in position while another man inside driver's compartment installs both cap screws which secure switch to dash.

(2) **CONNECT WIRING TO SWITCH** (fig. 59). On switch terminal marked "B-", install red wire from left-hand circuit breaker, lock washer, and nut. On terminal marked "SW", install black wire from harness, lock washer, and nut. On terminal on right side of switch (toward engine), install green wire from circuit breaker, lock washer, and nut. On terminal marked "A-," install negative cable from rear battery, red wire from harness, lock washer, and nut. On terminal marked "B+," install positive cable from front battery.

(3) **TEST OPERATION.** Start engine with cranking motor. Normal operation of cranking motor and generating system indicates correct switch installation.

(4) **INSTALL COWL OPENING DOOR** (fig. 1). Place door in position on cowl opening and install the four toothed lock washers and screws.

**TRANSMISSION**

**92. CABLES.**

**a. Description** (fig. 54). Four heavy, high-amperage battery cables are used. They are of similar construction but of different lengths. Each consists of multiple strands of braided copper wire protected by an insulating covering. Each has a conventional battery terminal soldered on one end and a conventional tip on its other end. One leads from the negative post of the front battery to the cranking motor solenoid switch. Another leads from the positive terminal of the front battery to the series parallel cranking motor switch. The third leads from the negative post of the rear battery to the series parallel cranking motor switch. The remaining cable grounds the positive post of the rear battery to the frame.

**b. Maintenance.** Inspect battery cables. Be sure terminals are tight. Clean corrosion from connections. Apply a film of grease to connections which have a tendency to corrode. Note condition of insulation. If signs of wear are evident, install loom, wrap with tape, or replace cable.

**c. Removal** (fig. 106). Remove battery box cover and disconnect battery cable from battery. Trace cable toward its other end and open all clips along length of cable. Disconnect cable at remaining end. Work cable from vehicle.

**d. Installation** (figs. 54 and 106). Place cable into same position occupied by original cable. Connect cable to terminal on opposite end from battery. Trace cable toward battery and connect all cable clips. Connect cable tightly to battery. Apply a film of grease to terminal and battery post after connection is made. Depress cranking motor switch. Normal functioning of cranking motor indicates satisfactory installation. Install battery box cover.

---

**Section XXI**

**TRANSMISSION**

**93. DESCRIPTION AND TABULATED DATA.**

**a. Description** (fig. 60). The transmission is a selective sliding-gear type providing 5 speeds forward and one reverse. 12 screws and lock washers secure the transmission to the bell housing. Gears are changed by means of a shifting lever which comes up through the cab floor.

**b. Tabulated Data.**

Manufacturer	Clark
Model	326V0
Type—5 speed	Helical sliding gear
Mounting	Unit power plant

4- TO 5-TON 4x4 TRACTOR TRUCK (FEDERAL)

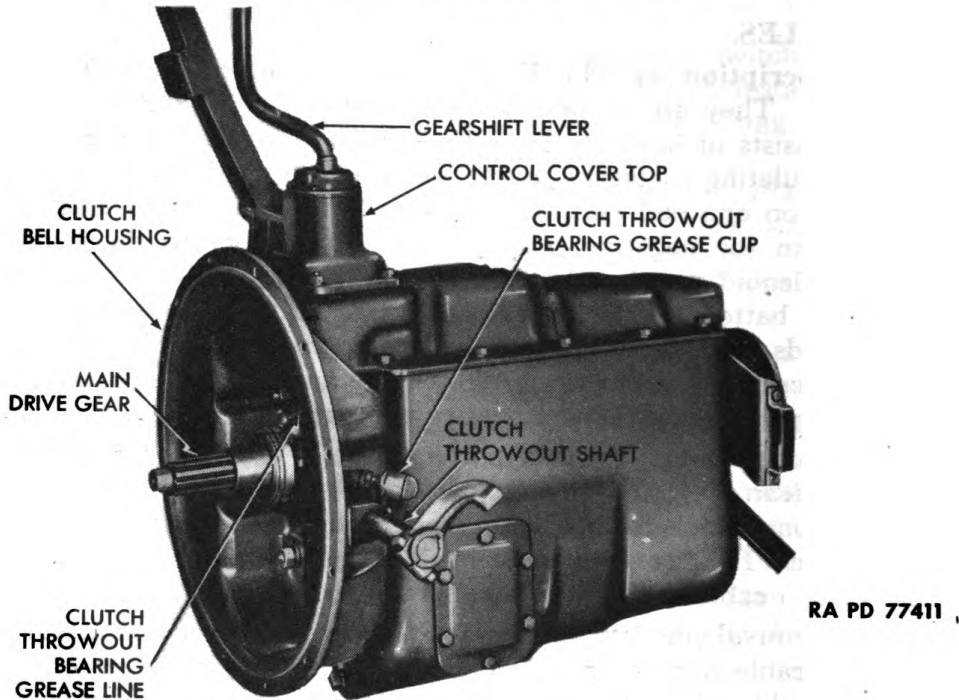


Figure 60 – Transmission

94. REMOVAL.

a. **Remove Shifter Lever Boots and Rear Motor Cover.** Remove seat cushions. Remove six screws and washers which secure motor cover and lever boots to seat riser brackets. Remove cover and boots as a unit.

b. **Remove Trailer Connections and Frame Platform** (fig. 26). Remove the two clamp nuts which secure the two air lines to the two tractor connections at front of frame platform. Remove two screws, lock washers, and nuts which secure trailer light connection to deck plates. Remove seven hexagon cap screws, flat washers, lock washers, and nuts which secure deck plates to frame. Remove plates.

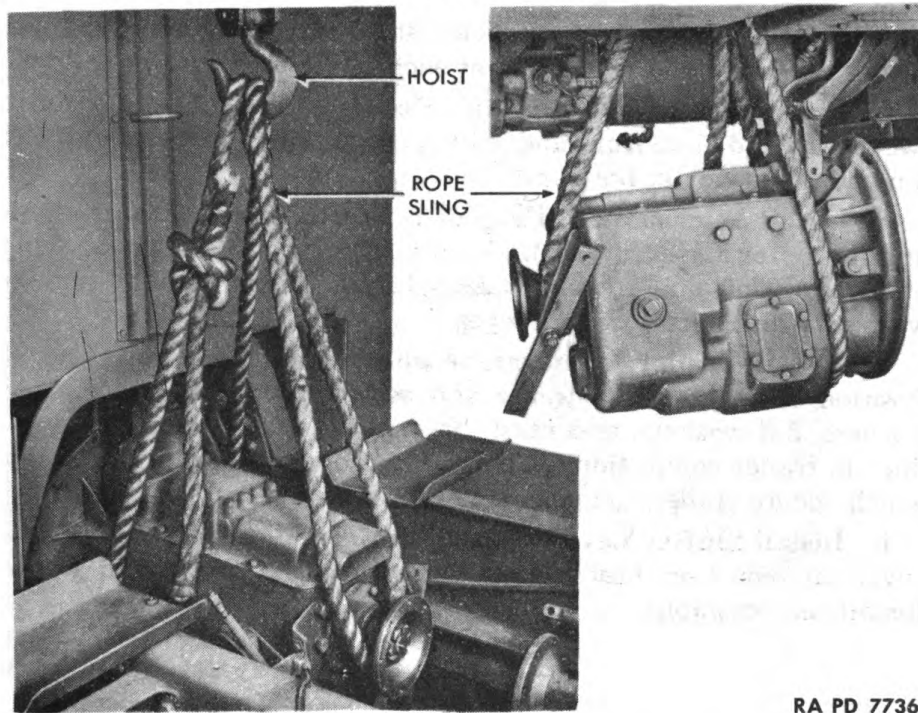
c. **Remove Intermediate Propeller Shaft (Between Transmission and Transfer Case)** (fig. 66). Remove 16 bolts, nuts, and lock washers which secure shaft to transmissions and transfer case. Remove shaft.

d. **Disconnect Transfer Case Shift Rod** (fig. 25). Remove cotter key and clevis pin at both ends of rod. Remove rod.

e. **Disconnect Front Axle Declutching Rods** (fig. 62). Remove cotter key and clevis pin at both ends of both rods. Remove rods.

f. **Disconnect Propeller Shaft Brake Rod** (fig. 25). Remove cotter key and clevis pin from both ends of rod. Remove rod.

**TRANSMISSION**



RA PD 77360

**Figure 61 – Transmission Removal**

- g. Remove Exhaust Pipe** (par. 69 b).
- h. Remove Front Axle Propeller Shaft** (fig. 65). Remove four bolts, lock washers and nuts which secure shaft at either end to driving flanges. *NOTE: Be careful not to drop shaft.*
- i. Remove Transmission** (fig. 61). Tie a rope sling around transmission and support its weight with a hoist. Remove 12 screws and lock washers which secure transmission to bell housing. Pull transmission straight back until main drive gear clears clutch. Lower transmission to floor and slide from under vehicle. *NOTE: Do not let transmission drag on clutch as this will damage clutch seriously.*

**95. INSTALLATION.**

- a. Position Transmission on Bell Housing** (fig. 61). Install 12 screws and lock washers which secure it to housing. Remove sling.
- b. Install Front Axle Propeller Shaft** (fig. 65). Position shaft between front axle and transfer case driving flanges. Install four bolts, lock washers, and nuts which secure it to flanges.
- c. Install Exhaust Pipe** (par. 69 c).
- d. Install Propeller Shaft Brake Rod** (fig. 25). Position rod between brake lever yoke plate and brake operating lever on propeller shaft brake. Install clevis pin and cotter key at both ends.
- e. Install Front Axle Declutching Rods** (fig. 62). Position rods between declutching rod yoke and right-hand bell crank yoke and

**4- TO 5-TON 4x4 TRACTOR TRUCK (FEDERAL)**

between left-hand bell crank yoke and rear declutching rod yoke. Install clevis pin and cotter key at each of the four ends.

f. **Install Transfer Case Shift Rod** (fig. 25). Position rod between shift rod yoke front and shift rod yoke rear. Secure with clevis pin and cotter key at both ends.

g. **Install Intermediate Propeller Shaft Between Transmission and Transfer Case** (fig. 65). Position shaft between driving flanges of transmission and transfer case. Install 16 bolts, nuts, and lock washers which secure it to flanges.

h. **Install Trailer Connections and Frame Platform** (fig. 26). Position deck plates on frame and secure with seven screws, lock washers, flat washers, and nuts. Install two clamp nuts securing air lines to trailer connections. Install two bolts, nuts, and lock washers which secure trailer connection to plates.

i. **Install Shifter Lever Boots and Rear Motor Cover**. Position cover on seat riser brackets. Secure with six screws and washers. Install seat cushions.

---

**Section XXII**

**TRANSFER CASE**

**96. DESCRIPTION AND TABULATED DATA.**

a. **Description** (fig. 63). Engine torque is transmitted to front and rear driving axles through a transfer case located in center of frame back of the transmission. Power connection is made by three propeller shafts. Gear ratio range selection is controlled by a lever within the cab (fig. 3). A second lever provides for engaging or declutching the front driving axle (fig. 3). The front axle drive may or may not be engaged, as desired, when the vehicle is operating in high range; but it is automatically engaged when vehicle is operating in low range.

**b. Tabulated Data.**

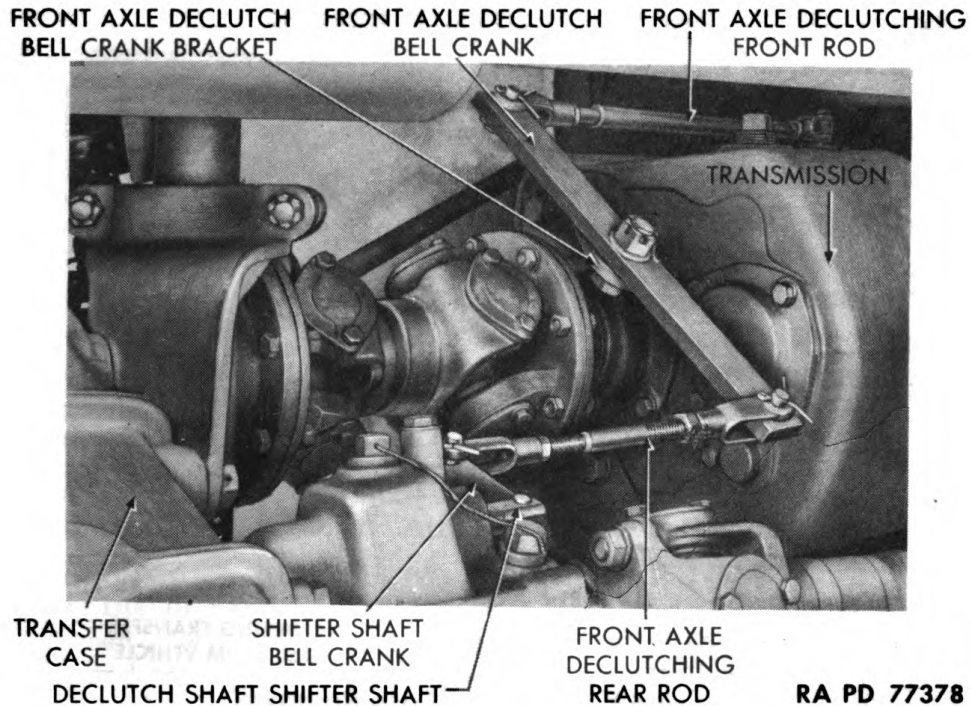
Manufacturer .....	Timken-Wisconsin
Model .....	T-76
Type .....	Two speed with front axle declutching unit
Mounting .....	3 point, amidship of frame

**97. LINKAGE REMOVAL.**

a. **Disconnect Transfer Case Shift Rod** (figs. 25 and 62.) Remove cotter key and clevis pin which secure rod at either end. Remove rod.



**TRANSFER CASE**



**Figure 62 – Transmission Case Linkage**

**b. Remove Front Axle Declutching Rods** (figs. 25 and 62). Disengage rear rod at left-hand bell crank yoke and rear declutching rod yoke by removing clevis pin and cotter key at either end. Remove rod. Disengage front rod at right-hand bell crank yoke and declutching rod yoke by removing clevis pin and cotter key at either end. Remove rod.

**98. LINKAGE INSTALLATION.**

**a. Install Front Axle Declutching Rods** (figs. 25 and 62.) Position rear rod between left-hand end of bell crank and rear declutching rod lever. Install clevis pin and cotter key at either end. Position front rod between right-hand end of crank and declutching rod lever. Install clevis pin and cotter key at either end.

**b. Install Transfer Case Shift Rod** (figs. 25 and 62). Position rod between transfer case shift lever and transfer case gearshift shaft. Install clevis pin and cotter key at either end.

**99. TRANSFER CASE REMOVAL** (fig. 63).

**a. Remove Frame Platform** (fig. 26). Remove the two clamp nuts securing trailer air connections to frame platform. Remove two screws, lock washers, and nuts securing trailer light connection to frame platform. Remove the seven cap screws, flat washers, lock washers, and nuts which secure platform to frame. Remove platform.

4- TO 5-TON 4x4 TRACTOR TRUCK (FEDERAL)

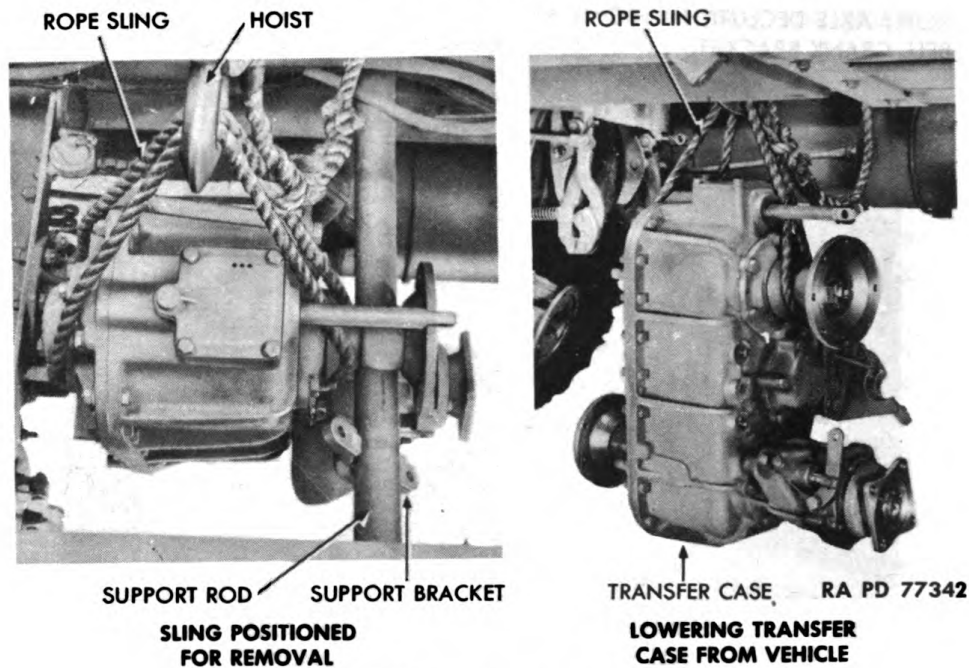


Figure 63 - Transfer Case Removal

b. Remove Front Axle Declutching Rod (fig. 25). Remove cotter key and clevis pin at bell crank. Drop rod down.

c. Remove Transfer Case Shift Rod (fig. 25). Remove cotter pin and clevis pin at both ends. Remove rod.

d. Remove Front Axle Propeller Shaft (fig. 25). Remove four flange bolts, lock washers, and nuts at either end. Remove shaft.

e. Remove Intermediate Propeller Shaft (fig. 65). Remove the eight bolts, lock washers, and nuts on either end. Remove shaft.

f. Disconnect Speedometer Cable (fig. 25). Disengage speedometer cable at idler shaft front bearing cover. Pull cable free.

g. Remove Propeller Shaft Brake Rod (fig. 25). Remove the cotter pin and clevis pin from each end of the rod.

h. Remove Propeller Shaft Brake Shoe Return Springs (fig. 25). Pull shoes together and unhook springs from bottom of shoes on either side of brake disk. Remove springs.

i. Disconnect Rear Axle Propeller Shaft and Brake Disk (fig. 25) (par. 103 a).

j. Disconnect Bond Strap (fig. 119). Remove screw and lock washer holding bond strap to frame. Bend strip back.

k. Remove Supports and Lower Transfer Case to Floor. Attach rope sling as illustrated (fig. 63). Remove two cap screws and lock washers securing transfer case bracket cap to support bracket. Remove four bolts, nuts, and cotter pins securing front support bracket

## TRANSFER CASE

caps to support rod. Remove eight cap screws, lock washers, and nuts securing support rod to frame. Slide rod over as necessary to free transfer case. Lower case from vehicle.

### 100. INSTALLATION.

**a. Attach Transfer Case to Support Brackets** (fig. 25). Attach rope sling as illustrated (fig. 63). Install eight screws, lock washers, and nuts securing support rod to frame. Position case to supporting rod. Secure front support bracket caps with two cap screws and lock washers.

**b. Install Rear Axle Propeller Shaft** (fig. 25). Position brake disk between brake shoes. Position rear propeller shaft driving flange to brake disk. Secure with the eight bolts, nuts, and lock washers.

**c. Install Propeller Shaft Brake Shoe Return Springs** (fig. 25). Pull brake shoes together. Attach springs to bottom of shoes on both sides.

**d. Install Propeller Shaft Brake Rod** (fig. 25). Position rod between lever adapter and operating lever. Secure with two clevis pins and cotter pins. Adjust brake (par. 130 b).

**e. Connect Speedometer Cable** (fig. 25). Position cable on idler shaft front bearing cover, tightening bushing which secures it to cover.

**f. Install Intermediate Propeller Shaft** (fig. 65). Position shaft between transmission and transfer case. Secure with eight flange bolts, lock washers, and nuts on either end. *NOTE: Tighten flange nuts alternately to prevent distortion.*

**g. Install Front Axle Propeller Shaft** (fig. 25). Position between transfer case and front axle. Secure with four flange bolts, lock washers, and nuts on either end. *NOTE: Tighten flange bolts alternately to prevent distortion that would cause a vibration.*

**h. Install Transfer Case Shift Rod.** Position rod between transfer case shift lever and transfer case gearshift shaft. Install clevis pin and cotter key at either end.

**i. Install Front Axle Declutching Rods.** Position rear rod between left-hand end of bell crank and rear declutching rod lever. Install clevis pin and cotter key at either end. Position front rod between right-hand end of crank and declutching rod lever. Install clevis pin and cotter key at either end.

**j. Connect Bond Strap** (fig. 119). Attach bond strap from transfer case to frame with one screw and lock washer which secure it to frame.

4- TO 5-TON 4x4 TRACTOR TRUCK (FEDERAL)

Section XXIII

PROPELLER SHAFTS AND UNIVERSAL JOINTS

101. DESCRIPTION AND TABULATED DATA.

a. **Description** (fig. 64). Engine power is transmitted to the driving axles by three propeller shafts. One (short) shaft connects the transmission to the transfer case. The other two (long) shafts connect the transfer case to the front and rear driving axles. Each propeller shaft has two universal joints. An allowance for back and forth movement of the axles is provided by a slip joint at one end of each shaft. If the slip joint is removed from shaft, care must be exercised when assembling to make sure yokes are in line.

b. **Tabulated Data.**

Manufacturer .....	Spicer
Number of shafts used .....	3
Number of universals used .....	6

102. FRONT AXLE PROPELLER SHAFT AND UNIVERSAL JOINTS.

a. **Removal** (fig. 65). Remove the four flange bolts, lock washers, and nuts at either end. Remove shaft.

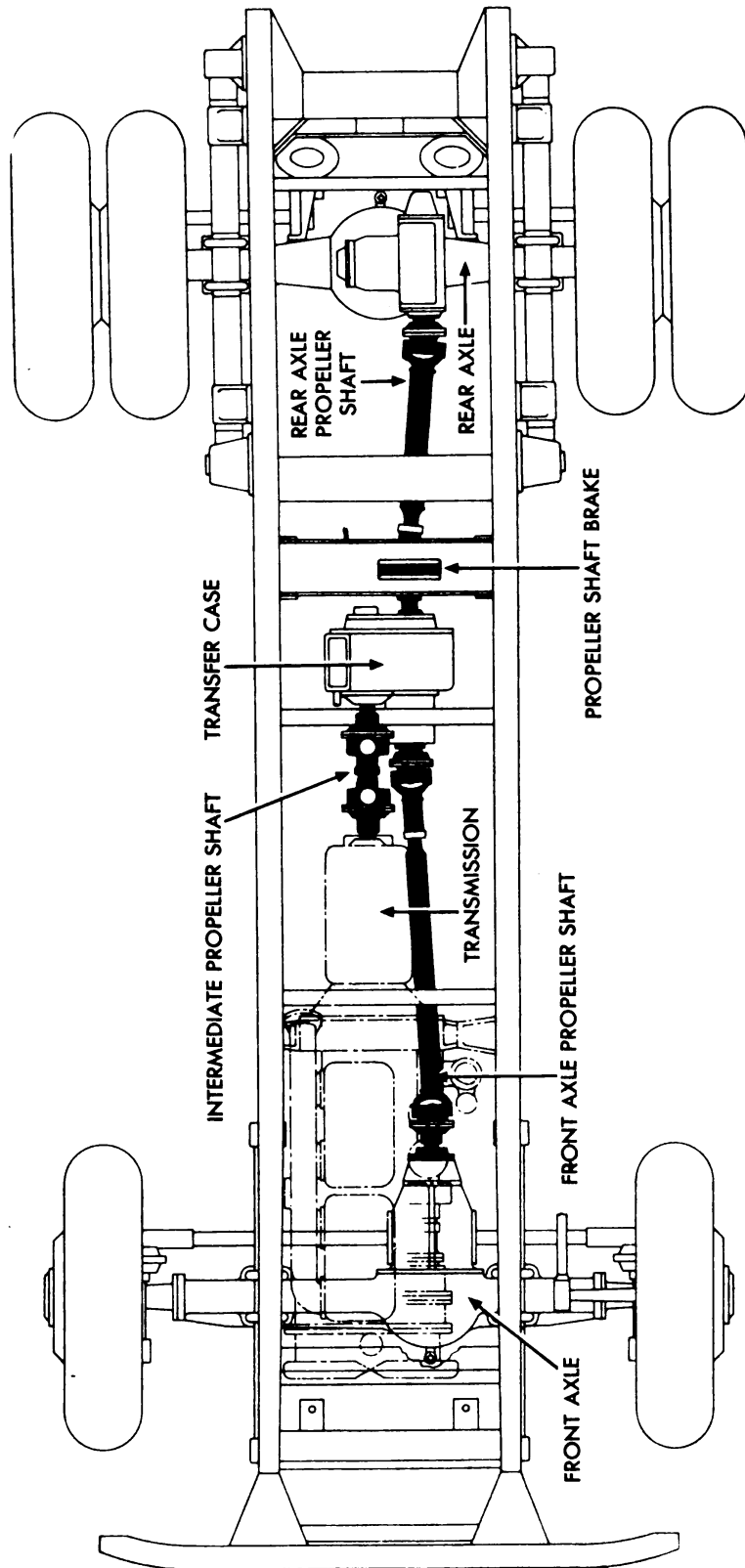
b. **Installation** (fig. 65). Position between transfer case and front axle. Secure with the four flange bolts, lock washers, and nuts on either end. *NOTE: Tighten flange bolts alternately to prevent distortion which would result in vibration.*

103. REAR AXLE PROPELLER SHAFT AND UNIVERSAL JOINTS.

a. **Removal** (fig. 65). Remove the eight nuts and lock washers from the eight bolts which attach flange at front of shaft to transfer case. Rear axle propeller shaft universal joint flange is attached to transfer case through propeller shaft brake disk. Remove or support disk and remove the eight bolts. Remove cotter pin and through shaft nut. Pull end yoke from through shaft and lift propeller shaft from vehicle. Tap through shaft key from through shaft.

b. **Installation** (fig. 65). Tap through shaft key into its slot in through shaft. Slide end yoke onto through shaft and key. Install through shaft nut and cotter pin. Place propeller shaft brake disk and propeller shaft front flange in position on transfer case driving flange. Install eight bolts, lock washers, and nuts.

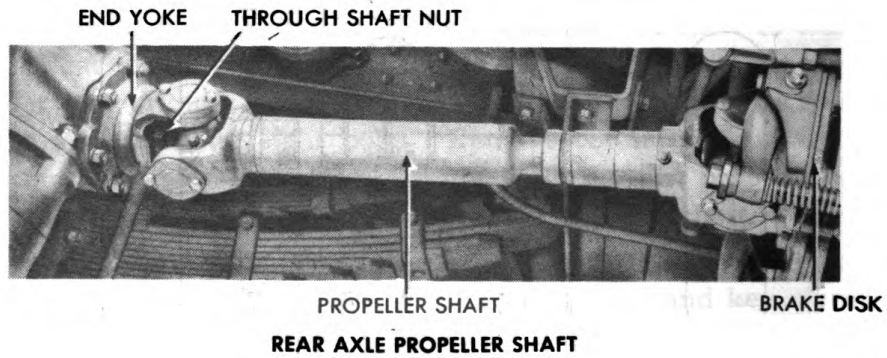
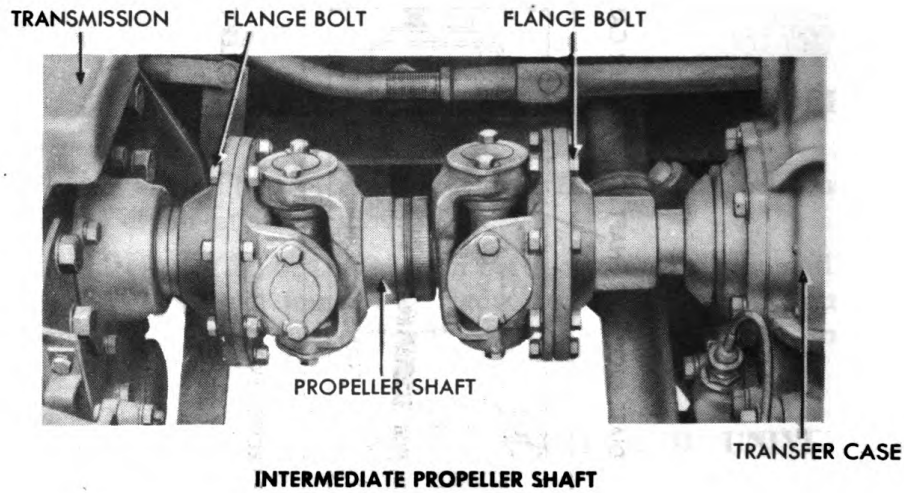
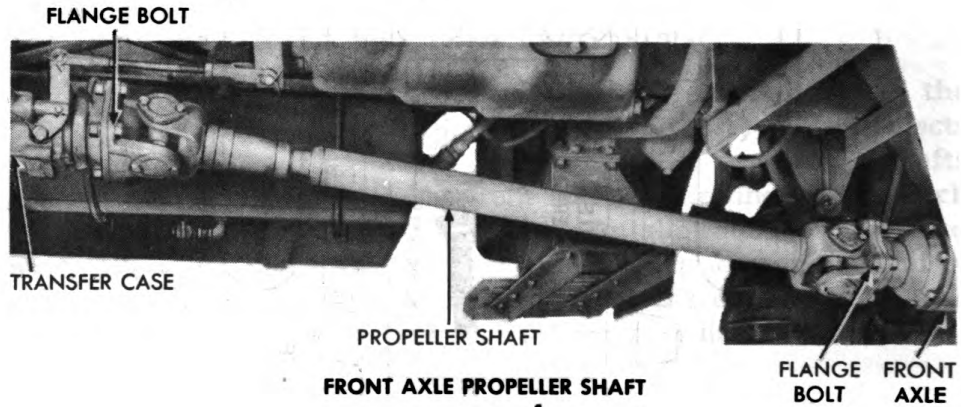
PROPELLER SHAFTS AND UNIVERSAL JOINTS



RA PD 77346

Figure 64 — Propeller Shaft Lay-out

4- TO 5-TON 4x4 TRACTOR TRUCK (FEDERAL)



RA PD 77371

Figure 65.— Propeller Shafts Installed

**FRONT AXLE**

**104. INTERMEDIATE PROPELLER SHAFT AND UNIVERSAL JOINTS.**

a. **Removal** (fig. 65). Remove the eight flange bolts, lock washers, and nuts on either end. Remove shaft.

b. **Installation** (fig. 65). Position shaft between transmission and transfer case. Secure with eight flange bolts, lock washers, and nuts on either end. *NOTE: Tighten flange bolt nuts alternately to prevent distortion.*

---

**Section XXIV**

**FRONT AXLE**

**105. DESCRIPTION AND TABULATED DATA.**

a. **Description** (fig. 66). The front axle is designed to permit use of a double reduction type of differential carrier unit with full-floating housing construction. The carrier unit is offset to left of axle center. This permits propeller shaft to pass to left of engine oil pan and thus provides full road clearance. Specially designed steering knuckles containing universal joints connect axle to wheels. Toe-in and steering synchronization of front wheels is controlled by a three-piece type tie rod with yoke ends threaded on a cross tube. The yoke ends connecting to knuckle flanges are locked in position with steel pins. The tube ends have different thread pitches to provide for minute adjustment of toe-in.

b. **Tabulated Data.**

**Front axle**

Manufacturer .....	Timken-Wisconsin
Model .....	F-2090-W-73-X-1
Ratio .....	8.43-1
Type .....	Full-floating

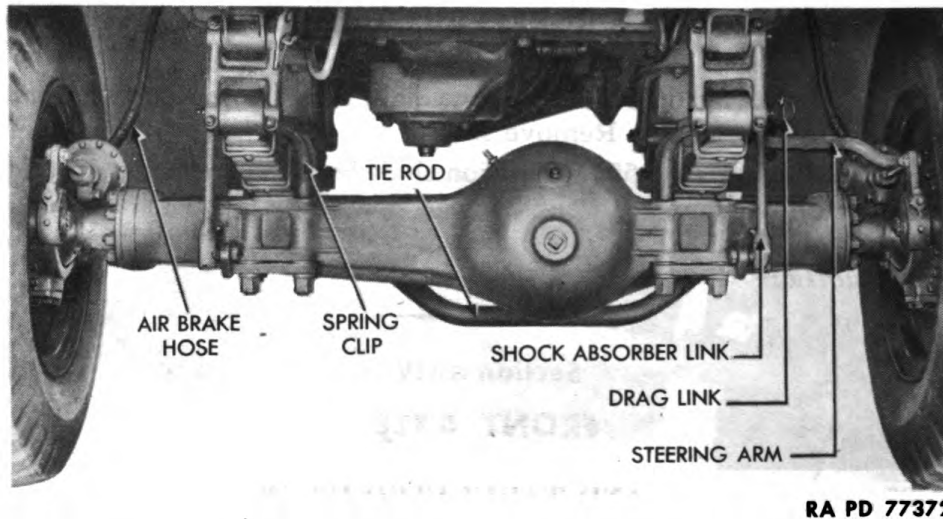
**Axle alinement**

Toe-in .....	$\frac{1}{8}$ - $\frac{3}{16}$ in.
Camber angle .....	0 deg
Caster .....	4 deg-6 deg

**106. ADJUSTMENT.**

a. **Toe-in Test.** Turn wheels to straight-ahead position. Mark each tire at front tire center lines with a fine line at wheel center height. Measure distance between lines. Measure distance from lines to ground. Move chassis forward until tire markings are at rear of axle. (Height from ground must be same as when front measurement was taken.) Measure distance between lines. Distance between measurements determines amount of toe-in. Proper adjustment is  $\frac{1}{8}$  to  $\frac{3}{16}$  inch.

4- TO 5-TON 4x4 TRACTOR TRUCK (FEDERAL)



RA PD 77372

**Figure 66 – Front Axle Installed – Front View**

**b. Toe-in Adjustment (fig. 67).** Remove cotter pin, tie rod yoke bolt nut, and tie rod yoke bolt which secure tie rod to wheel assembly. Loosen tie rod end lock nut. Loosen two tie rod yoke clamp nuts. Turn yoke end to increase or decrease length to proper setting. Left-hand end has 16 threads per inch, right-hand, 12 threads per inch. Slide yoke on its boss and install tie rod yoke bolt. Measure toe-in (step a). Repeat adjustment until toe-in measures  $\frac{1}{8}$  to  $\frac{3}{16}$  inches. Tighten end clamp bolts and tube end lock nut. Install tie rod yoke bolt nut and cotter pin.

**107. REMOVAL.**

**a. Anchor Vehicle and Raise Front End.** Block rear wheels or apply propeller shaft brake to prevent chassis movement. Attach lifting tackle to frame cross member and raise chassis until weight is removed from springs. If jacks are used, attach to frame at rear of front spring rear hangers.

**b. Disconnect Air Brakes (fig. 67).** Disengage from brake air hoses by loosening nut which secures each to brake diaphragm chambers.

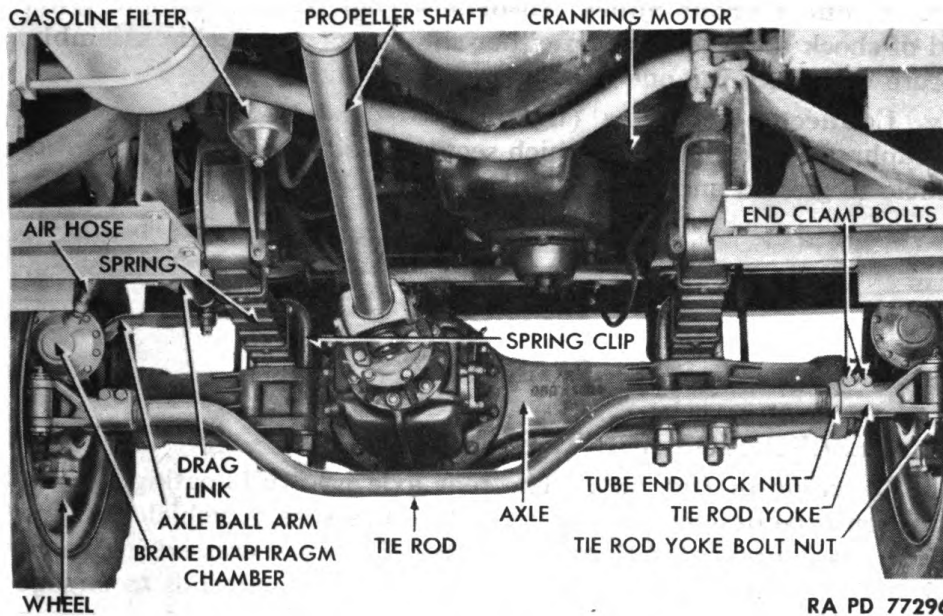
**c. Disconnect Front Shock Absorbers (fig. 66).** Disengage shock absorber links at lower end. Remove one bolt, lock washer and nut which secure each to spring shackle assembly.

**d. Disconnect Front Axle Propeller Shaft (fig. 67).** Remove the four flange bolts, lock washers and nuts at either end. Remove shaft.

**e. Disconnect Steering Drag Link at Axle Ball Arm (fig. 66).** Remove cotter pin from end of adjusting plug on lower reach rod.



**FRONT AXLE**



**Figure 67 – Front Axle Installed – Rear View**

Turn plug counterclockwise until it can be raised from ball assembly. Free rod from assembly.

f. **Remove Spring Clips (U-Bolts)** (fig. 66). Remove two spring clips, four nuts, and four lock washers which secure springs to axle on either side. Drive clips out of clip holes in axle. **NOTE: Use a soft hammer or other soft tool to avoid damage to threaded ends of clips.** Raise vehicle and roll axle free.

g. **Remove Tie Rod** (fig. 67). Remove the two cotter pins, nuts, and tie rod end pins which secure rod to wheel assemblies. **NOTE: Use soft tool to avoid damage to threaded ends of pins.** Remove rod.

h. **Remove Front Wheels** (par. 134 b).

**108. INSTALLATION.**

a. **Install Front Wheels** (par. 134 c).

b. **Install Tie Rod.** Position rod between wheels. Install two end pins, nuts, and cotter pins which secure rod to wheel assemblies.

c. **Attach Axle to Spring** (fig. 66). Position axle assembly so that clip holes (U-bolt holes) in axle line up with clips. Install two clips, four nuts, and four lock washers which secure springs to axle.

d. **Connect Steering Drag Link at Axle Ball Arm** (fig. 66). Insert arm in link. Tighten adjusting plug which secures link to arm. Lock plug in position by installing cotter pin.

e. **Connect Front Axle Propeller Shaft** (fig. 65). Position shaft. Secure with eight flange bolts, lock washers and nuts on either end. **NOTE: Tighten flange bolt nuts alternately to prevent distortion.**

**4- TO 5-TON 4x4 TRACTOR TRUCK (FEDERAL)**

f. **Connect Front Shock Absorbers** (fig. 66). Position lower end of shock absorber link on either side to spring shackle assembly. Secure each with the one bolt, lock washer, and nut.

g. **Connect Air Brakes** (fig. 66). Fit air brake hose assemblies to diaphragm. Tighten nut which secures hose to diaphragm. Lower vehicle to ground and remove wheel blocks.

---

**Section XXV**

**REAR AXLE**

**109. DESCRIPTION AND TABULATED DATA.**

a. **Description** (fig. 68). The rear axle is a full-floating double-reduction type designed for heavy duty. Pressure of vehicle load on axle shafts is prevented through the use of sleeves pressed into each end of axle housing. The shafts are splined on inner ends to engage corresponding splined differential side gears. Twelve studs attach outer end cap flanges to wheel hubs.

**b. Tabulated Data.**

Rear axle	
Manufacturer .....	Timken-Wisconsin
Model .....	R-2090
Ratio .....	8.43-1
Type .....	Full-floating
Differential	
Type .....	Double-reduction

**110. REMOVAL.**

a. **Disconnect Rear Axle Propeller Shaft.** Refer to paragraph 103 a.

b. **Disconnect Brake Air Hoses** (fig. 68). Unscrew nut from fitting on each end of fitting or hose. Trace tubing its entire length and remove all clips. Work tubing or hose from vehicle.

c. **Disconnect Shock Absorber Link at Axle Bracket** (fig. 68). Refer to paragraph 139 c.

d. **Remove Spring Clip Nuts** (fig. 68). Refer to paragraph 138 b.

e. **Remove Chassis from Axle** (fig. 68). Raise axle slightly with floor jacks or other suitable lifting equipment. Attach chain fall or other type of power lift and lift chassis from axle. Remove axle.

f. **Remove Wheels** (fig. 68). Refer to paragraph 134 b.

**111. INSTALLATION.**

a. **Install Wheels** (fig. 68). Refer to paragraph 134 c.

REAR AXLE

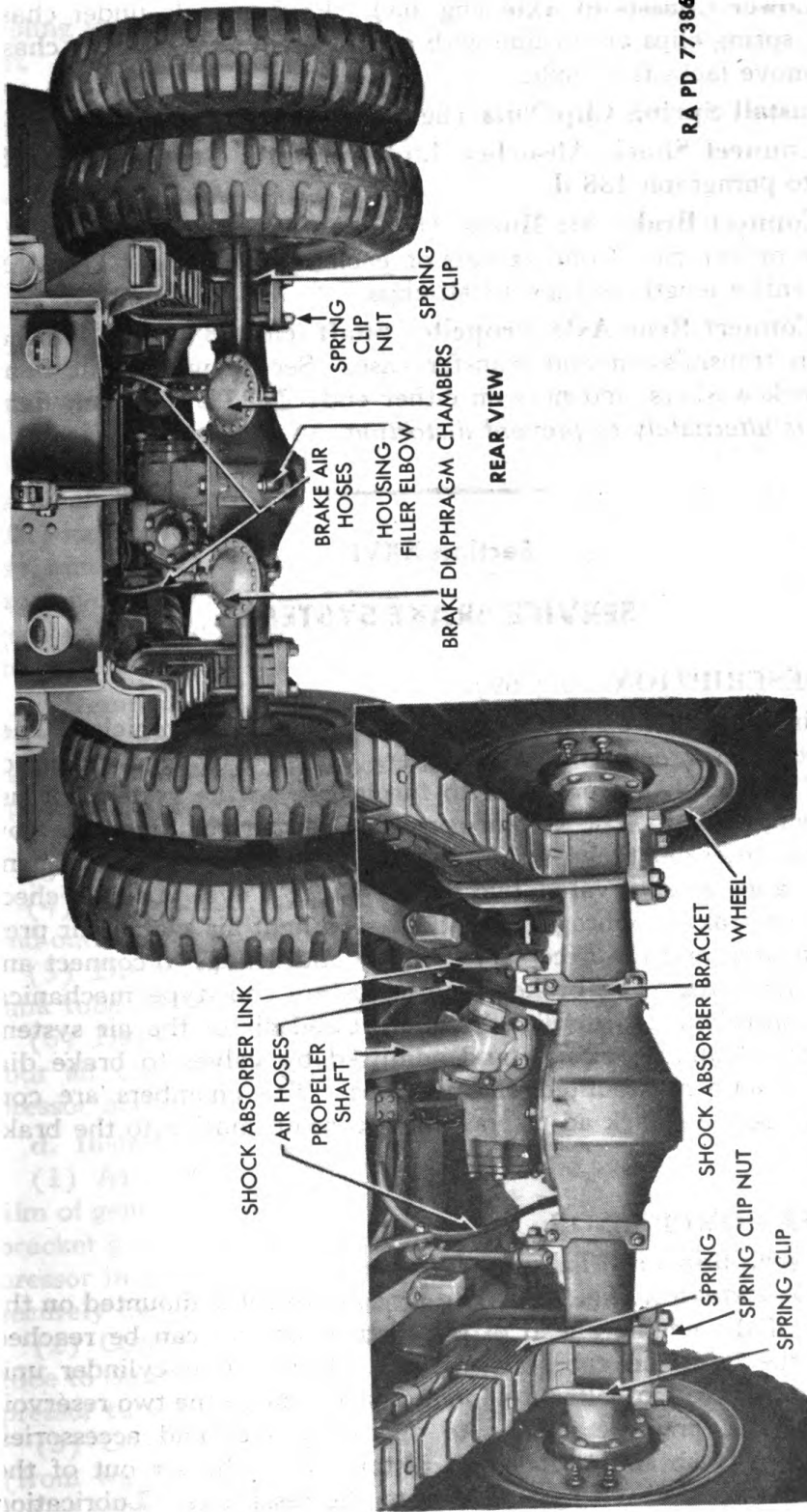


Figure 68 - Rear Axle Installed

**4- TO 5-TON 4x4 TRACTOR TRUCK (FEDERAL)**

**b. Lower Chassis to Axle** (fig. 68). Position axle under chassis so that spring clips are in line with clip holes in axle. Lower chassis and remove jacks from axle.

**c. Install Spring Clip Nuts** (fig. 68). Refer to paragraph 138 c.

**d. Connect Shock Absorber Links at Axle Bracket** (fig. 68). Refer to paragraph 138 d.

**e. Connect Brake Air Hoses** (fig. 68). Work or place tubing in position on vehicle. Connect nuts on each end of fitting. Trace tubing its entire length and install all clips.

**f. Connect Rear Axle Propeller Shaft** (fig. 68). Position shaft between transmission and transfer case. Secure with eight flange bolts, lock washers, and nuts on either end. *NOTE: Tighten flange bolt nuts alternately to prevent distortion.*

---

**Section XXVI**

**SERVICE BRAKE SYSTEM**

**112. DESCRIPTION** (fig. 69).

**a. Air controlled service brakes** are used on this vehicle. They serve both the tractor and the trailer. Emergency connections on front of the truck are provided to furnish air to the system for use while being towed. The system consists of an air compressor, a governor, two reservoir tanks, a safety valve, a foot control valve, a hand control valve, a relay valve, two double check valves, a single check valve, four brake diaphragm chambers, stop light air switch, air pressure indicator, and the necessary air lines and fittings to connect and control the units. The brakes themselves are shoe-type mechanical brakes controlled and applied by compressed air of the air system. Air is stored under pressure and admitted by valves to brake diaphragm chambers mounted on the axles. The chambers are connected by rods to slack adjusters which transmit motion to the brake shoes.

**113. AIR COMPRESSOR.**

**a. Description and Tabulated Data.**

(1) **DESCRIPTION** (fig. 70). The air compressor is mounted on the left side of the engine ahead of the distributor and can be reached through the left-hand cab skirt opening. It is a twin-cylinder unit driven by the two fan belts. Its function is to charge the two reservoir tanks with air pressure needed to operate brakes and accessories. Air pressure is obtained when the pistons force the air out of the cylinder bore past discharge valves into the reservoirs. Lubrication

**SERVICE BRAKE SYSTEM**

is obtained from the engine pressure system by direct connections. Cooling is accomplished by connections from the engine cooling system. One water line discharges water into the radiator outlet pipe while another receives it directly from engine water pump. Modified cooling fins on the exterior of the cylinders are also provided.

**(2) TABULATED DATA.**

Manufacturer .....	Westinghouse
Model .....	2 UE
Capacity .....	7¼ cu ft

**b. Maintenance and Adjustment.**

(1) Remove snap ring and lift curled-hair element from compressor air cleaner (fig. 70). Clean element in dry-cleaning solvent. Dry carefully, oil lightly, and install element.

(2) When required in paragraph 22, check unloader valve rocker arm movement (fig. 70). Oil the fulcrum pin. Check unloader valve clearance with a feeler gage. Clearance should be 0.010 to 0.015 inch. Notify higher authority if not within these limits. Remove cap nuts and check discharge valve seats for carbon. If carbon is excessive, remove cylinder head and use a wire brush to clean carbon from valve seats, chambers and springs. Use new gasket when installing head.

**c. Removal.**

(1) REMOVE LEFT-HAND CAB SKIRT OPENING DOOR (fig. 2). Remove the 10 screws and toothed lock washers which secure door to opening. Lift door from opening.

(2) REMOVE FAN BELTS (fig. 70) (par. 78 c).

(3) DRAIN ENGINE COOLING SYSTEM (par. 73 b).

(4) DISCONNECT WATER LINES (fig. 70). Disconnect water inlet and outlet lines from fittings on compressor.

(5) DISCONNECT AIR LINES (fig. 70). Disconnect compressor to tank tube and governor to compressor tube from compressor.

(6) DETACH COMPRESSOR FROM ENGINE (fig. 70). Remove the four air compressor attaching screws and lock washers. Lift compressor and gasket from bracket.

**d. Installation.**

(1) ATTACH COMPRESSOR TO ENGINE (fig. 70). Spread a thin film of general purpose grease over both sides of a new air compressor bracket gasket. Place gasket in position on bracket. Place air compressor in position on top of gasket on bracket. Install and tighten securely four lock washers and air compressor attaching screws.

(2) CONNECT AIR LINES (fig. 70). Connect compressor to tank tube to compressor main discharge fitting. Connect governor to compressor tube to compressor to governor tube outlet elbow.

(3) CONNECT WATER LINES (fig. 70). Connect water inlet tube (from water pump) to air compressor inlet elbow. Connect water outlet tube to compressor water discharge connector.

4- TO 5-TON 4x4 TRACTOR TRUCK (FEDERAL)

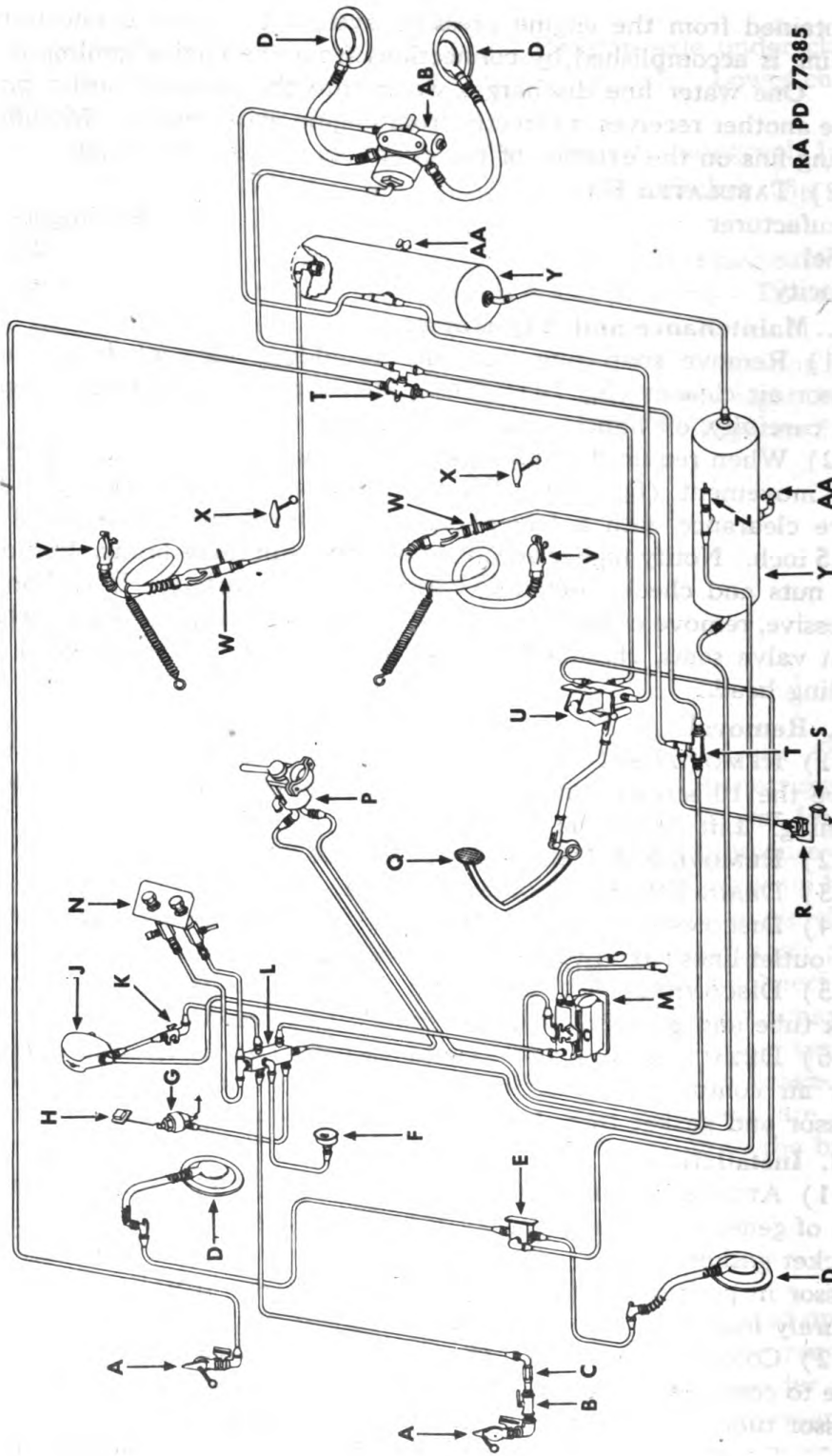


Figure 69 — Brake System

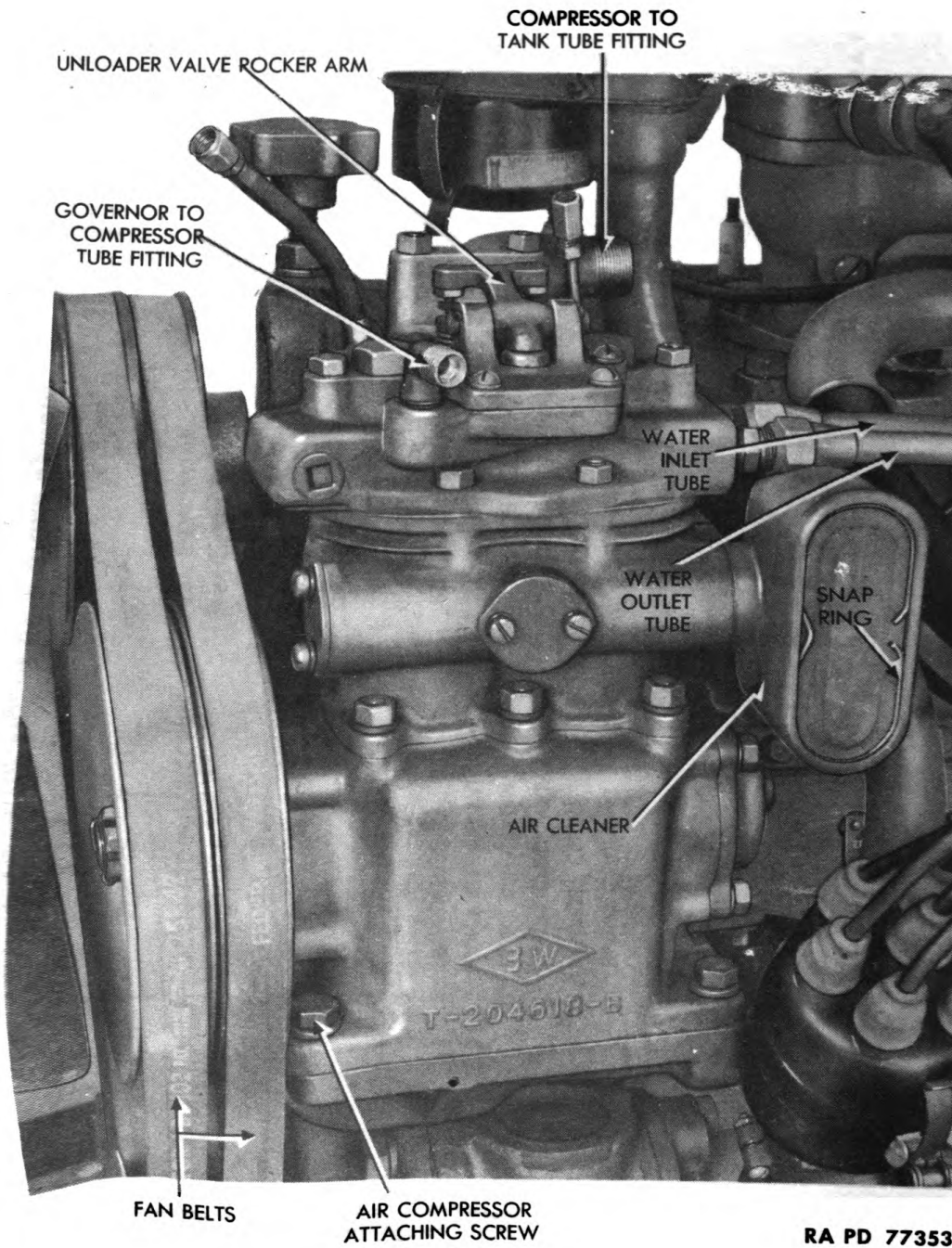
**SERVICE BRAKE SYSTEM**

- |                             |                      |
|-----------------------------|----------------------|
| A—TRAILER COUPLING          | P—HAND CONTROL VALVE |
| B—SHUT-OFF COCK             | Q—BRAKE PEDAL        |
| C—SINGLE CHECK VALVE        | R—STOP LIGHT SWITCH  |
| D—BRAKE DIAPHRAGM CHAMBER   | S—STOP LIGHT         |
| E—QUICK RELEASE VALVE       | T—DOUBLE CHECK VALVE |
| F—PRESSURE GAGE             | U—FOOT CONTROL VALVE |
| G—PRESSURE INDICATOR        | V—TRAILER COUPLING   |
| H—BUZZER                    | W—SHUT-OFF COCK      |
| J—GOVERNOR                  | X—DUMMY COUPLING     |
| K—AIR SUPPLY VALVE          | Y—RESERVOIR TANK     |
| L—MANIFOLD TEE              | Z—SAFETY VALVE       |
| M—AIR COMPRESSOR            | AA—DRAIN COCK        |
| N—WINDSHIELD WIPER CONTROLS | AB—RELAY VALVE       |

RA PD 77385B

**Legend for Figure 69 — Brake System**

4- TO 5-TON 4x4 TRACTOR TRUCK (FEDERAL)



**Figure 70 — Air Compressor Installed**



**SERVICE BRAKE SYSTEM**

(4) **INSTALL FAN BELTS** (fig. 70) (par. 78 d).

(5) **FILL ENGINE COOLING SYSTEM.** Close both drain cocks and fill cooling system completely (par. 73 c).

(6) **TEST INSTALLATION.** Start engine and allow to run until a full 105 pounds air pressure is built up. Inspect connections to see if leaks are present by covering connections with soapsuds. Satisfactory operation of air compressor and absence of leaks indicate proper installation.

(7) **INSTALL CAB SKIRT OPENING DOOR** (fig. 2). Place door in position over opening and install the 10 toothed lock washers and screws.

**114. GOVERNOR.**

**a. Description and Tabulated Data.**

(1) **DESCRIPTION** (fig. 71). The governor is located on the dash above the cranking motor switch, and is easily accessible from the driver's compartment. Two lines connect to it, one from the compressor and one from the manifold located immediately below the governor. The function of the governor is to control pressure of air in the system. This is done by its opening the unloader valves in the compressor, when a pressure of 105 pounds is reached, thus rendering the compressor ineffective. When a minimum pressure of 85 pounds is reached, the governor closes the unloader valves and allows the compressor to again become effective. Pressure from the air reservoir tanks, routed through the manifold, operates the governor.

(2) **TABULATED DATA.**

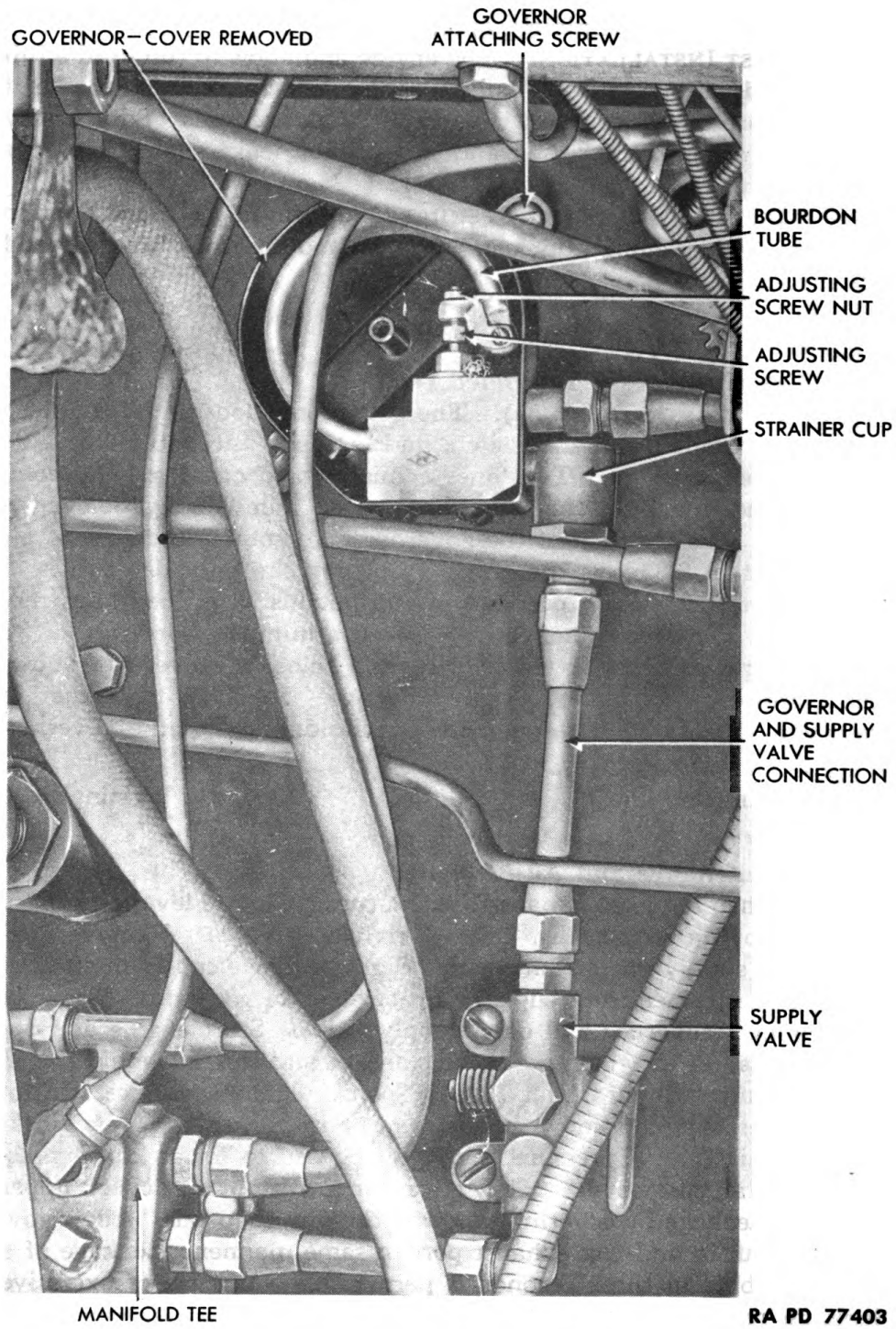
Manufacturer ..... Westinghouse  
Model ..... 0-1

**b. Maintenance and Adjustment.**

(1) When required in paragraph 22, turn crosswise lever on supply valve below governor (fig. 71). This closes valve. Remove governor and supply valve connection. Screw strainer cap from strainer cup. Pull strainer from cup. Wash strainer in gasoline. Assemble and connect governor and open supply valve. Start engine and observe pressures at which governor cuts out and in. It should cut in at 85 pounds and cut out at 15-to-20 pounds higher pressure. If not within these limits, remove case cover. Turn adjusting screw clockwise to raise cut-in pressure, counterclockwise to lower cut-in pressure. Install case cover. Allow governor to cut out and check upper valve for leakage by covering exhaust port with soapsuds. Allow governor to cut in and test exhaust port in same manner. Leakage of a 3-inch bubble in three seconds is permissible. In case of excessive leakage replace governor (par. 114 c).

(2) When required (par. 22) remove case cover. Lubricate valve stem with a few drops of penetrating oil. Install case cover.

4- TO 5-TON 4x4 TRACTOR TRUCK (FEDERAL)



**Figure 71 - Air Pressure Regulator Governor**

## SERVICE BRAKE SYSTEM

### c. Removal.

(1) **DISCONNECT TUBING** (fig. 71). Screw governor and supply valve connection from governor. Screw governor to compressor tube from governor.

(2) **DETACH GOVERNOR FROM DASH** (fig. 71). Remove both governor attaching screws. Do not lose spacers. Lift governor from dash.

### d. Installation.

(1) **ATTACH GOVERNOR TO DASH** (fig. 71). Place governor in position on dash. Place spacers between governor and dash and install both governor attaching screws.

(2) **CONNECT TUBING** (fig. 71). Screw governor to compressor tube onto upper fitting on governor. Connect governor and supply valve connection to elbow on governor.

(3) **TEST OPERATION** (fig. 71). Start engine and observe pressures at which governor cuts out and in. Satisfactory operation indicates correct installation. Adjust if necessary (step b (1) above).

## 115. RESERVOIR TANKS.

### a. Description and Tabulated Data.

(1) **DESCRIPTION**. Two reservoir tanks are provided. One is located below the left-hand frame side rail adjacent to the fuel tank (fig. 72). The other is installed transversely between the two frame side rails, even with the front of the rear wheels (fig. 73). Each is equipped with a drain cock. A tank-to-tank tube connects the two tanks. Their function is to store a sufficient quantity of compressed air to operate the service brakes and air accessories.

### (2) TABULATED DATA.

Manufacturer .....	Westinghouse
Model .....	217321
Length .....	26 in.
Diameter .....	8 in.

**b. Removal** (fig. 73). Open drain cock on lower center of tank and allow all air to escape. Disconnect all tubing (three tubes on side tank, four on transverse tank) from fittings on tank. Remove nuts and lock washers from U-bolts or steel straps. Lift tank from vehicle.

**c. Installation** (fig. 73). Place tank in position on frame of vehicle. Place U-bolts or steel straps in position around tank and install the lock washers and nuts. Connect tubing (three tubes on side tank, four on transverse tank) to fittings on tank.

## 116. SAFETY VALVE.

### a. Description and Tabulated Data.

(1) **DESCRIPTION** (fig. 72). A safety valve is screwed into the

4- TO 5-TON 4x4 TRACTOR TRUCK (FEDERAL)

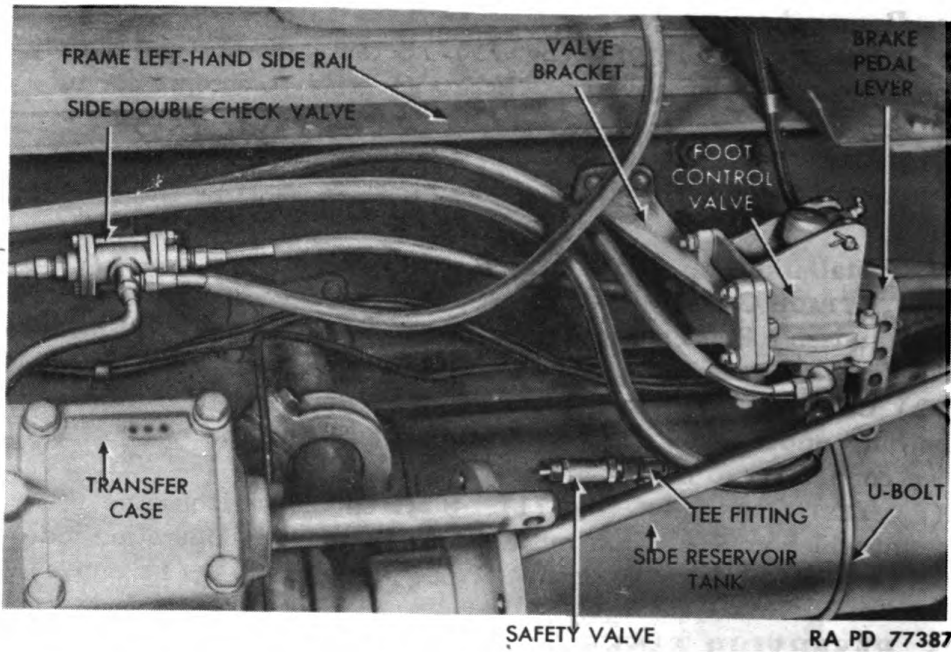


Figure 72 – Air Pressure System Valves and Side Reservoir Tanks

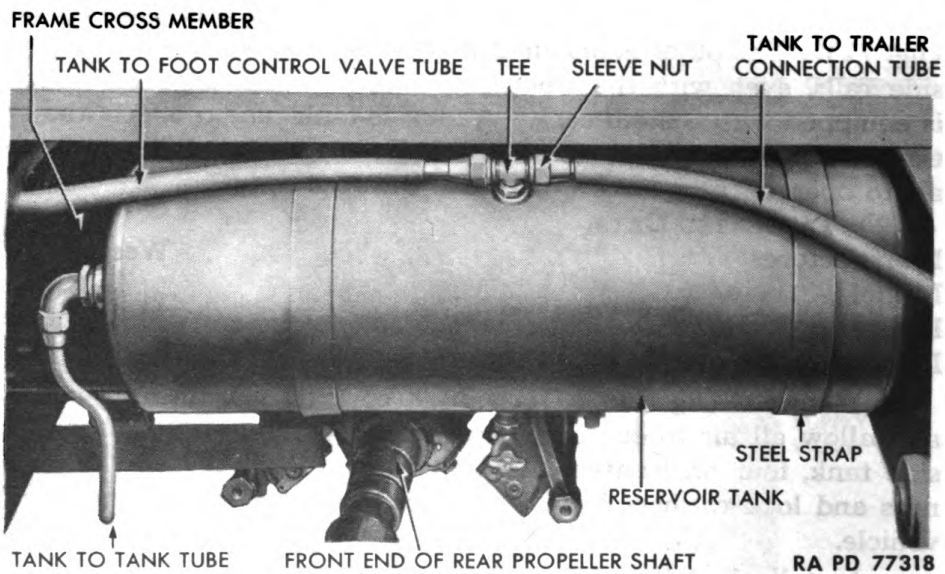


Figure 73 – Rear Air Reservoir Tank Installed

tee on top of the side reservoir tank. Its function is to protect the air system from damage due to excessive pressure in case of failure in the pressure control system. It does not function if the pressure control system is working properly. A coil spring holds ball valve on its seat. A spring seat regulates spring tension. When the pres-

### SERVICE BRAKE SYSTEM

sure exceeds 150 pounds, the ball lifts off its seat permitting air to escape.

(2) **TABULATED DATA.**

Manufacturer ..... Bendix Westinghouse  
Model ..... 205105  
Operating pressure ..... 150 lb

**b. Removal (fig. 72).** Open drain cock on bottom of side reservoir tank. Screw safety valve from tee on top of tank.

**c. Installation (fig. 72).** Screw safety valve into tee on top of side reservoir tank. Close drain valve on bottom of tank.

### 117. FOOT CONTROL VALVE.

**a. Description and Tabulated Data.**

(1) **DESCRIPTION (fig. 72).** The foot control valve is attached to the bracket on the inside of the frame left side rail about even with the spare tire. It is connected by a rod to the brake pedal. When the pedal is depressed, the valve admits air to the brake diaphragm chambers to operate the brakes. When the pedal is released, the valve exhausts the pressure from the brake diaphragm chambers to release the brakes.

(2) **TABULATED DATA.**

Manufacturer ..... Westinghouse  
Type ..... B4B  
Model ..... 216213

**b. Removal.**

(1) **DISCONNECT AIR LINES (fig. 72).** Disconnect all three air tubes from fittings on valve.

(2) **DETACH BRAKE PEDAL ROD (fig. 72).** Remove cotter pin and clevis pin which attach brake pedal rod to valve. Lift yoke from brake valve lever.

(3) **DETACH VALVE FROM BRACKET (fig. 72).** Remove four nuts, lock washers, and bolts which attach valve to bracket. Lift valve from bracket.

**c. Installation.**

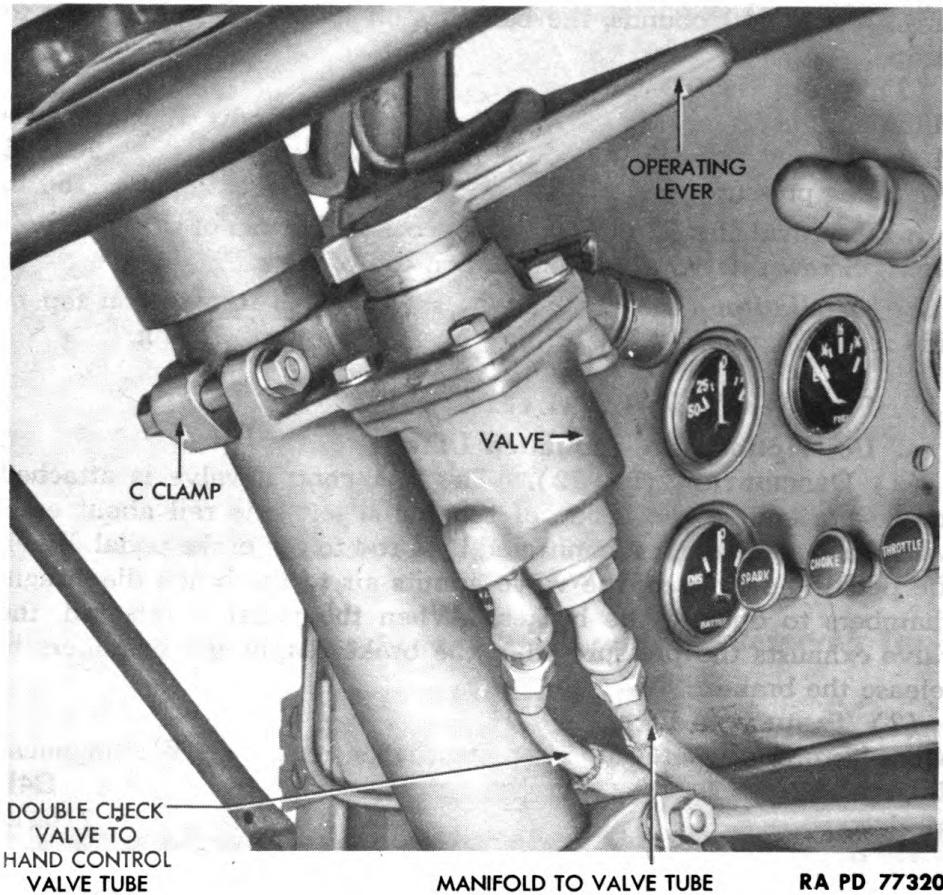
(1) **ATTACH VALVE TO BRACKET (fig. 72).** Position valve on bracket. Install the four bolts, lock washers, and nuts which hold valve to bracket.

(2) **CONNECT AIR LINES (fig. 72).** Connect quick release valve to foot valve tube to fitting on right side of valve. Connect reservoir tank to brake valve tube to fitting on left side of valve. Connect double check valve to foot valve tube to fitting on bottom of valve.

(3) **CONNECT BRAKE PEDAL ROD (fig. 72).** Place yoke on end of rod in position on middle hole of brake pedal lever. Install clevis pin and cotter pin. Check position of stop brake pedal lever. It should rest against brake valve cover with pedal released. Depress pedal

TM 9-820  
117-118

**4- TO 5-TON 4x4 TRACTOR TRUCK (FEDERAL)**



**Figure 74 – Air-brake Hand Control Valve Installed**

and observe position of brake valve lever return spring seat. It must clear brake valve cover. Move brake pedal rod to another hole on brake valve lever, if necessary, to secure these clearances.

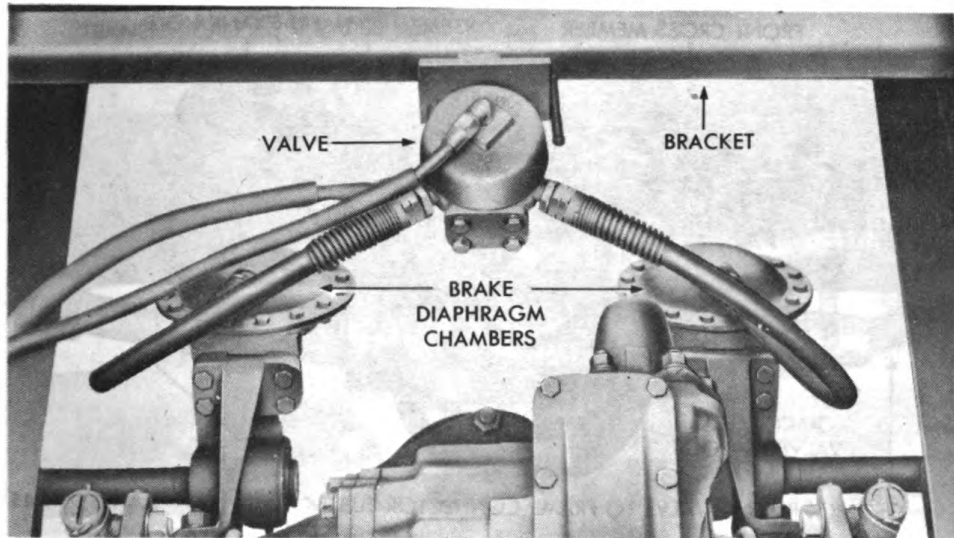
(4) **TEST OPERATION.** Start engine and run until 105-pound air pressure is developed. Apply and release brakes by depressing foot pedal. Satisfactory operation indicates correct installation.

**118. HAND CONTROL VALVE.**

**a. Description and Tabulated Data.**

(1) **DESCRIPTION (fig. 74).** The hand control valve is located on the steering column immediately below the steering wheel. It is used to operate brakes on the trailer. This valve consists of an intake valve and exhaust valve combined on a single piece stem. Movement of the lever toward "ON" position forces the piston downward against the exhaust seat. This closes the exhaust valve and opens the intake valve. Movement of the lever to the "OFF" position removes the downward force on the piston. Consequently, the exhaust valve opens while the intake valve closes.

**SERVICE BRAKE SYSTEM**



RA PD 77390

**Figure 75 – Relay Valve Installed**

**(2) TABULATED DATA.**

Manufacturer .....	Westinghouse
Type .....	HP
Model .....	215748

**b. Removal (fig. 74).** Disconnect both air tubes from fittings on valve. Remove both nuts, lock washers, and bolts which hold valve to steering column. Lift valve and C-clamp from steering column.

**c. Installation (fig. 74).** Place valve and C-clamp in position on steering column. Install both bolts, lock washers, and nuts which clamp valve and C-clamp together around steering column. Connect manifold to valve tube to right-hand fitting on valve. Connect double check valve to hand control valve tube to left-hand fitting on valve. Start engine and build up 105-pound air pressure. Apply trailer brakes with hand valve. Check valve connections for leaks using soapsuds. Proper functioning of brakes and absence of leaks indicate satisfactory installation.

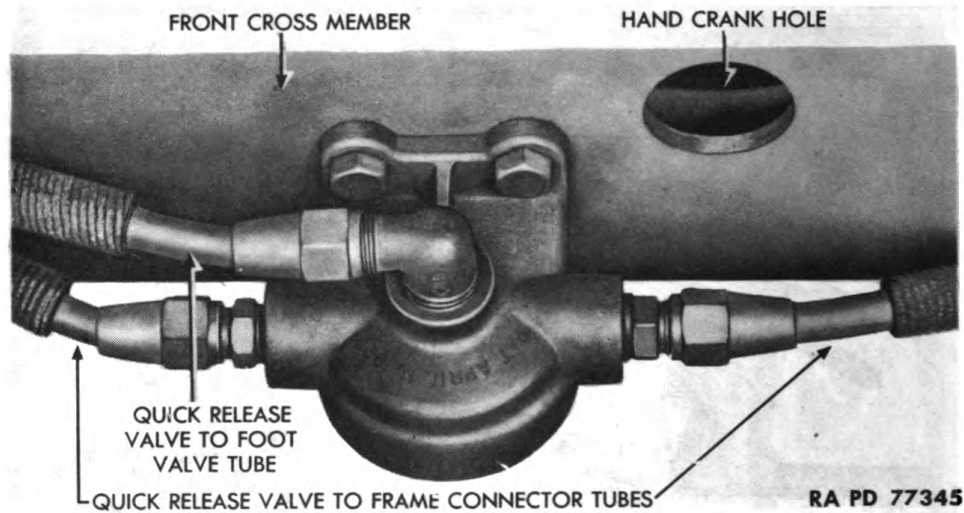
**119. RELAY VALVE.**

**a. Description and Tabulated Data.**

**(1) DESCRIPTION (fig. 75).** The relay valve is attached to a bracket which runs transversally between the main frame side rails. It is located almost exactly over the rear axle differential. This valve acts as a relay station to speed up application and release of rear wheel brakes and trailer brakes. Air from the foot control valve enters an upper chamber and actuates a diaphragm. The large volume of air required for brake application is supplied directly from the adjacent reservoir tank, thus giving a quick application. Fast brake release is obtained through this valve because released air is vented

**TM 9-820  
119-120**

**4- TO 5-TON 4x4 TRACTOR TRUCK (FEDERAL)**



**Figure 76 – Quick Release Valve Installed**

directly to the atmosphere instead of traveling back through the brake control valve.

**(2) TABULATED DATA.**

Manufacturer ..... Westinghouse  
Model ..... 217383

**b. Removal (fig. 75).** Disconnect all four air lines from valve. Remove both nuts, lock washers, and bolts which secure valve to bracket.

**c. Installation (fig. 75).** Place valve in position on bracket. Install two bolts, lock washers, and nuts which attach valve to bracket. Connect two relay-valve-to-diaphragm hoses to two large fittings on sides of valve. Connect tank-to-valve tube to fitting on side of valve. Connect double check valve to relay valve tube to fitting on top of valve. Start engine and build up air pressure. Apply brakes and check valve for air leaks. Satisfactory brake performance and absence of leakage indicate proper valve installation.

**120. QUICK RELEASE VALVE.**

**a. Description and Tabulated Data.**

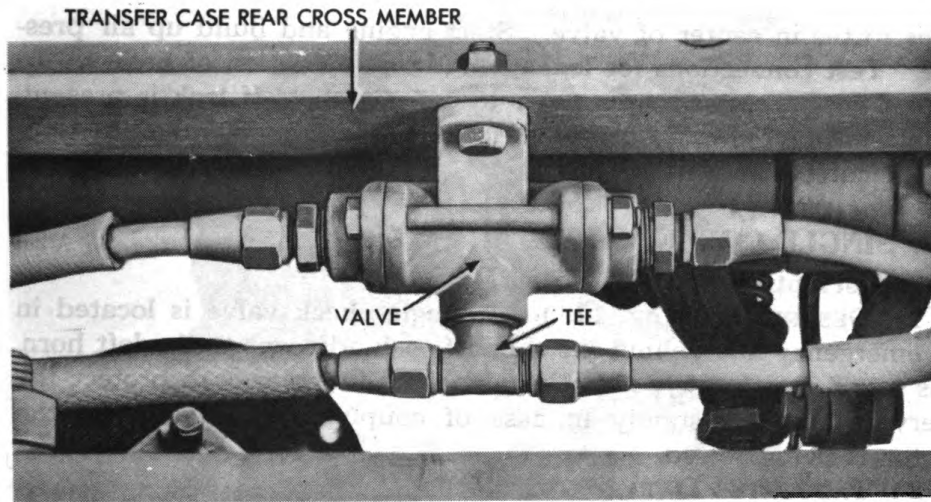
**(1) DESCRIPTION (fig. 76).** A quick release valve is bolted to the under side of the main frame front cross rail. It is located directly under the center of the radiator. This valve is connected in the line from the foot control valve to the brake diaphragm chambers for the front wheel brakes. The valve speeds up front wheel brake release by venting exhaust air to the atmosphere.

**(2) TABULATED DATA.**

Manufacturer ..... Westinghouse  
Model ..... 205000



**SERVICE BRAKE SYSTEM**



**Figure 77 – Double Check Valve Installed**

**b. Removal** (fig. 76). Disconnect all three air tubes from valve. Remove two nuts, lock washers and bolts which secure valve to frame. Lift valve from frame.

**c. Installation** (fig. 76). Place valve in position on frame front cross rail. Install two bolts, lock washers, and nuts which attach valve to frame. Connect quick release valve to foot valve tube to top fitting on valve. Connect quick release valve to frame connector tubes to fittings on the sides of the valve. Start engine and build up 105-pound air pressure. Apply brakes and inspect valve for leakage. Satisfactory brake application and absence of leakage indicate proper installation.

**121. DOUBLE CHECK VALVES.**

**a. Description and Tabulated Data.**

(1) **DESCRIPTION** (figs. 72 and 77). Two double check valves are used to prevent loss of air pressure through an open exhaust of the brake valves which are not being operated. These valves are secured to the chassis frame.

(2) **TABULATED DATA.**

Manufacturer .....	Westinghouse
Model .....	217698
Number used .....	2

**b. Removal** (fig. 77). Disconnect the four air tubes from fittings at each end of valve and from tee in center of valve. Remove two nuts, lock washers, and bolts which attach valve to frame.

**c. Installation** (fig. 77). Place valve in position on frame. Install two bolts, lock washers, and nuts which secure valve to frame. Connect air tube to fitting on each end of valve. Connect two a:

Generated on 2013-06-23 10:13 GMT / http://hdl.handle.net/2027/uc1.b3243770  
Public Domain, Google-digitized / http://www.hathitrust.org/access\_use#pd-google

**TM 9-820  
121-123**

**4- TO 5-TON 4x4 TRACTOR TRUCK (FEDERAL)**

tubes to tee in center of valve. Start engine and build up air pressure. Test connections for leakage and test operation of breaks. In case of doubt, apply soapy water to connections. If leak is present, bubble will be blown. Absence of leakage and proper brake functioning indicate correct installation.

**122. SINGLE CHECK VALVE.**

**a. Description and Tabulated Data.**

(1) **DESCRIPTION** (fig. 113). A single check valve is located in the emergency line behind the shut-off cock adjacent to the left horn. It is a one-way ball-type check valve. Its function is to protect the reservoir tank air supply in case of coupling breakage while the tractor is being towed.

(2) **TABULATED DATA.**

Manufacturer ..... Westinghouse  
Model ..... 220306

**b. Removal** (fig. 113). Disconnect air tube from elbow on rear end of valve. Screw valve from fitting on shut-off cock.

**c. Installation** (fig. 113). Screw valve to fitting on shut-off cock. Connect air line to elbow on rear of valve. Start engine and build up 105-pound air pressure. Inspect valve for leaks. Absence of leakage indicates correct installation.

**123. BRAKE DIAPHRAGM CHAMBERS.**

**a. Description and Tabulated Data.**

(1) **DESCRIPTION** (figs. 78 and 84). Four brake diaphragm chambers are used. One is located adjacent to each wheel. Their function is to convert air pressure to mechanical motion to apply the brakes. Air pressure is admitted to each chamber when the brake pedal is depressed. This pressure moves a diaphragm. The diaphragm motion is transmitted to the brake cam by means of a push rod and a slack adjuster. As the pedal is released, the air pressure is exhausted from the chamber. A spring then returns the diaphragm, push rod, and slack adjuster to their normal positions. Thus the brakes are released.

(2) **TABULATED DATA.**

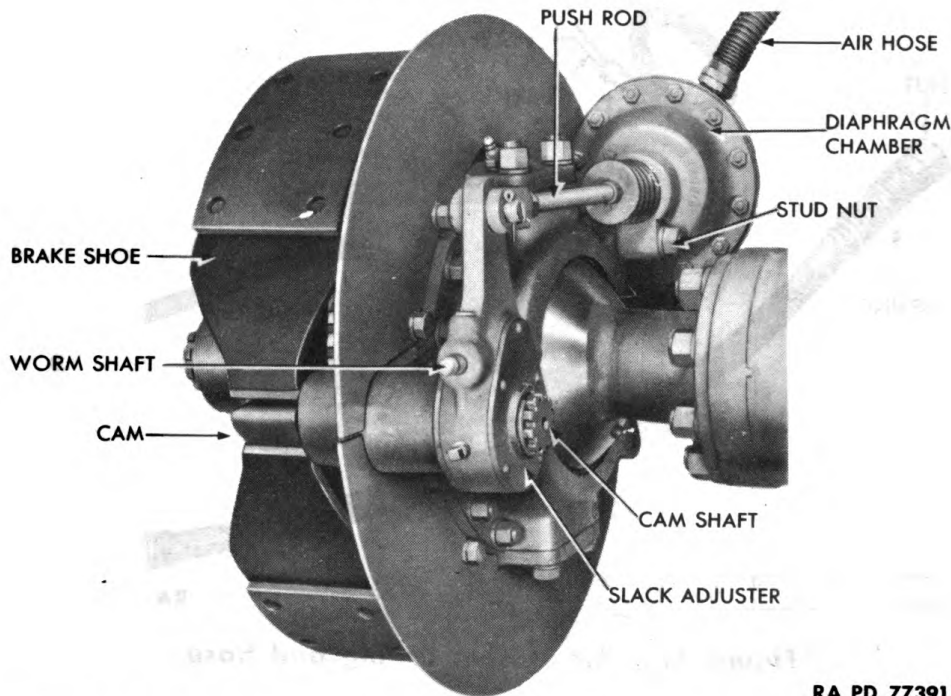
Manufacturer ..... Westinghouse  
Type:  
Front ..... E  
Rear ..... B

**b. Removal.**

(1) **DISCONNECT SLACK ADJUSTER** (figs. 78 and 84). Remove cotter pin and clevis pin which attach slack adjuster to push rod yoke.

(2) **DISCONNECT AIR HOSE** (figs. 78 and 84). Screw hose nut from fitting on chamber.

**SERVICE BRAKE SYSTEM**



RA PD 77391

**Figure 78 – Front Brake Diaphragm Chamber and Slack Adjuster**

(3) **DETACH CHAMBER** (figs. 78 and 84). Remove stud nut and lock washer (front wheel brake) or four nuts, lock washers, and bolts (rear wheel brake) which attach chamber. Lift chamber from vehicle.

**c. Installation.**

(1) **ATTACH CHAMBER** (figs. 78 and 84). Place chamber in position backing plate (front wheel brake) or bracket (rear wheel brake). Install lock washer and stud nut (front wheel brake) or four bolts, lock washers, and nuts (rear wheel brake) which attach chamber.

(2) **CONNECT AIR HOSE** (figs. 78 and 84). Screw air hose onto fitting on chamber.

(3) **CONNECT SLACK ADJUSTER** (figs. 78 and 84). Place slack adjuster in position within push rod yoke. Install clevis pin and cotter pin.

(4) **TEST INSTALLATION.** Start engine and build up 105 pounds air pressure. Test operation of brakes. Inspect chamber hose connection for leakage while brakes are applied. Proper functioning of brakes and absence of leaks indicate correct chamber installation.

**124. MANIFOLD TEE.**

**a. Description and Tabulated Data.**

(1) **DESCRIPTION** (fig. 5). A manifold tee, or junction block, is located on the driver's side of the dash in line with the steering column. It is a hollow block of metal equipped with fittings to which air tu

TM 9-820  
124-125

4- TO 5-TON 4x4 TRACTOR TRUCK (FEDERAL)

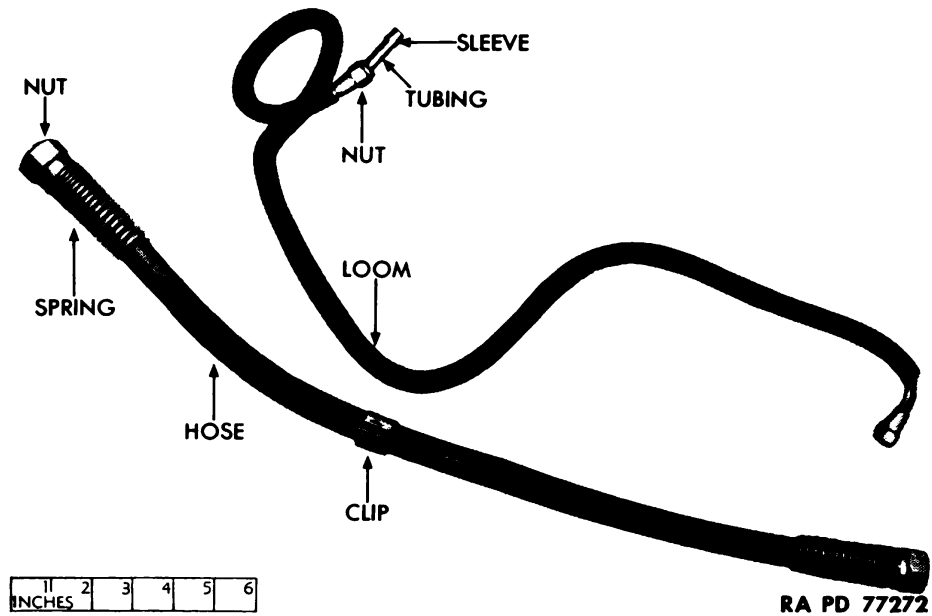


Figure 79 – Air System Tubing and Hose

are connected. It serves as a means of connecting several air tubes together so as to equalize pressure in all tubes.

(2) TABULATED DATA.

Part Number ..... Federal 10A7118

b. **Removal** (fig. 5). Disconnect all eight air lines from fitting on manifold. Remove the two screws and lock washers which attach manifold tee to dash. Lift tee from dash.

c. **Installation** (fig. 5). Place tee in position on dash and install two lock washers and screws. Connect all eight air lines to fittings on manifold. Start engine and build up 105-pound air pressure. Inspect manifold tee connections to see if any leaks are present. If in doubt, apply soapy water to connections. Bubbles indicate leaks. Absence of leaks indicates satisfactory installation.

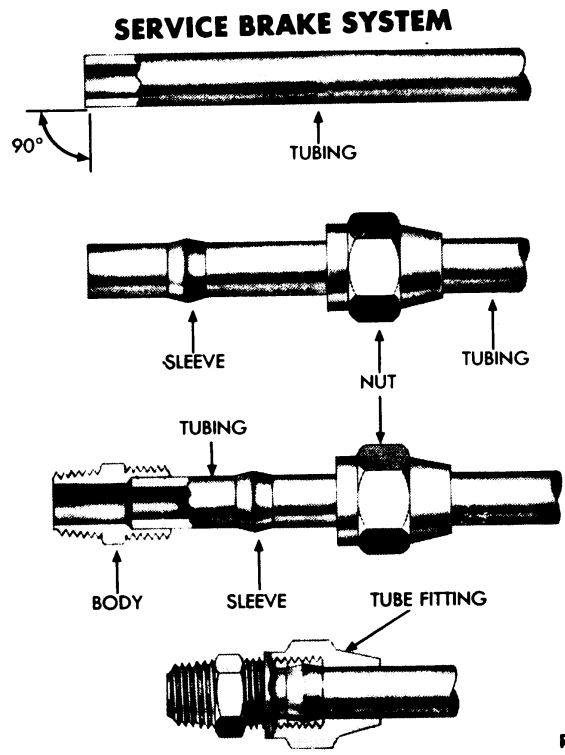
125. TUBING AND HOSES.

a. **Description and Tabulated Data.**

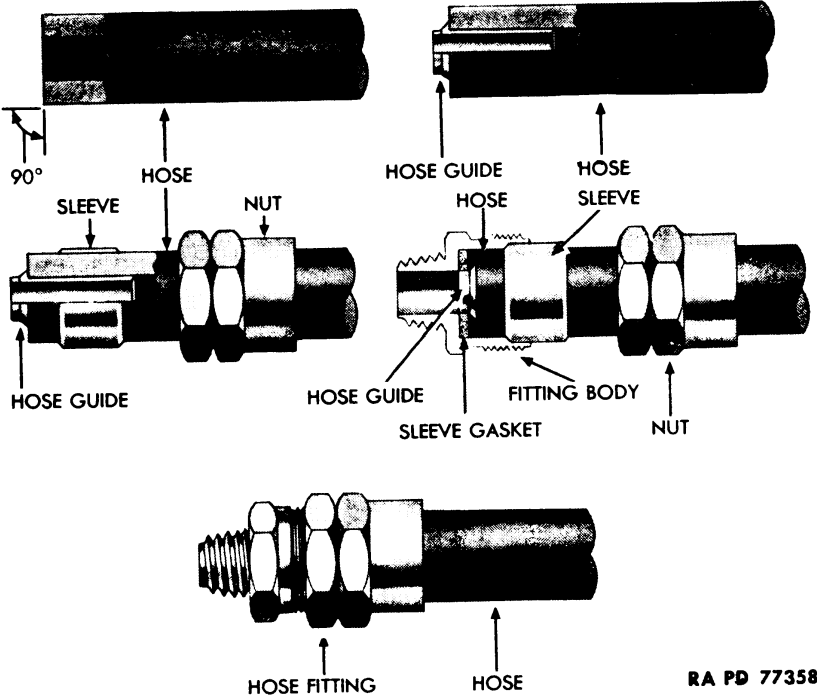
(1) **DESCRIPTION** (fig. 79). Copper tubing is used throughout for the brake air system. It is carefully selected to avoid line friction and is heat treated to withstand vibration. Sleeve (ferrule) and nut connections are used. Rubber hose of heavy design is used at points in the system requiring flexible couplings. Hoses are furnished with detachable fittings.

(2) **TABULATED DATA.**

Tubing .....	Heat-treated copper
Hoses .....	Heavy rubber
Fittings .....	Brass nut and sleeve

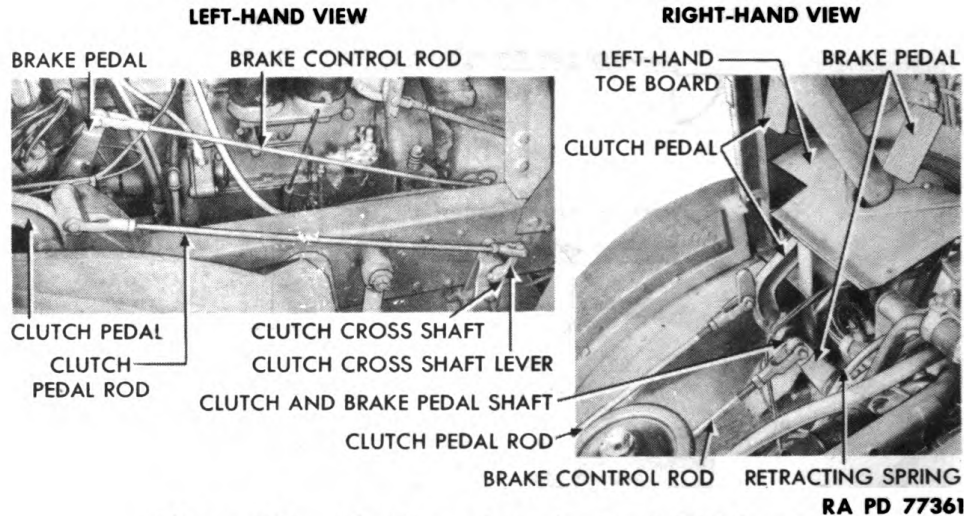


**Figure 80 – Installation of Fittings on Tubing**



**Figure 81 – Installation of Fittings on Hose**

**4- TO 5-TON 4x4 TRACTOR TRUCK (FEDERAL)**



**Figure 82 – Clutch and Brake Pedal Linkage**

**b. Removal** (fig. 79). Unscrew nut from fitting on each end of tubing or hose. Trace tubing its entire length and remove all clips. Work tubing or hose from vehicle.

**c. Maintenance.**

(1) **CUT TUBING AND INSTALL FITTINGS** (fig. 80). Cut new tubing same length as that being replaced. Cut ends square and smooth up with a file. Slide nut and sleeve (ferrule) on each end (fig. 79).

(2) **SHAPE TUBING.** Bend tubing to shape of original piece. Avoid sharp bends. Tubing  $\frac{3}{8}$  inch in diameter can be bent on a 3-inch radius;  $\frac{1}{2}$  inch diameter tubing can be bent on a 4-inch radius.

(3) **CUT HOSE AND INSTALL FITTINGS** (fig. 81). Cut new hose same length as original equipment. Screw hose guide into end of hose. Slide spring (if used) and nut onto end of hose. Install sleeve on end of hose. Place sleeve gasket in fitting body and screw nut onto body. Repeat process to install fitting on other end of hose.

**d. Installation** (fig. 79). Work or place tubing or hose into position on vehicle. Connect nuts on each end of fittings. Trace tubing its entire length and install all clips.

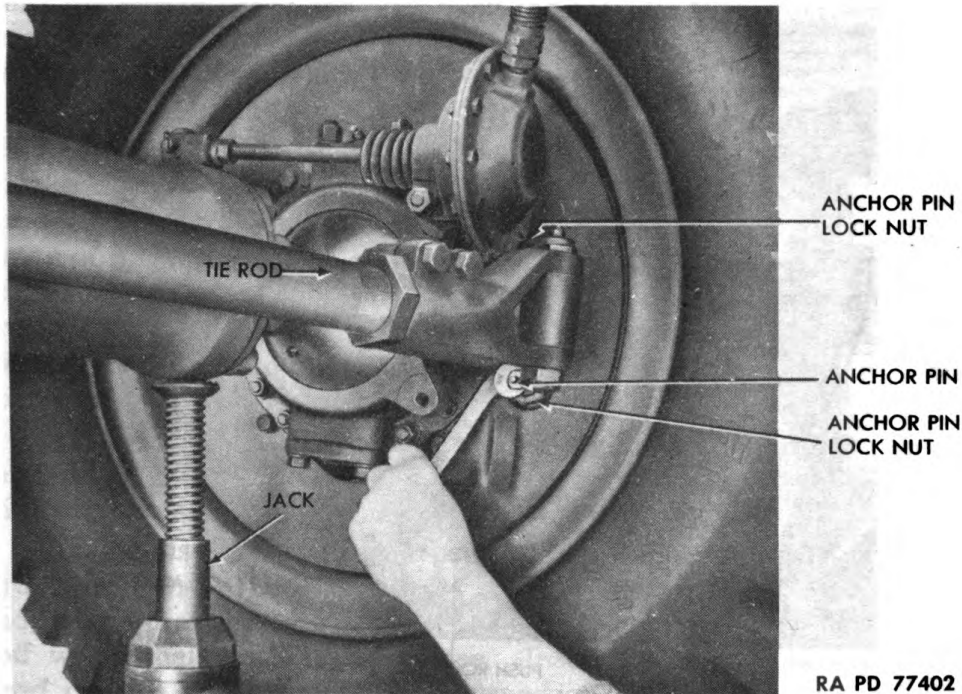
**126. BRAKE PEDAL AND BRAKE CONTROL ROD.**

**a. Description** (figs. 3 and 82). A conventional type brake pedal is used. It pivots on the clutch and brake pedal shaft. A retracting spring pulls it back to OFF position after it has been depressed. It is connected to the foot control valve by means of brake control rod with a yoke on each end.

**b. Removal.**

(1) **REMOVE TOEBOARD** (fig. 82). Remove screws and toothed lock washers which hold left-hand toeboard in position. Lift floor board from cab.

**SERVICE BRAKE SYSTEM**



**Figure 83 - Anchor Pin Adjustment**

(2) **DETACH PEDAL** (fig. 82). Disconnect retracting spring from pedal. Remove cotter pin and clevis pin which attach brake control rod to pedal. Drive taper pin from clutch and brake pedal shaft.

(3) **REMOVE BRAKE CONTROL ROD**. Remove cotter pin and taper pin which attach rod to brake pedal lever on foot control valve. Lift rod from vehicle.

**ĕ. Installation.**

(1) **ATTACH BRAKE CONTROL ROD TO FOOT CONTROL VALVE**. Place rod in position with its rear yoke alined with center hole in brake pedal lever on foot control valve. Install the clevis pin and cotter pin which attach rod to lever.

(2) **ATTACH PEDAL** (fig. 82). Slide pedal and pedal shaft collar onto protruding end of clutch and brake pedal shaft. Drive taper pin through holes in collar and shaft. Peen pin. Place yoke of brake control rod in position about its flange on pedal and install clevis pin and cotter pin. Hook retracting spring into its hole in pedal. Inspect end of spring and bend if necessary to make sure it remains in position in pedal.

(3) **INTALL TOEBOARD** (fig. 82). Place toeboard in position and install toothed lock washers and screws which secure it.

**127. SLACK ADJUSTERS.**

**a. Description and Tabulated Data.**

(1) **DESCRIPTION** (figs. 78 and 84). Slack adjusters are the special

4- TO 5-TON 4x4 TRACTOR TRUCK (FEDERAL)

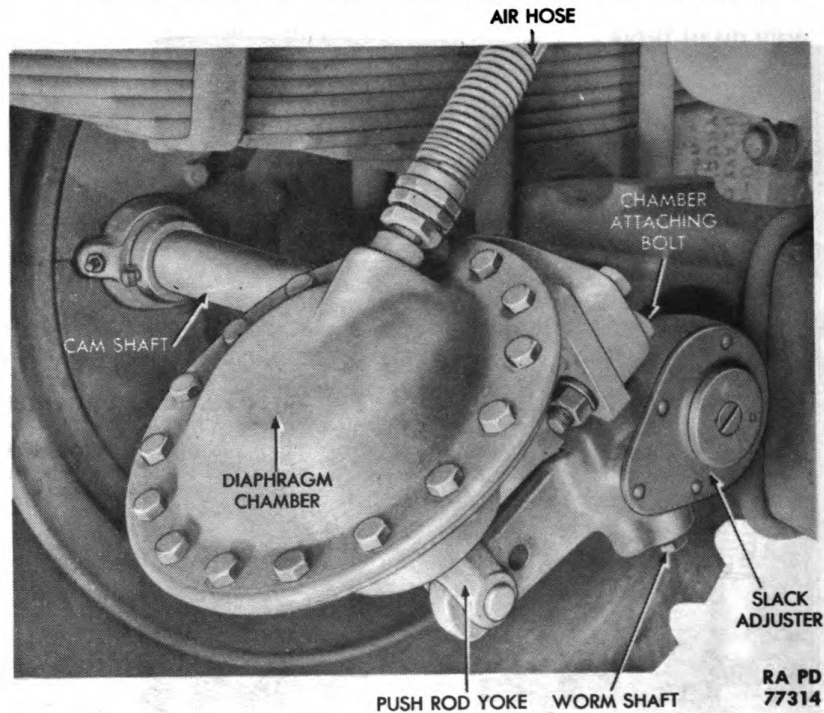


Figure 84 – Rear Brake Diaphragm Chamber and Slack Adjuster

levers which connect the brake diaphragm chamber push rods to the brake camshafts. Four are used on the tractor, one for each wheel. Brake adjustment to compensate for lining wear is made at the slack adjuster at each wheel. The slack adjuster fits onto the splines on the shaft of the brake cam. An adjustable worm is meshed with a worm gear within the slack adjuster. Turning the worm shaft pivots the entire slack adjuster about the shaft of the brake cam. In this way, the brake adjustment is made.

(2) TABULATED DATA.

Manufacturer .....	Westinghouse
Model	
Front .....	220688
Rear – RH .....	217919
Rear – LH .....	217920
Type	
Front .....	K
Rear .....	K

b. Adjustment.

(1) GENERAL. Adjustment of service brakes given here is made chiefly by adjusting slack adjusters. First adjustment consists of steps (3), (4), and (5) below. Subsequent check and adjustments normally consist of steps (2), (3), (4), and (6) below.

(2) CHECK BRAKE ADJUSTMENT. Make check by applying brakes



## SERVICE BRAKE SYSTEM

and measuring brake chamber push rod travel. If this exceeds original measurement (step (5) below), adjust brakes (steps (3), (4), and (6) below).

(3) **ADJUST ANCHOR PINS (FRONT WHEEL BRAKES ONLY)** (fig. 83). Loosen anchor pin lock nut. Remove inspection hole cover on brake drum. With end wrench on anchor pin and with feeler gage under heel of shoe through inspection hole, turn pin slowly until clearance of 0.008 inch is obtained. Hold anchor pin to keep it from turning and tighten anchor pin lock nut. Again check clearance and readjust if it has been disturbed. Repeat process to adjust other anchor pin on same wheel. Repeat process to adjust anchor pins on other front wheel.

(4) **BUILD UP AIR PRESSURE.** Start engine and build up air pressure to at least 80 pounds. Maintain at least 60 pounds throughout adjustment.

(5) **ADJUST BRAKES AND RECORD PUSH ROD TRAVEL (FIRST ADJUSTMENT ONLY)** (figs. 78 and 84). Jack up each wheel. Turn slack adjuster worm shaft until brake shoes are tight against drum. Back off worm shaft until wheel is free. Insert feeler gage between toe end of shoe and drum through inspection hole. Turn worm shaft until 0.008 to 0.010-inch clearance is obtained. Apply brakes and measure brake diaphragm push rod travel. Record measurement for future use in checking (step (2) above) and adjusting (step (6) below) brakes. *NOTE: If adjustment is correct, push rod travel will be same for both wheels on an axle. Dimensions will be about  $\frac{5}{8}$  inch on front brakes and about  $\frac{7}{8}$  inch on rear brakes.*

(6) **ADJUST BRAKES (ALL SUBSEQUENT ADJUSTMENTS)** (figs. 78 and 84). Turn slack adjuster worm shaft until brake diaphragm chamber push rod travel measures same as in original adjustment (step (5) above). If measurement is not available, adjust as outlined for first adjustment (step (5) above), and record dimensions to facilitate future adjustments.

**c. Removal** (figs. 78 and 84). With a steel scribe, mark relative positions of slack adjuster and camshaft to expedite installation. Remove cotter pin and clevis pin which connect brake diaphragm chamber push rod to slack adjuster. Pry lock ring from shaft of brake cam. Tap adjuster from shaft.

**d. Installation** (figs. 78 and 84). Tap slack adjuster onto protruding end of brake camshaft in same position as originally installed. Scribe marks made during removal will help. Pry lock ring into position on end of shaft. Place yoke of brake diaphragm chamber push rod in position on end of adjuster. Install clevis pin and cotter pin which connect push rod and adjuster.

4- TO 5-TON 4x4 TRACTOR TRUCK (FEDERAL)

128. BRAKE SHOES.

a. Description and Tabulated Data.

(1) DESCRIPTION (figs. 85 and 86). Two brake shoes are installed on a backing plate within each of the four brake drums. Adjoining ends of the two shoes are held in place by anchor pins. The other ends of the two shoes are pulled together by a brake shoe spring. A cam is located between these ends of the shoe. When the brakes are applied, the cam pivots and pushes the ends of the shoes apart. This causes the lining, riveted to the shoes, to be pressed against the brake drum, thus causing a braking action. When the brakes are released, the cam pivots back to its original position and the brake shoe spring draws the brake shoes toward each other. Thus the lining loses contact with the drum, and the braking action stops. Slight differences exist between the design of front and rear wheel brakes. Because of space limitations on the front wheels, a shorter lift is provided on the operating cams. The front shoes are also mounted on eccentric pins which can be rotated to bring the shoes closer to the drum at anchor pin end. On the front brakes the operating cam is in front of the axle, while on the rear brakes the cam is to the rear of the axle.

(2) TABULATED DATA.

Rear axle brakes

Manufacturer	Timken
Size	17 $\frac{1}{4}$ x 4 x $\frac{3}{4}$ in.
Lining	
Federal part number	11B2304
BLMA number	4055

Model - front

RH upper	A2-3822F6
RH lower	A1-3822E5
LH upper	A2-3822E5
LH lower	A1-3822F6

Model - rear

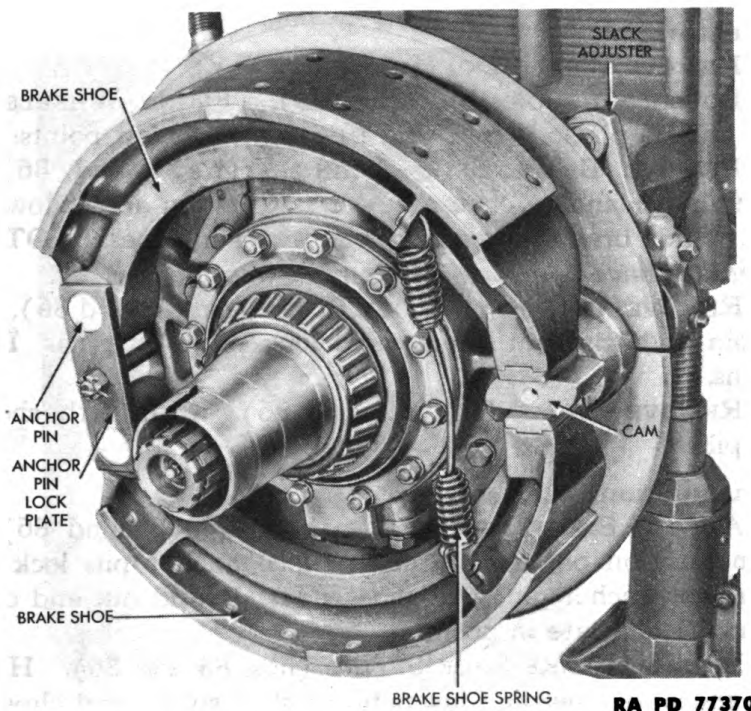
Upper	A27-3222B210
Lower	A28-3222B210

Front axle brakes

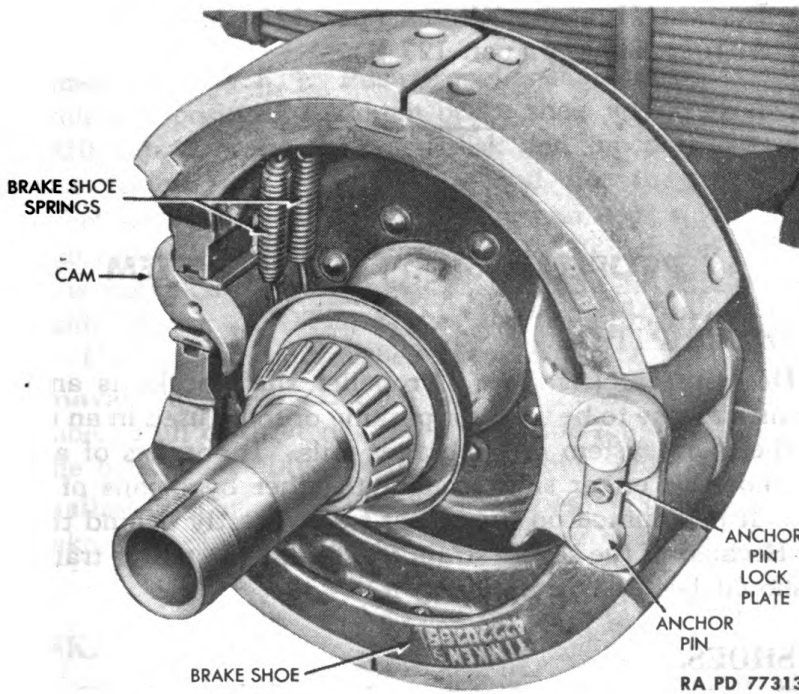
Manufacturer	Timken
Size	17 $\frac{1}{4}$ x 4 x $\frac{3}{8}$ in.
Lining	
Federal part number	17B7060
BLMA number	1131

b. Adjustment. Adjustment of brake shoes is made by adjusting slack adjusters. On the front wheels only, the anchor pins must also be adjusted. The entire procedure is given under adjustment of slack adjusters (par. 127 b above).

**SERVICE BRAKE SYSTEM**



**Figure 85 – Front Brake Shoes Installed**



**Figure 86 – Rear Brake Shoes Installed**

**TM 9-820**  
**128-130**

**4- TO 5-TON 4x4 TRACTOR TRUCK (FEDERAL)**

**c. Removal**

- (1) REMOVE WHEEL AND HUB (par. 135 c).
- (2) LOWER ANCHOR PINS (fig. 85). (FRONT WHEELS ONLY).  
Loosen anchor pin lock nuts and turn pin to lowest points.
- (3) REMOVE BRAKE SHOE SPRING (figs. 85 and 86). Turn camshaft by means of slack adjuster until shoes are at lowest point on cam. Slide brake shoe spring from holes in shoes. NOTE: *Rear wheel brakes have two springs. Remove in same manner.*
- (4) REMOVE ANCHOR PIN LOCK PLATE (figs. 85 and 86). Remove cotter pin and stud nut which hold lock plate on pins. Lift plate from pins.
- (5) REMOVE SHOES (figs. 85 and 86). Pull both shoes from anchor pins.

**d. Installation.**

- (1) ATTACH SHOES TO ANCHOR PINS (figs. 85 and 86). Place shoes in position on anchor pins. Place anchor pin lock plate in position over anchor pins and shoes. Install stud nut and cotter pin which hold lock plate in position.
- (2) INSTALL BRAKE SHOE SPRING (figs. 85 and 86). Hold loose ends of shoes together and insert brake shoe spring and clips through holes provided for the purpose in brake shoes. On rear wheel brake, install second brake shoe springs.
- (3) INSTALL HUB AND WHEEL (par. 135 d).
- (4) ADJUST BRAKES (par. 127 b).

---

**Section XXVII**

**PROPELLER SHAFT BRAKE SYSTEM**

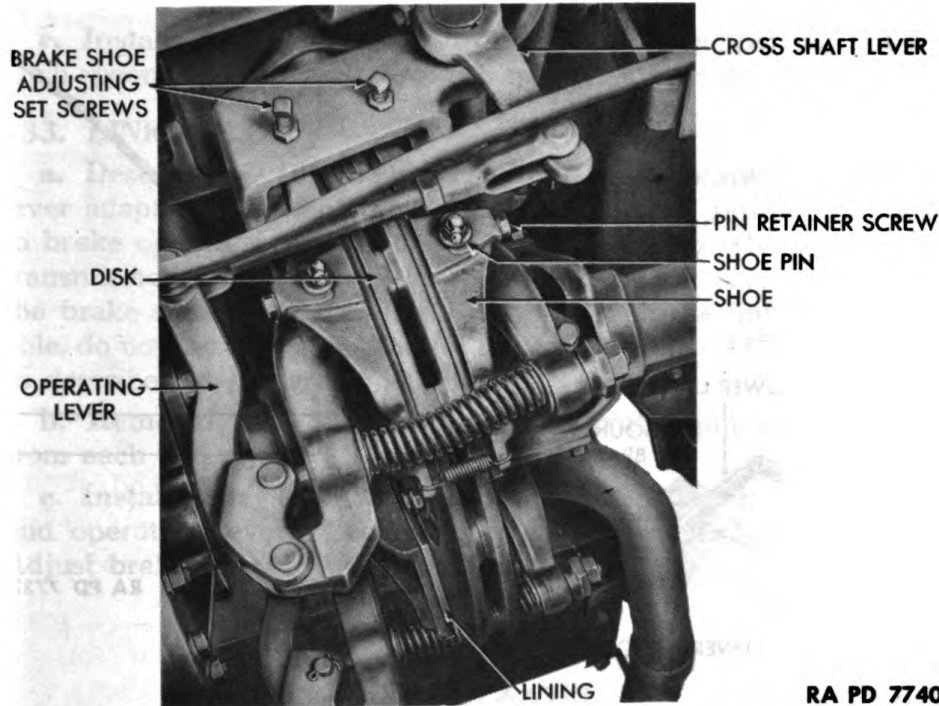
**129. DESCRIPTION.**

**a. Description** (fig. 87). Propeller shaft brake is an auxiliary mechanical brake to be used for parking or to be used in an emergency when the main system of air brakes fails. It consists of a disk with brake shoes on either side brought together by means of cams and levers. It is mounted on the power train directly behind the transfer case. Because of the severe strain exerted on the power train, extreme care should be used in applying it.

**130. SHOES.**

**a. Description** (fig. 87). Four brake shoes, located two on either side and two on either end of disk, provide propeller shaft braking power. A series of cams and levers step up the pressure exerted by the hand-operated propeller shaft brake lever.

### PROPELLER SHAFT BRAKE SYSTEM



RA PD 77406

**Figure 87 – Propeller Shaft Brake Installed**

**b. Adjustment** (fig. 87). Push propeller shaft brake lever (fig. 3) down to released position. Tighten brake shoe, adjusting set screws to get 0.030-inch clearance between disk and top of shoes on both sides. Use feeler gage. Tighten tie rod nut to get 0.030-inch clearance between disk and bottom of shoes on both sides. Recheck clearance at top and repeat procedure until 0.030-inch top and bottom clearance is obtained. Observe same procedure to adjust shoes on opposite side of disk. *NOTE: Never shorten propeller shaft brake lever rod. Use procedure described above.*

**c. Removal** (fig. 87). Loosen the pin retainer screw at back of each shoe. Pull or drive out the brake shoe pin which holds each shoe to the brake assembly. Remove the four shoes.

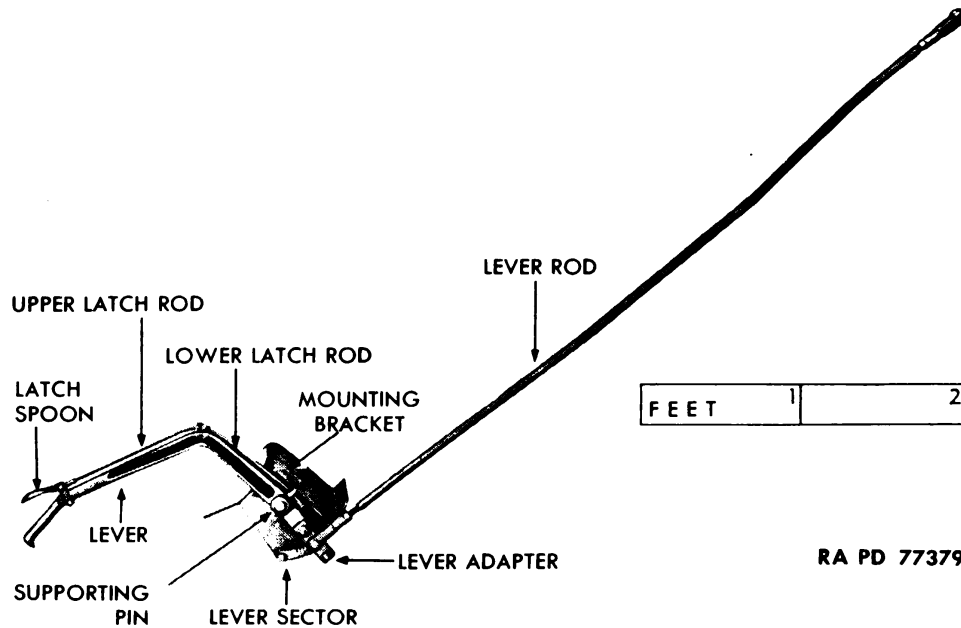
**d. Installation** (fig. 87). Position shoes on brake assembly. Insert brake shoe pin in each. Secure each pin with its pin retainer screw.

### 131. DISK.

**a. Description** (fig. 87). The disk is located between shoes in center of assembly at rear of transfer case. It consists of two flat metal disks welded together at intervals through bosses which are an integral part of each disk. Purpose of disk is to provide a surface against which brake shoes may act to stop vehicle.

**TM 9-820  
131-132**

**4- TO 5-TON 4x4 TRACTOR TRUCK (FEDERAL)**



**Figure 88 – Propeller Shaft Brake Lever and Linkage**

**b. Removal** (fig. 87). Remove two brake shoe springs, one on either side, which hold shoes in a vertical position. Remove eight bolts, lock washers, and nuts which secure brake disk to driving flanges of transfer case and rear axle propeller shaft. Remove disk.

**c. Installation** (fig. 87). Position disk between shoes and between driving flanges of transfer case and rear axle propeller shaft. Secure with the right bolts, lock washers, and nuts. Install two springs which hold shoes vertical.

**132. LEVER.**

**a. Description** (fig. 88). The propeller shaft brake lever is located in cab at right of operator's seat. The purpose of lever is to operate propeller shaft brake by applying brake shoes under pressure to the brake disk. Pressure is created through a series of cams and levers. Attached to brake lever is a latch rod which permits setting and holding brake lever in the position necessary to keep vehicle from moving. To operate brake, the latch spoon at upper end of brake must be depressed. Releasing spoon sets latch rod latch in lever sector and prevents brake lever from moving.

**b. Removal** (fig. 88). Remove cotter pin, flat washer, and spring which secure lever to mounting bracket. Depress latch spoon at upper end of latch rod and slide lever from supporting pin.

**WHEELS, HUBS, WHEEL BEARINGS, AND TIRES**

c. **Installation** (fig. 88). Position lever on supporting pin with latch spoon depressed. Secure with spring, flat washer, and cotter pin.

**133. LINKAGE.**

a. **Description** (fig. 88). The linkage is located between the lever adapter at base of the brake lever and the push rod attached to brake operating lever. The purpose of linkage (lever rod) is to transmit action of the brake lever to the cams and levers which press the brake shoes against brake disk. Although the linkage is adjustable, do not use it as a method for adjusting brake. Make adjustment as described in paragraph 127 b.

b. **Removal** (fig. 88). Remove the cotter pin and clevis pin from each end of rod. Remove rod.

c. **Installation** (fig. 88). Position rod between lever adapter and operating lever. Secure with two clevis pins and cotter pins. Adjust brake (par. 130 b).



**Section XXVIII**

**WHEELS, HUBS, WHEEL BEARINGS, AND TIRES**

**134. WHEELS.**

a. **Description and Tabulated Data.**

(1) **DESCRIPTION** (figs. 89 and 90). The vehicle is equipped with 7 or 8 (depending on whether vehicle has 1 or 2 spares) identical wheels which may be mounted either singly or dually on front and rear hub assemblies. One or two spare wheels are carried at rear of cab. Ten combination inner and outer axle hub and wheel stud nuts are used to mount wheels singly or in pairs. Outer nuts have hexagon heads, inner nuts square heads. Wheels are installed in reverse position to each other when mounted as duals. Outer stud nuts are installed even when outer wheel is not used. All stud nuts on right-hand side of truck have right-hand threads and are stamped "R" on the end. Nuts on left-hand side of truck have left-hand threads and are stamped "L" on the end.

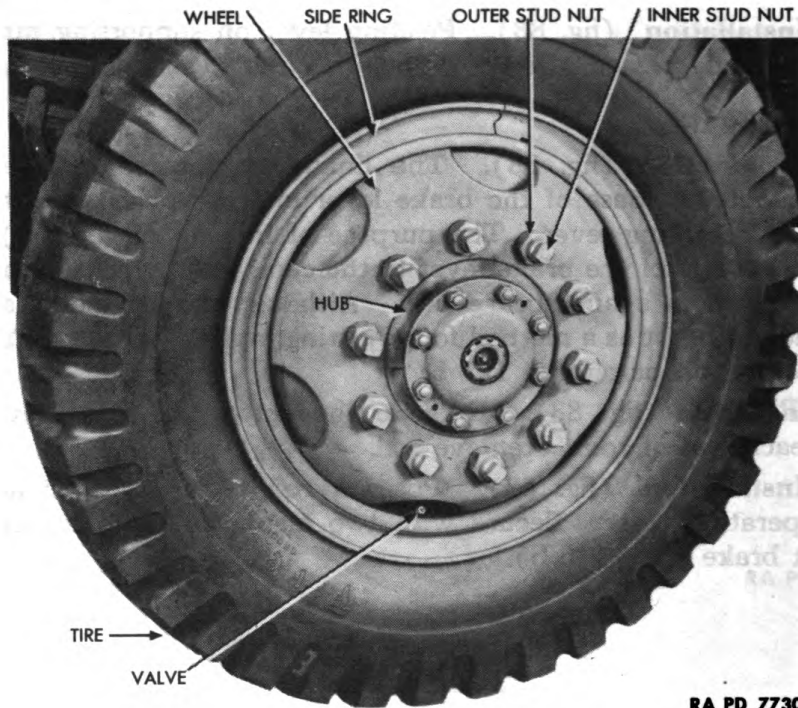
(2) **TABULATED DATA:**

Manufacturer .....	Budd
Size .....	20 x 8
Type rim .....	L - M
Part number .....	11 C 7072

b. **Removal** (figs. 89 and 90). Block wheels to prevent vehicle moving. Loosen the 10 stud nuts which secure wheel to hub assembly one full turn. (Note thread marking on nut ends.) Use hydraulic jack or other suitable lifting device and raise wheel clear of floor

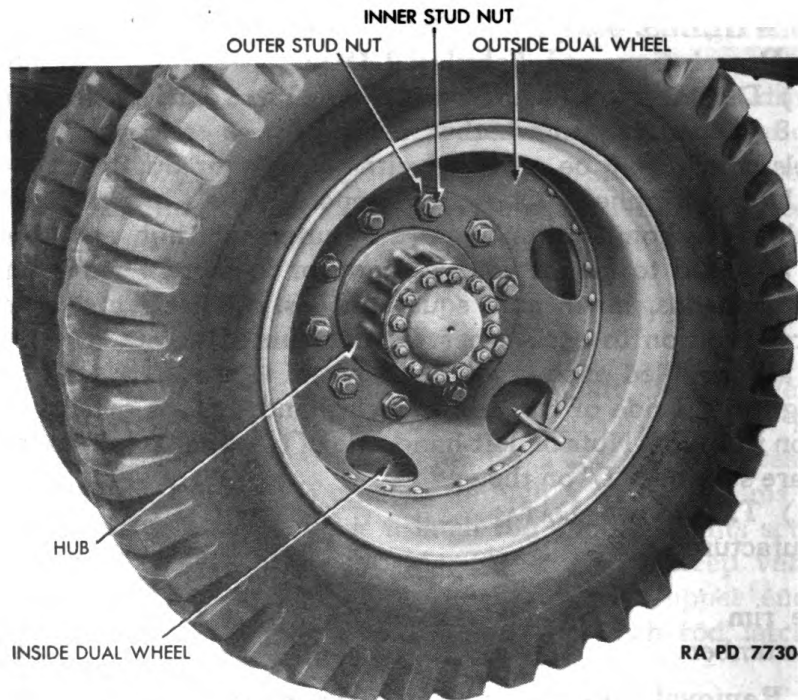
TM 9-820  
134

**4 TO 5-TON 4x4 TRACTOR TRUCK (FEDERAL)**



RA PD 77301

**Figure 89 – Front Wheel**



RA PD 77304

**Figure 90 – Rear Wheel Installed**



**WHEELS, HUBS, WHEEL BEARINGS, AND TIRES**

Remove the 10 stud nuts. Lift wheel from hub. **NOTE:** *If 2 wheels attached to the same drum are to be removed, remove outer wheel first as outlined above. This wheel is attached by outer stud nuts. Then remove inner wheel as outlined above. This wheel is attached by inner stud nuts.*

c. **Installation** (figs. 89 and 90). Position wheel on hub assembly. Install the 10 stud nuts which secure wheel to hub. Tighten nuts in opposite positions alternately to insure proper alinement of wheel and hub. **NOTE:** *If 2 wheels are to be mounted on the same drum, inner stud nuts must be installed first to secure inner wheel. Then mount and secure outer wheel with outer stud nuts. Make sure nuts are tight. Lower wheel to floor and remove wheel blocks.*

**135. HUBS AND WHEEL BEARINGS.**

a. **Description and Tabulated Data.**

(1) **DESCRIPTION** (figs. 91 and 92). Hubs and wheel bearings are located on each end of axle housing, front and rear. The two bearing cups and cones are fitted snugly to axle shaft. The hub assembly is installed on these bearings and secured by a bearing nut. The bearings are packed with grease. The grease is prevented from passing into hub brake drum by a felt oil seal and two retainer washers located between inner bearing cone and brake housing assembly.

(2) **TABULATED DATA:**

Make .....	Timken
Wheel bearings:	
Front inner cone .....	Timken 594
Front inner cup .....	Timken 592
Front outer cone .....	Timken 498
Front outer cup .....	Timken 493
Rear inner and outer cone .....	Timken 5557
Rear inner and outer cup .....	Timken 5520

b. **Adjustment** (figs. 91 and 92). Block wheels to prevent vehicle from moving. Use suitable lifting device to raise wheel clear of floor. Remove retainer snap ring (front hub only). Remove axle shaft driving flange (axle shaft on rear axle) and gasket by removing the eight (12 on rear axle) stud nuts and lock washers which secure flange to hub assembly. Remove wheel bearing jam nut and nut lock (called jam nut washer on rear axle). While tightening wheel bearing nut rotate wheel in both directions until wheel binds. Back off nut about 1/4 turn to allow wheel to rotate freely without excessive play. Test for excessive play by lifting with a bar or other suitable lifting device. Tighten nut enough to eliminate play but not enough to cause binding. Install nut lock (jam nut washer and jam nut). Recheck wheel adjustment. Install driving flange (or axle shaft`

4- TO 5-TON 4x4 TRACTOR TRUCK (FEDERAL)

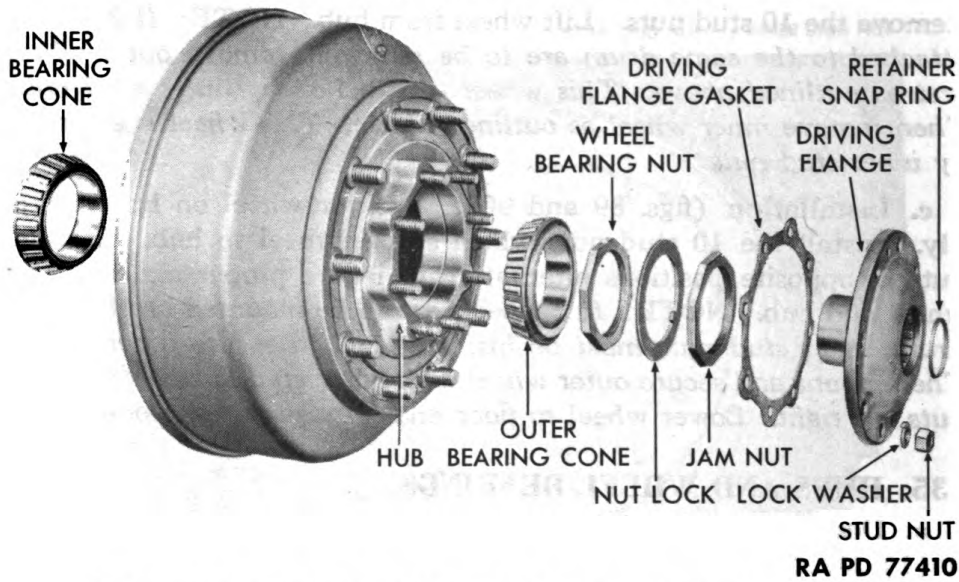


Figure 91 — Front Hub and Bearings Disassembled

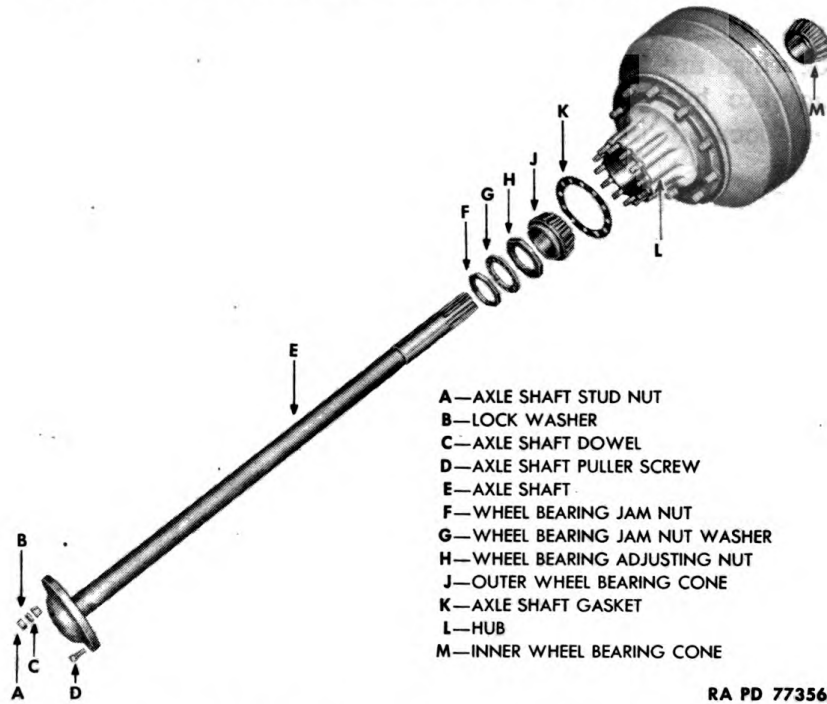


Figure 92 — Rear Hub and Bearings Disassembled

and new gasket, and secure with the eight (or 12) stud nuts and lock washers. Lower wheel to floor and remove wheel blocks.

c. Removal (figs. 91 and 92). Remove wheel (par. 134 b). Pry retainer snap ring (front wheel only) from center of driving flange. Remove axle driving flange (axle shaft on rear axle), jam nut, and

**WHEELS, HUBS, WHEEL BEARINGS, AND TIRES**

nut lock (called jam nut washer on rear axle). Remove rear axle shaft with attached driving flange as follows: Remove wire seal attached to the two axle shaft puller screws. Remove the 12 nuts and lock washers, and the three dowels and dowel washers securing flange to hub assembly. Pull flange and attached shaft from assembly. If necessary, tighten puller screws to aid in removal of shaft. Remove wheel bearing nut. Remove wheel outer bearing cone by prying alternately on either side. Remove hub. Pry off wheel inner bearing cone. Remove felt oil seal and the two retainer washers. Remove the 10 stud nuts from inner ends of wheel attaching studs and lift brake drum from hub. Remove lubricant from all parts with a clean cloth.

**d. Installation** (figs. 91 and 92). Position brake drum on hub and install the 10 stud nuts which attach drum to hub. Install new felt oil seal and two retainer washers. Soak felt thoroughly with engine lubricant. Apply new lubricant to wheel inner bearing cone and install. Install hub. Install outer bearing cone. Install bearing nut. Complete the installation as described in (par. 135 b). **NOTE:** *Install rear axle driving flange and axle shaft as a unit as follows: Release puller screws if they were used in removal. Position flange and shaft in hub assembly and secure with the 12 nuts, lock washers, and the 3 dowel washers and dowels. Wire rear axle puller screws. Install wheels (par. 136 d) and release brake.*

**136. TIRES.**

**a. Description and Tabulated Data.**

(1) **DESCRIPTION** (fig. 89). The vehicle is equipped with 7 or 8 (depending on whether 1 or 2 spare wheels are furnished) 10-ply bus-balloon type tires mounted on the 7 or 8 wheels previously described.

(2) **TABULATED DATA:**

Manufacturer ..... Firestone  
Type ..... Bus-balloon-Lug  
Size ..... 9.00 x 20  
Air pressure:

Hard surface road operation ..... 65 lb  
Off-road operation ..... 55 lb

**b. Maintenance.** Efficiency and usefulness of vehicle depend upon proper care of tires. Check tire pressures, load distribution, and wheel adjustment frequently. Outer tires are subject to side wall cuts and scraping. Inner tires often carry an overload due to road crown. Shift tires periodically to distribute wear. Observe recommendation shown under description and tabulated data (subpar. a (2) above) for proper inflation.

**c. Removal** (fig. 89). Remove wheel (par. 134 b). Lay tire flat with valve pointing up. Release air from tire by removing valve

Generated on 2013-06-23 14:15 GMT / http://hdl.handle.net/2027/uc1.b3243770  
Public Domain, Google-digitized / http://www.hathitrust.org/access\_use#pd-google

**4- TO 5-TON 4x4 TRACTOR TRUCK (FEDERAL)**

core. Remove side ring from wheel as follows: Pry ring from wheel by inserting tire iron in niche at end of ring; hammer tool all the way around between ring and wheel until ring is free. Loosen tire from wheel by forcing a flat tire iron between tire casing and wheel all the way around. Use necessary care to avoid damaging valve. When tire is free, depress valve through opening and lift tire from wheel. Pull flap and tube from tire, exercising care not to tear either one where they may have adhered to tire.

**d. Installation** (fig. 89). Install tube and flap in tire casing. Install valve core. Partially inflate tube. Check installation to make sure that tube is not twisted or buckled and that flap completely covers exposed side of tube. Position tire on wheel. Pull valve through opening. Install side ring. Check position of valve to see that it does not touch wheel. Inflate tire to pressure required (par. 136 a (2)). Mount wheel on hub assembly (par. 134 c).

---

**Section XXIX**

**SPRINGS AND SHOCK ABSORBERS**

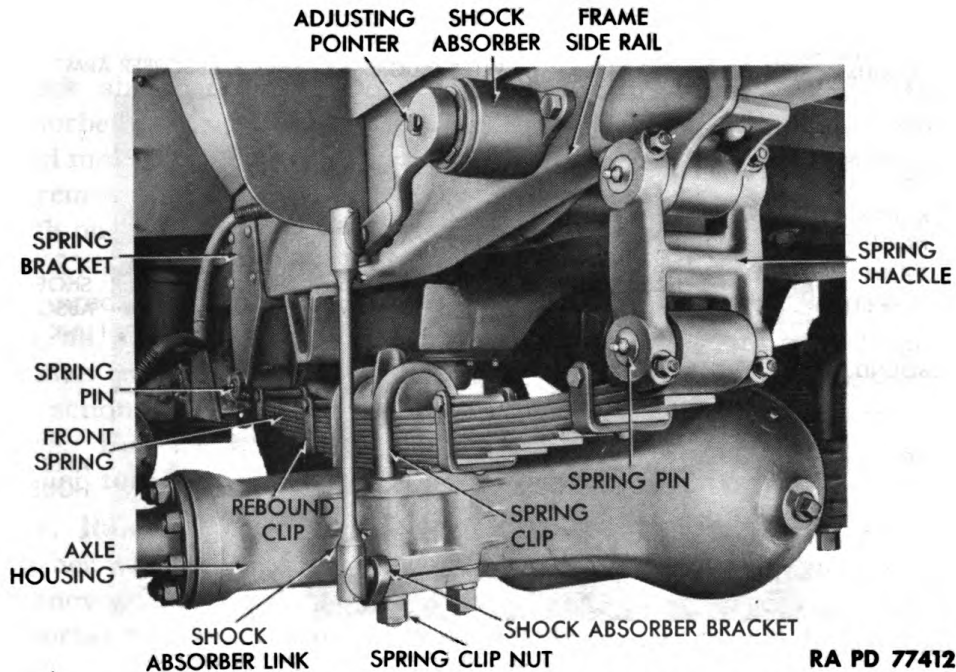
**137. FRONT SPRINGS.**

**a. Description** (fig. 93). Springs are attached to frame side rails and front axle housing. Two spring clips (U-bolts) secure spring at center to housing. Spring is attached to frame at rear by a bracket, at front by a shackle. The spring clip nuts must be kept tight at all times to insure proper wheel alignment, to prevent leaf breakage, and to facilitate steering.

**b. Removal** (fig. 93). Clean spring free of dirt and grease. Apply kerosene or penetrating oil liberally to spring clip nuts and spring pins. Disconnect shock absorber link from bracket (par. 139 c). Remove the four spring clip nuts and lock washers which secure clips to axle housing. Screw out lubrication fitting from front and rear spring pins. Remove the four nuts and lock washers which secure the four draw keys to spring pin assembly. Drive keys out. Lift vehicle to take load off springs and to cause weight of axle to loosen spring clips from axle housing. Remove clips and clip seats. Drive out spring pins from inner end. Use soft tool to avoid damaging pins. Remove spring.

**c. Installation** (fig. 93). Replace parts that show noticeable wear or do not fit snugly. Position spring between shackle and bracket. Turn slotted side of spring pins down and insert (front outer end) at each end of spring. Wedge the four draw keys against slotted side of the two pins. Secure each key with lock washer and nut. Install

**SPRINGS AND SHOCK ABSORBERS**



**Figure 93 – Front Spring and Shock Absorber**

clip seats and clips. Lower vehicle so that full weight rests on springs. Secure spring clips with the four lock washers and nuts. Connect shock absorber link to spring clip plate (par. 139 d). Remove lifting equipment.

**138. REAR SPRINGS.**

**a. Description (fig. 94).** Springs are attached to frame side rails and axle housing. They are assisted in carrying heavy loads by auxiliary springs mounted above them. The springs are solidly mounted to bracket at front. At rear, they are supported by special brackets attached to frame. When rear springs flatten out, auxiliary springs contact special auxiliary spring brackets at each end and help carry vehicle load.

**b. Removal (fig. 94).** Clean spring free of dirt and grease. Apply kerosene or penetrating oil to clip nuts and spring pin. Disconnect shock absorber link from bracket (par. 139 c). Remove four clip nuts and lock washers which secure clips to axle housing. Raise rear end of vehicle until spring clips loosen from axle housing. Remove clips and clip seats. Screw out lubrication fitting from front end of spring. Remove the two nuts and lock washers which secure draw keys to pin assembly. Drive keys out. Drive out spring pin from inner end. Use soft tool to prevent damage to pin. Remove spring.

**c. Installation (fig. 94).** Replace parts that show wear or that do not fit snugly. Position spring between supporting brackets. In-

4- TO 5-TON 4x4 TRACTOR TRUCK (FEDERAL)

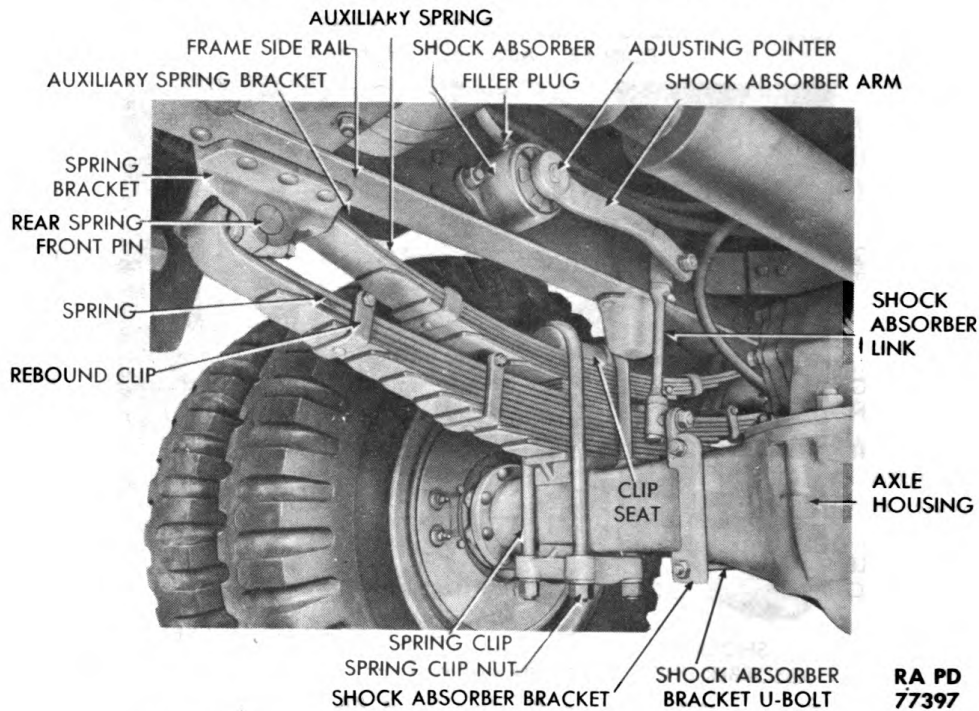


Figure 94 — Rear Spring and Shock Absorber

sert spring pin (from outer side) at front end of spring (slotted side down). Wedge the two draw keys against slotted side of pin. Secure draw keys with the two lock washers and nuts. Screw in lubrication fitting at outer end of spring pin. Install clip seat and clips. Lower vehicle until full weight rests on axle housing. Secure clips with four lock washers and nuts. Connect shock absorber link to spring clip plate (par. 139 d). Remove lifting equipment.

139. SHOCK ABSORBERS.

a. Description and Tabulated Data.

(1) DESCRIPTION (figs. 93 and 94): Shock absorbers are mounted on frame side rails just ahead of front and rear axles. The two rear shock absorbers are mounted inside frame rails, one on each side; the two front shock absorbers are mounted similarly, only outside rails. Shock absorbers are of the rotary-type and are connected to axles by arms and links.

(2) TABULATED DATA:

Manufacturer .....	Houdaille
Model—front axle .....	BBCLV
rear axle .....	BBH

b. Maintenance and Adjustment.

(1) MAINTENANCE (figs. 93 and 94). Refill shock absorbers as follows: Remove the one bolt, nut, and flat washer which secure

**STEERING GEAR**

shock absorber arm to link. Clean dirt and grease from around filler plug. Remove filler plug. Fill reservoir to bottom of filler hole with shock absorber fluid. Do not fill above this level. Work shock absorber arm up and down several times to expel air from system. Add more fluid if necessary. When reservoir is properly filled and air is removed, install filler plug. Connect shock absorber arm to link with one nut and lock washer which secure them.

(2) **ADJUSTMENT** (figs. 93 and 94). No adjustment of links is required. Shock absorber tension is increased or decreased by rotating an adjusting pointer on the outside of the housing. Turning pointer counterclockwise stiffens its action; turning it clockwise softens its action. Make adjustments in 1/16-inch steps or one notch at a time. Full range of adjustment lies between two stops on housing. Never turn pointer beyond these stops.

**c. Removal** (figs. 93 and 94). Remove one jam nut and lock washer which secure link to shock absorber bracket on axle housing. Remove two bolts, nuts, and lock washers which secure shock absorber to frame. Remove shock absorber, arm, and link as a unit.

**d. Installation** (figs. 93 and 94). Position shock absorber on frame and secure with two bolts, nuts, and lock washers. Install one jam nut and lock washer which secure link to axle housing.

---

**Section XXX**

**STEERING GEAR**

**140. DESCRIPTION AND TABULATED DATA.**

**a. Description** (figs. 95 and 97). Steering gear assembly is located mainly in left side of cowl. Its upper end extends through a jacket tube assembly to the steering wheel located in front of the instrument panel; its lower end extends through two drag links (upper and lower) and an idler arm lever to a steering arm attached to the left front wheel. Steering gear is a roller-mounted twin-lever type of cam and lever design.

**b. Tabulated Data:**

Manufacturer ..... Ross  
Model ..... T71  
Type ..... Cam and lever

**141. MAINTENANCE AND ADJUSTMENT.**

**a. Maintenance.** Inspect the two drag links for end play or excess slack. Check steering jacket tube assembly for end play by

4- TO 5-TON 4x4 TRACTOR TRUCK (FEDERAL)

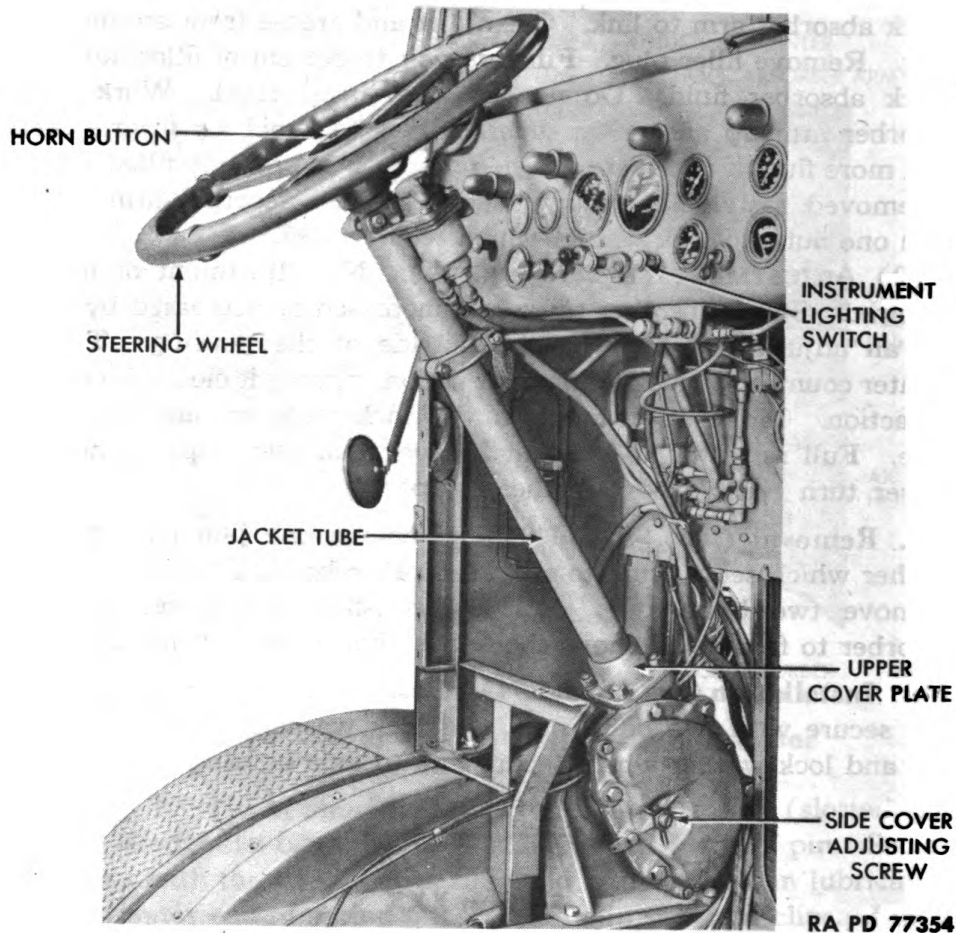


Figure 95 – Steering Gear Installed

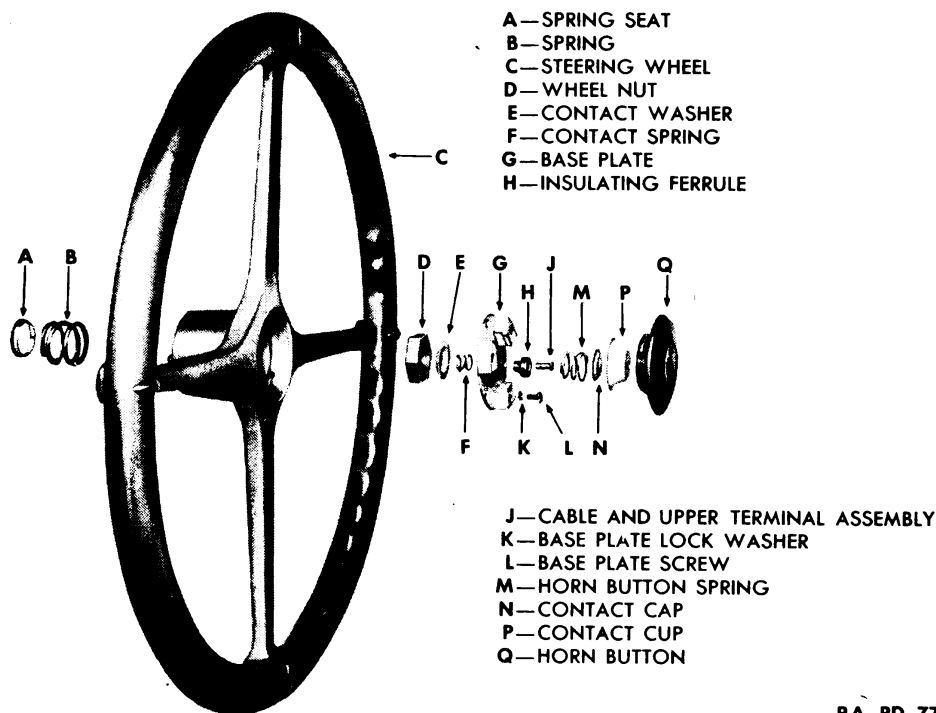
attempting to move tube back and forth on its axis. Keep steering gear housing filled with proper lubricant.

**b. Adjustment.** Main adjustments of steering gear are vertical end play in jacket tube, lever shaft end play, and end play of drag links or reach rods. Always adjust jacket tube before making adjustments to lever shaft.

(1) **ADJUST VERTICAL END PLAY OF JACKET TUBE** (fig. 95). Disconnect drag link from steering arm (par. 143) and loosen dash bracket clamp so that no drag will hinder adjustment. Loosen side cover adjusting screw lock nut and side cover adjusting screw at right-hand side of housing. Slide up upper cover plate by removing four lock washers and nuts which secure it to housing. Remove one of the shims between cover plate and housing. Replace cover and secure with four lock washers and nuts. Test adjustment. Continue this procedure, removing or replacing shims until drag is barely perceptible, actually one to two pounds pull on rim of steering wheel. Adjust lever shaft end play (step (2) below).



**STEERING GEAR**



RA PD 77392

**Figure 96 – Steering Wheel and Horn Button Disassembled**

(2) **ADJUST LEVER SHAFT END PLAY** (fig. 95). Because of the closer mesh of studs in cam groove through midposition of travel, place steering gear in this position before adjusting. Then tighten side cover adjusting screw until a very slight drag is felt through midposition. Tighten adjusting screw lock nut. Check adjustment for proper drag after lock nut is tight.

(3) **ADJUST DRAG LINK OR REACH ROD END PLAY** (fig. 97). End play at either end of each drag link is adjusted as follows: Remove cotter pin which holds adjusting plug in position. Turn adjusting plug a half turn at a time until slack is removed. Install cotter pin. Do not tighten more than necessary.

**142. STEERING WHEEL** (fig. 96).

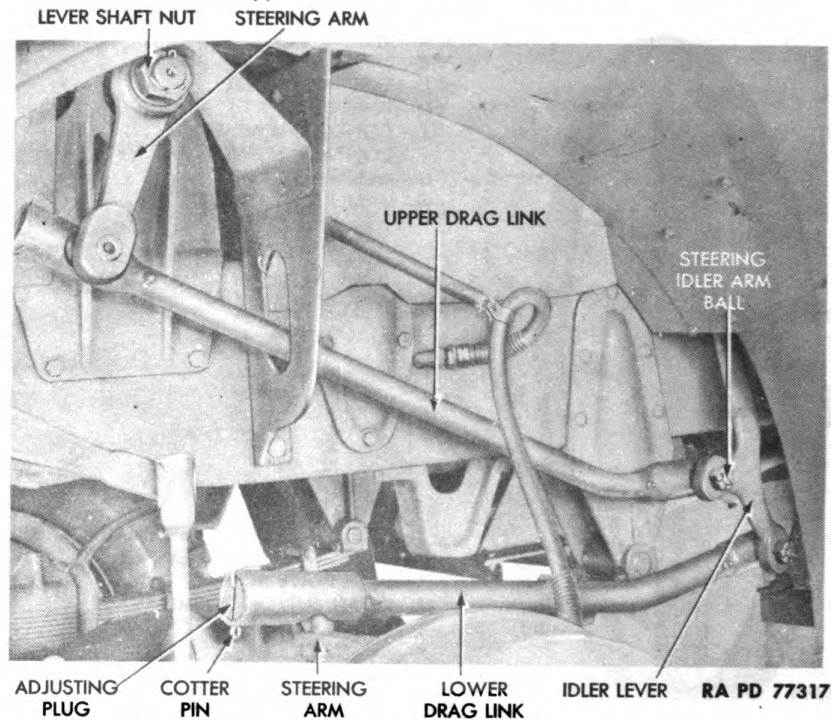
**a. Removal.** Remove horn button assembly (par. 167 b). Remove wheel nut. Lift steering wheel from jacket tube. Remove spring and spring seat from jacket tube ball bearing assembly.

**b. Installation.** Position spring and spring seat in jacket tube ball bearing assembly. Position steering wheel on jacket tube assembly. Install wheel nut. Install horn button assembly (par. 167 c).

**143. DRAG LINKS (UPPER AND LOWER)** (fig. 97).

**a. Removal.** Remove cotter pin at each end of both links. Screw

**4- TO 5-TON 4x4 TRACTOR TRUCK (FEDERAL)**



**Figure 97 - Drag Links and Steering Arm**

out adjusting plug at each end of both links until they can be removed from steering arms and idler lever. Remove links.

**b. Installation.** Position one end of links on idler lever. Position other end of upper drag link on steering arm attached to lever shaft. Position other end of lower drag link on steering arm attached to left front wheel. Tighten the four adjusting plugs until all slack is removed. Secure each plug with a cotter pin and lubricate.

**144. STEERING (PITMAN) ARM (fig. 97).**

**a. Removal.** Remove cotter pin, nut, and lock washer, securing arm to tapered spline end of lever shaft. Tap arm from shaft. Disconnect arm from drag link (par. 143).

**b. Installation.** Tap steering arm on tapered spline end of lever shaft. Secure by installing lock washer, nut, and cotter pin. Attach drag link to arm (par. 143).

---

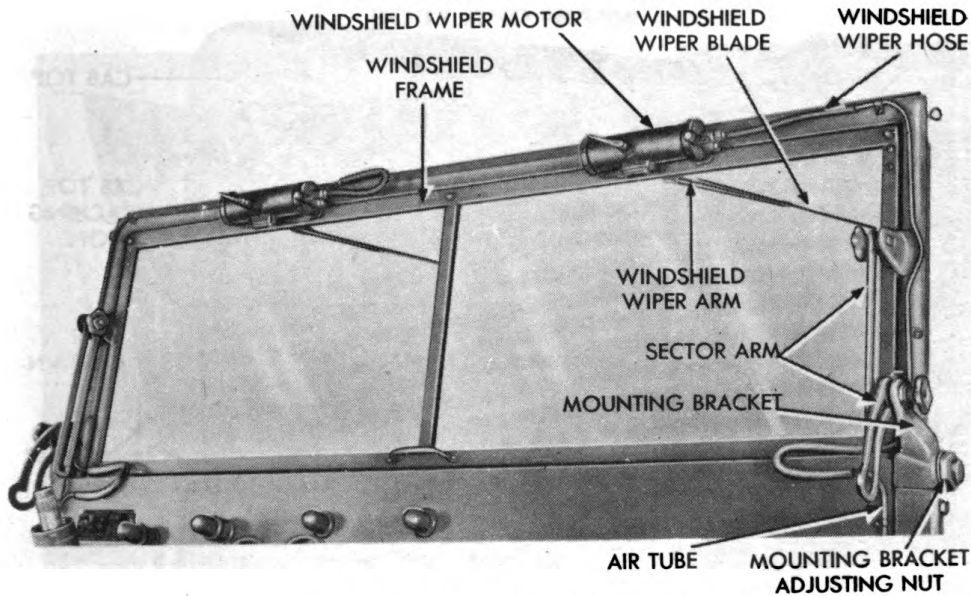
**Section XXXI**

**BODY AND FRAME**

**145. DESCRIPTION.**

**a. Cab.** The Federal cab is of silhouette design with demountable fabric top, removable side curtains, adjustable driver's seat, adjustable

**BODY AND FRAME**



**Figure 98 – Windshield Installed**

RA PD 77393

windshield, and dual windshield wipers. Cab skirts are provided with removable panels permitting access to the engine and miscellaneous engine equipment.

**b. Frame.** The frame is of welded and riveted construction. Frame attachments include bumper, towing hooks, pintle hook, fenders, and step plates.

**146. WINDSHIELD WIPERS.**

**a. Description and Tabulated Data.**

(1) **DESCRIPTION** (fig. 98). The wipers are individually operated and are located at top center of windshields. These wipers are air operated by means of an air line connected to the air brake system. Speed of wiper action is regulated by two valves on the instrument panel (fig. 3).

(2) **TABULATED DATA:**

Manufacturer .....	Trico Folberth
Part number .....	F-P 678
Number of assemblies .....	2

**b. Maintenance** (fig. 98). Check air lines for plugged line or fittings, kinked hose or tubing, and leaks. Tighten all connections. Lubricate seal felts around shaft with light engine oil at each lubrication period. If wiper fails to operate after line had been thoroughly checked, replace the entire assembly. Replace deteriorated wiper blades or blades that will not clean windshield properly.

**c. Removal** (fig. 98). Disconnect hose from air line. Remove cap screw which secures wiper arm to wiper motor. Remove arm

4- TO 5-TON 4x4 TRACTOR TRUCK (FEDERAL)

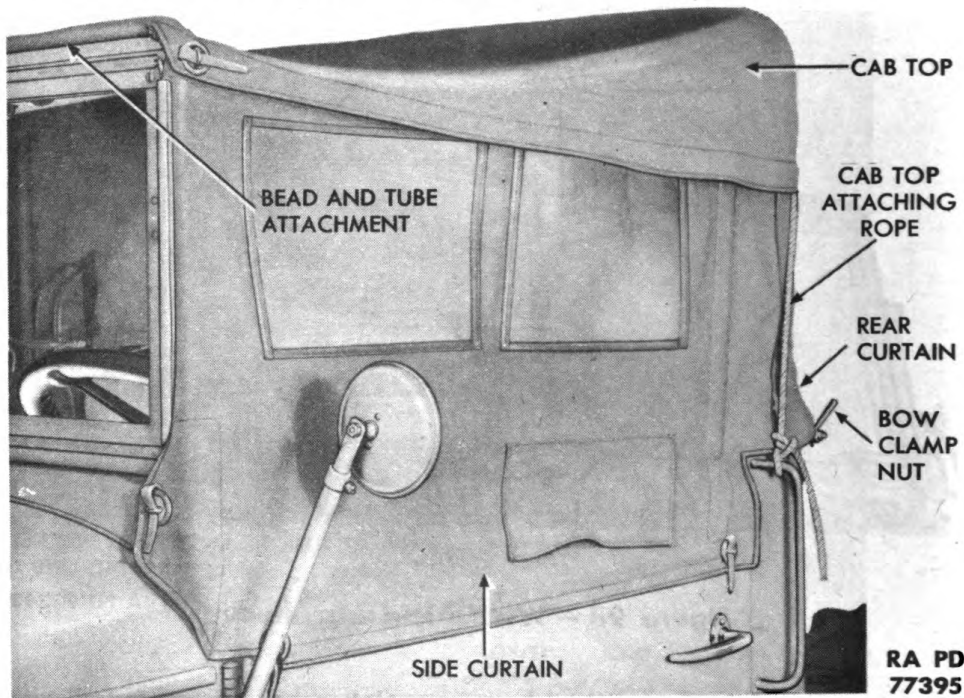


Figure 99 – Cab Top Installed – Exterior

and blade as a unit. Remove two screws and lock washers which secure wiper motor to windshield frame. Remove unit.

d. **Installation** (fig. 98). Position wiper motor to windshield frame and secure with two screws and lock washers. Attach wiper arm to motor by installing the cap screw which secures it. Connect hose to vacuum tube.

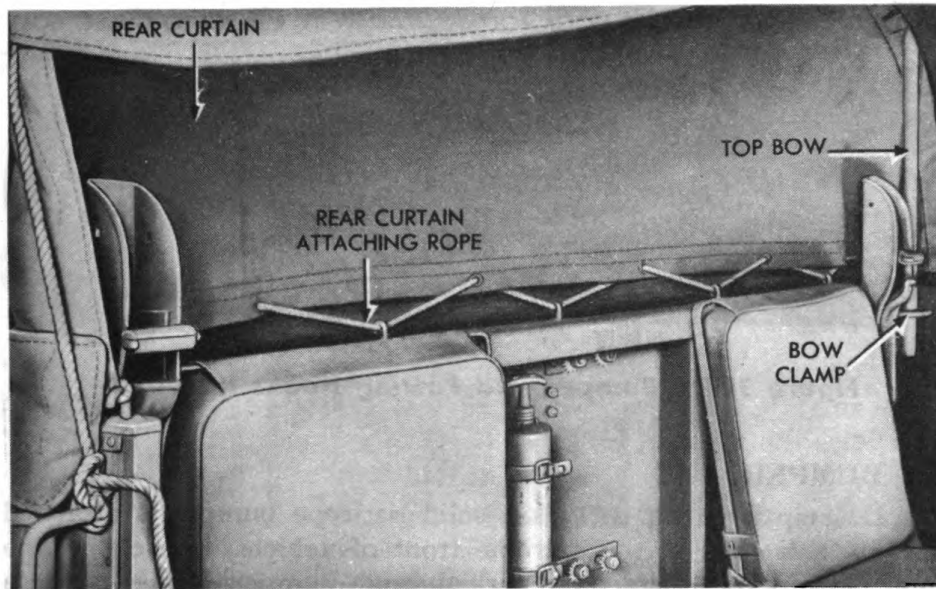
#### 147. WINDSHIELD ASSEMBLY.

a. **Description** (fig. 98). The windshield is located at top rear of cowl assembly. It provides protection from the weather, road dirt, and insects without interfering with the operator's vision. Sector arms, manually controlled, make it possible to open the windshield to any degree desired. If desired, the entire windshield assembly can be folded forward on the cowl.

b. **Removal** (fig. 98). Disconnect air hose from air tube at bottom of windshield on either side. Loosen windshield mounting bracket, adjusting stud nut, and adjusting stud on each end of windshield assembly. Lift assembly from mounting brackets and remove.

c. **Installation** (fig. 98). Position windshield assembly in mounting brackets. Tighten two adjusting studs and adjusting stud nuts which secure assembly to brackets. Connect air hoses to vacuum tubes at bottom of windshield on each side.

**BODY AND FRAME**



RA PD 77396

**Figure 100 – Cab Top Installed – Interior**

**148. CAB TOP.**

**a. Description** (figs. 99 and 100). The cab top is attached to cab between the windshield, top bow, and rear top of cab. It is provided with side curtains and serves to protect interior of cab from the weather. Side curtains are windowed to provide side vision when curtains are installed. The top is attached at the front by means of a beading which slides into a tube at top of windshield frame. It is attached at the rear with the rope threaded through grommets in the seam slips under hooks attached to cab just above tire carrier assembly.

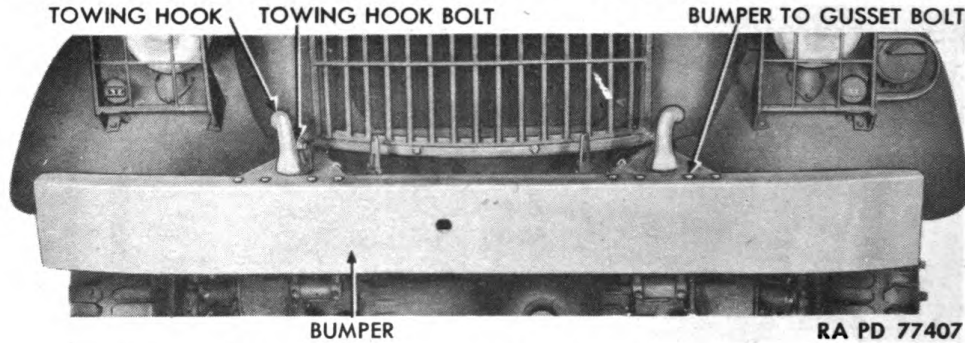
**b. Maintenance.** While cab top and side curtains are installed, keep all fasteners and lashing ropes securely fastened. When top and side curtains are removed, stow them in the space under the driver's seat. Never fold top or curtains when they are wet.

**c. Removal** (figs. 99 and 100). Unhook the three ropes which secure top cover to cab. Pull cab top over roof bow and windshield. Slide bead at front edge of top from tube attached to top of windshield frame. Remove top from cab. Loosen top bow clamps and nuts. Detach rope securing rear curtain to cab. Remove curtain and top bow as a unit.

**d. Installation** (figs. 99 and 100). Install top bow and cab rear curtain at rear of cab. Lash rope threaded through curtain seam to lashing hooks on cab. Slide bead at front edge of top cover through tube at top of windshield. Pull cover over top bow. Attach three ropes which secure cover to cab.

**TM 9-820  
149-151**

**4- TO 5-TON 4x4 TRACTOR TRUCK (FEDERAL)**



**Figure 101 – Bumper and Towing Hooks Installed**

**149. BUMPER.**

**a. Description** (fig. 101). A solid bar-type bumper is attached to frame side rails at the extreme front of vehicle. A hole in the center permits use of starting crank through bumper. Chief purpose is to provide protection to front of vehicle.

**b. Removal** (fig. 101). Remove the ten bumper to gusset bolts, lock washers, and nuts which secure bumper to frame. Remove bumper.

**c. Installation** (fig. 101). Position bumper on frame side rails. Secure with the ten gusset to bumper bolts, lock washers, and nuts.

**150. TOW HOOKS.**

**a. Description** (fig. 101). Two tow hooks are attached to top of frame side rails just behind the bumper. When vehicle is to be towed, attach pulling apparatus to tow hooks.

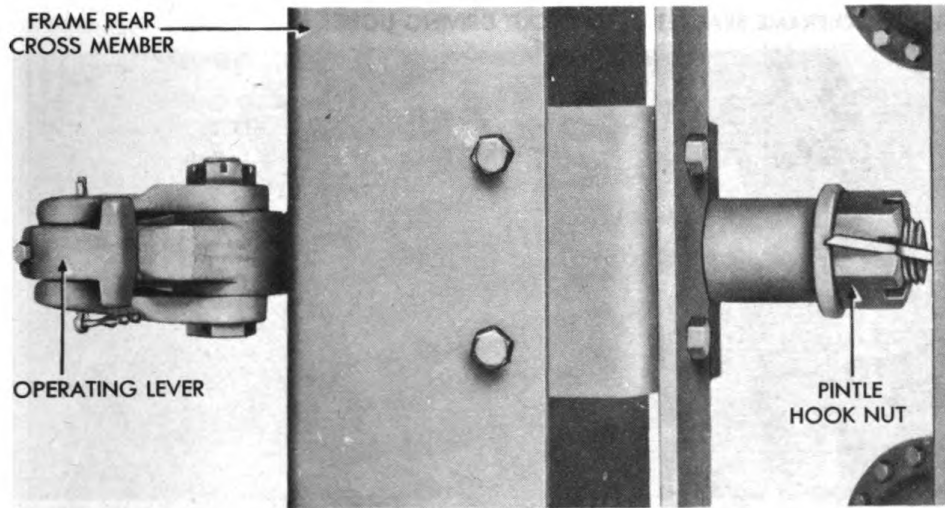
**b. Removal** (fig. 101). Remove two towing hook bolts, lock washers, and nuts which secure tow hook to frame side rail. Remove two hooks.

**c. Installation** (fig. 101). Position tow hook on frame side rail. Install two towing hook bolts, lock washers, and nuts which secure it to frame.

**151. PINTLE HOOK.**

**a. Description** (fig. 102). The pintle hook is attached to rear cross member of frame midway between side rails. The top of hook consists of an operating lever which provides a two-inch opening. The lever is locked in either the open or closed position by means of the engagement of a square shaped tooth in the operating lever into a similarly shaped recess in the body of the hook. A spring attached to lever holds these parts in engagement. In the closed position, the tooth and lever can be locked together with a latch pin attached by a chain to the pintle body. A heavy coil spring around the pintle shaft serves to absorb shocks in starting and stopping.

**BODY AND FRAME**



RA PD 77464

**Figure 102 – Pintle Hook Installed**

**b. Maintenance.** If the pintle hook latch pin and latch pin lock screw are worn, replace them. Replace latch pin with a  $\frac{7}{8}$ -inch hexagon head steel bolt,  $3\frac{3}{4}$  inches long, 2 tapered washers, a castellated nut and lock washer. When installing the bolt be sure to lock the pintle latch. Plug the latch pin lock screw hole with a wooden plug.

**c. Removal** (fig. 102). Remove cotter pin and pintle hook nut which secure pintle hook to frame cross member and supports. Remove pintle from vehicle. Remove coil spring from between cross member and support.

**d. Installation** (fig. 102). Position pintle in rear frame cross member and supports. Place coil spring around shaft between cross member and support. Install nut and cotter pin which secures pintle hook to frame. Tighten nut sufficiently to prevent spring from rattling.

**152. FENDERS.**

**a. Description** (fig. 103). Two front fenders are attached to cowl, cab, and frame above front wheels. The fenders are used as a means of entering or leaving cab. They are protected from wear by scuff plates attached at top center. Headlights, blackout lights, and brush guards are mounted on brackets at front of each fender. The two rear fenders, attached to an upper and lower support channel, are positioned in front of rear wheels. They protect wheels from dirt and water thrown back from front wheels.

**b. Maintenance.** Keep mounting bolts and nuts tight at all times to prevent vibration, cracking and rattling. Keep painted surfaces clean and repaint them when paint wears off.

4- TO 5-TON 4x4 TRACTOR TRUCK (FEDERAL)

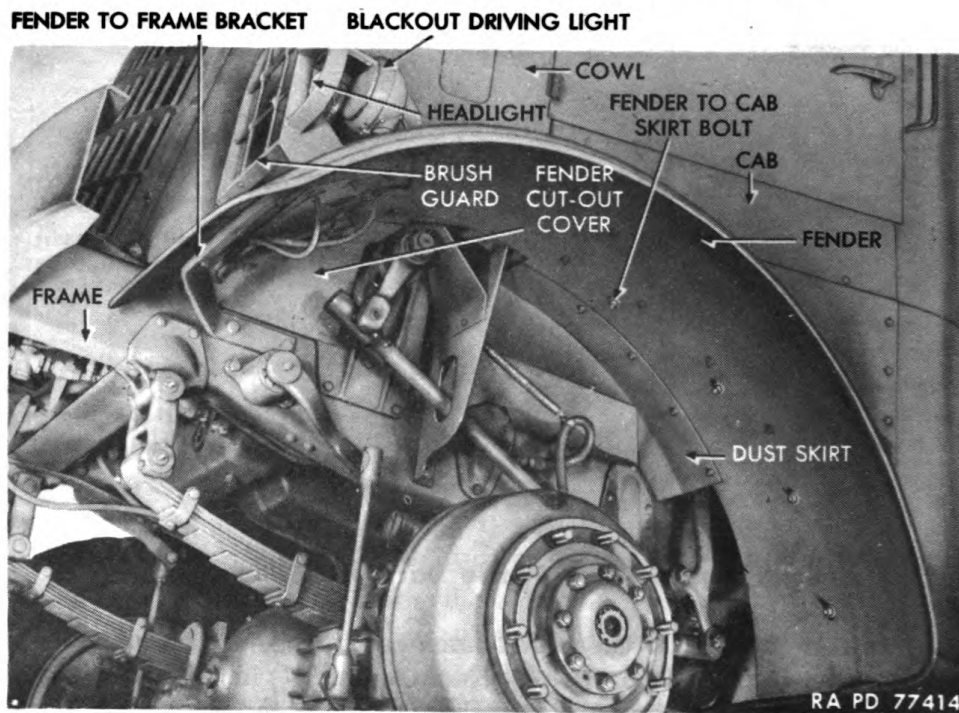


Figure 103 - Fender Installed

**c. Removal (fig. 103).**

(1) **FRONT FENDER.** Remove brush guard, headlight (par. 157 c), blackout marker light (par. 159 c), and blackout driving light (par. 158 c). Remove four dust skirt to fender bolts, nuts, and toothed lock washers. Remove three bolts and nuts attaching fender to frame bracket. Remove four toothed lock washers, and bolts which secure fender to cab skirt. Remove the three nuts, lock washers, and bolts which secure fender to cowl. Remove five screws, two lock washers, two plain washers, and two nuts which secure fender cutout cover to cowl. Remove fender assembly.

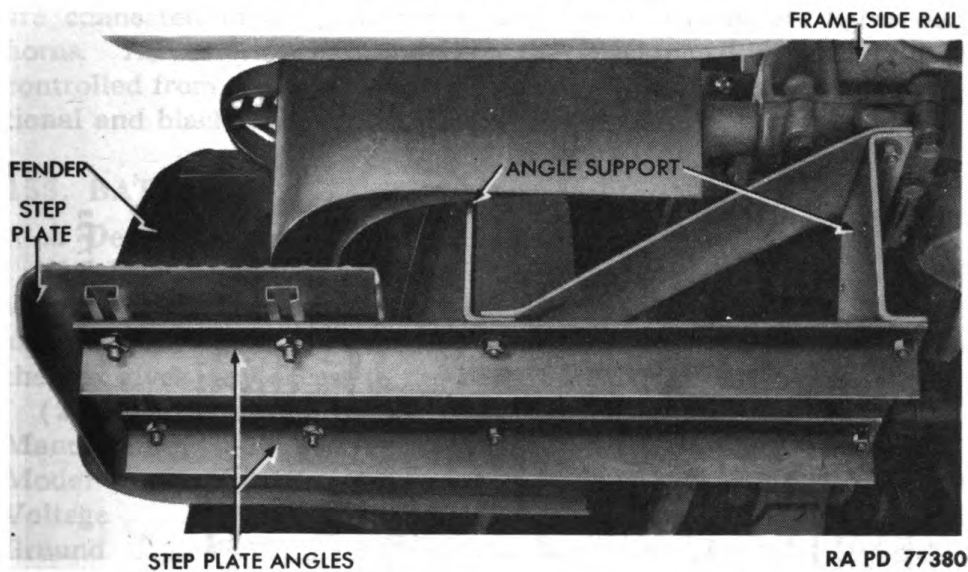
(2) **REAR FENDER.** Remove four bolts, eight toothed lock washers, and four nuts which fasten each fender to frame brackets.

**d. Installation (fig. 103).**

(1) **FRONT FENDER.** Position fender to cowl, cab, and frame. Install the five screws, two lock washers, two plain washers, and two nuts which secure fender cutout cover to cowl. Install the three bolts, lock washers, and nuts which secure fender to cowl. Install the four bolts, toothed lock washers, and nuts which secure fenders to cab skirt. Install the three bolts and nuts securing fender to frame bracket. Install the four bolts, plain washers, and nuts securing dust skirt to cowl. Install blackout driving light (par. 158 d), blackout marker light (par. 159 d), headlight (par. 157 d), and brush guard.



## BATTERY AND LIGHTING SYSTEM



**Figure 104 – Step Plate Installed**

(2) **REAR FENDER.** Position each fender and secure with four bolts, eight toothed lock washers, and four nuts.

### 153. STEP PLATES.

a. **Description** (fig. 104). Step plates, one on each side of vehicle, are positioned behind lower edge of front fenders. They serve as an aid to entering or leaving cab. Each plate is supported by an angle support assembly attached to frame side rails.

b. **Maintenance.** Observe maintenance instructions in paragraph 154 b.

c. **Removal** (fig. 104). Disconnect step plates and step plate angles by removing four nuts, toothed lock washers, and bolts that secure each to angle supports. Remove plates and angles.

d. **Installation** (fig. 104). Position step plates and step plate angles to angle supports. Install four bolts, toothed lock washers, and nuts which secure each to angle supports.

---

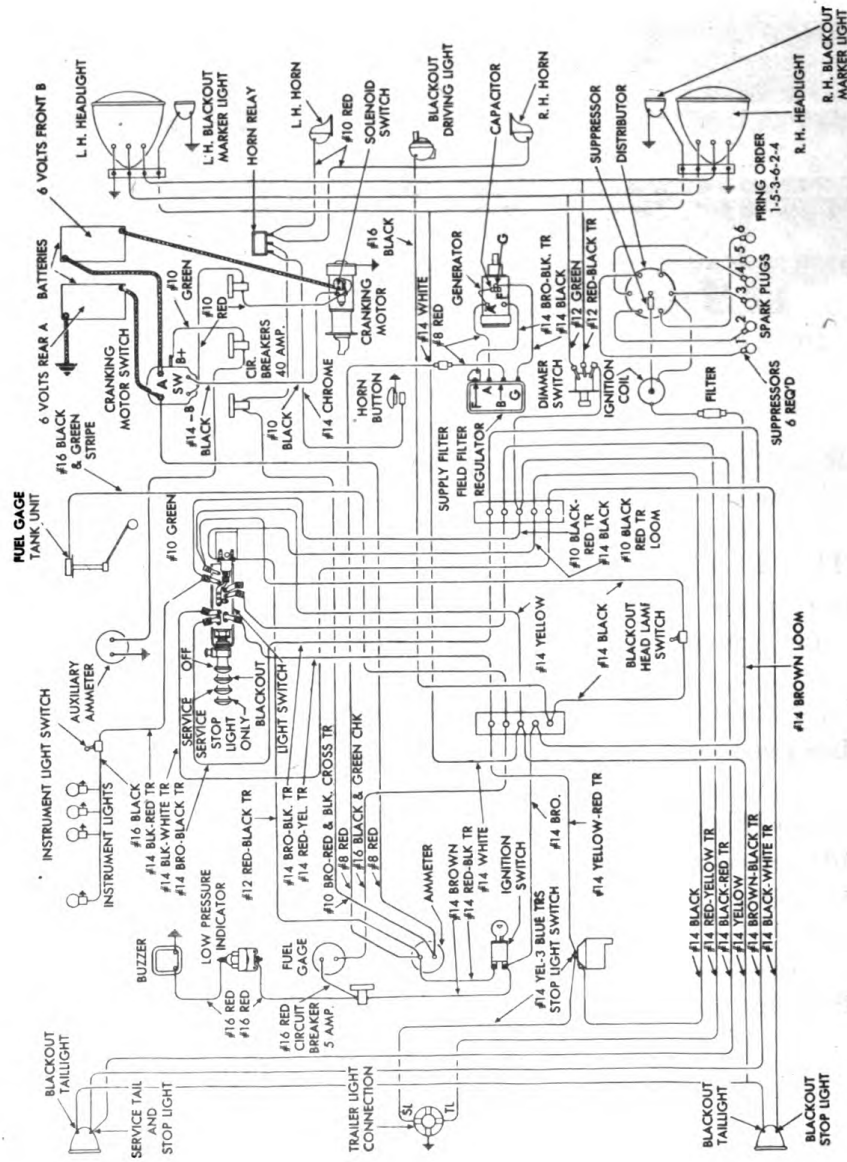
## Section XXXII

## BATTERY AND LIGHTING SYSTEM

### 154. DESCRIPTION (fig. 105).

a. The battery and lighting system ties into the ignition system and the starting and generating systems previously described. A 6-volt lighting system is used. The two 19-plate, 6-volt batteries

4- TO 5-TON 4x4 TRACTOR TRUCK (FEDERAL)



RA PD 77333

Figure 105 — Wiring Diagram

## BATTERY AND LIGHTING SYSTEM

are connected in parallel to provide current to operate lights and horns. All exterior lights, except the blackout driving light, are controlled from a single switch. Two complete sets of lights, conventional and blackout, are provided.

### 155. BATTERIES.

#### a. Description and Tabulated Data.

(1) DESCRIPTION (fig. 106). Two 19-plate 6-volt storage batteries are used. They are carried in a steel battery box bolted to the right side of the frame behind the cab step plate. A removable cover on the box gives easy access to the batteries.

#### (2) TABULATED DATA:

Manufacturer	Auto-Lite
Model	T-S-4-19
Voltage	6
Ground	Positive
Number used	2
Specific gravity:	
Full charge	1.260 to 1.300
Recharge	1.200

#### b. Maintenance.

(1) TEST ELECTROLYTE. Read specific gravity with a hydrometer. A reading of 1.275 to 1.300 in each cell indicates a fully charged battery. Under 1.225 (1.250 in cold weather) indicates need of recharge. Variance of 20 points or more between cells indicates a faulty battery. Notify higher authority.

(2) ADD WATER TO BATTERY (fig. 106). Remove vent caps from battery and observe quantity of electrolyte in cells weekly (more often under condition of severe use or excessively high temperatures). Solution should completely cover tops of plates but should not exceed  $\frac{1}{4}$ -inch depth above plates. Add pure distilled water whenever necessary to maintain level.

(3) MAKE HIGH-RESISTANCE TEST (fig. 106). High-resistance in battery circuit is indicated by slow starter action and brightening of lights with increased engine speed. Use a low-reading voltmeter to check for high-resistance if the condition is indicated. Check voltage drop between grounded battery terminal (positive post of rear battery) and frame. Place one prod of voltmeter on grounded battery post and other prod on frame. Leave ignition switch "OFF" and crank engine with cranking motor. Voltage reading in excess of  $\frac{1}{10}$  volt indicates excessive resistance in this circuit. In same manner check voltage drop between negative post of rear battery and positive post of front battery. Voltage in excess of  $\frac{1}{10}$  volt indicates high resistance in circuit. Make test in like manner between negative post of front battery and copper connector between cranking motor

4- TO 5-TON 4x4 TRACTOR TRUCK (FEDERAL)

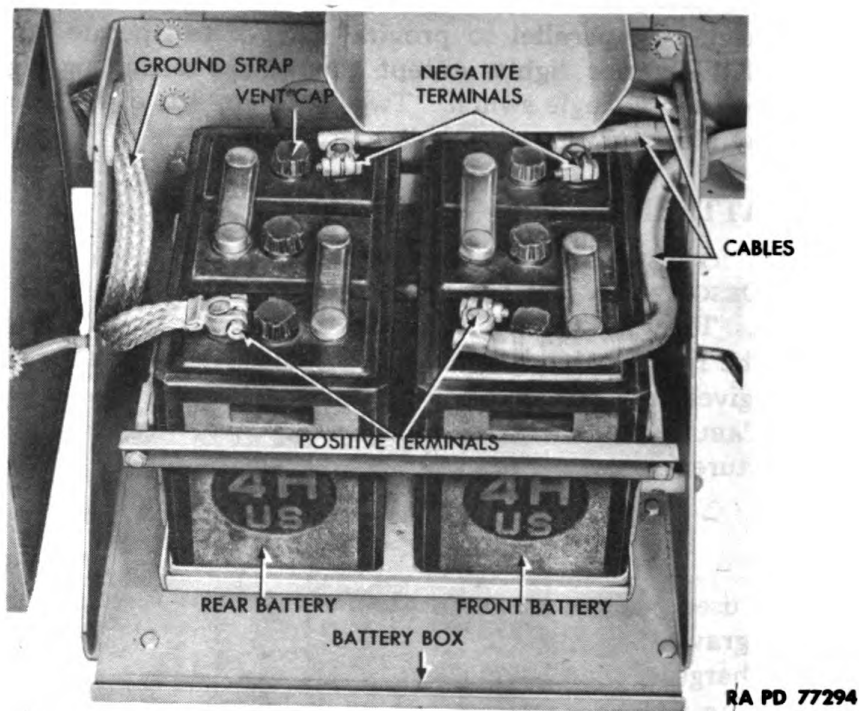


Figure 106 - Batteries Installed

solenoid switch and cranking motor. A reading in excess of  $\frac{1}{10}$  volt indicates high resistance in circuit.

(4) **CORRECT HIGH-RESISTANCE IN BATTERY CIRCUIT.** Disconnect cables in faulty circuit and clean the connections. If cables are frayed, replace with new cables of proper size. If resistance persists, replace series parallel cranking motor switch (par. 91 b) and/or cranking motor solenoid switch (par. 90 b).

c. **Removal** (fig. 106). Loosen thumb screws and lift battery box cover from battery box. Loosen nuts on battery terminal clamps and pull terminals from battery posts. Loosen the two guard angle to end plate bolt nuts. Lift battery from vehicle.

d. **Installation** (fig. 106). Place battery in position in battery box with positive post (slightly larger post) to outside. If rear battery is being installed, connect as follows: cable from "A-" post of cranking motor switch to negative post; ground strap to positive post. If front battery is being installed, connect as follows: cable from cranking motor solenoid switch to negative post; cable from "B+" terminal of cranking motor switch to positive post. Spread a film of light grease over exposed metal parts of cable terminal and post after connection is made. Draw the two guard angles to end plate bolt nuts up snug but not tight. Start engine with cranking motor. Note charge as indicated by ammeter. Satisfactory starting of engine and in-

## BATTERY AND LIGHTING SYSTEM

dication of charge on ammeter testify to correct installation. Place battery cover in position on battery box and secure in place with the two wing nuts.

### 156. LIGHT SWITCH.

#### a. Description and Tabulated Data.

(1) DESCRIPTION (figs. 3 and 114). A push-pull type light switch, located on the instrument panel, controls all service and blackout lights except the blackout driving light. A safety button on the side of the switch prevents inadvertent pulling of switch past its second (blackout) position. By releasing the safety button and pulling knob out, the service lights are turned on. Pulling switch out to its fourth position permits operation of the service taillight only. The instrument light circuit is routed through this switch so that the instrument lights can be lighted only with the main light switch on.

#### (2) TABULATED DATA:

Manufacturer . . . . . Delco-Remy  
Type . . . . . Push-pull

b. Removal (figs. 3 and 114). Disconnect all wires from switch. Tag wires to aid in installation. Loosen set screw on knob. Screw knob from switch shaft. Loosen set screw on under side of push button housing. Pull housing from switch shaft. Remove nut and washer from switch collar. Pull switch from reverse side of instrument panel.

c. Installation (figs. 3 and 114). Place switch in position through its opening on instrument panel. Install washer and nut. Depress button on side of push button housing and slide it into position on switch shaft. Tighten set screw on under side of housing. Screw knob into position on shaft and tighten knob set screw. Connect wires to terminals of switch, using tags installed during removal to identify wires. In case tags were not used, connect wires as follows: brown-black wire from junction block to "S" terminal; black-white wire from junction block to "BS" terminal; two black-red wires from instrument light switch and from junction block to "HT" terminal; yellow wire from junction block and black wire from blackout driving light switch to "BHT" terminal; No. 10 black-red wire from junction block to "A" terminal; No. 10 black-red wire from ammeter to "B" terminal; red-yellow wire from junction block to "TT" terminal; yellow-red wire from junction block to "SS" terminal. Test operation of switch by placing it in each of its four positions and observing which lamps light. Proper functioning of lamps indicates correct installation.

### 157. HEADLIGHTS.

#### a. Description and Tabulated Data.

(1) DESCRIPTION (fig. 107). Two headlights are provided. They

4- TO 5-TON 4x4 TRACTOR TRUCK (FEDERAL)

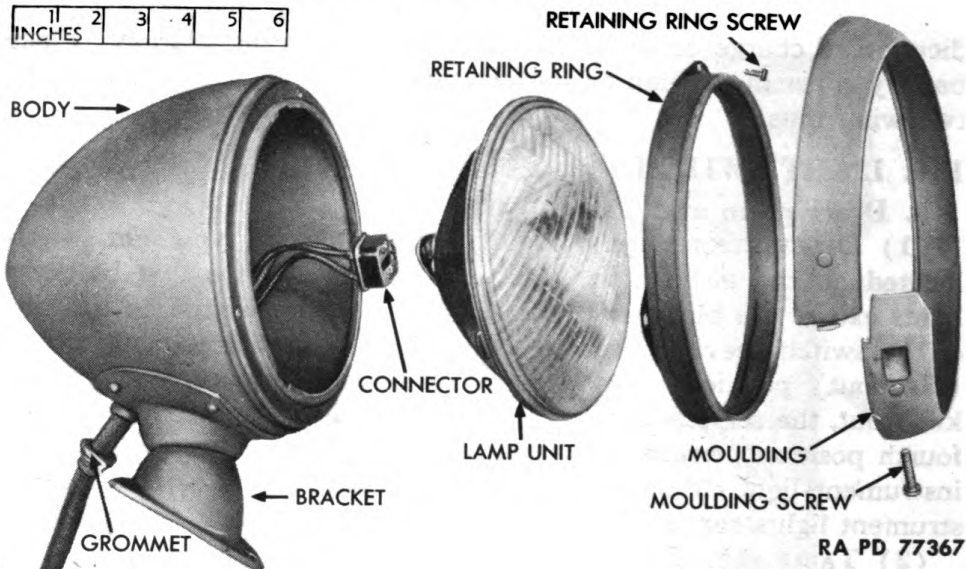


Figure 107 – Headlight Disassembled

are sealed-beam units. Lens, lamp, and reflector are built into one unit. The sealed-beam lamp unit is held in place by a retaining ring which is, in turn, covered by moulding.

(2) TABULATED DATA:

Type .....	Sealed-beam
Low beam .....	35 watts
High beam .....	45 watts

b. Maintenance.

(1) REPLACE SEALED-BEAM UNIT (fig. 107). Loosen molding screw and pull molding from body. Remove the three retaining ring screws and lift retaining ring from body. Carefully pull sealed-beam lamp unit a few inches from body, and pull connector from prongs on sealed-beam unit. Push connector onto prongs on back of new sealed-beam lamp unit. Place unit in position within body. Position retaining ring in body and install the three retaining ring screws. Push molding onto body and tighten molding screw.

c. Removal.

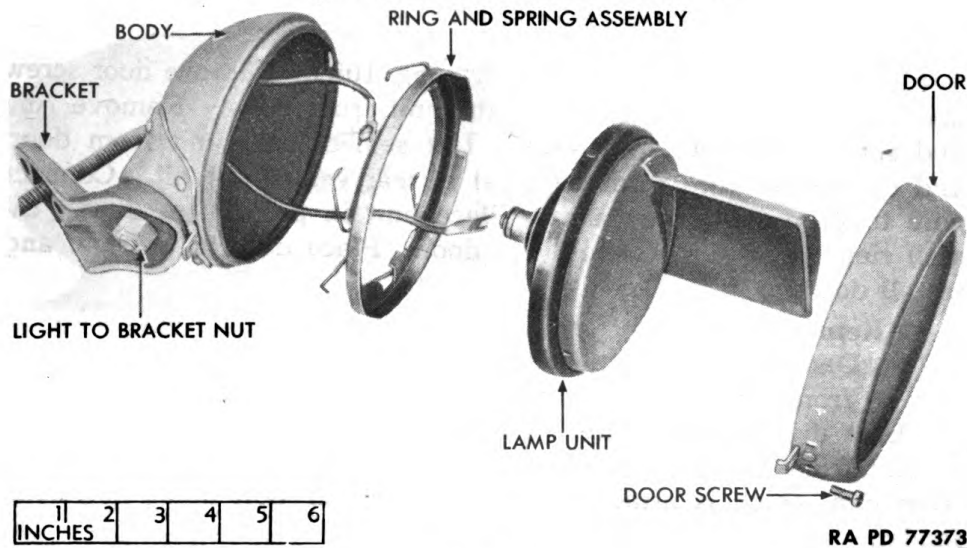
(1) DISCONNECT AND FREE WIRES (fig. 107). Remove adjacent cowl opening door (fig. 1). Disconnect wires from junction block immediately below opening. Pull cable from opening on inside fender skirt. Remove cable clip from brush guard bolt. Slide grommet, which protects cable from fender, out of fender and up on cable.

(2) DETACH LIGHT (fig. 107). From under fender, remove headlight nut and lock washer. Lift headlight from fender.

d. Installation.

(1) ATTACH LIGHT (fig. 107). Place headlight in position on its

**BATTERY AND LIGHTING SYSTEM**



**Figure 108 – Blackout Driving Light Disassembled**

bracket. From under fender, install headlight lock washer and nut.

(2) **POSITION WIRES** (fig. 107). Push wires down through hole in fender. Work grommet down on cable and into position around cable within hole in fender. Push wires into opening in inside fender skirt. Install wire clip on brush guard bolt.

(3) **CONNECT WIRES** (fig. 107). Work through cowl opening. Connect wires to junction block terminals so that colors of wires match colors of other wires leading to respective terminals. Ground black wire to junction block mounting screw.

(4) **TEST INSTALLATION**. Turn on lights. Trip foot dimmer switch. Proper functioning of light indicates correct installation.

(5) **INSTALL COWL OPENING DOOR** (fig. 1). Place door in position on opening. Install four toothed lock washers and screws which attach door to cowl.

**158. BLACKOUT DRIVING LIGHT.**

**a. Description and Tabulated Data.**

(1) **DESCRIPTION** (fig. 108). A blackout driving light is located on the left front fender. It is designed to supply a small amount of light to aid the driver during blackouts with minimum chance of detection from above. All but a small portion of the lens is opaqued. The transparent part of the lens is covered with a horizontal shield. Lamp, reflector, lens, and shield are all one part and constitute a sealed-beam unit.

(2) **TABULATED DATA:**

Manufacturer	.....	Guide
Model	.....	3012-8
Type	.....	Sealed-beam

**4- TO 5-TON 4x4 TRACTOR TRUCK (FEDERAL)**

**b. Maintenance.**

(1) **REPLACE SEALED-BEAM UNIT** (fig. 108). Remove door screw and lift door and sealed-beam light unit from body. Remove ring and spring assembly from door. Lift sealed-beam unit from door, and disconnect wire from terminal at rear center of unit. Connect wire to terminal of new unit. Place unit in position in door. Install ring and spring assembly in door. Place door in position and install door screw.

**c. Removal.**

(1) **DISCONNECT WIRE.** Remove left-hand cowl opening door (fig. 1) from terminal block immediately inside opening, and remove blackout driving light wire. This wire is attached to the terminal second from bottom in left-hand row of terminals. Remove wire from clip which is attached to cowl-to-fender bolt under left-hand fender.

(2) **DETACH LIGHT** (fig. 108). Remove light-to-bracket nut and lock washer. Lift light from bracket.

**d. Installation.**

(1) **ATTACH LIGHT** (fig. 108). Thread wire through hole in bracket to under side of fender. Place light in position on bracket. Install light-to-bracket lock washer and nut.

(2) **CONNECT WIRE** (fig. 105). Insert wire through opening into cowl space in front of steering column. Connect wire to terminal second from bottom on left-hand row of terminals on terminal block immediately inside of cowl opening. Attach wire clip to cowl-to-fender bolt under fender.

(3) **TEST OPERATION.** Turn light on. Satisfactory lighting of lamp indicates proper installation.

(4) **INSTALL COWL OPENING DOOR** (fig. 1). Place door in position on opening. Install four toothed lock washers and screws which attach door to cowl.

**159. BLACKOUT MARKER LIGHTS.**

**a. Description and Tabulated Data.**

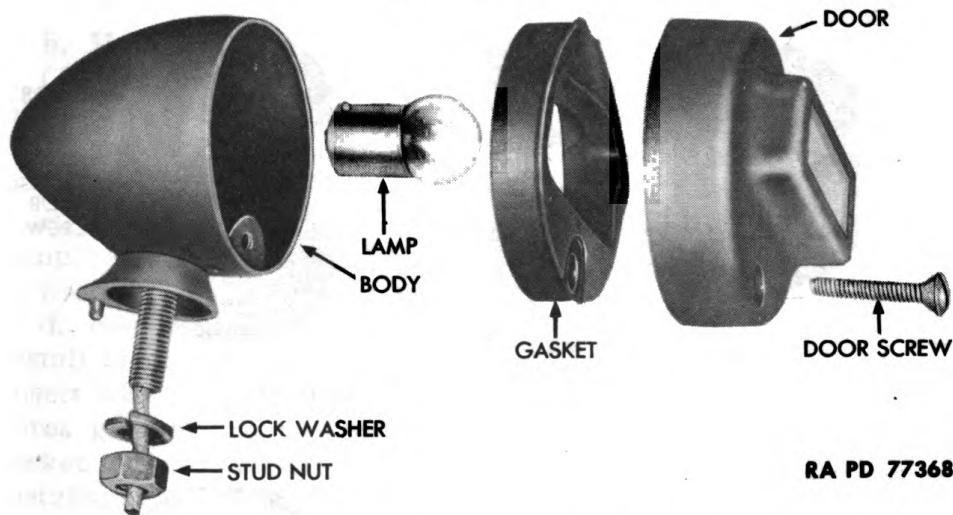
(1) **DESCRIPTION** (fig. 109). Two blackout marker lights are used. They are mounted adjacent to the headlights on brackets attached to the headlight brush guards. Each light is equipped with a door containing a lens. All but two small translucent triangular portions of the lens are covered. The door is shaped to shield the triangles from all directions except straight ahead. Consequently, no beam is cast by the light. It serves only as a marker. The body of the light contains a conventional single contact socket.

(2) **TABULATED DATA:**

Manufacturer .....	Guide
Bulb:	
Make .....	Mazda 63



**BATTERY AND LIGHTING SYSTEM**



RA PD 77368

**Figure 109 – Blackout Marker Light Disassembled**

Candlepower .....	3
Base .....	Single contact

**b. Maintenance.**

(1) **REPLACE LAMP** (fig. 109). Remove door screw. Lift door from body. Turn counterclockwise and pull lamp from socket. Push and twist new lamp into socket. Place door in position on body and install door screw.

**c. Removal.**

(1) **DISCONNECT WIRE** (fig. 109). Remove adjacent cowl opening door (fig. 2) and disconnect wire from terminal block below door. Wire is attached to lower terminal. Remove wire clip from headlight brush guard bolt under fender.

(2) **DETACH LIGHT** (fig. 109). Remove blackout marker light stud nut and lock washer. Lift light from bracket.

**d. Installation.**

(1) **ATTACH LIGHT** (fig. 109). Thread wire through stud hole on bracket and through hole in fender. Place light in position on bracket. Install lock washer and stud nut.

(2) **CONNECT WIRE** (fig. 109). Install wire clip on headlight brush guard bolt under fender. Insert wire through hole into cowl space beside radiator. Connect wire to lowest terminal on terminal block below cowl opening.

(3) **TEST OPERATION**. Turn on blackout lights. Proper functioning of light indicates correct installation.

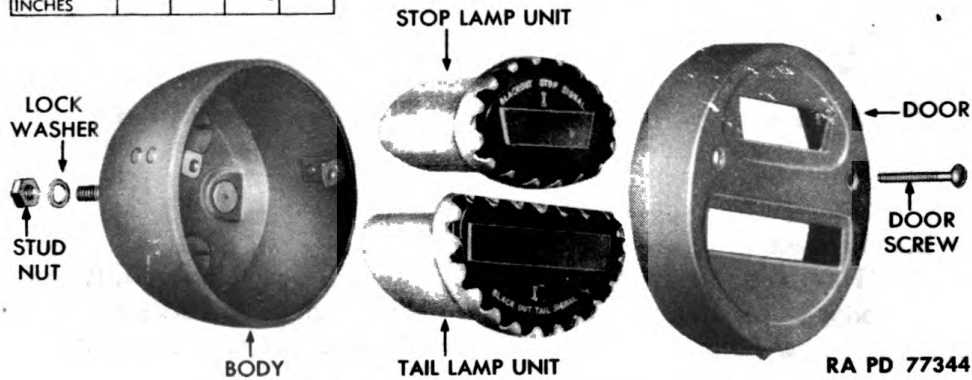
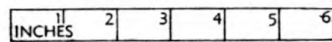
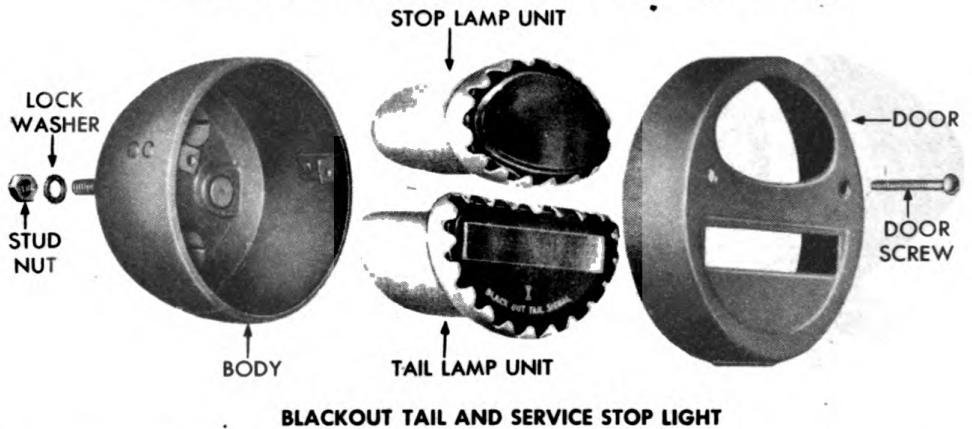
(4) **INSTALL COWL OPENING DOOR** (fig. 1). Place door in position on opening and install the four toothed lock washers and screws.

**160. BLACKOUT TAIL AND SERVICE STOP LIGHT.**

**a. Description and Tabulated Data.**

(1) **DESCRIPTION** (fig. 110). A blackout tail and service stop

4- TO 5-TON 4x4 TRACTOR TRUCK (FEDERAL)



RA PD 77344

BLACKOUT TAIL AND BLACKOUT STOP LIGHT

**Figure 110 – Tail and Stop Lights – Disassembled**

light is attached to the rear cross member of the frame to the left of the pintle hook. It contains two sealed-beam lamp units. Each unit consists of a reflector, lamp and lens replaceable only as a unit. The blackout tail lamp emits two small triangles of red light shielded from view except from the rear. The service stop light has a large oval red lens.

(2) TABULATED DATA:

Manufacturer .....	Guide
Type .....	Sealed-beam
Tail lamp:	
Model .....	5933078
Candlepower .....	3
Base .....	Single contact
Service stop lamp:	
Model .....	5933104
Candlepower .....	21
Base .....	Double contact

**BATTERY AND LIGHTING SYSTEM**

**b. Maintenance.**

(1) **REPLACE LAMP** (fig. 110). Remove both door screws, and lift door from body. Pull lamp unit from body. Insert new unit into body and push completely into socket. Place door in position on body, and install both body screws.

**c. Removal** (fig. 110). Remove both plugs from sockets behind lamp. Remove the two stud nuts and lock washers which attach light to frame. Lift light from frame.

**d. Installation** (fig. 110). Place light in position on frame and install two lock washers and stud nuts which attach light to frame. Insert wire plugs into sockets on rear of light. The plug with two wires goes to the top socket, the plug with one wire to bottom socket. Test operation of lights. Proper functioning indicates correct installation.

**161. BLACKOUT TAIL AND BLACKOUT STOP LIGHT.**

**a. Description and Tabulated Data.**

(1) **DESCRIPTION** (fig. 110). Blackout tail and blackout stop light is attached to the rear cross member of the frame to the right of the pintle hook. It is similar to the blackout tail and service stop light described in the preceding paragraph. The chief visual exception is that the stop light emits only a small triangle of well shielded light when the brakes are applied.

(2) **TABULATED DATA:**

Manufacturer .....	Guide
Type .....	Sealed-beam
Tail lamp:	
Model .....	5933078
Candlepower .....	3
Base .....	Single contact
Stop lamp:	
Model .....	5933121
Candlepower .....	3
Base .....	Single contact

**b. Maintenance.**

(1) **REPLACE LAMP** (fig. 110) (par. 160 b (1)).

**c. Removal** (fig. 110) (par. 160 c).

**d. Installation** (fig. 110). Place light in position on frame and install the two lock washers and stud nuts which secure light to frame. Install wire plugs into sockets on rear of light. The plug with black wire goes to the top socket, the yellow to the bottom socket. Test operation of lights. Proper functioning indicates correct installation.

**162. STOP LIGHT SWITCH.**

**a. Description and Tabulated Data.**

(1) **DESCRIPTION** (fig. 111). The stop light switch is mounted on

4- TO 5-TON 4x4 TRACTOR TRUCK (FEDERAL)

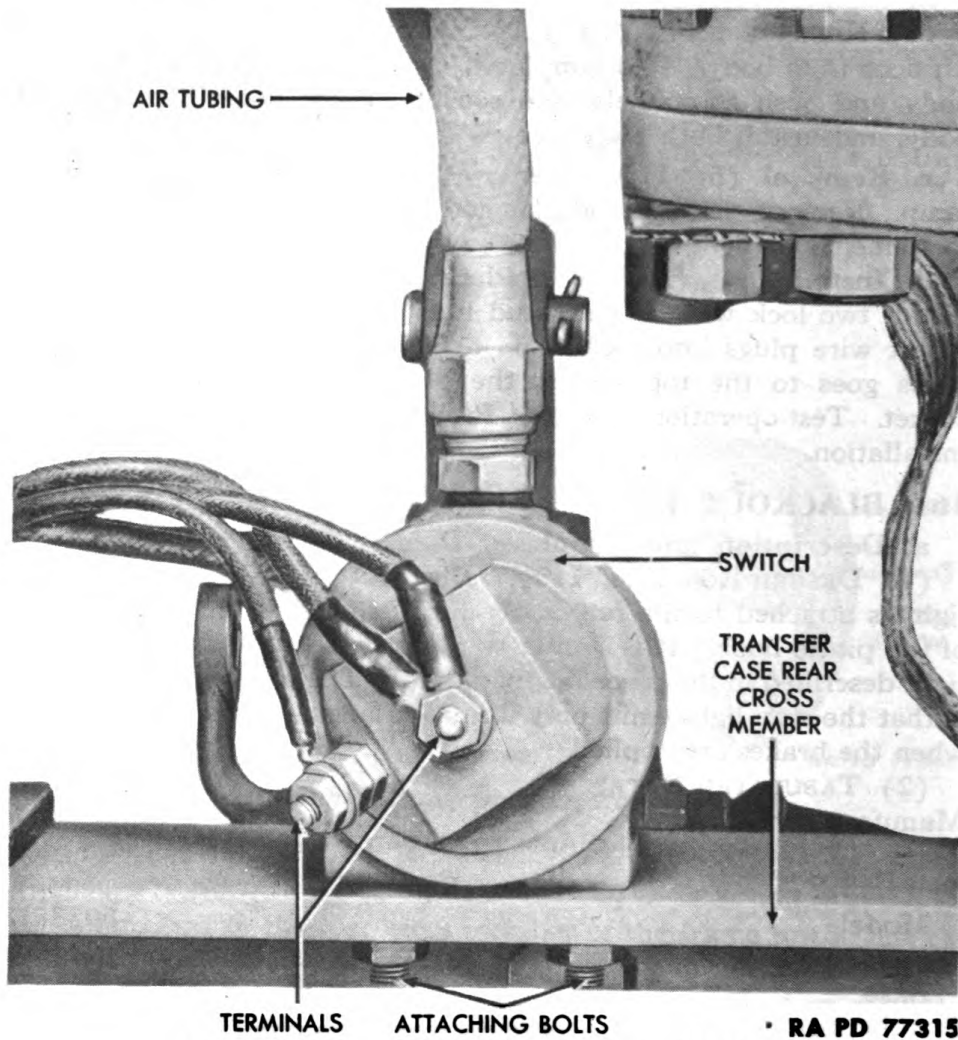


Figure 111 - Stop Light Switch Installed

the transfer case rear cross member to the left of the transfer case. This switch is operated by air pressure. Its working parts are a diaphragm, two contact points, and a coil spring. When the brakes are applied, air enters the switch and lifts the diaphragm, and this closes the contacts. When the brakes are released, the pressure is exhausted from the switch. The coil spring then pushes the diaphragm down and opens the contact points.

(2) TABULATED DATA:

Manufacturer ..... Westinghouse  
Model ..... 215537

b. Removal (fig. 111). Disconnect wires from terminals on switch. Disconnect air tubing from fitting on switch. Remove two nuts, lock washers, and bolts which attach switch to frame.

**BATTERY AND LIGHTING SYSTEM**

**c. Installation** (fig. 111). Place switch in position on transfer case rear cross member. Install the two bolts, lock washers, and nuts which attach switch to frame. Connect air tubing from double check valve to switch. Connect two yellow wires to one terminal of switch. Connect black wire to other terminal. Start engine and build up air pressure. Test operation of stop lights. Inspect switch for air leakage. Proper functioning of stop lights and absence of air leaks indicate satisfactory installation.

**163. INSTRUMENT LIGHTS.**

**a. Description and Tabulated Data.**

(1) **DESCRIPTION** (fig. 3). Four instrument lights are mounted on the instrument panel. These lights are made as units and are not intended to be disassembled. In case of failure, the entire light should be replaced.

(2) **TABULATED DATA:**

Manufacturer .....	Mazda
Model .....	T51
Candlepower .....	1
Wires to light .....	1

**b. Removal** (figs. 3 and 114). Disconnect wire at connector behind light. Pull light from instrument panel.

**c. Installation** (figs. 3 and 114). Insert wire through instrument light hole in panel. Connect wire at connector. Push light into position on instrument panel. Turn on headlights or blackout marker lights and turn instrument lights on. Lighting of instrument lights indicates correct installation.

**164. INSTRUMENT LIGHT SWITCH.**

**a. Description and Tabulated Data.**

(1) **DESCRIPTION** (figs. 3 and 114). A push-pull type switch is provided to control instrument lights. This switch is located on the instrument panel beneath the speedometer. The circuit to this switch is routed through the main light switch. The headlights must be on before the instrument lights will work.

(2) **TABULATED DATA:**

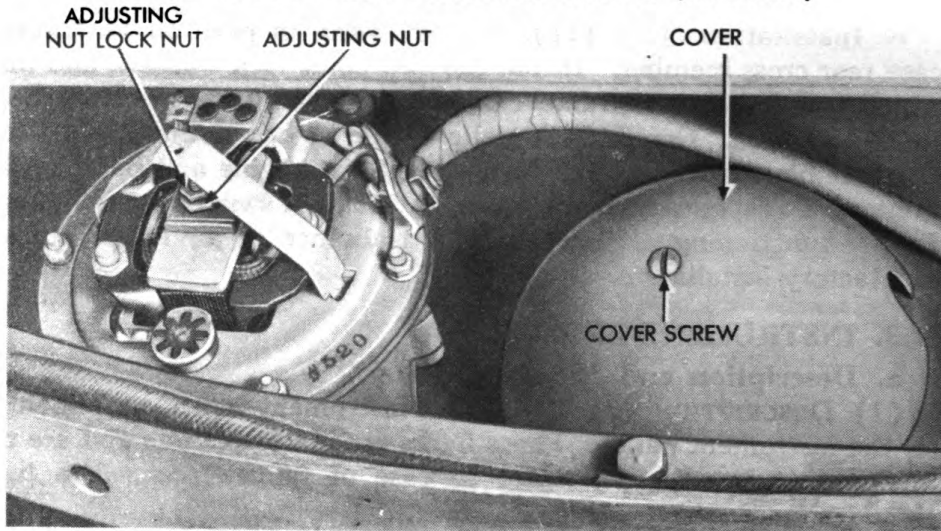
Manufacturer .....	Delco-Remy
Type .....	Push-pull

**b. Removal** (figs. 3 and 114). Disconnect all wires from switch. Loosen knob set screw, and unscrew knob from switch shaft. Remove switch retaining nut and lock washer. Lift switch from reverse side of instrument panel.

**c. Installation** (figs. 3 and 114). Place switch in position from reverse side of instrument panel. Install switch retaining nut lock washer and nut. Screw knob onto end of switch shaft and tighten

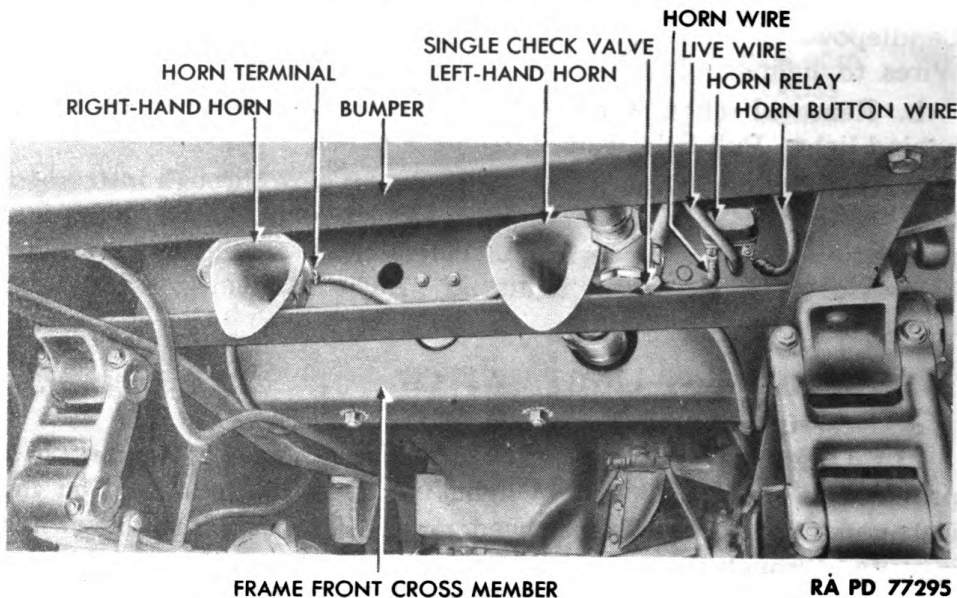
TM 9-820  
164-165

**4- TO 5-TON 4x4 TRACTOR TRUCK (FEDERAL)**



RA PD 77302

**Figure 112 – Horn Adjustment**



RA PD 77295

**Figure 113 – Horns Installed**

knob set screw. Connect wire from "HT" terminal of main light switch to one terminal of instrument light switch. Connect wires leading to instrument lights to other terminal of instrument light switch.

**165. TWIN HORNS.**

**a. Description and Tabulated Data.**

(1) **DESCRIPTION** (fig. 113). Twin horns are mounted on the frame front cross member behind the bumper. They are the vibra-

### BATTERY AND LIGHTING SYSTEM

tor-type. The left-hand horn is adjusted to a low tone while the right-hand horn is adjusted to a high tone. The two pitches are matched at the factory to give the most striking warning. A relay switch (controlled by the horn button switch) draws current directly from the ammeter to operate the horns.

(2) TABULATED DATA:

Manufacturer ..... Delco-Remy  
Type ..... Air-electric  
Model:

Left-hand horn ..... 1999519  
Right-hand horn ..... 1999520

**b. Maintenance.**

(1) ADJUST HORN (fig. 112). Do not adjust horn tone unless horns have been tampered with or damaged. When necessary, adjust as follows: Unscrew horn cover screw and lift cover from horn. Loosen adjusting nut, lock nut. Screw adjusting nut up or down until desired pitch is attained. Hold adjusting nut to keep it from turning, and tighten lock nut. Place cover in position on horn, and install cover screw.

c. Removal (fig. 113). Disconnect wire from horn terminal. Remove the two nuts, lock washers, and bolts which attach each horn to bracket. Lift each horn from bracket.

d. Installation (fig. 113). Place horn in position on bracket and install the two bolts, lock washers, and nuts which attach horn to bracket. Attach horn wire to horn terminal. If installing left-hand horn, also attach lead to other horn to terminal. Press horn button. Proper sounding of horn indicates correct installation.

### 166. HORN RELAY.

**a. Description and Tabulated Data.**

(1) DESCRIPTION (fig. 113). A standard magnetic relay switch is used in the horn circuit. It is located on the left front side of the frame front cross member. It is to the left rear of the left-hand horn. Its function is to deliver current directly from the ammeter to the horns when the horn button is pressed.

(2) TABULATED DATA:

Manufacturer ..... Delco-Remy  
Model ..... 116775

b. Removal (fig. 113). Disconnect all wires from terminals on relay switch. Remove the two nuts, lock washers, and bolts which attach relay to frame. Lift relay from frame.

c. Installation (fig. 113). Place relay in position on frame front cross member. Install two bolts, lock washers, and nuts which attach relay to frame. Attach wire leading to horn button to left-hand

**TM 9-820  
166-168**

**4- TO 5-TON 4x4 TRACTOR TRUCK (FEDERAL)**

terminal of relay. Connect wire leading to horns to right-hand terminal of relay. Install live wire from harness on middle terminal of relay. Press horn button. If horns blow, correct installation of relay is indicated.

**167. HORN BUTTON.**

**a. Description and Tabulated Data.**

(1) DESCRIPTION (fig. 96). The horn button is located at the center of the steering wheel. Pressing it completes the circuit from the horn relay, thus causing the horns to operate.

(2) TABULATED DATA:

Manufacturer . . . . . Ross Gear  
Model . . . . . 450029

**b. Removal** (fig. 96). Turn horn button  $\frac{1}{8}$  turn to right or left and lift from steering wheel. Pick contact cup, contact cap, and horn button spring from base plate. If necessary to remove cable and upper terminal assembly, disconnect cable from horn relay left-hand terminal. Pull cable and upper terminal assembly and insulating ferrule from top of steering column.

**c. Installation** (fig. 96). Thread cable and upper terminal assembly through insulating ferrule and down into steering column. Connect lower end of cable to horn relay left-hand terminal. Place in position on base plate the horn button spring, contact cap, and contact cup. Place horn button squarely on top of contact cup, depress almost to blowing position and turn  $\frac{1}{8}$  turn to right or left, thus locking button in place.

**168. CIRCUIT BREAKERS.**

**a. Description and Tabulated Data.**

(1) DESCRIPTION (fig. 59). Identical 40-ampere circuit breakers are used in the horn circuit, auxiliary ammeter circuit, and cranking motor solenoid switch circuit. These circuit breakers are mounted on the left-hand dashboard and can be reached through the left-hand cowl opening. From left to right, the circuits they protect are: solenoid, ammeter, and horn. All circuit breakers on this vehicle are the thermal type. Heat produced by a short circuit causes the breaker to alternately open and close intermittently until the short circuit is located and corrected. Other circuit breakers used includes one to protect the lighting circuit which is located at the light switch. Another, located on the fan cover, protects the buzzer and fuel gage circuit. The generator circuit breaker, located in the voltage regulator, has been previously described (par. 88 a).

(2) TABULATED DATA:

Manufacturer . . . . . Delco-Remy  
Type . . . . . Thermal cut-out



## BATTERY AND LIGHTING SYSTEM

### Capacity:

Horn circuit . . . . .	40 amperes
Ammeter circuit . . . . .	40 amperes
Solenoid circuit . . . . .	40 amperes
Light circuit . . . . .	30 amperes
Buzzer and fuel gage . . . . .	5 amperes

b. **Removal** (fig. 59). Remove both wires from terminals on circuit breaker. Remove the two nuts, lock washers, and bolts which attach breaker to vehicle.

c. **Installation** (fig. 59). Place circuit breaker in position and install the two attaching bolts, lock washers, and nuts. Connect wire to each terminal on circuit breaker.

### 169. TRAILER LIGHT CONNECTION.

a. **Description** (fig. 26). A trailer light connection is located at the front center of the frame platform. It is a female receptacle with four metal contact blades. A spring cover keeps the receptacle tightly closed at all times when not in use. It is wired into the stop light and lighting circuits.

#### b. Removal.

(1) **DETACH CONNECTION** (fig. 26). Remove the two nuts, lock washers, and bolts which hold connection to frame platform.

(2) **DISCONNECT WIRING** (fig. 26). Remove screw and lock washer which attach back cover to receptacle. Disconnect wires from terminals of receptacle.

#### c. Installation.

(1) **CONNECT WIRES** (fig. 26). Connect yellow and blue wire to connection terminal marked "SL". Connect red and yellow wire to connection terminal marked "TL". Connect black wire to connection ground terminal. Place connection back cover in position on connection. Install lock washer and screw which hold back cover to connection.

(2) **ATTACH CONNECTION** (fig. 26). Place connection in place on frame cover plate. Install two bolts, lock washers, and nuts which attach connection to plate.

(3) **TEST INSTALLATION**. Connect trailer male plug to trailer light connection. Start engine and build up air pressure. Turn on lights and apply brakes. Proper functioning of trailer marker lights and stop lights indicates correct connection installation.

4- TO 5-TON 4x4 TRACTOR TRUCK (FEDERAL)

Section XXXIII  
INSTRUMENTS

170. AMMETERS.

a. Description and Tabulated Data.

(1) DESCRIPTION.

(a) *Ammeter* (fig. 3). The ammeter is the upper instrument of the two located on the instrument panel directly in front of the steering column. This instrument registers the generator output by means of a hand. It covers a discharge or charge range of 0 amperes to 50 amperes.

(b) *Auxiliary Ammeter* (fig. 3). The auxiliary ammeter is the instrument on the instrument panel located directly below the ammeter. Its purpose is to indicate charge or discharge operation of auxiliary storage battery.

(2) TABULATED DATA:

Manufacturer . . . . . Stewart-Warner Corp  
Model:

Ammeter . . . . . 400047  
Auxiliary ammeter . . . . . 440008

b. **Removal** (fig. 114). Disconnect the five wires attached to ammeter. Disconnect the two wires attached to auxiliary ammeter. Note position of wires to make sure they are reconnected properly. Remove the two nuts and lock washers holding each ammeter to bracket and panel. Pull bracket from rear of each ammeter. Pull each ammeter from front of instrument panel.

c. **Installation** (fig. 114). Position each ammeter in instrument panel (fig. 3). Position brackets at back of ammeters and secure each with the two nuts and lock washers. Connect the five wires to the ammeter: red and orange to the terminal on right-hand side of vehicle; black and the two red and black wires to terminal on left-hand side. Connect the two wires to terminal on left side. Connect the two wires to the auxiliary ammeter: green ground to terminal on right-hand side of vehicle; other green to terminal on left-hand side.

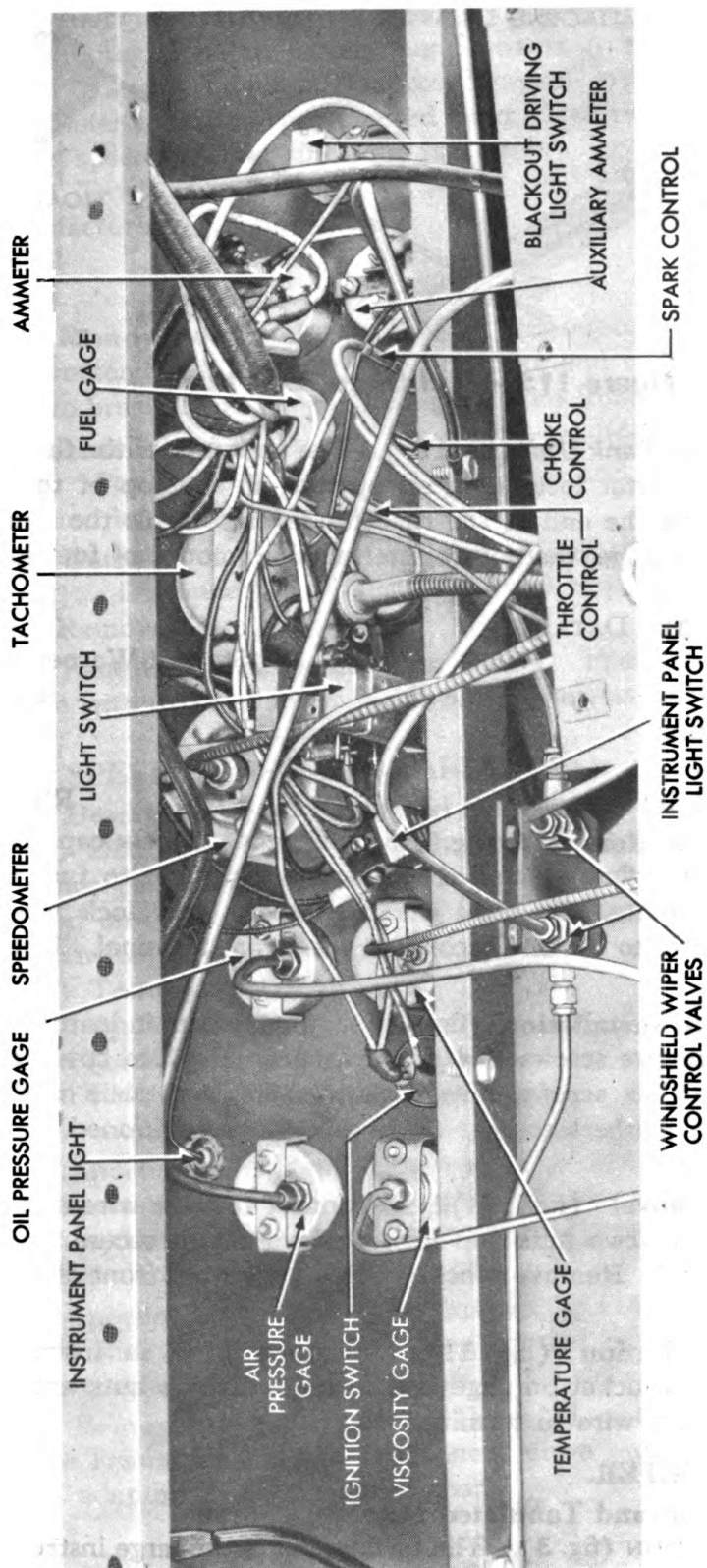
171. FUEL GAGE.

a. Description and Tabulated Data.

(1) DESCRIPTION.

(a) *Fuel Gage* (fig. 3). The fuel gage is an instrument which indicates the amount of fuel in the fuel tank. It is operative when the ignition switch is turned on. The fuel gage is located at the left center of the instrument panel at the right and adjacent to the ammeter.

**INSTRUMENTS**



RA PD 77332

**Figure 114 — Instrument Panel — Rear View**

4- TO 5-TON 4x4 TRACTOR TRUCK (FEDERAL)



RA PD 77316

Figure 115 – Fuel Gage Tank Unit

(b) *Fuel Gage Tank Unit* (fig. 115). The tank unit of the fuel gage consists of a rheostat located in an opening in the top of the fuel tank. A float on the end of the rheostat lever controls the amount of current to the gage, thereby registering the amount of fuel in the fuel tank.

(2) TABULATED DATA:

Manufacturer .....	Stewart-Warner Corp
Model (gage) .....	441023
Model (tank unit) .....	95500
Type (gage) .....	Dial
Type (tank unit) .....	Rheostat

b. **Tank Unit Removal** (fig. 115). Remove the six cap screws, lock washers, and flat washers connecting cover plate to fuel tank. Remove cover plate. Remove the five screws and lock washers securing tank unit to tank. Disconnect wire from terminal. Lift out unit.

c. **Tank Unit Installation** (fig. 115). Position unit in fuel tank and secure with five screws and lock washers. Replace cover plate and secure with six screws, nuts, lock washers, and plain washers. **NOTE:** *Install washers so that flat washers are positioned next to cover plate.*

d. **Gage Removal** (fig. 114). Disconnect the one wire attached to gage. Remove two nuts and lock washers which secure gage to bracket and panel. Remove bracket. Pull gage from front of instrument panel.

e. **Gage Installation** (fig. 114). Position gage in instrument panel. Position bracket on gage and secure with two nuts and lock washers. Connect wire to terminal.

172. TACHOMETER.

a. **Description and Tabulated Data.**

(1) **DESCRIPTION** (fig. 3). The tachometer is the large instrument

## INSTRUMENTS

located left center on the instrument panel, at the right and adjacent to the fuel gage. Its purpose is to register engine speed in revolutions per minute. The indicating hand covers a range of 0 to 2,500 revolutions per minute. The key control located just below the tachometer is used to reset the red hand which registers the maximum engine speed reached since the last reset.

(2) **TABULATED DATA:**

Manufacturer ..... Stewart-Warner Corp  
Model ..... 424BE  
Range ..... 0 to 2,500 rpm

b. **Removal of Head** (fig. 114). Disconnect cable from rear of tachometer head. Remove the two nuts and lock washers securing gage to bracket and panel. Pull gage from front of instrument panel.

c. **Installation of Head** (fig. 114). Position gage in instrument panel. Position bracket on back of gage and secure with the two nuts and lock washers. Attach cable.

d. **Removal of Tachometer Drive (Located on Distributor Drive Shaft)**. Disconnect tachometer on drive end. Remove drive adapter. Remove drive gear.

e. **Installation of Tachometer Drive**. Position drive gear and secure with drive adapter. Connect tachometer drive cable.

### 173. SPEEDOMETER AND CABLE.

a. **Description and Tabulated Data.**

(1) **DESCRIPTION** (fig. 3). The speedometer indicates road speed in miles per hour and records both trip and total mileage. It is located on the left center of the instrument panel at the right and adjacent to the tachometer.

(2) **TABULATED DATA:**

Manufacturer ..... Stewart Warner Corp  
Model (head) ..... 590-AB  
Model (cable) ..... 97800  
Range ..... 0 to 60 mph

b. **Speedometer Head Removal** (fig. 114). Disconnect cable from speedometer head. Remove the two wing nuts and lock washers which secure bracket to speedometer and panel. Remove bracket. Pull speedometer from front of panel.

c. **Speedometer Head Installation** (fig. 114). Position speedometer in instrument panel. Position bracket on back of speedometer and secure with the two wing nuts and lock washers. Attach cable.

d. **Removal of Speedometer Drive (Located on the Left Side of the Transfer Case)**. Disconnect drive end of cable. Remove drive adapter. Remove drive gear.

**4- TO 5-TON 4x4 TRACTOR TRUCK (FEDERAL)**

**e. Installation of Speedometer Drive.** Position drive gear. Secure drive gear with drive adapter. Connect speedometer cable at drive end.

**f. Cable.**

(1) **REMOVAL** (figs. 114 and 116). Disconnect cable from speedometer and transfer case by screwing out nut which secures each. Detach clip holding cable to frame side rail. Remove cable.

(2) **INSTALLATION** (figs. 114 and 116). Position cable between transfer case and speedometer on instrument panel. Attach nut which secures each. Attach clip which holds cable to frame side rail.

**174. OIL PRESSURE GAGE.**

**a. Description and Tabulated Data.**

(1) **DESCRIPTION** (fig. 3). The oil pressure gage is located on the instrument panel at the right and adjacent to the speedometer. This instrument indicates the engine oil pressure and covers a range of from 0 to 80 pounds per square inch.

(2) **TABULATED DATA:**

Manufacturer	Stewart-Warner Corp
Model	444063
Range	0 to 80 lb

**b. Removal** (fig. 114). Remove tube nut which secures tube to rear of gage. Remove two nuts and lock washers which secure bracket to gage and panel. Remove bracket. Pull gage from front of panel.

**c. Installation** (fig. 114). Position gage in instrument panel. Position bracket at back of gage and secure with two nuts and lock washers. Attach tube by securing with tube nut.

**175. TEMPERATURE GAGE.**

**a. Description and Tabulated Data.**

(1) **DESCRIPTION** (fig. 3). This gage indicates the temperature of the water in the engine. It covers a range of 100 to 220° F. It is located on the instrument panel directly below the oil pressure gage.

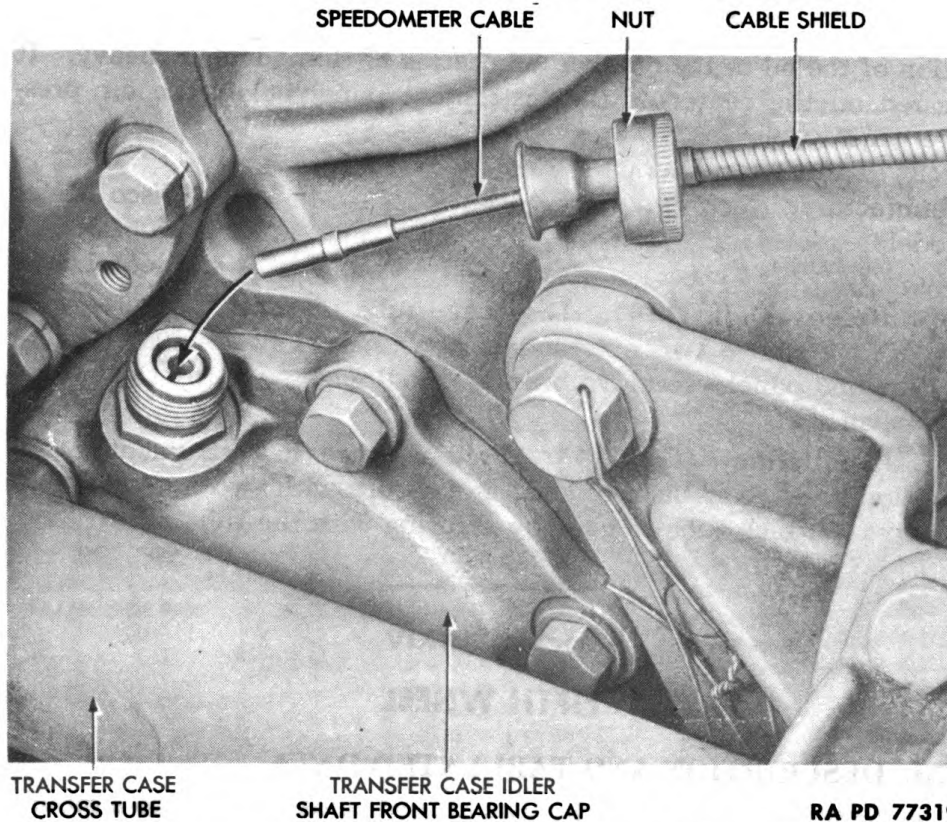
(2) **TABULATED DATA:**

Manufacturer	Stewart-Warner Corp
Type	Thermal band
Range	100 to 220° F.

**b. Removal** (fig. 114). Detach nut which secures wire to gage. Remove two nuts and lock washers which secure bracket to gage and instrument panel. Remove bracket. Pull gage from front of panel.

**c. Installation** (fig. 114). Position gage in instrument panel. Position bracket at rear of gage and secure with two nuts and lock washers. Attach wiring to gage by installing the nut which secures it.

**INSTRUMENTS**



**Figure 116 - Speedometer Cable Connection - Drive End**

**176. AIR PRESSURE GAGE.**

**a. Description and Tabulated Data.**

(1) **DESCRIPTION** (fig. 3). This gage is located on the center of the instrument panel at the right and adjacent to the oil pressure gage. It shows the amount of air pressure available in the service brake system. The gage registers from 0 to 150-pound air pressure per square inch.

(2) **TABULATED DATA:**

Manufacturer .....	Stewart-Warner Corp
Model .....	40057
Range .....	0 to 150 lb

**b. Removal** (fig. 114). Detach tube nut which secures tube to gage. Remove two nuts and lock washers which secure bracket to gage and instrument panel. Remove bracket. Pull gage from front of instrument panel.

**c. Installation** (fig. 114). Position gage in instrument panel. Position bracket at back of gage and secure with two nuts and lock washers. Attach tube to gage by installing the tube nut.

**177. VISCOSITY GAGE.**

**a. Description and Tabulated Data.**

(1) **DESCRIPTION** (fig. 3). The viscosity gage indicates the con-

**4- TO 5-TON 4x4 TRACTOR TRUCK (FEDERAL)**

dition of the oil in the crankcase in terms of thin, ideal, or heavy. It located on the center of the instrument panel below the air pressure gage.

(2) TABULATED DATA:

Manufacturer .....Visco Meter  
Model .....3804A  
Range .....Thin, ideal, heavy

b. **Removal** (fig. 114). Disengage tube nut which secures tube to gage. Remove two nuts and lock washers which secure bracket to gage and panel. Remove bracket. Pull gage from front of instrument panel.

c. **Installation** (fig. 114). Position gage in instrument panel. Position bracket at back of gage and secure with two nuts and lock washers. Attach tube to gage by securing with the tube nut.

---

**Section XXXIV**

**FIFTH WHEEL**

**178. DESCRIPTION AND TABULATED DATA.**

a. **Description** (fig. 117). The fifth wheel is attached to a mounting plate bolted to the frame side rails at the rear of the truck. The wheel is used to couple the tractor and trailer together. It is a swivel mounted, flat, round steel-plate type. Rear half of plate forms a "V" shaped opening which serves to guide the kingpin neck of the trailer coupling to the coupler jaws at the center of the plate. Contact of necks snap jaws shut and releases a lever handle to a position which locks jaws shut. Disengagement is effected by pulling handle forward and pushing lever toward the center of the vehicle. This opens jaws and permits tractor to be pulled from trailer. The only service, in addition to lubrication necessary to fifth wheel concerns the kingpin and jaw surfaces. These will wear with use, and when wear results in an appreciable backlash, refer fifth wheel to higher authority for replacement of jaws.

b. **Tabulated Data.**

Manufacturer .....Austin

**179. REMOVAL** (fig. 117).

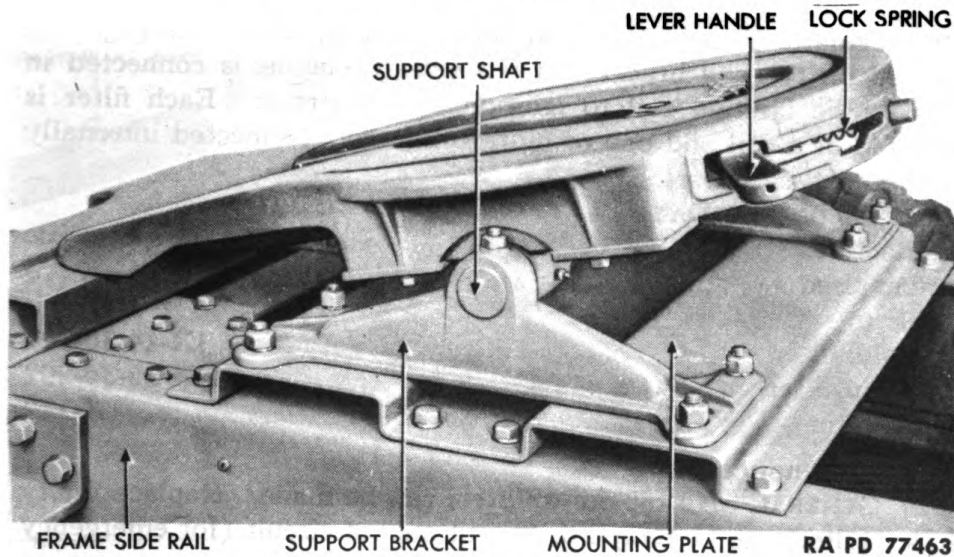
a. Remove the four bolts, nuts, and lock washers which secure the two support brackets to the mounting plate. Remove brackets and wheel as an assembly.

**180. INSTALLATION** (fig. 117).

a. Position fifth wheel assembly on mounting plate. Install the four bolts, nuts, and lock washers which secure brackets to plate.



**RADIO NOISE SUPPRESSION SYSTEM**



**Figure 117 – Fifth Wheel Installed**

**SECTION XXXV**

**RADIO NOISE SUPPRESSION SYSTEM**

**181. DESCRIPTION.**

a. Automotive ignition systems and ungrounded automotive parts are sources of radio interference which actually broadcast radio waves. This action not only interferes with reception on any near-by radio, but also enables the enemy to locate the vehicle with detecting instruments. To overcome this handicap, a radio noise suppression system is used. It consists of an ignition filter, supply filter (fig. 57), field filter (fig. 57), distributor resistor suppressor, 6 spark plug resistor suppressors, 16 bond straps, and necessary cadmium plated bolts, nuts, and lock washers to bond sheet metal parts.

b. Because of importance of radio noise suppression under combat conditions, extreme care must be taken during installation of assemblies to replace bond straps as originally installed. Keep all parts of this system in good working order at all times.

**182. FILTERS.**

**a. Description and Tabulated Data.**

(1) **DESCRIPTION.** Three filters are used. A supply filter (fig. 57), mounted on right-hand dash under voltage regulator, is connected in series in the regulator, to ammeter circuit. A field filter (fig. 57) is mounted on the right-hand dash and held in place by the lower right-hand regulator mounting screw. It is connected in series

**4- TO 5-TON 4x4 TRACTOR TRUCK (FEDERAL)**

in the regulator to generator field circuit. An ignition filter (fig. 49), mounted on the coil bracket on left side of engine, is connected in series in the ignition coil to ignition switch circuit. Each filter is composed of a coil and one or more condensers connected internally in a metal case.

**(2) TABULATED DATA:**

Manufacturer .....	Sprague
Number used .....	3
Model:	
Supply filter .....	JX-14-36-292
Ignition filter .....	JX-15-36-292
Field filter .....	JX-112

**b. Maintenance.**

(1) **GENERAL.** No repairs to filters can be made. Replace faulty filters. Filters can be temporarily "cut out" of circuit (for emergency operation) if no replacement is available. Radio noise suppression is ineffective with one or more filters "cut out." Therefore, replacement must be made at earliest opportunity. To "cut out" field filter, remove filter and connect filter generator wire on regulator field terminal. To "cut out" supply filter, remove short filter-to-regulator wire from regulator battery terminal and connect filter-to-ammeter wire on battery terminal. To "cut out" ignition filter, remove coil-to-filter wire from coil and connect ignition-switch-to-filter wire to ignition coil.

(2) **TEST FILTERS.** Supply and field filters with open or short circuits affect generator circuit and cause ammeter to show discharge. Open or short circuit in ignition coil cuts current from coil, thereby rendering engine inoperative. To test for open circuit, place probes of test light on two filter terminals. Failure of lamp to light signifies open circuit. No field test for a short circuit exists except to replace filter. If new filter causes proper functioning of circuit, a short circuit in original equipment is indicated.

**c. Removal** (figs. 57 and 49). Remove wire from each of the two terminals on filter. Tag wires to aid in installation. Remove attaching screws or bolts and lift filter from vehicle.

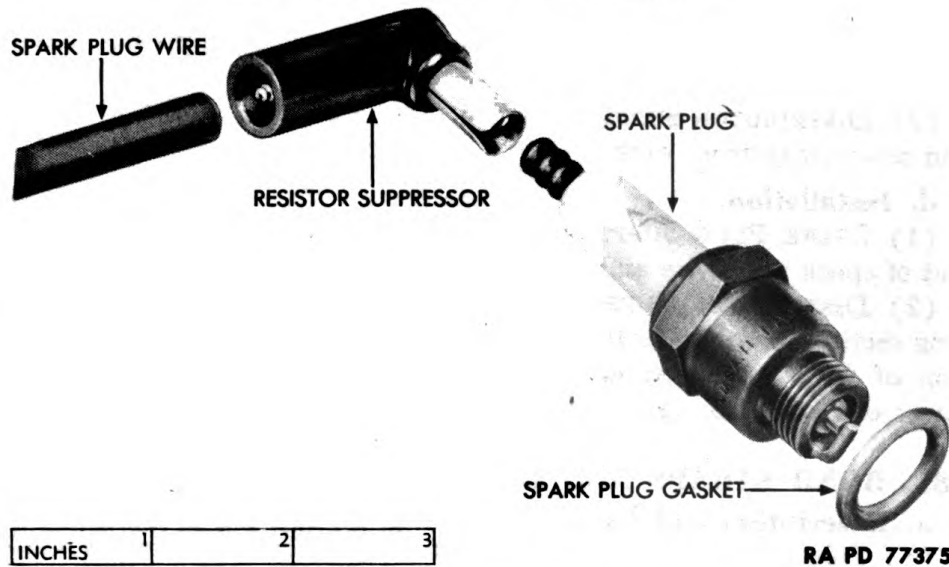
**d. Installation** (figs. 57 and 49). Place filter in position and install attaching screws or bolts. Connect wires to same terminals from which removed. In case of question as to where to connect wires, refer to wiring diagram (fig. 105).

**183. CAPACITOR.**

**a. Description and Tabulated Data.**

(1) **DESCRIPTION** (fig. 55). A capacitor or condenser is used on the generator. It is mounted on the generator ground screw and its lead is attached to the generator armature terminal. Its function is

**RADIO NOISE SUPPRESSION SYSTEM**



**Figure 118 – Spark Plug Resistor Suppressor Installation**

to lessen the generator's tendency to create sparks and thus develop radio noise.

(2) **TABULATED DATA:**

Manufacturer ..... Sprague  
Model ..... S-13-23A

**b. Removal (fig. 55).** Disconnect lead from generator armature terminal. Remove generator ground screw and lift capacitor from generator.

**c. Installation (fig. 55).** Position capacitor on generator. Install generator ground screw. Connect capacitor lead to generator armature terminal.

**184. RESISTOR SUPPRESSORS.**

**a. Description and Tabulated Data.**

(1) **DESCRIPTION.** Seven resistor suppressors are used, one on top of each spark plug (fig. 118). The other suppressor is inserted in the coil-to-distributor high-tension wire about an inch above the distributor cap (fig. 51). Their function is to suppress radio interference.

(2) **TABULATED DATA:**

**Spark plug suppressors:**  
Federal part number ..... 16A3995  
**Distributor suppressor:**  
Federal part number ..... 16A3996

**b. Maintenance.** Clean dirt and moisture from suppressors with a clean cloth. Examine each carefully. Replace if cracked or scorched.

**4- TO 5-TON 4x4 TRACTOR TRUCK (FEDERAL)**

**c. Removal.**

(1) **SPARK PLUG SUPPRESSOR** (fig. 118). Pull suppressor from spark plug and screw suppressor from spark plug wire.

(2) **DISTRIBUTOR SUPPRESSOR** (fig. 69). Pull wire from distributor and screw wire from each end of suppressor.

**d. Installation.**

(1) **SPARK PLUG SUPPRESSOR** (fig. 118). Screw suppressor onto end of spark plug wire and push suppressor onto spark plug.

(2) **DISTRIBUTOR SUPPRESSOR** (fig. 51). Screw suppressor onto long section of coil-to-distributor high-tension wire. Screw short section of wire into other end of suppressor. Push wire into center tower of distributor cap.

**185. BOND STRAPS AND BOLTS.**

**a. Description and Tabulated Data.**

(1) **DESCRIPTION** (fig. 119). Continuity of circuit between various metal parts is ensured by liberal use of bond straps and cadmium plated bolts, nuts, and lock washers. Sheet metal parts are bonded to each other by means of the special bolts. Cadmium plated toothed lock washers are used to ensure good contact.

(2) **TABULATED DATA:**

Number of bond straps .....	16
Location of bond straps:	
Frame to engine support bracket .....	LH side
Frame to clutch housing .....	RH side
Oil pan to engine front support .....	RH side
Transfer case to cross member .....	LH side
Radiator air deflector to fender brace .....	Both sides
Air cleaner to frame .....	RH side
Battery box to cover (2 required) .....	RH side
Brush guard to frame .....	Both sides
Steering column to support bracket .....	LH side
Tire carrier to cab .....	Both sides
Cylinder head to cab cross brace .....	RH side
Water manifold to cylinder head .....	LH side
Fuel tank to bracket .....	LH side

**b. Maintenance.** Inspect bond straps and bond bolts. Replace broken or damaged straps. Tighten loose nuts.

**c. Removal** (fig. 119).

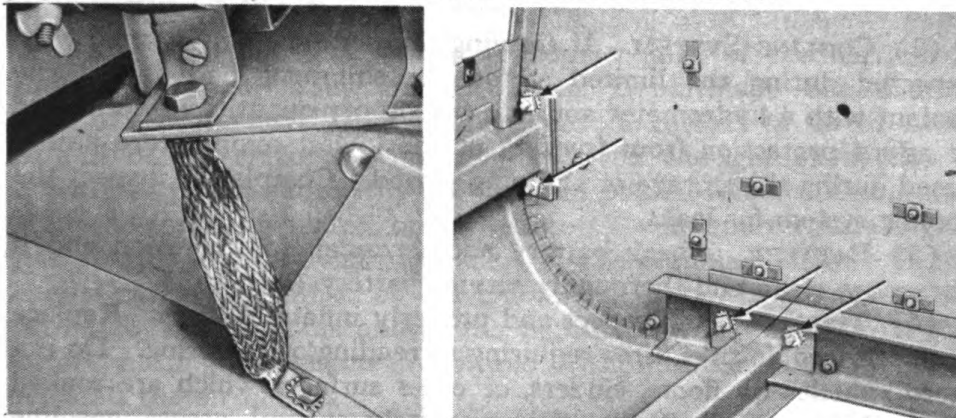
(1) **BOND STRAP.** Remove nut, lock washer, and bolt which secure each end of strap to vehicle. Lift strap from vehicle.

(2) **BOND LOCK WASHERS.** Remove nut and lock washer. Pull bolt and second lock washer from sheet metal.

**d. Installation** (fig. 119).

(1) **BOND STRAP.** Clean corrosion from strap and attaching parts.

**SHIPMENT AND TEMPORARY STORAGE**



RA PD 77359

**Figure 119 – Typical Bonding Installations**

Place strap in position on vehicle. Install bolt, lock washer, and nut which attach each end. Tighten bond bolt securely.

(2) **BOND LOCK WASHERS.** Clean corrosion from bolt and attaching parts. Place lock washer on bolt. Insert bolt. Install remaining lock washer and nut. Tighten securely.

---

**SECTION XXXVI**

**SHIPMENT AND TEMPORARY STORAGE**

**186. GENERAL INSTRUCTIONS.**

a. Preparation for domestic shipment of the vehicle is the same as preparation for temporary storage or bivouac. Preparation for shipment by rail includes instructions for loading and unloading the vehicle, blocking necessary to secure the vehicle on freight cars, number of vehicles per freight car, clearance, weight and other information necessary to properly prepare the vehicle for rail shipment. For more detailed information and for preparation for indefinite storage refer to AR 850-18.

**187. PREPARATION FOR TEMPORARY STORAGE OR DOMESTIC SHIPMENT.**

a. Vehicles to be prepared for temporary storage or domestic shipment are those ready for immediate service but not used for less than thirty days. If vehicles are to be indefinitely stored after shipment by rail, they will be prepared for such storage at their destination.

b. If the vehicles are to be temporarily stored or bivouacked, take the following precautions.

(1) **LUBRICATION.** Lubricate the vehicle completely (par. 17).

**4- TO 5-TON 4x4 TRACTOR TRUCK (FEDERAL)**

(2) **COOLING SYSTEM.** If freezing temperature may normally be expected during the limited storage or shipment period, test the coolant with a hydrometer and add the proper quantity of antifreeze to afford protection from freezing at the lowest temperature anticipated during the storage or shipping period. Completely inspect the cooling system for leaks.

(3) **BATTERY.** Check battery and terminals for corrosion and if necessary, clean and thoroughly service battery (par. 155).

(4) **TIRES.** Clean, inspect and properly inflate all tires. Replace with serviceable tires, tires requiring retreading or repairing. Do not store vehicles on floors, cinders, or other surfaces which are soaked with oil or grease. Wash off immediately any oil, grease, gasoline or kerosene which comes in contact with the tires under any circumstances.

(5) **ROAD TEST.** The preparation for limited storage will include a road test of at least 5 miles (after the battery, cooling system, lubrication, and tire service) to check on general condition of the vehicle. Correct any defects noted in the vehicle operation, before the vehicle is stored or note on a tag attached to the steering wheel, stating the repairs needed or describing the condition present. A written report of these items will then be made to the officer in charge.

(6) **FUEL IN TANKS.** It is not necessary to remove the fuel from the tanks for shipment within the United States, nor to label the tanks under Interstate Commerce Commission Regulations. Leave fuel in the tanks except when storing in locations where fire ordinances or other local regulations require removal of all gasoline before storage.

(7) **EXTERIOR OF VEHICLES.** Remove rust appearing on any part of the vehicle with sandpaper. Repaint painted surfaces whenever necessary to protect wood or metal. Coat exposed polished metal surfaces susceptible to rust, such as winch cables, chains, and in the case of track laying vehicles, metal tracks, with medium grade preventive lubricating oil. Close firmly all cab doors, windows, and windshields. Vehicles equipped with open type babs with collapsible tops will have the tops raised, all curtains in place, and the windshield closed. Make sure paulins and window curtains are in place and firmly secured. Leave rubber mats, such as floor mats, where provided, in an unrolled position on the floor, and not rolled or curled up. Equipment such as pioneer and truck tools, tire chains, and fire extinguishers will remain in place in the vehicle.

(8) **INSPECTION.** Make a systematic inspection just before shipment or temporary storage to insure all above steps have been covered and that the vehicle is ready for operation on call. Make a list of all missing or damaged items and attach it to the steering wheel. Refer to "Before Operation Service" (par. 12).

(9) **ENGINE.** To prepare the engine for storage, remove the air cleaner from the carburetor. Start the engine and set the throttle

## SHIPMENT AND TEMPORARY STORAGE

to run the engine at a fast idle, pour 1 pint of medium grade preservative lubricating oil, Ordnance Department Specification AXS-674, of the latest issue in effect, into the carburetor throat, being careful not to choke the engine. Turn off the ignition switch as quickly as possible after the oil has been poured into the carburetor. With the engine switch off, open the throttle wide and turn the engine five complete revolutions by means of the cranking motor. If the engine cannot be turned by the cranking motor with the switch off, turn it by hand or disconnect the high-tension lead and ground it before turning the engine by means of the cranking motor. Then reinstall the air cleaner.

(10) **BRAKES.** Release brakes and check the wheels.

### c. Inspections in Limited Storage.

(1) Vehicles in limited storage will be inspected weekly for conditions of tires and battery. If water is added when freezing weather is anticipated, recharge the battery with a portable charger or remove the battery for charging. Do not attempt to charge the battery by running the engine.

## 188. LOADING AND BLOCKING FOR RAIL SHIPMENT.

a. **Preparation.** In addition to the preparation described in paragraph 2, when Ordnance vehicles are prepared for domestic shipment, the following preparations and precautions will be taken.

(1) **EXTERIOR.** Cover the body of the vehicle with a canvas cover supplied as an accessory.

(2) **TIRES.** Inflate pneumatic tires from 5 to 10 pounds above normal pressure.

(3) **BATTERY.** Disconnect the battery to prevent its discharge by vandalism or accident. This may be accomplished by disconnecting the positive lead, taping the end of the lead, and tying it back away from the battery.

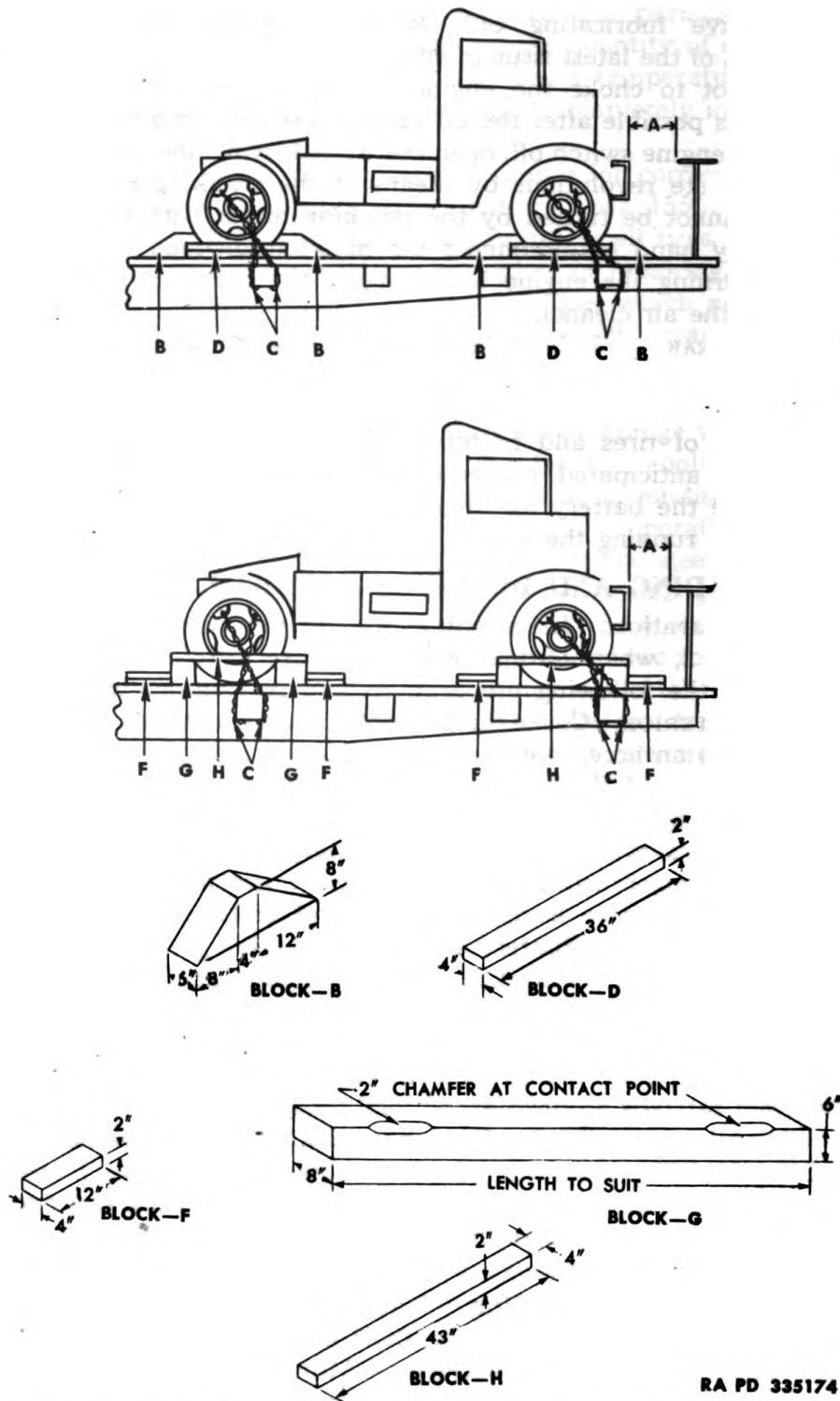
(4) **BRAKES.** The brakes must be applied and the transmission placed in low gear after the vehicle has been placed in position with a brake wheel clearance of at least 6 inches (fig. 120 "A"). The vehicles will be located on the car in such a manner as to prevent the car from carrying an unbalanced load.

(5) All cars containing Ordnance vehicles must be placarded "DO NOT HUMP".

(6) Ordnance vehicles may be shipped on flat cars, and door box cars, side-door box cars, or drop and gondola cars, whichever type car is the most convenient.

b. **Facilities for Loading.** Whenever possible, load and unload vehicles from open cars under their own power, using permanent end ramps and spanning platforms. Movement from one flat car to another along the length of the train is made possible by cross-over plates or spanning platforms. If no permanent end ramp is available,

4- TO 5-TON 4x4 TRACTOR TRUCK (FEDERAL)



RA PD 335174

Figure 120 - Blocking Requirements for Securing Wheeled Vehicles on Railroad Cars



**SHIPMENT AND TEMPORARY STORAGE**

an improvised ramp can be made from railroad ties. Vehicles may be loaded in gondola cars without drop ends by using a crane. In case of shipment in side-door cars, use a dolly type jack to warp the vehicles into position within the car.

**c. Securing Vehicles.** In securing or blocking a vehicle, three motions, lengthwise, sidewise, and bouncing, must be prevented. There are two approved methods of blocking the vehicles on freight cars, as described below. When blocking dual wheels, all blocking will be located against the outside wheel of the dual.

(1) **METHOD 1** (fig. 120). Locate eight blocks "B", one to the front and one to the rear of each wheel. Nail the heel of each block to the car floor using five 40-penny nails to each block. That portion of the block under the tread will be toenailed to the car floor with two 40-penny nails to each block. Locate two blocks "D" against the outside face of each wheel. Nail the lower block to the car floor with three 40-penny nails and the top block to the lower block with three 40-penny nails. Pass four strands, two wrappings, of No. 8 gage, black annealed wire "C" through tow hook at the front of the vehicle and then through a stake pocket on the railroad car. Perform the same operation at the rear of the vehicle passing the wire through the pintle hook. Duplicate these two operations on the opposite side of the vehicle. Tighten the wires enough to remove slack. When a box car is used, this strapping must be applied in a similar fashion and attached to the floor by the use of blocking or anchor plates. This strapping is not required when gondola cars are used.

(2) **METHOD 2** (fig. 120). Place four blocks "G", one to the front and one to the rear of each set of wheels. These blocks are to be at least 8 inches wider than the over-all width of the vehicle at the car floor. Using sixteen blocks "F" locate two against blocks "G" to the front of each wheel and two against blocks "G" to the rear of each wheel. Nail the lower cleat to the floor with three 40-penny nails and the top cleat to the cleat below with three 40-penny nails. Locate four cleats "H" on the outside of each wheel to the top of each block "G" with two 40-penny nails. Pass four strands, two wrappings, of No. 8 gage, black annealed wire "C" through tow hook (front) and also pintle hook (rear) as described in Method 1 above.

**d. Shipping Data.**

Length over-all	203 in.
Width over-all	96 in.
Height over-all	109 in.
Shipping weight	11,220 lb
Approximate floor area	136 sq ft
Approximate volume	1,230 cu ft
Bearing pressure (lb per sq ft)	83

**4- TO 5-TON 4x4 TRACTOR TRUCK (FEDERAL)**

**REFERENCES**

**PUBLICATIONS INDEXES.**

The following publications indexes should be consulted frequently for latest changes or revisions of references given in this section and for new publications relating to materiel covered in this manual:

Introduction to Ordnance Catalog (explaining SNL system).....	ASF Cat. ORD 1 IOC
Ordnance Publications for Supply Index (index to SNL's).....	ASF Cat. ORD 2 OPSI
Index to Ordnance Publications (listing FM's, TM's, TC's and TB's of interest to ordnance personnel, OPSR, MWO's, BSD, S of SR's, OSSC's OFSB's, and includes Alphabetical List of Major Items with Publications Pertaining Thereto).....	OFSB 1-1
List of Publications for Training (listing MR's, MTP's, T/BA's, T/A's, FM's, TM's, and TR's concerning training).....	FM 21-6
List of Training Films, Film Strips, and Film Bulletins (listing TF's, FS's, and FB's by serial number and subject).....	FM 21-7
Military Training Aids (listing Graphic Training Aids, Models, Devices, and Displays) ..	FM 21-8

**STANDARD NOMENCLATURE LISTS.**

Truck, 4- to 5-ton, 4 x 4, C.O.E., tractor (Federal) .....	SNL G-513
Cleaning, preserving and lubrication materials, recoil fluids, special oils, and miscellaneous related items .....	SNL K-1
Interchangeability chart of organizational tools for ordnance vehicles.....	SNL G-19
Soldering, brazing and welding materials, gases and related items .....	SNL K-2
Tool sets—motor transport.....	SNL N-19

**EXPLANATORY PUBLICATIONS.**

<b>Fundamental Principles.</b>	
Automotive electricity:.....	TM 10-580
Automotive lubrication.....	TM 10-540
Basic Maintenance Manual.....	TM 38-250

REFERENCES

Driver's Manual.....	TM 10-460
Electrical fundamentals.....	TM 1-455
Military motor vehicles.....	AR 850-15
Motor vehicle inspections and preventive maintenance service.....	TM 9-2810
Precautions in handling gasoline.....	AR 850-20
Standard Military Motor Vehicles.....	TM 9-2800
The internal combustion engine.....	TM 10-570
<b>Maintenance and Repair.</b>	
Cleaning, preserving, lubricating and welding materials and similar items issued by the Ordnance Department.....	TM 9-850
Cold weather lubrication and service of combat vehicles and automotive materiel.....	OFSB 6-11
Maintenance and care of pneumatic tires and rubber treads.....	TM 31-200
Ordnance Maintenance: 4- to 5-ton tractor truck (Autocar and Federal).....	TM 9-1816
Ordnance Maintenance: Hercules engines....	TM 9-1832A
Ordnance Maintenance: Electrical equipment (Auto-Lite).....	TM 9-1825B
Ordnance Maintenance: Power brake systems (Bendix-Westinghouse).....	TM 9-1827A
Ordnance Maintenance: Carburetors (Zenith).....	TM 9-1826C
Ordnance Maintenance: Fuel Pumps.....	TM 9-1828A
Tune-up and adjustment.....	TM 10-530
<b>Protection of Materiel.</b>	
Camouflage.....	FM 5-20
Chemical decontamination, materials and equipment.....	TM 3-220
Decontamination of armored force vehicles....	FM 17-59
Defense against chemical attack.....	FM 21-40
Explosives and demolitions.....	FM 5-25
<b>Storage and Shipment.</b>	
Ordnance storage and shipment chart, group G — Major items.....	OSSC-G
Registration of motor vehicles.....	AR 850-10
Rules governing the loading of mechanized and motorized army equipment also major caliber guns, for the United States Army and Navy, on open top equipment published by Operations and Maintenance Department of Association of American Railroads.	
Storage of motor vehicle equipment.....	AR 850-18

4- TO 5-TON 4x4 TRACTOR TRUCK (FEDERAL)

INDEX

A	Page	Page	
AGO Form No. 461 .....	53, 59, 60	twin horns .....	247
AGO Form No. 478, description		valve mechanism (road test) .....	58, 59
and use .....	46, 51, 78	valve tappet .....	105
Accelerator		wheels (road test) .....	68, 71
description of pedal .....	10	Air brake system	
disconnect rod .....	117	connect brakes .....	186
install cross shaft and support		disconnect brakes .....	184
bracket assembly .....	153	leaks	
remove cross shaft and support		road test .....	57
bracket assembly .....	151	run-in test .....	51
road test .....	57	maintenance (air brake tanks)	
Accessories		after operation and weekly ..	34
after-operation service .....	32	before operation .....	25
at-halt service .....	30	road test	
before-operation service .....	25	application valve and reservoir	72
road test .....	58	rear brakes .....	73
run-in test .....	47	run-in test (air brake tanks) ..	47
Accident report No. 26 .....	27, 51, 78	Air cleaner	
Adapter (See Tachometer, drive and		capacities .....	8
adapter)		connect to carburetor .....	132
Adjusters, slack		description and data .....	139
connect .....	203	disconnect from carburetor ..	132
data and adjustment .....	208	installation	
description .....	207	air cleaner .....	139
disconnect .....	202	tube .....	123
removal and installation .....	209	lubrication notes .....	41
Adjustment		maintenance	
air compressor .....	189	after operation and weekly ..	32
brake shoes .....	210	at halt .....	30
brakes .....	208, 209	before operation .....	25
road test .....	67, 69	general .....	139
breaker point gap .....	159	operation (cold weather) .....	20
carburetor .....	130	removal .....	139
clutch .....	126	road test .....	63
clutch pedal (road test) .....	72	run-in test .....	47
distributor .....	158	Air compressor	
road test .....	63	connect lines .....	123
drive belts (road test) .....	62	data, maintenance, adjustment,	
engine idle (road test) .....	64	removal and installation ..	189
fan belts .....	153	description .....	188
governor .....	193	disconnect lines .....	119
ignition timing (road test) .....	64	road test .....	61
second echelon maintenance .....	53	Air pressure gage	
shock absorbers .....	222	data, removal, and installation	255
slack adjusters .....	208	description .....	11, 255
spark plugs .....	101, 160	maintenance	
steering gear .....	224	before operation .....	26
		during operation .....	29

INDEX

	Page		Page
<b>A—Cont'd</b>			
Air pressure gage—Cont'd		propeller shaft . . . . .	175, 178, 180
road test		rear axle . . . . .	186
air pressure . . . . .	54	road test	
air pressure gage . . . . .	55	front axle . . . . .	71
run-in test . . . . .	49	gear oil lever and leaks . . . . .	57
trouble shooting . . . . .	97	unusual noises . . . . .	58
Ammeters		run-in test . . . . .	48
data, removal, and installation	250	trouble shooting . . . . .	87, 88
description . . . . .	10, 250		
maintenance		<b>B</b>	
before operation . . . . .	26	Batteries	
during operation . . . . .	28	attach to cranking motor . . . . .	123
road test . . . . .	54	connect . . . . .	124
run-in test . . . . .	49	data	
trouble shooting . . . . .	96	batteries . . . . .	235
Antifreeze compound		cables . . . . .	164
antifreeze chart . . . . .	144	description . . . . .	233, 235
antifreeze compound chart . . . . .	18	disconnect . . . . .	113, 117
record of (road test) . . . . .	60	location of battery box . . . . .	5
use of . . . . .	18	maintenance	
precautions . . . . .	19	after operation and weekly . . . . .	32
Axles		in general . . . . .	235
adjustment (front axle) . . . . .	183	operation	
capacities . . . . .	8	cold weather . . . . .	19
connect propeller shaft		hot weather . . . . .	22
front axle . . . . .	185	removal and installation . . . . .	236
rear axle . . . . .	188	road test . . . . .	59
data		run-in test . . . . .	47
front axle . . . . .	183	storage and shipment	
rear axle . . . . .	186	rail shipment . . . . .	263
description		temporary or domestic . . . . .	262
declutch lever . . . . .	8	trouble shooting . . . . .	84, 85, 95
front axle . . . . .	183		
rear axle . . . . .	186	Belts, drive	
disconnect (front axle)		maintenance	
declutch rod . . . . .	119, 174	after operation . . . . .	32
propeller shaft . . . . .	184	at halt . . . . .	30
installation		before operation . . . . .	25
front axle . . . . .	185	road test (unusual noises) . . . . .	58
declutching		run-in test . . . . .	47
rods . . . . .	122, 175, 177, 179	Blackout lights	
propeller shafts . . . . .	175, 179, 180	data	
rear axle . . . . .	186	driving light . . . . .	239
maintenance		marker light . . . . .	240
after operation . . . . .	33	tail and service stop light . . . . .	241
at halt . . . . .	30	tail and stop light . . . . .	243
operation (front axle drive) . . . . .	14	description	
removal		driving light . . . . .	239
front axle . . . . .	184	driving light switch . . . . .	12
declutching rod . . . . .	177, 179	light switch . . . . .	11
		marker lights . . . . .	240

4- TO 5-TON 4x4 TRACTOR TRUCK (FEDERAL)

<b>B—Cont'd</b>	<b>Page</b>		<b>Page</b>
Blackout lights—Cont'd		service brake system	88
tail and service stop light	241	Brake valve, hand, description	12
tail and stop light	243	<b>Brakes</b>	
installation, maintenance, and removal		adjustment	208, 209
driving light	240	connect pedal rod	197
marker light	241	data (diaphragm chambers)	202
tail and service stop light	243	description and removal	
tail and stop light	243	diaphragm chambers	202
<b>Body</b>		pedal and control rod	206
after-operation services	34	disconnect clutch and brake rods	119
at-halt service	30	during-operation service	28
before-operation inspection	27	installation	
during-operation service	29	brake and clutch rods	122
road test (unusual noises)	57	diaphragm chambers	203
run-in test	48	pedal and control rod	207
trouble shooting	95	road test	
Bond straps and bolts	260	front brakes	68
Brake bands, cold-weather		parking brakes	55, 56
operation	20	rear brakes	66
Brake drums		service brakes	55, 56
at-halt service	30	run-in test	50
road test	57	storage and shipment	263
run-in test	51	(See also Air brake system)	
Brake governor, lubrication of upper valve stem	43	<b>Breaker points, adjust gap and replace</b>	159
Brake hose (tractor to trailer), road test	75	<b>Breather caps</b>	
Brake lever, propeller shaft, description	8	after-operation and weekly services	32
Brake lines, road test	74	road test	63
Brake pedal, service		run-in test	47
description	10	<b>Bumper</b>	
road test	72	at-halt service	30
Brake shoes	210, 212	before-operation service	27
Brake system		description, removal, and installation	230
adjustment	213	road test	76
description		run-in test	48
brake lever	214	<b>Bushings, rubber, lubrication notes</b>	43
propeller shaft brake	212		
service brake system	188		
installation			
brake lever	215		
propeller shaft brake	213		
removal			
brake lever	215		
propeller shaft brake	213		
trouble shooting			
propeller shaft brake	93		

**C**

<b>Cab</b>	
description	
cab	226
cab top	229
disconnect and remove from vehicle	115
installation	
cab	108
cab skirt opening door	107
cab top	229

INDEX

<b>C—Cont'd</b>	<b>Page</b>		<b>Page</b>
<b>Cab—Cont'd</b>		<b>Circuit breakers</b>	
install on and connect to		description and data . . . . .	248
vehicle . . . . .	124	removal and installation . . . . .	249
transverse cab supports . . . . .	105	road test . . . . .	76
maintenance (cab top) . . . . .	229	<b>Cleaning</b>	
removal		after operation and weekly . . . . .	34
cab skirt opening door . . . . .	105	all parts . . . . .	41
cab top . . . . .	229	commutator . . . . .	165
transverse cab support . . . . .	103	cooling system . . . . .	18
replacement, cab skirt opening		fuel lines . . . . .	138
door . . . . .	132	oil pan . . . . .	109
road test		road test	
cab . . . . .	76	front axle . . . . .	71
cab mountings . . . . .	73	front brakes . . . . .	69
types of . . . . .	7	front wheels . . . . .	70
(See also Body)		fuel filter . . . . .	63
<b>Cables</b>		generator and starter . . . . .	61
description and maintenance . . . . .	173	governor and starter . . . . .	61
removal and installation . . . . .	173, 254	rear brakes . . . . .	67
<b>Capacities data</b> . . . . .	8	rear wheels . . . . .	68
<b>Capacitor</b>		second echelon maintenance . . . . .	53
description and data . . . . .	258	spark plugs . . . . .	101, 161
removal and installation . . . . .	259	strainer and water trap . . . . .	110
<b>Carbon, removal</b> . . . . .	103	<b>Clutch</b>	
<b>Carburetor</b>		-adjustment and data . . . . .	125
air cleaner . . . . .	139	description	
air leaks . . . . .	80	clutch . . . . .	125
cold-weather operation . . . . .	20	pedal . . . . .	10
connect controls . . . . .	108	disconnect clutch and brake rods . . . . .	119
data . . . . .	129	installation	
description and adjustment . . . . .	130	brake and clutch rods . . . . .	122
disconnect controls . . . . .	107	linkage . . . . .	128
installation and removal . . . . .	132	maintenance	
road test . . . . .	63	during operation . . . . .	28
(See also Accessories)		in general . . . . .	125
<b>Centrifugal advance (distributor)</b>	62	removal of linkage . . . . .	127
<b>Chains</b> . . . . .	78	road test	
<b>Chassis</b>		clutch . . . . .	56
cold-weather operation . . . . .	20	clutch pedal . . . . .	72
lower to axle . . . . .	188	run-in test . . . . .	50
lubrication . . . . .	17	trouble shooting . . . . .	81
removal from axle . . . . .	186	<b>Commutator</b>	
<b>Choke</b>		cleaning . . . . .	165
before-operation service . . . . .	26	trouble shooting . . . . .	84, 85
connect controls . . . . .	153	<b>Compression, engine</b>	
disconnect controls . . . . .	117, 151	low compression . . . . .	80
road test . . . . .	63	road test . . . . .	59
run-in test . . . . .	48	test . . . . .	101
use of in cold-weather operation . . . . .	20	<b>Condenser</b>	
		description, data, and removal . . . . .	156

4- TO 5-TON 4x4 TRACTOR TRUCK (FEDERAL)

<b>C—Cont'd</b>	<b>Page</b>		<b>Page</b>
Condenser—Cont'd		trouble shooting	79, 85
installation	157	Cylinder, reverse flushing	144
Controls, engine		Cylinder block	
after-operation and weekly		attach pump to	148
services	33	drain	113
description	8	removal	
during-operation service	28	fuel pump	133
use in operation	12	oil filter assembly	112
Coolant supply		Cylinder head	
before-operation service	25	connect fan bracket to	104
weekly inspection	19	disconnect fan bracket from	103
Cooling system		installation	
capacities	8, 101	cap screws	104
description	143	heads	103
drain	101	removal	101, 103
fill	105	road test	58
maintenance			
hot weather	21	<b>D</b>	
in general	143	Dash, attach and detach cranking	
protection of	18	motor switch	172
replace fluid	124	Dash instruments	
reverse flushing and draining	144	road test	54
storage and shipment	262	run-in test	50
trouble shooting	83	Data (See data under specific item)	
(See also Antifreeze compound)		Declutch lever (front axle), description	8
Cowl dash		Decontamination	23
disconnect radiator from	146	Decontaminator	
secure radiator to	147	after-operation service	32
Cowl opening door, installation	239	before-operation service	27
Crankcase		second echelon maintenance	77
installation, removal, and		Description (See description under specific item)	
maintenance of ventilator	113	Differential	
keeping oil fluid	17	data	186
lubrication notes	42	lubrication	16
road test	60	run-in test ( housings)	51
Cranking motor		Diluents (tabular data)	18
attach switch, battery, and ground		Dimmer switch, foot, description	10
cables	123	Disk	
cold-weather operation	19	description	213
data	163, 164	removal and installation	214
description		Distributor	
motor	168	cold-weather operation	19
switch	11, 172	data, maintenance, and adjustment	158
disconnect switch	117	description	157
inspection of mechanism	20	installation	
installation and removal		distributor	160
motor	168		
switch	172		
lubrication notes	42		



INDEX

<b>D—Cont'd</b>	<b>Page</b>		<b>Page</b>
Distributor—Cont'd		before operation	
suppressor	260	engine operation	27
lubrication notes	42	oil	25
removal of suppressor	260	during operation	28
road test	62	operation (cold weather)	20
trouble shooting	83	position on vehicle	121
Door, cowl opening, installation		removal	
and removal	172	covers	101, 107, 113
Doors (road test)	76	from vehicle	113, 121
Drag links (upper and lower)		replace lubricant	124
installation	226	road test	56, 58, 71
removal	225	run-in test	50
Drive belts (road test)	62	starting	
Driver's permit (before-operation		cold weather	20
check)	27	in general	12
Driver's Report-Accident Standard		stopping	15
Form No. 478	51	storage and shipment	262
Driver's Trip Ticket and Preventive		trouble shooting	79
Maintenance Service Record	24	tune-up	101
Drives (before-operation service)	25	warming	19
		warm-up	
		before operation	26
		run-in test	48
<b>E</b>		Engine controls	
Echelons (preventive maintenance		after-operation and weekly ser-	
duties)		vices	33
first echelon	23	during-operation service	28
first echelon participation in second		run-in test	49
echelon and second echelon	51	Exhaust pipe	
Electrical systems, cold-weather		connect	108
operation	19	description, installation, and	
Engine		removal	142
attach to engine		disconnect	107
compressor	189	road test	74
cranking motor	168	Exhaust system (See Intake and	
generator	166	exhaust systems)	
rope sling	120		
cleaning	34	<b>F</b>	
description and data	99	Fan	
detach from engine		description, data, and removal	151
compressor	189	installation	152
cranking motor	168	road test	60
disconnect support bolts	121	Fan belts	
drain lubricant	113	description, data, and adjust-	
installation		ment	153
covers	105, 108, 124	installation and removal	154
engine	121	maintenance (hot weather)	21
support bolts	122	trouble shooting	83
maintenance		Fenders	
after operation (engine opera-		at-halt service	30
tion)	31		

4- TO 5-TON 4x4 TRACTOR TRUCK (FEDERAL)

<b>F—Cont'd</b>	<b>Page</b>	<b>Page</b>
<b>Fenders—Cont'd</b>		connect fuel lines to fuel pump 123
before-operation service . . . . .	27	disconnect fuel line to fuel pump 117
description and maintenance . . . . .	231	road test . . . . . 63
removal and installation . . . . .	232	run-in test . . . . . 47
road test . . . . .	76	<b>Fuel lines, description, maintenance</b>
run-in test . . . . .	48	removal, and installation . . . . . 138
<b>Filters</b>		<b>Fuel pump (See Pump, fuel)</b>
data . . . . .	257	<b>Fuel supply</b>
description		after-operation service . . . . . 31
filters . . . . .	257	at-halt service . . . . . 29
gasoline filters . . . . .	134	before-operation service . . . . . 25
maintenance, removal, and instal- lation		run-in test . . . . . 47
filters . . . . .	258	storage or shipment . . . . . 262
gasoline filters . . . . .	134	water in . . . . . 81
(See also Fuel filters)		<b>Fuel system</b>
<b>Fire extinguisher</b>		cold-weather operation . . . . . 20
after-operation service . . . . .	32	description and data . . . . . 129
before-operation service . . . . .	25	inoperative . . . . . 80
data . . . . .	44	trouble shooting . . . . . 82
run-in test . . . . .	47	<b>Fuel tank</b>
second echelon maintenance . . . . .	77	capacities . . . . . 8
<b>First aid kit, second echelon</b>		clogged cap vent . . . . . 80
maintenance . . . . .	78	data . . . . . 130, 250
<b>Fittings, lubrication notes</b> . . . . .	41	description and maintenance 136, 250
<b>Flange nuts (See Wheel and flange nuts)</b>		installation . . . . . 138, 252
<b>Floor, removal</b> . . . . .	151	removal . . . . . 137, 252
<b>Frame</b>		road test . . . . . 73
description . . . . .	227	
installation of frame plat- form . . . . .	124, 176	<b>G</b>
removal		<b>Gages</b>
frame . . . . .	119	road test . . . . . 54
frame platform . . . . .	119, 174, 177	run-in test . . . . . 50
road test . . . . .	73, 76	(See also Air pressure gage, Fuel gage, Oil gage, Oil pressure gage, Temperature gage, and Viscosity gage)
trouble shooting . . . . .	95	<b>Gaskets (and cylinder head)</b>
<b>Fuel gage</b>		installation . . . . . 103
before-operation service . . . . .	26	removal . . . . . 101
data . . . . .	250	road test (gaskets) . . . . . 58, 63
description . . . . .	10, 250	<b>Gasoline, cold-weather operation</b> . 16
during-operation service . . . . .	29	<b>Gear cases, lubrication notes</b> . . . 42
removal and installation . . . . .	252	<b>Gears, check oil levels after</b>
road test . . . . .	55	operation . . . . . 33
run-in test . . . . .	49	<b>Gearshift lever (main transmission), description</b> . . . . . 8
trouble shooting . . . . .	96	<b>Generating system, trouble</b>
<b>Fuel filter</b>		shooting . . . . . 84
after-operation and weekly ser- vices . . . . .	33	



4- TO 5-TON 4x4 TRACTOR TRUCK (FEDERAL)

<b>I—Cont'd</b>	<b>Page</b>	<b>Page</b>
Ignition system—Cont'd		Lever, propeller shaft brake . . . . . 214
removal		Lights
cable tube . . . . .	103	cold-weather operation . . . . . 20
coil . . . . .	155	data
switch . . . . .	161	lights . . . . . 237
trouble shooting . . . . .	84	service stop light . . . . . 241
(See also Timing, ignition)		description
Inspection		instrument light switch . . . . . 245
coolant . . . . .	19	lighting system . . . . . 233
cooling system units . . . . .	143	lights . . . . . 237
cranking motor mechanism . . . . .	20	service stop light . . . . . 241
daily and weekly . . . . .	23	installation and removal
definition of terms . . . . .	24, 52	lights . . . . . 237
generator . . . . .	164	service stop light . . . . . 243
storage and shipment . . . . .	262	maintenance
Instruments		after operation . . . . . 32
after-operation service . . . . .	31	before operation . . . . . 27
before-operation service . . . . .	26	service stop light . . . . . 241
description		road test . . . . . 76
instruments . . . . .	8	run-in test . . . . . 49
light switch . . . . .	12, 245	trouble shooting . . . . . 95
during-operation service . . . . .	28	(See also Headlights, Blackout
instrument light switch . . . . .	245	lights, and Trailer lights)
road test . . . . .	54	Linkage, removal and installation
run-in test . . . . .	48, 50	propeller shaft brake system . . 215
trouble shooting . . . . .	96	transfer case . . . . . 176, 177
use in operation . . . . .	12	Lubrication
Intake and exhaust systems		after operation and weekly . . . . . 34
description . . . . .	139	by ordnance maintenance
trouble shooting . . . . .	82	personnel . . . . . 43
		chassis points and oilcan points 17
<b>L</b>		detailed instructions . . . . . 41
Leaks		lubrication guide . . . . . 35
after-operation service . . . . .	33	points requiring none . . . . . 43
at-halt service . . . . .	30	precautions . . . . . 17
before-operation service . . . . .	25	road test
carburetor and manifold . . . . .	80	distributor . . . . . 62
manifold gasket or exhaust pipe		fifth wheel . . . . . 75
flange . . . . .	82	front brakes . . . . . 69
repair (cooling system) . . . . .	18	front wheels . . . . . 71
road test		governor and starter . . . . . 61
crankcase . . . . .	60	rear wheels . . . . . 68
general leaks . . . . .	57, 64	vehicle . . . . . 74
run-in test		run-in test . . . . . 48
air brake system . . . . .	51	second echelon maintenance . . . 53
general leaks . . . . .	49	steering gear housing . . . . . 17
transmission case and transfer		storage and shipment . . . . . 261
case . . . . .	86	transmission and differential . . 16

INDEX

<b>M</b>	<b>Page</b>	<b>N</b>	<b>Page</b>
<b>Maintenance</b>		<b>Noises, unusual</b>	
before-operation service		road test	
(road test) . . . . .	54	attachments, cab, and wheels	57
by ordnance maintenance person-		engine . . . . .	56, 58
nel . . . . .	43	run-in test . . . . .	50
first echelon . . . . .	23		
first echelon participation in		<b>O</b>	
second echelon duties . . . . .	51	<b>Odometer, run-in test . . . . .</b>	<b>49</b>
purpose of . . . . .	23	<b>Oil</b>	
second echelon . . . . .	51	drain (engine) . . . . .	109
definition of terms . . . . .	52	run-in test . . . . .	47
publications and reports . . . . .	78	<b>Oil capacities . . . . .</b>	<b>101, 139</b>
road test . . . . .	54	<b>Oil consumption, excessive . . . . .</b>	<b>81</b>
special services . . . . .	53	<b>Oil filler pipe</b>	
tools and equipment . . . . .	77	installation . . . . .	104
(See also maintenance under		removal . . . . .	103
specific items)		<b>Oil filters</b>	
<b>Major unit assembly replacement</b>		lubrication notes . . . . .	42
record . . . . .	46, 51, 78	maintenance . . . . .	111
<b>Manifold</b>		removal and installation . . . . .	112
air leaks . . . . .	80	road test . . . . .	60
attach, water outlet manifold . . . . .	123	<b>Oil gage</b>	
connect crankcase ventilator		before-operation service . . . . .	26
tube (intake manifold) . . . . .	107, 108	run-in test . . . . .	48
data (tee manifolds) . . . . .	204	trouble shooting . . . . .	97
description (tee manifolds) . . . . .	203	<b>Oil leaks, external . . . . .</b>	<b>81</b>
disconnect crankcase ventilator		(See also Leaks)	
tube (intake manifold) . . . . .	105, 107	<b>Oil levels</b>	
installation		gear	
intake and exhaust manifolds . . . . .	108	after-operation check . . . . .	33
tee manifolds . . . . .	204	road test . . . . .	57
water outlet manifold . . . . .	105	crankcase (road test) . . . . .	60
removal		<b>Oil pan, removal and cleaning . . . . .</b>	<b>109</b>
intake and exhaust manifolds . . . . .	107	<b>Oil pressure gage</b>	
tee manifolds . . . . .	204	connect tube . . . . .	123
water outlet manifolds . . . . .	103, 117	data, removal, and installation . . . . .	254
road test . . . . .	63	description . . . . .	11, 254
<b>Metals, effect of low temperatures</b>		disconnect tube . . . . .	117
on . . . . .	21	during-operation service . . . . .	28
<b>Misfires (engine) . . . . .</b>	<b>80</b>	road test . . . . .	54
<b>Mixtures, carburetor idling and</b>		<b>Oil supply</b>	
high-speed adjustment . . . . .	131	after-operation service . . . . .	31
<b>Modification work orders . . . . .</b>	<b>46, 51, 78</b>	at-halt service . . . . .	29
<b>Muffler</b>		<b>Oil viscosity</b>	
description and removal . . . . .	142	incorrect . . . . .	79
installation . . . . .	143	too low . . . . .	81
road test . . . . .	74	(See also Viscosity gage)	
trouble shooting . . . . .	83	<b>Oilcan points . . . . .</b>	<b>17, 43</b>

# TM 9-820

## 4- TO 5-TON 4x4 TRACTOR TRUCK (FEDERAL)

<b>O—Cont'd</b>	<b>Page</b>	<b>Page</b>	
<b>Operation</b>		<b>description</b>	
after-operation and weekly services .....	31	brake system shaft .....	212
after starting the engine but before moving vehicle .....	13	shaft brake lever .....	8
at-halt service .....	29	disconnect	
before-operation service .....	25	brake lever bracket .....	103
cold weather		brake rod .....	174
chassis .....	20	installation	
cooling systems .....	18	brake lever bracket .....	104
electrical systems .....	19	brake rod and brake shoe return springs .....	178
gasoline and lubrication .....	16	intermediate shaft .....	122, 176, 179, 183
starting and operating engine .....	20	shafts (brake system) .....	213
during-operation service .....	27	shafts .....	175
in hot weather .....	21	removal	
in mud, snow, ice, sand, and flood .....	23	brake rod and brake shoe return springs .....	178
of vehicle .....	14	intermediate shaft .....	174, 178, 183
road test (before-operation service) .....	54	shaft (brake system) .....	213
use of instruments and controls .....	12	run-in test .....	48
		road test	
		front shaft .....	71
		rear shaft .....	72
		unusual noises .....	58
		trouble shooting	
		shafts .....	87
		shafts (brake system) .....	93
		(See also under Axles)	
		<b>Pump, fuel</b>	
		cold-weather operation .....	20
		connect fuel lines to fuel filter .....	123
		data .....	129
		description .....	132
		disconnect fuel lines to fuel filter .....	117
		installation, maintenance, and removal .....	133
		road test .....	64
		trouble shooting .....	82
		<b>Pump, water</b>	
		description, data, and removal .....	147
		installation .....	148
		inoperative .....	83
		maintenance, hot weather .....	21
		road test .....	60
		<b>Pump, oil, trouble shooting</b> .....	97
		<b>R</b>	
		<b>Radiator</b>	
		attach lower hose assembly .....	123
		data .....	145

INDEX

<b>R—Cont'd</b>	<b>Page</b>		<b>Page</b>
<b>Radiator—Cont'd</b>		description, data, maintenance	
description .....	144	and adjustment .....	222
disengage lower hose assembly .....	115	disconnect (front shock	
drain .....	113	absorbers) .....	184
installation .....	146	installation and removal .....	223
reverse flushing .....	144	lubrication notes .....	42
road test .....	60	road test (front shock absorbers) .....	70
trouble shooting .....	83	trouble shooting .....	93
<b>Radio noise suppression system</b>		<b>Solenoid switch</b>	
description .....	257	connect to cranking motor ...	169
trouble shooting .....	85, 98	data .....	163
<b>Reflectors</b>		description, removal, and	
after-operation service .....	32	installation .....	169
before-operation service .....	27	disconnect from cranking motor .....	168
run-in test .....	49	<b>Spare parts and equipment data</b> .....	44
road test .....	76	<b>Spark control, description</b> .....	12
<b>Regulator unit</b>		<b>Spark plugs</b>	
noisy .....	98	clean and adjustment ....	101, 160
road test .....	65	cold-weather operation .....	19
<b>Repair (leaks in cooling system)</b> .....	18	description, data, and mainte-	
<b>Resistor suppressors</b>		nance .....	160
description, data, and		installation	
maintenance .....	259	spark plugs .....	161
installation and removal .....	260	suppressor .....	260
<b>Road test</b>		wires .....	162
final test .....	78	removal	
preliminary procedures .....	54	suppressor .....	260
storage and shipment .....	262	wires .....	162
<b>Run-in test, new vehicle</b>		road test .....	59
procedures .....	47	trouble shooting .....	84
purpose .....	46	<b>Specific gravity (batteries)</b>	
test .....	50	hot-weather operation .....	22
<b>Running boards (road test)</b> .....	76	road test .....	59
<b>Running gear (during-operation</b>		<b>Specifications, vehicle</b> .....	7
service) .....	29	<b>Speedometer</b>	
		cold-weather operation (cable) .....	21
		description and data .....	10, 253
		during-operation service .....	29
		installation and removal .....	254
		road test .....	55
		run-in test .....	49
		trouble shooting .....	97
		<b>Speeds, shifting to lower</b> .....	14
		<b>Splash guards (road test)</b> .....	76
		<b>Springs</b>	
		after-operation service .....	33
		at-halt service .....	30
		before-operation service .....	27

**S**

<b>Seals, lubricant retainer, installa-</b>	
tion .....	52
<b>Shift lever (transfer case),</b>	
description .....	8
<b>Shifting to lower speeds</b> .....	14
<b>Shimmy (front wheels)</b> .....	94
<b>Shipment (See Storage and</b>	
shipment)	
<b>Shock absorbers</b>	
connect (front shock absorbers) .....	186

4- TO 5-TON 4x4 TRACTOR TRUCK (FEDERAL)

S—Cont'd	Page		Page
Springs—Cont'd		loading and blocking (rail shipment) . . . . .	263
description, removal, and installation		temporary storage or domestic shipment . . . . .	261
front springs . . . . .	220	Strainer and water trap	
rear springs . . . . .	221	installation and cleaning . . . . .	110
road test		removal . . . . .	109
front springs . . . . .	70	Suspensions	
rear springs . . . . .	73	after-operation service . . . . .	33
run-in test . . . . .	48	at-halt service . . . . .	30
trouble shooting . . . . .	93	before-operation service . . . . .	27
Starter (road test) . . . . .	61, 64	run-in test . . . . .	48
Starting system			
data . . . . .	163	<b>T</b>	
description . . . . .	162	Tachometer	
starting the engine	12	attach distributor to drive . . . . .	160
in cold weather . . . . .	20	before-operation service . . . . .	26
trouble shooting . . . . .	84	connect cable . . . . .	123
Steering		data . . . . .	252
removal and installation		description . . . . .	10, 252
steering arm . . . . .	226	during-operation service . . . . .	29
steering wheel . . . . .	225	installation and removal . . . . .	253
road test . . . . .	56, 70	road test	
run-in test . . . . .	50	drive and adapter . . . . .	62
Steering gear		tachometer . . . . .	55
adjustment . . . . .	224	run-in test . . . . .	49
capacities . . . . .	8	trouble shooting . . . . .	97
description, data, and maintenance . . . . .	223	Tanks, air brake	
during-operation service . . . . .	29	after-operation and weekly services . . . . .	34
lubrication		before-operation service . . . . .	25
housing . . . . .	17	description, data, installation, and removal . . . . .	195
tube upper bearing . . . . .	43	(See also Air brake system)	
trouble shooting . . . . .	94	Tarpaulin	
(See also Steering and Steering linkage)		after-operation services . . . . .	34
Steering linkage		at-halt service . . . . .	30
after-operation service . . . . .	33	before-operation service . . . . .	27
at-halt service . . . . .	30	Temperature gage	
before-operation service . . . . .	27	before-operation service . . . . .	26
run-in test . . . . .	48	connect cable and tube . . . . .	123
Step plates, description, removal, and installation . . . . .	233	data, removal, and installation . . . . .	254
Stop lights		description . . . . .	11, 254
blackout stop light . . . . .	243	disconnect cable and tube . . . . .	117
service stop light . . . . .	241	during-operation service . . . . .	28
stop light switch . . . . .	243	road test . . . . .	55
Stopping vehicle and engine . . . . .	15	run-in test . . . . .	49
Storage and shipment		trouble shooting . . . . .	83, 97
gasoline (cold-weather storage) . . . . .	16	Thermostat	
		data, maintenance, and removal . . . . .	150



## INDEX

<b>T—Cont'd</b>	<b>Page</b>	<b>Towing</b>	<b>Page</b>
Thermostat—Cont'd		description, removal, and installation of tow hooks	230
description	149	devices	78
installation	151	facilities of vehicle to start vehicle or disabled vehicle	8
maintenance (hot weather)	21		15
trouble shooting	83	(See also Towing connections)	
Throttle		Towing connections	
connect controls	153	after-operation and weekly services	34
description of controls	12	at-halt service	30
disconnect controls	117, 151	before-operation service	27
road test	63	run-in test	48
Tie rod (front axle), removal and installation	185	Traction devices	78
Timing, ignition		Tractor truck	
cold-weather operation	19	cleaning	34, 41
improper timing	80	data	7
road test	64	description	5
set	158	lubrication	
Tire carrier		after-operation and weekly	34
installation	124	detailed instructions	41
removal	115	guide	35
Tires		run-in test	48
after-operation and weekly services	33	maintenance	
at-halt service	30	after-operation	31
before-operation service	27	at-halt	29
data	45, 219	before-operation	25
description, maintenance, and removal	219	during-operation	31
installation	220	first echelon	23
rail shipment	263	second echelon	51
road test	65	operation	14
run-in test	47	cold weather	16
storage or shipment	262	hot weather	21
trouble shooting	93, 94	mud, snow, sand, and flood	23
Toeboards		reports and publications	51
installation	124, 153	road test	54, 74
removal	114, 151, 206	run-in test (new vehicle)	46
Toe-in (wheels)		stopping	15
road test	75	tools and equipment	
test and adjustment	183, 184	organizational	79
Tool box, location of	5	run-in test	49
Tool sets	79	towing	15
Tools and equipment		trouble shooting	79
after-operation and weekly services	35	use of instruments and controls	12
before-operation service	27	Trailer connections	
run-in test	49	disconnect	119
second echelon maintenance	77	installation	124, 176
storage on vehicle	44	removal	174

4- TO 5-TON 4x4 TRACTOR TRUCK (FEDERAL)

T—Cont'd	Page		Page
Trailer light, description, removal, and installation of light connection .....	249	rear axle and service brake system .....	88
Transfer		springs and shock absorbers ...	93
after-operation service .....	33	starting and generating systems	84
at-halt service .....	30	steering gear .....	94
during-operation service .....	28	transmission and transfer case	86
road test .....	56, 57, 58, 72	wheels, hubs, and tires .....	93
run-in test .....	48, 50	Tubing (See Hoses and tubing)	
Transfer case		Tune-up, engine .....	101
capacities .....	8	Turntable (fifth wheel), lubrication notes .....	43
description and data			
shift lever .....	8	<b>U</b>	
transfer case .....	176	U-bolts, front axle, removal .....	185
disconnect shift rod .....	119, 174	Universal joints	
installation		lubrication notes .....	42
shift rod .....	123, 176	removal and installation ..	180, 183
transfer case .....	179	road test .....	58
removal .....	177	run-in test .....	48
run-in test .....	51	trouble shooting .....	87
trouble shooting .....	86		
Transmission		<b>V</b>	
at-halt service .....	30	Vacuum test (road test) .....	64
capacities .....	8	Valve, double check .....	201
description and data		Valve, foot control .....	197
gearshift lever .....	8	Valve, hand control	
transmission .....	173	description and data .....	198
during-operation service .....	28	removal and installation .....	199
installation .....	122, 175	Valve, quick release	
lubrication .....	16	description and data .....	200
position on bell housing .....	175	removal and installation .....	201
removal .....	119, 174, 175	Valve, relay	
road test .....	56, 57, 58, 72	data, installation, and removal	200
run-in test .....	50, 51	description .....	199
trouble shooting .....	86	Valve, safety	
Trouble shooting		data, installation, and removal	197
battery and lighting systems ...	95	description .....	195
body and frame .....	95	Valve, single check .....	202
clutch .....	81	Valve (See also regulator valves under Windshield wiper and Brake valve, hand)	
cooling system .....	83	Valve mechanism (road test) ...	58
engine .....	79	Valve tappet, adjustment .....	105
front axle and universal joints	87	Ventilator tube, intake manifold crankcase	
fuel system .....	82	connect .....	107, 108
ignition system .....	84	disconnect .....	105, 107
instruments .....	96		
intake and exhaust systems ...	82		
propeller shaft .....	87		
brake system .....	93		
radio noise suppression .....	98		

INDEX

<b>V-Cont'd</b>	<b>Page</b>	<b>Page</b>
<b>Ventilators</b>		lubrication of bearings . . . . . 43
installation, removal and main-		removal (steering wheels) . . . . . 225
tenance . . . . .	113	road test
road test . . . . .	76	bearings . . . . . 57, 58
<b>Vents, axle and transfer</b>		fifth wheel . . . . . 75
after-operation service . . . . .	33	front wheels . . . . . 70
at-halt service . . . . .	30	rear wheels . . . . . 68
run-in test . . . . .	48	trouble shooting . . . . . 93, 94
<b>Viscometer</b>		(See also Toe-in, wheels and
before-operation service . . . . .	26	Wheel and flange nuts)
during-operation service . . . . .	29	<b>Windshield wipers</b>
road test . . . . .	55	after-operation service . . . . . 31
run-in test . . . . .	49	before-operation service . . . . . 26
<b>Viscosity gage</b>		data, maintenance, and removal 227
connect tube . . . . .	123	description
description and data . . . . .	11, 255	regulator valves . . . . . 11
disconnect tube . . . . .	117	windshield wipers . . . . . 227
removal and installation . . . . .	256	installation . . . . . 228
trouble shooting . . . . .	98	road test
<b>Voltage regulator</b>		windshield . . . . . 76
data . . . . .	163	windshield wipers . . . . . 55
description and removal . . . . .	167	run-in test . . . . . 49
installation . . . . .	168	trouble shooting . . . . . 95
		<b>Wiring, electrical</b>
<b>W</b>		after-operation service . . . . . 32
<b>W.D. Form No. 48, use of . . . . .</b>	<b>24</b>	cold-weather operation . . . . . 19
<b>Water supply</b>		connect
after-operation service . . . . .	31	headlight wiring . . . . . 239
at-halt service . . . . .	29	to cranking motor switch . . . . . 172
run-in test . . . . .	47	to solenoid switch . . . . . 169
<b>Water trap (See Strainer and water</b>		wires . . . . . 160
<b>trap)</b>		wiring . . . . . 156
<b>Wheel and axle flange nuts</b>		data and maintenance . . . . . 162
after-operation service . . . . .	34	description . . . . . 161
at-halt service . . . . .	30	disconnect
before-operation service . . . . .	27	generator-to-regulator and
run-in test . . . . .	48	ground wires . . . . . 117
<b>Wheels</b>		to cranking motor switch . . . . . 172
description, data, and removal		to solenoid switch . . . . . 169
fifth wheel . . . . .	256	wires . . . . . 160
wheels . . . . .	215	wiring . . . . . 155
installation		position headlight wires . . . . . 239
fifth wheel . . . . .	256	road test . . . . . 63, 73
steering wheel . . . . .	225	run-in test . . . . . 47
wheels . . . . .	219	<b>Work sheet for wheeled and half-</b>
		<b>track vehicles . . . . . 53</b>

☆ U. S. GOVERNMENT PRINTING OFFICE ○—1947