

TECHNICAL MANUAL

OPERATOR'S, ORGANIZATIONAL, DIRECT  
SUPPORT, AND GENERAL SUPPORT  
MAINTENANCE MANUAL

FOR

**CHARGER, BATTERY PP-1659/G AND  
PP-1659A/G  
(NSN 6130-00-985-8185)**

This copy is a reprint which includes current  
pages from Change 1.

---

HEADQUARTERS, DEPARTMENT OF THE ARMY

28 FEBRUARY 1977

CHANGE

HEADQUARTERS  
DEPARTMENT OF THE ARMY  
Washington, DC, 15 June 1988

No. 1

OPERATOR'S, ORGANIZATIONAL, DIRECT SUPPORT  
AND GENERAL SUPPORT MAINTENANCE MANUAL

CHARGER, BATTERY  
PP-1659/G AND PP-1659A/G  
(NSN 6130-00-985-8185)

TM 11-5895-238-14, 28 February 1977, is changed as follows:

1. Remove old pages and insert new pages as indicated below. New or changed material is indicated by a vertical bar in the margin of the page. Added or revised illustrations are indicated by a vertical bar adjacent to the identification number.

| <i>Remove pages</i>                    | <i>Insert pages</i>        |
|--|----------------------------|
| Warning (inside front cover) . . . . . | A/(B blank)                |
| i and ii . . . . .                     | i and ii                   |
| 1-1 and 1-2 . . . . .                  | 1-1 through 1-3/(14 blank) |
| 2-1 through 2A . . . . .               | 2-1 through 2-4            |
| 4-1 through 4-4 . . . . .              | 4-1 through 4-4            |
| A-1 . . . . .                          | A-1/(A-2 blank)            |
| C-3 and CA . . . . .                   | C-3 and C-4                |

2. File this change sheet in the front of the publication for reference purposes.

**Distribution authorized to the Department of Defense and DOD contractors only for official use or for administration or operational purposes. This determination was made on 18 February 1988. Other requests for this document will be referred to Commander, US Army Communications-Electronics Command and Fort Monmouth, ATTN: ANSEL-IC-ME-P, Fort Monmouth, NJ 07703-5000.**

**DESTRUCTION NOTICE—Destroy by any method that will prevent disclosure of contents or reconstruction of the document.**

By Order of the Secretary of the Army:

CARL E. VUONO  
*General, United States Army*  
*Chief of Staff*

Official:

R.L. DILWORTH  
*Brigadier General, United States Army*  
*The Adjutant General*

DISTRIBUTION:

To be distributed in accordance with DA Form 12-36 literature requirements for PP-1659, -1659A.

**WARNING**

High voltages and currents exist in this equipment. Serious injury or death may result from contact with the output terminals. Reenergize the equipment before connecting or disconnecting the load to be powered and before performing any maintenance.

**DON'T TAKE CHANCES!**

**WARNING**

Do not attempt to lift this equipment alone as the total weight is 60 pounds. When lifting or handling heavy objects use two persons to prevent possible back injury.



Technical Manual }  
 No. 11-6130-238-14 }

HEADQUARTERS  
 DEPARTMENT OF THE ARMY  
 WASHINGTON, DC 28 February 1977

**OPERATOR'S, ORGANIZATIONAL, DIRECT SUPPORT, AND  
 GENERAL SUPPORT MAINTENANCE MANUAL  
 FOR  
 CHARGER, BATTERY  
 PP-1659/G AND PP-1659A/G  
 (NSN 6130-00-985-8185)**

REPORTING ERRORS AND RECOMMENDING IMPROVEMENTS

You can help improve this manual. If you find any mistakes or if you know of a way to improve the procedures, please let us know. Mail your letter, DA Form 2028 (Recommended Changes to Publications and Blank Forms), or DA Form 2028-2 located in back of this manual direct to Commander, US Army Communications-Electronics Command and Fort Monmouth, ATTN: AMSEL-LC-ME-PS, Fort Monmouth, NJ 07703-5000.

In either case, a reply will be furnished direct to you.

|         | Paragraph   | Page     |
|---------|---|----------|
| Chapter | 1. INTRODUCTION   |          |
| Section | I. General  |          |
|         | Scope . . . . .   | 1-1 1-1  |
|         | Consolidated index of Army publications and blank forms . . . . . | 1-2 1-1  |
|         | Maintenance forms, records, and reports . . . . .                 | 1-3 1-1  |
|         | Reporting equipment improvement recommendations (EIR) . . . . .   | 1-4 1-1  |
|         | Administrative storage . . . . .                                  | 1-5 1-1  |
|         | Destruction of Army electronics material . . . . .                | 1-6 1-1  |
|         | II. Description and data  |          |
|         | Purpose and use . . . . .   | 1-7 1-1  |
|         | Technical data . . . . .  | 1-8 1-1  |
|         | Description of equipment . . . . .                                | 1-9 1-2  |
|         | Differences between models . . . . .                              | 1-10 1-2 |
| Chapter | 2. OPERATION  |          |
| Section | I. Service upon receipt of equipment                              |          |
|         | Unpacking . . . . .   | 2-1 2-1  |
|         | Checking unpacked equipment . . . . .                             | 2-2 2-3  |
|         | II. Controls, indicator, and operating instruction                |          |
|         | operating controls and indicators . . . . .                       | 2-3 2-3  |
|         | Preliminary adjustments . . . . .                                 | 2-4 2-4  |
|         | opening procedure . . . . .                                       | 2-5 2-4  |
| Chapter | 3. OPERATOR AND ORGANIZATIONAL MAINTENANCE INSTRUCTIONS           |          |
|         | Scope of maintenance . . . . .                                    | 3-1 3-1  |
|         | Preventive maintenance . . . . .                                  | 3-2 3-1  |

\*This manual supersedes TM 11-6130-238-12, 1 February 1965, and so much of TM 11-6130-238-45, 6 October 1965, as pertains to general support maintenance.

|          |  |      |     |
|----------|--|------|-----|
|          | Preventive maintenance checks and services periods . . . . .   | 3-3  | 3-1 |
|          | Daily preventive maintenance checks and services chart . . . . .                                       | 3-4  | 3-1 |
|          | Weekly preventive maintenance checks and services chart . . . . .                                      | 3-5  | 3-2 |
|          | Monthly preventive maintenance checks and services chart . . . . .                                     | 3-6  | 3-2 |
|          | Quarterly preventive maintenance checks nad services chart . . . . .                                   | 3-7  | 3-2 |
|          | Cleaning . . . . .   | 3-8  | 3-2 |
|          | Touchup painting Instructions. . . . .   | 3-9  | 3-3 |
|          | General Troubleshooting Information . . . . .  | 3-10 | 3-3 |
|          | Troubleshooting chart . . . . .  | 3-11 | 3-3 |
|          | Replacement of indicator lamp. . . . .   | 3-12 | 3-3 |
| Chapter  | 4. FUNCTIONING OF EQUIPMENT  |      |     |
|          | Input control circuit . . . . .  | 4-1  | 4-1 |
|          | Voltage selection and rectification circuit . . . . .  | 4-2  | 4-1 |
|          | Output circuit . . . . .   | 4-3  | 4-4 |
| Section  | 5. GENERAL SUPPORT MAINTENANCE INSTRUCTIONS  |      |     |
|          | I. Troubleshooting   |      |     |
|          | General . . . . .  | 5-1  | 5-1 |
|          | Organizational of troubleshooting procedures . . . . .   | 5-2  | 5-1 |
|          | Test Equipment required . . . . .  | 5-3  | 5-1 |
|          | Localizing troubles. . . . .   | 5-4  | 5-1 |
|          | General parts replacement techniques. . . . .  | 5-5  | 5-2 |
|          | Additional troubleshooting data . . . . .  | 5-6  | 5-2 |
|          | II. Test Procedures  |      |     |
|          | General. . . . .   | 5-7  | 5-3 |
|          | Test Equipment and Tools . . . . .   | 5-8  | 5-3 |
|          | Physical tests and inspection . . . . .  | 5-9  | 5-4 |
|          | Input and output power tests . . . . .   | 5-10 | 5-6 |
|          | 230 vac operational test and insulation breakdown test . . . . .                                       | 5-11 | 5-7 |
|          | Test data summary . . . . .  | 5-12 | 5-8 |
| Appendix | A. REFERENCES . . . . .  |      | A-1 |
|          | B. BASIC ISSUE ITEMS LIST (BILL) AND ITEMS TROOP INSTALLED OR AUTHORIZED LIST (ITIAL) (Not applicable) |      |     |
| Section  | C. MAINTENANCE ALLOCATION  |      |     |
|          | I. Introduction . . . . .  | C-1  | C-1 |
|          | II. Maintenance allocation chart . . . . .   |      | C-3 |



*Figure 1-1. Charger, battery PP-1659/G AND PP-1659A/G.*

# CHAPTER 1

## INTRODUCTION

### Section I. GENERAL

#### 1-1. Scope

This manual describes Chargers, Battery PP-1659 and PP-1659A/G (fig. 1-1 and fig. 1-2) and provides instructions for installation, operation, as well as operator, organizational, and general support maintenance instructions. It includes instructions for cleaning and inspection of the equipment and replacement of parts available to operator and organizational repair personnel. It also includes instructions for troubleshooting, testing, and repairing the equipment, as well as tools, materials, and test equipment required for maintenance by general support.

#### 1-2. Consolidated Index of Army Publications and Blank Forms

Refer to the latest issue of DA Pam 25-30 to determine whether there are new editions, changes or additional publications pertaining to the equipment.

#### 1-3. Maintenance Forms, Records, and Reports

*a. Reports of Maintenance and Unsatisfactory Equipment.* Department of the Army forms and procedures used for equipment maintenance will be those prescribed by DA Pam 738-750, as contained in Maintenance Management Update.

*b. Report of Packaging and Handling Deficiencies.* Fill out and forward SF 364 (Report of Discrepancy (ROD)) as prescribed in AR 735-11-2/DLAR 4140.55/NAVMATINST 4355.73B/AFR 400-54/MCO 4430.3H.

*c. Discrepancy in Shipment Report (DISREP) (SF 361).* Fill out and forward Discrepancy in Shipment Report (DISREP) (SF 361) as prescribed in AR 55-38/NAVSUPINST 4610.33C/AFR 75-18/MCO P4610.19D/DLAR 4500.15.

#### 1-4. Reporting Equipment Improvement Recommendations (EIR)

If your equipment needs improvement, let us know. Send us an EIR. You, the user, are the only one who can tell us what you don't like about the design. Put it on an SF 368 (Quality Deficiency Report). Mail it to Commander, US Army Communications-Electronics Command and Fort Monmouth, ATTN: AMSEL-PA-MA-D, Fort Monmouth, New Jersey 07703-5000. We'll send you a reply.

#### 1-5. Administrative Storage

Administrative storage of equipment issued to and used by Army activities shall be in accordance with TM 740-90-1.

1-6. Destruction of Army Electronics Materiel  
Destruction of Army electronics materiel to prevent enemy use shall be in accordance with TM 750-244-2.

### Section II. DESCRIPTION AND DATA

#### 1-7. Purpose and Use

*a. Purpose.* Charger, Battery PP-1659/G and PP-1659A/G (battery charger) converts 115-or 230-volt alternating current (at) to unregulated direct current (dc) at a selected voltage.

*b. Use.* The battery charger is used to charge storage batteries.

#### 1-8. Technical Data

Power Input:  
Voltage..... 115 or 230 volts ac, 50 to 60 Hz.  
Phase..... Single.  
Maximum current..... 30 amperes (full load, 115 volts ac) or 15 amperes (full load, 230 volts ac) for PP-1659/G.

25 amperes (full load, 115 volts ac) or 12.5 amperes (full load, 230 volts ac) for PP-1659A /G.  
Power consumption..... 2,875 watts for PP-1659/G.  
2,890 watts for PP-1659A/G.  
Power Output:  
voltage..... Variable to 135 volts dc.  
Maximum current..... 12 amperes for PP-1659/G.  
15 amperes for PP-1659A/G.  
Weight..... 44 lb for PP-1659/G.  
60 lb for PP-1659A/G.  
Ambient operating temperature range..... 40° F (-40° C) to +130° F (54.5° C) for PP-1659/G.  
-40° F (-40° C) to +150° F (66° C) for PP-1659A/G.



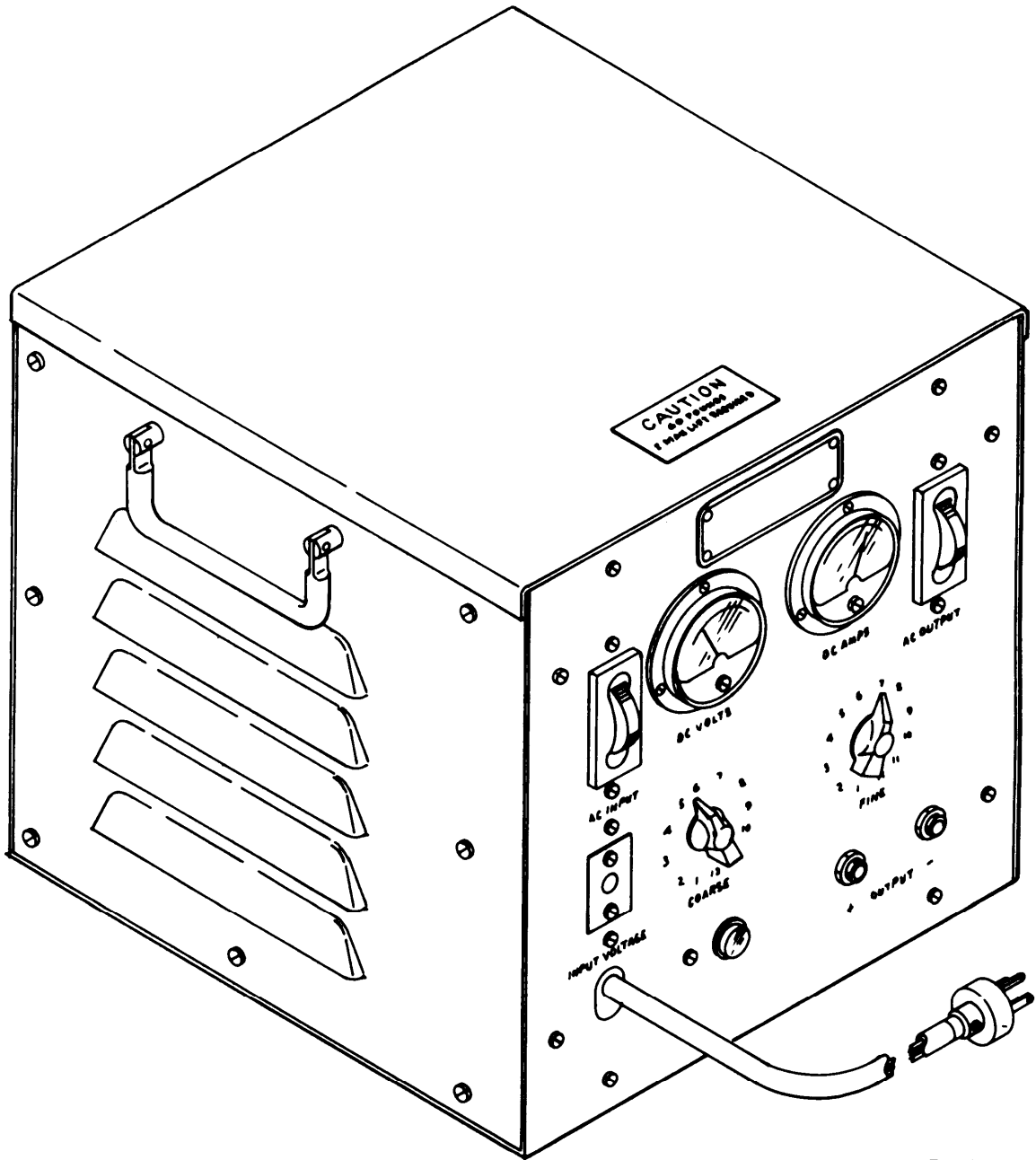

EL2ZZ001A

Figure 1-2. Charger, battery PP-1659A/G.

### 1-9. Description of Equipment (fig. 1-1 and fig. 1-2)

*a.* Chargers, Battery PP-1659/G and PP-1659A/G are each self-contained units in a metal cabinet. The PP-1659/G is 10-7/8 inches high, 10-3/4 inches wide, and 10-7/8 inches deep. The PP-1659A/G is 12 inches high, 11-3/16 inches wide, and 11-1 5/16 inches deep, and contains carrying handles on each side.

*b.* Operating controls and indicators are mounted on the front panel. Louvers are provided

for venting the equipment. The ac input cable (8 feet long on the PP-1659/G, 10 feet long on the PP-1659A/G) is terminated with a heavy duty plug connector. The battery charger includes one spare indicator lamp and technical manuals.

### 1-10. Differences between Models

The external appearance of the PP-1659/G and PP-1659A/G are the same; however, the PP-1659A/G is substantially different from the PP-1659/G in physical (para 1-9) and electronic parts. Parts listings are provided in TM 11-6130-238-24P.

## CHAPTER 2 OPERATION

### Section I. SERVICE UPON RECEIPT OF EQUIPMENT

#### 2-1. Unpacking

##### a. PP-1659/G.

(1) *Packaging data.* When packed for shipment, Charger, Battery PP-1659/G is placed in a carton and packed in a 14- by 13- by 14- inch wooden packing case. A typical wooden packing case and its contents are shown in figure 2-1. The volume is 1.5 cubic feet and the total weight is 54 pounds.

(2) *Removing contents.*

(a) Cut and fold back the metal straps.

**CAUTION**

Do not attempt to pry off the top and side. This may result in equipment damage.

(6) Remove the nails from the top and one side of the box with a nailpuller. Remove the top and side.

(3) Slide the outer corrugated carton out of the wooden packing case.

(4) Remove the envelope that contains the technical manuals.

(5) Remove the outer corrugated carton that is wrapped in the moisture-vaporproof barrier.

(6) Remove the inner corrugated carton that is wrapped in a moisture-vaporproof barrier.

(7) Open the inner corrugated carton.

(8) Remove the equipment.

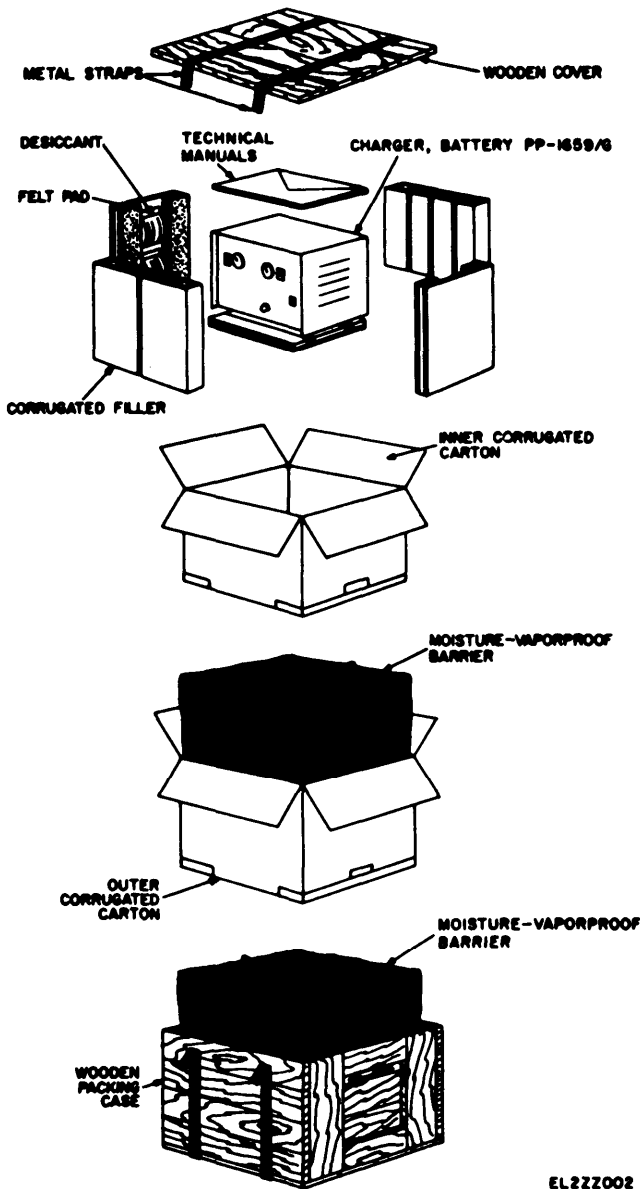

Figure 2-1. Charger, battery PP-1659/G packaging.

EL22Z002

b. PP-1659A/G.

**WARNING**

Do not attempt to lift this equipment alone as the total weight is 60 pounds. When lifting or handling heavy objects use two persons to prevent possible back injury.

(1) *Packing data.* When packed for shipment, Charger, Battery PP-1659A/G is placed in a 14-by-13-1/4 by-12-3/4-inch weatherproof corrugated carton. A typical packing case and its contents is shown in figure 2-2. The volume is 1.4 cubic feet and the total weight is 60 pounds.

(2) *Removing contents.*

(a) Very carefully cut the tape on the top of the carton.

(b) Open the top of the carton and remove the envelope containing the technical manual.

(c) Remove the top corrugated filler and microfoam.

(d) Remove the equipment.

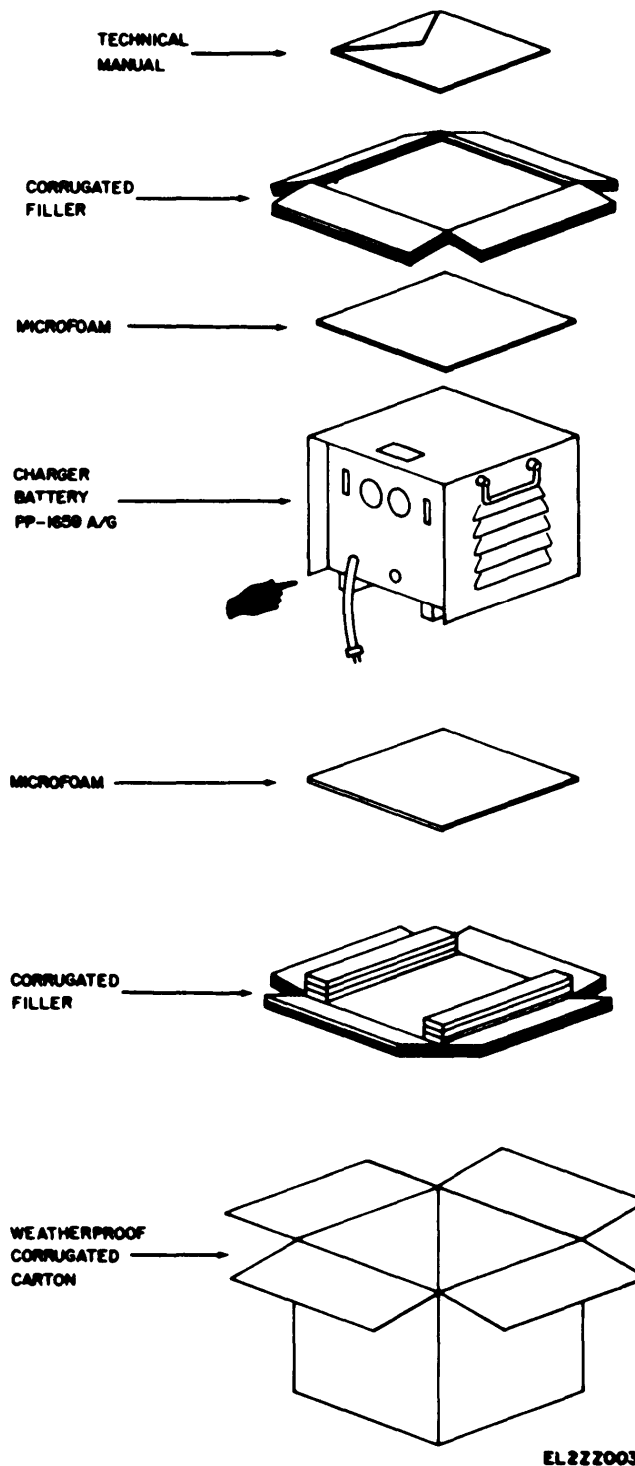

EL222003

Figure 2-2. Charger, battery PP-1659A /G packaging.

**2-2. Checking Unpacked Equipment**

a. Inspect the equipment for damage incurred during shipment. If the equipment has been damaged, report the damage on SF 364 (para 1-3).

b. Check the equipment against the component listing in the operator's manual and the packing slip to see if the shipment is complete. Report all discrepancies in accordance with paragraph 1-3. The equipment should be placed in service even though a minor

assembly or part that does not affect proper functioning is missing.

c. Check to see whether the equipment has been modified. (Equipment which has been modified will have the MWO number on the front panel, near the nomenclature plate.) Check also to see whether all currently applicable MWO's have been applied. (Current MWO's applicable to the equipment are listed in DA Pam 25-30.)

**Section II. CONTROLS, INDICATORS, AND OPERATING INSTRUCTIONS**

**2-3. operating Controls and Indicators (fig. 2-3)**

| Controls, Indicator, or Terminal  | Function                               | Action  |
|---|--|---|
| INPUT VOLTAGE switch (two-position toggle behind red plate) .<br>AC INPUT switch and circuit breaker (two-position toggle). | Switch pos 230V (down) 115V (up)<br>up | Connects battery charger for 230 volts ac input.<br>Connects battery charger for 115 volts l c input.<br>Connects ac input to battery charger. (Circuit breaker is connected internally to switch; shuts battery charger off automatically when input current is excessive. )   |
| DC OUTPUT switch and circuit breaker (two-position toggle).   | Down<br>up                             | Disconnects ac input to battery charger.<br>Connects battery charger dc output to + and - OUTPUT terminals.   |
| COARSE and FINE switches (12-position rotaries).<br>Indicator lamp<br>DC VOLTS meter  | Down<br>1-12                           | Disconnects dc output.<br>Adjust the dc output voltage in twelve increments to 135 volts.<br>Illuminates when the battery charger is on.<br>Indicates battery charger dc output voltage. (When storage battery is connected to the + and - OUTPUT terminals and the battery charger is not energized, will indicate the voltage of the storage battery. ) |
| DC AMPS meter<br>+OUTPUT terminal<br><br>-OUTPUT terminal   |  | Indicates battery charger dc output current.<br>Provides positive dc terminal connection between battery charger and storage battery being charged.<br>Provides negative dc terminal connection between battery charger and storage battery being charged.  |

**CAUTION**

The power input line electrical connections must be made by authorized installation personnel and should be protected with a 30-ampere fuse for 115-volt ac input or

with a 15-ampere fuse for 230-volt ac input. These connections should be controlled by an external switch for convenient removal of power from the battery charger during maintenance.

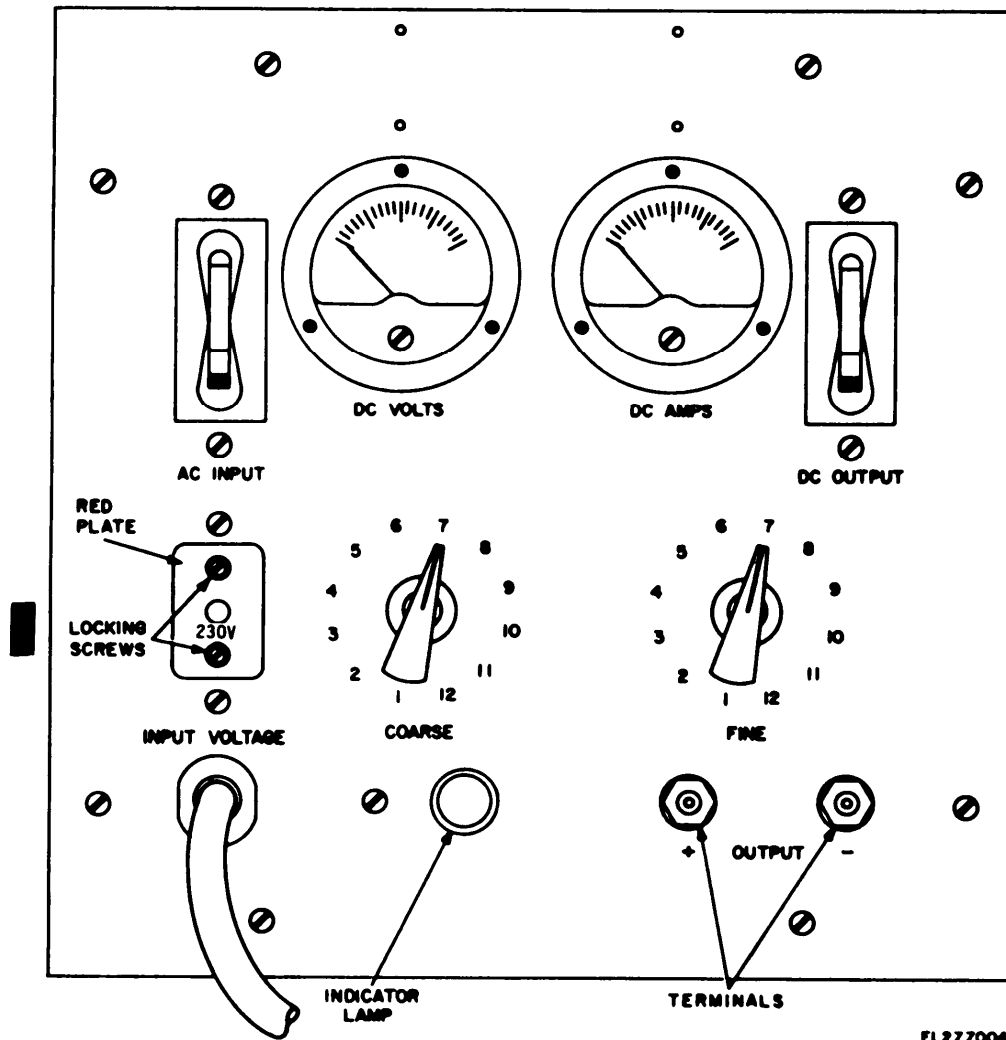

EL22Z004

Figure 2-3. Charger, battery PP-1659/G and PP-1659A/G controls and indicators.

#### 2-4. Preliminary Adjustments

a. Remove the red plate (fig. 2-3) that locks the INPUT VOLTAGE switch in either the up or down position by removing the two locking screws.

b. Set the INPUT VOLTAGE switch in the up position for 115 volts ac input power or in the down position for 230 volts ac input power.

c. The opening in the center of the red plate will lock the INPUT VOLTAGE switch in the up or down position as required by using one side of the red plate for the up position or the other side of the red plate for the down position. The visible side of the red plate when used to lock the INPUT VOLTAGE switch in the up position is marked 115V and the visible side of the red plate when used to lock the INPUT VOLTAGE switch in the down position is marked 230V.

d. Secure the red plate to the battery charger using the two locking screws.

#### 2-5. Operating Procedure

##### CAUTION

Before operating the equipment, be sure the INPUT VOLTAGE switch is set to the correct ac input voltage Position (para 2-4). Failure to set the INPUT VOLTAGE switch to the appropriate voltage setting may result in equipment damage when power is applied.

a. Set the AC INPUT and DC INPUT switches to the down (off) position.

b. Set the COARSE and FINE switches to 1.

c. Connect the negative terminal of the storage battery to be charged to the - OUTPUT terminal of the battery charger.

d. Connect the positive terminal of the storage battery to be charged to the + OUTPUT terminal of the battery charger.

*e.* Connect the battery charger power cable to the ac voltage input source.

*f.* Set the AC INPUT and DC INPUT switches to the up (on) position.

*g.* Adjust the COARSE and FINE switches as required to obtain the prescribed battery charging current rate (for the storage battery under charge), as indicated on the DC AMPS meter.

*h.* Periodically observe that the charging current is correct.

*i.* After the storage battery has been fully charged, set the AC INPUT and DC INPUT switches to the down (off) position; disconnect the storage battery from the battery charger.

## CHAPTER 3

# OPERATOR AND ORGANIZATIONAL MAINTENANCE INSTRUCTIONS

### 3-1. Scope of Maintenance

The maintenance duties assigned to operator and organizational repair personnel of the equipment are listed below together with a reference to the paragraphs covering the specific maintenance functions.

- a. Daily preventive maintenance checks and services (para 3-4).
- b. Weekly preventive maintenance checks and services (para 3-5).
- c. Monthly preventive maintenance checks and services (para 3-6).
- d. Quarterly preventive maintenance checks and services (para 3-7).
- e. Cleaning (para 3-8).
- f. Touchup painting (para 3-9).
- g. Troubleshooting (para 3-10 and 3-11).
- h. Replacement of indicator lamp (para 3-12).

### 3-2. Preventive Maintenance

Preventive maintenance is the systematic care, servicing, and inspection of equipment to prevent the occurrence of trouble, to reduce downtime, and to assure that the equipment is serviceable.

a. *Systematic Care.* The procedures given in paragraphs 3-4 through 3-8 cover routine systematic care and cleaning essential to proper upkeep and operation of the equipment.

b. *Preventive Maintenance Checks and Services.* The preventive maintenance checks and services

charts (para 3-4 through 3-7) outline functions to be performed at specific intervals. These checks and services are to maintain Army electronic equipment in a constant serviceable condition; that is, in good general (physical) condition and in good operating condition. To assist operators in maintaining combat serviceability, the chart indicates what to check, how to check, and the normal indicators. The References column lists the paragraphs or manuals that contain detailed repair or replacement procedures. If the defect cannot be remedied by performing the corrective actions listed, higher category of maintenance or repair is required. Records and reports of these checks and services must be made in accordance with the requirements set forth in TM 38-750.

### 3-3. Preventive Maintenance Checks and Service Periods

Preventive maintenance checks and services of the equipment are required daily, weekly, monthly, and quarterly.

a. Paragraph 3-4 specifies checks and services that must be accomplished daily (or at least once each week if the equipment is maintained in standby condition).

b. Paragraphs 3-5, 3-6, and 3-7 specify additional checks and services that must be performed on a weekly, monthly, and quarterly basis, respectively.

### 3-4. Daily Preventive Maintenance Checks and services Chart

| Step No. | Item                            | Procedure  | Reference |
|----------|---------------------------------|--|-----------|
| 1        | Completeness                    | See that the equipment is complete.  |           |
| 2        | Exterior surfaces               | Clean the exterior surfaces, including the panel and meter glasses (para 3-8). Check all meter glasses and indicator lenses for cracks.  |           |
| 3        | Connectors                      | Check the tightness of all connectors.   |           |
| 4        | Controls and indicators         | While making the operating checks (items 5 through 10), observe that the mechanical action of each knob and switch is smooth and free of external or internal binding, and that there is no excessive looseness. Also, check the meters for sticking or bent pointers. |           |
| 5        | INPUT VOLTAGE switch            | See that the INPUT VOLTAGE switch is up for 115 vac input power or down for 230 vac input power.   | Para 2-4  |
| 6        | Storage battery                 | Connect the storage battery to the OUTPUT terminals  | Para 2-5  |
| 7        | COARSE and FINE switches        | Set both switch to 1.  |           |
| 8        | AC INPUT and DC OUTPUT switches | Set both switches to up (on). Note that the indicator lamp glows.  |           |



**3-4. Daily Preventive Maintenance Checks and Services Chart-Continued**

| Step No. | Item                            | Procedure   | Reference |
|----------|---------------------------------|---|-----------|
| 9        | COARSE and FINE switches        | Adjust as necessary (pare 2-6).<br>Note that voltage and current readings on DC VOLTS meter and DC AMPS meter increase at each step and indicate voltage and current, respectively. |           |
| 10       | AC INPUT and DC OUTPUT switches | Set both switches to down (off). Note that indicator lamp gas out.  |           |

**3-5. Weekly Preventive Maintenance Checks and services Chart**

| Step No. | Item           | Procedures   | Reference |
|----------|----------------|--|-----------|
| 1        | Cable          | Inspect cable for chafed, crocked, or frayed insulation. Replace connector that is broken. arced, stripped, or worn excessively. | Para 3-9  |
| 2        | Metal surfaces | Inspect exposed metal surfaces for rust and corrosion. Clean and touchup paint as required.                                      |           |

**3-6. Monthly Preventive Maintenance Checks and Services Chart**

| Step No. | Item                   | Procedure   | Reference |
|----------|------------------------|---|-----------|
| 1        | Transformer terminals  | Inspect terminals on power transformer. All nuts must be tight. There should be no evidence of dirt or corrosion. |           |
| 2        | Terminal blocks        | Inspect terminal blocks for loose connections and cracked or broken insulation.                                   |           |
| 3        | Gaskets and insulators | Inspect gaskets, insulators, bushings, and sleeves for cracks, chipping, and excessive wear.                      |           |
| 4        | Interior               | Clean interior of chassis and cabinet.  |           |

**3-7. Quarterly Preventive Maintenance Checks and Services Chart**

| Step No. | Item          | Procedure   | Reference                  |
|----------|---------------|---|----------------------------|
| 1        | Publications  | See that all publications are complete, serviceable, and current.   | DA Pam 310-4               |
| 2        | Modifications | Check DA Pam 310-7 to determine if new applicable MWO's have been publishd. ALL URGENT MWO's must be applied immediately. ALL NORMAL MWO's must be scheduled. | TM 38-750 and DA Pam 910-7 |
| 3        | spare parts   | Check spare part for general condition and method of storage. No overstock should be evident and all shortages must be on valid requisitions.                 | TM 11 -6130-238-24P        |

**3-8. Cleaning**

Inspect the exterior of the equipment. The exterior surfaces should be free of dust, dirt, grease, and fungus

a. Remove dust and loose dirt with a clean soft cloth.

**WARNING**

The fumes of trichloroethane are toxic.

Provide thorough ventilation whenever used. **DO NOT USE NEAR AN OPEN FLAME.** Tnchloroethane is not flammable, but exposure of the fumes to an open frame or hot metal surface forma highly toxic phosgene gas.

b. Remove grease, fungus, and ground-in dirt

from the case; use a cloth dampened (not wet) with trichloroethane.

c. Remove dust or dirt from OUTPUT terminals with a brush.

**CAUTION**

Do not press on the meter face (glass) when cleaning; the meters may become damaged.

d. Clean the front panel, meters, and control knobs; use a soft cloth. If necessary, dampen the cloth with water; mild soap may be used for more effective cleaning.

**3-9. Touchup Painting Instructions**

Remove rust and corrosion from metal surfaces by lightly sanding them with fine sandpaper. Brush two thin coats of paint on the bare metal to protect it from further corrosion. Refer to applicable cleaning and refinishing practices specified

in TB 43-0118. Refer to SB 11-573 for supplies available for field painting and preservation.

**3-10. General Troubleshooting Information**

Troubleshooting the battery charger is based upon the operational check contained in the daily preventive maintenance checks and services chart (para 3-4). To troubleshoot the battery charger perform all functions starting with item No. 5 in the daily preventive maintenance checks and services chart (para 3-4) and proceed through the items until an abnormal indication or result is observed; note the item number and turn to the corresponding item number in the troubleshooting chart (para 3-11). If the corrective measures indicated do not result in correction of the trouble, higher category maintenance is required.

**3-11. Troubleshooting Chart**

| Step No. | Trouble symptom  | Probable cause   | Checks and corrective measure  |
|----------|--|--|--|
| 1        | Indicator lamp does not light  | Defective indicator lamp   | Replace indicator lamp (para 3-12).  |
| 2        | a. DC VOLTS meter indication does not vary in accordance with changed settings of COARSE and FINE switches.<br>b. DC AMPS meter indicates zero at all times. | a. DC VOLTS meter is defective or COARSE or FINE switch is shorted<br><br>b DC AMPS meter is defective | a. Higher category maintenance is required.<br><br>b. Higher category maintenance is required. |
| 3        | With AC INPUT switch down (off), DC VOLTS meter or DC AMPS meter does not indicate zero, and indicator lamp does not extinguish                              | Short circuit across AC INPUT switch.  | Higher category maintenance is required.   |

**3-12. Replacement of Indicator Lamp**

a. Turn the glass indicator lamp jewel (fig. 2-3) counterclockwise and pull it out to expose the defective lamp.

b. Press in on the indicator lamp and turn it counterclockwise to unlock it.

c. Pull the defective indicator lamp out and replace it with a new one. Push the indicator lamp in and twist it clockwise to lock it.

## CHAPTER 4

FUNCTIONING OF EQUIPMENT

---

**4-1. Input Control Circuit (fig. 4-1 and 4-2)**

The input control circuit consists of power plug P1, AC INPUT switch and circuit breaker CB1, indicator lamp DS1, INPUT VOLTAGE switch S1, and the primary winding of power transformer T1. INPUT VOLTAGE switch S1 has a red safety plate which must be removed from the front panel in order to position the switch to 115 or 230. For 115-volt alternating-current (ac) input power switch S1 is placed in the 115 position (up), and the two primary windings of T1 (1-2 and 3-4) are connected in parallel across the power input terminals of P1. For 230-volt ac input power, switch S1 is placed in the 230 position (down), and the two primary windings of T1 (1-2 and 3-4) are connected in series across the power input terminals of P1. Indicator lamp DS1 lights to indicate the presence of the ac input voltage when the AC

INPUT switch and circuit breaker CB1 is set to the up position (on). AC INPUT switch and circuit breaker CB1 also provides protection for short circuits and overloads.

**4-2. Voltage Selection and Rectification Circuit (fig. 4-1 and 4-2)**

*a.* The two secondary windings of power transformer T1 (terminals 1 through 12 in series with terminals 13 through 24) are connected to two 12-position rotary switches (S2 and S3). COARSE switch S3 connects to the taps of terminals 1 through 12 of T1, and FINE switch S2 connects to the taps of terminals 13 through 24 of T1. The magnitude of the ac voltage applied to the bridge rectifier consisting of CR1 through CR4 is controlled by the setting of switches S2 and S3.

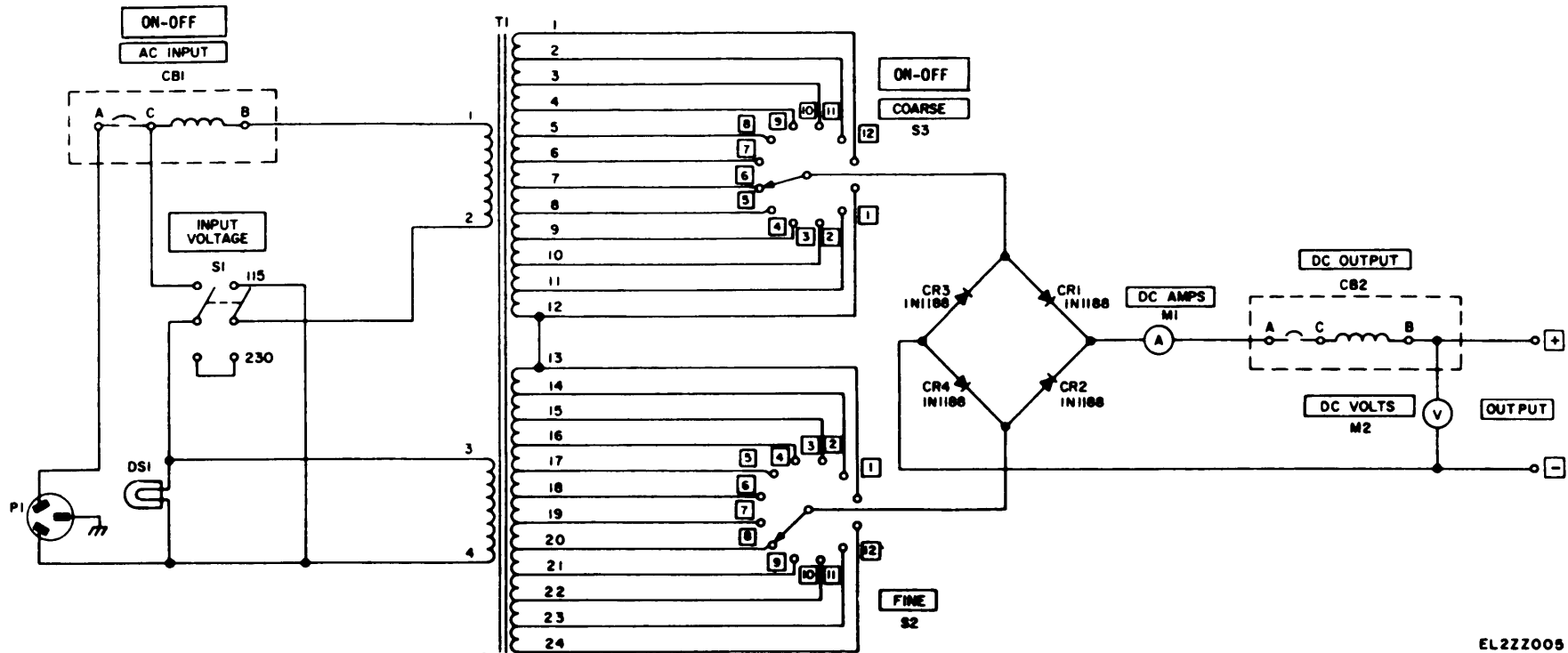
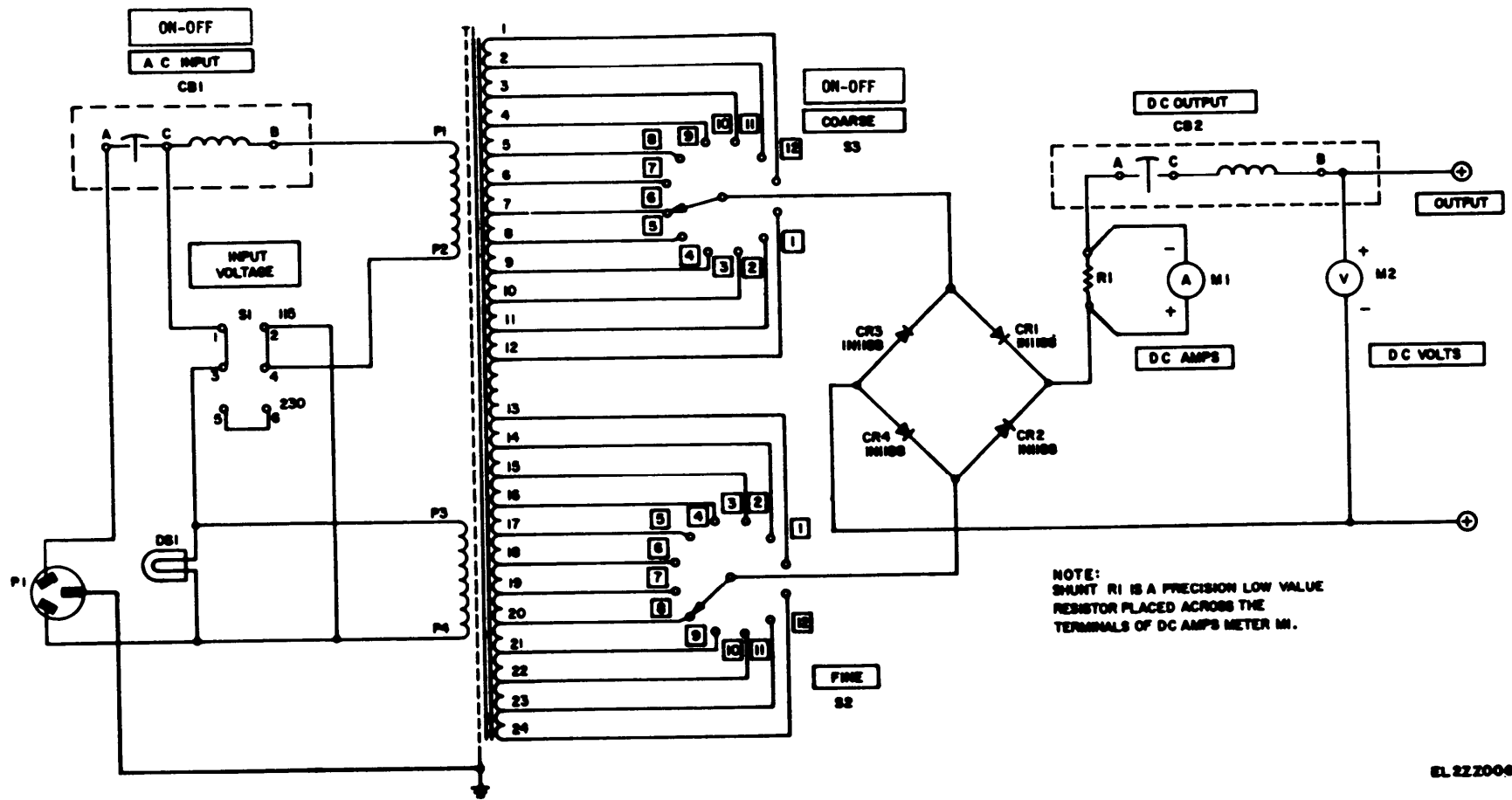

Figure 4-1. Charger, battery PP-1659/G schematic diagram.

EL222005



NOTE:  
SHUNT R1 IS A PRECISION LOW VALUE  
RESISTOR PLACED ACROSS THE  
TERMINALS OF DC AMPS METER M1.

EL 222004

Figure 4-2 Battery PP-1659A/G schematic diagram.

b. The minimum output voltage is obtained with switches S2 and S3 set to position 1. When switches S2 and S3 are advanced from positions 1 through 12, the battery charger output voltage varies accordingly and the maximum output voltage is obtained at position 12. Bridge rectifier CR1 through CR4 provides full-wave rectification of the ac voltage across the secondary of power transformer T1. The direct current (dc) output voltage from the bridge rectifier is connected to the - OUTPUT terminal (taken from the junction of CR3 and CR4) and the + OUTPUT terminal (Taken from the junction of CR1 and CR2 in series with DC AMPS meter M1 and DC OUTPUT switch and circuit breaker CB2).

#### 4-3. Output Circuit

The output circuit of Charger, Battery PP-1659/G (fig. 4-1) consists of DC AMPS meter M1, DC

VOLTS meter M2 and DC OUTPUT switch (circuit breaker CB2). The output circuit of Charger, Battery PP-1659A/G (fig. 4-2) consists of DC AMPS meter M1 in parallel with shunt R1, DC VOLTS meter M2 and DC OUTPUT switch (circuit breaker CB2). With a storage battery connected to the — and + OUTPUT terminals and CB1 and CB2 set to the up position (on), direct current flows from the junction of CR3 and CR4, through the storage battery, CB2, and M1 (on pp-1659/G) or M1 and R1 (on PP-1659A/G to the junction of CR1 and CR2. Shunt R1 is a precision low-value resistor placed across the terminals of DC AMPS meter M1. DC AMPS meter M 1 indicates the storage battery charging current. DC VOLTS meter M2 indicates the charging voltage.

## CHAPTER 5

# GENERAL SUPPORT MAINTENANCE INSTRUCTIONS

---

### Section I. TROUBLESHOOTING

#### WARNING

When servicing the battery charger, be extremely careful of the high voltages.

#### 5-1. General

Troubleshooting at general support includes all the techniques outlined for operator's and organizational maintenance and any special or additional techniques required to isolate a defective part.

#### 5-2. Organization of Troubleshooting Procedures

*a. General.* The first step in servicing a defective battery charger is to localize the fault, which means tracing the fault to a defective circuit responsible for the abnormal indication. The second step is to isolate the fault, which means locating the defective part or parts. Some defective parts, such as shorted transformers, can often be located by sight, smell, and hearing. Most defective parts; however, must be isolated by checking voltages and resistance.

*b. Localization and Isolation.* The first step in tracing trouble is to locate the circuit or part at fault by the following methods.

(1) *Visual inspection.* The purpose of visual inspection is to locate faults without testing or measuring the circuits. All meter indications or other visual signs should be observed and an attempt made to localize the fault to a particular part.

(2) *Operational tests.* Operational tests frequently indicate the general location of trouble. In many instances, the test will help in determining the exact nature of the fault. The daily maintenance service and inspection chart (para 3-4) contains a good operational test.

(3) *Troubleshooting chart.* The troubleshooting chart (para 5-4d) lists symptoms of common troubles and gives (or references) the corrective measures. Such a chart obviously cannot include all trouble symptoms that may occur. The repair technician should use this chart as a guide in analyzing symptoms that may not be listed.

#### 5-3. Test Equipment Required

The test equipment required for troubleshooting the battery charger is Multimeter AN/USM-223 /U. Multimeter AN/USM-223/U is used for continuity tests and dc voltage measurements.

#### 5-4. Localizing Troubles

*a. General.* In the troubleshooting chart (d below), procedures are outlined for localizing troubles and for isolating troubles within the various circuits of the battery charger. Refer to figure 5-1 for the parts locations. Refer to the schematic diagram (fig. 4-1 and 4-2) to identify the circuit components.

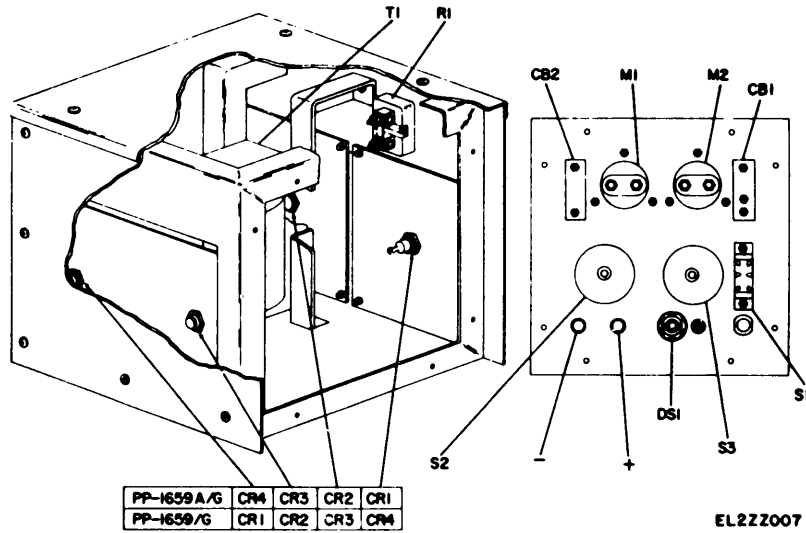

Figure 5-1. Charger, battery PP-1659/G and PP-1659A/G parts location diagram.

b. *Use of Chart.* When an abnormal symptom has been observed in the equipment, look for a description of this symptom in the Symptom column and perform the corrective measure shown in the Corrective Measures column. If no operational symptoms are known, begin with item 5 of the daily preventive maintenance checks and

services chart (para 3-5) and proceed until a trouble symptom appears.

c. *Conditions to Tests.* All checks outlined in the troubleshooting chart are to be conducted with the battery charger connected to a power source (no load connected to OUTPUT terminals).

d. *Troubleshooting Chart.*

| Symptom  | Probable trouble   | Corrective measures  |
|--|--|--|
| 1. Indicator lamp DS1 does not light when AC INPUT switch and circuit breaker CB1 is on (up).                                    | No ac power applied to battery charger.<br>Defective CB1.        | Check for input voltage.<br>Check CB1; replace if defective.                               |
| 2. Indicator lamp DS1 illuminates but no output voltage is present regardless of position of COARSE (S3) and FINE (S2) switches. | Open in output circuit.<br>Defective power transformer T1.       | Check for loose connection broken lead, or faulty component. Replace power transformer T1. |
| 3. Output voltage does not change when COARSE (S3) and FINE (S2) switches are turned from position 1 to position 12.             | Defective switch S3 or S2.<br>Defective power transformer T1.    | Replace defective switch.<br>Replace power transformer T1.                                 |
| 4. Low output voltage.   | Defective rectifier CR1, CR2, CR3, or CR4.                       | Replace defective rectifier.   |
| 5. Indication on DC VOLTS meter M2 differs from voltage present at OUTPUT terminals.   | Defective DC VOLTS meter M2.                                     | Replace DC VOLTS meter M2.   |
| 6. Indication on DC AMPS meter M1 differs from current present at OUTPUT terminals.  | Defective DC AMPS meter M1.<br>Defective Shunt R1 on PP-1659A/G. | Replace DC AMPS meter M1.<br>Replace Shunt R1.   |

**5-5. General Parts Replacement Techniques**

The battery charger parts can be reached and replaced easily without special procedures. Refer to figure 5-1 for the locations of parts. When soldering connections to the diodes (CR1, CR2, CR3, and CR4), solder quickly; use a heat sink (such as long-nosed pliers) between the soldered joint and the diode.

**5-6. Additional Troubleshooting Data**

a. *Voltage Outputs.* The voltage output data of the battery charger (no load applied) is provided in tables 5-1 and 5-2 below as an aid to troubleshooting.



Table 5-1. PP-1659/G

| Coarse switch<br>S3 setting | Fine switch<br>S2 setting | Dc voltage<br>indications |
|-----------------------------|---------------------------|---------------------------|
| 2                           | 1                         | 11.5 ±1                   |
| 2                           | 1                         | 23 ±2                     |
| 4                           | 1                         | 34.5 ±3                   |
| 5                           | 1                         | 46 ±4                     |
| 6                           | 1                         | 57.5 ±5                   |
| 7                           | 1                         | 69 ±6                     |
| 8                           | 1                         | 80.5 ±7                   |
| 9                           | 1                         | 92 ±8                     |
| 10                          | 1                         | 103.5 ±9                  |
| 11                          | 1                         | 115 ±10                   |
| 12                          | 1                         | 126.5 ±11                 |
| 1                           | 2                         | 1 ±0.2                    |
| 1                           | 3                         | 2 ±0.4                    |
| 1                           | 4                         | 3 ±0.6                    |
| 1                           | 5                         | 4 ±0.8                    |
| 1                           | 6                         | 5 ±1                      |
| 1                           | 7                         | 6 ±1.2                    |
| 1                           | 8                         | 7 ±1.4                    |
| 1                           | 9                         | 8 ±1.6                    |
| 1                           | 10                        | 9 ±1.8                    |
| 1                           | 11                        | 10 ±2                     |
| 1                           | 12                        | 11 ±2.2                   |

Table 5-2. PP-1659A/G

| Coarse switch<br>S3 setting | Fine switch<br>S2 setting | Dc voltage<br>indications |
|-----------------------------|---------------------------|---------------------------|
| 1                           | 1                         | .7 ±.2                    |
| 2                           | 1                         | 11.5 ±1                   |
| 3                           | 1                         | 23 ±2                     |
| 4                           | 1                         | 34.5 ±3                   |
| 5                           | 1                         | 46 ±4                     |
| 6                           | 1                         | 57.5 ±5                   |
| 7                           | 1                         | 69 ±6                     |
| 8                           | 1                         | 80.5 ±7                   |
| 9                           | 1                         | 92 ±8                     |
| 10                          | 1                         | 103.5 ±9                  |
| 11                          | 1                         | 115 ±10                   |
| 12                          | 1                         | 126.5 ±11                 |
| 1                           | 2                         | 1.5 ±.4                   |
| 1                           | 3                         | 2.5 ±.6                   |

Table 5-2. PP-1659/G -Continued

| Coarse switch<br>S3 setting | Fine switch<br>S2 setting | Dc voltage<br>indications |
|-----------------------------|---------------------------|---------------------------|
| 1                           | 4                         | 3.5 ±.8                   |
| 1                           | 5                         | 4.5 ±1.0                  |
| 1                           | 6                         | 5.5 ±1.2                  |
| 1                           | 7                         | 6.5 ±1.4                  |
| 1                           | 8                         | 7.5 ±1.6                  |
| 1                           | 9                         | 8.5 ±1.8                  |
| 1                           | 10                        | 9.5 ±2.0                  |
| 1                           | 11                        | 1.05 ±2.2                 |
| 1                           | 12                        | 11.5 ±2.4                 |

b. Dc Resistances of Transformer T1. The dc resistance data ((3) below) are provided as an aid to troubleshooting. When using the data, observe the following

**CAUTION**

Do not measure resistance of the windings when input power is applied to the battery charger and when the AC INPUT switch and circuit breaker is on (up). Disconnect the input power plug and place the AC INPUT switch and circuit breaker off (down).

(1) Before making resistance measurements of the windings, determine that faulty operations is probably caused by a faulty transformer. To do this, follow the troubleshooting procedures as outlined in paragraph 5-4 d.

(2) Do not use the resistance measurements as the sole basis for discarding a transformer as defective. The values given in (3) below are typical average values.

(3) The dc resistances of transformer T1 are less than 1 ohm between the windings of the primary (fig. 4-1 and 4-2), and less than 1 ohm between the windings of the secondary.

**Section II. TEST PROCEDURES**

**5-7. General**

a. Testing procedures are prepared for use by maintenance shops and service organizations responsible for general support maintenance of electronic equipment to determine the acceptability of repaired equipment. These procedures set forth specific requirements that repaired equipment must meet before it is returned to the using organization. A summary of the performance standards is given in paragraph 5-12.

b. Comply with the instructions preceding each

chart before proceeding to the chart. Perform each step in sequence. Do not vary the sequence. For each step, perform all the actions required in the Control settings columns; then perform each specific test procedure and verify it against its performance standard.

**5-8. Test Equipment and Tools**

All test equipment and tools required to perform the testing procedures given in this chapter are listed in a and b below.

*a. Test Equipment.*

| Nomenclature                           | NSN              | Technical Manual  |
|--|------------------|-------------------|
| Multimeter AN/USM-33                   | 6625-00-648-9172 | TM 11-6625-314-15 |
| Multimeter AN/USM-223/U (Rs TS-352B/U) | 6625-00-999-7465 | TM 11-6625-654-14 |
| Multimeter ME-26D/U                    | 6626-00-913-9781 | None              |
| Multimeter ME-452AJ                    | 6625-00-519-2493 | None              |
| Ohmmeter ZM-21A/U                      | 6625-00-581-2466 | TM 11-2050        |
| Transformer, Variable TF-171/USM       | 5950-00-503-0632 | None              |
| Dummy Load, Electrical DA-638/U        | 6625-00-422-2111 | None              |

*b. Tools.* All the tools required are included in Tool Kit, Electronic Equipment TK-105/G.

*b. Test Connections and Conditions.* No connections necessary.

5-9. Physical Tests and Inspections

*c. Procedures.*

*a. Test Equipment and Materials.* None required.

| Step no. | Control settings |                                  | Test procedure  | Performance standard   |
|----------|------------------|----------------------------------|---|--|
|          | Test equipment   | Equipment under test             |   |  |
| 1        | None             | Controls may be in any position. | <p>a. Inspect case and chassis for damage, missing parts, and condition of paint.</p> <p style="text-align: center;">NOTE</p> <p>Touchup painting recommended instead of refinishing whenever practical; screwheads, binding posts, receptacles, and other plated parts will not be painted or polished with abrasives.</p> <p>b. Inspect all controls and mechanical assemblies for loose or missing screws, bolts, and nuts.</p> <p>c. Inspect socket and meters for looseness, damage, or missing parts.</p> | <p>a. No damage evident or parts missing. External surfaces intended to be painted will not show bare metal. Panel lettering will be legible.</p> <p>b. Screws, bolts, and nuts will be tight; none missing.</p> <p>c. No loose parts or damage. No missing parts.</p> |
| 2        | None             | Controls may be in any position. | <p>a. Rotate COARSE (S3) and FINE (S2) switches throughout the limits of travel.</p> <p>b. Operate AC INPUT and DC OUTPUT switches and circuit breakers, and INPUT VOLTAGE switch.</p>  | <p>a. Switches will rotate freely, without binding or excessive looseness.</p> <p>b. AC INPUT and DC OUTPUT switches and circuit breakers, and INPUT VOLTAGE switch will operate properly.</p>   |

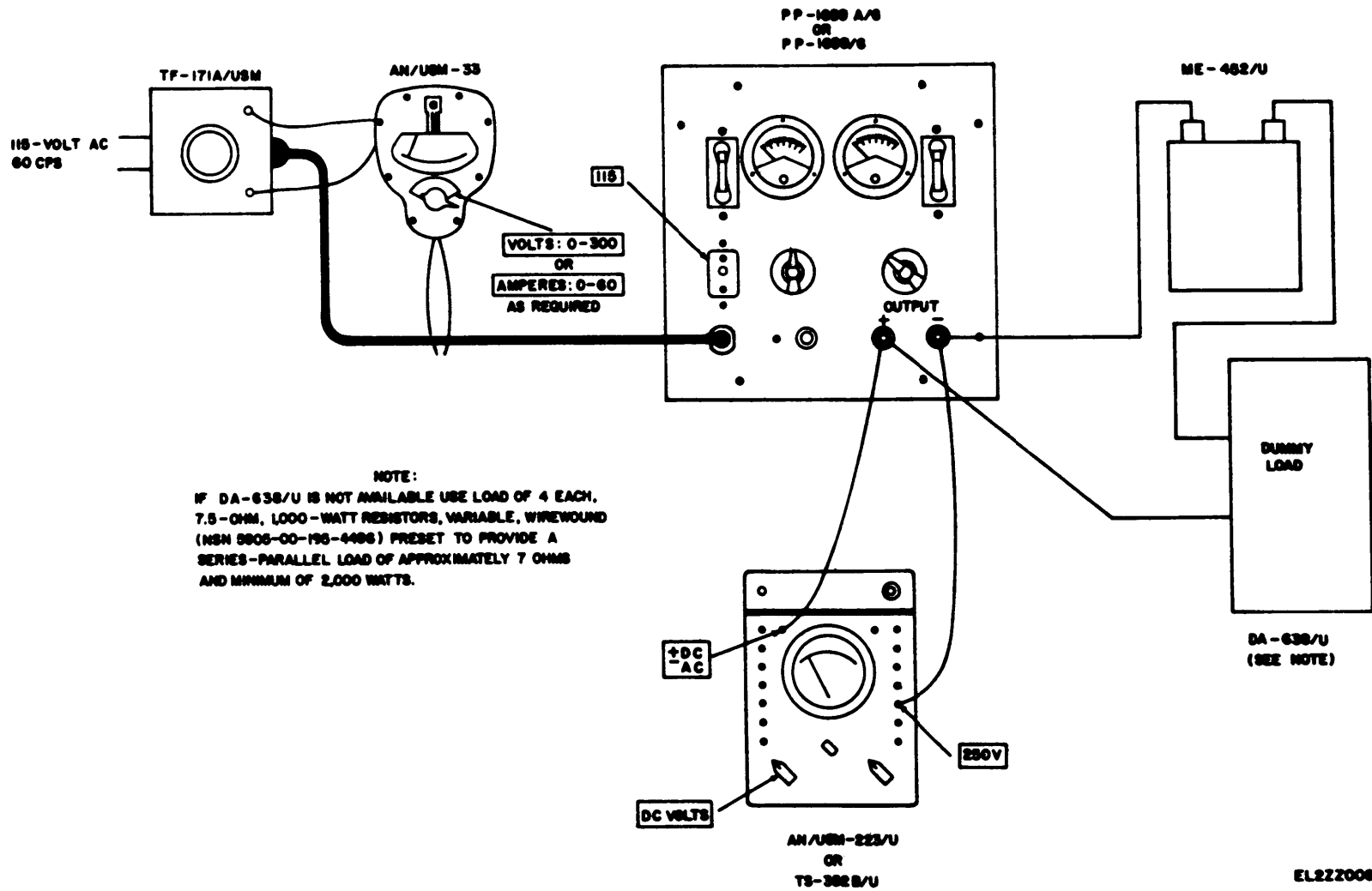

Figure 5-2. Input and output power test (115 volt ac input power) connection diagram.

**5-10. Input and Output Power Test**

*a. Test Equipment Materials.*

- (1) Multimeter ME-452/U.
- (2) Transformer, Variable Power RF-171A/USM.
- (3) Multimeter AN/USM-223/U.
- (4) Multimeter AN/USM-33.
- (5) Dummy Load, Electrical DA-638/U.

*b. Test Connections and Conditions.* Connect the equipment as shown in figure 5-2. This test is established for 115-volt ac operation.

**CAUTION**

Do not connect the Dummy Load DA-638/U until instructed to do so in c below.

*c. Procedure.*

| Step no. | Control settings   |   | Test procedure  | Performance standard   |
|----------|--|---|---|--|
|          | Test equipment   | Equipment under test  |   |  |
|          | TF-171A/USM<br><br>Control: 115                                | INPUT VOLTAGE switch: 115<br>AC INPUT switch and circuit breaker: Off (down). | a. Connect the PP-1659/G or PP-1659A/G to a 115-volt ac source.<br><br>b. Adjust the control on the TF-171A/USM for 115-volt ac output.   | a. None<br><br>b. None   |
|          | AN/USM-33<br>FUNCTION RANGE                                    | DC OUTPUT switch and circuit breaker: Off (down).<br>COARSE switch: 1.        | c. Set the AC INPUT and DC OUTPUT switches and circuit breakers on (up).<br>d. Rotate the COARSE and FINE switches from positions 1 through 12 while observing the indication on the AN/USM-223/U and DC VOLTS meter on the PP-1659/G or PP-1659A/G.  | c. None<br><br>d. The voltage reading should increase progressively from less than 2 volts to more than 105 volts as the COARSE and FINE switches are rotated to 12.                                   |
|          | AN/USM-223/U<br>FUNC-TION: DC VOLTS<br>FUNC-TION: 0-30 amperes | FINE switch: 1  | e. Set the DC OUTPUT switch and circuit breaker off (down).<br>f. Connect the Dummy Load DA-638/U (fig. 5-2) across the + and - OUTPUT terminals of the PP-1659/G or PP-1659A/G.<br><br>g. Connect the ME-452/U in series with the load.  | e. None<br><br>f. None   |
|          |  |   | h. With the COARSE and FINE switches set to 12, adjust the load for an indication of 15 amperes both on the DC AMPS meter of the battery charger and ME-452/U.<br>i. Adjust the load and the COARSE and FINE switches for 105 volts dc output at 15 amperes while observing the current indication on the AN/USM-33.<br>j. Set the AC INPUT and DC OUTPUT switches and circuit breakers off (down). | h. The reading is 15 amperes and the voltage indicated on the AN/USM-223/U is greater than 105 volts.<br><br>i. The current indication on the AN/USM-33 should be less than 25 amperes.<br><br>j. None |

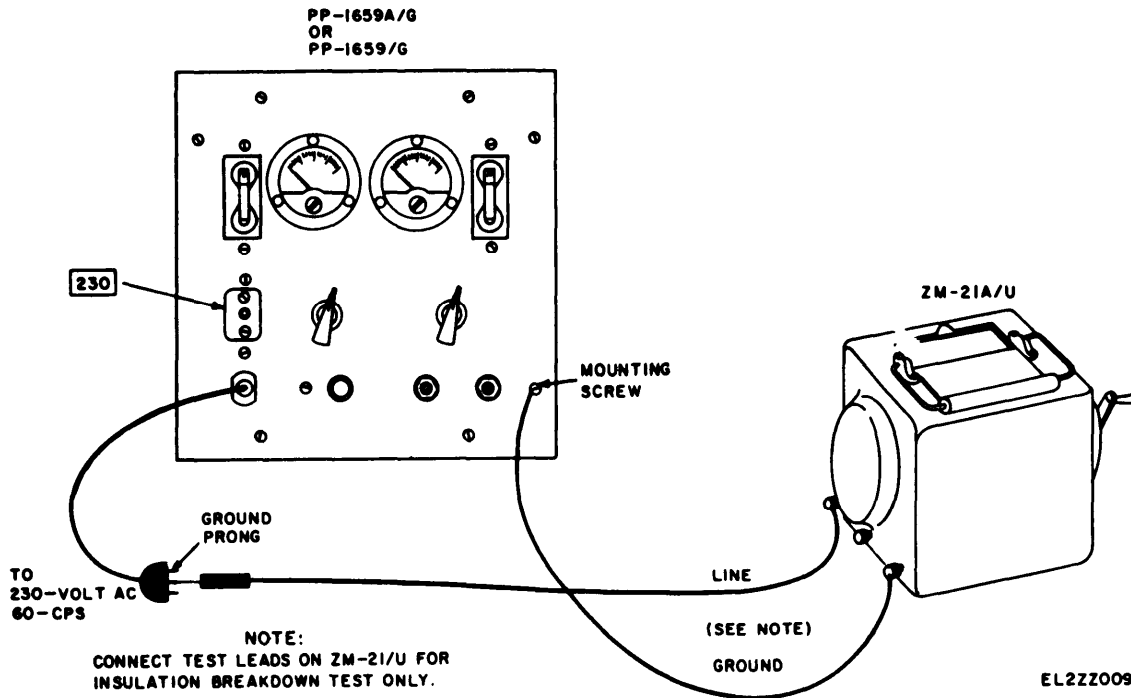

Figure 5-3. Insulation breakdown test connection diagram.

**5-11. 230 Volt Ac Operational Test and Insulation Breakdown Test**

a. *Test Equipment.* The only test equipment required in Ohmmeter ZM-21A/U.

b. *Test Connections and Conditions.* Connect the equipment as shown in figure 5-3.

**CAUTION**

Do not connect the test leads on the ZM-21A/U to the PP-1659/G or PP-1659A/G until instructed to do so in step 2 of the procedures given in c below.

c. *Procedure.*

| Step no. | Control settings |  | Test procedure   | Performance standard  |
|----------|------------------|--|--|---|
|          | Test equipment   | Equipment under test   |  |   |
| 1        |                  | INPUT VOLTAGE switch : 230<br>AC INPUT switch and circuit breaker: Off (down)<br>DC OUTPUT switch and circuit breaker: Off (down position)<br>Coarse switch: 12<br>FINE switch: 12 | a. Connect the Charger, Battery to 230-volt ac source.<br>b. Set the AC INPUT and DC OUTPUT switches and circuit breakers on (up).<br>c. Set the AC INPUT and DC OUTPUT switches and circuit breakers off (down).<br>d. Disconnect the PP-1659/G or PP-1659A/G from the 230-volt ac source.  | a. None<br>b. The DC VOLTS meter reading is greater than 105 volts.<br>c. None<br>d. None |
| 2        |                  | AC INPUT switch and circuit breaker: On (up)   | a. Connect the ground lead on the ZM-21A/U to the case of the PP-1659/G or PP-1659A/G.<br>b. Connect the line lead on the ZM-21A/U to either one of the ac prongs on the ac plug, operate the ZM-21A/U, and observe the indication on the ZM-21A/U meter.<br>c. Set the AC INPUT switch and circuit breaker off (down) and disconnect the ZM-21A/U from the PP-1659/G or PP-1659A/G. | a. None<br>b. The meter reading is greater than 10 megohms.<br>c. None                    |

**5-12. Test Data Summary**

a. *Input.*

- (1) Voltage 115 volts
- (2) Frequency 60 cps
- (a) Phase single

b. *Output.*

Power (COARSE and FINE switches set to 12) Greater than 105 volts with 15-ampere load.

c. *Input Current.*

Output adjusted for 105 volts dc with 15-ampere load. Input current less than 25 amperes.

## APPENDIX A

## REFERENCES

---

|                        |  |
|------------------------|--|
| DA Pam 25-30           | Consolidated Index of Army Publications and Blank Forms  |
| DA Pam 738-750         | The Army Maintenance Management System (TAMMS)   |
| TM 11-5850-242-12      | Operator's and Organizational Maintenance Manual: Airborne Data Annotation System AN/AYA-10 (NSN 5895-00-235-4520)   |
| TM 11-6130-392-12      | Operator's and Organizational Maintenance Manual for Charger, Battery, PP-7286/U (NSN 6130-01-041-3490)  |
| TM 11-6625-537-15      | Operator, Organizational, Field and Depot Maintenance Manual: Voltmeter, Electronic ME-202/U   |
| TM 11-6625-2478-12     | Operator's and Organizational Maintenance Manual: Test Set, Control Monitor-Recording Head, AN/AYM-9 (NSN 662540-150-1882)   |
| TM 11-6625-2479-12     | Operator's and Organizational Maintenance Manual (Including Repair Parts and Special Tools List): Test Set, Signal Data Converter AN/AYM-8 (NSN 6625-00-1327-2289)   |
| TM 11-6625-2941-14&P   | Operator's, Organizational, Direct Support and General Support Maintenance Manual Including Repair Parts and Special Tools List for Counter, Electronic, Digital Readout AN/USM-459 (Hewlett-Packard Model 5328A/E42) (NSN 6625-01-061-8928) |
| TM 11-6625-3052-14     | Operator's, Organizational, Direct Support and General Support Maintenance Manual for Multimeter, Digital AN/PSM-45 (NSN 6625-01-139-2512)   |
| TM 11-6625-3135-12     | Operator's and Organizational Maintenance Manual for Oscilloscope AN/USM-488 (NSN 6625-01-187-7847)  |
| TM 11-55-110-213-10    | Operator's Manual: OV-ID/RV-ID Aircraft  |
| (C)TM 55-1510-213-10/1 | Operator's Manual: Supplement OV-ID/RV-ID Aircraft (U)   |
| TM 740-90-1            | Administrative Storage of Equipment  |
| TM 750-2442            | Procedures for Destruction of Electronics Materiel to Prevent Enemy Use (Electronics Command)  |

## APPENDIX C

### MAINTENANCE ALLOCATION

---

#### Section I. INTRODUCTION

##### **C-1. General**

This appendix provides a summary of the maintenance operations for the PP-1659/G and PP-1659A/G. It authorizes categories of maintenance for specific maintenance functions on repairable items and components and the tools and equipment required to perform each function. This appendix may be used as an aid in planning maintenance operations.

##### **C-2. Maintenance Function**

Maintenance functions will be limited to and defined as follows:

*a. Inspect.* To determine the serviceability of an item by comparing its physical, mechanical, and/or electrical characteristics with established standards through examination.

*b. Test.* To verify serviceability and to detect incipient failure by measuring the mechanical or electrical characteristics of an item and comparing those characteristics with prescribed standards.

*c. Service.* Operations required periodically to keep an item in proper operating condition, i.e., to clean, preserve, drain, paint, or to replenish fuel/lubricants/hydraulic fluids or compressed air supplies.

*d. Adjust.* Maintain within prescribed limits by bringing into proper or exact position, or by setting the operating characteristics to the specified parameters.

*e. Align.* To adjust specified variable elements of an item to about optimum or desired performance.

*f. Calibrate.* To determine and cause corrections to be made or to be adjusted on instruments or test measuring and diagnostic equipment used in precision measurement. Consists of the comparison of two instruments, one of which is a certified standard of known accuracy, to detect and adjust any discrepancy in the accuracy of the instrument being compared.

*g. Install.* The act of emplacing, seating, or fixing into position an item, part, module (component or assembly) in a manner to allow the proper functioning of the equipment/system.

*h. Replace.* The act of substituting a serviceable

like-type part, subassembly, model (component or assembly for an unserviceable counterpart.

*i. Repair.* The application of maintenance services (inspect, test, service, adjust, align, calibrate, replace) or other" maintenance actions (welding, grinding, riveting, straightening, facing, remachining, or resurfacing) to restore serviceability to an item by correcting specific damage, fault, malfunction, or failure in a part, subassembly, module/component/assembly, end item or system. This function does not include the trial and error replacement of running spare type items such as fuses, lamps, or electron tubes.

*j. Overhaul.* That periodic maintenance effort (service/action) necessary to restore an item to a completely serviceable/operational condition as prescribed by maintenance standards (e.g., DM WR) in appropriate technical publications. Overhaul is normally the highest degree of maintenance performed by the Army. Overhaul does not normally return an item to like-new condition.

*k. Rebuild.* Consists of those services/actions necessary for the restoration of unserviceable equipment to a like-new condition in accordance with original manufacturing standards. Rebuild is the highest degree of material maintenance applied to Army equipment. The rebuild operation includes the act of returning to zero those age measurements (hours, miles, etc. ) considered in classifying Army equipment /components.

##### **C-3. Column Entries**

*a. Column 1, Group Number.* Column 1 lists group numbers, the purpose of which is to identify components, assemblies, subassemblies and modules with the next higher assembly.

*b. Column 2, Component/Assembly.* Column 2 contains the noun names of components, assemblies, subassemblies, and modules for which maintenance is authorized.

*c. Column 3, Maintenance Functions.* Column 3 lists the functions to be performed on the item listed in column 2. When items are listed without maintenance functions, it is solely for purpose of



having the group number in the MAC and RP-STL coincide.

*d. Column 4, Maintenance Category.* Column 4 specifies, by the listing of a “worktime” figure in the appropriate subcolumn(s), the lowest level of maintenance authorized to perform the function listed in column 3. This figure represents the active time required to perform that maintenance function at the indicated category of maintenance. If the number of complexity of the tasks within the listed maintenance function vary at different maintenance categories, appropriate “worktime” figures will be shown for each category. The number of task-hours specified by the “worktime” figure represents the average time required to restore an item (assembly, subassembly, component, module, end item or system) to a serviceable condition under typical field operating conditions. This time includes preparation time, troubleshooting time and quality assurance/quality control time in addition to the time required to perform the specific tasks identified for the maintenance functions authorized in the maintenance allocation chart. Subcolumns of column 4 are as follows:

- C–Operator/Crew
- O–Organizational
- F–Direct Support
- H–General Support
- D–Depot

*e. Column 5, Tools and Equipment.* Column 6 specifies by code, those common tool sets (not individual tools) and special tools, test, and support equipment required to perform the designated function.

**C-4. Tool and Test Equipment Requirements (Table 1)**

*a. Tool or Test Equipment Reference Code.* The number in this column coincide with the numbers used in the tools and equipment column of the MAC. The numbers indicate the applicable tool or test equipment for the maintenance functions.

*b. Maintenance Category.* The codes in this column indicate the maintenance category allocated the tool or test equipment.

*c. Nomenclature.* This column lists the noun name and nomenclature of the tools and test equipment required to perform the maintenance functions.

*d. National/NA Stock Number.* This column lists the National/NATO stock number of the specific tool or test equipment.

*e. Tool Number.* This column lists the manufacturer’s part number of the tool followed by the Federal Supply Code for Manufacturers (5-digit) in parentheses.

(Next printed page is C-3)

SECTION II MAINTENANCE ALLOCATION CHART  
FOR

BATTERY CHANGER PF-1659/G AND PF-1659A/G

| (1)<br>GROUP<br>NUMBER | (2)<br>COMPONENT/ASSEMBLY   | (3)<br>MAINTENANCE<br>FUNCTION | (4)<br>MAINTENANCE CATEGORY |     |     |          |   | (5)<br>TOOLS AND<br>EQUIPMENT |
|------------------------|-----------------------------|--------------------------------|-----------------------------|-----|-----|----------|---|-------------------------------|
|                        |                             |                                | C                           | O   | F   | H        | D |                               |
| 00                     | CHARGER, Battery PF-1659A/G | Inspect <sup>1</sup>           | 0.1                         |     |     |          |   |                               |
|                        |                             | Service <sup>2</sup>           | 0.1                         |     |     |          |   |                               |
|                        |                             | Adjust <sup>2</sup>            | 0.1                         |     |     |          |   |                               |
|                        |                             | Test <sup>2</sup>              | 0.2                         |     |     |          |   |                               |
|                        |                             | Inspect <sup>3</sup>           |                             | 0.1 |     |          |   | 1                             |
|                        |                             | Service <sup>3</sup>           |                             | 0.5 |     |          |   | 1                             |
|                        |                             | Repair <sup>4</sup>            |                             | 0.2 |     |          |   | 1                             |
|                        |                             | Test <sup>5</sup>              |                             |     |     | 1.0      |   | 2 thru 9                      |
|                        |                             | Repair <sup>6</sup>            |                             |     |     | 1.5      |   | 2 thru 9                      |
| Overhaul               |                             |                                |                             |     | 9.0 | 2 thru 9 |   |                               |

- (1) Exterior.
- (2) Operational.
- (3) Interior.
- (4) Lamps, cable connectors.
- (5) All tests.
- (6) All repairs.

TABLE 1. TOOL AND TEST EQUIPMENT REQUIREMENTS FOR

BATTERY CHARGER FF-1659/G AND FF-1659A/G

| TOOL OR TEST EQUIPMENT REF CODE | MAINTENANCE CATEGORY | NOMENCLATURE                            | NATIONAL/NATO STOCK NUMBER | TOOL NUMBER |
|---------------------------------|----------------------|---|----------------------------|-------------|
| 1                               | 0                    | Tool Kit, Electronic Equipment TK-101/G | 5180-00-064-5178           |             |
| 2                               | H,D                  | Tool Kit, Electronic Equipment TK-105/G | 5180-00-610-8177           |             |
| 3                               | H,D                  | Multimeter AN/USM-33                    | 6625-00-648-9172           |             |
| 4                               | H,D                  | Multimeter AN/PSM-45                    | 6625-01-139-2512           |             |
|                                 |                      | OR                                      | 6625-00-999-7465           |             |
|                                 |                      | Multimeter TS-352B/U                    |                            |             |
| 5                               | H,D                  | Multimeter ME-26D/U                     | 6625-00-913-9781           |             |
| 6                               | H,D                  | Multimeter ME-452/U                     | 6625-00-519-2493           |             |
| 7                               | H,D                  | Ohmmeter EM-21A/U                       | 6625-00-581-2466           |             |
| 8                               | H,D                  | Transformer, Variable TF-171/USM        | 5950-00-503-0632           |             |
| 9                               | H,D                  | Dummy Load, Electrical DA-638/U         | 6625-00-422-2111           |             |

By Order of the Secretary of the Army:

**BERNARD W. ROGERS**  
*General, United States Army*  
*Chief of Staff*

Official:

**PAUL T. SMITH**  
*Major General, United States Army*  
*The Adjutant General*

**Distribution:**

Active Army:

USASA (2)  
 COE (1)  
 TSG (1)  
 USAARENBD (1)  
 DARCOM (1)  
 TECOM (2)  
 TRADOC (2)  
 LOGC (3)  
 USACC (4)  
 OS Maj Comd (4)  
 MDW (1)  
 Armies (2)  
 corps (2)  
 Instl (2) except  
     Ft Gillem (10)  
     Ft Gordon (10)  
     Ft Huachuca (10)  
     Ft Carson (S)  
 SAAD (30)  
 LBAD (14)  
 TOAD (14)  
 SHAD (3)  
 HISA (Ft Monmouth) (33)  
 Ft Richardson (ECOM Ofc) (2)  
 Svc Colleges (1)  
 USASIGS (6)  
 USAICS (3)  
 USAADS (2)  
 USAFAS (2)  
 USAARMS (2)  
 USAIS (2)  
 USAES (2)

MAAG (1)  
 USARMIS (1)  
 USAERDAA (1)  
 USAERDAW (1)  
 Sig FLDMS (1)  
 Units org under fol TOE:.1 ea.  
     11-16  
     11-117  
     11-4500(AA-AC)  
     20-134  
     20-136

**ARNG: State AG (3).**

USAR: None.

**For explanation of abbreviations used, see AR 310-60.**



# SOMETHING WRONG WITH THIS MANUAL?

THEN... JOT DOWN THE DOPE ABOUT IT ON THIS FORM, TEAR IT OUT, FOLD IT AND DROP IT IN THE MAIL!

FROM: (YOUR UNIT'S COMPLETE ADDRESS)

Commander  
Stateside Army Depot  
ATTN: AMSTA-US  
Stateside, N.J. 07703

DATE 10 July 1975

PUBLICATION NUMBER

TM 11-5840-340-12

DATE

23 Jan 74

TITLE

Radar Set AN/SPC-76

BE EXACT... PIN-POINT WHERE IT IS

| PAGE NO. | PARA-GRAPH | FIGURE NO. | TABLE NO. |
|----------|------------|------------|-----------|
| 2-25     | 2-28       |            |           |
| 3-10     | 3-3        |            | 3-1       |
| 5-6      | 5-8        |            |           |
|          |            | FO3        |           |

IN THIS SPACE TELL WHAT IS WRONG AND WHAT SHOULD BE DONE ABOUT IT:

Recommend that the installation antenna alignment procedure be changed through to specify a 2° IFF antenna lag rather than 1°.

REASON: Experience has shown that with only a 1° lag, the antenna servo system is too sensitive to wind gusting in excess of 27 knots, and has a tendency to rapidly accelerate and decelerate as it hunts, causing strain to the drive train. Hunting is minimized by adjusting the lag to 2° without degradation of operation.

Item 5, Functions column. Change "2 db" to "3db."

REASON: The adjustment procedure for the TRANS POWER FAULT indicator calls for a 3 db (500 watts) adjustment to light the TRANS POWER FAULT indicator.

Add new step f.1 to read, "Replace cover plate removed in step e.1, above."

REASON: To replace the cover plate.

Zone C 3. On J1-2, change "+24 VDC to "+5 VDC."

REASON: This is the output line of the 5 VDC power supply. + 24 VDC is the input voltage.

TYPED NAME, GRADE OR TITLE, AND TELEPHONE NUMBER

SSG I. M. DeSpirito 999-1776

SIGN HERE:

*SSG I. M. DeSpirito*

TEAR ALONG DOTTED LINE



FILL IN YOUR  
UNIT'S ADDRESS

FOLD BACK

DEPARTMENT OF THE ARMY

OFFICIAL BUSINESS

Commander  
US Army Electronics Command  
ATTN: DRSEL-MA-Q  
Fort Monmouth, New Jersey 07703

FOLD BACK

TEAR ALONG DOTTED LINE

