

TM 5-6115-423-15

DEPARTMENT OF THE ARMY TECHNICAL MANUAL

OPERATOR, ORGANIZATIONAL, DIRECT AND GENERAL
SUPPORT AND DEPOT MAINTENANCE MANUAL

LOAD BANK, 0-30 KW; AC; PORTABLE, SKID-MOUNTED
(SUN ELECTRIC CORP MODEL GPT-3D-1)
FSN 6115-964-1091 AND (SUN ELECTRIC CORP MODEL
GPT-3D) FSN 6115-903-8174

This copy is a reprint which includes current
pages from Change 1.

HEADQUARTERS, DEPARTMENT OF THE ARMY
AUGUST 1967

SAFETY PRECAUTIONS

BEFORE OPERATION

Ground the Load Bank frame to avoid shock hazard. Ground stud is located on the housing just below the control panel.

DURING OPERATION

Never remove panels on the Load Bank without first disconnecting the unit from the power source.

Do not connect, disconnect or touch electrical leads or parts until unit is shutdown.

If excessive vibration or unusual noises occur turn off the unit

Use CO₂, not water in putting out an electrical fire.

If motor or other components heat up excessively, stop the Load Bank at once.

If Selenium rectifier has failed or is burning (accompanied by acrid stench), de-energize Load Bank at once and remove to outside to dissipate fumes.

AFTER OPERATION

Never use or store the unit in an upside down or on end position.

CHANGE }
No. 1 }

HEADQUARTERS
DEPARTMENT OF THE ARMY
WASHINGTON, DC, 17 May 1973

Operator, Organizational, Direct Support,
General Support and Depot Maintenance Manual
LOAD BANK, 0-30 KW; AC; PORTABLE, SKID-MOUNTED
(SUN ELECTRIC CORP. MODEL GPT-3D-1)
FSN 6115-964-1091 AND (SUN ELECTRIC CORP MODEL
GPT-3D) FSN 6115-903-8174

TM 5-6115-423-15, 10 August 1967, is changed as follows:

Page 3. Paragraph 1b, the third sentence is deleted. Appendix C contains *** of this equipment”.

The title is changed to read as shown above.

Page 49. Appendix A is superseded as follows:

**APPENDIX A
REFERENCES**

A-1. Painting

AR 746-1 Color, Marking and Preparation of Equipment for Shipment

Bank 0-30 KW AC, Portable, Skit Mounted (Sun Electric Corp Model GPT-3D-I) FSN 6115-964-1091 and (Model GPT-3D) FSN 6115 903-6174

A-2. Maintenance

FM 29-2 Organizational Maintenance Management

TM 5-764 Electric Motor and Generator Repair

A-3. Ship and Storage

TM 11-483 Radio Interference Suppression

TB 740-97-2 Preservation of USAFE-COM Mechanical Equipment for Storage

TM 38-750 The Army Maintenance Management System (TAMMS)

TM 740-90-1 Administrative Storage of Equipment

TM 5-6115-423-25P Organizational, Direct and General Support, and Depot Maintenance Repair Parts and Special Tools Lists; had

A-4. Demolition

TM 750-244-3 Procedures for Destruction of Equipment to Prevent Enemy Use

APPENDIX C

BASIC ISSUE ITEMS LIST AND ITEMS TROOP INSTALLED OR AUTHORIZED AUTHORIZED

Section 1. INTRODUCTION

C-1. Scope

This appendix lists items required by the operator for operation of the load bank.

C-2. General

This list is divided into the following sections:

a. Basic Issue Items List — Section II. Not applicable.

b. Items Troop Installed or Authorized List — Section III. A list of items in alphabetical sequence, which at the discretion of the unit commander may accompany the load bank. These items are NOT SUBJECT TO TURN-IN with the load bank when evacuated.

C4. Explanation of Columns

The following provides an explanation of columns in the tabular list of Basic Issue Items List, Section II, and Items Troop Installed or Authorized, Section III.

a. Source, Maintenance and Recoverability Code (SMR). Not applicable.

b. Federal Stock Number. This column indicates the Federal stock number assigned to the item and will be used for requisitioning purposes.

c. Description. This column indicates the Federal item name and any additional description of the item required.

d. Unit of Measure (U/M). A two-character alphabetic abbreviation indicating the amount or quantity of the item upon which the allowances are based, e. g., ft, ea, pr, etc.

e. Quantity Furnished with Equipment (BIIL), Not applicable.

f. Quantity Authorized (Items Troop Installed or Authorized). This column indicates the quantity of the item authorized to be used with the equipment.

SECTION III. ITEMS TROOP INSTALLED OR AUTHORIZED LIST				
(1) SMR code	(2) Federal stock number	(3) Description Ref No. & mfr code	(4) Unit of meas	(5) Qty auth
	7520-559-9618	CASE: Maintenance and Operation Manuals	EA	1

By Order of the Secretary of the Army:

CREIGHTON W. ABRAMS
General, United States Army
Chief of Staff

Official:

VERNE L. BOWERS
Major General, United States Army
The Adjutant General

Distribution:

To be distributed in accordance with DA Form 12-25D, Operator requirements for Generator Sets, 30 KW, 60 HZ Precise Power and 30 KW, 400 HZ Precise Power.

Operator, Organizational, Direct And General Support
 And Depot Maintenance Manual

**LOAD BANK, 0-30 KW; AC; PORTABLE, SKID-MOUNTED
 (SUN ELECTRIC CORP MODEL GPT-3D-1) FSN 6115-964-1091
 AND (SUN ELECTRIC CORP MODEL GPT-3D)
 FSN 6115-903-8174**

	Paragraph	Page
CHAPTER 1. INTRODUCTION		
Section I. General	1,2	3
II. Description and data	3-5	3-9
CHAPTER 2. INSTALLATION AND OPERATING INSTRUCTIONS		
Section I. Service upon receipt of equipment	6-10	11-12
II. Movement to new worksite	11-12	12-13
III. Controls and Instruments	13,24	13
IV. Operation of equipment	15-24	14-17
CHAPTER 3. OPERATOR AND ORGANIZATIONAL MAINTENANCE INSTRUCTIONS		
Section I. Special tools and equipment	25-27	19
II. Lubrication.....	28,29	19
III. Preventive maintenance services.....	30-32	19-32
IV. Operator maintenance.....	33-42	22-24
v. Troubleshooting.....	43-49	24-25
VI. Radio Interference suppression	50-53	25-26
CHAPTER 4. DEMOLITION OF EQUIPMENT		
Section 1. Demolition of load bank to prevent enemy use	54-58	27
CHAPTER 5. DIRECT SUPPORT, GENERAL SUPPORT AND DEPOT MAINTENANCE INSTRUCTIONS		
Section I. General	59,60	29
II. Description and data	61,62	29-30
CHAPTER 6. GENERAL MAINTENANCE INSTRUCTIONS		
Section I. Special tools and equipment.....	63,64	31
II. Trouble shooting.....	65-70	31
III. Removal and installation of major components	71-78	31-38
CHAPTER 7. REPAIR INSTRUCTIONS		
Section 1. Repair of variable transformer	79,80	39
II. Repair of auto transformer.....	81,82	39
III. Repair of rectifier	83,84	39-40
IV. Repair of relay	85,86	40
v. Repair of contactor	87,88	40
VI. Repair of power absorber	89,90	40-41
VII. Repair of control transformer.....	91,92	41-48
APPENDIX A. REFERENCES		49
B. MAINTENANCE ALLOCATION CHART		51
c. BASIC ISSUE ITEMS LIST		55
INDEX		59

CHAPTER 1

INTRODUCTION

Section 1. GENERAL

1. scope

a. These instructions are published for use by personnel to whom the load bank is issued. Chapters 1 through 4 provide information on operation, preventive maintenance services, and organizational maintenance of equipment, accessories, components and attachments. Also, included are instructions for destroying the equipment to prevent capture by an enemy. Chapter 5 through 7 provides information for direct, general support, and depot maintenance. Included are descriptions of main units and their functions in relationship to other components.

b. Appendix A contains a list of publications applicable to this manual. Appendix B contains the maintenance allocation chart. Appendix C contains a list of basic issue items authorized by the operator of this equipment. The organizational, direct and general support and depot maintenance repair parts and special tools are listed in TM5-6115-423-25P.

c. Numbers in parentheses following nomenclature callouts on illustrations indicate

quantity; numbers preceding nomenclature callouts indicate preferred maintenance sequence.

d. DA Form 2028 (Recommended Changes to DA Publication) will be used for reporting discrepancies and recommendations for improving this equipment publication. This form will be completed by the individual using the manual and forwarded direct to Commanding General, U.S. Army Mobility Equipment Command, ATTN: AMSME-MP, 4300 Goodfellow Blvd., St. Louis, Mo. 63120.

e. Report all equipment improvement recommendations as prescribed by TM 38-750.

2. Record and Report Forms

a. DA Form 2258 (Depreservation Guide for Vehicles and Equipment).

b. For other record and report forms applicable to operator, crew and organizational maintenance refer to TM 38-750.

Note. Applicable forms, excluding Standard Form 46 (United States Government Motor Vehicle Operator's identification card) which is carried by the operator shall be kept in a canvas bag mounted on the equipment.

Section II. DESCRIPTION AND DATA

3. Description

a. General. The Sun Electric Corp., Load Bank, Model GPT-3D-1 is a portable skid mounted test unit fully self-contained and mounted within a welded steel, weather tight cabinet built integrally into a welded steel chassis.

b. Purpose. The load bank (fig. 1) functions as a loading and testing device for electrical

generating equipment. Testing is accomplished by applying to the generating equipment, resistive loads in increments. They can be manipulated in various combinations to simulate any resistive electrical load within the load bank rating. The load bank itself generates no power. Its operation is entirely dependent upon external power sources, and operates through the system to which it is connected and must test. Loading characteristics may be

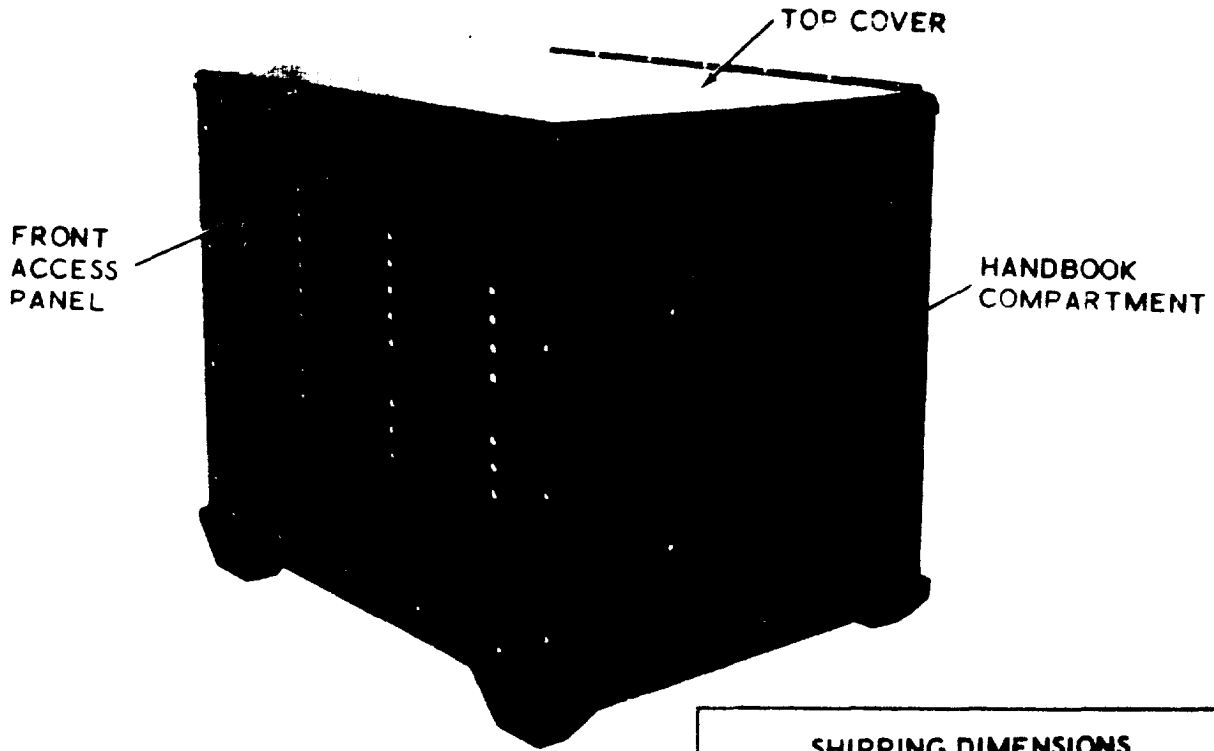

SHIPPING DIMENSIONS	
LENGTH	36.5 INCHES
WIDTH	23.5 INCHES
HEIGHT	27.0 INCHES
SHIPPING WEIGHT	415 POUNDS

MEC 6115-423-15/1

Figure 1. Load bank, right front, three-quarter view with shipping dimensions.

set up and controlled. Thus the capabilities of the power generating equipment to perform under these conditions can be tested and measured. The load bank is designed to test the output characteristics of generating plants rated 120/208 and 240/416 volts three phase 4-wire; 240-volts three phase 3-wire; 120 or 240 volts single phase 2-wire. Tests can be applied at frequencies between 50 and 1000 cycles per second. Power cables connecting the load bank and the equipment to be tested

are connected to the terminal strip adjacent to the control panel. Cables are not furnished with the equipment.

- (1) The load bank has a 3, 6 and two 9 kilowatt switches by which it can apply any fixed load in increments of 3 up to 27 kilowatts. It can apply variable loads 0.5 to 3 kilowatts at frequencies between 50 and 1000 cycles per second.

- (2) When fixed and variable loads are applied in combination, the load bank can apply any load from 0.5 t, 30 kilowatts on either single or balanced three phase operation.

c. *Major Assemblies and Components.* The major assemblies and components of the load bank includes a cabinet and cabinet assembly, control panel assembly, power absorbers, variable transformer, contactor, rectifier, terminal strip, and relay. Major components of the load bank are illustrated in figures 1 through 4.

- (1) *Cabinet and cabinet assembly.* The cabinet assembly which completely

encloses all components is made up of an integral welded steel frame and housing. Removable top and side panels allow access to the cabinet interior for service, maintenance and inspection. A hinged drop door protects the controls and can be swung back to assure access to controls. On the back a hinged metal door protects an expanded metal ventilating panel. The load bank is ventilated and heat dissipated through the expanded metal. Latches secure the doors to assure protection during storage and

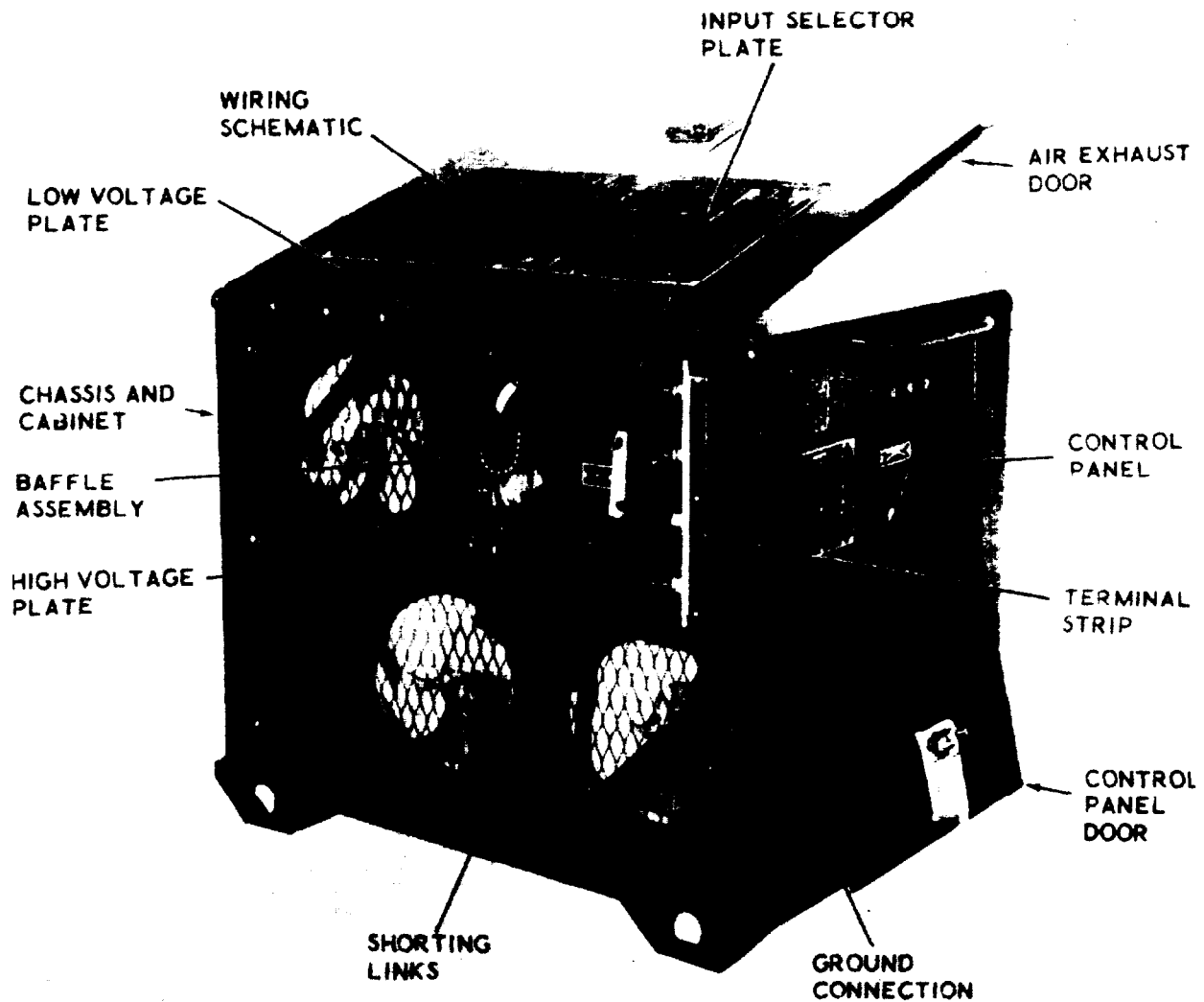

Figure 2. Load bank, left rear, three-quarter view.

shipment. Carry handles welded at the top of the cabinet permit carrying the unit. A fork lift tong, inserted between four corner feet can be used to transport the unit for a short distance. Feet which support the load bank 2 1/4-inches off the ground will accept tie rods, cables or lashing suitable for fastening the unit to a skid, pallet or trailer.

- (2) *Control panel assembly.* Located on the recessed control panel (fig. 2) are a toggle type master switch, five toggle load switches, and one variable load control knob. They provide all necessary controls for test to which the load bank is applied. The load increments identifying each control are indicated by identification plates located on the face of the control panel.
- (3) *Power absorbers.* Three duct-type 10 kilowatt power absorbers (figure 3)

provide necessary resistive loads. Resistive elements are made of 1/8 inch-corrugated nichrome ribbon enclosed within a slotted housing. Fan motors (part of connected load) cool the absorbers by circulating air drawn through openings in the cabinet and forcing it out through venting doors. Resistive elements can withstand surface temperatures over 1000°F. Restriction of intake cooling air will cause rapid temperature rise and result in drop of load. Air flow vane is pivoted on a shaft on each power absorber so that impact of cooling air actuates a switch which remains closed as long as air flows through. If air flow stops, it cuts off load. The thermal overload shall cause the load bus contractors to drop load in the event that temperatures in excess of 248°F develop in the resistive module. If temperature overload occurs, it will

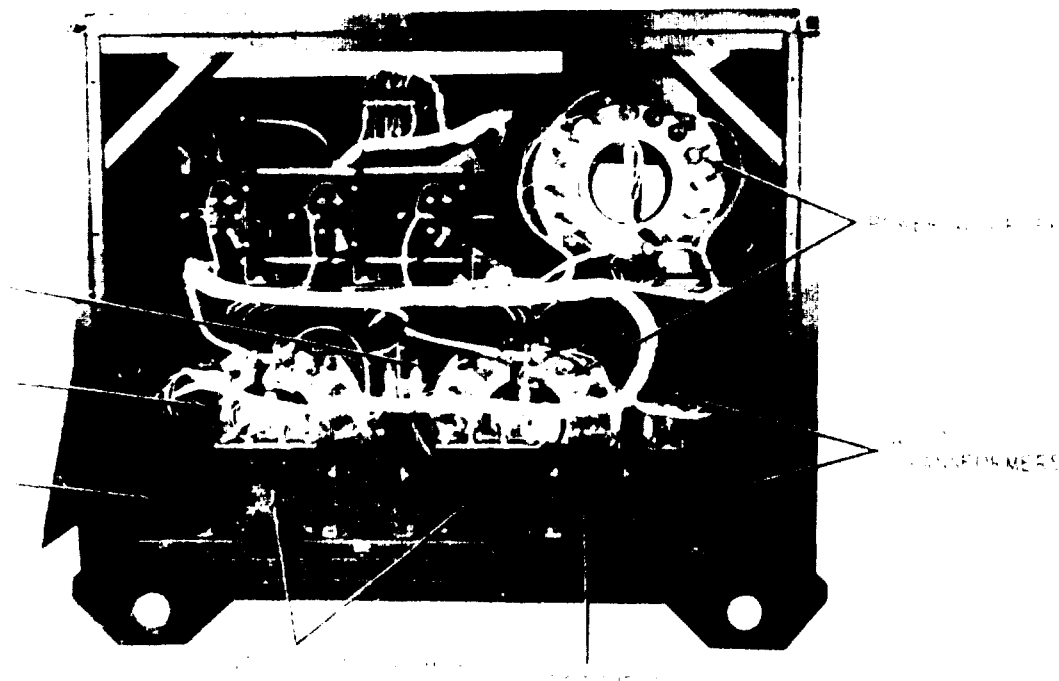
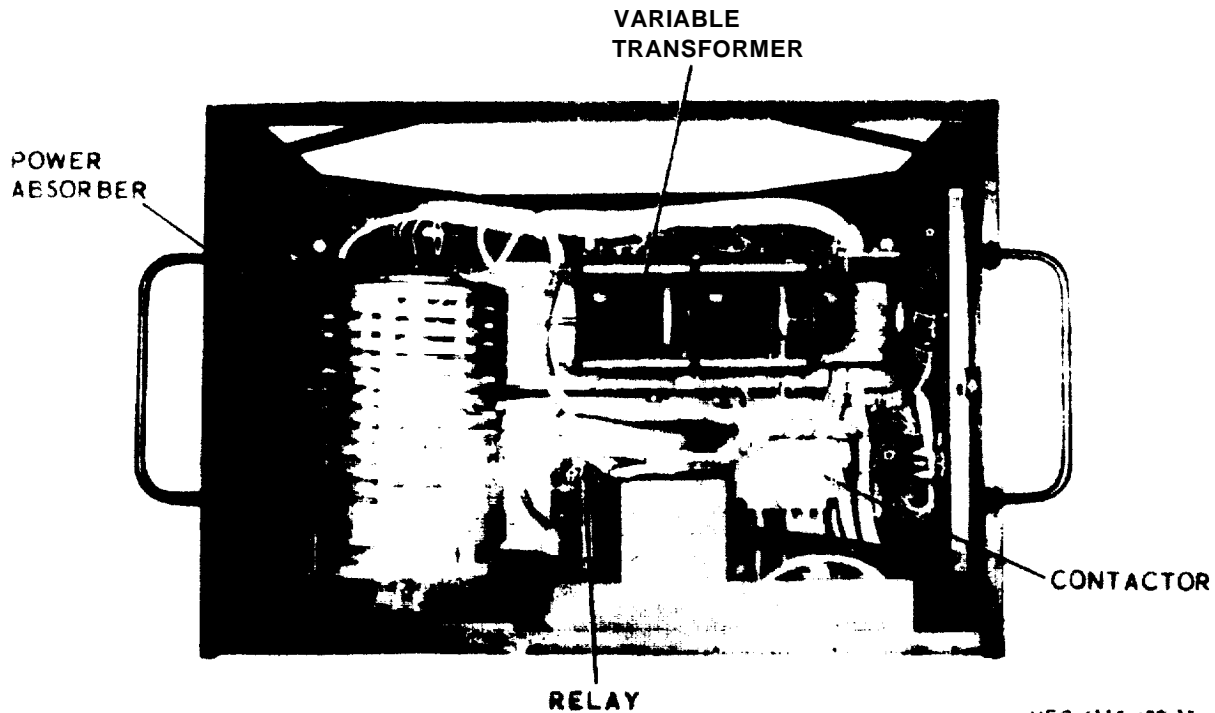

Figure 3. Load bank front view, front access panel removed.

- reset automatically after resistive elements cool down.
- (4) **Variable transformer.** The three-gang variable transformer (fig. 4) provides changeable control of load from 0 to 3 KW. It is operated manually by a variable control knob located on the control panel. With the variable load switch and the variable control knob, the variable transformer controls loads from 0.5 KW to 3 KW on single phase or balanced 3-phase operation. Therefore, using a combination of the fixed load switches and the variable load control, loads from 0.5 KW to 30 KW may be provided.
 - (5) **Contactors.** A 3 PST (Pole Single throw) 200 ampere, 200 volt AC; 400 cycle 28 VDC coil contactor (fig. 4) incorporated into the circuitry makes and breaks applied loads as set up by increment or air-flow switches.
 - (6) **Rectifier.** The rectifier (fig. 3) converts the line voltage to a nominal 28 volts DC at 10 amperes for operation of the power absorber fan motors.
 - (7) **Terminal strip.** Four terminal studs (L_1 , L_2 , L_3 , and L_0) with 3/8-24 threads and bakelite connecting knob, are located on the terminal strip (fig. 2) which is located at the back of the load bank. Two copper shorting links tie terminals together for single phase operation.
 - (8) **Relay.** The relay (fig. 4) with 150 volt minimum, 200 volt maximum pull-in, operates over a frequency range of 50-1000 cps (cycles per second). It senses the input power of the source as determined by connection to terminal strip TB1.
 - (9) **Auto transformers.** The auto transformers are only in use when the load bank is used for high voltage (240/416 VAC). They reduce the high voltage to low voltage so the same components can be used regardless of whether the load bank is used.



MEC 6115-423-15 4

Figure 4. Load bank, top view, cover removed.

for high or low voltage.

- (10) *Control transformers.* The control transformers reduce the 120 VAC to nominal 28-volts. This voltage then goes to the rectifiers.

4. Identification and Tabulated Data

a. Identification. The load bank has 12 major identification plates. The information contained on these plates is listed below.

- (1) *Corps of engineers identification plate.* The plate identifying corps of engineers U.S. Army Data is attached to the right side of the load bank case. It lists serial number, contract number, stock number, model number, shipping weight and other pertinent unit data.
- (2) *Company plate.* The plate is located just below the corps of engineers identification plate. It lists Sun Electric Corporation part number, model number, stock number and contact number as well as the rating of the load bank.
- (3) *Ground plate.* The plate (fig. 2) is attached to the cabinet below and to the left of the control panel and directly below the ground connection.
- (4) *Input selector plate.* The input selector identification plate (fig. 2) is attached to the baffle assembly in the back of the unit. It identified the connector plug connations.
- (5) *High voltage connector plate.* This plate (fig. 2) is attached to the baffle assembly at the rear of the load bank. It identifies high voltage connector receptacle, JIB.
- (6) *Low voltage connector plate.* This plate (fig. 2) is attached to the baffle assembly at the rear of the load bank. It identifies the low voltage connector receptacle, J1A.
- (7) *Terminal plate.* The terminal identification plate (fig. 8) is located on the baffle to the right of the terminal strip TB1. It identifies terminals L₁, L₂, L₃ and L₀.
- (8) *Instuction plate,* The plate with operating instructions is attached to the

control panel door on the left wall of the case, It explains the operating procedure and automatic safety devices and shows connections for various load voltages.

- (9) *Schematic plate.* The electrical schematic plate (fig. 2) is attached to the inside face of the air exhaust door at the back of the load bank. It illustrates complete unit w-i ring.
- (10) *Load switch plate.* The plate identifying the load switches (fig. 7) is attached to the control panel on the left of the load bank. The plate indicates load increments applied by each load toggle switch.
- (11) *Master switch plate.* The plate identifying the master switch (fig. 7) is located on the control panel directly above the load switch plate.
- (12) *Variable load control plate.* The plate identifying variable load control (fig. 7) is located to the right of the load switch plate. An arrow indicates a clockwise turn of the variable load control knob necessary to increase the load.

b. Tabulated Data.

(1) *Load bank.*

Manufacturer _____ Sun Electric Corp.
 Model _____ GPT-3D-1
 Type-- _____ Portable skid mounted,
 self contained
 Power _____ From connected power
 plant

(2) *Power absorbers.*

Manufacturer _____ Sun Electric Corp.
 Type _____ Wound nichrome wire
 (1/8-inch) resistive
 elements. Fan cooled
 with thermal overload

(3), *Rectifier..*

Manufacturer _____ International Rectifier
 Corp.
 Type _____ Selenium rectifier with 4
 3 x 3 40 v rms cells
 single ph.

(4) *Control transformer.*

Manufacturer _____ Hevi-Duty Electric Co.
 Type _____ Dual voltage, 120/240 v
 input; 31.5 ± .4 volt

(5) *Auto-transformer.*

Manufacturer-----Basler Electric Co.
 Type-----240 v, 50-1000 cps single
 phase input 120 v \pm 1%
 output at 1 kw

(6) *Variable transformer.*

Manufacturer-----General Electric Co.
 Type-----Stepless output, manually
 adjusted 3 gang, 240 v
 input, 0-240 v output
 3 ph 10 amp. max
 output

(7) *Contractor.*

Manufacturer-----Hartman Electric Mfg. Co.
 Type-----3PST 200 amp, 200 v;
 400 cycle 28 v. DC

(8) *Fan motor.*

Manufacturer-----Universal Electric Co.
 Type-----28 v DC; 300 watts single
 phase; 800 watts 3
 phase

(9) *Relay.*

Manufacturer-----Magnecraft Electric Co.
 Type-----150 VAC min; 200 VAC
 max. 500-1000 cps

(10) *Load bank capacity.*

Continuous rating-----120/208 volt 3-phase 4-wire
 240/416 volt 3-phase,
 4-wire 240 volt 3-phase,
 3-wire 120 volt 2-wire
 single phase 240 volt
 2-wire single phase
 Fixed loads -----3, 6, 9 or any combination
 up to 27 kw in multiples
 of 3 kw
 Variable loads-----0 to 3 kw at 50-1000 cps.
 Combined fixed and
 variable control of load
 between 0.5 kw and 30

kw single phase or
 balanced 3-phase opera-
 tion with fixed and
 variable load switches in
 proper combination

Temperature limits-----25 degree F to +125
 degree F (-32°C to
 -52°C) at relative
 humidity up to 100%

Altitude range-----Sea level to 8000 feet

Acceleration limits-----2.5 g momentarily applied
 to any 3 major axis; in
 both directions

(11) *Dimensions and weights.*

Length-----36.5 inches
 Width-----23.5 inches
 Height-----27.0 inches
 Weight-----325 pounds
 Shipping weight-----415 pounds

(12) *Wiring diagram.* Refer to figure 5
 for the practical wiring diagram.

(13) *Base plan.* Refer to figure 6 for the
 base plan.

5. Difference in Models

This manual covers the Sun Electric Corp.
 models GPT-3D and GPT-3D-1, load bank,
 0-30 KW, AC. The difference in models is
 that several parts used is the two models are
 not interchangeable. Refer to TM 5-6115-
 423-25P for the correct part used. Also, model
 GPT-3D is physically slightly smaller than
 model GPT-3D-1.

Figure 5. Practical wiring diagram.

(Located in back of manual)

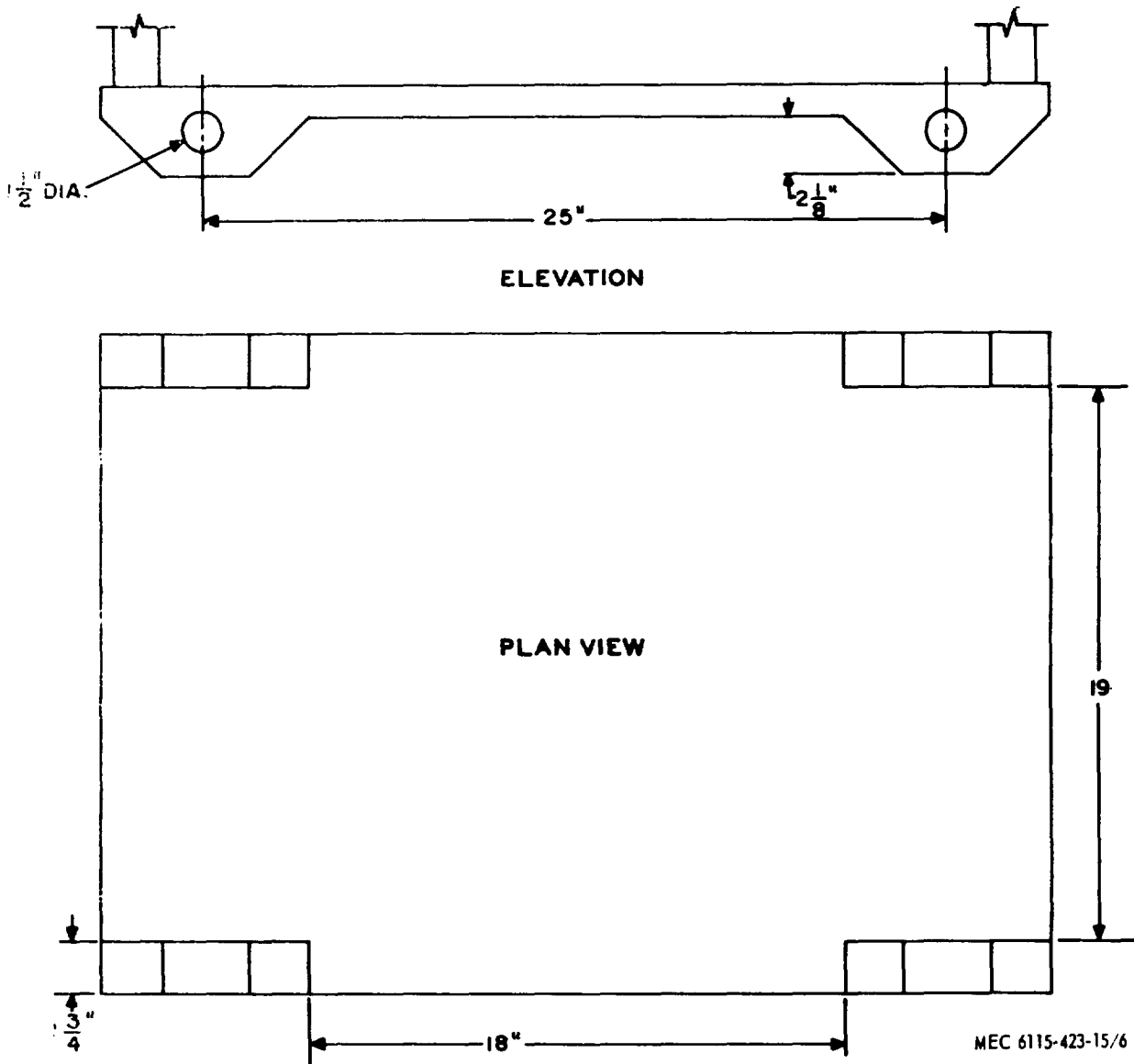

Figure 6. Base plan.

CHAPTER 2

INSTALLATION AND OPERATING INSTRUCTIONS

Section 1. SERVICE UPON RECEIPT OF EQUIPMENT

6. Unloading the Equipment

The load bank is shipped completely assembled enclosed in a wooden crate with blocking supports that prevent shifting during transit. The base of the crate is raised to allow tongs of a fork lift to be inserted in order to move the load bank to site of operation or to storage.

7. Unpacking the Equipment

Remove top, sides, and ends of the crate and strip away weather resistant protective wrapping. Remove the cushioning packing material from cabinet interior and the dessicants placed to remove moisture in transit. In uncrating, not indication of damage to crate or to equipment. Strip away pressure-sensitive tape over doors and openings. Remove hexagon head bolts and flat washers that secure the base to the load bank.

8. Inspecting and Servicing

Warning: Do not connect the Load Bank to power source and energize until initial inspection procedures have been carried out.

a. Following the unpacking of the load bank, inspect the equipment making the following checks:

- (1) Check chassis and cabinet for indications of possible damage.
- (2) Check interior components for in-transit damage.
- (3) Check wiring and posts for loose connections.
- (4) Brush or wipe away dust or other impurities on the power absorbers, variable transformer, rectifier assembly

and other electrical parts where dust might interfere with operation.

- (5) Look over switches and other interior components for security of mounting. Be sure the variable control knob turns as indicated and that transformer components move as knob is turned.

b. Refer to paragraph 31 for daily preventive maintenance service.

9. Installation of Separately Packed Components

The load bank is shipped as a completely self-contained unit. No installation of separately packed components is required.

10. Installation or Setting-Up Instructions

a. Location. Select an area that will insure free circulation of air around the unit and with sufficient working area for operating and servicing. Front access panel and air exhaust door are easily removed for servicing. Allow adequate space for opening doors.

Caution: Allow a minimum of 25 feet separation from fuel storage, combustible or volatile materials. Operate in an area free from obstructions, with sufficient space for opening doors and gaining access to components for operating and servicing.

b. *Outdoor Installation.* Protection against inclement weather and temperature extremes should be considered. Need for a shelter will be dictated by temperature, dust and climatic conditions. Use of a tarpulin or cover when the load bank is not in use is recommended,

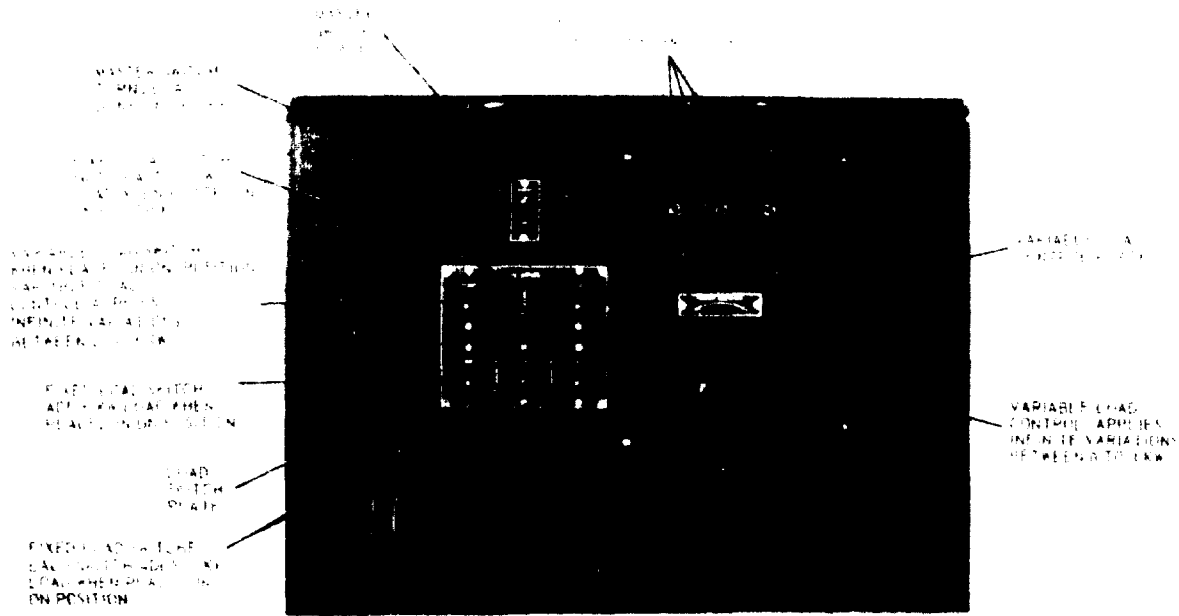

MEC 6115-423-15 7

Figure 7. Controls and instruments-control panel.

When exposed to high moisture conditions particularly in warm climates, components such as fan motors, selenium rectifiers, and variable transformer should be treated to make them moisture and fungus resistant. Housing can be sprayed with a varnish which offers protection against these hazards.

c. Indoor Installation. The load bank should be set up in level position for best oper-

ation either on its own base or secured to pallet, trailer, or skid. It is advisable to set up and use the load bank in an area with sufficient ventilation and free from corrosive atmospheres or oily contaminants. Keep clear of hazardous electrical connections or wires. Assure adequate working space for convenience and safety. Store in dry, clean area and cover to keep dust off the load bank.

Section II. MOVEMENT TO NEW WORKSITE

11. Dismantling for Movement

Disconnect the load bank from power plant before removing parts or assemblies. Procedure for dismantling the load bank in preparation for moving to a new worksite is to:

- a. Disconnect the load as follows:
 - (1) Rotate the variable load control knob (fig. 7) full counterclockwise.
 - (2) Place all fixed load switches 3 through 7 in OFF position.
 - (3) Stop tested equipment.

- (4) Disconnect leads to tested equipment terminal strip. Secure copper shorting links to cabinet by threaded stud and wing nut. Electrical leads and circuits should not be removed unless their purpose is understood. Tag all leads and terminals to identify them for reinstallation.

b. Inspection interior components for security in mounting.

c. Close and lock air exhaust door, control panel door and other panels. Cover seams with pressure sensitive waterproof tape.

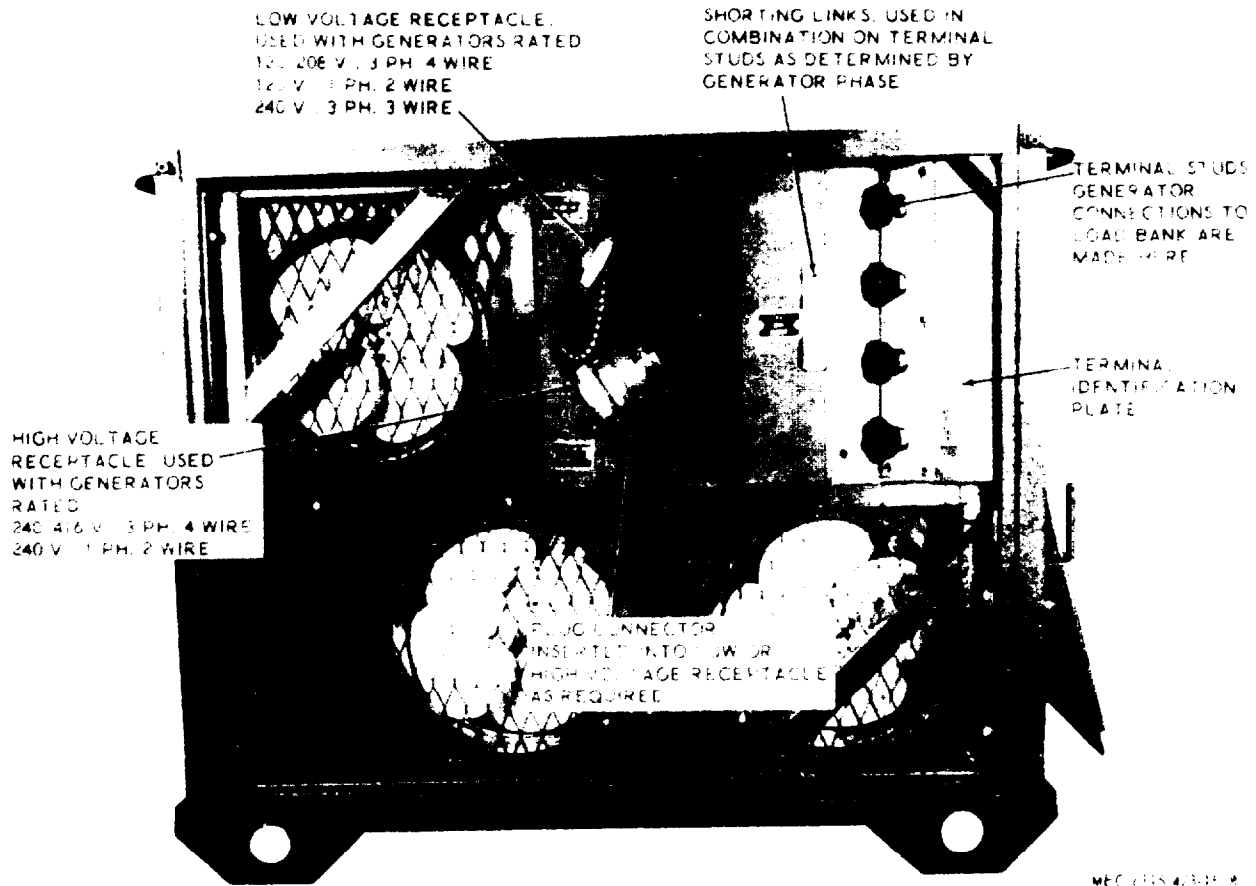

Figure 8. Controls and instruments-baffle assembly.

d. Remove mounting bolts or tie down rods, cables or lashing that fasten load bank to its foundation, skid or trailer.

e. Enclose the tester in an envelope of water resistant barrier material and seal with water-proof pressure sensitive tape.

f. Encase the load bank and its envelope of water resistant barrier material in a strong wooden crate or box of adequate size. When shipped by truck, rail, or air the unit should

be blocked at the base and sides to prevent shifting during transit. The load bank is designed to withstand an acceleration of 2.5 g for a period of 0.10 seconds applied along each of the three major axis in both directions.

12. Reinstallation After Movement

Refer to paragraph 10 (Installation or Setting-Up Instructions) for procedure in re-installing the load bank after movement.

Section III. CONTROLS AND INSTRUMENTS

13. General

This section describes, locates, illustrates and furnishes the operator, crew or organizational maintenance personnel with sufficient information about the various controls and instru-

ments for proper operation of the load bank.

14. Controls and Instruments

The purpose of the controls and instruments and the normal and maximum reading of the instruments are illustrated in figure 7.

Section IV. OPERATION OF EQUIPMENT

15. General

a. The instructions in this section are published for the information and guidance of personnel responsible for operation of the load bank.

b. The operator must know how to perform every operation of which this load bank is capable. This section gives instructions for starting and stopping, basic operations of the load bank and coordination of these functions to perform the specific tasks for which the equipment is designed. Since nearly every job presents a different problem, the operator may have to vary a given procedure to fit the individual job.

16. Starting the Equipment

a. Preparation for starting.

- (1) Perform the necessary daily preventive maintenance services.
- (2) Check load requirements.
- (3) Make sure that all ventilating doors are open and unobstructed, that toggle switches are in OFF position, and that variable load control knob is turned full counterclockwise.
- (4) Open the exhaust door for access to the connector plug, two receptacles and terminal strip TB. Plug connector and receptacles are located on the baffle assembly. The plug when inserted in the low voltage receptacle for loading generators rated 120/208 volts, 3-phase 4-wire; 120 volts single phase two wire or 240 volts 3-phase, 3-wire. High voltage receptacle JIB sets up input connections for loading generators rated 240/416 volts, 3-phase 4-wire and 240 volts single phase 2-wire. Depending upon whether the relay senses high or low voltage, the Plug P, must be inserted into the proper receptacle (either J1A and J1B) for the loading circuitry to function.
- (5) Connect leads to tested equipment to terminal strip for single or three

phase load tests, Make the following connections.

- (a) *Single Phase Connection.* To load a single phase generator tie the terminals L_1 , L_2 , and L_3 together by means of two copper shorting links (fig. 8) which are furnished with the unit. Connect leads from tested equipment securely to L_1 and L_0 on terminal board. Hand tighten knobs.
- (b) *Three Phase, Three Wire Connection.* To load a three phase, three-wire generator, connect leads to terminals L_1 , L_2 , and L_3 . Do not use the copper shorting links to tie the terminals together.
- (c) *Three Phase, Four Wire Connections.* To load a three phase, four-wire generator connect leads to terminals L_1 , L_2 , L_3 , and neutral line L_0 . Do not use the copper shorting links to tie the terminals together.
- (d) *Ground lead.* Connect the ground lead (fig. 2) on the control panel to an adequate ground such as a water pipe so as to properly ground the metal chassis and cabinet.

b. *Starting.* Refer to figure 9 and start the load bank.

Warning: High currents and voltages may be present at the load bank resistive elements during check out test. Dangerous shock hazards are present, Do not place hands or tools near the motor fan while the Load Bank is energized.

Warning: Very toxic fumes of selenium dioxide are given off when selenium coated plates burn. Never breathe the fumes. Keep fumes or compound away from your skin. Handle the burned plates with gloves; dispose of gloves or contaminated materials as prescribed for toxic materials.

17. Stopping the Equipment

- a. Refer to figure 10 and stop the load bank.

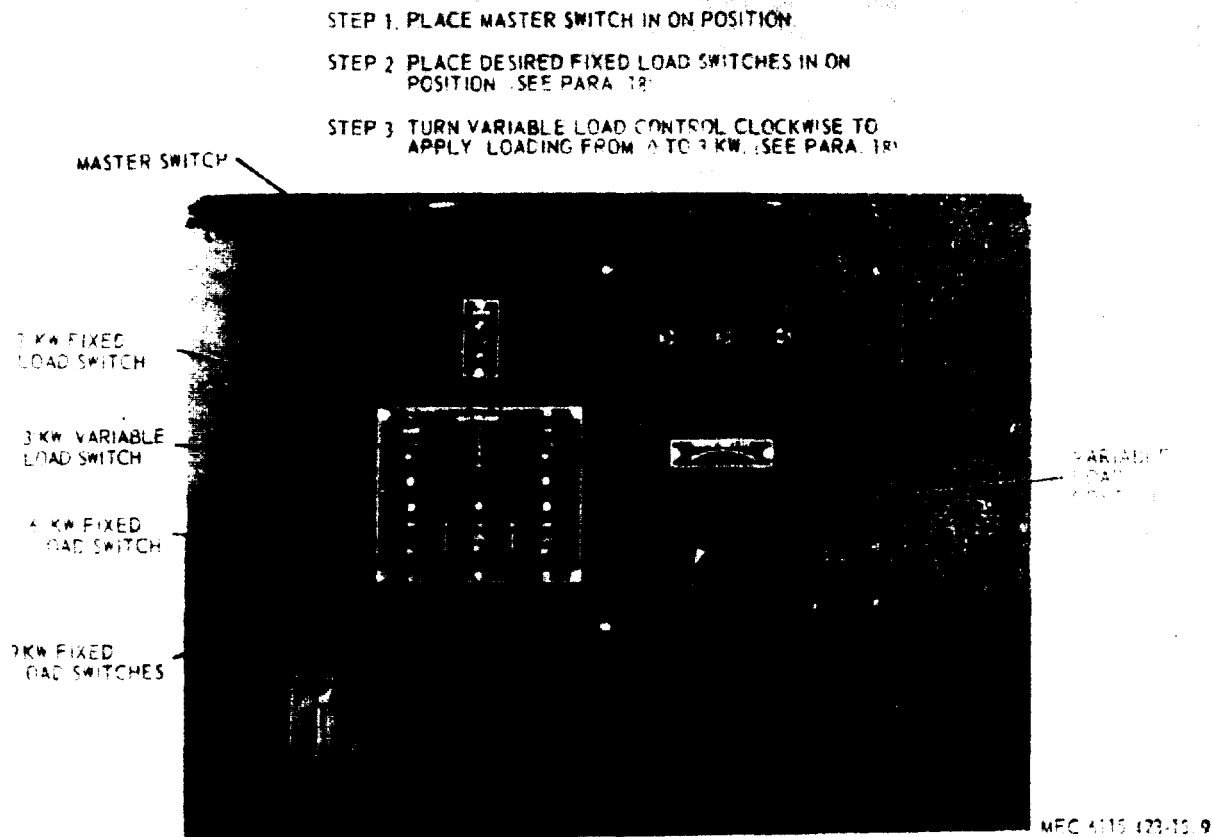

Figure 9. Starting load bank.

b. Perform the necessary daily preventive maintenance services (para 31).

18. Operation Under Usual Conditions

a. Insert the plug connector into the proper receptacle as described in paragraph 16, Starting The Equipment.

b. Combine fixed loads in increments of 3 KW up through 27 KW and variable loads infinite variations from 0 to 3 KW. It is possible to apply any load to the generator under test from 0 to 30 KW. Several examples of how fixed and variable loads can be combined to achieve types of loading are given here:

(1) *Example 1.* Apply a load of 20 kilowatts,

(a) Close fixed load toggle to apply a fixed load of 18 kilowatts. Select either a combination of two 9 kilowatt switches or the 3, 6 or 9 kilowatt switches.

(b) Add kilowatt by turning the variable switch on and the variable control knob to a 2 kilowatt reading.

(2) *Example 2.* Apply a load of 2 1/2 kilowatts. Turn the variable control knob to a reading of 2 1/2 kilowatts.

(3) *Example 9.* Apply a load of 28 kilowatts.

(a) Close all fixed toggle switches (3, 6, 9, and 9 KW) to apply a load of 27 kilowatts.

(b) Turn the variable switch on and turn the variable control knob to a 1 KW reading. This adds 1 kilowatt to the 27 kilowatts, giving a total loading of 28 kilowatts.

Note. The loads described above as well as other combinations can be applied to any generator capable of being tested by the load bank.

- STEP 1. TURN VARIER TO OFF POSITION.
- STEP 2. PLACE MASTER SWITCH IN OFF POSITION.
- STEP 3. ALLOW COOLING FAN TO STOP BEFORE PLACING MASTER SWITCH IN OFF POSITION.
- STEP 4. PLACE MASTER SWITCH IN OFF POSITION.

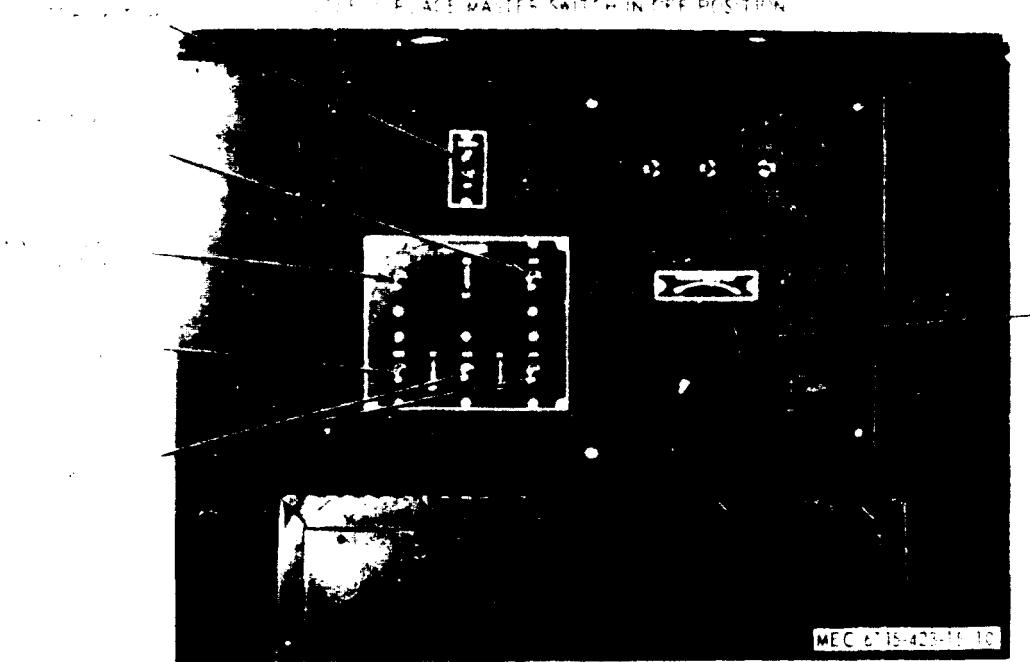

Figure 10. Stopping load bank.

19. Operation in Extreme Cold [Below 0° F)

The load bank is designed to operate at temperatures above minus 25 degrees Fahrenheit, but not below this temperature. Where the load bank is subjected to sub-zero temperatures, adequate protection should be provided against the deteriorating effects of wind, snow and ice. When practical portable electric heaters may be placed inside the load bank to raise ambient temperature to at least zero degrees Fahrenheit. Remove heater before putting load bank in operation.

20. Operation in Extreme Heat

The load bank is designed to operate at temperatures up to 125 degrees F., but prolonged exposure to environments of excessively

high temperature and humidity requires special treatment, with particular attention to use of dessicants to inhibit corrosive action due to high moisture content.

21. Operation in Dusty or Sandy Areas

Inspect the load bank every 50 operating hours or every month. Clean out and remove accumulated dust and sand. Wipe electrical components with a dampened soft cloth. Clean the interior of the load bank with a low pressure jet of dry air. Do not wipe insulation with cleaning solvents that may damage insulation. In dusty atmosphere a fine screen can be placed across the front and back of the load bank so that air drawn through the unit is freed of dust.

22. Operation under Rainy or Humid Conditions

Adequate use of dessicants will insure reduction of corrosion due to high humidity conditions in the atmosphere. Under conditions of excessive humidity or moisture and high temperature, fungus growth is a possibility. Treat components such as the selenium rectifier, variable transformer and power absorber fan motors with a protective coating such as varnish that is resistant to moisture and fungi.

23. Operation in Salt Water Areas

Operation near salt water presents no additional problems other than those described in paragraph 22.

24. Operation in High Altitudes

The load bank is designed to operate satisfactorily at altitudes from sea level to 8000 feet. It is not advisable to operate it above an altitude of 8000 feet because electrical characteristics of insulation and connections change.

CHAPTER 3

OPERATOR AND ORGANIZATIONAL MAINTENANCE INSTRUCTIONS

Section 1. SPECIAL TOOLS AND EQUIPMENT

25. Special Tools and Equipment

No special tools or equipment are required by the operator or organizational maintenance personnel for the maintenance of the load bank.

26. Basic Issue Tools and Equipment

Tools and repair parts issued with or author-

ized for the load bank are listed in the basic issue items list, Appendix C of this manual.

27. Organizational Maintenance Repair Parts

Organizational maintenance repair parts are listed and illustrated in TM 5-6115-423-25P.

Section II. LUBRICATION

28. General Lubrication Information

No lubrication of the components of the load bank is required. Three power absorber fan motors are equipped with factory lubricated sealed for life bearings.

29. Detailed Lubrication Information

An occasional drop of lubricating oil should be applied to the cabinet door hinges when required.

Section III. PREVENTIVE MAINTENANCE SERVICES

30. General

To insure that the load bank is ready for operation at all times it must be inspected systematically so that defects may be discovered and corrected before they result in serious damage or failure. The necessary preventive maintenance services to be performed are listed and described in paragraphs 31 and 32. The item numbers indicate the sequence of minimum inspection requirements. Defects discovered during operation of the unit shall be noted for future correction, to be made as soon as operation has ceased. Stop operation immediately if a deficiency is noticed during opera-

tion which would damage the equipment if operation were continued. All deficiencies and shortcomings will be recorded together with corrective action taken on DA Form 2404 (Equipment Inspection and Maintenance Worksheet) at the earliest possible opportunity.

31. Daily Preventive Maintenance Service

This paragraph contains an illustrated tabulated listing of preventive maintenance service which must be performed by the operator. The item numbers are figure 11 for the daily preventive maintenance services.

PREVENTIVE MAINTENANCE SERVICES DAILY

TM5-6115-423-15SUN ELECTRIC MODEL GPT-3D-1LOAD BANK

ITEM		PAR REF
1	<u>CONNECTIONS.</u> Look for damaged wires, insulation, loose connections, insecure mountings.	-
2	<u>TERMINALS.</u> Clean corroded or oxidized terminals.	40
3	<u>ELECTRICAL COMPONENTS.</u> Wipe dust or oil off components with soft cloth.	-
4	<u>FAN MOTOR.</u> Listen for excessive hum; check for overheating. Tighten loose mounting.	36
	<u>NOTE 1. OPERATION.</u> During operation observe for any unusual noise or vibration.	

MEC 6115-423-15/11

Figure 11. Daily preventive maintenance services.

PREVENTIVE MAINTENANCE SERVICES QUARTERLY

TM5-6115-423-15

SUN ELECTRIC MODEL GPT-3D-1

LOAD BANK

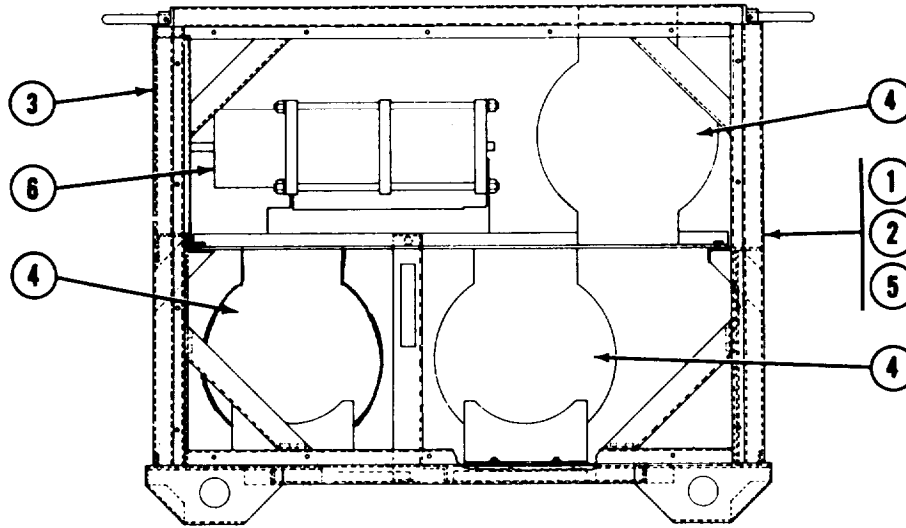

ITEM		PAR REF
1	GENERAL INSPECTION. Inspect interior and exterior of Load Bank. Clean away dirt, oil film, and rust from frame, expanded metal grill or components. Repaint bare metal exposed by clean up.	-
2	CONNECTIONS. Check for damaged wires, loose connections and insecure mountings. Retighten and replace where needed.	-
3	SWITCHES. Check switches for clean action and tight mountings. Replace if faulty.	38
4	FAN MOTOR. Check for overheating and excessive vibration.	36
5	TERMINALS. Clean corroded terminals.	40
6	ELECTRICAL COMPONENTS. Wipe oil, dust and dirt off components with soft cloth.	-
	NOTE 1. OPERATIONAL TEST. During operation observe for any unusual noise or vibration.	
	NOTE 2. ADJUSTMENTS. Make all necessary adjustments during operational test.	

MEC 6115-423-15/12

Figure 12. Quarterly preventive maintenance services.

32. Quarterly Preventive Maintenance Services

a. This paragraph contains an illustrated tabulated listing of preventive maintenance services which must be performed by organizational maintenance personnel at quarterly intervals. A quarterly interval is equal to 3-

calendar months or 250 hours of operation, whichever ever occurs first.

b. The item numbers are listed consecutively and indicate the sequence of minimum requirements. Refer to figure 12 for the quarterly preventive maintenance services.

Section IV. OPERATOR MAINTENANCE

33. General

The instructions in this section are published for the information of the operator in maintaining the load bank.

34. Fuse Replacement

Fuses F_1 , F_2 , and F_3 are located in holders mounted on the control panel in the upper right hand corner (fig. 7). To replace a fuse unscrew it counterclockwise (direction of arrow). Replace with new fuse. Screw in new fuse clockwise until snug. Do not overtighten.

35. Identification Plate Replacement

There are 12 identification plates on the GPT-3D-1 load bank. To remove any plate, remove rivets holding the plate to the chassis. Use new rivets to fasten the replacement plate to the chassis in the same location.

36. Fan Service

Refer to figure 15 and adjust the fan. Inspect or adjust fan only when load bank is disconnected from power source. To remove fan from fan motor shaft, loosen set screw on fan hub. Slip fan off shaft by placing fingers behind blades and pulling gently toward end of shaft. Check for damage or distortion. To replace fan, slip hub of fan 3/8 inch from end of shaft. Retighten set screw firmly. To check for unbalance in blade, snap master switch to "on",

Warning: Fan revolves at high speed, so keep hands and tools free of path of rotating blades

37. Doors and Panels

a. Removal and Installation. Refer to figure 13 to remove and install the door, panel, and cover.

b. Cleaning and Inspection. Clean all parts with an approved cleaning solvent and dry thoroughly. Inspect for cracks, breaks, or other damage. Replace all defective parts.

38. Wind Switch and Toggle Switches

a. Wind Switch. There is one wind switch (fig. 15) located in each power absorber assembly. Inspect each switch for loose connections, damage, and mechanical operation. Test switch for continuity.

b. Toggle Switches. Inspect six toggle switches located on the control panel for loose connections, damage, tightness of mounting and mechanical operation. Test each switch for continuity.

39. Rectifier

Inspect rectifier (fig. 3) for evidence of burning on plates, loose connections, and secure mounting. Report burned plates to appropriate maintenance facility for repair.

40. Terminal Studs

a. Removal. The four terminal studs are located on input terminal board TBI and are removed as follows:

- (1) Disconnect and tag wires from back of terminal board (see wiring diagram).
- (2) Refer to figure 14 and remove the terminal studs.

b. Cleaning and Inspection. Clean all parts with an approved cleaning solvent and dry thoroughly. Inspect for cracks, breaks, and damaged or stripped threads. Replace all defective parts.

c. Installation. Refer to figure 14 and the wiring diagram and install the terminal studs.

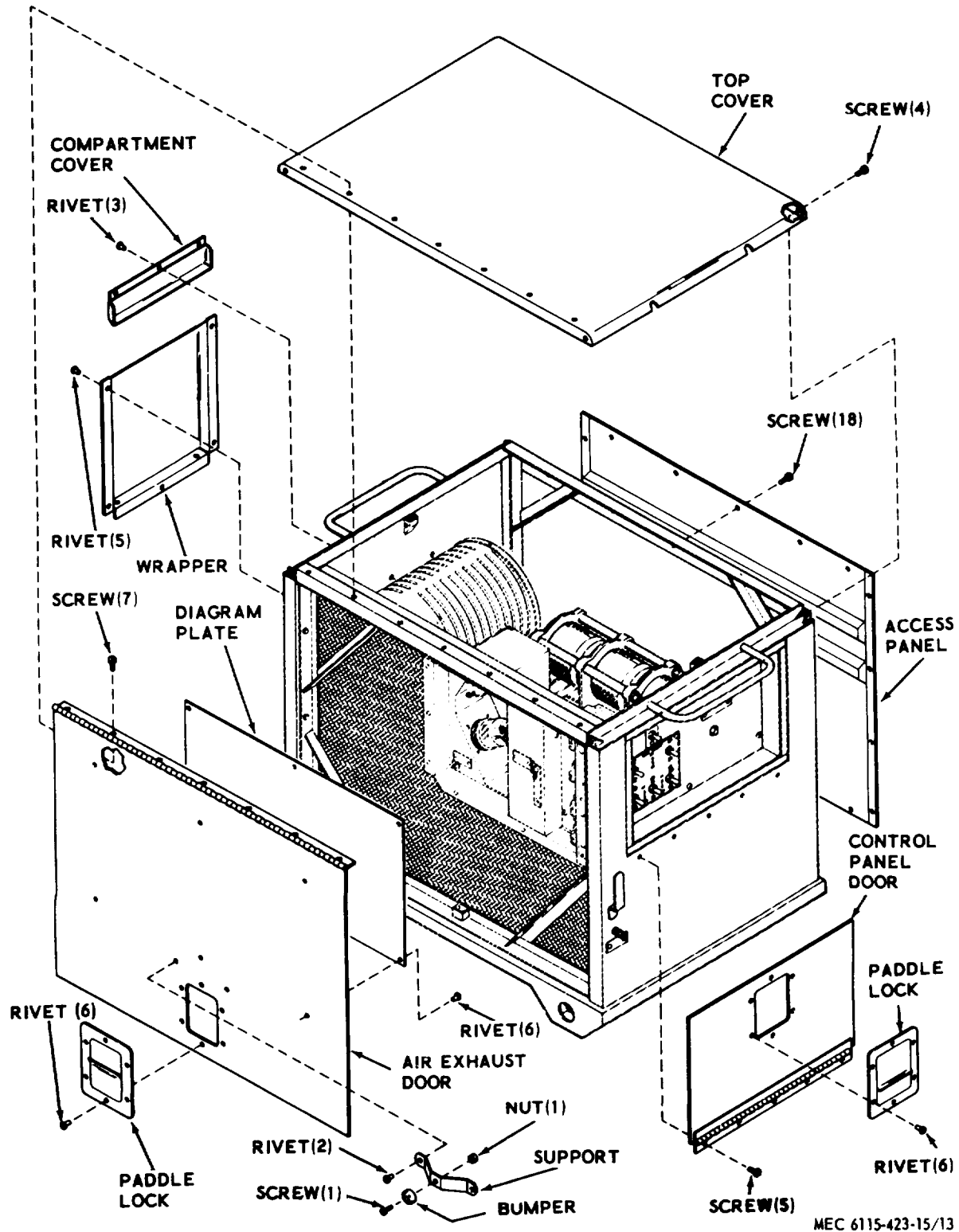

Figure 13. Doors and panels.

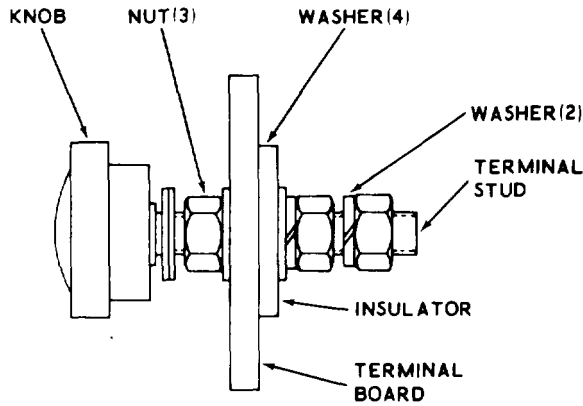

Figure 14. Terminal studs.

41. Filter Capacitors

Inspect the filter capacitors (fig. 3) visually for damage and loose connections. Test for

shorts and proper capacitance if a capacitor tester is available. Use an ohmmeter to test for shorts Wing RX 10,000 scale. Make sure the capacitor is discharged prior to testing. Place one lead on body of capacitor and other lead on terminal. If there are no shorts, the ohmmeter will read infinity (∞). Then place leads on capacitor in reverse of above without touching the capacitor with your fingers and the needle should jump momentarily and then settle back to ∞ resistance. Replace defective capacitor by disconnecting leads and removing mounting screw.

42. Connectors

Inspect connectors located on baffle assembly visually for damaged threads, broken connections, and broken or damaged pins. Test for continuity. Replace defective connector by disconnecting and tagging electrical leads and removing four mounting screws and nuts.

Section V. TROUBLESHOOTING

43. General

This section provides information useful in diagnosing and correcting unsatisfactory operation or failure to the load bank and its components. Each trouble symptom stated is followed by a list of probable causes of the trouble. The possible remedy recommended is described opposite the probable cause. Any trouble beyond the scope of organizational maintenance shall be reported to direct support maintenance.

44. Load Bank Fails to Start

Probable cause	Possible remedy
Plug P ₁ is inserted in wrong receptacle.	Insert Plug P ₁ in correct receptacle (para 16).
Blown fuses-----	Replace blown fuses F ₁ , F ₂ , and F ₃ . Find control or generator fault which caused stoppage. Make continuity check of circuit.

45. Fixed Load Switches are on but no load is Applied

Probable cause	Possible remedy
Broken lead _____	Replace faulty wire.
Loose connection -----	Tighten connection.
Plug P ₁ is in wrong receptacle.	(para 44)

46. Power Absorber Overheats

Probable cause	Possible remedy
Insufficient ventilation----	Clear blocked air openings, clear away obstructions.

47. Radio Interference

Probable cause	Possible remedy
Loose or broken suppressor brush on motor.	Tighten or replace brush.
Load Band not grounded---	Be sure the chassis and cabinet are grounded.
Defective capacitors C ₁ and C ₂ .	Replace capacitors.

48. Variable Load Switch Does Not Apply

Probable cause	Possible remedy
Variable Load Control switch not in ON position	Position load switch to ON .
Loose or broken leads----	Tighten or replace leads.
Plug P ₁ in wrong receptacle.	(para 44)

49. Load Drops Suddenly

Probable cause	Possible remedy
Fuses F ₁ , F ₂ , and F ₃ , blown	Replace blown fuses. Reapply load.
Generator failure-----	Check and replace with new generator.
Selenium rectifier burning or has failed (accompanied by acrid stench) .	De+energize load bank, remove outside to dissipate fumes. Replace damaged rectifier.

Section VI. RADIO INTERFERENCE SUPPRESSION

50. Definitions

a. Interference. The term “interference” as used herein applies to electrical disturbances in the radio frequency range which are generated by the load bank and which may interfere with the proper operation of radio receivers or other electronic equipment, or enable an enemy to locate the equipment.

b. Interference Suppression. The term “interference suppression” as used herein applies to the methods used to eliminate or effectively reduce radio interference generated by the load bank.

51. General Methods Used to Attain Proper Suppression

Essentially, suppression is attained by providing a low resistance path to ground stray

currents. The methods used include shielding the ignition and high-frequency wires, grounding the frame with bonding straps, and using capacitors and resistors.

52. Radio Interference Suppression Components

Suppression is attained through a radio suppression brush grounded to the frame of the motor housing and which rides on the motor housing and which rides on the rotating shaft and through capacitors C₁ and C₂. Sparking and other electrical disturbances are quickly grounded and suppressed.

53. Replacement of Suppression Components

Refer to figure 15 and replace the radio interference suppression components.

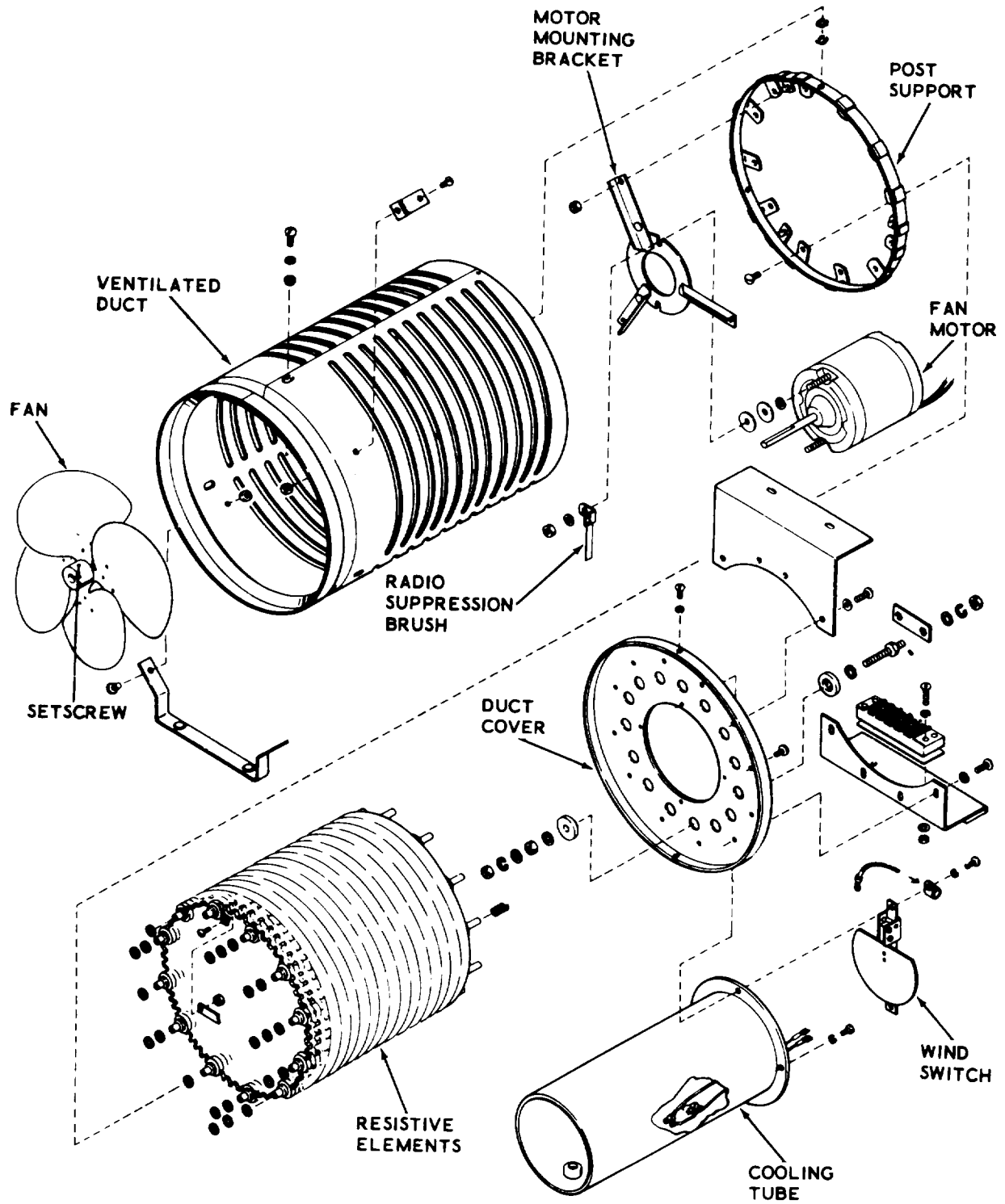

MEC 6115-423-15/15

Figure 15. Radio interference suppression.

CHAPTER 4

DEMOLITION OF EQUIPMENT

Section 1. DEMOLITION OF LOAD BANK TO PREVENT ENEMY USE

54. General

a. When capture or abandonment of the load bank to an enemy is imminent, the responsible unit commander must make the decision either to destroy the equipment or render it inoperative. Based on this decision, orders are issued which cover the desired extent of destruction. Whatever method of demolition is employed, it is essential to destroy the same vital parts of all load banks and all corresponding spare parts.

b. When lack of time or personnel prevents complete destruction of the equipment, the following priorities will be used in the destruction of essential parts

- (1) Control panel assembly
- (2) Power absorbers
- (3) Variable transformer
- (4) Contactor
- (5) Rectifier

55. Demolition to Render the Equipment Inoperative

a. Mechanical Means. Use sledge hammers, crowbars, picks, axes or any other heavy tools which may be available to completely destroy the following:

- (1) Control panel
- (2) Power absorbers
- (3) Variable transformer

Note. The above steps are minimum requirements for this method of destruction.

56. Demolition by Explosive or Weapons Fire

a. Explosives. Place charges in interior of unit and detonate them simultaneously with a suitable detonator and detonating cord.

b. Weapons Fire. Fire on the load bank with the heaviest practical weapons available.

57. Other Demolition Methods

a. Scattering and Concealment. Remove all easily accessible parts and scatter them through dense foliage, bury them in a lake, stream, or other body of water.

b. Burning. Pack rags, clothing, or canvas inside, under and around the load bank. Saturate this packing with gasoline, oil or diesel fuel and ignite it.

c. Submersion. Totally submerge the equipment in water to provide water damage and concealment. Salt water does greater damage to metal parts than fresh water.

58. Training

All operators should receive training in the destruction of the load bank. Refer to FM 5-25. Simulated destruction using all of the methods listed, should be included in the training program. It must be emphasized in training that demolition operations are usually necessitated by critical situations when time available for carrying out destruction is limited. For this reason, it is necessary that operators be thoroughly familiar with all methods of destruction of equipment, and be able to carry out demolition instructions without reference to this or any other manual.

CHAPTER 5

DIRECT SUPPORT, GENERAL SUPPORT AND DEPOT MAINTENANCE INSTRUCTIONS

Section I GENERAL

59. Scope

These instructions are published for the use of field and depot maintenance personnel maintaining the Sun Electric Model GPT-3D-1 load bank. They provide information on the maintenance of the equipment which is beyond the scope of the tools, equipment, personnel or supplies normally available to using organizations.

60. Record and Report Forms

For record and report forms applicable to direct and general support and depot maintenance, refer to TM 38-750.

Note. Applicable forma, excluded standard Form 46 (United States Government Vehicles Operator's Identification Card) which is carried by the operator shall be, kept in a canvas bag mounted on the equipment.

Section II. DESCRIPTION AND DATA

61. Description

For a complete description of the load bank Model GPT-3D-1 see paragraph 8.

62. Tabulated Data

a. General. This paragraph contains all the overhaul data pertinent to the direct and general support and depot maintenance personnel. A wiring schematic (fig. 16) is also included.

b. Electrical Power Absorber, Classification and Rating.

Rating ----- 10 kw
Resistive element ----- 1/8-inch Nichrome wire, wound counterclockwise, number of turns, spacing and length of ribbon is determined by wiring assembly. Motor leads, thermal overload (kilixon) and air switch leads brought out through clamp to terminal board.

Mounting----- Mount fan hub 3/8-inch from end of shaft.

Figure 16. Load bank wiring schematic.
(Located in back of manual)

c. Fan Motor.

Type----- 28 volts DC from AC input power through transformer-rectifier module.
Rating ----- 1/20 HP minimum at 3600 RPM
Duty----- Continuous
Degree enclosure----- Full
Mounting----- Motor mounting bracket within power absorber
Rpm----- 3600 rpm minimum
 4000 rpm maximum

d. Auto-transformer, Classification and Rating.

Rating----- 240 volt, 50-1000 cps, single phase input, 120 volts ±1% output at 1 km Forced air cooling at 600 Lineal feet/minute
 125° F ambient

Mounting dimensions _____ width: 4 inches
 height: 4 5/8 inches plus
 1 1/8 inches (terminal)
 length: 5 1/4 inches
 5/6 x 9/16 inches
 elongated mounting
 holes in base

e. Control transformer, Classification and Rating.

Rating... ----- 120/240 volt, 50-1000 cps
 single phase dual voltage
 input, output:

Rating _____ 34.5 ±0.4 at open circuit
 31.5 ±0.4 volts at 2.0
 amperes
 26.0 * 0.4 volts at 6.0
 amperes

Capacity _____ 115 VA, forced air cooled
 at 500 lineal feet per
 minute. At 125° F.
 ambient must be capable
 of operating at 138/276
 volts input

Mounting dimensions ----- Width: 3 5/8 inches
 height: 4 3/16 inches
 plus 5/8 inches (ter-
 minals)
 Length: 4 1/2 inches.

f. Selenium Rectifier, Classification and Rating.

Rating-_____ 2.5 amperes, 30 volts DC
 at 122° F ambient con-
 vection cooled composed
 of four 3.3 inch, 40 volt
 RMS cells connected in

single phase, full wave
 bridge

g. Contactor, Classification and Rating.

Rating ----- 3 PST 200 amperes, 200
 volts 40 cycle 28 volt
 DC
 Controls 40 kw 3-phaae
 wye connected bal.
 resistive load
 120/208 v. 3-phase,
 4-wire 240 v. 3 phase,
 3 wire 240/416 v. 3-
 phase 4-wire input at
 50-1000 cycles/see.

h. Relay, Classification and Rating.

Type rating ----- 150 volts minimum
 200 volts maximum
 50-1000 cps

i. Variable Transformer, Classification and Rating.

Rating ----- 0-3 KW 3-gang 3-phase
 10 amperes maximum
 output
 Rating _____ Stepless, manually adjusted,
 output 0-240 volts
 240 volt input constant
 impedance load, 319°
 rotation
 Dimensions ----- Length: 16 7/8 inches
 Height: 5 5/8 inches
 Width: 6 inches

j. Practical Wiring Diagram. Figure 5 shows
 the practical wiring diagram for this load bank.

CHAPTER 6

GENERAL MAINTENANCE INSTRUCTIONS

Section 1. SPECIAL TOOLS AND EQUIPMENT

63. Special Tools and Equipment

No special equipment or tools are required by direct and general support and depot maintenance personnel for performing maintenance on the load bank.

64. Specially Designed Tools and Equipment

No specially designed equipment or tools are required by direct and general and depot maintenance personnel for performing maintenance on the load bank.

Section II. TROUBLESHOOTING

65. General

This section provides information useful in diagnosing and correcting unsatisfactory operation or failure of the load bank or any of its components. Each trouble symptom stated is followed by a list of probable causes of trouble. The possible remedy recommended is described opposite the probable cause.

66. Fixed Load Switches are on but no Load is Applied

<p>Probable cause</p> <p>Defective contactor <i>K-1</i> .-</p> <p>Defective increment or air flow switches.</p> <p>Defective relay <i>K-2</i>-----</p> <p>Thermal switches _____</p> <p>Transformers -----</p> <p>Rectifiers-----</p> <p>Fixed and variable load switches.</p> <p>Wind switches -----</p>	<p>Possible remedy</p> <p>Replace or repair contactor (para 76, 88).</p> <p>Replace switches (fig. 15).</p> <p>Replace or repair relay (para 75, 86).</p> <p>(para 3c(3))</p> <p>(para 79, 82 and 92)</p> <p>(para 39)</p> <p>(para 86b)</p> <p>(para 38a)</p>
---	---

67. Power Absorber Overheats

<p>Probable cause</p> <p>Fan inoperative _____</p>	<p>Possible remedy</p> <p>Repair or replace fan motor if faulty. Tighten fan blade if loose. Check and retighten connections to fan motor (para 36 and 90).</p>
--	---

68. Relay Does Not Operate

<p>Probable cause</p> <p>Relay is defective _____</p>	<p>Possible remedy</p> <p>Test and replace relay if defective (para 75)</p>
---	---

69. Variable Load Switches Does Not Apply Load

<p>Probable cause</p> <p>Variac brushes worn _____</p>	<p>Possible remedy</p> <p>Check and replace variable transformer if brushes are worn (para 72 and 79) .</p>
--	---

70. Load Drops Suddenly

<p>Probable cause</p> <p>Contactor (<i>K₁</i>) operating improperly.</p>	<p>Possible cause</p> <p>Replace contactor (<i>K₁</i>) (para 76).</p>
---	--

Section III. REMOVAL AND INSTALLATION OF MAJOR COMPONENTS

71. General

This section contains instructions for the removal and installation of the variable trans-

formers, auto transformers, rectifier, relay, contactor, power absorbers, and control transformers. Refer to figure 13 to remove any

panel or door allowing access to the major component.

72. Variable Transformer

a. On Equipment Test.

- (1) Refer to figure 6 and 9.
- (2) De-energize load bank and connect voltmeter to terminals # 1 and #4.
- (3) Energize load bank. Reading should be of 240 volts AC.
- (4) De-energize load bank and connect voltmeter to terminals #3 and #4.
- (5) Energize load bank and turn the variable control all the way counterclockwise. The voltmeter should read 0. volts. Turn the variable control gradually clockwise until it is all the way clockwise. The voltmeter reading should gradually increase to 240 volts AC.
- (6) If these readings are not obtained, replace the variable transformer.

b. Removal and Installation. Refer to figure 17 to remove and install the variable transformer.

73. Auto Transformers

a. On Equipment Test.

- (1) Refer to figure 5 and 18.
- (2) De-energize load bank and connect voltmeter to terminals H1 and X2.
- (3) Energize load bank with 240/416 volts AC.
- (4) Voltmeter should read 240 volts.
- (5) De-energize load bank and connect voltmeter to X1—X2.
- (6) Re-energize load bank and voltmeter should read 120 volts AC.
- (7) If this reading is not obtained, replace auto transformer.

b. Removal and Installation. Refer to figure 18 to remove and install the auto transformers.

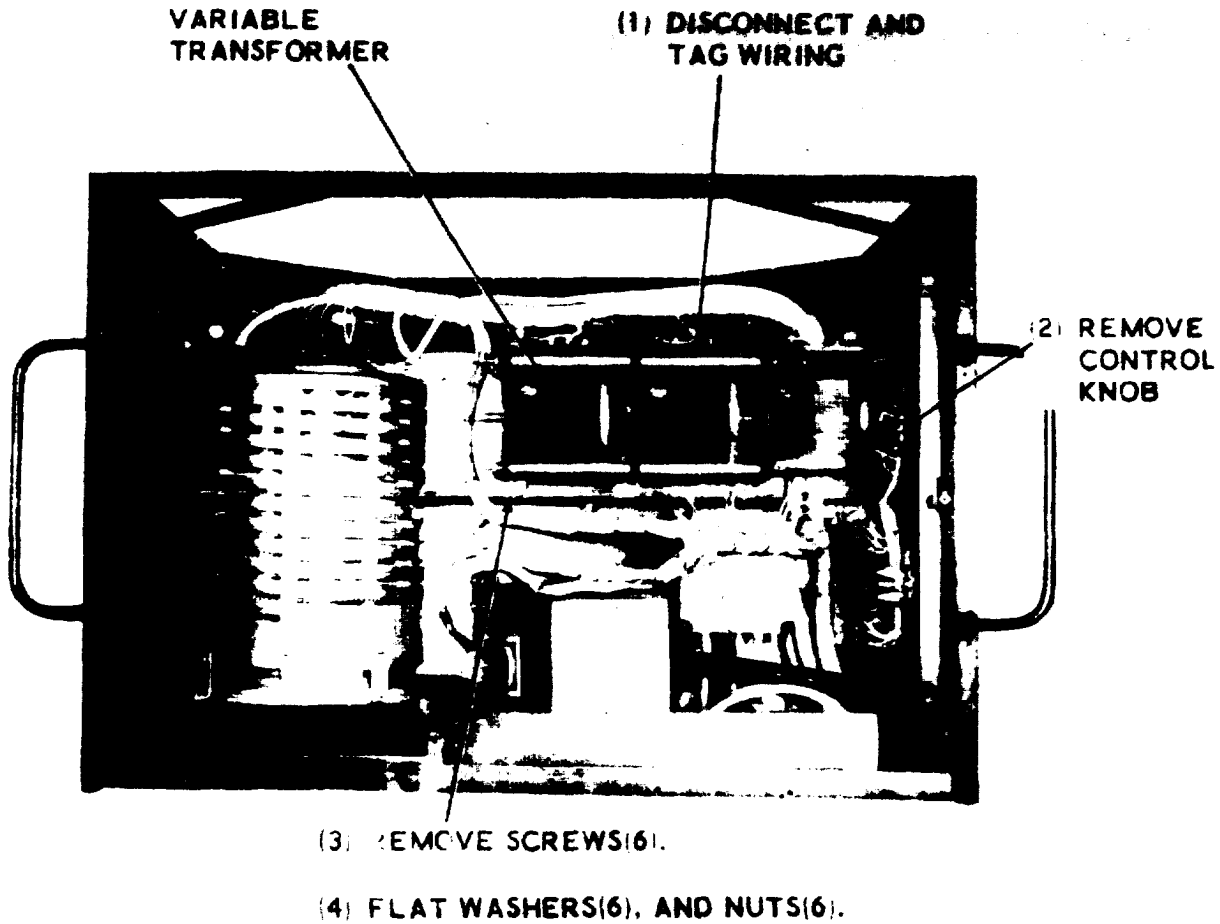

MEC 6115-423-15/17

figure 17. Variable transformer removal and indstallation.

74. Rectifier

a. *On Equipment Test.* Refer to paragraph 84d.

b. *Removal and Installation.* Refer to figure 19 to remove and install rectifier.

75. Relay

a. *On Equipment Test,* Refer to paragraph 82d.

b. *Removal and In.stallation.* Refer to figure 20 to remove and install the relay.

76. Contactor

a. *On Equipment Test.* Refer to paragraph 84d.

b. *Removal and Installation.* Refer to figure 21 to remove and install the contractor.

77. Power Absorbers

a. *On Equipment Test.*

- (1) De-energize load bank,
- (2) Remove all wires and tags.
- (3) Check each coil for continuity.
- (4) Check for grounds.
- (5) Replace wires.

b. *Removal and Installation.* Refer to figure 22 to remove and install the power absorbers.

78. Control Transformers

a. *On Equipment Test.*

- (1) De-energize load bank, and connect voltmeter to terminals H1 and H2.
- (2) Energize the load bank and the voltmeter should read 120 VAC.
- (3) Repeat by connecting to terminals H3 and H4. The same reading should be obtained.

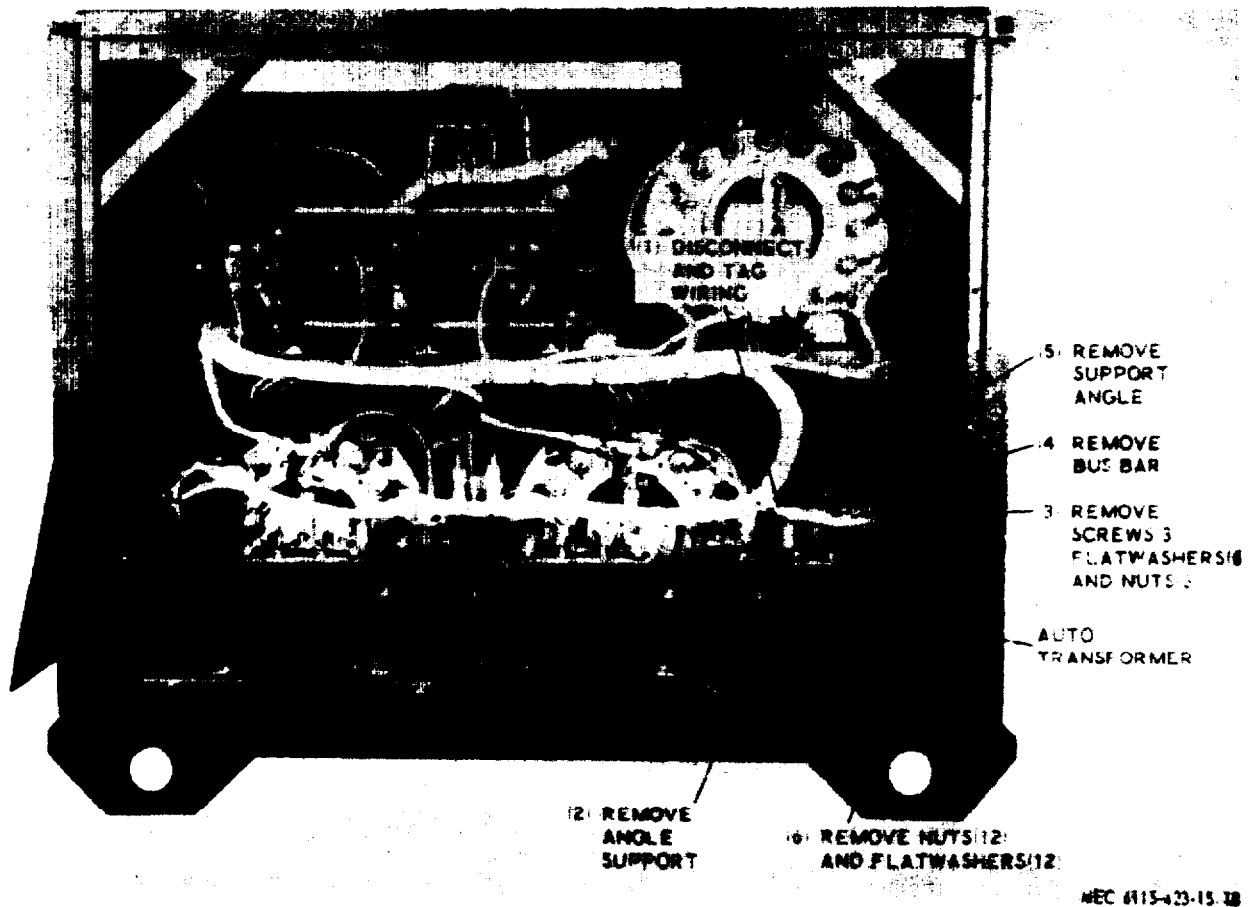
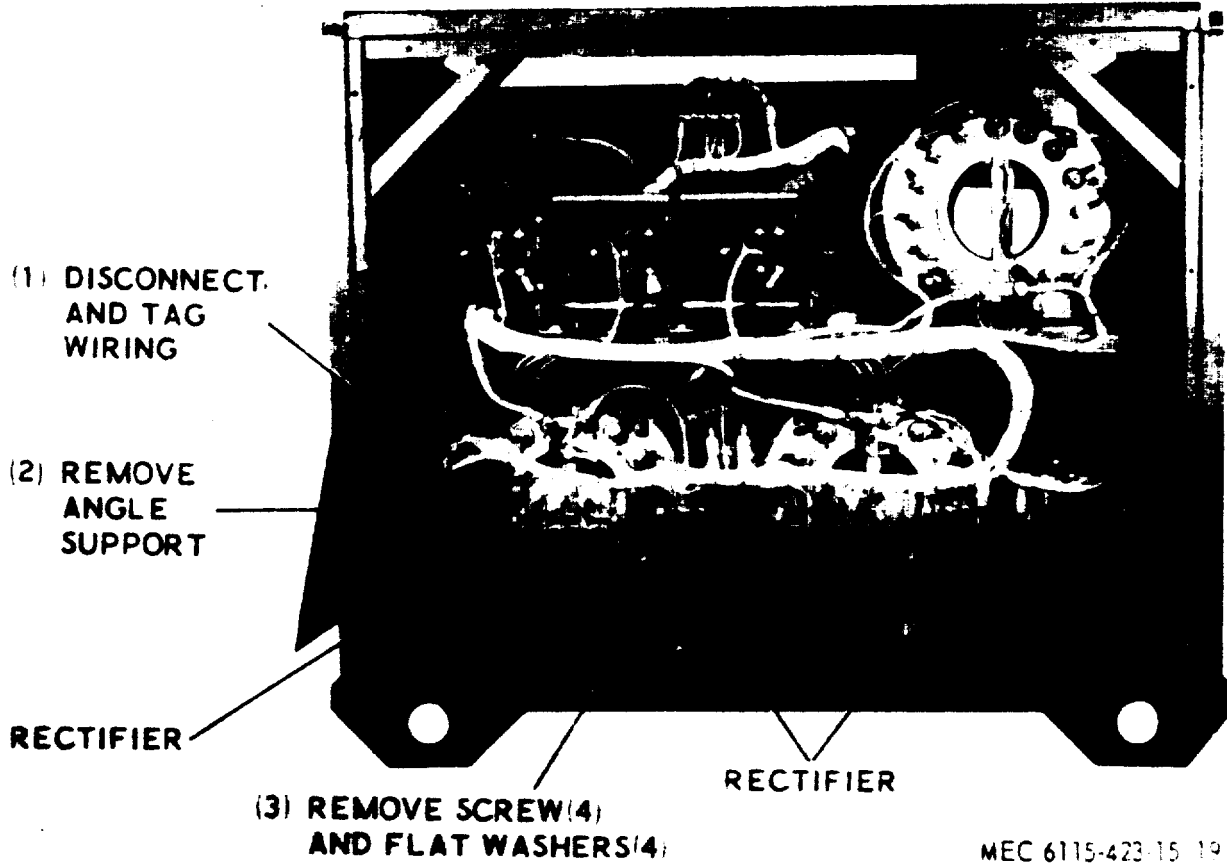

Figure 18. Auto transformer removal and installation.

- (4) De-energize the load bank and connect voltmeter to terminals X1 and X2.
- (5) Energize load bank and the voltmeter should read between 24 and 30 volts AC.

(6) If these readings are not obtained, replace the control transformer.

b. Removal and Installation. Refer to figure 23 to remove and install the step down transformers.



MEC 6115-423-15 19

Figure 19. Rectifier removal and installation

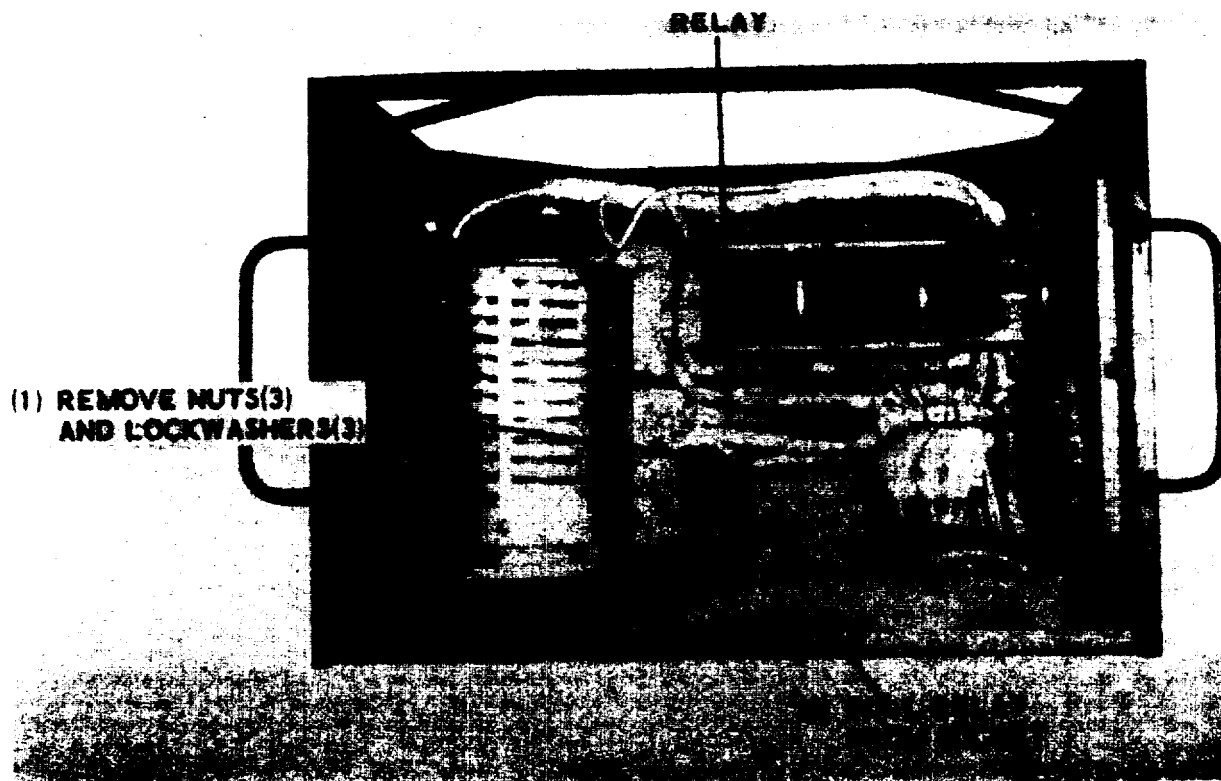

Figure 20. Relay removal and installation.

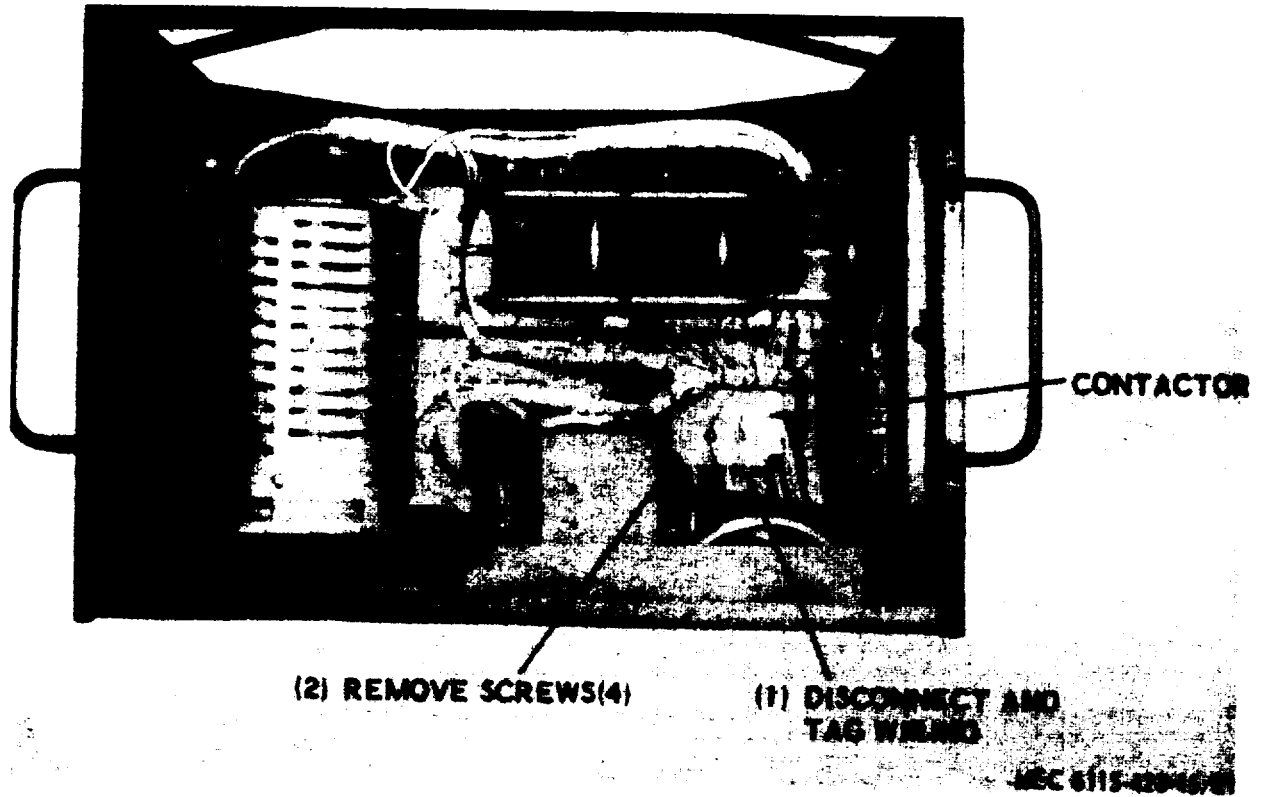
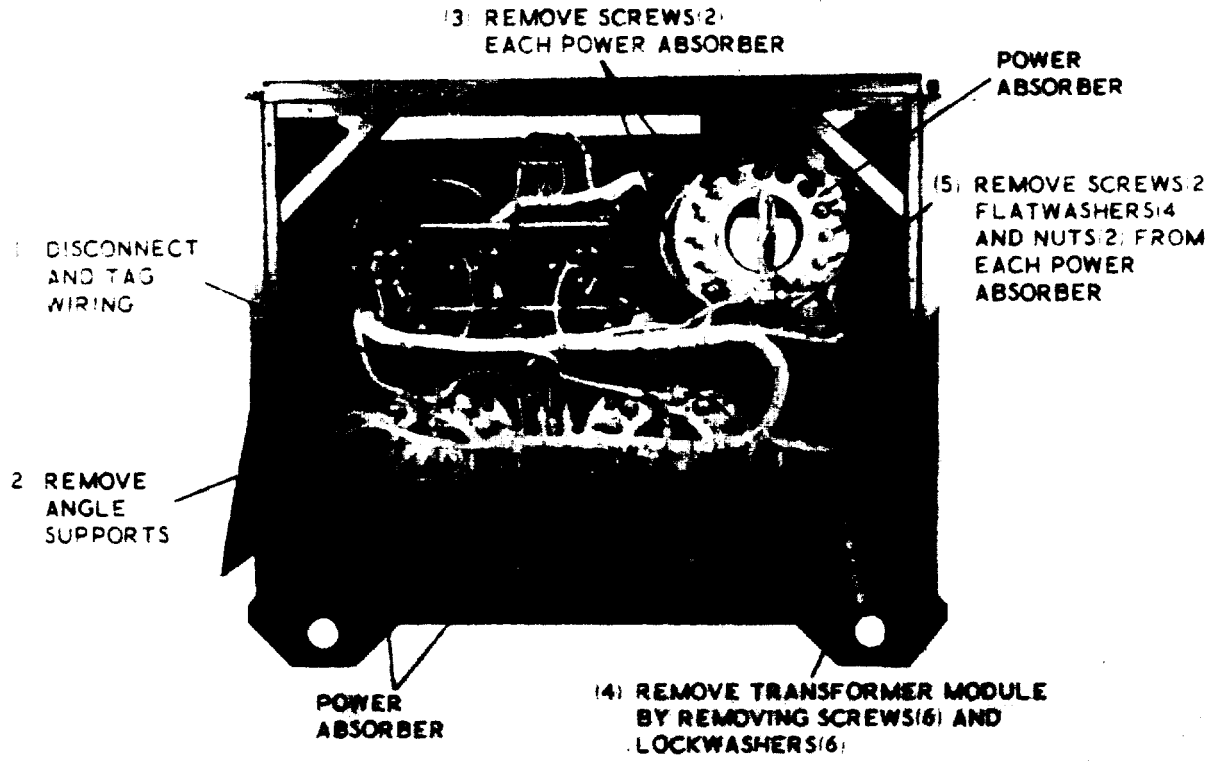
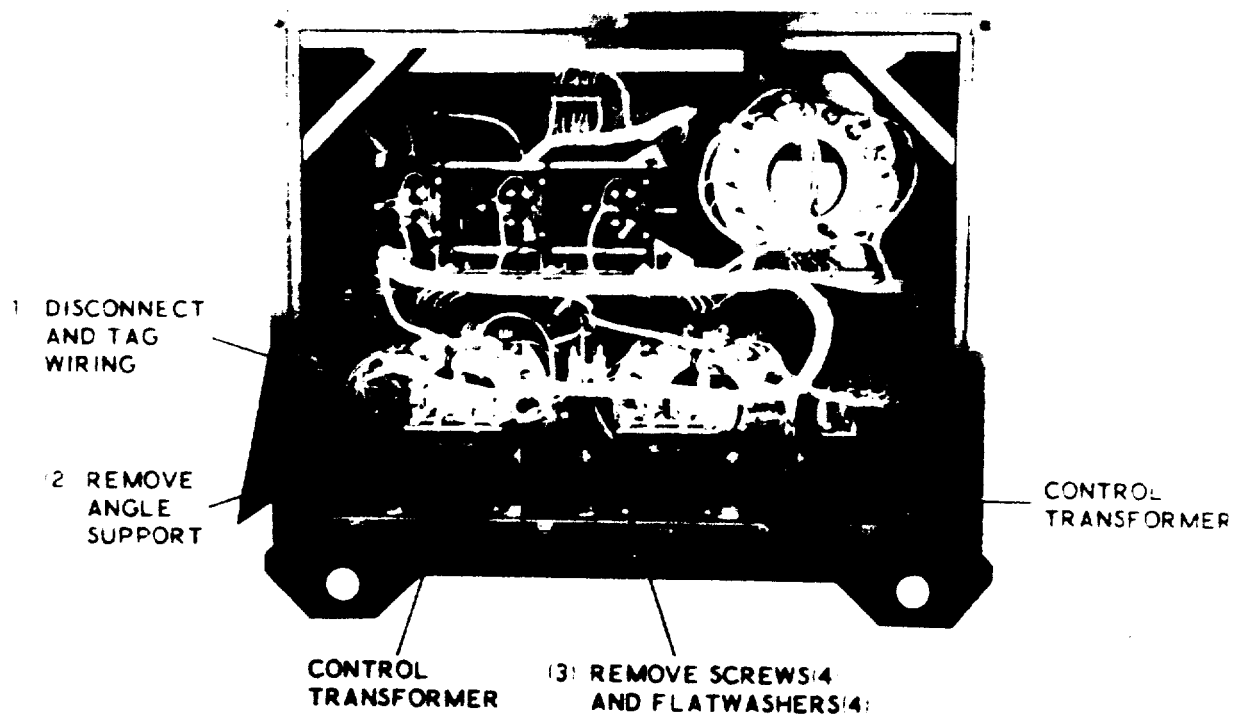

Figure 21. Contactor removal and installion.



MEC 6115-423-15/22

Figure 22. Power absorber removal and installation.



MEC 6115-423-15 23

Figure 23. Relay removal and installation.

CHAPTER 7

REPAIR INSTRUCTIONS

Section 1. REPAIR OF VARIABLE TRANSFORMER

79. General

The variable transformer is a three gang, 240 volt, 50 to 1000 cps input, 0 to 240 volt, 10 ampere maximum output, three phase wye constant impedance load unit. It provides stepless control of load from 0 to 3 kw. It is operated manually by a control knob located on the control panel.

80. Repair of Variable Transformer

On Equipment Test. Refer to paragraph 72.

b. Removal and Installation. Refer to paragraph 72 to remove and install the variable transformer.

c. Cleaning. Clean all metal parts with an approved cleaning solvent and dry thoroughly.

d. Inspecting. Visually inspect the variable transformer for cracks, damaged threads, and bent terminals. Inspect variac brushes for wear, corrosion, or damage.

e. Testing.

- (1) Test each gang transformer for open circuits using a multimeter applied to each of two terminals in combination.
- (2) Test each gang transformer for grounds or insulation breakdown by applying one probe of multimeter to each terminal and the other to ground.

Section II. REPAIR OF AUTO TRANSFORMER

81. General

The auto transformer is rated as follows: 240 volt, 50 to 1000 cps, single phase input; 120 volt ± 1 percent output at 1 KW; forced air cooling at 500 lineal feet per minute, 125 degree F. ambient.

82. Repair of Auto Transformer

a. On Equipment Test. Refer to paragraph 73.

b. Removal and Installation. Refer to paragraph 73 to remove and install the auto transformer.

c. Cleaning. Clean dust and dirt from auto transformer using compressed air.

d. Inspecting. Visually inspect the auto transformer for bent terminals, damaged or stripped threads, loose connections, and frayed insulation.

e. Testing.

- (1) Test the auto transformer for open circuits using a multimeter applied to each of two terminals in combination.
- (2) Test the auto transformer for grounds or insulation breakdown by applying one probe to multimeter to each terminal in turn, and the other probe to ground.

Section III. REPAIR OF RECTIFIER

83. General

The rectifier is of the selenium type, consisting of four 3 by 3 inch, 40 volt rms cells

connected in single phase, full wave bridge, rated at 30 volt DC at 122 degrees F ambient, and is convection cooled.

84. Repair of Rectifier

a. Removal and Installation. Refer to paragraph 74 to remove and install the rectifier.

b. Cleaning. Clean dust and dirt from rectifier using compressed air.

c. Inspecting. Visually inspect the rectifier for bent terminals, stripped or damaged threads, and bent or damaged plates.

d. Testing. Apply probes of multimeter across the cells of rectifier and observe reading. Reverse the multimeter probes and observe reading. The difference between the two readings is the front-to-back ratio and should be about 500 to 1 or greater. Replace rectifier with high front-to-back ratio.

Section IV. REPAIR OF RELAY

85. General

The relay is rated as follows: 3 pole double throw, 3 ampere inductive at 120 volts AC and 1 ampere inductive at 240 volts AC, 50 to 1000 cps, continuous duty, 240 volt coil nominal. Pull-in between 150 and 200 volts maximum with maximum differential between start of pull-in and sealed condition of 12 volts at any frequency between 50 and 1000 cps.

86. Repair of Relay

a. Removal and Installation. Refer to paragraph 75 to remove and install the relay.

b. Cleaning. Clean case of relay with an approved cleaning solvent and dry thoroughly.

c. Inspecting. Visually inspect the relay for stripped or damaged threads, and for damage to the case.

d. Testing. Monitor each contact using 115 volt AC lamp in series with each contact (6 lamps). No dimming of the lamps should occur between 0 to 150 volts 50 to 1000 cycles input. Lamps should be at full brightness at an input of 200 volts, 50 to 1000 cycles.

Section V. REPAIR OF CONTACTOR

87. General

The contactor is rated at 200 ampere, 200 volt, 400 cycle, 3-pole single throw, 28 volt DC operated. It is capable of controlling a 40 kw, 3 phase wye connected balanced resistive load at 120/208 volt, 3-phase, 4-wire; 240 volt, 3-phase, 3-wire; or 240/416 volt, 3-phase, 4-wire input at any frequency between 50 to 1000 cycles.

88. Repair of Contactor

a. Removal and Installation. Refer to paragraph 76 to remove and install the contactor.

b. Cleaning. Clean case of contactor with an approved solvent and dry thoroughly.

c. Inspecting. Visually inspect contactor for damage to case.

d. Testing. Apply a voltage to coils of contactor and check that they operate. Check for burned or pitted contacts

Section VI. REPAIR OF POWER ABSORBERS

89. General

The three duck-type, 10 kw power absorbers provide the load bank with the necessary resistive loads. The resistive elements are 1/8 inch corrugated nichrome ribbon enclosed within a slotted housing. The unit is fan cooled, and

protected by a wind switch and a thermal overload switch set at 120 degrees C.

90. Repair of Power Absorbers

a. Removal and Installation. Refer to paragraph 77 to remove and install the power absorbers.

b. Disassembly. Disassemble the power absorbers in the numerical sequence shown or figure 24.

c. Cleaning. Clean all non-electrical parts with an approved cleaning solvent and dry thoroughly. Clean all electrical parts with a dry lint-free cloth.

d. Inspecting. Visually inspect all parts for cracks, damage and stripped or damaged threads. Check wind switch for continuity. Use a Strobotac and check the rpm of the fan motor shaft. Allowable tolerance is 3300 to 4000 rpm.

e. Reassembly. Reassemble the power absorber in the reverse of the numerical sequence

as illustrated on figure 24. Observe the following:

- (1) Start winding the resistive element at the fan end of absorber at post No. 1, in second groove. Wind in a counterclockwise direction.
- (2) Mount fan with hub 3/8 inch from end of shaft.
- (3) Feed motor leads, thermal overload switch leads, and wind switch leads through clamp (50) and behind bus bar (39). After connecting leads to terminal board (45) dress them away from bus bar.

Section VII. REPAIR OF CONTROL TRANSFORMERS

91. General

The control transformers are rated as follows: 120/240 volt, 50 to 1000 cps, single phase, dual volt input; 34.5 \pm 0.4 volt at open circuit, 31.5 \pm 0.4 volts at 2.0 ampere, 26.0 \pm 0.4 volts at 5.0 ampere output. The transformer is forced air cooled at 500 lineal feet per minute at 125 degrees F.

92. Repair of Control Transformer

a. On Equipment Test. Refer to paragraph 78.

b. Removal and Installation. Refer to paragraph 78 to remove and install the control transformer.

c. Cleaning. Clean the control transformer with compressed air and a dry lint-free cloth.

d. Inspecting. Visually inspect the control transformer for bent terminals, stripped or damaged threads, and frayed or damaged insulation.

e. Testing.

- (1) Test the control transformer for open circuits using a multimeter applied to each of two terminals in combination.
- (2) Test the control transformer for grounds or insulation breakdown by applying one probe of multimeter to each terminal in turn, and the other probe to ground.

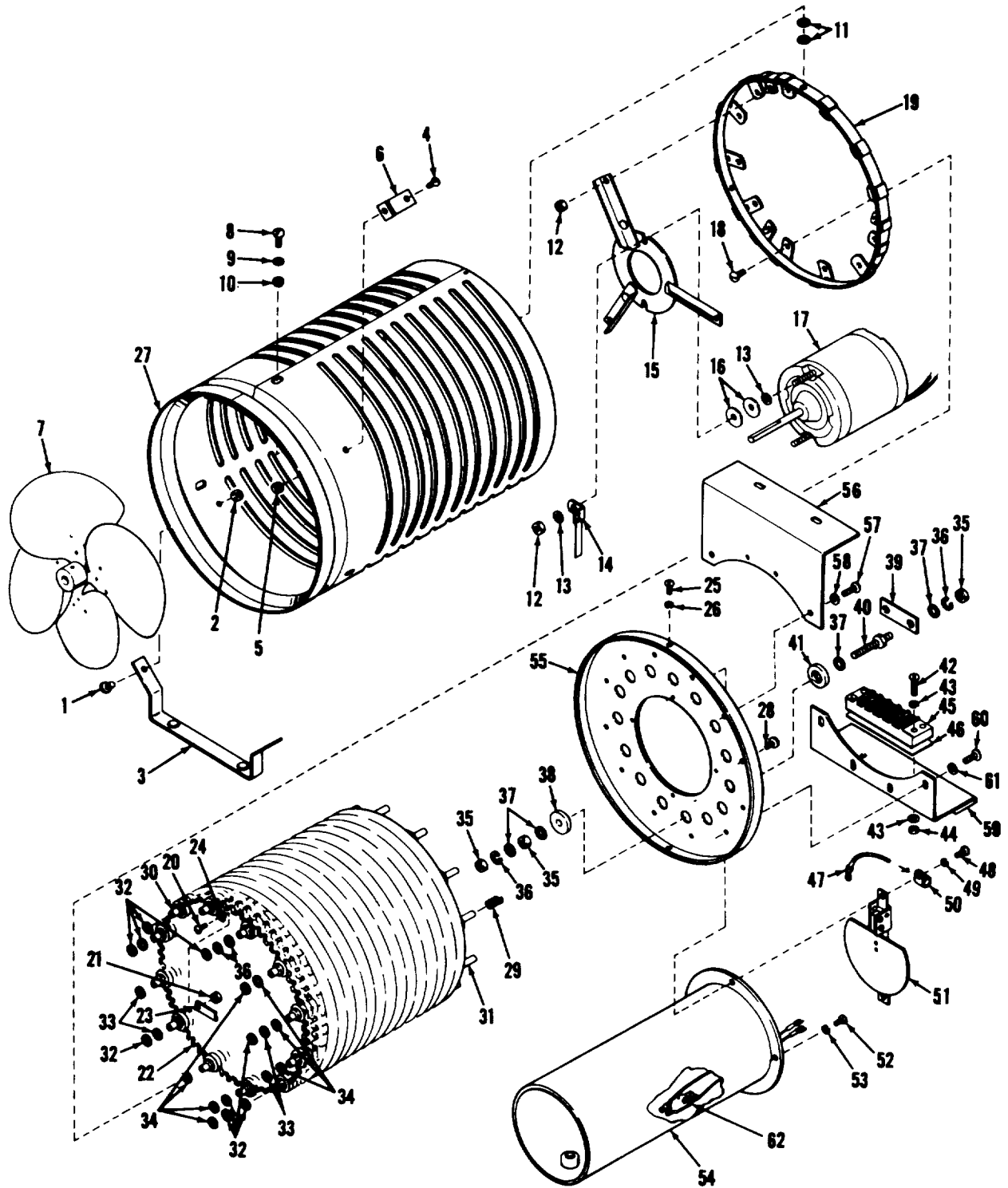

MEC 6115-423-15/24

Figure 24. Diassembly of electrical power absorbers.

1	Machine screw, 10-32x 3/8 (2)	32	Spacer (9)
2	Nut, 10-32 (2)	33	spacer (4)
3	support	34	Spacer (9)
4	Machine screw, 10-32 x 3/8 (2)	35	Nut 1/4-20 (3)
5	Nut, 10-32 (2)	36	Lock washer 1/4 (2)
6	Bracket (2)	37	Flat washer 1/4 (4)
7	Fan	38	Shoulder bushing
8	Machine screw, 6-32 x 1/2 (3)	39	Bus bar
9	Flat washer, No. 6 (3)	40	Terminal stud
10	Nonmetallic washer (3)	41	Shoulder bushing
11	Nonmetallic washer (6)	42	Machine screw, 8-32 x 5/8 (4)
12	Nut, 10-32 (6)	43	Flat washer, No. 8 (4)
13	Flat washer, No. 10 (4)	44	Nut, 8-32 (4)
14	Radio suppression brush	46	Terminal board
15	Bracket	46	Marker strip
16	Flat washer, No. 10 (4)	47	Lug terminal
17	Fan motor	48	Thread cutting screw, 6 x 3/8 (2)
18	Machine screw, 8-32 x 1/4 (12)	49	Lock washer, No. 6 (2)
19	support	50	Loop clamp
20	Machine screw, 8-32 x 3/6 (18)	51	Wind switch
21	Nut, 8-32 (18)	52	Thread cutting screw, 6 X 3/8 (2)
22	Resistive element (9)	53	Lock washer, No. 6 (2)
23	Bus bar (2)	64	Cooling tube assy
24	Lug terminal (14)	55	cover
25	Thread cutting screw, 6 x 8/8 (2)	56	Plate
26	Lock washer No. 6 (2)	57	screw (2)
27	Duct	56	Washer (2)
28	Machine screw, 8-32 x 1/4 (12)	59	Plate
29	Spring (12)	60	Screw (4)
30	Insulator (96)	61	washer (4)
31	Post (12)	62	Breaker Assembly

Figure 24—Continued.

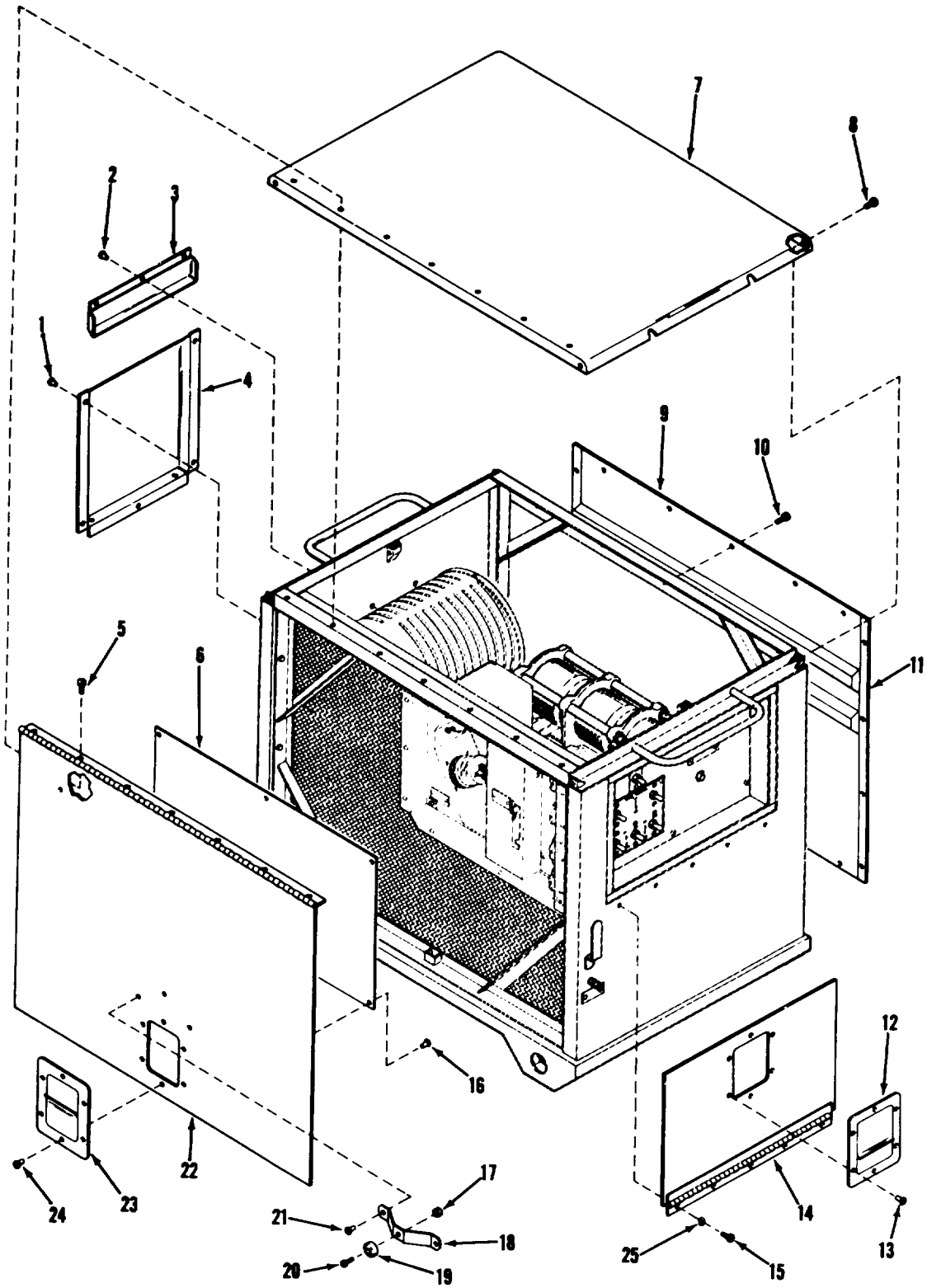

MEC 6115-423-15/25

Figure 25.

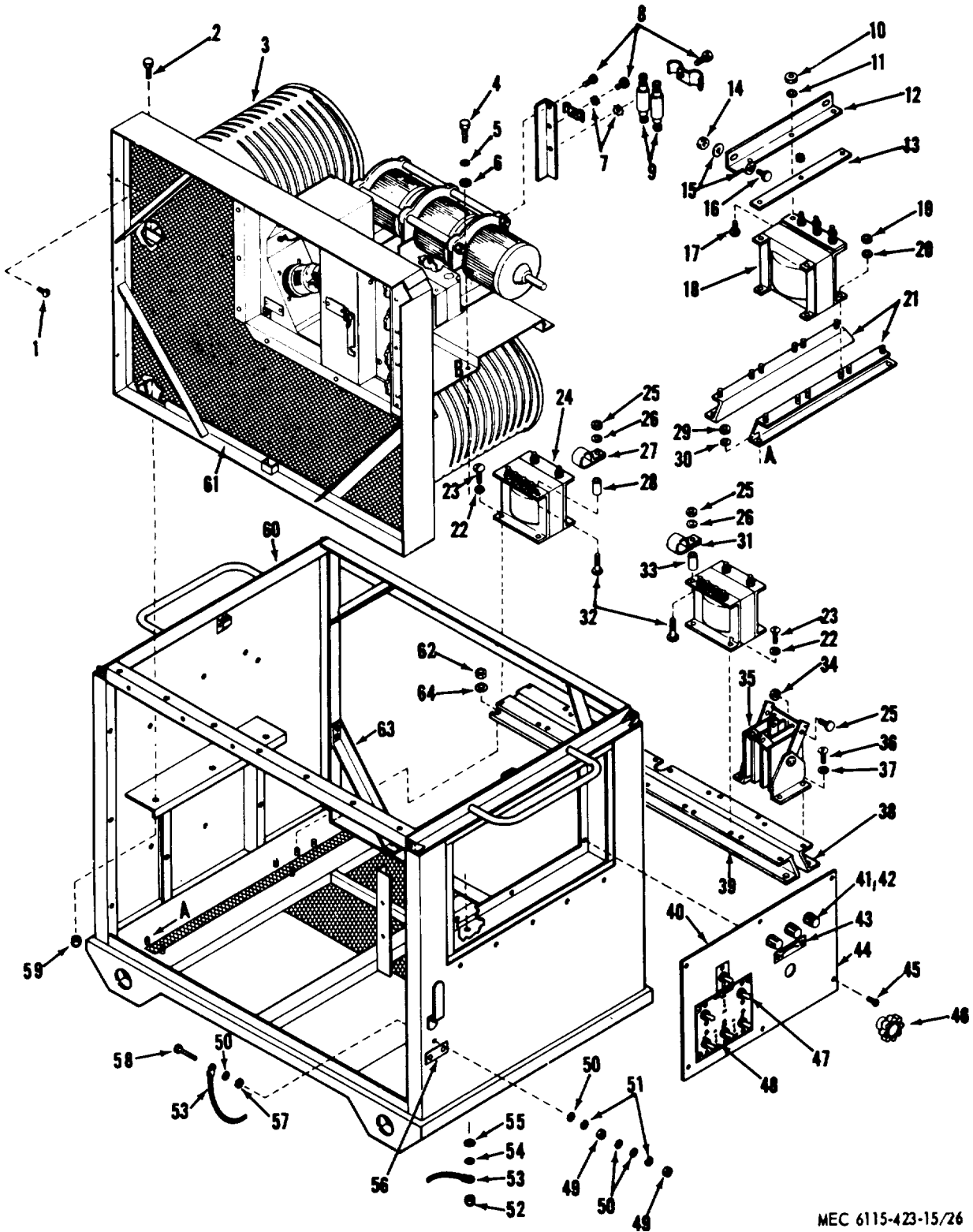

MEC 6115-423-15/26

Figure 26

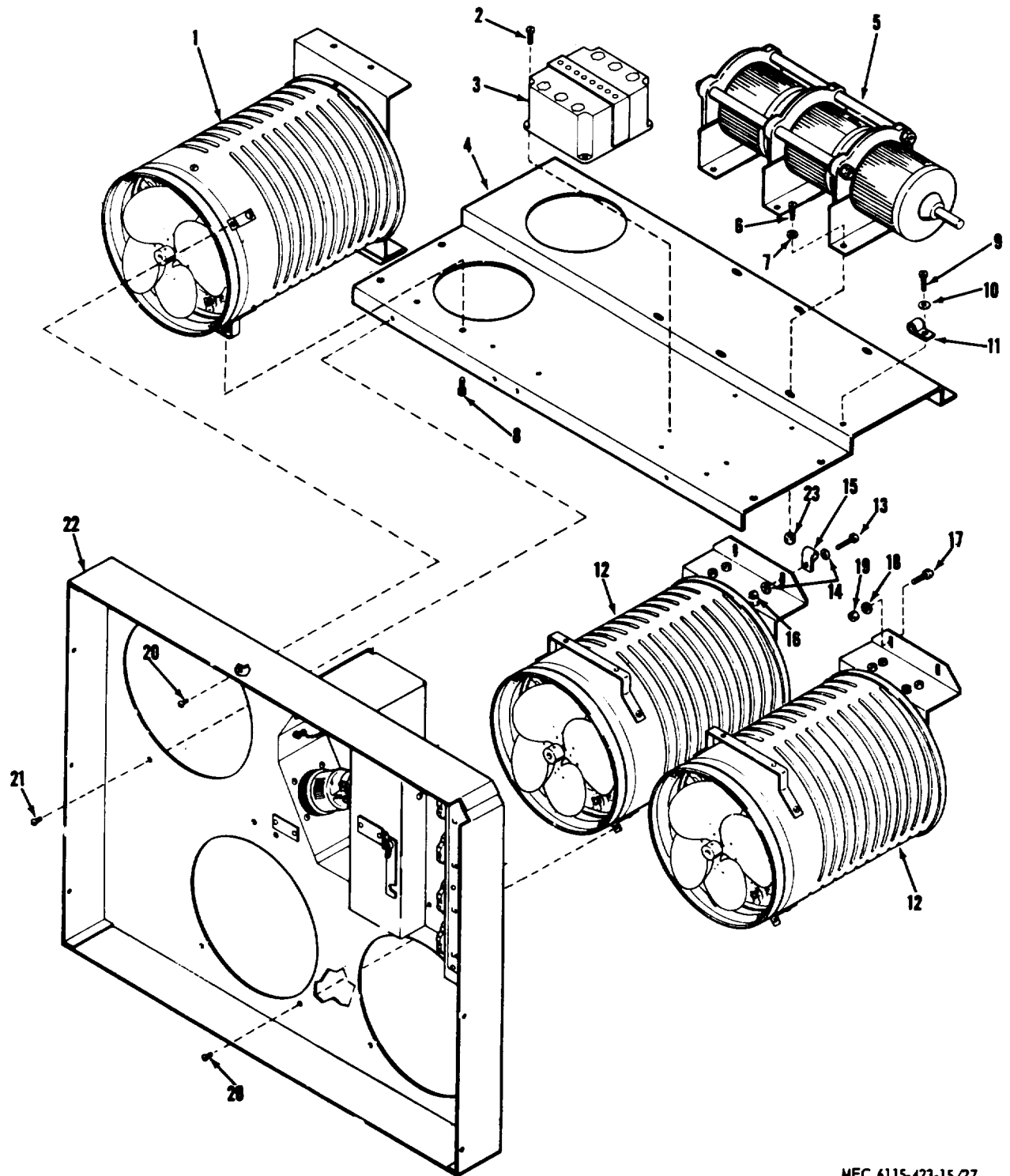

MEC 6115-423-15/27

Figure 27.

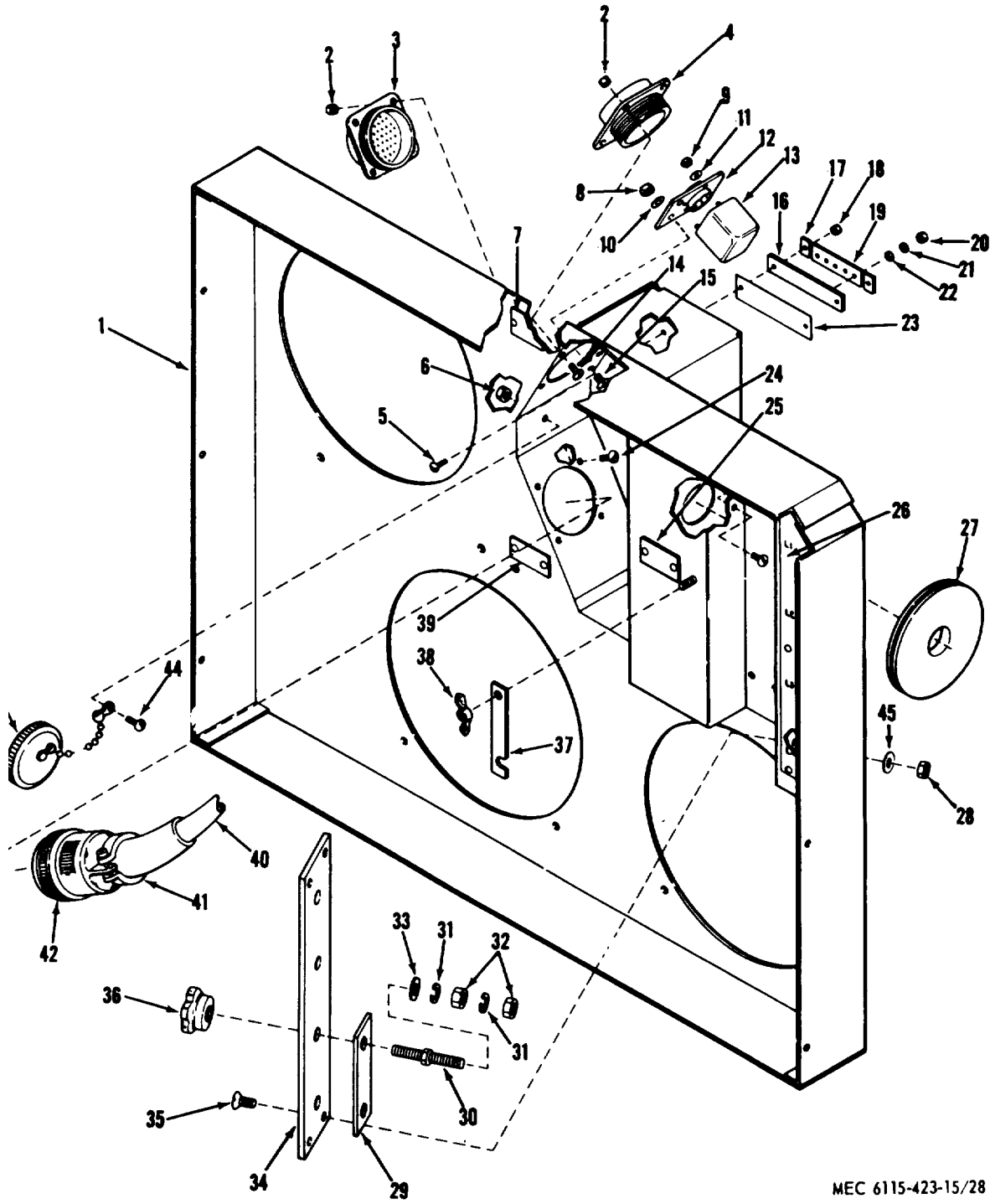

MEC 6115-423-15/28

Figure 28.

16. Deleted

17. Deleted

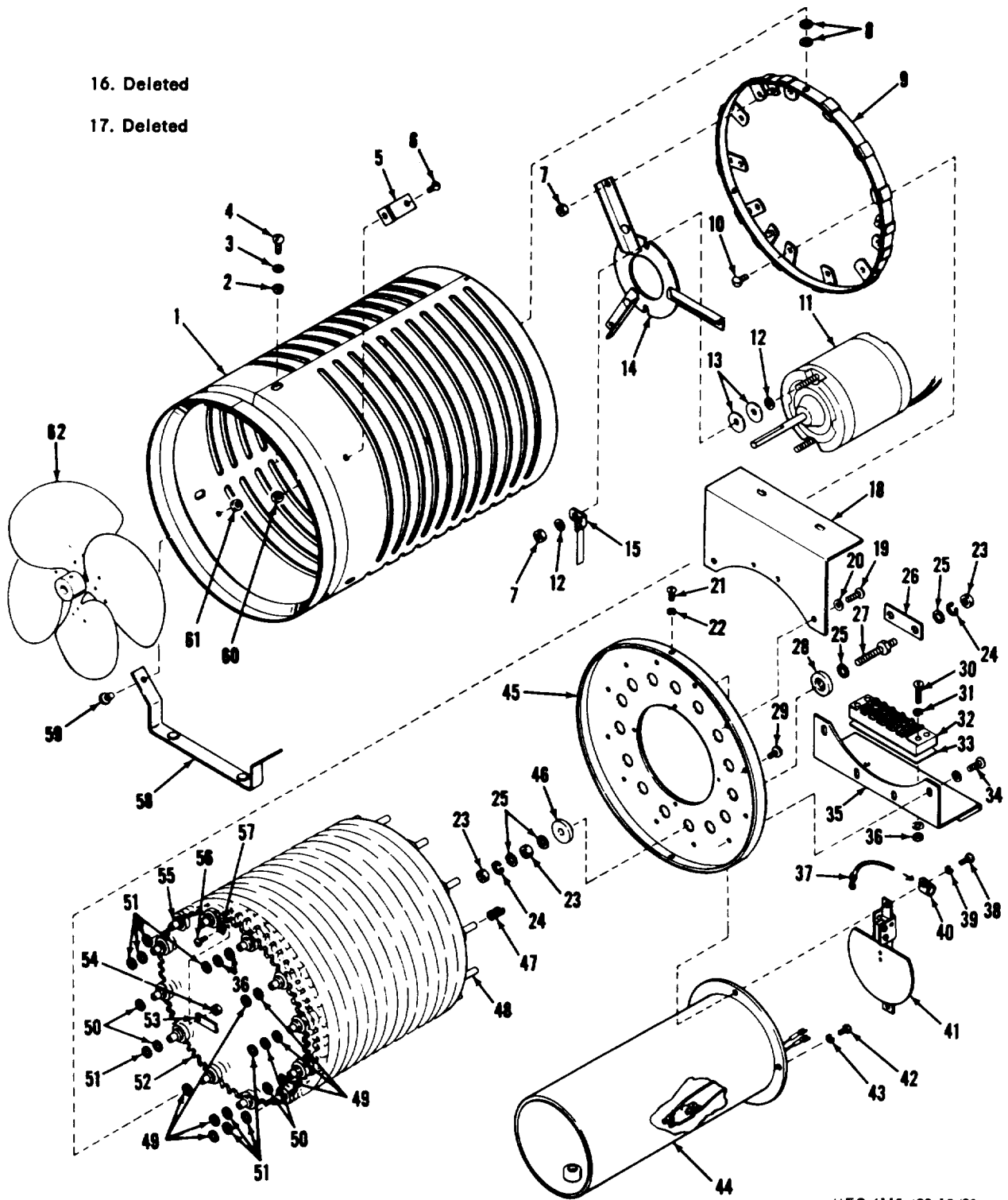

MEC 6115-423-15/29

Figure 29.

APPENDIX A

REFERENCES

- TM 38-750 ----- The Army Equipment Record System and Procedures.
- TM 5-6115-423-25P ----- Organizational, Direct and General Support and Depot Maintenance Repair Parts and Special Tools Manual.

APPENDIX B

MAINTENANCE ALLOCATION CHART

Section 1. INTRODUCTION

1. General

a. This section provides a general explanation of all maintenance and repair functions authorized at various maintenance levels.

b. Section II designates overall responsibility for the performance of maintenance operations on the identified end item or component. The implementation of the maintenance tasks upon the end item or component will be consistent with the assigned maintenance operations.

c. Section III lists the special tools and test equipment required for each maintenance operation as referenced from section II.

2. Explanation of Columns in Section II

a. Functional Group Number. The functional group is a numerical group set up on a functional basis. The applicable functional grouping indexes (obtained from TB 750-93-1, Functional Grouping Codes) are listed on the Maintenance Assignment in the appropriate numerical sequence. These indexes are normally set up in accordance with their function and proximity to each other.

b. Component Assembly Nomenclature. This column contains a brief description of the components of each functional group.

c. Maintenance Functions and Maintenance Categories. This column lists the various maintenance functions (A through K) and indicates the lowest maintenance category authorized to perform these operations. The symbol designations for the various maintenance categories are as follows:

- C — Operator or crew
- O — Organizational maintenance

- F — Direct support maintenance
- H — General support maintenance
- D — Depot maintenance

The maintenance functions are defined as follows:

- A—Inspect: Verify serviceability and detect incipient electrical or mechanical failure by close visual examination.
- B-Test: Verify serviceability and detect incipient electrical or mechanical failure by measuring the mechanical or electrical characteristics of the item and comparing those characteristics with authorized standards. Tests will be made commensurate with test procedures and with calibrated tools and/or test equipment referenced in the maintenance assignment.
- C-Service: Operations required periodically to keep the item in proper operating condition, i.e., to clean, preserve, drain, paint, and replenish fuel, lubricant, hydraulic, and deicing fluids, or compressed air supplies.
- D—Adjust: Regulate periodically to prevent malfunction. Adjustments will be made commensurate with adjustment procedures and associated equipment adjustment specifications.
- E-Align: Adjust two or more components of an electrical or mechanical system so that their functions are properly synchronized or adjusted.
- F—Calibrate: Determine, check, or rectify the graduation of an instrument weapon, or weapons system or components of a weapons system.

- G—Install: Remove and install the same item for service or when required for the performance of other maintenance operations.
- H—Replace: Substitute serviceable components, assemblies and subassemblies for unserviceable counterparts.
- I—Repair: Restore to a serviceable condition by replacing unserviceable parts or by any other action required using available tools, equipment and skills, including welding, grinding, riveting, straightening, adjusting and facing.
- J—Overhaul: Restore an item to a completely serviceable condition (as prescribed by serviceability standards developed and published by the commodity commands) by employing techniques of "Inspect and Repair Only As Necessary" (I ROAN). Maximum use of diagnostic and test equipments combined with minimum disassembly during overhaul. "Overhaul" may be assigned to any level of maintenance except organizational, provided the time, tools, equipment, repair parts authorization, and technical skills are available at that level. Normally, overhaul as applied to end items, is 1 limited to depot maintenance level.

K—Rebuild: Restore to a condition comparable to new by disassembling to determine the condition of each component part and reassembling using serviceable, rebuilt, or new assemblies sub-assemblies, and parts.

d. Reference Note. This column, subdivided into columns L and M, is provided for referencing the Special Tool and Test Equipment Requirements (sec. HI) that may be associated with maintenance functions (Section II).

3. Explanation of Columns in Section III

a. Referenre Code. This column consists of a number and a letter separated by a dash. The number references the T&TE requirements column on the Maintenance assignment. The letter represents the specific maintenance function the item is to be used with. The letter is representative of columns A through K on the Maintenance assignment.

b. Maintenance Category. This column shows the lowest level of maintenance authorized to use the special tool or test equipement.

c. Nomenclature. This column lists the name or identification of the tool or test equipment.

d. Tool Number. This column lists the manufacturer's code and part number, or Federal stock number of tools and test equipment.

Section II. MAINTENANCE ASSIGNMENT

Functional group number	Component assembly nomenclature	Maintenance functions											Note reference	
		A	B	C	D	E	F	G	H	I	J	K	L	M
		Inspect	Test	Service	Adjust	Align	Calibrate	Install	Replace	Repair	Overhaul	Rebuild	Tools and equipment	Remarks
15	FRAME													
	Frame assembly													
1501	Frame center -----	--	--	--	--	--	--	--	F	F				
18	BODY; CAB; HOOD; HULL:													
1808	Lock Paddle -----	O	--	--	--	--	--	--	O	O				
	Door air exhaust -----	O	--	O/C	--	--	--	--	O	F				
2210	Data Plates:													
	Plate designation -----	--	--	--	--	--	--	--	O					
	Plate identification -----	--	--	--	--	--	--	--	O					

Functional group number	Component assembly nomenclature	Maintenance functions											Note reference	
		A	B	C	D	E	F	G	H	I	J	K	L	M
		Inspect	Test	Service	Adjust	Align	Calibrate	Install	Replace	Repair	Overhaul	Rebuild	Tools and equipment	Remarks
40	Electric Motors and Generators													
4000	Motor Assembly:													
	Motor electric -----	F								F				
	Brush, radio suppression -----					O				O	O			
4004	Ventilating System:													
	Guard assembly, fan -----									F	F			
	Impeller fan, axial -----	O		O						O				
4012	Switches:													
	Switch, air flow -----	O	O			F				F	F			
	Switch, toggle -----	O	O							O				
42	Electrical Equipment													
4201	Transformer, Power Line or Distribution:													
	Transformer, variable -----	F	F							F	F			
	Auto transformer -----	F	F							F	F			
	Rectifier, metal -----	O	F							F				
4202	Electrical controls (main and auxiliary):													
	Terminal board -----	F	F							F				
	Terminal stud -----	O	O							O				
4203	Circuit Breakers, Cut Out Devices, Fuse and Fuse Holders:													
	Fuse holder -----	O	O							O	O			
	Relay -----	F	F							F				
	Socket, tube -----	F	F							F				
4204	Voltage and Current Regulators:													
	Capacitor, filter -----	O	O							O				
	Contactors -----	F	F							F				
4205	Control Resistances:													
	Absorber, electrical power -----	F	F							F				
4211	Power Receptacles:													
	Connector, receptacle, electrical -----	O	O							O	O			

Section III. SPECIAL TOOL AND SPECIAL TEST EQUIPMENT REQUIREMENTS

Reference code	Maintenance level	Nomenclature	Tool number
NO SPECIAL TOOLS REQUIRED			

APPENDIX C

BASIC ISSUE ITEMS

Section 1. INTRODUCTION

1. Scope

This appendix lists items which accompany the load bank or are required for installation, operation, or operator's maintenance.

2. General

Basic Issue Items-Section II. This section is a listing of accessories, repair parts, tools, and publications required for operator's maintenance and operation, initially issued with, or authorized for the load bank.

3. Explanation of Columns

The following provides an explanation of columns in the tabular list of basic issue items, Section II:

a. Source, Maintenance, and Recoverability Codes (SMR), Column 1:

- (1) **Source Code** indicates the selection status and source for the listed item. Source codes are:

Code	Explanation
P	Applied to repair parts which are stocked in or supplied from GSA/DSA Army supply system, and authorized for use at indicated maintenance categories.
M	Applied to repair parts which are not procured or stocked but are to be manufactured at indicated maintenance categories.
A	Applied to assemblies which are not procured or stocked as such, but made up of two or more units, each of which carry individual stock numbers and descriptions and are procured and stroked and can be assembled by units at indicated maintenance categories.

Code	Explanation
X	Applied to parts and assemblies which are not procured or stocked, the mortality of which is normally below that of the applicable end item, and the failure of which should result in retirement of the end item from the supply system.
x1	Applied to repair parts which are not procured or stocked, the requirement for which will be supplied by use of the next higher assembly or components,
x2	Applied to repair parts which are not stocked. The indicated maintenance category requiring such repair parts will attempt to obtain them through cannibalization; if not obtainable through cannibalization, such repair parts will be requisitioned with supporting justification through normal supply channels.
C	Applied to repair parts authorized for local- procurements. If not obtainable from local procurement, such repair parts will be requisitioned through normal supply channels with a supporting statement of nonavailability from local procurement.
G	Applied to major assemblies that are procured with PEMA (Procurement Equipment Missile Army) funds for initial issue only to be used as exchange assemblies at DSU and GSU level or returned to depot supply level.

Note. Source code is not shown on common hardware items known to be readily available in Army supply channels and through local procurement.

- (2) **Maintenance code** indicates the lowest category of maintenance authorized to install the listed item. The maintenance level code is:

Code	Explanation
C	Operator/crew

(3) Recoverability Code indicates whether unserviceable items should be returned for recovery or salvage. Items not coded are expendable. Recoverability codes are:

Code	Explanation
R	Applied to repair parts and assemblies which are economically repairable at DSU and GSU activities and are normally furnished by supply on an exchange basis.
T	Applied to high dollar value recoverable repair parts which are subject to special handling and are issued on an exchange basis. Such repair parts are normally repaired or overhauled at depot maintenance activities.
u	Applied to repair parts specifically selected for salvage by reclamation units because of precious metal content, critical materials, high dollar value reusable casings and castings.

b. *Federal Stock Number, Column 2.* This column indicates the Federal stock number for the item.

c. *Description, Column 3.* This column indicates the Federal item name and any additional description required. A five-digit manufacturer's or other service code is shown in parentheses followed by the manufacturer's part number. Repair parts quantities included in kits, sets, and assemblies that differ from the

actual quantity used in the specific item, are listed in parentheses following the repair part name.

d. *Unit of Issue, Column 4.* This column indicates the unit used as a basis of issue, e.g., ea, pr, ft, yd, etc.

e. *Quantity Incorporated in Unit Pack, Column 5.* This column indicates the actual quantity contained in the unit pack.

f. *Quantity Incorporated in Unit, Column 6.* This column indicates the quantity of the item used in the equipment.

g. *Quantity Furnished With Equipment, Column 7.* This column indicates the quantity of an item furnished with the equipment in excess of the quantity incorporated in the unit.

h. *Quantity Authorized, Column 8.* This column indicates the quantity of an item authorized the operator/crew to have on hand or to obtain as required. As required items are indicated with an asterisk.

i. *Illustration, Column 9.* This column is divided as follows:

- (1) Figure Number, column 9a, indicates the figure number of the illustration in which the item is shown.
- (2) Item Number, column 9b, indicates the callout number used to reference the item in the illustration.

Section II. BASIC ITEMS LIST

(1) Source, maint. and recv code	(2)			(3) Description	(4) Unit of issue	(5) Qty inc in unit	(6) Qty inc in unit	(7) Qty furn in with equip	(8) Qty auth	(9) Illustration	
	(a)	(b)	(c)							(a) Fig no.	(b) Issue no.
P	O			Group 31 — Basic Issue Items Manufacturer Installed							
P	O	7510-889-3494		3100 — Basic Issue Items Manufacturer or Depot Installed			1		1		
P	O	7520-559-9618		Binder, Log Book (GE)							
P	O			Case: Maintenance and Operational Manuals, Cotton Duck Water Repellent, Mildew Resistant, MIL-B-11743B (GE)							
P	O			Manual: Manufacturer's operating and Maintenance Manual with Parts List, USA Interim TM 5-6115-423-15			2		2		
				<i>Note.</i> Non DA Manuals will be requisitioned through repair parts supply channels							
				Group 32 — Basic Issue Items Troop Installed							
				Group 3200 — Basic Issue Items Troop Installed or Authorized					*	2	
				Department of the Army Operator Organizational, Direct and General Support Maintenance and Depot Maintenance Manual TM 5-6115-423-15					*	2	
				Department of the Army Organizational, Direct and General Support Maintenance and Depot Maintenance, Repair Parts and Special Tool List, TM 5-6115-423-25P					*	2	

INDEX

Auto transformers	73	82
Auto transformer, repair of	82	89
Basic issue tools and equipment	26	19
Capacitors, filter	41	24
Connectors	42	24
Contactors	76	33
Contactors, repair of	88	40
Controls and instruments	14	13
Control transformers	78	33
Control transformer, repair of	92	41
Daily preventive maintenance service	81	19
Definitions	60	25
Description	3	3
Detailed lubrication information	29	19
Difference in models	5	9
Dismantling for movement	11	12
Doors and panels	37	22
Fan service	86	22
Filter capacitors	41	24
Fixed load switches are on but no load is applied	45	24
Forms, record and report	2	3
Fuse replacement	84	22
General lubrication information	28	19
General methods used to attain proper suppression	51	25
Identification and tabulated data	4	8
Identification plate replacement	85	22
Inspecting and servicing	8	11
Installation of separately packed components	9	11
Installation or setting-up instructions	10	11
Load bank fails to start	44	24
Load drops suddenly	49	25
Lubrication information, detailed	29	19
Lubrication information, general	28	19
Operation in dusty or sandy areas	21	16
Operation in extreme cold	19	16
Operation in extreme heat	20	16
Operation in high altitudes	24	17
Operation in salt water areas	23	17
Operation under rainy or humid conditions	22	17
Operation under usual conditions	18	15
Organization maintenance repair parts	27	19
Panels, doors and	87	22
Power absorbers	77	88

	Paragraph	Page
Power absorber overheats -----	46	24
Power absorbers, repair of -----	90	40
Preventive maintenance service, daily -----	31	19
Preventive maintenance services, quarterly -----	32	22
Quarterly preventive maintenance services -----	32	22
Radio interference -----	47	24
Radio interference suppression components -----	52	25
Record and report forms -----	2	3
Reinstallation after movement -----	12	13
Rectifier -----	39	22
Relay -----	75	33
Repair of Autotransformer -----	82	39
Repair of contactor -----	88	40
Repair of control transformer -----	92	41
Repair of power absorbers -----	90	40
Repair of rectifier -----	84	40
Repair of relay -----	86	40
Repair of variable transformer -----	80	39
Replacement of suppression components -----	53	25
Scope -----	1	3
Special tools and equipment -----	25	18
Specially designed tools and equipment -----	64	31
Starting the equipment -----	16	14
Stopping the equipment -----	17	14
Tabulated data -----	62	29
Tabulated data identification and -----	4	8
Terminal studs -----	40	22
Toggle switches, wind switch and -----	38	22
Transformers, auto -----	73	32
Transformers, control -----	78	33
Transformers, variable -----	72	33
Unloading the equipment -----	6	11
Unpacking the equipment -----	7	11
Variable load switch does not apply load -----	48	25
Variable transformer -----	72	32
Variable transformer, repair of -----	80	39
Wind switch and toggle switches -----	38	22

By Order of the Secretary of the Army:

HAROLD K. JOHNSON
General, United States Army,
Chief of Staff.

Official:

KENNETH G. WICKHAM,
Major General, United States Army,
The Adjutant General.

Distribution:

Active Army.

USASA (2)	TOAD (3)
ACSI (1)	MOTBA (2)
DCSLOG (1)	MOTBY (2)
CNGB (1)	MOTKI (2)
TSG (1)	MOTSU (2)
CofEngrs (3)	EAMTMTS (1)
CC-E (1)	CAMTMTS (1)
Dir of Trans (1)	WAMTMTS (1)
CofSpts (1)	Div Sngr (2)
USAMB (1)	Engr Dist (2)
USAARTYBD (2)	USAERDL (3)
USA Armour Bd (2)	USAMECOM (46)
USAIB (2)	Engr Cen (5)
USARADB (2)	USAREUR Engr Proc Cen (2)
USAAESWBD (2)	USAREUR Engr Sup Con Agcy (10)
USAAVNTBD (2)	Engr FLDMS (2)
USCONARC (3)	Ft Knox FLD Maint (10)
OS Maj Comd (5) except	Fld Comd, DASA (8)
USARJ (1)	AMS (3)
USASETAF (2)	USAREURCOMZ (2)
USAMC (1)	USAC (1)
MDW (1)	MAAG (1)
Armies (2)	JBUSMC (1)
Corps (2)	Army Attaches (1)
Div (2)	Military Missions (1)
Engr Bde (1)	Units org under fol TOE:
Svc Colleges (2)	5-48 (2)
Br Svc Sch (2)	5-237 (5)
USACDCEC (10)	5-262 (5)
USMA (2)	5-267 (1)
GENDEP (10)	5-278 (5)
Engr Dep (10)	5-279 (2)
Army Dep (2) except	39-61 (2)

NG: State AG (3)

USAR: Same as active Army except allowance is one (1) copy for each unit.

For explanation of abbreviations used, see AR 320-50.

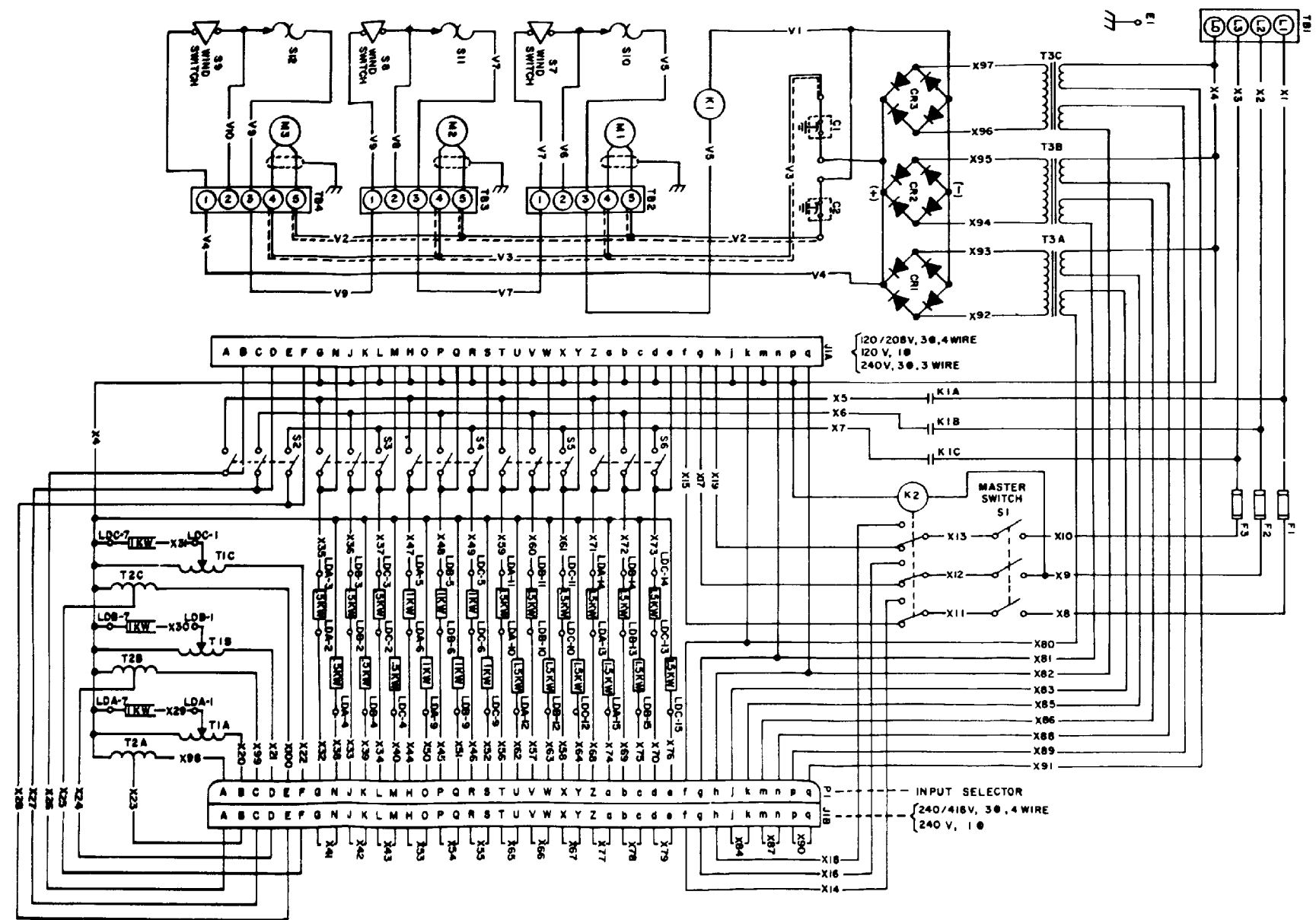

Figure 16. Load bank wiring schematic.

- LEGEND
- C1 AND C2 CAPACITORS
 - CR1, CR2, CR3 RECTIFIERS
 - F1 F2 F3 FUSES
 - J1A LOW VOLTAGE RECEPTACLE
 - J1B HIGH VOLTAGE RECEPTACLE
 - K1 CONTACTOR COIL
 - K1A, K1B, K1C CONTACTORS
 - K2 RELAY
 - M1 FAN MOTOR
 - M2 FAN MOTOR
 - M3 FAN MOTOR
 - P1 PLUG CONNECTOR
 - S1 MASTER SWITCH
 - S2 0-3 KW SWITCH
 - S3 3 KW FIXED SWITCH
 - S4 6KW FIXED SWITCH
 - S5 9 KW FIXED SWITCH
 - S6 9 KW FIXED SWITCH
 - S7 WIND SWITCHES
 - S8 WIND SWITCHES
 - S9 WIND SWITCHES
 - S10 THERMO SWITCH
 - S11 THERMO SWITCH
 - S12 THERMO SWITCH
 - T1A VARIABLE TRANSFORMERS
 - T1B VARIABLE TRANSFORMERS
 - T1C VARIABLE TRANSFORMERS
 - T2A AUTO TRANSFORMERS
 - T2B AUTO TRANSFORMERS
 - T2C AUTO TRANSFORMERS
 - T3A CONTROL TRANSFORMERS
 - T3B CONTROL TRANSFORMERS
 - T3C CONTROL TRANSFORMERS
 - TB1 TERMINAL BOARDS
 - TB2 TERMINAL BOARDS
 - TB3 TERMINAL BOARDS
 - TB4 TERMINAL BOARDS

