

**AIR FORCE TO 31W1-2U-1461  
ARMY TM 11-5805-780-12&P  
MARINE CORPS TM 08789B-12/1**

---

**TECHNICAL MANUAL**

**OPERATION AND MAINTENANCE INSTRUCTIONS  
WITH  
ILLUSTRATED PARTS BREAKDOWN**

**DIGITAL NON-SECURE VOICE TERMINAL  
WITH DIGITAL DATA PORT TA-1042A/U  
PART NUMBER 5285000-001  
NSN 5805-01-318-8421**

SCI TECHNOLOGY, INC.

F04606-89-D-0097

**DISTRIBUTION STATEMENT - Distribution authorized to the Department of Defense and US DOD contractors only for administrative or operational use, 30 June 1991. Other requests for this document shall be referred to Sacramento SM-ALC/TILBE, McClellan AFB CA 95652-5609. Handle in compliance with distribution statement and destroy by any method that will prevent disclosure of the contents or reconstruction of the document.**

Published under authority of the Secretary of the Air Force

---

**30 JUNE 1991**

INSERT LATEST CHANGED PAGES. DESTROY SUPERSEDED PAGES

**LIST OF EFFECTIVE PAGES**

Note: The portion of the text affected by changes is indicated by a vertical line in the margin of the page. Changes to illustrations are indicated by miniature pointing hands. Changes to wiring diagrams are indicated by shaded areas.

Dates of issue for original and changed pages are:

Date of original...30 June 91

TOTAL NUMBER OF PAGES IN THIS PUBLICATION IS 72 CONSISTING OF THE FOLLOWING:

Page No.	*Change No.	Page No.	*Change No.	Page No.	*Change No.
Title	0	4-5	0	B-5	0
A	0	4-6	0	B-6	0
i	0	4-7	0	C-1	0
ii	0	4-8	0	C-2	0
iii	0	5-1	0	C-3	0
iv	0	5-2	0	C-4 blank	0
v	0	5-3	0	D-1	0
vi	0	5-4 blank	0	D-2	0
vii	0	6-1	0	D-3	0
viii blank	0	6-2	0	D-4	0
1-1	0	6-3	0	D-5	0
1-2	0	6-4	0	D-6	0
1-3	0	7-1	0	D-7	0
1-4 blank	0	7-2 blank	0	D-8	0
2-1	0	8-1	0	D-9	0
2-2	0	8-2	0	D-10	0
2-3	0	8-3	0	D-11	0
2-4	0	8-4 blank	0	D-12	0
3-1	0	A-1	0	D-13	0
3-2 blank	0	A-2 blank	0	D-14 blank	0
4-1	0	B-1	0	INDEX 1	0
4-2	0	B-2	0	INDEX 2	0
4-3	0	B-3	0	INDEX 3	0
4-4	0	B-4	0	INDEX 4 blank	0

\*Zero in this column indicates an original page.

TABLE OF CONTENTS

Chapter	Title	Page
SAFETY SUMMARY . . . . .		iii
FOREWORD . . . . .		iv
PURPOSE OF MANUAL . . . . .		iv
ARRANGEMENT OF MANUAL . . . . .		iv
USE OF MANUAL . . . . .		iv
(Army only) ERROR REPORTING AND IMPROVEMENT RECOMMENDATIONS		v
MAINTENANCE FORMS, RECORDS, AND REPORTS . . . . .		v
EQUIPMENT IMPROVEMENT RECOMMENDATIONS (EIR) . . . . .		v
(USMC only) REPORTING ALL DEFICIENCIES . . . . .		v
RELATED PUBLICATIONS . . . . .		vi
GLOSSARY OF SYMBOLS AND ABBREVIATIONS . . . . .		vi
CHAPTER 1 GENERAL INFORMATION . . . . .		1-1
1-1. GENERAL INFORMATION . . . . .		1-1
1-2. EQUIPMENT CHARACTERISTICS . . . . .		1-1
1-3. FUNCTIONAL CHARACTERISTICS . . . . .		1-1
CHAPTER 2 INSTALLATION . . . . .		2-1
2-1. GENERAL . . . . .		2-1
CHAPTER 3 PREPARATION FOR USE AND RESHIPMENT . . . . .		3-1
Section I. Preparation for Use . . . . .		3-1
3-1. INSTRUCTIONS . . . . .		3-1
Section II. Preparation for Reshipment . . . . .		3-1
3-2. INSPECTION . . . . .		3-1
CHAPTER 4 OPERATION . . . . .		4-1
4-1. GENERAL . . . . .		4-1
Section I. Controls and Indicators . . . . .		4-1
4-2. OPERATING CONTROLS . . . . .		4-1
Section II. Operating Instructions . . . . .		4-4
4-3. OPERATING INSTRUCTIONS . . . . .		4-4
Section III. Emergency Operation . . . . .		4-8
Section IV. Preventive Maintenance Checks and Services (PMCS) . . . . .		4-8
CHAPTER 5 THEORY OF OPERATION . . . . .		5-1
Section I. Functional System(s) Operation . . . . .		5-1
5-1. GENERAL . . . . .		5-1
5-2. POWER SOURCES . . . . .		5-1
5-3. OPERATING MODES . . . . .		5-3
Section II. Functional Operation of Electronic Circuits . . . . .		5-3
Section III. Functional Operation of Mechanical Assemblies . . . . .		5-3

TABLE OF CONTENTS - CONTINUED

Chapter	Title	Page
CHAPTER 6	MAINTENANCE . . . . .	6-1
6-1.	GENERAL . . . . .	6-1
6-2.	WARRANTY . . . . .	6-1
	Section I. Organizational and Intermediate Maintenance . .	6-1
6-3.	ORGANIZATIONAL MAINTENANCE . . . . .	6-1
6-4.	INTERMEDIATE MAINTENANCE . . . . .	6-1
6-5.	OPERATIONAL CHECKOUT AND TROUBLESHOOTING . . . . .	6-1
	Section II. Special Maintenance . . . . .	6-4
	Section III. Performance Test Checks . . . . .	6-4
CHAPTER 7	CIRCUIT DIAGRAMS . . . . .	7-1
	(Not Applicable)	
CHAPTER 8	ILLUSTRATED PARTS BREAKDOWN . . . . .	8-1
	Section I. Introduction . . . . .	8-1
8-1.	GENERAL . . . . .	8-1
	Section II. Maintenance Parts List (MPL) . . . . .	8-3
(ARMY ONLY)	APPENDIX A REFERENCES . . . . .	A-1
(ARMY ONLY)	APPENDIX B MAINTENANCE ALLOCATION CHART (MAC) . . . .	B-1
(ARMY ONLY)	APPENDIX C COMPONENT OF END ITEM LIST (COEIL) . . . .	C-1
(ARMY ONLY)	APPENDIX D ORGANIZATIONAL MAINTENANCE REPAIR PARTS AND SPECIAL TOOLS LIST . . . . .	D-1
ALPHABETICAL INDEX	. . . . .	INDEX-1

LIST OF ILLUSTRATIONS

Number	Title	Page
1-1	Digital Non-Secure Voice Terminal TA-1042A/U . . . . .	1-2
4-1	Controls and Indicators . . . . .	4-3
5-1	Block Diagram . . . . .	5-2
8-1	Digital Non-Secure Voice Terminal TA-1042A/U Illustrated Parts Breakdown . . . . .	8-2

LIST OF TABLES

Number	Title	Page
1-1	Equipment Characteristics . . . . .	1-1
1-2	Functional Characteristics . . . . .	1-3
2-1	DDP Connector Pinouts . . . . .	2-3
4-1	Controls and Indicators . . . . .	4-1
4-2	Precedence Modes . . . . .	4-5
6-1	Troubleshooting Procedures . . . . .	6-2

SAFETY SUMMARY

The following warning appears in the text of this manual, and is repeated here for emphasis.

---

**WARNING**

---

Voltages as high as +56 may be present on field wires. To avoid possible injury, handle field wires and the binding posts to which field wires are attached only by insulated areas.

## FOREWORD

1. **PURPOSE OF MANUAL.** This manual provides operating procedures and maintenance instructions with an illustrated parts breakdown for the Digital Non-Secure Voice Terminal (DNVT) with Digital Data Port (DDP) TA-1042A/U, part number 5285000-001, hereafter referred to as the DNVT. The procedures contained in this manual allow personnel to perform the maintenance tasks necessary to ensure the unit meets minimum performance standards of operation.

2. **ARRANGEMENT OF MANUAL.** This manual contains the following chapters of text:

Chapter 1	General Information
Chapter 2	Installation
Chapter 3	Preparation for Use and Reshipment
Chapter 4	Operation
Chapter 5	Theory of Operation
Chapter 6	Maintenance
Chapter 7	Circuit Diagrams
Chapter 8	Illustrated Parts Breakdown
Alphabetical Index	
(Army only) Appendix A	References
(Army only) Appendix B	Maintenance Allocation Chart (MAC)
(Army only) Appendix C	Components of End Item List (COEIL)
(Army only) Appendix D	Repair Parts and Special Tools List (RPSTL)

3. **USE OF MANUAL.** The table of contents indicates chapter, section, paragraph, title, and page numbers to facilitate location of information. Illustrations and tables are located throughout the publication to supplement the text material. The list of illustrations and tables indicate the number, title, and page number. Abbreviations, phrases, and words that appear on a decal or an engraving are presented in the text exactly as the items appear on the decal or engraving.

4. **(Army only) ERROR REPORTING AND IMPROVEMENT RECOMMENDATIONS.** You can help improve this manual. If you find any mistakes or if you know of a way to improve the procedures, please let us know. A Copy of DA Form 2028 is provided at the end of this manual. A reply will be sent to you. Mail your letter, or DA Form 2028 (Recommend Changes to Publications and Blank Forms) directly to:

Commander, U.S. Army Communications-Electronics Command and Fort Monmouth, ATTN: AMSEL-LC-LM-LT  
Fort Monmouth, NJ 07703-5000

5. **MAINTENANCE FORMS, RECORDS, AND REPORTS.** If the need arises to report maintenance and unsatisfactory equipment, item and packaging discrepancies, or to fill out a transportation discrepancy report (TDR) follow the directions given below:

- a. Reports of Maintenance and Unsatisfactory Equipment. Department of the Army forms and procedures used for equipment maintenance will be those prescribed by DA PAM 738-750, as contained in Maintenance Management Update.
- b. Reporting of Item and Packaging Discrepancies. Fill out and forward SF 364 (Report of Discrepancy (ROD)) as prescribed in AR 735-11-2/DLAR 4140.55/SECNAVINST 4355.18/AFR 400-54/MCO 4430.3J.
- c. Transportation Discrepancy Report (TDR) (SF 361). Fill out and forward transportation discrepancy report (TDR) (SF 361) as prescribed in AR 55-38/NAVSUPINST 4610.33C/AFR 75-18/MCO P4610.19D/DLAR 4500.15.

6. **EQUIPMENT IMPROVEMENT RECOMMENDATIONS (EIR).** Report any improvement recommendations per the following paragraphs:

- a. If the DNVT needs improvement, submit a completed SF 368 (Quality Deficiency Report). A reply will be sent as soon as possible.
- b. (Army only) Mail the SF 368 to:

Commander, U.S. Army Communications-Electronics Command and Fort Monmouth, ATTN: AMSEL-ED-PH  
Fort Monmouth, NJ 07703-5000

7. **(USMC only) REPORTING ALL DEFICIENCIES.** Report any deficiencies (equipment or technical manual) found in this manual in accordance with MCO 4855.10., Quality Deficiency Report (QDR). Mail the QDR to:

Commanding General  
MCLB Albany  
Code (801-1)  
Albany, GA 31704-5000

**8. RELATED PUBLICATIONS.** The following related publications are applicable to this manual:

MIL-STD-188-113 17 FEB 87	Interoperability and Performance Standards for Analog-to-Digital Conversion Technique
MIL-STD-188-216 09 Mar 87	Interoperability Standards for Data Adapter Control Mode
MMC-88-072A 11 Jan 89	Performance Specification for Non-Development Item (NDI) Digital Non-Secure Voice Terminal with Digital Data Port (DNVT-DDP)
TB 11-5805-780-15	Warranty Technical Bulletin (Army Only)
TT-A3-4001-0014D thru SCN 09, 1 Jun 88	Data Adapter Electrical Interface Requirements
TT-B1-4204-0028B thru SCN 02, 22 Apr 84	Performance Specification Digital Non-Secure Voice Terminals (DNVT) TA-954()/TT and TA-984()/TT
TT-A3-9012-0046 thru SCN 04, 20 NOV 84	Digital Loop Signaling/Supervision Plan (U) (Confidential)

**9. GLOSSARY OF SYMBOLS AND ABBREVIATIONS.** The following list defines nonstandard symbols, abbreviations, and acronyms used in this manual. Standard abbreviations are contained in MIL-STD-12D, Abbreviations, for Use on Drawings, Specifications, Standards and in Technical Documents.

SYMBOL OR ABBREVIATION	DEFINITION
AP	Attaching Parts
CDP	Conditioned Diphas
CT	Communications Terminal
CVSD	Continuously Variable Slope Delta
DDD	Digital Data Device
DDP	Digital Data Port
DNVT	Digital Non-Secure Voice Terminal
LDF	Lightweight Digital Facsimile
ROD	Report Of Discrepancy
TCS	Tactical Circuit Switch
TDR	Transportation Discrepancy Report



10. This manual is prepared in accordance with the following specifications:

MIL-M-38784B	Military Specification Manuals, Technical: General Style and Format Requirements
MIL-M-38798B	Military Specification Manuals, Technical: Operation Instructions Maintenance Instructions, Circuit Diagrams, Alignment Procedures, and Installation Planning
MIL-M-38807A	Military Specification Manuals, Technical: Illustrated Parts Breakdown, Preparation of



CHAPTER 1

GENERAL INFORMATION

1-1. **GENERAL INFORMATION.** The Digital Non-Secure Voice Terminal (DNVT) (figure 1-1) is a ruggedized field telephone. It is operable as a table top device in tents, shelters, and office environments. It may also be operated outdoors while strapped to a tree or pole. The DNVT is designed for durability to exposure of the elements during operation and transportation. Voice communication is accomplished through the handset. Digital data from an external device interfaces through the TA-1042A/U's Digital Data Port (DDP). The major characteristics of the DNVT are presented in table 1-1.

1-2. **EQUIPMENT CHARACTERISTICS.** The DNVT transmits and receives full duplex, conditioned diphas digital voice and loop signaling information at 16 or 32 Kbps rates. The DNVT is a non-secure telephone with no encryption capability. It digitizes voice information using continuously variable slope delta (CVSD) modulation. Digital communication transmissions, both to and from the DNVT, are accomplished using a conditioned diphas (CDP) data transmission method. This is accomplished by the use of the DDP. The DNVT operates in both common battery mode and local battery point-to-point mode, but not simultaneously.

Table 1-1. Equipment Characteristics

---

Overall Dimensions:	
Width . . . . .	7 inches
Height . . . . .	4.25 inches
Length . . . . .	9.75 inches
Weight 4.5 pounds (approximately)	
Temperature Range:	
Normal Operating . . . . .	-30 C (-22 F) to +52 C (+125 F)
Storage . . . . .	-57 C (-70 F) to +71 C (+160 F)
Humidity Range . . . . .	Up to 98%
Power Requirements:	
A.	20-56 VDC, 1.5 watt (common battery mode)
B.	5.5-28 VDC, 50 milliamp (local battery mode)

---

1-3. **FUNCTIONAL CHARACTERISTICS.** The functional characteristics of the DNVT are provided in table 1-2.

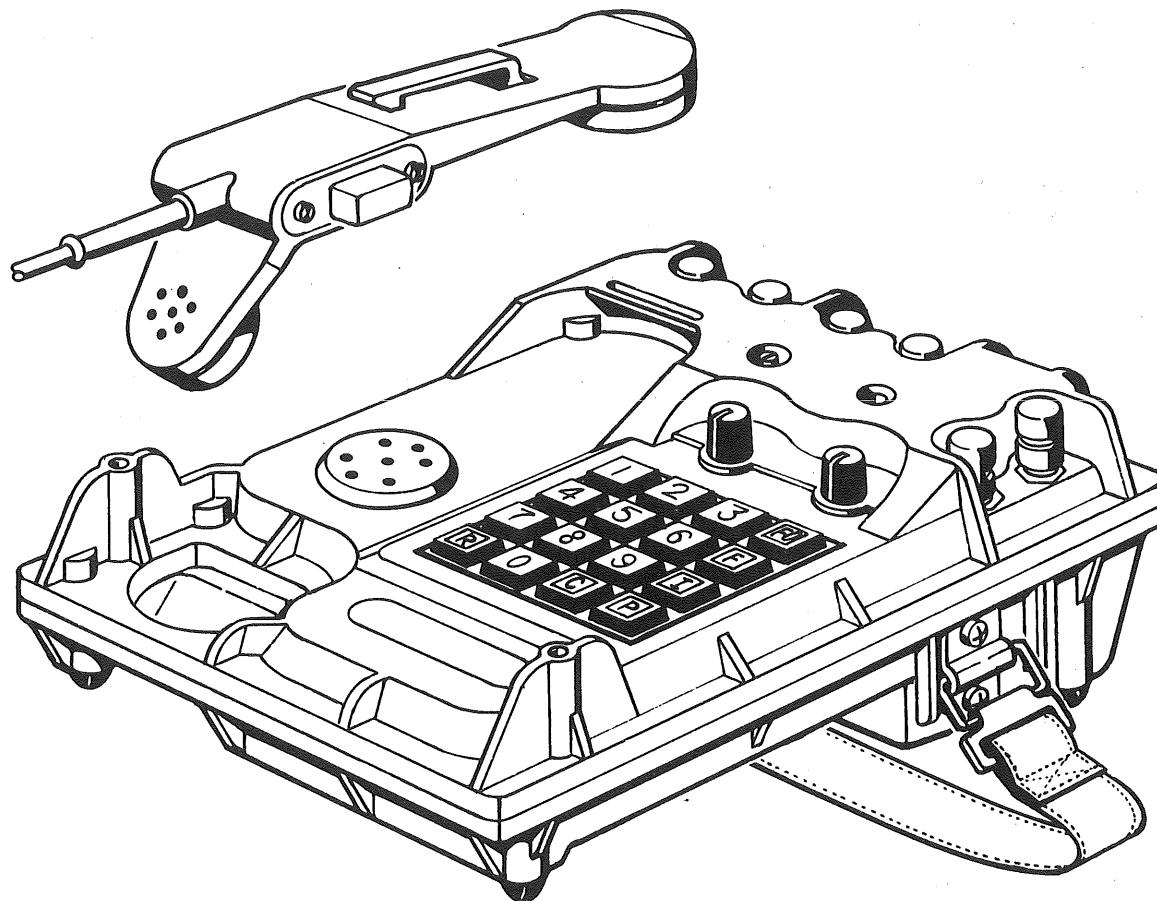

Figure 1-1. Digital Non-Secure Voice Terminal TA-1042A/U

Table 1-2. Functional Characteristics

---

Analog-to-digital/digital-to-analog conversion

Audio interface through handset H-350 (which is a hot MIC)  
(or H-250 not provided)

Automatic dialing/auto answering data devices

Data device interface (common battery)

Extension network interface (common battery)

Loop interface (modem) (full duplex only)

Power conversion

Secure lighting and audio indicators

Signaling and supervision

Local battery (point-to-point communication)

---



## CHAPTER 2

### INSTALLATION

2-1. **GENERAL.** This chapter provides step-by-step instructions for preparing the Digital Non-Secure Voice Terminal (DNVT) for two separate modes of operation, common battery (CB) mode and local battery (LB) mode. If a digital data device (DDD) is used, connect cable from the DDD to the digital data port (DDP) connector on the base of the DNVT. Refer to chapter 5, paragraph 5-3 for additional information. Connector pinout data for the DDP is provided in table 2-1.

---

#### WARNING

---

Voltages as high as +56 may be present on field wires. To avoid injury, handle field wires and the binding posts to which field wires are attached only by insulated areas.

- a. Common battery (CB) mode. Perform the following procedures.
  - (1) Identify transmit field wires. Remove insulation from and connect transmit field wires to the black spring loaded binding posts labeled XMT on top side of the DNVT.
  - (2) Identify receive field wires. Remove insulation from and connect receive field wires to the red spring loaded binding posts labeled RCV on top side of the DNVT.
  - (3) Using a common straight blade screwdriver, turn select switch labeled SEL to position labeled CB (16 or 32) on top side of the DNVT.
  - (4) Operator should lift handset to verify receipt of dial tone. If no dial tone is heard but ring indicator illuminates the phone is properly installed but the tactical circuit switch (TCS) is not on line. The ring indicator will go out within 10 seconds after replacing the handset.

- b. Local battery (LB) mode. Perform the following procedures.

**NOTE**

When field wire directly connects two DNVTs in the LB mode the transmit and receive pairs must be transposed.

- (1) Identify transmit field wires. Remove insulation from and connect transmit field wires to the black spring loaded binding posts labeled XMT on top side of the DNVT.
- (2) Identify receive field wires. Remove insulation from and connect receive field wires to the red spring loaded binding posts labeled RCV on top side of the DNVT.
- (3) Using a common straight blade screwdriver, turn select switch labeled SEL to position labeled LB (16 or 32) on top side of the DNVT.
- (4) Connect an external power source (5.5-28 VDC, 75 milliamp) to the PWR binding posts. Positive lead of power source attaches to the red binding posts, negative lead of power source attaches to the black binding posts. (See figure 4-1.) If the local termination is a time division multiplexer (TDM) the local battery power is available via the loop modem card in the TDM. In this case the LB power is provided via the XMT/RCV connections.



Table 2-1. DDP Connector Pinouts

Pin	Nomenclature
1	Signal Ground (SIGNAL GND)
2	Transmit Audio Shield (TA SHIELD)
3	Spare
4	Extension Ring Output (EXT RING-P)
5	Spare
6	Transmit Audio Return (TA RET)
7	Transmit Audio Input (TA)
8	TA-1035 Indicator (TA-1035 IND-P) (Signal is 0 volt output from the DNVT)
9	Resync Command Input (RESYNC CMD-P) (DNVT toggles Transmit Ready (TXRDY-P) line upon receipt of valid RESYNC CMD-P input)
10	EXT R1 Input (Dialed Digit Control Line)
11	EXT Off Hook Input (EXT OFF HK-P)
12	Reserved
13	Dial Output (DIAL-P) (Indicates DNVT dial state)
14	Reserved
15	Voice/Data (VOICE-N/DATA-P) (Selects voice or data mode of DNVT)
16	Transmit Clock Output (TXCLK-P)
17	EXT R2 Input (Dialed Digit Control Line)
18	Ring/Busy Indicator Output (RING/BUSY/IND)
19	Reserved
20	Reserved
21	Data Device/Extension Network Power (VDD) (This is a control line, and is not to be used to derive power from the DNVT)
22	Spare
23	Data Device Off-Hook Input (DD OFF HK-P)
24	Transmit Data Input (TXDPT)
25	Read Dialed Digit Input (EXT DAV)
26	Reserved
27	Extension Push-to-Talk Input (EXT PTT-P)
28	Reserved
29	Transmit Ready Output (TXRDY-P)
30	Reserved
31	Ring Data Output (RING DATA-P)
32	EXT C1 Input (Dialed Digit Control Line)
33	Reserved
34	Spare
35	Extension Network Connection Signal Input (EXT VDD LOOP)
36	Data Device Connection Signal Input (DD VDD LOOP)
37	Loop Back Input (LOOP-P)

Table 2-1. DDP Connector Pinouts - Continued

Pin	Nomenclature
38	Rate Change Flag Output (RCFLG-P)
39	Receive Data Output (RXDPT-P)
40	EXT C2 Input (Dialed Digit Control Line)
41	Reserved
42	Spare
43	Reserved
44	Spare
45	Half Duplex Flag Output (HDX FLG-P) (Signal is 0 V output from DNVT)
46	Receive Clock Output (RXCLK-P)
47	Local Off Hook Output (OFF HK-P)
48	TA-1042 Indicator Output (TA-1042 IND-P) (Signal is +6 V, +0.8 V/-0.5 V, output from the DNVT)
49	Receive Audio Return (RA RET)
50	Receive Audio Output (RA)
51	Codewords Output (CODEWORDS-P) (Dial digit codewords from the DNVT to TCS)
52	Go On Hook Output (GO ON HK-P) (Pulse Output)
53	Frame Ground (FRAME GND)
54	Receive Audio Shield (RA SHIELD)
55	BUSY Tone Output (BUSY-P) (Set when the DNVT detects BUSY or ERROR signals from the TCS)

CHAPTER 3

PREPARATION FOR USE AND RESHIPMENT

Section I. Preparation for Use

3-1. **INSTRUCTIONS.** Refer to chapter 2 for instructions concerning preparation of the Digital Non-Secure Voice Terminal (DNVT) for operation. Refer to chapter 5, paragraph 5-3 for additional information.

Section II. Preparation for Reshipment

3-2. **INSPECTION.** Inspect the DNVT for any loose or missing parts. Pack the unit in plastic bubble wrap prior to shipping. Army units refer to Warranty Technical Bulletin TB 11-5805-780-15 for shipping instructions. The U.S. Marine Corps units must request shipping instructions from MCLB Albany (Code 845-1) in accordance with MCO P4400.82F WIR procedures.



CHAPTER 4

OPERATION

4-1. **GENERAL.** This chapter contains operational instructions for the Digital Non-Secure Voice Terminal (DNVT).

Section I. Controls and Indicators

4-2. **OPERATING CONTROLS.** The controls and indicators listed in table 4-1 are used by the operator to control the function of the DNVT. All controls are located on the front panel of the DNVT. (See figure 4-1.) The function of each control is presented in the following paragraphs.

Table 4-1. Controls and Indicators

Name	Function
Magnetic Hookswitch (internal to telephone base)	Allows the operator to select the off-hook condition of the DNVT by lifting the handset.
Volume Control	Adjusts the level of audio present at handset earphone.
Ring Control	Adjusts the audio level of the tone ringer device.
Ring Indicator	Flashing light emitting diode (LED) informs the operator when the DNVT is ringing and a steady-on LED indicates that the DNVT is busy sending or receiving data.
Keypad	Provides the means by which the operator enters address (phone no.), precedence, and other control information.
Select Switch	Allows the operator to select the operating mode (CB or LB) and digital data transfer rate (16 or 32 Kbps) of the DNVT.

Table 4-1. Controls and Indicators - Continued

Name	Function
Push-to-talk (PTT)	Net radio interface (NRI) only - not used for normal phone calls.

a. Magnetic Hookswitch. The magnetic hookswitch consists of a magnetic switch located in the sealed chassis of the DNVT, and the permanent magnets located in the handset. When the handset is in place on the base of the DNVT, the magnetic hookswitch assumes the ON HOOK position. With the hookswitch in the ON HOOK position and no receive conditioned diphas (CDP) is present on field wires, the DNVT remains in the idle state until an incoming call is detected. When the ring voice codeword is detected, the DNVT responds with ring acknowledge and simultaneously the LED begins flashing, and the audible ring indicator sounds. When the ring data codeword is detected, the DNVT responds with ring acknowledge and simultaneously sets the appropriate control lines at the DDP to inform the data device of an incoming call.

b. Volume Control. The rotary volume (VOL) control adjusts the level of audio present at the handset earphone. The volume control is configured such that rotating the control counterclockwise (CCW) reduces the audio level. Rotating the volume control clockwise (CW) increases the audio level.

c. Ring Control. The rotary ringer volume control (RING) adjusts the audio level of the tone ringer device. The ringer volume control is configured such that rotating the control CCW reduces the ringer level. Rotating the ringer volume control CW increases the audio level. A switch is provided at the minimum volume position which completely disables the tone ringer.

d. Ring Indicator. The ring/busy indicator (RING) is a green visual indicator which informs the operator when the DNVT is ringing or is busy passing data traffic. The indicator is off (non-illuminated) when the DNVT is in the idle mode. When the DNVT is being rung (receiving a ring voice command from the Tactical Circuit Switch (TCS)), the indicator will flash at a rate of one half second on and one half second off (+ or - 10%) as an indication of an incoming call. The indicator will remain steadily illuminated whenever the DNVT is electrically OFF HOOK, either for voice or data communications.

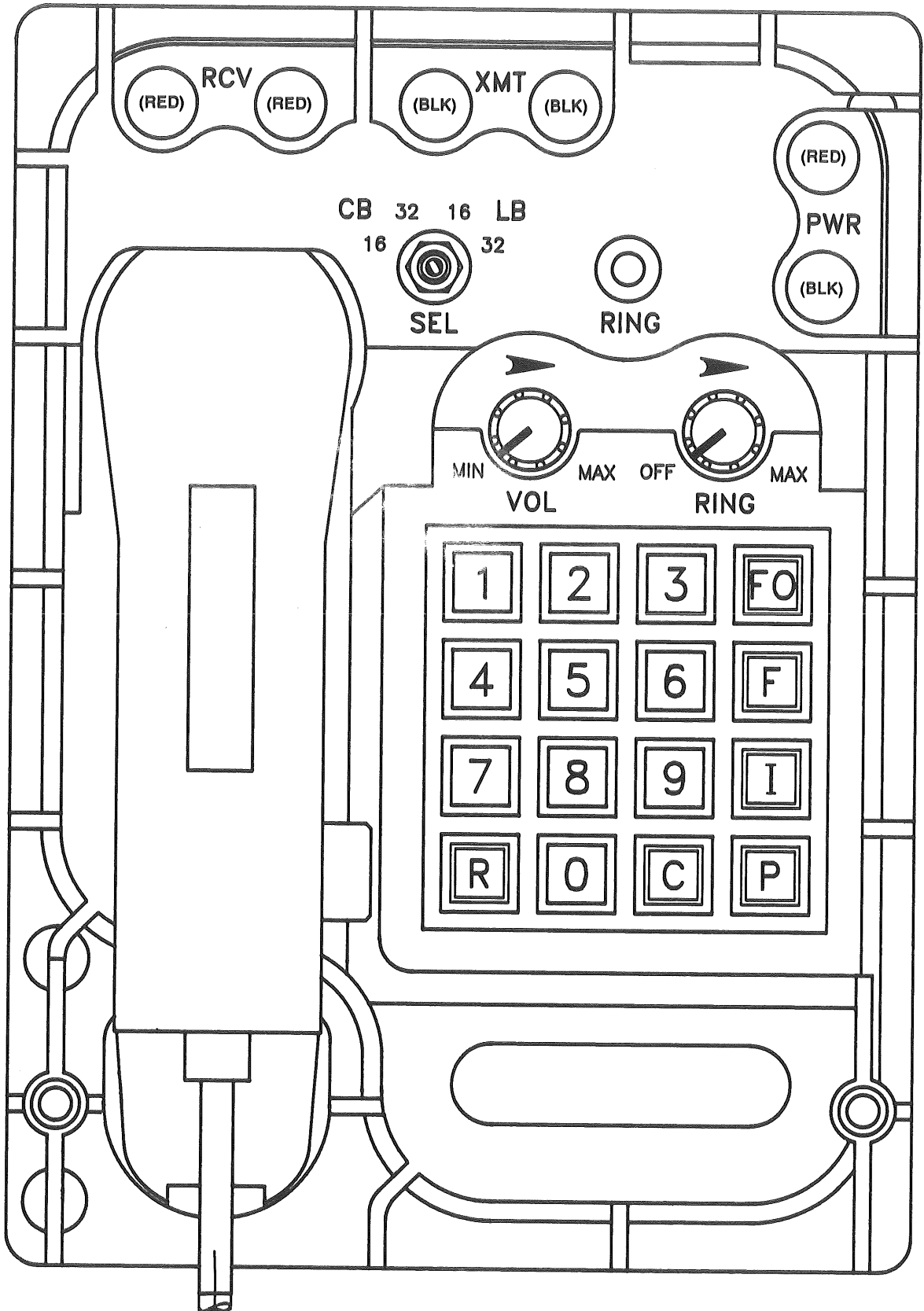

Figure 4-1. Controls and Indicators

e. Keypad. The 16-key keypad provides the means by which the operator enters address (phone number), precedence, and other control information necessary for operation of the DNVT. The function of each key is discussed in the Operating Instructions section of this technical manual.

f. Select Switch. The four position function select switch (SEL) allows the operator to select the operating mode (CB or LB) and digital data transfer rate (16 or 32 Kbps) of the DNVT. A common straight blade screwdriver should be used to change setting of the select switch. The position of the select switch slot indicates selected function.

## Section II. Operating Instructions

4-3. **OPERATING INSTRUCTIONS.** Instructions for operating the DNVT are provided in the following paragraphs.

a. Data Rate Selection. Prior to using the DNVT, the operator must set the select (SEL) switch for the proper operating mode and data rate as specified by the field wire plan. A common straight blade screwdriver should be used to change setting of the select switch. The two operating modes, local battery and common battery, are indicated by the notation LB and CB, respectively, on the SEL switch. Each operating mode position allows for the selection of a 16 Kbps or a 32 Kbps data rate.

b. Local Battery Mode. When operated in the LB mode, the DNVT allows direct communication with another DNVT. Communications with the distant DNVT is initiated by removing the handset from the base and speaking into the microphone. All supervisory and precedence functions are disabled when the DNVT is used in the LB mode.

c. Common Battery Mode. In CB mode, communication is initiated through the TCS.

(1) Placing a call. The operator lifts the handset from the base of the DNVT and listens in the handset earphone for a supervisory dial tone. The operator then enters on the keypad the precedence level, if any, of the call; followed by the 3, 5, or 7 digit code corresponding to the DNVT the caller wishes to contact. When the called station answers, voice communication is carried out through the earphone and microphone contained in the handset. The level of the handset earphone audio may be adjusted with the volume (VOL) control. Should a BUSY tone be heard, after the code is dialed, it indicates that the DNVT being called is in use.



(2) Precedence modes. If the communication is imperative or of an emergency nature, the operator may interrupt the conversation in process on the busy DNVT by using any of the four precedence modes. Precedence is established by pressing one of the four precedence keys prior to entering the code of the station to be called. There are four precedence keys on the keypad; these correspond to the four precedence modes, and are listed in table 4-2. The key labeled "R" presently serves no function to the DNVT operators in the Air Force and USMC services. However, when the DNVT is interfaced with the AN/TTC-39D circuit switch or an MSE switch, the "R" key allows a mobile operator to re-affiliate the terminal with the TCS.

Table 4-2. Precedence Modes

Key	Precedence Mode	Priority Level	Description
FO	Flash Override	1	Preempts the called station if the called station is involved in a Flash or lower precedence call. The called station will then be forced on-hook and begin to ring. The called DNVT must hang up and then go off hook to answer the call.
F	Flash	2	Preempts the called station if the called station is involved in an Immediate or lower precedence call. The called station will then be forced on-hook and begin to ring. The called DNVT must hang up and then go off hook to answer the call.

Table 4-2. Precedence Modes - Continued

Key	Precedence Mode	Priority Level	Description
I	Immediate	3	<p>Preempts the called station if the called station is involved in a Priority or lower precedence call.</p> <p>The called station will then be forced on-hook and begin to ring. The called DNVT must hang up and then go off hook to answer the call.</p>
P	Priority	4	<p>Preempts the called station if the called station is involved in a routine call to another party. The called station will then be forced on-hook and begin to ring. The called DNVT must hang up and then go off hook to answer the call.</p>

(3) Receiving a call. When a call is received, the DNVT will provide both a visual and an aural alert signal of the incoming call. The volume of the aural alert signal may be adjusted with the RING control. A flashing visual RING indicator is an indication of an incoming call. When the handset is OFF-HOOK, as when placing or answering a call, the visual RING indicator will be steadily illuminated. Data communication may be initiated or answered through the DNVT without operator intervention. When the DNVT is "busy" with either voice or data communication, the visual RING indicator will be steadily illuminated. It is not necessary for the handset to be OFF-HOOK in order for the external data device to place a call through the data port of the DNVT.

(4) Conference calling. Conference calling allows the operator to establish communication between many DNVT terminals simultaneously. Conferencing is accomplished by pressing the "C" key on the keypad, followed by the number code of the station to be called for the conference call. Additional conferees are called by pressing the "C" key. The TCS will then provide a dial tone and the conference initiator will dial the next conferee.

(5) Supervisory tones. There are several aural warning tones, known as supervisory tones which the operator will hear in day-to-day use of the DNVT. The supervisory tones and the meaning of each are discussed in the following paragraphs.

(a) Dial tone. A DIAL TONE is heard in the handset earphone whenever the operator lifts the handset from the base of the DNVT. The dial tone indicates that communication has been established with the TCS.

(b) Keypad side tone. The SIDE TONE is an audio tone heard in the handset earphone whenever the operator presses a key on the keypad.

(c) Ring-back tone. When the operator of the DNVT enters the phone number of a distant DNVT he wishes to contact, the supervisory RING-BACK tone is heard in the handset earphone as an indication that the distant DNVT is ringing.

(d) Busy. The BUSY tone indicates that the distant DNVT being called is in use.

(e) Error. The ERROR tone indicates that the call was not completed, and should be attempted again. The ERROR tone sounds much like a BUSY tone, but is sounded at a noticeably faster rate.

(f) Preempt tone. The PREEMPT tone is sounded during a conversation whenever a priority call is about to be sent to an in-use DNVT as an indication that the conversation in process is about to be disconnected by the TCS so that the priority call can be completed. The PREEMPT tone is heard in the handset earphone of both parties engaged in the conversation. Once the PREEMPT tone is sounded, the conversation will terminate in 2 to 3 seconds. The called DNVT must hang up and go off hook to answer the call.

(6) Digital Data Port. The digital data port (DDP) allows a UGC-144 Communications Terminal (CT), or a AN/UXC-7 Lightweight Digital Facsimile (FAX) Machine (LDF) to be connected to it. When using either of these devices through the DNVT, refer to the T.M. for the digital data device (DDD) being used for operating instructions (IE: placing calls, answering calls, etc.) pertaining to that device. A table containing pin out data for the DDP is provided in Table 2-1 of this T.M.

### Section III. Emergency Operation

There are no emergency operation procedures applicable to the DNVT.

### Section IV. Preventive Maintenance Checks and Services (PMCS)

(Army Only) There are no preventive maintenance procedures applicable to the DNVT.

## CHAPTER 5

### THEORY OF OPERATION

#### Section I. Functional System(s) Operation

5-1. **GENERAL.** The Digital Non-Secure Voice Terminal (DNVT) is a ruggedized field telephone which transmits and receives full duplex, digital (conditioned diphase) voice and data communication signals. Supervisory tones, generated by equipment external to the DNVT, prompt the operator for inputs, or notify the operator of problem or error conditions. Two modes of operation, local battery (LB) and common battery (CB), are supported by the DNVT. Figure 5-1 is a block diagram showing the external connections to the DNVT. Circuitry internal to the DNVT provides the audio interface, analog-to-digital (A/D) and digital-to-analog (D/A) conversion, digital data loop interface, signaling, supervision, and all user interface functions required for operation. Reference to figure 5-1 will facilitate a better understanding of the following text. A source of earphone audio, denoted as EAR, and microphone audio, denoted as MIC, interfaces with the DNVT through the handset. The handset used with the DNVT provides both a microphone for transmitting and an earphone for listening to audio signals. The handset interfaces to the DNVT through the audio connector. Digital data from an external device interfaces with the DNVT through the DDP connector. The DNVT uses the continuously variable slope delta (CVSD) method of A/D and D/A conversion. All transmissions both to and from the DNVT are carried out using a conditioned diphase (CDP) data transmission method. Digital data signals are received by the DNVT over the field wires connected to the receive (RCV) binding posts. Signals generated by the DNVT and transmitted to another DNVT or a Tactical Circuit Switch (TCS) are sent over the field wires connected to the transmit (XMT) binding posts.

5-2. **POWER SOURCES.** Power for the DNVT is derived by two methods. When operating in the CB mode, power is derived from the TCS over the field wires. In the LB mode, power is derived from an external power source or the loop modem card in a time division multiplexer (TDM) transmission system. The external power source is connected to the DNVT through the power (PWR) binding posts. Refer to table 1-1 located in chapter 1 for power requirements. The loop modem card in the TDM provides the LB power through the XMT/RCV binding posts.

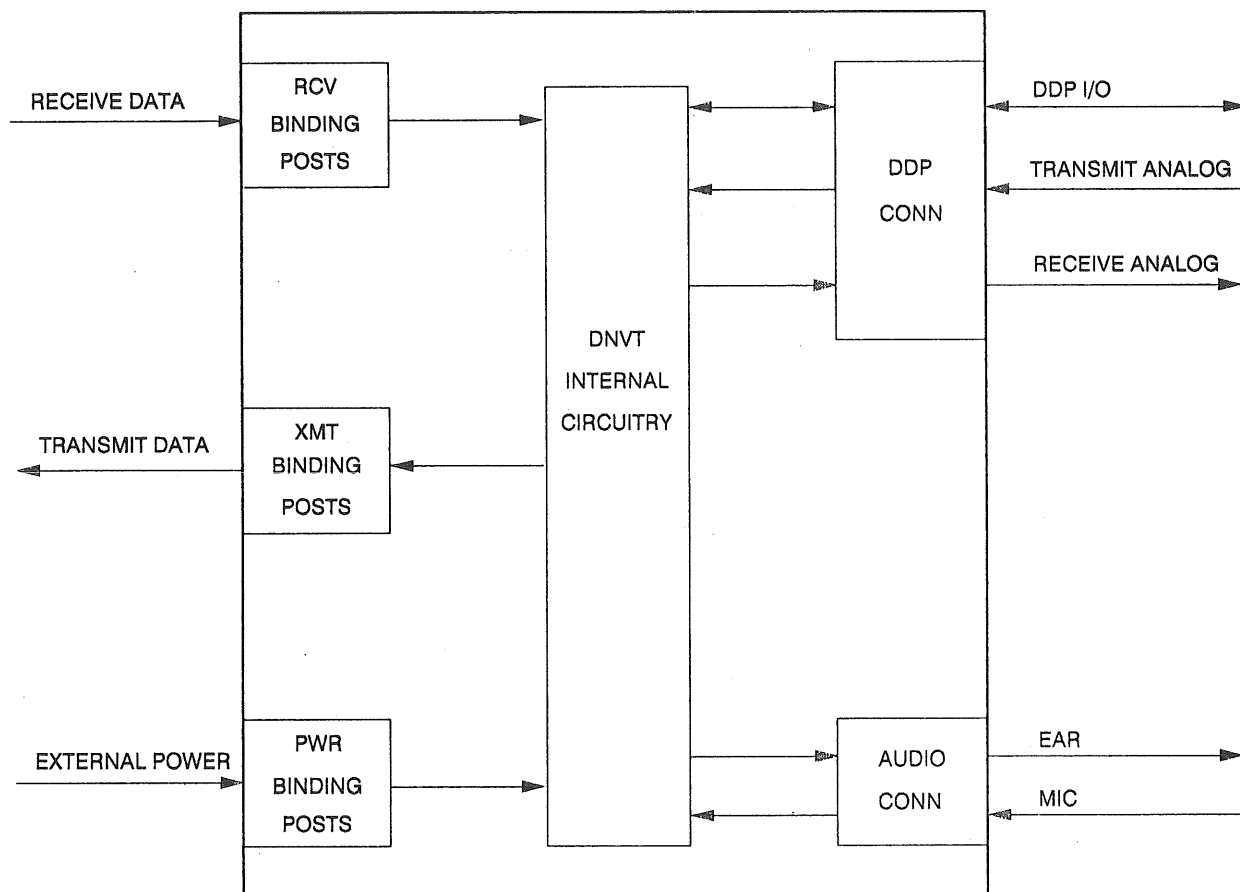

Figure 5-1. Block Diagram

5-3. **OPERATING MODES.** The DNVT may be used for both point-to-point communications (LB mode) and communications through a TCS (CB mode). The CB mode allows voice and data communications. The LB mode allows only voice communications. Voice signals are derived from the handset of the DNVT. The digital data port allows a UGC-144 Communications Terminal (CT), or a AN/UXC-7 Lightweight Digital Facsimile (FAX) Machine (LDF) to be connected to it. All data transmissions take place over the field wires irregardless of the handset's position on the base of the DNVT. The CB mode allows the DNVT to be used as a terminal and operate through a TCS. In CB mode, the DNVT communicates with other DNVTs through the TCS. Power for the DNVT circuitry is obtained from the TCS. Supervisory tones and operational functions available to the operator in the CB mode are discussed in chapter 4, section II. The LB mode allows one DNVT to communicate with another DNVT in a direct point-to-point hook-up configuration. In LB mode, power is derived from a local power source located external to the DNVT.

Section II. Functional Operation of Electronic Circuits

(Not Applicable)

Section III. Functional Operation of Mechanical Assemblies

(Not Applicable)





## CHAPTER 6

### MAINTENANCE

6-1. **GENERAL.** This chapter contains maintenance instructions required for the Digital Non-Secure Voice Terminal (DNVT).

6-2. **WARRANTY.** The DNVT is under warranty for five years following the date stamped on the nameplate. If the nameplate seal is broken the warranty is invalid. Army units refer to Warranty Technical Bulletin, TB 11-5805-78-15. U.S. Marine Corps units refer to the published Material Fielding Plan.

#### Section I. Organizational and Intermediate Maintenance

6-3. **ORGANIZATIONAL MAINTENANCE.** Organizational maintenance of the DNVT consists of replacing failed units with new DNVT units. There are no formal repair procedures authorized for the DNVT.

6-4. **INTERMEDIATE MAINTENANCE.** Intermediate maintenance is not applicable to the DNVT. There is no maintenance authorized above the organizational level.

6-5. **OPERATIONAL CHECKOUT AND TROUBLESHOOTING.** There are no specific procedures for the operational checkout of the DNVT. Verify that the DNVT is operating by following the operating instructions provided in chapter 4. If the DNVT does not operate properly, refer to table 6-1.

Table 6-1. Troubleshooting Procedures

Malfunction	Test or Inspection	Corrective Action
DNVT not operating.	<p>Verify that the DNVT is receiving power by taking the handset off-hook and observing the ring/off-hook indicator. If the DNVT is receiving power, the ring/off-hook indicator will be illuminated. If the ring off-hook indicator does not illuminate, measure the input voltage as follows:</p> <p>a. When operating in the LB mode, ensure that the red PWR binding post is positive with respect to the black PWR binding post and the voltage measured is between 5.5 and 28 VDC. If LB power is supplied from a TDM, ensure that the RCV binding posts are positive with respect to the XMT binding posts and the voltage measured is between 20 and 56 VDC.</p>	<p>a. In the LB mode, reverse the polarity of the input voltage source, if incorrect or if the voltage at the power binding posts does not fall within 5.5 to 28 VDC, replace the power source with a known good power source.</p>

Table 6-1. Troubleshooting Procedures - Continued

Malfunction	Test or Inspection	Corrective Action
DNVT not operating.	<p>b. When operating in the CB mode, ensure that the receive (RCV) binding posts are positive with respect to the transmit (XMT) binding posts and that the voltage measured is between 20 and 56 VDC.</p> <p>If the DNVT is receiving power, verify that the rate selector switch is in the correct position as follows:</p>	<p>b. In the CB mode, reverse the polarity of the field wires, if the polarity is incorrect. If the polarity is correct and the measured voltage is not within 20 to 56 VDC, notify the circuit switch operator of the problem.</p>
	<p>a. When operating in the LB mode, verify by listening in the handset earphone that the called DNVT is producing a ring back tone.</p>	<p>a. In the LB mode, if no ring back tone is heard, check position of rate selector switch. The rate selector switch must be set to the correct data rate position on the LB switch settings. The rate selector switch setting must be the same at both the local and distant DNVTs. If no ring back tone is heard, try selecting the other data rate setting and listen for ring back tone. Use a common straight blade screwdriver to change setting of the select switch.</p>

Table 6-1. Troubleshooting Procedures - Continued

Malfunction	Test or Inspection	Corrective Action
No dial tone (CB) or ring back tone (LB).	<p>b. When operating in the CB mode, verify by listening in the handset earphone that the DNVT is receiving a dial tone.</p> <p>If the rate selector switch is in correct position, the power is connected correctly, and the DNVT is not producing ring back or dial tone.</p>	<p>b. In the CB mode, if no dial tone is heard, check position of rate selector switch. The rate selector switch must be set to the correct data rate position on the CB switch settings. The rate selector switch setting must match the TCS loop data rate. If no dial tone is heard, try selecting the other data rate setting and listen for dial tone. Use a common straight blade screwdriver to change setting of the select switch.</p> <p>Replace the DNVT with known good unit.</p>

Section II. Special Maintenance

There are no special maintenance requirements for the DNVT.

Section III. Performance Test Checks

There are no performance test checks applicable to the DNVT.

CHAPTER 7  
CIRCUIT DIAGRAMS

(Not Applicable)



## CHAPTER 8

### ILLUSTRATED PARTS BREAKDOWN

#### Section I. Introduction

8-1. **GENERAL.** This chapter provides a listing of all parts which are coded for replacement on the Digital Non-Secure Voice Terminal (DNVT). The maintenance parts list consist of columns containing figure and index number, part number, FSCM, description, units per assembly, usable on code, and SM&R code. (See figure 8-1.)

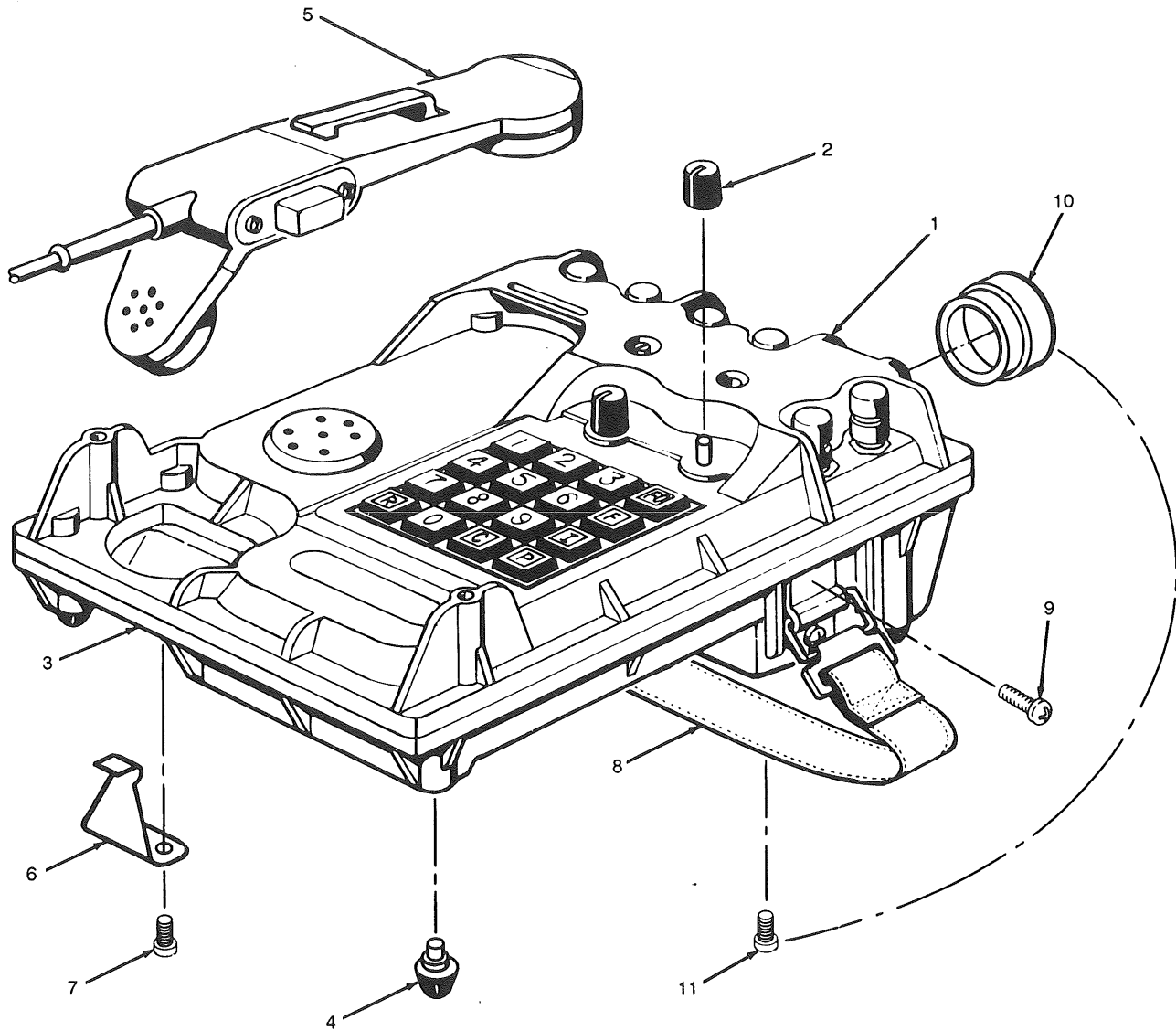

Figure 8-1. Digital Non-Secure Voice Terminal TA-1042A/U  
Illustrated Parts Breakdown



Section II. Maintenance Parts List (MPL)

Figure & Index No.	Part Number	FSCM	1234567 Description	Units Per Assy	Usable On Code	SMR Code
1	5285000-001	2J622	DIGITAL NON- . . SECURE VOICE TERMINAL	1		PAOOO
1-1	5285010-001	2J622	.PANEL, MOLDED .	1		XA
1-2	5285038-001	2J622	..KNOB . . . . .	2		PAOZZ
1-3	5285015-001	2J622	.BASE, MOLDED .	1		XA
1-4	5285050-001	2J622	..FOOT, MOLDED .	4		PAOZZ
1-5	H-350/U	81134	.HANDSET . . . . .	1		PAOZZ
1-6	5285052-001	2J622	.SPRING, HANDSET RETAINER	1		PAOZZ
1-7	MS51957-13		.SCREW (AP) . . .	2		PAOZZ
1-8	5285037-001	2J622	.STRAP ASSEMBLY	1		PAOZZ
1-9	MS51861-34C		.SCREW (AP) . . .	4		PAOZZ
1-10	MS27502B17C		.CAP, DUST . . . .	1		PAOZZ
1-11	MS51861-22C		.SCREW (AP) . . .	1		PAOZZ



**APPENDIX A**  
**REFERENCES**

---

**A-1. Scope**

This appendix lists all forms, pamphlets, field manuals, technical bulletins, and technical manuals referenced in this manual.

**A-2. Forms**

Recommended Changes to Publications and Blank Forms . . . . . DA FORM 2028  
Transportation Discrepancy Report (TDR) . . . . . SF 361  
Report of Discrepancy (ROD) . . . . . SF 364  
Product Quality Deficiency Report . . . . . SF 368

**A-3. Field Manuals**

First Aid for Soldiers . . . . . FM 21-11

**A-4. Technical Bulletins**

Warranty Program for DNVT Equipment . . . . . TB 11-5805-780-15

**A-5. Technical Manuals**

Procedures for Destruction of Electronics Materiel to  
Prevent Enemy Use (Electronics Command) . . . . . TM 750-244-2

**A-6. Miscellaneous Publications**

Consolidated Index of Army Publications and Blank Forms . . . DA Pam 25-30  
The Army Maintenance Management System (TAMMS) . . . . . DA Pam 738-750



- C - Operator/Crew
- O - Unit
- H - General Support
- D - Depot

e. *Column 5, Tools and Equipment.* Column 5 specifies by code, those common tool sets (not individual tools) and special tools, test, and support equipment required to perform the designated function.

f. *Column 6, Remarks.* Column 6 contains an alphabetic code which leads to the remarks in Section IV, Remarks, which is pertinent to the item opposite the particular code.

#### **B-4. Tool and Test Equipment Requirements (Sect. III)**

a. *Tool or Test Equipment Reference Code.* The numbers in this column coincide with the numbers used in the tools and equipment column of the MAC. The numbers indicate the applicable tool or test equipment for the maintenance functions.

b. *Maintenance Category.* The codes in this column indicate the maintenance category allocated the tool or test equipment.

c. *Nomenclature.* This column lists the noun name and nomenclature of the tools and test equipment required to perform the maintenance functions.

d. *National/NATO Stock Number.* This column lists the National/NATO stock number of the specific tool or test equipment.

e. *Tool Number.* This column lists the manufacturer's part number of the tool followed by the Federal Supply Code for manufacturers (5-digit) in parentheses.

#### **B-5. Remarks (Sect. IV)**

a. *Reference Code.* This code refers to the appropriate item in section II, column 6.

b. *Remarks.* This column provides the required explanatory information necessary to clarify items appearing in section II.

Section II. MAINTENANCE ALLOCATION CHART  
 for  
 TELEPHONE, DIGITAL, NON-SECURE VOICE TA-1042A/U

(1) GROUP NUMBER	(2) COMPONENT/ASSEMBLY	(3) MAINTENANCE FUNCTION	(4) MAINTENANCE LEVEL					(5) TOOLS AND EQUIPMENT	(6) REMARKS
			C	O	F	H	D		
00	TELEPHONE, DIGITAL, NON-SECURE VOICE, TA-1042A/U	INPSECT	0.1						A
		SERVICE		0.2					
		INSTALL		0.3					
		REPLACE		0.3					
		REPAIR		0.3				1, 2, 3	B
		TEST		0.3				C	
01	BASE	REPLACE		0.3					
		REPAIR		0.3				1, 2, 3	D

Section III. TOOLS AND TEST EQUIPMENT REQUIREMENTS  
for  
TELEPHONE, DIGITAL, NON-SECURE VOICE TA-1042A/U

REF. CODE	MAINT. LEVEL	NOMENCLATURE	NATIONAL/NATO STOCK NUMBER	TOOL NUMBER
1	0	SCREWDRIVER, FLAT TIP	5120-00-222-8852	
2	0	SCREWDRIVER, #2 CROSS-TIP	5120-00-234-8913	
3	0	KEY SET, HEX	5120-00-046-5079	

Section IV. REMARKS  
for  
TELEPHONE, DIGITAL, NON-SECURE VOICE TA-1042A/U

REFERENCE CODE	REMARKS
A	VISUAL
B	REPAIR BY REPLACEMENT OF THE HAND SET AND EXTERNAL BASE PIECE PARTS.
C	OPERATIONAL TEST ON SITE
D	REPAIR BY REPLACEMENT OF THE EXTERNAL BASE PIECE PART.



APPENDIX B  
MAINTENANCE ALLOCATION

---

Section I. INTRODUCTION

**B-1. General**

This appendix provides a summary of the maintenance operations for the DNVT equipment. It authorizes categories of maintenance for specific maintenance functions on repairable items and components and the tools and equipment required to perform each function. This appendix may be used as an aid in planning maintenance operations.

**B-2. Maintenance Function**

Maintenance functions will be limited to and defined as follows:

- a. *Inspect.* To determine the serviceability of an item by comparing its physical, mechanical, and/or electrical characteristics with established standards through examination.
- b. *Test.* To verify serviceability and to detect incipient failure by measuring the mechanical or electrical characteristics of an item and comparing those characteristics with prescribed standards.
- c. *Service.* Operations required periodically to keep an item in proper operating condition, i.e., to clean (decontaminate), to preserve, to drain, to paint, or to replenish fuel, lubricants, hydraulic fluids, or compressed air supplies.
- d. *Adjust.* To maintain, within prescribed limits, by bringing into proper or exact position, or by setting the operating characteristics to the specified parameters.
- e. *Align.* To adjust specified variable elements of an item to bring about optimum or desired performance.
- f. *Calibrate.* To determine and cause corrections to be made or to be adjusted on instruments or test measuring and diagnostic equipments used in precision measurement. Consists of comparisons of two instruments, one of which is a certified standard of known accuracy, to detect and adjust any discrepancy in the accuracy of the instrument being compared.
- g. *Install.* The act of emplacing, seating, or fixing into position an item, part, or module (component or assembly) in a manner to allow the proper functioning of the equipment or system.
- h. *Replace.* The act of substituting a serviceable like type part, subassembly, or module (component or assembly) for an unserviceable counterpart.

i. *Repair*. The application of maintenance services (inspect, test, service, adjust, align, calibrate, replace) or other maintenance actions (welding, grinding, riveting, straightening, facing, remachining, or resurfacing) to restore serviceability to an item by correcting specific damage, fault, malfunction, or failure in a part, subassembly, module (component or assembly), end item, or system.

j. *Overhaul*. That maintenance effort (service/action) necessary to restore an item to a completely serviceable/operational condition as prescribed by maintenance standards (i.e., DMWR) in appropriate technical publications. Overhaul is normally the highest degree of maintenance performed by the Army. Overhaul does not normally return an item to like new condition.

k. *Rebuild*. Consists of those services/actions necessary for the restoration of unserviceable equipment to a like new condition in accordance with original manufacturing standards. Rebuild is the highest degree of materiel maintenance applied to Army equipment. The rebuild operation includes the act of returning to zero those age measurements (hours, miles, etc.) considered in classifying Army equipments/components.

### B-3. Column Entries

a. *Column 1, Group Number*. Column 1 lists group numbers, the purpose of which is to identify components, assemblies, subassemblies, and modules with the next higher assembly.

b. *Column 2, Component/Assembly*. Column 2 contains the noun names of components, assemblies, subassemblies, and modules for which maintenance is authorized.

c. *Column 3, Maintenance Functions*. Column 3 lists the functions to be performed on the item listed in column 2. When items are listed without maintenance functions, it is solely for purpose of having the group numbers in the MAC and RPSTL coincide.

d. *Column 4, Maintenance Category*. Column 4 specifies, by the listing of a "work time" figure in the appropriate subcolumn(s), the lowest level of maintenance authorized to perform the function listed in column 3. This figure represents the active time required to perform that maintenance function at the indicated category of maintenance. If the number or complexity of the tasks within the listed maintenance function varies at different maintenance categories, appropriate "work time" figures will be shown for each category. The number of task-hours specified by the "work time" figure represents the average time required to restore an item (assembly, subassembly, component, module, end item or system) to a serviceable condition under typical field operating conditions. This time includes preparation time, troubleshooting time, and quality assurance/quality control time in addition to the time required to perform the specific tasks identified for the maintenance functions authorized in the maintenance allocation chart. Subcolumns of column 4 are as follows:

APPENDIX C  
COMPONENTS OF END ITEM LIST

---

Section I. INTRODUCTION

C-1. Scope

This appendix lists integral components of and basic issue items for the DNVT to help you inventory items required for safe and efficient operation.

C-2. General

This Components of End Item List is divided into the following sections:

a. *Section II. Integral Components of End Item.* These items, when assembled, comprise the (DNVT) and must accompany it whenever it is transferred or turned in. The illustrations will help you identify these items

b. *Section III. Basic Issue Items.* These are the minimum essential items required to place the (DNVT) in operation, to operate it, and to perform emergency repairs. Although shipped separately packed they must accompany the LTACFIRE during operation and whenever it is transferred between accountable officers. This manual is your authority to requisition replacement BII, based on TOE/MTOE authorization of the end item.

C-3. Explanation of Columns

a. *Illustration Number (Illus Number).* This column indicates the figure number of the illustration on which the item is shown.

b. *National Stock Number.* Indicates the National stock number assigned to the item and which will be used for requisitioning.

c. *Description.* Indicates the Federal item name and, if required, a minimum description to identify the item. The part number indicates the primary number used by the manufacturer, which controls the design and characteristics of the item by means of its engineering drawings, specifications, standards, and inspection requirements to identify an item or range of items. Following the part number, the Federal Supply Code for Manufacturers (FSCM) is shown in parentheses.

d. *Quantity Required (Qty Reqd).* This column lists the quantity of each item required for a complete major item.

e. *Quantity.* This column is left blank for use during an inventory. Under the Rcvd column, list the quantity you actually receive on your major item. The Date columns are for your use when you inventory the major item.

Section II. INTEGRAL COMPONENTS OF END ITEM

(1) ILLUS NUMBER	(2) NATIONAL STOCK NUMBER	(3) DESCRIPTION  PART NUMBER (FSCM)		(4) QTYD REQD	(5) QUANTITY	
					RCVD	DATE
	5805-01-318-8421	Telephone, Digital, Non-Secure Voice TA-1042A/U		1		
	5965-00-043-3463	Handset H-250		1		
		or				
	5965-01-128-3944	Handset H-350		1		

Section III. BASIC ISSUE ITEMS

(1) ILLUS NUMBER	(2) NATIONAL STOCK NUMBER	(3) DESCRIPTION  PART NUMBER (FSCM)		(4) QTYD REQD	(5) QUANTITY	
					RCVD	DATE
		TM 11-5805-780-12&P, Operator's and Unit Maintenance Manual for DNVT		1		
		TB 11-5805-780-15, Warranty Technical Bulletin for DNVT		1		



APPENDIX D

ORGANIZATIONAL MAINTENANCE  
REPAIR PARTS AND SPECIAL TOOLS LIST

---

Section I. INTRODUCTION

D-1. Scope

This appendix lists and authorizes spares and repair parts; special tools; special test, measurement, and diagnostic equipment (TMDE); and other special support equipment required for performance of organizational maintenance of the TA-1042A/U. It authorizes the requisitioning, issue, and disposition of spares, repair parts and special tools as indicated by the source, maintenance and recoverability (SMR) codes.

D-2. General

This Repair Parts and Special Tools List is divided into the following sections:

a. Section II. Repair Parts List. A list of spares and repair parts authorized by this RPSTL for use in the performance of maintenance. The list also includes parts which must be removed for replacement of the authorized parts. Parts lists are composed of functional groups in ascending numeric sequence, with the parts in each group listed in ascending item number sequence. Figure numbers are listed directly beneath the group header.

b. Section III. Special Tools List. Not applicable.

c. Section IV. Cross-Reference Indexes. A list, in National item identification number (NIIN) sequence, of all National stock numbered items appearing in the listing, followed by a list in alphameric sequence of all part numbers appearing in the listings. National stock numbers and part numbers are cross-referenced to each illustration figure and item number appearance. The figure number and item number index list figure and item numbers in numeric sequence and cross-references National stock number, Commercial and Government Entity Code, and part numbers.

D-3. Explanation of Columns (Section II and III)

a. Item No. (Column (1)). Indicates the number used to identify items called out in the illustration.

b. SMR Code (Column (2)). The source, maintenance, and recoverability (SMR) code is a five-position code containing supply/requisitioning information, maintenance category authorization criteria, and disposition instruction, as shown in the following breakout:

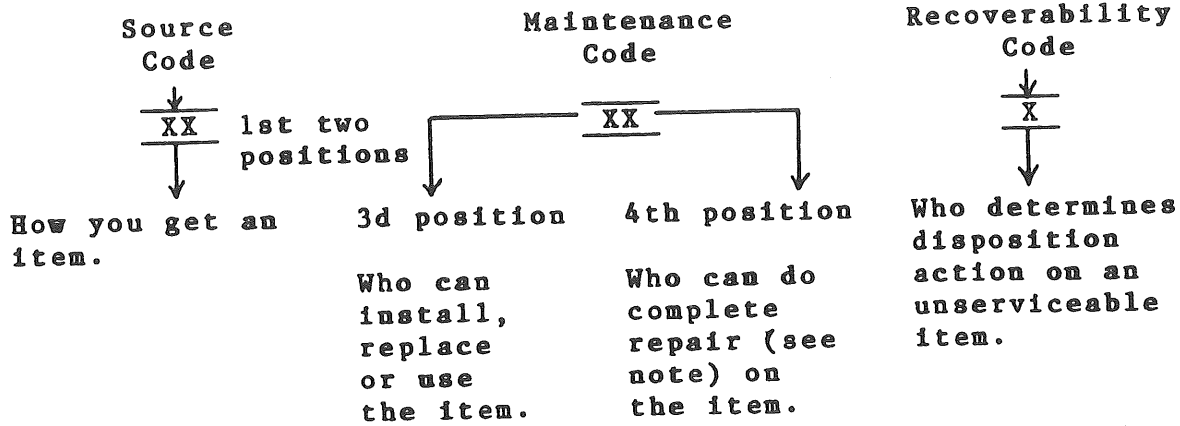

**NOTE**

Complete repair: Maintenance capacity, capability, and authority to perform all corrective maintenance tasks of the "repair" function in a use/user environment in order to restore serviceability to a failed item.

(1) Source code. The source code tells you how to get an item needed for maintenance, repair, or overhaul of an end item/equipment. Explanations of source codes follows:

Code

Explanation

PA  
PB  
PC  
PD  
PE  
PF  
PG

Stocked items: use the applicable NSN to request/requisition items with these source codes. They are authorized to the category indicated by the code entered in the third position of the SMR code.

**NOTE**

Items coded PC are subject to deterioration.

KD  
KF  
KB

Items with these codes are not to be requested/requisitioned individually. They are part of a kit which is authorized to the maintenance category indicated in the third position of the SMR code. The complete kit must be requisitioned and applied.



<u>Code</u>	<u>Explanation</u>
MO - Made at org/AVUM category	Items with these codes are not to be requested/requisitioned individually. They must be made from bulk material which is identified by the part number in the description and usable on code (UOC) column and listed in the Bulk Material group of the repair parts list. If the item is authorized to you by the third position code of the SMR code, but the source code indicates it is made at a higher category, order the item from the higher category of maintenance.
MF - Made at DS/AVIM category	
MH - Made at GS category	
ML - Made at Specialized Repair Activity (SRA)	
MD - Made at Depot	
AO - Assembled by org/AVUM category	Items with these codes are not to be requested/requisitioned individually. The parts that make up the assembled item must be requisitioned or fabricated and assembled at the category of maintenance indicated by the source code. If the third position code of the SMR code authorizes you to replace the item, but the source code indicates the item is assembled at a higher category, order the item from the higher category of maintenance.
AF - Assembled by DS/AVIM category	
AH - Assembled by GS category	
AL - Assembled by SRA	
AD - Assembled by Depot	

<u>Code</u>	<u>Explanation</u>
XA - Do not requisition an "XA" coded item. Order its next higher assembly.	
XB - If an "XB" item is not available from salvage, order it using the CAGEC and part number given.	
XC - Installation drawing, diagram, instruction sheet, field service drawing, that is identified by manufacturer's part number.	
XD - Item is not stocked. Order an "XD" coded item through normal supply channels using the CAGEC and part number given, if no NSN is available.	

**NOTE**

Cannibalization or controlled exchange, when authorized, may be used as a source of supply for items with the above source codes, except for those source coded "XA" or those aircraft support items restricted by requirements of AR 750-1.

(2) Maintenance code. Maintenance codes tell you the category of maintenance authorized to USE and REPAIR support items. The maintenance codes are entered in the third and fourth positions of the SMR code as follows:

(a) The maintenance code entered in the third position tells you the lowest maintenance category authorized to remove, replace, and use an item. The maintenance code entered in the third position will indicate authorization to one of the following categories of maintenance.

<u>Code</u>	<u>Application/Explanation</u>
C	- Crew or operator maintenance done within organizational or aviation maintenance.
O	- Organizational or aviation unit category can remove, replace, and use the item.
F	- Direct support or aviation intermediate category can remove, replace, and use the item.
H	- General support category can remove, replace, and use the item.
L	- Specialized repair activity can remove, replace, and use the item.
D	- Depot category can remove, replace, and use the item.

(b) The maintenance code entered in the fourth position tells whether or not the item is to be repaired and identifies the lowest maintenance category with the capability to do complete repair (i.e., perform all authorized repair functions). This position will contain one of the following maintenance codes.

NOTE

Some limited repair may be done on the item at a lower category of maintenance, if authorized by the Maintenance Allocation Chart (MAC) and SMR codes.

<u>Code</u>	<u>Application/Explanation</u>
O	- Organizational or aviation unit is the lowest category that can do complete repair of the item.
F	- Direct support or aviation intermediate is the lowest category that can do complete repair of the item.
H	- General support is the lowest category that can do complete repair of the item.
L	- Specialized repair activity (designate the specialized repair activity) is the lowest category that can do complete repair of the item.
D	- Depot is the lowest category that can do complete repair of the item.

<u>Code</u>	<u>Application/Explanation</u>
Z -	Nonreparable. No repair is authorized.
B -	No repair is authorized. (No parts or special tools are authorized for the maintenance of a "B" coded item.) However, the item may be reconditioned by adjusting, lubricating, etc., at the user category.

(3) Recoverability code. Recoverability codes are assigned to items to indicate the disposition action on unserviceable items. The recoverability code is entered in the fifth position of the SMR Code as follows:

<u>Recoverability codes</u>	<u>Application/Explanation</u>
Z -	Nonreparable item. When unserviceable, condemn and dispose of the item at the category of maintenance shown in the third position of SMR code.
O -	Reparable item. When uneconomically repairable, condemn and dispose of the item at organizational or aviation unit category.
F -	Reparable item. When uneconomically repairable, condemn and dispose of the item at direct support or aviation intermediate category.
H -	Reparable item. When uneconomically repairable, condemn and dispose of the item at general support category.
D -	Reparable item. When beyond lower category repair capability, return to depot. Condemnation and disposal of item not authorized below depot category.
L -	Reparable item. Condemnation and disposal not authorized below specialized repair activity (SRA).
A -	Item requires special handling or condemnation procedures because of specific reasons (e.g., precious metal content, high dollar value, critical material, or hazardous material). Refer to appropriate manuals/directives for specific instructions.

c. CAGEC (Column (3)). The Commercial and Government Entity Code (CAGEC) is a 5-digit numeric code which is used to identify the manufacturer, distributor, or Government agency, etc., that supplies the item.

d. Part Number (Column (4)). Indicates the primary number used by the manufacturer (individual, company, firm, corporation, or Government activity), which controls the design and characteristics of the item by means of its engineering drawings, specifications, standards, and inspection requirements to identify an item or range of items.

NOTE

When you use an NSN to requisition an item, the item you receive may have a different part number from the part ordered.

e. Description and Usable on Code (UOC) (Column (5)). This column includes the following information.

(1) The Federal item name and, when required, a minimum description to identify the item.

(2) The statement "END OF FIGURE" appears just below the last item description in Column (5) for a given figure in both section II and section III.

f. Qty (Column (6)). Indicates the quantity of the item used in the breakout shown on the illustration figure, which is prepared for a functional group, subfunctional group, or an assembly. A "V" appearing in this column in lieu of a quantity indicates that the quantity is variable and the quantity may vary from application to application.

D-4. Explanation of Columns (Section IV)

a. National Stock Number (NSN) Index.

(1) Stock number column. This column lists the NSN by National item identification number (NIIN) sequence. The NIIN consists of the last nine digits of the NSN. When using this column to locate an item, ignore the first four digits of the NSN. When requisitioning items use the complete NSN (13 digits).

(2) Fig. column. This column lists the number of the figure where the item is identified/located. The illustrations are in numerical sequence in sections II and III.

(3) Item column. The item number identifies the item associated with the figure listed in the adjacent Fig. column. This item is also identified by the NSN listed on the same line.

b. Part Number Index. Part numbers in this index are listed by part number in ascending alphameric sequence.

(1) CAGEC column. This column lists the Commercial and Government Entity Code (CAGEC).

(2) Part number column. This column indicates the part number assigned to the item.

(3) Stock number column. This column lists the National stock number for the associated part number and manufacturer identified in the part number and CAGEC columns to the left.

(4) Fig. column. This column lists the number of the figure where the item is identified/located in sections II and III.

(5) Item column. The item number is that number assigned to the item as it appears in the figure referenced in the adjacent figure number column.

c. Figure and Item Number Index.

(1) Fig. column. This column lists the number of the figure where the item is identified/located in sections II and III.

(2) Item column. The item number is that number assigned to the item as it appears in the figure referenced in the adjacent figure number column.

(3) Stock number column. This column lists the National stock number for the item.

(4) CAGEC column. The Commercial and Government Entity Code (CAGEC) is a 5-digit numeric code used to identify the manufacturer, distributor, or Government agency, etc., that supplies the item.

(5) Part number column. Indicates the primary number used by the manufacturer (individual, firm, corporation, or Government activity), which controls the design and characteristics of the item by means of its engineering drawings, specifications, standards, and inspection requirements to identify an item or range of item.

D-5. Special Information

National stock numbers (NSN's) that are missing from P source coded items have been applied for and will be added to this TM by future change/revision when they are entered in the Army Master Data File (AMDF). Until the NSN's are established and published, submit exception requisitions to: Commander, US Army Communications-Electronics Command and Fort Monmouth, ATTN: AMSEL-LC-MM, Fort Monmouth, NJ 07703-5000 for the part required to support your equipment.

**NOTE**

An item SMR coded "H" in the third, fourth, and fifth position is interpreted as intermediate for Air Force Repair.

**D-6. How to Locate Repair Parts**

**a. When National stock number or part number is not known.**

(1) **First.** Using the table of contents, determine the assembly group or subassembly group to which the item belongs. This is necessary since figures are prepared for assembly groups and subassembly groups, and listings are divided into the same groups.

(2) **Second.** Find the figure covering the assembly group or subassembly group to which the item belongs.

(3) **Third.** Identify the item on the figure and note the item number.

(4) **Fourth.** Refer to the Repair Parts List for the figure to find the part number for the item number noted on the figure.

(5) **Fifth.** Refer to the Part Number Index to find the NSN, if assigned.

**b. When National stock number or part number is known.**

(1) **First.** Using the index of National stock numbers and part numbers, find the pertinent National stock number or part number. The NSN index is in National item identification number (NIIN) sequence (para C-4a(1)). The part numbers in the part number index are listed in ascending alphameric sequence (para C-4b). Both indexes cross-reference you to the illustration figure and item number of the item you are looking for.

(2) **Second.** After finding the figure and item number, verify that the item is the one you're looking for, then locate the item number in the repair parts list for the figure.

**D-7. Abbreviations**

**Not applicable.**

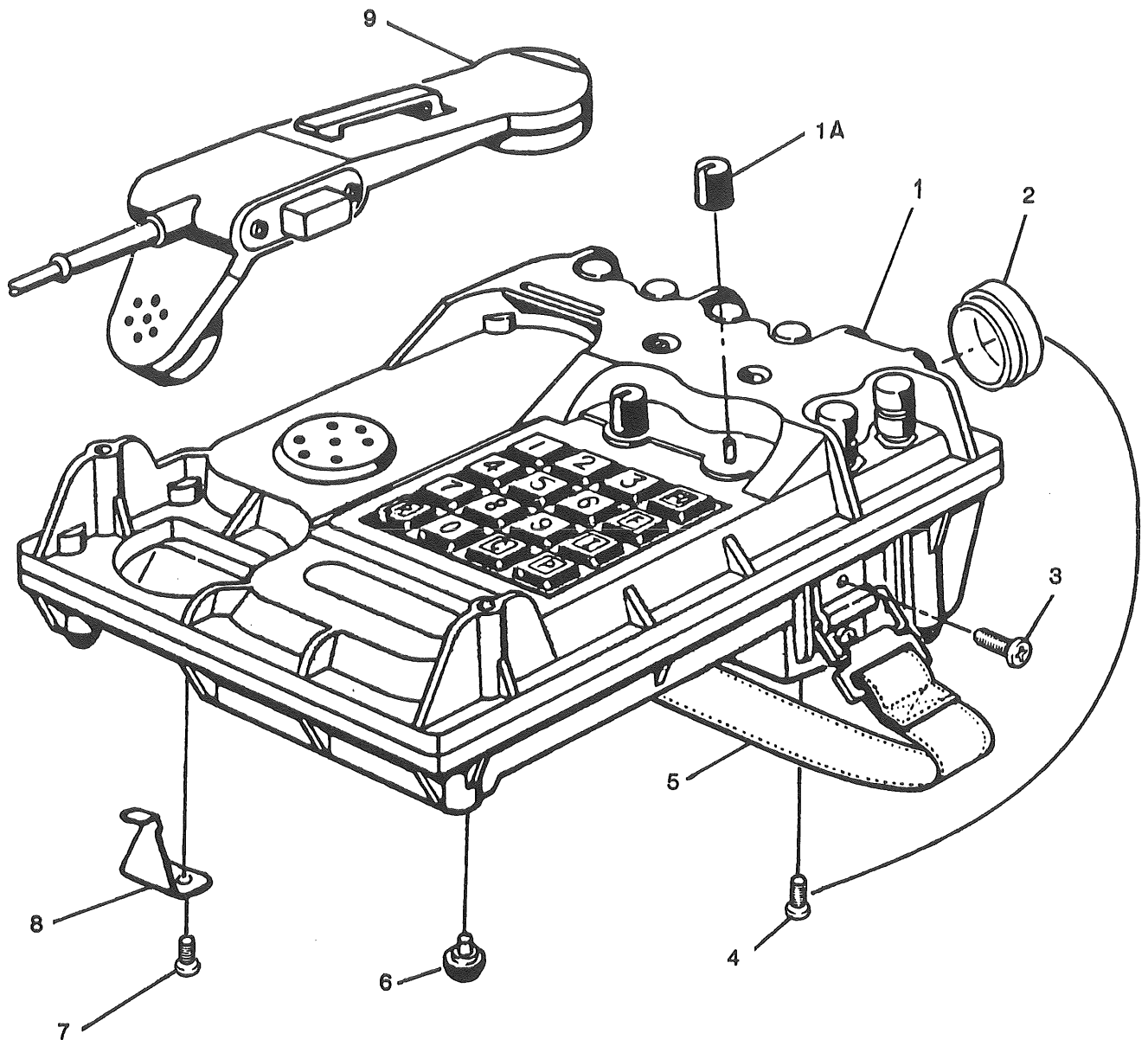

Figure D-1 Digital Non-Secure Voice Terminal, TA-1042A/U

AIR FORCE 31W1-2U-1461  
 ARMY TM 11-5805-780-12&P  
 MARINE CORPS TM 08789B-12/1

SECTION II			(4)	(5)	(6)
(1)	(2)	(3)	(4)	(5)	(6)
ITEM	SMR	CAGEC	PART	DESCRIPTION AND USABLE ON CODES(UDC)	QTY
NO	CODE		NUMBER		
GROUP 00 DIGITAL NON-SECURE					
VOICE TERMINAL					
TA-1042A/U					
FIGURE 1					
1	PAODD	80058	TA-1042A/U	TELEPHONE,DIGITAL.....	1
1A	PAOZZ	2J622	5285038-001	KNOB.....	2
2	PAOZZ	96906	MS27502B17C	COVER,ELECTRICAL CO.....	1
3	PAOZZ	96906	MS51861-34C	SCREW,TAPPING,THREA.....	4
4	PAOZZ	96906	MS51861-22C	SCREW,TAPPING,THREA.....	1
5	PAOZZ	2J622	5285037-001	STRAP,ASSEMBLY.....	1
6	PAOZZ	2J622	5285050-001	FOOT,MOLDED.....	4
7	PAOZZ	96906	MS51957-13	SCREW,MACHINE.....	2
8	PAOZZ	2J622	5285052-001	SPRING,HANDSET RETA.....	1
9	PAOZZ	80058	H-350/U	HANDSET.....	1
10	XBOZZ	2J622	5285000-001	PLATE,IDENTIFICATI (NOT ILLUSTRATED).....	1

END OF FIGURE



SECTION IV

TM11-5805-780-12&P

CROSS-REFERENCE INDEXES

STOCK NUMBER	NATIONAL STOCK NUMBER INDEX		FIG.	ITEM
	FIG.	STOCK NUMBER		
5305-00-054-5647	1	7		
5305-00-139-6757	1	3		
5935-00-387-2147	1	2		
5965-01-128-3944	1	9		
5305-01-298-2436	1	4		

AIR FORCE 31W1-2U-1461  
ARMY TM 11-5805-780-12&P  
MARINE CORPS TM 08789B-12/1

SECTION IV

CROSS-REFERENCE INDEXES

CAGEC	PART NUMBER	PART NUMBER INDEX STOCK NUMBER	FIG.	ITEM
80058	H-350/U	5965-01-128-3944	1	9
96906	MS27502B17C	5935-00-387-2147	1	2
96906	MS51861-22C	5305-01-298-2436	1	4
96906	MS51861-34C	5305-00-139-6757	1	3
96906	MS51957-13	5305-00-054-5647	1	7
80058	TA-1042A/U		1	1
2J622	5285000-001		1	10
2J622	5285037-001		1	5
2J622	5285038-001		1	1A
2J622	5285050-001		1	6
2J622	5285052-001		1	8

SECTION IV

CROSS-REFERENCE INDEXES

FIG.	ITEM	FIGURE AND ITEM NUMBER INDEX		PART NUMBER
		STOCK NUMBER	CAGEC	
1	1		80058	TA-1042A/U
1	1A		2J622	5285038-001
1	2	5935-00-387-2147	96906	MS27502B17C
1	3	5305-00-139-6757	96906	MS51861-34C
1	4	5305-01-298-2436	96906	MS51861-22C
1	5		2J622	5285037-001
1	6		2J622	5285050-001
1	7	5305-00-054-5647	96906	MS51957-13
1	8		2J622	5285052-001
1	9	5965-01-128-3944	80058	H-350/U
1	10		2J622	5285000-001



INDEX

Subject	Paragraph, Figure, Table Number
B	
Block Diagram . . . . .	F5-1
C	
Components of End Item List (COEIL) . . . . .	B-1
Conference Calling . . . . .	4-6
Controls and Indicators . . . . .	4-1 T4-1 F4-1
D	
Data Rate Selection . . . . .	4-4
Digital Data Port . . . . .	4-7
E	
Equipment Characteristics . . . . .	1-1 T1-1
Equipment Improvement Recommendations (Army only) . . . . .	v
F	
Functional Characteristics . . . . .	1-1 T1-2
Functional System(s) Operation . . . . .	5-1
G	
Glossary of Symbols and Abbreviations . . . . .	vi
I	
Illustration Parts Breakdown . . . . .	8-1 F8-1
Installation . . . . .	2-1
Common Battery Mode . . . . .	2-1
Local Battery Mode . . . . .	2-1

INDEX - CONTINUED

Subject	Paragraph, Figure, Table Number
K	
Keypad . . . . .	4-3
M	
Magnetic Hookswitch . . . . .	4-3
Maintenance Allocation Chart (MAC) . . . . .	A-1
Maintenance Forms, Records, and Reports (Army only) . . . . .	V
Maintenance . . . . .	6-1
Operational Checkout and Troubleshooting . . . . .	6-1 T6-1
Maintenance Parts List . . . . .	8-3
O	
Operation . . . . .	4-1
Operating Controls . . . . .	4-1
Operating Instructions . . . . .	4-3
Precedence Modes . . . . .	T4-2
Operating Modes . . . . .	5-3
Operational Checkout . . . . .	6-1
P	
Power Sources . . . . .	5-1 F5-1
Preparations for Reshipment . . . . .	3-1
Inspection . . . . .	3-1
Preparation for use . . . . .	3-1
Instructions . . . . .	3-1
R	
Related Publications . . . . .	vi
Reporting all Deficiencies (USMC only) . . . . .	V
Ring Control . . . . .	4-3
Ring Indicator . . . . .	4-3
S	
Safety Summary . . . . .	iii
Select Switch . . . . .	4-3
Supervisory Tones . . . . .	4-6

INDEX - CONTINUED

Subject	Paragraph, Figure, Table Number
T	
Tones . . . . .	4-6
Busy . . . . .	4-7
Dial . . . . .	4-6
Error . . . . .	4-7
Preempt . . . . .	4-7
Ring-back . . . . .	4-7
Side . . . . .	4-6
Supervisory . . . . .	4-6
Troubleshooting . . . . .	6-1
	T6-1
W	
Warranty . . . . .	6-1
V	
Volume Control . . . . .	4-3

