

1/4 bl
4113
12
TM
1945

TM 9-792

WAR DEPARTMENT TECHNICAL MANUAL

U.S. Dept. of Army

4-TON, 2-WHEEL, AMMUNITION TRAILER M21

RESTRICTED DISSEMINATION OF RESTRICTED MATTER—
No person is entitled solely by virtue of his grade or position to knowledge or possession of classified matter. Such matter is entrusted only to those individuals whose official duties require such knowledge or possession. (See also paragraph 23b, AR 380-5, 15 March 1944.)

Generated on 2013-06-26 09:33 GMT / http://hdl.handle.net/2027/uc1.b3243759
Public Domain, Google-digitized / http://www.hathitrust.org/access_use#pd-google

WAR DEPARTMENT TECHNICAL MANUAL
TM 9-792

This manual supersedes TM 9-792, dated 5 August 1944.

4-TON, 2-WHEEL,
AMMUNITION
TRAILER M21



WAR DEPARTMENT • *5 FEBRUARY 1945*

RESTRICTED DISSEMINATION OF RESTRICTED MATTER—
No person is entitled solely by virtue of his grade or position to knowledge or possession of classified matter. Such matter is entrusted only to those individuals whose official duties require such knowledge or possession (See also paragraph 23*b*, AR 380-5, 15 March 1944.)

WAR DEPARTMENT

Washington 25, D. C., 4 September 1944

TM 9-792, 4-ton, 2-wheel, Ammunition Trailer M21, is published for the information and guidance of all concerned.

[A. G. 300.7 (4 Sep 44)
O.O.M. 461/Rar. Ars. (6 Feb 45)R]

BY ORDER OF THE SECRETARY OF WAR:

G. C. MARSHALL,
Chief of Staff.

OFFICIAL:

J. A. ULIO,
*Major General,
The Adjutant General.*

DISTRIBUTION: AAF (10); AGF (10); ASF (2); S Div ASF (1); Dept (10); AAF Comd (2); Arm & Sv Bd (2); Tech Sv (2); SvC (10); PC&S (1); PE (Ord O) (5); Dist O, 9 (5); Dist Br O, 9 (3); Reg O, 9 (3); Establishments, 9 (5); Decentralized Sub-O, 9 (3); Gen & Sp Sv Sch (10); USMA (20); A (10); CHQ (10); D (2); AF (2); T/O & E 6-337 (3); 9-7 (3); 9-9 (3); 9-37 (3); 9-57 (3); 9-65 (2); 9-67 (3); 9-76 (2); 9-127 (3); 9-197 (3); 9-317 (3); 9-325 (2); 9-327 (3); 9-328 (3); 9-377 (3).

(For explanation of symbols, see FM 21-6.)

CONTENTS

U113
.2
TM 9:792
1945
* *

PART ONE — INTRODUCTION

SECTION		Paragraphs	Pages
I.	General	1- 2	1- 4
II.	Description and data	3- 4	5- 8
III.	Tools, parts, and accessories	5- 7	8- 10

PART TWO—OPERATING INSTRUCTIONS

SECTION	IV.	General	8	11
	V.	Service upon receipt of equipment	9- 11	11- 13
	VI.	Controls and operation	12- 13	13- 17
	VII.	Operation of auxiliary equipment	14- 15	17- 19
	VIII.	Operation under unusual conditions	16- 18	19- 21
	IX.	Demolition to prevent enemy use	19- 20	21- 22

PART THREE—MAINTENANCE INSTRUCTIONS

SECTION	X.	General	21	23
	XI.	Special organizational tools and equipment	22	23
	XII.	Lubrication	23- 24	23- 27
	XIII.	Preventive maintenance services	25- 31	27- 39
	XIV.	Trouble shooting	32- 40	40- 46
	XV.	Suspension (springs and radius rods)	41- 44	46- 51
	XVI.	Wheels, hubs, bearings, tires, and tubes	45- 49	51- 58
	XVII.	Axle	50- 53	59- 61
	XVIII.	Brake mechanism	54- 58	61- 65
	XIX.	Air brake power system	59- 70	65- 81
	XX.	Parking brake	71- 74	81- 84

CONTENTS (Contd.)

	Paragraphs	Pages
SECTION XXI. Landing wheel and rear prop support	75- 76	84- 87
XXII. Electrical system	77- 80	87- 91
XXIII. Body, frame, drawbar, and shell racks	81- 87	92- 96

PART FOUR—AUXILIARY EQUIPMENT

SECTION XXIV. General	88	97
-----------------------------	----	----

PART FIVE—REPAIR INSTRUCTIONS

SECTION XXV. General	89	98
XXVI. Trouble shooting	90- 93	98- 99
XXVII. Springs and radius rods	94- 96	99-101
XXVIII. Brake spider, drum, shoes, and lining	97-100	101-104
XXIX. Axle	101-103	105-107
XXX Body, frame, drawbar, shell racks, and landing wheel ...	104-105	107-110

APPENDIX

SECTION XXXI. Shipment and limited storage ..	106-108	111-114
XXXII. References	109-111	115-117
INDEX		118-122

RESTRICTED

This manual supersedes TM 9-792, dated 5 August 1944.

PART ONE—INTRODUCTION**Section I****GENERAL****1. SCOPE.**

a. These instructions are published for the information and guidance of all concerned. They contain information on operation and maintenance of the equipment as well as descriptions of major units and their functions in relation to other components of this vehicle. They apply only to the Ammunition Trailer M21 and are arranged in five parts: Part One, Introduction; Part Two, Operating Instructions; Part Three, Maintenance Instructions; Part Four, Auxiliary Equipment; and Part Five, Repair Instructions.

b. The appendix at the end of the manual contains instructions for shipment and limited storage, and a list of references including standard nomenclature lists, technical manuals, and other publications applicable to the vehicle.

c. The stock and part numbers which appear throughout the manual are extracted from ORD 7, SNL G-213, 1 November 1944.

2. RECORDS.

a. Forms and records applicable for use in performing prescribed operations are listed below with brief explanations of each:

(1) W.D., A.G.O. FORM NO. 7360, ARMY MOTOR VEHICLE OPERATOR'S PERMIT. This form will be issued by commanding officers of posts, camps, stations, or organizations, to all operators of military vehicles who have passed the driver's examination (TM 21-300) and are qualified to drive the particular vehicles noted on the permit.

(2) WAR DEPARTMENT LUBRICATION ORDER. War Department Lubrication Order No. 726 prescribes lubrication maintenance for this vehicle. A Lubrication Order is issued with each vehicle and is to be carried with it at all times.

(3) STANDARD FORM NO. 26, DRIVER'S REPORT—ACCIDENT, MOTOR TRANSPORTATION. One copy of this form will be kept with the vehicle at all times. In case of an accident resulting in injury or property damage, it will be filled out by the driver on the spot or as promptly as practical thereafter.

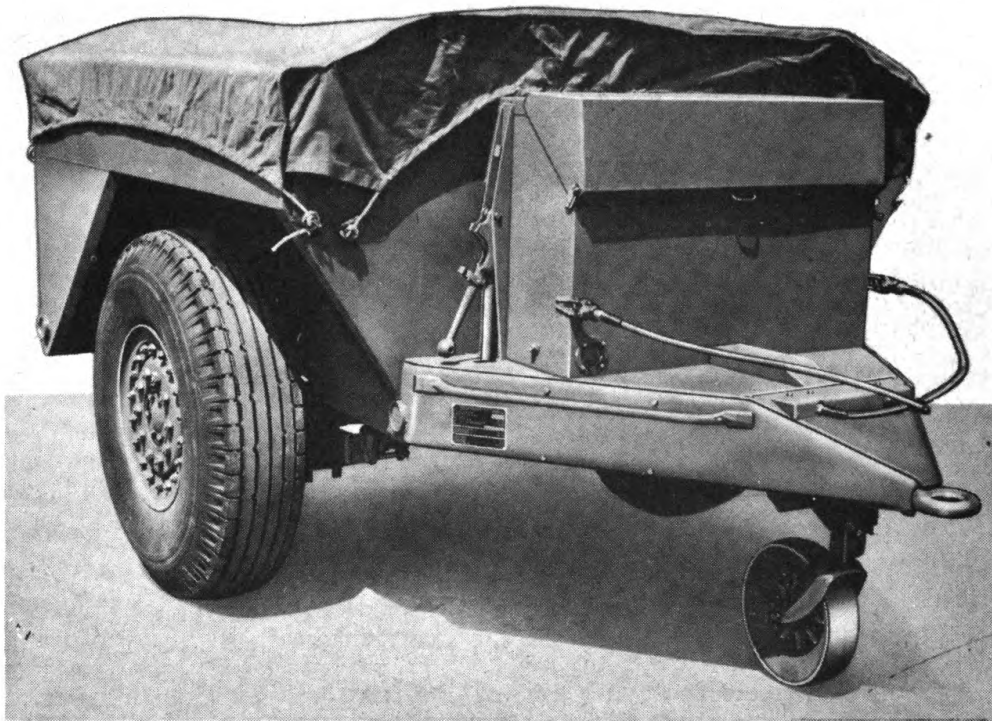

RA PD 318829

Figure 1—Ammunition Trailer M21—Front View

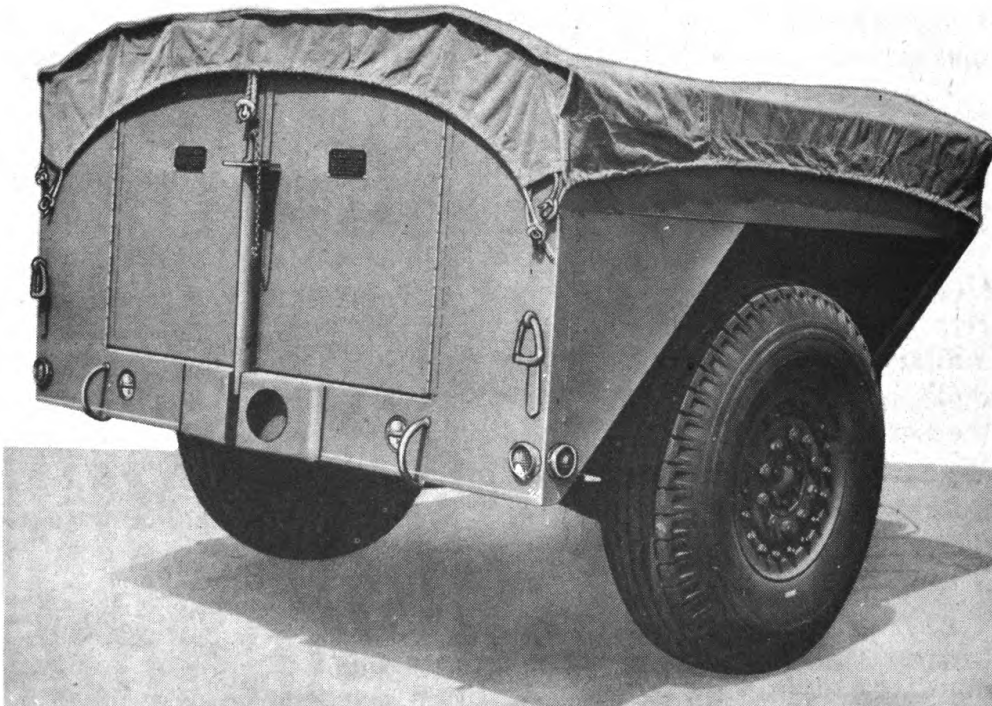

RA PD 318830

Figure 2—Ammunition Trailer M21—Rear View

General

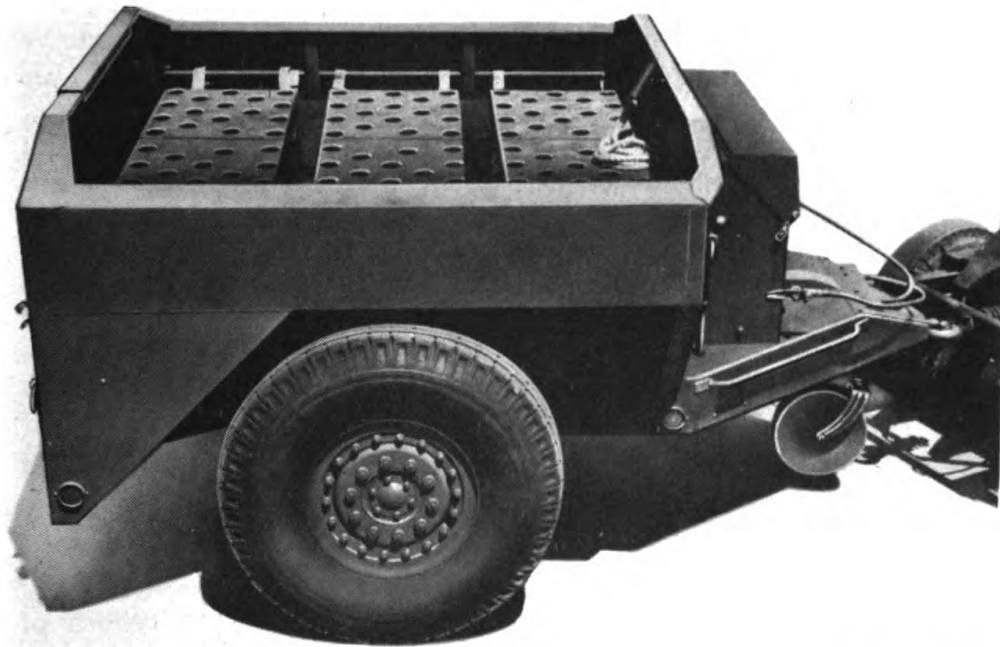

RA PD 340617

Figure 3—Ammunition Trailer M21—Top View

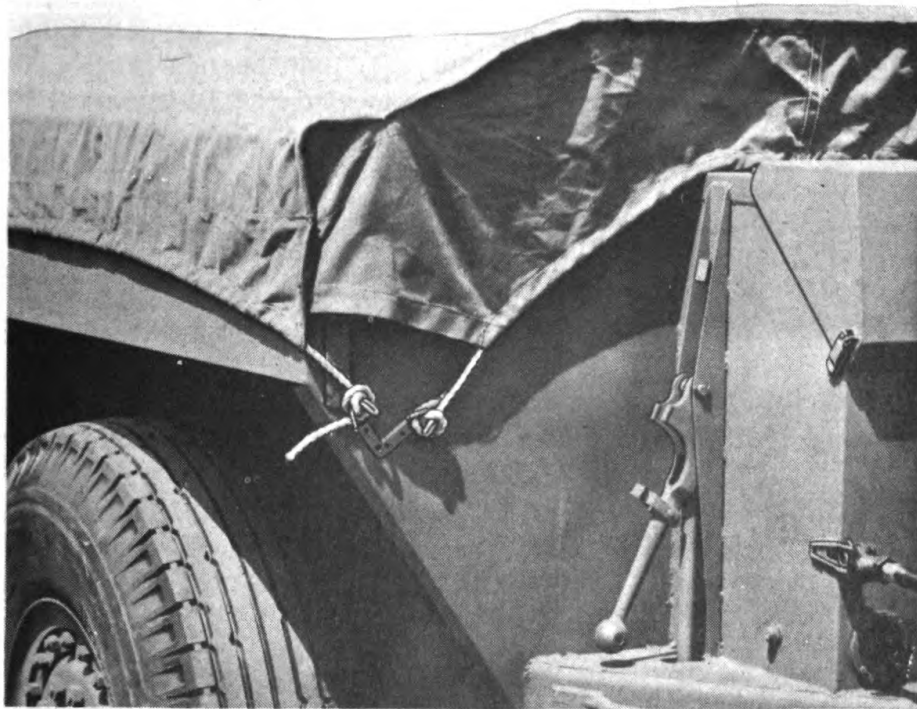

RA PD 318834

Figure 4—Tarpaulin Fastened in Place

Part One—Introduction

(4) **WAR DEPARTMENT FORM NO. 48, DRIVER'S TRIP TICKET AND PREVENTIVE MAINTENANCE SERVICE RECORD.** This form, properly executed, will be furnished to the driver when his vehicle is dispatched on nontactical missions. The driver and the official user of the vehicle will complete in detail appropriate parts of this form. These forms need not be issued for vehicles in convoy or on tactical missions. The reverse side of this form contains the driver's daily and weekly preventive maintenance service reminder schedule.

(5) **W.D., A.G.O. FORM NO. 478, MWO AND MAJOR UNIT ASSEMBLY REPLACEMENT RECORD.** This form, carried with the vehicle, will be used by all personnel completing a modification or major unit assembly replacement to record clearly the description of work completed, date, vehicle hours and/or mileage, and MWO number or nomenclature of unit assembly. Personnel performing the operation will initial in the column provided. Minor repairs, parts, and accessory replacements will not be recorded.

(6) **W.D., A.G.O. FORM NO. 6, DUTY ROSTER.** This form, slightly modified, will be used for scheduling and maintaining a record of vehicle maintenance operations. It may be used for lubrication records.

(7) **W.D., A.G.O. FORM NO. 461, PREVENTIVE MAINTENANCE SERVICE AND TECHNICAL INSPECTION WORK SHEET FOR WHEELED AND HALF-TRACK VEHICLES.** This form will be used for all 1,000-mile (monthly) and 6,000-mile (semiannual) maintenance services and all technical inspections performed on wheeled or half-track vehicles.

(8) **W.D., A.G.O. FORM NO. 9-70, SPOT-CHECK INSPECTION REPORT FOR ALL MOTOR VEHICLES.** This form may be used by all commanding officers or their staff representatives in making spot-check inspections on all vehicles.

(9) **W.D., A.G.O. FORM NO. 468, UNSATISFACTORY EQUIPMENT REPORT.** This form will be used for reporting manufacturing, design, or operational defects in materiel with a view to improving and correcting such defects, and for use in recommending modifications of materiel. This form will not be used for reporting failures, isolated materiel defects, or malfunctions of materiel resulting from fair wear and tear or accidental damage; nor for the replacement, repair, or the issue of parts and equipment. It does not replace currently authorized operational or performance records.

(10) **W.D., A.G.O. FORM NO. 9-81, EXCHANGE PART OR UNIT IDENTIFICATION TAG.** This tag, properly executed, may be used when exchanging unserviceable items for like serviceable assemblies, subassemblies, parts, vehicles, and tools.

*Description and Data***Section II****DESCRIPTION AND DATA****3. DESCRIPTION.**

a. **General.** The Ammunition Trailer M21 (figs. 1, 2, and 3) is a vehicle designed to transport ammunition. The trailer is a short, 2-wheeled vehicle, having a square steel body with an open top. The trailer is capable of being towed over unimproved roads, trails, and open, rolling, and hilly cross-country by any towing vehicle equipped with pintle hook.

b. **Body.** The body is designed to carry 102 rounds of 4.5-inch gun shells or 72 rounds of 155-mm howitzer shells together with the complementary load of propelling powder charges, fuzes, and primers. The shells are carried in an upright position in the lower part of the body, and are held at the bottom in stamped cups and at the top by special racks. The powder containers are carried above the upper shell racks. Fuzes are carried at the front of the body in a metal compartment with hinged cover. The fuze primers, as well as tools and service manuals, are carried in a compartment of the fuze box. The body is covered with a tarpaulin which is fastened at the four corners by short tie ropes (fig. 4) and supported at the center by a longitudinal spring-loaded rope. The rear of the body is equipped with hinged doors which are held closed at the top by a channel retainer and at the bottom by the retracted rear prop. No cross header is used, and the channel retainer is a part of the doors so that when the doors are opened, a clear opening is presented into the body. Four lifting rings are mounted at the corners of the body and are of such strength that any two diagonally opposite rings can be used to lift the fully loaded trailer. An A-type drawbar, rigidly connected to the front of the body, is equipped with a lunette eye mounted at the point of the drawbar.

c. **Suspension and Landing Gear.** Two semielliptical springs, bracketed to the body, support a tubular axle. Two radius rods keep the springs and axle alined. Single wheels, using 14.00 x 20 tires, are attached to each end of the axle. A caster-type landing wheel is mounted under the drawbar in back of the lunette eye. A safety prop is mounted at the rear of the body to prevent the vehicle from tipping backward when disconnected from the towing vehicle.

d. **Brakes.** The vehicle is equipped with air-operated service brakes and hand-controlled parking brakes. The parking brake hand levers are mounted just ahead of the trailer body on either side of the fuze box (fig. 1). Two air line connections are permanently attached to the front of the trailer (fig. 1). The service air line is located on the right or curb side, and the emergency air line is located

on the left side. The hose couplings of both lines, when not in use, must be connected to their respective dummy couplings located on the fuze box at the front of the trailer.

e. **Electrical System.** Two taillights are mounted at the rear of the trailer. The left-hand light is a combination blackout taillight and service taillight and stop light. The right-hand light is a combination blackout taillight and stop light. A blackout switch, mounted in the right side panel of the fuze box, controls the taillight. An electrical coupling socket is located at the lower right-hand corner of the fuze box (fig. 1). An electrical jumper cable (fig. 6) provides a connection between the trailer and towing vehicle electrical systems to permit use of the trailer taillights. The jumper cable plugs into the trailer electrical coupling socket and a similar socket on the towing vehicle.

4. DATA.

a. Load Data.

Vehicle weight, less payload.....	5,300 lb
Payload	8,000 lb
Maximum vehicle gross weight.....	13,300 lb
Maximum lunette load.....	275 lb

b. Maximum speeds at gross weight:

Smooth concrete highway.....	45 mph
Average cross-country terrain.....	25 mph

c. Dimensions.

Center of axle to center of lunette eye.....	91 in.
Minimum axle clearance under U-bolt at full load.....	12 ⁷ / ₈ in.
Lunette height: with trailer in loaded level position, height from ground to horizontal center line of lunette eye	27 in.
Tread width, center-to-center.....	83 in.
Angle of departure.....	30 deg
Length, over-all	144 in.
Length, inside	83 ¹ / ₂ in.
Width, over-all	98 in.
Width, inside	87 in.
Height, over-all	75 in.
Height, inside	40 in.

d. Tires, Tubes, Rims, and Wheels.

Tire size	14.00 x 20
Tire pressure	75 lb
Tire type	Combat

Description and Data

Tire plies 18
Tire tubes Heavy duty
Rims Divided
Wheels (U. S. Army standard type) 10 x 5³/₈ in.
Spare wheel and tire assembly None

e. Service Brakes.

Make Timken-Detroit
Type Two-shoe internal expanding
Size 17¹/₄ x 4 in.
Operating pressure Min. 80 lb
Relay emergency valve Bendix-Westinghouse 220353
Brake chamber Bendix-Westinghouse 215001
Slack adjuster Bendix-Westinghouse 217915
and 217916

f. Axle.

Make Timken-Detroit
Model T-2090-W-X-14

Dimensions:

Track 83 in.
Tube 5-in. O.D. x 4-in. I.D.

g. Bearings.

Cones Timken Roller 5557
Cups Timken Roller 5520

h. Parking Brake.

Make Trailer Company of America
Type Hand-operated

i. Landing Wheel Assembly.

Make Saginaw
Type Caster
Part No. 6347-F
Operation Manual
Wheel size 16-in. dia x 4-in. face

j. Radius Rod.

Make Trailer Company of America
Type Adjustable
Adjustment ¹/₂ in.

k. Springs.

Make Burton
 Type Slip
 Number of leaves 19
 Thickness 1/4 in.
 Width 3 1/2 in.
 Length of main leaf 43 in.

l. Drawbar.

Make Trailer Company of America
 Type Integral with body
 Lunette eye dimensions 3 5/8-in. I.D. x 6 5/8-in. O.D.

m. Lights.

Make K-D Co.
 Type Blackout
 Blackout tail and blackout stop KD 965-I-6
 Blackout tail and service tail and stop light KD 964-I-6

Section III

TOOLS, PARTS, AND ACCESSORIES

5. PURPOSE.

a. The lists in this section are for information only. They are not to be used as a basis for requisition.

6. ON-VEHICLE TOOLS (fig. 5).

Quantity per Vehicle	Ordnance Drawing Number	Official Stock Number	Item Name	Stowage Location
1	B 108566	41-H-1541	HANDLE, wheel nut wrench	Tool box
1	THCX1	41-F-1652	PLIERS, combination, slip-joint, 8-in.	Tool box
1	TGBX1	41-S-1385	SCREWDRIVER, machinists', 5-in. blade	Tool box
1	TKAX3	41-W-488	WRENCH, adjustable, single-end, 12-in.	Tool box
1			WRENCH, wheel hub adjustment	Tool box
1	C116115	41-W-3843-25	WRENCH, wheel nut	Tool box

Tools, Parts, and Accessories

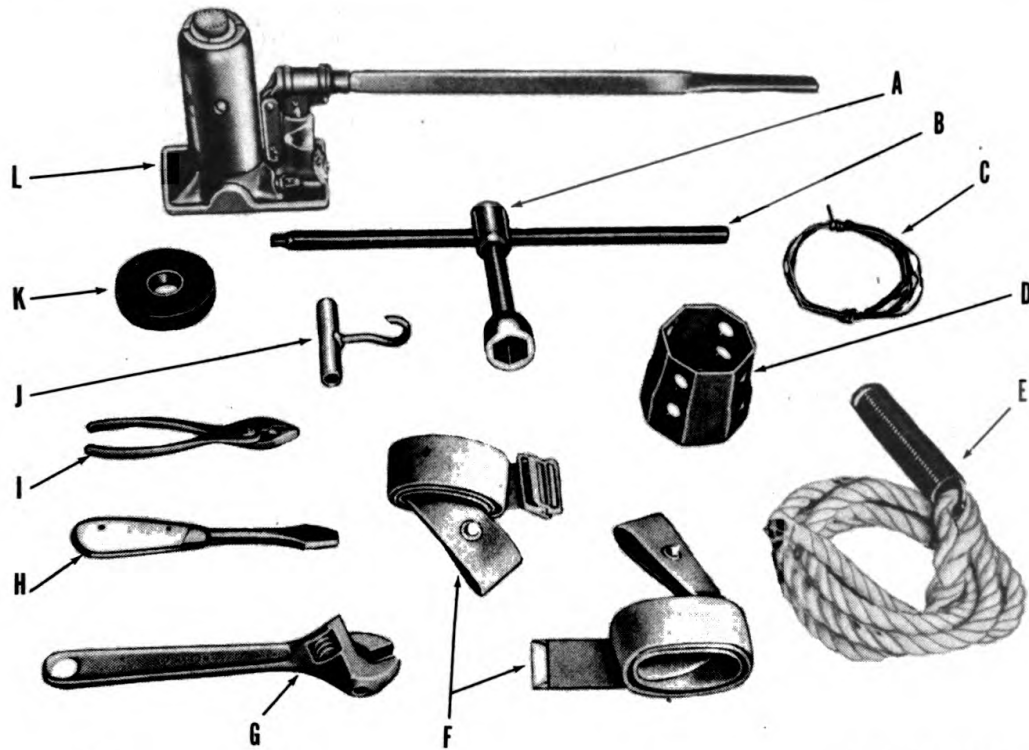

Key	Item	Part Number
A	WHEEL AND RIM STUD NUT WRENCH	41-W-3843-25
B	WHEEL AND RIM STUD NUT WRENCH HANDLE	41-H-1541
C	BAILING WIRE	22-W-1642-150
D	WHEEL BEARING NUT WRENCH	8500-3256E5
E	TARPAULIN SUPPORT SPRING AND ROPE ASS'Y	8720-514-A28-1
F	POWDER CONTAINER BINDING STRAP ASS'Y	8720-31-A7-1
G	SINGLE END ADJUSTABLE WRENCH	41W-488
H	MACHINISTS SCREWDRIVER	41S-1385
I	SLIP-JOINT PLIERS	41-P-1652
J	SHELL LIFTING HOOK	41H-2644-725
K	FRICTION TAPE	17-T-805
L	HYDRAULIC JACK	41-J-73

RA PD 318864

Figure 5—Tools and Equipment

7. ON-VEHICLE EQUIPMENT.

Quantity per Vehicle	Ordnance Drawing Number	Official Stock Number	Item Name	Stowage Location
1	07955-W		CABLE ASSEMBLY, 6 ft	Tool box
1			CATALOG, service parts, SNL G-213	Manual rack in tool box
1	7015955		COVER, trailer	On trailer

TM 9-792

7

Part One—Introduction

Quantity per Vehicle	Ordnance Drawing Number	Official Stock Number	Item Name	Stowage Location
4	B280389		HOOK, shell lifting	Tool box
1			MANUAL, techni- cal, TM 9-792	Manual rack in tool box
1	A31244C	17-T-805	TAPE, friction, $\frac{3}{4}$ in. wide, 30-ft roll	Tool box
1	BFWX1	22-W-1642-150	WIRE, soft iron, 14-ga, 10-ft	Tool box
1	A214422	41-J-73	JACK, hydraulic, 5-ton, w/handle	Tool box

PART TWO—OPERATING INSTRUCTIONS

Section IV GENERAL

8. SCOPE.

a. Part Two contains information for guidance of personnel responsible for operation of this equipment. It contains information on operation of equipment with description and location of controls and instruments.

Section V SERVICE UPON RECEIPT OF EQUIPMENT

9. PURPOSE.

a. When a new or reconditioned vehicle is first received by the using organization, it is necessary for second echelon personnel to determine whether the vehicle has been properly prepared for service by the supplying organization, and to be sure it is in condition to perform any mission to which it may be assigned when placed in service. For this purpose inspect all assemblies, subassemblies, and accessories to be sure they are properly assembled, secure, clean, and correctly adjusted and or lubricated. Check all tools and equipment against section III (Tools, Parts, and Accessories) to be sure every item is present, in good condition, clean, and properly mounted or stowed.

b. Whenever practicable, the first echelon personnel (driver) will assist in the performance of these services.

10. CORRECTION OF DEFICIENCIES.

a. Deficiencies disclosed during the course of these services will be treated as follows:

(1) Correct any deficiencies within the scope of the maintenance echelons of the using organization before the vehicle is placed in service.

(2) Refer deficiencies beyond the scope of the maintenance echelons of the using organization to a higher echelon for correction.

(3) Bring deficiencies of a serious nature to the attention of the supplying organization through proper channels.

11. SPECIFIC PROCEDURES.

a. Vehicle.

(1) **TIRES.** Inspect tires for damage and underinflation. Remove objects lodged in treads and carcasses. Be sure valve caps are present and finger-tight. Refer to paragraph 4 d for correct tire pressure.

(2) **TOWING CONNECTIONS.** Remove tape and rust and corrosion material from lunette and towing eye, air lines, and electrical connections. Examine landing gear and wheel assembly to see that they are in good condition and operate properly.

(3) **WHEEL AND FLANGE NUTS.** Remove rust and corrosion material from wheel side rings, wheel mounting and hub nuts and cap screws. See that all wheel mounting and hub nuts and cap screws are present and secure.

(4) **LAMPS (LIGHTS) AND REFLECTORS.** Remove all tape from lamps, warning reflectors, and connections. Clean all lenses and reflectors. Examine lamps and reflectors to see that they are securely mounted and connected. Test light switches to see that all lights respond properly.

(5) **ELECTRICAL WIRING.** Inspect all accessible wiring and conduits to see that they are in good condition and securely mounted and connected.

(6) **BODY AND TARPAULIN.** Examine body to see that it is in good condition and securely mounted, and that fuze box cover and rear doors open freely and latch securely when closed. Inspect ammunition racks, hinges, and latches to be sure they operate properly. See that tarpaulin is in good condition and is securely lashed.

(7) **SPRINGS AND SUSPENSIONS.** Inspect springs and radius rods for indications of looseness or damage. Be sure all clips and attaching bolts, nuts, and cap screws are present and secure.

(8) **SERVICE AND PARKING BRAKES.** Test service brakes to be sure they stop the trailer effectively. When the trailer is not attached to the towing vehicle, test parking brakes to see that they hold the trailer satisfactorily and that the parking lever remains in the applied position. Examine slack adjusters, chambers, and rods to be sure that they are correctly assembled and adjusted.

(9) **AIR BRAKE CYLINDER.** Inspect air brake cylinder for secure mounting and connections. Drain condensation from cylinder, and close the drain cock. Examine air lines and connections to see that they are securely supported and connected.

Controls and Operation

(10) **TOOLS AND EQUIPMENT.** Check to see that all items in On-vehicle Stowage List (par. 6) are present, in good condition, and properly mounted or stowed.

(11) **VEHICLE LUBRICATION.** Perform a complete lubrication service on the trailer according to instructions in Lubrication Order (par. 23).

b. Vehicle Publications and Reports.

(1) **PUBLICATIONS.** See that vehicle Operator's Manual, Lubrication Order, and W.D., A.G.O. Form No. 478 (MWO and Major Unit Assembly Replacement Record) are in the vehicle, legible, and properly stowed. *NOTE: U.S.A. registration number and vehicle nomenclature must be filled in on Form No. 478 for new vehicles.*

(2) **REPORTS.** Report general condition of the vehicle to designated individual in authority.

Section VI**CONTROLS AND OPERATION****12. CONTROLS.**

a. Blackout Switch. The blackout switch is located at the bottom of the right-hand panel of the fuze box (fig. 6). The switch is operated by means of a screwdriver or similar tool inserted in the slot in the switch head. There is no "OFF" position on the switch. It is either at the blackout position or at the standard light position. The flow of current is controlled at the towing vehicle.

b. Parking Brakes. Two hand brake levers are mounted just ahead of the trailer body at either side of the fuze box. The brake lever on the right side of the trailer operates the brake on the right-hand wheel (fig. 6). The brake lever on the left side of the trailer operates the brake on the left-hand wheel. The brakes are applied when the levers are pulled downward. Both brakes should be applied when the trailer is uncoupled from the towing vehicle. When the trailer is moved by hand, and a short turn is desired, the hand brake on the side on which the turn is made should be set to permit that wheel to act as a pivot.

c. Landing Wheel (fig. 7). The landing wheel is mounted on the underside of the drawbar to the rear of the lunette eye. It is raised, for towing, by pulling out on the latch pin and swinging the

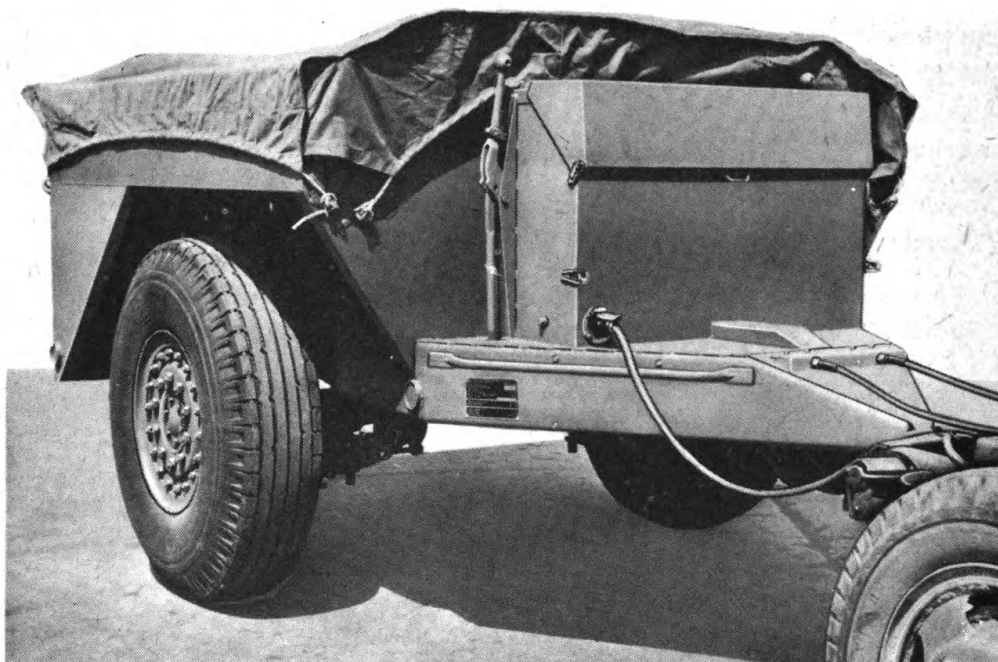

RA PD 318831

Figure 6—Trailer Coupled to Towing Vehicle

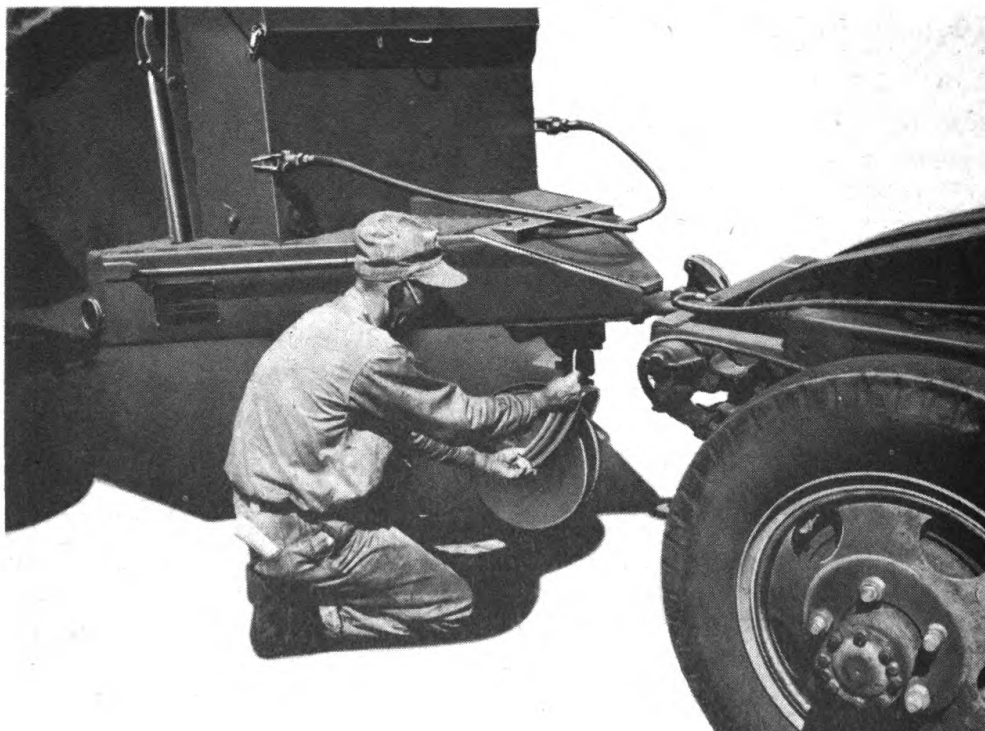

RA PD 340618

Figure 7—Raising Landing Wheel

Controls and Operation



RA PD 340615

Figure 8—Coupling Trailer to Towing Vehicle

wheel upward until the latch pin automatically locks the wheel in position. It is lowered, for parking, by pulling out on the latch pin.

d. Rear Prop (fig. 2). The rear prop is mounted in the prop bracket welded to the rear of the body. Always lower the rear prop before the trailer is uncoupled from the towing vehicle to prevent the trailer from tipping backward. After the trailer is coupled and the rear doors are closed, the rear prop is raised up against the doors and serves as a door lock and brace.

13. OPERATION.

a. Before-operation Service. Perform the services in paragraph 27 before using the vehicle.

b. Coupling Trailer to Towing Vehicle (fig. 8).

(1) **FASTEN TRAILER TO TOWING VEHICLE.** Open pintle hook at rear of towing vehicle by removing cotter pin and pulling locking latch upward and outward. Back towing vehicle up to drawbar lunette eye at front of trailer. Place drawbar lunette eye into bottom half of pintle hook, slam pintle hook locking latch into position, and lock with cotter pin.

Part Two—Operating Instructions

(2) **CONNECT JUMPER CABLES.** Plug electrical jumper cable into electrical coupling socket at rear of towing vehicle and into electrical coupling socket at front of trailer.

(3) **CONNECT AIR BRAKE LINES.** Disconnect hose coupling of both lines from dummy couplings (fig. 1). Connect trailer hose couplings to couplings on towing vehicle by pressing trailer hose couplings face down against face of towing vehicle hose couplings. Place gaskets in each hose coupling one over the other, and turn coupling hose cap downward until stopped by pin in hose coupling. **CAUTION:** *Be sure to connect emergency hose from trailer to emergency coupling on towing vehicle, and service hose from trailer to service coupling on towing vehicle.*

(4) **RAISE REAR PROP.** Raise rear prop against the doors, and drop the pin through the upper latch plate and prop leg foot.

(5) **RAISE LANDING WHEEL.** Raise landing wheel by pulling out latch pin and swinging wheel upward until latch pin automatically locks wheel in position. **CAUTION:** *The trailer, after being coupled to the towing vehicle, must not be moved until the landing wheel is raised into running position.*

(6) **RELEASE PARKING BRAKES.** Release both parking brakes by pulling the hand brake levers upward (fig. 6).

c. **Driving Truck and Trailer.** Trailer brakes and lights are operated simultaneously with those of the towing vehicle and are operated by the same controls. Drive the truck-trailer combination in the same manner as a straight truck, taking care when braking, turning corners, or backing up. When turning corners, the trailer wheels turn inside the turning circle of the towing vehicle. When backing up, steer the towing vehicle in the direction opposite to that in which it is desired that the trailer be turned.

d. **Stopping Truck and Trailer.** Apply trailer brakes in coordination with towing vehicle brakes. Never permit trailer brakes to carry the entire braking load. Apply the trailer brakes smoothly and promptly enough to stop vehicle without skidding tires. When placing unit in operation, check air pressure on dash gage of towing vehicle. This pressure should not be less than 80 pounds for proper application. With vehicle moving, apply brakes and check their effectiveness before operating unit at full speed.

e. **Disconnecting Truck from Trailer** (fig. 7).

(1) **APPLY PARKING BRAKES.** Apply both parking brakes by pulling hand brake levers down (fig. 1).

Operation of Auxillary Equipment

(2) **LOWER THE LANDING WHEEL.** Lower the landing wheel by pulling out the pins. The landing wheel will drop into position. **CAUTION:** *The landing wheel must be lowered before the trailer is uncoupled from the towing vehicle.*

(3) **LOWER THE REAR PROP.** Pull out pin and drop rear prop to lowered position. Insert pin through holes in prop bracket and prop leg. **CAUTION:** *The rear prop must be lowered before the trailer is uncoupled from the towing vehicle.*

(4) **DISCONNECT ELECTRICAL JUMPER CABLE.** Unfasten jumper cable from trailer and truck electrical sockets, and stow cable in trailer tool box.

(5) **DISCONNECT AIR BRAKE LINES.** Uncouple the service and emergency air brake hoses from the towing vehicle, and couple the hose ends to the dummy couplings mounted on the fuze box.

(6) **UNFASTEN TRAILER FROM TOWING VEHICLE.** Open pintle hook by removing cotter pin and pulling locking latch outward and upward. Lift up on drawbar lunette eye to clean opening in pintle hook, and move towing vehicle forward.

Section VII**OPERATION OF AUXILIARY EQUIPMENT****14. SHELL RACKS (figs. 3 and 9).**

a. Racks are provided in the trailer body to position and hold the shells.

b. The lower rack is made up of a number of stamped cups permanently set into the floor of the trailer. The cups are 1 inch and 2 inches deep, and the shells are set into them in the upright position.

c. The upper rack assembly is made up of six individual racks which fit over the nose of the shells and serve to clamp them down (fig. 3). In the locked position, they are parallel to the floor of the trailer and provide a smooth surface for the loading of powder charges above the shells. The racks are hinged at the sides of the shell compartment. The three right-hand racks are provided with a lever and cam mechanism positioned approximately on the center line of body, with tie rods and hooks extending downward to engage in the floor of the trailer. When the levers are thrown to the locked position, the racks are pulled down on the shells, the left-hand racks being engaged by means of flanges extending under the right-hand racks. Make sure the safety locking pin is applied. Two selective

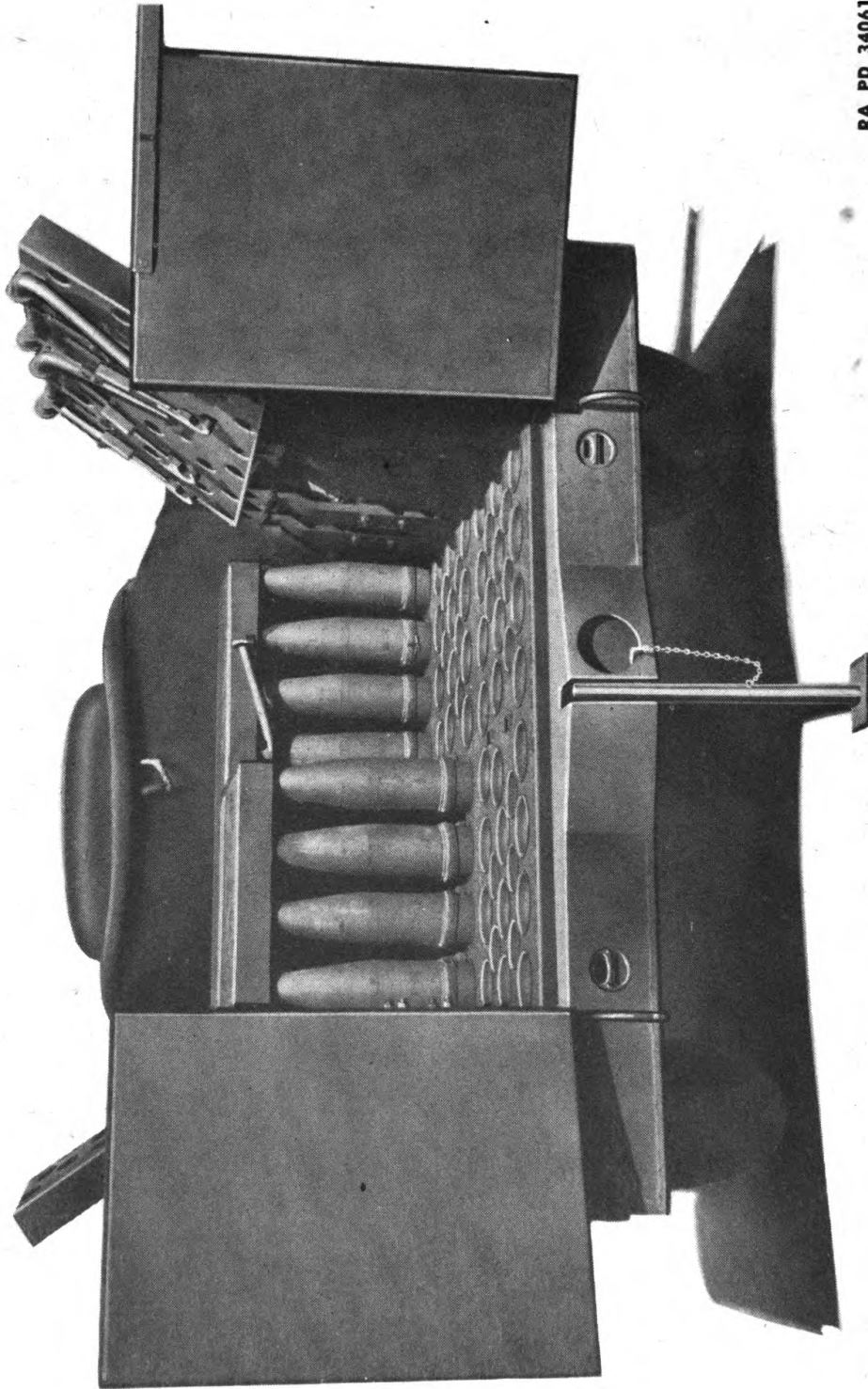

RA PD 340616

Figure 9—Projectiles Loaded in Trailer

Operation Under Unusual Conditions

vertical positions are provided at the hinge mountings and on the tie rods to provide for the difference in height of the two sizes of shells carried. Close adjustment in each position is provided by screwing the hooks up or down on the tie rods, the final setting being secured by lock nuts.

15. POWDER CONTAINER BINDING STRAPS.

a. Propelling charges are carried in the upper part of the trailer body above, and to the sides of, the projectile compartment. The charges are usually packed in "clover leaf" bundles which permits "nesting," and are laid flat and longitudinally in the trailer body. Binding straps hold the bundles securely in the body.

Section VIII

OPERATION UNDER UNUSUAL CONDITIONS

16. COLD WEATHER CONDITIONS.

a. **General.** Since sub-zero temperatures affect both metals and lubricants, operation of equipment at sub-zero temperatures presents problems that demand special precautions. Extremely careful servicing from both operating and maintenance personnel is required if poor performance and total functional failure are to be avoided.

b. Lubrication.

(1) Lubricate all points where No. 0 general purpose grease is specified above 0°F (par. 23) with the same grease below 0°F.

(2) When extreme low temperatures are encountered and No. 0 general purpose grease is not satisfactory where specified above, No. 00, O.D. grease, Ordnance Department Specification AXS-1169 may be used.

(3) For oilcan points where engine oil is prescribed for above 0°F, use special preservative lubricating oil.

c. Maintenance.

(1) **WIRING.** Check, clean, and tighten all electrical connections. Care should be taken that no short circuits are present.

(2) **BRAKES.** Freezing has a tendency to cause brakes to stick or bind when vehicles are parked at sub-zero temperatures. A blow-torch may be used to warm up these parts if they bind when attempting to move the vehicle. Parking the vehicle with the brake released will eliminate most of the binding. Precaution must be taken under

these circumstances to block the wheels or otherwise prevent movement of the vehicle.

(3) **ENTIRE VEHICLE.** Inspect the vehicle frequently. Shock resistance of metals, or resistance against breaking, is greatly reduced at extremely low temperatures. Operation of vehicles on hard, frozen ground causes strain and jolting which will result in screws breaking or nuts jarring loose.

17. DUSTY CONDITIONS.

a. Operation of the trailer under extreme sand or dust conditions necessitates frequent inspection, cleaning, and lubrication of the trailer working parts. Keep the tarpaulin lashed securely in place to keep dust and dirt out of the ammunition carried.

18. SUBMERSION.

a. **General.** When a vehicle has been driven through deep water or completely submerged in water, certain precautions must be taken to avoid serious damage. If it is known that water, dirt, and abrasives have entered the various units of the vehicle, notify the proper authority at once. Each unit which has been submerged should be completely dismantled, cleaned, and lubricated.

b. **Emergency Procedure if Vehicle Has Been Submerged.** If tactical situation makes complete dismantling and thorough cleaning of units impossible, each unit should be inspected, cleaned, and lubricated as follows to defer as much damage as possible. **CAUTION:** *Emergency cleaning cannot be considered as assurance that further damage will not occur.*

(1) **WHEEL BEARINGS AND BRAKES.** Remove the hub and drum assemblies, and clean the brake drums and shoes. Clean and repack the wheel bearings (par. 49). Replace the oil seals. If contaminated with dirt, oil seals must be replaced to avoid damage to the seal surfaces and prevent lubricant leakage.

(2) **BODY.** Open rear doors, and drain cargo compartment. Remove all water and dirt, and clean compartment thoroughly.

(3) **LUBRICATE VEHICLE COMPLETELY.** Lubricate entire vehicle (par. 23).

c. **Submersion in Salt Water.** If vehicle is submerged in salt water, immediate servicing must be done, or electrical equipment and metal parts will damage to such an extent that complete rebuilding or replacement of assemblies will be necessary. Only by prompt and thorough cleaning can parts be salvaged. In all cases of salt water submersion, notify the proper authority.

Demolition to Prevent Enemy Use

d. **Vehicles Subjected to Salt Air.** When the vehicle is operated near bodies of salt water, keep all exposed metal surfaces painted. Salt air will attack unpainted metal surfaces and quickly cause formation of rust. If the rust is not removed and the surface protected by a coating of paint, the metal will continue to rust away and the paint surrounding the damaged portion will peel off, causing additional deterioration of paint and metal.

Section IX

DEMOLITION TO PREVENT ENEMY USE

19. GENERAL.

a. Destruction of the vehicle when subject to capture or abandonment in the combat zone will be undertaken by the using arm only when, in the judgment of the military commander concerned, such action is necessary.

b. The instructions which follow are for information only. The conditions under which destruction will be affected are command decisions in each case, according to the tactical situation.

c. If destruction is resorted to, the vehicle must be so badly damaged that it cannot be restored to a usable condition in the combat zone either by repair or cannibalization. Adequate destruction requires that all parts essential to the operation of the vehicle be destroyed or damaged beyond repair. Equally important, the same essential parts must be destroyed on all like vehicles so that the enemy cannot construct one complete operating unit from several partially damaged ones.

20. DETAILED INSTRUCTIONS.

a. **Methods.** The following instructions contain several methods of demolition of this trailer, in the order of their effectiveness.

b. **Method No. 1.** Place 2-pound charges of TNT inside each wheel over the axle. Insert tetryl nonelectric caps with at least 5 feet of safety fuze in each charge. **CAUTION: If charges are prepared beforehand and carried in the vehicle, keep the caps and fuzes separated from the charges until they are to be used.** Ignite the fuzes and take cover.

c. **Method No. 2.**

(1) Ignite an M14 incendiary grenade under each tire or deflate

Part Two—Operating Instructions

the tires and destroy them with an ax, pick, or machine gun fire. Pour spare gasoline over each tire and ignite.

(2) Fire on the vehicle, using tank, antitank, or other artillery, or antitank rockets or grenades. If a good fire is started, the vehicle may be considered destroyed.

d. Method No. 3.

(1) Smash the lights, reflectors, jumper cable and socket, air lines, and connections.

(2) Place an M14 incendiary grenade under each tire or deflate tires and destroy them with an ax, pick, or machine gun fire.

(3) Pour gasoline over the entire unit.

(4) Ignite the incendiary grenades, or, if not used, ignite the vehicle by other means.

PART THREE—MAINTENANCE INSTRUCTIONS

Section X

GENERAL

21. SCOPE.

a. Part Three contains information for the guidance of the personnel of the using organizations responsible for the maintenance (first and second echelon) of this equipment. It contains information for the performance of the scheduled lubrication and preventive maintenance services, as well as description and maintenance of the major systems and units and their functions in relation to other components of the equipment.

Section XI

SPECIAL ORGANIZATIONAL TOOLS AND EQUIPMENT

22. SPECIAL TOOLS.

a. No special tools are required for first and second echelon maintenance of this vehicle.

Section XII

LUBRICATION

23. LUBRICATION ORDER.

a. War Department Lubrication Order No. 726 (fig. 10) prescribes lubrication maintenance for 4-ton, 2-wheel Ammunition Trailer M21.

b. A lubrication order is placed on or is issued with each vehicle and is to be carried with it at all times. In the event the vehicle is received without a copy, the using arm shall immediately requisition a replacement from an Adjutant General Depot. See lists in FM 21-6.

c. Lubrication instructions on the order are binding on all echelons of maintenance and there shall be no deviations.

Part Three—Maintenance Instructions

WAR DEPARTMENT LUBRICATION ORDER No. 726
 WAR DEPARTMENT, WASHINGTON 25, D. C., 26 AUGUST 1944

TRAILER, 4-TON, 2-W, AMMUNITION, M21
 SNL G-213 For detailed instructions, refer to TM 9-792

Interval • Lubricant

- M CG** Landing Wheel Swivel Pin — C, fig. 11
- M CG** Landing Wheel Bearing
- M CG** Brake Cross Shaft — B, fig. 11
- M CG** Spring Wear Plate
Clean and coat
- M CG** Brake Anchor Pin — D, fig. 11
Sparingly
- 6M WB** Wheel Bearings
Remove, clean and repack
- M CG** Brake Camshaft — A, fig. 11
Sparingly
- 6M CG** Slack Adjuster Sparingly
Remove plug, insert fitting to lubricate, replace plug
- M CG** Spring Wear Plate
Clean and coat

NOTES

Clean fittings before lubricating. Lubricate after washing.
 Clean parts with Solvent, dry cleaning, or Oil, fuel, Diesel. Dry before lubricating.
 Reduce intervals under severe operating conditions. Lubricate dotted arrow points on both sides. Opposite points are shown by short arrows.
OIL CAN POINTS—Monthly, lubricate hand brake linkage, landing gear control, clevises, door and shelf hinges and shelf linkage with OE.
DO NOT LUBRICATE—Springs, radius rod bushings.

Copy of this Lubrication Order will remain with the equipment at all times; instructions contained therein are mandatory and supersede all conflicting lubrication instructions dated prior to 26 August 1944.

By Order of the Secretary of War:
 Official: G. C. Marshall, Chief of Staff.
 J. A. Ulio, Major General,
 The Adjutant General.

KEY

LUBRICANTS	LOWEST ANTICIPATED AIR TEMPERATURES		
	Above + 32°F.	+ 32°F. to 0°F.	Below 0°F.
OE —Oil, Engine	SAE 30	SAE 10	PS
CG —Grease, general purpose	No. 1	No. 0	No. 0
WB —Grease, general purpose, No. 2—All temperatures	INTERVALS M—Monthly 6M—6 Months		
PS —Oil, lubricating, preservative, special			

Cold Weather: For lubrication and service below 0°F., refer to TM 9-792

NOT TO BE REPRODUCED in whole or in part without permission of the Office of the Chief of Ordnance.

RA PD 345541

Figure 10—Lubrication Order

Lubrication

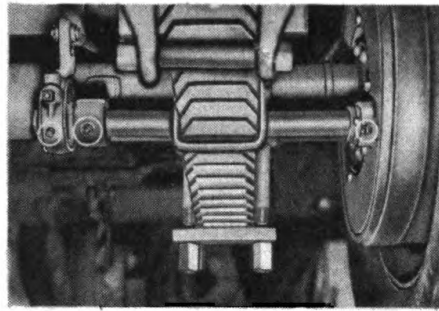

A—Brake Camshaft

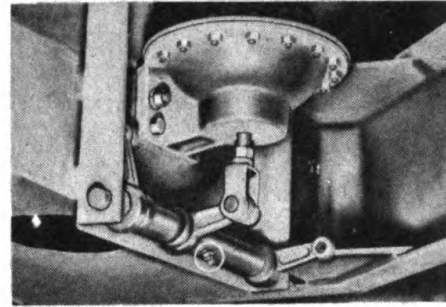

B—Brake Cross Shaft

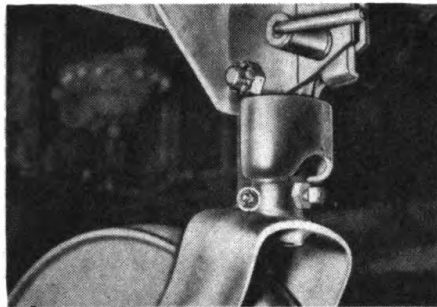

C—Landing Wheel Swivel Pin

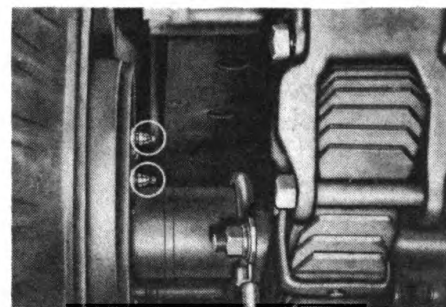

D—Brake Shoe Anchor Pins

RA PD 318835

Figure 11—Localized Lubrication Views

d. Service intervals specified on the order are for normal operating conditions above 0°F. Reduce these intervals under extreme conditions such as excessively high or low temperatures, prolonged periods of high speed, continued operation in sand or dust, immersion in water, or exposure to moisture, any one of which may quickly destroy the protective qualities of the lubricant and require servicing in order to prevent malfunctioning or damage to the materiel. Intervals may be extended when the trailer is not in use.

e. Lubricants are prescribed in the "Key" in accordance with three temperature ranges; above +32°F, +32°F to 0°F and below 0°F. Determine the time to change grades of lubricants by maintaining a close check on operation of the vehicle during the approach to change-over periods. Ordinarily it will be necessary to change grades of lubricants *only when air temperatures are consistently in the next higher or lower range.*

24. DETAILED LUBRICATION INSTRUCTIONS.

a. Lubrication Equipment.

(1) Operate lubricating guns carefully and in such manner as to insure a proper distribution of the lubricant. If lubrication fitting valves stick and prevent the entrance of lubricant, remove the fitting

and determine cause. Replace broken or damaged lubricators. If lubricator cannot be replaced immediately, cover hole with tape as a temporary expedient to prevent the entrance of dirt.

b. Points of Application.

(1) Lubrication fittings, grease cups, oilers and oilholes are readily located by references to the Lubrication Order. Wipe clean such lubricators and the surrounding surfaces before lubricant is applied.

(2) Where relief valves are provided, apply new lubricant until the old lubricant is forced from the vent.

(3) Always wipe clean the metal surfaces on which a film of lubricant must be maintained by manual application before the film is renewed.

c. Cleaning. Use dry-cleaning solvent or Diesel fuel oil to clean or wash all parts. Use of gasoline for this purpose is prohibited. After washing, dry all parts thoroughly before applying lubricant.

d. Lubrication Notes on Individual Units and Parts. The following instructions supplement and repeat for clarity those notes on the Lubrication Order which pertain to lubrication and service of individual units and parts.

(1) **WHEEL BEARINGS.** Remove bearing cone assemblies from hub. Wash bearings, cones, spindle, and inside of hub and dry thoroughly. Do not use compressed air. Inspect bearing races and replace if damaged. Coat the spindle and inside of hub and hub cap with No. 2 general purpose grease to a maximum thickness of $\frac{1}{16}$ inch, only to retard rust. Lubricate bearings with No. 2 general purpose grease with a packer or by hand, kneading lubricant into all spaces in the bearing. Use extreme care to protect the bearings from dirt, and immediately reassemble and replace wheel. Do not fill hub or hub cap. The lubricant in the bearing is sufficient to provide lubrication until the next service period. Any excess might result in leakage into the drum. Adjust bearings.

(2) **BRAKE SHOE ROLLERS AND CAMS.** At periods of wheel bearing lubrication or if trailer is subjected to standing for long periods in deep mud or water, remove the wheels after each immersion and clean, inspect, and lubricate brake shoe rollers and cams with No. 1 general purpose grease above $+32^{\circ}\text{F}$, and No. 0 below $+32^{\circ}\text{F}$, to insure proper brake action.

(3) **OILCAN POINTS.** Monthly, lubricate hand brake linkage, landing gear control, clevises, door and shelf hinges, shelf linkage, etc., with engine oil SAE 30 above $+32^{\circ}\text{F}$, SAE 10 from $+32^{\circ}\text{F}$ to 0°F , and special preservative lubricating oil below 0°F .

Preventive Maintenance Services

(4) **ANCHOR PIN AND CAMSHAFT FITTINGS.** Lubricate anchor pin and camshaft spider bearing fittings sparingly to prevent excessive lubricant from entering brake mechanism.

(5) **DO NOT LUBRICATE.** Do not lubricate springs and radius rod bushings.

e. Reports and Records.

(1) Report unsatisfactory performance of materiel to the Ordnance officer responsible for maintenance as prescribed in TM 38-250.

(2) A record of lubrication may be maintained in the Duty Roster (W.D., A.G.O. Form No. 6).

Section XIII

PREVENTIVE MAINTENANCE SERVICES

25. GENERAL.

a. Responsibility and Interval. Preventive maintenance services as prescribed by AR 850-15 are a function of using organization echelons of maintenance, and their performance is the responsibility of the commanders of such organizations. These services consist generally of Before-operation, During-operation, At-halt, After-operation, and Weekly services performed by driver, and the scheduled services to be performed at designated intervals by organizational maintenance personnel.

b. Definition of Terms. The general inspection of each item applies also to any supporting member or connection, and is generally a check to see whether the item is in good condition, correctly assembled, secure, or excessively worn.

(1) The inspection for "good condition" is usually an external visual inspection to determine whether the unit is damaged beyond safe or serviceable limits. The term "good condition" is explained further by the following: Not bent or twisted, not chafed or burned, not broken or cracked, not bare or frayed, not dented or collapsed, not torn or cut, not deteriorated.

(2) The inspection of a unit to see that it is "correctly assembled" is usually an external visual inspection to see whether it is in its normal assembled position in the vehicle.

(3) The inspection of a unit to determine if it is "secure" is usually an external visual examination; a wrench, hand-feel, or a pry-bar check for looseness. Such an inspection must include any brackets, lock washers, lock nuts, locking wires, or cotter pins used in assembly.

(4) "Excessively worn" will be understood to mean worn beyond serviceable limits or to a point likely to result in failure if the unit is not replaced before the next scheduled inspection.

26. DRIVER MAINTENANCE (FIRST ECHELON).

a. Purpose. To insure mechanical efficiency it is necessary that the vehicle be systematically inspected at intervals each day it is operated and weekly, so defects may be discovered and corrected before they result in serious damage or failure. Certain scheduled maintenance services will be performed at these designated intervals. Any defects or unsatisfactory operating characteristics beyond the scope of first echelon to correct must be reported at the earliest opportunity to the designated individual in authority. The services set forth in paragraphs 27, 28, 29, and 30 are those performed by the driver, Before-operation, During-operation, At-halt, and After-operation and weekly.

b. Use of W. D. Form No. 48. Driver preventive maintenance services are listed on the back of W. D., Form No. 48, Driver's Trip Ticket and Preventive Maintenance Service Record, to cover vehicles of all types and models. Items peculiar to this vehicle but not listed on W. D., Form No. 48 are covered in manual procedures under the items with which they are related. Certain items listed on the form that do not pertain to this vehicle are eliminated from the procedures as written into the manual. Every organization must thoroughly school each driver in performing the maintenance procedures set forth in this manual, whether they are listed specifically on W. D., Form No. 48 or not. The items listed on W. D., Form No. 48 that apply to this vehicle are expanded in this manual to provide specific procedures for accomplishment of the inspections and services. The services are arranged to facilitate inspection and conserve the time of the driver, and are not necessarily in the same numerical order as shown on W. D., Form No. 48. The item numbers, however, are identical with those shown on that form.

27. BEFORE-OPERATION SERVICE.

a. Purpose. This inspection schedule is designed primarily as a check to see that the vehicle has not been damaged, tampered with, or sabotaged since the After-operation Service was performed. Various combat conditions may have rendered the vehicle unsafe for operation, and it is the duty of the driver to determine whether the vehicle is in condition to carry out any mission to which it is assigned. This operation will not be entirely omitted, even in extreme tactical situations.

b. Procedures. Before-operation Service consists of inspecting items listed below according to the procedure described, and correct-

Preventive Maintenance Services

ing or reporting any deficiencies. Upon completion of the service, results will be reported promptly to the designated individual in authority.

(1) **ITEM 1, TAMPERING AND DAMAGE.** Look over the trailer and its attachments and equipment generally for damage which may have occurred from tampering, sabotage, shell fire, or collision since parking.

(2) **ITEM 5, AIR BRAKE TANK.** Drain condensate from air tank. Inspect tank, filters, valves, fittings, and lines for damage and loosened mountings or connections.

(3) **ITEM 12, LAMPS (LIGHTS) AND REFLECTORS.** Clean all glass, and inspect tail and stop light assemblies and warning reflectors for looseness and damage. If tactical situation permits, test light switches to see if lights respond properly.

(4) **ITEM 13, WHEEL AND FLANGE NUTS.** Inspect side ring, wheel mounting and hub nuts, or cap screws to see if they are all present and secure.

(5) **ITEM 14, TIRES.** Inspect tires for damage and underinflation; remove objects embedded in treads or carcasses.

(6) **ITEM 15, SPRINGS AND SUSPENSIONS.** Examine springs and all suspension units for looseness and damage.

(7) **ITEM 18, TOWING CONNECTIONS.** Inspect lunette eye, landing wheel assembly, and rear support for looseness or damage. When trailer is not connected to prime mover, parking brakes should be applied and the mechanism inspected to be sure it operates properly and locks securely in applied position. If connected to prime mover, be sure towing connection locking devices, air line, and electrical couplings are secure, and that landing wheel and rear support are locked in raised position.

(8) **ITEM 19, BODY, LOAD, AND TARPAULIN.** Inspect body for damage. See that loaded shells and powder containers are evenly distributed and properly secured by clamps or straps. If in use, see that tarpaulin and ridge rope and spring are in good condition, correctly installed, and securely lashed; or that they are properly stowed.

(9) **ITEM 21, TOOLS AND EQUIPMENT.** Be sure all items are present and properly and securely mounted or stowed.

28. DURING-OPERATION SERVICE.

a. Observations. While vehicle is in motion, listen for any sounds such as rattles, knocks, squeals, or hums that may indicate trouble. Be alert for odors indicating overheated components or units (such as brakes) or other trouble. When brakes are used, consider this a test and note any unsatisfactory or unusual performance.

b. Procedures. During-operation Services consist of observing items listed below according to the procedures following each item, and investigating any indications of serious trouble. Note minor deficiencies to be corrected or reported at earliest opportunity, usually the next scheduled halt.

(1) **ITEM 27, AIR BRAKES.** During operation, when trailer air brake control on prime mover is applied, observe if trailer brake action appears to be satisfactory.

(2) **ITEM 34, RUNNING GEAR.** Be on the alert when trailer is in motion for any unsatisfactory operating characteristics of springs, axle, or wheels that might indicate looseness, damage, inadequate lubrication, or underinflated tires.

(3) **ITEM 35, BODY.** Be on the alert for excessive sway or sagging of trailer body that might indicate loose mounting of assembly nuts or screws, broken welds, or improperly connected towing devices.

29. AT-HALT SERVICE.

a. Importance. At-halt Services may be regarded as minimum maintenance procedures, and should be performed under all tactical conditions even though more extensive maintenance services must be slighted or omitted altogether.

b. Procedures. At-halt Services consist of investigating any deficiencies noted during operation, inspecting items listed below according to the procedures following the items, and correcting any deficiencies found. Deficiencies not corrected should be reported promptly to the designated individual in authority.

(1) **ITEM 39, TEMPERATURES: HUBS AND BRAKE DRUMS.** Cautiously hand-feel each wheel hub and brake drum for indications of overheating.

(2) **ITEM 42, SPRINGS AND SUSPENSIONS.** Inspect springs and radius rods for indications of looseness or damage, and investigate any unusual condition noticed during operation.

(3) **ITEM 44, WHEEL AND FLANGE NUTS.** Inspect side ring, wheel mounting and hub nuts, or cap screws to see if they are all present and secure.

(4) **ITEM 45, TIRES.** Inspect tires for damage and underinflation; remove objects embedded in treads or carcasses.

(5) **ITEM 50, TOWING CONNECTIONS.** At each halt, examine all towing connections to see if they are in good condition and secure.

(6) **ITEM 51, BODY, LOAD, AND TARPAULIN.** Inspect body for damage and loose mounting or assembly units, and see that all attachments are secure. Make certain that loaded shells and powder

Preventive Maintenance Services

containers are evenly distributed and properly secured. Be sure tarpaulin is properly installed and lashed (if in use), or safely stowed.

30. • AFTER-OPERATION AND WEEKLY SERVICE.

a. Purpose. After-operation Services are particularly important because at this time the driver inspects the vehicle to detect any deficiencies that may have developed, and to correct those they are permitted to handle. They should promptly report results of the inspection to the designated individual in authority. If this schedule is performed thoroughly, the vehicle should be ready to roll again on a moment's notice. The Before-operation Service, with few exceptions, is then necessary only to ascertain whether the vehicle is in the same condition in which it was left upon completion of the After-operation Service. The After-operation Service should never be entirely omitted, even in extreme tactical situations, but may be reduced to the bare fundamental services outlined for the At-halt Service if necessary.

b. Procedures. When performing the After-operation Service, the driver must remember and consider any irregularities noticed in the Before-operation, During-operation, and At-halt Services. The After-operation Service consists of inspecting and servicing the following items. Those items of the After-operation Service that are marked by an asterisk (*) require additional Weekly Services, the procedures for which are indicated in subparagraph (b) of each applicable item.

(1) **ITEM 59, LAMPS (LIGHTS) AND REFLECTORS.** Clean all light and reflector glass, and inspect units for looseness and damage. If tactical situation permits, test switches and observe if lights respond properly.

(2) **ITEM 64, ELECTRICAL WIRING.** Inspect all accessible trailer wiring and conduits for damage and for loose mountings or connections. Wipe off accumulated dirt or moisture.

(3) **ITEM 68, *TIRES.**

(a) With tires properly inflated, inspect for damage. Remove all objects lodged in treads or carcasses. See that valve stems are in good condition and valve caps finger-tight.

(b) *Weekly.* Replace excessively damaged or worn tires with serviceable ones. Apparent mechanical deficiencies that might contribute to tire wear should be reported for attention by higher echelon.

(4) **ITEM 69, SPRINGS AND SUSPENSIONS.** Examine springs and radius rods for looseness and damage. Look particularly for broken or shifted spring leaves, missing rebound clips, and loose hangers or U-bolts.

(5) ITEM 75, *AIR BRAKE TANKS.

(a) Drain condensate from air tank and inspect tank, valves, lines, and all fittings to be sure they are in good condition, correctly assembled, and secure.

(b) *Weekly.* Remove bottom plugs from air line filters and drain off accumulated sediment and water.

(6) ITEM 77, TOWING CONNECTIONS. Inspect lunette eye, landing wheel assembly, and rear support for looseness or damage. When trailer is not connected to prime mover, parking brakes should be applied and mechanism inspected to be sure it operates properly and locks securely in applied position. If connected to prime mover, be sure towing connection locking devices, air line, and electric couplings are secure, and that landing wheel and rear support are locked in raised position. *NOTE: Before trailer is disconnected from prime mover, landing wheel and rear support must be lowered and securely locked at ground position.*

(7) ITEM 78, BODY, LOAD, AND TARPAULIN. Inspect body for damage. See that loaded shells and powder containers are evenly distributed and properly secured by clamps or straps. If in use, see that tarpaulin and ridge rope and spring are in good condition, correctly installed, and securely lashed, or properly stowed.

(8) ITEM 82, *TIGHTENING.

(a) Securely tighten all trailer and attachment mounting or assembly nuts or screws found loose during this inspection.

(b) *Weekly.* Tighten wheel side ring, mounting and hub nuts and screws, spring U-bolts and clips, body and attachment mounting and assembly nuts and screws, and ammunition rack and boxes. Be sure all air and parking brake mechanism lock nuts, clevis pins, cotter pins are in place and secure.

(9) ITEM 83 *LUBRICATION.

(a) Lubricate all points of the trailer where this inspection has indicated the necessity.

(b) *Weekly.* Lubricate all trailer units indicated on the War Department Lubrication Order as requiring attention on a weekly or mileage basis.

(10) ITEM 84, *CLEAN VEHICLE.

(a) Remove all expended shell casings, powder containers, dirt, or trash from inside vehicle stowage spaces. Remove dirt or excess grease from entire vehicle.

(b) *Weekly.* Wash vehicle when facilities and tactical situation permit. If washing is impractical, wipe off as clean as possible. Look for rust spots or for polished surfaces on finish or camouflage pattern that may cause glare or reflections, unless covered for tactical reasons.

Preventive Maintenance Services

See that vehicle markings are legible. **NOTE:** *If trailer is towed into a stream or pool for washing, care must be taken that water and dirt do not get into brakes or onto electrical units or wiring.*

(11) **ITEM 85, *TOOLS AND EQUIPMENT.**

(a) Check to be sure all tools and items of equipment are present and properly mounted or stowed.

(b) *Weekly.* Clean all tools and items of equipment assigned to trailer. Check to see if they are in good condition, and mount or stow them properly and securely. Be sure all stowage compartment locking devices are properly fastened.

31. ORGANIZATIONAL MAINTENANCE (SECOND ECHELON).

a. Frequency. The frequency of preventive maintenance services outlined herein is considered a minimum requirement for normal operation of vehicles. Under unusual operating conditions such as extreme temperatures, severe dust, sandy or extremely wet terrain, it may be necessary to perform certain maintenance services more frequently.

b. First Echelon Participation. The drivers should accompany their vehicles and assist the mechanics while periodic second echelon preventive maintenance services are performed. Ordinarily the vehicle should be presented for a scheduled preventive maintenance service in a reasonably clean condition; that is, it should be dry, and not caked with mud or grease to such an extent that inspection and servicing will be seriously hampered. However, the vehicle should not be washed or wiped thoroughly clean because certain types of defects such as cracks, leaks, and loose or shifted parts or assemblies are more evident if the surfaces are slightly soiled or dusty.

c. Sources of Additional Information. If instructions other than those contained in the general procedures in subparagraph **d**, or the specific procedures in subparagraph **i**, which follow, are required for proper performance of a preventive maintenance service or for correction of a deficiency, they may be secured from other sections of this manual or from the designated individual in authority.

d. General Procedures. These general procedures are basic instructions which are to be followed when performing the services on the items listed in the specific procedures. **NOTE:** *The second echelon personnel must be thoroughly trained in these procedures so that they will apply them automatically.*

(1) When new or overhauled subassemblies are installed to correct deficiencies, care must be taken to see that they are clean, correctly installed, and properly lubricated and adjusted.

(2) When installing new lubricant retainer seals, a coating of the lubricant should be wiped over the sealing surface of the lip of the seal. When the new seal is a leather seal, it should be soaked in SAE 10 engine oil at least 30 minutes. The oil should be warm, if practicable. Then the leather lip should be worked carefully by hand before installing the seal. The lip must not be scratched or marred.

e. **Definition of Terms.** Refer to paragraph 25 b.

f. **Special Services.** These are indicated by repeating the item numbers in the columns which show the interval at which the services are to be performed and the parts or assemblies which are to receive certain mandatory services. For example, an item number in one of both columns opposite a **TIGHTEN** procedure means that the actual tightening of the object must be performed. The special services include:

(1) **ADJUST.** Make all necessary adjustments in accordance with the pertinent section of this manual, special bulletins, or other current directives.

(2) **CLEAN.** Clean the units of the vehicle with dry-cleaning solvent to remove excess lubricant, dirt, and other foreign material. After the parts are cleaned, rinse in clean solvent and dry thoroughly. Take care to keep the parts clean until reassembled, and be certain to keep cleaning solvent away from rubber or other material which it will damage. Clean the protective grease coating from new parts since this material is usually not a good lubricant.

(3) **SPECIAL LUBRICATION.** This applies both to lubrication operations that do not appear on the vehicle lubrication order and to items that do appear on the Order but should be performed in connection with the maintenance operations if parts have to be disassembled for inspection or service.

(4) **SERVE.** This usually consists of performing special operations such as replenishing battery water, draining and refilling units with oil, and changing or cleaning the oil filter, air cleaner, or cartridges.

(5) **TIGHTEN.** All tightening operations should be performed with sufficient wrench torque (force on the wrench handle) to tighten the unit according to good mechanical practice. Use a torque-indicating wrench where specified. Do not overtighten as this may strip threads or cause distortion. Tightening will always be understood to include the correct installation of lock washers, lock nuts, lock wire, or cotter pins provided to secure the tightening.

g. **Special Conditions.** When conditions make it difficult to perform all preventive maintenance procedures at one time, they can sometimes be handled in sections, planning to complete all opera-

Preventive Maintenance Services

tions within the week if possible. All available time at halts and in bivouac areas must be utilized, if necessary, to assure that maintenance operations are completed. When time is limited by the tactical situation, items with Special Services in the columns, should be given first consideration.

h. Work Sheet. The numbers of the preventive maintenance procedures that follow are identical with those outlined on W. D., A.G.O. Form No. 461, which is the Preventive Maintenance Service Work Sheet for Wheeled and Half-track Vehicles. Certain items on the work sheet that do not apply to this vehicle are not included in the procedures in this manual. In general, the numerical sequence of items on the work sheet is followed in the manual procedures, but in some instances there is deviation for conservation of the mechanic's time and effort.

i. Specific Procedures. The procedures for performing each item in the 1,000-mile (monthly) and 6,000-mile (6-month) maintenance procedures, whichever shall occur first, are described in the following chart. Each page of the chart has two columns at its left edge corresponding to the 6,000-mile and the 1,000-mile maintenance respectively. Very often it will be found that a particular procedure does not apply to both scheduled maintenances. In order to determine which procedure to follow, look down the column corresponding to the maintenance due and, wherever an item number appears, perform the operations indicated opposite the number.

ROAD TEST

MAINTENANCE	
6000 Mile	1000 Mile
1	1
5	5
10	10

NOTE: *When practicable, it is desirable to road-test the trailer by towing it with the prime mover. The road test should be confined to the minimum distance necessary to make proper observations.*

Before-operation Inspection. Before making the road test, perform the Before-operation Service as outlined in paragraph 27.

Brakes (Service and Parking). With the trailer in motion, test the service brakes by operation of controls on the prime mover, observing if they operate effectively and if there are any indications of side pull, noise, or chatter. Observe also if the air controls function properly. Stop vehicle and test parking brakes. Observe if control mechanism operates properly and holds vehicle effectively.

Unusual Noise. Observe if there is any unusual noise from trailer attachments, body, suspension units, or wheel that might indicate looseness, damage, inadequate lubrication, or underinflated tires.

MAINTENANCE	
6000 Mile	1000 Mile
12	12
13	13
47	47
48	
	49

Air Brake System Leaks. At completion of road test, check all air brake units of trailer for leaks. With brakes applied, there should be no appreciable drop in air pressure in 1 minute.

Temperatures (Brake Drums and Wheel Hubs). Cautiously hand-feel each brake drum and wheel hub for indication of overheating.

MAINTENANCE OPERATIONS

Tires and Rims. Inspect and service as follows:
VALVE STEMS AND CAPS. Observe if valve stems are in good condition and in correct position. See that valve caps are present.

CONDITION. With tires properly inflated, examine for cuts, bruises, breaks, and blisters. Remove such objects as glass, nails, or stones embedded in treads or carcasses. Look for irregular tread wear such as flat spots, cupping, feather edges, or one-sided wear. Remove tires worn thin or otherwise unserviceable, and exchange for new or retreaded tires. If tires are worn unevenly but still are serviceable, switch wheels to even the wear. Apparent mechanical deficiencies that will cause tire wear should be corrected or reported.

MATCHING. Tires with different types of treads or with differences in over-all circumference in excess of 3/4 inch should not be used on the same vehicle.

RIMS. Inspect rims to see if they are in good condition. Tighten all side ring and mounting nuts securely. See that valve caps are finger-tight. *NOTE: If tires or wheels have been removed, do not install them until wheel bearing and brake services (items 48, 49, and 52) have been performed.*

Brakes (Drums, Supports, Cams, and Shafts). Remove wheels, hubs, and drums. Inspect brake drums to see if they are in good condition and secure to hubs. Look particularly for excessive scoring or distortion. Examine supports (backing plates) for looseness or damage. See if operating cams and shafts are free, and examine for excessive wear or damage.

Brake Shoes (Linings, Links, Guides, Anchors, and Retracting Springs). Examine brake linings through inspection openings to see if they are so worn that bolt

Preventive Maintenance Services

MAINTENANCE	
6000 Mile	1000 Mile
49	
50	50
	52
52	
69	69
70	70

heads may contact drums in the next 1,000 miles of operation. If vehicle has been operated in water, mud, loose sand, or dirt which may have entered drums, remove one wheel hub and drum assembly and inspect linings for damage. If this lining must be replaced, also replace linings on opposite side, lubricate bearings, and adjust bearings and brakes as outlined for 6,000-mile maintenance in item 52 following.

With wheel, hub, and drum assemblies removed, inspect linings to see if they are in good condition, securely bolted to shoes, in good wearing contact with drums, and not oil-soaked or excessively worn. See that shoes are in good condition, properly secured, and guided by anchors and guides; and that retracting springs have sufficient tension to return shoes to correct released position. Thickness of lining above bolt heads must be sufficient for at least 1,000 miles of operation.

CLEAN. Clean linings and operating mechanism with a brush, and blow off with compressed air.

ADJUST. Adjust bearings and brakes.

50 50 Torque (Radius) Rods. Inspect radius rods to see if they are in good condition and securely connected.

52 Wheels (Bearings, Seals, and Hub Nuts). Inspect wheels to see if they are in good condition. Revolve wheels and observe any condition of bearing looseness or dry or damaged bearings. Tighten hub and cap nuts or screws securely.

52 Remove wheel bearings and oil seal. Wash thoroughly in dry-cleaning solvent and inspect bearing cups, cones, and oil seals for damage and excessive wear.

SPECIAL LUBRICATION. When all related items are performed to a point where bearings are to be installed, lubricate according to instructions in the War Department lubrication order for this vehicle.

ADJUST. Adjust wheel bearings, and be sure all hub and cap nuts or screws are secure.

69 69 Air Brake Valves. Examine all valves on trailer brake system to see if they are in good condition and securely mounted and connected.

70 70 Air Brake Reservoirs. Examine air reservoir tank for good condition and secure mountings and connections. Drain condensation from tank and close drain cock.

MAINTENANCE	
6000 Mile	1000 Mile
76	76
77	77
75	75
79	79
80	80
81	81
83	83
	83
83	
85	85
91	91
92	92
100	100

Air Brake (Chambers, Rods, and Slack Adjusters). Inspect these components to see if they are in good condition, correctly assembled, and secure. Be sure operating mechanism is free but not excessively worn.

Springs (Clips, Leaves, U-bolts, and Hangers). Inspect these components to see if they are in good condition, correctly assembled, and secure. Look particularly for broken or shifted spring leaves. Tighten all loose spring U-bolts, rebound clips, and hanger mountings securely.

Axle. Inspect axle for distortion or damage.

Body Mountings. Inspect all body to frame mounting nuts or welds to be sure they are secure.

Frame. Inspect frame rails and crossmembers to see if they are in good condition and secure.

Wiring. Inspect all trailer electrical wiring and conduits to see that they are in good condition and securely supported.

Brake Lines (Fittings and Hose). Inspect all trailer brake lines, fittings, and hose to see if they are in good condition and securely connected and mounted. Be sure jumper hose and connections are not damaged.

Drain water and sediment from brake line filters.

Remove brake line filter bowls and elements, wash in dry-cleaning solvent, and reinstall securely using new gaskets as necessary.

Vehicle Lubrication. Perform a complete lubrication service on the vehicle according to instructions in War Department Lubrication Order. Omit only those items that have been lubricated or serviced during performance of the foregoing specific procedures. Replace missing or damaged lubrication fittings.

Lamps (Lights) and Reflectors. Wipe off lenses, and inspect tail and stop light assemblies to see if all units and connections are in good condition and secure.

Safety Reflectors. Wipe off glass, and examine units to see if they are in good condition and securely mounted.

Body (Panels, Rear Doors, Ammunition Racks and Boxes, Stowage Compartment, and Tarpaulin). Examine all these items to see if they are in good condition and securely mounted or connected. Be sure hinges and

Preventive Maintenance Services

MAINTENANCE	
6000 Mile	1000 Mile
124	124
127	127
130	130
131	131
141	141
142	142

latches operate properly and are free but not excessively worn. Look for missing or loose assembly bolts, nuts, or screws and broken assembly welds. Clean out stowage compartments. Examine powder box straps for damage, and test shell rack locking devices to be sure they function properly. Examine tarpaulin for rips or other damage. If in use, be sure ridge rope and spring are properly anchored and tarpaulin properly lashed. If not in use, stow securely.

Tow Hitch. Examine drawbar and lunette to see if they are in good condition and secure.

Landing Gear (Wheel, Axle, Swivel, and Rear Lock Support). Examine these components to see if they are in good condition, correctly assembled, and secure. Be sure wheel is free on axle and swivel but that there is no excessive looseness. Inspect locking devices of landing wheel and rear support to see that they are present and in good condition. *NOTE: If trailer is connected to prime mover, landing wheel and rear support should be left in raised position after inspection.*

Parking Brakes. Inspect parking brake levers and operating linkage to see if they are in good condition, correctly assembled, securely connected or mounted, and not excessively worn. Test operation of mechanism to be sure it functions properly.

Tools and Equipment. Check to see that all items are present, in good condition, and properly mounted or stowed.

Modifications. Inspect vehicle to be sure all Modification Work Orders have been completed and entered on Form No. 478. Enter any modifications or major unit assembly replacements made at time of this service.

Final Road Test. After completion of the maintenance operations, it is advisable to road-test the trailer in conjunction with the prime mover, to be sure all services performed are satisfactory. Confine final road test to the least mileage necessary to make proper observations.

NOTE: Correct or report any deficiencies found during final road test.

Section XIV**TROUBLE SHOOTING****32. GENERAL.**

a. This section contains trouble shooting information and tests which can be made to help determine the causes of some of the troubles that may develop in use under average conditions. Each symptom of trouble given under the individual unit or system is followed by a list of possible causes of the trouble. The tests necessary to determine which one of the possible causes is responsible for the trouble are given after each possible cause.

33. SUSPENSION (SPRINGS AND RADIUS RODS).**a. Hard Riding.**

(1) **RADIUS RODS EXTREMELY BENT OR BROKEN.** Remove and replace (par. 43 b and c).

(2) **TIE BOLT IN SPRING HANGER BROKEN.** Replace (par. 42 b and c).

(3) **LOOSE SPRING U-BOLTS CAUSING SPRINGS OR AXLE TO SHIFT.** Aline axle on spring seats and tighten spring U-bolt nuts (par. 53).

(4) **UNEVEN LOAD DISTRIBUTION.** Distribute load evenly to front or rear of axle.

(5) **BROKEN SPRING LEAVES.** Refer to higher authority.

(6) **BROKEN SPRING CENTER BOLTS.** Refer to higher authority.

b. Excessive Noise.

(1) **LOOSE SPRING U-BOLT NUTS CAUSING MISALINEMENT OF AXLE AND SPRINGS.** Aline axle on spring seats and tighten U-bolt nuts (par. 53).

34. AXLE AND BRAKE MECHANISM.**a. Hard Pulling.**

(1) **EXCESSIVE BEND IN AXLE.** Refer to higher authority.

(2) **WHEEL BEARINGS IMPROPERLY ADJUSTED.** Adjust wheel bearings (par. 49 c).

(3) **WORN WHEEL BEARINGS.** Replace (par. 49 a and b).

(4) **RADIUS RODS EXTREMELY BENT OR BROKEN.** Remove and replace (par. 43 b and c).

b. Weak Brakes.

(1) **GREASE ON BRAKE LININGS.** Replace brake shoe (par. 56 b and c), and check and replace oil seal if necessary or refer to higher authority to have brake lining replaced.

Trouble Shooting

- (2) **INEFFECTIVE AIR POWER.** Refer to paragraph 60.
- (3) **WEAR OF BRAKE LININGS.** Adjust brakes (par. 55).
- (4) **WORN-OUT BRAKE LINING.** Replace brake shoe (pars. 56 b and c) or refer to higher authority to have brake lining replaced.

c. Excessive Wear on Brake Lining.

- (1) **WEAK OR BROKEN BRAKE SHOE RETURN SPRING.** Replace brake shoe return spring (par. 56 b and c).
- (2) **SLACK ADJUSTER ADJUSTMENT TOO TIGHT.** Adjust brakes through slack adjuster (par. 55).

d. Brake Drag.

- (1) **WEAK OR BROKEN BRAKE SHOE RETURN SPRING.** Replace brake shoe return springs (par. 56 b and c).
- (2) **SLACK ADJUSTER ADJUSTMENT TOO TIGHT.** Adjust brakes through slack adjuster (par. 55).

e. Grabbing Brake.

- (1) **GREASE-SOAKED BRAKE LINING.** Replace brake shoe and check and replace oil seal if necessary (par. 56 b and c) or refer to higher authority to have brake lining replaced.
- (2) **CRACKED OR SCORED BRAKE DRUM.** Replace brake drum (par. 48 b and d).
- (3) **WORN BRAKE LINING.** Replace brake shoe (pars. 46 c and 47 c) or refer to higher authority to have brake lining replaced.

f. Noisy Brakes.

- (1) **DIRTY BRAKE LININGS.** Replace brake shoe (pars. 46 c and 47 c) or refer to higher authority to have brake lining replaced.
- (2) **LOOSE BRAKE LINING.** Refer to higher authority.
- (3) **BRAKE DRUM DISTORTED.** Replace brake drum (par. 48 b and d).

35. BENDIX-WESTINGHOUSE AIR POWER.

a. Insufficient Brakes.

- (1) **LOW AIR PRESSURE IN THE AIR BRAKE POWER SYSTEM (BELOW 80 POUNDS).** Check air brake system on towing vehicle for low pressure. Check air brake system on towing vehicle and trailer for excessive leakage (par. 60).

Part Three—Maintenance Instructions

(2) **BRAKE VALVE DELIVERY PRESSURE FROM TOWING VEHICLE BELOW NORMAL.** Check brake valve delivery pressure on towing vehicle. Adjust brake valve linkage, or replace brake valve.

(3) **DEFECTIVE RELAY EMERGENCY VALVE.** Replace relay emergency valve (par. 61 c and d).

b. Brakes Apply Too Slowly.

(1) **LOW AIR PRESSURE IN THE AIR BRAKE SYSTEM (BELOW 80 POUNDS).** Check brake system on towing vehicle.

(2) **BRAKE VALVE DELIVERY PRESSURE FROM TOWING VEHICLE BELOW NORMAL.** Check brake valve delivery pressure. Adjust brake valve linkage, or replace brake valve.

(3) **BENT ROD IN BRAKE CHAMBER.** Straighten rod or replace brake chamber (par. 62 c and d).

(4) **BENT ROD IN BRAKE LINKAGE.** Straighten rod or replace (pars. 73 and 74).

(5) **RESTRICTION IN TUBING LINE.** Service or replace tubing line (par. 70 b, c, and d).

(6) **RESTRICTION IN HOSE LINE.** Service or replace hose line (par. 69 b, c, and d).

(7) **CLOGGED AIR LINE FILTER.** Clean filter (par. 66 b).

(8) **EXCESSIVE LEAKAGE WITH BRAKES APPLIED.** See causes and remedies under subparagraph i below.

c. Brakes Release Too Slowly.

(1) **DEFECTIVE EXHAUST CHECK VALVE IN EXHAUST PORT OF RELAY EMERGENCY VALVE.** Service or replace exhaust check valve (par. 70 b, c, and d).

(2) **RESTRICTION IN TUBING LINE.** Service or replace tubing line (par. 70 b, c, and d).

(3) **RESTRICTION IN HOSE LINE.** Service or replace hose line (par. 69 b, c, and d).

(4) **CLOGGED AIR LINE FILTER.** Clean filter (par. 66 b).

(5) **BINDING CAM OR BINDING SLACK ADJUSTER.** Lubricate parts (par. 24) and align properly.

d. Brakes Do Not Apply.

(1) **BRAKE SYSTEM NOT PROPERLY CONNECTED TO BRAKE SYSTEM OF TOWING VEHICLE.** Connect hose couplings correctly (par. 13 b).

(2) **NO AIR PRESSURE IN AIR BRAKE SYSTEM.** Charge air brake system.

(3) **RESTRICTION IN TUBING LINE.** Service or replace tubing line (par. 70 b, c, and d).

Trouble Shooting

(4) **RESTRICTION IN HOSE LINE.** Service or replace hose line (par. 69 b, c, and d).

(5) **CLOGGED AIR LINE FILTER.** Clean filter (par. 66 b).

e. Brakes Do Not Release.

(1) **BRAKE SYSTEM IMPROPERLY CONNECTED TO BRAKE SYSTEM OF TOWING VEHICLE.** Connect lines properly (par. 13 b).

(2) **BRAKE VALVE ON TOWING VEHICLE IN APPLIED POSITION.** Move brake valve to released position.

(3) **RELAY EMERGENCY VALVE IN EMERGENCY POSITION (TRAILER COUPLED).** Build up pressure in air brake system if connected to a towing vehicle.

(4) **RESTRICTION IN TUBING LINE.** Service or replace tubing line (par. 70 b, c, and d).

(5) **RESTRICTION IN HOSE LINE.** Service or replace hose line (par. 69 b, c, and d).

f. Brakes Grab.

(1) **DEFECTIVE BRAKE VALVE ON TOWING VEHICLE.** Service or replace.

(2) **DEFECTIVE RELAY EMERGENCY VALVE.** Replace (par. 61 c and d).

g. Uneven Brakes.

(1) **LEAKING BRAKE CHAMBER DIAPHRAGM.** Replace brake chamber (par. 62 c and d).

h. Excessive Leakage with Brakes Released.

(1) **RELAY EMERGENCY VALVE LEAKING.** Replace relay emergency valve (par. 61 c and d).

(2) **LEAKING TUBING LINE.** Service or replace tubing line (par. 70 b, c, and d).

(3) **LEAKING HOSE LINE.** Service or replace hose line (par. 69 b, c, and d).

i. Excessive Leakage with Brakes Fully Applied.

(1) **LEAKING RELAY EMERGENCY VALVE.** Replace relay emergency valve (par. 61 c and d).

(2) **LEAKING BRAKE CHAMBER DIAPHRAGM.** Tighten bolts around brake chamber diaphragm flange (par. 62 b (2) (a)).

(3) **LEAKING BRAKE CHAMBER DIAPHRAGM.** Replace brake chamber (par. 62 c and d).

(4) **LEAKING TUBING LINE.** Service or replace tubing line (par. 70 b, c, and d).

(5) **LEAKING HOSE LINE.** Service or replace hose line (par. 69 b, c, and d).

(6) **DAMAGED GASKET IN HOSE COUPLING.** Replace gasket (par. 68 c and d).

j. Excessive Leakage with Brakes Applied and Relay Emergency Valve in Emergency Position.

(1) **DEFECTIVE RELAY EMERGENCY VALVE.** Replace relay emergency valve (par. 61 c and d).

k. Excessive Oil and Water Present in Air Brake System.

(1) **RESERVOIR NOT BEING DRAINED DAILY.** Drain reservoir daily. Clean system if necessary.

(2) **COMPRESSOR ON TOWING VEHICLE PASSING EXCESSIVE OIL.** Replace compressor.

36. PARKING BRAKE.

a. Failure in Operation.

(1) **BROKEN OR WORN LINKAGE.** If air brake system successfully applies both brakes and either parking brake hand lever fails to do so, check the linkage directly above the idler lever assembly. Test each parking brake separately. A missing yoke pin, used for attaching hand brake yoke assembly to idler lever assembly, will cause failure of parking brake operation. A missing hand brake lever swivel pin will cause failure of parking brake operation. Check paragraphs 73 and 74 for removal and installation of parking brake linkage.

(2) **WEAK BRAKES.** Refer to paragraph 34 b.

(3) **EXCESSIVE WEAR ON BRAKE LININGS.** Refer to paragraph 34 c.

(4) **BINDING CAM OR BINDING SLACK ADJUSTER.** Lubricate (par. 24) and aline properly.

37. WHEELS, TIRES, AND TUBES.

a. Excessive Wear and Scuffed Tires.

(1) **TIRES WEARING EVENLY BUT TOO RAPIDLY DUE TO BENT AXLE.** Report to higher authority.

(2) **RIM OR WHEEL BENT.** Replace wheel (par. 46).

(3) **LOW TIRE PRESSURE.** Keep tires inflated to 75 pounds.

b. Cupped Tires.

(1) **LOOSE WHEEL BEARINGS.** Adjust wheel bearings (par. 49 c.)

(2) **LOOSE WHEELS.** Tighten wheel stud nuts.

Trouble Shooting

38. LANDING WHEEL.**a. Faulty Operation.**

- (1) **LACK OF LUBRICATION.** Lubricate landing wheel (par. 24).
- (2) **BROKEN LANDING WHEEL.** Replace landing wheel (par. 75 c and d).
- (3) **BENT FORK OR BRACKET.** Straighten or replace (par. 75 c and d).
- (4) **BENT LATCH PIN OR BROKEN SPRING.** Refer to higher authority.

39. LIGHTS AND WIRING.**a. No Lights or Dim Lights.**

- (1) **SHORT IN BATTERY IN TOWING VEHICLE OR CORRODED BATTERY TERMINALS.** Refer to trouble shooting section of towing vehicle manual.
- (2) **BROKEN OR BURNED-OUT COUPLING SOCKET.** Replace (par. 78 b and c).
- (3) **BURNED-OUT TAILLIGHT LAMP-UNITS.** Replace (par. 79 d).
- (4) **SHORT CIRCUIT IN WIRING.** Check wiring for short circuit.
- (5) **LOOSE, DIRTY, OR CORRODED TERMINALS.** Clean and tighten.
- (6) **BROKEN OR BURNED-OUT BLACKOUT SWITCH.** Replace (par. 80 b and c).
- (7) **DAMAGED ELECTRICAL JUMPER CABLE OR PLUG.** Replace.
- (8) **BROKEN REFLEX REFLECTOR.** Replace (par. 87 b and c).

40. BODY AND COMPONENTS.**a. Body or A-frame Sagging.**

- (1) **CRACKED WELDS.** Refer to higher authority.
- (2) **DAMAGED STEEL SECTIONS.** Refer to higher authority.

b. Loose Coupling.

- (1) **LOOSE OR BROKEN DRAWBAR LUNETTE EYE.** Tighten or replace (par. 82 b and c).
- (2) **LOOSE CONNECTION.** Check pintle hook on towing vehicle.

c. Torn Tarpaulin.

- (1) **BROKEN OR LOOSE ROPE TIES.** Repair or replace ropes (par. 85 b and c).

Part Three—Maintenance Instructions

(2) **SIDE SWIPING TREE LIMBS OR OTHER OBJECTS.** Drive carefully.

(3) **LOOSE OR BROKEN ROPE-LOCKS.** Refer to higher authority.

(4) **BROKEN SPRING-LOADED ROPE.** Repair or replace rope (par. 86 b and c).

d. Shell Racks.

(1) **LOOSE SHELL RACKS.** Tighten or replace nuts on shell rack hinges.

(2) **MISSING STUDS ON SHELL RACKS.** Refer to higher authority.

(3) **LOOSE SHELLS.** Adjust tie rod on end of cam and lever mechanism (par. 83 c (5)).

(4) **CAM AND LEVER JUMPING OUT OF LOCKED POSITION.** Pull out locking pin and drop it over angle on end of cam lever handle.

e. Powder Container.

(1) **POWDER CONTAINERS SHIFTING POSITION DUE TO BROKEN OR LOOSE BINDING STRAP.** Fasten strap securely at center and also at end with bolt, washer, and nut. Replace broken strap (par. 84 b and c).

Section XV**SUSPENSION (SPRINGS AND RADIUS RODS)****41. DESCRIPTION AND DATA.**

a. Description (figs. 12 and 13). The M21 suspension consists of two main spring assemblies, two radius rods, and necessary brackets. The semielliptical-type main spring is mounted underneath the axle. The center bolt of the spring fits into the holes in the spring seat and the spring clip plate. Two large U-bolts, installed through holes in the spring seat and the spring clip plate, surround the axle and hold each spring assembly to the axle. The ends of the spring are slip type and fit into the bottom openings of the spring hangers. Spring tie bolts prevent the spring from jumping out of the spring hangers. The radius rods keep the axle and springs aligned, and are the means of attaching the axle and springs to the frame. One end of the radius rod is attached to the spring seat which is welded to the axle. The other end of the radius rod is attached to the spring hanger which is welded to a body bolster.

Suspension (Springs and Radius Rods)

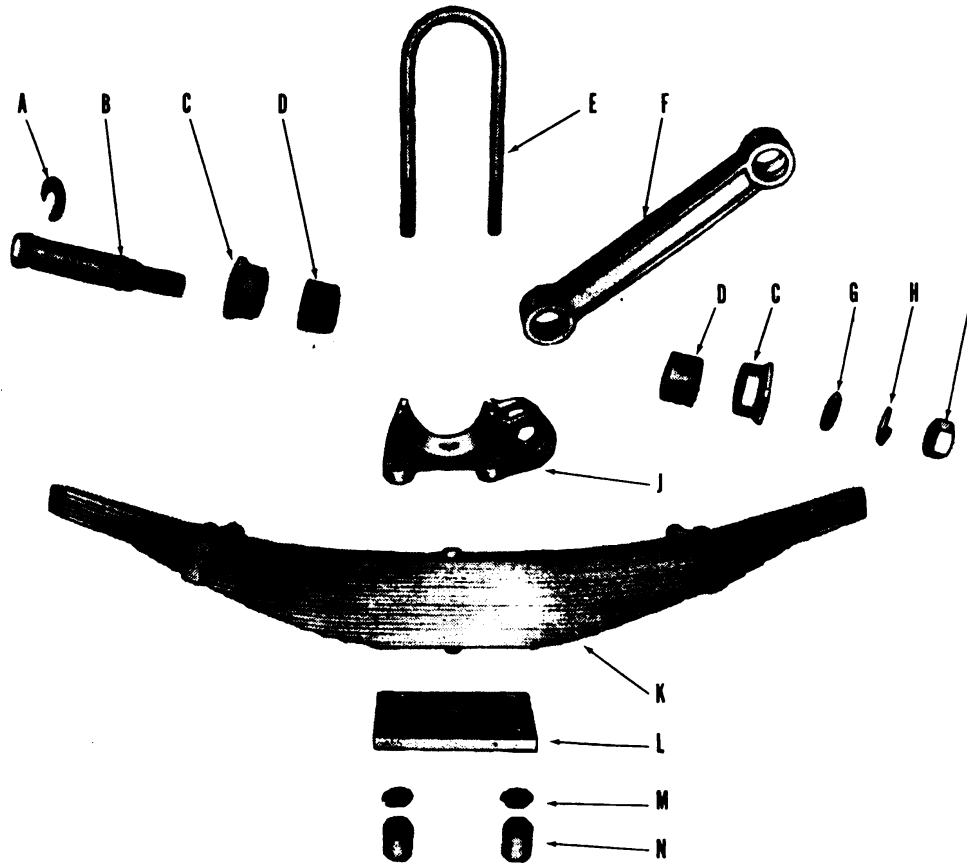

Key	Item	Part Number
A	RADIUS ROD PIN OPEN-END WASHER	8720-3-57-1
B	RADIUS ROD PIN	8720-3-13-5
C	RADIUS ROD ADJUSTING ECCENTRIC BUSHING	8720-3-55-1
D	RADIUS ROD RUBBER SHOCK BUSHING	8720-3-12-1
E	SPRING U-BOLT	8720-3-7-17
F	RADIUS ROD	
G	RADIUS ROD PIN WASHER	8720-3-56-1
H	RADIUS ROD PIN LOCK WASHER	H001-15-18017
I	RADIUS ROD PIN NUT	H001-07-18030
J	SPRING SEAT	
K	SPRING ASS'Y	8720-3-3-96
L	SPRING TIE PLATE	
M	SPRING U-BOLT LOCK WASHER	H001-15-18016
N	SPRING U-BOLT NUT	8720-3-76-2

RA PD 318863

Figure 12—Suspension Disassembled

b. Data.

(1) SPRINGS.

Make	Burton
Type	Slip
Number of leaves	19
Thickness	1/4 in.
Width	3 1/2 in.
Length of main leaf	43 in.

(2) RADIUS RODS.

Make	Trailer Company of America
Type	Adjustable
Adjustment	1/2 in.

42. SPRINGS.

a. Description (figs. 12 and 13).

(1) **GENERAL.** The semielliptical, slip-type spring consists of 19 leaves held together and in alinement by a center bolt and two rebound clips.

(2) **CHANGE IN SPRING DESIGN.** The first M21 trailers were constructed with the main springs having the three top leaves equal in length and gradually reducing the length of each subsequent spring leaf. Due to slip-type construction and use of tie bolt it was discovered that on extremely rough terrain, the spring had a tendency to jump out of the spring hanger over the tie bolts. To remedy this condition (since a large quantity of the springs were already constructed), a roller was installed over the tie bolt on all trailers constructed with the original designed spring. The balance of the trailers and springs, furnished as spare parts, have the first six leaves equal in length thus preventing slip end of spring from jumping out of spring hanger and eliminating the use of the roller. *NOTE: If springs having only the first three leaves of equal length are salvaged or sent to depot for repairs, be sure to salvage rollers for installation.*

b. Removal (figs. 12 and 13).

- (1) Jack up rear of trailer body to relieve tension from springs.
- (2) Remove the four nuts from the two U-bolts holding spring tie plate and spring to axle spring seat.
- (3) Force off spring tie plate.
- (4) Remove cotter pin, castle nut, and spring hanger tie bolt from rear spring hanger. See subparagraph a (2) above.
- (5) Pull out spring.

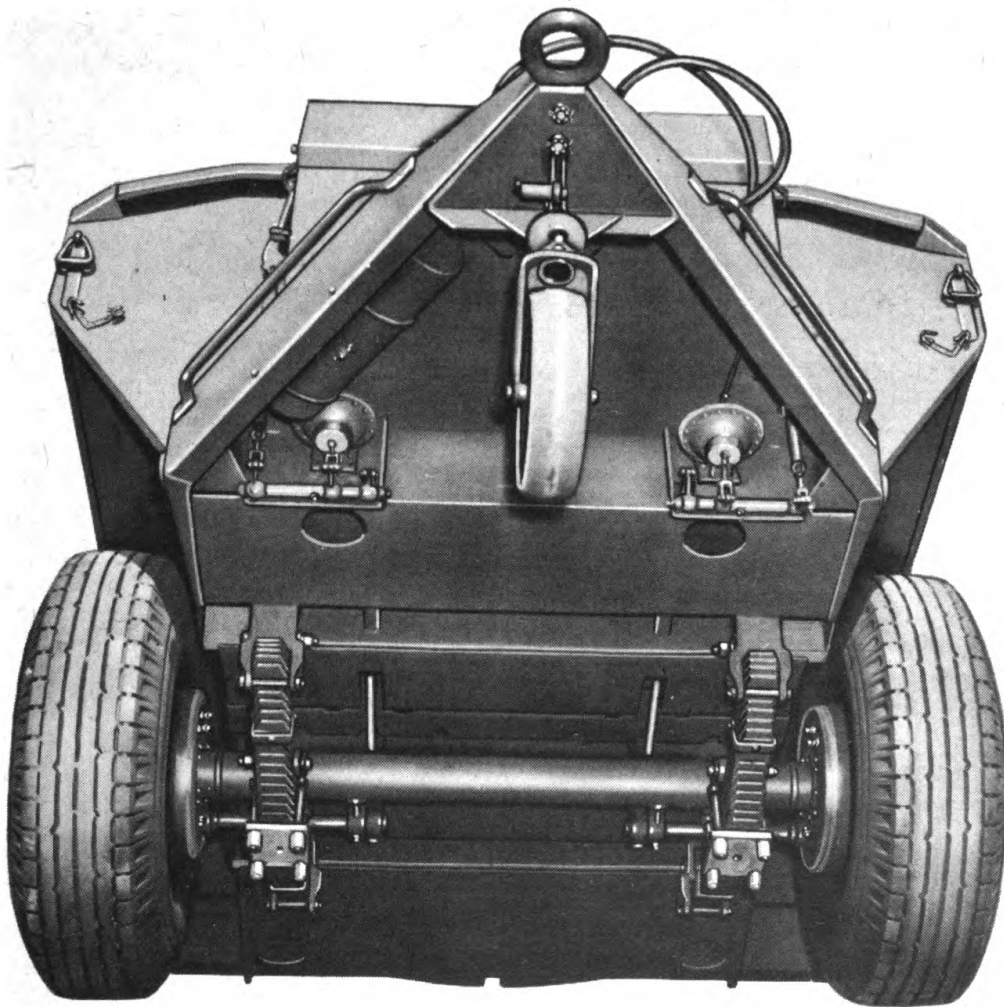
Suspension (Springs and Radius Rods)

RA PD 318832

Figure 13—Bottom View of Ammunition Trailer M21**c. Installation (See subpar. a (2) above).**

(1) Insert one end of spring over front spring hanger tie bolt. Guide the spring through the two U-bolts.

(2) Position other end of spring through opening in bottom of rear spring hanger. Install spring hanger tie bolt, castle nut, and cotter pin.

(3) Force on spring tie plate.

(4) Install the four nuts onto the two U-bolts. Tighten alternately until spring is tight against spring seat.

(5) Remove jack from underneath body.

(6) Make proper entry on W. D., A.G.O. Form No. 478, MWO and Major Unit Assembly Replacement Record.

43. RADIUS RODS.

a. Description (figs. 12 and 13). The radius rod consists of a casting, both ends of which are fitted with rubber bushings capped with steel eccentric adjusting bushings. The front ends of the radius rods are attached to the front spring hangers. The rear ends of the rods are fastened to the axle spring seats. The eccentric bushings permit the rods to be adjusted.

b. Removal (figs. 12 and 13).

- (1) Jack up rear of trailer body to relieve tension from springs.
- (2) Note position of radius rod eccentric bushings.
- (3) Remove radius rod pin nut, lock washer, and radius rod pin washer.
- (4) Drive out radius rod pin. Remove eccentric steel bushings, rubber bushings, and open-end washer.

c. Installation.

(1) Place one end of radius rod between opening in front spring hanger opposite large holes in hanger. Place other end of radius rod between jaws in axle spring seat.

(2) Insert rubber bushings through holes in spring hanger and spring seat. Insert eccentric steel bushings, one on each side of rubber bushings. The steel bushings will extend beyond holes in spring hanger and spring seat.

(3) Insert radius rod pin with open-end washer attached.

(4) Force end of pin through far enough to install radius rod pin washer, lock washer, and nut. *NOTE: The radius rod pin nut is toward the inside at the front spring hanger, but it is toward the outside at the spring seat.*

(5) Tighten nut. The rubber bushings will be forced into proper position by this operation. The steel eccentric bushings will be stopped by the machined boss on the spring hanger and spring seat.

(6) If further adjustment is necessary, refer to subparagraph **d** below.

(7) Remove jack.

(8) Make proper entry on W. D., A.G.O. Form No. 478, MWO and Major Unit Assembly Replacement Record.

d. Adjustment. To lengthen or shorten radius rod, remove nut, lock washer, and pin washer at either end of radius rod. Tap steel adjusting bushing out of hanger approximately $\frac{1}{4}$ inch until the knurl on bushing is free of hanger. Turn bushing 90 degrees for every $\frac{1}{8}$ -inch adjustment required. After adjustment is made, tap steel adjusting bushing into position in hanger, install washers and nut on

Wheels, Hubs, Bearings, Tires, and Tubes

radius rod pin, and tighten nut securely. Adjustment can be made at either end of radius rods on both sides of trailer.

44. COMPLETE SUSPENSION, AXLE, AND WHEELS.

a. Removal (figs. 12 and 13). To remove complete suspension, including axle and wheels, proceed as follows:

- (1) Jack up rear of trailer body, just ahead of trailer axle, to relieve tension from springs.
- (2) Remove cotter pins and yoke pins from brake-operating rear pull rod yokes at slack adjusters on both sides of trailer axle.
- (3) Remove radius rods from both front spring hangers as outlined in paragraph 43 b.
- (4) Remove cotter pin, castle nut, and spring tie bolt from each rear spring hanger.
- (5) Roll out complete suspension, including axle and wheels.

b. Installation.

- (1) Roll complete suspension under trailer, lifting front end of slip-type springs over tie bolts in front spring hangers. At the same time, guide radius rods through upper openings in front spring hangers.
- (2) Install radius rod bushings, pins, washers, etc., as outlined in paragraph 43 c.
- (3) Position rear end of springs through openings in bottom of rear spring hangers. Install spring hanger tie bolts, castle nuts, and cotter pins. See paragraph 42 a (2).
- (4) Position brake-operating rear pull rod yokes onto slack adjusters. Install yoke pins and cotter pins.
- (5) Remove jack.
- (6) If further adjustment is necessary, refer to paragraph 43 d.
- (7) Make proper entry on W. D., A.G.O. Form No. 478, MWO and Major Unit Assembly Replacement Record.

Section XVI

WHEELS, HUBS, BEARINGS, TIRES, AND TUBES

45. DESCRIPTION AND DATA.

a. Description (figs. 14 and 15). The wheels are of the pressed-steel, ventilated-disk combat type. The tire is held in position on the wheel by a hinged-type steel beadlock. The two opposed inner and outer wheel bearings are the same size and are Timken roller bearings. The tires and tubes are combat type.

b. Data.

(1) TIRES, TUBES, RIMS, AND WHEELS.

Tire size	14.00 x 20
Tire pressure	75 lb
Tire type	Combat
Tire plies	18
Tire tube	Heavy duty
Rims	Divided
Wheels (U. S. Army standard type)	10- x 5 ³ / ₈ -in.
Spare wheel and tire assembly	None
Beadlock	Hinged

(2) BEARINGS.

Cones	Timken Roller 5557
Cups	Timken Roller 5520

46. WHEELS.

a. Description (figs. 14 and 15). The pressed-steel, ventilated-disk combat-type wheels are equipped with side rings which are secured to the wheels with studs and nuts. The wheel on the right side of the trailer is attached to the hub with right-hand threaded studs and nuts. The wheel on the left side of the trailer is attached to the hub with left-hand threaded studs and nuts.

b. Removal.

(1) Partially loosen each of the 10 stud nuts. **NOTE:** *The right wheel nuts have right-hand threads and the left wheel nuts have left-hand threads.*

(2) Jack up axle till wheel clears ground.

(3) Remove stud nuts.

(4) Place greased board under wheel assembly. Lift wheel off studs and lower onto board. **CAUTION:** *The wheel and tire assembly weighs approximately 650 pounds; therefore, have assistance when removing wheel assembly.*

c. Installation.

(1) Clean contacting surface of wheel and hub so wheel will run true.

(2) Place greased board into position under axle spindle. Roll wheel assembly onto board, and slide and lift wheel onto studs, taking care not to scrape against stud threads. Install top nut, but do not tighten.

(3) Holding wheel in place, see that wheel holes are centered on studs. Install balance of nuts alternately on opposite sides of wheel.

Wheels, Hubs, Bearings, Tires, and Tubes

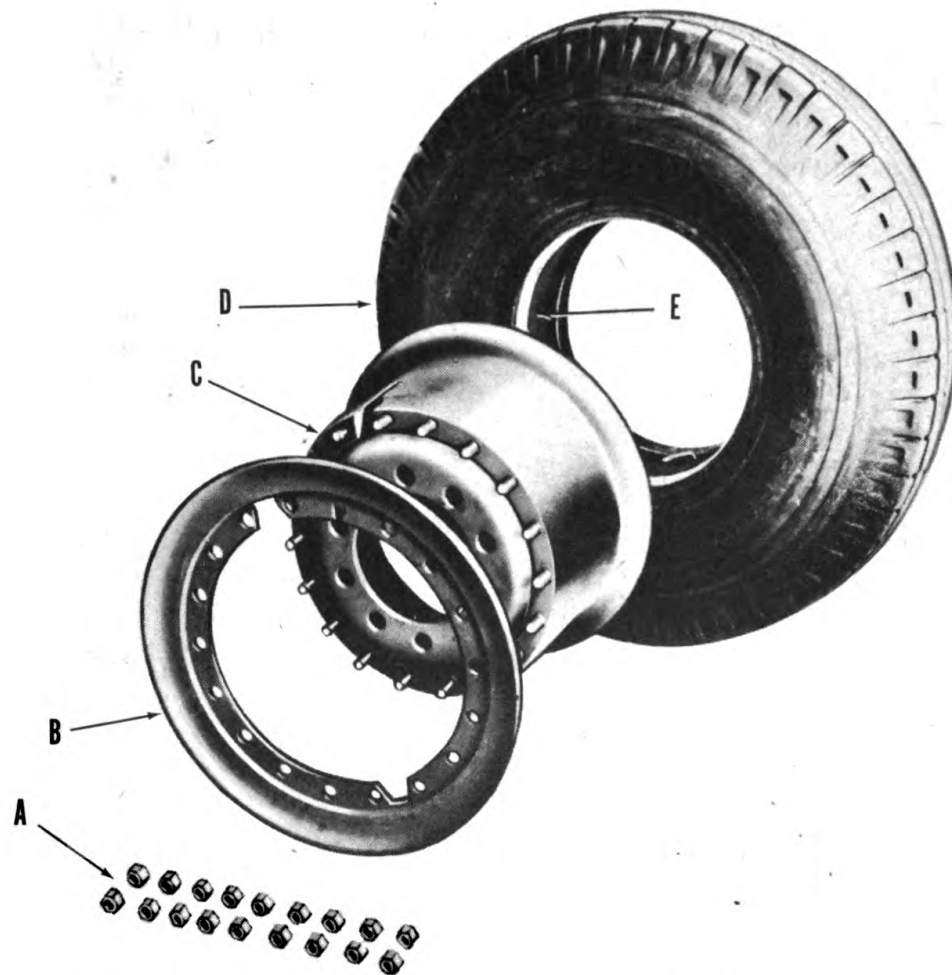

Key	Item	Part Number
A	SIDE RING STUD WHEEL NUT	C039-02-07201
B	SIDE RING	
C	DISK AND RIM ASS'Y	
D	COMBAT-TYPE TIRE	14.00x20 (COMBAT)
E	COMBAT TIRE BEADLOCK	C039-02-34946
A, B, C	COMBAT-TYPE WHEEL ASS'Y	G134-03-69730

RA PD 318859

Figure 14—Tire and Wheel Assembly

- (4) Tighten nuts alternately. Do not force them.
- (5) Tighten nuts again after 15 miles of operation, in order to take up looseness.
- (6) Make proper entry on W.D., A.G.O., Form No. 478, MWO and Major Unit Assembly Replacement Record.

47. TIRES, TUBES, AND BEADLOCK.

a. **Description** (fig. 14). The 14.00 x 20 tires are combat type with hinged beadlock. The tubes are of the heavy-duty type. The correct tire pressure is 75 pounds (maximum) cold.

b. Removal.

(1) Remove wheel (par. 46 b).

(2) Deflate tire by removing valve core. Install valve cap.
CAUTION: *Injury may result if tire is not deflated.*

(3) Remove side flange nuts, leaving two nuts on opposite sides of wheel to hold rim in place until balance of nuts have been removed.

(4) Loosen side flange with universal tire iron or usual type tire tool. Insert tool between flange and bead to pry off side flange. If side flange does not loosen readily, drive a tire iron or chisel between wheel and flange. Turn tire over, and loosen other bead from wheel.

(5) After tire has been completely loosened, drop wheel on a wooden block and tire will fall free.

(6) To free hinged-type beadlock from bead, stand tire up with valve at bottom and push valve into tire as far as possible. Use foot to push beadlock into tire near valve.

(7) Insert tire tool between beadlock and tire on side of beadlock and across the split from the pad about 10 inches back from the split. Press down on tire tool and collapse beadlock. **CAUTION:** *Keep hands away from hinge area.*

(8) Turn beadlock at right angle to tire, and pull it off the tube by pulling over valve cap carefully.

(9) Remove tube.

c. Installation.

(1) Position tube in tire.

(2) Collapse hinged-type beadlock at hinge. Slip beadlock over valve with beadlock at right angle to tire. Roll tire one-quarter turn to left, and push beadlock into tire.

(3) Turn tire around and push beadlock into position, using tire tool if necessary.

(4) Grasp beadlock about 10 inches from collapsed end and with the foot at bottom of beadlock opposite the hands, jerk up, snapping beadlock into place. Be sure beadlock is centered on tire.

(5) Place tire on wheel with valve pointed up in slot.

(6) Place side flange into position, lining up valve slot. Use tire tool to hold side flange in position, and force flange down far enough to start on nuts.

Wheels, Hubs, Bearings, Tires, and Tubes

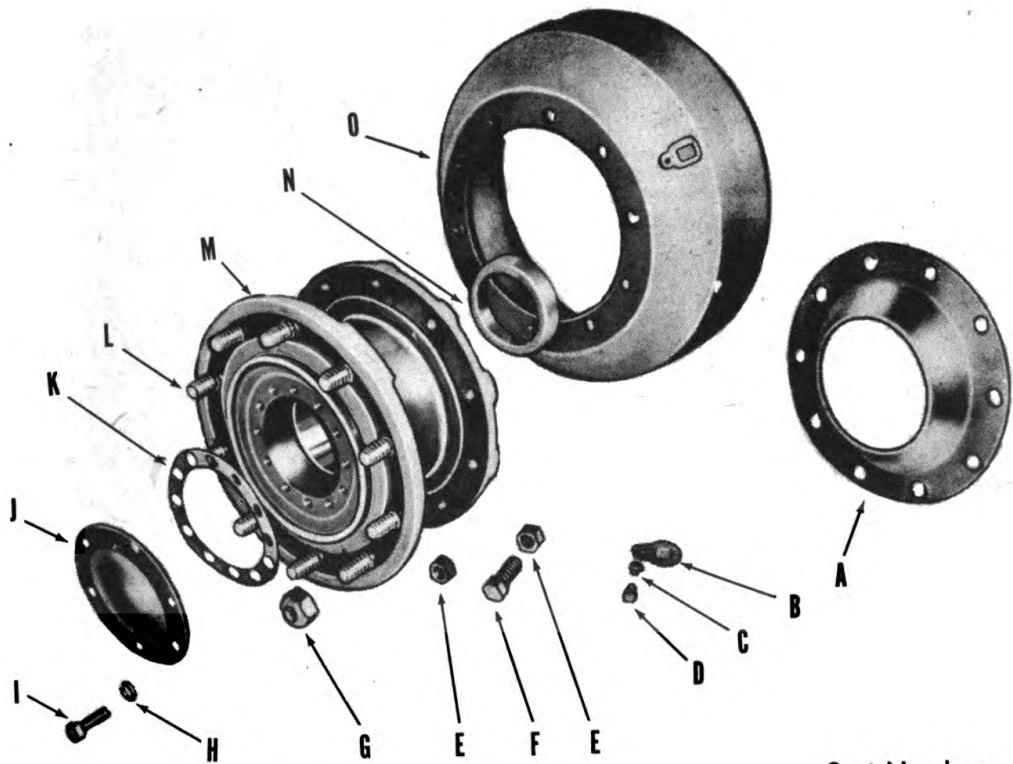

Key	Item	Part Number
A	BRAKE DRUM OIL SLINGER	
B	BRAKE DRUM INSPECTION HOLE COVER	
C	LOCK WASHER	H001-15-18009
D	CAP SCREW	H001-10-13028
E	BRAKE DRUM & HUB & WHEEL STUD NUT	H001-07-18028
F	BRAKE DRUM AND HUB CAP SCREW	G067-04-00530
G	WHEEL STUD CAP NUT, L. H.	G067-04-00540
H	WHEEL STUD CAP NUT, R. H.	H001-15-18011
I	HUB CAP LOCK WASHER	H001-10-13071
J	HUB CAP CAP SCREW	8500-3262E31
K	HUB CAP	G509-01-93817
L	HUB CAP GASKET	G067-04-00850
M	WHEEL STUD, L. H.	G067-04-00860
N	WHEEL STUD, R. H.	8500-A1333Q615
O	HUB AND STUD ASS'Y, L. H.	8500-A2333Q615
	HUB AND STUD ASS'Y, R. H.	H012-62-12620
	WHEEL BEARING CUP	G509-01-56602
	WHEEL BRAKE DRUM	

RA PD 318860

Figure 15—Hub and Brake Drum—Disassembled

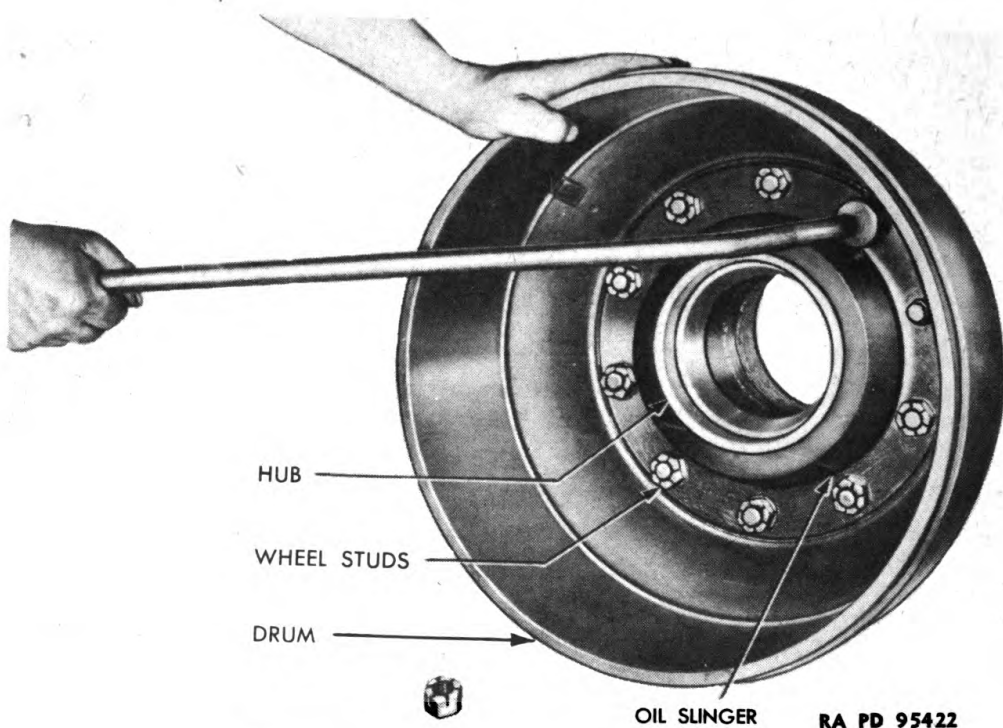

Figure 16—Removing Brake Drum

(7) Install first nut near valve and second nut directly opposite. Install balance of nuts in alternate positions.

(8) After side flange is fastened securely in place, insert valve core and inflate tire to 75 pounds air pressure.

(9) Install wheel (par. 46 c).

(10) Make proper entry on W.D., A.G.O., Form No. 478, MWO and Major Unit Assembly Replacement Record.

48. HUB AND DRUM ASSEMBLY.

a. **Description** (fig. 15). The hub supports the wheel on 10 studs on its outer face, and the brake drum and oil slinger on its inner face. The hub turns on opposed tapered roller bearings which also serve to hold the hub in place on the axle and in correct alignment.

b. Removal.

(1) Remove wheel (par. 46 b).

(2) Remove hub cap, outer jam nut, pin-type lock washer, inner adjusting nut, and outer wheel bearing.

(3) Slide the hub and drum assembly straight off the axle.

Wheels, Hubs, Bearings, Tires, and Tubes

(4) Tap inner bearing cone and roller assembly loose and remove from axle spindle.

(5) Tap oil seal felt inner retainer, washer, felt, and outer retainer loose and remove from axle spindle.

(6) To separate hub from drum, remove the 10 nuts and 10 screws holding drum and oil slinger to hub (fig. 16).

c. Inspection and Maintenance.

(1) **INSPECTION.** Inspect felt retainers, felt washer, and oil seal felt. If damaged, replace with new parts. Inspect inner and outer bearing cone and roller assemblies, and repack (par. 24) or replace if necessary. Inspect oil slinger for cracks or dents, and wipe off grease. Replace if necessary.

(2) **STUD REPLACEMENT.** Remove nut from broken or worn stud. Using a long $\frac{5}{8}$ -inch punch or bar, drive out broken stud. Insert new stud in hole, alining stud shoulder with hole. Drive stud into position with a soft hammer. Install and tighten stud nut.

d. Installation.

(1) Install oil slinger and brake drum on hub, and secure with 10 screws and nuts.

(2) Install inner felt retainer, felt washer, oil seal felt, and outer felt retainer on axle spindle, in the order named.

(3) Install inner bearing cone and roller assembly on axle spindle.

(4) Install hub and drum on axle.

(5) Install outer wheel bearing cone and roller assembly on axle spindle. Install inner adjusting nut, pin-type lock washer, and outer jam nut. Adjust wheel bearings (par. 49 c).

(6) Lubricate wheel bearings (par. 24), and install hub cap.

(7) Install wheel and tire assembly (par. 47 c).

(8) Lower the axle, and remove jack.

(9) Make proper entry on W.D., A.G.O. Form No. 478, MWO and Major Unit Assembly Replacement Report.

49. WHEEL BEARINGS (figs. 15 and 17).**a. Removal.**

(1) Remove wheel bearing cone and roller assemblies (par. 48 b).

(2) To remove wheel bearing cups, remove hub and drum as outlined in paragraph 48 b. The hub is grooved on opposite sides of both inner and outer bearing cups. Place soft drift in groove and, with alternate strokes, drive cup from hub.

b. Installation.

(1) **INSTALL BEARING CUPS.** Remove all old grease from inside hub, and clean hub bore with dry-cleaning solvent. Dry and place hub on wood block. Start new bearing cup square with the bore, having the smaller inside diameter placed so that it will be on the inside when cup is in place. Place a piece of hardwood over the cup face, and drive in cup until flush with outer edge of hub. Place old cup over new one, and drive in new cup until it is absolutely tight against the cup bore flange. Be sure that new cup is properly seated, because if not, it will alter the distance between the bearing centers and prevent proper reassembly of the wheel. Swab the two bearing cups with general purpose grease.

(2) **INSTALL INNER BEARING CONE AND ROLLER ASSEMBLY.** Remove all old grease from axle spindle, and clean spindle with dry-cleaning solvent. Install inner felt retainer, felt washer, oil seal felt, and outer felt retainer on axle spindle. Inspect, clean, dry, and lubricate inner bearing cone and roller assembly (par. 24). Slide inner bearing cone roller assembly on axle, and tap into position against oil seal. Install hub and drum assembly (par. 48 d).

c. Adjustment.

(1) Jack up axle until wheel is free to turn. Make certain that brakes are released.

(2) Remove hub cap by removing six cap screws, six lock washers, and hub cap gasket.

(3) Remove outer jam nut and pin-type lock washer.

(4) Gradually tighten inner adjusting nut, turning it tight against outer bearing so that wheel binds. At the same time, revolve wheel to be sure all working surfaces on bearing come into contact. Back off nut enough to allow wheel to rotate freely, but without end play.

(5) Test adjustment by placing one end of a bar between tire and floor, at the same time holding one finger on cage of outer bearing. Work bar up and down to detect any excessive play or looseness. If there is a slight perceptible shake and the wheel will rotate freely, the adjustment is correct.

(6) Install pin-type lock washer and outer jam nut. Tighten the nut. Test adjustment with bar again, since, in tightening outer jam nut, it is possible to wedge nut so tight against inner adjusting nut that adjustment is destroyed. This extra caution assures normal bearing operation.

(7) Lubricate wheel bearings as necessary (par. 24). Position hub cap gasket, and install hub cap. Secure with six lock washers and six cap screws. Lower the axle, and remove jack.

Axle

Section XVII

AXLE

50. DESCRIPTION AND DATA.

a. **Description** (fig. 17). The trailer is equipped with a tubular trailer axle. The flanges and spindles are integrally welded to form a one-piece axle. The camber, based on standard road crown, is forged into the axle at time of manufacture. The camshaft brackets and spring seats are welded to the axle beam. The tubular axle supports the weight of the trailer and, together with the radius rods, keeps the wheels in alinement and resists the stresses that occur when the brakes are applied.

b. **Data.**

(1) **AXLE.**

Make Timken-Detroit Axle
 Model T-2090-W-X-14
 Type Tubular, trailer

Dimensions:

Track 83 in.
 Tube 5-in. O.D. x 4-in. I.D.

51. REMOVAL.

- a. Follow instructions outlined in paragraph 44 a.
- b. To free springs from axle, remove nuts from U-bolts, force off spring tie plate, and lower the spring to ground.
- c. To remove wheels, hubs, bearings, drums, etc., from axle, refer to paragraphs 46 through 49.

52. INSTALLATION.

- a. If axle has been stripped of wheels, hubs, bearings, drums, etc., refer to paragraphs 46 through 49 for installation instructions.
- b. Roll complete axle under trailer, and install as outlined in paragraph 44 b.
- c. If springs have been removed from axle, install as outlined in paragraph 42 c.
- d. Make proper entry on W.D., A.G.O. Form No. 478, MWO and Major Unit Assembly Replacement Record.

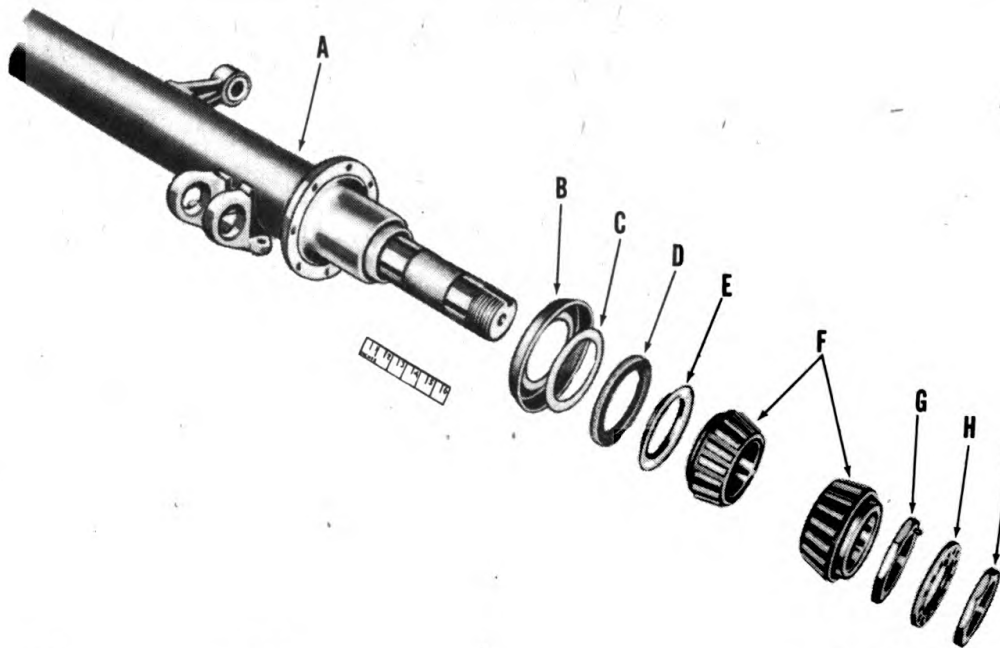

Key	Item	Part Number
A	AXLE BEAM ASSEMBLY	
B	OIL SEAL FELT INNER RETAINER	G509-03-67750
C	OIL SEAL FELT RETAINING WASHER	G509-03-43017
D	WHEEL BEARING FELT OIL SEAL	G033-01-00390
E	OIL SEAL FELT OUTER RETAINER	G509-03-67785
F	WHEEL BEARING CONE WITH ROLLERS ASS'Y	H012-61-28640
G	WHEEL BEARING ADJUSTING NUT	
H	WHEEL BEARING NUT LOCK WASHER	
I	WHEEL BEARING ADJUSTING JAM NUT	G067-03-00740

RA PD 318855

Figure 17—Axle Beam, Cones, Oil Seals, and Adjusting Nuts

53. AXLE ALINEMENT.

a. Jack up rear of trailer, and remove wheel and hub assemblies (par. 48 b). It is not necessary to separate wheel from hub.

b. Using steel tape, measure distance from center of drawbar lunette eye to near edge of trailer axle spindle at both sides of trailer. The distance on the right side should not be less than 1/8 inch nor more than 1/4 inch shorter than the same distance on the road side. Any dimension within this range is acceptable.

c. Remove radius rod nut, lock washer, and pin washer. Tap steel adjusting bushing out of hanger approximately 1/4 inch to relieve knurl on bushing from hanger. Turn bushing 90 degrees for every 1/8-inch adjustment required.

Brake Mechanism

d. It may be necessary to adjust radius rod steel bushing at both seat and hanger, and also on both sides of trailer in order to get axle in complete alinement. Replace washers and nut on each section removed.

e. Replace hub and wheel assembly (par. 48 d).

Section XVIII

BRAKE MECHANISM

54. DESCRIPTION AND DATA.

a. **Description** (figs. 18 and 19). The heavy-duty, two-shoe brake used on the trailer is operated by the air brake power system or by the hand brake levers. Both these systems are connected to the brake idler lever assemblies which are attached to the brake pull rods forming a linkage to the slack adjusters and camshafts. The motion of the slack adjuster turns the S-head of the camshaft and pushes the brake shoe toward the brake drum until the brake lining comes in contact with the drum. When the brake pressure is released, the brake return spring pulls the shoe away from the drum to its non-operating position. Each brake shoe is anchored to an individual anchor pin which is locked in position with an anchor pin lock. The camshaft is mounted in the end of brake spider that is equipped with slotted bushing. An oil seal felt and a drum oil slinger seals the bearing grease away from the brake lining. Dust shields keep sand, mud, and dust from entering brake mechanism.

b. **Data.**

Make	Timken-Detroit Axle Co.
Type	Two-shoe, double-anchor
Size	17 ¹ / ₄ - x 4-in.
Lining—number of pieces each axle.....	8
Lining—thickness	³ / ₄ in.
Lining—kit number	TCA-7-A10-1

55. BRAKE ADJUSTMENT.

a. **Brake Adjustment.** Brake adjustments are made through the slack adjusters on the outer end of the camshafts.

- (1) Jack up the trailer axle until tires are off the ground.
- (2) Make certain that brake chamber is in off position by opening drain cock on reservoir.

Part Three—Maintenance Instructions

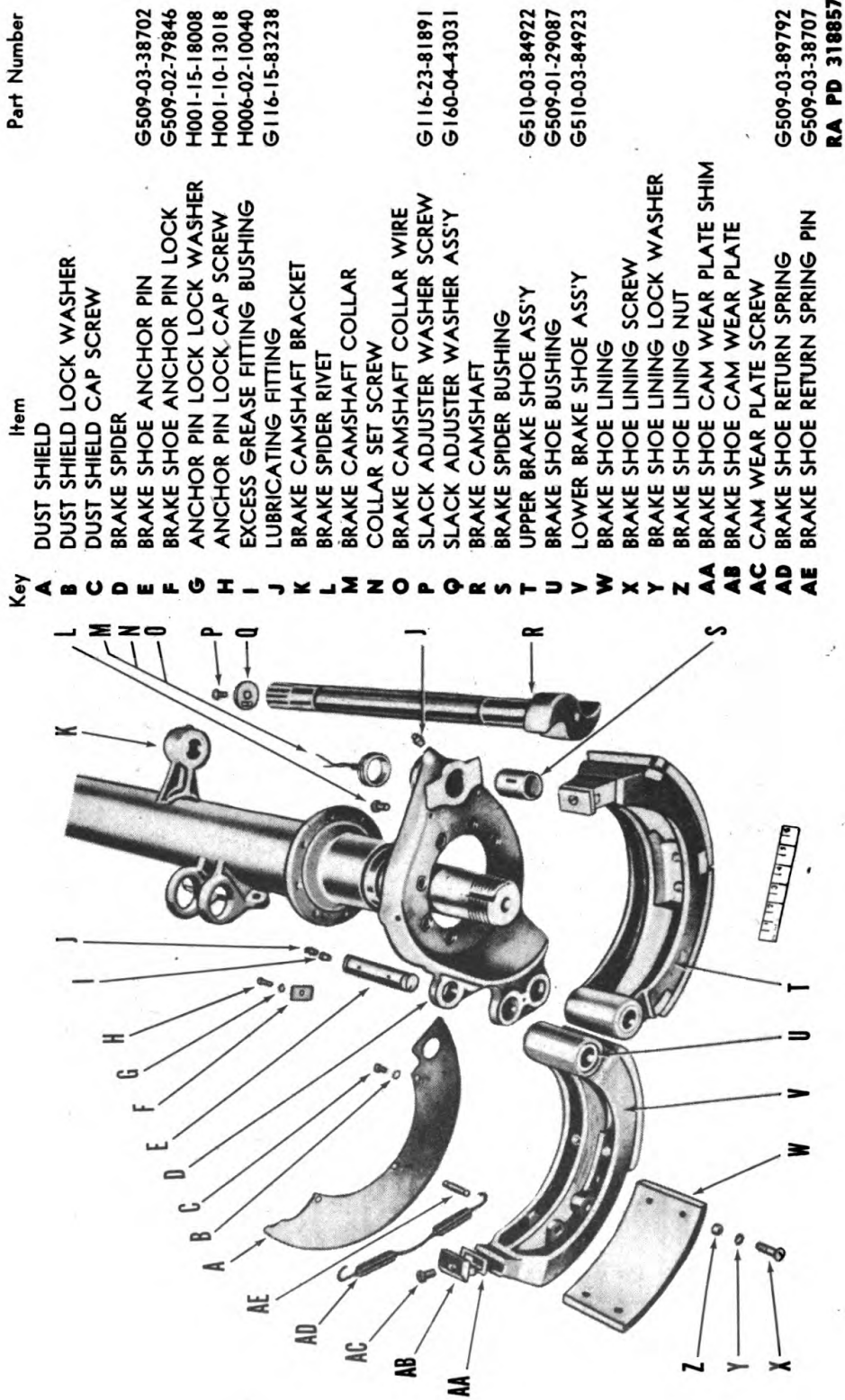

Figure 18—Brake Mechanism—Disassembled

Brake Mechanism

- (3) Turn slack adjuster adjusting nut until brake lining is tight against drum.
- (4) Back off slack adjuster nut two or three notches, measured by clicks in slack adjuster. This should allow wheel to turn freely.
- (5) Repeat adjusting operation on other slack adjuster. **NOTE:** *There are 360 degrees of adjustment in slack adjuster, and it is not necessary to relocate it on camshaft.*

56. BRAKE SHOE.

a. Description (figs. 18 and 19). The brake shoes are equipped with wear plates secured to the cam end of each shoe. When the S-head of the camshaft turns, it contacts the shoe wear plate. Each brake shoe has two $\frac{3}{4}$ -inch lining blocks bolted to the shoe by four brass bolts, lock washers, and nuts. Each brake shoe has two bronze bushings pressed into position in the anchor end.

b. Removal.

(1) **REMOVE TIRE, WHEEL, HUB, AND DRUM ASSEMBLY** (figs. 14 and 15).

(a) Remove hub cap, outer jam nut, lock washer, and inner adjusting nut.

(b) Jack up axle so tire clears floor. Pull wheel hub and drum assembly off axle spindle. Be careful outer bearing cone does not slip from hub and fall to floor since this might cause damage to cage.

(2) **REMOVE BRAKE SHOE** (figs. 18 and 19).

(a) Remove anchor pin lock screw and washer, holding anchor pin lock in position. Slide anchor pin lock from grooves in anchor pins.

(b) Using soft drift, drive anchor pins from shoe and spider.

(c) Lift out brake shoes and brake shoe return springs.

c. Installation.

(1) **INSTALL BRAKE SHOE** (figs. 18 and 19).

(a) Install brake shoe return springs onto spring pins of both brake shoes.

(b) Position shoes between openings in brake spider at anchor end of spider.

(c) Lubricate anchor pins sparingly with general purpose grease No. 1 or No. 0. Install anchor pins through holes in spider and brake shoe.

(d) Slide anchor pin lock into grooves in anchor pins. Use square end of anchor pin for turning pin to line up grooves. Secure lock with anchor pin lock screw and washer.

- (2) Install tire, wheel, and hub and drum assembly (par. 48 d) (figs. 15 and 16).
- (3) Adjust wheel bearings (par. 49 c).
- (4) Make proper entry on W.D., A.G.O. Form No. 478, MWO and Major Unit Assembly Replacement Record.

57. CAMSHAFT.

a. **Description** (figs. 18 and 19). The camshaft consists of the S-head cam and shaft, forged integrally for strength. The camshaft is mounted in the bushed end of the brake spider. Air pressure in the brake cylinder moves the slack adjusters, which turn the S-heads of the camshafts, thus expanding the brake shoes.

b. **Removal** (figs. 18 and 19).

- (1) Remove tire, wheel, and hub and drum assembly (par. 56 b (1)).
- (2) Loosen camshaft collar set screw wire and camshaft collar set screw.
- (3) Remove slack adjuster retaining washer screw and washer assembly.
- (4) Slide off slack adjuster.
- (5) Spread open brake shoes.
- (6) Remove camshaft. Using soft drift, knock camshaft off serrated end, if necessary, to assist removal. Camshaft collar will slide off end of camshaft when removing camshaft.

c. **Installation** (figs. 18 and 19).

- (1) Inspect brake spider bushings and, if worn, report to higher authority.
- (2) Inspect camshaft bracket bushings and, if worn, report to higher authority.
- (3) With brake shoes spread open, insert serrated end of camshaft (noting right-hand or left-hand) through brake spider opening. Install collar onto camshaft, and feed end of camshaft through camshaft bracket.
- (4) Slide slack adjuster onto serrated end of camshaft. Install slack adjuster retaining washer assembly, and secure with screw.
- (5) Move camshaft collar next to brake spider, tighten collar set screw, twist wire around collar, and twist ends of wire together.
- (6) Lubricate camshaft bracket and brake spider bushing sparingly (par. 24).

Air Brake Power System

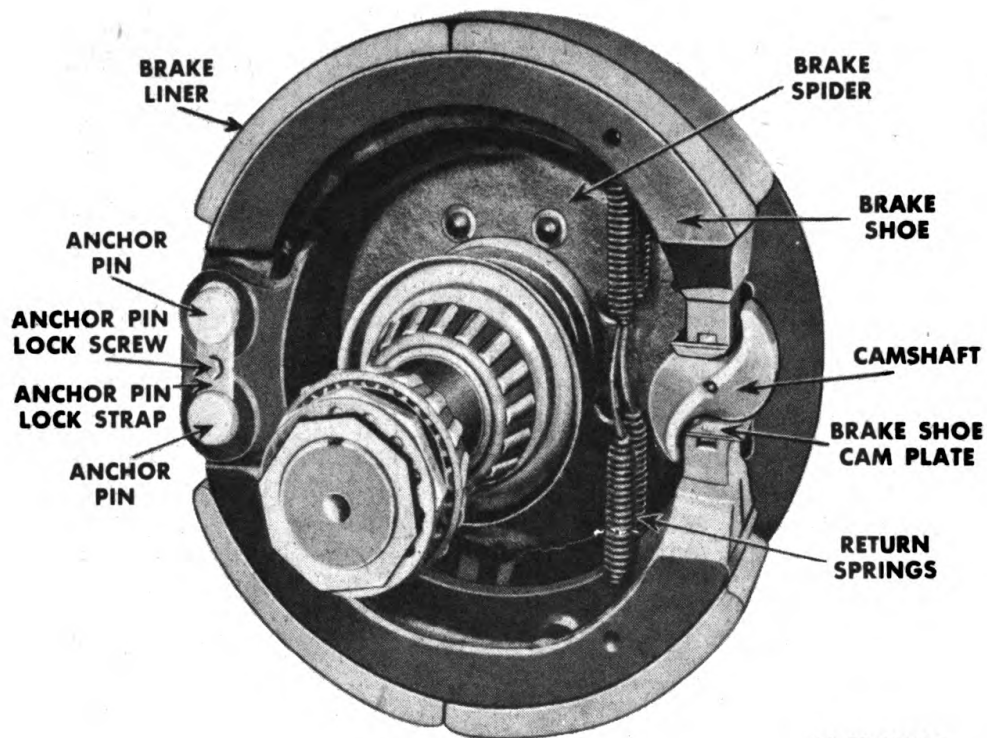

RA PD 318865

Figure 19—Brake Mechanism on Trailer Axle

58. DUST SHIELDS.

a. **Removal** (fig. 18). Remove three cap screws and lock washers securing dust shield to brake spider located on each end of the trailer axle.

b. **Installation** (fig. 18). Straighten dust shields, unless severely damaged, and position dust shield on brake spider. Secure dust shield to spider with three lock washers and cap screws.

Section XIX

AIR BRAKE POWER SYSTEM

59. DESCRIPTION AND DATA.

a. **General.** The purpose of the air brake equipment is to provide a means of operating the trailer brakes through the medium of compressed air and in conjunction with the air brake system on the towing vehicle (fig. 20). Fundamentally, the air brake system con-

sists of the air devices necessary to direct and control the flow of the compressed air, and those necessary to transform the energy of compressed air into the mechanical force and motion to apply the brakes. The components of this air brake system (fig. 21) and their functions are described in paragraphs 61 to 70 inclusive.

b. Data.

Make	Bendix-Westinghouse Automotive Air Brake Co.
Reservoir	7 x 24 in.
Tubing	3/8-in. dia
Tubing	1/2-in. dia
Hose	3/4-in. O.D.
Filter—type E	Bendix-Westinghouse 221474
Relay emergency valve	Bendix-Westinghouse 220353
Chamber—type C	Bendix-Westinghouse 215001
Slack adjuster—type K (5-in. lever)	Bendix-Westinghouse 217915 and 217916

60. TESTING SYSTEM FOR SERVICEABILITY.

a. Preparation. Connect hose lines of trailer to hose couplings on towing vehicle. Start engine, and build up air pressure to 100 pounds as registered by dash gage on towing vehicle.

b. Leakage Tests.

- (1) With engine stopped and brakes released, observe rate of drop in air pressure registered by dash gage. The rate of drop in air pressure must not exceed 3 pounds per minute.
- (2) With engine stopped and brakes fully applied, observe rate of drop in air pressure. The rate of drop must not exceed 4 pounds per minute.
- (3) Leakage in either of the above tests is the combined leakage in both the air brake system on towing vehicle and the air brake system on trailer. Leakage in trailer air brake system is determined by comparing leakage in above tests with leakage found in similar tests with cut-out cocks in connecting hose lines closed. If leakage in either of the above tests is excessive, check all units and connections for leakage, and repair or replace.

c. Operating Tests.

- (1) With vehicles moving, apply brakes and check their effectiveness. Check for quick braking response on all wheels during application and release of brakes.
- (2) With vehicles stopped, close cut-out cock in emergency line at rear of towing vehicle. Disconnect trailer emergency hose line from towing vehicle. Be sure trailer brakes apply automatically

Air Brake Power System

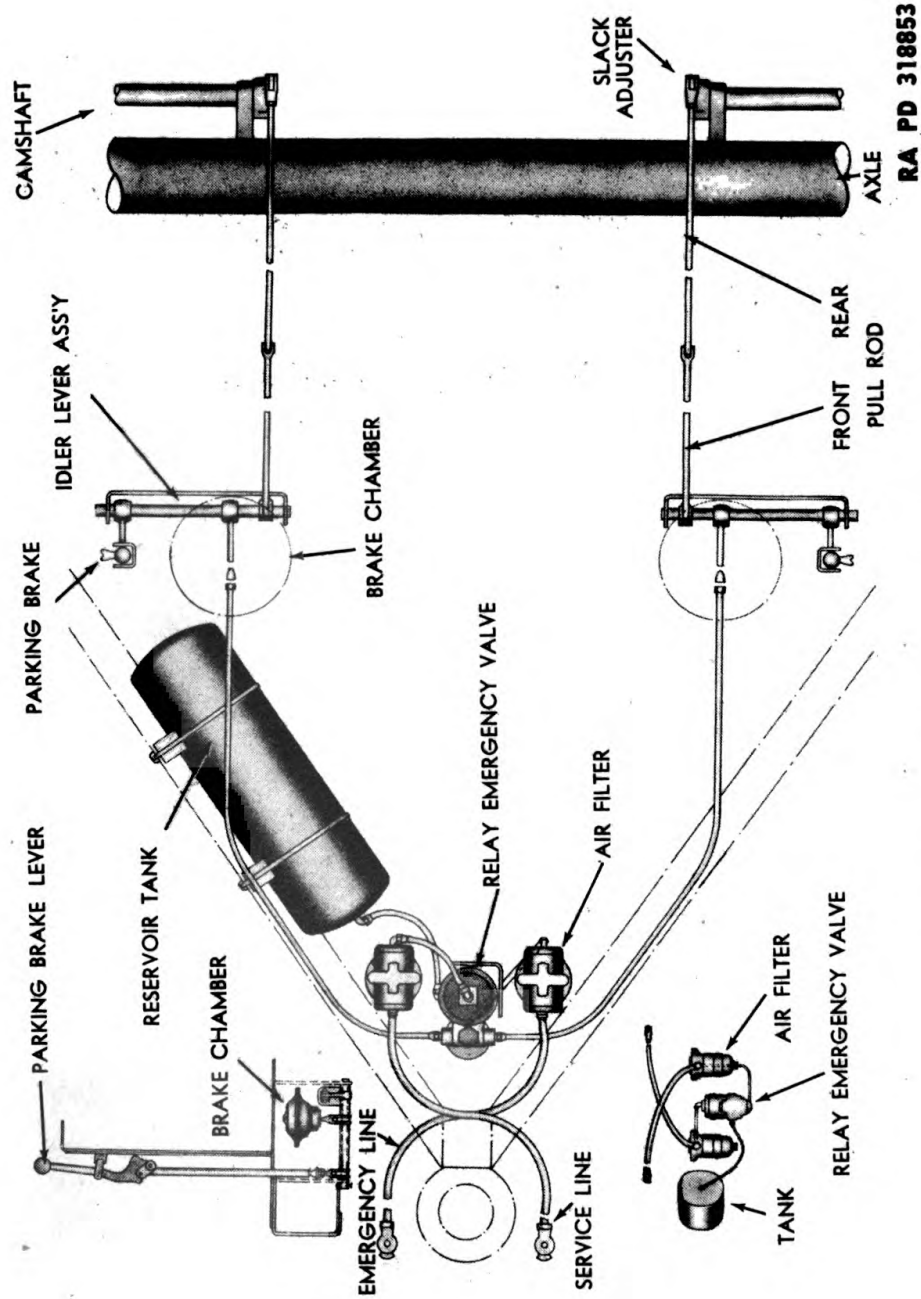
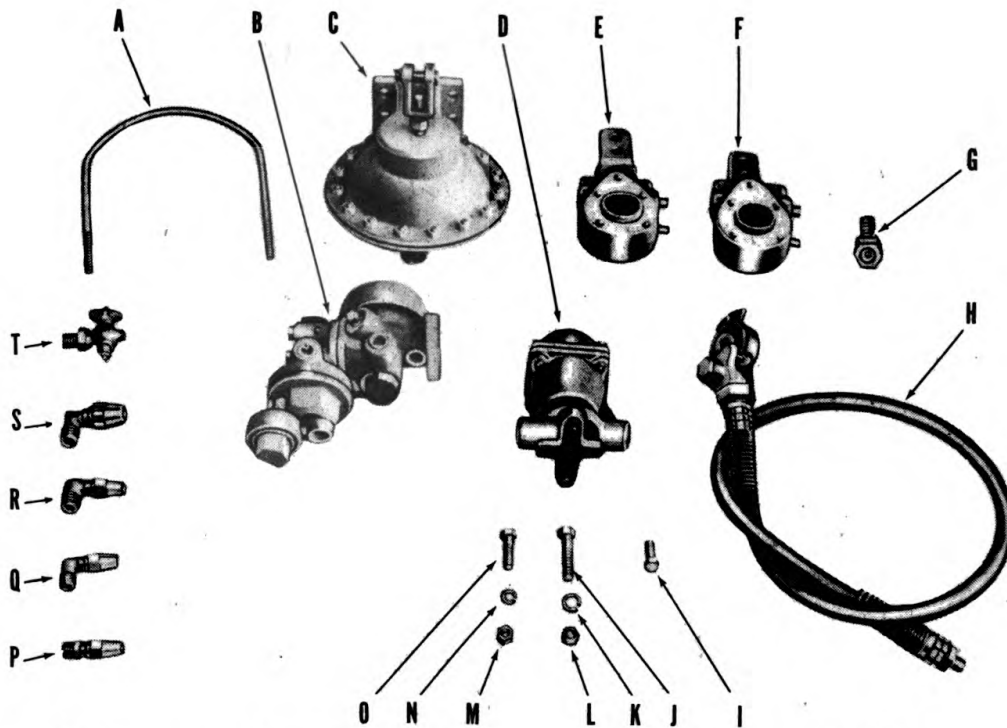

Figure 20—Brake System Diagram



Key	Item	Part Number
A	TANK MOUNTING U-BOLT	
B	RELAY EMERGENCY VALVE	0850-220353
C	AIR BRAKE CHAMBER	0850-215001
D	AIR FILTER	D024-02-01881
E	SLACK ADJUSTER, R. H.	C039-01-03931
F	SLACK ADJUSTER, L. H.	C039-01-03930
G	EXHAUST CHECK VALVE	D024-02-01882
H	AIR BRAKE CONTROL JUMPER HOSE ASS'Y	0850-216464
I	FILTER MOUNTING CAP SCREW	H001-10-13030
J	BRAKE CHAMBER MOUNTING CAP SCREW	H001-10-13270
K	BRAKE CHAMBER MOUNTING LOCK WASHER	H001-15-18010
L	BRAKE CHAMBER MOUNTING NUT	H001-07-18024
M	RELAY EMERGENCY VALVE AND BRACKET MOUNTING NUT	H001-07-18023
N	RELAY EMERGENCY VALVE AND BRACKET MOUNTING LOCK WASHER	H001-15-18009
O	RELAY EMERGENCY VALVE AND BRACKET MOUNTING CAP SCREW	H001-10-13246
P	VALVE TO CHAMBER TUBING CONNECTOR	H006-03-12600
Q	AIR FILTER AND RELAY EMERGENCY VALVE TUBING ELBOW	G098-56-00210
R	RELAY EMERGENCY VALVE EMERGENCY TUBING ELBOW	G098-56-00190
S	RELAY EMERGENCY VALVE TO RESERVOIR TUBING ELBOW	G150-01-69029
T	RESERVOIR DRAIN COCK	H006-01-00805
		RA PD 318858

Figure 21—Air Power Brake Components

Air Brake Power System

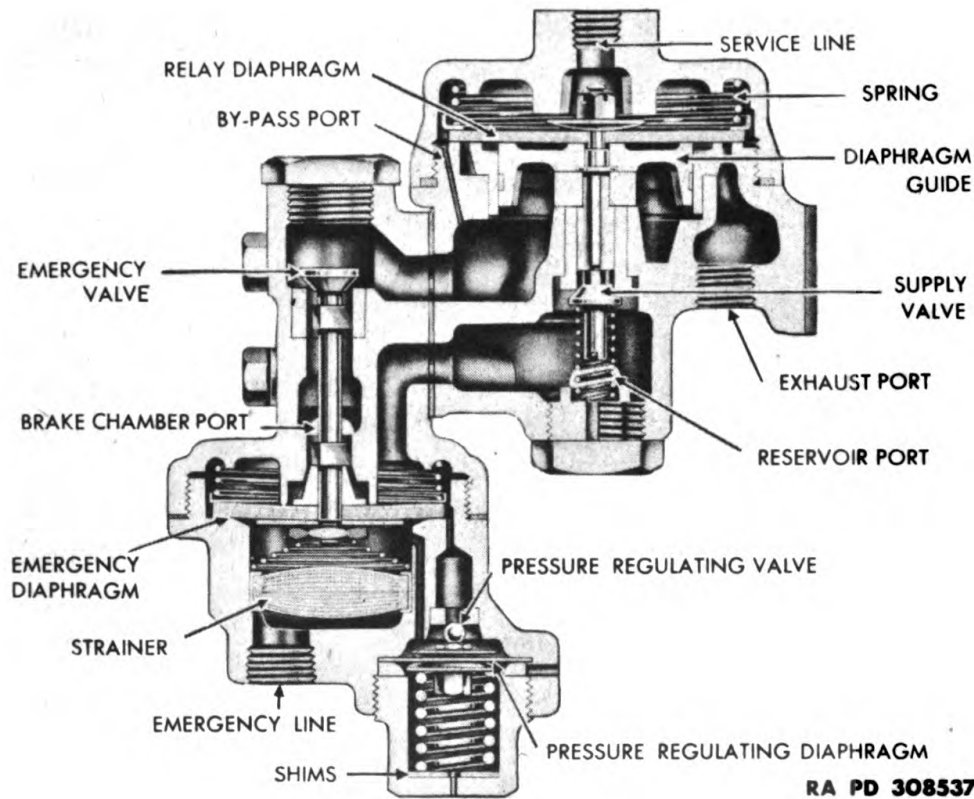

RA PD 308537

Figure 22—Relay Emergency Valve—Sectionalized

without any noticeable leakage at emergency line connection at front of trailer or at relay emergency valve.

(3) Check all units for serviceability if brake system fails to pass any of the above operating tests.

61. RELAY EMERGENCY VALVE (figs. 20, 21, and 22).

a. Description. The function of the relay emergency valve is to act as a relay station to control the brakes on the trailer, and to also automatically apply the brakes on the trailer should it break away from the towing vehicle. The relay valve also speeds up the operation of the trailer brakes both during application and release.

b. Testing for Serviceability (fig. 22).

(1) OPERATING TESTS.

(a) With air brake system charged, apply brakes and check to be sure brakes on both wheels of trailer apply properly.

(b) Release brakes, and check to be sure air pressure is exhausted promptly through exhaust check valve.

(c) With trailer brake system fully charged, close cut-out cock in emergency line on towing vehicle and disconnect emergency line from trailer. Check to be sure trailer brakes apply automatically. Connect emergency line, open cut-out cock on towing vehicle, and check to be sure brakes automatically release.

(2) **LEAKAGE TESTS.**

(a) With brakes released, coat exhaust port of exhaust check valve with soap suds to determine leakage.

(b) With brakes fully applied, coat exhaust port with soap suds to determine leakage.

(c) With relay emergency valve in emergency position (operating test subpar. b. (1) above), coat exhaust port with soap suds to determine leakage. Also test for leakage at emergency line hose coupling and connector (par. 68 b).

(d) Leakage in any of the above tests must not exceed a 3-inch soap bubble in 3 seconds. If excessive leakage is found, replace the relay emergency valve.

c. Removal (figs. 20 and 21).

(1) Lower the landing wheel.

(2) Drain air brake system.

(3) Disconnect air line at reservoir tank.

(4) Disconnect relay valve to brake chamber air lines at relay valve.

(5) Remove the four nuts, lock washers, and bolts attaching cover plate to A-frame, and lift off complete assembly including air line hoses, filters, and relay emergency valve.

(6) Disconnect air filter to relay emergency valve lines at valve. Remove the nuts, lock washers, and bolts holding relay emergency valve to angle bracket, and lift off valve.

d. Installation (figs. 20 and 21).

(1) Position relay emergency valve to angle bracket attached to cover plate, and secure with bolts, lock washers, and nuts.

(2) Connect air filter to relay emergency valve lines at valve.

(3) Position cover plate onto A-frame, and install with the four bolts, lock washers, and nuts.

(4) Connect reservoir line and brake chamber air lines to the relay emergency valve.

(5) Test for serviceability (subpar. b above).

(6) Make proper entry on W.D., A.G.O. Form No. 478, MWO and Major Unit Assembly Replacement Record.

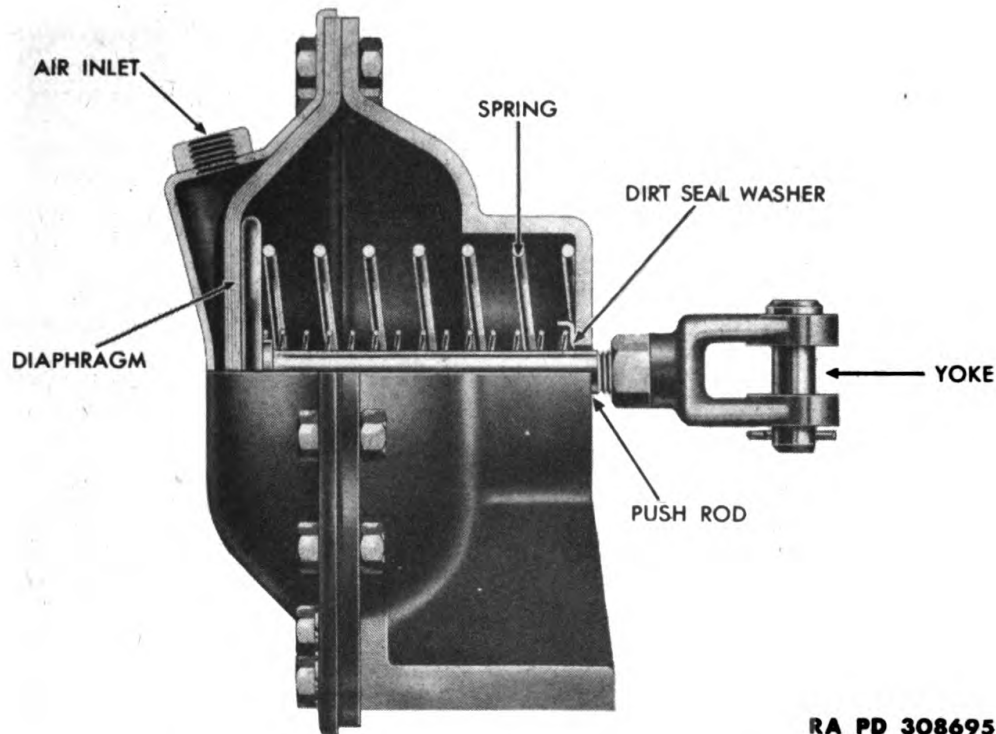

Figure 23—Brake Chamber—Sectionalized

62. BRAKE CHAMBER (figs. 20, 21, and 23).

a. Description. The function of the brake chamber is to convert the energy of compressed air into the mechanical force and motion necessary to operate the brakes. One brake chamber is used to operate the brakes on each wheel.

b. Testing for Serviceability.

(1) OPERATING TESTS.

(a) Apply brakes, and observe that brake chamber push rods move promptly without binding.

(b) Release brakes, and observe that brake chamber push rods return to released position promptly without binding.

(2) LEAKAGE TESTS.

(a) With brakes fully applied, coat bolting flanges holding diaphragm in place with soap suds to check for leakage. No leakage is permissible. If leakage is found, tighten flange bolts evenly and sufficiently to prevent leakage. Do not cause the flange to bulge by forcing the nuts too tight.

(b) With brakes fully applied, check for leakage through diaphragm by coating clearance hole around push rod and drain holes

in nonpressure plate with soap suds. No leakage is permissible. If leakage is found, replace diaphragm.

(c) Excessive push rod travel will cause premature failure of brake chamber diaphragm. When diaphragms are being replaced, check brake chamber release spring and replace if necessary. Install same type of spring as removed, otherwise uneven braking will result.

c. Removal (figs. 13, 20, and 21).

- (1) Disconnect air line at brake chamber.
- (2) Disconnect push rod yoke from idler lever assembly.
- (3) Remove nuts and lock washers from mounting bolts, and remove chamber.
- (4) To remove diaphragm, remove all nuts around flange.

d. Installation (figs. 13, 20, and 21).

- (1) Install new diaphragm and release spring, if necessary. Install bolts around flange, and tighten just enough to prevent leakage.
- (2) Mount brake chamber in position and attach with bolts, lock washers, and nuts.
- (3) Connect air line at brake chamber.
- (4) Connect push rod to idler lever assembly.
- (5) Adjust brakes (par. 55).
- (6) Test brake chamber for serviceability (subpar. b above).
- (7) Make proper entry on W.D., A.G.O. Form No. 478, MWO and Major Unit Assembly Replacement Record.

63. SLACK ADJUSTER (figs. 20 and 21).

a. Description. Slack adjusters consist of a worm and gear enclosed in a body which also serves as an adjustable lever. They provide a quick and easy means of adjusting the brakes to compensate for brake lining wear. During brake operation, the entire slack adjuster rotates bodily with the brake camshaft. During brake adjustments, the worm moves the gear so as to change the position of the lever arm in relation to the brake camshaft. One slack adjuster is used for the brakes on each wheel.

b. Testing for Serviceability. Adjust brakes (par. 55). Make several brake applications, and check motion of brake operating rods and slack adjusters. If slack adjusters move, but fail to turn the camshafts, replace slack adjusters (subpars. c and d below).

c. Removal (fig. 20).

- (1) Remove yoke pin holding brake-operating rear rod yoke to slack adjuster.

Air Brake Power System

(2) Remove retaining screw and washer from end of camshaft, and slide off slack adjuster.

d. Installior (fig. 20).

(1) Be sure slack adjuster is the same size and type as one used on opposite side.

(2) Slide slack adjuster onto camshaft, and install screw and washer.

(3) Insert yoke pin through brake-operating rear rod yoke and slack adjuster. Secure with new cotter pin.

(4) Adjust brakes (par. 55).

(5) Test air brake system from serviceability (par. 60).

(6) Make proper entry on W.D., A.G.O. Form No. 478, MWO and Major Unit Assembly Replacement Record.

64. RESERVOIR.

a. Description. The function of the reservoir (fig. 20) is to provide a place to store compressed air so there will be an ample supply available for immediate use in brake operation. It also provides storage for sufficient compressed air to permit several brake applications even after the engine has stopped. Another function of the reservoir is to provide a place where the air may cool and the oil and water vapors condense.

b. Testing for Serviceability (fig. 20).

(1) **LEAKAGE TEST.** With brake system charged, coat outside of reservoir with soap suds to check for leakage. No leakage is permissible. If leakage is found, replace reservoir.

(2) **INSPECTION.** Inspect inside and outside surfaces for damage or corrosion. A small flashlight is helpful when inspecting interior. Replace reservoir if any damage or corrosion is found that would weaken the reservoir.

c. Removal (fig. 20).

(1) Drain air brake system.

(2) Disconnect air line at reservoir. Remove mounting bolts, wood mounting blocks; and reservoir.

d. Installation (fig. 20).

(1) Install new drain cock in reservoir.

(2) Position reservoir so that drain cock opening is at lowest point.

(3) Install wood mounting blocks, U-bolts, and nuts.

(4) Connect air line at reservoir.

(5) Test reservoir for serviceability (subpar. b above).

(6) Make proper entry on W.D., A.G.O. Form No. 478, MWO and Major Unit Assembly Replacement Record.

65. DRAIN COCK.

a. **Description** (fig. 21). The drain cock is installed in the bottom of the reservoir for the purpose of draining water from the reservoir. The drain cock is open when the handle is parallel to the body of the drain cock, and closed when it is at right angle to the body. Open drain cock by hand. Do not strike the handle with a hammer as the cock will become damaged, and leakage will develop.

b. **Test for Serviceability.** With air brake system charged, coat drain cock with soap suds, and check body and key for leakage. Leakage in excess of a 3-inch soap bubble in 3 seconds is not permissible. Leakage is caused by a dirty or scored key or body. Leakage due to dirt is corrected by cleaning, and applying a thin coating of general purpose grease No. 1 or No. 0 on the key before assembly. Replace drain cock if leakage is due to scored key or body.

c. **Removal.** Unscrew drain cock from reservoir.

d. **Installation.**

- (1) Screw drain cock in bottom of reservoir.
- (2) Test for serviceability (subpar. b above).

66. AIR FILTER (figs. 20, 21, and 24).

a. **Description** (fig. 24). Air filters are used in the service line and emergency line on the trailer to trap any dirt or matter which might get into these lines. The correct flow of air through the filter is indicated by an arrow cast on the body. Air flowing from the towing vehicle to the trailer must pass through the filter in the direction indicated by the arrow. Air flowing through the filter readily passes through the strainer, but any dirt which might be present in the air stream is stopped by the strainer. Moisture or dirt which may collect in the filter is removed through the drain plug.

b. **Testing for Serviceability** (fig. 24).

(1) **OPERATING TESTS.**

(a) Remove cover, and inspect condition of air strainer. Clean strainer by carefully brushing any dust or dirt off the outside. Install new strainer if old one is covered with an oily or gummy deposit or if it is very dirty. Always use new gasket when assembling the filter.

(b) Frequency of cleaning the filter or replacing the strainer depends entirely on operating conditions and amount of dirt passing into filter.

Air Brake Power System

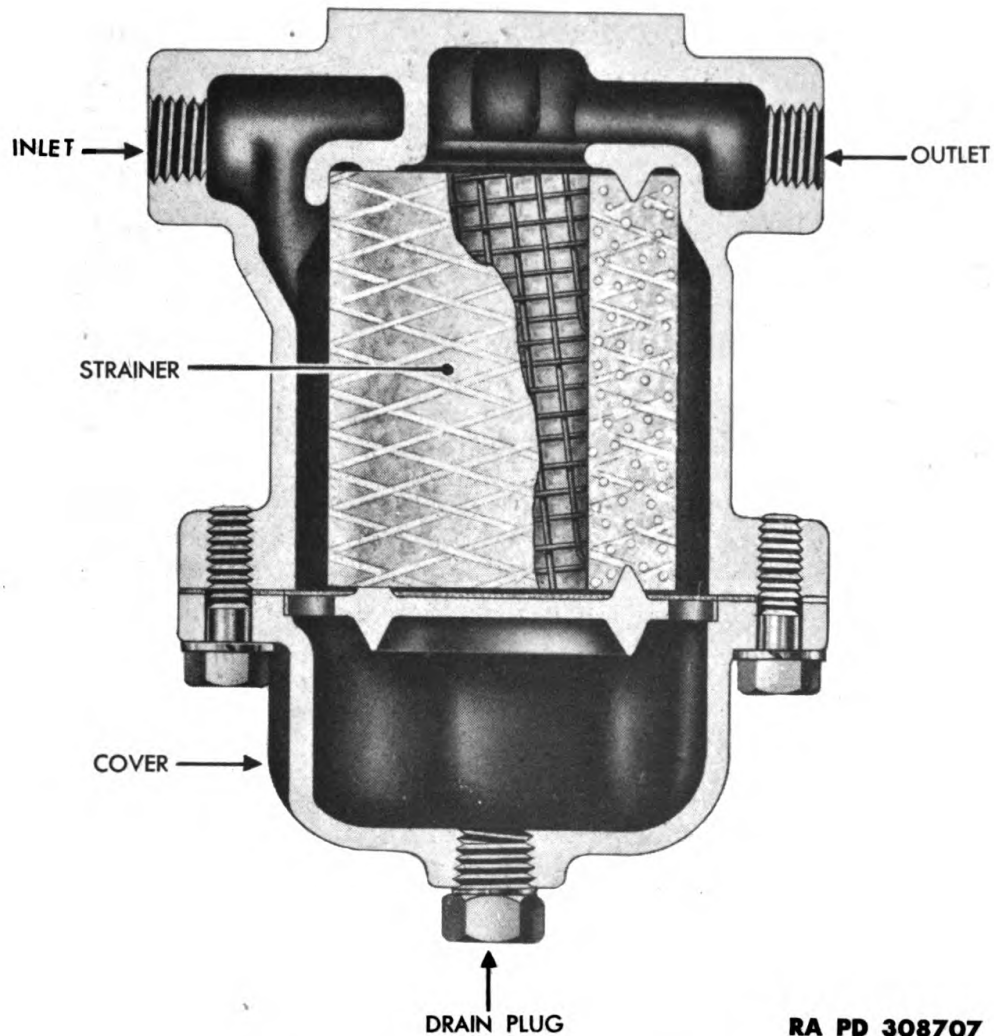

Figure 24—Air Filter—Sectionalized

(2) **LEAKAGE TESTS.** With brakes applied, coat outside of filter with soap suds to check for leakage. No leakage is permissible. If leakage is found through walls of filter, replace filter. If leakage is found past gasket between cover and body of filter, tighten cover or install new gasket.

c. Removal (figs. 20 and 21).

- (1) Perform operations (1) to (5), paragraph 61 c.
- (2) Disconnect air filter to relay emergency valve lines at the air filters.
- (3) Remove cap screws securing filter to cover plate.

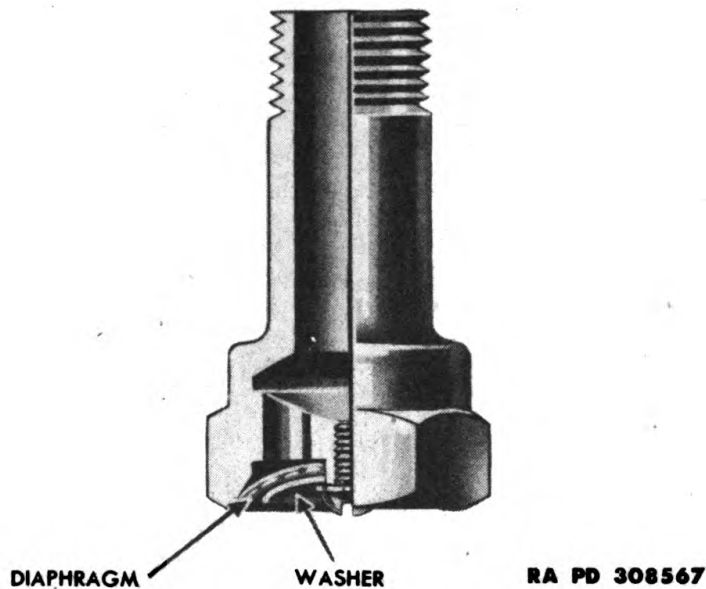

Figure 25—Exhaust Check Valve

(4) Remove four cap screws to dismantle the air filter to install new strainer or new gasket.

d. Installation (figs. 20 and 21).

- (1) Position filter so that the arrow on body points toward air line leading to relay emergency valve.
- (2) Install cap screws.
- (3) Connect air filter to relay emergency valve lines at the air filters.
- (4) Install cover plate, and connect air lines (par. 61 d).
- (5) Test air filter for serviceability (subpar. b above).
- (6) Make proper entry on W.D., A.G.O. Form No. 478, MWO and Major Unit Assembly Replacement Record.

67. EXHAUST CHECK VALVE (figs. 21 and 25).

a. Description. The exhaust check valve is a small rubber diaphragm-type check valve used to prevent dirt and water from entering exhaust port of relay emergency valve.

b. Testing for Serviceability. Remove exhaust check valve from relay emergency valve, and immerse in water the lower half of valve containing diaphragm. Check for leakage of water past diaphragm into check valve. No leakage is permissible. If leakage is found, remove diaphragm and inspect its condition, also condition of

Air Brake Power System

diaphragm seat. If leakage is caused by presence of dirt, cleaning the diaphragm and diaphragm seat should correct trouble. If leakage is caused by defective diaphragm, replace diaphragm. If leakage is caused by defective diaphragm seat, replace complete exhaust check valve.

c. Removal. Unscrew exhaust check valve from relay emergency valve exhaust port (fig. 22).

d. Installation. Screw new exhaust check valve into exhaust port of relay emergency valve (fig. 22). Test for serviceability (subpar. **b** above).

68. HOSE COUPLINGS AND DUMMY COUPLINGS (figs. 20, 21, and 26).

a. Description.

(1) **HOSE COUPLING** (fig. 26). Hose couplings are installed on the ends of the air hose assemblies of the trailer for the purpose of connecting the air power line from the towing vehicle to the trailer. When two hose couplings are coupled together, pressure is put on the two rubber gaskets making an airtight seal. The hose couplings are fitted with friction locks.

(2) **DUMMY COUPLING.** Dummy couplings are welded to the fuze box on the trailer. The hose couplings must be attached to the dummy couplings when the air power system is not connected for operation to prevent dirt from entering the lines.

b. Testing for Serviceability. With hose couplings connected and brakes applied, coat hose couplings and connections at the air filters with soap suds to check for leakage. No leakage is permissible. Leakage is usually caused by worn, damaged, or improperly installed gasket. Install new gasket to stop leakage. Replace hose coupling if damaged (subpars. **c** and **d** below).

c. Removal.

(1) Remove old gasket by prying it out of hose coupling with screwdriver.

(2) Remove coupling from end of hose by placing one wrench close to threaded end of coupling, another wrench on hose connector, and turn in opposite directions.

d. Installation (fig. 26).

(1) **GASKET.**

(a) Clean the groove in hose coupling.

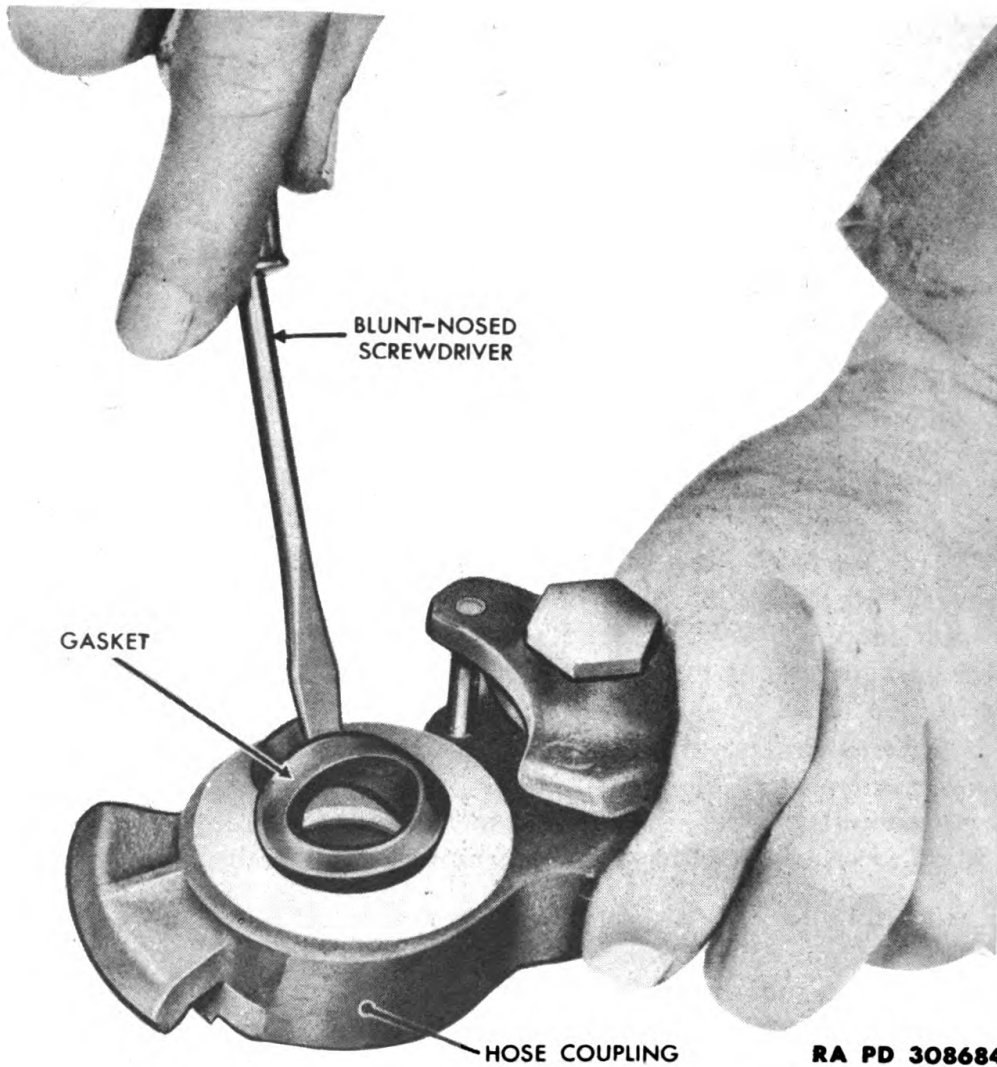

Figure 26—Installing Hose Coupling Gasket

(b) Partially collapse gasket with fingers, and enter one side of gasket flange into groove in hose coupling.

(c) Use blunt nose of screwdriver to push gasket into place.

(d) When properly installed, the exposed face of gasket will be flat and not twisted or bulged at any point.

(2) HOSE COUPLING.

(a) Screw hose coupling onto connector at end of hose assembly.

(b) Test for serviceability (subpar. b above).

Air Brake Power System

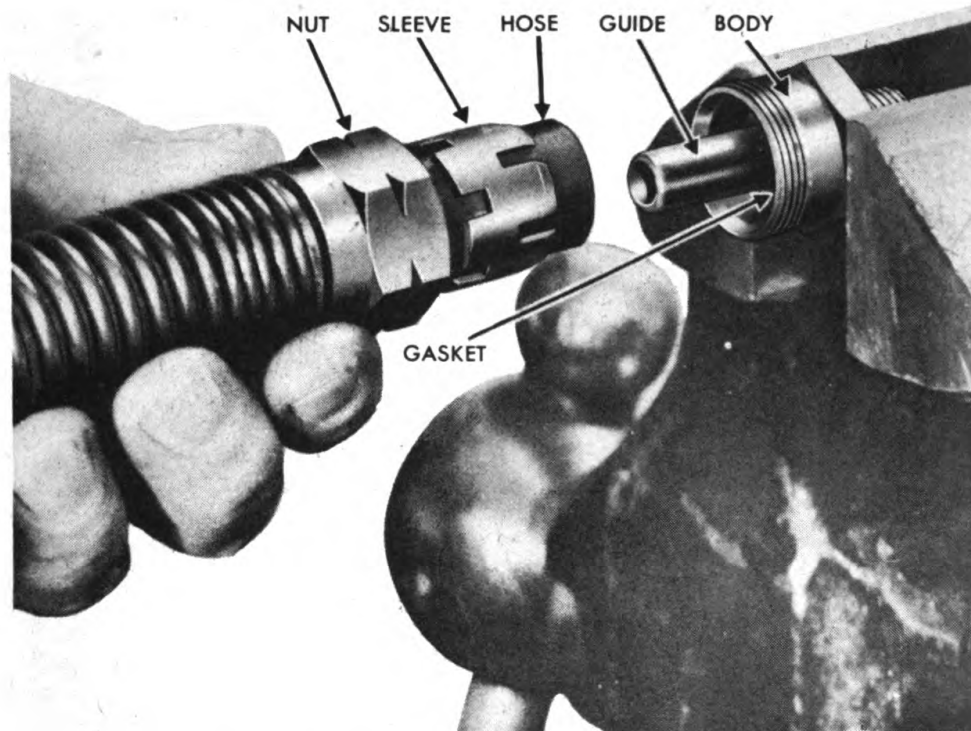

RA PD 308680

Figure 27—Placing Hose in Connector Body

69. HOSE, HOSE ASSEMBLIES, AND HOSE CONNECTORS
(figs. 20 and 21).

a. **Description.** Hose and hose fittings are used to provide flexible air connections between towing vehicle and trailer. The hose assemblies have detachable hose connectors with spring guards.

b. **Testing for Serviceability.**

(1) **OPERATING TEST.** If hose line is restricted, remove coupling and connectors and blow air through hose to clear passage.

(2) **LEAKAGE TEST.** With brakes applied, coat hose and hose couplings with soap suds to check for leakage. No leakage is permissible. Tighten connectors to check leakage. If this fails to correct leakage, replace the connectors, hose, or both.

c. **Removal.**

- (1) Remove detachable connectors at trailer end of hose.
- (2) Remove connector and hose coupling from other end of hose. Do not attempt to remove used sleeve from hose.

d. **Installation (fig. 27).**

- (1) Cut piece of hose to required length at right angles to outside wall of hose. Smooth off end of hose.

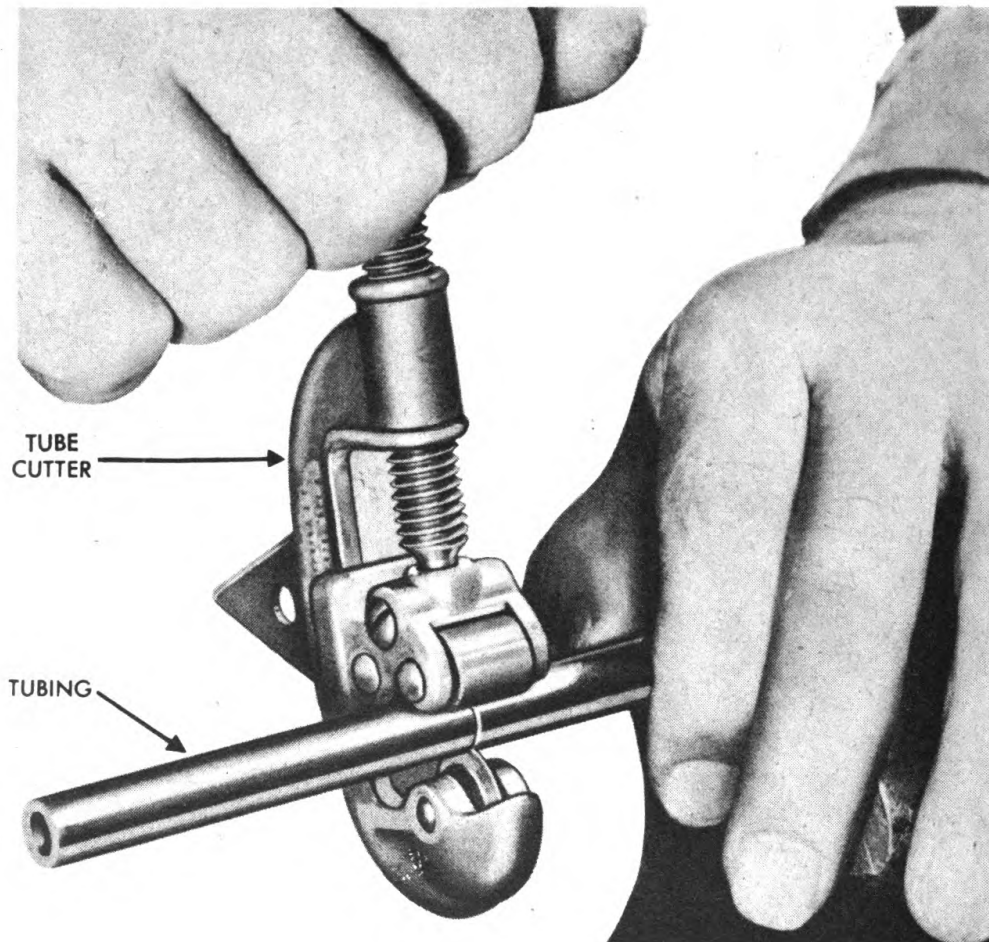

RA PD 95423

Figure 28—Cutting Tubing With Tube Cutter (41-C-2825)

- (2) Blow out hose to remove all cuttings.
- (3) Position connector nut and sleeve on hose. Make sure the barbs on inside of sleeve point toward end of hose being connected.
- (4) Position new gasket over end of guide in connector body so that side with removable protector covering will be next to hose. Remove protector covering from gasket, and push gasket into bottom of recess in connector body.
- (5) Put end of hose in connector body against gasket.
- (6) Move sleeve until it is against edge of connector body. Tighten connector nut sufficiently to ensure airtight joint.

70. TUBING AND FITTINGS (figs. 20 and 21).

a. Description. Copper tubing is used to connect various devices in the air brake system. It is important that tubing of the cor-

Parking Brake

rect inside and outside diameter be used in repair, otherwise the operation of the air brake equipment will be seriously affected. Three-piece compression-type tubing fittings are used throughout the system. Flare-type fittings, such as those used in gasoline lines, must not be used in the air brake power system.

h. Testing for Serviceability.

(1) OPERATING TESTS.

(a) Inspect tubing for partial restrictions caused by dents or kinks. Replace if necessary.

(b) If tubing line is restricted, remove and blow air through line to clear passage.

(2) **LEAKAGE TEST.** With brakes applied, coat tubing and fittings with soap suds to check for leakage. No leakage is permissible. Tighten fittings. If this fails to correct leakage, replace the fitting. If leakage is found in tubing, install new piece.

c. Removal.

(1) Remove defective tubing by removing tubing fittings.

(2) Old fittings can be used again if they are serviceable. However, do not use old sleeve.

d. Installation (fig. 28).

(1) Cut copper tubing to required length with hack saw or tube cutter. Make sure end of tubing is smooth and is cut squarely with tubing wall. Do not crimp or partially close ends of tubing. Ream or file ends of tubing if necessary.

(2) It is important to blow out tubing to remove all cuttings and filings.

(3) Place nut and new sleeve on tubing, and put end of tubing into recess in tubing fitting body.

(4) Hold tubing at bottom of recess, and tighten nut until sufficient pressure is placed on sleeve to prevent leakage.

Section XX

PARKING BRAKE

71. DESCRIPTION (figs. 1, 13, and 29).

a. Two parking brake hand levers, mounted just ahead of the trailer body at either side of the fuze box, are used to apply the brakes when the trailer is not coupled to a towing vehicle. The brake hand lever on the right side of the trailer operates the brake on the right-hand wheel. The hand brake lever on the left side of the trailer

Part Three—Maintenance Instructions

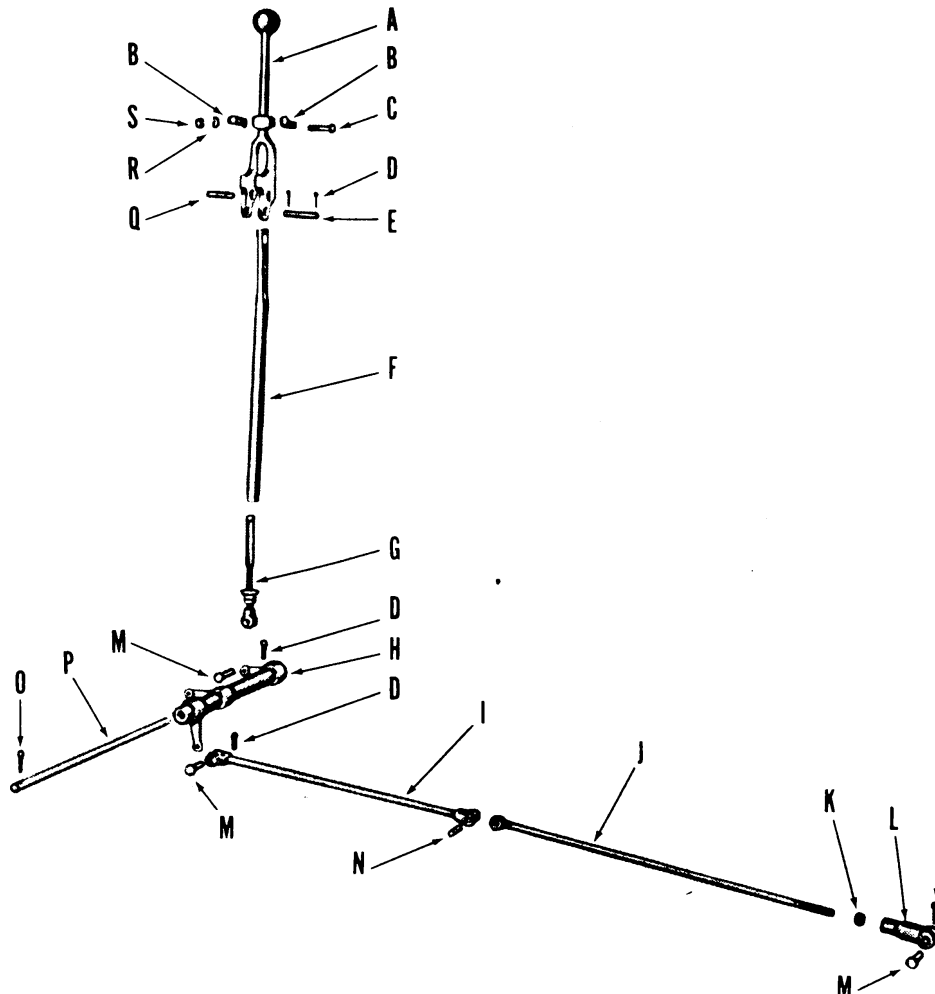

Key	Item	Part Number
A	HAND BRAKE LEVER	
B	HAND BRAKE LEVER LOCK SPRING	8720-9-12-2
C	HAND BRAKE LEVER LOCK SPRING CAP SCREW	H001-10-13007
D	COTTER PIN	H001-08-11052
E	HAND BRAKE LEVER PIN	8720-9-35-3
F	HAND BRAKE PUSH ROD	
G	HAND BRAKE YOKE ASS'Y	8720-9-A43-1
H	LEFT-HAND IDLER LEVER ASS'Y	
I	BRAKE OPERATING FRONT PULL ROD	8720-17-45-2
J	BRAKE OPERATING REAR PULL ROD	8720-17-45-3
K	BRAKE OPERATING PULL ROD LOCK NUT	H001-07-18025
L	BRAKE OPERATING REAR PULL ROD YOKE	H001-18-10060
M	YOKE PIN	H001-08-23006
N	BRAKE OPERATING PULL ROD JOINT PIN	8720-17-33-2
O	IDLER LEVER SHAFT COTTER PIN	H001-08-11101
P	IDLER LEVER SHAFT	
Q	HAND BRAKE PUSH ROD PIN	8720-9-42-12
R	HAND BRAKE LEVER LOCK SPRING LOCK WASHER	H001-15-18007
S	HAND BRAKE LEVER LOCK SPRING NUT	H001-07-18001

RA PD 318856

Figure 29—Right-hand Parking Brake—Linkage

Parking Brake

operates the brake on the left-hand wheel. The brakes are applied when the brake hand levers are pulled downward (fig. 1). The parking brake linkage consists of the hand levers and push rods which are attached to the idler lever assemblies and the operating pull rods which are attached to the idler lever assemblies and the slack adjusters. The brake mechanism and the brake linkage, from the idler lever assembly to the slack adjuster, are the same as those used for the air brake power system. Both brakes should be applied when the trailer is uncoupled from the towing vehicle. When the trailer is moved by hand, and a short turn is desired, the hand brake on the side on which the turn is made must be set to permit that wheel to act as a pivot.

72. ADJUSTMENT.

a. The two nuts on the hand brake push rod yoke assembly can work loose and cause adjustment to exceed 1 inch. Position the washer on the hand brake push rod yoke assembly 1 inch from the lower end of the push rod (with the parking brake in the released position) by moving top nut up against the washer to the required position and locking it there with the lower nut.

73. REMOVAL.

a. **General** (fig. 29). Removal of parking hand brake linkage as a complete assembly will not be necessary in order to replace component parts.

(1) Remove hand brake lever by removing cotter pins and lever pin attaching lever to bracket. Chip the weld off the push rod pin on the inside of the push rod at the top. Remove pin.

(2) Remove hand brake push rod yoke assembly by removing cotter pin and yoke pin at idler lever assembly. The yoke assembly will slide out from bottom of push rod.

(3) Remove cotter pin and yoke pin attaching front operating pull rod to idler lever assembly. Remove cotter pin and yoke pin attaching rear operating pull rod to slack adjuster. Slide rod assembly toward rear of trailer, and remove pull rod joint pin to separate the two rods.

(4) To remove idler lever assembly, remove cotter pin and yoke pin attaching front operating pull rod to idler lever. Remove cotter pin and yoke pin attaching brake chamber to idler lever assembly. Remove cotter pin from end of idler lever shaft, slide out shaft, and remove idler lever assembly. Remove cotter pin and yoke pin attaching hand brake push rod yoke assembly to idler lever.

74. INSTALLATION.

a. **General** (fig. 29). Install new parts required, using new yoke pins and cotter pins if necessary.

(1) Position idler lever assembly between the mounting angle bracket, with vertical lever toward center of trailer and horizontal levers toward front of trailer. Insert idler lever shaft and install $\frac{1}{4}$ -x 2-inch cotter pin through trailer gusset and outside end of lever shaft.

(2) Connect brake chamber push rod yoke to idler lever, and install yoke pin and cotter pin.

(3) Insert end of hand brake push rod yoke assembly into bottom opening of push rod. Connect yoke to idler lever, and install yoke pin and cotter pin. Adjust washer to 1 inch from bottom of push rod (par. 72).

(4) If complete operating pull rod has been removed, attach front operating pull rod to rear operating pull rod with joint pin. Feed front operating pull rod through box section, and connect front operating pull rod to idler lever assembly with yoke pin and cotter pin. Connect rear operating pull rod to slack adjuster with yoke pin and cotter pin.

(5) Install lubricating fittings in bottom of idler lever assembly and lubricate (par. 24).

(6) Make proper entry on W.D. A.G.O. Form No. 478, MWO and Major Unit Assembly Replacement Record.

Section XXI

LANDING WHEEL AND REAR PROP SUPPORT

75. LANDING WHEEL.

a. **Description** (fig. 30). The landing wheel supports the front of the trailer when the trailer is not coupled to the towing vehicle. The landing wheel is mounted under the drawbar to the rear of the lunette eye. It consists of a single 16-inch, disk-type, steel wheel attached to a swivel housing and fork assembly. A quadrant assembly is attached to the trailer mounting bracket by a bolt. The spindle of the quadrant is grooved, and the swivel housing and fork assembly is attached to the spindle by a set screw, thus permitting the wheel and fork to turn. A spring-type latch pin assembly is used to secure the landing wheel quadrant in the lowered or raised position. The landing wheel is raised, for towing, by pulling out on the latch pin and swinging the wheel upward until the latch pin automatically

Landing Wheel and Rear Prop Support

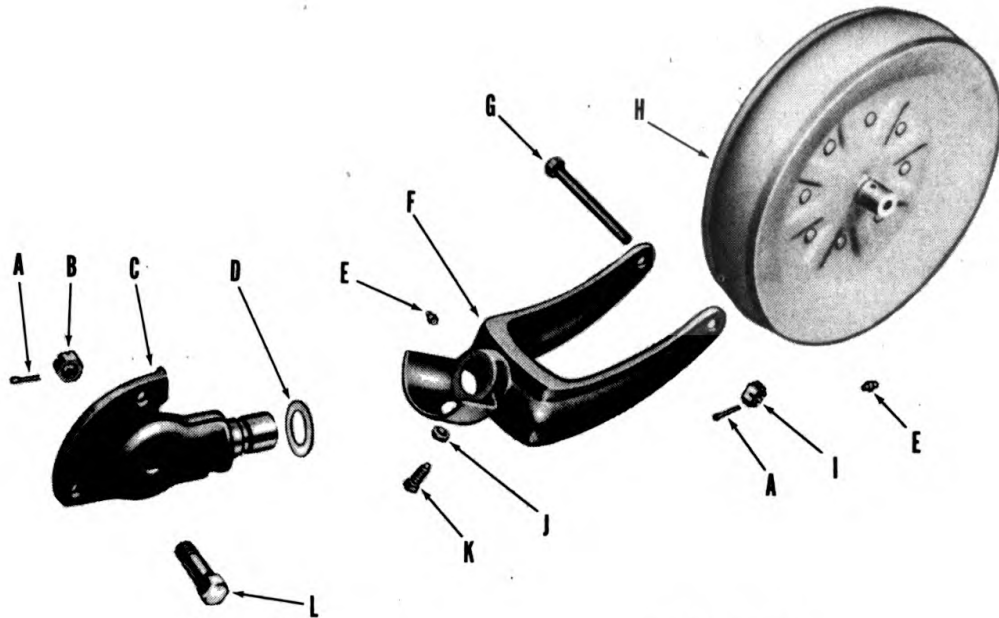

Key	Item	Part Number
A	COTTER PIN	H001-08-11056
B	SWIVEL BOLT NUT	H001-07-13004
C	QUADRANT ASS'Y	
D	THRUST WASHER	G518-04-43017
E	LUBRICATING FITTING	H002-05-04208
F	HOUSING AND FORK ASS'Y	
G	AXLE	G518-03-84675
H	WHEEL	
I	AXLE NUT	7740-6347-8B
J	QUADRANT SET SCREW NUT	H001-07-16005
K	QUADRANT SET SCREW	H101-541399
L	SWIVEL BOLT	8720-4-25-11

RA PD 318862

Figure 30—Landing Wheel—Disassembled

locks the wheel in position (fig. 6). It is lowered, for parking, by pulling out on the latch pin. **CAUTION:** *The landing wheel must be lowered before uncoupling trailer from towing vehicle. The trailer, after being coupled to the towing vehicle, must not be moved until the landing wheel is raised into running position.*

b. Data.

Make Saginaw
 Type Caster
 Part No. 6347-F
 Operation Manual
 Wheel size 16-in. dia x 4-in. face

c. Removal (fig. 30).

- (1) Be sure trailer is coupled to towing vehicle before attempting to work on landing wheel.
- (2) Remove landing wheel swivel bolt cotter pin, castle nut, and bolt. Pull out on latch pin, and lower complete landing wheel assembly to ground.
- (3) Loosen landing wheel quadrant set screw jam nut, and loosen set screw sufficiently to permit swivel housing and fork assembly to slide off quadrant spindle. Salvage thrust washer for installation.
- (4) Remove cotter pin, slotted nut and landing wheel axle to remove wheel from swivel housing and fork assembly.
- (5) If spring in latch pin assembly loses tension and requires replacement, saw latch pin at the handle and pull out collar end of latch pin and spring through hole in landing wheel mounting bracket. Salvage all parts possible for installation.

d. Installation (fig. 30).

- (1) Insert new spring and install collar end of latch pin through hole in landing wheel mounting bracket so that cut end extends toward right side of trailer. Weld on old handle end at right angles, or weld on bar steel about 4 inches in length to serve as handle.
- (2) Position landing wheel between fork and install axle, slotted nut, and cotter pin.
- (3) Install thrust washer over spindle end of quadrant, hold in place, and position swivel housing and fork over spindle. Tighten set screw so that pointed end of screw fits in groove in spindle. Lock in position by tightening set screw jam nut.
- (4) Pull out on latch pin, and position quadrant end of landing wheel assembly so that swivel hole in quadrant lines up with holes in mounting bracket. Install swivel bolt, castle nut, and cotter pin.
- (5) Test operation of landing wheel.
- (6) Make proper entry on W.D., A.G.O. Form No. 478, MWO and Major Unit Assembly Replacement Record.

76. REAR PROP SUPPORT.

a. Description. The rear prop is mounted in the prop bracket welded to the rear of the body. It consists of a leg and a foot. A pin and chain assembly is used to secure the prop in both the lowered or raised position. When the rear prop is in the lowered position, the pin is inserted through the holes in the prop bracket and the prop leg. When the rear prop is in the raised position, the pin is dropped through the upper latch plate and the prop leg foot. The rear prop is always lowered before the trailer is uncoupled from the towing vehicle to prevent the trailer from tipping backward (fig. 8). After the trailer is

Electrical System

coupled and the rear doors are closed, the rear prop is raised against the doors and serves as a door lock and brace (fig. 2). **CAUTION:** *The rear prop must be lowered before loaded or unloaded trailer is uncoupled from towing vehicle.*

b. Removal.

(1) Chip off weld from pin on inside of prop leg. Remove pin and lift off complete rear prop support.

c. Installation.

(1) Straighten bent leg. Position rear prop support between bracket, install pin and tack-weld pin on inside of leg.

Section XXII

ELECTRICAL SYSTEM

77. DESCRIPTION.

a. The electrical system consists of the wiring circuits including the lights, blackout switch, and coupling socket. Current for the lights is supplied by the towing vehicle, and is transmitted through the electrical jumper cable and coupling socket located on the tool box at the front of the vehicle.

b. The wiring diagram (fig. 31) shows the complete wiring for the trailer including the location of the taillights, coupling socket, and blackout switch. All wiring is 14-gage, stranded, insulated wire made into harnesses and inserted in conduit.

78. COUPLING SOCKET.

a. Description. Current for the trailer lighting system is supplied from the towing vehicle. The electrical jumper coupling cable, furnished with the trailer, must be connected to the coupling socket (fig. 32) located in the front panel of the fuze box at the front of the trailer and to the coupling socket located on the towing vehicle.

b. Removal.

(1) Lift out box covering over coupling socket and blackout switch from lower right corner of tool compartment of fuze box.

(2) Remove the four nuts, lock washers, and bolts securing coupling socket to fuze box. Pull out coupling socket through front fuze box panel. This operation also detaches ground wire from bolt at frame.

(3) Disconnect wiring harness from terminals. Tag wires "TL" and "SL" for installation.

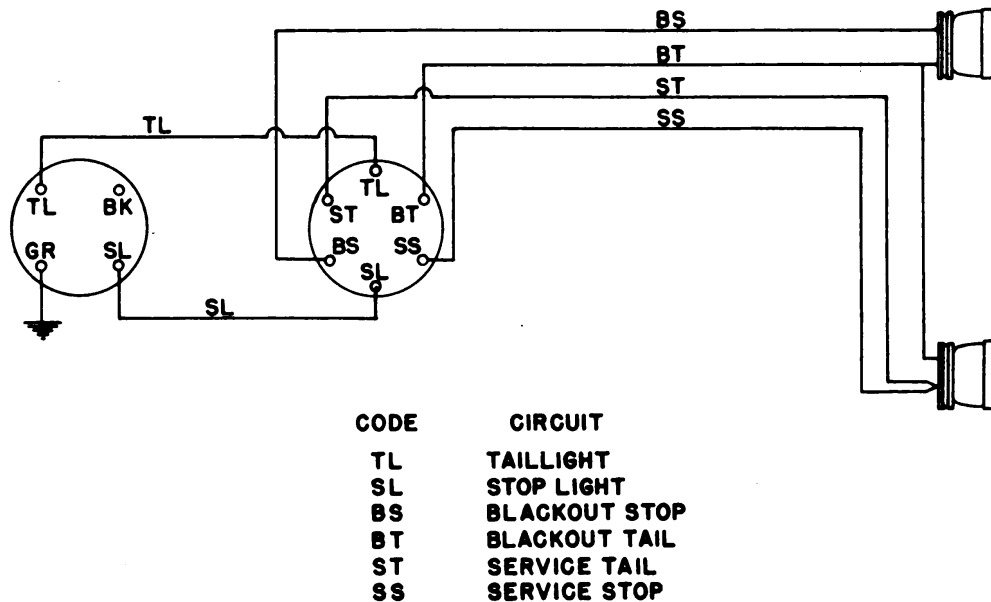

RA PD 318836

Figure 31—Electrical Wiring Diagram

(4) Disconnect ground wire from coupling socket. Salvage for installation.

c. Installation.

- (1) Connect tagged wires to “TL” terminal and to “SL” terminal accordingly.
- (2) Connect ground wire to terminal “GR.”
- (3) Position socket and install the four bolts through coupling socket flange and panel of fuze box. Connect ground wire to one of the bolts. Secure with lock washers and nuts.
- (4) Install box covering over coupling socket and blackout switch.

79. TAILLIGHTS.

a. Description (fig. 32). Two resilient-type taillights are mounted at the rear of the trailer. The left-hand light is a combination blackout taillight and service taillight and stop light. The right-hand light is a combination blackout taillight and stop light. The lens of each taillight is designed to produce two beams. These two beams will merge into a highly visible single beam when one truck is following a preceding truck at a specified distance.

b. Removal (figs. 32 and 33).

- (1) Twist taillight wire contact plug connectors one-eighth turn, and pull out from taillight sockets.

Electrical System

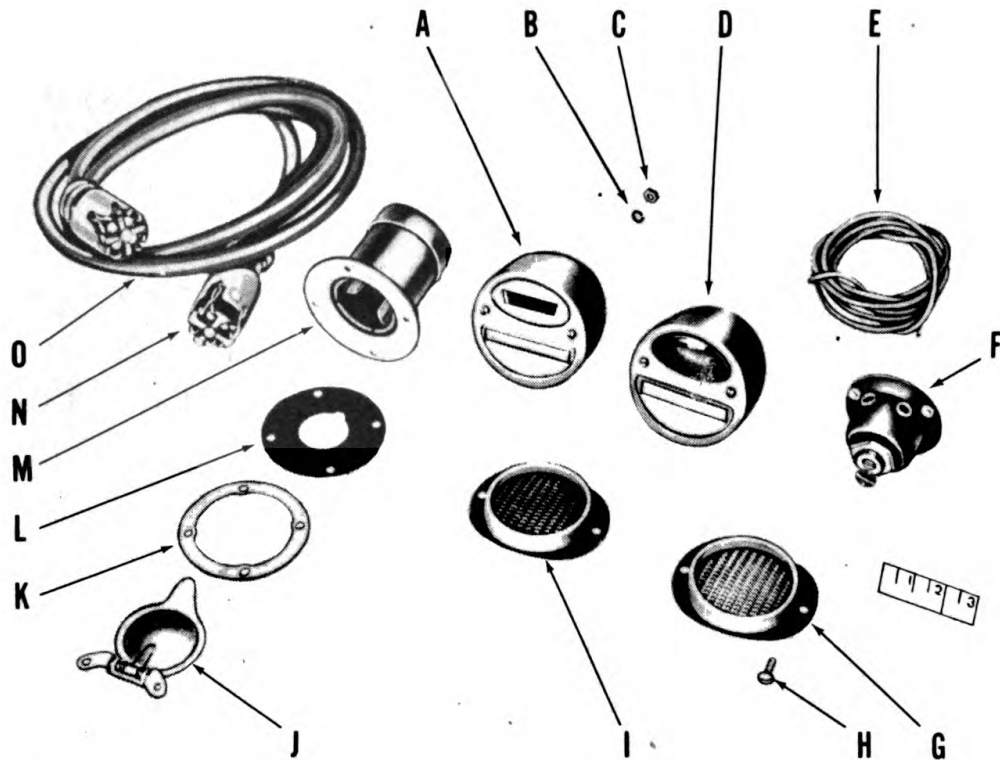

Key	Item	Part Number
A	BLACKOUT TAIL AND BLACKOUT STOP LIGHT	H004-504413
B	LOCK WASHER	H001-15-18007
C	HEX NUT	H001-07-18001
D	BLACKOUT TAIL AND SERVICE TAIL AND STOP LIGHT	H004-504406
E	ELECTRICAL STRANDED WIRE	15-C-2170
F	BLACKOUT SWITCH	8-S-8625
G	REFLEX REFLECTOR	H017-05-06102
H	SELF-THREADING SCREW	8720-50-19F-58
I	REFLEX REFLECTOR	H017-05-06101
J	COUPLING SOCKET COVER	G074-01-00218
K	SOCKET DUST SEAL RING	D017-03-09544
L	SOCKET DUST SEAL	F226-02-42470
M	ELECTRICAL COUPLING SOCKET	H004-03-55720
N	COUPLING CABLE PLUG	G544-05-83750
O	ELECTRICAL JUMPER COUPLING CABLE	G544-01-62590

RA PD 318866

Figure 32—Electrical Parts

(2) Remove the two nuts and lock washers holding taillight and resilient mounting parts to bracket, and remove the complete assembly.

c. Installation.

(1) Position taillight and resilient mounting parts onto mounting bracket, and install the two lock washers and nuts.

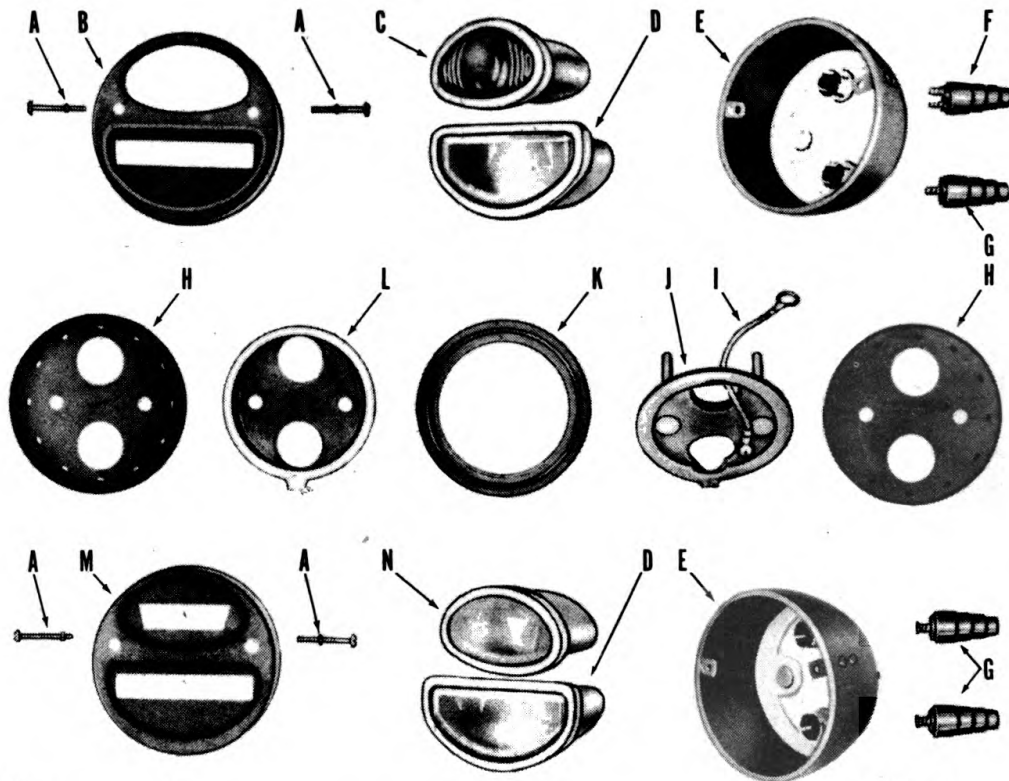

Key	Item	Part Number
A	TAILLIGHT DOOR SCREW	H001-10-30088
B	SERVICE TAIL AND STOP AND BLACKOUT TAILLIGHT DOOR	G067-09-02472
C	SERVICE TAIL AND STOP LAMP-UNIT	H004-504417
D	BLACKOUT STOP LAMP-UNIT	H004-504423
E	TAILLIGHT BODY	
F	DOUBLE CONTACT PLUG	
G	SINGLE CONTACT PLUG	
H	RESILIENT MOUNTING RETAINING CUP	
I	TAILLIGHT GROUND WIRE	
J	RESILIENT MOUNTING INNER PLATE	
K	RESILIENT MOUNTING RUBBER SHOCK ABSORBER	
L	RESILIENT MOUNTING BACKING PLATE	
M	BLACKOUT STOP AND BLACKOUT TAILLIGHT DOOR	G067-09-02471
N	BLACKOUT TAIL LAMP-UNIT	H004-504420
		RA PD 318854

Figure 33—Blackout Tail, Stop, and Service Lights—Disassembled

Electrical System

(2) Insert taillight wire contact plug connectors in taillight sockets, and twist one-eighth turn to lock.

d. Lamp-unit Replacement.

(1) REMOVAL.

(a) Remove the two screws from taillight door, and remove door.

(b) Pull sealed lamp-unit out of taillight body.

(2) INSTALLATION.

(a) Insert proper sealed lamp-units in taillight body.

(b) Position door and install the two screws through door to taillight body.

80. BLACKOUT SWITCH.

a. Description. The blackout switch (fig. 32), mounted in the right side panel of the fuze box of the trailer (fig. 5), controls the current to the taillights. There are two selective positions on the blackout switch. When the slot is opposite the "S" on the switch, the service taillight and stop light are the only lights receiving current from the towing vehicle. When the slot is opposite "BO" on the switch, the two blackout taillights and the blackout stop light receive the current.

b. Removal.

(1) Lift out box covering over blackout switch and coupling socket from lower right corner of tool compartment of fuze box.

(2) Remove nut from outside end of blackout switch, holding switch to panel of fuze box. Slack wire permits removal of switch from inside of fuze box. Replace nut on switch after removal.

(3) Disconnect wires from blackout switch terminals, and tag wires for identification purposes for installation.

c. Installation.

(1) Connect wires to blackout switch, using tags as guide to proper terminal.

(2) Remove nut from end of switch, and position switch through hole in panel of fuze box. Install nut and tighten.

(3) Position slack wire, and install box covering over blackout switch and coupling socket.

Section XXIII

BODY, FRAME, DRAWBAR, AND SHELL RACKS

81. DESCRIPTION AND DATA.

a. **Description** (figs. 1, 2, 3, 13, and 34). The body and A-frame of the trailer are welded into an integral assembly. The A-frame is used to attach the drawbar lunette eye and the landing wheel assembly. The suspension is attached directly to the body by means of spring hangers which are welded to the body bolsters. The body is square and has open top. The double steel floor of the body has stamped cups, properly spaced, to hold 102 rounds of 4.5-inch gun shells or 72 rounds of 155-mm howitzer shells in upright position. The metal compartment at the front of the trailer is welded to the body and the A-frame. It serves as a storage space for the fuzes, fuze primers, tools, and service manuals. The rear of the body is equipped with hinged doors which are held closed at the top by a channel retainer and at the bottom by the retracted rear prop. No rear cross header is used, and the channel retainer is a part of the doors, so that there is a clear opening when the doors are opened. Four lifting rings are mounted at the corners of the body and are of such strength that any two diagonally situated rings will lift the fully loaded trailer.

b. **Data.**

(1) **BODY DIMENSIONS.**

Length, inside	83½ in.
Width, inside	87 in.
Height, inside	40 in.

(2) **LOAD DATA.**

4.7-inch gun ammunition	102 rounds*
155-mm howitzer ammunition	72 rounds*
Payload	8,000 lb
Gross weight	13,300 lb

(3) **DRAWBAR:**

Make	Trailer Company of America
Type	Integral with body
Lunette eye dimensions	3⅝-in. I.D. x 6⅝-in. O.D.

*Complete round includes projectile, propelling charge, fuze, and primer.

82. DRAWBAR LUNETTE EYE.

a. **Description** (fig. 34). An A-type drawbar is rigidly welded into the front of the body. A lunette eye is bolted to the A-frame at the point of the drawbar for the purpose of coupling trailer to towing vehicle.

Body, Frame, Drawbar, and Shell Racks

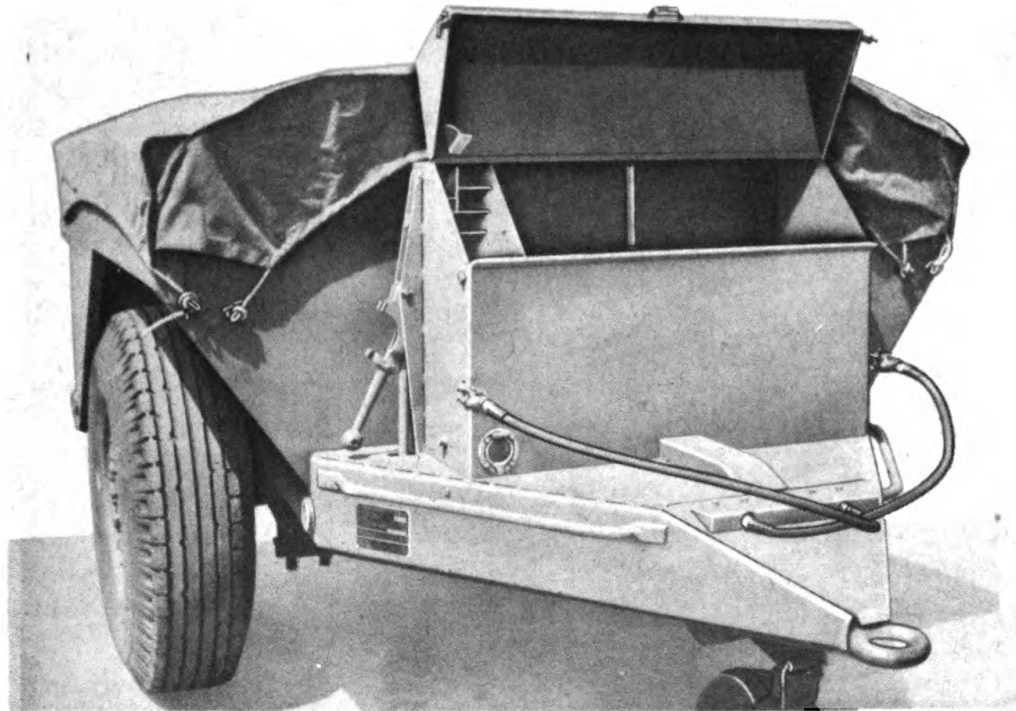

RA PD 318833

Figure 34—Fuze Box—Open

b. Removal (fig. 35).

- (1) Remove A-frame cover plate as outlined in paragraph 61 c, steps (1) to (5) inclusive.
- (2) Remove cotter pins, castle nuts, and bolts from shank of lunette eye.
- (3) Pull lunette eye out of housing.

c. Installation.

- (1) Insert shank of lunette eye into housing at end of drawbar A-frame.
- (2) Position holes and install the two bolts, castle nuts, and cotter pins.
- (3) Install A-frame cover plate as outlined in paragraph 61 d, steps (3) to (6) inclusive.

83. SHELL RACKS.

a. Description (figs. 3 and 9). The lower shell rack is made up of a number of stamped cups permanently set into the floor of the trailer. Seventy-two of these cups hold both the 155-mm howitzer shells and the 4.5-inch gun shells. Thirty of the cups hold only the

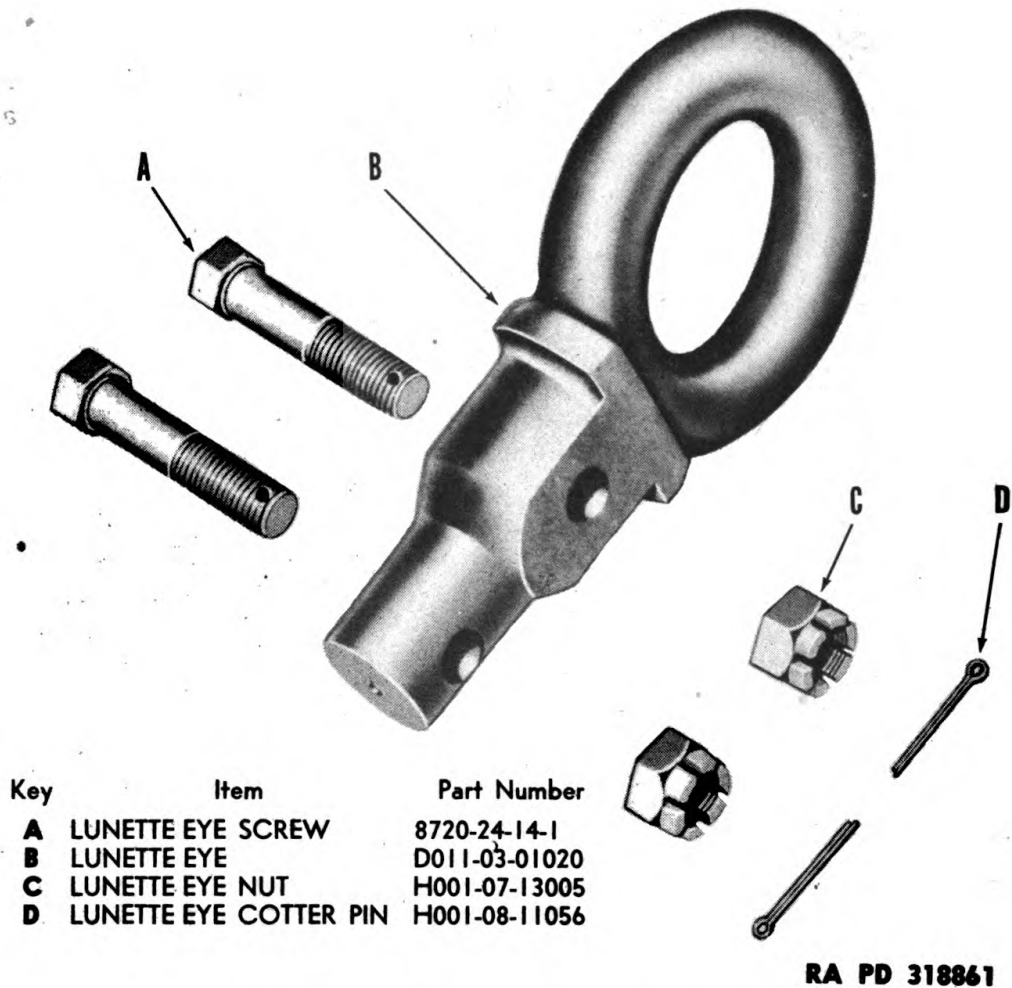

Figure 35—Drawbar Lunette Eye and Attaching Parts

4.5-inch gun shells. The upper rack assembly is made up of six individual racks which fit over the nose of the shells and serve to clamp them down. In the locked position, they are parallel to the floor of the trailer and provide a smooth surface for the loading of powder charges above the shells. The racks are hinged at the sides of the shell compartment. The three right-hand racks are equipped with a lever and cam mechanism positioned approximately on the center line of the body with tie rods and hooks extending downward to engage in the floor of the trailer. When the levers are thrown to the locked position, the racks are pulled down on the shells. The left-hand racks are engaged by means of flanges extending under the right-hand racks. Two selective vertical positions are provided at the shell rack hinge mountings and on the tie rods to allow for difference in height of the two sizes of shells carried. The hinge mounting bolts are welded to the body, and the hinge is mounted through the two ex-

Body, Frame, Drawbar, and Shell Racks

treme holes when the 155-mm howitzer shells are loaded, and through the two holes close to the top of the rack when the 4.5-inch gun shells are loaded. The tie rods are adjusted in like manner except that the bolts are also removable. Close adjustment in either position is provided by screwing the hooks up or down on the tie rods. The final setting is secured by lock nuts.

b. Removal (figs. 3 and 9).

- (1) Remove nuts and lock washers from hinge mounting studs on right side of body. Disengage hook of tie rod from floor, and lift out right-hand shell racks.
- (2) Remove nuts and lock washers from hinge mounting studs on left side of body, and lift out left-hand shell racks.

c. Installation.

- (1) Determine size of shell to be loaded in trailer. Position left-hand shell racks on hinge mounting studs through the two extreme holes in hinge if 155-mm howitzer shells are to be carried. Install lock washers and nuts.
- (2) Position left-hand shell racks on hinge mounting studs through the two holes close to top of rack if 4.5-inch gun shells are being hauled. Install lock washers and nuts.
- (3) Position tie rod and hook opposite lower or upper hole in lever and cam mechanism to correspond with proper size of shell. Install bolt, castle nut, and cotter pin.
- (4) Position right-hand racks in corresponding holes. Install lock washers and nuts.
- (5) After shells are loaded and hook end of tie rod is engaged in floor, make necessary adjustment for tighter fit of shell racks at the lock nut on the tie rod.

84. POWDER CONTAINER BINDING STRAPS.

a. Description (fig. 5). Propelling charges are carried in the upper part of the trailer body above and to the sides of the projectile compartment. The charges are usually packed in "clover leaf" bundles which permit "nesting," and are laid flat and longitudinally in the trailer body. Binding straps hold the bundles securely in the body.

b. Removal (fig. 5). Remove nut, plain washers, and bolt from each end of powder container binding strap.

c. Installation. Loop end of powder container binding strap around pipe at side of body. Aline holes and position plain washer on top and bottom. Install bolt and nut.

85. TARPULIN AND TARPULIN ROPE CENTER SUPPORT.

a. **Description** (figs. 3 and 4). The tarpaulin rope center support is a spring-loaded rope fastened permanently at the front of the trailer body. It extends longitudinally on the center line of the trailer and passes over and down the rear end of the body where it is fastened to a special rope hook (fig. 2). The tarpaulin is placed over the body and is tied at two points on each of the four corners. The body is approximately square and the front of the tarpaulin is stenciled "FRONT" for proper installation. See figure 6 for method of tying ropes at corners.

b. **Removal.** Cut off worn portion of rope, or cut rope at end of spring loop.

c. **Installation.** Splice rope, or install new rope using 9 feet of $\frac{5}{8}$ -inch diameter rope, and tie securely to end of spring loop.

86. SPRING-LOADED ROPE.**a. Removal.**

(1) If end of rope is worn beyond safety facture, cut rope if splicing can be accomplished.

(2) To remove complete rope, remove the wire clip at hem in tarpaulin located about equal distance from each end, and pull rope out of tarpaulih.

b. Installation.

(1) Attach $\frac{3}{8}$ -inch diameter rope to small wrench, and feed rope through hem in tarpaulin. The sides and rear of tarpaulin require ropes 116 inches long; the front requires rope 122 inches long.

(2) If available, clip rope to tarpaulin at center, allowing 16 inches of rope to extend from each end for tying (fig. 6).

87. REFLEX REFLECTORS.

a. **Description.** Two amber reflex reflectors are mounted on each side of the trailer at the front (fig. 3). Four red reflex reflectors are mounted at the rear of the trailer (fig. 2), two facing the rear and two facing the side.

b. **Removal.** Remove screws holding reflectors to frame of trailer and remove reflectors (figs. 2 and 3).

c. Installation.

(1) Postion red reflectors to rear corners of trailer body and secure with self-tapping metal screws (fig. 2).

(2) Position amber reflectors to side of body frame at front of trailer and secure with self-tapping metal screws (fig. 3).

PART FOUR—AUXILIARY EQUIPMENT

Section XXIV

GENERAL

88. SCOPE.

- a. Due to the type of construction, and the use for which this trailer was designed, no items of auxiliary equipment are necessary.

PART FIVE—REPAIR INSTRUCTIONS

Section XXV

GENERAL

89. SCOPE.

a. These instructions are published for information and guidance of personnel responsible for third and higher echelons of maintenance on this equipment. They contain information on the maintenance which is beyond the scope of the tools, equipment, or supplies normally available to using organizations.

Section XXVI

TROUBLE SHOOTING

90. GENERAL.

a. This section contains trouble shooting information beyond the scope of second echelon. The remedies required are those normally performed by Ordnance maintenance personnel. The symptoms in section XIV that were referred to higher authority are repeated here, together with the proper remedy.

91. SUSPENSION (SPRINGS AND RADIUS RODS).

a. Hard Riding.

- (1) **BENT RADIUS RODS.** Straighten the radius rods (par. 96 **b**).
- (2) **BROKEN SPRING LEAVES.** Replace broken leaves (par. 95 **a** and **c**).
- (3) **BROKEN SPRING CENTER BOLT.** Replace broken center bolt (par. 95 **a** and **c**).

92. AXLE AND BRAKE MECHANISM.

a. Hard Pulling.

- (1) **BENT AXLE.** Straighten bent axle (par. 103).
- (2) **BENT RADIUS RODS.** Straighten the radius rods (par. 96 **b**).

b. Weak Brakes.

- (1) **GREASE ON BRAKE LININGS.** Replace brake linings (pars. 98 **c** and 100 **c**).

Springs and Radius Rods

(2) **WORN-OUT BRAKE LININGS.** Replace brake linings (pars. 98 c and 100 c).

c. Excessive Wear on Brake Lining.

(1) **WORN-OUT BRAKE LINING.** Replace brake lining (pars. 98 c and 100 c).

(2) **DAMAGED BRAKE SHOE BUSHINGS.** Replace bushings (pars. 98 b and 100 d).

d. Grabbing Brake.

(1) **GREASED-SOAKED BRAKE LINING.** Replace brake lining (pars. 98 c and 100 c).

(2) **SCORED BRAKE DRUM.** Machine brake drum (par. 99 c (2)).

(3) **WORN BRAKE LINING.** Replace brake lining (pars. 98 c and 100 c).

e. Noisy Brakes.

(1) **DIRTY BRAKE LININGS.** Replace brake lining (pars. 98 c and 100 c).

f. Tires Wearing Evenly But Too Rapidly.

(1) **BENT AXLE.** Straighten axle (par. 103).

93. BODY AND COMPONENTS.

a. Body or A-frame Sagging.

(1) **CRACKED WELDS.** Reweld faulty seams.

(2) **DAMAGED STEEL SECTIONS.** Straighten or replace damaged sections par. 105).

Section XXVII

SPRINGS AND RADIUS RODS

94. DESCRIPTION AND DATA.

a. Description.

(1) **SPRINGS.** The semielliptical-type main spring (fig. 36) consists of 19 leaves held together by 2 rebound clips and a center bolt. The ends of the spring are slip type.

(2) **RADIUS RODS.** The radius rod consists of a main bar which is attached to the spring seat on the axle and to the front spring hanger. Rubber bushings absorb the shock. Steel bushings permit adjustment. The radius rods are secured with heavy pins.

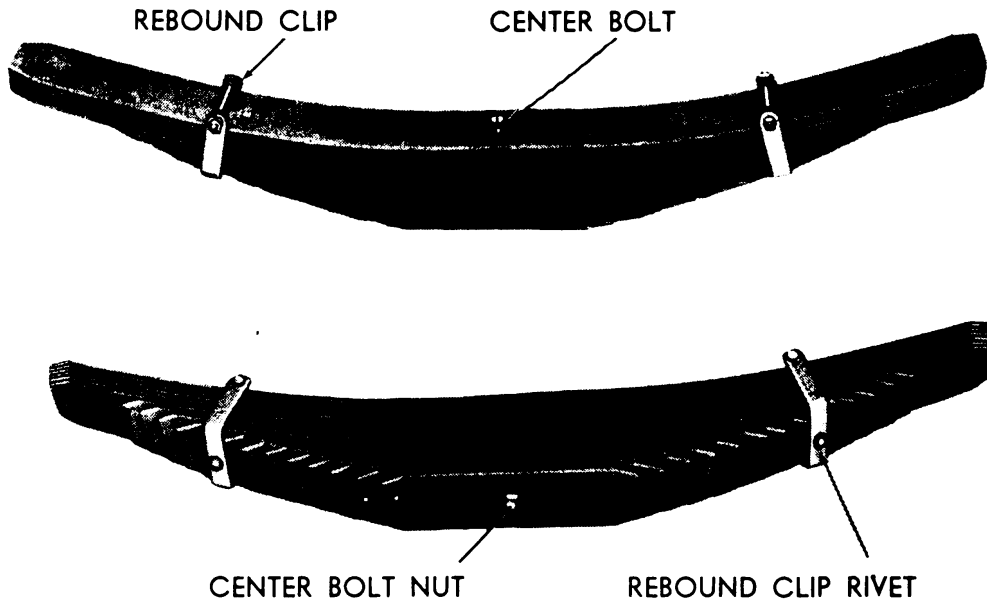

RA PD 318846

Figure 36—Springs

b. Data.

(1) SPRINGS.

Make	Burton
Type	Slip
Number of leaves	19
Thickness of leaves	1/4 in.
Width of leaves	3 1/2 in.
Length of main leaf	43 in.

(2) RADIUS RODS.

Make	The Trailer Company of America
Type	Adjustable
Adjustment	1/2 in.

95. SPRINGS.

a. Disassembly.

- (1) Remove main spring (par. 42 b).
- (2) Place C-clamp over entire main spring near center bolt, and tighten C-clamp.
- (3) Remove center bolt nut and center bolt. Remove C-clamp.
- (4) Remove the two rebound clip nuts, bolts, and spacers to free top leaves of spring.
- (5) Remove rivet holding rebound clip to spring leaf if spring leaf or rebound clip are damaged beyond use.

Brake Spider, Drum, Shoes, and Lining

b. Cleaning, Inspection, and Repair.

- (1) Clean all parts of spring with wire brush and dry-cleaning solvent.
- (2) Inspect for broken spring leaves, worn or broken spring center bolts, and loose rebound clip rivets.
- (3) Tighten rivet attaching rebound clip to spring leaf by heating rivet and hitting it with hammer. If rebound clip has been removed, install it in tenth spring leaf.

c. Assembly.

- (1) Group spring leaves together (shortest leaf on bottom), using long thin rod to line up holes. Open rebound clips sufficiently to position top leaves.
- (2) Place C-clamp over entire spring near center bolt hole. Tighten C-clamp.
- (3) Install center bolt through holes in spring leaves. Head of bolt is to be next to longest spring leaf when installed. Install nut, and peen end of center bolt.
- (4) Close rebound clips over edge of longest spring leaf. Install spacer, bolt, and nut. Peen end of bolt.
- (5) Remove C-clamp.
- (6) Install main spring on trailer (par. 42 c).

96. RADIUS RODS.

a. Cleaning and Inspection. Clean radius rod with wire brush and dry-cleaning solvent. Inspect for bent, cracked, or broken condition. If radius rod is cracked, it is unserviceable.

b. Repair. Straighten radius rod if bent but not twisted or cracked. Radius rod must be straightened cold. *NOTE: Under no circumstances should heat or welding be applied to radius rod since it is a malleable casting.*

Section XXVIII

BRAKE SPIDER, DRUM, SHOES, AND LINING

97. DESCRIPTION.

a. The brake spider, riveted to the axle flange, holds the brake shoe in proper alignment with the brake drum. The brake shoe return springs pull the brake shoe away from the drum to its inoperable position after brake pressure is released. The anchor pins

hold the heel end of the brake shoes in alignment with the drum. The anchor pins take all the braking thrust, and are the only positive connection between the brake shoes and the axle. When the S-head of the camshaft turns, it contacts the wear plate secured to the cam end of the brake shoe. The $\frac{3}{4}$ -inch brake shoe lining is bolted to the brake shoe. The end of the brake spider, through which the camshaft rotates, contains a slotted bushing.

98. DISASSEMBLY.

a. General. By following the procedure outlined in section XVIII, most of the component parts of the brake mechanism can be removed from brake assembly. No further disassembly is required except for the brake spider and brake shoe. **NOTE:** *All disassembly operations can be made as separate functions.*

b. Remove Brake Shoe Bushings (fig. 18).

(1) Place blunt tool against inside edge of bushing in anchor end of brake shoe and drive out bushing. **NOTE:** *There are two bushings in anchor end of each brake shoe.*

c. Remove Brake Lining (fig. 37).

(1) Remove the four brass bolts, lock washers, and nuts securing each brake lining block to brake shoe.

(2) If lining is being removed due to excessive wear, remove all four lining blocks from the two brake shoes on the same side of the trailer. All four lining blocks must be replaced on the same side of the brake mechanism in order to permit proper adjustment and obtain braking contact at all possible points on the brake drum.

d. Remove Brake Shoe Cam Wear Plate (figs. 18 and 19).

(1) Remove machine screw securing brake shoe cam wear plate to brake shoe.

(2) Lift off cam wear plate and cam wear plate shim.

e. Remove Brake Spider (figs. 18 and 19).

(1) Use cold chisel and hammer to cut rivets securing brake spider to axle flange.

(2) Place blunt tool against bushing in camshaft hole end of spider and drive out bushing.

99. CLEANING, INSPECTION, AND REPAIR.

a. Cleaning. Clean all parts removed from brake mechanism with dry-cleaning solvent or Diesel fuel oil. After washing with dry-

Brake Spider, Drum, Shoes, and Lining

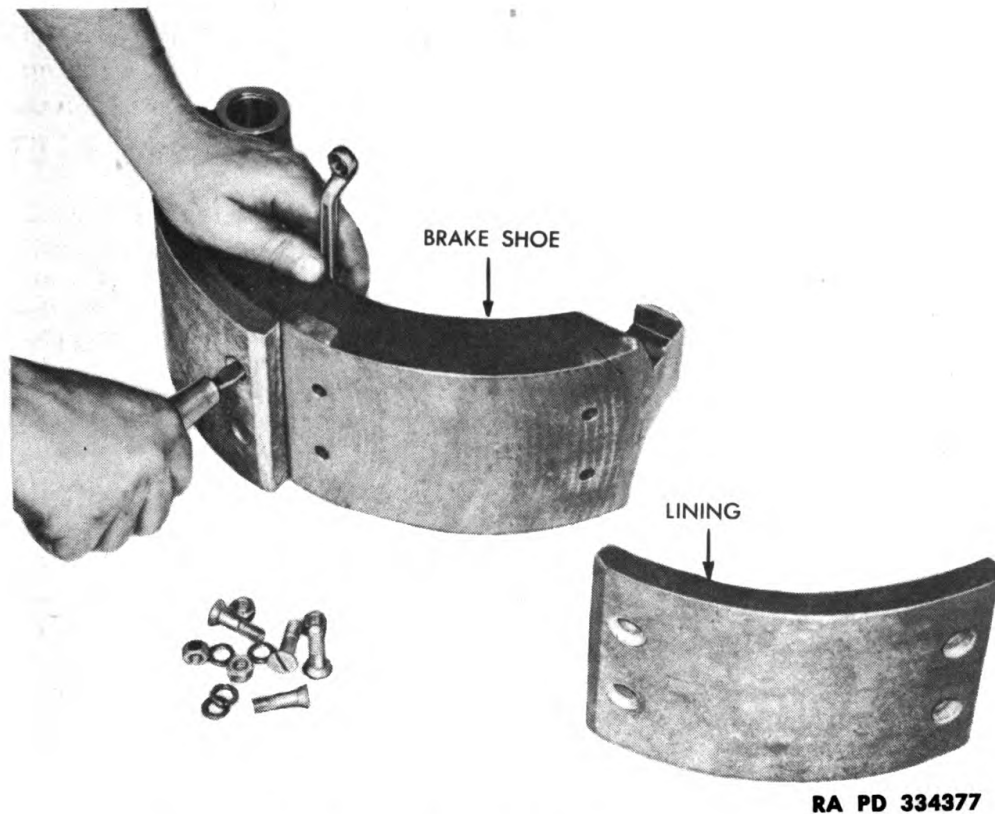

Figure 37—Removing Lining From Brake Shoe

cleaning solvent, dry all parts thoroughly before inspecting or installing onto trailer assembly.

b. Inspection.

- (1) In most cases, visual inspection will determine need for replacement parts.
- (2) Inspect for worn bushings in anchor end of brake shoe and cam end of brake spider.
- (3) Inspect for scored drum or heat checks in drum.
- (4) Inspect for bent brake spider.

c. Repair.

- (1) Replacement with new parts, rather than repair, is recommended for most of the brake mechanism component parts.
- (2) Brake drums have an original inside diameter of from 17.245 to 17.255 inches. Repair scored or out-of-round drums by turning the drum in suitable lathe. The maximum amount of material to be removed on the diameter of the drum is $\frac{1}{4}$ inch. Remove this ma-

terial in increments of $\frac{1}{16}$ inch. When an inside diameter of $17\frac{1}{2}$ inches is reached, no further machining can be made on the brake drum.

100. ASSEMBLY.**a. Install Brake Spider (figs. 18 and 19).**

- (1) Position bushing into camshaft hole in brake spider so that slot in bushing will line up with lubricating fitting opening in brake spider.
- (2) Drive bushing into brake spider, and burnish bushing to from 1.499 to 1.501 inches inside diameter.
- (3) Position brake spider to axle flange so the camshaft hole lines up with hole in camshaft bracket on axle.
- (4) Rivet spider to axle flange. *NOTE: Spider can be bolted to axle flange if riveting equipment is not available.*

b. Install Brake Shoe Cam Wear Plate (figs. 18 and 19).

- (1) Position brake shoe cam wear plate shim onto brake shoe cam end.
- (2) Place cam wear plate over shim, and secure both items with machine screw.

c. Install Brake Shoe Lining (fig. 37).

- (1) Install all new brake lining on same side of trailer brake mechanism assembly at same time.
- (2) Position brake lining blocks onto brake shoe so that shoe and lining holes are alined. Secure lining to shoe with brass bolts, lock washers, and nuts.

d. Install Brake Shoe Bushings (fig. 18).

- (1) Position bushing on outer edge of anchor pin hole in brake shoe. Drive bushing flush with edge of opening.
- (2) Turn brake shoe over, and position second bushing on outer edge of anchor pin hole. Drive bushing flush with edge of opening. Bushing is 1.244 to 1.246 inches in diameter before installation. Ream to from 1.254 to 1.256 inches in diameter.
- (3) The two bushings will be spaced apart in the center of the brake shoe to provide for proper lubrication.

e. General. Follow the procedure outlined in section **XXVIII** to complete the assembly, lubrication, and adjustment of the brake mechanism.

Axle

Section XXIX

AXLE

101. DESCRIPTION AND DATA.

a. **Description.** The axle (fig. 17) is a tubular trailer axle. The flanges and spindles are integrally welded to form a one-piece axle. The camber, based on standard road crown, is forged into the axle at time of manufacture. The camshaft brackets and spring seats are welded to the axle beam. The tubular axle supports the weight of the trailer, keeps the wheels in alinement, and resists the stresses that occur when brakes are applied. The axle beam tube has a 5-inch diameter, and the wall is 1/2 inch thick. The axle flanges have eight holes for riveting the brake spider. The spindles are machined to take Timken Roller Bearing Company No. 5557 inner and outer cone and roller bearing assemblies. The spindles are keywayed to hold the wheel bearing nut lock washer in place after bearings have been adjusted.

b. **Data.**

Make	Timken-Detroit Axle
Model	T-2090-W-X-14
Type	Tubular, trailer

Dimensions:

Track	83 in.
Tube, outside diameter	5 in.
Tube, inside diameter	4 in.
Spindle diameter for inner oil seals felt retainers	3.441 to 3.436 in.
Spindle diameter for bearing cone and roller assemblies	2.6873 to 2.6863 in.
Threads on end of spindle	2 5/8-16 national fine (special)
Spring centers	48 in.

102. CLEANING AND INSPECTION.

- a. Steam clean the axle beam, if possible. Scrape or sand all rust scale from the axle beam. If steam-cleaning equipment is not available, use dry-cleaning solvent.
- b. Check axle spindle nut threads for excessive wear or damage.
- c. Check bearing seats for rough surface.
- d. Check seat and inner oil seal felt retainer for rough surface.
- e. Check axle beam and spindles for bend. Indications of bent spindle are binding bearings which can not be adjusted properly and extremely uneven wear of brake linings. However, if bearings do not

bind and trailer brakes are seldom used, do not discard axle unless authorized by higher authority. If slow-acting hydraulic press is available, axle beams and spindles that are bent, but not cracked, can be straightened (par. 103).

f. Axle is cambered $\frac{3}{8}$ to $\frac{1}{2}$ inch at time of manufacture. The primary purpose for cambering axles was to offset excessive inside tire wear on commercial semitrailers operating from 50,000 to 100,000 miles a year over crowned roads. Only in cases of severe damage due to excessive overload or accident should the axle be replaced.

g. Check threads on outer jam nut and inner adjusting nut. If nut threads are badly worn or damaged, discard nut.

103. REPAIR.

a. File or grind smooth the high spots or rough edges on bearing seats and inner oil seal felt retainer seats.

b. Using a fine file, file off burs from spindle threads.

c. Hand-chase threads on end of spindle if necessary. The threads are $2\frac{5}{8}$ -16 national fine.

d. If seats for bearings or inner oil seal felt retainers are excessively worn and will not seat bearings and inner oil seal felt retainers, build up seating surface with chrome plate and grind to required diameter. Grind to from 3.441 to 3.436 inches for inner oil seal felt retainer. Grind to from 2.6873 to 2.6863 inches for bearings.

e. In order to machine the axle spindle surfaces or machine-chase threads accurately in accordance with dimensions given in subparagraph d above, it is necessary to remove the camber from the axle beam. This can be done if a slow-acting hydraulic press having 20- to 40-ton capacity is available. Place an extremely sturdy steel table, capable of withstanding pressure from the hydraulic press, underneath the hydraulic press. Set up the stripped axle beam on two seats high enough to permit axle to clear top of table, and allow about 6-inches deflection in axle beam if necessary. These seats should be positioned at the track line which is $41\frac{1}{2}$ inches from each side of center line of axle beam. The top of the axle, indicated by punch marks, must be positioned nearest the hydraulic press die. Center the beam under the press so that the die will contact the axle beam at the center line. Use a blunt-end die to prevent denting axle beam. Also provide a stop to control the travel of the hydraulic press to prevent bending axle too much in opposite direction. Do not attempt to straighten axle in one operation, but gradually increase the travel of the hydraulic press to reduce the camber in the

Body, Frame, Drawbar, Shell Racks, and Landing Wheel

axle until the beam is straight. Gage the beam between the axle flanges with a straight bar to determine when axle beam is straight.

f. Recamber the axle beam by setting up axle under slow-acting hydraulic press, as instructed in subparagraph e above. However, make certain the punch marks indicating the top of the axle are now on the bottom. In the case of the axle used on the M21 trailer, the spring seats will then be on the side of the beam closest the hydraulic press die. Provide a stop to control the travel of the hydraulic press to prevent bending axle too much. Do not attempt to place the $\frac{3}{8}$ - to $\frac{1}{2}$ -inch camber in the axle beam in one operation, but gradually increase the travel of the hydraulic press die. Gage the camber in the axle beam after each operation. Place a mark on the bottom side of the axle beam (now nearest hydraulic press) 18 inches on each side of the center line of the axle. Use a 36-inch straight bar to contact these two points. When the space between the bar and the axle beam at the center line measures $\frac{7}{32}$ inch, plus or minus $\frac{1}{64}$ inch, the camber in the axle will be $\frac{3}{8}$ to $\frac{1}{2}$ inch.

Section XXX**BODY, FRAME, DRAWBAR, SHELL RACKS, AND LANDING WHEEL****104. DESCRIPTION AND TABULATED DATA.**

a. **Description.** The body and the A-frame of the trailer are welded into an integral assembly. The A-frame is used to attach the drawbar lunette eye and the landing wheel assembly. The suspension is attached directly to the body by means of spring hangers which are welded to the body bolsters. The body is square and has open top. The double steel floor of the body serves as the lower shell rack, and cups are stamped into top plate to carry the shells in upright position. The upper shell rack assembly is made up of six separate steel racks which fit over the shells and clamp them down. The racks are hinged at the side and are adjustable. A cam and lever mechanism, attached to the right-hand shell racks, tightens the racks securely over the nose end of the shells. This mechanism is adjustable to allow for difference in size of shells. A safety locking pin is located near the end of the lever and holds the handle in a locked position when it is pulled out and dropped over the angle welded near the end of the handle. The metal compartment at the front of the trailer is welded to the body and the A-frame. It serves as a storage space for the fuzes, fuze primers, tools, and service manuals. The rear of the body is equipped with hinged steel doors which are held

closed at the top by a steel channel retainer, and at the bottom by the retracted rear prop. The channel retainer is held in locked position by a safety snap. The rear doors are equipped with continuous piano-type hinge, welded to side of body. A spring-loaded rope, welded permanently to the front of the trailer body and fastened to a special rop-loc at the rear of the body, holds the tarpaulin higher in the center. Two rop-loc hooks are welded to each corner of the body for tying tarpaulin securely over the body load. Four steel lifting rings are welded at the corners of the body. Six binding straps are looped around a pipe on each side of the body and bolted together. These straps hold the powder containers securely in the body.

b. Data.

(1) DIMENSIONS.

Center of axle to center of lunette eye	91 in.
Minimum axle clearance under U-bolt at full load	12 ⁷ / ₈ in.
Lunette eye height:	
With trailer in loaded level position, height from ground	
to horizontal center line of lunette eye	27 in.
Tread width, center-to-center	83 in.
Angle of departure	30 deg
Length, over-all	144 in.
Length, inside body	83 ¹ / ₂ in.
Width, over-all	98 in.
Width, inside body	87 in.
Height, over-all	75 in.
Height, inside body	40 in.

(2) DRAWBAR.

Make	Trailer Company of America
Type	Integral with body
Lunette eye dimensions	3 ⁵ / ₈ -in. I.D. x 6 ⁵ / ₈ -in. O.D.

(3) FUZE BOX*.

Width	39 ¹ / ₄ in.
Height	28 ¹ / ₂ in.
Depth	17 in.
Capacity (fuze)	6 boxes

(4) SHELL RACKS.

Capacity:	
4.5-inch gun ammunition	102 rounds**
155-mm howitzer ammunition	72 rounds**

*Dimensions shown do not include portion of front compartment reserved for tools, service manuals, and primers.

**Complete round includes projectile and propelling charge. Fuze and primer are located in fuze box compartment.

*Body, Frame, Drawbar, Shell Racks, and Landing Wheel***105. INSPECTION AND REPAIR.**

- a. Inspect body and A-frame for cracks in steel members or at welds. Reweld or splice new section.
- b. Straighten bent body members and bracket members in conventional manner. Do not overheat steel.
- c. Check lifting rings, rop-locs, towing eyes, and handles for rigid welding. Reweld if loose.
- d. Inspect lunette eye for damage or looseness. Tighten or replace (par. 82 b and c).
- e. Check tarpaulin spring-loaded rope for proper tension (par. 86).
- f. Check tarpaulin and tarpaulin ropes. All ropes must be in good condition in order to secure tarpaulin over corners of body. Repair tarpaulin if torn.
- g. Replace missing shell rack bolts (welded to the sides of the body).
- h. Replace landing wheel latch pin spring if tension of spring is gone, and latch pin fails to lock landing wheel in position (par. 75 c and d).
- i. Remove damaged section from body or A-frame by cutting across the outside of the damaged section at a 30-degree angle.
- j. Cut splice section at a 30-degree angle to fit section removed. By cutting at a 30-degree angle, the cut and the weld are distributed over a greater area and result in a stronger weld.
- k. Back up all spliced joints with a plate or channel reinforcement extending about 6 inches on each side of the joint on the inner side of the splice section. The reinforcing member should be at least as thick as the splice section. The width of the reinforcing plate should be the same as the splice section unless the splice section is a channel. In that case, the over-all width of the reinforcing plate should be made to fit inside the channel.
- l. To repair slight cracks in body or A-frame or to repair broken welds, weld the broken place and reinforce it, if possible, with an additional backing plate.
- m. Weld loose lifting rings, rop-locs, towing eyes, and handles direct to body or A-frame steel member.
- n. If upper shell rack hinge studs work loose or are missing, insert either $\frac{3}{4}$ -16 x $2\frac{1}{4}$ -inch or $\frac{3}{4}$ -16 x $3\frac{1}{4}$ -inch hex head cap screws

through side panel and channel from outside of body. Tack weld head of cap screw to body. Remove wheel and tire assembly if necessary (par. 46).

o. Straighten bent steel rods in conventional manner. Do not overheat steel.

p. Straighten rear door assemblies in conventional manner by heating and hammering and the use of jacks where practical. Do not overheat steel. Weld outside edges of piano-type hinge to door panel and to rear post by welding 1 inch and skipping 2 inches. Tack-weld each segment of hinge barrel to door panel and to rear post.

q. Slightly bent shell racks can be straightened by applying heat and hammering. If cups and shell racks are damaged beyond serviceability, replace shell rack.

APPENDIX

Section XXXI

SHIPMENT AND LIMITED STORAGE

106. GENERAL INSTRUCTIONS.

a. Preparation for domestic shipment of the vehicle is the same, with the exception of minor added precautions, as preparation for limited storage. Preparation for shipment by rail includes instructions for loading the vehicle, blocking necessary to secure the vehicle on freight cars, and other information necessary to properly prepare the vehicle for domestic rail shipment. For more detailed information and for preparation for indefinite storage, refer to AR 850-18 and FM 9-25.

107. PREPARATION FOR LIMITED STORAGE OR DOMESTIC SHIPMENT.

a. **General.** Vehicles to be prepared for limited storage or domestic shipment are those temporarily out of service for less than 30 days, or vehicles that must be ready for operation on call. If the vehicles are to be indefinitely stored after shipment by rail, they will be prepared for such storage at their destination.

b. **Limited Storage.** If the vehicles are to be placed in limited storage, take the following precautions:

- (1) **LUBRICATION.** Lubricate the vehicle completely (par. 24).
- (2) **TIRES.** Clean, inspect, and properly inflate all tires. Replace with serviceable tires all tires requiring retreading or replacing. Do not store vehicles on floors, cinders, or other surfaces which are soaked with oil or grease. Wash off any oil, grease, gasoline, or kerosene which comes in contact with tires under any circumstances.
- (3) **ROAD TEST.** The preparation for limited storage will include a road test of at least 5 miles, after lubrication and tire services have been made, to check on general condition of the vehicle. Correct any defects noted in the vehicle operation before the vehicles are stored, or attach a tag to parking brake lever stating the repairs needed or describing the conditions present. A written report of these items will then be made to the officer in charge.
- (4) **EXTERIOR OF VEHICLE.** If time permits, remove rust from any part of the vehicle exterior with flint paper. Repaint painted surfaces whenever necessary to protect wood or metal. Coat exposed polished surfaces susceptible to rust, such as chains, with medium grade preservative lubricating oil. Close the doors firmly and lock in place with the rear prop. Equipment, such as tools, will remain in place in the vehicle.

(5) **CARE OF AMMUNITION.** Remove all shells, powder fuzes, and primers from vehicle to be packed and shipped according to AR 30-955. Refer to TM 9-1900.

(6) **INSPECTION.** Make a systematic inspection just before shipment or limited storage to insure all above steps have been covered, and that the vehicles are ready for operation on call. Make a list of all damaged or missing items and attach to the parking brake lever. Refer to the Before-operation Service (par. 27).

(7) **BRAKES.** Release brakes, and chock the wheels.

c. **Inspections in Limited Storage.** Vehicles in limited storage will be inspected weekly for condition of tires to be sure the vehicle will be ready for operation on call.

108. LOADING AND BLOCKING FOR RAIL SHIPMENT.

a. **Preparation.** In addition to the preparation described in paragraph 107, when Ordnance vehicles are prepared for domestic shipment, the following preparations and precautions must be taken:

(1) **TIRES.** Inflate tires from 5 to 10 pounds above normal pressure.

(2) **EXTERIOR.** Place tarpaulin in place and lash down securely. Cover entire vehicle with a canvas cover if available.

(3) **MARKING CARS.** All cars containing Ordnance vehicles must be placarded "DO NOT HUMP."

b. **Placing Vehicles on Cars.**

(1) **TYPES OF CARS.** Ordnance vehicles may be shipped on flat cars, end door box cars, side door cars, or drop-end gondola cars, whichever type is the most convenient.

(2) **FACILITIES FOR LOADING.** Whenever possible, load and unload vehicles from open cars, using permanent end ramps and spanning platforms. Movement from one flat car to another along the length of the train is made possible by crossover plates or spanning platforms. If no permanent end ramp is available, an improvised ramp can be made from railroad ties. Vehicles may be loaded in gondola cars without drop ends by using a crane.

(3) **BRAKE WHEEL CLEARANCE.** If flat cars are used, position the vehicle with a brake wheel clearance of at least 6 inches (A, fig. 38). Locate the vehicles on the car in such a manner as to prevent the car from carrying an unbalanced load. Apply the brakes.

c. **Securing Vehicles.** In securing or blocking vehicles, three motions, lengthwise, sidewise, and bouncing, must be prevented. Two methods for blocking vehicles on freight cars (fig. 38) are given below. The following instructions apply when the trailer is shipped without the transporting vehicle. Remove the ammunition, fuzes, powder, and primers to be shipped in crates or boxes provided. Do not remove the trailer wheels since the tires are required to give a cushioning effect to the trailer during shipment.

Shipment and Limited Storage

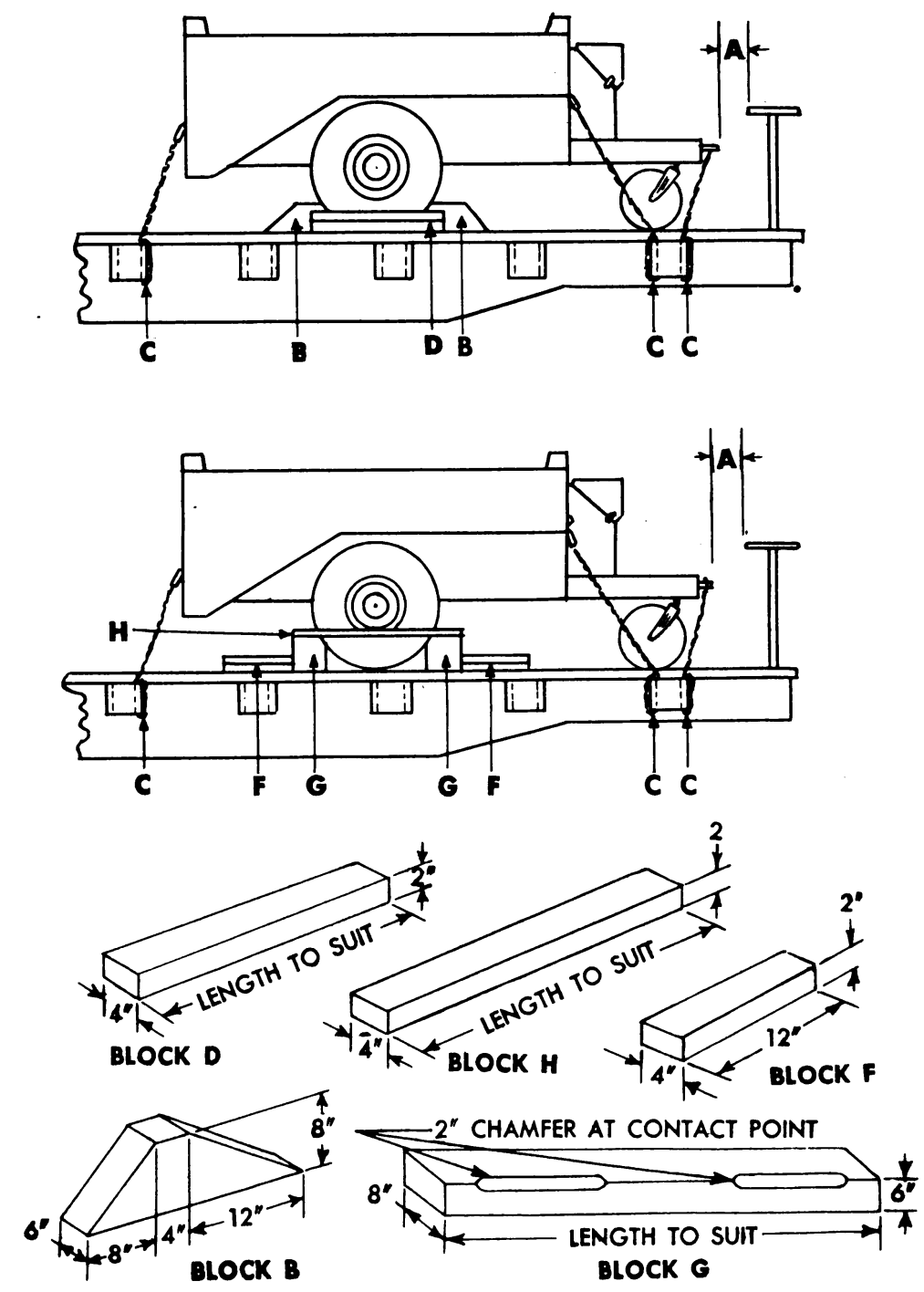

RA PD 345069

Figure 38—Blocking Requirements for Rail Shipment

(1) **METHOD 1.** After locating the trailer on the car, place landing wheel in position to hold trailer in a horizontal position (fig. 38). The rear prop must be placed in a retracted position to hold doors firmly closed. Locate four blocks (B), one to the front and one to the rear of each wheel. Nail the heel of each block to the car floor with five 40-penny nails. Toenail the portion of the block under the tire to the car floor with two 40-penny nails. Locate two cleats (D) against the outside face of each wheel. Nail the lower cleat (D) to the freight car floor with three 40-penny nails, and the top cleat to the cleat below with three 40-penny nails. When a flat car is used, pass four strands, two wrappings, of No. 8-gage black annealed wire (C) from the four lifting rings to the nearest stake pockets, and tighten enough to remove slack. In a similar manner, tie the lunette ring to both sides of the car. When a box car is used, this strapping must be applied in a similar fashion and attached to the floor by use of blocking or anchor plates. This strapping is not required when gondola cars are used.

(2) **METHOD 2.** After locating the trailer on the car, place landing wheel in position to hold trailer in a horizontal position (fig. 38). The rear prop must be in retracted position to hold the doors firmly closed. Locate two blocks (G), one to the front and one to the rear of each wheel. *NOTE: These blocks (G) must be at least 8 inches wider than the over-all width of the vehicle at the freight car floor.* Locate eight cleats (F), two against blocks (G) to the front and rear of each blocked wheel. Nail lower cleats to the freight car floor with three 40-penny nails, then nail top cleat (F) to lower cleat (F) with three 40-penny nails. Position two cleats (H), one over two cleats (G) and against the outside of each blocked wheel. Nail each end of cleat (H) to cleats (G) with three 40-penny nails. Pass four strands, two wrappings, of No. 8-gage, black annealed wire (C fig. 38) through the lifting rings at each corner of the vehicle and attach to the nearest stake pockets. In a similar manner, tie the lunette ring to each side of the car. Tighten the wires enough to remove a slack. When a box car is used, this strapping must be used in a similar fashion and attached to the floor with blocking or anchor plates. The strapping is not required when a gondola car is used.

d. Shipping Data.

Length, over-all	144 in.
Width, over-all	98 in.
Height, over-all	75 in.
Shipping weight	5,300 lb
Area of car floor occupied by vehicle (approximate) ..	98 sq ft
Volume occupied per vehicle (approximate)	612 cu ft
Bearing pressure (lb per sq ft)	54

References

Section XXXII

REFERENCES

109. PUBLICATIONS INDEXES.

The following publications indexes should be consulted frequently for latest changes to or revisions of the publications given in this list of references and for new publications relating to materiel covered in this manual:

Ordnance Catalog (explains SNL system)	ASF Cat. ORD-1 IOC
Ordnance publications for supply index (index to SNL's)	ASF Cat. ORD-2 OPSI
Index to Ordnance Publications (lists FM's, TM's, TC's, and TB's of interest to Ordnance personnel, MWO's, OPSR's, BSD, S of SR's, OSSC's and OFSB's, includes alphabetical listing of Ordnance major items with publications pertaining thereto)	OFSB 1-1
List of publications for training (lists MTP's, TR's, TC's, FM's, TM's, WDTB's, Firing Tables and charts and Lubrication Orders)	FM 21-6
List of administrative and supply publications (lists MP's, MWO's, SB's, RR's, and War Department Pamphlets)	WD Pamphlet 12-6
List of training films, film strips and film bulletins (lists TF's, FS's, and FB's by serial number and subject)	FM 21-7
Military training aids (lists graphic training aids, models, devices and displays)	FM 21-8

110. STANDARD NOMENCLATURE LISTS.

a. Ammunition.

Ammunition, blank, for pack, light and medium field, tank, and antitank artillery	ORD 11 SNL R-5
Ammunition, fixed and semifixed, including subcaliber, for pack, light and medium field, aircraft, tank, and antitank artillery, including complete round data	ORD 11 SNL R-1

Appendix

Ammunition instruction material for pack, light and medium field, aircraft, tank, and antitank artillery	ORD 11 SNL R-6
Projectiles and propelling charges, separate loading, for medium field artillery, including complete round data	ORD 11 SNL R-2
Service fuzes and primers for pack, light and medium field, aircraft, tank, and antitank artillery	ORD 11 SNL R-3
b. Maintenance.	
Cleaning, preserving and lubricating materials; recoil fluids, special oils, and miscellaneous related items	ORD 5 SNL K-1
Soldering, brazing and welding materials, gases and related items	ORD 5 SNL K-2
Tool-sets, for ordnance service command automotive shops	SNL N-30
Tool-sets (common), specialists' and organizational	ORD 6 SNL G-27 (section 2)
Tool-sets (special), automotive and semi-automotive	ORD 6 SNL G-27 (section 1)
c. Trailer, 4-ton, 2-wheel, ammunition, M21	SNL G-213

111. EXPLANATORY PUBLICATIONS.

a. Fundamental Principles.	
Ammunition, general	TM 9-1900
Basic maintenance manual	TM 38-250
Driver selection and training	TM 21-200
Driver's manual	TM 10-460
Electrical fundamentals	TM 1-455
Field artillery and field mortar ammunition	OFSB 3-3
Military motor vehicles	AR 850-15

References

-
- Motor vehicle inspections and preventive maintenance service TM 9-2810
- Ordnance service in the field..... FM 9-5
- Precautions in handling gasoline..... AR 850-20
- Qualifications in arms and ammunition training allowances AR 775-10
- Range regulations for firing ammunition for training and target practice..... AR 750-10
- Standard military motor vehicles..... TM 9-2800
- Targets, target material, and training course lay-outs TM 9-855
- b. Maintenance and Repair.**
- Cleaning, preserving, sealing, lubricating and related materials issued for ordnance materiel TM 9-850
- Maintenance and care of pneumatic tires and rubber treads TM 31-200
- Ordnance maintenance: Power brake systems (Bendix-Westinghouse) TM 9-1827A
- c. Protection of Materiel.**
- Camouflage FM 5-20
- Decontamination TM 3-220
- Decontamination of armored force vehicles... FM 17-59
- Defense against chemical attack..... FM 21-40
- Explosives and demolitions..... FM 5-25
- d. Storage and Shipment.**
- Ordnance company, depot..... FM 9-25
- Ordnance storage and shipment chart—group G—major items OSSC-G
- Registration of motor vehicles..... AR 850-10
- Rules governing the loading of mechanized and motorized army equipment, also major caliber guns, for the United States Army and Navy, on open top equipment published by Operations and Maintenance Department of Association of American Railroads.
- Storage of motor vehicle equipment..... AR 850-18

INDEX

A	Page		Page
Accessories	8	Blocking for rail shipment	112
After-operation and weekly service	31	Body	
Air brake cylinder	12	after-operation service	32
Air brake power system		at-halt service	30
description and data	65	before-operation service	29
leaks	36	data	92, 108
removal and installation	70	description	5, 92, 107
road test (leaks)	36	during-operation service	30
testing for serviceability	66	inspection and repair	109
trouble shooting	41	maintenance operations	38
Air brake tanks		service upon receipt	12
after-operation service	32	submersion	20
before-operation service	29	trouble shooting	45, 99
Air brakes		Brake chamber, description and	
connecting lines	16	testing	71
during-operation service	30	Brake drums	
maintenance operations		at-halt service	30
brakes	38	maintenance operations	36
reservoirs and valves	37	road test	36
trouble shooting	41	Brake lines	
Air filter		maintenance operations	38
description and testing	74	trouble shooting	99
installation	76	Brake mechanism	
removal	75	description and data	61
Ammunition racks	38	trouble shooting	40, 98
Ammunition trailer M21		Brake shoes	
description	5	description and removal	63
operation of controls	13	installation	
(See also vehicle)		linings and bushings	104
Axles		shoes	63
alinement	60	lubrication of rollers and cams	26
cleaning and inspection	105	maintenance operations	36
data	7, 59, 105	removal of linings and	
description	59, 105	bushings	102
maintenance	38	Brake spider	
removal and installation	51, 59	description	101
repair	106	disassembly, cleaning, inspec-	
trouble shooting	40, 98	tion, and repair	102
		installation	104
B		Brakes, parking	
Beadlock	54	adjustment and removal	83
Before-operation service	28	data	7
Blackout switch	91	description	5, 81
		installation	84

Index

B—Contd.	Page	Page	
Brakes, parking (Contd.)		Dummy couplings (See Couplings)	
maintenance operations	39	During-operation service	29
operation	13	Dust shields	65
releasing	16	Duty Roster (W.D., A.G.O. Form	
road test	35	No. 6)	27
submersion	20		
service upon receipt	12	E	
trouble shooting	44	Electrical system	6, 87
Brakes, service		Electrical wiring	12
adjustment	61	Equipment	
data	7	auxiliary	97
description	5	before-operation service	29
dragging, grabbing, or noisy	41	maintenance operations	39
maintenance operations	36	on-vehicle	9
road test	35	operation	17
service upon receipt	12	service upon receipt	11, 13
trouble shooting	40, 99	Exhaust check valve	
(See also Air brakes)		description and testing	76
C		removal and installation	77
Cables			
connecting jumper	16	F	
disconnecting jumper	17	Filter (See Air filter)	
Cam wear plate		Final road test	39
installation	104	Fittings (See Tubing and fittings)	
removal	102	Frames	
Camshaft, description, removal,		data	92, 108
and installation	64	description	92, 107
Coupling socket		inspection and repair	109
description and removal	87	maintenance operations	38
installation	88	trouble shooting	45, 99
Couplings (hose and dummy)	77	Fuze box, data	108
Cylinders, air brake	12		
D		H	
Demolition to prevent enemy use	21	Hose, description	79
Diaphragm (air brake)	43	Hub and drum assembly	
Dimensions data	6, 108	inspection, maintenance, and	
Drawbar		installation	57
data	8, 92, 108	removal	56
description	92	Hubs	
inspection and repair	109	at-halt service	30
Drivers trip ticket and Preventive		data	52
Maintenance Service Rec-		description	51
ord, W.D. Form No. 48	28	road test	36
Drain cock, description, testing,			
removal, and installation	74		

Index

L	Page	Page
Lamp-unit replacement	91	MWO and Major Unit Assembly Replacement Record, W.D., A.G.O. Form No. 478
Lamps (lights)		39, 50, 53, 56
after-operation service	31	
before-operation service	29	
maintenance operations	38	
service upon receipt	12	
Landing wheel		O
data	7, 85, 107, 108	Oilcan points
description	5, 84	26
inspection and repair	109	Operating instructions
lowering	17	11
maintenance	39	
operation	13	P
raising	16	Powder container binding straps
removal and installation	86	description
trouble shooting	45	19, 95
Leaks		removal and installation
airbrake power system	36, 66	95
brake chamber	71	trouble shooting
relay emergency valve	70	46
reservoir	73	Preventive Maintenance Service
Lights		• Work Sheet for Wheeled and Half-track vehicles, W.D., A.G.O. Form No. 461
data	8	35
description	6	Prop supports, rear
trouble shooting	45	description
Limited storage	111	86
Load		operation
after-operation service	32	15
at-halt service	30	raising
before-operation service	29	16
Lubrication		removal and installation
equipment for	25	87
points of application	26	
under unusual conditions	19	R
Lubrication order	23	Radius rods
Lunette eye, drawbar		adjustment, description, removal and installation
data	108	50
description	92	cleaning, inspection, and repair
removal and installation	93	101
		data
M		7, 99
Maintenance		description
cold weather	19	99
driver (first echelon)	28	trouble shooting
instructions	23	98
preventive	27	Rail shipment, loading and blocking
		112
		Reflex reflectors
		96
		Relay emergency valve
		description and testing
		69
		trouble shooting
		44
		Reports and records
		1, 27
		Reservoirs
		73
		Road test
		35
		Rims
		data
		6
		(See also <i>Wheels and Tires</i>)

Index

S		Page
Services		
after-operation and weekly	31	
at-halt service	30	
before-operation	28	
special	34	
Shell racks		
data	92, 108	
description	92, 93, 107	
inspection and repair	109	
operation	17	
removal and installation	95	
trouble shooting	46	
Shields, dust (See Dust shields)		
Shipping data	114	
Shipment and storage	111	
Slack adjuster		
description, testing, and removal	72	
installation	73	
Special services	34	
Spring-loaded rope	96	
Springs		
after-operation service	31	
at-halt service	30	
before-operation service	29	
cleaning, inspection, repairs, and assembly	101	
data	8, 48, 99	
description	48, 99	
disassembly	100	
installation	49	
maintenance operations	38	
removal	48	
service upon receipt	12	
Stowage compartment	38	
Suspensions		
after-operation service	31	
at-halt service	30	
before-operation service	29	
data	46	
description	5, 46	
service upon receipt	12	
trouble shooting	40, 98	
T		
Taillights		
data	8	
description	6, 89	
removal and installation	89	
(See also Electrical system)		
Tampering and damage	29	
Tarpaulin rope center support	96	
Tests		
air brake power system	66	
brake chamber	71	
relay emergency valve	69	
reservoir	73	
slack adjuster	72	
Tires		
after-operation service	31	
at-halt service	30	
before-operation service	29	
data	6, 52	
description, removal, and installation	54	
maintenance operations	36	
service upon receipt	12	
trouble shooting	44	
Tools		
after-operation service	33	
before-operation service	29	
maintenance operations	39	
on-vehicle	8	
service upon receipt	13	
special organizational	23	
Torque (radius) rods	37	
Tow hitch	39	
Towing connections		
after-operation service	32	
at-halt service	30	
before-operation service	29	
service upon receipt	12	
Trouble shooting	40, 98	
Truck-trailer combination	16	
Tubes		
data	6, 52	
description, removal, and installation	54	
trouble shooting	44	
Tubing and fittings		
description	80	
testing, removal, and installation	81	

