

TM 11-433

WAR DEPARTMENT

TECHNICAL MANUAL

TIME INTERVAL APPARATUS EE-56,
EE-85, EE-86-A
LINE CONNECTOR UNIT EE-87
TIME INTERVAL SIGNAL BE-65
AND BELL MC-153

August 17, 1942

W113
10

TM 11-433

TECHNICAL MANUAL }
No. 11-433

WAR DEPARTMENT,
WASHINGTON, August 17, 1942.
TM 11-433
1942

**TIME INTERVAL APPARATUS EE-56, EE-85, EE-86-A, LINE
CONNECTOR UNIT EE-87, TIME INTERVAL SIGNAL BE-65,
AND BELL MC-153**

SECTION I. General.

	Paragraph
Purpose.....	1
Use.....	2
Description.....	3
Capabilities.....	4
II. Employment.	
Installation.....	5
Preparation for use.....	6
Operation.....	7
III. Detailed functioning of parts.	
Time interval apparatus EE-56.....	8
Time interval apparatus EE-86-A.....	9
Time interval apparatus EE-85.....	10
Line connector unit EE-87.....	11
Time interval signal BE-65.....	12
IV. Servicing and repair.	
Servicing.....	13
Inspection.....	14
Lubrication.....	15
Special adjustments.....	16
V. Lists of replaceable parts.	
Time interval apparatus EE-56.....	17
Time interval apparatus EE-86-A.....	18
Time interval apparatus EE-85.....	19
Line connector unit EE-87.....	20
Time interval signal BE-65.....	21
	Page
APPENDIX. Addresses of manufacturers.....	66

**SECTION I
GENERAL**

	Paragraph
Purpose.....	1
Use.....	2
Description.....	3
Capabilities.....	4

M558382

1. **Purpose.**—*a.* Time interval apparatuses EE-56, EE-85, and EE-86-A* are designed to afford chronological coordination of all functions of fire control of the Coast Artillery Corps. The battery commander and personnel concerned with the several functions at observation posts, plotting rooms, and gun positions thus to a great extent are guided and their functions coordinated, by means of proper control of the time element, through accurate time interval programs.

b. Time interval apparatuses EE-56 and EE-86-A, with the associated bells MC-153, are designed for use in permanently installed fire-control systems of fixed seacoast artillery. Time interval apparatus EE-86-A is of later design and includes certain improvements and refinements.

c. Time interval apparatus EE-85, with the associated line connector unit EE-87 and time interval signal BE-65, is designed for use in fire-control systems of mobile seacoast artillery.

2. **Use.**—*a. General.*—(1) Seacoast artillery must be able to fire simultaneously on a number of relatively small, rapidly moving, armored targets; make necessary changes in types of projectiles or weights of propelling charges; and take full advantage of fleeting opportunities to deliver an intensive and accurate fire.

(2) Time interval equipment is, therefore, an integral part of fire-control communication systems of both fixed and mobile seacoast artillery.

b. Provision for time interval signals.—(1) In fixed seacoast artillery, either time interval apparatus EE-56 or time interval apparatus EE-86-A is used to provide the timing of time interval signals. Either is capable of providing time intervals suitable for any or all elements of armament controlled from one fire-control switchboard without requiring relays and local power supply in distant stations. A section of the regimental headquarters battery, except in the case of separate battalions, is responsible for operation and maintenance of the fire-control communication system, including the time interval system. Installations and major repair or replacement are the responsibility of the corps area signal officer.

(*a*) The EE-56 produces electrical signal impulses at 10-, 15-, 20-, and 30-second intervals concurrently. The time interval impulses are transmitted to bells MC-153 at observation posts, plotting rooms, battery commanders' rooms, and gun wells and platforms of gun emplacements. Additional auxiliary equipment is necessary for switching desired time interval signals to all batteries and distributing the signals to various locations within each firing battery. Switch-

*No production was ever made under the nomenclature "time interval apparatus EE-86," the first production having been designated "EE-86-A."

boards BD-15 (time interval switch-panel), BD-74, or BD-78, provide for switching any one of the four time intervals to each firing battery. Frame FM-5 provides for distributing the time interval signals in use in each battery to all bells employed within the battery time interval system.

(b) Time interval apparatus EE-86-A differs from the EE-56 in that it produces electrical signal impulses for 1-, 5-, 10-, 15-, 20-, 30-, 40-, and 60-second intervals and ordinarily would be used with either switchboard BD-74 or switchboard BD-78, both of which provide for switching and distribution.

(2) In mobile seacoast artillery, time interval apparatus EE-85, line connector unit EE-87, time interval signal BE-65, and batteries BB-50 are used to supply desired time interval signals. In mobile units, each battery is responsible for installation, operation, and maintenance of its own time interval equipment; each is supplied with one time interval apparatus EE-85, one line connector unit EE-87, five time interval signals BE-65, and two batteries BB-50 (12-volt storage).

(a) The EE-85 produces electrical signal impulses for 1-, 5-, 10-, 15-, 20-, 30- and 45-second intervals, or other specially desired intervals as explained in paragraph 3c(4)(b) and (c).

(b) Line connector unit EE-87 produces a 1,000-cycle tone which is superimposed on telephone lines in signal impulses as determined by time interval apparatus EE-85, to which it is connected.

(c) Time interval signals BE-65 are installed at gun positions and in the plotting room. The time interval signals BE-65 are connected directly to the time interval apparatus EE-85.

3. Description.—*a. Time interval apparatus EE-56.*—This apparatus is mounted on a hollow oak base and is provided with a protecting oak cover (fig. 1). A bakelite terminal strip with seven binding posts and a dial switch is mounted at the front of the base. The dial switch positions are designated OFF and ON. Two binding posts are marked 30 VOLTS d-c for connection to 30-volt direct-current power supply, and five binding posts are marked C, 10, 15, 20, and 30 for connection to the common connection and 10-, 15-, 20-, and 30-second connections respectively of the time interval program circuits. The motor, governor, cam arbor, and contactor assemblies are mounted on a bronze casting which is bolted to the oak base. Over-all dimensions of the complete unit are 13¾ by 10½ by 14¼ inches and the net weight is 45 pounds.

(1) The motor is of series type, runs at 1,280 revolutions per minute with 30-volt direct-current power supply, and is equipped with ball bearings. The motor is mounted vertically on the front end of the

bronze frame, and the adjustable-speed centrifugal-type governor is mounted on an extension of the motor shaft. A 100-ohm resistor is in series with the motor circuit. The motor drives a cam arbor through a gear train consisting of two stages of speed reduction. One stage is at the worm gear cut on the extended motor shaft and the other is a set of spur gears, the larger of which is mounted with the cam arbor assembly as the driving gear. The smaller spur gear is cut on one end of the shaft on which the worm wheel is mounted.

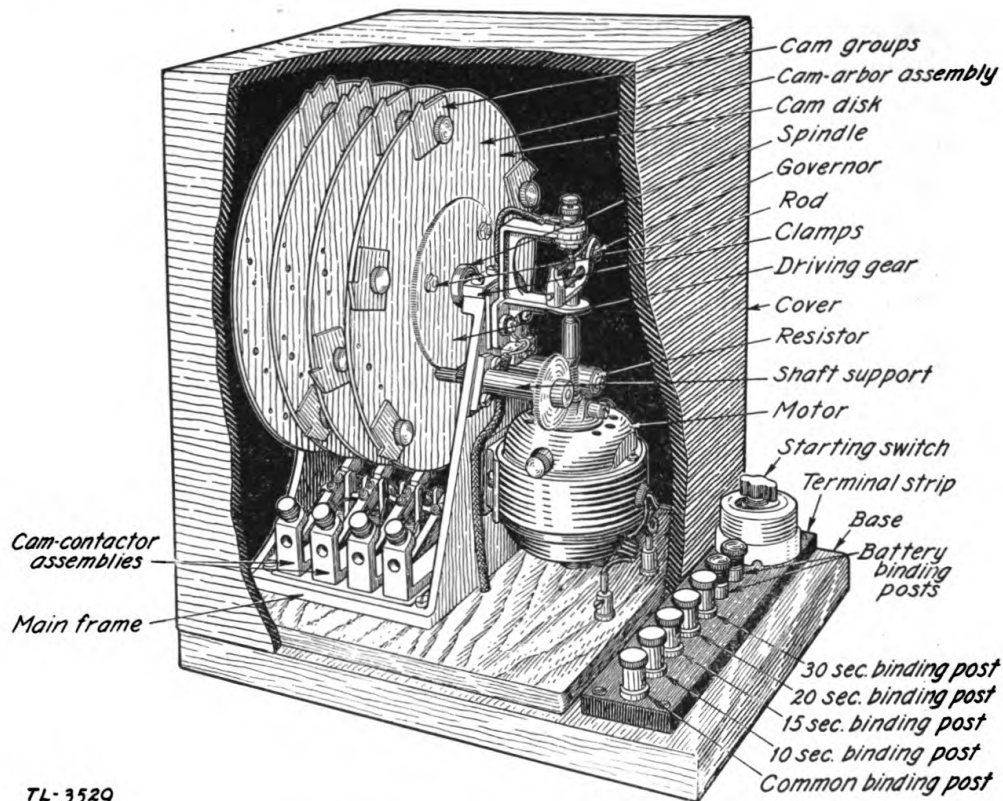

FIGURE 1.—Time interval apparatus EE-56.

(2) The cam-arbor assembly is mounted on a spindle carried by a stationary steel shaft clamped at front and rear by two brackets which form part of the frame casting. The spindle revolves about the stationary shaft on ball bearings, and is pinned to the driving gear at the front end. The driving gear and four cam disks and the bushings for separating them are mounted on the spindle and on three rods. The front ends of the rods are bolted to the driving gear at three equidistant points close to the periphery of the gear. The other ends of the rods are bolted to the fourth cam disk which is pinned to the arbor spindle to prevent lateral movement of the cam disks. All four cam disks are equipped with cam groups having projections which operate con-

factors associated with the cam disks. Each cam group is fitted with two dowel pins and a knurled-head screw which fit into two drilled holes and one drilled and tapped hole close to the periphery of the cam disk, and secure the group in place. All four cam disks are drilled and tapped to receive cam groups necessary for any one of the four time intervals. All disks and cam groups are interchangeable.

NOTE: Time interval apparatus EE-56 is normally assembled when issued so that cam groups are arranged for 10-, 15-, 20-, and 30-second synchronized intervals on the first, second, third, and fourth disks from the front of the apparatus. The first disk has six three-projection cam groups equally spaced at 60°, each producing the firing signal and 1- and 2-second warning signals. The second disk has four three-projection cam groups equally spaced at 90°, and the third disk has three equally spaced at 120°. The fourth disk has two three-projection cam groups equally spaced at 180°, each producing the firing and warning signals, and two single-projection cams leading the other cam groups by 30°, each producing a 5-second warning signal. Each disk is drilled and tapped in the same manner so that if the cam groups are rearranged, any disk can produce any of the four intervals and also a 60-second interval to meet the needs of the particular harbor defense project. Several additional single-projection and three-projection cam groups are included so that various arrangements of preliminary, warning, firing, and observing signals are possible.

(3) Four cam-contactor assemblies are mounted on the base of the casting and are insulated from it by a bakelite strip. Each has screw adjustments for duration of contact closure and for operation of rubber bumpers which cushion the fall of the rocker arms.

b. Time interval apparatus EE-86-A.—This is constructed similarly to time interval apparatus EE-56 (fig. 2). Important changes are the use of mahogany instead of oak, addition of four cam disks to gain four more time intervals, increase of speed of the motor to 1,380 revolutions per minute, addition of a master timing contact (fig. 3), an improved type of motor governor, and inclusion of a stroboscopic tuning fork. Mounted on the terminal strip are a toggle switch and eleven binding posts to accommodate the four additional time interval program circuits. The positions of the switch and the battery and time interval binding posts are designated as are those of the EE-56. Over-all dimensions of the complete unit are 18 by 11 by 15½ inches, and the net weight is 72 pounds.

(1) (a) The improved governor is more positive in its adjustment and operation. The governor gives constant motor shaft speed within ± 0.25 percent at 27 to 30 volts.

(b) The stroboscopic tuning fork is contained in a compartment in the rear of the base of the apparatus. It is used to regulate the motor speed, having a frequency such that when it indicates a stationary pattern of the governor the speed of the motor is 1,380 revolutions per

minute (± 0.05 percent). The fork is made of chromium steel alloy and the ends of the tines are each fitted with slotted brass pieces. The entire fork is fastened securely in a black metal case which has apertures to make it possible to look through the slots of the fork.

(2) A master 1-second timing-contact cam is driven through another worm gear by the same worm which drives the cam-arbor

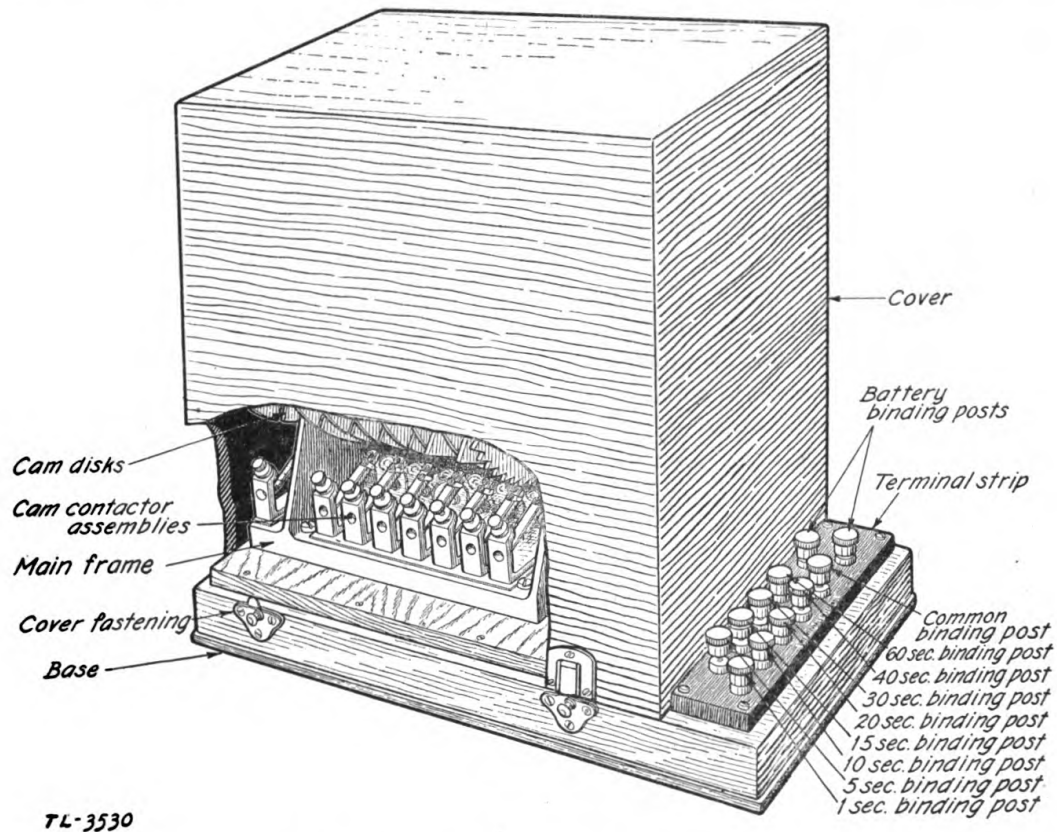

FIGURE 2.—Time interval apparatus EE-86-A.

worm gear. This cam operates the master timing contact which acts as the make contact of all time interval circuits.

(3) Additional disks and an improved method of spacing the drilled and tapped holes are used in the cam-arbor assembly of the EE-86-A. Seven disks are mounted in the same way as the four disks of the EE-56. The eighth cam disk is pinned to a secondary spindle mounted on an extension of the arbor shaft. This secondary spindle is driven from the forward spindle through a two-stage spur-gear train providing a step-up ratio of two to three, so that it rotates at $1\frac{1}{2}$ revolutions per minute. The first cam disk is cut from one piece of steel to provide 60 projections equally spaced around its periphery. The next six cam disks are drilled and tapped to receive cam groups

at twelve equidistant points about their peripheries. The eighth cam disk, which is located on the $1\frac{1}{2}$ -revolutions-per-minute spindle, is drilled and tapped at eight equidistant points around its periphery. Cam groups of the eighth cam disk are not interchangeable with those of the other six drilled and tapped disks.

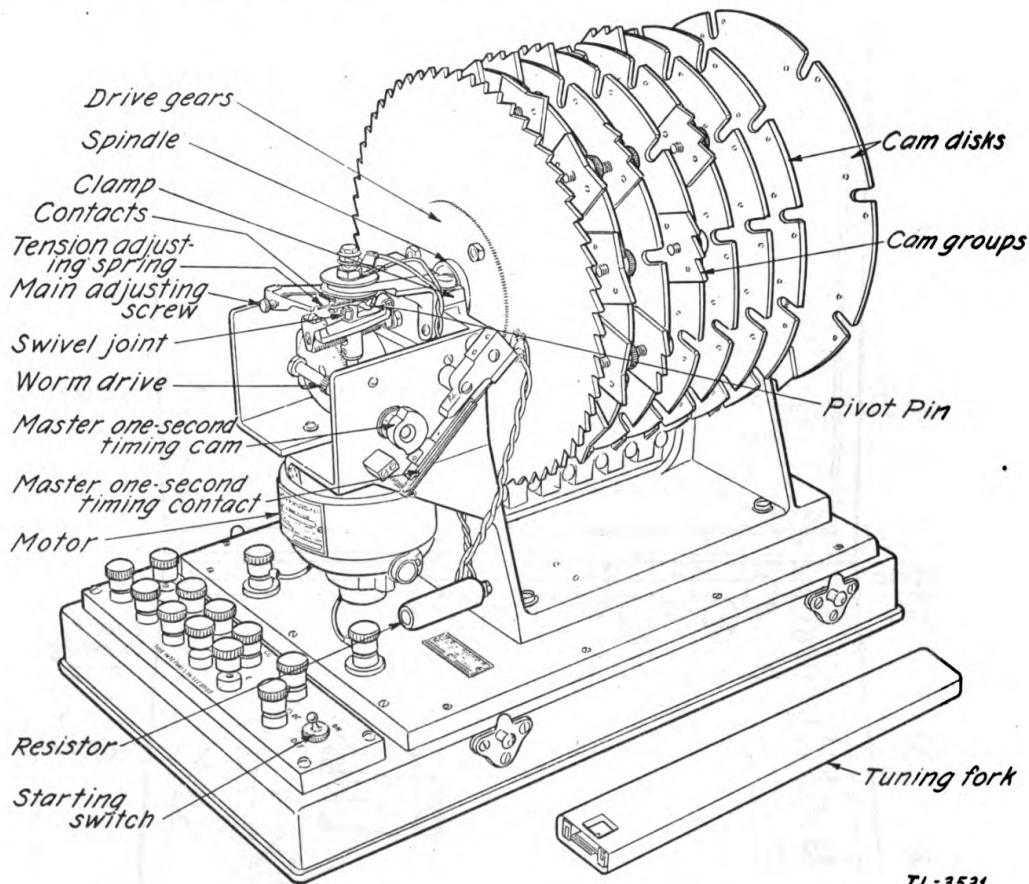

FIGURE 3.—Time interval apparatus EE-86-A—master 1-second timing contact and governor.

NOTE: Time interval apparatus EE-86-A is normally assembled so that cam groups are arranged for 1-, 5-, 10-, 15-, 20-, 30-, 40-, and 60-second synchronized intervals on successive disks from the front of the apparatus. The projections are cut into the periphery of the 1-second disk, and the 5-second disk has twelve single-projection cams equally spaced at 30° . The 10-second disk has six three-projection cam groups equally spaced at 60° , each producing the firing signal and 1- and 2-second warning signals. The 15-second disk has four three-projection cam groups equally spaced at 90° , the 20-second disk has three at 120° , the 30-second disk has two at 180° , the 40-second disk has one, and the 60-second disk has one. Because cam groups are interchangeable for all but the 1- and 40-second disks, any of the other six intervals may be produced on any of the six disks, if cam groups are rearranged to meet the needs of a particular harbor defense project. Additional single-projection and three-projection cam groups are provided so that various arrangements of preliminary, warning, firing, and observing signals are possible.

c. *Time interval apparatus EE-85.*—This apparatus is contained in a birch case with hinged cover and web carrying strap. A flush-hasp clasp holds the cover securely in place. A spring-hinged section on the left side of the cover provides entrance for field wire and battery

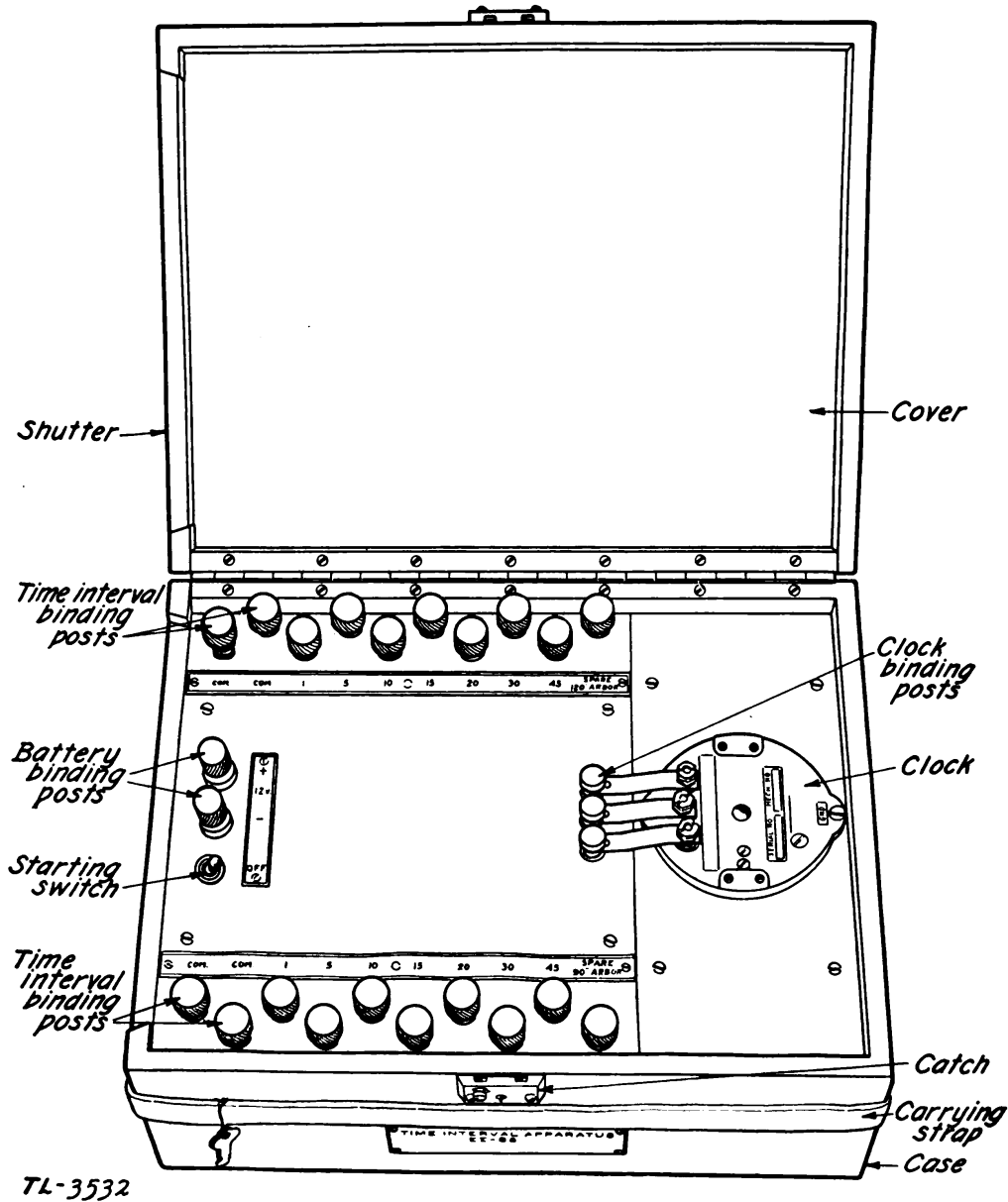

FIGURE 4.—Time interval apparatus EE-85.

leads. The case is 7 by 11¼ by 14½ inches, and the entire apparatus weighs 14 pounds.

(1) Two bakelite panels are mounted at the top of the case (fig. 4), one providing an opening for the clock and a means for holding it rigidly, and the other having switch SW-105 and 25 binding posts on

top and the interval-producing mechanism mounted on the under side (fig. 6). Only the OFF position of this two-position toggle switch is designated. Three binding posts TM-152, with no designation, are provided for the metal straps connecting the clock, and two binding posts TM-109 are designated + and - 12 volts for battery connection.

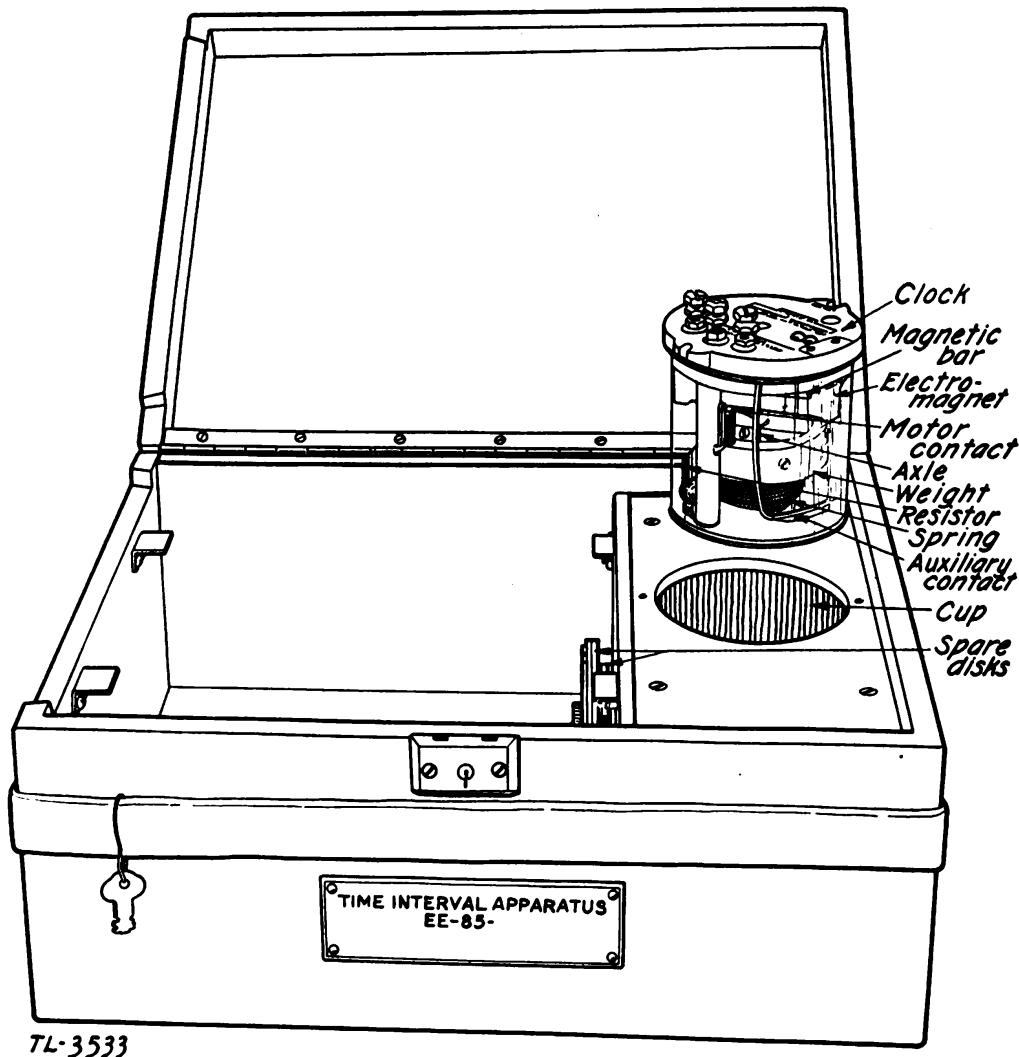

FIGURE 5.—Time interval apparatus EE-85—clock and spare disks.

Also, four binding posts TM-175 are provided for common connection, for any of the desired time intervals, two each for the 1-, 5-, 10-, 15-, 20-, 30-, and 45-second intervals, one for the spare contact on the 90-second arbor, and one for the spare contact on the 120-second arbor. The time interval contacts are designated COM., 1, 5, 10, 15, 20, 30, 45, SPARE 90" ARBOR, and SPARE 120" ARBOR respectively.

(2) The clock is resonance type, electromagnetically driven from the 12-volt battery supply (fig. 5). It consists of a center vertical

axle upon which is mounted a heavy cylindrical weight, a contact operating mechanism, and a magnetic bar suspended between the windings of an electromagnet. At the bottom of the axle is fastened a heavy spiral spring. The spring also is connected to a contact arm which closes a heavy auxiliary contact. The time of one complete oscillation of the clock is 1 second. A capacitor and a resistor in

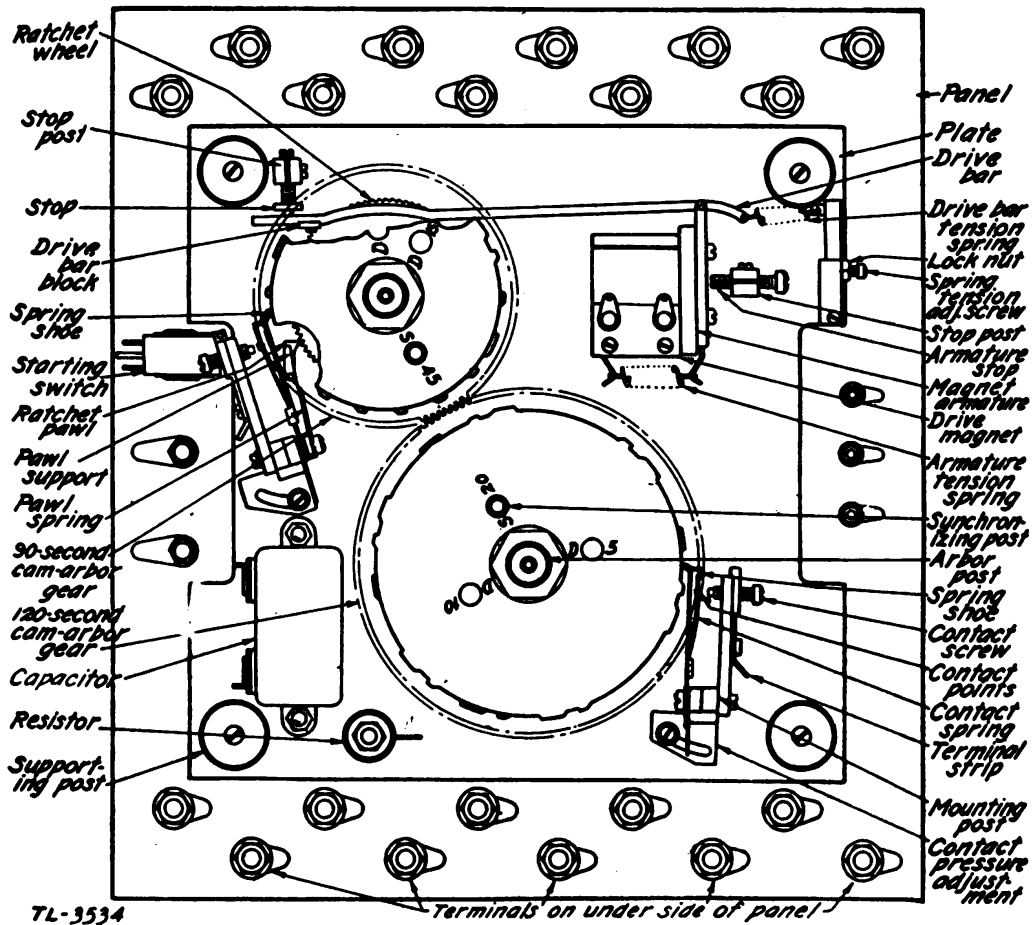

FIGURE 6.—Time interval apparatus EE-85—driving, interval-producing, and contact mechanisms.

series are bridged across the motor contact of the clock. Also, a 10-ohm resistor in series with two 0.5-microfarad capacitors in parallel is bridged across the auxiliary contact.

(3) The driving mechanism consists of a driving magnet which turns the 90-second arbor through a ratchet bar (fig. 6). The 120-second arbor is geared to the 90-second arbor and turned by it.

(4) The actual interval-producing mechanism consists of the 90-second and 120-second arbor pins, four bakelite disks mounted on each of them, and heavy wiping contacts operated by the disks (fig. 6).

(a) In addition to the main arbor pin of each arbor assembly, there is a synchronizing pin projecting from each of the two gears, parallel to the arbor. The bakelite disks are drilled to fit on both these pins, one hole being at the center for the main arbor pin and the other hole being off-center for the synchronizing pin. On each arbor assembly, the disks are separated from the gear and from each other by small spacers. They are held in place by a brass washer and nut on the main arbor pin, and may be removed easily.

(b) The 5-second-interval disk is mounted next to the gear on the 90-second arbor and has raised sections cut on its circumference to hold the corresponding contact closed 1 second of each 5 seconds. Next to this disk is the 15-second disk, having a raised section cut to hold its contact closed for the last 3 seconds of each 15-second interval. The third disk is the 45-second disk, cut to close its contact for the fortieth second and for the last 3 seconds of each 45-second interval. These three disks are synchronized so that the last second of each series of the 45-second interval coincides with that of the 5-second interval for two positions of the arbor, and the last second of each series of the 15-second interval coincides with that of the 5-second interval for six positions. It is the position of the holes for the synchronizing pin which affords synchronization, the holes being marked S5, S15, and S45, respectively. The fourth disk operates the contact connected to the binding post marked SPARE 90'' ARBOR, the disk furnished being a 45-second disk similar to the other except that there are three arbor-pin holes. To obtain delayed time interval programs instead of synchronized programs, holes are drilled at two positions other than the synchronized position on this fourth disk. The hole for the synchronized position is marked S45, and the others are marked D5 and D15 (fig. 6) to denote 5- and 15-second delays in the time intervals from the intervals of the synchronized position. To obtain the desired delayed program, the synchronizing-pin hole so marked is fitted over the synchronizing pin.

(c) On the 120-second arbor next to the gear is the 10-second disk, the raised sections of which hold the corresponding contact closed for the last 3 seconds of each 10-second interval. Next is the 20-second disk, cut to close its contact for the fifteenth second and for the last 3 seconds of each 20-second interval. Third is the 30-second disk, closing its contact for the twenty-fifth second and for the last 3 seconds of each interval. These three disks are synchronized by the location of their synchronizing-pin holes and are marked S10, S20, and S30, respectively. The fourth disk operates the contact connected to the binding post marked SPARE 120'' ARBOR. Either of two disks are

available to be used as the fourth disk. They are furnished with synchronizing-pin holes marked S20, D5, and D10 for one, and S30, D10, and D15 for the other. These disks provide delayed 20- and 30-second intervals as indicated. One of these disks is carried on the

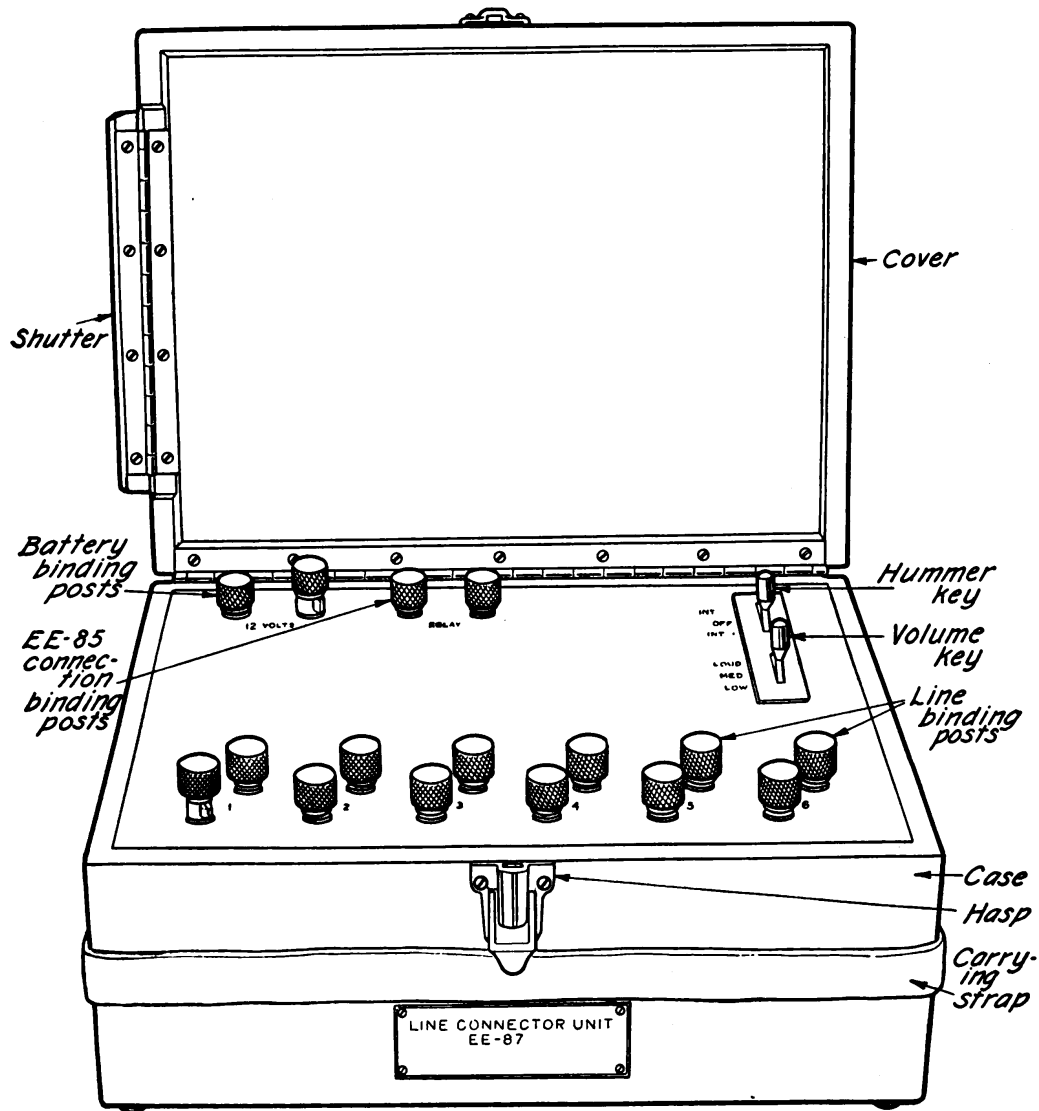

FIGURE 7.—Line connector unit EE-87.

TL-3535

120-second arbor, and the other is mounted on a stud inside the case (fig. 5), with two blank 90-second and two blank 120-second disks which may be cut for any desired intervals within the scope of their respective arbors.

(d) The contact closed by the raised portions of each disk is in series with battery, switch, auxiliary contact of the clock, and corresponding interval binding post and common binding posts (fig. 20). Each contact consists of a light spring armature which rides on the

disk, and a make-contact point which is in itself a screw adjustment.

d. *Line connector unit EE-87.*—The unit is contained in a birch case similar to that of the EE-85, and has a hinged cover and web carrying strap (fig. 7). A flush-hasp clasp holds the cover in place, a spring-hinged section on the side of the cover providing entrance for

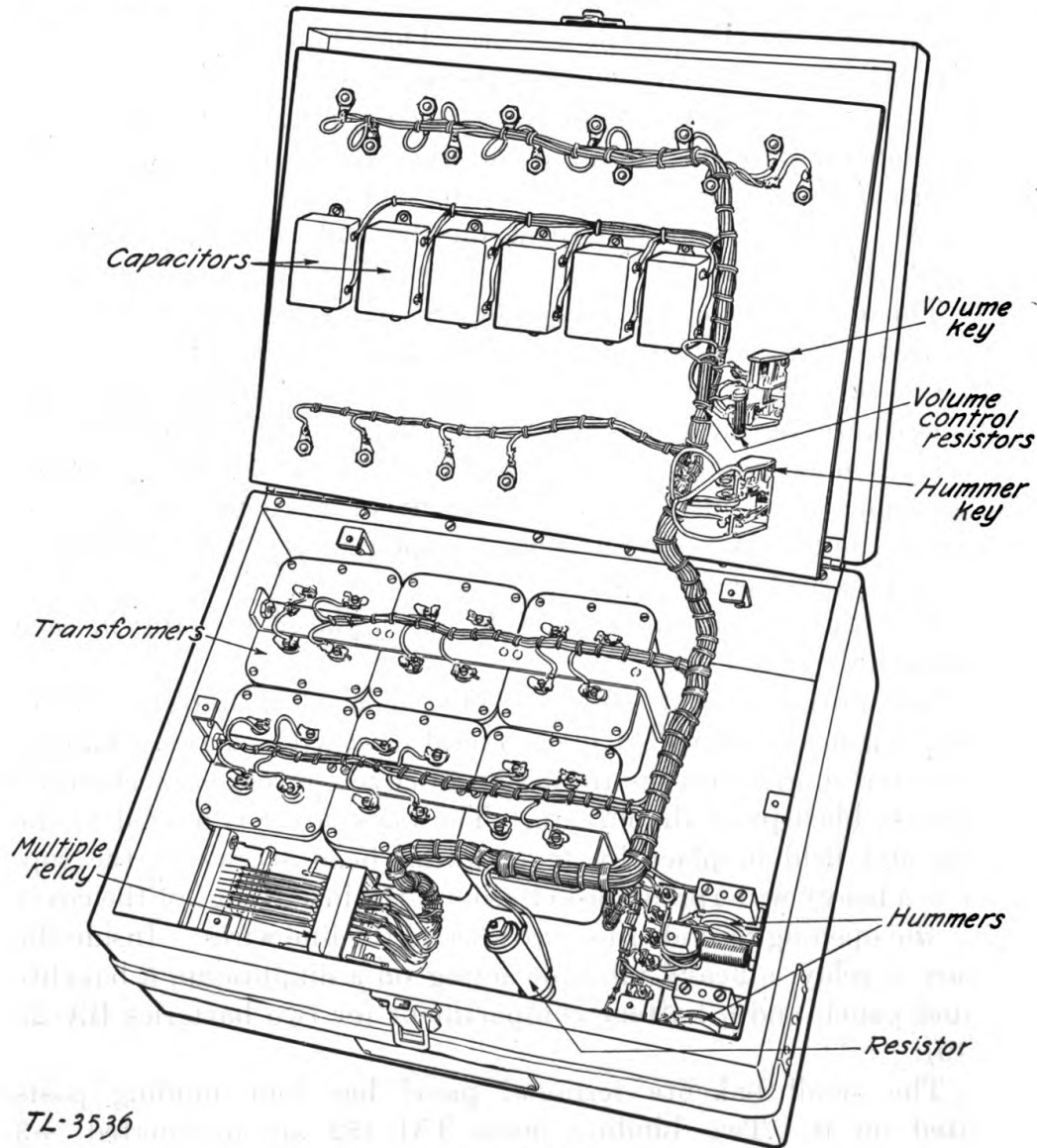

FIGURE 8.—Line connector unit EE-87—internal view.

field wire and battery leads. A bakelite panel, mounted at the top of the case, has sixteen binding posts TM-175 and two Western Electric 479-type key switches fitted on it. Inside the case are mounted six transformers, one North Electric Company multiple relay, two duplicate General Radio 572B microphone hummers, and six 0.1 μ f capacitors (fig. 8). The case is 7 by 11 by 14½ inches, and the entire unit weighs 26½ pounds.

(1) Of the bakelite panel fittings, two binding posts are designated +12 VOLTS—for battery connection, two are designated RELAY for connection to common and desired time interval terminals of the time interval apparatus EE-85, and 12 are designated in pairs for connection to six telephone lines. One key switch, designated INT. 1, OFF, and INT. 2 for the three positions of the key lever, connects one or the other hummer to the circuit. The other key switch marked LOUD, MED., and LOW, controls the volume of the hummer tone.

(2) Six transformers C-231, wired as shown in figure 21, induce the voltage output of either hummer on the telephone line terminals. Transformer C-231 has 350 turns on the coil connected to terminals numbered 1 and 2, and 850 turns on the coil connected to those numbered 3 and 4.

(3) The multiple-contact relay (fig. 8) has seven knife contacts. The moving contacts are mounted on flat springs. One contact completes the circuit to the hummer coil primaries and the other six contacts complete the six circuits to the telephone line terminals.

(4) Each microphone hummer (fig. 8) produces 1,000-cycle tone. The hummer is a push-pull arrangement of a carbon-microphone transmitter button opposing a vibrator-type receiver. A small transformer is a part of each hummer.

(5) A 0.1-microfarad capacitor CA-166 is placed in series in each telephone line circuit (fig. 21).

e. Time interval signal BE-65.—This is a local battery howler housed in a heavy, crackled black metal case with carrying handle. A heavy screen grille on the front (fig. 9) covers a resonator chamber and heavy, blast-proof diaphragm. The back cover is hinged at the bottom and held in place by two knurled-head screws at the top. There is a heavy waterproof gasket around the inside edge of the cover and at the opening provided for entrance of the line wires. Inside the case are a relay, a heavy vibrator acting on a diaphragm, a bakelite terminal panel, and a battery compartment for two batteries BA-23 (fig. 10).

(1) The small bakelite terminal panel has four binding posts mounted on it. Two binding posts TM-152 are designated +3 VOLTS— and two binding posts TM-195 are designated LINE.

(2) The battery compartment consists of a metal slide held in place when the cover is closed, upon which two batteries BA-23 are clamped in wooden cradles by means of metal straps and thumbscrews. Leads are provided for connecting the dry batteries in series and to binding posts on the terminal panel.

(3) The relay is of great sensitivity, having a large number of turns on the coil, the resistance of which is 1,950 ohms. The moving contact point is mounted on the pivoted armature, at the end away from the coil. Stops for motion of armature both backward and forward, a return tension spring, and a coil spring bumper are parts of

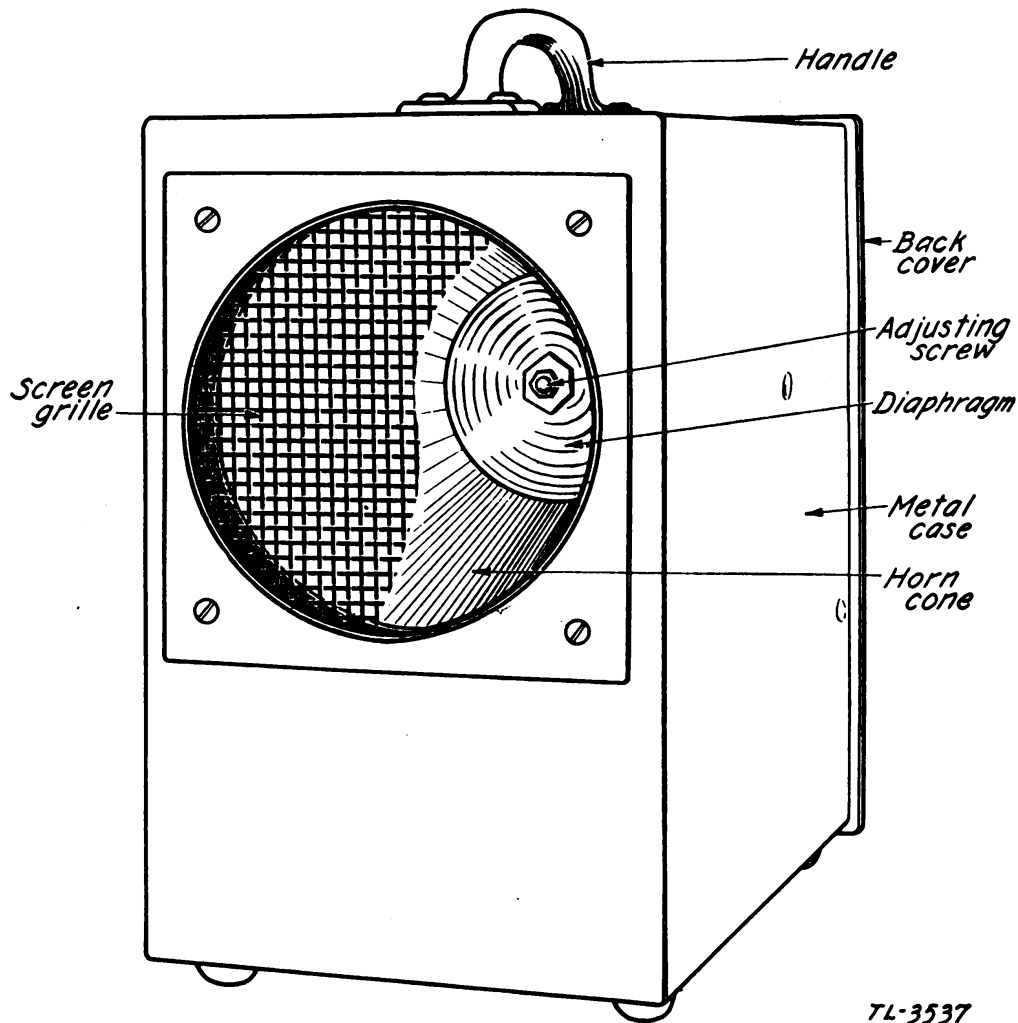

7L-3537

FIGURE 9.—Time interval signal BE-65—front view.

the relay, the entire mechanism being mounted on an insulating plate. The relay coil is connected to the terminals of the binding posts marked LINE and the contact which it operates is in the horn magnet circuit.

(4) The vibrator-diaphragm-resonator assembly, or horn assembly, is of extremely rugged construction (fig. 11). There is a strong U-shaped electromagnet of only 0.1-ohm coil resistance. A diaphragm

is fastened to the armature of this magnet. A post is fastened to the diaphragm and passes back through the magnet to the magnet contact

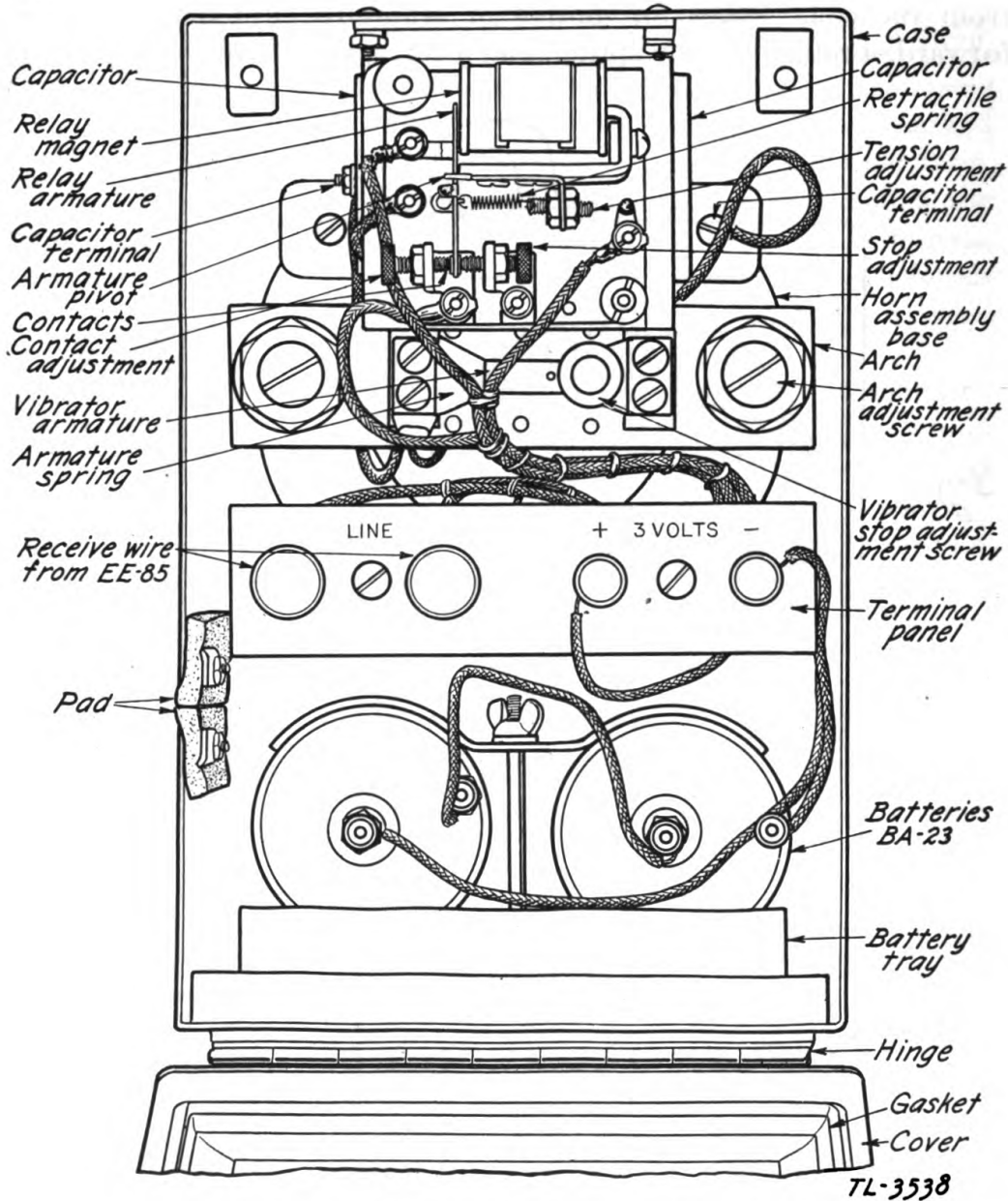

FIGURE 10.—Time interval signal BE-65—back with cover open.

assembly, or vibrator contact assembly. A 6-microfarad capacitor is connected in parallel across the vibrator contact, as part of the vibrator circuit. A cone-shaped resonator is mounted in front of the diaphragm.

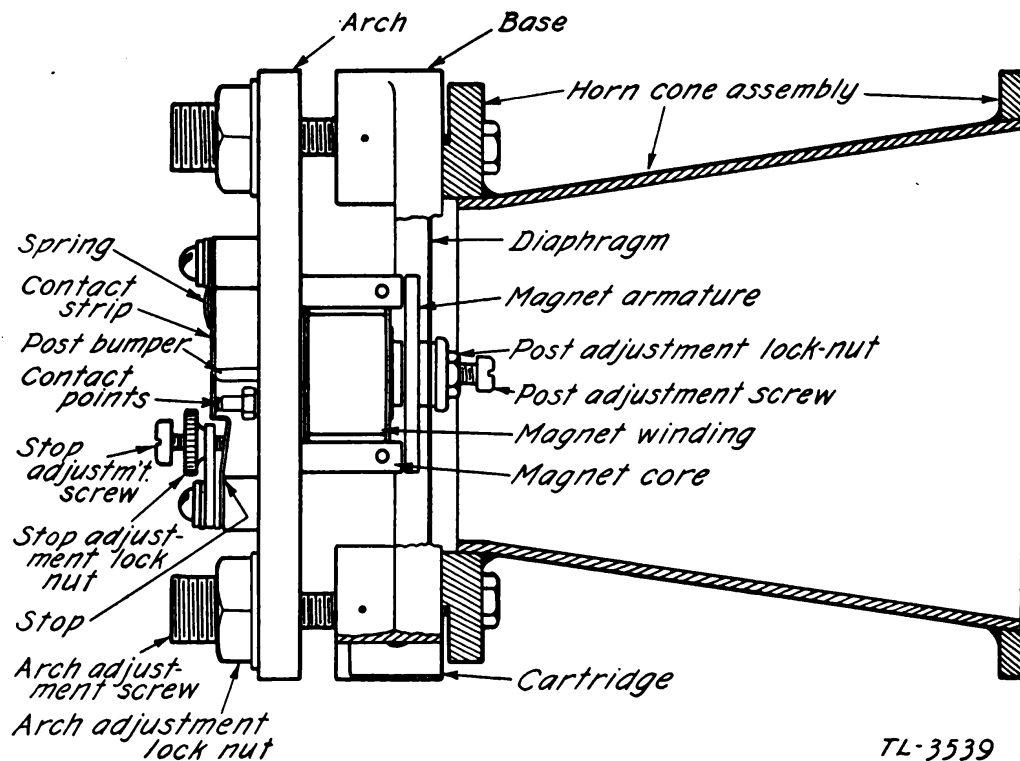

FIGURE 11.—Time interval signal BE-65—horn assembly.

4. Capabilities.—*a. Fixed seacoast artillery time interval equipment.*—(1) Accuracy of the motor governor, controlling factor of accuracy of time intervals, of time interval apparatus EE-86-A is well within the limits of accuracy of other functions of fire control and their corresponding equipment. Accuracy of the motor governor of time interval apparatus EE-56 is lower, but is commensurate with accuracy of the other parts. It is necessary that personnel whose functions are directed by time intervals be trained to react instantly upon hearing the bell, so that no lack of uniformity in time of observation or time of firing results.

(2) In providing 1-, 5-, 10-, 15-, 20-, 30-, 40-, and 60-second intervals, time interval apparatus EE-86-A provides all time intervals necessary for observation, for firing of all calibers of guns, and for all methods of placing fire on the target. Though fewer time intervals are provided by time interval apparatus EE-56, proper use of available intervals results in almost equal flexibility.

(3) If bells MC-153 are connected properly (par. 5a(3)(d)), either time interval apparatus EE-86-A or time interval apparatus EE-56 will provide signals at all stations at which bells are located.

b. Mobile seacoast artillery time interval equipment.—(1) Accuracy of the clock, controlling factor of accuracy of time intervals, of time inter-

val apparatus EE-85 is lower than that of the motor governor of the EE-86-A, but is greater than the combined accuracy of equipment of other functions of fire control effected.

(2) Time interval apparatus EE-85 and associated equipment provide all time intervals necessary for observation and firing.

(3) Time interval apparatus EE-85 will provide signals at all places where time interval signals BE-65 are to be located and at all telephone stations which have the 1,000-cycle tone signals superimposed on their circuits by line connector unit EE-87.

SECTION II

EMPLOYMENT

	Paragraph
Installation.....	5
Preparation for use.....	6
Operation.....	7

5. Installation.—*a. Fixed seacoast artillery time interval systems.*—

(1) *Responsibility.*—Installation of time interval apparatus EE-56 and EE-86-A in permanent coast artillery fire-control communication systems is under technical control of the corps area signal officer. Also, any major repair to the time interval system which is beyond the capacity of local coast artillery troops is referred to the corps area signal officer.

(2) *Location.*—Either the EE-56 or EE-86-A is installed in the fire-control switchboard room, as it is required that time interval apparatus provide time intervals for any or all elements of armament controlled from one fire-control switchboard, without relays and local power supply in distant stations. Whether connected directly to bells or through switching equipment, time interval apparatus is located conveniently to the fire-control switchboard and other switching equipment and where it is free from vibration and extreme temperature change.

(3) *Connection.*—(a) It is recommended that both time interval apparatus EE-56 and EE-86-A be used with switching equipment in providing signals at the bells of all stations. For the installation of either time interval apparatus, the binding posts marked 30-VOLT d-c are connected across the 30-volt switchboard battery supply bus by running two lines directly to switchboard BD-65 (power panel). When time interval apparatus EE-56 is used with switchboard BD-15 (switching panel) and frame FM-5 (fig. 12), each time interval binding post 10, 15, 20, and 30 is connected to the corresponding time interval bus 10, 15, 20, or 30 of the BD-15, and the common binding post C is

connected through the 30-volt switchboard battery supply bus (at the BD-65) to the common bus C of the BD-15. Switchboard BD-15 provides the desired time interval for any gun battery and frame FM-5 distributes the time interval to all bells within the battery. In effect, time interval apparatus program circuit, battery, switchboard, frame, and bell are connected in series.

(b) Either time interval apparatus EE-56 or EE-86-A is used with switchboard BD-74 or BD-78. Both switchboards have a double row of jacks in each section, an upper row of line jacks and a lower row of tie jacks, as shown in figure 13. The common binding post C of the EE-86-A is connected through the 30-volt switchboard battery supply bus (at the BD-65) to the tip terminals T1 of all tie jacks and the tip terminals T of all line jacks of the BD-74 or BD-78 which are used to furnish any of the eight time intervals. Each time

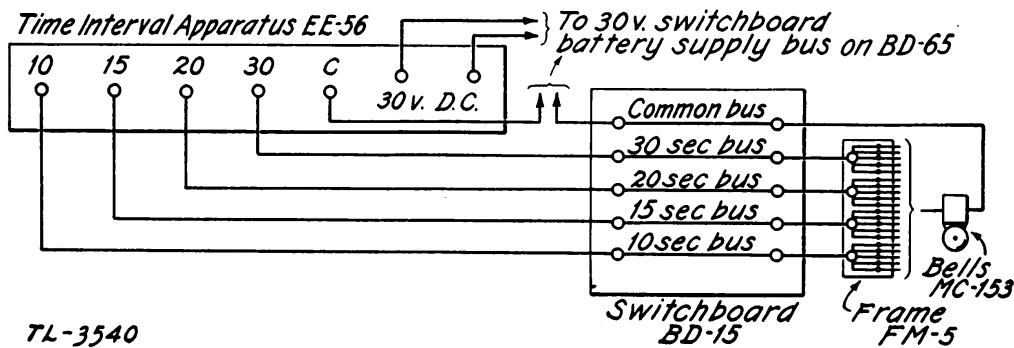

FIGURE 12.—Time interval apparatus EE-56—connection through switching equipment.

interval binding post (1, 5, 10, 15, 20, 30, 40, and 60) is connected to the sleeve terminals R1 of the tie jacks and the sleeve terminals R of the line jacks which are designated as furnishing that particular time interval. The line which runs to the bells of each battery is connected to the tip terminal T and the sleeve terminal R of one of the tie jacks which furnishes that time interval which is customarily used by that battery. Careful examination of figure 13 shows that when no plug is in the tie jack to which the line of the particular battery is connected, the customary time interval is connected directly to that battery. If another time interval is desired, a patching cord is plugged into a line jack designated as furnishing the newly desired time interval and into the tie jack to which the line of that battery is connected. Plugging into the tie jack disconnects the formerly desired time interval circuit at the tie jack and applies the presently desired time interval supplied by the patching cord. Thus each battery receives its customary time interval without the use of patching cords and their use is resorted to only under unusual circumstances

requiring a different time interval, which then is available at a selected number of line jacks. In effect, time interval apparatus EE-86-A, 30-volt battery supply, switchboard BD-74 or BD-78, and bells MC-153 complete a series circuit. Very few EE-86-A have been procured and at the time of writing none of them have been installed. All switchboards BD-74 and BD-78 in use are connected to time interval apparatus EE-56. The connections are similar to those described above except that only 10-, 15-, 20- and 30-second intervals are available.

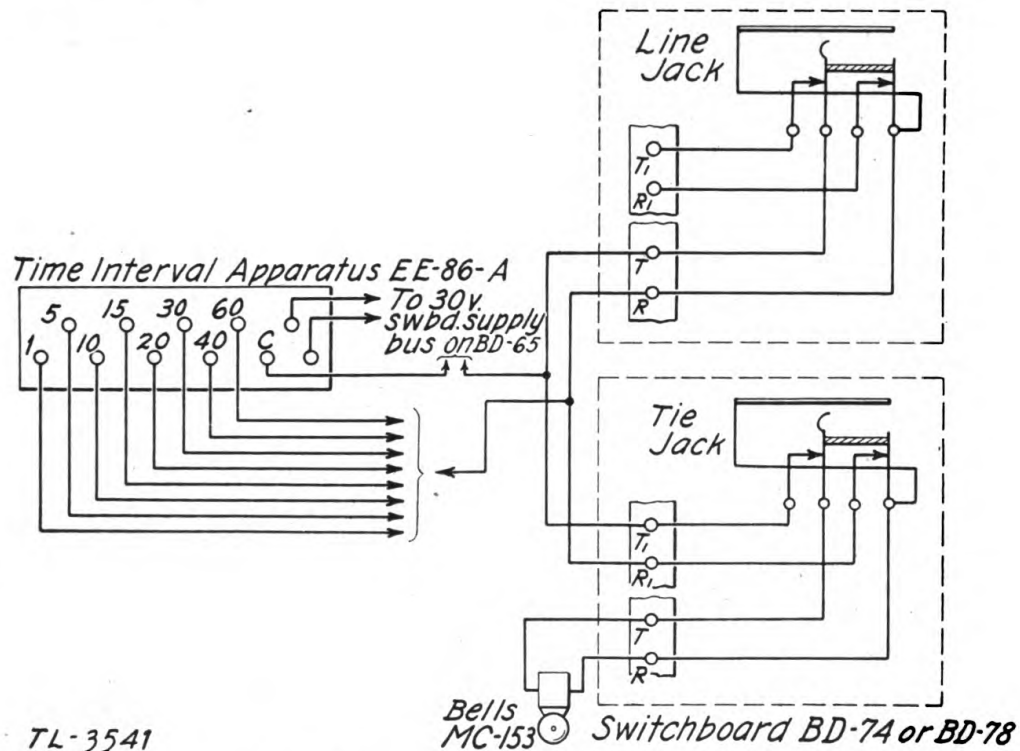

FIGURE 13.—Time interval apparatus EE-86-A—connection through switching equipment.

(c) If the bells are connected directly to the time interval apparatus without the use of any switching equipment, the arrangement is a series connection of time interval apparatus, battery supply, and bell (figs. 12 and 13).

(d) Time interval apparatus EE-86-A is designed to operate with bells MC-153, and it is recommended that bells MC-153 be used also with the time interval apparatus EE-56, although the EE-56 was originally designed for use with several older types of bells. For best operation it is suggested that the two coils of each bell MC-153 be connected in parallel up to the distance where the line loop resistance is 500 ohms, and in series beyond that point. Whether one or several bells are connected to one line depends on positions of the bells in

relation to each other and distances of the bells from the time interval source. Also, if several bells are connected to one line, determination of whether the bells should be connected in series or parallel with each other depends on the distance from the time interval source and the number of bells connected. Never does one line carry bells of more than one seacoast artillery battery. The characteristics of the bell-wiring system which must be considered in designing the system are that 15 bolts are required to operate each bell and that the calculated direct-current resistance of the line and bells between the source and a particular bell should be approximately equal to and never appreciably greater than the resistance offered by that bell.

b. Mobile seacoast artillery time interval equipment.—(1) *Responsibility.*—Installation of time interval apparatus EE-85 and associated equipment, line connector unit EE-87, and time interval signal BE-65, is the responsibility of the gun battery in either tractor-drawn or railway seacoast artillery. Each gun battery is allotted one time interval apparatus EE-85, one line connector unit EE-87, and five time interval signals BE-65, in addition to the necessary number of storage batteries.

(2) *Location.*—(a) Time interval apparatus EE-85 is installed in the plotting room*, in a convenient and safe place, preferably in a place which allows space for associated equipment and which also is easily accessible to the telephone strip into which come readers' telephone circuits. Line connector unit EE-87 is installed in the plotting room adjacent to the EE-85 (fig. 14).

(b) Time interval signals BE-65 are installed at gun positions and in the plotting room in the manner best suited to assure that firing crews of all guns and range and fire-control crews will hear all signals easily. This arrangement may be for a BE-65 at each gun, one for two guns, etc., depending on distances between guns and the decision of the battery commander. In addition there should be at least one time interval signal BE-65 in the plotting room (fig. 14). The one BE-65 in the plotting room provides time interval signals for the plotting room stations of range, deflection, and battery order nets, while those at the guns provide signals for the gun position stations of these same nets. For this reason it is not obligatory to superimpose tone on telephones to these stations (fig. 14).

(3) *Connection.*—(a) Both time interval apparatus EE-85 and line connector unit EE-87 are connected to the same 12-volt battery power supply. Care must be taken to connect the battery to the correct

* The plotting room may be a tent, a railway car, or any other predesignated location.

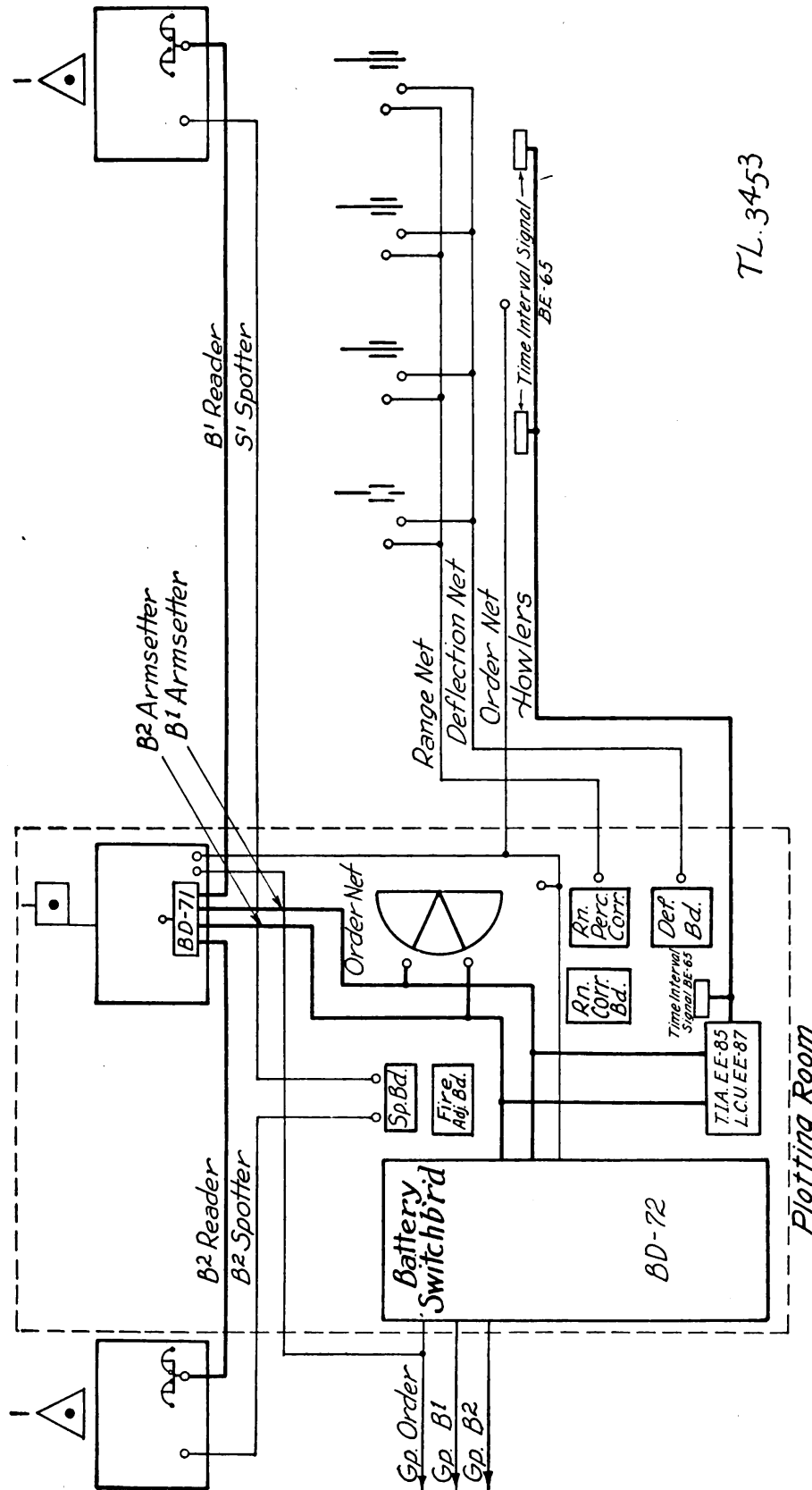

TL 3453

FIGURE 14.—Time interval equipments in mobile seacoast artillery.

binding posts as designated plus or minus or +12 VOLTS— on the EE-85 and EE-87.

(b) The binding post of the EE-85 marked C and the one required

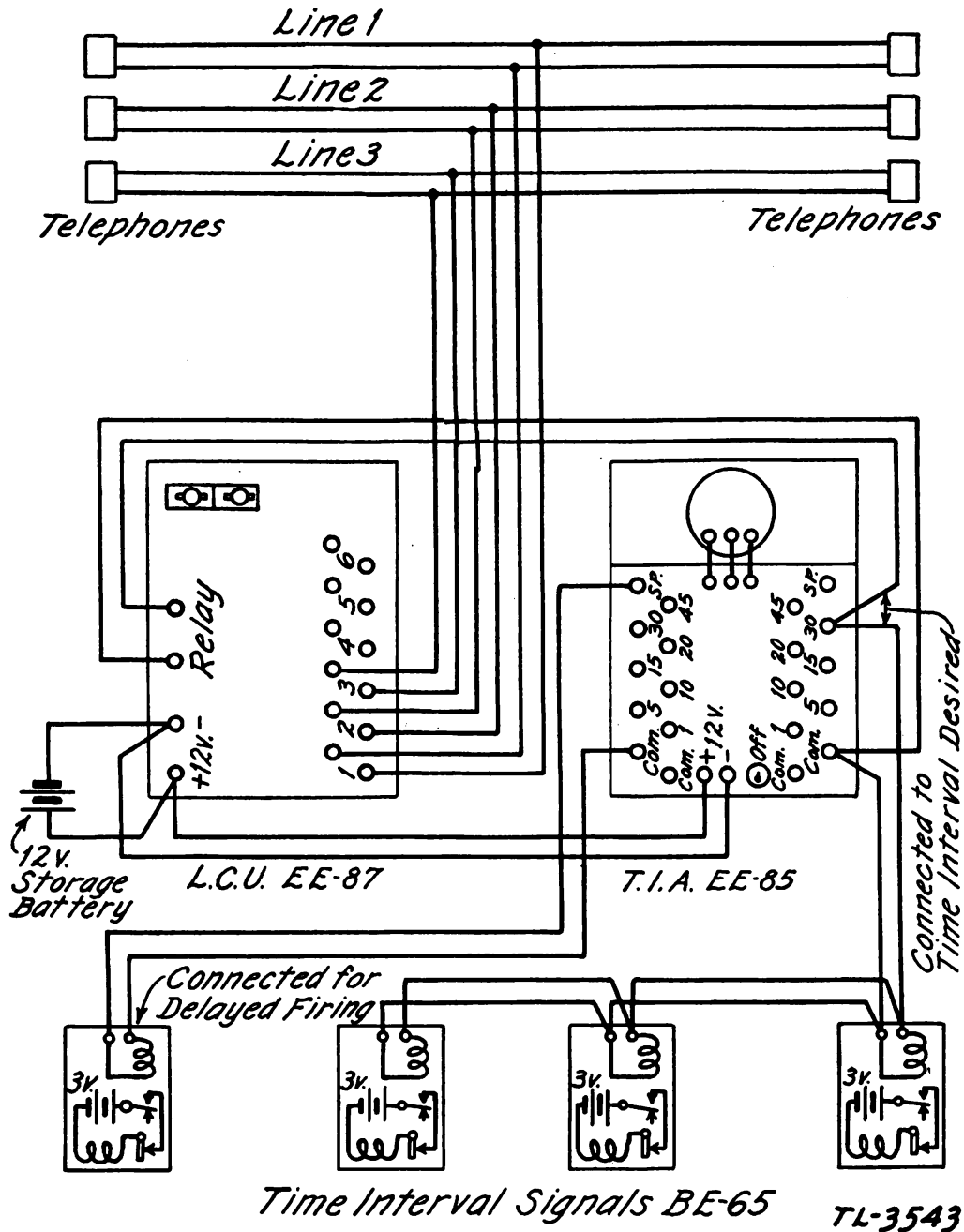

FIGURE 15.—Installation diagram for mobile artillery time interval equipments.

for the time interval program desired for observation purposes are connected to the RELAY binding posts of the EE-87 (fig. 15).

(c) To superimpose the 1,000-cycle tone on telephone lines to the observers, connection is made from two of six pairs of line terminals

of the EE-87 to the two armsetters' telephone lines (fig. 14), preferably at the terminal strip. Because the armsetters' lines are connected directly to the readers and because observers' headsets are connected to readers' telephones in parallel with readers' headsets, tone is available to observers.

(d) The other four pairs of line terminals of the line connector may be used, if desired, for a third observer, to the two spotters' lines, to the range net, to the deflection net, or to the battery order net. If any of these extra lines are used, it will be principally for supplementary coordination, because the signals of the time interval signals BE-65 will be available to all mentioned except the spotters who are concerned with the splash or impact of the projectile.

(e) Similarly, the common C and time interval binding posts of the EE-85 which provide the desired firing time interval program are connected to the time interval signals BE-65 at the binding posts marked LINE. Delayed firing programs or different programs may be desired for different guns, but all time interval signals BE-65 for which the same time interval program is desired should be connected in parallel to keep voltage drops at a minimum and to assure good operation of every BE-65 (fig. 15).

(f) The two batteries BA-23 of each BE-65 are connected in series and to the binding posts +3 VOLTS—, care being taken to connect the plus binding post of one battery to the terminal strip binding post marked plus, and the negative binding post of the other battery to the terminal strip binding post marked minus. *Center binding post of BA-23 is positive.* **Caution:** The two batteries BA-23 must be disconnected from the terminal strip binding posts (fig. 10) when time interval signal BE-65 is not in use. This prevents battery drain if the sensitive relay should close during handling, and assures long life for the batteries.

6. Preparation for use.—a. Fixed seacoast artillery time interval equipment.—While no preliminary adjustment should usually be necessary for time interval apparatus EE-56 or EE-86-A, it may be necessary to check the governor adjustment.

(1) The governor adjustment of the EE-56 may be checked to sufficient accuracy with the use of only a stop watch. Using the small tension adjustment screw on the rotating arm of the governor (fig. 16) and timing the revolution of a mark on one of the disks, the governor may be set so that the disk arbor rotates at the required one revolution per minute, and correspondingly, the motor runs at 1,280 revolutions per minute within desired limits of accuracy. To increase the speed of the motor the screw is turned in a counterclockwise direction.

(2) The governor of time interval apparatus EE-86-A also may be adjusted to a very high degree of accuracy.

(a) The stroboscopic tuning fork (fig. 3) affords a positive and direct means of adjustment in connection with the use of the adjusting screw which changes the tension on the secondary spring of the governor (fig. 3). Remove the cover from the governor housing by loosening the four screws holding it in place. Remove the stroboscopic tuning fork from its compartment in the rear of the base of the apparatus. Place a light in such position that it illuminates the governor thoroughly, and shade it so that it does not shine in the eyes of the observer at the front of the apparatus. Pinch the tines of the fork to start vibration and view the rotating arm of the governor through the slots in the brass pieces at the ends of the tines of the fork. To obtain the sharpest pattern it will be necessary to turn the fork so that the plane of the viewing slots form an acute angle with the eye, thus narrowing the angle of vision. For best results in viewing the governor pattern, close the eye which is not being used.

(b) If the governor is correctly adjusted and the motor is running at correct speed, the viewing eye should see a sharp pattern of the rotating governor arm which may oscillate slightly back and forth. If the apparent motion of the governor is continuously in one direction, the governor should be adjusted by means of the knurled-head screw at the front of the extension arm near the top of the shaft. If the apparent motion of the governor arm is clockwise (when viewed through the slots in the fork), turn the adjusting screw in a clockwise direction to bring the motor to correct speed. If the apparent motion of the governor arm is counterclockwise, turn the adjusting screw in a counterclockwise direction to bring the motor to correct speed. Correct speed of the motor will be indicated when the viewing eye sees the sharp slowly oscillating pattern of the governor arm as previously described. In general, when it is necessary to speed up the motor, turn the governor adjusting screw slightly in a clockwise direction, and when it is necessary to slow down the motor, turn the governor adjusting screw slightly in a counterclockwise direction. Directly in back of the knurled head of the screw, the proper direction of turning the screw is designated by an arrow and the words FAST—SLOW.

b. Time interval equipment of mobile seacoast artillery.—This equipment, including time interval apparatus EE-85, line connector unit EE-87, and time interval signal BE-65, requires no preliminary adjustment.

7. Operation.—*a. Fixed seacoast artillery time interval equipment.*—(1) The organizational unit of fixed seacoast artillery which

is responsible for operation of the fire-control telephone communication system is responsible also for operation of the time interval system. This responsibility depends upon the harbor-defense project and the desires of the local commanders.

(2) Since all time interval program circuits of either time interval apparatus EE-56 or EE-86-A, when operated with switching equipment, are connected directly to busses at all times, no changes in connections need be made at any time during operation. The starting switch must be turned to the ON position and the apparatus runs with no further attention, other than routine maintenance inspection. If any change of time interval program to any battery is desired, the change is made by means of the switching equipment in use.

(3) If time interval programs are connected to bells directly, when using either EE-56 or EE-86-A, any change in program is made by changing the connection at the terminal strip. The wire to the particular battery is changed from one time interval binding post to the desired time interval binding post (figs. 1 and 2). No change in the wire to the common connection binding post C is necessary.

(4) The metal cover of the governor housing of the EE-86-A must be fastened securely in place to reduce electrical disturbance. The wooden covers must be placed on both the EE-56 and EE-86-A for protection from dust and moisture.

b. Mobile seacoast artillery time interval equipment.—(1) Each gun battery of either tractor-drawn or railway artillery is responsible for operation of time interval apparatus EE-85 and associated equipment, line connector unit EE-87, and time interval signals BE-65.

(2) Once all connections have been made to supply observing and firing intervals as prescribed, no particular supervision is necessary other than to see that all equipment is functioning properly. The toggle switch of the time interval apparatus EE-85 (fig. 4) is thrown to the ON position to start the generation of time interval impulses transmitted to both line connector unit EE-87 and time interval signals BE-65.

(3) The starting key of the line connector unit EE-87 (fig. 7) is thrown either to position INT. 1 or to position INT. 2. The hummers connected to either position give signals of equal strength and clearness when new. After some use it may be more desirable to use one hummer than the other. The key of the EE-87 controlling loudness is thrown to position marked LOUD, MED., or LOW, whichever provides the most desirable signal in the head sets of observers and readers.

(4) Any change in time interval program for observing interval or

firing interval may be made by changing connections to either time interval signals BE-65 or line connector unit EE-87 at the time interval apparatus EE-85 (fig. 5). It is necessary to change only the wire to the time interval binding post, the common connection C remaining unchanged.

(5) When equipment is operating, all covers are fastened securely so that the several units will be protected from dust and moisture. This is possible because each is provided with openings for entrance of all connecting wires.

SECTION III

DETAILED FUNCTIONING OF PARTS

	Paragraph
Time interval apparatus EE-56.....	8
Time interval apparatus EE-86-A.....	9
Time interval apparatus EE-85.....	10
Line connector unit EE-87.....	11
Time interval signal BE-65.....	12

8. Time interval apparatus EE-56.—*a.* The motor of time interval apparatus EE-56 is the prime mover actuating all mechanisms which operate the several electrical contacts. These contacts in turn supply the various time interval impulses by completing circuits through a 30-volt battery power supply and switching equipment to the bells. As controlled by the adjustable-speed centrifugal-type governor, the motor runs at 1,280 revolutions per minute, if the power supply remains at from 27 to 30 volts direct current.

b. (1) The action of the governor is to open and close a contact which places a shunt across the 100-ohm resistor in series with the motor. This is done by the centrifugal force on the small weight as it rotates (fig. 16). This force acts against a tension spring, tending to cause the lever or strip to be lowered. Since the lower or movable governor contact is mounted on this strip, the contact is broken if the speed is so great that the strip is moved downward far enough. Conversely, as the motor slows up the centrifugal force is reduced, the strip is raised, the contact is closed, and the resistor is again shunted out of the motor circuit. These effects alternate continually as the governor rotates, keeping the motor at a constant speed.

(2) When the resistor is in series with the circuit of the series field motor, resistance of the circuit is greater and the field current less. Also, the reduction in field current slows the motor. As the shunt again is placed across the resistor, in series with the motor field winding, by reduced centrifugal force, resistance is reduced and the current and speed increase until the shunting contact is broken and the sequence is repeated.

(3) The lower, movable contact is connected through the governor parts and the shaft to the contact spring which is wired to one side of the resistor. The upper, stationary contact is connected through the upper contact screw, which is insulated from the rest of the governor parts, to a terminal wired to the other side of the resistor.

(4) There are two possible adjustments which change the motor speed at which the contact is made and broken (fig. 16). One is the tension adjustment of the governor spring which, when turned counterclockwise, increases the tension of the spring. The speed of the motor necessary to overcome this tension, by creating enough force on

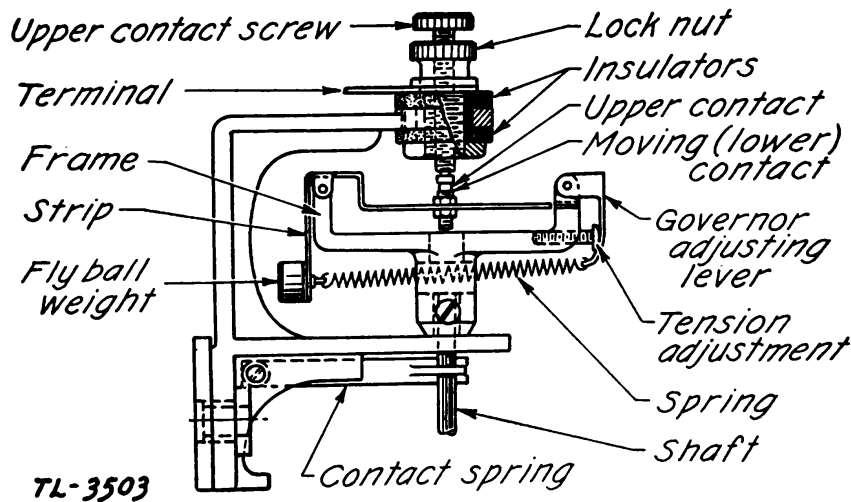

FIGURE 16.—Time interval apparatus EE-56—governor.

the weight to break the contact, is increased. Turning the adjusting screw clockwise decreases the motor speed. The other adjustment, by moving the upper contact screw, is less precise. However, if the screw is turned clockwise or downward, the contact is lowered and it takes greater movement of the strip and weight, and consequently higher speed, to break the contact. Turning this contact screw counterclockwise decreases the motor speed.

c. The reduction in speed afforded by the gear train between motor shaft and spindle shaft of the cam-arbor assembly is such that the arbor assembly rotates at one revolution per minute. The entire program group assembly is synchronized so that at least once every complete revolution all firing-signal cams, or final signals of the time interval cam groups, strike their corresponding rocker arms simultaneously.

d. (1) As each cam projection strikes the striking block at the upper end of the rocker arm, the rocker arm pivots (fig. 17). Then the lower, moving contact, mounted on the strip fastened to the rocker arm, makes contact with the upper contact as long as the rocker arm is held

down by the cam projection. As the cam projection releases the rocker arm, the lower contact falls because of its weight and the tension of the retractile spring.

(2) The cam-contactor assemblies are mounted on the base of the casting and are provided with two adjustments. The first adjustment regulates the duration of contact closure. This adjustment also per-

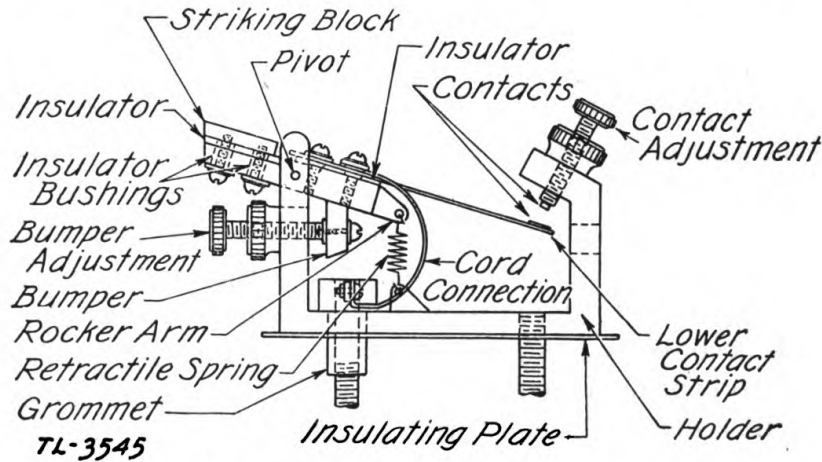

FIGURE 17.—Time interval apparatus EE-56—cam contactor.

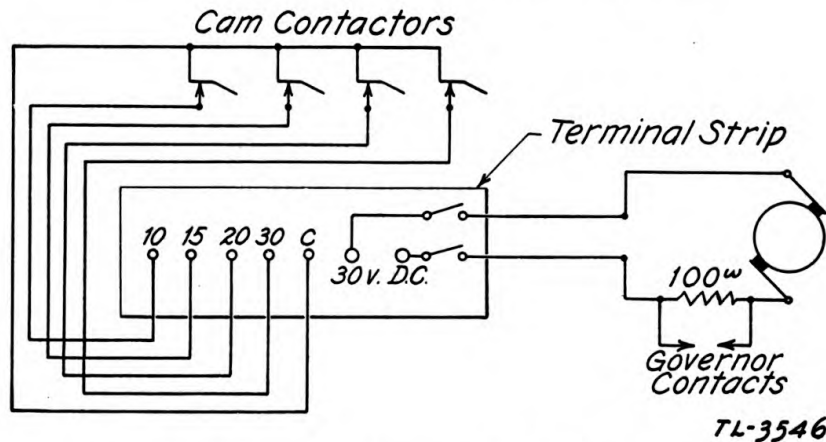

FIGURE 18.—Time interval apparatus EE-56—circuit diagram.

mits adjustment of the time of making contact so that all circuits may be made simultaneously at the synchronized position of the cam arbor. The second adjustment regulates the bumper position to secure quiet operation of the contactors and avoid metallic noise.

(3) In the electrical circuit, the terminal of the moving contact of all contactors is brought out to the common terminal C on the terminal strip, and the other terminals of the contacts are brought out individually to the terminals on the terminal strip marked 10, 15, 20, or 30, corresponding with the 10-, 15-, 20-, or 30-second time interval cam disks (fig. 18).

9. Time interval apparatus EE-86-A.—*a.* The motor of time interval apparatus EE-86-A differs from that of time interval apparatus EE-56 only in that it is designed to run at 1,380 revolutions per minute and that an electrical interference suppressor circuit is provided (fig. 19).

b. (1) The mechanical action of the governor is different from that of the EE-56, though the use of centrifugal force in making and breaking an electrical contact is fundamental. In the EE-56, the action of centrifugal force on the tension spring of the moving arm causes the strip to be lowered. However, on the governor of the EE-86-A, the vertical movement of this strip as it whirls is transmitted to a second, nonturning strip by means of a small swivel-like joint. This joint consists of tiny jaws fastened to the lower, rotating strip, which clutch a projection from the upper, stationary strip, and impart vertical movement but no rotating motion to the second strip (fig. 3).

(2) This second strip is pivoted at one end, moving against the tension of the coil spring attached to the moving arm of the governor, but aided by the tension of a coil spring attached to a stationary arm, and operates the lower contact mounted on the other end. This contact moves only up and down, so that the excessive wear of the rotating lower contact of the EE-56 is eliminated and necessary adjustments are greatly reduced in frequency and amount.

(3) Adjustment of the governor is made by turning a small screw on the stationary arm which is attached to the second, nonrotating spring. This screw adjustment is made as explained in paragraph 6*a*(2). There are also the same two adjustments which are part of the governor of the EE-56, the up-and-down adjustment of the upper contact and the adjustment of the tension spring mounted on the rotating arm. However, the primary screw adjustment explained in detail is the only one necessary for operating personnel to use.

(4) The electrical action differs only in that the resistor in series with the motor is a 125-ohm resistor, and that an interference suppressor across the contact consisting of a 0.1-microfarad capacitor in series with a 100-ohm resistor, is provided (fig. 19).

c. The cam-arbor assembly of the EE-86-A is driven like that of the EE-56, but has the additional gear train to drive the shaft of the eighth cam disk from the main shaft, increasing the speed from 1 revolution per minute to 1½ revolutions per minute, or from 60 seconds to 40 seconds for a complete revolution. The entire program group assembly is synchronized so that once for every complete revolution of the 60-second disk all firing signal cams strike their corresponding rocker arms simultaneously.

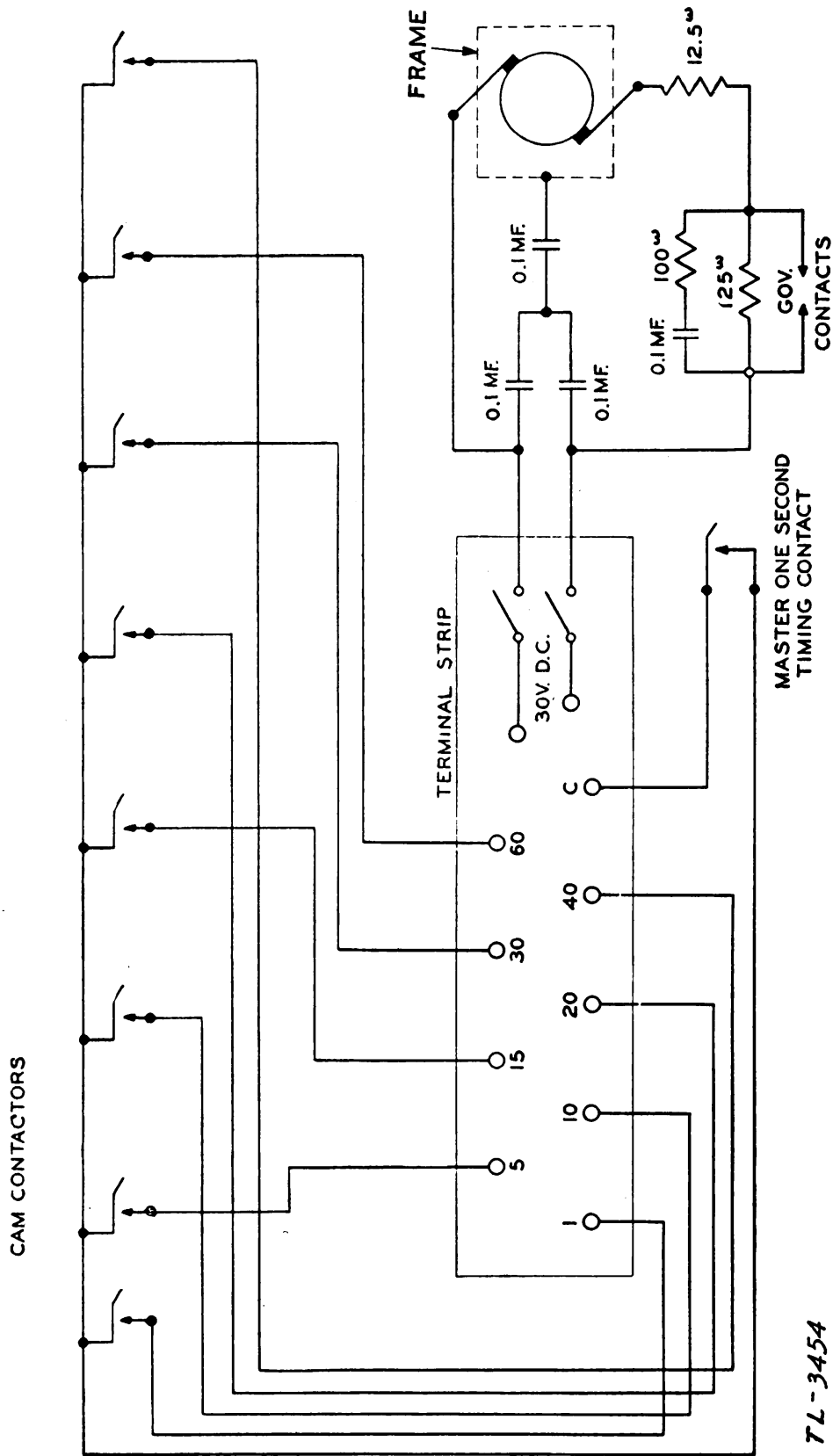

FIGURE 19.—Time interval apparatus EE-86-A—circuit diagram.

7L-3454

d. Action and adjustments of the cam-contactor assemblies of the EE-86-A are similar to those of the EE-56. However, the importance of the adjustments is reduced by use of the master 1-second timing contact. The master 1-second timing contact cam (fig. 3) is driven at one revolution per second, through a worm gear, by the same worm which drives the cam-arbor drive worm gear. The position of the master cam on its shaft is such that, if necessary adjustments are made on the cam-contactor assembly, all contacts which are actuated by disk cams close and open before the corresponding operation of the master 1-second timing contact. The master cam is designed so that it will hold the master contact closed until after any or all of the time interval circuits, which were closed that particular second, are opened by the disk cam projections (fig. 3). The contact is closed by the raised portion of the master cam which operates the contact spring, the spring opening the contact.

e. From *d* above it is seen that when any disk cam closes the contact of its circuit for any particular second, that circuit is completed by the master contact and opened by the disk cam contact. Thus the master cam assures the accuracy of every time interval, and the cam-contactor assembly adjustments determine the length of contact closure. As long as the governor is correctly adjusted with the stroboscopic tuning fork, the time interval is accurate because of the master cam. The time intervals remain constant over a long period because of the carefully adjusted motor speed.

10. Time interval apparatus EE-85.—*a.* The clock, or electromagnetic motor, of time interval apparatus EE-85 operates the motor contact, its own driving circuit contact, the auxiliary contact, the contact which completes the driving magnet circuit, and also the time interval program circuits (fig. 20). In the stopped position of the clock, the mechanism holds the motor contact closed so that when the apparatus is turned on and battery applied, the circuit is completed through the electromagnet, giving an impulse to the bar. The contact-operating mechanism is so constructed that the contact is closed once for each complete oscillation of the bar and weight, the time of oscillation being 1 second. The capacitor and resistor bridged in series across the motor contact prevent electrical interference with radio and other communications.

b. The auxiliary contact remains closed approximately 0.4 second during each 1-second oscillation of the clock. Each time it closes it completes one circuit through battery, switch, and driving magnet; another circuit to common connection C and 1-second interval binding posts 1 through battery and switch, which provides the 1-second interval direct from the auxiliary contact; and all circuits to the com-

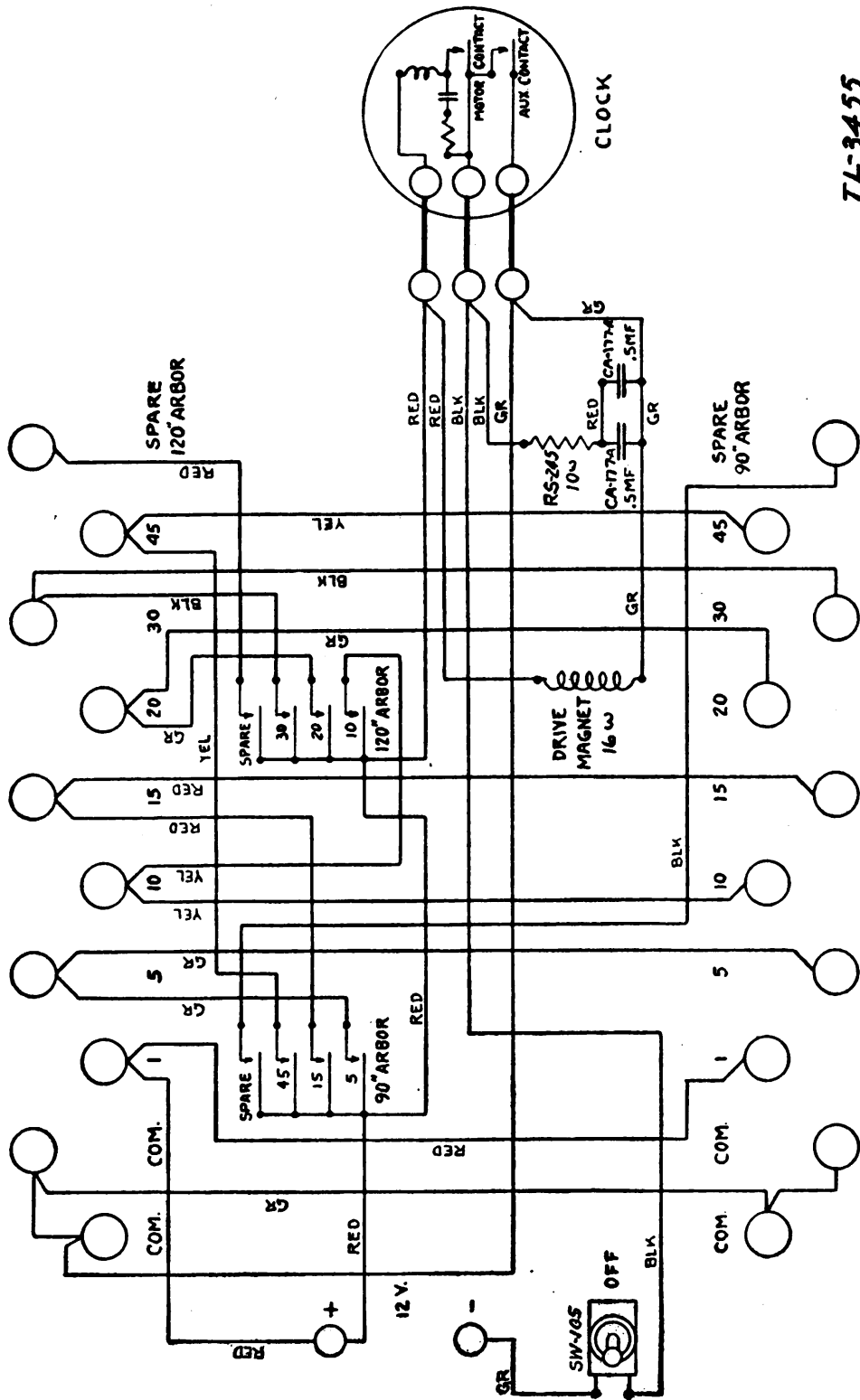

TL-3455

FIGURE 20.—Time interval apparatus EE-85—circuit diagram.

mon C and the other interval binding posts through battery, switch, and any interval wiping contact which is closed at the time (fig. 20).

c. As the circuit is completed through the driving magnet, the magnet armature moves the ratchet bar against the tension of the two springs. As the circuit is broken, the armature is released and the armature and ratchet bar are returned by the spring tension (fig. 6). As the ratchet bar moves back, the fitting across the long slot in the bar contacts a tooth of the ratchet wheel and turns the wheel one notch. There are 90 teeth on the ratchet wheel, so that it makes one complete revolution in 90 seconds. The small pawl, which is kept against the teeth of the ratchet wheel by the flat spring, prevents the ratchet wheel from backing up. The tension adjustment on the one spring which returns the ratchet bar, and the stop adjustments of the magnet armature stop and of the stop at the ratchet-wheel end of the ratchet bar, determine the proper action and travel of the ratchet wheel.

d. As the 90-second arbor is turned by the ratchet, it turns the 120-second arbor through two spur gears, so that the latter makes one complete revolution in 120 seconds. As the two arbors turn, the raised portions of the disks mounted on the arbors operate the wiping contacts against the action of flat contact springs which make the spring shoes ride firmly on the peripheries of the disks (fig. 6). As the moving contacts which are mounted on the contact springs are operated by the raised portions of the disks, the contacts for the particular time interval program disks are closed.

e. The disk-operated contacts close before and open after the auxiliary contact, whether the raised portion of the disk includes signals for 3 seconds or for only 1 second. Thus accuracy of length of the interval and duration of the signal both are determined by operation of the auxiliary contact. The circuit, consisting of a resistor in series with two capacitors in parallel, bridged across the auxiliary contact, reduces arcing and prevents electrical interference with radio and other communications (fig. 20).

11. Line connector unit EE-87.—*a.* The fundamental operation of line connector unit EE-87 is actuation of the multiple relay by time interval impulses generated by time interval apparatus EE-85. The coil of the relay is connected to the binding posts by which the EE-85 is connected to the EE-87 (fig. 15). When the coil is energized it moves the armature about the pivot point of the relay and against the force of the return spring of each contact. All seven contacts are closed simultaneously, completing one circuit through the battery, resistor RS-55, and the primary coil, transmitter, and receiver of the hummer in use, and six circuits each through a transformer secondary, and a capacitor CA-166 to the line binding posts (fig. 21).

b. As the contact completes the circuit through the one push-pull type microphone hummer which is turned on, the carbon-granule transmitter button resonates with the vibrator-type receiver. Resonance is at approximately 1,000 cycles per second, producing the tone which is induced in the secondary winding of the hummer with an increased voltage. The volume is controlled by the amount of resistance put on the circuit by the volume switch: zero for loud, 20,000 ohms for medium, and 70,000 ohms for low. The circuit is complete through the secondary coil of the hummer, the connections of the two hummer keys, and the primaries of all six transformers C-231 in series.

c. Because the six circuits through the transformer secondaries are completed by the relay simultaneously with the production of 1,000-cycle tone in the primaries, 1,000-cycle tone is induced in the transformer secondaries and put out on all lines connected. There are 350 turns of wire in the primary coil of the transformer and 850 turns in the secondary, a voltage increase of 2.43 to 1. The transformer secondary windings are connected through individual relay contacts and 0.1-microfarad capacitors to the line binding posts (fig. 21), so that the telephone lines will not be inductively coupled to one another except for the 0.4-second periods during which tone is actually being superimposed on the lines. The 0.1-microfarad capacitors prevent battery drain when connected to common battery telephone lines.

12. Time interval signal BE-65.—*a.* The coil of the relay of time interval signal BE-65 is connected to a time interval circuit of time interval apparatus EE-85 and receives the impulses produced on that particular time interval circuit. As the coil is energized, it moves the armature of the relay against the tension of a coil spring (fig. 10). The armature closes the contact which completes a circuit through the batteries and the horn magnet (fig. 22). The contact remains closed for the duration of the 0.4-second signal impulse, being opened by the spring tension when the coil is no longer energized.

b. As the sensitive relay completes the horn circuit, the two batteries BA-23 energize the horn magnet. The horn magnet is a strong electromagnet, the current through the coil being relatively great. The magnet moves the heavy magnet armature which is attached to the diaphragm. A post, attached to the diaphragm, runs back through the center of the armature and the magnet (fig. 11). As the armature is drawn to the magnet, the other end of this post strikes the heavy contact spring of the vibrator contact. Because the moving contact point is mounted on this spring, the post breaks the circuit through the batteries and horn magnet.

c. The circuit may now be completed only through the 6-microfarad capacitor, which will pass only current of changing voltage, no direct

current (fig. 22). However, the magnet coil does not lose its energy instantaneously; instead, the energy falls rapidly to zero. The capacitor will pass this changing current very readily. Therefore, its effect on the entire circuit through batteries, horn magnet, and capacitor is to increase the speed with which the magnet loses its energy.

d. When the horn magnet loses its energy, the armature is released, the diaphragm tends to return to its original position, and the contact spring forces the post away and remakes the vibrator contact. This

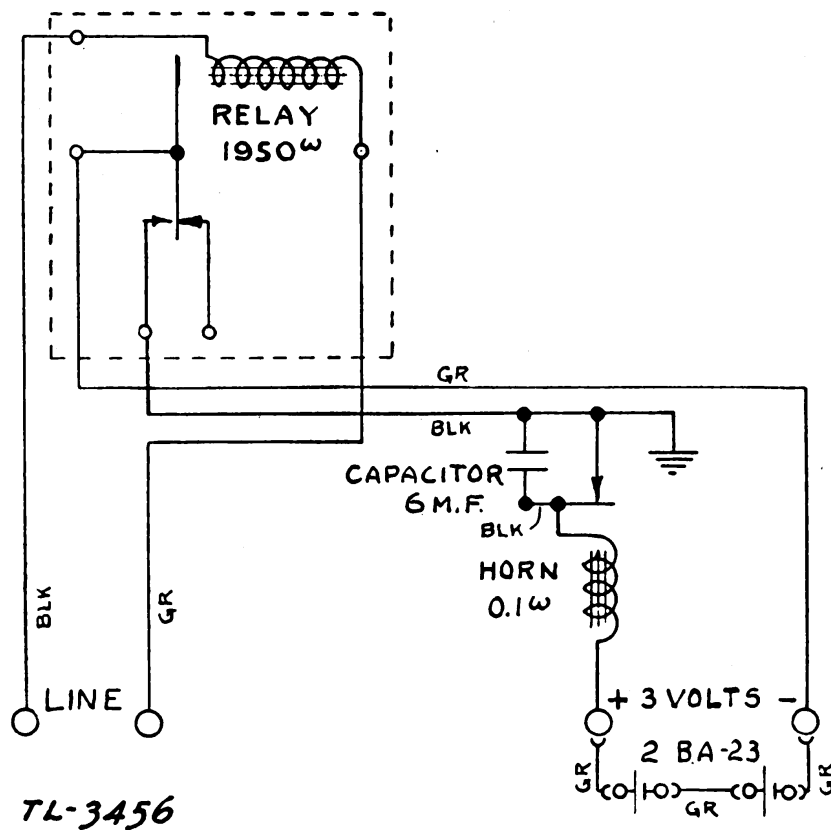

FIGURE 22.—Time interval signal BE-65—circuit diagram.

shunts the capacitor out of the circuit, again a circuit is complete for the passage of direct current through batteries and horn magnet, the magnet is energized, and the motion of the armature moves the diaphragm and breaks the magnet (vibrator) contact.

e. The rapidity with which the magnet is energized and then loses its energy, with the aid of the capacitor, is such that this action occurs many times during the 0.4-second when the relay contact is closed. Thus, the metal diaphragm vibrates rapidly, giving off a hornlike sound, the sound being intensified by the shape of the cone. The capacitor also serves to reduce arcing at the magnet contact and to prevent electrical interference with radio and other communications.

SECTION IV

SERVICING AND REPAIR

	Paragraph
Servicing.....	13
Inspection.....	14
Lubrication.....	15
Special adjustments.....	16

13. Servicing.—*a.* Servicing of time interval apparatus EE-56 and EE-86-A is limited to those minor repairs which may be made by competent mechanics of the organization which is responsible for operation of the fire-control communication system of the particular fixed seacoast artillery project. Major repair and replacement parts are the responsibility of the unit supply officer.

b. Servicing of time interval apparatus EE-85 and the associated line connector unit EE-87 and time interval signal BE-65 is the responsibility of mechanics of the communication section of a battery headquarters of mobile seacoast artillery. Procurement of replacement parts and repairs which cannot be made with available tools is the responsibility of the unit supply officer.

c. Minor repairs made by mechanics of the responsible organizations include making the adjustments explained in section III and paragraph 16, cleaning contacts, and repairing electrical connections and circuits. Contacts should be cleaned with rough paper (not sandpaper) or a burnishing tool.

14. Inspection.—*a.* It is necessary to make routine inspections of time interval equipments to see that they are functioning properly and are free of dust and grease.

b. It is advisable to check the length of one of the time intervals being generated by time interval apparatus EE-56, EE-86-A, or EE-85, when it is being first put into use. In service, contacts of the governor of the EE-56 and EE-86-A wear and setting of the governor must be readjusted every 3 months as explained in paragraphs 8*b*(4) and 9*b*(3).

c. To maintain good operation it is necessary to make frequent inspections of all adjustments of contacts, spiral tension and flat springs, stops, bumpers, and vibrators. Also, all contact points should be inspected for cleanliness, and electrical circuits for broken wires or worn insulation and loose or poor connections.

15. Lubrication.—*a.* No lubrication is required for the motor of either time interval apparatus EE-56 or EE-86-A, because it is inclosed in a dustproof cover and the bearings are permanently packed in grease.

b. On the EE-86-A there are two oil cups, one inside the governor housing and one on the rear bracket of the frame casting. These cups are required to be filled every 6 months with a high-grade lubricant such as liquid petrolatum.

c. No lubrication is required for time interval apparatus EE-85, line connector unit EE-87, and time interval signal BE-65.

16. Special adjustments.—*a. Time interval apparatus EE-56.*—In addition to adjustments of the governor as explained in paragraph 8b(4), there are two adjustments of the cam-contact assembly.

(1) *Duration-of-contact closure adjustment.*—The duration-of-contact closure, or length of time the contacts are closed, is adjustable from a minimum of 0.1 second to a maximum of 0.55 second. To secure this adjustment, use either of the test circuits illustrated in figure 23, which are used for adjusting both the EE-56 and the EE-86-A. Make connection to the time interval program circuit which it is desired to adjust. Since the normal speed of the motor is 1,280 revolutions per minute or 21.3 revolutions per second, the time in seconds for any given number of revolutions may be calculated by dividing the number of revolutions by 21.3. The duration-of-contact closure, therefore, is calculated from the number of revolutions of the governor arm (and hence the motor) from the time the contact closes to the time it opens. With the starting switch at the OFF position, rotate the governor manually in a counterclockwise direction and observe the milliammeter or light in the test circuit. **Caution:** Disconnect all lines from apparatus to battery supply bus except those shown in figure 23ⓐ. Note the position of the governor arm when the reading of the milliammeter in the test circuit first exceeds 10 milliamperes or the light begins to glow. Continue rotating the governor arm, counting the number of revolutions, until the milliammeter first drops to zero or the light is extinguished. The number of revolutions of the governor arm counted may then be translated into seconds by dividing by 21.3. The result will be the duration-of-contact closure when the motor is running at the speed of 1,280 revolutions per minute. In a similar manner, the interval between circuit operations in a program group or between similar points in adjacent program groups is obtained. If the duration-of-contact closure is not satisfactory, it may be changed. To increase the duration-of-contact closure, loosen the locknut on the appropriate adjusting screw (fig. 17) and turn the screw a few turns in a clockwise direction. To decrease the duration-of-contact closure, turn the adjusting screw in a counterclockwise direction. After an adjustment has been made, the duration-of-contact closure may be rechecked by the method previously used.

(2) *Adjustment for quiet operation.*—Adjustment of the rubber bumper to secure quiet operation is accomplished by means of the knurled head screws on the left-hand side of the contactor assembly just under the cam disks (fig. 17). The adjustment of this screw should be such that when the contactor arm falls off the cam projection it will first hit the rubber bumper attached to the screw and not the cam depression. Lock the adjusting screw with the locknut when the adjustment is obtained.

b. *Time interval apparatus EE-86-A.*—In addition to adjustments of the governor as explained in paragraph 9b(3), the same two adjustments are made of the cam-contactor assembly as in the EE-56. However, adjustment of the interval between circuit operations in the

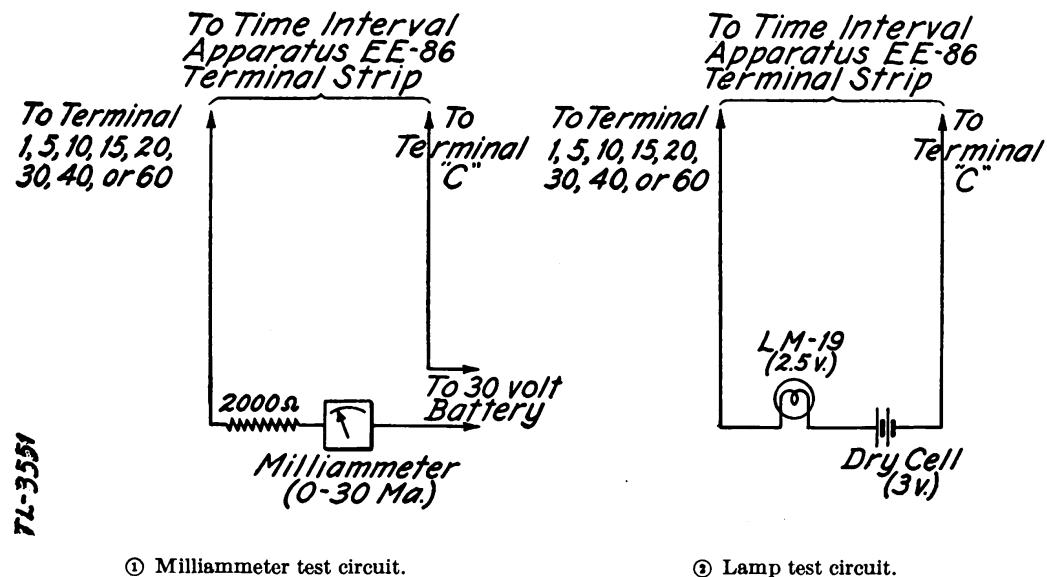

① Milliammeter test circuit.

② Lamp test circuit.

FIGURE 23.—Test circuits for both time interval apparatus EE-56 and EE-86-A.

program group and between similar points in adjacent program groups is rendered unimportant by the master 1-second timing attachment. If this latter adjustment or test is used, it must be remembered that the speed is 1,380 revolutions per minute or 23 revolutions per second, the number of revolutions being divided by 23.

c. *Time interval apparatus EE-85.*—(1) The two extra uncut 90-second and two extra uncut 120-second arbor disks (fig. 5) may be cut for any program of intervals, synchronized, or with any desired delay. The desired program and holes for the synchronizing post are laid out with ruler, protractor, and compass. The holes are drilled and the circumference is cut out with a chisel and filed smooth.

(2) The driving mechanism of time interval apparatus EE-85 has several adjustments of the springs and stops which determine its

correct operation (fig. 6). The screw adjustment of tension of the spring which is fastened to the drive bar must be such that the spring will return the magnet armature and drive bar far enough to turn the ratchet wheel one notch, or far enough for the pawl to fall into place and to hold the wheel. This spring tension also pulls the drive bar down on the next notch as the armature is pulled to the magnet, and must be adjusted properly to do so. The stops of the armature and the drive bar must be so adjusted that the armature and the drive arm will return far enough to advance the ratchet wheel a complete notch, and that they will not return too far and operate loosely or allow the ratchet wheel to advance an extra notch. Each adjustment screw has a locking device.

(3) There are two possible adjustments of the arbor-cam contactor assemblies. To press the spring shoes of the contact springs of the time interval circuits against the disk with proper pressure, the screw in the slotted angle at the base of posts upon which the contacts are mounted may be loosened and the entire contactor assembly turned until the desired firmness of pressure is obtained (fig. 6). Also, to adjust the pressure of individual spring shoes on the disks, the contact springs may be bent adjacent to the mounting posts with a pair of longnose pliers until the desired pressure is obtained. The positions of the stationary contacts mounted on the terminal blocks with screws may be adjusted by turning the screws. These contacts must make and break easily under the motion imparted to the spring shoes by the raised portions of the disks.

d. Line connector unit EE-87.—(1) The contact springs of the multiple-contact relay may be adjusted by bending the top springs up or down with a pair of longnose pliers.

(2) The springs acting on the moving contact points of the two keys may be adjusted with longnose pliers to assure that the contacts make and break properly as the keys are thrown to their various positions.

(3) The vibrator of the hummer may be adjusted for spacing and proper operation with the small screw provided, which fastens the vibrating arm to the larger post upon which the coil is mounted.

e. Time interval signal BE-65.—(1) The armature of the small, sensitive relay may be adjusted for best operation by changing the spring tension with the screw adjustment provided and by adjusting the two screw stops (fig. 10).

(2) There are three adjustments which enter into the operation of the vibrator. While tone or volume may not be changed materially, the vibrator may be set for best operation.

(a) The stop of the contact spring of the vibrator must be adjusted so that the contact will make and break properly under action of the armature and post (fig. 11).

(b) The post is adjustable also, and access to its adjustment may be obtained by removing the screen at the front of the box (fig. 9). The post may be moved in or out by turning its slotted end (fig. 11) with a screw driver, a locknut being used to lock the adjustment. The post must be in such a position that the bumper will break the vibrator contact when the armature is pulled to the magnet, and will pull back far enough to allow the contact to be made under pressure of the spring when the armature is released.

(c) The arch mounted on the large base casting with the two heavy screws and upon which the vibrator contact is mounted must be parallel with the base casting. This position is adjusted by using the large screws with their locknuts (fig. 11).

SECTION V

LISTS OF REPLACEABLE PARTS

	Paragraph
Time interval apparatus EE-56	17
Time interval apparatus EE-86-A	18
Time interval apparatus EE-85	19
Line connector unit EE-87	20
Time interval signal BE-65	21

17. Time interval apparatus EE-56.—a. Motor.

See fig. no.	Stock no.	Name	Description	Function	Mfr.	Drawing no.	
						(Mfr.'s)	(Sig. C.)
1	4H3056	EE-56	Time interval apparatus EE-56	Device for making and breaking electrical contacts at predetermined intervals; used at permanent seacoast defenses.			
1	4H3056/6	Motor	Series wound, 30-volt d-c, 1,280-rpm motor.	Prime mover	Emerson		
1	4H3056/6A	do	Series wound, 30-volt d-c, 1,280-rpm motor.	do	Djehl		
1	4H3056/6/1	Brush	Carbon brush	For Emerson motor			
1	4H3056/6.1/2	Spring	Brush spring	For Fort Wayne motor			
1	4H3056/6.2/1	Armature	Motor armature	For WE&M Co. 30-volt d-c, 1,280-rpm motor.	WE&M		
1	4H3056/6.2/3	Spring	Brush spring with wicking for grease cup.	For WE&M Co. motor			
1	4H3056/6.2/4	Wicking	Grease cup wicking	do			
1	4H3056/6.25	Brush	Carbon brush, 1 1/4" sq. x 3/16" long, with spring, 2 per set.	do			

b. Frame.

1	4H3056/28	Bracket	Brass, black oxidized finish, 2 1/2" long x 1 1/16" wide.	Motor mounting bracket			20,001D3.
1		Support	Tobin bronze, black oxidized finish, 1 5/16" long x 3/16" diam.	Support and bushing for shaft of worm wheel and containing drive pinion.			20,001D3.

c. Contacts.

See fig. no.	Stock no.	Name	Description	Function	Mfr.	Drawing no.	
						(Mfr.'s)	(Sig. C.)
17	4H3056/40	Holder	Brass, brass oxidized finish, 2 1/16" x 3/4" x 1 23/32" high.	Mounting frame for contact assembly.			20,001D4.
17		Screw	Brass, 2" long, threaded full length, 0.1894" diam. x 32 threads per inch.	Fastens holder to wooden base			20,001D4.
17		do.	Brass, black oxidized finish, 2 1/4" long, threaded 1 1/2" at 32 threads per inch, 0.1894" diam., end slotted and drilled.	Fastens holder to wooden base and receives cord connecting lower contact strip to common connection.			20,001D4.
17		Grommet	Hard rubber, 1 3/16" long, #9 drill	Insulates screw from holder			20,001D4.
17	4H3056/47	Rocker arm	Brass, black oxidized finish, 1 1/16" long by 1/4" wide.	Pivots on holder at stroke of cam projections, causing contact to make.			20,001D4.
17		Striking block	Medium hard steel, black oxidized finish, 1/8" x 1/4" x 1 1/16" long.	Receives stroke of cam projections.			20,001D4.
17	4H3056/51	Bushing	Bakelite or mica, 1/4" long, #43 drill.	Insulator for controller plate contact block screw.			20,001D4.
17	4H3056/52	do.	Bakelite or mica, 1/8" long, #43 drill.	Insulator for contact strip screw			20,001D4.
17		do.	Brass, 5/16" long, #52 drill.	Bearing for rocker arm pivot pin			20,001D4.
17	4H3056/54	Strip	Nickel silver with platinum points, 2 1/8" x 1/4" wide.	Lower contact strip, fastened to rocker arm.			20,001D4.
17	4H3056/55	Spring	0.0115 phosphorus bronze spring wire, 3/8" long.	Retractable spring on rocker arm			20,001D4.
17	4H3056/56	Screw	Hard brass, black oxidized finish, knurled head, #8-32, 1 3/16".	Bumper adjustment screw			20,001D4.
17	4H3056/57	do.	Hard brass, black oxidized finish with platinum point, knurled head, #8-32, 1 3/16".	Main contact point and contact adjustment screw.			20,001D4.
17	4H3056/58	Nut	Hard brass, black oxidized finish, std. for #8-32 screw.	Lock nut for bumper and contact screw adjustments.			20,001D4.
17	4H3056/59	Washer	1/2" and 3/8" faces by 3/16" thick, leather.	Leather bumper			20,001D4.

TIME INTERVAL APPARATUS, ETC.

17	4H3056/60	Pin	Steel, 5/8" long	Rocker arm pivot pin	20,001D4
17	4H3056/61	Cord	Copper braid with terminals, 2" long	Connection between lower contact strip and common connection bus	20,001D4
17		Plate	Bakelite or mica, 3 7/8" x 2 1/2" x 1/32" thick	Insulates holders from brass frame	20,001D4
<i>d. Contact controller.</i>					
1		Spindle	Brass, black oxidized finish, 3 7/8" x 1 1/32" diam.	Hollow spindle upon which disks and gears are mounted.	20,001D5
1		Disk	Brass, black oxidized finish, 9" diam. x 1/8" thick.	10-, 15-, and 20-second cam disks, upon which cam groups are mounted.	20,001D5
1		do	Brass, black oxidized finish, 9" diam. x 1/8" thick.	30-second cam disk, pinned to spindle.	20,001D5
1		Bushing	Brass, black oxidized finish, 7/8" long x #9 drill.	Spacers between disks.	20,001D5
1		do	Brass, black oxidized finish, 1/8" long x #9 drill.	Spacers between gear and 10-second disk.	20,001D5
1		Rod	Brass, 3 3/16" long x 0.1894" diam., 32 threads per inch, threaded 1/4" each end.	Mounts disks and gear on spindle.	20,001D5
1		Shaft	Cold rolled steel, 5 1/4" x 3/8" diam.	Stationary shaft on which entire cam-arbor assembly revolves.	20,001D5
1		Pin	Brass, 1/4" long x 0.096" diam.	Pin gear and 30-second disk to spindle.	20,001D5
1	4H3056/85	Block	3-tooth block, medium hard steel, 1 1/2" x 1 7/32" x 1/8" thick.	3-projection program group cam.	20,001D5
1	4H3056/86	Screw	Brass, black oxidized, knurled head, #10-32 x 1 1/16"	Fasten program cams to disks.	20,001D5
1	4H3056/87	Block	Single-tooth block, medium hard steel, 1 1/2" x 1 7/32" x 1/8" thick.	Single projection program cam.	20,001D5
1		Bearing	Annular ball bearing, bore 0.2756", diam. 0.8661", width 0.2756".	Bearings for rotation of spindle about stationary shaft.	20,001D5

e. Governor.

See fig. no.	Stock no.	Name	Description	Function	Mfr.	Drawing no.	
						(Mfr.'s)	(Sig. C.)
16	4H3056/91	Frame	Aluminum alloy, 2" long x 1 3/16" high x 1/2" wide.	Rotating governor fly-ball support.			20,001D6-6.
16	4H3056/92	Strip	Steel, nickel dip finish, 1 3/16" x 1" x 1/4" wide.	Lower contact strip.			20,001D6-6.
16	4H3056/93	Pin	Stubs steel, 3/4" x 0.041" diam.	Pivot pin for lower contact strip, fastening it to governor frame.			20,001D6-6.
16	4H3056/94	Fly-ball	Brass, nickel dip finish, 5/16" diam.	Governor fly-ball.			20,001D6-6.
16	4H3056/95	Contact	Steel, blue finish, with tungsten contact; 2 7/8" long x 1/8" diam., threaded 48 t. p. i.	Lower governor contact.			20,001D6-6.
16	4H3056/96	Nut	Hard brass, nickel dip finish, hex nut, #5-48 x 1/16" thick.	Lower contact nut.			20,001D6-6.
16	4H3056/97	Screw	Headless setscrew, #6-32 x 3/16"; iron, nickel dip finish.	Fastens rotating support to motor shaft.			20,001D6-6.
16	4H3056/98	do	Brass, nickel dip finish, slotted head, #5-48 x 1/4".	Governor spring tension adjustment screw.			20,001D6-6.
16	4H3056/99	Spring	0.016" spring steel wire, 1 5/8" long.	Governor fly-ball tension spring.			20,001D6-6.
16	4H3056/100	Lever	Sheet brass, nickel dip finish, 3/8" x 3/4" x 1/2" wide.	Governor spring tension adjusting lever.			20,001D6-6.
16	4H3056/101	Bushing	Hard rubber grommet, 3/8" long x 5/16" drill.	Insulates upper contact screw of governor.			20,001D6-6.
16	4H3056/102	do	Hard brass, black oxidized finish, 5/8" long x #28 drill.	Receives upper contact screw of governor.			20,001D6-6.
16		Terminal	Hard brass, nickel dip finish, 1" x 1/4" x 0.034" thick.	Provides connection for stationary contact.			20,001D6-6.
16	4H3056/104	Washer	Hard rubber, 3/4" diam. x 3/32" thick.	Insulates upper contact screw from governor bracket.			20,001D6-6.
16	4H3056/106	Screw	Hard brass, black oxidized finish with platinum point and knurled head, #6-32 x 1 1/8"	Upper contact screw.			20,001D6-6.

16	Nut.....	Hard brass, black oxidized finish, knurled head, $\frac{3}{32}$ " thick x #30 drill.	Locks upper governor contact screw.....	20,001D6-6.
16	4H3056/108.....	Contact spring.....	Governor shaft contact spring.....	20,001D6-6.
16	4H3056/109.....	Bushing.....	Insulates governor bracket from frame of apparatus.	20,001D6-6.
16	4H3056/110.....	do.....	Insulates governor mounting screw from frame of apparatus.	20,001D6-6.

f. Shaft.

1	4H3056/120-124.....	Steel.....	Shaft connecting motor and governor.	
---	---------------------	------------	--------------------------------------	--

g. Coils.

1	4H3056/130-35.....	Coil.....	Governing resistance in series with motor field.	
1	4H3056/131, 133, 134.....	do.....	Governing resistance in series with motor field.	
1	4H3056/133.....	do.....	Governing resistance in series with motor field.	

h. Motor binding post.

1	4H3056/140-44.....	Binding post.....	Provide connection for lead direct from motor; wired to binding posts to which battery is connected.	
1	4H3056/150.....	Block.....	Mounting block of terminal strip.....	
1	4H3056/151/1.....	Screw.....	Binding post screw.....	

i. Gears.

See fig. no.	Stock no.	Name	Description	Function	Mfr.	Drawing no.	
						(Mfr.'s)	(Sig. C.)
1	4H3056/161	Gear	Brass, black oxidized finish 5/8" long	Driving gear for cam-arbor assembly			
1	4H3056/162	Worm	3 1/32" long	Motor shaft worm			
1	4H3056/163	Shaft	Brass, 1.6875" pitch diameter, 80 teeth.	Gear and pinion shaft			
1		Gear		Worm gear			

18. Time interval apparatus EE-86-A.—a. Motor.

3		Motor	Series wound, 30-volt d-c, 1,380-rpm, ball bearing, 20° C. rise.	Prime mover			
3		Brush	Carbon brush	For motor			
3		Spring	Flat spring	Brush spring			
3		Armature		For grease cup			
3		Wicking	0.1/μf	Prevents radio interference from motor.			
3		Capacitor	0.1/μf	do			

b. Frame.

3	Support	Tobin bronze, black oxidized finish	Support and bushing for shaft of worm wheel and containing drive pinion of cam-arbor.
---	---------	-------------------------------------	---

c. Contactor assembly.

17	Screw	Brass	Fastens holder to wooden base. Fastens holder to wooden base and receives cord connecting lower contact strap to common connection.
17	do	do	
17	Grommet	Hard rubber	Insulates connection screw from holder.
17	Rocker arm	303 stainless steel	Pivots on holder at stroke of cam projections, causing contact to make.
17	Bushing	Hard rubber	Insulates contact strip screw
17	Strip	With tungsten contact	
17	Spring	Spiral, beryllium copper	Lower contact strip, fastened to rocker arm.
17	Screw	Fillet head with slot	
17	do	Fillet head with slot, tungsten contact.	Retractable spring on rocker arm. Bumper adjusting screw. Stationary contact point and contact adjustment.
17	Washer	Leather	Rocker arm bumper
17	Bearing	303 stainless steel	Bearing for rocker arm pivot pin.
17	Cord	Copper braid with terminals	Connecting cord for contact maker
17	Plate	Bakelite	Insulates holders from frame

d. Contact controller.

See fig. no.	Stock no.	Name	Description	Function	Mfr.	Drawing no.	
						(Mfr.'s)	(Sig. C.)
3		Spindle	Brass, black oxidized finish	Hollow spindle upon which disks and gear are mounted.			
3		Disk	do	5-, 10-, 15-, 20-, and 30-second disks, upon which cam groups are mounted.			
3		do	do	60-second disk, pinned to spindle.			
3		do	do	40-second disk			
3		do	Steel, bright finish	1-second disk			
3		Bushing	Brass, black oxidized finish	Spacers between disks			
3		do	do	Spacers between gear and 1-second disk.			
3		Rod	Brass	Holds gear and disks on spindle, except 40-second disk.			
3		Shaft	Cold rolled steel	Stationary shaft on which entire cam-arbor assembly rotates.			
3		do	do	Idle shaft of drive of 40-second disk.			
3		Pin	Brass	Pin 60-second disk and gear to spindle.			
3		do	Brass, taper turned	Pin hubs of gears to idler shaft.			
3		Block	3-tooth block, medium hard steel	3-projection program group cams for 10-, 15-, 20-, 30-, and 60-second disks.			
3		do	do	3-projection program group cam for 40-second disk.			
3		do	Single-tooth block, medium hard steel.	Single-projection program cams for 5-second disk.			
3		Screw	Knurled head	Fasten program cams to disks			
3		Bearing	Annular ball-bearing	Bearings for rotation of spindle about stationary shaft.			
3		Gear	Steel	Cam-arbor driving gear			
3		do	do	Turned by cam-arbor, drives idler assembly.			

3	do	do	Driven gear of idler assembly		
3	do	do	Driving gear of idler assembly, drives 40-second disk.		
3	do	do	Gear on 40-second disk spindle.		
3	Frame	Brass	Supports idler assembly		
3	Clamps	do	Fasten idler shaft to frame.		
<i>e. Governor.</i>					
3	Cover	Sheet steel stamping, black	Protecting cover of governor assembly.		
3	Frame	Aluminum-alloy	Rotating governor fly-ball support.		
3	Strip	Steel, nickel dip finish	Holds clutching device which actuates lower contact strip.		
3	do	do	Lower contact strip		
3	Pin	Steel	Pivot pin for strip on governor fly-ball support.		
3	Fly-ball	Brass, nickel dip finish	Governor fly-ball		
3	Contact	Tungsten	Lower contact point		
3	do	do	Upper contact point		
3	Spring	Spring steel, spiral	Governor fly-ball tension spring.		
3	do	do	Lower contact tension spring		
3	Screw	Hard brass, black oxidized finish	Upper contact screw holding upper contact point.		
3	do	do	Adjusts lower contact spring tension.		
3	Strip	Steel, nickel dip finish	Pivoted on stationary arm, moved by screw adjusting lower contact spring.		
3	do	do	Stationary arm upon which lower contact spring adjustment strip is mounted.		
3	Resistor	125-ohm	Governing resistance in series with motor field.		
3	do	1000-ohm	Prevents radio interference of contact arc.		

f. Shaft.

See fig. no.	Stock no.	Name	Description	Function	Mfr.	Drawing no.	
						(Mfr.'s)	(Sig. C.)
3		Shaft.....	Steel.....	Connects motor shaft to governor fly-ball support.			

g. Master cam assembly.

3		Gear.....	Fiber.....	Worm gear driven from worm on motor shaft..		
3		Shaft.....	Steel.....	Shaft between worm gear and cam.		
3		Cam.....	Brass.....	Actuates master 1-second contact.		
3		Contact strip.....	Steel.....	Holds moving contact.		
3		do.....	Steel.....	Holds stationary contact.		
3		Screw.....	Brass.....	Stop for moving strip of contact.		

h. Tuning fork.

3		Fork.....	Chromium steel alloy, 46 vibrations per second $\pm 0.05\%$.	Provides correct adjustment of governor.	Riverbank	
---	--	-----------	---	--	-----------	--

i. Panel assembly.

2		Binding.....	Bakelite cap and base and brass screw.	Binding posts for time interval connections and battery connections.		
2		Switch.....	Toggle, with silver plated contacts.	Starting switch.....		

TIME INTERVAL APPARATUS, ETC.

j. Box assembly.

3	Binding posts.....	Bakelite cap and base and brass screw.	Provide connection for leads direct from motor; wired to binding posts to which battery is connected.		
2	Clasp.....	Spring clasp, nickel plated.	Fasten cover to base.		
3	Wire.....	"Ravine" #18 AWG, stranded, tinned, rubber covered, braided, and lacquered.	All wiring, except busses	Belden.	

k. Worm drive.

3	Worm.....	Fiber.....	Mounted on motor shaft to drive worm wheel.		
3	Worm gear.....	Fiber.....	Mounted on shaft which has pinion cut on it.		
3	Shaft.....	Steel.....	Upon which worm gear is mounted and on which pinion is cut, to drive cam-arbor assembly.		

19. Time interval apparatus EE-85.

5	Clock.....	Electro-magnetic motor, 10-12 v., d-c.	Drives time interval mechanism	W & T	SK-3917-B	SC-D-3841-B.
---	------------	--	--------------------------------	-------	-----------	--------------

a. Box assembly (SC-D-3842-B).

4	Hinge.....	Brass, dull white nickel finish, 13 $\frac{3}{16}$ " long x 1 $\frac{1}{16}$ " wide.	Hinges box top to box.	V-R.	1221	SC-D-3843-C.
5	Bracket.....	Brass angle, dull white nickel finish, 1 $\frac{1}{2}$ " x 1 $\frac{1}{2}$ ", #12 B & S ga.	Support binding post panel.			SC-D-3843-C.
4	Strap clamp.....	Brass, dull white nickel finish, 1 $\frac{1}{4}$ " x 2" x 1 $\frac{1}{16}$ ".	Clamps carrying strap.			SC-D-3843-C.

a. Box assembly—Continued

See fig. no.	Stock no.	Name	Description	Function	Mfr.	Drawing no.	
						(Mfr.'s)	(Sig. C.)
5		Disk mounting	Brass, dull white nickel finish, 1 1/16" x 1" diam.	Mounting for spare disks			SC-D-3843-C.
4		Hinge	Brass, dull white nickel finish, 7 1/2" long x 1/16" wide.	Hinges shutter to cover	V.R.	1221	SC-D-3844-O.
4		Spring	Steel, nickel plate, #14 music wire, 50 turns.	Shutter hinge spring			SC-D-3844-C.
5		Disk	Brass, dull white nickel finish, 1/2" x 1" diam.	Fastens spare disks to mounting disk			SC-D-3844-O.
5		Bracket	Brass angle, dull white nickel finish, 1/2" x 1/2" x #12 B & S ga.	Support clock, mounting panel			SC-D-3844-C.
4		Strap	OD cotton webbing 1" x 1.33 oz. x 20" long.	Carrying strap			SC-D-3842-B.
4		Recess bumper	#02 rubber tip	Protect exterior	H S		SC-D-3842-B.
4		Catch	#01796F flush hasp, brass, nickel finish.	Fastens cover	Eagle	01796F	SC-D-3842-B.

b. Time interval assembly (SC-D-3845-D).

6		Post	Aluminum alloy, 53 S-T, anodized, 1 1/2" x 5/16" square.	Holds magnet armature stop			SC-D-3846-D.
6		do.	Aluminum alloy, 53 S-T, anodized, 1 1/2" x 5/16" square.	Holds drive bar stop			SC-D-3846-D.
6		Block	Aluminum alloy, 53 S-T, anodized, 3/4" x 7/16" x 1/4".	Holds drive bar spring arm			SC-D-3846-D.
6		Spring arm	Aluminum alloy, 53 S-T, anodized, 1 7/16" x 1 3/32" x 3/16".	Holds drive bar spring			SC-D-3846-D.
6		Stud	Nickel silver, 1 3/32" x 1/16" diam.	Fastens spring to spring arm			SC-D-3846-D.
6		Drive bar	Nickel silver, 52 1/32" x 3/8" x 0.054" thick.	Rotates ratchet			SC-D-3846-D.

TIME INTERVAL APPARATUS, ETC.

6	Spring.....	Steel, Parkerized, linseed oil finish.	Drive bar spring, retracts drive bar.	SC-D-3846-D.
6	do.....	Steel, Parkerized, linseed oil finish, #10 music wire, 14 turns.	Magnet armature spring, retracts armature.	SC-D-3846-D.
6	Block.....	Tool steel, hardened and blued, 3/8" x 1/4" x 1/4".	Fastens to drive bar, contacting ratchet.	SC-D-3847-C.
6	Stop.....	Tool steel, hardened 1 1/16" x #6-32 thread.	Drive bar stop.....	SC-D-3847-C.
6	Arm.....	Nickel silver, 1 1/16" x 3/16" x 5/32".	Fastens to magnet armature, holding drive bar.	SC-D-3847-C.
6	Screw pin.....	Brass, dull white nickel finish, 3/8" x 1/16" diam.	Fastens drive bar to arm.....	SC-D-3847-C.
6	Armature.....	Armcoingot iron, nickel plate, 1 1/32" x 3 1/32" x 3/16".	Actuates drive bar.....	SC-D-3847-C.
6	Hook.....	Steel, dull white nickel finish, 5/8" long x #18 A. W. G.	Fastens spring to magnet armature.	SC-D-3847-C.
6	do.....	Steel, dull white nickel finish, 7/16" long x #18 A. W. G.	Fastens spring to core piece.....	SC-D-3847-C.
6	Insulator.....	Vulcanized fiber, 1" x 1" x 0.010" thick.	Insulates winding from coil.....	SC-D-3847-C.
6	Plate.....	Natural "X" phenolic plate, 1" x 5/8" x 5/8" x 3/32".	Fastens to core, mounting for terminals.	SC-D-3847-C.
6	Spacer.....	Natural "X" phenolic plate, 1/4" thick x 3/32" diam.	Insulates resistor from fastenings.	SC-D-3847-C.
6	do.....	Hard brass, dull white nickel finish, 1 3/16" x 3/16" diam.	Insulates capacitors.....	SC-D-3847-C.
6	3D177A.....	CA-177-A, 0.5 µf, fixed, paper, 160 v., d-c.	Auxiliary contact arc-spark suppressor.	SC-D-512.
6	3Z10116.....	TM-1/16 oval single ear, brass (tinned)	Provides connection to magnet winding.	RL-A-878.
6	Resistor.....	RS-245, 10-ohm.....	Auxiliary contact spark suppression.	RL-D-6223.
6	Eyelet.....	Brass, #1832.....	Part of magnet winding connection.	SC-D-3845-D.
6	Insulation.....	Varnished cambric.....	Insulates magnet from core.	SC-D-3845-D.
6	Thread.....	Soft white cotton.....	Protects winding.....	SC-D-3845-D.
6	Pin.....	Steel, nickel plate, 0.076" x 3/16" long.	Pivot between armature and core.	SC-D-3845-D.
6	Escutcheon pin.....	Brass, #21 (0.032") x 3/4" long.	Shields armature contact with core.	SC-D-3845-D.

c. Panel assembly (SC-D-3848-C).

See fig. no.	Stock no.	Name	Description	Function	Mfr.	Drawing no.	
						(Mfr.'s)	(Sig. C.)
4		Strap	Brass, dull white nickel finish, 2 3/8" x 1/16" x #20 B & S ga.	Connect clock to time interval mechanism circuits.			SC-D-3848-C.
4		do	do	do			SC-D-3848-C.
4	3Z8105	Switch	SW-105, toggle, single-circuit SPST	Starting switch	A-H & H	20994-CN	SC-A-1042-C.
4		Binding post	TM-195, brass, dull white nickel finish, knurled cap.	Provide connection to time interval circuits.			SC-D-1132.
4	3Z252	do	TM-152, composition, knurled cap and base.	Provide connection to clock			SC-D-530.
4	3Z209	do	TM-109, bakelite, knurled cap and base, Eby Junior P-3.	Provide connection to battery	Eby		SC-D-530.
6	3Z9913	Terminal	TM-13, eye clip, oval, brass (tinned).	Provide connection to battery binding posts.			RL-A-320.
6	3Z9936	do	TM-36, eye clip, flat, brass	Provide connection to clock binding posts.			10701B1.
6		do	Brass, #4012	Provide connection to interval circuit binding posts.	P-M		SC-D-3848-C.

d. Support assembly (SC-D-3849-C).

6		Post	Aluminum alloy 61 S-T, 2 3/8" x 1/2" diam.	Forms stand for complete panel assembly.			SC-D-3849-C.
6		Collar	Aluminum alloy 61 S-T, 1/2" diameter x 1/4" thick.	Spacers between plate and panel			SC-D-3849-C.
6		Bumper	Rubber tip, #02	Cushions on end of posts.	H S		SC-D-3849-C.

e. Disk assembly (SC-D-3850-D).

6		Stud	410 stainless steel, 2 7/8" x 1 5/16" diam.	Forms disk arbor			SC-D-3850-D.
6		Sleeve	Brass, dull white nickel finish, 2" x 1/2" diam.	Fits over stud of disk arbor			SC-D-3850-D.

TIME INTERVAL APPARATUS, ETC.

6	Stud	410 stainless steel, 1 $\frac{1}{32}$ " x $\frac{3}{16}$ " diam	Synchronization posts mounted on gears.	SC-D-3850-D.
6	Spacer	Aluminum alloy 61 S-T anodized, $\frac{3}{4}$ " diam. x $\frac{3}{16}$ " thick.	Separates ratchet and first disk of 90-sec. arbor.	SC-D-3850-D.
6	do.	Aluminum alloy 61 S-T anodized, $\frac{3}{4}$ " diam. x $\frac{1}{4}$ " thick.	Separates gear and first disk of 120-sec. arbor.	SC-D-3850-D.
6	do.	do.	Separate time interval disks.	SC-D-3850-D.
6	Gear	Aluminum alloy 52 S-H anodized, 3" P. D. x $\frac{1}{8}$ ".	90-sec. arbor pinion	SC-D-3850-D.
6	do.	Aluminum alloy 52 S-H alloy, 4" P. D. x $\frac{1}{8}$ ".	120-sec. arbor gear	SC-D-3850-D.
6	Ratchet	Steel, nickel plate 2 $\frac{1}{4}$ " diam. x $\frac{1}{16}$ " thick.	Drives time interval arbors	SC-D-3851-D.
6	Disk	XXX natural phenolic plate, $\frac{3}{8}$ " diam. x $\frac{3}{32}$ ".	Generates 10-sec. synchronized intervals.	SC-D-3851-D.
6	do.	do.	Generates 20-sec. synchronized intervals.	SC-D-3851-D.
6	do.	do.	Generates 30-sec. synchronized intervals.	SC-D-3851-D.
6	do.	do.	Generates 20-sec. intervals; 5- and 10-sec. delay and synchronized.	SC-D-3851-D.
6	do.	do.	Generates 30-sec. intervals; 10- and 15-sec. delay and synchronized.	SC-D-3851-D.
6	do.	XXX natural phenolic plate, 2 $\frac{3}{4}$ " diam. x $\frac{3}{32}$ ".	Generates 5-sec. synchronized intervals.	SC-D-3851-D.
6	do.	do.	Generates 15-sec. synchronized intervals.	SC-D-3851-D.
6	do.	do.	Generates 45-sec. synchronized intervals.	SC-D-3851-D.
6	do.	do.	Generates 45-sec. intervals; 5- and 15-sec. delay and synchronized.	SC-D-3851-D.
5	do.	XXX natural phenolic plate, 3 $\frac{5}{8}$ " diam. x $\frac{3}{32}$ ".	Spares for 90-sec. arbor	SC-D-3852-A.
5	do.	XXX natural phenolic plate 2 $\frac{3}{4}$ " diam. x $\frac{3}{32}$ ".	Spares for 120-sec. arbor	SC-D-3852-A.

f. *Contact assembly* (SC-D-3853-D).

See fig. no.	Stock no.	Name	Description	Function	Mfr.	Drawing no.	
						(Mfr.'s)	(Sig. C.)
6		Post	Aluminum alloy 53 S-T cold finish anodized, 2 1/16" x 3/16" sq.	Provides mounting for contactor assembly of 120-sec. arbor.			SC-D-3854-D.
6		do.	do.	Provides mounting for contactor assembly of 90-sec. arbor.			SC-D-3854-D.
6		Plate	XXX phenolic plate, 1 1/16" x 1 1/16" x 1/8" thick.	Insulates and provides mounting for terminal blocks.			SC-D-3854-D.
6		Angle	Aluminum alloy 52 S 1/2-H, anodized, 3/8" x 9/16" x 3/32" thick.	Provides adjustment of contact spring pressure against disks.			SC-D-3854-D.
6		Terminal block (l. h.)	Hard brass, gold plated, 1 1/32" x 1/4" x 1/8".	Hold adjustable stationary contact and terminal of 90-sec. arbor contactor assembly.			SC-D-3854-D.
6		Terminal block (r. h.) 1/8".	do.	Hold adjustable stationary contact and terminal of 120-sec. arbor contactor assembly.			SC-D-3854-D.
6		Spring shoe	302 stainless steel, 1 1/16" x 1/4" x 3/32" thick.	Makes pressure contact with disks.			SC-D-3854-D.
6		Strap	Brass, gold plated, 1 1/8" x 1 1/16" x #24 B & S ga.	Straps moving contact connections together to get common connection for 90-sec. arbor.			SC-D-3854-D.
6		do.	Brass, gold plated, 1 1/8" x 1 1/16" x #24 B & S ga.	Straps moving contact connections together on armature to get common connection for 120-sec. arbor.			SC-D-3854-D.
6		Contact spring	Beryllium copper, gold plated, 1 3/16" x 1/4" x #33 B & S ga.	Mounting for moving contact.			SC-D-3854-D.
6		Contact screw	Beryllium copper, gold plated, 1/2" long x #6-32 thread.	Mounting for stationary contact, placed in terminal block.			SC-D-3854-D.
6		Contact	Palladium, 1/16" thick x 1/8" diam.	Moving contact.			SC-D-3854-D.
6		do.	Palladium, 3/32" diam. x 0.025 thick.	Stationary contact.			SC-D-3854-D.
6		Pawl support	Brass, dull white nickel finish, 1 3/8" x 7/32" x 1/8".	Mounted on post, supporting pawl and pawl spring of ratchet wheel.			SC-D-3854-D.

6	Pawl.....	Tool steel hardened and blued, 2 $\frac{3}{32}$ " x $\frac{3}{16}$ " x 0.099".	Prevents ratchet wheel from back- ing up.	SC-D-3854-D.
6	Pawl spring.....	Beryllium copper, 1 $\frac{3}{16}$ " x $\frac{7}{32}$ " x #33 B & S ga.	Presses pawl against ratchet wheel	SC-D-3854-D.
6	Washer.....	Brass, gold plated, $\frac{3}{16}$ " diam. x $\frac{1}{32}$ ".	Fastens straps and springs on post	SC-D-3854-D.
6	Pin.....	Nickel silver, $\frac{1}{16}$ " x $\frac{1}{4}$ " long.....	Mounts pawl in pawl support.	SC-D-3853-C.

9. Clock mounting assembly.

5	Cup.....	Black molded phenolic, 4 $\frac{1}{16}$ " high x 3 $\frac{1}{16}$ " diam.	Contains clock.....	SC-D-3855-B.
5	Gasket.....	Thiokol (D) compound no. 2100, 3 $\frac{3}{8}$ " diam. x $\frac{1}{16}$ ".	Placed between clock and panel as cushion.	SC-D-3855-B.
5	Screw.....	Brass, black oxide finish, 4 $\frac{5}{8}$ " long x #10-32 thread.	Fastens cup to box.....	SC-D-3855-B.

20. Line connector unit EE-87.

8	Relay.....	Multiple, 7-contact, 10-12-v.....	Completes circuit through hummer and line circuits upon impulse from time interval apparatus EE-85.	North..... 400-Z.....	SC-D-3719-C.
8	Hummer.....	Microphone hummer, type 572-B.....	Produces 1,000-cycle tone for lines	G. R.....	SC-D-3719-C.
8	Washer.....	Countersunk, brass, no. C-145, nickel finish.	Fastening resistor to bottom of box	Simpson.....	SC-D-3719-C.
8	Terminal.....	TM-36, eye clip, oval, brass (tinned).	For "B" connection on microphone side of hummer primary.	10701-B-1.	10701-B-1.
8	Resistor.....	RS-55, 45-ohms $\pm 5\%$ porcelain tube	Limits voltage across hummer pri- mary.	RL-D-6223.	RL-D-6223.
8	Washer.....	Phenolic plate, $\frac{5}{8}$ " o. d. x 1 $\frac{3}{4}$ " i. d. x $\frac{3}{32}$ " thick.	Insulates resistor.....	SC-D-3719-C.	SC-D-3719-C.

a. Transformer C-231 assembly.

See fig. no.	Stock no.	Name	Description	Function	Mfr.	Drawing no.	
						(Mfr.'s)	(Sig. C.)
8		Transformer	Type C-231	Steps up voltage of hummer output, placing it on telephone lines.			SC-D-1614-C.
8	3Z10104	Terminal	TM-104, brass (tinned), front ear	Transformer terminal			RL-D-5035.

b. Box assembly.

7		Strap clamp	Brass, dull white nickel finish, 2" x 1 1/16" x 1/16" thick.	Fastens carrying strap			SC-D-3721-C.
8		Support	Aluminum alloy, 2 7/32" x 1 3/4" x #14 B & S ga.	Supports relay			SC-D-3721-C.
8		do.	Aluminum alloy, 3 3/16" x 2 1/16" x #14 B & S ga.	do.			SC-D-3721-C.
8		Transformer strap	Brass, dull white nickel finish, 10 3/32" x 3/4" x 1/8" thick.	Strap transformers in place			SC-D-3721-C.
7		Hinge spring	Steel, nickel plated, #14 music wire, 50 turns.	Shutter hinge spring			SC-D-3721-D.
7		Hinge	Brass, dull white nickel finish, #1221, 7 1/2" long x 1 1/16" wide.	Hinges shutter to cover	V-R	1221	SC-D-3722-B.
7		do.	Brass, dull white nickel finish, #1221, 13 3/16" long x 1 1/16" wide.	Hinges cover to box	V-R	1221	SC-D-3722-B.
8		Bracket	Brass angle, dull white nickel finish, 1/2" x 1/2" x #12 B & S ga.	Supports panel assembly			SC-D-3722-B.
7		Catch	#01796F brass flush hasp, nickel finish.	Fastens cover to box	Eagle	01796F	SC-D-3720-B.
7		Recess bumper	Rubber tip #02	Cushions on bottom and back of box.	H S		SC-D-3720-B.
8		Washer	Countersunk, brass #145, nickel finish.	Fastens ends of transformer straps to box.	Simpson		SC-D-3720-B.
7		Strap	OD cotton webbing 1" x 1.33 oz. x 20" long.	Carrying strap			SC-D-3720-B.

c. Panel assembly.

8	Clip.....	Brass, 3/8" wide x #20 B&S ga. thick	Fastens laced wire cable to plate	SC-D-3723-B.
7	Binding post.....	TM-195, brass, dull white finish, knurled cap.	Provides connection to line circuits	SC-D-1132.
7	do.....	TM-195, brass, dull white nickel finish, knurled cap.	Provides connection to relay circuit, from time interval apparatus EE-85.	SC-D-1132.
7	3Z209.....	TM-109, bakelite, knurled cap and base.	Provides connection for battery leads.	SC-D-530.
8	3D166.....	CA-166, 0.1 μ f, fixed, paper, 200-v., d-c.	Prevent drain from telephone system batteries.	SC-D-512.
8	3Z9913.....	TM-13, eye clip, oval, brass (tinned)	For binding posts for battery leads	RL-A-320.
8	do.....	#4012	For binding posts of line circuits	SC-D-3723-B.
8	do.....	#4012	For binding posts of relay circuit	SC-D-3723-B.
7	Key.....	3-position, #479EP	Controls volume of hummers	SC-D-3723-B.
7	do.....	3-position, #479G	Switches hummers on and off	SC-D-3723-B.
8	Resistor.....	Type F-1/3, 20,000-ohm, 1/2-w	Regulates hummer volume	SC-D-3723-B.
8	do.....	Type F-1/3, 50,000-ohm, 1/2-w	do	SC-D-3723-B.

21. Time interval signal BE-65.

9	4H5005.....	BE-65.....	Time interval signal BE-65.....	SC-D-3827-A.
10	do.....	Capacitor.....	6- μ f, 400-v., FU-748, PC-753.....	SC-D-3827-A.
10	do.....	Relay.....	Model 2C with coil #38.....	SC-D-3827-A.
10	do.....	Terminal.....	Brass, #903.....	SC-D-3827-A.

a. Box assembly.

See fig. no.	Stock no.	Name	Description	Function	Mfr.	Drawing no.	
						(Mfr.'s)	(Sig. C.)
10		Hinge	Brass, dull white nickel finish, 5/8" long x 1 1/16" wide.	Hinges cover to box.	V-R		SC-D-3830-B.
10		Strip	SAE 1020, 1/32" cold rolled steel, 5 1/16" x 3/8" x 7/32"	Retains gasket in place on cover.			SC-D-3830-B.
10		do.	SAE 1020, 1/32" cold rolled steel, 9 1/16" x 3/8" x 7/32"	do.			SC-D-3830-B.
10		Angle	SAE 1020, 1/16" cold rolled steel, 9 1/2" x 1 1/32" x 7/32"	Forms slide with bottom of box for battery assembly plate.			SC-D-3830-B.
10		Bracket	SAE 1020, 1/4" cold rolled steel, 7/8" x 1/2" x 1/2" wide.	Receives screw which fastens cover to box.			SC-D-3830-B.
10		Clamp	Brass, dull white nickel finish, 1 1/8" x 1" x 1/8"	Fastens pad to side of box at wire entrance.			SC-D-3830-B.
10		Pad	Thiokol "D" compound #2100, 1 1/2" x 1 1/4" x 3/16"	Waterproofs wire entrance.	Thiokol		SC-D-3830-B.
10		Gasket	Thiokol "D" compound #2100, 9 3/4" x 6 3/8" x 1/4" sq.	Waterproofing between box and cover.	Thiokol		SC-D-3830-B.
9		Plate	1/16" cold rolled steel, pressing, 5 1/2" sq. x 3/16"	Fastens screen to front of box.			SC-D-3831-A.
9		Screen	Bronze, black oxidized finish 5/4" sq., 6-mesh, 0.047" wire, 0.120" opening.	Covers horn opening in front of box.			SC-D-3831-A.
9		Gasket	Thiokol "D" compound #2100, 5 3/4" diam. x 1/8"	Waterproofing between plate and front of box.	Thiokol		SC-D-3831-A.
10		Screw	Brass, dull white nickel finish, knurled head, 1 1/2" x #10-32 thread.	Fastens cover to brackets on box.			SC-D-3831-A.
10		Washer	Vulcanized fiber, 7/16" o. d., 3/16" i. d. x 1/32"	Used with screw which fastens cover.			SC-D-3831-A.
10		Spacer	SAE 1020 cold rolled steel, 5 5/8" x 1/2" x 1/8"	Flat spacer between hinge and bottom of box.			SC-D-3831-A.
10		Support	Brass, dull white nickel finish, 2 1/16" x 1 5/8" x 2 1/2" wide x 1/16" thick	Supports relay at top of box.			SC-D-3831-A.

9	9	Rubber tip #02. Steel, #482, size #2	Cushions on bottom of box. For carrying box	H S Stanley	SC-D-3828-C. SC-D-3828-C.
<i>b. Horn assembly.</i>					
11	Diaphragm	Nickel silver, 4 1/16" diam. x #19 B&S ga. 2 rings and cone of aluminum alloy welded together to form a horn, 5 1/2" diam. x 5 7/8" long (approx.). Brass, dull white nickel finish, 7/8" x 3/8" diam.	Vibrates with action of magnet armature. Intensifies sound of diaphragm.		SC-D-3833-C.
11	Cone assembly				SC-D-3833-C.
11	Cartridge	Brass, dull white nickel finish, 1 5/8" x 1/16"-32 thrd. Brass, dull white nickel finish, 5 3/4" x 1 1/2" x 3/8" x 1/8" thick. Brass, dull white nickel finish, 1 1/8" x 5/8"-27 thrd.	Fits in drilled slots at sides of base, receiving screw which fastens horn assembly to side of box. Fastens arch to base, fitting into adjusting screw. Mounting for contact assembly		SC-D-3833-C.
11	Stud	Brass, dull white nickel finish, 1 5/8" x 5/16"-32 thrd.	Fastens arch to base, fitting into adjusting screw.		SC-D-3833-C.
11	Arch	Brass, dull white nickel finish, 5 3/4" x 1 1/2" x 3/8" x 1/8" thick.	Mounting for contact assembly		SC-D-3833-C.
11	Screw	Brass, dull white nickel finish, 1 1/8" x 5/8"-27 thrd.	Adjusts contacts, moving arch		SC-D-3833-C.
11	Nut	Brass, dull white nickel finish, 5/16" thick hex., x 5/8"-27 tap.	Fits on adjusting screw of arch		SC-D-3833-C.
11	Washer	Brass, dull white nickel finish, 1 1/8" o. d. x 1 1/16" i. d. x 1/16" thick.	do		SC-D-3833-C.
11	Nut	Brass, dull white nickel finish 1 3/32" long x 3/8"-27 thrd., x #10-32 tap.	Fastens armature to diaphragm		SC-D-3834-C.
11	Washer	Brass, dull white nickel finish, 5/8" o. d. x .377" i. d. x 3/64" thick.	do		SC-D-3834-C.
11	Armature	Steel, 1/8" nickel plate, 1 7/8" x 3/8" x 7/32".	Magnet armature which actuates diaphragm.		SC-D-3834-C.
11	Post	Brass, dull white nickel finish, 2 1/4" x #10-32 thrd.	Actuated by armature to break contact, adjustable for contact spacing.		SC-D-3834-C.
11	Bumper	XX Black phenolic rod, 7/16" x 3/32" diam.	Fits on end of post which breaks contact.		SC-D-3834-C.
11	Screw	Brass, dull white nickel finish, slotted, 5/8" x #60-40 thrd.	Adjusts stop of contact spring		SC-D-3834-C.
11	Nut	Brass, dull white nickel finish, 3/16" thick x #6-40 tap.	Locks adjustment of stop of contact spring.		SC-D-3834-C.

b. Horn assembly—Continued.

See fig. no.	Stock no.	Name	Description	Function	Mfr.	Drawing no.	
						(Mfr.'s)	(Sig. C.)
11		Plate	Brass, dull white nickel finish, $3\frac{1}{2}$ " x $3\frac{1}{2}$ " x $3\frac{1}{2}$ ".	Holds stop adjustment screw			SC-D-3834-C.
11		do.	Brass, dull white nickel finish, $3\frac{1}{4}$ " x $1\frac{1}{16}$ " x $1\frac{1}{16}$ ".	Forms clamp on contact mountings on arch.			SC-D-3834-C.
11		Spring	Beryllium copper, $7\frac{1}{8}$ " x $3\frac{1}{4}$ " x 0.020 ".	Increases action of contact spring.			SC-D-3834-C.
11		Contact spring	Beryllium copper, $1\frac{3}{4}$ " x $1\frac{1}{8}$ " x 0.030 ".	Mounting for moving contact.			SC-D-3834-C.
11		Stop	Beryllium copper, $1\frac{1}{16}$ " x $3\frac{1}{4}$ " x $1\frac{1}{8}$ " x 0.040 ga.	Contact armature stop.			SC-D-3834-C.
11		Screw	Nickel silver, $3\frac{3}{4}$ " x $5\frac{1}{2}$ " x #6-32 thrd.	Mounting for stationary contact.			SC-D-3835-A.
11		Block	"LE" natural phenolic plate, 1 " x $\frac{1}{2}$ " x $1\frac{3}{32}$ ".	Part of contact mounting on arch, spacing.			SC-D-3835-A.
11		do.	"LE" natural phenolic plate, 1 " x $\frac{1}{2}$ " x $5\frac{1}{16}$ ".	do.			SC-D-3835-A.
11		Insulator	XXX natural phenolic plate, $2\frac{1}{2}$ " x $1\frac{1}{2}$ " x 0.050 ".	Insulates metallic parts of contact mounting on arch.			SC-D-3835-A.
11		Bushing	XXX natural phenolic tubing $1\frac{3}{4}$ " long x $\frac{1}{4}$ " o. d. x 0.196 " i. d.	Insulates long screws from metal parts of contact mounting.			SC-D-3835-A.
11		do.	XXX natural phenolic tubing, $3\frac{1}{2}$ " long x $\frac{1}{4}$ " o. d. x 0.196 " i. d.	do.			SC-D-3835-A.
11		Contact	Palladium, $3\frac{1}{2}$ " diam. x $1\frac{1}{16}$ " long.	Stationary contact point.			SC-D-3835-A.
11		do.	Palladium, $3\frac{1}{2}$ " diam. x 0.025 " thick.	Moving contact point.			SC-D-3835-A.
11		Pin	Nickel silver #14 (0.064") B and S gage x $1\frac{1}{16}$ " long.	Goes through base and screw, fastening arch to base.			SC-D-3832-B.

c. Horn magnet assembly.

11		Angle	Brass, dull white nickel finish, $\frac{1}{4}$ " x $\frac{1}{4}$ " x $1\frac{1}{8}$ " long x $\frac{1}{16}$ " thick.	Forms base of magnet			SC-D-3836-C
----	--	-------	--	----------------------	--	--	-------------

11	Clip.....	Nickel silver, $\frac{3}{8}$ " x $1\frac{3}{16}$ " x 0.020 "	Fastens winding to core.	SC-D-3836-C.
11	Sleeve.....	Black "L.E." phenolic tubing, $1\frac{1}{16}$ " sq. x $\frac{3}{32}$ " long x $\frac{1}{32}$ " thick.	Spool upon which winding is placed.	SC-D-3836-C.
11	Insulator.....	"L.E." phenolic plate, $1\frac{3}{16}$ " sq. x $\frac{3}{64}$ ".	Insulates winding from bottom head.	SC-D-3836-C.
11	Head.....	"L.E." phenolic plate, $1\frac{3}{16}$ " sq. x $\frac{1}{32}$ ".	Holds winding in shape and insulates it at top and bottom.	SC-D-3836-C.

d. Panel assembly.

10	Spacer.....	Brass, dull white nickel finish, $1\frac{1}{2}$ " x $\frac{1}{2}$ " o.d. x $1\frac{3}{64}$ " i.d.	Separates panel from base	SC-D-3837-A.
10	Binding post.....	TM-152, composition, knurled cap and base.	Provides connection for battery leads	SC-D-530.
10	do.....	TM-195, brass, dull white nickel finish, knurled cap.	Connection for line wires	SC-D-1132.
10	Terminal.....	TM-36, eye clip, flat, brass.....	For battery binding posts.	10701B1.
10	do.....	#4012.....	For line wire binding posts.	SC-D-3837-A.

e. Battery tray assembly.

10	Battery support.....	Black molded phenolic compound, XM-3510 black bakelite, $5\frac{1}{2}$ " x $1\frac{1}{4}$ " x $\frac{3}{4}$ ".	Supports battery	SC-D-3838-B.
10	Insert.....	Brass, knurled, $\frac{1}{4}$ " long x $\frac{1}{4}$ " o.d. x #6-32 tap.	Receives screws fastening supports to plate.	SC-D-3838-B.
10	do.....	Brass, knurled, $\frac{3}{8}$ " long x $\frac{1}{2}$ " o.d. x #10-32 tap.	Receives threaded end of post in center of support.	SC-D-3838-B.
10	Clamp.....	Brass, dull white nickel finish, $5\frac{1}{32}$ " x $\frac{1}{2}$ " x $\frac{3}{8}$ " wide x $\frac{1}{16}$ " ga.	Holds batteries on supports	SC-D-3838-B.
10	Post.....	Brass, dull white nickel finish, 3" x 10-32 thrd.	Mounting for clamps	SC-D-3838-B.
10	Terminal.....	TM-29, spade clip, brass (tinned)	For battery wires	10701B1.
10	Wire.....	#18 (0.0403") AWG x 6" long green wire, code "ravine".	Connect batteries in series and to panel terminals.	SC-D-3838-B.

SIGNAL CORPS

APPENDIX

ADDRESSES OF MANUFACTURERS

Diehl.....	Diehl Manufacturing Co.....	Elizabethport, New Jersey.
Emerson...	The Emerson Electric Mfg. Co.....	St. Louis, Missouri.
WE&M....	Westinghouse Electric & Mfg. Co....	Pittsburgh, Pennsylvania.
Riverbank..	Riverbank Laboratories.....	Geneva, Illinois.
Belden.....	Belden Manufacturing Co.....	Chicago, Illinois.
W&T.....	Wallace & Tiernan Products, Inc.....	Belleville, New Jersey.
V-R.....	Veeder-Root, Inc.....	Bristol, Connecticut.
H S.....	Hammacher, Schlemmer & Co.....	New York, New York.
Eagle.....	The Eagle Lock Co.....	Terryville, Connecticut.
Waterbury..	Waterbury Brass Goods, Inc.....	Waterbury, Connecticut.
A-H & H...	Arrow-Hart & Hegeman Electric Co..	Hartford, Connecticut.
Eby.....	Hugh H. Eby, Inc.....	Philadelphia, Pennsylvania.
P-M.....	Patton-MacGuyer Co.....	Providence, Rhode Island.
Thiokol....	Thiokol Corporation.....	Yardville, New Jersey.
North.....	North Electric Manufacturing Co....	Galion, Ohio.
G. R.....	General Radio Co.....	Cambridge, Massachusetts.
Simpson....	Edwin B. Simpson Co.....	Brooklyn, New York.
Tobe.....	Tobe Deutschmann Corporation.....	Canton, Massachusetts.
W. E.....	Western Electric Co.....	Chicago, Illinois.
IRC.....	International Resistance Co.....	Philadelphia, Pennsylvania.
C-D.....	Cornell-Dublier Electric Corporation..	South Plainfield, New Jersey.
K E.....	Kurman Electric Co.....	New York, New York.
Stanley....	The Stanley Works.....	New Britain, Connecticut.

[A. G. 062.11 (7-10-42).]

BY ORDER OF THE SECRETARY OF WAR:

G. C. MARSHALL,
Chief of Staff.

OFFICIAL:

J. A. ULIO,
Major General,
The Adjutant General.

DISTRIBUTION:

IC and H 4 (5); IC 11 (3).
(For explanation of Symbols see FM 21-6.)

