

1/2 d
-4
113
-m
1944

TM 9-1729A

WAR DEPARTMENT TECHNICAL MANUAL

U.S. Dept. of Army

ORDNANCE MAINTENANCE

LIGHT TANKS M5, M5A1, AND M24, 75-MM HOWITZER MOTOR CARRIAGE M8, AND TWIN 40-MM GUN MOTOR CARRIAGE M19: ENGINES, COOLING SYSTEMS AND FUEL SYSTEMS

RESTRICTED DISSEMINATION OF RESTRICTED MATTER —
The information contained in restricted documents and the essential characteristics of restricted material may be given to any person known to be in the service of the United States and to persons of undoubted loyalty and discretion who are cooperating in Government work, but will not be communicated to the public or to the press except by authorized military public relations agencies. (See also paragraph 23b, AR 380-5, 15 March 1944.)

WAR DEPARTMENT • 28 NOVEMBER 1944

WAR DEPARTMENT TECHNICAL MANUAL

TM 9-1729A

This manual, together with TM 9-1825A, dated 12 January 1944 and TM 9-1826A, dated 11 February 1944, supersedes TM 9-1727B, dated 4 January 1943 and TM 9-1732A, dated 21 September 1942, with the exception of the sections relating to fuel pumps. These sections will be superseded by TM 9-1828A when it is published.

ORDNANCE MAINTENANCE

LIGHT TANKS M5, M5A1,
AND M24, 75-MM HOWITZER
MOTOR CARRIAGE M8, AND
TWIN 40-MM GUN
MOTOR CARRIAGE M19:
ENGINES, COOLING SYSTEMS
AND FUEL SYSTEMS



WAR DEPARTMENT

• *28 NOVEMBER 1944*

RESTRICTED DISSEMINATION OF RESTRICTED MATTER—
The information contained in restricted documents and the essential characteristics of restricted material may be given to any person known to be in the service of the United States and to persons of undoubted loyalty and discretion who are cooperating in Government work, but will not be communicated to the public or to the press except by authorized military public relations agencies. (See also paragraph 23*b*, AR 380-5, 15 March 1944.)

WAR DEPARTMENT
Washington 25, D. C., 28 November 1944

TM 9-1729A, Ordnance Maintenance: Light Tanks M5, M5A1, and M24, 75-mm Howitzer Motor Carriage M8, and Twin 40-mm Gun Motor Carriage M19—Engines, Cooling Systems, and Fuel Systems, is published for the information and guidance of all concerned.

[A. G. 300.7 (11 Jan 44)
O.O.M. 461/Rar/Ars (29 Nov 44)R]

BY ORDER OF THE SECRETARY OF WAR:

G. C. MARSHALL,
Chief of Staff.

OFFICIAL:

J. A. ULIO,
Major General,
The Adjutant General.

DISTRIBUTION: Armies (10); Corps (10); SvC (10); Depts (10); D (incl Hq AF & AF Comds) (2); Tech Sv (2); Arm & Sv Bds (2); P, C, & S (1); Ord Decentralized Sub-O (3); PE (Ord O) (5); H & R Points (5); Ord Dist O (5); Ord Reg O (3); Ord Dist Br O (3); Ord Establishments (5); Gen & Sp Sv Sch (10); T/O & E: 9-7 (3); 9-9 (3); 9-57 (3); 9-65 (2); 9-67 (3); 9-76 (2); 9-127 (3); 9-197 (3); 9-317 (3); 9-325 (2); 9-327 (3); 9-328 (3); 9-377 (3).

(For explanation of symbols, see FM 21-6.)

CONTENTS

U 113
.2
TM 9:1729A
1944



	Paragraphs	Pages
CHAPTER 1. INTRODUCTION	1- 2	1- 5
CHAPTER 2. ENGINE	3-17	6- 92
SECTION I. Engine description and data	3- 4	6- 20
II. Disassembly of engine	5- 6	21- 36
III. Disassembly, cleaning, inspection, repair, and assembly of sub- assemblies	7-14	37- 66
IV. Assembly of engine	15	66- 84
V. Test and adjustment	16	84- 87
VI. Fits and tolerances	17	87- 92
CHAPTER 3. COOLING SYSTEM	18-24	93-113
SECTION I. Description and Data	18-20	93- 97
II. Disassembly, cleaning, inspection, repair, and assembly of sub- assemblies	21-23	98-113
III. Fits and tolerances	24	113
CHAPTER 4. FUEL SYSTEM	25-30	114-133
SECTION I. Description and data	25-26	114-118
II. Disassembly, cleaning, inspection, repair, and assembly of sub- assemblies	27-30	119-133
CHAPTER 5. SPECIAL TOOLS	31	134-136
REFERENCES		137-141
INDEX		142-145

ORDNANCE MAINTENANCE — LIGHT TANKS M5, M5A1, AND M24, 75-MM HOWITZER MOTOR CARRIAGE M8, AND TWIN 40-MM GUN MOTOR CARRIAGE M19: ENGINES, COOLING SYSTEMS AND FUEL SYSTEMS

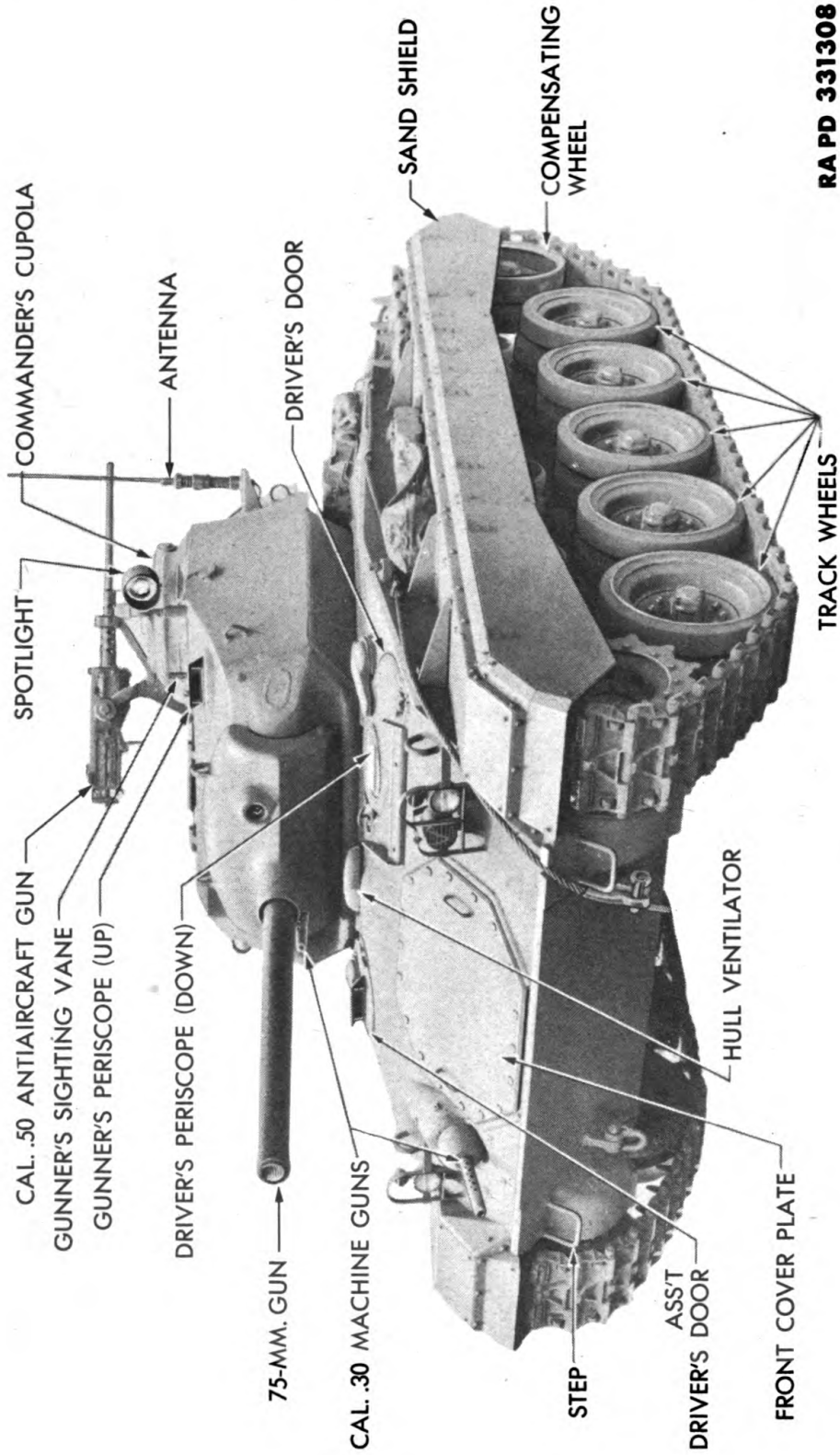

RA PD 331308

Figure 1 — Light Tank, M24

RESTRICTED

This manual, together with TM 9-1825A, dated 12 January 1944 and TM 9-1826A, dated 11 February 1944, supersedes TM 9-1727B, dated 4 January 1943 and TM 9-1732A, dated 21 September 1942, with the exception of the sections relating to fuel pumps. These sections will be superseded by TM 9-1828A when it is published.

CHAPTER 1

INTRODUCTION

1. SCOPE.

a. The instructions contained in this manual are for the information and guidance of personnel charged with the maintenance and repair of Light Tanks M5, M5A1, and M24, and Motor Carriages M8 and M19. These instructions are supplementary to Field and Technical Manuals prepared for the using arms. This manual does not contain information which is intended primarily for the using arms, since such information is available to Ordnance maintenance personnel in 100-series TM's or FM's.

b. This manual contains a description of, and procedure for disassembly, cleaning, inspection, repair and assembly of the engines, and of components of the cooling systems and fuel systems. Included are the 1G series engines used on M5, M5A1, and M8 vehicles, and the 3G series used on M19 and M24 vehicles.

c. TM 9-1729B contains description and procedure for disassembly, cleaning, inspection, repair and assembly of the transmission, transfer unit, propeller shafts, controlled differential and final drives of Light Tank M24 and Twin 40-mm Gun Motor Carriage M19.

d. TM 9-1729C contains the same essential information on the hull, turret, electrical system and track suspension of the Light Tank M24 and Twin 40-mm Gun Motor Carriage M19.

e. TM 9-1727K contains description and procedure for disassembly, cleaning, inspection, repair and assembly of the hydraulic traversing mechanism in these vehicles.

f. TM 9-1825A contains description and procedure for disassembly, cleaning, inspection, repair and assembly of the electrical components in these vehicles.

g. TM 9-1826A contains description and procedure for disassembly, cleaning, inspection, repair and assembly of the carburetors for these vehicles.

h. TM 9-1828A contains description and procedure for disassembly, cleaning, inspection, repair and assembly of the fuel pumps for these vehicles.

ORDNANCE MAINTENANCE — LIGHT TANKS M5, M5A1, AND M24, 75-MM HOWITZER MOTOR CARRIAGE M8, AND TWIN 40-MM GUN MOTOR CARRIAGE M19: ENGINES, COOLING SYSTEMS AND FUEL SYSTEMS

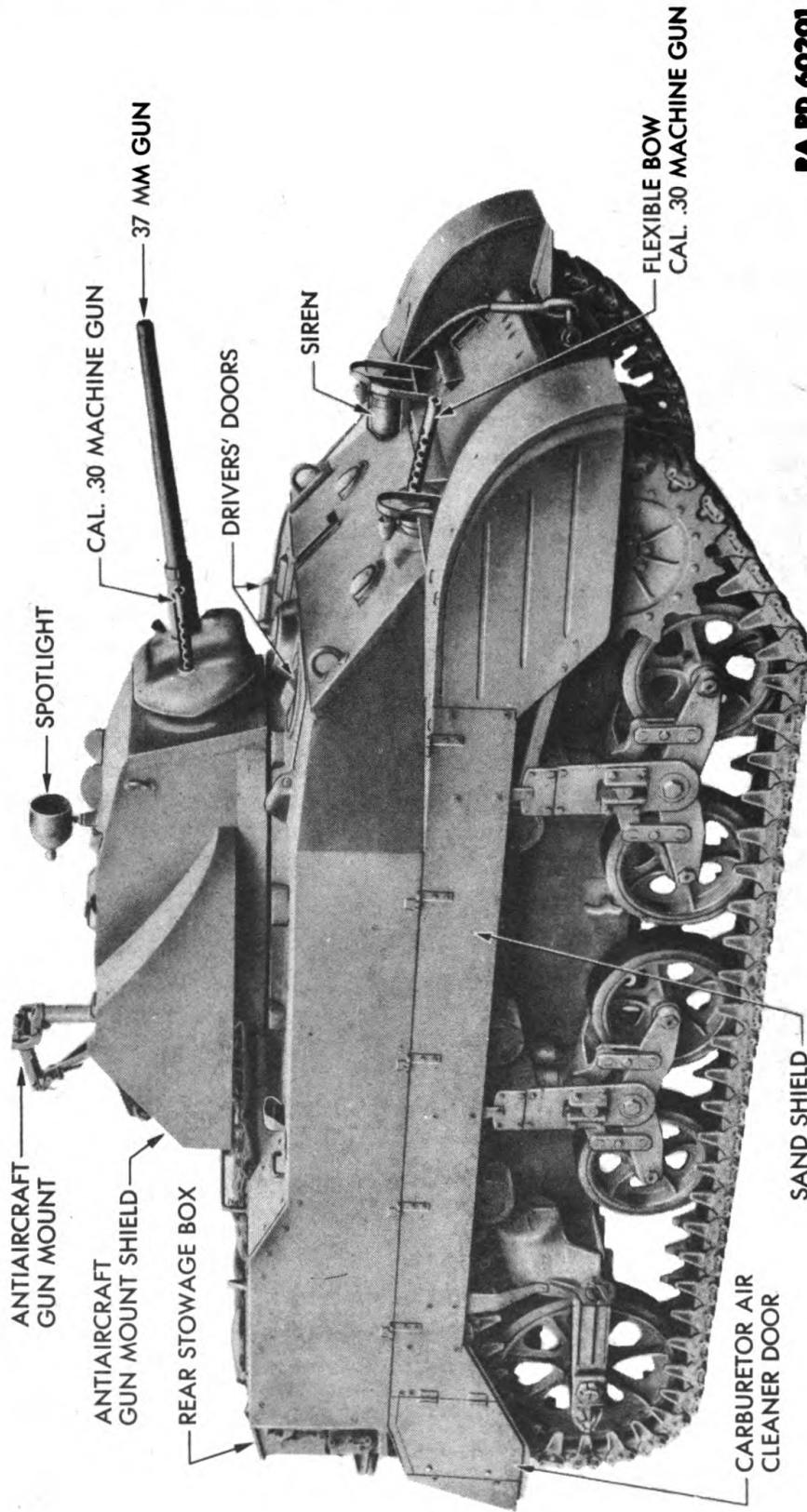

RA PD 60201

Figure 2 — Light Tank, M5A1

INTRODUCTION

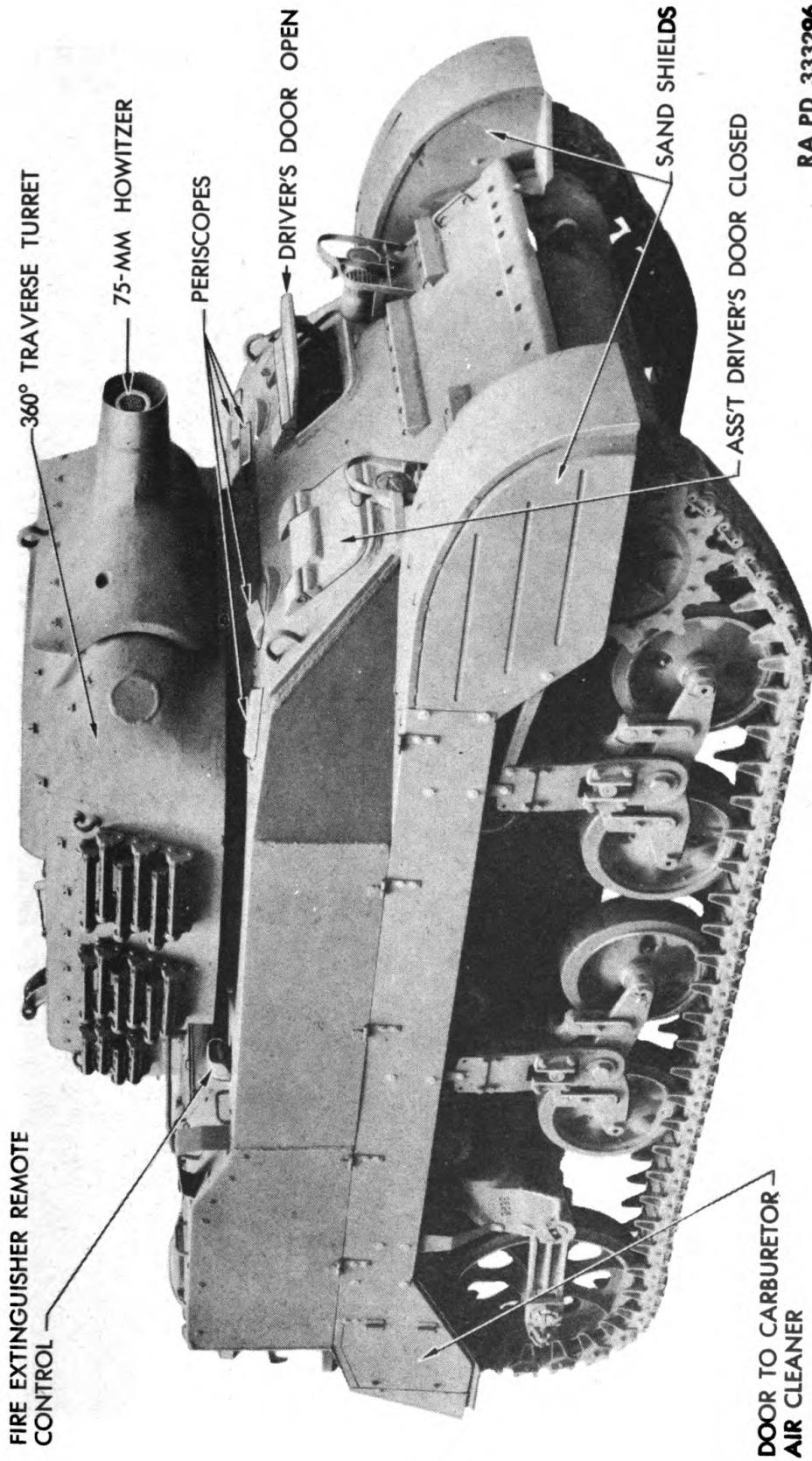

RA PD 333296

Figure 3 — 75-mm Howitzer Motor Carriage M8

ORDNANCE MAINTENANCE — LIGHT TANKS M5, M5A1, AND M24, 75-MM HOWITZER MOTOR CARRIAGE M8, AND TWIN 40-MM GUN MOTOR CARRIAGE M19: ENGINES, COOLING SYSTEMS AND FUEL SYSTEMS

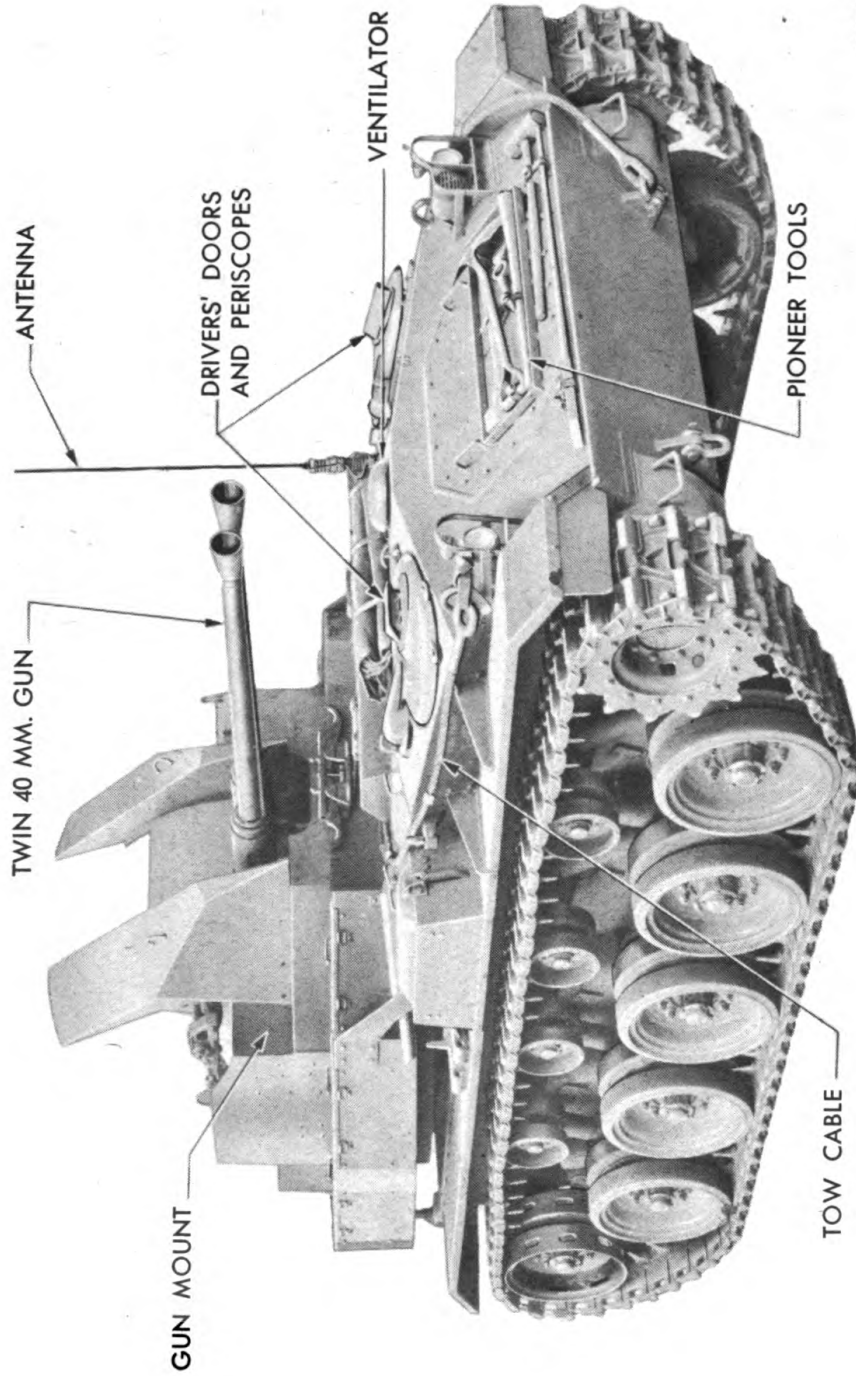

RA PD 331557

Figure 4 — Twin 40-mm Gun Motor Carriage, M19

INTRODUCTION

i. TM 9-1829A contains description and procedure for disassembly, cleaning, inspection, repair and assembly of the speedometers and tachometers used in these vehicles.

2. MODIFICATION WORK ORDER AND MAJOR UNIT ASSEMBLY REPLACEMENT RECORD.

a. **Description.** Every vehicle is supplied with a copy of A.G.O. Form No. 478, which provides a means of keeping a record of each complete modification, or major unit assembly replaced. This form includes spaces for the vehicle name and U. S. A. registration number, instructions for use, and information pertinent to the work accomplished. It is very important that the form be used as directed, and that it remain with the vehicle until the vehicle is removed from service.

b. **Instructions for Use.** Personnel performing modifications or major unit assembly replacements must record clearly on the form a description of the work completed and must initial the form in the columns provided. When each modification is completed, record the date, hours and/or mileage and MWO number. When unit assemblies such as engines, transmissions, transfer units are replaced, record the date, hours and/or mileage and nomenclature of the unit assembly. Minor repairs and minor parts and accessory replacements need not be recorded.

c. **Early Modifications.** Upon receipt by a third or fourth echelon repair facility of the vehicle for modification or repair, maintenance personnel will record the MWO numbers of modifications applied prior to date of A.G.O. Form No. 478.

CHAPTER 2

ENGINE

Section I

ENGINE DESCRIPTION AND DATA

3. DESCRIPTION.

a. **General.** The engines used in these vehicles are gasoline-fueled, with spark ignition, and are water-cooled. They have eight cylinders in a 90-degree vee, and an L-head valve arrangement with manifolds centrally located in the vee.

b. **Serial Numbers.**

(1) **M5 AND M8 ENGINES.** These engines have the serial number prefix of 1G. Right- and left-hand engines are different. The engine serial number is stamped on the top flange of the upper flywheel housing between the two upper screws. It is also stamped on the upper edge of the water jacket on the front or timing case end of the left cylinder block.

(2) **M19 AND M24 ENGINES.** The engine serial number prefix for these engines is 3G. There is no difference between right- and left-hand engines, except the exhaust connection which may be installed to suit right- and left-hand installation in vehicles. The serial number is stamped on the top flange of the upper flywheel housing between the two upper screws. The number is also stamped on a machined pad, flush with the top of the block immediately above the water pump.

c. **Points of Reference.**

(1) In making reference to the engines themselves, the timing case end of the engine is designated as the "front" end, even though it faces the rear of the vehicle, and the flywheel end as the "rear" end, the same as in automobile practice. The "right" and "left" sides of the engines and Hydra-Matic transmissions are as viewed from the flywheel end.

(2) When considering engines as complete units, however, the left-hand engine is the one on the left side of the hull (driver's left), and the right-hand engine is on the right side of the hull.

d. **Engine Block.** The cylinder block and crankcase assembly encloses the working parts of the engine. It is made of a single casting of grey iron, which has cored passages for cooling fluid and

ENGINE

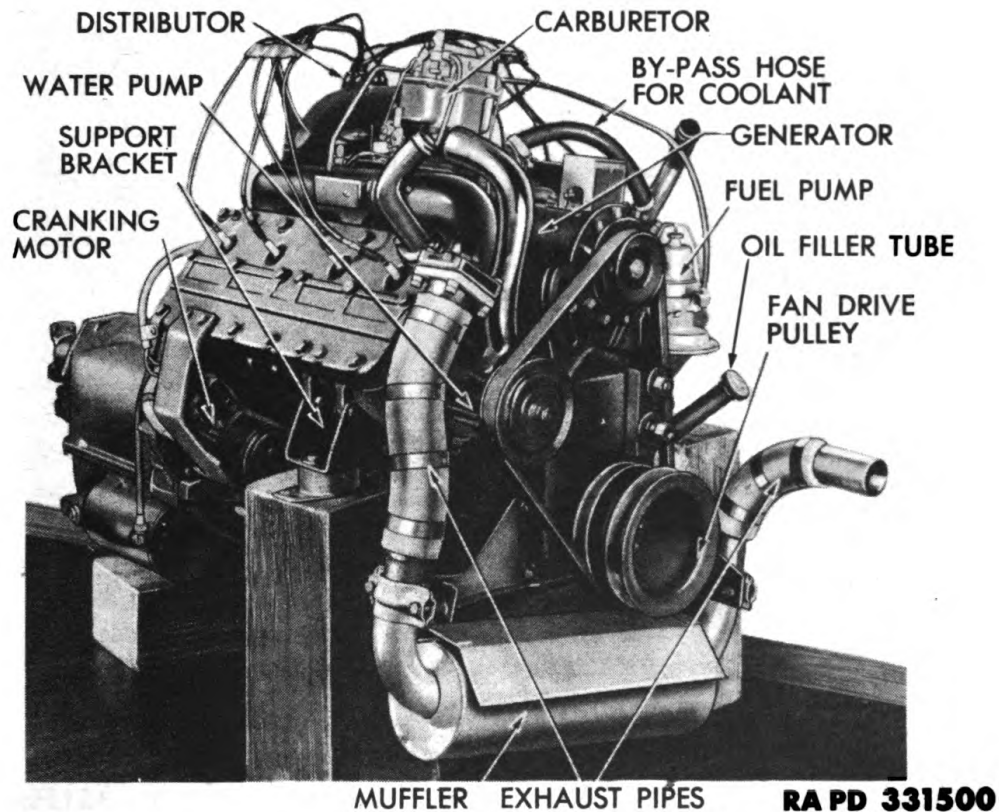
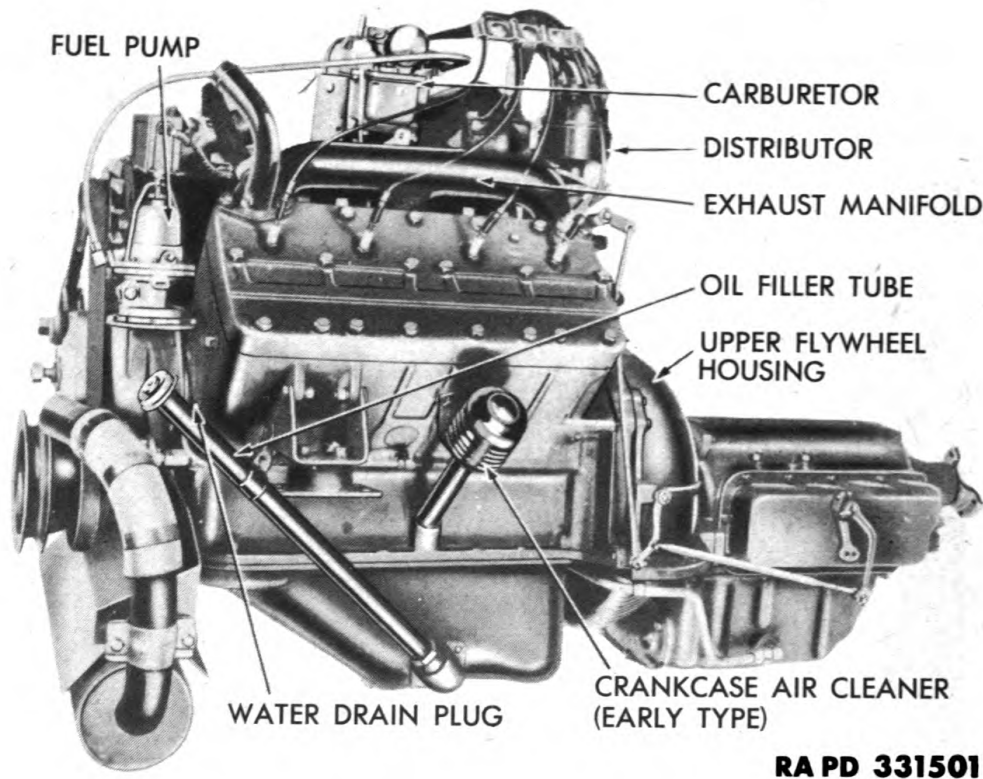

Figure 5 – Engine, 1G Series, Right Front View

crankcase ventilation, drilled passages for the oiling system, and machined surfaces for bearings and for the attachment of parts. The cylinder bores are arranged in two banks of four each, 90 degrees apart and 45 degrees from the vertical, ground and honed to precise limits. On 1G series engines, brackets mounted on each side of the block provide for the attachment to the engine support mountings on the hull floor and walls of the engine compartment. On the 3G series engines, two mounting brackets are provided at the timing case cover end of the block and two more under the transmission.

e. Crankshaft and Main Bearings. A forged, heat-treated steel crankshaft is mounted in the crankcase and rotates on three steel-backed, precision babbitt bearings. These bearings are retained by three cast-iron bearing caps attached to the crankcase with special alloy steel cap screws and lock washers. End thrust is taken by the flanged center main bearing. The crankshaft has four crank pin journals, each carrying two opposing connecting rods. The journals and rods are balanced by six counterweights, four of which are integral with the crankshaft, while the others (Nos. 2 and 5) are attached to the crankshaft with special cap screws and locating dowels.

ORDNANCE MAINTENANCE — LIGHT TANKS M5, M5A1, AND M24, 75-MM HOWITZER MOTOR CARRIAGE M8, AND TWIN 40-MM GUN MOTOR CARRIAGE M19: ENGINES, COOLING SYSTEMS AND FUEL SYSTEMS



RA PD 331501

Figure 6 — Engine, 1G Series, Left Side View

f. **Flywheel.** A steel flywheel, 15 inches in diameter, is located on the end of the crankshaft by means of two dowels, and is attached by six cap screws, except on early 1G series engines (up to tank serial number 1501 on M8 and 4900 on M5), on which it was attached by six studs fitted with nuts and lock washers. A special metal-type gasket seals the crankshaft to flywheel junction. A ring gear is shrunk and welded on the outside diameter of the flywheel to provide a means of cranking the engine with the cranking motor.

g. **Connecting Rods.** Eight connecting rods of forged steel are mounted on the crankshaft, the rods for the opposite cylinder of the right and left banks being mounted on the same journal. The rod for the left-hand cylinder is always toward the front of the engine. The lower or larger end of each connecting rod is split crosswise at an angle to permit removal of the rod and piston assembly from the top of the engine. The connecting rod cap is attached to the rod by a long and a short cap screw. These cap screws and the lock washers used under them are of special alloy steels. Split, shell-type, steel-backed babbitt bearings are used in the connecting rod and cap.

ENGINE

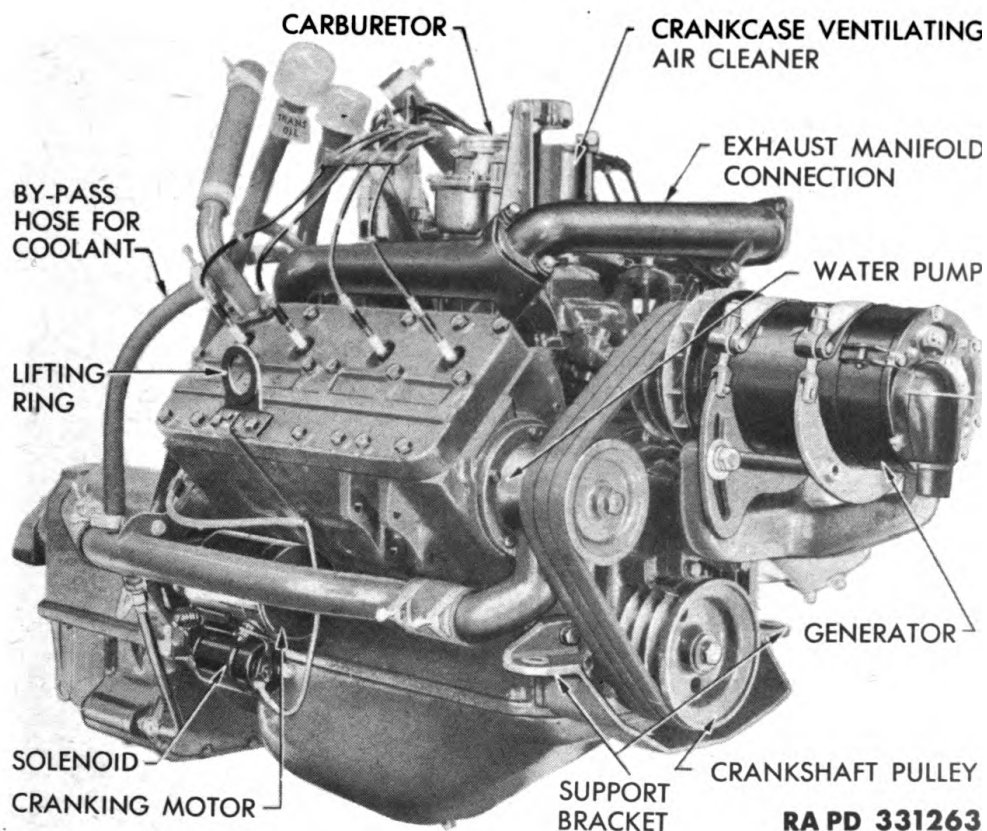
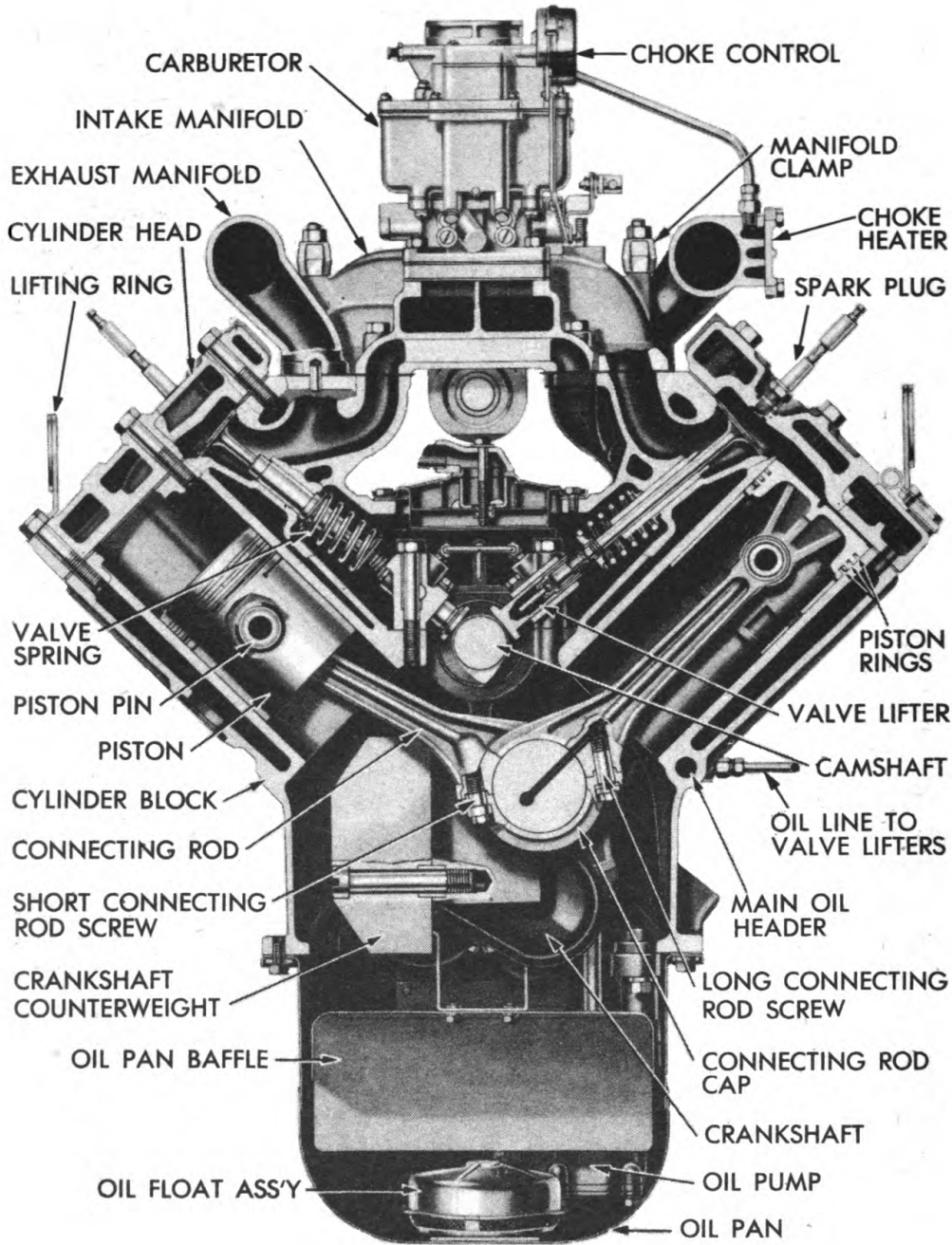

Figure 7 — Engine, 3G Series, Right Front View

These bearings are positioned by tabs on the shells which fit in slots in the rod and cap. Upper and lower bearing halves are not interchangeable because of oilholes in the upper bearing. The upper end of the connecting rod is drilled for piston pin lubrication. The pin is carried in a bronze bushing which is pressed into the rod and machined to exact size after installation.

h. Pistons. The pistons are aluminum alloy castings, machined and ground on the outside surfaces, and anodized after grinding to provide a hard aluminum-oxide wearing surface. In design, the piston skirts are slightly elliptical and tapered, having a T-slot on one side and a horizontal slot on the other. These features permit the piston to conform closely to the cylinder walls when heated to operating temperatures. The piston pins are made of alloy steel carefully ground to size. They float in the connecting rod bushing and in bosses in the pistons, being held in place by snap rings. Three piston rings are used, located above the piston pin. The two upper rings are compression rings to prevent exhaust gases or fuel vapors from seeping down into the crankcase. The third ring is an oil ring which controls the amount of oil that is left on the cylinder walls.

ORDNANCE MAINTENANCE — LIGHT TANKS M5, M5A1, AND M24, 75-MM HOWITZER MOTOR CARRIAGE M8, AND TWIN 40-MM GUN MOTOR CARRIAGE M19: ENGINES, COOLING SYSTEMS AND FUEL SYSTEMS



RA PD 331558

Figure 8 — Engine Front Cross Section, 3G Series

ENGINE

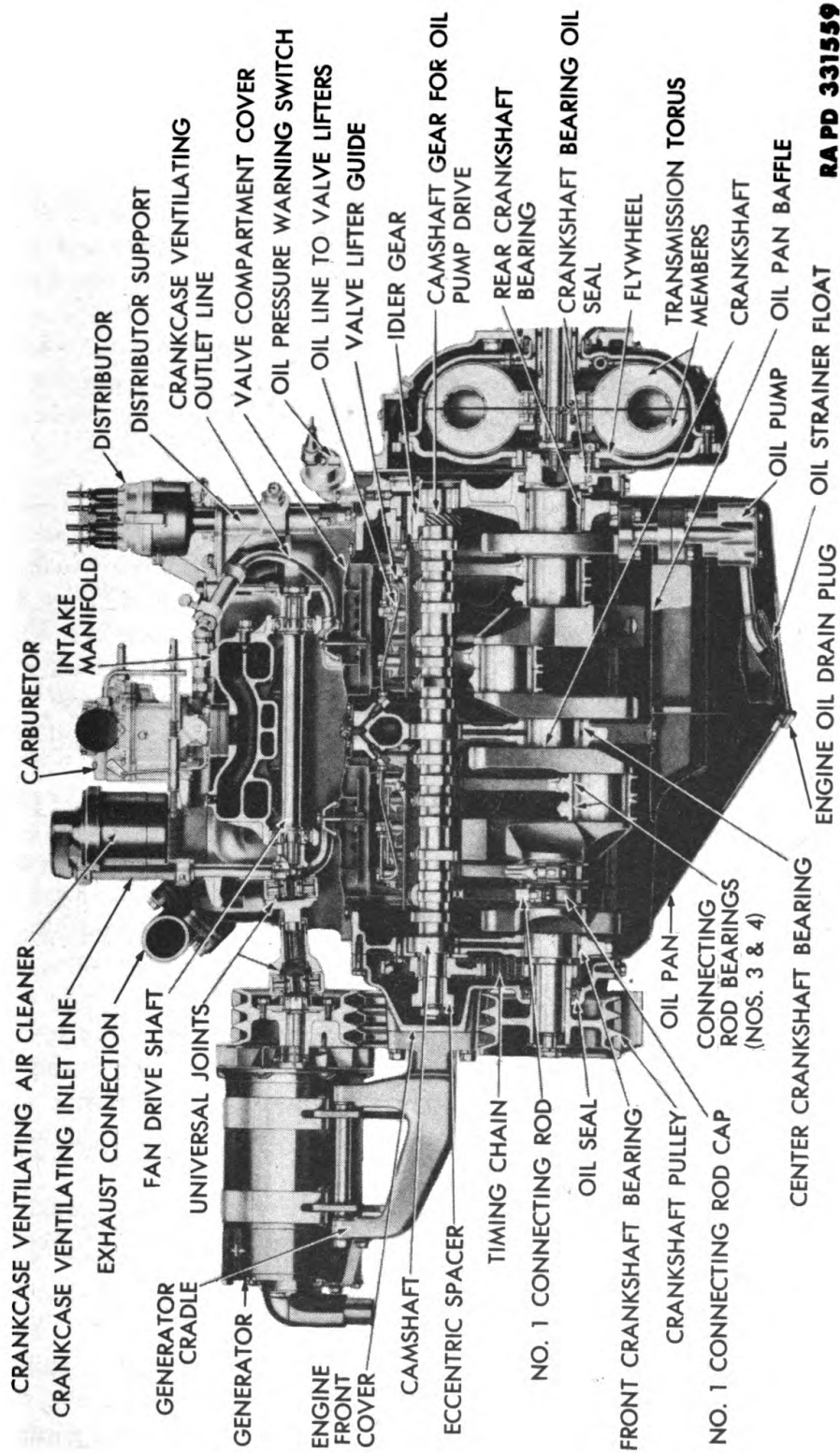

Figure 9 — Engine Side Cross Section, 3G Series

ORDNANCE MAINTENANCE — LIGHT TANKS M5, M5A1, AND M24, 75-MM HOWITZER MOTOR CARRIAGE M8, AND TWIN 40-MM GUN MOTOR CARRIAGE M19: ENGINES, COOLING SYSTEMS AND FUEL SYSTEMS

i. Cylinder Heads. A cylinder head of cast-iron is mounted on each bank of cylinders by means of 21 cap screws. The head covers the cylinders and forms the tops of the combustion chambers. A terneplate-asbestos gasket between cylinder block and head prevents water or compression leakage.

j. Camshaft. The camshaft is a solid alloy cast-iron shaft mounted in the engine block directly above the crankshaft, and supported by three steel-backed babbitt bushings which are pressed into the crankcase bulkheads. Integral with the camshaft are 16 cam lobes which operate the engine valves through the hydraulic valve lifters. On 1G series, the front end of the crankshaft carries an eccentric that drives the fuel pump. On the 3G series this eccentric is used, but as a spacer only.

k. Timing Chain and Sprockets. The camshaft is driven at one-half crankshaft speed by a link-belt timing chain operated by gear-type sprockets on the front end of the crankshaft and camshaft. These sprockets are a hand-push fit on the shaft to which they are keyed. The sprockets are marked to assure correct timing when installed. The timing chain and sprockets are enclosed by a cast-iron timing case cover which is mounted on the front of the crankcase with two dowels and nine mounting screws, and is sealed to the oil pan with three cap screws.

l. Valves and Valve Lifters.

(1) The valves are forgings of special alloy steel, opening and closing against valve seats machined in the cylinder block. One intake and one exhaust valve per cylinder are used. Valves slide up and down in lubricated cast iron valve guides which are pressed into the cylinder block.

(2) Valve lifters transmit the lifting action of the cams to the valve stems through a hydraulic mechanism in which spring and oil pressure act to keep the lifter plungers expanded, maintaining zero clearance between stem and lifter to provide quiet and efficient valve action.

(3) The 16 valve lifters are mounted four each in four brackets bolted to the engine block. Oil is fed to them through an external pipe from the oil header on the left side of the crankcase.

m. Manifolds.

(1) The dual intake manifold is in reality two separate manifold passages made up in a single casting. Each passage delivers the fuel mixture to the two center cylinders on one side, and two end cylinders on the opposite side to assure uniform delivery of fuel and air to all cylinders.

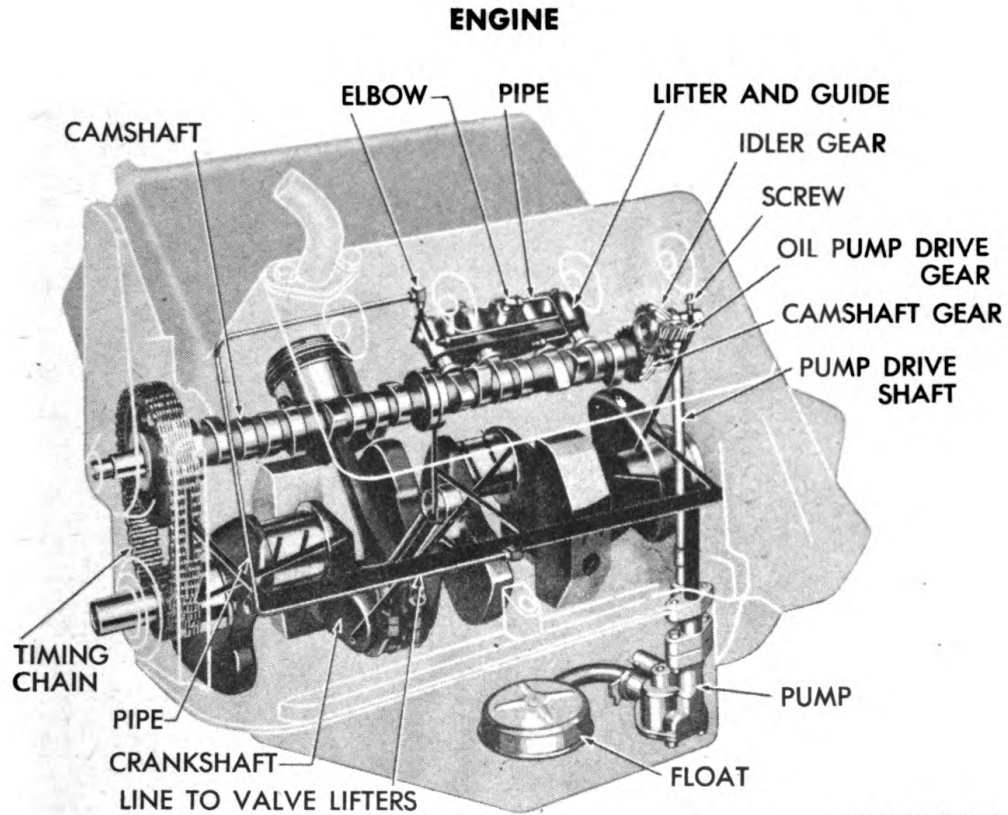

RA PD 331502

Figure 10 – Engine Lubrication System, 1G Series

(2) Two exhaust manifolds are used, clamped to the top of each bank of cylinders. On 1G series, they are connected by a cross-over pipe at the rear. On 3G series, they are connected by a cross-over pipe at the front. This cross-over pipe can be installed with the exhaust outlet flange either to the right or left, as required by right-hand or left-hand engine installations in the vehicles with 3G series engines.

n. Engine Oiling System.

(1) A sheet metal pan is attached to the lower surface of the crankcase to serve as an oil reservoir. Baffles to prevent excessive oil surge and foaming are mounted on brackets on the center and rear main bearing caps.

(2) The gear-type oil pump is mounted on the bottom of the crankcase at the left of the rear main bearing, and is driven by the same vertical shaft that drives the distributor. The oil pressure regulator is built into the pump housing.

(3) The pump draws oil from the oil pan through a screened floating intake, and forces it through a drilled passage to the main oil header which is drilled lengthwise along the left side of the crankcase (fig. 10). From this header, other drilled passages branch through the bearing support bulkheads to the three main and three camshaft bearings.

ORDNANCE MAINTENANCE — LIGHT TANKS M5, M5A1, AND M24, 75-MM HOWITZER MOTOR CARRIAGE M8, AND TWIN 40-MM GUN MOTOR CARRIAGE M19: ENGINES, COOLING SYSTEMS AND FUEL SYSTEMS

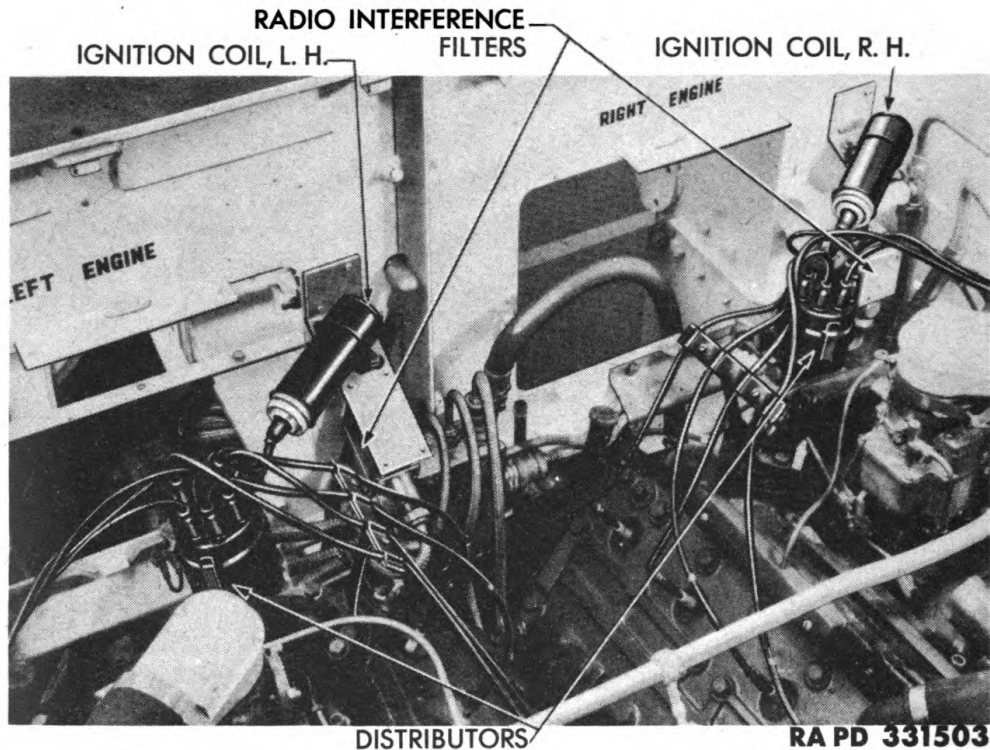

Figure 11 — Ignition Units, 1G Series Engine

(4) Oil from the main bearings passes through drilled passages in the crankshaft to the connecting rod bearings, from which part of the oil flows up through drilled passages in the rods to lubricate the piston pins, and some passes through metering holes in the large ends of the rods to lubricate the cylinder bores.

(5) Oil is carried from the rear camshaft bearing to the distributor and oil pump drive shaft gears, and from the front camshaft bearing to the timing chain. Oil passes through an external pipe from the main oil header to the four sets of hydraulic valve lifters. The oil pressure switch is located on the top rear of the block just in back of the vee; except on early 1G series engines, on which it was at the front end of the main oil header.

o. Oil Filters. Each engine is equipped with an oil filter in a bracket attached to the front of the engine. Oil enters the filter through a pipe connected to the main oil header at the front of the engine block. After the oil passes through the filter, it is returned to the engine through another pipe connected to the engine front cover.

p. Crankcase Ventilators. The crankcase ventilating system provides a positive air circulation whenever the engine is running. On the 1G series, air is drawn into the crankcase through an oil bath air

ENGINE

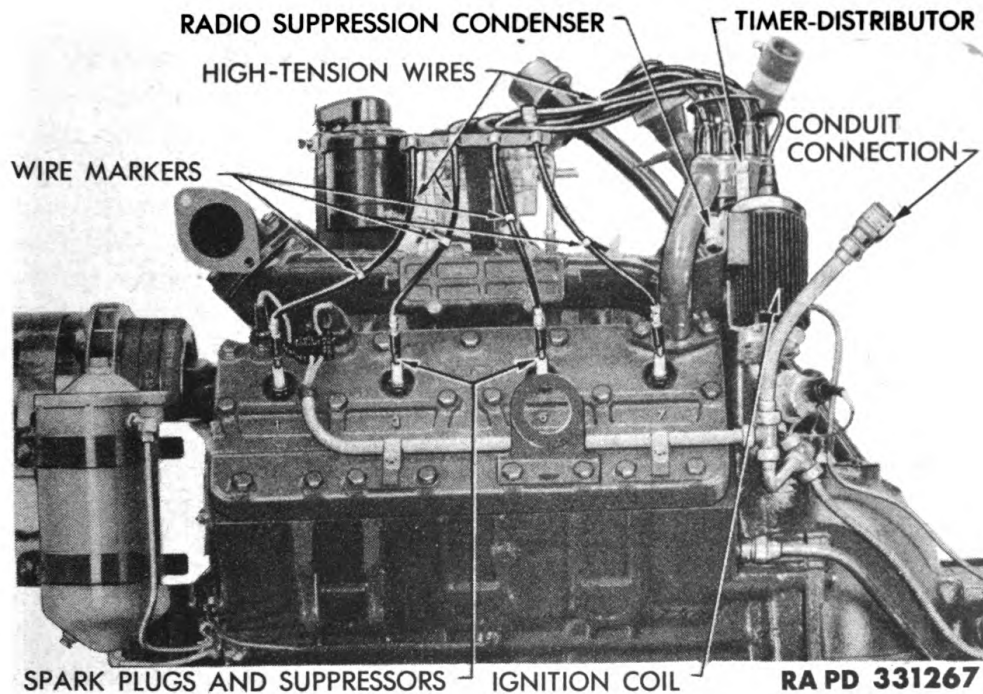

Figure 12 — Ignition Units, 3G Series Engine

cleaner and the air circulates through the crankcase and passes out through baffled openings in the valve covers, carrying contaminated vapors with it. It is then drawn through passageways leading to the upper flywheel housing. Fins on the flywheel draw the air from these passageways and force it through openings in the flywheel housing lower pan. On 3G engines, the air is drawn through the oil bath air cleaner, circulating through the crankcase and is then drawn out of the crankcase by manifold vacuum. It then passes through the intake manifold and out through the exhaust system.

q. Drive Belts.

(1) 1G SERIES. A double pulley mounted on the front of the camshaft drives two V-belts on 1G series. The inner belt drives the water pump and generator; the outer belt drives the fan. Adjustable brackets on the front and top of the timing case provide for mounting the fan and generator, respectively, and permit belt adjustments.

(2) 3G SERIES. A triple-grooved pulley, mounted on the front of the crankshaft, carries three V-belts which drive the water pump and generator on the 3G series. A bracket on the engine front cover provides for mounting the generator and a movable cradle assembly permits belt adjustment. These belts also drive the fan at the rear of the engine through a drive line fitted with two double universal joints. The fan drive shaft (mounted on sealed bearings under the intake manifold) is connected to the inner end of the generator shaft

ORDNANCE MAINTENANCE — LIGHT TANKS M5, M5A1, AND M24, 75-MM HOWITZER MOTOR CARRIAGE M8, AND TWIN 40-MM GUN MOTOR CARRIAGE M19: ENGINES, COOLING SYSTEMS AND FUEL SYSTEMS

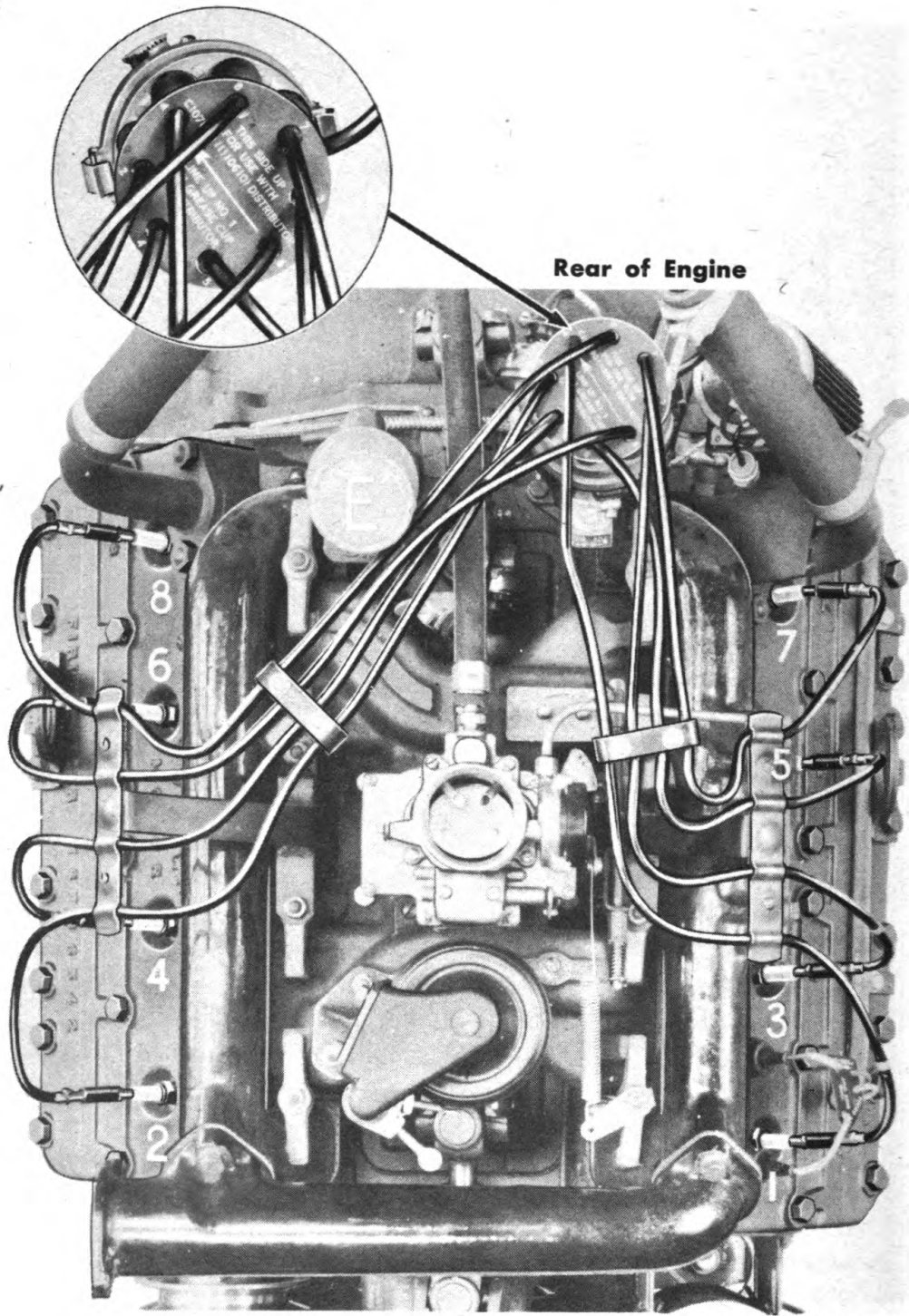

RA PD 331275

Figure 13 — Engine Cylinder Numbering

ENGINE

by a universal joint shaft. The second universal joint shaft connects the fan shaft to the fan drive shaft.

r. Ignition System.

(1) **1G SERIES** (fig. 11). Each ignition system consists of an ignition coil mounted on the engine compartment side of the bulk-head; a timer, located inside the distributor housing, which interrupts the low-tension (12-volt) current from the battery; a condenser, also located in the distributor housing, which—acting with the timer—produces a high-tension voltage in the secondary circuit of the coil; a distributor which directs the high voltage to each of the spark plugs in turn; the spark plugs themselves which ignite the fuel mixture; the resistors and filters which minimize electrical interference with the radio equipment; and the necessary wiring to connect these items.

(2) **3G SERIES** (fig. 12). Each ignition system consists of a 24-volt ignition coil mounted on a bracket on the left rear corner of the engine; a timer inside the distributor housing; a condenser, also located inside the distributor housing; a distributor which directs the high voltage to each of the spark plugs; the spark plugs themselves, and the necessary wiring to connect these units.

s. Engine Cylinder Numbering. The order in which the cylinders fire is 1, 8, 7, 3, 6, 5, 4, 2, based upon the cylinder numbering. The left front cylinder is numbered "1," and the left bank of cylinders carry odd numbers, while the right front cylinder is numbered "2," and the right bank of cylinders carry even numbers (fig. 13).

4. DATA.

a. These specifications are given for one engine only and apply to either right- or left-hand engine, unless otherwise noted:

b. General.

Bore and stroke	3½ x 4½ in.
Compression pressure: (lb per sq in.)	
At cranking speed	116-121
At 1,000 rpm	172
Compression ratio	7.06 to 1
Cylinder arrangement	90 deg V-8
Cylinder head material	cast-iron
Engines, number	2
Engine make	Cadillac
Engine supports—	
Number 1G Series	3
Number 3G Series	4

TM 9-1729A

4

ORDNANCE MAINTENANCE — LIGHT TANKS M5, M5A1, AND M24, 75-MM HOWITZER MOTOR CARRIAGE M8, AND TWIN 40-MM GUN MOTOR CARRIAGE M19: ENGINES, COOLING SYSTEMS AND FUEL SYSTEMS

Firing order	1, 8, 7, 3, 6, 5, 4, 2
Horse power (net installed) at 3400 rpm.....	110
Piston displacement	346 cu in.
Valve arrangement	L-head
Weight of engine with accessories—	
1G Series	1,300 lb
3G Series	1,385 lb

c. Piston and Piston Rings.

Piston:

Diameter, standard	3.4966 to 3.4986 in.
Diameter, 0.020-in. oversize	3.5166 to 3.5186 in.
Diameter, 0.040-in. oversize	3.5366 to 3.5386 in.
Length	4 $\frac{1}{8}$ in.
Material (aluminum alloy)	Anodized finish
Type	T-slot
Weight (w/o rings, pin or locking rings).....	1.151 lb
Weight (w/rings, pin and locking rings).....	1.54016 lb

Rings:

Compression, number per piston	2
Compression, width, top ring	$\frac{5}{64}$ in.
Compression, width, bottom ring	$\frac{5}{64}$ in.
Oil, number per piston	1
Oil, width	$\frac{3}{16}$ in.

d. Connecting Rods, Piston Pins.

Connecting rods:

Bearing material	Steel-backed alloy (Moraine)
Bearing type	Shell
Length—center to center.....	8 $\frac{3}{4}$ in.
Weight (with bushing, less shells).....	2.218 lb
Crankshaft journal diameter and length.....	2.460 x 2 $\frac{1}{32}$ in.

Piston pin:

Diameter	$\frac{7}{8}$ in.
Hole finish	(Diamond bore in rod, bearingized in piston)
Length	3 $\frac{1}{16}$ in.
Type	Floating

e. Crankshaft.

Counterweights, number	6
End thrust, taken by.....	Center main bearing

ENGINE

Main bearings—

Journal dimensions, diameter and length:

No. 1	2.4590 x 1 $\frac{1}{16}$ in.
No. 2	2.4590 x 1 $\frac{5}{32}$ in.
No. 3	2.4590 x 1 $\frac{3}{32}$ in.

Material	Steel-backed babbitt
Type	Shell

f. Timing Chain.

Adjustment	None
Length (opened)	23 in.
Links, number	62
Make	Link Belt
Model	Type No. 3736TC-15
Pitch	$\frac{3}{8}$ in.
Width	1 $\frac{1}{8}$ in. side guide

g. Valves.

Head diameter, exhaust	1.626-1.636 in.
Head diameter, intake	1.876-1.886 in.
Lift, exhaust	0.345 in.
Lift, intake	0.335 in.
Seat angle, exhaust and intake	45 deg
Stem diameter, exhaust	0.3405-0.3415 in.
Stem diameter, intake	0.3415-0.3425 in.
Stem length, exhaust and intake	5 $\frac{3}{64}$ in.

Timing:

Intake opens	T.D.C.
Intake closes	42 deg A.B.C.
Exhaust opens	52 deg B.B.C.
Exhaust closes	10 deg A.T.C.

h. Lubrication.

Camshaft bearing	Pressure
Capacity of oil reservoir	8 qt
Connecting rod bearings	Pressure
Crankcase ventilation	Forced circulation
Main bearings	Pressure
Oil pressure, at idle	15 lb min
Oil pressure at which relief valve opens	30 lb min
Oil pump, type	Helical gear
Oil reservoir gage, type	Dip stick
Piston pins	Pressure

TM 9-1729A

4

ORDNANCE MAINTENANCE — LIGHT TANKS M5, M5A1, AND M24, 75-MM HOWITZER MOTOR CARRIAGE M8, AND TWIN 40-MM GUN MOTOR CARRIAGE M19: ENGINES, COOLING SYSTEMS AND FUEL SYSTEMS

System, type Pressure
 Timing sprockets Positive
 Type of oil drain Threaded plug
 Valves Splash

i. Ignition.

Coil:

Amperage draw (at idle) 1½ amp
 Make Delco
 Type No., 1G Series DR-1115079
 Type No., 3G Series DR-1115281
 Voltage 24

Condenser (distributor):

Capacity 0.18-0.23 mfd
 Make Delco-Remy
 Type No. DR-1900272

Distributor:

Automatic advance 22 deg
 Contact point gap 0.013 to 0.018 in.
 Contact spring tension 19 to 23 oz
 Dwell angle 31 deg
 Direction of rotation (from top) Clockwise

Make:

Delco-Remy
 Type No., 1G Series DR-1110609, 10, or 11
 Type No., 3G Series DR-1110611
 Timing adjustment Rotate on mounting
 Vacuum advance None

Spark plugs:

Gap 0.028 to 0.033 in.
 Heat range Middle range
 Make A.C.
 Number used 8 per engine
 Thread 10-mm
 Model 104

Switch, ignition:

Make Delco-Remy
 Number used 2
 Type No. DR-1997756

Timing:

Location, 3G Series Flywheel cover and
 crankshaft pulley
 Location, 1G Series Flywheel cover
 Mark IG-A
 Mark calibration 9 degrees ahead of TDC

ENGINE

Section II

DISASSEMBLY OF ENGINE

5. PRELIMINARY INSTRUCTIONS.

a. **Mount Engine on Stand.** Install engine on a suitable rotating engine mounting stand (fig. 14).

b. **Remove Accessories.** Remove the following engine accessories: carburetor, oil filter assembly, generator, distributor, coil, spark

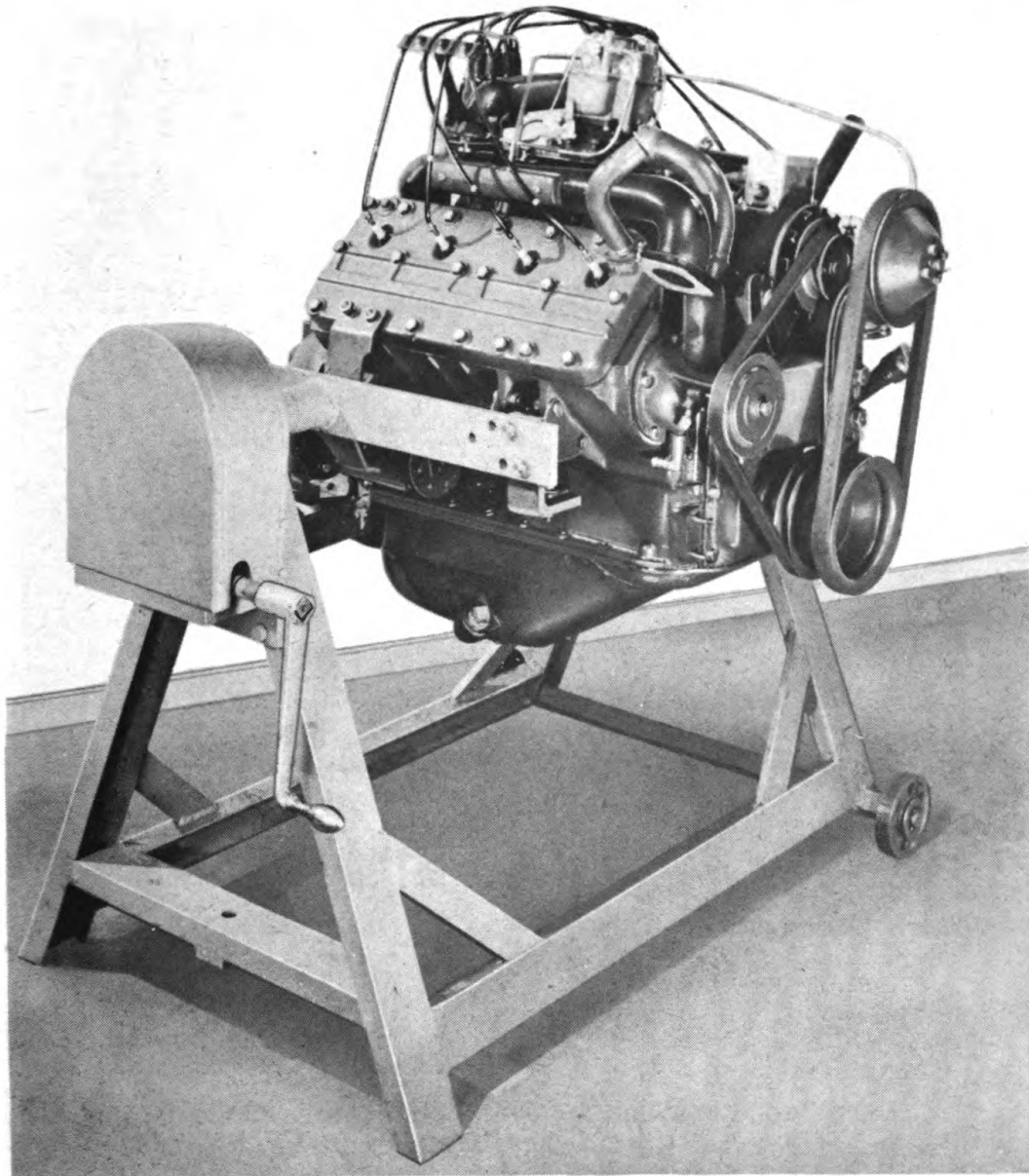

Figure 14 – 1G Series Engine in Stand

RA PD 8878

ORDNANCE MAINTENANCE — LIGHT TANKS M5, M5A1, AND M24, 75-MM HOWITZER MOTOR CARRIAGE M8, AND TWIN 40-MM GUN MOTOR CARRIAGE M19: ENGINES, COOLING SYSTEMS AND FUEL SYSTEMS

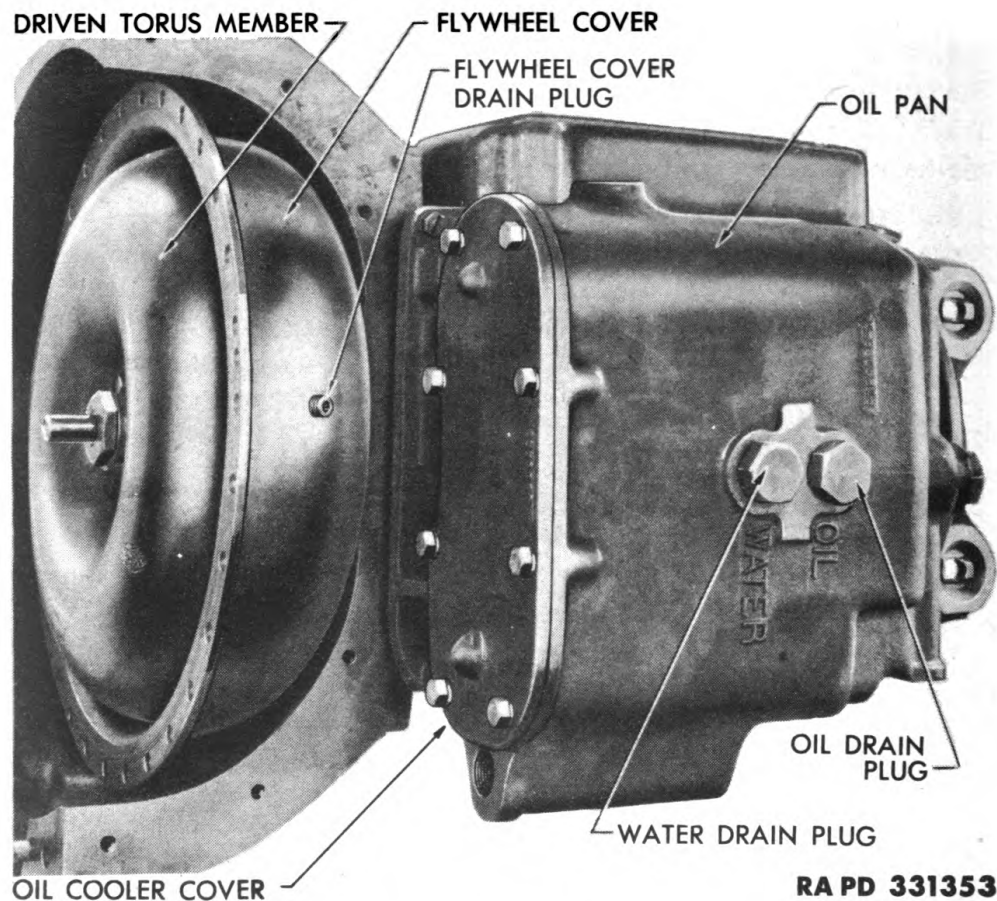

Figure 15 — Transmission Drains

plugs and connecting wires, and cranking motor (TM 9-729 for light tank, M24; TM 9-757 for 40-mm gun motor carriage, M19; TM 9-732 for light tanks, M5, M5A1; TM 9-732B for 75-mm howitzer motor carriage, M8).

c. **Clean Exterior of Engine.** Plug all openings to interior of engine and remove all dirt and grease with dry-cleaning solvent or steam-cleaning equipment. **CAUTION:** *Do not permit solvent or steam to get into sealed ball bearings in water pump or fan drive shaft.*

6. DISASSEMBLY.

a. Procedure.

(1) **DRAIN OIL FROM CRANKCASE.** Remove drain plug from bottom of oil pan, and drain oil. Install and tighten drain plug.

(2) **DRAIN OIL FROM FLUID COUPLING AND TRANSMISSION.** Remove six cap screws and lock washers holding lower flywheel housing

ENGINE

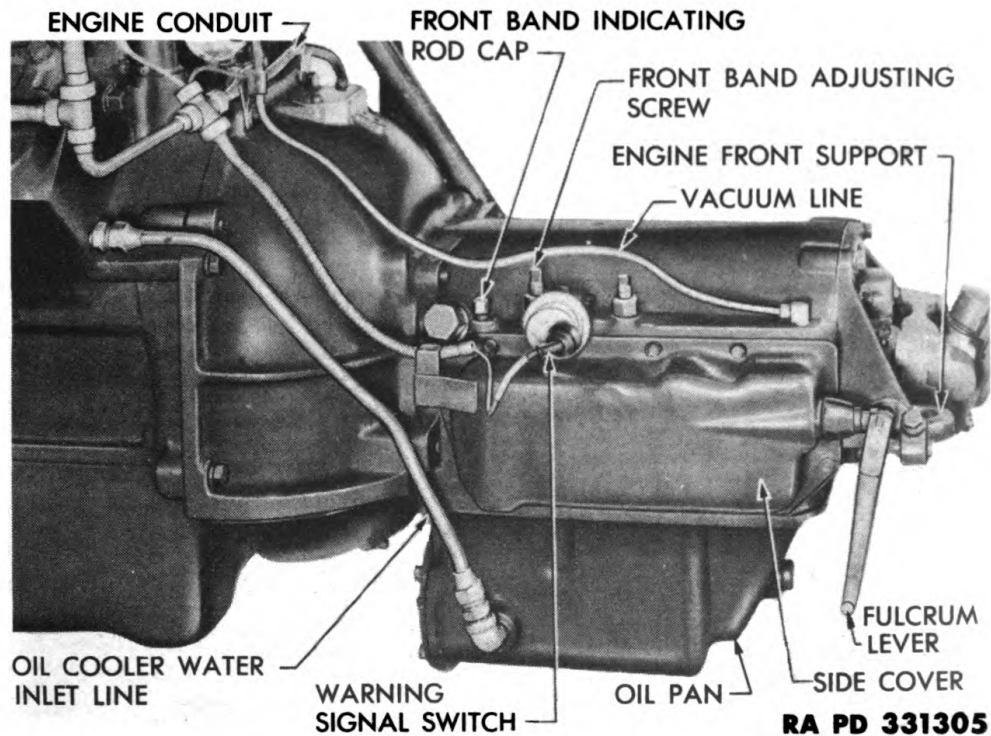

RA PD 331305

Figure 16 – Transmission Mounting, 3G Series

to upper flywheel housing and remove. Rotate flywheel by installing a 1-inch socket wrench on crankshaft pulley mounting screw, and turning crankshaft until flywheel drain plug is toward bottom of engine (fig. 15). Remove drain plug and allow oil to drain. Install and tighten plug. Remove transmission oil pan drain plug (fig. 15) and allow oil to drain completely. Install and tighten drain plug.

(3) **REMOVE TRANSMISSION.** Disconnect right and left oil cooler lines at transmission oil pan fittings, at engine block and at water pump (1G series) and remove lines. Loosen hose clamp on hose connecting transmission and engine oil filler tubes at transmission filler (3G series). Remove screw and washer holding filler tube to transmission case, remove nut and washer holding tube to rear manifold stud, and slide tube from case. Disconnect vacuum line at fitting on intake manifold, and elbow on transmission case (fig. 16) and remove line (3G series). Disconnect throttle rod from throttle valve lever on transmission and from relay on upper flywheel housing (1G series). Remove cotter pin holding relay to flywheel housing, and slide relay off stud (1G series). Disconnect warning signal switch wire at switch on transmission, and pull conduit out of clip on side cover. Install lifting eye (41-B-1586-300) in top of transmission case. Connect hoist to eye, and take up weight of transmission

ORDNANCE MAINTENANCE — LIGHT TANKS M5, M5A1, AND M24, 75-MM HOWITZER MOTOR CARRIAGE M8, AND TWIN 40-MM GUN MOTOR CARRIAGE M19: ENGINES, COOLING SYSTEMS AND FUEL SYSTEMS

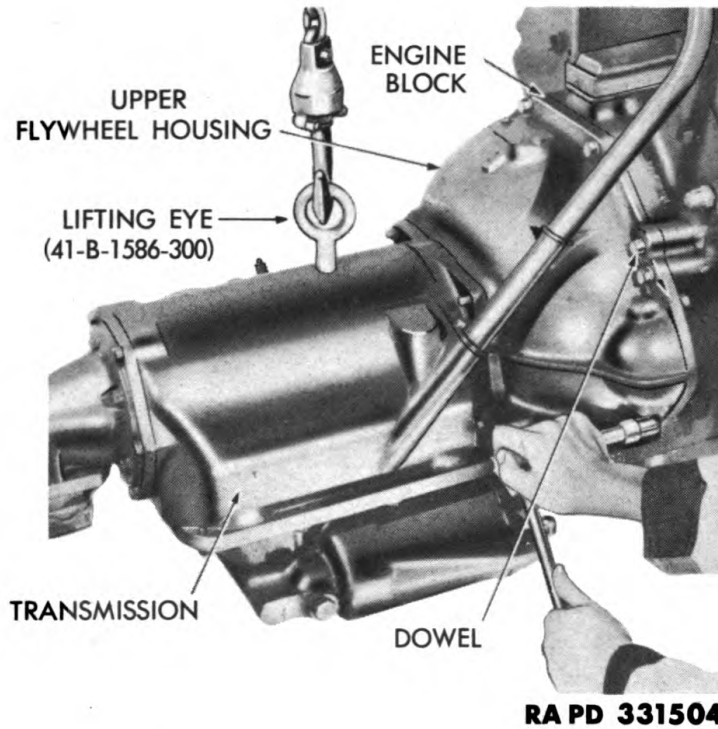

Figure 17 — Removing Transmission, 1G Series

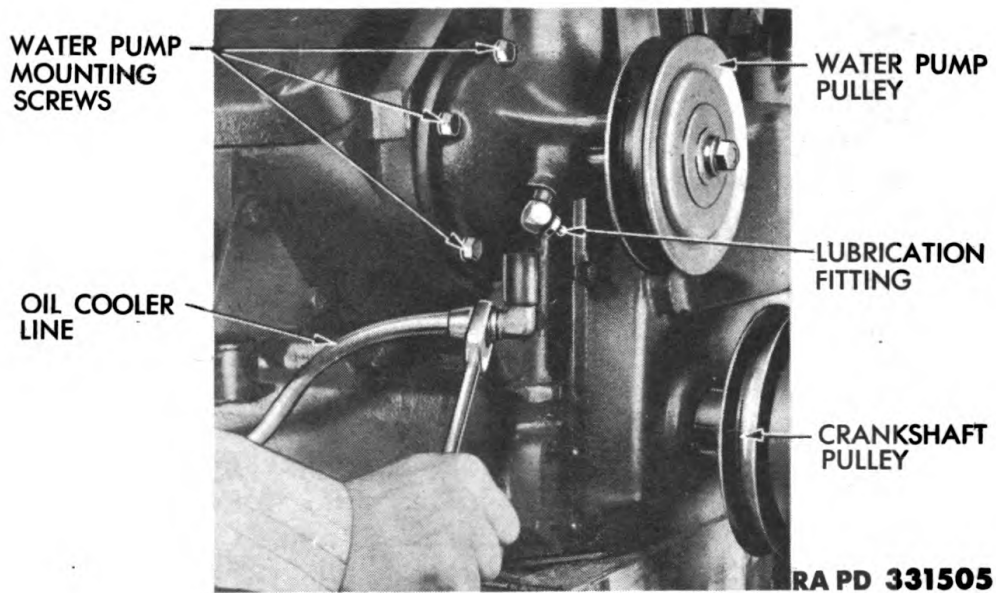

Figure 18 — Removing Water Pump, 1G Series

ENGINE

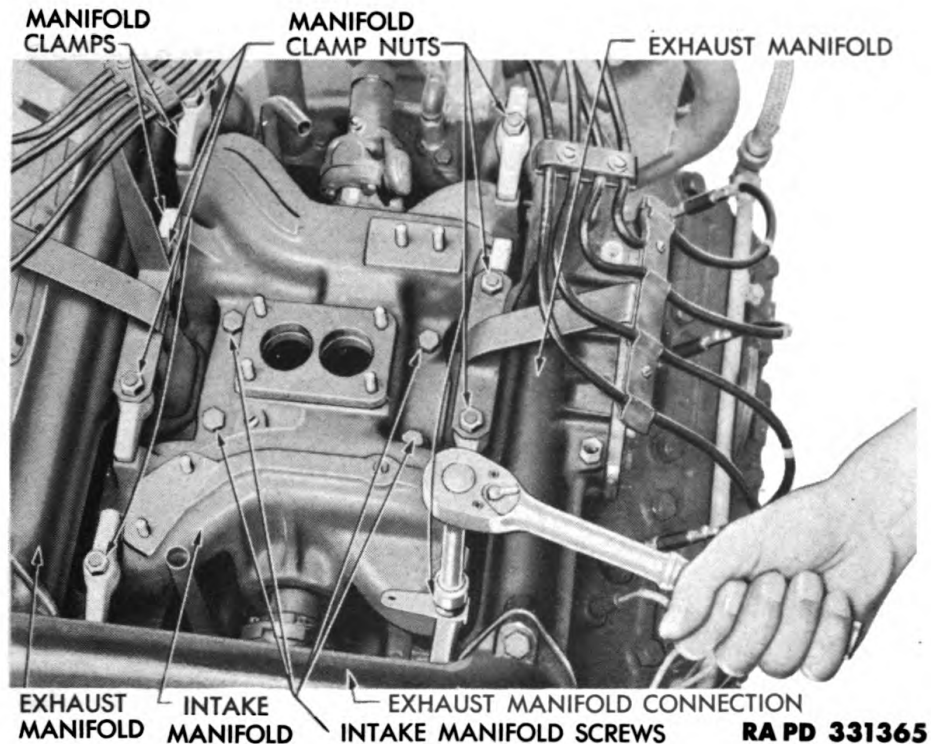

Figure 19 – Removing Exhaust Manifold, 3G Series

(fig. 17). Remove 30 screws holding flywheel cover to flywheel. Remove six screws holding upper flywheel housing to crankcase and place engine conduit out of the way. Pull transmission back to slide flywheel housing off dowel pins in crankcase, and mainshaft pilot out of bearing in end of crankshaft, and remove transmission.

(4) **REMOVE ENGINE OIL PRESSURE WARNING SIGNAL SWITCH.** Remove oil pressure warning signal switch by unscrewing switch from fitting at rear of engine vee.

(5) **REMOVE MUFFLER AND EXHAUST PIPES (1G SERIES ONLY).** Remove shield from muffler by taking out two mounting screws and lock washers (fig. 5). Remove four nuts and screws holding muffler inlet pipe to exhaust manifold flange. Remove four nuts holding muffler support brackets to studs on crankcase. Lift muffler and pipe assembly from engine.

(6) **REMOVE WATER PUMP.** Disconnect water pump by-pass hose from left cylinder outlet elbow and water pump (1G series). Disconnect water pump inlet tube hose at bottom of water pump, remove nut and bolt holding tube to crankcase separator plate, and remove tube (3G series). Remove five water pump mounting screws (fig. 18). Remove water pump and gasket.

ORDNANCE MAINTENANCE — LIGHT TANKS M5, M5A1, AND M24, 75-MM HOWITZER MOTOR CARRIAGE M8, AND TWIN 40-MM GUN MOTOR CARRIAGE M19: ENGINES, COOLING SYSTEMS AND FUEL SYSTEMS

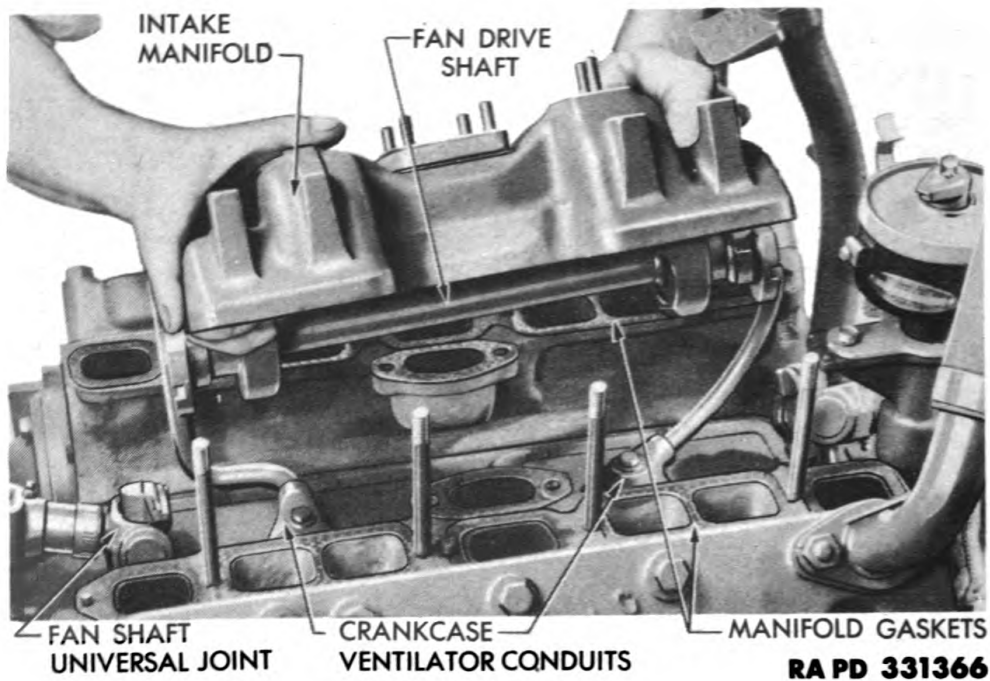

Figure 20 — Removing Intake Manifold, 3G Series

(7) **REMOVE EXHAUST MANIFOLD.** Remove two nuts and washers holding engine crankcase air cleaner to intake manifold; loosen lower hose clamp and remove air cleaner assembly (3G series). Remove four screws holding exhaust connection to left and right exhaust manifold (3G series). Lift up connection and discard gaskets. **NOTE:** 1G series connection was removed when spark plugwire supports were taken off in paragraph 5 b. Remove nuts and clamps holding exhaust manifolds to cylinder block (fig. 19). Remove manifolds.

(8) **REMOVE INTAKE MANIFOLD.** On 3G series, bend back lock plates for screws holding fan shaft universal yoke to front end of intake manifold. Remove four screws and remove generator drive flange, shaft and yoke. Bend back lock plates for screws holding fan shaft universal yoke to rear end of intake manifold. Remove four screws and remove rear yoke and shaft. On all series, remove four screws holding intake manifold to crankcase (fig. 20). Remove intake manifold and exhaust manifold gaskets.

(9) **REMOVE DISTRIBUTOR SUPPORT.** Disconnect carburetor throttle rod at distributor support, and disconnect throttle rod at outer end of relay on distributor support (1G series). Remove two screws holding distributor support to crankcase and remove distributor support.

ENGINE

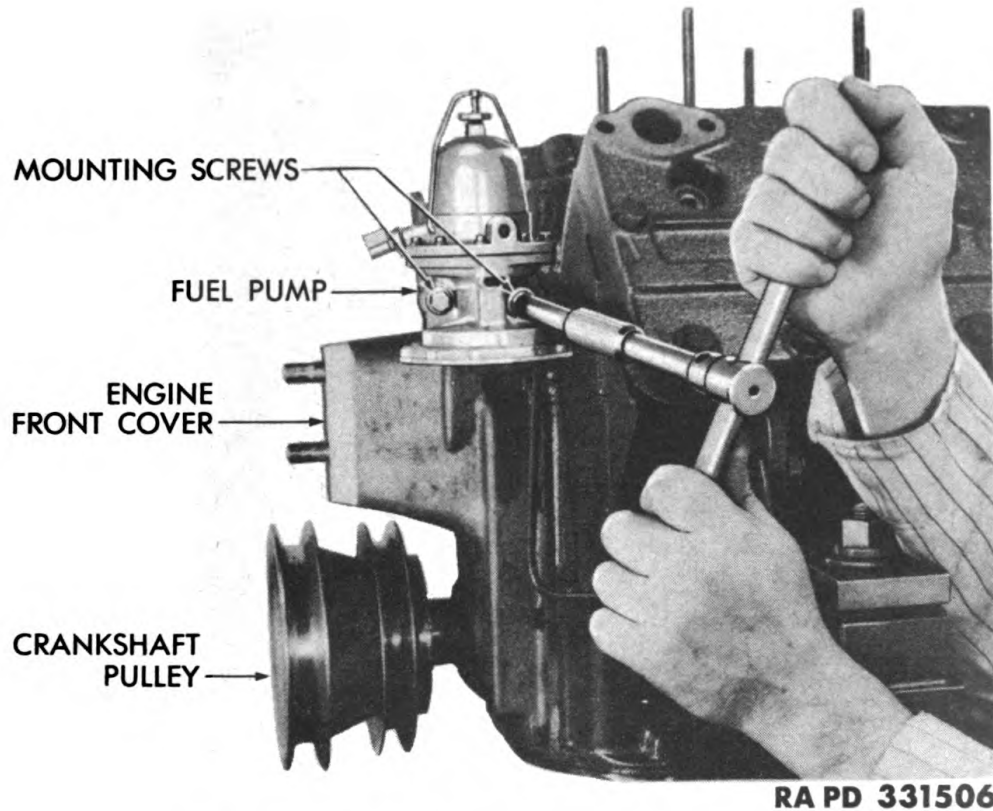

Figure 21 – Removing Fuel Pump, 1G Series

(10) **REMOVE FUEL PUMP (1G SERIES).** Remove two screws holding fuel pump to left side of engine front cover while supporting fuel pump (fig. 21). Remove fuel pump and gasket.

(11) **REMOVE CYLINDER HEADS.** Remove two screws holding each water outlet elbow to cylinder head. **NOTE:** *The water outlet elbows are on the front of the cylinder heads on 1G engines and at the rear of the cylinder head on 3G engines.* Remove two screws holding starter solenoid relay guard to right cylinder head and remove guard (early 1G series only). Remove four screws holding engine lifting rings to cylinder head (3G series). Remove remaining cylinder head screws and remove cylinder head and gasket. **CAUTION:** *Support cylinder head while removing last screw to prevent head from sliding down and damaging valves.*

(12) **REMOVE VALVE COMPARTMENT COVERS.** Remove two screws holding front and rear crankcase ventilating tubes to valve compartment covers and remove tubes and gaskets (3G series). Remove two screws holding crankcase ventilator conduit to valve compartment covers, and remove conduit and gaskets (1G series). Remove 16

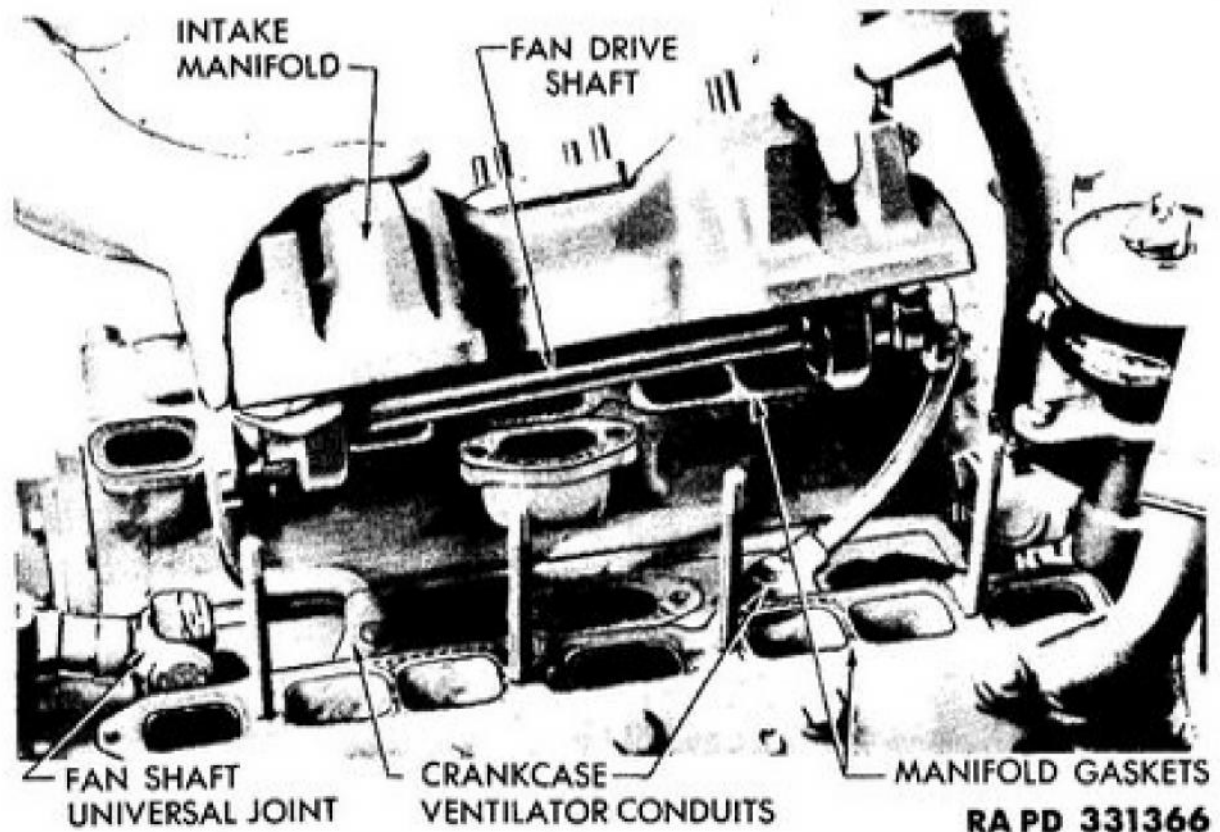

Figure 20 — Removing Intake Manifold, 3G Series

(7) **REMOVE EXHAUST MANIFOLD.** Remove two nuts and washers holding engine crankcase air cleaner to intake manifold; loosen lower hose clamp and remove air cleaner assembly (3G series). Remove four screws holding exhaust connection to left and right exhaust manifold (3G series). Lift up connection and discard gaskets. **NOTE:** 1G series connection was removed when spark plugwire supports were taken off in paragraph 5 b. Remove nuts and clamps holding exhaust manifolds to cylinder block (fig. 19). Remove manifolds.

(8) **REMOVE INTAKE MANIFOLD.** On 3G series, bend back lock plates for screws holding fan shaft universal yoke to front end of intake manifold. Remove four screws and remove generator drive flange, shaft and yoke. Bend back lock plates for screws holding fan shaft universal yoke to rear end of intake manifold. Remove four screws and remove rear yoke and shaft. On all series, remove four screws holding intake manifold to crankcase (fig. 20). Remove intake manifold and exhaust manifold gaskets.

(9) **REMOVE DISTRIBUTOR SUPPORT.** Disconnect carburetor throttle rod at distributor support, and disconnect throttle rod at outer end of relay on distributor support (1G series). Remove two screws holding distributor support to crankcase and remove distributor support.

ENGINE

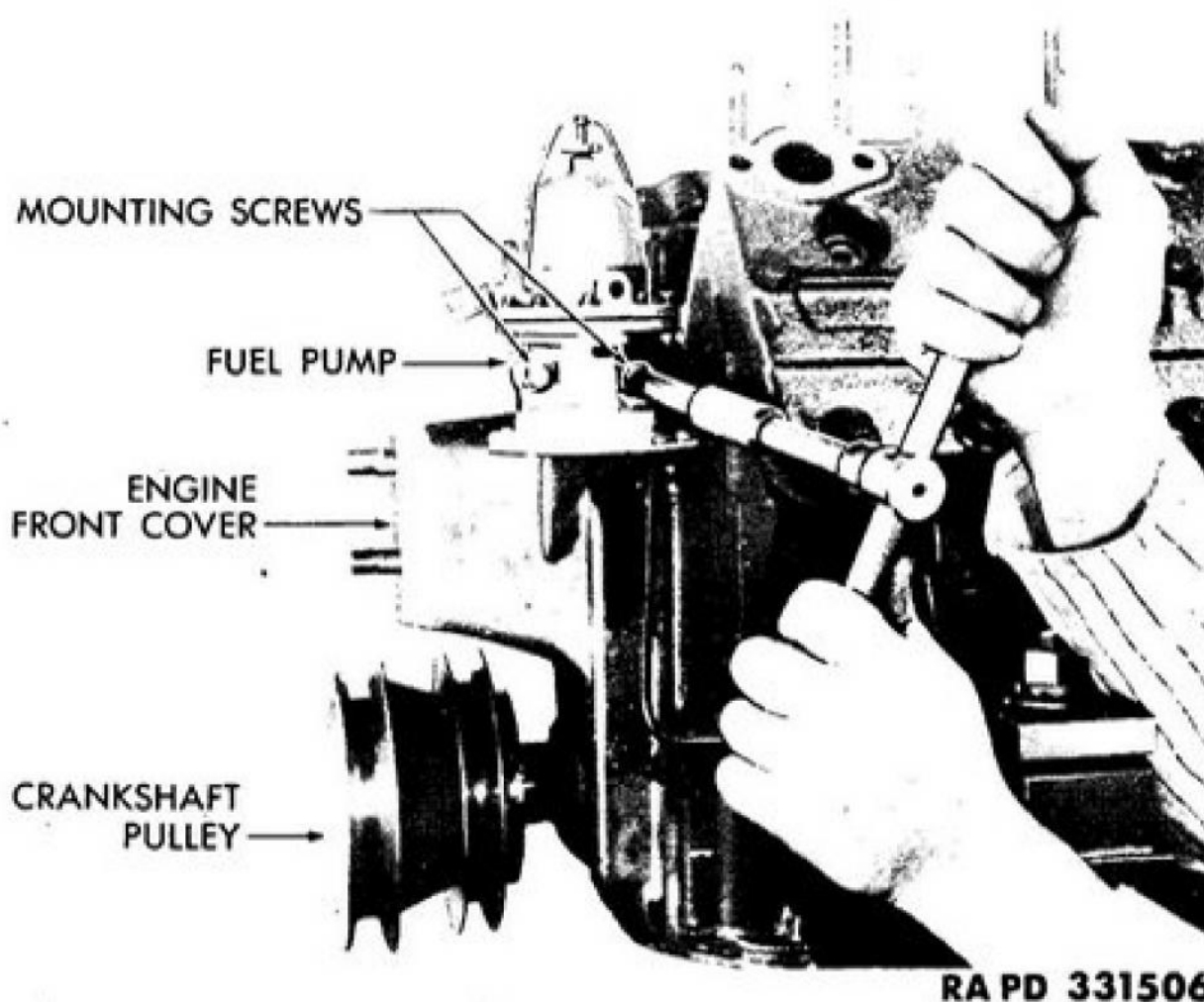

Figure 21 – Removing Fuel Pump, 1G Series

(10) **REMOVE FUEL PUMP (1G SERIES).** Remove two screws holding fuel pump to left side of engine front cover while supporting fuel pump (fig. 21). Remove fuel pump and gasket.

(11) **REMOVE CYLINDER HEADS.** Remove two screws holding each water outlet elbow to cylinder head. **NOTE:** *The water outlet elbows are on the front of the cylinder heads on 1G engines and at the rear of the cylinder head on 3G engines.* Remove two screws holding starter solenoid relay guard to right cylinder head and remove guard (early 1G series only). Remove four screws holding engine lifting rings to cylinder head (3G series). Remove remaining cylinder head screws and remove cylinder head and gasket. **CAUTION:** *Support cylinder head while removing last screw to prevent head from sliding down and damaging valves.*

(12) **REMOVE VALVE COMPARTMENT COVERS.** Remove two screws holding front and rear crankcase ventilating tubes to valve compartment covers and remove tubes and gaskets (3G series). Remove two screws holding crankcase ventilator conduit to valve compartment covers, and remove conduit and gaskets (1G series). Remove 16

ORDNANCE MAINTENANCE — LIGHT TANKS M5, M5A1, AND M24, 75-MM HOWITZER MOTOR CARRIAGE M8, AND TWIN 40-MM GUN MOTOR CARRIAGE M19: ENGINES, COOLING SYSTEMS AND FUEL SYSTEMS

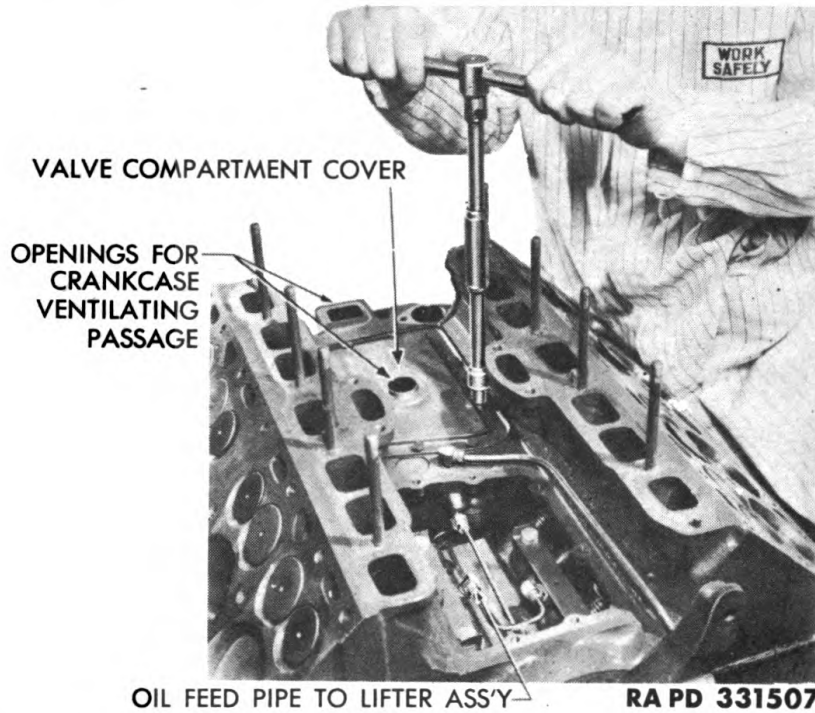

Figure 22 — Removing Valve Compartment Covers (1G shown)

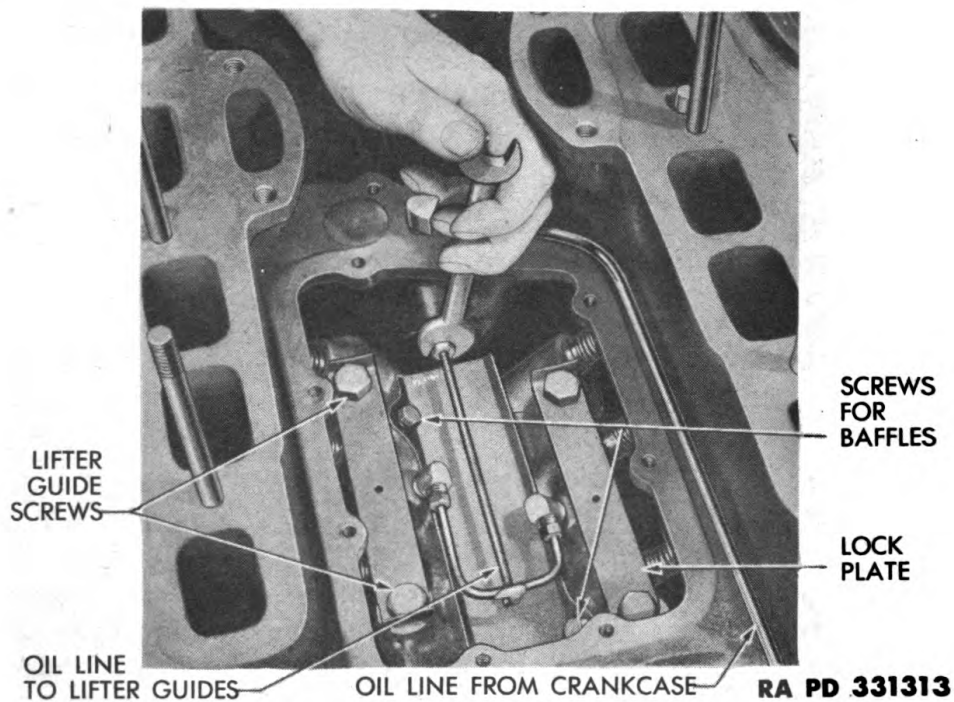
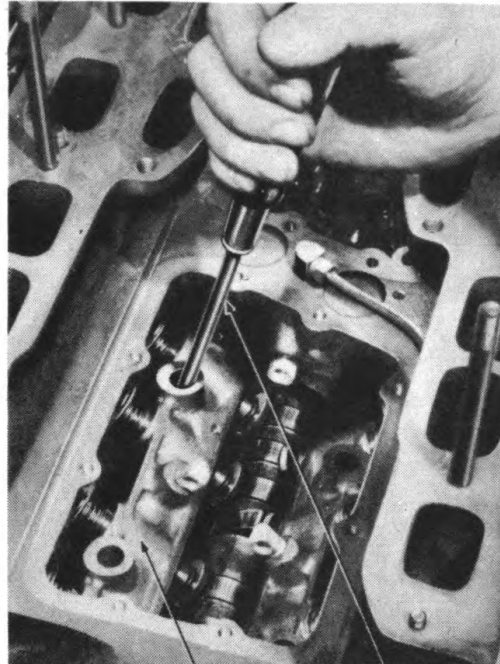

Figure 23 — Valve Compartment and Oil Lines

ENGINE



VALVE LIFTER GUIDE ASSEMBLY SCREWDRIVER
RA PD 331272

Figure 24 — Removing Valve Lifter Guide Assemblies

screws holding valve compartment covers to cylinder and crankcase (fig. 22). Remove valve compartment covers and valve compartment cover gaskets.

(13) **REMOVE VALVE LIFTER GUIDE ASSEMBLIES.** Disconnect oil lines from lifter guide assemblies and elbows on center bulkhead and remove lines (fig. 23). Remove four screws holding valve compartment baffles to valve lifter guide assemblies and remove baffles. Straighten each end of the four valve lifter guide assembly lock plates. Remove eight screws holding valve lifter guide assemblies to crankcase (fig. 23). Pry valve lifter guide assemblies out from under valve stems and remove assemblies (fig. 24). **CAUTION:** *Do not turn assemblies upside down, or plunger assemblies will fall out.*

(14) **REMOVE VALVES.** Place wire mesh screen in valve compartment below ends of valve stems to prevent dirt or valve parts from falling into engine. Insert valve remover adapter in hollow end of valve lifter (41-L-1425). Install valve replacer on valve. Adjustable pointed end of tool fits in center hole on valve head, and hollow end of valve lifter fits around lower end of valve stem (fig. 25). Compress valve spring by rotating handle of lifter. Lock valve lifter with valve spring in compressed position by tightening tool handle lock nut. Insert a screwdriver through slot in hollow end of valve

ORDNANCE MAINTENANCE — LIGHT TANKS M5, M5A1, AND M24, 75-MM HOWITZER MOTOR CARRIAGE M8, AND TWIN 40-MM GUN MOTOR CARRIAGE M19: ENGINES, COOLING SYSTEMS AND FUEL SYSTEMS



Figure 25 — Removing Valves

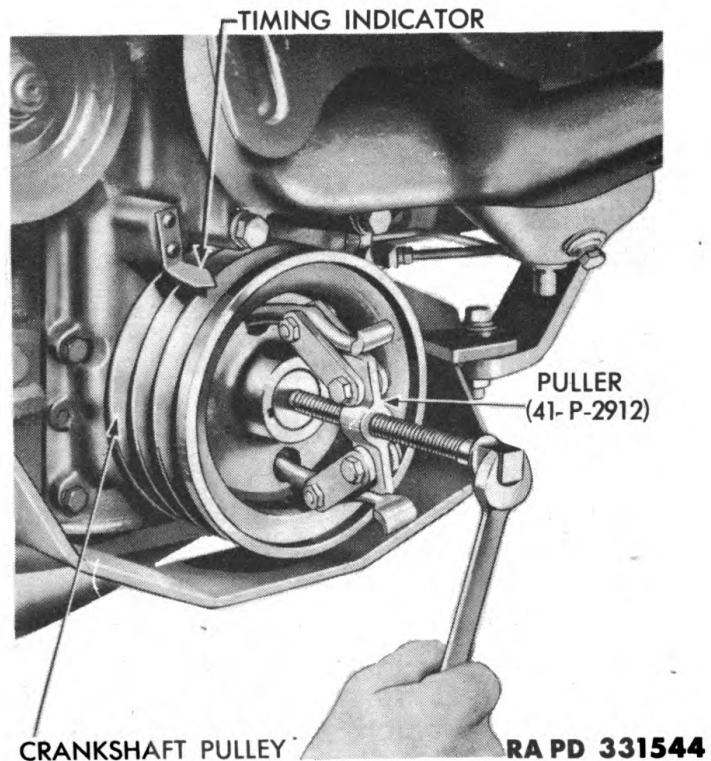

Figure 26 — Removing Crankshaft Pulley, 3G Series

ENGINE

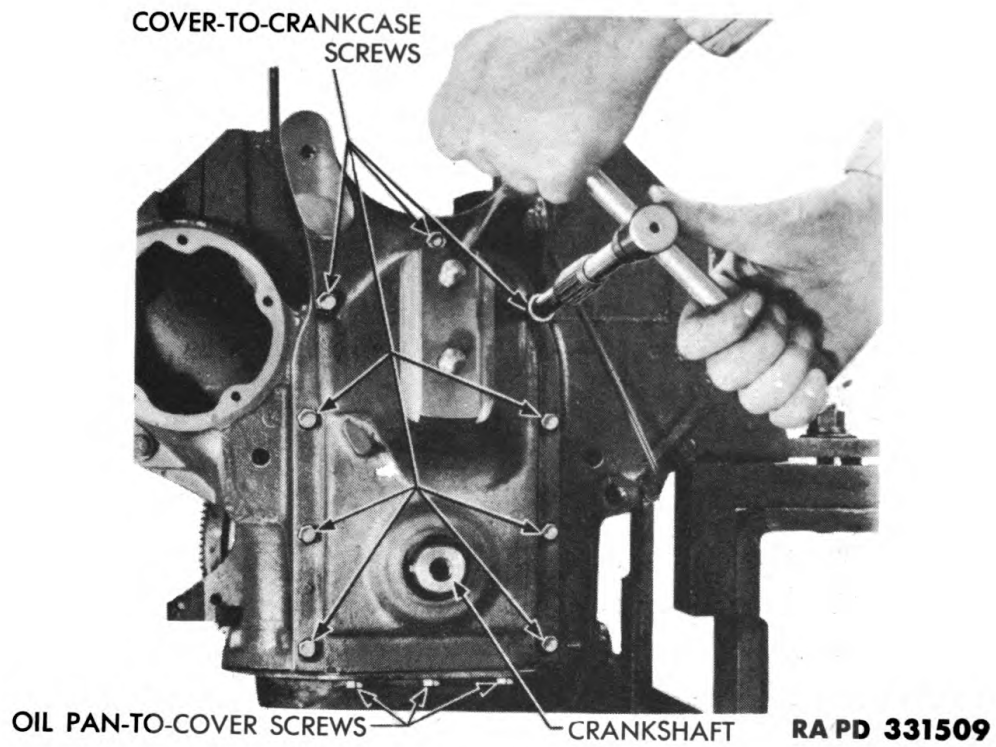

Figure 27 - Removing Engine Front Cover

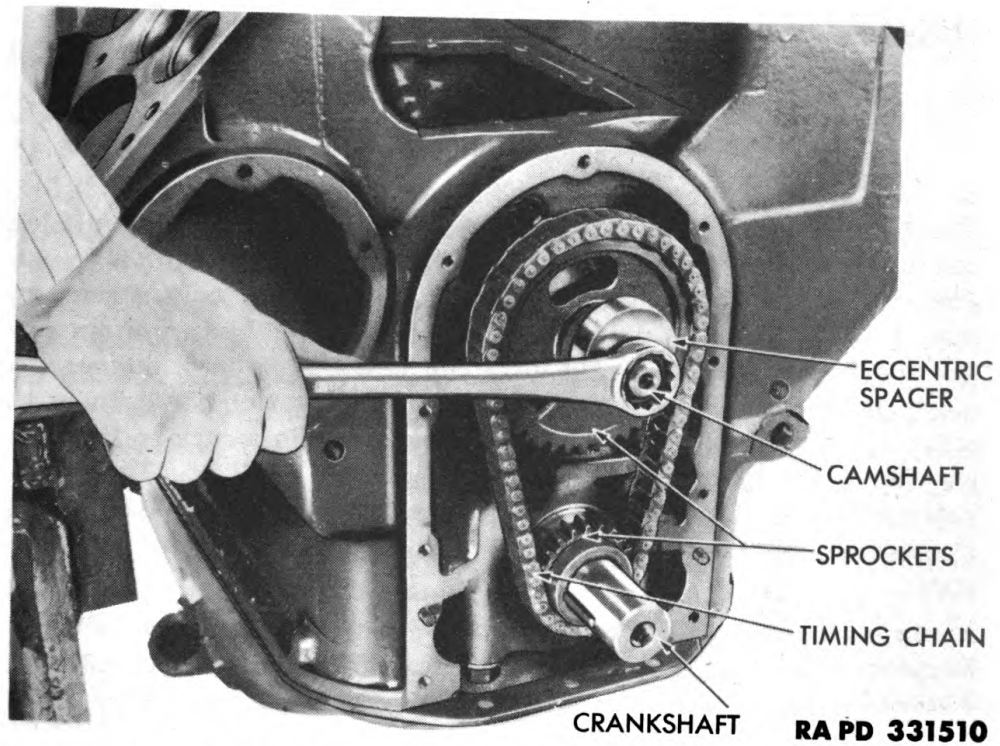

Figure 28 - Removing Fuel Pump Eccentric Spacer

ORDNANCE MAINTENANCE — LIGHT TANKS M5, M5A1, AND M24, 75-MM HOWITZER MOTOR CARRIAGE M8, AND TWIN 40-MM GUN MOTOR CARRIAGE M19: ENGINES, COOLING SYSTEMS AND FUEL SYSTEMS

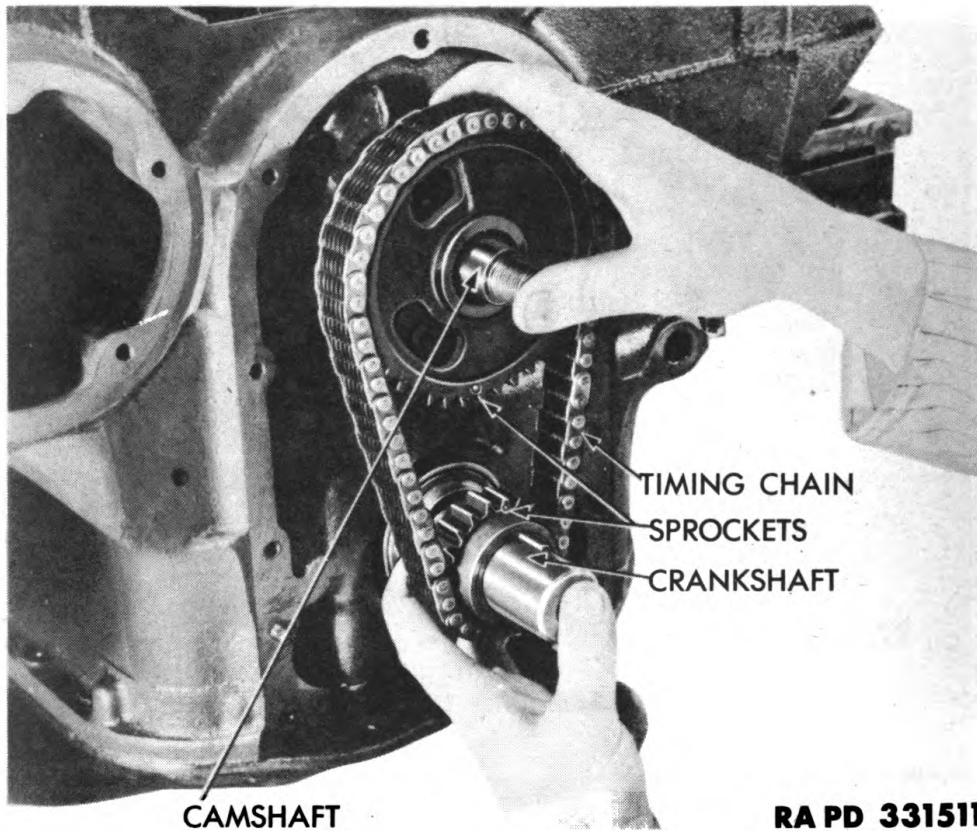
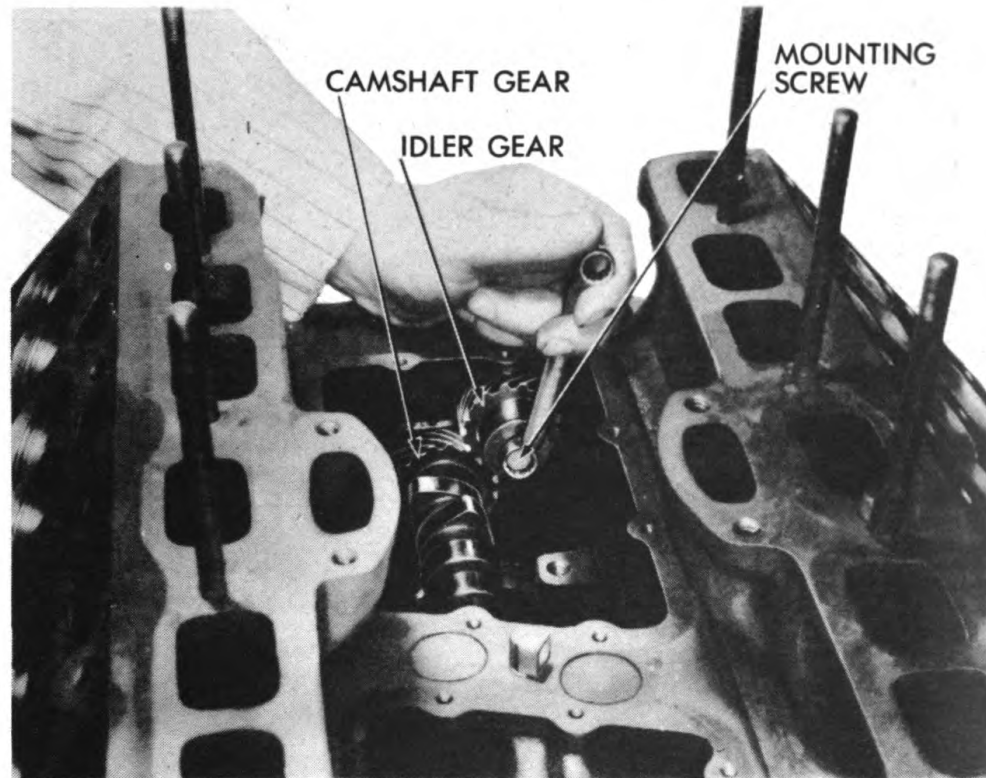

Figure 29 — Removing Timing Chain and Sprockets

lifter, and knock valve locks off valve stem. Loosen lifter handle lock nut and release valve spring. Hold lifter underneath valve, and grasp valve spring and seats. Remove lifter, valve locks, spring and seats from engine as a unit. **NOTE:** *Hold lifter in an upright position while removing to avoid dropping valve locks into engine.* Remove valve locks from lifter. Repeat this operation for each of the other 15 valves. Remove all valves, and place in a rack so that they may be reinstalled in the same valve guides. **NOTE:** *The special valve lifter (41-L-1425) has been superseded by lifter (41-L-1408), from third echelon tool-set No. 1, which may be used for this operation.*

(15) **REMOVE FAN AND WATER PUMP DRIVE BELT PULLEY.** Remove screw, lock washer and plain washer holding fan and water pump drive pulleys to front end of crankshaft. Grasp pulley on opposite sides with both hands and pull both pulleys as an assembly off front end of crankshaft (1G series). **NOTE:** *On 3G series, it will*

ENGINE



RA PD 331512

Figure 30 – Removing Idler Gear

be necessary to use puller (41-P-2912) to remove pulley from shaft (fig. 26).

(16) **REMOVE ENGINE FRONT COVER.** Remove nine screws holding engine front cover to crankcase and three screws holding oil pan to cover (fig. 27). Remove cover and gasket.

(17) **REMOVE TIMING CHAIN AND SPROCKETS.** Before removing chain, check for excessive wear. If slack in chain exceeds $\frac{3}{4}$ inch total motion when pressing on side of chain, chain should be replaced, together with camshaft sprocket if sprocket is worn. Remove nut which holds fuel pump eccentric and camshaft sprocket on front end of camshaft (fig. 28). **NOTE:** *The fuel pump eccentric is used on 3G engines only as a spacer.* Pry fuel pump eccentric off front end of camshaft with a screwdriver. Loosen crankshaft and camshaft timing chain sprockets on crankshaft and camshaft, then grasp both sprockets and pull sprockets and timing chain off front end of crankshaft and camshaft (fig. 29). If a pry bar is used, pressure must not be applied to ends of timing chain pins.

(18) **REMOVE DISTRIBUTOR AND OIL PUMP IDLER GEAR.** Remove screw holding distributor and oil pump idler gear on idler gear

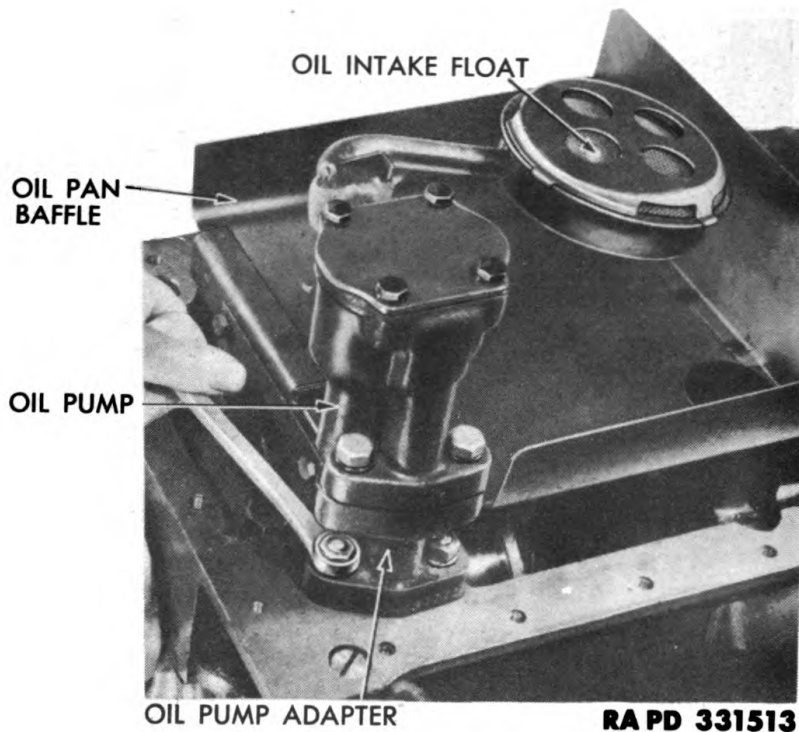

Figure 31 — Removing Oil Pump

support (fig. 30). Slide idler gear and washer off front end of support.

(19) **REMOVE CAMSHAFT.** Remove two screws holding camshaft thrust plate to crankcase, and remove plate. Pull camshaft out of front end of crankcase, being careful to see that camshaft lobes do not damage camshaft bushings.

(20) **REMOVE OIL PAN.** Turn engine upside down in overhaul stand, and remove screws holding oil pan to crankcase and rear crankshaft bearing cap. Remove oil pan, and oil pan gasket.

(21) **REMOVE OIL PUMP.** Remove two nuts and washers on oil pump adapter mounting studs, and remove oil pump and oil pump adapter as a unit (fig. 31).

(22) **REMOVE OIL PAN BAFFLE.** Remove two screws holding rear end of oil pan baffle to mounting bracket on rear crankshaft bearing cap. Remove two screws holding oil pan baffle to mounting bracket on center crankshaft cap, and remove oil pan baffle.

ENGINE

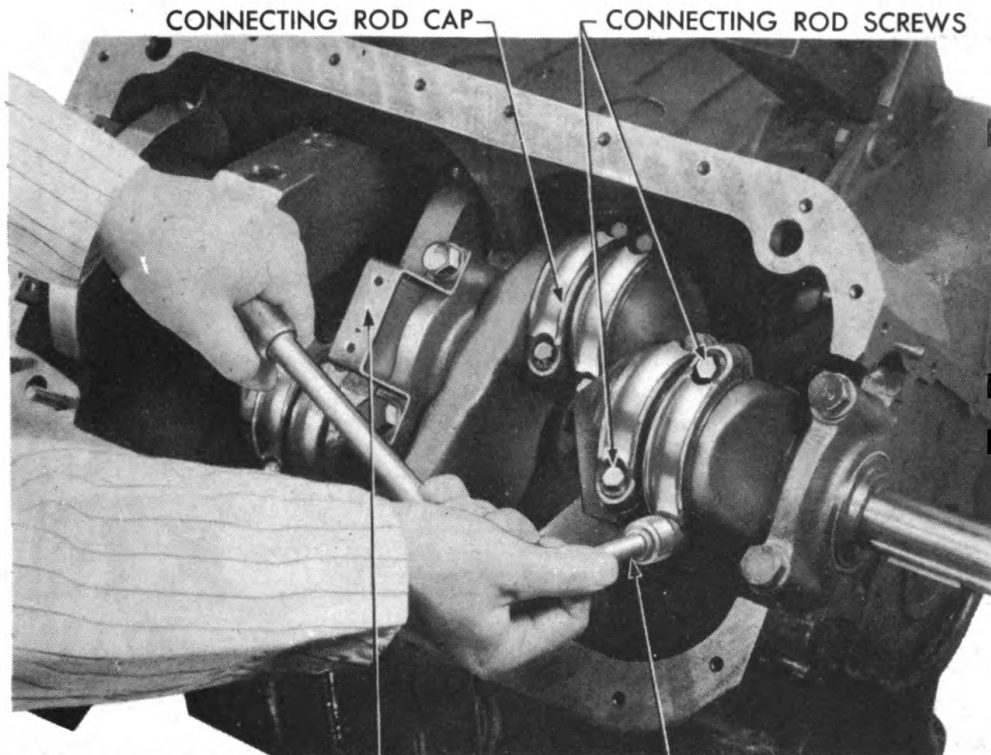

BRACKET FOR OIL PAN Baffle WRENCH (41-W-2598-500) RA PD 344113

Figure 32 – Removing Connecting Rod Cap Screw

(23) **REMOVE CONNECTING ROD AND PISTON ASSEMBLIES.** The cylinder must be reamed to remove the ridge around the top edge of the cylinder bore and facilitate removal of the piston. Cover top of piston to prevent cuttings from lodging between piston and cylinder wall. Then position ridge reamer (41-R-2275) to avoid cutting below top of upper ring position in bore. Adjust cutters for depth to avoid cutting more than necessary in order to remove ridge. Repeat this operation at each bore. Remove connecting rod bearing cap and lower half of connecting rod bearing as a unit. Push connecting rod and piston assembly up into cylinder until piston protrudes part way from cylinder block. Grasp top of piston and pull piston and rod assembly out from top of cylinder block, being very careful not to scratch cylinder with connecting rod. Reinstall bearing cap on rod and tighten screws finger-tight. Repeat this step for removing the other seven connecting rod assemblies.

(24) **REMOVE TRANSMISSION MAINSHAFT PILOT BEARING.** Compress and remove transmission mainshaft pilot bearing lock wire in end of crankshaft. Pull bearing out of end of crankshaft.

ORDNANCE MAINTENANCE — LIGHT TANKS M5, M5A1, AND M24, 75-MM HOWITZER MOTOR CARRIAGE M8, AND TWIN 40-MM GUN MOTOR CARRIAGE M19: ENGINES, COOLING SYSTEMS AND FUEL SYSTEMS

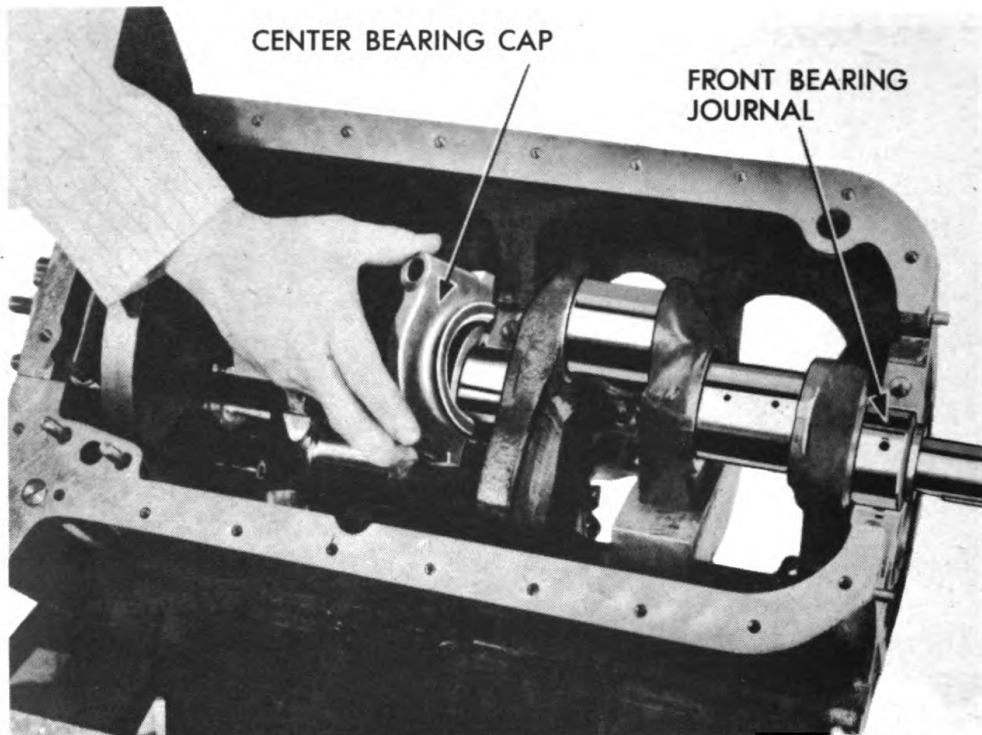

RA PD 331545

Figure 33 — Removing Center Crankshaft Bearing Cap

(25) **REMOVE CRANKSHAFT BEARING CAPS.** Remove two screws holding front crankshaft bearing cap to crankcase. Remove bearing cap and lower half of front crankshaft bearing. Remove two screws holding center crankshaft bearing cap to crankcase. Remove oil pan baffle front support from center bearing cap. Remove bearing cap and lower half of center crankshaft bearing (fig. 33). Remove two screws holding rear crankshaft bearing cap to crankcase. Remove oil pan baffle support from rear bearing cap. Remove bearing cap and lower half of rear crankshaft bearing. **NOTE:** *If bearing cap is tight in crankcase, it can be loosened by raising crankshaft and flywheel assembly evenly.*

(26) **REMOVE CRANKSHAFT AND FLYWHEEL ASSEMBLY.** Lift crankshaft and flywheel assembly from crankcase. Remove upper crankshaft bearing halves from crankcase. If upper bearing halves do not come out of crankcase easily, they may be loosened by tapping the edges with a hammer handle.

ENGINE**Section III****DISASSEMBLY, CLEANING, INSPECTION, REPAIR,
AND ASSEMBLY OF SUBASSEMBLIES****7. ENGINE BLOCK AND HEADS.****a. Description.**

(1) **ENGINE BLOCK.** The engine cylinder block and crankcase assembly is made of a single casting of gray iron, which has cored passages for cooling fluid, drilled passages for oil, and machined surfaces for bearings and for the attachment of parts. The cylinder bores are arranged in two banks of four each, 90 degrees apart and 45 degrees from the vertical, and ground and honed to precise limits.

(2) **CYLINDER HEADS.** The cylinder heads are cast of gray iron with cored passages for the cooling liquid and with cored areas for the tops of the combustion chambers.

(3) **FLYWHEEL HOUSING.** The flywheel housing is an iron casting bolted to the rear of the engine and to the front of the transmission. It is machined carefully to match the engine block and provide accurate alinement for the transmission shafts. Because of this matching, the engine number is stamped on the flywheel housing as well as on the engine block.

b. Disassembly.

(1) **REMOVE IDLER GEAR SUPPORT FROM ENGINE BLOCK.** On 1G series engines, remove cap screw next to distributor support opening. On 3G series engines, remove oil pressure warning signal unit fitting. On all series, remove set screw holding distributor idler gear support in crankcase, using $\frac{7}{32}$ -inch socket head set screw wrench (fig. 34). Tap the inner end of the support with a heavy hammer to drive support out of crankcase.

(2) **CYLINDER HEADS.** The cylinder heads are completely disassembled when removed from the engine.

(3) **FLYWHEEL HOUSING.** The flywheel housing is removed from the engine with the transmission (par. 6), and is disassembled from the transmission and serviced as explained in TM 9-1729B.

c. Cleaning.

(1) **ENGINE BLOCK.** Strip off gaskets and sealing compound from all machined surfaces. Clean inside and outside of block with steam-cleaning equipment or with brush dipped in solvent. Remove access plugs and clean all oil passages with steam or with kerosene and compressed air.

ORDNANCE MAINTENANCE — LIGHT TANKS M5, M5A1, AND M24, 75-MM HOWITZER MOTOR CARRIAGE M8, AND TWIN 40-MM GUN MOTOR CARRIAGE M19: ENGINES, COOLING SYSTEMS AND FUEL SYSTEMS



Figure 34 — Removing Set Screw For Idler Gear Support

(2) **CYLINDER HEADS.** Scrape carbon deposits from combustion chambers in cylinder heads. Clean the entire head with dry-cleaning solvent and a stiff wire brush.

d. Inspection.

(1) **BLOCK ASSEMBLY.** Inspect the entire block assembly carefully for cracks, fractures or damage to flanges or webbing. Inspect expansion plugs for condition and tight seal, replacing any which show indications of leakage. Inspect machined surfaces for scratches, nicks, burrs or similar damage. Slight scratches can be cleaned up with a fine stone. Inspect all threaded holes and retap any that are stripped or otherwise damaged.

(2) **CYLINDER BORES.** Visually inspect cylinder bores by holding a light at the lower end of each bore and checking condition carefully. If rust pits are in evidence, or the cylinder is deeply scratched or scored, rehonng will be necessary. If cylinder appears to be in good condition, measure diameter, using a 3- to 4-inch inside micrometer or cylinder indicator gage. If cylinder is tapered more than 0.004 inch from top to bottom of ring travel, rehonng will be necessary.

ENGINE

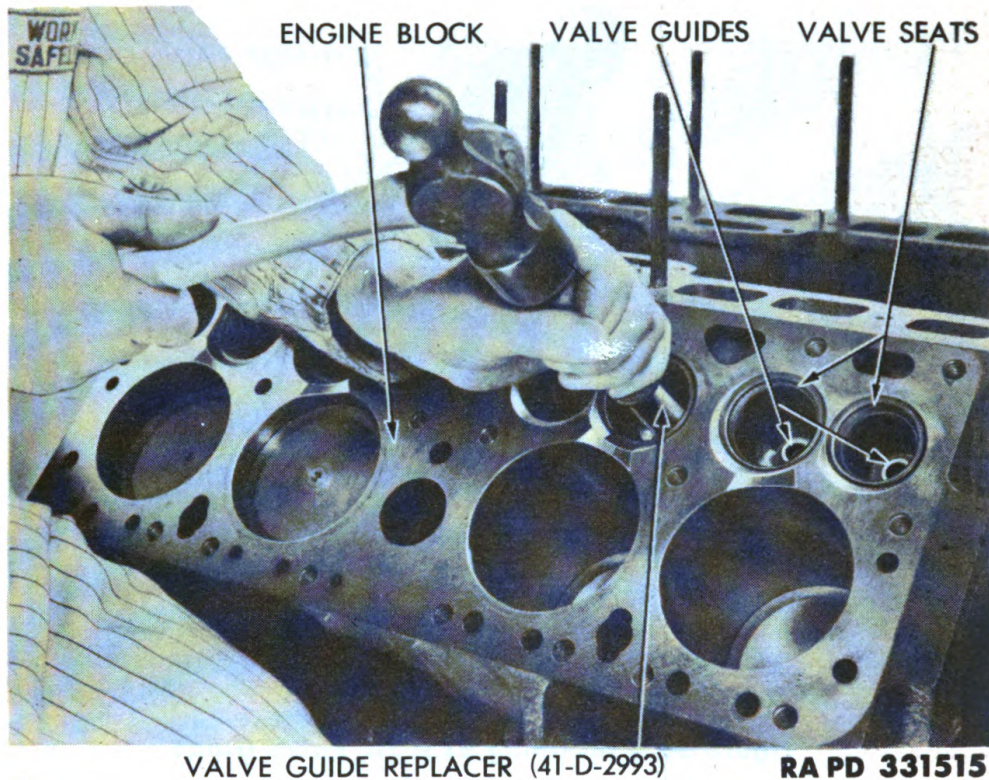

Figure 35 – Removing Valve Guides

If bores are apparently in good condition, piston fit can be checked later as explained in subparagraph e.

(3) **VALVE GUIDES.** Inspect valve guides for condition, freedom from cracks or fractures and snug fit in block. If condition is satisfactory, check diameter with plug gage or hole gage. If guide is worn beyond 0.3487-inch diameter, measured $\frac{1}{8}$ inch from bottom of counterbore, or is otherwise not in satisfactory condition, replace as outlined in subparagraph e.

(4) **CAMSHAFT BUSHINGS.** Inspect camshaft bushings for condition, secure mounting in block, and freedom from scratches or scores. Measure diameter with inside micrometers and replace bushings as explained in subparagraph e, if worn to more than 2.413-inch diameter (front and center) or 2.007-inch (rear).

(5) **CYLINDER HEADS.** Inspect cylinder heads for cracks, fractures or other damage. Inspect cylinder head gasket faces for scratches or burs or other conditions that might prevent a good gasket seal. Inspect condition of threads on spark plug mounting holes. Nicks or burs on the gasket face can be removed with a fine stone if not too deep. Replace heads if other conditions are found.

ORDNANCE MAINTENANCE — LIGHT TANKS M5, M5A1, AND M24, 75-MM HOWITZER MOTOR CARRIAGE M8, AND TWIN 40-MM GUN MOTOR CARRIAGE M19: ENGINES, COOLING SYSTEMS AND FUEL SYSTEMS

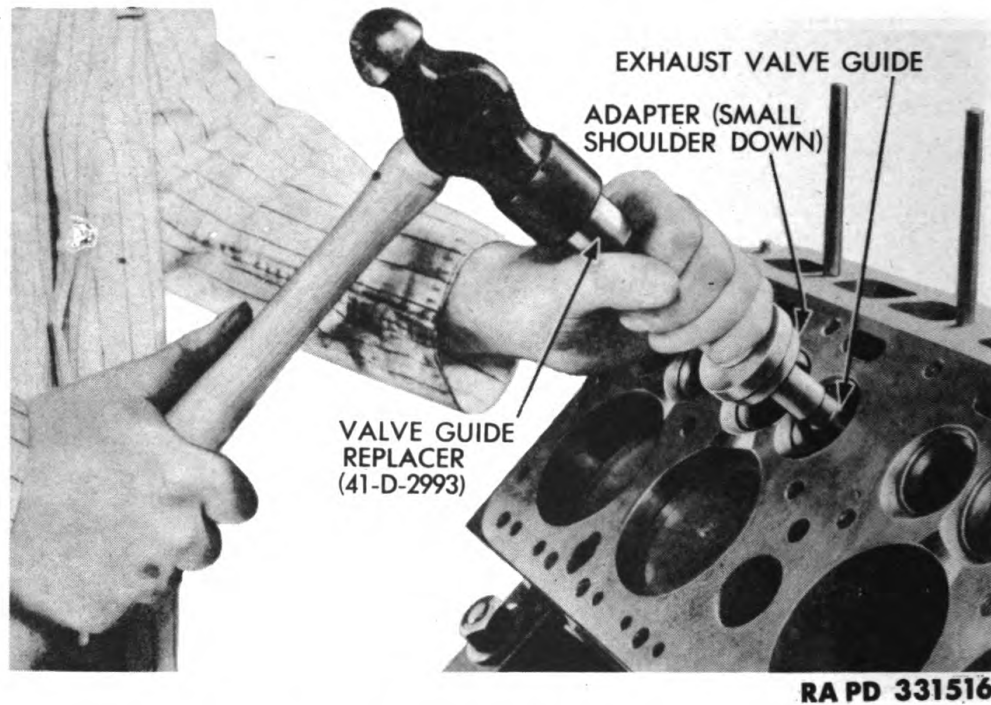

Figure 36 — Installing Exhaust Valve Guide

e. Repair.

(1) VALVE GUIDE REPLACEMENT.

(a) Remove Valve Guides. Insert valve guide replacer in valve guide and drive guide down into valve compartment, using a heavy hammer (fig. 35). Catch guide before it falls down into crankcase. Repeat this operation for each of the other 15 valve guides.

(b) Install Valve Guides. Position valve guide driver adapter on driver tool (41-D-2993). Place narrow shoulder on adapter toward pilot end of driver tool when installing exhaust valve guides (fig. 36). Position adapter on driver tool with wide shoulder toward pilot end when installing intake valve guides (fig. 37). Position a new valve guide on driver and adapter and place guide and driver tool on top of valve guide mounting hole. Drive valve guide into position until adapter on driver tool strikes top of valve opening. Repeat this operation for each of the other 15 valve guides, reversing adapter on driver tool as required for intake and exhaust valve guides. **CAUTION:** Tool must be held square with bushing to avoid chipping top of bushing.

(2) REPLACING CAMSHAFT BUSHINGS.

(a) Remove Camshaft Rear Bushing. Install camshaft rear bushing pilot (41-R-2373-600) in rear camshaft bushing from front. Insert

ENGINE

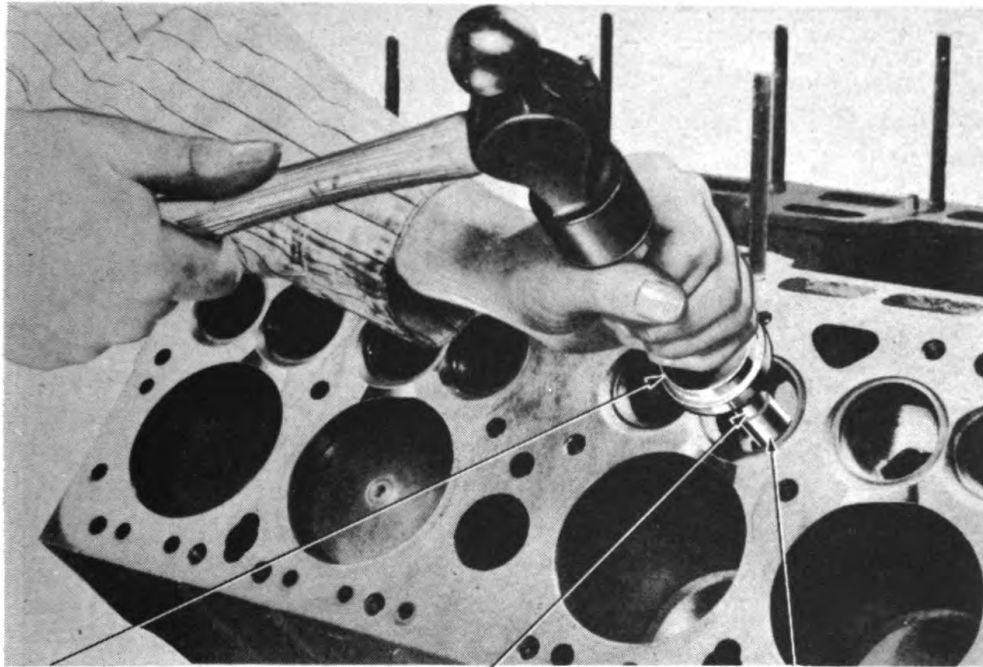

ADAPTER (LARGE SHOULDER DOWN) VALVE GUIDE REPLACER (41-D-2993) INTAKE VALVE GUIDE
RA PD 331517

Figure 37 – Installing Intake Valve Guide

camshaft bushing replacer through pilot on rear camshaft bushing, and knock out expansion plug in crankcase behind rear camshaft bushing. Install camshaft front bushing pilot over front end of replacer, and insert in front camshaft bushing (fig. 38). Push replacer toward rear of crankcase until collar on replacer contacts camshaft rear bushing pilot. Drive out camshaft rear bushing by tapping on front end of replacer, using a lead hammer to prevent damaging tool. Remove camshaft rear bushing pilot, but do not remove replacer.

(b) *Remove Center Camshaft Bushing.* Pull replacer forward past center camshaft bushing. Install center camshaft bushing pilot in place on front of center camshaft bushing. Push replacer back through center camshaft bushing pilot until collar on replacer contacts pilot (fig. 38). Drive out center camshaft bushing by striking front end of replacer, using a lead hammer to prevent damaging tool. Remove replacer and front center camshaft bushing pilots.

(c) *Remove Front Camshaft Bushing.* Install camshaft front bushing pilot in camshaft front bushing from the rear. Insert replacer through rear and center camshaft bushing openings, and through pilot in front bushing until collar contacts pilot (fig. 38). Install camshaft rear bushing pilot over replacer from rear end into position in camshaft rear bushing opening. Drive out camshaft front bushing

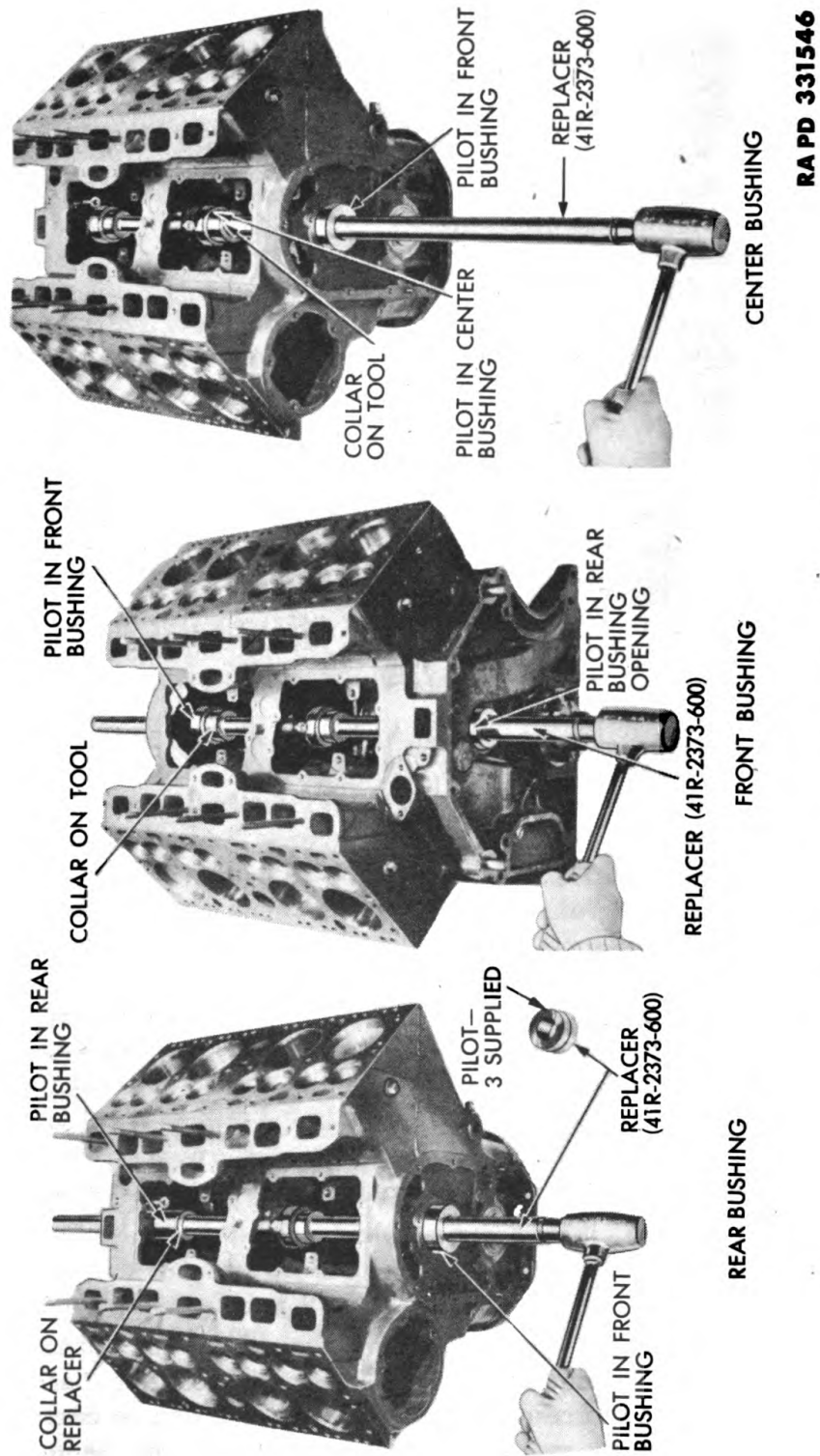

Figure 38 — Removing Camshaft Bushings

ENGINE

by striking rear end of replacer, using a lead hammer to prevent damaging tool. Remove camshaft rear bushing pilot, replacer, and camshaft front bushing pilot.

(d) *Install Camshaft Rear Bushing.* Position rear camshaft bushing on pilot. Coat outside of bushing with white lead. Insert camshaft bushing replacer (41-R-2373-600) through front and center camshaft bushing openings. Install camshaft front bushing pilot in front camshaft bushing opening around replacer tool. Place camshaft rear bushing pilot and bushing on front edge of opening in crankcase, making sure that oilhole in bushing will line up with oil passage in crankcase when bushing is installed. Insert replacer tool through camshaft rear bushing pilot and drive camshaft rear bushing into place. Withdraw replacer tool from pilot and center camshaft bushing opening, but leave it in place in camshaft front bushing pilot. Remove pilot from camshaft rear bushing.

(e) *Install Camshaft Center Bushing.* Position camshaft center bushing on pilot. Coat outside of bushing with white lead. Place camshaft center bushing pilot and bushing on front end of center camshaft opening, making sure that oilhole in bushing will line up with oil passage in crankcase when bushing is installed. Insert replacer tool through camshaft center bushing pilot and drive bushing into opening until both ends are flush with edges of crankcase. Remove replacer tool and camshaft front bushing pilot from crankcase, but leave camshaft center bushing pilot in place.

(f) *Install Camshaft Front Bushing.* Position camshaft front bushing on pilot. Coat outside of bushing with white lead. Place pilot and bushing on front edge of front opening in crankcase, making sure that the oilhole in bushing will line up with oil passage in crankcase when bushing is installed. Insert replacer tool through camshaft front and center bushing pilots and drive camshaft front bushing into place until ends of bushing are flush with ends of crankcase. Remove replacer tool and pilots. Coat edges of a new expansion plug liberally with joint and thread compound and push plug into rear end of rear camshaft opening in crankcase until it bottoms against shoulder. Strike center of plug several smart blows with a light hammer to expand plug and lock it in place. Wipe up joint and thread compound from inside of camshaft hole.

(3) FITTING PISTONS.

(a) *Measure Cylinder Bores.* Insert a 3- to 4-inch inside micrometer in each cylinder bore $1\frac{1}{4}$ inches down from the top and at right angles to the camshaft (fig. 39). Set micrometer barrel snugly enough to prevent change of reading, and remove micrometer from cylinder. Measure inside micrometer with an outside micrometer, using the same feel as used in measuring pistons. Record these

ORDNANCE MAINTENANCE — LIGHT TANKS M5, M5A1, AND M24, 75-MM HOWITZER MOTOR CARRIAGE M8, AND TWIN 40-MM GUN MOTOR CARRIAGE M19: ENGINES, COOLING SYSTEMS AND FUEL SYSTEMS

3"–4" INSIDE MICROMETER

MEASURE CYLINDER CROSSWISE TO CYLINDER

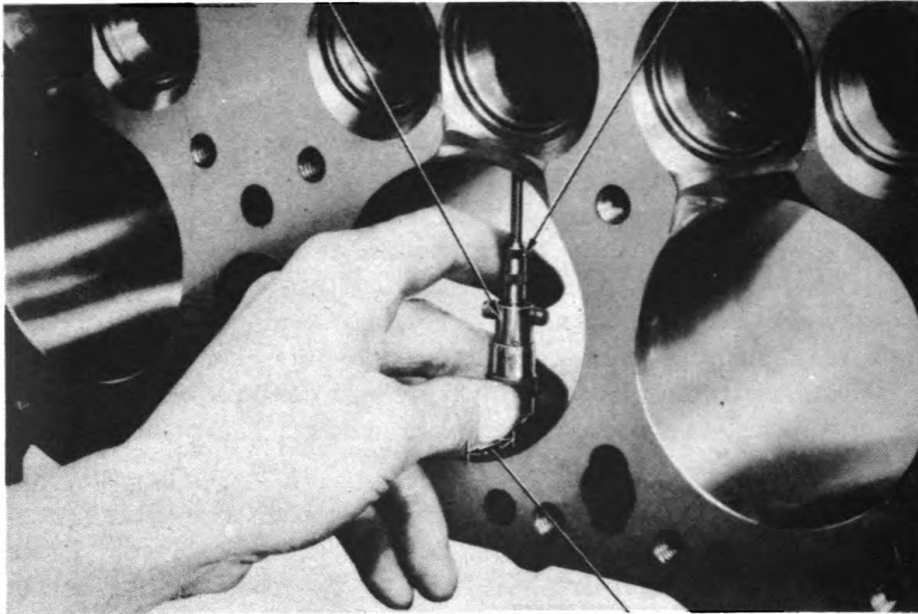

1¼" FROM TOP OF CYLINDER

A—MEASURING CYLINDER BORE

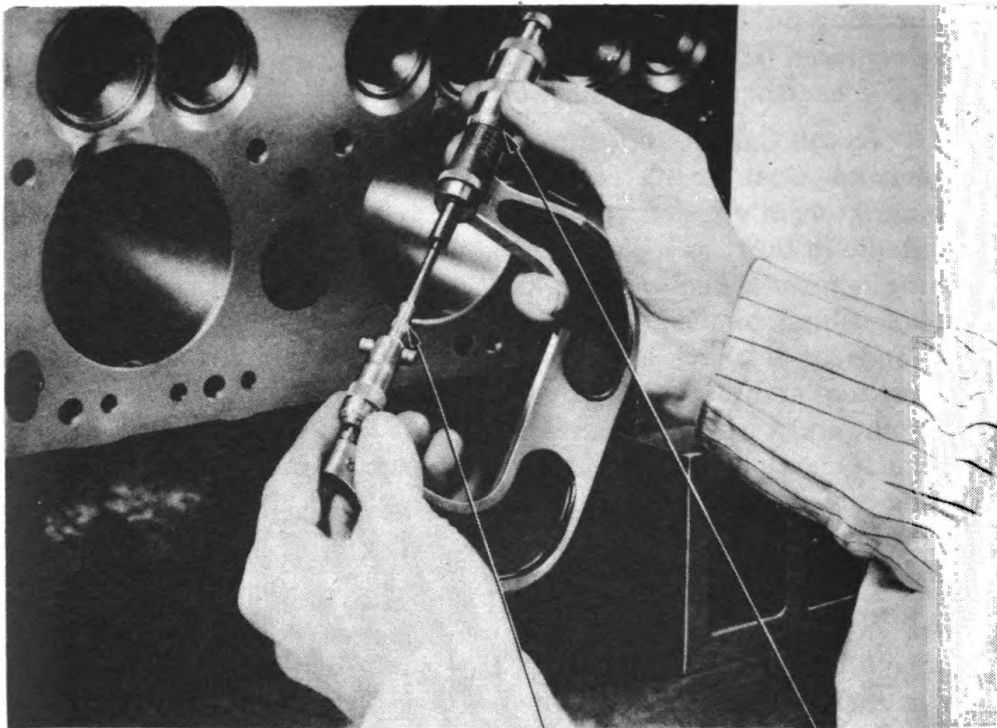

INSIDE MICROMETER — OUTSIDE MICROMETER

B—CHECKING INSIDE MICROMETER

RA PD 344114

Figure 39 — Measuring Cylinder Bores

ENGINE

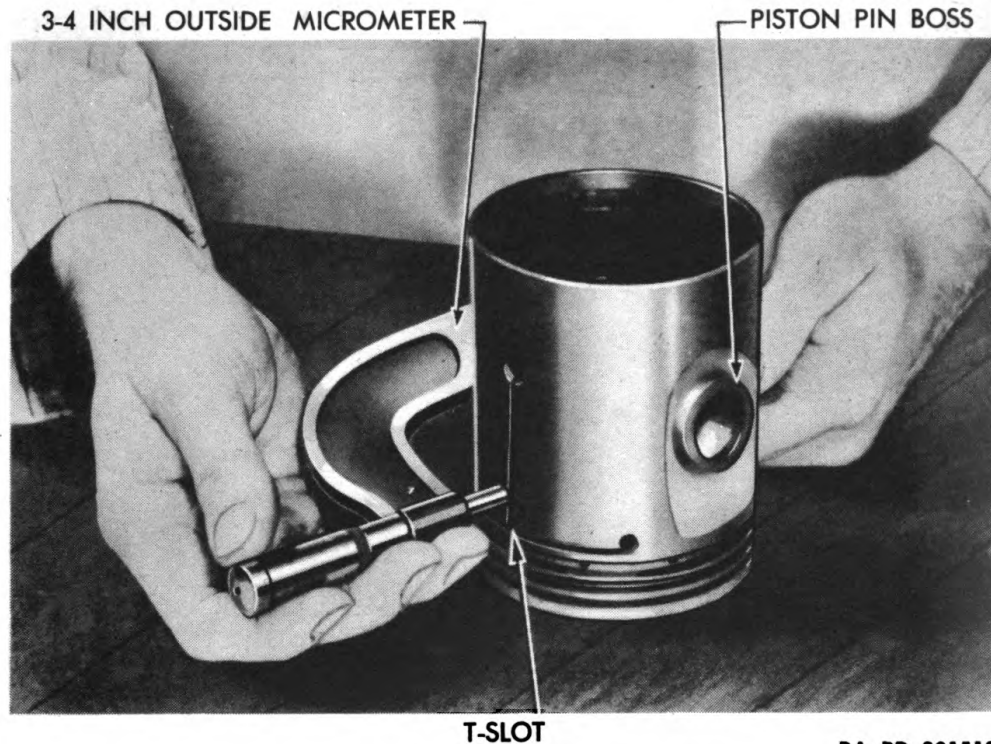

RA PD 331519

Figure 40 — Measuring Piston Diameter

measurements. **NOTE:** *The steps in this procedure are based on the assumption that the cylinder bores and pistons are still serviceable. The procedure will be similar if bores must be re honed and new pistons fitted.*

(b) **Measure Piston Diameter.** After pistons have been cleaned, repaired and found serviceable (par. 8 d), measure piston diameter with outside micrometer placed next to vertical slot and just under cross slot (fig. 40). No measurement of the lower or open end of the piston skirt is necessary.

(c) Compute clearance by subtracting piston measurement from cylinder measurement. Interpret measurement as follows:

0.0033 to 0.0037 inch—ideal condition, new or reconditioned cylinders.

0.0038 to 0.0042 inch—ideal condition after run-in test.

0.006 inch—medium condition, fit for further use, but new piston rings must be installed.

0.009 inch—worn condition, reboring and refitting required.

(4) **CYLINDER BORE RECONDITIONING.** If cylinder bores are not in satisfactory condition, or cannot be fitted with available pistons,

ORDNANCE MAINTENANCE — LIGHT TANKS M5, M5A1, AND M24, 75-MM HOWITZER MOTOR CARRIAGE M8, AND TWIN 40-MM GUN MOTOR CARRIAGE M19: ENGINES, COOLING SYSTEMS AND FUEL SYSTEMS

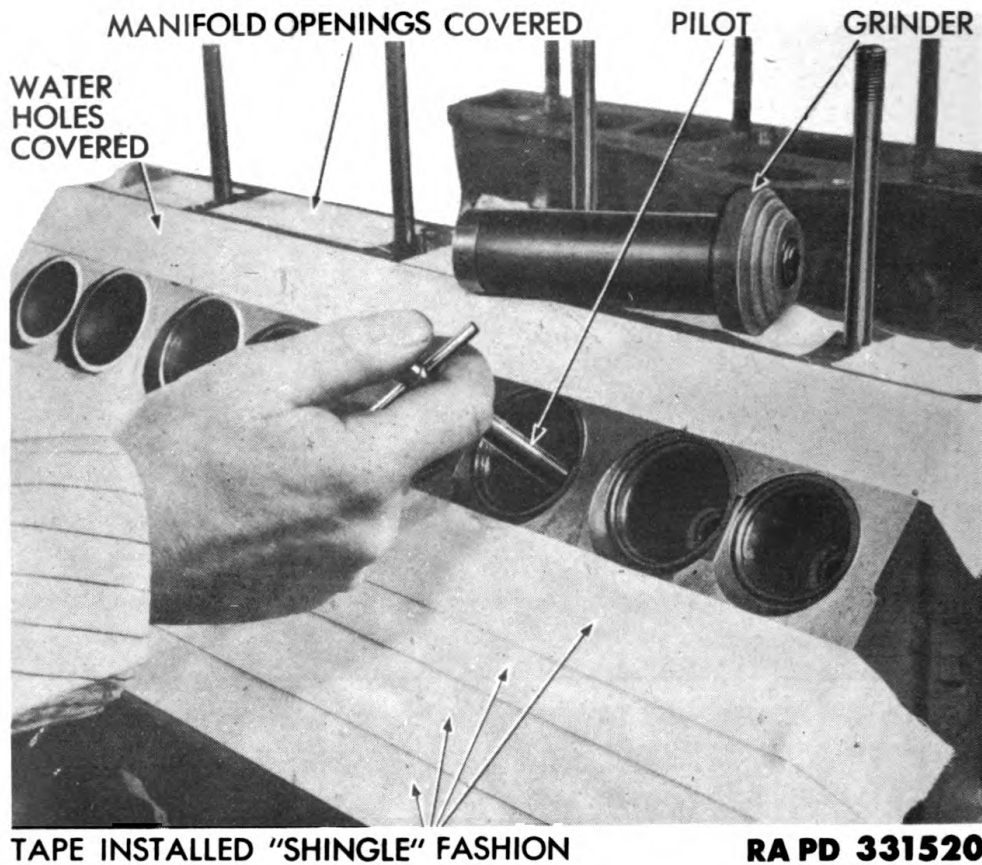

Figure 41 — Inserting Grinder Pilot

re boring and re honing will be necessary. Detailed procedures depend upon the available equipment, but the following precautions should be observed:

(a) No attempt should be made to hone 0.020 inch out of a cylinder. The job should be re bored to within 0.001 to 0.003 inch of finished size depending upon the kind of surface the boring bar leaves, honed within 0.0005 with the 150 stones and the 350 stones used only for smoothing up the surface after the rough stones.

(b) Use stones of 350 to 400 grit if only a few ten thousandths are to be removed. Use 150 grit stones for roughing, if considerable stock must be taken off. Bores must be round and straight within 0.0007 inch over the total length, and free from chatter and dug-in spots. The best finish shows very fine hone marks with a dull appearance.

(c) The effect of heat during honing on the finished job can be minimized by using a steady, small stream of filtered kerosene or

ENGINE

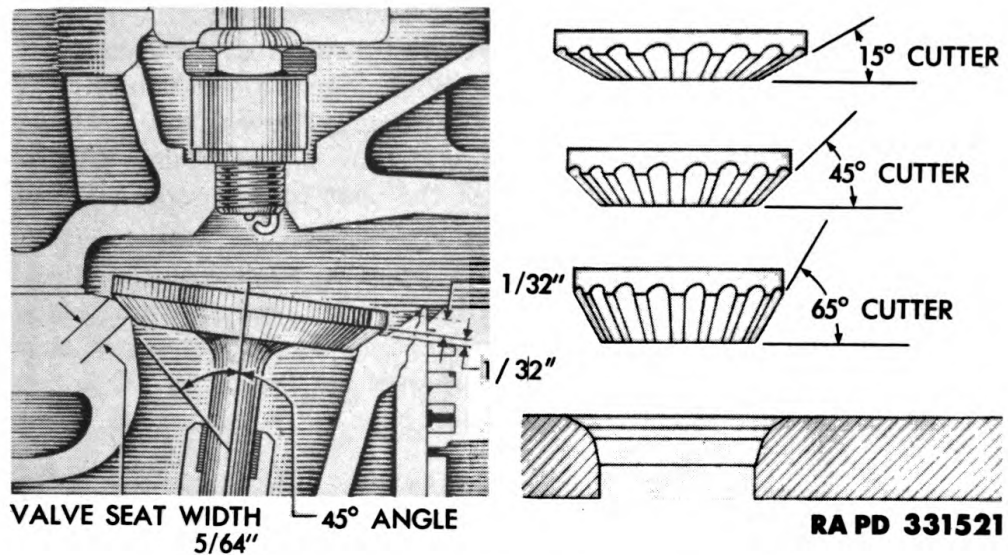

Figure 42 – Valve Seat Angles and Width

Diesel fuel on the hone. Dry honing is not recommended. Driving the hone at a speed of 150 revolutions per minute or less will keep the heat down.

(d) The greatest wear in the cylinder is parallel with the crank shaft and at the upper end of the ring travel, which is the last point in the cylinders to clean up. If these spots are not more than 1/2 inch wide when the cylinders are finished for the 0.020-inch oversize, allow them to remain, as they will have very little effect on ring life or performance.

(5) VALVE AND VALVE SEAT RECONDITIONING. Detailed procedures for grinding valves and valve seats are not given because they vary with the equipment available. The following precautions apply, however, with any type of equipment:

(a) *Cover Engine Openings.* Keep all engine openings covered to keep grinding compound or small parts from entering. Shellacked cardboard can be used over valve compartments and manifold openings. Scotch tape can be laid in "shingle" fashion (fig. 41) over the cylinder bores.

(b) *Valve Stem Clearance.* Check clearance between valve stems and guides before grinding valve seats. The valve guides may wear unevenly and permit an off-center position of the grinder pilot. Select a pilot which can be installed in the guide easily (fig. 41) as a pilot inserted by force will tend to follow any irregularities in the valve guide, and may give inaccurate results. **NOTE:** *The pilot and*

ORDNANCE MAINTENANCE — LIGHT TANKS M5, M5A1, AND M24, 75-MM HOWITZER MOTOR CARRIAGE M8, AND TWIN 40-MM GUN MOTOR CARRIAGE M19: ENGINES, COOLING SYSTEMS AND FUEL SYSTEMS

grinder shown in figure 41 are part of valve reseating outfit (40-V-535).

(c) *Valve Seat Specifications.* Valve seats must be concentric within 0.002-inch total indicator reading. This is very important to assure a good seal and quiet valve seating. The valve seats must be at a 45-degree angle, with a seat width of $\frac{5}{64}$ inch, and no less than $\frac{1}{32}$ inch from the outer edge of the seat to the outer edge of the valve head (fig. 42).

(d) *Assembly.* Install idler gear support in engine block. Position idler gear support in rear end of crankcase, and tap into place until shoulder on support contacts crankcase. Install set screw that holds support in position. Install plug over set screw on 1G series engine, or engine oil pressure signal unit over set screw on 3G series engines.

8. PISTON AND CONNECTING ROD ASSEMBLIES.

a. Description.

(1) **PISTONS.** The pistons are aluminum alloy castings, completely machined on outside surfaces, and anodized after machining to provide a hard aluminum oxide wearing surface. The piston skirts are slightly elliptical, are tapered slightly outward at the bottom, and have a T-slot on one side and a straight horizontal slot on the other. These features offset tendencies toward uneven expansion, so that the piston closely conforms to the cylinder walls when heated to operating temperature. The piston pins are made of alloy-steel carefully ground to size. They float in the connecting rod bushing and in bosses in the pistons, being held in place by snap rings. Three piston rings are used, located above the piston pin. The two upper rings are compression rings to prevent exhaust gases or fuel vapor from seeping down into the crankcase. The third ring is an oil ring which controls the amount of oil that is left on the cylinder walls for lubricating walls and compression rings. The top rings on 3G and later 1G engines are chromium-plated to minimize cylinder and ring wear.

(2) **CONNECTING RODS.** Eight connecting rods of forged steel are mounted on the crankshaft, the rods for the opposite cylinders of the right and left blocks being mounted on the same journal. The rod for the left-hand cylinder is always toward the front of the engine. The lower or large end of each connecting rod is split crosswise at an angle to permit removal of the rod and piston assembly from the top of the engine. The connecting rod cap is held to the rod by a long and a short cap screw. These cap screws and the lock washers used under them are of special alloy steels. Each time a connecting rod is disassembled, new lock washers must be used in reassembling. Split, shell-type, steel-backed babbitt bearings are used in the connecting

ENGINE

rod and cap around the crankshaft journal. These bearings are positioned by tangs on the bearings which fit into grooves in the rod and cap. Upper and lower bearing halves are not interchangeable, because of oilholes in the upper bearing. The upper end of the connecting rod is drilled for the piston pin. The pin is carried in a bronze bushing which is pressed into the rod and machined to exact size after installation.

b. Disassembly.

(1) **REMOVE PISTON FROM ROD.** Remove retaining rings that hold piston pin in piston at each end and push piston pin out of piston and connecting rod. **NOTE:** *It is not necessary to heat piston in order to remove the pin at ordinary room temperatures.*

(2) **REMOVE RINGS.** Using a standard type piston ring expander, remove all piston rings from each piston, taking care not to damage ring.

(3) **REMOVE CAP AND BEARING.** Remove the two screws and lock washers holding the connecting rod bearing cap to the rod and take off the cap and the upper and lower halves of the bearing. **NOTE:** *These caps were installed finger-tight when rods were removed from engine.*

c. Cleaning.

(1) **PISTON.** Immerse piston in dry-cleaning solvent and remove all carbon deposits from piston head ring grooves, etc. If necessary, use a piece of broken piston ring to scrape deposits from ring grooves. Clean any accumulation from piston rings, using cleaning solvent.

(2) **CONNECTING ROD.** Clean rod and bearing cap with solvent and cloth or wire brush, as required.

d. Inspection.

(1) **CONNECTING ROD.** Inspect connecting rod and cap carefully for cracks, fractures or other evidence of damage. Force compressed air through oil passage from journal opening to piston pin bushing to make sure that oil line is not plugged. Inspect piston pin bushing for damage or evidence of excessive wear. If bushing appears satisfactory, check diameter with inside micrometer. If inside diameter exceeds 0.876 inch or if bushing is in poor condition, replace pin with 0.005-inch oversize pin as explained in subparagraph e below.

(2) **PISTON PIN.** Inspect piston pin for nicks, burs, or scratches. Fine scratches can be cleaned up with oilstone, but severe markings make replacement necessary. Check clearance between piston pin and piston, and piston pin and bushing as explained in subparagraph e below.

(3) **PISTON AND RINGS.** Go over piston very carefully, inspecting for any small cracks or nicks which might cause oil leakage or later

ORDNANCE MAINTENANCE — LIGHT TANKS M5, M5A1, AND M24, 75-MM HOWITZER MOTOR CARRIAGE M8, AND TWIN 40-MM GUN MOTOR CARRIAGE M19: ENGINES, COOLING SYSTEMS AND FUEL SYSTEMS

failure. Install piston rings on piston, using the standard ring expander, and measure clearance between each ring and edge of ring groove. The clearance should be interpreted as follows:

Top Groove	2nd Groove	3rd Groove	
0.0022 to 0.0035-in.	0.0022 to 0.0035-in.	0.0013 to 0.0026-in.	Ideal condition, new parts
0.006-in.	0.004-in.	0.003-in.	Medium condition, replace rings
0.012-in.	0.006-in.	0.004-in.	Worn out, replace piston and rings

If pistons and rings are satisfactory, insert each ring in turn in the cylinder in which it was used and measure gap with feeler gage. Gap should not exceed 0.060-inch.

e. Repair.

(1) PISTON PIN FITTING.

(a) Measure Pin Clearance. Measure diameter of piston pin, using a 1-inch micrometer. This diameter for standard size pins should be 0.8742 to 0.8745 inch. Measure inside diameter of piston pin bushing in connecting rod, using a telescope gage and 1-inch micrometer. The clearance between the piston pin and the bushing should be 0.0002 to 0.0008 inch. The clearance between the piston pin and the piston should be 0.00005 to 0.0001 inch or a hand push fit at 72° F.

(b) Fitting Oversized Pin. If clearance between piston pin and connecting rod bushing or piston is excessive, a 0.005-inch oversized pin must be installed after honing the connecting rod bushing and the piston for the oversized pin. Observe the following precautions:

1. Mount hone in a vise and rotate rod or piston slowly by hand—never use power to hone these parts.
2. Use a very fine abrasive on the hone and wash with solvent frequently.
3. Always wash piston or connecting rod thoroughly before attempting to insert oversized pin. **NOTE:** *If bushing in connecting rod is worn excessively, the complete rod assembly must be replaced.*

f. Assembly.

(1) INSTALL PISTON RINGS. Install the three piston rings on the piston, as shown in figure 43, using a standard-type piston ring expander. Be sure to get the rings in the proper grooves: the oil ring in the lower groove, the ferroxed ring (which is darker in color) in the middle groove, and the plain or chrome plated compression ring in

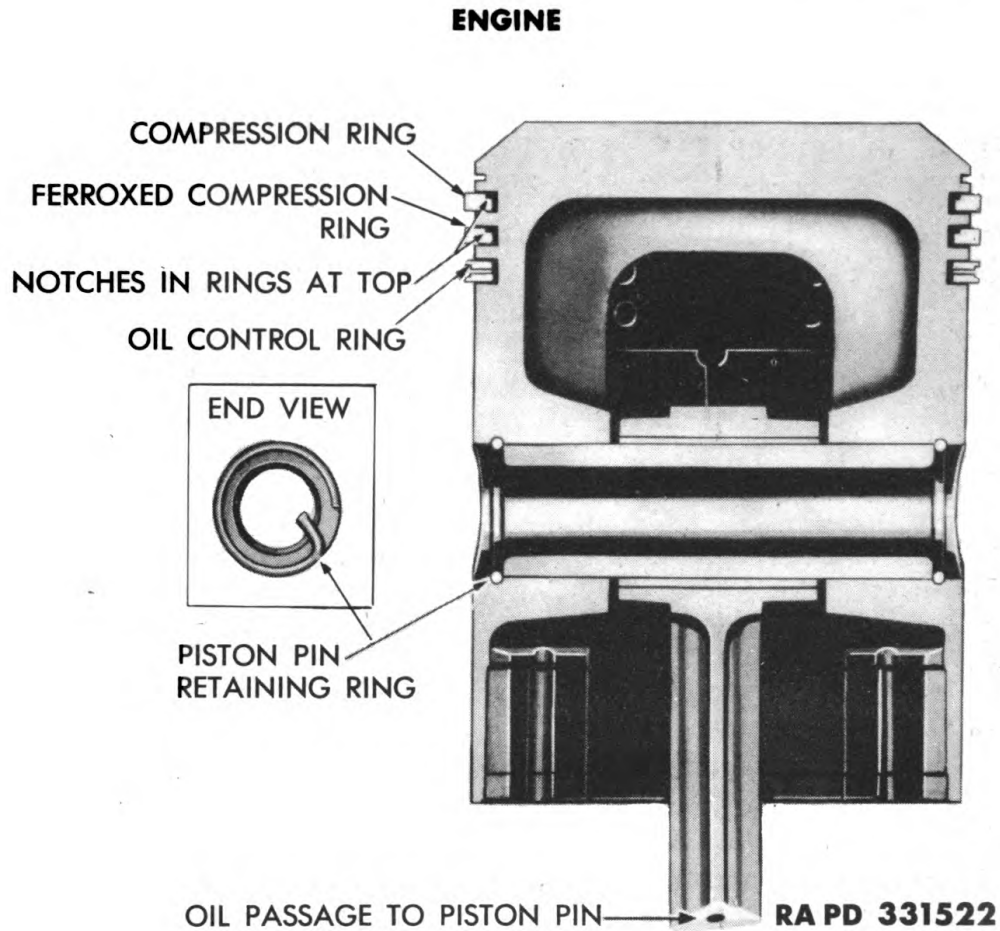

Figure 43 – Piston Cross Section

the upper groove. Make sure that the inner grooves on the compression rings are toward the top of the piston (fig. 43).

(2) **INSTALL PISTON PIN.** Lubricate piston pin with clean engine oil. Position connecting rod in piston so that the T-slot on piston will be toward the left side of engine when installed. Line up piston pin bore in piston with bushing in connecting rod and push pin through piston and rod. Install new retaining rings over each end of piston pin (fig. 43).

(3) **INSTALL BEARINGS.** Install new upper and lower connecting rod bearing halves in rod and rod cap, making sure to put the bearing with the oil holes in the rod and the other bearing in the cap.

g. Connecting Rod Alinement.

(1) **INSTALL ASSEMBLY ON FIXTURE** (fig. 44). The connecting rod can be checked with or without the piston installed. Seat the piston pin on the V-blocks of the aliner (41-A-135). The lower journal of the connecting rod (with cap attached) must be over the swinging arbor of the aliner (fig. 44).

ORDNANCE MAINTENANCE — LIGHT TANKS M5, M5A1, AND M24, 75-MM HOWITZER MOTOR CARRIAGE M8, AND TWIN 40-MM GUN MOTOR CARRIAGE M19: ENGINES, COOLING SYSTEMS AND FUEL SYSTEMS

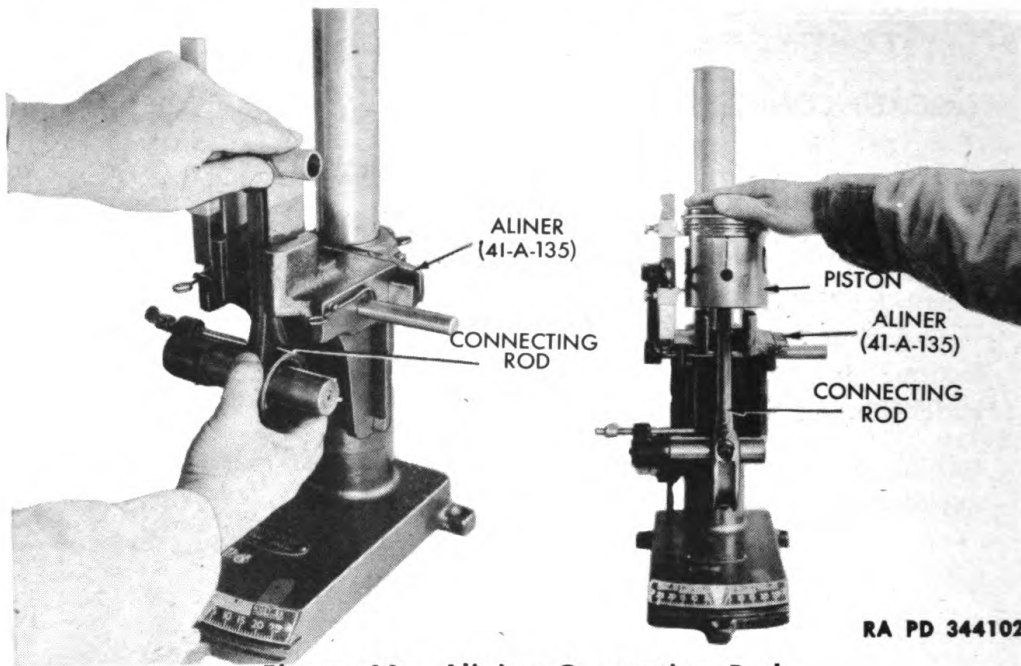

Figure 44 — Alining Connecting Rod

(2) **CHECK ROD ALINEMENT.** Hold connecting rod firmly in place. Move swinging arbor up so that the top blade in the arbor contacts the upper inside surface of the connecting rod journal. The pointer in the base of the aliner will indicate the amount of connecting rod is out of alinement.

(3) **CHECK ROD FOR TWIST.** Hold connecting rod firmly in place. Move swinging arbor so that the rear blade in the arbor contacts the rear inside surface of the connecting rod journal. The pointer in the base of the aliner will indicate the amount of twist.

(4) **STRAIGHTEN ROD.** If connecting rod is bent or twisted, it should be straightened, using a bending tool. A bent rod will hold its shape better if corrected a little further than necessary, and then bend back to correct alinement.

(5) **RECHECK ALINEMENT.** After a connecting rod has been straightened, make a final recheck of alinement before installing in engine.

9. CRANKSHAFT AND FLYWHEEL ASSEMBLY, AND CAM-SHAFT.

a. Description.

(1) **CRANKSHAFT AND FLYWHEEL ASSEMBLY.** The crankshaft is a forged, heat-treated steel shaft (fig. 45) with three main bearing journals and with four crank pin journals, each of which carries two opposing connecting rods. The crank pins and rods are balanced by

ENGINE

six counterweights, four of which are integral with the shaft, while the others (Nos. 2 and 5) are attached with special cap screws, lock washers and locating dowels. A steel flywheel 15 inches in diameter is mounted on the end of the crankshaft with two dowels and six cap screws with locking wires. **NOTE:** *On some early 1G series engines, the flywheel was attached with six studs, nuts and lock washers.* A ring gear is shrunk and welded to the outside diameter of the flywheel to provide a means of cranking the engine.

(2) **CAMSHAFT.** The camshaft is a solid, alloy iron shaft carried in the engine block directly above the crankshaft and mounted on three steel-backed babbitt bushings. Machined on the shaft are the 16 cams, each of which operate an engine valve through a hydraulic valve lifter. The front end of the camshaft carries an eccentric that drives the fuel pump on 1G series engines, but serves merely as a spacer on 3G series engines. A helical gear is machined in the shaft at the rear to drive the distributor and oil pump through a bronze idler gear and a steel helical gear on a vertical shaft.

b. Disassembly.

(1) **REMOVE FLYWHEEL FROM CRANKSHAFT.** Remove lock wires from screws, take out screws and take flywheel off dowels. Remove gasket. On early type 1G series shafts, remove nuts and lock washers from studs to remove flywheel.

c. **Cleaning.** Wash camshaft, crankshaft and flywheel thoroughly in dry-cleaning solvent. Blow out drilled oil passages in crankshaft with compressed air and solvent. There are no drilled passages in camshaft.

d. Inspection and Repair.

(1) **CRANKSHAFT.** Place crankshaft assembly on V-blocks (fig. 45) or on centers, and measure run-out on center main bearing journal, using dial indicator (41-I-100). If run-out exceeds 0.0010 inch, discard shaft. Inspect crankshaft assembly for loose attachment of counterweights. Replace crankshaft assembly if either counterweight has loosened, as even a brief period of operation with loose counterweights makes a shaft unfit for further use. Inspect crankshaft main and crankpin journals for scores or damage. Light scratches can be corrected by polishing with crocus cloth, but heavier scores will require regrinding down to the first undersize (see specifications). Inspect key-slot and threads on front end of shaft for burs or damage, and repair as required. Check diameter of main and crankshaft journals with a micrometer at several places. If journals are worn below 2.4580 inches or are out of round more than 0.0005 inch, regrind for first or second undersize as required.

(2) **CAMSHAFT.** Inspect camshaft carefully for nicks, scores, scratches or evident wear on bearing journals, cams and teeth of

ORDNANCE MAINTENANCE — LIGHT TANKS M5, M5A1, AND M24, 75-MM HOWITZER MOTOR CARRIAGE M8, AND TWIN 40-MM GUN MOTOR CARRIAGE M19: ENGINES, COOLING SYSTEMS AND FUEL SYSTEMS

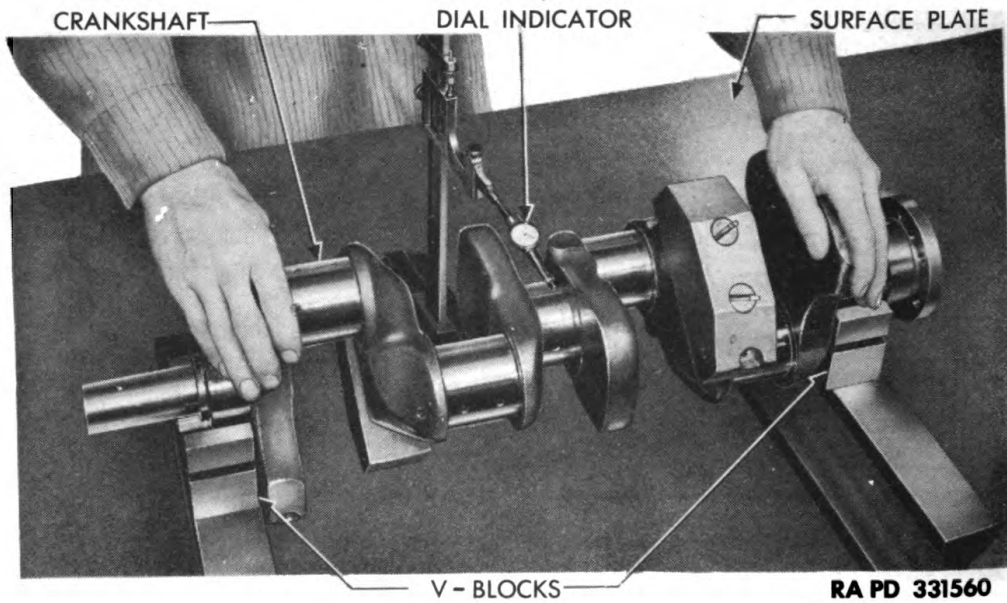

Figure 45 — Checking Crankshaft Alinement

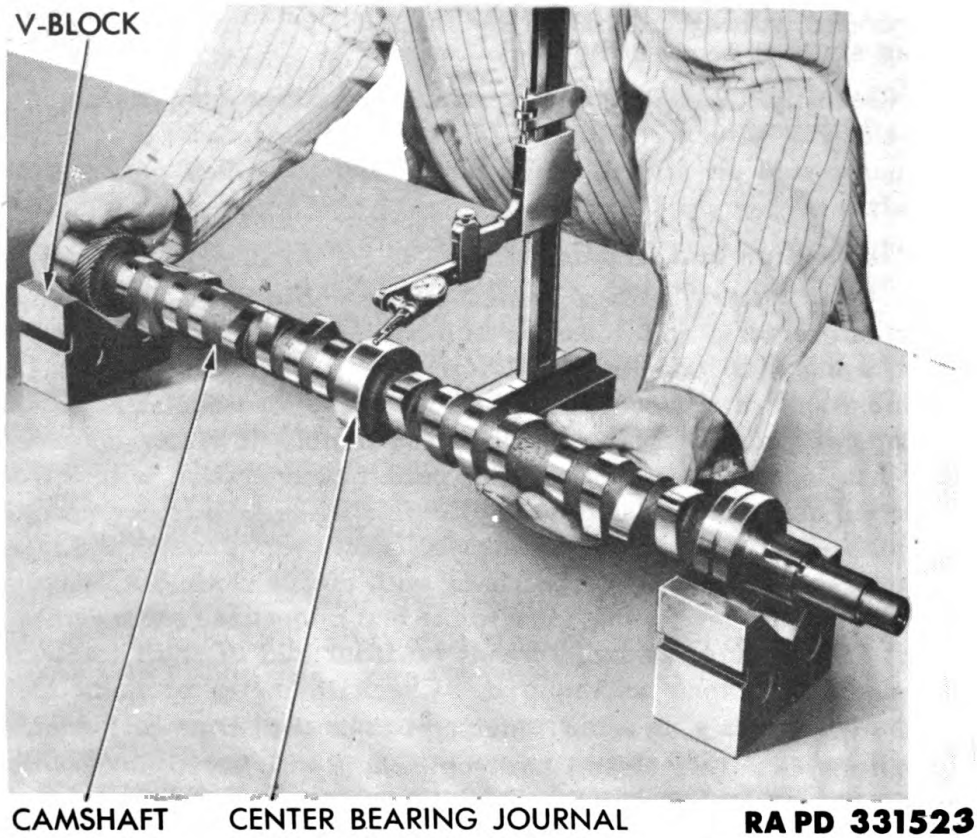

Figure 46 — Checking Camshaft Alinement

ENGINE

integral gear. If any such damage exists, replace camshaft. Place camshaft on V-blocks on front and rear bearing journals, or on centers over a surface plate (fig. 46). Check center bearing journal through 360 degrees and base circle of each cam lobe through 180 degrees. If run-out of more than 0.0025 inch total indicator reading is discovered, camshaft is sprung. Replace camshaft. **CAUTION:** *Camshaft is made of cast iron and must be handled very carefully to avoid springing or other damage.*

(3) **FLYWHEEL.** Inspect flywheel carefully for cracks, fractures or damage to ring gear teeth. If any of these conditions exist, replace the flywheel. Check flywheel cover area for nicks or burs, and remove with crocus cloth or fine stone.

e. Assembly.

(1) **ASSEMBLE FLYWHEEL TO CRANKSHAFT.** If crankshaft is of early type with studs for flying attachment, remove studs from shaft and attach flywheel with cap screws, as used on late type shafts. Place a new gasket on end of shaft, install flywheel, and attach with six cap screws. Tighten screws to from 70 to 75 foot-pounds, and lock screws in pairs with lock wire.

10. TIMING CHAIN, SPROCKETS AND FRONT COVER.

a. **Description.** The camshaft is driven at one-half crankshaft speed by a flexible timing chain, operated on gear-type sprockets on the front end of the crankshaft and camshaft. These sprockets are a hand-push fit on the shaft to which they are keyed. The sprockets are marked to assure correct timing when installed. The timing chain and sprockets are protected by a cast-iron cover which is mounted on the front of the crankcase with two dowels and nine mounting screws, and attached to the oil pan with three mounting screws. On 1G engines the fan support bracket is bolted to the engine front cover while on the 3G engines the engine front cover forms a support to which is attached the generator mounting cradle.

b. Disassembly.

(1) **TIMING CHAIN AND SPROCKETS.** The timing chain is a link-type chain held together by rivets. No attempt should be made to remove these rivets to remove a link and shorten the chain. No disassembly can be performed on the sprockets.

(2) **CRANKCASE FRONT COVER.** Remove crankcase front cover oil seal by driving out the seal with a hammer and brass drift.

c. **Cleaning.** Wash timing chain, sprockets, and crankcase front cover thoroughly in dry-cleaning solvent. Dry with compressed air.

d. Inspection.

(1) **TIMING CHAIN.** Inspect timing chain for wear. Inspect for

loose rivets on timing chain links. If either condition exists, replace chain.

(2) **SPROCKETS.** Inspect teeth on sprocket for wear. Inspect sprockets for wear from chain links. Replace worn sprockets. **NOTE:** *The camshaft sprocket is cast iron, and will wear more rapidly than the crankshaft sprocket, which is steel.*

(3) **CRANKSHAFT FRONT COVER.** Inspect crankcase front cover machined surfaces for nicks and burs which may cause oil leaks. Small burs and nicks can be removed with a fine file. On 1G engines, inspect threads for fan bracket mounting studs; also inspect threads for fuel pump mounting screws.

e. Assembly.

(1) **CRANKCASE FRONT COVER.** Install a new crankcase front cover oil seal by tapping in place with hammer and soft drift. **NOTE:** *Be sure oil seal is pressed into cover until it contacts recess in cover.*

(2) **TIMING CHAIN AND SPROCKETS.** No assembly is necessary.

11. VALVE LIFTERS.

a. Description. Hydraulic valve lifters transmit the lifting action of the cam. The lifters are carried in groups of four in a housing which serves also as an oil reservoir. Oil enters the chamber in the valve lifter body through a small hole, opens the ball check valve in the inner cylinder, and passes into the space in the cylinder below the plunger. The spring lifts the plunger until it contacts the valve stem, thus taking up all clearance between stem and lifter. When rotation of the camshaft brings the cam under the lifter and raises the lifter against the resistance of the valve spring, the plunger is kept from sliding down into the cylinder by the oil in the space below the plunger, which is trapped by closing of the ball check valve.

b. Disassembly.

(1) **REMOVE VALVE LIFTER ASSEMBLIES FROM GUIDE.** Expand lock ring on small end of valve lifter assembly; remove lock ring and push assembly out of lower end of valve guide (fig. 47).

(2) **DISASSEMBLE LIFTER ASSEMBLY.** Pull plunger assembly out of lifter body. Twist plunger clockwise to unlock spring on cylinder, and pull plunger and spring out of cylinder. **NOTE:** *Keep cylinders and plungers in sets as they are disassembled. They are not interchangeable.*

c. Cleaning. Wash all valve lifter parts thoroughly in dry-cleaning solvent.

ENGINE

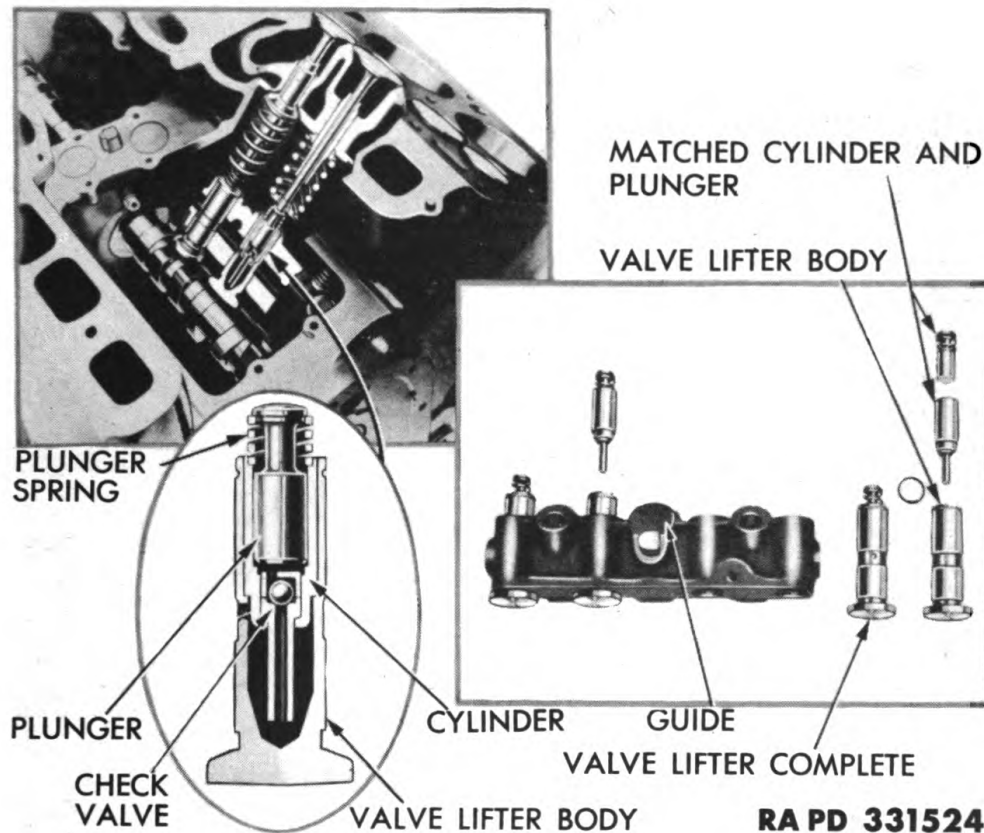

Figure 47 – Valve Lifter Assembly

d. Inspection.

(1) **VISUAL INSPECTION.** Inspect machined surfaces of all valve lifter parts for any nicks or burrs that might cause sticking or oil leakage. Inspect lifter guides for evidence of cracks or warpage. Check tension of valve lifter body lock ring. It should fit snugly in groove of body. Shake cylinder and note whether ball check valve rattles. If ball does not rattle, clean cylinder or replace complete cylinder and plunger assembly. Insert plunger in cylinder and press down quickly. Plunger should bounce back due to air compression. Insert cylinder in body and see that it will slide in and out easily when free of oil. Inspect end of valve lifter body which contacts camshaft for excessive wear. Do not replace body which merely shows signs of rotation on camshaft, as this is a normal condition.

(2) **VALVE LIFTER LEAK-DOWN TEST.** The clearance between the valve lifter plunger and cylinder controls the time required for oil to leak down between plunger and cylinder. The leak-down rate of valve lifter assemblies is tested by comparing the leak-down rate of any lifter against that of a master lifter whose leak-down rate is known

ORDNANCE MAINTENANCE — LIGHT TANKS M5, M5A1, AND M24, 75-MM HOWITZER MOTOR CARRIAGE M8, AND TWIN 40-MM GUN MOTOR CARRIAGE M19: ENGINES, COOLING SYSTEMS AND FUEL SYSTEMS

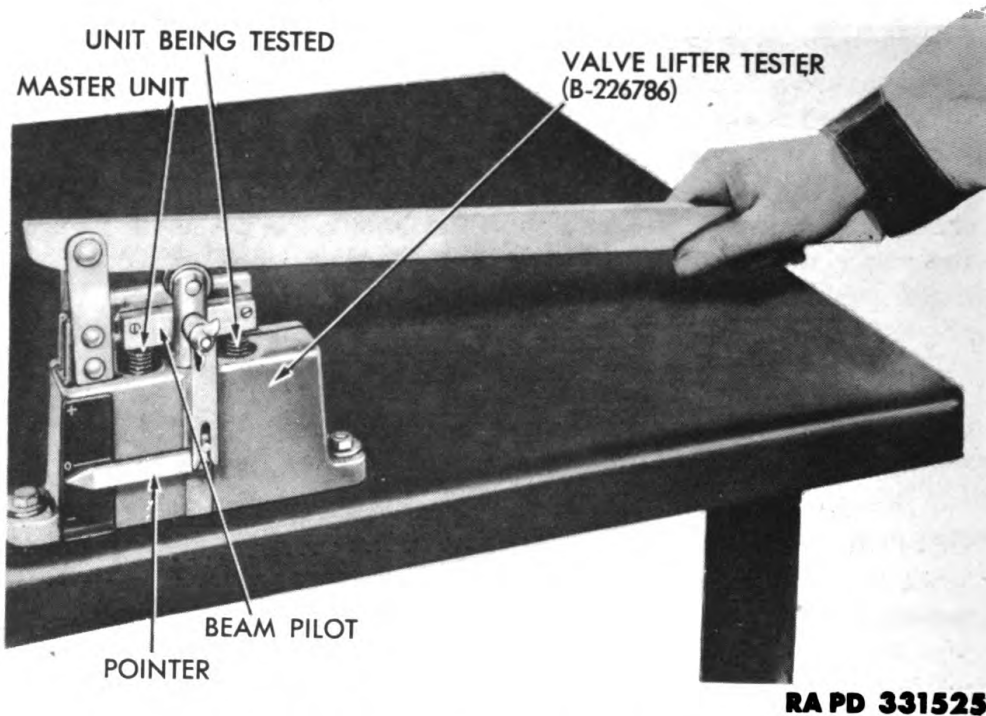

Figure 48 — Testing Valve Lifter Leak-down Rate

to be correct. This test is made by using tester (41-T-1598-35) (fig. 48), as follows:

(a) *Install Master Lifter.* Fill reservoir of tester with dry-cleaning solvent. Insert master hydraulic valve lifter (furnished with tester) on pin in reservoir so that bottom of cylinder is below level of solvent, and pump master valve lifter plunger in cylinder to remove all air and fill cylinder completely with solvent. **NOTE:** *The master hydraulic valve lifter may be identified by the leak-down rate of the lifter which is etched on the outside of the cylinder.* Insert master valve lifter in left socket of tester.

(b) *Install Lifter to Be Tested.* Insert valve lifter to be tested on pin in reservoir so that bottom of cylinder is below level of solvent, and pump plunger up and down to remove air from the cylinder and fill completely with solvent. Insert valve lifter unit to be tested in right socket of tester.

(c) *Test Lifter.* Position tester beam pilot over the top of both hydraulic valve lifters. Swing handle of tester over beam pilot and allow handle to rest on beam pilot. Check indicator pointer of tester to see that end of pointer is at zero mark on scale. If end of pointer is toward plus side or minus side on scale, loosen thumb screw on beam pilot and adjust to zero by hand. Tighten thumb screw.

ENGINE

Press down on tester quickly several times and note movement of pointer.

(d) *Interpret Pointer Movement.* If pointer stays at zero or goes up toward plus side of scale, the leak-down rate of the lifter being tested is equal to or less than that of the master lifter and the lifter is satisfactory for use. If pointer goes down toward the minus side of scale, the leak-down rate of lifter being tested is greater than that of the master lifter and the lifter should be discarded. Repeat the above steps four or five times to make sure that an accurate test reading is obtained.

e. Assembly.

(1) **ASSEMBLE PLUNGER AND CYLINDER.** Push plunger and spring into cylinder, and lock in place by rotating plunger spring clockwise so that it engages in cylinder.

(2) **INSTALL PLUNGER AND CYLINDER IN LIFTER BODY.** Fill valve lifter body with clean engine oil and push plunger and cylinder assembly into lifter body, allowing excess oil in body to leak out between body and cylinder. **NOTE:** *Do not depress valve lifter plunger after oil has been added to lifter body, because this will pump oil into valve lifter cylinder and prevent installation of valve lifter in engine.*

(3) **INSTALL LIFTER IN GUIDE.** Push valve lifter assembly into valve lifter guide and lock in place with lock ring. Place valve lifter assembly in a clean container or wrap in dustproof paper until ready for installation in engine. Dirt or dust must not collect on these parts.

12. DISTRIBUTOR SUPPORT ASSEMBLY.

a. **Description.** The distributor is supported on a vertical support bolted to the crankcase at the rear of the engine Vee. A vertical shaft extending through the support drives the distributor and tachometer gear at the top and the engine oil pump at the bottom. The vertical shaft is driven off the camshaft by a bronze idler gear.

b. Disassembly.

(1) **NOTE:** *First of all, inspect distributor support to determine if disassembly is necessary. Rotate oil pump and distributor drive shaft to see that it operates freely in distributor support. Check for wear between shaft and lower bushing. If clearance between the shaft and the bushings exceed 0.005 inch, complete distributor support assembly should be replaced or the support disassembled and parts replaced as necessary.*

(2) **REMOVE DRIVE GEAR AND SHAFT.** File head of pin holding distributor drive gear to oil pump and distributor drive shaft, and

ORDNANCE MAINTENANCE — LIGHT TANKS M5, M5A1, AND M24, 75-MM HOWITZER MOTOR CARRIAGE M8, AND TWIN 40-MM GUN MOTOR CARRIAGE M19: ENGINES, COOLING SYSTEMS AND FUEL SYSTEMS

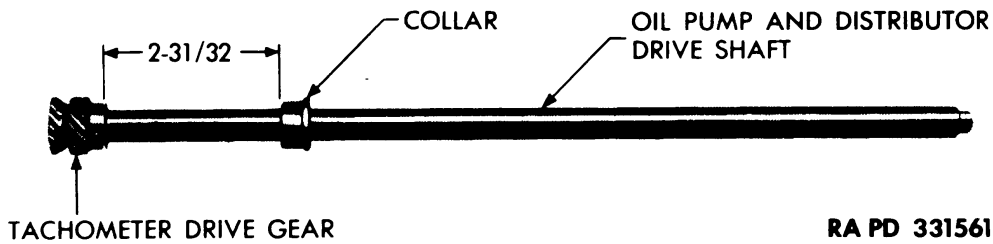

RA PD 331561

Figure 49 — Gear and Collar on Distributor Drive Shaft

drive pin out of shaft. Press shaft up through support to force gear off shaft.

(3) **REMOVE TACHOMETER DRIVEN GEAR AND ADAPTER.** Remove plug over tachometer gear by driving punch into plug and prying out plug. Drive tachometer adapter driven shaft out of tachometer driven gear, using a hammer and drift. Remove adapter and gear.

(4) **REMOVE BUSHINGS.** Drive both bushings out of lower end of distributor support, using a bushing driver.

(5) **REMOVE TACHOMETER DRIVE GEAR.** File head of pin holding tachometer drive gear to oil pump and distributor drive shaft. Drive pin out of gear. Press gear off shaft.

c. **Cleaning.** Wash all parts thoroughly in dry-cleaning solvent. Blow out oil passages at base of distributor support.

d. **Inspection.** Inspect distributor and oil pump drive shaft for scores, scratches or other damage. Scratches can be removed from shaft using a fine file and crocus cloth. Place shaft on V-blocks and check shaft for run-out, using a dial indicator. Run-out of shaft should not exceed 0.005 inch. Straighten shaft if necessary. Inspect teeth on oil pump and distributor drive gear. Inspect teeth on tachometer drive gear. Nicks and burs may be removed, using a fine hone. Inspect distributor support for nicks, cracks, and burs. Nicks and burs may be removed using a fine file. Replace support if cracked. Inspect oil holes in support. See that passages are clear.

e. **Assembly.**

(1) **INSTALL BUSHINGS.** Place new lower bushing over opening in distributor support and press bushing flush with bottom of support. Place upper bushing over bushing installer and slide into housing until pilot on bushing installer passes through lower bushing. Drive in upper bushing until it is flush with boss on inside of housing. **NOTE:** *Bushing must not cover oilhole in support.* Line ream bushings in housing to from .4938 to .4948 inch.

(2) **INSTALL TACHOMETER DRIVE GEAR.** Slide tachometer gear

ENGINE

over top of shaft until distance from bottom of gear to top of collar is $2\frac{3}{32}$ inches (fig. 49). Drill shaft with a $\frac{1}{8}$ -inch drill and install pin. Peen pin with a light hammer, being careful not to damage teeth on gear.

(3) **INSTALL DRIVE SHAFT.** Lubricate distributor drive shaft and slide into distributor support until collar on shaft contacts upper bushing in distributor support.

(4) **INSTALL DRIVE GEAR.** Place drive gear over drive shaft and press gear on shaft until there is 0.0015 to 0.002-inch clearance between gear and lower end of support. Drill hole through shaft, using a $\frac{3}{16}$ -inch drill. Install a new pin through gear and shaft, and peen ends of pin, being careful not to damage teeth on gear.

(5) **INSTALL TACHOMETER DRIVEN GEAR.** Slide tachometer adapter driven shaft into opening in distributor support. Place tachometer driven gear over end of shaft with shoulder on gear toward outside of support. Press gear onto shaft until there is 0.001 to 0.0015-inch clearance between gear and distributor support. Lubricate shaft and gear and install a new tachometer gear plug, tapping plug into body until it is flush with support. **NOTE:** *Coat plug with sealing compound before installing into distributor support.*

13. OIL PUMP, STRAINER, AND LINES.

a. **Description.** A sheet-metal pan is attached to the bottom of the crankcase to serve as an oil reservoir. Baffles to prevent excessive oil splashing are mounted on brackets on the center and rear main bearing caps. The gear-type oil pump is mounted on the bottom of the crankcase at the left of the rear main bearing, and driven by the same vertical shaft that drives the distributor. The oil pressure regulator is built into the pump housing. The pump draws oil from the oil pan through a screened floating intake and forces it through a drilled passage to the main oil header which is drilled lengthwise along the left side of the crankcase (fig. 10).

b. Disassembly.

(1) **REMOVE ADAPTER.** Remove two nuts holding adapter to oil pump. Remove adapter from pump.

(2) **REMOVE STRAINER FLOAT.** Remove cotter pin from hinge connecting oil intake float to oil pump housing (fig. 10). Remove oil strainer float by pulling intake pipe out of hole in oil pump housing.

(3) **REMOVE PRESSURE REGULATOR.** Holding oil pressure regulator spring in place with screwdriver, remove cotter pin from housing using a pair of pliers. Remove regulator spring retainer, regulator spring, and oil pressure valve from inside of housing. These parts fall out after cotter pin has been removed.

ORDNANCE MAINTENANCE — LIGHT TANKS M5, M5A1, AND M24, 75-MM HOWITZER MOTOR CARRIAGE M8, AND TWIN 40-MM GUN MOTOR CARRIAGE M19: ENGINES, COOLING SYSTEMS AND FUEL SYSTEMS

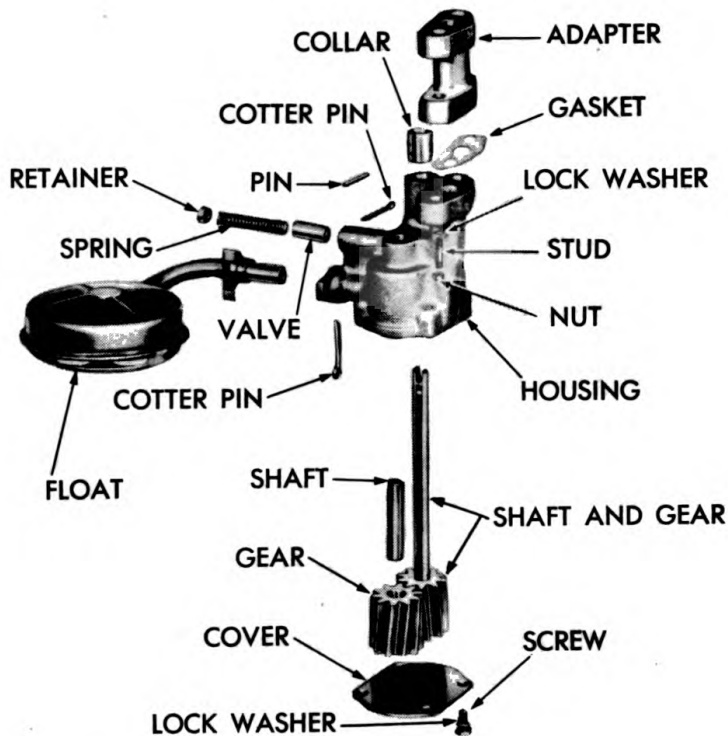

RA PD 331526

Figure 50 — Engine Oil Pump, Disassembled View

(4) REMOVE GEARS AND SHAFTS. Remove pin holding collar on end of oil pump drive gear shaft. Place drive gear shaft in arbor press and press off collar. Remove burrs left when collar is removed. Remove four cap screws and lock washers holding cover to oil pump housing. Remove cover from bottom of housing. Slide driving shaft and integral driving gear out through bottom of pump housing. Slide driven gear off driven gear shaft, removing it from pump housing. Press out driven gear shaft.

c. **Cleaning.** Clean oil pump parts thoroughly in dry-cleaning solvent. Wash oil pan thoroughly and remove old gasket from flange of oil pan.

d. **Inspection.**

(1) **PUMP AND ADAPTER BODY.** Inspect oil pump body and cover at gear contact areas, for small nicks or cracks and burrs. Small burrs may be removed with a fine file. Inspect machined surfaces of oil pump body adapter for nicks and burrs and remove any burrs with a fine file.

(2) **GEARS AND SHAFTS.** Inspect driven gear shaft for nicks or burrs that might cause bearing failure. Inspect oil pump drive shaft

ENGINE

for nicks or burs and for any bends in the shaft. Inspect oil pump gears for wear and any evidence of damage.

(3) **CLEARANCES.** Insert both oil pump gears in oil pump body and check backlash between gears using a feeler gage. This backlash should be from 0.008 to 0.012 inch. Lay a piece of 0.004-inch shim stock above both oil pump gears, and install oil pump cover securely. Check to see whether oil pump drive shaft can be rotated with gears and shims just installed. A 0.004-inch shim should remove all end play in oil pump gears and make them tight in oil pump body so that considerable effort is required to rotate drive shaft. Check clearance between oil pump body and drive shaft using a telescope gage in the oil pump body and a 1-inch micrometer on the drive shaft. The clearance should be from 0.0010 to 0.0025 inch. Check clearance between oil pump body and oil pump gear, using a feeler gage. This clearance should be 0.003 to 0.005 inch.

(4) **OIL PRESSURE REGULATOR.** Measure free length of oil pressure regulator valve spring. This free length should be $2\frac{5}{64}$ inches. Compress oil pressure regulator valve spring to $1\frac{3}{32}$ inches and measure pressure while compressed. The pressure should be from $5\frac{1}{2}$ to $6\frac{1}{4}$ pounds. Measure clearance between oil pressure regulator plunger and oil pump body, using a 1-inch micrometer on the plunger and a telescope gage on the body. This clearance should be 0.002 to 0.0035 inch.

(5) **STRAINER FLOAT.** Inspect strainer on oil float for broken mesh. Shake float, listening for sounds which would indicate presence of oil within the float. Check float for leaks.

e. Assembly.

(1) **INSTALL GEARS AND SHAFTS.** Press driven gear shaft into body $\frac{1}{16}$ inch below face of cover. Install drive shaft and integral drive gear in housing. Place drive shaft in arbor press and press collar on end of shaft so that the holes for pin line up. Drive a new pin into collar through driving shaft. Replace driven gear on driven gear shaft.

(2) **INSTALL COVER.** Install cover on bottom of housing so that machined surface is next to gears. Install four cap screws with lock washers which hold cover to oil pump housing and tighten screws.

(3) **INSTALL OIL PRESSURE REGULATOR.** Position oil pressure valve, oil pressure regulator spring, and regulator spring retainer in housing in order named. Compress spring with screwdriver enough to install cotter pin which holds pressure regulator parts in place, and spread cotter pin.

(4) **INSTALL FLOAT.** Insert float assembly in housing and lock in place with cotter pin.

TM 9-1729A
13-14

ORDNANCE MAINTENANCE — LIGHT TANKS M5, M5A1, AND M24, 75-MM HOWITZER MOTOR CARRIAGE M8, AND TWIN 40-MM GUN MOTOR CARRIAGE M19: ENGINES, COOLING SYSTEMS AND FUEL SYSTEMS

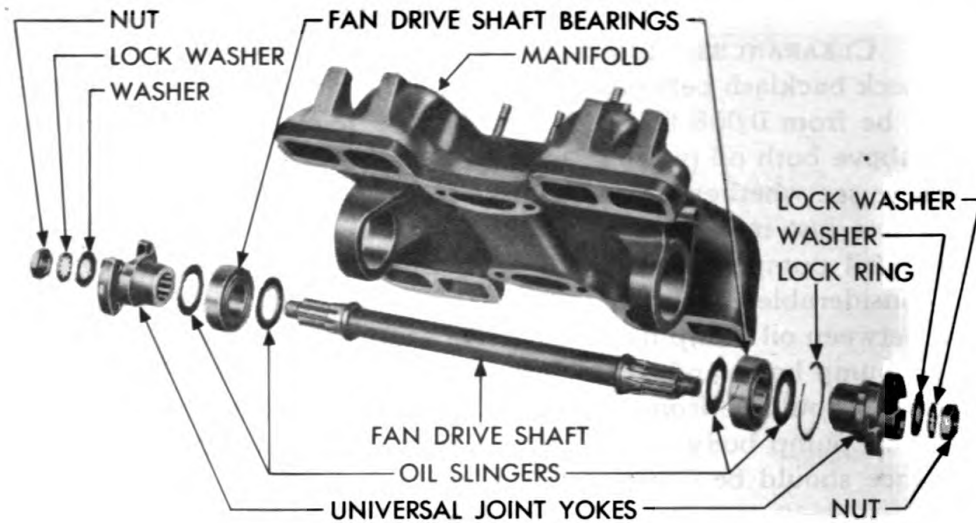

RA PD 331562

Figure 51 — Intake Manifold and Fan Shaft, 3G Series

(5) **INSTALL ADAPTER.** Position oil pump adapter and gasket on pump and install two mounting nuts and lock washers.

14. INTAKE AND EXHAUST MANIFOLDS.

a. Description.

(1) **INTAKE MANIFOLDS.** The intake manifold is in reality two separate manifolds, made up in a single casting. Each manifold delivers the fuel mixture to the two center cylinders on one side and the two end cylinders on the opposite side. On 3G series engines, the fan drive shaft is carried on two sealed bearings in the bottom of the intake manifold casting (fig. 51).

(2) **EXHAUST MANIFOLDS.** Two exhaust manifolds are used, clamped to the top of each bank of cylinders and connected by a cross-over pipe at the rear on 1G engines and at the front on 3G engines. There are three exhaust ports in each cylinder bank, the end cylinders having individual ports while the center cylinders are grouped together in one port, from which a passage leads to the heating chamber of the intake manifold. The outlet to the exhaust pipe and muffler is located at the right front on 1G engines. On 3G engines, the exhaust cross-over pipe can be changed from one side to the other to make a right- or left-hand engine.

b. Disassembly.

(1) **REMOVE FAN SHAFT FROM 3G SERIES INTAKE MANIFOLD.** Remove nuts, internal tooth lock washer and flat washer holding universal yokes to both ends of intake manifold (fig. 51). Slide

ENGINE



Joe Dope is a guy you can't teach-
Here's the way he closes a breach!
When he gets through this chore
On the enemy's shore
They'll spread him all over the beach.

Don't be a dope!

HANDLE EQUIPMENT RIGHT!

ORDNANCE MAINTENANCE — LIGHT TANKS M5, M5A1, AND M24, 75-MM HOWITZER MOTOR CARRIAGE M8, AND TWIN 40-MM GUN MOTOR CARRIAGE M19: ENGINES, COOLING SYSTEMS AND FUEL SYSTEMS

yokes off shaft. Remove slinger from each end of shaft. Remove snap ring holding rear fan shaft bearing in intake manifold. Tap on rear end of shaft with a soft hammer and drive front bearing out of manifold. Remove shaft and bearing. Push rear bearing out of intake manifold and remove inside slingers from shaft.

(2) **NOTE:** *No disassembly is required of the exhaust manifolds or the 1G series intake manifold.*

c. **Cleaning.** Scrape carbon deposit from inside of intake and exhaust manifold. Blow out passages with compressed air. Wash all fan shaft parts, with the exception of the two sealed bearings, in dry-cleaning solvent. These bearings are sealed units and should not be cleaned by washing.

d. **Inspection.**

(1) **MANIFOLDS.** Inspect carburetor mounting studs on intake manifold. Inspect studs on intake manifold for throttle cross shaft mounting bracket. Inspect crossover pipe mounting screw holes in exhaust manifolds. Renew studs or retap threads as required. Inspect manifolds for cracks or fractures and replace if so damaged.

(2) **FAN SHAFT.** Inspect fan drive shaft for cracks, bends or other damage and replace if such conditions are found. Rotate bearings by hand to check for roughness or wear, and replace if necessary.

e. **Assembly.**

(1) **ASSEMBLE FAN SHAFT IN 3G INTAKE MANIFOLD.** Place oil slingers over each end of fan drive shaft. Press front bearing on shaft till it contacts slinger. Slide shaft and front bearing through front end of intake manifold until bearing seats in boss in manifold. Press rear bearing over shaft until bearing is seated on boss in rear of manifold. Install lock ring holding rear bearing in manifold. Place outer oil slinger over shaft and install both universal yokes. Position flat washer, internal tooth lock washer, and nut on both ends of shaft. While holding wrench on one end, tighten opposite end to from 90 to 95 foot-pounds, using a torque wrench.

Section IV

ASSEMBLY OF ENGINE

15. ASSEMBLY PROCEDURE.

a. **Assembly Procedure.**

(1) **CHECK DESIGN OF REAR CRANKSHAFT BEARING.** Inspect new rear crankshaft bearings issued for installation to determine whether they are first or second type (fig. 52). Install second type bearings,

ENGINE

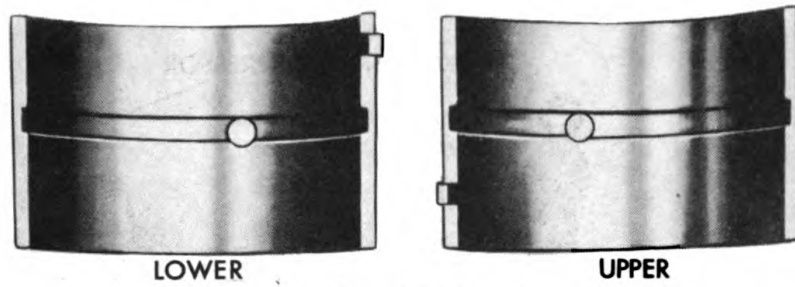

EARLY TYPE BEARING

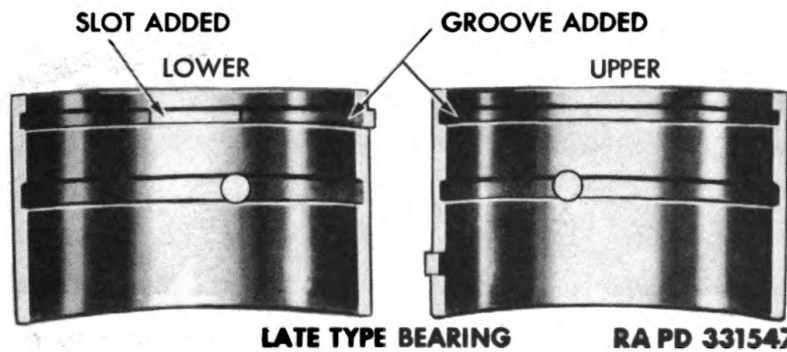

Figure 52 – Rear Crankshaft Bearings

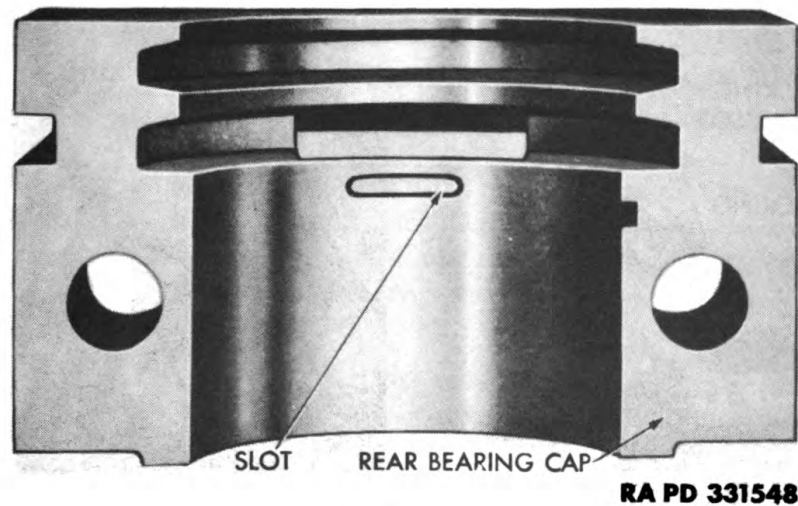
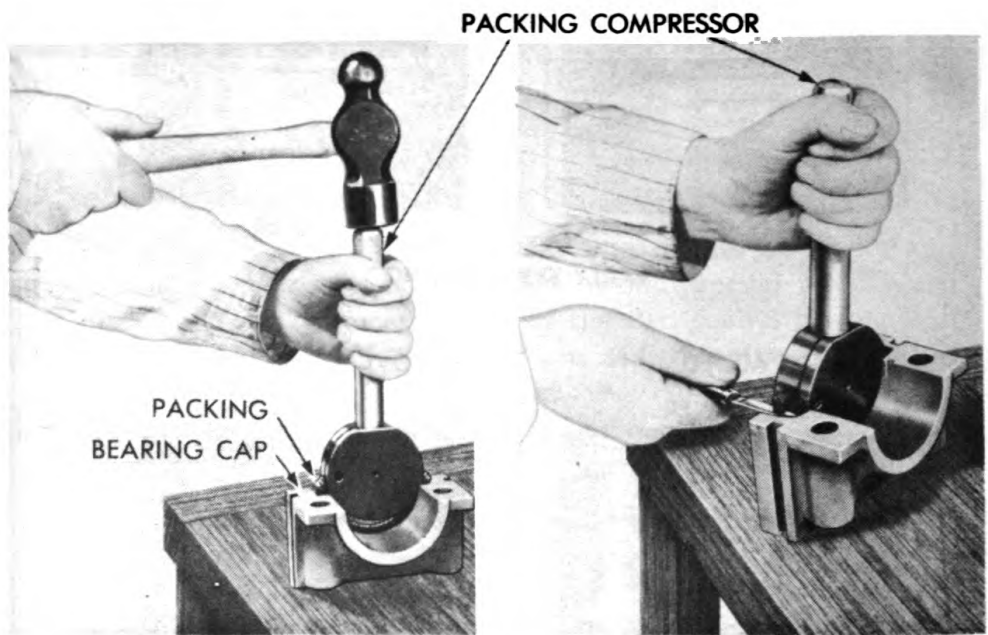

Figure 53 – Slot In Rear Bearing Cap

having the extra groove and oil slot, whenever they are available. First type bearings, which were used as original equipment on many 1G series engines, can be installed in an emergency in either 1G or

ORDNANCE MAINTENANCE — LIGHT TANKS M5, M5A1, AND M24, 75-MM HOWITZER MOTOR CARRIAGE M8, AND TWIN 40-MM GUN MOTOR CARRIAGE M19: ENGINES, COOLING SYSTEMS AND FUEL SYSTEMS



INSTALLING PACKING IN CAP

CUTTING PACKING IN CAP

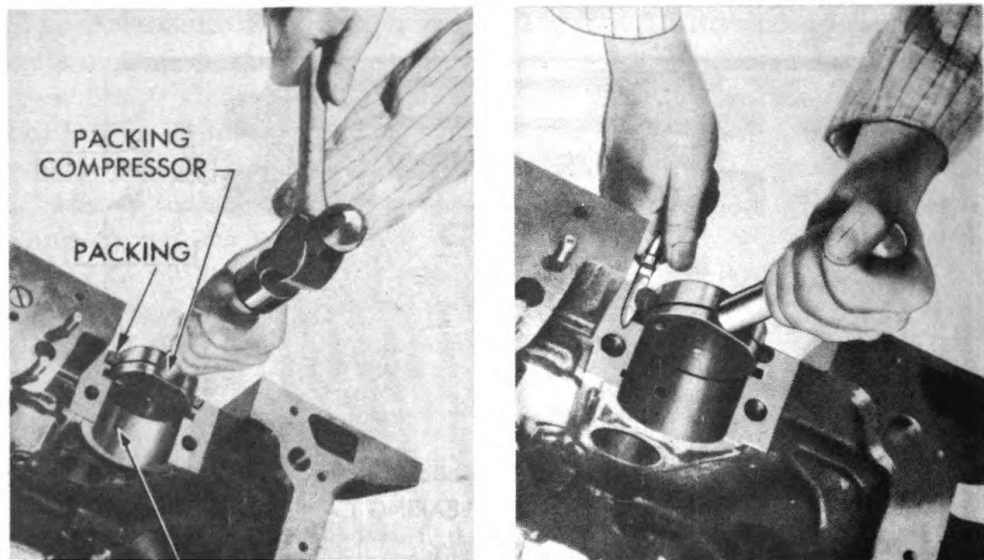

BEARING OPENING IN BLOCK

INSTALLING PACKING IN BLOCK

CUTTING PACKING IN BLOCK

RA PD 331527

Figure 54 — Installing Packing For Rear Crankshaft Bearing

ENGINE

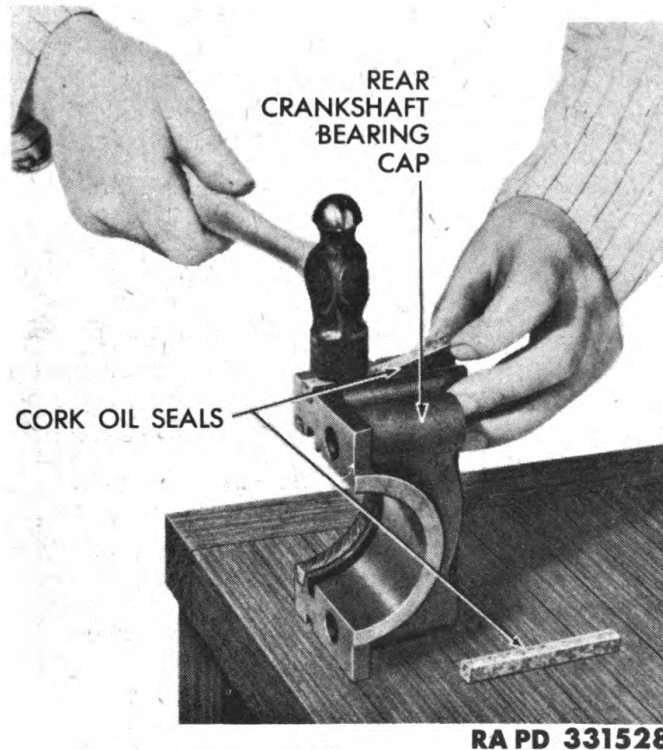

Figure 55 – Installing Oil Seal In Rear Crankshaft Bearing Cap

3G series engines. **CAUTION:** Both the upper and lower bearing must be of the same type.

(2) **DRILL REAR BEARING CAP. (1G SERIES ONLY).** If second type bearings are to be installed in 1G series engines originally fitted with first type, drill a slot in the cap (fig. 53) as follows: Place lower half of new type bearing in cap, and mark outline of slot in oil groove on cap. Remove bearing from cap. Center punch and drill out slot in cap using $\frac{1}{8}$ -inch drill. Clean up slot and remove rough edges with $\frac{1}{8}$ -inch round file. Wash cap in cleaning solvent to remove all metal particles.

(3) **INSTALL BEARING PACKING AND SEAL.** Lay a new rear bearing packing in groove in crankcase opening for rear crankshaft bearing. Position compressor (41-C-2554) on packing and tap carefully into groove in bearing opening. **NOTE:** The compressor (41-C-2554) is no longer an item of issue and is included for information only. Large shoulder on compressor should pilot in crankshaft oil slinger groove in crankcase (fig. 54). Using a sharp knife, cut ends of packing off flush with top of bearing surface (fig. 54). Position new packing in groove in rear crankshaft bearing cap. Tap packing into groove in bearing cap, using a compressor. Large shoulder on compressor

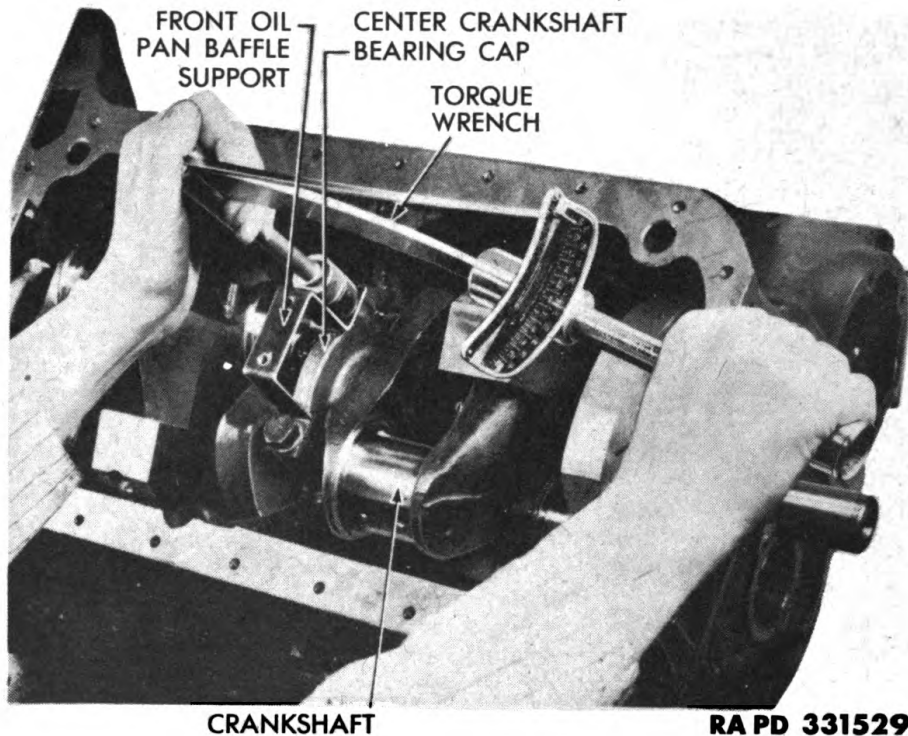

Figure 56 — Tightening Screws For Center Bearing Cap

should pilot in groove in bearing cap (fig. 54). Using sharp knife, cut ends of packing off flush with top of bearing cap (fig. 54). Install two new oil seals in groove in side of bearing cap, using a light hammer (fig. 55). Use gasket paste on seals to facilitate installation. **NOTE:** *Seals should protrude from both ends of caps approximately $\frac{3}{32}$ inch.*

(4) **INSTALL CRANKSHAFT AND FLYWHEEL ASSEMBLY.** With engine block turned upside down in stand, install upper half of rear crankshaft bearing in crankcase, making sure tang on bearing fits in groove in case. Install upper half of center crankshaft bearing and upper half of front crankshaft bearing, making sure in each instance that tang on bearing fits in groove in case. Lubricate bearings with clean engine oil. On 3G series, place sealing plate over crankshaft up against back of flywheel. Lift crankshaft and flywheel assembly and lower into place on upper halves of crankshaft bearings. Rotate crankshaft to see that it turns freely. Slide sealing plate (3G series) over dowels on crankcase.

(5) **INSTALL CRANKSHAFT BEARING CAPS.** Insert lower half of rear crankshaft bearing in rear bearing cap and tap cap into position on crankcase, being careful not to damage oil seals. Position rear oil

ENGINE

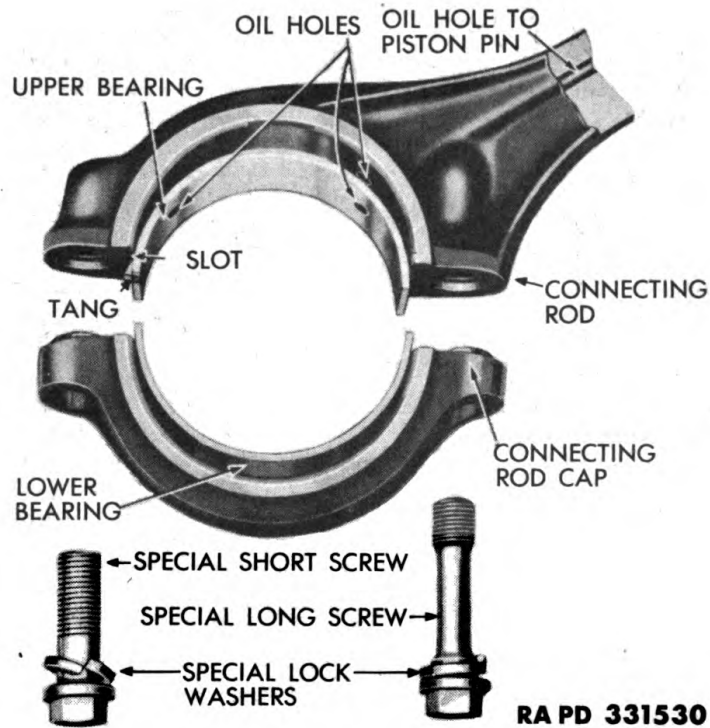

Figure 57 — Connecting Rod Bearings

pan baffle support on rear bearing cap and install rear bearing cap mounting screws and new lock washers finger-tight. Insert lower half of center crankshaft bearing in center bearing cap and tap cap into place on crankcase, using a light hammer. Position front oil pan baffle support on center bearing cap and install two center bearing cap mounting screws and new lock washers finger-tight. Insert lower half of front crankshaft bearing in front bearing cap and tap cap into place in crankcase. Install two front bearing cap mounting screws and new lock washers finger-tight. Tighten all crankshaft bearing cap mounting screws evenly to a torque tightness of 130 to 140 foot-pounds, using torque wrench (41-W-3631) (fig. 56). **NOTE: Crankshaft assembly should turn freely with only a slight amount of drag. Any indication of binding should be checked and corrected.**

(6) **INSTALL TRANSMISSION MAINSHAFT PILOT BEARING.** Tap transmission mainshaft pilot bearing into mounting hole in rear end of crankshaft. Be sure to tap evenly around bearing so that it seats properly. Install retainer wire for bearing in end of crankshaft. Lubricate bearing with clean engine oil.

(7) **INSTALL CONNECTING ROD BEARINGS.** Install lower half of No. 1 connecting rod bearing in No. 1 connecting rod bearing cap.

ORDNANCE MAINTENANCE — LIGHT TANKS M5, M5A1, AND M24, 75-MM HOWITZER MOTOR CARRIAGE M8, AND TWIN 40-MM GUN MOTOR CARRIAGE M19: ENGINES, COOLING SYSTEMS AND FUEL SYSTEMS

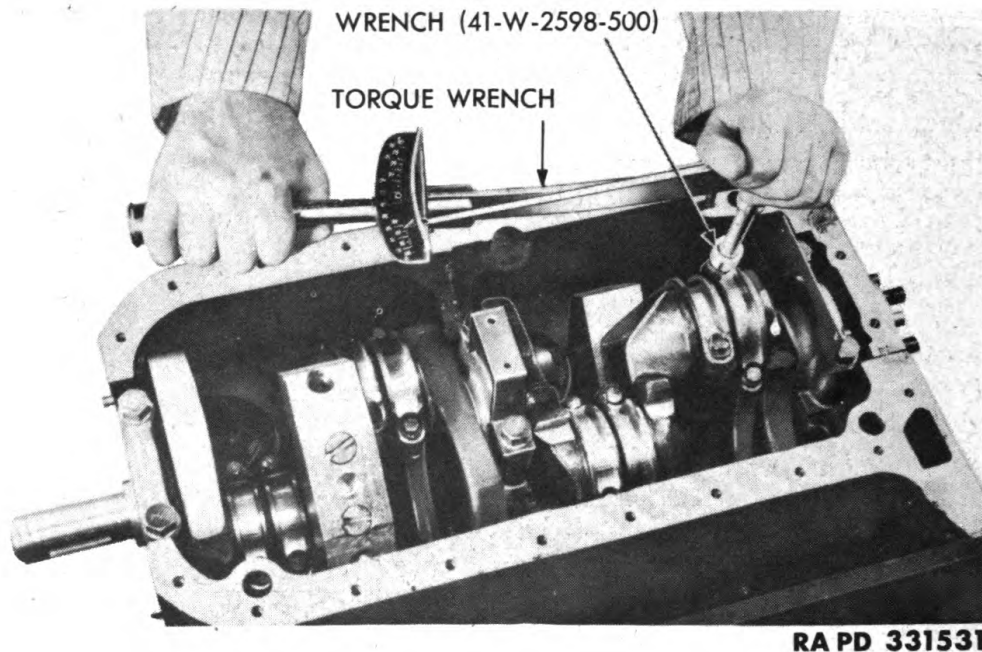

RA PD 331531

Figure 58 — Tightening Connecting Rod Screws

Install upper half of No. 1 connecting rod bearing in No. 1 connecting rod. Repeat these steps for each of the other seven connecting rods and caps. **CAUTION:** *Make sure that connecting rod bearing halves are not interchanged.* The bearing half with oilholes should be installed on the connecting rod, and the bearing half with no oilholes should be installed in the connecting rod cap (fig. 57). Also check to see that tangs on bearings are in grooves in connecting rod and connecting rod bearing cap.

(8) **INSTALL CONNECTING ROD AND PISTON ASSEMBLIES.** Lubricate pistons and piston rings with clean engine oil. Space the piston rings on the piston so that ring caps are about 120 degrees apart. Rotate crankshaft until journal is opposite cylinder opening. Insert connecting rod and piston assembly into cylinder on left-hand cylinder block down as far as piston pin, being careful not to allow lower end of rod to touch cylinder bore. **CAUTION:** *T-slot on piston must be toward the left side of engine.* Compress piston rings, using a standard piston ring compressor, and tap piston down into cylinder block, using a rawhide hammer. Push connecting rod down over top of crankshaft/journal, making certain that bearing in rod remains in place. Install connecting rod bearing cap, making sure that number on cap lines up with the number on rod. Install long and short connecting rod screws and new lock washers finger-tight. Repeat these

ENGINE

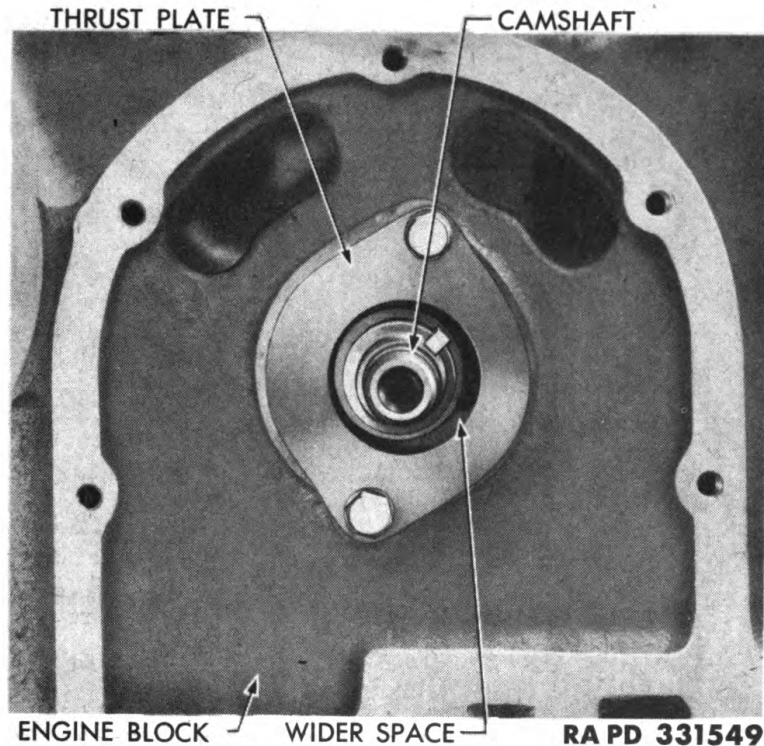

Figure 59 – Camshaft Thrust Plate Installation

steps for the other seven connecting rod and piston assemblies, installing them in respective numerical order. Make sure that numbers on rods and caps are toward bottom of engine and that they correspond to each other and are in proper order. Tighten all connecting rod screws, using the connecting rod socket (41-W-2598-500) and a torque wrench (41-W-3630). Screws should be tightened to a torque tightness of 60 to 65 foot-pounds (fig. 58).

(9) **INSTALL OIL PAN BAFFLE.** Position oil pan baffle on front and rear oil pan baffle mounting brackets. Install two screws holding rear end of oil pan baffle to mounting bracket. Install two screws holding oil pan baffle to front mounting bracket on center main bearing cap. **NOTE:** *Leave oil pump and pan off for later installation.*

(10) **INSTALL CAMSHAFT.** Place camshaft sprocket spacer on front end of camshaft and install camshaft sprocket Woodruff key by driving into place with a light hammer. Lubricate inside of camshaft bushings with clean engine oil and install camshaft from front of crankcase, being careful to see that edges of camshaft lobes do not damage camshaft bushings. Position camshaft thrust plate in place on front end of crankcase. **NOTE:** *Camshaft plate is eccentric with camshaft to permit lubrication of sprocket. Maximum clearance*

ORDNANCE MAINTENANCE — LIGHT TANKS M5, M5A1, AND M24, 75-MM HOWITZER MOTOR CARRIAGE M8, AND TWIN 40-MM GUN MOTOR CARRIAGE M19: ENGINES, COOLING SYSTEMS AND FUEL SYSTEMS

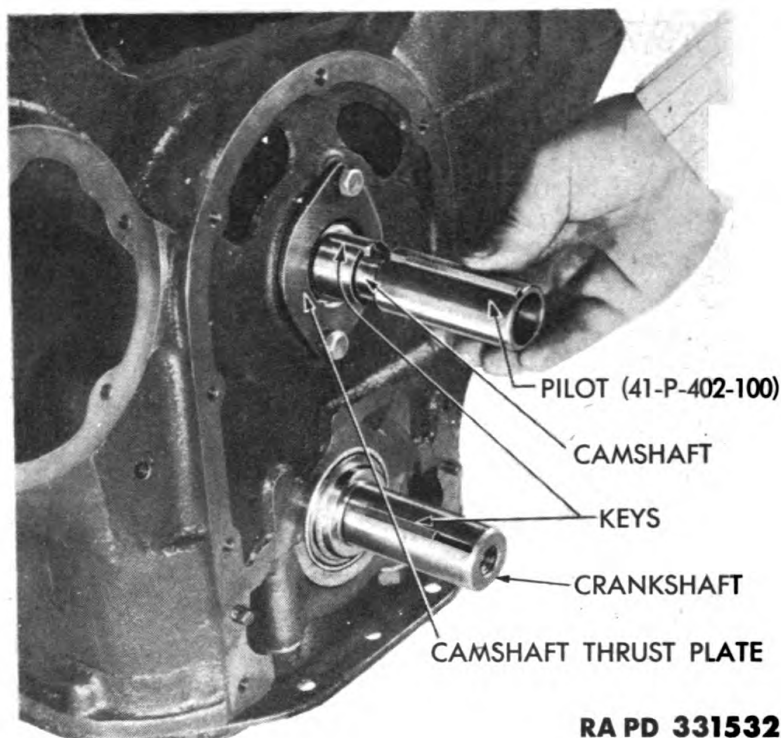

RA PD 331532

Figure 60 — Camshaft Sprocket Pilot

between shaft and plate should be toward left side of engine (fig. 59). Install thrust plate mounting screws and lock washers and tighten to from 15 to 18 foot-pounds.

(11) **INSTALL DISTRIBUTOR AND OIL PUMP IDLER GEAR.** Install bronze idler gear on support so that long shoulder on gear is toward front of crankcase. Install cap screw and large washer holding distributor idler gear on support. **NOTE:** *Be sure pin on large washer fits into hole on support.* Tighten screw to from 15 to 18 foot-pounds.

(12) **INSTALL TIMING CHAIN AND SPROCKETS.** Position camshaft sprocket pilot (41-P-402-100) on front end of camshaft (fig. 60). Place crankshaft timing chain sprocket and camshaft sprocket inside of timing chain with timing marks "O" on both sprockets next to each other. Note position of key slots in crankshaft and camshaft sprockets and rotate crankshaft and camshaft until Woodruff keys on front end of both shafts are in the same relative position as the key slots in sprockets. Grasp crankshaft and camshaft sprockets with both hands, push timing chain and sprockets over front end of crankshaft and camshaft and remove pilot. Lay a straightedge over front ends of crankshaft and camshaft so that it lines up with center of shaft. Check to see that timing marks "O" on sprockets line up (fig. 61).

ENGINE

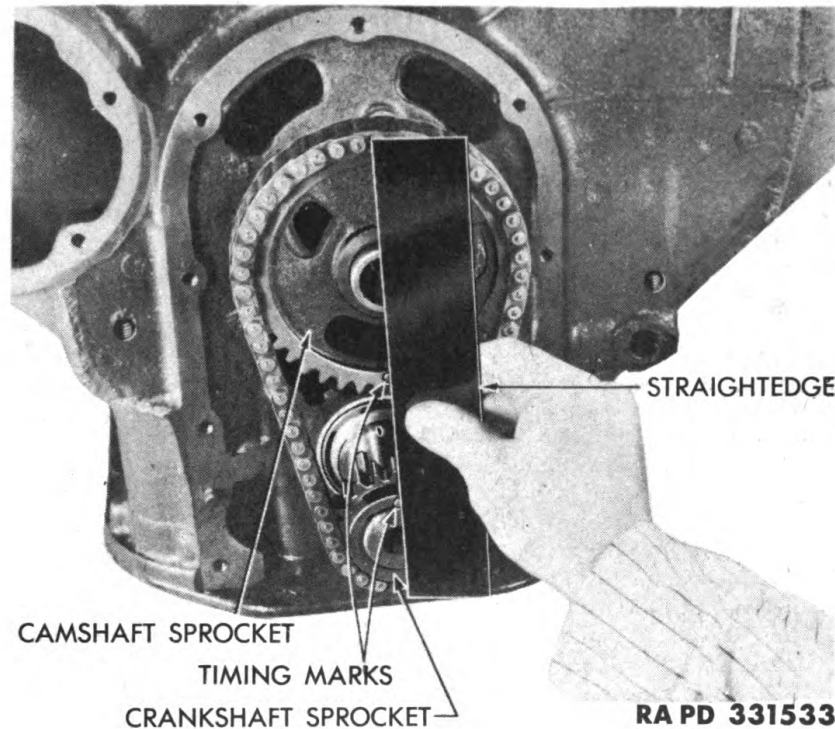

Figure 61 – Checking Timing Marks

Using a soft hammer, tap both sprockets all the way onto crankshaft and camshaft over Woodruff keys until sprockets reach stops on both shafts. **NOTE:** *The pilot (41-P-402-100) is no longer an item of issue, and is included for information only. The operation can be performed without use of the pilot.*

(13) **INSTALL CAMSHAFT ECCENTRIC SPACER.** Position eccentric on front end of camshaft so that Woodruff key in camshaft will enter key slot in eccentric. **NOTE:** *On 1G series this eccentric drives the fuel pump; on 3G series it is used only as spacer.* Tap eccentric on front end of camshaft over Woodruff key until end of eccentric contacts front end of camshaft sprocket. Install a new toothed lock washer and install nut to hold eccentric and sprocket on front end of camshaft (fig. 62). Tighten nut to from 80 to 85 foot-pounds, using a torque wrench.

(14) **INSTALL ENGINE FRONT COVER.** Install a new front cover gasket on front end of crankcase. Tear off bottom cross piece of gasket (fig. 63). This crosspiece is perforated for easy removal. Place oil slinger on front end of crankshaft. Position cover on front end of crankcase. Install nine screws holding cover to crankcase and tighten to from 15 to 18 foot-pounds.

ORDNANCE MAINTENANCE — LIGHT TANKS M5, M5A1, AND M24, 75-MM HOWITZER MOTOR CARRIAGE M8, AND TWIN 40-MM GUN MOTOR CARRIAGE M19: ENGINES, COOLING SYSTEMS AND FUEL SYSTEMS

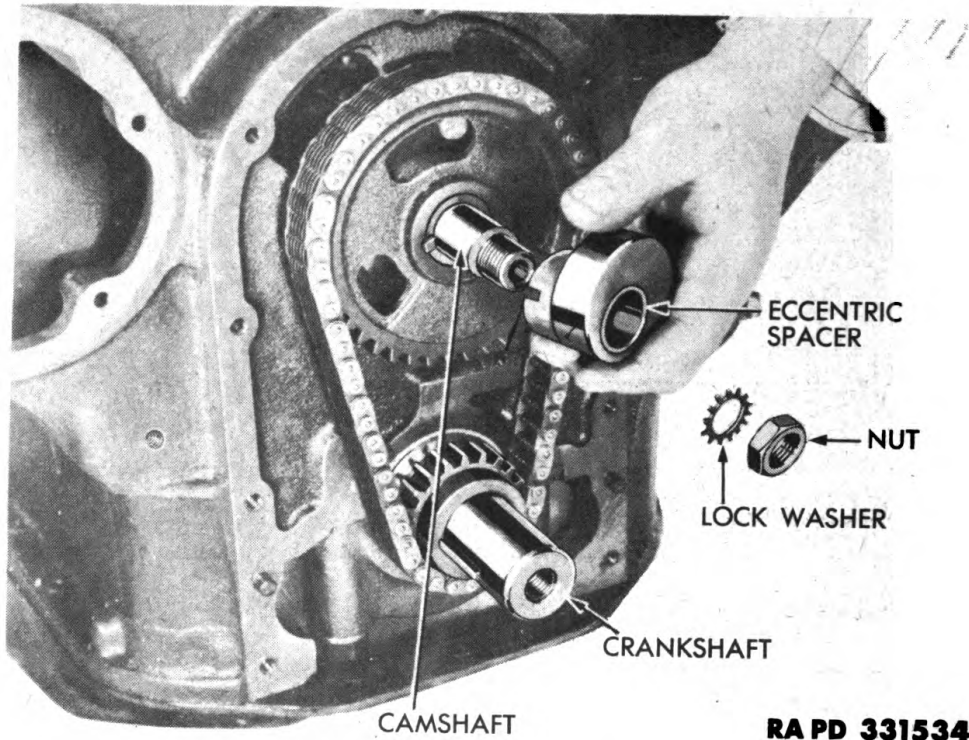

Figure 62 — Installing Eccentric Spacer

(15) **INSTALL DRIVE PULLEY.** Position belt drive pulley on front end of crankshaft so that Woodruff key lines up with slot, and tap pulley into place. Install flat washer, lock washer, and screw holding pulley to front end of crankshaft, and tighten screw to from 95 to 100 foot-pounds.

(16) **INSTALL VALVES.** Position No. 1 cylinder exhaust valve in valve guide and check distance from bottom end of valve stem to heel of lobe on camshaft, using valve stem length gage (41-G-504) (fig. 64). This distance should be a minimum of 3.000 inches. Check gage before using. If tool will not slide freely between lower end of valve stem and heel of cam, end of valve stem should be ground off square until 3.000 to 3.020-inch clearance is obtained. Install valve stem lock installer adapter on valve lifter (41-L-1425). Position two valve stem locks in installer adapter on valve lifter (fig. 65). Place upper valve spring seat, valve spring, and lower valve spring seat (fig. 66) in position in crankcase around valve stem. While supporting valve spring and upper and lower seats in place around valve stem, install valve lifter on valve. Pointed end of valve lifter should be positioned in center hole on valve head, and hollow end of tool should be positioned beneath lower end of valve stem. Line up lower end of valve

ENGINE

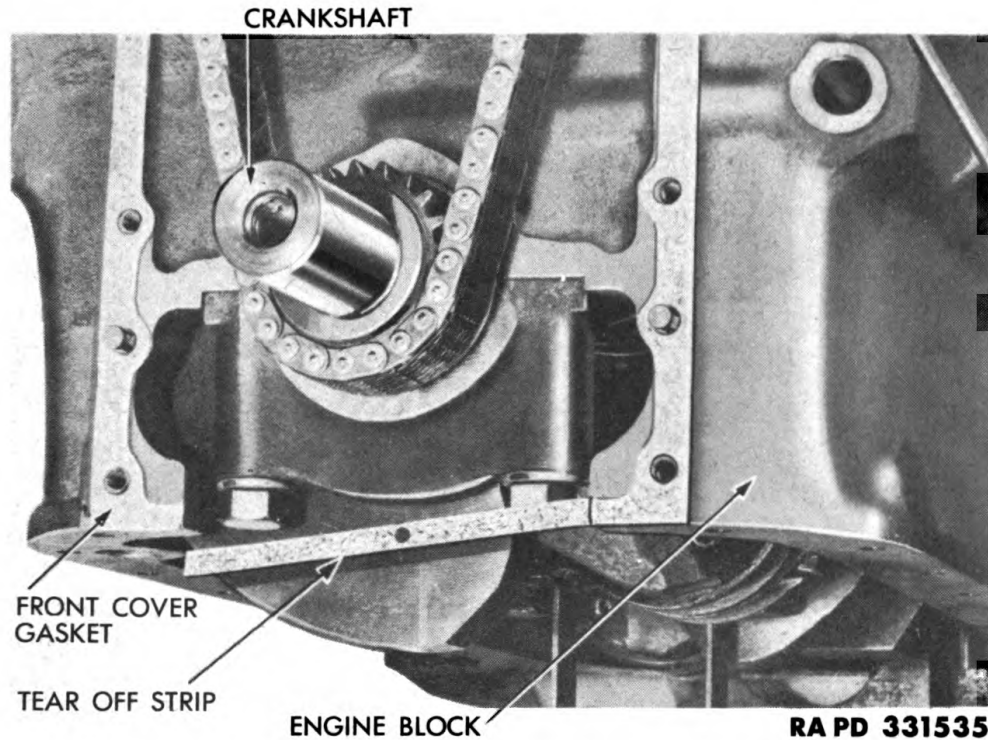

Figure 63 — Front Cover Gasket

lifter so that valve stem is directly over hole in installer adapter, and compress valve spring slowly until valve locks snap into place in grooves in valve stem. Loosen valve replacer by rotating handle until valve spring pressure is released, and remove lifter from valve. Release slowly, making sure valve locks are in proper position. Repeat the above steps for each of the other 15 valves. **CAUTION:** *Keep tool in exact alignment with valve. A click will be heard when valve locks enter grooves in valve stem. Do not compress valve springs further after hearing click.* **NOTE:** *The special valve lifter (41-L-1425) has been superseded by valve lifter (41-L-1408), from third echelon tool-set No. 1. If lifter 41-L-1408 is used, the valve stem locks must be installed by hand.*

(17) **INSTALL VALVE LIFTER GUIDE ASSEMBLIES.** Using a socket wrench on fan pulley mounting screw, rotate crankshaft until cams for intake and exhaust valves on cylinders Nos. 1 and 3 point away from ends of valve stems; that is, so that all four valves will be closed after valve lifters are installed. Place guide assembly over camshaft with plunger ends pointing toward valves. Hold assembly firmly in this position and compress hydraulic plungers with screwdriver enough so that they slide under valve stems (fig. 67). Line up mounting

ORDNANCE MAINTENANCE — LIGHT TANKS M5, M5A1, AND M24, 75-MM HOWITZER MOTOR CARRIAGE M8, AND TWIN 40-MM GUN MOTOR CARRIAGE M19: ENGINES, COOLING SYSTEMS AND FUEL SYSTEMS

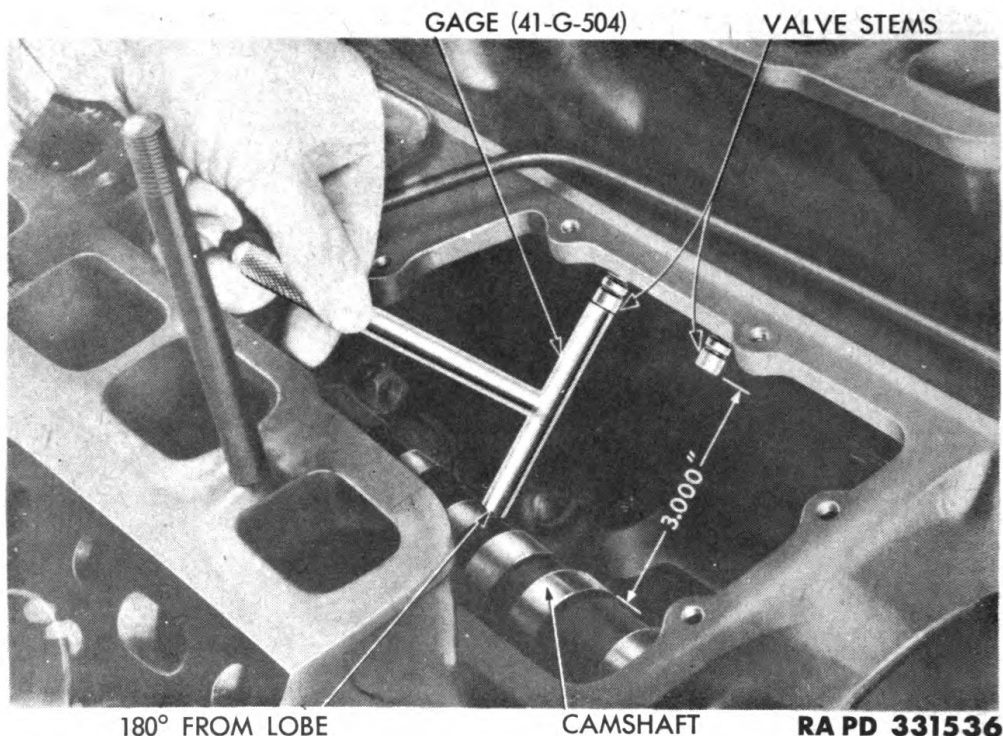
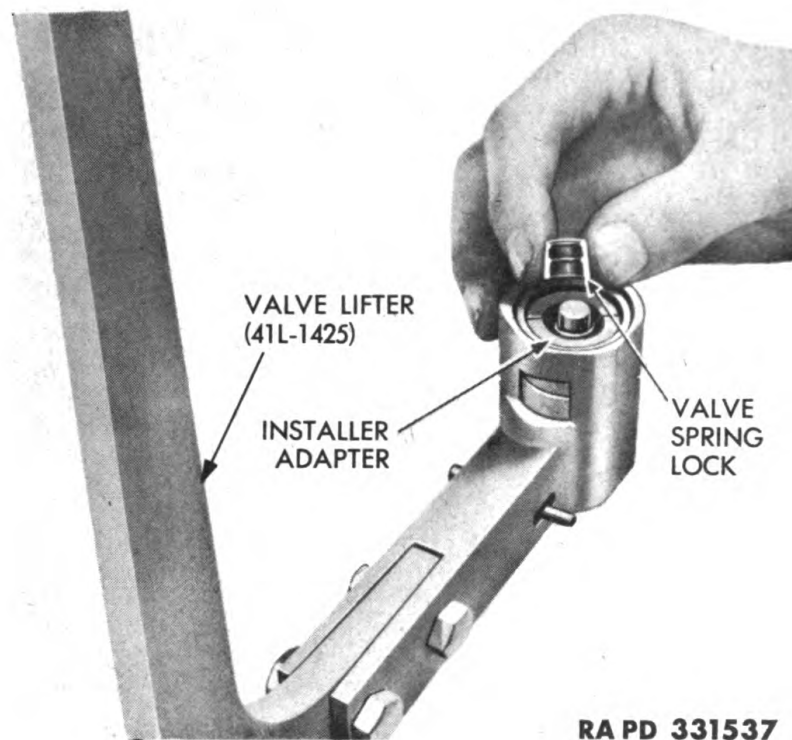

Figure 64 — Checking Valve Stem Length

holes with a drift punch and install lock plate and screws. Tighten screws to from 45 to 50 foot-pounds. Bend up edges of lock plate to keep screws from loosening. Repeat this operation for the other three lifter guide assemblies. **NOTE:** *After installing last lifter guide assembly, rotate crankshaft until No. 1 piston is at top dead center and both valves are closed. Crankshaft must be in this position when distributor support is installed as in step (18) below.* Place the two oil baffles over the lifter guide assemblies and install mounting screws and washers. Tighten screws to from 10 to 12 foot-pounds. Connect the two oil feed lines from lifter guide assemblies to the center bulkhead on crankcase.

(18) **INSTALL DISTRIBUTOR SUPPORT.** Check to make sure that No. 1 piston is on top dead center with both valves closed. Assemble distributor to distributor support, and position it approximately in the center of the timing adjustment range. Hold support just above mounting hole and turn shaft until distributor rotor points toward No. 1 insert in distributor cap. Lower support into place, meshing drive gear with the idler gear (fig. 68). Recheck position of rotor after gears are fully meshed and remesh if incorrect. Install two distributor support housing mounting screws and tighten to from 15

ENGINE



RA PD 331537

Figure 65 – Inserting Valve Stem Locks

to 18 foot-pounds. Remove distributor from support so that it will not interfere with further engine assembly.

(19) **INSTALL VALVE COMPARTMENT COVERS.** Place two new valve compartment cover gaskets on crankcase. Position valve compartment covers over gaskets and install mounting screws and washers. Tighten screw to from 3 to 5 foot-pounds. Install oil feed pipe from center bulkhead to oil header on side of crankcase. Using two new gaskets on valve covers, install crankcase ventilating conduits (1G series) or ventilating tubes (3G series) and install mounting screws. Turn screws up just enough to tighten.

(20) **INSTALL CYLINDER HEADS.** Coat new cylinder head gasket with joint and thread compound, and position on cylinder block. **NOTE:** *Be sure surfaces of block and head are clean and free of carbon or other uneven particles.* Position cylinder head over gasket, being careful not to damage gasket or valves. Install all screws with the exception of the two that hold water outlet elbow. Be sure engine lifting ring (on 3G series) is in proper location on cylinder head (fig. 69). **CAUTION:** *The two screws that hold outlet elbows to cylinder head, have special heads, are longer than the other screws, and must not be used in any other position, or else cylinder block may be*

ORDNANCE MAINTENANCE — LIGHT TANKS M5, M5A1, AND M24, 75-MM HOWITZER MOTOR CARRIAGE M8, AND TWIN 40-MM GUN MOTOR CARRIAGE M19: ENGINES, COOLING SYSTEMS AND FUEL SYSTEMS

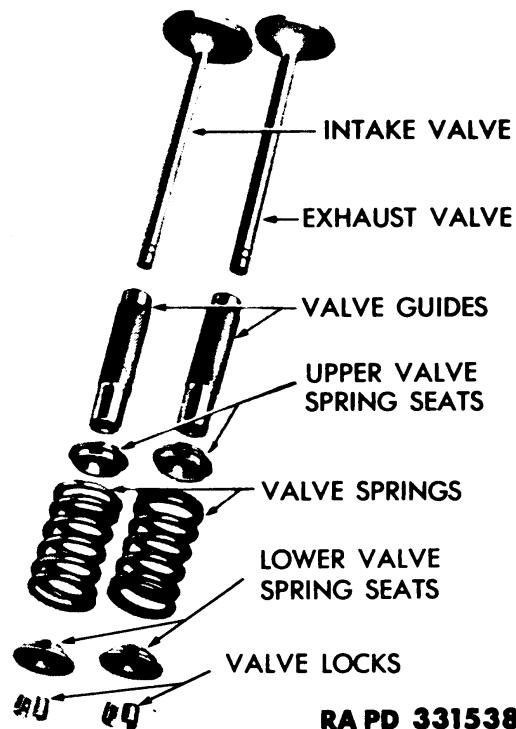

Figure 66 — Valves and Springs

damaged. Coat a new water outlet elbow gasket with joint and thread compound and position on cylinder head. Place outlet elbow over gasket and install the two long cylinder head screws with the special heads. Tighten all cylinder head screws to from 70 to 75 foot-pounds torque. **CAUTION:** *Cylinder head screws must be tightened evenly and in the order shown in figure 69.*

(21) **INSTALL FUEL PUMP (1G SERIES).** Install a new fuel pump gasket on fuel pump mounting boss on engine front cover. Turn engine until eccentric is in downward position. Position fuel pump on engine front cover so that the operating arm extends downward inside front cover and rests on fuel pump eccentric. Install two cap screws holding fuel pump to front cover. Tighten screws to from 15 to 18 foot-pounds.

(22) **INSTALL INTAKE MANIFOLD.** On 3G series engines only, position fan shaft universal joint trunnions and shaft against yoke at rear end of intake manifold. Install four screws holding yoke and trunnions together and bend over lock plates. Position fan shaft trunnions, shaft, and generator drive flange against yoke at front end of intake manifold. Install four screws holding yoke and trunnions together, and bend lock plates over screws. **NOTE:** *Screws should*

ENGINE

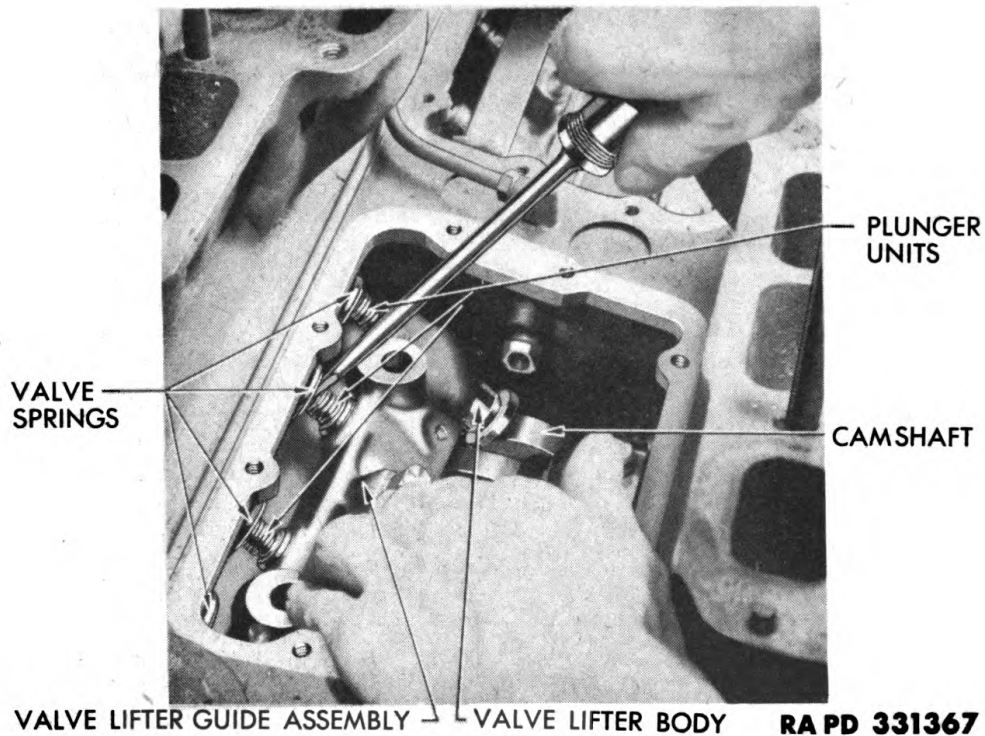

Figure 67 – Installing Valve Lifter Guide Assemblies

be tightened to from 10 to 12 foot-pounds. On all series engines, clean gasket surfaces on crankcase and manifold. Place two new intake and exhaust manifold gaskets on crankcase. Lower intake manifold into position on crankcase. Install four screws holding intake manifold to cylinder block. Using a torque wrench, tighten screws to from 25 to 30 foot-pounds.

(23) **INSTALL EXHAUST MANIFOLDS.** Position both exhaust manifolds on gaskets and install intake and exhaust manifold clamps and clamp nuts. Using a torque wrench, tighten nuts to from 25 to 30 foot-pounds. **NOTE:** *On 3G series, leave the four center nuts off so that the spark plug wire support may be installed later.*

(24) **INSTALL WATER PUMP.** Coat a new water pump gasket with joint and thread compound and position gasket on water pump mounting boss on front end of crankcase. Position water pump on gasket and install five mounting screws and lock washers. Tighten screws to from 15 to 18 foot-pounds. Connect by-pass hose on left cylinder outlet elbow to water pump connection (1G series). Connect pipe from transmission oil cooler to elbow on pump body (1G series only). Connect by-pass hose on right cylinder outlet elbow and water pump inlet tube (3G series). Connect inlet tube to water pump (3G series). Tighten hose clamps securely.

ORDNANCE MAINTENANCE — LIGHT TANKS M5, M5A1, AND M24, 75-MM HOWITZER MOTOR CARRIAGE M8, AND TWIN 40-MM GUN MOTOR CARRIAGE M19: ENGINES, COOLING SYSTEMS AND FUEL SYSTEMS

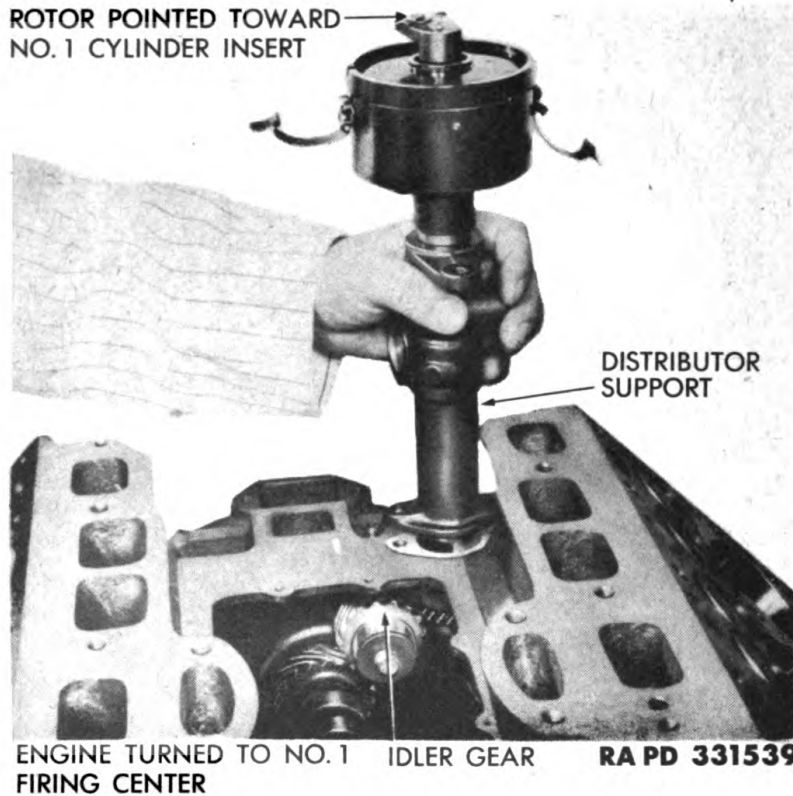

Figure 68 — Installing Distributor Support

(25) **INSTALL MUFFLER AND EXHAUST PIPE (1G SERIES ONLY).** Position muffler and pipe assembly on front of engine, so that studs on crankcase enter holes in support brackets. Install nuts on each of the four support bracket studs and tighten to from 25 to 30 foot-pounds. Place a new gasket between flange on exhaust manifold and muffler inlet pipe and install four screws. Position shield on muffler and install two screws and lock washers. **NOTE:** *Muffler for 3G series engines is not installed until after engine is installed in vehicle.*

(26) **INSTALL ENGINE OIL PRESSURE WARNING SIGNAL UNIT.** Install engine oil pressure warning signal unit in fitting at rear of the engine vee.

(27) **INSTALL OIL PUMP.** Turn engine upside down in engine stand. Place a new gasket over the oil pump mounting studs. Position oil pump and adapter on oil pump mounting studs in crankcase. **NOTE:** *Be careful when installing oil pump to line up slot in drive shaft with tongue on distributor drive shaft.* Install oil pump mounting nuts on studs and tighten to from 25 to 30 foot-pounds.

(28) **INSTALL OIL PAN.** Install a new set of oil pan gaskets on

ENGINE

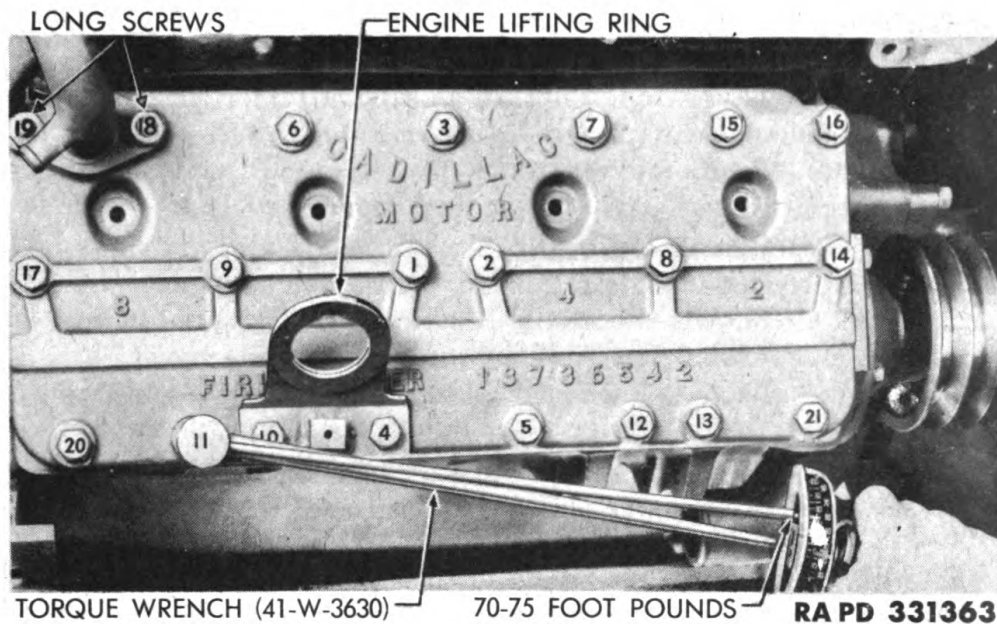

Figure 69 – Tightening Cylinder Head Screws, 3G Series

bottom of crankcase. Position oil pan on gaskets and install screws holding oil pan to crankcase, front cover, and rear main bearing cap. Tighten screws to from 7 to 10 foot-pounds, using a torque wrench. Turn engine right side up in engine overhaul stand.

(29) **MOUNT TRANSMISSION ON ENGINE.** NOTE: *Before installing the transmission on the engine, check the serial number on the upper flywheel housing to be sure it is identical with the serial number on the engine block. The engine block and upper flywheel housing are machined as a unit and must not be separated.* Position a new flywheel cover gasket on flywheel and cement it in place with rubber cement. Nothing but rubber cement should be used on this gasket. Install transmission lifting eye (41-B-1586-300) in threaded hole in top of transmission (fig. 17). Connect hoist to transmission lifting eye and bring transmission into position behind engine. Line up dowel pins on rear end of crankcase with holes in flywheel housing and dowel pins on flywheel with holes on flywheel cover, and slide transmission and housing on dowel pins. Take care not to damage gasket.

(30) **ATTACH TRANSMISSION TO ENGINE.** Install six screws holding flywheel housing to crankcase and tighten to from 45 to 50 foot-pounds, using a torque wrench. Tighten lower bolts first, upper bolts last. Insert a punch through a screw hole in flywheel cover to line up cover holes properly with flywheel holes and dowel pins. Install 4 screws, 90 degrees apart, tighten to 15 foot-pounds, to hold cover in position while installing the other 26 screws. Use a socket wrench

ORDNANCE MAINTENANCE — LIGHT TANKS M5, M5A1, AND M24, 75-MM HOWITZER MOTOR CARRIAGE M8, AND TWIN 40-MM GUN MOTOR CARRIAGE M19: ENGINES, COOLING SYSTEMS AND FUEL SYSTEMS

installed on the fan and generator pulley mounting screw to rotate crankshaft. Tighten all screws holding flywheel cover to flywheel to a torque tightness of from 25 to 30 foot-pounds on 1G series, and 40 to 45 foot-pounds on 3G series. Remove lifting eye from top of transmission case. Position lower flywheel cover over flywheel and install six mounting screws. Tighten screws to from 15 to 18 foot-pounds.

(31) **CONNECT ENGINE AND TRANSMISSION CONNECTIONS.** On 1G series, connect throttle rod from throttle valve lever on transmission to relay on flywheel housing. Connect warning signal switch wire on transmission and push conduit into clip on side cover. On 3G series, connect vacuum line at fitting on intake manifold and elbow on transmission case. On 3G series, slide filler tube into transmission case, install screw and washer, and connect hose clamp on transmission and engine oil filler tubes. Slide filler tube upper mounting bracket on rear manifold stud and install nut. Connect right and left oil cooler lines at transmission oil pan fittings, engine block, and water pump.

(32) **INSTALL ACCESSORIES.** Install the following engine accessories: carburetor, oil filter assembly, generator, distributor, coil, spark plugs and connecting wires, and cranking motor (TM 9-729 for M24 engines, TM 9-757 for M19 engines, TM 9-732 for M5, M5A1, and TM 9-732B for M8).

Section V

TEST AND ADJUSTMENT

16. TESTS AND ADJUSTMENTS ON ENGINE.

a. **Before-test Adjustments.** Before testing engine, the following items must be checked and adjusted according to the procedures in the pertinent TM's, in order to make sure that the engine is operating at peak performance:

- (1) Adjust carburetor.
- (2) Adjust transmission throttle linkage to carburetor (1G series only).
- (3) Set distributor timing, using a synchroscope.

b. **Run-in Schedule.**

(1) **COMPLETE SCHEDULE.** Engines on which new pistons have been installed and cylinder bores reconditioned will be run-in so that they will be ready for any type of use when installed. It may be necessary to momentarily speed up the engine to 2,100 revolutions per minute with no load in order to insure transmission shift to 4th gear before starting dynamometer run. The following test schedule is

ENGINE

based on engine complete—all accessories, including air cleaners, generator, cooling fan, exhaust muffler, hydromatic transmission, water pump, and fuel pump.

Period	Time Minutes	ENGINE R.P.M.	B.H.P. Approx.
1.....	15**	1,000	None
*2.....	15	1,000	5
*3.....	30	1,500	10
4.....	30	2,000	15
5.....	30	2,500	25
*6.....	30	2,800	35
7.....	30	3,000	40
*8.....	30	3,100	45
*9.....	30	3,200	50
10.....	30	3,300	55
*11.....	30	3,400	60
12.....	30	3,500	65
13.....	30	3,600	70
14.....	30	3,700	75
15.....	30	3,800	80
16.....	30	4,000	90
17.....	5	4,000	Full Throttle

Engine to produce a minimum of 110 B.H.P. (corrected to standard conditions) during period 17.

(2) Be sure that the transmission is in fourth gear during all dynamometer checking. Since a fluid coupling is used in the transmission, both engine and transmission speed must be measured and dynamometer speed used in computing brake horsepower. The transmission throttle linkage must be connected and adjusted.

(3) **CONDITIONS OF RUN-IN.** The run-in schedule shall be made under the following conditions and must include the following adjustments:

(a) Water temperature not lower than 160° F, or higher than approximately 170° F.

(b) Crankcase filled with eight quarts of engine oil, SAE 10.

(c) Oil must be changed when the engine has run up to 3500 revolutions per minute, or a total of 5½ hours, and also when the full 8 hour test has been completed. This means that oil is changed once for engines run-in a total of 5½ hours, and twice for engines given the complete run-in. When the engine has been run-in up to

**NOTE: Periods 2, 3, 6, 8, 9, and 11 can be eliminated during test run provided engine has been equipped during overhaul with chromium-plated upper compression ring. This ring carries the same part number as the old type unplated ring and can only be identified by visual inspection. A chrome-plated ring will have chromium on the cylinder-contacting face of the ring, which is highly polished bright metal, and the body of the ring will be grey iron. The line of demarcation between these two metals can be clearly seen.*

***Until valve lifters become quiet.*

ORDNANCE MAINTENANCE — LIGHT TANKS M5, M5A1, AND M24, 75-MM HOWITZER MOTOR CARRIAGE M8, AND TWIN 40-MM GUN MOTOR CARRIAGE M19: ENGINES, COOLING SYSTEMS AND FUEL SYSTEMS

3500 revolutions per minute, or a total of 5½ hours, and the oil is changed, the oil pan and oil pan baffle must be removed and cleaned thoroughly before adding new oil.

(d) Keep records of oil consumption during the run-in schedule. Consumption should not exceed 2½ pints fc. the full 8 hour run. If oil consumption exceeds this figure, the engine shall be disassembled, and a check made to see that piston rings and bearings are seating properly.

(e) Cylinder heads must be removed and cylinder walls inspected for indications of scuffing. Scuffing appears as a group of tiny scratches on cylinder walls due to improper seating of pistons and rings. Scuffing which can be seen but not felt when rubbing a finger across the mark on the cylinder wall may be disregarded, as any scratches which are too light to be felt will not hamper engine performance. If any deeper scuffs, which can be felt by hand are encountered, the engine shall be disassembled and cylinder walls reconditioned (par. 7 d). After the scuffing inspection, cylinder heads and gaskets shall be reinstalled. If original cylinder head gaskets are used, the mounting screws should be tightened only to 65 foot-pounds. If new gaskets are used, engine must be run for 15 minutes at 2500 revolutions per minute at normal load and the cylinder head screws retightened to 70 foot-pounds at the end of the 15-minute run. Gasket sealer must be used on cylinder head gaskets in all cases.

c. Oil Pressure Inspection.

(1) **NORMAL PRESSURE.** The engine oil pressure should be at least 15 pounds at idle speed and 30 pounds at normal operating speed, as measured with direct reading oil gage, connected to the front of the oil header on the cylinder block. **NOTE:** *An electric oil gage connected to the oil pressure indicator on the rear of the engine "V" should not be used due to the possibility of faulty oil pressure indicator.*

(2) **LOW PRESSURE.** Low engine oil pressure is usually an indication of a faulty oil pump. Remove and disassemble oil pump and check the regulator spring tension and gear clearance (par. 13).

(3) **TRANSMISSION OIL PRESSURE.** Oil pressure in the Hydra-Matic transmission should be at least 85 pounds when engine is running approximately 1000 revolutions per minute, and transmission oil is hot. Diagnosis and correction of low oil pressure in the transmission is covered in TM 9-1729B.

d. Compression Pressure. The compression pressure of the engines should be checked at cranking speed and at 1000 revolutions per minute, using a standard compression gage screwed into one of the spark plug holes in the cylinder head. The compression pressure at

ENGINE

cranking speed should be 100 pounds; at 1000 revolutions per minute it should be 175 pounds. If the compression pressure falls below 90 pounds at cranking speed, or 160 pounds at 1000 revolutions per minute, the engine should be disassembled and a check made to see that the valves are seating properly, are not sticking, and have specified clearance at the stems.

e. **Engine Noises.** The personnel whose duty it is to test engines on the test stand should be constantly on the alert for any unusual noises which might indicate incorrect operation of any of the various units.

f. **Leakage Inspection.** While the engine is being run on the test stand, watch for any signs of gasoline, oil, or water leakage, either from the engine itself or from the connections on the engine test stand. As soon as any leakage is discovered, the engine should be stopped and the cause of the leakage determined and corrected at once. **CAUTION:** *Do not operate the engine after leakage has been noted, due to danger of fire in the case of fuel leakage and damage to the engine in the case of oil or water leakage.*

Section VI

FITS AND TOLERANCES

17. FITS AND TOLERANCES.

a. **Clearances.**

(1) **CAMSHAFT.**

Bushing clearance	0.0015 to 0.0033 in.
Bushing run-out, not over	0.0025 in.
Diameter of journal:	
No. 1 journal	2.4071 to 2.4078 in.
No. 2 journal	2.4071 to 2.4078 in.
No. 3 journal	2.0009 to 2.0016 in.
Diameter of bushing in block:	
No. 1 bushing	2.4093 to 2.4104 in.
No. 2 bushing	2.4093 to 2.4104 in.
No. 3 bushing	2.0031 to 2.0042 in.
Allowable undersize for regrinding	None
Allowable maximum run-out when supported on V-block	0.0025 in.
Permissible wear of lobes from heel to toe	0.002 in.
Straighten if run-out is more than	0.0025 in.
Allowable run-out of base circle of cam	0.001 in.
Interference O.D. of bushing to I.D. of case	0.0037 to 0.004 in.
End play of camshaft when installed	0.008 to 0.010 in.

ORDNANCE MAINTENANCE — LIGHT TANKS M5, M5A1, AND M24, 75-MM HOWITZER MOTOR CARRIAGE M8, AND TWIN 40-MM GUN MOTOR CARRIAGE M19: ENGINES, COOLING SYSTEMS AND FUEL SYSTEMS

(2) CONNECTING RODS AND CONNECTING ROD BEARINGS.

Clearance between bearing and crankshaft	0.0005 to 0.0020 in.
Side clearance of connecting rod bearing to crankshaft	0.008 to 0.014 in.
Diameter of lower end without bearing	2.5845 to 2.5850 in.
Diameter of bearing installed in rod	2.4600 to 2.4610 in.
Maximum amount allowable removable from parting surface of:	
Cap	None
Rod	None
Maximum out-of-round (horizontal)	0.0005 in.
Diameter of piston pin hole	0.9295 to 0.9305 in.
Allowable twist of connecting rod	0.002 in.
Correction can be made by straightening	
Balance of rod within	$\frac{1}{16}$ oz
Total weight of rod (less bearings)	2.2118 to 2.224 lb
Thickness of connecting rod bearing:	
Standard	0.06225 in.
0.010 in. undersize	0.06725 in.
0.020 in. undersize	0.07225 in.
0.030 in. undersize	0.07725 in.

(3) CYLINDER HEAD.

Maximum allowable warpage, full length	0.010 in.
--	-----------

(4) CRANKSHAFT AND CRANKSHAFT BEARINGS.

Connecting rod bearing journal—	
Standard	2.4590 to 2.4595 in.
0.010 in. undersize	2.4490 to 2.4495 in.
0.020 in. undersize	2.4390 to 2.4395 in.
0.030 in. undersize	2.4290 to 2.4295 in.
Connecting rod bearing journal out-of-round—	
Maximum, new or reground shaft	0.00025 in.
Maximum, used shaft	0.0010 in.
Crankshaft bearing journal—	
Standard	2.4990 to 2.4995 in.
0.010 in. undersize	2.4890 to 2.4895 in.
0.020 in. undersize	2.4790 to 2.4795 in.
0.030 in. undersize	2.4690 to 2.4695 in.
Crankshaft bearing journal out-of-round—	
Maximum, new or reground shaft	0.00025 in.
Maximum, used shaft	0.001 in.
Crankshaft bearing clearance	0.0015 to 0.0025 in.
End play in crankshaft (bearings installed)	0.001 to 0.005 in.
Run-out of flywheel mounting face	0.002 in.

ENGINE

Run-out of flywheel face when mounted on crankshaft	0.003 in.
Inside diameter of crankshaft bearings when installed at proper torque tightness:	
Vertical	2.5003 to 2.5015 in.
Horizontal	2.5013 to 2.5025 in.
I.D. bearing bore (less bearings) at proper torque tightness	2.7493 to 2.7500 in.
Amount of bearing crush	0.0000 to 0.0015 in.
Maximum amount removable from machined parting surface of caps and block	None
Thickness of bearing:	
Standard	0.12425 to 0.12450 in.
0.010 in. undersize	0.12925 to 0.12950 in.
0.020 in. undersize	0.13425 to 0.13450 in.
0.030 in. undersize	0.13925 to 0.13950 in.
Over-all width of center bearing at thrust surfaces:	
Standard	1.372 to 1.374 in.
0.010 in. undersize	1.372 to 1.374 in.
0.020 in. undersize	1.382 to 1.384 in.
0.030 in. undersize	1.382 to 1.384 in.
Thickness of lead coating on bearing thrust surfaces	0.002 to 0.010 in.
Thickness of lead coating in bearing liner	0.002 to 0.0025 in.

(5) CYLINDERS AND BLOCK.

Diameter, standard	3.500 to 3.5020 in.*
Out-of-round, new blocks, not over	0.0005 in.
Taper, new blocks, not over	0.0007 in.
Taper, worn limit, not over	0.004 in.
Maximum pressure per sq. in. for testing block for leaks	17 lb
Maximum allowable warpage, full length of block	0.010 in.

(6) OIL PUMP.

Backlash between drive gears, not over	0.008 to 0.012 in.
Clearance between pump body and drive shaft	0.0010 to 0.0025 in.
Clearance between pump body and gears	0.003 to 0.005 in.
End play in pump gears	0.001 to 0.004 in.
Oil pressure regulator spring:	
Free length (approx.)	2 ²⁵ / ₆₄ in.
Pressure at 1 ¹³ / ₃₂ in.	5 ¹ / ₂ to 6 ¹ / ₄ lb
Clearance between regulator valve plunger and housing	0.0020 to 0.0035 in.
Output of pump	Approx. 2.5 gal./min @ 1000 rpm @ 30 lb

*Pistons are selected for installation in new engines from seven closely ranged sizes to keep clearances within limits.

ORDNANCE MAINTENANCE — LIGHT TANKS M5, M5A1, AND M24, 75-MM HOWITZER MOTOR CARRIAGE M8, AND TWIN 40-MM GUN MOTOR CARRIAGE M19: ENGINES, COOLING SYSTEMS AND FUEL SYSTEMS

Inside diameter of body	1.499 to 1.500 in.
Drive shaft diameter	0.4979 to 0.4984 in.
Driven shaft diameter	0.4979 to 0.4984 in.

(7) PISTONS.

Piston diameter:

Standard	3.4966 to 3.4986 in.*
0.020 in. oversize	3.5166 to 3.5186 in.
0.040 in. oversize	3.5366 to 3.5386 in.
Clearance, piston to bore	0.0032 to 0.0036 in.
Weight, piston only	1.151 lb
Width of ring groove	
Groove No. 1—top	0.0802 to 0.0810 in.
Groove No. 2	0.0802 to 0.0810 in.
Groove No. 3	0.1878 to 0.1886 in.

(8) PISTON PINS.

Clearance between pin and bushing	0.0002 to 0.0008 in.
Clearance between pin and piston	0.00005 to 0.0001 in.
Diameter of pin:	
Standard	0.8742 to 0.8745 in.
0.005 in. oversize	0.8792 to 0.8795 in.
Piston pin bore diameter in piston	0.8743 to 0.8745 in.

(9) PISTON RINGS.

Clearance between rings and sides of grooves in piston:	
Top compression ring	0.0022 to 0.0035 in.
Bottom compression ring	0.0022 to 0.0035 in.
Oil ring	0.0013 to 0.0026 in.
Gap between ends in cylinder (new or reconditioned)	
Compression rings	0.007 to 0.023 in.
Oil ring	0.007 to 0.023 in.
Worn limit, not over	0.060 in.

(10) TIMING CHAIN.

Slack at center line of chains	1/8 to 3/4 in.
--------------------------------------	----------------

(11) VALVE LIFTER GUIDE.

I.D. of guide bore	0.7198 to 0.7201 in.
Clearance between valve lifter and lifter guide	0.0015 to 0.0028 in.
O.D. of valve lifter	0.7173 to 0.7182 in.
Clearance between valve lifter and plunger unit	0.0025 to 0.0055 in.
O.D. of plunger unit	0.5910 to 0.5920 in.
I.D. of valve lifter	0.5945 to 0.5965 in.
Clearance between cylinder and plunger	matched set

*Pistons are selected for installation in new engines from seven closely ranged sizes to keep clearances within limits.

ENGINE

(12) **EXHAUST VALVES.**

Clearance between stem and guide	0.0022 to 0.0042 in.
Head diameter, over-all	1.626 to 1.636 in.
Stem length, over-all (new)	5 ³³ / ₆₄ in.
Stem diameter	0.3405 to 0.3415 in.
Lift	0.345 in.
Seat angle	45°
Seat width (minimum)	⁵ / ₆₄ in.
Seat eccentricity, not over (total indicator reading)	0.002 in.
Minimum thickness of valve head after refacing	¹ / ₃₂ in.

(13) **INTAKE VALVES.**

Clearance between stem and guide	0.0012 to 0.0032 in.
Head diameter, over-all	1.876 to 1.886 in.
Stem length, over-all (new)	5 ³³ / ₆₄ in.
Stem diameter	0.3415 to 0.3425 in.
Lift	0.335 in.
Seat angle	45°
Seat width (minimum)	⁵ / ₆₄ in.
Seat eccentricity, not over (total indicator reading)	0.002 in.
Minimum thickness of valve head after refacing	¹ / ₃₂ in.

(14) **VALVE GUIDES.**

I.D. of valve guide	0.3437 to 0.3447 in.
Maximum wear	0.004 in.
Interference O.D. of valve guide and I.D. of cylinder bore	0.0010 to 0.0015 in.

(15) **VALVE SPRINGS.**

Free length	2.210 in.
Pressure in pounds:	
Compressed to 1 ⁵⁹ / ₆₄ in. (valve closed)	60 to 67 lb
Compressed to 1 ³⁷ / ₆₄ in. (valve open)	139.5 to 150.5 lb

b. Torque Tightnesses.

	Thread Size	Torque Tightness (ft-16)	
			Max.
Camshaft sprocket nut	³ / ₄ -16	80	85
Camshaft thrust plate screws	⁵ / ₁₆ -18	15	18
Choke heater screws	¹ / ₄ -20	10	12
Connecting rod screws	Special	60	65
Crankcase ventilator conduit screws (1G series) (3G Series)	¹ / ₄ -20	1	2
	¹ / ₄ -20	5	6
Crankshaft counterweight screws	⁵ / ₈ -18	145	155
Crankshaft pulley screw	⁵ / ₈ -18	95	100
Cylinder head screws	⁷ / ₁₆ -14	70	75

TM 9-1729A
17

ORDNANCE MAINTENANCE — LIGHT TANKS M5, M5A1, AND M24, 75-MM HOWITZER MOTOR CARRIAGE M8, AND TWIN 40-MM GUN MOTOR CARRIAGE M19: ENGINES, COOLING SYSTEMS AND FUEL SYSTEMS

		(initial)	
		65	70
		(retightening)	
Distributor clamp arm screw	1/4-20	10	12
Distributor support screws	5/16-18	15	18
Engine support to cushion	7/16-20	55	60
Engine to engine support cushion	1/2-20	100	110
Exhaust manifold connection screws	3/8-16	25	30
Exhaust manifold nuts	3/8-24	25	30
Fan support nuts (1G series)	5/8-11	85	95
Flywheel to crankshaft cap screws	7/16-20	70	75
Flywheel cover screws (1G series)	5/16-24	25	30
(3G series and late 1G)	3/8-24	40	45
Flywheel upper housing screws	7/16-14	45	50
Fuel pump screws (1G series)	5/16-18	15	18
Generator screws (1G series)	7/16-14	45	50
Generator cradle (3G series)	1/2-13	80	85
Intake manifold screws	3/8-16	25	30
Crankshaft bearing cap screws	9/16-12	130	140
Muffler mounting nuts (1G series)	5/16-24	25	30
Oil filler tube bracket screws	5/16-18	15	18
Oil pan baffle support screws	1/4-28	10	12
Oil pan drain plug (1G series)	1/2-20	10	15
(3G series)	5/8-18	35	40
Oil pan screws	5/16-18	7	10
Oil pump adapter mounting nuts	3/8-24	25	30
Oil pump and distributor idler gear screw	5/16-24	15	18
Spark plugs	10-mm	7	10
Starter screws	7/16-14	45	50
Front cover screws	5/16-18	15	18
Valve compartment cover screws	1/4-20	3	5
Valve lifter bracket baffle screws	1/4-20	10	12
Valve lifter bracket screws	7/16-14	45	50
Water pump screws	5/16-18	15	18

CHAPTER 3
COOLING SYSTEM

Section I

DESCRIPTION AND DATA

18. DESCRIPTION.

a. **Complete Systems.** Two identical but completely independent cooling systems, one for each engine and Hydra-Matic transmission, are used in these vehicles. Each system contains the following major units: radiator with pressure cap and overflow valve, water pump, thermostat and necessary connections and by-pass, engine fan, and an oil cooler for the Hydra-Matic transmission.

b. **Radiators.** The radiators are each mounted in a horizontal position above their respective engines in the 1G series (fig. 70). On the 3G series, the radiators are mounted in a position tilted slightly from the vertical just ahead of their respective engines and just over the Hydra-Matic transmissions (fig. 71). Each radiator consists of a core of tube-and-fin construction, with an inlet and outlet tank bolted to the top and the bottom of the core respectively. The inlet tank incorporates both the filler neck and the thermostat housing to which the engine-to-radiator hoses are connected. The outlet tank incorporates the elbow to which the radiator-to-water pump hoses and tube are connected.

c. **Filler Caps.** The radiator filler cap is provided with a pressure-operated vent valve. Fluid must pass through this vent valve in order to reach the overflow pipe and pass out of the cooling system. Since a pressure of 15 pounds is required to open the vent valve, the boiling point of the cooling solution is raised to approximately 250° F, making the loss of coolant, and particularly antifreeze compound, less likely under severe operating conditions.

d. **Water Pump.** The water pump is mounted on the right engine block and driven from the crankshaft by the V-belts, one on 1G series and three on 3G series, that also drive the generator (figs. 5 and 7). The water pump shaft carries a vaned impeller which forces the water through the system. Chevron type, spring-loaded packings prevent leakage of coolant around the shaft.

e. **Thermostat.** A blocking type, bimetal thermostat is mounted in the inlet elbow of each radiator. This thermostat is equipped with balanced double poppet valves to control water temperature by regulating the flow of coolant from cylinder heads to radiator. A fixed by-pass circulates coolant back to water pump when thermostat is closed. Cooling fluid is drawn from radiator outlet back to water

TM 9-1729A
18

ORDNANCE MAINTENANCE — LIGHT TANKS M5, M5A1, AND M24, 75-MM HOWITZER MOTOR CARRIAGE M8, AND TWIN 40-MM GUN MOTOR CARRIAGE M19: ENGINES, COOLING SYSTEMS AND FUEL SYSTEMS

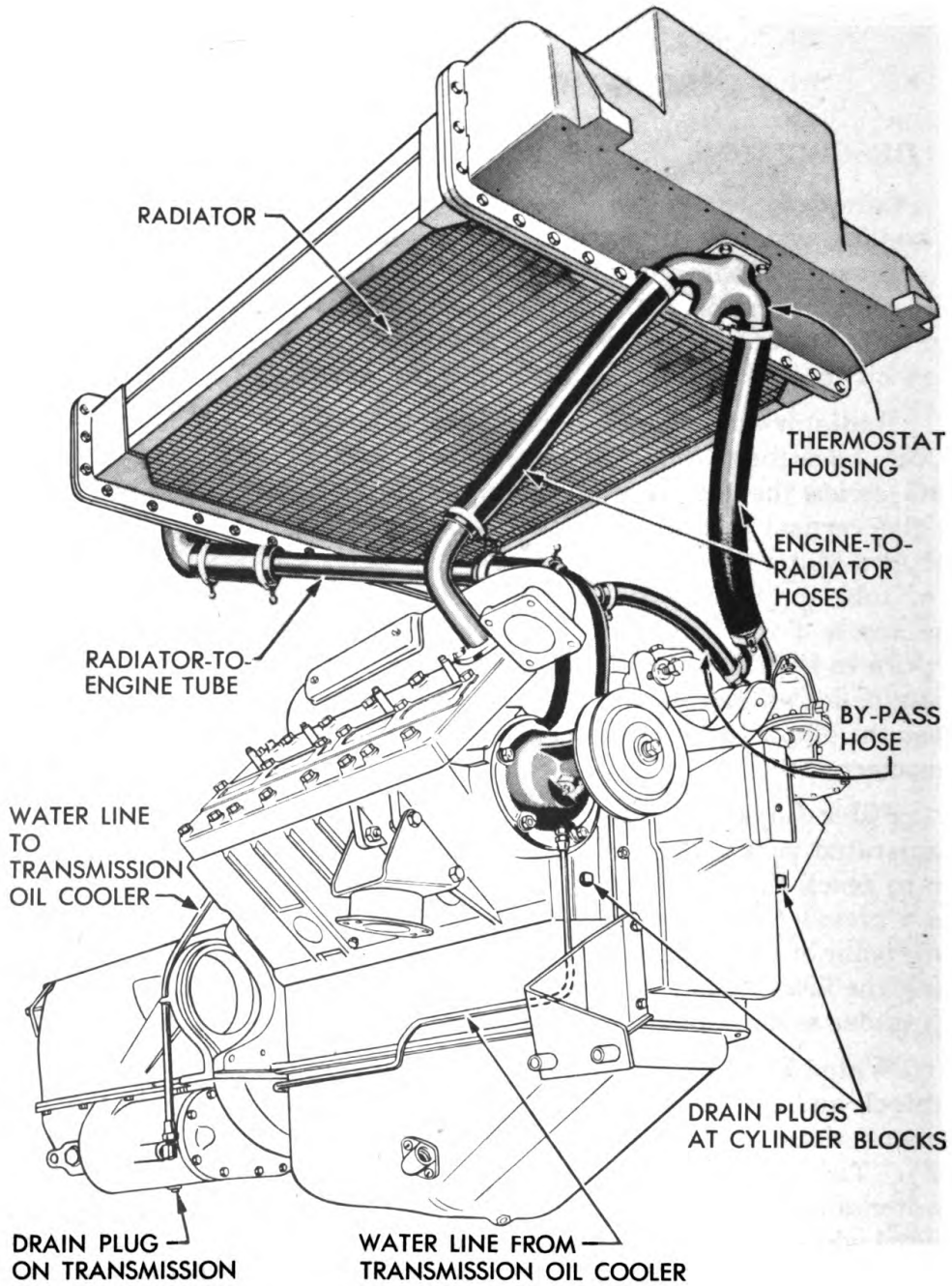

RA PD 60208

Figure 70 — Cooling System, 1G Series

COOLING SYSTEM

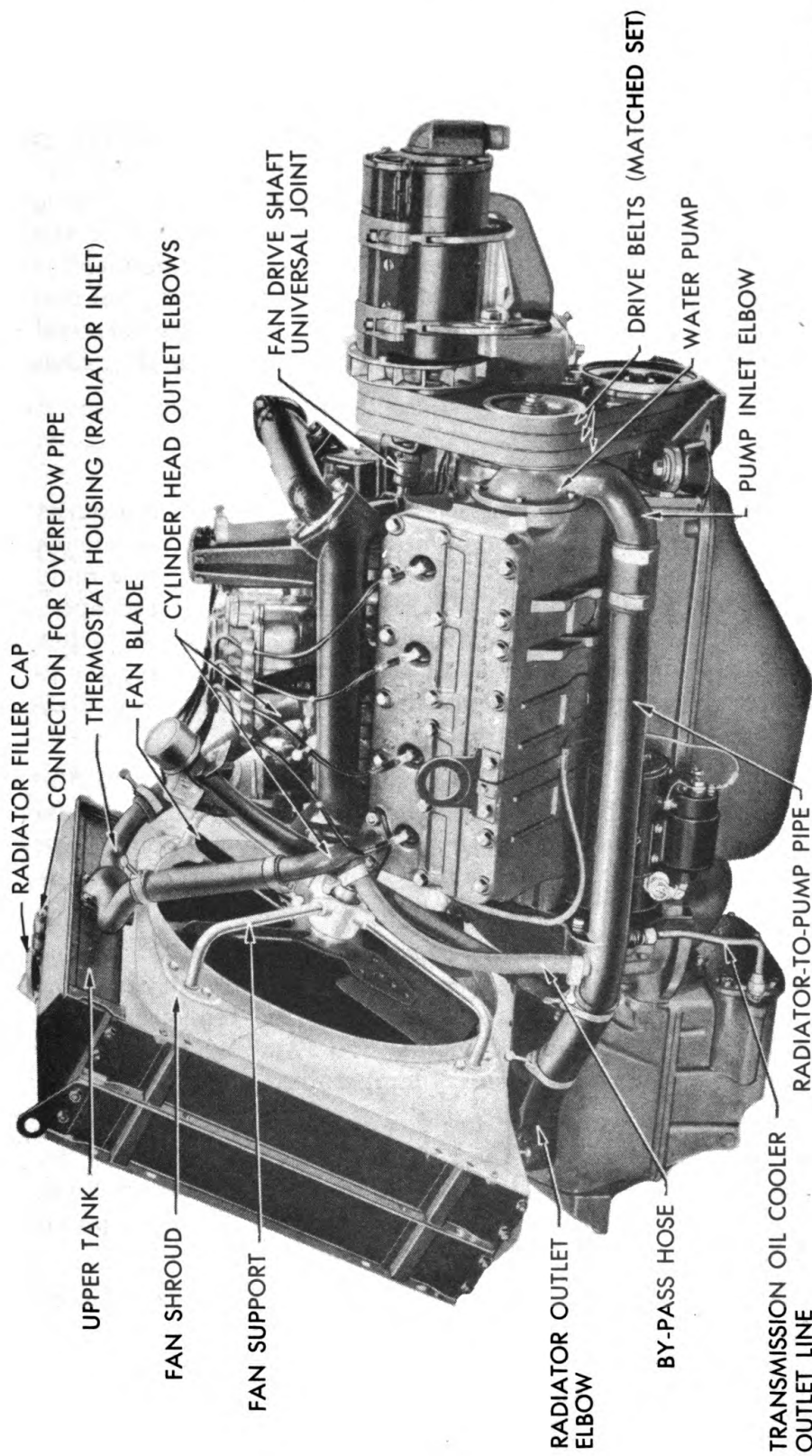

RA PD 331372

Figure 71 — Cooling System, 3G Series

ORDNANCE MAINTENANCE — LIGHT TANKS M5, M5A1, AND M24, 75-MM HOWITZER MOTOR CARRIAGE M8, AND TWIN 40-MM GUN MOTOR CARRIAGE M19: ENGINES, COOLING SYSTEMS AND FUEL SYSTEMS

pump through a long tube and connecting hoses, and is returned through hoses connecting the outlet elbows on each cylinder head with the thermostat housing on the radiator inlet tank.

f. **Engine Fan.** The engine fan on the 1G series is mounted on an adjustable support on the engine front cover, and is driven at crankshaft speed by a V-belt direct from the crankshaft. The engine fan on the 3G series is carried in a mounting bracket attached to the radiator at the rear. The fan is driven by a drive shaft mounted in ball bearings under the intake manifold through a universal joint and yoke connected to the pulley on the generator. A second universal joint and yoked shaft connect the fan to the drive shaft at the radiator end.

19. OPERATION.

a. When the engine is running, coolant is drawn from the outlet tank of the radiator by the water pump and forced into the engine water jackets. Part of this fluid circulates through the right-hand cylinder block and head, and part of it passes through a cored opening in the crankcase to the left-hand cylinder block and head. After circulating through the cylinder blocks, around the valves and manifolds and through the cylinder heads, the heated liquid is forced up through the outlet hoses to the radiator.

b. When the engine is first started and the coolant is cold, the thermostat located in the radiator inlet housing is closed and the pump pressure causes the liquid to flow across the by-pass hose back to the water pump. With no circulation through the radiator, the engine is rapidly warmed to operating temperatures.

c. As the engine approaches operating temperatures, the heated liquid causes the thermostat to open and permit flow through the radiator. The thermostat opening increases as the temperature increases, until there is a full flow of cooling liquid through the radiator as the engine reaches normal operating temperature.

d. Water pump pressure also forces some cooling liquid through an external pipe at the rear of the right-hand cylinder block to the transmission oil cooler, where it absorbs heat from the transmission oil, and is then returned through an external pipe to the water pump on 1G series, and to the water pump return pipe on 3G series.

e. On 1G series engines, rotation of the fan draws air in through a grilled opening in the engine compartment roof and through hinged openings at the top of the bulkhead in the fighting compartment. This air passes down through the radiator cores, across the top of the engines, and out through fan shrouds and the grille just below the engine compartment door. On 3G series engines, rotation of the fan

COOLING SYSTEM

draws air in through an armor-protected opening at the front of the engine compartment roof, and through armored inlets on the fuel tank compartment covers. This air then passes through the differential oil cooler and radiator cores, across the top of the engines and out through an armor-protected opening in the engine compartment roof at the rear.

20. DATA.

a. Fan.

	M5 and M8	M19 and M24
Blades, angle	32 deg	32 deg
Blades, diameter	22 in.	21 in.
Blades, number of	4	4
Drive	V-belt	Belts, drive shaft and universal joints
Drive ratio	1 to 1	1.1 to 1
Lubrication	None	None
Manufacturer	Hayes	Hayes

b. Radiator.

Capacity, each complete system	35 qt	40 qt
Core area	672 sq in.	540.5 sq in.
Manufacturer	Harrison	Harrison
Type	Tube-and-fin	Tube-and-fin

c. Thermostat.

Location	Radiator inlet housing	Radiator inlet housing
Manufacturer	Dole	Dole
Opening temperature		
First type	161 to 166° F	141 to 146° F
Second type	141 to 146° F	
Type	Bimetal	Bimetal

d. Water Pump.

Drive	Belt	Triple belt
Lubrication	Fitting	Fitting
Packings	Spring-loaded chevron type	Spring-loaded chevron type
Type	Centrifugal	Centrifugal

Section II

**DISASSEMBLY, CLEANING, INSPECTION, REPAIR,
AND ASSEMBLY OF SUBASSEMBLIES**

21. FAN AND SHROUD ASSEMBLY.

a. Removal.

(1) **1G SERIES.** Removal of fan and fan shrouds on vehicles with 1G series engines is covered in TM 9-732 and TM 9-732B.

(2) **3G SERIES.** Removal of fan and fan shrouds on vehicles with 3G series engines can be performed when either the radiator or the engine is out of the vehicle. If radiator is out, remove fan shroud from radiator after taking out four attaching nuts, washers and bolts, and remove fan and bracket assembly from vehicle by sliding fan-shaft out of drive yoke after loosening knurled packing nut (fig. 72). If engine is out, remove fan and bracket assembly by taking out eight cap screws and lock washers holding bracket to shroud, and remove shroud by taking out four attaching nuts, washers and bolts.

b. Disassembly.

(1) **DISASSEMBLE FAN SHROUDS.** Disassembly of fan shrouds on vehicles with 1G series engines is accomplished along with their

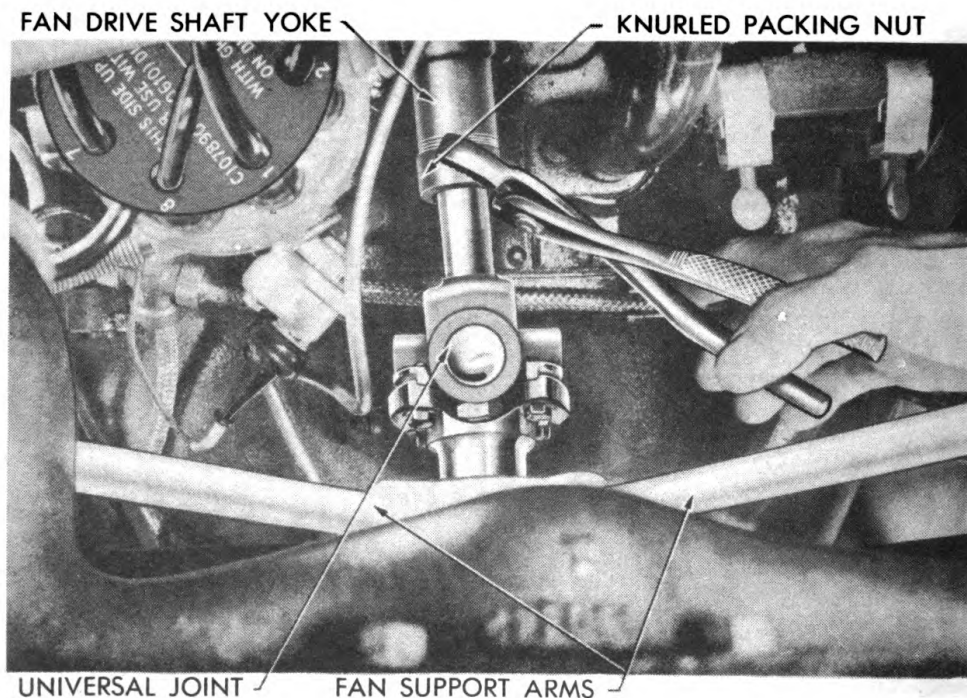

RA PD 331320

Figure 72 — Loosening Fan Shaft Packing Nut

COOLING SYSTEM

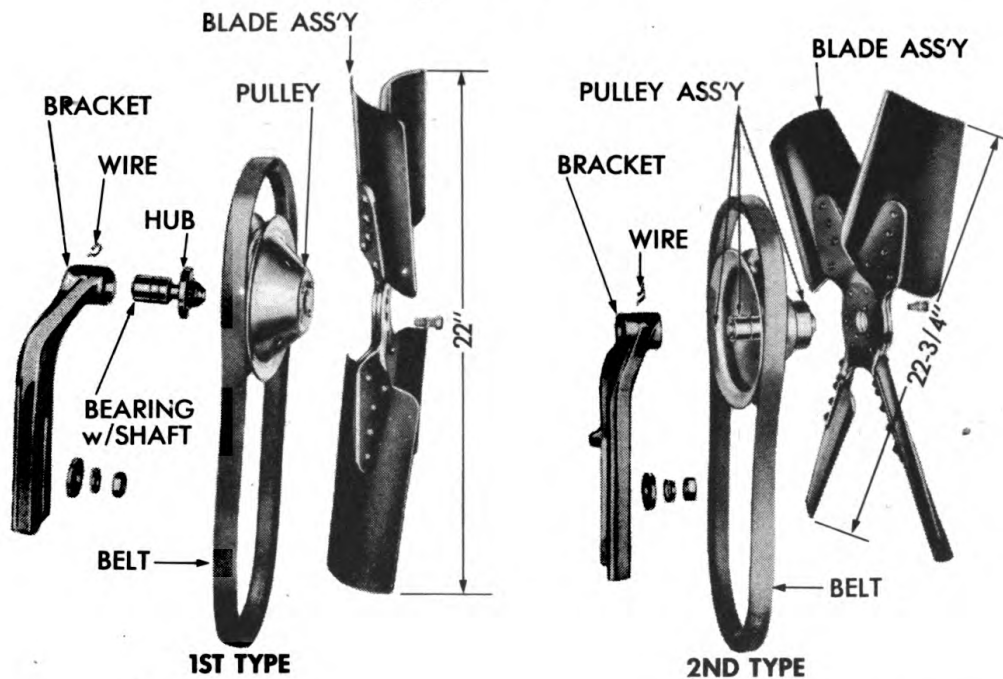

RA PD 331550

Figure 73 — Fan and Bracket Assemblies, 1G Series, Disassembled View

removal from the vehicle, as covered in TM 9-732 and TM 9-732B. There is no disassembly of the fan shrouds used with 3G series engines.

(2) **DISASSEMBLE 1G SERIES FAN (FIRST TYPE).** Remove four screws and lock washers holding fan blade assembly and fan drive pulley to hub (fig. 73) and remove blade assembly and pulley. Remove lock ring holding fanshaft and bearing in bracket (fig. 74). Place fan bracket, shaft and bearing assembly in arbor press, and press shaft and bearing assembly out of bracket. Press pulley hub off shaft and bearing assembly. **NOTE:** Some hubs will be welded to shaft and cannot be removed.

(3) **DISASSEMBLE FAN (SECOND TYPE).** Remove four screws and lock washers holding fan blade assembly to pulley (fig. 73) and remove blade assembly. Remove lock ring holding fan shaft bearing and pulley assembly in bracket and, using arbor press, press assembly out of bracket. **NOTE:** The second type shaft bearing and pulley assembly cannot be disassembled further.

(4) **DISASSEMBLE 3G SERIES FAN.** Remove four screws and lock washers holding fan blade assembly to hub (fig. 75) and remove blade assembly. Remove four screws and washers holding universal joint to yoke on fan shaft and remove joint. **NOTE:** Do not attempt further disassembly of universal joint. Remove nut and washers holding

ORDNANCE MAINTENANCE — LIGHT TANKS M5, M5A1, AND M24, 75-MM HOWITZER MOTOR CARRIAGE M8, AND TWIN 40-MM GUN MOTOR CARRIAGE M19: ENGINES, COOLING SYSTEMS AND FUEL SYSTEMS



LOCK RING

FAN HUB

FAN BRACKET

RA PD 331540

Figure 74 — Removing Lock Ring For Fan Drive Shaft (First Type)

yoke to shaft and tap off yoke. Remove bearing shield. Place fan support on arbor press with fan hub down and press fan shaft and front bearing assembly out of rear bearing and support hub. Tap rear bearing out of support hub. Remove bearing spacer.

c. **Cleaning.** Wash all parts (except bearings) thoroughly in dry-cleaning solvent. **NOTE:** *Fan bearings are sealed and do not require cleaning or removal of grease.*

d. Inspection and Repair.

(1) **FAN BRACKET.** Inspect fan bracket for bent condition, cracks or fractures, and replace if these conditions exist. Inspect bearing bore in fan bracket for nicks or burs, which may be removed with crocus cloth.

(2) **HUB SHAFT AND BEARINGS.** Inspect fan shaft for nicks or burs, which can be removed with crocus cloth, or for cracks or fractures, which make replacement necessary. Inspect pulley mounting hub, and replace if cracked or damaged. Spin fan bearings on inner race, and check for roughness, tightness, or flat spots. Replace if any of these conditions exist.

(3) **BLADE ASSEMBLY.** Inspect fan blade assembly for bent blades by placing on a surface plate with one side down and then the other, and noting whether each inner corner contacts the plate.

COOLING SYSTEM

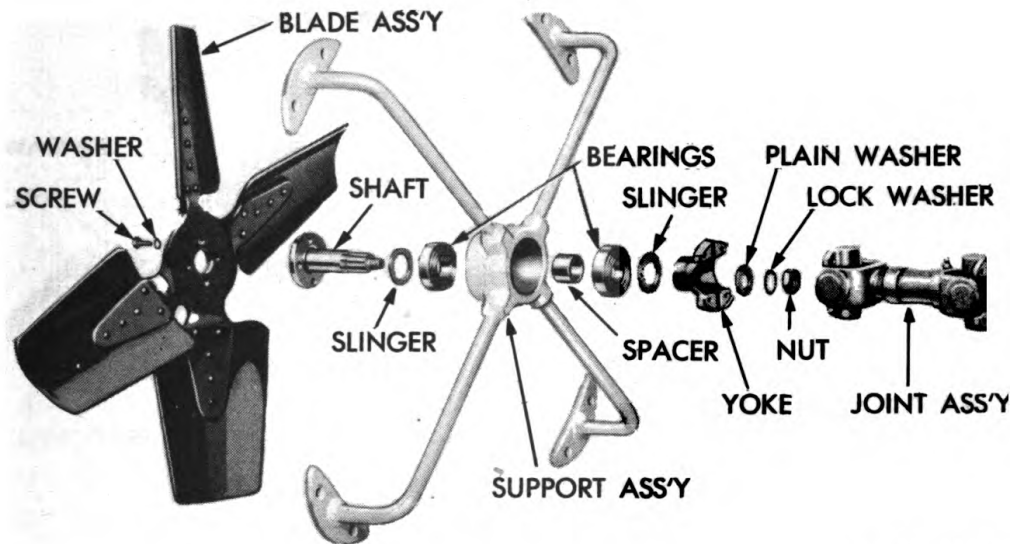

RA PD 331541

Figure 75 – Fan, Bracket, and Shroud Assembly, 3G Series, Disassembled View

Straighten blades, or replace assembly if badly bent. Inspect rivets holding blades to spider, and replace complete assembly if any blades are loose.

(4) **PULLEY (1G SERIES)**. Check pulley for cracks, damage or warpage, and replace if these conditions exist. Check for nicks or dents that might cause belt failure, and clean up with a fine file.

(5) **SHAFTS AND UNIVERSAL JOINTS (3G SERIES)**. Inspect fan shafts and universal joint yokes for concentricity and for wear at the splines. Rotate universal joints slowly to check for wear, looseness or roughness, and replace if any of these conditions exist.

e. Assembly.

(1) **ASSEMBLE 1G SERIES FAN (FIRST TYPE)**. If pulley hub is not welded to shaft, support pulley hub on bed of arbor press and press fan shaft through hub until it extends 11/16 inch through hub (fig. 76), and then weld in this position. **CAUTION:** *To keep heat of welding from damaging bearing, submerge bearing end of shaft in heavy oil, or pack bearing and middle part of shaft in wet asbestos.* Place fan bracket on bed of press, and press shaft and bearing assembly into bracket until groove on bearing lines up with slot in bracket. Install a new fan bearing lock wire through slot in fan bracket. Position fan pulley on mounting hub with concave side of pulley toward fan bracket so that mounting screw holes in pulley line up with tapped holes for mounting screws in hub. Position fan blade assembly over fan pulley, lining up mounting screw holes, and install four mounting screws and lock washers.

ORDNANCE MAINTENANCE — LIGHT TANKS M5, M5A1, AND M24, 75-MM HOWITZER MOTOR CARRIAGE M8, AND TWIN 40-MM GUN MOTOR CARRIAGE M19: ENGINES, COOLING SYSTEMS AND FUEL SYSTEMS

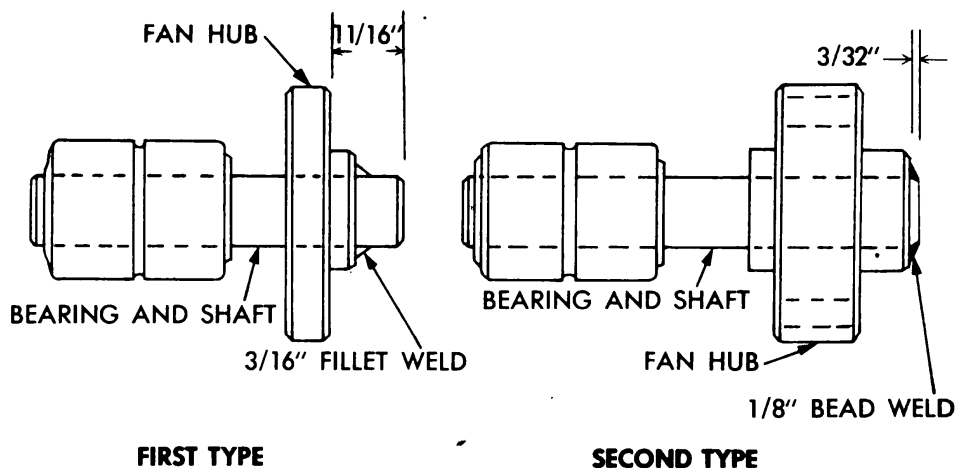

RA PD 331551

Figure 76 — Fan Hub Mounting on Shaft, 1G Series

(2) ASSEMBLE 1G SERIES FAN (SECOND TYPE). NOTE: If pulley and hub are supplied not assembled to shaft and bearing, first bolt pulley to hub, then press shaft and bearing assembly through hub until shaft extends $\frac{3}{32}$ inch past hub (fig. 76), then weld securely as indicated. Position fan bracket in arbor press, and press fan shaft, bearing and pulley into bracket until groove in bearing lines up with slot in bracket. Install a new fan bearing lock wire through slot in bracket. Position blade assembly on pulley and install four attaching screws and lock washers.

(3) ASSEMBLE 3G SERIES FAN. Install bearing spacer and rear bearing in counterbore in fan support (fig. 75). Place fan support and fan shaft, bearing and hub in arbor press, with hub end of fan shaft on press bed. Using a short piece of 1-inch pipe, or other suitable spacer, press shaft assembly into rear bearing and fan support. Place rear bearing shield over end of shaft, and then install washers, universal joint yoke and nut (fig. 75). Tighten nut to 90 foot-pounds, assemble universal joint yoke with four screws and washers. Position fan blade assembly on hub and install four screws and lock washers.

f. Installation.

(1) 1G SERIES. Installation of fan and fan shrouds on vehicles with 1G series engines is covered in TM 9-732 and TM 9-732B.

(2) 3G SERIES. Position fan shroud on radiator and attach with four nuts, washers and bolts. Position fan and bracket assembly on shroud and attach with eight cap screws and lock washers. NOTE: This procedure applies either if radiator is out of vehicle or radiator

COOLING SYSTEM

is in and engine is out. Then, as a final step, install engine or radiator as covered in TM 9-729.

22. RADIATOR AND THERMOSTAT.

a. Disassembly.

(1) 1G SERIES.

(a) *Remove Seals.* Remove large seal from hull side of radiator by removing eight screws and three cap screws and washers. Remove small seal from opposite side of radiator at outlet end by removing cap screw and lock washer.

(b) *Remove Radiator Inlet Tank.* Working at radiator inlet end, remove 19 nuts and lock washers from bolts, and 13 nuts and lock washers from studs. Remove tank and gasket from radiator core (fig. 77). Remove drain plug from thermostat housing. Remove four screws and lock washers holding thermostat housing to radiator tank and remove housing and thermostat. Take thermostat out of housing.

(c) *Remove Radiator Outlet Tank.* Working at radiator outlet end, remove 28 bolts, lock washers and nuts, and 4 nuts and lock washers from studs. Remove radiator tank and gaskets from radiator core. Remove drain plug from radiator tank.

(2) 3G SERIES.

(a) *Remove Inlet and Thermostat Housing.* Remove four screws and nuts holding fan shroud to radiator and remove shroud. Remove four screws and washers holding lower radiator tank outlet to tank and discard gasket. Remove four screws and washers holding upper radiator inlet housing and thermostat on upper tank, and discard gasket. Remove thermostat.

(b) *Remove Radiator Channels.* Remove four nuts at top and four at bottom of each channel holding channels to radiator assembly (fig. 78). Remove mounting nuts for channels on other side of radiator also. Break solder seal at top and bottom of each channel and lift off channels.

(c) *Remove Radiator Inlet Tank.* Break solder seal around upper header of radiator core and header of inlet tank and pry back lip of radiator core header and lift inlet tank off core.

(d) *Remove Radiator Outlet Tank.* Break solder seal around lower header of radiator core and outlet tank header, pry back lip of radiator core header, and lift outlet tank off core.

b. Inspection.

(1) THERMOSTAT. Check thermostat by placing it with bimetal coil down on a brick in a pan of water also containing a thermometer

ORDNANCE MAINTENANCE — LIGHT TANKS M5, M5A1, AND M24, 75-MM HOWITZER MOTOR CARRIAGE M8, AND TWIN 40-MM GUN MOTOR CARRIAGE M19: ENGINES, COOLING SYSTEMS AND FUEL SYSTEMS

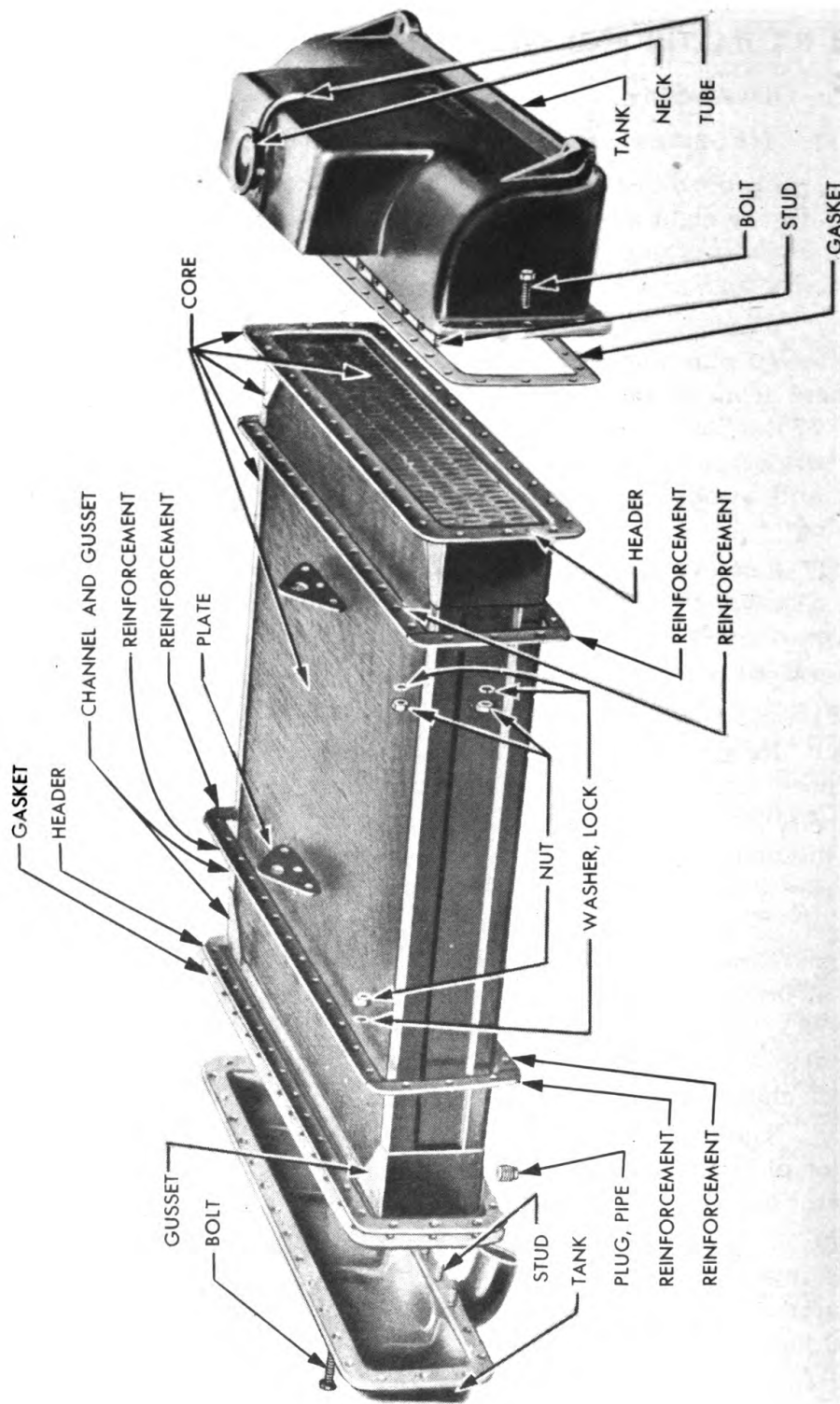

RA PD 9186

Figure 77 — Radiator, 1G Series, Disassembled View

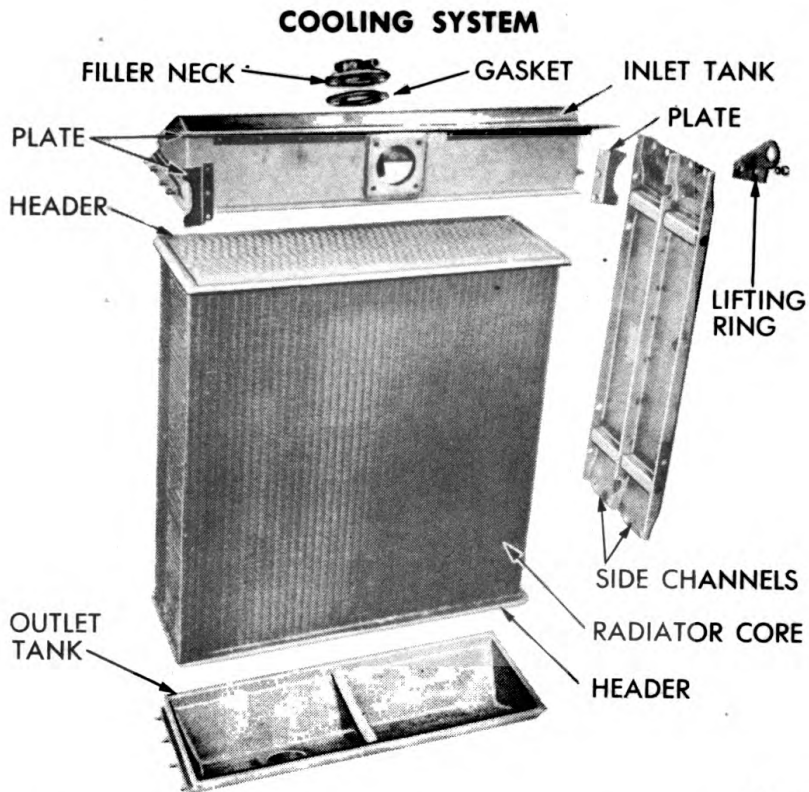

RA PD 331570

Figure 78 — Radiator, 3G Series, Disassembled View

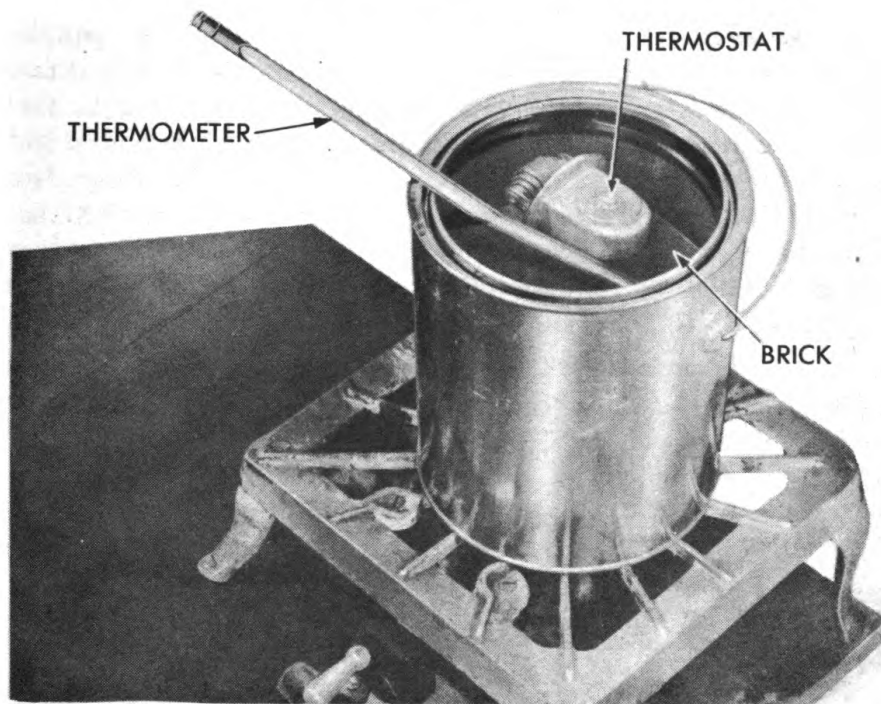

RA PD 331542

Figure 79 — Testing Radiator Thermostat

ORDNANCE MAINTENANCE — LIGHT TANKS M5, M5A1, AND M24, 75-MM HOWITZER MOTOR CARRIAGE M8, AND TWIN 40-MM GUN MOTOR CARRIAGE M19: ENGINES, COOLING SYSTEMS AND FUEL SYSTEMS

(fig. 79). **CAUTION:** *Do not place either the thermostat or the thermometer on the bottom of the pan because of the uneven concentration of heat at that point when the pan is heated over a burner.* Heat the water until the thermostat valve begins to open. The temperature at which this occurs depends upon whether the thermostat is of the first type or second type. First type 1G series thermostats open at 161 to 165° F; second type 1G and all 3G thermostats open at 141 to 146° F. The operating temperature is stamped on the housing flange of most thermostats.

(2) **TANKS AND CORES.** Inspect air passages through radiator core for plugged condition due to dirt, sand, leaves, etc., being drawn into radiator through front air inlet. If oil was spilled on radiator core, clean with steam if available. Inspect all parts for cracks or corrosion. Clean out water passages by observing instructions in current directives.

c. Assembly.

(1) **1G SERIES.**

(a) *Install Outlet Tank.* Install radiator outlet tank by applying joint and thread compound to gasket and positioning gasket and tank on core at outlet end. Position flange reinforcement on tank and install 28 bolts, lock washers, and nuts. Place four lock washers and nuts on studs and tighten. Install drain plug in tank.

(b) *Install Inlet Tank.* Install radiator inlet tank by applying joint and thread compound to gasket and positioning gasket and tank on radiator core at inlet end. Position flange reinforcements on tank and install 19 bolts, nuts and lock washers. Install 13 nuts and lock washers on studs and tighten. Apply gasket sealer to thermostat housing gasket and position gasket on radiator tank. Position thermostat in opening with valve up (fig. 80), place housing over thermostat, and install and tighten four screws and lock washers to a torque tightness of 18 foot-pounds. Install drain plug in thermostat housing.

(c) *Install Seals.* Position large seal on hull side of radiator and secure by tightening eight screws and three cap screws and lock washers. Position small seal at outlet end of radiator on opposite side from large seal and secure by tightening cap screw and lock washer.

(d) *Check for Leaks.* Check for leaks, using compressed air at a pressure not exceeding 15 pounds per square inch and plugging all openings. Solder all leaks unless core is so badly corroded that repairs are impractical.

(2) **3G SERIES.**

(a) *Install Inlet and Thermostat Housing.* Place joint and thread compound on radiator outlet elbow gasket and install gasket on outlet

COOLING SYSTEM

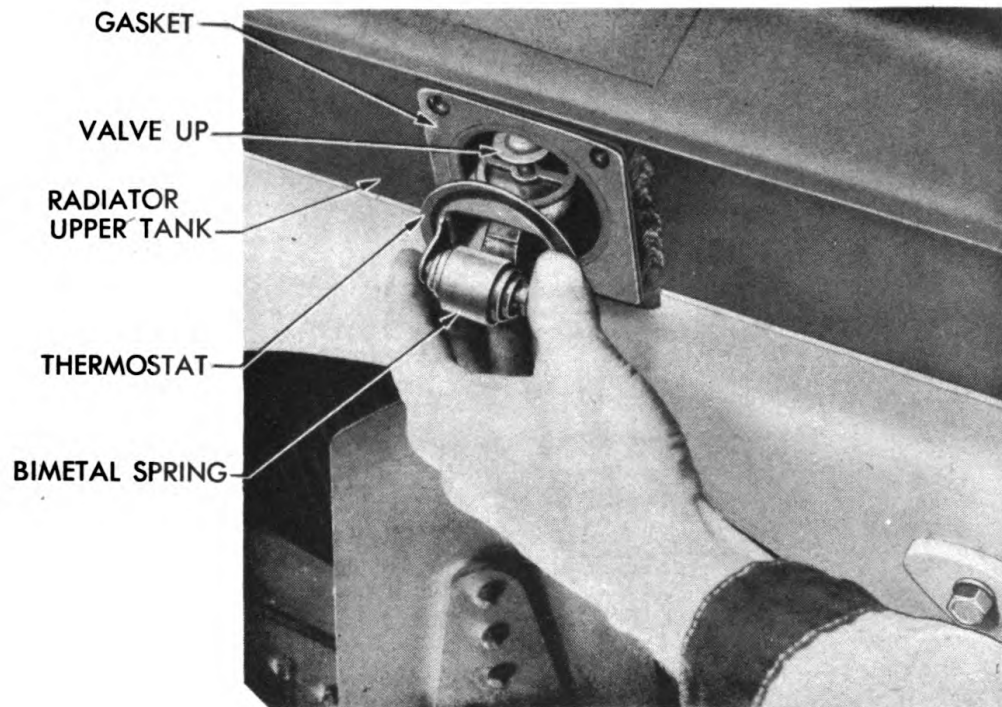

RA PD 331348

Figure 80 – Installing Radiator Thermostat, 3G Series

opening at bottom of outlet tank. Position outlet elbow over gasket and install four screws and washers holding elbow to tank. Coat upper tank inlet and thermostat housing gasket with joint and thread compound and position on tank opening. Place thermostat in opening with valve extending into radiator tank with axis of thermostat horizontal (fig. 80). Position housing on radiator making sure that thermostat flange fits into recess in housing. Install four screws and washers holding housing to upper tank and tighten to 18 foot-pounds.

(b) *Install Radiator Inlet Tank.* Position tank on radiator core and bend core header over tank header and seal with solder.

(c) *Install Radiator Outlet Tank.* Position outlet tank on radiator core and bend radiator core header over outlet tank header and seal with solder. Test for leaks as explained in subparagraph c (1) (d).

(d) *Install Radiator Channels.* Position channels on side of radiator core with lifting eye at top of radiator core. Install four nuts at top and four nuts at bottom of channel. Seal channel to upper and lower tank with solder. Repeat this operation for installing channels on other side of radiator assembly.

(e) *Install Fan Shroud.* Place radiator shroud in position on radiator and install four screws and nuts holding shroud to radiator.

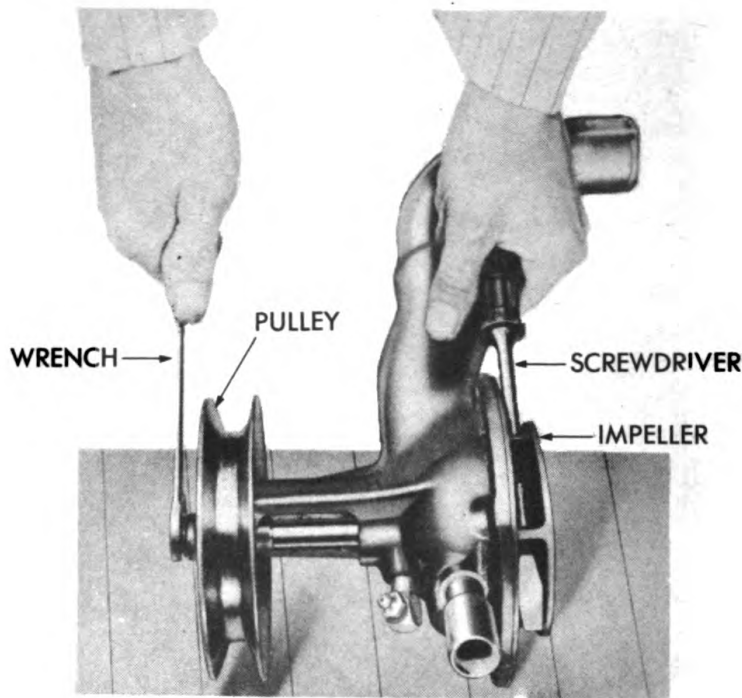

RA PD 331543

Figure 81 — Removing Water Pump Pulley Nut, 1G Series

23. WATER PUMP.

a. Disassembly.

(1) **1G SERIES.** Remove water pump pulley retaining nut and lock washer (fig. 81) while holding water pump drive shaft stationary with bar or screwdriver. Tap pulley from drive shaft, using a soft hammer. Remove key from end of shaft. Remove lock wire (fig. 82) holding front drive shaft bearing in water pump body, using a small screwdriver. Push impeller and shaft away from water pump body enough to remove split retainers in back of front bearing on drive shaft. Slide impeller and drive shaft out of water pump body. Tap front bearing and collar out of front end of body using a light hammer and a brass drift. **CAUTION:** Tap on outer race of bearing only. Place front bearing and collar assembly in an arbor press, supporting bearing on inner race, and press collar out of bearing. Remove snap ring from inner end of water pump body, using a small screwdriver. Tap water pump packing assembly, including chevron packings, packing rings, spacer and packing spring, out of water pump body, using a light hammer and a brass drift. Discard chevron packings.

(2) **3G SERIES.** Remove nut and lock washer holding pump pulley on shaft while holding impeller stationary with screwdriver.

COOLING SYSTEM

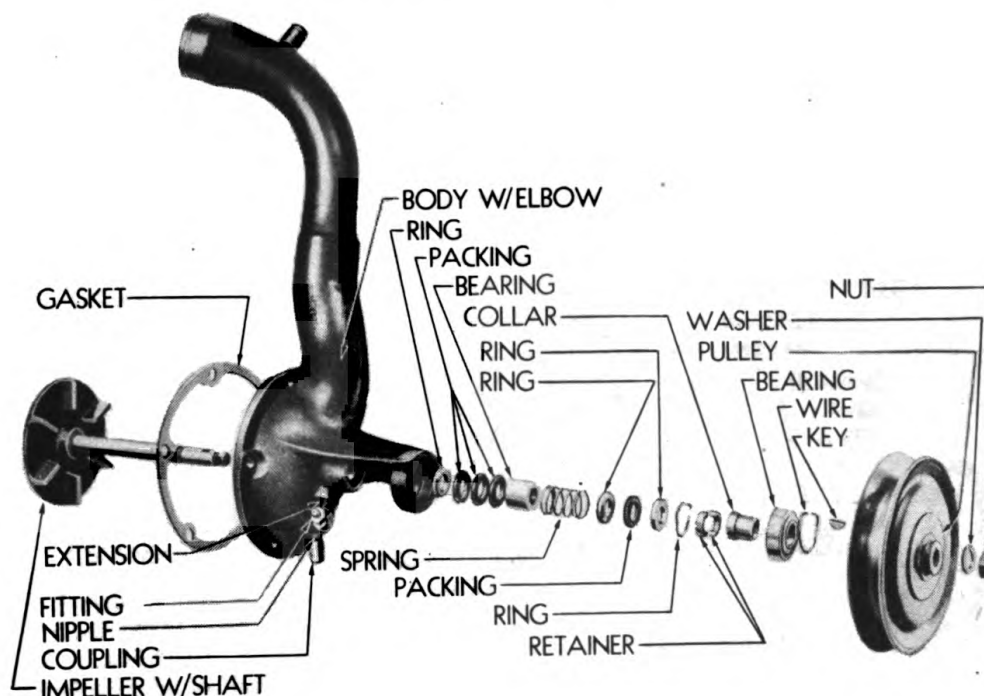

RA PD 8894

Figure 82 – Water Pump, 1G Series, Disassembled View

Tap pulley from pump shaft, using a soft hammer. Remove key from end of shaft. Remove lock ring holding pump shaft bearing in body (fig. 83). Place pump assembly on arbor press with drive side down, and support outside edge of body at bearing opening. Use brass drift on shaft end, press pump shaft and bearing assembly out of impeller and pump body. Place pump shaft and bearing assembly on arbor press with impeller end of shaft down, and support bearing inner race. Press shaft out of bearing, and remove washer. Remove snap ring from inner end of pump body and tap pump packings, packing rings, spacer and spring out of pump body, using a light hammer and brass drift.

b. Inspection. Clean all water pump parts, except the front bearing, in dry-cleaning solvent. The front water pump bearing is a sealed bearing and does not require cleaning or removing of lubricant. Inspect bearing by rotating slowly by hand, and replace bearing if tight, rough or badly worn. Inspect water pump body for cracks or evidence of damage. Inspect machined surfaces of water pump body, particularly bearing and bushing bores, for nicks or burs which might cause water leakage. Small burs can be removed with a fine file or whetstone. Inspect water pump impeller for corroded vanes. Inspect water pump drive shaft for bends, nicks or burs, or grooves which

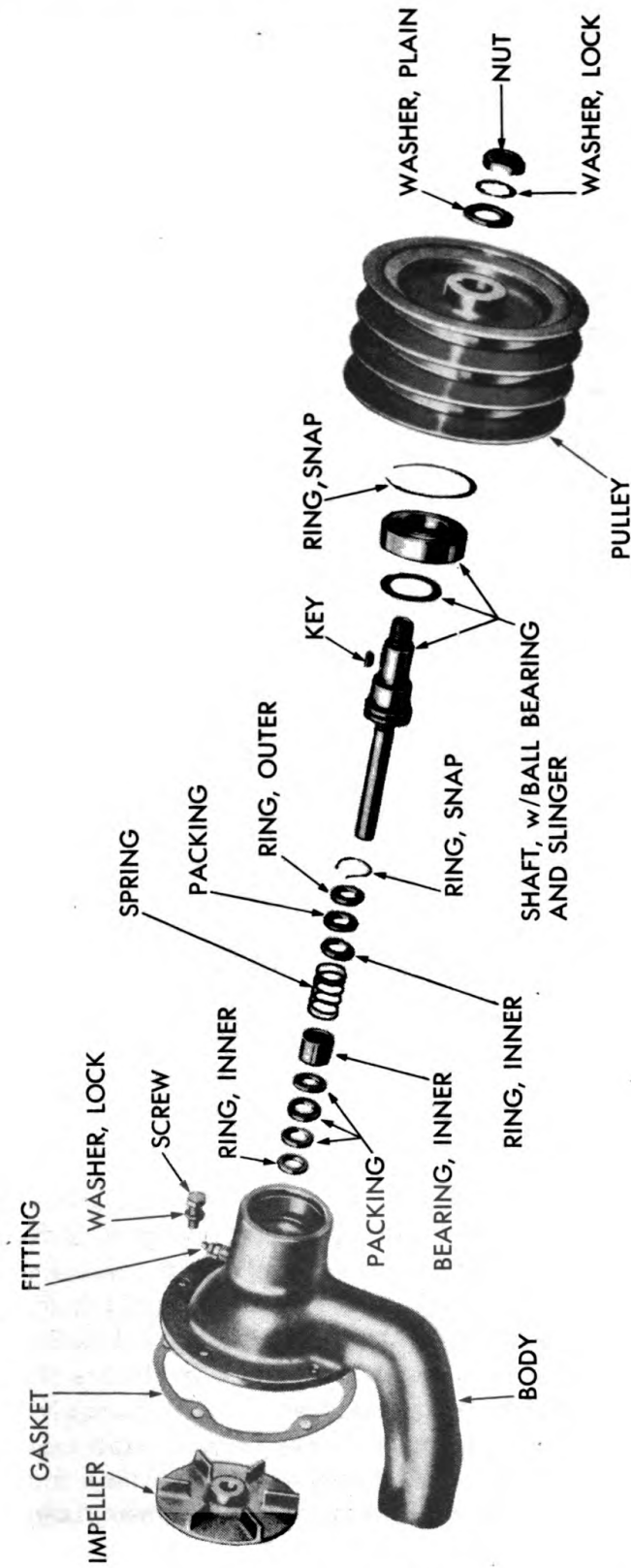

Figure 83 — Water Pump, 3G Series, Disassembled View

COOLING SYSTEM

might cause water leakage or roughness in the bushing. Replace any worn or damaged parts.

c. Assembly.

(1) 1G SERIES.

(a) *Install Packings.* Push impeller shaft packing ring (fig. 82) into water pump body until it seats on shoulder of body. **NOTE:** *Square end of ring should point toward impeller end of water pump body.* Lubricate three new chevron packings, using water pump grease, and install packings in pump body. Install bearing and packing retaining spring in water pump body. Install center packing ring in water pump body. **NOTE:** *Square end of ring should point toward impeller end of water pump body.* Install one chevron packing next to center ring after lubricating it with water pump grease. Install front packing ring in water pump body. **NOTE:** *Grooved edge of ring should be toward front chevron packing.* Compress water pump packing assembly, using a brass drift and a light hammer, until groove in water pump body for snap ring appears ahead of packing assembly. Install snap ring holding packing assembly in water pump body, using a small screwdriver.

(b) *Install Front Bearing.* Install front bearing and collar in an arbor press, and press bearing on collar until it seats on shoulder of collar. **CAUTION:** *Spindle of press must bear on inner race of bearing only.* Slide bearing and collar assembly into place on front of water pump body, being careful not to damage bearing. Install large lock wire holding bearing in water pump body, using a pair of pliers.

(c) *Install Impeller.* Install pilot thimble (41-P-418) on end of water pump shaft. Wrap groove in shaft, where split retainers seat on shaft, with string or tape to prevent damage to chevron packings while shaft is being installed. Install impeller and shaft assembly in water pump body from impeller end of body until pilot thimble protrudes from front of body (fig. 84). As soon as pilot thimble protrudes, remove thimble from end of shaft and string or tape from groove in shaft. Install split retainers on shaft and slide impeller and shaft into pump body until retainers are held in position by front bearing collar.

(d) *Install Pulley.* Install Woodruff key in front end of impeller shaft using a light hammer. Slide drive pulley over front end of shaft and install lock washer and nut. Keep drive shaft from turning while tightening pulley retaining nut by holding impeller on opposite end of water pump shaft (fig. 81).

(2) 3G SERIES.

(a) *Assemble Shaft and Bearing.* Place shaft bearing on arbor press and support inner race (fig. 83). Place bearing shield over

MAINTENANCE — LIGHT TANKS M5, M5A1, AND M24, 75-MM HOWITZER MOTOR CARRIAGE 8, AND TWIN 40-MM GUN MOTOR CARRIAGE M19: ENGINES, COOLING SYSTEMS AND FUEL SYSTEMS

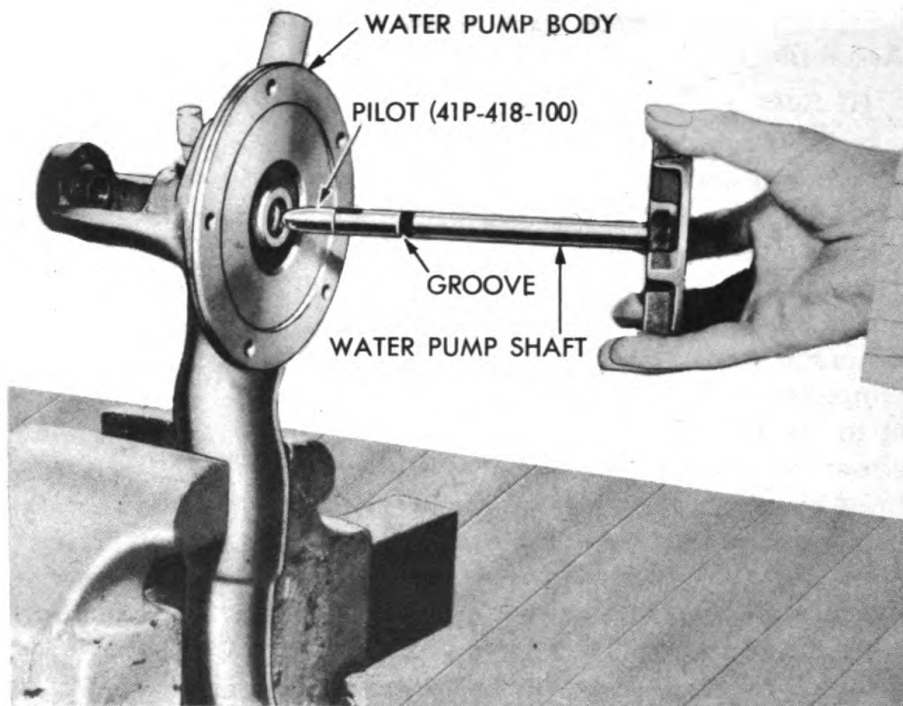

RA PD 331556

Figure 84 — Installing Water Pump Impeller and Shaft, 1G Series

threaded end of pump shaft and install on bearing. Press shaft into bearing until bearing inner race seats against bearing shield and pump shaft shoulder.

(b) *Install Packings.* Push inner impeller shaft packing ring into pump body until it seats on shoulder of body (fig. 83). **NOTE:** *square end of ring should point toward impeller end of body.* Lubricate three new chevron packings and install packings in pump body with convex side of packings up. Install bearing and packing retaining spring pump body. Install center packing ring in pump body with square end toward impeller. Lubricate one packing and install in pump body with convex side up. Install rear packing ring in pump body with grooved side toward packing. Tap packing assembly with brass drift and hammer, and compress until snap ring groove in body appears ahead of packing assembly. Install packing lock ring.

(c) *Install Impeller and Shaft.* Press impeller on pump shaft, with vanes toward pulley end, until impeller face is flush with end of shaft. Install shaft in pump body from impeller end of body until shaft protrudes at other end, being careful to prevent damage to packings. Place pump assembly on arbor press with impeller end on bed

COOLING SYSTEM

of press, and press bearing on shaft and into counterbore in body. Install bearing snap ring.

(d) *Install Pulley.* Install Woodruff key in slot in pump shaft end. Slide pulley on shaft and over Woodruff key, lining up slot in pulley with key on shaft. Install plain washer, lock washer and nut on shaft. Tighten nut while holding impeller with screwdriver through vanes.

Section III

FITS AND TOLERANCES

24. FITS AND TOLERANCES.

	1G Series	3G Series
a. Fan.		
Diameter of shaft	0.6262 in.	0.9846 in
I. D. of bearing support	1.1606 in.	2.0471 in
Run-out of pulley	0.010 in.	0.010 in
b. Water Pump.		
Diameter of shaft	0.4975 in.	0.4975 in
Clearance between impeller and pump body	0.050 to 0.092 in.	0.050 to 0.075 in
End play	0.002 in.	0.002 in
Free length packing spring (max.)	1¼ in.	1¼ in
Packing spring compressed to ½-in.	2½ to 3 lb	2½ to 3 lb

CHAPTER 4

FUEL SYSTEM

Section I

DESCRIPTION AND DATA

25. GENERAL.

a. Description, 1G Series.

(1) This fuel system (fig. 85) consists of two 43-gallon fuel tanks located in the sponsons on each side of the engine compartment, from which lines lead to a combination filter and shut-off valve on the left front of the bulkhead, and thence back to the mechanical fuel pumps, one on each engine, and up to the carburetors.

(2) An air cleaner is carried in a special compartment at the rear of each sponson. Air from the fighting compartment passes around the fuel tanks, through the oil and filtering elements of the cleaners and through carefully sealed air inlet tubes to the carburetors.

(3) The fuel system for the auxiliary power plant (used on M5, M5A1 vehicles only) consists of a fuel line from the left-hand tank (fig. 85), a separate filter and shut-off valve, and a line down to the carburetor on the auxiliary power plant. There is also a separate oil-bath air cleaner and air intake tube to the carburetor. There is no separate fuel tank for this system, and no fuel pump, as the system has a gravity feed.

b. Description, 3G Series.

(1) This fuel system (fig. 86) consists of two fuel tanks of 55-gallon capacity carried in narrow deep compartments on each side of the engine compartment. Each tank contains a support assembly (fig. 95) on which an electric fuel pump is mounted at the bottom of the tank, and which includes two self-cleaning cylindrical strainers.

(2) A fuel line extends from each fuel pump through the top of the fuel pump support assembly, forward to a check valve and then to the shut-off valve and to a connecting line carried across the radiator support at the front of the engine compartment. This line contains two T-connections from which a rubber line extends to the carburetors. This makes it possible for either tank to supply fuel to both engines.

(3) The flow of fuel and selection of the tank is controlled by a pair of levers and switches at the front center of the driving compartment roof (fig. 87). From each of these levers a control cable

FUEL SYSTEM

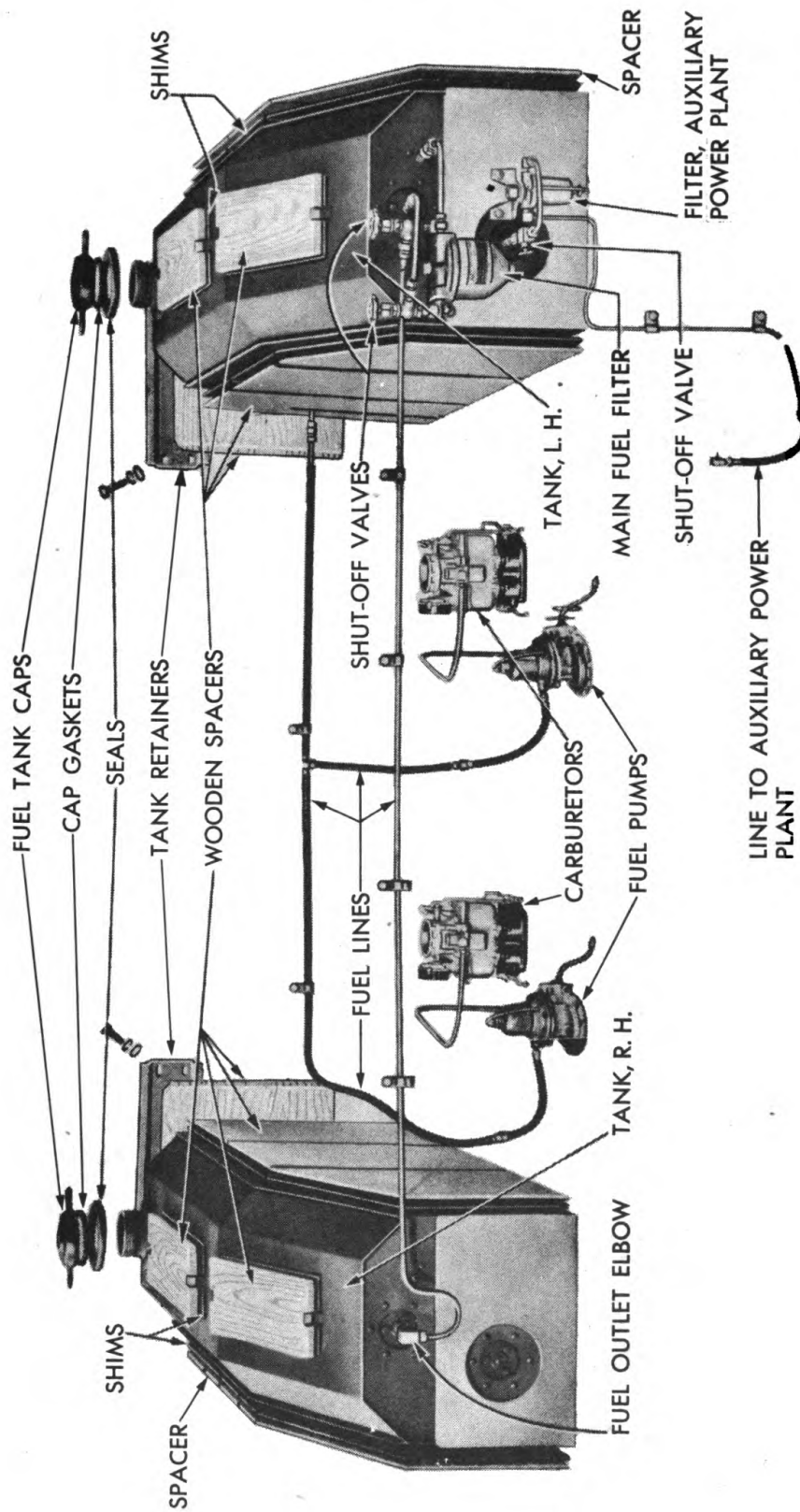

RA PD 331564

Figure 85 — Fuel System, M5A1, 1G Series

ORDNANCE MAINTENANCE — LIGHT TANKS M5, M5A1, AND M24, 75-MM HOWITZER MOTOR CARRIAGE M8, AND TWIN 40-MM GUN MOTOR CARRIAGE M19: ENGINES, COOLING SYSTEMS AND FUEL SYSTEMS

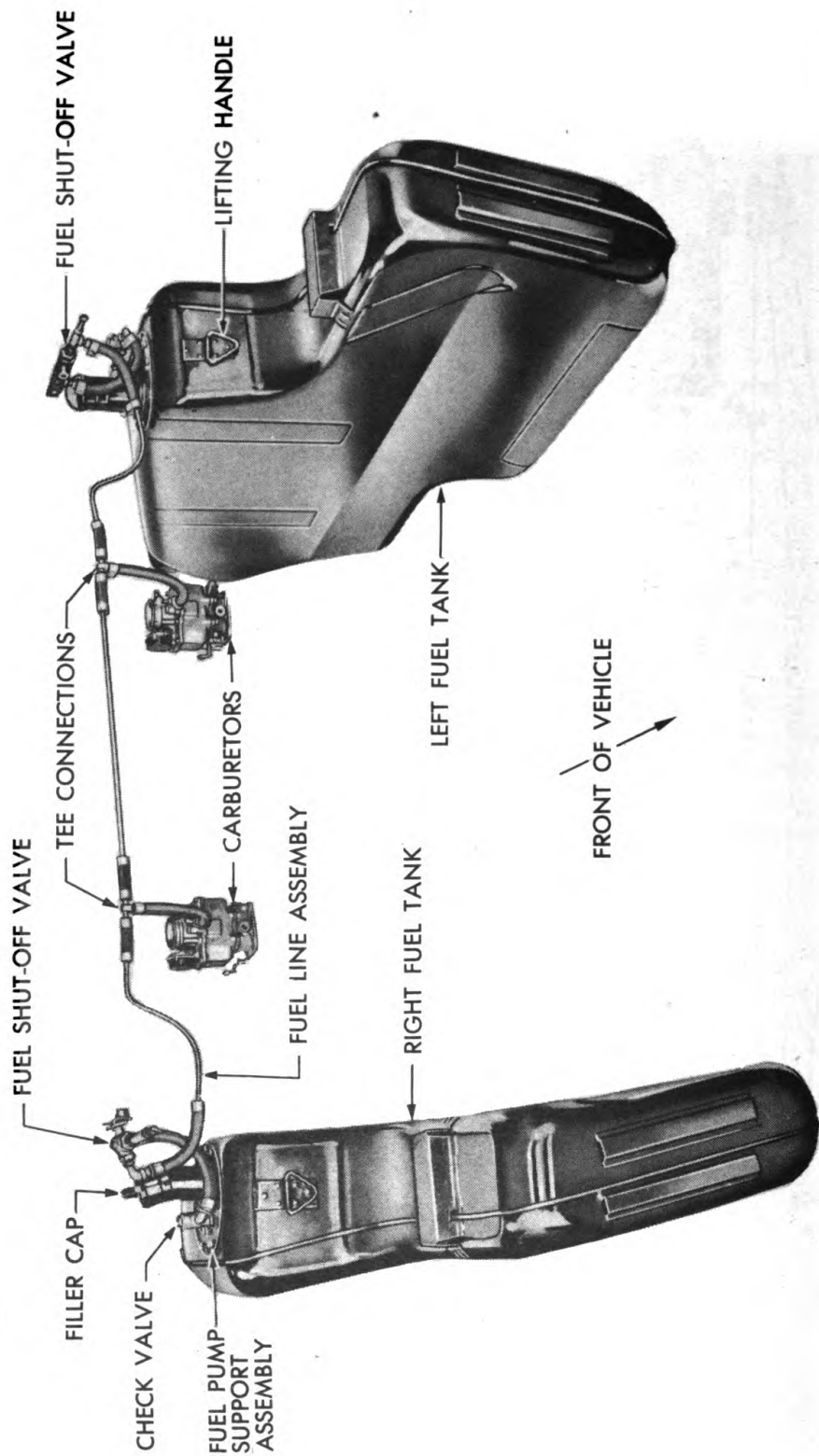

RA PD 331381

Figure 86 — Fuel System, M24, 3G Series

FUEL SYSTEM

extends back to the shut-off valve, and the feed wire for the pump extends back to the terminal on top of the fuel pump support assembly, from which it is carried in an insulated conduit to the pump.

c. Service Information.

(1) **CARBURETORS.** Information on the disassembly, cleaning, inspection, repair and assembly of carburetors used on 1G and 3G series, is given in TM 9-1826A.

(2) **FUEL PUMPS.** Service information on the AC mechanical fuel pumps used in 1G systems, in TM 9-1829A.

(3) **LINES AND FITTINGS.** Service information on the fuel lines and fittings appears in TM 9-729.

(4) **OTHER UNITS.** Service information on the remaining units appears in later paragraphs of this manual.

26. DATA.

a. The specifications as given below are for one carburetor, fuel pump, air cleaner, etc. They apply to either right- or left-hand units unless otherwise indicated.

	1G Series	3G Series
b. Carburetor.		
Make	Carter	Carter
Type	WCD dual downdraft	WCD dual downdraft
Model	WCD 566 SA 578 S	WCD 583S
Idling adjustment	Screw type	Screw type
Flange size	1 1/4 in.	1 1/4 in.
Gas line connection	3/8 in. elbow	3/8 in. hose nipple
Accelerating pump type	High-pressure	High-pressure
Choke type	Automatic	Automatic
Choke valve type	Offset butterfly valve	Offset butterfly valve

c. Fuel Pump.

Make	AC	Carter
Model	BE	24 volt
Number	2	2
Type	Diaphragm	Centrifugal
Drive	Eccentric cam	Electrical
Capacity	20-24 cc. per stroke	200 gals. per hr @ no back pressure
Pressure	3 1/2 to 5 lb	6 lb
Octane rating of fuel (Min.)	80	80

ORDNANCE MAINTENANCE — LIGHT TANKS M5, M5A1, AND M24, 75-MM HOWITZER MOTOR CARRIAGE M8, AND TWIN 40-MM GUN MOTOR CARRIAGE M19: ENGINES, COOLING SYSTEMS AND FUEL SYSTEMS

d. Engine Fuel Filter.

	1G Series	3G Series
Make	AC	Cadillac
Type	Laminated strainer	Self-cleaning, 24 x 110 mesh
Strainers		Filler support, pump inlet
Surface area	12.85 sq in.
Filtering area	4.48 sq in.
Model No.	358 or 359
Valves, shut-off		
Location	Front of bulkhead	Fuel compartment
Number	2	2

e. Air Cleaner.

Number used	2	2
Type	Oil bath	Oil bath
Make	AC	AC & Donaldson
Filter element	Steel mesh	Steel mesh
Reservoir capacity	3 pt	3 qt

f. Auxiliary Power Plant Fuel Filter (M5, M5A1 only).

Make	AC
Type	Laminated strainer
Strainers		
Surface area	2.764 sq in.
Filtering area	0.96 sq in.
Number	81
Valve, shut-off		
Location	Front of bulkhead
Number	1

g. Auxiliary Power Plant Air Cleaner (M5, M5A1 only).

Make	AC
Filter element	Copper mesh
Reservoir oil capacity	Approx. 1/4 pt
Number used	1

FUEL SYSTEM

Section II

**DISASSEMBLY, CLEANING, INSPECTION, REPAIR,
AND ASSEMBLY OF SUBASSEMBLIES**

27. FUEL VALVES AND CONTROLS (3G SERIES).

a. Fuel Valve Controls.

(1) **DISASSEMBLY.** NOTE: *The following procedure applies to one of the two controls of the fuel valve controls. Each handle and component parts are identical and the procedure for disassembly, etc., is the same.* Loosen jam nut on switch lever and remove cotter pin from trunnion on link. Remove cotter pin holding fork and turnbuckle to control handle and remove clevis pin, two spacers, fork and link assembly from handle. Disassemble link, if necessary, by removing two nuts, trunnion and spring. Remove two cotter pins and two clevis pins holding control handle in position and remove handle from mounting. Remove eye and jam nut from switch lever. Disconnect wires from terminal on underside of switch. Remove rubber cap, lock nut, lock washer and lock plate. Remove switch from mounting. Remove two circuit breaker mounting screws and disconnect wires from circuit breaker.

(2) **CLEANING AND INSPECTION.** Clean all parts except switches with dry-cleaning solvent and dry thoroughly with compressed air. Inspect parts for wear or damage.

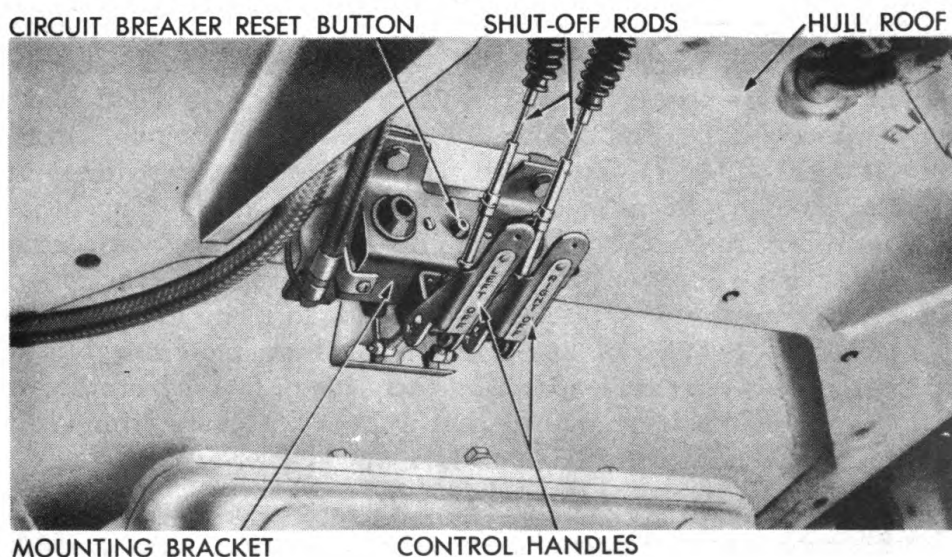

RA PD 331552

Figure 87 – Fuel Valve Controls, 3G Series

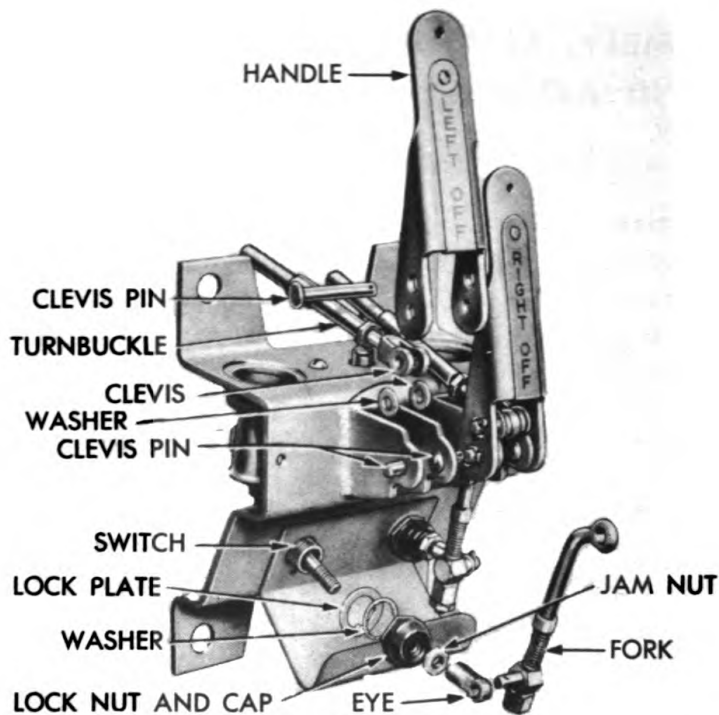

RA PD 331553

Figure 88 — Fuel Valve Controls, 3G Series, Disassembled View

(3) **ASSEMBLY.** Connect wires to post on circuit breaker, position circuit breaker in mounting and install two mounting screws. Connect wire from circuit breaker to "ON" terminal of switch and insert switch in control mounting bracket. Install lock plate on switch, being sure tangs on plate are properly positioned in groove on switch and hole in control mounting bracket. Install lock washer on switch. Install lock nut with rubber cap on switch. Install jam nut on switch lever to end of threads. Install eye, screwing it down until it contacts jam nut. Position trunnion on link assembly in eye and lock in position with cotter pin. Position control handle on mounting bracket and install two clevis pins and cotter pins. Position fork and link in mounting bracket so that eye of link points away from mounting bracket and install clevis pin with a spacer on each side of fork. Install cotter pin. Adjust switch lever eye so that it does not cause trunnion to bind on link assembly, then tighten lock nut against eye.

b. Fuel Valves. NOTE: Both fuel valves are serviced as an assembly; however, the following information is given as a guide for servicing whenever replacement valves are not available.

(1) **DISASSEMBLY.** Remove two screws and lock washers holding valve body assembly to mounting bracket. Remove cotter pin hold-

FUEL SYSTEM

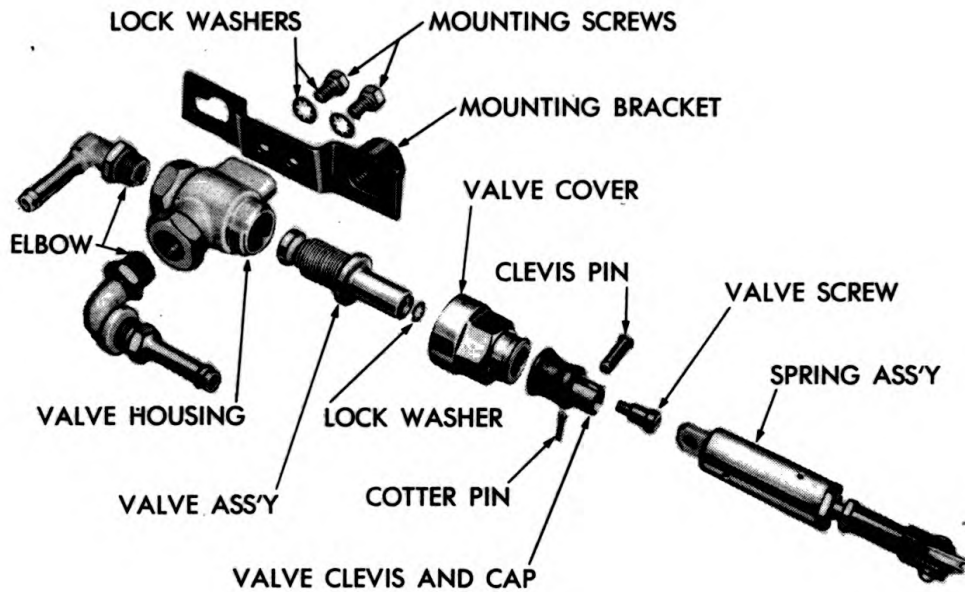

RA PD 331554

Figure 89 – Fuel Shut-off Valve, 3G Series, Disassembled View

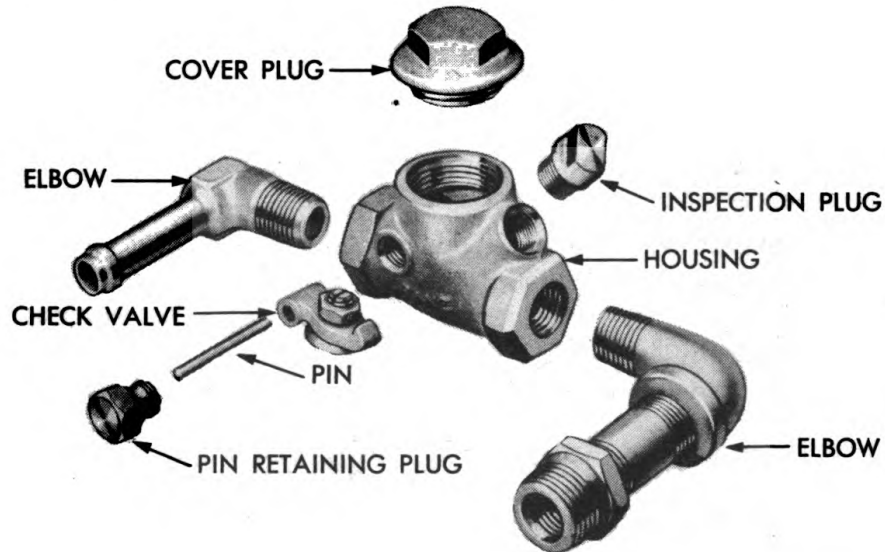

RA PD 331555

Figure 90 – Fuel Check Valve, 3G Series, Disassembled View

ing spring assembly to clevis. Remove clevis pin and spring assembly. Remove screw in valve clevis and lift off clevis, rubber cap and washer (fig. 89). Back off valve cover from valve housing and lift out valve assembly. Remove both elbows from housing.

(2) **CLEANING AND INSPECTION.** Clean all parts in dry-cleaning

ORDNANCE MAINTENANCE — LIGHT TANKS M5, M5A1, AND M24, 75-MM HOWITZER MOTOR CARRIAGE M8, AND TWIN 40-MM GUN MOTOR CARRIAGE M19: ENGINES, COOLING SYSTEMS AND FUEL SYSTEMS

solvent and dry thoroughly with compressed air. Inspect hoses, valve assembly and rubber caps for deterioration or wear.

(3) **ASSEMBLY.** Insert valve assembly in valve housing and install valve cover, tightening securely. Place washer in recess in end of valve assembly. Position valve clevis and rubber cap over valve cover and install screw. Place spring assembly in clevis and install clevis pin and new cotter pin. Install both fuel line elbows in valve housing. Install housing on mounting bracket.

c. **Check Valves.**

(1) **INSPECTION BEFORE DISASSEMBLY.** The small, threaded, inspection plug (fig. 90) is provided so that a quick inspection and service of the valve may be made without complete disassembly of the unit. Remove plug and insert screwdriver through opening until it contacts screw head in valve assembly. Turning the screw in a forward or backward motion will assist in removing dirt or sediment that may accumulate on valve or seat.

(2) **DISASSEMBLY.** Remove cover plug on top of check valve assembly. Remove pin retaining plug on side of assembly, lift out pin and remove valve from housing. Remove elbows from valve. **NOTE:** *Both check valves are serviced as an assembly; however, the following information is given as a guide for servicing whenever replacement valves are not available.*

(3) **CLEANING AND INSPECTION.** Clean all parts with dry-cleaning solvent and dry thoroughly with compressed air. Inspect all parts for unusual wear.

(4) **ASSEMBLY.** Use pipe joint cement or sealer on all threaded surfaces of elbows before installing. Position valve assembly in housing so that screw head faces toward top opening in housing. Insert pin and install pin retaining plug, drawing up securely. Install inspection plug and cover plug in housing.

28. VALVES AND FILTERS (1G SERIES).

a. **Inlet Shut-off Valve.**

(1) **DISASSEMBLY.**

(a) *(First Type M5 Only).* Screw both valve assemblies off nipples and remove valve assemblies (fig. 91). Remove screw holding one valve assembly handle on valve stem and remove handle from valve stem. Remove packing nut while holding stem and packing retainer from turning. Lift valve spring off valve stem. Unscrew valve stem and packing retainer from valve body while holding body. Screw stem out of packing retainer and remove packing from other end of retainer. Disassemble other shut-off valve in same manner.

FUEL SYSTEM

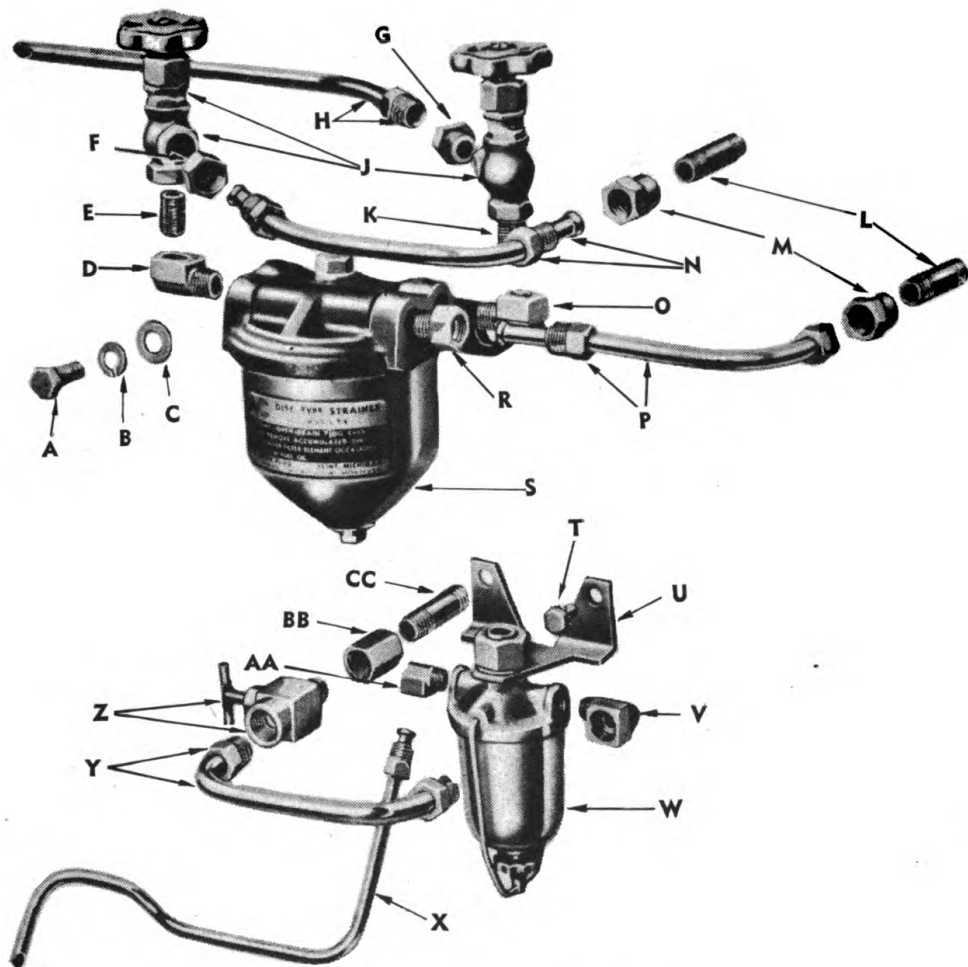

- | | |
|-------------------|-------------------|
| A — SCREW | P — LINE, ASS'Y |
| B — WASHER, LOCK | R — CONNECTOR |
| C — WASHER, PLAIN | S — FILTER, ASS'Y |
| D — ELBOW | T — SCREW |
| E — NIPPLE | U — BRACKET |
| F — CONNECTOR | V — ELBOW |
| G — CONNECTOR | W — FILTER, ASS'Y |
| H — LINE, ASS'Y | X — LINE, ASS'Y |
| J — VALVE | Y — LINE, ASS'Y |
| K — NIPPLE | Z — COCK |
| L — NIPPLE | AA — ELBOW |
| M — CONNECTOR | BB — COUPLING |
| N — LINE, ASS'Y | CC — NIPPLE |
| O — ELBOW | |

RA PD 50335

Figure 91 — Fuel Filter Connections, First Type, 3G Series

ORDNANCE MAINTENANCE — LIGHT TANKS M5, M5A1, AND M24, 75-MM HOWITZER MOTOR CARRIAGE M8, AND TWIN 40-MM GUN MOTOR CARRIAGE M19: ENGINES, COOLING SYSTEMS AND FUEL SYSTEMS

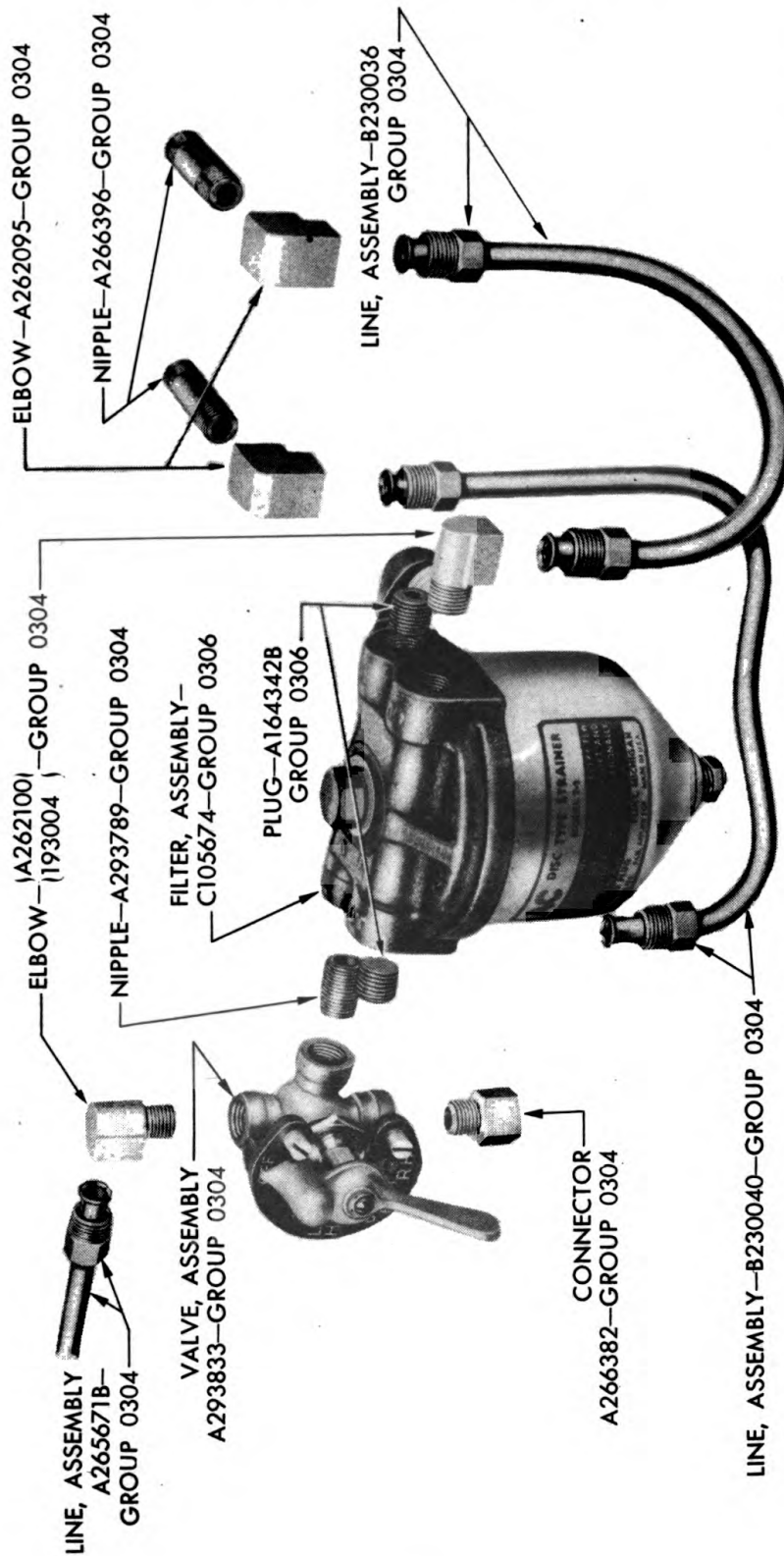

RA PD 331124

Figure 92 — Fuel Filter Connections, Second Type, 3G Series

FUEL SYSTEM

(b) (*Second Type M5 and M8*). Remove shut-off valve from fuel filter. Remove screw and lock washer holding dial valve pointer on valve. Remove pointer. Remove detent plunger and spring from pointer. Remove two screws and lock washers holding valve dial on valve. Remove valve stem packing nut. Remove packing from packing nut. Remove packing ring from valve stem. Remove valve stem retainer from valve. Remove valve tension spring from valve body. Remove valve and valve stem from valve body. Remove pin holding valve stem to valve. Remove fittings from valve body.

(2) **INSPECTION.** Inspect valve stems and valve seats for evidence of damage or improper seating on first type M5 vehicles. Recut valve seat faces as required to obtain a good seal on first type M5 vehicles. Check valve packing. If packing is worn and dried out, it should be replaced.

(3) **ASSEMBLY.**

(a) (*First Type M5 Only*). Position a new valve stem packing on packing retainer and screw valve stem into packing retainer assembly. Screw valve stem and packing retainer assembly into valve body while holding body. Install valve spring in body around valve stem and install packing nut while holding valve stem and packing retainer. Position valve assembly handle on valve stem and install mounting screw. Screw valve assembly on nipples on fuel filter. Assemble and install the other shut-off valve in a like manner.

(b) (*Second Type M5 and M8*). Install fittings on valve body. Elbow fitting to right fuel tank should be installed on upper end of valve when valve outlet points to right. Opening on elbow should point toward left. Position valve stem in valve and install lock pin. Install valve in valve body so that one opening points downward and the other opening points toward left when valve outlet points toward right. Install valve tension spring on top of valve around valve stem. Install valve retaining nut. Install valve stem packing ring around valve stem. Install valve stem in packing nut. Install nut on valve retainer nut. Position dial on valve body and install two mounting screws and lock washers. Position valve pointer detent spring and plug in valve pointer. Position valve pointer on valve stem so that detent plug is in "OFF" position. Install valve pointer mounting screw and lock washer in valve stem. Install valve assembly on fuel filter.

b. Fuel Filter.

(1) **DISASSEMBLY.** Remove shut-off valve fittings from fuel filter body on first type M5 vehicles. Remove screw and gasket holding cover to shell and remove cover and cover gasket. Remove plug from lower end of shell. Lift strainer assembly and spring out of shell. Remove strainer gasket from strainer assembly.

ORDNANCE MAINTENANCE — LIGHT TANKS M5, M5A1, AND M24, 75-MM HOWITZER MOTOR CARRIAGE M8, AND TWIN 40-MM GUN MOTOR CARRIAGE M19: ENGINES, COOLING SYSTEMS AND FUEL SYSTEMS

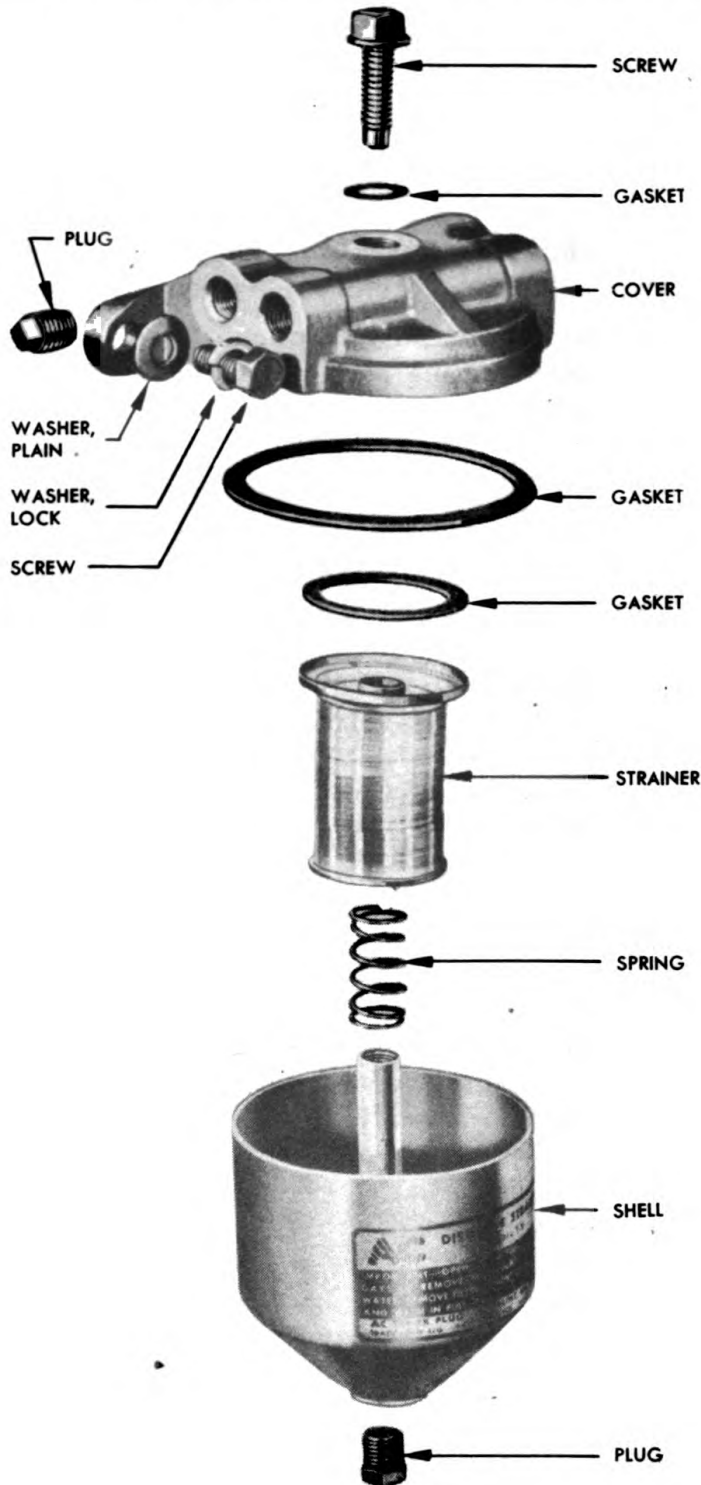

RA PD 9127

Figure 93 — Fuel Filter, 1G Series, Disassembled View

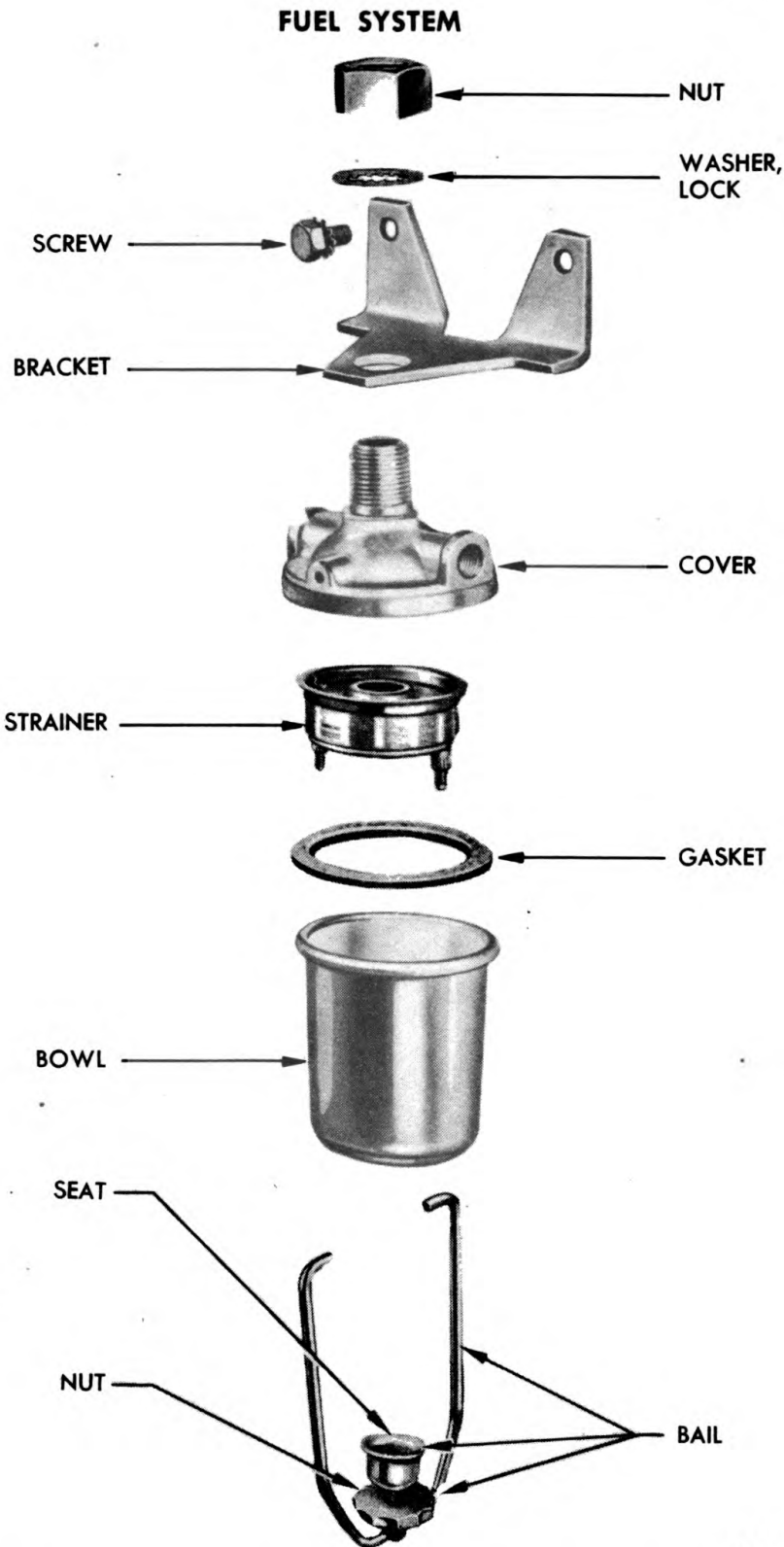

RA PD 9128

**Figure 94 – Fuel Filter Auxiliary Power Plant M5, M5A1,
Disassembled View**

ORDNANCE MAINTENANCE — LIGHT TANKS M5, M5A1, AND M24, 75-MM HOWITZER MOTOR CARRIAGE M8, AND TWIN 40-MM GUN MOTOR CARRIAGE M19: ENGINES, COOLING SYSTEMS AND FUEL SYSTEMS

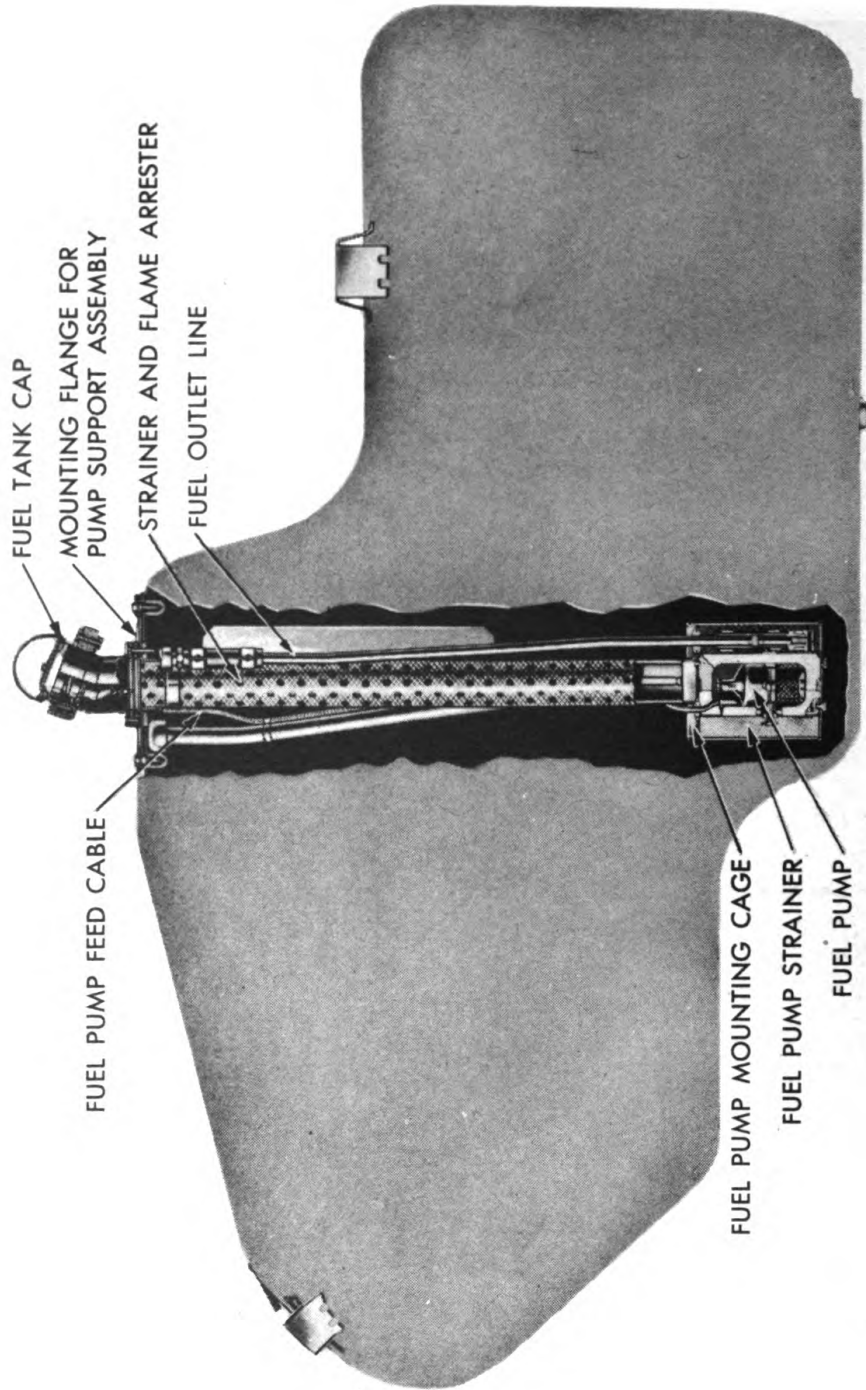

RA PD 331565

Figure 95 — Fuel Pump Support and Strainer Assembly

FUEL SYSTEM

(2) **CLEANING AND INSPECTION.** Clean all fuel filter parts thoroughly in dry-cleaning solvent and dry with compressed air. Check all passages in filter cover for obstructions or dirt and clean as required. Inspect filter cover for nicks, cracks or burs. Inspect filter shell for bends or damage on surface which contacts cover. Check laminated filter strainers to see that strainers are flat and form a close contact with each other.

(3) **ASSEMBLY.** Position a new strainer gasket on strainer assembly and install strainer assembly on fuel filter cover. Position spring over stems in shell assembly. Position shell gasket in filter cover, and install shell, fastening with retaining screw and lock washers. Install drain plug in shell.

c. Auxiliary Power Plant Fuel Filter (M5 Only).

(1) **DISASSEMBLY.** Remove inlet and outlet elbows from filter cover. Loosen bowl bail nut and swing bail to one side. Remove filter bowl from cover (fig. 94). Lift strainer assembly and gasket off filter cover. Spread upper end of bail where it is attached to cover until prongs of bail can be removed from holes in cover. Mark position of filter mounting bracket on cover and remove nut and lock washer holding mounting bracket to cover. Remove bracket.

(2) **INSPECTION AND CLEANING.** Clean all filter parts thoroughly in dry-cleaning solvent and dry with compressed air. Inspect filter cover for nicks and burs. Check bowl for bends or irregularities which might cause poor contact with filter cover. Insert strainer assembly and gasket in filter cover to see that a good fit is obtained between strainer and cover. Inspect valve stem and seat for evidence of damage or poor valve seating. Recut valve stem seat as required. Check valve packing and replace if worn or dried out.

(3) **ASSEMBLY.** Position filter mounting bracket on filter cover, lining up marks on cover and bracket which were made before bracket was removed. Install nut and lock washer holding bracket to filter cover. Spread prongs of bowl bail until prongs can be inserted in mounting holes in cover. Position a new strainer assembly gasket on filter cover and install strainer assembly on cover. Position a new filter bowl gasket on cover and install bowl on cover. Swing bowl bail over bowl and tighten bail nut. Install inlet and outlet elbows on filter cover.

29. SUPPORT AND STRAINER ASSEMBLY (3G SERIES).

a. **Disassembly.** Remove four screws at bottom of fuel pump mounting cage and remove lower screen and plate. Remove pump mounting cushions. Loosen fuel line hose clamp at pump. Remove four screws from terminal bracket at mounting flange and then lower fuel pump sufficiently to allow removal of feed wire from fuel pump motor housing by backing off feed wire nut and removing screw hold-

RA PD 331119

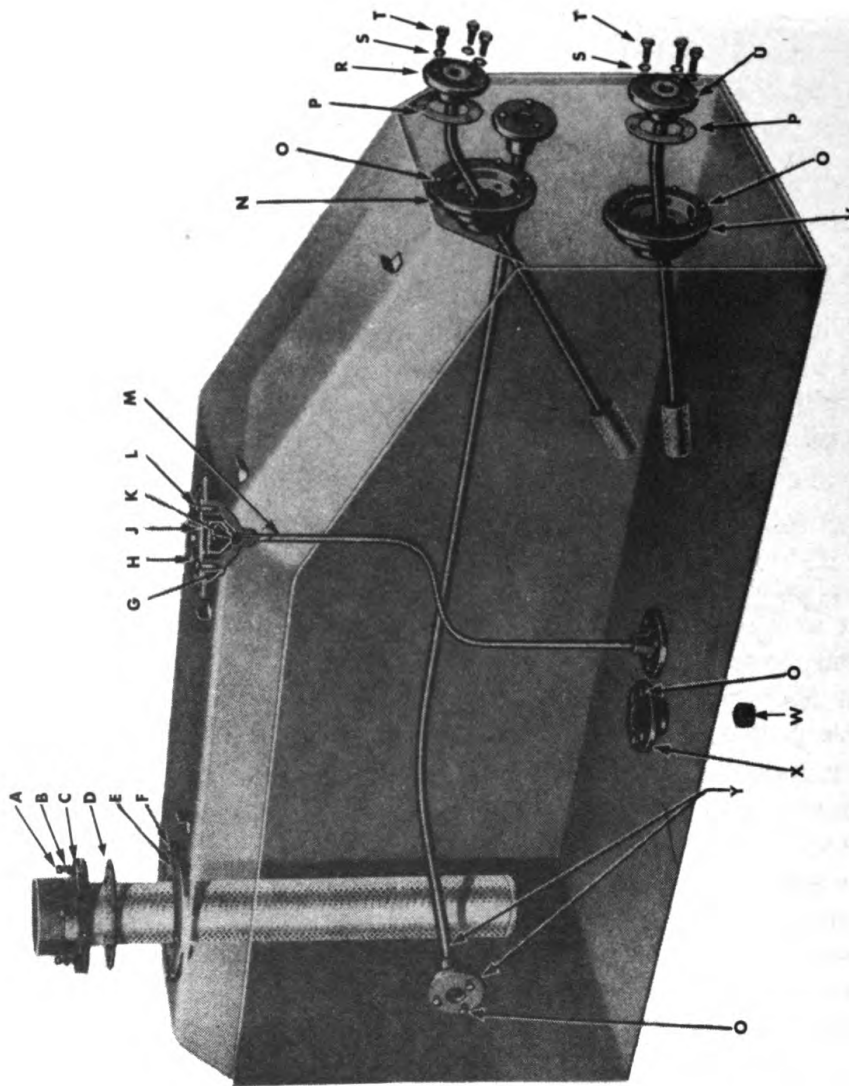

Figure 96 — Fuel Tank Assembly (L. H.) 1G Series

FUEL SYSTEM

- | | | |
|--|---------------------------------------|---------------------------------------|
| A —CAP SCREW | J —PRESSURE RELIEF VALVE COVER | S —LOCK WASHER |
| B —LOCK WASHER | K —PRESSURE RELIEF VALVE SEAL | T —CAP SCREW |
| C —FLAME ARRESTER | L —CAP SCREW | U —FUEL FILTER SCREEN |
| D —FLAME ARRESTER GASKET | M —RELIEF VALVE LINE | V —FUEL FILTER SCREEN FLANGE |
| E —FLAME ARRESTER PLATE | N —OUTLET FLANGE | W —DRAIN PLUG |
| F —RIVET | O —RIVET | X —DRAIN PLUG FLANGE |
| G —PRESSURE RELIEF VALVE | P —OUTLET ADAPTER FLANGE | Y —FUEL LEAD THROUGH FUEL TANK |
| H —PRESSURE RELIEF VALVE GASKET | R —OUTLET FUEL FILTER SCREEN | |

RA PD 33119B

RA PD 33119B

Legend for Figure 96 — Fuel Tank Assembly (L. H.) IG Series

ORDNANCE MAINTENANCE — LIGHT TANKS M5, M5A1, AND M24, 75-MM HOWITZER MOTOR CARRIAGE M8, AND TWIN 40-MM GUN MOTOR CARRIAGE M19: ENGINES, COOLING SYSTEMS AND FUEL SYSTEMS

ing wire in housing. Remove feed wire from support assembly by bending back three clips holding wire to vent line and then removing grommet from upper plate of fuel pump mounting cage. Remove outlet line by loosening hose clamps at the top of fuel pump support assembly at outlet elbow and sliding hose down on line, then loosening hose clamps at mounting cage and pulling line out and up.

b. Cleaning and Inspection. Clean all parts in dry-cleaning solvent and dry thoroughly with compressed air. Inspect both upper and lower screen. Inspect feed wire and shielding for breaks. Check outlet line and hoses for any signs of breaks or deterioration. Inspect upper and lower screen for security of mounting and vent line for breaks in solder seal at upper and lower mounting.

c. Assembly. Insert feed wire through hole in mounting cage and position grommet. Install screw in feed wire mounting in housing and tighten feed wire nut. Position pump in mounting cage and install rubber mountings and cotter pins. Install outlet line in lower hose and tighten clamps. Draw upper hose up on outlet elbow and tighten clamps. Position terminal bracket on underside of mounting flange and install four screws. Place feed wire under three clips and bend clips back in position. Place lower screen and plate in position and install four mounting screws.

30. FUEL TANKS.

a. Disassembly, IG Series. *NOTE: The fuel tanks are of brazed construction and, therefore, cannot be disassembled unless new plates are again brazed in place. The outlet lines, screens, and drain plugs can be removed.*

(1) **DISASSEMBLE RIGHT-HAND TANK.** Straighten brackets holding both top fuel tank wooden shims in position and remove shims. Remove three screws and lock washers holding fuel tank outlet screen assembly and gasket and take screen out of fuel tank. Remove six screws and washers holding flame arrester and filler assembly to plate on top of fuel tank. Remove flame arrester assembly and gasket. Remove two screws holding cover over relief valve, and take out cover and valve.

(2) **DISASSEMBLE LEFT-HAND TANK.** The left-hand tank is disassembled in the same manner as the right-hand tank with the following additions on M5, M5A1 fuel tanks. Remove three screws and lock washers holding auxiliary power plant outlet screen assembly and gasket from fuel tank.

b. Cleaning, Inspection, and Repair, IG Series. Inspect brazed joints of fuel tank to make sure that they are not leaking. Check screen on outlet pipe assembly and replace if broken or damaged in

FUEL SYSTEM

such a way that sediment in the fuel tank could pass into the fuel lines. Inspect relief valve assembly. Inspect the vent in the fuel tank filler cap to make sure it is open. Make sure that vent float does not stick. Inspect condition of mounting flanges on outlet pipe assembly and flame arrester inlet to make sure they are smooth and flat. Remove any nicks or burs with a fine file. Clean according to procedures in TM 9-1726F.

c. Assembly, 1G Series.

(1) **ASSEMBLE RIGHT-HAND TANK.** Position a new flame arrester and filler assembly gasket on top of fuel tank. Install flame arrester and filler assembly in fuel tank and install six screws and washers holding assembly to tank. Install drain plug in bottom of fuel tank. Install relief valve gasket and cover. Position a new fuel tank outlet screen assembly gasket on front end of fuel tank and install outlet screen assembly in front of tank. Install three screws and lock washers holding screen assembly to tank. Position both top fuel tank wooden shims in position on tank, and bend brackets over notches in shims.

(2) **ASSEMBLE LEFT-HAND TANK.** NOTE: *The left-hand tank is assembled in exactly the same manner as the right-hand fuel tank with the following additions.* Position a new auxiliary power plant outlet screen assembly gasket on front end of fuel tank and position outlet screen assembly in fuel tank (M5, M5A1 only). Install the three screws and lock washers which hold auxiliary plant outlet screen assembly to flange on fuel tank (M5 only).

d. **Disassembly, 3G Series.** Remove drain plug. Remove fuel pump support and strainer assembly by taking out the 12 attaching screws and lifting support assembly out. Remove two cap screws and take off hold-down spring at upper rear mounting bracket.

e. **Cleaning, Inspection and Repair, 3G Series.** Inspect brazed joints to make sure they are not leaking. Inspect flat metal areas, particularly on sides, for cracks or leakage. If leaks are found around or near the upper mounting brackets, unsolder these brackets to make thorough brazing repairs beneath them. Inspect mounting flange for fuel pump support assembly to make sure that it is smooth and flat. Clean tank according to procedures in TM 9-1726F.

f. **Assembly, 3G Series.** Install drain plug. Position hold-down spring on upper rear mounting bracket and attach with two cap screws. Lower fuel pump support assembly into tank and attach with 12 cap screws and lock washers.

CHAPTER 5
SPECIAL TOOLS

31. SPECIAL TOOLS.

a. The special tools required for servicing the engines, cooling systems and fuel systems of M5, M5A1, M8, M19 and M24 vehicles are given below. This list is for information and is not to be used as a basis for requisitioning.

Tool Name	Ordnance No.	Federal Stock No.
BOLT, eye, transmission lifting	A266327	41B-1586-300
DRIVER, valve stem guide (removing and installing)	B226789	41D-2993
GAGE, valve stem length	A266510	41G-504

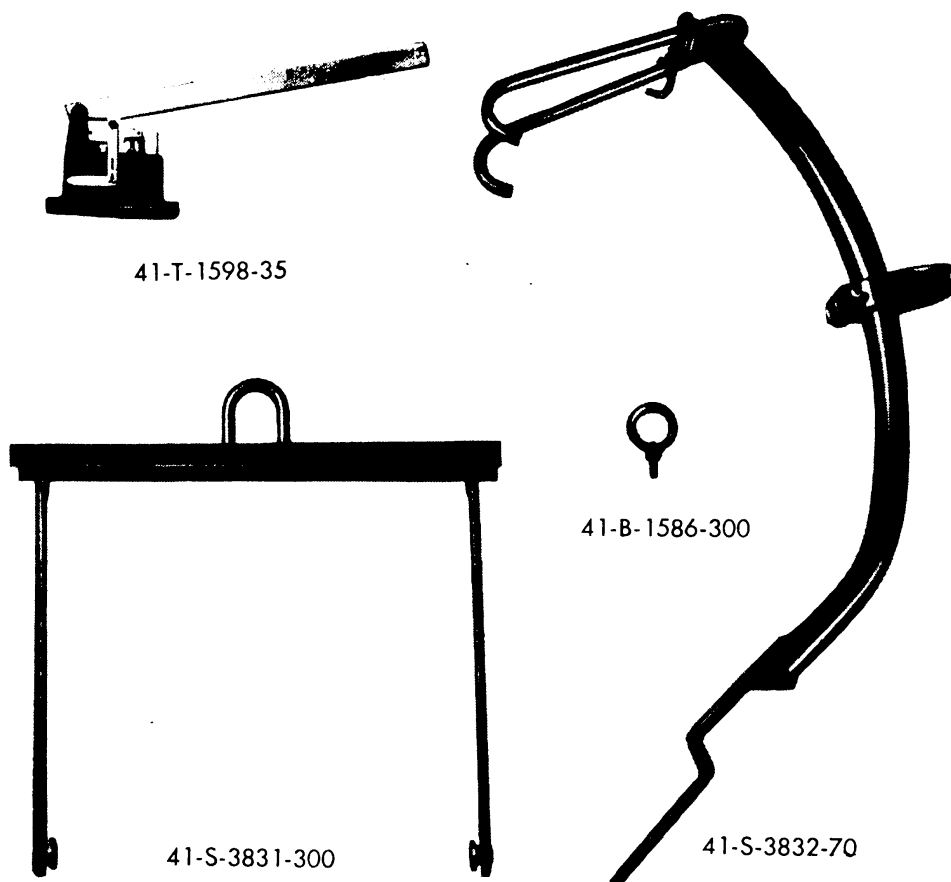

RA PD 344116

Figure 97 — Engine Lifting Tools and Valve Lifter Tester

SPECIAL TOOLS

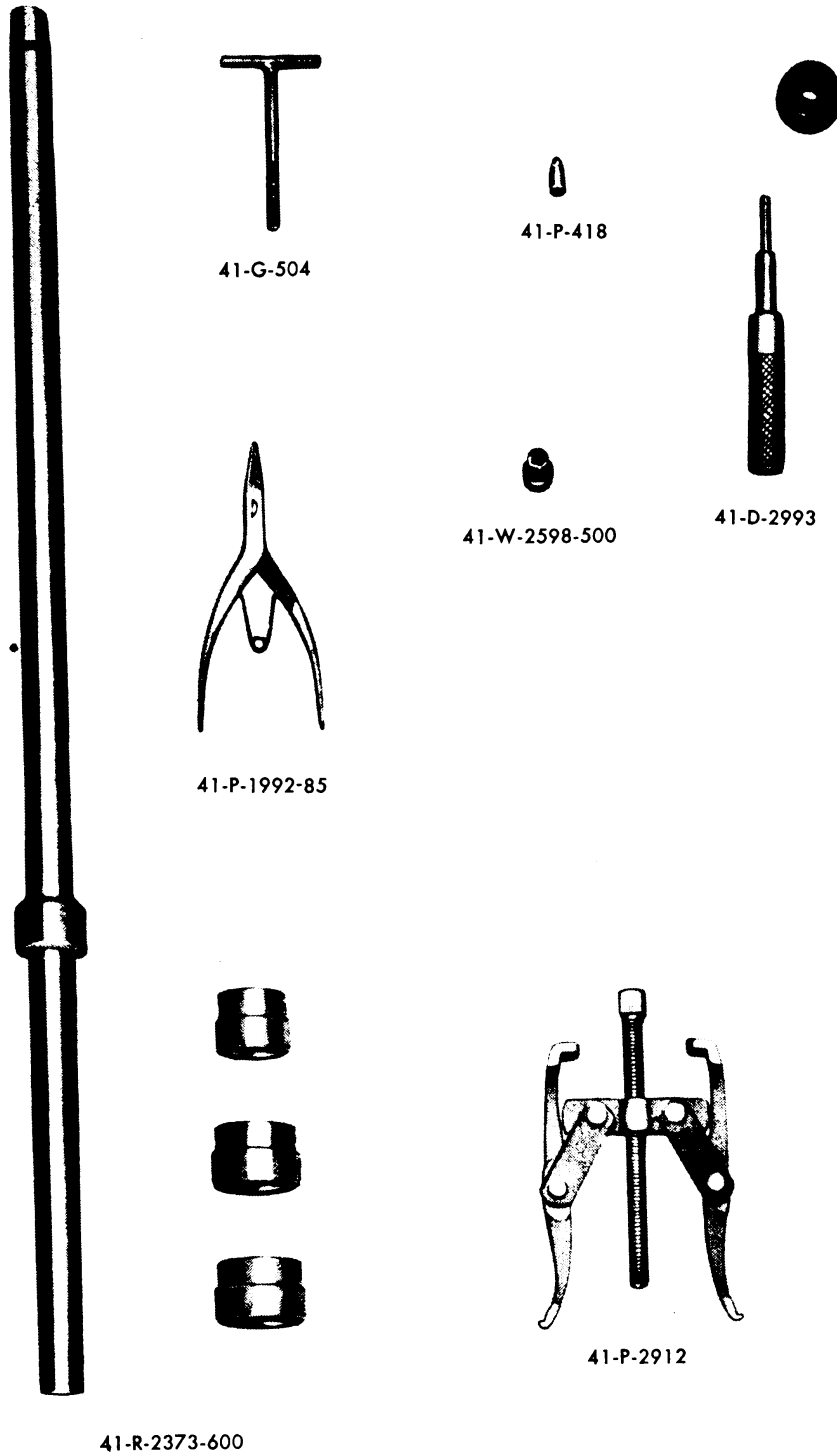

RA PD 344115

Figure 98 — Engine, Cooling, and Fuel System Tools

ORDNANCE MAINTENANCE — LIGHT TANKS M5, M5A1, AND M24, 75-MM HOWITZER MOTOR CARRIAGE M8, AND TWIN 40-MM GUN MOTOR CARRIAGE M19: ENGINES, COOLING SYSTEMS AND FUEL SYSTEMS

PILOT, thimble, water pump shaft pilot (1G)	B226792	41P-418
PLIERS, snap ring removing	A266329	41P-1992-85
PULLER, crankshaft pulley	C130732	41P-2912
REMOVER AND REPLACER, camshaft bearing	B226791	41R-2373-600
SLING, engine lifting (1G)	C107502	41S-3832-70
SLING, engine lifting (3G)	C7079282	41S-3831-300
SLING, engine compartment roof (1G)	B226796	41S-3832-20
TESTER, hydraulic valve lifter leak-down	B226786	41T-1598-35
WRENCH, socket, connecting rod bolt	A266512	41W-2598-500

REFERENCES

PUBLICATIONS INDEXES.

The following publications indexes should be consulted frequently for latest changes or revisions of references given in this list of references and for new publications relating to materiel covered in this manual:

- a. Introduction to Ordnance Catalog (explaining SNL system) ASF Cat.
ORD 1 IOC
- b. Index (index to SNL's) ASF Cat.
ORD 2 OPSI
- c. Index to Ordnance Publications (listing FM's, TM's, TC's, and TB's of interest to ordnance personnel, OPSR, FSMWO's, BSD, S of SR's, OSSC's, and OFSB's, and including alphabetical listing of ordnance major items with publications pertaining thereto) OFSB 1-1
- d. List of Publications for Training (listing MR's, MTP's, FM's, TM's, TR's, TB's, MWO's, SB's, WDLO's, and FT's) FM 21-6
- e. List of Training Films, Film Strips, and Film Bulletins (listing TF's, FS's, and FB's by serial number and subject) FM 21-7
- f. Military Training Aids (listing graphic training aids, models, devices, and displays) FM 21-8

STANDARD NOMENCLATURE LISTS.

- a. **Ammunition.**
 - Ammunition, blank, for pack, light and medium field, tank, and antitank artillery ORD 11
SNL R-5
 - Ammunition, fixed and semifixed, including sub-caliber, for pack, light and medium field, aircraft, tank, and antitank artillery, including complete round data ORD 11
SNL R-1
 - Ammunition instruction material for pack, light and medium field, aircraft, tank, and antitank artillery ORD 11
SNL R-6
 - Service fuzes and primers for pack, light and medium field, aircraft, tank, and antitank artillery ORD 11
SNL R-3

ORDNANCE MAINTENANCE — LIGHT TANKS M5, M5A1, AND M24, 75-MM HOWITZER MOTOR CARRIAGE M8, AND TWIN 40-MM GUN MOTOR CARRIAGE M19: ENGINES, COOLING SYSTEMS AND FUEL SYSTEMS

b. Armament.

Gun, 75-mm, M5; and Mount, combination gun, T90	SNL C-66
Gun, machine, cal. .30, Browning, M1919A4, fixed and flexible; M1919A5, fixed and M1916A6, flexible	SNL A-6
Gun, machine, cal. .50, Browning, M2, heavy barrel, fixed and flexible; and ground mounts ..	SNL A-39

c. General.

Cleaning, preserving and lubrication materials; recoil fluids, special oils, and miscellaneous re- lated items	ORD 5 SNL K-1
Soldering, brazing and welding material, gases and related items	SNL K-2
Tool-sets (common) specialists and organiza- tional	SNL G-27 Section 2
Tool-sets (special) automotive and semi-auto- motive	SNL G-27 Section 1

d. Sighting Equipment.

Kit, instrument, repair M4 (for field artillery and coast artillery)	SNL F-206
Mount, telescope, T94 (for 75-mm gun in light tank, T24)	SNL F-296
Periscopes, telescopes for periscopes, and direct sighting telescopes for use in tanks	SNL F-235
Quadrant, gunner's, M1 (mils)	SNL F-140

e. Vehicle.

Tank, light, M24 (T24)	SNL G-200
------------------------------	-----------

REFERENCES

EXPLANATORY PUBLICATIONS.

a. Fundamental Principles.

Ammunition, general	TM 9-1900
Automotive electricity	TM 10-580
Auxiliary fire-control instruments (field glasses, eyeglasses, telescopes, and watches)	TM 9-575
Basic maintenance manual	TM 38-250
Browning machine gun, cal. .30, HB, M1919A4 (mounted in combat vehicles)	FM 23-50
Browning machine gun, cal. .50, HB, M2 (mount- ed in combat vehicles)	FM 23-65
Driver selection and training	TM 21-300
Driver's manual	TM 10-460
Electrical fundamentals	TM 1-455
Field artillery and field mortar ammunition	OFSB 3-3
Fuels and carburetion	TM 10-550
Instruction guide: small arms data	TM 9-2200
Military motor vehicles	AR 850-15
Motor vehicle inspections and preventive main- tenance services	TM 9-2810
Ordnance service in the field	FM 9-5
Precautions in handling gasoline	AR 850-20
Qualifications in arms and ammunition training allowances	AR 775-10
Radio fundamentals	TM 11-455
Radio sets SCR-508, SCR-528, and SCR-538	TM 11-600
Range regulations for firing ammunition for training and target practice	AR 750-10
Small arms ammunition	OFSB 3-5
Small arms ammunition	TM 9-1990
Targets, target materials, and rifle range con- struction	TM 9-855
The radio operator	TM 11-454
75-mm gun T13E1 and aircraft mount T13E2	TM 9-312
2-inch mortar M3	TM 9-293

TM 9-1729A

ORDNANCE MAINTENANCE — LIGHT TANKS M5, M5A1, AND M24, 75-MM HOWITZER MOTOR CARRIAGE M8, AND TWIN 40-MM GUN MOTOR CARRIAGE M19: ENGINES, COOLING SYSTEMS AND FUEL SYSTEMS

b. Maintenance and Repair.

Cleaning, preserving, sealing, lubricating and related materials issued for ordnance materiel	TM 9-850
Maintenance and care of pneumatic tires and rubber treads	TM 31-200
Ordnance maintenance: Carburetors (Carter)	TM 9-1826A
Ordnance maintenance: Controlled differential, final drive, tracks and suspension for light tanks M5, M5A1, and 75-mm howitzer motor carriage M8	TM 9-1727E
Ordnance maintenance: Differential, final drives, track suspension, hull and turret for light tank M24 and twin 40-mm gun motor carriage M19	TM 9-1729C

c. Operation of Material.

Light tank T24 (M24)	TM 9-729
Light tanks M5 and M5A1	TM 9-732
75-mm howitzer motor carriage M8	TM 9-732B
Ordnance maintenance: Electrical equipment (Delco-Remy)	TM 9-1825A
Ordnance maintenance: Electrical system, instruments, and auxiliary generator for light tanks M5, M5A1, and 75-mm howitzer motor carriage M8	TM 9-1727F
Ordnance maintenance: Fire extinguishers	TM 9-1799
Ordnance maintenance: Fuel pumps	TM 9-1828A
Ordnance maintenance: Hull and turret for light tanks M5, M5A1, and 75-mm howitzer motor carriage M8	TM 9-1727G
Ordnance maintenance: Hydra-matic transmission and propeller shafts for light tanks M5, M5A1, and 75-mm howitzer motor carriage M8	TM 9-1727C
Ordnance maintenance: Hydra-matic transmission and transfer unit for light tank M24 and twin 40-mm gun motor carriage M19	TM 9-1729B
Ordnance maintenance: Hydraulic traversing mechanism for light tank M5 (Oilgear)	TM 9-1727K

REFERENCES

- Ordnance maintenance: Speedometers, tachometers, and recorders TM 9-1829A
- Ordnance maintenance: Transfer unit for light tanks M5, M5A1, and 75-mm howitzer motor carriage M8 TM 9-1727D
- d. **Protection of Materiel.**
- Camouflage FM 5-20
- Chemical decontamination company FM 3-70
- Decontamination TM 3-220
- Decontamination of armored force vehicles FM 17-59
- Defense against chemical attack FM 21-40
- Explosives and demolitions FM 5-25
- Military chemistry and chemical agents TM 3-215
- e. **Storage and Shipment.**
- Ordnance company, depot FM 9-25
- Ordnance storage and shipment chart-group G—major items OSSC G
- Preparation of unboxed ordnance materiel for shipment SB 9-4
- Registration of motor vehicles AR 850-10
- Rules governing the loading of mechanized and motorized army equipment, also major caliber guns, for the United States Army and Navy, on open top equipment published by Operations and Maintenance Department of Association of American Railroads.
- Storage of motor vehicle equipment AR 850-18

ORDNANCE MAINTENANCE — LIGHT TANKS M5, M5A1, AND M24, 75-MM HOWITZER MOTOR CARRIAGE M8, AND TWIN 40-MM GUN MOTOR CARRIAGE M19: ENGINES, COOLING SYSTEMS AND FUEL SYSTEMS

INDEX

A	Page		Page
Accessories, installation	84	Covers	
Adapters		assembly of crankcase and crank-	
cleaning and inspection	62	shaft	56
installation		disassembly	
oil pump	64	crankcase	55
tachometer	61	crankshaft	56
removal		installation	
oil pump	61	engine front	75
tachometer	60	oil pump housing.....	63
Air cleaners, data	118	valve compartment	79
Auxiliary power plant fuel filters		removal	
(See Fuel filters, auxiliary power		compartment	27
plant)		engine front	33
		Crankcase assembly, description	
C		assembly	6
Camshaft		ventilators	14
description	12	Crankshaft	
inspection of bushings.....	39	assembly of fly wheel to cam-	
installation		shaft	55
bushings	43	description	7
camshaft	73	fits and tolerances	88
removal		inspection and repair.....	53
bushings	41	installation	70
camshaft	34	removal	36
Carburetor, data	117	Cylinder block	
Connecting rods		description	6
alinement	51	fits and tolerances.....	89
data	18	Cylinder bore, reconditioning.....	45
description		Cylinder heads	
assembly	48	cleaning	38
rods	8	description	12
disassembly, cleaning, and inspec-		disassembly	37
tion	49	fits and tolerances.....	88
fits and tolerances	88	inspection	39
installation	72	installation	79
removal	35	removal	27
repair and assembly of assem-		Cylinders	
blies	50	assembly and installation (valve	
Cooling systems		lifter)	59
data	97	fits and tolerances (engine).....	89
description	93	numbering (engine)	17
fits and tolerances	113		
operation	96		

INDEX

D	Page	F	Page
Distributor		Fan	
cleaning, inspection, and assembly of support.....	60	assembly	101
description and disassembly of support	59	cleaning, inspection, and repair....	100
fits and tolerances	92	description	96
installation		disassembly and removal.....	98
distributor	74	fits and tolerances.....	113
support	78	installation	102
removal	33	removal of shaft.....	64
Drive belts		Filler caps, description.....	93
description	15	Filters (See Oil filters and Fuel filters)	
removal of pulleys	32	Fits and tolerances, clearance data..	87
Drive gear		Flywheel	
installation		assembly to crankshaft.....	55
distributor	61	description	8, 37
oil pump	63	disassembly of housing.....	37
tachometer	60	fits and tolerances.....	92
removal		installation	70
distributor	59	Fuel filters	
oil pump	62	cleaning, inspection, and assembly	129
tachometer	60	data	118
Drive shaft		disassembly	125
installation		Fuel filters, auxiliary power plant	
distributor	61	data	119
oil pump	63	disassembly, inspection, cleaning, and assembly	129
removal		Fuel pump	
distributor	59	data and service information.....	117
oil pump	62	installation	80
Driven gear shaft		removal	27
installation		Fuel system	
oil pump	63	assembly, cleaning, and inspection of support and strainer assembly	132
tachometer	61	data	117
removal		description	114
oil pump	62	disassembly of support and strainer assembly	129
tachometer	60	service information	117
		Fuel tanks (See Tanks, fuel)	
		Fuel valves (See Valves, fuel)	
E		I	
Eccentric spacer	75	Ignition system	
Engine blocks		data	20
cleaning	37	description	17
description	6, 37		
inspection	38		
Engines			
assembly	66		
data	17		
description	6		
disassembly	21		
serial numbers	6		
test and adjustment.....	84		

TM 9-1729A

ORDNANCE MAINTENANCE — LIGHT TANKS M5, M5A1, AND M24, 75-MM HOWITZER MOTOR CARRIAGE M8, AND TWIN 40-MM GUN MOTOR CARRIAGE M19: ENGINES, COOLING SYSTEMS AND FUEL SYSTEMS

L	Page	L	Page
Leakage, inspection	87	Plunger, assembly and installation..	59
Lubrication, data	19	Pressure, oil, inspection.....	86
M			
Manifolds		Pressure regulator	
cleaning, inspection, and assem- bly	66	inspection and installation.....	63
description	12, 64	removal	61
disassembly	64	Pump, water	
installation		assembly	111
exhaust	80	description	93
intake	81	disassembly	108
removal	26	fits and tolerances.....	92, 113
Modification Work Order and Major Unit Assembly Replace- ment Record	5	inspection	109
Muffler, removal	25	installation	81
		removal	25
		(See also Oil pump and Fuel pump)	
O			
Oil filters, description.....	14	R	
Oil pan, removal.....	34	Radiator	
Oil pressure (See Pressure, oil, in- spection and Pressure regula- tor)		assembly	106
Oil pump		description	93
cleaning and inspection.....	62	disassembly and inspection.....	103
description and disassembly.....	61	Reports and records.....	5
fits and tolerances.....	89, 92	T	
installation of idler gear.....	74	Tachometer	
removal		installation of driven and drive gears	61
gears and shafts.....	62	removal of driven gear, adapter, and drive gear	60
idler gear	33	Tanks, fuel	
Oil system (engine).....	13	assembly	133
P			
Pistons		disassembly, cleaning, inspection, and repair	
data	18	1G series	132
description		3G series	133
assembly	48	Thermostat	
pistons	9	assembly	106
disassembly, cleaning, and inspec- tion of assembly.....	49	description	93
fits and tolerances.....	90	disassembly and inspection.....	103
fitting	43	Timing chains	
installation of assemblies.....	72	data	19
measuring and computing clear- ance	45	description	12
removal of assemblies.....	35	disassembly, cleaning, and in- spection	55
repair and assembly.....	50	fits and tolerances	90
		installation	74
		removal	33

INDEX

T — Contd.	Page		Page
Tools, data	134	inspection and leak-down test.....	57
Transmission		installation of guide assemblies....	77
installation of mainshaft pilot bearing	71	removal of guide assemblies.....	29
mount on engine.....	83	Valves	
removal		data	19
mainshaft pilot bearing.....	35	description	12
transmission	23	fits and tolerances.....	91
		installation	77
		reconditioning	47
		removal	29
		Valves, fuel	
V		assembly	122, 125
Valve compartment covers.....	29	cleaning	121, 122
Valve guides		disassembly	
inspection	39	controls	119
replacement	40	valves	121, 122
Valve lifters		inspection	121, 122, 125
description, disassembly, and cleaning	56		

