

Research Note 84-31

AD A 137713

AN/TTC-39 PROGRAM: A CASE STUDY OF  
MANPOWER, PERSONNEL AND TRAINING REQUIREMENTS DETERMINATION

F. E. O'Connor, R. L. Fairall, and E. H. Birdseye  
Information Spectrum, Inc.

Arthur Marcus, Contracting Officer's Representative

Submitted by

Bruce W. Knerr, Acting Chief  
SYSTEMS MANNING TECHNICAL AREA

and

Jerrold M. Levine, Director  
SYSTEMS RESEARCH LABORATORY



U. S. Army

Research Institute for the Behavioral and Social Sciences

January 1984

Approved for public release; distribution unlimited.

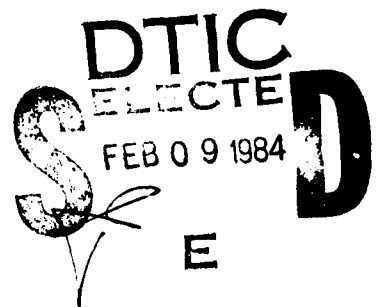

This report, as submitted by the contractor, has been cleared for release to Defense Technical Information Center (DTIC) to comply with regulatory requirements. It has been given no primary distribution other than to DTIC and will be available only through DTIC or other reference services such as the National Technical Information Service (NTIS). The views, opinions, and/or findings contained in this report are those of the author(s) and should not be construed as an official Department of the Army position, policy, or decision, unless so designated by other official documentation.

84 02 09 019

DTIC FILE COPY

REPORT DOCUMENTATION PAGE		READ INSTRUCTIONS BEFORE COMPLETING FORM
1. REPORT NUMBER Research Note 84-31	2. GOVT ACCESSION NO. AD-A157 713	3. RECIPIENT'S CATALOG NUMBER
4. TITLE (and Subtitle) AN/TTC-39 Program: A Case Study of Manpower, Personnel, and Training Requirements Determination		5. TYPE OF REPORT & PERIOD COVERED Final Report
		6. PERFORMING ORG. REPORT NUMBER
7. AUTHOR(s) F. E. O'Connor, R. L. Fairall and E. H. Birdseye		8. CONTRACT OR GRANT NUMBER(s) MDA903-81-C-0386
9. PERFORMING ORGANIZATION NAME AND ADDRESS Information Spectrum, Inc. 1745 S. Jefferson Davis Highway Arlington, VA 22202		10. PROGRAM ELEMENT, PROJECT, TASK AREA & WORK UNIT NUMBERS 2Q162722A791
11. CONTROLLING OFFICE NAME AND ADDRESS US Army Research Institute for the Behavioral & Social Sciences, 5001 Eisenhower Avenue Alexandria, VA 22333		12. REPORT DATE January 1984
		13. NUMBER OF PAGES 104
14. MONITORING AGENCY NAME & ADDRESS (if different from Controlling Office)		15. SECURITY CLASS. (of this report) Unclassified
		15a. DECLASSIFICATION/DOWNGRADING SCHEDULE
16. DISTRIBUTION STATEMENT (of this Report)  Approved for public release; unlimited distribution		
17. DISTRIBUTION STATEMENT (of the abstract entered in Block 20, if different from Report)		
18. SUPPLEMENTARY NOTES		
19. KEY WORDS (Continue on reverse side if necessary and identify by block number)  Human Factors Engineering                      Materiel Acquisition Process Life Cycle System Management Model        Personnel Requirements Manpower Requirements                        Training Requirements		
20. ABSTRACT (Continue on reverse side if necessary and identify by block number)  This report describes and analyzes the procedures used to determine Manpower, Personnel, and Training (MPT) requirements for the AN/TTC-39 Circuit Switch Program and related accomplishment of actual MPT events/documents to those called for in the Life Cycle System Management Model (LCSMM). It addresses concerns being raised about the adequacy and timeliness of the Army's MPT REQUIREMENTS DETERMINATION PROCEDURES.		

**AN/TTC-39  
CIRCUIT SWITCH**



**AN/TYC-39  
MESSAGE SWITCH**

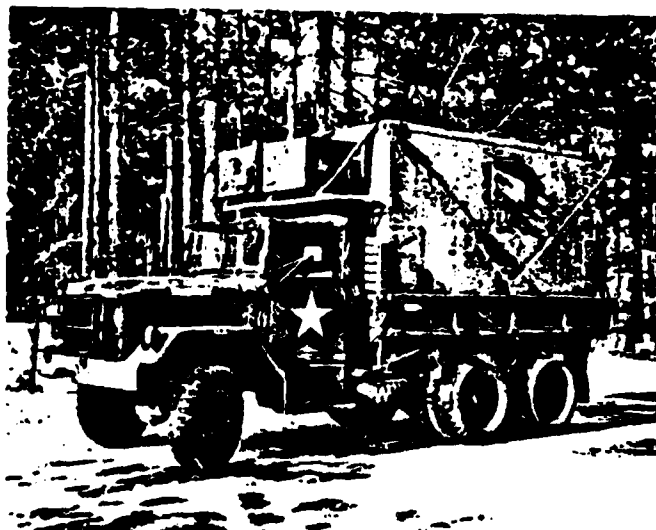

Accession For	
NTIS GRA&I	<input checked="" type="checkbox"/>
DTIC TAB	<input type="checkbox"/>
Unannounced	<input type="checkbox"/>
Justification	
By _____	
Distribution/	
Availability Codes	
Dist	Avail and/or Special
A-1	

## FOREWORD

↙ The Army is currently implementing a broadly based force modernization program featuring the introduction of a large number of sophisticated new materiel systems and simultaneous redesign of its force structure (Division 86) in an all-volunteer environment. This ambitious effort places heavy demands on the Army's manpower and training resources. Projected declines in the qualitative and quantitative manpower pool from which the Army must recruit its future soldiers will compound that problem over the next several years.

A necessary early step in coping with the Manpower, Personnel, and Training (MPT) resource problem is the production of an accurate and timely accounting of the number of people and skills needed, system by system and in the aggregate, to operate and maintain new equipment once fielded. To this end, the Army has developed an elaborate materiel acquisition process and a number of regulations and instructions which address the MPT issues to be considered during system development and acquisition. Nevertheless, a number of negative judgements, summarized below and generally supported by previous study findings, have been made about the Army's ability to determine MPT requirements for new systems.

- o Tools and techniques for predicting manpower requirements and guidance for their application are both inadequate and unevenly applied.
- o The process whereby MPT requirements are documented and transmitted is overly complex, slow, and fails to include direct early participation of Army personnel community representatives.

- o Materiel developers often fail to understand the impact that MPT requirements have on the ultimate cost and operational utility of a new piece of hardware once fielded; consequently, insufficient funds and effort are devoted to MPT analysis and human factors engineering during early stages of system development.

Jointly sponsored by the Defense Systems Management College (DSMC) and the US Army Research Institute for the Behavioral and Social Sciences (ARI), this study effort by Information Spectrum, Inc. under contract MDA 903-81-C-0386 is one of several initiatives designed to respond to concerns being raised about the adequacy and timeliness of the Army's MPT requirements determination procedures. It supports ARI's intensive system manning technology research and development program and DSMC's increased educational emphasis on performance of more effective man-machine tradeoffs during early stages of the materiel acquisition process.

This report is one of five resulting from ISI's research effort. Each of the first four is a case study that describes and analyzes the procedures used to determine MPT requirements for a specific materiel system, and relates accomplishment of actual MPT events/documents to those called for in the Life Cycle System Management Model (LCSMM). A fifth report analyzes findings from the four case studies, draws systemic conclusions, and makes recommendations for improving the MPT requirements determination process.

## EXECUTIVE SUMMARY

### BACKGROUND

Growing concern with the soldier-machine interface problem, the future manpower pool available to the Army, and the Army's ability to make accurate and timely determinations of the quantitative and qualitative Manpower, Personnel, and Training (MPT) requirements for newly developed systems provided the impetus for the study of several emerging materiel systems. This report examines the AN/TTC-39 Program, one of four systems selected for study. A comparative analysis report will examine the results of the four system case studies, identify systemic problems with the Army's MPT requirements determination procedures, and recommend solutions to identified deficiencies.

### APPROACH

The AN/TTC-39 Program review was divided into three major phases: literature review, data collection, and data analysis. Official Department of Defense (DOD) and Department of the Army (DA) publications concerning the MPT effort within the system acquisition process were reviewed; earlier and on-going studies were also researched. Specific AN/TTC-39 Program data was obtained from interviews with and draft and final MPT documentation prepared by Army materiel developers, combat developers, trainers, testers, manpower planners, personnel managers, and logisticians. Data was analyzed within the context of the MPT documents/events identified in the Life Cycle System Management Model (LCSMM), as modified by the AN/TTC-39 Program acquisition

strategy. Tools and techniques used to determine system MPT requirements were evaluated against those prescribed by the Army. The analysis paid particular attention to how much emphasis was placed on MPT issues in early requirement and contractual documents.

#### MAJOR FINDINGS

Human Factors Engineering (HFE) had little influence on the design of either switch because neither requests for proposals nor validation/engineering development phase contracts included definitive and/or enforceable HFE requirements. Some of the same HFE problems identified early in the engineering development phase (1974 - 1975) were still being cited as deficiencies in various government tests conducted between June 1978 and March 1980, including a formal HFE analysis.

Early estimates of qualitative manpower requirements prepared by the switch contractor (GTE) in 1975 and 1976 were not supported by any detailed task and skill analysis, and were accorded only a cursory review by the Army. These data remained essentially unchallenged until initial government development/operational testing, which began in June 1978 (some 6 1/2 years after program start), was completed near the end of the engineering development phase in May 1980. Consequently, significant Military Occupational Specialty (MOS) changes and concomitant training adjustments had to be made after the switches were approved for production. These late MOS and training modifications have caused turbulence in the Army Signal personnel and

training communities and adversely affected timely and efficient conduct of the follow-on evaluations of switching equipment mandated by the DSARC III decision for both switches.

Estimated quantitative maintenance manpower requirements above the organizational level so far have not been validated by either testing, Logistic Support Analyses (LSA), or by any other analytically based method. True requirements may not be known until sometime after the switches are fielded. Should those requirements prove to have been underestimated, supportability of initially fielded systems could be adversely affected.

A number of existing field communication equipments and Army Signal organizations, as well as communication-electronic materiel still under development, must eventually interface with the AN/TTC-39 Program switches. The indirect, but nevertheless real and possibly significant, impact that switch deployment will have on the manpower and training requirements of these other systems and organizations is still unknown.



## CONTENTS

<u>SECTION</u>	<u>PAGE</u>
FOREWORD .....	v
EXECUTIVE SUMMARY .....	vii
<b>I. INTRODUCTION</b>	
A. BACKGROUND .....	1
B. PURPOSE .....	6
C. APPROACH .....	7
1. System Selection .....	7
2. Scope .....	7
3. Literature Review .....	9
4. Data Collection .....	9
5. Analysis .....	10
<b>II. SYSTEM SUMMARY</b>	
A. REQUIREMENT .....	11
B. ACQUISITION STRATEGY .....	12
1. Validation Phase .....	12
2. Engineering Development Phase .....	12
3. Production Deployment Phase .....	15
C. SYSTEM DESCRIPTION .....	16
1. General .....	16
2. Like or Similar Systems Replaced .....	17
3. AN/TTC-39 Circuit Switch .....	18
4. AN/TYC-39 Message Switch .....	18
D. ORGANIZATIONAL CONCEPT .....	21
E. OPERATIONAL CONCEPT .....	23
F. MAINTENANCE & SUPPORT CONCEPTS .....	23
<b>III. DETERMINATION OF MPT REQUIREMENTS - DISCUSSION</b>	
A. INTRODUCTION .....	26
B. CONCEPTUAL PHASE .....	27
C. VALIDATION PHASE .....	29
D. FULL SCALE ENGINEERING DEVELOPMENT PHASE .....	34
1. Human Factors Engineering .....	34
2. Logistics Support Analysis .....	38
3. QQPRI/BOIP/MOS Decisions .....	39
a. General .....	39
b. Contractor QQPRIs .....	40
c. Government QQPRIs .....	42
d. BOIP .....	46
e. MOS Decisions .....	47
4. Operational and Organizational Concept .....	49
5. Manpower Analyses .....	50
a. Manpower Analysis Paper III .....	50
b. Communications - Electronics Functional Review .....	51
6. Training .....	51

<u>SECTION</u>	<u>PAGE</u>
7. Government Test and Evaluation .....	54
a. Introduction .....	54
b. Test and Evaluation Findings .....	54
c. DSARC III/IIIA .....	57
E. PRODUCTION AND DEPLOYMENT PHASE .....	58
1. Follow-On Testing and Evaluation .....	58
a. WINTEX-81 .....	60
b. Fault Insertion Demonstration .....	61
c. RAM Assessment .....	62
d. Other Testing .....	63
2. Manpower Modifications .....	63
3. Training Modifications .....	64
a. MOS 36L .....	64
b. MOS 36C(M) .....	65
c. MOS 72E22 .....	65
d. Other MOSS .....	65
e. NET .....	66
4. Manual Modifications .....	67
 IV. DETERMINATION OF MPT REQUIREMENTS-ANALYSIS	
A. INTRODUCTION .....	68
B. HUMAN FACTORS ENGINEERING .....	69
C. QUALITATIVE MANPOWER REQUIREMENTS .....	71
D. QUANTITATIVE MANPOWER REQUIREMENTS .....	74
E. TRAINING REQUIREMENTS .....	76
 V. CONCLUSIONS	
A. EARLY CONSIDERATION OF MPT REQUIREMENTS .....	79
B. HFE EFFORTS .....	79
C. CONTRACTOR QQPRI's .....	79
D. GOVERNMENT QQPRI's .....	80
E. LSA STOPPAGE .....	80
F. GOVERNMENT TESTING & EVALUATION--TIMELINESS .....	80
G. GOVERNMENT TESTING & EVALUATION--ADEQUACY .....	81
H. INDIRECT MANPOWER & TRAINING REQUIREMENTS .....	81

APPENDICES

<u>TITLE</u>	<u>PAGE</u>
A. POLICY AND PROCEDURAL DOCUMENTS REVIEWED .....	A-1
B. AN/TTC-39 PROGRAM DATA COLLECTION SOURCES .....	B-1
C. AN/TTC-39 PROGRAM DOCUMENTS REVIEWED .....	C-1
D. GLOSSARY OF TERMS .....	D-1

LIST OF TABLES

<u>TABLE</u>	<u>TITLE</u>	<u>PAGE</u>
III-1	CONTRACTOR QQPRI SUMMARY .....	43
III-2	FQQPRI QUALITATIVE MANPOWER ESTIMATES .....	45
III-3	CIRCUIT SWITCH CREW SIZE .....	48
III-4	MESSAGE SWITCH CREW SIZE .....	48
III-5	QUANTITATIVE MANPOWER REQUIREMENTS - SELECTED MOSS .....	52
III-6	RAM GOALS VERSUS PERFORMANCE DURING TESTS .....	63

LIST OF FIGURES

<u>FIGURE</u>	<u>TITLE</u>	<u>PAGE</u>
II-1	MAJOR ACQUISITION MILESTONES .....	13
II-2	AN/TTC-39 CIRCUIT SWITCH (300 Line) .....	19
II-3	AN/TTC-39 CIRCUIT SWITCH (600 Line) .....	20
II-4	AN/TYC-39 MESSAGE SWITCH .....	22
III-1	MPT RELATED EVENTS - CONCEPT PHASE .....	28
III-2	MPT RELATED EVENTS - VALIDATION PHASE .....	31
III-3	MPT RELATED EVENTS - ENGINEERING DEVELOPMENT PHASE .....	35
III-4	MPT RELATED EVENTS - PRODUCTION AND DEPLOYMENT PHASE .....	59

## SECTION I - INTRODUCTION

### A. BACKGROUND

Matériel Systems Acquisition programs are the subject of continuing analyses, reviews, and evaluations. The scope and extent of these program appraisals are consistent with the high cost of matériel systems over a life cycle, their impact on operational capability and effectiveness, and their demand on current and future resources. Specific guidelines have been established for development and acquisition of major systems by the Departments of Defense (DOD) and the Army (DA). The process is detailed and involves many management levels.

Despite the detail and depth of documentation and directives governing the acquisition process, problems regarding establishment of manpower requirements and their true cost have been prevalent. Sufficient numbers of properly trained personnel are essential to operate, maintain, and support current and future matériel systems. The improvements in these systems offered by new technology, a corresponding requirement for more highly skilled personnel, the steady upward trend in operating and support costs, and the projected reduced availability of the recruitable population demand a close and early look at manpower requirements for matériel systems under development to measure both supportability and affordability.

A number of previous studies, some of which are cited below, have highlighted problems associated with the determination of

Manpower, Personnel, and Training (MPT) requirements for new systems.

1. In December 1978, the Logistics Management Institute concluded a study of manpower planning for new weapon systems for the Assistant Secretary of Defense, Manpower, Reserve Affairs, and Logistics (ASD, MRA&L), complemented by seven case studies. Two of these concerned Army systems, i.e., TACFIRE and Patriot.<sup>1</sup> Significant findings from that study included the following:

- o Most estimates of manpower requirements made during acquisition programs are too low.
- o Operating and support concepts are likely to vary throughout the acquisition process, causing fluctuations in the estimates of manpower requirements.
- o There is greater uncertainty associated with maintenance manning than with any other element of new weapon system manpower requirements.
- o Estimates of new system manpower requirements frequently reflect program goals rather than unbiased assessments of manpower needs.
- o Manpower goals or constraints established for new systems have addressed only the aggregate manning of the using unit, not total manpower or skill level requirements.
- o Controlling training requirements can be as important as constraining manning levels.
- o Operational test and evaluation conducted prior to DSARC III does not normally test the intermediate level of maintenance support.

2. In August 1980, Generals Walter T. Kerwin and George S. Blanchard prepared a discussion paper for the Army Chief of Staff

---

<sup>1</sup>Betaque, Norman E., Jr., et al, Manpower Planning for New Weapon Systems, WN ML 801-1 Through WN ML 801-9. Logistics Management Institute. July - December 1978.

concerning the soldier-machine interface (SMI) problem.<sup>2</sup> In that report, Generals Kerwin and Blanchard stated,

"The Army has made some progress in dealing with this problem. Many efforts are underway. However, these efforts, while representing steps in the right direction, are fragmented, based on reactions rather than vision, and, to a large extent, individually initiated. In our opinion, these efforts will fall short in coping with the extent of the problem in time to have an impact in the near term. Significant improvement will not occur quickly unless efforts are integrated, the personnel and doctrine people become more actively involved early in the materiel development process, and the Army addresses man/machine interface in its broadest sense and begins to think tactical system development in lieu of individual materiel development, individual people development and individual support development."

Specific observations presented in the report included:

- o The Life Cycle System Management Model (LCSMM) must be disciplined concerning the manpower, personnel, training and logistics aspects of the process. Qualitative and Quantitative Personnel Requirements Information (QQPRI) and Basis of Issue Plans (BOIP) were singled out as examples.
- o Careful consideration of MPT impacts must precede any variation in strategy which skips a phase of development for the purpose of achieving an early initial Operational Capability (IOC).
- o Better utilization of and improvements in the QQPRI process are needed.
- o MPT requirements must be better defined during concept evaluation.
- o System development programs must recognize training constraints and employ sophisticated techniques to reduce training requirements.
- o Human Factors Analysis and Engineering must become a mandated part of system development early in the cycle.

---

<sup>2</sup>Blanchard, George S. & Kerwin, Walter T., Man/Machine Interface - A Growing Crisis, Army Top Problem Areas, Discussion Paper Number 2, August 1980.

- o PMS and TSMS must increase their emphasis on the MPT features of the Integrated Logistics Support (ILS) process.
- o The personnel community must become an active, rather than reactive, part of the acquisition process.

3. Some of the problems with the BOIP/QQPRI process identified by Generals Kerwin and Blanchard, were also discussed in a 7 January 1980 report by the Army Force Modernization Coordination Office (AFMCO).<sup>3</sup> In its examination, the BOIP/QQPRI Task Force reviewed the status of 76 new systems and found that of these 76, the BOIP/QQPRI were late in 29 of the systems by an average of 19.5 months. Note: the task force considered current status of the primary item only, it did not consider associated equipment; Test, Measurement, and Diagnostic Equipment (TMDE); or training devices. Nor did the task force consider BOIP/QQPRI quality.

Regarding the impact of the late BOIP/QQPRI, the task force stated:

"When the BOIP/QQPRI are not submitted on time, there is a high probability that the fielded system will be inadequately supported. At a low intensity of modernization there is some opportunity to offset late BOIP/QQPRI by shifting personnel and materiel resources to take advantage of other system delays and the general phase-in of equipment. However, the increased intensity of modernization during the next four to five years will not allow this opportunity. In short, twenty-nine of the Army Modernization Information Memorandum (AMIM) systems to be fielded in the next three years may not be adequately supported in the field."

---

<sup>3</sup>HQDA, Office of the Chief of Staff, BOIP/QQPRI Task Force Report, 9 January 1980.



The report goes on to say:

"There are many reasons for the number of late BOIP/QQPRI in the set of systems the task force examined. Part of the reason is a failure to adequately discipline the system. In many cases it is due to inadequate priorities being assigned to the extreme importance and value of the system with a consequent under resourcing of manpower at all levels. Above all, there exists no mechanism to centrally manage and police the preparation and submission of the BOIP/QQPRI."

4. A previous ISI study conducted for ARI,<sup>4</sup> identified and analyzed the MPT information required to be generated by the Army's LCSMM process. That study concluded that, if properly prepared in the sequence stipulated, MPT information should be adequate to meet LCSMM milestone goals. However, it also confirmed findings of other studies that the information generated in preparation for recent Army and Defense System Acquisition Review Council (ASARC/DSARC) reviews had been inadequate in some quality and timeliness of MPT planning and programming during the LCSMM process.

5. In January 1981, amid growing concern that its materiel systems are becoming too complex, HQDA directed U.S. Army Training and Doctrine Command (TRADOC) to lead an internal Army study to assess the impact of the SMI on total systems management and how the Army can better match men, skills, and machines.<sup>5</sup> The study was designed to either validate or recommend revision

---

<sup>4</sup>Rhode, Alfred S., et al, Manpower, Personnel and Training Requirements for Materiel System Acquisition, ARI, February 1980.

<sup>5</sup>HQDA, Soldier-Machine Interface Requirements (Complexity) Study, January 1982.

to the existing materiel system acquisition procedures to insure that the Army pursues the best possible course to match men, skills, and machines during the next decade.

To accomplish the task, the study addressed in a very broad sense 30 different systems representative of most system types in various mission areas. Further, for each system, the study addressed all system-specific tasks associated with the immediate soldier-machine interface at operator; maintainer, and repairer (through GS) levels.

Since the objectives of that complexity study were similar to those of this effort, coordination was established with the complexity study team and information exchanged.

#### B. PURPOSE

This is one of four historical case studies dealing with Manpower, Personnel, and Training problems associated with the Army's acquisition of the following materiel systems.

- o AN/TYC-39 Message Switch & AN/TTC-39 Circuit Switch (TCC-39 Program)
- o Multiple Launch Rocket System (MLRS)
- o UH-60A Helicopter (BLACKHAWK)
- o AN/TPW-36 Mortar Locating Radar & AN/TPQ-37 Artillery Locating Radar (FIREFINDER)

Each case study examines the Army's ability to comply with its stated MPT requirements determination procedures during the development of specific systems, and assesses the timeliness and

quality of the MPT products. A fifth report, which accompanies these case studies, analyzes the four systems, identifying similarities and differences in the acquisition process and drawing comparisons where appropriate. It is stressed that the principal objective is to examine when and how well MPT requirements were developed and expressed, particularly during the early stages of system development.

## C. APPROACH

### 1. System Selection

The systems selected for study represent a cross section of Army combat development mission areas, e.g., Fire Support (MLRS), Aviation (BLACKHAWK), Tactical Surveillance, Reconnaissance, and Target Acquisition (FIREFINDER), and Communications (AN/TTC-39 Program). Each of the systems selected has a high development priority and is well along in the acquisition process, thus permitting a more comprehensive examination of actual MPT events and documentation. Availability of US Army Materiel Development and Readiness Command (DARCOM) Project Managers (PM) and US Army Training and Doctrine Command (TRADOC) System Managers (TSM) to interact with study team members also influenced the choice of systems.

### 2. Scope

For each system case study, actual MPT events/documents and organizational elements responsible for their accomplishment are identified down to subordinate elements within DARCOM and the

subordinate proponent school level within TRADOC.

Occurrence of events are portrayed in time relative to the sequence called for in the Life Cycle Systems Management Model (LCSMM).<sup>6</sup> The May 1975 LCSMM was used as a baseline although some early acquisition stages in the systems examined began prior to that date. Tools and techniques used to generate MPT requirements are described and their value assessed. Qualitative and quantitative changes in MPT requirements are tracked, beginning with the initial establishment of system need and continuing through the latest completed event in the system's acquisition process. Reasons for such changes are also stated in those instances where data availability permitted such a determination to be made.

Where possible, the adequacy and timeliness of MPT information are assessed to determine whether ASARC; DSARC; Planning, Programming, and Budgeting System (PPBS); and fielding needs were met. If not, reasons for such deficiencies and their impact are stated.

The fifth report identifies and analyzes differences in when and how well MPT requirements were developed and expressed. The reasons for and impact, if any, of the identified differences are assessed to identify particularly effective/ineffective approaches to generation of MPT data; common problems and lessons learned are also highlighted. Recommendations for correction of identi-

---

<sup>6</sup>HQDA, Pamphlet No. 11-25, Life Cycle System Management Model for Army Systems, May 1975.

fied deficiencies are made, taking into account significant efforts either recently completed or currently underway by the Department of Defense (DOD) and the Army to improve the MPT requirements determination process, e.g., Carlucci initiatives; changes in Army policies and procedures for processing QQPRI and BOIP (AR 70-2); and staffing a proposed new Military Standard for Weapon System and Equipment Support Analysis (MIL-STD-1388A).

The research effort was divided into three major phases: Literature Review; Data Collection; and Data Processing and Analysis.

### 3. Literature Review

The study effort began with a review of literature pertinent to the development and expression of MPT requirements for new materiel systems. It included an examination of policies and procedures promulgated by DOD; Headquarters, Department of the Army (HQDA); Headquarters, DARCOM; and Headquarters, TRADOC. Related study efforts and research reports such as those mentioned in paragraph A, supra, were also reviewed for background, ideas for data gathering and analysis methods, and to avoid unnecessary overlap and duplication of earlier efforts. Major policy and procedural document sources examined during this review are cited in Appendix A.

### 4. Data Collection

The evolution of MPT information for the FIREFINDER Program in response to materiel development policies and procedures,

including the LCSMM and the Integrated Logistics Support Management Model (ILSMM) processes, was tracked through each phase of the acquisition process. Data was gathered through examination of draft and final MPT documents and face-to-face interviews with Subject Matter Experts (SME) representing combat/materiel developers, trainers, testers, manpower/personnel planners, and personnel managers. Data cutoff was 31 May 1982. Specific organizational elements contacted during the collection effort are identified in Appendix B. The major MPT source documents are listed in Appendix C.

#### 5. Analysis

Information collected was cataloged and analyzed across acquisition milestones, measured against MPT data requirements in the LCSMM, and where appropriate, compared with like or similar systems; basic criteria for analysis were timeliness and adequacy of data relative to LCSMM and Army regulatory standards. The criteria were applied in examining the following major issues.

- o Tools, techniques, and standards used to compute and express MPT requirements and tradeoffs.
- o MPT requirements documentation and flow of information to decision makers.
- o The acquisition process itself, in terms of MPT requirements determination.

## II. SYSTEM SUMMARY

### A. REQUIREMENT

In May 1971, DOD established the Joint Tactical Communication Office (TRITAC) to design and implement a tri-service tactical communication system which would make efficient use of the existing analog inventory and establish common standards for transitioning to the rapidly improving digital technology. The Joint Chiefs of Staff (JCS), in a September 1971 memorandum to the Secretary of Defense, initiated a Joint Operational Requirement (JOR)<sup>7/</sup> for a key element of that system: a family of automatic hybrid (analog/digital) message and voice switches which would provide secure high speed interconnection between existing analog and new digital communication equipment in a tactical environment. The Secretary of Defense established the AN/TTC-39 Program (AN/TTC-39 Circuit Switch & AN/TYC-39 Message Switch) in January 1972 as the central and lead component of the TRITAC effort, and assigned development responsibilities to the Department of the Army.<sup>8/</sup> The basic requirement document was amended in August 1974.<sup>9/</sup> The AN/TTC-39 Program requirements were reiterated in a Mission Element Need Statement (MENS) prepared in November 1978 to comply with DODD 5000.1 and 5000.2.

---

<sup>7/</sup> JCS Memorandum 407 1, "Validation of Requirements for TRITAC Transitional Switch (Model A Switch)", 8 September 1971.

<sup>8/</sup> Secretary of Defense Memorandum, "AN/TTC-39 Program", 3 January 1972.

<sup>9/</sup> JCS Memorandum 352-74, "Single Shelter 300 Line Non-Expandable AN/TTC-39 Circuit Switch", 16 August 1974.

## B. ACQUISITION STRATEGY

The acquisition program was structured to have three phases: validation, full-scale engineering development, and production/deployment. As the tasked service, the Army funded the validation and engineering phases and acts as the procuring service for all DOD quantities in the current production phase. Test and evaluation of the AN/TTC-39 Program has been coordinated by TRITAC Office through a Joint Test Element at Fort Huachuca, Arizona that is funded by each Service/Agency on a pro-rata basis. Major acquisition milestones are depicted in Figure II-1.

1. Validation Phase (Phase I). Competitive prototype design contracts were awarded in June, 1972 on a cost-plus-fixed-fee basis to two contractors, General Telephone and Electronics (GTE) and International Telephone and Telegraph (ITT), for an 18-month period. As part of Phase I, the contractors submitted engineering development design proposals for Phase II and proposed performance trade-offs. A Source Selection Evaluation Board, supported by a Requirements Tradeoff Evaluation Group, evaluated the results of Phase I.

2. Full Scale Engineering Development Phase (Phase II). The Defense Systems Acquisition Review Council (DSARC II) authorized the AN/TTC-39 program to enter full scale engineering development on 12 April 1974 (Decision Coordinating paper (DCP) 135). DSARC II also authorized extension of Phase II from 18 to 36 months.

A cost-plus-incentive-fee contract was awarded to GTE Sylvania on 16 April 1974 for the design and fabrication of nine AN/TTC-39 circuit switches and seven AN/TYC-39 message switches.



# AN/TTC-39 PROGRAM MAJOR ACQUISITION MILESTONES

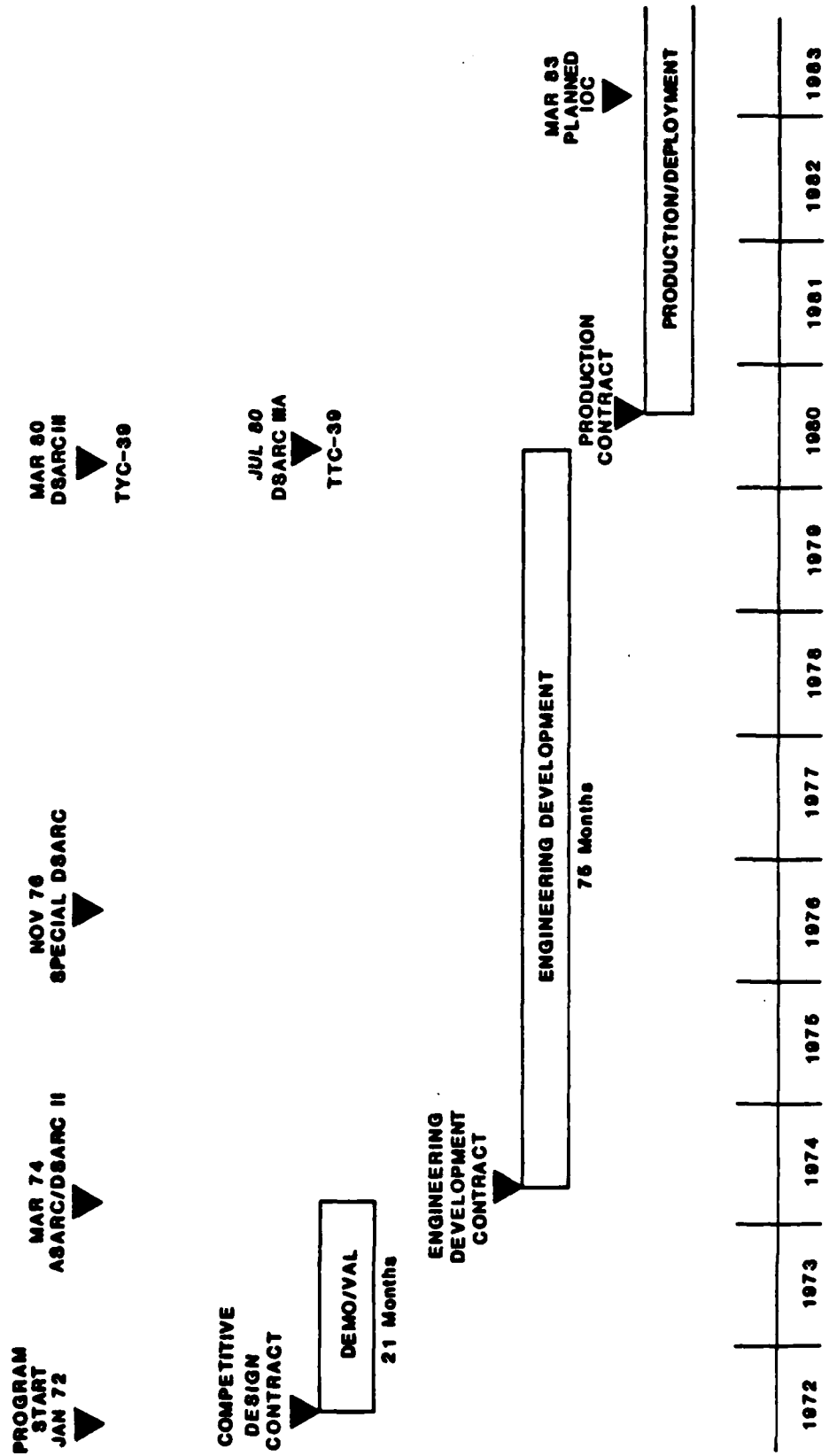

FIGURE II-1

Initial delivery of equipment was scheduled to begin in April 1977.

During the early stages of development, problems were encountered by the contractor in the design of both hardware and software. By May 1976, the Program Manager concluded that the lack of contractor progress threatened to breach the Decision Coordinating Paper (DCP) Cost and Schedule thresholds and recommended a special DSARC review of the program.

On the recommendation of the special DSARC, continuation of the program was authorized in accordance with a revised schedule approved on 14 January 1977. The revised schedule permitted a 9-month slip in development of the AN/TYC-39 Message Switch and a 16-month slip for the AN/TTC-39 Circuit Switch. These new goals could not be met; therefore, an Army approved Cover Sheet Update to DCP 135 proposed revised cost and schedule changes and a new acquisition strategy that called for award of a sole source, 3-year, multi-year contract for Phase III instead of the originally planned award of a Long Lead Item contract. It was forwarded to OSD in April 1978, and was finally approved on 21 August 1979.

The DCP Cover Sheet goal of October 1979 for the DSARC III production decision milestone was based upon complete development but limited operational testing of the circuit switch. In June 1979, the joint services test community indicated that meaningful operational testing of the Circuit Switch could not be initiated until November 1979. This issue and solution alternatives were assessed by the Army and Air Force test commanders and the TRITAC Office. Based on their recommendation, the Assistant Secretary of Defense, Communication, Command, Control and Intelligence

(ASD, C<sup>3</sup>I), by memorandum, dated 24 July 1979, directed rescheduling of the DSARC III Milestone from October 1979 to March 1980.

In January 1980, it was determined that there would be insufficient operational testing to support an AN/TTC-39 production decision by March 1980. The AN/TTC-39 Message Switch proceeded alone to DSARC III and received a positive production decision on 25 March 1980. Meanwhile, the AN/TTC-39 was still undergoing initial operational testing and evaluation. Although a production decision for the AN/TTC-39 was delayed, a single production award for both switches remained the preferred contracting approach.

The AN/TTC-39 Circuit Switch proceeded to DSARC IIIA on 8 July 1980, and was found ready to enter the full production phase. On 28 July 1980, the Secretary of Defense approved the findings of the DSARC and the contracting approach of awarding a single initial production contract for both switches. The Army was also directed to validate fixes on prototype equipment by further testing prior to achieving Initial Operational Capability (IOC). Follow-on test results, including a manpower and training assessment were to be reported to OSD within 18 months.

3. Production/Deployment Phase (Phase III). A multi-year, sole source procurement for three years was awarded to GTE Sylvania, the Phase II contractor, in September 1980. A follow-on competitive procurement for the balance of service/agency requirements is planned for award in FY 84.

## C. SYSTEM DESCRIPTION

### 1. General.

The AN/TTC-39 Program is made-up of a family of modular and transportable communications switching systems designed to provide secure, automatic, processor controlled switching for tactical voice and message traffic. The family consists of two types of switches, circuit (AN/TTC-39) and message (AN/TYC-39), which perform different but complementary functions.

The Circuit Switch handles analog and digital voice as well as data communications. The Message Switch handles data exclusively for store and forward service.

The switches are designed to operate in a stand alone mode, with each other, or as components of the total Army Integrated Tactical Communications System (INTACS)/TRITAC system. The designs of the switches and other INTACS/TRITAC equipment is such that a synergistic improvement in capability occurs when they are employed together. To achieve this effect, the TRITAC equipment being developed by the various services and their contractors on varying schedules must all interoperate in accordance with TRITAC specifications. The development of precise interfaces for the message and circuit switches will continue well into the life of the equipment.

The switches use microelectronic components and design techniques to reduce size, weight, and power consumption, and they are stored-program controlled. They have a high degree of hardware commonality in design to include component parts,

central processor, peripheral subsystems, main memory, and general design approach.

The switch equipment modules are designed to be mounted in existing S-280 mobile shelters, and they can also be placed in fixed plant configurations. Capabilities have been incorporated for using the switches in strategic as well as tactical applications.

## 2. Like Or Similar Systems Replaced

The Message Switch will replace torn paper tape manual relays that are current standard tactical equipment. These paper tape systems are housed in truck-mounted semi-trailer vans and are manpower intensive, extremely heavy, and use 1950 era technology. The Circuit Switch will replace manual, cord-and-plug switchboards that are slow and also manpower intensive. Primary equipments to be replaced are listed below:

- o Telephone Central Offices (AN/MTC-1 and AN/MTC-9)
- o Electromechanical Automatic Telephone Central Offices (AN/TTC-28)
- o Interim Processor Controlled Automatic Central Offices (AN/TTC-25, AN/TTC-30, and AN/TTC-38)
- o Manual Record Traffic (messages) Central offices and Relays (AN/MGC-19, AN/MGC-32, AN/MGC-23, AN/MGC-22, and AN/MYQ-2).

Full manpower savings will not be realized immediately since the shortage of switching equipment will preclude retirement of obsolete manual equipment until sometime in FY86 when almost all the automatic switches and their support equipment are scheduled to be fielded to the active Army.

### 3. AN/TTC-39 Circuit Switch (CS)

The AN/TTC-39 has two basic configurations, a single shelter 300 line model (Figure II-2) and a dual shelter 600 line model (Figure II-3). Each has electrically and mechanically interchangeable switch matrices which can be either analog or digital. The initial fielding mix of 80 percent analog, 20 percent digital can be changed as the communications environment changes to predominantly digital. The Circuit Switch is capable of interfacing with a wide variety of existing commercial and military switches and telephone instruments. Subscriber features include precedence and pre-emption; preprogrammed and progressive conferencing (maximum 20 parties); broadcast conferencing (maximum 30 parties); call transfer; call forwarding; abbreviated dialing; fixed directory for mobile subscribers; attendant recall; automatic intercept; recorded announcements; and full operator service.

In addition to its complement of switching equipment, the Circuit Switch provides a set of peripheral equipments consisting of two magnetic tape units, a video display unit, and two teletype-writers for the loading of programs and the data base, modification of the data base, output of fault and status reports and requests for execution of maintenance routines. An attendant (operator) position is provided within the shelter and up to three additional remote positions can be accommodated.

### 4. AN/TYC-39 Message Switch (MS)

The Message Switch in 25- and 50-line versions, provides the store and forward capability of receiving and delivering message

300 LINE SINGLE SHELTER CIRCUIT SWITCH

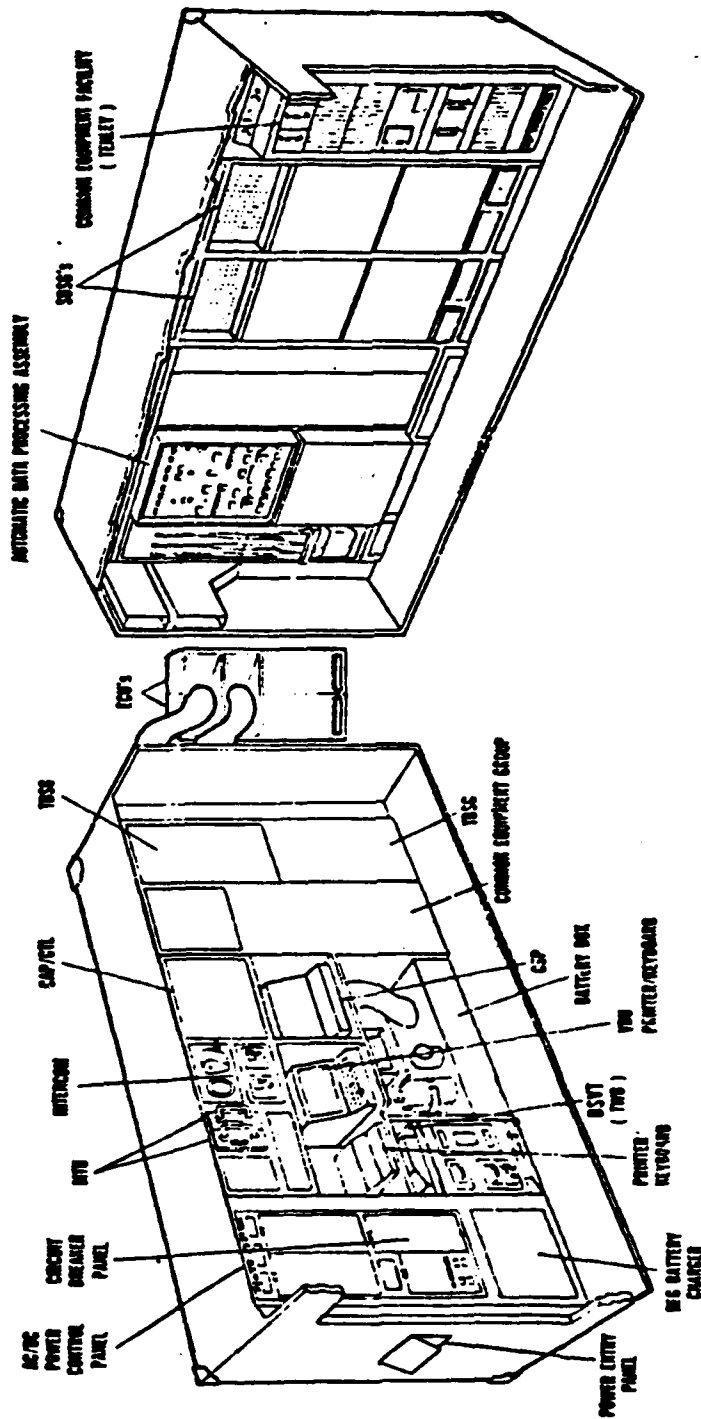

FIGURE II-2

600 LINE CIRCUIT SWITCH, DEPLOYED

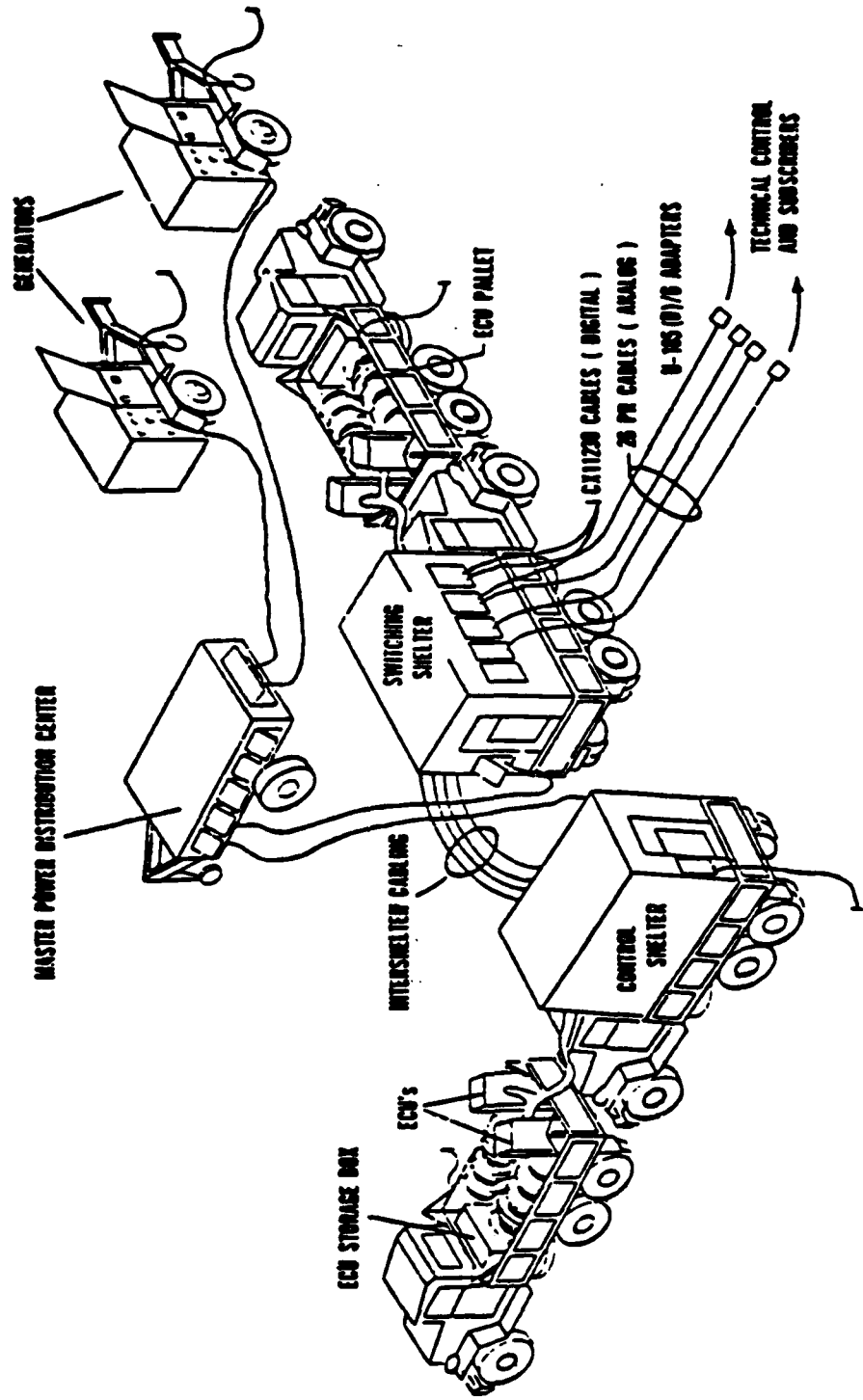

FIGURE II-3



traffic for both dedicated and switched subscribers in tactical and strategic environments. Subscriber and service features include eight levels of message security; individual and collective routing with an average processing time of two seconds per message; message queuing determined by six levels of precedence; absolute message traffic accountability; and message history storage up to 30 days.

The Message Switch is housed in two S-280 shelters as depicted in Figure II-4. In addition to its complement of switching equipment, the AN/TYC-39 also includes visual display units, keyboards, magnetic type units, and line printer units. A Switch Supervisor enters commands into the system and monitors the status of the system. A Traffic Service Operator receives copies of service messages sent to subscribers by the switch and messages addressed to the switch. The on-line maintenance function is performed using the Switch Supervisor's position or the teletypewriter located in the Communications interface shelter.

#### D. ORGANIZATIONAL CONCEPT

Both switches will be assigned to existing US Army Signal units serving the Corps Headquarters, the Corps Area Communication System, the Theater Army Main, Theater Unified Headquarters, the Theater Army Area Command Headquarters, and the Theater Area Communication System. Currently, seven different Army Signal organizations are scheduled to be equipped with either one or both of the switches. Some eight additional different Army organizations will be directly affected by deployment of the switches, primarily because of a requirement for additional maintenance/support personnel and/or equipment.

50 LINE MESSAGE SWITCH

**COMMUNICATIONS INTERFACE SHELTER**

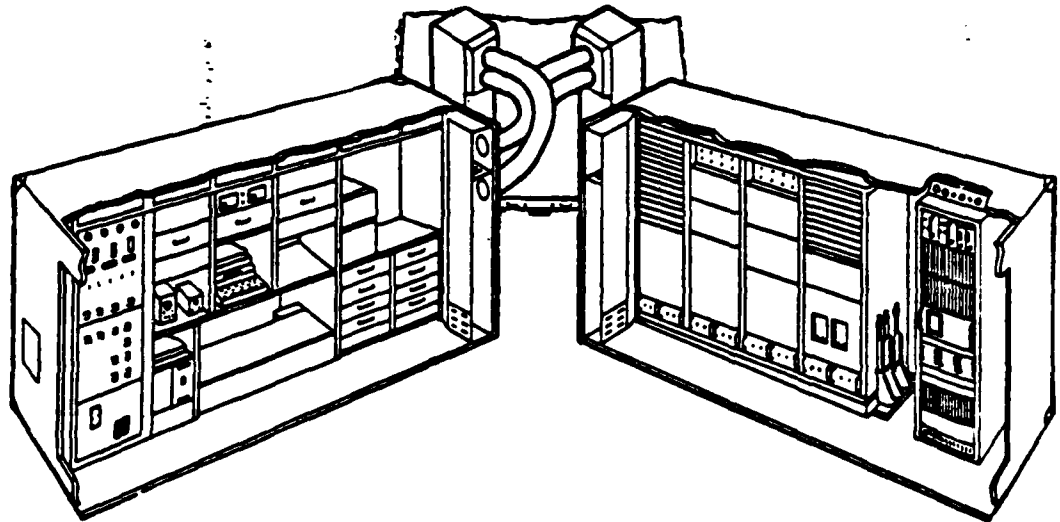

**MESSAGE PROCESSING SHELTER**

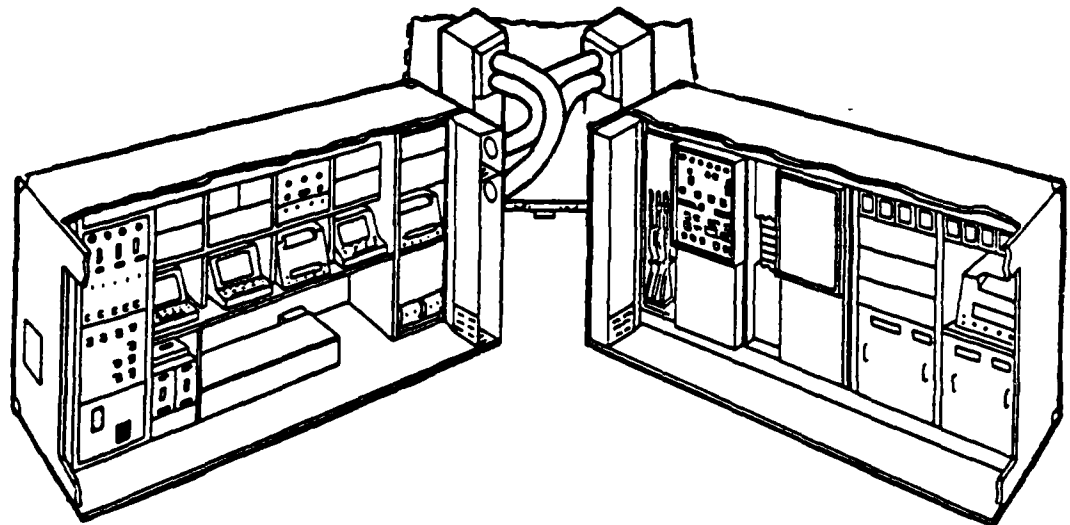

FIGURE II-4

#### E. OPERATIONAL CONCEPT

It is envisioned that each switch employed by a typical Corps in combat will displace at least once every 48 hours. After allowing for set-ups, teardown, and transit time, approximately 40 hours of the 48 hour mission will be devoted to communication. Peace time activity rates are 24 hours per day, 7 days per month (2016 hours per year) for active forces, and 8 hours per day, 63 days per year for reserve components. In peacetime, the combat mission profile applies during exercises.

#### F. MAINTENANCE AND SUPPORT CONCEPTS

Maintenance of both switches and Communications Security (COMSEC) equipment is accomplished at the Organizational level (OL) through the use of Built-In Test Equipment (BITE) and maintenance and diagnostic programs resident in the systems. The combination of these two approaches permits 95 percent of maintenance actions to be performed at the OL. The general technique is removal and replacement at OL of faulty modules, Printed Circuit Boards (PCB), power supplies, sub-assemblies, etc. Selected high mortality rate spares will be stocked at OL to support this concept.

The Army plans to use its standard logistic concept which splits the intermediate level into direct support and general support maintenance. Direct Support (DS) maintenance will provide a direct exchange system for trading functional modules for defective ones. DS maintenance personnel can make repairs requiring disassembly, reassembly, and adjustments to the equipment using common and special purpose tools. DS maintenance will be performed on location at each communications node by maintenance

personnel organic to the signal unit. Each node will have a DS maintenance shelter (S-511/ARM-164), and a storage shelter (S-552/ARM-164) for storage of organizational and DS spare parts, for both switches. General Support (GS) maintenance will involve repair of modules, circuit cards and power supplies, using the AN/USN-410 (EQUATE) automated test equipment. GS maintenance will generally be performed in Light Equipment Maintenance Companies found within Corps and Theater Army Area Commands. COMSEC maintenance above DS level will be performed at General Support level special repair activities or Depot using the TSFC/ST-51 automatic test equipment.

The depot will be responsible for all repairs not accomplished at lower echelons of maintenance. Major components will be repaired at the depot with selected items being sent to the vendors for repair. The depot capability necessary to preclude this approach is presently not available and the costs necessary to acquire it would far exceed costs of using contractor support based on a 20-year life cycle. The depot will contract independently with the required vendors. This is the only area where contractor support is anticipated.

The Army, as the designated lead service for both switches and COMSEC components, with the exception of the KG-84, will be responsible for providing single service wholesale logistic support to include depot maintenance. The Air Force has been designated as the lead service for providing single service wholesale logistic support and depot maintenance for the KG-84 component of the TRITAC COMSEC family of equipments.

The Air Force and Army will be using the same logistic resources developed on the AN/TTC-39 Program contract except where service doctrine or other preferences dictate otherwise.

Examples of this are:

- o Automatic test equipment. The Air Force will be using a portable digital card tester at the intermediate level whereas the Army will rely on the AN/USN-410. The Army depot support system will provide repair of PCB's beyond the Air Force field capability, on a reimbursable basis.
- o Ground support equipment. Where the Army and Air Force have different items of TMDE to accomplish the same function, each Service has the option to elect its preferred item.

There are many support items common to the two switches. When the switches are employed together, which is the objective approach, a common support package will be shared. When the switches are deployed independently, the total spares required to provide separate support is higher. Initial spares provisioning accommodates Army and Air Force independent employment concepts.

The Central Processor Group (CPG), used in the AN/TTC-39 and AN/TYC-39, is basically the same as that used in the TACFIRE and AN/TSO-73 systems. Logistic support for the switches capitalizes on the commonality among these systems.

The maintenance and support concepts for the AN/TTC-39 and AN/TYC-39 were largely determined by using Generalized Electronic Maintenance Model (GEMM) runs. The Manpower, Personnel, and Training implications associated with these concepts are discussed and analyzed in Sections III and IV.

### III. DETERMINATION OF MPT REQUIREMENTS - DISCUSSION

#### A. INTRODUCTION

The discussion in this Section is based on examination of available MPT data gathered through review of documents and interviews with Subject Matter Experts (SMEs). The discussion is organized chronologically to show progressive steps and changes in information as the AN/TTC-39 Program proceeded through the various phases of the acquisition process. Use is made of figures, tables, and summaries to provide the reader with a more complete understanding of the interrelationship of events and the data flowing from them.

As mentioned in Section I, MPT events are portrayed in time relative to the sequence called for in the Life Cycle System Management Model (LCSMM). The LCSMM, promulgated by DA PAM 11-25, May 1975, depicts the process by which Army materiel systems are initiated, validated, developed, deployed, supported, and modified. It is divided into four major segments corresponding to the four acquisition phases, i.e., Conceptual, Validation, Full Scale Development, and Production and Deployment.

It must be remembered that the model is not rigid. It is possible for many of the LCSMM events to be bypassed. Only events deemed pertinent and necessary for the development of the particular system are accomplished. In the development of some systems, entire phases may be bypassed; such was the case with the AN/TTC-39 Program which combined the Conceptual and Validation phases.

## B. CONCEPTUAL PHASE

In this phase, the technical, military and economic basis for proposed systems are established and concept formulation initiated through pertinent studies. Critical issues and logistical support problems and actions are identified for investigation and resolution in subsequent phases to minimize future development risks. This phase is a highly interactive process with activities performed simultaneously and/or sequentially. No specific period of time in months or years is prescribed for the Conceptual Phase since the phase length is determined by the characteristics and status of the operational and technical factors making up the proposed program, the urgency of meeting the predicted operational threat, or environment and resource constraints. For systems that require DSARC approval, the phase ends at Milestone I with Event 14, DSARC I/DCP I approval and Secretary of Defense (SECDEF) authority to proceed to the Validation Phase.<sup>10/</sup> Figure III-1 identifies the LCSMM events that address MPT/MPT-related issues in the concept phase. Since publication of DA PAM 11-25, the upfront requirements have become more formalized. A Milestone 0 was added and an approved Mission Element Need Statement (MENS) was established as the authority to proceed into the Conceptual Phase for new major system acquisitions. Recent changes in the acquisition process substituted a Justification for Major System New Starts (JMSNS) for the MENS, and required it to be submitted not later than the

---

<sup>10/</sup> LCSMM, page 2.

# CONCEPT PHASE

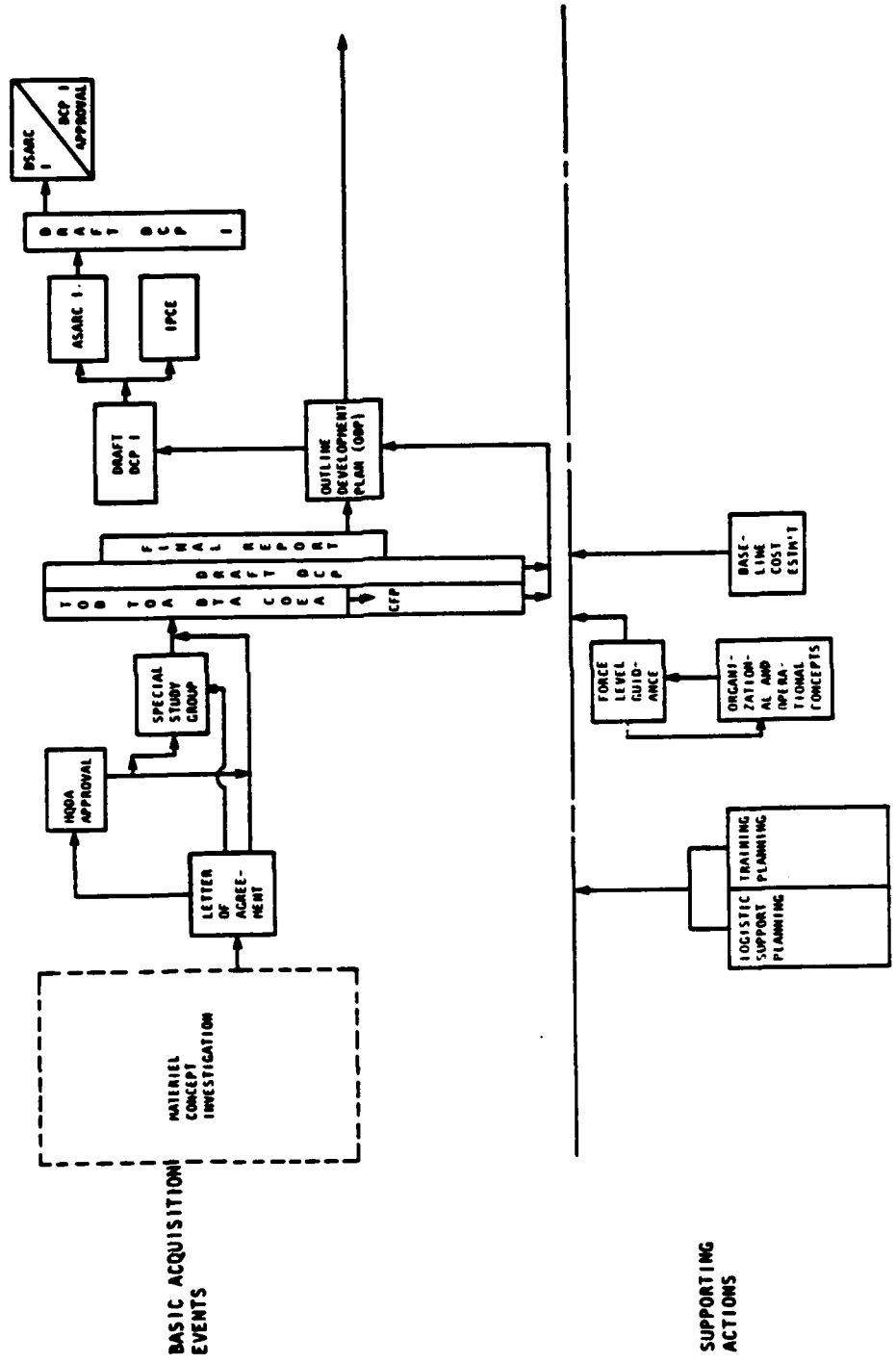

FIGURE III-1



Program Objective Memorandum (POM) submission in which funding is to be included.

While the AN/TTC-39 Program did not formally proceed through the Conceptual Phase, the military, technical and economic bases for the system had been examined to some extent before the SECDEF established the program in 1972. However, this study effort was unable to find evidence in the form of specific documentation concerning the degree of consideration given to MPT issues prior to formal program initiation.

#### C. VALIDATION PHASE

This phase consists of those steps required to verify preliminary design and engineering, accomplish necessary planning, analyze trade-off proposals, resolve or minimize logistics problems identified during the conceptual phase, prepare a formal requirements document and validate a concept for full-scale development. The validation process may be conducted by competitive or sole source contractors or by in-house laboratories. Advanced development prototypes (brassboard) should be used and tested (Development Test/Operational Test (DT/OT I)) during the validation phase to provide data to estimate the prospective system's military utility, cost, environmental impact, safety (noise level, radiation and toxicological effects), human engineering, operational effectiveness and suitability to include surety and/or technological factors, and to refine configuration prior to entering full-scale development.<sup>11/</sup>

---

<sup>11/</sup> LCSMM, page 2.

Figure III-2 illustrates the LCSMM events that address MPT/MPT-related issues in the validation phase versus those actually accomplished according to available data for the AN/TTC-39 Program.

As indicated in Section II, the validation phase began with the initiation of a Joint Operational Requirement (JOR) by the JCS in September 1971. Neither that basic requirement document, the August 1974 amendment, nor the November 1978 Mission Element Need Statement (MENS) addressed MPT requirements or constraints in any definitive way. The MENS only predicted considerable quantitative personnel savings on the basis of maximum use of information processing techniques and highly reliable digital components; a common logistics support system in which a single service (Army) will perform depot maintenance and support; and use of automated test support systems and Built-In Test Equipment (BITE) to reduce repair time.

The Request for Proposal (RFP) for the validation phase, released in February 1972, placed primary emphasis on prototype modeling, and provided very little guidance to bidders concerning either Human Factors Engineering (HFE) or MPT requirements/constraints to be considered during this competitive design phase. One section of the RFP, called "Operational Considerations", did point out that design trade-offs should stress the following factors, some of which are MPT related.

- o Simplicity of Operation
- o Mobility
- o Reliability and Availability
- o Reduction in Cost, Size, Weight and Maintenance

That section of the RFP also indicated that, in the operation and maintenance area, the prime objectives were to reduce the



number and skill levels of required personnel; however, no definitive qualitative or quantitative statements concerning system manpower requirements/constraints were included. The contractor was called upon to perform a task and skill analysis so as to identify specific numbers of personnel of each skill needed to support every possible switch configuration. In the area of training, the RFP called for preparation of a training plan to identify skills to be acquired and to provide a basis for determining course lengths and content.

Competitive prototype design contracts were awarded to two contractors, GTE and ITT, in June 1972 (LSCMM Event 16) for an 18-month period. In response to a 9 July 1973 government solicitation No. DAAB07-74-Q-0005, the two contractors also submitted engineering development design proposals for the next phase.

The solicitation indicated that contract award for the full-scale development phase would be based on the prototype modeling results and evaluation of written proposals in the technical, cost, and management areas. The technical and cost areas were considered to be of equal importance and each was more important than the management area.

Under the technical area, the following evaluation factors were listed. Of the factors, the first three were listed in order of importance and were individually more important than any of the last three which were of equal importance with each other.

1. Circuit Switch Design
2. Message Switch Design
3. Communications Security
4. Integrated Logistics Support
5. Circuit Switch Technical Control
6. Message Switch Technical Control

Under the Cost area, the following evaluation factors were listed. Of these factors, the first two were of equal importance, and each was more important than the other factors which were listed in order of importance.

1. Design-to-Unit Production Cost
2. Life Cycle Cost Analysis
3. Contract Price Proposal
4. Use of Government Property

Under the management area, the following factors were listed. Of these factors, the first three were of equal importance, and each was more important than the fourth factor.

1. Control and Reporting Systems
2. Production Planning
3. Competence, Experience, and Past Performance
4. Management Organization

No government testing was performed during the Validation Phase. Development testing was conducted by the contractors using limited prototype models to demonstrate proposed equipment design and prove the performance specifications. Testing was witnessed by representatives of the TRITAC Office, Defense Communications Agency (DCA) National Security Agency (NSA), and the Army during the period October-December 1973. No operational testing was conducted.

A Source Selection Evaluation Board (SSEB), using the factors described above, evaluated the competing contractors on the basis of their prototype modeling effort; results of associated design trade-off analyses; and their engineering development phase design proposals. Although HFE and MPT were not weighed as specific factors, evaluation of Integrated Logistics Support (ILS) included consideration of some MPT issues, e.g., the description of maintenance engineering analysis techniques for determining maintenance manpower/training requirements.

There is no evidence that any other Validation Phase MPT events called for in the LCSMM were accomplished prior to DSARC II. The Program was approved for entry into the Full-Scale Development Phase following DSARC II in April 1974.

D. FULL SCALE ENGINEERING DEVELOPMENT (FSED) PHASE

During this phase, the system, including all items for its support, is fully developed and engineered, fabricated, tested (DT/OT II), and a decision is made as to whether the item is ready for production. Concurrently, nonmateriel aspects, e.g., MPT, required to deploy an integrated system are developed, refined, and finalized.<sup>12/</sup>

Figure III-3 illustrates the MPT/MPT-related issues identified in the LCSMM which address the Engineering Development Phase versus those actually accomplished according to available data for the AN/TTC-39 Program.

1. Human Factors Engineering (HFE). Following the award of the Engineering Development Contract in April 1974, General Telephone and Electronics (GTE), the winning contractor, prepared an HFE plan for each switch. The U.S. Army Human Engineering Laboratory (HEL) reviewed the draft plans for the Program Manager, Multi-Service Communications System (PM-MSCS). The plans were found to be weak in that they failed to indicate responsibilities and authority of the Contractor HFE Group and its relationship to other GTE organizational elements; failed to describe major subcontractor (Litton) HFE efforts and organization; and omitted major switch components requiring HFE

---

<sup>12/</sup> LCSMM, page 2.



applications. The final HFE plans, submitted in November 1974, responded to HEL criticism by assigning well-qualified personnel to the HFE effort on a full time basis; providing for GTE monitorship of subcontractor HFE efforts; and placing the HFE Group in an organizational position and giving it functional authority which, at least on paper, seemed to assure its influence in the design process.<sup>13/</sup>

Although there was little emphasis on HFE in the Engineering Development Contract, the Human Engineering Lab, at the request of and funded by the PM-MSCS, monitored GTE's HFE effort, and provided advice and assistance to the contractor's HFE Group during some eight visits to GTE facilities between August 1975 and August 1976. The HEL also witnessed and evaluated the results of the HFE portion of the Research and Development Acceptance Tests (RDAT) during 1978. The HEL representative who worked with GTE's Human Factors Engineering Group indicated that he had good rapport with the Human Factors engineers and characterized them as being competent and dedicated. However, he also indicated that, in practice, the Group had neither the authority implied in the GTE HFE plan nor even a very strong voice in the design process.

Some of the same HFE problems, identified early in the Engineering Development Phase, were still being cited as deficiencies during various government tests (DT, OT, & RDAT) conducted between June 1978 and May 1980.

---

<sup>13/</sup> GTE-Sylvania, Human Factors Engineering Plans, Circuit Switch (CDRL COO1) & Message Switch (CDRL OO2), 13 November 1974.



The November 1979 report of a Human Factors Engineering Analysis (HFEA) performed by HEL also reiterated HFE problems identified early in the design process for each switch. Some of those persistent deficiencies are listed below.

- o The noise level in each switch shelter exceeds contractual requirements. While the noise is not at a hazardous level, it affects interpersonnel communications, thereby increasing the chance of operator error.
- o Air conditioning units in each switch shelter lack BTU capacity to adequately cool operator working areas during hot summer days, thereby reducing operator efficiency. This condition could require shorter shifts and a possible concomitant increase in manpower requirements.
- o The size and weight of the module test set makes it difficult to transport and causes it to block the shelter aisle, thereby hindering normal operator movement.
- o Inadequate space exists in both switch shelters for storage of tools and manuals required for day-to-day operations.
- o The amount of coding, abbreviations, and inconsistencies present in the control/display formats cause heavy reliance on manuals and have an impact on training and MOS selection.
- o Intershelter cables are difficult to hookup when shelters are truck mounted.
- o There is an unequal distribution of workload between the Message Switch operator/maintainer and the Message Switch traffic service.

The HFEA prepared by HEL concluded that Low Rate Initial Production (LRIP) of both switches should be delayed until the human factor problems had been corrected. It should be noted that the production decision was not delayed by the findings of the HFEA. According to PM-MSCS and HEL representatives, a Memorandum of Understanding (MOU) was signed by both agencies whereby HEL agreed to withdraw its objection to proceeding with production in return for a PM-MSCS assurance that deficiencies would be fixed during early production.

## 2. Logistic Support Analysis.

Logistic Support Analysis (LSA), as promulgated by Military Standard (MIL-STD) 1388, 15 October 1973 and called for in the Full Scale Engineering Development (FSED) contract, was not accomplished for the AN/TTC-39 Program. During the first two years of FSED (1974-1976), GTE used some of the techniques described in MIL STD 1388 in their development of switch maintenance requirements, including manpower; however, full implementation of LSA procedures and generation of LSA Records (LSAR) never occurred. In April 1976, the PM-MSCS advised the US Army Materiel Support Activity (MRSA), with the concurrence of the US Army Communication and Electronics Readiness Command (CERCOM)-- now known as the Communication and Electronics Command (CECOM)-- that the contractor had been directed to cease activity on the LSA program.<sup>14/</sup> A GTE spokesman cited early systemic problems with the automated LSAR and LSA procedures, which were perceived to be overly complicated, as the rationale for never fully implementing the program and finally stopping it altogether.

The contractor's early LSA effort included the use of the Generalized Electronics Maintenance Model (GEMM) to predict baseline system maintenance requirements for each switch. Inputs to the model came from system specifications and estimates made by the materiel developer (PM-MSCS and CECOM) concerning how the switches were going to be employed and supported in the field. There was no Organizational and Operational (O&O) concept written

---

<sup>14/</sup> PM-MSCS, Integrated Logistic Support Plan, February 1980 Chapter 11.

at this time, and no evidence could be found to indicate that the combat developer (TRADOC) played any significant role in establishing parameters, e.g., wartime switch rates, for the GEMM runs. Outputs from the model became inputs to various early system support requirements documents such as QQPRI's.

### 3. QQPRI/BOIP/MOS Decisions

a. General. The QQPRI and BOIP are iterative documents that provide manpower and training planners the earliest and most current information concerning the numbers and qualifications of personnel required to operate, support, and maintain a materiel system under development. For the majority of acquisition programs, input to both documents comes from a variety of organizational sources within the materiel development (DARCOM) and combat development (TRADOC) communities. A substantial amount of basic data in both documents is derived from Logistics Support Analysis (LSA). The materiel developer, e.g., CECOM in the case of the AN/TTC-39 Program, initiates both the BOIP and QQPRI processes by preparing BOIP Feeder Data (BOIPFD). The BOIPFD lists all principal and associated items of equipment, component items, to include Test, Measurement, and Diagnostic Equipment (TMDE) required to support the new system. The materiel developer also concurrently prepares a proposed QQPRI which lists skills, tasks, and knowledge required to operate and support the new item and its Associated Items of Support Equipment (AIOSE), and estimates of time required to maintain it. Both the BOIPFD and proposed QQPRI are forwarded by the materiel developer through DARCOM channels to TRADOC. The materiel developer's

proposed QQPRI is refined at TRADOC by adding the training, support and doctrinal implications of the new system. Using data from both the QQPRI and BOIPFD along with the O&O concept, a TRADOC proponent school, e.g., US Army Signal School in the case of the AN/TTC-39 Program, develops the BOIP. The BOIP is a planning document which predicts organizational quantitative equipment and personnel requirements for a system.

Following TRADOC's refinement of the QQPRI and development of the BOIP, both documents are staffed at the Soldier Support Center-National Capital Region (SSC-NCR) and HQDA to determine if the system falls within manpower constraints; reflects the appropriate Military Occupational Specialty (MOS)/Special Skill Identifier (SSI)/Additional Skill Identifier (ASI); meets Standard of Grade Authorization (SGA); has a feasible grade structure; and can be supported by Army recruiting and training capabilities. As the system proceeds through the development process, QQPRI and BOIP must be updated to reflect the latest outputs from the LSA, and other events which indirectly feed the BOIP and QQPRI.

b. Contractor QQPRI's. The Contractor, GTE, prepared the first two iterations of the QQPRI for each switch. The first set was submitted in July 1975 and the final version was provided to the Army in January 1976 for the Circuit Switch and February 1976 for the Message Switch.

Both versions for each switch were based on a three-level maintenance concept, i.e., organizational, intermediate, and depot. Each QQPRI identified types and numbers of personnel

thought to be necessary for operation and organizational maintenance, and types of personnel predicted for intermediate maintenance; however, neither version addressed depot maintenance requirements. Types of personnel were expressed in terms of those MOSs listed in Army Regulation (AR) 611-201, Enlisted Career Management Fields and MOSs, which most closely matched anticipated duties. The MOSs selected were not supported by any detailed task/skill analyses. In fact, the skill and knowledge requirements for each MOS listed in the July 1975 QQPRI were simply copied from the AR. Maintenance Engineering Analysis (MEA) was cited as a reference used in preparing each QQPRI; however, Direct Productive Annual Maintenance Manhours (DPAMMH) by MOS, system component and level of maintenance--prime QQPRI data elements--were not included in either version of the Switch QQPRI. It could not be determined whether this failure to show DPAMMH was due to either a technical inadequacy of GTE's MEA and/or early LSA tools to generate such data or simply a lack of understanding of what kind of information needed to be included in the QQPRI.

Both versions suggested that each switch could be operated and maintained at the organizational level by a crew of two enlisted personnel per shift. No crew size rationale was provided in the QQPRI; however, a GTE subject matter expert indicated that it was based on the crewing of similar systems, and to some extent, the size of the S-280 shelters used to house the switches. The July 1975 QQPRI for each switch further estimated a requirement for a 10 enlisted person crew (operation

and organizational maintenance) for each switch on an annual basis in an operational status, assuming positions are manned continuously. Table III-1 summarizes the qualitative and quantitative manpower estimates made in the two contractor QQPRI's for each switch.

Consolidated government comments concerning the July 1975 QQPRI's were provided to the contractor in September 1975 and served as a basis for changes reflected in the January/February 1976 version. No record of any consolidated government critique of the second iteration of the contractor's QQPRI's was found. Furthermore, there was no evidence to suggest that either iteration was used by manpower planners/decision makers in any early assessment of system manpower requirements.

c. Government QQPRI's.

(1) Provisional QQPRI. A provisional QQPRI was initiated by CECOM in April 1977, a copy of which could not be located. However, correspondence concerning its content suggested that the primary source of data for this earliest government QQPRI were the January/February 1976 contractor versions. Following amendment in December 1977 to reflect planned use of Automatic Test Equipment AN/USM-410 (EQUATE) at both the intermediate and depot maintenance levels, the document was reviewed by the US Army Signal Center (USASC). In comments, dated April 1978, USASC highlighted the lack of qualitative and quantitative maintenance data needed to support realistic estimates of types and numbers of maintenance personnel and their training. The USASC recommended that support requirements be based on the

Table III-1

**SUMMARY OF DATA  
CONTRACTOR QQPRIS**

POSITIONS	JULY 1975			JAN/FEB 1976			
	No./ Shift	No./ Single Shift Day	Number- Continuous Operation (Annual Basis)	MOS	No./ Shift	No./ Single Shift Day	Number- Continuous Operation (Annual Basis)
<u>Operation/Organizational Maintenance:</u>							
Circuit Switch	1		5	72C	1-4*		
Call Service Attendant Switch Supervisor Operator/Maintainer	1		5	-	1-4*		
Message Switch							
Traffic Service Attendant	1		5	72F	1		
Switch Supervisor Operator/Maintainer	1		5	-			Not Speci- fied
					1		
<u>Intermediate Level Maintenance:</u>							
Both Switches							
1L Maint Technician		1		34D***	1		
Master Power Distribution Technician	1		Not Speci- fied	52B	1		
Teletype Repairman		1		31J		1	
Wire Maintenance Man		1		36C		SOP	
Environmental Control Unit Repairman		1		51L	1		
General Cryptographic Repairman		1		31S		1	

\* Depends on deployment mode.

\*\* 32D & 36L listed as other choices.

\*\*\* 36L listed as an alternative in MS  
QQPRI.

Army's standard four level (organization, direct support, general support, depot) maintenance concept rather than the three levels addressed in contractor QQPRI's. A number of MOS changes were also suggested, most of which were reflected in the final QQPRI's.

(2) Final QQPRI. A "so-called" Final QQPRI for each switch was initiated in December 1978, again by CECOM. Each, for the first time, listed DPAMMH by MOS for switch components at organizational, direct support, and general support maintenance levels. Depot level DPAMMH had not yet been calculated at this time. Since GTE's LSA effort stopped in 1976, the DPAMMH were not extracted from any up-to-date LSAR. Instead, they were based on the best judgement of CECOM maintenance engineers using available data concerning like and similar systems and output from limited MEA performed by the contractor. Both QQPRI's confirmed the earlier estimates that a two-person enlisted crew could operate each switch, and indicated that the MOS 36L should be the crew supervisor for each switch. Neither made any prediction concerning the crew size needed for continuous operation. Table III-2 summarizes the qualitative manpower estimates for both switches.

(3) Amendments to Final QQPRI's. Three amendments to each switch QQPRI were initiated by CECOM during the first 9 months after origination of the FQQPRI. The first two amendments, in May and June 1979, added associated items of equipment and direct support tools/test items to each switch with a corresponding increase in DPAMMH for some maintenance MOSSs. Qualitative changes noted included the addition of the following



Table III-2

FINAL QOPRI Qualitative Manpower Requirements		
PSN TITLE/MOS	MS AN/TYC-39	CS AN/TTC-39
<u>Operation:</u>		
Telecommunication Central Operator/72E	X	
*Electronic Switching System Repairer/36L	X	X
Wire Systems Installer/Operator/36C		X
<u>Maintenance:</u>		
Organizational:		
*Electronic Switching System Repairer/36L	X	X
Wire Systems Installer/Operator/36C	X	
Utilities Equipment Repairer/52C	X	X
Power Generation and Wheel Vehicle Mechanic/63B	X	X
Direct Support:		
Electronic Switching System Repairer/36L	X	X
Utilities Equipment Repairer/52C	X	X
Power Generation Equipment Repairer/52D	X	X
Teletypewriter Repairer/31J	X	X
General Support:		
Electronic Switching Systems Repairer/36L	X	X
Utilities Equipment Repairer/52C	X	X
Power Generation Equipment Repairer/52D	X	X
Field Systems COMSEC Repairer/31T	X	X
Automotive Repairman/63H	X	X
Teletypewriter Repairer/31J	X	X
Electronic Instrument Repairer/35B	X	X
* Same Individual - performs both operational and organizational maintenance duties.		

MOSs in support of each switch at the maintenance levels indicated.

- o MOS 31E Field Radio Repairer (OL, DS, GS)
- o MOS 31S Field General COMSEC Repairer (DS, GS)
- o MOS 31T Field Systems COMSEC Repairer (DS, GS)
- o MOS 44B Metal Worker (GS)

The September 1979 amendment designated the 5-ton truck as the prime mover for each switch and removed the direct support tools/test items from the basic switches and placed them in support facilities.

In August 1979, USASC recommended that the FQQPRI be further amended to show MOS 72G vice 72E for the Message Switch Traffic Service Attendant and that the MOS 72G be designated as the shift supervisor instead of MOS 36L. Findings of the Initial Operational Test and Evaluation, discussed in paragraph 6.b. below, were cited as the basis for these changes. These recommended changes do not appear in any QQPRI iteration reviewed during this study, but are reflected in the BOIP, discussed in d. below.

d. BOIP

The USASC has prepared several iterations of the BOIP for each switch since receiving the December 1978 FQQPRI from the materiel developer in early 1979. Since there is no requirement for anyone to retain previous editions of BOIPs once a new one is published, it was not possible to review all iterations. However, a comparison was made between BOIPs prepared in August 1979 for each switch and "so called" Final BOIPs published in February 1981 and again in December 1981.

The planned quantitative changes shown by MOS for each TOE directly affected by deployment of the switches were the same in all three versions of the BOIP for each switch. Crew sizes for 24-hour operation of each switch, illustrated in Tables III-3 (Circuit Switch) and III-4 (Message Switch), were also the same in the August 1979 and February 1981 BOIPs; no crew sizes were shown in the December 1981 BOIPs.

e. MOS Decisions.

A tentative MOS decision for both switches was issued in July 1980, 4 months following DSARC III for the Message Switch and about 1 week after DSARC IIIA for the Circuit Switch. It differed from the FQQPRI, as amended, in two areas.

First, the MOS decision for the Message Switch showed a Warrant Officer, Telecommunications Technician, MOS 290A under "Operator Personnel". This position was never identified as a requirement in any QQPRI reviewed during this study, although it was listed in Message Switch BOIPs.

Secondly, the tentative MOS decision changed the Message Switch Traffic Service Attendant MOS from 72E to 72G. The apparent rationale for this shift was a common finding during DT and OT that Message Switch duties, which include operating in the Automatic Digital Network (AUTODIN), more closely approximated the skills possessed by MOS 72G than MOS 72E.

The final MOS decision in October 1981 changed MOS 72G back to 72E with an Additional Skill Identifier (ASI) Z2. The change back was apparently based on a study, not directly related to the AN/TYC-39 development, which converted MOS 72E to

Table III-3

AN/TTC-39 Circuit Switch Crew Size  
(BOIPs 79-0046 & 79-0047F)

Number	Grade	MOS	Position
1	E7	31240	*Section Chief
1	E5	36L20	Operator/Maintainer
1	E4	36L10	Operator/Maintainer
2	E4	36C10	Call Service Attendant
1	E3	36C10	Call Service Attendant

\* Not fully chargeable to the CS. Also responsible for operation of other equipment assigned his section.

Table III-4

AN/TYC-39 Message Switch Crew Size  
(BOIP 76-0098F)

Number	Grade	MOS	Position
1	NO	290A	Section Leader
1	E6	72G30	Shift Supervisor
1	E5	72G20	Traffic Service Attendant
1	E5	36L20	Operator/Maintainer
1	E4	72G10	Traffic Service Attendant
1	E4	36L10	Operator/Maintainer

a purely tactical MOS. Before, it had included some fixed station duties. The ASI provides the 72E with the capability to operate AUTODIN which is included in the 72G (fixed station only) MOS. The final MOS decision also changed the MOS 63H Automotive Repairer at GS level to MOS 63W Wheel Vehicle Repairer.

Although not identified in any QQPRI, BOIP, or MOS decision paper, another MOS--76C (Equipment Repair Parts Specialist)--is shown as a member of both switch crews in the Army Modernization Information Memorandum (AMIM), August 1981. On the crew for the Circuit Switch, the 76C replaces one of the two 36C10s; on the Message Switch crew, the 76C is an added space. The 76C is also counted as an asset for each switch in a Communications and Electronics Functional Review (CEFR) prepared by the Soldier Support Center - National Capital Region (SSC-NCR), and discussed further in paragraph 5.b below.

One other known MOS decision affecting the AN/TTC-39 Program has been made recently. It creates a new MOS (36M) as a Call Service Attendant dedicated to the AN/TTC-39 Circuit Switch. This MOS change will appear in change 19, AR 611-201, effective 1 March 1983.

#### 4. Operational and Organizational Concept (O&O)

Preparation of an O&O Concept is called for in the Conceptual Phase of the LCSMM in order to support subsequent development of QQPRI, BOIP, and the test support package. The first system specific O&O concept found during this study was not drafted until March 1979, although general concepts for employment of both switches were outlined in the Integrated

Tactical Communications System (INTACS) study approved in 1976. No definitive O&O concept was available to support either switch design efforts or early MPT requirements determination.

5. Manpower Analyses

a. Manpower Analysis Paper (MAP) III. This document, prepared at USASC in December 1979, presented the manpower impact of fielding both switches, less COMSEC requirements. It assumed that all switches programmed for procurement at the time the analysis was made would be purchased and fielded. It consolidated the quantitative manpower changes in TOEs affected by the fielding of both switches as reported in the August 1979 BOIPs. The MAP then applied those quantitative changes to a projected FY86 force structure as specified in the Army's Force Accounting System as of 1 November 1979. The analysis concluded that full fielding of both switches would result in an increase of only 11 spaces in the total active force, 168 spaces in the National Guard, and 86 spaces in the U.S. Army Reserve. Even with those small increases, the analysis also offered tradeoff recommendations which would change the total force impact from +265 to -16 overall.

The MAP also evaluated the impact of switch fielding on combat support/combat service support units, using the Force Analysis Simulation of Theater Administrative and Logistics Support (FASTALS) model. It concluded that while there would be some increase in theater requirements for DS and GS automotive and power generation maintenance manpower, the increase would not be large enough to require the addition of maintenance units to the theater.

b. Communications - Electronics (C-E) Functional Review (CEFR). Using a variety of sources including data from The Personnel Structure and Composition System (PERSACS), SSC-NCR prepared a CEFR in January 1982. It projects aggregate C-E manpower requirements by MOS by grade over the Fiscal Years 1982-1985. It also breaks out those projected requirements chargeable to the Message and Circuit switches as shown in Table III-5.

#### 6. Training

Initial training of Army instructors, key personnel, and personnel required to participate in development and operational testing of both switches began in late 1977 for the Message Switch and early 1978 for the Circuit Switch. Training courses were conducted at the contractor's plant in Needham Heights, MA; USASC, Ft. Gordon, GA; and at the test site, Ft. Huachuca, AZ. Initial training courses and materials were developed by the contractor and coordinated with the USASC.

Longer term training requirements for switch Operation and maintenance were first estimated by USASC in the FQQPRI for each switch. That estimate indicated that, except for MOS 36L (Operator and OL, DS, GS Maintenance for both switches), only minor increases in resident course lengths, ranging from one to three weeks, would be required to qualify recommended MOSs for either Message or Circuit Switch duties. No increase in resident course instruction was foreseen for MOS 36C (36M) (Call Service Attendant for the Circuit Switch); however, a 40-hour exportable transition training package was proposed. This basic resident

Table III-5  
AN/TTC-39 PROGRAM  
QUANTITATIVE MANPOWER REQUIREMENTS  
FOR SELECTED MOS

MOS/GRADE	FY83				FY84				FY85				△
	1	2	3	4	1	2	3	4	1	2	3	4	
<b>36L (TYC-39)</b>													
E6	-	2	6	13	19	23	28	31	32	36	36	36	+36
E5	-	2	6	13	17	19	21	21	22	23	23	23	+23
E4	-	<u>2</u>	<u>6</u>	<u>13</u>	<u>17</u>	<u>19</u>	<u>21</u>	<u>21</u>	<u>22</u>	<u>23</u>	<u>23</u>	<u>23</u>	<u>+23</u>
TOTAL	-	6	18	39	53	61	70	73	76	82	82	82	+82
<b>36L (TTC-39)</b>													
E5	-	-	-	2	2	9	16	24	30	36	36	36	+36
E4	-	-	-	<u>2</u>	<u>2</u>	<u>9</u>	<u>16</u>	<u>24</u>	<u>30</u>	<u>36</u>	<u>36</u>	<u>36</u>	<u>+36</u>
TOTAL	-	-	-	4	4	18	32	48	60	72	72	72	+72
<b>72E ASI Z2 (TYC-39)</b>													
E6	-	2	6	13	17	19	22	22	23	24	24	24	+24
E5	-	2	6	13	17	19	22	22	23	24	24	24	+24
E4	-	<u>2</u>	<u>6</u>	<u>13</u>	<u>17</u>	<u>19</u>	<u>22</u>	<u>22</u>	<u>23</u>	<u>24</u>	<u>24</u>	<u>24</u>	<u>+24</u>
TOTAL		6	18	39	51	57	66	66	69	72	72	72	+72
<b>36C (TTC-39)</b>													
E4	-	-	-	4	4	18	32	48	60	72	72	72	+72
E3	-	-	-	<u>2</u>	<u>2</u>	<u>9</u>	<u>16</u>	<u>24</u>	<u>30</u>	<u>36</u>	<u>36</u>	<u>36</u>	<u>+36</u>
TOTAL				6	6	27	48	72	90	108	108	108	+108
<b>76C (TTC/ TYC-39)</b>													
E4	-	2	6	15	21	30	38	47	54	61	61	61	+61



training philosophy was reiterated in the initial Individual and Collective Training Plan (ICTP) published in 1979.

Prior to development of the Message and Circuit Switches, all MOS 36Ls were trained in a single 38 week course regardless of future duty positions. The addition of Message and Circuit training to the resident MOS 36L course would extend it to an estimated 56 weeks. As an alternative, the USASC recommended a multi-level restructuring of the MOS as follows.

- o Establish a skill level of 36L10, Operator/Organizational Maintenance, and provide 18 weeks of resident training on the AN/TTC-39 plus 4 weeks systems training.
- o If the first projected assignment for a trainee is to a AN/TYC-39 unit, provide an additional 8 weeks of training on that switch and award an ASI.
- o If first assignment is to be with an AN/TTC-38 switch unit, provide an additional 8 weeks of TTC-38 training and award an ASI.
- o Establish a skill level of 36L30, Intermediate (DS or GS) Maintenance, and provide a trained 36L10, upon his/her first reenlistment, with an additional 18 weeks of resident training which covers both switches plus 4 weeks of systems training.
- o If the first assignment of a 36L30 after training is to a unit which has or repairs TTC-38 switches, provide an additional 8 weeks of training and award an ASI.

A New Equipment Training Plan (NETP) prepared by the materiel developer during this phase envisioned that equipment would be deployed with personnel school trained at the operator through GS maintenance level; therefore no requirement for New Equipment Training Teams (NETT) was foreseen. However, the NETP did project a requirement for a Doctrine Training Team to be provided by the combat developer (TRADOC). The team is scheduled to teach a 120-hour course to gaining units for both switches concerning operational and organizational concepts.

## 7. Government Test and Evaluation

### a. Introduction

A Development Test and Evaluation (DTE) and an Initial Operational Test and Evaluation (IOTE) of each Engineering Development Model Message and Circuit switch were conducted at the TRITAC Joint Test Facility, Fort Huachuca, AZ during the time periods shown below.

- o DTE
  - AN/TYC-39 (MS) June 1978 - February 1979<sup>15/</sup>
  - AN/TTC-39 (CS) February - November 1979<sup>16/</sup>
- o IOTE
  - AN/TYC-39 (MS) February - June 1979<sup>17/</sup>
  - AN/TTC-39 (CS) November - December 1979 and February - May 1980<sup>18/</sup>

These tests were the first formal government controlled evaluations to be performed on either switch since the program was established in January 1972, some 6 1/2 years earlier.

### b. Test and Evaluation Findings

In addition to the results mentioned in paragraph 1. supra, which primarily concern Human Factors Engineering, a number of MPT related findings suggesting needed improvements were outlined in test and evaluation reports for both switches; some of the more significant are listed below.

---

<sup>15/</sup> US Army Electronic Proving Ground, (USAEPG) Development Test and Evaluation Report - AN/TYC-39, July 1979.

<sup>16/</sup> USAEPG, Development Test and Evaluation Report - AN/TTC-39, January 1980.

<sup>17/</sup> US Army Operational Test and Evaluation Agency (OTEA), Independent Evaluation of AN/TYC-39, IER-OT-590, September 1979.

<sup>18/</sup> OTEA, Independent Evaluation of AN/TTC-39 with Associated COMSEC, IER-OT-123, November 1980.

(1) System design of the Message Switch permits uncontrolled operator alteration of the computer software in the processor. Should operator error occur, the computer program could improperly process messages, including classified traffic over unsecured lines.

(2) The majority of Message Switch (MS) test players, (12 of 15 Operator and Traffic Service Attendent (TSA) personnel and all 7 IOTE maintenance personnel), as well as test controllers for both switches, stated that pre-test training had been inadequate. They opined that added MS training was needed in such areas as use of test equipment, data base generation, message recovery, interpretation of alarms, queries and displays, operation and maintenance of environmental control units and cryptographic equipment, and set-up/tear-down procedures. Players for both switches spent an inordinate amount of time referring to Technical Manuals on the above subjects, and all too often, failed to find answers.

(3) For both switches, Technical Manuals were inadequate, difficult to understand, inaccurate, and out-of-date. Specific improvements were recommended for MS manuals, including explanation of message transmissions, message precedence, language media formats, general language formats, and definition of symbols in logic diagrams. Flow charts did not always follow the path expected, and diagrams were missing from some manuals. It should be noted that Improved Technical Documentation for Training (ITDT) requirements--now known as Skill Performance Aids (SPAS)--were not included in the Engineering Development Contract and were waived for the Message Switch IOTE.

(4) The message switch Traffic Service Attendant (TSA) should be changed from MOS 72E (telecommunications center operator) to data communications switching center specialist (MOS 72G), who is better trained to operate equipment in automatic digital message switching centers.

(5) The message switch supervisor should be MOS 72G vice MOS 36L (electronic switching systems repairer). The 36L has limited experience in operating an electronic switch in a traffic network, which is a highly complicated process dependent on strict adherence to established procedures. Since that is the primary mission of the switch, it should be supervised by a TSA of appropriate grade.

(6) Strong consideration should be given to combining operator and service attendant duties now split between MOS 36L and MOS 72E for the Message Switch and between MOS 36L and MOS 36C for the Circuit Switch. The MOS 36Ls assigned to each switch crew dedicated to organizational maintenance duties while the service attendant would be responsible for all operational duties.

(7) The units used for the conduct of IOTE for both switches were not typical of the Army organizations that will operate the equipment in the field. The company-size organization was a Table of Distribution and Allowances (TDA) unit which had no Standing Operating Procedures (SOPs), no integrated company training, and little coordinated communications system experience and/or mission orientation. Further, DS and GS maintenance activities for both switches could not be fully assessed in an operational environment due to the nature of test

site facilities and lack of a full complement of components/equipment subject to DS/GS maintenance.

(8) The message switch met the user criterion for Mean Time To Repair (MTTR) for GS level maintenance (60 minutes), but failed to meet the criterion for organizational level maintenance by a factor of four (58.5 minutes versus 15 minutes), and for DS level maintenance by a factor of two (59.1 minutes versus 30 minutes). The Message Switch test report suggested that the amount of time spent on a maintenance problem might have been less if the overall switch supervisor had been traffic versus maintenance oriented (see Finding 5.). It was also suggested that inadequate Technical Manuals and limited van work space contributed to failure to meet MTTR criteria.

(9) A unit supporting a Corps Headquarters with two message switches and one crew cannot effectively execute anticipated frequent jumps; therefore, full crews should be provided for each message switch assigned to units supporting Corps Headquarters.

(10) Independent Evaluation Reports (IER) of IOTE for both switches called for additional testing in a tactical environment to demonstrate improvement in a number of areas including human factors, training, organization and doctrine, and Reliability/Availability/Maintainability (RAM).

c. DSARC III/IIIA

Following review of DSARC III proceedings on the AN/TYC-39 Message Switch, the Deputy SECDEF approved it for entry into the Production and Deployment Phase (Phase III) in April 1980.<sup>19/</sup>

---

<sup>19/</sup> Deputy SECDEF, Secretary of Defense Decision Memorandum (SDDM) on the AN/TYC-39 Message Switch, DSARC III, 15 April 1980.

In July 1980, he approved the DSARC IIIA proceedings which recommended that the AN/TTC-39 Circuit Switch also enter Phase III.<sup>20/</sup>

In both decisions, the Deputy SECDEF directed that additional testing be conducted to validate correction of deficiencies identified during DTE/IOTE and to evaluate the adequacy of planned personnel skill levels and training. Partial results of follow-on testing, as well as other actions taken by the Combat Developer (TRADOC) and Materiel Developer (DARCOM) on the basis of previous test results, are discussed in paragraph E. below.

E. PRODUCTION AND DEPLOYMENT PHASE

During this phase, system deficiencies found in previous testing are corrected, operational units are trained, equipment is procured and distributed, and logistic support is provided. The primary objective is to produce and deliver to an operating unit an effective, supportable system.<sup>21/</sup>

Figure III-4 illustrates the MPT and MPT related events identified in the LCSMM for the Production and Deployment Phase versus those actually accomplished according to available data for the AN/TTC-39 Program.

1. Follow-On Testing and Evaluation

An independent and formal Follow-On Evaluation (FOE) of each switch is tentatively scheduled to be performed by OTEA in

---

<sup>20/</sup> Deputy SECDEF, Secretary of Defense Decision Memorandum (SDDM) on the AN/TTC-39 Circuit Switch, DSARC IIIA, 28 July 1980.

<sup>21/</sup> LCSMM, page 2.

# PRODUCTION/DEPLOYMENT PHASE

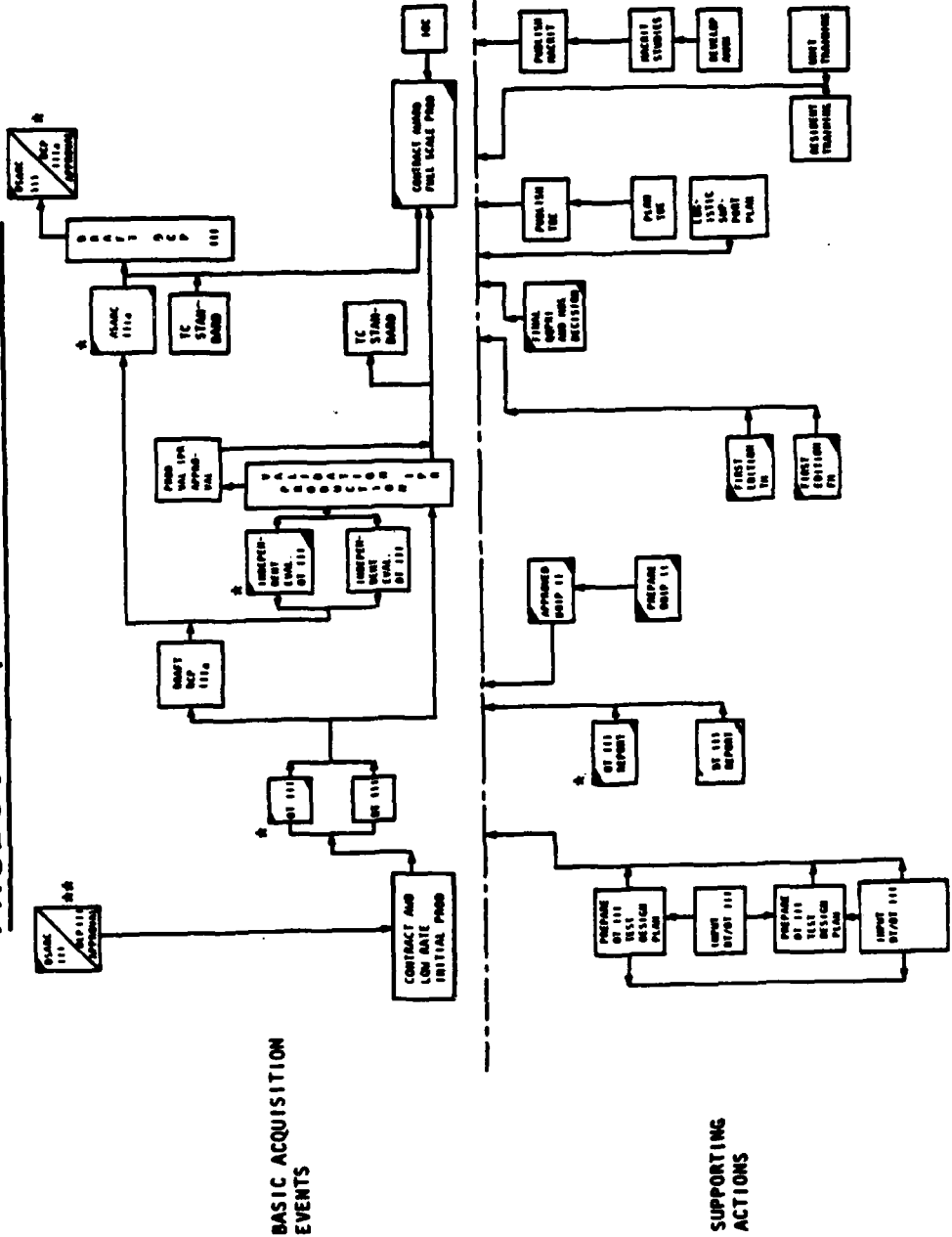

FIGURE 111-4

EVENT/ACTION ACCOMPLISHED FOR AM/TC - 35 PROGRAM  
 \* AM/TC - 35 ONLY  
 \*\* AM/TC - 35 ONLY

the Initial Operational Capability (IOC) unit at FT Hood, TX during the 2d QTR FY83 for the Message Switch and the 4th QTR FY83 for the Circuit Switch. The purpose of these FOEs is to document verification of the correction of deficiencies noted during DTE/IOTE for both switches.

In order to satisfy the Deputy SECDEF's requirement to verify selected deficiency corrections prior to fielding, a number of post DSARC III/IIIA evaluations have been made of both switches, the results of which are summarized below.

a. WINTEX-81

One AN/TYC-39 (MS) was deployed to U.S. Army Europe (USAREUR), and integrated into the communications network supporting a major Command Post Exercise (WINTEX-81), conducted 8-21 March 1981. The switch was installed, operated, and maintained at the organizational level by personnel school trained at USASC; contractor personnel performed DS, GS, and Depot Maintenance. Switch performance was evaluated by OTEA and documented in an Independent Evaluation Report (IER-OT-590), dated June 1981.

The on-site presence of contractor personnel hindered objective observations concerning skills and training needs of switch personnel because contractor personnel frequently assisted in switch operations and organizational maintenance. Nevertheless, the evaluation confirmed earlier test findings that MOS 72G vice 36L was best for the position of switch supervisor; that MOS 72G should perform all operational duties now shared with the MOS 36L, who should devote full attention to switch maintenance; and



that resident training needs to be expanded, with particular emphasis on practical hands-on applications. Technical Manuals were considered adequate, although poor organization of content was a frequent criticism.

The IOTE MTTR criterion of 15 minutes at organizational level was changed by the combat developer (TRADOC-TSM) to 30 minutes for follow-on evaluations. An MTTR of 46 minutes at organizational level was achieved during the WINTEX 81 performance evaluation compared to the MTTR of 58.5 minutes measured during IOTE.

b. Fault Insertion Demonstration

A Fault Insertion Demonstration (FID) was performed on two AN/TYC-39 Message Switches at FT Huachuca, AZ from 4 May to 21 July 1981. The demonstration was monitored by OTEA and results documented in a letter report dated 17 May 1982.

Isolation and repair of 60 faults by each of three teams, two recently trained Army crews and one Air Force crew, yielded an organizational level MTTR of 44.27 minutes versus a 30 minute criterion. However, the overall median repair time was 35 minutes which approaches the user established requirement.

An assessment of training during the FID further confirmed findings of previous tests that formal training did not cover all major equipment areas to the extent necessary to minimize the need for extensive On-The-Job Training (OJT). Specific areas for increased training were identified and USASC representatives at the demonstration indicated that resident courses would be appropriately modified.

During the FID, an analysis of fault isolation and diagnostic procedures contained in Technical Manuals (TM) concluded that the manuals did not provide sufficient detail in a clear, easy to read format; 27 needed changes to TMs were documented.

c. RAM Assessment

RAM data were collected during the period from 1 June to 18 September 1981 when three AN/TTC-39 Circuit Switches and two AN/TYC-39 Message Switches were deployed at FT Huachuca, AZ in support of the Communications Nodal Control Element (CNCE) IOTE. Some 440 RAM incidents were recorded and assessed; however, the MTTR data collected above the organizational level was not considered valid since DS and GS maintenance support at FT Huachuca is unlike that which will support the fielded systems. RAM performance statistics compiled during CNCE testing generally showed improvement over data collected during previous tests.

- o Mean Time Between Unscheduled Maintenance Actions (MTBUMA) improved over IOTE and approaches the criterion of 72 hours for both switches.
- o Mean Time Between Mission Failures (MTBMF) is much better than that achieved in IOTE.
- o Inherent and Operational Availability ( $A_i$  &  $A_o$ ) meet and exceed respective criterion.
- o MTTR (OL) has remained relatively stable at around 45 minutes. It is unlikely that significant changes can be expected or that the criterion of 30 minutes will be met.

Table III-6 summarizes RAM Goals versus performance during several tests for each switch.

TABLE III-6

RAM GOALS VERSUS  
TEST PERFORMANCE

RAM CRITERIA	TEST PERFORMANCE					
	IOTE	AN/TYC-39 (MS)			AN/TTC-39 (CS)	
		WINTEX-81	FID	CNCE (RAM)	IOTE	CNCE (RAM)
MTBUMA (72 Hrs)	16.74	46.60	-	71.90	11.20	66.59
MTBMF (- Hrs)*	116.30	126.00	-	743.00	142.50	2930.00
MTTR (OL) (30 Mins)	58.50	46.10	44.27	47.81	40.50	46.50
A <sub>i</sub> (.999)	0.9944	1.0	-	0.9955	0.9976	0.9998
A <sub>o</sub> (.97)	0.9630	0.9970	-	0.9956	0.9896	0.9997

\*Because of the built-in component redundancy and capability to repair/replace defective items without impairing switch capability, many unscheduled maintenance actions have minimal impact on mission accomplishment. Although no criteria was set for MTBMF, it is a more meaningful measure of reliability than MTBUMA.

d. Other Testing

Thermal and acoustical noise testing of message switches was done during January and March 1981 respectively. Following the thermal test, the Program Manager concluded that the cooling and airflow design is now capable of meeting the Message Switch high temperature specifications. The acoustical test showed reductions in noise levels compared to levels measured in previous DTE.

2. Manpower Modifications

On the basis of consistent findings in all tests of both switches, the duties of the service attendants and operators, initially shared by two MOSSs for each switch (72E/36L--Message Switch & 36C (M)/ 36L--Circuit), were consolidated under one MOS for each switch (72E--Message & 36C (M)--Circuit). The MOS 36L

was then restructured to include only maintenance duties at OL, DS, and GS levels. The qualifying electronics aptitude area (EL) score under the Armed Services Vocational Attitude Battery (ASVAB) for MOSs 72E and 36C (M) was raised from 90 to 100.

### 3. Training Modifications

#### a. MOS 36L

The multi-level structuring and training of MOS 36L, described in paragraph D.6. supra, was modified in this phase. The basic change calls for all potential MOS 36L10s to receive 28 weeks of training which covers both the AN/TYC-39 and AN/TTC-39 switches, it also includes overall systems training. A trainee whose first assignment will be to unit equipped with the old circuit switch (AN/TTC-38) will receive additional training of yet undetermined length and be awarded an Additional Skill Identifier (ASI); a source at USASC indicated that the TTC-38 training will be something less than the current 24 weeks.

Rationale cited for this modification was the elimination of Message and Circuit Switch operator duties from MOS 36L, following test experience which supported use of MOS 36L exclusively as the system maintainer. Another reason offered by a USASC source was a lack of confidence in the Army's ability to manage enlisted communications personnel by ASI. Under the previous training scheme, all 36L10s would have carried an ASI to indicate which of three switches (AN/TYC-39, AN/TTC-39, or AN/TTC-38) they were regarded as competent to operate and maintain at the organizational level. Under the new plan, all MOS 36L10s are considered qualified to maintain either the AN/TYC-39

or AN/TTC-39 switch. Those considered also competent to maintain the AN/TTC-38 switch at OL will be awarded an ASI.

b. MOS 36C (M)

As mentioned in paragraph D.6 supra, no increase in the initial resident instruction for the AN/TTC-39 Circuit Switch Call Service Attendant was anticipated in original training plans prepared in 1979. Test experience, however, identified a need for more extensive resident training, and also resulted in combining service attendant duties with operator duties previously assigned to MOS 36L10. Consequently, the resident course has been doubled from 4 to 8 weeks.

c. MOS 72EZ2

Training input to the FQQPRI and the 1979 Individual and Collective Training Plan (ICTP) originally predicted an increase of 3 weeks in training for the Message Switch (MS) Traffic Service Attendant (TSA) which, at the time of the estimate, was MOS 72G. Subsequently, the MS TSA MOS was changed to 72E with an ASI Z2. The estimated increase in training for the ASI is now 7 weeks. This larger increase in training time is due to the fact that a number of skills required of the MS TSA are taught in the base MOS 72G course, but are not covered in the base MOS 72E instruction. This increase is partially offset by the reduction in number of students originally programmed to attend the MOS 72G course.

d. Other MOSs

Predicted minor changes in resident training for other enlisted MOSs supporting the operation and maintenance of both

switches remained unchanged by DTE/IOTE at the end of the FSED Phase and follow-on testing conducted so far in the Production Phase. However, follow-on evaluation the AN/TYC-39 MS indicated a need to increase resident training of MOS 290A, the Warrant Officer Telecommunications Technician, to 4 weeks versus the 1 week originally predicted in 1979.

e. New Equipment Training (NET)

Other than TRADOC doctrinal training, no NET was originally planned for either switch. It was assumed that sufficient numbers of resident trained personnel would be available to support the fielding schedule for both switches. It was also incorrectly assumed that the Full Scale Engineering Development (FSED) model switches currently available at the USASC for resident training would be quickly upgraded to resemble production models. It is now predicted that modifications to FSED model switches at USASC will not be made until about mid 1983. Even then, the FSED models will not look like the production switches and two sets of technical manual documentation will have to be maintained on each of the school switches. There is a plan to loan a production Message Switch to USASC sometime in 1983 for about a one year period.

Based on this situation, NET is now being planned to acquaint unit personnel with differences between the FSED model switches on which they were trained and the production switches they will be issued. This training will be conducted by the contractor as part of the materiel fielding process.

#### 4. Manual Modifications

Significant deficiencies in operator and maintenance manuals identified during DTE/IOTE and confirmed during follow-on testing during this phase, are being addressed. A separate Skill Performance Aids (SPA) contract with GTE was issued in September 1981 for both switches. However, products from that contract were not expected before December 1982, too late for use in resident training begun before that time and only 3 months prior to the Initial Operational Capability date for the Message Switch.

#### IV. DETERMINATION OF MPT REQUIREMENTS - ANALYSIS

##### A. INTRODUCTION

As discussed in Sections II and III, the AN/TTC-39 Program has not followed the acquisition pattern outlined in the Army's LCSMM. The skipped Conceptual Phase, abbreviated Demonstration and Validation Phase, and lengthy Engineering Development phase are examples of how the program departed from the suggested LCSMM process. Such deviations from "standard" are neither unusual nor necessarily damaging to a system development program, so long as the acquisition community takes steps to ensure that critical events are not skipped and to compensate for those steps that are bypassed.

Obviously, the key to making the process work, particularly when the LCSMM is significantly modified, is communication. Clear, continuous, and multiple lines of communication must be established early in the acquisition process between counterparts representing the materiel developer, combat developer, tester, and contractor(s). This sounds simple enough in theory but seems to rarely happen in actual practice. Often times, equivalent counterparts either do not exist or at best are hard to find in all segments of the heterogeneous acquisition community for a given system. Organizational and geographical separation combined with inequalities among counterparts in such areas as experience, training, grade level, organizational depth, program priority, and assignment stability also weaken communication effectiveness and consistency.



The AN/TTC-39 Program has not been immune to this problem. Underlying most of the issues addressed in this analysis is evidence of either good or poor communication, depending on how the issue was handled.

**B. HUMAN FACTORS ENGINEERING**

How well soldier and machine interface in any new system is largely a function of how well and how early human factors engineering is integrated into the total system design. This is not to imply that full or even prime responsibility for effective Soldier-Machine Interface (SMI) belongs to the Human Factors Engineer working for the system contractor. On the contrary, the ultimate responsibility for ensuring good system SMI rests with the Army itself. The Army acquisition community generally, and the combat developer or other appropriate user representative specifically, must become aggressively involved in the initial process of defining a new system. The definition must go beyond hardware description to include HFE/MPT requirements and constraints to be considered in the basic design.

The second and more difficult step is articulation of constraints and/or requirements to contractors in precise language that can be both understood and applied during the design process; simple reference to military standards and specifications is not enough. It can be argued that detailed specifications dampen design initiative and imagination and lead to development of systems which are inferior to those designed with relatively few constraints. The counter argument is that, life-cycle-cost considerations, in terms of both dollars and people,

demand that contractors be given some specific criteria concerning operation and maintenance of proposed systems. Otherwise, a contractor might design a highly capable and even cheap to produce system, but one which can be neither operated nor maintained by projected available manpower (quantitative or qualitative).

Language in RFPs and early development contracts related to MPT/HFE requirements and constraints must be definitive, precise, and most important, enforceable. In RFPs, for example, HFE/MPT issues should be specifically weighted in the source selection criteria or be a clearly identifiable part of Integrated Logistic Support (ILS), which itself should be given significant weight in the selection process.

Human Factors Engineering has had little influence on the design of either switch in the AN/TTC-39 Program, precisely because the Army's Combat developer (TRADOC) did not play any significant role in the development of early system requirements/specifications, and because the Army neither stressed nor demanded significant HFE effort from the contractor in RFPs and contracts. The Program Manager encouraged strong HFE performance during the FSED phase by funding and supporting HEL interaction with Human Factors Engineers at GTE. That this effort was not successful is attested to by the fact that HEL's formal HFE analysis of the switches near the end of the FSED phase found significant deficiencies in both. (Pgs. 30, 33, 34-37, supra).

### C. QUALITATIVE MANPOWER REQUIREMENTS

There is no reliable standard set of tools/techniques for determine qualitative manpower requirements for new Army systems; however, a number of research initiatives are underway to develop such a methodology. Currently, Subject Matter Experts (SME) in the Army's materiel (DARCOM) and combat (TRADOC) development communities independently estimate qualitative requirements using a variety of criteria such as professional judgement; operational and maintenance experience with like or similar systems; the existing MOS structure; and when available, task and skill analyses generated either by Logistic Support Analysis (LSA) or other similar processes. The qualitative estimation process is initiated by the materiel developer and documented in a QQPRI.

In the case of the AN/TTC-39 Program, the earliest qualitative manpower estimate for each switch was prepared by the contractor (GTE) rather than the materiel developer (CECOM/PM-MSCS). The estimate was prepared in response to a single sentence in the engineering development contract requiring GTE to prepare a QQPRI, and there is no evidence that the Army provided the contractor subsequent guidance and assistance in developing the qualitative estimate.

The duty positions and MOSs proposed by the contractor were not supported by any detailed task/skill analysis, and the required knowledge and qualifications cited for each proposed MOS were basically a repeat of those stated in AR 611-201. Most of the contractor proposed MOSs directly involved in the operation/

maintenance of both switches were subsequently changed in the FQQPRI to other MOSs in the same or related Career Management Fields (CMFs) (pgs. 40-45, supra).

In the process of determining qualitative manpower requirements, a detailed task/skill analysis by the contractor would have been a more useful product to the Army than a QQPRI. The contractor had little understanding and even less experience concerning either the development of or the purposes served by such a specific document. It is a product more appropriately prepared within the Army by SMEs, particularly those in the combat development community, who theoretically have a better understanding of the CMF(s) likely to be affected by introduction of a new system. A detailed task/skill analysis is a valuable and powerful tool which permits Army SMEs to assess the impact of a new system on a CMF and to make sensible tradeoffs between a need for adjustment of existing MOSs and creation of new ones.

Although the Army reviewed the QQPRI's prepared by the contractor, the depth and breadth of those reviews were limited by the lack of task/skill analyses. Such analyses were also unavailable to support independent Army estimates prior to testing. The following example is offered to illustrate that pre-DTE/IOTE estimates of proposed qualitative requirements were inadequate.

One contractor proposal in the earliest QQPRI, concerning the make-up and utilization of both switch crews, remained unchanged and even unchallenged by the Army until testing some 4 years later disproved the concept. The contractor proposed that the organizational level maintainer share Operational duties with

the service attendant for each switch and that the operator/maintainer also be the switch supervisor. Government testing and evaluation found that all operational duties should be performed by the service attendant for each switch and that the maintainer should have no other responsibilities, including supervisory. Had a detailed task/skill analysis been done in support of the QQPRI preparation, and interactively reviewed by the contractor, combat developer, and materiel developer, it is possible that the same conclusions could have been reached much earlier in the FSED phase. An earlier decision would have improved DTE/IOTE crew training and permitted earlier development of realistic and definitive resident training programs (pgs. 42, 45, & 47, supra).

Another early qualitative proposal disproved during DTE/IOTE was selection of MOS 72E as the Message Switch Traffic Service Attendant (TSA). Again, it is believed that an early task/skill analysis would have demonstrated that the TSA must be qualified to work in an automatic digital message switching center; that MOS 72E did not include that qualification; and that, therefore, MOS 72G or some new combination of 72E/72G would be better suited for performance of attendant duties. Although the TSA MOS was eventually changed back to 72E, it now carries an ASI which recognizes the specialized duties of the Message Switch attendant (pgs. 45, 49, & 57, supra).

Two qualitative decisions for which no formal supporting rationale could be found were the addition of MOS 76C to both switch crews and the addition of MOS 290A to the Message Switch crew as the overall switch supervisor.

The fact that a detailed task and skill analysis was not available to support QQPRI qualitative judgements may be attributable in part to limited early performance and eventual stoppage of LSA by the contractor early in the FSED phase (pg. 38, supra).

D. QUANTITATIVE MANPOWER REQUIREMENTS

The tools and techniques for determining quantitative manpower requirements are no more standard or analytically sound than those in use for estimating qualitative needs. Quantitative estimation techniques currently in use include professional judgment, particularly for operator positions; operational and maintenance experience with like or similar systems; O&O concepts, including usage and displacement rates; and for maintenance requirements, DPAMMH, either estimated or generated by the LSA process, in combination with factors provided in AR 570-2, Manpower Authorization Criteria (MACRIT).

The quantitative process, like the qualitative, is initiated by the materiel developer (usually a subordinate Materiel Development/Readiness Command (MDC/MRC) within DARCOM) through preparation of a QQPRI. Quantitative inputs to the QQPRI by the MDC/MRC include an estimate of direct operators needed to make up a single shift crew, and DPAMMH by MOS and level of maintenance for each system component and Associated Support Items of Equipment (ASIOE). Except for the direct crew size, the materiel developer makes no independent estimate of quantitative manpower requirements. The combat developer (usually a proponent school within TRADOC) makes the quantitative estimate using data from the QQPRI, and employing some combination of the nonstandard

tools listed above. The quantitative estimate is then documented in a BOIP which lists changes in manpower by MOS and grade required in each Army organization slated to receive the system.

The earliest quantitative manpower estimates for the TTC-39 Program were made in QOPRIs prepared by the contractor in July 1975 and January/February 1976 (Table III-1, Supra). Rationale for numbers of personnel estimated was not provided, but the data appears to have been based primarily on experience with like or similar systems. No DPAMMH were either reported in contractor QOPRIs or even cited as a basis for computing quantitative manpower estimates.

The contractor's estimated crew size of 10 for continuous operation of each switch was subsequently reduced to six by Army estimates, the rationale for which could not be determined (Tables III-3 and III-4, Supra). This crew size has been found to be adequate by testing conducted thus far. However, the addition of one MOS 76C to the MS crew and substitution of a 76C for a 36C (M) on the Circuit Switch as shown in the 1981 AMIN is not supported by any rationale that could be found during this study. Quantitative maintenance requirements above Organizational Level (OL) so far have not been validated by either testing, LSA data, or any other analytically based method. The validity of those estimates will probably not be known until sometime after the switches are fielded.

The only documented attempt to analytically estimate aggregate manpower requirements for the TTC-39 Program was found in the Manpower Analysis Paper III (MAP III), prepared by USASC in

support of DSARC III/IIIA. Based on the per system quantitative requirements estimated in the BOIPs, it predicts that the direct impact of fielding both switches on the Army's total manpower requirements will be minimal (pgs. 50 & 51, supra).

The analysis, however, made no attempt to estimate the indirect impact that switch fielding may have on the Army's total manpower bill. This impact could be significant, given the proliferation of existing and other new communication systems which eventually must interface with the AN/TTC-39 switches. The Soldier Support Center-National Capital Region (SSC-NCR) is attempting, through its functional reviews, to improve the Army's ability to forecast aggregate manpower requirements (pgs. 51 & 52, supra).

#### E. TRAINING REQUIREMENTS

An estimate of training requirements (course length & content) for a new system can be only as good as the prediction of qualitative manpower required to operate and maintain it. The two are inexorably linked, thereby suggesting that the combat developer (TRADOC proponent school) should be the key participant in the process of performing both appraisals.

Within the acquisition community, a proponent school for any given Career Management Field (CMF) is theoretically in the best position to know all the dynamics affecting MOSs in that CMF, e.g., other new systems planning to use the same MOS, training shortfalls reported by field units, CMF restructuring studies, and difficulties in meeting training projections (input or output).



In the case of the AN/TTC-39 Program, the US Army Signal Center (USASC) is the proponent school. The Center has been actively involved in the MPT requirements determination process since 1979, but had little impact on it prior to the closing months of the FSED phase.

The Army's acceptance of the contractor's approach of using the MOS 36L as an operator/organizational level maintainer and switch supervisor for both switches resulted in overtraining the MOS 36L personnel and undertraining switch service attendants (MOS 72E & MOS 36C) for DTE/IOTE. The inefficacy of that approach, predictable through analysis, but recognized only after testing, has also caused major late changes to be made to resident training plans for all three MOSs, some of which are still underway and most of which lengthen the courses (pgs. 51, 57 & 66-67, supra).

Another example of inadequate analysis prior to testing which affected training concerns the Message Switch attendant. In a critique of the contractor's 1976 QQPRI, The Army suggested that the Traffic Service Attendant (TSA) should be MOS 72E, without modification; the government's subsequent FQQPRI also made the same choice. Acceptance of that MOS without any apparent pretest analysis, resulted in poor performance of the MOS 72E during DTE/TOTE because of inadequate training (pgs. 45 & 57, supra).

Evidence examined during this study suggests that major revisions in the original training requirements estimate may have been avoidable had the contractor/materiel developer produced a

detailed task/skill analysis prior to preparation of the December 1978 QQPRI and had the combat developer become more aggressively involved in the MPT requirements determination process prior to 1979.

## V. CONCLUSIONS

A. Manpower, Personnel, and Training (MPT) requirements/ constraints were neither well defined in early requirements and contractual documents nor adequately addressed in early system development documents and events.

B. Despite the best efforts of the Human Factors Engineering (HFE) Group within GTE, and close monitorship and support of the HFE effort by the Human Engineering Laboratory (HEL), HFE had little effect on the design of either switch. Numerous Soldier-Machine Interface (SMI) problems, both environmental, e.g., high noise and low air conditioning levels, and operational, e.g., inconsistent displays/printouts, although defined early in the development process, continued to plague both switches as the program entered the Production and Deployment Phase. The minimal influence of HFE on design is primarily attributable to a lack of definitive guidance, clearly stated specific objectives, and obligatory language concerning HFE in Requests for Proposals and the Engineering Development Contract.

C. Early Qualitative and Quantitative Personnel Requirements Information (QQPRIs) prepared by the contractor, with minimal guidance from the Army, were of little value in the process of estimating manpower requirements for either switch; they provided no quantitative maintenance data and only the barest outline of tasks and skills required to operate and maintain the switches. There was no substantive review and critique of these documents by the Army.

D. Subsequent QQPRI's prepared by the Army during the engineering development phase provided fairly consistent estimates of qualitative manpower requirements; a number of these requirements, however, were found to be inaccurate by government testing. Each of the Army QQPRI's presented the same set of Direct Productive Annual Maintenance Manhours (DPAMMH) based on a preliminary and substantially incomplete maintenance engineering analysis.

E. Stoppage of formal Logistic Support Analysis (LSA) by GTE in 1976 has hindered the Army's ability to predict maintenance manpower and training requirements for both switches. Early Maintenance Engineering Analyses (MEA) based on Generalized Electronic Maintenance Model (GEMM) runs, provided initial rough estimates of requirements. However, the continuous data flow of steadily improving quality, theoretically provided by the LSA process, has not been available to planners. Periodic LSA output reports such as the "Personnel and Skill Summary" and the "Direct Annual Maintenance and Operator Man-Hours by Skill Specialty Code and Level of Maintenance" are nonexistent in the AN/TTC-39 Program.

F. Formal government testing and evaluation did not begin until both switches were nearing the end of the engineering development phase, some 6 1/2 years after program start. Consequently, a number of training inadequacies, qualitative personnel questions, and soldier-machine interface design deficiencies either went undetected or at least avoided being seriously addressed until DTE/IOTE test reports were written.

G. Government testing to date has not adequately assessed the maintainability of either switch by military personnel above the organizational level. The next government test likely to measure maintainability at Direct Support (DS) and General Support (GS) maintenance levels is a Follow-on-Evaluation (FOE) by the U.S. Army Operational Test and Evaluation Agency scheduled with the Initial Operational Capability (IOC) unit in the 4th Qtr, FY 83. Should this very late testing fail to substantiate current estimates of DS/GS manpower and training requirements, supportability of initially fielded systems could be adversely affected. If problems are serious enough, scheduled fielding, already late, could be further delayed.

H. Fielding of the Message and Circuit Switches is expected to affect both qualitative and quantitative manpower and training requirements for other existing/emerging communications systems and organizations which must eventually interface with one or both AN/TTC-39 Program switches. Such effects have not been accurately measured; hence, the Army's long-range manpower and training needs attributable to deployment of the Message and Circuit Switches is still unknown.

APPENDIX A

MAJOR MPT RELATED REFERENCES

POLICIES & PROCEDURES

Department of Defense

DoD Directive 5000.1, Major System Acquisition

DoD Directive 5000.39, Acquisition and Management Support for Systems and Equipment

DoD Instruction 5000.2, Major Systems Acquisition Process

ASD(MRA&L) Memorandum, "Manpower Analysis Requirements for System Acquisition", August 1978.

MIL-STD-1388 Logistic Support Analysis, October 1973

Proposed MIL-STD-1388A, Weapon System and Equipment Support Analysis, November 1981 (Draft)

MIL-STD-1472B, Human Engineering Design Criteria for Military Systems, Equipment, and Facilities, December 1974

MIL-H-46855B, Human Engineering Requirements for Military Systems, Equipment, and Facilities

Department of the Army

AR 1-1 Planning Programming and Budgeting Within the Department of the Army

AR 10-4 US Army Operational Test and Evaluation Agency

AR 10-5 Department of the Army

AR 10-11 US Army Materiel Command

AR 10-25 US Army Logistics Evaluation Agency

AR 10-41 US Army Training and Doctrine Command

AR 11-4 System Program Reviews

AR 11-8 Principles and Policies of the Army Logistic System

AR 15-14 Systems Acquisition Review Council Procedures

AR 70-1 Army Research, Development and Acquisition

AR 70-2 Materiel Status Recording

AR 70-10 Test and Evaluation During Development and Acquisition of Materiel

AR 70-16 Department of the Army System Coordinator (DASC) System

AR 70-27 Outline Development Plan/Development Plan, Army Program Memorandum/Defense Program Memorandum/ Decision Coordinating Paper

AR 70-61 Type Classification of Army Materiel

AR 71-1 Army Combat Developments

AR 71-2 Basis of Issue Plans

AR 71-3 User Testing

AR 71-9 Materiel Objectives and Requirements

AR 71-10 Department of the Army Force Integration Staff Officer (FISO) System

AR 310-31 Management System for Tables of Organization and Equipment (The TOE System)

AR 310-34 Equipment Authorization Policies and Criteria, and Common Tables of Allowances

AR 310-49 The Army Authorization Documents System (TAADS)

AR 350-1 Army Training

AR 350-10 Management of Army Individual Training Requirement and Resources

AR 350-35 New Equipment Training and Introduction

AR 570-2 Organization and Equipment Authorization Tables - Personnel

AR 602-1 Human Factors Engineering Program

AR 611-1 Military Occupational Classification Structure Development and Implementation

AR 611-201 Enlisted Career management Field and MOSs

AR 70-18 Provisioning of U.S. Army Equipment

AR 700-127 Integrated Logistic Support

AR 702-3 Army Materiel Reliability, Availability and Maintainability (RAM)

AR 750-1 Army Materiel Maintenance Concepts and Policies

AR 750-43 Test, Measurement, and Diagnostic Equipment

AR 1000-1 Basic Policies for Systems Acquisition

DA PAM 11-2 Research and Development Cost Guide for Army Materiel Systems

DA PAM 11-3 Investment Cost Guide for Army Materiel Systems

DA PAM 11-4 Operating and Support Cost Guide for Army Materiel Systems

DA PAM 11-5 Standards for Presentation and Documentation of Life Cycle Cost Estimates for Materiel Systems

DA PAM 11-25 Life Cycle System Management Model for Army Systems

DA PAM 700-125 Integrated Logistics Support (ILS) Management Model and Glossary

Army Modernization Information (AMIN), 1979, 1980, 1981.

U.S. Army Training and Doctrine Command (TRADOC)

TRADOC Reg 11-1 Manpower Analysis and Force Structuring in the Combat Development Process

TRADOC Reg 11-8 Combat Development Studies

TRADOC Reg 71-9 User Test and Evaluation

TRADOC Reg 71-12 Total System Management - TRADOC System Manager (TSM)

TRADOC Reg 71-77 Unit Reference Sheets

TRADOC Reg 350-4 The TRADOC Training Effectiveness Analysis (TEA) System

TRADOC Cir 351-8 ICTP for Developing Systems

TRADOC PAM 70-2 DARCOM/TRADOC Materiel Acquisition HDBK, January 1980

TRADOC PAM 351-4 Job and Task Analysis Handbook, August 1979.

U.S. Army Materiel Development and Readiness Command (DARCOM)

DARCOM HDBK 700-1.1-81 ILS primer (1st and 2nd Editions)

DARCOM HDBK 700-2.1-81 LSA, December 1981



STUDIES

Betaque, Norman E., Jr. et al, Manpower Planning for New Weapon Systems, WN ML 801-1 Through WN ML 801-9. Logistics Management Institute. July - December 1978.

Blanchard, George S. & Kerwin, Walter, T., Man/Machine Interface- A Growing Crisis, Army Top Problem Areas, Discussion Paper Number 2, U.S. Army Materiel Systems Analysis Activity, August 1980.

Bonder, Seth, A Review, of Army Force Modernization and Associated Manpower, Personnel, and Training Processes, Work Paper PUTA 81-2, ARI, January 1981.

GAO, Effectiveness of U.S. Forces Can Be Increased Through Improved Weapon System Design, Report Number PSAD-81-17, January 29, 1981.

HQDA, Office of the Chief of Staff, BOIP/QQPRI Task Force Report, 9 January 1980.

O'Connor, Francis E., et al, MLRS -- A Case Study of MPT Requirements Determination, 30 November 1982.

O'Connor, Francis E., et al, AN/TTC-39 Program -- A Case Study of MPT Requirements Determination, 31 March 1983.

O'Connor, Francis E., et al, BLACKHAWK (UH-60A) -- A Case Study of MPT Requirements Determination, April 1983.

O'Connor, Francis E., et al, FIREFINDER -- A Case Study of MPT Requirements Determination, April 1983.

Rhode, Alfred S., et al, Manpower, Personnel and Training Requirements for Materiel System Acquisition, ARI, February 1980.

## APPENDIX B

### TTC-39 Program Data Collection Sources

#### (Agencies/Offices)

#### Headquarters, Department of the Army (HQDA), Washington, D.C.

- o DA System Coordinator (DASC), Office of the Deputy Chief of Staff, Research, Development, and Acquisition (ODCSRDA).
- o Force Integration System Officer (FISO), Office of the Deputy Chief of Staff, Operations (ODCSOPS).
- o Requirements Directorate, ODCSOPS
- o Training Directorate, ODCSOPS
- o Army Force Modernization Coordination Office (AFMCO), ODCSOPS
- o Manpower Programs and Budget Directorate, Office of the Deputy Chief of Staff, Personnel (ODCSPER)

#### US Army Materiel Development and Readiness Comand (DARCOM)

- o Headquarters, DARCOM, Alexandria, VA
  - Directorate for Development, Engineering & Acquisition
  - Directorate for Management
  - Directorate for Supply, Maintenance & Transportation
- o Communications and Electronics Command (CECOM), FT Monmouth, NJ
  - Project Management Office, Multi-Service Communications Systems (PM-MSCS)
  - Maintenance Engineering Directorate
  - Integrated Logistics Support Directorate
- o Materiel Readiness Support Activity (MRSA), Lexington Blue Grass Army Depot, KY
  - Maintenance Division
  - Readiness Division
- o Human Engineering Laboratory (HEL), Aberdeen, MD

- o Materiel Systems Analysis Activity (AMSAA), Aberdeen, MD
  - Combat Support Division
  - Reliability, Availability, and Maintainability Division

**US Army Training and Doctrine Command (TRADOC)**

- o Headquarters, TRADOC, Ft Monroe, VA
  - Deputy Chief of Staff, Combat Developments
  - Deputy Chief of Staff, Training
- o US Army Signal School and Ft. Gordon, GA
  - TRADOC System Manager (TSM), Tactical Automatic Switches
  - Combat Developments Directorate
  - Training Developments Directorate
  - Training and Doctrine Directorate
- o Soldier Support Center - National Capital Region (SSC-NCR), Alexandria, VA
  - Military Occupational Development Directorate
  - Personnel Resources Analysis Directorate
- o Logistics Center, Lt Lee, VA
- o Training Support Center, Ft Eustis, VA

**US Army Operational Test and Evaluation Agency (OTEA), Falls Church, VA**

**GTE Products Corporation (Sylvania Systems Group), Needham Heights, MA**

- o Communication Systems Division
  - ILS Manager, AN/TTC-39 Systems

## APPENDIX C

### AN/TTC-39 PROGRAM DOCUMENTATION REVIEW

#### System Requirements/Decisions

Decision Coordinating Paper (DCP) #135, January 1977, HQDA  
Cover Sheet Update to DCP #135, November 1978, HQDA  
(Approved by DOD, August 1979)  
Mission Element Need Statement (MENS), November 1978, HQDA  
Materiel System Requirements Specification, February 1979, HQDA  
Decision Coordinating Paper IIIA, April 1980, HQDA  
Integrated Program Summary IIIA, April 1980, HQDA  
Secretary of Defense Decision Memorandum (AN/TYC-39), April 1980  
Secretary of Defense Decision Memorandum (AN/TTC-39), July 1980

#### Contractual

System Performance Specification TT-B1-1101-0001, January 1972  
Statement of Work (SOW), Phase I (Demonstration/Validation), February 1972  
Government Solicitation (RFQ) DAA B07-74-Q-0005, Phase II (Engineering Development), July 1973  
SOW, Phase II, March 1974, Revised April 1974  
Contract DAA B07-74-C-0339, Phase II, April 1974  
SOW, Phase III (Production/Deployment), July 1979

#### Human Factors Engineering (HFE)

HFE Plan, CDRL 0001 (AN/TTC-39), November 1974, GTE  
HFE Plan, CDRL 0002 (AN/TYC-29), November 1974, GTE  
HFE Progress/Trip Reports, July, August, September & November 1975; January, March, May, June & August 1976; and March, May & September 1978, Human Engineering Laboratory (HEL)  
HFE Findings - AN/TYC-39, Research & Development Acceptance Test (RDAT), March 1978, HEL  
HFE Findings - AN/TTC-39, RDAT, September 1978, HEL  
HFE Analysis (HFEA) (MS&CS), November 1979, HEL  
Memorandum of Understanding Between HEL & PM-MSCS Concerning HFEA Findings, January 1980

#### Manpower/Personnel

QQPRI, CDRL 0007 (AN/TTC-39), July 1975 & January 1976, GTE  
QQPRI, CDRL 0008 (AN/TYC-39), July 1975 & February 1976, GTE

Amended Provisional QQPRI, December 1977, DARCOM  
FQQPRI (AN/TTC-39), December 1978, DARCOM  
FQQPRI (AN/TYC-39), December 1978, DARCOM  
Amended FQQPRI (AN/TTC-39), May & September 1979, DARCOM  
Amended FQQPRI (AN/TYC-39), May & September 1979, DARCOM  
BOIP 76-0098F (AN/TYC-39), August 1979, February &  
December 1981, TRADOC  
BOIP 79-0046F (AN/TTC-39 - 300 Line), August 1979,  
February & December 1981, TRADOC  
BOIP 79-0047F (AN/TTC-39 - 600 Line), August 1979,  
February & December 1981, TRADOC  
Manpower Analysis Paper (MAP) III, (AN/TYC & TTC-39),  
December 1979, TRADOC  
Tentative MOS Decision for MS, CS, and Associated Equip-  
ment, July 1980, MILPERCEN  
Final MOS Decision for MS, CS, and Associated Equipment,  
October 1981, ODCSPER, HQDA  
Communications-Electronics Functional Review, January  
1982, SSC-NCR

### Training

Training Aids & Devices Study, CDRL C009 (AN/TTC-39),  
June 1975, GTE  
Training Aids & Devices Study, CDRL C010 (AN/TYC-39),  
June 1975, GTE  
New Equipment Training Plan (NETP), June 1976, DARCOM  
NETP (EL122), Quarterly 1981, DARCOM  
Individual and Collective Training Plan, December 1979,  
TRADOC

### Development/Operational Test and Evaluation

Development Test & Evaluation Report (AN/TYC-39), July  
1979, Joint Test Element, Joint Tactical Communica-  
tions Office  
Development Test & Evaluation Report (AN/TTC-29),  
January 1980, US Army Electronic Proving Ground  
Independent Evaluation Report, IER-OT-590 (AN/TYC-39),  
September 1979, OTEA  
Independent Evaluation Report, IER-OT-123 (AN/TTC-39),  
November 1980, OTEA  
Letter, Test Criteria for Follow-On Evaluation of TTC-39  
Family of Automatic Switches, August 1980, USASC  
Independent Evaluation of AN/TYC-39 During European  
Deployment - WINTEK 81, June 1981, OTEA  
Status Report of Follow-On Testing of AN/TYC-39, May  
1981, OTEA  
Outline Test Plan for Follow-On Evaluation of AN/TTC-39,  
July 1981, OTEA  
RAM Assessment Report (CS&MS), December 1981, OTEA  
Fault Insertion Demonstration Report (AN/TYC-39), May  
1982, OTEA

Miscellaneous

Proposal Evaluation and Source Selection Final Report  
for Phase II, March 1974, PM for Army Tactical  
Communications Systems

Support Report Number 4, CDRL G016, March 1976, GTE  
Integrated Logistics Support Plan, February 1980,  
PM-MSCS

Matériel Fielding Plan, August 1980, PM-MSCS  
Operational and Organizational Concept, August 1979,  
USASC

Army Modernization Information Memorandum, (AN/TYC-39  
and AN/TTC-39), 1979, 1980, 1981, HQDA

APPENDIX D

GLOSSARY OF ACRONYMS

AAO--Authorized Acquisition Objective  
 AAPMH--Available Annual Productive Man-Hours  
 AD--Advanced Development  
 ADP--Automatic Data Processing  
 ADTA--Aircraft Development Test Activity  
 AEFA--Aviation Engineering Flight Activity  
 AFH--Annual Flight Hours  
 AFMCO--Army Force Modernization Coordination Office  
 ALMC--Army Logistics Management Center  
 AMIM--Army Modernization Information Memorandum  
 AMMH--Annual Maintenance Manhours  
 AMSAA--Army Material Systems Analysis Activity  
 AP--Acquisition Plan  
 APA--Aviation Procurement-Army  
 APM--Army Program Memorandum  
 AR--Army Regulation  
 ARI--Army Research Institute for the Behavioral and Social Sciences  
 ARTEP--Army Training Evaluation Program  
 ASARC--Army System Acquisition Review Council  
 ASD,C I--Assistant Secretary of Defense, Command, Contro, Communications, and Intelligence  
 ASD, MRAL--Assistant Secretary of Defense, Manpower, Reserve Affairs, and Logistics  
 ASI--Additional Skill Identifier  
 ASIOE--Associated Support Items of Equipment  
 ASP--Ammunition Supply Plant  
 ASVAB--Armed Services Vocational Appitude Battery  
 ATE--Automatic Test Equipment  
 ATSC--Army Training Support Center  
 AURS--Automated Unit Reference Sheet  
 AUTODIN--Automatic Digital Network  
 AVIM--Aviation Intermediate Maintenance  
 AVUM--Aviation Unit Maintenance  
 BCE--Baseline Cost Estimate  
 BCS--Battery Computer System  
 BITE--Built-In Test Equipment  
 BLACKHAWK--UH-60 Utility Helicopter  
 BN--Battalion  
 BOI--Basis of Issue  
 BOIP--Basis of Issue Plan  
 BTA--Best Technical Approach  
 BTRY--Battery  
 C--Command, Control, & Communications  
 C I--Command, Control, & Communications, and Intelligence  
 CAC--US Army Combined Arms Center  
 CAIG--Cost Analysis Improvement Group  
 CARDS--Catalog of Approved Requirements Documents  
 CD--Combat Developer  
 C-E--Communications-Electronics  
 CECOM--US Army Communications and Electronics Command  
 CEFR--Communications-Electronics Functional Review  
 CFE--Contractor Furnished Equipment  
 CFP--Concept Formulation Package  
 CFV--Cavalry Vehicle System  
 CM--Configuration Management  
 CMF--Career Management Field  
 CMMH--Corrective Maintenance Manhours  
 COA--Comptroller of the Army  
 COEA--Cost and Operational Effectiveness Analysis  
 COMSEC--Communications Security  
 CONUS--Continental United States  
 CPFF--Cost Plus Fixed Fee  
 CPIF--Cost Plus Incentive Fee  
 CPG--Central Processor Group  
 CPX--Command Post Exercise  
 CSA--Chief of Staff, US Army

CTA--Common Table of Allowances  
 CTEA--Cost and Training Effectiveness Analysis  
 CTP--Coordinated Test Program  
 DA--Department of the Army  
 CSAC--Combat Support Aviation Company  
 DAPAM--US Army Materiel Development and Readiness Command  
 DASC--Department of the Army System Coordinator  
 DCA--Defense Communication Agency  
 DCP--Decision Coordinating Paper  
 DCSLOG--Deputy Chief of Staff for Logistics  
 DCSOPS--Deputy Chief of Staff for Operations and Plans  
 DCSPER--Deputy Chief of Staff for Personnel  
 DCSRDA--Deputy Chief of Staff for Research, Development, and Acquisition  
 DDRE--Director of Defense Research and Engineering  
 DEPSECDEF--Deputy Secretary of Defense  
 DIO--Director of Industrial Operations  
 DOD--Department of Defense  
 DODD--Department of Defense Directive  
 DODI--Department of Defense Instruction  
 DP--Development Plan  
 DPAMMH--Direct Productive Annual Maintenance Manhours  
 DPM--Defense Program Memorandum  
 DS--Direct Support  
 DSARC--Defense System Acquisition Review Council  
 DSMC--Defense Systems Management College  
 DT--Developmental Testing  
 DT (I, II, III)--Development Test (I, II, III)  
 DTC--Design to Cost  
 DTUPC--Design to Unit Production Cost  
 EARA--Equipment Authorization Review Activity  
 ECP--Engineering Change Proposal

EQUATE--Electronic Quality Assurance Test Equipment  
 FACS--Field Artillery Center & School  
 FAMAS--Field Artillery  
 Meteorological Acquisition System  
 FDTE--Force Development Testing and Experimentation  
 FIREFINDER--AN/TPQ-36 Mortar Locating Radar & AN/TPQ-37 Artillery Locating Radar  
 FISO--Force Integration System Officer  
 FM--Field Manual  
 FMRS--Force Modernization Milestone Reporting System  
 FOE--Follow-On Evaluation  
 FORSCOM--US Army Forces Command  
 FQPRI--Final QPPI  
 FSED--Full Scale Engineering Development  
 FVS--Fighting Vehicle System  
 FY--Fiscal Year  
 FYTP--Five Year Test Program  
 GCT--Government Competitive Test  
 GEMM--Generalized Electronics Maintenance Model  
 GFE--Government Furnished Equipment  
 GS--General Support  
 GSR5--General Support Rocket System  
 HEL--US Army Human Engineering Laboratory  
 HEMAT--Heavy Expanded Mobility Ammunition Trailer  
 HEMTT--Heavy Expanded Mobility Tactical Truck  
 HET--Heavy Expanded Truck  
 HF--Human Factors  
 HFE--Human Factors Engineering  
 HHS--Headquarters and Headquarters & Service Battery  
 HQDA--Headquarters, Department of the Army  
 ICTP--Individual and Collective Training Plan  
 IEP--Independent Evaluation Plan



IBER--Independent Evaluation Report  
 IFV--Infantry Fighting Vehicle  
 ILS--Integrated Logistic Support  
 ILSM--Integrated Logistic Support Manager  
 ILSMM--Integrated Logistic Support Management Model  
 ILSMT--Integrated Logistic Support Management Team  
 IOC--Initial Operational Capability  
 IPR--In Process Review  
 IPS--Integrated Program Summary  
 IPTF--Indirect Productive Time Factor  
 ISI--Information Spectrum, Inc.  
 ISMMH--Inspection & Servicing Maintenance Manhours  
 ITV--Improved TOW Vehicle  
 JCS--Joint Chiefs of Staff  
 JTA--Joint Table of Allowances  
 JWG--Joint Working Group  
 LCSMM--Life Cycle System Management Model  
 LEA--US Army Logistics Evaluation Agency  
 LIN--Line Item Number  
 LLM--Launcher Loader Module  
 LOA--Letter of Agreement  
 LOGCEN--US Army Logistics Center  
 LOGSACS--Logistic Structure & Composition Sys.  
 LON--Letter of Notification  
 LP/C--Launch Pod/Container  
 LR--Letter Requirement  
 LRIP--Low Rate Initial Production  
 LSA--Logistic Support Analysis  
 LSAR--Logistic Support Analysis Record  
 LSP--Logistic Support Plan  
 MAA--Mission Area Analysis  
 MACOM--Major Army Command  
 MACRIT--Manpower Authorization Criteria  
 MADP--Material Acquisition Decision Process  
 MAP--Manpower Analysis Paper  
 NCC--Mission Configuration Change  
 MD--Material Developers  
 MDC--Material Development Command  
 MEA--Maintenance Engineering Analysis  
 MENS--Mission Element Need Statement  
 MFK--Mission Flexibility Kit  
 MFP--Material Fielding Plan  
 MICOM--US Army Missile Command  
 MILPERCEN--US Army Military Personnel Center  
 MIRAT--MILPERCENT Initial Recruiting & Training Plan  
 MIST--Man Integrated System Technology  
 MLRS--Multiple Launch Rocket System  
 MOE--Measure of Effectiveness  
 MOS--Military Occupation Specialty  
 MPT--Manpower, Personnel, and Training  
 MRC--Materiel Readiness Command  
 MRF--Milestone Reference File  
 MRSA--US Army Material Readiness Support Activity  
 MTBF--Mean-Time Between Failures  
 MTBM--Mean Time Between Maintenance  
 MTBR--Mean Time Between Removal  
 MTOE--Modification Table of Organization Equipment  
 MN--Material Need  
 MTTR--Mean-Time-To-Repair  
 NET--New Equipment Training  
 NETP--New Equipment Training Plan  
 NETT--New Equipment Training Team  
 NSA--National Security Agency  
 OCO--Operational Capability Objective  
 ODP--Outline Development Plan  
 OLM--Organizational Maintenance  
 OOC--Operational & Organizational Concept  
 OPA--Other Procurement-Army  
 OSA--Office, Secretary of the Army  
 ODS--Office, Secretary of Defense  
 OT--Operational Testing  
 OT--(I, II, III)--Operational Test (I, II, III)  
 OTE--Operational Test and Evaluation

OTEA--US Army Operational Test and Evaluation Agency  
 OTP--Outline Test Plan  
 PCB--Printed Circuit Board  
 PERSACS--Personnel Structure and Composition System  
 PGSE--Peculiar Ground Support Equipment  
 PIP--Product Improvement Proposal  
 PLDMD--Platoon Leader's Digital Message Device  
 PM--Project Manager  
 PMP--Project Management Plan  
 POC--Point of Contact  
 POM--Program Objective Memorandum  
 PPBS--Planning, Programming, and Budgeting System  
 PQQPRI--Provisional QQPRI  
 PTTDAR--Personnel, Training, and Training Devise Analysis Report  
 QQPRI--Qualitative and Quantitative Personnel Requirements Information  
 RAM--Reliability, Availability, Maintainability  
 RDTE--Research, Development, Test and Evaluation  
 REOC--Replenishment of Expendables and Operational Checks  
 RFP--Request for Proposal  
 ROC--Required Operational Capability  
 SA--Secretary of Army  
 SACS--Structure and Composition System  
 SECDEF--Secretary of Defense  
 SIMOR--Space Imbalance MOS.  
 SISMS--Standard Integrated Support Management System  
 SME--Subject Matter Expert  
 SMI--Soldier-Machine Interface  
 SMIR--Soldier-Machine Interface Requirements  
 SOW--Statement of Work  
 SPAS--Skill Performance Aids  
 SPLL--Self-Propelled Launcher Loader  
 SQT--Skill Qualification Test

SRC--Stadard Requirements Code  
 SSC-NCR--Soldier Support Center - National Capital Region  
 SSEB--Source Selection Evaluation Board  
 SSG--Special Study Group  
 SSI--Specialty Skill Identifier  
 STF--Special Task Force  
 STOG--Science and Technology Objectives Guide  
 TAADS--The Army Authorization Documents  
 TACFIRE--Field Artillery Tactical Fire Direction System  
 TAMMS--The Army Maintenance Management System  
 TC--Type Classification  
 TDR--Training Device Requirement  
 TDA--Table of Distribution and Allowances  
 T&E--Test and Evaluation  
 TECOM--US Army Test and Evaluation Command  
 TEMP--Test and Evaluation Master Plan  
 TIWG--Test Integrated Working Group  
 TM--Technical Manual  
 TMOS--Tentative Military Occupation Specialty  
 TOA--Trade-Off Analysis  
 TOD--Trade-Off Determination and Equipment  
 TOE--Table of Organization and Equipment  
 TRADE--Training Devices  
 TRADOC--US Army Training and Doctrine Command  
 TRASSO--TRADOC System Staff Officer  
 TRITAC--Tri-Service Tactical Communication System  
 TSARCOM--US Army Troop Support and Aviation Material Readiness Command  
 TSM--TRADOC System Manager  
 USAAC--US Army Aviation Center  
 USAFAC--US Army Field Artillery Center  
 USAMMCS--US Army Missile & Munitions Center and School  
 USAREUR--US Army Europe  
 USASC--US Army Signal Center  
 USATSC--US Army Training Support Center  
 UTTAS--Utility Tactical Aircraft System  
 VCSA--Vice Chief of Staff Army