

1/6d  
4  
W13  
2  
TM  
1941

TM 9-855

WAR DEPARTMENT  
*U.S. Dept. of Army*

---

TECHNICAL MANUAL

**TARGETS, TARGET MATERIALS,  
AND RIFLE RANGE CONSTRUCTION**

June 19, 1941

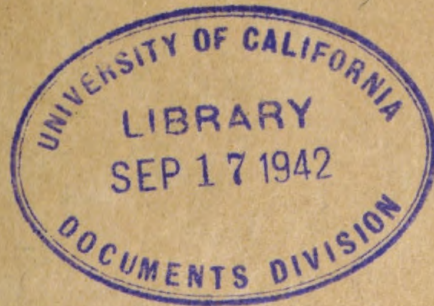

# TECHNICAL MANUAL TARGETS, TARGET MATERIALS, AND RIFLE RANGE CONSTRUCTION

CHANGES }  
No. 1 }

WAR DEPARTMENT,  
WASHINGTON, August 5, 1942.

TM 9-855, June 19, 1941, is changed as follows:

U113  
.2  
TM 9:85:  
1941  
★ ★

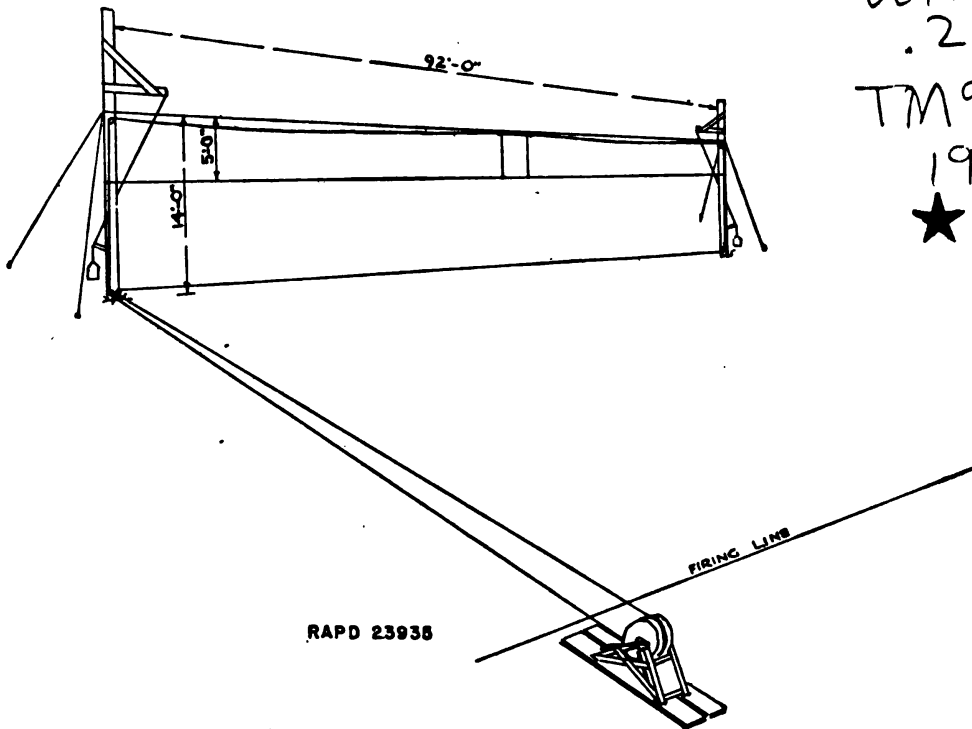

FIGURE 21.—Horizontal target.

[A. G. 062.11 (11-19-41).] (C 1, Aug. 5, 1942.)

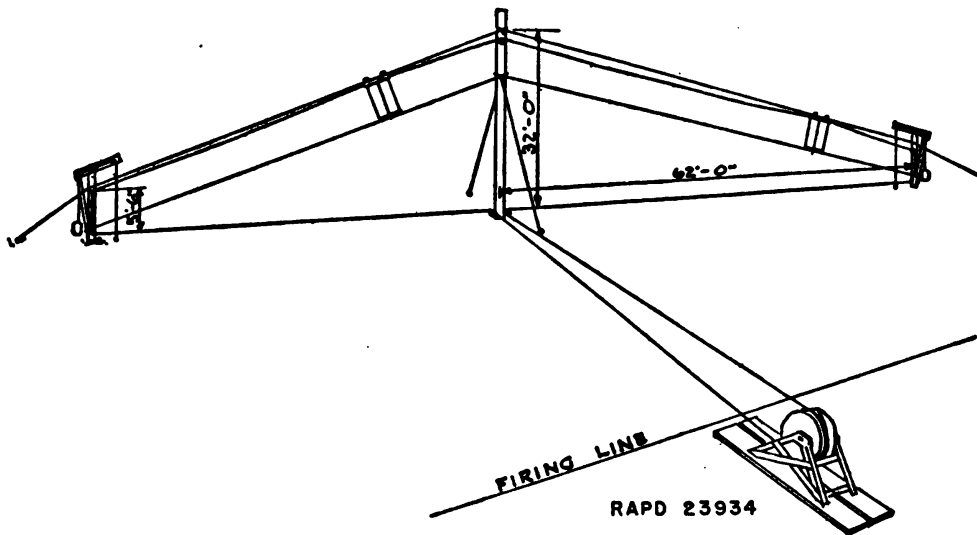

FIGURE 22.—Double climbing and diving target.

[A. G. 062.11 (11-19-41).] (C 1, Aug. 5, 1942.)

478225°—42

M574641

Original from  
UNIVERSITY OF CALIFORNIA

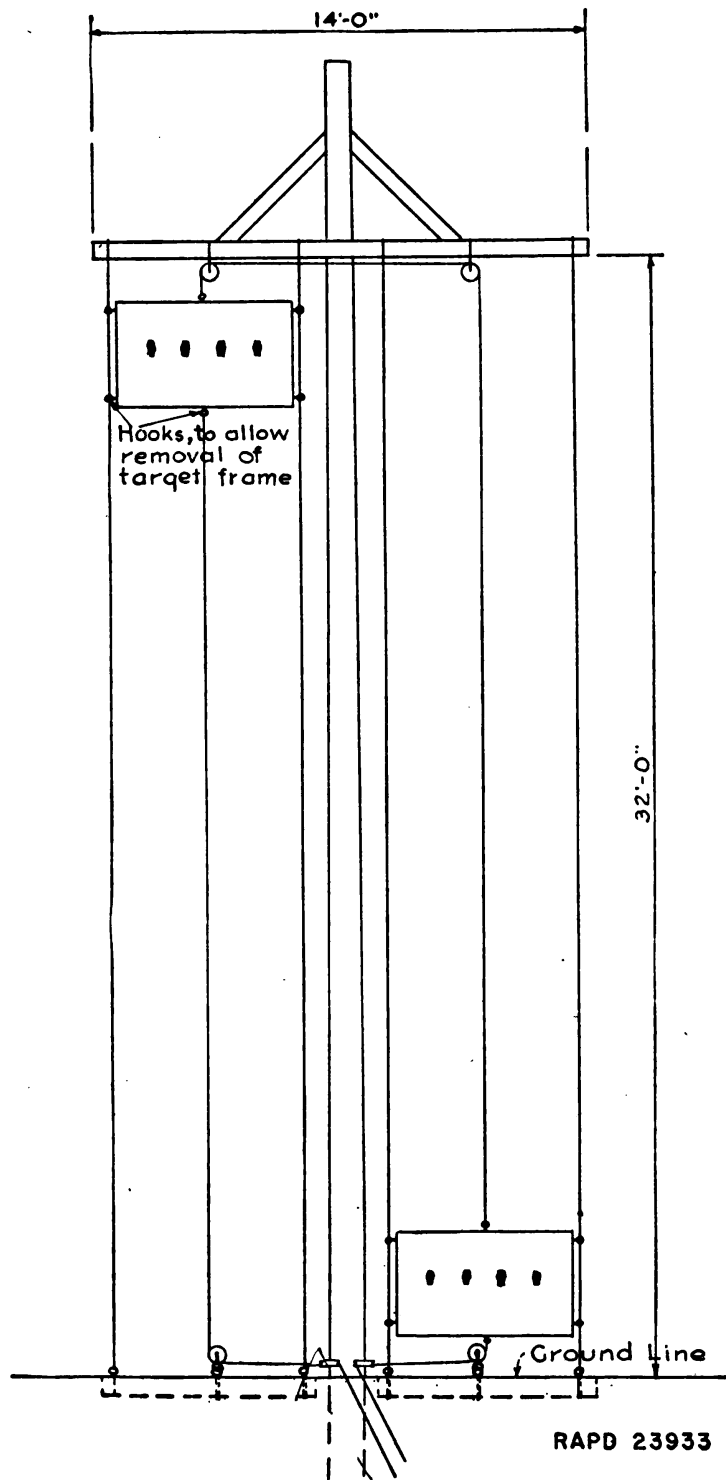
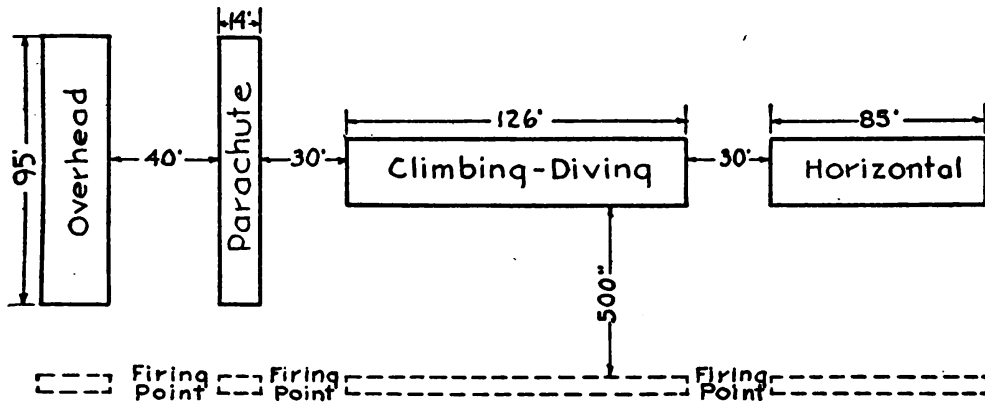

FIGURE 23½.—Parachute target.

[A. G. 062.11 (11-19-41).] (C 1. Aug. 5, 1942.)



RAPD 23932

FIGURE 24.—Arrangement of targets.

[A. G. 062.11 (11-19-41).] (C 1, Aug. 5, 1942.)



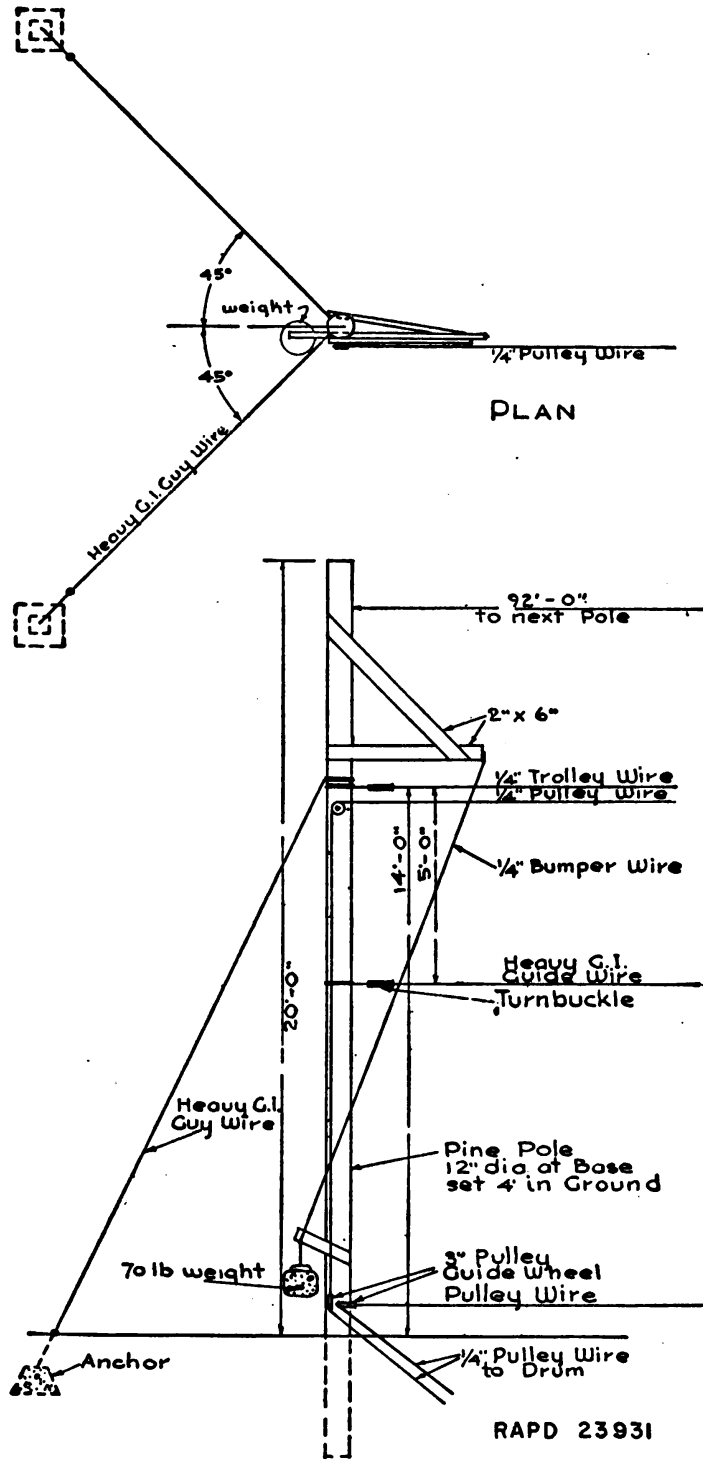

FIGURE 27.—End section of horizontal target showing detailed construction of operating wires, guide wires, pulleys and bumper.

[A. G. 062.11 (11-19-41).] (C 1, Aug. 5, 1942.)

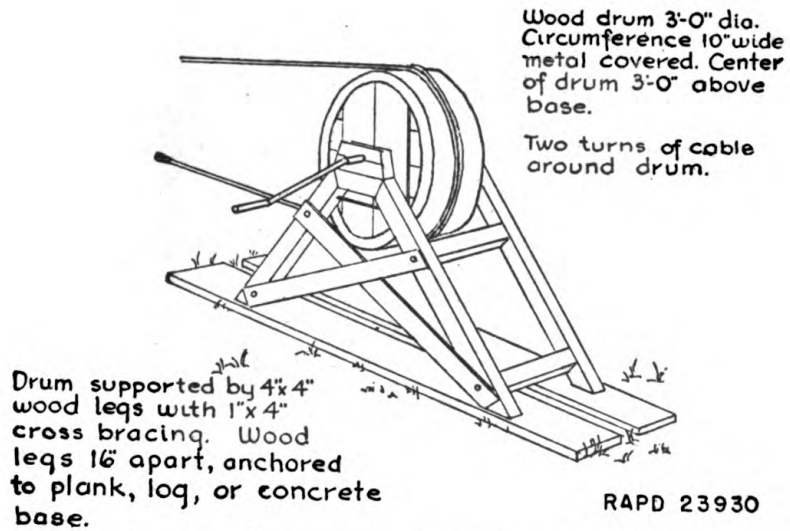
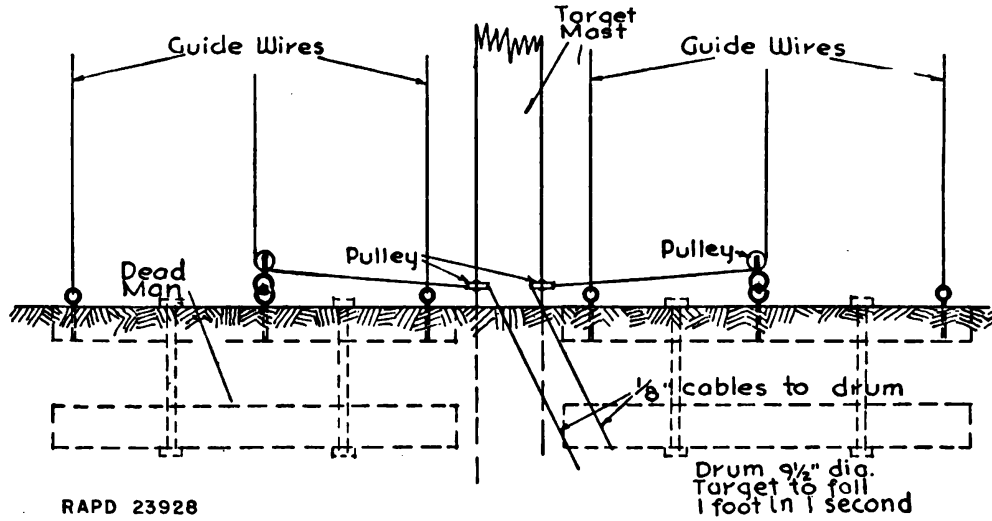

FIGURE 29.—Operating drum for moving targets. (One complete turn moves target 15 feet.)

[A. G. 062.11 (11-19-41).] (C 1, Aug. 5, 1942.)





RAPD 23928

FIGURE 31 1/2.—Lower section of parachute target showing arrangement of guide wires, operating wires, and pulleys.

[A. G. 062.11 (11-19-41).] (C 1, Aug. 5, 1942.)

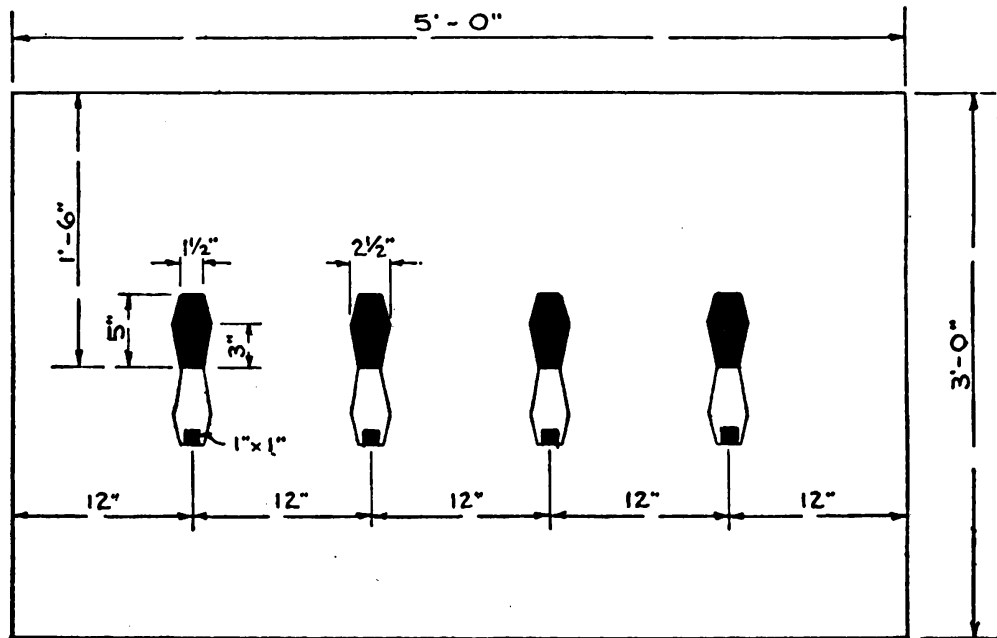

RAPD 23927

FIGURE 51 1/2.—Aiming and leading parachute target.

[A. G. 062.11 (11-19-41).] (C 1, Aug. 5, 1942.)

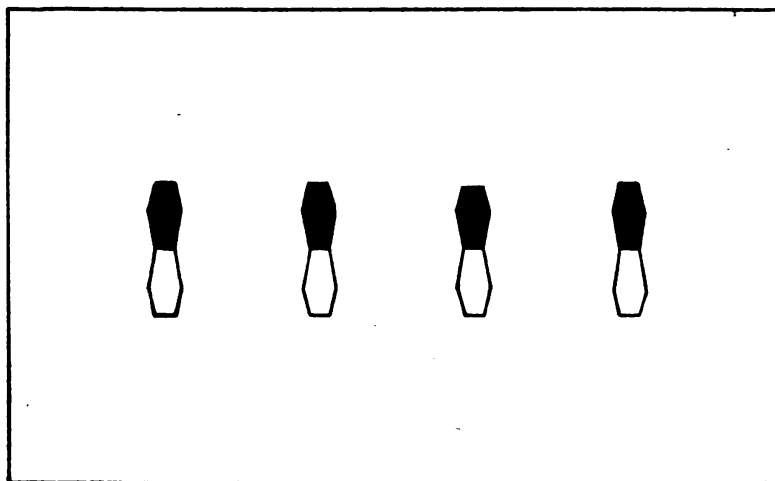

RAPD 23926

FIGURE 51½.—Parachute instruction target.

[A. G. 062.11 (11-19-41).] (C 1, Aug. 5, 1942.)

BY ORDER OF THE SECRETARY OF WAR:

G. C. MARSHALL,  
*Chief of Staff.*

OFFICIAL:

J. A. ULIO,  
*Major General,  
The Adjutant General.*



TECHNICAL MANUAL }  
No. 9-855

WAR DEPARTMENT,  
WASHINGTON, June 19, 1941.

## TARGETS, TARGET MATERIALS, AND RIFLE RANGE CONSTRUCTION

Prepared under direction of  
the Chief of Ordnance  
and  
The Quartermaster General

	Paragraphs
SECTION I. General.....	1-4
II. Selection of target ranges.....	5-6
III. Construction of target ranges and lay-outs of various other ranges, courses, and athletic fields..	7-14
IV. Targets and equipment for class A and class B ranges.....	15-49
V. Targets and equipment for moving artillery tar- get ranges.....	50-53
VI. Targets and equipment for harbor defense target ranges.....	54-62
APPENDIX. List of references.....	Page 129
INDEX .....	131

### SECTION I

#### GENERAL

	Paragraph
Purpose .....	1
Scope .....	2
References.....	3
Types of target ranges.....	4

1. **Purpose.**—The purpose of this manual is to furnish to the Army of the United States, its components and auxiliaries, and to the several agencies functioning under the supervision of the War Department, descriptions, general and technical information, and instructions for the construction or erection, care and handling, and use of targets and target materials.

\*This manual supersedes War Department Document No. 1052; Ordnance Manual No. 1991; and Ordnance Manual No. 1994.

**2. Scope.**—The targets and target materials described in this manual are required or authorized for the conduct of bayonet training, various marksmanship courses, technique of fire, tactical training, including field firing exercises and gunnery practices authorized and described in Basic Field Manuals and other War Department instructions.

**3. References.**—All publications to be used in conjunction with this manual are shown in the appendix.

**4. Types of target ranges.**—Target ranges include—

*a. Class A.*—Class A ranges are more or less limited in extent and are primarily intended for use in the firing of known distance marksmanship courses with small arms and automatic guns.

(1) The fundamentals governing the selection of class A ranges are outlined in FM 23-5 and FM 23-10. Since these ranges may, due to the limited firing area available, be used for other than rifle marksmanship training, due consideration should be given to their suitability for the installation of facilities for other types of marksmanship training.

(2) A type of class A range is shown in figure 1.

*b. Class B.*—Class B ranges are of extended area and diversified terrain and are used for training in technique of fire and tactical exercises involving field firing. Ranges between firing points and targets are unknown and variable on this type range.

(1) Training in technique of fire is team training consisting of instruction in the application and control of the collective fire of fire units as described in the appropriate Field Manuals for the weapons concerned. This type of training requires a 1,000-inch landscape target range and a field firing range.

(2) Tactical exercises involving field firing combine individual marksmanship training and training in technique of fire with tactical training.

*c. Artillery.*—Artillery target ranges are similar to class B ranges but of more extended area. The fundamentals governing the selection of land are availability, accessibility, sparse population, and low cost.

*d. Harbor defense.*—Harbor defense target ranges include the plotted water area within the range of the cannon. The fundamentals governing the selection of sites for location of harbor defense cannon also govern in the use of the area for target practice. The targets used are usually water-towed targets which are described under appropriate headings.



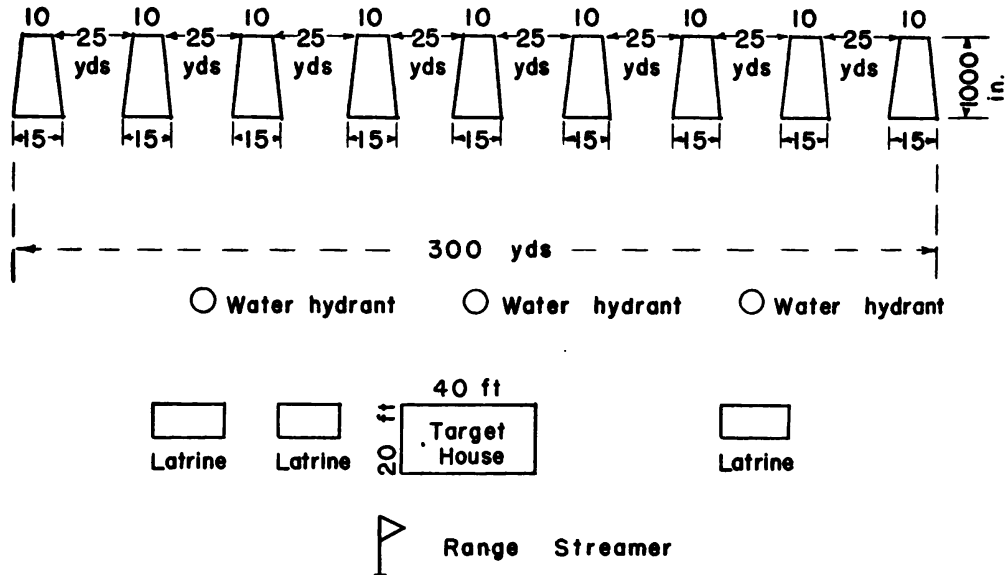

FIGURE 2.—Landscape target range (1,000-inch).

NOTE.—For details of range construction and safety factors see FM 23-5 or 23-10 and AR 750-10.

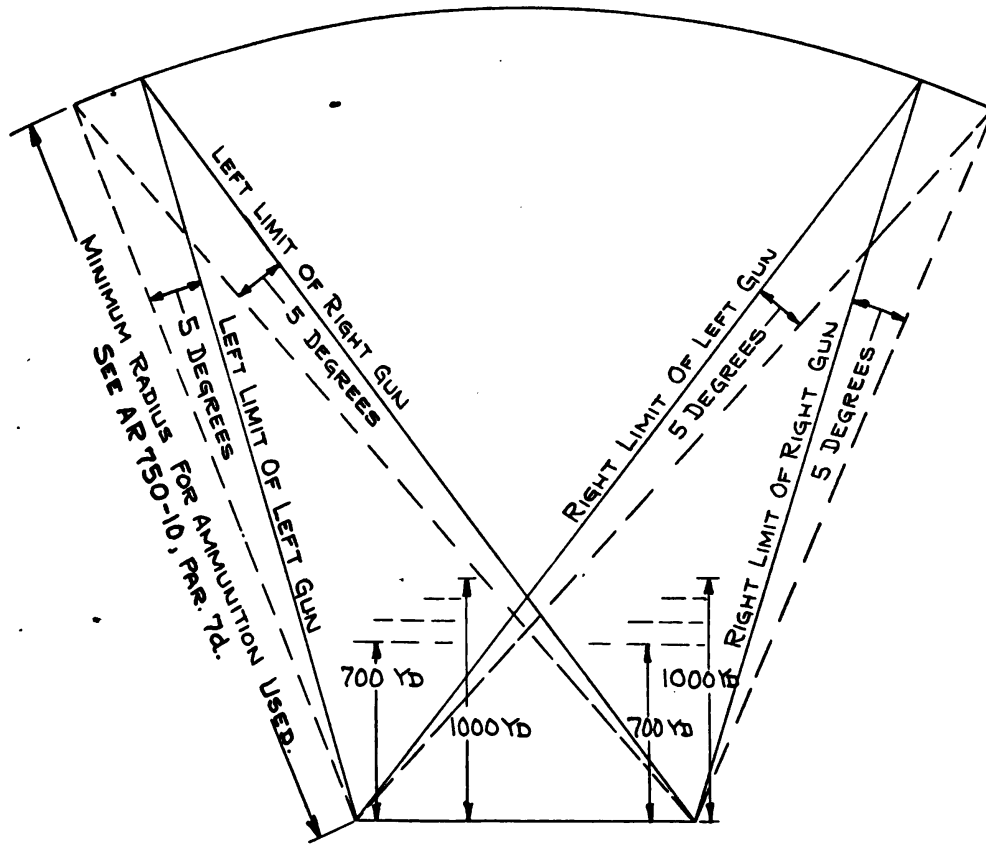
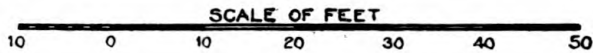
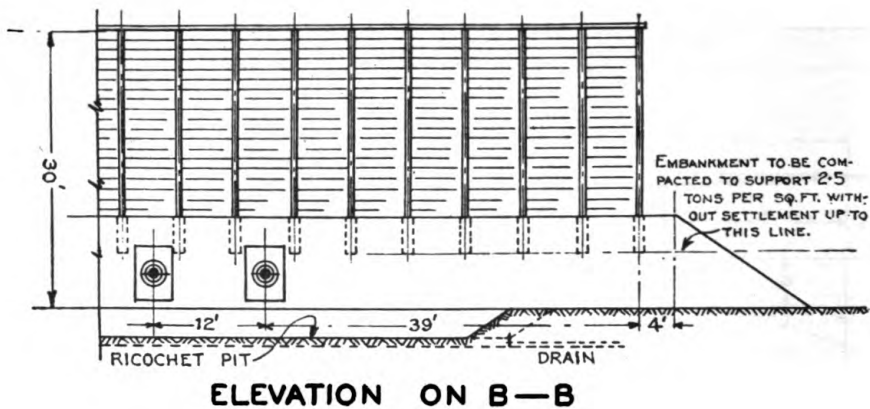

FIGURE 3.—Field firing target range—caliber .30 machine-gun direct fire.

NOTE.—For additional information see FM 23-55. Arrangement of targets paralleling those shown in figure 13 may prove useful. For safety factors see AR 750-10 and FM 23-55.







NOTE: FOR CONSTRUCTION DETAILS SEE PLANS Nos. 416-131, & 416-132, ON FILE IN THE OFFICE OF THE QUARTERMASTER GENERAL, WAR DEPT., WASHINGTON, D.C.  
FOR DETAILS OF DEPRESSED TRACK SEE PLAN No. 416-134 SAME FILE.

**ORD.  
Q.M.C. 416-119**

FIGURE 4.—Small-arms range, 1,000-inch, open type—Continued.

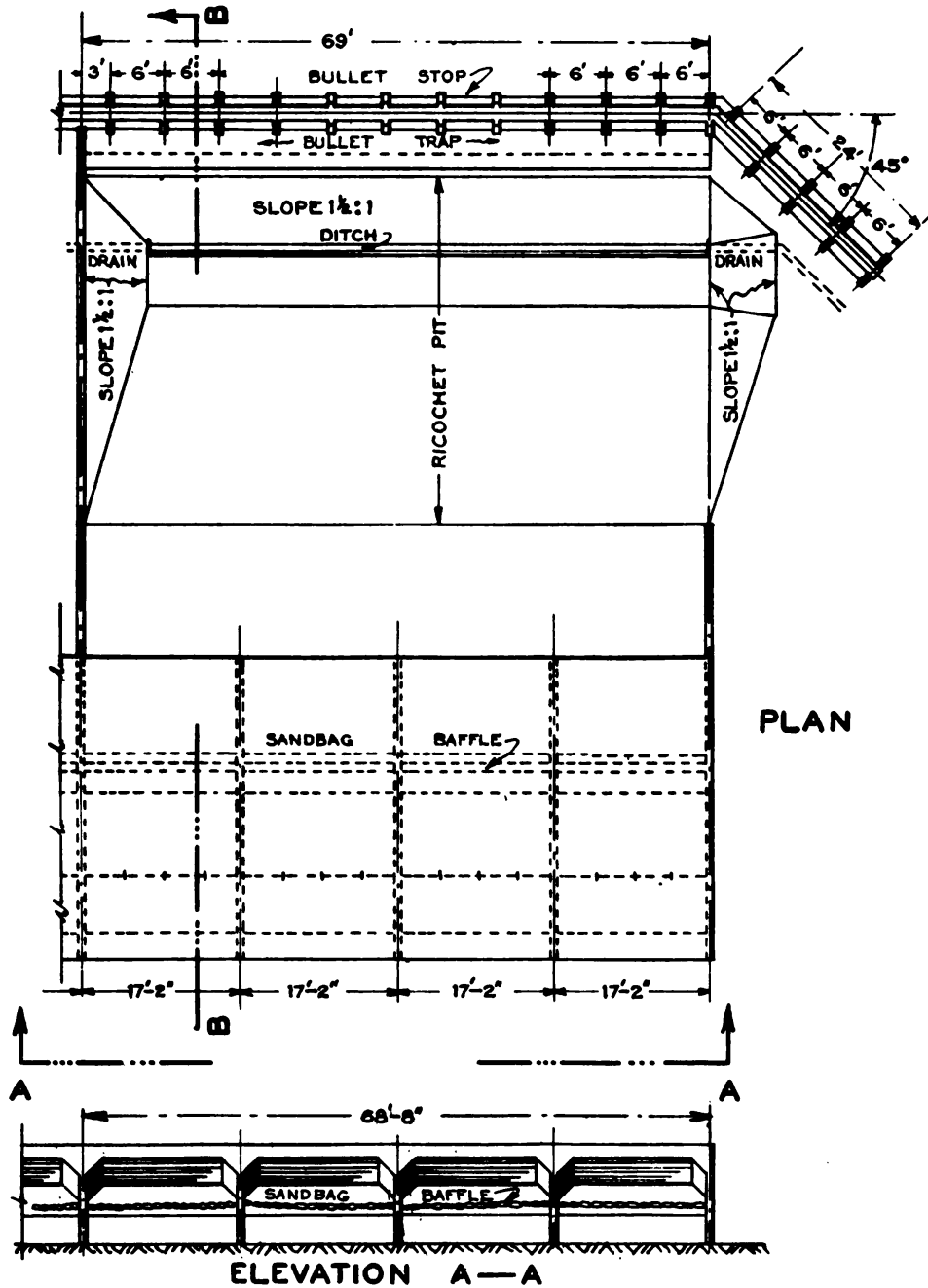
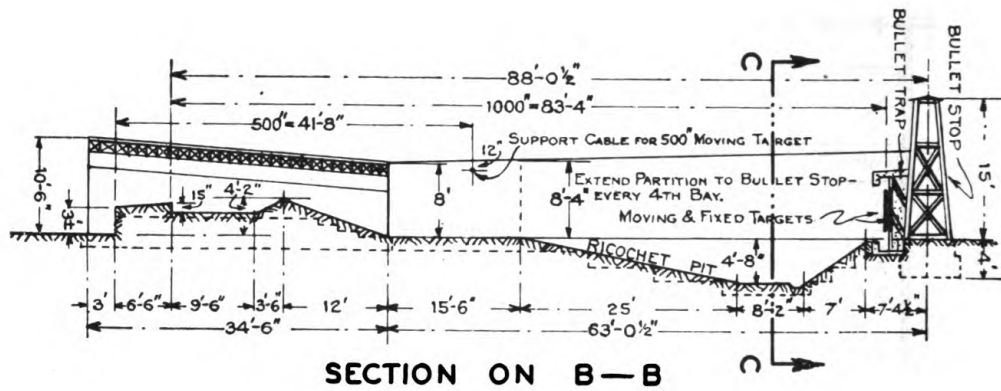
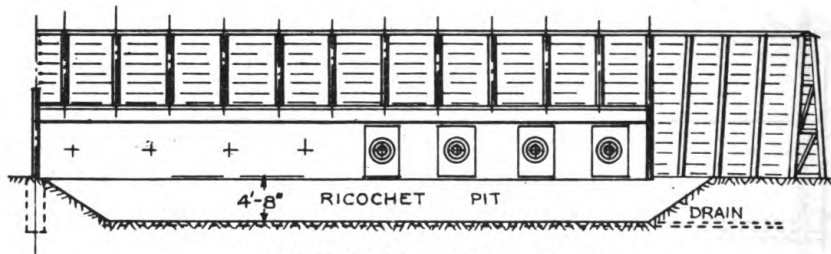

FIGURE 5.—Small-arms range, 1,000-inch, protected type.



SECTION ON B-B



SECTION ON C-C

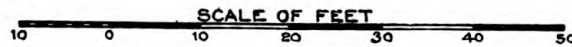

NOTE: FOR CONSTRUCTION DETAILS SEE PLANS Nos. 416-131., 416-132., 416-133 & 416-134., ON FILE IN THE OFFICE OF THE QUARTERMASTER GENERAL, WAR DEPT., WASHINGTON, D. C.

ORD.  
Q.M.C. 416-119

FIGURE 5.—Small-arms range, 1,000-inch, protected type—Continued.

SECTION II

SELECTION OF TARGET RANGES

General.....	Paragraph 5
Selection of range site.....	6

**5. General.**—*a.* The training in marksmanship with the various small arms and automatic guns used in the Regular Army, National Guard, Organized Reserves, and auxiliaries is accomplished on ranges constructed to suit the arm used and courses or exercises to be fired.

*b.* Some types of guns require the use of more than one type of range, as for example, marksmanship training with the caliber .30 rifle which requires the use of a 1,000-inch range, a known distance (A) range, a miniature air target range, a towed target range, a landscape target range, and a moving ground target range.

*c.* The ranges may be either of a permanent or temporary nature. Those located on Government or State reservations where the probability of changing the location is remote and where the type of construction is of a lasting nature may be classed as a permanent range, while those constructed upon Government or State leased land and using knock-down type construction would come under the head of a temporary range.

*d.* The Quartermaster Corps is charged with the duty of constructing the various types of ranges for use of the different arms and services. This work includes the necessary clearing, excavating and grading; construction of target butts, target pits, drainage facilities, storeroom or range house, and firing points. For regulations pertaining to the construction and maintenance of ranges see AR 30-1505.

*e.* The Ordnance Department is charged with the duty of providing the necessary targets, target material, and target accessories for all small arm ranges. For information pertaining to nomenclature, procurement, and allowances of target equipment, targets, and target accessories see AR 760-40; and Standard Nomenclature List L-1.

*f.* The Signal Corps is charged with the installation, supervision, and maintenance of target range communications. (See AR 105-5 and 105-20.)

**6. Selection of range site.**—*a. Class A.*—The following factors should be considered in the selection and laying out of class A ranges:

(1) *General.*—(*a*) In selecting a range site, AR 750-10 must be consulted and strictly complied with. This regulation prescribes the safety limits, danger areas, and safety precautions required for

firing all types of weapons and ammunition. The Field Manuals pertaining to weapons supplement these Army Regulations insofar as training in the particular weapon is concerned.

(b) For safety to the public, the range should be so located that the line of fire with its corresponding danger area will not include any habitable building, traveled highways, navigable waterways, railroads, airports, or recreation resorts.

(2) *Terrain.*—(a) On flat terrain the range should, if possible, be located so that the target pits and firing points may be drained easily and the intervening space between the former and latter may be traversed easily at all times. The above conditions may be fulfilled on the side slope of a valley, the line of fire being parallel to the direction of the valley as shown on figure 1. Land along the shores of lakes, bays, or oceans with the line of fire either at right angles to or parallel to the shore line may also be used.

(b) Where practicable, a range should be so located that the firing is toward or slightly to the east of north. This gives a good light on the face of the targets during the greater part of the day. However, security and suitable grounds are more important than direction.

(c) On rough terrain the range should be located so that the line of fire is at right angles, or nearly so, to and into high ground, such as a steep hill or bluff, with attention being given to the drainage of the target pits. Suggested location conforming to the above is shown by figure 1.

(d) Care should be exercised in selecting the direction of fire so that no intervening knolls, ridges, large trees, etc., obstruct the visibility of the targets.

(e) Smooth, level ground or ground with only a very moderate slope is best adapted for a range. The targets should be on the same level with the firing point or only slightly above. Firing downhill should be avoided. If it becomes necessary to raise a firing point on account of low ground, a low mound of earth no higher than absolutely required should be made. The mound should be level, sodded, and not less than 12 feet square. If the entire firing line is raised, the firing mound should be level, sodded, and not less than 12 feet wide on top.

(3) *Amount of land required.*—(a) *Danger areas.*—The amount of land required for a range must be determined by calculating the length and breadth of the danger area required to fulfill the requirements of AR 750-10 insofar as it relates to the type of weapon, ammunition, and firing exercises to be fired on the range.



(b) *Size of range.*—The size of the range is determined by its plan and by the number of troops that will fire over it at a time. There are two general plans used in range construction: one with a single target pit and firing points for each range; the other with firing points on one continuous line, the target pits for the various ranges being in echelon. The latter type requires more ground and is less suitable for training troops.

(c) *Intervals between targets.*—To reduce to a minimum the amount of labor required in preparing the range, the targets should be no farther apart than is necessary to obviate the probability of a shot being fired on the wrong target. As a general rule, the intervals between targets are equal to the width of the targets themselves; that is, at short and midrange, 6 feet; at long range, 12 feet. Where the necessity exists for as many targets as possible in a limited space, this interval may be reduced one-half without materially affecting the value of the instruction.

Firing range (yards)	Flat terrain		
	Width (yards)	Length from fir- ing points (yards)	Area (acres)
200	88	5,400	98
300	133	5,400	148
500	222	5,400	248
800	355	5,400	396
1,000	444	5,400	596

(d) The widths in the above table do not include the theoretical diverging danger areas beyond the target.

(e) For class A ranges having more than one target, add 4 yards to the widths tabulated above for each additional target.

(f) It may seldom be possible to obtain land of exact dimensions as tabulated above, in which case judgment must be exercised in selecting that area which will most nearly fulfill the provisions under this paragraph.

(g) Class B range areas will vary in nearly all essential dimensions, depending upon practice requirements.

(h) The tabulated data for class A ranges are based upon the following:

1. *Width.*—For flat terrain, the widths given are the theoretical widths of the danger areas at the target for the firing range used.

2. *Length.*—For flat terrain the length given is assumed as the extreme firing range of the service rifle at 30° elevation when used at the 200-yard firing point.

(4) *Distance from post.*—The location of the range should be as near as possible to the home station or post of the units using it, due consideration in selection of location being given to the distance, kind of highways to be traversed, and the time required on the road.

(5) *Permanency of location.*—In selecting a location for a permanent range, the following conditions should be observed:

- (a) Ownership of the land.
- (b) Available adjacent land for extensions.
- (c) Nearness to the posts of units using it.
- (d) Liability of injunction by adjacent property owners.
- (e) Sufficiency of area.
- (f) Value of land.
- (g) Proximity to direction of population expansion.

(6) *Available additional land.*—When selecting a range site, the fact must be kept in mind that future extensions of the target butts may be required as well as increased firing ranges, hence data should be secured relative to adjacent available land.

(7) *Natural drainage.*—The range site selected should, if possible, be such that the target pits and firing points may be drained and at a minimum of cost.

(8) *Character of soil.*—The character of soil between firing points and targets enters into the final decision of location of the open and protected types of 1,000-inch ranges only. Select that location, after firing tests, which shows the smallest deflections both ways of ricochets.

*b. Class B.*—(1) *General.*—The availability of ground, the number and size of the ranges required, the type of weapons to be accommodated, training to be accomplished, the classes of fire to be executed, and the safety features prescribed in AR 750-10 determine the selection and location of terrain for class B ranges and ranges used for air target and moving ground target marksmanship training.

(2) *Terrain.*—(a) Where possible class B ranges should be selected so as to make available varied terrain suitable for the employment of all of the small arms, automatic weapons, mortars, and small cannon with which the units to be trained are armed. Any ground satisfactory for maneuvers will usually be suitable for training in technique of fire and tactical exercises involving field firing, provided the necessary safety features are taken into consideration and provided for.

(b) When practicable, the location and extent of a class B range should afford terrain suitable for the maneuver of small tactical units in the area approaching the range proper and have sufficient depth within the firing area to permit considerable advance through the area for training in fire and movement.

(c) Tracts that have been set aside as permanent class B ranges can be operated efficiently without an elaborate system of shelters and dug-outs; simple pits to accommodate the target operators are sufficient. Every effort should be made to avoid altering the natural appearance of the terrain when locating and constructing pits.

(3) *Conversion of class A range.*—In the absence of other facilities a known-distance class A range may be used for field firing exercises by arranging exercises so that they will begin off of the range and require the delivery of fire on the range and in a safe direction.

SECTION III

CONSTRUCTION OF TARGET RANGES AND LAY-OUTS OF VARIOUS OTHER RANGES, COURSES, AND ATHLETIC FIELDS

	Paragraph
Approval of proposed construction.....	7
Target butts.....	8
Range house or storerooms.....	9
Firing points.....	10
Telephone and other facilities.....	11
Care of range and facilities.....	12
Data pertaining to multitarget butts.....	13
Lay-outs for other ranges, courses, and athletic fields.....	14

**7. Approval of proposed construction.**—When a site for a small arms range has been selected, a plan showing its general location and distance from the station of the units to be accommodated, boundaries of the tract, all buildings, roads, waterways, contours, and a profile along the line of fire should be prepared. Also prepare detailed plans showing size and construction of butt, backstops, firing points, and location of telephone line, storehouse, and other contemplated construction, with an estimate of cost of each class of work. Itemize this estimate to show quantity and unit prices of materials and labor required. These plans and estimates will be sent to the office of The Quartermaster General for his approval before construction is started.

**8. Target butts.**—*a.* The target butts on permanent class A ranges consist of a retaining wall backed up with earth on the side

next to the firing points and a target pit on the opposite side. They may be constructed of plain or reinforced concrete, or in localities where rock is plentiful use rubble masonry laid up in cement mortar.

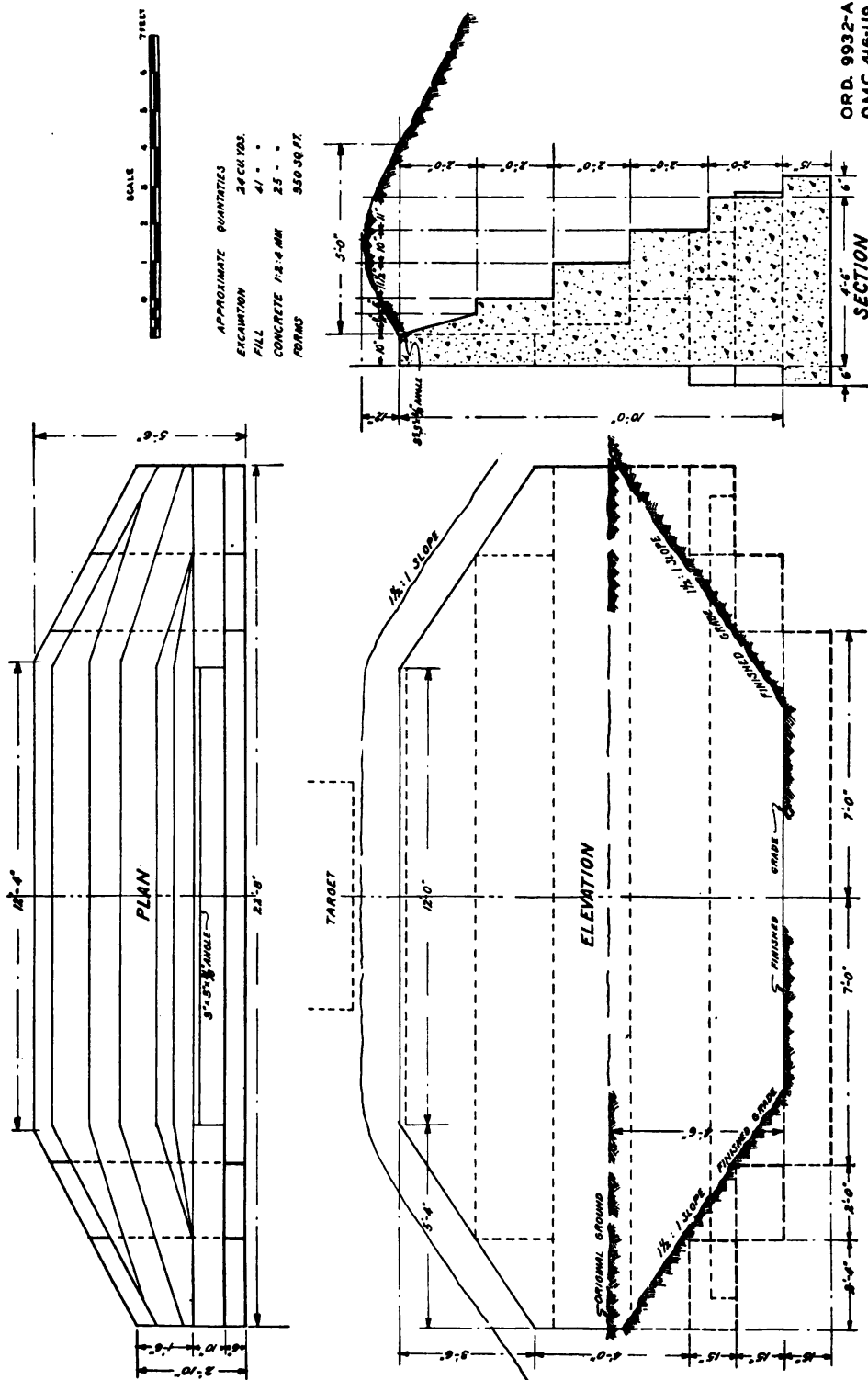

ORD. 9932-A  
Q.M.C. 416-119

FIGURE 6.—Plain concrete gravity type target butt.

*b.* (1) The various approved designs for retaining walls to serve the above purpose are as follows: Plain concrete (fig. 6) multitarget reinforced concrete wall with integral target pit and storeroom (figs. 7, 8, and 9); lay-outs of target frame support piers for various conditions (fig. 10); and rubble masonry (fig. 11).

(2) For 1,000-inch open range on flat terrain when the depth of the danger area prescribed by AR 750-10 cannot be obtained, a bullet stop will be provided immediately in rear of the targets, in the shape of an earth-filled timber wall or a reinforced concrete one of the required height, as shown in figure 4; figure 5 shows the protected type of 1,000-inch range.

*c.* Construction details of figures 4 and 5 on drawings 416-131 to 416-134, inclusive, are on file in the office of The Quartermaster General, blueprints of which may be secured on application.

*d.* The excavation for the foundation of the wall may be carried down to depths varying from 3 to 8 feet, depending upon the terrain, character of material, and feasibility of draining the target pit. In all cases it should be carried down below frost line.

*e.* On temporary ranges a reinforced concrete or pressed steel cribbing type of retaining wall for the butt is suggested, due to the 100 percent salvage value that is obtained when necessary to move the range. Any of the successful commercial types of the above cribbing may be employed.

*f.* When target pits are constructed, the pit should be inclosed with a wall extending from the bottom of the excavation to a height of 3 feet. The earth outside the pit to be graded on a 1½:1 slope from the top of the inclosing wall to the surface of the original ground.

*g.* The floor of the target pit may or may not be paved, depending upon soil conditions.

*h.* Where target pit paving is omitted, the concrete piers for supporting the target frame supports should be increased in size below grade of pit and carried down at least 2 feet 6 inches below the elevation of top of pier as shown.

*i.* Along the top of slope of the grading to the pit, a cut-off ditch should be constructed to take care of all surface waters.

*j.* On the completion of grading of all slopes of parapet, parados, and target pit, the surfaces should be sodded or planted with grass seed to prevent scour.

*k.* On the 1,000-inch ranges, the material composing the ricochet pits should consist of soft, sandy loam, having all foreign hard substances screened from it, and at the opening of the shooting season the surface should be thoroughly harrowed and all rocks, grass, weeds, etc., raked from the surface.





TARGETS, TARGET MATERIALS, RIFLE RANGE CONSTRUCTION

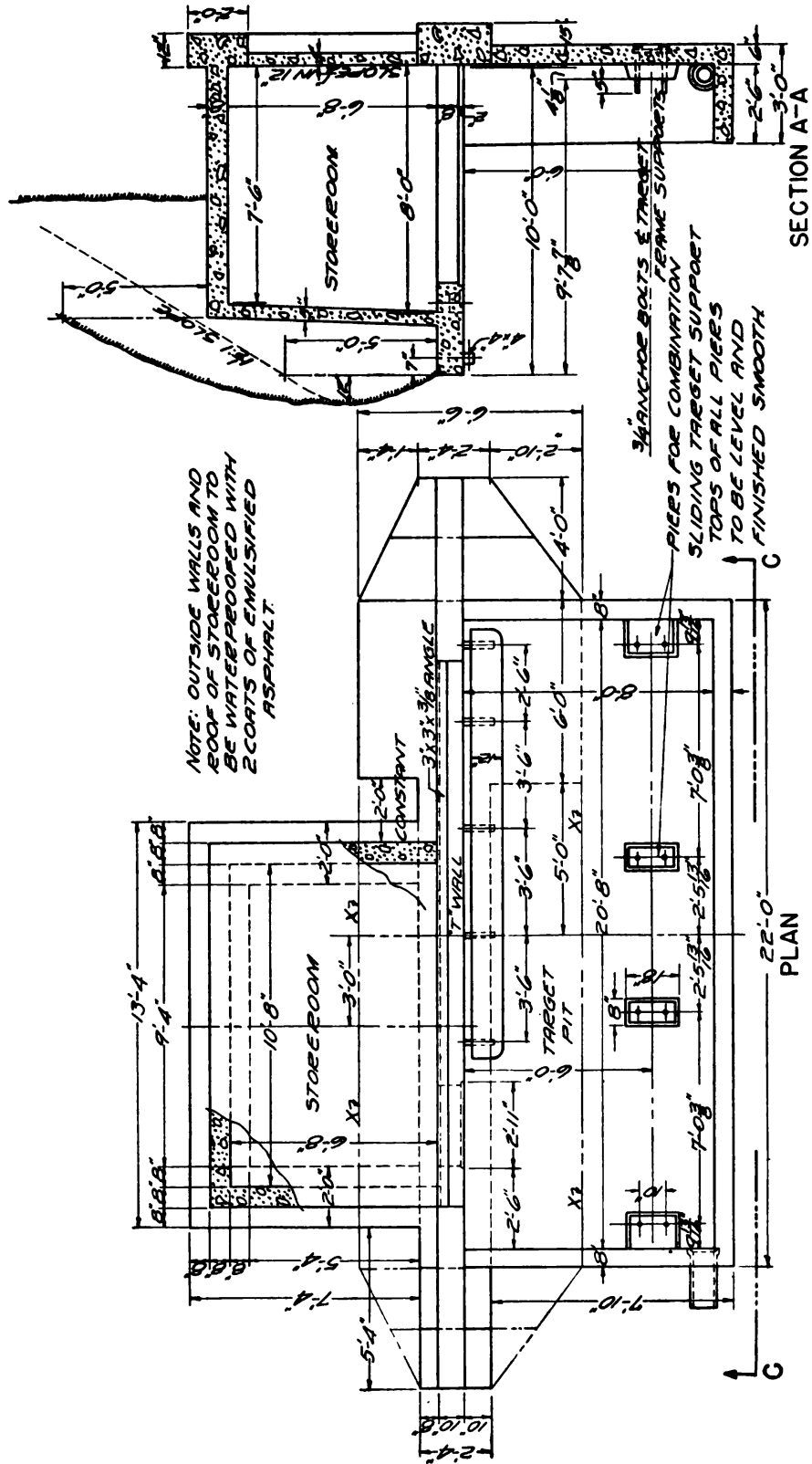

FIGURE 7.—Standard short and midrange multitarget butts with integral target pit and storeroom—Continued.

NOTE: IF STORE ROOM IS OMITTED THE FOUNDATION SLAB OF THE WALL SHALL BE SYMMETRICAL ABOUT THE CENTER LINE OF THE BUTT AND AS OUTLINED BY THE 2-DOT AND DASH LINE MARKED 'X'. SECTION OF WALL SHALL BE AS SHOWN BY SECTION 'B-B' FOR CONSTRUCTION DETAILS SEE DWGS. NOS. 416-123&16-124 ON FILE IN THE OFFICE OF THE Q.M.G.

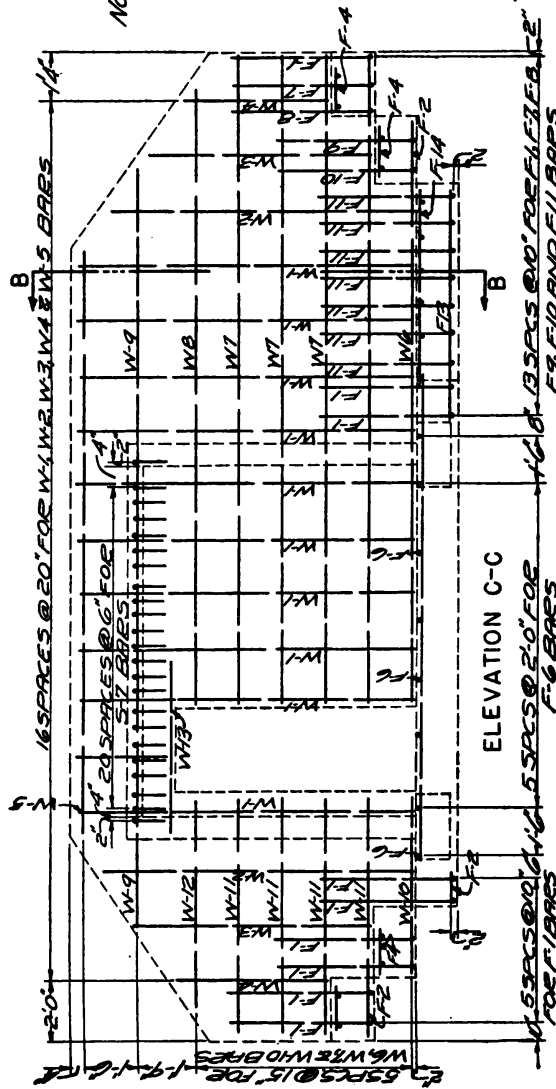

FIGURE 8.—Standard short and midrange multitarget butts with integral target pit and storeroom, reinforcing steel.

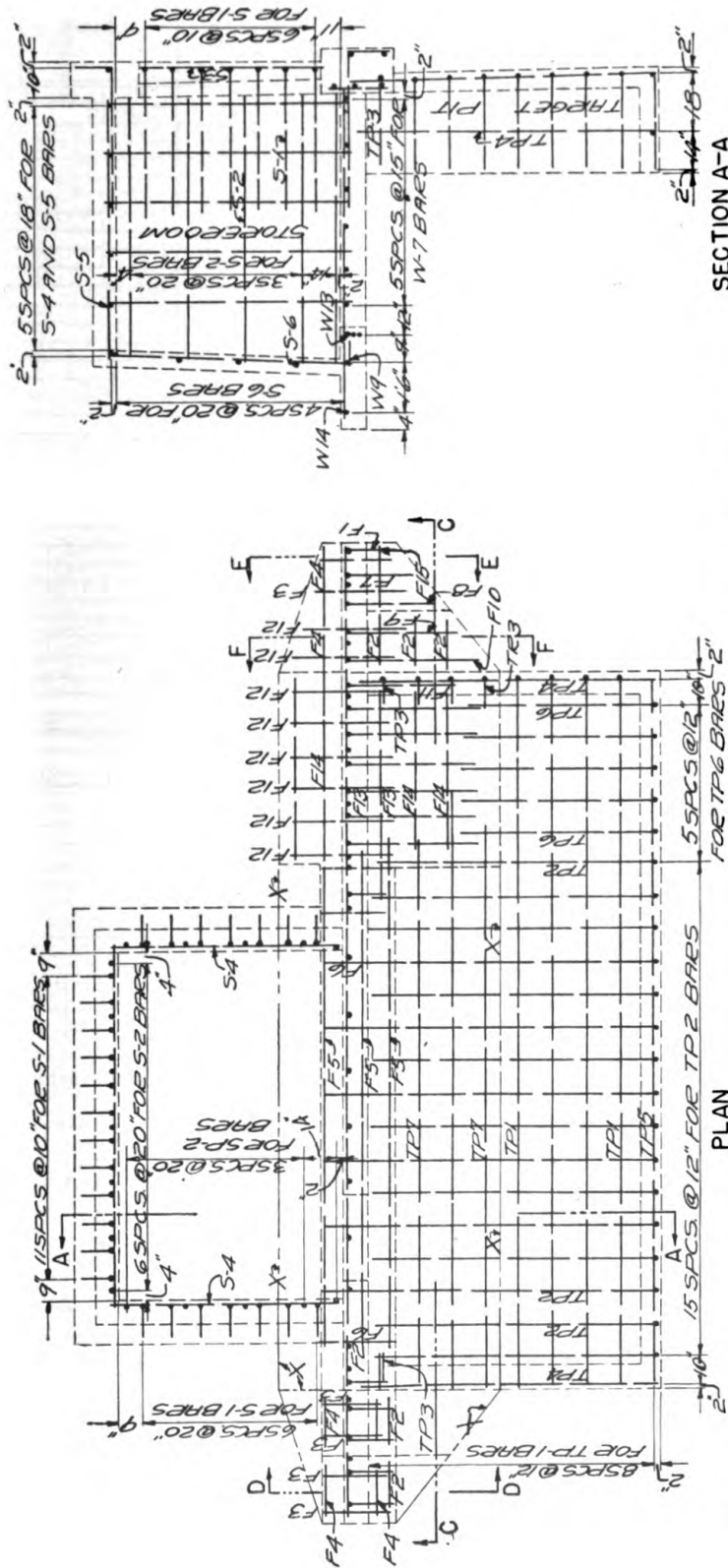

Figure 8.—Standard short and midrange multitarget butts with integral target pit and storeroom, reinforcing steel—Continued.

Generated on 2016-06-11 07:11 GMT / http://hdl.handle.net/2027/uc1.b3243773  
 Public Domain, Google-digitized / http://www.hathitrust.org/access\_use#pd-google

REINFORCING STEEL FOR TWO-TARGET BUTT WITH INTEGRAL "T." WALL, TARGET PIT, AND STOREROOM.							REINFORCING STEEL FOR SAME WITH INTEGRAL "T" WALL AND TARGET PIT ONLY.						
STRUCTURE	MARK	SIZE	NUMBER	LENGTH	SHAPE	TOTAL LENGTH	TOTAL WEIGHT	NUMBER	LENGTH	SHAPE	TOTAL LENGTH	TOTAL WEIGHT	
"T" WALL	F-1	#3	9	5'6"	4'2"   16"	49.5	74.3	2	5'6"	4'2"   16"	11.0	16.5	
	F-2	#3	7	1'2"	STRAIGHT	8.2	5.5	6	1'2"	STRAIGHT	7.0	4.7	
	F-3	#3	5	2'0"	"	10.0	6.7	2	2'0"	"	4.0	2.7	
	F-4	#3	8	1'6"	"	12.0	8.0	8	1'6"	"	12.0	8.0	
	F-5	#3	3	15'0"	"	45.0	67.5						
	F-6	#3	8	2'0"	"	16.0	10.7						
	F-7	#3	1	6'0"	4'2"   1'10"	6.0	9.0	2	6'0"	4'2"   1'10"	12.0	18.0	
	F-8	#3	1	6'6"	4'2"   2'4"	6.5	9.8	2	6'6"	4'2"   2'4"	13.0	19.6	
	F-9	#3	1	7'4"	4'2"   3'2"	7.3	11.0	2	7'4"	4'2"   3'2"	14.6	22.0	
	F-10	#3	1	7'8"	4'2"   3'6"	7.7	11.6	2	7'8"	4'2"   3'6"	15.4	23.2	
	F-11	#3	2	8'2"	4'2"   4'0"	57.2	85.8	27	8'2"	4'2"   4'0"	220.8	330.8	
	F-12	#3	9	3'2"	STRAIGHT	28.5	19.1	23	3'2"	STRAIGHT	88.7	59.4	
	F-13	#3	2	7'0"	"	14.0	9.4	2	21'8"	"	43.3	29.0	
	F-14	#3	4	5'6"	"	22.0	14.7	4	21'8"	"	86.6	58.0	
	F-15	#3	1	1'10"	"	1.8	1.2	2	1'10"	"	3.7	2.5	
"T" WALL	W-1	#3	10	9'10"	STRAIGHT	98.3	147.5	11	9'10"	STRAIGHT	108.1	162.3	
	W-2	#3	2	9'0"	"	18.0	27.0	2	9'0"	"	18.0	27.0	
	W-3	#3	2	7'0"	"	14.0	21.0	2	7'0"	"	14.0	21.0	
	W-4	#3	2	4'6"	"	9.0	13.5	2	4'6"	"	9.0	13.5	
	W-5	#3	1	2'6"	"	2.5	3.8						
	W-6	#3	1	17'8"	"	17.7	11.9	1	25'8"	"	25.7	17.2	
	W-7	#3	4	19'8"	"	78.7	52.7	4	29'8"	"	118.7	79.5	
	W-8	#3	1	19'0"	"	19.0	12.7	1	28'0"	"	28.0	18.8	
	W-9	#3	1	23'0"	"	23.0	15.4	1	23'0"	"	23.0	15.4	
	W-10	#3	1	4'9"	"	4.7	3.1						
	W-11	#3	4	6'6"	"	26.0	17.4						
	W-12	#3	1	6'0"	"	6.0	4.0						
	W-13	#3	3	5'0"	"	15.0	10.1						
	W-14	#3	1	18'0"	"	18.0	12.1	1	18'0"	"	18.0	12.1	
TOTAL WEIGHT "T" WALL							696.5	TL.WT. "T" WALL					961.1
TARGET PIT	TP-1	#3	4	27'0"	2'8"   2'8"   2'8"	108.0	72.4	4	27'0"	2'8"   2'8"   2'8"	108.0	72.4	
	TP-2	#3	16	11'2"	2'8"   8'6"	178.7	119.7						
	TP-3	#3	5	3'8"	2'8"   12"	18.4	12.3	8	3'8"	2'8"   12"	29.4	19.7	
	TP-4	#3	3	8'9"	STRAIGHT	26.3	17.4	2	8'9"	STRAIGHT	17.5	11.7	
	TP-5	#3	2	21'8"	"	43.3	29.0	2	21'8"	"	43.3	29.0	
	TP-6	#3	5	8'5"	2'8"   5'9"	42.1	28.2	21	8'5"	2'8"   5'9"	176.8	118.5	
	TP-7	#3	3	19'6"	2'8"   16'10"	58.5	39.2						
TOTAL WEIGHT TARGET PIT							318.2	TL.WT. TARGET PIT					251.3
STOREROOM	S-1	#3	26	5'2"	4'2"   12"	134.3	139.7						
	S-2	#3	17	8'2"	STRAIGHT	138.8	144.4						
	S-3	#3	2	6'0"	"	12.0	8.0						
	S-4	#3	10	8'0"	"	80.0	53.6						
	S-5	#3	7	11'4"	STRAIGHT	79.3	53.1						
	S-6	#3	3	11'4"	"	34.0	12.8						
	S-7	#3	23	8'4"	8"   7'-0"   8"	191.6	72.0						
TOTAL WEIGHT STOREROOM							483.6	GRAND TOTAL					1212.4
GRAND TOTAL							1498.3	GRAND TOTAL					1212.4

Approximate Square Feet, Forms.----- 1191.      Approx. Sq.Ft. Forms.----- 716.  
 " " Cubic Yards, Concrete.-----25.      " Cu.Yds. Concrete----- 20.

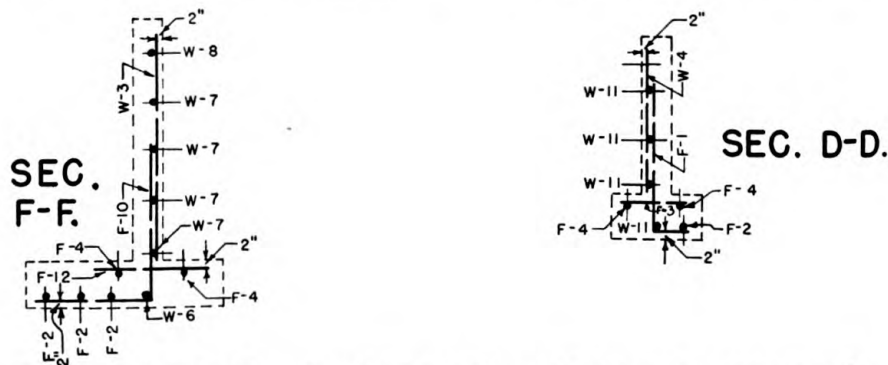

FIGURE 9.—Standard short and midrange multitarget butts with integral target pit and storeroom, material tabulation.



**9. Range house or storerooms.**—The number, size, and type of storerooms depend upon the number and size of the targets to be stored therein, with the type being governed by the permanency of the range.

*a.* They may be of frame, concrete, tile, galvanized steel, or other material, the governing factors being suitability, availability, and cost.

*b.* Generally, permanent ranges should be equipped with structures of more lasting material, whereas the temporary ranges will require a less expensive and easily removed type of construction.

*c.* Figures 7, 8, and 9 show a permanent storeroom integral with the butt, while figure 12 shows the minimum size of a frame portable storeroom.

*d.* Storerooms should be located off the danger area and near the line of targets produced or in case this is not feasible, they may be constructed back of the retaining wall in the target pit with the roof low enough to be protected by the butt. In all cases, the location should be such as will insure dryness of the contents.

**10. Firing points.**—*a.* For a one-target range, the firing point consists of a level space 12 by 12 feet in dimensions and graded slightly above adjacent ground.

*b.* For more than one target add 12 feet for each target, continuously from the first, and in the direction parallel to the line of targets.

*c.* In some cases due to the terrain it may be necessary to build up the firing point for the longer ranges. This should be done by building up the firing line with earth to the size needed. On completion of the necessary filling in with earth, the sides of the firing line should be either sodded or sown with grass seed to prevent erosion.

*d.* On the 1,000-inch protected range, the firing points are covered with a bulletproof frame housing divided by bulletproof partitions as shown in figure 5.

**11. Telephone and other facilities.**—Generally, the line of communication should be permanently installed either on poles or in conduits. The range should be provided with a water supply and comfort stations with the necessary sewage line.

**12. Care of range and facilities.**—*a.* The area between the firing points and targets will be kept free of all rubbish, large weeds, shrubs, etc.

*b.* The drainage ditches, drains, and target pits will be kept free of dirt, rubbish, and decayed vegetable matter.

*c.* Growth of large weeds should not be allowed on any of the slopes around the target butt and pit but a good sod of grass should be maintained at all times, if possible.

*d.* At the close of the target practice period all targets, temporary telephone wire and accessories, as well as all other movable equipment will be removed and stored neatly in the storeroom, and the range thoroughly policed, leaving it in a neat, clean condition.

**13. Data pertaining to multitarget butts.**—The following data pertain to multitarget reinforced concrete butts having integral storeroom and target pits after the designs shown in figures 7, 8, 9, and 10.

*a.* Figures 7, 8, and 9 show construction details of a two-target butt for use on the short or midranges only.

*b.* Figures 4 and 5 show general plans of the open and protected types of 1,000-inch ranges.

*c.* (1) Figure 10 shows various lay-outs of piers for the different types of standard target frame supports that may be used for the short ranges, midranges, and long ranges. The distances between centers of targets shown are the minimum allowed by Army Regulations, and the length of top of wall of butt for any number of targets is based upon these figures.

(2) Figure 10 also shows a typical set-up of the standard combination sliding target frame supports for either the 6- by 6-foot or the 6- by 10-foot targets.

*d.* The butts shown in figures 8 to 10, inclusive, are so designed that various combinations of parts of the whole structure may be used with a minimum of change in the design. For example, if the storeroom is omitted, the foundation slab of the wall and the target pit paving are changed as shown; if the target pit is omitted, there will be no change in the remainder of the structure; and if storeroom and target pit are left off, the foundation slab of the T-wall will be altered as noted in the figures.

*e.* The standard frame for the 6- by 6-foot target is approximately 6 feet by 9 feet by 4 inches and the standard Aiken target frame is approximately 6 feet by 9 feet 4 inches by 1 inch.

*f.* The standard 6- by 10-foot target frame is approximately 6 feet 3 inches by 10 feet by 1 inch and the standard Aiken target frame 6 feet by 10 feet by  $1\frac{1}{8}$  inches.

*g.* Using the above dimensions of target frames, the 6-foot 8-inch by 10-foot 8-inch storeroom will house approximately 60 of the 6- by 6-foot standard frames; or 60 standard 6- by 6-foot Aiken frames; or 60 of the 6- by 10-foot frames of either the standard or Aiken type.





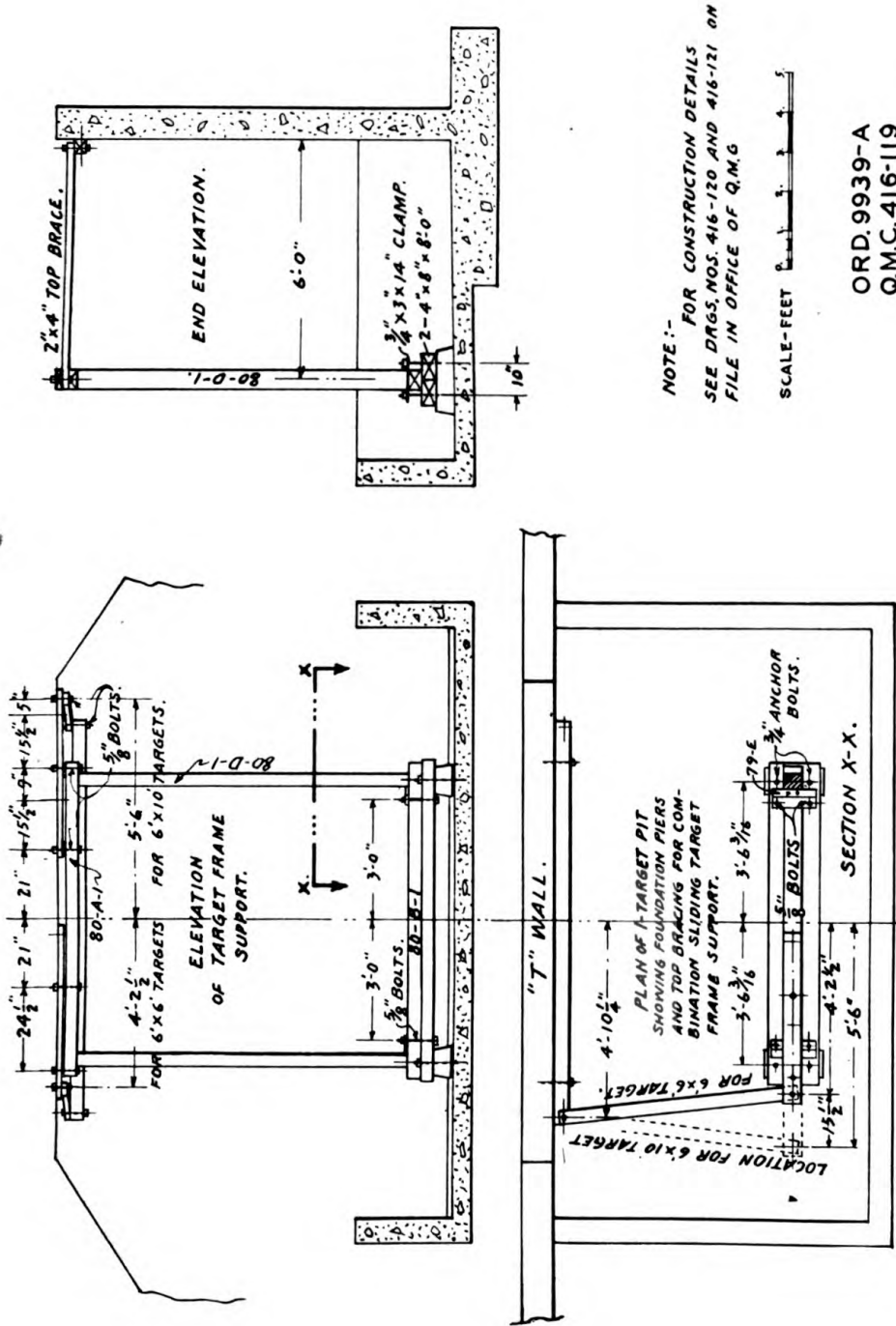

FIGURE 10.—Lay-out of foundation piers and typical set-up of standard combination sliding target frame support—Continued.

APPROXIMATE QUANTITIES	
EXCAVATION & BORROW	102 CU.YD.
ROCK (RUBBLE)	30 "
CONCRETE PAVING	3 "
REINFORCING STEEL-BARS, #7 2 LBS.	OR
WELDED STEEL FABRIC, 45 LBS. @ 42 LBS. PER 100	
STEEL ANGLE, 3x3x1/2"	
CEMENT	27 BLS.
SAND	12 CU.YD.
GRAVEL	3 "

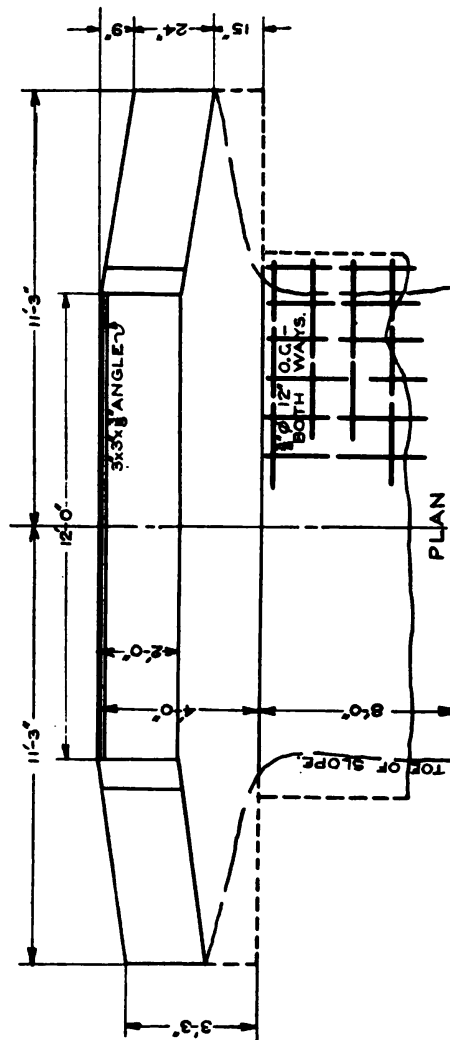
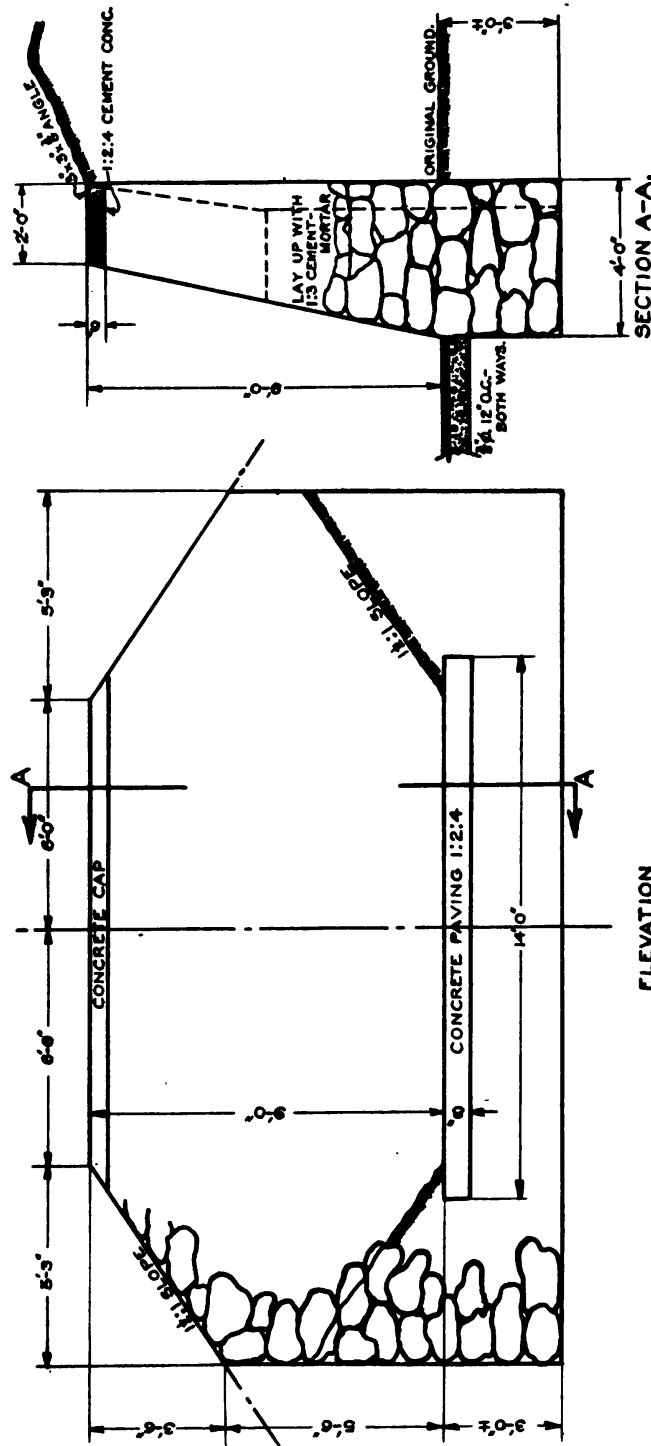

FIGURE 11.—One target rubble masonry rifle butt.



ELEVATION

FIGURE 11.—One target rubble masonry rifle butt—Continued.

MATERIALS.	NOTES.
6 - 10x8" POSTS	IF CORR. GALV. IRON IS USED ON ROOF, SPIKE
3 - 2x8 1/2" SIDE & END SILL	2x4-NAILING STRIPS BETWEEN RAFTERS.
1 - 10x16" - 3 LIGHT STOCK DOOR.	PROVIDE TIGHT WOOD SHUTTER OVER
2 - 2x6 1/2" JOIST PLATES.	WINDOW, HINGED ON BOTTOM AND FASTENED
9 - 2x6 1/2" FLOOR JOISTS.	AT TOP WITH HOOK & EYE.
8 - 2x4 1/2" PLATES.	IF BUILDING MAY BECOME SUBJECT TO
4 - 4x4 1/2" CORNER POSTS.	REMOVAL, LAY FLOORING DIAGONALLY.
20 LBS. 20# . . .	
8 - 2x4 1/2" STUDS.	
10 - 8d. NAILS.	
10 - 6d. . . .	
8 - 2x4 1/2" RAFTERS.	
13 - 2x4 1/2" HEADERS, BRACES, ETC.	
2 PAIRS 1x2" BUTTS.	
1 - 1x3" . . .	
2 - 1x3 1/2" CLEATS.	
140 LIN. FT. 1x4" TRIM.	
1 - MORTISE LOCK.	
72 SQ. FT. 1x6" ROUGH FLOORING.	
23 GAL. PAINT, COLOR AS SPECIFIED.	
315 . . . SIDING.	
100 . . . ROOF SHEATHING.	

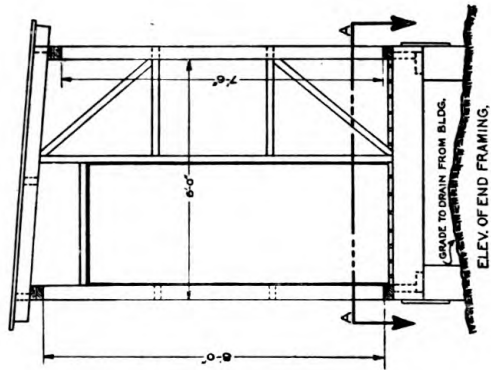
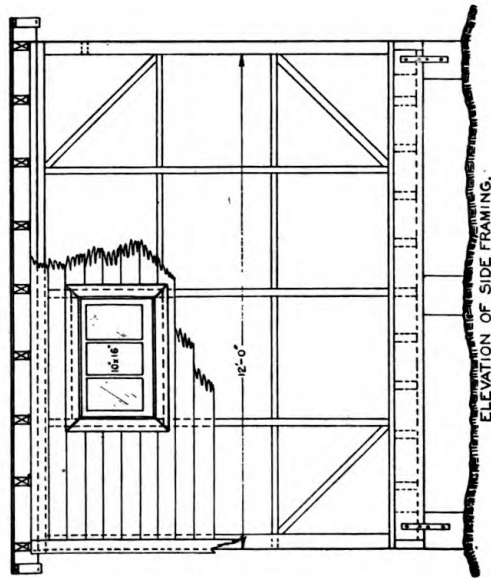
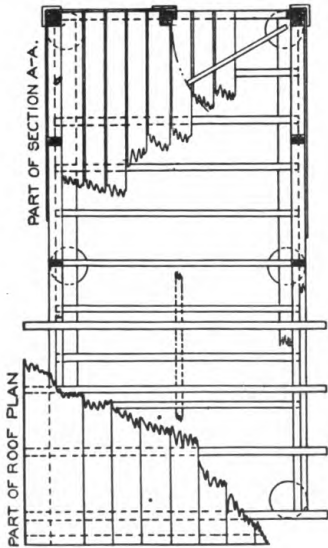

ORD 9942-A  
 Q.M.C. 416-119

FIGURE 12.—Rifle range storehouse, details.

TARGETS, TARGET MATERIALS, RIFLE RANGE CONSTRUCTION 13

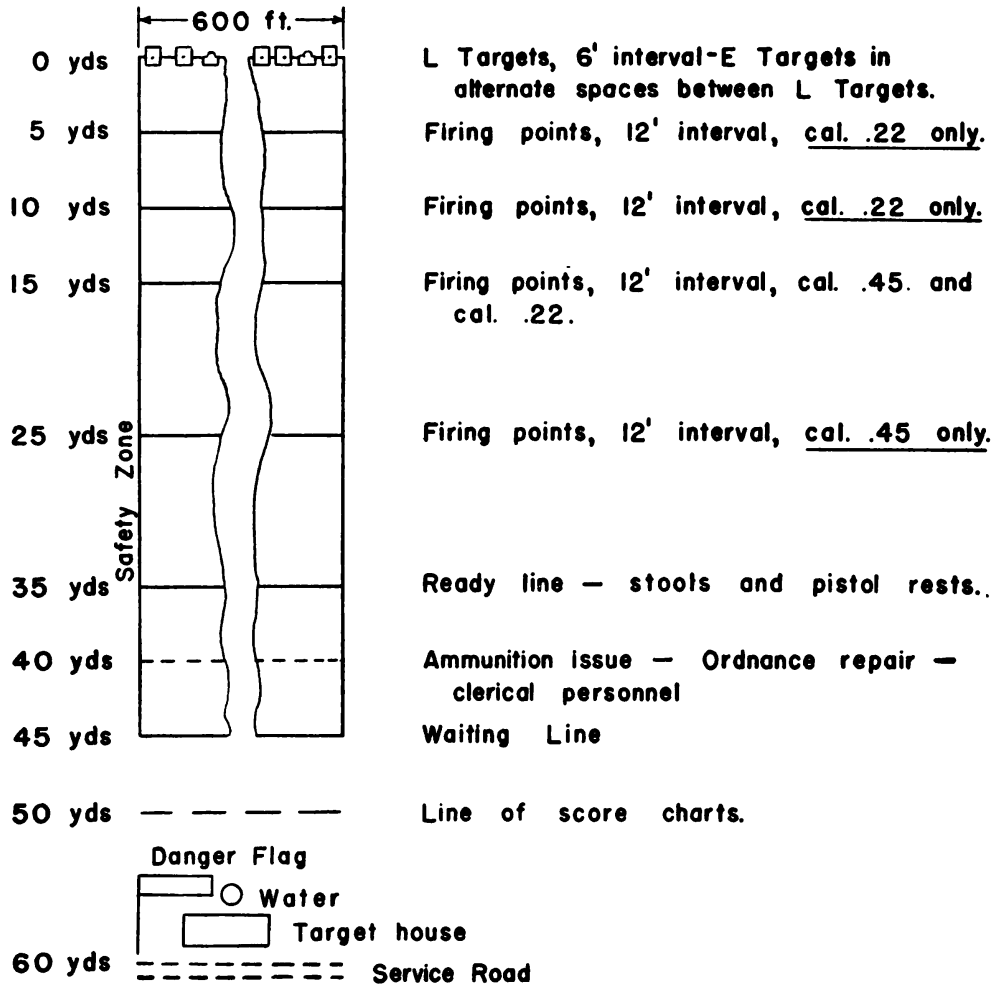

100 yds Latrine

FIGURE 13.—Caliber .22 and caliber .45 pistol range.

- NOTES.—1. For details of range construction and safety factors see paragraphs 63, FM 23-35, AR 750-10, and schematic plan of consolidated ranges above.
2. Natural or artificial butts must be 30 feet high with slope not less than 45°.
3. If necessary, the interval between L targets may be reduced. While it is desirable to have a minimum of 15 feet between bobbing E targets, the intervals may be reduced to permit placing one in each interval between L targets. See paragraph 54, FM 23-35.

h. Figure 9 shows the approximate quantities of material required for each combination of the two-target butt.

i. The break-down of the quantities for the two-target butt, according to each part of the structure, is shown in table I, with a similar break-down per running foot for each class of material for each part of the structure, shown in table II.

TABLE I.—Material quantities for two-target butt

Part of structure	Forms (square feet)	Reinforced steel (pounds)	Angle, 3 inches by 3 inches by 3/8 inch (pounds)	Concrete (cubic yards)
T-wall.....	526	696	130	12. 05
Target pit.....	190	318	-----	5. 24
Storeroom, 6 feet 8 inches by 10 feet 8 inches.....	475	484	-----	8. 56
Total.....	1, 191	1, 498	130	25. 85

TABLE II.—Running foot quantities for two-target butt

Part of structure	Forms (square feet)	Reinforced steel (pounds)	Angle, 3 inches by 3 inches by 3/8 inch (pounds)	Concrete (cubic yards)
T-wall.....	20	33. 00	7. 2	. 61
Target pit.....	6	9. 65	-----	. 16
Storeroom, 6 feet 8 inches by 10 feet 8 inches.....	22	23. 80	-----	. 442
Total.....	48	66. 45	7. 2	1. 212

j. Using the two-target butt as a base, table III shows the approximate quantities of materials required for the short and mid-range butts to accommodate from 2 to 21 targets, inclusive. Table IV shows the same data for the long-range butts for 2 to 20 targets, inclusive.

TABLE III.—Material quantities for short and midrange butts

Size of butt		Forms (square feet)				Reinforcing steel (pounds)					1:2:4 concrete (cubic yards)				Remarks
Number of targets	Top length of wall "L"	T-wall	Target pit	Storeroom, 5 feet 8 inches by 10 feet 8 inches	Total square feet for butt	T-wall		Target pit	Storeroom	Total pounds for butt (bars only)	T-wall	Target pit	Storeroom	Total cubic yards for butt	
						Reinforcing bar	Angle, 3 inches by 3 inches by 3/4 inch								
	<i>Ft.</i>														
1	12	378	184	475	1,037	452	86.0	260.4	484	1,196.4	8.20	4.33	8.56	21.09	---
2	18	526	190	475	1,191	696	129.6	318.0	484	1,498.0	12.05	5.24	8.56	25.86	---
3	30	766	262	475	1,503	1,092	216.0	433.8	484	2,009.8	19.37	7.16	8.56	35.09	---
4	42	1,006	334	475	1,815	1,488	302.4	549.6	484	2,521.6	26.69	9.08	8.56	44.33	---
5	54	1,246	406	475	2,127	1,884	388.8	665.4	484	3,033.4	34.01	11.00	8.56	53.57	---
6	66	1,486	478	475	2,439	2,280	475.2	781.2	484	3,545.2	41.33	12.92	8.56	62.81	1
7	78	1,726	550	475	2,751	2,676	561.6	897.0	484	4,057.0	48.65	14.84	8.56	72.05	---
8	90	1,966	622	475	3,063	3,072	648.0	1,012.8	484	4,568.8	55.97	16.76	8.56	81.29	---
9	102	2,206	694	475	3,375	3,468	734.4	1,128.6	484	5,080.6	63.29	18.68	8.56	90.53	---
10	114	2,446	766	475	3,687	3,864	820.8	1,244.4	484	5,592.4	70.61	20.60	8.56	99.77	---
11	126	2,686	838	475	3,999	4,260	907.2	1,360.3	484	6,104.2	77.93	22.52	8.56	109.01	2
12	138	2,926	910	475	4,311	4,656	993.6	1,476.0	484	6,616.0	85.25	24.44	8.56	118.25	---
13	150	3,166	982	475	4,623	5,052	1,080.0	1,591.8	484	7,127.8	92.57	26.36	8.56	127.49	---
14	162	3,406	1,054	475	4,935	5,448	1,166.4	1,707.6	484	7,639.6	99.89	28.28	8.56	136.73	---
15	174	3,646	1,126	475	5,247	5,844	1,252.8	1,823.4	484	8,151.4	107.21	30.20	8.56	145.97	---
16	186	3,886	1,198	475	5,559	6,240	1,339.2	1,939.2	484	8,663.2	114.53	32.12	8.56	155.21	3
17	198	4,126	1,270	475	5,871	6,636	1,425.6	2,055.0	484	9,175.0	121.85	34.04	8.56	164.45	---
18	210	4,366	1,342	475	6,183	7,032	1,512.0	2,170.8	484	9,686.8	129.17	35.96	8.56	173.69	---
19	222	4,606	1,414	475	6,495	7,428	1,598.4	2,286.6	484	10,198.6	136.49	37.88	8.56	182.93	---
20	234	4,846	1,486	475	6,807	7,824	1,684.8	2,402.4	484	10,710.4	143.81	39.80	8.56	192.17	---
21	246	5,086	1,558	475	7,119	8,220	1,771.2	2,518.3	484	11,222.3	151.13	41.72	8.56	201.41	4



TABLE IV.—Material quantities for long-range butts

Size of butt		Forms (square feet)				Reinforcing steel (pounds)					1:2:4 concrete (cubic yards)				Remarks
Number of targets	Top length of wall "L," Ft.	T-wall	Target pit	Storeroom, 5 feet 8 inches by 10 feet 8 inches	Total square feet for butt	T-wall		Target pit	Storeroom	Total pounds for butt (bars only)	T-wall	Target pit	Storeroom	Total cubic yards for butt	
						Reinforcing bar	Angle, 3 inches by 3 inches by 3/8 inch								
1	12	378	184	475	1,037	452	86.0	260.4	484	1,196.4	8.20	4.33	8.56	21.09	----
2	21	586	208	475	1,269	795	151.2	347.0	484	1,626.0	13.88	5.72	8.56	28.16	----
3	36	886	298	475	1,659	1,290	259.2	491.8	484	2,265.8	23.03	8.12	8.56	39.71	----
4	51	1,186	388	475	2,049	1,785	367.2	636.5	484	2,905.5	32.18	10.52	8.56	51.26	----
5	66	1,486	478	475	2,439	2,280	475.2	781.3	484	3,545.3	41.33	12.92	8.56	62.81	1
6	81	1,786	568	475	2,829	2,775	583.2	926.0	484	4,185.0	50.48	15.32	8.56	74.36	----
7	96	2,086	658	475	3,219	3,270	691.2	1,070.8	484	4,824.8	59.63	17.72	8.56	85.91	----
8	111	2,386	748	475	3,609	3,765	799.2	1,215.5	484	5,464.5	68.78	20.12	8.56	97.46	----
9	126	2,686	838	475	3,999	4,260	907.2	1,360.3	484	6,104.3	77.93	22.52	8.56	109.01	2
10	141	2,986	928	475	4,389	4,755	1,015.2	1,505.0	484	6,744.0	87.08	24.92	8.56	120.56	----
11	156	3,286	1,018	475	4,779	5,250	1,123.2	1,649.8	484	7,383.8	96.23	27.32	8.56	132.11	----
12	171	3,586	1,108	475	5,169	5,745	1,231.2	1,794.5	484	8,023.5	105.38	29.72	8.56	143.66	----
13	186	3,886	1,198	475	5,559	6,240	1,339.2	1,939.3	484	8,663.3	114.53	32.12	8.56	155.21	3
14	201	4,186	1,288	475	5,949	6,735	1,447.2	2,084.0	484	9,303.0	123.68	34.52	8.56	166.76	----
15	216	4,486	1,378	475	6,339	7,230	1,555.2	2,228.8	484	9,942.8	132.83	36.92	8.56	178.31	----
16	231	4,786	1,468	475	6,729	7,725	1,663.2	2,373.5	484	10,582.5	141.98	39.32	8.56	189.86	----
17	246	5,086	1,558	475	7,119	8,220	1,771.2	2,518.3	484	11,222.3	151.13	41.72	8.56	201.41	4
18	261	5,386	1,648	475	7,509	8,715	1,879.2	2,663.0	484	11,862.0	160.28	44.12	8.56	212.96	----
19	276	5,686	1,738	475	7,899	9,210	1,987.2	2,807.8	484	12,501.8	169.43	46.52	8.56	224.51	----
20	291	5,986	1,828	475	8,289	9,705	2,095.2	2,952.5	484	13,141.5	178.58	48.92	8.56	236.06	----

NOTE.—Figures in "Remarks" column denote that the butts in tables Nos. III and IV are identical except for the number of targets.

14. Lay-outs for other ranges, courses, and athletic fields.—

a. The lay-outs shown in figures 14 to 20 and 44 to 46, inclusive, for various other ranges and courses pertaining to the training of the soldier in the use of arms are—

- (1) Pistol course, mounted (fig. 14).
- (2) Saber qualification course (fig. 15).
- (3) Bayonet instruction and qualification course (fig. 16).
- (4) Antiaircraft cal. .22 training range (fig. 17).
- (5) Ground target machine-gun range for flexible guns (fig. 18).
- (6) Ground target machine-gun range for fixed guns (fig. 19).
- (7) Aerial bombing, low-altitude target, and aerial bombing, intermediate- and high-altitude target (fig. 20).

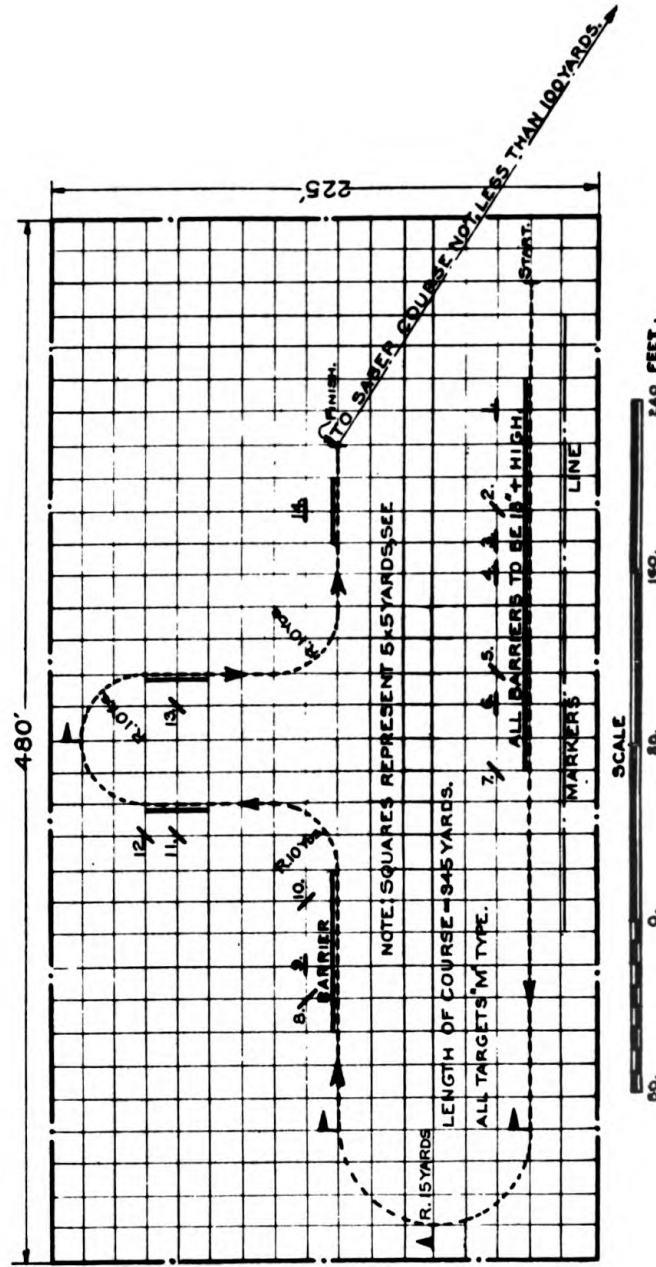

FIGURE 14.—Pistol course, mounted.

ORD. 9943-A  
Q.M.C. 416-119



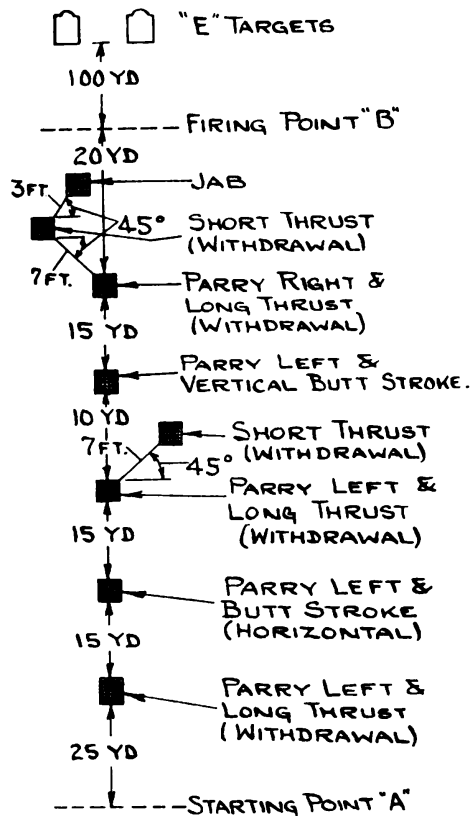

FIGURE 16.—Bayonet instruction and qualification course.

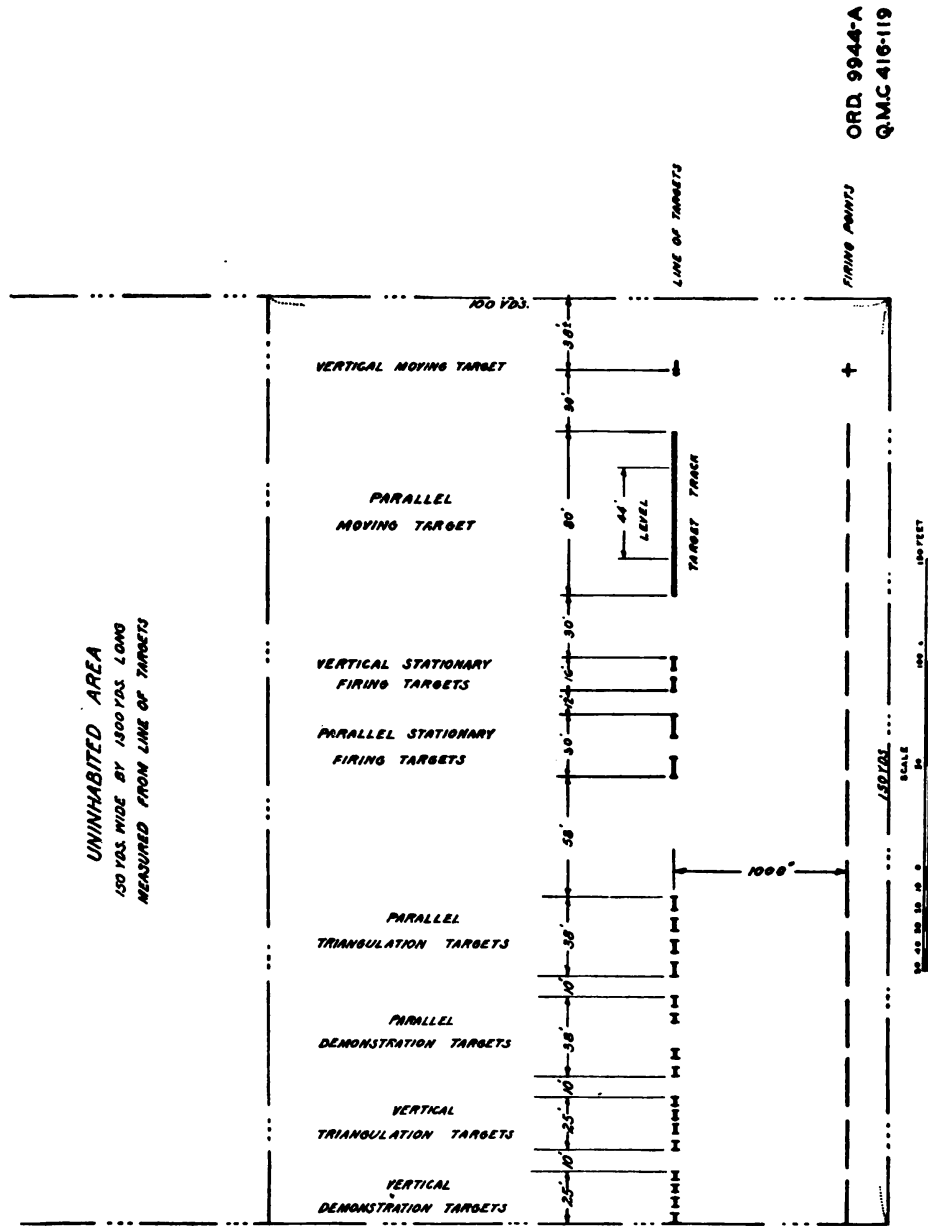

FIGURE 17.—Lay-out of antiaircraft caliber .22 training range.

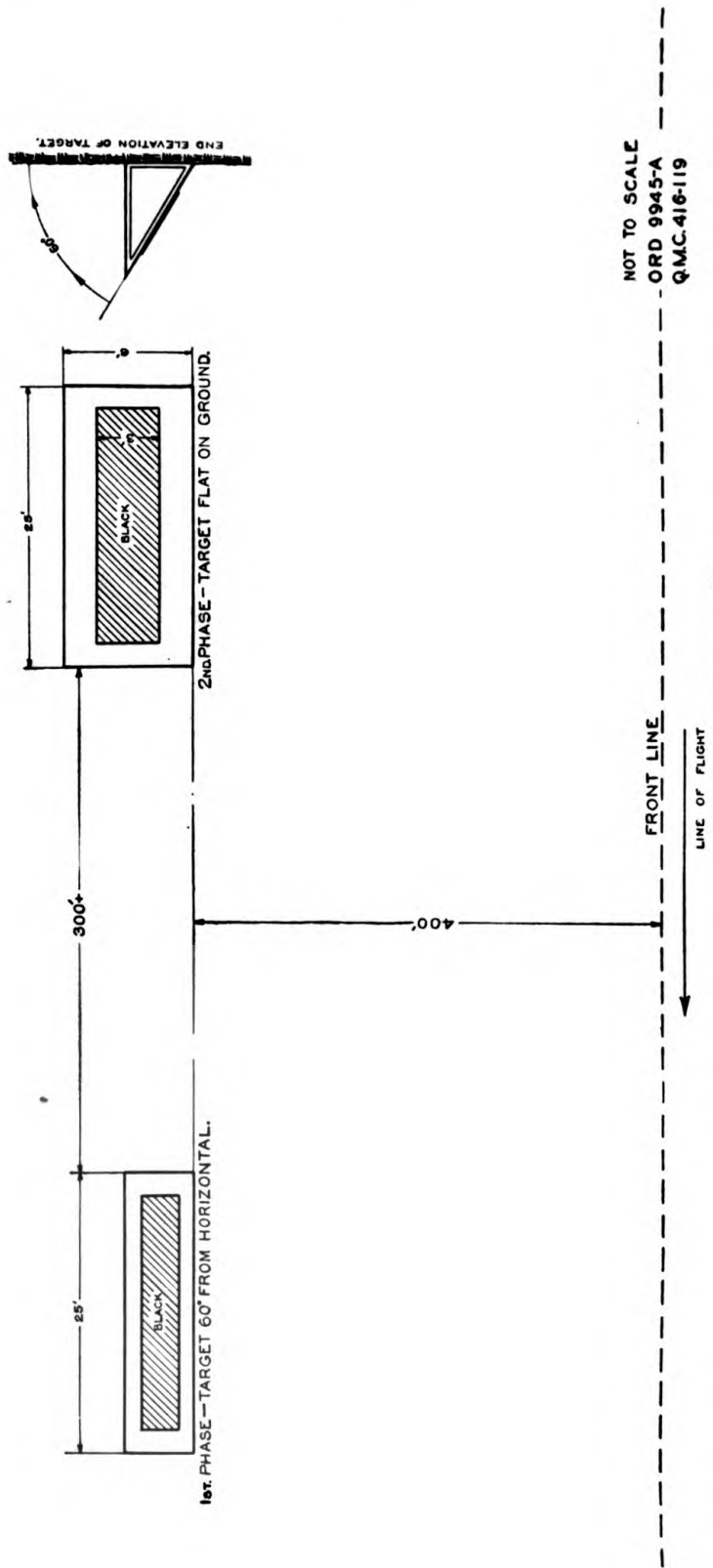
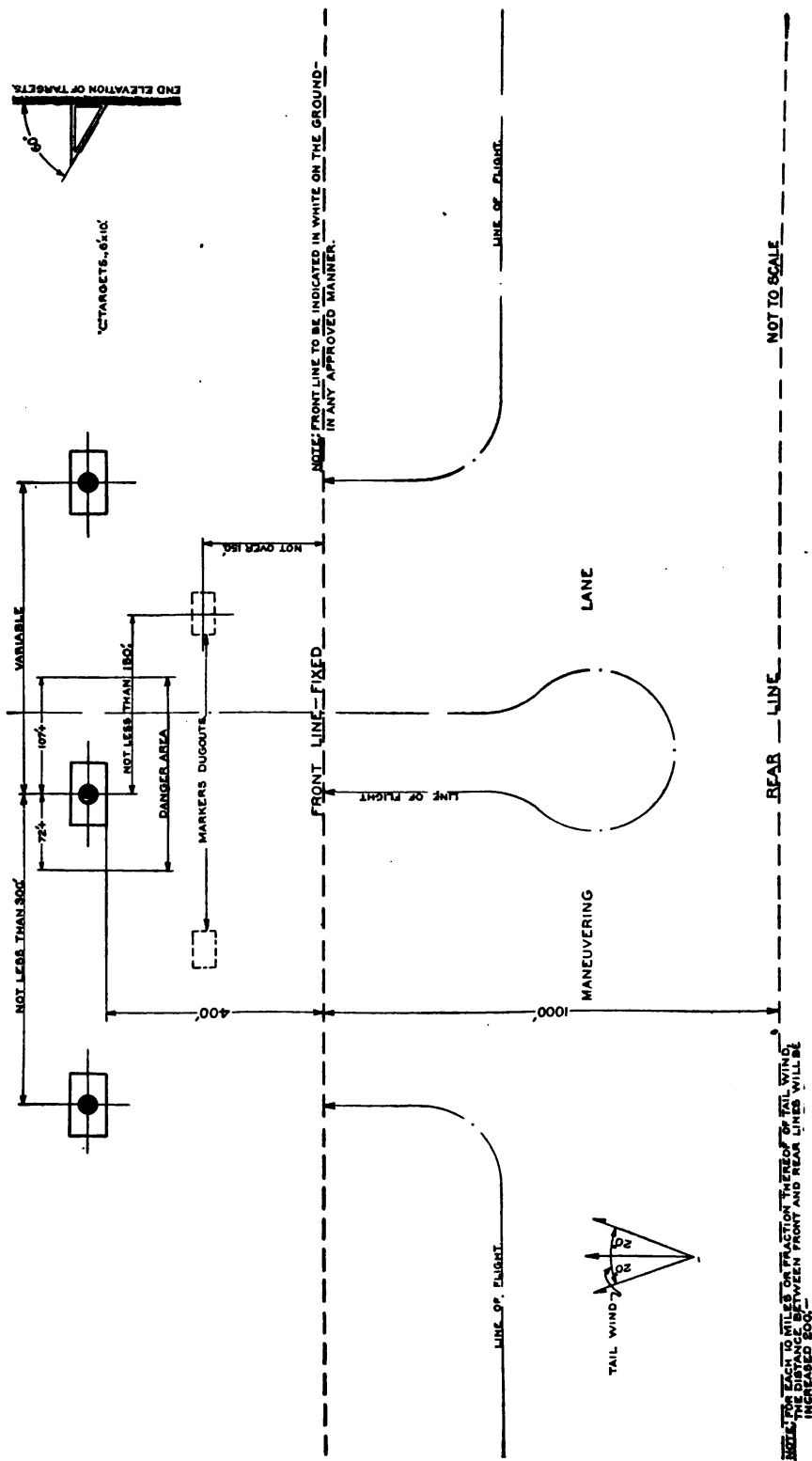
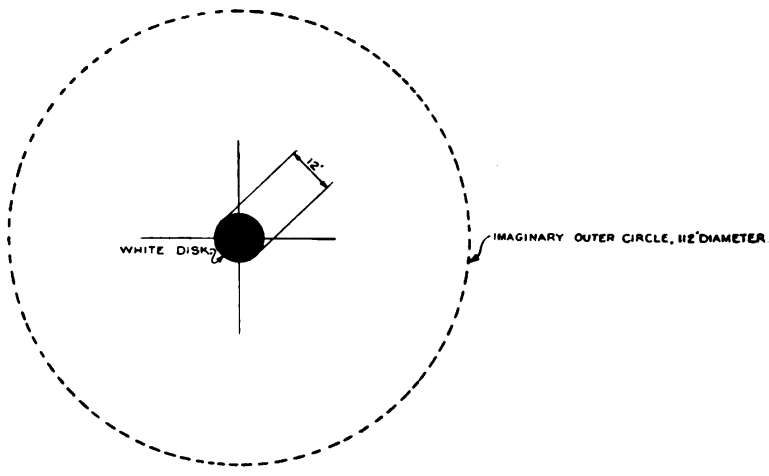
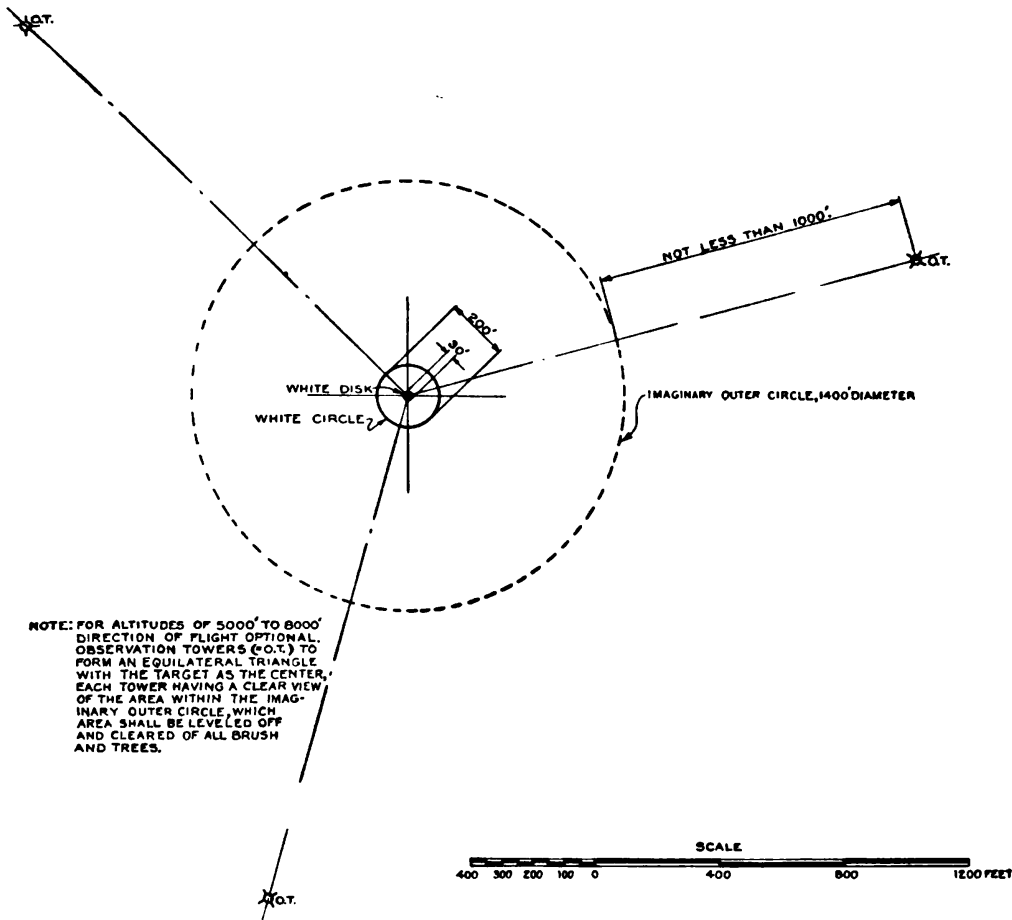

FIGURE 18.—Aerial ground target machine-gun range for flexible guns.



ORD. 99467A  
Q.M.C. 416-119

FIGURE 19.—Aerial gunnery ground target machine-gun range for fixed guns.



ORD. 9947-B  
Q.M.C. 416-119

FIGURE 20.—Aerial bombing—low-, intermediate-, and high-altitude targets.



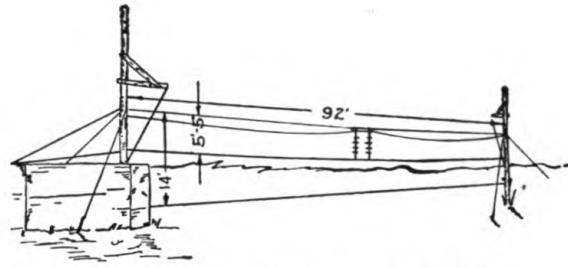

FIGURE 21.—Horizontal target.

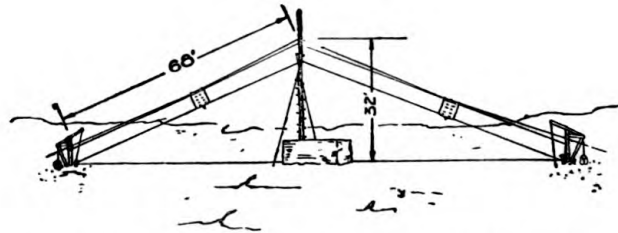

FIGURE 22.—Double climbing and diving target.

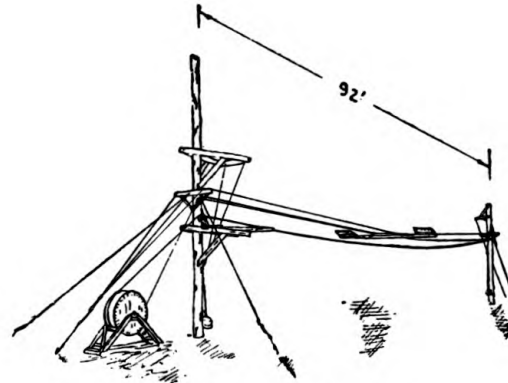

FIGURE 23.—Overhead target.

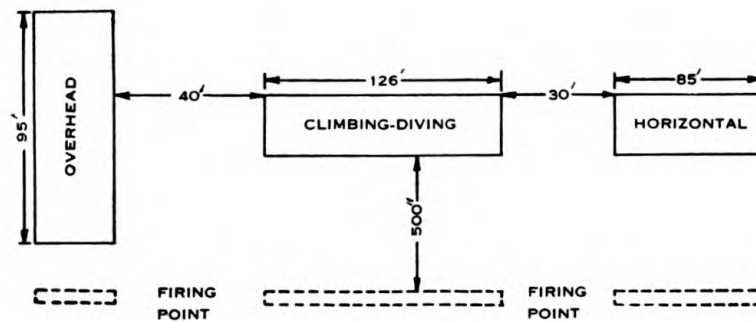

FIGURE 24.—Arrangement of targets.

TARGETS, TARGET MATERIALS, RIFLE RANGE CONSTRUCTION

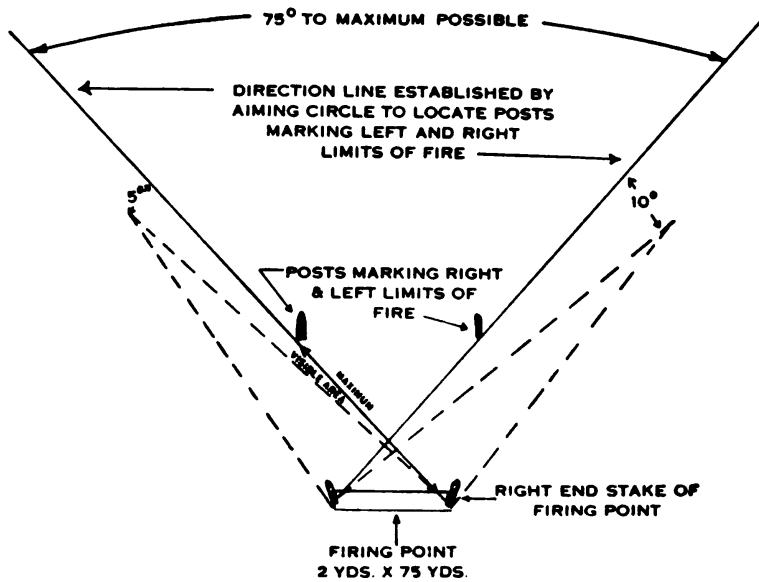

FIGURE 25.—Towed target range showing firing points and limits of fire. Dotted lines show danger areas.

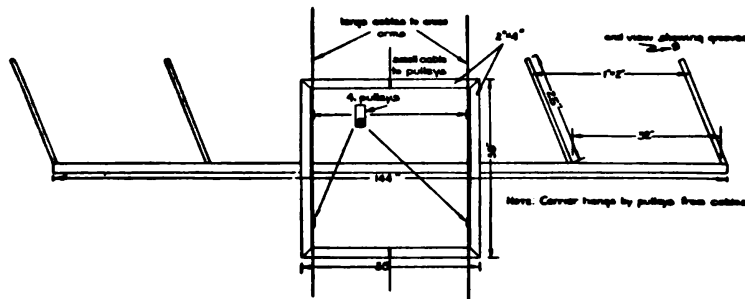

FIGURE 26.—Overhead target carrier.

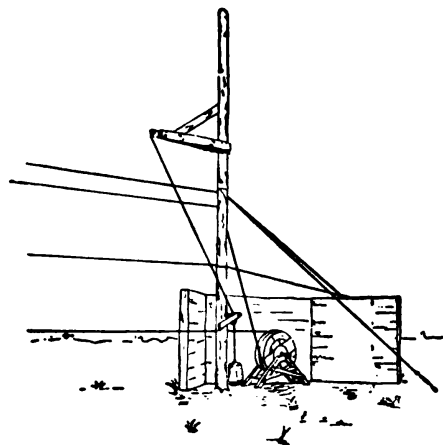
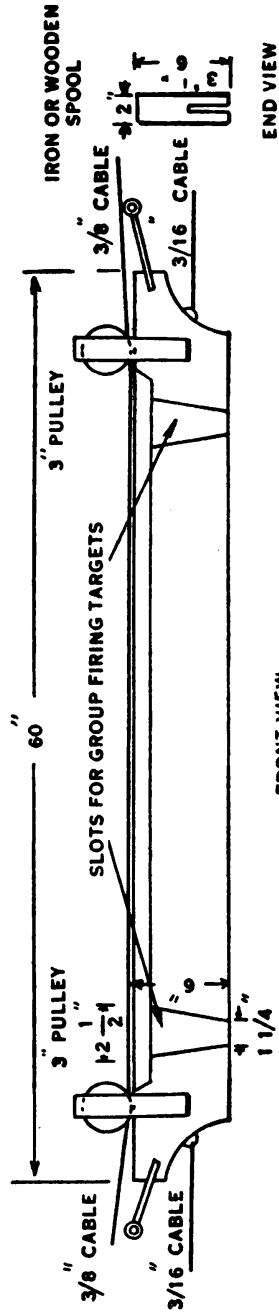

FIGURE 27.—Rear view of nonoverhead range butts, showing drum, guide wires, and bumper.



FRONT VIEW

END VIEW

FIGURE 28.—Nonoverhead target carrier.

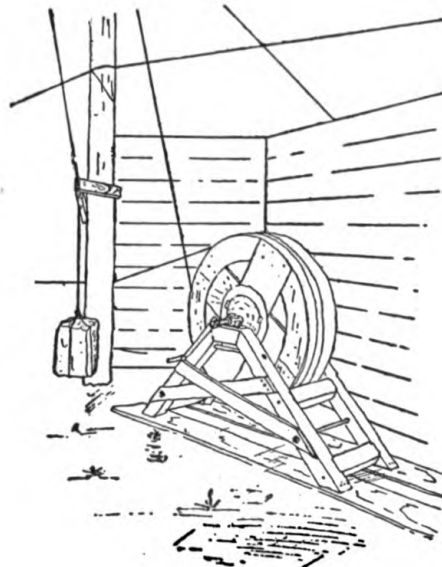

FIGURE 29.—Moving target drum.

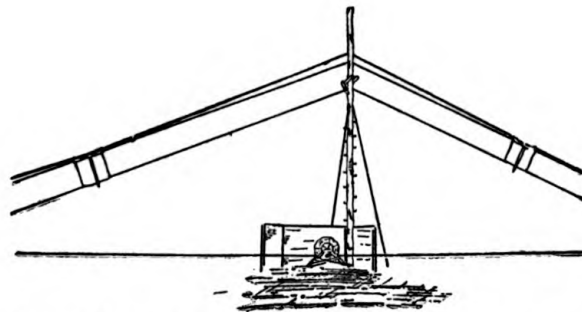

FIGURE 30.—Rear view of climbing and diving target.

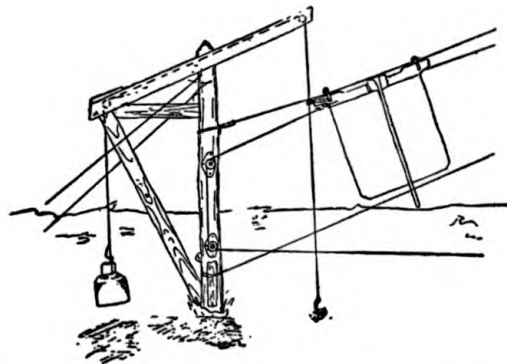

FIGURE 31.—Rear view of climbing and diving target and method of securing target to frame.



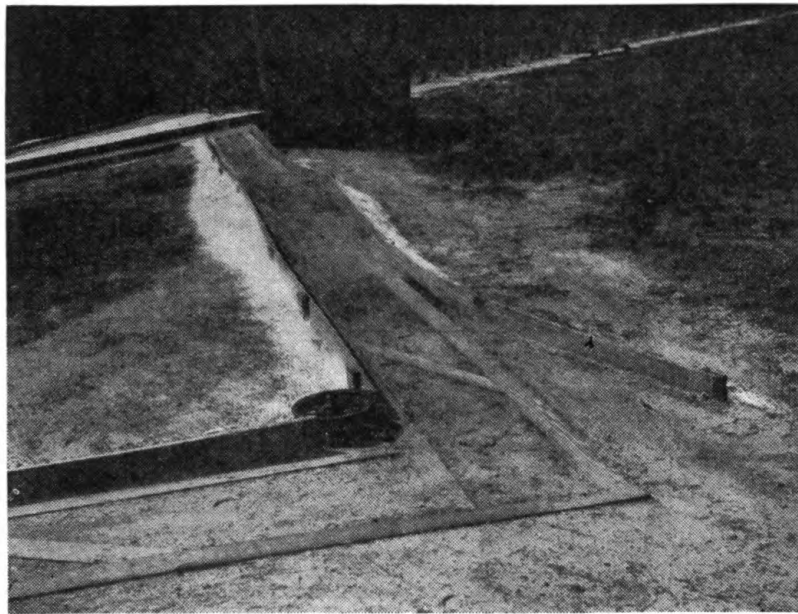

FIGURE 33.—Detailed construction of apex oblique course, 1,000-inch range.

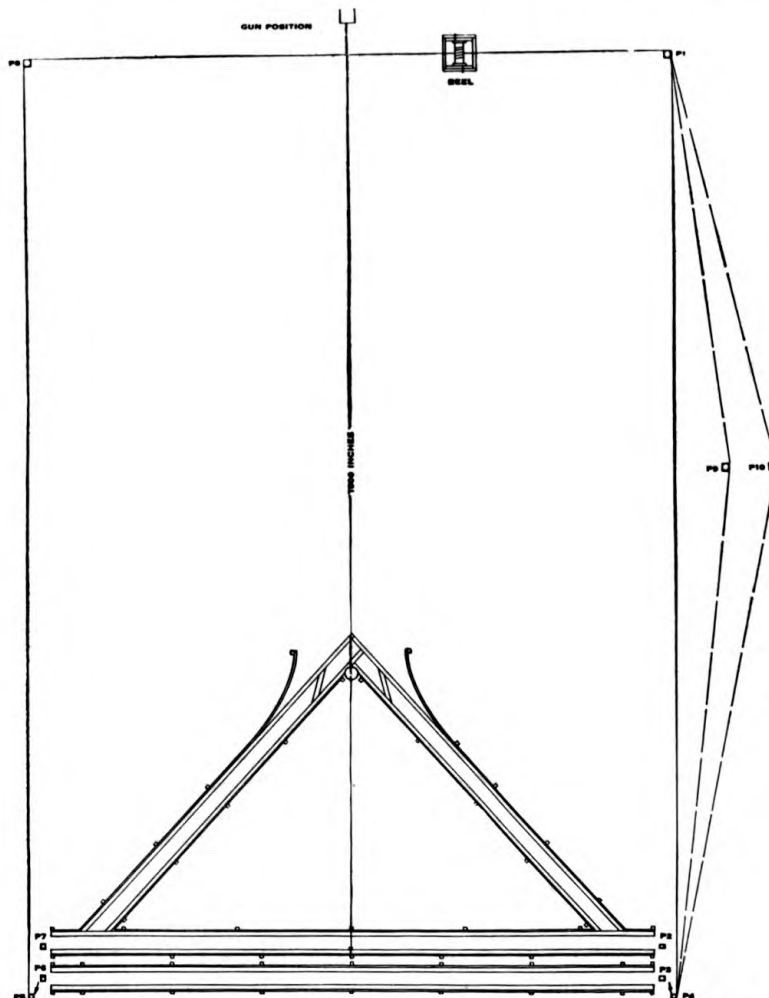

FIGURE 34.—Arrangement of 1,000-inch range unit, showing position of pulleys and hand-operated drum.

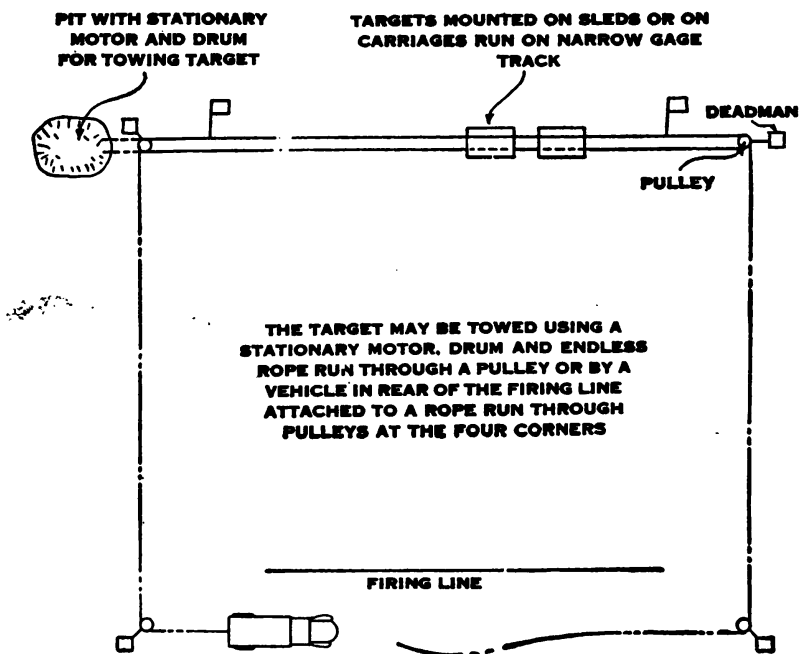

FIGURE 35.—Range for caliber .30 moving field target.

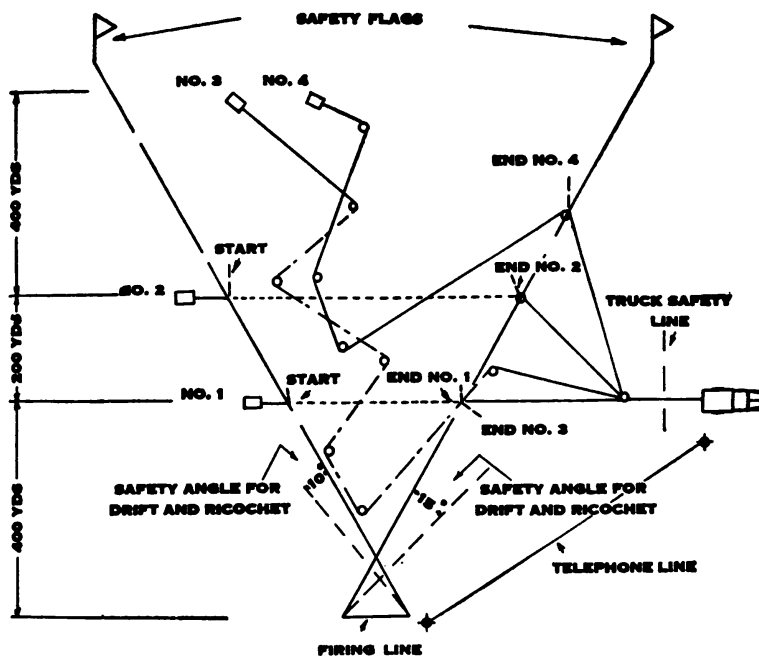

FIGURE 36.—Range for firing 37-mm ammunition at towed targets.

PULLEY LAYOUT.  
GROUND MOVING-TARGET RANGE

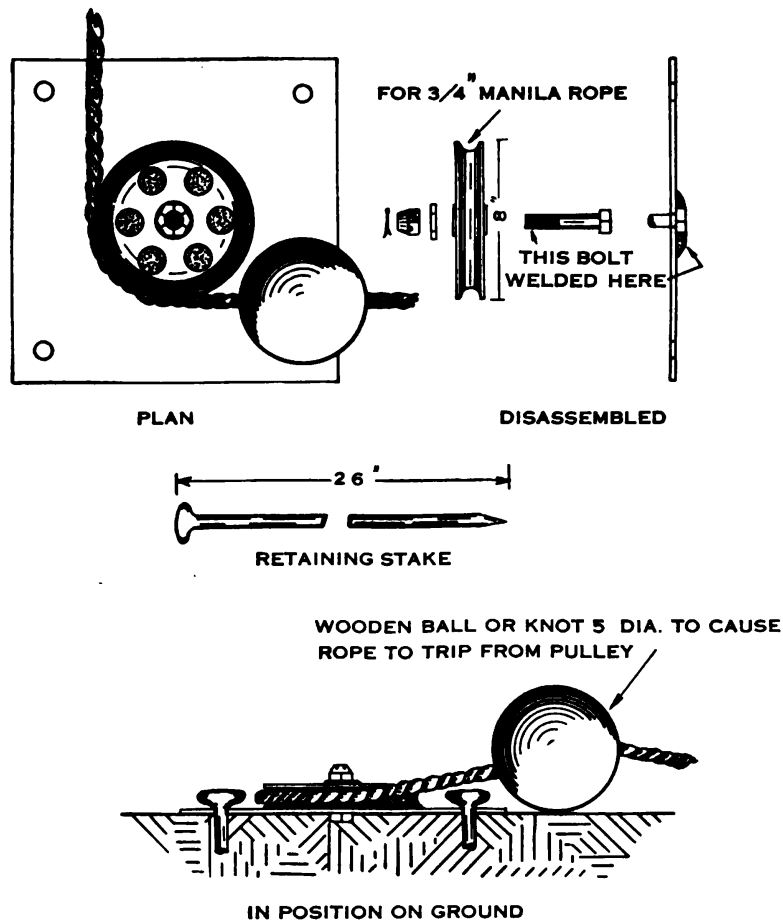

FIGURE 37.—Pulley lay-out for towed target range shown in figure 36.



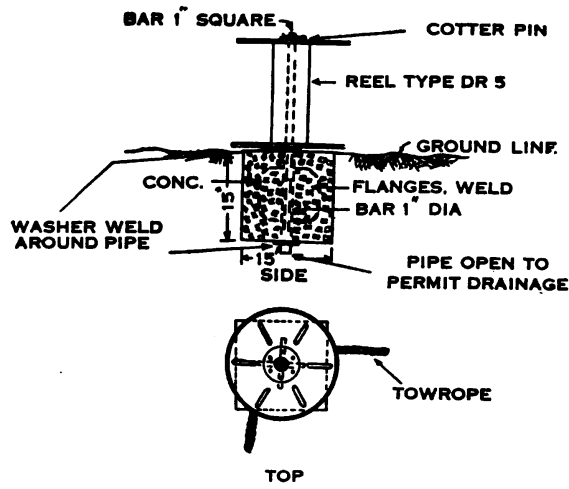

FIGURE 38.—Roadway drum for towed target range shown in figure 36.

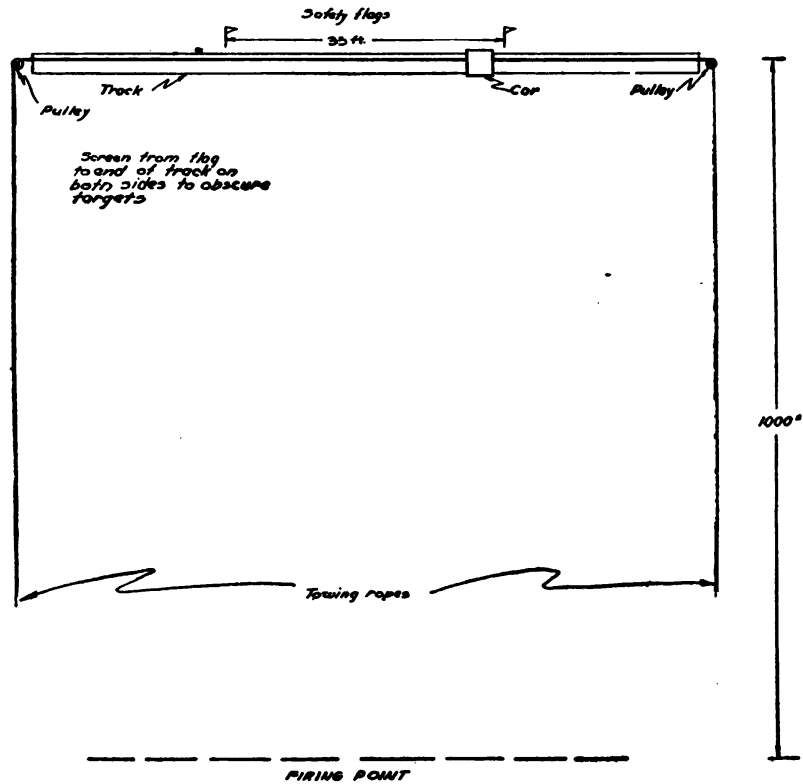

FIGURE 39.—Arrangement of a 1,000-inch moving target range, track type.

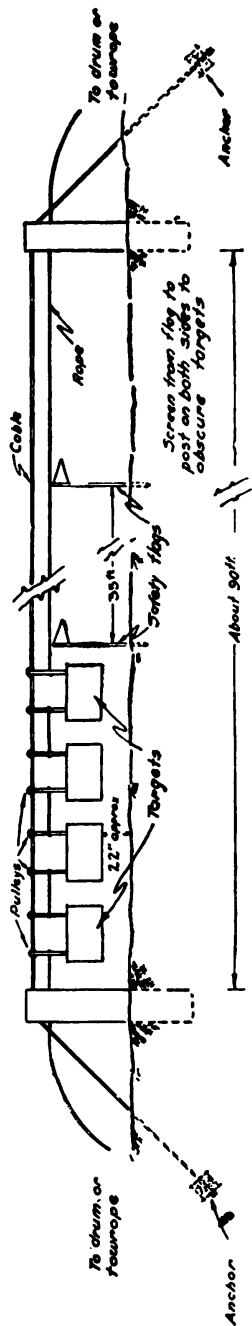

FIGURE 40.—Arrangement of 1,000-inch moving target range, cable type.

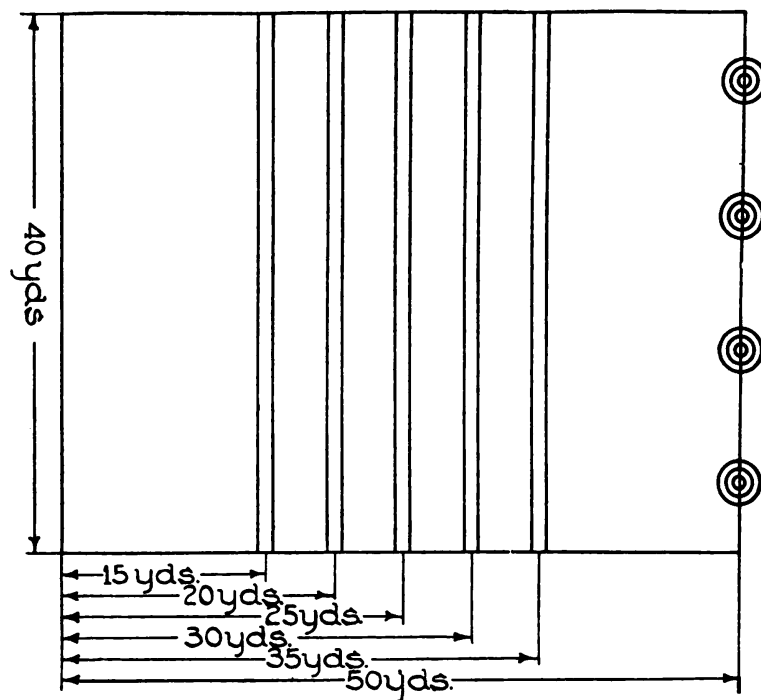

FIGURE 41.—Grenade courts, main court.

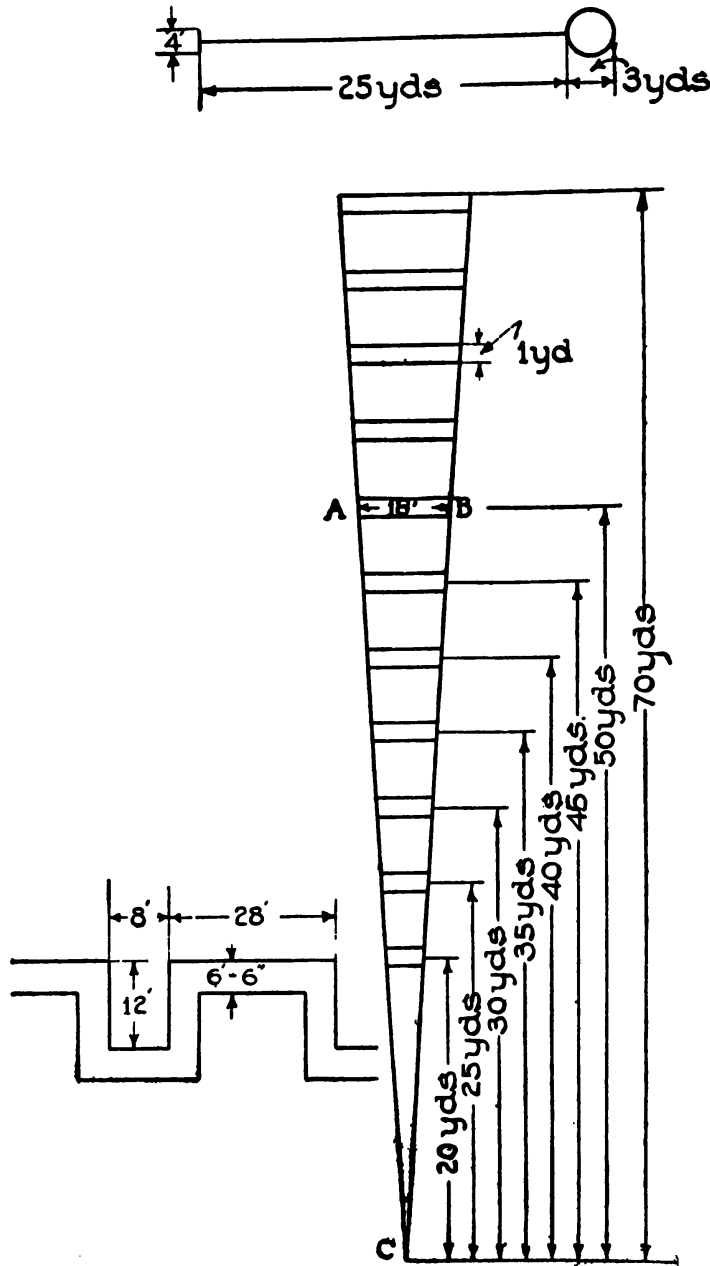

FIGURE 42.—Grenade courts, angle, crater, and trench courts.

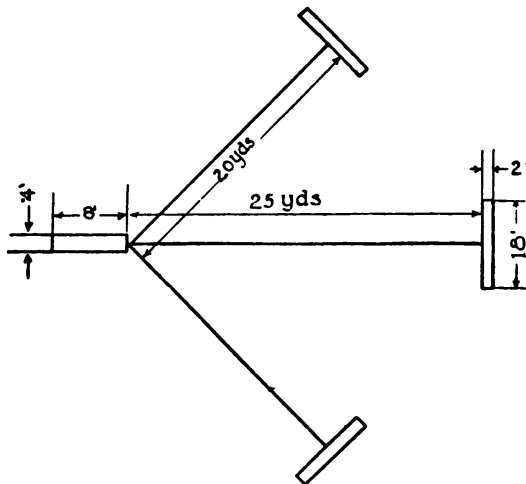
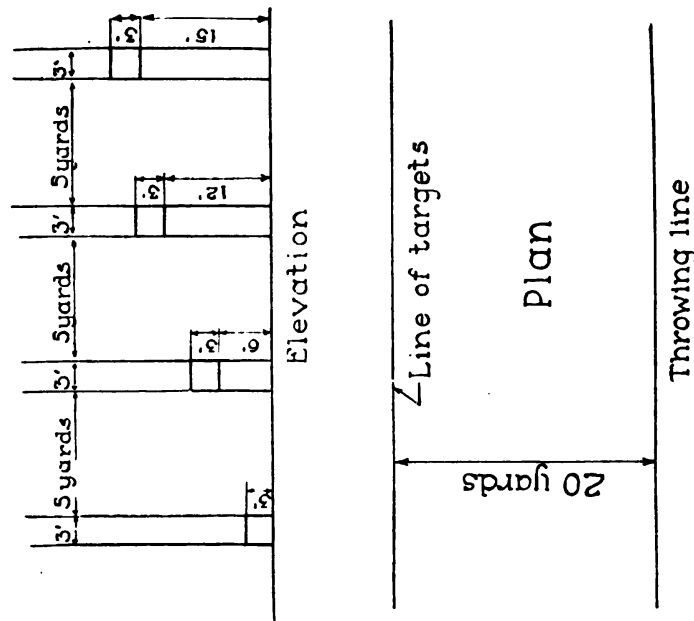

FIGURE 48.—Grenade courts, throwing pits, and vertical targets.

- (8) Trapshooting range (fig. 44).
- (9) Skeet range, general and detail lay-outs (fig. 45).
- (10) Skeet range, details of structures required (fig. 46).

b. As various athletic exercises and games are a part of the physical, moral, and intellectual training of a soldier, lay-outs for some of the most frequently used grounds, courts, etc., are included herein. The instructions and official rules for the various exercises and

games pertaining to the lay-out shown may be obtained from any bookstore. The lay-outs include—

- (1) Athletic field, running tracks (fig. 47).
- (2) Polo field (fig. 48).
- (3) Baseball diamond (fig. 49).
- (4) Tennis court (fig. 50).

SECTION IV

TARGETS AND EQUIPMENT FOR CLASS A AND CLASS B RANGES

	Paragraph
General .....	15
Rubber balloon, M1 .....	16
Repair centers .....	17
Bayonet practice disk, M1 .....	18
Flags and streamer .....	19
Frames .....	20
Ink, lithographic .....	21
Markers .....	22
Skeet outfit, electric release .....	23
Pasters .....	24
Spotters .....	25
Staff, H .....	26
Staves .....	27
Antiaircraft targets .....	28
Antitank targets .....	29
Automatic rifle target, 1,000-inch .....	30
Bobbing target, M1913 .....	31
Bombing targets .....	32
Combination sliding target, complete .....	33
Kneeling targets .....	34
Prone target .....	35
Gallery rifle targets (official) .....	36
Ground target, fixed gun aerial .....	37
H target, complete .....	38
I target, M1913, complete .....	39
Landscape target, complete .....	40
Machine-gun targets .....	41
Pistol targets .....	42
Rifle targets .....	43
Rolling target, machine-gun, complete .....	44
Silhouette targets .....	45
Stationary targets, AA .....	46
Tank target, 1,000-inch .....	47
Trapezoidal target .....	48
U. S. rifle, M1, target, 1,000-inch .....	49

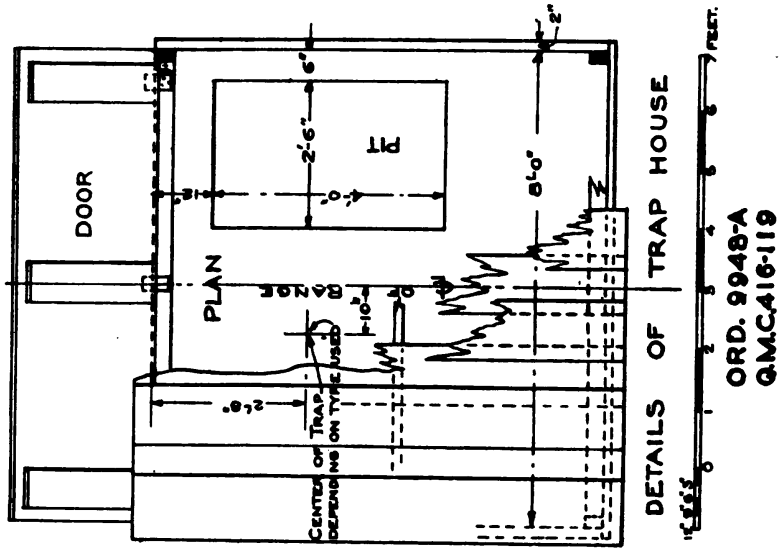
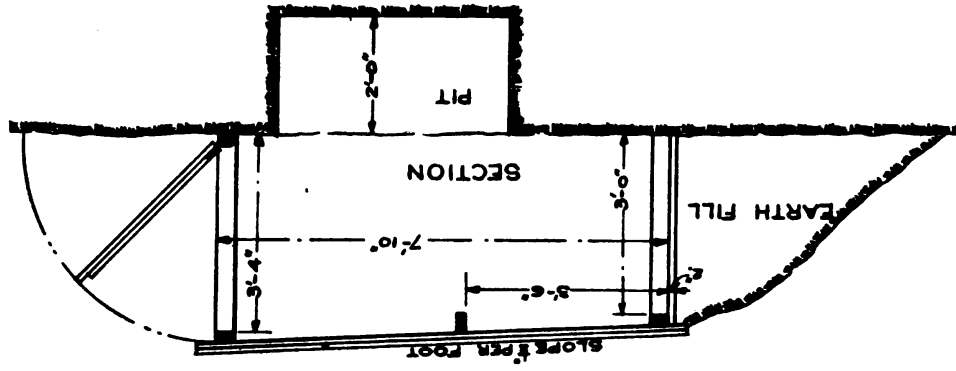

ORD. 9948-A  
QMC.416-119

- MATERIALS.**
- 4 PCS. 2x4x8' RAFTERS
  - 1 " 1x12x8' POSTS.
  - 1 " 1x12x8' ROOF.
  - 1 " 1x12x8' DOOR.
  - 2 " 2x10x8' SIDES.
  - 3 " 3x3' BUTTS.
  - 1 " HASP & STAPLE.
  - 1 " PADLOCK.
  - SLBS. 20d. SPIKES
  - 10 " " 8d. NAILS.

FIGURE 44.—Trapshooting range.

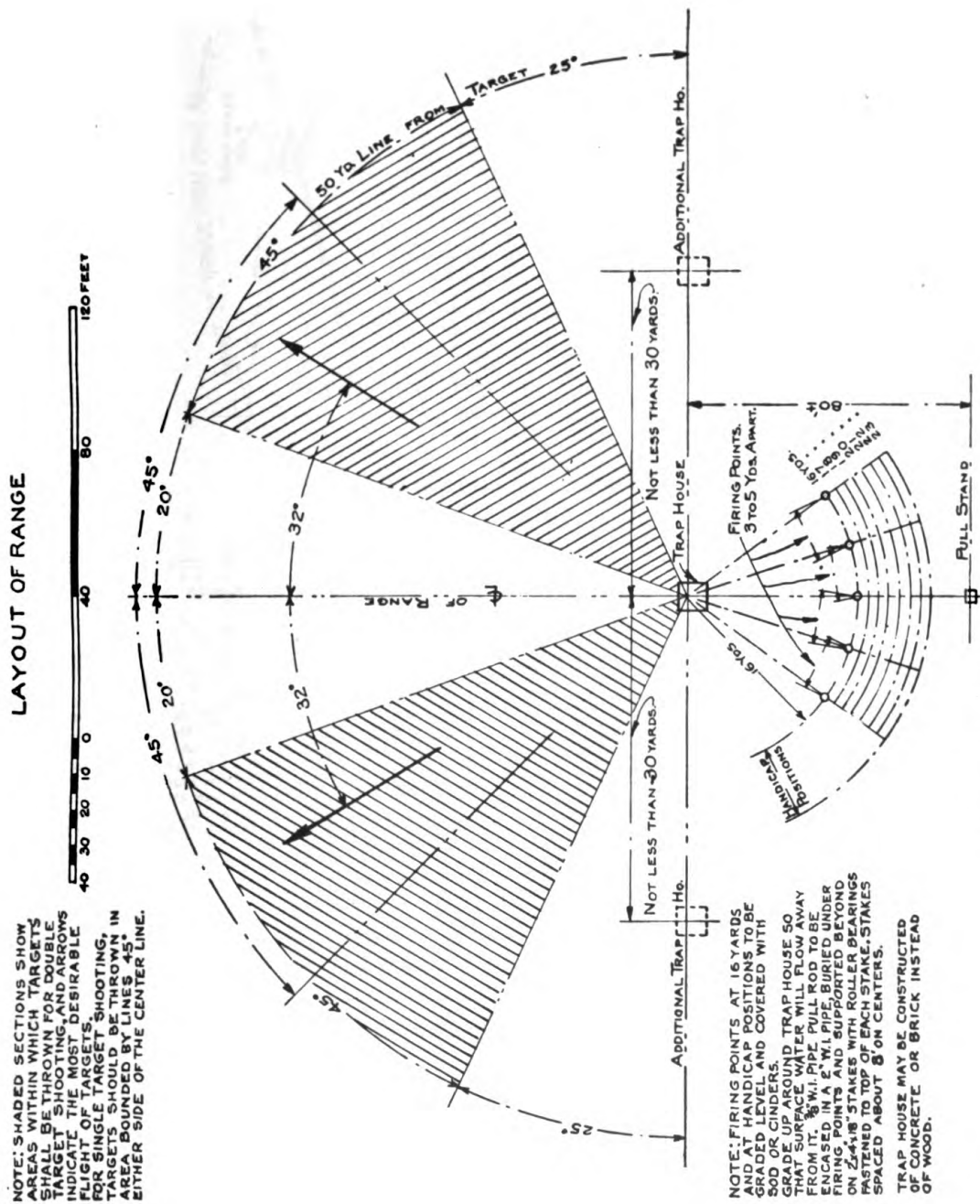

FIGURE 44.—Trapshooting range—Continued.



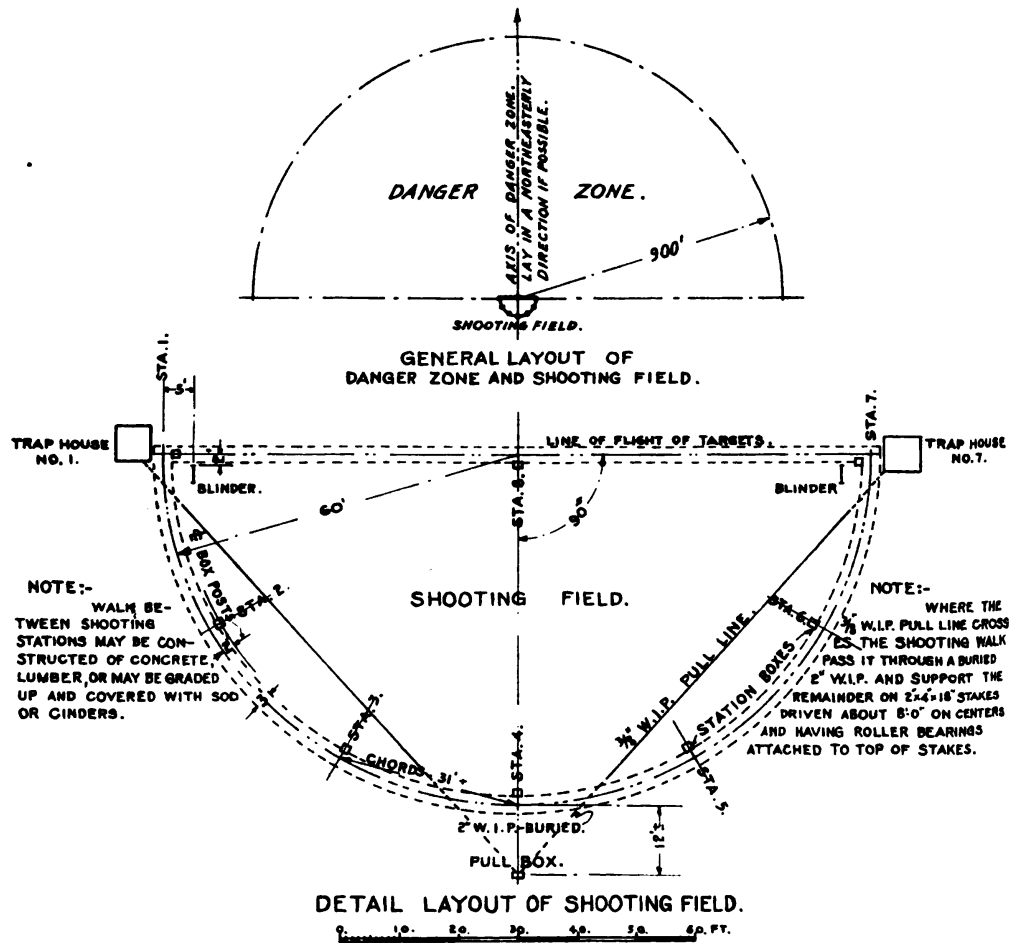
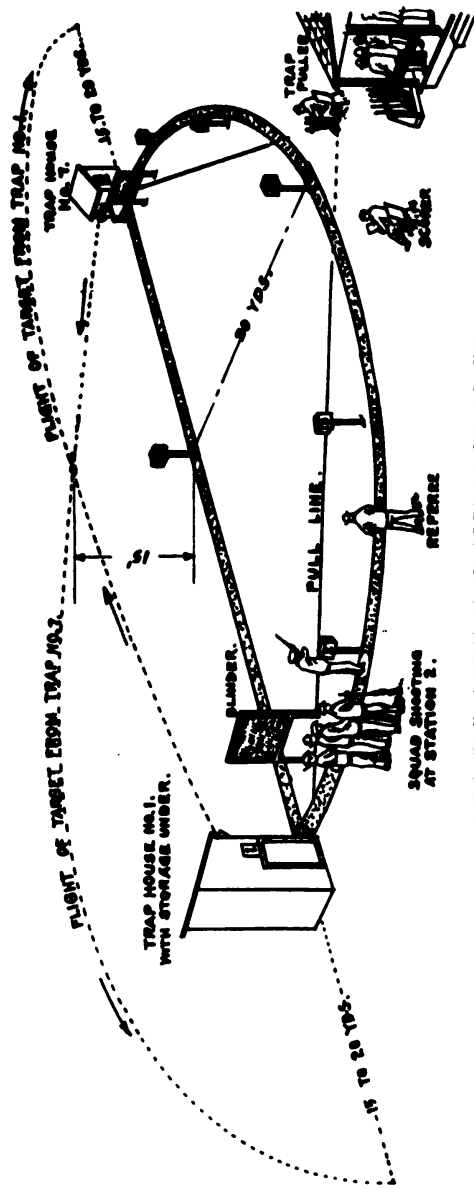

FIGURE 45.—Skeet range, general and detail lay-outs.



BIRDS-EYE VIEW OF PROPERLY EQUIPPED SKEET RANGE IN OPERATION.

ORD. 9949-A  
Q.M.C. 416-119

DATA OBTAINED FROM "SKEET" PUBLISHED BY "HUNTING & FISHING" AND "NATIONAL SPORTSMAN" MAGAZINES.  
FIGURE 45. Skeet range, general and detail lay-outs—Continued.

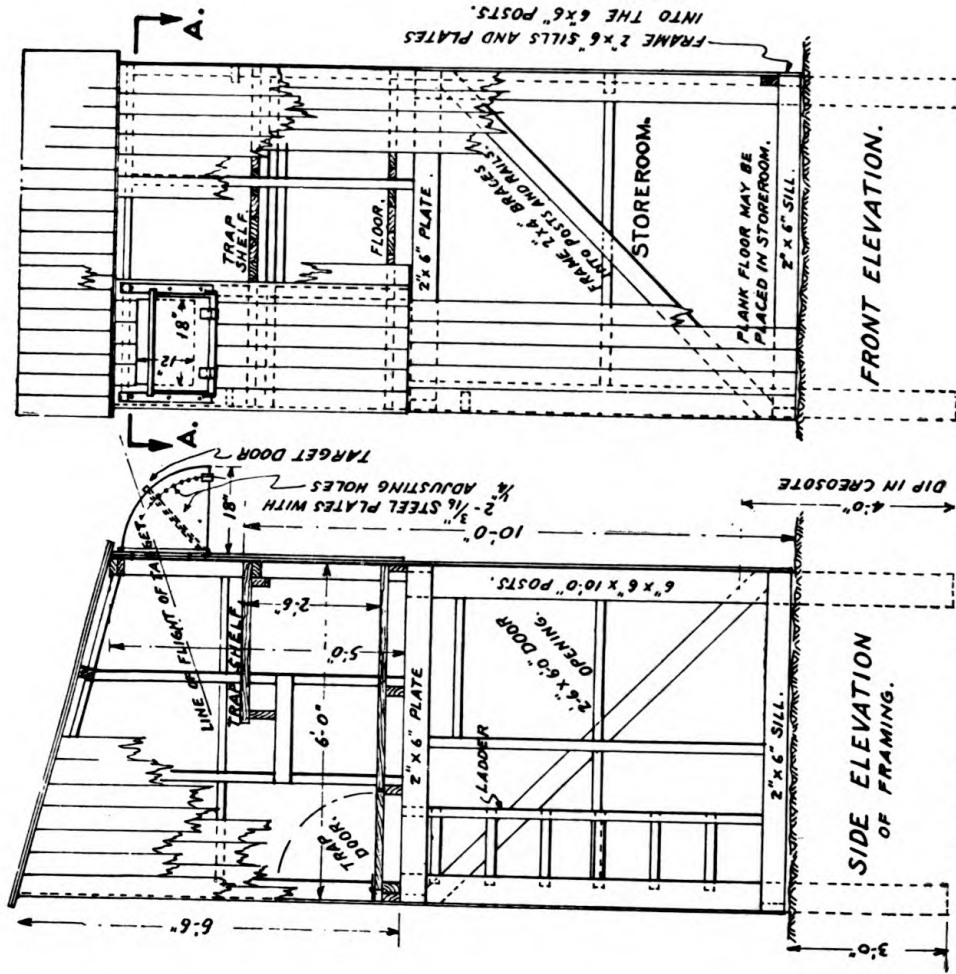

FIGURE 46.—Skeet range, details of structures required.

ROOF TO CONSIST OF TWO THICKNESSES OF 7/8" T. & G. BOARDS HAVING ALL JOINTS THOROUGHLY COATED WITH WHITE LEAD & OIL PAINT JUST BEFORE LAYING. FIRST LAYER TO BE HEAVILY PAINTED AND SECOND LAYER TO BE APPLIED WHILE PAINT IS WET.

NOTE NO. 7 TRAP HOUSE TO BE SAME SIZE AS NO. 1 BUT LOWERED TO SUCH HEIGHT THAT THE TOP OF THE TRAP SHELF SHALL BE 3'-0" ABOVE THE GROUND. OMIT TRAP DOOR AND PLACE THE 2'-6" x 6'-0" DOOR ON THE REAR FACE. FRONT AND SIDE NEXT THE SHOOTING FIELD, IN BOTH TRAP HOUSES, TO BE DOUBLE SHEATHED WITH 7/8 T. & G. BOARDS. COVER WITH TWO COATS OF PAINT AS DIRECTED. EACH HOUSE TO BE EQUIPPED WITH AN IMPROVED TARGET TRAP WHICH SHALL BE CONNECTED TO THE PULL LEVERS LOCATED IN REAR OF SHOOTING STATION NO. 4.

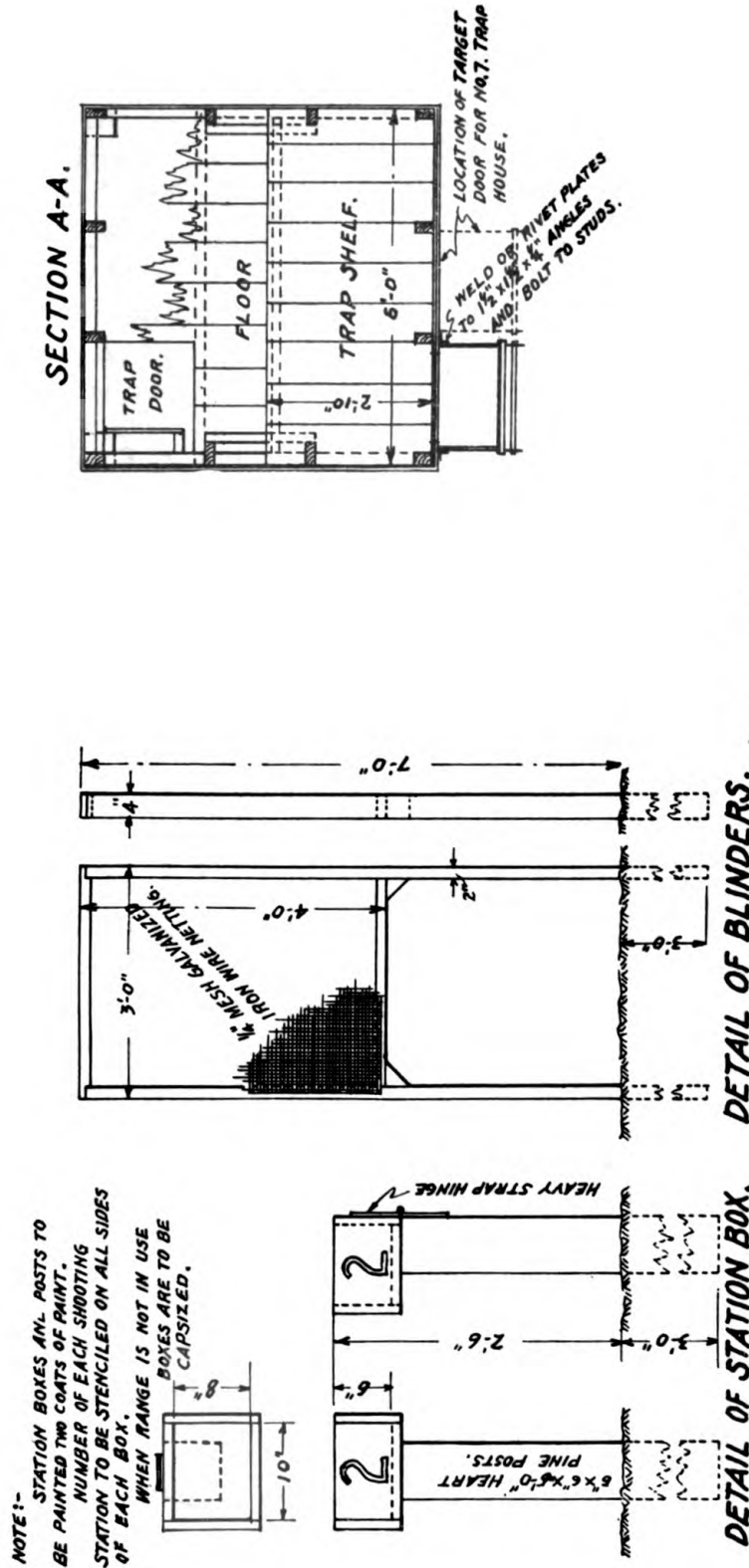

FIGURE 46.—Skeet range, details of structures required—Continued.

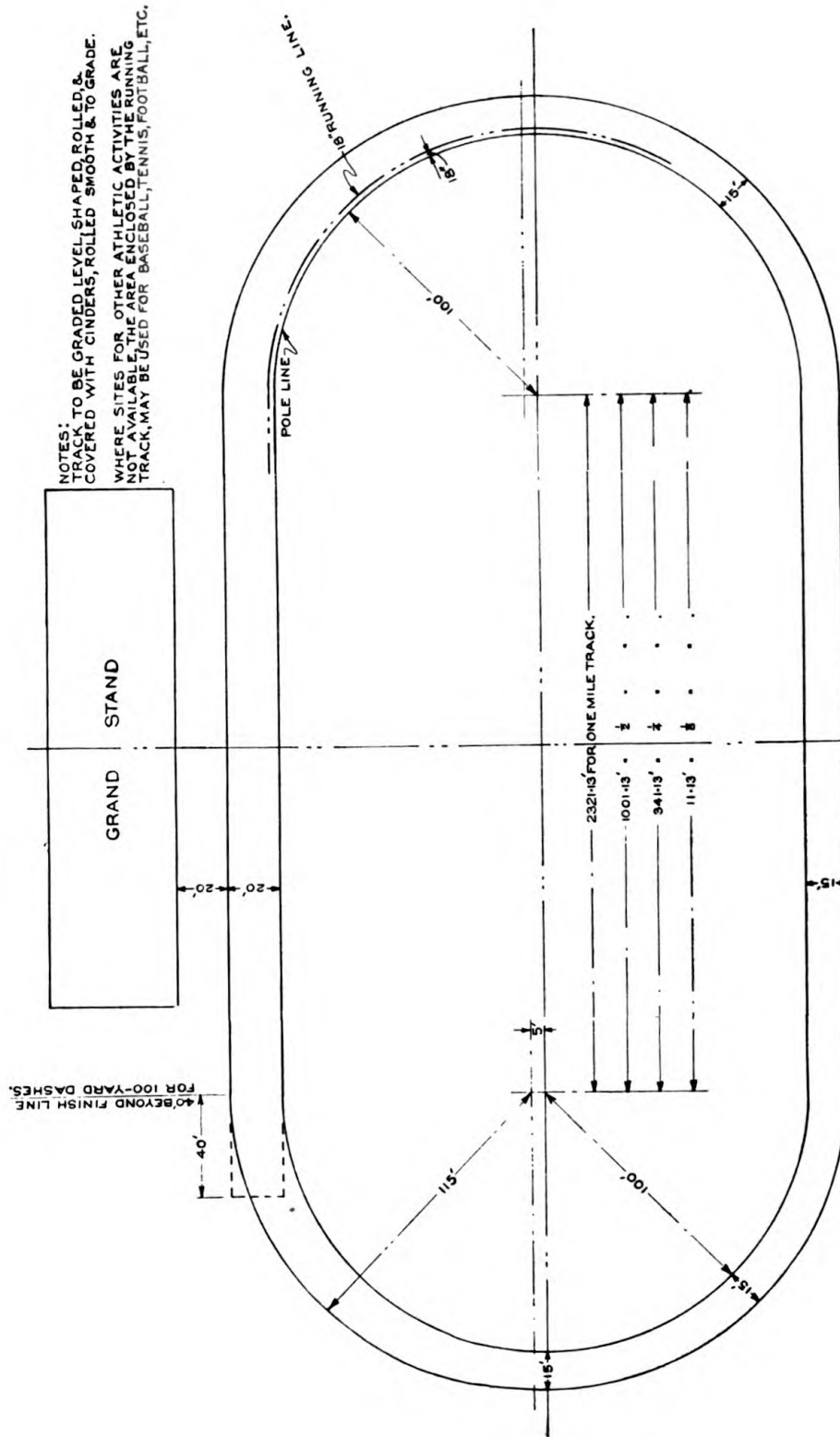

FIGURE 47.—Lay-out of athletic field, running tracks.

**15. General.**—The articles described in this section are normally required and installed on class A and class B target ranges.

**16. Rubber balloon, M1.**—The rubber balloon, M1, is required for antiaircraft instruction practice and for machine-gun training of pursuit pilots. The balloon is made of rubber having high strength and elasticity. Hydrogen is used to inflate the balloon and when inflated for use as a target the balloon is spherical in shape and is approximately 20 inches in diameter.

**17. Repair centers.**—Target repair centers are provided for rifle paper targets A, B, and D, and for pistol paper target L. They are pasted over the paper targets when the paper targets are badly perforated with bullet holes. By using these repair centers, which may be quickly applied with target paste, the paper targets can be continued in service indefinitely. It will be noted that the outer rings or spaces on these repair centers are in segments, permitting ease in matching when applying to the appropriate paper target. Each type of repair center is of buff manila target paper, packed in rolls of 100, each roll wrapped completely and securely in paper, with label suitably printed to describe contents pasted on the outside of the roll.

*a. A-C.*—The A-C repair center is  $24\frac{3}{8}$  inches high and 24 inches wide; the 4 ring is shown in segments. The bull's-eye is identical with the bull's-eye on the rifle paper target A.

*b. B-C.*—the B-C repair center is  $36\frac{1}{2}$  inches high and 36 inches wide; the 4 ring is shown in segments. The bull's-eye is identical with the bull's-eye on the rifle paper target B.

*c. D-C.*—The D-C repair center is 36 inches high and  $36\frac{1}{2}$  inches wide. It includes all the 4 space and the upper corners contain segments of the 3 space. The bull's-eye is identical with the bull's-eye on the rifle paper target D.

*d. L-C.*—The L-C repair center is  $24\frac{3}{8}$  inches high and 24 inches wide. It includes the bull's-eye and rings 9 to 5 with segments of the 4 ring, and fits pistol paper target L.

**18. Bayonet practice disk, M1.**—For obtaining accuracy of bayonet thrusts, disks are used on practice dummies. They are made from cardboard, 6 inches in diameter and approximately  $\frac{1}{16}$  inch thick. They are attached to dummies by means of thumbtacks or small nails.

**19. Flags and streamer.**—To indicate that target ranges are in use and to signal danger, streamers and danger flags are required.

*a. Streamer.*—The streamer is of scarlet woolen bunting, 18 feet fly. The halyard end is 5 feet  $9\frac{3}{8}$  inches wide, bound with olive-

ORDNANCE DEPARTMENT

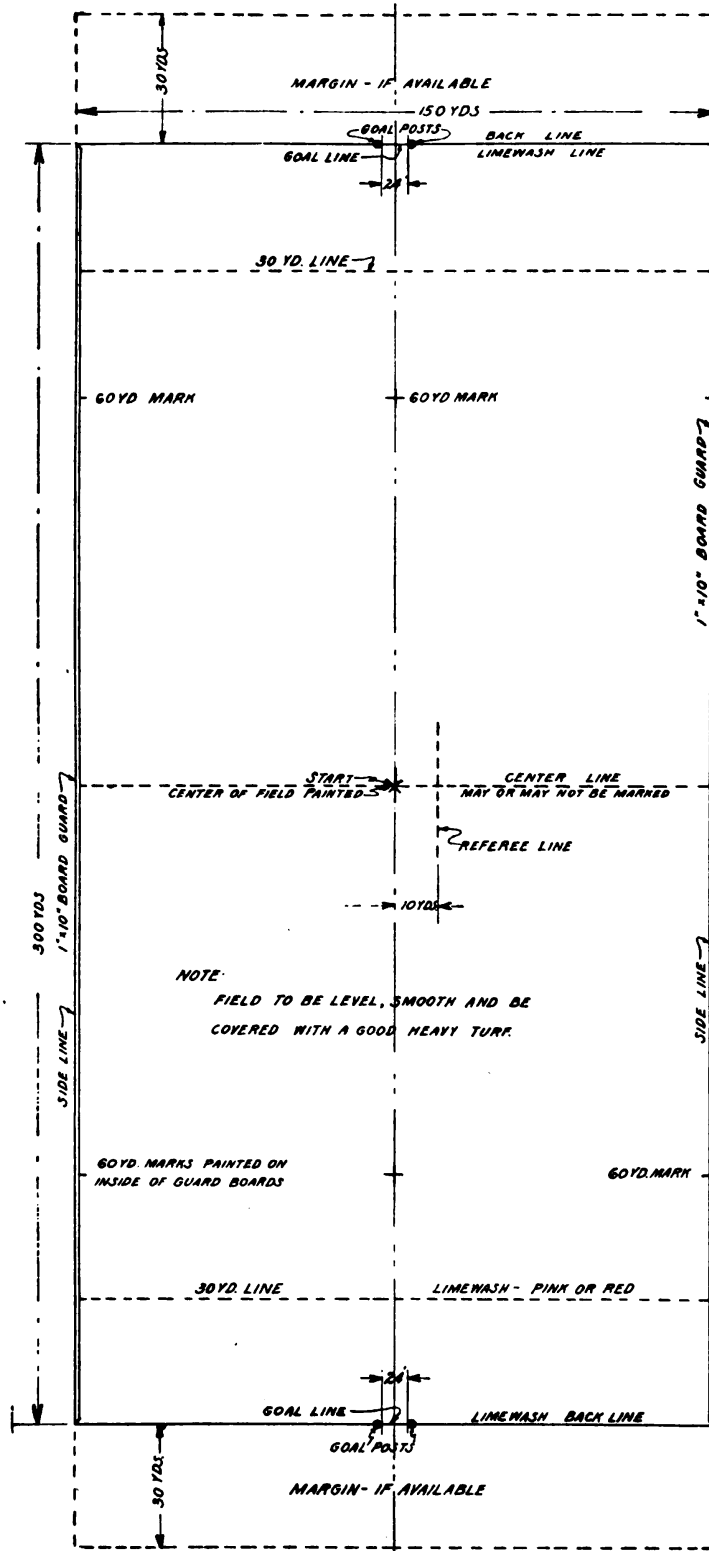
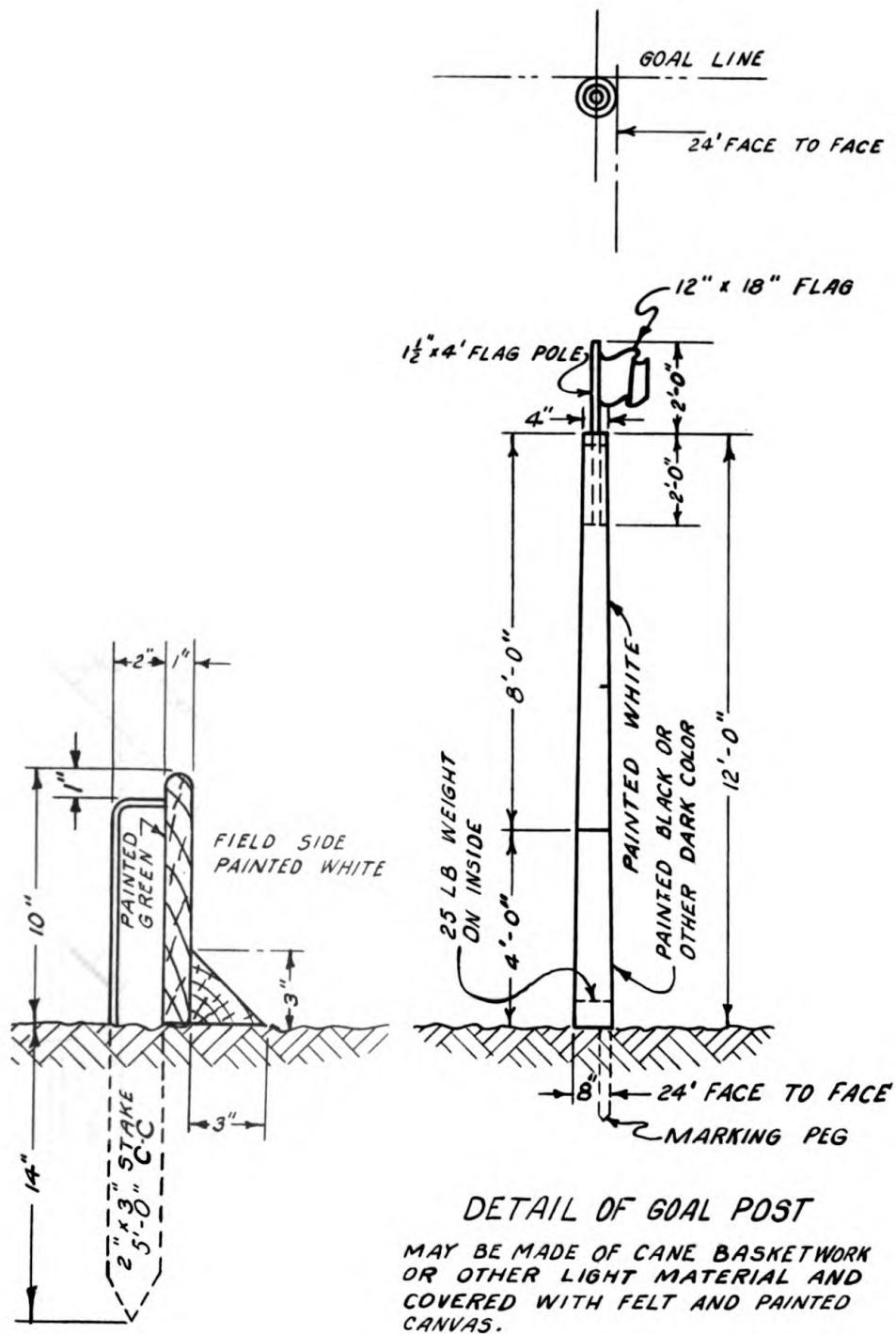

FIGURE 48.—Lay-out of polo field.



SECTION OF SIDE LINE  
GUARD BOARDS

FIGURE 48.—Lay-out of polo field—Continued.



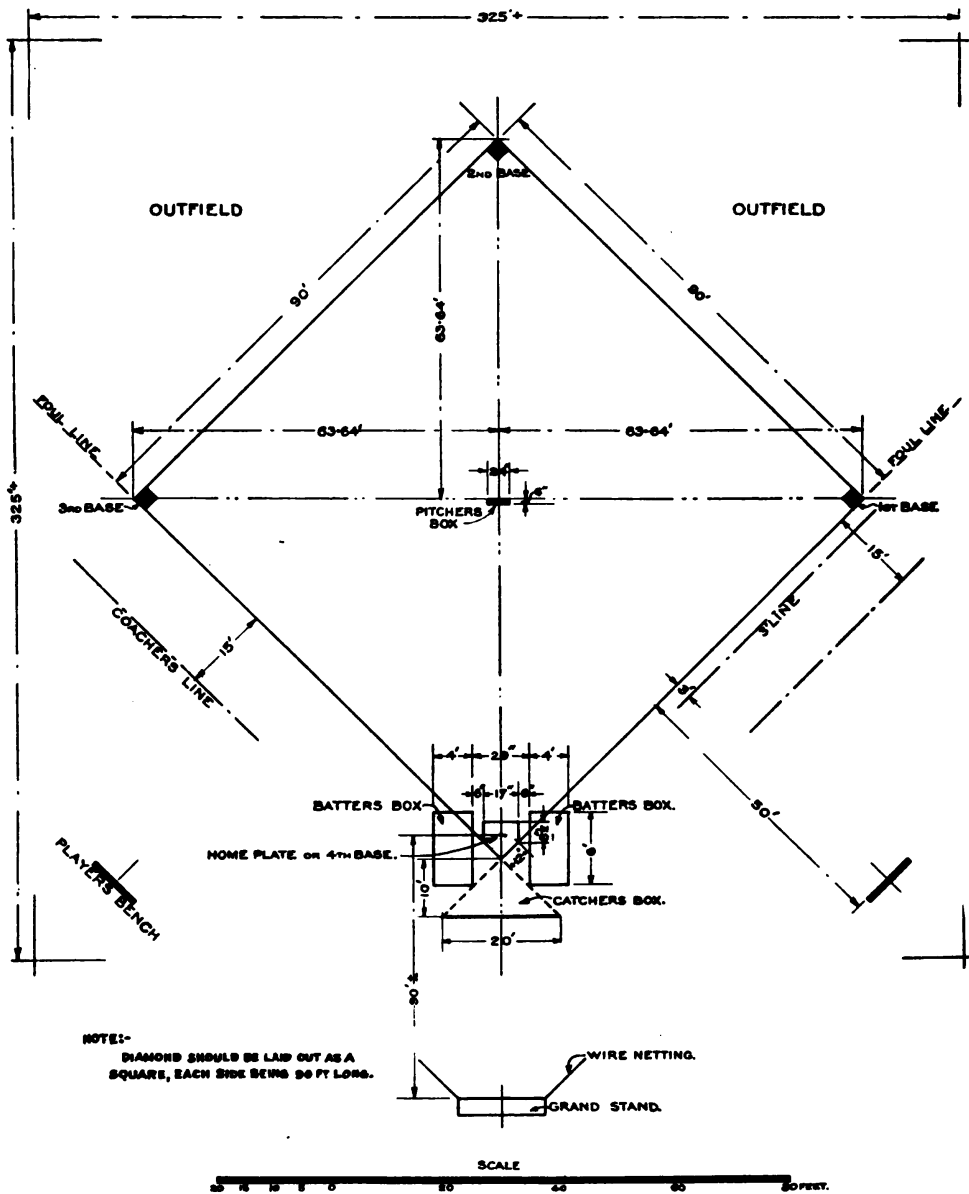

ORD. 9953-A  
QMC 416-119

FIGURE 49.—Lay-out of baseball diamond.

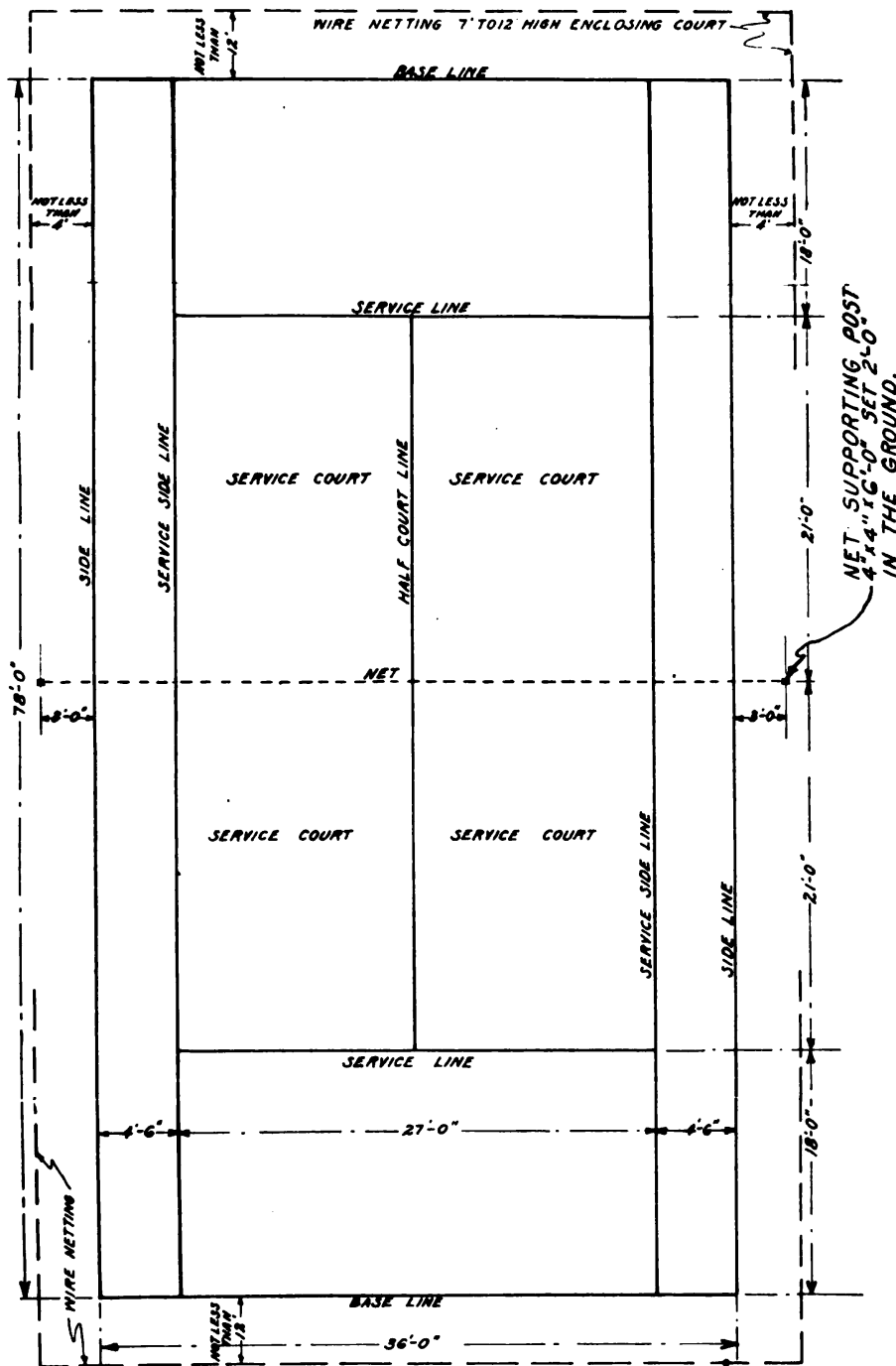

**NOTE :**  
 COURT TO BE GRADED LEVEL AND ROLLED SMOOTH AND HARD WHEN CONSTRUCTED OF EARTH OR SAND CLAY. WHEN BUILT OF CONCRETE MAKE THICKNESS NOT LESS THAN 4" WITH TEMPERATURE STEEL OF 42 LBS. PER 100 SQ. FT. OF WELDED WIRE FABRIC. COURT LINES SHOULD BE 2" WIDE AND LAID DOWN WITH DRY OR WET LIME AND IN CASE OF CONCRETE COURTS MAY BE PAINTED OR Poured WITH A COLORED CEMENT.

FIGURE 50.—Lay-out of tennis court.

drab webbing, with a 1½-inch D-ring with roller sewed on each end. The lower edge of the streamer tapers for its full length to the fly end which is 3 feet wide. Each streamer is provided with one halyard assembly consisting of 30 feet of 7/32-inch linen sash cord and one No. 5 screw eye. The streamer is hoisted on the mast provided at the commencement of firing and lowered at cease firing.

*b. Danger flag.*—The danger flag is of scarlet woolen bunting, 24 inches wide and 36 inches fly, reinforced on one end with olive-drab webbing 1 inch wide. The reinforced piece has a 1-inch D-ring sewed on each end. For use in target pits where one is required per target position, the flag may be fastened to the target staff H. They are used in the target pits to signal misses and are displayed at all times when the targets are not ready. Additional danger flags are located on the outer boundaries of the target range as directed by the commanding officer.

NOTE.—A limited stock of old-style ricochet flags, having a 7½- by 8½-inch scarlet woolen center superimposed on each side of the flag body may be in service. These centers should be ripped off.

*c. Range flag.*—The range flag is of the same dimensions and construction as the danger flag described in *b* above, but is of white cotton drill. Its primary use is on artillery ranges.

**20. Frames.**—Target frames are required for mounting paper targets. They may be used alone or installed as part of a target assembly. Occasionally target frames other than those described below are required and may be improvised or manufactured from materials procured locally.

*a. Target frame, 6- by 10-feet.*—This target frame is part of the combination sliding target, mounting the rifle paper target C. It is also used for mounting the pistol paper target L.

(1) The target frame consists of two horizontal rails, two vertical rails, two target frame supports, and four dowels.

(2) The dowels are of wood and are used to attach the target frame supports to the horizontal rails. The horizontal rails are 10 feet long, 2 inches wide and 1 inch thick, and are drilled for the dowels 26⅞ inches from the ends. The drilled holes are at an angle of 20° and correspond to the dowel holes in the target frame support. The vertical rails are mortised and are 6 feet 2½ inches long, 2 inches wide, and 1 inch thick. The target frame supports are 8 feet 9¾ inches long, 3⅝ inches wide, and 1⅝ inches thick. Each support has two grooves which are drilled at a 20° angle for the dowels.

(3) To assemble the target frame, lay the two horizontal rails on a bench or horses so they are approximately parallel and 6 feet

apart. Fit the target frame supports to the horizontal rails, being careful to have the dowel holes correspond. Drive in the dowels through the horizontal rails and into the target frame supports. The dowels should be flush with the face of the horizontal rails in order that the target cloth may be smoothly installed. Now fit the vertical rails by fitting the tenons on the horizontal rails into the appropriate mortises in the vertical rails.

(4) When the target frame is assembled it should be covered with target cloth. The cloth supplied is 72-inch wide unbleached cotton sheeting, approximately 14 ounces per linear yard. It is supplied in commercial yardage bolts. In covering the target frame with this cloth it is advisable to have the frame on a bench or horses so that the cloth may be attached without moving the frame. Unroll approximately 7 feet of cloth but do not cut or tear off. Lay the cloth on the frame and have handy at least 60 double-pointed tacks. Tack the free end of the target cloth about midway on one vertical rail and then stretching it tightly, tack it midway on the other vertical rail. Then tack midway on the horizontal rails. Complete the tacking by finishing at diagonal corners, placing the tacks about 6 inches apart and keeping the cloth smooth and taut. Cut the cloth from the bolt so as to have a clean free edge for use on the next frame.

*b. Target frame, 6- by 6-foot.*—This target frame is part of the combination sliding target, mounting the rifle paper targets A, B, and D. It is also used as the foundation for the tank machine-gun target M.

(1) The target frame consists of two vertical rails with an overall length of 8 feet  $11\frac{5}{8}$  inches,  $3\frac{5}{8}$  inches wide, and  $1\frac{5}{8}$  inches thick, and two horizontal rails which are 6 feet long,  $3\frac{5}{8}$  inches wide, and  $1\frac{5}{8}$  inches thick. The ends of the horizontal rails are machined to  $1\frac{1}{2}$  inches to form tenons to fit into mortises formed on the vertical rails. Assembling consists of fitting the tenons into the appropriate mortises.

(2) After assembly the frame is covered with target cloth as outlined in *a*(4) above.

*c. Machine-gun target frame, 3- by 5-foot.*—This target frame is part of the machine-gun rolling target assembly but in addition to mounting all machine-gun paper targets it is used for mounting automatic rifle and small bore rifle paper targets.

(1) The target frame consists of two target frame sides, two target frame ends, and two target staves.

(2) The sides are 5 feet long, 4 inches wide, and 1 inch thick; the ends are 3 feet long, 4 inches wide, and 1 inch thick. The staves

are  $45\frac{1}{2}$  inches long,  $31\frac{1}{2}$  inches wide, and  $\frac{3}{4}$  inch thick; one end of the stave is machined at an angle for  $4\frac{1}{2}$  inches to form a point.

(3) Assembling consists of nailing the ends and staves on the sides, using sixpenny wire nails, then covering with target cloth. The cloth supplied for this frame is 36 inches wide.

(4) Due to the spacing of the stave sockets in the beam of the rolling target the target frames must be right and left hand. The components of the right frame and left frame are identical, the difference being in the location of the stave on the target frame sides.

*d. Modification for use on Aiken targets.*—A number of ranges, especially in the National Guard, are equipped with the nonstandard Aiken target. The 6- by 6-foot and 6- by 10-foot target frames may be used on this target when properly modified in accordance with ordnance drawing 39-1-106.

*e. Storage.*—Target frames should be stored flat in a dry place. When storing the target frames at the end of the target season, remove the target cloth and salvage it, as the paste used in attaching the paper targets attracts rodents.

*f. Method of applying paper targets.*—(1) The target frame must be placed on some surface which will prevent the target cloth from sagging when the paper target is pasted on it. A table for this purpose can be constructed easily. The top of the table should be just the size of the inside of the target frame, with an edging around the top but an inch below it, so that when the target frame is placed on the table the cloth will be supported evenly by the table top, and the target frame, setting down over the edge, will be supported by the edging strip.

(2) Using the paste brush provided for the purpose, put the target paste thickly but evenly all over the back of the paper target, then fold the paper target from each end to the center, thus bringing pasted surfaces together, and place the paper target aside for a few minutes. This will allow the paste to soak into the paper target. In the meantime cover the cloth on the target frame with paste, getting the coat on evenly. Now open up the paper target and lay it on the target frame (frame being on the table), getting it started square and brushing out all the wrinkles with a clean paste brush. See that all the edges of the paper target are securely pasted down. When this target dries, it will be perfectly smooth and even.

*g. Method of making paste.*—The quartermaster corps issues target paste for pasting paper targets on target frames but if target paste is not available flour is issued.

(1) If target paste is issued it needs only to be mixed with water to the proper consistency.

(2) To make paste with flour, proceed as follows: Use an ordinary galvanized iron bucket which holds 12 quarts. In this bucket place 2 quarts of flour and pour in a little cold water gradually, stirring all the time until the flour is all wet and the lumps are broken up, making a rather thin dough. Next pour in boiling water, stirring rapidly. It is necessary that the water be boiling hot and that the paste be stirred very briskly. Do not fill the bucket entirely to the top with boiling water as the paste swells as soon as the boiling water is poured in and the stirring started. Do not make more paste than is needed at one time as it sours in a few days. If it gets too thick at any time it can be thinned with a little cold water. To keep rats from gnawing targets, put a tablespoonful of concentrated lye dissolved in a pint of water in each bucket of paste.

**21. Ink, lithographic.**—*a. General.*—(1) Lithographic ink is used for marking bullets for identification of hits on towed aerial targets. The ink is provided in four colors, orange, red, green, and blue. Before coating the bullets the ink must be mixed with spirits of turpentine.

(2) When properly mixed, the ink covers a bullet with a thin, evenly distributed solid coating that will become “tacky” after drying for about 24 hours. A tacky coating is defined as a coating that is sticky, yet not so dry as to fail to mark the finger when touched with a moderate amount of pressure. Such a coating is obtained by mixing the basic ink with spirits of turpentine in varying quantity in accordance with the atmospheric conditions prevailing at the time. As the spirits of turpentine evaporate, the coating will become increasingly dry and may thus fail to mark the target. Therefore, in no case will ammunition be marked more than 24 hours prior to the contemplated time of usage.

*b. Method of application.*—(1) Assemble the ammunition with links into belt of 25 rounds.

(2) Coil each belt tightly and wrap around midpoint with tape.

(3) Tap bullets lightly on a flat surface, to aline all bullet ends.

(4) Dip bullet ends of the coiled belt into the ink to a depth not exceeding  $\frac{3}{8}$  inch.

(5) Stand the loaded belt on a drain surface, bullet ends down, to allow the excess ink to drip off.

(6) To prevent possible fouling of the gun, care must always be taken that the ink is applied only to the tapered portion of the bullet and that the inked length does not extend to the full diameter.

*c. Identification of hits.*—The hits on a target can be identified as follows:

(1) The bullet holes in the fabric will be edged on the entering side only with a clear tint of the color used. If tubular targets are used and the bullet passes through both sides, each penetration can be identified in this manner.

(2) Crease hits will show a more pronounced color than penetration hits.

(3) The hole made by a plain bullet will be edged with black.

**22. Markers.**—Target markers are used to signal the value of hits made on targets. They consist of painted sheet steel disks attached to wooden staffs and held in place by carriage bolts, plain washers, and wing nuts. Each staff (except the pistol target marker) has two target marking disks, one right and one left. The right target marking disk is painted white on one side and red on the reverse side; the left target marking disk is painted white with a black cross on one side and black on the reverse side. For uniformity the disks are assembled on the marking disk staffs with the white and white with black cross, and the red and black, in related positions. The staffs of the two lengths, 9 and 10 feet, are slotted for particular disks and are painted with metallic red paint. The staffs are packed 20 in a bundle, bound with two strips of band iron.

*a. Short range.*—The short range target marking disks are 10 inches in diameter and are mounted on a marking disk staff 9 feet long. This target marked is used at 200- and 300-yard ranges.

*b. Midrange.*—The midrange target marking disks are 20 inches in diameter and are mounted on a marking disk staff 9 feet long. This target marker is used at 500- and 600-yard ranges.

*c. Long range.*—The long range target marking disks are 30 inches in diameter and are mounted on a marking disk staff 10 feet long. This target marker is used at 800- and 1,000-yard ranges.

*d. Pistol.*—The pistol target marker has only one disk which is 4 inches in diameter and painted white on one side and black on the reverse side. The disk is mounted on a marking disk staff, pistol, which is 9 feet long. This target marker is used with pistol paper target L in slow and rapid fire dismounted pistol practice.

**23. Skeet outfit, electric release.**—The skeet outfit and clay pigeons are provided for the use of authorized Air Corps personnel in shotgun practice firing on the ground which will be of value to them in aerial gunnery. In order to conserve skeet targets (clay pigeons), one commercial skeet net is authorized for issue to each Air Corps post or station where the annual consumption of shotgun shells for skeet is 15,000 rounds or more.

*a.* The electrical release skeet outfit is a commercial article and is supplied in either of three models: 110-volt, single phase, 60-cycle, alternating current; 110-volt, single phase, 25-cycle, alternating current; and 6-volt, 150 ampere hour, direct current (storage battery).

*b.* Figure 45 shows a detailed lay-out for a skeet range and also a bird's-eye view of a properly equipped skeet range in operation. As shown in figure 45, the trap houses are located so that the clay pigeon outlet apertures are on the centerline of the path between stations 1 and 7. In this figure both traps are right hand, causing the trap houses to be offset, right and left. The skeet net is not shown in figure.

**24. Pastors.**—Three colors of target pasters are supplied, black, buff, and olive drab. The pasters are 1 inch square and are supplied in perforated sheets of 100, not gummed.

*a.* The black and the buff target pasters are used for covering shot holes in black and in buff areas of paper targets, and for indicating aiming points on and covering shot holes in machine-gun and automatic rifle targets. These target pasters are supplied in envelopes, each envelope containing 10,000 pasters.

*b.* The olive-drab target pasters are used for covering shot holes in olive drab areas of paper targets. They are supplied in envelopes, each envelope containing 2,000 pasters.

*c.* To use the target pasters a board about 8 inches square should be provided. This board is heavily covered with target paste and the pasters laid thereon, face up. It is then an easy matter to slide a paster off the board on to the target to be pasted; the paster will adhere by reason of the paste on its under side. An appropriate color of target paster should be pasted over each shot hole before the target is raised for use.

**25. Spotters.**—Target spotters are supplied in three sizes and are used to indicate the location of shot holes on paper targets. The complete target spotter consists of a cardboard disk, white on one side and black on the reverse side. The disk has a  $\frac{5}{16}$ -inch hole in its center, in which is inserted a target spotter spindle. The spindle is of wood,  $3\frac{1}{4}$  inches long, and has a maximum diameter of  $1\frac{1}{32}$  inch. Disks and spindles are issued separately.

*a. 3-inch.*—The 3-inch target spotter consists of a target spotter disk 3 inches in diameter and a target spotter spindle. It is used for spotting shot holes on rifle paper targets A and D. In slow fire each shot is spotted as it hits; therefore only one target spotter per target position is required when using paper targets. In spotting rapid fire, 16 shots with the M1 rifle and 10 shots with the M1903 rifle are spotted



at a time; therefore for rapid fire 16 spotters should be available when firing with the M1 rifle and 10 spotters when firing with the M1903 rifle.

*b. 5-inch.*—The 5-inch target spotter consists of a target spotter disk 5 inches in diameter and a target spotter spindle. It is used for spotting shot holes on rifle paper target B. As this target is only used in slow fire where each shot is spotted as it hits, only one target spotter is required per target position.

*c. 10-inch.*—The 10-inch target spotter consists of a target spotter disk 10 inches in diameter and a target spotter spindle. It is used for spotting shot holes on rifle paper target C. As this target is only used in slow fire where each shot is spotted as it hits, only one target spotter is required per target position.

**26. Staff, H.**—This staff is a component of the H target and is also used for mounting the danger, ricochet, and range flags. It is made of wood, 1 inch by 1¼ inches by 9 feet, and is painted olive drab in color. One end of the staff is slotted to a depth of 40 inches and has equally spaced transverse tapered holes. 50 staffs and 150 wood taper pins are packed in a crate. The wood taper pins are a component of the H target.

**27. Staves.**—Target staves are made of wood, 3½ inches wide, ¾ inch thick, and are provided in three lengths: 24 inches, 45½ inches, and 84 inches. One end is formed into a point. The staves are packed 10 in a bundle, bound with two strips of band iron.

*a.* The 24-inch target stave is used for mounting the pasteboard target F, prone.

*b.* The 45½-inch target stave is used for mounting the pasteboard target E, kneeling, and also a component of the machine-gun target frame assembly.

*c.* The 84-inch target stave is a component of the target M, M1913, complete.

**28. Antiaircraft targets.**—*a. Permanent.*—The following anti-aircraft targets are for anti-aircraft marksmanship instruction practice with the rifle and automatic rifle. The permanent equipment is procured and constructed locally on a 500-inch range. The paper target used is the anti-aircraft, 500-inch.

(1) *Double climbing and diving AA target.*—For details of this target see figure 22.

(2) *Horizontal AA target.*—For details of this target see figure 21.

(3) *Overhead AA target.*—For details of this target see figures 11 and 23.

*b. 500-inch (fig. 51).*—This target is printed with black ink on buff manila paper, 48 inches high and 48 inches wide. It is a non-overhead instruction target, but other targets prescribed for antiaircraft firing with the rifle and automatic rifle may be made locally from this target. The targets are packed 50 in a roll, each roll wrapped completely and securely in paper, with label suitably printed to describe contents pasted on outside of roll.

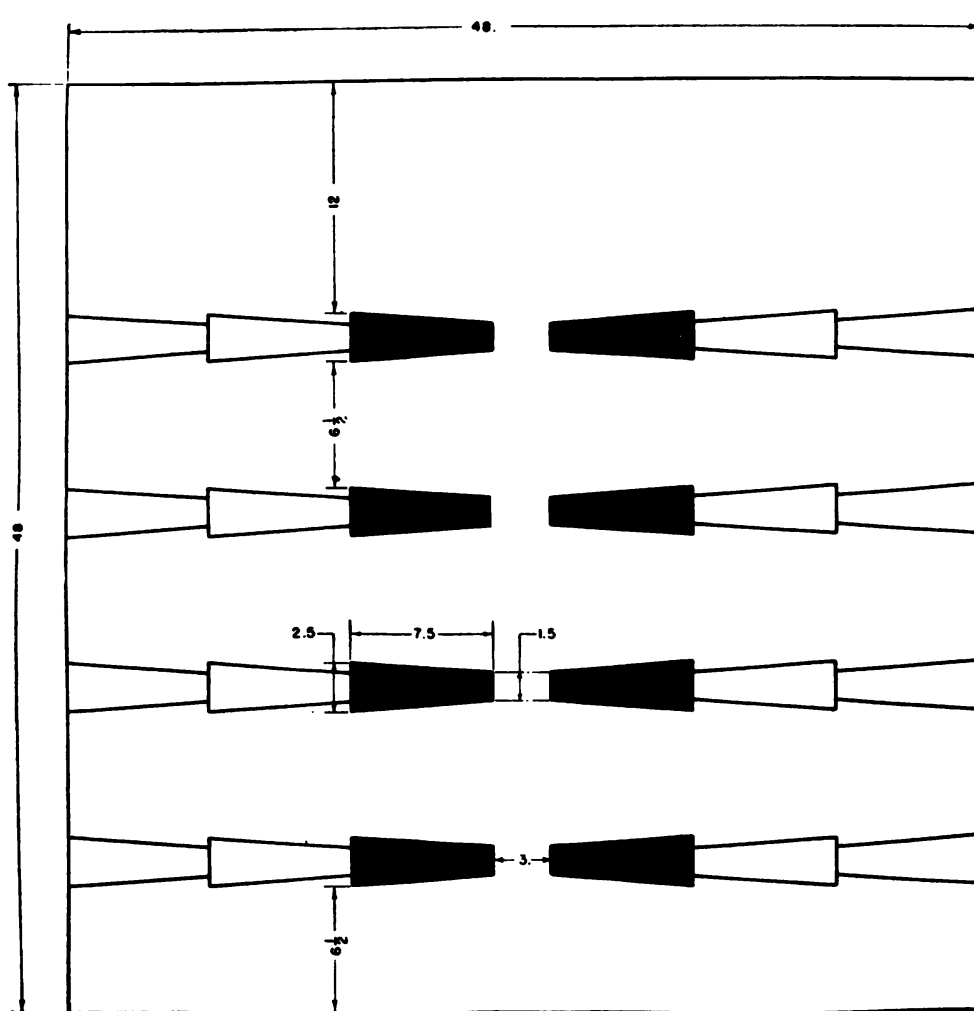

FIGURE 51.—Target, antiaircraft, 500-inch.

**29. Antitank targets.**—*a. 1,000-inch (fig. 52).*—The 1,000-inch target is printed with black ink on buff manila paper, 3 feet high and 5 feet wide. It is used for antitank marksmanship with the machine gun on the 1,000-inch range. The targets are packed 50 in a roll, each roll wrapped completely and securely in paper, with label suitably printed to describe contents pasted on outside of roll.

*b. Sled.*—There are two types of sled targets used in training with the 37-mm antitank gun; one, for instruction on the 1,000 range; the other, for moving target firing. Both are procured and constructed locally. Details of construction and operation of these two types of sled targets are given in chapters 3 and 5, FM 23-70.

*c. Suspended cable.*—This target is used for antitank marksmanship with the machine gun on the 1,000-inch range. The permanent equipment is procured and constructed locally; for composition, see paragraph 154, FM 23-60. The paper target used is the antitank, 1,000-inch.

**30. Automatic rifle target, 1,000-inch (fig. 53).**—This target is printed with black ink on buff manila paper, 3 feet high and 5 feet wide. This target is used for all types of firing with the Browning automatic rifle, caliber .30, M1918A1 (bipod and hinged butt plate), on the 1,000-inch range. The paper targets are packed 50 in a roll, each roll wrapped completely and securely in paper, with label suitably printed to describe contents pasted on outside of roll.

**31. Bobbing target, M1913.**—*a. Description.*—This target is used for dismounted pistol marksmanship. Figure 54 shows the complete target. It consists of a pivot stake, a crosspiece, two limit stakes, 175 feet of operating line ( $\frac{1}{4}$ -inch diameter, sash cord), a target rod, a target stave (37 inches long), and a pasteboard target, E, kneeling, M1917. The components of the target are issued knocked down and are assembled on the range.

*b. Method of assembling.*—Drive the pivot stake in the ground at the point selected for the target. In driving it, use a piece of wood as a buffer to prevent damaging the top. Place the crosspiece where indicated on the target rod (fig. 54), fastening it with two nails (one on each side). Drive the two limit stakes in position far enough to the rear to permit 90° movement of the target. Attach the operating line to the crosspiece, carrying it either under or over ground to the operator behind the firing point. The pasteboard target, E, kneeling, is fastened to the target stave with double-pointed tacks and the target stave is fastened to the target rod with nails. For replacement, the silhouette target E, kneeling, is pasted on the pasteboard target.

**32. Bombing targets.**—Several types of targets for practice bombing by aircraft, both on land and water, are used, all of which are constructed locally. The ground in the immediate vicinity of the ground targets should be leveled off and freed from brush and tall grass. The following bombing targets are the type most commonly used:



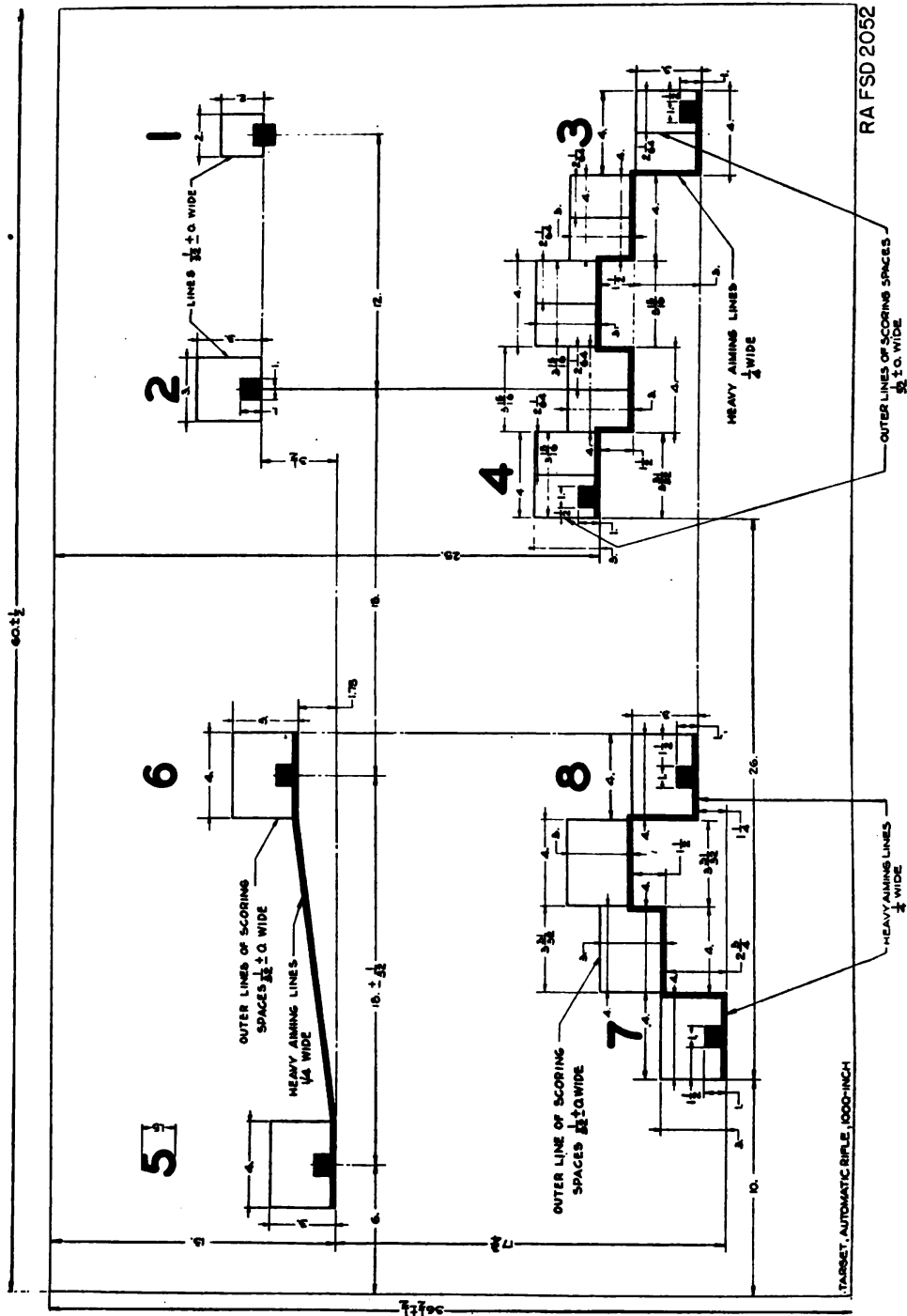

FIGURE 53.—Target, automatic rifle, 1,000-inch.

a. *50-yard square bull's-eye.*—This target is made by spreading lime over an area of ground 50 yards square.

b. *50-foot diameter bull's-eye.*—This target is made by spreading lime over an area of ground 50 feet in diameter, surrounded by two concentric circles of 100 feet and 150 feet diameter respectively.

c. *20-foot diameter bull's-eye.*—This target is made by spreading lime over an area of ground 20 feet in diameter, surrounded by two concentric circles of 40 feet and 60 feet diameter respectively.

d. *Water.*—An ordinary glass Florence flask, 1 liter capacity, filled with aluminum bronze powder, type A, is dropped by the aircraft. When it strikes the water the flask breaks and the powder spreads over an area and in comparatively smooth water forms a suitable target for bombing practice.

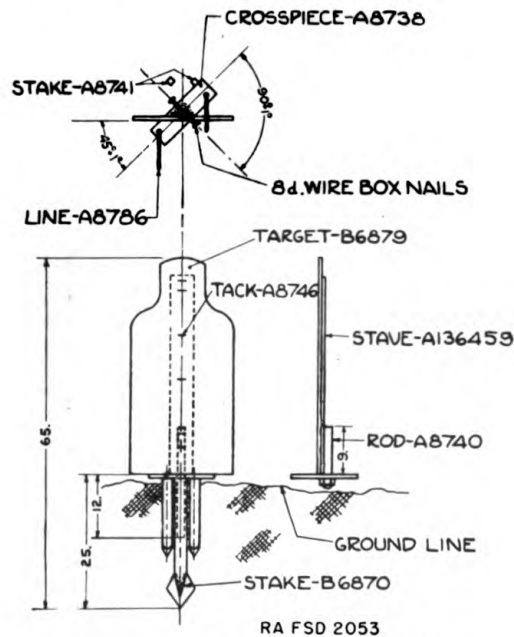

FIGURE 54.—Target, bobbing, M1913.

**33. Combination sliding target, complete.**—a. *General.*—The standard rifle marksmanship target installation consists of one or more 6- by 6-foot or 6- by 10-foot combination sliding targets projecting from the trench constructed as shown in figure 10. The components of the 6- by 6-foot and 6- by 10-foot combination sliding target, with the exception of the target frames, are identical. It is therefore the ranges the targets are intended for that determine the difference in designation. The target assemblies are shown in figures 55 and 56. The 6- by 6-foot combination sliding target is intended for erection on ranges of 200 to 600 yards and spaced

12 feet center to center. This gives a clearance of 6 feet between target frames. The 6- by 10-foot combination sliding target is intended for erection on ranges of 200 to 600 yards and spaced 15 feet center to center, giving a clearance of 5 feet between target frames. These clearances permit definite target designation in firing.

*b. Assembling.*—To assemble, assuming the trench has been prepared for the erection of the targets by providing a foundation for the main and cross sills, proceed as follows:

(1) *Timber frame support assembly.*—(a) Locate the main sill, the fastening block, the fastening plate, and a 1/2- by 6-inch lag screw. Attach the fastening block and fastening plate to the main sill with

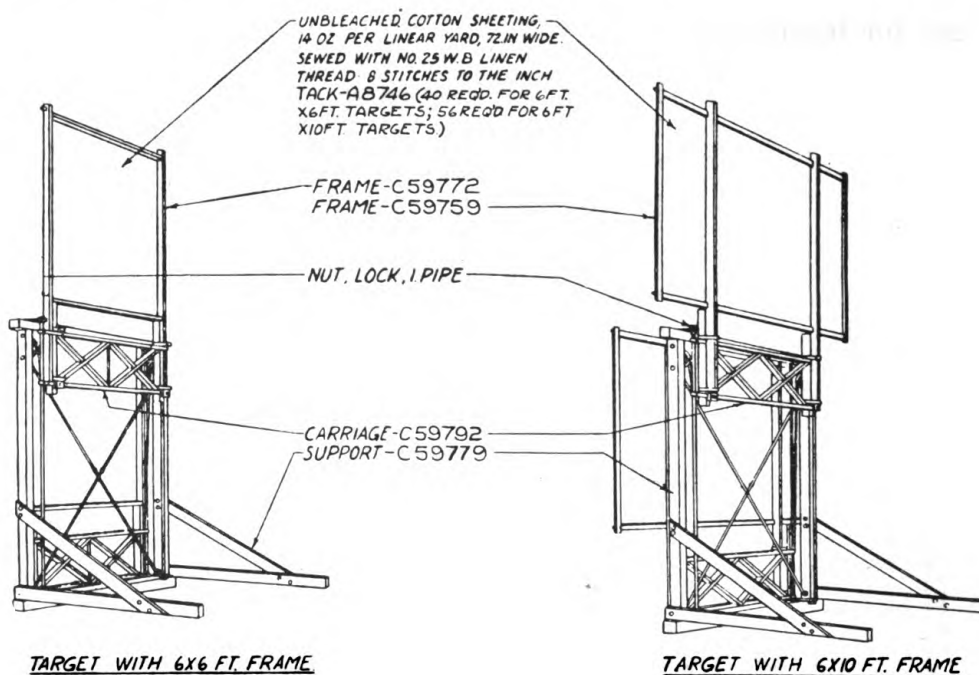

ORD. 10334

FIGURE 55.—Target, combination sliding, complete.

the lag screw inserted in the 5/16-inch hole which is drilled through the sill. Then nail the fastening block to the main sill with six ten-penny nails. Attach two slide rod plates to the main sill with 3/8- by 4 1/2-inch square head bolts, washers, and square nuts so that the plates are on the same side of the main sill as the fastening plate. Place the main sill in position so that when facing the rear of the trench the fastening plate is to the right of the center of the main sill.

(b) Locate the top beam, two slide rod plates, four 3/8- by 4 1/2-inch squarehead bolts with washers and nuts, four frame guides, and eight No. 14 by 2-inch flathead wood screws. Attach the slide rod

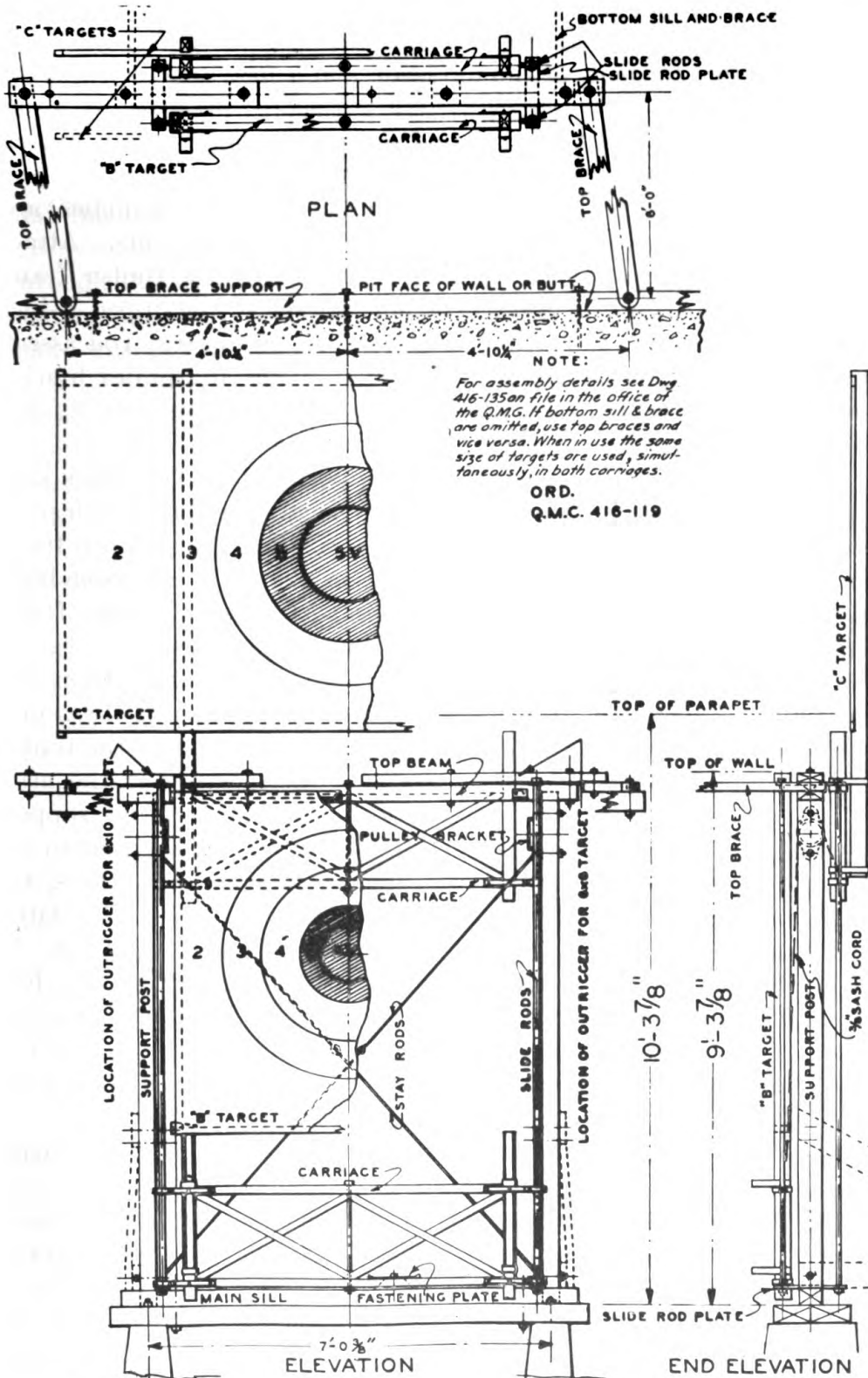

FIGURE 56.—Standard combination sliding target frame support, assembly.



plates to the upper face of the top beam, with the squarehead bolts. Attach the four frame guides with the wood screws so they are equal distances from the ends of the top beam and 5 feet 10 $\frac{3}{4}$  inches apart, center to center.

(c) Locate the two timber frame support posts, two stay rod assemblies (one short and one long stay rod with one short and one long eyebolt), two pulley plates, two pulley bracket assemblies, and two  $\frac{3}{8}$ - by 5-inch squarehead bolts with washers and nuts. Attach the pulley plates and pulley bracket assemblies to the timber frame support posts, using one squarehead bolt in each of the upper  $\frac{7}{16}$ -inch holes in each post. Insert the short eyebolts of the stay rod assemblies through the lower holes in the pulley plates and pulley bracket assemblies and secure to the timber frame support posts with  $\frac{3}{8}$ -inch hexagon nut and plain washer.

(d) Locate the two timber frame support braces, two cross sills, four  $\frac{3}{8}$ - by 7-inch and four  $\frac{3}{8}$ - by 5-inch squarehead bolts with plain washers and square nuts. Attach the cross sills to the timber frame support posts using the long eyebolts on the stay rod assemblies,  $\frac{3}{8}$ -inch hexagon nut and plain washers. Attach the timber frame support braces to the timber frame support posts with the  $\frac{3}{8}$ - by 7-inch squarehead bolts, plain washers, and square nuts. Then bolt the timber frame support braces to the cross sills with  $\frac{3}{8}$ - by 5-inch squarehead bolts, washers, and nuts. Fit the top beam to the timber frame support posts and set the posts in the mortises in the main sill. Tighten all nuts and stay rods until the timber frame support assembly is rigid, level, and plumb, and braced and secured to the foundation provided. In lieu of the bottom sills and braces, top braces may be used as shown in figure 8 and figure 31. This latter arrangement gives more freedom of movement in the target pit.

(e) Thread two pieces of  $\frac{3}{8}$ -inch linen sash cord, cut to 12 $\frac{1}{2}$  feet, through the pulley bracket assemblies. Locate the four slide rod assemblies (1-inch wrought iron or steel pipe 9 feet long, with two 1-inch pipe lock nuts). Make sure that the slide rods have no kinks or bends.

(2) *Installation of target frame carriage assembly.*—The two target frame carriage assemblies are issued set up and ready for installation.

(a) Set one carriage assembly on each side of the timber frame support with the support irons facing away from the timber frame support. Insert the four slide rod assemblies through the holes in the slide irons on the carriages, and in the slide rod plates on the timber frame support. Secure the slide rods with the 1-inch pipe lock nuts, tightening until snug. Raise and lower the carriages to see

that the motion is free and the carriages do not bind. Now run one carriage to the top, securing it in this position. Attach the free ends of the sash cord to the lower slide irons. Secure the other carriage to the main sill with a half turn of the fastening plate. Now attach one of the remaining free ends of the sash cord to the appropriate lower slide iron. Locate the sash cord clamp, weave the remaining free end of the sash cord through the sash cord clamp, then wrap around the neck of the appropriate slide iron and again weave through the sash cord clamp. By using the sash cord clamp in the manner described, practically all adjustments of the carriages can be made without disturbing the knotted ends of the sash cord.

(b) The carriages should now balance and move freely on the slide rods.

(c) Grease the slide rods and oil the pulleys. Paint any barren spots such as ends of bolts and abraided places on the timbers.

(3) *Installation of frames on carriages.*—Either the 6- by 6-foot target frame assembly or the 6- by 10-foot target frame assembly can be used on the installation described above. Target frames are described in detail in paragraph 20.

(a) *6- by 6-foot target frame.*—This target frame is provided for ranges of 200 yards to 600 yards, inclusive. Six frames are required for each target position on ranges of 200, 300, 500, and 600 yards (two for rifle paper target A, two for rifle paper target B, and two for rifle paper target D). The carriage slide irons are formed to fit the legs of the vertical rails of the target frame. Lower the carriage and lock to the main sill with a half turn of the fastening plate. With a man at each vertical rail, raise the target frame and set in place so that the lower horizontal rail rests on the tops of the vertical rails of the carriage.

(b) *6- by 10-foot target frame.*—This target frame is provided for ranges of 800 and 1,000 yards. Two frames are required with each installation for mounting rifle paper target C. With a man at each vertical rail, lift the target frame and slip the ends of the target frame supports through the upper support irons and downward through the lower support irons, where the bottoms of the target frame supports should rest on the support rests and the lower horizontal rail on the tops of the vertical rails of the carriage.

(c) Both target frames should have the cloth-covered side facing the firing line, should be level and plumb, and should counterbalance. If not level, adjust the sash cord by means of the sash cord clamp as described in (2) (a) above.

*c. Operation and maintenance.*—If the installation of the combination sliding target has been properly made, the targets should raise and lower freely. All parts except the target frames, sash cord, pulleys, and slide rods should be painted frequently. When not in use the pulleys and slide rods should be coated with grease.

**34. Kneeling targets.**—*a. E.*—This target represents a figure about the height of a soldier in the kneeling position and is constructed by fastening, with double-pointed tacks, a pasteboard target E, kneeling, to a target stave 45½ inches long. Assemble the pasteboard target to stave with the olive drab side to the front.

*b. E, M1917, complete.*—This target is made of pasteboard, ¼ inch in thickness, one surface being olive drab in color. It represents a figure about the height of a soldier in the kneeling position. The targets are packed 50 in a package, each package wrapped in waterproof lining paper and securely bound with cord.

**35. Prone target.**—*a. F.*—This target is made of pasteboard, ¼ inch in thickness, one surface being olive drab in color. It represents a figure about the height of a soldier in the prone position. The targets are packed 50 in a package, each package wrapped in waterproof lining paper and securely bound with cord.

*b. F, M1917, complete.*—This target represents a figure about the height of a soldier in the prone position. It is constructed by fastening a pasteboard target F, prone, to a 24-inch target stave by means of double-pointed tacks. Assemble the pasteboard target to stave with the olive drab side to the front.

**36. Gallery rifle targets (official).**—*a. 50-foot.*—This target, shown in figure 57, is required for target practice for National Guard organizations, schools, and colleges. It is printed with black ink on buff manila target paper, 10¾ inches high and 8 inches wide. The targets are packed 500 in a package, each package wrapped completely and securely in paper, with label suitably printed to describe contents pasted on outside of package.

*b. 75-foot.*—This target, shown in figure 58, is required for target practice for National Guard organizations, schools, and colleges. The target is 12 inches high and 10½ inches wide, made of the same stock, and packed 500 in a package as described in *a* above.

**37. Ground target, fixed gun aerial.**—This target is required for fixed machine-gun aerial gunnery practice on ground targets. The range lay-out for this target is shown in figure 19. The target consists of a rifle paper target C mounted on a 6- by 10-foot target frame. Wooden supports are used to hold the target inclined 60° from the horizontal.

38. H target, complete.—The H target is made in two types, kneeling and prone. They are made by inserting either the pasteboard target E, kneeling, or the pasteboard target F, prone, in the slot at the end of a target staff H, and fastening with wooden

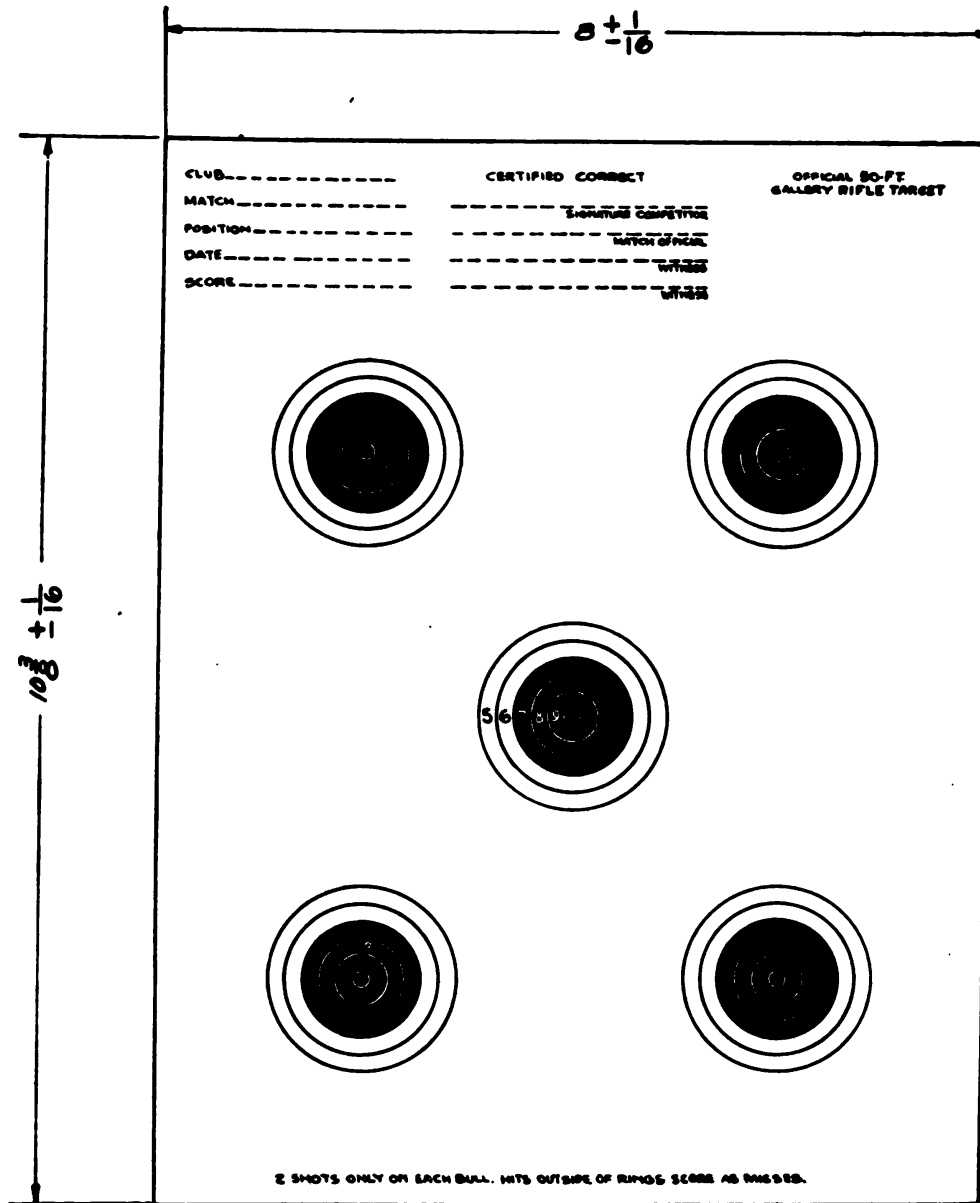

RA FSD 2054

FIGURE 57.—Target, gallery rifle (official, 50-foot).

taper pins. The targets are used for rifle and machine-gun training in the technique of fire. It is handled by a man, and is displayed for firing above a parapet or other shelter.

39. I target, M1913, complete.—*a. Description.*—This target, shown in figure 59, is used in rifle and machine-gun training in the technique of fire. The complete target consists of a beam in which are inserted eight targets. The targets may be the E, kneeling, M1917, complete, or the F, prone, F1917, complete, or a combination of the E and F targets. By means of a rope the beam is rotated

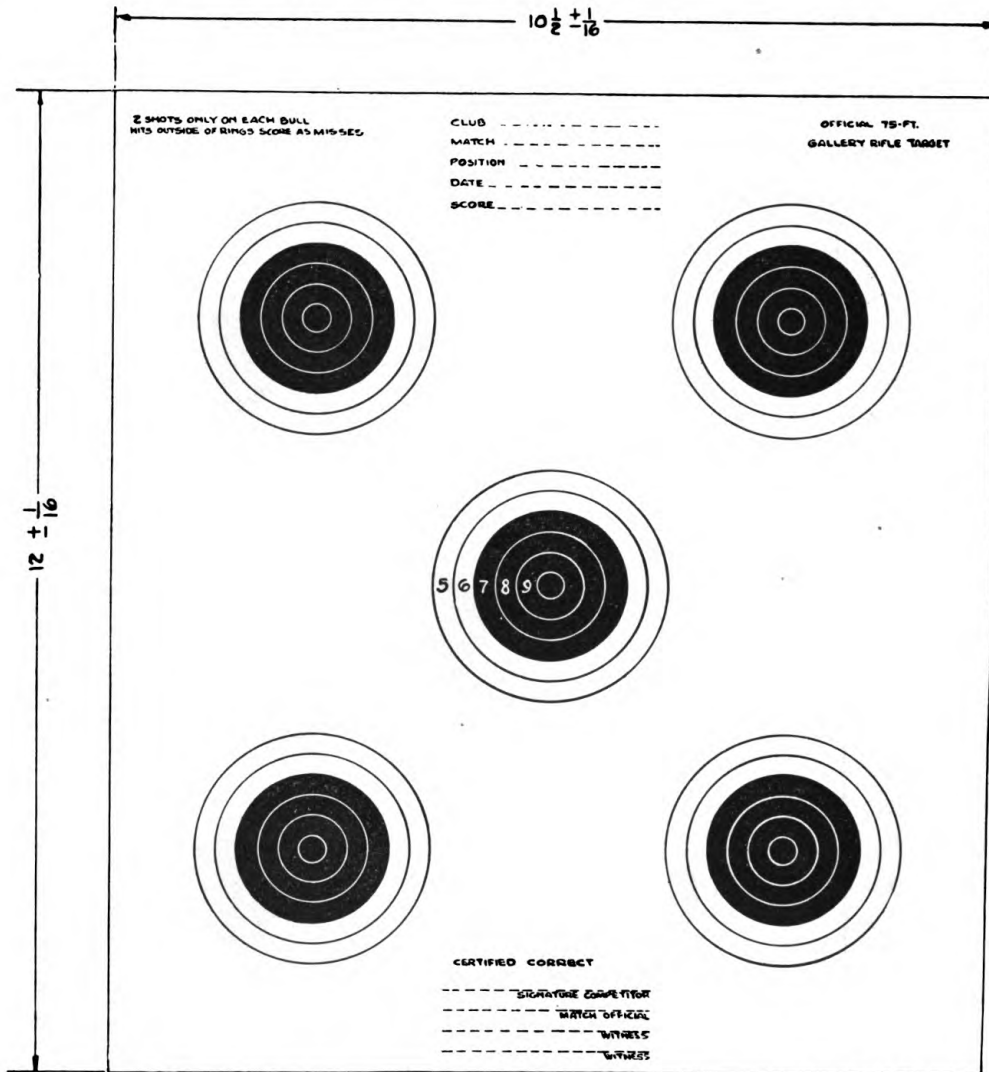

RA FSD 2055

FIGURE 58.—Target, gallery rifle (official, 75-foot).

so as to cause the targets to lie flat on the ground, or to rise to an erect position for firing upon. By this means the targets are made to appear and disappear.

*b. Method of assembling.*—(1) Provide a shallow trench the full length of the target beam and about 5 feet in width. Both in front and in rear of the center of the beam and at right angles to it,

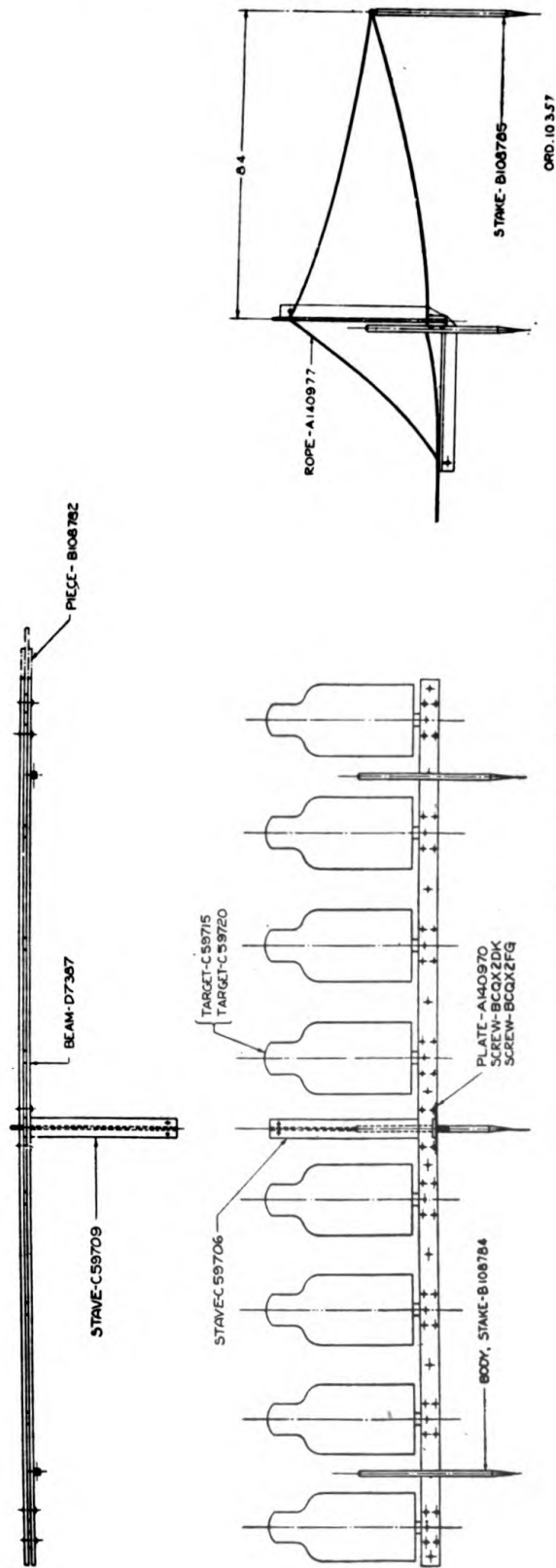

FIGURE 59.—Target I, M1913, complete.

provide a trench of sufficient depth for the front and rear operating staves when in the horizontal position.

(2) Drive two stakes (without screw eye) in the ground approximately 15 feet 6 inches apart, directly in front of the beam and in the forward part of the trench. Drive the third stake (with screw eye) about 7 feet in rear of the center beam.

(3) Assemble the front and rear operating staves in T-form, fastening them with the screws provided, then screw them into the sockets provided in the center of the beam.

(4) Fasten one end of the rope in the hole in rear operating stave, then pass it through the hole in front operating stave, then into the operating pit. Pass the other end of the rope over the beam and through the screw eye in stake in rear of the beam, then through the hole in rear operating stave where it is tied.

(5) The pit in which the operator is sheltered should be a sufficient distance in front of the beam to clear the front operating stave and of sufficient depth to provide protection for the operator.

(6) If it is desired to operate two or more beams simultaneously, they should be fastened together with the beam connecting piece and the bolts provided with each complete target. The beam connecting piece is inserted and bolted in the slots provided at each end of the beam. The beams should lie in the trench so that they cannot be struck by bullets.

(7) The staves of the E, kneeling, or F, prone, targets are inserted in slots provided in the target beam, each stave being secured with a nail.

**40. Landscape target, complete.**—Landscape targets are used in rifle practice on the 1,000-inch range. The complete target consists of a set of 5 black and white paper landscape targets, series A, mounted on individual target frames and held in place on six vertical posts by means of cleats and dowels. The complete set of five landscape paper targets, mounted and fastened on the target frame, make a panoramic picture of a landscape, and is of such size that all or nearly all of the salient features will be recognizable at a distance of 1,000 inches.

*a. Series A, black and white, set.*—These targets are made of poster paper. A set consists of five scenes showing a New England landscape, each scene composed of two sheets.

*b. Mounting.*—(1) The paper targets are mounted on frames made of 1- by 2-inch dressed lumber, with knee braces at the corners. The frames are 24 by 60 inches and are covered with target cloth which is tacked to the edges. It is advisable to paint the frames, but it is not necessary.

(2) Dampen the target cloth on the frame with a thin coat of target paste and let it dry for about an hour; apply a coat of paste similarly to the back of the paper target and let it dry about an hour; apply a second coat of paste to the back of the paper target and mount it on the target cloth; smooth out wrinkles, using a wet brush or sponge, and work from the center to the edges. The frame must be placed on some surface which will prevent the cloth from sagging when the paper target is pressed on it. A form for this purpose can easily be constructed. It must be of the same thickness as the lumber from which the frames are built, and must have approximately the same dimensions as the aperture of the frame.

*c. Method of constructing complete landscape target.*—Panels mounted as described above are set in a vertical frame consisting of 6 posts (about 4 by 4 inches) of sufficient height, placed upright in the ground, 5 feet from center to center, with horizontal pieces of 2 by 4 inches to support the panels, braced to insure stability. The panels are supported by cleats and dowels in order to allow for easy removal.

**41. Machine-gun targets.**—*a. A.*—This target (fig. 60) is required for instruction, preliminary, and record practice with the caliber .30 light machine gun on the 1,000-inch ground course. It is printed with black ink on buff manila target paper, 3 feet high and 5 feet wide. The targets are packed 50 in a roll, each roll wrapped

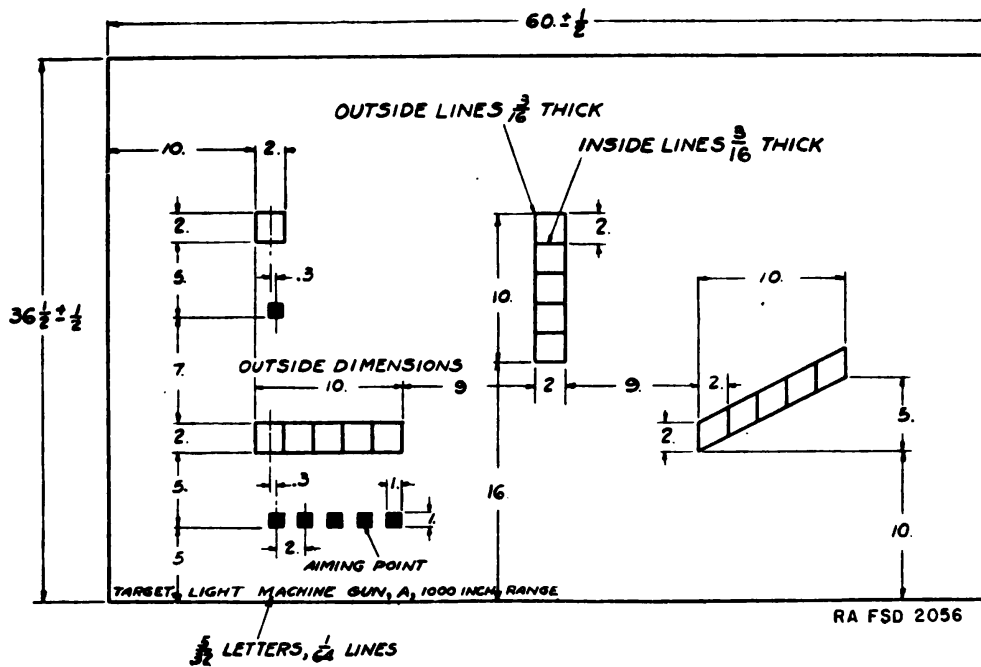

FIGURE 60.—Target, light machine-gun, A.



completely and securely in paper, with label suitably printed to describe contents pasted on outside of roll.

*b. M (armored car).*—This target (fig. 61) is required for instruction practice with the caliber .30 light machine gun on the 1,000-inch range, car course. The target is 3 feet high and 5 feet wide, made of the same stock and packed 50 in a roll as described in *a* above.

*c. M, M1913, complete.*—This target (fig. 62) is required for mounted pistol marksmanship and for armored car machine-gun target practice at 300 and 500 yards. The target represents a figure about the height of a soldier in the standing position and is constructed by fastening, with double-pointed tacks, a pasteboard target E, kneeling, for the upper portion of the figure, and a pasteboard target, trapezoidal, for the lower portion of the figure, to a target stave, 84 inches long. Assemble the pasteboard targets to stave with the olive drab side to the front.

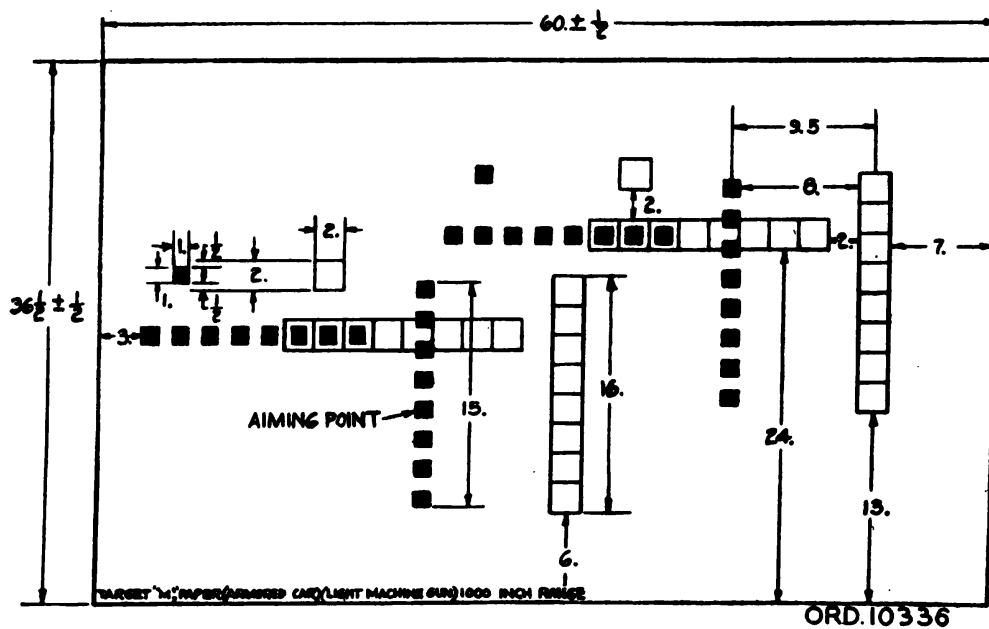

FIGURE 61.—Target, light machine-gun, M (armored car).

*d. M, tank, complete.*—This target (fig. 63) is required for machine-gun target practice fired from combat, armored, and scout cars on field ranges and tank machine-gun target practice on 500-yard ranges. The complete target consists of a 6-by-6-foot target frame covered with a reversed rifle paper target B. On this frame are pasted three paper silhouette targets E, kneeling, and three paper silhouette targets, trapezoidal, placed in line to represent standing figures.

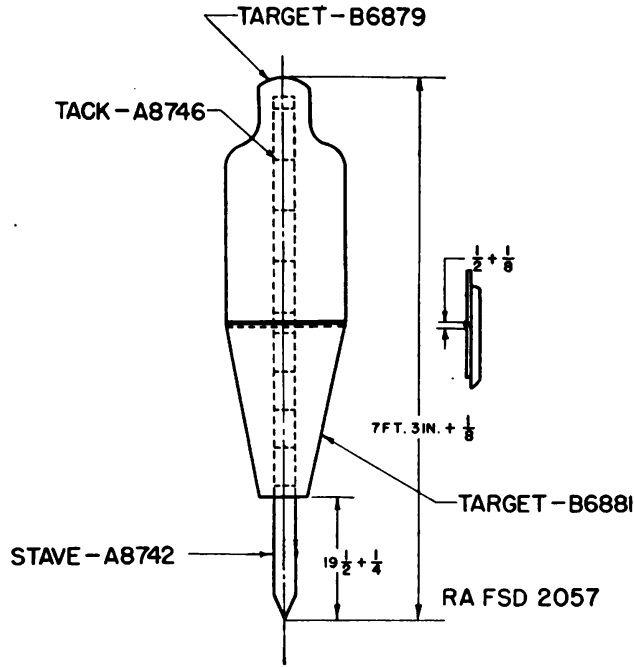

FIGURE 62.—Target M, M1913, complete.

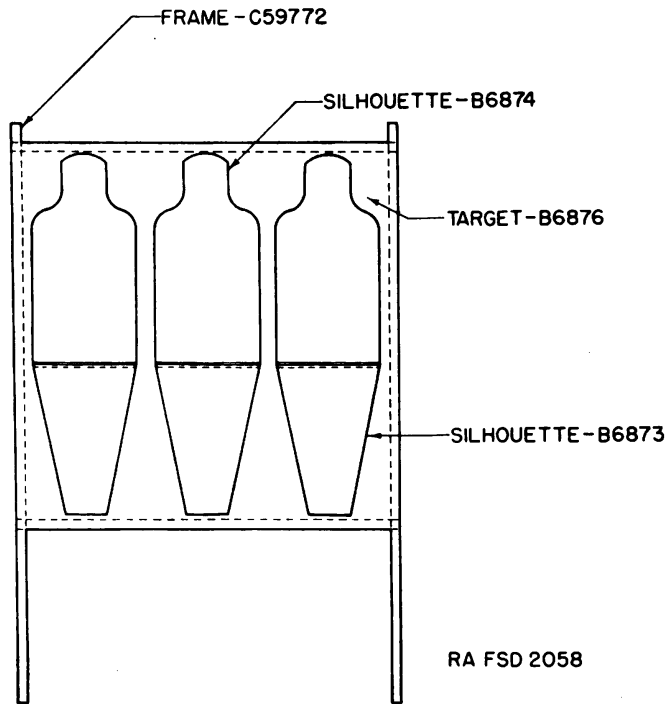

FIGURE 63.—Target M, tank machine-gun, complete.

*e. 1,000-inch.*—This target (fig. 64) is required for instruction and preliminary practice with the caliber .22 and caliber .30 machine guns and record practice with the caliber .30 machine gun, on the 1,000-inch range. The target is printed with black ink on buff manila

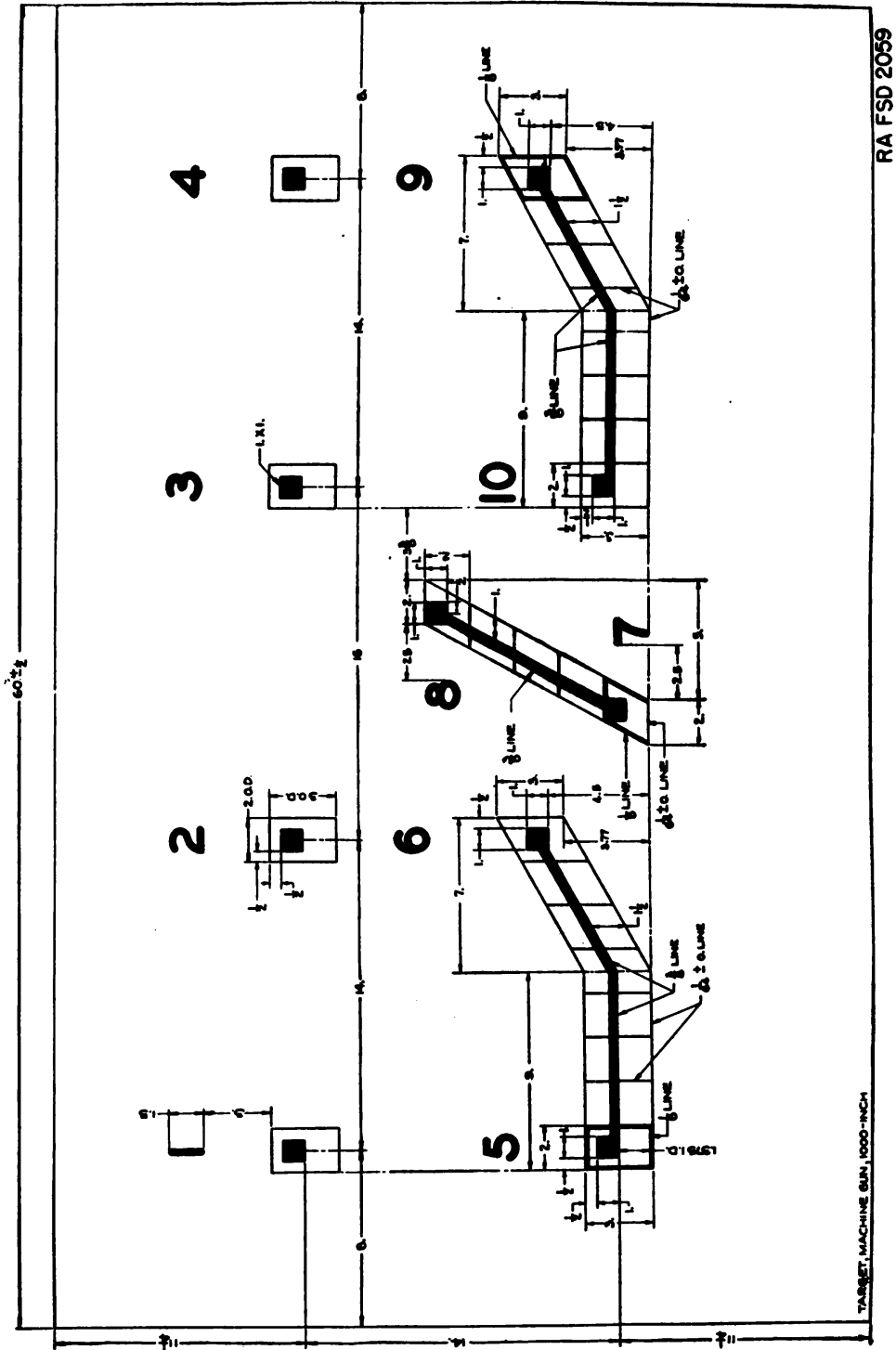

FIGURE 64.—Target, machine-gun, 1,000-inch.

target paper, 3 feet high and 5 feet wide. They are packed 50 in a roll, each roll wrapped completely and securely in paper, with label suitably printed to describe contents pasted on outside of roll.

*f. SB, 500-inch.*—This target is required for use with the caliber 22 machine gun on the 500-inch range. The target is 18 inches high and 30 inches wide and is printed the same as the 1,000-inch target described in *e* above and shown in figure 64, except dimensions are reduced one-half. They are made of the same stock and packed 50 in a roll as described in *e* above.

**42. Pistol targets.**—*a. L.*—This target (fig. 65) is printed with black ink on buff manila target paper, 6 feet square. The targets are packed 50 in a roll, each roll wrapped completely and securely in paper, with label suitably printed to describe contents pasted on outside of roll. The pistol target L is required for the following:

(1) Line of targets with firing point at 15 to 25 yards, for position exercises, dismounted pistol marksmanship.

(2) Line of targets with firing point at 25 yards, for trigger squeeze exercises, dismounted pistol marksmanship.

(3) Line of targets for slow and rapid fire exercises, dismounted pistol marksmanship.

*b. Overhead collective, complete.*—This target is used for squad mounted pistol practice and is constructed as follows: Eight pasteboard targets E, kneeling, are suspended from a flexible wire rope, which is stretched between poles sunk in the ground 90 feet apart and about 20 feet high. The pasteboard targets, with 4½ feet between centers, are suspended from the wire rope, by any suitable means, in such a manner that the lower edges of the targets will be about 10 feet from the ground. The wire rope is led down from one post to a stake in the ground, where it is securely fastened, and at the other end is led down to a cleat, where it can be loosened and the pasteboard targets lowered to the ground for marking and the pasting on of paper silhouette targets. Only the wire cable and the pasteboard targets E, kneeling, are issued, the other materials are procured locally.

*c. Standard American.*—This target is used in pistol target practice for competitions only and is provided in two types, 25-yard shown in figure 66 and 50-yard shown in figure 67. Both types of target are printed with black ink on buff manila target paper, 28 inches square. The difference between the two types is that on the 25-yard target the 9 and 10 rings are black while on the 50-yard target the 8, 9, and 10 rings are black. The targets are packed 100 in a roll, each roll wrapped completely and securely in paper,

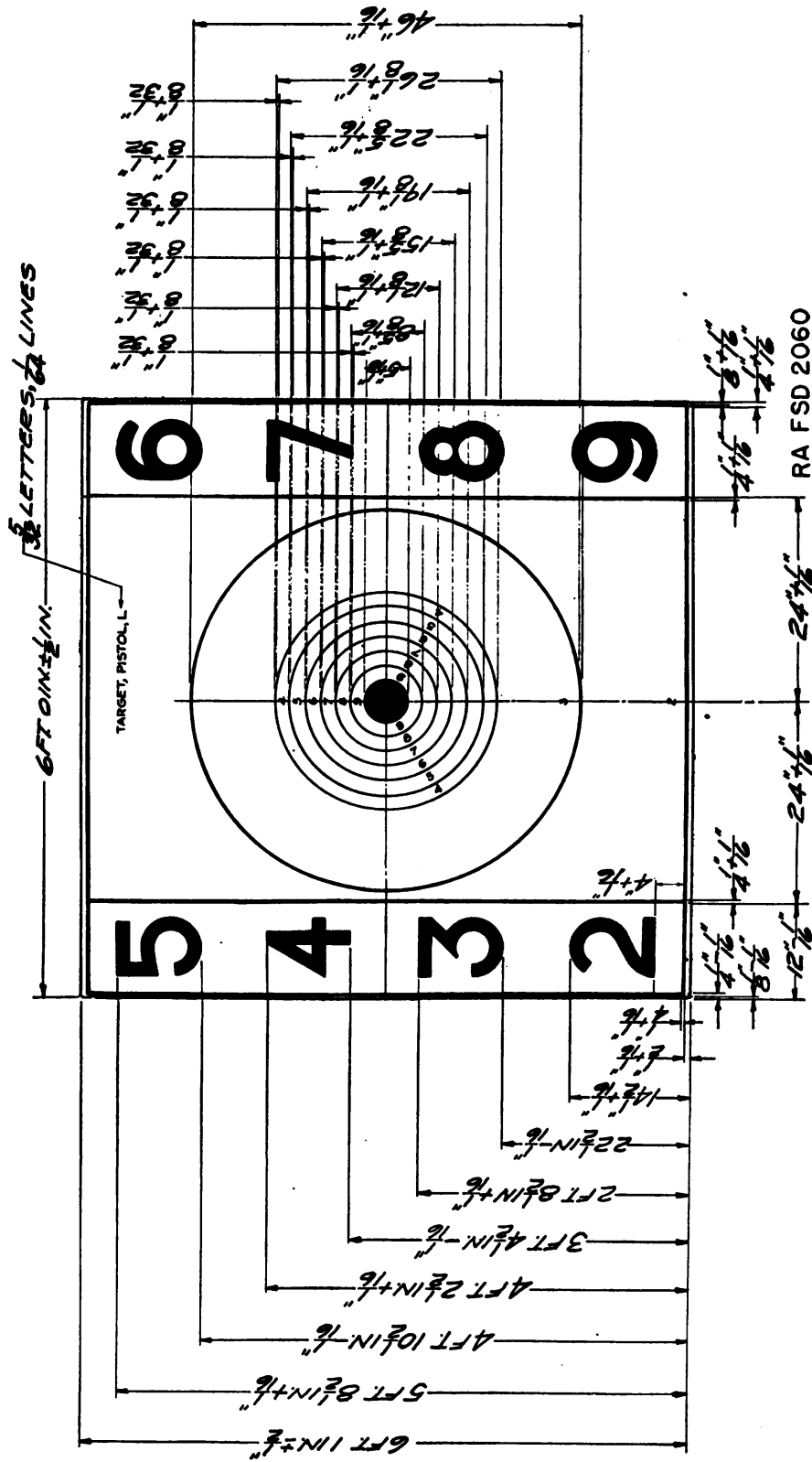

FIGURE 65.—Target, pistol, L.

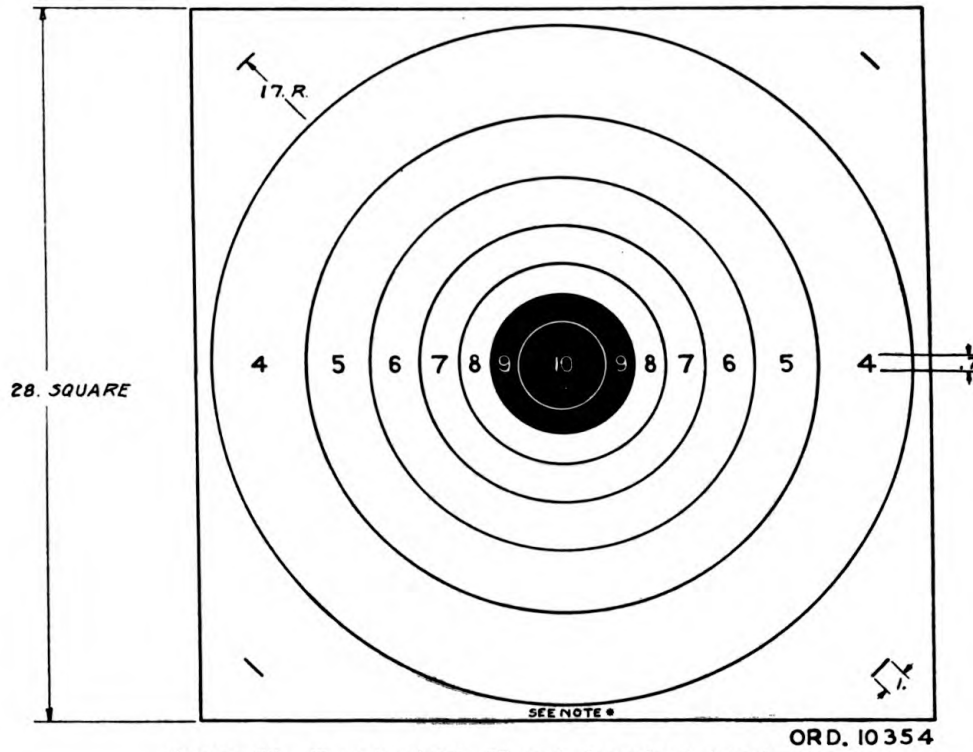

FIGURE 66.—Target, pistol, 25-yard (standard American).

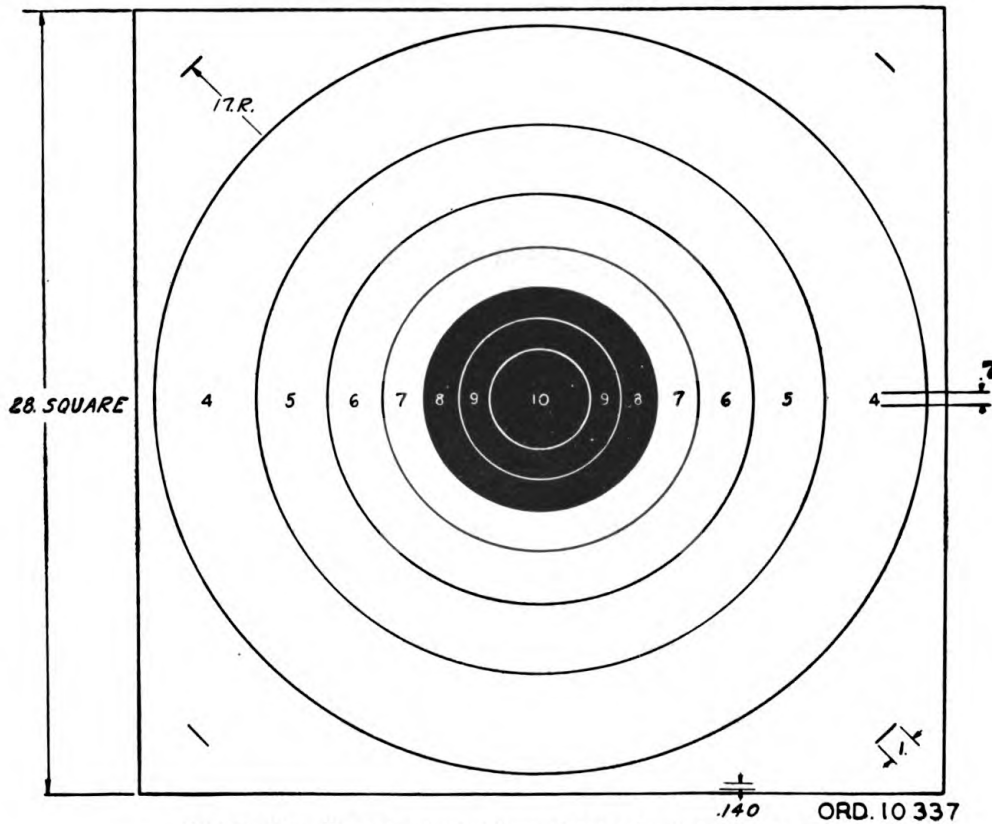
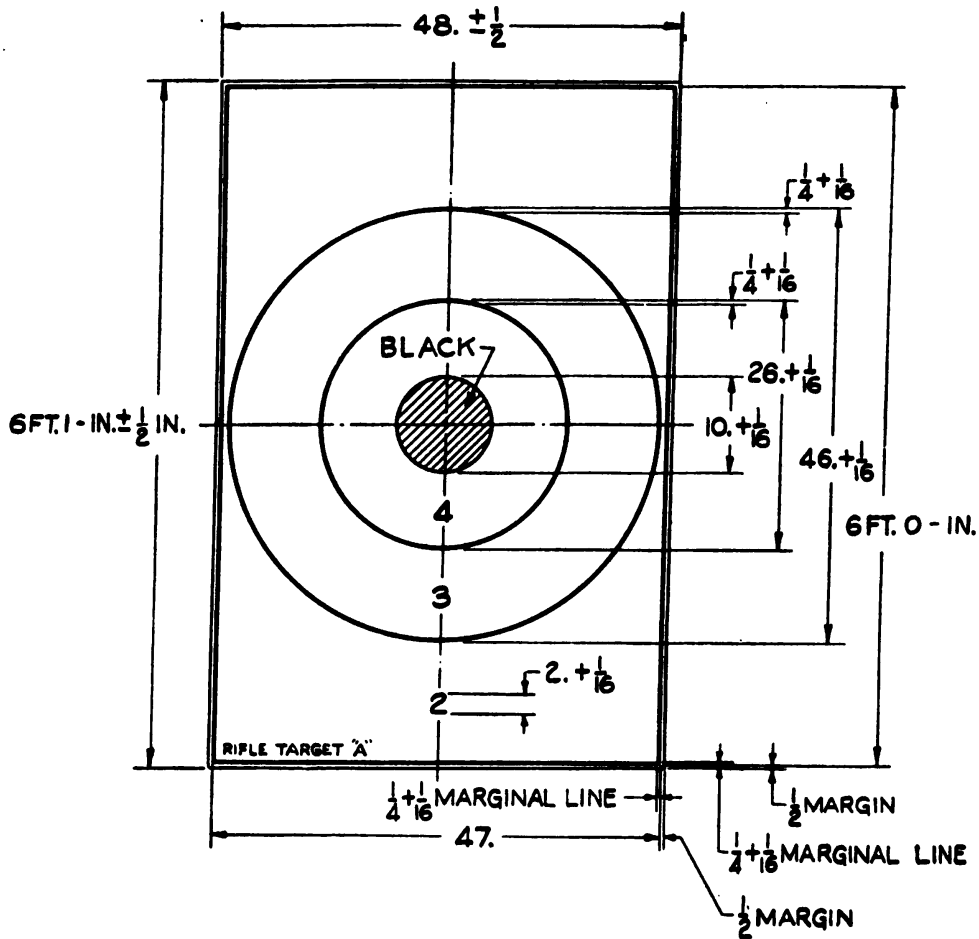

FIGURE 67.—Target, pistol, 50-yard (standard American).

with label suitably printed to describe contents pasted on outside of roll.

43. Rifle targets.—*a. A.*—This target (fig. 68) is printed with black ink on buff manila target paper, 6 feet high and 4 feet wide. The targets are packed 50 in a roll, each roll wrapped completely and securely in paper, with label suitably printed to describe con-



ORD. 10 366

FIGURE 68.—Target, rifle, A.

tents pasted on outside of roll. The rifle target A is required for the following:

- (1) Preparatory exercises in rifle marksmanship.
- (2) 200-300-yard slow fire practice, rifle marksmanship.
- (3) 37-mm tank gun subcaliber target practice at 200-300 yards.
- (4) 2.24-inch (6-pounder) tank gun subcaliber target practice at 500-600 yards.

b. *A*, 1,000-inch.—This target (fig. 69) is printed with black ink on buff manila target paper, 12 inches high and 8½ inches wide. The targets are required for firing courses A, B, C, and D on the 1,000-inch range with the caliber 30, M1903, and caliber .30, M1 rifles. They are packed 1,000 in a package, each package wrapped completely and securely in paper, with label suitably printed to describe contents pasted on outside of package.

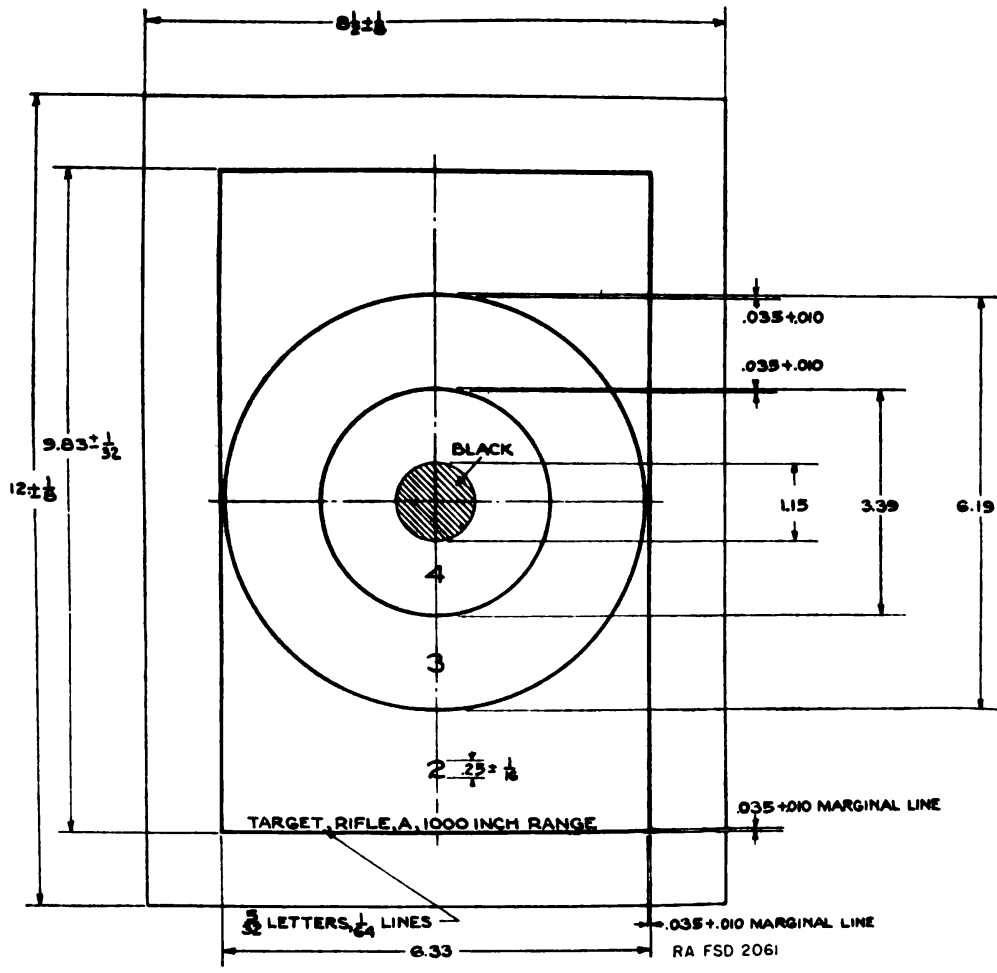

FIGURE 69.—Target, rifle, A, 1,000-inch.

c. *B*.—This target (fig. 70) is printed with black ink on buff manila target paper, 6 feet square. The targets are packed 50 in a roll, each roll wrapped completely and securely in paper, with label suitably printed to describe contents pasted on outside of roll. The rifle target B is required for the following:

Generated on 2016-06-11 07:56 GMT / http://hdl.handle.net/2027/uc1.b3243773  
 Public Domain, Google-digitized / http://www.hathitrust.org/access\_use#pd-google



- (1) Preparatory exercises in rifle marksmanship.
- (2) 500-yard slow fire practice, rifle marksmanship.
- (3) For known-distance instruction.
- (4) 500-600-yard machine rifle marksmanship.
- (5) 2.24-inch (6-pounder) tank subcaliber target practice at 500-600 yards.
- (6) Sighting target for 2.24-inch (6-pounder) tank gun marksmanship.

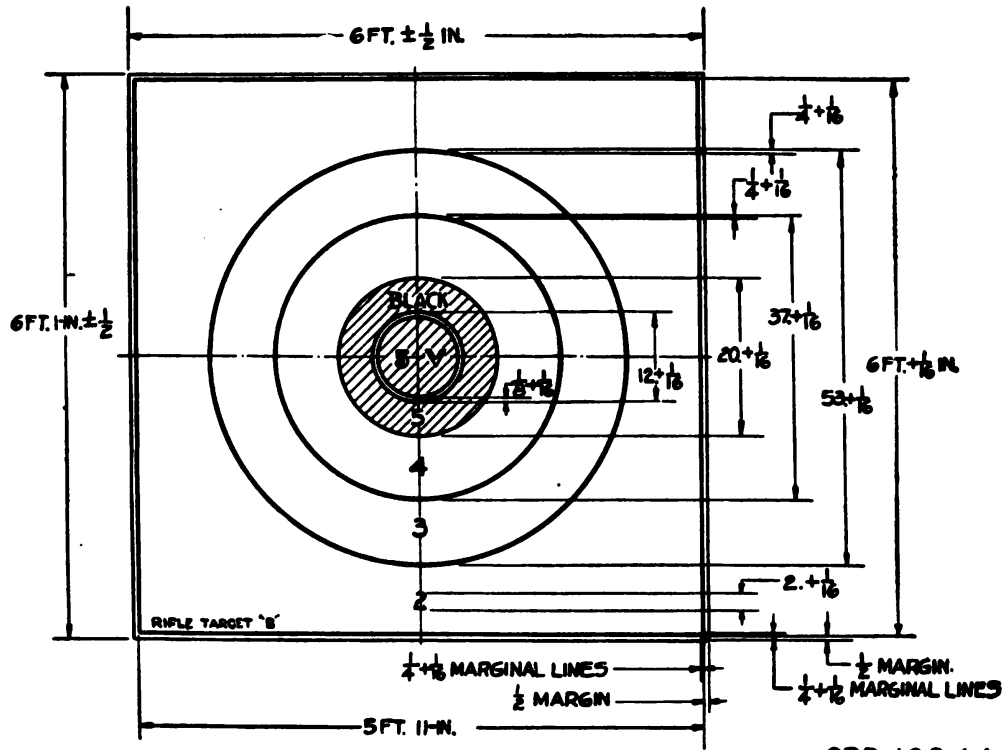

ORD. 10344

FIGURE 70.—Target, rifle, B.

*d. C.*—This target (fig. 71) is 6 feet high and 10 feet wide and made of the same stock and packed 25 in a roll as described in *c* above. The rifle target C is required for the following:

- (1) 800-1,000-yard slow fire practice, rifle marksmanship.
- (2) Fixed machine-gun aerial ground target.

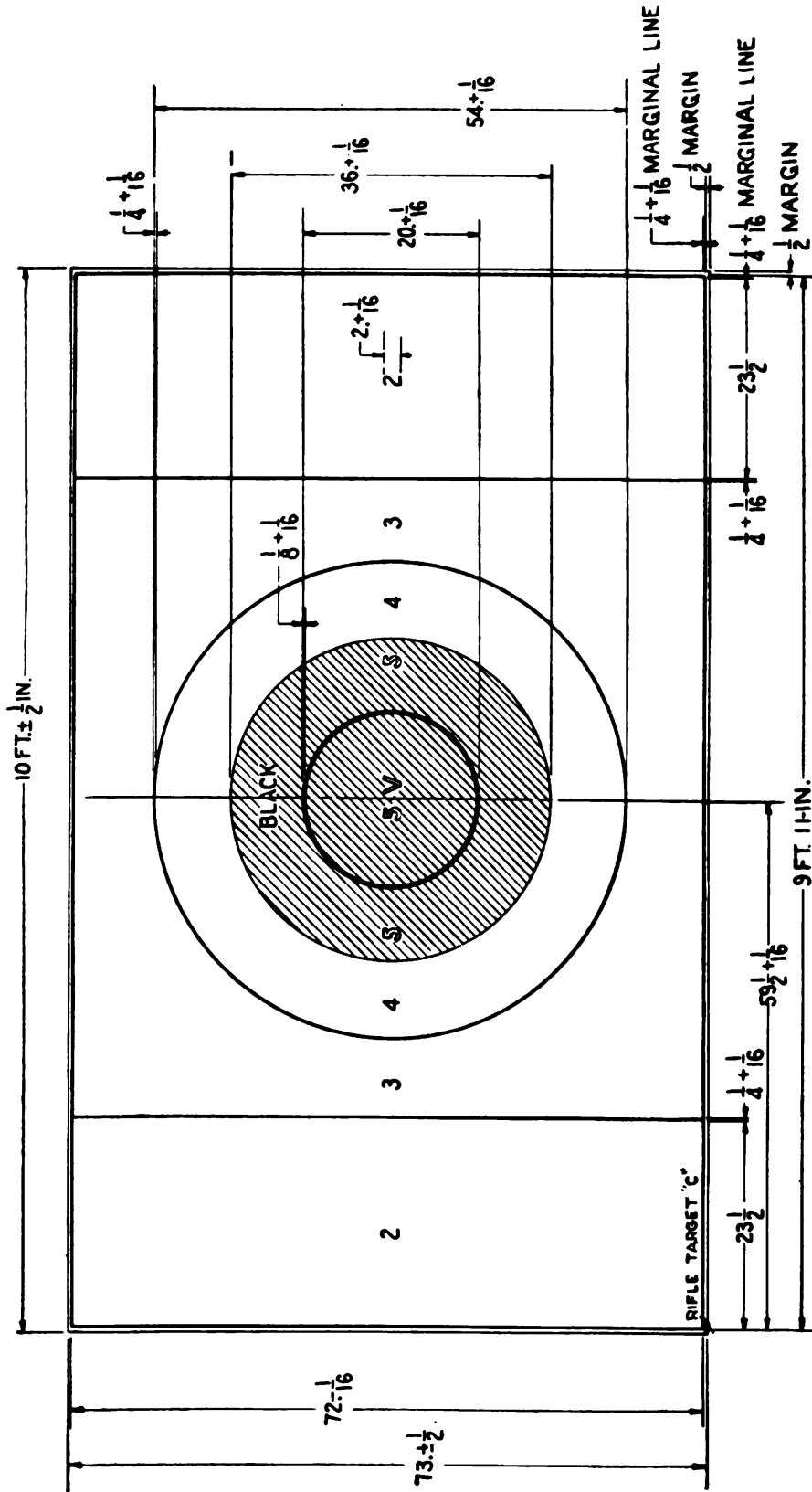

ORD. 10331

FIGURE 71.—Target, rifle, C.

e. D.—This target (fig. 72) is 6 feet square and made of the same stock and packed 50 in a roll as described in *d* above. The rifle target D is required for the following:

- (1) 200-300-yard rapid fire instruction and record practice, rifle marksmanship with the caliber .30 M1903 and M1 rifles.
- (2) All known-distance range firing, automatic rifle marksmanship.
- (3) 200-300-500-yard rapid fire instruction and record practice with the automatic rifle.
- (4) 200-300-600-yard rapid fire automatic rifle marksmanship.
- (5) Recording target in exercises in technique of fire.
- (6) Used in rifle combat practice as screen with target H.

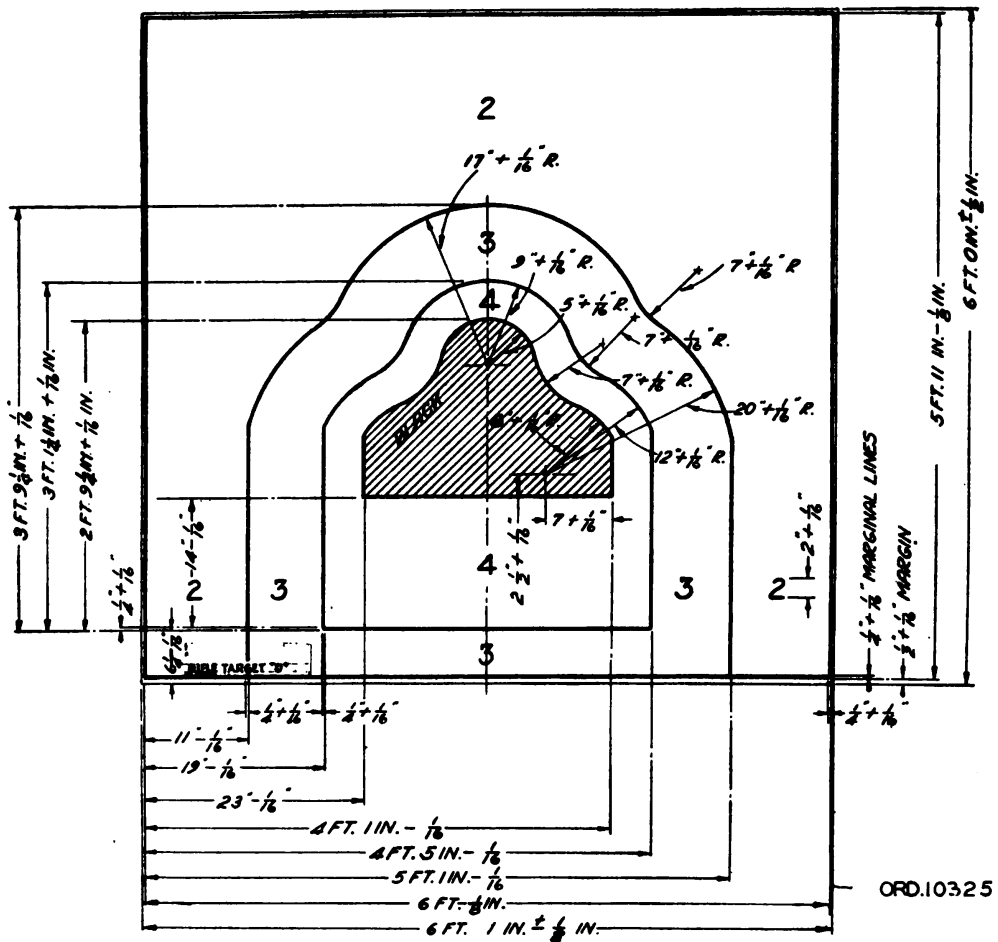

FIGURE 72.—Target, rifle, D.

*f. D, 1,000-inch.*—This target (fig. 73) is printed with black ink on buff manila target paper, 12 inches square. The targets are required for firing courses A, B, C, and D on the 1,000-inch range with the caliber .30 M1903 and M1 rifles. They are packed 1,000 in a package, each package wrapped completely and securely in paper, with label suitably printed to describe contents pasted on outside of package.

*g. SB-A.*—These targets for 50-, 100-, and 200-yard ranges, are printed with black ink on buff manila paper. They are packed 500 in a package, each package wrapped completely and securely in paper, with label suitably printed to describe contents pasted on outside of package.

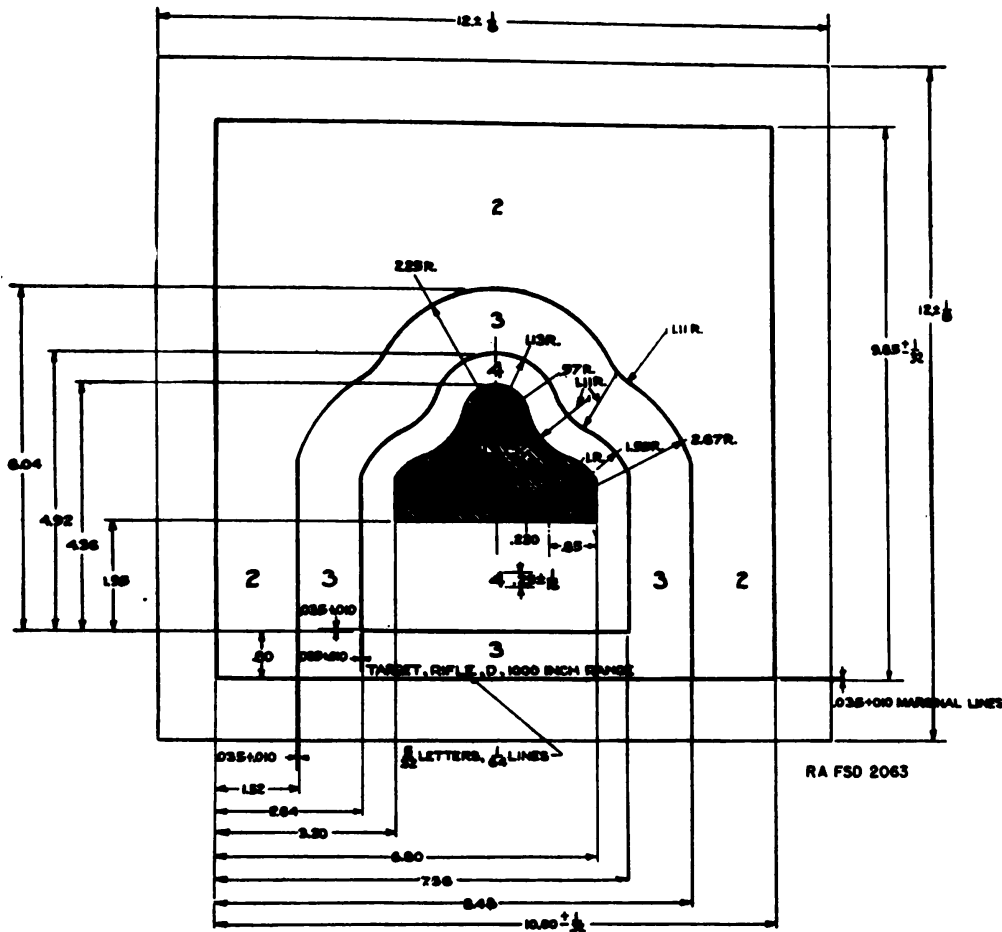

FIGURE 73.—Target, rifle, D, 1,000-inch.

(1) *SB-A, 50-yards.*—This target (fig. 74) is 13 inches square. It is required for instruction and record practice, slow fire, with the caliber .22 rifle on the 50-yard range.

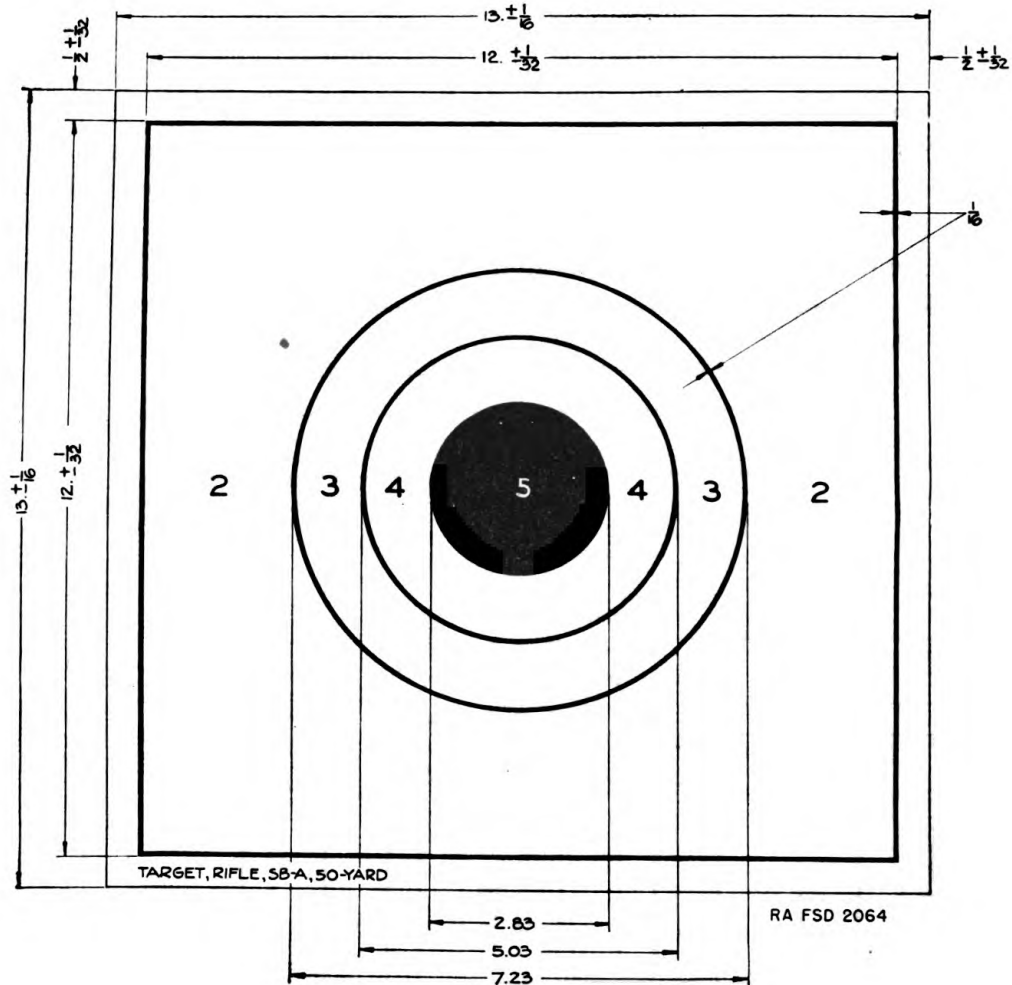

FIGURE 74.—Target, rifle, SB-A, 50-yard.

(2) *SB-A, 100-yards.*—This target (fig. 75) is 13 inches high and 18½ inches wide. It is required for instruction and record practice, slow fire, with the caliber .22 rifle on the 100-yard range.

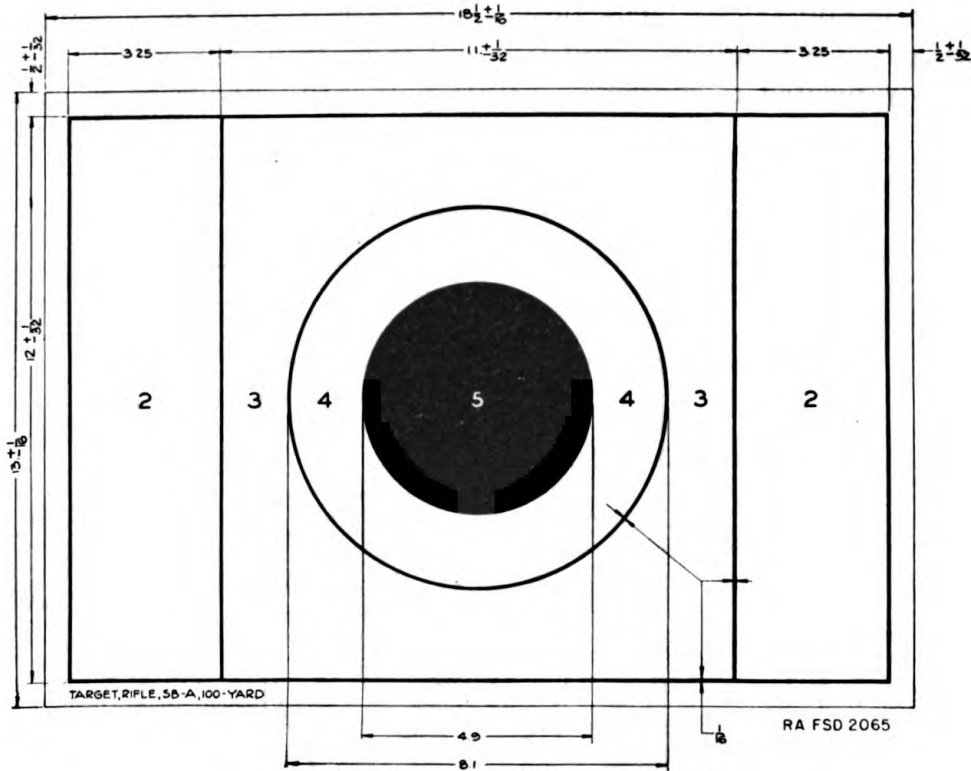

FIGURE 75.—Target, rifle, SB-A, 100-yard.

*h. SB-A-2.*—This target (fig. 76) is printed with black ink on buff manila target paper, 8 inches high and 6½ inches wide. It is required for instruction practice, slow fire, with the caliber .22 rifle on the 50-foot range and in competitions between teams of different organizations. The targets are packed 1,000 in a package, each package wrapped completely and securely in paper, with label suitably printed to describe contents pasted on outside of package.

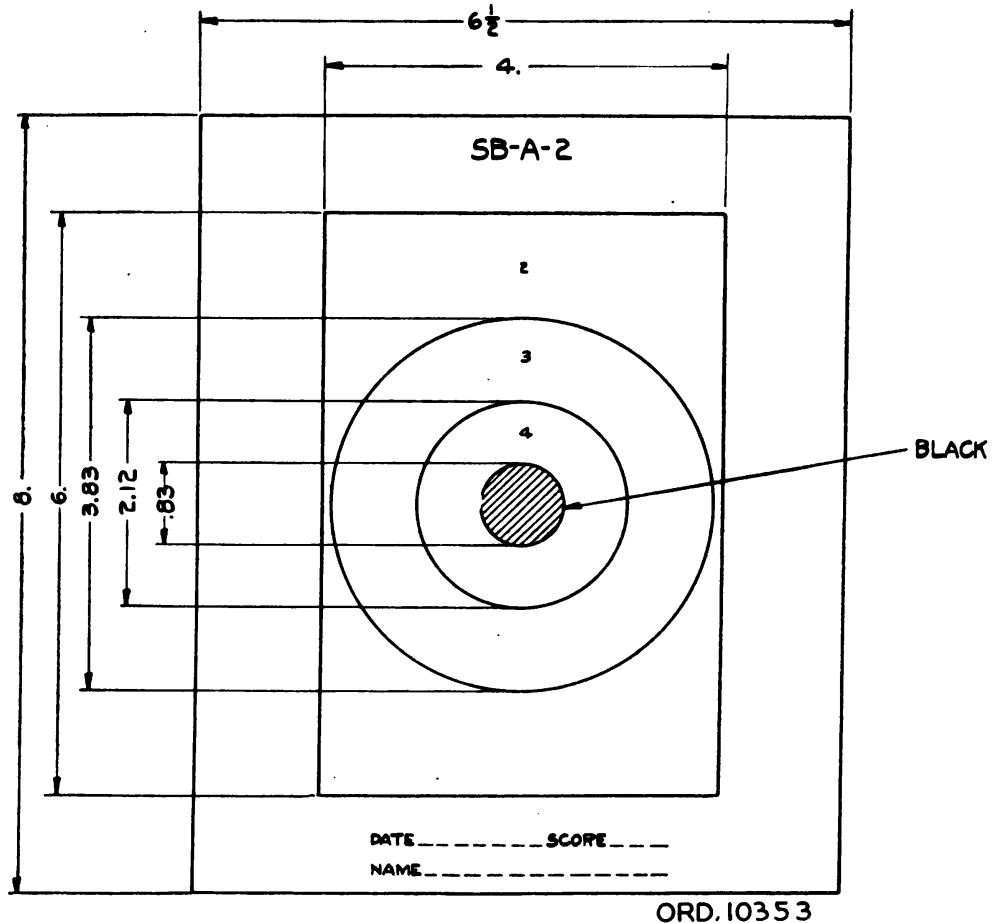

FIGURE 76.—Target, rifle, SB-A-2.

i. *SB-A-3*.—This target (fig. 77) is 8 inches high and 6½ inches wide and made of the same stock and packed 1,000 in a package as described in *h* above. It is required for instruction and record practice, slow fire, with the caliber .22 rifle on the 50-foot range and in competitions between teams of different organizations.

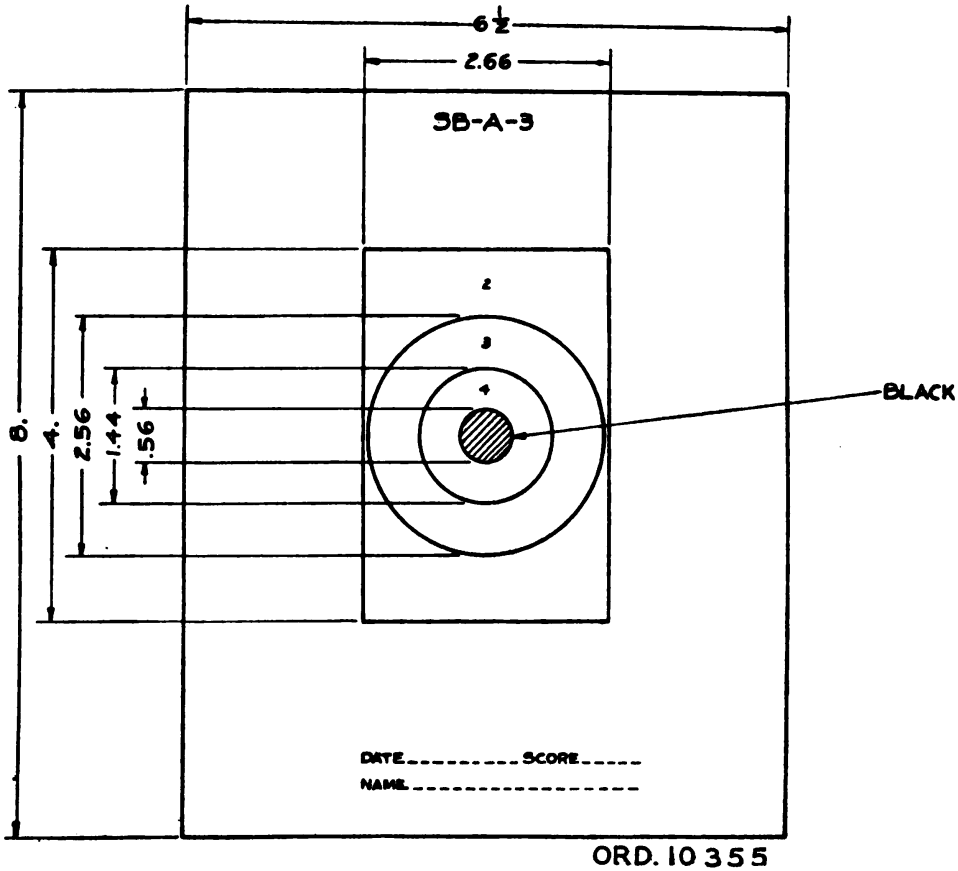

FIGURE 77.—Target, rifle, SB-A-3.



*j. SB-B-5.*—This target (fig. 78) is 8 inches high and 6½ inches wide and made of the same stock and packed 1,000 in a package as described in *h* above. It is required for instruction and record practice, slow fire, with the caliber .22 rifle on the 50-foot range and in competitions between teams of different organizations.

*k. SB-D.*—These targets, for 50- and 100-yard ranges, are printed with black ink on buff manila paper. They are packed 500 in a package, each package wrapped completely and securely in paper, with label suitably printed to describe contents pasted on outside of package.

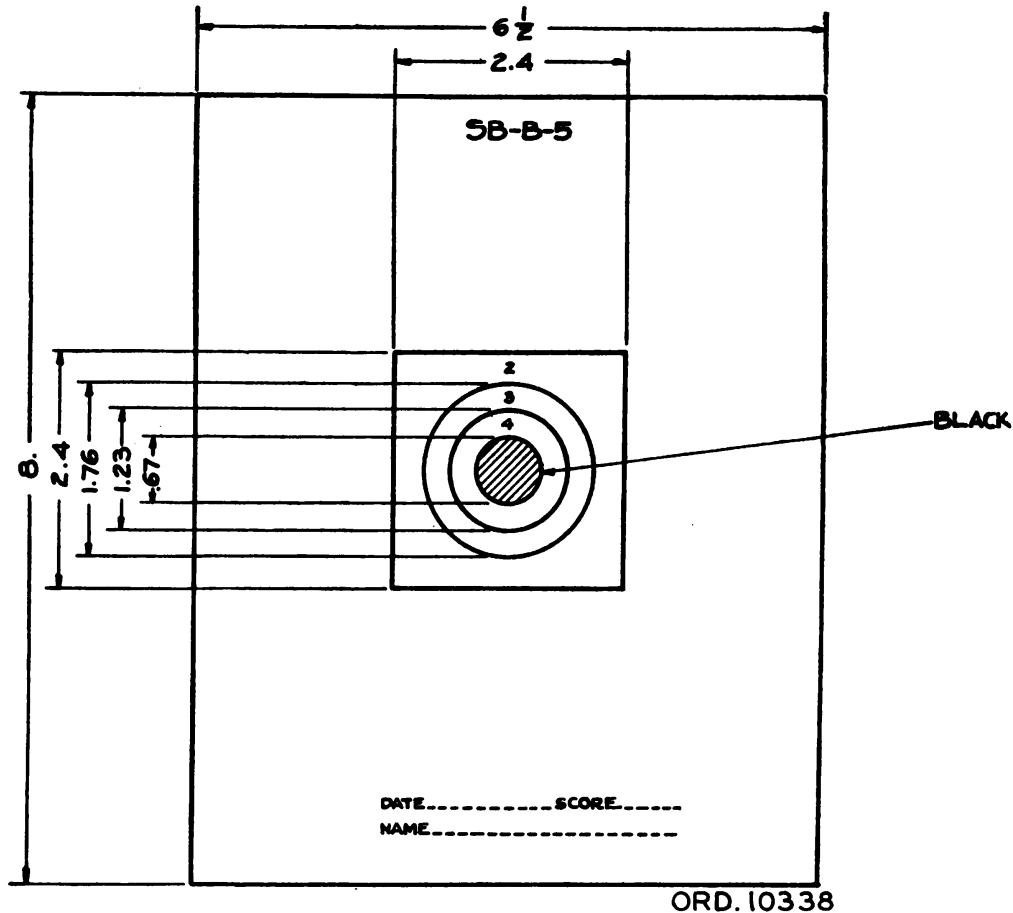

FIGURE 78.—Target, rifle, SB-B-5.

(1) *SB-D, 50-yard.*—This target (fig. 79) is 13 inches square. It is required for instruction practice, rapid fire, with the caliber .22 rifle on the 50-yard range.

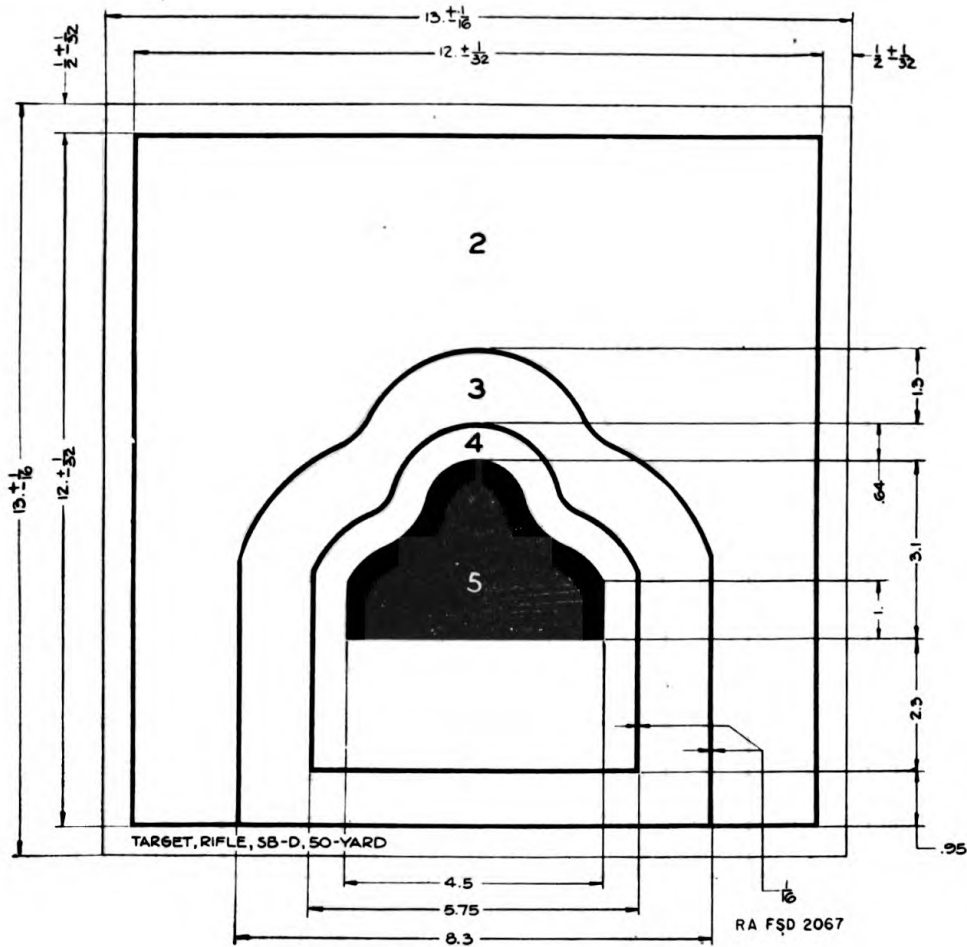

FIGURE 79.—Target, rifle, SB-D, 50-yard.

(2) *SB-D, 100-yard.*—This target (fig. 80) is approximately  $15\frac{5}{8}$  inches square. It is required for instruction and record practice, slow and rapid fire, with the caliber .22 rifle on the 100-yard range.

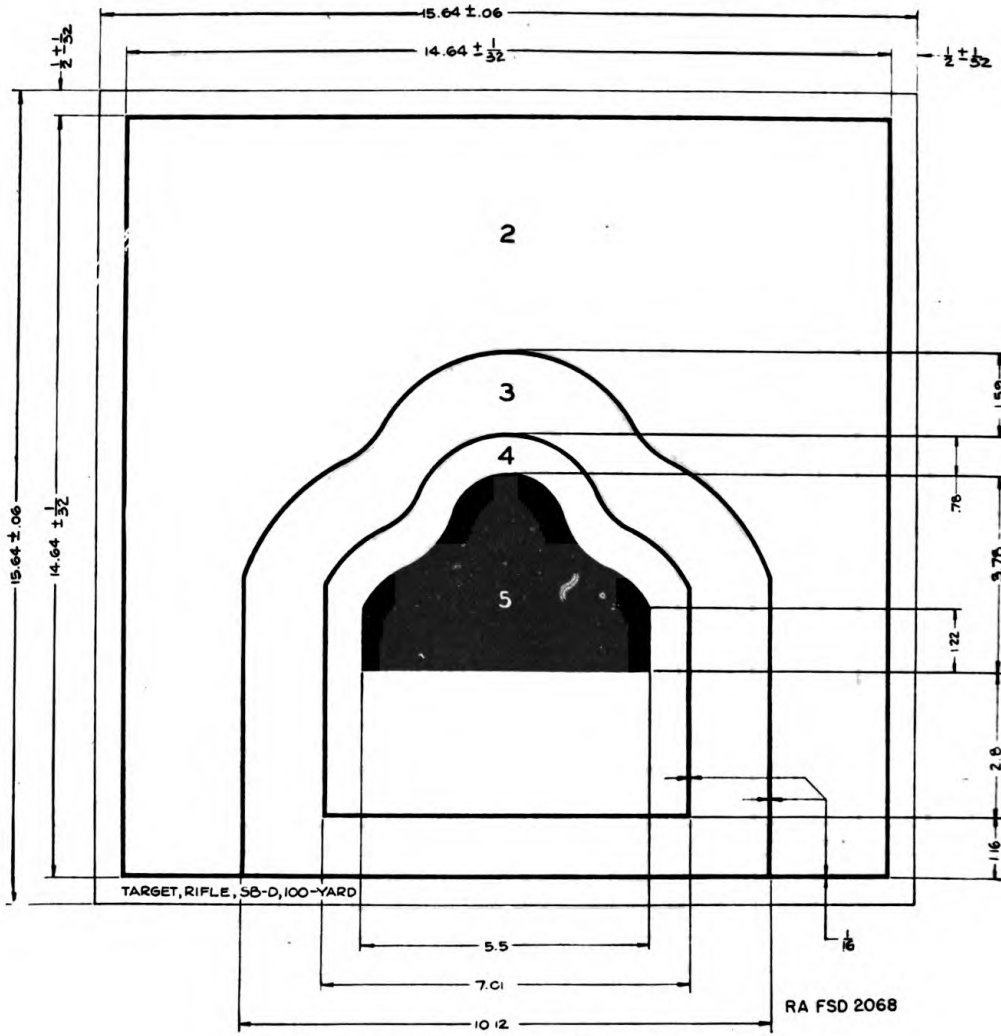
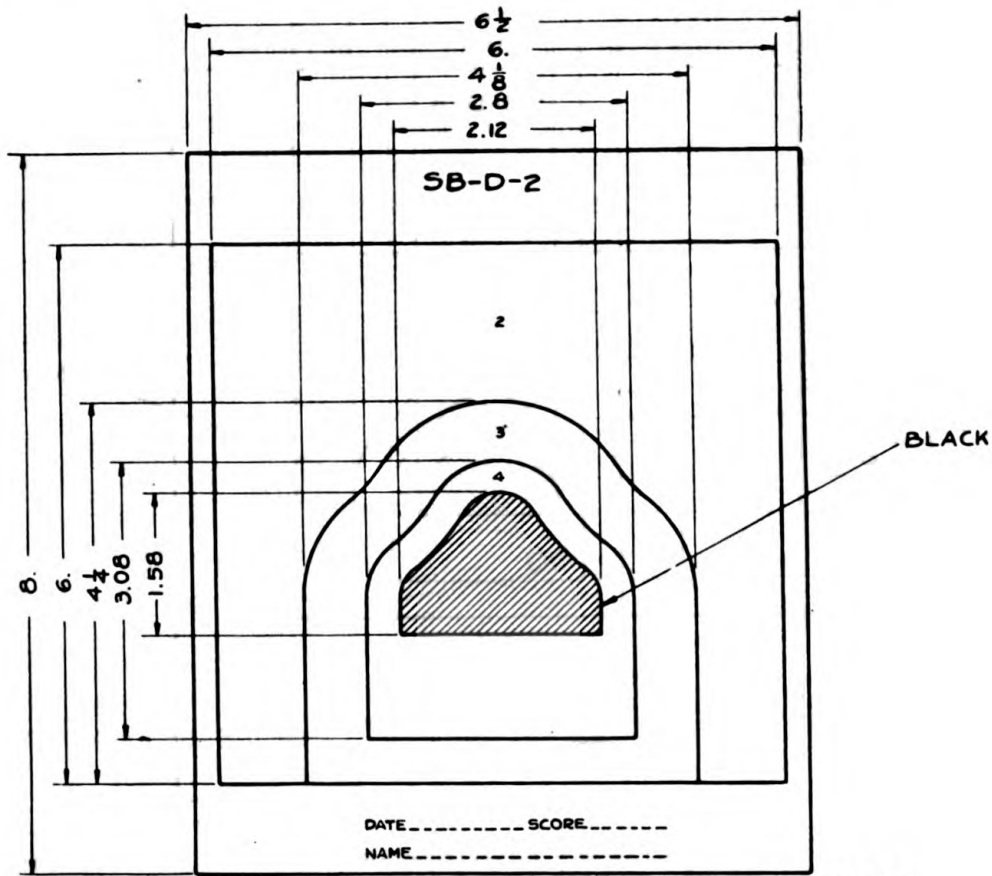

FIGURE 80.—Target, rifle, SB-D, 100-yard.

1. *SB-D-2*.—This target (fig. 81) is printed with black ink on buff manila target paper, 8 inches high and 6½ inches wide. It is required for instruction practice, rapid fire, with the caliber .22 rifle on the 50-foot range. The targets are packed 1,000 in a package, each package wrapped completely and securely in paper, with label suitably printed to describe contents pasted on outside of package.



ORD. 10347

FIGURE 81.—Target, rifle, SB-D-2.

*m. SB-D-3.*—This target (fig. 82) is 8 inches high and 6½ inches wide and made of the same stock and packed 1,000 in a package as described in *l* above. It is required for instruction and record practice, rapid fire, with the caliber .22 rifle on the 50-foot range.

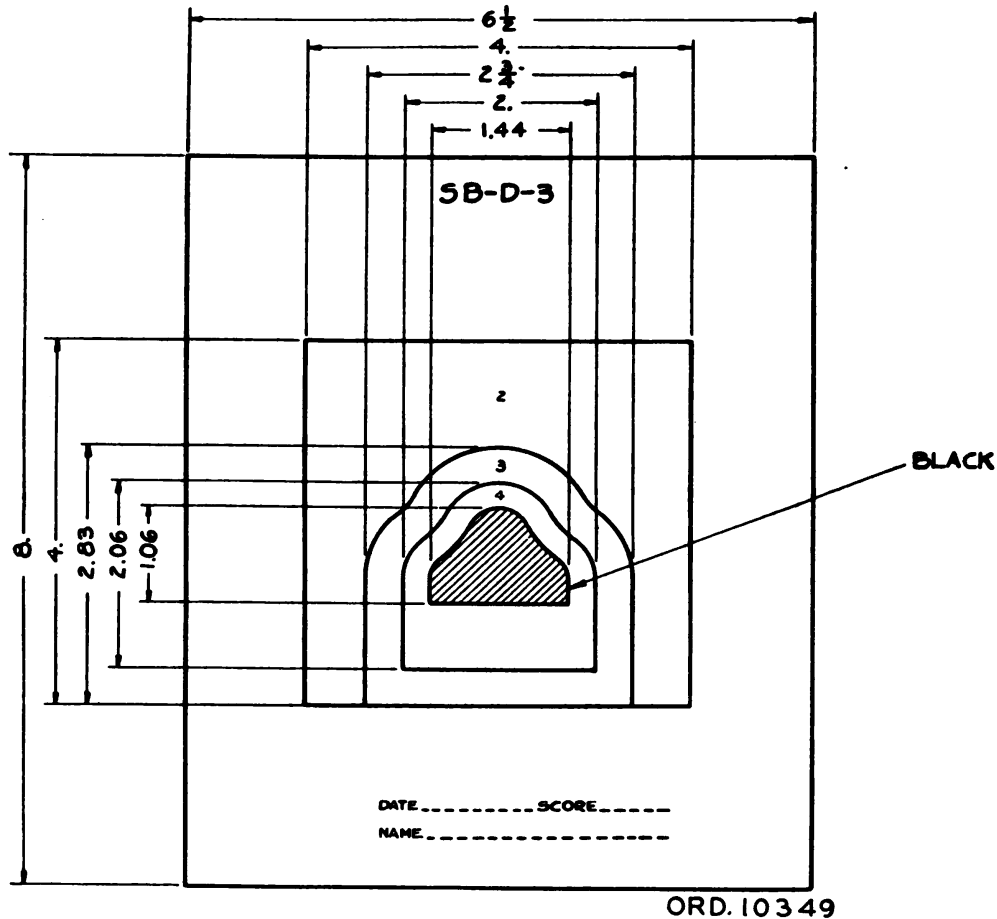

FIGURE 82.—Target, rifle, SB-D-3.

**44. Rolling target, machine-gun, complete.**—This target (fig. 83) is installed on the 1,000-inch machine-gun range and is used for machine-gun practice. It may also be used for 1,000-inch range automatic and machine rifle practice. The target, less beam and target frames, can be used as the foundation for the horizontal moving target in machine-gun combat practice and for the track type antitank target on the 1,000-inch range.

*a.* The principal parts of the machine-gun rolling target are a rolling target car assembly, 75 feet of track (assembly), one target beam assembly, two U-bolt assemblies, one wooden tackle block, 200 feet of ½-inch diameter manila rope and four machine-gun target frames (two right assemblies and two left assemblies). The per-

manent equipment, which does not include target frames and paper targets, is issued knocked down and assembled at range.

b. *Method of installing the machine-gun rolling target.*—(1) Lay the track on the range with one end abutting against the bullet stop and the other end extending toward the firing point. The ground on which the track is laid should be level. Place the car on the track. Attach the wooden tackle block to the cross rail of the track nearest the bullet stop. Run the rope through the tackle block, and attach one end of the rope to the front end of the car and the other end to the rear end of the car, pulling out the double rope to the firing point. Place the target beam on the car and run down as near to the bullet stop as possible. With the car in this position, measure 1,000 inches from the target beam toward the firing point, and at this point

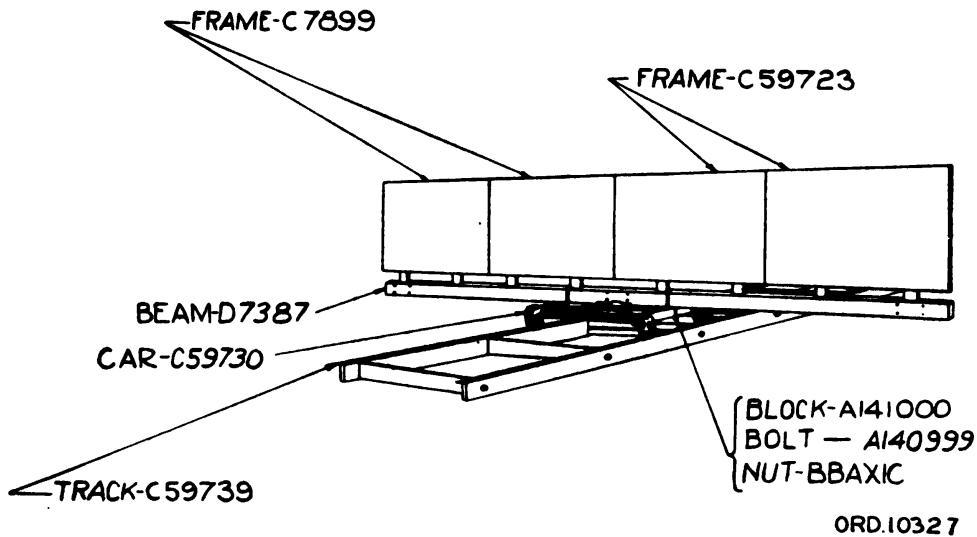

FIGURE 83.—Target, rolling, machine-gun, complete.

drive a stake. This stake marks the position of the gun pintle of the machine gun in firing. Construct a firing point around the stake, raising the ground about 1 foot above the level of the track, and making the mound large enough for the gun and gun crew.

(2) Paste the four machine-gun paper targets on the machine-gun target frames, then install the target frame assemblies on the rolling target by inserting the staves in the openings provided in the targets beam.

**45. Silhouette targets.**—Silhouette targets are made of target paper, olive drab in color on both sides. They are used for pasting over appropriate pasteboard targets when the pasteboard targets become badly perforated with bullet holes. They are supplied in three shapes.

a. *E, kneeling*.—This target is used to repair pasteboard target E, kneeling. They are packed 1,250 in a box.

b. *F, prone*.—This target is used to repair pasteboard target F, prone. They are packed 2,500 in a box.

c. *Trapezoidal*.—This target is used to repair pasteboard target, trapezoidal. They are packed 1,250 in a box.

46. **Stationary targets, AA.**—These targets are used in manipulation exercises with antiaircraft machine guns on the 1,000-inch range and represent the path traveled by an airplane in parallel, climbing or diving, and maneuvering flight. They are 3 feet high and 5 feet wide, and are printed with black ink on buff manila paper. The targets are packed 50 in a roll, each roll wrapped completely and securely in paper, with label suitably printed to describe contents pasted on outside of roll.

a. Target, stationary AA, "A" (fig. 84).

b. Target, stationary AA, "B" (fig. 85).

c. Target, stationary AA, "C" (fig. 86).

47. **Tank target, 1,000-inch.**—This target (fig. 87) is printed with black ink on buff manila target paper, 3 feet high and 5 feet wide. It is required for range practice with the caliber .30 and caliber .50 machine guns mounted in tanks (stationary) on the 1,000-inch range. The targets are packed 50 in a roll, each roll wrapped completely and securely in paper, with label printed to describe contents pasted on outside of roll.

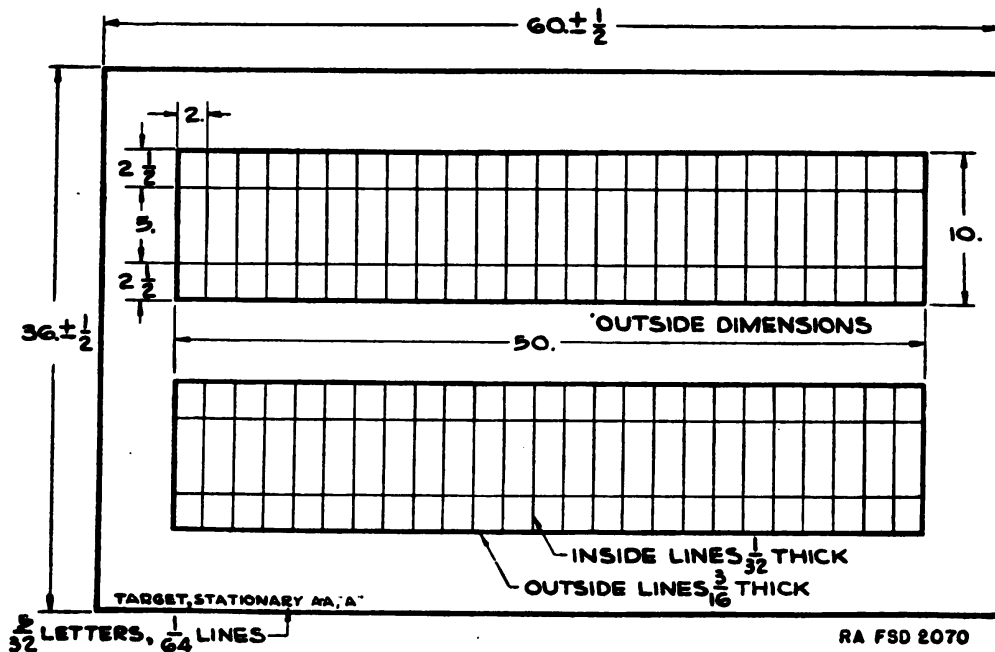

FIGURE 84.—Target, stationary AA, "A."

48. Trapezoidal target.—This target is made of pasteboard,  $\frac{1}{8}$  inch in thickness, one surface being olive drab in color. It is required as a component of target M, M1913, complete, in which it is used in combination with pasteboard target E, kneeling, to represent a stand-

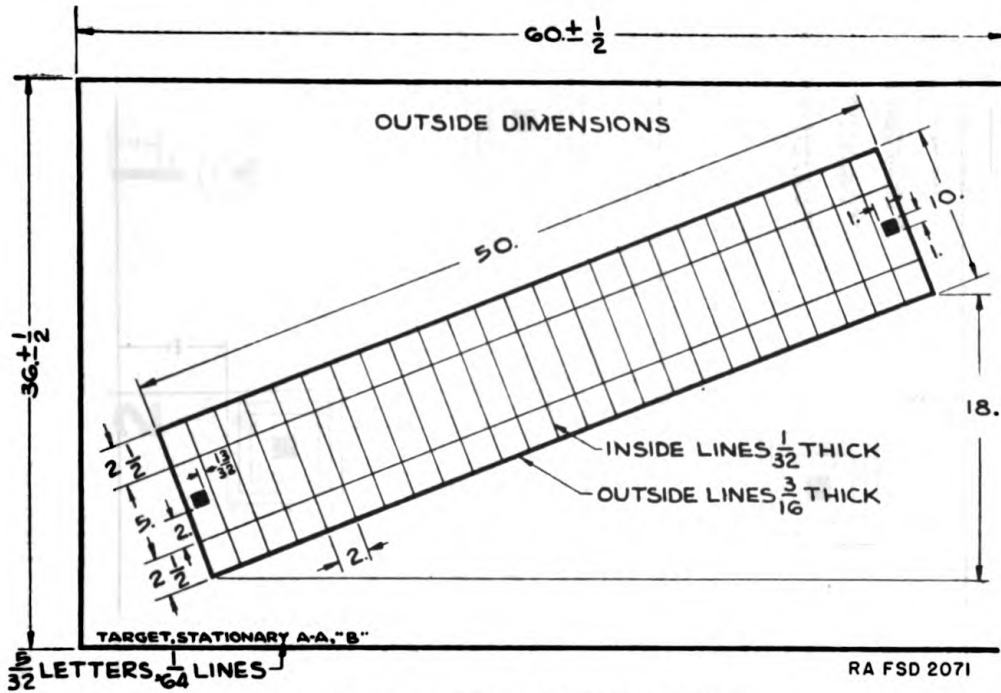

FIGURE 85.—Target, stationary AA, "B."

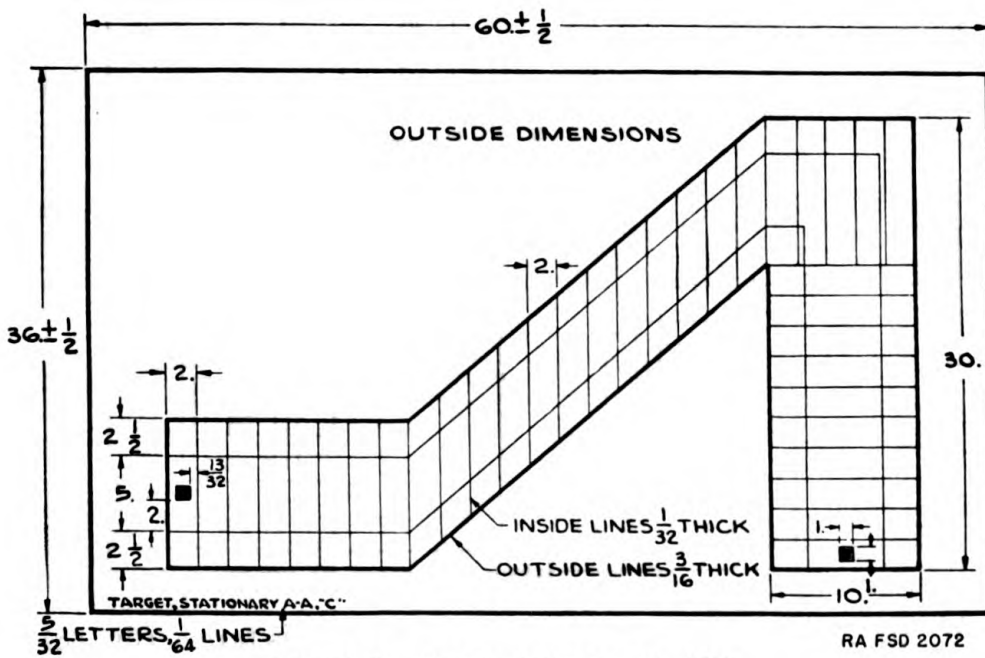

FIGURE 86.—Target, stationary AA, "C."



ing figure, the trapezoidal pasteboard target forming the legs of the figure. The targets are packed 50 in a package, each package wrapped in waterproof lining paper and securely bound with cord.

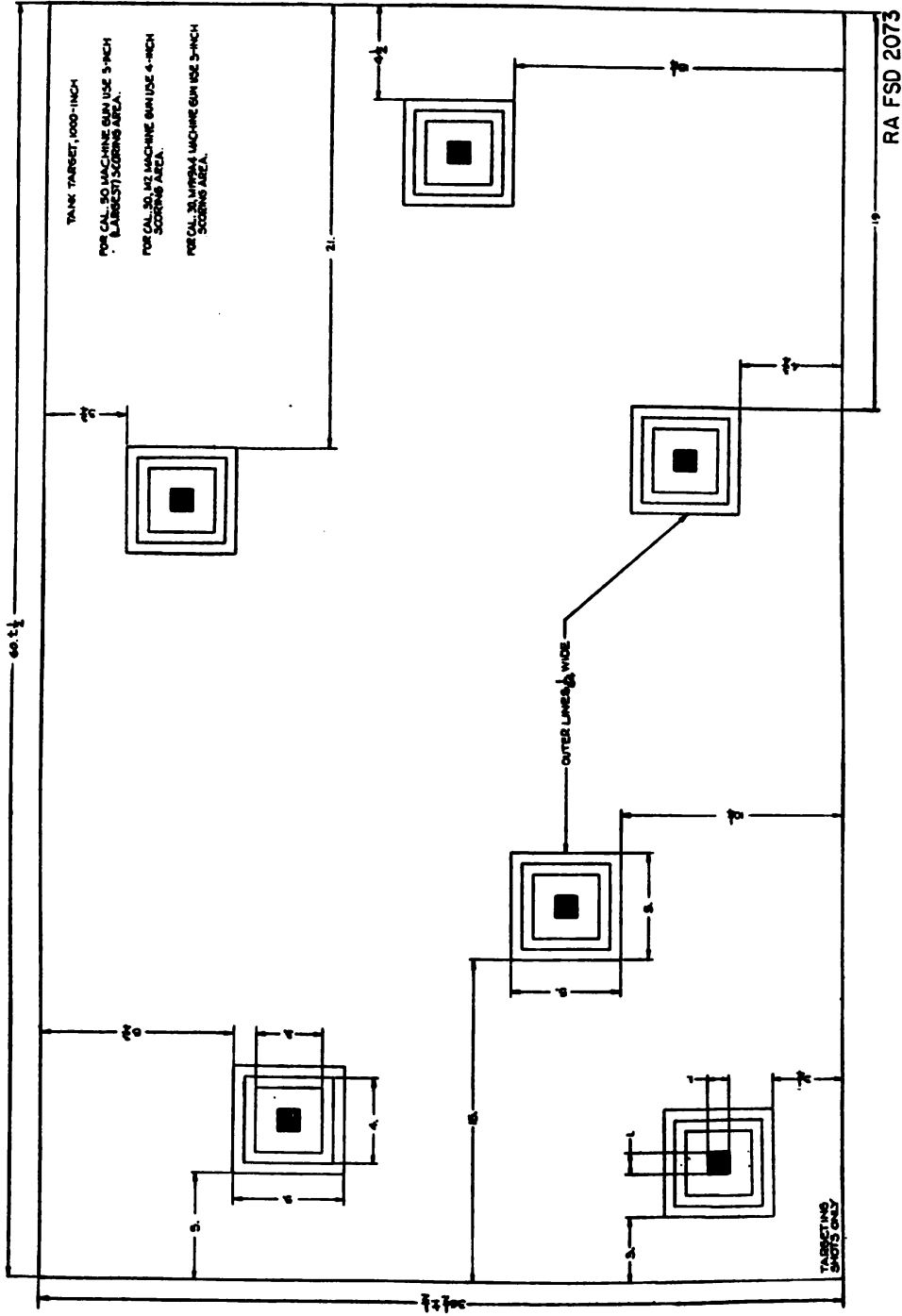
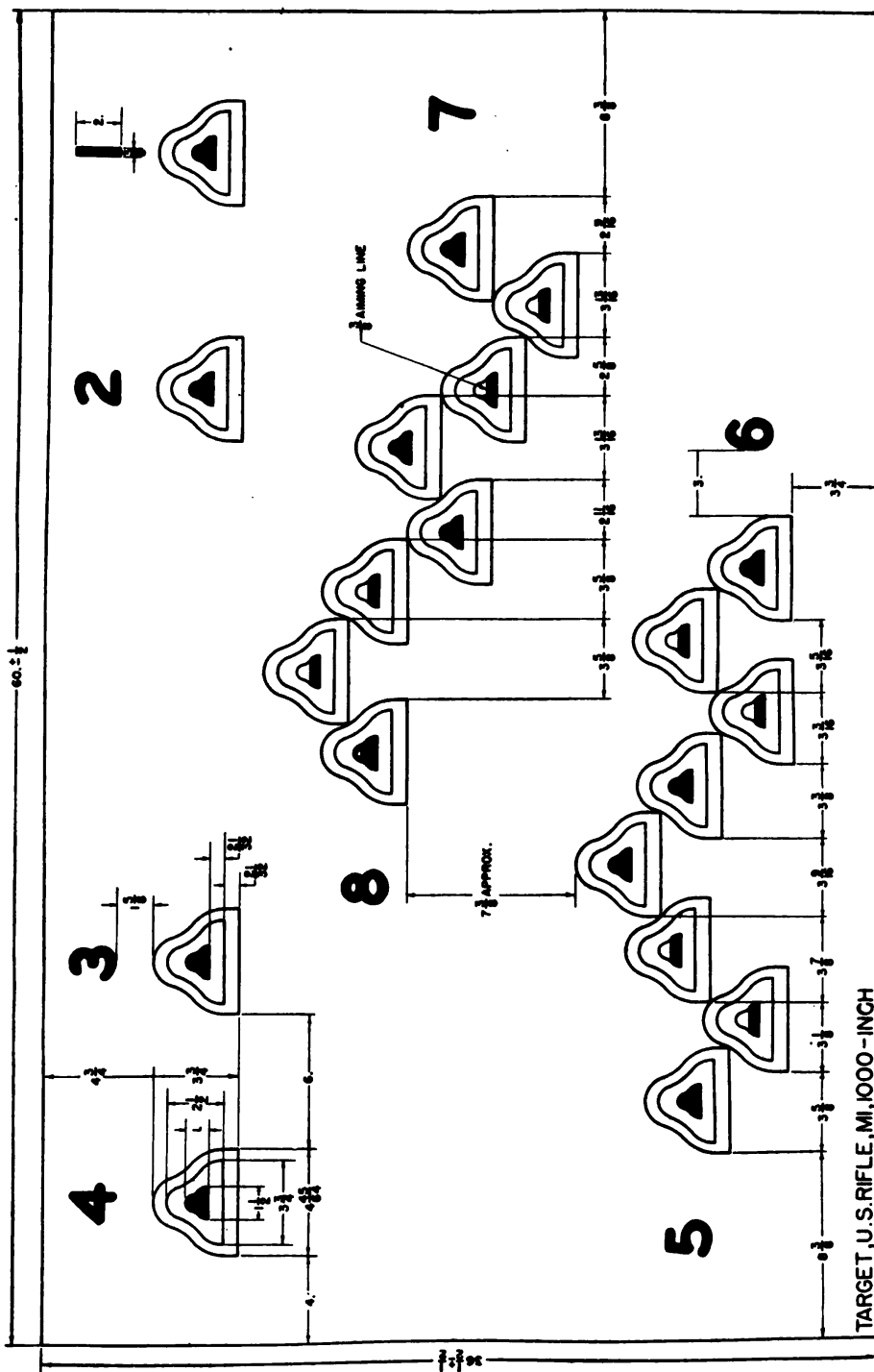

FIGURE 87.—Target, tank, 1,000-inch.

49. U. S. rifle, M1, target, 1,000-inch.—This target (fig. 88) is printed with black ink on buff manila target paper, 3 feet high and 5

Generated on 2016-06-11 08:08 GMT / http://hdl.handle.net/2027/uc1.b3243773  
Public Domain, Google-digitized / http://www.hathitrust.org/access\_use#pd-google

feet wide. It is required for all types of firing with the Browning automatic rifle, caliber .30, on the 1,000-inch range. The targets are packed 50 in a roll, each roll wrapped completely and securely in paper, with label suitably printed to describe contents pasted on outside of roll.



RA FSD 2074

FIGURE 88.—Target, U. S. rifle, M1, 1,000-inch.

SECTION V

TARGETS AND EQUIPMENT FOR MOVING ARTILLERY  
TARGET RANGES

	Paragraph
General.....	50
Target, ground, fast moving, M1.....	51
Target, ground, fast moving, M2.....	52
Targets, testing.....	53

**50. General.**—In addition to the target described below, surplus, obsolete, and condemned caissons, limbers, and other wheeled vehicles, tanks, etc., may be used as targets when such matériel is available.

**51. Target, ground, fast moving, M1.**—This target is for the purpose of providing a moving target representing tanks and armored cars. The targets are manufactured locally under the direction of corps area and department ordnance officers. The complete target includes two principal units: The target assembly, shown in figure 89 and the change of direction platform, shown in figures 90 and 91.

*a. Target, assembly.*—The target assembly (fig. 89) is a toboggan-type sled, from which trails a cloth sleeve target.

(1) The sled consists of a steel head made of  $\frac{1}{16}$ -inch boiler iron shaped similar to the prow of a boat, to which is riveted a galvanized roofing iron body 26 inches wide and 96 inches long. At the rear a triangular standard is erected and stayed by wires running to the head and body of the sled. A wire bridle is fastened to the steel head and the tow line attached thereto.

(2) The sleeve assembly is 30 inches in diameter, supported at the front by a 30-inch steel sleeve ring. Fourteen inches in front of the sleeve ring is a circular metal spacer 4 inches in diameter, which is connected to the sleeve ring by 4 pieces of No. 14 B and S gage annealed copper wire. A short piece of this type of wire is fixed in the center hole of the spacer and is used to connect the sleeve assembly to the apex of the sled standard.

(3) The diameter of the sleeve assembly is given in (2) above as 30 inches. This diameter is also shown on the ordnance drawings and applies where range practice is held. The lengths of sleeves vary from approximately 8 to 10 feet when the target is towed at slow (air) speeds (under 30 m. p. h.) to 5 to 7 feet when towed at speeds above 30 m. p. h. When using subcaliber ammunition at reduced ranges, relatively smaller sleeves, both in diameter and length, should be used. Hits on the sleeve are recorded.

*b. Platform, assembly.*—One or more platform assemblies are used as the principal change of direction apparatus. The platform con-

sists of a double thickness of 1-inch lumber, each side being 40 inches long. A circular piece is cut out of the upper layer and a bicycle wheel is mounted therein. Two sets of tripping blocks, each consisting of one wire guide block (A) and one lifting block (B) (fig. 90), are installed on the upper face of the platform so as to permit change of direction to either the right or left. Figure 90 shows only one set of these blocks. An offset head wooden guide wire peg is driven into the hole (D) (fig. 90), to retain the tow wire under the beveled edge of the guide wire block (A). As the guide wire peg is snapped off each time the tow wire is tripped from the platform, a plentiful supply should be on hand. The platform is anchored to the ground by a center stake, which also acts as the wheel bearing, and by four corner stakes. Care must be exercised in driving the

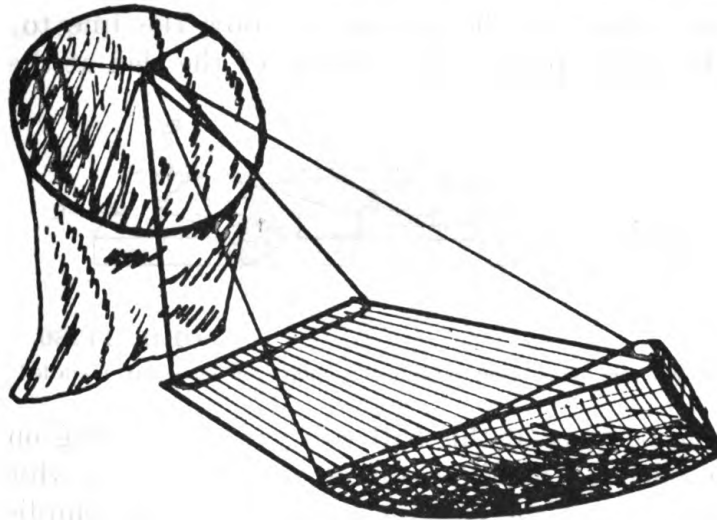

ORD. 14287

FIGURE 89.—Fast moving ground target, M1—target assembly (sled and sleeve).

center stake so that it remains plumb and the center hole is not burred. A drift is furnished to drive the center stake.

*c.* The target assembly requires approximately 3,300 feet of No. 12 galvanized iron wire, as a towline, and two or more wooden polo balls. The towline is carried on the reel assembly (fig. 92) when not in use. The polo balls are drilled through so as to slip onto the towline at the end where it is attached to the sled bridle.

*d. Operation.*—A dirt or other road over which the prime mover can develop speed approximating 50 m. p. h., and fairly open terrain are required. The tests showed that a light touring car made a satisfactory prime mover, while a  $\frac{3}{4}$ -ton truck was used to transport the target to position.

(1) One or more platforms (fig. 90) are installed to give such change of direction to the target as may be desired.

(2) To guide the towline around obstacles, pieces of lath are driven lightly into the ground. These laths guide the wire at critical points and are broken off by the polo balls or the steel head of the sled.

(3) Holes may be dug and the laths installed so that the target will pass over the hole and jump. With a towed speed of 40 m. p. h. the target will pass over a prepared hole and jump approximately 60 feet beyond the hole without upsetting.

(4) Lay out the towline along the route the target should follow. Place the towline in proper position on the platform. Before attaching the towline to the sled bridle, slip on one or two polo balls. The first polo ball should be strung on the towline and fastened at such distance ahead of the sled as to allow the line to straighten and turn the target prior to the arrival of the sled at the platform.

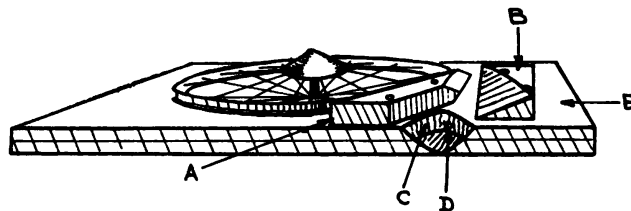

ORD. 14286

FIGURE 90.—Fast moving ground target, M1—platform assembly installed in position.

The desirable position of this ball will vary, depending on the speed at the turn, effect of wind, character of ground over which the target is traveling, and the amount of turn to be accomplished. For a right-angle turn, target moving at 30 m. p. h., a lead of 15 yards should be satisfactory. Moving at a speed of 40 m. p. h., the lead is doubled, that is, 30 yards. The other polo ball should be fastened in place at the bridle. It is used to assist in passage over rough ground and through bunchy grass. Additional balls may be necessary when the target is towed over rocky soil. They should be placed relatively close together to insure tripping.

(5) During the run the forward polo ball snaps off the guide wire peg (D), figure 90, and rides the upper beveled edge of the blocks (A) and (B), releasing the towline from the rim of the wheel, and the towline straightens out.

(6) Runs with a turn, zigzag runs and turns, and jumps are practicable. Officers in charge of firing should endeavor to lay out difficult and original runs.

*e. Requirements.*—Each battalion or separate battery of light field artillery will require two turning platforms, and each battery of light field artillery, three target assemblies, and one reel assembly, with 5,000 yards of No. 12 galvanized iron wire for two lines.

*f. Detailed description.*—(1) *Target, assembly.*—The target assembly (figure 89 and drawings 39-3-38, 39, and 40) consists of a toboggan type sled and a sleeve target.

(a) The sled consists of a welded steel head (43E) formed of  $\frac{1}{16}$ -inch thick boiler plate; a body made of a piece of approximately No. 22 gage corrugated galvanized iron (roofing) (43C), 26 inches wide and 96 inches long, which is riveted to the steel head; a triangular standard (43A) which is riveted in an upright position on the rear of the body and stayed in place with No. 14 B and S gage brass wire.

(b) The sleeve, assembly (39C), consists of a cylindrical target cloth sleeve (39A), 30 inches in diameter, the front end being held

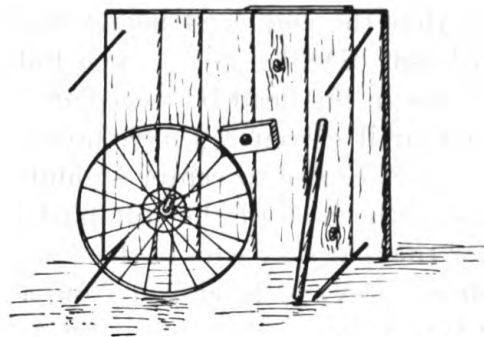

ORD. 14288

FIGURE 91.—Fast moving ground target, M1—bottom view of platform assembly showing center spike, wheel shaft, and bicycle wheel disassembled.

open by a steel sleeve ring (43G). Four pieces of No. 14 B and S gage copper wire equally spaced on the sleeve ring are led to a spacer (39B) which when installed is located approximately 14 inches forward of the sleeve ring. From the center hole in the spacer a short piece of this wire is used to attach the sleeve assembly to the top of the sled standard (43A).

(c) *Construction of sled.*

1. The steel head consists of four pieces of  $\frac{1}{16}$ -inch boiler plate and a bridle, formed as shown on drawings 39-3-39 and 43, piece marks 39D, 43B, 43D, and 43F. The bottom head-plate (43D), is cut to dimensions, and nine  $\frac{3}{32}$ -inch holes drilled as shown for attaching the body (43C) and then formed to correspond to the lower edge of the head side plates. The two head side plates (43F) are cut according

to the template and drilled as shown under piece mark 43E. The rear holes are for the standard (43A) stay wires, and the forward holes for the bridle (39D). The head brace (43B) is cut to dimensions given.

2. The head side plates (43F) head bottom plate (43D) and brace (43B) are then welded together at all points of contact. Paint with one or two coats of red lead. Make a bridle (39D), and insert the free ends through the forward holes in the head side plates (43F) and securely fasten them to the head brace (43B).
3. The body (43C) is made from a standard piece of corrugated iron roofing. Its over-all width is 26 inches and is cut to 96 inches long. No. 22 gage galvanized iron roofing is preferred, the normal corrugations being 2 inches between centers, but lighter weights (No. 24-26 gage) may be used. The edges at one end should be tapered for a distance of  $3\frac{3}{4}$  inches so that the end is 24 inches wide, or an easy fit in the steel head. Drill nine  $\frac{9}{32}$ -inch holes to correspond to similar holes in the head bottom plate (43D). At the opposite end drill eleven  $\frac{5}{16}$ -inch holes. Ten of the holes 2 inches apart center to center should correspond to similar holes in the base of the standard (43A). The single hole is for the rear stay wire to the standard.
4. The standard (43A) is developed from a piece of  $\frac{1}{4}$ - by  $\frac{1}{2}$ -inch flat steel  $8\frac{3}{4}$  feet long. It is formed as shown, and the joint welded. The base is drilled on 2-inch centers with  $\frac{5}{16}$ -inch drill to correspond with similar holes in the body (43C).
5. *Method of assembling.*—Rivet the body (43C) to the head bottom plate with  $\frac{9}{32}$ -inch buttonhead rivets approximately  $\frac{3}{4}$  inch long. Rivet the standard (43A) to the body (43C) with ten  $\frac{5}{16}$ -inch buttonhead rivets approximately  $\frac{3}{4}$  inch long. Attach three stay wires made of No. 14 B and S gage brass wire at the apex of the standard (43A). Two of the stay wires are then secured in the rear holes in the headplate sides (43E) and the remaining stay wire is secured in the  $\frac{5}{16}$ -inch hole near the rear edge of the body (43C). The free ends of the bridle (39D) are inserted in the forward holes in the headplate sides (43F) and secured to the head brace (43B).

(d) *Construction of sleeve assembly.*—The sleeve assembly (39C) consists of the target cloth sleeve, made in accordance with piece

mark (39A) and of suitable length for the towed (air) speed. (See *a*(3) above.) The sleeve ring (43G) is formed from a piece of  $\frac{1}{4}$ -inch steel wire or drill rod 93.5 inches long. The joint is welded and the sleeve ring then sewed in one end of the sleeve. The spacer (39B) is formed from a piece of .125-inch (No. 11 U. S. gage) sheet steel. Five  $\frac{5}{16}$ -inch holes are drilled as shown. Four pieces of No. 14 B and S gage copper wire are attached to the sleeve ring and the free ends inserted in the outer holes of the spacer (39B). The wires should be of sufficient length so that the spacer is approximately 14 inches in front of the sleeve ring. Through the center hole in the spacer (39B) insert a short length of the above-described wire to act as a coupling between the sleeve assembly (39C) and the apex of the standard (43A).

(2) *Platform, assembly.*—The platform assembly (figs. 90 and 91 and drawings 39-3-40 and 41) is the change of direction apparatus. It consists of a 40- by 40-inch wooden platform pegged to the ground at each corner and through the center, with a 26-inch bicycle wheel mounted so as to revolve in a horizontal plane on the upper surface of the platform. The bicycle wheel is countersunk in the platform to prevent the towline from riding under the wheel. In the hub of the bicycle wheel is a short axle, one end of which is screwed into and locked in the tapped end of the wheel shaft (41C) which in turn revolves in the center spike (41B). Two sets of blocks (40B and 40C) are attached to the upper face of the platform body, together with wire guide pegs (40E).

(a) *Metal components.*—The metal components consist of the following:

1. One 26-inch clincher type bicycle wheel with axle. This wheel should be procured locally or obtained from salvage. Adjust and lock the bearings in place. One end of the bicycle wheel axle is screwed into the tapped end of the wheel shaft (41C).
2. The wheel shaft (41C) is made from  $\frac{3}{4}$ -inch steel rod 8 inches long. One end is drilled and tapped to correspond with the bicycle wheel axle, and the outside turned to .74-inch diameter or so that the wheel shaft will revolve freely in the center spike (41B). Lock the bicycle wheel axle in in the wheel shaft.
3. The center spike (41B) acts as the principal anchorage for the platform and is the bearing in which the wheel revolves. It is made from  $1\frac{1}{2}$ -inch steel rod, approximately 36 inches long. This length may prove excessive in hard



- or rocky soils, therefore, it is an arbitrary length. One end is tapered and the center of the other end is drilled to a depth of 8 inches with a  $\frac{3}{4}$ -inch drill. The drilled hole acts as a bearing for the wheel shaft.
4. The drift (41D) is made from a piece of  $1\frac{1}{2}$ -inch grade B half hard brass rod approximately 9 inches long. For a distance of 3 inches one end is turned to a diameter of .73 inch or so that it provides a free fit in the drilled hole in the center spike. The shoulder should be square as the drift is used to drive the center spike into place.
  5. The cone (41F) is made from a piece of terne plate 11 inches in diameter. The template which is a development of the cone, is shown as piecemark 41G. The cone fits over the upper portion of the bicycle wheel axle and is wired to the wheel spokes. Its purpose is to prevent the towline from snagging on the shaft when the towline is tripped.
  6. Four spikes (41A) are made from  $\frac{3}{8}$ -inch steel rod approximately 24 inches long;  $\frac{3}{4}$ -inch heads are formed and the ends are tapered. These spikes are inserted in the four corner holes to secure the platform to the ground.
  7. Eight  $\frac{3}{8}$ - by 3-inch lag screws and a quantity of eightpenny and thirtypenny nails are required. The lag screws are used in attaching the blocks (40B and 40C) to the platform (40A).

(b) *Wooden components.*—The wooden components consist of the following:

1. The base is 40 by 40 inches and made of two layers of 1- by 10-inch yellow pine, securely nailed with eightpenny nails. A circular piece  $26\frac{1}{2}$  inches in diameter is cut from the center of the upper layer. This is to permit adjustment of the lower edge of the bicycle rim below the upper surface of the base. At the center of the bottom of the base, a shaft supporting block (40D) is nailed with 6 thirtypenny nails. This block is made from a piece of 2- by 4- by 8-inch yellow pine and contains a  $1\frac{1}{2}$ -inch diameter hole which is drilled after assembly. To take the center spike (41B), a  $1\frac{1}{2}$ -diameter hole is bored through the platform and assembled shaft supporting block (40B). Three-eighth-inch diameter holes are drilled through the base at the corners to take the spikes (41A).
2. Two cone-shaped depressions are shaped in one side of the base as shown in cross sections shown on 40A. These

cupped surfaces prevent the wooden polo ball (tripping ball) from snagging on the edge of the platform. A  $\frac{5}{16}$ -inch diameter hole is drilled in each cone-shaped depression  $\frac{3}{4}$  inch from a line tangent with the wheel and  $2\frac{1}{4}$  inches from the platform edge. These holes are for the wire guide peg (40E).

3. Two guide wire blocks (40B) are attached as shown and adjacent thereto are attached the lifting blocks (40C). These blocks are held in place with  $\frac{3}{8}$ - by 3-inch lag screws. The towline passes under the beveled edge of the guide wire block (40B) until the wooden polo ball on the towline breaks the wire guide peg and passes over the beveled edges of the blocks, continuing until it throws the towline from the wheel.
4. The wire guide peg is made of yellow pine. The shank is  $\frac{1}{4}$  inch in diameter by  $3\frac{3}{8}$  inches long. The head, formed at a right angle to the shank, is  $\frac{3}{8}$  inch in diameter and  $1\frac{1}{4}$  inches long. This peg is placed in the  $\frac{5}{16}$ -inch hole in the cupped surface of the platform and is used to retain the towline under the wire guide block (40B) until broken by the polo ball. As one peg is required each time the target is operated, a quantity should be readily available.

(c) *Installation.*—Set the platform flush with the ground. Drive the center spike (41B), using the drift (41D) to avoid burring the end, through the center hole in the platform and into the ground until the upper end is flush with the platform. Oil the wheel bearings and the wheel shaft. Set the wheel in place and adjust the platform until the wheel revolves freely. Drive the spikes (41A) and the platform is ready for use.

(3) *Towline and polo balls.*—The towline is No. 12 galvanized iron wire. The reel holds approximately 3,300 feet, which is normally sufficient for one tow. Two or more polo balls per towline should be drilled through so they may be strung on the towline. Secure the polo balls in position on the towline by wrapping a short section of wire on the line immediately to the rear of the polo ball. These balls trip the towline as they pass between the beveled edges of the wire guide block (40B) and lifting block (40C). Their location on the towline is described in *d*(4) above.

(4) *Reel, assembly.*—The reel assembly (fig. 70 and drawings 39-3-41 and 42) consists of a  $3\frac{1}{2}$ -foot wooden reel (42B) mounted on a wooden reel platform (42A). It holds the towline when the line is not in use.

(a) *Metal parts.*—The metal parts consist of the following:

1. The reel shaft (41K) is made from a piece of 1½-inch galvanized steel pipe (approx. 1.9-inch O. D.), 20 inches long; 1¼ inches from one end a 2<sup>5</sup>/<sub>32</sub>-inch hole is drilled for the handle (41H). After assembly in the reel, two more holes are drilled to correspond to the holes in the washers (42C).
2. Two cast iron bridge washers (42C) are drilled as shown, and assembled on reel shaft (41K) with 3/8- by 4-inch steel pins.
3. The handle (41H) is formed from 3/4-inch diameter steel rod. One end is threaded for 4 inches for 0.75-10NC-2 hexagon nuts. It is secured in the reel shaft with two nuts.
4. A quantity of sixpenny, tenpenny, and thirtypenny nails is required.

(b) *Wooden parts.*—The construction of the reel assembly is simple and the wooden parts are sufficiently detailed on the drawings, therefore, no description is given herein.

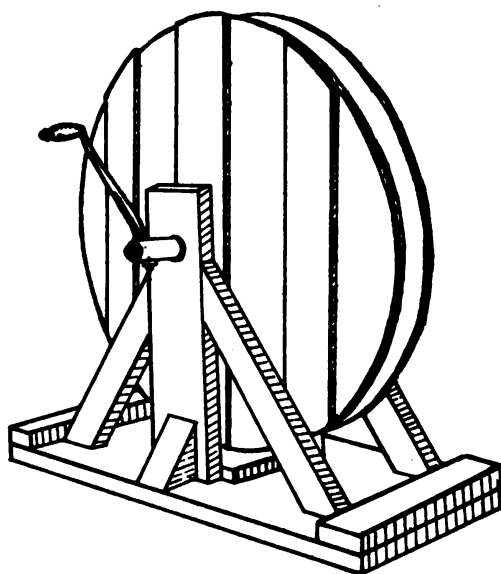

ORD. 14285

FIGURE 92.—Fast moving ground target, M1—reel assembly and towline.

52. **Target, ground, fast moving, M2.**—This target, shown in figure 93 (drawing 39-3-45), is an improved design of fast moving ground target issued by the Ordnance Department. It consists of a steel frame mounted on runners and is provided with facilities for attaching panels made of target cloth. The target is moved by

means of a cable (running over sheaves placed in suitable positions) attached to a truck.

*a.* The frame is composed of two each vertical angles, B168182 and B168183, secured to the runners, C73828 (made of seamless steel tubing), and the angles, B168179, which connect both ends of the runners. The runners and angles, B168179, are braced vertically by means of angles, A186436 and A186437. The frame is braced cross-wise by angles, B168180, connecting the angles, B168179; by angles, B168181, connecting the tops of the uprights, B168182 and B168183; and by the ends, B168178 (made of seamless steel tubing), connecting the ends of the runners.

*b.* Rectangular panels, B168186 and B168187, and triangular panels, B168185, made of target cloth are stitched with a loop along all edges and are secured to the frame on wires threaded through the loops. The wires are hooked to close coiled springs, A186440 (provided to keep the wire under tension), which are attached at various points of the frame.

*c.* Cables, A186439A, attached to the ends of the runners, cable, A186439B, attached to the middle of end, B168178, and cable, A186439C, attached to the truck, are joined by means of ring, A186441, and are secured by cable clamps, A186433.

*d.* Sheaves, B168184, are provided to guide cable, A186439C, where a change in direction of the target is desired. The sheave is mounted on plate, A186443, which is secured in position by pin, A186442, assembled through a hole in the end of the plate driven in the ground.

**53. Targets, testing.**—Testing targets are used for the verification and adjustment of the gun sights. They are printed with black ink on white bond paper. For the drawing number, description, and method of using the several designs of testing targets, refer to the Standard Nomenclature List and Technical Manual covering the different caliber weapons.

*a.* The testing target for use with the field artillery trainer. M1. is shown on drawing D29707 and plate 7 of Supplement to SNL L-4, part 1. It is of paper and contains four registering targets, one for each trainer of the battery. It is designed to permit of bore sighting from the muzzle; this method is adopted due to the difficulty of bore sighting from the breech of the piece. Four targets are packed in a manila envelope with each battery.

*b.* The testing target for the 37-mm antitank gun is shown in figure 11, FM 23-70; its use is described in paragraph 27*c*(3), FM 23-70.

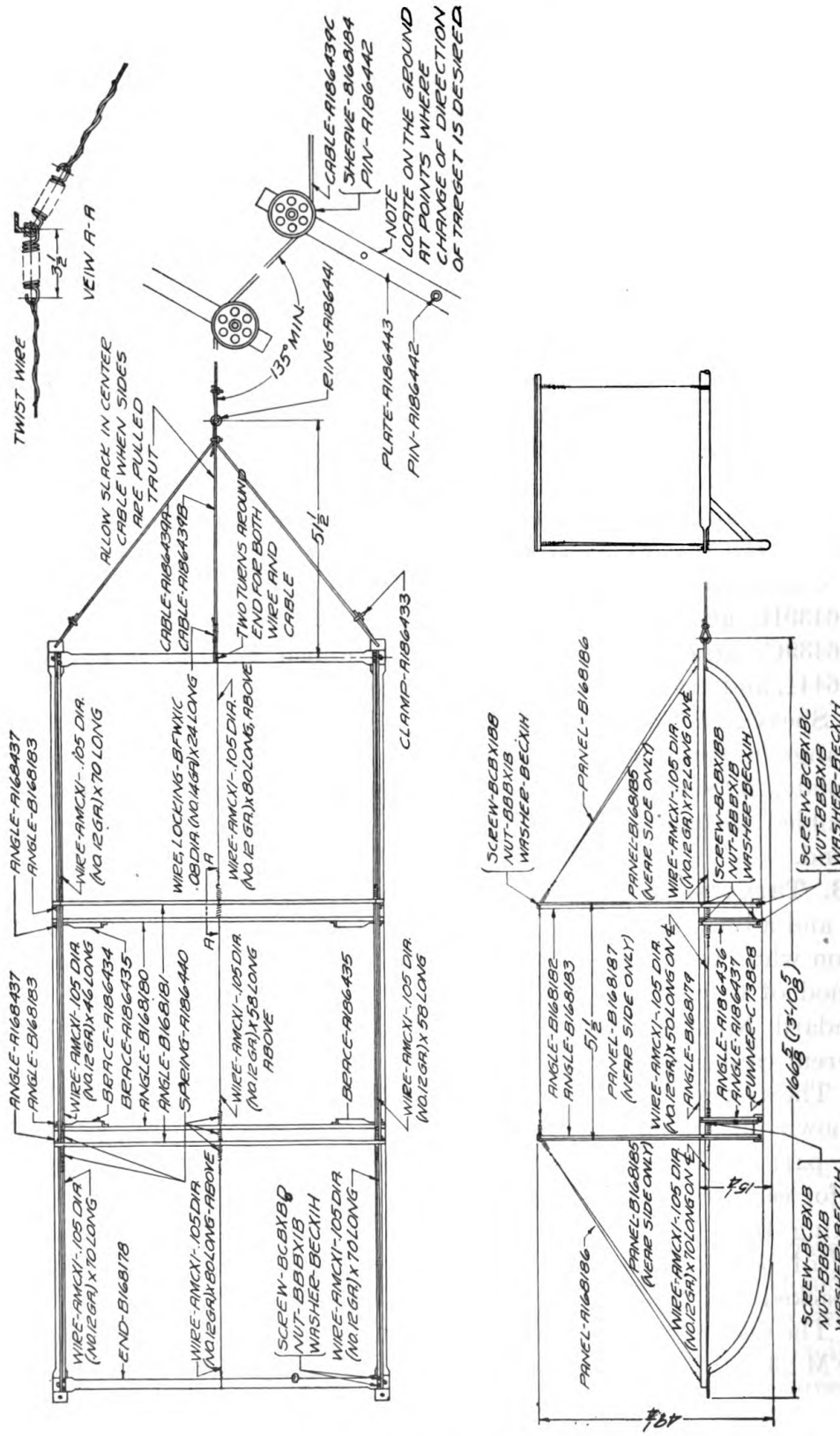

FIGURE 93.—Fast moving ground target, M2.

SECTION VI

TARGETS AND EQUIPMENT FOR HARBOR DEFENSE  
TARGET RANGES

	Paragraph
Target, seacoast, small, M1917.....	54
Target, seacoast, triangular, M1917.....	55
Target, seacoast, pyramidal, M1917.....	56
Bridle.....	57
Anchor.....	58
Towline.....	59
Flag, safety.....	60
Target, seacoast, fast towing, M2.....	61
Care and preservation of targets and tows.....	62

54. Target, seacoast, small, M1917.—This target, drawing 39-2-3, is provided for 3-inch and other small caliber target practice. It is a towed water target and is constructed as follows:

a. The base is made up of two running timbers 3 by 12 inches by 29 feet, braced by three cross planks 2 by 10 inches by 12 feet notched into the running timbers and held by 5/8- by 10-inch lag screws. Two cross planks 2 by 12 inches by 12 feet are nailed to the beveled front end of the running timbers to form a prow. A towing iron is attached to the prow end of each running timber by means of 5/8-inch bolts with nuts and washers.

b. The superstructure is a vertical rectangular frame 10 by 24 feet consisting of three upright masts and two longitudinal boards. Each mast consists of two 2- by 4-inch boards nailed together at right angles and supported on the cross planks in pillow blocks. Each mast is braced by four guy wires, two of which are attached to each running timber. All guy wires are made of 1/4-inch diameter flexible wire sash cord and are supplied with 1/4-inch hook and eye turnbuckles with 4-inch take-up. The center mast is extended 6 feet above the rest of the superstructure in order to provide a sight rod which is painted in alternate bands of white and red, each band 18 inches wide.

c. A twine net, 1/2-inch square mesh, of No. 15 twine, is strung among the three masts. The net is bound with a 5/8-inch diameter manila rope on four sides, and is secured to the masts and longitudinal boards by means of screw hooks. A piece of vermilion bunting, 3 feet wide and 18 3/4 feet long, is attached to the target. All wood and metal parts are given two coats of metallic red lead paint, except the white bands on the end of the center mast (sight rod) which are painted with white lead paint.

**55. Target, seacoast, triangular, M1917.**—This target, drawing 39-4-11, is provided for medium and major caliber subcaliber target practice. It is a towed water target and is constructed as follows:

*a.* The base is made up of two running timbers 3 by 12 inches by 14 feet, braced by two cross planks 2 by 10 inches by 10 feet notched into the running timbers and held by  $\frac{5}{8}$ -by 10-inch lag screws. A towing iron is attached to the prow end of each running timber by means of  $\frac{5}{8}$ -inch bolts with nuts and washers.

*b.* The superstructure consists of two target legs, one of which is attached at the center of each cross plank by means of target leg blocks. The target legs are set at angles of  $22^\circ$  with the vertical and are nailed together at the point where they cross. The right target leg is 4 feet longer than the left target leg and has the part above the point of attachment of the left target leg painted in alternate bands of white and red, each band 12 inches wide, to furnish a suitable sight rod. The superstructure is braced by two guy wires made of  $\frac{1}{8}$ -inch diameter flexible wire sash cord, which are attached by nut eyebolts to the target legs near the point where they cross and to each of the running timbers. Each guy wire is supplied with a  $\frac{1}{4}$ -inch hook and eye turnbuckle with a 4-inch take-up. All wood and metal parts are given two coats of metallic red lead paint except the white bands on the end of the right leg (sight rod) which are painted with white lead paint.

*c.* A piece of vermilion bunting is attached to the two target legs by tacks and leather washers and extends from 15 inches below the bottom of the sight rod to 5 feet above the running timbers.

**56. Target, seacoast, pyramidal, M1917.**—This target, drawing 39-4-3, is provided for major caliber target practice. It is a towed water target and is constructed as follows:

*a.* The base is made up of three running timbers 3 by 12 inches by 15 feet, braced by two cross planks 2 by 10 inches by 15 feet notched into the running timbers and held by  $\frac{5}{8}$ -by 10-inch lag screws. A prow cleat, 1 by 12 inches by 15 feet, is nailed to the beveled front ends of the running timbers. A towing iron is attached to the front and rear end of each outside running timber with  $\frac{5}{8}$ -inch bolts with nuts and washers, to permit towing two or more targets at once.

*b.* Two mast boards, 1 by 4 inches by  $16\frac{1}{2}$  feet, are bolted to the middle running timber and are nailed together at the top. They are braced with 1-by 4-inch by 10-foot boards nailed to the middle running timber. Guy wires made of  $\frac{1}{8}$ -inch diameter flexible wire sash cord are attached to the mast boards by nut eyebolts and run to the

front and rear of each of the outside running timbers where they are attached by means of  $\frac{1}{4}$ -inch hook and eye turnbuckle with 4-inch take-up. These guy wires should be kept taut in order to prevent straining or dislocating the mast boards. All wood and metal parts are given two coats of metallic red lead paint.

*c.* The cover of the target extends to within 3 feet 8 inches of the base and is made of vermilion bunting. It is tied to  $\frac{1}{2}$ -inch diameter manila ropes which lead from the front and rear ends of the outside running timbers to the top of the mast where they pass through a hole in the mast boards.

**57. Bridle.**—For attaching the towline to the target, a bridle of manila rope is used. The bridle is made of 1-inch diameter rope and has two branches of 20 feet each. Attached to the end of each branch is a  $\frac{3}{4}$ -inch hook with eye shank and thimble. After the hooks are inserted in the holes of the towing irons on the running timbers of the target, they are lashed in place with No. 15 gage copper wire. A  $\frac{3}{4}$ -inch wire rope thimble is provided in the middle of the bridle for the attachment of the towline.

**58. Anchor.**—The anchor is manufactured locally. It consists of a 100-pound cast concrete block with eyebolt.

**59. Towline.**—The towline is not a part of the three seacoast targets described in paragraphs 54, 55, and 56. The towline used for towing these targets is  $1\frac{1}{4}$ -inch diameter (3.93-inch circumference) medium laid, 3-strand, manila rope. The normal length of the towline is 2,000 feet but the length actually used for towing varies for different districts.

**60. Flag, safety.**—Two scarlet streamers are authorized for each post where target practice is held; one for use on the towing tug and one for use on shore. The streamer is described in paragraph 19.

**61. Target, seacoast, fast towing, M2.**—This target is provided for use as a fast towing water target in coast artillery target practice. The target weighs approximately 11,000 pounds and is capable of being successfully towed at any speed up to 25 knots per hour.

*a.* The assemblies, details, and bill of materials for the target are shown on drawings 39-4-12; 39-4-12A; 39-4-13; and 39-4-14.

*b.* The target consists of a specially constructed raft 25 feet long and 12 feet wide having metal fins made of  $\frac{1}{4}$ -inch steel plate 12 feet long extending below the raft on each side at the rear. Secured to the deck of the raft is a 20-foot mast which is held in place by four double guy wires, with turnbuckles, which are attached to the deck and to the mast about its midpoint and a point about 19 feet from the deck. The aiming point is a flag of vermilion bunting, 4



feet wide and 9 feet fly, secured to the top of the mast by means of a pulley and halyard.

*c.* All lumber should be given a coat of boatbuilder's copper paint (all surfaces) before cutting for the target. The complete target should be given a second coat of paint after completion, before launching.

*d.* The towline for this target is 2,000 feet long and made of medium laid, 3-strand, manila rope 6 inches in circumference.

**62. Care and preservation of targets and towlines.—***a.* When not in use the targets should be placed on skids about 1 foot from the ground and, if practicable, out of the wind.

*b.* Targets should be painted with sufficient frequency to preserve them from deterioration.

*c.* The nets, bridles, and towlines will be removed from the targets when not in use.

*d.* Great care is necessary to preserve rope that has been wet with salt water from rapid deterioration. All rope should be removed from the targets and coiled when not in use. Before coiling, it should be dried, and after coiling, should be stored in a dry building.

APPENDIX

LIST OF REFERENCES

1. **Standard Nomenclature Lists.**
  - Small arms targets and target material..... SNL L-1
  - Fixed armament targets and target material..... SNL L-3
  - Mobile artillery targets and target material..... SNL L-4
2. **Technical Manual.**
  - Construction of small bore target ranges..... TM 9-860
3. **Field Manuals.**
  - U. S. rifle, cal. .30, M1..... FM 23-5
  - U. S. rifle, cal. .30, M1903..... FM 23-10
  - Browning automatic rifle, cal. .30, M1918A2, with  
bipod ..... FM 23-15
  - Browning automatic rifle, cal. .30, M1918A2 without  
bipod..... FM 23-20
  - Bayonet, M1905..... FM 23-25
  - Hand grenades..... FM 23-30
  - Automatic pistol, cal. .45, M1911 and M1911A1..... FM 23-35
  - Thompson submachine gun, cal. .45, M1928A1..... FM 23-40
  - Browning machine gun, cal. .30, HB, M1919A4,  
ground..... FM 23-45
  - Browning machine gun, cal. .30, HB, M1919A4  
(mounted in combat vehicles)..... FM 23-50
  - Browning machine gun, cal. .30, M1917..... FM 23-55
  - Browning machine gun, cal. .50, HB, M2, ground... FM 23-60
  - Browning machine gun, cal. .50, HB, M2 (mounted  
in combat vehicles)..... FM 23-65
  - 37-mm gun, antitank, M3..... FM 23-70
4. **Army Regulations.**
  - Range regulations for firing ammunition in time  
of peace..... AR 750-10
  - Promotion of rifle practice..... AR 850-100
  - Rifle and pistol competitions in schools and col-  
leges..... AR 850-110
5. **Table of Allowances.**
  - Targets and target equipment..... T/A
6. **U. S. Army specifications.**
  - Standard specifications for marking shipments... Spec. 100-2



INDEX

	Paragraphs	Pages
Aerial bombing, low-altitude target and intermediate- and high-altitude target lay-outs.....	14	32
Anchor.....	58	127
Antiaircraft cal. 22 training range, lay-out.....	14	32
Antiaircraft targets.....	28	72
Antitank target.....	29	73
Approval of proposed construction.....	7	13
Athletic field lay-outs.....	14	32
Automatic rifle target, 1,000-inch.....	30	74
Balloon, rubber, M1.....	16	61
Baseball diamond lay-out.....	14	32
Bayonet instruction and qualification course lay-out.....	14	32
Bayonet practice disk, M1.....	18	61
Bobbing target, M1913.....	31	74
Bombing targets.....	32	74
Bridle.....	57	127
Care and preservation, targets and towlines.....	62	128
Care of range and facilities.....	12	22
Class A and B ranges, targets and equipment.....	15-49	61
Combination sliding target, complete.....	33	77
Comfort stations, target ranges.....	11	22
Construction:		
Approval of proposed.....	7	13
Firing points.....	10	22
Multitarget butts.....	13	23
Other ranges, courses, and athletic fields.....	14	32
Range house or storerooms.....	9	22
Target butts.....	8	13
Equipment. See targets and equipment.		
Flags and streamer.....	19, 60	61, 127
Firing points.....	10	22
Frames.....	20	66
Gallery rifle targets.....	36	82
Ground target machine-gun ranges for flexible guns and fixed guns.....	14	32
Ground targets:		
Fast moving:		
M1.....	51	114
M2.....	52	122
Fixed gun aerial.....	37	82
H target, complete.....	38	83
Harbor defense target ranges, targets and equipment for.....	54-62	125
I target, M1913, complete.....	39	84
Ink, lithographic.....	21	69

	Paragraphs	Pages
Kneeling targets.....	34	82
Landscape target, complete.....	40	86
Machine-gun targets.....	41	87
Markers.....	22	70
Moving artillery target ranges, targets and equipment for.....	50-53	114
Multitarget butts.....	13	23
Pasters.....	24	71
Pistol course, mounted.....	14	32
Pistol target.....	42	91
Polo field lay-out.....	14	32
Preservation, targets and towlines.....	62	128
Prone target.....	35	82
Range house or storerooms.....	9	22
Range site, selection.....	6	9
References.....	App.	129
Repair centers.....	17	61
Rifle target.....	43	94
Rolling target, machine-gun, complete.....	44	108
Saber qualification course.....	14	32
Seacoast targets:		
Fast towing, M2.....	61	127
Pyramidal, M1917.....	56	126
Small, M1917.....	54	125
Triangular, M1917.....	55	126
Selection, target ranges.....	5, 6	9
Silhouette targets.....	45	109
Skeet outfit, electric release.....	23	70
Skeet range lay-out.....	14	32
Spotters.....	25	71
Staff, H.....	26	72
Stationary targets, AA.....	46	110
Stoves.....	27	72
Streamer.....	19	61
Tank target, 1,000-inch.....	47	110
Target butts.....	8	13
Target ranges:		
Care.....	12	22
Class A and B, targets and equipment for.....	15-49	61
Construction.....	7-11	13
Harbor defense, targets and equipment for.....	54-62	125
Moving artillery, targets and equipment for.....	50-53	114
Selection.....	5, 6	9
Types.....	4	2
Targets and equipment:		
Class A and B ranges:		
Balloon, rubber, M1.....	16	61
Bayonet practice disk, M1.....	18	61

INDEX

Targets and equipment—Continued.

Class A and B ranges—Continued.

	Paragraphs	Pages
Flags and streamer.....	19	61
Frames.....	20	66
Ink, lithographic.....	21	69
Markers.....	22	70
Pasters.....	24	71
Repair centers.....	17	61
Skeet outfit, electric release.....	23	70
Spotters.....	25	71
Staff, H.....	26	72
Stoves.....	27	72
<b>Targets:</b>		
Antiaircraft.....	28	72
Antitank.....	29	73
Automatic rifle 1,000-inch.....	30	74
Bobbing, M1913.....	31	74
Bombing.....	32	74
Combination sliding, complete.....	33	77
Gallery rifle.....	36	82
Ground, fixed gun aerial.....	37	82
H, complete.....	38	83
I, M1913, complete.....	39	84
Kneeling.....	34	82
Landscape, complete.....	40	86
Machine-gun.....	41	87
Pistol.....	42	91
Prone.....	35	82
Rifle.....	43	94
Rolling, machine-gun, complete.....	44	108
Silhouette.....	45	109
Stationary, AA.....	46	110
Tank, 1,000-inch.....	47	110
Trapezoidal.....	48	111
U. S. Rifle, M1, 1,000-inch.....	49	112
<b>Harbor defense target ranges:</b>		
Anchor.....	58	127
Bridle.....	57	127
Care and preservation of targets and towlines.....	62	128
Flag, safety.....	60	127
<b>Targets, seacoast:</b>		
Fast towing, M2.....	61	127
Pyramidal, M1917.....	56	126
Small, M1917.....	54	125
Triangular, M1917.....	55	126
Towlines.....	59, 62	127, 128
<b>Moving artillery target ranges:</b>		
<b>Target, ground, fast moving:</b>		
M1.....	51	114
M2.....	52	122
Target, testing.....	53	123

INDEX

	Paragraphs	Pages
Telephones.....	11	22
Tennis court lay-out.....	14	32
Towlines.....	59, 62	127, 128
Trapezoidal target.....	48	111
Trapshooting range lay-out.....	14	32
U. S. Rifle, M1, target, 1,000-inch.....	49	112
Water supply, target ranges.....	11	22

[A. G. 062.11 (1-9-41).]

BY ORDER OF THE SECRETARY OF WAR:

G. C. MARSHALL,  
*Chief of Staff.*

OFFICIAL:

E. S. ADAMS,  
*Major General,*  
*The Adjutant General.*

DISTRIBUTION:

D (5); B (3); R 1, 3, 8, 10 (3), 2, 4-7, 17 (5); Bn 1-7, 9, 11,  
17 (2); C 2-7, 9, 11, 17 (3).

(For explanation of symbols, see FM 21-6.)

U. S. GOVERNMENT PRINTING OFFICE: 1941

For sale by the Superintendent of Documents, Washington, D. C. . . . . Price 20 cents

